

DATE: 4/01/97

CONTROLLING OFFICE FOR THIS DOCUMENT IS:

Department of the Army
Commandant
US Army Armor Center
Directorate of Training and Doctrine (DTDD)
Internet Information Services Management System
(ILSMS)

POC: David Nilsen

DISTRIBUTION STATEMENT A: Public release

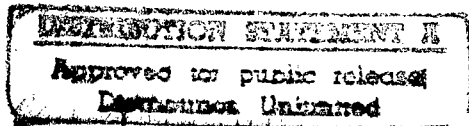

19970402 047

DTIC QUALITY INSPECTED 3

PART II - THE OFFENSE

M1A2s, Smart Ammunition, and Time and Space Theory

by Captain Mike Pryor

In the January-February 1996 *ARMOR*, I offered the theory that M1A2s with smart ammunition in the defense could destroy enemy armored vehicles at an amazing 11.5:1 ratio. This theoretical capability is the result of increased space and corresponding time provided by the Smart, Target Activated, Fire and Forget (STAFF) round's range, combined with enhanced digital battle command. These factors increase our lethality and situational awareness on the modern battlefield.

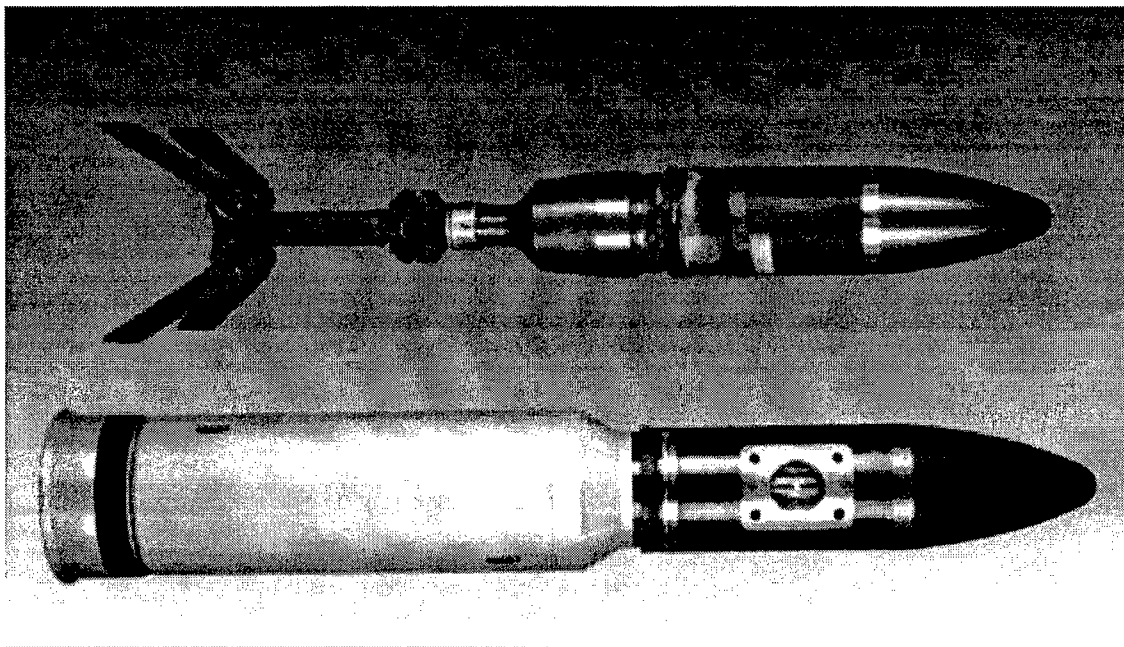

XM943 STAFF ROUND

But what happens when we are not defending? Can we still see a quantitative increase in our ability to destroy enemy vehicles offensively? The answer again is, yes. An attacking, pure M1A2 company can potentially halt an attacking Threat motorized rifle regiment (MRR) in a meeting engagement/battle. This is proven in time and space when we consider several assumptions.

METT-T Assumptions

MISSION: An M1A2 company attacks in order to halt enemy offensive operations in its zone.

ENEMY:

- The attacking MRR is BMP-2 and T-80 equipped, is at 100% strength and executes standard Threat meeting battle doctrine.
- The MRR deploys a Combat Reconnaissance Patrol (CRP), a Forward Security Element (FSE), and a motorized rifle battalion (MRB) as its Advance Guard main body.
- Threat forces move at a constant speed of 20 kph (50m every nine seconds).
- Threat forces maintain maximum doctrinal intervals for their formations.
- For the purposes of this article, enemy air is not introduced.

DTIC QUALITY INSPECTED 3

TIME AND SPACE:

- All tanks in our company fire at a constant rate of one round every nine seconds.
- On the move, we travel at a constant speed of 20 kph.
- We open engagement of the enemy at the STAFF round's **4km** maximum effective range.
- We want to maintain the maximum distance possible from the enemy in order to enhance force protection.

TROOPS and EQUIPMENT:

- We lead an M1A2 tank company at 100% strength.
- Each tank has a combat load of 40 STAFF rounds.
- All tanks have a proper boresight.
- No tanks experience a weapon system malfunction.
- No tanks in the company are lost to enemy fire during the engagement.
- STAFF rounds kill with a constant 40% probability of kill (**.4Pk**) over any distance out to 4000 meters.
- Enemy locations are constantly reported and updated on our IVIS system.

TERRAIN: We fight on terrain that is gently rolling, open and wide enough for the Threat and our forces to maintain formations.

Calculations

The assumptions above lead us to several key facts. First, attempting to prove the theory in the context of an attack/meeting battle provides us with the least battlefield time and space. In the defense, our static position coupled with the Threat's constant 20 kph speed gave us a closing distance and time of 50 meters every nine seconds.

When our tank company is also moving at a constant 20 kph speed in the offense, we close at 100 meters every nine seconds. In order to buy back the balance of time and space lost between defensive and offensive operations, we must increase our firepower. Hence, a company-sized attack.

A second key point concerns targeting. A .4Pk means we must fire 2.5 rounds (in 22.5 seconds) to destroy a target. Even though STAFF rounds seek out their victim, at least to some extent, we cannot blindly fire downrange believing we will kill targets - enemy vehicles must fall within the round's footprint. (For the CRP, we have three degrees of aiming arc at 4km in which to find a target; for the FSE and main body, six degrees per MRC-sized element.)

So, once enemy positions are downloaded onto our IVIS, we need a means of orienting our main gun in the proper direction.

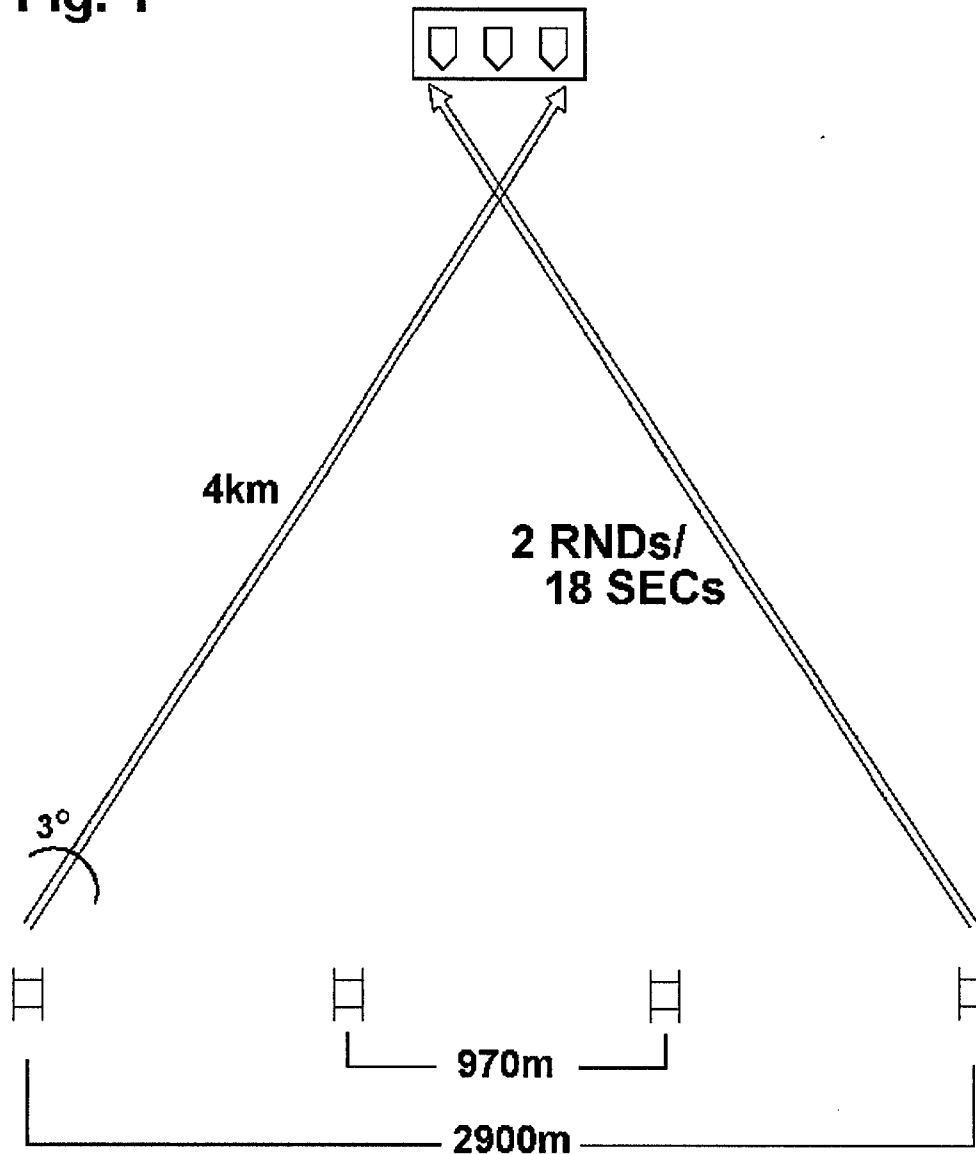
Fig. 1

Finally, our closing distance and time coupled with the .4Pk yields the following calculations:

- **Engaging the CRP.** (See Fig. 1.)

- This element closes with us at 100 meters every nine seconds.
- It will take one of our platoons two rounds per tank and 18 seconds/200 closing meters to destroy them.
- Since only one platoon is needed for this engagement, the rest of the company can disperse. For near flanks of the other two platoons to remain "tied-in" to the center, engaging platoon, the company can maintain a 500 meter distance between elements. This dispersion only allows the commander virtual battle command of his company. He cannot "see" his entire element at all times, but force protection is increased. So dispersed, our company frontage is approximately 11 kilometers.
- For all tanks in the platoon to range across the (doctrinal) space occupied by the CRP, we cannot maintain a frontage greater than 2900 meters.

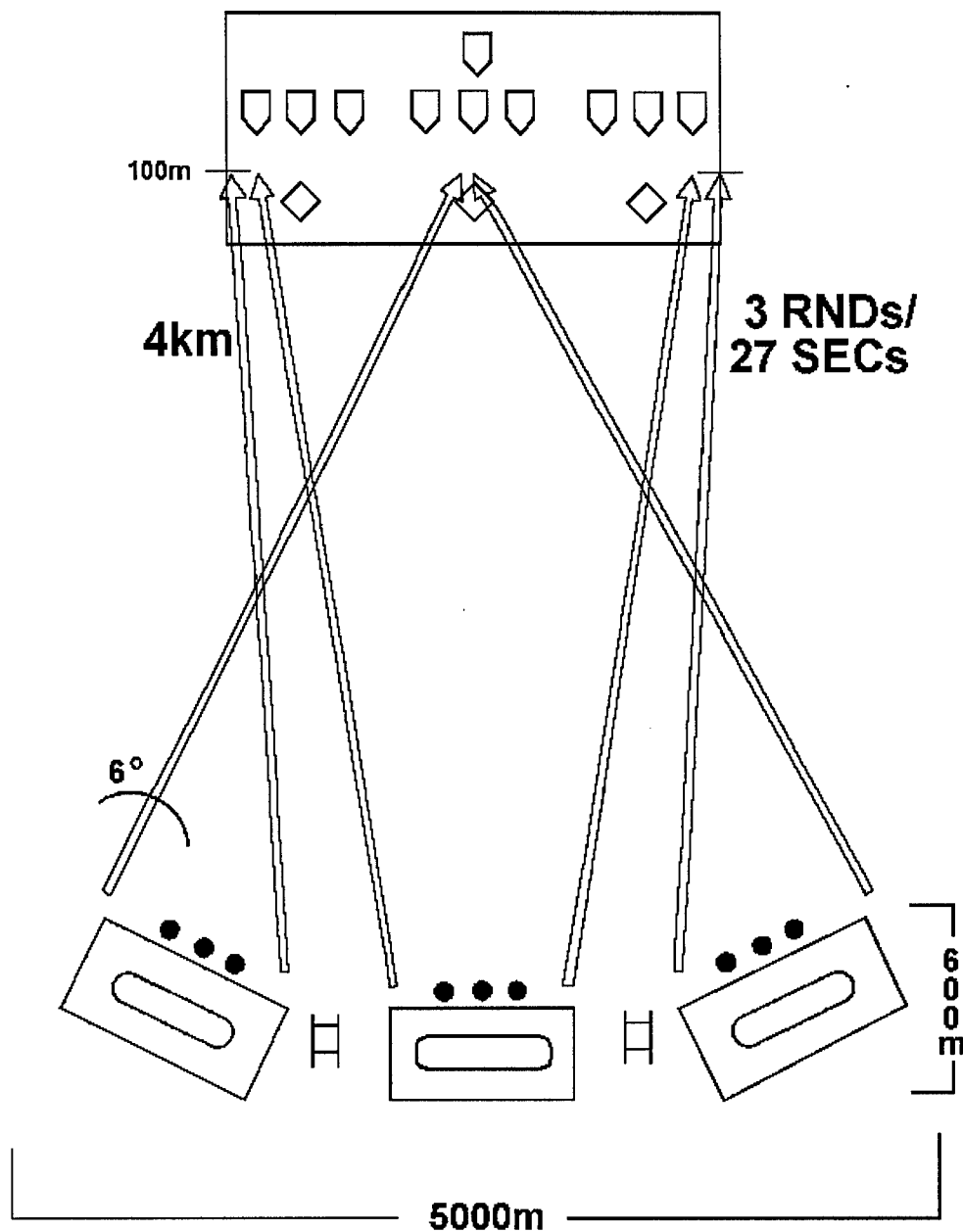

Fig. 2

• **Engaging the FSE.** (See Figure 2.)

- In approximately nine minutes, the FSE closes to within effective range of our company.
- To achieve company mass for engaging the FSE, we must shrink our 11 kilometer frontage. A five kilometer frontage allows us to "see" all of our elements, maintain proper battle command, and mass our fires. Maneuvering to this point, flank platoons must move at an inward, approximately 45-degree angle for five kilometers while maintaining their constant speed. This closes the company at 4500 meters from the FSE. It also provides us 45 seconds for company/platoon/crew fire commands.
- It will take our company three rounds per tank and 27 seconds/300 closing meters to destroy the FSE.

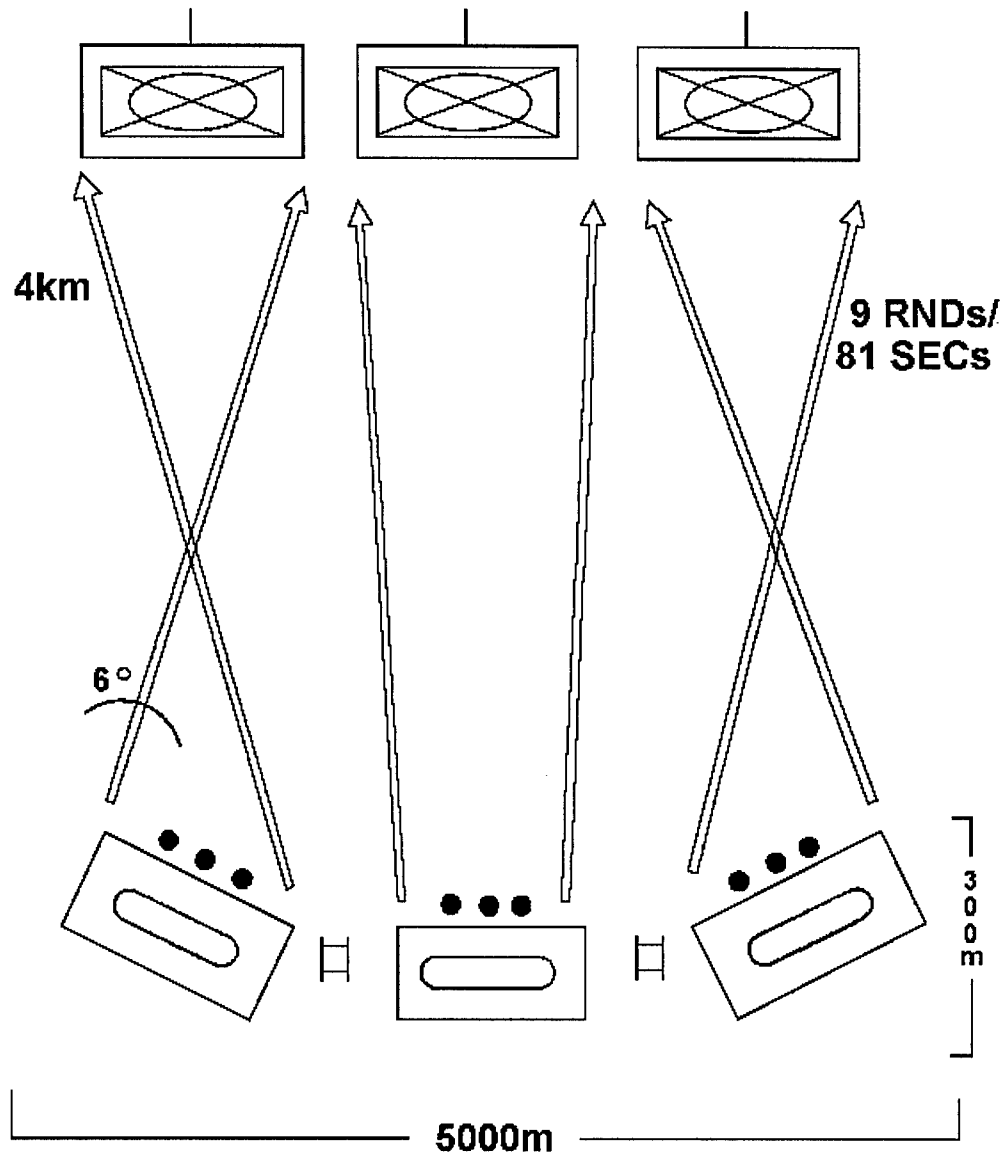

Fig. 3

- **Engaging the Advance Guard Main Body.** (See Figure 3.)
 - In up to another nine minutes, the Advance Guard main body comes into engagement range.
 - Our frontage is the same as when attacking the FSE. Each platoon engages one MRC of the Advance Guard in a frontal or cross pattern of fire. All tanks can range across MRC formations and 100 meters deep to open the engagement. Our formation depth, however, shrinks to 300 meters.
 - Our company must fire nine rounds per tank (in one minute, 21 seconds/900 closing meters) to destroy this element. We close to within 3100 meters of the enemy. While this does not favor force protection against ATGMs, it is still outside of maximum effective T-80 main gun range.
 - By doctrine, inability of the Advance Guard to halt our attack dictates a hasty defense by the enemy and provides us with mission success. We must now execute a sequel to our plan that meets the higher commanders' intent.
- **End State** (based on assumptions and the scenario above). From the first round fired, none of our tanks have expended more than 14 rounds, leaving us with enough to destroy about 140 more

enemy vehicles. Our attack traversed almost 12 kilometers in just under 20 minutes.

By comparison, we have just about equaled the destruction wrought by H.R. McMaster's cavalry troop in the Battle of 73 Easting during Desert Storm. However, our round expenditure, engagement distances, and situational awareness are quantitatively improved.

Capabilities

The above shows us it is possible to launch a tank company at a much larger, moving enemy force and destroy them bluntly in head-to-head confrontation. This is a non-maneuver warrior's dream. But what if commander's intent stated that our goal is to maximize dispersion for force protection and attack the enemy throughout the depth of his formation simultaneously within the capabilities of the company?

We know that the M1A2 company has the ability to destroy the Advance Guard. We are aware that we have more space and time when using the STAFF round's maximum effective range to open engagements. We also understand that the M1A2 provides us the means to both maneuver with greater speed and exercise battle command with greater precision.

It is therefore possible for one platoon to attack the CRP, two platoons to attack the FSE, and, with artillery support, for the company to place fires on the Advance Guard main body simultaneously. After destroying the CRP and FSE, we then mass the company to attack the Advance Guard main body. Time and space figures for maneuvering elements in this manner are a bit more complicated to calculate. However, the conditions surrounding our task are no different.

Our problem then, is one of battle command because of platoon dispersion. The company commander's battlespace is now tens of kilometers deep and wide for the initial attack. But without constant scrolling, his five-by-five kilometer IVIS screen does not allow him to "see" more than the platoon with which he maneuvers. A radical rethinking of the tools we provide the commander for his trade may be in order.

Digital Thoughts

The ability to attack and destroy an MRB(+) with one M1A2 company in 14 rounds/under 25 minutes/approximately 16 kilometers is revolutionary. This revolution, as with the platoon in the defense, raises both observations and questions about our digital force:

- A first, arrogant thought might be, "Who needs to task organize?" However, a thinking man would call for equipping the infantry with a faster antiarmor projectile (LOSAT?) that can be carried in greater quantity than TOW missiles. (We will not always fight entirely armored forces on prime tanker ground.)
- A distinct depth and frontage correlation is evident in offensive calculations: the wider the enemy's frontage and greater his depth, the narrower (to some extent) and shallower our company formation must be.
- Capabilities of an M1A2 platoon underscore the need to train that echelon and their leaders to proactively identify when and where to engage in combat and determine the time and space needed to complete the task.
- What is the proper training goal for our company or its parent battalion? Our rapid tempo can regularly close engagements and battles faster than ever before. Theoretically, it is also possible that a battalion(-) has the ability to ATTACK to halt an enemy division's unwanted incursions. Does this mean company and battalion commanders conduct operational maneuver for strategic objectives? How and when do we begin to teach them to think that big?
- As illustrated above, we can spread elements over vastly greater distances. Would a company commander then not need the ability to "see" all of his elements in order to properly command and control them? If he is to "see" everyone, he needs a screen that shows more than a five-by-five kilometer box. Or, to take a walk on the far side, is a traditional, fighting company commander no longer needed? (It is evident that the above attack did not need to end with the Advance Guard. The company still has the ability to destroy enemy forces in great number. The commander of this

element needs to see deeper before this fight is over in order to continue the attack and may not be able to do so if involved in the direct fire fight. For a commander to be successful in this enhanced role, will he have to remain a platoon leader for a much greater period of time?)

- While simultaneously attacking the enemy throughout his depth, we disregard traditional notions of a company formation. Two platoons forward and one back constitutes a company Vee formation. But does it remain a viable formation when we spread out over tens of kilometers with platoons alternating in defensive and offensive posture? Do we want to do this at so low an echelon simply because we can?
- How do we test these (and defensive) theories other than in the virtual world? We need a MILES-like system upgrade that replicates our direct fire time and space capabilities. Additionally, the size of the Combat Training Centers OPFOR must be increased appropriately. The current family of TADDS also needs modification to replicate our true capabilities.
- We know our speed, shock effect, and stand-off capabilities can carry us through the direct fire fight. However, the advent of smart mortar and artillery rounds presents a real threat to our force. Consequently, counterbattery fires are needed to provide true force protection. Could it then be that a fire support element complete with FIREFINDER Radar and a DS artillery battery is attached down to the company level?
- In (defensive or) offensive operations, the enemy's numerical advantage and subsequent ability to mass fires is functionally dislocated by our battle command enhancements and STAFF round effective range. The enemy's best way to counter this is to either seek out our technology for himself or tactically maneuver his current force to close direct fire distance faster. He also needs to consciously attack our ability to conduct information operations. If he cannot execute any of these options, a very temporary fix may be to seek more combat support fires. With no other options, might he use either weapons of mass destruction or directed energy weapons to meet his goals?
- Our CSS assets need the ability to cover more distance at a faster speed with larger quantities of CLASS III in order to support offensive operations. Based on this (and the earlier defensive theory), we should use less CLASS V than we do now.

Conclusion

I believe an M1A2 tank company can theoretically attack and destroy an enemy Advance Guard battalion (+), halting an MRR attack. Our ability to conduct offensive operations at greater than a 1:3 ratio in quantitatively increased battlespace is quite revolutionary. However, it calls into question many of our long held notions about battle command, organization, and doctrine. We must now proactively seek answers to these questions if we are to fully exploit digitization. I urge all soldiers to stress digital capabilities to their actual and theoretical limits. In so doing, we can make this warfighting leap a very long one.

I would like to acknowledge appreciation for the critique and comments on this article by COL (Ret.) Joe Strickland and 1LT Pete Robertson.

Go to Next Section: The Three to Six Second Advantage: Tank Combat in Restricted Terrain

Return to the Table of Contents

09 Mar 97/dcn

"Issues in Armor" I have some feedback. Add your thoughts to the discussion Questions for the Armor Magazine Staff, including subscriptions, etc. For technical questions on this web page, send email to Dave Nilsen