

**NAVAL POSTGRADUATE SCHOOL
MONTEREY, CALIFORNIA**



19970311 078

THESIS

**AAW EFFECTIVENESS OF THE DD-963
SPRUANCE CLASS DESTROYER:
AN ANALYTIC APPROACH**

by

Richard O. Johns

September, 1996

Thesis Advisor:

W. Max Woods

Approved for public release; distribution is unlimited.

DTIC QUALITY INSPECTED 1

DISCLAIMER NOTICE

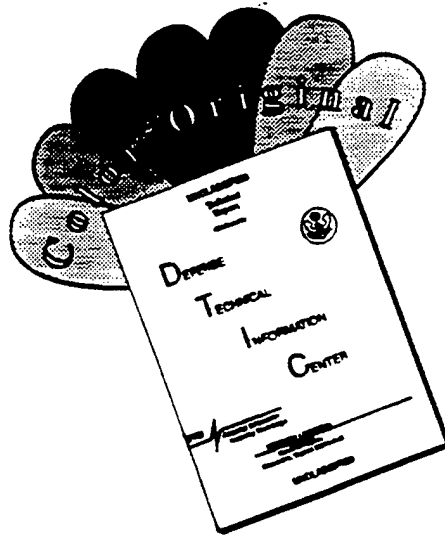

THIS DOCUMENT IS BEST QUALITY AVAILABLE. THE COPY FURNISHED TO DTIC CONTAINED A SIGNIFICANT NUMBER OF COLOR PAGES WHICH DO NOT REPRODUCE LEGIBLY ON BLACK AND WHITE MICROFICHE.

REPORT DOCUMENTATION PAGE

Form Approved OMB No. 0704-0188

Public reporting burden for this collection of information is estimated to average 1 hour per response, including the time for reviewing instruction, searching existing data sources, gathering and maintaining the data needed, and completing and reviewing the collection of information. Send comments regarding this burden estimate or any other aspect of this collection of information, including suggestions for reducing this burden, to Washington Headquarters Services, Directorate for Information Operations and Reports, 1215 Jefferson Davis Highway, Suite 1204, Arlington, VA 22202-4302, and to the Office of Management and Budget, Paperwork Reduction Project (0704-0188) Washington DC 20503.

1. AGENCY USE ONLY <i>(Leave blank)</i>	2. REPORT DATE September 1996	3. REPORT TYPE AND DATES COVERED Master's Thesis	
4. TITLE AND SUBTITLE AAW Effectiveness of the DD-963 Spruance Class Destroyer: An Analytic Approach		5. FUNDING NUMBERS	
6. AUTHOR(S) Richard O. Johns, LT, USN		8. PERFORMING ORGANIZATION REPORT NUMBER	
7. PERFORMING ORGANIZATION NAME(S) AND ADDRESS(ES) Naval Postgraduate School Monterey CA 93943-5000		10. SPONSORING/MONITORING AGENCY REPORT NUMBER	
9. SPONSORING/MONITORING AGENCY NAME(S) AND ADDRESS(ES) Naval Warfare Assessment Division, P.O. Box 5000, Corona CA 91718-5000		11. SUPPLEMENTARY NOTES The views expressed in this thesis are those of the author and do not reflect the official policy or position of the Department of Defense or the U.S. Government.	
12a. DISTRIBUTION/AVAILABILITY STATEMENT Approved for public release; distribution is unlimited.		12b. DISTRIBUTION CODE	
13. ABSTRACT <i>(maximum 200 words)</i> A typical naval ship has multiple systems which can be used to defend itself against a cruise missile threat. These systems may consist of surface-to-air missiles, MK 45 guns and the Close-in-Weapon-System to name a few. Until recently each of these system's effectiveness against a cruise missile was assessed independently of the other systems onboard the ship. The purpose of this thesis is to develop an overall system effectiveness model for the DD-963 Spruance class destroyer. The model considers the integration of the defensive systems onboard, the availability and reliability of these systems, and contains parameters that can be used to incorporate the crew's ability to employ the various weapon systems against a cruise missile threat.			
14. SUBJECT TERMS Effectiveness, Probability of Kill, Availability, AAW, DD-963		15. NUMBER OF PAGES 58	
17. SECURITY CLASSIFICATION OF REPORT Unclassified		16. PRICE CODE	
18. SECURITY CLASSIFICATION OF THIS PAGE Unclassified	19. SECURITY CLASSIFICATION OF ABSTRACT Unclassified	20. LIMITATION OF ABSTRACT UL	

NSN 7540-01-280-5500

Standard Form 298 (Rev. 2-89)
Prescribed by ANSI Std. Z39-18 298-102

Approved for public release; distribution is unlimited.

**AAW EFFECTIVENESS OF THE DD-963 SPRUANCE CLASS
DESTROYER: AN ANALYTIC APPROACH**

Richard O. Johns
Lieutenant, United States Navy
B.E.E., Villanova University, 1988

Submitted in partial fulfillment
of the requirements for the degree of

MASTER OF SCIENCE IN OPERATIONS RESEARCH

from the

NAVAL POSTGRADUATE SCHOOL

September 1996

Author:

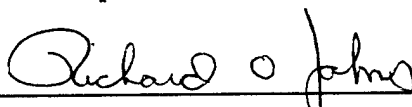

Richard O. Johns

Approved by:



W. Max Woods, Thesis Advisor



Robert E. Ball, Second Reader

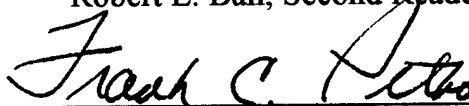

Frank C. Petho, Chairman
Department of Operations Research

ABSTRACT

A typical naval ship has multiple systems which can be used to defend itself against a cruise missile threat. These systems may consist of surface-to-air missiles, MK 45 guns and the Close-in-Weapon-System to name a few. Until recently each of these system's effectiveness against a cruise missile was assessed independently of the other systems onboard the ship. The purpose of this thesis is to develop an overall system effectiveness model for the DD-963 Spruance class destroyer. The model considers the integration of the defensive systems onboard, the availability and reliability of these systems, and contains parameters that can be used to incorporate the crew's ability to employ the various weapon systems against a cruise missile threat.

TABLE OF CONTENTS

I. INTRODUCTION	1
A. PURPOSE	2
II. BACKGROUND	3
III. MODEL DEVELOPMENT	7
A. ASSUMPTIONS	7
B. DEFINITIONS	8
1. System States	10
a. State ₁	12
b. State ₂	13
c. State ₃	14
2. Availability of the System States	14
a. A(State ₁)	15
b. A(State ₂)	16
c. A(State ₃)	16
3. PNSSMS _{mj}	17
4. PGun _{gj}	19
5. PChaff _{cj}	20
6. PCIWS _j	20

7. PECM _j	21
C. EQUATION DEVELOPMENT	21
IV. OBSERVATIONS	25
V. RECOMMENDATIONS FOR FUTURE STUDY	29
APPENDIX A. INTEGRATED DETECT-TO-ENGAGE CAPABILITY	31
APPENDIX B. SYSTEM EFFECTIVENESS EXAMPLE	33
LIST OF REFERENCES	45
INITIAL DISTRIBUTION LIST	47

EXECUTIVE SUMMARY

Today the cruise missile has become the weapon of choice for many of the countries of the world. Greater range and sophistication have allowed platforms to covertly launch the missiles and allow the target less reaction time when defending itself. As the cruise missile threat continues to improve and becomes more lethal, the challenge to build more effective and capable defensive systems increases as well. With the attack on the USS Stark in 1987 by an Exocet cruise missile, greater emphasis has been placed on measuring the effectiveness of defensive systems against anti-ship cruise missiles.

The typical naval ship has many systems to defend itself against a cruise missile threat. These systems consist of both active and passive measures that attempt to either destroy the missile (active) or deceive the missile by luring it away from its target (passive). Typical active measures are surface-to-air missiles, MK 45 5"/54 guns and the Close-in-Weapon-System (CIWS). The MK 36 Decoy Launching System (DLS) launches chaff as a passive defense against a missile threat. Until recently, each of these system's effectiveness against a cruise missile was assessed independently of the other systems onboard the ship. With this approach it is difficult to determine an **overall** effectiveness against a given threat. The technique used to calculate the effectiveness of the ship in defending itself should incorporate the integration and the common equipment shared among individual systems.

This thesis develops an analytic model to assess the overall effectiveness of the DD-963 Spruance class destroyer against an Exocet cruise missile threat. The model considers the detection capabilities, availability, reliability, and kill probabilities of the defensive systems

onboard as well as the readiness and training of the crew to initiate an engagement against the incoming threat. Availability of a component is defined as the probability that the component is operational (up) when called upon to function. The reliability of a component is the probability that the component remains up throughout the duration of the engagement. System state availabilities and reliabilities are computed using definitions of the system states and well known rules of probability algebra. The model considers distance at which the missile is first detected, the range of the threat at the time of launch, and the capability of the crew to launch (fire) the weapons in specified range intervals after detection. The configuration of the combat system, the firing policy and other weapon performance parameters are also employed in the model.

The analysis used to develop this model is not unique to this ship class. Given an integrated system diagram, a model for the AAW effectiveness of classes such as the CG-47, LHD-2, LPD-17 and many others can be developed following baseline concepts used in this methodology.

Due to the number of parameters contained in the model and the variability they may induce, enumeration of the model with parameter values chosen ad hocly but professionally were used to display a few of the relationships between parameters. An indepth study into the sensitivity of the model to various combinations of parameter values is needed.

I. INTRODUCTION

Since the advent of the anti-ship cruise missile over 20 years ago, the Navy has spent large amounts of time and money on defense against this formidable threat. As the cruise missile threat changes and becomes more lethal, the challenge to build more effective and capable defensive systems increases as well. Since the attack on the USS Stark in 1987 by an Exocet cruise missile, greater emphasis has been placed on measuring the effectiveness of defensive systems against anti-ship cruise missiles. System effectiveness in this thesis is the probability that the threat does not hit the ship.

The typical naval ship has multiple systems which can be used to defend itself against a cruise missile threat. These systems consist of both active and passive measures that attempt to either destroy the missile (active) or deceive the missile by luring it away from its target (passive). Typical active measures are surface-to-air missiles, MK 45 5"/54 guns and the Close-in-WeaponSystem (CIWS). The MK 36 Decoy Launching System (DLS) launches chaff as a passive defense against a missile threat. Until recently, each of these system's effectiveness against a cruise missile was assessed independently of the other systems onboard the ship. With this approach it is difficult to determine an **overall** effectiveness against a given threat.

A. PURPOSE

This thesis develops an analytic model to assess the overall effectiveness of the DD-963 Spruance class destroyer against an Exocet cruise missile threat. The model considers the availability, reliability, kill probabilities of the defensive systems onboard and the readiness and training of the crew to initiate an engagement against an incoming threat. The model also considers the distance at which the missile is first detected, the range of the threat at the time of launch, and the capability of the crew to launch (fire) the weapons in specified range intervals after detection. The configuration of the combat system, the firing policy and other weapon performance parameters are also employed in the model. The model has reliability, availability, and single shot probability of kill parameters which must be specified to compute an overall system effectiveness number in the interval (0.0, 1.0). Availability of a component is defined as the probability that the component is operational (up) when called upon and reliability of a component is the probability that the system remains up throughout the engagement.

II. BACKGROUND

In order to understand the analytic model, one must be familiar with the various systems employed by a Spruance class destroyer against a cruise missile. The Navy uses a layered defense that is referred to as "defense in depth." This means that the ship engages a threat with its longest range weapon first and as the missile approaches, the remaining weapons are employed as their engagement range allows. As mentioned previously, the Spruance class destroyer can defend itself with both active and passive systems. The active systems in order of their effective range are:

SLQ-32A (V)3 Electronic Countermeasures (ECM)

NATO Seasparrow Missile System (NSSMS)

MK 45 5"/54 Gun System

Close-in-Weapon System (CIWS).

The SLQ-32A (V)3 system passively detects enemy electronic emissions from targeting sources and missiles for identification, early warning, threat detection, and for support of other warfare missions [COMNAVSURFLANTINST C3516.6D]. In the case of a missile, the SLQ-32(V)3 will detect missile seeker activation, alert the operator, and report the missile line of bearing. The system uses a radiated beam of energy in an attempt to disrupt the missile's seeker from effectively targeting the ship.

The NSSMS is a surface-to-air missile system designed to destroy enemy aircraft and missiles threatening the ship. The system consists of a the MK 95 Radar, MK 91 Fire

Control System (FCS), and the MK 29 launcher containing eight missiles. Once launched, the missiles guide to the target using reflected energy from the MK 91 FCS. The missile also uses this energy to determine the arming and detonation timing for the warhead.

The Spruance class destroyer has two MK 45 5"/54 guns located on the forecastle (forward) and fantail (aft). These guns are unmanned and fire a variety of projectiles that destroy the missile using a blast fragmentation warhead. The guns are controlled by the Control Officer Console (COC) operator located in the Combat Information Center (CIC). From this console he can designate one or both guns to the target and select the type of projectiles to be fired.

Finally, the CIWS is the ship's last line of defense or point defense system. The system has a stand-alone search radar or can be sent initial targeting data from other shipboard sensors. Once the target is within range, CIWS fires hundreds of rounds, literally a wall of metal, at the incoming target.

The SLQ-32(V)3 is both a passive detection and active weapon system. It detects missile seeker activation and alerts an operator of the threat. The operator then employs a transmitter that emits a beam of energy that attempts to neutralize the missile's seeker before it can impact the ship.

The lone passive system employed by the Spruance class destroyer for its defense is the MK 36 Decoy Launching System (DLS). Prior to missile seeker activation the ship launches rounds of chaff which reach a predetermined altitude and explode deploying thousands of pieces of foil. This chaff region or "cloud" will appear larger in radar

cross-section than the destroyer and is designed to lure the missile away.

In order to successfully employ the defensive systems, the threat must be initially detected at a sufficient range. A few of the systems that are capable of detecting an inbound cruise missile are the MK 23 Target Acquisition System (TAS) Radar, AN/SPS-40, and MK 95 NSSMS Radar. These systems are air search radars that detect airborne contacts and pass target location data to the defensive systems. The farther the initial detection the more weapons that can engage the threat and the more time the crew has to make decisions regarding their employment of the weapon systems.

III. MODEL DEVELOPMENT

A. ASSUMPTIONS

The task of developing a system effectiveness equation that accounts for the integration of the many defensive systems described earlier and other factors such as training and crew capability is complicated. This task is more manageable if the following assumptions are made.

- 1) The threat will be a single Exocet missile approaching the ship from the starboard side so that only one CIWS mount (MT 21) will engage the target.
- 2) The ship has been alerted that an Exocet threat is present, therefore the ship's captain will likely use only a few system configurations.
- 3) The ship is only capable of engaging the target once with each of the weapon systems using a designated firing policy; e.g. shoot-shoot policy.
- 4) The capability of the NSSMS missile, MK 45 5"/54 gun and the MK 36 DLS to destroy or deceive the target is dependent on the range at which these systems are employed (launched, fired etc.). This is in turn dependent on the range at which the target is initially detected.
- 5) The ability of the crew to initiate an engagement at a particular range, given the range at which the threat is detected, varies from crew to crew and ship to ship. The crew's performance will be taken into account stochastically.
- 6) Each weapon system's single shot probability of kill is independent and has no

influence on the single shot probability of kill of any other systems.

- 7) The reliability of all system components, except the NSSMS missiles, MK 45 rounds, and the chaff are equal to one given the component is available (up) at the start of the detection scenario. Reliabilities of the three cited exceptions are accounted for in the system effectiveness equations.

B. DEFINITIONS

- I:** Maximum detection range of the missile by the ship for a given threat.
- I_i :** i^{th} detection sub-interval of I with I_1 being the sub-interval nearest the ship, $i = 1, 2, \dots, I$.
- State $_j$:** j^{th} combat system state, $j = 1, 2, \dots, J$.
- Detect $_{ij}$:** Event that threat is detected in sub-interval I_i given configuration State $_j$.

To account for the possibility that the NSSMS, MK 45 guns and MK 36 DLS may be dependent on range, each system has engagement sub-intervals which may or may not coincide with the detection sub-intervals. These sub-intervals will span the maximum detection range I and may be uniform in size for each system. Figure 1 illustrates how the detection and engagement intervals, i and m respectively, may look for the NSSMS. Similar intervals, g and c , exist for the MK 45 gun and chaff respectively.

Engagement Intervals

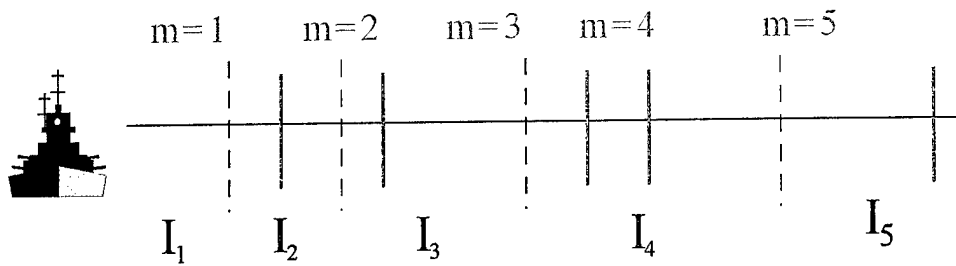

Detection Intervals

Figure 1

Figure 1 depicts the relationship that detection intervals (I) and engagement intervals (m) may have during a detect-to-engage sequence. Notice the intervals may be different in size and overlap depending on the weapon system.

Let

- L_{mj} : Event that missiles are launched when threat is in missile interval m given State $_j$ where $m = 1, 2, \dots, M$.
- Gun_{gj} : Event gun initiates firing when threat is in gun interval g given State $_j$ where $g = 1, 2, \dots, G$.
- $Chaff_{cj}$: Event that MK 36 DLS (chaff) engagement is launched when threat is in chaff interval c given State $_j$ where $c = 1, 2, \dots, C$.
- E_0 : Event that the ship is effective against the threat; i.e. the threat does not hit the ship.
- E_i : Event that component i is available (up) at the start of the detection process and stays up throughout the scenario.

E_i^{\wedge} : Event that component i is not available at the time it is needed during the scenario.

$E_o|Detect_{ij}$ = event that the threat does not hit the ship given $Detect_{ij}$.

$PNSSMS_{mj}$ = probability NSSMS kills threat given L_{mj} .

$PGUN_{gj}$ = probability 5"/54 MK 45 kills threat given Gun_{gj} .

$PCHAFF_{cj}$ = probability MK 36 DLS deceives threat given $Chaff_{cj}$.

$PCIWS_j$ = probability CIWS kills threat given $State_j$.

$PECM_j$ = probability SLQ-32 electronic countermeasure path kills threat given $State_j$.

1. System States

The DD-963 Spruance class destroyer has many sensors that can detect an inbound Exocet cruise missile and defensive systems that can be used against such a threat. Appendix A depicts the various elements of what is termed the detect-to-engage capability of the Spruance class destroyer. Appendix A shows the various detection elements, control or information processing equipment and weapon systems that can play a part in the detect-to-engage sequence. Because of the desire to detect the threat at a sufficiently large range for a NSSMS engagement, only three system states are considered in this thesis. These states differ in the availability of specific detection and control components and in the source of the initial detection. Given that the components required in each state are available, these three states would be preferred over any other detection path because of the

longer initial detection range capability. Figure 2 refers to these paths which are a subset of the paths displayed in Appendix A.

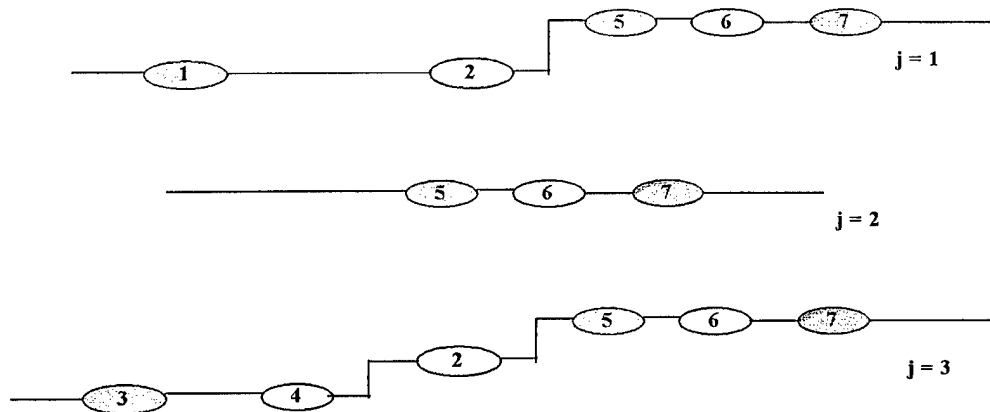

Figure 2

Figure 2 shows the three detection paths corresponding to states 1, 2, and 3. These states differ in the component used for initial detection of the threat. All of the detect-to engage are displayed in Appendix A.

The probability of detection in any state in which these detection components are unavailable multiplied by the probability that these elements are unavailable is very small. For example, let E_i signify the event that component i is available and let A_i denote the probability of E_i , i.e. the availability of E_i . If the MK 23 TAS and MK 95 NSSMS Radar (components 2 and 5 in Appendix A) are inoperable, the probability of detection, P_d , with both of these components inoperative is very small. This is the result of the MK 23 TAS and MK 95 NSSMS Radars being the primary detection sources for the NSSMS. Multiplying P_d by the probability that these components are unavailable results in a number close to zero.

$$Pd \cdot (1 - A_2) \cdot (1 - A_5) \cong 0 \quad (1)$$

As a result, all other detection states can be ignored.

Letting " * " denote "logical and", the general equation for State_j is

$$\text{State}_j = S_{Mj} * S_G * S_{CH} * S_E * S_{CIWS} \quad \text{for } j = 1, 2, \dots, J \quad (2)$$

where S_{Mj}, S_G, S_{CH}, S_E, and S_{CIWS} indicate that all components are available in the jth path traversed during the NSSMS, MK 45 gun, MK 36 DLS, SLQ-32(V)3, and CIWS engagement sequences respectively. Note in Appendix A that only the NSSMS path varies with j. This is due to the use of different components for the initial detection of the threat in the NSSMS engagement path. The probability of detection at distant ranges may be equal for each of the states described below but allowing for the possibility that they are not will yield a much more robust model.

a. State₁

Referring to Appendix A, State₁ uses the MK 23 TAS Radar without the Data Processing Set (element 1) as the primary detection source for the NSSMS engagement path. This is the preferred detection source for an anti-air defense based on recommendations presented in the DD-963 Combat Systems Doctrine [COMNAVSURFLANT C3516D]. The equation for State₁ is given as

$$\text{State}_1 = S_{M1} * S_G * S_{CH} * S_E * S_{CIWS} \quad (3)$$

S_{M1} represents the components that contribute to the engagement of the Exocet in the NSSMS path. Since the TAS Radar is linked directly to the NSSMS, the Command

Decision System (CDS, component 4) is not required for an engagement and is therefore excluded from the equation for S_{M1} . Since components 3, 8, 9, 10 and 11 send information through the CDS, these components do not contribute to S_{M1} . Since E_i denotes the event that component i is available in a particular path, the equation for S_{M1} becomes

$$S_{M1} = E_1 * E_2 * E_5 * E_6 * E_7 \quad (4)$$

The path selected for S_G , S_{CH} , S_E , S_{CIWS} are expressed as

$$S_G = (E_{10}, E_{11}) * E_{22} * (E_{13}, E_{14}) \quad (5)$$

$$S_{CH} = (E_{15}, E_{21}) * (E_{16}, E_{17}, E_{18}, E_{19}) \quad (6)$$

$$S_E = E_8 * E_{21} \quad (7)$$

$$S_{CIWS} = E_{20} \quad (8)$$

where (E_{10}, E_{11}) means that at least one of the components within the parentheses must be available.

b. State₂

In State₂, the MK 23 TAS Radar DPS (element 2) is no longer available. Because of the inability of the other detection sources to send data through the MK 23 TAS Radar DPS, this leaves the MK 95 NSSMS Radar (element 5) as the initial detection source for a missile engagement. State₂ becomes

$$State_2 = S_{M2} * S_G * S_{CH} * S_E * S_{CIWS} \quad (9)$$

where

$$S_{M2} = E_2^{\wedge} * E_5 * E_6 * E_7 \quad (10)$$

Here E_2^{\wedge} , complement of E_2 , indicates that the MK 23 TAS Radar DPS is not available.

Again the equations for S_G , S_{CH} , S_E , S_{CIWS} do not change with states.

c. State₃

The MK 23 TAS Radar is no longer available to detect the Exocet missile. Instead the data from the AN/SPS-40 Radar (element 3), an air search radar, is gathered by the CDS and then forwarded through the MK 23 TAS Radar DPS to the NSSMS Radar where the engagement takes place. In this instance $State_3$ is defined as

$$State_3 = S_{M3} * S_G * S_{CH} * S_E * S_{CIWS} \quad (11)$$

where

$$S_{M3} = E_1^{\wedge} * E_3 * E_4 * E_2 * E_5 * E_6 * E_7 \quad (12)$$

E_1^{\wedge} , complement of E_1 , denotes that the TAS Radar is not available.

2. Availability of the System States

Having defined the system states, the question of their availability must be addressed.

Let A_i be defined as the availability of element i at the beginning of the detection process and throughout the entire engagement sequence. The availability of each state, $A(State_j)$, can be calculated using the equations developed in the previous section. Since the system states are mutually exclusive, we shall assume that

$$\sum_{j=1}^J A(State_j) \leq 1. \quad (13)$$

a. $A(\text{State}_1)$

Using equations (3) thru (8), the availability of State_1 can be represented

as

$$A(\text{State}_1) = A(\text{S}_{\text{MI}}) \cdot A(\text{S}_{\text{G}}) \cdot A(\text{S}_{\text{CH}}) \cdot A(\text{S}_{\text{E}}) \cdot A(\text{S}_{\text{CIWS}}) \quad (14)$$

where

$$A(\text{S}_{\text{MI}}) = A_1 \cdot A_2 \cdot A_5 \cdot A_6 \cdot A_7 \quad (15)$$

$$A(\text{S}_{\text{G}}) = [(A_{10} \cdot A_{11}) + (A_{10} \hat{\cdot} A_{11}) + (A_{10} \cdot A_{11} \hat{\cdot})] \cdot A_{22} \cdot [1 - (1 - A_{13})^2] \quad (16)$$

$$A(\text{S}_{\text{CH}}) = [(A_{15} \cdot A_{21}) + (A_{15} \hat{\cdot} A_{21}) + (A_{15} \cdot A_{21} \hat{\cdot})] \cdot [A_{17}^4 + 3A_{17}^3 \cdot (1 - A_{17}) + 6A_{17}^2 \cdot (1 - A_{17}^2)] \quad (17)$$

$$A(\text{S}_{\text{E}}) = A_8 \cdot A_{21} \quad (18)$$

$$A(\text{S}_{\text{CIWS}}) = A_{20} \quad (19)$$

When attempting to understand equations (16) and (17) it may be helpful to refer to Appendix A. Note that in the gun engagement path there are two ways to proceed to element 23. This is referred to as a parallel path across components 10 and 11. There are three combinations that are possible in order to cross over these components. Either both components are or one or the other are available. These combinations are displayed mathematically at the beginning of equation (16). The same concept was used to deal with the parallel paths across both gun mounts in the gun path, the SLQ-32(V)3 and bridge display consoles and chaff launchers in the chaff engagement path, Equation (17). Because the SLQ-32(V)3 display console is assumed to be operational in equation (18), the availability across both display consoles in the chaff path is equal to 1 and equation (17) can

be rewritten as

$$A(S_{CH}) = [A_{17}^4 + 3A_{17}^3 \cdot (1-A_{17}) + 6 A_{17}^2 \cdot (1-A_{17}^2)] . \quad (20)$$

b. $A(\text{State}_2)$

Using equation (9) the formula for the availability of State_2 is

$$A(\text{State}_2) = A(S_{M2}) \cdot A(S_G) \cdot A(S_{CH}) \cdot A(S_E) \cdot A(S_{CIWS}) \quad (21)$$

where

$$A(S_{M2}) = (1 - A_2) \cdot A_5 \cdot A_6 \cdot A_7 \quad (22)$$

$$A(S_G) = [(A_{10} \cdot A_{11}) + (A_{10} \hat{\cdot} A_{11}) + (A_{10} \cdot A_{11} \hat{\cdot})] \cdot A_{22} \cdot [1 - (1 - A_{13})^2] \quad (23)$$

$$A(S_{CH}) = [A_{17}^4 + 3A_{17}^3 \cdot (1-A_{17}) + 6 A_{17}^2 \cdot (1-A_{17}^2)] \quad (24)$$

$$A(S_E) = A_8 \cdot A_{21} \quad (25)$$

$$A(S_{CIWS}) = A_{20} . \quad (26)$$

c. $A(\text{State}_3)$

From equation (11), the availability of State_3 is defined as

$$A(\text{State}_3) = A(S_{M3}) \cdot A(S_G) \cdot A(S_{CH}) \cdot A(S_E) \cdot A(S_{CIWS}) \quad (27)$$

with

$$A(S_{M3}) = (1 - A_1) \cdot A_3 \cdot A_4 \cdot A_2 \cdot A_5 \cdot A_6 \cdot A_7 \quad (28)$$

and $A(S_G)$, $A(S_{CH})$, $A(S_E)$, $A(S_{CIWS})$ are defined as before.

3. PNSSMS_{mj}

The probability that the target is destroyed by the NSSMS is dependent on how many missiles are launched, missile launch probability, the missile performance reliability during flight, and the probability that the missile kills the target at intercept. The MK 29 launcher consists of eight individual cells having an equal probability of successfully launching a missile. Let $P_L(i)$ be the probability that i missiles are launched while attempting to launch two missiles. Assuming that the launcher is fully loaded, $P_L(1)$ is the probability that only one of the eight available missiles can be launched. So,

$$P_L(1) = 8P_m \cdot (1-P_m)^7 \quad (29)$$

where P_m is the common probability of successfully launching any one of the eight missiles. Since the policy is to shoot two missiles, the probability of launching two missiles, $P_L(2)$, is

$$P_L(2) = 1 - [P_L(0) + P_L(1)] = 1 - [(1 - P_m)^8 + 8P_m \cdot (1 - P_m)^7]. \quad (30)$$

Assuming that a missile or missiles have been launched, the next step is to calculate the probability that the NSSMS kills the target. Steigers [1993] alluded to the fact that the Seasparrow missile will have a varying probability of kill depending on the range at intercept. Because it is only powered for a portion of its flight, as the missile coasts toward the target it loses some of its maneuverability. This results in a decrease in the probability of killing the target. The actual probability of kill can be obtained from the six degree of freedom simulations conducted at the Naval Air Warfare Center China Lake, Ca. Figure 3 shows a graphical representation of P_k versus percent maximum range of the missile. This

information can be used in this system effectiveness model.

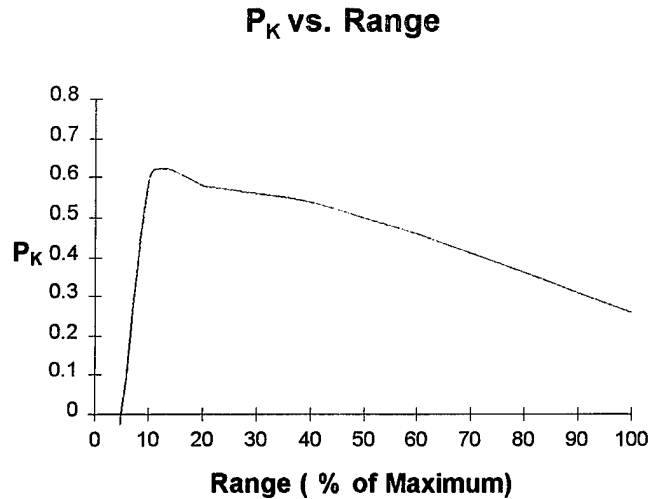

Figure 3

Figure 3 displays what a plot of P_k data for the j^{th} state versus percent of the maximum range of the Seasparrow missile might look like. The data can be obtained from six degree of freedom simulations run at the Naval Warfare Center China Lake Ca.

The probability of killing the target is written as

$$\begin{aligned}
 \text{PNSSMS}_{mj} = & [P_L(1) \cdot P_{k_{mj}}(1) \cdot R_m] + \{ P_L(2) [P_{k_{mj}}(2) \cdot R_m^2 + \\
 & 2 P_{k_{mj}}(1) \cdot R_m \cdot (1-R_m)] \} \quad (31)
 \end{aligned}$$

where $P_{k_{mj}}(i)$ is the probability of kill when i missiles are launched given the target is in missile interval m at the time of launch and the system is in state j . This probability may also be produced from simulations similar to those for a single missile. R_m is the probability that the missile performs properly in flight. Substituting Equation (29) and (30) into Equation (31) results in

$$\begin{aligned}
 \text{PNSSMS}_{mj} = & \{ [8P_m \cdot (1-P_m)^7] \cdot P_{k_{mj}}(1) \cdot R_m \} + \{ 1 - [(1-P_m)^8 + 8P_m \cdot \\
 & (1-P_m)^7] \} \cdot [P_{k_{mj}}(2) \cdot R_m^2 + 2P_{k_{mj}}(1) \cdot R_m \cdot (1-R_m)]. \quad (32)
 \end{aligned}$$

4. $PGun_{gj}$

In calculating the probability that the MK 45 guns destroy the target we assume that the gun mounts operate independently and have equal probability of shooting a round successfully, P_G . The probabilities of shooting one or two rounds when attempting to shoot two rounds are

$$P [\text{shoot 1 round}] = 2P_G \cdot (1-P_G) \quad (33)$$

$$P [\text{shoot 2 rounds}] = P_G^2 \quad (34)$$

Normally, a variable-timed fragmentation (VT-Frag) round is used against an air target. The round is given a time setting based on the intercept range with the target and at the intercept point explodes sending a "wall" of metal fragments toward the target. The probability that the target is killed by a 5" round is highly dependent on the round operating as designed. The accuracy of the targeting data provided by the system also impacts the P_{kill} , therefore the configuration of the system must be taken into consideration. The probability that the target is killed by the 5" gun mounts is dependent on the interval in which the engagement is initiated and on the system state. This probability is derived similarly to that for the NSSMS and is represented as

$$PGun_{gj} = [2P_G \cdot (1-P_G)] \cdot Pk_{gj}(1) \cdot R_B + \{P_G^2 \cdot [Pk_{gj}(2) \cdot R_B^2 + 2 Pk_{gj}(1) \cdot R_B \cdot (1-R_B)]\} \quad (35)$$

where $Pk_{gj}(i)$ is the probability that the target is destroyed when i rounds are fired given the target is in gun interval g and the system state is j . R_B is defined as the reliability of a round exploding at the predetermined range.

5. PChaff_{cj}

The Spruance Class destroyer is equipped with four individual chaff launchers each containing six cells from which to launch a chaff round for a total of twenty-four. Assume that the ships doctrine is to deceive an incoming threat by launching two chaff rounds. Let P_C be the probability of launching a chaff round, then the probability of launching one or two chaff rounds respectively is

$$P [\text{shoot one round}] = 24P_C \cdot (1 - P_C)^{23} \quad (36)$$

$$P [\text{shoot two rounds}] = 1 - [(1 - P_C)^{24} + 24P_C \cdot (1 - P_C)^{23}]. \quad (37)$$

Let R_C represent the reliability of a chaff round exploding at the correct height and $P_{k_j}(i)$ be the probability of deceiving the target when i rounds are launched assuming the target is in chaff interval c and the system is in state j . The probability of deceiving the target with chaff is then

$$P_{\text{CHAFF}_{cj}} = 24P_C \cdot (1 - P_C)^{23} \cdot P_{k_j}(1) \cdot R_C + \{1 - [(1 - P_C)^{24} + 24P_C \cdot (1 - P_C)^{23}] \cdot [P_{k_j}(2) \cdot R_C^2 + 2P_{k_j}(1) \cdot R_C \cdot (1 - R_C)]\}. \quad (38)$$

6. PCIWS_j

The CIWS, a point defense weapon, is the ships last defense against an incoming threat. Due to the limited range of the CIWS, the assumption is made that this P_{kill} is independent of the targets range and may only be dependent on the state j of the entire system.

7. **PECM_j**

It is assumed that the probability of the SLQ-32 (V)3 "killing" the target is constant throughout its effective range and that its probability may also be affected by the system state j .

C. **EQUATION DEVELOPMENT**

In order to develop the equation for the effectiveness of the ship against an inbound missile threat, it is necessary to understand the interrelationship between the various weapon systems in terms of the common detection components they share. Figure 4, a summary diagram of these relationships, shows two distinctive engagement processing paths. The NSSMS, MK 45 guns, and the MK 36 DLS can be thought of as parallel paths because of the numerous detection and control components each have in common. The CIWS and SLQ-32(V)3 engagement paths are essentially stand-alone paths and have basically no detection or control components in common with the others or each other.

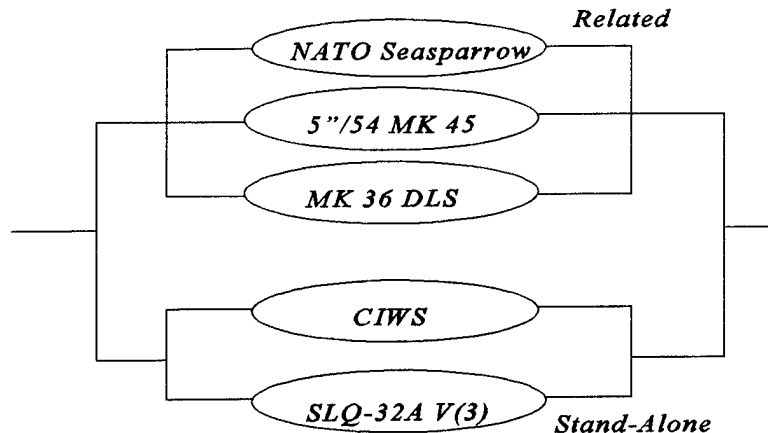

Figure 4

Figure 4 shows the two distinctive engagement processing paths. The related path has many common detection and control components. The stand-alone systems have nothing in common with the other systems or each other.

When attempting to calculate the effectiveness of each of these systems given a detection and an engagement interval, there are $2^3 - 1 = 7$ combinations for the related path and $2^2 - 1 = 3$ combinations for the stand-alone path. Rather than attempt to enumerate these possible events, it is often easier to think of these events not occurring and reduce the number of calculations to be made. A substantial factor in the effectiveness of a weapon system is the capability of the crew to employ it effectively. In order to fully assess the effectiveness of these systems, the crew's ability to respond to the threat and employ the weapon systems at their maximum effective range must be considered. Factors such as training, ability to handle stress, and many other intangibles can affect the crew's proficiency. There are other factors as well that may affect the ship's ability to employ a weapon within a given interval for a particular detection interval. All of these factors are

lumped together in this model and are referred to as crew capability. Let $PCREW_M_{mij}$, $PCREW_G_{gij}$, and $PCREW_CH_{cij}$ be the probability that the crew launches a missile, 5" round or chaff in interval m , g , or c respectively, given the threat is detected in interval i and the system is in state j .

Let $Q_{ij}(M,G,C)$ be the probability that the NSSMS, MK 45 guns and MK 36 DLS **do not kill** the threat in any of their launch intervals given the threat is detected in interval i and the system is in state j . $Q_{ij}(M,G,C)$ is defined as

$$Q_{ij}(M,G,C) = (1-PkNSSMS_{ij}) \cdot (1-PkGUN_{ij}) \cdot (1-PkCHAFF_{ij}) \quad (39)$$

where

$$PkNSSMS_{ij} = \sum_m PNSSMS_{mj} \cdot PCREW_M_{mij} \quad (40)$$

$$PkGUN_{ij} = \sum_g PGUN_{gj} \cdot PCREW_G_{gij} \quad (41)$$

$$PkCHAFF_{ij} = \sum_c PCHAFF_{cj} \cdot PCREW_CH_{cij} \quad (42)$$

Similarly, let $Q_j(CIWS,ECM)$ be the probability that the CIWS and SLQ-32(V)3 are ineffective against the missile given system state j . Recall that the probability of kill for these systems does not depend on the interval in which the engagement was initiated.

$Q_j(CIWS,ECM)$ is then defined as

$$Q_j(CIWS,ECM) = (1-PCIWS_j) \cdot (1-PECM_j) \quad (43)$$

Multiplying this term by $Q_{ij}(M,G,C)$ gives the probability that none of the systems were effective against the Exocet missile. Taking its complement, subtracting it from the certain event, provides the probability that the system is effective (is not hit by the threat) given a detection interval i and system state j . An expression for the probability that the ship

survives the attack given the threat was detected in interval i and the system is in state j can now be defined as

$$P(E_0|\text{Detect}_{ij}, \text{State}_j) = 1 - Q_{ij}(M, G, C) \cdot Q_j(\text{CIWS}, \text{ECM}) . \quad (44)$$

Finally, equation (44) is predicated upon knowing what state the system is in and the interval in which the initial detection occurred. This result must now be multiplied by the probability that the missile is in fact detected in interval i and by the availability of system state j to produce the overall effectiveness of the system for any state and all possible detection intervals. That is, system effectiveness, the probability that a single Exocet missile does not hit the ship, is given by

$$SE = \sum_{j=1}^J \sum_{i=1}^N P(E_0|\text{Detect}_{ij}, \text{State}_j) \cdot P(\text{Detect}_{ij}) \cdot A(\text{State}_j) . \quad (45)$$

IV. OBSERVATIONS

With the model and the methodology behind it defined, the question of how the model's various inputs affect the overall effectiveness of the DD-963 to defend itself needs to be answered. Looking at the numerous parameters that are required to calculate an answer and the variability that they may induce, lead to assessing only a few input sets. Microsoft Excel 7.0 was used to enumerate the model using initial values specified in the example shown in Appendix B .

Initially the P_{kill} for both the 5" and chaff rounds is looked at to determine their contribution to the effectiveness of the system. Maintaining the baseline inputs and varying the P_{kill} of the rounds from 0.3 to 0.9 one at a time, results in a constant system effectiveness curves in Figure 5.

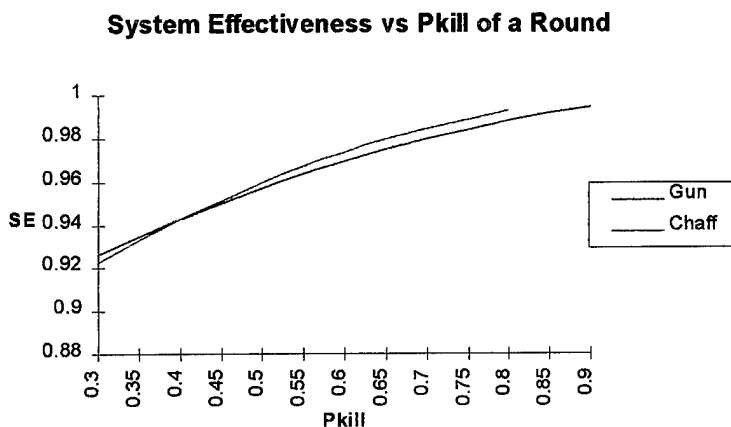

Figure 5

Figure 5 represents the change in the system effectiveness when the P_{kill} for a chaff and 5" round are varied while maintaining the baseline values.

Earlier the CIWS and the SLQ-32(V)3 were identified as "stand-alone" systems in that they have very little components in common with each other or the other defensive systems onboard. The P_{kill} for these systems are modified to see their affect on the system's effectiveness. The results for the CIWS are shown in Figure 6. Similar results are obtained when working with the SLQ-32 which may be attributed to these systems operating in "parallel" as shown in Figure 4.

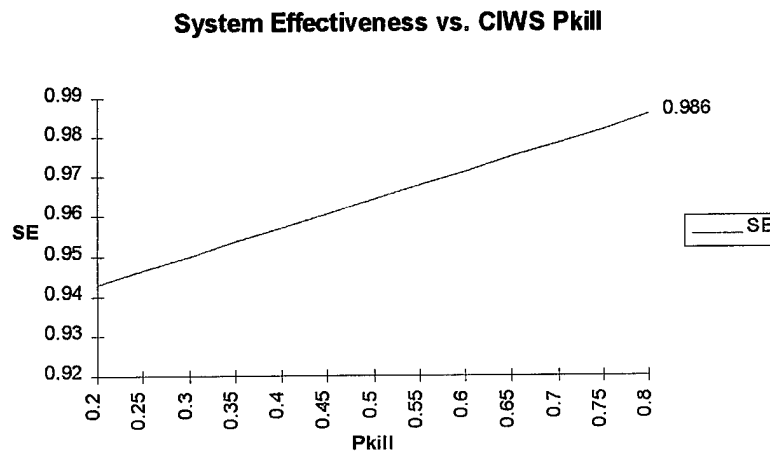

Figure 6

Figure 6 displays the change in system effectiveness as the P_{kill} for the CIWS changes.

The probability of detection plays a large part throughout the model and is therefore the next parameter to be considered. The baseline values are used for all parameters with the probability of detection for interval i being a variable. Probabilities of detection for the farthest interval, i , and the next closest interval, $i-1$, are used. For example, a probability of detection of 0.2 is placed in interval i followed by a probability of detection of 0.8 placed

in interval $i-1$. This is repeated for interval intervals $i = 2$ thru 10 with the results for two combinations displayed in Figure 7.

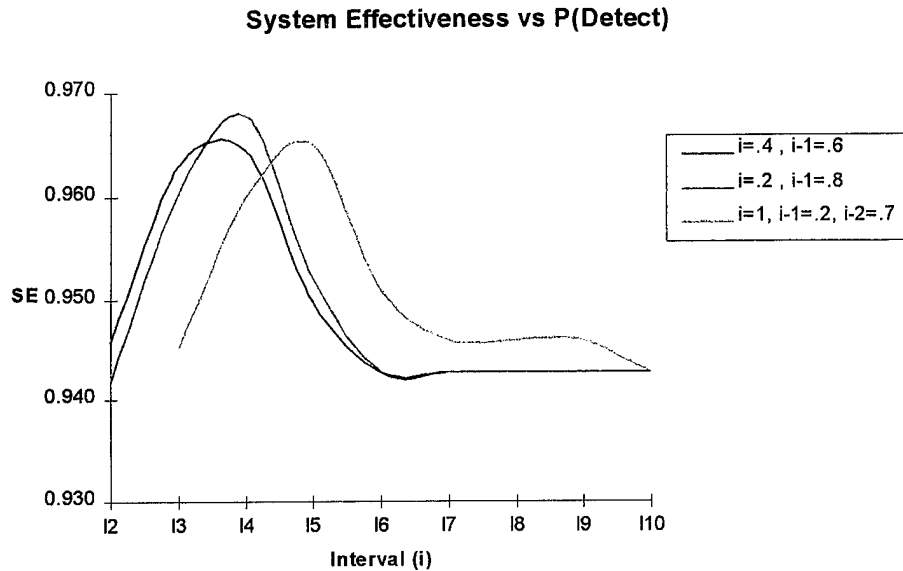

Figure 7

Figure 7 shows the change in the system effectiveness when the initial detection interval, i , and the next closest intervals, vary.

Looking at Figure 7, the graphs are almost identical except for the interval where the maximum effectiveness occurs. With detection possibilities in three intervals, the maximum probability of survival for the ship occurs in interval five vice interval four for the dual probability case.

Does the crew's ability to employ the ship's weapons affect the system's effectiveness? The probability of initial detection is fixed in interval seven with a probability

of 0.1 followed by 0.2 in interval six and finally 0.7 in interval five. Case one represents a crew that is well prepared to defend the ship against the Exocet missile. This equates to a probability of firing a weapon in the same interval that the threat is detected, given the weapon has a capability in that interval, of 0.9. The crew also employs the weapon in the next closest interval with probability of 0.1. For this example, if the threat is detected in interval seven the crew will fire the NSSMS, MK 45 guns and chaff in interval seven with a probability of 0.9 and in interval six with a probability of 0.1. Case Two and Case Three differ from the previous case in that they use different probabilities of employing the weapons. Case two uses 0.7 for the probability of engaging the target in the same interval it is detected and 0.3 for the next closest interval. Case three uses 0.7 for the probability of engaging in the same interval that the threat is detected, 0.2 for the next closest interval and 0.1 for the second interval closer than the interval of detection. The system effectiveness results are shown in the table below.

<i>Case 1</i>	<i>Case 2</i>	<i>Case 3</i>
.943	.945	.936

These figures show that the crew's ability to employ weapons early in the engagement process does have some affect on the probability that the ship survives a cruise missile attack. This effect seems to be minimal if the crew is certain to launch a weapon in some interval.

V. RECOMMENDATIONS FOR FUTURE STUDY

Assessing the effectiveness of a ship's defensive systems against a cruise missile is an issue that will be talked about for years to come. This thesis provides a model to assess the effectiveness of integrated systems onboard a DD-963 Spruance class destroyer. It also considers intangible factors such as the crew's ability to employ these systems and their contribution to the success of the ship in defending itself.

An in-depth study into the sensitivity of the model to various combinations of parameter values is needed. This could best be done by developing or using a computer program in which these parameters can be varied to identify their affect on the overall effectiveness of the system. Identifying key parameters can also be used to aid decision makers when allocating funds for improvements in individual systems to increase the system effectiveness.

Simulation methodologies are currently being developed throughout the Department of the Navy and by civilian contractors to answer this question as well. The analytical model in this thesis can be used as a tool to verify these simulations as well.

APPENDIX A. INTEGRATED DETECT-TO-ENGAGE CAPABILITY

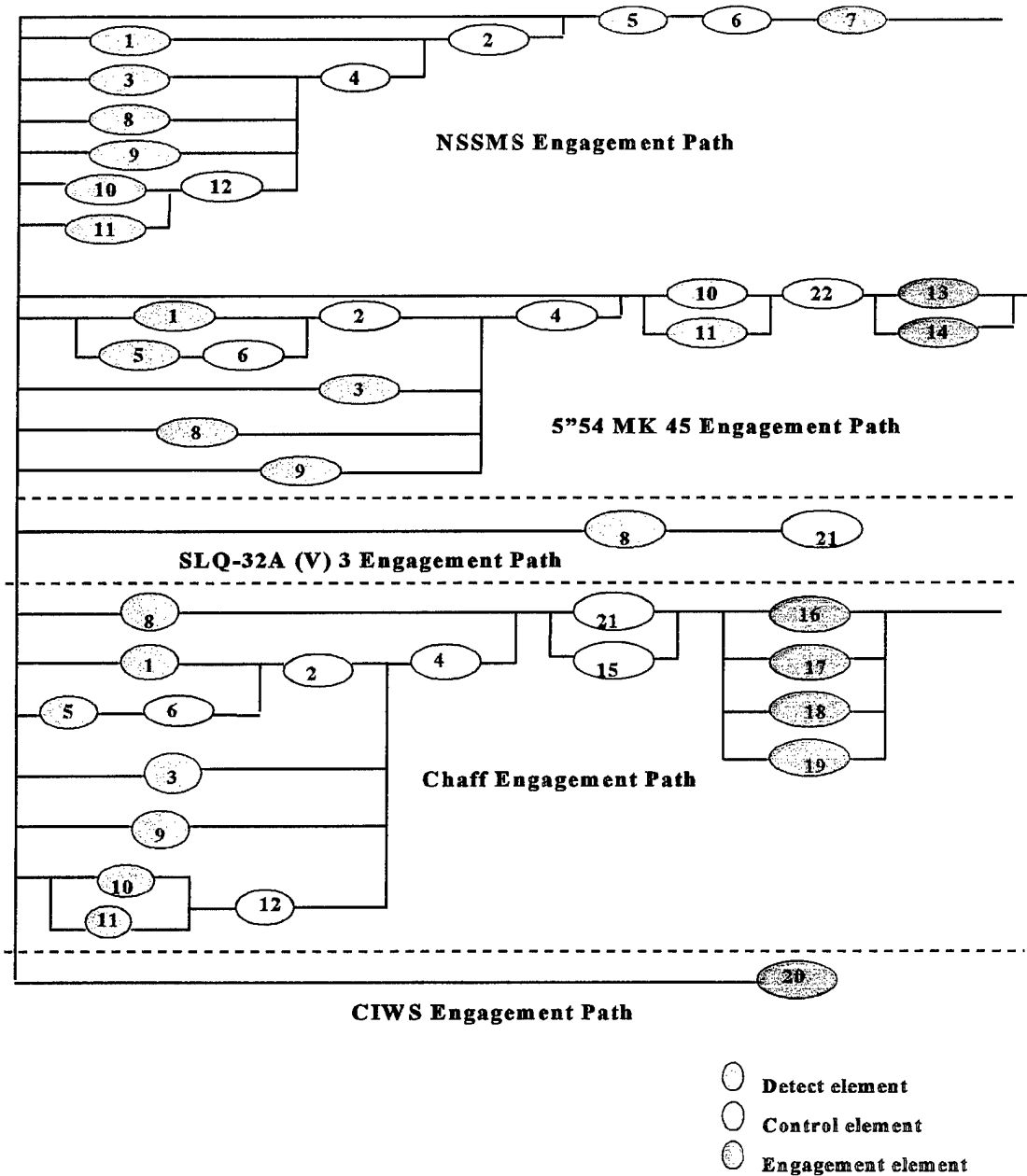

Figure 7

Figure 7 represents the DD-963 Integrated Self-defense detect-to-engage capability [Zakka, June 1995]. In this diagram the various paths from initial detection through engagement are displayed. The index for the components is on the next page.

Figure 7 Index

- 1 - MK 23 TAS Radar
- 2 - MK 23 TAS Radar with Data Processing Set (DPS)
- 3 - AN/SPS-40 Air Search Radar
- 4 - CDS Baseline 6
- 5 - MK 95 NSSMS Radar
- 6 - MK 91 NSSMS Fire Control System (FCS)
- 7 - MK 29 NSSMS GMLS (Guided Missile Launching System)
- 8 - SLQ-32(V)3 Receiver/Processor
- 9 - AN/SPS-55 Surface Search Radar
- 10 - AN/SPQ-9A Gun Fire Control Radar
- 11 - AN/SPG-60 Gun Fire Control Radar
- 12 - MK 86 Gun Fire Control System (GFCS)
- 13 - MK 45 5"/54 Mount 51
- 14 - MK 45 5"/54 Mount 52
- 15 - MK 36 Decoy Launching System (DLS) Bridge Control Unit
- 16 - Chaff Launcher # 1
- 17 - Chaff Launcher # 2
- 18 - Chaff Launcher # 3
- 19 - Chaff Launcher # 4
- 20 - Close in Weapon System (CIWS) Mount 21
- 21 - SLQ-32(V)3 Display Console
- 22 - MK 86 GFCS Control Officers Console

APPENDIX B. SYSTEM EFFECTIVENESS EXAMPLE

The following example will compute only the term in the system effectiveness equation (equation 45) that corresponds to detection in interval seven and system state one. The remaining terms for system state one corresponding to other detection intervals would be computed in the same manner. The same is true for system states two and three. A red box will be used to highlight values used in the system effectiveness calculations. For simplicity the engagement intervals for the NSSMS, MK 45 5"/54 guns and the MK 36 DLS are the same as the detection intervals. This means that the intervals for each weapon system coincide exactly with each of the detection intervals. The maximum detection range for the ship will be the outermost limit of detection interval ten.

INTERVALS

| 1
| 2
| 3
| 4
| 5
| 6
| 7
| 8
| 9
| 10

next assumption is that all of the equipment for each of the engagement paths is available, that is the system is in State₁. Although this may not be a realistic assumption, it makes the example more manageable.

Equipment Availability (A_i)

MK 23 TAS	$A_1 = .98$	MK 86 GFCS	$A_{12} = 1$
MK 23 TAS w/ DPS	$A_2 = .98$	MT 51	$A_{13} = 1$
AN/SPS-40	$A_3 = .98$	MT 52	$A_{14} = 1$
CDS Baseline 6	$A_4 = .98$	MK 36 DLS (BCU)	$A_{15} = 1$
MK 95 NSSMS Radar	$A_5 = .98$	Chaff Launcher #1	$A_{16} = 1$
MK 91 NSSMS FCS	$A_6 = .985$	Chaff Launcher #2	$A_{17} = 1$
MK 29 NSSMS GMLS	$A_7 = .985$	Chaff Launcher #3	$A_{18} = 1$
SLQ-32(V) 3 RCVR/PROC	$A_8 = .985$	Chaff Launcher #4	$A_{19} = 1$
AN/SPS-55	$A_9 = 1$	MT 21	$A_{20} = 1$
AN/SPQ-9A	$A_{10} = 1$	SLQ-32(V) 3 Display Console	$A_{21} = 1$
AN/SPG-60	$A_{11} = 1$	MK 86 GFCS COC	$A_{22} = 1$

Table 1

Table 1 represents the availability of the components used in the engagement paths of the various weapon systems.

With this assumption the calculation of the availability of each state is calculated using equations (14), (21), and (27).

	State ₁		State ₂		State ₃
$A(S_{M1})$	0.91	$A(S_{M2})$	0.02	$A(S_{M3})$	0.02
$A(S_G)$	1.00	$A(S_G)$	1.00	$A(S_G)$	1.00
$A(S_{CH})$	0.99	$A(S_{CH})$	0.99	$A(S_{CH})$	0.99
$A(S_E)$	1.00	$A(S_E)$	1.00	$A(S_E)$	1.00
$A(S_{CIWS})$	1.00	$A(S_{CIWS})$	1.00	$A(S_{CIWS})$	1.00
$A(State_1)$	0.90	$A(State_2)$	0.02	$A(State_3)$	0.02

Table 2

Table 2 shows the availability of the components of each state and the overall availability of the states as well. The red box indicates that only State₁ will be used throughout this engagement.

From Table 2 we see that State₁ will be the only state in which the system will operate because of the assumption that all of the equipment is available.

The next task is to define the probability of kill for each of the weapon systems given the engagement is initiated in interval five. The probability of kill for the NSSMS, MK 45 guns and chaff depend on the reliability of the rounds, the successful firing of a round and the probability of kill for each round. The numbers below represent hypothetical values.

Reliability of Rounds		Probability of Successfully Firing a Round		Probability of Kill		
R_M	0.8	P_M	0.9	P_{k_B}	0.4	for all g
R_B	0.98	P_B	0.9	$P_{k_{CH}}$	0.4	for all c
R_{CH}	0.98	P_{CH}	0.9			

Table 3

Table 3 lists numbers required to calculate the P_{kill} for NSSMS, MK 45 guns and chaff.

These values are used in equations (29) thru (38) to calculate the P_{kill} of each weapon system given the threat is detected in interval i and the system is in state j. For simplicity the tables for the MK 45 guns and chaff assume that each weapon system's single round performance is constant throughout the intervals in which it is effective (i.e., no dependence on range) and are also independent of state j. The P_{kill} 's for the events that a single round or a two round salvo are given below. The zeros indicate that the weapon system has no capabilities in that interval.

NSSMS						
Launch Interval (m)	Pk _{Mj} (1)			Pk _{Mj} (2)		
	State ₁	State ₂	State ₃	State ₁	State ₂	State ₃
1	0.29	0.27	0.25	0.50	0.47	0.44
2	0.48	0.45	0.42	0.73	0.70	0.66
3	0.61	0.57	0.56	0.85	0.82	0.81
4	0.41	0.39	0.36	0.65	0.63	0.59
5	0.32	0.28	0.27	0.54	0.48	0.47
6	0	0	0	0	0	0
7	0	0	0	0	0	0
8	0	0	0	0	0	0
9	0	0	0	0	0	0
10	0	0	0	0	0	0

Guns						
Launch Interval (g)	Pk _{Gj} (1)			Pk _{Gj} (2)		
	State ₁	State ₂	State ₃	State ₁	State ₂	State ₃
1	0.40	0.40	0.40	0.64	0.64	0.64
2	0.40	0.40	0.40	0.64	0.64	0.64
3	0.40	0.40	0.40	0.64	0.64	0.64
4	0.40	0.40	0.40	0.64	0.64	0.64
5	0.40	0.40	0.40	0.64	0.64	0.64
6	0	0	0	0	0	0
7	0	0	0	0	0	0
8	0	0	0	0	0	0
9	0	0	0	0	0	0
10	0	0	0	0	0	0

Chaff						
Launch Interval (c)	Pk _{Cj} (1)			Pk _{Cj} (2)		
	State ₁	State ₂	State ₃	State ₁	State ₂	State ₃
1	0.40	0.40	0.40	0.64	0.64	0.64
2	0.40	0.40	0.40	0.64	0.64	0.64
3	0.40	0.40	0.40	0.64	0.64	0.64
4	0.40	0.40	0.40	0.64	0.64	0.64
5	0.40	0.40	0.40	0.64	0.64	0.64
6	0.40	0.40	0.40	0.64	0.64	0.64
7	0.40	0.40	0.40	0.64	0.64	0.64
8	0.40	0.40	0.40	0.64	0.64	0.64
9	0.40	0.40	0.40	0.64	0.64	0.64
10	0.40	0.40	0.40	0.64	0.64	0.64

Table 4

Table 4 shows what the probability of kill for NSSMS, MK 45 guns, and chaff might be for a single salvo or dual salvo given a launch interval (m,g,c) and system state j.

Because P_{kill} of the CIWS and the SLQ-32(V)3 are assumed to be independent of range, they are only affected by the state in which the system is operating and their P_{kill} 's may look similar to the values in Table 5.

PCIWS _j			PECM _j		
State ₁	State ₂	State ₃	State ₁	State ₂	State ₃
0.2	0.2	0.2	0.15	0.15	0.15

Table 5

Table 5 represents the probability of kill for CIWS and SLQ-32(V)3 given system state j . Note these P_{kill} 's are not dependent on the engagement interval.

The parameters needed to calculate the probability that the individual weapon systems kill the target when launched in a given interval are now defined.. Substituting the numbers presented in Table 3 into equations (29) and (30), the probability of launching a single missile or a salvo of two missiles is given by

$$P_L(1) = .0000007$$

$$P_L(2) \cong 1.00$$

Substituting values from Tables 3 and 4 as well as these results into equation (31), the probability that the NSSMS kills the missile when attempting to shoot two missiles is

<u>PNSSMS_{Mj}</u>			
Launch Interval (m)	State ₁	State ₂	State ₃
1	0.41	0.39	0.36
2	0.62	0.59	0.56
3	0.74	0.70	0.70
4	0.55	0.53	0.49
5	0.45	0.40	0.39
6	0.00	0.00	0.00
7	0.00	0.00	0.00
8	0.00	0.00	0.00
9	0.00	0.00	0.00
10	0.00	0.00	0.00

Table 6

Table 6 represents the probability that the NSSMS kills the target when launched in the indicated intervals.

Similarly, using equations (33) thru (38), the probabilities that the guns and chaff kill the target are

<u>PGUN_{Gj}</u>				<u>PCHAFF_{Gj}</u>			
Launch Interval (g)	State ₁	State ₂	State ₃	Launch Interval (c)	State ₁	State ₂	State ₃
1	0.58	0.58	0.58	1	0.63	0.63	0.63
2	0.58	0.58	0.58	2	0.63	0.63	0.63
3	0.58	0.58	0.58	3	0.63	0.63	0.63
4	0.58	0.58	0.58	4	0.63	0.63	0.63
5	0.58	0.58	0.58	5	0.63	0.63	0.63
6	0.00	0.00	0.00	6	0.63	0.63	0.63
7	0.00	0.00	0.00	7	0.63	0.63	0.63
8	0.00	0.00	0.00	8	0.63	0.63	0.63
9	0.00	0.00	0.00	9	0.63	0.63	0.63
10	0.00	0.00	0.00	10	0.63	0.63	0.63

Table 7

Table 7 displays the probability that the guns and chaff destroy the target when launched in the indicated intervals.

In equation (39) the probability that neither NSSMS, MK 45 guns or chaff destroy the targets, $Q_{ij}(M,G,C)$, is the complement of the product of the probability that they kill the target. In other words

$$Q_{ij}(M,G,C) = (1-PkNSSMS_{ij}) \cdot (1-PkGUN_{ij}) \cdot (1-PkCHAFF_{ij})$$

where

$$PkNSSMS_{ij} = \sum_m PNSSMS_{mj} \cdot PCREW_M_{mij}$$

$$PkGUN_{ij} = \sum_g PGUN_{gj} \cdot PCREW_G_{gij}$$

$$PkCHAFF_{ij} = \sum_c PCHAFF_{cj} \cdot PCREW_CH_{cij}$$

In equations (40), (41) and (42) PCREW is introduced as a parameter to account for intangible factors such as stress, sleep deprivation, and training that affect successful employment of the weapon systems. The next step is to calculate the probability that any one of the NSSMS, MK 45 guns or chaff is effective against the missile given weapons are employed and the target is detected in interval seven. The PCREW parameters are dependent on detection interval, engagement interval and system state. They are defined as $PCREW_M_{mij}$, $PCREW_G_{gij}$, $PCREW_CH_{cij}$ for the NSSMS, MK 45 guns, and chaff respectively. Table 8 gives some hypothetical values for $PCREW_M_{mij}$.

PCREW_Mrij

Launch Interval = 4				Launch Interval = 5				Launch Interval = 6			
Detection Interval	State ₁	State ₂	State ₃	Detection Interval	State ₁	State ₂	State ₃	Detection Interval	State ₁	State ₂	State ₃
l ₁	0	0	0	l ₁	0	0	0	l ₁	0	0	0
l ₂	0	0	0	l ₂	0	0	0	l ₂	0	0	0
l ₃	0	0	0	l ₃	0	0	0	l ₃	0	0	0
l ₄	0.8	0.8	0.8	l ₄	0	0	0	l ₄	0	0	0
l ₅	0.2	0.2	0.2	l ₅	0.8	0.8	0.8	l ₅	0	0	0
l ₆	0.1	0.1	0.1	l ₆	0.9	0.9	0.9	l ₆	0	0	0
l ₇	0.1	0.1	0.1	l ₇	0.9	0.9	0.9	l ₇	0	0	0
l ₈	0	0	0	l ₈	1	1	1	l ₈	0	0	0
l ₉	0	0	0	l ₉	1	1	1	l ₉	0	0	0
l ₁₀	0	0	0	l ₁₀	1	1	1	l ₁₀	0	0	0

Table 8

Table 8 represents the ability of the crew to employ the NSSMS in intervals four, five, and six for detection intervals one thru ten. For detection interval seven and launch interval five, PCREW_M is equal to 0.9 . This states that if the target is detected in interval seven the weapon will be employed with probability of 0.9 in interval five. In Table 6 the P_{kill} for the NSSMS for launch intervals farther than interval five is zero signifying the weapon has no capability in these intervals. Launch interval five is the first chance for the crew to employ the weapon and thus results in a larger number. Launch intervals less than five have values equal to zero because the crew cannot launch in interval five if they haven't detected the target yet.

The red blocks in Table 8 present crew launch probabilities for the NSSMS in launch intervals for, five, and six given the target is detected in interval seven. For detection interval seven and launch interval five, PCREW_M is equal to 0.9 . This states that if the target is detected in interval seven the weapon will be employed with probability 0.9 in interval five. In Table 6 the P_{kill} for the NSSMS for launch intervals farther than interval five is zero signifying the weapon has no capability in these intervals. Thus, launch interval five is the first chance for the crew to employ the weapon and kill the missile resulting in

a larger probability. In Table 8 when launching in interval five, detection intervals less than five have values equal to zero because the crew cannot launch in interval five if they haven't detected the target yet. Using the expression defined above and values located in Tables 6 and 8, the probability that the NSSMS kills the threat given the threat is detected in interval seven and the system is in state one is given by adding the cross products from Tables 6 and 8 for launch intervals six, five and four in that order to get

$$PkNSSMS_{71} = (0 \cdot 0) + (.45 \cdot .9) + (.55 \cdot .1) = .46$$

Table 9 represents the probability of the crew firing a 5" round in intervals four, five, and six for various detection intervals. The zeros in launch interval six signify that the crew will not attempt to fire a 5" round in this interval.

PCREW_{G₅}

Launch Interval = 4				Launch Interval = 5				Launch Interval = 6			
Detection Interval	State ₁	State ₂	State ₃	Detection Interval	State ₁	State ₂	State ₃	Detection Interval	State ₁	State ₂	State ₃
l ₁	0	0	0	l ₁	0	0	0	l ₁	0	0	0
l ₂	0	0	0	l ₂	0	0	0	l ₂	0	0	0
l ₃	0	0	0	l ₃	0	0	0	l ₃	0	0	0
l ₄	0.7	0.7	0.7	l ₄	0	0	0	l ₄	0	0	0
l ₅	0.3	0.3	0.3	l ₅	0.7	0.7	0.7	l ₅	0	0	0
l ₆	0.2	0.2	0.2	l ₆	0.8	0.8	0.8	l ₆	0	0	0
l ₇	0.1	0.1	0.1	l ₇	0.9	0.9	0.9	l ₇	0	0	0
l ₈	0	0	0	l ₈	1	0	0	l ₈	0	0	0
l ₉	0	0	0	l ₉	1	0	0	l ₉	0	0	0
l ₁₀	0	0	0	l ₁₀	1	0	0	l ₁₀	0	0	0

Table 9

Table 9 represents the probability of the crew firing a 5" round in intervals four, five, and six for various detection intervals. The zeros in launch interval six signify that the crew will not attempt to fire a 5" round because the weapon does not have a capability to engage the target in this interval.

From Tables 7 and 9, the probability that the MK 45 guns kill the threat given the threat is detected in interval seven and the system is in state one is given by adding the cross products from Tables 7 and 9 for launch intervals six, five and four in that order to get

$$PkGUN_{71} = (0 \cdot 0) + (.58 \cdot .9) + (.58 \cdot .1) = .58$$

Table 10 shows the probability of the crew launching chaff in intervals five, six, and seven for various detection intervals. Using Tables 7 and 10, the probability of the chaff successfully "destroying" the missile given it is detected in interval seven and the system is in state one is

$$PkCHAFF_{71} = (.63 \cdot .7) + (.63 \cdot .2) + (.63 \cdot .1) = .63$$

PCREW_CH₁

Launch Interval = 5				Launch Interval = 6				Launch Interval = 7			
Detection Interval	State ₁	State ₂	State ₃	Detection Interval	State ₁	State ₂	State ₃	Detection Interval	State ₁	State ₂	State ₃
I ₁	0	0	0	I ₁	0	0	0	I ₁	0	0	0
I ₂	0	0	0	I ₂	0	0	0	I ₂	0	0	0
I ₃	0	0	0	I ₃	0	0	0	I ₃	0	0	0
I ₄	0	0	0	I ₄	0	0	0	I ₄	0	0	0
I ₅	0.7	0.8	0.8	I ₅	0	0	0	I ₅	0	0	0
I ₆	0.2	0.1	0.1	I ₆	0.7	0.8	0.8	I ₆	0	0	0
I ₇	0.1	0.1	0.1	I ₇	0.2	0.1	0.1	I ₇	0.7	0.8	0.8
I ₈	0	0	0	I ₈	0.1	0.1	0.1	I ₈	0.2	0.1	0.1
I ₉	0	0	0	I ₉	0	0	0	I ₉	0.1	0.1	0.1
I ₁₀	0	0	0	I ₁₀	0	0	0	I ₁₀	0	0	0

Table 10

Table 10 represents the probability of the crew firing a chaff round in intervals five, six, and seven for various detection intervals.

Given a detection interval and a system state, the sum across all engagement intervals for each crew factor should be less than or equal to one signifying that the crew may launch a weapon before the missile impacts the ship. The probability that neither the NSSMS, MK 45 guns or chaff kill the target given they are employed, the system is in state one and the target is detected in interval seven is given by

$$Q_{71}(M,G,C) = (1 - .46) \cdot (1 - .58) \cdot (1 - .63) = .084$$

The probability that the missile survives the CIWS and SLQ-32(V)3 is calculated by

$$Q_1(\text{CIWS,ECM}) = (1 - \text{PCIWS}_1) \cdot (1 - \text{PECM}_1)$$

and these values are represented in Table 11.

Q _j (CIWS,ECM)		
State ₁	State ₂	State ₃
0.68	0.68	0.68

Table 11

Table 11 represents the probability that the missile survives both the CIWS and SLQ-32 given state j.

Multiplying $Q_1(\text{CIWS,ECM})$, the probability that CIWS and SLQ-32(V)3 do not destroy the target, by the probability that neither the NSSMS, MK 45 guns or chaff kill the target, $Q_{71}(M,G,C)$, and then taking the complement yields the probability that the ship survives given the missile is detected in interval seven and engaged in interval five.

$$P(E_0 | \text{Detect}_{71}, \text{State}_1) = 1 - (.084 \cdot .68) = .943$$

This assumes the detection occurred in interval seven and that the system is in state one. The probability that the missile is in fact detected in interval seven and the availability of state one must now be taken into consideration. Table 12 displays what the probability of detection might look like for the three system states.

Interval	P(Detect _i)		
	State ₁	State ₂	State ₃
I ₁	0	0	0
I ₂	0	0	0
I ₃	0	0	0
I ₄	0	0	0
I ₅	0	0.1	0.2
I ₆	0.1	0.4	0.4
I ₇	0.3	0.4	0.3
I ₈	0.5	0.1	0.1
I ₉	0.1	0	0
I ₁₀	0	0	0

Table 12

Table 12 represents possible values for the probability of detection given a particular system state.

Using the probability of detection for interval seven from Table 12 and the availability of state one from Table 2, the system effectiveness term in equation (45) corresponding to interval seven and system state one is

$$(.943) \cdot (.3) \cdot (.9) = .2546$$

To obtain the overall effectiveness of the ship, this process needs to be replicated and then summed across all possible detection intervals and system states.

LIST OF REFERENCES

Commander, Naval Surface Forces Atlantic, Norfolk, Virginia / Commander, Naval Surface Forces Pacific, Pearl Harbor Hawaii, COMNAVSURFLANTINST C3516.C/COMNAVSURFPACINST C3516.6D, *DD-963 Class Combat Systems Doctrine (U)*, CONFIDENTIAL, 15 March 1994.

Steigers, C.W. *A Critical Analysis of a Range Dependent Probability of Kill for the NATO Seasparrow Missile System*, Master's Thesis, Naval Postgraduate School, Monterey, California, March 1993.

Zakka, G. , Naval Warfare Assessment Division, China Lake, California, *Integrated Assessment*, Integrated Ship Defense In-Service Review, June 1995.

INITIAL DISTRIBUTION LIST

		No. Copies
1.	Defense Technical Information Center 8725 John J. Kingman Rd., STE 0944 Ft. Belvoir, VA 22060-6218	2
2.	Dudley Knox Library Naval Postgraduate School 411 Dyer Rd. Monterey, CA 93943-5101	2
3.	Professor W. Max Woods OR/WO Naval Postgraduate School Monterey, CA 93943-5002	5
4.	Professor Robert E. Ball AA/Bp Naval Postgraduate School Monterey, CA 93943-5002	1
5.	Naval Warfare Assessment Division Code QA30 (Attn: Gus Zakka) P.O. Box 5000 Corona, CA 91718-5000	5
6.	Program Executive Office Theater Air Defense Integrated Ship Defense (ATTN: Lorraine Shea,D112) 2531 Jefferson Davis Highway Arlington, VA 22242	1
7.	LT Richard Johns 310 Frostiway Eustis, FL 32726	2