

Cardiac Growth and Regeneration

*Edited by William C. Claycomb
and Paolo Di Nardo*



Annals of the New York Academy of Sciences
Volume 752

ANNALS OF THE NEW YORK ACADEMY OF SCIENCES

Volume 752



EDITORIAL STAFF

Executive Editor

BILL BOLAND

Managing Editor

JUSTINE CULLINAN

Associate Editor

COOK KIMBALL

*The New York Academy of Sciences
2 East 63rd Street
New York, New York 10021*

THE NEW YORK ACADEMY OF SCIENCES
(Founded in 1817)

BOARD OF GOVERNORS, July 1994–June 1995

JOSHUA LEDERBERG, *Chairman of the Board*

HENRY M. GREENBERG, *President*

MARTIN L. LEIBOWITZ, *President-Elect*

Honorary Life Governor

WILLIAM T. GOLDEN

HENRY A. LICHSTEIN, *Treasurer*

Governors-at-Large

ELEANOR BAUM

BARRY R. BLOOM

D. ALLAN BROMLEY

EDWARD COHEN

SUSANNA CUNNINGHAM-RUNDLES

BILL GREEN

SANDRA PANEM

RICHARD A. RIFKIND

DOMINICK SALVATORE

DAVID E. SHAW

WILLIAM C. STEERE, JR.

SHMUEL WINOGRAD

CYRIL M. HARRIS, *Past Chairman*

HELENE L. KAPLAN, *General Counsel [ex officio]*

RODNEY W. NICHOLS, *Chief Executive Officer [ex officio]*

REPORT DOCUMENTATION PAGE

Form Approved OMB No. 0704-0188

Public reporting burden for this collection of information is estimated to average 1 hour per response, including the time for reviewing instructions, searching existing data sources, gathering and maintaining the data needed, and completing and reviewing the collection of information. Send comments regarding this burden estimate or any other aspect of this collection of information, including suggestions for reducing this burden to Washington Headquarters Services, Directorate for Information Operations and Reports, 1215 Jefferson Davis Highway, Suite 1204, Arlington, VA 22202-4302, and to the Office of Management and Budget, Paperwork Reduction Project (0704-0188), Washington, DC 20503.

1. AGENCY USE ONLY (Leave blank)		2. REPORT DATE 14 November 1996	3. REPORT TYPE AND DATES COVERED Conference Proceedings	
4. TITLE AND SUBTITLE Cardiac Growth and Regeneration			5. FUNDING NUMBERS F6170894W0620	
6. AUTHOR(S) Conference Committee				
7. PERFORMING ORGANIZATION NAME(S) AND ADDRESS(ES) Laboratory of Cellular and Molecular Cadiology University of Rome Rome 00173 Italy			8. PERFORMING ORGANIZATION REPORT NUMBER N/A	
9. SPONSORING/MONITORING AGENCY NAME(S) AND ADDRESS(ES) EOARD PSC 802 BOX 14 FPO 09499-0200			10. SPONSORING/MONITORING AGENCY REPORT NUMBER CSP 94-1013	
11. SUPPLEMENTARY NOTES				
12a. DISTRIBUTION/AVAILABILITY STATEMENT Approved for public release; distribution is unlimited.			12b. DISTRIBUTION CODE A	
13. ABSTRACT (Maximum 200 words) The Final Proceedings for Cardiac Growth and Regeneration, 19 June 1994 - 24 June 1994 The Topics covered include: gene transfer, cardiac muscle cell division and determination, cardiac hypertrophy, angiogenesis, growth factors and cardiac growth.				
14. SUBJECT TERMS			15. NUMBER OF PAGES 525	
			16. PRICE CODE N/A	
17. SECURITY CLASSIFICATION OF REPORT UNCLASSIFIED	18. SECURITY CLASSIFICATION OF THIS PAGE UNCLASSIFIED	19. SECURITY CLASSIFICATION OF ABSTRACT UNCLASSIFIED	20. LIMITATION OF ABSTRACT UL	

**CARDIAC GROWTH AND
REGENERATION**

ANNALS OF THE NEW YORK ACADEMY OF SCIENCES
Volume 752

**CARDIAC GROWTH AND
REGENERATION**

Edited by William C. Claycomb and Paolo Di Nardo

19970130 081



DTIC QUALITY INSPECTED 2

The New York Academy of Sciences
New York, New York
1995

Copyright © 1995 by the New York Academy of Sciences. All rights reserved. Under the provisions of the United States Copyright Act of 1976, individual readers of the Annals are permitted to make fair use of the material in them for teaching and research. Permission is granted to quote from the Annals provided that the customary acknowledgment is made of the source. Material in the Annals may be republished only by permission of the Academy. Address inquiries to the Executive Editor at the New York Academy of Sciences.

Copying fees: For each copy of an article made beyond the free copying permitted under Section 107 or 108 of the 1976 Copyright Act, a fee should be paid through the Copyright Clearance Center, Inc., 222 Rosewood Drive, Danvers, MA 01923. For articles of more than 3 pages the copying fee is \$1.75.

∞ The paper used in this publication meets the minimum requirements of American National Standard for Information Sciences—Permanence of Paper for Printed Library Materials, ANSI Z39.48-1984.

Cover (paper edition): The upper panel shows a freshly isolated adult rat ventricular cardiac muscle cell. The lower panel shows an autoradiograph of an adult rat ventricular cardiac muscle cell that has been in culture for two weeks which has been labeled with ³H-thymidine. Silver grains over the nuclei show that these terminally differentiated cardiac muscle cells are able to enter the S-phase of the cell cycle and replicate their DNA indicating that it may be possible to induce these highly differentiated cells to divide and thus repair injured cardiac muscle by controlled myocyte proliferation. (Micrographs courtesy of William C. Claycomb, Department of Biochemistry and Molecular Biology, LSU Medical Center, New Orleans, LA 70112.)

Library of Congress Cataloging-in-Publication Data

Cardiac growth and regeneration / edited by William C. Claycomb and Paolo Di Nardo.
p. cm. — (Annals of the New York Academy of Sciences, ISSN 0077-8923 ; v. 752)
Includes bibliographical references and index.
ISBN 0-89766-929-0 (cloth : alk. paper). — ISBN 0-89766-930-4 (pbk. : alk. paper)
1. Heart cells—Congresses. 2. Heart—Growth—Congresses.
3. Neovascularization—Congresses. 4. Heart—Hypertrophy—Congresses. I. Claycomb, William C. II. Di Nardo, Paolo.
III. New York Academy of Sciences. IV. Series.
[DNLM: 1. Cardiomyopathy, Hypertrophic—congresses.
2. Cardiovascular System—growth & development—congresses.
3. Cardiovascular System—physiopathology—congresses. 4. Growth Substances—congresses. 5. Muscle, Smooth, Vascular—cytology—congresses. W1 AN626YL v.752 1995 / WG 102 C2657 1995]
Q11.N5 vol. 752
[QP114.C44]
500 s—dc20
[612.1'7]
DNLM/DLC
for Library of Congress

95-2609
CIP

MC/PCP
Printed in the United States of America
ISBN 0-89766-929-0 (cloth)
ISBN 0-89766-930-4 (paper)
ISSN 0077-8923

ANNALS OF THE NEW YORK ACADEMY OF SCIENCES

Volume 752
March 27, 1995

CARDIAC GROWTH AND REGENERATION^a

Editors and Conference Chairs

WILLIAM C. CLAYCOMB AND PAOLO DI NARDO

CONTENTS

Preface. <i>By</i> THE EDITORS	xiii
Part I. Cardiac Muscle Cell Division and Determination	
Commitment, Differentiation, and Diversification of Avian Cardiac Progenitor Cells. <i>By</i> NATASHA MELNIK, KATHERINE E. YUTZEY, MAUREEN GANNON, AND DAVID BADER	1
Adenovirus Infection Induces Rentry into the Cell Cycle of Terminally Differentiated Skeletal Muscle Cells. <i>By</i> MARCO CRESCENZI, SILVIA SODDU, ADA SACCHI, AND FRANCO TATÒ	9
Response of Neonatal Rat Cardiomyocytes to Repetitive Mechanical Stimulation <i>In Vitro</i> . <i>By</i> HERMAN H. VANDENBURGH, ROSA SOLERSSI, JANET SHANSKY, JOHN W. ADAMS, SCOTT A. HENDERSON, AND JULIE LEMAIRE	19
Stimulation of Proliferative Events in the Adult Amphibian Cardiac Myocyte. <i>By</i> JOHN O. OBERPRILLER, JEAN C. OBERPRILLER, DONALD G. MATZ, AND MARK H. SOONPAA	30
Ischemic Cardiomyopathy: Myocyte Cell Loss, Myocyte Cellular Hypertrophy, and Myocyte Cellular Hyperplasia. <i>By</i> PIERO ANVERSA, JAN KAJSTURA, KRZYSZTOF REISS, FEDERICO QUAINI, ALESSANDRA BALDINI, GIORGIO OLIVETTI, AND EDMUND H. SONNENBLICK	47
Hamster Cardiomyocytes: a Model of Myocardial Regeneration? <i>By</i> A. CARBONE, M. MINIERI, M. SAMPAOLESI, R. FIACCAVENTO, A. DE FEO, P. CESARONI, G. PERUZZI, AND P. DI NARDO	65
Cardiac Myocyte Terminal Differentiation: Potential for Cardiac Regeneration. <i>By</i> S. K. C. TAN, W. GU, V. MAHDAVI, AND B. NADAL-GINARD	72
Proliferative Potential and Differentiated Characteristics of Cultured Cardiac Muscle Cells Expressing the SV40 T Oncogene. <i>By</i> ANDREI B. BORISOV AND WILLIAM C. CLAYCOMB	80

^a This volume contains the papers from a NATO Advanced Research Workshop entitled *Cardiac Growth and Regeneration*, which was held by the University of Rome "Tor Vergata" and the Louisiana State University Medical Center in Viterbo, Italy on June 19-24, 1994.

<i>In Vitro</i> Clonal Analysis of Cardiac Outflow Tract Mesenchyme. <i>By</i> MAYA SIEBER-BLUM AND KAZUO ITO	92
Characterization of Human Cardiac Desmosomal Cadherins. <i>By</i> BRIGITT D. ANGST, ROGER S. BUXTON, AND ANTHONY I. MAGEE	101
The Growth of the Individual Segments of the Embryonic Rat Heart. <i>By</i> M. W. M. KNAAPEN, B. C. M. VROLIJK, AND A. C. G. WENINK	105
Structural Basis of Cardiomyopathy in Duchenne/Becker Carriers: Endomyocardial Biopsy Evaluation. <i>By</i> G. NIGRO, S. DI SOMMA, L. I. COMI, L. POLITANO, S. PAPPARELLA, B. RESTUCCI, V. R. PETRETTA, M. A. M. GIUGLIANO, A. CAROTENUTO, F. M. LIMONGELLI, AND O. DE DIVITIIS	108
Proliferative Activity of Myocytes in Transplanted Hearts Investigated Using BrdU. <i>By</i> C. DI LORETO, D. ARTICO, N. FINATO, AND C. A. BELTRAMI	111

Part II. Cardiac Hypertrophy

Signaling Pathways for Cardiac Growth and Hypertrophy: Recent Advances and Prospects for Growth Factor Therapy. <i>By</i> GIUSEPPE LEMBO, JOHN J. HUNTER, AND KENNETH R. CHIEN	115
Cytoskeletal Rearrangements in Adult Rat Cardiomyocytes in Culture. <i>By</i> HANS M. EPPENBERGER, MONIKA EPPENBERGER-EBERHARDT, AND CECILIA HERTIG	128
Mechanical Regulation of Cardiac Myofibrillar Structure. <i>By</i> D. G. SIMPSON, W. W. SHARP, T. K. BORG, R. L. PRICE, A. M. SAMAREL, AND L. TERRACIO	131
Cardiac Myocytes Differ in mRNA Composition for Sarcoplasmic Reticulum Ca ²⁺ Channels and Ca ²⁺ Pumps. <i>By</i> LUISA GORZA, SILVIA VETTORE, POMPEO VOLPE, VINCENZO SORRENTINO, JANE- LYSE SAMUEL, MARIELLE ANGER, AND ANNE MARIE LOMPRÉ	141
Possible Cellular Mechanisms of Heart Muscle Growth in Invertebrates. <i>By</i> MARINA G. MARTYNOVA	149
Protein Kinase C in Angiotensin II Signalling in Neonatal Rat Cardiac Fibroblasts: Role in the Mitogenic Response. <i>By</i> GEORGE W. BOOZ AND KENNETH M. BAKER	158
Mechanical and Neurohumoral Regulation of Adult Cardiocyte Growth. <i>By</i> ROBERT S. DECKER, MARLENE L. DECKER, MONICA M. BEHNKE-BARCLAY, DONNA M. JANES, AND WILLIAM A. CLARK	168
Phospholipase Signalling Pathways in Thyroxine-Induced Cardiac Hypertrophy. <i>By</i> SEAN WILLIAMS, NASRIN MESAELI, AND VINCENZO PANAGIA	187
Regulation of Alpha-Smooth Muscle Actin Expression in Adult Cardiomyocytes through a Tyrosine Kinase Signal Transduction Pathway. <i>By</i> H. EID, J. H. CHEN, AND A. J. DE BOLD	192
Evaluation of DNA Content by Static Cytometry in Hypertrophic Cardiomyopathy (HCM). <i>By</i> B. BIONDO, E. GROSSO, A. M. LAVEZZI, L. ROSSI, AND L. MATTURRI	202

Effect of Propionyl-L-Carnitine (PLC) on the Kinetic Properties of the Myofibrillar System in Pressure Overload Cardiac Hypertrophy. <i>By</i> C. REGGIANI, M. CANEPARI, R. MICHELETTI, V. CAPPELLI, AND M. C. ZANARDI	204
Propionyl-L-Carnitine Improves Mechanical Performance of Papillary Muscle from Dilated Cardiomyopathic Hamsters. <i>By</i> P. MARESCA, N. CORSICO, E. ARRIGONI-MARTELLI, R. MANCINELLI, AND E. MANNI	207
Markers of Cardiac Hypertrophy. <i>By</i> ROBERT M. KLEIN, BRIAN K. MACGILLIVRAY, AND JAMES C. MCKENZIE	210
Evidence of a Correlation between Pulmonary Hypertension and Collagen Content in Chronically Overloaded Human Right Atria. <i>By</i> F. L. DINI, V. NARDINI, S. GALLINA, A. M. CALAFIORE, AND A. BARSOTTI	218
Acute Heart Failure Secondary to Myocardial Tissue Water Changes in Isolated Working Rat Hearts. <i>By</i> A. BARSOTTI, P. DI NAPOLI, F. L. DINI, E. DI GIROLAMO, S. GALLINA, AND M. DI MUZIO	222
β -Myosin Mutations in Hypertrophic Cardiomyopathies. <i>By</i> ALDA ALFARANO, LUCIA GASTALDI, GIOVANNA GIGLIO TOS, ANTONELLA ROETTO, AND CLARA CAMASCHELLA	227
Effects of Isoprenaline on Force of Contraction, cAMP Content, and Phosphorylation of Regulatory Proteins in Hearts from Chronic β -Adrenergic-Stimulated Rats. <i>By</i> BIRGITTE STEIN, SABINE BARTEL, SABINE KOKOTT, ERNEST-GEORG KRAUSE, THORSTEN SCHLICHTMANN, WILHELM SCHMITZ, AND HASSO SCHOLZ	230
Diagnosis of Myocardial Injury in Marathon Runners. <i>By</i> ARNOLD KOLLER, JOHANNES MAIR, MARKUS MAYR, CHARLES CALZOLARI, CATHERINE LARUE, AND BERND PUSCHENDORF	234
The Regulation of Collagen Deposition in the Hypertrophying Heart. <i>By</i> JILL E. BISHOP, SUZANNE RHODES, GEOFFREY J. LAURENT, ROBERT B. LOW, AND WILLIAM S. STIREWALT	236
Examination of a Potential Upper Limit to Cardiac Muscle Hypertrophy. <i>By</i> RICHARD P. SPENCER	240
Function of C-Protein and Troponin I Phosphorylation in the Heart. <i>By</i> S. BARTEL, P. KARCEWSKI, I. MORANO, AND E.-G. KRAUSE	243

Part III. Angiogenesis

The Regulation of Blood Vessel Growth by Vascular Endothelial Growth Factor. <i>By</i> NAPOLEONE FERRARA, HENRY HEINSOHN, CLAIRE E. WALDER, STUART BUNTING, AND G. ROGER THOMAS	246
Coronary Angiogenesis: from Morphometry to Molecular Biology and Back. <i>By</i> KAREL RAKUSAN	257
Cardiomyocyte Transfer into the Mammalian Heart: Cell-to-Cell Interactions <i>In Vivo</i> and <i>In Vitro</i> . <i>By</i> JOSEPH B. DELCARPIO AND WILLIAM C. CLAYCOMB	267

Connective Tissue and Repair in the Heart: Potential Regulatory Mechanisms. <i>By</i> KARL T. WEBER, YAO SUN, LAXMANSA C. KATWA, JACK P. M. CLEUTJENS, AND GUOPING ZHOU	286
Analysis of Homozygous TGF β 1 Null Mouse Embryos Demonstrates Defects in Yolk Sac Vasculogenesis and Hematopoiesis. <i>By</i> JULIE S. MARTIN, MARION C. DICKSON, FRANCES M. COUSINS, ASHOK B. KULKARNI, STEFAN KARLSSON, AND ROSEMARY J. AKHURST	300

Part IV. Growth Factors and Cardiac Growth

Molecular Analysis of TGF β Signal Transduction: Dominant-Inhibitory Mutations of the Type II and Type I TGF β Receptor. <i>By</i> MICHAEL D. SCHNEIDER AND THOMAS BRAND	309
Mechanisms of Cell Transformation in the Embryonic Heart. <i>By</i> JIAN-XIAN HUANG, JAY D. POTTS, ERIC B. VINCENT, DANIEL L. WEEKS, AND RAYMOND B. RUNYAN	317
Secretion of Plasminogen Activator Activity from Neonatal Rat Heart Cells Is Regulated by Hormones and Growth Factors. <i>By</i> RONAL R. MACGREGOR, ROBERT M. KLEIN, AND DEVI D. BANSAL	331
Intracellular Signaling and Genetic Reprogramming during Agonist-Induced Hypertrophy of Cardiomyocytes. <i>By</i> H. A. A. VAN HEUGTEN, H. W. DE JONGE, K. BEZSTAROSTI, H. S. SHARMA, P. D. VERDOUW, AND J. M. J. LAMERS	343
Regulation of Basic Fibroblast Growth Factor (bFGF) and FGF Receptors in the Heart. <i>By</i> ELISSAVET KARDAMI, LEI LIU, S. KISHORE B. PASUMARTHI, BRADLEY W. DOBLE, AND PETER A. CATTINI	353
Multifactorial Regulation of Cardiac Gene Expression: an <i>In Vivo</i> and <i>In Vitro</i> Analysis. <i>By</i> J. L. SAMUEL, I. DUBUS, F. FARHADIAN, F. MAROTTE, P. OLIVIERO, A. MERCADIER, F. CONTARD, A. BARRIEUX, AND L. RAPPAPORT	370
Mechanical Load and Polypeptide Growth Factors Stimulate Cardiac Fibroblast Activity. <i>By</i> RICHARD P. BUTT, GEOFFREY J. LAURENT, AND JILL E. BISHOP	387
Reactive Oxygen Intermediates (ROIs) Are Involved in the Intracellular Transduction of Angiotensin II Signal in C2C12 Cells. <i>By</i> PIER LORENZO PURI, MARIA LAURA AVANTAGGIATI, VITO LELIO BURGIO, PAOLO CHIRILLO, DANIELA COLLEPARDO, GIOACCHINO NATOLI, CLARA BALSANO, AND MASSIMO LEVRERO	394
Characterization of Fibroblast Growth Factor Receptor 1 RNA Expression in the Embryonic Mouse Heart. <i>By</i> KISHORE B. S. PASUMARTHI, YAN JIN, MARGARET E. BOCK, ARISTIDES LYTRAS, ELISSAVET KARDAMI, AND PETER A. CATTINI	406

Presence of Basic Fibroblast Growth Factor in Cultured Rat Cardiomyocytes and Its Release in Culture Medium. <i>By</i> L. BASTAGLI, T. LAZZAROTTO, C. M. CALDARERA, C. GUARNIERI, C. VENTURA, G. PEPE, AND P. PUDDU	417
Morphometry and GH/IGF-1 Axis Deficiency May Identify a Form of Dilated Cardiomyopathy Which Is Corrected by Recombinant Human Growth Hormone (rHGH). <i>By</i> A. FRUSTACI, A. ZURLO, G. A. PERRONE, A. RUSSO, M. CALDARULO, AND M. A. RUSSO	422
Pro-Alpha2(I) Collagen and Transforming Growth Factor-Beta 1 Gene Expression in the Myocardial Hypertrophy of the Old Rat. <i>By</i> G. ANNONI, B. AROSIO, D. SANTAMBROGIO, N. GAGLIANO, AND C. VERGANI	426
Growth Hormone and Insulin-Like Growth Factor 1 in Normopituitary Patients with Various Degrees of Heart Failure. <i>By</i> ENRICO MANGIERI, CARLO TOSTI CROCE, GAETANO TANZILLI, ANTONIETTA LOMURNO, MASSIMO CIAVOLELLA, FRANCESCO MANGIARACINA, FRANCESCO BARILLÀ, AND PIETRO PAOLO CAMPA	429

Part V. Gene Transfer to Study Cardiac Growth

Regulatory Networks of the Retinoblastoma Protein. <i>By</i> WEN-HWA LEE, PHANG-LANG CHEN, AND DANIEL J. RILEY	432
Potential Approaches for Myocardial Regeneration. <i>By</i> MARK H. SOONPAA, ADIL I. DAUD, GOU YOUNG KOH, MICHAEL G. KLUG, KYUNG KEUN KIM, HE WANG, AND LOREN J. FIELD	446
Gene Transfer in Models of Myocardial Ischemia. <i>By</i> PATRICIA MCDONALD, MARTIN N. HICKS, STUART M. COBBE, AND HOWARD PRENTICE	455
Development of Cardiomyocytes Expressing Cardiac-Specific Genes, Action Potentials, and Ionic Channels during Embryonic Stem Cell- Derived Cardiogenesis. <i>By</i> ANNA M. WOBUS, J. ROHWEDER, V. MALTSEV, AND J. HESCHELER	460
X-Linked Dilated Cardiomyopathy: Novel Mutation of the Dystrophin Gene. <i>By</i> W. M. FRANZ, M. CREMER, R. HERRMANN, E. GRÜNIG, W. FOGEL, T. SCHEFFOLD, H. H. GOEBEL, R. KIRCHEISEN, W. KÜBLER, T. VOIT, AND H. A. KATUS	470
<i>In Vivo</i> Definition of a Cardiac Specific Promoter and Its Potential Utility in Remodeling the Heart. <i>By</i> JEFFREY ROBBINS, JOSEPH PALERMO, AND HANSJÖRG RINDT	492
Retroviral Targeting of FGF and FGFR in Cardiomyocytes and Coronary Vascular Cells during Heart Development. <i>By</i> TAKASHI MIKAWA	506
Subject Index	517
Index of Contributors	523

Financial assistance was received from:

- CHROI
- UNIVERSITY OF ROME "TOR VERGATA"
- NORTH ATLANTIC TREATY ORGANIZATION,
BRUSSELS, BELGIUM
- COMUNE DI VITERBO, ITALY
- PROCTER & GAMBLE, USA
- U.S. AIR FORCE—E.O.A.R.D.
- ITALIAN NATIONAL RESEARCH COUNCIL (CNR)

The New York Academy of Sciences believes it has a responsibility to provide an open forum for discussion of scientific questions. The positions taken by the participants in the reported conferences are their own and not necessarily those of the Academy. The Academy has no intent to influence legislation by providing such forums.

ACKNOWLEDGMENT

The Editors wish to thank DR. MARILENA MINIERI for her continued and invaluable scientific and organizational contribution.

Preface

Mammalian cardiac muscle, unlike skeletal muscle, cannot regenerate. Division and proliferation of the terminally differentiated heart muscle cell in the adult mammal is not activated after injury such as that caused by a myocardial infarction. We do not understand how mitosis is irreversibly blocked in these myocytes during early development. Knowledge of the mechanisms that control the cardiac muscle cell cycle would allow us to design reagents or procedures to initiate repair or regeneration of the adult myocardium following injury. Ideally, we would like to be able to revert cardiac muscle cells in the intact heart to the biochemical state they were in during early fetal growth when they were actively dividing and proliferating. While the potential for cell division in response to injury is retained in myocardial cells of amphibians, reptiles and the mammalian atrium, it is apparently irreversibly lost in the adult mammalian ventricular cardiac muscle cells.

The purpose of this Workshop was to discuss and gather the most current information dealing with the regenerative potential of cardiac muscle in the vertebrate heart. Topics that were covered included cardiac and skeletal muscle cell determination, hyperplasia and hypertrophy, growth factors involved in this growth, cardiac angiogenesis and state-of-the-art gene transfer methodology to study and alter cardiac growth and regeneration.

*William C. Claycomb
Paolo Di Nardo*

Commitment, Differentiation, and Diversification of Avian Cardiac Progenitor Cells

NATASHA MELNIK, KATHERINE E. YUTZEY,
MAUREEN GANNON, AND DAVID BADER

*Program for Cell Biology and Genetics
Cornell University Medical College
1300 York Avenue
New York, New York 10021*

INTRODUCTION

Prior to the initiation of circulation, heart formation is characterized by the conversion of mesoderm to the cardiac cell lineage, the differentiation of committed cardiac progenitors into cardiac myocytes, and the diversification of atrial and ventricular cardiac myocytes. These lineage events occur concurrently with morphogenesis of the primitive heart tube and the initiation of cardiac function. Our laboratory has focused on the cellular and molecular events underlying the generation of specific cardiac lineages during the earliest stages of avian heart formation. In this communication, we review the results which we have obtained concerning the commitment, differentiation, and diversification of cardiac progenitor cells.

Specification and Commitment of Cardiac Progenitor Cells

In the avian embryo, cardiac progenitors were mapped through several different groups of experiments. By chorioallantoic grafting of avian blastoderm explants, Rawles determined the location of cells with heart forming capacity in anterior lateral plate mesoderm.¹ Precardiac cells were located in the epiblast layer (pregastrulated epithelium) by using tritiated thymidine-labeled transplants which demonstrated that cells with heart-forming potential initially move medially in the epiblast, invaginate via the primitive streak, and enter the mesodermal layer.² Once in the mesoderm, they migrate laterally and anteriorly to form the lateral plate. The origin of the cardiovascular system was shown by the construction of quail/chick transplantation chimeras and by labeling cells with vital fluorescent dye in the primitive streak.³ It was found that at Hamburger and Hamilton stage 3,⁴ the most rostral part of the primitive streak contains prospective cardiogenic cells, and within the streak these cells are arranged in rostrocaudal fashion.

These studies identified the origins of cardiogenic cells in the avian embryo, but did not clarify when these cells become committed to the myocardial pathway. Two levels of developmental commitment were defined by Slack.⁵ The first, speci-

fication, reflects the ability of cells or tissue fragments to differentiate according to their known fate when cultured in a neutral environment. Cells or tissue fragments that have the ability to differentiate in a novel or ectopic environment, in contrast, represent the second level of commitment known as determination. Therefore, specified cells are capable of autonomous differentiation but are susceptible to inhibitory signals, whereas determined cells are irreversibly committed to a particular developmental fate.

Our group has studied commitment of cardiac mesoderm in the avian embryo. These studies were directed towards determining when cardiogenic mesoderm is specified, *i.e.*, when cardiogenic precursor cells have the ability to differentiate in the absence of other embryonic tissues. We have shown that newly gastrulated stage 4 cardiac precursors possess cardiogenic potential as defined by the ability to differentiate at clonal density *in vitro*.⁶ It was later demonstrated that even pregastrulated cells (stage 3) are capable of cardiomyogenic differentiation, but that pregastrulated cells require cell-to-cell interactions in order to differentiate.⁷ Only postgastrulated cells have the capacity for autonomous differentiation. Thus we define newly gastrulated stage 4 cardiac mesoderm as specified to the cardiac lineage, because it is capable of autonomous differentiation.

Additional studies were necessary to identify when cardiogenic mesoderm becomes determined (*i.e.*, when these cells differentiate when placed in an ectopic location in the embryo). Our previous data suggested that at least one maturation event occurs between specification and differentiation. Cardiogenic cells at stages 4–8 were treated with the cardiogenic agent 12-O-tetradecanoyl-13-acetate (TPA),⁶ which has been shown to inhibit myogenic differentiation.⁸ We demonstrated that cells from stages 4 and 8 embryos differ in their sensitivity to TPA treatment. While cardiac precursors at stage 8 were able to differentiate after exposure to TPA, differentiation of cardiac precursors from earlier stages was blocked. Similar results were seen when cardiogenic mesoderm from stage 4–8 embryos was treated with bromodeoxyuridine (BrdU).⁷ BrdU acts via a TPA-independent pathway to block myocardial differentiation in chicken embryos.⁹ These studies confirmed that stage 4–6 cardiogenic cells can be prevented from differentiating by two independent chemical treatments, whereas stage 7–8 cells are insensitive to these treatments and are able to differentiate. These *in vitro* studies also suggest that stage 4–6 cardiogenic mesoderm is specified, whereas stage 7–8 cardiogenic mesoderm may be determined.

To study determination of cardiac mesoderm *in vivo*, we transplanted cardiogenic tissue fragments from stage 4–8 embryos adjacent to the neural tube of recipient embryos.¹⁰ It has been shown in amphibian embryos that neural tube has an inhibitory effect on differentiation of cardiogenic mesoderm.¹¹ The results of these experiments reflected the age-dependent differences in cardiac commitment observed *in vitro*. Transplanted cardiogenic cells from stages 4–7 did not show positive staining with MF20, a monoclonal antibody to sarcomeric myosin heavy chain after 24–36 hours in whole embryo culture.¹² Only the grafts from stage 7+–8 embryos were capable of differentiation (*e.g.*, were MF20 positive) in this environment, and by definition were determined. Therefore, cardiac progenitors at stages 4–7 are specified, because they are capable of myocardial differentiation *in vitro*; but cells at stages 7+–8 have the added ability to differentiate

in an ectopic environment and are determined. Taken together with the *in vitro* experiments, these experiments suggest that cardiac commitment occurs in two phases. Specification appears to occur at approximately stage 4, and determination during stage 7. The molecular bases of these developmental events are unknown.

Differentiation of Cardiac Progenitor Cells

We have defined cardiomyogenic differentiation as the expression of cardiac- and muscle-specific genes.¹³ Many of the classic studies which have analyzed heart development have used rhythmic beating as an indicator of differentiation.^{14,15} These studies placed the time of cardiac myocyte differentiation at a point after the definitive heart tube was formed. Beating is a very stringent definition of myogenic differentiation as it requires expression and proper assembly of cellular components which regulate cell coupling, the membrane systems governing excitation/contraction coupling, and the contractile apparatus. We have analyzed the initial stages of this process by focusing on the activation of cardiac specific gene expression.

We have re-examined cardiomyogenic differentiation *in vivo* and *in vitro* using the expression of muscle- and cardiac-specific genes as indicators of myocyte differentiation. In these studies, we have analyzed the accumulation of contractile protein mRNAs and their respective protein products. Using PCR analysis of stage 2–8 RNA to detect VMHCl mRNA, a ventricular myosin heavy chain, we were able to detect muscle-specific gene expression as early as stage 7.¹⁶ Therefore, cardiac-specific gene expression is evident prior to heart tube formation at least ten hours before the initiation of contraction which occurs at stage 10. With whole mount *in situ* hybridization analysis, VMHCl transcripts were observed in the anterior portions of the anterior lateral plate as early as stage 8+ and in progressively more posterior cardiogenic mesoderm cells in later stages.¹⁷ These studies demonstrate that VMHCl is one of the first muscle-specific genes expressed in all differentiating cardiac myocytes. Cardiac-specific troponin I, a truly heart-specific gene,¹⁸ is also expressed at this time and is present within the same population of cells.¹⁹ The conversion of progenitor to differentiated myocyte as visualized by the accumulation of muscle- and cardiac-specific transcripts proceeds in an anteroposterior manner within the lateral mesoderm.¹⁷ The protein products of these genes are also detected in the same time frame and their expression also proceeds in an anteroposterior manner.²⁰ The subcellular distribution of myosin heavy chains is initially in a nonmyofibrillar pattern between stages 7–9.²⁰ It is only at stage 9+–10 that myosin heavy chain protein becomes localized to myofibrillar structures. Our studies place the differentiation of cardiogenic mesoderm much earlier than previously reported. The first cells to differentiate are in close association with the anterior intestinal portal and are clearly some of the most anterior cells within the cardiogenic mesoderm. By stage 9+, a relatively large portion of the partially fused heart tube has differentiated but these myocytes do not yet contract. It is apparent that the noncontractile myocyte is a distinct member of the cardiomyogenic cell lineage.

The anteroposterior pattern of cardiac-specific gene activation from stage 7–15

reflects the conversion of committed cardiogenic mesoderm to differentiated cardiac myocytes. Therefore, regulatory proteins involved in cardiac-specific gene expression should be expressed during this time. Our laboratory has characterized an E box-dependent DNA binding activity antigenically related to the skeletal muscle regulatory protein MyoD.²¹ This binding activity is present in stage 6–13 heart protein extracts but is not detected later in development. A cDNA, cardiac muscle factor 1 (CMF1) was isolated and encodes a protein antigenically related to MyoD that binds DNA in an E box-dependent manner.²² Whole mount *in situ* hybridization analysis of CMF1 gene expression in stage 8–15 chicken embryos demonstrated that CMF1 is activated in an anteroposterior pattern that corresponds with the activation of cardiac-specific gene expression. These results are consistent with a role for CMF1 in cardiomyogenic differentiation.

In addition to examining the molecular effectors of cardiac commitment and differentiation present within cardiogenic precursors, we are also interested in the role other cell or tissue types may play throughout the early stages of heart development (*i.e.*, specification, determination, differentiation, and contraction). Traditionally, the anterior or pharyngeal endoderm has been thought to have an influence on one or more of these events. An inductive role for anterior endoderm in heart differentiation was described based on studies in amphibians as well as the chick, where in the majority of cases removal of this endoderm resulted in embryos that lacked beating heart tissue.^{23,24} From these studies it was concluded that anterior endoderm is essential for heart differentiation as assayed by beating. As mentioned previously, the ability to beat requires the integration of many subcellular components. Using the expression of myosin heavy chain as a marker for differentiation, we have re-examined the role of endoderm throughout early avian heart development.²⁵

In order to analyze the role of anterior endoderm in differentiation of cardiac progenitors, anterior endoderm was removed from the cardiogenic region on one side of stage 4–8 embryos, and cardia bifida was generated by clipping the anterior intestinal portal. Embryos were then allowed to develop for 24 hours in minimal medium. In all cases examined, embryos from which endoderm was removed at stage 4–6 showed two distinct heart tubes where the operated side failed to beat and the control side beat normally. In all cases, however, both heart tubes differentiated as indicated by MF20 reactivity. Embryos from which endoderm was removed at stage 7–8 showed a significant decrease in the requirement of endoderm for beating. These studies confirmed that an early association between endoderm and cardiogenic mesoderm is important *in vivo* for beating, but is not necessary for differentiation (*i.e.*, the expression of heart-specific genes). The stage-dependent differences in the requirement of endoderm for contractility suggest that effects of endoderm *in vivo* may be temporally dependent.

In order to examine the temporal effects of anterior endoderm, we analyzed the requirement for endoderm in differentiation of cardiogenic mesodermal explants using a developmental series from stage 4–9. Recently, several studies analyzed the role of endoderm in cultured explants of avian cardiogenic mesoderm in defined minimal media.^{26–29} These experiments confirmed a requirement for an early association with endoderm in order for beating to occur, but failed to show cardiac differentiation in explants from stage 4–5. Based on the results we obtained

in vivo, we re-examined differentiation in cardiac mesodermal explants by assaying for the expression of VMHCl and cardiac troponin I mRNAs using *in situ* hybridization.²⁵ Cardiogenic mesoderm explanted without endoderm prior to stage 7 fails to beat when cultured in minimal medium. However, these explants from stage 4–6 all express VMHCl and cardiac troponin I. As *in vivo*, the presence of endoderm in culture is not required for the initiation of beating in mesoderm removed from embryos after stage 7+. These *in vivo* and *in vitro* results suggest that endoderm is not required for specification and differentiation (*i.e.*, cardiac-specific gene expression) of cardiogenic precursors after these cells have gastrulated. However, some association with anterior endoderm is required prior to stage 7+–8 in order for these cells to attain the ability to contract. It remains to be determined what factor(s) are provided by the endoderm and how long precontractile cardiogenic mesoderm needs to be exposed to this factor(s).

Diversification of Cardiac Progenitor Cells

By the time a four-chambered heart is formed, atrial and ventricular cell lineages are functionally and morphologically distinct. The diversification of these lineages occurs very early in cardiogenesis when the heart is still a tubular structure.³⁰ The precise timing of the divergence of these two lineages is not known, and the mechanisms by which these lineages become distinct have not been characterized. The primitive heart tube forms initially along the anteroposterior axis of the embryo. The ventriculogenic region of the heart is present in the anterior ~2/3 of the cardiogenic crescent and the atriogenic portion is the remaining posterior ~1/3.^{30,31} Therefore, preventricular cells differentiate prior to preatrial cells and may represent temporally and spatially distinct populations within the forming heart. Morphologically these two populations are indistinguishable within the linear heart tube. We and others have found that monoclonal antibodies directed against chamber-specific myosin heavy chain isoforms could be used as molecular markers to distinguish between atrial and ventricular cells.^{32–34} These studies demonstrated that the two populations diverged by the time the heart tube begins to loop and form distinct chambers (stage 12–15). However, within the linear heart tube (stage 10–11), diverged populations were not observed, leading to the hypothesis that atrial and ventricular lineages diverge subsequent to primitive heart tube formation and differentiation.

Recently, we isolated an atrial-specific myosin heavy chain cDNA, AMHCl.¹⁷ This cDNA was used to establish the origins of diversified populations of atrial and ventricular myocytes. Expression of AMHCl was compared to the expression of VMHCl which is expressed in all differentiating myocytes in a developmental series of whole mount *in situ* hybridizations from stage 4 to embryonic day 8. These studies demonstrated that anterior ventriculogenic cardiac myocytes differed from the posterior atriogenic myocytes in their myosin expression patterns from the initiation of cardiogenic differentiation. Specifically, the anterior progenitors which differentiate during stages 8–9 express VMHCl but not AMHCl. In contrast, the posterior progenitors activate both genes when they differentiate beginning at stage 9+. The expression of AMHCl continues to be atrial-specific throughout

development. Therefore from these studies, it appears that atrial and ventricular populations are distinct as early as differentiation before the heart tube has formed.

The mechanisms underlying the diversification of cardiac lineages are unknown. The presence of anterior/ventriculogenic cells versus posterior/atriogenic cells suggests that positional information based on A-P polarity could be involved in establishing diversified cardiac lineages. Transplantation studies in which posterior cardiogenic cells placed within the anterior heart forming region take on an anterior phenotype support this hypothesis.³⁵ Retinoic acid has been used to study a variety of polarized systems based on A-P information.^{36,37} Treatment of pre-gastrula zebrafish embryos resulted in the deletion of the ventriculogenic region of the two-chambered heart.³⁸ In addition, studies of retinoic acid effects during avian heart formation have demonstrated changes in heart morphogenesis.³⁹ Our studies focused on the effect of retinoic acid treatment on cardiac lineage diversification by observing chamber-specific myosin isoform gene expression in retinoic acid-treated embryos.¹⁷ These studies demonstrated a time-dependent expansion of the posterior lineage producing an effective posteriorization of the cardiac phenotype with retinoic acid treatment. In some cases, the posterior phenotype was expanded without affecting the morphology of the heart demonstrating a change in lineage without an accompanying change in structure. The time frame for retinoic acid-induced changes in diversified phenotype as measured by changes in AMHCl gene expression appears to end at differentiation. After differentiation, anterior cells can no longer be recruited to the posterior phenotype. Therefore, the anterior and posterior cell fates are mutable prior to differentiation and may be dependent on A-P positional information to establish diversified phenotypes.

Our studies with AMHCl *in vivo* demonstrated that atriogenic and ventriculogenic populations are distinct when they differentiate. In addition, the diversified phenotypes can be altered prior to differentiation with retinoic acid treatment. Further work is necessary to determine when predifferentiated cardiogenic cells are specified as atrial or ventricular and to study the effectors of diversification. Earlier studies from our laboratory demonstrated that chamber-specific myosin heavy chain proteins were expressed after explants of predifferentiated cardiac mesoderm and accompanying endoderm were allowed to differentiate in growth factor-rich medium.⁶ Recently, we used explants incubated in defined minimal medium to determine when cardiogenic mesoderm takes on specified atrial or ventricular phenotypes.⁴⁰ Explants were removed at stage 4–8, allowed to differentiate into beating cultures, and assayed for AMHCl expression and MF-20 reactivity. These experiments demonstrated that diversified phenotypes were evident as AMHCl positive and negative cells were detected within differentiated populations as measured by MF-20 reactivity. In addition, the two populations were spatially distinct as early as stage 4 demonstrating the maintenance of positional information within the explants. Anterior and posterior explants cultured separately differentiate into different diversified phenotypes when explanted as early as stage 5.⁴⁰ Thus, this culture system of mesoderm and endoderm explanted together in minimal media can be manipulated to determine the necessary elements for diversification. Taken together with our studies *in vivo* these experiments demonstrate that lineage diversification occurs very early in development, perhaps as early as gastrulation. The diversified phenotype, however, appears to be based

on position and can be altered as a result of retinoic acid treatment or transplantation prior to differentiation. By the time the heart tube has differentiated and formed, diversified atrial and ventricular lineages are evident and are stable.

REFERENCES

1. RAWLES, M. E. 1943. The heart-forming region of the early chick blastoderm. *Physiol. Zool.* **16**: 22–42.
2. ROSENQUIST, G. C. & R. L. DEHAAN. 1966. Migration of precardiac cells in the chick embryo: a radioautographic study. *Carnegie Inst. Wash. Publ.* 625: Contrib. to embryol. (38): 111–121.
3. GARCIA-MARTINEZ, V. & G. C. SCHOENWOLF. 1993. Primitive streak origin of the cardiovascular system in avian embryos. *Dev. Biol.* **159**: 706–719.
4. HAMBURGER, V. & H. L. HAMILTON. 1951. A series of normal stages in the development of the chick embryo. *J. Morph.* **88**: 49–67.
5. SLACK, J. M. W. 1983. Determinative events in early development. *In* *From Egg to Embryo*. Cambridge University Press. Cambridge, MA.
6. GONZALEZ-SANCHEZ, A. & D. BADER. 1990. *In vitro* analysis of cardiac progenitor differentiation. *Dev. Biol.* **139**: 197–209.
7. MONTGOMERY, M. O., J. LITVIN, A. GONZALEZ-SANCHEZ & D. BADER. 1994. Staging and commitment and differentiation of avian cardiac myocytes. *Dev. Biol.* **164**: 63–71.
8. COHEN, R., M. PACIFICI, N. RUBENSTEIN, J. BIEHL & H. HOLTZER. 1977. Effect of a tumor promoter on myogenesis. *Nature* **266**: 538–540.
9. CHACKO, S. & X. JOSEPH. 1974. The effect of 5-bromodeoxyuridine (BrdU) on cardiac muscle differentiation. *Dev. Biol.* **40**: 340–354.
10. MELNIK, N. & D. BADER. In preparation.
11. JACOBSON, A. G. 1960. Influences of ectoderm and endoderm on heart differentiation in the newt. *Dev. Biol.* **2**: 138–154.
12. BADER, D., T. MASAKI & D. FISCHMAN. 1982. Immunochemical analysis of myosin heavy chain in avian myogenesis *in vivo* and *in vitro*. *J. Cell Biol.* **95**: 763–770.
13. LITVIN J., M. O. MONTGOMERY, A. GONZALEZ-SANCHEZ, J. BISAHA & D. BADER. 1991. Commitment and differentiation of cardiac myocytes. *Trends Cardiol. Res.* **2**: 27–32.
14. LEWIS, M. R. 1919. The development of cross-striations in the heart muscle of the chick embryo. *Bull. Johns Hop. Hosp.* **30**: 176–188.
15. JOHNSTONE, P. 1925. Studies on the physiological anatomy of the embryonic heart. *Bull. Johns Hop. Hosp.* **36**: 299–311.
16. BISAHA, J. & D. BADER. 1991. Identification and characterization of a ventricular-specific myosin heavy chain, VMHCl. *Dev. Biol.* **148**: 355–364.
17. YUTZEY, K. E., J. T. RHEE & D. BADER. 1994. Expression of the atrial-specific myosin heavy chain AMHCl and the establishment of anteroposterior polarity in the developing chicken heart. *Development* **120**: 871–883.
18. HASTINGS, K. E. M., R. KOPPE, E. MARMOR, D. BADER, Y. SHIMADA & N. TOYOTA. 1991. Structure and developmental expression of troponin I isoforms. cDNA clone analysis of avian cardiac troponin I mRNA. *J. Biol. Chem.* **29**: 19659–19665.
19. GANNON, M. & D. BADER. Unpublished data.
20. HAN, Y., J. DENNIS, L. COHEN-GOULD, D. BADER & D. FISCHMAN. 1991. Expression of sarcomeric myosin in the presumptive myocardium of chicken embryos occurs within six hours of myocyte commitment. *Dev. Dyn.* **193**: 257–265.
21. LITVIN, J., M. O. MONTGOMERY, D. GOLDHAMMER, C. EMERSON & D. BADER. 1993. Identification of DNA-binding proteins in the developing heart. *Dev. Biol.* **156**: 409–417.
22. LITVIN, J., Y. WEI & D. BADER. In preparation.
23. ORTS-LLORCA, F. & D. R. GIL. 1965. Influence of the endoderm on heart differentiation. *Wilhelm Roux' Arch. Ent. Org.* **156**: 368–370.

24. JACOBSON, A. G. & A. K. SATER. 1988. Features of embryonic induction. *Development* **104**: 341-359.
25. GANNON, M. & D. BADER. In preparation.
26. LOUGH, J. W., D. L. BOLENDER & R. R. MARKWALD. 1990. A culture model for cardiac morphogenesis. *Ann. N.Y. Acad. Sci.* **588**: 421-424.
27. YAMAZAKI, Y. & R. HIRAKOW. 1991. Factors required for differentiation of chick precardiac mesoderm culture *in vitro*. *Proc. Jpn. Acad.* **67**: 165-169.
28. ANTIN, P. B., R. G. TAYLOR & T. YATSKIEVYCH. 1994. Precardiac mesoderm is specified during gastrulation in quail. *Dev. Dyn.* **200**: 144-154.
29. SUGI, Y. & J. LOUGH. 1994. Anterior endoderm is a specific effector of terminal myocyte differentiation of cells from the embryonic heart forming region. *Dev. Dyn.* **200**: 155-162.
30. DEHAAN, R. L. 1965. Morphogenesis of the vertebrate heart. *In Organogenesis*. R. L. DeHaan & H. Ursprung, Eds. 377-419. Holt, Rinehart & Winston. New York.
31. STALSBERG, H. & R. L. DEHAAN. 1969. The precardiac areas and formation of the tubular heart in the chicken embryo. *Dev. Biol.* **19**: 128-159.
32. GONZALEZ-SANCHEZ, A. & D. BADER. 1984. Immunohistochemical analysis of myosin heavy chains in the developing chicken heart. *Dev. Biol.* **103**: 151-158.
33. SWEENEY, L. J., R. ZAK & F. J. MANASEK. 1987. Transitions in cardiac isomyosin expression during differentiation of the embryonic chicken heart. *Circ. Res.* **61**: 287-295.
34. DEJONG, F. W., J. C. GEERTS, W. H. LAMERS, J. A. LOS & A. F. M. MOORMAN. 1990. Isomyosin expression pattern during formation of the tubular chicken heart: a three dimensional immunohistochemical analysis. *Anat. Rec.* **226**: 213-227.
35. SATIN, J., S. FUJI & R. L. DEHAAN. 1988. Development of cardiac beat rate in early chick embryos is regulated by regional cues. *Dev. Biol.* **19**: 103-113.
36. TICKLE, C., J. LEE & G. EICHELE. 1985. A quantitative analysis of the effect of all-trans-retinoic acid on the pattern of chick wing development. *Dev. Biol.* **109**: 82-95.
37. CONLAN, R. A. & J. ROSSANT. 1992. Exogenous retinoic acid rapidly induces anterior ectopic expression of murine Hox-2 genes *in vivo*. *Development* **116**: 357-368.
38. STANIER, D. Y. R. & M. C. FISHMAN. 1992. Patterning the zebrafish heart tube: acquisition of anteroposterior polarity. *Dev. Biol.* **153**: 91-101.
39. OSMOND, M. K., A. J. BUTLER, F. C. T. VOON & R. BELLAIRS. 1991. The effects of retinoic acid on heart formation in the early chick embryo. *Development* **113**: 1405-1417.
40. YUTZEY, K. E., M. A. GANNON & D. BADER. In preparation.

Adenovirus Infection Induces Reentry into the Cell Cycle of Terminally Differentiated Skeletal Muscle Cells^a

MARCO CRESCENZI,^{b,c,d} SILVIA SODDU,^c ADA SACCHI^c AND
FRANCO TATÒ^b

^b*Department of Cellular and Developmental Biology
University of Rome "La Sapienza"
Via degli Apuli, 1
00185 Rome, Italy*

and
^c*Molecular Oncogenesis Laboratory
Regina Elena Cancer Institute
Via delle Messi d'Oro, 156
00158 Rome, Italy*

INTRODUCTION

The parenchymal cells of several important organs in the human body (*e.g.*, brain, heart, skeletal muscle) are characterized by highly specialized functions and loss of reproductive capacity. The acquisition of specialized functions and the entailed loss of proliferative competence are collectively defined "terminal differentiation." The irreversible growth arrest of terminally differentiated (postmitotic) cells is qualitatively different from reversible quiescence. Postmitotic cells do not respond with proliferation to growth factors,¹ even though they possess receptors for them.² They also do not respond with proliferation to activation of retroviral oncogenes such as *myc*³ or *src*.⁴

At present, we can only offer generic, unsatisfactory explanations as to why extreme differentiation should necessarily take place at the expense of reproductive competence. Nor do we understand in detail the molecular mechanisms that tightly link the final stages of differentiation with irreversible withdrawal from the cell cycle. It has been shown in the past that *MyoD*, a gene able to trigger skeletal muscle differentiation, is also independently capable of inducing growth arrest in various cell types, including those refractory to myogenic conversion.^{5,6} This suggests that differentiation and terminal growth arrest are elicited by the same regulatory molecules. Recent work has also indicated that *MyoD* exerts its growth-suppression effect through direct binding of the ubiquitous growth-regulatory protein Rb.^{7,8} Despite this progress, much further work is necessary to define the molecular mechanisms involved in terminal differentiation.

^a The financial support of Telethon-Italy (Grant No. 467), AIRC (Progetto Oncosoppressori), CNR (P. F. ACRO), and Fondazione Cenci Bolognetti is gratefully acknowledged.

^d Address correspondence to: Dr. Marco Crescenzi, Molecular Oncogenesis Laboratory, Regina Elena Cancer Institute, Via delle Messi d'Oro, 156, 00158 Rome, Italy.

Terminal differentiation poses unique problems in both physiological and pathological conditions. Some organs and systems, though mainly composed of terminally differentiated cells, retain a stem cell compartment for their self-renewal (*e.g.*, skeletal muscle, skin, hematopoietic system, epithelial lining of the gut). Others, however, do not possess stem cells and are unable to replace ill, injured, or dead cells (*e.g.*, heart, nervous system).

At present it is not known with certainty whether terminally differentiated cells retain an intact proliferative machinery that can be reactivated or they have irreversibly lost essential components of their reproductive apparatus. Distinguishing between these two possibilities would be important to further our knowledge of terminal differentiation. Moreover, if postmitotic cells could be induced to replicate—while retaining their differentiative potential—this could lead to therapeutic applications to heart or nervous system diseases and traumas. In such illnesses, having the ability to replace the injured cells would have a dramatic impact on therapy and prognosis.

A classical instance of terminal differentiation is that of skeletal muscle.⁹ Many established cell lines exist, capable of recapitulating *in vitro* the main stages of muscle differentiation. Proliferating undifferentiated myoblasts can be induced to differentiate *in vitro* by subtracting growth factors. In these conditions, myoblasts irreversibly withdraw from the cell cycle, express muscle-specific genes, and eventually fuse into multinucleated myotubes.¹⁰

Adenoviruses are human viruses with oncogenic potential in animals.¹¹ They are capable of infecting a wide variety of cells, including postmitotic ones.^{12,13} Early after infection, they express the oncogene E1A, which has the ability to stimulate the cell cycle.¹⁴

In the present paper we describe the reactivation of the cell cycle in terminally differentiated skeletal muscle cells. This was obtained by simple adenovirus infection of myotubes, and consequent expression of E1A. Our data indicate the great potential of adenoviruses as tools to investigate the terminally differentiated state. They might be used, in principle, to design therapeutic strategies.

MATERIALS AND METHODS

Cells

C2C12 cells are an established myoblast cell line,¹⁵ routinely cultured in Dulbecco's Minimal Essential Medium (DMEM) supplemented with 10% fetal bovine serum (growth medium). Differentiation was induced by plating the cells at densities ranging from 3,100 to 15,500 cell/cm², depending on the purpose of the experiment, and switching them to serum-free (SF) medium (DMEM + 10 μ g/ml insulin, and 5 μ g/ml transferrin).

Viruses

Wild-type adenovirus serotype 5 (Ad5) was grown and titered in A549 human adenocarcinoma cells.¹⁶ Its deletion mutant dl520¹⁷ was grown and titered in the

permissive human 293 cell line,¹⁸ which bears an integrated adenoviral E1 region. Titrations were performed by plaque assay. Infections were performed for two hours in a total volume of 1 ml per 35-mm dish at the appropriate multiplicity of infection (MOI).

Immunofluorescence

The following MoAbs and antisera were employed for immunofluorescence. E1A: monoclonal antibody (MoAb) M73; 5-bromo-2'-deoxyuridine (BrdU): anti-BrdU MoAb (UBI); myosin heavy chain (MHC): MoAb MF-20,¹⁹ or rabbit anti-MHC antiserum (a kind gift of G. Salvatori and G. Cossu). MoAbs were detected by affinity-purified, anti-mouse-IgG goat serum (Organon Teknika, West Chester, PA). Reaction of rabbit antisera was detected by affinity-purified, anti-rabbit-IgG goat serum (Organon Teknika). Secondary antisera were conjugated with either rhodamine or fluorescein. Nuclei were stained after immunofluorescence treatments by incubating the cells for three minutes with a 1 μ g/ml solution of Hoechst 33258 dye in phosphate-buffered saline.

RESULTS

We performed our experiments with the skeletal muscle cell line C2C12, a widely used *in vitro* model of muscle differentiation. Extensive differentiation into myotubes, triggered by switching the cells to SF medium, took place within three days. At this time, multinucleated myotubes were infected with wild-type Ad5 or with the mutant dl520. The latter expresses only one of the two major E1A alternative splice products, E1A 12S, but not E1A 13S. Both viruses were used at various MOI to determine the optimal conditions for infection. E1A expression was detected by immunofluorescence in the majority of the myotubes at MOI 300 (not shown), and was confirmed by immunoprecipitation (not shown). In these conditions, wild-type Ad5 induced approximately 4% of the myotubes to synthesize DNA, as evidenced by immunodetection of incorporated BrdU. However, Ad5 caused significant cytopathic effects and cell loss. In contrast, dl520 caused no major damages to the cells, and was highly effective at inducing DNA synthesis in up to 97% of the myotubes within the first 48 hr post infection (p.i.) (not shown). No BrdU incorporation was detected in uninfected myotubes. Subsequent experiments were performed using dl520.

That the observed DNA synthesis was due to true DNA replication was manifested by the subsequent occurrence of mitoses, most abundant at 48 hr p.i. To demonstrate mitoses, dl520-infected myotubes were subjected to immunofluorescent staining of myosin heavy chain (MHC), a marker of muscle differentiation, and Hoechst 33258 staining, to detect DNA. FIGURE 1 shows examples of mitoses taking place in terminally differentiated myocytes. At 48 hr p.i., the frequency of mitotic figures in MHC-positive cells closely matched that of undifferentiated myoblasts (approximately 4.3%).

A time-course experiment was carried out, in the continuous presence of BrdU.

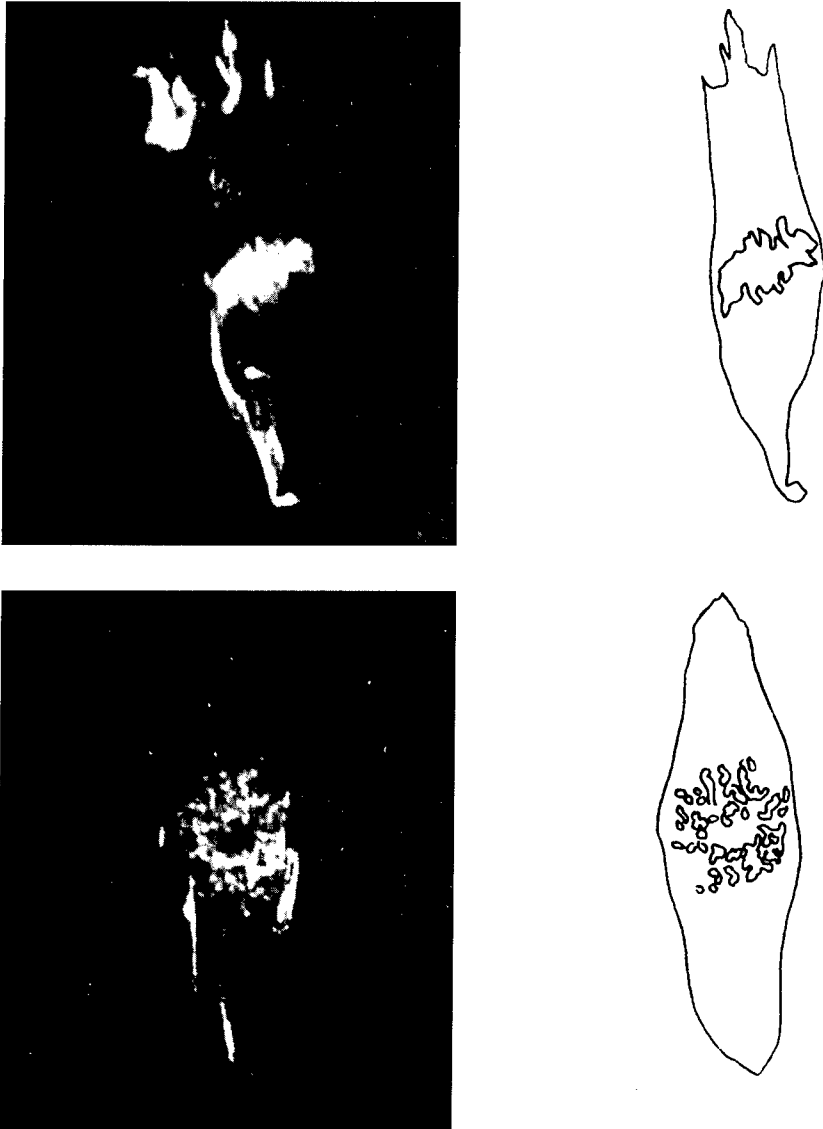

FIGURE 1. Mitoses in terminally differentiated C2C12 cells. Infected myotubes were fixed 48 hr p.i., stained for MHC detection, and counterstained with propidium iodide, an intercalating DNA dye. The cells were then viewed and photographed using a Leitz confocal microscope. The *left panels* depict two instances of metaphases in MHC-positive cells. MHC fluorescence outlines the shapes of the myocytes. Metaphase plates are visible in the middle of the cells. The drawings on the *right panels* are aids for the interpretation of the photographs.

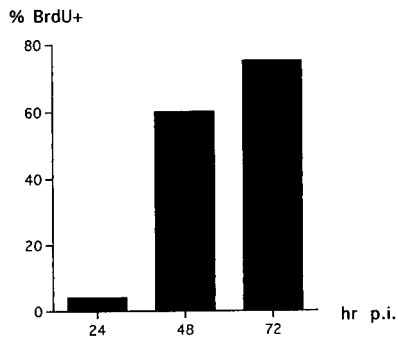

FIGURE 2. DNA synthesis in C2C12 myotubes. Myotubes were infected at MOI 300 and BrdU was immediately added to the culture medium. Identical dishes of cells were fixed at 24, 48, or 72 hr p.i. and stained for MHC and BrdU immunofluorescent detection. The percentages of BrdU⁺/MHC⁺ cells are shown at each time point.

It demonstrated that most DNA synthesis takes place between 24 and 48 hr p.i. (FIG. 2). Analogous experiments were performed to determine the timing of mitoses (FIG. 3). Interestingly, while DNA synthesis was unaffected by the absence of serum, the number of mitoses was reduced fivefold at all time points if the cells were cultured in SF medium, compared to growth medium (FIG. 3). Cell death took place in the SF-medium-containing dishes, starting at 48 hr p.i., approximately the same time when mitoses occur in the presence of serum (not shown). Cell death was observed at no time point in the serum-containing dishes. Neither DNA synthesis nor mitoses occurred in myotubes of control, uninfected dishes.

Multinucleated myotubes did not survive long after mitosis. Their nuclei coalesced into giant formations or fragmented into innumerable micronuclei. Despite

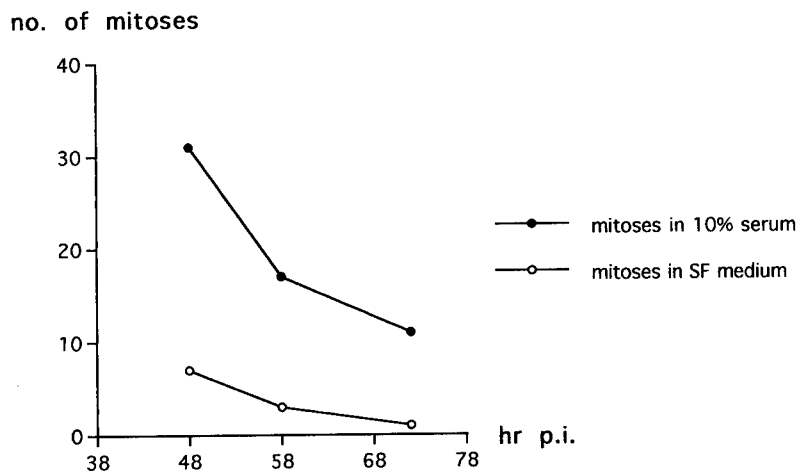

FIGURE 3. Mitoses in myotubes in the presence or absence of serum. C2C12 myotubes were infected in SF medium and either kept in SF or switched to growth medium at 24 hr p.i. At the indicated times p.i., the cumulative number of mitoses in all the MHC⁺ cells present in 60 microscopic fields (312 \times) was assessed.

this, many myotubes entered a second S phase, evidenced by short BrdU pulses, but died shortly thereafter (not shown). However, terminally differentiated, mononucleated myocytes appeared to survive. To determine whether postmitotic, mononucleated cells could proliferate for extended periods of time, we took serial microphotographs of the same microscopic fields at various times p.i. FIGURES 4 and 5 show examples of terminally differentiated cells that gave rise to small colonies after dl520 infection. To verify that we were able to distinguish myocytes from myoblasts on morphological grounds, cell dishes identical to the ones from which we took the serial pictures were photographed and stained by immunoperoxidase for MHC, and the same areas were photographed again. One of us (M. C.) blindly identified 21 differentiated myocytes in the first set of pictures. All of them turned out to be MHC-positive in the second set. Thus, morphological identification of terminally differentiated, C2C12-derived myocytes is possible and reliable. These experiments lead us to conclude that postmitotic cells can fully reenter the cell cycle and proliferate extensively.

DISCUSSION

In this paper we show that terminally differentiated skeletal muscle cells can be forced to synthesize DNA, enter mitosis, and proliferate by means of adenovirus infection. We have shown elsewhere²⁰ by genetic analysis that E1A is the sole adenoviral gene responsible for the reentry of myotubes into the cell cycle. Thus, it is very unlikely that adenoviral gene products may replace missing cellular components of the replicative apparatus. These results demonstrate that at least one type of terminally differentiated cell has an intact proliferative machinery that can be reactivated by appropriate stimuli.

We previously reported experiments, similar to the ones described here, performed using myotubes of quail, rat, and human origin.²⁰ All these myotubes, including those derived from primary quail, mouse, and human myoblasts, were efficiently induced to synthesize DNA and undergo mitosis by dl520.²⁰ Thus, application of this method is limited neither by species barriers nor by the unimmortalized, untransformed status of the cells. As a means to force postmitotic cells into the cell cycle, adenovirus infection has a number of advantages. It is easily performed, reproducible, and applicable to cells of a number of species, from quail to man. Furthermore, it can be applied equally well to primary cells.²⁰ We have shown elsewhere²⁰ that adenoviruses can induce at least another terminally differentiated cell type to reenter the cell cycle, namely, the adipocyte. Finally, adenoviruses can infect a wide variety of different cell types.^{12,13} Thus, adenovirus infection promises to be a powerful method to explore the determinants of the "irreversible" growth arrest that accompanies terminal differentiation. Moreover, it could be applied to the solution of practical, therapeutic problems. The fact that adenovirus infection is capable of activating the cell cycle in at least two types of terminally differentiated cells allows us to hope that it might also force proliferation of, for example, adult myocytes and neurons. The possibility of inducing proliferation of these two cell types might permit us to design innovative therapeutic strategies. Experiments are in progress to evaluate this potentiality.



34 hr p.i.



41 hr p.i.

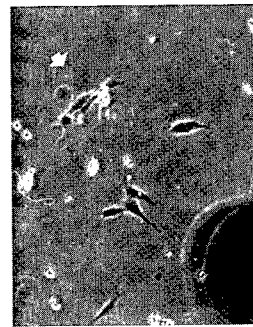

55.5 hr p.i.

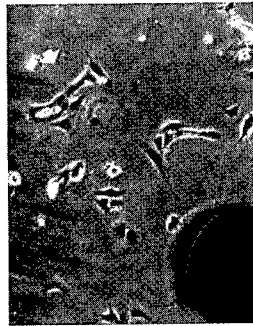

74.5 hr p.i.

48 hr p.i.

FIGURE 4. Long-term proliferation of a dl520-infected myocyte. Sparsely seeded, mostly mononucleated myocytes were infected and photographed in phase contrast at the indicated times p.i. A myocyte (*arrow*) divides several times and forms a small colony.

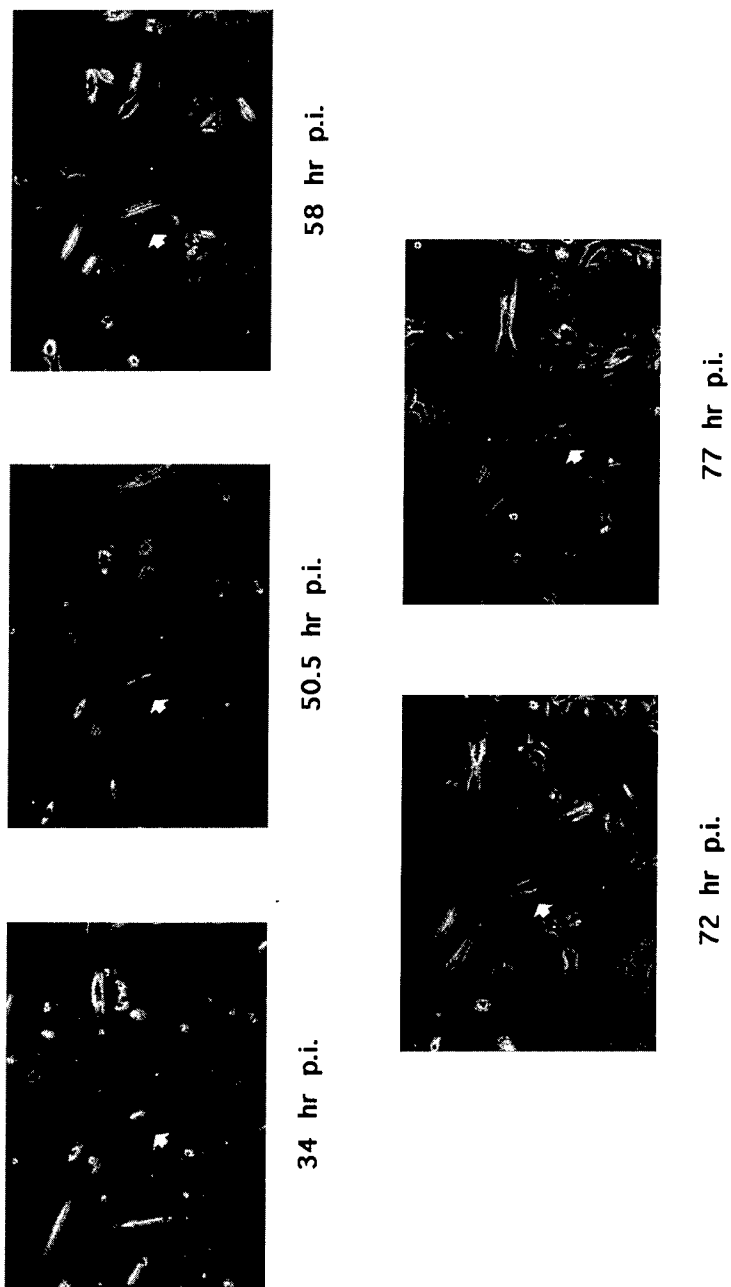

FIGURE 5. Long-term proliferation of a dl520-infected myocyte. A myocyte (*arrow*) divides into two cells (50.5 hr p.i.), fuses into a presumably binucleated myotube (58 hr p.i.), and divides again altogether into four cells (77 hr p.i.).

Since adenovirus seems to perform equally well in human and animal cells, the task of transferring results obtained in animal models to humans should be relatively easy.

SUMMARY

Different cell types in the body of higher animals undergo terminal differentiation. In such a process, cells acquire specialized functions and irreversibly lose their ability to divide, therefore entering the postmitotic state. Terminally differentiated cells do not proliferate in response to growth factors or following the expression of activated, retroviral oncogenes. In this paper we demonstrate that adenovirus infection is an efficient and convenient means to induce terminally differentiated cells to reenter the cell cycle. These findings constitute a first step toward defining the molecular determinants of the irreversible withdrawal from the cell cycle of terminally differentiated cells. They may also open the way to therapeutic applications.

ACKNOWLEDGMENTS

We are grateful to A. M. Lewis, Jr. for providing viruses and for invaluable advice. We are indebted to G. Salvatori and G. Cossu for the generous gifts of primary mouse and human cells, and anti-MHC antiserum. Our gratitude goes to L. Castellani for confocal microscopy.

REFERENCES

1. CLEGG, C. H. & S. D. HAUSCHKA. 1987. Heterokaryon analysis of muscle differentiation: regulation of the postmitotic state. *J. Cell Biol.* **105**: 937-947.
2. ENDO, T. & B. NADAL-GINARD. 1986. Transcriptional and posttranscriptional control of *c-myc* during myogenesis: its mRNA remains inducible in differentiated cells and does not suppress the differentiated phenotype. *Mol. Cell. Biol.* **6**: 1412-1421.
3. CRESCENZI, M., D. H. CROUCH & F. TATÒ. 1994. Transformation by *myc* prevents fusion but not biochemical differentiation of C2C12 myoblasts: mechanisms of phenotypic correction in mixed culture with normal cells. *J. Cell Biol.* **125**: 1137-1145.
4. FALCONE, G., S. ALEMÀ & F. TATÒ. 1991. Transcription of muscle-specific genes is repressed by reactivation of pp60^{V-SRC} in postmitotic quail myotubes. *Mol. Cell. Biol.* **11**: 3331-3338.
5. CRESCENZI, M., T. P. FLEMING, A. B. LASSAR, H. WEINTRAUB & S. A. AARONSON. 1990. MyoD induces growth arrest independent of differentiation in normal and transformed cells. *Proc. Natl. Acad. Sci. USA* **87**: 8442-8446.
6. SORRENTINO, V., R. PEPPERKOK, R. L. DAVIS, W. ANSORGE & L. PHILIPSON. 1990. Cell proliferation inhibited by *MyoD* independently of myogenic differentiation. *Nature* **345**: 813-815.
7. GU, W., J. W. SCHNEIDER, G. CONDORELLI, S. KAUSHAL, V. MAHDAVI & B. NADAL-GINARD. 1993. Interaction of myogenic factors and the retinoblastoma protein mediates muscle cell commitment and differentiation. *Cell* **72**: 309-324.
8. SCHNEIDER, J. W., W. GU, L. ZHU, V. MAHDAVI & B. NADAL-GINARD. 1994. Reversal

- of terminal differentiation mediated by p107 in Rb^{-/-} muscle cells. *Science* **264**: 1467–1471.
9. OKAZAKI, K. & H. HOLTZER. 1966. Myogenesis: fusion, myosin synthesis, and the mitotic cycle. *Proc. Natl. Acad. Sci. USA* **56**: 1484–1490.
 10. PEARSON, M. L. & H. F. EPSTEIN, Eds. 1982. *Muscle Development: Molecular and Cellular Control*. Cold Spring Harbor Laboratory, Cold Spring Harbor, NY.
 11. LEWIS, A. M., JR. & J. L. COOK. 1984. The interface between adenovirus-transformed cells and cellular immune response in the challenged host. *Curr. Top. Microbiol. Immunol.* **110**: 1–22.
 12. LE GAL LA SALLE, G., J. J. ROBERT, S. BERRARD, V. RIDOUX, L. D. STRATFORD-PERRICAUDET, M. PERRICAUDET & J. MALLET. 1993. An adenovirus vector for gene transfer into neurons and glia in the brain. *Science* **259**: 988–990.
 13. QUANTIN, B., L. D. PERRICAUDET, S. TAJBAKHSH & J.-L. MANDEL. 1992. Adenovirus as an expression vector in muscle cells *in vitro*. *Proc. Natl. Acad. Sci. USA* **89**: 2581–2584.
 14. BOULANGER, P. A. & E. G. BLAIR. 1991. Expression and interactions of human adenovirus oncoproteins. *Biochem. J.* **275**: 281–299.
 15. BLAU, H. M., C.-P. CHIU & C. WEBSTER. 1983. Cytoplasmic activation of human nuclear genes in stable heterokaryons. *Cell* **32**: 1171–1180.
 16. GIARD, D. J., S. A. AARONSON, G. J. TODARO, P. ARNSTEIN, J. H. KERSEY, H. DOSIK & W. P. PARKS. 1973. *In vitro* cultivation of human tumors: establishment of cell lines derived from a series of solid tumors. *J. Natl. Cancer Inst.* **51**: 1417–1423.
 17. COOK, J. L., D. L. MAY, A. M. J. LEWIS & T. A. WALKER. 1987. Adenovirus E1A gene induction of susceptibility to lysis by natural killer cells and activated macrophages in infected rodent cells. *J. Virol.* **61**: 3510–3520.
 18. HARRISON, T., F. L. GRAHAM & J. WILLIAMS. 1977. Host-range mutant of adenovirus type 5 defective for growth in HeLa cells. *Virology* **77**: 319–329.
 19. BADER, D., T. MASAKI & D. A. FISCHMAN. 1982. Immunochemical analysis of myosin heavy chain during avian myogenesis *in vivo* and *in vitro*. *J. Cell Biol.* **95**: 763–770.
 20. CRESCENZI, M., S. SODDU & F. TATÒ. 1994. Mitotic cycle reactivation in terminally differentiated cells by adenovirus infection. *J. Cell. Physiol.* In press.

Response of Neonatal Rat Cardiomyocytes to Repetitive Mechanical Stimulation *In Vitro*

HERMAN H. VANDENBURGH,^a ROSA SOLERSSI,^a JANET
SHANSKY,^a JOHN W. ADAMS,^b SCOTT A. HENDERSON,^b AND

JULIE LEMAIRE^a

^a*Department of Pathology and Laboratory Medicine
Brown University School of Medicine*

*and
The Miriam Hospital
164 Summit Avenue*

Providence, Rhode Island 02906

^b*Department of Physiological Science
University of California, Los Angeles
Los Angeles, California 90024*

INTRODUCTION

Differentiation and maintenance of a specific cell phenotype *in vitro* requires supplying the proper extracellular matrix, nutrients, and growth factors. But even under optimal tissue culture conditions, extensive intercellular interactions rarely occur that lead to the organization of the cells into two- and three-dimensional organs comparable to their *in vivo* counterparts. Spatial and chemical gradients play important roles in early organization of embryonic tissues,^{1,2} while mechanical forces generated in the enlarging embryo by the growing skeleton, contracting muscles, and fluid pressure and flow influence subsequent organogenesis and growth.³ Especially in skeletal muscle⁴ and the heart,⁵ these mechanical forces play important regulatory roles in the formation of adult structure. The recent development of computerized mechanical cell stimulators for tissue-cultured cells allows the application of *in vivo*-like external mechanical forces to monolayer cultures for the study of mechanogenic growth and organogenesis.^{6,7} For example, proliferating skeletal muscle myoblasts *in vitro* have been mechanically stimulated to form three-dimensional functional muscle "organoids" with many morphological and biochemical characteristics of the adult tissue,⁸ and to serve as models for the study of mechanogenic second messenger systems.⁹ *In vitro* systems are more amenable than animals for studying the complex interactions of growth factors, nutrients, extracellular matrix, and mechanical forces in regulating tissue growth. They allow the manipulation of each variable separately from the others. Although an artificial environment is created *in vitro*, what is learned in tissue culture will assist in designing more targeted *in vivo* studies.

In most species, the left ventricle increases 2–3-fold in weight during the first week postnatally, and the left ventricular cardiomyocytes increase in cell volume

several fold.¹⁰ The cardiomyocytes are organized into layers of rod-shaped cells parallel to each other and connected by gap junctions and intercalated discs, critical components for efficient pumping by the heart.¹¹ After birth, the left ventricle's workload is dramatically increased due to both increased blood volume^{12,13} and increased blood pressure.¹⁴ These unidirectional mechanical stresses placed on the heart cells are in addition to the repetitive stretch/relaxation cycles that occur as the heart pumps blood. Both forms of mechanical stretch have been implicated as major growth regulators in the heart.^{15,16} In order to repetitively mechanically load neonatal cardiomyocytes to the extreme levels that occur during the early phases of growth *in vivo*, we performed initial experiments outlined in this paper to determine the ability of neonatal cardiomyocytes to attach and grow without injury on an actively moving substratum in computerized mechanical cell stimulators. We present some of our observations on the morphological and biochemical responses of neonatal cardiomyocytes to applied *in vivo*-like repetitive mechanical forces. The results indicate that neonatal rat cardiomyocytes can be grown in a highly active mechanical environment without significant detachment or damage, making these computer model systems suitable for future work on the role of mechanical forces in physiological growth and organogenesis in this vital tissue.

MATERIALS AND METHODS

Cell Cultures

Neonatal rat myocardial cells were prepared as outlined previously.¹⁷ Myocytes were separated from nonmuscle heart cells and cellular debris by centrifugation on a one-step, discontinuous Percoll gradient (Pharmacia, 1.059 g/ml and 1.082 g/ml). The final cell preparation contained 85–92% cardiomyocytes, based on immunocytochemical staining for sarcomeric tropomyosin (Sigma Chemical Co., St. Louis, MO). The cells were plated on collagen and laminin-coated silicone rubber membranes¹⁸ at a density of 2,800–4,200 cells/mm². After overnight attachment, the medium was replaced with Eagle's Basal Medium containing 10% (v/v) horse serum, 5% (v/v) avian embryo extract, and 50 units/ml penicillin.¹⁹ The cultures were confluent and spontaneously contractile by 24 h postplating. After overnight attachment, the cells were repetitively mechanically stimulated for up to 5 days.

Mechanical Cell Stimulators (MCS)

The cells were grown attached to the elastic substratum in either 15 mm diameter circular wells of a computerized vertical mechanical cell stimulator (MCS-3, FIG. 1)⁶ or the rectangular wells (10 × 18 mm) of a computerized horizontal mechanical cell stimulator (MCS-2, FIG. 2).⁷ Each setup contains 12–18 wells that can be subjected to mechanical loading in 30–35 μ m increments by a computer-controlled stepper motor. An equal number of wells are used as static controls. In the MCS-3, radial stretch is applied to the substratum by a vertically moving

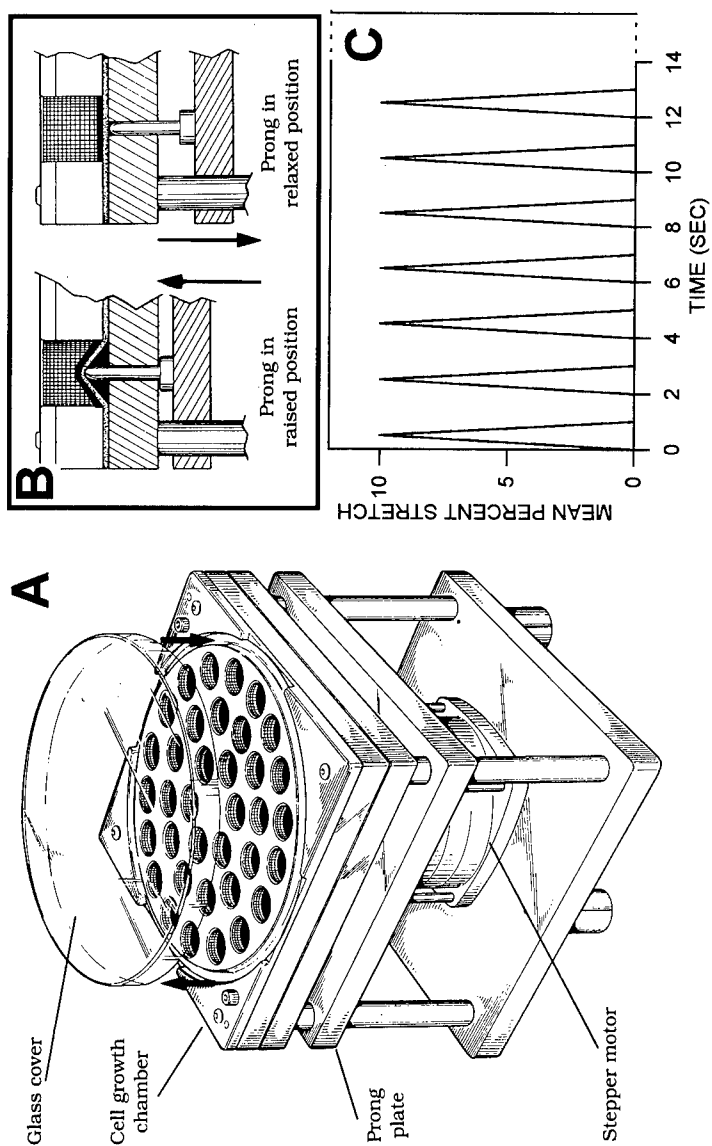

FIGURE 1. Vertical mechanical cell stimulator, model 3 (MCS-3). (A) The stainless steel cell growth chamber contains 36 Teflon-lined culture wells 15 mm in diameter; (B) 2-mm diameter prongs move up and down to stretch and relax the cells; (C) typical computer-generated pattern of stretch-relaxation activity used to simulate the beating heart. Rates up to 200 beats per minute can be generated. (Modified from Vandenburg *et al.*³⁰ Apparatus available from Cell Kinetics, Inc., Providence, RI.)

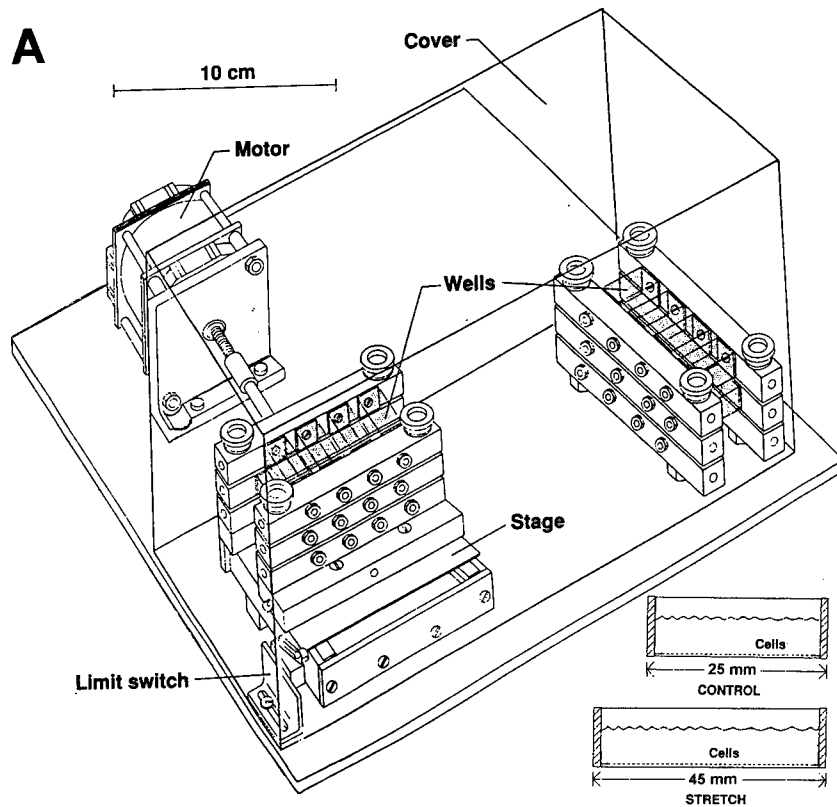

FIGURE 2. Horizontal mechanical cell stimulator, model 2 (MCS-2). (A) Perspective line drawing of the horizontal mechanical cell stimulator, showing stepper motor, linear positioning translation stage, control culture wells (*right*), and mechanically stretched wells (*left*). Wells are constructed entirely of silicone rubber. Not shown is the computer that controls the motor activity pattern. (Modified from Vandenberg *et al.*³¹) (B) Typical unidirectional mechanical stretch pattern, consisting of unidirectional stretching at $35 \mu\text{m}/\text{step}$ at different rates from $35 \mu\text{m}/10 \text{ min}$ to $1 \text{ mm}/\text{sec}$.

2-mm diameter piston positioned underneath the center of each circular stretch well. In the MCS-2, the rectangular stretch wells are placed on a mechanical translation stage and held stationary at one end, while the other end is linearly stretched by the computer-controlled stepper motor. A complete description of the hardware and computer software for both setups is presented elsewhere.^{6,7} The cells in the mechanical cell stimulators are maintained sterilely at 37°C in a 5% CO_2 incubator.

Morphometric and Biochemical Methods

At varying times after plating, the cells were fixed and stained in the elastic wells with either hematoxylin and eosin for general morphology, or immunocyto-

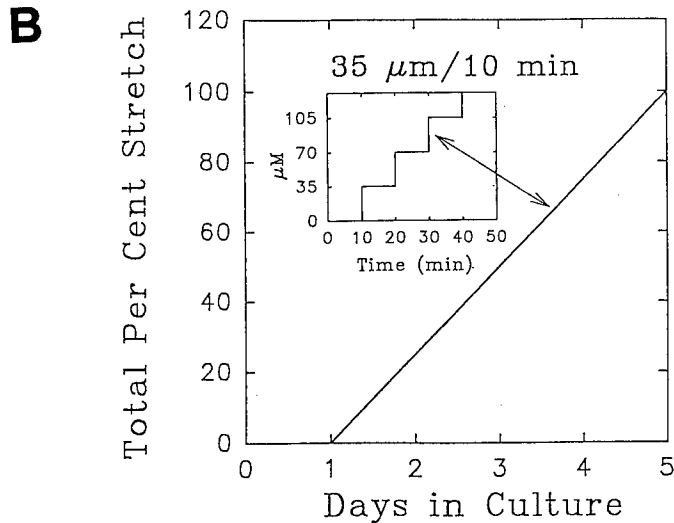

FIGURE 2. (Continued)

chemically with an antibody against sarcomeric tropomyosin to identify the cardiomyocytes.²⁰ Microscopic fields were observed using a Zeiss light microscope equipped with a drawing tube attachment focused onto a Numonics 2210 Digitizing Tablet connected to an IBM-compatible computer. The stained cells and tablet mouse could be seen while looking through the microscope eyepieces. Nuclei counts and morphological measurements were made using morphometry software (SIGMASCAN, Jandel Scientific, Sausalito, CA), as previously described.²⁰

Soluble and particulate creatine kinase (CK) activity released from the cell layer into serum-free DMEM-F12 culture medium were used as measures of stretch-induced cell damage and detachment, respectively. CK activity was assayed spectrophotometrically with a clinical diagnostic kit, according to the manufacturer's protocol (Sigma Chem. Co. CK47-10).

RESULTS AND DISCUSSION

Cell Detachment and Damage in Response to Stretch

Cardiomyocytes are subjected to continuous mechanical loading throughout their life span, which, since the cells are postmitotic soon after birth, is the life of the organism. They must therefore be capable of withstanding not only normal mechanical loading and unloading for many years, but also increased acute and chronic loads caused by changes in beating frequency, blood pressure, and blood volume. This is especially so in the neonate, where blood pressure and blood volume both increase 50–100% within hours after birth.^{13,14} It was therefore expected that the isolated neonatal cardiomyocytes would be fairly elastic cells,

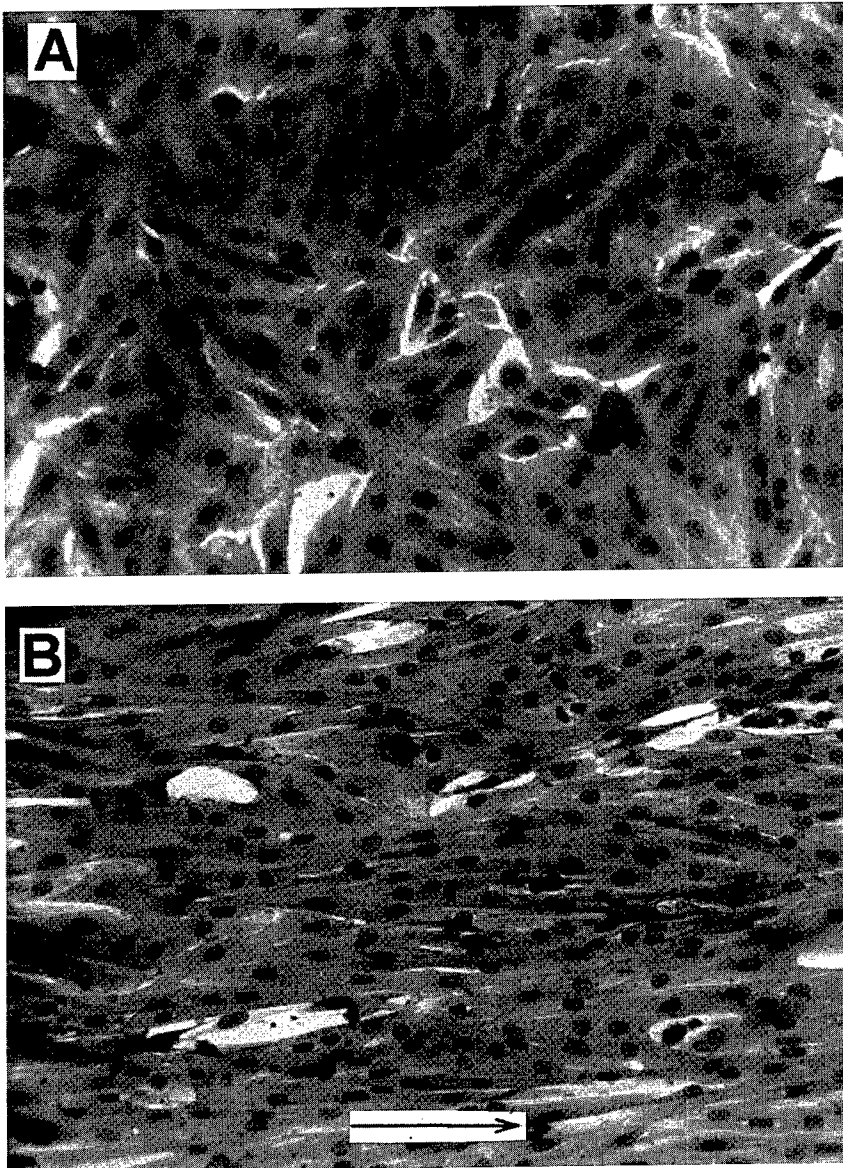

FIGURE 3. Neonatal cardiomyocytes are extremely elastic cells. Neonatal cardiomyocytes one day after isolation were unidirectionally stretched for 1 h at the rate of 15% substratum lengthenings every 5 min without relaxation (total substratum stretch of 180% in MCS-2). (A) Unstretched control cardiomyocytes; (B) stretched cardiomyocytes. *Arrow* shows direction of stretch. Cells were stained immunocytochemically with a sarcomeric tropomyosin antibody, and counterstained with hematoxylin.

capable of resisting significant stretch-induced cell damage. Rapid, progressive lengthening of the substratum and attached neonatal cardiomyocytes by 180% over a one hour period (MCS-2: 15% unidirectional substratum stretches every 5 min without relaxation, see FIG. 2) leads to significant cell deformation without any evidence of cell detachment (FIG. 3). Quantitative morphometric measurements of the sarcomeric tropomyosin stained cardiomyocytes indicated that the cardiomyocytes were deformed in the direction of stretch to a similar percent as the substratum, while their diameter perpendicular to the direction of stretch was significantly reduced (FIG. 4). Interestingly, the shape of the noncardiomyocytes was *not* altered by the rapid stretching, probably due to the high rate at which these cells can detach and reattach their contact points to the extracellular matrix.²¹

Release of soluble creatine kinase, a well-established marker of myocardial damage, was used as a measure of stretch-induced membrane damage *in vitro*, while the release of particulate creatine kinase into the medium was measured to determine the extent of cell detachment from the stretching substratum. Based on soluble creatine kinase activity in the medium during and after a rapid stretching protocol, cell damage was minimal since only 2.6% of total creatine kinase activity was released; particulate creatine kinase activity released from the cell layer into

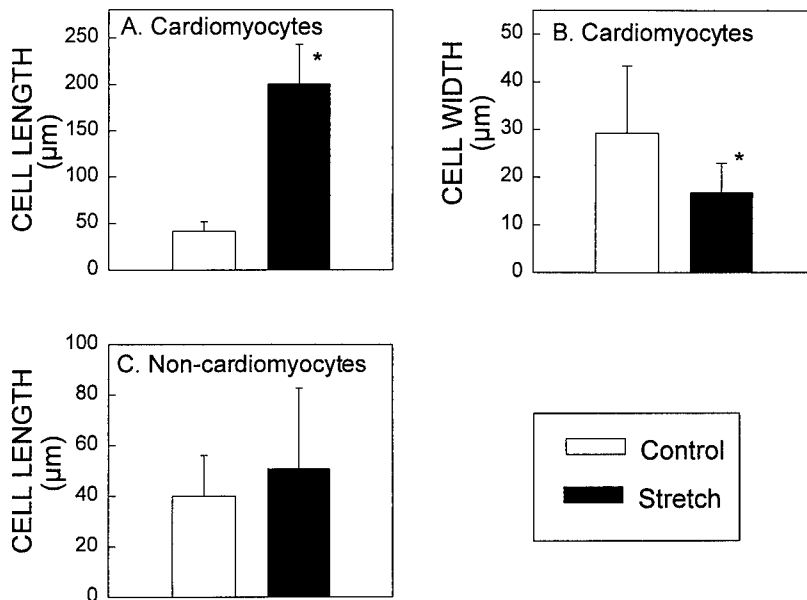

FIGURE 4. Neonatal cardiomyocytes are stretched as the substratum is stretched. Day 1 postplating cardiac cultures were mechanically stretched at 3.0 mm every 5 min over a one-hour period without relaxation (total substratum stretch of 180%), fixed, stained for sarcomeric tropomyosin, and counterstained with hematoxylin. The cells were embedded in Spurr embedding medium, and cellular dimensions of tropomyosin positive (A, B), and negative (C) cells measured under the light microscope as described in Materials and Methods. Each bar represents measurements on 80 cells. * $p < 0.001$.

TABLE 1. Stretch-Induced Release of Creatine Kinase (CK) Activity from Cardiomyocyte Cultures^a

Exp. #	Time after Plating (Days)	Total Stretch (%)	Total Intracellular Creatine Kinase (U/L)	Released Soluble CK (U/L)	% of Total	Released Particulate CK (U/L)	% of Total
1	1	120	516.7 ± 18.4	13.3 ± 3.1	2.6%	<5.5	<1.1%
2	1	180	524.6 ± 8.5	63.6 ± 6.2	12.1%	18.5 ± 10.3	3.5%
3	2	180	362.2 ± 60.9	<5.5	<1.5%	<5.5	<1.5%

^a Cultures were stretched for one hour at either 0.4 mm/min (Exp. 1) or 0.6 mm/min (Exps. 2 and 3) in serum free medium and creatine kinase enzymatic activity assayed as outlined in Materials and Methods. Each value is the mean ± S.E. of 3–4 samples. Unstretched controls released less than 5.5 U/L CK during the one-hour incubation (data not shown).

the medium was not detected, indicating minimal cell detachment during the stretching protocol (TABLE 1 Experiment 1). These results did not change even when incubation of the cells was continued for up to 24 hours after stretch and creatine kinase activity in the medium measured (data not shown). When the percent of cell stretch was increased to 180% over a one-hour period (15% unidirectional substratum stretches every 5 min without relaxation), release of particulate and soluble creatine kinase was significantly increased (TABLE 1, Experiment 2), but the percent total creatine kinase released even with this extreme stretch was quite small. In a second experiment with older tissue-cultured cells, even this rapid, extreme stretch did not damage the cells (TABLE 1, Experiment 3). Similar results were obtained when release of lactate dehydrogenase activity was measured or when the cardiomyocytes were repetitively stretched and relaxed 10–20% (data not shown). In all instances, significant cell proliferation and cardiomyocyte hypertrophy occurred when the cells were repetitively mechanically stimulated by these activity patterns.²⁰ Rapid rearrangement of the cardiomyocyte's sarcolemma-cytoskeleton network must occur, which allows the extreme deformation of the cells' shape without significant membrane damage. This is very different from most other cell types studied. Similar patterns of mechanical loading cause severe cell detachment and plasma membrane damage in differentiated avian skeletal myofibers²² and adult rat cardiomyocytes.¹⁸ The neonatal cardiomyocytes therefore appear to be highly elastic cells uniquely designed for handling extreme mechanical loads.

Cell Orientation in Response to Stretch

It has been speculated that the complex combined patterns of repetitive stretch-relaxation during work cycling and unidirectional stretches caused by blood pressure and volume increases during development, help direct the pattern of organogenic heart growth *in vivo*.^{23,24} We have shown in the section above that unidirectional stretching of the substratum without relaxation caused the cardiomyocytes to organize into parallel arrays of rod-shaped cells (FIG. 3). Morphologically, this sheet of parallel cardiomyocytes looks very similar to the individual layers of the

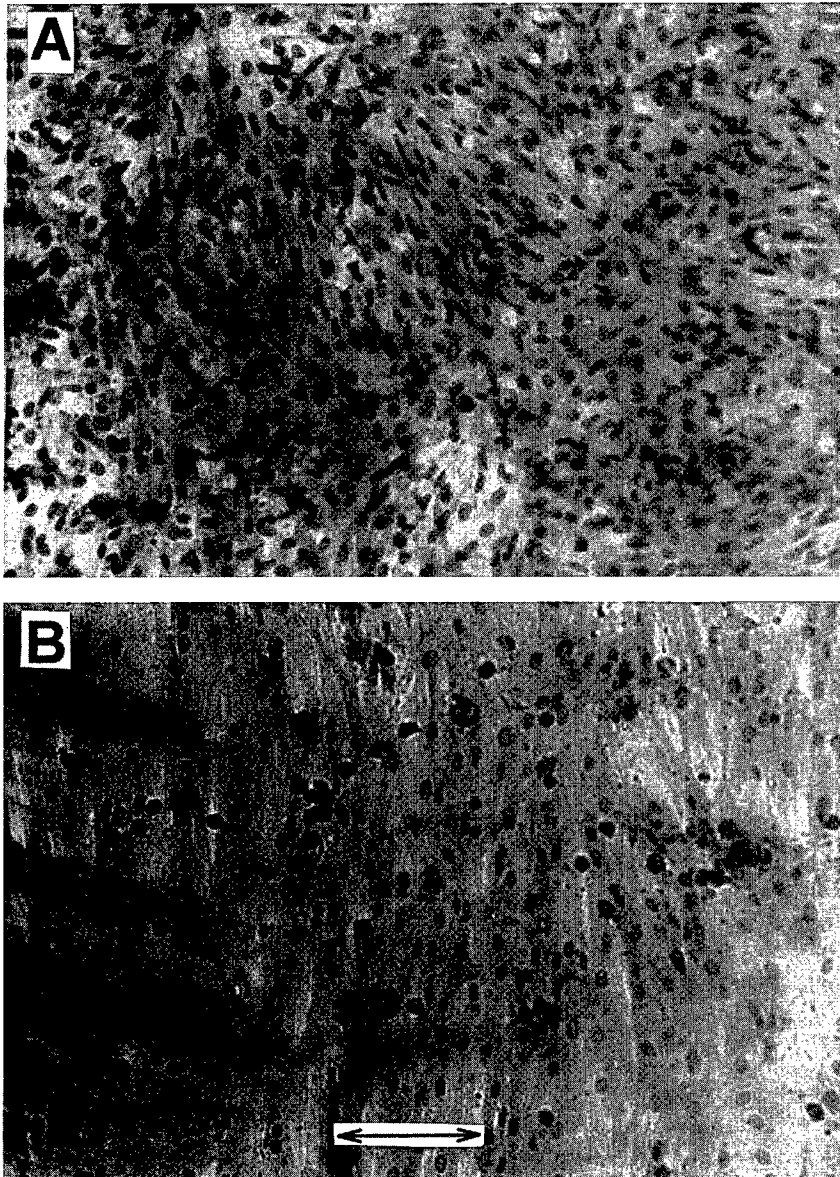

FIGURE 5. Neonatal cardiomyocytes realignment is dependent on the pattern of mechanical loading. (A) Neonatal cardiomyocytes grown for 5 days in static culture wells; (B) cardiomyocytes repetitively stretched and relaxed 5–10% at 10–30 Hz for 3–4 days (similar to the pattern shown in FIG. 1C). The direction of the stretch/relaxation is shown by the *double arrowheads*; (C) cardiomyocytes stretched unidirectionally by a pattern similar to that shown in FIGURE 2B for 3–4 days (35 μ m every 10 min without relaxation, *single arrowhead*). This was followed by 4 days of the repetitive stretch-relaxation activity (*double arrowheads*) similar to that in FIGURE 1C. The cells were stained with hematoxylin and eosin.



FIGURE 5. (Continued)

intact heart. Neonatal cardiac cells were subjected to other patterns of repetitive mechanical load in tissue culture, and cell orientation analyzed. When subjected to repetitive stretch/relaxation cycling of the substratum by 10–15% for several days in the MCS-3, the cells aligned *perpendicular* to the direction of substratum stretch (FIG. 5B). This is similar to the response of the neonatal rat cardiomyocytes²⁵ and to avian skeletal myoblasts^{6,26} when subjected to repetitive stimulation. Once the cells have been aligned parallel to the direction of stretch by unidirectional stretching similar to that shown in FIGURE 3, repetitive stretch/relaxation of the substratum for 3 to 4 days did not realign the cells perpendicular to the direction of stretch (FIG. 5C), as seen when repetitive stretch/relaxation was initiated on freshly isolated cells. The cardiomyocytes most likely become fixed in orientation once significant intercellular and extracellular matrix contacts are made. The extracellular matrix synthesized by the interstitial fibroblasts probably plays an important role in the organization of the cardiomyocytes in response to stretch,^{27,28} as it does in skeletal muscle organogenesis *in vitro*.⁸ Mechanical stimulation of cardiac fibroblasts *in vitro* has been shown by Carver *et al.*²⁹ to stimulate specific extracellular matrix components which are involved in cell attachment and organogenesis. The connective tissue producing noncardiomyocytes may be “cell sensors” of mechanical loading, and play a significant role in organizing the cardiomyocytes *in vivo* as well as *in vitro*.²¹

In summary, the results of our initial studies indicate that neonatal cardiomyocytes are extremely elastic cells, and can be extensively and repeatedly stretched without significant cell damage. They can be aligned mechanically, and their alignment is dependent on the pattern of mechanical loading. The ability to mechani-

cally stimulate neonatal cardiomyocytes by patterns which more closely simulate those found during development *in vivo* should allow the use of these systems to further study cardiomyocyte organogenesis and the mechanogenic transduction processes involved in the neonatal to adult physiological growth process.

REFERENCES

1. SUMMERBELL, D., J. LEWIS & L. WOLPERT. 1973. *Nature* **244**: 492-496.
2. SUMMERBELL, D. 1974. *J. Embryol. Exp. Morph.* **32**: 227-237.
3. WEISS, P. 1933. *Am. Nat.* **118**: 389-407.
4. STEWART, D. M. 1972. *The Role of Tension in Muscle Growth. Regulation of Organ and Tissue Growth.* R. J. Goss, Ed. 77-100. Academic Press. New York.
5. MORGAN, H. E., E. E. GORDEN, Y. KIRA, B. H. L. CHUA, & L. A. RUSSO *et al.* 1987. *Ann. Rev. Physiol.* **49**: 533-543.
6. VANDENBURGH, H. H. 1988. *In Vitro* **24**: 609-619.
7. VANDENBURGH, H. H. & P. KARLISCH. 1989. *In Vitro* **25**: 607-616.
8. VANDENBURGH, H. H., S. SWADISON & P. KARLISCH. 1991. *FASEB J.* **5**: 2860-2867.
9. VANDENBURGH, H. H. 1992. *Am. J. Physiol.* **262**: R350-R355.
10. ANVERSA, P., G. OLIVETTI & A. V. LOUD. 1980. *Circ. Res.* **46**: 495-502.
11. KATZ, A. M. 1993. *Physiology of the Heart.* Raven Press. New York.
12. ANVERSA, P., J. M. CAPASSO, G. OLIVETTI & E. H. SONNENBLICK. 1992. *Acta Paediatr. Scand.* **81**(Suppl. 383): 29-31.
13. BEINLICH, C. J. & H. E. MORGAN. 1993. *Mol. Cell. Biochem.* **119**: 3-9.
14. LITCHFIELD, J. B. 1958. *Physiol. Rev.* **31**: 1-6.
15. COOPER, G. 1987. *Ann. Rev. Physiol.* **49**: 501-518.
16. MORGAN, H. E. & K. M. BAKER. 1991. *Circulation* **83**: 13-25.
17. HENDERSON, S. A., M. SPENCER, A. SEN, C. KUMAR, M. SIDDIQUI & K. R. CHIEN. 1989. *J. Biol. Chem.* **264**: 18142-18148.
18. SAMUEL, J.-L. & H. H. VANDENBURGH. 1990. *In Vitro* **26**: 905-914.
19. VANDENBURGH, H. H., P. KARLISCH & L. FARR. 1988. *In Vitro* **24**: 166-174.
20. VANDENBURGH, H. H., R. SOLERSI, J. SHANSKY, J. ADAMS & S. A. HENDERSON. 1994. *In preparation.*
21. STOPAK, D. & A. K. HARRIS. 1982. *Dev. Biol.* **90**: 383-398.
22. HATFALUDY, S., J. SHANSKY & H. H. VANDENBURGH. 1989. *Am. J. Physiol* **256**(Cell Physiol. 25): C175-181.
23. THOMPSON, D. W. 1917. *On Growth and Form. 1.* Cambridge University Press. Cambridge, UK.
24. TERRACIO, L., A. TINGSTRÖM, W. H. PETERS III & T. K. BORG. 1990. *Ann. N.Y. Acad. Sci.* **588**: 48-60.
25. TERRACIO, L., B. MILLER & T. K. BORG. 1988. *In Vitro* **24**: 53-58.
26. VANDENBURGH, H. H. 1982. *Dev. Biol.* **93**: 438-443.
27. BORG, T. K., K. RUBIN, E. LUNDGREN, K. BORG & B. OBRINK. 1984. *Dev. Biol.* **104**: 86-96.
28. TERRACIO, L., K. RUBIN, D. GULLBERG, E. BALOG, W. CARVER *et al.* 1991. *Circ. Res.* **68**: 734-744.
29. CARVER, W., M. L. NAGPAL, M. NACHTIGAL, T. K. BORG & L. TERRACIO. 1991. *Circ. Res.* **69**: 116-122.
30. VANDENBURGH, H. H., J. SHANSKY, R. SOLERSI & J. CHROMIAK. 1994. *J. Cell. Physiol.* *In press.*
31. VANDENBURGH, H. H., S. HATFALUDY, P. KARLISCH & J. SHANSKY. 1991. *J. Biomech.* **24**(Suppl.): 91-99.

Stimulation of Proliferative Events in the Adult Amphibian Cardiac Myocyte

JOHN O. OBERPRILLER,^a JEAN C. OBERPRILLER,^a
DONALD G. MATZ,^a AND MARK H. SOONPAA^b

^a*Department of Anatomy and Cell Biology
University of North Dakota School of Medicine
Grand Forks, North Dakota 58202*

and

^b*Krannert Institute of Cardiology
Indianapolis, Indiana 46202*

INTRODUCTION: RESPONSE TO INJURY *IN VIVO*

The adult newt heart has a trabeculated structure, with no coronary vascular system. Cardiomyocytes of the uninjured adult heart are virtually nonproliferative, but *in vivo* experiments involving both adult newt and frog hearts have demonstrated a DNA synthetic and mitotic response in myocytes adjacent to an injury.^{1,2} Thus, cells of the adult heart in these amphibians are able to re-enter the cell cycle from a nonproliferative quiescent state. In the newt, this response has been demonstrated in both ventricular and atrial myocytes.^{3,4}

Experiments were designed to increase the amount of injured tissue and thus increase the proliferative response.^{5,6} This involved amputation of the apical portion of the newt ventricle and mincing and replacing it onto the amputation gap. Degeneration of the minced myocardium occurred, which was followed by a period of proliferation which peaked at 16 days after mincing with a thymidine labeling index of 24.6%. The end result, at 45 days after mincing, was some degree of reorganization with the formation of small mini-ventricles on the experimental hearts.

An attempt was made to determine the nature of the minced heart response, including a characterization of the resultant nuclei of the cardiomyocytes at 45 days post-mincing.⁷ This involved a series of injections of tritiated thymidine from days 15 to 20 post-mincing, the peak time of proliferative activity. Following fixation at 45 days post-mincing, the myocytes were separated and examined for labeling and ploidy. As can be seen in TABLE 1, 46.78% of the total myocytes were labeled, compared with no label in myocytes of control (unminced) hearts.

Ploidy determinations indicated that the ventriculomyocytes of the newt are virtually all (98.3%) mononucleated with diploid nuclei, while 0.82% are binucleated with diploid nuclei and 0.89% are mononucleated with tetraploid nuclei. Thus, the ventriculomyocytes of the amphibian heart differ considerably from the polyploid ventriculomyocytes seen in mammals in general,⁸ which may be one reason why the genome of the amphibian ventriculomyocyte is so easily reactivated as a result of injury. In the minced zone of the 45-day experimental hearts, most of the 46.78% of the myocytes which were labeled were mononucleated and diploid,

TABLE 1. Summary of Nuclear Characteristics of Myocytes Taken from Control (Unoperated) and Minced Newt Ventricles 45 Days after Mincing^a

Ploidy Levels	Control Ventricles	Minced Ventricles
2C	98.30 ± 0.64	87.20 ± 4.86
2C × 2	0.82 ± 0.65	4.30 ± 2.35
4C	0.89 ± 0.08	6.84 ± 5.11
4C × 2	0	1.70 ± 2.50
8C	0	0.17 ± 0.17
Total labeled myocytes	0	46.78 ± 2.00

^a Animals were injected with tritiated thymidine from 15 to 20 days after mincing. Values are given as a percentage of total myocytes examined. All percentages differ significantly from control values at the level $p < 0.001$.

indicating that these cells probably underwent complete mitosis with cytokinesis after having been labeled during their DNA synthetic period. An overall examination of the labeled and unlabeled myocytes in the system indicated that a total of 13% of the myocytes were polyploid and therefore cytokinesis did not occur in these instances. It appears that, even after injury, polyploidization in this system occurs less frequently than does a process of mitosis which includes cytokinesis, whereas in mammalian hypertrophy, polyploidization seems to be the predominant nuclear event,^{9,10} with a relatively minor degree of hyperplasia.¹¹

Cardiomyocytes In Vitro

In order to further understand the process of cell division in the amphibian heart, the adult newt ventriculomyocyte was placed into cell culture. Cell division had been demonstrated in organ culture by Nag *et al.*^{12,13} One of the major advantages in a cell culture study of the newt is its large chromosomes¹⁴ and the fact that cultures can easily be maintained and observed at 25°C.

The basic culture method has been described by Tate and Oberpriller.¹⁵ Ventricles taken for use in isolation of cardiomyocytes were held in Leibovitz L-15 culture medium, modified to a concentration of 70%, for a period of 18 hours. The holding period appears to be important in obtaining a good yield of cells in the separation procedure. Enzymatic separation of the myocytes was carried out in a solution of 0.5% trypsin (Gibco) and 625 units/ml of collagenase type II (Worthington Biochemical Corp.) in amphibian wash medium, using a Dubnoff shaking incubator at 25°C for a period of 8 to 10 hours. Generally, it is possible to plate one dish of myocytes (50,000 cells) from 2 ventricles.

Cells (5×10^4 cells/ml) were preplated in modified Leibovitz L-15 medium with 10% fetal bovine serum (FBS), allowing for attachment of most nonmyocyte cell types. The unattached myocytes were then removed at 48 hours along with their medium and plated onto laminin-coated culture dishes. After a period of 3 days to allow for attachment of the myocytes, the cultures were fed on alternate days with modified L-15 medium, supplemented with 10% fetal bovine serum. Attempts to maintain these cardiomyocytes in serum-free cell culture have thus far met with limited success. The replating process allowed for a relatively pure

culture of myocytes by eliminating most of the nonmyocytes from the cultures. Using immunofluorescent studies with MF-20, it was determined that at 5 days, 93.5% of the cells in the cultures were myocytes. At day 10, 93% were myocytes, at day 15, 91% were myocytes and at day 20, 90% were myocytes. Cytosine arabinoside was considered as a possible alternative for eliminating the nonmyocytes, but it was determined that this substance interfered with the process of cell division in cardiac myocytes. Cultures treated with cytosine arabinoside had a level of DNA synthesis that was 42% of that of cultures which were untreated and subjected to preplating.

Cellular Characteristics

Newly isolated ventricular myocytes exhibited a normal myofibrillar arrangement at the ultrastructural level. The myocytes were often branched, with three to six arm-like appendages. Cellular length was $162.75 \pm 39 \mu\text{m}$ and width was $16.54 \pm 4.65 \mu\text{m}$.¹⁶ All measurements were taken from formalin-fixed isolated cells on glass slides. The branching of the myocytes may lead to stability in a myocardial wall which consists of narrow trabeculae, whereas hearts from mammals such as the rat have unbranched myocytes in a thick myocardial wall with relatively fewer trabeculae.

Light and electron microscopic observations indicate that most of the myocytes undergo an initial period of morphological disorganization characterized by a rounding up of the cells,¹⁵ followed by a period which involves attachment to the laminin substratum. Although the cells spread out, resume spontaneous contraction and undergo protein synthesis by 10 days in culture, the myofibrillae still appeared to be in varying states of development. With increasing time, the myocytes began to show cytoplasmic vacuoles so that, by day 30, approximately half of the myocytes exhibited vacuoles and many had lipid droplets. In 41-day cultures, beating strands made up of myocytes and nonmyocytes were observed.

DNA Synthesis

DNA synthetic activity in cultures of newt ventriculomyocytes has been studied using a 24-hour exposure to tritiated thymidine, followed by fixation, periodic acid-Schiff (PAS) staining and subsequent autoradiographic analysis.¹⁷ Nuclear labeling was first seen at six days, with 7.5% of the myocytes labeled, increasing to 30.5% at 10 days and gradually declining to 19.4% at 15 days, 16.8% at 20 days and 6.8% at 25 days. Mitotic indices near the peak time were found to be 0.48 ± 0.1 at 8 days, 1.7 ± 0.6 at 10 days and 1.55 ± 0.67 at 12 days. This data corresponds somewhat with that of Reider and Hard,¹⁴ who reported a peak in DNA synthesis and mitosis in newt lung epithelial cells occurring at 14 days after placement in culture, with a mitotic index of 4%.

As the cultures aged, the percentages of both binucleated and multinucleated cells increased.¹ Binucleation was only 0.93% on day 6, but increased to 17.74% on day 25, while multinucleation, with more than two nuclei, occurred only to a

minor degree until day 20, when it reached a level of 6.16% and then increased rapidly to 13.53% at day 25.

Mitosis

Mitotic myocytes are readily observed in 10–15 day cultures. Recently, 26 mitotic myocytes, beginning as mononucleated prophase cells, were videotaped using time-lapse video recording. Although it is difficult to determine accurately the timing of mitosis through the entire cycle, it was found that the average time from nuclear membrane breakdown to midbody formation is 3 hours. Total time observed for the mitotic process was 5 to 6 hours. This timing must be approximate because of difficulty in determining the onset of prophase in phase microscopic observations of living cells. Of the myocytes studied, 81% underwent cytokinesis and 19% formed binucleated daughter cells. The rather lengthy time for myocyte mitosis in this system may be somewhat typical for a differentiated amphibian cell. Reider and Hard¹⁴ have reported that the process in the *Taricha* pneumocyte may be over six hours long.

FIGURE 1, beginning with a mononucleated prophase cell, shows a mitotic sequence which demonstrates that myofibrillae can be observed throughout the entire process which, in this case, resulted in complete cytokinesis with two mononucleated daughter myocytes. FIGURE 2, beginning with a binucleated prophase, shows another mitotic sequence which resulted in two binucleated myocytes. Other types of binucleated mitoses which have been observed include one in which no cytokinesis occurred with the resultant cell being tetranucleated, and another in which one mononucleated cell and one trinucleated cell formed. It would be of utmost interest to be able to understand the mechanisms governing polyploidization both *in vivo* and *in vitro* for the amphibian myocyte, but information relevant to this is not yet available.

As can be seen in FIGURE 1, at the light microscopic level, myofibrils can often be observed throughout the process of mitosis. This has been demonstrated by many investigators^{1,2} and has been shown for the embryonic newt myocyte by Kaneko *et al.*¹⁸ In fact, observations of myocytes with video time-lapse phase microscopy have demonstrated that they may continue to beat throughout most stages of mitosis. However, many appear to cease beating as they pass through metaphase. At the ultrastructural level, it was observed that there was a considerable breakdown in myofibrillae (FIG. 3), which is also indicated by the fact that there is a more diffuse pattern of myosin staining during the mitotic process using MF20. It appears that many myofibrils break down at the Z band level, although perhaps not to the same extent as observed *in vivo*. It is thought that this breakdown and rearrangement might be necessary for the mitotic process and especially for the cytokinetic process.^{1,2}

Other very distinctive changes occur in the cytoskeleton as the cell passes through mitosis.¹⁹ One of the most obvious changes is that most of the cells begin to round up, leaving retraction fibers behind. In many cases, they remain attached to neighboring myocytes with which they continue to beat synchronously. In the cells which show the most rounding, many membranous blebs begin to form at

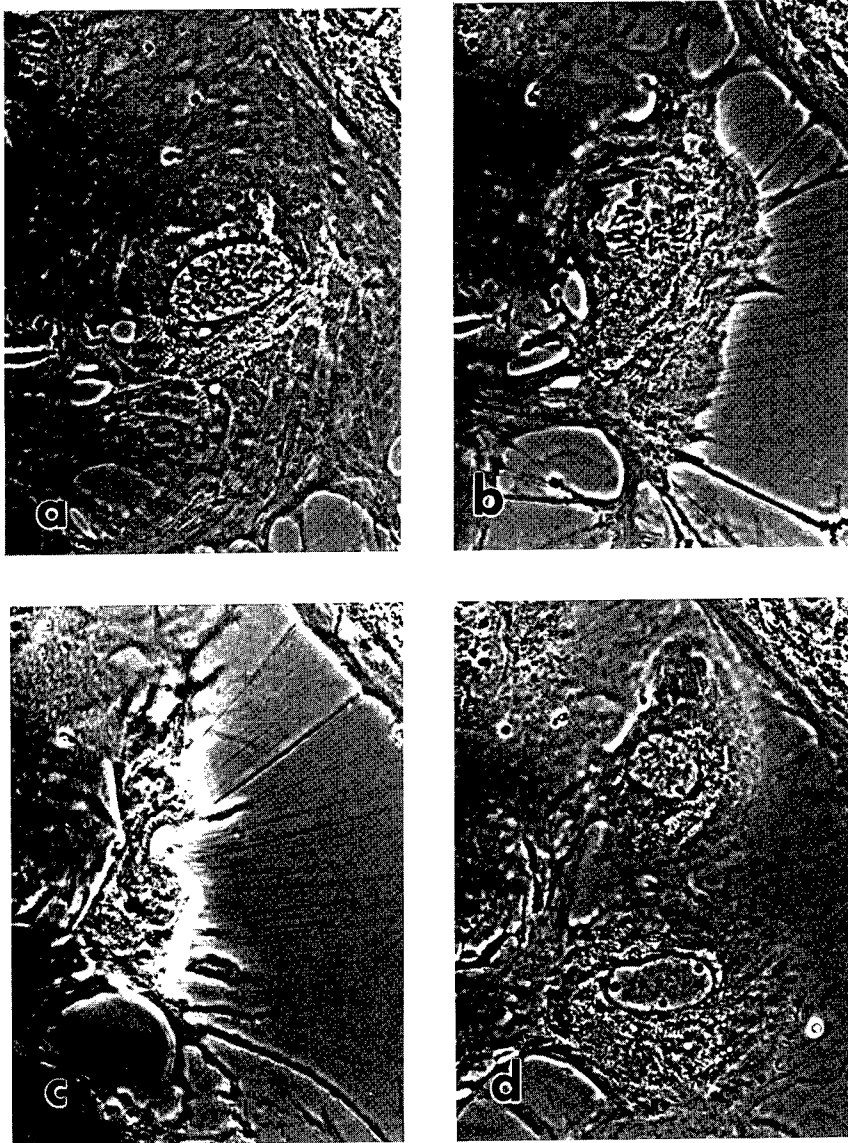

FIGURE 1. Sequence (a–d) of mitosis in a mononucleated cultured myocyte at 12 days in culture. $360\times$. (a) Mononucleated prophase at time 0:00. (b) At metaphase, cell is rounding up, forming retraction fibers at time 1:09. (c) Cell is more rounded, with contractile ring forming at time 2:39. (d) Two mononucleated daughter cells at time 5:36. Time is expressed in hours:minutes.

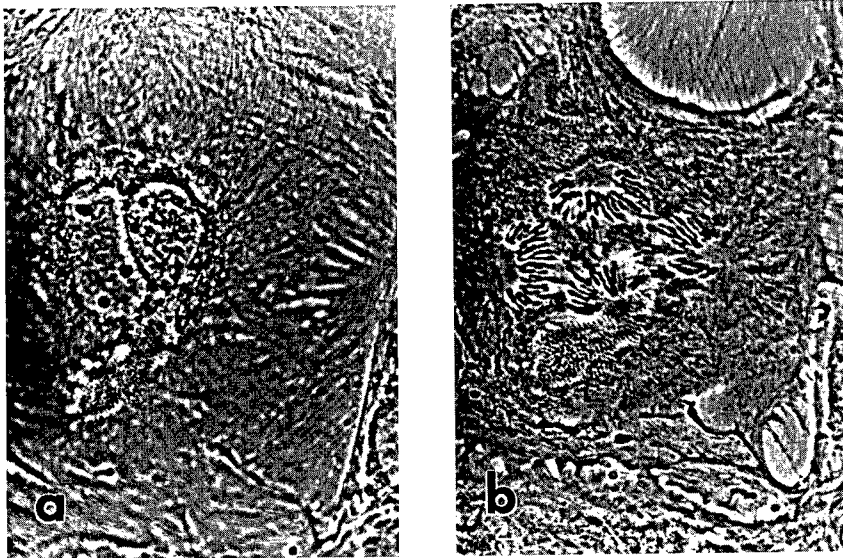

FIGURE 2. Sequence (a–b) of mitosis in a binucleated cultured myocyte at 12 days in culture. 360 \times . (a) Binucleated prophase at time 0:00. (b) Binucleated anaphase with four poles at time 2:20. Time is expressed in hours:minutes.

metaphase and continue to form through anaphase. The function of this process is unknown and may be a phenomenon of culture. At interphase, vimentin filaments are dispersed throughout the cytoplasm and in the area of myofibrillar Z bands, with a dense arrangement around the nucleus. During mitosis, the vimentin staining occurs within the nuclear area and spindle with no Z band staining observed. Desmin staining is observed as a filamentous network throughout the cytoplasm during interphase, with Z band staining and a dense network around the nucleus. In mitosis, desmin forms a cage around the spindle area and staining is more diffuse, without noticeable Z band staining. Staining of a telophase myocyte with rhodamine phalloidin indicates the presence of filamentous actin in the contractile ring area and also in myofibrils (FIG. 4), which are fewer in number than can be observed at interphase (FIG. 5). Mitosis of this differentiated cell thus involves an elaborate series of cytoskeletal changes, which are currently being examined.

Agents Affecting DNA Synthesis

One important aspect of understanding the mechanisms which govern the proliferation of cardiac myocytes is to identify and characterize the actions of the agents involved in this phenomenon and those which influence it. A number of growth factors have been demonstrated to stimulate DNA synthesis in adult rat

ventricular myocyte cultures, including epidermal growth factor (EGF), insulin-like growth factor-1 (IGF-1) and the agent 12-O-tetradecanoyl phorbol-13-acetate (TPA).²⁰ Kardami²¹ has demonstrated that basic fibroblast growth factor (bFGF), IGF-1 and IGF-2 increase DNA synthesis in chick ventricular and atrial cultures and that TGF- β is inhibitory. A number of growth factors have been localized to the cardiac myocyte, including TGF- β ,^{22,23} acidic fibroblast growth factor (aFGF) and basic fibroblast growth factor (bFGF).²⁴ A number of papers dealing with myocyte growth factors are in this volume and are reviewed elsewhere.^{25,26}

Myocyte-Conditioned Medium (MCM)

Since cardiac myocytes have been shown to be associated with certain growth factors, it seemed important to determine if our cultures were able to produce substances which were stimulatory to the system.²⁷ In the first set of experiments, myocyte cultures were fed on days 5, 7, 9 and 11 with medium that was conditioned by cultures of cardiac myocytes which were being maintained in modified L-15 with 10% FBS. The conditioning cultures were the same age as the experimental cultures, or were 7 or 21 days older. Cultures were then exposed to tritiated

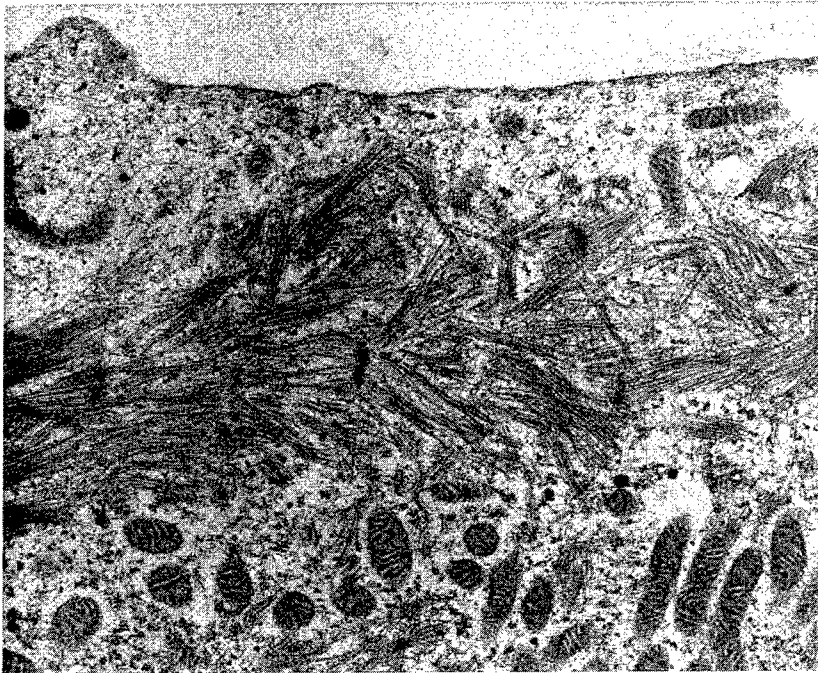

FIGURE 3. Electron micrograph of a metaphase myocyte at 14 days in culture, showing disarray of peripheral myofibrils and apparent loss of Z bands. 12,000 \times .

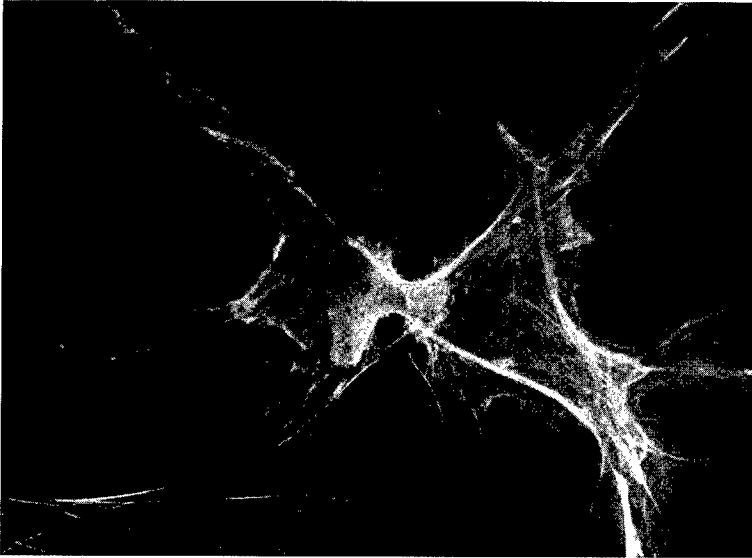

FIGURE 4. Telophase myocyte at 12 days in culture stained with rhodamine phalloidin indicating the presence of filamentous actin in the contractile ring area and in myofibrils. 360 \times .

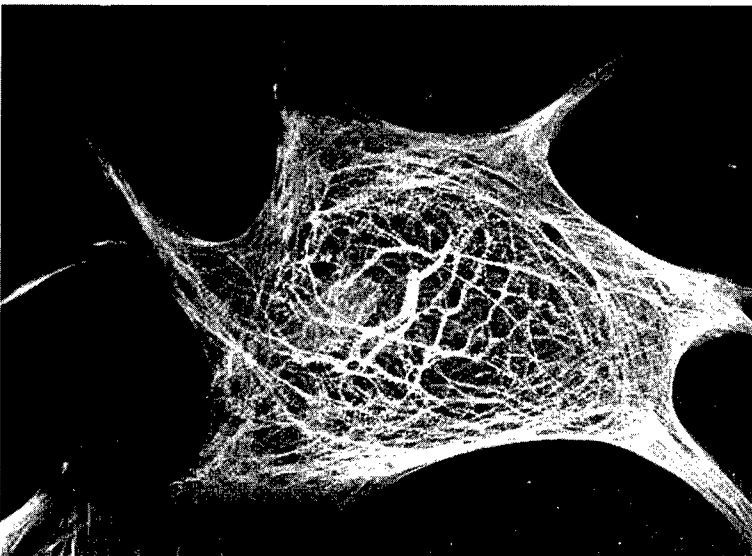

FIGURE 5. Interphase myocyte at 12 days in culture stained with MF-20. 360 \times .

TABLE 2. The Effect of Myocyte (MCM) and Nonmyocyte (NMCM) Conditioned Medium on DNA Synthesis in Cultured Adult Newt Cardiomyocytes^a

Treatment	Age of CM	Effect of CM	CM + Heparin (50 μ g/ml)
MCM	none	100.0 \pm 4.60	14.4 \pm 1.01
	same age	146.7 \pm 6.69	—
	1 week older	160.9 \pm 5.94	—
	3 weeks older	229.7 \pm 17.70	180.6 \pm 11.43
NMCM	none	100.0 \pm 6.54	14.4 \pm 1.01
	same age	172.9 \pm 5.68	—
	1 week older	165.3 \pm 4.75	—
	2 weeks older	148.9 \pm 6.45	75.2 \pm 3.18
	3 weeks older	176.3 \pm 5.48	—
	5 weeks older	177.0 \pm 6.07	—
	6 weeks older	195.4 \pm 52.17	—

^a Cultures received 1 μ Ci/ml tritiated thymidine 24 hours before fixation on day 12. Counts were made of labeled nuclei of periodic acid-Schiff (PAS)-stained myocytes and are expressed as % of controls. All values are significantly different from untreated controls, $p < 0.001$.

thymidine (1 μ Ci/ml) for a period of 24 hours and fixed on day 12 with subsequent PAS staining and processing for autoradiography. The myocyte thymidine index was then determined for mononucleated, binucleated and multinucleated cells. As TABLE 2 indicates, the conditioned medium stimulated DNA synthesis in all cases, with the age of the conditioning cultures correlating positively with the degree of stimulation. Same-day conditioned medium stimulated DNA synthesis to 146.7% of control values, 7-day conditioned medium stimulated to 160.9% of control values and 21-day conditioned medium stimulated to 229.7% of controls. The age correlation may simply have to do with the increased number of cells in the older culture, thus contributing to an increased addition of growth substances to the medium.

Heparin was added to the medium in doses of 25, 50 and 100 μ g/ml and was found to significantly inhibit DNA synthesis in culture to 31.5 \pm 2.77% of controls, 14.4 \pm 0.91% and 9.2 \pm 1.76%, respectively. Heparin (50 μ g/ml) was also added to the medium conditioned by the cultures 21 days older than the experimental group and the thymidine index decreased from 229.7% of controls to 180.6%, a level which was approximately 79% of the unheparinized cultures. This was a significant inhibition of DNA synthesis, but one that was considerably less than was seen in heparin-treated controls. Active agents in the MCM apparently include a large share of nonheparin-sensitive agents which are stimulatory for DNA synthesis.

Nonmyocyte-Conditioned Medium (NMCM)

There is some evidence that nonmyocytes may contribute to the stimulation effects seen in the culture system.^{27,28} We therefore examined the effect of medium which had been conditioned by cultures of nonmyocytes which were saved from

the preplating step. These cells were primarily endothelial, mesothelial, blood and connective tissue cells. The NMCM was obtained from cultures which were the same age as the experimental myocyte cultures and from those which were 1, 2, 3, 5 or 6 weeks older than the myocyte cultures. As seen in TABLE 2, NMCM stimulated DNA synthesis above control values in all the experimental groups. Same-day NMCM increased DNA synthesis to 172.9% of the control values, 1 week to 165.3%, 2 weeks to 148.9%, 3 weeks to 176.3%, 5 weeks to 177% and 6 weeks to 195.4% of control values. There was no significant correlation between the age of the nonmyocyte cultures conditioning the medium and the response obtained from the corresponding NMCM. Experiments were done in which nonmyocytes were grown in the same cultures as the myocytes. This involved elimination of the preplating step and placement of the cell suspensions on laminin-coated plates immediately after the isolation procedure. Myocytes grown in the presence of nonmyocytes routinely had a higher proliferation rate (39.1 to 65.5% higher) than did myocytes grown in relatively pure cultures. This data should be viewed with some caution, since the combined cultures were necessarily grown on laminin from the initial plating time, while the preplated cultures were not placed on laminin until 48 hours later. However, cultures were examined from days 11 to 13 and no differences were seen within the myocyte group (28.8%, 28.5% and 28.3% of myocytes labeled), while the nonmyocyte/myocyte group were consistently higher with 40.1%, 47.7% and 44.2% labeled on days 11, 12 and 13, respectively.

When heparin (50 $\mu\text{g/ml}$) was added to the control cultures, DNA synthesis was reduced to 14.4% of control values, a decrease which is noted routinely for heparin-treated cultures. When heparin was added to the NMCM (from the 2-week older nonmyocytes), the degree of labeling in the experimental myocytes was approximately 50% of the control cultures, a reduction from 148.9% to 75.2% of controls. The decreased labeling indicates that, although a significant amount of the stimulation may be related to heparin-sensitive growth substances, the nonmyocytes seem to be also producing proliferation-stimulating substances which are not sensitive to heparin.

It seems evident that both cultured myocytes and nonmyocytes of newt can produce substances which can stimulate the proliferative process. Attempts are being made currently to isolate the active agents involved in the MCM and NMCM stimulation of DNA synthesis.

Survey of Proliferation-Promoting Substances

A number of agents have been used to determine how they affect DNA synthesis in the cultured adult newt ventricular myocytes.^{27,29,30} In all cases, the general protocol used to test the effect of various agents was the same. Primary cell cultures were fed and maintained in modified L-15 medium with the addition of 10% FBS. All attempts to maintain the cultures in serum-free medium were never more than mildly successful, and therefore all experiments using growth substances involved the addition of FBS to the medium of control and experimental groups.

All cultures were fed on days 5, 7, 9 and 11 with medium (controls) or with

medium supplemented with the appropriate concentrations of the factor being tested. Cultures were then exposed to tritiated thymidine (1 $\mu\text{Ci/ml}$) for a period of 24 hours and fixed on day 12 with subsequent PAS staining and processing for autoradiography. The myocyte thymidine index was then determined for mononucleated, binucleated and multinucleated cells.

The most effective substance used was TPA, which at a concentration of 10 ng/ml resulted in labeling at a level $204.1 \pm 4.71\%$ of that of control untreated myocytes. At 1000 ng/ml, the level was $233.1 \pm 4.26\%$ of controls.²⁷ TPA was also reported to have a stimulatory effect on adult rat ventricular myocytes in culture.^{20,31}

Of the natural agents tested, endothelial cell growth supplement (ECGS) was found to give the highest degree of stimulation of DNA synthesis (TABLE 3). At 500 $\mu\text{g/ml}$, the labeling was $151.0 \pm 4.71\%$ of untreated controls and at 200 $\mu\text{g/ml}$, it was $192.7 \pm 5.32\%$ of controls. The mitotic index at 12 days in culture was 1.5% in control cultures, while it rose to 3.4% in cultures treated with ECGS. This was also noted by Nag *et al.*,³² who found a stimulatory effect of ECGS in their work with cultured embryonic chick myocytes. In addition to an increase in the mitotic index, binucleation in the newt cultures increased to 243.6% of control at 50 $\mu\text{g/ml}$ and to 305.7% of controls at 75 $\mu\text{g/ml}$, indicating that the increase in mitotic activity was accompanied by nuclear division in the myocytes.

Significant stimulation of DNA synthetic activity in cultured newt ventriculo-myocytes, but to a lesser degree than with ECGS, was found with platelet-derived growth factor (PDGF),²⁹ bFGF and aFGF,²⁷ endothelin (ET-1), retinoic acid (RA) and bombesin.³⁰ In the PDGF (porcine) dose-response curve, 1 ng/ml optimally stimulated DNA synthesis to 120% of control values. A time-course study involved feeding experimental cultures with medium supplemented with 1 ng/ml PDGF, while control cultures were fed with modified L-15 and 10% FBS on alternate days (5, 7, 9 and 11). On each of days 6 to 13, groups of control and experimental myocytes were fixed after a 24-hour exposure to tritiated thymidine. This time-course study demonstrated that PDGF stimulated the myocytes above control values on all days tested and that the curve of PDGF-stimulated myocytes peaked

TABLE 3. The Effect of Endothelial Cell Growth Supplement (ECGS) on DNA Synthesis, Mitosis and Binucleation in Cultured Adult Newt Cardiomyocytes^a

Treatment	Nuclear Label ^b	Binucleation ^b	Mitotic Index ^c
0	100.0 \pm 4.12	100.0	1.5
10 $\mu\text{g/ml}$	137.7 \pm 3.94	143.9	—
25 $\mu\text{g/ml}$	134.9 \pm 3.97	171.7	—
50 $\mu\text{g/ml}$	151.0 \pm 4.71	243.6	3.4
75 $\mu\text{g/ml}$	155.7 \pm 4.43	305.7	—
100 $\mu\text{g/ml}$	167.7 \pm 4.20	245.8	—
150 $\mu\text{g/ml}$	190.5 \pm 4.98	245.9	—
200 $\mu\text{g/ml}$	192.7 \pm 5.32	242.3	—

^a Cultures received 1 $\mu\text{Ci/ml}$ tritiated thymidine 24 hours before fixation on day 12. Counts were made of labeled nuclei of periodic acid-Schiff (PAS)-stained myocytes and number of nuclei per myocyte.

^b Expressed as % of controls.

^c Mitotic figures per 100 cells examined with phase microscopy.

and fell off in the same pattern as the control curve does. The stimulation of myocyte DNA synthesis was therefore due to an increase in daily labeling and not due to a temporal shift of the curve seen in the controls.

In a dose-response curve for aFGF,²⁷ all concentrations tested (0.5, 1, 5 and 10 ng/ml) were able to significantly increase myocyte DNA synthesis, with a maximal increase of 128.9% of controls with 1 ng/ml. A similar dose-response curve for bFGF, with concentrations of 0.25, 0.5 and 1 ng/ml, showed that DNA synthesis increased significantly, with a peak at 119.4% of controls at 0.5 ng/ml.²⁷ Concentrations of 10 and 20 ng/ml significantly inhibited DNA synthesis to a level of 89.6% and 88.8% of controls, respectively. The stimulatory effect of aFGF and bFGF has been reported for other ventriculomyocyte culture systems.^{20,21} The inhibitory effect at higher concentrations has not been reported and, in fact, these are in the range reported to be effective in stimulation of DNA synthesis for other systems.^{20,21}

ET-1 was found to significantly stimulate DNA synthesis in a concentration of 10 nM to a level of $124.5 \pm 3.33\%$ of control values (TABLE 4). At 10 nM, binucleation was found to occur at 170.1% of control values, which indicates that, beyond DNA synthesis, mitosis with nuclear division occurred in the stimulated system. Cardiac myocytes have been shown to have receptors for ET-1, which has been demonstrated to induce hypertrophy.^{33,34} ET-1 is known to be secreted by the cardiac myocyte³⁵ and, thus, it may be involved in autocrine and paracrine control of myocyte DNA synthesis.

RA and bombesin were both found to increase DNA synthetic activity in myocyte cultures (TABLE 5). RA induced a maximum DNA synthetic activity of 140% of control values at a concentration of 100 nM. RA has a number of different biological effects. It basically seems to be a differentiating agent,³⁶ which can decrease the rate of DNA synthesis in cultures of the mouse myogenic C2 cell line and chicken satellite cells.³⁷ However, it has been demonstrated to stimulate DNA synthesis in cultured corneal stromal fibroblasts.³⁸

The dose-response curve for bombesin indicates that this agent causes its maximum response at 100 nM, stimulating DNA synthesis to a rate of 120% of controls. Bombesin causes an increase in DNA synthetic activity in other cell types, but has not previously been demonstrated to be active for stimulation of proliferation in the cardiomyocyte. It was first extracted from the skin of the amphibian (frog)

TABLE 4. The Effect of Endothelin (ET-1) on DNA Synthesis and Binucleation in Cultured Adult Newt Cardiomyocytes^a

Treatment	Nuclear Label	Binucleated Myocytes
0	100.0 \pm 3.02	100.0
1 nM	120.8 \pm 2.70	154.6
10 nM	124.5 \pm 3.33	170.1
100 nM	120.1 \pm 3.23	160.1

^a Cultures received 1 μ Ci/ml tritiated thymidine 24 hours before fixation on day 12. Counts were made of labeled nuclei of periodic acid-Schiff (PAS)-stained myocytes and number of nuclei per myocyte. Values are presented as % of controls. All values are significantly different from untreated controls, $p < 0.001$.

TABLE 5. The Effect of Retinoic Acid and Bombesin on DNA Synthesis in Cultured Adult Newt Cardiomyocytes^a

Treatment	Concentration	Nuclear Label
Retinoic acid	untreated	100.0 ± 3.37
	0.01 nM	103.3 ± 1.91
	0.1 nM	108.6 ± 4.83
	10 nM	122.2 ± 1.99***
	100 nM	135.8 ± 2.46***
	1000 nM	123.6 ± 3.65***
Bombesin	untreated	100.0 ± 3.72
	40 nM	94.5 ± 7.80
	100 nM	120.2 ± 3.03*
	150 nM	112.4 ± 6.70
	200 nM	104.6 ± 5.97

^a Cultures received 1 μ Ci/ml tritiated thymidine 24 hours before fixation on day 12. Counts were made of labeled nuclei of periodic acid-Schiff (PAS)-stained myocytes, expressed as % of controls.

*** Values are significantly different from control untreated values at level of $p < 0.001$.

* Values are significantly different from control untreated values at level of $p < 0.05$.

and has been shown to stimulate DNA synthesis and cell division in Swiss 3T3 cells³⁹ and other cell types.

Inhibition of DNA Synthesis

Three substances, heparin, transforming growth factor-beta (TGF- β) and thyroxine (T4), were identified which have a strong inhibitory effect on DNA synthesis in adult newt cardiomyocytes. Heparin is the most inhibitory of these agents at all concentrations used. Soonpaa *et al.*²⁷ reported that, at 25 μ g/ml, the level of DNA synthesis was 31.5% of control values, at 50 μ g/ml it was 14.4% of controls and at 100 μ g/ml it was 9.2% of controls. This inhibitory activity might mean that much of the DNA synthetic activity which occurs normally in these cultures is due to heparin-sensitive factors, or there may be a specific inhibitory action of heparin itself.

TGF- β significantly inhibited DNA synthetic activity in all concentrations (0.01, 1, 2 or 4 ng/ml), but maximum inhibition occurred with 1 ng/ml lowering the DNA synthesis in the system to 38.3% of control values.²⁷ Kardami²¹ found inhibition of DNA synthesis by 2 ng/ml TGF- β in cultures of embryonic cardiomyocytes from 12-day chick embryos and neonatal rat cardiomyocytes. There was more inhibition in the embryonic cultures, which are more active in DNA synthesis than are the adult cells.

T4 inhibits DNA synthesis in cultures of newt ventriculomyocytes. A dose-response curve indicates that at 10 nM, it will reduce the level of DNA synthesis to 39% of control values, while at 100 nM, the level is 55.1% of controls and at 1 μ M it is 46.6% of controls. This hormone is known to favor the expression of myosin isoform V₁, which is characteristic of the terminally differentiated myocyte.⁴⁰ T4 has also been demonstrated to inhibit hyperplastic myocyte growth in neonatal rats.⁴¹

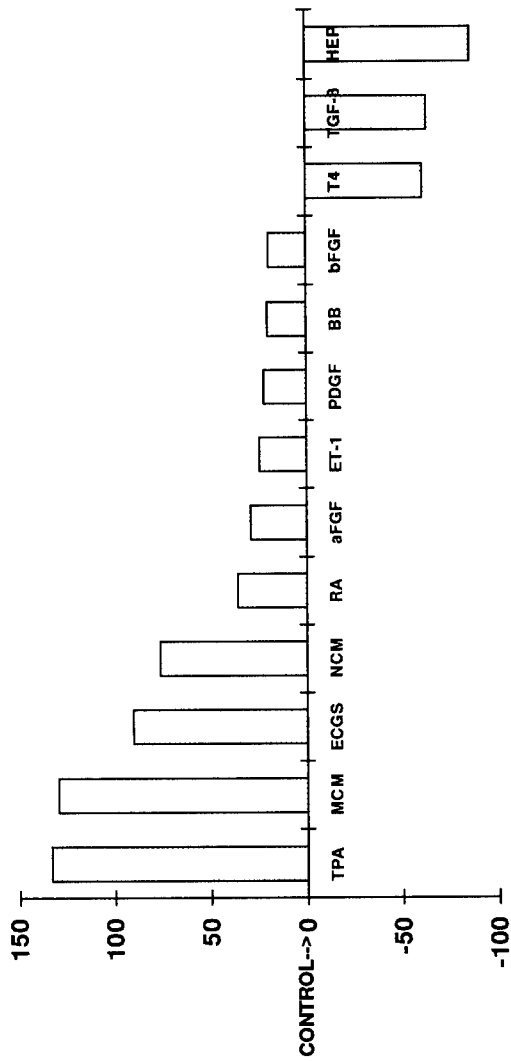

FIGURE 6. Summary of factors affecting DNA synthesis in cultured newt cardiomyocytes. Tritiated thymidine nuclear label was determined on autoradiographs of periodic acid-Schiff (PAS)-stained myocytes after treatments with: 12-0-tetradecanoylphorbol-13-acetate (TPA) at 1 μ g/ml, myocyte conditioned medium (MCM), endothelial cell growth supplement (ECGS) at 150 μ g/ml, nonmyocyte conditioned medium (NCM), retinoic acid (RA) at 100 nM, acidic fibroblast growth factor (aFGF) at 1 ng/ml, endothelin (ET-1) at 10 nM, platelet-derived growth factor (PDGF) at 1 ng/ml, bombesin (BB) at 100 nM, basic fibroblast growth factor (bFGF) at 0.5 ng/ml, thyroxine (T4) at 10 nM, transforming growth factor-beta (TGF- β) at 1 ng/ml and heparin (HEP) at 50 μ g/ml. Values are presented as either % above controls or % below controls.

CONCLUSION

A variety of agents are potent mitogens in this system (FIG. 6). An understanding of how these factors affect the system and an understanding of the interactions between these factors will help elucidate the pathways leading to gene activation for proliferation. Since the newt heart myocyte is a good model of a proliferative adult differentiated cell and it can be easily stimulated and inhibited by various agents, it appears to have great potential for the possible identification and sequencing of proliferative factors. A molecular comparison of stimulated and nondividing cardiac myocytes both *in vivo* and *in vitro* should provide that information, with the ultimate potential of using those factors to manipulate cardiac myocytes of other species.

REFERENCES

1. OBERPRILLER, J. O. & J. C. OBERPRILLER. 1991. Cell division in adult newt cardiac myocytes. *In* The Development and Regenerative Potential of Cardiac Muscle. J. O. Oberpriller, J. C. Oberpriller & A. Mauro, Eds. 293–311. Harwood Academic Publishers. New York.
2. RUMYANTSEV, P. P. 1991. Growth and Hyperplasia of Cardiac Muscle Cells. B. M. Carlson, Ed. Harwood Academic Press. New York.
3. OBERPRILLER, J. O. & J. C. OBERPRILLER. 1974. Response of the adult newt ventricle to injury. *J. Exp. Zool.* **187**: 249–260.
4. McDONNELL, T. J. & J. O. OBERPRILLER. 1984. The response of the atrium to direct mechanical wounding in the adult heart of the newt, *Notophthalmus viridescens*. An electron-microscopic and autoradiographic study. *Cell Tissue Res.* **235**: 583–592.
5. BADER, D. & J. O. OBERPRILLER. 1978. Repair and reorganization of minced cardiac muscle in the adult newt (*Notophthalmus viridescens*). *J. Morphol.* **155**: 349–358.
6. BADER, D. & J. O. OBERPRILLER. 1979. Autoradiographic and electron microscopic studies of minced cardiac muscle regeneration in the adult newt *Notophthalmus viridescens*. *J. Exp. Zool.* **208**: 177–194.
7. OBERPRILLER, J. O., J. C. OBERPRILLER, A. M. AREFYEVA, V. I. MITASHOV & B. M. CARLSON. 1988. Nuclear characteristics of cardiac myocytes following the proliferative response to mincing of the myocardium in the adult newt, *Notophthalmus viridescens*. *Cell Tissue Res.* **253**: 619–624.
8. ZAK, R. 1974. Development and proliferative capacity of cardiac muscle cells. *Circ. Res.* **35** (Suppl. II): 17–26.
9. SANDRITTER, W. & G. SCOMAZZONI. 1964. Deoxyribonucleic acid content (Feulgen photometry) and dry weight (interference microscopy) of normal and hypertrophic heart muscle fibers. *Nature* **202**: 100–101.
10. BRODSKY, V. Y. 1991. Cell ploidy in the mammalian heart. *In* The Development and Regenerative Potential of Cardiac Muscle. J. O. Oberpriller, J. C. Oberpriller & A. Mauro, Eds. 253–292. Harwood Academic Publishers. New York.
11. ANVERSA, P., G. OLIVETTI, E. H. SONNENBLICK, L. G. MEGGS & J. M. CAPASSO. 1991. Myocyte hypertrophy and hyperplasia contribute to wall remodeling in long-term pressure overload cardiac hypertrophy. *In* The Development and Regenerative Potential of Cardiac Muscle. J. O. Oberpriller, J. C. Oberpriller & A. Mauro, Eds. 157–174. Harwood Academic Publishers. New York.
12. NAG, A. C., C. J. HEALY & M. CHENG. 1979. DNA synthesis and mitosis in adult amphibian cardiac muscle cells *in vitro*. *Science* **205**: 1281–1282.
13. NAG, A. C., M. CHENG & C. J. HEALY. 1980. Studies of adult amphibian heart cells *in vitro*: DNA synthesis and mitosis. *Tissue Cell* **12**: 125–139.

14. REIDER, C. I. & R. HARD. 1990. Newt lung epithelial cells: cultivation, use, and advantages for biomedical research. *Int. Rev. Cytol.* **122**: 153–220.
15. TATE, J. M. & J. O. OBERPRILLER. 1989. Primary cell culture and morphological characterization of ventricular myocytes from the adult newt, *Notophthalmus viridescens*. *Anat. Rec.* **224**: 29–42.
16. TATE, J. M., T. J. McDONNELL, J. C. OBERPRILLER & J. O. OBERPRILLER. 1987. Isolation of cardiac myocytes from the adult newt, *Notophthalmus viridescens*. An electron microscopic and quantitative light microscopic analysis. *Tissue Cell* **19**: 577–585.
17. TATE, J. M., J. O. OBERPRILLER & J. C. OBERPRILLER. 1989. Analysis of DNA synthesis in cell cultures of the adult newt cardiac myocyte. *Tissue Cell* **21**: 335–342.
18. KANEKO, H., M. OKAMOTO & K. GOSHIMA. 1984. Structural changes of myofibrils during mitosis of newt embryonic myocardial cells in culture. *Exp. Cell Res.* **153**: 483–498.
19. MATZ, D. G., J. O. OBERPRILLER & J. C. OBERPRILLER. 1992. Characterization of the cytoskeleton of the dividing newt cardiac ventriculomyocyte. *Anat. Rec.* **232**: 57A.
20. CLAYCOMB, W. C. & R. L. MOSES. 1988. Growth factors and TPA stimulate DNA synthesis and alter the morphology of cultured terminally-differentiated adult rat cardiac muscle cells. *Dev. Biol.* **127**: 257–265.
21. KARDAMI, E. 1990. Stimulation and inhibition of cardiac myocyte proliferation *in vitro*. *Mol. Cell. Biochem.* **92**: 129–135.
22. ROBERTS, A. B., M. A. ANZANO, L. C. LAMB, J. M. SMITH & M. B. SPORN. 1981. New class of transforming growth factors potentiated by epidermal growth factor: isolation from non-neoplastic tissues. *Proc. Natl. Acad. Sci. USA* **78**: 5339–5343.
23. CASSCELLS, W., F. BAZOBERY, E. SPEIR, N. THOMPSON, K. FLANDERS, P. KONDAIAH, V. J. FERRANS, S. E. EPSTEIN & M. SPORN. 1990. TGF-beta 1 in normal heart and in myocardial infarction. *Ann. N.Y. Acad. Sci.* **593**: 148–161.
24. CASSCELLS, W., E. SPEIR, J. SASSE, M. KLAGSBRUN, P. ALLEN, M. LEE, B. CALVO, M. CHIBO, L. HAGGROTH, J. FOLKMAN & S. E. EPSTEIN. 1990. Isolation, characterization, and localization of heparin-binding growth factors in the heart. *J. Clin. Invest.* **85**: 433–441.
25. PARKER, T. G. & M. D. SCHNEIDER. 1991. Growth factors, proto-oncogenes, and plasticity of the cardiac phenotype. *Annu. Rev. Physiol.* **53**: 179–200.
26. SCHNEIDER, M. D. & T. G. PARKER. 1990. Cardiac myocytes as targets for the action of peptide growth factors. *Circulation* **81**: 1443–1456.
27. SOONPAA, M. H., J. O. OBERPRILLER & J. C. OBERPRILLER. 1994. Factors altering DNA synthesis in the cardiac myocyte in the adult newt, *Notophthalmus viridescens*. *Cell Tissue Res.* **275**: 377–382.
28. LONG, C. S., C. J. HENRICH & P. C. SIMPSON. 1991. A growth factor for cardiac myocytes is produced by cardiac nonmyocytes. *Cell Reg.* **2**: 1081–1095.
29. SOONPAA, M. H., J. O. OBERPRILLER & J. C. OBERPRILLER. 1992. Stimulation of DNA synthesis by PDGF in the newt cardiac myocyte. *J. Mol. Cell. Cardiol.* **24**: 1039–1046.
30. OBERPRILLER, J. C., J. O. OBERPRILLER & A. ROTHFUSZ. 1993. Stimulation of DNA synthesis in adult newt cardiac myocytes *in vitro*. *Anat. Rec.* **235** (Suppl. 1): 90A.
31. NAG, A. C. 1991. Reactivity of cardiac muscle cells under traumatic conditions. *In The Development and Regenerative Potential of Cardiac Muscle*. J. O. Oberpriller, J. C. Oberpriller & A. Mauro, Eds. 313–331. Harwood Academic Publishers. New York.
32. NAG, A. C., M. INGLAND & M. CHENG. 1985. Factors controlling embryonic heart cell proliferation in serum-free synthetic media. *In Vitro* **21**: 553–562.
33. SUBEITA, H. E., P. M. McDONOUGH, A. N. HARRIS, K. U. KNOWLTON, C. C. GLEMBOTSKI, J. H. BROWN & K. R. CHIEN. 1990. Endothelin induction of inositol phospholipid hydrolysis, sarcomere assembly and cardiac gene expression in ventricular myocytes: a paracrine mechanism for myocardial cell hypertrophy. *J. Biol. Chem.* **265**: 20555–20562.
34. ITO, H., Y. TAKAGI, M. HIROE, M. TSUJINO, S. ADACHI, T. TAKAMOTO, M. NITTA, K. TANIGUCHI & F. MARUMO. 1991. Endothelin-1 induces hypertrophy with enhanced

- expression of muscle-specific genes in cultured neonatal rat cardiomyocytes. *Circ. Res.* **69**: 209–215.
35. SUZUKI, T., T. KUMAZAKI & Y. MITSUI. 1993. Endothelin-1 is produced and secreted by neonatal rat cardiac myocytes *in vitro*. *Biochem. Biophys. Res. Commun.* **191**: 823–830.
 36. ROBERTS, A. B. & M. B. SPORN. 1984. Cellular biology and biochemistry of the retinoids. *In* *The Retinoids*. M. B. Sporn, A. B. Roberts, & D. S. Goodman, Eds. 209–286. Academic Press. Orlando.
 37. HALEVY, O. & O. LERMAN. 1993. Retinoic acid induces adult muscle cell differentiation mediated by the retinoic acid receptor-alpha. *J. Cell. Physiol.* **154**: 566–572.
 38. KIRSCHNER, S. E., A. CIACCIA & J. L. UBELS. 1990. The effect of retinoic acid on thymidine incorporation and morphology of corneal stromal fibroblasts. *Eye Res.* **9**: 1121–1125.
 39. ROZENGURT, E. & J. SINNETT-SMITH. 1983. Bombesin stimulation of DNA synthesis and cell division in cultures of Swiss 3T3 cells. *Proc. Natl. Acad. Sci. USA* **80**: 2936–2940.
 40. NAG, A. C., M. L. LEE & J. R. KOSIUR. 1990. Adult cardiac muscle cells in long-term serum-free culture—myofibrillar organization and expression of myosin heavy chain isoforms. *In Vitro Cell. Dev. Biol.* **26**: 464–470.
 41. GERDES, M. A., J. KRISEMAN & S. P. BISHOP. 1983. Changes in myocardial cell size and number during the development and reversal of hyperthyroidism in neonatal rats. *Lab. Invest.* **48**: 598–602.

Ischemic Cardiomyopathy: Myocyte Cell Loss, Myocyte Cellular Hypertrophy, and Myocyte Cellular Hyperplasia

PIERO ANVERSA,^{a,b,c} JAN KAJSTURA,^a KRZYSZTOF REISS,^a
FEDERICO QUAINI,^a ALESSANDRA BALDINI,^a GIORGIO
OLIVETTI,^a AND EDMUND H. SONNENBLICK^b

^a*Department of Medicine
New York Medical College
Valhalla, New York 10595*

and
^b*Division of Cardiology
Department of Medicine
Albert Einstein College of Medicine
New York, New York 10461*

Cellular Mechanisms of Ventricular Remodeling in Ischemic Cardiomyopathy

Ischemic heart disease is a complex and diverse clinical syndrome in which an imbalance between blood supply and demand is created by complete or partial occlusion of a major epicardial coronary artery, resulting in myocardial infarction and/or multiple isolated sites of tissue injury. In addition, alterations of the intramural arterial branches of the coronary vasculature or defects of the microcirculation may generate varying degrees of ischemia and scattered necrotic myocyte cell death.¹⁻⁸ These types of myocardial damage frequently coexist in the patient population, leading to different forms of cardiac pathology which reflect the characteristics of myocytes loss in the myocardium.⁷⁻¹² On this basis, segmental fibrosis, replacement fibrosis, and interstitial fibrosis have recently been used as quantitative definitions of these aspects of myocyte cell death with collagen accumulation in the ventricular wall. In the human heart, segmental fibrosis has been considered to correspond to a healed myocardial infarct that comprises an area of myocardium greater than one cm², whereas replacement fibrosis has been claimed to describe discrete areas of myocardial scarring developed as a result of focal myocyte cell loss.⁸ These smaller sites of myocardial injury are less than one cm² in size. Finally, interstitial fibrosis reflects widening on the extracellular space with collagen deposition between groups of myocytes, as a consequence of diffuse myocyte cell death in the wall.⁸ Interstitial fibrosis may also occur in the absence of myocytolytic necrosis through activation of fibroblasts via humoral and/or mechanical factors.⁹⁻¹¹

^c Address for correspondence and reprints: Piero Anversa, M.D., Department of Medicine, Vosburgh Pavilion—Room 302, New York Medical College, Valhalla, New York 10595.

Although myocyte loss is the initiating event of acute wall and chamber remodeling following ischemia, the growth processes of the viable myocytes are responsible for the anatomical modifications implicated in the chronic evolution of the cardiomyopathic heart towards end stage failure. Myocyte hypertrophy may involve lengthening, an increase in diameter, or a combination of both which affect differently ventricular size and shape.^{6,7,13,14} These are significant factors because an increase in the longitudinal dimension of myocytes would lead to ventricular dilation and relative thinning of the wall, whereas an expansion in myocyte diameter would result in wall thickening and in an increase in the wall thickness-to-chamber radius ratio.¹⁵⁻¹⁷ When myocyte length and diameter increase proportionally, the augmentation in chamber volume is accompanied by a corresponding increase in wall thickness and a preservation of the ventricular mass-to-chamber volume ratio. If this relationship is not maintained, cavitory size may exceed the growth reaction of the muscle compartment of the myocardium, resulting in a decrease in the ventricular mass-to-chamber volume ratio.

Myocyte proliferation has been shown to participate to the growth adaptation of the injured ventricle, altering cardiac dimension.¹⁸⁻²⁵ In this regard, numerous quantitative morphological studies, published in the last four decades, have provided strong supportive evidence that ventricular myocytes are not terminally differentiated cells and myocyte cellular hyperplasia may constitute a significant component of ventricular remodeling in the human heart.^{18-21,25} Moreover, proliferation of myocytes may be accompanied by little²² or no^{18-21,23,26} myocyte hypertrophy, raising the possibility that myocyte enlargement is self limiting. A relevant aspect of myocyte regeneration concerns the pattern by which new myocytes are formed and integrated within the tissue.^{22,24} A progressive increase in ventricular muscle mass does not necessarily imply an improvement in cardiac pump function. In ischemic heart disease⁸ and other myopathies^{18-21,25} end-stage cardiac failure is commonly characterized by a dilated hypertrophied heart in which the magnitude of myocardial damage is relatively modest, involving at most 20% of the ventricular wall.⁸ The total volume of the spared myocardium may be as much as 2 or 3 times that of a normal heart,¹⁸⁻²⁰ but ventricular function is irreversibly compromised and intractable congestive heart failure ensues. Ventricular dilation has a poor prognostic outcome in ischemic myopathy,²⁷⁻²⁹ and the insertion in series of newly formed myocytes may contribute to the expansion in cavitory volume and the development of the terminal phases of the disease. Therefore, ventricular remodeling in the cardiomyopathic heart of ischemic origin is the consequence of the interaction of myocyte cell loss, myocyte cellular hypertrophy, and myocyte cellular hyperplasia which comprise the major determinants of cardiac anatomy.

Ischemic Cardiomyopathy and Different Forms of Myocardial Damage

A relevant issue in ischemic cardiomyopathy concerns the understanding of the impact of the various types of myocardial injury on ventricular remodeling and cardiac pump function. The clinical spectrum ranges from acute myocardial infarction to chronic ischemic cardiomyopathy. The latter case may take the form

of a dilated myopathy characterized by multiple focal sites of tissue damage in the ventricular wall.⁷ In the most common manifestation, in which scattered foci of replacement fibrosis and diffuse interstitial fibrosis are found in conjunction with a healed infarct, the question remains regarding the pathophysiologic significance of these aspects of myocardial lesions. Until recently, it was unknown whether the segmental loss of myocardium associated with coronary artery occlusion and infarction was the principal determinant of myocyte cell loss, wall thinning, ventricular dilation, and worsening of the hemodynamic performance with time, or whether the multiple isolated sites of replacement fibrosis in the noninfarcted portions of the wall were major factors in the progression of the myopathy.^{2,3,7} Moreover, interstitial fibrosis *per se* has been shown to have a significant detrimental effect on the compliance properties of the ventricle and its mechanical behavior,⁹⁻¹¹ suggesting that this form of myocardial damage may impair ventricular function in ischemic cardiomyopathy.

The contribution of segmental myocardial scarring, replacement fibrosis, and interstitial fibrosis to the accumulation of collagen in the ventricles was recently measured in pathologic hearts affected by ischemic cardiomyopathy.⁸ The quantitative structural characteristics of the myocardium in patients undergoing cardiac transplantation as a result of chronic ischemic heart disease were analyzed and compared with hearts collected at autopsy from normal individuals. As illustrated in FIGURE 1, the volume percent of myocardial scarring associated with healed infarcts was seen to comprise an average 9% of the left ventricular wall, whereas replacement fibrosis involved 14% of the myocardium. Moreover, interstitial fibrosis occupied 6% of the nondamaged tissue. In comparison with normal left ventricles, the relative amounts of replacement and interstitial fibrosis were increased 4-fold and 2-fold, respectively. When the three different forms of myocardial fibrosis were combined, 28% of the ventricular wall was found to be represented by fibrotic tissue. These relative changes produced a significant amount of collagen accumulation in the entire ventricular wall. In the diseased heart, there was a 7.4-fold and 3.7-fold increase in the total volume of replacement and interstitial fibrosis. The expansion of the whole collagen compartment was found to be 8.3-fold. Importantly, the increase in connective tissue exceeded the increase in left ventricular mass, which, in turn, exceeded the expansion in total myocyte volume.⁸ A similar phenomenon was documented at the level of the right ventricle in which the magnitude of replacement and interstitial fibrosis increased 6.9-fold and 4.6-fold. As a whole, connective tissue increased 5.3-fold. In the right ventricle, segmental fibrosis was absent in all cases. Thus, ischemic cardiomyopathy is characterized by accumulation of collagen biventricularly, mostly in the form of replacement and interstitial fibrosis which exceed the magnitude of scarring produced by myocardial infarction and segmental fibrosis.

Although there is general agreement that myocyte loss is the etiological factor of replacement fibrosis in the ventricular wall,^{7,9-12} less clear is the mechanism responsible for activation of the cardiac interstitium, resulting in the accumulation of fibrillar collagen between myocytes. Claims have been made that hormonal and/or hemodynamic overloads⁹⁻¹² may trigger fibroblast proliferation and collagen neosynthesis in the myocardium independent of myocytolytic necrosis and muscle cell loss. However, death of individual myocytes occurs with coronary artery

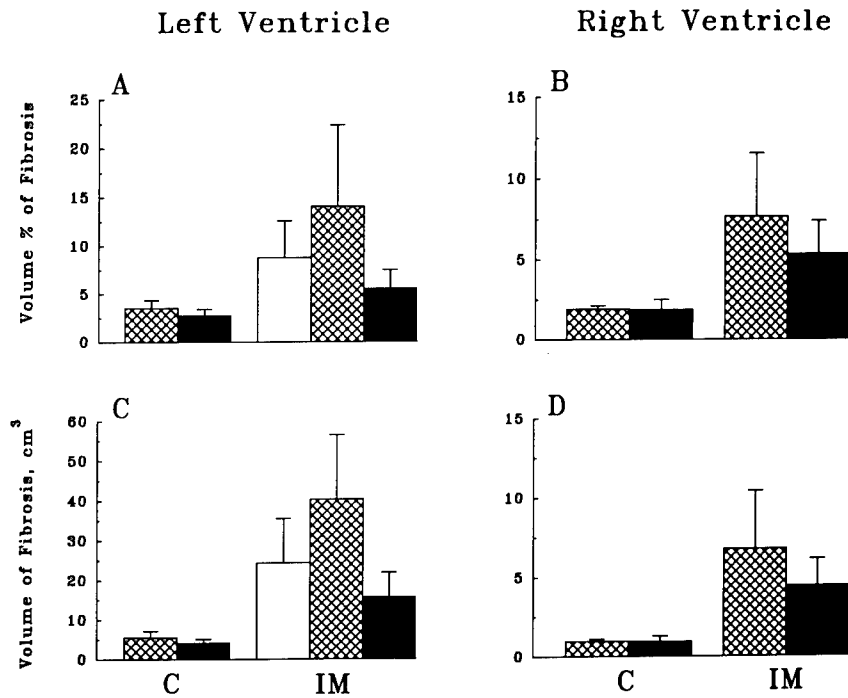

FIGURE 1. Effects of ischemic cardiomyopathy (IM) in humans on myocardial fibrosis in the left and right ventricles. Results are presented as means \pm SD. All changes with IM were statistically significant. C = control hearts; *cross hatched bars* = replacement fibrosis; *solid bars* = interstitial fibrosis; *open bars* = segmental fibrosis.

constriction,⁷ and this phenomenon may stimulate discrete healing processes contributing to the expansion of the interstitium.

In summary, scattered myocyte loss leading to the formation of multiple foci of replacement fibrosis in the myocardium, in combination with interstitial fibrosis, appears to be the major cause of ventricular restructuring in the cardiomyopathic heart of ischemic origin. Myocardial infarction is a consistent determinant of this process, and contributes to the alterations in size and shape of the heart, but it does not represent the principal etiologic factor in the accumulation of collagen in the ventricular wall with the progression of the disease. Replacement and interstitial fibrosis account for nearly 70% of the amount of fibrotic tissue in the myocardium, whereas myocardial infarction comprises approximately 30%.

Ischemic Cardiomyopathy, Myocyte Cell Loss, and Ventricular Performance

In coronary artery disease in humans the severity of the atherosclerotic involvement of the coronary circulation frequently does not correlate with the impairment

of cardiac pump function, so that the anatomic condition is a poor predictor of clinical outcome and mortality of patient population.²⁹⁻³¹ Moreover, pathologic findings in failing hearts indicate that moderate quantities of viable tissue have been lost, at variance with the severity of the clinical picture.^{2,3,8} On the other hand, areas of infarction and multiple isolated sites of replacement fibrosis often coexist, clouding the relative contribution of these two different forms of damage to the development of ventricular dysfunction and failure. In view of the impossibility of analyzing these factors separately in the human heart, animal models have been employed to characterize the pathophysiologic implications of coronary occlusion and a segmental loss of myocytes,³²⁻³⁴ and coronary constriction and a diffuse loss of cells.⁷ The rat model has been utilized because rodents are not affected by coronary atherosclerosis and do not possess coronary collaterals. Under these conditions, the impact of the pattern of myocyte cell loss on cardiac function was established, independently from variables related to the coronary circulation.

A sudden constriction of the left main coronary artery leads acutely and subacutely to left side failure, whereas over time, different changes in ventricular dynamics, ranging from moderate to severe dysfunction and failure, occur.^{7,35,36} A more uniform deterioration in ventricular function becomes apparent during the late evolution of the disease.³⁷ Conversely, occlusion of a major coronary artery, resulting in transmural myocardial infarction, is associated with acute cardiac failure,^{6,13} which persists during the healing process¹⁴ and long thereafter.^{38,39} In addition, the alterations in right ventricular function are fully predictable after infarction, since they reflect the extent of left ventricular decompensation.³⁴ This is not the case with coronary artery constriction. Importantly, no correlation has been found between the extent of constriction of the coronary vessel and the magnitude of ventricular deadadaptation,⁷ whereas a direct relationship exists between infarct size and ventricular performance in animals^{33,34} and humans.²⁸ Although these observations emphasized potential differences between occlusive and nonocclusive coronary artery stenosis, the question remained whether both conditions required a similar magnitude of myocyte loss to generate ventricular dysfunction and failure.

On the basis of quantitative morphological findings, the conclusion has been reached that a loss of myocytes, diffuse throughout the ventricle, has a much greater impact on cardiac performance than an identical loss of cells in a segmental fashion, acutely and chronically.^{7,36} In particular, coronary artery narrowing, associated with a 5% to 10% myocytolytic necrosis, results in left side failure,⁴⁰ whereas a 45% damage of the wall is required for myocardial infarction to induce a comparable impairment in cardiac pump function.¹³ However, a partial recovery in ventricular dynamics occurs chronically with coronary artery constriction, since myocyte losses involving a 10% and 20% of the whole muscle cell population have been found to be accompanied by ventricular dysfunction and failure, respectively.³⁶ In contrast, the hemodynamic characteristics of the heart are not altered by infarcts affecting less than 30% to 35% of myocytes acutely and chronically.^{6,13,28} Moreover, in the presence of a 40% to 50% infarct, ventricular performance does not improve during the evolution of the myopathy.^{6,14,28}

Although the mechanism and extent of acute myocyte cell death with myocar-

dial infarction can be directly related to the obstruction of the supplying coronary artery and interruption of blood flow, studies designed to establish whether myocardial ischemia with coronary artery narrowing plays a primary role on tissue and cellular injury have been elusive. Resting coronary blood flow has been found to be normal, whereas coronary reserve is impaired.⁴⁰ These findings are difficult to interpret because there is little knowledge of the relationship between coronary blood flow levels and local ischemia. There is only one report in which it has been demonstrated that resting coronary blood flow must be reduced to 25% to 50% its control value to produce irreversible myocardial injury, ischemic in nature.⁴¹ Thus, the changes measured following coronary artery constriction are not consistent with ischemic myocyte cell death. It cannot be excluded, however, that vasospasm of the intramural branches of the coronary circulation may occur, resulting in focal areas of myocytolytic necrosis. Moreover, small emboli, originating from the site of constriction, may have occluded comparable vessels downstream.⁴² Other potential mechanisms that have to be considered may involve increased levels of circulating and tissue catecholamines,⁴³ as well as calcium overloading through the activation of surface α_1 -adrenergic receptors and abnormal entry of extracellular calcium.⁴⁴ Finally, the possibility has to be advanced that coronary blood flow determination by the use of radioactive microspheres may not be sensitive enough to detect small areas of ischemia across the ventricular wall.

In view of the difficulties of reconciling the nature and characteristics of myocyte cell death with the alterations in coronary blood flow hemodynamics following coronary artery constriction, the suggestion has been made that acute myocyte damage may develop as a result of the generation of unbearable forces within the myocardium provoking mechanical cell death.⁷ This hypothesis has been advanced in relation to the structural mechanisms implicated in acute ventricular dilation which involves an architectural rearrangement of myocytes with side-to-side slippage of cells within the wall.¹³ In this regard, morphological evidence for single myocyte cell death and necking down of the cell profile has been obtained.⁴⁰ However, foci of myocardial damage affecting a large number of myocytes are also present, indicating that myocardial ischemia may contribute to myocyte loss and the development of the myopathy.⁷ In an attempt to establish whether ischemic myocyte necrosis takes place shortly after coronary artery constriction, a myosin monoclonal antibody was injected in rats and its localization in the myocardium examined 24 hours later.⁴³ As illustrated in FIGURE 2, positive cells were found documenting unequivocally that myocytolytic necrosis with rupture of the cell membrane and irreversible cell damage occurs under this setting. Thus, these preliminary data are consistent with the notion that myocardial ischemia is, at least in part, responsible for myocyte loss after coronary artery narrowing.

Mechanical myocyte cell death falls into the category of programmed cell death or apoptosis.⁴⁵⁻⁴⁷ A prerequisite for its demonstration is the detection of DNA strand breaks in myocyte nuclei in otherwise apparently normal cells. This is because programmed cell death is characterized by an activation of an endogenous endonuclease which leads to endonucleolysis.⁴⁷⁻⁴⁹ DNA degradation triggered by this mechanism is specific to spacer regions, leaving the DNA associated with the nucleosome intact.^{49,50} The detection in the cells of DNA fragments of a size equivalent to nucleosome combined with its multiplicity, *i.e.*, nucleosomal ladder,

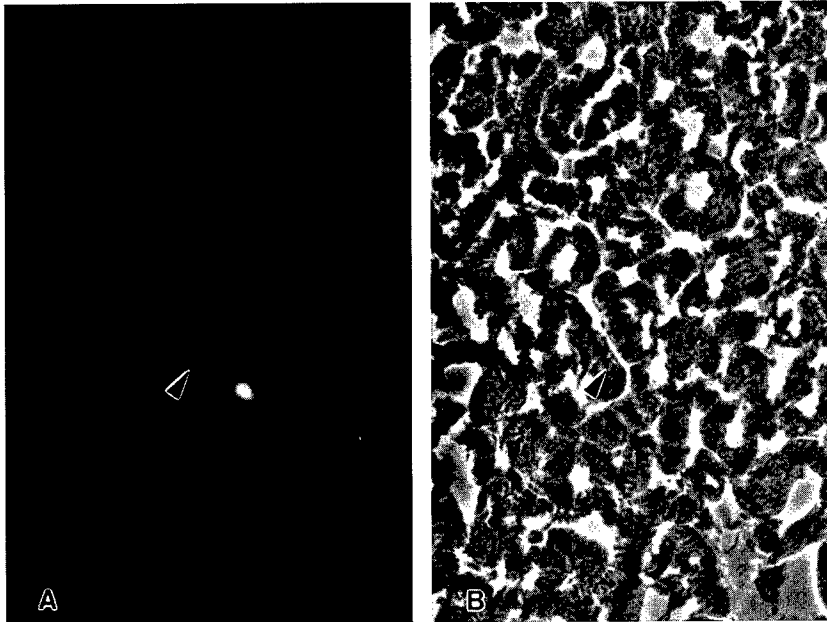

FIGURE 2. (A) myosin monoclonal antibody localization in left ventricular myocytes shortly after coronary artery constriction. (B) illustrates by phase contrast microscopy the same field shown in (A). *Arrowheads* indicate the same myocytes in both panels. Magnification, $\times 400$.

is frequently considered the trademark of apoptosis.⁴⁷ Thus, the occurrence of apoptosis was determined after coronary artery constriction by the detection of endonucleolysis.⁴⁸ Specifically, DNA strand breaks in myocytes were labeled with biotinylated deoxyuridyl triphosphate (dUTP), using exogenous terminal deoxynucleotidyl transferase.⁴⁸

As illustrated in FIGURE 3, programmed myocyte cell death was found in the ventricular myocardium shortly after coronary artery narrowing. In particular, this form of cell death was more frequently encountered in the subendocardium where it involved groups of one to three cell profiles. Such a phenomenon was seen in the midmyocardium and epimyocardium as well. These observations are consistent with the suggestion that physical forces generated by increases in left ventricular end diastolic pressure may induce local myocyte cell death and side-to-side slippage of cells across the wall.⁷ Although the relative contribution of ischemic and nonischemic myocyte cell death to the development of nonocclusive coronary artery constriction-induced cardiac myopathy remains to be evaluated, programmed myocyte cell death may represent the etiologic factor responsible for the chronic loss of myocytes under this setting. Whether apoptosis of myocytes is restricted to the condition of coronary artery narrowing or participates to ventricular remodeling after coronary occlusion and myocardial infarction is an impor-

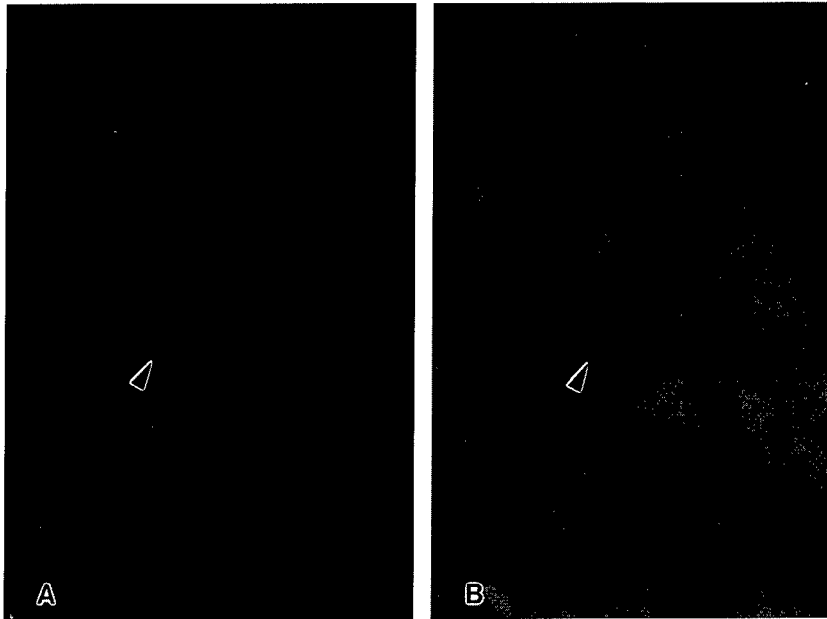

FIGURE 3. (A) Detection of DNA strand breaks by dUTP labeling in a left ventricular myocyte (*arrowhead*) shortly after coronary artery constriction. (B) Myocytes are labeled by anti α -sarcomeric actin. *Arrowhead* indicates the same cell shown in (A). Magnification, $\times 950$.

tant unanswered question. Finally, the possibility may be raised that segmental fibrosis and replacement fibrosis are both mediated by myocyte cell death, ischemic in nature, whereas interstitial fibrosis may be the consequence of activation of interstitial fibroblasts following apoptotic myocyte cell death.

Ischemic Cardiomyopathy, Myocyte Cellular Hypertrophy, and Ventricular Remodeling

The phenomenon of myocyte cell loss in ischemic cardiomyopathy, in a segmental, focal or diffuse pattern, complicates the analysis of the magnitude of reactive growth in the ventricular myocardium. Under these conditions, measurements of ventricular weight changes will provide a significant underestimation of the actual magnitude of hypertrophy at the cellular level. Such a dissociation between the increase in organ weight and the increase in myocyte cell volume has been documented repeatedly in humans^{8,25} and animal models.^{14,36} This relevant problem applies not only to the ischemic cardiomyopathic heart but also to all cardiac disease states characterized by myocyte cell death in the ventricle. In particular, myocyte cell loss has been demonstrated to interfere with the determination of hypertrophic growth in aging,^{23,51} hypertension,²⁶ and coronary artery

constriction and hypertension combined.⁵² Importantly, to the best of our knowledge, heart failure is never encountered in the absence of a considerable degree of myocyte cell death in the myocardium.^{6-8,18-21,25}

Several experimental studies, in which the effects of myocyte loss on cell growth have been analyzed, have indicated that a direct relationship exists between the extent of cell death in the ventricle and the amount of reactive hypertrophy in the remaining viable muscle cells.^{6,36} It should be emphasized, however, that this correlation persists only when ventricular performance is essentially maintained. In contrast, in the presence of acute, subacute and chronic cardiac failure, an additional cellular response has been identified. Under the condition of severe impairment of ventricular function, DNA synthesis myocyte nuclear mitotic division and cellular hyperplasia occur, further complicating the analysis of the cellular mechanisms involved in the reactive growth adaptation of the injured ventricle.^{23,24,53} Myocyte cellular hypertrophy will be discussed here, whereas myocyte proliferation will be addressed subsequently.

In the absence of myocyte proliferation, any loss of cardiac mass from ischemic necrosis can be expected to result in a proportional loss of myocytes followed by the accumulation of a proportional amount of connective tissue scar in the ventricle.⁶ On the other hand, the initial volume of spared myocardium will be proportional to the number of myocytes remaining in the ventricular wall. These relationships are illustrated in FIGURE 4. In particular, FIGURE 4A shows the graphical comparison of the percent of scar tissue in the whole left ventricle versus the total number of myocytes measured in the spared myocardium chronically after infarction in several rats. The regression line demonstrates a significant negative slope indicating that smaller residual number of myocytes are associated with larger infarcts. However, the consequences of infarct size on reactive myocyte growth are illustrated in FIGURE 4B, which documents that larger infarcts are accompanied by a greater cellular hypertrophic response. Importantly, no changes were seen in ventricular weight after infarction, a measurement which would have implied the lack of a growth adaptation in the spared tissue.⁶

The extent more than the pattern of myocyte cell death appears to influence the magnitude of hypertrophy in the unaffected muscle cells.^{6,7} This phenomenon was confirmed following coronary artery constriction in rats³⁶ which resulted in either a 10% or 20% loss of ventricular myocytes over a period of one month (FIG. 4C). Since tissue damage was mostly located in the endomyocardium, the changes in muscle cell volume in this region of the wall were measured and found to indicate a corresponding 39% and 71% increase in myocyte size (FIG. 4D). However, the augmentation in ventricular weight was 23% and 30%, respectively. Thus, different forms of myocyte loss induce comparable degrees of myocyte cellular reactive hypertrophy which are proportional to the magnitude of myocyte loss in the ventricle.

Although myocyte loss and myocyte hypertrophy are important determinants of cardiac anatomy, the changes in myocyte shape are additional relevant factors in ventricular remodeling,^{6,14} since they are the direct consequences of the alterations in ventricular loading.^{15,16} Increasing pressure load in the heart induces concentric ventricular hypertrophy in which wall thickness increases without chamber enlargement.^{15,16} In its compensated form, mural thickening is a result of an in-

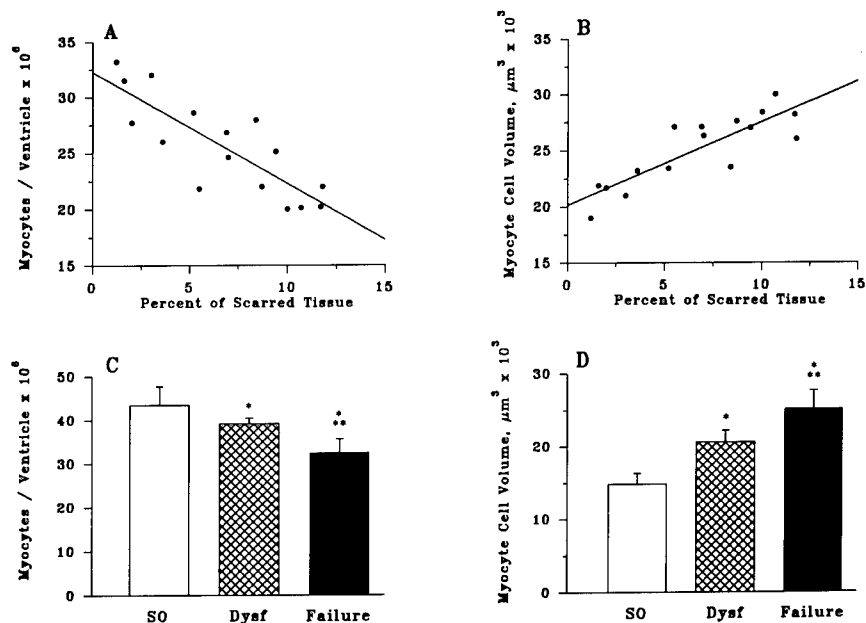

FIGURE 4. (A) Graphical representation of the total number of myocytes vs the volume % of scarred tissue in each infarcted ventricle of the 16 animals studied. (B) Plot of mean cell volume vs the percent of scarred tissue in each of the 16 infarcted ventricles examined. (C) Effects of chronic coronary artery narrowing on the total number of myocytes in the left ventricle. Results are presented as means \pm SD. *Value significantly different from the corresponding result in control animals (SO). **Value significantly different from the corresponding result in animals with left ventricular dysfunction (Dysf). (D) Effects of chronic coronary artery narrowing on myocyte size in the subendocardial layer of the left ventricle. Results are presented as means \pm SD. *Value significantly different from the corresponding result in control animals (SO). **Value significantly different from the corresponding result in animals with left ventricular dysfunction (Dysf).

crease in myocyte diameter with no change in the mural number of myocytes or in the aggregate number of cells in the entire ventricle. On the other hand, an increased volume load typically results in eccentric ventricular hypertrophy in which chamber volume enlarges without a relative increase in wall thickness.^{15,16} Myocyte diameter also increases, so that a modest absolute increase in wall thickness occurs and the ratio of wall thickness-to-chamber radius remains constant. When these relations are not preserved, decompensated concentric and eccentric ventricular hypertrophy develop. In ischemic cardiomyopathy the myocyte cellular reactive response consists of a prevailing increase in myocyte length with respect to diameter leading to ventricular dilation which characterizes the chronic stage of the disease.¹⁴ In addition, the inadequate lateral expansion of myocytes, coupled with diffuse, focal, or segmental myocyte loss, results in mural thinning and an increase in the longitudinal axis of the heart.^{14,36} These anatomical modifications are consistent with eccentric hypertrophy in its decompensated form.

Ischemic Cardiomyopathy, Myocyte Cellular Hyperplasia, and Ventricular Remodeling

The possibility that adult ventricular myocytes are not terminally differentiated cells and possess the capacity to proliferate in response to a hemodynamic overload is a matter of controversy. Although observations in humans^{18,21,25} and animals^{22-24,26,53,54} have indicated that myocyte cellular hyperplasia may occur under a variety of pathological conditions, cardiac myocytes are commonly compared to neurons for their postulated inability to replace damaged myocardium. The bases for these opposing views are not clear, because only limited data are available in animal models favoring the concept that myocytes cannot synthesize DNA and undergo mitotic division,^{55,56} whereas strong evidence has been obtained experimentally and in man supporting the regenerative capacity of these cells.^{18-21,25,57} In addition, recent findings have indicated that cardiac failure, in combination with a marked elevation in diastolic wall stress, may be required for the initiation of this cellular hyperplastic response.⁵⁷ Unfortunately, very little emphasis has been given so far to the hemodynamic state of the heart as a major conditioning factor of the characteristics of myocyte growth. This limitation and the difficulty of establishing the cell of origin in the presence of mitosis^{24,56} may represent the most important reasons for the controversy on the existence of myocyte cellular hyperplasia in the mammalian heart.

Myocardial damage is a consistent component of the failing, ischemic cardiomyopathic heart, and this phenomenon affects the analysis of the cellular processes involved in ventricular remodeling. In particular, the simultaneous presence of myocyte loss complicates the estimation of the amount of newly formed cells in the myocardium by any methodological procedure currently available. The observation that segmental, replacement and interstitial fibrosis are major factors in the restructuring of the ventricle demonstrates that a significant magnitude of myocyte loss has occurred but does not provide a direct indication of its extent at the cellular level.

Myocyte loss is computed from the residual number of viable myocytes in the ventricle which is influenced by myocyte cellular hyperplasia. Thus, myocyte loss results in an underestimation of myocyte cellular hyperplasia in the tissue, whereas myocyte cellular hyperplasia leads to an underestimation of the magnitude of myocyte death in the myocardium.²³⁻²⁵ In an attempt to document that myocytes are not terminally differentiated cells and cell proliferation may occur in ischemic cardiomyopathy, the presence of DNA synthesis and myocyte nuclear mitotic division and the possibility of an absolute increase in myocyte cell number in the left and right ventricular myocardium was examined after coronary artery constriction in rats.²⁴ DNA replication (FIG. 5) and mitosis (FIG. 6) were present in the overloaded myocardium of the left and right ventricles indicating that myocyte cellular hyperplasia contributed to biventricular remodeling under this setting (FIG. 7). Similar findings have been observed after myocardial infarction⁵⁸ in which the activation of the DNA synthetic machinery in the remaining viable myocytes and nuclear mitotic division have been seen to occur initially in the region adjacent to the necrotic tissue and subsequently in the remote myocardium as well.

Chronically after coronary artery constriction, quantitative analyses have been

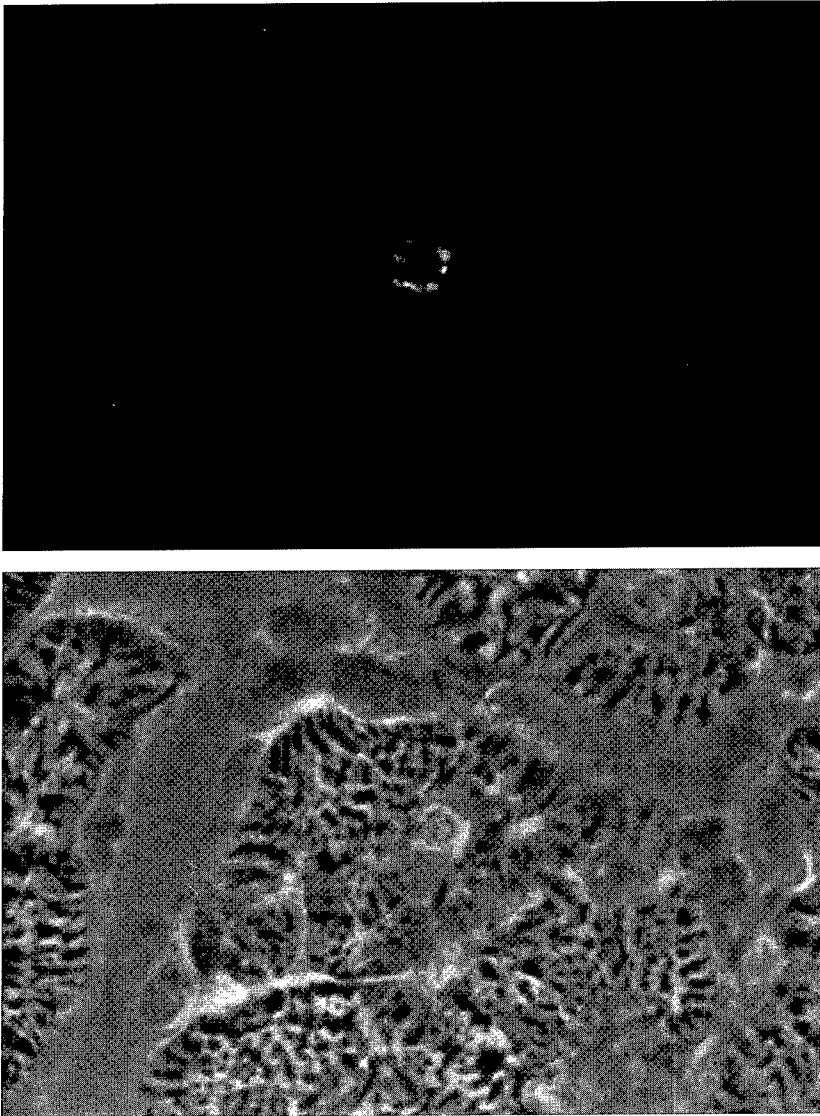

FIGURE 5. Frozen sections of ventricular myocardium illustrating bromodeoxyuridine (BrdU) labeling of a myocyte nucleus one week after coronary artery narrowing. *Top panel* illustrates BrdU labeling by immunofluorescence whereas the *lower panel* shows the same field by phase contrast microscopy and bisbenzimidazole H33258 fluorescence. Magnification, $\times 1,100$.

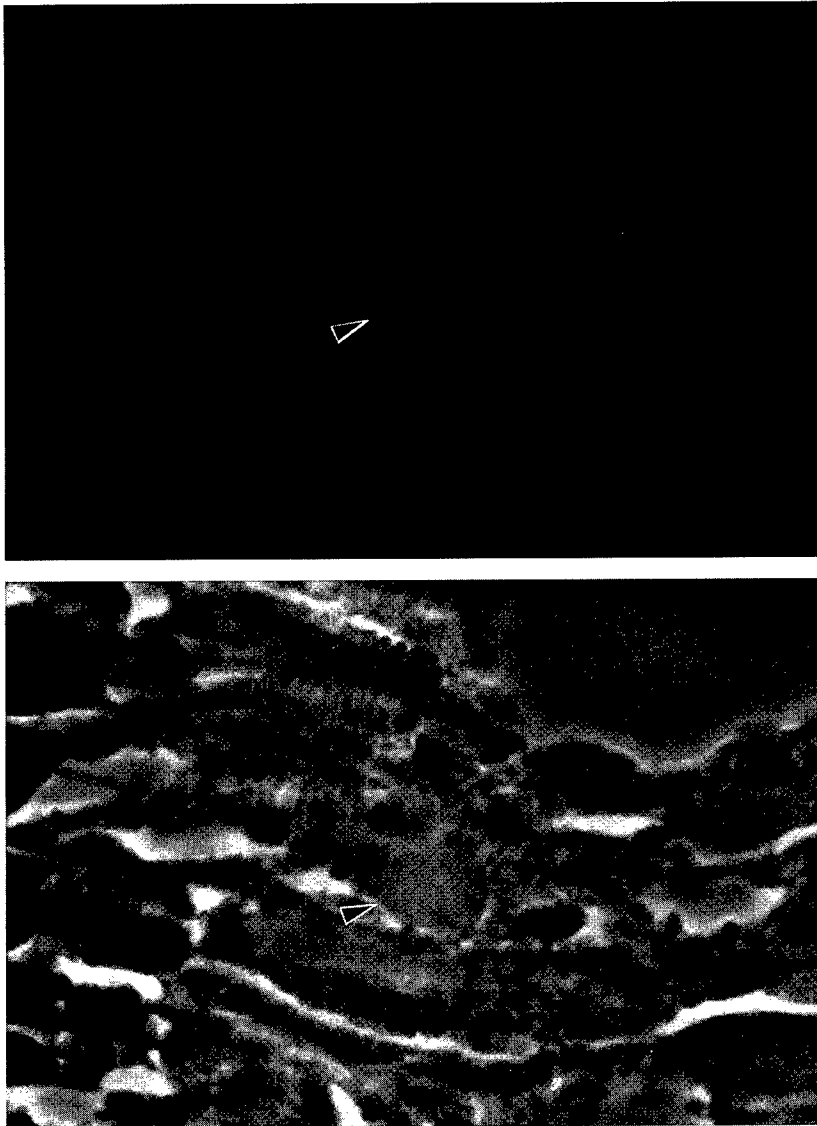

FIGURE 6. Frozen sections of ventricular myocardium from a coronary artery narrowed rat one week after surgery. The animal was injected with colchicine 4 hours prior to sacrifice. A myocyte nucleus undergoing mitosis is illustrated on the *top panel* by bisbenzimidazole H33258 fluorescence and on the *lower panel* by a combination of phase contrast microscopy and bisbenzimidazole H33258 fluorescence. *Arrowheads* indicate the myocyte nucleus undergoing mitosis. Magnification, $\times 1,200$.

able to document a 40% increase in the aggregate number of cells in the right ventricle (FIG. 7), due to a 110% and 36% increase of mononucleated and binucleated myocytes, respectively.²⁴ In contrast, myocyte proliferation in the left ventricle was not associated with an increase in the total number of myocytes (FIG. 7). Myocardial damage and cell loss exceeded the hyperplastic response of muscle cells in this chamber, so that the left ventricle possessed 44% and 32% fewer mononucleated and binucleated muscle cells.²⁴ These losses resulted in a 32% reduction in the number of myocytes in this ventricle (FIG. 7). Such data have been summarized here in order to emphasize the complexity of evaluating the actual magnitude of myocyte cellular hyperplasia when myocyte cell loss is an important component of the pathologic process.

In the presence of chronic coronary artery constriction, the fraction of myocytes synthesizing DNA in the left ventricle has been found to be consistently higher than that in the right ventricle.²⁴ However, as indicated above, the occurrence of myocyte cell death in the left ventricle made it impossible to establish with certainty the magnitude of cellular hyperplasia in this side of the heart. On the other hand, based on the percentage of bromodeoxyuridine (BrdU)-labeled myocytes and the total number of muscle cell nuclei in the right ventricle, an aggregate number of 43,200 BrdU-positive nuclei was calculated for the right ventricle at 1 to 2 weeks after coronary artery stenosis. Such a magnitude of BrdU labeling resulted in the generation of 1.49×10^6 new myocytes at 3 months (FIG. 7). If a similar relation existed in the left ventricle, the corresponding 438,000 BrdU-labeled nuclei at 1 to 2 weeks should have resulted in the accumulation of 15.1×10^6 new myocytes at 3 months. This would imply that coronary artery constriction was accompanied by a 69% increase in the number of left ventricular myocytes during this period. Conversely, cell loss could be calculated to involve 60% of the myocyte population or 13.3×10^6 myocytes.²⁴ Importantly, myocyte

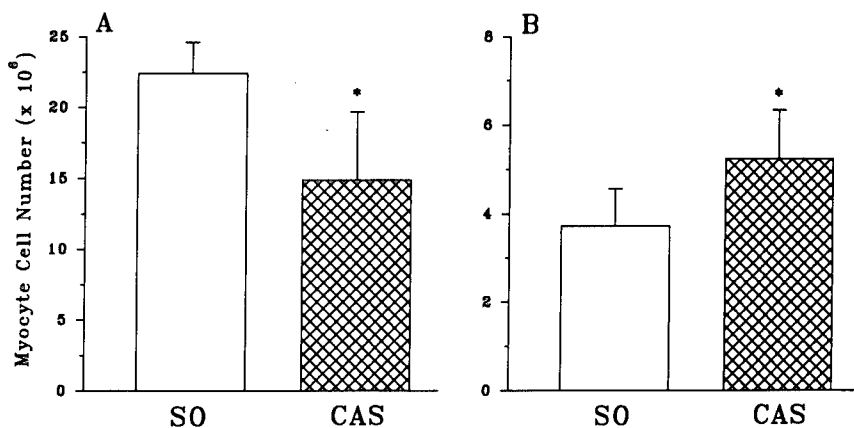

FIGURE 7. Bar graphs showing effects of coronary artery stenosis (CAS) of 3 month duration on the total number of myocytes in the left (A) and right (B) ventricular myocardium. Results are presented as means \pm SD. *Significantly different, $p < 0.05$. SO = sham-operated control animals.



FIGURE 8. Semithin section of plastic-embedded ventricular myocardium obtained from a severely anemic rat with ventricular dysfunction. A mitotic image in a myocyte is shown between two nondividing muscle cells. Toluidine blue staining. Magnification, $\times 1,000$.

cellular hypertrophy was seen to participate in the regenerative response of the cardiac muscle mass resulting in a 49% and 21% increase in the average volume of left and right ventricular myocytes, respectively. Finally, the 40% increase in myocyte cell number in the right ventricle contributed, in part, to wall thickening through the lateral addition of new cells, and, in part, to ventricular dilation through the in-series addition of newly formed cells in the myocardium. A similar adaptation has been found following chronic anemia (FIG. 8)⁵⁴ and myocardial aging.²³

In summary, adult ventricular myocytes can proliferate and this process leads to the restoration of large quantities of muscle cells lost as a result of ischemic injury. The recognition that myocyte loss is a significant variable of cardiac disease processes suggests that myocyte cellular hyperplasia may be present more frequently than expected and masked by the phenomenon of myocyte cell death and tissue injury. Moreover, myocyte proliferation can be characterized by the parallel and in-series addition of new muscle cells leading to wall thickening and/or chamber dilation. Myocyte mitotic division may occur concurrently with cellular hypertrophy and not as a secondary event that takes place after exhaustion of the hypertrophic growth capacity of these cells, as postulated in humans.

REFERENCES

1. ROBERT, W. C. 1976. The coronary arteries and left ventricle in clinically isolated angina pectoris: a necropsy analysis. *Circulation* **54**: 338-390.

2. SCHUSTER, E. H. & B. H. BULCKLEY. 1980. Ischemic cardiomyopathy: a clinicopathologic study of fourteen patients. *Am. Heart J.* **100**: 506–512.
3. PANTELY, G. A. & J. D. BRISTOW. 1984. Ischemic cardiomyopathy. *Prog. Cardiovasc. Dis.* **27**: 95–114.
4. WARNES, C. A. & W. C. ROBERTS. 1984. Sudden coronary death: relation of amount and distribution of coronary narrowing at necropsy to previous symptoms of myocardial ischemia, left ventricular scarring and heart weight. *Am. J. Cardiol.* **54**: 65–73.
5. BUJA, L. M. & J. T. WILLERSON. 1987. The role of coronary artery lesions in ischemic heart disease: insight from recent clinicopathologic, coronary arteriographic, and experimental studies. *Hum. Pathol.* **18**: 451–461.
6. ANVERSA, P. & E. H. SONNENBLICK. 1990. Ischemic cardiomyopathy: pathophysiologic mechanisms. *Prog. Cardiovasc. Dis.* **33**: 49–70.
7. ANVERSA, P., P. LI, X. ZHANG, G. OLIVETTI & J. M. CAPASSO. 1993. Ischemic myocardial injury and ventricular remodeling. *Cardiovasc. Res.* **27**: 145–157.
8. BELTRAMI, C. A., N. FINATO, M. ROCCO, G. A. FERUGLIO, C. PURICELLI, E. CIGOLA, F. QUAINI, E. H. SONNENBLICK, G. OLIVETTI & P. ANVERSA. 1994. Structural basis of end-stage failure in ischemic cardiomyopathy in humans. *Circulation* **89**: 151–163.
9. WEBER, K. T., J. S. JANICKI, S. G. SHROFF, R. PICK, R. M. CHEN & R. I. BASHEY. 1988. Collagen remodeling of the pressure overloaded, hypertrophied nonhuman primate myocardium. *Circ. Res.* **62**: 757–765.
10. WEBER, K. T., J. S. JANICKI, R. PICK, J. M. CAPASSO & P. ANVERSA. 1990. Myocardial fibrosis and pathologic hypertrophy in the rat with renovascular hypertension. *Am. J. Cardiol.* **65**: 1G–7G.
11. WEBER, K. T. & C. G. BRILLA. 1991. Pathological hypertrophy and cardiac interstitium: fibrosis and renin-angiotensin-aldosterone system. *Circulation* **83**: 1849–1865.
12. WHITTAKER, P. & R. A. KLONER. 1991. Ventricular remodeling of the heart. *Curr. Opin. Cardiol.* **6**: 346–351.
13. OLIVETTI, G., J. M. CAPASSO, E. H. SONNENBLICK & P. ANVERSA. 1990. Side-to-side slippage of myocytes participates in ventricular wall remodeling acutely after myocardial infarction in rats. *Circ. Res.* **67**: 23–34.
14. OLIVETTI, G., J. M. CAPASSO, L. G. MEGGS, E. H. SONNENBLICK & P. ANVERSA. 1991. Cellular basis of chronic ventricular remodeling after myocardial infarction in rats. *Circ. Res.* **68**: 856–869.
15. GROSSMAN, W., D. JONES & L. P. McLAURIN. 1975. Wall stress and patterns of hypertrophy in the human left ventricle. *J. Clin. Invest.* **56**: 56–64.
16. GROSSMAN, W., B. A. CARABELLO, S. GUNTHER & M. A. FIFER. 1983. Ventricular wall stress and the development of cardiac hypertrophy and failure. *In: Perspective in Cardiovascular Research: Myocardial Hypertrophy and Failure.* Alpert, N. R., Ed. Vol. 7: 1–18. Raven Press. New York.
17. MCKAY, R. G., M. A. PFEFFER, R. C. PASTERNAK, J. E. MARKIS, G. C. COME, C. NAKAO, J. D. ALDERMAN, J. J. FERGUSON, R. D. SAFIAN & W. GROSSMAN. 1986. Left ventricular remodeling after myocardial infarction: a corollary to infarct expansion. *Circulation* **74**: 693–702.
18. LINZBACH, A. J. 1960. Heart failure from the point of view of quantitative anatomy. *Am. J. Cardiol.* **5**: 370–382.
19. ASTORRI, E., A. CHIZZOLA, O. VISIOLI, P. ANVERSA, G. OLIVETTI & L. VITALI-MAZZA. 1971. Right ventricular hypertrophy: a cytometric study on 55 human hearts. *J. Mol. Cell. Cardiol.* **2**: 99–110.
20. ASTORRI, E., R. BOLOGNESI, B. COLLA, A. CHIZZOLA & O. VISIOLI. 1977. Left ventricular hypertrophy: a cytometric study on 42 human hearts. *J. Mol. Cell. Cardiol.* **9**: 763–775.
21. GRAJEK, S., M. LESIAK, M. PYDA, M. ZAJAC, S. PARADOWSKI & E. KACZMAREK. 1993. Hypertrophy or hyperplasia in cardiac muscle: postmortem human morphometric study. *Eur. Heart J.* **14**: 40–74.
22. OLIVETTI, G., R. RICCI, C. LAGRASTA, E. MANIGA, E. H. SONNENBLICK & P. ANVERSA. 1988. Cellular basis of wall remodeling in long-term pressure overload-induced right ventricular hypertrophy in rats. *Circ. Res.* **63**: 648–657.

23. ANVERSA, P., T. PALACKAL, E. H. SONNENBLICK, G. OLIVETTI, L. G. MEGGS & J. M. CAPASSO. 1990. Myocyte cell loss and myocyte cellular hyperplasia in the hypertrophied aging rat heart. *Circ. Res.* **67**: 871–885.
24. KAJSTURA, J., X. ZHANG, K. REISS, E. SZOKE, P. LI, C. LAGRASTA, W. CHENG, Z. DARZYNKIEWICZ, G. OLIVETTI & P. ANVERSA. 1994. Myocyte cellular hyperplasia and myocyte cellular hypertrophy contribute to chronic ventricular remodeling in coronary artery narrowing-induced cardiomyopathy in rats. *Circ. Res.* **74**: 383–400.
25. OLIVETTI, G., M. MELISSARI, T. BALBI, F. QUAINI, E. H. SONNENBLICK & P. ANVERSA. 1994. Myocyte nuclear and possible cellular hypertrophy contribute to ventricular remodeling in the hypertrophic senescent heart in humans. *J. Am. Coll. Cardiol.* **24**: 140–149.
26. ANVERSA, P., T. PALACKAL, G. OLIVETTI & J. M. CAPASSO. 1990. Hypertensive cardiomyopathy: myocyte nuclei hyperplasia in the mammalian heart. *J. Clin. Invest.* **85**: 994–997.
27. PFEFFER, M. A., G. A. LAMAS, D. E. VAUGHAN, A. F. PARISI & E. BRAUNWALD. 1988. Effect of captopril on progressive ventricular dilation after anterior myocardial infarction. *N. Engl. J. Med.* **319**: 80–86.
28. PFEFFER, M. A. & E. BRAUNWALD. 1990. Ventricular remodeling after myocardial infarction. *Circulation* **81**: 1161–1172.
29. BUJA, L. M. & J. T. WILLERSON. 1981. Clinicopathologic correlates of acute ischemic heart disease syndromes. *Am. J. Cardiol.* **47**: 343–356.
30. HARRISON, D. G., C. W. WHITE, L. F. HIRATZKA, D. B. DOTY, D. H. BARNES, C. L. EASTHAM & M. L. MARCUS. 1984. The value of lesion cross-sectional area determined by quantitative coronary angiography in assessing the physiologic significance of proximal left anterior descending coronary arterial stenosis. *Circulation* **69**: 1111–1119.
31. WHITE, C. W., C. B. WRIGHT, D. B. DOTY, L. F. HIRATZKA, C. L. EASTHAM, D. G. HARRISON & M. L. MARCUS. 1984. Does the visual interpretation of the coronary arteriogram predict physiological significance of a coronary stenosis. *N. Engl. J. Med.* **310**: 819–824.
32. FISHBEIN, M. C., D. MACLEAN & P. R. MAROKO. 1978. Experimental myocardial infarction in the rat. Qualitative and quantitative changes during pathologic evolution. *Am. J. Pathol.* **90**: 57–70.
33. FLETCHER, P. J., J. M. PFEFFER, M. A. PFEFFER & E. BRAUNWALD. 1981. Left ventricular diastolic pressure-volume relations in rats with healed myocardial infarction. *Circ. Res.* **49**: 618–626.
34. PFEFFER, M. A., J. M. PFEFFER, M. C. FISHBEIN, P. J. FLETCHER, J. SPADARO, R. A. KLONER & E. BRAUNWALD. 1979. Myocardial infarct size and ventricular function in rats. *Circ. Res.* **44**: 503–512.
35. CAPASSO, J. M., A. MALHOTRA, P. LI, X. ZHANG, J. SCHEUER & P. ANVERSA. 1992. Chronic nonocclusive coronary artery constriction impairs ventricular function, myocardial structure and cardiac contractile protein enzyme activity in rats. *Circ. Res.* **70**: 148–162.
36. ANVERSA, P., X. ZHANG, P. LI & J. M. CAPASSO. 1992. Chronic coronary artery constriction leads to moderate myocyte loss and left ventricular dysfunction and failure in rats. *J. Clin. Invest.* **89**: 618–629.
37. ANVERSA, P., A. MALHOTRA, X. ZHANG, P. LI, J. SCHEUER & J. M. CAPASSO. 1992. Long-term coronary stenosis in rats: cardiac performance, myocardial morphology and contractile protein enzyme activity. *Am. J. Physiol.* **263**: H117–H124.
38. DEFELICE, A., R. FRERING & P. HORAN. 1989. Time course of hemodynamic changes in rats with healed severe myocardial infarction. *Am. J. Physiol.* **257**: H289–H296.
39. PFEFFER, J. M., M. A. PFEFFER, P. J. FLETCHER & E. BRAUNWALD. 1991. Progressive ventricular remodeling in rat myocardial infarction. *Am. J. Physiol.* **260**: H1406–H1414.
40. CAPASSO, J. M., P. LI & P. ANVERSA. 1991. Nonischemic origin of myocardial damage induced by short-term nonocclusive constriction of the coronary artery in rats. *Am. J. Physiol.* **260**: H651–H661.

41. TOMANEK, R. J., J. C. GRIMES & J. N. DIANA. 1981. Relationship between the magnitude of myocardial ischemia and ultrastructural alterations. *Exp. Mol. Pathol.* **35**: 65-83.
42. FOLTS, J. D., K. GALLAGHER & G. G. ROWE. 1982. Blood flow reductions in stenosed canine coronary arteries: vasospasm or platelet aggregation. *Circulation* **65**: 248-255.
43. BENJAMIN, I. J., E. JALIL, L. B. TAN, K. CHO, K. T. WEBER & W. A. CLARK. 1989. Isoproterenol-induced myocardial fibrosis in relation to myocyte necrosis. *Circ. Res.* **65**: 657-670.
44. SEN, L., B. T. LIANG, W. S. COLUCCI & T. W. SMITH. 1990. Enhanced α_1 -adrenergic responsiveness in cardiomyopathic hamster cardiac myocytes. Relation to the expression of pertussis toxin sensitive G protein and α_1 -adrenergic receptors. *Circ. Res.* **67**: 1182-1192.
45. PEXIEDER, T. 1975. Cell death in the morphogenesis and teratogenesis of the heart. *Adv. Anat. Embryol. Cell Biol.* **51**: 1-100.
46. CLARK, E. B. 1984. Functional aspects of cardiac development. *In Growth of the Heart in Health and Disease*. R. Zak, Ed. 81-103. Raven Press. New York.
47. WYLLIE, A. H. 1992. Apoptosis and the regulation of cell numbers in normal and neoplastic tissue: an overview. *Cancer Metast. Rev.* **11**: 95-103.
48. DARZYNKIEWICZ, Z., S. BRUNO, G. DELBINO, W. GORCZYCA, M. A. HOTZ, P. LASSOTA & F. TRAGANOS. 1992. Features of apoptotic cells measured by flow cytometry. *Cytometry* **13**: 795-808.
49. WYLLIE, A. H., R. G. MORRIS, A. L. SMITH & D. DUNLOP. 1984. Chromatin cleavage in apoptosis: association with condensed chromatin morphology and dependence on macromolecular synthesis. *J. Pathol.* **142**: 67-77.
50. ARRENDTS, M. J., R. G. MORRIS & A. H. WYLLIE. 1990. Apoptosis: the role of endonuclease. *Am. J. Pathol.* **136**: 593-608.
51. OLIVETTI, G., M. MELISSARI, J. M. CAPASSO & P. ANVERSA. 1991. Cardiomyopathy of the aging human heart: myocyte loss and reactive cellular hypertrophy. *Circ. Res.* **68**: 1560-1568.
52. LI, P., X. ZHANG, J. M. CAPASSO, L. G. MEGGS, E. H. SONNENBLICK & P. ANVERSA. 1993. Myocyte loss and left ventricular failure characterise the long term effects of coronary artery narrowing or renal hypertension in rats. *Cardiovasc. Res.* **27**: 1066-1075.
53. REISS, K., J. KAJSTURA, J. M. CAPASSO, T. A. MARINO & P. ANVERSA. 1993. Impairment of myocyte contractility following coronary artery narrowing is associated with activation of the myocyte IGF₁ autocrine system, enhanced expression of late growth related genes, DNA synthesis and myocyte nuclear mitotic division in rats. *Exp. Cell. Res.* **207**: 348-360.
54. OLIVETTI, G., F. QUAINI, C. LAGRASTA, R. RICCI, G. TIBERTI, J. M. CAPASSO & P. ANVERSA. 1992. Myocyte cellular hypertrophy and hyperplasia contribute to ventricular wall remodeling in anemia-induced myocardial dysfunction in rats. *Am. J. Pathol.* **141**: 227-240.
55. MORKIN, E. & T. P. ASHFORD. 1968. Myocardial DNA synthesis in experimental cardiac hypertrophy. *Am. J. Physiol.* **215**: 1409-1413.
56. GROVE, D., K. G. NAIR & R. ZAK. 1969. Biochemical correlates of cardiac hypertrophy. III. Changes in DNA content: the relative contributions of polyploidy and mitotic activity. *Circ. Res.* **25**: 463-471.
57. CAPASSO, J. M., S. BRUNO, P. LI, X. ZHANG, Z. DARZYNKIEWICZ & P. ANVERSA. 1993. Myocyte DNA synthesis with aging: correlation with ventricular loading in rats. *J. Cell Physiol.* **155**: 635-648.
58. REISS, K., J. KAJSTURA, X. ZHANG, P. LI, E. SZOKE, G. OLIVETTI & P. ANVERSA. 1994. Acute myocardial infarction leads to upregulation of the IGF-1 autocrine system, DNA replication, and nuclear mitotic division in the remaining viable cardiac myocytes. *Exp. Cell Res.* **213**: 463-472.

Hamster Cardiomyocytes: a Model of Myocardial Regeneration?^a

A. CARBONE,^b M. MINIERI, M. SAMPAOLESI,
R. FIACCAVENTO, A. DE FEO, P. CESARONI, G. PERUZZI,
AND P. DI NARDO^c

*Laboratory of Cellular and Molecular Cardiology
Department of Internal Medicine
University of Rome "Tor Vergata"
00173 Rome, Italy*

*and
^bInstitute of Pathology
Catholic University
00168 Rome, Italy*

INTRODUCTION

The regenerative potential of cardiomyocytes has been extensively studied only in amphibian hearts. Adult frogs and newts are able to reactive DNA synthesis and mitosis in ventricles after injury or stress^{1,2} and in atria after local³ and ventricular lesions.^{4,5} The ability to regenerate has also been documented in amphibian hearts grafted with minced myocardium and in cultured ventricular myocytes.⁶ The regeneration capability of adult amphibian cardiomyocytes and the effect of growth factors has also been confirmed in culture, as elsewhere reported in this book.

Conversely, only inconclusive results have yet been obtained from attempts to regenerate myocytes in mammalian myocardia after injury or stress. Hyperplastic processes have been suggested to occur in models of post-ischemic cardiomyopathy⁷ and in adult patients with hypertrophic cardiomyopathy.⁸ An exhaustive demonstration of the regenerative potential of mammalian cardiomyocytes has been obtained only *in vitro*. In fact, isolated atrial myocytes obtained from transgenic mice (AT-1) have been shown to reactivate the cell cycle depending on environmental conditions.⁹ This demonstrates that it is possible to modulate the molecular program leading to cell division vs cell differentiation in the mammalian myocardium.

Previous⁸ as well as original observations suggested evaluating the possibility that hyperplastic processes could be involved in the pathophysiology of hypertrophic cardiomyopathy. In this respect, the cardiomyopathic hamster represents a

^a This study was supported in part by National Research Council (CNR) Grants 92.03307.11 and 93.03391.11, and by MURST Grant (60%) 70.200.14.

^c Address for correspondence: Paolo Di Nardo, MD, Laboratory of Cellular and Molecular Cardiology, Department of Internal Medicine, University of Rome "Tor Vergata," I-00173 Rome, Italy.

suitable model of hypertrophic cardiomyopathy¹⁰ that approximates very closely the natural history of the disease in human beings.

Animal Model

Hamster hypertrophic cardiomyopathy is an hereditary disease mainly affecting the cardiac muscle and transmitted by an autosomal recessive gene. All investigations performed on cardiomyopathic hamsters referred to initial studies that pointed out four different phases in the natural history of the cardiomyopathy.¹⁰ In a first phase (up to 40 days of life) the myocardium appears substantially intact. Rare degenerative foci have been described in atria and ventricles. In a second phase necrotic processes progressively invade the myocardium destroying large areas of the muscle (40–100 days of life). The third phase has been reported to be characterized by scarring and hypertrophic processes (100–160 days of life) followed by heart dilation and congestive cardiac failure leading hamsters to death (approx. 250 days of life).

Careful hemodynamic and microscopy studies performed in UM-X7.1 cardiomyopathic hamsters (CMPH) allowed a more detailed characterization of the model. Hemodynamic assessment has shown that the CMPH left ventricular end-diastolic pressure (LVEDP) is significantly increased, while a progressive decrease of the left ventricular peak systolic pressure (LVSP) and $+dP/dt$ occurs only when animals are 150 days old. The increase in the LVEDP provokes structural modification only later in the CMPH life. In fact, a modification of cardiomyocyte mid-nuclear transverse diameter significant for hypertrophy does not occur in CMPH before the age of 210 days. Therefore, hamster cardiomyopathy develops in two phases: during the first phase (40–150 days) the degeneration of the myocardium prevails on damages caused by hemodynamic loading; the second phase (from 150 days to death) is characterized by the effects induced on the cardiovascular system by the hemodynamic overload. Nevertheless, a remarkable increase of ANF gene expression occurs in the ventricular myocardium (notably in the interventricular septum) of nonoverloaded CMPH and determines increased levels of the peptide in the blood stream.¹¹ The pathophysiological relevance of this phenomenon remains to be understood.

Gross and histopathological examination demonstrated that no sign of ischemia were detectable in coronary arteries and/or in the cardiac tissue of hemodynamically nonoverloaded CMPH (*i.e.*, aged less than 150 days). Small degenerative foci are seldom observed in the ventricular myocardium of 20-day-old CMPH. The ventricular myocardium of these animals appears otherwise similar to that of control animals (FIG. 1A). Clusters of small (in respect to the surrounding normal cardiomyocytes), densely packed, noninflammatory cells are present throughout the myocardial tissue when CMPH are 40–120 days old. In fact, these clusters are not present in the heart of 20-day-old CMPH (FIG. 1A), but become visible in 60–70-day-old CMPH and reach their maximal size in 80–90-day-old CMPH (FIG. 1B). Subsequently, clusters reduce their volume (FIG. 1C), while degenerative processes affect cells that are progressively substituted by scars and calcifications (FIG. 1D). Cluster-cells are poorly differentiated, with large, pale nuclei and scant cytoplasm (FIG. 1, FIG. 2). No cross striations are detectable in these cells.

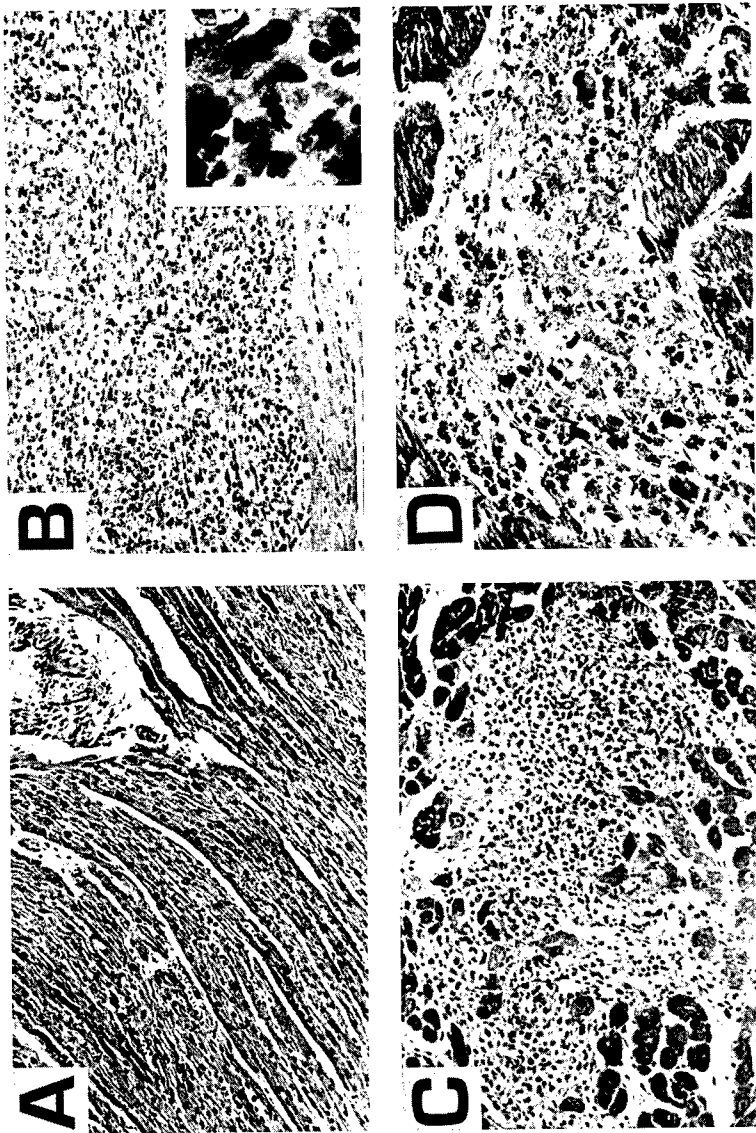

FIGURE 1. Appearance and evolution of cluster-cells in the ventricular myocardium of cardiomyopathic hamsters (CMPH). (A) Left ventricular free-wall of 20-day-old CMPH. Note the regular arrangement of cardiomyocytes with no evidence of cluster-cells (H&E; $\times 200$). (B) Left ventricular free-wall of 90-day-old CMPH. Large agglomerate of poorly differentiated cells with sharp demarcation with the surrounding, apparently normal, myocardium. Nuclei are large, often with vesicular chromatin and nucleolus, with blastic appearance. The cytoplasm is inapparent or scant. High power observation discloses a certain number of mitotic and apoptotic figures (*inset*) (H&E, $\times 200$; *inset*: $\times 1000$). (C) Left ventricular free-wall of 110-day-old CMPH. Cluster-cell volume is decreased. Cells are less packed and no sign of fibrosis or calcification is detectable (H&E; $\times 200$). (D) Left ventricular free-wall of 200-day-old CMPH. Cluster-cells are replaced by fibrosis with calcification spots (H&E; $\times 200$).

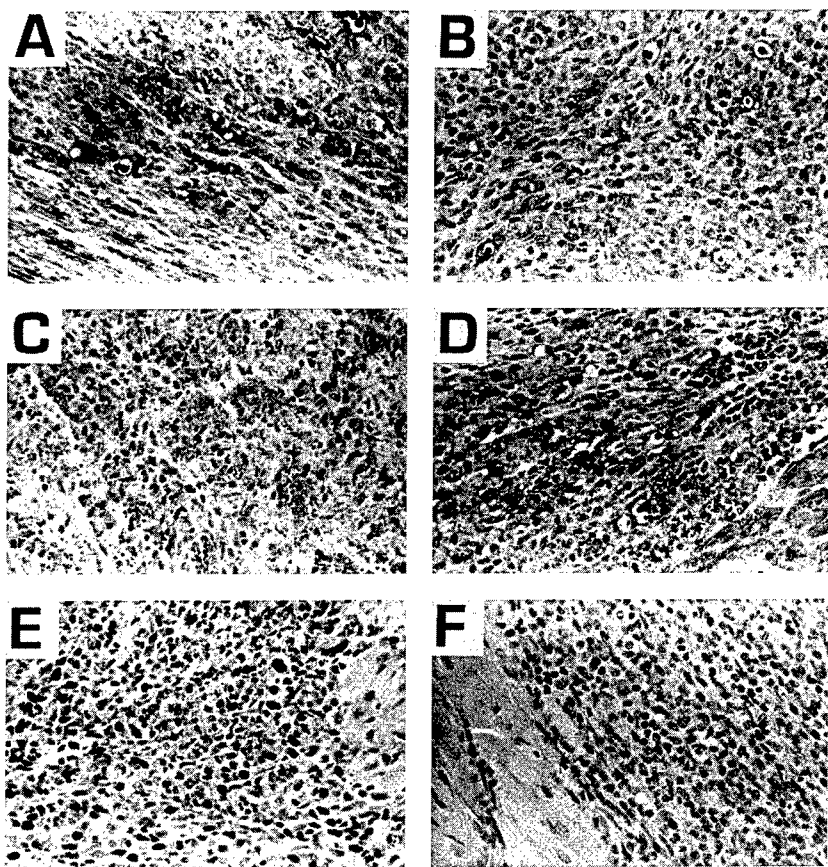

FIGURE 2. Immunohistochemical staining (ABC method) of left ventricular free-wall of 90-day-old cardiomyopathic hamsters. (A) Desmin (DE-U10 mouse monoclonal antibody). The vast majority of the cells in the cluster show clear positivity of the cytoplasm. Note the evidence of "Z" bands in the apparently normal surrounding cardiomyocytes (*left lower corner*). (B) α -Sarcomeric actin (α -Sr-1 mouse monoclonal antibody). A focal reactivity of intermediate intensity is present. In the *central upper portion* of the field a mitosis is observed. (C) Myoglobin (rabbit polyclonal antibody). Coarse and granular positivity in the cytoplasm of most cells. (D) α/γ -Muscle actin (HHF35 mouse monoclonal antibody). Most of the cells show positive reaction. A mitosis is observed in the *central portion* of the field. Apparently, normal cardiomyocytes are evident in the *right lower corner*. (E) PCNA (proliferating cell nuclear antigen; PC-10 mouse monoclonal antibody). Several cells show strong nuclear positivity (*dark nuclei*). (F) Negative control (no primary antibody added). No specific reaction is observed. In the *middle-upper portion* of the field a mitosis is seen. All slides were briefly counterstained with hematoxylin. Original magnification of all micrographs: $\times 400$.

TABLE 1. Immunoreactivity of Myocardial Cluster-Cells in 90-Day-Old Cardiomyopathic Hamsters^a

Antigen	Antibody	Specificity	Reactivity
α -Sarcomeric actin	α -Sr-1	Sk, C	+
α/γ Muscle actin	HHF35	Sk, C, SM	+
Myoglobin	(rPoAb)	Sk, C, (SM)	+
Desmin	DE-U10	Sk, C ("Z" band), SM	+
Factor VIII	(rPoAb)	endothelial cells, MC	-
PCNA (cyclin)	PC-10	cycling cells	+++

^a (rPoAb): rabbit polyclonal antibody; Sk: skeletal; C: cardiac; SM: smooth muscle; MC: megacariocytes.

In cluster-cells of 80–90-day-old CMPH myocardium, several mitoses and apoptotic figures are also present (FIG. 1B, inset).

Hamster Myocardial Hyperplasia

The finding of cluster-cells in the CMPH myocardium has raised the question of their origin. Immunohistochemical analysis demonstrated that cluster-cells show specific immunoreactivity for desmin, α -sarcomeric actin, myoglobin, and α/γ -muscle actin (FIG. 2A, 2B, 2C, and 2D, respectively), while no specific staining is detectable when cluster-cells are challenged with anti-factor VIII antibody (TABLE 1). Desmin is an intermediate filament protein of 53 kd located at "Z" disks of cardiac as well as skeletal muscle (see the longitudinally sectioned normal cells in the lower left corner of FIG. 2A),¹² but is also expressed in nonmuscle cells (*e.g.*, endothelial, stromal and mesangial cells).^{13,14} Myoglobin is a protein found in muscle having a greater affinity for oxygen than hemoglobin. Muscle actin immunoreactivity (HHF35 monoclonal antibody) in cluster-cells reveals the presence of the four muscle actin isoforms (α -SM, α -SK, α -CARD, and γ -SM actins).^{15,16} The immunostaining with anti- α -sarcomeric actin antibody demonstrates that cluster-cells are striated muscle in origin, while the absence of reactivity when cells are challenged with anti-factor VIII antibody excludes that they could be endothelial in origin. Furthermore, the finding that several cluster-cells are active in mitosis and specifically reactive to proliferating cell nuclear antigen (PCNA) antibody (FIG. 2E) demonstrates that cluster-cells are cycling cells. In fact, PCNA is a protein necessary for δ polymerase activity and for DNA leading-strand synthesis, and the increase of its intranuclear concentration could be considered as a marker of cell cycle activation.¹⁷ These results, together with the absence of morphological markers of cardiomyocyte maturation, might suggest that cluster-cells could derive from the proliferation of poorly differentiated myocytes present among differentiated myocardial cells or could result from dedifferentiation processes affecting CMPH cardiomyocytes.

CONCLUSION

The regenerative capability of AT-1 cells demonstrates that mammalian cardiomyocytes could re-enter the cell cycle. CMPH cluster-cells could represent a new

model to study the regenerative potential of mammalian cardiomyocytes. Further investigations are needed to obtain conclusive evidence that cluster-cells are cardiomyocytes in origin and to elucidate basic mechanisms reactivating the regenerative potential. In this respect, the most important future achievement is the selective culture of cluster-cells. This would allow a better understanding of cellular characteristics and the possibility of manipulating environmental parameters as well as cellular genome. Several problems in isolating and placing in culture cluster-cells are still unsolved. In particular, the differential culture of normal cardiomyocytes vs cluster-cells needs new approaches, all procedures already described being substantially not efficient. Cluster-cell culture will permit investigation of molecular mechanisms involved in the reactivation of the cell cycle and the role of autocrine or paracrine effectors in triggering or modulating mitotic activity. Finally, the electrical and mechanical behavior of cluster-cells will be evaluated in order to understand how clusters could impair heart function and provoke the failure of the whole cardiocirculatory system.

ACKNOWLEDGMENTS

The authors are grateful to A. Rinelli and P. Coltellesse for skillful technical assistance.

REFERENCES

1. RUMYANTSEV, P. P. 1973. Post-injury DNA synthesis, mitosis and ultrastructural reorganization of adult frog cardiac myocytes. *Z. Zellforsch.* **139**: 431-450.
2. OBERPRILLER, J. O. & J. C. OBERPRILLER. 1974. Response of the adult newt ventricle to injury. *J. Exp. Zool.* **187**: 249-260.
3. McDONNELL, T. J. & J. O. OBERPRILLER. 1983. The response of the atrium to direct mechanical wounding in the adult heart of newt, *Notophtalmus viridescens*. An electron-microscopic and autoradiographic study. *Cell Tissue Res.* **235**: 583-592.
4. McDONNELL, T. J. & J. O. OBERPRILLER. 1983. The atrial proliferative response following partial ventricular amputation in the heart of the adult newt, *Notophtalmus viridescens*. A light and electron microscopic autoradiographic study. *Tissue Cell* **15**: 351-364.
5. OBERPRILLER, J. O., V. J. FERRANS, T. J. McDONNELL & J. C. OBERPRILLER. 1985. Activation of DNA synthesis and mitotic events in atrial myocytes following atrial and ventricular injury. *In Pathobiology of Cardiovascular Injury*. H. L. Stone & W. B. Weglicki, Eds. 410-421. Martinus Nijhoff Publishing, Boston, MA.
6. OBERPRILLER, J. O. & J. C. OBERPRILLER. 1991. Cell division in adult newt cardiac myocytes. *In The Development and Regenerative Potential of Cardiac Muscle*. J. O. Oberpriller, J. C. Oberpriller & A. Mauro, Eds. 293-311. Harwood Academic Publishers, New York.
7. KAJSTURA, J., X. ZHANG, K. REISS, E. SZOKE, P. LI, C. LAGRASTA, W. CHENG, Z. DARZYNKIEWICZ, G. OLIVETTI & P. ANVERSA. 1994. Myocyte cellular hyperplasia and myocyte cellular hypertrophy contribute to chronic ventricular remodeling in coronary artery narrowing-induced cardiomyopathy in rats. *Circ. Res.* **74**: 383-400.
8. FERRANS, V. J. & J. A. SANCHEZ. 1991. Possible contribution of myocyte hyperplasia to the pathogenesis of hypertrophic cardiomyopathy. *In The Development and Regenerative Potential of Cardiac Muscle*. J. O. Oberpriller, J. C. Oberpriller & A. Mauro, Eds. 175-195. Harwood Academic Publishers, New York.

9. STEINHELPER, M. E., N. A. LANSON, JR., K. P. DRESDNER, J. B. DELCARPIO, A. L. WIT, W. C. CLAYCOMB & L. J. FIELD. 1990. Proliferation *in vivo* and in culture of differentiated adult atrial cardiomyocytes from transgenic mice. *Am. J. Physiol.* **259**: H1826-H1834.
10. JASMIN, G. & L. PROSCHEK. 1982. Hereditary polymyopathy and cardiomyopathy in the Syrian hamster. I. Progression of heart and skeletal muscle lesions in the UM-X7.1 line. *Muscle Nerve* **5**: 20-25.
11. DI NARDO, P., M. MINIERI, A. CARBONE, N. MAGGIANO, R. MICHELETTI, G. PERUZZI & G. TALLARIDA. 1993. Myocardial expression of atrial natriuretic factor gene in early stages of hamster cardiomyopathy. *Mol. Cell. Biochem.* **125**: 179-192.
12. LAZARIDES, E., B. L. GRANGER, D. L. GARD, C. M. O'CONNOR, J. BRECKLER, M. PRICE & S. I. DANTO. 1982. Desmin- and vimentin-containing filaments and their role in the assembly of the Z-disk in the muscle cells. *Cold Spring Harbor Symp. Quant. Biol.* **46**: 351-378.
13. SAPPINO, A. P., W. SCHÜRCH & G. GABBIANI. 1990. Biology of disease. Differentiation repertoire of fibroblastic cells: expression of cytoskeletal proteins as marker of phenotypic modulations. *Lab. Invest.* **63**: 144-161.
14. FUJIMOTO, T. & S. J. SINGER. 1986. Immunocytochemical studies of endothelial cells *in vivo*. I. The presence of desmin only, or of desmin plus vimentin, or vimentin only, in the endothelial cells of different capillaries of the adult chicken. *J. Cell Biol.* **103**: 2775-2786.
15. TSUKADA, T., D. TIPPENS, D. GORDON, R. ROSS & A. M. GOWN. 1987. HHF35, a muscle-actin-specific monoclonal antibody. I. Immunocytochemical and biochemical characterization. *Am. J. Pathol.* **126**: 51-60.
16. TSUKADA, T., M. A. McNUTT, R. ROSS & A. M. GOWN. 1987. HHF35, a muscle-actin-specific monoclonal antibody. II. Reactivity in normal, reactive and neoplastic human tissues. *Am. J. Pathol.* **127**: 389-402.
17. PRELICH, G. P., M. KOSTURA, D. R. MARSHAK, M. B. MATHEWS & B. STILLMAN. 1987. The cell-cycle regulated proliferating cell nuclear antigen is required for SV40 DNA replication *in vitro*. *Nature* **326**: 471-475.

Cardiac Myocyte Terminal Differentiation

Potential for Cardiac Regeneration

S. K. C. TAM,^{a,c} W. GU,^b V. MAHDAVI,^b AND
B. NADAL-GINARD^b

^a*Cardiac Surgical Unit
Massachusetts General Hospital
and*

^b*Department of Cardiology
The Children's Hospital
and*

*Departments of Surgery and Pediatrics
Harvard Medical School
Boston, Massachusetts 02115*

INTRODUCTION

Most mammalian cells are highly differentiated with capacity for specific functions and reside in G₀, a quiescent state. Upon appropriate stimulation, they can re-enter the cell cycle and undergo mitosis. Hepatocytes present a good example of this biologic behavior. However, in skeletal myocytes, the development and maintenance of the differentiated phenotype and entry to the cell cycle appear to be mutually exclusive.¹ That is, cycling myoblasts do not express differentiated phenotype and differentiated mature myocytes permanently withdraw from cell cycle. This process, termed *terminal differentiation*, represents an irreversible commitment to the differentiated phenotype and permanent cell cycle arrest, despite the fact that these cells retain functional growth factor receptors, as shown by their ability to respond by induction of immediate early response gene expression.²

Mammalian myocardial response in developmental growth, to increased workload and to injury is determined by the fact that cardiac myocytes also become terminally differentiated and incapable of undergoing mitosis shortly after the postnatal period.³ In human beings, the capability to undergo mitosis and hyperplasia is lost three to six months postnatally.⁴⁻⁶ For this reason, further response to growth, increased workload, and injury is restricted to increase in cell mass of existing myocytes, *i.e.*, hypertrophy. Hypertrophy, as measured by increase in cell volume, can be as much as 30-40-fold during normal developmental growth.⁷ The molecular mechanism(s) responsible for terminal differentiation, in particular, the cell cycle arrest, in cardiac myocytes is completely unknown. Similar to the skeletal myocytes, growth factor receptors appear to be intact with upregulation

^c Correspondence: Stanley K. C. Tam, M.D., Cardiac Surgical Unit, 300 Mount Auburn Street, Suite 516, Cambridge, MA 02138.

of immediate early response genes, like c-myc, with pressure overload-induced cardiac hypertrophy.⁸

Even though the exact mechanism underlying terminal differentiation is unknown, important biochemical clues were provided by studies of a group of DNA tumor viruses, SV40, polyoma, and adenovirus. These viruses can inhibit and reverse terminal differentiation in skeletal myogenic primary and established cells.⁹ The oncoproteins of these viruses, SV40 T antigen, polyoma T, adenovirus E1A, in addition to papilloma virus E7 have the common property of targeting the retinoblastoma protein (Rb) and related pocket proteins.¹⁰⁻¹³ Rb is a nuclear phosphoprotein which possesses antiproliferative activity that is regulated by phosphorylation. Numerous studies have indicated that Rb is an important cell cycle regulator.¹⁴ The under- or unphosphorylated form of Rb is the active form and is predominant in G1. The hyperphosphorylated form of Rb is the inactive form and is predominant during G1/S phase transition. Rb is also known as pocket protein due to the presence of a sequence called pocket domain, consisting of about 40% of the polypeptide. This pocket domain is necessary for the binding of SV40 T antigen and adenovirus E1A protein.^{10,11,15} By using a temperature-sensitive T antigen¹⁶ and a mutant T antigen that neither binds to the pocket domain of Rb nor transforms cells,^{15,17} it has been convincingly shown that SV40 T antigen renders terminal-differentiated skeletal myocytes responsive to serum growth factor stimulation to re-enter the cell cycle by binding to the pocket domain of Rb, thus inactivating it and at the same time disrupting the binding of MyoD, a member of the basic helix loop helix skeletal myogenic lineage determination gene family,¹⁸⁻²⁰ to Rb.²¹ Furthermore, in homozygous Rb knockout skeletal myocytes, terminal differentiation is readily reversed by growth factor stimulation alone.²² This reversal is blocked by ectopic expression of wild type Rb and is unaffected by Rb that has a mutation in the pocket domain. (unpublished) Taken together, this evidence suggests the critical role that Rb plays in terminal differentiation of skeletal myocytes and that terminal differentiation can be reversed by inactivating Rb.

Pocket Protein Tumor Suppressor Gene Expression in Cardiac Development and Hypertrophy

Rb, a member of the pocket protein family which includes P107²³ and P120,²⁴ is a known antiproliferative protein (tumor suppressor), important in the regulation of G1 phase to S phase progression in the cell cycle.^{14,25,26} As indicated above, in the skeletal muscle system which is more amenable to experimental manipulation, due to the existence of established cell lines, terminal differentiation can be reversed by inactivation of Rb, such that fully differentiated muscle cells (myotubes) re-enter the cell cycle by initiating DNA replication (S phase) in response to growth factor stimulation. Since cardiac myocytes and skeletal myocytes are similar in many respects, Rb may also play an important role in the development and maintenance of terminal differentiation in cardiac myocytes. As a first step in evaluating this hypothesis, the pattern of expression of Rb and its phosphorylation status were evaluated in newborns (less than 24 hours of age) when cardiac myo-

cytes are able to undergo mitosis; in adult and adult hypertrophic rat hearts when myocytes are known to have lost the capacity for hyperplasia. A reliably reproducible model of cardiac hypertrophy in rat was established by ascending aortic banding via a left thoracotomy. This model was characterized by increase in the left ventricular weight to body weight ratio and induction of left ventricular myocyte expression of atrial natriuretic factor.⁸

Protein extracts were obtained from newborn, adult and adult hypertrophic rat hearts. As shown in FIGURE 1, immunoblot with specific anti-Rb antibodies showed that Rb was present in newborn, adult and adult hypertrophic hearts. But Rb appeared to be hyperphosphorylated (inactive) only in newborn hearts where myocytes have the capacity for hyperplastic growth. Rb was underphosphorylated (active) in adult and adult hypertrophic hearts, consistent with the fact that these myocytes were terminally differentiated. The presence of P107, another member of the pocket protein family, was also evaluated by immunoblot in newborn, adult and adult hypertrophic heart protein extracts. Interestingly, as shown in FIGURE 1, P107 was only detectable in the newborn hearts, raising the possibility that P107 is functionally important only in cycling cardiac myocytes. The restricted expression of P107 in cycling cells was also noted in the skeletal muscle system.²² All this is consistent with P107's known association with E2F, a transcription factor which targets many genes that are expressed during S phase;²⁷ cyclin E, a G1/S phase transition cyclin and cyclin A, an S phase cyclin.^{28,29}

Since whole heart protein extracts will include nonmuscle cells as well as muscle cells, the expression of Rb and P107 were evaluated in individual cardiac myocytes using immunohistochemistry. Primary newborn cardiac myocytes were isolated in culture. Myocytes were distinguished from fibroblasts by the presence of myosin heavy chain, a myogenic differentiation marker, using specific anti-myosin heavy chain antibody. Consistent with immunoblot results, Rb and P107 were detected in cardiac myocytes with nuclear staining early in culture, while they were able to enter S phase with DNA replication as determined by their ability to take up bromodeoxyuridine (BrdU). As the cardiac myocytes aged in culture, and failed to take up BrdU, *i.e.*, lost the capacity to undergo mitosis, Rb continued to be present while P107 became undetectable, again consistent with the immunoblot results. Similar immunohistochemical studies were carried out with primary adult cardiac myocytes in culture. As expected, adult cardiac myocytes failed to take up BrdU, immunostained positive for Rb and negative for P107.

Cyclin D and Cyclin-Dependent Kinase 2 (Cdk₂) Expressions in Cardiac Development and Hypertrophy

Based on studies in the skeletal muscle system and results shown above, underphosphorylated Rb may play a critical role in the formation of a blockade which excludes terminally differentiated cardiac myocytes from G1 progression and G1/S transition. In cycling cells, two other cell cycle regulators critical in G1 progression and G1/S transition, namely, cyclin D and Cdk2, respectively, appear to be responsible for breaking down this blockage.

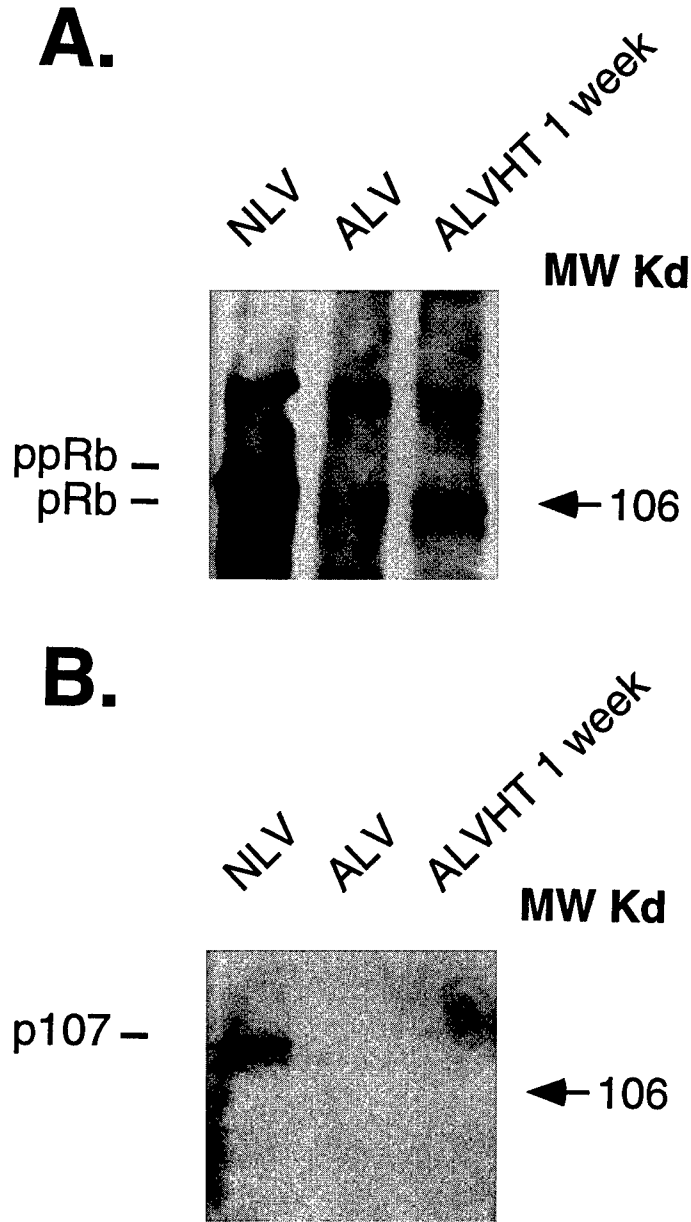

FIGURE 1. Immunoblot of protein extracts from newborn left ventricles (NLV), adult left ventricles (ALV), and adult hypertrophic left ventricles of one week duration (ALVHT 1 week) using specific anti-retinoblastoma protein antibody (**A**) and anti-P107 antibody (**B**). ppRb: phosphorylated or hyperphosphorylated retinoblastoma protein; pRb: un- or under-phosphorylated retinoblastoma protein.

Cyclin D₁, a member of a family that includes at least two other genes, cyclin D₂ and D₃,³⁰ was initially isolated through its ability to complement mutant CLN genes in progression through START, a G1 restriction point, and commit budding yeast to enter S phase.^{31,32} D-type cyclins are found early in G1 when cells are stimulated to enter the cell cycle by growth factors and rapidly disappear upon withdrawal of growth factors.³³ Cyclin D along with Cdk partners appear to be required for G1 progression as a cell enters the cell cycle.³⁴

Cell division cycle (*cdc*) gene and its regulatory subunits, cyclins, controls both G1/S (START) and G2/M transition in yeast.³⁵ In mammalian cells, an homologue to *cdc2*, *cdk2*, is required for G1/S transition.^{36,37} One of the substrates of *cdk2* may well be Rb at the G1/s transition.³⁸ Phosphorylated Rb prevents its interaction with E2F thereby allowing E2F to promote gene expression.²⁷ *Cdk2* activity is regulated by oscillation of cyclin E, its regulatory subunit, in cycling cells while *cdk2*'s level remains unchanged.³⁵

In an attempt to understand why this blockage exists in terminally differentiated but not cycling cardiac myocytes, *i.e.*, what the mechanism is that is responsible for Rb being maintained in its underphosphorylated form in terminally differentiated myocytes, we evaluated cyclin D and *cdk2* expression in newborn, adult, and adult hypertrophic hearts. Protein extracts were obtained. Immunoblot with specific anti-cyclin D and anti-*cdk2* antibody showed that in newborn, cyclin D₁, D₂, and D₃ and *cdk2* were present. However, as terminal differentiation occurs in adult and adult hypertrophic hearts, cyclin D₁ (also possibly D₂) and *cdk2* become undetectable. The pattern of *cdk2* expression through cardiac developmental growth and hypertrophy was confirmed by *in vitro* kinase activity assay using histone H1 as a substrate. Similarly, *cdc2* was only detected in newborn hearts.

SUMMARY

The exact mechanism of terminal differentiation in cardiac myocytes is currently unknown. Studies in the skeletal muscle system provided a model where muscle lineage termination gene directly interacts with Rb to produce and maintain the terminally differentiated state.²¹ This interaction provided the critical components for the lock in cell cycle arrest in skeletal muscle cell. Cardiac muscle appears on the surface very similar to skeletal muscle especially since they share large numbers of structural and contractile proteins. However, it is clear that cardiac muscle cells are distinct biologically at the regulatory level. First and foremost, differentiation and capacity for hyperplasia (mitosis) is not mutually exclusive, in that the heart being the first functional organ embryologically is able to grow via cell division until shortly after birth. Thereafter further growth is provided by hypertrophy. In skeletal muscle, these two processes, differentiation and ability to undergo mitosis, appear to be mutually exclusive. Second, cardiac muscles have not been shown to express any of the skeletal muscle determination basic helix loop helix factors like myoD or any proteins that are functionally similar.³⁹ Third, heterokaryons of cardiac myocytes and fibroblasts reveal a lack of dominance of the cardiac muscle phenotype.⁴⁰ This is distinctly different in skeletal muscle, whose phenotype is dominant which provided a platform to iden-

tify the skeletal muscle determination gene, *myoD*.¹⁸ Although various basic helix loop helix proteins and homeobox genes⁴¹ have been identified in cardiac myocytes, their function remains to be elucidated. At this time no cardiac determination gene has been identified. Despite these differences, we have shown that the biology of pocket proteins Rb and P107 is similar in skeletal and cardiac myocytes. Namely, that Rb is hyperphosphorylated in cycling cells and becomes underphosphorylated during maturation with the loss of the capacity of hyperplasia. Similarly, the P107 expression in cycling cell is downregulated during maturation in both cell types. This raises the possibility that pocket protein is also responsible for the production and the maintenance of terminal differentiation in cardiac myocytes. However, the *myoD* equivalent, *i.e.*, Rb's partner for establishment of the lock in cell cycle arrest in skeletal muscle, has not been identified in cardiac myocytes.

Since D type cyclins contain a sequence motif that is shared by Rb binding viral oncoproteins and have been shown to interact directly with Rb facilitating its phosphorylation^{42,43} and perhaps competing with its binding to E2F, the downregulation of cyclin D and *cdk₂* may well be the upstream mechanism which maintain Rb in its underphosphorylated form in terminally differentiated cardiac myocytes. As a result, reversal of terminal differentiation in cardiac myocytes may be able to be achieved by manipulation of pocket proteins and/or cyclin D and *cdk₂* expression and function, thus achieving cardiac regeneration.

REFERENCES

1. NADAL-GINARD, B. 1978. Commitment, fusion, and biochemic differentiation of a myogenic cell line in the absence of DNA synthesis. *Cell* **15**: 855–864.
2. ENDO, T. & B. NADAL-GINARD. 1986. Transcriptional and posttranscriptional control of *c-myc* during myogenesis: its mRNA remains inducible in differentiated cells and does not suppress the differentiated phenotype. *Mol. Cell. Biol.* **6**: 1412–1421.
3. ZAK, R. 1974. Development and proliferative capacity of cardiac muscle cells. *Cir. Res. Suppl.* **2**: 17–26.
4. BROWN, A. L. 1971. Morphologic factors in cardiac hypertrophy. *In Cardiac Hypertrophy*. N. R. Alpert, Ed. 11–18. Academic Press. New York.
5. KATZBERG, A. A., B. B. FARMER & R. A. HARRIS. 1977. The predominance of binucleation in isolated rat heart myocytes. *Am. J. Anat.* **149**: 489–495.
6. LIMAS, C. J. 1978. Myocardial nuclear protein kinases during postnatal development. *Am. J. Physiol.* **234**: H338–H344.
7. OPARIL, S. 1985. Pathogenesis of ventricular hypertrophy. *J. Am. Coll. Cardiol.* **5**: 57B–65B.
8. IZUMO, S., B. NADAL-GINARD & V. MAHDAVI. 1988. Protooncogene induction and reprogramming of cardiac gene expression produced by pressure overload. *Proc. Natl. Acad. Sci.* **85**(2): 339–343.
9. ENDO, T. & B. NADAL-GINARD. 1989. SV40 large T-antigen induces re-entry of terminally differentiated myotubes into the cell cycle. *In The Cellular and Molecular Biology of Muscle Development*. L. H. Kedes & F. E. Stockdale, Eds. 95–104. A. R. Liss, Inc. New York.
10. DECAPRIO, J. A., J. W. LUDLOW, J. FIGGE, J. Y. SHEW, C. M. HUANG, W. H. LEE, E. MARSILIO, E. PAUCHA & D. M. LIVINGSTON. 1988. SV40 large tumor antigen forms a specific complex with the product of the retinoblastoma susceptibility gene. *Cell* **54**: 275–283.
11. WHYTE, P., K. J. BUCKOVICH, J. M. HOROWITZ, S. H. FRIEND, M. RAYBUCK, R. A.

- WEINBERG & E. HARLOW. 1988. Association between an oncogene and an anti-oncogene: the adenovirus E1A proteins bind to the retinoblastoma gene product. *Nature* **334**: 124–127.
12. DYSON, N., P. M. HOWLEY, K. MUENGER & E. D. HARLOW. 1989. The human papillomavirus-16 E7 oncoprotein is able to bind to the retinoblastoma gene product. *Science* **243**: 934–940.
 13. DYSON, N., R. BERNARDS, S. H. FRIEND, L. R. GOODING, J. A. HASEL, E. O. MAJOR, J. M. PIPAS, T. VAN DYKE & E. HARLOW. 1990. Large T-antigens of many polyoma viruses are able to form complexes with the retinoblastoma protein. *J. Virol.* **64**: 1353–1356.
 14. MARSHALL, C. J. 1991. Tumor suppressor genes. *Cell* **64**: 313–326.
 15. KAELIN, W. G., JR., M. E. EWEN & D. M. LIVINGSTON. 1990. Definition of the minimal simian virus 40 large T antigen- and adenovirus E1A-binding domain in the retinoblastoma gene product. *Mol. Cell. Biol.* **10**: 3761–3769.
 16. TEGTMEYER, P. & H. L. OZER. 1971. Temperature sensitive mutant of simian virus 40 infection of permissive cells. *J. Virol.* **8**: 516–524.
 17. CHEN, S. & E. PAUCHA. 1990. Identification of a region of simian virus 40 large T antigen required for cell transformation. *J. Virol.* **64**: 3350–3357.
 18. OLSON, E. N. 1990. MyoD family: a paradigm for development? *Genes Dev.* **4**: 1454–1461.
 19. WEINTRAUB, H., R. DAVIS, S. TAPSCOTT, M. THAYER, M. HOLLENBERG, Y. ZHUANG, & A. LASSAR. 1991. The myoD gene family: nodal point during specification of the muscle cell lineage. *Science* **251**: 761–766.
 20. TAPSCOTT, S. J. & H. WEINTRAUB. 1991. MyoD and the regulation of myogenesis by helix-loop-helix proteins. *J. Clin. Invest.* **87**: 1133–1138.
 21. GU, W., J. W. SCHNEIDER, G. CONDORELLI, S. KAUSHAL, V. MAHDAVI & B. NADALGINARD. 1993. Interaction of myogenic factors and the retinoblastoma protein mediates muscle cell commitment and differentiation. *Cell* **72**: 309–324.
 22. SCHNEIDER, J. W., W. GU, L. ZHU, V. MAHDAVI & B. NADALGINARD. 1994. Reversal of terminal differentiation mediated by p107 in Rb^{-/-} muscle cells. *Science* **264**: 1467–1470.
 23. ZHU, L., S. VAN DEN HEUVEL, K. HELIN, A. FATTAEY, M. EWEN, D. LIVINGSTON, N. DYSON & E. HARLOW. 1993. Inhibition of cell proliferation by p107, a relative of the retinoblastoma protein. *Genes Dev.* **7**: 1111–1125.
 24. MAYOL, X., X. GRANA, A. BALDI, N. SANG, Q. HU & A. GIORDANO. 1993. Cloning of a new member of the retinoblastoma gene family (pRb2) which binds to the E1A transforming domain. *Oncogene* **8**: 2561–2566.
 25. WEINBERG, R. A. 1991. Tumor suppressor genes. *Science* **254**: 1138–1146.
 26. GOODRICH, D. W., N. P. WANG, Y.-W. QIAN, E. Y.-H. P. LEE & W.-H. LEE. 1991. The retinoblastoma gene product regulates progression through the G1 phase of the cell cycle. *Cell* **67**: 293–302.
 27. NEVINS, J. R. 1992. E2F: a link between the Rb tumor suppressor protein and viral oncoproteins. *Science* **258**: 424–429.
 28. LEES, E., B. FAHA, V. DULIC, S. I. REED & E. HARLOW. 1992. Cyclin E/cdk₂ and cyclin A/cdk₂ kinases associate with p107 and E2F in a temporally distinct manner. *Genes Dev.* **6**: 1874–1885.
 29. EWEN, M. E., B. FAHA, E. HARLOW & D. M. LIVINGSTON. 1992. Interaction of p107 with cyclin A independent of complex formation with viral oncoproteins. *Science* **255**: 85–87.
 30. MATSUSHIME, H., M. F. ROUSSEL, R. A. ASHMUN & C. J. SHERR. 1991b. Colony-stimulating factor 1 regulates novel cyclins during the G1 phase of the cell cycle. *Cell* **65**: 701–713.
 31. REED, S. I. 1991. G1-specific cyclins: in search of an S-phase-promoting factor. *Trends Genet.* **7**: 94–99.
 32. LEW, D. J., V. DULIC & S. I. REED. 1991. Isolation of three novel human cyclins by rescue of G1 cyclin (Cln) function in yeast. *Cell* **66**: 1197–1206.
 33. MATSUSHIME, H., M. E. EWEN, D. K. STROM, J.-Y. KATO, S. K. HANKS, M. F. ROUSSEL

- & C. J. SHERR. 1992. Identification and properties of an atypical catalytic subunit (p34^{PSKJ33}/cdk4) for mammalian D type G1 cyclins. *Cell* **71**: 323-334.
34. SHERR, C. J. 1993. Mammalian G₁ cyclins. *Cell* **73**: 1059-1065.
 35. NORBURY, C. & P. NURSE. 1992. Animal cell cycles and their control. *Annu. Rev. Biochem.* **61**: 441-470.
 36. FANG, F. & J. W. NEWPORT. 1991. Evidence that the G1-S and G2-M transitions are controlled by different cdc₂ protein in higher eukaryotes. *Cell* **66**: 731-742.
 37. TSAI, L.-H., E. LEES, B. FAHA, E. HARLOW & K. RIABOWOL. 1993. The cdk₂ kinase is required for the G1-to-S transition in mammalian cells. *Oncogene* **8**(6): 1593-1602.
 38. HINDS, P. W., S. MITTNACHT, V. DULIC, A. ARNOLD, S. I. REED & R. A. WEINBERG. 1992. Regulation of retinoblastoma protein functions by ectopic expression of human cyclins. *Cell* **70**: 993-1006.
 39. SKERJANC, I. S. & M. W. MCBURNEY. 1994. The E box is essential for activity of the cardiac actin promoter in skeletal but not in cardiac muscle. *Dev. Biol.* **163**: 125-132.
 40. EVANS, S. E., L.-J. TAI, V. P. TAN, C. B. NEWTON & K. R. CHIEN. 1994. Heterokaryons of cardiac myocytes and fibroblasts reveal the lack of dominance of the cardiac muscle phenotype. *Mol. Cell. Biol.* **14**(6): 4269-4279.
 41. KOMURO, I. & S. IZUMO. 1993. *Csx*: a murine homeobox-containing gene specifically expressed in the developing heart. *Proc. Natl. Acad. Sci. USA* **90**(17): 8145-8149.
 42. EWEN, M. E., H. K. SLUSS, C. J. SHERR, H. MATSUSHIME & J. KATO. 1993. Functional interactions of the retinoblastoma protein with mammalian D-type cyclins. *Cell* **73**: 487-497.
 43. DOWDY, S. F., P. W. HINDS, K. LOUIE, S. I. REED, A. ARNOLD & R. A. WEINBERG. 1993. Physical interaction of the retinoblastoma protein with human D cyclins. *Cell* **73**: 499-511.

Proliferative Potential and Differentiated Characteristics of Cultured Cardiac Muscle Cells Expressing the SV40 T Oncogene^a

ANDREI B. BORISOV^{b,c} AND WILLIAM C. CLAYCOMB^{b,d}

^b*Department of Biochemistry and Molecular Biology
Louisiana State University Medical Center
New Orleans, Louisiana 70112*

and
^c*Institute of Cytology
Russian Academy of Sciences
St. Petersburg, 194064 Russia*

INTRODUCTION

Differentiation of cardiac muscle cells during embryonic development is associated with a progressive decrease in their proliferative activity. Cardiac myocytes in mammals cease hyperplastic growth and undergo terminal differentiation early in the postnatal period. Unlike skeletal muscle, the adult mammalian myocardium does not contain undifferentiated myoblastic cells of myosatellite type that can resume proliferation in the area of injury (reviews: Ref. 1, 2). This explains why fibrosis occurs after infarction and other types of myocardial lesions and why, in contrast to skeletal muscle, the myocardium is extremely rarely a source of primary tumors. Cardiomyogenic differentiation has long been considered to be an irreversible process associated with the complete loss in the ability of the cells to reenter the mitotic cycle. To date, data from several laboratories documents that terminally differentiated cardiomyocytes are able to resume DNA synthesis and karyokinetic activity both *in vivo* and in cell culture.³⁻⁷ These experiments make us reconsider the view that terminally differentiated cardiac myocytes are cells which have exhausted their proliferative potential. However, this capacity to reactivate the proliferative program is apparently limited to one or several additional rounds of DNA replication.

Little is known about the mechanisms regulating growth and differentiation of cardiomyocytes at the cellular and molecular levels. An understanding of the factors causing withdraw of the cells from the mitotic cycle during the postnatal period and triggering DNA synthesis and mitosis in differentiated cardiac myocytes are especially important for basic and clinical cardiology. A useful experimental object

^a Supported by Grants HL 43124 and HL 45453 from the NIH.

^d Correspondent: William C. Claycomb, Ph.D., Department of Biochemistry and Molecular Biology, Louisiana State University Medical Center, 1901 Perdido Street, New Orleans, LA 70112.

for such studies could be permanent lines of proliferating cardiac muscle cells with stable or controlled differentiated properties. Studies of cell lines and primary skeletal myoblasts differentiating in culture contributed significantly to the understanding of interrelations of proliferation and differentiation during skeletal myogenesis. However, no cell line is currently available that is able to undergo spontaneous or inducible differentiation from precursor-like myoblastic cells into more or less differentiated cardiac myocytes.

Until recently, the attempts to maintain long-term proliferation of cardiac muscle cells and to prevent their developmentally programmed transition to terminal differentiation *in vivo* and *in vitro* were not successful. For this reason, of special interest are reports on the ability of cells transfected with oncogenes, as well as derived from transgenic animals, to give rise to lines of proliferating cells originating from tissues which normally show a low incidence of spontaneous immortalization and transformation.⁸⁻¹¹ The large T oncogene of the monkey papovavirus SV40 is a potent inducer of cell proliferation. Proliferating cells expressing the SV40 T oncogene, as observed in several nonmuscle cell types, can retain the traits of the differentiated phenotype.⁸⁻¹¹ However, reactivation of DNA synthesis in skeletal muscle fibers induced by the expression of SV40 T oncogene is followed by cell death.¹² Taking into account the basic difference in histogenesis of cardiac and skeletal muscle mentioned above and antagonistic interrelations of proliferation and differentiation in myogenesis, an important point to study is how the proliferative potential of cardiac muscle cells expressing the SV40 T oncogene correlates with their differentiated properties.

The development of techniques of gene transfer and generation of transgenic animals has provided a new approach to studies of mechanisms regulating cell growth and differentiation. Recently, hyperplastic growth of cardiac muscle cells was observed in transgenic mice expressing the SV40 T oncogene under control of the tissue-specific human atrial natriuretic factor (ANF) promoter and rat α -cardiac myosin heavy chain promoter.¹⁴ The expression of the oncogene under control of the first of these promoters results in atrial hyperplasia,^{13,14} whereas the expression of the second DNA construct causes hyperplastic growth both in atria and in ventricles.^{14,15} Hyperplastic cardiac muscle cells expressing the atrial natriuretic factor promoter-SV40 T construct can be passaged subcutaneously as ectopic grafts in syngeneic animals and express several markers of the highly differentiated cardiac phenotype.¹⁶⁻¹⁸

The purpose of the present study was to investigate comparatively the proliferative potential and differentiated properties of cardiac muscle cells isolated in culture from the atria of transgenic mice expressing the SV40 T oncogene in the myocardium under the control of tissue-specific promoters.

MATERIALS AND METHODS

The technique of generation of transgenic mice expressing the SV40 T oncogene under control of the tissue-specific promoters of the human atrial natriuretic factor gene and rat α -cardiac myosin heavy chain gene has been described and performed by Field.^{13,14}

Atrial Cells Expressing the SV40 T Oncogene under Control of the Human Atrial Natriuretic Factor Promoter (AT-1 Cells)

Subcutaneous passaging of the SV40 T transgenic atrial tissue, isolation and culture of the cells was performed as described previously.^{16,17} In brief, after the tissue was aseptically removed from the anesthetized syngeneic recipient mouse, it was minced into 3–4-mm fragments and incubated overnight in 0.125% trypsin solution at 4°C. The tissue was then dissociated by a series of 10–15-min treatments with a 0.1% solution of collagenase in serum-free PC-1 medium (Ventrex, Portland, ME) on a shaker at 37°C. The cells from several isolated fractions were pooled, centrifuged at 1000–1200 rpm and plated at densities of $8\text{--}10 \times 10^6$ cells in 10-cm Petri dishes containing gelatin and fibronectin coated coverslips. The medium (PC-1) was supplemented with 10% fetal calf serum, 15 $\mu\text{g}/\text{ml}$ of insulin, 1 nM dexamethasone, 100 IU/ml of penicillin and 100 $\mu\text{g}/\text{ml}$ of streptomycin and was changed every other day.

Atrial Cells Expressing the SV40 T Oncogene under Control of the Rat α -Cardiac Myosin Heavy Chain Promoter (AT-2 Cells)

Hyperplastic atrial tissue was aseptically removed from the atria of the anesthetized transgenic animals, minced into 2–3-mm fragments and incubated overnight in 0.125% trypsin solution at 4°C. The tissue was then dissociated by a series of 10–15-min treatments with a 0.1% solution of collagenase in serum-free PC-1 medium on a shaker at 37°C. All subsequent steps of cell isolation and cell culture were performed identically to the technique described for AT-1 cells. After formation of a confluent cell monolayer, the cells were detached from the culture vessel with 0.125% trypsin solution (Sigma Chemical Company, St. Louis, MO) and passaged.

Immunocytochemistry

For indirect immunofluorescent staining the cells were grown on coverslips and fixed with 2.5% paraformaldehyde solution in phosphate buffered saline (PH 7.2) for 15 min at 4°C and permeabilized with a 0.05% solution of Triton X-100 in the same buffer for 10 min. For immunostaining of intermediate filaments methanol fixation was used. The primary antibodies used for indirect immunofluorescent staining were anti-SV40 T monoclonal antibody PAb 419 (Oncogene Science, New York), monoclonal antibodies to α -sarcomeric actin, α -smooth muscle actin, vimentin and desmin (all from Sigma), monoclonal antibody MF-20 to sarcomeric myosin heavy chain (kindly provided by Drs. D. A. Fischman and D. M. Bader of Cornell University Medical College, New York) and monoclonal anti-desmoplakin (Boehringer, Mannheim). The secondary antibody was FITC-conjugated goat anti-mouse immunoglobulin G (Sigma). To identify the cells in interphase and mitosis and to count the mitotic indices, the cultured cells were counterstained for nuclear DNA with the fluorescent DNA-binding dye Hoechst 33258.

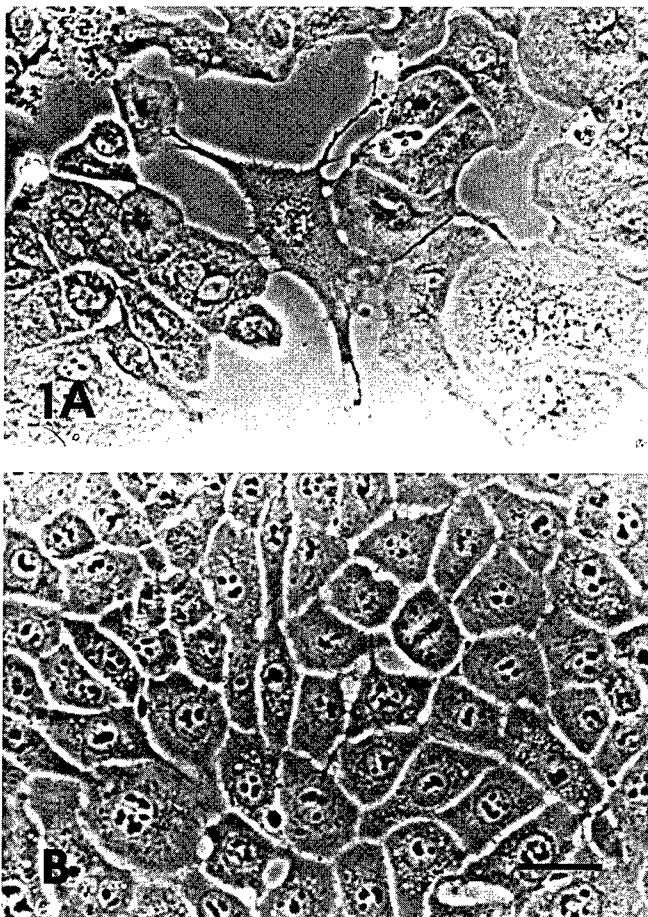

FIGURE 1. Cell cultures of AT-1 (A) and AT-2 cells (B). Phase contrast. Note the difference in morphology of AT-1 and AT-2 cells. Mitotic cells are seen in both cultures. Bar, 60 μ m.

RESULTS

Proliferative Potential of Atrial Cells Expressing the SV40 T Oncogene

The proliferating potential and differentiated properties of myocardial cells expressing the SV40 T oncogene under control of two different tissue-specific promoters were comparatively studied in cell cultures prepared from hyperplastic heart tissue of SV40 T-transgenic mice. Atrial cells expressing the SV40 T oncogene under control of the human atrial natriuretic factor promoter (AT-1 cells) and atrial cells expressing this oncogene under control of the rat α -myosin heavy chain promoter (AT-2 cells) demonstrated intense proliferation and significantly prolonged lifespan *in vitro*. Phase contrast photographs of cell cultures of AT-1 and AT-2 cells are presented in FIGURE 1A,B. In culture, the atrial cells continued

DNA synthesis and mitotic activity. The mitotic index was 0.4–1.7% and 2.5–2.9% in AT-1 and AT-2 cell cultures, respectively. Labeling with ^3H -thymidine and anti-proliferating cell nuclear antigen (PCNA) antibody (FIG. 2) showed that most of the cells are able to synthesize DNA. Both types of atrial cells stably expressed the SV40 T oncogene in culture. Intense immunoreactivity for the oncoprotein was detected in the nuclei of virtually all cultured cells (FIG. 3A–C). During mitosis, the oncoprotein changed its nuclear localization and was diffusely distributed in the cytoplasm of dividing AT-1 and AT-2 cells (FIG. 3B,C).

AT-1 cells have been supported as a continuously proliferating cell population of transplantable tumor cells for over 4 years. In cell culture they can only be passaged a few times. AT-2 cells continue to proliferate for more than 300 passages retaining a high level of the oncoprotein expression in their nuclei and thus demonstrating unlimited growth potential. Population doubling time in AT-2 cell cultures was 27 h at passage 20 and 23 h at passage 139.

Differentiated Properties of Cardiac Muscle Cells Expressing the SV40 T Oncogene

Data concerning the expression of myocardial-specific markers in AT-1 and AT-2 cells are summarized in TABLE 1. AT-1 cells exhibit rhythmic contractile activity. These cells express the major myofibrillar proteins (FIG. 4A,B) and are able to assemble them into myofibrils (FIG. 4B). Positive immunostaining for atrial natriuretic peptide indicates that AT-1 cells maintain the tissue-specific secretory function (FIG. 4C). The levels of development of the contractile system and intracellular accumulation of atrial natriuretic peptide varied significantly in individual cells. All AT-1 cells were immunopositive for desmin, a muscle-specific intermediate filament protein, that was detected as a filamentous network (FIG. 5A,B). Immunoreactivity for another intermediate filament protein, vimentin, that is expressed in mesodermal cells including embryonic cardiac and skeletal muscle and downregulated in differentiated muscle cells, was weak or negative in cultured AT-1 myocytes (FIG. 4D). As revealed by immunostaining for desmoplakin, AT-1 cells formed well-developed desmosomal intercellular contacts (FIG. 2), which is typical of cardiac muscle cells *in vivo*. Mitotic muscle cells were positive for muscle-specific proteins (FIG. 5A,B) which indicates that the AT-1 cell population does not contain undifferentiated myoblastic cells.

Unlike AT-1 cells, the expression of sarcomeric proteins (sarcomeric myosin heavy chain and the sarcomeric isoform of α -actin) in the AT-2 cell line could not be detected after 14–15 passages in culture. By this time no immunoreactivity for atrial natriuretic peptide was observed. However, after 130 passages in culture AT-2 cells expressed α -smooth muscle actin, desmin, and vimentin and were weakly positive for desmoplakin (FIG. 6A–D). The intensity of immunostaining for desmin and desmoplakin in AT-2 cultures was significantly lower than that of AT-1 cells (compare FIGS. 2 and 6D). The expression of immunocytochemical markers of the cardiac phenotype in AT-2 cells was unstable, and a large number (up to 60–70%) of cultured cells did not express desmoplakin and desmin. However, most of the cells reacted with different intensity to anti-smooth muscle actin and

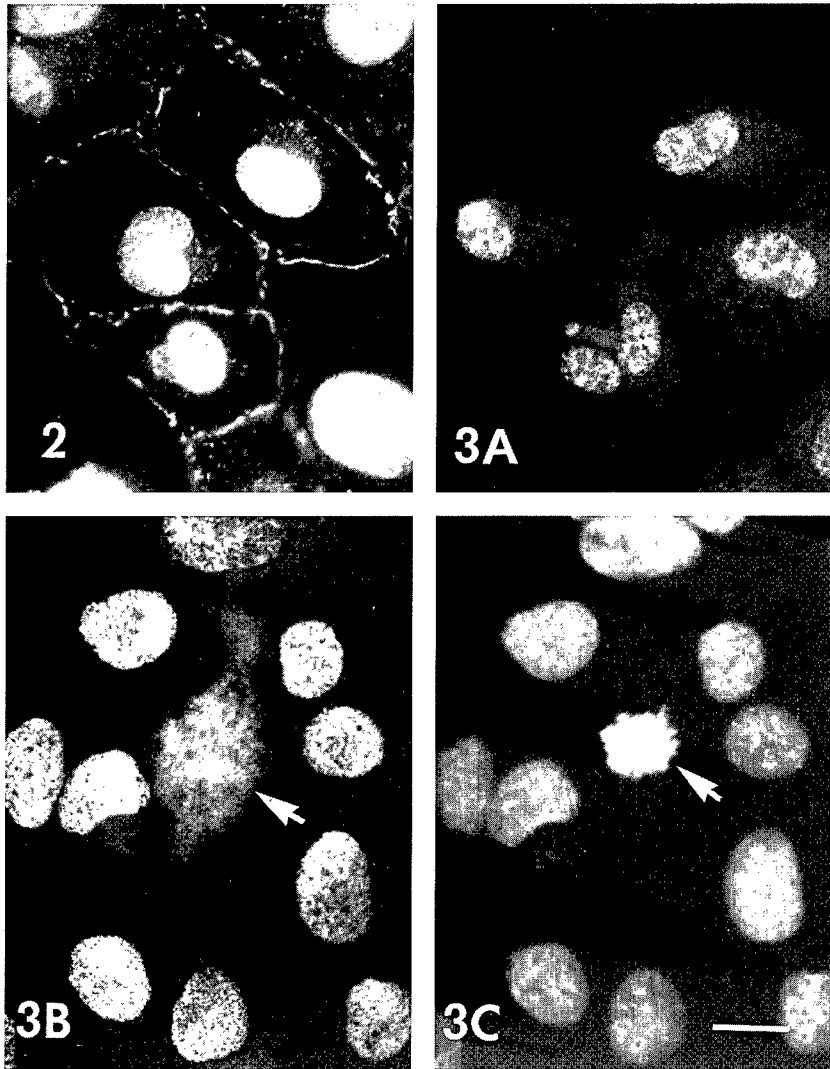

FIGURE 2. Indirect immunofluorescent staining for proliferating cell nuclear antigen (PCNA) and desmoplakin in AT-1 cardiac muscle cells. Double immunolabeling. Cell nuclei are immunopositive for PCNA. The areas of desmosomal intercellular contacts along the perimeters of the cells are immunopositive for desmoplakin.

FIGURE 3. Stable expression of the SV40 T oncogene in AT-1 (A) and AT-2 (B,C) cells. Nuclei of virtually all the cells are strongly immunopositive for the oncoprotein. (A,B) Indirect immunofluorescence, (C) nuclear DNA staining with Hoechst 33258 in the field shown in (B). *Arrow* in (B) indicates a mitotic cell with diffuse cytoplasmic staining for the oncoprotein; *arrow* in (C) indicates prometaphase chromosomes in the mitotic cell. *Bar*, 25 μm (A) and 20 μm (B,C).

TABLE 1. Myocardium-Specific Markers in Cultured Cardiac Cells Expressing the SV40 T Oncogene^a

Markers of the Differentiated Phenotype	Expression of the Marker	
	AT-1 Cells	AT-2 Cells
Rhythmic contractile activity	yes	no
Formation of fasciae adherentes-like intercellular contacts	yes	no
Sarcomeric myosin heavy chain	+++	not detected
α -Sarcomeric actin	++	not detected
α -Smooth muscle actin	++	++
Atrial natriuretic peptide	++	not detected
Desmin	+++	++ ^b
Vimentin	+	++
Desmoplakin	+++	+ ^b

^a Level of the expression as evaluated by the intensity of the reaction of indirect immunostaining: +++-intensely reactive; ++-moderately reactive, +-weakly reactive.

^b Unstable expression.

anti-vimentin antibody. All AT-2 cells at later passages were strongly immunopositive for the SV40 T oncoprotein which indicates their transgenic origin.

DISCUSSION AND CONCLUSIONS

In this paper we demonstrate that cardiac muscle cells expressing the SV40 T oncogene can be supported in cell culture in a proliferating state for an extended period of time. The results of this study show that atrial myocytes possess the ability to proliferate after isolation *in vitro* and to be immortalized in culture. The immunoreactivity for muscle-specific proteins detected in the dividing AT-1 cells agrees well with the data on the absence of undifferentiated myoblastic cells in the mammalian heart. Modulations of the differentiated phenotype resulting in morphological heterogeneity of individual cells observed in the SV40 T-expressing cardiac muscle cells are also typical of primary myocardial cell cultures.^{19,20} Atrial myocytes immortalized by the SV40 T oncogene under control of the human atrial natriuretic factor promoter and the rat α -cardiac myosin heavy chain promoter demonstrate different differentiated characteristics. It is not easy to conclude without additional experiments whether this significant difference in the differentiated properties of the cells results from the type of the promoter controlling the oncogene expression, or whether it is associated with the positional effect of the transgene integration into the muscle cell genome.

In confluent culture, AT-2 cells form a dense monolayer with some traits of epithelial morphology. For this reason, of special interest is the difference in intensity and morphological pattern of staining for desmoplakin in AT-1 and AT-2 cells. Both phylogenetically and ontogenetically, the mammalian myocardium is a developmental derivative of the mesodermal epithelium.^{1,21,22} Differentiated cardiomyocytes and epithelial cells express biochemically and immunochemically similar types of proteins in desmosomal intercellular contacts.²³ Desmosomes between the cells are formed early in heart development before formation of myofi-

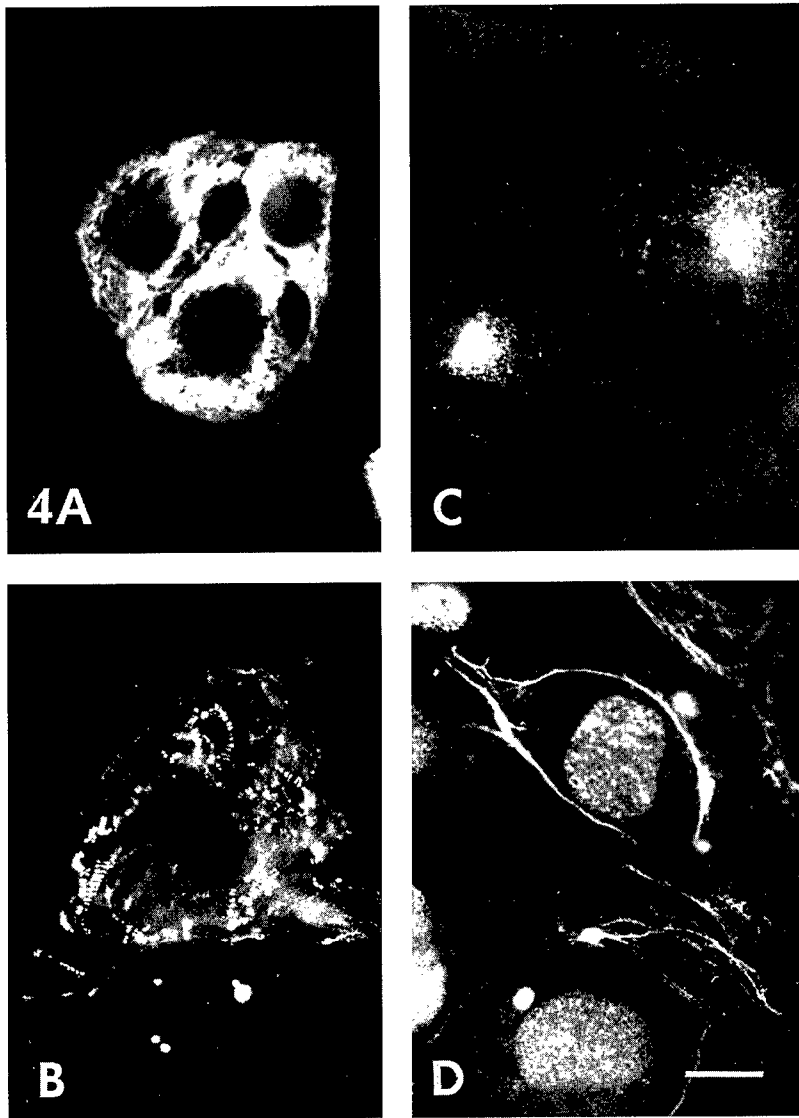

FIGURE 4. Expression of cardiac-specific markers in AT-1 cells. Indirect immunofluorescent staining for (A) sarcomeric myosin heavy chain. (Note well-developed intercellular contacts between the neighboring cells), (B) α -sarcomeric actin, (C) atrial natriuretic peptide, and (D) double immunolabeling for the SV40 T oncoprotein and vimentin. In (D), the reactivity for the oncoprotein is localized in cell nuclei; surrounding cells with the SV40 T-positive nuclei are mostly negative for vimentin. 4 days in culture (A); 11 days in culture (B,C,D). Bar, 20 μ m.

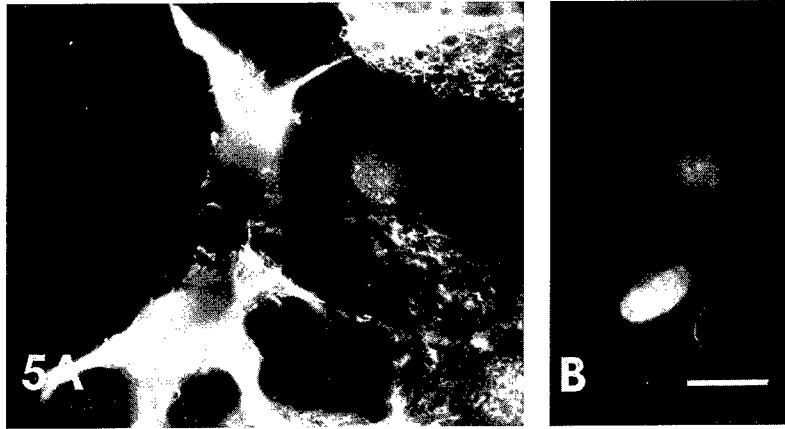

FIGURE 5. Desmin in a dividing AT-1 cell. (A) Indirect immunofluorescent staining for desmin. Note the resorption of desmin filaments in the perinuclear area and near the cleavage furrow. (B) DNA staining of daughter cell nuclei with Hoechst 33258 in the field shown in (A). 6 days in culture. Bar, 20 μm .

brils.^{1,21} To this end, the dotted pattern of distribution of desmosomal contacts detected in AT-2 cells by immunostaining for desmoplakin is similar morphologically to distribution of "spot" desmosomes observed in contacting cardiomyoblasts at early stages of heart development *in vivo*.^{1,21} At the same time the expression of other markers of the early cardiomyogenic phenotype in AT-2 cells such as desmin and α -smooth muscle actin may also indicate their muscle origin. Smooth muscle actin is the first isoactin synthesized in the myocardium during development,^{24,25} and its synthesis is reactivated in terminally differentiated cardiac myocytes in cell culture.²⁶ Desmin is also one of the earliest myogenic markers expressed in myogenic cells at the premyofibril stage of differentiation.^{27,28} Therefore, one can suggest two alternative origins of AT-2 cells: (1) dedifferentiation of atrial myocytes in the direction of their phylogenetic and ontogenetic ancestor—the epithelium of mesodermal origin, or (2) selection of a cell line of primitively differentiated cells preexisting in the hyperplastic atrial tissue expressing the SV40 T oncogene. In terms of further characterization of the AT-2 cells it is important to study their ability to express the markers of endothelial and smooth muscle cells to exclude the leaky expression of the transgene in other cell types and the ability of these cells to modulate the phenotype under influence of differentiation-promoting agents.

This comparative study of cultured cardiac myocytes has shown that the proliferative potential and differentiated properties of cells stimulated to proliferate by the same oncogene can be very different and may depend on a number of factors that include the anatomical origin of the tissue, type of the promoter controlling the oncogene expression, the level of the transgene expression in the cells, and, possibly, the site of integration of the transgene into the cell genome.

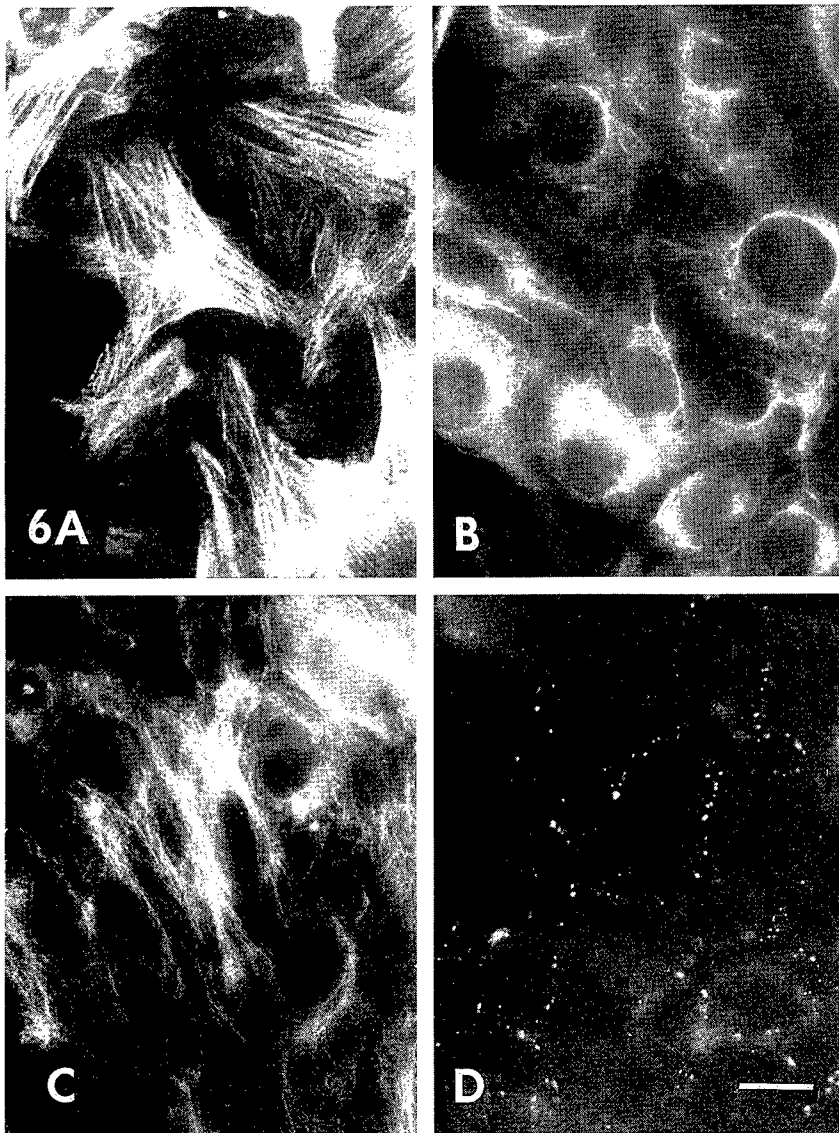

FIGURE 6. Expression of contractile proteins, intermediate filaments and desmoplakin in AT-2 cells. Indirect immunofluorescent staining for (A) smooth muscle actin, (B) a cluster of cells immunopositive for desmin, (C) vimentin, and (D) desmoplakin. Passage 139. Bar, 20 μm .

REFERENCES

1. RUMYANTSEV, P. P. 1991. Growth and Hyperplasia of Cardiac Muscle Cells. Harwood Academic Publishers. New York, Paris, London.
2. CARLSON, B. M. 1991. Skeletal muscle regeneration. *In* The Development and Regenerative Potential of Cardiac Muscle. J. O. Oberpriller, J. C. Oberporiller & A. Mauro, Eds. 439–454. Harwood Academic Publishers. New York, Paris, London.
3. RUMYANTSEV, P. P. 1991. Replicative behavior of different types of cardiomyocytes in terms of experimental conditions, age and systematic position of animals. *In* The Development and Regenerative Potential of Cardiac Muscle. J. O. Oberpriller, J. C. Oberpriller & A. Mauro, Eds. 81–91. Harwood Academic Publishers. New York, Paris, London.
4. CLAYCOMB, W. C. 1991. Proliferative potential of the mammalian ventricular cardiac muscle cell. *In* The Development and Regenerative Potential of Cardiac Muscle. J. O. Oberpriller, J. C. Oberpriller & A. Mauro, Eds. 351–363. Harwood Academic Publishers. New York, Paris, London.
5. CLAYCOMB, W. C. 1992. Control of cardiac muscle cell division. *Trends Cardiovasc. Med.* **2**: 231–236.
6. OBERPRILLER, J. O. & J. C. OBERPRILLER. 1991. Cell division in adult newt cardiac myocytes. *In* The Development and Regenerative Potential of Cardiac Muscle. J. O. Oberpriller, J. C. Oberpriller & A. Mauro, Eds. 293–311. Harwood Academic Publishers. New York, Paris, London.
7. BORISOV, A. B. & P. P. RUMYANTSEV. 1991. Atrial myocytes: myoendocrine cells possessing an enhanced ability to re-enter the mitotic cycle *in vitro* and *in vivo*. *In* The Development and Regenerative Potential of Cardiac Muscle. J. O. Oberpriller, J. C. Oberpriller & A. Mauro, Eds. 115–137. Harwood Academic Publishers. New York, Paris, London.
8. PFEIFER, A. M. A., K. E. COLE, D. T. SMOOT, A. WESTON, J. D. GROOPMAN, P. G. SHIELDS, P. G. VIGNAUD, J.-M. JUILLERAT, M. M. LIPSKY, B. F. TRUMP, J. F. LECHNER & C. C. HARRIS. 1993. Simian virus 40 large tumor antigen immortalized normal human liver epithelial cells express hepatocyte characteristics and metabolize chemical carcinogens. *Proc. Natl. Acad. Sci. USA* **90**: 5123–5127.
9. AMSTERDAM, A., A. ZAUBERMAN, G. MEIR, O. PINHASI-KIMHI, B. S. SUH & M. OREN. 1988. Contransfection of granulosa cells with simian virus 40 and Ha-ras oncogene generates stable lines capable of induced steroidogenesis. *Proc. Natl. Acad. Sci. USA* **85**: 7582–7586.
10. ERFAT, S., S. LINDE, H. KOFOD, D. SPECTOR, M. DELANNOY, S. GRANT, D. HANAHAN & S. BAEKKESKOV. 1988. Beta-cell lines derived from transgenic mice expressing a hybrid insulin gene-oncogene. *Proc. Natl. Acad. Sci. USA* **85**: 9037–90041.
11. MALLEIN-GERIN, F. & B. R. OLSEN. 1993. Expression of simian virus 40 large T (tumor) oncogene in mouse chondrocytes induces cell proliferation without loss of the differentiated phenotype. *Proc. Natl. Acad. Sci. USA* **90**: 3289–3293.
12. ENDO, T. & B. NADAL-GINARD. 1989. SV40 large T-antigen induces re-entry of terminally differentiated myotubes into the cell cycle. *In* The Cellular and Molecular Biology of Muscle Development. L. H. Kedes & F. F. Stockdale, Eds. 95–104. Wiley-Liss, Inc. New York.
13. FIELD, L. J. 1988. Atrial-natriuretic factor-SV40 T antigen transgenes produce atrial tumors and cardiac arrhythmias in mice. *Science* **239**: 10029–10033.
14. STEINHELPER, M. E. & L. J. FIELD. 1991. SV40 large T antigen induces myocardiocyte proliferation in transgenic mice. *In* The Development and Regenerative Potential of Cardiac Muscle. J. O. Oberpriller, J. C. Oberpriller & A. Mauro, Eds. 365–384. Harwood Academic Publishers. New York, Paris, London.
15. KATZ, E. B., M. STEINHELPER, J. B. DELCARPIO, A. I. DAUD, W. C. CLAYCOMB & L. J. FIELD. 1992. Cardiomyocyte proliferation in mice expressing alpha-cardiac myosin heavy chain-SV40 T-antigen transgene. *Am. J. Physiol.* **262**: H1867–H1876.
16. STEINHELPER, M. E., N. A. LANSON, JR., K. P. DRESDNER, J. B. DELCARPIO, A. L. WIT, W. C. CLAYCOMB & L. J. FIELD. 1990. Proliferation *in vivo* and in culture of

- differentiated adult atrial cardiomyocytes from transgenic mice. *Am. J. Physiol.* **259**: H1826–H1834.
17. LANSON, N. A., JR., C. C. GLEMBOTSKI, M. E. STEINHELPER, L. J. FIELD & W. C. CLAYCOMB. 1992. Gene expression and atrial natriuretic factor processing and secretion in cultured AT-1 cardiomyocytes. *Circulation* **85**: 1835–1841.
 18. DELCARPIO, J. B., N. A. LANSON, JR., L. J. FIELD & W. C. CLAYCOMB. 1991. Morphological characterization of cardiomyocytes isolated from a transplantable cardiac tumor derived from transgenic mouse atria (AT-1 cells). *Circ. Res.* **69**: 1591–1600.
 19. BORISOV, A. B., E. A. GONCHAROVA, G. P. PINAEV & P. P. RUMYANTSEV. 1989. Changes in localization of alpha-actinin and myofibrillogenesis in rat cardiac myocytes in the course of cultivation. *Tsitologia* **31**: 642–646.
 20. HILENSKI, L. L., L. TERRACIO & T. K. BORG. 1991. Myofibrillar and cytoskeletal assembly in neonatal rat cardiac myocytes cultured on laminin and collagen. *Cell Tissue Res.* **264**: 577–587.
 21. MANASEK, F. J. 1968. Embryonic development of the heart. I. A light and electron microscopic study of myocardial development in the early chick embryo. *J. Morphol.* **125**: 329–366.
 22. PENG, I., J. E. DENNIS, E. RODRIGUES-BOULAN & D. A. FISCHMAN. 1990. Polarized release of enveloped viruses in the embryonic chick heart: demonstration of epithelial polarity in the presumptive myocardium. *Dev. Biol.* **141**: 164–172.
 23. FRANKE, W. W., R. MOLL, D. L. SCHILLER, E. SCHMID, J. KARTENBECK & H. MUELLER. 1982. Desmoplakins of epithelial and myocardial desmosomes are immunologically and biochemically related. *Differentiation* **23**: 15–27.
 24. RUZICKA, D. L. & R. J. SCHWARTZ. 1988. Sequential activation of α -actin genes during avian cardiogenesis: vascular smooth muscle actin gene transcripts mark the onset of cardiomyogenic differentiation. *J. Cell Biol.* **107**: 2575–2586.
 25. SUGI, Y. & J. LOUGH. 1992. Onset of expression and regional deposition of alpha-smooth and sarcomeric actin during avian heart development. *Dev. Dynamics* **193**: 116–124.
 26. EPPENBERGER-EBERHARDT, M., I. FLAMME, I. KURER & H. M. EPPENBERGER. 1990. Re-expression of α -smooth muscle actin isoform in cultured adult rat cardiomyocytes. *Dev. Biol.* **139**: 269–278.
 27. FURST, D. O., M. OSBORN & K. WEBER. 1989. Differential onset of expression of myogenic proteins and the involvement of titin in myofibril assembly. *J. Cell Biol.* **109**: 517–527.
 28. SCHULTHEISS, T., Z. X. LIN, H. ISHIKAWA, I. ZAMIR, C. J. STOECKERT & H. HOLTZER. 1991. Desmin/vimentin intermediate filaments are dispensable for many aspects of myogenesis. *J. Cell Biol.* **114**: 953–966.

***In Vitro* Clonal Analysis of Cardiac Outflow Tract Mesenchyme^a**

MAYA SIEBER-BLUM^b AND KAZUO ITO^c

*Department of Cellular Biology and Anatomy
Medical College of Wisconsin
8701 Watertown Plank Road
Milwaukee, Wisconsin 53226*

INTRODUCTION

The mesenchyme that contributes to the partitioning of the cardiac outflow tract originates from the posterior rhombencephalic neural crest.¹ Neural crest cells from neural tube spanning the axial levels from midotic placode to somite 3 leave the forming neural tube, migrate through the posterior visceral arches (III, IV and VI) and form the conotruncal ridges in the cardiac outflow tract, in addition to contributing to the formation of the hyoid arch skeleton and giving rise to the ganglia of the enteric nervous system in the preumbilical intestine (reviewed in Ref. 2). The conotruncal ridges fuse in a spiraling fashion, partitioning the conotruncal region into the aorta and the pulmonary artery.³ Various common malformations of the cardiac outflow tract are due to neural crest defects. A lack of fusion of the conotruncal ridges leads to persistent truncus arteriosus (PTA). In PTA a large arterial outflow vessel overrides the ventricular septum and receives blood from both the left and right ventricles. Infants born with persistent truncus arteriosus are highly cyanotic; without treatment, 60–70% of these individuals die within 6 months. Transposition of the great vessels occurs when the conotruncal ridges fail to spiral. This results in two separate circulatory arcs, with the right ventricle emptying into the aorta instead of the pulmonary artery, while the left ventricle empties into the pulmonary artery instead of the aorta. This lesion is the most common cause of cyanosis in newborn infants (reviewed in Ref. 4). These outflow tract defects can be induced in avian embryos by ablating the cardiac neural crest.⁵ The cardiac neural crest is therefore an important contributor to normal heart development. *In vitro* clonal analyses of cardiac outflow tract mesenchyme at different stages of migration indicated that many of these cells are pluripotent and that some developmental options are lost with progressing embryonic development.

MATERIALS AND METHODS

Primary Cultures

Cardiac neural crest primary cultures were prepared as described.^{6,7} Briefly, dorsal segments from somitic levels 1–3 were dissected from Hamburger and

^a Supported by USPHS Grant HD21423 and Grant-in-Aid 91013790 from the American Heart Association.

^b Corresponding author.

^c Present address: Department of Biology, Osaka University, Osaka 560, Japan.

Hamilton⁸ stage 10 +/11 quail embryos (37 hours of incubation at 38.0°C). Neural tubes were released from neighboring tissues by trypsinization and gentle trituration and then transferred to collagen-coated culture dishes. The culture medium consisted of 75% alpha-modified minimum essential medium, 15% of a selected batch of horse serum and 10% of day-11 chick embryo extract and was supplemented with 50 µg/ml gentamicin.

Primary cultures of posterior visceral arch mesenchymal cells were performed as described.⁹ Posterior visceral arches III and IV were dissected according to the method of Ciment and Weston.¹⁰ The pharyngeal region was dissected and played by cutting along the ventral midline using electrolytically sharpened tungsten needles. The dorsal and ventral limits of arches III and IV were then cut. The isolated visceral arches were cut into small pieces and placed into collagen-coated culture dishes. The culture medium was the same as that for cardiac neural crest cells, and was replaced every other day.

Clonal Cultures

Clonal cultures of neural crest cells and visceral arch mesenchyme were prepared as described previously.^{6,7,9} Primary explants of neural tubes or visceral arches were scraped with a tungsten needle 24 hr after explantation. The remaining mesenchymal cells were resuspended by trypsinization (0.025% trypsin in Ca²⁺-, Mg²⁺-free phosphate-buffered saline containing 0.02% EDTA). The cell density of the resulting virtually single cell suspension was diluted to 75–250 cells per ml of culture medium. One-milliliter aliquots were placed in a series of 35-mm culture dishes that had been coated with a collagen gel and conditioned for 3–4 hr with 1 ml of culture medium containing 20 µg/ml of plasma fibronectin that had been purified from horse serum according to Yamada.¹¹ Viable cells were firmly attached to the collagen substratum within 1 hr. Three hours after plating, the dishes were carefully screened with an inverted microscope and single cells were marked by engraving a circle of 3 mm diameter on the bottom of the culture dish with a diamond marker. Clones were inspected daily. Since many cells died during the first 24 hours of culture and because, with the exception of some mixed and unpigmented large colonies, the colonies did not reach 3 mm in diameter, individual clones did not contact each other in most cases. Rare clones that did grow together towards the end of the culture period were excluded from evaluation.

Immunocytochemistry

The following cell type-specific antibodies were used. 1) Rabbit anti-desmin (Chemicon) which stains muscle cells but not fibroblasts or epithelial cells;^{12–14} 2) rabbit serum and monoclonal antibodies against intracellular and extracellular collagen type II (gift of Dr. T. Linsenmayer¹⁵); 3) monoclonal antibody M-38 against procollagen type I (Hybridoma Bank) to identify connective tissue cells;¹⁶ 4) monoclonal anti-smooth muscle α -actin (Sigma) to identify smooth muscle cells; 5) monoclonal anti-tropomyosin antibodies CH106 (recognizing skeletal, car-

diac and smooth muscle tropomyosin) and CH291 (specific to skeletal and cardiac muscle tropomyosin; gifts to Dr. J. J. Lin¹⁷); 6) monoclonal antibodies against the stage-specific embryonic antigen-1 (SSEA-1; gift of Dr. D. Solter¹⁸) that specifically recognizes cells in the sensory neuron lineage in the quail embryo and in culture;^{19,20} 7) rabbit anti-serotonin antibodies (IncStar) to visualize serotonergic (putative enteric) neurons. For double-staining experiments with anti-desmin and M-38 or anti-actin antibodies, the cultures were fixed with ethanol and treated with pooled primary antibodies for 2 hr at room temperature. For immunostaining of desmin, collagen type II, tropomyosin, and SSEA-1, a freshly prepared 4% solution of paraformaldehyde was used as fixative for 2 hr on ice. The following antibody combinations were used for double stainings. 1) Anti-SSEA-1 and anti-desmin; 2) anti-SSEA-1 and anti-collagen type II; 3) anti-tropomyosin and anti-desmin. These procedures are detailed in References 6 and 9.

RESULTS

Cardiac Neural Crest

Five classes of clones that could be distinguished morphologically were observed in cultures of cardiac neural crest cells. 1) *Mixed clones* (FIG. 1a) contained several hundreds to thousands of pigmented and unpigmented cells. 2) *Unpigmented dense clones* (FIG. 1b) contained several hundreds of small unpigmented cells that were aligned in swirls. 3) *Unpigmented large clones* (FIG. 1c) contained thousands of small stellate cells. 4) *Pigmented clones* (FIG. 1d) were smaller and exclusively consisted of melanocytes. 5) *Unpigmented loose clones* (FIG. 1e) were smaller than unpigmented large clones and consisted of large flattened cells that were loosely arranged. The average frequencies of the five different clones were the following (FIG. 2, upper panel). 1) Mixed clones, 26%; 2) unpigmented dense clones, 24%; 3) unpigmented large clones, 18%; pigmented clones, 9%; unpigmented loose clones, 23%.

Immunocytochemical analyses using cell type-specific antibodies indicated that mixed clones can contain up to 6 phenotypes (FIG. 2, upper panel); 1) pigment cells (P), 2) smooth muscle cells (SmM; desmin-positive, smooth muscle α -actin-immunoreactive, smooth muscle tropomyosin [CH106]-immunoreactive, skeletal and cardiac muscle tropomyosin [CH291]-negative), 3) connective tissue cells (CT; pro-collagen type I immunoreactive), 4) chondrocytes (Ch, collagen type II immunoreactive); 5) sensory neuron precursors (SN; SSEA-1-positive), and 6) serotonergic neurons (5-HT; serotonin-immunoreactive). The data were derived from double stainings. Because of technical limitations the presence of all 6 phenotypes could not be ascertained in each clone tested. All cells in unpigmented loose clones were smooth muscle cells, and all cells in pigmented clones were melanocytes. Unpigmented dense and unpigmented large clones contained 4 and 3 phenotypes, respectively (FIG. 2, upper panel). Photomicrographs of immunostained cells are presented in the original paper by Ito and Sieber-Blum.⁶

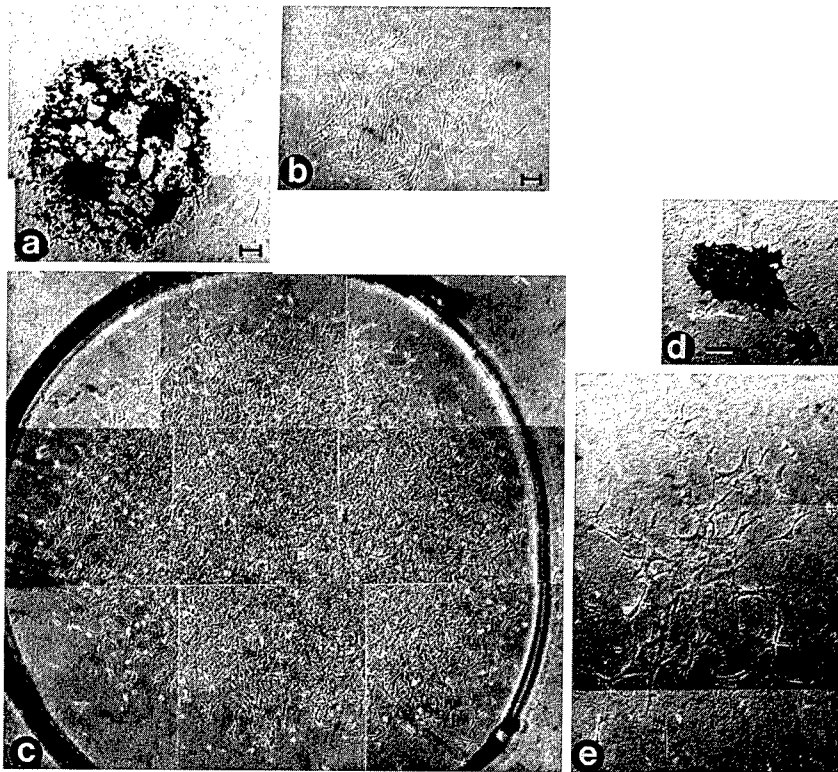
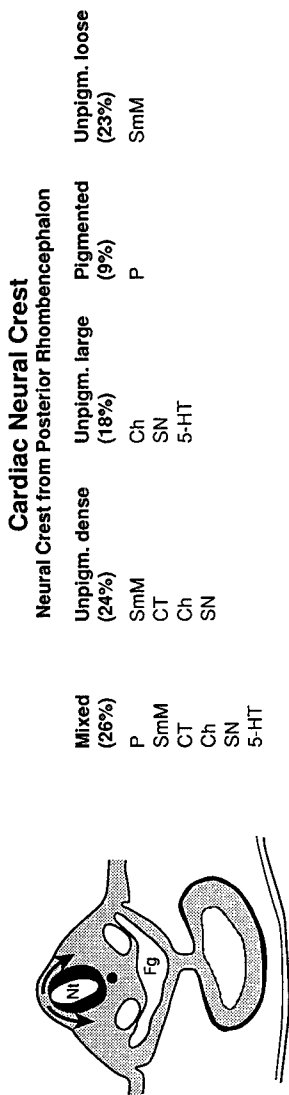

FIGURE 1. Morphology of the different types of clones observed at day 6 of clonal culture of cardiac neural crest cells. (a) Mixed clone, consisting of pigmented and unpigmented cells. (b) Unpigmented dense clone consisting of small unpigmented cells that were arranged in swirls. (c) Unpigmented large clone consisting of a large number of small unpigmented cells. (d) Pigmented clone containing pigmented cells only. (e) Unpigmented loose clone where all cells were smooth muscle cells. (From Ito & Sieber-Blum.⁶ Reprinted by permission from *Developmental Biology*.)

Visceral Arch Mesenchyme

Four morphologically different types of clones were observed in cultures of visceral arch mesenchyme (FIG. 2, lower panel). 1) *DP* clones consisted of densely packed polygonal cells with flattened large cells at the periphery of the colonies. They contained an average of $3,735 \pm 1,924$ cells. 2) *DS* clones contained densely packed spindle shaped cells, with an average of $7,649 \pm 2,316$ cells per colony. 3) *DF* clones consisted of densely packed small cells surrounded by large flattened cells at the periphery of the clone. Average cell numbers were $4,170 \pm 1,940$. 4) *LF* clones consisted entirely of large flattened cells, with an average of 256 ± 114 cells per colony. The average frequencies of the four types of clones changed



Mesenchymal Cells from Visceral Arches III and IV

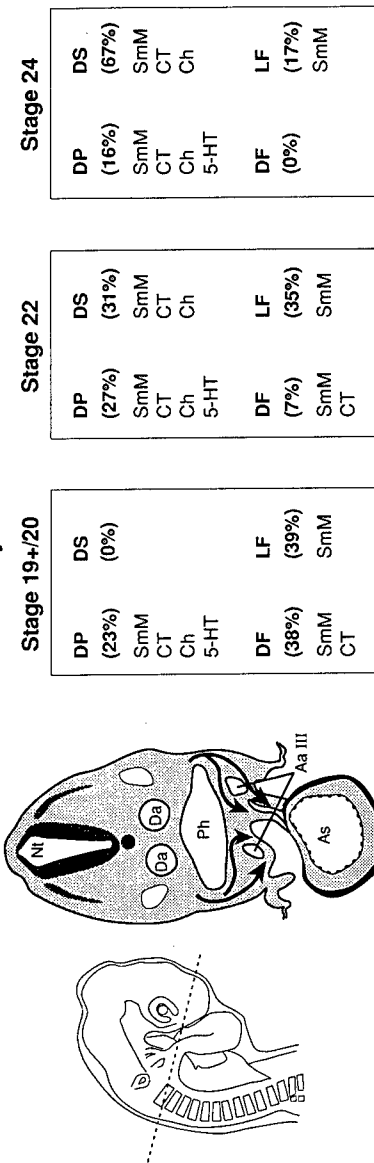

FIGURE 2. Upper panel. *Left:* transverse section through the pericardial region of an approximately 29-hr embryo (stage 10+/11) during early migration of the posterior rhombencephalic neural crest (*arrow*). *Right:* types and frequencies of the 5 different classes of clones in the cardiac neural crest and summary of phenotypic analysis. Lower panel. *Left:* cross section through the cardiac region of an approximately stage 14/15 embryo, around the time when cardiac mesenchyme (*arrows*) enters the visceral arches. *Right:* types and changing frequencies of the 4 different classes of clones with progressing embryonic development; summary of phenotypic analysis. *Abbreviations:* P, pigment cell; SmM, smooth muscle cell; CT, connective tissue cell; Ch, chondrocyte; SN, sensory neuroblast; 5-HT, serotonergic neuron; Nt, neural tube; Fg, foregut; Da, dorsal aorta; Ph, pharynx; Aa III, third aortic arch; As, aortic sac.

with embryonic age. At Hamburger and Hamilton stage 19+/20 DP (23%), DF (38%), and LF (39%) but no DS clones were observed. At stage 22, there were 27% DP, 31% DS, 7% DF, and 35% LF clones. By stage 24, the frequencies changed to 16% DP, 67% DS, and 17% LF, but no DF clones were observed (FIG. 2, lower panel).

Phenotypic analysis (FIG. 2, lower panel) indicated that DP clones contained up to 4 phenotypes; smooth muscle cells, connective tissue cells, chondrocytes and serotonergic neurons. DS clones contained smooth muscle cells, connective tissue cells and chondrocytes. By contrast, DF clones contained only smooth muscle cells and connective tissue cells, and all cells in LF clones were smooth muscle cells. DP and DS clones contained cells that expressed HNK-1, an epitope that is characteristic for neural crest cells and known to be lost as the cells migrate towards the cardiac outflow tract. By contrast DF and LF clones did not express HNK-1. For photomicrographs see Reference 9.

DISCUSSION

In vitro clonal analyses of cardiac neural crest cells and mesenchymal cells in the posterior visceral arches yielded the following major results. Already at initiation of emigration from the neural tube, the cardiac outflow tract mesenchyme consists of a heterogeneous population of cells with regard to developmental potential. Some clone-forming cells are pluripotent, in the sense that their derivatives can generate more than one phenotype. Other clone-forming cells are more restricted in their options, whereas still others appear to be committed to a particular phenotype. The clone forming cells that give rise to mixed clones can generate up to 6 cell types, whereas the cells generating unpigmented dense and unpigmented large clones are restricted in their options. Moreover, unpigmented loose clones seem to be formed by cells that are committed to the myogenic lineage, and pigmented clones by committed melanogenic cells. The significance of early committed myogenic and melanogenic cells remains to be determined. Richardson and Sieber-Blum²¹ have shown that the leading edge of the laterally migrating population of crest cells that is destined to give rise to the pigment cells in the skin, contains a significant portion of pluripotent cells. By contrast, work by Artinger and Bronner-Fraser²² suggests that the trailing edge of the same population of cells consists of committed melanogenic cells. Since neural crest cells are exposed to the ectoderm even before initiation of migration, it is conceivable that the longer contact between ectoderm and neural crest is maintained, the higher the probability is that melanocytes are being generated. This is most likely due to a signal exerted by the ectoderm. Indeed Jerdan *et al.*²³ and Fukuzawa and Bagnara²⁴ have isolated activities that stimulate and inhibit melanin production. It is conceivable that similar mechanisms operate in the commitment of pluripotent cells to the smooth myogenic lineage. There is an increasing rostro-caudal gradient with regard to committed melanogenic cells within the neural crest.²⁵ Conversely, there is a decreasing rostro-caudal gradient with regard to committed smooth myogenic cells in the early neural crest (unpublished observations). These axial level-dependent differences in the commitment to the smooth myogenic and mel-

nogenic lineages most likely reflect axial-level specific differences laid down during gastrulation.

If mesenchymal cells from the posterior visceral arches are compared with cardiac neural crest, two major differences become apparent. 1) The capacity to form primary sensory neurons is apparently lost within the visceral arches, since no SSEA-1-immunoreactive cells were present in any of the clones. 2) The capacity to form pigment cells appears to be lost as well, confirming similar observations by Ciment and Weston.^{10,26} The mechanisms by which developmental options are suppressed remain to be determined.

The frequencies of the different classes of clone-forming cells changes with progressing embryonic age. Thus DS clones are missing at stage 19 + /20, the time when neural crest cells enter the visceral arches. By contrast, DS clones constitute 31% of all clones at stage 22, and by stage 24 the majority of clones (67%) are of the DS type. Morphologically, DS clones most closely resembled unpigmented dense clones within the cardiac crest. It is conceivable that unpigmented dense clone-forming cells within the neural crest become DS clone-forming cells within the arches by losing the capacity to form sensory neurons. These cells then seem to accumulate within the arches and may form the visceral arch-derived structures. By contrast, other types of cells, such as committed smooth myogenic cells, may pass through the arches on their way to their final destinations. However, our data do not permit final conclusions on the dynamic interplay between cell migration, proliferation and changes in developmental option, which all take place concomitantly.

The control of proliferation and cessation of proliferation are critical features in organogenesis. Our work with trunk neural crest cells indicates that growth factors to which the cells are exposed in either a paracrine or autocrine fashion, play a critical role in cell proliferation and differentiation.^{27,28} The combination of basic fibroblast growth factor (bFGF) in combination with a neurotrophin such as nerve growth factor, brain derived neurotrophic factor (BDNF), or neurotrophin-3 (NT-3) acts as a mitogen.²⁸ More precisely, exposure to bFGF leads to an acceleration of the cell cycle time and appears to render the cells dependent on a neurotrophin for survival. Alternatively, transforming growth factor- β (TGF- β) stops proliferation, even in the presence of the bFGF/neurotrophin combination.²⁸ Since the neurotrophin, NT-3,²⁹ and its high-affinity receptor, trkC,³⁰ are expressed not only in the nervous system but in other structures, such as the cardiac outflow tract, as well, it will be of interest to determine the role of growth factors in outflow tract development.

SUMMARY

In vitro clonal analyses were performed to gain insight into the mechanisms that control development of neural crest-derived cardiac outflow tract mesenchyme of quail embryos. The cardiac neural crest originates from the posterior rhombencephalic neural tube. The cells leave the neural tube and migrate through the posterior visceral arches to the outflow tract of the heart, where they form the conotruncal ridges. Mesenchyme cells derived from the neural tube from somitic levels

1–3 contained 5 types of clone-forming cells. One class of clones contained up to 6 phenotypes; smooth muscle cells, connective tissue cells, chondrocytes, sensory neuron precursors, serotonergic (putative enteric) neurons, and pigment cells. Another type of clone was totally pigmented, containing melanocytes only, whereas a third type consisted entirely of smooth muscle cells. The remaining classes of clones contained 3 and 4 phenotypes, respectively. Subsequently, mesenchymal cells obtained from posterior visceral arches were cloned *in vitro*. The major observations from these experiments are the following. 1) The cells have lost the capacity to form sensory neurons. 2) The capacity to form pigment cells is lost as well. 3) Four types of morphologically distinguishable clones were found. The frequency of one type of clone that contains ectomesenchymal cells only (smooth muscle cells, connective tissue cells, and chondrocytes) increased from zero at Hamburger and Hamilton stage 19 + /20 to 67% at stage 24, possibly giving rise to visceral arch-derived structures. The frequency of the other 3 types of clones decreased with progressing embryonic development, indicating that these clone-forming cells either pass through the visceral arches, and/or are being converted to cells with fewer developmental potentials. These observations indicated that already at the level of the neural crest, cardiac mesenchyme is a heterogeneous population of cells with regard to the developmental potentials of the cells. Some precursor cells are pluripotent, others seem restricted in their developmental potentials, whereas still others appear to be committed to a particular phenotype. Moreover, developmental potentials and frequencies of various classes of clones change during advanced cell migration and progressing embryonic development. It is speculated that cell proliferation and differentiation are controlled at least in part by signals, such as growth factors, that originate from the embryonic microenvironment.

ACKNOWLEDGMENTS

We thank Carolyn Snyder for the artwork, Deborah Generotzky for photographic work, and Jeanette Saskowski for reading the manuscript.

REFERENCES

1. KIRBY, M. L., T. F. GALE & D. E. STEWART. 1983. Neural crest cells contribute to normal aorticopulmonary septation. *Science* **220**: 1059–1061.
2. LE DOUARIN, N. 1982. *The Neural Crest*. Cambridge University Press. Cambridge.
3. KRAMER, T. C. 1942. The partitioning of the truncus and conus and the formation of the membranous portion of the interventricular septum of the human heart. *Am. J. Anat.* **71**: 343–370.
4. CARLSON, B. M. 1992. *Human Embryology and Developmental Embryology*. Mosby. St. Louis.
5. BOCKMAN, D. E., M. E. REDMOND, K. WALDO, H. DAVIS & M. L. KIRBY. 1987. Effect of neural crest ablation on development of the heart and arch arteries of the chick. *Am. J. Anat.* **180**: 332–341.
6. ITO, K. & M. SIEBER-BLUM. 1991. *In vitro* clonal analysis of quail cardiac neural crest development. *Dev. Biol.* **148**: 95–106.
7. SIEBER-BLUM, M. & F. SIEBER. 1985. *In vitro* analysis of quail neural crest differentiation. *In Cell Culture in the Neurosciences*. J. E. Bottenstein and G. Sato, Eds. 193–222. Plenum. New York.

8. HAMBURGER, V. & H. L. HAMILTON. 1951. A series of normal stages in the development of the chick embryo. *J. Morphol.* **88**: 49–92.
9. ITO, K. & M. SIEBER-BLUM. 1993. Pluripotent and developmentally restricted neural-crest-derived cells in posterior visceral arches. *Dev. Biol.* **156**: 191–200.
10. CIMENT, G. & J. A. WESTON. 1983. Enteric neurogenesis by neural crest-derived branchial arch mesenchymal cells. *Nature* **305**: 424–427.
11. YAMADA, K. M. 1982. Isolation of fibronectin from plasma and cells. *In* *Immunochemistry of the Extracellular Matrix*. H. Furthmayr, Ed. Vol. 1: 111–123. CRC Press. Boca Raton, FL.
12. LAZARIDES, E. 1978. The distribution of desmin (100Å) filaments in primary cultures of embryonic chick cardiac cells. *Exp. Cell Res.* **112**: 265–273.
13. LAZARIDES, E. & D. R. BALZER, JR. 1978. Specificity of desmin to avian and mammalian muscle cells. *Cell* **14**: 429–438.
14. LAZARIDES, E. & B. D. HUBBARD. 1976. Immunological characterization of the subunit of the 100Å filaments from muscle cells. *Proc. Natl. Acad. Sci. USA* **73**: 4344–4348.
15. LINSSENMAYER, T. F. & M. J. C. HENDRIX. 1980. Monoclonal antibodies to connective tissue macromolecules: type II collagen. *Biochem. Biophys. Res. Commun.* **92**: 440–446.
16. McDONALD, J. A., T. J. BOEKELMANN, M. LOU MATHEKE, E. CROUCH, M. KOO & C. KUHN III. 1986. A monoclonal antibody to the carboxyterminal domain of procollagen type I visualizes collagen synthesizing fibroblasts. *J. Clin Invest.* **78**: 1237–1244.
17. LIN, J. J., C. CHOU & J. L. LIN. 1985. Monoclonal antibodies against chicken tropomyosin isoforms: production, characterization, and application. *Hybridoma* **4**: 223–242.
18. SOLTER, D. & B. B. KNOWLES. 1978. Monoclonal antibodies defining a stage-specific mouse embryonic antigen (SSEA-1). *Proc. Natl. Acad. Sci. USA* **75**: 5565–5569.
19. SIEBER-BLUM, M. 1989. SSEA-1 is a specific marker from the spinal sensory neuron lineage in the quail embryo and in neural crest cell cultures. *Dev. Biol.* **134**: 362–375.
20. SIEBER-BLUM, M. 1989. Commitment of neural crest cells to the sensory neuron lineage. *Science* **243**: 1608–1611.
21. RICHARDSON, M. K. & M. SIEBER-BLUM. 1993. Pluripotent neural crest cells in the developing skin of the quail embryo. *Dev. Biol.* **157**: 348–358.
22. ARTINGER, K. B. & M. BRONNER-FRASER. 1992. Partial restriction in the developmental potential of late emigrating avian neural crest cells. *Dev. Biol.* **149**: 149–157.
23. JERDAN, J. A., H. H. VARNER, J. H. GREENBERG, V. J. HORN & G. R. MARTIN. 1985. Isolation and characterization of a factor from calf serum that promotes the pigmentation of embryonic and transformed melanocytes. *J. Cell Biol.* **100**: 1493–1498.
24. BURUZAWA, T. & J. T. BAGNARA. 1989. Control of melanoblast differentiation in amphibia by alpha-melanocyte stimulating hormone, a serum melanization factor, and a melanization inhibiting factor. *Pigment Cell Res.* **2**: 171–181.
25. SIEBER-BLUM, M., K. ITO, M. K. RICHARDSON, C. J. LANGTIMM & R. S. DUFF. 1993. Distribution of pluripotent neural crest cells in the embryo and the role of brain-derived neurotrophic factor in the commitment to the primary sensory neuron lineage. *J. Neurobiol.* **24**: 173–184.
26. CIMENT, G. & J. A. WESTON. 1985. Segregation of developmental abilities in neural-crest-derived cells: identification of partially restricted intermediate cell types in the branchial arches of avian embryos. *Dev. Biol.* **111**: 73–83.
27. SIEBER-BLUM, M. 1991. Role of the neurotrophic factors BDNF and NFG in the commitment of pluripotent neural crest cells. *Neuron* **6**: 949–955.
28. ZHANG, J. M. & M. SIEBER-BLUM. 1992. Anti-proliferative and neurogenic effects by $TGF\beta_1$ on neural crest cells override mitogenic and adrenogenic effects exerted by the bFGF/NGF peptide factor combination. *Mol. Biol. Cell* **3**: 285a.
29. SCARISBRICK, I. A., E. G. JONES, & P. J. ISACKSON. 1993. Coexpression of mRNAs for NGF, BDNF, and NT-3 in the cardiovascular system of pre- and post-natal rats. *J. Neurosci.* **13**: 875–893.
30. TESSAROLLO, L., P. TSOLFAS, D. MARTIN-ZANCA, D. J. GILBERT, N. A. JENKINS, L. E. COPELAND & L. PARADA. 1993. TrkC, a receptor for neurotrophin-3, is widely expressed in the developing nervous system and in non-neuronal tissues. *Development* **118**: 463–475.

Characterization of Human Cardiac Desmosomal Cadherins

BRIGITT D. ANGST, ROGER S. BUXTON, AND
ANTHONY I. MAGEE

*National Institute for Medical Research
The Ridgeway, Mill Hill
London NW7 1AA, United Kingdom*

Desmosomes are adhesive junctional complexes, shared by neighboring cells in vertebrate epithelial, arachnoidal and myocardial cells. They consist of an intercellular core portion apparently mediating stable intercellular adhesion and an electron-dense cytoplasmic plaque portion bearing attachment sites to which intermediate filaments link up and thus form a continuous network throughout the respective tissue.¹ They occupy ~30% of the area of the intercalated discs between adult cardiomyocytes.²

In recent years two desmosomal subfamilies of the cadherin superfamily of adhesion molecules, the desmocollins (DSC) and the desmogleins (DSG) have been identified in epithelia.³ Cadherins are transmembrane proteins responsible for calcium-dependent homophilic cell adhesion. These vital adhesion molecules exhibit a tissue-specific expression pattern and play key roles in many developmental processes.⁴ Each family of desmosomal cadherins consists of at least three distinct genes (FIG. 1),³ which are differentially expressed in epithelial maturation.⁵

To identify the human cardiac desmosomal cadherins we performed polymerase chain reaction (PCR), essentially as described,⁶ using specific oligonucleotide primer pairs to the known human DSC and DSG isoforms. An adult cardiac λ ZAP library, as well as a keratinocyte λ library were analyzed (FIG. 2).

From the human heart library we amplified PCR products with oligonucleotide primers specific for DSG2 and DSC2 isoforms only. These PCR products were subcloned into Bluescript and sequencing confirmed their identity. Performing PCR with pan-DSC or pan-DSG oligonucleotide primers on the heart library and subsequent sequencing of these products we found no novel desmosomal cadherin. We conclude DSG2 and DSC2 to be the desmosomal cadherins present in heart. They are the isoforms most commonly expressed across tissues as well as in the basal cells of the epidermis and can be regarded as the basic types of desmosomal cadherins. Our DSG2 data are consistent with work published by Schäfer *et al.*⁷

REFERENCES

1. GARROD, D. R. 1993. *Curr. Opin. Cell Biol.* 5(1): 30-40.
2. ANGST, B. D., L. U. R. KHAN, A. I. MAGEE, N. J. SEVERS, S. ROTHERY & R. G. GOURDIE. Unpublished observation.
3. BUXTON, R. S., P. COWIN, W. W. FRANKE, D. R. GARROD, K. J. GREEN, I. A. KING,

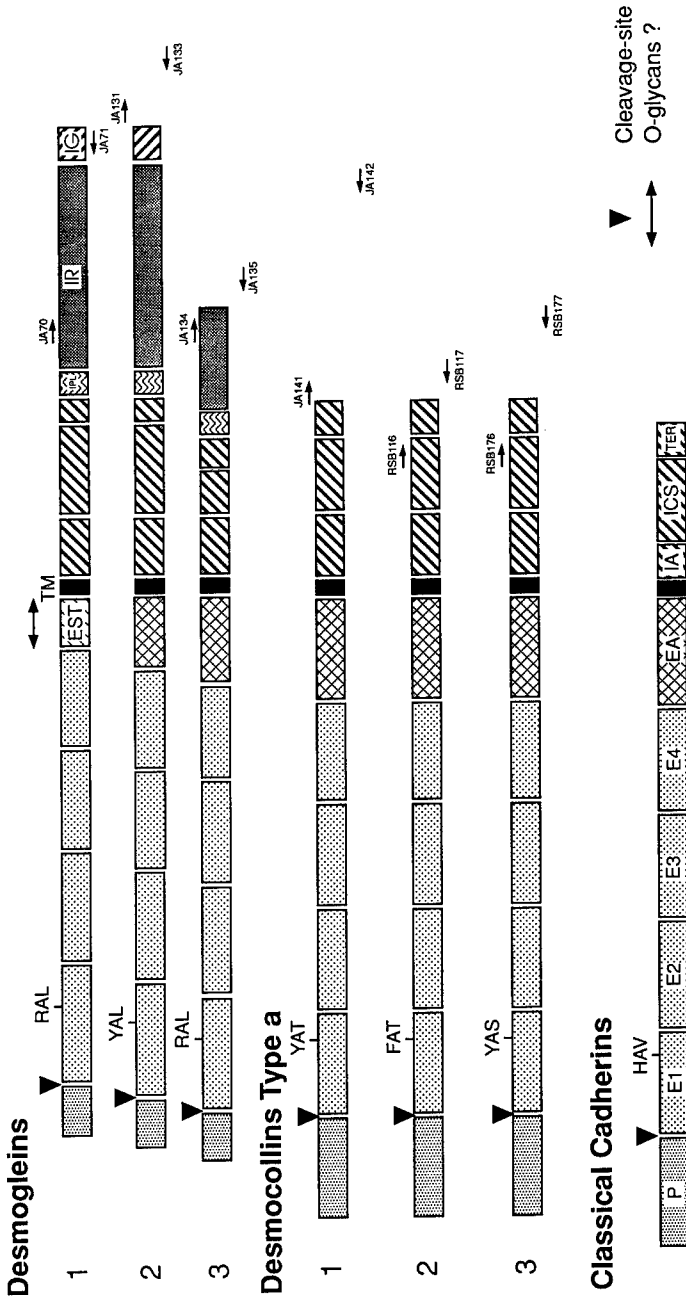

FIGURE 1. Structural organisation of the desmosomal cadherins: N-Cadherin found in neural and cardiac tissue is depicted as an example of a classical cadherin. Note that the desmocollin family members display additional cytoplasmic sequences. Each member of the desmocollin family also possesses a shorter desmocollin b splice variant exhibiting 11 C-terminal amino acids specific for and highly conserved in the DSCb variants. Key to all domain abbreviations: P, precursor sequence; E1-E4, cadherin repeat, including putative calcium binding sites; EA, external anchor domain; TM, transmembrane domain; IA, intracellular anchor domain; ICS, intracellular cadherin type segment; TER, terminal cadherin homology; IPL, proline-rich sequence; IR, intracellular repeat region; IG, intracellular glycine and serine-rich sequence; EST, potential site for O-linked glycosylation. The tripeptide core of the cell adhesion recognition region is shown in repeat E1. *Arrows* indicate primer pairs used in PCR. *Space bar* = 100 amino acids.

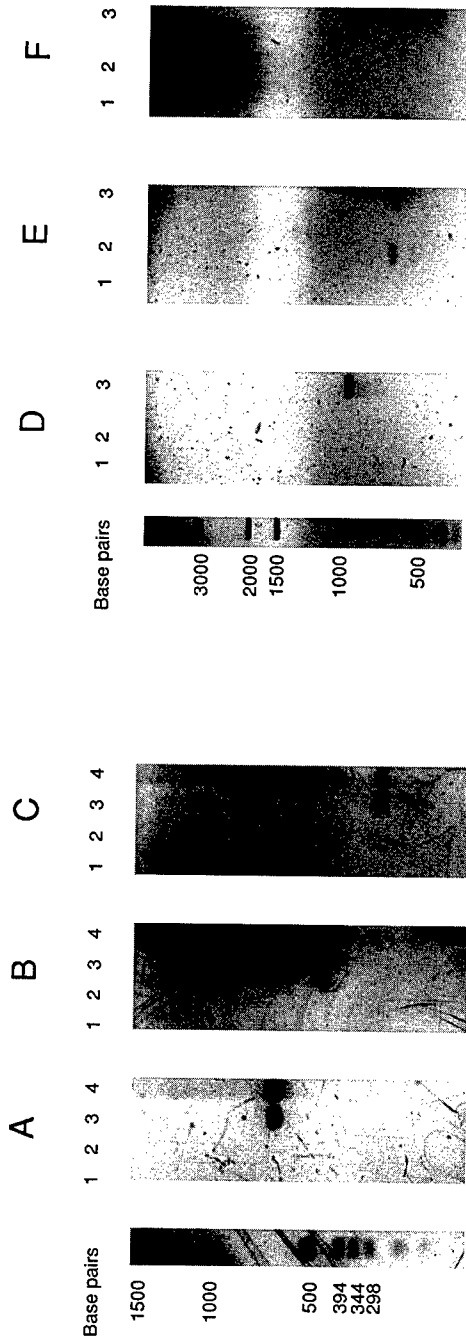

FIGURE 2. Identification of human cardiac desmosomal cadherins. Direct, hot start PCR was carried out essentially as described.⁵ Amplified products were visualized on a 1.5% agarose gel. PCR was performed on *lane 1*, a blank control; *lane 2*, an adult human cardiac λ ZAP library (Stratagene Ltd.); *lane 3*, a keratinocyte λ library; *lane 4*, genomic DNA from the SV40 transformed epithelial cell line SVK-14, with oligonucleotide primer pairs specific for: *panel A*, DSG1; *panel B*, DSG2; *panel C*, DSG3; *panel D*, DSC1; *panel E*, DSC2; *panel F*, DSC3. The amplified DSG2 and DSC2 products were subcloned into Bluescript and their identity verified by sequencing using the Sequenase kit (United States Biochemical Corp.).

- P. J. KOCH, A. I. MAGEE, D. A. REES & J. R. STANLEY. 1993. *J. Cell Biol.* **121**: 481-483.
4. KEMLER, R. 1993. *Trends Genet.* **9**(9): 317-321.
 5. ARNEMANN, J., K. H. SULLIVAN, A. I. MAGEE, I. A. KING & R. S. BUXTON. 1993. *J. Cell Sci.* **104**: 741-750.
 6. ARNEMANN, J., N. K. SPURR, G. N. WHEELER, A. E. PARKER & R. S. BUXTON. 1991. *Genomics* **10**: 640-645.
 7. SCHÄFER, S., P. J. KOCH & W. W. FRANKE. 1994. *Exp. Cell Res.* **211**: 391-399.

The Growth of the Individual Segments of the Embryonic Rat Heart

M. W. M. KNAAPEN,^a B. C. M. VROLIJK,^a AND

A. C. G. WENINK^b

*Department of Anatomy
University of Leiden
The Netherlands*

It has been suggested that embryonic growth rate shows discrete changes at specific moments in time. These changes are supposed to correlate with specific differentiation processes in the embryo.¹ Growth rate changes of the heart have been correlated with embryonic crown-rump-length.² The different segments of the embryonic heart have appeared to function differently: the atrioventricular canal and the ventricular outflow tract have been reported to show slow conduction velocity and slow contraction.³ In the present study, cardiac growth is further detailed. Myocardial growth of the individual cardiac segments is studied in relation to developmental age. The quantitative data are then used to evaluate the functional role of each segment during embryonic development. To this end, 35 rat embryos, age from 11 to 17 days, were perfusion fixed and serially sectioned at 2 μm . Myocardial volumes were estimated with Cavalieri's point counting method. The volumes of all individual segments and junctional zones were separately estimated.

The total myocardial volume increased from 0.0416 mm³ at day 11 to 2.7785 mm³ at day 17. The growth curve showed exponential growth (FIG. 1). The relative volumes (*i.e.*, the percentages of the total volume) of the individual segments and junctions developed as follows (FIG. 2):

The **sinus venosus** (*i.e.*, the first segment of the embryonic heart, which collects the venous blood) and the **sinuatrial junction** had the smallest proportion, which did not change between day 11 and day 17.

The volume of the **atrium** increased proportionally, although there was a small relative increase between day 11 and day 13.

The **atrioventricular canal** showed a dramatic decrease from an important proportion at day 11 to a proportion similar to that of sinus venosus and sinuatrial junction at day 17.

The **ventricular inlet segment** (future left ventricle) occupied nearly $\frac{1}{3}$ of the total volume, but had the highest proportion before day 13. The **primary fold** (the boundary between the two ventricular segments, giving rise to the septum) showed a remarkable increase of its relative volume from 4% at day 12 to 10% at day 14. The **proximal outlet segment** (apical part of the future right ventricle) first increased

^a Supported by NHS Grant 90-288.

^b Corresponding address: Dr. A. C. G. Wenink, Department of Anatomy, PO Box 9602, 2300 RC Leiden, The Netherlands.

its relative volume, but from day 14 kept pace with the inlet segment. The **distal outlet segment** (giving rise to both outflow tracts), like the atrioventricular canal, initially had a large relative volume, but decreased dramatically from day 13 onwards.

We conclude that, initially, the **ventricular inlet segment** is the most important part of the ventricular mass. Blood is propelled through the interventricular communication directly into the distal outlet segment, probably bypassing the still unimportant proximal part of the outlet segment. The **proximal outlet segment** only gradually acquires a similar pumping function, in particular when two atrioventricular blood streams evolve.

The **primary fold** increases importantly until day 14, to start ventricular septation. From that time it grows proportional to the total ventricular mass.

The **atrioventricular canal** has an important constrictive function in early stages, when valves are not yet present. Cushion tissue is then compressed to prevent backward flow into the atrium. The special physiological properties of this junctional myocardium highlight its crucial function.³ With development of the atrioventricular valves, such a constricting tube is no longer necessary.

The **distal outlet segment** similarly serves to compress cushion tissue and to prevent backward flow in early stages. With development of the semilunar valves this segment loses its mechanical function.

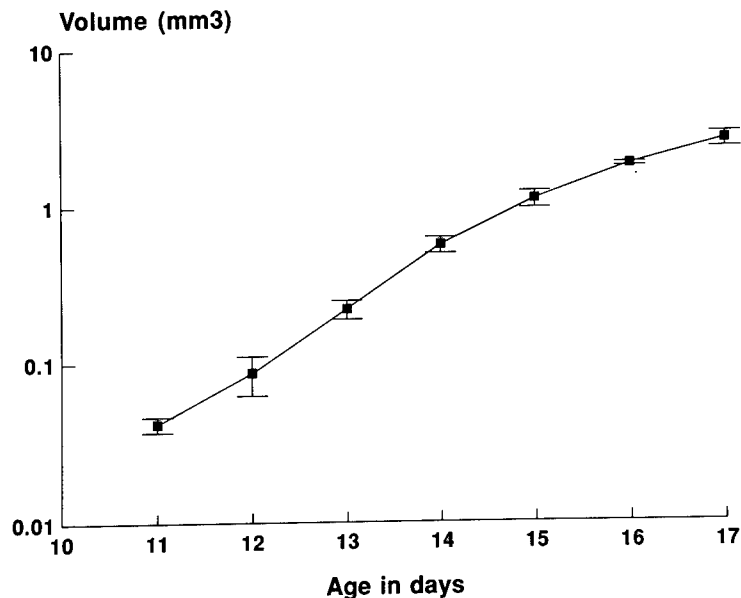

FIGURE 1. The total myocardial volumes of rat embryonic hearts from 11 to 17 days.

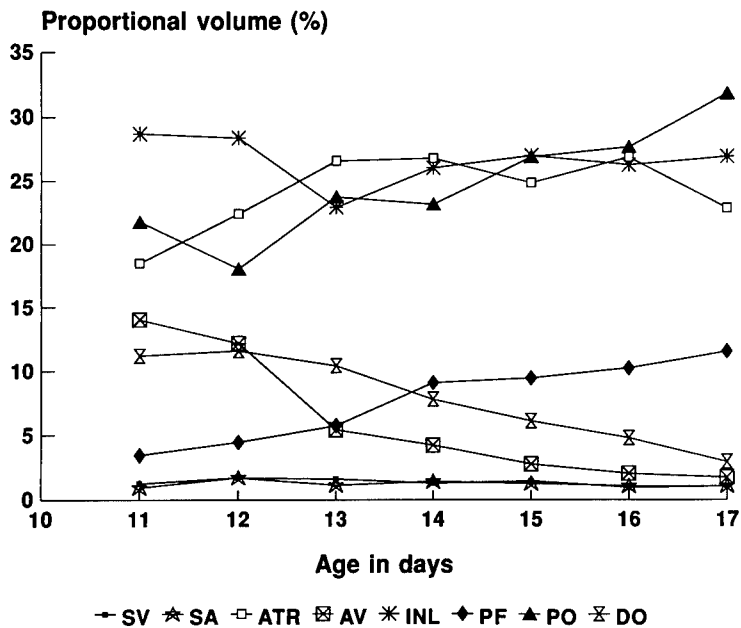

FIGURE 2. The myocardial volumes of the individual segments and junctions, expressed as a percentage of the total myocardial volume (see FIG. 1), in rat embryonic hearts from 11 to 17 days. SV: sinus venosus, SA: sinuatrial junction, ATR: atrium, AV: atrioventricular canal, INL: ventricular inlet segment, PF: primary fold, PO: proximal ventricular outlet segment, DO: distal ventricular outlet segment.

REFERENCES

1. GOEDBLOED, J. F. 1972. Embryonic and postnatal growth of rat and mouse. *Acta Anat.* **82**: 305-336.
2. MANDARIM-DE-LACERDA, C. A. 1991. Growth allometry of the myocardium in human embryos (from stages 15 to 23). *Acta Anat.* **141**: 251-256.
3. DE JONG, F., A. A. M. OPTHOF, M. J. WILDE, R. JANSE, R. CHARLES, W. H. LAMERS & A. F. M. MOORMAN. 1992. Persisting zones of slow impulse conduction in developing chicken hearts. *Circ. Res.* **71**: 240-250.

Structural Basis of Cardiomyopathy in Duchenne/Becker Carriers

Endomyocardial Biopsy Evaluation^a

G. NIGRO, S. DI SOMMA, L. I. COMI, L. POLITANO,
S. PAPPARELLA,^a B. RESTUCCI,^a V. R. PETRETTA,
M. A. M. GIUGLIANO, A. CAROTENUTO, F. M. LIMONGELLI,
AND O. DE DIVITIIS

*Interdepartmental Center for Genetic, Immunologic, and
Cardiovascular Diseases (GIMEC)*

and

*^aPathology and Environmental Interdepartmental Center
(CIUPA)*

*University of Naples
Naples, Italy*

Dystrophin gene mutations provoke at least three diseases: (1) Duchenne muscular dystrophy (DMD) caused by marked dystrophin deficiency in all striated muscles; (2) Becker muscular dystrophy (BMD) caused by qualitative and/or quantitative dystrophin abnormalities in all striated muscles; and (3) X-linked dilated cardiomyopathy (XLCM) caused by qualitative dystrophin abnormalities only in myocardium. This third type of cardiomyopathy seems not to be related to familial cases of DMD or BMD. However, many Duchenne and Becker carriers can show exactly the same clinical profiles, probably arising from a similar pathogenesis.

Such an apparently isolated cardiomyopathy was described by Comi *et al.*¹ in a population of females with a close relationship with subjects suffering from Duchenne or Becker muscular dystrophy. In that population 125 (59.6%) Duchenne and 15 (65.2%) Becker consultands showed signs of myocardial involvement.

Since its classical definition, the pathogenesis of dilated cardiomyopathy remains unknown. It is therefore natural to assume that detailed inspection of the myocardium could be rewarding. However, the value of endomyocardial biopsy is very high in clarifying the pathogenesis of the disease.

Olsen reported that biopsy of the heart was helpful in 85% of cases; biopsy confirmed the suspected clinical diagnosis in 59% of cases and disclosed unsuspected conditions in 26%.

Dilated cardiomyopathy is considered an indication for endomyocardial biopsy. It has already been used in skeletal muscle disorder to better clarify the pathogenesis of cardiac muscle abnormalities in these patients, in order to:

1. Evaluate myocardial ultrastructure and metabolism in Duchenne/Becker carriers with myocardial involvement and in patients affected by dilated cardiomyopathy of unknown aetiology;

^a This work was supported by grants from Italian Telethon.

2. Demonstrate that cardiac involvement in carriers of Duchenne/Becker dystrophinopathy is related to myocardial damage due to dystrophin anomalies; and
3. Find a relationship between myocardial dystrophin abnormalities and changes in tissular respiratory chain.

Thirty carriers of Duchenne/Becker gene with clinically evident cardiomyopathy and 20 patients affected by idiopathic dilated cardiomyopathy underwent a myocardial and muscular biopsy, after informed consent.

Both groups were previously submitted to clinical and instrumental examination (standard and dynamic ECG, 2D and M-mode echodoppler cardiography, 201 Tl and 99Tc myocardium scintigraphy, and chest X-rays).

All patients were previously submitted to DNA analysis.

Myocardial biopsy was performed in the CHAT-lab at the Cardioangiology Department of the Medical School of Federico II, Naples University, with ECG monitoring and under fluoroscopic control.² Four to six samples were taken successively for the following examinations:

1. Optical microscopy (liquid nitrogen—70°C);
2. Electronic microscopy (paraldeide); and
3. Histochemistry for enzymes of mitochondrial respiratory system and dystrophin (liquid nitrogen—70°C).

Immunostaining of dystrophin was performed according to the Nicholson procedure.³ All samples were labelled with rod MAb, C-terminus MAb, and amino-terminal MAb.

Beta-spectrin MAb (SPEC 1) was used as a control for muscle membrane integrity in fibers which appeared negative for dystrophin labelling.

DNA was prepared by standard procedure from peripheral frozen blood sample; multiplex PCR amplification was performed modifying the original protocol of Chamberlain; the amplification products were analyzed by Etbr.

RESULTS

Preliminary data concerned 6 obligatory female carriers, aged 32–68 yrs, of Duchenne/Becker dystrophinopathy and 6 female patients, age matched, with primary dilated cardiomyopathy.

TABLE 1. Myoglobin Content in Myocardial Tissue of Dystrophinopathic Carriers

	Dystrophin	Myoglobin (g/100 g Dried Tissue)		
		Min	Mean	Max
Duchenne/Becker carriers (n = 6)	5–95%	0.22	0.51	0.61
Controls (n = 6)	100%	1.35	1.53	1.68

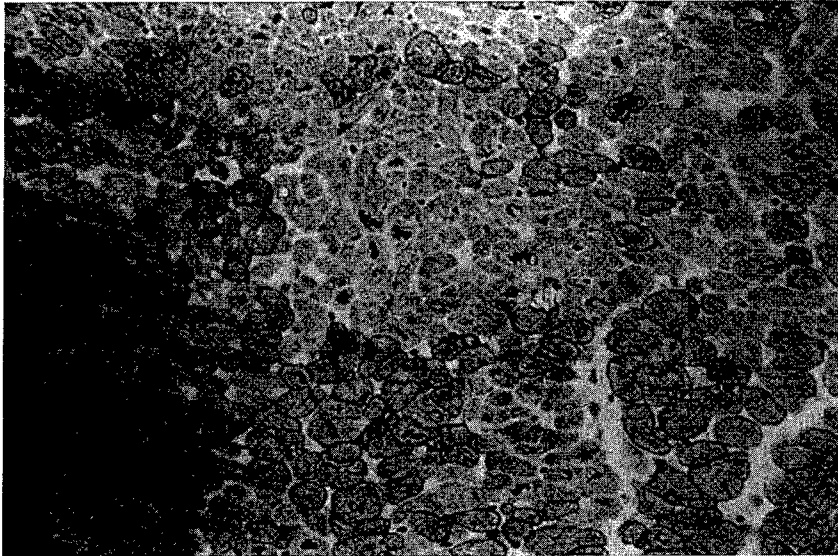

FIGURE 1. Positive and negative fibers occurring singly or in clusters.

Histological Findings

Dystrophin in cardiac myocytes of patients with dilated cardiomyopathy (control group) was normally localized to the sarcolemma and was uniformly positive; in carriers, on the contrary, cardiac muscle stained in a mosaic pattern of fully dystrophin positive and completely negative myocytes. Positive and negative fibers occurred singly or in clusters (FIG. 1).

Biochemical Assessment

A positive relationship between the content of dystrophin and the level of myoglobin is evident (TABLE 1).

REFERENCES

1. COMI, L. I., G. NIGRO, L. POLITANO & V. PETRETTA. 1992. The cardiomyopathy of Duchenne/Becker consultants. *Intl. J. Cardiol.* **34**: 297.
2. FOWLES. 1992. Cardiac biopsy.
3. NICHOLSON, L. V. B., K. DAVISON & G. FALKOUS. 1989. Dystrophin in skeletal muscle. I. Western blot analysis using a monoclonal antibody. *J. Neurol Sci.* **94**: 125.

Proliferative Activity of Myocytes in Transplanted Hearts Investigated Using BrdU

C. DI LORETO, D. ARTICO, N. FINATO, AND

C. A. BELTRAMI

*Pathology Institute
University of Udine
33100 Udine, Italy*

INTRODUCTION

In the past, myocytes were considered terminally differentiated cells that no longer possess the capacity of undergoing DNA synthesis and mitotic division. Recently, experimental evidence suggests that cardiac muscle cells capable of synthesizing DNA and dividing are present during the postnatal period and in adult life.^{1,2}

The aim of the present study was to assess the DNA synthetic activity of ventricular myocytes in adult man using 5-bromo-2'-deoxy-uridine (BrdU). BrdU is a nonradioactive analogue of thymidine that is incorporated into cells during S-phase and can be detected by standard immunocytochemical methods using monoclonal antibody against BrdU.

MATERIAL AND METHODS

Sixty-three endomyocardial biopsy specimens of the right side of the interventricular septum of transplanted hearts from 18 patients, 19–62 years old (mean age 48.8 yr) were examined. From each biopsy, at least four fragments were fixed in formalin and embedded in paraffin for histopathological diagnosis, four to six small fragments were incubated for 2 hours in presence of BrdU, washed, formalin fixed and paraffin embedded. The detection of BrdU was carried out on the sections with monoclonal antibody against BrdU (Euro-diagnostic, Holland) followed by peroxidase labelled rabbit anti-mouse immunoglobulin (Dakopatts, Denmark). The BrdU-positive nuclei were brown with a speckled to uniform staining pattern (FIG. 1). All nuclei definitely identified were counted at 400× magnification on the whole section. The cells were classified as lymphocytes, interstitial stromal cells and cardiac muscle cells if an evident striation of the sarcoplasm was present.

RESULTS

The total number of cells counted in all biopsies was 82780 (mean 1314 per endomyocardial biopsy). The number of cells identified as myocytes was 21292

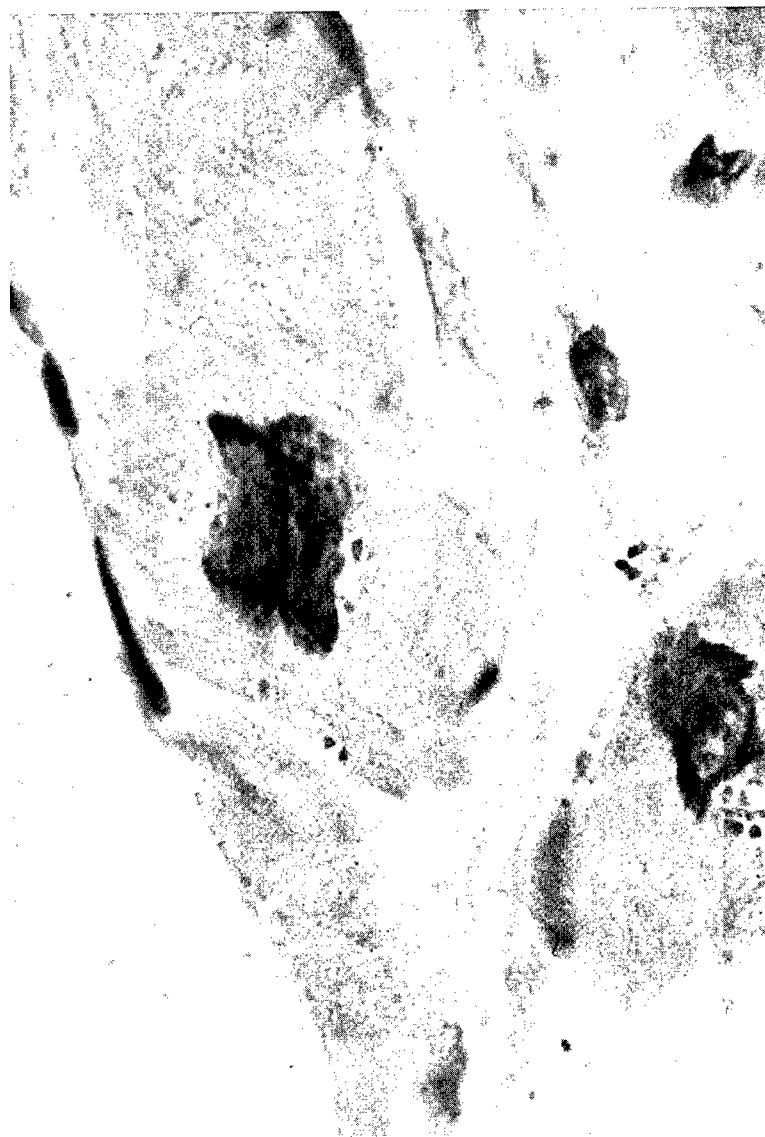

FIGURE 1. Endomyocardial biopsy showing a myocyte with BrdU positive nucleus. (Immunoperoxidase-hematoxylin, $\times 1000$.)

TABLE 1. Number of Cells Definitely Identified in 63 Endomyocardial Biopsies

Total cells	82780
Myocytes	21292
Cells/biopsy (mean)	1314
Myocytes/biopsy (mean)	338
% Myocytes	25.7%
Total BrdU-positive cells	384
Total BrdU-positive myocytes	14
Other BrdU-positive cells	370

(mean 337 per biopsy), which represented 25.7% of the cells. Fourteen myocytes showed positivity for BrdU; BrdU-positive lymphocytes and interstitial cells were 370. BrdU-positive myocytes were found in nine of 18 patients; the percentage of positivity ranged from 0.053% to 1.075% (mean 0.096%). No significant correlation was found between the presence of positive myocytes and grading of rejection, age of patients, days from transplantation, or clinical status.

Considering the total number of myocytes, the percentage of BrdU-positive myocytes was 0.06% (TABLE 1); because in the normal right ventricle the mean number of myocytes nuclei was about 2.25×10^9 ,³ we could estimate that the myocytes synthesizing DNA were 1,350,000.

CONCLUSIONS

The positive BrdU staining of cardiac myocytes reflects DNA synthesis. This phenomenon can occur as part of a cell repair process or as a part of a reduplication of DNA content. Because the positivity parallels the pattern of chromatin and is distributed on the whole nucleus, we suppose that the BrdU staining is correlated to a reduplication of DNA. DNA synthesis can explain the increase of myocyte ploidy found in cytofluorometric studies.⁴

Our data show a low percentage of BrdU-positive nuclei, but in our experimental conditions the incorporation of BrdU occurs both *in vitro* and after a short period of incubation; probably this percentage is understated with respect to the prevalence of myocytes DNA synthesis *in vivo*. Moreover, our material was obtained from patients who had undergone cardiac orthotopic transplantation, so we cannot establish if DNA replication in myocytes occurs as a physiologic phenomenon or is switched on in pathological conditions.

REFERENCES

1. OLIVETTI, G., R. RICCI & P. ANVERSA. 1987. Hyperplasia of myocyte nuclei in long-term cardiac hypertrophy in rats. *J. Clin. Invest.* **80**: 1818-1822.
2. ANVERSA, P., T. PALACKAL, E. H. SONNENBLICK, G. OLIVETTI, L. G. MEGGS & J. M. CAPASSO. 1990. Myocyte cell loss and myocyte cellular hyperplasia in the hypertrophied aging rat heart. *Circ. Res.* **67**: 871-885.
3. OLIVETTI, G., M. MELISSARI, J. M. CAPASSO & P. ANVERSA. 1991. Cardiomyopathy of

- the aging human heart: myocyte cell loss and reactive cellular hypertrophy. *Circ. Res.* **68**: 1560-1568.
4. ANVERSA, P., T. PALACKAL, E. H. SONNEMBLICK, G. OLIVETTI & J. M. CAPASSO. 1990. Hypertensive cardiomyopathy: myocyte nuclei hyperplasia in the mammalian heart. *J. Clin. Invest.* **85**: 994-997.

Signaling Pathways for Cardiac Growth and Hypertrophy

Recent Advances and Prospects for Growth Factor Therapy

GIUSEPPE LEMBO, JOHN J. HUNTER, AND
KENNETH R. CHIEN^a

*Department of Medicine
Center for Molecular Genetics
and*

*The American Heart Association-Bugher Foundation Center for
Molecular Biology
University of California, San Diego
La Jolla, California 92093*

INTRODUCTION

The adult mammalian heart adapts to hemodynamic stress such as that induced by hypertension, valvular heart disease, and loss of contractile myocytes (as with myocardial infarction or cardiomyopathy), by developing compensatory hypertrophy of the remaining myocytes.¹ Alterations in gene expression appear to be a central feature of this adaptive physiological process, including alterations in contractile protein content and composition, the induction of embryonic markers such as atrial natriuretic factor, and the expression of proto-oncogenes and other immediate early genes (for a review, see Ref. 2). Although adaptive in origin, lowering wall stress by thickening the wall in concentric hypertrophy, or increasing chamber size to preserve forward stroke volume in volume overload or myocardial infarction, the development of ventricular hypertrophy also appears to be an early step in pathological ventricular remodeling, eventually leading to a decrease in global cardiac function.

The mechanisms by which the hemodynamic stress is sensed by myocytes and growth-related signals activated and integrated to selectively regulate the cardiac muscle gene program during myocardial hypertrophy are largely unknown. The relative absence of hypertrophy in the right heart following aortic constriction³ and the selective growth of the right ventricle after pulmonary artery banding⁴ suggests that circulating factors are unlikely to be principal mediators of these forms of hypertrophy. The underlying general hypothesis is that identifiable growth factors are produced by cardiac non-muscle cells or by the myocytes

^a Address correspondence to: Kenneth R. Chien, M.D., Ph.D., Department of Medicine, 0613-C, University of California, San Diego, 9500 Gilman Drive, La Jolla, California 92093-0613.

themselves in response to hemodynamic stress, and that these factors, through specific cell-surface receptors and intracellular signaling cascades, regulate transcription of genes of the contractile apparatus, as well as others involved in cell growth. The isolation and molecular cloning of numerous growth factors during the past 5 years and the demonstration that some of these factors are synthesized in the heart, have had a major impact on our thinking about cardiac growth. New information is being generated with such rapidity that a comprehensive discussion of all aspects of these latest developments is beyond the scope of this article, and recent discussion can be found elsewhere in this volume. However, this brief review highlights a few of the candidate growth factors which have been implicated in activating a hypertrophic response in various cardiac model systems (TABLE 1). The number of distinct growth factors actually expressed in the myocardium is not yet known. The identification and characterization of cardiac growth factors and their receptors are a rapidly expanding area in cardiovascular research. Among those that have been identified in the heart include transforming growth factor-beta (TGF- β), insulin-like growth factor-1 (IGF-1), endothelin, angiotensin II, and a burgeoning number of new cardiac growth factors. We also describe present studies utilizing mouse genetics to dissect signaling pathways which mediate *in vivo* growth and hypertrophy of embryonic and adult myocardium, which should allow a direct evaluation of the role of these various signaling pathways in the activation of this adaptive physiologic response. Finally, we summarize recent work with IGF-1 which underscores the potential of growth factor therapy for cardiac muscle dysfunction.

TABLE 1. Growth Factors Implicated in Activating a Hypertrophic Response in Various Cardiac Model Systems^a

Growth Factor	Activity	References
Angiotensin	↑ release in stretch-induced hypertrophy	(22)
	↑ immediate early genes	(21)
	↑ ANF and skeletal α -actin expression	(21)
	ACE inhibitor or AT ₁ antagonists block cardiac hypertrophy	(13,14)
Endothelin	presence of binding sites in cardiac myocytes	(26-29)
	↑ mRNA preproendothelin-1 during cardiac hypertrophy	(33)
	↑ immediate early genes	(23)
	↑ ANF and MLC-2v	(23,30,31,32)
	ET _A receptor antagonist blocks cardiac hypertrophy	(33)
TGF- β	↑ mRNA during cardiac hypertrophy	(36-38)
	↑ β -MHC, α -skeletal actin, α -smooth actin, ANF	(39)
	↓ α -MHC	(39)
IGF-1	↑ IGF-1 mRNA and protein during cardiac hypertrophy	(50)
	↑ β -MHC, MLC-2v, troponin I	(48)
	↑ number of nascent myofibrils	(49)
	IGF-1 deficient mice show a preferential phenotype on cardiac and skeletal muscle growth	(52)

^a See text for abbreviations.

Angiotensin II

The renin-angiotensin system is considered one of the principal regulators of intravascular volume and systemic blood pressure. This system is primarily based on the proteolytic enzyme renin, which is synthesized by the kidney and secreted into the circulation, where it hydrolyzes the decapeptide angiotensin I from the amino-terminal end of angiotensinogen. Angiotensin I is converted to the octapeptide angiotensin II by the dipeptidyl carboxypeptidase, angiotensin-converting enzyme (ACE).⁵ However, renin may not be the only rate-limiting step for angiotensin II production, since several tissue-derived enzymes, such as cathepsin D, can cleave angiotensinogen to produce angiotensin I. Enzymes that can directly cleave angiotensinogen to release angiotensin II have been described, including cathepsin G, kallikrein, and tonin. Recently, a chymotrypsin-like protease has been cloned from the human heart (heart chymase), which has been suggested to represent an alternative pathway for the conversion of angiotensin I to angiotensin II.⁶ In the heart, angiotensin II binding sites have been described and the recent development of non-peptide angiotensin II antagonists has led to the discovery of two types of angiotensin II receptors designated as AT₁ and AT₂.⁷⁻⁹ The AT₁ receptor subtype is a seven transmembrane-domain protein that transmits angiotensin II effects through G-protein-coupled pathways. The AT₂ receptor is not G-protein linked and its biological function remains unknown.

Angiotensin II has both direct and indirect actions on myocardium affecting heart contractility, and cell growth.¹⁰⁻¹² Clinical and experimental studies have clearly indicated that ACE inhibitors or angiotensin receptor antagonists can cause regression of cardiac hypertrophy, an effect which in some experimental models seems independent from their effect on blood pressure.^{13,14} Moreover, in the past decade, mounting experimental evidence suggests that the renin-angiotensin system is not solely an endocrine system, but is present within several peripheral tissues including the heart.^{15,16} Renin and angiotensinogen mRNAs have been demonstrated in all four chambers of the heart,^{17,18} and ACE mRNA is induced more than fourfold in left ventricular tissue from hypertrophied hearts. Angiotensin II can diffuse from the myocardial microvasculature through the cardiac interstitium to activate receptors on cardiac myocytes, leading to increased contractility and/or growth. Angiotensin II can also activate the sympathetic nervous system.¹⁹ Recently, Baker *et al.* reported that angiotensin II increases protein synthesis in chick cardiac myocytes,²⁰ and Sadoshima *et al.* observed that angiotensin II is able to cause hypertrophy of rat cardiac myocytes and hyperplasia of cardiac non-myocytes, both actions mediated by the AT₁ receptor.²¹ Furthermore, Sadoshima *et al.*, using an *in vitro* model of stretch-induced cardiac hypertrophy, recently demonstrated that mechanical stretch causes release of angiotensin II from cardiac myocytes, and thus may act as an initiator of the stretch-induced hypertrophic response. By electron microscopy, these investigators observed that immunoreactive angiotensin II is preferentially localized in what appear to be secretory granules in ventricular myocytes.²² These observations are consistent with the hypothesis that locally produced angiotensin II acts as an endogenous growth factor regulating myocardial growth, and at the same time may affect the level of expression of other growth factor genes. Gene-targeted mice, which con-

tain "knockouts" of various components of the renin-angiotensin system, are currently being characterized by a number of laboratories, which should allow a direct evaluation of the role of this system in the hypertrophic response.

Endothelin

Recent studies in our laboratory showed that another powerful vasoconstrictor, endothelin-1, is a potent stimulus for myocardial cell growth and hypertrophy in a cultured myocardial cell model.²³ As predicted by the primary structure of the full-length cDNA, endothelin-1 is synthesized as a pre-propeptide of approximately 200 residues, which is subsequently cleaved to a 38–39-residue "big endothelin" molecule.²⁴ Further proteolytic processing results in the mature, biologically active 21-amino acid peptide which is highly conserved among species.²⁵ Although endothelin was initially thought to be localized exclusively in vascular endothelial cells, endothelin-1, endothelin-2, and endothelin-3 have now been found in extravascular tissues, including lung, pancreas, spleen, and neural tissue.^{26–28} Although previous studies demonstrated the presence of high-affinity endothelin-receptors on the surface of ventricular myocardial cells,^{29–32} the role of endothelin-1 in the regulation of ventricular function continues to be a subject of speculation. However, the results of a recent study provided clear evidence that endothelin-1 can activate a hypertrophic response in cultured neonatal rat ventricular myocardial cells, including the acquisition of several features of *in vivo* cardiac hypertrophy, such as an increase in cell size, activation of immediate early gene expression, induction of contractile protein gene synthesis, and the reactivation of a program of embryonic gene isoforms.¹⁵ Thus, stimulation of neonatal rat myocardial cells by endothelin-1 leads to the development of morphologic, structural, biochemical, and genetic markers of myocardial hypertrophy indistinguishable from those induced by documented *in vivo* and *in vitro* stimuli for adult myocardial cells. As endothelin is released from endothelial cells that lie immediately adjacent to the myocytes within the intact myocardium, the activation of myocardial cell hypertrophy may represent another important paracrine mechanism for the regulation of cardiac growth. Evidence to support such a phenomenon was recently demonstrated in an animal model of coarctation of the aorta.³³ During the development of left ventricular hypertrophy, prepro ET-1 messenger RNA1 was increased in the hypertrophied left ventricle as compared with sham-operated control animals. This rise showed a peak at 24 hours and returned to the basal level after 4 days. It would seem, therefore, that pressure overload induces gene expression for endothelin-1 within the heart. When the animals were given a specific endothelin-1A receptor subtype antagonist (BQ123), despite the hemodynamic overload, mRNA for genetic markers of cardiac hypertrophy, skeletal alpha-actin and ANP, remained at control levels, suggesting a specific role of endothelin signal in the development of certain features of left ventricular hypertrophy.³³

Transforming Growth Factor-Beta

Transforming growth factor-beta (TGF- β) is a stable, multifunctional polypeptide growth factor (for a review, see Ref. 34). While specific receptors for this

protein have been found on almost all mammalian cells examined, the effect depends on the cell type and growth conditions. Generally, TGF- β is stimulatory for cells of mesenchymal origin and inhibitory for cells of epithelial or neuroectodermal origin. The originally-described form of TGF- β , now designated TGF- β 1, is only one member of a family of regulatory proteins consisting of factors distantly related to TGF- β 1 (30–40% sequence identity), including the activins, inhibins, and bone morphogenetic proteins (BMPs), as well as more closely related proteins (70–80% sequence identity) designated TGF- β 2, TGF- β 3, TGF- β 4, and TGF- β 5. TGF- β 1 is synthesized as a 390 amino-acid precursor protein, which is cleaved to generate an N-terminal remnant and a monomer of mature TGF- β , which is then secreted as a latent complex. The mature TGF- β 1 dimer (25 kD) is noncovalently associated with a dimer of the N-terminal peptide, latency-associated protein (80 kD), which in turn is linked by disulfide bonds to the 125- to 160-kD TGF- β 1 binding protein. Mutational analysis in the pre-pro region of TGF- β have demonstrated that this region is necessary for proper folding, stability, and secretion of the latent complex. Once secreted, the latent complex can be activated by extreme pH, heat, or proteolytic enzymes to release mature dimeric TGF- β . This complex posttranslational control permits the rapid release of large stores of TGF- β and probably represents another mechanism to regulate the biological effects of TGF- β *in vivo*. Sporn and Roberts³⁴ have emphasized that TGF- β should not be viewed as a molecule with an intrinsic action, but rather as a cellular switch, serving as a mechanism for coupling cells to their environment and thus providing them with the plasticity to respond appropriately to environmental changes. The heart represents a good model for these complex actions. In the adult heart, significant levels of this cytokine are seen in cardiac myocytes, endothelium, smooth muscle cells, fibroblasts, and conductive tissue; its actions affect the pattern of expression of contractile proteins of the gene myocytes, the proliferation of smooth muscle cells in coronary arteries, and the synthesis of extracellular matrix proteins that form the cardiac skeleton.^{35,36} Induction of TGF- β in the adult ventricle, as with other growth factors, has been observed during hypertrophy provoked by aortic banding,³⁷ as well as in the compensatory hypertrophy distant from areas of myocardial infarction.³⁸ Furthermore, using cultured neonatal myocardial cells, treatment with TGF- β upregulates the expression of a number of cardiac genes³⁹ and regulates the beating rate of these myocytes when cultured in serum-free medium, maintaining their regular rhythm and their rate of beating.⁴⁰ Moreover, TGF- β can antagonize the suppressive effects of interleukin-1 β (a putative mediator of acute and chronic cardiac damage) on the beating rate of the myocytes, similar to its ability to counteract many interleukin-1 actions on other cell types.^{40–43} The relevance of these *in vitro* findings to the *in vivo* context is unknown, but currently the focus of study by several laboratories.

IGF-1

IGF-1 is a nonglycosylated, single chain peptide of 70 amino acid residues with structural and biological function homology to proinsulin (for a review, see Ref. 44). To date, six forms of IGF binding proteins (IGFBPs) that range in size from

24 to 45 kDa have been identified and sequenced. The IGFbps transport the IGFs in plasma and across capillary membranes, control the interaction of the IGFs with receptors, and generally modulate the actions of IGF-1.⁴⁵ At least four serum proteases that specifically cleave the IGFbps have been described.⁴⁶ The actions of these proteases are believed to alter the manner in which each IGFbp binds to and presents IGF-1. The proteolytic processing of IGFbp, along with other posttranslational modifications such as phosphorylation, provide the potential for multiple levels of control of IGF function upon binding to these carriers. The IGF-1 receptor is structurally similar to the insulin receptor.⁴⁷ Both are synthesized as single chains that become glycosylated and cleaved, producing alpha and beta subunits. The mature receptor is a heterotetramer with two 125-kDa alpha chains oriented extracellularly and two 95-kDa beta chains extending through the membrane and containing tyrosine kinase activity. Although the pituitary secretion of growth hormone stimulates the production of IGF-1, primarily in the liver (endocrine mode), most tissues synthesize IGF-1 locally (autocrine/paracrine mode⁴⁵).

Recently, IGF-1 has also been shown to be a growth factor for cardiac myocytes. In cultured cardiac myocytes, specific IGF-1 receptors are present and IGF-1 stimulation increases the mRNA for beta-MHC, MLC2 and troponin I; protein synthesis is also enhanced by IGF-1 in adult cardiomyocytes.⁴⁸ More recently, it has been reported that IGF-1-treated adult cardiac myocytes showed a dramatic increase of the number of nascent myofibrils compared with controls.⁴⁹ An increase in left ventricular IGF-1 mRNA and IGF-1 protein has been described in pressure overload cardiac hypertrophy in various models of high, moderate, and low-renin hypertension, suggesting that IGF-1 may be an important common mediator of an adaptive hypertrophic response.⁵⁰ Transgenic mice expressing human IGF-1, under the control of the metallothionein promoter, do not have detectable transgene mRNA in the heart and do not develop increased cardiac mass despite 1.5-fold elevated circulating IGF-1 levels and enlargement of other organs.⁵¹ IGF-1 deficient mice, generated by mutating the IGF-1 gene in embryonic stem cells by homologous recombination, demonstrate an effect on cardiac and skeletal muscle growth and myogenesis.⁵² Unfortunately the homozygotes die perinatally; since IGF-1 is expressed in a wide variety of cell types throughout the body, it is likely that widespread organ failure or dysfunction in this model may make it difficult to ascertain the specific effects of IGF-1 on cardiac muscle cells. As noted later in this review, recent collaborative work between our laboratory and that of J. Ross, Jr. has documented that the *in vivo* infusion of IGF-1 into experimental animals can result in cardiac enlargement and features of cardiac hypertrophy.⁵³ These results suggest the possibility that local IGF-1 production and IGF-1-dependent signaling pathways may be important in cardiac myocyte hypertrophy in response to stress. Accordingly, defects in the IGF-1 signaling pathways might impair compensatory hypertrophy during cardiac overload and lead to a failing cardiac muscle phenotype. Recently, a mutation in the submembranous region of the IGF-1 receptor was shown to create a dominant negative phenotype, and essentially to block IGF-1-dependent proliferation in cultured fibroblast.⁵⁴ The generation of transgenic mice which harbor the fusion gene between a MLC-2v promoter and such a dominant negative IGF-1 receptor coding region

may eventually allow a direct test on the heart of the role of IGF-1-dependent pathways in either adaptive or maladaptive hypertrophy in the *in vivo* context.

IGF-1-Mediated Hypertrophy, Ventricular Remodeling, and Performance in Dysfunctional Hearts

The association of IGF-1 administration *in vivo* with a physiologic hypertrophic response in normal animals has suggested its potential value as a therapeutic agent to alter remodeling and improve global cardiac function in the setting of heart failure. In previous experiments, rats with doxorubicin-induced cardiomyopathy showed no significant increase in heart weight after IGF-1 infusion (0.8 mg/kg/day for 3 weeks), although body weight increased transiently and the cardiac index was higher in treated compared to untreated animals.⁵⁵ A recent study utilized a well-characterized experimental model of cardiac failure after myocardial infarction in the rat,⁵⁶ providing evidence that IGF-1 can enhance cardiac size and improve cardiac performance during the development of experimental cardiac failure. The observed increase in left ventricular end-diastolic volume occurred without a change in the thickness of the non-infarcted wall, consistent with the concept that IGF-1 administration in this post-infarct setting produced an eccentric form of hypertrophy; moreover, there was no significant increase in end-systolic volume. LV dilation in the IGF-1-treated animals was associated with enhanced function, as estimated by the stroke volume, angiographic cardiac output when normalized to tibia length, and improved ejection fraction in rats with large infarctions. The above responses to IGF-1 differ from those when angiotensin-converting enzyme inhibitors are used after myocardial infarction to reduce excessive left ventricular dilation, and perhaps to inhibit hypertrophy.⁵⁷ However, there are important differences between the progressive cardiac dilation that occurs in heart failure after myocardial infarction and the cardiac enlargement accompanying IGF-1 treatment. Following myocardial infarction, progressive LV dilation and failure primarily occur with side-to-side cell and fiber bundle shear or slippage associated with concomitant wall thinning, increased wall stress and depressed stroke volume and ejection fraction. This dilation, with increased end-diastolic and end-systolic volumes associated with a reduced ejection fraction, has been a prognostic indicator of increased morbidity and mortality. On the other hand, LV dilation after infarction with IGF-1 treatment appeared to occur with a concomitant increase in muscle mass, without wall thinning or increased end-systolic volume, which could be beneficial in restricting elevations in diastolic and systolic wall stress. These effects of IGF-1 on cardiac size and improved cardiac performance were not secondary to an effect on myocardial infarct size, which was similar in both the treated and untreated groups. Since no evidence of significant mitral regurgitation was found in these animals, the improvement was not explained by a differential effect on mitral regurgitation, which could lead to an increase in total stroke volume.

After myocardial infarction, the ensuing hypertrophic response is of the volume overload type, which is associated with decreased capillary density.⁵⁸ The recent findings of unchanged capillary density in the IGF-1-treated group suggest the

possibility that, despite additional hypertrophy, IGF-1 may stimulate appropriate growth of capillaries in this setting. Coupled with the lack of increased fibrosis, such findings may characterize a physiologic form of hypertrophy.

Thus, our recent studies challenge the view that the eccentric hypertrophy and chamber enlargement associated with cardiac injury necessarily result in pathological ventricular remodeling and a concomitant decrease in left ventricular function. They suggest, rather, that the activation of a physiological form of hypertrophy may, in fact, be beneficial in the setting of heart failure and that growth factor therapy might represent a new and rational therapeutic approach for treating some forms of cardiac failure. It should be recognized that the present study concerned the short-term use of relatively large doses of IGF-1 in an evolving myocardial infarction model of left ventricular dysfunction, and longer-term studies are planned. Also, IGF-1 stimulated substantial growth of many organs and body mass in this study. Since IGF-1 is a pleiotropic growth factor, the isolation and characterization of growth factors with relatively restricted cardiac selectivity could be advantageous. On the other hand, since weight loss and muscle atrophy are often significant problems in severe clinical heart failure, the trophic effects of IGF-1 on skeletal muscle might be beneficial in that setting. Based on these initial observations, additional experiments seem warranted to further evaluate the potential therapeutic role of IGF-1 and other novel and/or known growth factors which might be capable of activating physiological forms of cardiac hypertrophy in the failing heart.

Mapping Signaling Pathways for Cardiac Growth and Hypertrophy in Genetically Manipulated Mice

The difficulty in harnessing genetic-based approaches to cardiac model systems has contributed to our current lack of molecular insights into the *in vivo* signaling pathways for cardiac chamber growth and hypertrophy. Recent advances in mouse genetics and embryonic stem cell technology suggest their utility to directly assess the role of individual candidate genes in the pathogenesis of defects in ventricular chamber growth in both the embryonic and adult contexts. As noted above, a number of defined growth factors and candidate signaling molecules have been implicated in the activation of features of a hypertrophic response in a cultured cardiac muscle cell model system. Recently, we used the MLC-2v 250-bp promoter to target expression of heterologous genes to the ventricular compartment in transgenic mice.^{59,60} Based upon insights derived from the *in vitro* model system,^{61,62} we subsequently targeted the expression of dominantly active or inhibiting forms of specific signaling molecules to the ventricular chamber in transgenic mice. Since studies in the *in vitro* model system have implicated Ras-dependent pathways in the activation of cardiac hypertrophy,⁶³ we generated transgenic mice which harbor an MLC-activated Ras fusion gene.⁶⁴ The ventricular targeted expression of mutant, constitutively active p21 Ras in mice heterozygous for an MLC-Ras transgene results in a modest (7%) increase in LV mass/BW ($p < 0.04$) versus wild type, without detectable changes in chamber or myocyte architecture or cardiac function (as detected by microangiography and LV manometry). How-

ever, mice homozygous for the MLC-Ras transgene display a marked increase in LV mass/BW versus wild type littermates (~57%), a >20-fold increase in ANF mRNA expression, and an increase in myocyte size. Histological analysis reveals concentric left ventricular hypertrophy with the absence of myocyte necrosis and clear evidence of myocyte disarray indistinguishable from hypertrophic cardiomyopathy in man. Global systolic function (LVEF), contractility (dp/dt), and isoproterenol-induced increases in dp/dt are preserved, while the homozygous MLC-Ras mice display impaired LV relaxation. Left atrial mass is selectively increased, consistent with chronic elevations in LVEDP, while right atrial mass is not significantly increased versus wild type levels. The RV is not as significantly hypertrophied in the homozygous MLC-Ras mice, suggesting that the Ras phenotype may be modulated by the extent of hemodynamic workload. Thus, the homozygous MLC-Ras transgenic mice display a cardiac phenotype consistent with ventricular hypertrophy in man in the absence of increased blood pressure *per se*. Further analysis of the homozygous phenotype is currently in progress, and crosses into other genetic backgrounds are being conducted to examine interactions with other signaling pathways.

Congenital heart disease annually affects 1/200 live births in the U.S. today, with the most frequent defects affecting ventricular chamber growth and development, including conoseptal VSDs, muscular VSDs, atrioventricular defects, and chamber hypoplasia. In collaboration with the laboratory of Ron Evans at the Salk Institute, we recently characterized a RXR α -deficient mouse model, generated by targeted gene disruption in embryonic stem cells, which harbors ventricular chamber growth defects that resemble congenital heart phenotypes in man.⁶⁵ The defect which causes lethality is associated with hypoplasia of the ventricular compact zone. High speed contrast fluorescence videomicroscopy of individual RXR α -deficient embryos (with placental circulation intact) provided direct evidence of ventricular dysfunction and a muscular VSD. *In situ* analysis with an MLC-2v probe provides evidence of a normal pattern of ventricular specification,⁶⁶ with restricted expression of MLC-2v to the ventricular segment of the heart tube. However, MLC-2a is persistently expressed in the ventricular chamber, and is not appropriately downregulated during expansion of the compact zone,⁶⁷ indicating maturational delay and/or arrest of ventricular muscle cell lineages.⁶⁸ In collaboration with Tomas Pexieder at the University of Lausanne, we have utilized microdissection and scanning electron microscopy to identify defects in the conotruncal segments of the developing heart tube. In the RXR α -deficient embryos, we have observed malformations in the conotruncal cushions, which are accompanied by conoseptal VSDs, and an increased incidence of double outlet right ventricle. Since endocardial cushion formation requires interaction between cardiac muscle cells and endocardial cells, the possibility exists that the maturational arrest of muscle in the conotruncal segment of the developing heart tube might secondarily lead to abnormal development of the corresponding cushions. Embryos heterozygous for the defective RXR α allele do not display defects in the conotruncus. The central objective of our current efforts is to identify candidate genes that are located downstream from RXR α and which may be linked to ventricular dysmorphogenesis. Consequently, the role of each of the candidate genes can be explored in both *in vitro* and *in vivo* model systems by examining their

ability to partially or completely rescue the mutant phenotype. In this manner, we hope to begin the genetic dissection of this congenital heart disease phenotype, which includes ventricular chamber hypoplasia, ventricular muscular septal defects, and defects related to the conotruncal segment of the heart tube.

These novel mouse models, coupled with unique systems to monitor the *in vivo* physiological phenotype^{3,4,68,69} provide a valuable, new approach for the study of ventricular chamber growth, hypertrophy, and morphogenesis. Our hope is that these insights will ultimately shed light on the molecular determinants of abnormal cardiac growth and hypertrophy in defined cardiac disease states in man.

REFERENCES

- GROSSMAN, W. 1980. Cardiac hypertrophy: adaptation or pathologic process. *Am. J. Med.* **69**: 576–583.
- CHIEN, K. R., K. U. KNOWLTON, H. ZHU & S. CHIEN. 1991. Regulation of cardiac gene expression during myocardial growth and hypertrophy: molecular studies of an adaptive response. *FASEB J.* **5**:3037–3046.
- ROCKMAN, H. A., R. S. ROSS, A. N. HARRIS, K. U. KNOWLTON, M. E. STEINHELPER, L. FIELD, J. ROSS & K. R. CHIEN. 1991. Segregation of atrial specific and inducible expression of an ANF transgene in an *in vivo* murine model of cardiac hypertrophy. *Proc. Natl. Acad. Sci. USA* **88**: 8277–8281.
- ROCKMAN, H. A., S. ONO, R. S. ROSS, L. R. JONES, M. KARIMI, V. BHARGAVA, J. ROSS, JR. & K. R. CHIEN. 1994. Molecular and physiological alterations in murine ventricular dysfunction. *Proc. Natl. Acad. Sci. USA* **91**: 2694–2698.
- PEACH, M. J. 1977. Renin-angiotensin systems: biochemistry and mechanisms of action. *Physiol. Rev.* **57**: 313–370.
- URATA, H., A. KINOSHITA, F. M. MISONO, F. M. BUMPUS & A. HUSAIN. 1990. Identification of a highly specific chymase as the major angiotensin II-forming enzyme in the human heart. *J. Biol. Chem.* **265**: 348–357.
- ROGG, H., A. SCHMID & M. DE GASPARO. 1990. Identification and characterization of angiotensin II receptor subtypes in rabbit ventricular myocardium. *Biochem. Biophys. Res. Commun.* **173**: 416–422.
- MURPHY, T. J., R. ALEXANDER, K. K. GRIENDLING, M. S. RUNGE & K. E. BERNSTEIN. 1991. Isolation of a cDNA encoding the vascular type-1 angiotensin II receptor. *Nature* **351**: 233–236.
- MUKOYAMA, M., M. NAKAJIMA, M. HORIUCHI, H. SASAMURA, R. E. PRATT & V. J. DZAU. 1993. Expression cloning of type 2 angiotensin II receptor reveals a unique class of seven-transmembrane receptors. *J. Biol. Chem.* **268**:24539–24542.
- KOCH-WESER, J. 1964. Myocardial actions of angiotensin. *Circ. Res.* **14**: 337–344.
- KOBAYASHI, M., Y. FURUKAWA & S. CHIBA. 1978. Positive chronotropic and inotropic effects of angiotensin II in the dog heart. *Eur. J. Pharmacol.* **50**: 17–25.
- NEYES, L. & H. VETTER. 1989. Action of atrial natriuretic peptide and angiotensin II on the myocardium: studies in isolated rat ventricular cardiomyocytes. *Biochem. Biophys. Res. Commun.* **163**: 1435–1443.
- LINZ, W., B. A. SCHOELKENS & D. WONTEN. 1989. Converting enzyme inhibitor specifically prevents development and induces the regression of cardiac hypertrophy in rats. *Clin. Exp. Hypertens.* **11**: 1325–1350.
- BAKER, K. M., M. I. CHERIN, S. K. WIXON & J. F. ACETO. 1990. Renin angiotensin system involvement in pressure-overload cardiac hypertrophy in rats. *Am. J. Physiol.* **259**: H324–H332.
- DOSTAL, D. E. & K. M. BAKER. 1993. Evidence for a role of an intracardiac renin-angiotensin system in normal and failing hearts. *Trends Cardiovasc. Med.* **3**: 67–74.
- DZAU, V. J. & R. N. RE. 1987. Evidence for the existence of renin in the heart. *Circulation* **75**: 1134–1136.

17. LINDPAINTNER, K. & D. GANTEN. 1991. The cardiac renin-angiotensin system: an appraisal of present experimental and clinical evidence. *Circ. Res.* **68**: 905–921.
18. DOSTAL, D. E., K. C. ROTHBLUM, M. I. CHERNIN, G. R. COOPER & K. M. BAKER. 1992a. Intracardiac detection of angiotensinogen and renin: evidence for a localized renin-angiotensin system in neonatal rat. *Am. J. Physiol. (Cell Physiol.)* **32**: C838–C850.
19. NOSHIO, T., K. SHIMIZU, D. WAY, Y. MIURA & B. P. McGRATH. 1994. Angiotensin II enhances norepinephrine spillover during sympathetic activation in conscious rabbits. *Am. J. Physiol.* **266**: H1864–H1871.
20. ACETO, J. F. & K. M. BAKER. 1990. [Sar¹] angiotensin II receptor-mediated stimulation of protein synthesis in chick heart cells. *Am. J. Physiol.* **258**: H806–H813.
21. SADOSHIMA, J. & S. IZUMO. 1993. Molecular characterization of angiotensin II-induced hypertrophy of cardiac myocytes and hyperplasia of cardiac fibroblasts. Critical role of the AT₁ receptor subtype. *Circ. Res.* **73**: 413–423.
22. SADOSHIMA, J., Y. XU, H. S. SLAYTER & S. IZUMO. 1993. Autocrine release of angiotensin II mediates stretch-induced hypertrophy of cardiac myocytes *in vitro*. *Cell* **75**: 977–984.
23. SHUBEITA, H. E., P. M. McDONOUGH, A. N. HARRIS, K. U. KNOWLTON, C. C. GLEMBOTSKI, J. HELLER-BROWN & K. R. CHIEN. 1990. Endothelin induction of inositol phospholipid hydrolysis, sarcomere assembly, and cardiac gene expression in ventricular myocytes. *J. Biol. Chem.* **265**: 20555–20562.
24. YANAGISAWA, M., H. KURIHARA, S. KIMURA, Y. TOMOBE, M. KOBAYASHI, Y. MITSUI, Y. YAZAKI, K. GOTO & T. MASAKI. 1988. A novel potent vasoconstrictor peptide produced by vascular endothelial cells. *Nature* **332**: 411–415.
25. SAIDA, K., Y. MITSUI & N. ISHIDA. 1989. A novel peptide, vasoactive intestinal contractor, of a new (endothelin) peptide family. *J. Biol. Chem.* **264**: 14613–14616.
26. DAVENPORT, A. P., D. J. NUNEZ, J. A. HALL, A. J. KAUMANN & M. J. BROWN. 1989. Autoradiographical localization of binding sites for porcine [¹²⁵I] endothelin-1 in humans, pigs, and rats: functional relevance in humans. *J. Cardiovasc. Pharmacol.* **13**: S166–S170.
27. NEUSER, D., W. STEINKE, G. THEISS & J. P. STASCH. 1989. Autoradiographic localization of [¹²⁵I] endothelin-1 & [¹²⁵I] atrial natriuretic peptide in rat tissue: a comparative study. *J. Cardiovasc. Pharmacol.* **13**: S67–S73.
28. KOSEKI, C., M. IMAI, Y. HIRATA, M. YANAGISAWA & T. MASAKI. 1989. Binding sites for endothelin-1 in rat tissues: an autoradiographic study. *J. Cardiovasc. Pharmacol.* **13**: S153–S154.
29. GU, X. H., D. J. CASLEY & W. G. NAYLER. 1989. Characterization of [¹²⁵I] endothelin-1 binding sites in rat cardiac membrane fragments. *J. Cardiovasc. Pharmacol.* **13**: S171–S173.
30. FUKUDA, Y., Y. HIRATA, H. YOSHIMA, T. KOJIMA, Y. KOBAYASHI & T. MASAKI. 1988. Endothelin is a potent secretagogue for atrial natriuretic peptide in cultured rat atrial myocytes. *Biochem. Biophys. Res. Commun.* **155**: 167–172.
31. IIDA, H. & E. PAGE. 1989. Determinants of atrial natriuretic peptide secretion in cultured atrial myocytes. *Am. J. Physiol.* **256**: c608–c613.
32. SEI, C. A. & C. C. GLEMBOTSKI. 1990. Calcium dependence of phenylephrine-, endothelin-, and potassium chloride-stimulated atrial natriuretic factor secretion from long-term primary neonatal rat atrial cardiocytes. *J. Biol. Chem.* **265**: 7166–7172.
33. ITO, H., M. HIROE, Y. HIRATA, H. FUJISAKI, S. ADACHI, H. AKIMOTO, Y. OHTA & F. MARUMO. 1994. Endothelin ET_A receptor antagonist blocks cardiac hypertrophy provoked by hemodynamic overload. *Circulation* **89**: 2198–2203.
34. SPORN, M. B. & A. B. ROBERTS. 1992. Transforming growth factor- β : recent progress and new challenges. *J. Cell Biol.* **119**: 1017–1021.
35. SCHNEIDER, M. D. & T. D. PARKER. 1991. Cardiac growth factors. *Rec. Prog. Growth Factor Res.* **3**: 1–26.
36. VILLARREAL, F. J. & W. H. DILLMANN. 1992. Cardiac hypertrophy-induced changes in messenger RNA levels for TGF- β 1, fibronectin, and collagen. *Am. J. Physiol.* **262**: 1861–1866.

37. KOMURO, I., Y. KATOH, E. HOH, F. TAKAKU & Y. YAZAKI. 1991. Mechanisms of cardiac hypertrophy and injury: possible role of protein kinase C activation. *Jpn. Circ. J.* **55**: 1149–1157.
38. THOMPSON, N. L., F. BAZOBBERRY, E. H. SPEIR, W. CASSCELLS, V. J. FERRANS, K. C. FLANDERS, P. KONDAIAH, A. G. GEISER & M. B. SPORN. 1988. Transforming growth factor beta-1 in acute myocardial infarction in rats. *Growth Factors* **1**: 91–99.
39. PARKER, T. G., S. E. PACKER & M. D. SCHNEIDER. 1990. Peptide growth factors can provoke "fetal" contractile protein gene expression in rat cardiac myocytes. *J. Clin. Invest.* **85**: 507–514.
40. ROBERTS, A. B., N. S. ROCHE, T. S. WINOKUR, J. K. BURMESTER & M. B. SPORN. 1992a. Role of TGF-beta in maintenance of function of cultured cardiac myocytes: autocrine action and reversal of damaging effects of interleukin-1. *J. Clin. Invest.* **90**: 2056–2062.
41. GULICK, T., M. K. CHUNG, S. J. PIEPER, L. G. LANGE & G. F. SCHREINER. 1989. Interleukin-1 and tumor necrosis factor inhibit cardiac myocyte beta-adrenergic responsiveness. *Proc. Natl. Acad. Sci. USA* **86**: 6753–6757.
42. MUSSO, T., I. ESPINOZA-DELGADO, K. PULKKI, G. L. GUSELLA, D. L. LONGO & L. VARESI. 1990. Transforming growth factor-beta downregulates interleukin-1 (IL-1) induced IL-6 production by human monocytes. *Blood* **76**: 2466–2469.
43. HEINO, J. & T. HEINONEN. 1990. Interleukin-1 beta prevents the stimulatory effect of transforming growth factor-beta on collagen gene expression in human skin fibroblasts. *Biochem. J.* **271**: 827–830.
44. LEROITH, D. & C. T. ROBERTS, JR. 1993. Insulin-like growth factors. *Ann. N. Y. Acad. Sci.* **692**: 1–9.
45. LANGFORD, K. S. & J. P. MIELL. 1993. The insulin-like growth factor-1/binding protein axis: physiology, pathophysiology and therapeutic manipulation. *Eur. J. Clin. Invest.* **23**: 503–516.
46. BANG, P., K. BRISMAR & R. G. ROSENFELD. 1994. Increased proteolysis of insulin-like growth factor-binding protein-3 (IGFBP-3) in noninsulin-dependent diabetes mellitus serum, with elevation of a 29-kilodalton (kDa) glycosylated IGFBP-3 fragment contained in the approximately 130- to 150-kDa ternary complex. *J. Clin. Endocrinol. Metab.* **78**: 1119–1127.
47. WHITE, M. F. & C. R. KAHN. 1994. The insulin signaling system. *J. Biol. Chem.* **269**: 1–4.
48. ITO, H., M. HIROE, Y. HIRATA, M. TSUJINO, S. ADACHI, M. SHICHIRI, A. KOIKE, A. NOGAMI & F. MARUMO. 1993. Insulinlike growth factor-1 induces hypertrophy with enhanced expression of muscle-specific genes in cultured rat cardiomyocytes. *Circulation* **87**: 1715–1721.
49. DONATH, M. Y., J. ZAPF, M. EPPENBERGER-EBERHARDT, E. R. FROESCH & H. M. EPPENBERGER. 1994. Insulin-like growth factor-1 stimulates myofibril development and decreases smooth muscle α -actin of adult cardiomyocytes. *Proc. Natl. Acad. Sci. USA* **91**: 1686–1690.
50. DONOHUE, T. J., L. D. DWORKIN, M. N. LANGO, K. FLIEGNER, R. P. LANGO, J. A. BENSTEIN, W. R. SLATER & V. M. CATANESE. 1994. Induction of myocardial insulin-like growth factor-1 gene expression in left ventricular hypertrophy. *Circulation* **89**: 799–809.
51. MATHEWS, L. S., R. E. HAMMER, R. R. BEHRINGER, A. J. D'ERCOLE, G. I. BELL, R. L. BRINSTER & R. D. PALMITER. 1988. Growth enhancement of transgenic mice expressing human insulin-like growth factor-1. *Endocrinology* **123**: 2827–2833.
52. POWELL-BRAXTON, L. P., P. HOLLINGSHEAD, C. WARBURTON, M. DOWD, S. PITTS-MEEK, D. DALTON, N. GILLET & T. A. STEWART. 1993. IGF-1 is required for normal embryonic growth in mice. *Genes Dev.* **7**: 2609–2617.
53. DUERR, R., S. HUANG, H. R. MIRALIAKBAR, R. CLARK, K. CHIEN & J. ROSS, JR. 1994. IGF-1 enhances ventricular hypertrophy and function during the onset of experimental cardiac failure. *J. Clin. Invest.* Submitted.
54. HSU, D., P. E. KNUDSON, A. ZAPF, G. C. ROLBAND & J. M. OLEFSKY. 1994. NPXY

- motif in the insulin-like growth factor-1 receptor is required for efficient ligand-mediated receptor internalization and biological signaling. *Endocrinology* **134**: 744–750.
55. AMBLER, G. R., B. M. JOHNSTON, L. MAXWELL, J. B. GAVIN & P. D. GLUCKMAN. 1993. Improvement of doxorubicin induced cardiomyopathy in rats treated with insulin-like growth factor-1. *Cardiovasc. Res.* **27**: 1368–1373.
 56. PFEFFER, J. M., M. A. PFEFFER, P. J. FLETCHER & E. BRAUNWALD. 1991. Progressive ventricular remodeling in rat with myocardial infarction. *Am. J. Physiol.* **260**: H1406–H1414.
 57. PFEFFER, M. A., E. BRAUNWALD, L. A. MOYE, L. BASTA, E. J. BROWN, JR., T. E. CUDDY, B. R. DAVID, E. M. GELTMAN, S. GOLDMAN, G. C. FLAKER, M. KLEIN, G. A. LAMAS, M. PACKER, J. ROULEAU, J. L. ROULEAU, J. RUTHERFORD, J. H. WERTHEIMER & C. M. HAWKINS. 1992. Effect of captopril on mortality and morbidity in patients with left ventricular dysfunction after myocardial infarction. Results of the survival and ventricular enlargement trial. The SAVE Investigators. *N. Engl. J. Med.* **327**: 669–677.
 58. ANVERSA, P., C. BEGHI, Y. KIKKAWA & G. OLIVETTI. 1986. Myocardial infarction in rats. Infarct size, myocyte hypertrophy, and capillary growth. *Circ. Res.* **58**: 26–37.
 59. LEE, K. J., R. S. ROSS, H. A. ROCKMAN, A. HARRIS, T. X. O'BRIEN, M. VAN BILSEN, H. SHUBEITA, R. KANDOLF, G. BREM, J. PRICE, S. M. EVANS, H. ZHU, W. M. FRANZ & K. R. CHIEN. 1992. Myosin light chain-2 luciferase transgenic mice reveal distinct regulatory programs for cardiac and skeletal muscle-specific expression of a single contractile protein gene. *J. Biol. Chem.* **267**: 15875–15885.
 60. LEE, K. J., R. HICKEY, H. ZHU & K. R. CHIEN. 1994. Positive regulatory elements (HF-1a and HF-1b) and a novel, negative regulatory element (HF-3) mediate ventricular muscle-specific expression of myosin light-chain 2-luciferase fusion genes in transgenic mice. *Mol. Cell. Biol.* **14**: 1220–1229.
 61. KNOWLTON, K. U., E. BARACCHINI, R. S. ROSS, A. N. HARRIS, S. A. HENDERSON, S. M. EVANS, C. C. GLEMBOTSKI & K. R. CHIEN. 1991. Co-regulation of the atrial natriuretic factor and cardiac myosin light chain-2 genes during α -adrenergic stimulation of neonatal rat ventricular cells. *J. Biol. Chem.* **266**: 7759–7768.
 62. KNOWLTON, K. U., M. C. MICHEL, M. ITANI, H. E. SHUBEITA, K. ISHIIHARA, J. H. BROWN & K. R. CHIEN. 1993. The α_{1A} -adrenergic receptor subtype mediates biochemical, molecular, and morphologic features of myocardial cell hypertrophy. *J. Biol. Chem.* **268**: 15374–15380.
 63. THORBURN, A., J. THORBURN, S-Y. CHEN, S. POWERS, H. E. SHUBEITA, J. R. FERAMISCO & K. R. CHIEN. 1993. HRas dependent pathways can activate morphological and genetic markers of cardiac muscle cell hypertrophy. *J. Biol. Chem.* **268**: 2244–2249.
 64. HUNTER, J. J., H. A. ROCKMAN, J. ROSS, JR. & K. R. CHIEN. Manuscript in preparation.
 65. SUCOV, H. M., E. DYSON, C. L. GUMERINGER, J. PRICE, K. R. CHIEN & R. M. EVANS. 1994. RXR α mutant mice establish a genetic basis for vitamin A signaling in heart morphogenesis. *Genes Dev.* **8**: 1007–1018.
 66. O'BRIEN, T. X., K. J. LEE & K. R. CHIEN. 1993. Positional specification of ventricular myosin light chain-2 expression in the primitive murine heart tube. *Proc. Natl. Acad. Sci. USA* **90**: 5157–5161.
 67. KUBALAK, S. W., W. C. MILLER-HANCE, T. X. O'BRIEN, E. DYSON & K. R. CHIEN. 1994. Chamber specification of atrial myosin light chain-2 expression precedes septation during murine cardiogenesis. *J. Biol. Chem.* **269**: 16961–16970.
 68. DYSON, E., S. W. KUBALAK, G. W. SCHMID-SCHÖNBEIN, F. DELANO, H. SUCOV, R. M. EVANS, J. ROSS, JR. & K. R. CHIEN. Manuscript in preparation.
 69. MILANO, C. A., L. F. ALLEN, H. A. ROCKMAN, P. C. DOLBER, T. R. McMINN, K. R. CHIEN, T. D. JOHNSON, R. A. BOND & R. J. LEFKOWITZ. 1994. Enhanced myocardial function in transgenic mice overexpressing the β_2 -adrenergic receptor. *Science* **264**: 582–586.

Cytoskeletal Rearrangements in Adult Rat Cardiomyocytes in Culture

HANS M. EPPENBERGER, MONIKA EPPENBERGER-
EBERHARDT, AND CECILIA HERTIG

*Institute of Cell Biology
ETH Zurich
CH-8093 Zurich, Switzerland*

INTRODUCTION

Growth of the heart in maturing mammals is primarily the result of hypertrophy of a pre-existing, fixed number of cardiomyocytes rather than cellular proliferation. Shortly after birth in mammals, ventricular myocytes rapidly and permanently leave the cell cycle and only infrequently undergo additional rounds of DNA replication associated with the process of endomitosis leading to binucleation, *e.g.*, in rat heart cells. Subsequently there begins a process of cellular hypertrophy of ventricular heart muscle cells until the adult heart size is reached. Adaptive compensatory hypertrophy of the adult heart on the other hand usually follows the increase in work load that has been imposed on the heart. Such a greater workload is mainly due to an increased afterload in patients with hypertension or after myocardial infarction, when the remaining muscle has to assume the work of that part of the myocard that was lost through myocardial cell death.

The question arises as to how the involved cells do react to compensate for the increased work they have to produce. What are the signals required to transduce increased workload into cell growth? Is there, besides neuronal and hormonal influence, an intracellular signal generating mechanism based on, *e.g.*, mechanical stimuli? Stretch appears to induce autocrine and paracrine mechanisms which may generate those increased rates of protein synthesis or may be responsible for those decreased rates of protein degradation which are necessary to cope with an increasing size of cardiomyocytes.¹ The cellular junctions between single cardiomyocytes, the so-called intercalated discs, as well as the interconnecting cytoskeleton and the contractile apparatus are also strongly involved when the size of cardiomyocytes increases. Since the complexity of the events that accompany hypertrophy *in vivo* imposes many limitations on studying interactions between single cardiomyocytes, more and more, isolated cardiac muscle cells are used when elaborating hypertrophic events.²

Isolated adult rat cardiomyocytes (ARC) in culture represent an excellent experimental system to monitor changes in the molecular and cellular behavior of cardiac cells. In addition, they allow the study of a number of fundamental problems in cardiology as well as of the differentiation of cross-striated muscle in general. ARC can generally be cultured in two different ways: first, in the "rapid attachment model" where the cells are kept in serum-free medium and where they maintain characteristic morphological features of intact, rod-shaped cells for about

a week;³ and second, in the "redifferentiation model" where the cells attach to a variety of substrates and are kept in a serum-containing medium for periods up to 4 weeks.⁴⁻⁶

The inability to proliferate is one of the reasons that no repair mechanism is effective after cell damage within the myocardium. Like cardiomyocytes *in vivo*, ARC in culture cannot divide; up to now no feasible way has been found to release ARC from the very strong mitotic block and to reactivate the cell cycle of ventricular cardiomyocytes. However, video time lapse experiments in our laboratory have shown that, after some time in culture, ARC tend very strongly to re-establish contact with neighboring cells. Since the number of cells in culture does not increase and since ARC do not move in culture at the various substrate conditions employed, new cell-cell contacts can be made only by an increase in the size of the individual cell. As contact with neighboring cells is sought, a considerable enlargement of the cells occurs, resulting in a surface area about 5 times larger than that of the rod-shaped cells.⁷ This enlargement necessitates changes in the cellular cytoskeleton which presumably also occur in hypertrophic cells *in vivo*. Thus, analysis of these changes in ARC can shed light on processes that are likely to occur upon increased demand *in vivo*.

In the redifferentiation model of culture, ARC pass through several gradual morphological transitions, which have been followed by video time lapse microscopy experiments. Starting with the elongated rod-shaped cardiac cells present in adult heart tissue cells progress to a rounded-up shape. The transition to these rounded-up cells is accompanied by the loss of myotypic structures and organelles like myofibrils, which form the contractile apparatus, and of the disruption of intercalated discs, which build the cell-cell contacts in cardiac tissue.⁶ Thus, the ARC initially lose most traits of the cardiac phenotype. However, the general state of cardiac determination is not lost; after some time the ARC attach to the substrate followed by flattening and spreading into a polymorphic cell morphology. During this stage, single cells show the tendency to join into a multicellular complex, which shows signs of functional, even though two-dimensional, heart tissue: most remarkably, the cells resume contraction, thus, after a phase of intensive redifferentiation, myotypy is regained.

RESULTS AND DISCUSSION

The long-term culture model for ARC, which represents the major system for our *in vitro* studies on cellular and molecular events in cardiac development^{6,8} was recently considerably improved.^{7,9,10} In parallel the recent development of confocal microscopy and the analysis of 3-dimensional data sets made available by the use of an improved image processing system was very important for the progress of the study of the reformation of intercalated discs in regenerating ARC.¹¹

The techniques of confocal microscopy have been applied to investigate the dedifferentiation and redifferentiation steps of the ARC in culture. Due to the analysis by confocal microscopy the drastic changes of the intracellular and extracellular reorganization could be investigated in a rather sophisticated way. During

the cellular changes that accompany the redifferentiation processes in the ventricular ARC several changes of gene activity have been observed, like the reappearance of α -smooth muscle actin, β -myosin heavy chain and atrial natriuretic factor.^{6,8,10} An analysis of the role of N-cadherin (A-CAM) during the redifferentiation of ARC was undertaken.

Chicken N-cadherin cDNA could be successfully microinjected and transiently expressed in the rat cardiomyocytes. After microinjection into ARC, expression of the chicken N-cadherin was demonstrated by using a chicken-specific antibody. This antibody discriminated between homologous cadherin isoforms of different species, and thus only reacted with the chicken epitope. The exogenous chicken N-cadherin was over-expressed and specifically localized to the sites of cell-cell contacts exactly as the endogenous (rat) N-cadherin does.¹² Chicken cadherin overexpression did not disturb the precise localization and function of the rat homologue. Moreover it was also involved in newly synthesized adherens junctions and contact formation of ARC cocultivated with fetal rat cardiomyocytes. These observations were of importance since they indicated that exogenous chicken N-cadherin complemented the endogenous protein at the contact sites, provided that both were identical isoproteins. This allowed us to manipulate the cDNA coding for chicken N-cadherin and to do structure/function relationship studies with the chicken protein.

Using this set-up and also considering the fact that extracellular contacts are only formed in the presence of Ca^{++} , we could manipulate the establishment of new intercalated discs. Removal of Ca^{++} by EGTA complexation resulted in a break-up of newly formed discs and in the disappearance of N-cadherin from the membrane.

In order to obtain an additional fluorescent signal for the chicken N-cadherin DNA, an additional heterologous epitope tag was inserted into the C-terminal end of the cDNA. This technique is well established in our laboratory.¹³ The tag consisted of 11 amino acids of the C-terminus of the VSV-G-protein. Appropriate localization of the chicken N-cadherin in the cell periphery could be demonstrated; obviously no interference of the tag with proper sorting of chicken N-cadherin was observed. The presence of the C-terminus tag allowed subsequent deletions of the N-terminal extracellular domain of N-cadherin, which also contained the epitope specific for the monoclonal anti-chicken N-cadherin antibody available.

REFERENCES

1. SADOHIMA, J. & S. IZUMO. 1993. *EMBO J.* **12**(4): 1681–1692.
2. BOHELER, K. R. & K. SCHWARTZ. 1992. *Trends Cardiovasc. Med.* **2**: 176–182.
3. PIPER, H. M. *et al.* 1982. *J. Mol. Cell. Cardiol.* **14**: 397–412.
4. CLAYCOMB, W. & M. C. PALAZZO. 1980. *Dev. Biol.* **80**: 466–482.
5. CLAYCOMB, W. C. 1992. *Trends Cardiovasc. Med.* **2**(6): 231–236.
6. EPPENBERGER, M. *et al.* 1988. *Dev. Biol.* **130**: 1–15.
7. MESSERLI, M. *et al.* 1993. *Histochemistry* **100**: 193–202.
8. EPPENBERGER, M. *et al.* 1990. *Dev. Biol.* **139**: 269–278.
9. EPPENBERGER-EBERHARDT, M. *et al.* 1991. *J. Cell Biol.* **113**: 289–302.
10. EPPENBERGER-EBERHARDT, M. *et al.* 1993. *J. Mol. Cell. Cardiol.* **25**: 753–757.
11. MESSERLI, M. *et al.* 1993. *Cytometry* **14**: 725–735.
12. EPPENBERGER, H. M. *et al.* 1994. *Trends Cardiovasc. Med.* **4**. In press.
13. SOLDATI, T. & J.-C. PERRIARD. 1991. *Cell* **66**: 277–289.

Mechanical Regulation of Cardiac Myofibrillar Structure^a

D. G. SIMPSON,^b W. W. SHARP,^b T. K. BORG,^b R. L. PRICE,^b
A. M. SAMAREL,^c AND L. TERRACIO^b

^b*Department of Developmental Biology and Anatomy
University of South Carolina School of Medicine
Columbia, South Carolina 29208*

and
^c*Department of Medicine
Loyola University of Chicago
Stritch School of Medicine
Maywood, Illinois 60153*

INTRODUCTION

Experimental evidence derived from a variety of *in vitro* model systems has consistently indicated that the mechanical events of excitation-contraction coupling serve to regulate many aspects of cardiac metabolism.¹ For example, a sustained static stretch is sufficient to activate cytoplasmic second messengers and accelerate protein synthesis in perfused hearts,^{2,3} isolated papillary muscle preparations,⁴ and cultured myocytes,⁵⁻⁷ even in the absence of rhythmic contractile activity. Mechanical forces also appear to play a crucial role in regulating myofibrillar structure at a posttranslational site of control. When spontaneously contracting neonatal cardiac myocytes are maintained in suspension culture they fail to assemble a fully mature myofibrillar apparatus.⁸ Conversely, contractile arrest of long-term adherent cardiac myocytes initiates the dissolution of existing myofibrils.⁹ These data suggest that some, as yet to be defined, threshold of mechanical load may be necessary to initiate the assembly of myofibrils. It is presently unclear if an extrinsic mechanical load, in the absence of the phasic calcium transients normally associated with excitation-contraction coupling, is sufficient to stabilize the structure of preexisting myofibrils. In this study we address this issue by examining cardiac myofibrillar structure in beating and nonbeating neonatal cardiac myocytes subjected to a sustained period of static stretch.

MATERIAL AND METHODS

Cell Isolation

All reagents were purchased through Sigma Chemical Corporation (St. Louis, MO) unless otherwise noted. Myocytes were enzymatically dissociated from 4-5-

^a D. G. Simpson is a NRSA Post Doctoral Fellow (HL08541) at the University of South Carolina School of Medicine. This work is supported by Grants HL 42249, HL 37669, HL 40424, HL 34328, and HL 43582.

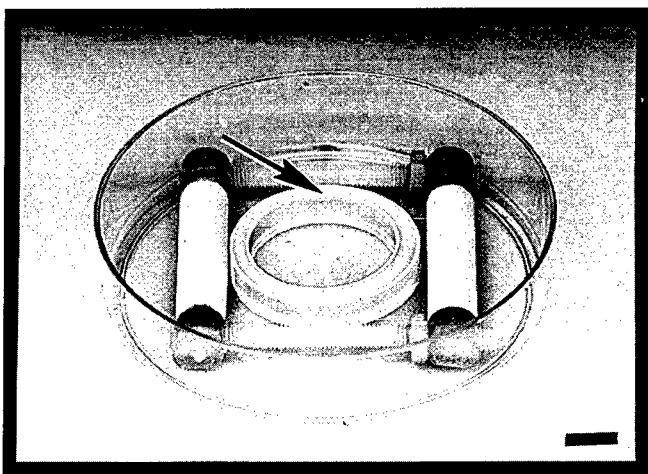

FIGURE 1. Static stretching devices. Static stretching devices were assembled and autoclaved. Type I collagen (Celtrix; Palo Alto, CA) was applied directly to the sterile silastic membranes and allowed to polymerize for 60 minutes at 37°C. A small retaining ring (*arrow*) was used to facilitate plating cells. After 24 hours of culture the retaining ring was removed, the cells were rinsed and refed. Experimentation was carried out on day four of culture. *Bar* = 10 mm.

day-old neonatal rats as previously described.¹⁰ Freshly isolated myocytes were suspended in DMEM (Gibco; Grand Island, NY) supplemented with 8.0% horse serum (Flow Laboratories; Mclean, VA) and 5.0% newborn bovine serum (Gibco; Grand Island, NY). Cells were plated onto silastic membranes (size 0.010; Dow Corning; Midland, MI) for 24 hours (3×10^6 myocytes/stretching cassette: see FIG. 1), rinsed and subsequently fed at daily intervals. Cytosine arabinoside (10 $\mu\text{g}/\text{ml}$) was added to all media to suppress interstitial cell proliferation.

Experimental Protocol

On day 4 *in vitro* myocytes were rinsed and transferred to serum-defined media (1:1:1, DMEM:F12:PC-1) supplemented with 3 mM glutamine, 1 $\mu\text{g}/\text{ml}$ fungizone, 100 $\mu\text{g}/\text{ml}$ streptomycin, 100 units/ml penicillin and 10 $\mu\text{g}/\text{ml}$ cytosine arabinoside. PC-1 base media was purchased from Hycor Biomedical Corporation (Portland, ME). Parallel cultures of myocytes were then exposed for 24 hours to the loading conditions described below. Group I; Beating cells, spontaneously contracting myocytes. Group II; Beating cells + stretch, spontaneously contracting myocytes subjected to a sustained 5% static stretch. Group III; Nonbeating cells, myocytes treated with the calcium channel blocker nifedipine (12 μM). Group IV; Nonbeating cells + stretch, myocytes treated with nifedipine (12 μM) and subjected to a sustained 5% static stretch. At the conclusion of 24 hours of treatment the cells were fixed and processed for microscopic evaluation. Actin

was visualized with rhodamine phalloidin (1:100; Molecular Probes; Eugene, OR) and cells were examined with a BIORAD MRC 600 scanning confocal microscope.¹¹ Myocytes were prepared after the methods of Reynolds (1963) for transmission electron microscopy.¹² Specimens were embedded in Poly/Bed 812 (Poly-sciences, Warrington, PA), cut into 0.2 μm thick sections and viewed at accelerating voltages of 120 kV or 160 kV with a JEOL 200 CX microscope.

RESULTS

Phenotypic Properties of Beating Myocytes

At the plating densities used in this study, beating myocytes were densely packed on the substratum after 120 hours of culture. Staining with rhodamine phalloidin revealed elaborate arrays of well-differentiated myofibrils (FIG. 2A). These filaments were in close apposition and radiated throughout the sarcoplasm. In thin section, these filaments exhibited well delineated sarcomeres and Z-bands (FIG. 2B).

Phenotypic Properties of Beating Myocytes Subjected to a 5% Static Stretch

The application of static stretch to beating cells did not appear to drastically alter myofibrillar organization. The myofibrils of these cells were present throughout the sarcoplasm and had clearly defined I-bands. A small percentage of cells displayed evidence of mechanical damage to the sarcomeres (FIG. 3A). At the ultrastructural level, stretched cells often displayed myofibrils that terminated into a common Z-band in a plexiform-like pattern (FIG. 3B). This pattern of organization was not routinely observed in contracting myocytes that were not subjected to a period of static stretch.

Phenotypic Properties of Nonbeating Myocytes

In myocytes that had been beating in culture for 96 hours the application of 12 μM nifedipine resulted in immediate and sustained contractile arrest. Conspicuous myofibrillar abnormalities were evident within 24 hours of nifedipine treatment. Staining with rhodamine phalloidin revealed poorly defined myofibrils. These contractile filaments were sparsely distributed in the sarcoplasm and displayed aberrant I-bands (FIG. 4A). Ultrastructural examination of nonbeating cells disclosed haphazardly organized thick and thin filaments (FIG. 4B).

Phenotypic Properties of Nonbeating Myocytes Subjected to a 5% Static Stretch

Confocal and electron microscopic analysis suggests that an external episode of a 5% static stretch can act to partially stabilize myofibrillar structure in the absence of rhythmic contractile activity. Stretched nonbeating cells appeared to

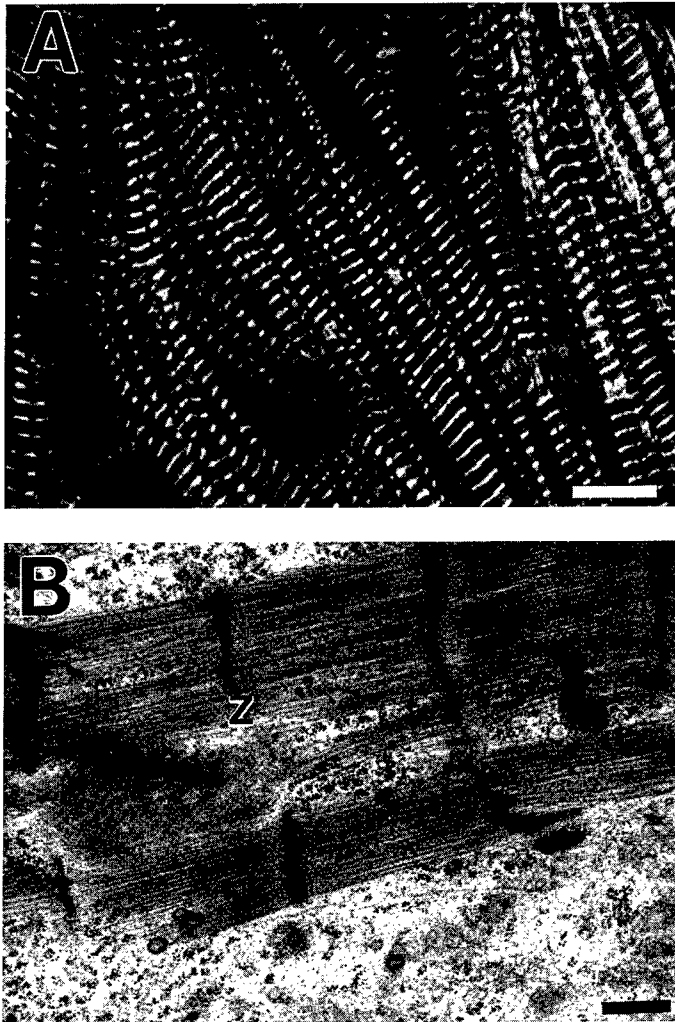

FIGURE 2. Confocal and ultrastructural assessment of myofibrillar structure in spontaneously contracting myocytes. The myofibrils of beating myocytes were densely packed in the sarcoplasm. The sarcomeres were clearly delineated at the (A) light and (B) ultrastructural level. Z = Z band. *Bar* in (A) = 10 μm , (B) = 0.5 μm .

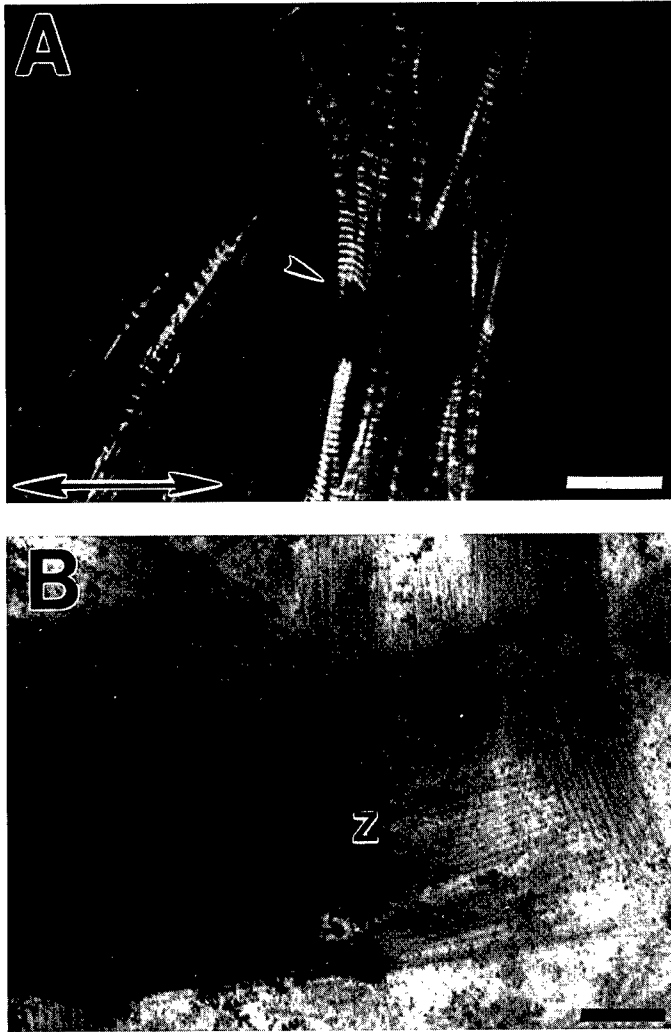

FIGURE 3. Confocal and ultrastructural analysis of myofibrillar structure in spontaneously contracting myocytes subjected to a 5% static stretch. Stretched beating cells displayed well defined I-bands; however, a small percentage of cells displayed myofibrils that exhibited evidence of mechanical damage (A) (*arrow head*). The random nature of these filaments may contribute to this phenomenon. They are arrayed along several different vectors, possibly making them more susceptible to damage *in vitro* during an episode of stretch. In thin section the sarcomeres often displayed a complex branching pattern (B); this feature appears to be characteristic of stretched cells (see also FIG. 5B). Z = Z band. *Large arrow* in (A) defines direction of stretch; the direction of strain is not defined in (B). *Bar* in (A) = 10 μm , (B) = 0.5 μm .

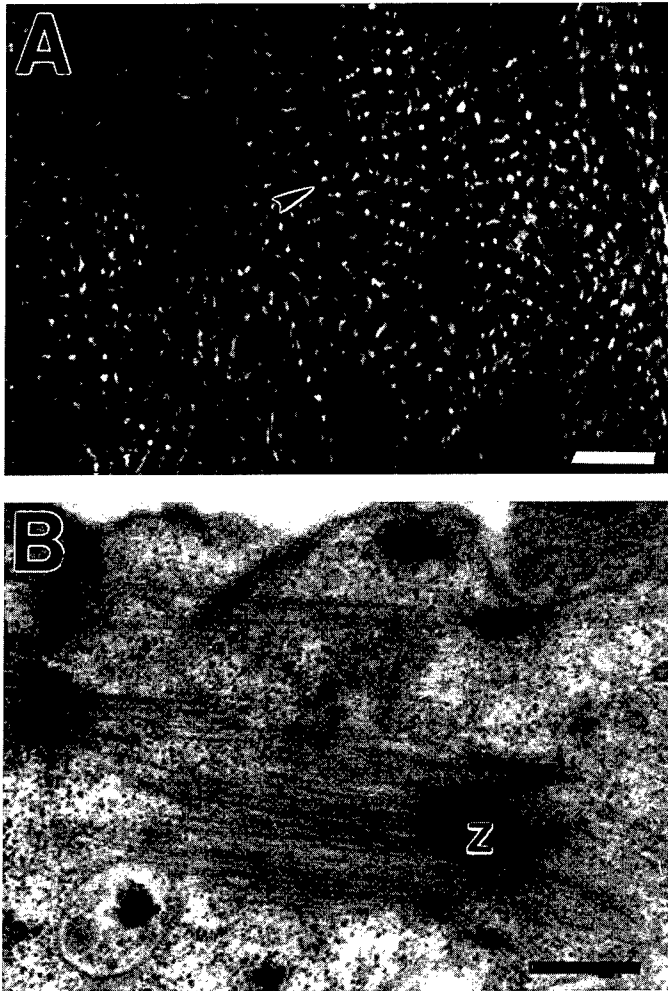

FIGURE 4. Confocal and ultrastructural analysis of myofibrillar structure in nifedipine-treated, nonbeating myocytes. Nonbeating myocytes exhibited sparsely distributed myofibrils and aberrant I-bands (A) (arrow head; compare also Figs. 2A and 4A). Ultrastructural assessment revealed abnormal Z-bands (B); in many planes of section thick and thin filaments were not organized into sarcomeres. Z = Z band. Bar in (A) = 10 μm , (B) = 0.5 μm .

retain more phalloidin-positive myofibrils that displayed a higher state of I-band organization than their nonbeating, nonstretched counterparts (compare Figs. 5A and 4A). The myofibrils of these cells also appeared to be thicker in diameter and packed in closer apposition with one another than the actin-based filaments of quiescent myocytes. At the ultrastructural level, stretched, nonbeating cells often displayed myofibrils that exhibited a branching pattern (Fig. 5B). In many thin

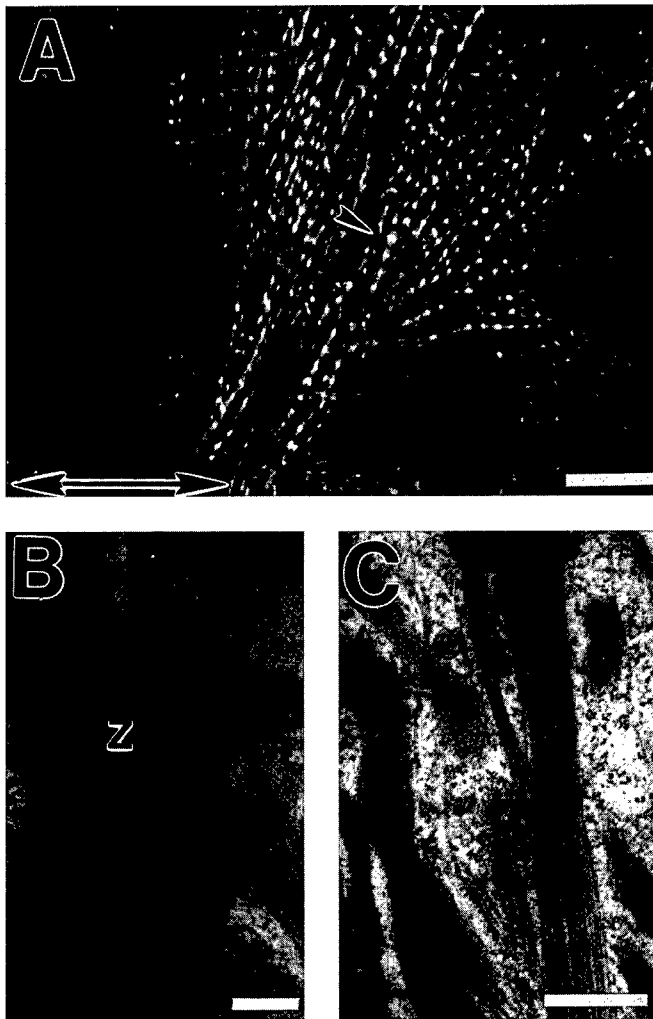

FIGURE 5. Confocal and ultrastructural analysis of myofibrillar structure in nifedipine-treated, nonbeating myocytes subjected to a 5% static stretch. The phalloidin-positive filaments of stretched, nonbeating myocytes (A) displayed a pattern of fluorescence at the I-band (*arrow head*) that appeared to be intermediate to that of their nonbeating counterparts (FIG. 4A) and spontaneously contracting myocytes (FIG. 2A). At the ultrastructural level, thick and thin filaments were arrayed into sarcomeres, (B) and (C). Myofibril exhibiting immature pattern of organization (C). Z = Z band. *Large arrow* in (A) defines the direction of stretch; the direction of strain in (B) is not defined. *Bar* in (A) = 10 μm , (B) = 0.5 μm .

sections the myofibrils of these cells displayed an immature profile. However, the thick and thin filaments of these myofibrils were clearly organized into sarcomeres (FIG. 5C).

DISCUSSION

In vivo and *in vitro* experiments suggest that myofibrillar assembly is regulated by mechanical forces at two distinct levels of control. The earliest phases of load-induced hypertrophy are associated with the increased transcription of ribosomal subunits^{3,13} and an acceleration in the expression and synthesis of a variety of contractile,¹⁴⁻¹⁶ stress,¹⁷ and regulatory^{7,18,30} proteins. Thus, mechanical forces serve to accelerate the transcription of genes encoding a variety of cardiac proteins while simultaneously acting to augment the capacity of the heart cell to utilize these transcripts.

There is also evidence to suggest that mechanical forces regulate the process of myofibrillar assembly at a posttranslational site of control. In primary culture, nonbeating heart cells can be pharmacologically stimulated to express immediately gene sequences associated with hypertrophic growth,^{9,15,19} synthesize contractile proteins at elevated rates, and accumulate protein.^{13,19} However, unless these cells are allowed to undergo rhythmic contraction they do not appear to nucleate and assemble myofibrils.⁹ In the converse experiment, nonbeating heart cells will rapidly assemble myofibrils when they are stimulated to contract, even when new protein synthesis is inhibited up to 90%.²⁰ These data suggest that a sarcoplasmic pool of contractile proteins exists, and given the appropriate conditions these proteins can be recruited for the assembly of nascent myofibrils.

The processes that mediate the disassembly of myofibrils during cardiac atrophy are not as well defined as the events associated with the assembly of these filaments. Experiments with the heterotopic heart transplant model suggest that cardiac atrophy is associated with a depression in the capacity of the heart cell to synthesize and accumulate contractile proteins.²¹ In primary culture, contractile arrest is associated with a depression in *beta* myosin heavy chain and *alpha* cardiac actin gene expression²² and a marked acceleration in contractile protein degradation.^{9,23}

The cellular mechanisms that are responsible for promoting accelerated contractile protein degradation during cardiac atrophy are presently unclear. However, myofibrillar abnormalities are commonly observed in many model systems that are used to study this process. Surgically unloading a beating papillary muscle in the intact heart leads to the misalignment of the myofibrils, the focal depletion of electron-dense Z-disk material, and pronounced atrophy of the tissue.²⁴⁻²⁸ *In vitro*, contractile arrest initiates the dissolution of myofibrils in adult²⁰ and neonatal heart cells.⁹

Protein turnover studies have suggested that myofibrillar proteins exist in multiple kinetic compartments.^{23,29} For contractile proteins, an obvious candidate for one of these compartments is the myofibril. A loss in myofibrillar integrity may serve to release contractile proteins into a sarcoplasmic pool and place them in a compartment where they are more susceptible to degradative events. Thus,

under steady state conditions, the intact myofibril may represent a compartment that acts to segregate contractile proteins from degradative processes.

In conclusion, mechanical forces serve to modulate the processes that regulate the synthesis and assembly of contractile proteins into myofibrils.¹ Present observations suggest that these forces also act to regulate the structure of myofibrils once they are assembled. In the absence of phasic calcium transients, the application of an external static load appears to partially stabilize myofibrillar structure and inhibit the evolution of I-band anomalies. A key issue that remains to be resolved is the determination if the myofibril represents a compartment that acts to segregate contractile proteins from degradative events.

SUMMARY

The excitation-contraction coupling cycle (ECC) consists of a complex cascade of electrochemical and mechanical events; however, the relative contributions of these different processes in the regulation of cardiac myofibrillar structure are not well understood. There is extensive evidence to suggest that the mechanical aspects of the ECC play a crucial role in controlling the availability of contractile proteins for myofibrillar assembly. To examine if these physical forces might also serve to stabilize the structure of preexisting myofibrils, beating and nonbeating cultures of neonatal cardiac myocytes (NCM) were subjected to a 5% static stretch. Contractile arrest was achieved by treating NCM with 12 μ M nifedipine, which resulted in immediate and sustained contractile arrest and initiated the evolution of marked myofibrillar abnormalities within 24 hours. As judged by scanning confocal and transmission electron microscopic examination, an external load appears to partially stabilize myofibrillar structure in nonbeating NCM. These results suggest that the maintenance of myofibrillar structure may be highly dependent upon the mechanical aspects of ECC.

ACKNOWLEDGMENTS

The authors wish to thank Margaret Currie for her expert technical support in isolating and maintaining neonatal heart cells in culture. We also thank Dunbar VanDerveer for his interest and critical comments concerning the experimental design.

REFERENCES

1. SIMPSON, D. G., W. CARVER, T. K. BORG & L. TERRACIO. 1994. *Int. Rev. Cyt.* **150**: 69-94.
2. XENOPHONTOS, X. P., P. A. WATSON, B. H. CHUA, T. HANEDA & H. E. MORGAN. 1989. *Circ. Res.* **65**(3): 647-656.
3. WATSON, P. A., T. HANEDA & H. E. MORGAN. 1989. *Am. J. Physiol.* **256**(6 Pt 1): C1257-C1261.
4. PETERSON, M. B. & M. LESCH. 1972. *Circ. Res.* **31**: 317-327.

5. SADOSHIMA, J., L. JAHN, T. TAKAHASHI, T. J. KULIK & S. IZUMO. 1992a. *J. Biol. Chem.* **267**(15): 10551–10560.
6. SADOSHIMA, J., T. TAKAHASHI, L. JAHN & S. IZUMO. 1992b. *Proc. Natl. Acad. Sci. USA* **89**(20): 9905–9909.
7. SADOSHIMA, J. & S. IZUMO. 1993. *EMBO J.* **12**: 1681–1692.
8. MARINO, T. A., L. KUSERYK & I. K. LAUA. 1987. *Am. J. Physiol.* **253**: H1391–H1399.
9. SHARP, W. W., L. TERRACIO, T. K. BORG & A. M. SAMAREL. 1993. *Circ. Res.* **73**(1): 172–183.
10. BORG, T. K., K. RUBIN, E. LUNDGREN, K. BORG & B. OBRINK. 1984. *Dev. Biol.* **104**: 86–96.
11. TERRACIO, L. T., D. G. SIMPSON, L. HILENSKI, W. CARVER, R. S. DECKER, N. VINSON & T. K. BORG. 1990. *J. Cell. Physiol.* **145**: 78–87.
12. REYNOLDS, E. S. 1963. *J. Cell Biol.* **17**: 208–212.
13. McDERMOTT, P. J., L. I. RATHBLUM, S. D. SMITH & H. E. MORGAN. 1989. *J. Biol. Chem.* **264**: 18220–18227.
14. McDERMOTT, P. J., M. DAOAD & I. KLEIN. 1985. *Am. J. Physiol.* **249**: H763–H769.
15. IZUMO, S., B. NADAL-GINARD & V. MAHDAVI. 1988. *Proc. Natl. Acad. Sci. USA* **85**: 339–343.
16. IZUMO, S., A. M. LOMPRES, R. MATSUOKA, G. KOREN, K. SCHWARTZ, B. GINARD-NADAL & V. MAHDAVI. 1987. *J. Clin. Invest.* **79**: 979–977.
17. SNOECKX, L. H., F. CONTARD, J. L. SAMUEL, F. MAROTTE & L. RAPPAPORT. 1991. *Am. J. Physiol.* **261**: H1443–H1451.
18. KOMURO, I., M. KURABAYASHI, Y. SHIBAZAKI, Y. KATOH, E. HOE, T. KAIDA, K. IEKI, F. TAKAKU & Y. YAZAKI. 1990. *Jpn. Circ. J.* **54**: 526–534.
19. KOMURO, I., Y. KATOH, T. KAIDA, Y. SHIBAZAKI, M. KURABAYASHI, E. HOE, F. TAKAKU & Y. YAZAKI. 1991. *J. Biol. Chem.* **266**: 1265–1268.
20. SIMPSON, D. G., M. L. DECKER, W. A. CLARK & R. S. DECKER. 1993. *J. Cell Biol.* **123**: 323–336.
21. KLEIN, I., A. M. SAMAREL, R. W. WELIKSON & C. HONG. 1991. *Circ. Res.* **68**(4): 1100–1107.
22. SAMAREL, A. M. & G. L. ENGELMANN. 1991. *Am. J. Physiol.* **261**(4 Pt 2): H1067–H1077.
23. SAMAREL, A. M., M. L. SPRAGIA, V. MALONEY, S. A. KAMAL & G. L. ENGELMANN. 1992. *Am. J. Physiol.* **263**(3 Pt 1): C642–C652.
24. COOPER, G. & R. J. TOMANEK. 1982. *Circ. Res.* **50**: 788–798.
25. THOMPSON, E. W., T. A. MARINO, C. E. UBOH, R. L. KENT & G. COOPER. 1984. *Circ. Res.* **54**: 367–377.
26. COOPER, G., R. L. KENT, C. E. UBOH, E. W. THOMPSON & T. A. MARINO. 1985. *J. Clin. Invest.* **74**: 1403–1414.
27. KENT, R. L., C. E. UBOH, E. W. THOMPSON, S. S. GORDON, T. A. MARINO, J. K. HOOBER & G. COOPER. 1985. *J. Mol. Cell. Cardiol.* **17**: 153–165.
28. COOPER, G. C., W. E. MERCER, J. K. HOOBER, P. R. GORDON, R. L. KENT, I. K. LAUVA & T. A. MARINO. 1986. *Cir. Res.* **58**: 692–705.
29. CLARK, W. A. 1993. *J. Biol. Chem.* **268**: 20243–20251.
30. MOALIC, J. M., D. CHARLEMAGNE, P. MANSIER, B. CHEVALIER & B. SWYNGHEDAUV. 1993. *Circulation* **87**: IV21–IV26.

Cardiac Myocytes Differ in mRNA Composition for Sarcoplasmic Reticulum Ca²⁺ Channels and Ca²⁺ Pumps^a

LUISA GORZA, SILVIA VETTORE, POMPEO VOLPE,
VINCENZO SORRENTINO,^b JANE-LYSE SAMUEL,^c MARIELLE
ANGER,^d AND ANNE MARIE LOMPRÉ^d

*CNR Unit for Muscle Biology and Physiopathology
and*

*Department of Biomedical Sciences
University of Padova
Via Trieste, 75
35121 Padova, Italy*

^b *Institute of Histology
University of Siena
and
Dibit-HSR
Milan, Italy*

^c *INSERM U 127
Hôpital Lariboisière
Paris, France*

^d *CNRS URA 1131
Orsay, France*

Changes in cytosolic Ca²⁺ concentration regulate different functions in cardiac myocytes. Ca²⁺ is necessary to evoke the contractile response, and elevations in cytosolic Ca²⁺ alter cardiac impulse generation and impulse conduction.¹ Ca²⁺ concentration is modulated by the concerted activities of plasma membrane and sarcoplasmic reticulum channels and pumps. Here we present evidence that cardiac myocytes are heterogeneous in mRNA composition of sarcoplasmic reticulum Ca²⁺ channels and Ca²⁺ pumps, and we discuss the possibility that such a difference is due to distinct functional requirements.

Intracellular Ca²⁺ Release Channels Sensitive to Inositol 1,4,5-Trisphosphate (IP₃R)

The presence in cardiac muscle of IP₃R has long been questioned due to the low values of ³[H]IP₃ binding detected in cardiac muscle and the variability of the

^a This work was supported by grants from the Ministero dell'Università e della Ricerca Scientifica e Tecnologica (40% to P. V.; 60% to L. G. and to V. S.), by the Consiglio Nazionale delle Ricerche (Grants 93.00301.CT04 and 94.02424.CT04), and by Telethon-Italy.

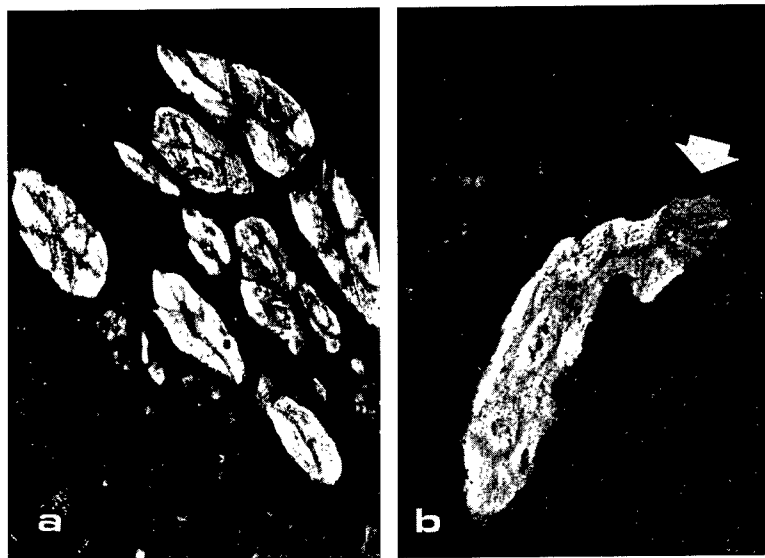

FIGURE 1. IP₃R immunoreactivity in the bovine heart. Indirect immunofluorescence of cryosections of the moderator band (a) and left ventricle (b). Note strong labelling of Purkinje myocyte bundles, which also display heterogeneity (arrow).

inotropic effects observed after exposure to IP₃.² However, by means of immunological and nucleic acid probes several laboratories independently demonstrated that IP₃R_s are expressed in cardiac myocytes.³⁻⁶ In particular, we found that microsomal membrane preparations obtained from the moderator band of bovine heart bound about eightfold more ³[H]IP₃ than similar preparations derived from the ventricular free wall or from the atrial myocardium.⁴ The specificity of the binding was confirmed by Western blot analysis performed with peptide-specific antibodies raised against the brain type of IP₃R.⁴ Immunofluorescence studies on the bovine heart showed that the IP₃R is concentrated in a population of cardiac myocytes, the Purkinje myocytes, which correspond to the ventricular compartment of the heart conduction system (FIG. 1). Labelling of Purkinje myocytes showed a certain degree of heterogeneity, in that some bundles or single Purkinje myocytes did not differ in labelling intensity from the weak staining displayed by working myocytes (FIG. 1b, arrow). On the other hand, intense labelling of Purkinje myocytes was detectable in bovine hearts from fetal stages, suggesting that ventricular conduction myocytes are characterized by high expression of IP₃R already during prenatal development.⁴ Double labelling experiments with anti-IP₃R and anti-calsequestrin antibodies showed that expression of the receptor is associated with the presence of intracellular Ca²⁺ stores (FIG. 2), which correspond to corbular sarcoplasmic reticulum.⁷ These findings were confirmed by *in situ* hybridization studies. A cRNA probe transcribed from a rat type 1 IP₃R cDNA⁸ hybridized strongly with conduction myocytes and coronary smooth muscle cells of the rat heart (FIG. 3).

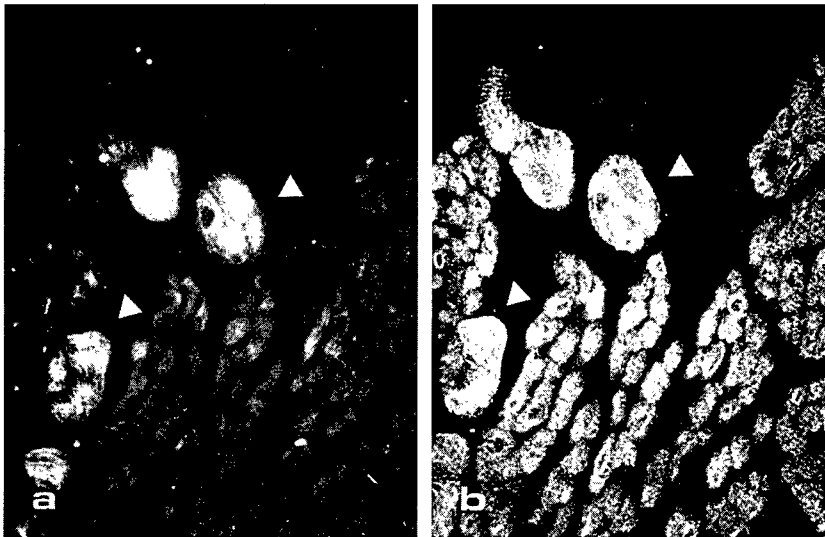

FIGURE 2. IP₃R (a) and calsequestrin (b) immunoreactivity in the bovine heart. Double immunofluorescence showing colocalization of stainings in Purkinje myocytes (*arrowheads*).

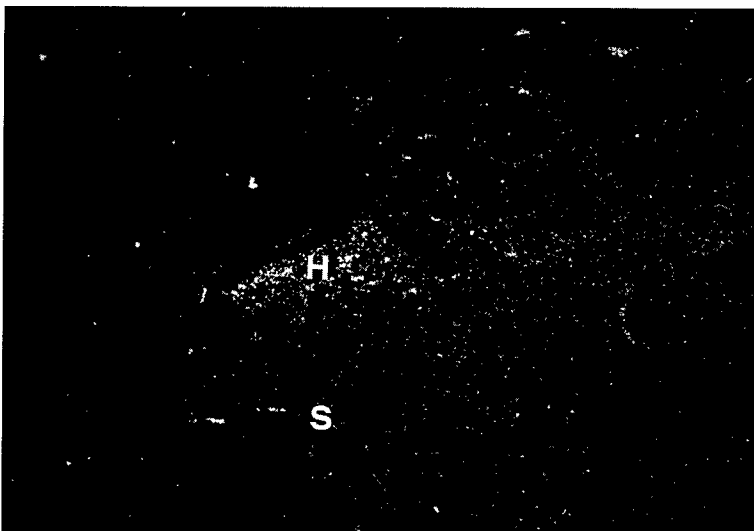

FIGURE 3. Type 1 IP₃R mRNA accumulation in the rat heart. Dark field micrograph of *in situ* hybridization of the atrioventricular node and the atrioventricular bundle region (H). Note higher accumulation of silver grains in conduction system regions, whereas working myocytes of the interventricular septum (S) display a very weak signal.

In Purkinje myocytes, release of Ca^{2+} from IP_3 -sensitive Ca^{2+} stores may be involved in the increase of automaticity consequent to autonomic or hormonal stimulation. By means of a specific inhibitor of α_{1A} -adrenergic receptor in canine Purkinje myocytes, del Balzo *et al.*⁹ suggested that either diacylglycerol, IP_3 or both, are "mechanistically involved in the positive chronotropic response that follows α_1 -adrenergic stimulation." Also activation of thrombin receptor increases automaticity and, in isolated dog Purkinje myocytes, is followed by a rise in intracellular Ca^{2+} , caused, at least in part, by activation of IP_3 -gated Ca^{2+} -channels.¹⁰

Intracellular Ca^{2+} Release Channels/Ryanodine Receptors (RyR)

The RyR gene family is composed by three members:¹¹ RyR 1, which is predominantly expressed in skeletal muscle; RyR 2, which is predominantly expressed in heart and brain, and the recently identified member RyR 3,¹² which is expressed in a wide variety of tissues. Northern blot and RNase protection analysis have given contrasting results concerning the level of expression of RyR 3 mRNA in the heart.^{12,13} We have used *in situ* hybridization procedures in order to study the expression and the distribution of RyR mRNAs in cardiac myocytes. Radiolabelled sense and antisense cRNAs were transcribed by mouse cDNAs specific for RyR 1, RyR 2 and RyR 3 mRNAs (G. Giannini and V. Sorrentino, manuscript in preparation). *In situ* hybridization studies were performed on cryostat sections of adult mouse heart as previously described.⁴ No hybridization signal was detected for RyR 1 mRNA (not shown), whereas strong hybridization signals were observed on working cardiac myocytes with the RyR 2 probe (FIG. 4a). Hybridization with the RyR 3 probe showed weak signals on the majority of cardiac myocytes and strong signals in a subset of myocytes that correspond to conduction myocytes (FIG. 4b). Experiments performed in the rat heart confirmed the presence of strong hybridization signals for RyR 3 mRNA in conduction myocytes, whereas very low hybridization levels for RyR 2 mRNA were detected in these myocytes (FIG. 5).

Thus, the composition in intracellular Ca^{2+} release channel mRNAs differ between two populations of cardiac myocytes, that correspond to working and conduction myocytes. Working myocytes show higher accumulation of RyR 2 mRNA, whereas conduction myocytes appear enriched in type 1 IP_3R and RyR 3 mRNAs. The functional properties of RyR 3 in conduction myocytes, as for other heart cell types, remains to be determined. It has been shown that its expression in mink lung epithelial cells is induced by $\text{TGF-}\beta$ and that the receptor is not apparently activated by caffeine, but requires Ca^{2+} released after subliminal activation of IP_3 -sensitive Ca^{2+} stores.¹² Studies performed on skinned preparations of dog Purkinje myocytes have shown that a higher free Ca^{2+} concentration is required to induce Ca^{2+} release;¹⁴ with respect to this finding, the preferential accumulation of RyR 3 mRNA in conduction myocytes might be related to the abundance of IP_3Rs detected in these myocytes.

Sarcoplasmic Reticulum Ca^{2+} ATPase (SERCA)

SERCA is encoded by three different genes, among which SERCA 2 generates two mRNAs dubbed 2a and 2b, through alternative splicing mechanism. Both

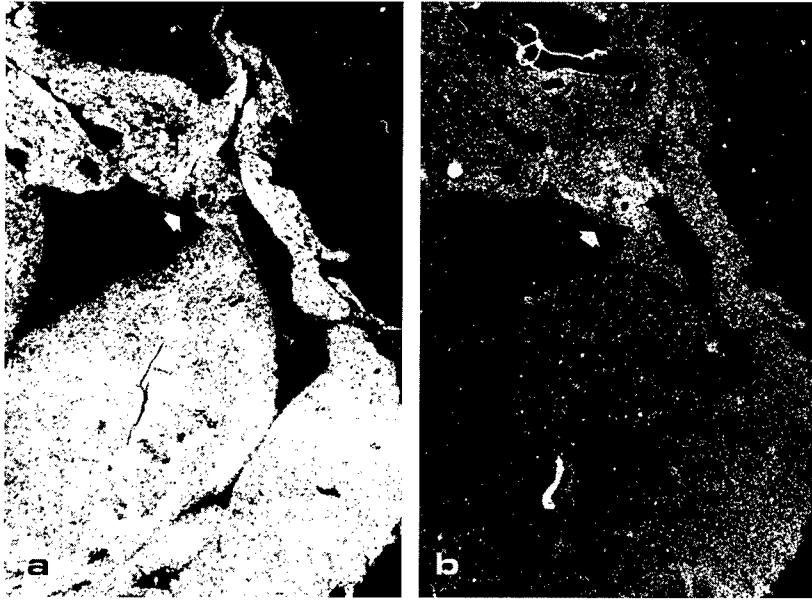

FIGURE 4. RyR 2 and RyR 3 mRNA accumulation in the mouse heart. Dark field micrographs of adult mouse heart cryosections hybridized for RyR 2 (a) and RyR 3 (b) mRNAs. Signals for RyR 2 mRNA appear homogeneously distributed among cardiac myocytes, whereas hybridization with RyR 3 probe is concentrated in the atrioventricular node region (arrow).

SERCA 2a and 2b and SERCA 3 mRNAs are expressed in the heart from early developmental stages.^{15,16} Radiolabelled cRNAs specific for each isoform were transcribed *in vitro*¹⁶ and used for *in situ* hybridization experiments on cryosections from rat hearts, serial to those hybridized with intracellular Ca²⁺ release channel mRNAs. SERCA 2a probe hybridized strongly with working myocytes, whereas it showed very low hybridization signals with conduction myocytes (FIG. 5). On the other hand, no apparent difference in hybridization signals between working and conduction myocytes was detected with SERCA 2b and SERCA 3 probes. SERCA 3 mRNA was observed in the intimal layer of the coronary arteries.¹⁶ Heterogeneity in the expression of SERCA 2a mRNA in myocytes has been reported in the developing rat heart. High hybridization signals were detected in myocytes of the primitive ventricle and of the inflow tract, whereas a low level of hybridization was observed in myocytes at the atrioventricular junction, *i.e.*, in conduction system precursors, and in myocytes of the outflow tract.^{16,17}

Low levels of SERCA mRNA and protein have been related to a low rate of Ca²⁺ uptake.¹⁸ A possible consequence is represented by the increase in diastolic free Ca²⁺ concentration, which would hamper the complete relaxation of myofibrils. In Purkinje myocytes, this event may have a protective effect against stretch or other plasma membrane deformations, which could perturb the electrical stabil-

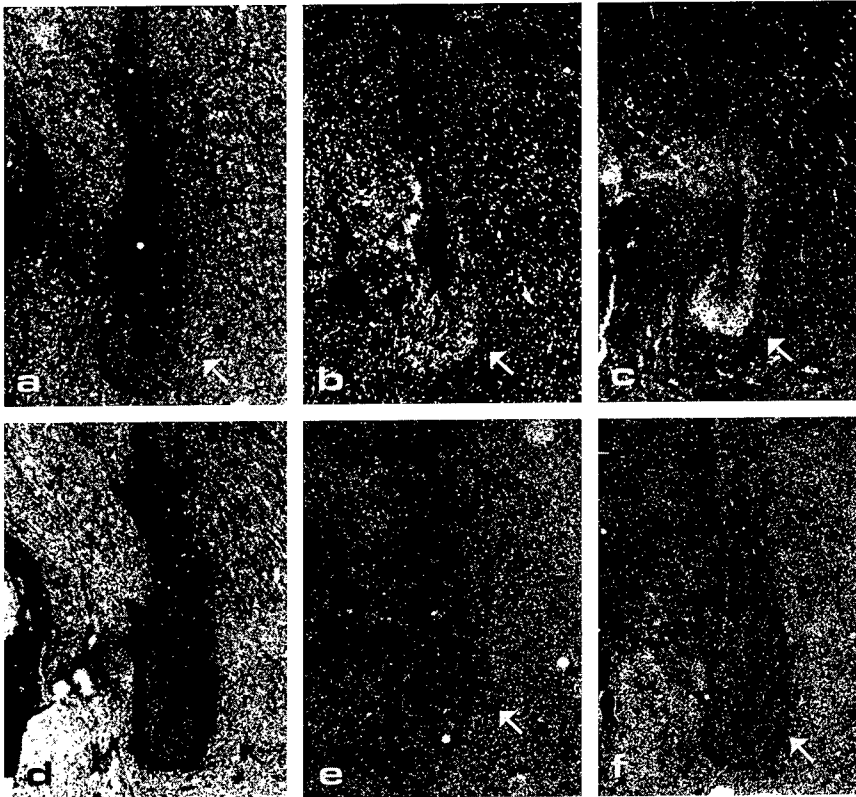

FIGURE 5. Dark field micrographs of *in situ* hybridization of RyR 2 (a), RyR 3 (b), type 1 IP₃R (c), SERCA 2a (d), SERCA 2b (e) and SERCA 3 (f) probes in the rat heart. Note that working myocytes hybridize strongly with RyR 2 (a) and SERCA 2a (d) probes, whereas conduction myocytes (arrow) show higher level of hybridization with RyR 3 (b) and type 1 IP₃R (c) probes and a lower level of hybridization with RyR 2 (a) and SERCA 2a (d) probes than working myocytes. Sections hybridized with SERCA 2b (e) and SERCA 3 (f) probes were overexposed in order to detect any possible difference in signal intensity between working and conduction myocytes.

ity. Moreover, Purkinje myocyte myofibrils display the lowest Ca²⁺ sensitivity,¹⁴ and thus, high systolic free Ca²⁺ is required for activation of contraction. Interestingly, in the rat heart higher systolic and diastolic concentrations of free Ca²⁺ have been measured in ventricular subendocardial myocytes with respect to subepicardial myocytes.¹⁹ On the other hand, elevation in cytosolic calcium may have important effects on automaticity and/or impulse conduction in Purkinje myocytes:¹ it can provoke oscillations in membrane voltage, whose amplitude could be sufficient to generate repetitive action potentials, or it can reduce conductance across the gap junctions.

In conclusion, important differences in the composition of sarcoplasmic reticu-

lum Ca²⁺ channel and Ca²⁺ pumps mRNAs occur in conduction and working myocytes. Working myocytes are characterized by accumulation of RyR 2 and SERCA 2a mRNAs, whereas conduction myocytes show preferential accumulation of type 1 IP₃R and RyR 3 mRNAs and low levels of SERCA 2a mRNA. Such a different composition appears to be related to the distinct functional role played by these two myocytes populations²⁰ and suggests that polymorphism of sarcoplasmic reticulum channel and pump genes may have a role in the modulation and the control of cytosolic Ca²⁺ concentration.

ACKNOWLEDGMENTS

The authors thank Dr. Sudhof for the gift of type 1 IP₃R cDNA (clone pI2a) and Mr. M. Fabbri for assistance in photography.

REFERENCES

1. BILLMAN, G. E. 1992. Cellular mechanisms for ventricular fibrillation. *NIPS* **7**: 254–259.
2. VOLPE, P., F. DI VIRGILIO, G. BRUSCHI, G. REGOLISTI & T. POZZAN. 1989. Phosphoinositide metabolism and excitation-contraction coupling in smooth, cardiac and skeletal muscles. *In* Inositol Lipids in Cell Signalling. R. H. Mitchell, A. H. Drummond & C. P. Downes, Eds. 377–404. Academic Press. London, San Diego.
3. FURUICHI, T., C. SHIOTA & K. MIKOSHIBA. 1990. Distribution of inositol 1,4,5-trisphosphate receptor mRNA in mouse tissues. *FEBS Lett.* **267**: 85–88.
4. GORZA, L., S. SCHIAFFINO & P. VOLPE. 1993. Inositol 1,4,5-trisphosphate receptor in heart: evidence for its concentration in Purkinje myocytes of the conduction system. *J. Cell Biol.* **121**: 345–353.
5. KIJIMA, Y., A. SAITO, T. L. JETTON, M. A. MAGNUSON & S. FLEISCHER. 1993. Different intracellular localization of inositol 1,4,5-trisphosphate and ryanodine receptors in cardiomyocytes. *J. Biol. Chem.* **268**: 3499–3506.
6. MOSCHELLA, M. C. & A. R. MARKS. 1993. Inositol 1,4,5-trisphosphate receptor expression in cardiac myocytes. *J. Cell Biol.* **120**: 1137–1146.
7. JORGENSEN, A. O., A. G. MCLEOD, K. P. CAMPBELL & G. H. DENNEY. 1984. Evidence for the presence of calsequestrin in both peripheral and interior regions of sheep Purkinje fibers. *Circ. Res.* **55**: 267–270.
8. MIGNERY, G. A., C. L. NEWTON, B. T. ARCHER & T. C. SUDHOF. 1990. Structure and expression of the rat inositol 1,4,5-trisphosphate receptor. *J. Biol. Chem.* **265**: 12679–12685.
9. DEL BALZO, U., M. R. ROSEN, G. MALFATTO, L. M. KAPLAN & S. F. STEINBERG. 1990. Specific α_1 -adrenergic receptor subtypes modulate catecholamine-induced increases and decreases in ventricular automaticity. *Circ. Res.* **67**: 1535–1551.
10. STEINBERG, S. F., R. B. ROBINSON, H. B. LIEBERMAN, D. N. STERN & M. R. ROSEN. 1991. Thrombin modulates phosphoinositide metabolism, cytosolic calcium and impulse initiation in the heart. *Circ. Res.* **68**: 1216–1229.
11. MCPHERSON, P. S. & K. P. CAMPBELL. 1993. The ryanodine receptor/Ca²⁺ release channel. *J. Biol. Chem.* **268**: 13765–13768.
12. GIANNINI, G., E. CLEMENTI, R. CECI, G. MARZIALI & V. SORRENTINO. 1992. Expression of a ryanodine receptor-Ca²⁺ channel that is regulated by TGF β . *Science* **257**: 91–94.
13. HAKAMATA, Y., J. NAKAI, H. TAKESHIMA & K. IOMOTO. 1992. Primary structure and distribution of a novel ryanodine receptor/calcium release channel from rabbit brain. *FEBS Lett.* **312**: 229–235.
14. FABIATO, A. 1982. Calcium release in skinned cardiac cells: variation with species, tissues, and development. *Fed. Proc.* **41**: 2238–2244.

15. LOMPRÉ, A. M., F. LAMBERT, E. G. LAKATTA & K. SCHWARTZ. 1991. Expression of sarcoplasmic reticulum Ca^{2+} ATPase and calsequestrin genes in rat heart during ontogenic development and aging. *Circ. Res.* **69**: 1380–1388.
16. ANGER, M., J. L. SAMUEL, F. MAROTTE, F. WUYTACK, L. RAPPAPORT & A. M. LOMPRÉ. 1994. *In situ* mRNA distribution of sarco(endo)plasmic reticulum Ca^{2+} ATPase isoforms during ontogeny in the rat. *J. Mol. Cell. Cardiol.* **26**: 539–550.
17. MOORMAN, A. F. M. & W. H. LAMERS. 1994. Molecular anatomy of the developing heart. *Trends Cardiovasc. Med.* In press.
18. NAYLER, W. G. & E. FASSOLD. 1977. Calcium accumulating and ATPase activity of cardiac sarcoplasmic reticulum before and after birth. *Cardiovasc. Res.* **11**: 231–237.
19. FIGUEREDO, V. M., R. BRANDES, M. W. WEINER, B. M. MASSIE & S. A. CAMACHO. 1993. Endocardial versus epicardial differences of intracellular free calcium under normal and ischemic conditions in perfused rat hearts. *Circ. Res.* **72**: 1082–1090.
20. GORZA, L., S. VETTORE & M. VITADELLO. 1994. Molecular and cellular diversity of heart conduction myocytes. *Trends Cardiovasc. Med.* **4**: 153–159.

Possible Cellular Mechanisms of Heart Muscle Growth in Invertebrates^a

MARINA G. MARTYNOVA^b

*Institute of Cytology
Russian Academy of Sciences
Tikhoretsky Avenue, 4
194064 St. Petersburg, Russia*

INTRODUCTION

Cardiac muscle of vertebrates has a number of particular characteristics which distinguishes it from skeletal muscle. One of the most important is the lack of undifferentiated myogenic stem cells in the cardiac muscle and, respectively, the absence of reciprocal exclusivity of the processes of differentiation and proliferation in cardiomyogenesis. However, the organization of the cardiac muscle in vertebrates is by no means the only possible mode of structure of muscle tissue that can be seen in hearts and heart-like organs in the animal kingdom. In invertebrates, we find a diversity of types of heart muscle with peculiar cellular mechanisms of growth. Investigation of invertebrate heart muscles is interesting not only because these animals constitute 95% of all animals species, but because it may also contribute to our understanding of how the true cardiac muscle (*i.e.*, that of vertebrates) evolved, what type of organization might precede its emergence, and whether it develops only once in evolution, namely, in vertebrates, or appears in the other phylogenetic groups as well. And these are only a few of the possible questions.

The purpose of this paper is to gather all the information available concerning the histological organization of the heart muscle in coelomate invertebrates, to evaluate possible cellular mechanisms of growth, and to explore the limits of our knowledge in the field. Only the cytological features of the reproductive capacities of heart muscle are considered here. The general anatomical, onto- and phylogenetic data have been mainly adopted from handbooks on zoology and comparative embryology of invertebrates. The material in this article is arranged in conformity with the model of the phylogenetic tree proposed by Ivanov.¹ Accordingly, all the coelomata are divided into five independent superphyla: trochozoa, tentaculata, pogonophora, chaetognatha and deuterostomia.

Embryologically the heart (or heartlike organs) of all coelomates are derived from the mesoderm. However, in phylogenetic groups hearts are nonhomologous organs, because heart primordium originates from different areas of the mesoderm, and the mode of forming the mesoderm differs among the phylogenetic groups. Therefore, there is no single evolutionary line of heart muscle development.

^a Work in the author's laboratory is supported by Russian Basic Research Foundation Grant 93-04-21809.

^b FAX No. for correspondence: 7 812 247 03 41.

Trochozoa

Trochozoa (annelids, arthropods, molluscs) are the protostomatous coelomate groups with teloblastic differentiation of mesodermal bands and schizocoelic coelom formation. It is generally accepted that arthropods are derived from annelids, the latter having common ancestors with molluscs.

Annelids

The annelids have a closed circulatory system. The pumping function is not centralized in any one organ. Instead, the main vessels, dorsal and ventral, have contractile properties and may function as hearts. In some species, heartlike organs are found to be in pairs, lateral to the gut. The muscle cells of the blood vessels arise from the mesoblasts of the splanchnic part of somites. The formation of the main blood vessels is considered to be in close relation to the gut sinus.² Investigation of annelid pulsating organs at the ultrastructural level are not numerous. Hama³ has described the main dorsal and ventral circulatory vessels of the earthworm *Eisenia foetida* (oligochaeta) as trunks which are lined on the luminal side by an extracellular basal lamina which is covered by a continuous layer of myoepithelial cells with longitudinal obliquely-striated myofibrils. On the outside of the myoepithelial cells muscle cells with circularly oriented myofibrils are positioned. Spies⁴ on *Flabelliderma commensalis* and Jensen⁵ on *Arenicola marina* (both species are polychaetes) have examined the structure of the heartlike organs. Their walls have been shown to consist of a basal lamina, facing the heart lumen, and an outer layer of myoepithelial cells with myofibrils of a nonstriated type.

The hirudinea constitute the peculiar group of the annelids with a significantly reduced vascular system which is in essence a system of coelomic channels nonhomologous to the main vessels and heartlike organs of other annelids.² More interesting is the morphological similarity between them. According to Hammersan and Staudte,⁶ the wall of the contractile lateral vessel of the leech *Hirudo medicinalis* consists of a basal lamina covered with a layer of myoepithelial cells with myofibers of longitudinal orientation and an outer layer of muscle cells with circular myofibers. The myofibers are composed of sarcomeres. Unlike other annelids, the leech contractile vessel has an inner endothelial lining of basal lamina.

All the data cited are insufficient and inadequate to draw any conclusions about possible cellular mechanisms underlying muscle tissue growth in annelid contractile organs. The problem seems to be complicated by the fact that in some species two types of muscle cells are present; myoepithelial cells with their nuclei situated in sarcoplasmic outpocketings, and muscle cells with nuclei located centrally.

Arthropods

The arthropods have tubular or saclike hearts. Their circulatory system is open. The heart is derived embryologically from a pair of cellular clusters of somitic mesoderm fusing on the dorsal midline above the gut. In 1964 Midsukami reported the presence of satellite cells in the hearts of two species of crabs, and later, in

1981,⁷ described them in the hearts of all the 21 species of decapoda he examined. Since then satellite cells have also been found in hearts of scorpions,⁸ tanaidacea,⁹ onychophora,¹⁰ and insecta (Komarova, personal communication). Thus the presence of satellite cells in the heart seems to be a common feature of all arthropods. Their heart muscle, in the same manner as the vertebrates' skeletal muscle, consists of multinucleated cross-striated myofibers and mononucleated satellite cells that are devoid of myofilaments and closely adhere to myofibers. Autoradiographic studies of incorporation of tritiated thymidine into heart cells of crayfish *Astacus astacus*¹¹ have shown that satellite cells in crayfish heart muscle are capable of DNA synthesis and fusion with myofibers, their DNA-synthesizing activity and differentiation being in close relation to the molt cycle. These results suggest that satellite cells in the heart muscle of arthropods may function like myogenic stem cells involved in muscle growth, similar to satellite cells in the skeletal muscle of vertebrates. However, the mechanism of regulation of their behavior is probably altogether different. We have attempted to activate the satellite cells in the heart of the crayfish by a mechanical injury to the heart,¹² but it appears that these cells, in contrast to the satellite cells of the vertebrate skeletal muscle, do not respond to damage by reentering the cell cycle and fusing with other myofibers. Proliferation and differentiation of satellite cells in the arthropod heart are most likely mediated by molting hormones. That, however, remains to be proved experimentally.

Thus, organization of the heart muscle tissue of arthropods differs fundamentally from that of vertebrates and is apparently similar to the structure of the lymph heart muscle of lower vertebrates.¹³ This resemblance may be accounted for by the fact that both organs originate from the somitic mesodermal cells.

Molluscs

The Molluscs show a wide range of progressive changes in their circulatory apparatus. According to the mollusc's embryonic origin and development, it is closely associated with the gut sinus. As such the molluscan heart is homologous to the heart of annelids.² The fact that in most bivalvia the heart ventricle is transpierced by the gut is considered to be a reminiscence of the ontogenetic relationships. The hearts of other molluscan groups lie dorsally or, in very rare cases, ventrally to the gut. The circulatory system of molluscs is open, with the exception of cephalopoda, whose circulatory system is considered to approximate a closed system. Molluscs have a chambered heart—a ventricle and some auricles from one to four in quantity, which is reminiscent of the vertebrate heart to such an extent that it may be a brilliant illustration of convergent evolution. The myocardium is organized as a network of separate mononucleated muscle cells with myofilaments oriented differently in adjacent cells and even within a single cell. The myonuclei are situated centrally. Although numerous publications have been devoted to the heart ultrastructure in different molluscan species, possible cellular mechanisms of heart growth so far remain obscure. Hearts of three molluscan species are currently under investigation in our laboratory (Bystrova, Martynova, in preparation). These are *Mytilus edulis* (bivalvia), with smooth myofibrils; snail

Helix aspersa (gastropoda), with obliquely striated myofibrils; and cattlesfish *Rossia macrosoma* (cephalopoda), with cross-striated myofibrils. Ultrastructural study has shown the presence of non- and little-differentiated mononucleated cells scattered among the mature muscle cells of the myocardium in all three species. Autoradiographic experiments with tritiated thymidine have indicated that these undifferentiated cells are capable of DNA synthesis, while more differentiated and mature muscle cells are not. These preliminary results suggest to us the presence of stem cells in the molluscan myocardium and, if that is the case, postulating a special type of muscle tissue that is formed by mononucleated muscle cells. In connection with molluscan heart muscle organization, of particular concern are such features as the presence of stem cells in the smooth muscle in the heart of bivalvia. Smooth muscle cells of vertebrates lack stem cells and grow by mitosis of mature cells. Also, there is a lack of fusion of myogenic stem cells in molluscan hearts during their differentiation as takes place in vertebrate skeletal and arthropod heart muscle. It is noteworthy that molluscan body muscle also consists of mononucleated cells.

Tentaculata

The phylogenetic position of the phylum tentaculata, as well as the phylogenetic relationships between different classes of the phylum, are not quite clear. The enterocoelous mode of mesoderm formation approximates that of deuterostomes (see Nielson¹⁴ for discussion). Phoronids and brachiopods possess a developed circulatory system. Phoronids have a closed circulatory system with two principal vessels, a dorsal one and a ventral one, the former performing contractile function. The brachiopod circulatory system is open, with one or more hearts. Ultrastructural studies of the circulatory system of tentaculata have been limited mainly to a description of tentacular blood vessels. We have investigated the heart structure of the brachiopod *Rhinchonella psittacea*.¹⁵ This study revealed three layers that form the heart wall: an outer layer of smooth myoepithelial cells and epicytes, an intermediate layer of a filamentous basal lamina, and an inner discontinuous endothelial lining. The epicytes are nonmuscular mononucleated cells which are scattered among the myoepithelial cells and closely adjacent to them. Occasionally, bundles of myofilaments can be seen in the basal portion of the epicytes anchored between the contractile branches of the myoepithelial cells. It is tempting to consider these findings as some morphological indications of occasional conversion of epicytes into myocytes and to assume that the epicytes are myogenic stem cells.

Pogonophora

There are contradictory views on the mode of mesoderm formation and, correspondingly, on the phylogenetic position of the pogonophorans. According to the data presented by Norrevang,¹⁶ the mesoderm of pogonophorans develops from teloblasts, which is suggestive of their relation to the annelids. Gureeva and Iva-

nov¹⁷ have described an enterocoelic modus of mesoderm formation and considered pogonophora to occupy an intermediate position between protostomians and deuterostomians, being closer to the latter.

Pogonophorans have a closed circulatory system with the anterior part of the dorsal vessel functioning as a heart. A saclike pericardium adjoins the heart dorsally. The pericardial sac is derived from the right protocoel, which enables embryologists to consider it to be homologous to the pericardium of the hemicordata and to the axial complex of the echinodermata.¹⁸ Ontogenetic relationships between pericardium and the myocardium of the pogonophorans are not clear. Data on the ultrastructure of pogonophoran heart are extremely scarce and come to two reports. Gupta and Little¹⁹ have described muscle cells of the *Nereilinum punctatum* heart. Their description is limited to the transversal alignment of the dense bodies and the sarcoplasmic reticulum, which makes muscle fibers look striated. Jensen and Myklebust²⁰ have studied the blood vessel muscles of *Siboglinum fioldircum*. It has been shown to be formed by a basal lamina with myoepithelial cells of a nonstriated type covering it from the outside. Occasionally, a sarcomere-like organization of the myofilaments has been observed.

With only this information available, we are obviously far from even a superficial understanding of how the pogonophoran heart is developed and organized histologically.

Chaetognatha

Chaetognatha lack a circulatory system.

Deuterostomia

Three phyla are generally combined as deuterostomia. These are the echinodermata, hemichordata and chordata. From last group only tunicata will be considered here. The hypothesis generally accepted is that these phyla descend from a common ancestor. They are characterized by the enterocoelic mode of coelom formation. The central organs of their circulatory system are believed to relate to the anterior coeloms by their origin.

Echinoderms

Among the Echinodermata classes, the degree of development of the hemal system varies considerably, from the system of lacunae in the crinoids, ophiuroids and asteroids to the rather elaborately developed hemal system in echinoids and especially in holothurians. The latter possess dorsal, ventral and collateral (the echinoids) or transverse (the holothurians) blood vessels capable of periodical contractions. Diversity of hemal system organization in echinoderms can be clearly illustrated by the fact that in the holothurian *Stichopus moebii* up to 150 muscular single-chambered "hearts" are formed from the specialized branches of the dorsal vessel.²¹ Besides the contractile vessels mentioned above, in some

echinoderm groups, there are the contractile vessel (the echinoids) or madreporic vesicles (the ophiuroids and asteroids) which are the constituents of the axial complex, the latter being a derivative of the anterior coeloms. Ultrastructural studies have shown that the contractile organs of echinoderms consist of an outer layer formed by smooth myoepithelial cells, of a middle layer representing basal lamina, and, in some cases, of an inner endothelial lining. In the myoepithelial layer mononucleated nonmuscle cells are usually found which are described under various terms: coelomic epithelial cells on the holothurian *Cucumaria fondosa*,²² epicytes on the asteroid *Asterias rubens*,²³ flagellated epithelial cells on the holothurian *Parastichopus tremulus*,²⁴ ciliated epithelial cells on the holothurian *Stichopus moebii*,²¹ and epithelial cells on the echinoid *Sphaerechinus granularis*.²⁵ Jensen has noted that sometimes bundles of microfilaments in the basal portion of flagellated epithelial cells differentiated apparently into myofibrils. This is reminiscent of our findings mentioned above on epicytes of the brachiopod heart, which may be interpreted as an initial stage of muscle differentiation.

Hemicordates

Hemicordates possess a partly open circulatory system with main dorsal and ventral vessels. The dorsal vessel goes into the central heart sinus, which is bounded by the stomochord and myocardium. The myocardium is formed as an infolding of the pericardial vesicle. The blood does not run through this heart vesicle, which appears to be derived from the proto-coel. The myocardium consists of a basal lamina covered with myoepithelial cells that may be either smooth, as in *Rhabdopleura compacta*²⁶ and *Cephalodiscus gracilis*,²⁷ or cross-striated, as in *Saccoglossus kowalevskii*.²⁸ These authors have not mentioned the presence of any undifferentiated cells in the myoepithelial layer. However, this may result from a lack of special attention to this question, which needs further investigation.

Tunicates

Tunicates have an open circulatory system. All tunicates appear to have hearts. We are going to consider here the ascidia heart, which is more extensively studied. The ascidian pericardium arises as a mesodermal plate lying near the ventral wall of the gut or, according to other data, as a protrusion of this wall.²⁹ The ascidian pericardial vesicle is considered to be a possible homologue of the anterior coelom of hemichordates. However, unlike the heart of hemichordates, that of ascidians is disposed on the ventral side. The ascidian myocardium is formed by the invagination of the pericardial wall similar to what is observed in the hemichordates. The site of invagination is discernible by a ligament of amorphous noncellular material and is called "the raphe." The myocardium consists of myoepithelial cells resting on a basal lamina. The polarity in the arrangement of organelles in these cells is clearly apparent but not so pronounced as in the myoepithelial cells of, for example, the contractile organs of brachiopods and echinoderms, where the nuclei are situated in hernialike sarcoplasmic outpocketings. We have carried out ultrastruc-

tural and autoradiographic studies of *Ascidia obliqua* heart cells³⁰ and found that the differentiated cells of myocardium containing myofibrils are capable of incorporating tritiated thymidine. We failed to observe mitosis. However, the abundance of binucleated myoepithelial cells suggests that DNA synthesis is probably followed in them by acytokinetic mitosis. It may be supposed that the presence of the highly organized cross-striated myofibrils becomes an obstacle to the progression of cytokinesis, through a complex mechanism of myofiber disassembling accompanied by the resorption of Z-bands that is shown to be functioning in some vertebrate cardiomyocytes.³¹ This appears to be lacking in ascidians. In the raphe region more thymidine-labeled cells are observed than in the myocardium. Another characteristic of this region is that prophasic nuclei occur frequently. These findings enable us to assume that the raphe region is the zone of active cell proliferation and, very probably, a source for myocardial cell replenishing, being a kind of myogenic cambial zone.

CONCLUSION

This brief review of data dealing with muscle tissue organization of the propulsive organs of invertebrates reveals that our ignorance of the cellular mechanisms underlying the growth of these tissues is much greater than our knowledge of the subject. However, analysis of the data available would encourage us to make some preliminary assumptions. Because of their diversity, muscle tissues of pulse organs of invertebrates may be classified into four types. (1) The layer of myoepithelial cells resting on a basal lamina and probably possessing some nonmuscle cells. This common basic principle of organization with some deviations is shared by annelids, brachiopods, pogonophorans, echinoderms and hemichordates. This type of heart muscle is probably the most primitive and initial. (2) A network made up of mononucleated muscle cells with undifferentiated mononucleated cells being scattered among them. This type is characteristic of the molluscan heart. (3) Heart muscle of a type that is much like the skeletal muscle of the vertebrates—multinucleated myofibers and adjoining mononucleated satellite cells. We find this type in the hearts of arthropods. (4) A layer of myoepithelial cells, which are capable of DNA synthesis and karyokinesis, plus a definitely localized cambial zone. This muscle type is inherent in the ascidian heart.

The important point to note is that all the types of heart muscle of invertebrates described here seem to possess a pool of undifferentiated cells which appear to be myogenic stem cells. In this case, in invertebrates the genesis of heart muscle goes according to a myoblastic model of myogenesis.

Thus, true cardiac muscle, much resembling the cardiac muscle of vertebrates, with myocytes differentiated but capable of DNA synthesis, arises in chordata phylum as early as at the level of the nonvertebrate group ascidia, there being there a developmental novelty.

Further investigations of this subject may probably confirm our working hypotheses and make them clearer or disprove them.

REFERENCES

1. IVANOV, A. V. 1976. The relations between the protostomia and the deuterostomia and the classification of the animal kingdom. *Zool. Zh.* **55**: 1125–1137 (in Russian, English summary).
2. MARTIN, A. W. 1980. Some invertebrate myogenic hearts: the hearts of worms and molluscs. *In* Hearts and Heart-like organs. G. H. Bourne, Ed. Vol. 1: 1–39. Academic Press. New York.
3. HAMA, K. 1960. The fine structure of some blood vessels of the earthworm *Eisenia foetida*. *J. Biophys. Biochem. Cytol.* **7**: 717–724.
4. SPIES, R. B. 1973. The blood system of the flabelligarid polychaete *Frabelliderma commensalis* (Moore). *J. Morphol.* **139**: 465–490.
5. JENSEN, H. 1974. Ultrastructural studies on the hearts in *Arenicola marina* L. (Annelida: Polichaeta). *Cell Tissue Res.* **150**: 355–369.
6. HAMMERSEN, F. & H. W. STAUDTE. 1969. Beitrage zum Feinbau der Blutgefasse von Invertebraten. I. Die Ultrastruktur des Sinus lateralis von *Hirudo medicinalis* L. *Z. Zellforsch.* **100**: 215–250.
7. MIDSUKAMI, M. 1981. The structure and distribution of satellite cells of cardiac muscle in decapod crustaceans. *Cell Tissue Res.* **219**: 69–83.
8. TJONNELAND, A., S. OKLAND & B. MIDTTUN. 1985. Myocardial ultrastructure in five species of scorpions (Chelicerata). *Zool. Anz.* **214**: 7–17.
9. NYLUND, A. 1986. Myocardial ultrastructure of *Tanais cavolinii* (Crustacea: Tanaidacea) and some phylogenetic considerations. *J. Crustacean Biol.* **6**: 199–206.
10. NYLUND, A., H. RUHBERG, A. TJONNELAND & B. MEIDELL. 1988. Heart ultrastructure in four species of *Onychophora* (Peripatopsidae and Perpatidae) and phylogenetic implications. *Zool. Beltr.* **32**: 17–30.
11. MARTYNOVA, M. G. 1993. Satellite cells in the crayfish heart muscle function as stem cells are characterized by molt-dependent behaviour. *Zool. Anz.* **230**: 181–190.
12. MARTYNOVA, M. G. & S. Y. KHAITLINA. 1991. Attempt to stimulate regenerative processes in the heart of the crayfish *Astacus astacus*: an autoradiographic and electrophoretic study. *Tsitologiya* **33**: 23–28 (in Russian, English summary).
13. RUMYANTSEV, P. P. & M. I. KRYLOVA. 1990. Ultrastructure of myofibers and cells synthesizing DNA in the developing and regenerating lymph-heart muscle. *Int. Rev. Cytol.* **120**: 1–50.
14. NIELSEN, C. 1991. The development of the brachiopod *Crania (Neocrania) anomala* (O. F. Muller) and its phylogenetic significance. *Acta Zool.* **72**: 7–28.
15. MARTYNOVA, M. G. & O. Y. CHAGA. Ultrastructural study of the heart cells of the brachiopod *Rhinchonella psittacea*. In press.
16. NORREVANG, A. 1970. The position of pogonophora in the phylogenetic system. *Z. Zool. Syst. Evolut-Forsch.* **8**: 161–172.
17. GUREEVA, M. A. & A. V. IVANOV. 1986. On the coelomic mesoderm formation in embryos of *Oligobrachia mashikoi* (Pogonophora). *Zool. Zh.* **65**: 780–788 (in Russian, English summary).
18. IVANOV, A. V. 1975. Embryonalentwicklung der Pogonophora und ihre systematische Stellung. *Z. Zool. Syst. Evolut-Forsch. Sonderheft: The Phylogeny and Systematic Position of Pogonophora.* 10–44.
19. GUPTA, B. L. & C. LITTLE. 1975. Ultrastructure, phylogeny and pogonophora. *Z. Zool. Syst. Evolut-Forsch. Sonderheft: The Phylogeny and Systematic Position of Pogonophora.* 45–63.
20. JENSEN, H. & R. MYKLEBUST. 1975. Ultrastructure of the muscle cells in *Siboglinum fiordicum* (Pogonophora). *Cell Tissue Res.* **163**: 185–197.
21. HERREID, C. F., V. F. LARUSSA & C. R. DEFESI. 1976. Blood vascular system of the sea cucumber, *Stichopus moebii*. *J. Morphol.* **150**: 423–452.
22. DOYLE, W. L. 1967. Vesiculated axons in haemal vessels of an holothurian: *Cucumaria frondosa*. *Biol. Bull.* **132**: 329–336.
23. BARGMANN, W. & G. HEHN. 1968. Ueber das Axialorgan ("mysterious gland") von *Asterias rubens* L. *Z. Zellforsch.* **88**: 262–277.

24. JENSEN, H. 1975. Ultrastructure of the dorsal hemal vessel in the sea-cucumber *Parastichopus tremulus* (Echinodermata: Holothuroidea). *Cell Tissue Res.* **160**: 355-369.
25. BACHMANN, S. & A. GOLDSCHMID. 1978. Ultrastructural, fluorescence microscopic and microfluorimetric study of the innervation of the axial complex in the sea urchin, *Sphaerechinus granularis* (Lam.). *Cell Tissue Res.* **194**: 315-326.
26. LESTER, S. M. 1982. Fine structure of the heart vesicle and pericardium in the pterobranch *Rhabdopleura* (Hemichordata). *Am. Zool.* **22**: 938.
27. DILLY, P. N., U. WELSCH & G. REHKAMPER. 1986. Fine structure of heart, pericardium and glomerular vessel in *Cephalodiscus gracilis* M'Intoch, 1882 (Pterobranchia, Hemichordata). *Acta Zool.* **67**: 173-179.
28. BALSER, E. J. & E. E. RUPPERT 1990. Structure, ultrastructure, and function of the preoral heart-kidney in *Saccoglossum kowalevskii* (Hemichordata: Enteropneusta) including new data on the stomochord. *Acta Zool.* **71**: 235-249.
29. NUNZI, M. G., P. BURIGHEL & S. SCHIAFFINO. 1979. Muscle cells differentiation in the ascidian heart. *Dev. Biol.* **68**: 371-380.
30. MARTYNOVA, M. G. & A. NYLUND. Ultrastructural and autoradiographic studies of the heart of *Ascidia obliqua* (Tunicata), with special reference to its relationship to the vertebrate myocardium the cardiac muscle of brachyura. *Okajimas Folia Anat. Jpn.* **40**: 173-185.
31. RUMYANTSEV, P. P. 1991. Growth and Hyperplasia of Cardiac Muscle Cells. Harwood Acad. Publ. Chur, Switzerland.

Protein Kinase C in Angiotensin II Signalling in Neonatal Rat Cardiac Fibroblasts

Role in the Mitogenic Response^a

GEORGE W. BOOZ AND KENNETH M. BAKER^b

*Weis Center for Research
Geisinger Clinic
Danville, Pennsylvania 17822*

INTRODUCTION

The octapeptide hormone, angiotensin II (AII) exerts a number of actions on cardiac cellular function, including effects on contractility, metabolism, growth, and gene expression.¹ These actions are initiated by the binding of AII to a plasma membrane receptor that stimulates phospholipase C_β (PLC) to hydrolyze phosphatidylinositol 4,5-bisphosphate, thus forming diacylglycerol (DAG) and inositol 1,4,5-triphosphate (IP₃). The subsequent rise in intracellular Ca²⁺ that results from IP₃-mediated release of Ca²⁺ from intracellular stores, together with DAG, activates protein kinase C (PKC), a process associated with its translocation from the cytosolic to the particulate (including the plasma membrane) compartment of the cell.² In some cell types, a delayed activation of Ca²⁺ channels and/or sustained formation of DAG from (Ca²⁺- or PKC-initiated) PLC- or phospholipase D (PLD)-mediated hydrolysis of phosphatidylcholine has been proposed to result in persistent activation of PKC by AII.³

Since phorbol esters which activate PKC elicit many of the same cellular responses as AII, it is logical to predict that PKC would play a central role in the intracellular signalling cascade initiated by AII. Evidence to support this conclusion, however, is circumstantial, and there are several cautionary notes: in contrast to DAG, phorbol esters are poorly metabolized and thus produce a persistent, nonphysiological activation of PKC; the older class of PKC inhibitors are poorly selective for PKC; and phorbol esters are such potent activators of PKC, that some substrate selectivity is lost, particularly at supramaximal concentrations of phorbol esters.⁴ Moreover, ten isozymes of PKC that form three major groups have been identified to date.² These PKC isozymes differ in substrate specificity

^a This work was supported by grants from the National Institutes of Health (HL44883 and HL44379), the American Heart Association (91003030), the Pennsylvania Affiliate of the American Heart Association, and the Geisinger Clinic Foundation. Dr. G. W. Booz is a recipient of a National Research Service Award Postdoctoral Fellowship. Dr. K. M. Baker is an Established Investigator of the American Heart Association.

^b Correspondence should be addressed to: Kenneth M. Baker, M.D., Weis Center for Research, 26-11, 100 North Academy Avenue, Danville, PA, 17822.

and sensitivity to activators: conventional (c-)PKC isozymes (α , β , γ) are activated by both Ca^{2+} and DAG; novel (n-)PKC isozymes (δ , ϵ , η , θ) are activated by DAG and not Ca^{2+} ; and atypical (a-)PKC isozymes (ζ , λ) are not activated by either Ca^{2+} or DAG. The three groups of PKC isozymes show subtle differences in lipid cofactor requirements, suggesting that their activation *in situ* may be regulated in a complex manner that is overridden by phorbol esters.² The purpose of the studies reported here, as well as elsewhere,⁵ is to evaluate the importance of PKC in AII-stimulated fibroblast proliferation, a response that may have importance in the remodeling of the cardiac interstitium in a variety of pathological conditions.⁶

METHODS

Assay of Membrane PKC

Following treatment, serum-deprived cultures of neonatal rat cardiac fibroblasts (NRCF) were placed on ice, washed $2 \times$ with Ca^{2+} -free Hanks' buffered salt solution (HBSS), and scraped into hypotonic lysis buffer (in mM): 20 Tris (pH 7.4), 10 EDTA, 5 EGTA, 5 β -mercaptoethanol, 10 benzamidine, with (per ml) 1 mg leupeptin, 50 μg PMSF, 0.1 mg ovalbumin, and 0.1 μg aprotinin. The lysate was dounced and centrifuged at 100,000 g for 40 min (4°C), the pellet resuspended in lysis buffer, and PKC extracted with 0.1% NP-40 for 1 h on ice. Following centrifugation, the detergent-soluble PKC in the supernatant was assayed by following the incorporation of ^{32}P from ATP into [Ser²⁵]PKC(19–31). This peptide, henceforth referred to as α -peptide, represents a segment of the pseudosubstrate region of PKC α , with serine substituted for alanine at position 25, and is a good substrate for all PKC isozymes.⁷ The assay was performed at 30°C in reaction mixture: 50 mM Hepes (pH 7.4), 10 mM Mg acetate, 25 μM [γ - ^{32}P]ATP, 5 μM α -peptide, and (in $\mu\text{g}/\text{ml}$) 240 phosphatidylserine and 16 diolein. Aliquots of the reaction mixture were spotted on phosphocellulose paper, washed 5×10 min in 75 mM H_3PO_4 , dried, and counted by liquid scintillation spectroscopy (LSS). Results are expressed as pmol of ^{32}P incorporated from ATP into substrate/min/ μg protein.

Western Analysis

Following treatment, cells were lysed as described above, and the supernatant from the high speed centrifugation saved as the cytosolic extract. The pellet was washed with lysis buffer, resuspended in lysis buffer containing 1% Triton X-100, and incubated for 20 min at 4°C . The detergent extract was centrifuged at 15,000 g for 20 min at 4°C and the supernatant saved as the detergent-soluble membrane protein. Equal amounts of protein (60 μg) were separated on 8% SDS-PAGE, with prestained molecular weight markers (Bio-Rad, Hercules, CA) and rat brain cytosolic extracts. Separated proteins were wet-transferred to Immobilon-P membranes (Millipore, Bedford, MA), and nonspecific sites blocked by incubation for

1 h at 22°C with Blotto: 20 mM Tris (pH 7.4), 500 mM NaCl, 5% nonfat dry milk, 0.05% Tween 20, and 2% NP-40. PKC α anti-peptide antibody (GIBCO BRL, Grand Island, NY) was diluted to 3 μ g/ml in Blotto and incubated with membranes overnight at 4°C. Blots were rinsed 2 \times in TBS-T (20 mM Tris, pH 7.4, 500 mM NaCl, and 0.5% Tween 20) and incubated 2 h in Blotto with anti-rabbit IgG peroxidase-conjugated antibody adsorbed with human IgG (Sigma, St. Louis, MO). Detection was by enhanced chemiluminescence (ECL) using Renaissance reagents (DuPont NEN, Boston, MA), and exposure to Kodak X-Omat film. Autoradiographs were analyzed by densitometric scanning using ImageQuant (Molecular Dynamics, Sunnyvale, CA).

PKC in Situ Assay

Serum-deprived NRCF were exposed to agonist or PMA, then permeabilized with a solution of (in mM) 142.4 KCl, 0.3 H_2PO_4 , 0.4 KH_2PO_4 , 20 Hepes (pH 7.2), 10 MgCl_2 , 25 β -glycerophosphate, 5 EGTA, and 2.5 CaCl_2 , containing 1 mg/ml glucose, 0.01% saponin, 30 μ Ci/ml [γ - ^{32}P]ATP, 100 μ M ATP, and either 10 μ M α -peptide or 100 μ M glycogen synthase (GS)-peptide. Following a 5–10-min incubation (37°C), reactions were terminated by adding TCA to a final concentration of 6.7%. Reaction mixtures were centrifuged for 5 min and aliquots spotted on phosphocellulose paper, which were washed in H_3PO_4 . Results are expressed as described above.

[^3H]Thymidine Incorporation into DNA

Serum-deprived NRCF were exposed to agonist for 24 h. [^3H]Thymidine (1.25 μ Ci/ml) was added 3 h before the end of incubation; plates were washed with ice-cold HBSS and incubated for 10 min with 10% TCA. The cell precipitates were washed with 95% ethanol, solubilized in 0.2 N NaOH, and counted by LSS.

Statistics

Results are expressed as mean \pm SEM for n dispersions of cells or as a representative experiment for n plates of cells from a single dispersion. Ventricles from 80 rat pups were used in each dispersion.

RESULTS AND DISCUSSION

Angiotensin II-Induced PKC Activity

Translocation of PKC to the Membrane Fraction

PKC has been shown to undergo a translocation from the cytosolic to the membrane compartment of cells in response to agonist-induced DAG formation or increased intracellular Ca^{2+} in the case of cPKCs.² This translocation event is

frequently used as an index of PKC activation. Exposure of NRCF for 1 min to 1 μM [Sar¹]AII induced a 90% increase in the amount of PKC enzyme activity associated with the membrane fraction (FIG. 1). Membrane PKC levels subsequently declined, returning to nonstimulated levels after 5 min. The phorbol ester PMA (100 μM) produced a nearly instantaneous and sustained (>60 min) increase of more than 600% in membrane PKC activity, representing complete translocation of the Ca²⁺- and lipid-sensitive cytosolic kinase activity towards α -peptide.

Further evidence that AII causes translocation of PKC was obtained by Western analysis. As seen in FIG. 2, exposure of NRCF for 1 min to 1 μM [Sar¹]AII caused a 71% reduction in the cytosolic pool of PKC α and a corresponding 98% increase in membrane-bound enzyme.

Activation of PKC in Situ

The above described increase in membrane PKC did not translate into appreciable activation of the cellular pool of PKC, as repeated attempts to detect enhanced PKC activity in permeabilized cells following exposure to 1 μM [Sar¹]AII (for upwards of 15 min) were unsuccessful (FIGS. 3A & 3B). In these experiments, either GS-peptide or α -peptide were employed as substrate. GS-peptide is an ade-

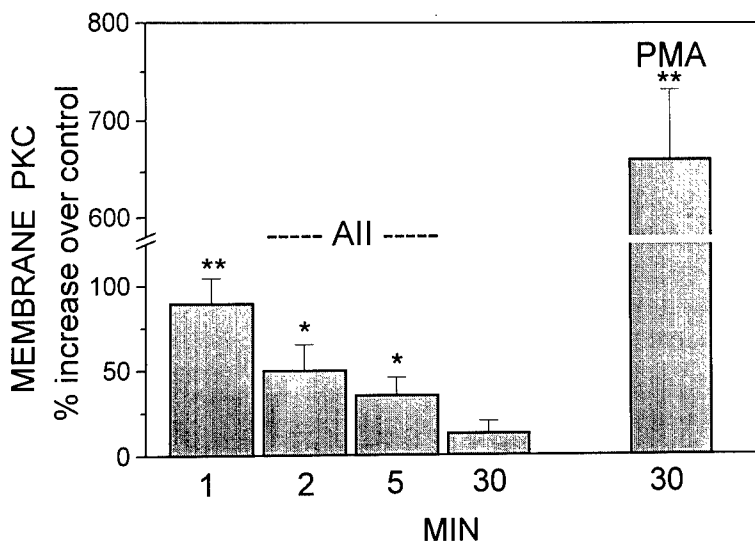

FIGURE 1. Percent increase over vehicle-treated control in membrane PKC activity of cardiac fibroblasts following exposure to 1 μM [Sar¹]angiotensin II (AII) or 100 nM phorbol 12-myristate 13-acetate (PMA). Enzymatic activity of the detergent-soluble membrane fraction was determined as described in the text using α -peptide as substrate (in the presence of 0.7 mM CaCl₂, 240 $\mu\text{g}/\text{ml}$ phosphatidylserine, and 16 $\mu\text{g}/\text{ml}$ diolein). Mean \pm SEM ($n = 4$). Statistical significance of the difference from the respective control (expressed as 100%) was assessed by one-tailed, paired Student t test: * $p < 0.05$, ** $p < 0.01$.

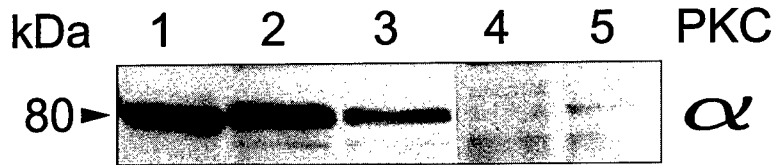

FIGURE 2. Western analysis of AII-induced redistribution of PKC α in cardiac fibroblasts. Serum-starved cells were exposed to 1 μ M [Sar¹]AII for 1 min, and the cytosolic and membrane fractions collected. Equal amounts of protein were separated by SDS-PAGE and transferred to Immobilon-P membranes. PKC α was detected with an antipeptide antibody. Binding to the PKC isozyme-specific band was eliminated by preincubation of the antibody for 10 min with the synthetic peptide against which the antibody was raised (data not shown). *Lanes:* 1, brain cytosolic extract (positive control); 2 and 4, cytosol and membranes from vehicle-exposed fibroblasts, respectively; 3 and 5, cytosol and membranes from [Sar¹]AII-exposed fibroblasts, respectively.

quate, and α -peptide an excellent substrate for all PKC isozyme types (c-, n-, and α PKCs).⁷ The highly specific PKC inhibitor, compound 3 (500 nM) reduced basal kinase activity in permeabilized cells towards α -peptide by $67.7 \pm 3.2\%$ ($n = 3$).

In NRCF, 1 μ M [Sar¹]AII produces a robust (>510 nM) increase in free cytosolic Ca²⁺, resulting from the release of Ca²⁺ from intracellular stores.⁶ This observation provides circumstantial evidence that the AII receptor of NRCF, characterized pharmacologically as AT₁, couples to phospholipase C activation. However, using the conventional assay employing DAG kinase,⁸ we were not successful in detecting significant DAG formation in NRCF following AII stimulation (unpublished observation). Angiotensin II may induce translocation of cPKC (viz., PKC α) via a Ca²⁺-dependent process, but only weakly activate PKC due to modest activator (*i.e.*, DAG) accumulation, as well as rapid proteolysis via a Ca²⁺-dependent protease (calpains). Evidence indicates that AII does activate PKC in cardiac fibroblasts. As previously reported,⁹ AII stimulates mitogen-activated protein (MAP) kinase activity in NRCF by both PKC-dependent and PKC-independent pathways. Second, as reported for mesangial cells,¹⁰ AII activates PLD in NRCF in part through a PKC-dependent process (K. Baker, unpublished data).

Role of PKC in Angiotensin II-Induced Growth

Angiotensin II is a consistent mitogen for NRCF.⁶ In contrast, the phorbol ester PMA at 100 nM is without effect on [³H]thymidine incorporation into DNA in these cells.⁵ The ineffectiveness of PMA to stimulate cell proliferation was not likely due to partial downregulation of PKC activity, as no positive effect on [³H]thymidine incorporation into DNA was observed at a 100-fold lower concentration of this agent. Moreover, two other phorbol esters, phorbol 12,13-dibutyrate (PDB) and 12-deoxyphorbol 13-phenylacetate 20-acetate (dPPA), were also ineffective in stimulating [³H]thymidine incorporation into DNA at 10⁻⁸ M, and at higher concentrations tended to exert an inhibitory action (TABLE 1). Under the

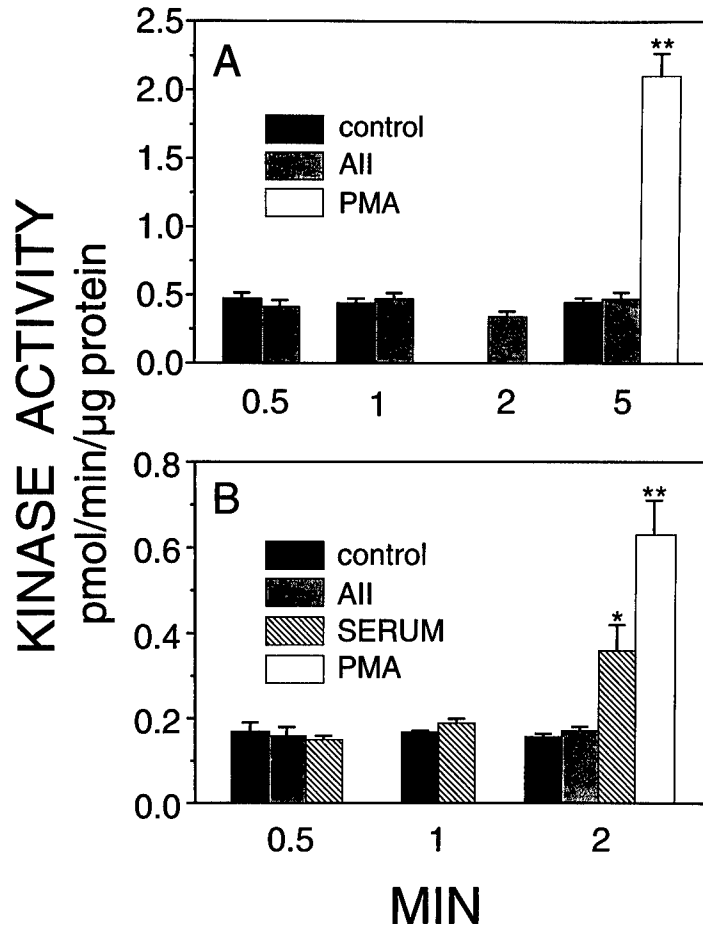

FIGURE 3. Inability of AII to activate *in situ* PKC of cardiac fibroblasts. Cells were exposed to vehicle (control), 1 μ M [Sar¹]AII, 10% new-born calf serum, or 100 nM PMA for various lengths of time. Subsequently, cells were permeabilized and PKC assayed using either (A) α -peptide of (B) GS-peptide as substrate. Shown are representative experiments: mean \pm SEM ($n = 3$); * $p < 0.05$ and ** $p < 0.01$ by two-tailed, unpaired Student t test.

same culture conditions, 10% serum stimulated [³H]thymidine incorporation into DNA by more than 700%.

In terms of PKC activation, these phorbol esters can be ranked as follows: PMA \geq PDB \gg dPPA. PDB is less hydrophobic than PMA, while dPPA has been shown to be more selective in activating PKC β , than other PKC isozymes.¹¹ The lack of a stimulating effect of phorbol esters on [³H]thymidine incorporation appears to be cell type specific, as exposure of serum-deprived Swiss 3T3 fibroblasts to 500 nM PMA for 24 h stimulated thymidine incorporation by more than

TABLE 1. Effect of Phorbol Esters on the Incorporation of [³H]Thymidine into DNA in Neonatal Rat Cardiac Fibroblasts^a

	% Change over Control		
	PMA	PDB	dPPA
10 ⁻⁸ M	-42.7 ± 8.1†	7.7 ± 18.4	32.0 ± 7.0*
10 ⁻⁷ M	8.4 ± 13.6	-44.0 ± 5.4	-26.4 ± 4.1
10 ⁻⁶ M	—	-33.4 ± 6.4	-49.3 ± 1.5*

^a Serum-deprived neonatal rat cardiac fibroblasts were exposed for 24 h to phorbol ester at the indicated concentrations; PMA, phorbol 12-myristate 13-acetate; PDB, phorbol 12,13-dibutyrate; dPPA, 12-deoxyphorbol 13-phenylacetate 20-acetate. Over the final 3 h, cells were pulse-labeled with [³H]thymidine (1.25 μCi/ml). Incorporation of thymidine into the acid-precipitated cellular fraction was determined. Values are the mean ± SEM for *n* determinations on separate dispersions: *n* = 4, except †*n* = 14. Statistical significance of the difference from the respective vehicle-treated control (0.02% v/v DMSO) was determined using a two-tailed, paired Student *t* test. **p* < 0.05.

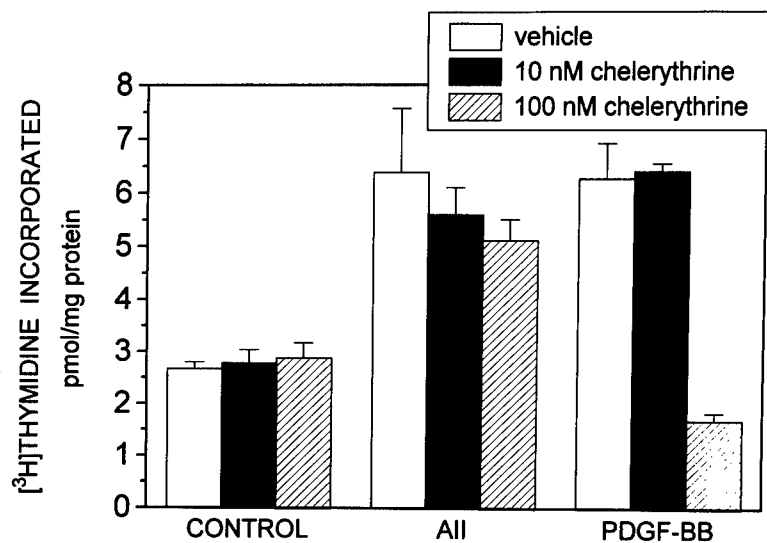

FIGURE 4. Effect of the PKC inhibitor, chelerythrine on angiotensin II- and PDGF-induced thymidine incorporation into DNA. Serum-starved cells were preincubated for 40 min with either 10 or 100 nM chelerythrine, then incubated 24 h with 1 μM [Sar¹]AII or 0.5 ng/ml PDGF-BB. Over the final 3 h, cells were pulse-labeled with 1.25 μCi/ml [³H]thymidine. Incorporation of radiolabeled thymidine into the TCA-precipitated cellular fraction was determined. Shown are the results of a single experiment with the effect of each exposure determined on 3 plates of cells: mean ± SEM (*n* = 3).

1,200%. These results argue against the hypothesis that PKC activity alone is sufficient to explain the growth-promoting effects of AII in NRCF.

Effect of Chelerythrine

As shown in FIG. 4, pretreatment of NRCF for 40 min with the PKC inhibitor, chelerythrine (LC Laboratories, Woburn, MA) at a concentration of 100 nM failed to block AII-induced [³H]thymidine incorporation into DNA; however, the PDGF-BB-induced response (0.5 ng/ml) was eliminated. This finding is in agreement with several recent reports demonstrating the importance of PKC for PDGF-induced proliferation of other cell types.¹²

Effect of PKC Downregulation

Further evidence that PKC activation *per se* is not responsible for the proliferative effect of AII on NRCF was obtained from studies in which NRCF were exposed to 500 nM PMA for 48 h to downregulate PKC. The loss of phorbol ester-sensitive PKC isozymes (*viz.*, α , δ , ϵ) was confirmed by both *in vitro* kinase assays and Western analysis.⁵ As previously reported,⁹ PKC downregulation had no effect on AII-induced [³H]thymidine incorporation into DNA ($96 \pm 5\%$, $n = 3$). The PDGF-induced response (5 ng/ml) was reduced from >400% to the same level as that of AII.

CONCLUSIONS

The AT₁ receptor has been shown to couple to phospholipase C _{β} activation, thereby generating the second messengers IP₃ and the endogenous activator of PKC, DAG. In NRCF, we have provided evidence that AII does activate PKC. However, the results presented here and elsewhere⁵ highlight two caveats concerning the importance of PKC in AII cellular signalling in general. First, activation by AII of PKC in NRCF is modest and transient, and alone does not account for the long-term effects of AII on cell growth. For growth responses, other intracellular signalling events, such as activation of tyrosine kinases, appear to play a more important role.¹³ Secondly, AII activates many intracellular signalling pathways in NRCF (*e.g.*, PLD, MAP kinases, and *c-fos* expression) via redundant, PKC-dependent and PKC-independent routes. In conclusion, AII-stimulated increases in PKC activity do not appear to represent an important signal transduction pathway involved in the mitogenic response of cardiac fibroblasts to this hormone. The involvement of PKC in G-protein receptor-mediated growth responses is likely to be cell and tissue type dependent.

SUMMARY

The mitogenic effects of angiotensin II on cardiac fibroblasts are mediated by membrane receptors that are classified as AT₁. These receptors are prototypical

of the seven transmembrane group of receptors that couple, via G-proteins, to phospholipase C, thereby generating the endogenous activator of protein kinase C, diacylglycerol. Phorbol ester activators of protein kinase C exhibit growth-promoting effects in many cell types, suggesting that this enzyme may be responsible for the growth effects of angiotensin II on cardiac fibroblasts. Both kinase assays and Western analysis demonstrated that angiotensin II does induce translocation of protein kinase C to the detergent-soluble, membrane compartment of cardiac fibroblasts. Although translocation is commonly interpreted to mean activation of protein kinase C, *in situ* assays on permeabilized cells failed to detect increased enzymatic activity in response to angiotensin II. Nonetheless, this hormone did activate protein kinase C, leading to activation of mitogen-activated protein (MAP) kinases. However, a PKC-independent pathway for activation of MAP kinases exists as well. Downregulation and inhibitor studies indicated that protein kinase C is not critically involved in angiotensin II-induced thymidine incorporation into DNA. Furthermore, phorbol esters that activate protein kinase C do not elicit a mitogenic response in these cells. In conclusion, the mitogenic effects of angiotensin II on cardiac fibroblasts are not simply explained by activation of protein kinase C.

ACKNOWLEDGMENTS

The authors gratefully acknowledge the expert technical assistance of Mr. David M. Cooney in performing the tissue dispersions. The PKC inhibitor, compound 3 was a generous gift of Dr. Thomas Rawson (Genentech, South San Francisco, CA).

REFERENCES

1. BOOZ, G. W., D. E. DOSTAL & K. M. BAKER. 1994. Regulation of cardiac second messengers by angiotensin. *In* Cardiac Renin-Angiotensin System. K. Lindpaintner & D. Ganten, Eds. 101–124. Futura Medical Publishers. New York.
2. HUG, H. & T. F. SARRE. 1993. Protein kinase C isozymes: divergence in signal transduction? *Biochem J.* **291**: 329–343.
3. TUOMINEN, R. K., M. H. WERNER, H. YE, M. K. McMILLIAN, P. M. HUDSON, Y. A. HANNUN & J. S. HONG. 1993. Biphasic generation of diacylglycerol by angiotensin and phorbol ester in bovine adrenal chromaffin cells. *Biochem. Biophys. Res. Commun.* **190**: 181–185.
4. WILKINSON, S. E. & T. J. HALLAM. 1994. Protein kinase C: is its pivotal role in cellular activation over-stated? *Trends Pharmacol. Sci.* **15**: 53–57.
5. BOOZ, G. W., D. E. DOSTAL, H. A. SINGER & K. M. BAKER. 1994. Involvement of protein kinase C and calcium in angiotensin II-induced mitogenesis of cardiac fibroblasts. *Am. J. Physiol.* **267**: C1308–C1318.
6. SCHORB, W., G. W. BOOZ, D. E. DOSTAL, K. M. CONRAD, K. C. CHANG & K. M. BAKER. 1993. Angiotensin II is mitogenic in neonatal rat cardiac fibroblasts. *Circ. Res.* **72**: 1245–1254.
7. KAZANIEZ, M. G., L. B. ARECES, A. BAHADOR, H. MISCHAK, J. GOODNIGHT, J. F. MUSHINSKI & P. M. BLUMBERG. 1993. Characterization of ligand and substrate specificity for the calcium-dependent and calcium-independent protein kinase C isozymes. *Mol. Pharmacol.* **44**: 298–307.

8. PREISS, J. E., C. R. LOOMIS, R. M. BELL & J. E. NIEDEL. 1987. Quantitative measurement of *sn*-1,2-diacylglycerols. *Methods Enzymol.* **141**: 294-300.
9. BOOZ, G. W., H. A. SINGER & K. M. BAKER. 1993. Role of protein kinase C in angiotensin II-induced mitogenesis of neonatal rat cardiac fibroblasts. *Physiologist* **36**: A-11.
10. BARNETT, R. L., L. RUFFINI, L. RAMSAMMY, R. PASMANTIER, M. M. FRIENDLAENDER & E. P. NORD. 1993. Angiotensin-mediated phosphatidylcholine hydrolysis and protein kinase C activation in mesangial cells. *Am. J. Physiol.* **265**: C1100-C1108.
11. RYVES, W. J., A. T. EVANS, A. R. OLIVIER & F. J. EVANS. 1991. Activation of the PKC-isotopes α , β_1 , γ , δ and ϵ by phorbol esters of different biological activities. *FEBS Lett.* **288**: 5-9.
12. GHOSH CHOUDHURY, G., P. BISWAS, G. GRANDALIANO & H. E. ABBOUND. 1993. Involvement of PKC- α in PDGF-mediated mitogenic signaling in human mesangial cells. *Am. J. Physiol.* **265**: F634-F642.
13. SCHORB, W., T. C. PEELER, N. N. MADIGAN, K. M. CONRAD & K. M. BAKER. 1994. Angiotensin II induced protein tyrosine phosphorylation in neonatal rat cardiac fibroblasts. *J. Biol. Chem.* **269**: 19626-19632.

Mechanical and Neurohumoral Regulation of Adult Cardiocyte Growth^a

ROBERT S. DECKER, MARLENE L. DECKER, MONICA M.
BEHNKE-BARCLAY, DONNA M. JANES,
AND WILLIAM A. CLARK

*Department of Medicine/Cardiology S 207
Northwestern University Medical School
303 E. Chicago Avenue
Chicago, Illinois 60611*

Culture of adult cardiac myocytes provides an opportunity to directly explore potential regulatory pathways that modulate the growth of the mature heart cell.¹ Identifying subcellular events and signal transduction pathways that mediate the growth of the adult cardiac myocyte in response to stresses that provoke cardiac hypertrophy is limited when whole animals are employed, because unraveling "cause from effect" *in vivo* is often complicated by the cellular heterogeneity of the heart and the likely neurohumoral interactions that exist within the intact myocardium.²⁻⁴ Changes in neurotransmitter release, fluctuating plasma hormone levels and attendant alterations in hemodynamic load make it difficult, at best, to precisely determine how postulated chemical and physical signals regulate cellular growth *in vivo*. Cultured cardiac myocytes provide an experimental paradigm to more definitively identify and characterize putative pathways that control cardiocyte growth in a defined and relatively uncomplicated environment. There are several caveats, however, that should be considered before contemplating the use of such a model system. The production of two-dimensional adult cardiocyte cultures minimizes, in most instances, myocyte-nonmyocyte interactions, alters the geometry of this reestablished "*in vitro* myocardium" and modifies the extracellular environment (*i.e.*, the culture medium and extracellular matrix) that supports cardiocyte growth. The source of the heart cells employed for study (*i.e.*, are they derived from developing or adult heart) also deserves special consideration. Cardiac myocytes isolated from embryonic, neonatal or adult hearts possess unique properties that make each of them useful for the study of specific aspects of cardiac growth and development. Embryonic heart cells are, perhaps, ideal for exploring cardiogenic determination, while neonatal myocytes are well suited for investigating postnatal myocardial growth. In contrast, adult cardiocytes can be usefully employed to explore the regulation of physiologic and, perhaps, pathophysiologic hypertrophy. The principal focus of this report will be to compare and contrast how *mechanical loading* and *neurohumoral activation* modulate the growth of adult cardiac myocytes and, where possible, to determine whether the

^a These investigations were supported by grants from USPHS (HL33616) and NASA (NAGW3615). Support from the Feinberg Cardiovascular Research Institute was greatly appreciated.

pathways believed to regulate the growth of the neonatal myocyte are those that initiate adult cardiocyte cellular hypertrophy.

Mechanical Loading in Vitro

Although it is well recognized that changes in preload/afterload are closely correlated with the evolution of cardiac hypertrophy, how mechanical stress/strain on the myocardium or striated muscle is transduced into cellular growth is a topic of considerable speculation.^{4,5} Peterson and Lesch⁶ first documented that the development of active tension accelerated protein synthesis in isolated papillary muscles and that such changes were proportional to developed tension.⁷ Elevating aortic pressure in arrested hearts also was recognized to stimulate anabolic pathways^{8,9} probably by accelerating ribosomal RNA production¹⁰ while simultaneously inhibiting protein degradation.¹¹ The observations derived from these papillary muscle preparations and perfused hearts implied that whatever signal transduction pathways were activated by mechanical stress/strain, they ultimately modulated protein turnover by suppressing proteolysis and enhancing the capacity of the myocardium to synthesize protein.

Passively stretched, field-stimulated and spontaneously beating cardiocyte cultures represent the principal model systems that have been employed to simulate an *in vitro* mechanical load. Since cultured heart cells are firmly anchored either to a plastic substratum or a deformable membrane via specific extracellular matrix proteins, the stress/strain generated within the cardiocyte is predominantly isometric in character. That the maintenance of the adult and neonatal cardiac phenotype is dependent on active mechanical loading is, perhaps, best exemplified by the observations that heart cells disassemble myofibrils (*i.e.*, phenotypically atrophy) when they are cultured in a quiescent state¹²⁻¹⁶ (FIG. 1A,B) or when contractile activity is suppressed by either sarcolemmal depolarization or Ca²⁺ channel blockade.^{14,17-19} Although nonbeating adult myocytes appear to retain the capacity to synthesize contractile proteins at *normal* rates,¹⁸ such passively anchored heart cells²⁰ are unable to maintain the organization of the contractile apparatus in long-term culture.¹²⁻¹⁵ These observations raise an important question—is the passive stretch of nonbeating adult myocytes a sufficient stimulus to provoke myofibrillar reassembly and cellular hypertrophy, or is the generation of active tension produced during field stimulation required to maintain myofibrillar structure and enhance myocyte growth? Results derived from our laboratory suggest that passive stretch will initiate myofibril reorganization but induce only a small degree of growth, whereas field stimulation enables myocytes to reassemble the contractile apparatus, enhance rates of contractile protein synthesis and accumulate significant amounts of contractile protein.

When preparations of adult myocytes are attached to silastic membranes²¹ and passively stretched 10% of their rest length, the rate of protein and RNA synthesis is elevated acutely.²² However, these observations failed to reveal whether the response of passively-stretched, nonbeating heart cells results in an accumulation of contractile protein or merely reflects enhanced protein turnover. When adult feline myocytes are passively stretched over a 48-h interval, the fractional rates

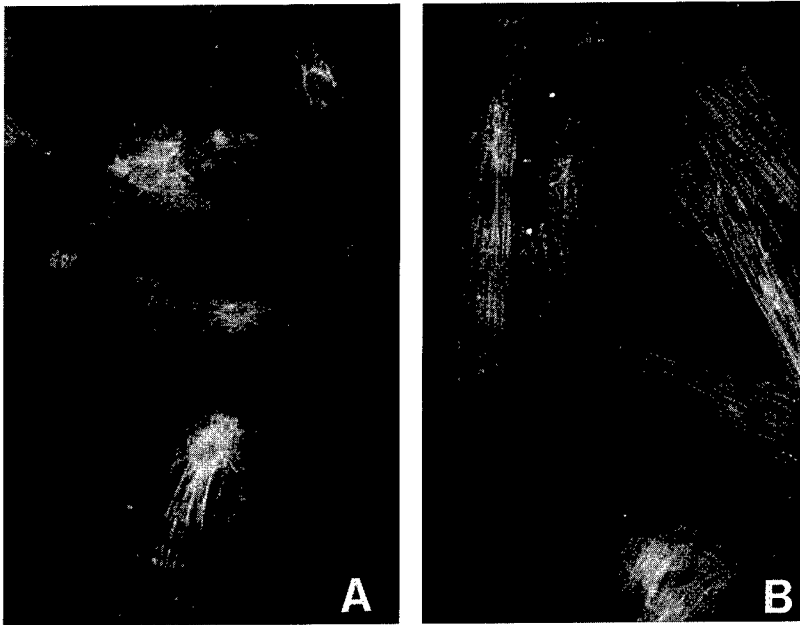

FIGURE 1. Myosin distribution in two-week-old cultures of (A) quiescent and (B) beating adult feline myocytes. Myofibrillar structure is maintained in field-stimulated (1 Hz), contracting heart cells.

(K_S) of total and contractile protein synthesis are increased significantly within 4 h, with the total protein K_S rising about 30% ($p < 0.01$) above control values after 48 h (FIG. 2A). Marked increases in the fractional synthesis rate of actin, α actinin and myosin heavy chain (MHC) mirror that documented for total protein (FIG. 2B); nevertheless, when changes in the [3 H] leucine content of total or contractile protein (*i.e.*, MHC) are monitored, no significant increase in total protein-bound leucine ($\sim 8\%$) could be documented in these passively stretched heart cells (FIG. 2C). Such observations suggest that passive stretch enhances the turnover of contractile proteins, but during the first 48 h of increased loading, no hypertrophic growth evolves in the adult cardiac myocyte. These results raise an additional query—do the changes in protein metabolism reported above reflect an adaptive response of the heart cells to an increased physical load? Since Terracio *et al.*²¹ first reported that passive stretching rapidly altered the organization and polarity of the contractile apparatus of cultured neonatal heart cells, immunofluorescence microscopy was employed to assess whether passive stretch induced structural changes in the cytoskeleton of adult feline myocytes. Altering the passive tension on the myocytes appears to provoke a complex reorganization of the cytoskeleton which commences with the remodelling of adhesion plaques followed by the reassembly of myofibrils, presumably, from such sites (FIG. 3A). After 48 h, the contractile apparatus appears restructured (FIG. 3B); whether continued passive load-

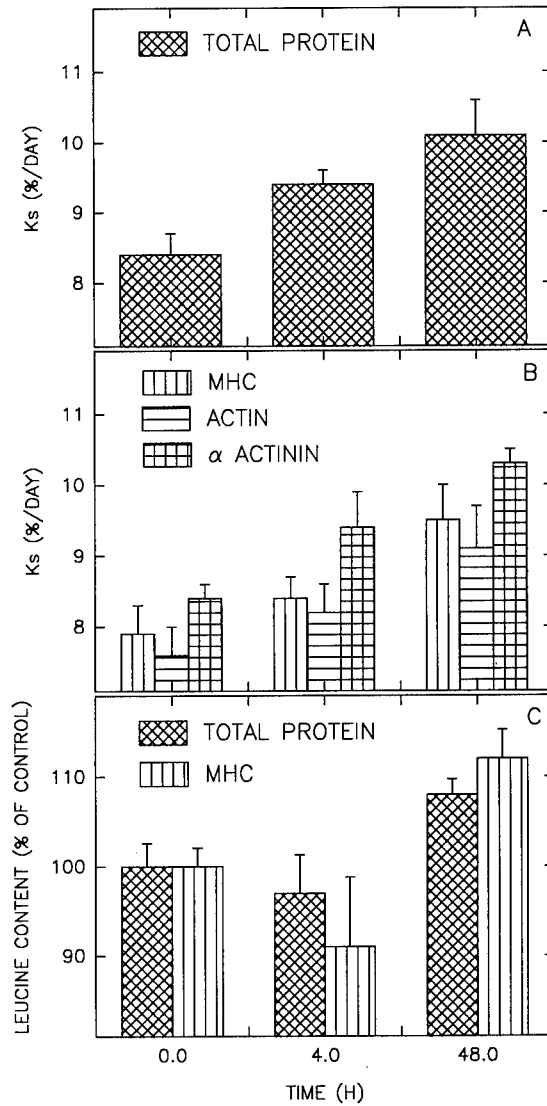

FIGURE 2. Feline heart cells passively stretched 10% of their rest length for 4 and 48 h show increases in the fractional synthesis rate (K_s) of (A) total and (B) contractile protein, while (C) the leucine content (dpm [3 H] leucine accumulated in TCA precipitable protein) of total protein and myosin heavy chain (MHC) does not rise correspondingly. Values are means \pm SEM, $n = 5-7$ duplicate cultures.

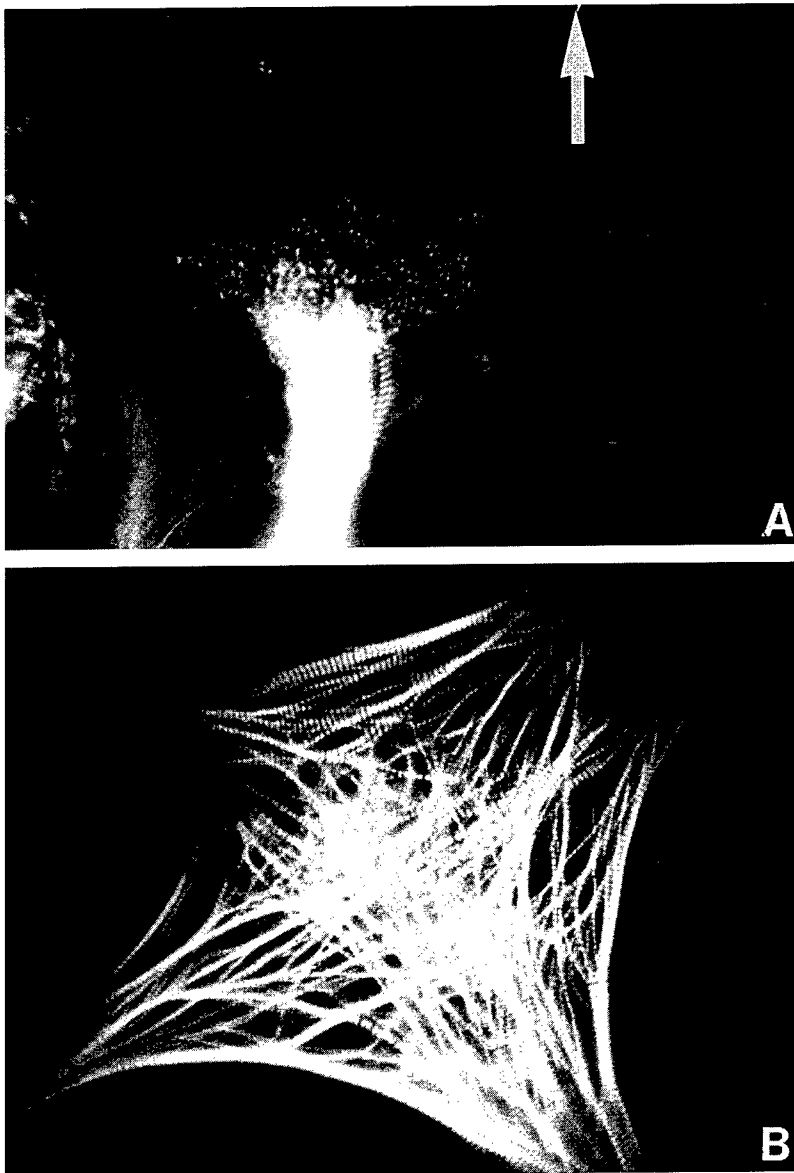

FIGURE 3. Changes in actin distribution in the distal processes of one-week-old nonbeating feline myocytes stretched for (A) 4 h and (B) 48 h, respectively. At 4 h heart cells develop bifurcated processes with few intact myofibrils; at 48 h, the cells have spread significantly and reassembled myofibrils. *White arrow* indicates direction of stretch.

ing will induce cellular hypertrophic growth and further subcellular reorganization will require additional experiments. What signal transduction pathways are triggered in response to physical deformation have yet to be explored extensively with cultured adult heart cells, but observations from Yazaki²³⁻²⁵ and Izumo^{26,27} bare directly on this issue.

In contrast to results derived from adult heart cells, neonatal myocytes hypertrophy (*i.e.*, accumulate protein) significantly in response to a stretch protocol similar^{24,26} to the paradigm described above; however, these myocytes were beating and, therefore, the accumulation of protein may reflect an increase in response to enhanced active loading. Nevertheless, passively stretching either quiescent²³ or contracting^{26,27} neonatal rat heart cells appears to induce the expression of immediate early (IE) genes (*e.g.*, *c-fos*, *c-jun* and *c-myc*), and this induction is followed within 12 h by the expression of a cardiac fetal gene program that includes the transcription of skeletal α actin, atrial natriuretic factor (ANF) and β myosin heavy chain (MHC). The expression of this fetal gene program appears to correspond with an increase in protein mass in this preparation,^{24,26} but it remains unclear whether the upregulation of the IE and fetal gene cascade directly initiates cardiocyte hypertrophy. The search for the rate limiting signal transduction pathways responsible for the upregulation of IE genes, fetal isogenes and enhanced rates of protein synthesis has provided some rather surprising results. Instead of activating a single signalling pathway, the production of several second messengers is believed to be stimulated in response to passive stretch.^{25,28} A variety of kinases, including the tyrosine kinases, mitogen activated protein (MAP) kinases, S_6 kinases and protein kinase C (PKC) are activated as are three phospholipases (PLC, PLD and, perhaps, PLA_2); conversely, activation of protein kinase A (PKA) via adenylate cyclase and cAMP does not appear to be a major player in this system.²⁸ Preliminary observations also suggest that passive stretch may modulate $[Ca^{2+}]_i$ and limit myofibril disruption and the enhanced degradation of contractile proteins normally encountered in heart cells exposed to Ca^{2+} channel blockers like verapamil.^{17,19,29} The complexity of the neonatal response to stretch will likely make it difficult to identify how physical force generation is transduced into a unique chemical signal; some preliminary experiments implicate angiotensin II, a modulator of PKC, as a potential autocrine regulator stretch-induced hypertrophy.³⁰

In contrast to the small changes in protein mass provoked by passively stretching nonbeating adult feline myocytes, field-stimulating paired heart cell preparations at a frequency of 1 or 2 Hz initiates a more robust increase in protein synthesis than that observed in passively stretched cardiocytes. Fractional rates of total and contractile protein synthesis are elevated approximately 45% above control values after 48 h with a significant increase in K_s (~31%) apparent within 4 h following the activation of beating (FIG. 4A). Moreover, changes in the synthesis of actin, α actinin and MHC parallel those for total protein (FIG. 4B) and result in a significant increase (~24%) in the total/contractile (*i.e.*, MHC) protein content of such preparations (FIG. 4C). The results from these experiments imply that passive stretch promotes myofibrillar reorganization, but the development of active tension is required to induce cellular hypertrophy in adult cardiac myocytes. Observations from McDermott's laboratory support this contention by revealing

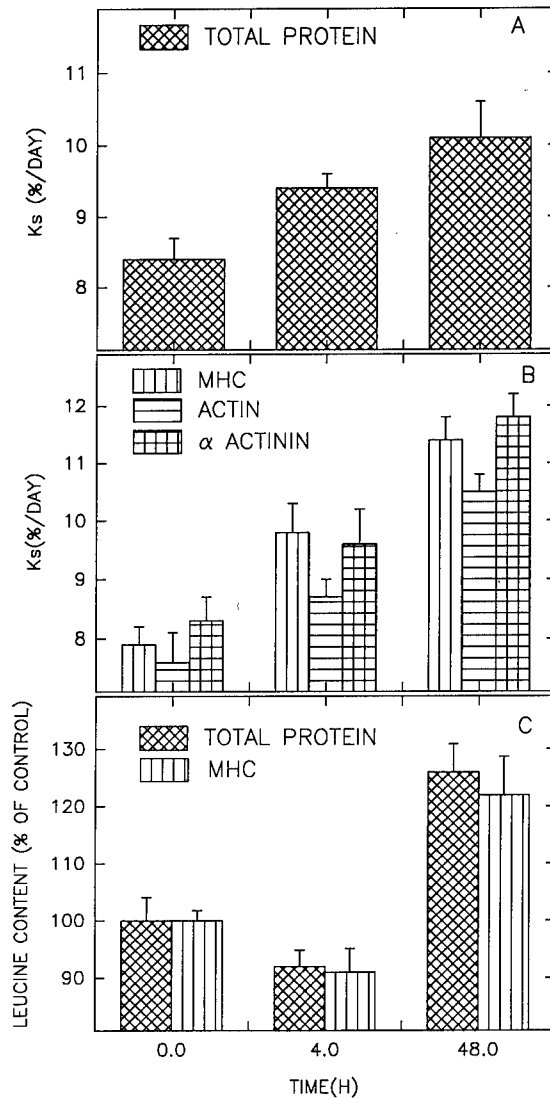

FIGURE 4. Field stimulation at 1 Hz increases the fractional synthesis rate (K_s) of (A) total and (B) contractile proteins and (C) significantly elevates the [^3H] leucine content (nanomoles) of protein and MHC in one-week-old feline myocyte cultures after 48 h of pacing. Values are mean \pm SEM, $n = 4-6$ duplicate preparations.

that the application of 2,3-butanedione monoxime (BDM) at concentrations that minimally affect Ca^{2+} influx effectively uncouples the electrical component of excitation-contraction coupling from the mechanical one and blocks field-stimulated enhancement of protein synthesis.³¹ In our laboratory, BDM treatment also inhibits changes in contractile protein synthesis suggesting that the subcellular event most closely correlated with fluctuations in protein metabolism may well be actomyosin crossbridge cycling and not Ca^{2+} flux *per se*, because neither BDM nor high KCl reduces $[\text{Ca}^{2+}]_i$ significantly, unlike Ca^{2+} channel blockers like verapamil or nifedipine. McDermott's laboratory further revealed that the acute changes in protein synthesis evolve independently of new transcription for actinomycin D failed to block accelerated protein synthesis.³¹

Somewhat similar experiments have been conducted with electrically paced neonatal heart cells, and the results of these experiments suggest that increases in the protein/DNA ratio, which are indicative of cellular hypertrophy, are mediated primarily via changes in the protein synthetic capacity of the cardiocytes, since the rate of expression of α cardiac actin, β MHC and rRNA increase proportionately in cultures of field-stimulated heart cells.³² Using a nearly identical experimental paradigm, McDonough and Glembotski¹⁶ propose that electrically induced contraction markedly enhances the expression, synthesis and secretion of ANF and the expression of myosin light chain 2 (MLC-2) gene. Both responses are blocked by either nifedipine or W7, an agent that inhibits Ca^{2+} -calmodulin interactions. Alterations in the expression and processing of ANF and the transcription of MLC-2 mRNA also are not associated with elevations in intracellular cAMP or inositol phosphates. Such results suggest that neither PKA or PKC are directly involved in mediating the expression of these proteins when the heart cells are actively loaded by field stimulation. Furthermore, such observations imply that mechanical loading is sufficient to elevate the rate of protein synthesis independently of neurohumoral involvement in neonatal heart cells, and that the modulation of protein metabolism is regulated through translational mechanisms immediately following field stimulation, but that changes in the rate of growth may, ultimately, be controlled by modulating the protein synthetic capacity of the heart cells.³²

Neurohumoral Modulation of Cellular Hypertrophy in Vitro

Even though hemodynamic load can enhance cardiac growth independently of sympathetic activation,^{3,4,33} both α and β adrenergic agonists have been reported to induce cardiac hypertrophy in the absence of significant changes in mechanical loading.³⁴ Nevertheless, definitively isolating and characterizing load- and hormone-dependent effects in intact heart is problematic, because adrenergic agonists also modulate myocardial contractility and peripheral vascular resistance. Adult cardiac myocytes maintained in cell culture make it possible to independently evaluate the contributions of α and β adrenergic hormones in mediating cellular hypertrophy and to distinguish such responses from those induced by passive stretch or field stimulation. Although a considerable effort has been expended in identifying the mode of action of adrenergic agonists in regulating neonatal myo-

cyte growth,³⁵⁻³⁸ there are a number of reasons to suspect that the activation of signal transduction pathways that are believed to regulate neonatal myocyte growth may not be operative or share the same regulatory properties in the adult heart. For example, the density of α adrenergic receptors is reported to vary considerably on cardiocytes of different ages,³⁹ neonatal heart cells synthesize contractile proteins at rates 5-7-fold greater than adult myocytes,^{18,40-42} and the activation of immediate early genes after aortic stenosis fluctuates in rats of different ages.⁴³ Such observations infer that the responsiveness of adult myocytes to α and/or β adrenergic agonists also may be modified when compared to those responses exhibited by their neonatal counterparts.

Several adult cardiocyte culture models have been employed to investigate catecholamine-mediated growth, including heart cells isolated from rats, rabbits and cats. Three aspects of the experimental design may have important consequences when the results of these studies are evaluated and compared to the observations derived from neonatal heart cells. (1) Some experiments have been conducted in the presence of fetal bovine serum (FBS),^{14,18,42} while others have employed some combination of serum supplementation followed by serum deprivation,^{44,45} or the influence of catecholamines has been tested in a serum-free environment.^{46,47} The consequences of manipulating the serum content may be significant, since cultures of serum-supplemented neonatal³⁵ and adult⁴⁴ heart cells reveal FBS to be a more potent enhancer of cardiocyte growth than norepinephrine. (2) Mechanical load (*i.e.*, beating) in these preparations must also be considered, for contractile activity profoundly affects protein metabolism and myofibrillar organization of adult cardiocytes independently of adrenergic activation.^{12-14,18,42,48} (3) The stability of adult myocyte populations must also be monitored since significant cell loss develops in adult rabbit and rat preparations during the first week of culture;^{46,49,50} the feline myocyte model, on the other hand, appears to represent an exception to this rule.¹⁴ Therefore, variations in experimental design require that considerable care be taken when interpreting the growth-promoting properties of α and/or β adrenergic agonists in the different adult myocyte preparations.

In an attempt to distinguish direct actions of α and/or β adrenergic agonists on cellular hypertrophic growth from indirect changes in protein metabolism provoked by potential changes in chronotropy or inotropy (*i.e.*, mechanical loading), one-week-old low density, rabbit cardiocyte cultures that *remain quiescent* in response to catecholamines were examined so changes in overt mechanical loading could be minimized as a factor in modulating myocyte growth. The physiologic, sympathetic neurotransmitter, norepinephrine (NE), stimulates a 20% increase in protein mass over a 4-day interval, which is paralleled by a similar rise in total RNA content (FIG. 5A). The experiments discussed above were conducted in the presence of serum. When parallel studies were performed in a serum-free environment (*i.e.*, MEM plus 0.2% BSA), such preparations exhibit a negative nitrogen balance, and although serum-deprived cultures supplemented with NE exhibit elevated levels of protein and RNA (FIG. 5B), such cells still display a negative nitrogen balance (*i.e.*, atrophy) when compared to their serum-supplemented counterparts (FIG. 5A). These results indicate that rabbit heart cells respond to NE by enhancing their rates of growth, regardless of whether the cells

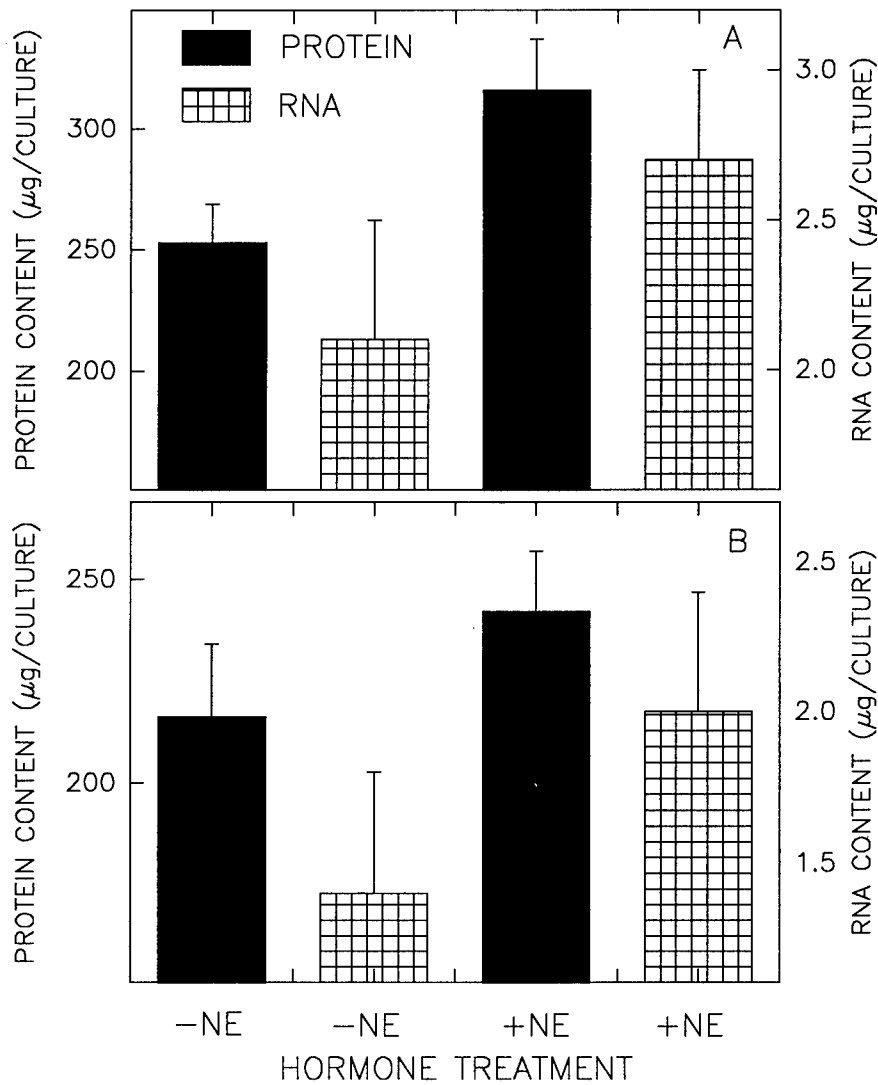

FIGURE 5. Norepinephrine (NE) induces one-week-old quiescent adult rabbit heart cells to accumulate protein and RNA in the (A) presence or (B) absence of fetal bovine serum after a 4-day exposure to the catecholamine ($10 \mu\text{M}$). Serum, however, increases cellular hypertrophy to a greater degree than NE alone. Values are mean \pm SEM, $n = 9-15$ duplicate cultures.

are maintained in the presence or absence of serum; however, only in the presence of serum do these quiescent myocytes exhibit "real" growth (*i.e.*, positive nitrogen balance). In many reports it is difficult to discern whether "real" growth evolves in nonbeating adult rat heart cells exposed to catecholamines or whether the rate of atrophy is simply reduced.⁴⁵⁻⁴⁷ Ikeda *et al.*⁴⁴ support this contention by demonstrating that NE stimulates protein synthesis to about the same degree as serum (FBS) supplementation but does not increase the protein content of the cultures correspondingly, implying that catecholamines cannot reverse the enhanced rate of protein degradation provoked by culturing myocytes in a serum-free environment even though the heart cells may be beating.

The application of α_1/β_1 adrenergic antagonists reveals that they partially block NE-induced accumulation of protein in adult rabbit myocytes, demonstrating that both α and β receptors remain coupled to growth-promoting pathways in an *in vitro* environment.⁴² When the relatively specific β_1 (isoproterenol) or α_1 (phenylephrine) adrenergic agonists are utilized to stimulate growth, it is evident that isoproterenol (ISO) elevates the rate of protein accumulation (K_g) at greater rate (*i.e.*, ~40%) than phenylephrine (PE) (FIG. 6). Since the sum of the α and β -induced changes in K_g approximates that observed with NE alone, further sup-

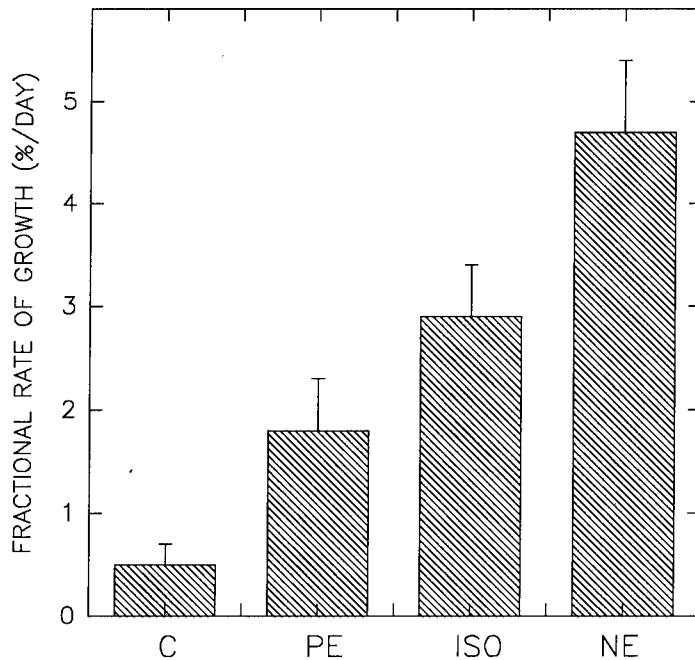

FIGURE 6. Norepinephrine (NE) enhances the fractional rate of growth (K_g) greater than either isoproterenol (ISO) or phenylephrine (PE), but all three catecholamines ($10 \mu\text{M}$) stimulate K_g when compared to rabbit heart cells maintained only in serum-supplemented medium (C). Values are mean \pm SEM, $n = 9-12$ duplicate cultures.

ports the hypothesis that both the α and β adrenergic receptors are coupled to growth enhancing pathways in these nonbeating heart cells. The fate of newly synthesized contractile protein in these quiescent myocyte preparations is unresolved; however, myofibrillar disruption occurs in nonbeating myocytes exposed to either α or β adrenergic agonists and may be associated with significant cell spreading that develops in quiescent rabbit heart cells.⁴² From these results we proposed that adrenergic activation of growth must be coupled to mechanical activity if the newly synthesized proteins are to be assembled into myofibrils.⁴² Moreover, the relatively *small* changes in the rate of growth provoked in quiescent rabbit heart cells when compared to values derived from feline myocytes may reflect an elevated rate of contractile protein turnover in this preparation, because the nonbeating rabbit myocytes fail to assemble myofibrils.

The culture of adult feline myocytes provides an opportunity to test this hypothesis, for unlike the rabbit preparation, adult feline myocytes contract in response to catecholamines possessing β adrenergic properties (*i.e.*, NE, ISO, metoprolol, etc.) or compounds [1-methyl-3-isobutylxanthine (IBMX), forskolin, dibutyryl cAMP] that effectively elevate intracellular cAMP levels.^{14,15} That the induction of beating is mediated by β agonists was demonstrated by the fact that propranolol blocks the contractile response evoked by either ISO or NE. Furthermore, treatment of feline myocyte cultures with ISO or NE activates cardiocyte beating immediately and contractile activity is sustained as long as the catecholamine is present in the culture medium; in contrast, the α agonist, PE, induces no visible changes in the mechanical properties of paired cultures. Although each catecholamine promotes significant cell spreading, only ISO- and NE-activated mechanical activity initiates the reassembly of the contractile apparatus,^{14,15} while no myofibrillar reorganization can be demonstrated in heart cells exposed to PE (FIG. 7A,B,C). Both ISO and NE significantly increase the protein content of treated cultures within 4 days of hormone treatment, whereas cell protein values rise only marginally (~16%) over the same interval in response to exogenous PE (FIG. 8). Like the rabbit preparation, α_1 and β_1 -adrenergic agonist-induced growth appears additive and approximately equal to that generated in response to NE (FIG. 8). Whether the enhanced rates of protein accumulation in feline preparations exposed to NE or ISO are the result of the direct action of the hormones or are correlated with the induction of beating require that neurohumoral activation be uncoupled from mechanical loading. The approach employed to discriminate between these alternatives was to inhibit beating by depolarizing the myocytes with KCl (50 mM)¹⁵ or by blocking contraction with 2,3-butandione monoxime (BDM, 7 mM)³¹ two days after the initiation of catecholamine treatment but prior to significant increases in protein content. In the absence of beating, ISO-induced changes in protein synthesis and accumulation are reduced significantly from values expected at day 4 (FIG. 9A). Small increases in protein content are apparent in cultures exposed to PE (FIG. 9B) and, interestingly, similar changes in protein accumulation are apparent when myocytes are subjected to NE treatment when the cultures are treated with KCl or BDM. The results of these experiments strongly suggest that increases in cellular hypertrophy that develop between days 2 and 4 of exposure to either ISO or NE are mediated primarily through the development of active tension generated during contraction and, therefore, may be regulated indirectly

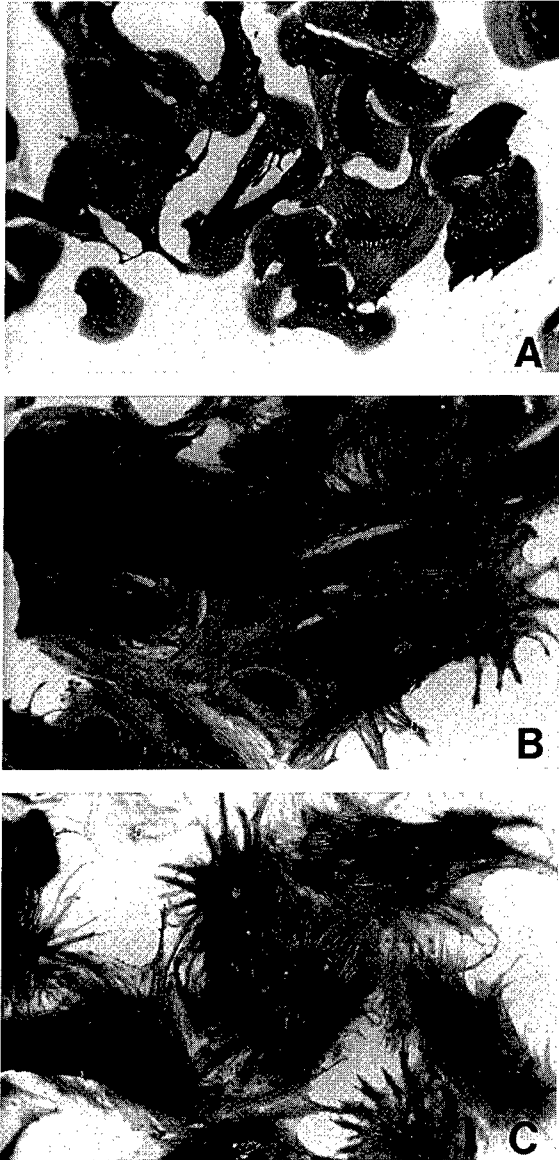

FIGURE 7. Distribution of anti-myosin peroxidase antibody in (A) two-week-old nonbeating adult feline heart cells, and in myocytes exposed to (B) phenylephrine (also quiescent) or (C) isoproterenol. Myofibrils are poorly organized in both quiescent paradigms (A,B), but the β agonist (C) induces beating and promotes myofibril reassembly.

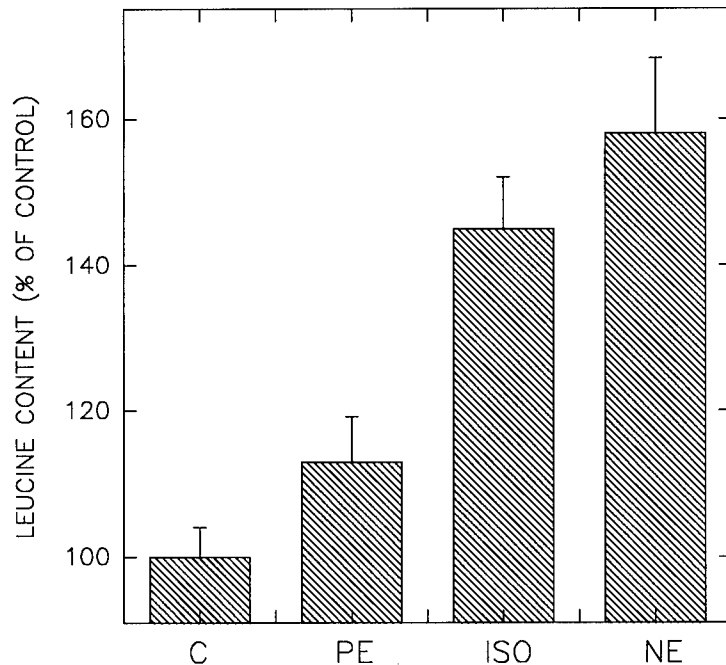

FIGURE 8. Norepinephrine (NE) and isoproterenol (ISO) induce beating and increase protein-bound leucine (*i.e.*, nanomoles of [^3H] leucine accumulated) content of cultures to a greater degree than phenylephrine (PE)-treated adult feline myocytes after a one-week treatment with the catecholamines ($10\ \mu\text{M}$). Control cultures (C). Values are mean \pm SEM, $n = 6$ – 9 duplicate cultures.

by catecholamine. If adrenergic activation is continued for one week, the fractional rate of protein synthesis returns to control values in ISO-treated cultures, whereas K_s remains elevated significantly in response to PE even though the protein content of PE-treated cultures remains significantly lower than cultures exposed to ISO.⁵¹ Such observations suggest that catecholamines with β properties transiently inhibit protein degradation while α agonists probably enhance the rate of proteolysis. This hypothesis may account for the small degree of cellular hypertrophy induced by α_1 agonists in adult feline heart cells (FIG. 8). An indirect measure of protein degradation in rabbit myocyte preparations supports this conclusion.⁴² The results derived from other laboratories that have investigated the regulation of protein turnover in cultured adult heart cells confirm that α and β adrenergic agonists provoke cellular hypertrophy independently of one another;^{44–47} however, several important questions remain unanswered: (1) what is the relationship between adrenergic activation and mechanical loading (beating) on the development of cellular hypertrophy; (2) can newly synthesized contractile proteins be assembled into myofibrils in the absence of beating but in response to catecholamine exposure; (3) is the maintenance of myofibrillar organization an important

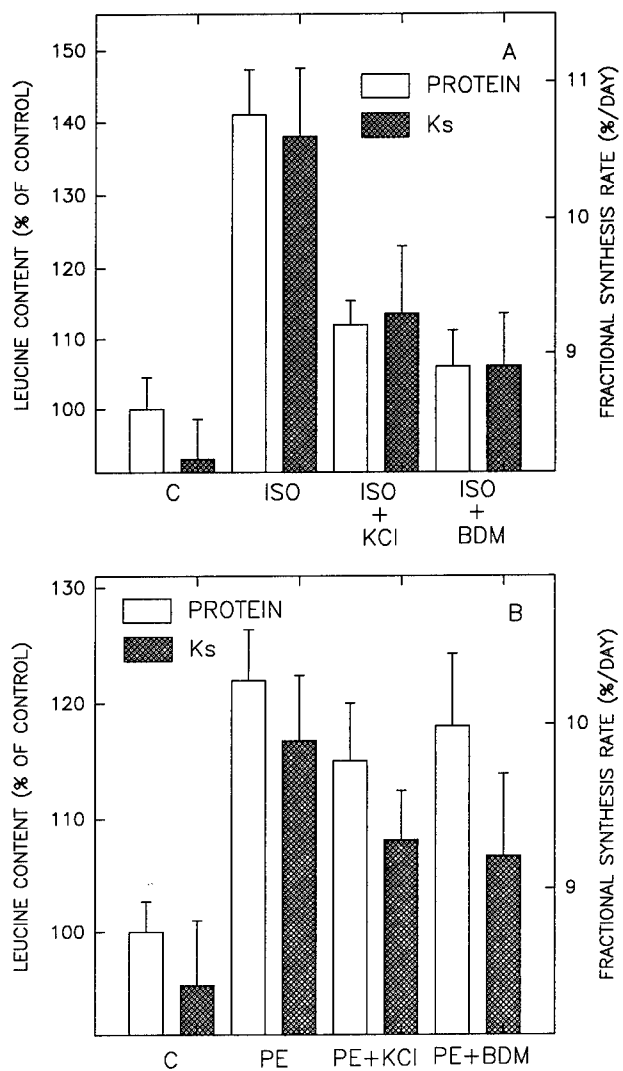

FIGURE 9. KCl (50 mM) and 2,3-butanedione monoxime (BDM, 7 mM) inhibit contraction and partially block enhanced rates of protein synthesis and accumulation ($[^3\text{H}]$ leucine content) in response to (A) isoproterenol, but provoke little change in heart cells exposed to (B) phenylephrine. Feline myocyte cultures were exposed to the catecholamines ($10 \mu\text{M}$) for 4 days; on day 2 of treatment, paired cultures were supplemented with either KCl or BDM and assayed for K_s or leucine content on day 4. Values are mean \pm SEM, $n = 6-9$ duplicate cultures.

feature of the hypertrophic response; and (4) are the pathways that regulate neonatal cardiocyte growth different than those that mediate adult cardiocyte growth?

The relative significance of adrenergic activation and mechanical load in modulating cardiocyte growth remains a controversial issue. Although freshly isolated myocytes and those cultured for a brief period appear to display enhanced rates of protein synthesis and accumulation in response to α but not β adrenergic agonists,^{47,52} our observations indicate that adult myocytes require a minimal period of exposure to ISO (~48 h) before a significant increase in protein synthesis and content can be documented.^{15,42,51} In fact, ISO actually depresses protein synthesis significantly during the first day of exposure in both cat and rabbit myocyte cultures, whereas PE enhances protein synthesis over the same interval.^{15,42,51} However, when protein content is monitored after 4 days of exposure to adrenergic agonists, ISO provokes a greater increase in protein content than does PE.^{42,51} An implication of these observations is that growth accompanies beating induced by ISO or NE, but since PE fails to change the contractile properties of the myocytes, little growth evolves in response to the α adrenergic agonist even though protein synthesis is elevated significantly. Therefore, beating (*i.e.*, mechanical loading) in all likelihood represents the principal regulator of the hypertrophic response in adult heart cells. That mechanical loading is a potent stimulus to growth is evident by the immediate rise in the fractional rate of protein synthesis that develops in response to passive stretch or field stimulation (Figs. 2 & 4). The results of the experiments outlined above and those from McDermott's laboratory^{31,32,48} support the hypothesis that catecholamines and mechanical loading stimulate protein accumulation in cultured cardiac myocytes and do so via different signalling pathways. Furthermore, our experiments suggest that in the absence of beating, rates of protein turnover may be enhanced and, consequently, little growth develops in adult heart cells exposed to α adrenergic agonists^{42,51} in contrast to the observations derived from neonatal heart cells.³⁷

Although Simpson³⁵ and Chien^{37,53,54} have reported that α_1 adrenergic agonists promote the assembly of myofibrils in association with the hypertrophy of neonatal heart cells, adult myocytes appear unable to reassemble myofibrils in response to PE (Fig. 7); nor does significant hypertrophic growth develop in such preparations even though total and contractile protein synthesis is accelerated almost immediately in response to the α agonist.^{42,51} Although adult myocytes hypertrophy modestly when exposed to α agonists, the changes in protein content may result from an increase in cell size that is not associated with the reassembly of myofibrils.^{42,51} Since PE appears to accelerate the fractional rate of protein degradation in adult preparations,⁴² perhaps, the pool of poorly organized actin and myosin in these myocytes becomes more susceptible to resident proteases when adult myocytes remain quiescent.^{19,29} In this regard, agents that fail to enhance mechanical loading (*i.e.*, increased stretch) or contractile activity may not promote myofibrillar assembly, and, thus, create a pool of nascent, labile protein that may turn over at accelerated rates.^{29,42} A somewhat similar situation may develop when adult feline myocytes are exposed to ISO in the presence of the Ca^{2+} channel blocker, nifedipine.^{14,51} Inhibiting contractile activity in this fashion suppresses MHC synthesis; moreover, Ca^{2+} channel blockers also appear to enhance the degradation of contractile proteins and disrupt myofibrillar order.⁵¹

Verapamil provokes similar structural changes in neonatal myocytes¹⁷ and significantly accelerates the degradation of actin and MHC,^{19,29} suggesting that marked reductions of $[Ca^{2+}]_i$ provoke a more severe form of atrophy than that which develops in myocytes maintained in a quiescent state. Observations derived from adult and neonatal cardiac myocytes support the thesis that beating stimulates cellular hypertrophic growth by enhancing the synthesis and assembly of myofibrils and, perhaps, by promoting the removal of contractile proteins from a pool that may be quite susceptible to degradation. ISO and NE accomplish this objective by inducing contractile activity while PE does not and, therefore, the induction of cellular hypertrophy in response to a β agonist is substantial while the response to α agonists is minimal.^{42,51}

Whether the pathways that regulate cellular hypertrophy (*i.e.*, protein accumulation) in adult myocytes are unique/distinct from those that enhance the growth of neonatal heart cells may be reflected in the degree to which α/β adrenergic agonists influence the growth of the cardiocytes rather than different pathways being induced at different stages of development. Although the expression of immediate early genes and the re-expression of fetal proteins have not been explored extensively in cultures of adult myocytes, the induction of c-myc expression,⁴⁴ ANF secretion⁵¹ and the activation of the fetal form of creatine kinase^{45,47} in response to α/β adrenergic agonists has been reported, and it is relatively clear that neonatal and adult myocytes display a robust hypertrophic response to NE.^{35-38,42,51} Nevertheless, adult cardiocytes appear to be more responsive to β adrenergic activation, while neonatal growth seems to be regulated primarily through the α_1 adenosine receptor. Since both α and β receptors modulate growth in adult heart cells,^{42,45,51} changes in mechanical load induced by powerful ionotropes (β adrenergic agonists) may assume a more important regulatory role in adult myocytes than in neonatal heart cells.

In conclusion, it seems likely that at least two independent regulatory pathways modulate the growth of the adult cardiac myocyte. We propose that mechanical load is the predominant stimulus to growth and may enhance adult cardiocyte hypertrophy by controlling two distinct processes: protein synthetic capacity and myofibrillar assembly. The former regulates how much contractile protein is produced while the latter stabilizes newly assembled contractile proteins. Thus, β adrenergic activation may well enhance cellular hypertrophy through its ionotropic properties. In contrast, α adrenergic agonists stimulate the rate at which contractile proteins are synthesized but appear to lack the property of promoting myofibrillar assembly in adult heart cells, which may account for its limited ability to promote cardiocyte growth. Therefore, regulating cardiocyte hypertrophy and atrophy may involve signalling pathways that control the expression and translation of contractile proteins as well as posttranslational processes that mediate myofibrillar assembly. Deciphering these pathways will provide new insights into how growth is modulated in the adult myocardium.

REFERENCES

1. JACOBSON, S. L. & H. M. PIPER. 1986. *J. Mol. Cell. Cardiol.* **18**: 439-448.
2. KLEIN, I. & G. S. LEVEY. 1984. *Am. J. Med.* **76**: 167-172.

3. COOPER, G. W. 1987. *Annu. Rev. Physiol.* **49**: 501–518.
4. MORGAN, H. E. & K. M. BAKER. 1991. *Circulation* **83**: 13–25.
5. VANDENBURGH, H. H. 1992. *Am. J. Physiol.* **262**: R350–R355.
6. PETERSON, M. B. & M. LESCH. 1972. *Circ. Res.* **31**: 317–327.
7. KENT, R. L., J. K. HOOBER & G. COOPER IV. 1989. *Circ. Res.* **64**: 74–85.
8. TAKALA, T. 1981. *Basic Res. Cardiol.* **76**: 44–61.
9. KIRA, Y., P. J. KOCHER, E. E. GORDON & H. E. MORGAN. 1984. *Am. J. Physiol.* **246**: 247–258.
10. CHUA, B. H. L., L. RUSSO, E. E. GORDON, B. J. KLEINHAUS & H. E. MORGAN. 1987. *Am. J. Physiol.* **252**: C323–C327.
11. GORDON, E. E., Y. KIRA, L. M. DEMERS & H. E. MORGAN. 1986. *Am. J. Physiol.* **250**: C932–C938.
12. DECKER, M. L., D. G. SIMPSON, M. BEHNKE, M. G. COOK & R. S. DECKER. 1990. *Anat. Rec.* **69**: 86–94.
13. DECKER, M. L., M. BEHNKE-BARCLAY, M. G., COOK, M. LESCH & R. S. DECKER. 1991. *Circ. Res.* **69**: 86–94.
14. CLARK, W. A., S. J. RUDNICK, J. J. LAPRES, M. LESCH & R. S. DECKER. 1991. *Am. J. Physiol.* **261**: C530–C542.
15. SIMPSON, D. G., M. L. DECKER, W. A. CLARK & R. S. DECKER. 1993. *J. Cell. Biol.* **123**: 323–336.
16. McDONOUGH, P. M. & C. C. GLEMBOTSKI. 1992. *J. Biol. Chem.* **267**: 11665–11668.
17. SAMAREL, A. M. & G. L. ENGLEMAN. 1991. *Am. J. Physiol.* **261**: H1067–H1077.
18. CLARK, W. A., S. J. RUDNICK, D. G. SIMPSON, J. J. LAPRES & R. S. DECKER. 1993. *Am. J. Physiol.* **264**: H573–H582.
19. SHARP, W. W., L. TERRACIO, T. K. BORG & A. M. SAMAREL. 1993. *Circ. Res.* **73**: 172–183.
20. COOPER, G. IV, W. E. MERCER, J. K. HOOBER, P. R. GORDON, R. L. KENT, I. K. LAUVA & T. A. MARINO. 1986. *Circ. Res.* **58**: 692–705.
21. TERRACIO, L., B. MILLER & T. K. BORG. 1988. *In Vitro* **24**: 53–58.
22. MANN, D. L., R. L. KENT & G. COOPER IV. 1989. *Circ. Res.* **64**: 1079–1090.
23. KOMURO, I., T. KAIDA, M. SHIBAZAKI, Y. KURABAYASHI, Y. KATOH, E. HOH, F. TAKAKU & Y. YAZAKI. 1990. *J. Biol. Chem.* **265**: 3595–3598.
24. KOMURO, I., Y. KOTOH, T. KAIDA, Y. SHIBAZAKI, M. KURABOYASHI, E. HOH, F. TAKAKU & Y. YAZAKI. 1991. *J. Biol. Chem.* **266**: 1265–1268.
25. KOMURO, I. & Y. YAZAKI. 1993. *Annu. Rev. Physiol.* **55**: 55–75.
26. SADOSHIMA, J., L. JAHN, T. TAKAHASHI, T. J. KULIK & S. IZUMO. 1992a. *J. Biol. Chem.* **267**: 10551–10560.
27. SADOSHIMA, J., L. JAHN & S. IZUMO. 1992b. *Proc. Natl. Acad. Sci. USA* **89**: 9905–9909.
28. SADOSHIMA, J. & S. IZUMO. 1993. *EMBO J.* **12**: 1681–1692.
29. SAMAREL, A. M., M. L. SPRAGIA, V. MALONEY, S. A. KAMAL & G. L. ENGELMANN. 1992. *Am. J. Physiol.* **263**: C642–C652.
30. SADOSHIMA, J., X. YUHUI, H. S. SLAYTER & S. IZUMO. 1993. *Circulation* **88**: I190.
31. IVESTER, C. T., R. L. KENT, H. TAGAWA, H. TSUTSUI, T. IMAMURA, G. COOPER IV & P. J. McDERMOTT. 1993. *Am. J. Physiol.* **265**: H666–H674.
32. JOHNSON, T. B., R. L. KENT, B. L. BUBOLZ & P. J. McDERMOTT. 1994. *Circ. Res.* **74**: 448–459.
33. COOPER, G., R. L. KENT, C. E. UBOH, E. W. THOMPSON & T. A. MARINO. 1985. *J. Clin. Invest.* **75**: 1403–1414.
34. ZIERHUT, W. & H. G. ZIMMER. 1989. *Basic Res. Cardiol.* **84**: 359–370.
35. SIMPSON, P. C. 1985. *Circ. Res.* **56**: 884–894.
36. SIMPSON, P. C., K. KARIYA, L. R. KARNS, C. S. LONG & J. S. KARLINER. 1991. *Mol. Cell Biochem.* **104**: 35–43.
37. MEIDELL, R. S., A. SEN, S. A. HENDERSON, M. F. SLAHETKA & K. R. CHIEN. 1986. *Am. J. Physiol.* **25**: H1076–H1084.
38. CHIEN, K. R., K. U. KNOWLTON, H. ZHU & S. CHIEN. 1991. *FASEB J.* **5**: 3037–3046.
39. SCHAFFER, W. & R. S. WILLIAMS. 1986. *Biochem. Biophys. Res. Commun.* **138**: 387–391.

40. PARMACEK, M. S., N. M. MAGID, M. LESCH, R. S. DECKER & A. M. SAMAREL. 1986. *Am. J. Physiol.* **251**: C727-C736.
41. ROBINSON, M. E. & A. M. SAMAREL. 1990. *J. Mol. Cell Cardiol.* **22**: 607-618.
42. DECKER, R. S., M. G. COOK, M. M. BEHNKE-BARCLAY, M. L. DECKER, M. LESCH & A. M. SAMAREL. 1993. *Am. J. Physiol.* **265**: H329-H339.
43. TAKAHASHI, T., H. SCHUNKEST, S. ISOYAMA, J. Y. WEI, B. NADAL-GINARD, W. GROSSMAN & S. IZUMO. 1992. *J. Clin. Invest.* **89**: 939-946.
44. IKEDA, U., Y. TSURUYA & T. YAGINUMA. 1991. *Am. J. Physiol.* **260**: H953-H956.
45. PINSON, A., K. D. SCHLUTER, X. J. ZHOU, P. SCHWARTZ, G. KESSLER-ICEKSON & H. M. PIPER. 1993. *J. Mol. Cell Cardiol.* **25**: 477-490.
46. DUBUS, I., J-L SAMUEL, F. MAROTTE, C. DELCAYRE & L. RAPPAPORT. 1990. *Circ. Res.* **66**: 867-874.
47. SCHLUTER, K. O. & H. M. PIPER. 1992. *Am. J. Physiol.* **262**: H1735-H1746.
48. McDERMOTT, P. J. & H. E. MORGAN. 1989. *Circ. Res.* **64**: 542-553.
49. HADDAD, J., M. L. DECKER, L-C. HSIEH, M. LESCH, A. M. SAMAREL & R. S. DECKER. 1988. *Am. J. Physiol.* **255**: C19-C27.
50. PIPER, H. M., S. L. JACOBSON & P. SCHWARTZ. 1988. *J. Mol. Cell Cardiol.* **20**: 825-835.
51. CLARK, W. A., S. J. RUDNICK, J. J. LAPRES, L. C. ANDERSEN & M. C. LAPOINTE. 1993. *Circ. Res.* **73**: 1163-1176.
52. FULLER, S. J., C. J. GAITANAKI & P. H. SUGDEN. 1990. *Biochem. J.* **266**: 727-736.
53. IWAKI, K., U. P. SUKHATME, H. E., SHUBEITA & K. R. CHIEN. 1990. *J. Biol. Chem.* **265**: 13809-13817.
54. KNOWLTON, K. U., M. C. MICHEL, M. ITANI, H. E. SHUBEITA, K. ISHIKARA, J. H. BROWN & K. R. CHIEN. 1993. *J. Biol. Chem.* **268**: 15374-15380.

Phospholipase Signalling Pathways in Thyroxine-Induced Cardiac Hypertrophy^a

SEAN WILLIAMS, NASRIN MESAELI, AND
VINCENZO PANAGIA^b

*Division of Cardiovascular Sciences
St. Boniface General Hospital Research Centre
and
Departments of Anatomy and Physiology
Faculty of Medicine
University of Manitoba
Winnipeg, Manitoba, Canada R2H 2A6*

INTRODUCTION

Hydrolysis of specific membrane phospholipids by receptor-linked phospholipases is involved in the transmembrane conduction of signals from various cell surface receptors.¹⁻³ Receptor stimulation leads to the activation of phospholipase signalling pathways of the cardiac cell membranes (sarcolemma, SL), which include: 1) phospholipase C (PLC), which hydrolyzes phosphatidylinositol 4,5-bisphosphate (PtdIns(4,5)P₂) to yield inositol 1,4,5-trisphosphate (Ins(1,4,5)P₃) and *sn*-1,2-diacylglycerol (DAG);¹ 2) phospholipase D (PLD), which selectively hydrolyzes phosphatidylcholine (PtdCho) to form phosphatidic acid (PtdOH), and is functionally coupled to a PtdOH phosphatase for producing PtdCho-derived DAG.³

Recent studies in stretch-induced cardiac hypertrophy⁴ and in a stroke-prone spontaneously hypertensive rat model⁵ have suggested that multiple second messenger systems are activated, including PLC and PLD. Since the heart can hypertrophy in response to other stimuli, we examined the status of these two receptor-associated phospholipases in a model of thyroxine-induced cardiac hypertrophy.

EXPERIMENTAL METHODS

Experimental Model

Myocardial hypertrophy was induced in Sprague-Dawley rats weighing 350–400 g by daily subcutaneous injection of L-thyroxine (T₄) (50 μg/100 g body weight) for

^a This research was supported by a grant from the Heart and Stroke Foundation of Manitoba. N. Mesaeli was the recipient of a Studentship Award from the Manitoba Health Research Council.

^b Address for correspondence: Vincenzo Panagia, M.D., Ph.D., Division of Cardiovascular Sciences, Saint Boniface General Hospital Research Centre, 351 Tache Avenue, Winnipeg, Manitoba, Canada R2H 2A6.

7 days.⁶ Age-matched controls were injected with saline solution. All the animals received food and water *ad libitum*. The thyroid status was assessed by measuring the serum levels of both triiodothyronine (T₃) and T₄ at the end of treatment from the above groups of animals. Duplicate aliquots were analyzed for T₃ and T₄ by time-resolved fluoroimmunoassay technique (Wallac, Tarku, Finland).

Preparation of Cardiac Sarcolemmal Membranes

At the end of the treatment period, all animals were sacrificed by decapitation, and the hearts were quickly excised and immersed in 0.6 M sucrose-10 mM imidazole (pH 7.0). Atrial, macrovascular and connective tissues were carefully removed, and the ventricular tissue was processed for the preparation of sarcolemmal membranes.⁷ As reported before,^{8,9} the membrane preparations used in these studies were highly enriched in cardiac SL. The final pellets were resuspended in 0.25 M sucrose-10 mM histidine (pH 7.4), frozen and stored in liquid N₂ until use. Protein measurements were done according to Lowry *et al.*¹⁰ using bovine serum albumin as standard.

Assay of Phospholipase C and D

The activity of SL PLC was determined as described elsewhere,⁸ while the PLD hydrolytic activity present in the membranes was assayed by measuring the formation of PtdOH from exogenous PtdCho.³

Statistical Analysis

The differences between the means of groups were evaluated for significance by Student *t* test. A probability of 95% or more was considered significant.

RESULTS

Thyroxine-treated rats showed a marked elevation in the serum levels of T₄ and triiodothyronine (T₃), as well as a significant increase of the ventricular to body weight ratio (TABLE 1). Our observation is consistent with earlier findings,

TABLE 1. Characteristics of the Experimental Animals^a

	H. Wt./B. Wt. × 1000	T ₄ (nmol/L)	T ₃ (nmol/L)
Control	2.18 ± 0.04	62.0 ± 1.8	1.30 ± 0.10
Thyroxine-treated	3.28 ± 0.06*	>300 ^b	>3 ^b

^a Data are expressed as mean ± SEM of 10–20 rats. Animals were treated as indicated in Experimental Methods. T₃ (triiodothyronine) and T₄ (thyroxine) levels were determined by time-resolved fluoroimmunoassay techniques (Wallac, Finland). H. Wt. = heart weight; B. Wt. = body weight.

^b Values were greater than the upper limit of the assay.

* Significantly different (*p* < 0.05) from control.

TABLE 2. Sarcolemmal and Cytosolic Phospholipase C Activities in Thyroxine-Induced Cardiac Hypertrophy^a

	Phosphoinositide Substrates		
	PtdIns	PtdIns4P	PtdIns(4,5)P ₂
Sarcolemma			
Control	0.18 ± 0.01	9.67 ± 0.19	13.46 ± 0.13
Hypertrophy	0.15 ± 0.02	9.65 ± 1.10	10.84 ± 0.64*
Cytosol			
Control	0.17 ± 0.007	10.71 ± 0.25	10.10 ± 0.197
Hypertrophy	0.13 ± 0.012*	8.46 ± 0.95*	7.98 ± 0.35*

^a PLC activity in sarcolemmal and cytosolic fractions was assayed under standard conditions as indicated in Experimental Methods in the presence of 20 μ M [³H]-PtdIns, [³H]-PtdIns4P or [³H]-PtdIns(4,5)P₂ for 2.5 min at 37°C. Values are mean \pm SEM of four to six experiments in triplicate, and are expressed as nmol of total inositolphosphate/mg protein/min. PtdIns, phosphatidylinositol; PtdIns4P, phosphatidylinositol 4-phosphate; PtdIns(4,5)P₂, phosphatidylinositol (4,5)-bisphosphate.

* Significantly different ($p < 0.05$) from control values.

in which administration of thyroid hormone induced left ventricular hypertrophy in young and old rats.^{11,12} Furthermore, other evidence suggested that cardiac hypertrophy is not affected by aging.¹³

Hypertrophy significantly decreased the rate of PtdIns(4,5)P₂ hydrolysis by SL PLC, while this effect was not observed when phosphatidylinositol 4-phosphate (PtdIns4P) or phosphatidylinositol (PtdIns) were used as substrates (TABLE 2).

Unlike SL PLC, the cytosolic PLC activity was significantly depressed even when tested with PtdIns4P and PtdIns (TABLE 2).

The hydrolysis of [¹⁴C]-PtdCho by SL PLD was decreased by 57% in hypertrophied hearts as compared to age-matched controls (FIG. 1).

DISCUSSION

Our studies demonstrate that the hydrolytic activities of SL PLC and PLD are depressed in T₄-induced cardiac hypertrophy. Other forms of hypertrophy (cardiomyocyte stretch model⁴ and stroke-prone spontaneously hypertensive rat model⁵) have been characterized by an activation of both phospholipases. This implies that diverse changes in phospholipase signalling pathways may occur in different types of cardiac hypertrophy, which may be related to the type of stimulus initiating the hypertrophic process.

Formation of important second messengers and bioactive molecules through the hydrolysis of specific membrane phospholipids by receptor-linked phospholipases is a primary biochemical event in the myocardial response to external stimuli. Cardiac sarcolemmal PLC, which is specific for phosphatidylinositol polyphosphates,⁸ is involved in the transmembrane conduction of signals from various cell surface receptors, including the α_1 -adrenoceptors.^{1,2,14} Receptor stimulation leads, via activation of a GTP-binding protein, to the PLC-catalyzed hydrolysis of PtdIns(4,5)P₂. This produces two second messengers, DAG and Ins(1,4,5)P₃,

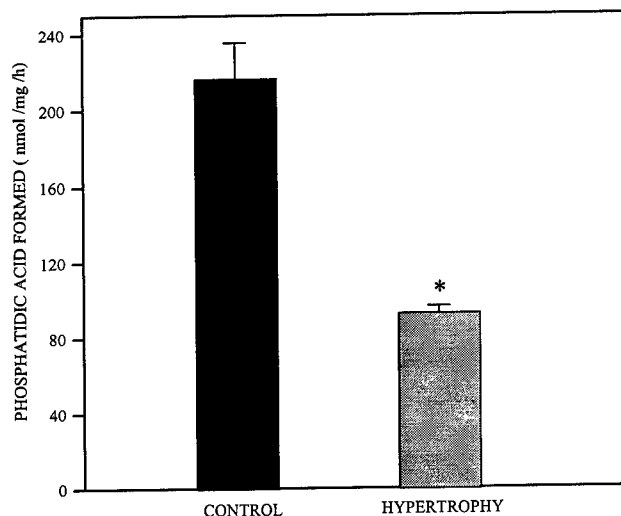

FIGURE 1. PLD activity in sarcolemmal membranes from control, and hypertrophied rat hearts. SL membranes were assayed under standard condition as indicated under Experimental Methods in the presence of 2.5 mM [14 C]-PtdCho for 60 min at 25°C. Values are mean \pm SEM of three to four experiments in triplicate. *Significantly different ($p < 0.05$) from control values.

which act on protein kinase C and a specific sarcoplasmic reticular (SR) receptor, respectively. Protein kinase C-dependent phosphorylation of distinct target proteins, and Ca^{2+} release via the SR $\text{Ins}(1,4,5)\text{P}_3$ receptor putatively modulate the level of intracellular Ca^{2+} , and may account for the α_1 inotropic response of the heart.^{1,14} In addition, we have found that alteration of the SL polyphosphoinositide content may be sufficient by itself to affect the SL Na^+ - Ca^{2+} exchange and Ca^{2+} pump activities, independently of other PtdIns(4,5) P_2 hydrolysis products.¹⁵ Therefore, we proposed that changes in membrane polyphosphoinositide levels can be taken into consideration as being part of the receptor-mediated signal transduction via the phosphoinositide pathway in the heart.¹⁶ The importance of the membrane effects of phospholipases' actions was very recently recognized.¹⁷

The phospholipase D activity associated with myocardial cell membrane hydrolyzes specifically PtdCho to form PtdOH, while choline is released into the cytosol.³ PLD is activated under agonist stimulation of the heart¹⁸ and is functionally coupled with PtdOH phosphohydrolase for the coordinate production of a DAG pool originating from PtdCho.³ Such DAG pool may differ in terms of fatty acid composition from the one derived from polyphosphoinositides¹⁹ and may activate different kinase C isoforms,²⁰ thus inducing protein kinase C-dependent phosphorylation of specific target proteins²¹ and different physiological responses. The importance of PLD for the heart muscle is also shown by *in vitro* studies that relate PLD activity and subsequent formation of PtdOH to changes in cellular Ca^{2+} movements and contractile performance.²²⁻²⁵

Given the above, we would like to suggest that the deactivation of SL PLC

and PLD activities seen in this study may contribute to compromising the signal transduction processes and the Ca²⁺ homeostasis in T₄-induced cardiac hypertrophy.

REFERENCES

1. MEIJ, J. T. A. & V. PANAGIA. 1991. *In* Catecholamines and Heart Disease. P. K. Ganguly, Ed. 245–266. CRC Press. Boca Raton, FL.
2. BROWN, J. H. & E. A. MARTINSON. 1992. *Trends Cardiovasc. Med.* **2**: 209–214.
3. PANAGIA, V., C. OU, Y. TAIRA, J. DAI & N. S. DHALLA. 1991. *Biochim. Biophys. Acta* **1064**: 242–250.
4. SADOSHIMA, J. & S. IZUMO. 1993. *EMBO J.* **12**: 1681–1692.
5. KAWAGUCHI, H., H. SANO, K. IZUCA, H. OKADA, T. KUDO, K. KAGEJAMA, S. MURAMOTO, T. MURAKAMI, H. OKAMOTA, N. MOCHIZUKI & A. KITABATAKE. 1993. *Circ. Res.* **72**: 966–972.
6. WILLIAMS, L. T. & R. J. LEFKOWITZ. 1977. *J. Biol. Chem.* **252**: 2787–2789.
7. PITTS, B. J. R. 1979. *J. Biol. Chem.* **254**: 6232–6235.
8. MEIJ, J. T. A. & V. PANAGIA. 1992. *Mol. Cell Biochem.* **116**: 27–31.
9. DAI, J., J. T. A. MEIJ, R. PADUA & V. PANAGIA. 1992. *Circ. Res.* **68**: 605–613.
10. LOWRY, O. H., N. J. ROSENBROUGH, A. L. FARR & R. J. RANDALL. 1951. *J. Biol. Chem.* **193**: 325–334.
11. ZITNIK, G. & G. S. ROTH. 1981. *Mech. Ageing Dev.* **15**: 19–28.
12. TOMANEK, R. J. & P. A. CONNELL. 1990. *Circulation* **82**: III-81.
13. TOMANEK, R. J., C. A. BUTTERS & M. B. ZIMMERMAN. 1993. *Am. J. Physiol.* **264**: H1041–H1047.
14. LAMERS, J. M. J., H. W. DE JONFE, V. PANAGIA & H. A. A. VAN HEUGTEN. 1993. *Cardioscience* **4**: 121–131.
15. PIERCE, G. N. & V. PANAGIA. 1989. *J. Biol. Chem.* **264**: 15344–15350.
16. MESAELI, N., J. M. J. LAMERS & V. PANAGIA. 1992. *Mol. Cell Biochem.* **117**: 181–189.
17. EXTON, J. H. 1994. *Biochem. Biophys. Acta.* **1212**: 26–42.
18. LINDMAR, R., K. LÖFFELHOLZ & J. SANDMANN. 1988. *Biochem. Pharmacol.* **37**: 4689–4695.
19. LAMERS, J. M. J., D. H. W. DEKKERS, N. MESAELI, V. PANAGIA & H. A. A. VAN HEUGTEN. 1993. *Biochem. Biophys. Res. Commun.* **191**: 487–494.
20. ALLEN, B. G. & S. KATZ. 1991. *Biochemistry* **30**: 4334–4343.
21. QU, Y., J. TORCHIA, T. D. PHAN, P. H. WU & A. K. SEM. 1992. *Biochem. Cell Biol.* **70**: 81–85.
22. PHILIPSON, K. D. & A. Y. NISHIMOTO. 1984. *J. Biol. Chem.* **259**: 16–19.
23. KNABB, M. T., R. RUBIO & R. M. BERNE. 1984. *Pflugers Arch.* **401**: 435–437.
24. BURT, J. M., T. L. RICH & G. A. LANGER. 1984. *Am. J. Physiol.* **247**: H880–H885.
25. LANGER, G. A. & T. L. RICH. 1985. *Circ. Res.* **56**: 146–149.

Regulation of Alpha-Smooth Muscle Actin Expression in Adult Cardiomyocytes through a Tyrosine Kinase Signal Transduction Pathway^a

H. EID,^b J. H. CHEN, AND A. J. de BOLD

*University of Ottawa Heart Institute
Research Centre
Ottawa, Ontario K1Y4E9, Canada*

INTRODUCTION

Adult rat ventricular myocytes (ARVM), after several days in culture, typically dedifferentiate taking on a spheroidal shape with rapid involution of the cytoskeletal architecture and loss of organized myofibrils.¹⁻⁵ By the second week, these muscle cells have assumed a flattened spread morphology, demonstrating only low amplitude contractions limited to the perinuclear area. This sequence of phenotypic changes is accompanied by the reexpression of a fetal gene program including the reexpression of embryonic contractile protein isoforms β -myosin heavy chain (β -MHC) and α -smooth muscle actin (α -SMA)⁶ and an increase in the ventricular expression of atrial natriuretic factor⁷ a peptide hormone normally produced by atrial myocytes.⁸ Similar reprogramming has also been reported following the development of cardiac hypertrophy.⁹

The cytoplasmic signal-transducing pathway and more particularly the involvement and the role of protein tyrosine phosphorylation in adult cardiac myocyte dedifferentiation *in vitro* and the consequent reinduction of fetal gene program is not known. Phosphorylation of proteins on tyrosine residues is a key biochemical reaction that mediates a large variety of cellular signals including the control of the cell cycle and cell differentiation.¹⁰⁻¹² Specific inhibitors of protein tyrosine kinases have been developed that might provide useful means for examining the role of tyrosine phosphorylation in a variety of cellular events. In recent years, several low-molecular-weight compounds have been shown to be inhibitors of growth factor receptor tyrosine kinases. Genistein is a specific inhibitor of a different class of kinase activity. This reagent is reported to be a potent and specific inhibitor of tyrosine kinase with little activity towards protein kinase C or protein kinase A.^{13,14} In this work, we have investigated the effect of inhibiting tyrosine phosphorylation on the differentiation of ARVM and more particularly on the

^a This work was supported by the Medical Research Council of Canada and by the Heart and Stroke Foundation of Canada.

^b Address for correspondence: Hoda Eid, Ph.D., University of Ottawa Heart Institute, Research Centre, 1053 Carling Ave. Rm. H247, Ottawa, Ontario K1Y 4E9, Canada.

expression of α -SMA and α -sarcomeric actin (α -SarcA) in long-term culture using genistein.

METHODS

Isolation and Culture of Adult Ventricular Myocytes

ARVM were isolated and cultured as previously described.¹⁵ For ARVM isolation and culture, adult rat hearts were perfused retrogradely following Langendorff's technique, first with Krebs-Henseleit (KH) and then with Ca free-buffer. In order to dissociate cardiac myocytes, the hearts were then perfused with a solution of 0.05% collagenase and 0.03% hyaluronidase. Following 20 min perfusion the ventricular tissue was minced and incubated in 0.02 mg/ml of trypsin and 0.02 mg/ml deoxyribonuclease for 15 min at 37°C. The cell suspension was filtered and centrifuged at 50 × g for 30 sec. The pellet was washed 5 times and then resuspended twice over 6% BSA gradient in order to eliminate contaminant cells. The final pellet obtained was resuspended in Duplecco's modified Eagle's medium (DMEM) containing 10% calf serum (CS) and 10 μ M of cytosine 1- β -D-arabinofuranoside (Ara-C), and then plated on laminin precoated dishes.

Tyrosine Kinase Inhibitor

Genistein, a competitive inhibitor of the ATP binding site of tyrosine kinases, known to inhibit tyrosine phosphorylation in whole cells¹³ was obtained from Gibco BRL (Burlington, ON). Genistein was diluted in culture medium from DMSO stock solutions and added to the cultures. Controls for these experiments included DMSO diluted in medium to the same extent as the drug stocks.

The effect of genistein on cell attachment was studied as follows. Freshly isolated ARVM were plated on laminin-coated culture dishes. After 24 hr, different concentrations of genistein were added to the cells and cell attachment was checked after 12 and 24 hr of exposure to genistein.

To assess the effect of genistein on cell spreading, ARVM were cultured for 7 days in the presence of Ara-C to avoid the growth of nonmuscle cells that could interfere with the effect of genistein. Usually, after 7 days in Ara-C, 85–90% of the cells kept their cylindrical shape. Different concentrations of genistein were added to the cells, and fresh medium with and without genistein was added to the cells every other day. After exposure to genistein for one or two weeks, the number of cells that kept their cylindrical shape or spread were counted using phase contrast microscopy.

Genistein and Contractile Protein Isoform Expression

The changing phenotype of the adult cardiocytes was investigated at two different time points. In the first time point, the cells were plated for the first 24 hr in DMEM + 10% CS; then different concentrations of genistein were added to the

cells. Fresh medium containing genistein was added to the cells every other day and the cells were extracted on the fourth day following the first addition of genistein and examined for the expression of α -SMA and total actins (TA). In the second time point the cells were cultured for the first 7 days in Ara-C; then different concentrations of genistein were added to the cells. The cells were extracted after 6 days following the treatment and the expression of α -SMA and α -SarcA was examined. On the day of the extraction, the cells were washed twice with cold phosphate-buffered saline, and 100 μ l of extraction buffer containing 100 mM $\text{Na}_4\text{P}_2\text{O}_7$, 5 mM EGTA, 5 mM DTT, 5 mM MgCl_2 , 5 mM MEM, 1 mM PMSF was added to the plates. The cells were extracted for 60 min on ice and then centrifuged for 25 min. The supernatant was aliquoted and stored at -70°C .

Myofibrillar proteins isolated from cultured myocytes in the presence or absence of genistein were separated on the basis of molecular weight by one-dimensional gel electrophoresis under denaturing conditions. The same amount of total proteins were loaded in each lane. A 7.5% polyacrylamide gel using the Laemmli discontinuous buffer system was used and stained with Coomassie blue for TA. α -SMA and α -SarcA reactivity with antibody was determined after electrophoretic transfer of protein from gels to nitrocellulose strips using a Bio-Rad Trans-Blot Electrophoretic Transfer Cell. Each nitrocellulose strip was reacted with monoclonals anti- α -SMA and anti- α -SarcA antibodies (Sigma Immunochemicals, St. Louis, MO) for 1 hr, washed and incubated for 1 hr with the appropriate alkaline phosphatase conjugated IgG secondary antibody. Membranes were developed in a solution containing 5-bromo-4-chloro-3-indolyl phosphate (BCIP) and nitroblue tetrazolium tablets (NBT) in alkaline phosphatase buffer.

RESULTS

Cell Attachment and Spreading

FIGURE 1 shows that genistein at high concentration affects cell attachment when added to the cells just after plating. After a 12-hr incubation period with genistein at 37°C , 50% of the cells exposed to 250 μM of genistein detached from the culture plate. After 24 hr, 10% of the cells exposed to 100 μM and 95% to 250 μM of genistein detached. However, if genistein was added to the cells 5 to 7 days after plating, when the cells began to spread, it did not affect cell attachment but it did affect cell spreading. As shown in FIGURE 2, genistein inhibits cell spreading in a dose-dependent manner. In the first week of culture, the number of cylindrical cells increases with increasing concentration of genistein.

After 2 weeks in culture no cylindrical cells were found in a typical culture of ARVM. In the presence of 60 μM and 100 μM of genistein 10 to 20% of the cells kept their cylindrical shape, however, the significant decrease in cell spreading was observed at only 100 μM .

α -Smooth Muscle Actin, Total Actins, and α -Sarcomeric Actin

FIGURE 3 shows that after 4 days in culture ARVM reexpress α -SMA. Following the treatment, a gradual inhibition in the expression of α -SMA at 10 μM is observed and becomes undetectable at 100 μM of genistein (FIG. 3).

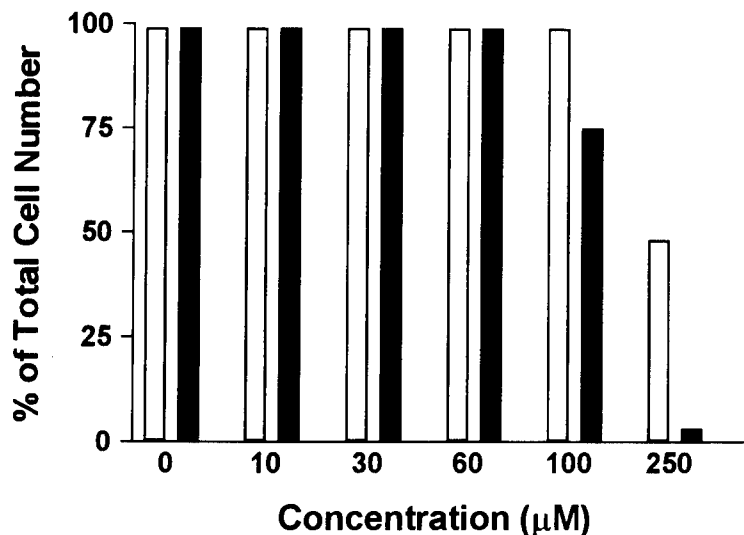

FIGURE 1. Adult rat ventricular myocytes were isolated and plated on laminin-coated culture dishes (30 µg/plate) at a density of 4×10^5 cells per 100-mm plate in DMEM + 10% CS. After 24 hr of cell equilibration to their new milieu, different concentrations of genistein were added and the cells were incubated at 37°C. After 12 hr (*open bars*) and 24 hr (*solid bars*), in the presence or absence of genistein, cells were monitored for attachment and spreading. Several areas on the culture plates were chosen randomly and cells were counted at these two time points using a phase contrast microscope.

When the treatment with genistein was started when the cells began to spread (after 7 days in culture), a dose-dependent inhibition of α -SMA was found that was more pronounced at 60 µM and at 100 µM of genistein (FIG. 4). In contrast, a dose-dependent increase in TA (FIG. 3) and no change in α -SarcA was observed in the early or the late exposure of ARVM to any concentration of genistein (FIGS. 3 and 4).

DISCUSSION

This study demonstrates that genistein, a specific inhibitor for tyrosine phosphorylation, affects ARVM differentiation in long-term culture. The adaptation of adult heart cells to an *in vitro* existence is accompanied by a significant number of structural changes.¹⁻⁵ Rat cardiac myocytes, when plated onto surfaces treated with laminin, attach and then spread. This morphology is reached either through a spherical intermediate state or as a result of spreading directly from the rod-shaped cells over the substratum where ARVM undergo successive stages in the disassembly of myofibrils and the subsequent assembly of new myofibrils. The precise mechanism(s) whereby signals from the extracellular matrix control cell growth, behavior, and differentiation, remains poorly defined. One concept

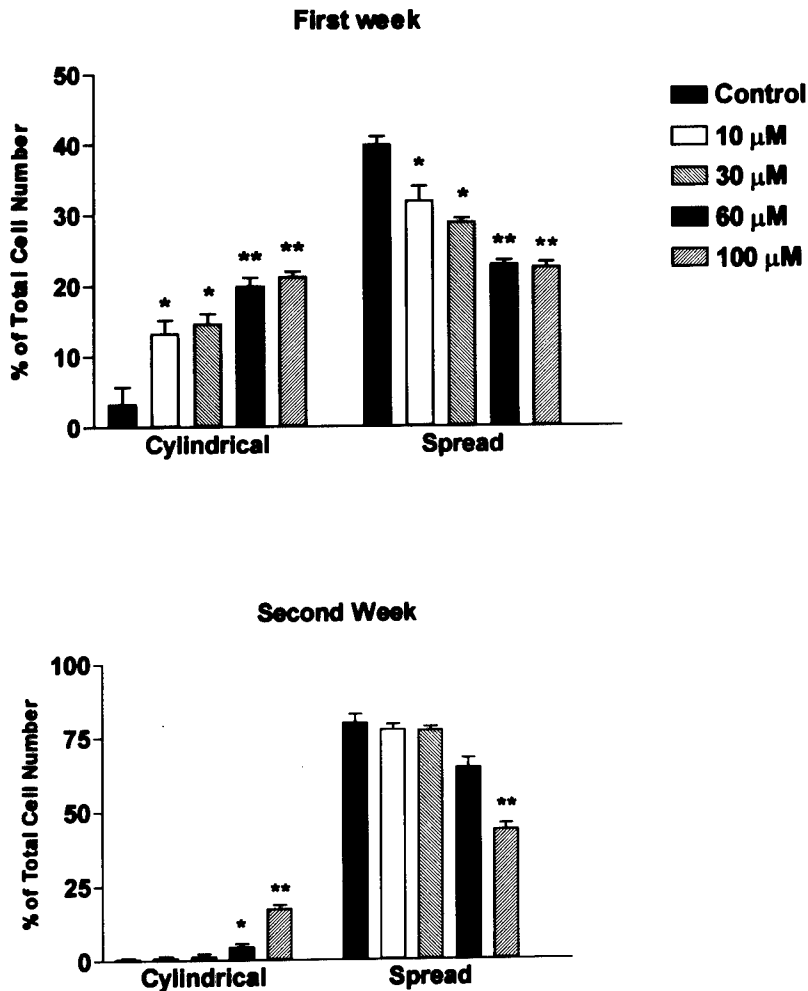

FIGURE 2. Adult rat ventricular myocytes were isolated and plated on laminin-coated culture dishes (30 $\mu\text{g}/\text{plate}$) at a density of 4×10^5 cells per 100-mm plate in DMEM + 10% CS. Ten μM of Ara-C was added to the cells during the first 7 days in culture to prevent any nonmuscle cell proliferation, since the cells were to be kept for a longer period of time in culture. After 7 days the medium was changed for fresh DMEM + 10% CS with and without different concentrations of genistein. The number of cylindrical and spread cells was counted choosing randomly different areas of the tissue culture plate over the period of the first and the second week in culture. Data are expressed as means \pm SEM from 3 different culture preparations. The average value of 5 different microscopic fields was taken as one data point. Statistical analysis was performed with Student's unpaired *t* test. Significantly different **p* < 0.05, and ***p* < 0.001.

suggests that cell adhesion molecules transmit signals by organizing the cytoskeleton, thus regulating cell shape and internal cellular architecture.¹⁶ It seems reasonable that appropriate cell shape and cytoskeletal organization might regulate the biosynthetic capabilities of the cell and thus contribute to cell growth or differentiation. The distal tips of the nascent myofibrils in ARVM after several days in culture have been shown to terminate in adhesion plaques that are the equivalent of the *in vivo* intercalated discs in terms of their molecular composition.¹⁶ Soler and Knusden¹⁷ demonstrate that N-cadherin, a cell surface, calcium-dependent adhesion molecule found in intercalated discs and extrajunctional sites in the myocardium mediate cardiac myocytes interaction, promotes myofibril formation necessary for functional activity of the myocardium. Adhesive interactions between cells and the extracellular matrix play a vital role in embryonic morphogenesis,^{18,19} in cardiac development²⁰ and in the regulation of gene expression in cells of the adult organism.²¹ The transmembrane signaling pathways that mediate the action

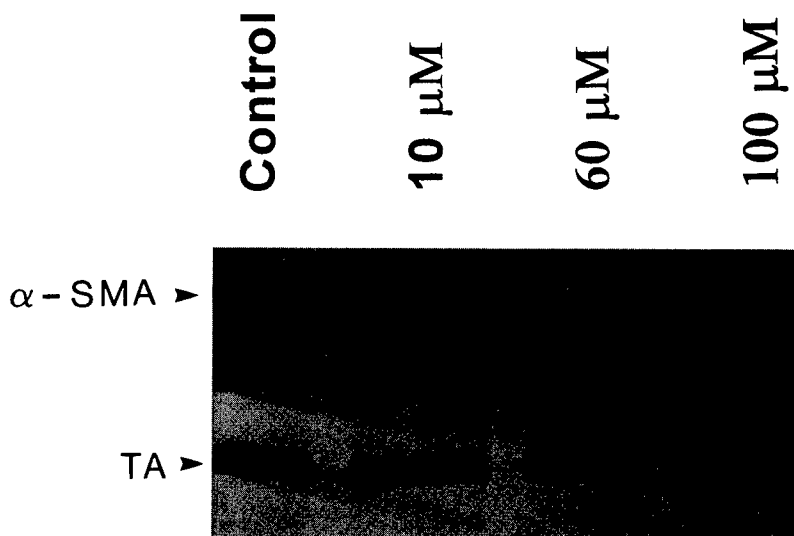

FIGURE 3. Adult rat ventricular myocytes were isolated and plated on laminin-coated culture dishes (30 $\mu\text{g}/\text{plate}$) at a density of 4×10^5 cells per 100-mm plate in DMEM + 10% CS. After 24 hr of cell equilibration to their new milieu, different concentrations of genistein were added and the cells were incubated at 37°C. After 4 days in culture, cells were extracted and myofibrillar proteins were separated on the basis of molecular weight by one-dimensional gel electrophoresis under denaturing conditions. 10 μg of total proteins were loaded on each lane. 7.5% polyacrylamide gel using the Laemmli discontinuous buffer system was used and stained with Coomassie blue for total actins. α -SMA immunoreactivity was determined after electrophoretic transfer of protein from gels to nitrocellulose and reacted with a monoclonal anti- α -SMA. The *top panel* is a western blot of α -SMA while the *bottom panel* is an SDS-PAGE of total actins, at an early stage in culture (4 days) in the absence and presence of different concentrations of genistein. The western blot of α -SMA revealed a concentration-dependent decrease in the relative amount of α -SMA in the presence of genistein, reaching undetectable levels at 100 μM . In contrast, total actins protein increased with 60 and 100 μM genistein.

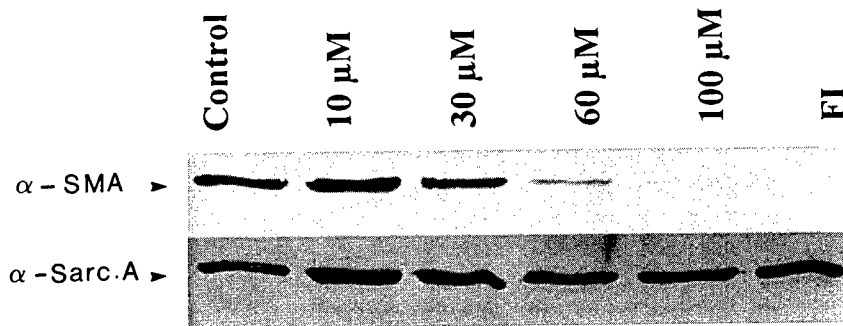

FIGURE 4. Adult rat ventricular myocytes were isolated and plated on laminin-coated culture dishes (30 μ g/plate) at a density of 4×10^5 cells per 100 mm plate in DMEM + 10% CS + 10 μ M of Ara-C for 7 days; then a fresh culture medium containing different concentrations of genistein were added to the cells. After 6 days in culture the cells were extracted. α -SMA and α -SarcA immunoreactivity was determined after electrophoretic transfer of protein from gels to nitrocellulose and reacted with monoclonals anti- α -SMA (top) or anti- α -SarcA (bottom).

of these cell adhesion molecules is not well known. Recently, a link between cell adhesion molecules and tyrosine phosphorylation in neurite outgrowth was reported²² as well as an increase in tyrosine phosphorylation in the focal adhesions of spreading and migrating human vascular endothelial cells. Another recent study by Yap *et al.*²³ reported that the earliest change associated with cell spreading was the accumulation of phosphotyrosine in developing focal adhesions, which was followed by stress fiber and microtubule assembly during thyroid cell attachment in culture. The role of tyrosine phosphorylation in the attachment of ARVM in long-term culture is not known. Our studies clearly show that inhibition of tyrosine phosphorylation in the first 24 to 48 hr after culturing the cells affects cell attachment. The effect of genistein on the expression of cell adhesion molecules during ARVM attachment and differentiation in long-term culture is currently under investigation.

ARVM attachment and spreading following culture is always accompanied by an altered pattern of gene expression. This is very well illustrated in our culture exposed to genistein, where the concentration that inhibited cell spreading also inhibited the expression of α -SMA. The synthesis of several proteins that are abundant in the fetal but not in the adult state has been reported to be reinduced. Although adult muscle tissue preferentially expresses a single actin isoform, coexpression of the various actins occurs during muscle differentiation *in vivo* and *in vitro*.²⁴ In adult muscle tissues, α -skeletal actin represents the predominant sarcomeric form in skeletal muscle, while α -cardiac is the most abundant striated actin in heart tissue. Little information is available about α -SMA gene activity in early myogenic cell lineages in developing embryos when expression of α -striated actins takes place. Ruzicka and Schwartz²⁴ reported that the α -SMA gene is broadly expressed in the heart during the earliest phases of cardiogenesis. Alpha-SMA gene activation occurs first and demarcates the beginning of cardiomyocyte differentiation in the avian embryo. In the rat, significant amounts of α -SMA

mRNA and protein are expressed in fetal rat heart tissue together with α -SarcA.²⁵ Our results on the reexpression of α -SMA in ARVM in long-term culture, detected by immunoblot using a monoclonal antibody, are consistent with the early report by Eppenberger *et al.*^{5,6} on the re-expression of α -SMA in the same culture model. In the present investigation, the application of genistein to the culture medium inhibited in a dose-dependent manner the expression of α -SMA in both early and late exposures. In order to determine whether this inhibition was particular for α -SMA or a general inhibition effect of genistein on cell protein content we also investigated the expression of TA and α -SarcA. Our results show that the expression of these actins did not decrease or even slightly increased in the case of TA with time in culture in the presence of genistein. This indicates that genistein inhibits the reexpression of the fetal isoform of certain protein and consequently, cell dedifferentiation but not total cell protein synthesis. Tyrosine phosphorylation has always been associated with the action of certain growth factors. A role for growth factors has already been demonstrated in the vertebrate heart and in cardiac cell culture.^{26,27} Polypeptide growth factors are synthesized within the myocardium, in part by cardiac myocytes but also by the neighboring nonmuscle cells, are regulated during cardiac development, and are induced during myocardial disease.²⁸ Parker and Schneider²⁹ reported in neonatal cardiac myocytes an increase in the expression of α -SMA after stimulating the cells with growth factors such as TGF β 1, bFGF and aFGF. Many of these growth factors mediate their pleotropic actions by binding to and activating cell surface receptors with an intrinsic protein tyrosine kinase activity.¹² The role of tyrosine phosphorylation during cardiac muscle development or in diseased heart is not yet known. In summary, our study provides evidence that tyrosine phosphorylation is involved in the dedifferentiation of ARVM in long-term culture and in the consequent re-expression of the α -SMA. These events could play an important role both in cardiac development and possibly in the induction and development of cardiac hypertrophy.

SUMMARY

Adult rat ventricular myocytes assume after 2 weeks in culture a flattened spread morphology and a loss in organized myofibrils. This sequence of phenotypic changes is accompanied by the reexpression of the fetal gene program. Although different signal transduction pathways were recently shown to be involved in cell growth and differentiation, not much is known about tyrosine kinase activation and cardiac myocyte differentiation. We investigated whether the tyrosine kinase signal transduction pathway is involved in the dedifferentiation of adult rat ventricular myocytes in long-term culture using a specific inhibitor of tyrosine phosphorylation, genistein. For this experiment, adult rat ventricular myocytes were cultured as previously described and incubated in culture medium containing different concentrations of genistein (10–250 μ M). After 24 hr of incubation and in a concentration-dependent manner genistein prevented cell spreading. However, at high concentration, cells detached from the plates (10% to 100 μ M and 95% at 250 μ M). The effect of genistein on adult rat ventricular myocyte phenotype

in culture was investigated by examining the expression of total actins and α -smooth muscle actin and α -sarcomeric actin in cells after 6 days of incubation with and without genistein. Myofibrillar proteins were extracted and separated by gel electrophoresis. Expression of α -smooth muscle actin and α -sarcomeric actin was determined by Western blotting using specific antibodies. While there was an increase in the amount of total actins and no change in the amount of α -sarcomeric actin in the cells exposed to genistein, the amount of α -smooth muscle actin decreased with increasing concentrations of genistein reaching undetectable levels at 100 μ M. These results demonstrate that genistein inhibits cell spreading and the reexpression of α -smooth muscle actin in adult rat ventricular myocytes in culture in a dose-dependent manner, therefore, inhibiting the process of dedifferentiation.

REFERENCES

1. CLAYCOMB, W. C. & M. C. PALAZZO. 1980. Culture of terminally differentiated adult cardiac muscle cell: a light and scanning electron microscope study. *Dev. Biol.* **80**: 466-482.
2. MOSES, R. L. & W. C. CLAYCOMB. 1982. Disorganization and reestablishment of cardiac muscle cell ultrastructure in cultured adult rat ventricular muscle cells. *J. Ultrastruct. Res.* **81**: 358-374.
3. JACOBSON, S. L. & H. M. PIPER. 1986. Cell cultures of adult cardiomyocytes as models of the myocardium. *Mol. Cell Cardiol.* **18**: 661-678.
4. BUGAISKY, L. B. & R. ZAK. 1989. Differentiation of adult rat cardiac myocytes in cell culture. *Circ. Res.* **64**(3): 493-500.
5. EPPENBERGER, M. E., I. HAUSER, T. BAECHI, M. C. SCHAUB, U. T. BRUNNER, CLAUDE A. DECHESNE & H. M. EPPENBERGER. 1988. Immunohistochemical analysis of the regeneration of myofibrils in long-term cultures of adult cardiomyocytes of the rat. *Dev. Biol.* **130**: 1-15.
6. EPPENBERGER-EBERHARDT, M., I. FLAMME, V. KURER & H. M. EPPENBERGER. 1990. Reexpression of α -smooth muscle actin isoform in cultured adult rat cardiomyocytes. *Dev. Biol.* **139**: 269-278.
7. CLAYCOMB, W. C. 1988. Atrial-natriuretic-factor mRNA is developmentally regulated in heart ventricles and actively expressed in cultured ventricular cardiac muscle cells of rat and human. *Biochem. J.* **255**: 617-620.
8. DE BOLD, A. J. 1985. Atrial natriuretic factor: a hormone produced by the heart. *Science* **230**: 767-770.
9. BILSEN, M. V. & K. R. CHIEN. 1993. Growth and hypertrophy of the heart: towards an understanding of cardiac specific and inducible gene expression. *Cardiovasc. Res.* **27**: 1140-1149.
10. WILKS, A. F. 1993. Protein tyrosine kinase growth factor receptors and their ligands in development, differentiation, and cancer. *Adv. Cancer Res.* **60**: 43-73.
11. FANTL, W. J., D. E. JOHNSON & L. T. WILLIAMS. 1993. Signalling by receptor tyrosine kinases. *Annu. Rev. Biochem.* **62**: 453-481.
12. ULLRICH, A. & J. SCHLESSINGER. 1990. Signal transduction by receptors with tyrosine kinase activity. *Cell* **61**: 203-212.
13. AKIYAMA, T. & H. OGAWARA. 1991. Use and specificity of genistein as inhibitor of protein-tyrosine kinases. *Methods Enzymol.* **201**: 362-370.
14. AKIYAMA, T., J. ISHIDA, S. NAKAGAWA, H. OGAWARA, S. WATANABE, N. ITOH, M. SHIBUYA & Y. FUKAMI. 1987. Genistein, a specific inhibitor of tyrosine-specific protein kinases. *J. Biol. Chem.* **262**(12): 5592-5595.
15. EID, H., D. M. LARSON, P. SPRINGHORN, A. A. MOHAMMED, R. C. NAYAK, T. W. SMITH & R. A. KELLY. 1992. Role of epicardial mesothelial cells in the modification

- of phenotype and function of adult rat ventricular myocytes in primary coculture. *Circ. Res.* **71**: 40–50.
16. LIN, Z., S. HOLTZER, T. SCHULTHEISS, J. MURRAY, T. MASAKI, D. A. FISCHMAN & H. HOLTZER. 1989. Polygons and adhesion plaques and the disassembly and assembly of myofibrils in cardiac myocytes. *J. Cell Biol.* **108**: 2355–2367.
 17. SOLER, A. P. & K. A. KNUDSEN. 1994. N-Cadherin involvement in cardiac myocyte interaction and myofibrillogenesis. *Dev. Biol.* **162**: 9–17.
 18. SANES, J. R. 1989. Extracellular matrix molecules that influence neural development. *Annu. Rev. Neurosci.* **12**: 491–516.
 19. VOLK, T., L. I. FESSLER & J. H. FESSLER. 1990. A role for integrin in the formation of sarcomeric cytoarchitecture. *Cell* **63**: 525–536.
 20. GORDON, L., J. WHARTON, S. E. MOORE, F. S. WALSH, J. G. MOSCOSO, R. PENKETH, J. WALLWORK, K. M. TAYLOR, M. H. YACOB & J. M. POLAK. 1990. Myocardial localization and isoforms of neural cell adhesion molecule (N-CAM) in the developing and transplanted human heart. *J. Clin. Invest.* **86**: 1293–1300.
 21. STREULI, C. H. & M. J. BISSEL. 1990. Expression of extracellular matrix components is regulated by substratum. *J. Cell Biol.* **110**: 1405–1415.
 22. ATASHI, S. R., S. G. KLINTZ, C. A. INGRAHAM, W. T. MATTEN, M. SCHACHNER & P. F. MANESS. 1992. Neural cell adhesion molecules modulate tyrosine phosphorylation of tubulin in nerve growth cone membranes. *Neuron* **8**: 831–842.
 23. YAP, A. S., J. R. KEAST & S. W. MANLEY. 1994. Thyroid cell spreading and focal adhesion formation depend upon protein tyrosine phosphorylation and actin microfilaments. *Exp. Cell Res.* **210**: 306–314.
 24. RUZICKA, D. L. & R. J. SCHWARTZ. 1988. Sequential activation of α -actin genes during avian cardiogenesis: vascular smooth muscle α -actin gene transcripts mark the onset of cardiomyocyte differentiation. *J. Cell Biol.* **107**: 2575–2586.
 25. WOODCOCK-MITCHELL, J., J. J. MITCHELL, R. R. LOW, M. KIENY, P. SENDEL, L. RUBBIA, O. SKALLI, B. JACKSON & G. GABBIANI. 1988. α -Smooth muscle actin is transiently expressed in embryonic rat cardiac and skeletal muscles. *Differentiation* **39**: 161–166.
 26. KARDAMI, E. & R. R. FRANDRICH. 1989. Basic fibroblast growth factor in atria and ventricles of the vertebrate heart. *J. Cell Biol.* **109**: 1865–1875.
 27. KARDAMI, E. 1990. Stimulation and inhibition of cardiac myocyte proliferation *in vitro*. *J. Mol. Cell Biochem.* **92**: 124–129.
 28. PARKER, T. G. & M. D. SCHNEIDER. 1991. Growth factors, proto-oncogenes, and plasticity of the cardiac phenotype. *Annu. Rev. Physiol.* **53**: 179–200.
 29. SCHNEIDER, M. D. & T. G. PARKER. 1990. Cardiac myocytes as targets for the action of peptide growth factors. *Circulation* **81**(5): 1443–1456.

Evaluation of DNA Content by Static Cytometry in Hypertrophic Cardiomyopathy (HCM)^a

B. BIONDO, E. GROSSO, A. M. LAVEZZI, L. ROSSI, AND
L. MATTURRI

*Institute of Pathology
University of Milan
Milan, Italy*

In the contexts of normal cardiac development in humans, the capability of mitosis is restricted to the intrauterine phase and a brief postnatal period. But various findings indicate that the final number of muscle cells may be increased by physiological and pathological stimuli which affect the heart also during adulthood.¹⁻³ The aim of this study is to determine variation in the capability of mitosis in hypertrophic myocardial fibrocells (HCM) using an image analyzer.

We examined 4 cases of HCM and 5 controls. Samples were taken from the free walls of the atria, right and left ventricular free walls, and the ventricular septum, fixed in 10% formalin buffer and embedded in paraffin. Sections of 5 μm thickness were stained with hematoxylin-eosin by the Feulgen procedure. Densitometric tests were performed on the sections with a VIDAS image analyzer (Zeiss-Kontron) and DNA content (integrated optical density) and nuclear area of myocytes were evaluated. An average of 300 well-defined coplanar fibrocells were evaluated from hypertrophic myocardial areas. This method is particularly suitable because of the stoichiometric binding with nuclear DNA. Integrated Optical Density (IOD) was evaluated in nuclei arranged in longitudinal sections. Ploidy was expressed as DNA index = ratio between peak DNA content of myocardial nuclei analyzed and peak reference lymphocytes. DNA index = 1 corresponds to diploidy, DNA index \neq 1 to aneuploidy. The results of our investigation are expressed as mean values and relative standard deviation. The level of $p < 0.05$ was selected as being statistically significant. We used the variance analysis test (F-test) to show the difference between the mean values observed compared with controls.

Densitometric analysis showed an aneuploid content of the triploid type, indicating an increased cell proliferation, an expression of hyperplasia. The factors that induce hyperplasia in HCM are not yet known. The increase of nuclear area of myocytes, confirmed by nuclear duplication, which is particularly evident in the septum and in the ventricle walls, seems to result from the presence of hypertrophy of myocardial fibrocells.

Cytometric analysis of normal heart myocardial biopsy samples has shown the presence of polyploidization in the nuclei with HCM while fibroblast and endothe-

^a Research supported by CNR-Targeted Project "FATMA."

lial nuclei show a diploid DNA profile. This polyploidization increases with age and/or the development of different types of hypertrophy.⁴ Polyploidization of myocytes may therefore represent a functional adaptation to the demand for higher protein synthesis leading to growth of myocytes in both normal and pathologic myocardium.

In conclusion our results show the presence both of hypertrophy, characterized by increased nuclear area and of hyperplasia, characterized by increased DNA content. The present study confirmed the presence of these alterations and underlines the need to further explore the evaluation of DNA content by densitometric analysis, which we consider a valid approach for assessing hyperplasia in HCM.

REFERENCES

1. FRENZEL, H., B. SCHWARTZKOPFF, P. REINECKE, K. KAMINO & B. LÖSSE. 1987. *Z. Kardiol.* 76(3): 14-19.
2. RAKUSAN, K. 1984. Cardiac growth, maturation and aging. *In* Growth of the Heart in Health and Disease. R. Zak, Ed. 131-164. Raven Press. New York.
3. FERRANS, W. J., & E. R. RODRIGUEZ. 1983. *Eur. Heart J.* 47(7): 2-22.
4. VLIEGEN, H. W., A. VAN DER LAARSE, F. EULDERINK, A. M. VOSSEPOEL & C. J. CORNELISSE. 1987. *In* Clinical Cytometry and Hystometry. G. Burger, J. S. Ploem & K. Goertler, Eds. 497-499. Academic Press. London.

Effect of Propionyl-L-Carnitine (PLC) on the Kinetic Properties of the Myofibrillar System in Pressure Overload Cardiac Hypertrophy

C. REGGIANI, M. CANEPARI, R. MICHELETTI,^a V. CAPPELLI,
AND M. C. ZANARDI

*Institute of Human Physiology
University of Pavia
via Forlanini, 6
I-27100 Pavia, Italy*

*and
^aPraxis Sigma-Tau Research Institute
via Forlanini, 1
I-20019 Settimo Milanese, Italy*

INTRODUCTION

Propionyl-L-carnitine (PLC) is an ester of L-carnitine with propionic acid which is present in small amounts in the body. PLC administration has been found to increase cardiac output in pressure-overloaded rats.¹ This effect has been subsequently shown to depend on a direct action on cardiac muscle contractility.² The reduction of shortening velocity and the prolongation of the timing parameters of the isometric contraction associated with pressure-overload hypertrophy were corrected by PLC administration. In this study we aimed to assess whether PLC treatment affects the functional properties of the myofibrillar apparatus.

METHODS

Male Wistar Kyoto rats were purchased at weaning and divided into two groups, one of which received PLC (180 mg/kg, b.w./day) in the drinking water. After four weeks of treatment both groups underwent either suprarenal aortic constriction or, alternatively, sham operation. Four weeks later animals were sacrificed under ether anesthesia. Hearts were removed and two or three trabeculae from the left ventricle were dissected out and chemically skinned with EGTA and X-100 Triton as previously described.³ Unloaded shortening velocity (V_0) was determined with the slack test method during maximal Ca activation (pCa 4.45) at 12°C, 2.1 μm sarcomere length.

From the free wall of the left ventricle washed and purified myofibrils were prepared as described.⁴ ATPase activity was determined at low ionic strength in the presence of calcium (pCa 4.45) and magnesium at 27°C. Data were expressed as means and standard errors.

TABLE 1. Body Weight (BW) and Left Ventricle Weight (LVW) of Experimental Groups of Animals

	Control Sham ^a	Control Clip ^b	PLC Sham ^c	PLC Clip ^d
BW (g)	290 ± 8	293 ± 12	284 ± 9	275 ± 12
LVW (mg)	718 ± 34	1042 ± 45*	725 ± 44	1025 ± 21*
n	11	11	8	10

^a Control sham: sham operation.

^b Control clip: aortic constriction.

^c PLC sham: sham operation and PLC treatment.

^d PLC clip: aortic constriction and PLC treatment.

* $p < 0.05$ vs corresponding sham group.

RESULTS AND DISCUSSION

PLC administration did not modify the left ventricle hypertrophy due to aortic constriction, as can be seen in TABLE 1 where body weight and left ventricle weight are reported.

The trabeculae isolated from the hypertrophic hearts from either the PLC or control groups were comparable to those from the sham-operated groups as regarded size and isometric tension (TABLE 2). The expected hypertrophy-induced decrease in shortening velocity was only seen in the control group, as PLC treatment prevented the reduction of V_o (FIG. 1A).

Myofibrillar ATPase activity was significantly reduced in hypertrophic ventricles of both the PLC-treated and control groups. The reduction was, however, significantly lower in the PLC group (FIG. 1B).

These results show that PLC treatment can directly affect the kinetic properties of the myofibrillar system of hypertrophic myocardium. The decrease in unloaded shortening velocity and in ATPase activity which is associated with the development of hypertrophy in control rats is partially prevented in PLC-treated animals. The changes of both V_o and ATPase activity are considered related to a shift in isomyosin composition. The observed effects on V_o and ATPase activity are, therefore, consistent with our previous finding that PLC partially prevents the isomyosin shift induced by pressure overload.² Although the mechanism underlying PLC action on isomyosins has not been directly investigated, it might be related to PLC metabolic activity. By decreasing the acetyl CoA-to-CoA ratio,⁵ PLC can relieve the inhibition of pyruvate dehydrogenase complex, thus enhancing glucose oxidation. Increased carbohydrate use has been shown to stimulate the expression of the fast alpha myosin heavy chain in ventricular myocardium.⁶ This would counteract the increase in beta myosin heavy chain expression due to pressure overload. However, additional effects of PLC cannot be ruled out. For example,

TABLE 2. Size and Isometric Tension (P_o) of Isolated Trabeculae

	Control Sham	Control Clip	PLC Sham	PLC Clip
Diameter (μm)	143 ± 13	150 ± 14	176 ± 15	138 ± 11
P_o (mN/mm ²)	28.5 ± 4.0	30.1 ± 5.5	21.5 ± 2.6	26.8 ± 3.5
n	15	12	17	15

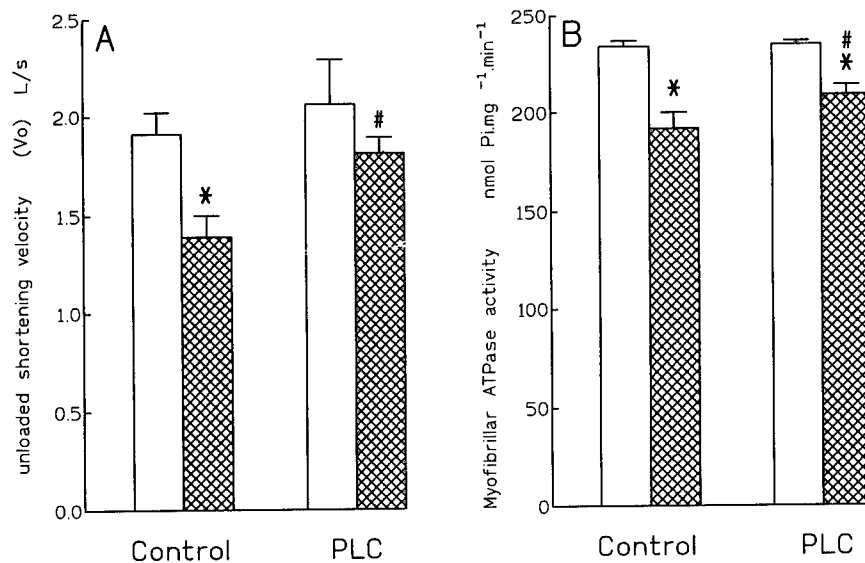

FIGURE 1. Effects of aortic constriction and PLC administration on unloaded shortening velocity (V_o) and myofibrillar ATPase activity. Values (means and standard errors) obtained in trabeculae and myofibrils from sham-operated animals are represented by *empty columns*, whereas values from aortic-constricted animals are represented by *filled columns*. *Significant difference ($p < 0.05$) between sham-operated and aortic-constricted; #significant difference ($p < 0.05$) between PLC-treated and controls.

the abbreviation of the time course of the isometric response² suggests a possible effect of PLC on sarcoplasmic reticulum.

REFERENCES

1. YANG, X. P., M. SAMAJA, E. ENGLISH, P. BENATTI, M. TARANTOLA, G. CARDACE, R. MOTTERLINI, R. MICHELETTI & G. BIANCHI. 1992. *J. Cardiovasc. Pharmacol.* **20**: 88-98.
2. MICHELETTI R., G. GIACALONE, M. CANEPARI, S. SALARDI, G. BIANCHI & C. REGGIANI. 1994. *Am. J. Physiol.* **266**: H2190-H2197.
3. MORNER, S. E. J. N., M. CANEPARI, R. BOTTINELLI, V. CAPPELLI & C. REGGIANI. 1992. *Acta Physiol. Scand.* **146**: 21-30.
4. CAPPELLI, V., R. BOTTINELLI, C. POGGESI, R. MOGGIO & C. REGGIANI. 1989. *Circ. Res.* **65**: 446-457.
5. TESSANI, V., S. CATTAPAN, L. MAGNANIMI & A. PESCHECHERA. 1994. *Biochem. Biophys. Res. Commun.* **199**: 949-953.
6. SHEER, D. & E. MORKIN. 1984. *J. Pharmacol. Exp. Ther.* **229**: 872-879.

Propionyl-L-Carnitine Improves Mechanical Performance of Papillary Muscle from Dilated Cardiomyopathic Hamsters

P. MARESCA, N. CORSICO, E. ARRIGONI-MARTELLI,
R. MANCINELLI, AND E. MANNI

*Research and Development
Department of Pharmacology
Sigma-Tau S.p.A.
Via Pontina Km 30.400
00040 Pomezia, Rome, Italy*

Few reproducible models of cardiomyopathies are available in experimental animals. The existence of a strain of Syrian hamsters with a genetically transmitted cardiomyopathy that terminates in congestive heart failure offers unique opportunities to study the sequence of events leading to a congestive state and, in particular, a progressive myocardial insufficiency.

In this animal model cardiac failure develops relatively slowly and progressively, as occurs in the human form.¹ On the other hand, it is known that propionyl-L-carnitine (PLC) has a beneficial effect on cardiac function in several experimental models of cardiomyopathy, improving both mechanical performance and energy production.² Two groups of male (8-month-old) Syrian hamsters were used: BIO F1B strain as control and BIO TO.2 strain with dilated cardiomyopathy. All animals were obtained from the Bio Research Institute, Inc., Cambridge, MA. After 7 weeks of oral treatment with PLC (60 mg/Kg os), we studied *in vitro* the contractility of the papillary muscle isolated from the left ventricle of these hamsters in terms of the length-tension relationship. The experimental procedure used was described previously.³ Briefly, the papillary muscle was continuously stimulated and its length was increased stepwise with increments of 0.02 Lo from its resting length to 1.14 Lo. Passive and active isometric tension were recorded on a Grass polygraph. The resting and developed tensions and their total were summarized and graphically represented in terms of mean values as observed at the different increasing lengths. The differences between the groups were analyzed using analysis of covariance (Ancova) for all parameters. All the statistical tests were two-sided and conducted at 0.05 alpha level.

RESULTS AND CONCLUSIONS

FIGURE 1 shows the length-tension relationships observed from papillary muscle obtained from the BIO F1B normal group and from the dilated cardiomyopathic

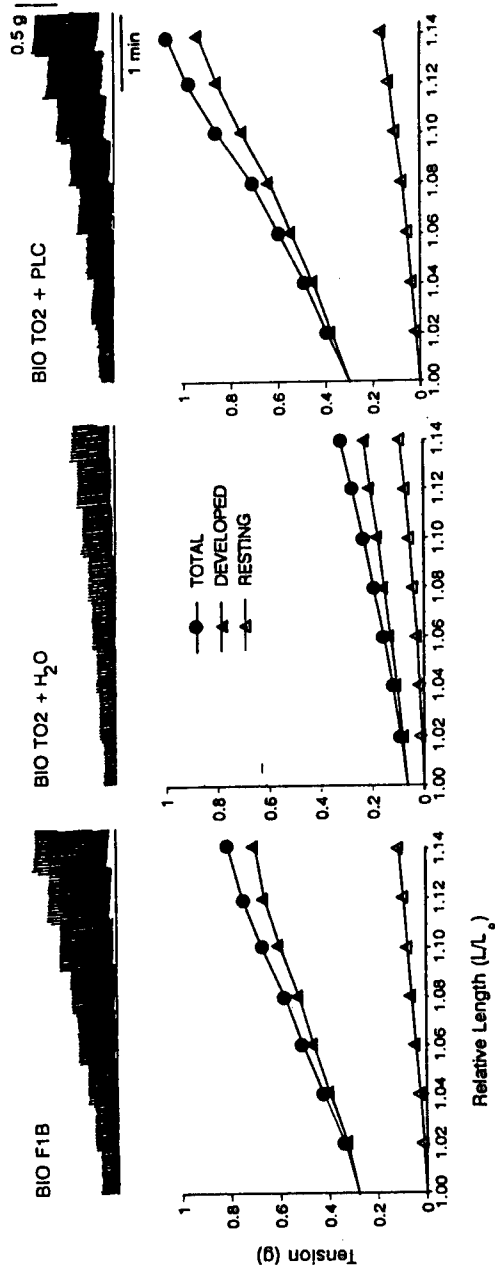

FIGURE 1. Length-tension relationships observed from papillary muscle obtained from the BIO F1B normal group and from the dilated cardiomyopathic groups BIO TO.2 treated with H₂O and PLC, respectively.

groups BIO TO.2 treated with H₂O and PLC, respectively. Both active and total tension were markedly depressed in papillary hearts of the H₂O-treated cardiomyopathic group as compared with the normal hamster hearts ($p < 0.001$). Active and total tension values significantly increased ($p < 0.001$) in papillary muscles of hamsters treated with PLC. At final length, values of developed tension (mean \pm standard deviation) were 0.69 ± 0.12 g, 0.24 ± 0.080 g, and 0.90 ± 0.16 g for normal and H₂O- and PLC-treated cardiomyopathic animals, respectively. The resting tension values were significantly ($p < 0.05$) higher (0.15 ± 0.03 g) for the PLC-treated BIO TO.2 strain in comparison to the H₂O-treated (0.09 ± 0.01 g) and normal hamster (0.10 ± 0.01 g) groups.

In conclusion, the finding clearly indicates that PLC administration restores depressed cardiac functions in a genetic model of dilatative cardiomyopathy. Connective tissue abnormalities may contribute to the progressive loss of ventricular function in cardiomyopathic Syrian hamsters, and a reduction in these abnormalities may provide an explanation for the leftward shifts of the passive curves of the PLC-treated group with respect to the vehicle-treated group.

REFERENCES

1. STROBECK, J. E., S. M. FACTOR, A. BHAN, M. SOLE, C. C. LIEW, F. FEIN & E. H. SONNENBLICK. 1979. Hereditary and acquired cardiomyopathies in experimental animals: mechanical, biochemical and structural features. *Ann. N. Y. Acad. Sci.* **317**: 59–88.
2. YANG, X. P., M. SAMAJA, E. ENGLISH, P. BENATTI, M. TARANTOLA, G. CARDACE, M. MOTTERLINI, R. MICHELETTI & G. BIANCHI. 1992. Hemodynamic and metabolic activities of propionyl-L-carnitine in rats with pressure-overload cardiac hypertrophy. *J. Cardiovasc. Pharmacol.* **20**: 88.
3. MANCINELLI, R., P. MARESCA, N. CORSICO, A. MORGANTI, E. ARRIGONI-MARTELLI & E. MANNI. 1993. Comparison of mechanical parameters of papillary muscle from normal (BIO F1.B), hypertrophic (BIO 14.6) and dilated (BIO TO.2) hearts in the Syrian hamster. *Exp. Physiol.* Submitted.

Markers of Cardiac Hypertrophy^a

ROBERT M. KLEIN,^{b,c} BRIAN K. MacGILLIVRAY,^c AND
JAMES C. MCKENZIE^d

^c*Department of Anatomy and Cell Biology
University of Kansas Medical Center
3901 Rainbow Boulevard
Kansas City, Kansas 66160-7400*

and
^d*Department of Anatomy
Howard University College of Medicine
Washington, DC 20059*

INTRODUCTION

Cardiac hypertrophy represents the adaptation of the heart wall to increased workload. Research in our laboratories has focused on the response of cardiomyocytes and interstitial cells to hypertrophic stimuli and potential cytokine communication between cardiac cells. Cardiomyocytes primarily undergo hypertrophy or enlargement while the interstitial cells replicate and increase in number during the adaptive response. In addition, there is increased deposition of extracellular matrix components during the adaptation process. The cascade of events which follows a hypertrophic stimulus includes expression of immediate early genes such as *c-fos* and *c-myc* and reversion to a fetal phenotype by the cardiomyocytes with reexpression of atrial natriuretic peptide (ANP) (see reviews^{1,2}). Under normal conditions, ANP is expressed in the ventricles during fetal cardiac development and is greatly reduced to barely detectable levels in the adult.^{3,4} Reexpression of ANP occurs in hypertension and congestive heart failure in response to increased ventricular workload.^{5,6}

The interstitial connective tissue which surrounds the cardiomyocytes and is present in the endocardium and epicardium also responds to the hypertrophic stimulus of increased workload (see review⁷). During injury and repair, intercellular communication occurs through the expression of growth factors and cytokines, polypeptides produced by macrophages, lymphocytes, fibroblasts, and a variety of other cells. Cytokines mediate developmental processes such as cell proliferation and differentiation which are involved in cardiac hypertrophy.

There are two sets of experiments described in this study: i) analysis of ANP expression by cardiomyocytes and ii) analysis of cytokine mRNA during the onset of cardiac hypertrophy induced by hypobaric hypoxia. The experiments described in the first part of the study were designed to determine the topographical distribution of ANP expression during cardiac hypertrophy. The hypothesis of this portion

^a Research was supported by the American Heart Association/Kansas Affiliate.

^b Corresponding author.

of the study is that ANP may be an early marker of stress in the ventricular wall. The specific aim of the second part of the study was to determine the temporal pattern of cytokine mRNA expression during the onset and development of cardiac hypertrophy. We hypothesize that cardiac hypertrophy is mediated by some of the same cytokines which are involved in injury and repair responses.

ANP Expression during Cardiac Hypertrophy

Right Ventricular Hypertrophy (RVH)

Cardiac hypertrophy was induced in rats and mice by exposure to chronic hypobaric hypoxia (0.5 atm; 380 torr) for up to 3 weeks as was carried out previously by our lab.⁸ RVH, expressed as the ratio of RV weight to left ventricular + septal weight (RV/LV + S⁹) increased significantly at 3 days in adult rats and was increased by 50% after 7 days of exposure (FIG. 1). The response in mice expressed as the ratio of RV to body weight (FIG. 2) is less dramatic than that in rats (FIG. 1), although hematocrit in these animals was elevated as early as one day of hypobaric exposure (FIG. 3).

ANP Localization

Hearts from rats exposed to hypobaric hypoxia revealed initial foci of ANP-immunoreactivity (ANP-ir) near the junction of the septum with the right ventricular free wall, as well as surrounding isolated blood vessels in the right ventricular wall. ANP-ir spread throughout the RV wall and right half of the septum at later

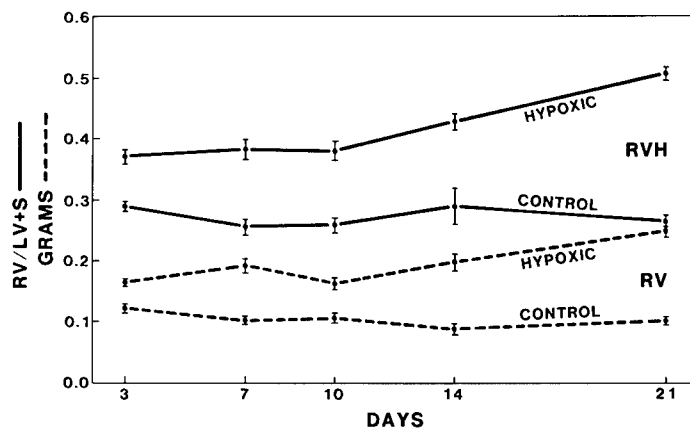

FIGURE 1. Right ventricular hypertrophy (RVH) in rats exposed to hypobaric hypoxia. Both ventricular weights and the ratio of the RV/LV + S (with SEMs) are shown for control rats and rats exposed to hypobaric hypoxia. Comparison by *t* test for unknown and unequal variance indicated significant differences beginning at day 3. (From McKenzie & Klein.⁸ Reprinted by permission from *Blood Vessels*.)

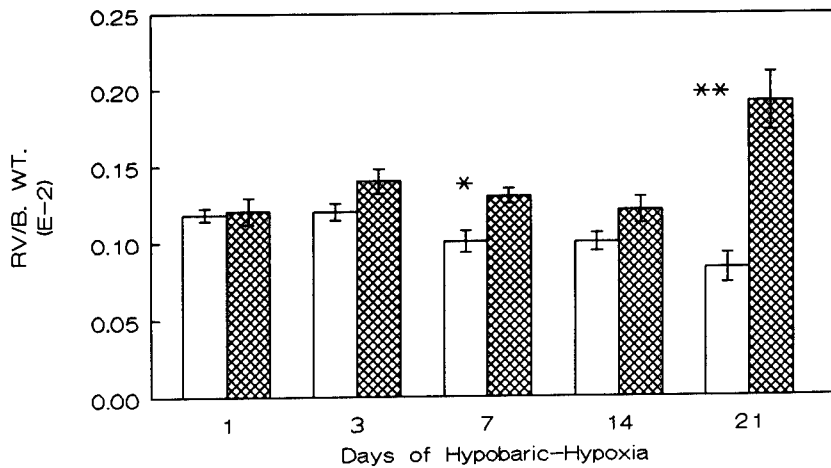

FIGURE 2. RVH (RV/B. WT.) in normoxic (*clear columns*) and hypoxic (*hatched columns*) mice. * $p < 0.05$, ** $p < 0.01$ with ANOVA.

time points (FIG. 4). After 14 days there was detectable ANP-ir in the left ventricle (FIG. 4), which increased by 21 days of hypobaric exposure.

Cytokine Expression during Cardiac Hypertrophy

Expression of cytokine message was determined by use of Northern blot analysis¹⁰ of right ventricles (RV) and left ventricles + septa (LV + S) from the hearts

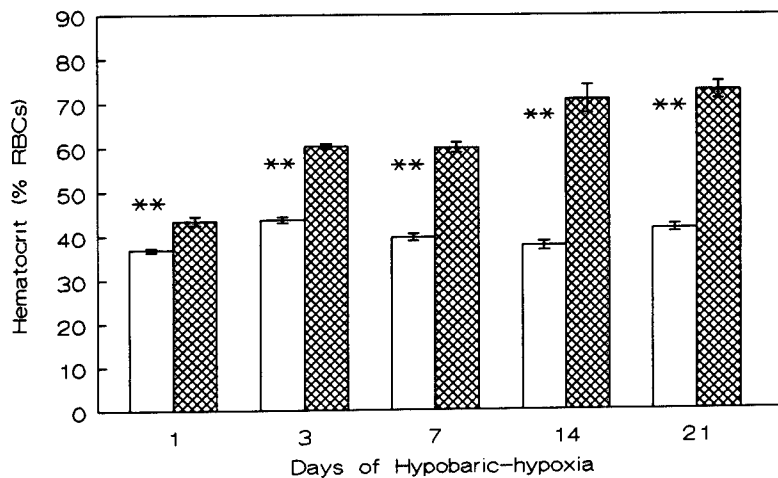

FIGURE 3. Hematocrit in normoxic (*clear columns*) and hypoxic (*hatched columns*) mice (statistics see FIG. 2).

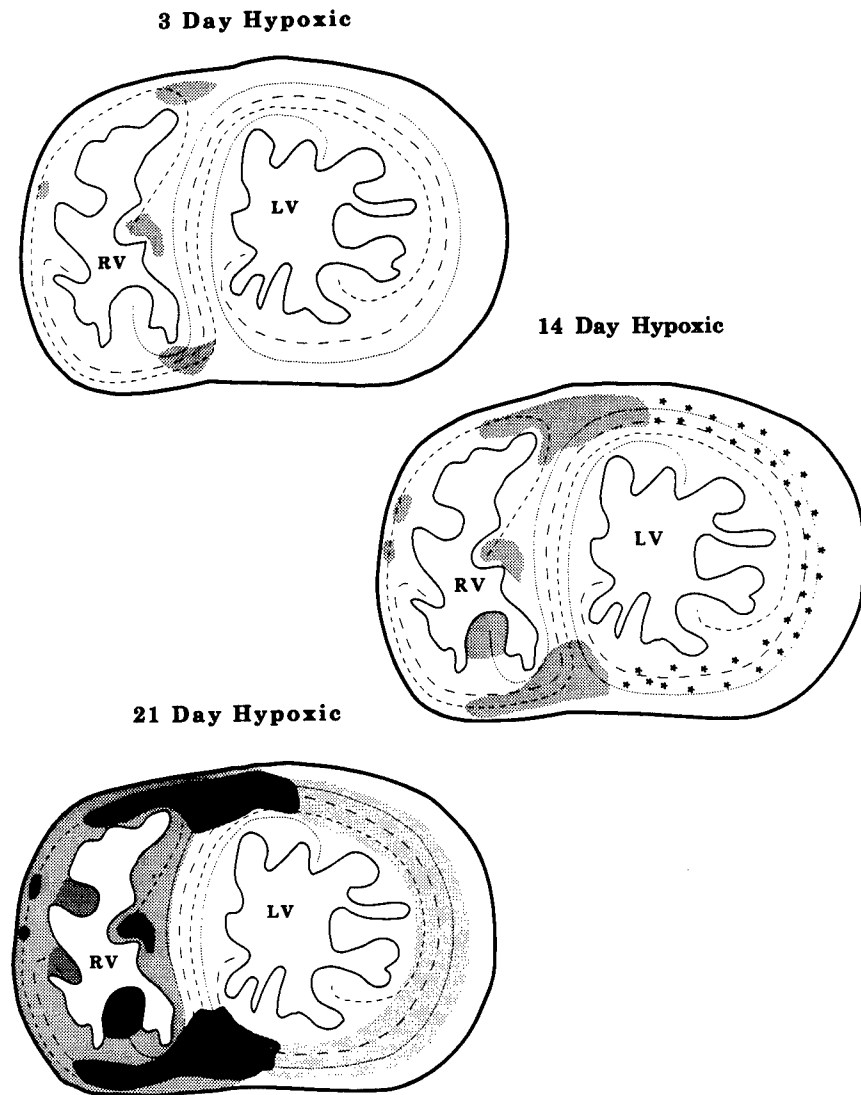

FIGURE 4. A diagrammatic summary of the immunocytochemical labeling for ANP-IV and proANP antibodies in the right and left ventricles of rats exposed to hypobaric-hypoxia for 3, 14 or 21 days. ANP immunocytochemistry was carried out using antibodies to ANP-IV and proANP.^{6,24} The asterisks indicate places where immunostaining for proANP occurred in the absence of similar recognition by the antibody to ANP-IV. (From McKenzie *et al.*⁶ Reprinted by permission from the *Journal of Molecular and Cellular Cardiology.*)

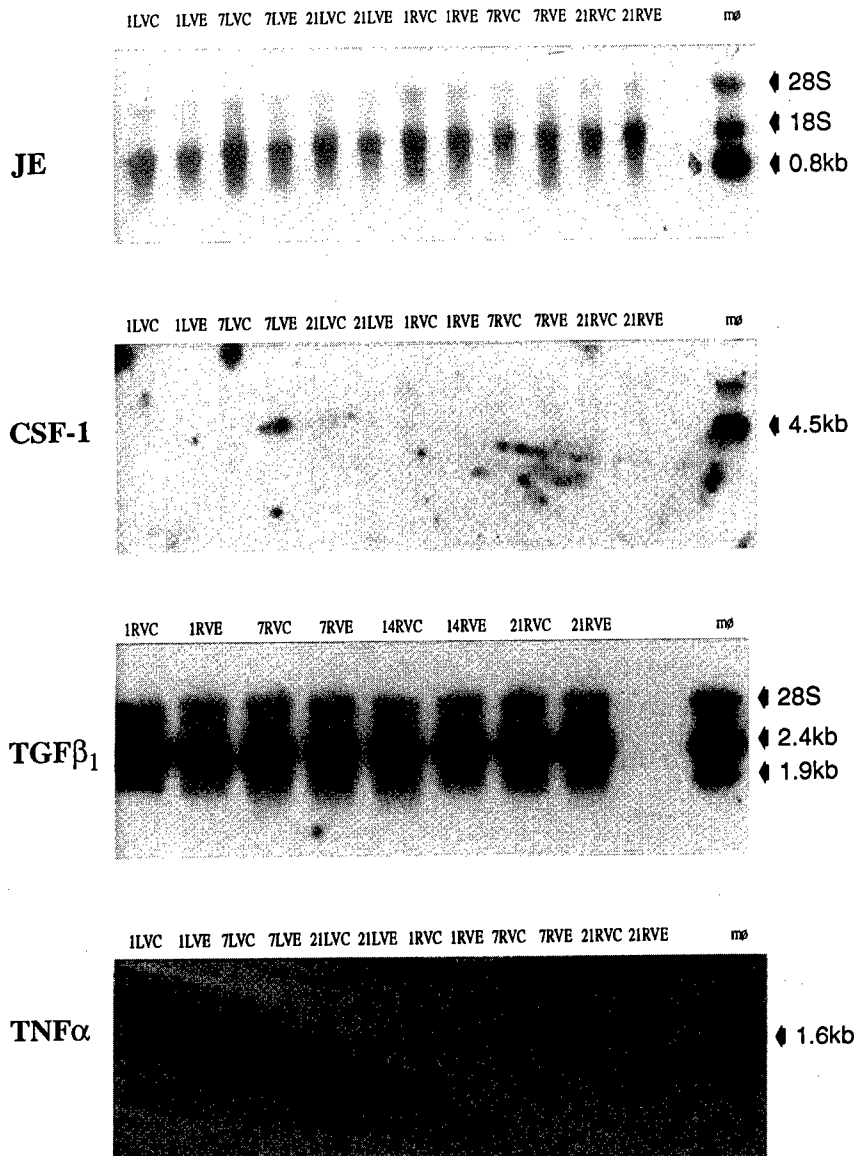

FIGURE 5. Northern blot analysis for JE/MCP-1 and CSF-1. RV = right ventricle, LV = left ventricle, C = control, E = hypoxic. Days = 1, 7, 14 or 21, mφ = macrophage control, a positive control, obtained by extracting RNA from J774 cells previously exposed to bacterial lipopolysaccharide.¹⁰ Seven RVs or 4 LVs were pooled for RNA analysis. Separate RNA samples were probed a minimum of 3 times.

of mice exposed to hypobaric hypoxia for 1 to 21 days. The chemoattractant cytokines, also known as chemokines, include JE/monocyte-chemoattractant protein (MCP-1),¹¹ which is involved in injury and repair responses such as those following renal ischemia.¹² Colony-stimulating factor (CSF-1) stimulates the proliferation and differentiation of mononuclear phagocytes and recruits macrophages to the site of an injury.¹³ In addition other factors such as tumor necrosis factor-alpha (TNF- α) and transforming growth factor-beta (TGF- β) are involved in intercellular communication, connective tissue remodelling and responses following injury. For example, both TNF- α and TGF- β stimulate angiogenesis,^{14,15} a process associated with cardiac hypertrophy, and both factors stimulate hypertrophy of cardiomyocytes *in vitro*. The cDNA probes for CSF-1,¹⁰ TNF- α ,¹⁰ TGF- β_1 ,¹⁶ and JE/MCP-1¹¹ were described previously.

The results of the cytokine Northern blot analysis are shown in FIGURE 5. There appears to be expression of JE/MCP-1 and CSF-1 only in the macrophage control. In the case of TNF- α and TGF- β_1 there is similar expression of these mRNAs in control and experimental right and left ventricles. In addition, in the case of TGF- β_1 there is expression of a second transcript in the macrophage control which does not appear to be present in the ventricles. This 1.9-kb transcript was previously identified in inflammatory responses including repair associated with myocardial infarction.¹⁷ It is not present in normal heart or right or left ventricles from the hearts of rats exposed to hypobaric hypoxia.

DISCUSSION

In the rat model of right ventricular hypertrophy, we were able to identify a specific spatial and temporal pattern of ANP-ir. The earliest ANP expression occurs in the areas of greatest wall tension following increased workload, indicating that ANP is a sensitive cardiomyocyte marker of ventricular hypertrophy. These data corroborate previous findings that stretch regulates release of ANP from the atria as well as hypertrophied ventricles.¹⁸

We developed a mouse model of hypobaric hypoxia, because the cDNA probes for the cytokines of interest are murine in origin. However, the response of the mouse right ventricular wall indicates a slower response to the hypoxic stimulus than observed in rats, particularly at the early time points. Interestingly, the mouse ventricle also differs in the pattern of ANP expression compared to rats.⁴ ANP expression in the mouse continues into adulthood compared to the rapid postnatal decline in rats.^{3,4} It appears that the chronically hypoxic rat may be a better model than the mouse because of the more rapid response of the ventricular wall, which shows some similarity to inflammatory responses at least in terms of the increase in the number of mast cells.²⁰

On the basis of the sensitivity of Northern blot analysis, it appears that there is no expression of JE/MCP-1 and CSF-1, and no differential expression of TGF- β_1 and TNF- α in the hypertrophied ventricles. The absence of differential expression of TGF- β_1 may be due to the inclusion of the right part of the septum in the left ventricular samples (LV + S). Further analysis of cytokine message expres-

sion during cardiac hypertrophy will require more sensitive methods such as reverse transcriptase-polymerase chain reaction.

Connective tissue remodelling⁷ and increased numbers of bone marrow-derived mast cells²⁰ occur during cardiac hypertrophy. Connective tissue remodelling during heart development has been correlated with expression of the cytokine, IL-1 α , which is localized with collagenase in areas of maximal remodelling.²¹ These may be the same regions in which ANP expression is initially expressed in the hypertrophied ventricle. Factors such as ANP secreted by cardiomyocytes may in turn influence local tissue remodelling events and cytokine expression. Interaction and coordination between the cardiomyocyte and noncardiomyocyte populations are essential for the maintenance of ventricular function, and many candidate molecules are currently being studied.^{22,23}

ACKNOWLEDGMENTS

The authors thank Dr. Tadashi Inagami (Vanderbilt University) and Dr. Gaetan Thibault (Clinical Research Institute of Montreal) for their generous gifts of anti-ANP-IV and anti-proANP, respectively. The authors also thank Dr. C. D. Stiles (Dana-Farber Cancer Institute) for his gift of the cDNA for JE/MCP-1; Dr. Leslie Gold (New York University) for the TGF- β_1 cDNA; Dr. D. Metcalf (Walter and Eliza Hall Institute, Melbourne, Australia) for the gift of the CSF-1 cDNA; and Genentech for the gift of TNF- α probe.

REFERENCES

1. SCHNEIDER, M. D., R. ROBERTS & T. G. PARKER. 1991. Modulation of cardiac genes by mechanical stress. The oncogene signalling hypothesis. *Mol. Biol. Med.* **8**: 167-183.
2. CHIEN, K. R., K. U. KNOWLTON, H. ZHU & S. CHIEN. 1991. Regulation of cardiac gene expression during myocardial growth and hypertrophy: molecular studies of an adaptive physiologic response. *FASEB J.* **5**: 3037-3046.
3. SCOTT, J. N. & L. H. JENNES. 1987. Distribution of atrial natriuretic factor in fetal rat atria and ventricles. *Cell Tissue Res.* **238**: 479-481.
4. SEIDMAN, C. E., E. V. SCHMIDT & J. G. SEIDMAN. 1991. cis-Dominance of rat atrial natriuretic factor gene regulatory sequences in transgenic mice. *Can. J. Physiol. Pharmacol.* **69**: 1486-1492.
5. THIBAUT, G., M. NEMER, J. DROUIN, J. P. LAVIGNE, J. DING, C. CHARBONNEAU, R. GARCIA, J. GENEST & M. CANTIN. 1989. Ventricles as a major site of atrial natriuretic factor synthesis and release in cardiomyopathic hamsters with heart failure. *Circ. Res.* **65**: 71-82.
6. MCKENZIE, J. C., K. B. KELLEY, E. M. MERISKO-LIVERSIDGE, J. KENNEDY & R. M. KLEIN. 1994. Developmental pattern of ventricular atrial natriuretic peptide (ANP) expression in chronically hypoxic rats as an indicator of the hypertrophic process. *J. Mol. Cell. Cardiol.* **26**: 753-767.
7. WEBER, K. T., C. G. BRILLA & J. S. JANICKI. 1993. Myocardial fibrosis: functional significance and regulatory factors. *Cardiovasc. Res.* **27**: 341-348.
8. MCKENZIE, J. C. & R. M. KLEIN. 1983. Protein synthesis in the rat pulmonary trunk during the early development of hypoxia-induced pulmonary hypertension. *Blood Vessels* **20**: 283-294.
9. FULTON, R. M., H. ACHINSON & A. M. JONES. 1952. Ventricular weight in cardiac hypertrophy. *Br. Heart J.* **14**: 413-420.

10. BURNS, T. M., J. A. CLOUGH, R. M. KLEIN, G. W. WOOD & N. E. J. BERMAN. 1993. Developmental regulation of cytokine expression in the mouse brain. *Growth Fact.* **9**: 253–258.
11. ROLLINS, B. J., E. D. MORRISON & C. D. STILES. 1988. Cloning and expression of JE, a gene inducible by platelet-derived growth factor and whose product has cytokine-like properties. *Proc. Natl. Acad. Sci. USA* **85**: 3738–3742.
12. SAFIRSTEIN, R., J. MEGYESI, S. SAGGI, P. PRICE, M. POON, B. ROLLINS & M. TAUBMAN. 1991. Expression of cytokine-like genes JE and KC is increased in renal ischemia. *Am. J. Physiol.* **261**: F1095–F1101.
13. RUEF, C. & D. L. COLEMAN. 1990. Granulocyte-macrophage colony-stimulating factor: pleiotropic cytokine with potential clinical usefulness. *Rev. Infect. Dis.* **12**: 41–62.
14. OLIVO, M., R. BHARDWAJ, K. SCHULZE-OSTHOFF, C. SORG, H. J. JACOB & I. FLAMME. 1992. A comparative study on the effects of tumor necrosis factor-alpha (TNF-alpha), human angiogenic factor (h-AF) and basic fibroblast growth factor (bFGF) on the chorioallantoic membrane of the chick embryo. *Anat. Rec.* **234**: 105–115.
15. YANG, E. Y. & H. L. MOSES. 1990. Transforming growth factor beta 1-induced changes in cell migration, proliferation, and angiogenesis in the chicken chorioallantoic membrane. *J. Cell Biol.* **111**: 731–741.
16. PELTON, R. W., M. D. JOHNSON, E. A. PERKETT, L. I. GOLD & H. L. MOSES. 1991. Expression of transforming growth factor (TGF)- β 1, TGF β 2 and TGF β 3 mRNA and protein in the murine lung. *Am. J. Respir. Cell Mol. Biol.* **5**: 522–530.
17. QIAN, S. W., P. KONDAIAH, W. CASSCELLS, A. B. ROBERTS & M. B. SPORN. 1991. A second messenger RNA species of transforming growth factor β 1 in infarcted rat heart. *Cell Regul.* **2**: 241–249.
18. MCKENZIE, J. C., I. TANAKA, T. INAGAMI, K. S. MISONO & R. M. KLEIN. 1986. Alterations in atrial and plasma atrial natriuretic factor (ANF) content during development of hypoxia-induced pulmonary hypertension in the rat. *Proc. Soc. Exp. Biol. Med.* **181**: 459–463.
19. KINNUNEN, P., O. VUOLTEENAHO & H. RUSKOAHO. 1993. Mechanisms of atrial and brain natriuretic peptide release from rat ventricular myocardium: effect of stretching. *Endocrinology* **132**: 1961–1970.
20. RAKUSAN, K., K. SARKAR, Z. TUREK & P. WICKER. 1990. Mast cells in the rat heart during normal growth and in cardiac hypertrophy. *Circ. Res.* **66**: 511–516.
21. Nakagawa, M., L. Terracio, W. Carver, H. Birkedal-Hansen & T.K. Borg. 1992. Expression of collagenase and IL-1 α in developing rat hearts. *Dev. Dyn.* **195**: 87–99.
22. LONG, C. S., C. J. HEINRICH & P. C. SIMPSON. 1991. A growth factor for cardiac myocytes is produced by cardiac nonmyocytes. *Cell Regul.* **2**: 1081–1095.
23. ENGELMANN, G. L. 1993. Coordinate gene expression during neonatal rat heart development. A possible role for the myocyte in extracellular matrix biogenesis and capillary angiogenesis. *Cardiovasc. Res.* **27**: 1598–1605.
24. KLEIN, R. M., K. B. KELLEY & E. M. MERISKO. 1993. A clathrin-coated vesicle-mediated pathway in atrial natriuretic peptide (ANP) secretion. *J. Mol. Cell. Cardiol.* **25**: 437–452.

Evidence of a Correlation between Pulmonary Hypertension and Collagen Content in Chronically Overloaded Human Right Atria

F. L. DINI, V. NARDINI,^a S. GALLINA, A. M. CALAFIORE,
AND A. BARSOTTI^b

*Institute of Clinical Cardiovascular Research
University of Chieti
S. Camillo De Lellis Hospital
Via C. Forlanini, 50
66100 Chieti, Italy*

*and
^aInstitute of Pathological Anatomy
University of Pisa
Pisa, Italy*

INTRODUCTION

Inadequate hypertrophy seems to be a fundamental factor capable of affecting hemodynamic evolution toward heart failure.^{1,2} Changes within cardiac interstitium are likely to be important ingredients implicated in the transition from the long-term compensatory phase of hyperfunction to the final stage of progressive exhaustion and fibrosis in cardiac response to a hemodynamic overload.³ Myocardial fibrosis develops as soon as pump function deteriorates as a result of myocyte inability to maintain the balance between the forces which tend to strain the chamber and their capacity to generate pressure inside the heart.⁴ Whether progressive fibrosis observed during the evolution from cardiac hypertrophy to cardiac failure simply follows the deterioration of the myocytic component or may otherwise directly contribute to the pathogenesis of chronic heart dysfunction is still an open question.

In order to investigate morphometric changes of myocardial tissue in the presence of inadequate myocyte growth unable to counterbalance elevated cardiac wall stress, we evaluated whether right atrial (RA) myocardial morphometric data relate to hemodynamic overload in patients with mitral valve disease (MVD) and pulmonary hypertension.

PATIENTS AND METHODS

We examined 26 patients (pts) with or without pulmonary artery hypertension (PAH) submitted to cardiac surgery. The selected pts were divided into two groups

^b Corresponding author.

as follows: group I (GI): 10 pts (2M, 8F) aged 59.3 ± 7.4 years with PAH secondary to MVD; group II (GII): 16 pts (12M, 4F) (7 aortic stenosis, 9 coronary artery disease) aged 62.1 ± 11.3 years without PAH. In GI echo-doppler evaluation of peak pulmonary artery pressure (PAP) showed a mean value of 51.5 ± 15.3 mm Hg. Histology was evaluated by light microscope in the Masson's trichrome stained sections from intraoperative RA samples. The collagen volume fraction (CVF, %), interstitial volume fraction (IVF, %) and the percent content of myocytes (MVF, %) were quantified morphometrically. Endocardial fibrosis was assessed by measuring the thickness of connective tissue from the endocardial surface to the myocardium.

RESULTS

Morphometric mean values showed a 68.6% MVF, a 9.5% IVF and a 21.9% CVF in GI, while in GII, MVF, IVF and CVF were 73.1%, 10.1% and 16.8%, respectively. Compared to normal autopsy hearts from pts of the same age, severe

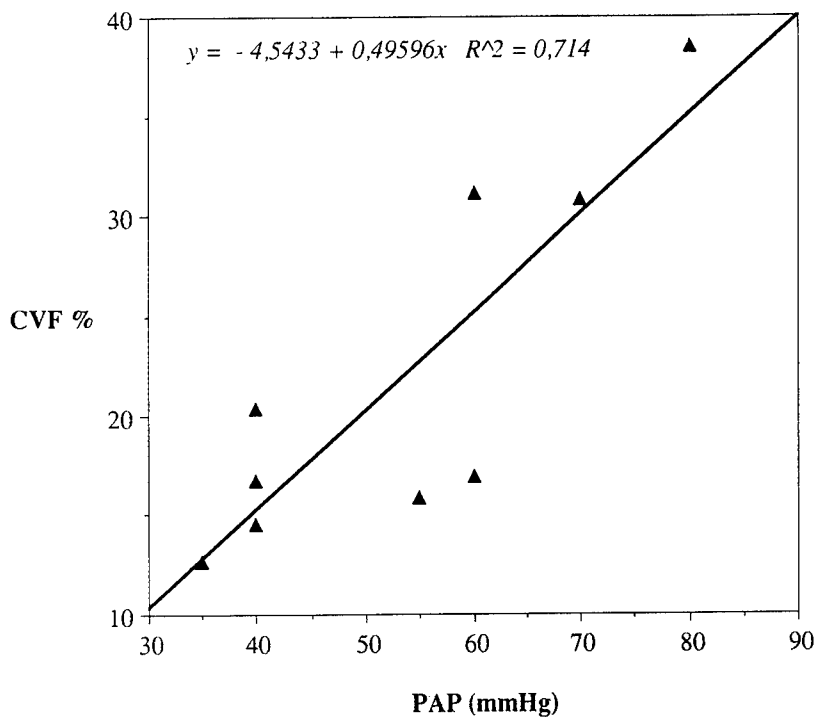

FIGURE 1. Correlation between CVF (%) and peak pulmonary artery pressure (PAP) derived from transtricuspidal gradient added to the clinically assessed right atrial pressure in mitral valve disease patients.

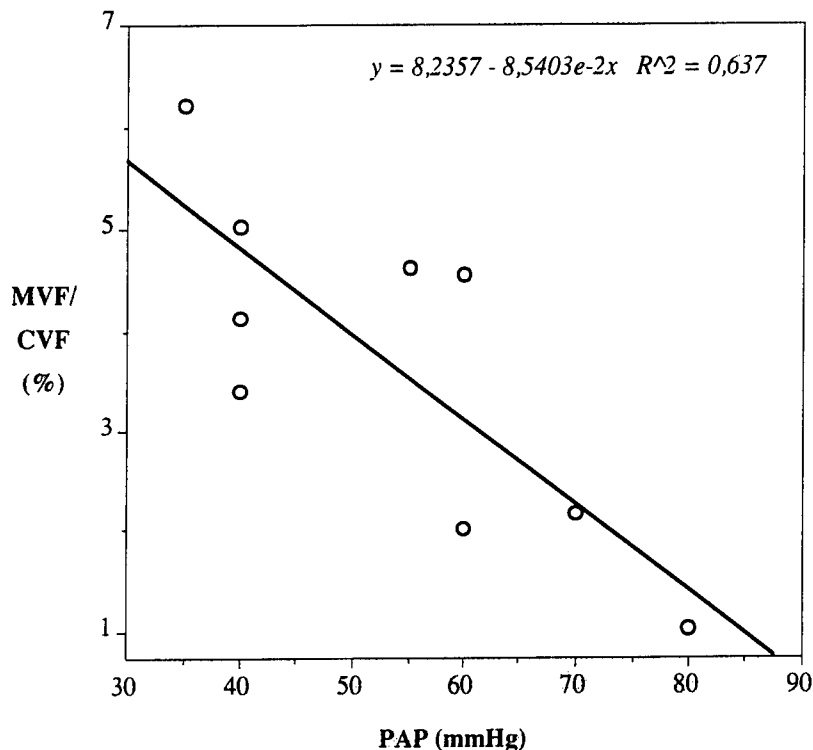

FIGURE 2. Correlation between MVF/CVF (%) and PAP in right atrial specimens in patients with pulmonary hypertension secondary to mitral valve disease.

interstitial fibrosis (CVF >25%) was reported in 30% of GI and in 6.2% of GII, moderate fibrosis (CVF between 15–25%) in 50% of GI and in 56.2% of GII, mild fibrosis (CVF between 5–15%) in 20% of GI and 37.5% of GII. In GI, a significant correlation was found between PAP and CVF ($r: 0.84; p = 0.004$) (FIG. 1) and MVF/CVF ($r: -0.79; p = 0.01$) (FIG. 2). In the same group, PAP significantly correlated also with endocardial thickness ($r: 0.66; p = 0.01$).

CONCLUSIONS

In conclusion, the evidence of diffuse interstitial fibrosis of varying severity in RA tissue from different cardiovascular diseases seems to account for its possible multifactorial origin. In MVD pts, the presence of a highly significant correlation between PAP and morphometric data appears to indicate that, as inadequate myocyte growth develops as in pressure/volume overloaded RA myocardium, the degree of RA myocardial fibrosis is consistent with the degree of PAH.

REFERENCES

1. STRAUER, B. E. 1993. Left ventricular dynamics, energetics and coronary hemodynamics in hypertrophic heart disease. *Eur. Heart J.* **4**(Suppl. A): 137-142.
2. STRAUER, B. E. 1980. *Hypertensive Heart Disease*. Springer-Verlag. Heidelberg.
3. WEBER, K. T. 1992. Cardiac interstitium: extracellular space of the myocardium. *In The Heart and Cardiovascular System*. H. A. Fozzard, E. Haber, R B. Jennings, A. M. Katz & H. E. Morgan, Eds. 1465-1480. Raven Press. New York.
4. BARSOTTI, A. & F. L. DINI. 1993. Ipertrofia miocardica e scompenso cardiaco: una relazione complessa. *Cardiologia* **38**(No. 3): 191-205.

Acute Heart Failure Secondary to Myocardial Tissue Water Changes in Isolated Working Rat Hearts

A. BARSOTTI, P. DI NAPOLI, F. L. DINI, E. DI GIROLAMO,
S. GALLINA, AND M. DI MUZIO^a

*Institute of Clinical Cardiovascular Research
and*

^a *Institute of Human Pathology and Social Medicine
University of Chieti
S. Camillo De Lellis Hospital
Via C. Forlanini, 50
66100 Chieti, Italy*

INTRODUCTION

Alterations in capillary interstitial liquid exchange may lead to fluid accumulation within myocardial interstitium.¹ An increased water content can influence tissue perfusion and myocyte vitality and probably, under certain circumstances, can contribute to myocardial dysfunction and to the onset of acute heart failure.² The aim of this study was to investigate whether myocardial tissue water changes may affect ventricular mechanical properties and myocardial structure in experimental preparations.

MATERIALS AND METHODS

We used isolated working rat hearts ($n = 50$) allocated into 5 groups and perfused with no recirculating hyposmotic buffer (Krebs-Henseleit diluted at 75%, group B), highly hyposmotic buffer (Krebs-Henseleit diluted at 60%, group C) and hyperosmotic buffers (Krebs-Henseleit plus sucrose 80 or 160 mM/l) (groups E and F). Control groups were perfused with normal Krebs-Henseleit buffer: A and D (the latter submitted to an afterload increase). Myocardial fluid volume changes were evaluated by comparing the differences in the wet weight to dry weight ratio (ww/dw). Left ventricular (LV) function was estimated by measuring every 10 min: heart rate (HR), aortic systolic pressure (SAP), cardiac output (CO), pressure rate product (PRP), coronary blood flow (CBF) and minute work (MW). The observation period lasted 100 min. Myocardial enzyme releases (CK and LDH) were detected in the eluate samples at the same intervals. Finally, electron microscopy was performed on rat heart specimens.

RESULTS

At the end of the experiment, an increased ww/dw provided evidence of enhanced myocardial tissue water content in group C ($p < 0.01$ vs group A), while

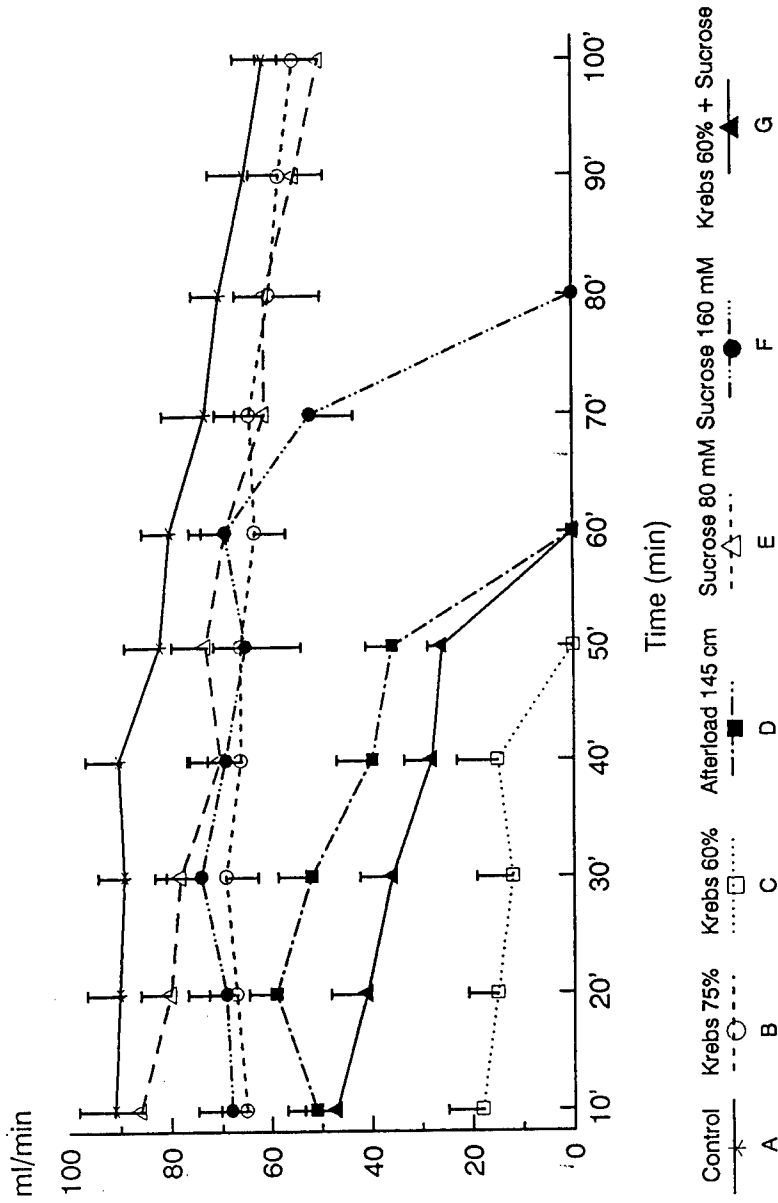

FIGURE 1. Cardiac output (CO) in the treated groups (B, C, E and F) and controls (A and D) during the experiments.

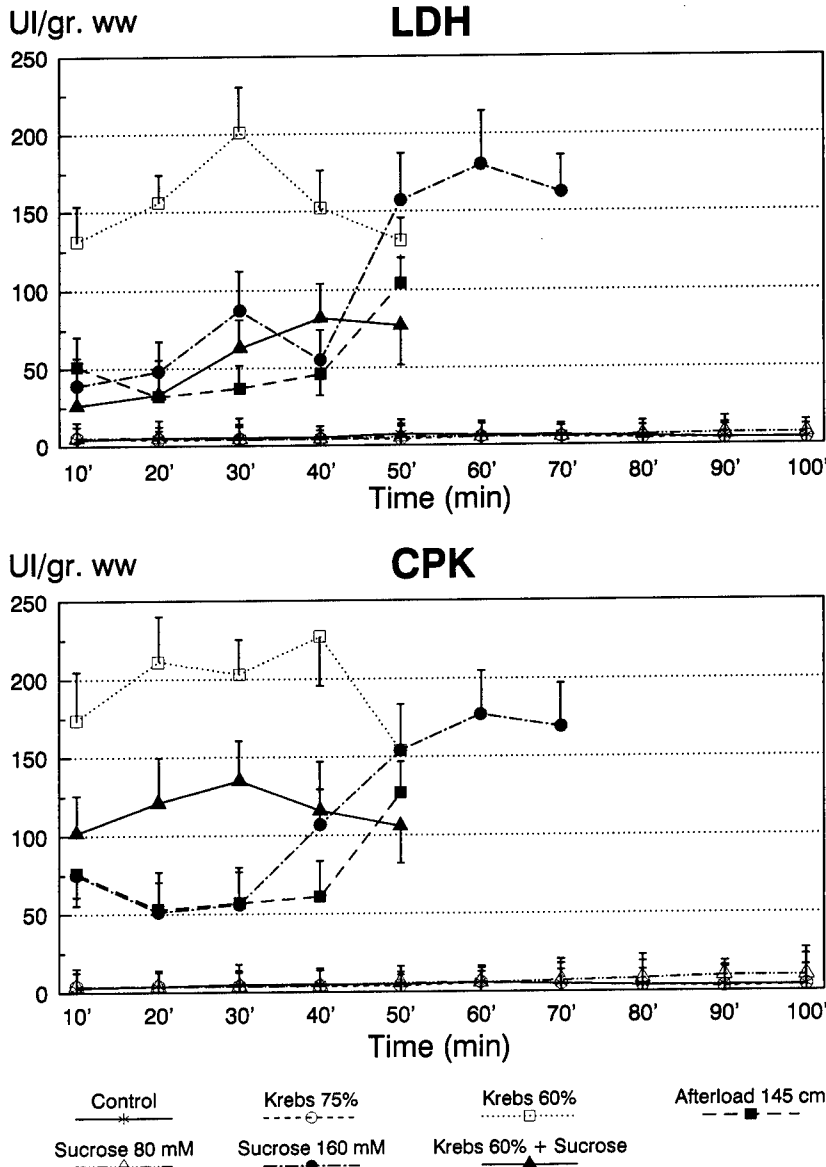

FIGURE 2. Myocardial necrosis enzyme release in the treated groups (B, C, E and F) and controls (A and D).

a significantly lower ww/dw in group E accounted for myocardial dehydration ($p < 0.01$ vs group A). With respect to the controls, group C exhibited significantly lower SBP, CO (FIG. 1), PRP and MW starting from the 10th min ($p < 0.01$) followed by a rapid decline and cardiac arrests arising between the 40th and 50th min. An impairment of the same LV indexes was observed also in group F ($p < 0.01$ vs group A; $p < 0.05$ vs group C at the 10th min) with cardiac arrests ranging between the 50th and 80th min. CK and LDH increased significantly in group C and E ($p < 0.01$ vs group A, B and E) (FIG. 2). Ultrastructural findings demonstrated widespread signs of interstitial and intramyocyte oedema in group B and C and aberrant myofilament organization and swollen mitochondria associated with interstitial space changes in groups C, E and F (FIG. 3).

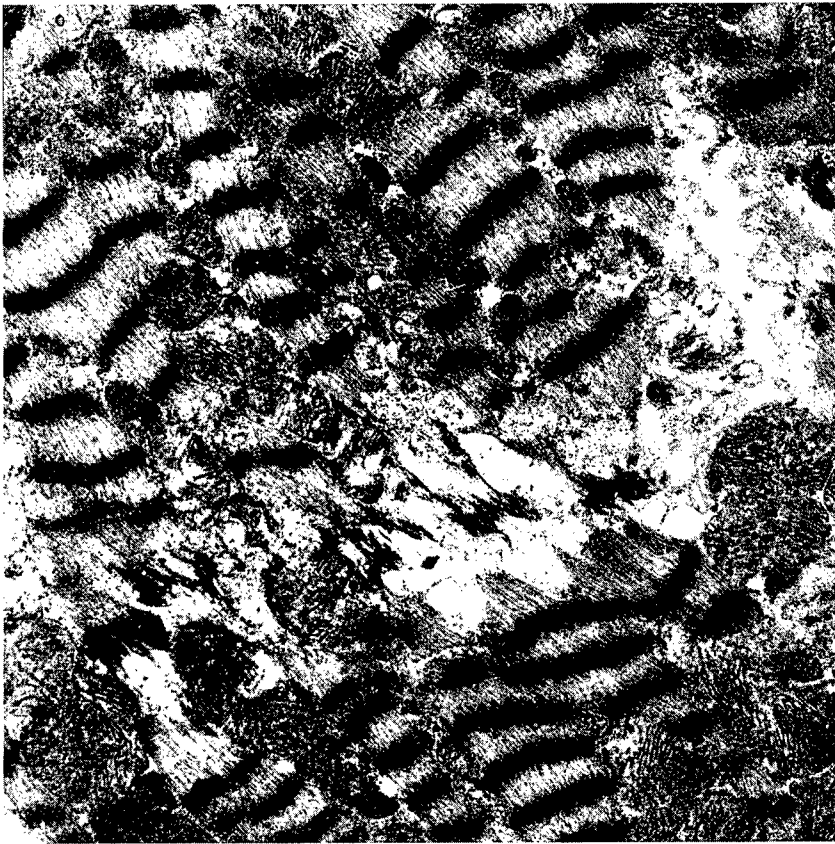

FIGURE 3. Electron micrograph of a longitudinal section of cardiac muscle treated with hyposmotic buffer (Krebs-Henseleit diluted at 75%; group B) (*above*). Mitochondrial disarrangements observed in samples treated with Krebs-Henseleit solution diluted at 60% (group C) (*below*).

CONCLUSIONS

In conclusion, myocardial interstitial fluid volume changes following alterations in Starling's force balance appears to directly contribute to the onset of acute myocardial failure through different mechanisms which are likely to involve myocyte injury, interstitial network disarrangements and microvascular resistance increase. Changes in interstitial tissue water content seem to affect the myocyte supply-demand ratio and myocardial function either because of alterations of transcapillary hydrostatic and oncotic pressure gradients or because of an increased endothelial permeability or as a consequence of an impaired cardiac lymphatic flow;³ however, by focusing our attention on myocardial interstitial space, a much better comprehension of certain clinical-hemodynamic situations should be obtained.

REFERENCES

1. GUYTON, A. C., A. E. TAYLOR & R. E. BRACE. 1976. A synthesis of interstitial fluid regulation and lymph formation. *Fed. Proc.* **35**: 1881.
2. BARSOTTI, A., G. DI GREGORIO, P. DI NAPOLI, E. DI GIROLAMO, P. VITULLO, M. DI MUZIO & G. P. TREVI. 1992. Modificazioni acute dell'acqua interstiziale miocardica e meccanica cardiaca: basi teoriche e dati sperimentali. *Cardiologia* **37**(No. 12, Suppl. 1): 207-220.
3. DHALLA, N. S., P. K. DAS & G. P. SHARMA. 1989. Subcellular basis of cardiac contractile failure. *J. Mol. Cell. Cardiol.* **21**: 1063.

β -Myosin Mutations in Hypertrophic Cardiomyopathies^a

ALDA ALFARANO,^b LUCIA GASTALDI,^b
GIOVANNA GIGLIO TOS,^b ANTONELLA ROETTO,^b
AND CLARA CAMASCHELLA^{b,c,d}

^b *Department of Biomedical Sciences and Human Oncology
Clinical Section
University of Turin
and
^c CNR CII-CIOS
Turin, Italy*

INTRODUCTION

Familial hypertrophic cardiomyopathy (HCM) is an inherited autosomal dominant disorder characterized by unexplained myocardial hypertrophy in the absence of recognizable causative factors.¹ The extent and the degree of the hypertrophy are variable. Clinical manifestations are heterogeneous, the most important being sudden death. A striking genetic heterogeneity characterizes this syndrome. In some families the defective gene is the β -myosin heavy chain (β -MHC) mapping to 14q1.² Missense mutations have been demonstrated in highly conserved sequences of the β -MHC in a subset of HCM families.³⁻⁵ De novo germline mutations in the same gene are present in sporadic forms of HCM.⁶ However, other genes involved in HCM have been mapped on chromosome 1q3,⁷ 15q2⁸ and 11.⁹

We have preliminarily investigated the role of mutations in specific areas of the β -MHC gene in 8 Italian patients affected by HCM.

PATIENTS AND METHODS

Full cardiac evaluation of HCM patients included history and clinical, electrocardiographic and echocardiographic records. DNA was prepared from peripheral blood according to standard methods. Exons 9, 13, 16-17, 19-20 and 23 of the β -MHC gene amplified by PCR¹⁰ were digested with endonuclease (to analyze for known mutations)⁴ and screened for unknown mutations by using single strand conformation polymorphism (SSCP).¹¹ PCR was performed in an automated thermal cycler according to standard protocols for 40 cycles. For SSCP a dATP la-

^a Supported by Telethon Rome Grant 429.

^d Address for correspondence: Clara Camaschella, M.D., Dipartimento di Scienze Biomediche e Oncologia Umana, Sezione Clinica—Università di Torino, Ospedale S. Luigi Gonzaga, 10043 Orbassano-Torino, Italy.

TABLE 1. Clinical and Echocardiographic Features of the Patients under Study^a

Age/S	Clinical Symptoms		Electro-cardiogram		2-D Echocardiogram			
	Chest Pain	Dyspnea	BBB	LVH/ST	MaxLVPWT mm	Max-IVST mm	SAM	LA Size mm
1. 36/M	-	-	-	+	20	30	+	56
2. 42/F	+	+	-	+	16	20	+	56
3. 54/M	+	-	-	+	14	15	+	44
4. 54/M	+	+	-	+	13	20	+	55
5. 64/M	+	+	-	+	13	20	+	50
6. 34/M	+	+	L	+	14	9	+	40
7. 68/M	+	-	-	+	13	25	-	60
8. 37/M	+	+	L	+	10	23	+	50

^a BBB = bundle branch block, L = left; LVH/ST = left ventricular hypertrophy with ST changes; MaxLVPWT = maximum left ventricular posterior wall thickness; MaxIVST = maximum interventricular septal thickness; SAM = systolic anterior motion of the mitral valve; LA Size = left atrial size.

belled with ³⁵S was incorporated in the last PCR cycles. Samples with abnormal SSCP patterns were sequenced directly.

RESULTS AND CONCLUSIONS

3 patients with familial and 5 with sporadic forms were studied. Clinical and echocardiographic data are summarized in TABLE 1.

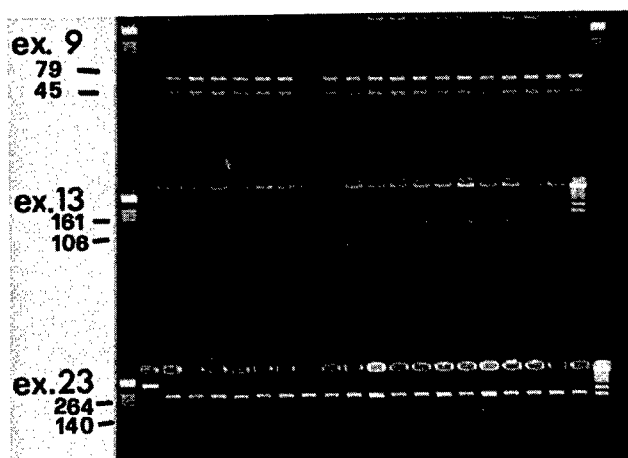

FIGURE 1. Restriction enzyme digestion with Eco RI (exon 9), Dde I (exon 13) and Pvu II (exon 23) to screen specific mutations (see text for details) in the 8 patients and several normal controls. *First and last lanes*: molecular weight markers. *Second lane*: undigest PCR products. All the expected fragments are present after digestion in both patients (*lanes 3-10*) and normal controls.

The mutations at 249 Glu->Arg (exon 9), 408 Arg->Gly (exon 13) and 908 Leu->Val (exon 23) were excluded in all the cases, using direct detection of the nucleotide changes by appropriate endonucleases (FIG. 1). Since the majority of the mutations so far described are clustered in 8 exons, we first studied these DNA areas following the hypothesis that they codify for the main functional areas of the protein and thus might be hot spots for mutations. SSCP changes were observed in only two patients, one with familial and the other with sporadic HCM in exon 13 and 23, respectively (not shown). Sequencing is in progress to ascertain the type of nucleotide changes which originate the abnormal conformation.

The remaining patients likely have mutations in other areas of the β -MHC or in genes other than β -MHC. Linkage analysis in families remains an important step in searching for mutation in HCM.

REFERENCES

1. LOUIE, E. K. & L. C. EDWARDS III. 1994. Hypertrophic cardiomyopathy. *Prog. Cardiovasc. Dis.* **36**: 275-308.
2. JARCHO, J. A., W. MCKENNA, J. A. P. PARE, S. D. SOLOMON, T. LEVI, K. DONIS-KELLER, J. G. SEIDMAN & C. SEIDMAN. 1990. Mapping gene for familial hypertrophic cardiomyopathy to chromosome 14q1. *N. Engl. J. Med.* **321**: 1372-1378.
3. GEISTERFER-LowRANCE, A.A., S. KASS, G. TANIGAWA, H.P. VOSBERG, W. MCKENNA, C.E. SEIDMAN & J.G. SEIDMAN. 1990. A molecular basis for familial hypertrophic cardiomyopathy: a beta cardiac myosin heavy chain gene missense mutation. *Cell* **62**: 999-1006.
4. ROSENZWEIG, A., H. WATKINS, D. S. HWANG, M. MIRI, W. MCKENNA, T. A. TRAILI, J. G. SEIDMAN & C. WEIDMAN. 1991. Preclinical diagnosis of familial hypertrophic cardiomyopathy by genetic analysis of blood lymphocytes. *N. Engl. J. Med.* **325**: 1753-1760.
5. WATKINS, H., A. ROSENZWEIG, D. S. HWANG, T. LEVI, W. MCKENNA, C. E. SEIDMAN & J. G. SEIDMAN. 1992. Characteristics and prognostic implications of myosin missense mutations in familial hypertrophic cardiomyopathy. *N. Engl. J. Med.* **326**: 1108-1114.
6. WATKINS, H., L. THIERFELDER, D. S. HWANG, W. MCKENNA, J. G. SEIDMAN & C. E. SEIDMAN. 1992. Sporadic hypertrophic cardiomyopathy due to de novo myosin mutations. *J. Clin. Invest.* **90**: 1666-1671.
7. WATKINS, H., C. MACRAE, L. THIERFELDER, Y. H. CHOU, M. FRENNEAUX, W. MCKENNA, J. C. SEIDMAN & E. SEIDMAN. 1993. A disease locus for for familial hypertrophic cardiomyopathy maps to chromosome 1q3. *Nature Genet.* **3**: 333-336.
8. THIERFELDER, L., C. MACRAE, H. WATKINS, J. TOMFOHRDE, M. WILLIAMS, W. MCKENNA, K. BOHM, G. NOESKE, M. SCHLEPPER, A. BOWCOCK, H. P. VOSBERG, J. G. SEIDMAN & C. SEIDMAN. 1993. A familial hypertrophic cardiomyopathy locus maps to chromosome 15q2. *Proc. Natl. Acad. Sci. USA* **90**: 6270-6274.
9. CARRIER, L., C. HENGSTENBERG, J. S. BECKMANN, P. GUICHENEY, C. DUFOUR, J. BERCOVICI, E. DAUSSE, I. BEREBBI-BERTRAND, C. WISNEWSKY, D. PULVENIS, L. FETLER, A. VIGNAL, J. WEISSENBACH, D. HILLARIE, J. FEINGLOD, B. BOUHOOR, A. HAGEGE, M. DESNOS, R. ISNARD, O. DUBOURG, M. KOMAJDA & K. SCHWARTZ. 1993. Mapping of a novel gene for familial hypertrophic cardiomyopathy to chromosome 11. *Nature Genet.* **4**: 311-313.
10. LIEW, C. C., M. J. SOLE, K. YAMAMUCHI-TAKIHARA, B. KELLAM, D. H. ANDERSON & J. C. LIEW. 1990. Complete sequence and organization of the human cardiac β -myosin heavy chain gene. *Nucleic Acids Res.* **18**: 3647-3651.
11. ORITA, M., Y. SUZUKI, T. SEKIYA & K. HAYASHI. 1989. Rapid and sensitive detection of point mutations and DNA polymorphisms using the polymerase chain reaction. *Genomics* **5**: 874-879.

Effects of Isoprenaline on Force of Contraction, cAMP Content, and Phosphorylation of Regulatory Proteins in Hearts from Chronic β -Adrenergic-Stimulated Rats^a

BIRGITT STEIN,^d SABINE BARTEL,^b SABINE KOKOTT,
ERNST-GEORG KRAUSE,^b THORSTEN SCHLICHTMANN,
WILHELM SCHMITZ,^c AND HASSO SCHOLZ

*Department of General Pharmacology
Eppendorf University Hospital
D-20246 Hamburg, Germany*

^b *MDC for Molecular Medicine
Berlin, Germany*

^c *Institute for Pharmacology and Toxicology
Münster, Germany*

INTRODUCTION

Myocardial hypertrophy induced by chronic β -adrenoceptor stimulation leads to a desensitization of the myocardial adenylyl cyclase, characterized by a down-regulation of β -adrenoceptors and an upregulation of Gi-proteins, resulting in a reduction of the isoprenaline (Iso)-stimulated force of contraction.¹ It is not known whether the myocardial hypertrophy induced by chronic β -adrenoceptor stimulation leads also to changes in the post-adenylyl cyclase signal transducing pathways. Therefore, we studied the effects of isoprenaline (30 nM) on force of contraction, cAMP content and phosphorylation of the regulatory proteins phospholamban (PLB), troponin inhibitor (TNI) and C-protein in isolated papillary muscles from rats treated by a 4-day subcutaneous infusion with either isoprenaline (2.4 mg/kg d, Iso) or NaCl (0.9%) as control.

METHODS

Force of contraction and cAMP content were detected as described.² The phosphorylation of the regulatory proteins was determined by "back phosphorylation" as described by Karczewski *et al.*³ In brief, papillary muscles were homogenized

^a This study was supported by the DFG.

^d Address for correspondence: Birgitt Stein, Abteilung Allgemeine Pharmakologie, Universitäts-Krankenhaus Eppendorf, Martinistraße 52, D-20246 Hamburg, FRG.

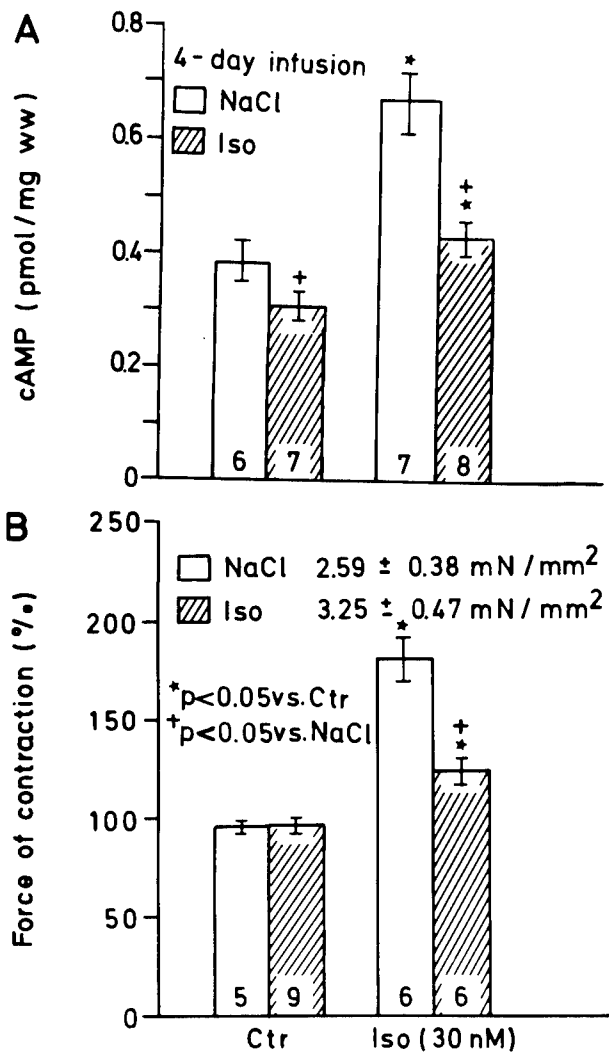

FIGURE 1. (A) cAMP content (pmol/mg ww) and (B) force of contraction (% predrug value) under control conditions (Ctr) and after addition of isoprenaline (Iso, 30 nM) in isolated electrically driven papillary muscles from rats after 4-day subcutaneous infusion of 0.9% NaCl (*open bars*) or isoprenaline (*hatched bars*, 2.4 mg/kg d). Nos. in bars indicate no. of papillary muscles. The isoprenaline-stimulated increase in cAMP content and force of contraction are diminished in papillary muscle from rats with myocardial hypertrophy compared to control rats.

and phosphorylated *in vitro* by adding the catalytic subunit of cAMP-dependent protein kinase and gamma-³²P-ATP until complete phosphate incorporation. Therefore, high *in vitro* P_i-incorporation demonstrated low *in vivo* phosphorylation and vice versa. Proteins were separated by gel electrophoresis (8–15% gradient gels) according to Laemmli.⁴ PLB, TNI and C-protein were identified immunologi-

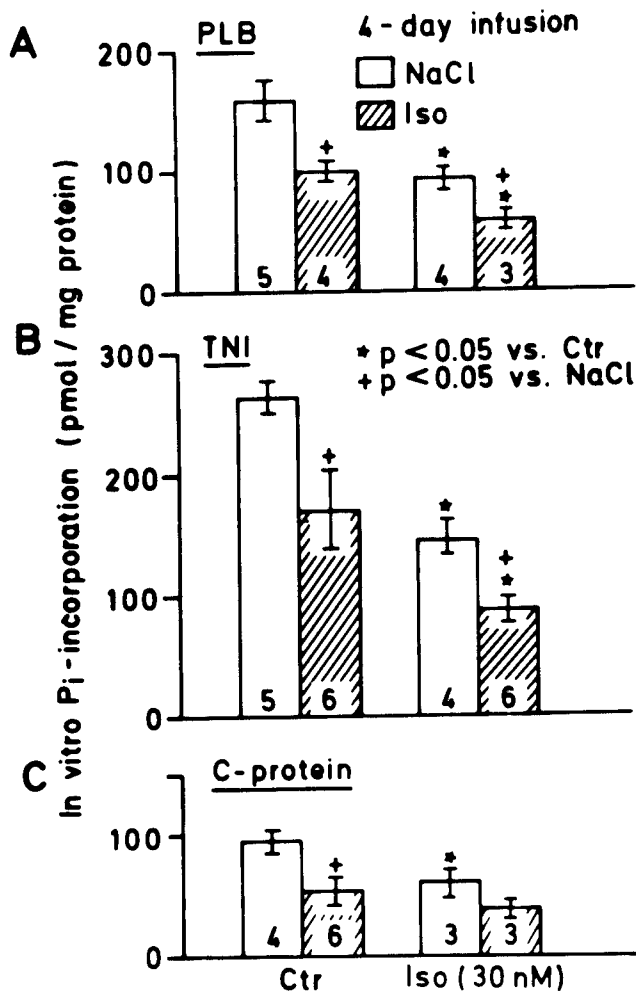

FIGURE 2. *In vitro* P_i-incorporation (pmol/mg protein) in (A) phospholamban (PLB), (B) troponin I (TNI), and (C) C-protein under control conditions (Ctr) and after addition of isoprenaline (Iso, 30 nM) in isolated electrically driven papillary muscles from rats after 4-day subcutaneous infusion of 9% NaCl (open bars) or isoprenaline (hatched bars, Iso, 2.4 mg/kg d). Nos. in bars indicate no. of papillary muscles. The isoprenaline-stimulated phosphorylation of PLB, TNI and C-protein is attenuated in papillary muscle from rats with myocardial hypertrophy compared to control rats.

cally using specific antibodies raised against PLB, TNI and C-protein, respectively. Radioactivity incorporated into PLB, TNI and C-protein was quantified with a phosphoimager.

RESULTS AND CONCLUSIONS

Rats treated by a 4-day subcutaneous infusion with isoprenaline developed ventricular hypertrophy with a heart/body weight ratio of 4.14 ± 0.02 ($n = 35$) compared with 3.12 ± 0.01 ($n = 42$) in NaCl-matched controls ($p < 0.05$). Basal force of contraction did not differ in both groups (FIG. 1B), whereas basal cAMP content was 0.26 ± 0.02 pmol/mg ww ($n = 7$) in isoprenaline-treated rats and 0.37 ± 0.03 pmol/mg ww ($n = 6$) in control rats (FIG. 1A). In contrast, basal phosphorylation of PLB, TNI and C-protein was higher in isoprenaline-treated rats by 38%, 34% and 45% compared to control rats (FIG. 2A–C). The isoprenaline-stimulated increase in force of contraction and cAMP content was diminished in isoprenaline-treated rats compared to control rats by 57% and 41% (FIG. 1B and A). Furthermore, the isoprenaline-stimulated phosphorylation of PLB, TNI and C-protein was reduced by 29%, 28% and 11% (FIG. 2A–C).

In conclusion, in hypertrophied myocardium from chronic β -adrenoceptor-stimulated rats the reduced isoprenaline-stimulated force of contraction is accompanied by a diminution in cAMP content and phosphorylation of PLB, TNI and C-protein. It is conceivable that chronic β -adrenoceptor stimulation attenuates the phosphorylation capacity.

REFERENCES

1. HAUSDORFF, W. P., M. G. CARON & R. J. LEFKOWITZ. 1990. *J. Biol. Chem.* **265**: 14784–14790.
2. DANIELSEN, W., H. VAN DER LEYEN, W. MEYER, J. NEUMANN, W. SCHMITZ, H. SCHOLZ, J. STARBATTY, B. STEIN, V. DÖRING & P. KALMAR. 1989. *J. Cardiovasc. Pharmacol.* **14**: 171–173.
3. KARCZEWSKI, P., S. BARTEL & E. G. KRAUSE. 1990. *Biochem. J.* **266**: 115–122.
4. LAEMMLI, U. K. *Nature* 1970. **227**: 680–685.

Diagnosis of Myocardial Injury in Marathon Runners

ARNOLD KOLLER,^{a,d} JOHANNES MAIR,^b MARKUS MAYR,^b
CHARLES CALZOLARI,^c CATHERINE LARUE,^c AND
BERND PUSCHENDORF^b

^a Department of Sportsmedicine

^b Department of Medical Chemistry and Biochemistry
University of Innsbruck School of Medicine
Innsbruck, Austria

and
^c Sanofi Recherche
Montpellier, France

Adams *et al.*¹ report a higher specificity of cardiac troponin I compared with creatine kinase MB in the diagnosis of perioperative myocardial infarction. Problems also arise in distinguishing skeletal from cardiac muscle trauma on the basis of conventional serum enzyme tests following severe muscle exercise, *e.g.*, in marathon runners with obscure symptoms.² We determined creatine kinase and creatine kinase MB activity (Merck, Darmstadt, Germany), creatine kinase MB mass (enzyme-immunometric assay, Abbott, North Chicago, IL), cardiac troponin I (enzyme-immunometric assay, E.R.I.A. Diagnostics Pasteur, Marnes-la-Coquette, France),³ and cardiac troponin T (enzyme-immunometric assay, Boehringer Mannheim, Mannheim, Germany)⁴ plasma concentrations in 19 male amateur runners (aged 25–55, mean 42 years) who took part in the Berlin Marathon. All were able to finish their races in times equivalent to that standard without evidence of myocardial ischemia or extraordinary exhaustion during or after competition. In contrast to cardiac troponin I and T, creatine kinase, creatine kinase MB activities and mass concentrations increased significantly ($p \leq 0.022$, Wilcoxon signed-rank test) above baseline values after the competition (TABLE 1). After the race cardiac troponin I and T could not be detected or were within the reference interval in all but one runner. In this completely symptomless athlete both cardiac troponins showed mild increases (cardiac troponin T: 1.0 $\mu\text{g/L}$; cardiac troponin I: 0.7 $\mu\text{g/L}$) and creatine kinase MB/creatinine ratios were positive as well. Because cardiac troponins were measured several weeks after the competition, no additional cardiological examinations could be performed on this foreign runner after the race. False positive troponin results can be excluded, because the troponin I assay shows no cross-reactivity with skeletal muscle troponin I isoforms,³ and the troponin T assay that was used had no substantial cross-reactivity with skeletal muscle troponin T (<0.5%).⁴ The mechanism of myocardial injury in this athlete remains obscure. It has been suggested⁵ that during extraordi-

^d Corresponding author: Arnold Koller, Ph.D., Institut für Sport- und Kreislaufmedizin, Universitätsklinik Innsbruck, Anichstraße 35, A-6020 Innsbruck, Austria.

TABLE 1. Biochemical Markers of Myocardial Injury in Marathon Runners^a

	Discriminator Value	3 Days Pre-Race	Post-Race	2 Days Post-Race
CK (U/L) (37°C)	195	142 (97-187)	264 (212-345)	217 (168-300)
CKMB (U/L) (37°C)	25	10 (5-20)	42 (37-57)	37 (12-47)
CKMB mass (µg/L)	7	6.1 (5.3-8.0)	8.3 (6.5-10.0)	8.4 (7.0-10.5)
cTnI (µg/L)	0.1	0 (0-0)	0 (0-0.02)	0 (0-0)
cTnT (µg/L)	0.2	0 (0-0.02)	0.01 (0-0.04)	0 (0-0.02)
% MB activity (%)	6	>DV in no runner	>DV in 15 runners	>DV in 6 runners
% MB mass (%)	2.5	>DV in 2 runners	>DV in 9 runners	>DV in 7 runners

^a Data given as median and interquartile range (in parentheses). Creatine kinase MB/creatin kinase ratios (% MB) were only calculated when creatine kinase and creatine kinase MB exceeded their discriminator limits. Abbreviations: CK: creatine kinase, cTnI: cardiac troponin I, cTnT: cardiac troponin T, DV: discriminator value.

nary endurance exercise high catecholamines might cause focal myocardial necrosis even in the absence of coronary atherosclerosis and ventricular hypertrophy. However, in this 51-year old man we cannot exclude silent myocardial ischemia on the basis of coronary atherosclerosis. We would emphasize the diagnostic value of using sensitive and truly cardiac-specific markers to assess the potential cardiac risk in athletes and in comparable situations.

REFERENCES

- ADAMS, J. E., III, G. A. SICARD, B. T. ALLEN *et al.* 1994. Diagnosis of perioperative myocardial infarction with measurement of cardiac troponin I. *N. Engl. J. Med.* **330**: 670-674.
- SIEGEL, A. J., L. M. SILVERMAN & B. L. HOLMAN. 1981. Elevated creatine kinase MB isoenzyme levels in marathon runners: normal myocardial scintigrams suggest noncardiac source. *JAMA.* **246**: 2049-2051.
- LARUE, C., C. CALZOLARI, J. P. BERTINCHANT, F. LECLERCQ, R. GROLLEAU & B. PAU. 1993. Cardiac-specific immunoenzymometric assay of troponin I in the early phase of acute myocardial infarction. *Clin. Chem.* **39**: 972-979.
- KATUS, H. A., S. LOOSER, K. HALLERMAYER *et al.* 1992. Development and *in vitro* characterization of a new immunoassay of cardiac troponin T. *Clin. Chem.* **38**: 386-393.
- ROWE, W. J. 1992. Extraordinary unremitting endurance exercise and permanent injury to normal heart. *Lancet* **340**: 712-714.

The Regulation of Collagen Deposition in the Hypertrophying Heart

JILL E. BISHOP,^{a,b} SUZANNE RHODES,
GEOFFREY J. LAURENT,^a ROBERT B. LOW, AND
WILLIAM S. STIREWALT

^a *Division of Cardiopulmonary Biochemistry
University College London Medical School
The Rayne Institute
5, University Street
London WC1E 6JJ, United Kingdom*

*and
Department of Physiology and Biophysics
Department of Obstetrics and Gynecology
University of Vermont
Burlington, Vermont 05405*

Collagens are the major extracellular matrix proteins in the heart, contributing to diastolic stiffness, maintenance of functional capacity and determination of cell phenotype. They are continuously synthesized and degraded throughout life, a balance between these processes being critical for the continued normal function of the myocardium. The fibrillar collagens, types I and III are most abundant, forming the weaves and struts of the collagen network described by Borg & Caulfield.¹ During the development of cardiac hypertrophy collagen deposition occurs. This may result in no change in collagen concentration, reflecting a coordinate increase in the myocardial contractile component and extracellular matrix; or an increase in collagen concentration, seen in the later stages after pressure overload, leading to cardiac fibrosis. Although an increase in content in the compensatory stage of hypertrophy may be beneficial, as the matrix grows to accommodate the hypertrophied muscle, increased concentration increases diastolic stiffness, which may contribute to eventual heart failure. For this reason there is now great interest in the pathways that regulate collagen deposition.

Collagen Metabolism in the Heart

Collagen is synthesized as a precursor molecule, procollagen, following many posttranscriptional and posttranslational steps. Collagen mRNA can be measured by Northern analysis in normal heart tissue, suggesting continued synthesis of the proteins. Types I and III collagen mRNA are expressed by cardiac and vascular fibroblasts, with little expression by myocytes.² Using the flooding dose method to measure the collagen fractional synthesis rate³ we have demonstrated the dynamic

^b Corresponding author.

nature of heart collagen.^{4,5} By injecting a flooding dose of unlabelled amino acid with radio-labelled proline the specific activity of proline rises to a plateau value which is maintained for several hours.³ Rates of collagen and noncollagen protein synthesis in the heart were calculated from the specific activity of free and protein-bound proline and hydroxyproline 3 hours postinjection. We found collagen fractional synthesis rates of 3%/day and 6%/day in the right and left ventricle of 2-kg rabbits respectively.⁴ This may be compared with 18%/day for noncollagen protein synthesis rates.

Collagens are degraded extracellularly, by a family of metalloproteases that degrade mature cross-linked collagen fibers; and intracellularly, where newly synthesized collagen molecules are degraded rapidly—as early as 8 minutes—after synthesis.⁶ Only a small fraction of collagen is degraded extracellularly in the normal heart. *In vivo* the proportion of collagen degraded rapidly is quantitated from the free labelled hydroxyproline compared to total hydroxyproline radioactivity.⁷ 30–50% of collagen synthesized in the heart is degraded by this pathway.^{4,5,8} This data indicates that heart fibroblasts of adult animals are actively synthesizing and degrading collagens and that a large proportion of these collagens are degraded rapidly after synthesis.

Regulation of Collagen Deposition during the Development of Cardiac Hypertrophy

Increases in steady state procollagen mRNA levels occur within days of the onset of cardiac hypertrophy^{5,9,10} indicating regulation of collagen deposition, at least in part, at the transcriptional level. Increases in collagen fractional synthesis rates also occur after pressure overload, the timing of the increase depending on the model of pressure overload.^{4,5,8} Changes in collagen fractional synthesis rate follow a similar pattern to the mRNA levels, although this has only been measured simultaneously in a limited number of studies.^{5,8} Two days after pulmonary artery banding we have shown collagen fractional synthesis rate increasing eightfold in the right ventricle⁵ (FIG. 1) with a fourfold increase in procollagen $\alpha_1(I)$ mRNA.⁵ Eleftheriades *et al.*⁸ saw no increase in collagen fractional synthesis rate until 16 weeks after suprarenal aortic coarctation in the rat, although this was consistent with the timing of an increase in $\alpha_1(I)$ mRNA levels. Type III mRNA increased one week after aortic constriction suggesting a differential regulation of the two collagen genes. Pressure overload was also associated with a fall in the proportion of newly synthesized collagen degraded rapidly.^{5,8} We found a decrease from 50% to 30% in the proportion degraded after two days of banding (FIG. 1). Together these data suggest both transcriptional and posttranslational mechanisms regulate collagen output.

Regulation of Collagen Metabolism

Cardiac fibroblasts respond rapidly to mechanical stimuli with changes at many sites in the synthetic and degradative pathways. Little is known, however, of the mechanisms involved in regulating cardiac collagen deposition. We hypothesize

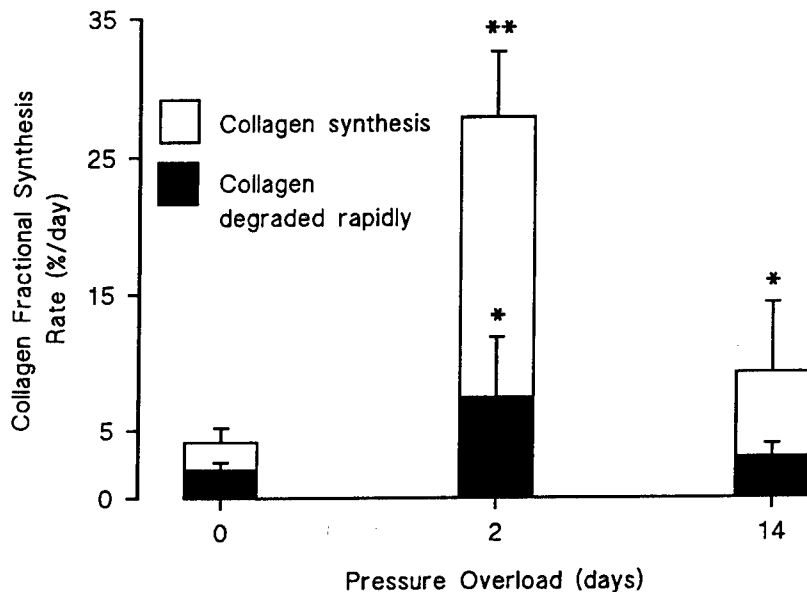

FIGURE 1. The effect of pulmonary artery banding on collagen metabolism in the right ventricle. Collagen synthesis and the proportion of collagen degraded rapidly were measured in 2-kg rabbits at two and 14 days after banding the pulmonary artery.⁵ Values (given as means \pm standard deviations) were compared with two-day sham-operated animals and the levels of significance from control are shown. ** = $p < 0.01$, * = $p < 0.05$.

that growth factors produced or localized in response to mechanical load interact synergistically with the direct effects of load on the cells. Such factors may include locally produced autocrine or paracrine agents, such as PDGF or TGF- β , or factors that originate from the circulation or the vascular wall, such as angiotensin or endothelin, which are then localized in the adventitia or interstitium due to increased permeability of the coronary vessels. These concepts are discussed in detail by Butt *et al.* in this volume.¹¹

REFERENCES

- BORG, T. K. & J. B. CAULFIELD. 1981. Fed. Proc. **40**: 2037-2041.
- EGHBALI, M., O. O. BLUMENFELD, S. SEIFTER *et al.* 1989. J. Mol. Cell. Cardiol. **21**: 103-113.
- LAURENT, G. J., P. COCKERILL, R. J. MCANULTY & J. R. B. HASTINGS. 1981. Ann. Biochem. **113**: 301-312.
- TURNER, J. E., M. H. OLIVER, D. GUERREIRO & G. J. LAURENT. 1986. Am. J. Physiol. **251**: H915-H919.
- BISHOP, J. E., S. RHODES, G. J. LAURENT, R. B. LOW & W. S. STIREWALT. 1994. Cardiovasc. Res. **28**: 1581-1585.
- BIENKOWSKI, R. S., M. J. COWAN, J. A. McDONALD & R. G. CRYSTAL. 1978. J. Biol. Chem. **253**: 4356-4363.

7. MCANULTY, R. J. & G. J. LAURENT. 1987. *Collagen Relat. Res.* **70**: 93-104.
8. ELEFThERIADES, E. G., J. DURAND, A. G. FERGUSON *et al.* 1992. *J. Clin. Invest.* **91**: 1113-1122.
9. CHAPMAN, D., K. T. WEBER & M. EGHBALI. 1990. *Circ. Res.* **67**: 787-794.
10. VILLARREAL, F. J. & W. H. DILLMANN. 1992. *Am. J. Physiol.* **262**: H1861-H1866.
11. BUTT, R. P., G. J. LAURENT & J. E. BISHOP. 1994. *Ann. N.Y. Acad. Sci.* This volume.

Examination of a Potential Upper Limit to Cardiac Muscle Hypertrophy

RICHARD P. SPENCER

*Department of Nuclear Medicine
University of Connecticut Health Center
Farmington, Connecticut 06030*

There has been recognition that the failing human heart is marked by a dilating ventricular cavity and a decreasing ejection fraction. To quantify this, we assumed that if cardiac output were approximately constant over a range of ventricular volumes (VV), then ventricular volume times ejection fraction equals a constant. Placing this in logarithmic form and rearranging, yields:

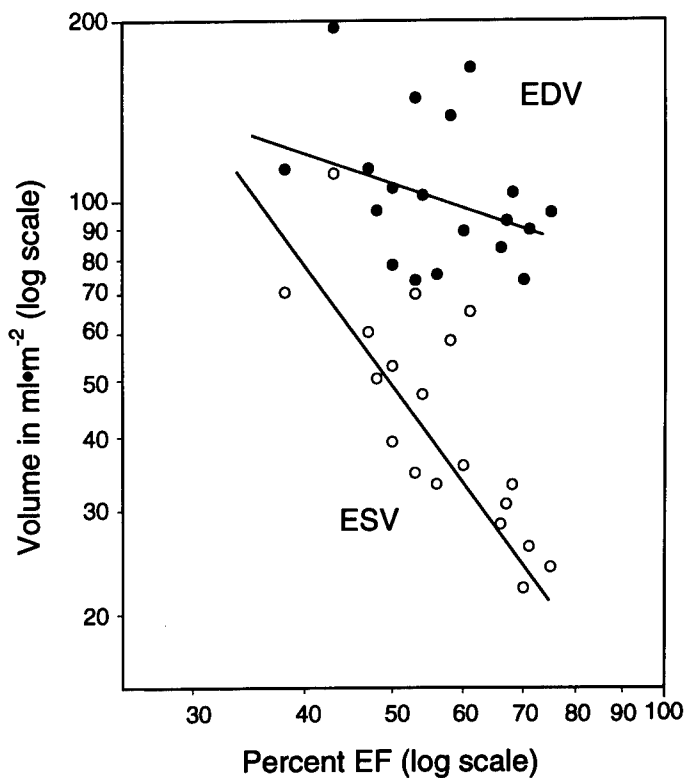

FIGURE 1. A log-log plot of ventricular volume as a function of EF. The line for ESV falls more rapidly than that for EDV. Extrapolated backward, the 2 lines would meet at a point where EDV = ESV. That point is at an EF value other than zero.

TABLE 1. A Summary of 7 Literature Series of Log VV versus Log EF^a

Study	Method	EF, when ESV = EDV	Log EDV Slope	Log ESV Slope	<i>p</i>
Gill <i>et al.</i> , 1986 ¹	RNCA, TOMO	18%	-0.59	-0.83	0.01
Higgins <i>et al.</i> , 1982 ²	DVSA	13%	-0.26	-0.49	NS
Upton <i>et al.</i> , 1982 ³	RNCA	15%	-0.71	-0.88	0.01
McKay <i>et al.</i> , 1986 ⁴	CATH	15%	-0.57	-0.85	0.01
Links <i>et al.</i> , 1982 ⁵	RNCA	16%	-0.72	-0.82	0.01
Stadius <i>et al.</i> , 1985 ⁶	RNCA, TOMO	18%	-0.61	-0.84	0.01
Dehmer <i>et al.</i> , 1980 ⁷	RNCA	16%*	-0.75	-1.52	0.01
Mean values:		16%	-0.60	-0.89	

^a *p* refers to probability of the log ESV line. TOMO = tomography; RNCA = radionuclide cine angiography; CATH = catheterization; DVSA = digital video subtraction angiography; * Patients without valvular disease (19% if all patients are included).

$$\log VV = \log K - \log EF$$

There were thus 2 sets of data for each literature series (end diastolic and end systolic volumes, EDV and ESV). A similar type of equation occurs if we assume that the specific rate of change of ventricular volume is negatively related to the specific rate of change of the ejection fraction.

We analyzed literature series which gave individual patient values for EF and EDV or ESV (from which the other could be calculated). Analyzed were all that included a broad spread of values, from normal to quite depressed EF. FIGURE 1 is a typical result, based on an echocardiographic study. In each of nearly 20 series analyzed from the literature, the following emerged.

1. The log ESV versus log EF data showed a more significant correlation than did log EDV values.
2. If extrapolated backward, the log EDV and log ESV lines always intersected at a value of EF that was significantly greater than zero. The mean value of EF, for 7 series with the lowest values (16%) is shown in TABLE 1.

Since the log EDV and log ESV lines intersect in each and every series of data, this may represent a biological invariant of human cardiac function. That value may approximate a maximum of cardiac filling or myocardial hypertrophy. Contributing factors may be: cardiac muscle at the limit of stretch and reduced cardiac output so that there is tissue hypoxia and degeneration. We are thus approaching a definition of an upper limit for cardiac muscle hypertrophy during life.

REFERENCES

1. GILL, J. B., R. H. MOORE, N. TAMAKI, D. D. MILLER, M. BARLAI-KOVACH, T. YASUDA, C. A. BOUCHER & H. W. STRAUSS. 1986. Multigated blood-pool tomography: new method for the assessment of left ventricular function. *J. Nucl. Med.* **27**: 1916-1924.
2. HIGGINS, C. B., S. L. NORRIS, K. H. GERBER, R. A. SLUTSKY, W. L. ASHBURN & N.

- BAILY. 1982. Quantitation of left ventricular dimensions and function by digital video subtraction angiography. *Radiology* **144**: 461-469.
3. UPTON, M. T., S. T. PALMIERI, R. H. JONES, R. E. COLEMAN & F. R. COBB. 1982. Assessment of left ventricular function by resting and exercise radionuclide angiography following acute myocardial infarction. *Am. Heart J.* **104**: 1232-1243.
 4. MCKAY, R. G., M. A. PFEFFER, R. C. PASTERNAK, J. E. MARKIS, P. C. COME, S. NAKAO, J. D. ALDERMAN, J. J. FERGUSON, R. D. SAFIAN & W. GROSSMAN. 1986. Left ventricular remodeling after myocardial infarction: a corollary to infarct expansion. *Circulation* **74**: 693-702.
 5. LINKS, J. M., L. C. BECKER, J. G. SHINDLEDECKER, P. GUZMAN, R. D. BUROW, E. L. NICKOLOFF, P. O. ALDERSON & H. N. WAGNER. 1982. Measurement of absolute left ventricular volume from gated blood pool studies. *Circulation* **65**: 82-91.
 6. STADIUS, M. L., D. L. WILLIAMS, G. HARP, M. CERQUEIRA, J. H. CALDWELL, J. R. STRATTON & J. L. RITCHIE. 1985. Left ventricular volume determination using single-photon emission computed tomography. *Am. J. Cardiol.* **55**: 1185-1191.
 7. DEHMER, G. J., S. E. LEWIS, L. D. HILLIS, D. TWIEG, M. FALKOFF, R. W. PARKEY & J. T. WILLERSON. 1980. Nongeometric determination of left ventricular volumes from equilibrium blood pool scans. *Am. J. Cardiol.* **45**: 293-300.

Function of C-Protein and Troponin I Phosphorylation in the Heart

S. BARTEL, P. KARCZEWSKI, I. MORANO, AND
E.-G. KRAUSE

*Max Delbrück Center for Molecular Medicine
Robert Rössle Straße 10
13125 Berlin-Buch, Germany*

INTRODUCTION

Two phosphorylatable proteins, namely, troponin I (TNI) and C-protein (C-P), are located on the thin and thick filament, respectively. These proteins represent substrates for cAMP-dependent protein kinase (PKA). It has been assumed that both proteins have not only structural but also regulatory relevance to myofibrillar contractility.¹⁻³ TNI phosphorylation seems to accelerate the relaxation of the heart during β -adrenergic stimulation.^{1,4} However, a corresponding role of C-P phosphorylation remains to be elucidated.^{1,4} In the developing heart TNI isoform expression changes from the slow skeletal type (ssTNI) to the cardiac type (cTNI).⁵⁻⁷ Only cTNI is a substrate for PKA based on the presence of a specific amino terminal extension containing the PKA motif.⁶⁻⁸ C-P, in contrast, is phosphorylated by PKA throughout development. Therefore, the developing myocardium is an excellent tool for distinguishing between the effects of TNI phosphorylation from C-P phosphorylation on the contractile behavior of cardiac fibers.

METHODS

The experiments were performed with chemically (Triton) skinned fibers prepared from ventricles of 3- and 28-day-old Wistar rats. Phosphoproteins were analyzed by cAMP-catalyzed ³²P-incorporation. The phosphorylation assay was performed in KCl-extracted supernatant fraction of homogenized skinned fiber preparations in the presence of 0.5 μ M of c-subunit of PKA (cPKA) and 50 μ M [γ -³²P ATP] as described.⁹ Proteins were separated by SDS gel electrophoresis. The P_i-incorporation was expressed as pmol P/mg supernatant protein analyzed with a BIO-Imaging system. Ca²⁺ sensitivity of the isometric tension generation of skinned fibers were performed in the absence or presence of cPKA as described.⁸

RESULTS

FIGURE 1 shows cPKA-mediated phosphorylation of C-protein and TNI of skinned cardiac fibers prepared from neonatal (neo, 3-day-old) and postnatal (pn, 28-day-old) rats. C-P phosphorylation slightly increased during cardiac develop-

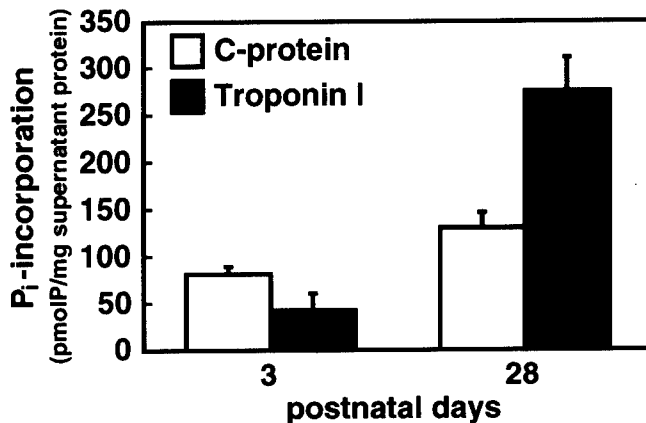

FIGURE 1. Phosphorylation of C-protein and troponin I of chemically skinned ventricular fibers prepared from neonatal (3-day-old) and postnatal (28-day-old) rats. Protein phosphorylation was measured in KCl-supernatant fraction. P_1 -incorporation into phosphoproteins was induced by cPKA in the presence of $[\gamma^{32}P\text{-ATP}]$ and is expressed as pmol P/mg supernatant protein. Data are means \pm SEM from 3 separate experiments.

ment, namely from (pmolP/mg supernatant protein) 81.5 ± 8.2 (neo) to 129.9 ± 16.2 (pn). In contrast, TNI-phosphorylation increased significantly from 42.1 ± 15.9 (neo) to 275.0 ± 35 (pn) reflecting the transition from the ssTNI to cTNI. Incubation of neonatal skinned cardiac fibers with cPKA had no effect on Ca^{2+} sensitivity (given as free Ca^{2+} at half-maximal force generation; pCa_{50}) (FIG. 2). In contrast, taking skinned fibers from postnatal animals, Ca^{2+} sensitivity significantly decreased from pCa_{50} 5.52 (before cPKA) to pCa_{50} 5.38 upon cPKA treatment (FIG. 2).

CONCLUSION

In accordance with previous studies, TNI and C-P phosphorylation by PKA desensitized the contractile apparatus of the postnatal and adult heart for Ca^{2+} .^{4,5,8} However, the contribution of both phosphoproteins on the change of Ca^{2+} sensitivity is not clear at present. The observation that C-P but not TNI is phosphorylated in the early stages of cardiac development⁸ provided the opportunity to selectively investigate the functional role of C-P phosphorylation. Our results demonstrate that C-P without concomitant TNI phosphorylation had no influence on Ca^{2+} sensitivity of skinned heart fibers. Therefore, we conclude that the decreased Ca^{2+} sensitivity caused by treatment of postnatal fibers with PKA is due to TNI but not C-P phosphorylation. The functional role of C-P phosphorylation by PKA still remains to be elucidated. Furthermore, C-P phosphorylation by other protein kinases and site-specific phosphorylation in relation to functional alterations await further investigation.

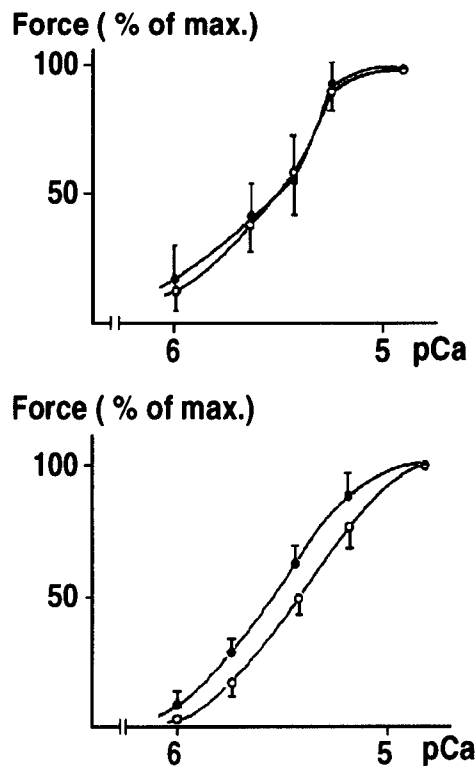

FIGURE 2. Ca^{2+} -dependence of isometric tension generation of skinned fiber bundles prepared from rat ventricles of 3-day-old animals (*upper part*) and 28-day-old animals (*lower part*) before (●) and after (○) incubation with cPKA. Force is expressed as % of the force obtained at maximal Ca^{2+} activation (pCa 4.5). Values are means \pm SEM (6 different fibers per group).

REFERENCES

1. GARREY, I. L., E. G. KRANIAS & R. I. SOLARO. 1988. *Biochem. J.* **249**: 709–714.
2. HOFMANN, P. A., H. C. HARTZELL & R. L. MOSS. 1991. *J. Gen. Physiol.* **97**: 1141–1163.
3. MORANO, I., K. HÄDICKE, S. GROM, A. KOCH, R. H. G. SCHWINGER, M. BÖHM, S. BARTEL, E. ERDMANN & E.-G. KRAUSE. 1994. *J. Mol. Cell. Cardiol.* **26**: 361–368.
4. ENGLAND, P. K. 1975. *FEBS Lett.* **50**: 57–60.
5. GORZO, L., S. AUSONI, N. MERCIAI, K. M. HASTINGS & S. SCHIAFFINO. 1993. *Dev. Biol.* **156**: 253–264.
6. HASTINGS, K. E., R. I. KOPPE, E. MARMOR, D. BADER, Y. SHIMADA & N. TOYOLA. 1991. *J. Biol. Chem.* **266**: 19659–19665.
7. MARTIN, A. F., K. BALL, L. Z. GAO, P. KUMAR & R. I. SOLARO. 1991. *Circ. Res.* **69**: 1244–1252.
8. BARTEL, S., I. MORANO, H. D. HUNGER, H. KATUS, H. T. PASK, P. KARCZEWSKI & E.-G. KRAUSE. 1994. *J. Mol. Cell. Cardiol.* **26**: 361–368.
9. KARCZEWSKI, P., S. BARTEL & E.-G. KRAUSE. 1990. *Biochem. J.* **266**: 115–122.

The Regulation of Blood Vessel Growth by Vascular Endothelial Growth Factor

NAPOLEONE FERRARA,^a HENRY HEINSOHN,^b CLAIRE E. WALDER, STUART BUNTING, AND G. ROGER THOMAS

*Departments of Cardiovascular Research and ^bProcess Science
Genentech, Inc.*

*460 Point San Bruno Boulevard
South San Francisco, California 94080*

A fundamental property of vascular endothelial cells is the ability to proliferate and form a network of capillaries.^{1,2} This process is known as "angiogenesis" and requires at least three steps: i) degradation of the extracellular matrix of a local venule, ii) chemotaxis of endothelial cells toward an angiogenic stimulus, and iii) proliferation of endothelial cells.^{1,2} Angiogenesis is prominent during embryonic development and somatic growth but in a normal adult it only takes place following injury or, in a cyclical fashion, in the endometrium and in the ovary.^{1,2} Angiogenesis plays a significant role in the pathogenesis of a variety of disorders including cancer, proliferative retinopathies, rheumatoid arthritis or psoriasis. Therefore, inhibition of angiogenesis may constitute an attractive strategy for the treatment of such disorders. Conversely, disorders characterized by inadequate tissue perfusion such as obstructive atherosclerosis and diabetes are expected to benefit from agents able to promote endothelial cell growth and angiogenesis.

A variety of factors have been identified as potential positive regulators of angiogenesis: aFGF, bFGF, EGF, TGF- α , TGF- β , PGE₂, monobutyryl, TNF- α , PD-ECGF, angiogenin and interleukin-8.^{1,2}

This article will review a recently identified family of directly-acting endothelial cell mitogens and angiogenic factors known as vascular endothelial growth factor (VEGF) or vascular permeability factor (VPF).^{3,4} These factors are products of the same gene and, by alternative exon splicing, may exist in four different isoforms.⁵⁻⁸ Recent studies point to VEGF as a major regulator of physiological and pathological angiogenesis. Furthermore, the angiogenic activity of VEGF appears to be sufficient to achieve therapeutic benefit in animal models of coronary or limb ischemia.

Biological Properties of VEGF

A unique aspect of VEGF is its target all specificity.⁹ VEGF is a potent mitogen (ED₅₀ 2–10 pM) for vascular endothelial cells, but it is apparently devoid of mitogenic activity for other cell types.⁹⁻¹¹ VEGF is also able to induce a marked angiogenic response in the chick chorioallantoic membrane.¹⁰⁻¹² VEGF also pro-

^a Corresponding author.

motes angiogenesis in a tridimensional *in vitro* model, inducing confluent microvascular endothelial cells to invade a collagen gel and form tube-like structures.¹³ These studies also provide evidence for a potent synergism between VEGF and bFGF in the induction of such *in vitro* angiogenic effects.¹³

VEGF has the same sequence as VPF, a tumor-derived protein so named because of its ability to promote Evans blue extravasation when injected in the guinea pig skin^{14,15} and proposed to be a mediator of hyperpermeability of tumor vessels. It has been suggested that extravasation of fibrinogen and other plasma proteins results in the formation of a fibrin gel that serves as a substrate for endothelial ant tumor growth.¹⁶

VEGF induces expression of the serine proteases urokinase-type and tissue-type plasminogen activators (PA) and also PA inhibitor (PAI-1) in cultured bovine microvascular endothelial cells.¹⁷ Furthermore, VEGF induces expression of the metalloproteinase interstitial collagenase in human umbilical vein endothelial cells but not in dermal fibroblasts.¹⁸ Interstitial collagenase is able to degrade type I and III collagen.¹⁸ The co-induction of plasminogen activators and collagenase by VEGF is expected to promote a prodegradative environment that facilitates migration of endothelial cells. The expression of PAI-1 may serve to regulate and balance the process.¹⁷

VEGF has also been shown to induce vasodilation in a dose-dependent fashion.¹⁹ Such effect appears to be mediated by endothelial cell-derived NO, as assessed by the requirement for an intact endothelium and the prevention of the effect by N-methyl-arginine.¹⁹

Structural and Genetic Properties of VEGF

VEGF purified from a variety of species and sources is a basic, heparin-binding, homodimeric glycoprotein of 45,000 daltons.⁹ These properties are similar to those of the 165-amino acid isoform (see below). VEGF is inactivated by reducing agents, but it is heat-stable and acid-stable. cDNA sequence analysis of a variety of VEGF clones indicates that VEGF may exist as one of four different molecular species, having respectively 121, 165, 189 and 206 amino acids (VEGF₁₂₁, VEGF₁₆₅, VEGF₁₈₉, VEGF₂₀₆).^{5,8,10} VEGF₁₆₅ is the predominant isoform secreted by a variety of normal and transformed cells. Transcripts encoding VEGF₁₂₁ and VEGF₁₈₉ are detected in the majority of cells and tissues expressing the VEGF gene.^{5,10} In contrast, VEGF₂₀₆ is a very rare form, so far identified only in a human fetal liver cDNA library.⁵ Compared to VEGF₁₆₅, VEGF₁₂₁ lacks 44 amino acids; VEGF₁₈₉ has an insertion of 24 amino acids highly enriched in basic residues and VEGF₂₀₆ has an additional insertion of 17 amino acids. The organization of the human VEGF gene has been elucidated.^{19,20} It is known that alternative splicing of RNA, rather than transcription of separate genes, is the basis for the molecular heterogeneity evidenced by cDNA sequence analysis.^{5,8} The VEGF gene is organized in eight exons and the size of its coding region has been estimated to be approximately 14 kb.⁸ VEGF₁₆₅ lacks the residues encoded by exon 6, while VEGF₁₂₁ lacks the residues encoded by exons 6 and 7. Interestingly, there is no intron between the coding sequence for the 24 amino acid insertion in VEGF and

the additional 17-amino acid insertion found in VEGF₂₀₆. The 5' end of the 51-base-pair insertion of VEGF₂₀₆ begins with GT, the consensus sequence for the 5'-splice donor necessary for mRNA processing. Therefore, the definition of the 5'-splice donor site for removal of a 1-kb intron sequence is variable.⁵

Hypoxia was recently identified as an important mechanism involved in the regulation of the expression of the VEGF gene, both *in vivo* and *in vitro*.^{20,21} Recent studies have shown that similarities exist between the oxygen-sensing mechanisms regulating the expression of VEGF and erythropoietin genes.²¹ The expression of both genes is significantly enhanced by cobalt chloride. Furthermore, the hypoxic induction of both VEGF and erythropoietin genes is inhibited by carbon monoxide, suggesting the involvement of a heme protein in the process of sensing oxygen levels.²¹

The VEGF Isoforms

VEGF₁₂₁ is a weakly acidic polypeptide that fails to bind to heparin. In contrast, VEGF₁₆₅ is a basic (isoelectric point ~8.5), heparin-binding protein. VEGF₁₈₉ and VEGF₂₀₆ are more basic and bind to heparin with even greater affinity.^{5,6,9} Thus, an acidic polypeptide (VEGF₁₂₁) can be converted into increasingly more basic proteins by alternative splicing of mRNA. Such differences in the isoelectric point and in affinity for heparin profoundly affect the targeting of the translated proteins following secretion from the cell.⁵⁻⁷ VEGF₁₂₁ is secreted as a freely soluble protein in the conditioned medium of transfected cells. VEGF₁₆₅ is also secreted, but a significant fraction remains bound to the cell surface or the extracellular matrix (ECM). The longer isoforms, VEGF₁₈₉ and VEGF₂₀₆, are almost completely sequestered in the ECM.^{6,7} However, they may be released from the bound state by a variety of agents such as suramin, heparin or heparinase.⁶ ECM prepared from cells expressing VEGF₁₈₉ or VEGF₂₀₆ promotes the growth of vascular endothelial cells.⁷ The observation that heparin releases these forms of VEGF suggests that their binding site is represented by heparin-containing proteoglycans, similar to that for bFGF. Furthermore, the long forms may be released by plasmin.^{6,7} This physiologically relevant protease is able to cleave VEGF₁₈₉ or VEGF₂₀₆ at the COOH terminus and generate a proteolytic fragment having molecular weight of ~34,000 daltons, which is active as an endothelial cell mitogen and as a vascular permeability agent.^{6,7} Plasminogen activation and generation of plasmin have been shown to play an important role in the angiogenesis cascade.²² It is possible that this property is not confined to plasmin. It may be that cleavage of VEGF can be brought about by a variety of inflammation-associated proteases. Thus, the VEGF proteins may be made available to endothelial cells by at least two different mechanisms: as freely soluble proteins (VEGF₁₂₁, VEGF₁₆₅) or following protease activation and cleavage of the longer isoforms. Therefore, the products of a single gene may provide a highly flexible system to control angiogenesis. The short forms of VEGF may be rapidly and efficiently released in response to the requirements of the microenvironment. In contrast, the longer forms are stably incorporated in the ECM but can become available in a diffusible form when this structure is degraded.^{6,7}

The VEGF Receptors

Characteristics of VEGF Binding to Endothelial Cells

Two classes of high-affinity VEGF binding sites have been identified on the cell surface of cultured endothelial cells, having K_d values of 10^{-12} and 10^{-11} M, respectively.^{23,24} Cross-linking studies using ^{125}I -VEGF revealed bands in the range of 180–230 Kda as well as a lower molecular weight (110 Kda) band in endothelial cells.^{23,24} The binding of VEGF to endothelial cells is stimulated by low concentrations of heparin and is inhibited by removal of cell-surface heparin sulfate by heparinases.²⁵ This presumably reflects the heparin-binding nature of VEGF and suggests also that a cell-surface proteoglycan may be required for binding. Lower-affinity binding sites on mononuclear phagocytes ($K_d \sim 300\text{--}500$ pM) were recently described.²⁶ The molecular nature of these sites remains to be elucidated. It has been suggested that such binding sites are involved in mediating chemotactic effects for monocytes by VEGF.²⁶

Distribution of High-Affinity Binding Sites for VEGF

Ligand autoradiography studies on tissue sections of adult rats revealed that high-affinity ^{125}I -VEGF binding sites were localized to the vascular endothelium of large or small vessels but not to other cell types.²⁷ Scatchard analysis of saturation isotherms in sections from a variety of tissues revealed a single class of binding sites with high affinity ($K_d = 16\text{--}35$ pM). Specific binding colocalized with Factor VIII-like immunoreactivity and was apparent on both proliferating and quiescent endothelial cells. Binding of ^{125}I -VEGF during development of rat embryos is first detectable in the blood islands of the yolk sac, which contain the earliest progenitors of hematopoietic and endothelial cells.²⁸ As the vascular system develops, VEGF binding sites continue to colocalize with the endothelium of blood vessels.²⁸

The Flt-1 and Flk-1/KDR Tyrosine Kinases

Two tyrosine kinases were recently identified as VEGF receptors.^{29,30} The flt-1 (fms-like-tyrosine kinase)²⁹ and KDR (kinase domain region)³⁰ proteins have been shown to bind VEGF with high affinity. The overall amino acid sequence identity between the two proteins is 44%. The murine homologue of KDR is known as flk-1³¹ and shares 85% sequence identity with human KDR. Both flt-1 and KDR/flk-1 have a single hydrophobic leader peptide, a single transmembrane domain, seven immunoglobulin-like domains in the extracellular domain, and a consensus tyrosine kinase sequence that is interrupted by a kinase-insert domain. Flt-1 and KDR share 30% sequence identity with c-fms, a known tyrosine kinase receptor for M-CSF-1. Recently, an alternatively spliced form of flt-1 lacking the seventh immunoglobulin-like domain, the cytoplasmic domain, and transmembrane sequence was identified in human umbilical vein endothelial cells.³² The encoded protein is expected to have 687 amino acids and is secreted as a soluble

protein. This soluble flt-1 protein is able to inhibit VEGF-induced mitogenesis and has been proposed to be a physiological negative regulator of VEGF action.

Characteristics of VEGF Binding to Flt-1 and KDR/Flk-1

Flt-1 has the highest affinity for rhVEGF₁₆₅, with a K_d of approximately 10–20 pM.²⁹ KDR has a somewhat lower affinity for VEGF: the K_d has been estimated to be approximately 75 pM.³⁰ The K_d for binding of rhVEGF₁₆₅ to flk-1 is 500–600 pM.^{33,34} Therefore, it is likely the binding of KDR/flk-1 to VEGF is partially species-specific. VEGF binding to these receptors was not completed by a structurally related peptide such as PDGF.^{29,30} Affinity cross-linking of ¹²⁵I-rhVEGF₁₆₅ to transfected COS cells expressing KDR/flk-1 revealed bands of 190–230 kDa.^{30,33}

VEGF as a Regulator of Physiological Angiogenesis

The proliferation of blood vessels is crucial for a wide variety of physiological processes such as embryonic development, normal growth and differentiation, wound healing and reproductive functions. The VEGF mRNA is expressed within the first few days following implantation in the giant cells of the trophoblast,^{28,35} suggesting a role for VEGF in the induction of vascular growth in the decidua, placenta and vascular membranes. At later development stages in mouse or rat embryos, VEGF mRNA is expressed in several organs, including heart, vertebral column, kidney, and along the surface of the spinal cord and brain.^{28,35} In the developing mouse brain, the highest levels of mRNA expression are associated with the choroid plexus and the ventricular epithelium.³⁵ This argues for a spatial relation between VEGF mRNA expression and angiogenesis, since the vascularization of the cerebral cortex in late prenatal and early postnatal ages proceeds from the pial surface toward the ventricular epithelium.³⁶

The first evidence supporting the hypothesis that VEGF may be a physiological regulator of angiogenesis was provided by *in situ* hybridization studies on the rat ovary.³⁷ Angiogenesis is a prominent aspect of the cyclical development of the corpus luteum. Following ovulation, vessels from the theca interna invade the ruptured follicle and a complex microvascular network that nourishes the developing corpus luteum.³⁸ Expression of the VEGF mRNA was temporally and spatially related to the proliferation of such microvessels. Minimal hybridization was detected in the avascular granulosa cells of preovulatory follicles, while a strong hybridization signal was present in the corpus luteum where 50–60% of the total cell population is represented by capillary endothelial cells and pericytes. A similar expression pattern was recently described in the primate ovary.³⁹

Also, recent studies provide evidence for the expression of VEGF mRNA in keratinocytes in a healing wound, suggesting the involvement of VEGF in a major pathophysiological process such as wound healing.⁴⁰

The Role of VEGF in Pathological Angiogenesis

Numerous tumor cell lines express the VEGF mRNA and secrete a VEGF-like protein in the medium,^{12,41,42} suggesting that this diffusible mitogen may facili-

tate tumor growth through its direct angiogenic effects. This hypothesis is supported by recent *in situ* hybridization studies that have shown that the VEGF mRNA is expressed at high level by a variety of human tumors, including renal cell carcinoma, colon carcinoma and several intracranial tumors.^{20,43-46} A strong correlation exists between degree of vascularization of the malignancy and VEGF mRNA expression.⁴³⁻⁴⁵ These studies indicate that, at least in tumors with a significant component of necrosis, local hypoxia is a major inducer of VEGF gene expression.^{20,44,46} VEGF-expressing cells are expected to have a growth advantage *in vivo* due to stimulation of angiogenesis. This hypothesis is supported by previous studies that show that expression of VEGF₁₆₅ or VEGF₁₂₁ confers on a nontumorigenic clone of Chinese hamster ovary cells the ability to proliferate *in vivo* and form vascularized tumors in nude mice.⁴⁷ However, VEGF expression did not result in a growth advantage *in vitro* for such cells, indicating that their ability to grow *in vivo* was due to paracrine rather than autocrine mechanisms. More direct evidence for a role of VEGF in tumor angiogenesis was recently made possible by the availability of specific monoclonal antibodies capable of inhibiting VEGF-induced angiogenesis *in vivo* and *in vitro*. Such antibodies exert a dramatic inhibitory effect on the growth of several human tumor cell lines in nude mice.⁴⁸ However, the antibodies (or VEGF) have no effect on the *in vitro* growth of the tumor cells. More recently, it was shown that VEGF is a major mediator of the *in vivo* growth of colon carcinoma cells in a nude mouse model of liver metastasis.⁴⁹ Treatment with anti-VEGF monoclonal antibodies resulted in a dramatic decrease in the size and number of liver metastases following injection of tumor cells into the spleen, again confirming that angiogenesis is a critical rate limiting step in tumorigenesis and that VEGF is a major mediator of this process.

Recent studies⁵⁰ suggest that VEGF is involved in the pathogenesis of another important angiogenic disease, rheumatoid arthritis (RA). The RA synovium is characterized by the formation of pannus, an extensively vascularized tissue that invades and destroys the articular cartilage. By its vascularity and rapid proliferation rate, the RA synovium has been likened to a tumor. Levels of immunoreactive VEGF were very high (100–1600 ng/ml) in the synovial fluid of RA patients, while they were very low or undetectable in the synovial fluid of patients affected by other forms of arthritis or by degenerative joint disease. Furthermore, the endothelial cell chemotactic activity of the RA synovial fluid was significantly reduced by an anti-VEGF antibody, indicating that immunoreactive VEGF was bioactive.

In addition, VEGF-induced angiogenesis is expected to play a pathogenic role in proliferative retinopathies. Intraocular neovascularization associated with conditions such as diabetes, occlusion of central retinal veins or prematurity and exposure to oxygen can lead to vitreous hemorrhage, retinal detachment and blindness.^{1,2} It is believed that an event common to all of these conditions is the release of diffusible factor(s) from the ischemic retina. VEGF, by its diffusible nature and hypoxia-inducibility, is an attractive candidate. Recent studies where VEGF levels were measured in the ocular fluids of over 160 patients demonstrate a strong correlation between levels of immunoreactive VEGF in the aqueous and vitreous humors and active proliferative retinopathy.⁵¹ VEGF levels were undetectable or very low (<0.5 ng/ml) in the eyes of individuals affected by non-neovascular disorders, background diabetic retinopathy or even proliferative diabetic retinopa-

thy in a quiescent stage. In contrast, the VEGF levels were in the range of 3–10 ng/ml in the presence of active proliferative retinopathy associated with diabetes, occlusion of central retinal vein or prematurity. These findings suggest that ischemia in the retina, regardless of its etiology, leads to release of VEGF, followed by neovascularization.

VEGF and Therapeutic Angiogenesis

An attractive possibility is that the VEGF protein or gene therapy with a VEGF cDNA may be used to promote revascularization in conditions of insufficient tissue perfusion. For example, chronic limb ischemia, most frequently caused by obstructive atherosclerosis affecting the superficial femoral artery, is associated with a high rate of morbidity and mortality, and treatment is currently limited to surgical revascularization or endovascular interventional therapy.^{52–54} Previous studies where bFGF was administered suggest that an angiogenic therapy may be effective in restoring perfusion following vascular injury.⁵⁵ Very recent studies indicate that even a single intraarterial or intramuscular administration of rhVEGF₁₆₅ may significantly augment perfusion and development of collateral vessels in a rabbit model of hindlimb ischemia.^{56,57} These studies provided angiographic evidence of neovascularization in the ischemic limbs. More recently, the hypothesis that the angiogenesis initiated by the administration of rhVEGF₁₆₅ improved muscle function in limbs rendered ischemic by surgical removal of the femoral artery was tested.⁵⁸ A single close-arterial injection of rhVEGF₁₆₅ augmented muscle function in this model of peripheral limb ischemia.⁵⁸ It is also a characteristic of this model that the ischemic limb cannot augment blood flow in response to oxygen demand during exercise. This exercise-induced hyperemia was significantly improved in ischemic limbs treated with rhVEGF₁₆₅. However, such improvement in perfusion was not seen in resting muscle, nor was it apparent in other nonischemic tissues including the contralateral limb (FIG. 1). Therefore, it appears that the neovascularization and the angiogenesis seen in response to rhVEGF₁₆₅ result in improvements in physiological parameters that indicate that this type of therapy may represent a significant advancement in the treatment of peripheral vascular disease.

Furthermore, it has been suggested that VEGF administration may result in increase in coronary blood flow in a dog model of coronary insufficiency.⁵⁹ Following occlusion of the left circumflex coronary artery, daily injections of rhVEGF distal to the occlusion resulted in a significant enhancement in collateral blood flow over a period of four weeks.

A further potential therapeutic application of VEGF is the prevention of restenosis following PTA. Between 15% and 75% of patients undergoing PTA for occlusive arterial disease develop restenosis within six months. The frequency of clinical stenosis depends on the size and location of the artery and the definition of stenosis.⁵⁴ It has been proposed that damage to the endothelium is the crucial event triggering fibrocellular intimal proliferation.^{54,60} Therefore, it is tempting to speculate that rapid reendothelialization promoted by VEGF may prevent the cascade of events leading to neointima formation and restenosis. The specificity of VEGF for endothelial cells may be especially useful for this application.

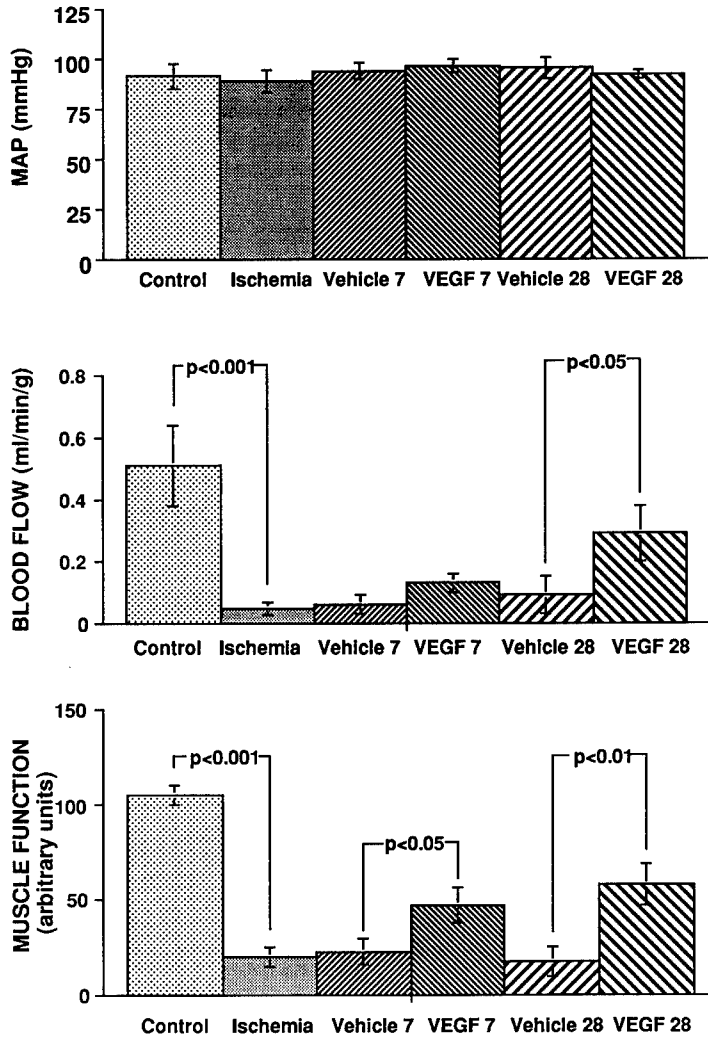

FIGURE 1. In male New Zealand White rabbits one femoral artery was surgically removed. After 7 days the animals were treated with a single bolus, intraarterial dose, of either rhVEGF₁₆₅ (1 mg) or vehicle into the iliac artery of the ischemic limb. At day 7 and day 28 after treatment animals were anesthetized with phenobarbital sodium (85 mg/kg i.v.) and both hind limbs were secured in a steel frame. The extensor digitorum longus was electrically stimulated and the twitch tension measured. Muscle blood flow was measured at rest and at work using radio-labeled microspheres. The *upper panel* shows that when the blood flow (*middle panel*) and the muscle function (*lower panel*) were measured the mean arterial pressures (MAP) were equivalent in all animals. The *middle panel* shows that 7 days of ischemia (Ischemia) causes a significant fall in perfusion compared to naive nonischemic animals (Control). This is paralleled by a loss of function (*lower panel*). Seven days after treatment there is significant improvement in muscle function (*lower panel*) in the VEGF-treated animals (VEGF 7) compared to vehicle controls (Vehicle 7). This is further evident at 28 days after treatment (VEGF 28 vs Vehicle 28) and is now accompanied by a significant increase in muscle blood flow (*middle panel*).

CONCLUSIONS AND PERSPECTIVES

The existence of a temporal and spatial relation between VEGF mRNA expression during embryonic development, corpus luteum differentiation, wound healing and blood vessel growth indicates that VEGF is an important regulator of angiogenesis in a variety of physiological processes.

The high expression of VEGF mRNA in human tumors⁴⁴⁻⁴⁶ and the presence of the VEGF protein at high levels in the synovial fluid of RA patients⁵⁰ and in the ocular fluids of individuals affected by proliferative retinopathies⁵¹ strongly support the hypothesis that VEGF is also a key mediator of pathological angiogenesis. Therefore, anti-VEGF antibodies or VEGF antagonists have the potential to be of therapeutic significance for a variety of highly vascularized and aggressive malignancies as well as other angiogenic disorders. An anti-VEGF therapy is expected to have low toxicity, perhaps limited to inhibition of wound healing and ovarian and endometrial function, since endothelial cells are essentially quiescent in most adult tissues.

The VEGF family of proteins was only recently identified but already appears to play a pivotal role in the regulation of normal and pathological angiogenesis as well as to have considerable therapeutic potential.

REFERENCES

1. FOLKMAN, J. & Y. J. SHING. 1992. *Biol. Chem.* **267**: 10931.
2. KLAGSBRUN, M. & P. A. D'AMORE. 1991. *Annu. Rev. Physiol.* **53**: 217.
3. FERRARA, N., K. HOUCK, L. JAKEMAN & D. W. LEUNG. 1992. *Endocr. Rev.* **13**: 18.
4. FERRARA, N. 1993. *Trends Cardiovasc. Med.* **3**: 244.
5. HOUCK, K. A., N. FERRARA, J. WINER, G. CACHIANES, B. LI & D. W. LEUNG. 1991. *Mol. Endocrinol.* **5**: 1086.
6. HOUCK, K. A., D. W. LEUNG, A. M. ROWLAND, J. WINER & N. J. FERRARA. 1992. *Biol. Chem.* **267**: 26031.
7. PARK, J. E., G-A. KELLER & N. FERRARA. 1993. *Mol. Biol. Cell.* **4**: 1317.
8. TISHER, E., R. MITCHELL, T. HARTMANN, M. SILVA, D. GOSPODAROWICZ, J. FIDDES & J. ABRAHAM. 1991. *J. Biol. Chem.* **266**: 11947.
9. FERRARA, N. & W. J. HENZEL. 1989. *Biochem. Biophys. Res. Commun.* **161**: 851.
10. LEUNG, D. W., G. CACHIANES, W-J. KUANG, D. V. GOEDEL & N. FERRARA. 1989. *Science*. **246**: 1306.
11. PLOUET, J., J. SCHILLING & D. GOSPODAROWICZ. 1989. *EMBO J.* **8**: 3801.
12. CONN, G., M. BAYNES, L. SODERMAN, P. W. KWOK, K. A. SULLIVAN, T. M. PALISI, D. A. HOPE & K. A. THOMAS. 1990. *Proc. Natl. Acad. Sci. USA* **87**: 2628.
13. PEPPER, M. S., N. FERRARA, L. ORCI & R. MONTESANO. 1992. *Biochem. Biophys. Res. Commun.* **189**: 824.
14. CONNOLLY, D. T. D. M. HEUVELMAN, R. NELSON, J. V. OLANDER, B. L. EPPLEY, J. J. DELFINO, N. R. SIEGEL, R. M. LEIMGRUBER & J. FEDER. 1989. *J. Clin. Invest.* **84**: 1470.
15. KECK, P. J., S. D. HAUSER, G. KRIVI, K. SANZO, T. WARREN, J. FEDER & D. T. CONNOLLY. 1989. *Science* **246**: 1309.
16. DVORAK, H. F. 1986. *N. Engl. J. Med.* **315**: 1650.
17. PEPPER, M. S., N. FERRARA, L. ORCI & R. MONTESANO. 1991. *Biochem. Biophys. Res. Commun.* **181**: 902.
18. UNEMORI, E., N. FERRARA, E. A. BAUER & E. P. AMENTO. 1992. *J. Cell. Physiol.* **153**: 557-562.

19. KU, D. D., J. K. ZALESKI, S. LIU & T. BROCK. 1993. *Am. J. Physiol.* **265**: H586.
20. SHWEIKI, D., A. ITIN, D. SOFFER & E. KESHET. 1992. *Nature* **359**: 843-845.
21. GOLDBERG, M. A. & T. J. SCHNEIDER. 1994. *J. Biol. Chem.* **269**: 4355.
22. MIGNATTI, P., R. TSUBOI, E. ROBBINS & D. B. RIFKIN. 1989. *J. Cell. Biol.* **108**: 671.
23. VAISMAN, N., D. GOSPODAROWICZ & G. NEUFELD. 1990. *J. Biol. Chem.* **265**: 19461.
24. PLOUET, J. & H. J. MOUKADIRI. 1990. *J. Biol. Chem.* **265**: 22071.
25. GITAY-GOREN, H., S. SOKER, I. VLODAVSKY & G. NEUFELD. 1992. *J. Biol. Chem.* **267**: 6093.
26. SHEN, H., M. CLAUSS, J. RYAN, A. M. SCHMIDT, P. TIJBURG, L. BORDEN, D. T. CONNOLLY, D. STERN & J. KAO. 1993. *Blood* **81**: 2767.
27. JAKEMAN, L. B., J. WINER, G. L. BENNETT, C. A. ALTAR & N. FERRARA. 1992. *J. Clin. Invest.* **89**: 244.
28. JAKEMAN, L. B., M. ARMANINI, H. S. PHILLIPS & N. FERRARA. 1993. *Endocrinology* **2**: 913.
29. DE VRIES, C., J. A. ESCOBEDO, H. UENO, K. A. HOUCK, N. FERRARA & L. T. WILLIAMS. 1992. *Science* **255**: 989.
30. TERMAN, B. I., M. D. VERMAZEN, M. E. CARRION, D. DIMITROV, D. C. ARMELLINO, D. GOSPODAROWICZ & P. BOHLEN. 1992. *Biochem. Biophys. Res. Commun.* **34**: 1578.
31. MATTHEWS, W., C. T. JORDAN, M. GAVIN, N. A. JENKINS, N. G. COPELAND & I. R. LEMISCHKA. 1991. *Proc. Natl. Acad. Sci. USA* **88**: 9026.
32. KENDELL, R. L. & K. A. THOMAS. 1993. *Proc. Natl. Acad. Sci. USA* **90**: 10705.
33. MILLAUER, B., S. WIZIGMANN-VOOS, H. SCHNURCH, R. MARTINEZ, N. P. MOLLER, W. RISAU & A. ULLRICH. 1993. *Cell* **72**: 835.
34. QUINN, T., K. G. PETERS, C. DEVRIES, N. FERRARA & L. T. WILLIAMS. 1993. *Proc. Natl. Acad. Sci. USA* **90**: 7533.
35. BREIER, G., U. ALBRECHT, S. STERRER & W. RISAU. 1992. *Development* **114**: 521.
36. EVANS, H. M. 1909. *Anat. Rec.* **3**: 498.
37. PHILLIPS, H. S., J. HAINS, D. W. LEUNG & N. FERRARA. 1990. *Endocrinology* **127**: 965.
38. BASSETT, D. L. 1943. *Am. J. Anat.* **73**: 251.
39. RAVINDRANATH, N., L. LITTLE-IHRIG, H. S. PHILLIPS, N. FERRARA & A. J. ZELENICK. 1992. *Endocrinology* **131**: 254.
40. BROWN, L. F., K. T. YEO, B. BERSE, T. K. YEO, D. R. SENGER, H. F. DVORAK & L. VAD DE WATER. 1992. *J. Exp. Med.* **176**: 1375.
41. ROSENTHAL, R., J. F. MEGYESI, W. J. HENZEL, N. FERRARA & J. FOLKMAN. 1990. *Growth Factors* **4**: 53.
42. SENGER, D., C. A. PERRUZZI, J. FEDER & H. F. DVORAK. 1986. *Cancer Res.* **46**: 5269.
43. BERSE, B., L. F. BROWN, L. VAN DE VATER, H. F. DVORAK & D. R. SENGER. 1992. *Mol. Biol. Cell* **3**: 211.
44. PLATE, K. H., G. BREIER, H. A. WEICH & W. RISAU. 1992. *Nature* **359**: 845.
45. BERKMAN, R. A., M. J. MERRILL, W. C. REINHOLD, W. T. MONACCI, A. SAXENA, W. C. CLARK, J. T. ROBERTSON, I. U. ALI & E. H. OLDFIELD. 1993. *J. Clin. Invest.* **91**: 153.
46. PHILLIPS, H. S., M. ARMANINI, D. STAVROU, N. FERRARA & M. WESTPHAL. 1993. *INT. J. ONCOL.* **2**: 913.
47. FERRARA, N., J. WINER, T. BURTON, A. ROWLAND, M. SIEGEL, H. S. PHILLIPS, T. TERRELL, G-A. KELLER & A. D. LEVINSON. 1993. *J. Clin. Invest.* **91**: 160.
48. KIM, K. J., B. LI, J. WINER, M. ARMANINI, N. GILLET, H. S. PHILLIPS & N. FERRARA. 1993. *Nature* **362**: 841.
49. WARREN, R. S., H. YUAN, M. R. MATLI, N. GILLET & N. FERRARA. *J. Clin. Invest.* In press.
50. KOCH, A. E., L. HARLOW, G. K. HAINES, E. P. AMENTO, E. N. UNEMORI, W. L. WONG, R. M. POPE & N. FERRARA. 1994. *J. Immunol.* **152**: 4149.
51. AIELLO, L. P., R. L. AVERY, P. G. ARRIGG, B. KEYT, H. D. JAMPOL, S. T. SHAH, L. R. PASQUALE, H. THIEMS, A. IWAMOTO, J. E. PARK, H. NGUYEN, L. M. AIELLO, N. FERRARA & G. L. KING. 1994. *N. Engl. J. Med.* **331**: 1480.
52. TOPOL, E. J. 1990. *Textbook of Interventional Cardiology*. W. B. Saunders Co. Philadelphia.

53. THOMPSON, R. W. & P. A. D'AMORE. 1990. *In: Clinical Ischemic Syndromes: Mechanisms and Consequences of Tissue Injury*. G. B. ZELENOCK, L. G. D'ALECY, J. C. FANTONE III, M. SHLAFFER & J. C. STANLEY, Eds. C. V. Mosby. St. Louis.
54. GRAOR, R. A. & B. H. GRAY. 1991. *In: Peripheral Vascular Diseases*. J. R. YOUNG, R. A. GRAOR, J. W. OLIN & J. R. BARTHOLOMEW, Eds. C. V. Mosby. St. Louis.
55. BAFFOUR, R., J. BERMAN, J. L. GARB, S. W. RHEE, J. KAUFMAN & P. J. FRIEDMAN. 1992. *Vasc. Surg.* **16**: 181.
56. TAKESHITA, S., L. ZHUNG, E. BROGI, M. KEARNEY, L-Q. PU, S. BUNTING, N. FERRARA, J. F. SYMES & J. M. ISNER. 1994. *J. Clin. Invest.* **93**: 662.
57. PU, L-Q., N. FERRARA, L. A. STEIN, A. D. SNIDERMAN, J. M. ISNER & J. F. SYMES. 1993. Abstract 66th Meeting American Heart Assoc. Nov. 8-11, 1993. Atlanta, GA.
58. WALDER, C. E., C. J. ERRETT, S. BUNTING, P. LINDQUIST, N. FERRARA & G. R. THOMAS. 1994. *FASEB J.* **8**: 764.
59. BANAI, S., M. SHOU, M. T. JAKTLISH, N. FERRARA, S. EPSTEIN & E. UNGER. 1992. 41st Sci. Sess. Am. Coll. Cardiol. April 12-16, 1992, Dallas, TX.
60. ESSED, C. D., M. V. D. BRAND & A. E. BECKER. 1983. *Br. Heart J.* **49**: 393.

Coronary Angiogenesis

From Morphometry to Molecular Biology and Back

KAREL RAKUSAN

*Department of Physiology
University of Ottawa
451 Smyth Road
Ottawa, Canada K1H 8M5*

INTRODUCTION

Research based on morphological methods and research based on the methods of molecular biology should complement each other, creating mutual influences, enrichments and cross-fertilizations. Morphometric mapping of cardiac vascularization in various physiological and pathological situations can provide a foundation for subsequent molecular biological investigations. For instance, evidence that most capillary growth in the rat heart takes place in the early stages of post-natal development^{1,2} was followed by the findings of concomitant changes in the expression of various growth factors.^{3,4} However, this ideal symbolic interaction has not yet been fully realized in the study of endothelial cell growth. Results obtained from *in vitro* examination of endothelial cells cannot be automatically extrapolated to the situation *in vivo*. For instance, transforming growth factor β , which suppresses the proliferation of endothelial cells *in vitro*, has an overall angiogenic effect *in vivo*.⁵ Several studies have reported differences between the *in vitro* reactions of endothelial cells obtained from larger vessels and the results using endothelial cells obtained from microvessels.^{5,6} Possible differences among endothelial cells obtained from vessels originating from various anatomical locations such as the coronary, cerebral or neural vasculatures have not yet been investigated. Investigations of angiogenesis by morphometry should permit the identification of situations associated with changes in vascularization, in order for molecular biology research to proceed under optimized conditions for the study of angiogenic mechanisms. Conversely, a morphometric finding of enhanced or impaired vascularization of tissue should serve as a final check of specific molecular biology manipulations.

Capillaries are remarkably stable structures. Turnover of endothelial cells in adult mammalian hearts is probably slightly faster than in most other tissues. Nevertheless, the cell half-life is estimated to be approximately 300 days.⁷ Similar estimates for the second type of capillary cell, pericytes, are not readily available. Most of the formation of new vascular material probably constitutes replacement of damaged cells and repopulation of denuded areas. An increased amount of capillary components in tissue, resulting in an increased capillary surface per volume of tissue, may take either of two forms: as an increase in the size of the vessel, as a result of increase in its width and/or length, or by the establishment of a new channel. While in both cases the result is an increased capillary surface

density, the latter situation is far more effective⁸ at increasing oxygenation. Thus, both the amount of new material as well as its geometrical arrangement are of functional importance.

It is possible to distinguish between *vasculogenesis*, which is usually defined as formation of new vessels *in situ* from pluripotent mesenchymal cells (angioblasts) and *angiogenesis*, defined as the outgrowth of new vessels from the preexisting network. Both cases have been documented during prenatal development of mammalian hearts.⁹⁻¹¹ In the case of rat heart, up to day 10 post-fertilization the endocardium is smooth, and the only mode of oxygen transport is by diffusion. This is followed by vasculogenesis in the form of sinusoids lined by a very thin endothelium which are located within the spongy musculature. Angiogenesis follows in the form of sprouts emanating from the branches of coronary arteries, starting in the subepicardial layer and proceeding towards the sinuses located in the endomyocardium. The newly formed vessels may subsequently regress, or persist as capillaries, or they may progress to form larger vessels of arterial or venous type.

Regulation of Vascular Growth

Regulation of vascular growth is a complex phenomenon, and various authors have proposed many putative mechanisms of angiogenesis. The three main stimuli most commonly considered are: 1) mechanical factors, 2) energy imbalance due to hypoxia and 3) inflammatory processes (FIG. 1). They were recently summarized by Hudlicka *et al.*¹² with a special emphasis on mechanical factors. The most prominent mechanical factors are a) an increased red blood cell-endothelial cell interaction, as in polycythemia, b) an increased wall tension as a result of an increased capillary pressure, and, c) an increased shear stress which occurs with increased velocity of flow. The energy imbalance hypothesis was reviewed by Adair *et al.*,¹³ who considered various situations of prolonged imbalances between the perfusion capabilities of blood vessels and the metabolic requirements of tissue. Changes in oxygenation have been implicated as a major triggering and controlling element. Finally, Shaper¹⁴ stressed the importance of inflammatory pro-

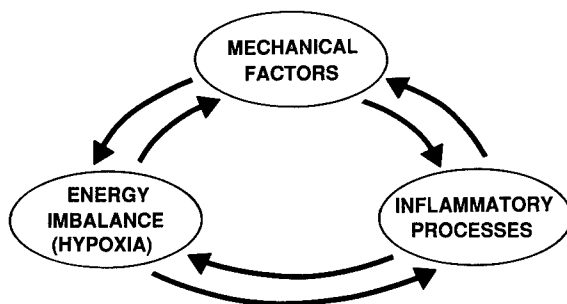

FIGURE 1. Major factors leading to the initiation of angiogenesis.

cesses associated with activation of endothelial cells and probably platelets, both of which express the adhesion molecules for monocytes. Monocytes, in turn would be the major source of the angiogenic growth factors.

Obviously, the above mechanisms are not mutually exclusive (FIG. 1). In fact, there are likely to be continual interactions among them, and each process of angiogenesis may be considered a mixture of these three aspects. As an illustration, inadequate oxygenation results in tissue hypoxia which is associated with adenosine-induced vasodilation and results in stretch of the vessel wall (*i.e.*, a mechanical factor). The associated increase in local blood flow can increase shear stress. Moreover, chronic hypoxia would also be accompanied by polycythemia which increases the red blood cell-endothelial cell interaction, a third mechanical factor. Alternatively, abnormal shear forces in the vessels may lead to the activation of endothelial cells, which would produce adhesion molecules, and thus initiate inflammatory processes.

The exact mechanisms of vascular growth are even more complex and less well understood. A survey of the literature shows that over fifty putative factors may be involved in angiogenesis. The list extends from simple ions like copper, magnesium and selenium to complex growth factors. The role of various growth factors in angiogenesis was recently reviewed by several authors.^{5,15-17} Effects vary depending on the environment and the concentration of these substances, with different results often obtained under *in vivo* and *in vitro* experimental conditions. They may positively or negatively influence various stages of the angiogenic cascade. The most often cited angiogenic peptides which are effective both *in vivo* and *in vitro* are acidic and basic fibroblast growth factors (FGF family), vascular endothelial growth factor (VEGF) and a similar vascular permeability factor (VPF), transforming growth factor alpha ($TGF\alpha$) and related epidermal growth factor (EGF) which share the same receptor, and, finally, platelet-derived endothelial cell growth factor (PD-ECGF).¹⁶⁻¹⁹ The cited references discuss these and additional angiogenic factors in depth. It is worth noting that from the above-mentioned growth factors, VEGF/VPF and PD-ECGF are mitogenic factors highly specific for endothelial cells, and VEGF may be induced by hypoxia. Basic FGF seems to be more potent *in vitro*, but acidic FGF is present in higher amount in the heart muscle. In addition to the above factors which are endothelial cell mitogens, there are angiogenic factors which are not mitogenic (*e.g.*, angiogenin) or are even inhibitory to endothelial cell proliferation *in vitro* (*e.g.*, transforming growth factor beta, $TGF\beta$, and tumor necrosis factor α , $TNF\alpha$).

In addition to the angiogenic factors above, vascular growth can be further modified and regulated by local geometric conditions: endothelial size and shape and the location of other cell types such as smooth muscle cells, pericytes, platelets, macrophages and mast cells. For instance, based on *in vitro* studies, it seems that flatter endothelial cells are characterized by higher DNA synthesis.¹⁸ *In vitro* studies have also revealed the inhibitory effect of smooth muscle cells and pericytes on the proliferation of endothelial cells. On the other hand, macrophages, in certain situations, may play a triggering and maintaining role in angiogenesis, which may be further enhanced by the degranulation of mast cells. The arrangement and composition of the extracellular matrix can also influence the final response. The extracellular matrix is not simply a mechanical scaffolding; its ar-

rangement and composition are equally important. For instance, when endothelial cells are plated on a basement membrane substrate (collagens IV and V), their proliferation slows down and early formation of tubes occurs. In contrast, the presence of the interstitial substrate (collagens I and III) results in cell proliferation, and the late, occasional appearance of tube-like structures.¹⁹

The complexity of the endothelial growth process and the large number of apparently redundant angiogenic factors are, according to Klagsbrun and D'Amore,¹⁶ a clear indication of the vital importance of the process itself. It appears that tissue does not rely on one angiogenic factor alone. Indeed, the fine tuning and interaction of various systems maintains this delicate balance for the optimal arrangement of vascular geometry.

Morphological Substrate of Angiogenesis

Figure 2 depicts all the major morphological components of the stable vessel which are potentially involved in the process of angiogenesis. The most prominent are the flat *endothelial cells*; usually two endothelial cells are required to encircle the capillary lumen. These cells can no longer be regarded as merely a passive lining of the microvessels, but rather must be considered in composite as a large and extremely active endocrine organ. The capillary as a whole is wrapped in a *basement membrane* which is only a fraction of the thickness of the endothelial cells. The basement membrane also covers infrequently occurring *pericytes* which are similar to smooth muscle cells. Pericytes probably contribute to the regulation of the vessel size and control the proliferation of endothelial cells. These "octopus like" cells can contact and regulate the growth of up to ten endothelial cells.²⁰ This regulation requires cell-to-cell contact and is probably mediated by $TGF\beta_1$ which suppresses endothelial proliferation. Therefore, it is not surprising that the highest ratio of pericytes to endothelial cells is in the retina where endothelial cell turnover is the lowest (approximately 1,000 days). Moreover, the dropout of

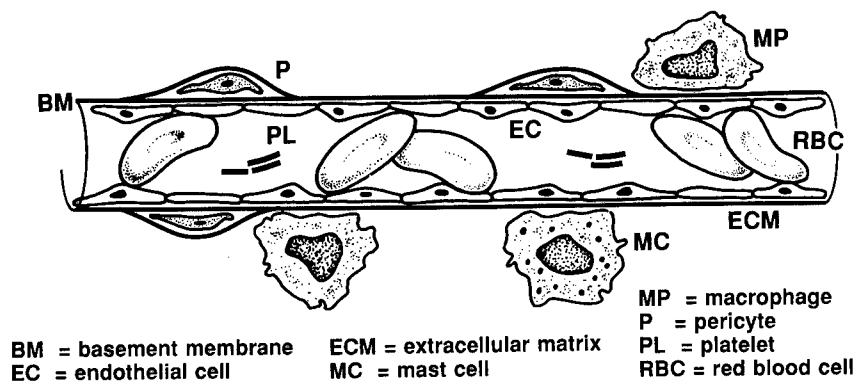

FIGURE 2. Stage 0 of angiogenesis: stable vessel. Major components of normal, stable capillary which can be involved in angiogenesis.

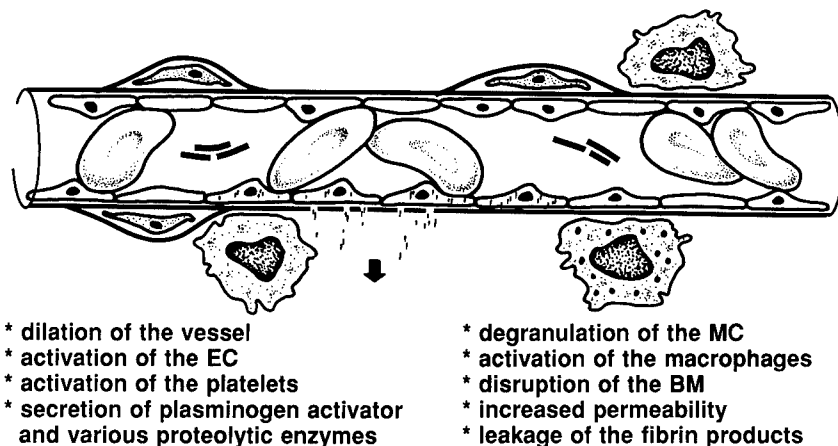

FIGURE 3. Stage 1 of angiogenesis: changes within the existing vessel.

pericytes correlates with the onset of retinal neovascularization in diabetes.²¹ In cardiac muscle, pericytes cover approximately 11%, and in skeletal muscle 21%, of the capillary surface.²² It would be interesting to compare angiogenic capacities of these two types of muscle.

Macrophages are another important and sometimes pivotal source of angiogenic factors, and are involved in all stages of vessel formation.^{25,26} Their angiogenic activity increases during hypoxia, or during phagocytosis of fibrin. The most prominent products of macrophages are $TNF\alpha$, $TGF\beta$, FGF, PDGF, colony-stimulating factor, interleukins 1 and 6, and interferon α .²³ Another source of modulation is provided by activated platelets (source of PD-ECGF, PDGF and $TGF\beta$) and the products of mast cell degranulation (histamine, heparin and various proteases).

As described in the previous section, the extracellular matrix plays an important role in the angiogenic process. The effect of various types of collagen on endothelial cell proliferation, motility and tube formation was described, as was the importance of noncollagenous adhesion molecules like laminin and fibronectin. Equally important are proteoglycans like heparins which act as a repository for angiogenic factors with an affinity for heparin. Heparins play an additional role as low-affinity receptors for these factors. Finally, fibrin deposits from the local extravasation of plasma fibrinogen may provide a provisional matrix for the sprouting vessel in addition to exhibiting chemotactic activities.

We propose that the process of vascular neof ormation can be divided into three main stages, as depicted in Figures 3–5: stage 1, changes within the existing vessel, stage 2, formation of a new channel and stage 3, maturation of the new vessel. In reality, angiogenesis occurs in discrete, overlapping steps and the above division into three stages is mainly didactic. Moreover, not all the described processes are present in every situation involving angiogenesis.

Major changes during stage 1 are summarized in FIGURE 3. One of the early

events is the dilation of the vessel. This is followed by the activation of the endothelial cells which, as a result of their stretching, show an increased sensitivity to various growth factors. The endothelial cells respond by secreting plasminogen activator and a variety of proteolytic enzymes, which dissolve the extracellular matrix where the growth factors, especially FGF, are stored. Subsequently, the basement membrane becomes disrupted and local extravasation of plasma takes place. Leaked fibrin and its products serve as a provisional matrix for future growth. Also, the activated endothelial cells start to synthesize new DNA while they are still within the parent vessel. Additional growth factors are provided by activated platelets and macrophages present at the site. This is further supported by the degranulation of mast cells, which are usually located in the vicinity of the vascular wall.

Stage 2 marks the formation of a new channel (FIG. 4). The process starts with the complete disruption of the basement membrane and degradation of the local extracellular matrix. The endothelial cells form pseudopodia and finally start to migrate, often attracted by the growth factors secreted by macrophages. The leading endothelial cells do not proliferate. Mitotic activity is concentrated in the region of endothelial cells following the "lead" cells. The latter step is the formation of tubes and loops.

The formation of new patent channels marks the beginning of *stage 3*, *i.e.*, maturation of the new vessel and final differentiation of all cells (FIG. 5). During this time, new connections are being formed and blood flow is finally established. Only at this stage is a basement membrane synthesized. The basement membrane of growing vessels is exceedingly thin, sometimes barely recognizable and new capillaries are relatively leaky. Maturation of the capillary wall is aided by the

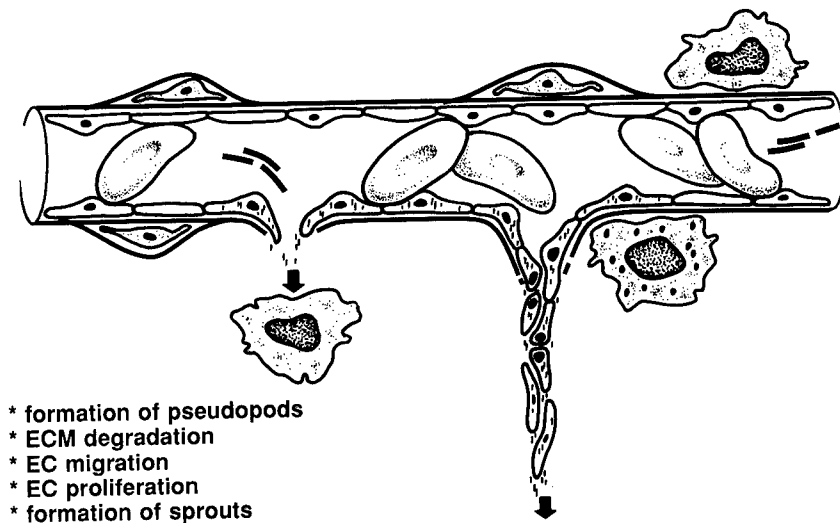

FIGURE 4. Stage 2 of angiogenesis: formation of a new channel.

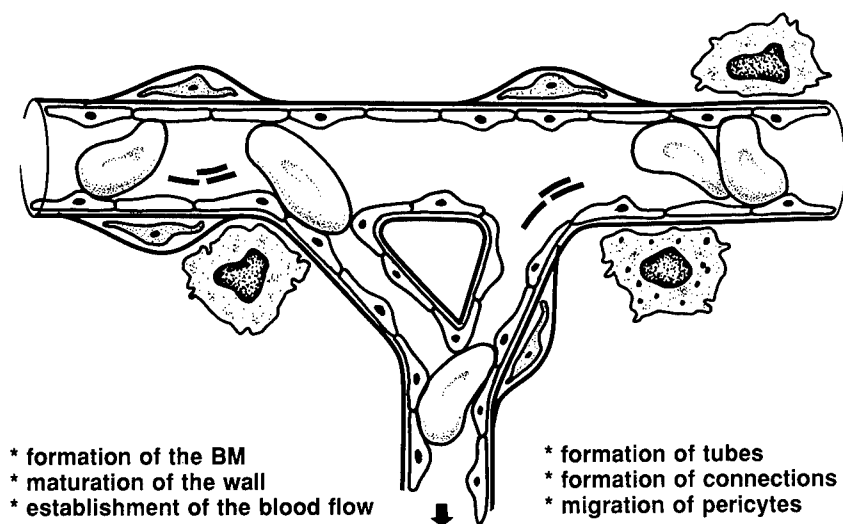

FIGURE 5. Stage 3 of angiogenesis: maturation of the new vessel.

presence of pericytes and fibroblasts which migrate to the site of a newly formed vessel.

Verification of the Results of Angiogenesis

One of the most important conclusions from the above events is the importance of optimal geometry of the terminal vascular bed, which is secured by several systems responsible for keeping the proper balance between stimulation and inhibition of vascular growth. The final outcome must be reflected in the actual situation in any individual tissue. We have repeatedly analyzed the effect of coronary capillary geometry on myocardial oxygenation.^{24,25} The first step is to determine reliable quantitative parameters.

The capillary supply of the heart is traditionally characterized by the numerical capillary density, that is the number of capillaries per unit of tissue cross-section. This is a good global indicator of capillary supply, which may be superseded by more advanced stereological parameters, such as capillary length density, capillary surface density or volume density of capillaries. Global indicators of capillary supply are, of course, not suitable for evaluating local capillarization in a small region. In this case, measurements of the local capillary domains, capillary segment lengths and capillary supply units are more appropriate.

Capillary domains are derived from tissue cross-sections with a domain being defined as a tissue region which is closer to a given capillary than to any other. The distribution of domain sizes serves as an indicator of the heterogeneity of capillary spacing. Until recently, data concerning longitudinal parameters were rare and at best semiquantitative. The task of following capillaries within longitudi-

nal sections is rather difficult. Our recent histochemical methods enable us to distinguish between the proximal (arteriolar) and distal (venular) portions of the capillary bed.²⁶ Thus, various longitudinal parameters can be measured, the most important of them being the capillary segment length (the distance between two ensuing branch points). Finally, values of arteriolar and venular capillary domain areas, and of arteriolar and venular segment lengths may be used to calculate the volume of a three-dimensional region of tissue supplied by a capillary segment. This product of the capillary domain area and capillary segment length is defined as the capillary supply unit.²⁷ In the following section we will provide several examples of the application of morphometric methods to the evaluation of angiogenic processes in cardiac tissue.

In mammalian hearts, the early postnatal period is marked by a substantial proliferation of new capillaries. According to our estimates, close to one half of all the capillaries present in the adult heart are formed during the first four postnatal weeks.²⁸ It is of interest that the rapid formation of new capillaries is accompanied by an increasing presence of mast cells in the heart. This is supported by our recent study of mast cells and coronary capillaries during postnatal development of the rat heart. From postnatal day 11 to day 30, the left ventricular mass increased 2.7 times, while the estimated total capillary length increased 19 times and the total number of mast cells increased 29 times. In contrast, from day 30 to day 270, further increases in left ventricular mass amounted to an additional 217% compared with only 59% for capillary length and 18% for mast cells. More detailed analysis of hearts from rats at 21 to 240 days of age revealed that the size of the capillary supply unit was smaller on the arteriolar (proximal) side of the capillary net than on the venular (distal) side. This difference was detectable even in the youngest animals and increased with increasing size of the heart. The size of the capillary supply unit also increased with the age and growth of the animal, due to increases in both domain area and segment length.²⁹ These results indicate a rapid expansion of the capillary net during the early stages of postnatal development, while after the weaning period, the growth of capillaries is less than the concomitant increase in the size of myocytes and cardiac weight.

Capillary growth may be detected even in the adult heart, as illustrated in the following two examples. The rate of growth, however, is substantially smaller than during the early postnatal period described above.

The treatment of adult WKY rats and spontaneously hypertensive rats with the calcium channel blocker nifedipine resulted in a moderate capillary growth. This was due to both increased branching of capillaries, resulting in smaller capillary domains, and an increased length of existing capillary segments. Capillary growth was evenly distributed between proximal and distal segments as documented by an unchanged proportion of these two components of the capillary net.³⁰

Another example of moderate capillary growth in the adult heart was found in rats treated with thyroxine. Capillary density in the hyperthyroid group was almost identical to capillary density in control hearts, despite the presence of considerable cardiac hypertrophy (over 50%). In this experimental situation, however, the formation of new capillary branches took place mainly along the proximal portion of the capillaries, which resulted in disappearance of the normally seen difference

between larger, proximal domains and smaller, distal domains. This was also supported by the finding of shorter segment lengths and an increase in the number of segments per path on the proximal side of capillaries in hearts with thyroxine-induced hypertrophy.³¹

SUMMARY AND CONCLUSIONS

We have reviewed briefly the current state of knowledge relating to the regulation of angiogenesis, including the role of angiogenic growth factors, and we have described the major structural components of the vascular wall and their changes during formation of new channels. Finally, we have described quantitative evaluations of vascular growth in cardiac muscle. Examples of substantial angiogenesis during the early postnatal stages of normal development were used together with examples depicting a more moderate stimulation of capillary growth in adult rat hearts treated with nifedipine or thyroxine.

Adequate capillary supply is a precondition for tissue survival and proper function. This is probably why vascular growth is so tightly regulated by several systems which may alternately stimulate or inhibit the formation of new vessels. Recent advances in molecular biology have enabled us to study the mechanisms of angiogenesis under both *in vitro* and *in vivo* conditions, but the final assessment of vascular growth should be accomplished through morphometric analysis.

REFERENCES

1. RAKUSAN, K. 1984 Cardiac growth, maturation and aging. *In* Growth of the Heart in Health Disease. R. Zak, Ed. 131–164. Raven Press. New York.
2. RAKUSAN, K. & Z. TUREK. 1985. *Circ. Res.* **37**: 393–399.
3. ENGELMANN, G. L., C. A. DIONNE & M. C. JAYE. 1991. *Ann. N.Y. Acad. Sci.* **638**: 463–466.
4. ENGELMANN, G. L., C. A. DIONNE & M. C. JAYE. 1993. *Circ. Res.* **72**: 7–19.
5. SCHOTT, R. J. & L. A. MORROW. 1993. *Cardiovasc. Res.* **27**: 1155–1161.
6. BOBIK, A. & J. H. CAMPBELL. 1993. *Pharmacol. Rev.* **45**: 1–32.
7. HUDLICKA, O. 1991. *J. Physiol.* **444**: 1–24.
8. RAKUSAN, K. & Z. TUREK. 1986. *Can. J. Cardiol.* **2**: 94–97.
9. OSTADAL, B., T. H. SCHIEBLER & Z. RYCHTER. 1975. *Adv. Exp. Med. Biol.* **53**: 375–388.
10. HUDLICKA, O. & K. R. TYLER. 1986. *Angiogenesis*. Academic Press. London.
11. RAKUSAN, K. 1990. Development of cardiac vasculature. *In* Handbook of Human Growth and Developmental Biology, III/B. E. Meisami & P. S. Timiras, Eds. 101–106. CRC Press. Boca Raton, FL.
12. HUDLICKA, O., M. BROWN & S. EGGINTON. 1992. *Physiol. Rev.* **72**: 369–417.
13. ADAIR, T. H., W. J. GAY & W. J. MONTANI. 1990. *Am. J. Physiol.* **259**: R393–R404.
14. SCHAPER, W. 1993. *Basic Res. Cardiol.* **88**: 193–198.
15. FOLKMAN, J. & Y. SHING. 1992. *J. Biol. Chem.* **267**: 10931–10934.
16. KLAGSBRUN, M. & P. D. D'AMORE. 1991. *Annu. Rev. Physiol.* **53**: 217–239.
17. KLAGSBRUN, M. & J. FOLKMAN. 1990. Angiogenesis. *In* Peptide Growth Factors and Their Receptors. M. B. Sporn & A. B. Roberts, Eds. 549–586. Springer-Verlag. Berlin.
18. FOLKMAN, J. & A. MOSCONA. 1978. *Nature* **273**: 345–349.
19. MADRI, J. A., S. K. WILLIAMS, T. WYATT & C. MEZZIO. 1983. *J. Cell Biol.* **97**: 153–165.
20. NEHLS, V. & D. DRENCKHAHN. 1991. *J. Cell Biol.* **113**: 147–154.

21. D'OLIVEIRA. 1966. *Br. J. Ophthalmol.* **50**: 134-143.
22. TILTON, R. G., C. KILO & J. R. WILLIAMSON. 1979. *Microvasc. Res.* **18**: 325-335.
23. SCHAPER, W. 1991. *In Endothelial Mechanisms of Vasomotor Control*. H. Drexler, A. M. Zeiher, E. Bassenge & H. Just, Eds. 51-55. Steinkopff Verlag. Darmstadt.
24. TUREK, Z., K. RAKUSAN, J. OLDERS, L. HOOFD & F. KREUZER. 1991. *J. Appl. Physiol.* **70**: 1845.
25. TUREK, Z., L. HOOFD & K. RAKUSAN. 1986. *Can. J. Cardiol.* **2**: 98-103.
26. BATRA, S. & K. RAKUSAN. 1991. *Microvasc. Res.* **41**: 39-50.
27. RAKUSAN, K., S. BATRA & M. I. HERON. 1994. *Proc. Soc. Exp. Biol. Med.* In Press.
28. RAKUSAN, K., K. SARKAR, Z. TUREK & P. WICKER. 1990. *Circ. Res.* **66**: 511-516.
29. BATRA, S. & K. RAKUSAN. 1992. *Am. J. Physiol.* **262**: H635-H640.
30. RAKUSAN, K., N. CICUTTI, S. KAZDA & Z. TUREK. 1994. *Hypertension* **24**: 205-211.
31. HERON, M. I. & K. RAKUSAN. 1994. *Am. J. Physiol.* **267**: H1024-H1031.

Cardiomyocyte Transfer into the Mammalian Heart

Cell-to-Cell Interactions *In Vivo* and *In Vitro*

JOSEPH B. DELCARPIO^{a,c} AND WILLIAM C. CLAYCOMB^b

^a *Department of Anatomy*
and

^b *Department of Biochemistry and Molecular Biology*
Louisiana State University Medical Center
1901 Perdido Street
New Orleans, Louisiana 70112-1393

INTRODUCTION

Skeletal muscle has the limited ability to regenerate following injury, owing to the presence of satellite cells. However, the adult heart has no such reserve capacity. Following injury to the myocardium, as a result of infarct or progressive heart diseases such as cardiomyopathy, cardiac muscle cells are lost resulting in a decline in ventricular function and ultimately failure. Several rather interesting approaches to repair damaged heart muscle have been investigated. Cardiomyoplasty has been used in which a part of the latissimus dorsi muscle, still attached to its nerve and vascular supply, was used, with limited success, to improve hemodynamic function in animals and in patients with dilated or ischemic cardiomyopathy.¹ This muscle has also been used to create an aortic diastolic counterpulsator, a sort of additional or second left ventricle.²

In a recent study, a line of skeletal muscle myoblasts derived from mouse skeletal muscle satellite cells called C2C12 cells³ were injected into mouse hearts.⁴ The C2C12 cells differentiated into myotubes, but apparently formed no functional junctions with the normal ventricular muscle cells, nor was there an apparent affect on cardiac output. Nevertheless, there was an absence of encapsulation or cellular response.

The above studies all employed either skeletal muscle or cells derived from skeletal muscle satellite cells. Over the last few years, transgenic mice were produced in which expression of the SV40 large T antigen was targeted to the cardiac atria.⁵ These mice typically exhibit unilateral right atrial tumorigenesis. Transgenic atrial cardiomyocytes isolated from these atria can give rise to transplantable tumor lineages when injected subcutaneously into syngeneic host mice.⁶⁻⁸ Cardiomyocytes derived from the transplantable tumor lineage, but not from the primary tumor, retain the capacity to proliferate in culture, and express cardiac specific genes.^{7,9} These cardiomyocytes exhibit all the morphological characteristics typi-

^c Correspondent: J. B. Delcarpio, Ph.D., Department of Anatomy, LSU Medical Center, 1901 Perdido Street, New Orleans, LA 70112-1393.

cal of normal adult atrial cardiac myocytes while retaining the ability to proliferate and have been designated AT-1 cells.⁸ These cells could therefore serve as an excellent continuous source of new material for the study of cardiac cell cycle events, as potential vectors for future gene therapies or as direct myocardial cell replacement for damaged hearts.

Towards this goal, freshly isolated AT-1 cells from subcutaneous tumors injected into host ventricles of syngeneic mice by us and others¹⁰ demonstrated that AT-1 cells were able to form intracardiac grafts without any evidence of myocardial dysfunction. However, they were unable to demonstrate cardiac-specific junctions between the grafted cells and normal ventricular myocytes. Using similar techniques, but injecting AT-1 cells into both syngeneic mice and immunosuppressed rats, we were able to demonstrate that AT-1 cells could form nascent intercalated disks with each other and morphologically rudimentary junctions with adjacent host myocytes.¹¹ In addition, we employed a co-culture system to demonstrate that AT-1 cells and normal neonatal rat ventricular cardiac muscle cells could form functional and morphological cardiac-specific junctional complexes.¹² These studies indicate that AT-1 cells can be used successfully in xenographic transplants as well as homographic transplants.

All these models involve the use of *in vivo* systems. Such studies make it difficult to access cell-to-cell interactions independent of the many physiological influences of the animal. Therefore, the use of a cell culture system to isolate the interacting normal cardiac muscle cells and AT-1 cells from these "background" influences may lead to a clearer picture of the ability of transplanted AT-1 cells and other transplanted cardiac muscle cells to interact with normal heart muscle cells. A discussion of these studies is presented in this paper.

METHODS

Cardiomyocyte Grafts

Injection of Cardiomyocytes into Rodents

Adult female C57BL/6J mice were anesthetized with 1.2% Avertin (Aldrich; Milwaukee, WI), intubated and ventilated with a pressure controlled respirator (Kent Scientific, Litchfield, CT). Using aseptic technique, a left parasternal thoracotomy was performed and the thoracic cavity opened exposing the heart. Ten μ l (approximately 10^4 cardiomyocytes in Joklik's medium) were injected into the ventricular wall using a glass micropuncture needle connected to a 100- μ l Hamilton syringe (Hamilton Co., Reno, Nevada). Control rodents received an injection of 10 μ l Joklik's medium only. The thoracic cavity was closed and evacuated. Lungs were inflated at a high positive end-expiratory pressure. Buprenex® (10 μ l, 0.3 mg buprenorphine/ml) was administered as necessary for pain.

Techniques similar to those mentioned for mice were utilized for adult female Sprague Dawley rats (190–220 g) with the following modifications. To prevent rejection of injected AT-1 cells, Cyclosporine (SandImmune™, Sandoz Pharmaceutical Corp., East Hanover, NJ) was administered by gavage tube (5 mg/kg)

approximately one day prior to surgery and then once daily thereafter to prevent rejection of the mouse AT-1 cells. Animals were sacrificed and hearts examined at various intervals post-injection using light and transmission electron microscopy.

Tissue Culture

Co-cultures

In order to assess the ability of cardiomyocytes from different species and ages to interact and to minimize the influence of physiological factors, such as the immune system, a series of co-culture experiments were employed. AT-1 cells were placed into culture with normal ventricular cardiac muscle cells from neonatal and adult rat. AT-1 cells were isolated from subcutaneous tumors excised from syngeneic hosts placed into tissue culture and combined with normal rat ventricular muscle cells. In addition, normal neonatal rat ventricular cardiomyocytes were placed in co-culture with adult rat ventricular cardiomyocytes.

Preparation of Isolated Fetal and Neonatal Rat Cardiomyocytes

Isolation and culturing of fetal and neonatal rat ventricular cardiac muscle cells followed exactly previously published protocols.¹³ Briefly, the hearts of two-day-old neonatal rats were dissected out, minced, and rinsed in sterile PBS. Tissue pieces were shaken overnight in 0.125% trypsin (GIBCO) in PBS at 4°C. After 16 hr, they were rinsed in PBS, and subjected to 4 or 5 sequential digestions in 0.1% collagenase in PBS at 37°C. Isolated cells from each digestion were rinsed in PBS and pooled.

Freshly isolated normal neonatal rat cardiomyocytes were mixed with freshly isolated AT-1 cells and plated into T25 flasks at a combined seeding density of 500,000 cells/ml (250,000 AT-1 and 250,000 ventricular cells). Also, for immunocytochemical studies, co-cultures were established in 12-well multiwell plates containing 15 mm circular glass coverslips. These were plated at 200,000 cells/well. Flasks and glass coverslips were precoated with gelatin/fibronectin 2 $\mu\text{g}/\text{cm}^2$.

Preparation of Adult Rat Ventricular Cardiomyocytes

Ventricular cardiomyocytes were isolated from adult female rats (200–300 g) using the protocols of Claycomb and Palazzo¹⁴ and modified after Claycomb and Lanson.¹⁵ Rats were anesthetized, and their hearts were removed and placed into cold Joklik's medium. Hearts were then attached to a short Friedrich's condenser by a three-way stopcock, perfused retrograde through the aorta with enzyme-free Joklik's medium. This was followed immediately by retrograde perfusion with Joklik's medium containing 1 mg/ml of Type II collagenase (Worthington). All solutions were maintained at 37°C and gassed with a 0.8 μm filtered mixture of 95% O₂, 5% CO₂. Once softened, the hearts were removed, minced, and subjected to gentle digestion in fresh collagenase by stirring in a heated rotating shaker bath.

Every 10 min, cells were collected, washed in serum free Joklik's medium, and pooled.

Unlike cultured neonatal rat cardiomyocytes, adult rat cardiomyocytes require up to a week to adapt to culture. Consequently, adult rat cardiomyocytes were placed into culture (500,000/ml) and left undisturbed for three days. This was followed by treatment with cytosine arabinoside, to eliminate noncardiomyocytes. On day seven, this medium was exchanged with normal ExCell 320 medium (JRH Biosciences, Lenexa, KS) supplemented with various nutrients as described below. Adult cardiomyocytes were then allowed to continue in mono-culture for 3 more days. On day 10, either AT-1 cells or neonatal rat ventricular cardiomyocytes were added at approximately 50,000/ml to the adult cardiomyocyte cultures. Co-cultures were carried for 2 to 4 days and then fixed for microscopy.

Preparation of AT-1 Cells

AT-1 cells were isolated from subcutaneous atrial tumors using techniques published earlier.^{7,8} Briefly, the tumors were excised from their subcutaneous location and rinsed in PBS. Tumors were minced in PBS, transferred to a trypsinizing flask containing 0.125% trypsin and treated as described above for neonatal rat ventricles. Cells were counted, pooled with cells isolated from normal ventricles and plated at a seeding density described above.

In those studies in which AT-1 cells were cultured prior to combining with normal cardiomyocytes, confluent cultures of AT-1 cells were trypsinized using a 0.05% solution of trypsin (GIBCO). Briefly, T25 flasks were rinsed with 3 ml of trypsin and then exposed to 1 ml of trypsin at 37°C for 7 min. Once the cells were free of the substrate, soybean trypsin inhibitor (GIBCO) was added at a concentration of 0.025 g/100 ml PBS. Approximately 250,000 AT-1 cells/ml were combined with the already isolated rat ventricular heart cells.

Cultures were grown in ExCell 320 with supplement, (JRH Biosciences), 5% fetal bovine serum (Whittaker), 10 μ g/ml insulin (GIBCO), 100 U/ml penicillin, 100 μ g/ml streptomycin (GIBCO), an additional 1X nonessential amino acids (GIBCO). Cells were fed at 5 ml/T25 flask approximately every 48 hrs, 15 ml/T75, or 1 ml/well for 12-well multiwell flasks. Cultures were maintained in a 100% humidified 5% CO₂ incubator at 37°C.

Mono-Cell Cultures

In addition to co-cultures, mono-cultures consisting of only one cardiac muscle cell type of either AT-1, neonatal, or adult ventricular muscle cells were plated at the same cell density and subjected to exactly the same culture conditions as the co-cultures.

All cultures were fixed for light and electron microscopy at various times post-plating. Cultures were monitored by inverted phase-contrast, fluorescence, and electron microscopy.

Microscopy

Electron Microscopy of Whole Tissue

Avertin or phenobarbital was administered to adult mice and rats, respectively, and a catheter was inserted into the carotid. Animals were perfused with a phosphate buffered 4% paraformaldehyde-1% glutaraldehyde fixative. Excised whole hearts were fixed overnight in 4.0% glutaraldehyde/0.1 M sodium cacodylate, then rinsed three times for 10 min each in 0.1 M sodium cacodylate buffer.

Tissue samples were post-fixed in 1.0% osmium tetroxide/0.1 M sodium cacodylate, *en bloc* stained using 0.5% aqueous uranyl acetate, dehydrated in acetone, and infiltrated and embedded in Polybed 812 (Polysciences). Thin sections were examined in a JEOL 1210 transmission electron microscope at 60 kV. Images were obtained on Kodak 4489 EM film.

Standard Light Histology

Adjacent blocks of tissue were prepared for light microscopy, embedded in paraffin, sectioned, and stained with hematoxylin (H) and eosin (E).

Electron Microscopy of Cultures

Cultures were prepared for electron microscopy using standard *in situ* techniques.¹⁶ Cells were fixed *in situ* in 4.0% glutaraldehyde/0.1 M sodium cacodylate, post-fixed in 1.0% osmium tetroxide/0.1 M sodium cacodylate and *en bloc* stained using 0.5% aqueous uranyl acetate. This was followed by dehydration in a graded alcohol series rather than in acetones, since the tissue culture flasks are soluble in acetone. The remaining steps were identical to the EM procedures described for whole tissue.

Light Microscopy of Cultured Cells

Simultaneous video and photographic images of the contracting activity and morphology of co-cultures and mono-cultures were captured using a Nikon Diaphot Inverted Phase-contrast Microscope equipped with a 35-mm camera and a black and white video camera.

To identify AT-1 cells and determine the extent of cell-to-cell interaction, immunofluorescence and confocal laser microscopy was employed. Since AT-1 cells are derived from a transgenic mouse line expressing large T antigen (TAG),⁵ AT-1 cells were labeled in culture using a mouse monoclonal rabbit anti-TAG antibody (Oncogene Science). Cardiac-specific markers including myosin and desmin (Hybridoma Bank) were used to study the formation of myofibrils. Anti-pan-cadherin (Sigma Immunochemicals) was used to identify adherens-type junctions found in intercalated discs.

Desmin and myosin were localized using procedures modified after Danto¹⁷

and Bader *et al.*,¹⁸ respectively. Cultures were fixed in methanol for 8 min followed by acetone for 8 min, both at -20°C , rinsed in PBS and exposed to the antibody overnight at 4°C . All primary antibodies were followed by the appropriate secondary antibodies conjugated to either rhodamine or fluorescein (FITC).

In dual-labeling experiments, co-cultures were rinsed in PBS, fixed in 2.5% paraformaldehyde in PBS for 5 min at 20°C , permeabilized with 0.5% Triton X-100 in PBS for 3 min at 20°C , post-fixed in methanol at -20°C for 8 min, rinsed in PBS and exposed to the primary antibody at 4°C overnight. This was followed by exposure to the rabbit anti-mouse monoclonal antibody to large T antigen overnight at 4°C . The next day coverslips were washed 3×10 min each in PBS and labeled using a rhodamine-conjugated goat anti-rabbit (Sigma) secondary antibody. After washing twice with PBS and once with distilled water, the coverslips were exposed to a primary mouse monoclonal antibody to pan-cadherin for 1 hr at 37°C , washed extensively in PBS, and labeled with a secondary antibody consisting of FITC-conjugated rabbit anti-mouse IgG (Santa Cruz). Cultures were examined on a Leica Confocal Scanning Electron Microscope (CLSM) equipped with an optical drive for the storage and retrieval of data. Selected images were captured using a Polaroid 35-mm Image Capture system on T-Max 35-mm black and white film.

RESULTS

AT-1 Cell Grafts

In H and E stained sections, AT-1 cell grafts were easily identifiable by their intense basophilia at one month post injection (FIGS. 1a, 2a). In both syngeneic hosts (FIG. 1b) and in immunosuppressed adult rats (FIG. 2b) numerous blood vessels penetrated the graft areas. These vessels varied in size from that of capillaries to small arterioles. Blood vessels of larger cross-sectional area coursed through the graft regions compared to the size of vessels in the adjacent host myocardium (FIG. 1b). This was more apparent in specimens perfused with a buffer wash containing heparin prior to fixation (FIG. 2b).

Electron microscopic examination confirmed the presence of AT-1 cells in the basophilic graft regions. Characteristic atrial-specific granules (FIG. 3a), and loosely organized myofibrils (FIG. 3b) were observed in these cells. Transplanted cardiomyocytes formed nascent junctional complexes with each other (FIG. 3b). While clearly defined junctions were not observed between graft AT-1 cells and host heart cells, collagen microfibrils were seen spanning the intercellular space of closely apposed AT-1 cells and host cardiomyocytes.

Co-Cultures

In mono-culture, AT-1 cells and both neonatal and adult cardiomyocytes had unique morphologies which afforded easy identification as to cell type. AT-1 cells were shaped like flattened discs, usually containing a single centrally placed nu-

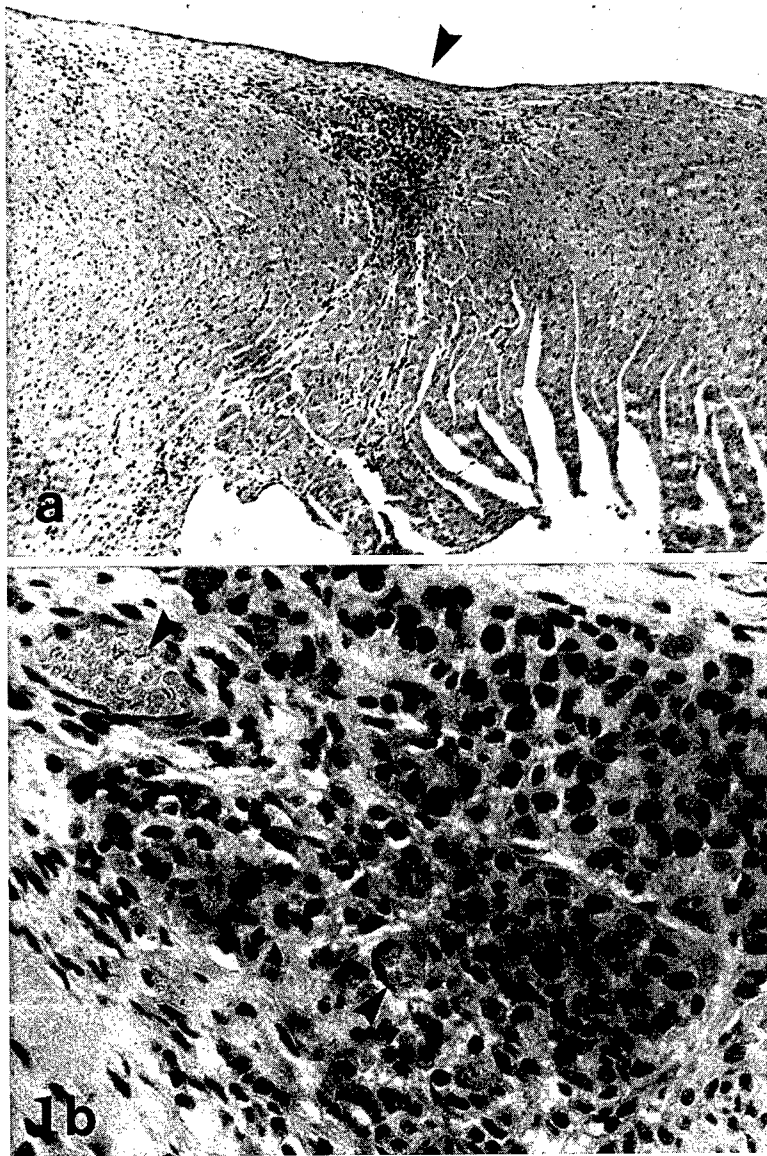

FIGURE 1. Four weeks post-transplantation of AT-1 cells into adult mouse ventricle. (a) Injected AT-1 cells, easily identified by their slight basophilia (*arrowhead*), have begun to establish themselves in the host myocardium. $\times 80$. (b) Enlargement of the area indicated by the arrowhead in (a). Note the greater nuclear to cytoplasmic ratio of the AT-1 cells compared to the host cardiomyocytes and the vessels present in the graft (*arrowheads*). H & E. $\times 450$.

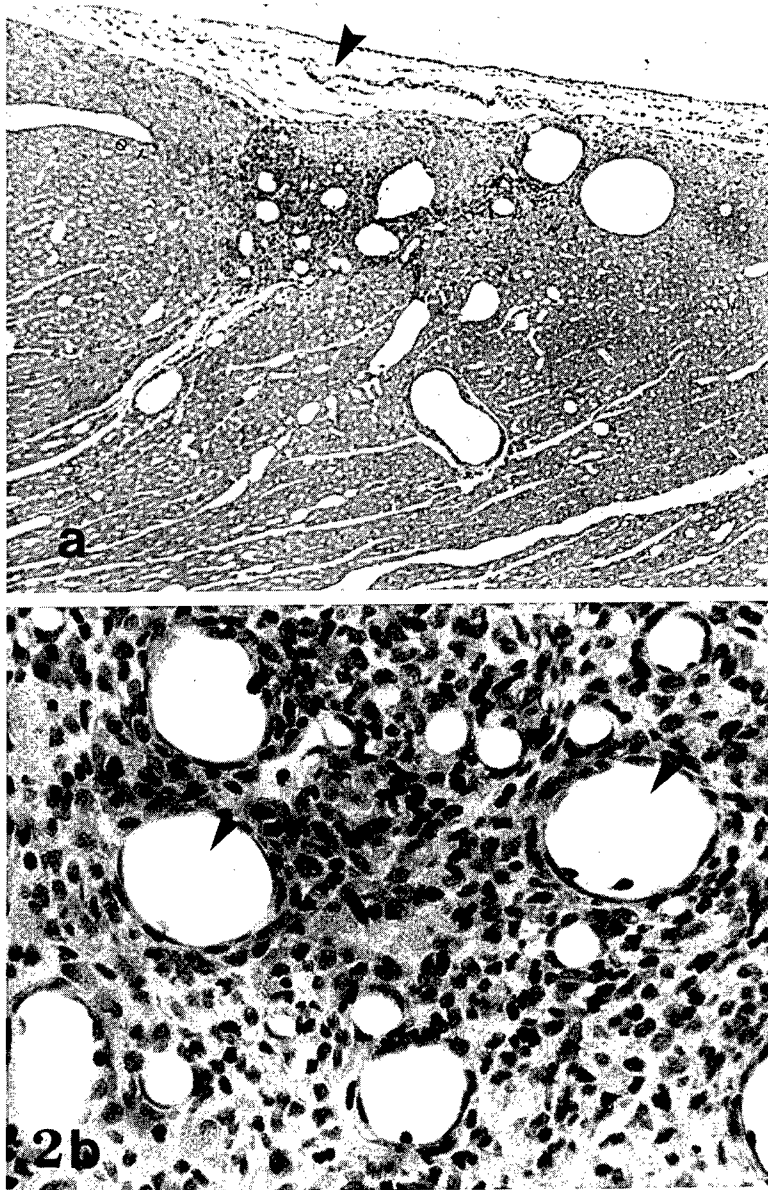

FIGURE 2. Four weeks post-transplantation of AT-1 cells into adult rat ventricle. (a) The graft (*arrowhead*) exhibits basophilic staining characteristics similar to that in the mouse graft. $\times 80$. (b) Enlargement of the graft site indicated in (a). Note the presence of large-diameter blood vessels in the graft (*arrowheads*). H & E. $\times 450$.

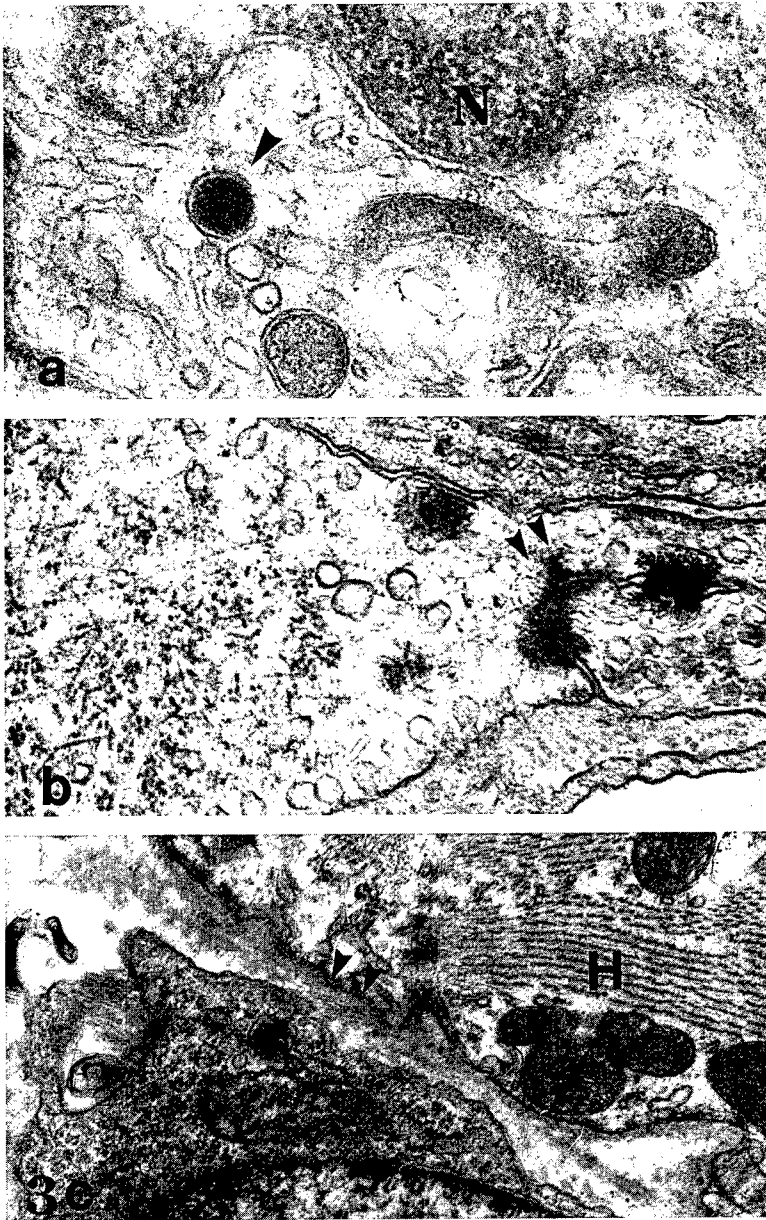

FIGURE 3. Graft reorganization of transplanted AT-1 cells in host mice at four weeks. (a) AT-1 cells are easily identified in the graft area by the presence of atrial specific granules (*arrowhead*). N, nucleus. $\times 68,000$. (b) An immature intercalated disc between several AT-1 cells in the graft (*double arrowheads*). $\times 42,000$. (c) An AT-1 cell, appears to be attached to a host cardiomyocyte (H) by tiny microfibrils (*arrowheads*). $\times 22,500$. All TEM.

cleus (FIG. 4a), and were not as refractile under phase-contrast microscopy as both the adult and neonatal cardiomyocyte (FIGS. 4b, 7a). Co-cultures consisting of AT-1 cells and neonatal rat cardiac ventricular myocytes were vigorously contracting by 2 days post plating. In areas where AT-1 cells and neonatal ventricular cardiomyocytes were contracting in synchrony, numerous phase-dense cell-to-cell contacts were observed between the AT-1 cells and the normal cardiomyocytes (FIG. 4c). The fact that both cell types were contracting in synchrony, suggests that functional intercalated discs formed couplings between the cultured AT-1 cells and the normal ventricular cardiomyocytes.

In cultures labeled with an antibody to desmin a circular ring was observed in the cytoplasm and filaments extended into the pseudopodia of AT-1 cells (FIG. 5a). In neonatal cardiomyocytes desmin was localized to regions of the Z discs forming parallel bands perpendicular to the longitudinal axis of the cell (FIG. 5a). Frequently, close contact between AT-1 cells and neonatal cardiomyocytes was indicated by brightly fluorescing regions involving desmin filaments in the AT-1 cells and Z discs in neonatal cells (FIG. 5a). Neonatal and AT-1 cells exhibited sarcomeric banding patterns typical of cardiac muscle cells in cultures labeled with antibodies to myosin (FIG. 5b). AT-1 cells were identified by their circular morphology, and poorly formed peripherally located myofibrils (FIG. 5). Neonatal cardiomyocytes contained well formed myofibrils as indicated by the intense label over the A band of the sarcomere (FIG. 5). Junctional contacts between the different cell types were suggested by the appearance of broad dark regions between the sarcomeric banding patterns of neonatal cardiomyocytes and the circular myofibrils of AT-1 cells (FIG. 5b). In dual labeling experiments, AT-1 cells, identified by expression of large T antigen, were clearly linked via adherens-type junctions, labeled with anti-pan cadherin, to neonatal cardiomyocytes (FIG. 5c).

Junctional contacts between AT-1 cells and neonatal cardiomyocytes were also observed when co-cultures were examined using electron microscopy (FIG. 6). Between some cells, small couplings containing only thin filaments were observed suggesting that junctions between the AT-1 and neonatal cardiomyocytes were in an early stage of development (FIG. 6a). At higher magnification, nascent intercalated discs were observed in which both a structural component (fascia adherens) and a communicating junction (gap) were seen (FIG. 6b).

To determine if normal immature muscle cells would form junctional contacts in culture with normal adult heart muscle cells, co-cultures of neonatal and adult rat cardiomyocytes were established. Adults were easily identified by the large size extending several hundred μm across (FIG. 7a). Neonatal cardiomyocytes were observed attached to the upper surface of or in between the filopodia of the adult cardiomyocytes (FIG. 7b). At higher magnifications, highly refractile areas were seen at the site of contact between the two cell types (FIGS. 7c, 8a). Neonatal cells were frequently aligned along the longitudinal axis of the adult cardiomyocyte (FIGS. 7b, c). Antibodies to the pan-cadherin family of cell adhesion molecules clearly indicated that the junctional contact between neonatal and adult rat cardiomyocytes was extensive and resembled that seen in the fascia adherens component of the cardiac intercalated disc (FIG. 8b).

In co-cultures of AT-1 cells with adult cardiomyocytes, the AT-1 cells were observed either on the apical surface of or in between the pseudopodia of the

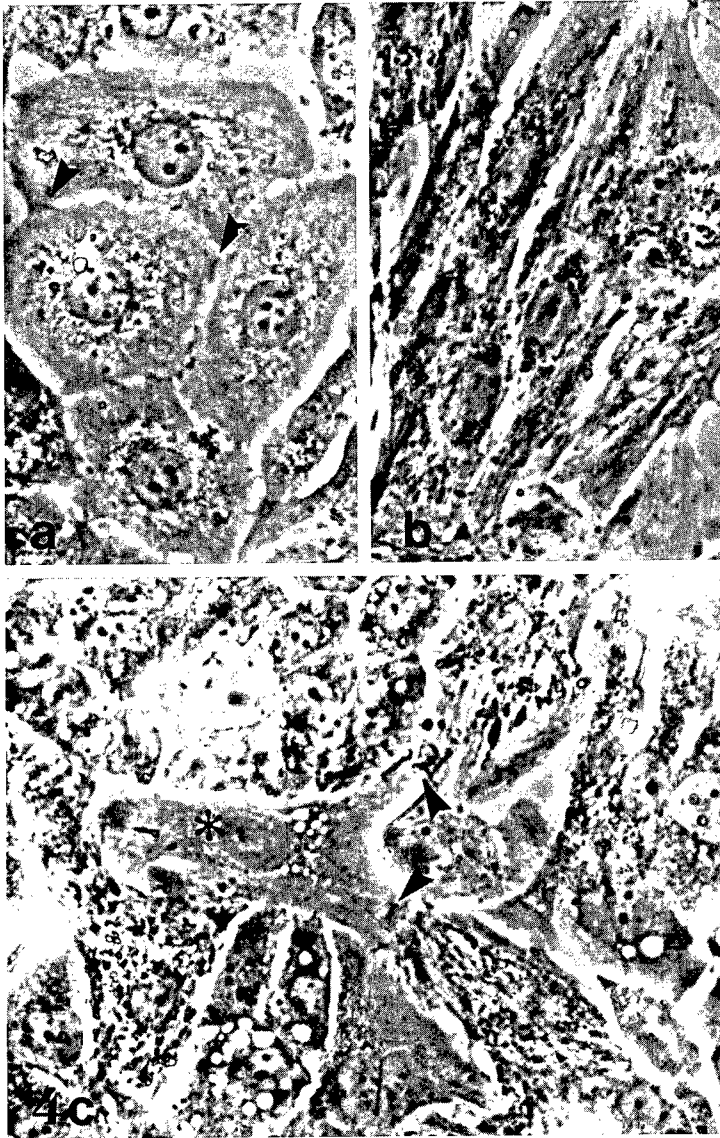

FIGURE 4. Co-cultures of neonatal rat ventricular cardiomyocytes and AT-1 cells. (a) Mono-culture of AT-1 cells four days post-plating. Note their circular shape, centrally located nuclei and junctional contacts (*arrowheads*). $\times 320$. (b) A similar culture of neonatal rat ventricular cardiomyocytes in mono-culture. These cardiomyocytes are easily distinguished from the AT-1 cells by their elongated, phase-dense morphology. $\times 320$. (c) In a four-day-old co-culture several neonatal cardiomyocytes are seen linked via intercalated discs (*arrowheads*) to an AT-1 cardiomyocyte (*). All three cells were contracting in synchrony indicating a mechanical and electrical connection had formed between the adjacent cells. $\times 320$. All phase-contrast.

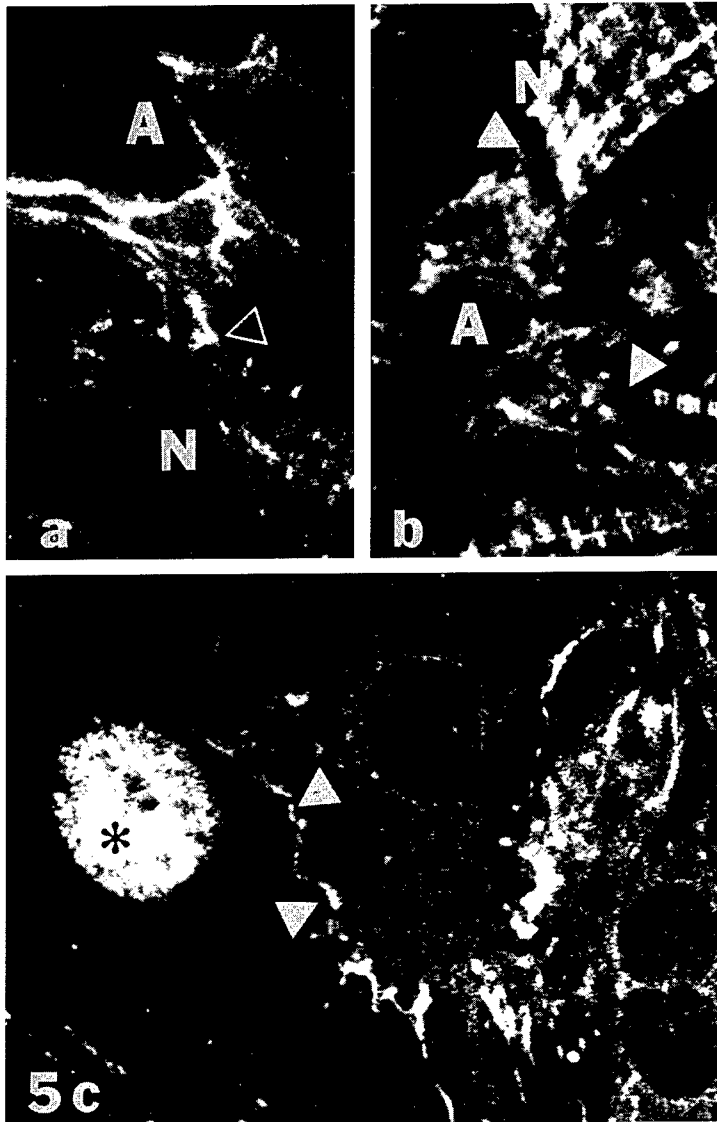

FIGURE 5. Cytoskeletal markers indicate AT-1 cells form junctions with normal ventricular cardiac muscle cells. (a) A bridge (*arrowhead*) appears to link an AT-1 cell (A) with a neonatal ventricular cardiac muscle cell (N) in this co-culture stained for desmin. (b) In co-cultures stained for myosin expression, neonatal cells (N) are easily identified by broad distinct myofibrils, while the AT-1 cells (A) contain thin poorly defined myofibrils. Two neonatal cells appear to be connected by intercalated discs (*arrowheads*) to a single AT-1 cell. (c) In dual labeling experiments, AT-1 cells, identified by expression of large T antigen (*), were clearly linked via adherens-type junctions (*arrowheads*), labeled with anti-pan cadherin, to neonatal cardiomyocytes. All $\times 580$, confocal laser microscopy.

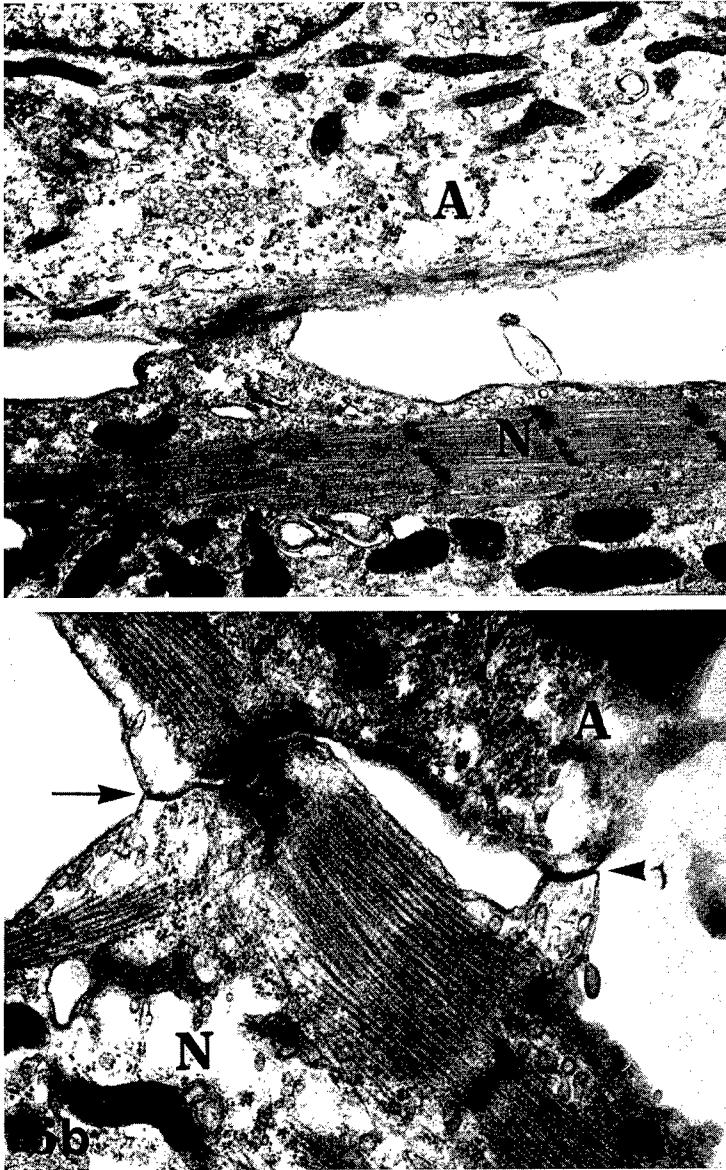

FIGURE 6. AT-1 and normal neonatal ventricular cells form functional cardiac-specific junctions in co-culture. (a) An AT-1 cell (A) is shown connected to a normal neonatal rat ventricular cardiomyocyte (N) via a small adherens-type junction in a four-day-old co-culture. $\times 15,600$. TEM. (b) Higher magnification of the junctional contact between normal neonatal ventricular muscle cells (N) and AT-1 cells (A) in co-culture. A fascia adherens-type junction (arrow) and a gap junction (arrowhead), components of the intercalated disc, link the two distinct cell types. $\times 23,400$. All TEM.

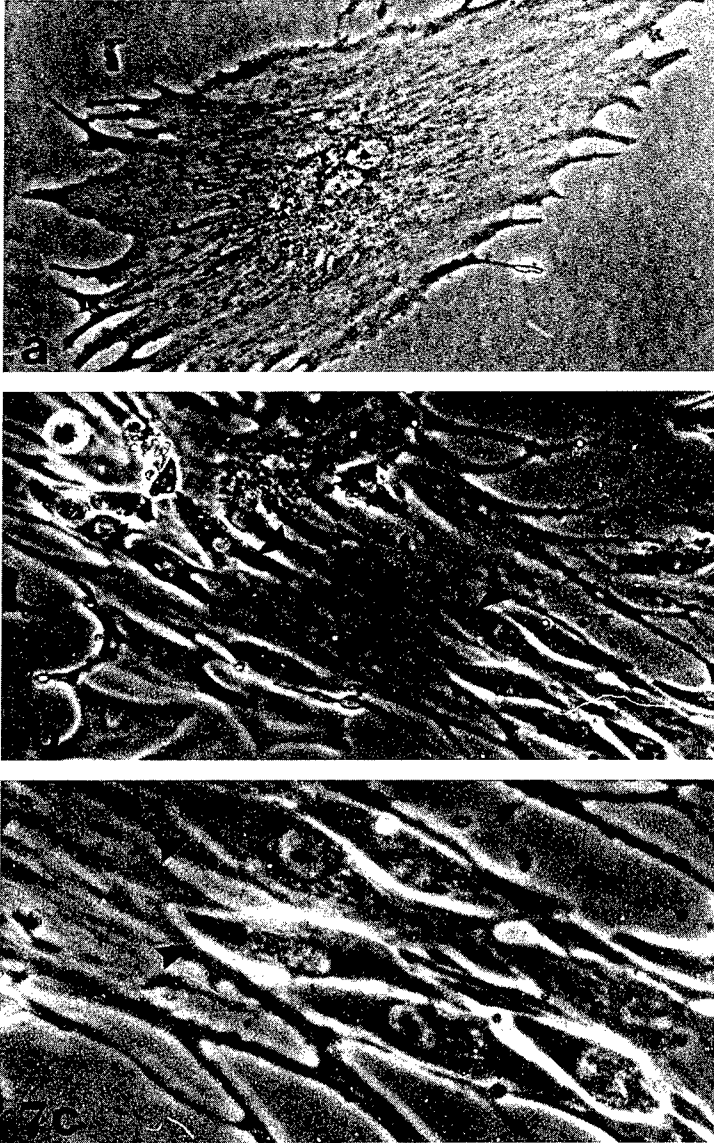

FIGURE 7. Adult and neonatal cardiomyocytes interactions in co-culture. (a) Adult cardiomyocyte in mono-culture demonstrating their much larger size compared to cultured neonatal cardiomyocytes. $\times 373$. (b) A co-culture of neonatal (*arrowheads*) and adult rat ventricular cardiomyocytes showing how the smaller muscle cell can align along the longitudinal axis of the adult cardiomyocyte. $\times 333$. (c) A higher magnification illustrating the apparent contact (*arrowheads*) between the neonatal and adult cardiac muscle cells. $\times 680$. All phase-contrast.

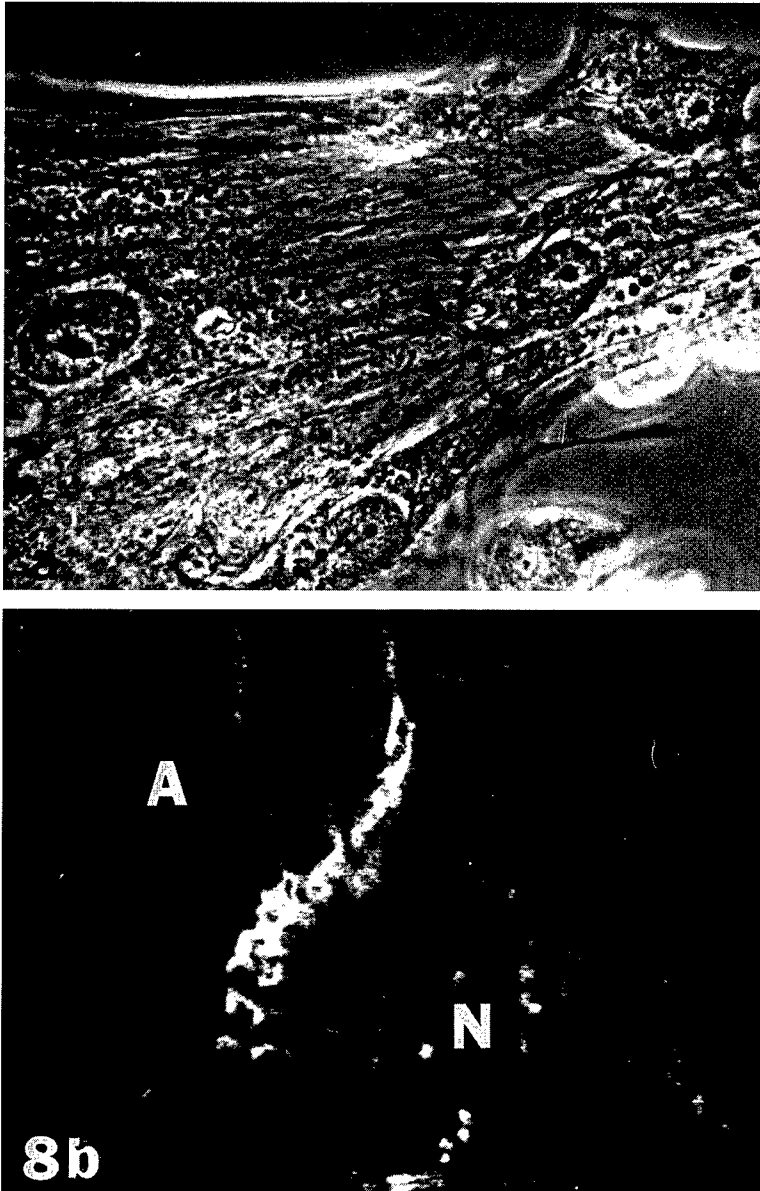

FIGURE 8. Antibodies to adherens-type junctions suggest that cardiac-specific junctions form between adult and neonatal cardiomyocytes in co-culture. (a) In this phase-contrast image, a broad zone of contact (*arrowheads*) is shown between an adult and neonatal cardiomyocytes. $\times 420$. (b) A similar broad adherens-type junction (*arrowheads*) between cultured adult (A) and neonatal (N) cardiomyocytes labeled with antibodies to pan-cadherins. $\times 540$. Confocal laser scanning microscopy.

larger adult rat cells (FIG. 9a). In cultures labeled for large T antigen and pan-cadherin expression, adherens-type junctions were also observed between AT-1 cells and adult cardiac muscle cells (FIG. 9b).

DISCUSSION

Results presented here and in several recent reports in which syngeneic mice (homografts) were used as hosts^{10,19} demonstrate that it is possible to successfully transplant cardiac muscle cells not only into a syngeneic host, but also into immunosuppressed rats (xenografts).^{11,12}

Transplanted AT-1 cells may increase the circulation in graft areas. While no direct measurement of blood flow through grafts and control areas exists to support this, such a possibility is suggested by the apparent increase in arterioles and small arteries not only within the graft but also within host tissue (FIGS. 1, 2). This implies that AT-1 cells may secrete an angiogenic factor. Such angiogenesis is typical of transformed tissues, but that which is secreted by AT-1 cells may be unique to the heart due to the cardiac origin of AT-1 cells. Angiogenesis is critical for several reasons to the survival of any grafted cells and ultimate repair of damaged heart muscle. An increase in the microcirculation would provide the grafted cells with a blood supply and also an avenue for removal of cellular debris associated with the primary injury.

Though it is possible to inject AT-1 cells into both syngeneic, which are probably closer to autografts than homografts, and immunosuppressed animals and achieve long-term survival without apparent rejection, it remains unclear as to the extent of AT-1 cell interaction with host myocytes. In an earlier report¹⁰ in which AT-1 cell grafts were established in syngeneic hosts, the authors were able to easily identify junctional contacts between AT-1 cells, but not between AT-1 cells and host muscle cells. In the present study, we were able to observe AT-1 cells forming nascent intercalated discs with each other (FIG. 3b), but only rudimentary connections between AT-1 cells and host cardiomyocytes. These regions were always adjacent to host Z lines (FIG. 3c), suggesting that they represented precursor connections prior to the actual formation of junctions. To address this question of AT-1 and host muscle cell interaction, we developed the tissue coculture models used in the present study. Results presented here clearly indicate that it is possible to establish true intercalated disc formation between AT-1 cells and normal neonatal and adult rat cardiomyocytes (FIGS. 4–6, 9).

The successful grafting of fetal cardiomyocytes isolated from transgenic mice expressing the β -galactosidase reporter gene into a syngeneic host has demonstrated that cardiac muscle cells from fetal or embryonic animals are capable of forming nascent intercalated discs with host muscle cells. However, the authors were unable to clearly demonstrate that a complete functional syncytium had formed.¹⁹ Nevertheless, it is apparent from the extensive cell-to-cell contact and the more differentiated state of the grafted cells that almost complete integration of the foreign cardiomyocytes occurred. It must be noted, however, that these studies used syngeneic animals, which are essentially immunologically identical, and, therefore, the injected cells behaved like a homograft, which leads to little

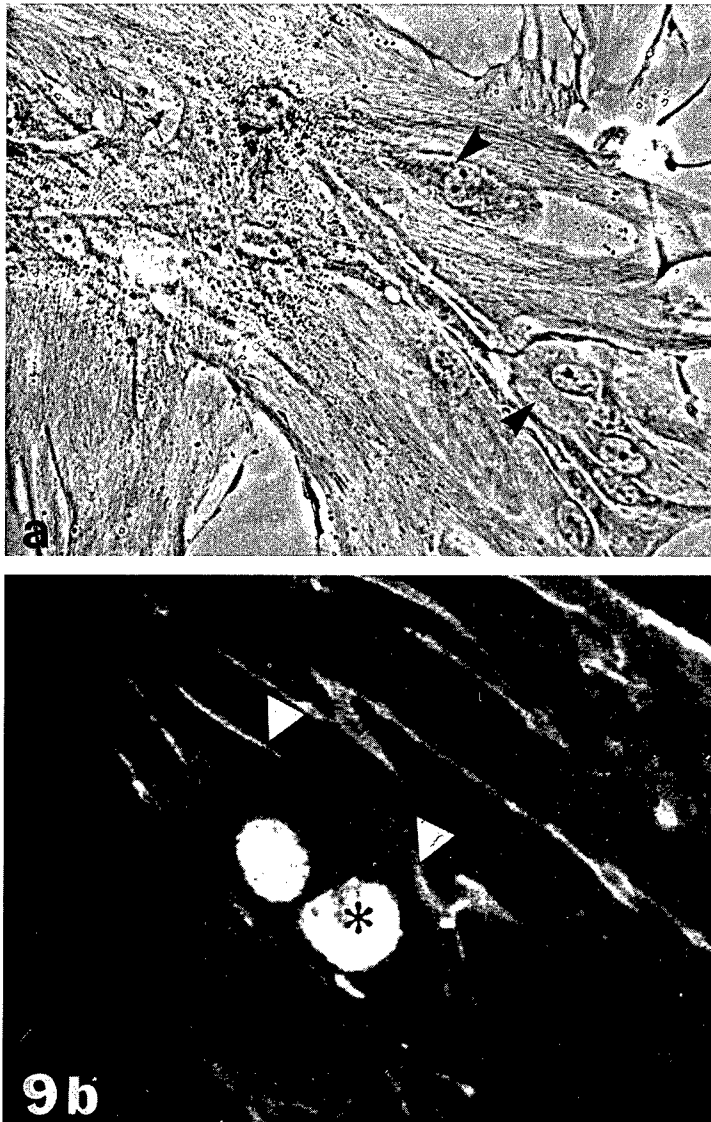

FIGURE 9. AT-1 cells can form adherens-type junctions with adult rat ventricular cardiomyocytes in co-culture. (a) Similar in appearance and size to neonatal cardiomyocytes, several AT-1 cells are shown in between the filopodia of and on top of a cultured adult rat ventricular cardiomyocyte. $\times 320$. (b) With dual labeling, AT-1 cells are identified by expression of large T antigen (*) and apparently are linked to the much larger adult cardiomyocyte by adherens-type junctions (*arrowheads*) following labeling with antibodies to the pan-cadherins (*arrowheads*). $\times 540$. Confocal laser scanning microscopy.

tissue rejection. With regard to future potential applications of this technique in therapies, it would be expected that cardiomyocytes from different individuals of the same species (homografts) and, perhaps, cross-species (xenografts) would be used. Therefore, any grafting procedures would necessarily have to employ an immunosuppressant, such as cyclosporine to prevent tissue rejection.

Recently, it was shown that the use of purified transplanted cells in which dendritic leukocytic cells were removed greatly reduced immunogenicity after transplantation.²⁰ This is perhaps best illustrated in experimental models of pancreatic islet transplantation where deletion of dendritic cells by prior tissue culture has led to prolonged survival of the islets after transplantation.²¹ The use of pure populations of cardiac muscle cells, which are attainable with cultured cells, such as AT-1 cells, should greatly increase the chances for successful homograft and xenograft survival. In the present studies in which AT-1 cells isolated from subcutaneous tumors were our primary cell source, some inflammation and the presence of lymphocyte infiltration were observed. We compensated by increasing the dose of cyclosporine and also by beginning treatment with cyclosporine 24 to 48 hrs prior to surgery. The use of cells which lack or have reduced immunogenicity such as embryonic cardiac muscle cells would also greatly improve chances for successful homografting and xenografting of cardiomyocytes.²¹

Development of *in vivo* and *in vitro* model systems to study direct cardiac muscle cell transplantation into damaged hearts will serve as an experimental tool in evaluating future therapeutic approaches employing homographic and xenographic cardiac muscle cell transplantation for the direct repair of myocardial damage due to cardiac disease. Also, perfection of such cell transplantation systems will provide an important tool in future cardiac gene therapy paradigms. In addition, cardiac cell transplants might be useful for inducing tolerance in potential transplant patients prior to subsequent organ transplant. This has been shown to be the case in pancreatic islet transplants.²²

These morphological results combined with the functional observations that AT-1 cells and neonatal cardiomyocytes contract in synchrony in co-culture along with recent studies¹⁹ support the hypothesis that transplanted cardiac muscle cells can form functional couplings *in vivo*.

REFERENCES

1. HOOPER, T. L. & L. W. STEPHENSON. 1993. Cardiomyoplasty for end-stage heart failure. *Surg. Annu.* **1**: 157-173.
2. NINAMI, H., A. POCHETTINO & L. W. STEPHENSON. 1991. Use of skeletal muscle grafts for cardiac assist. *Trends Cardiovasc. Med.* **1**: 122-126.
3. YAFFE, D. & O. SAXEL. 1977. Serial passage and differentiation of myogenic cells isolated from dystrophic mouse muscle. *Nature (London)* **270**: 725-727.
4. KOH, G. Y., M. G. KLUG, M. H. SOONPAA & L. J. FIELD. 1993. Long-term survival of C2C12 myoblast grafts in heart. *J Clin. Invest.* **92**: 1548-1554.
5. FIELD, L. J. 1988. Atrial natriuretic factor-SV40 antigen transgenes produce tumors and cardiac arrhythmias in mice. *Science* **239**: 1029-1033.
6. STEINHELPER, M. E. & L. J. FIELD. 1990. Cardiac tumors and dysrhythmias in transgenic mice. *Toxicol. Pathol.* **18**: 464-469.
7. STEINHELPER, M. E., N. A. LANSON, JR., K. P. DRESDNER, J. B. DELCARPIO, J. B., A. L. WILT, W. C. CLAYCOMB & L. J. FIELD. 1991. Proliferation *in vivo* and in

- culture of differentiated adult atrial cardiomyocytes from transgenic mice. *Am. J. Physiol.* **259**: H1826-1834.
8. DELCARPIO, J. B., N. A. LANSON, JR., L. J. FIELD & W. C. CLAYCOMB. 1991. Morphological characterization of cardiomyocytes isolated from a transplantable cardiac tumor derived from transgenic mouse atria (AT-1 cells). *Circ. Res.* **69**: 1591-1600.
 9. LANSON JR., N. A., C. GLEMBOTSKI, M. E. STEINHELPER, L. J. FIELD & W. C. CLAYCOMB. 1992. Gene expression and atrial natriuretic factor processing and secretion in cultured AT-1 cardiac myocytes. *Circulation* **85**: 1835-1841.
 10. KOH, G. Y., M. H. SOONPAA, M. G. KLUG & L. J. FIELD. 1993. Long-term survival of AT-1 cardiomyocyte grafts in syngeneic myocardium. *Am. J. Physiol.* **264** (Heart Circ. Physiol. **33**): H1727-H1733.
 11. DELCARPIO, J. B., R. W. BARBEE, B. D. PERRY & W. C. CLAYCOMB. 1993. Cardiomyocyte transfer into the rat and mouse heart. *J. Cell. Biochem.* **17**(D): 210a.
 12. DELCARPIO, J. B., R. W. BARBEE, B. D. PERRY & W. C. CLAYCOMB. 1993. Cardiomyocyte transfer into the rodent heart: host cell interactions and angiogenesis. *Circulation* **88**(4):1-139a.
 13. DELCARPIO, J. B., W. C. CLAYCOMB & R. L. MOSES. 1989. An ultrastructural morphometric analysis of cultured neonatal and adult rat ventricular cardiac myocytes. *Am. J. Anat.* **186**: 235-245.
 14. CLAYCOMB, W. C. & M. C. PALAZZO. 1980. Culture of the terminally differentiated adult cardiac muscle cell: a light and scanning electron microscope study. *Dev. Biol.* **161**: 249-265.
 15. CLAYCOMB, W. C. & N. A. LANSON, JR. 1984. Isolation and culture of the terminally differentiated adult cardiac muscle cell. *In Vitro.* **20**: 647-651.
 16. MOSES, R. L., E. G. UNDERWOOD, C. C. VIAL & J. B. DELCARPIO. 1989. In situ electron microscopy of cultured cells. *EMSA Bull.* **19**(1):60-66.
 17. DANTO, S. I. & D. A. FISCHMAN. 1984. Immunocytochemical analysis of intermediate filaments in embryonic heart cells with monoclonal antibodies to desmin. *J. Cell Biol.* **95**: 2170-2191.
 18. BADER, D., T. MASAKI & D. A. FISCHMAN. 1982. Immunocytochemical analysis of myosin heavy chain during avian myogenesis *in vivo* and *in vitro*. *J. Cell Biol.* **95**: 763-770.
 19. SOONPA, M. H., G. Y. KOH, M. G. KLUG & L. J. FIELD. 1994. Formation of nascent intercalated disks between grafted fetal cardiomyocytes and host myocardium. *Science* **264**: 98-101.
 20. AUSTYN, J. M. & C. P. LARSEN. 1990. Migration patterns of dendritic leukocytes: implications for transplantation. *Transplantation* **49**: 1-7.
 21. MORRIS, P. J. 1993. The immunobiology of cell transplantation. *Cell Transplant.* **2**: 7-12.
 22. MORRIS, P. J., K. J. WOOD & M. J. DALLMAN. 1992. Antigen-induced tolerance to organ allografts. *In: Antigen and Clone-Specific Immunoregulation.* R. L. Edelson, Ed. *Ann. N.Y. Acad. Sci.* Vol. 636: 295-305. New York Academy of Sciences. New York.

Connective Tissue and Repair in the Heart

Potential Regulatory Mechanisms^a

KARL T. WEBER,^b YAO SUN, LAXMANSAN C. KATWA,
JACK P. M. CLEUTJENS,^c AND GUOPING ZHOU

*Division of Cardiology
Department of Internal Medicine
University of Missouri Health Sciences Center
Columbia, Missouri 65212*

INTRODUCTION

The heart is composed of parenchyma and stroma, each of which normally reside in balanced equilibrium.¹ Stroma, a structural protein assembly consisting largely of type I and III fibrillar collagens,² is a major determinant of tissue tensile strength and stiffness.³ This assembly contributes to cardiac myocyte alignment, the transmission of myocyte-generated force to the atrial and ventricular chambers, and the relengthening of myocytes in diastole.⁴ The connective tissue network of atria and ventricles is a continuum with heart valve leaflets, their chordae tendineae and annuli fibrosi.⁵ Rhythmically flexed, absorbing constant stress as the heart performs its continuous pulsatile work, metabolic turnover of the collagen network is dynamic.^{6,7} This is particularly true for the valvular apparatus, where collagen synthesis and degradation must be high. Heart valve leaflets and their cellular components represent a unique site to examine connective tissue repair in the normal heart.

Connective tissue formation is also integral to tissue repair following myocyte necrosis of diverse causality. A reparative fibrosis preserves structural integrity of the myocardium after the loss of parenchyma. Scars represent another site of high collagen turnover.^{8,9} Other sites include: the fibrosis of the visceral pericardium that follows infection or trauma; and the perivascular fibrosis of intramyocardial coronary arteries that appears in response to vascular hyperpermeability.¹⁰⁻¹² These latter fibrous tissue responses do not mandate parenchymal cell loss. Connective tissue repair found in valve leaflets and fibrogenic components of myocardial and pericardial fibrosis each offer windows of opportunity in which the regulation of fibrous tissue formation can be explored. Emerging evidence would indicate

^a This work was supported in part by NIH Grant R01-HL-31701 and was conducted during Dr. Cleutjens' tenure with the Netherlands Organization for Scientific Research (NWO) (Grant S93.221.92) and the Netherlands Heart Foundation (Grant 90.282).

^b Correspondence and reprints: Karl T. Weber, M.D., University of Missouri-Columbia, Division of Cardiology, Rm. MA432 Medical Sciences Building, Columbia, MO 65212.

^c Current address: Department of Pathology, University of Limburg, P.O. Box 616, 6200 MD Maastricht, The Netherlands.

that connective tissue at these sites is a dynamic metabolic entity—tissue where peptide hormones are synthesized and degraded by angiotensin converting enzyme (ACE). In an autocrine and/or paracrine manner these peptides serve to regulate collagen turnover of fibroblasts or fibroblast-like cells and thereby modulate connective tissue formation at sites of repair.

Connective Tissue Formation in the Heart

Type I and III collagens represent the major fibrillar collagen found in the heart.^{2,13–15} Unlike the vasculature, where distensibility is an essential property of tissues that absorb constant pulsatile forces, elastin is not a major structural protein of the myocardium. Following birth, a period of rapid collagen formation appears during the neonatal period.¹⁶ Throughout most of adulthood, the proportion of parenchyma and stroma reside in balanced equilibrium.¹⁷ The collagen network has epi-, peri- and endomysial components, each of which serves various functions.¹⁸ An adverse accumulation of stroma or fibrillar collagen degradation can each appear in different pathologic states and compromise the architecture, geometry and function of the myocardium and its ventricular chambers.²

Collagen turnover in the heart is normally rapid. A daily fractional synthesis of 5% has been measured with nearly 60% of newly synthesized collagen degraded rapidly within lysosomes and endoplasmic reticulum of cardiac fibroblasts.⁷ Extracellular degradation is mediated by various neutral proteases, including collagenase, produced by fibroblasts and/or other cells such as macrophages.

Following cardiac myocyte necrosis, fibrillar collagen replaces lost cells. These sites were previously devoid of connective tissue, and the *reparative fibrosis*, or scarring, is an adaptation to the loss of parenchyma. The extent of repair is inversely proportional to the regenerative capacity of parenchyma.¹⁹ Cardiac myocytes are thought to be terminally differentiated, and therefore reparative fibrosis is essential to preserving the structural integrity of the heart. Scarring appears at a macroscopic level following myocardial infarction. Microscopic scars follow the discrete loss of myocytes, as occurs in response to catecholamines^{20–23} or potassium depletion.^{24,25} Fibrous tissue formation also appears in the absence of parenchymal loss. Pericardial or endocardial fibrosis are such examples, as is the perivascular fibrosis of intramural arterioles, the thickening of preexisting collagen fibers, and increased number of fibers that appear between viable myocytes. Such fibrogenic responses have therefore been referred to as a *reactive fibrosis*.

Fibrogenic Phase of Tissue Repair

Following exudative and inflammatory phases of healing, phenotypically transformed fibroblasts, referred to as myofibroblasts,²⁶ acquire α -smooth muscle actin filaments to facilitate their motility and contractility. Proliferation of fibroblast-like cells is evident on day 3.²⁷ Myofibroblasts proliferate as their synthesis of type III fibrillar collagen increases. The synthesis and appearance of type I collagen follows restoring the normal type I to III collagen ratio. This may herald a

reduction in number of myofibroblasts as granulation tissue is resorbed.²⁸ Type I collagen is the dominant fibrillar collagen at sites of reparative or reactive fibrosis.^{15,29} Hydroxyproline content is significantly increased on day 4 and 5²⁷ while fibrillar collagen accumulation in the form of an emerging scar can be detected by microscopy on day 7.³⁰ Hydroxyproline content and fibrillar collagen continue to accumulate for many weeks.^{9,31,32}

Collagen degradation is an early component of tissue repair that has received less attention. Matrix metalloproteinases (MMP) reside in the myocardium in a latent or inactive form.^{33,34} Hence, cellular production of MMP-1 is not needed to initiate collagen degradation. Once activated, MMP-1 (or interstitial collagenase) will degrade fibrillar collagen into characteristic one- and three-quarter fragments; MMP-2 and MMP-9 are gelatinases that further degrade these smaller fragments. A transient increase in collagenase activity appears in the infarcted left ventricle on day 2, peaks at day 7 and declines thereafter, together with a concomitant increase and contribution in collagenolytic activity of gelatinases.³⁵ This collagenase activity comes from the latent pool since an increase in collagenase (MMP-1) mRNA expression does not appear until day 7 in the infarcted ventricle. Changes in MMP-1 activity or mRNA expression are not observed at sites remote to the infarct. Tissue inhibitors (TIMP) neutralize collagenolytic activity. Transcription of TIMP mRNA occurs at 6 hours in the infarcted ventricle, peaks on day 2 and slowly declines thereafter. No change in TIMP mRNA expression is observed at remote sites. Fibroblast-like cells are responsible for the transcription of MMP-1 and TIMP mRNAs.

Hence at the site of infarction, posttranslational activation of latent collagenase (MMP-1) plays a dominant role in tissue repair. Transcription of collagenase mRNA occurs when latent extracellular MMP-1 is reduced through the activation of the latent pool of collagenase and gelatinases. In turn, TIMP mRNA synthesis is regulated by the activation of MMPs. The balance between collagenase activation and TIMP inhibition therefore determines collagenolysis in infarcted tissue. Fibroblasts and/or fibroblast-like cells, and their synthesis and degradation of collagen, are the essential elements to fibrogenesis and subsequent remodeling of fibrous tissue.

Ultimately, fibrous tissue may undergo retraction and/or resorption. Retraction is expressed as scar thinning and appears 4–6 weeks after myocardial infarction.^{9,32} Resorption of connective tissue can occur with foreign body granuloma.³⁶ The role of myofibroblasts in the retraction and/or resorption of fibrous tissue postinfarction requires further study.

Tissue Repair: ACE at Sites of High Collagen Turnover

Valve Leaflets

Heart valve leaflets are composed of fibrillar collagen and various cells: endothelial cells that line leaflet surfaces; smooth muscle cells found within the proximal leaflet near the annuli fibrosi; and fibroblast-like cells containing α -smooth muscle actin and referred to as valvular interstitial cells (VIC) which reside in

the interstices of the distal leaflet.^{37,38} Recent evidence³⁹ would implicate VIC in regulating valvular collagen turnover by virtue of their expression of type I collagen mRNA. An elaboration of locally generated peptides (FIG. 1), including angiotensin II (AngII), bradykinin (BK), and prostaglandins (PG), may ultimately be demonstrated in VIC. ACE is central to the generation of AngII and degradation of BK; it has been found in these cells.

In vitro autoradiography, using an iodinated derivative of lisinopril (¹²⁵I-351A) to localize and quantitate ACE binding density,^{32,40-44} has shown that ACE is not uniformly distributed in the heart. As seen in FIGURE 2A, heart valves are sites of high-density ACE binding.^{40,45,46} So too is the endothelium of the aorta and pulmonary artery and adventitia of intramyocardial coronary arteries (not shown). Low-density autoradiographic ACE binding is present in the ventricles and atria (atria > ventricles). As identified by monoclonal antibody,⁴⁷ ACE-labeled cells in valves are VIC (FIG. 2B). This was further confirmed in cultured VIC by immunohistochemistry and ¹²⁵I-351A binding. BK and AngII receptor binding has also been found in heart valves by autoradiography.⁴⁴ They are shown in FIGURE 2C, D. Conversion of various substrates (angiotensin I, BK, substance P, enkephalin) was identified in cultured VIC, and they were found to have AngII and BK receptors.³⁹ VIC contract in response to AngII.³⁷

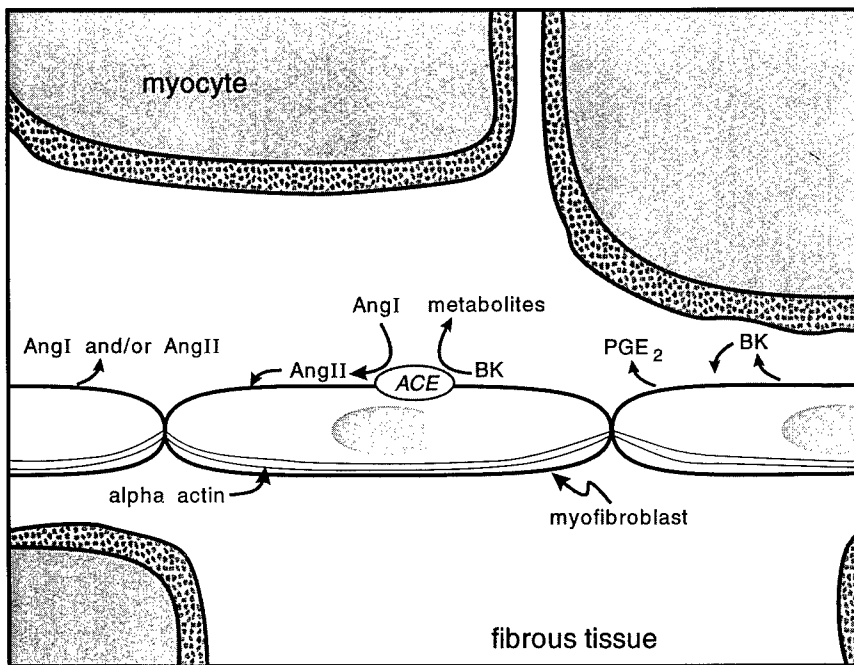

FIGURE 1. Schematic representation of myocardial fibrous tissue and peptide hormone turnover. Myofibroblasts contain α -smooth muscle actin and angiotensin converting enzyme (ACE). AngI and II = angiotensin I and II; BK = bradykinin; and PGE₂ = prostaglandin E₂. See text for details.

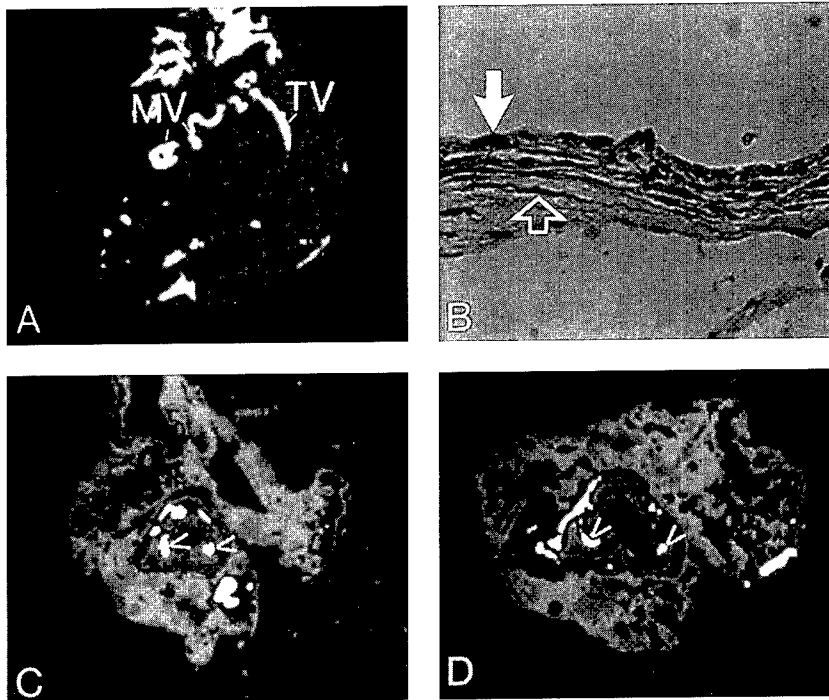

FIGURE 2. Localization of ACE binding and angiotensin II and bradykinin receptor binding in heart valve leaflets of normal rat heart. (A) *In vitro* autoradiography (^{125}I -351A) identified high density ACE binding in heart valves. White and light gray = high- and dark gray = low-density binding. Low-density binding is found in the myocardium. MV = mitral valve. TV = tricuspid valve. (B) Immunohistochemical labeling, using monoclonal ACE antibody, identifies endothelial cells (*closed arrow*) and valvular interstitial cell (*open arrow*) in distal portion of mitral valve leaflets as ACE-positive cells ($\times 400$). (C) Bradykinin receptor binding in aortic valve (*arrowheads*). (D) Angiotensin II receptor binding in aortic valve (*arrowheads*).

Sites of Reparative Fibrosis

Like heart valve leaflets, scars are a site of high collagen turnover and are associated with high-density ACE binding by *in vitro* autoradiography. ACE binding density is markedly increased in the scar tissue that appears at sites of cardiac myocyte necrosis, irrespective of its etiologic basis. This includes the macroscopic scarring that follows coronary artery ligation,^{32,48,49} the endomyocardial fibrosis that appears after isoproterenol administration⁵⁰ and the microscopic scarring associated with chronic AngII or aldosterone administration.⁴⁰ The density of ACE binding post-infarction or with AngII or aldosterone infusion increases in parallel with the progressive accumulation of fibrillar collagen at these sites.^{32,40} ACE-producing cells at the site of infarction included fibroblast-like cells, macrophages and endothelial cells in newly formed blood vessels.

Sites of Reactive Fibrosis

Fibrosis that appears remote to infarction and involving the right ventricle and interventricular septum or within the visceral pericardium following pericardiotomy (with or without coronary artery ligation) are other sites of high-density ACE binding.^{32,51,52} In the right ventricle, this is expressed as a perivascular fibrosis and microscopic scars while in the septum, an endocardial fibrosis also appears. Remote to the infarction immunohistochemistry identified ACE in fibroblast-like cells. At each of these reparative and reactive fibrous tissue sites, these cells were labeled with anti-alpha smooth muscle actin antibody. *In situ* hybridization identified that each of these ACE-producing, α -actin-containing cells expresses the transcript for type I collagen.³²

The anatomic coincidence between ACE binding in normal and pathologic expressions of connective tissue formation is apparent. High-density ACE binding is a marker for active collagen turnover. ACE-producing, α -actin-containing VIC or myofibroblasts express type I collagen mRNA. Stroma and its mesenchymal cells therefore appear to form a metabolic entity whose purpose may be to regulate collagen turnover via the elaboration of peptide hormones.⁵⁰ Accordingly, these cells are able to govern the connective tissue composition of the heart at normal and pathologic sites of repair. Further evidence in support of this proposition will now be considered.

Peptide Hormone Synthesis and Connective Tissue

If stroma and its constituent cells elaborate peptide hormones involved in regulating VIC or myofibroblast collagen turnover it requires that precursors, proteases and products be identified. Recent evidence suggests most angiotensin peptides are generated locally.⁵³

Angiotensin Peptides

Angiotensinogen is the only known precursor to angiotensin peptides. Therefore, it is obligatory to tissue angiotensin generation and requires demonstration of angiotensinogen synthesis.⁵³ Upon exposure to renin, the isolated crystalloid-perfused rat heart generates AngI and AngII.⁵⁴ The generation of these Ang peptides could be blocked by renin and ACE inhibitors, respectively. Dexamethasone induces angiotensinogen mRNA expression and angiotensinogen release into coronary venous effluent. Cells responsible for the release of angiotensinogen are uncertain. In the adult rat heart and aorta *in situ* hybridization localized mRNA expression of angiotensinogen within cells of mesenchymal origin—fibroblasts and brown adipocytes.^{55,56} In the neonatal rat heart, this transcript is localized to atria and ventricles (ventricles > atria) and within their cardiac myocytes and fibroblasts.⁵⁷ Both AngI and AngII have been detected in these cells.⁵⁸ Neonatal rat cardiac fibroblasts also contain the transcript for renin;⁵⁷ other serine and aspartyl proteases may also be present.^{59,60} Thus the neonatal phenotype of car-

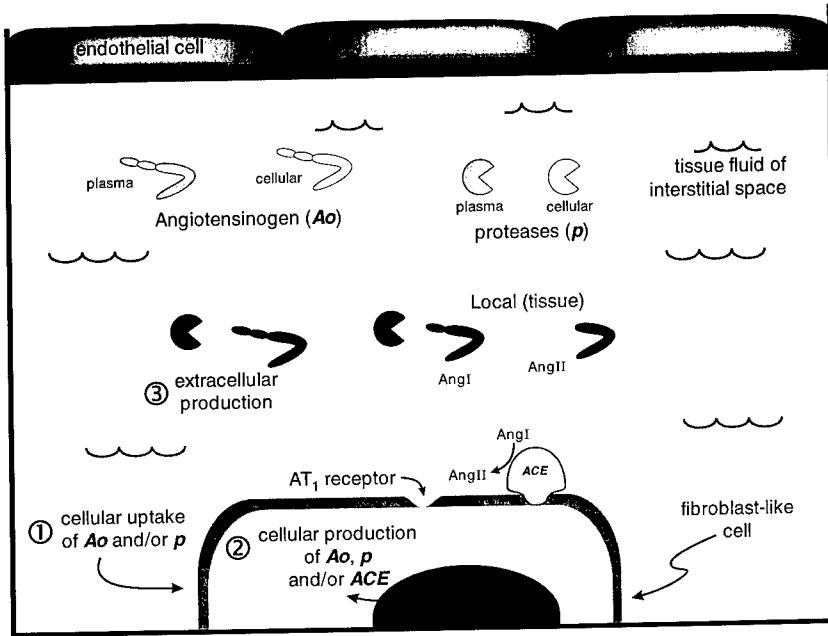

FIGURE 3. A tissue angiotensin system involves precursor (angiotensinogen) and various proteases derived from either plasma, intracellular sources, or the interstitial space. Angiotensin peptides can be generated intra- extracellularly. In this model, fibroblast-like cells are considered a site of tissue angiotensin generation.

diac fibroblast, which may resemble a phenotypically-transformed form of myofibroblast involved in wound healing, would appear capable of generating AngII.

Local production of angiotensin peptides is likely influenced by tissue-specific mechanisms of regulation. These may include either intra- or extracellular pathways (FIG. 3). Angiotensins I and II may be generated intracellularly from cleavage of either locally-synthesized angiotensinogen or angiotensinogen derived from plasma or that which has been taken up by the cell from the interstitial space. Various proteases, likewise produced by the cell or procured from its environment, may be involved in the generation of these angiotensin peptides.⁵⁹⁻⁶⁵ They include: cathepsin D, pepsin and other aspartyl proteases that can generate AngI; and tonin, cathepsin G, trypsin and other serine proteases that release AngII directly from angiotensinogen. Renin therefore would not be obligatory to such a tissue angiotensin system.

The involvement of AngII in tissue repair and fibrogenesis that follows inflammation can be inferred from studies of myocardial infarction. Local angiotensinogen production may lead to a significant increase in the concentration of this precursor in interstitial fluid. For any constant amount of protease in tissue fluid, the increase in angiotensinogen should be paralleled by an increase in angiotensin. On day 5 following coronary artery ligation, the expression of angiotensinogen mRNA was found to be increased in the rat left ventricle.⁶⁶ This precedes the

morphologic appearance of fibrillar collagen in the form of a scar.^{9,27,30-32,52} During the first 2 weeks post-ligation, AngII content of infarcted tissue has not been measured. It was found to be increased at 21 days and could be attenuated by delapril treatment initiated at the time of infarction.⁶⁷ Plasma renin and AngII concentrations were not increased in this model. In tissue homogenates, evidence of increased mRNA expression and ACE activity have been observed at sites remote to myocardial infarction (*e.g.*, right ventricle) as long as 12 wks after coronary ligation.⁶⁸ Moreover, plasma renin and ACE activity were not increased while the increase in ACE mRNA expression and activity was organ-specific. This is in keeping with the concept of contained fibrous tissue formation within an injured organ (heart).

Bradykinin and Prostaglandins

Kinins and prostanoids are also endogenous hormones. Their role as chemical mediators of inflammation is well recognized. BK, PGI₂ and PGE₂ have each been detected in coronary sinus drainage. During myocardial ischemia and following infarction BK in sinus effluent rises severalfold.⁶⁹⁻⁷² A similar response is observed for the sinus concentration of AngII⁷² and PGE₂.⁷³ Endothelial cells are able to elaborate BK and various prostanoids. Whether the early release of BK following infarction arises from the coronary vasculature and/or other cells is presently unknown. During the first several days after infarction, the release of PGE₂ is markedly increased by administration of BK suggesting inflammatory cells may be involved.⁷³

Various mesenchymal cells are also able to synthesize prostanoids. These include squamous epithelial cells of visceral and parietal pericardium, pleura and peritoneum,⁷⁴⁻⁷⁶ fibroblasts of various organs⁷⁷⁻⁷⁹ and cultured mesothelial cells of pericardium.⁸⁰ Whether these nonendothelial cells also release BK, a stimulus to prostaglandin synthesis,⁷⁷ is yet uncertain. Both BK and PGE₂ alter cultured cardiac fibroblast collagen turnover.^{77,81,82} Fibroblast-like cells, isolated from the site of infarction 7 days after coronary ligation, demonstrate increased cyclooxygenase activity and increased prostanoid production, including PGE₂.⁸³ At 30 days after infarction, BK-induced release of PGE₂ from the heart is increased.⁷³ Increased prostaglandin synthesis has been observed in microsomes prepared from infarcted myocardium at 3 wks and 3 months after coronary ligation. Thus, there is a persistence of PGE₂ production well beyond the inflammatory phase of tissue repair.

Peptide Hormones and Connective Tissue Formation

In Vivo Studies

The elaboration of angiotensin peptides, BK or PGE₂ by VIC or myofibroblasts has not yet been demonstrated. Nonetheless, receptor-ligand binding is a requisite if locally generated peptides are to influence fibrogenesis. Normally, high-density AngII receptor binding in the heart is confined to its pacemaker and conduction

tissue.⁸⁴ Depending on the experimental model, autoradiographic localization of type I AngII and BK receptor binding is anatomically coincident with sites of myocardial fibrosis and ACE binding.⁴⁴

The role of AngII and BK in regulating fibrogenesis can be inferred from *in vivo* studies wherein pharmacologic agents that interfered with their elaboration or receptor binding were used. Six-wk treatment with enalapril in 4-week-old rats retarded collagen formation in both the right and left ventricles, aorta and superior mesenteric artery.¹⁶ A small dose of quinapril, which did not prevent hypertension in 4-wk-old SHR, was found to inhibit aortic ACE activity by 60% without reducing plasma ACE activity. The expected rise in aortic collagen volume fraction, observed in untreated SHR at 30 wks of age, was not seen in quinapril-treated animals.⁸⁵

ACE inhibitors reduce fibrous tissue formation following infarction. Perindopril, given 1 wk after infarction, decreased the endomyocardial fibrosis that appeared in the nonnecrotic segment of left ventricle.⁸⁶ Captopril treatment commenced at the time of coronary artery ligation prevented the expected proliferation of fibroblasts and fibrosis of the right ventricle and septum that appeared at 1 and 2 wks following infarction.³¹ A type I AngII receptor antagonist, losartan, prevented fibrosis but not fibroblast proliferation at these remote sites.⁸⁷ In the model of cardiac myocyte necrosis associated with chronic AngII administration,^{12,88} lisinopril attenuated microscopic scarring despite the presence of myocyte injury.⁴²

The evidence gathered to date, albeit indirect, implicates ACE as an integral component of an AngII-generating system found in connective tissue and which can be attributed to mesenchymal cells involved in fibrillar collagen formation under normal and pathologic conditions (TABLE 1). Pharmacologic inhibition of ACE or antagonism of AT₁ receptor attenuates the appearance of connective tissue at various sites in the myocardium and arterial vasculature. The relative

TABLE 1. Normal and Pathologic Connective Tissue as Sites of High-Density ACE Binding^a

Cell	Tissue	Model
VIC	heart valve leaflets	heart
Pericyte	adventitia	aorta, heart
	perivascular fibrosis	AngII
		ALDO
MyoFb	scarring post-myocyte necrosis	remote to MI
		coronary ligation
		isoproterenol
		AngII
		ALDO
	endocardial fibrosis	remote to MI
	pericardial fibrosis	post-pericardiotomy

^a Both normal (valve leaflets and adventitia) and pathologic (various forms of fibrosis) connective tissue are sites of high-density ACE binding. ACE-labeled cells found at tissue sites in the heart and related structures are given based on findings obtained in various experimental models in the rat. VIC = valvular interstitial cell; MyoFb = myofibroblast; ALDO = aldosterone; MI = myocardial infarction.

importance of AngII and BK to collagen turnover—a paradigm of reciprocal regulation⁸⁹—requires further study. *In vitro* studies, however, shed light on this topic.

In Vitro Studies

Peptide hormones influence adult rat cardiac fibroblast collagen turnover. In serum-deprived cells, receptor-ligand binding by AngII increases net collagen production,⁹⁰ collagen synthesis⁹¹ and that of its type I and III collagens.⁹² This involves the AT₁ receptor subtype and appears to be a transcriptional event involving protein kinase C.⁹² Moreover, AngII reduces collagenolytic activity of culture medium.⁹¹ The mitogenic potential of these cells is not altered by AngII,^{90,91} which contrasts to the growth response seen in neonatal cardiac fibroblasts.^{93,94} AngII receptors in adult and neonatal cardiac fibroblasts are predominantly subtype I.^{90,95} Inhibitors of cardiac fibroblast collagen synthesis include BK and PGE₂, while these hormones stimulate collagenolytic activity.⁹² A dual effect of ACE inhibitors may therefore be responsible for preventing the appearance of myocardial fibrosis, either at or remote from the site of myocardial infarction. Such agents can reduce local concentrations of AngII while augmenting BK levels that lead to the stimulation of PGE₂ production. The relative importance of AngII has been considered by using an AT₁ receptor antagonist.⁸⁷ The contribution of BK and PGE₂ needs to be addressed by pharmacologic antagonism of BK receptors and cyclooxygenase inhibitors, respectively.⁹⁶

Another candidate peptide that could be involved in the local regulation of fibroblast collagen turnover is endothelin (ET). ET-1 and -3 each increases cardiac fibroblast collagen synthesis and the synthesis of types I and III collagens in a concentration-dependent manner.⁹⁷ Both ET_A and ET_B receptors were involved in this response. The expression of type I and III collagen mRNAs was increased by ET-1 and ET-3. Collagenase activity was reduced by ET-1, not ET-3, which could be blocked by an antagonist to the subtype A receptor. ET receptors in cardiac fibroblasts are predominately subtype B.⁹⁸

Endothelial cells elaborate substances that act in a paracrine manner to influence the growth and metabolic behavior of neighboring nonendothelial cells leading to a perivascular fibrosis of intramyocardial coronary and systemic arterioles. Such cell-cell signaling is now recognized to represent an important modulator of vascular structure. Relative to collagen turnover, such substances could be considered promoters (*e.g.*, AngII and ETs) or inhibitors (*e.g.*, BK, prostaglandins and nitric oxide).⁸⁹ Endothelial cell-conditioned medium has been found to increase fibroblast collagen synthesis and to increase collagenase activity of cardiac fibroblast culture medium.⁹⁹ The nature of this signal(s), however, is unknown.

Wound Healing Paradigm

An association between local or circulating hormones and the fibrogenic component of wound healing has been developed. Responsible mechanisms, however, remain to be elucidated. If indeed AngII and aldosterone prove to be chemical

mediators of fibrogenesis, then it would explain why a chronic activation of the renin-angiotensin-aldosterone system contributes to a progressive remodeling of the myocardium. Circulating hormones are involved when tissue injury is extensive and involves restoration of intravascular volume homeostasis. Through coagulation, platelet aggregation, vasoconstriction, tachycardia, and sodium and water retention homeostasis is restored. These are established hormonal properties of AngII, ET, ALDO and norepinephrine. By virtue of their biologic economy of action, AngII, ET and ALDO likewise enhance fibroblast collagen formation and reduce collagenolytic activity. These hormones, derived from the circulation or tissue sources such as vascular endothelial cells, fibroblasts or fibroblast-like cells, subserve both homeostasis and tissue repair. Inhibitors (*yin*) counterbalance the influence of stimulators (*yang*) on homeostatic responses; they likewise suppress fibroblast growth and collagen synthesis and enhance collagenolytic activity. Such a reciprocal regulation of collagen turnover includes BK, prostaglandins, nitric oxide, atrial natriuretic peptide and glucocorticoids.⁸⁹

In the wound healing paradigm reciprocal regulation exists between organs and tissues at the cellular and molecular levels. A distortion of this coordinate balance between *yin* and *yang* normally occurs as a compensatory response to injury. In the absence of injury a discordant balance in reciprocal regulation represents a wound healing response gone awry and can account for a progressive structural remodeling of the coronary and systemic vasculature.

SUMMARY

The heart is composed of highly differentiated cardiac myocytes, which constitute parenchyma, and stroma or connective tissue. Fibrillar collagen turnover in the heart and its valve leaflets, in particular, is dynamic and essential to tissue repair. Emerging evidence further suggests connective tissue is a metabolically active entity, where peptide hormones are generated and degraded and, in turn, these peptides regulate collagen turnover. This concept arose from quantitative *in vitro* autoradiography using an iodinated derivative of lisinopril (¹²⁵I-351A) as ligand to localize angiotensin converting enzyme (ACE) binding density within the heart. A heterogeneous distribution was found: low-density ACE binding within atria and ventricles; high ACE binding density at sites of high collagen turnover, such as valve leaflets, adventitia, and fibrous tissue of diverse etiologic origins. ACE-producing cells at these latter sites were identified by monoclonal ACE antibody. They included valvular interstitial cells (VIC) and fibroblast-like cells each of which also contained α -smooth muscle actin and the transcript for type I collagen (*in situ* hybridization). Substrate utilization in cultured VIC was found to include angiotensin I and bradykinin. Angiotensin II and bradykinin receptor-ligand binding was observed in VIC and at fibrous tissue sites. Connective tissue ACE is independent of circulating angiotensin II. *In vivo*, fibrous tissue formation is attenuated by ACE inhibition or antagonism of AT₁ receptor. Angiotensin II and bradykinin are stimulatory and inhibitory, respectively, to cultured adult cardiac fibroblast collagen synthesis suggesting a paradigm of reciprocal regulation to fibroblast collagen turnover. Stroma and its cellular constituents

represent a dynamic metabolic entity that regulates its own peptide hormone composition and turnover of fibrillar collagen. These findings may provide insights that could be used to advantage to either promote or forestall fibrous tissue formation depending on the nature of cardiovascular disease.

REFERENCES

1. MONTFORT, I. & R. PÉREZ-TAMAYO. 1962. *Lab. Invest.* **11**: 463–470.
2. WEBER, K. T. 1989. *J. Am. Coll. Cardiol.* **13**: 1637–1652.
3. WEBER, K. T., C. G. BRILLA & J. S. JANICKI. 1993. *Cardiovasc. Res.* **27**: 341–348.
4. ROBINSON, T. F., S. M. FACTOR & E. H. SONNENBLICK. 1986. *Sci. Am.* **254**: 84–91.
5. ROBINSON, T. F., M. A. GERACI, E. H. SONNENBLICK & S. M. FACTOR. 1988. *Circ. Res.* **63**: 577–592.
6. LAURENT, G. J., M. P. SPARROW, P. C. BATES & D. J. MILLWARD. 1978. *Biochem. J.* **176**: 419–427.
7. LAURENT, G. J. 1987. *Am. J. Physiol.* **252**: C1–C9.
8. JUDD, J. T. & B. C. WEXLER. 1969. *Circ. Res.* **25**: 201–214.
9. JUGDUTT, B. I. & R. W. M. AMY. 1986. *J. Am. Coll. Cardiol.* **7**: 91–102.
10. LAINE, G. A. & S. J. ALLEN. 1991. *Circ. Res.* **68**: 1713–1721.
11. REDDY, H. K., S. E. CAMPBELL, J. S. JANICKI, G. ZHOU & K. T. WEBER. 1993. *J. Lab. Clin. Med.* **121**: 510–521.
12. RATAJSKA, A., S. E. CAMPBELL, J. P. M. CLEUTJENS & K. T. WEBER. 1994. *J. Lab. Clin. Med.* **124**: 408–415.
13. MEDUGORAC, I. 1980. *Cardiovasc. Res.* **14**: 551–554.
14. MUKHERJEE, D. & S. SEN. 1990. *Circ. Res.* **67**: 1474–1480.
15. BISHOP, J., J. GREENBAUM, D. GIBSON, M. YACOB & G. J. LAURENT. 1990. *J. Mol. Cell. Cardiol.* **22**: 1157–1165.
16. KEELEY, F. W., A. ELMOSELHI & F. H. H. LEENAN. 1992. *Am. J. Physiol.* **262**: H1013–H1021.
17. CASPARI, P. G., K. GIBSON & P. HARRIS. 1976. *In Biochemistry and Pharmacology of Myocardial Hypertrophy, Hypoxia, and Infarction*. P. Harris, R. J. Bing & A. Fleckenstein, Eds. 99–104. University Park Press. Baltimore.
18. WEBER, K. T. 1991. *In The Heart and Cardiovascular System*. H. Fozzard, E. Haber, R. B. Jennings, A. M. Katz & H. E. Morgan, Eds. 1465–1480. Raven Press. New York.
19. WHALLEY, E. T. 1992. *In Pathological Basis of the Connective Tissue Diseases*. D. L. Gardner, Ed. 282–299. Lea & Febiger. Philadelphia.
20. TODD, G. L., G. BAROLDI, G. M. PIEPER, F. C. CLAYTON & R. S. ELIOT. 1985. *J. Mol. Cell. Cardiol.* **17**: 317–338.
21. TODD, G. L., G. BAROLDI, G. M. PIEPER, F. C. CLAYTON & R. S. ELIOT. 1985. *J. Mol. Cell. Cardiol.* **17**: 647–656.
22. BENJAMIN, I. J., J. E. JALIL, L. B. TAN, K. CHO, K. T. WEBER & W. A. CLARK. 1989. *Circ. Res.* **65**: 657–670.
23. RATAJSKA, A., S. E. CAMPBELL, Y. SUN & K. T. WEBER. 1994. *Cardiovasc. Res.* **28**: 684–690.
24. CAMPBELL, S. E., J. S. JANICKI, B. B. MATSUBARA & K. T. WEBER. 1993. *Am. J. Hypertens.* **6**: 487–495.
25. DARROW, D. C. & H. C. MILLER. 1942. *J. Clin. Invest.* **21**: 601–611.
26. GABBIANI, G. 1981. *In Connective Tissue Research: Chemistry, Biology, and Physiology*. Z. Deyl & M. Adam, Eds. 183–194. Liss. New York.
27. JUDD, J. T. & B. C. WEXLER. 1975. *Am. J. Physiol.* **228**: 212–216.
28. GARDNER, D. L. 1992. *In Pathological Basis of the Connective Tissue Diseases*. D. L. Gardner, Ed. 300–331. Lea & Febiger. Philadelphia.
29. CHAPMAN, D., K. T. WEBER & M. EGHBALI. 1990. *Circ. Res.* **67**: 787–794.
30. PICK, R., J. E. JALIL, J. S. JANICKI & K. T. WEBER. 1989. *Am. J. Pathol.* **134**: 365–371.

31. VAN KRIMPEN, C., J. F. M. SMITS, J. P. M. CLEUTJENS, J. J. DEBETS, R. G. SCHOE-MAKER, H. A. STRUYKER-BOUDIER, F. T. BOSMAN & M. J. DAEMEN. 1991. *J. Mol. Cell. Cardiol.* **23**: 1245-1253.
32. SUN, Y., J. P. M. CLEUTJENS, A. A. DIAZ-ARIAS & K. T. WEBER. 1994. *Cardiovasc. Res.* **28**: 1423-1432.
33. TYAGI, S. C., L. MATSUBARA & K. T. WEBER. 1993. *Clin. Biochem.* **26**: 191-198.
34. TYAGI, S. C., A. RATAJSKA & K. T. WEBER. 1993. *Mol. Cell. Biochem.* **126**: 49-59.
35. CLEUTJENS, J. P. M., J. C. KANDALA, E. GUARDA, R. V. GUNTAKA & K. T. WEBER. 1995. *J. Mol. Cell. Cardiol.* In press.
36. PÉREZ-TAMAYO, R. 1970. *Lab. Invest.* **22**: 137-141.
37. FILIP, D. A., A. RADU & M. SIMIONESCU. 1986. *Circ. Res.* **59**: 310-320.
38. LUPU, F. & M. SIMIONESCU. 1985. *J. Submicrosc. Cytol.* **17**: 119-132.
39. KATWA, L. C., A. RATAJSKA, J. P. M. CLEUTJENS, Y. SUN, G. ZHOU, S. J. LEE & K. T. WEBER. 1995. *Cardiovasc. Res.* **29**. In press.
40. SUN, Y., A. RATAJSKA, G. ZHOU & K. T. WEBER. 1993. *J. Lab. Clin. Med.* **122**: 395-403.
41. SUN, Y. & K. T. WEBER. 1993. *J. Lab. Clin. Med.* **122**: 404-411.
42. SUN, Y. & K. T. WEBER. 1993. *Am. J. Hypertens.* **6**: 4A.
43. SUN, Y., A. RATAJSKA & K. T. WEBER. 1994. *J. Mol. Cell. Cardiol.* In press.
44. SUN, Y., A. A. DIAZ-ARIAS & K. T. WEBER. 1994. *J. Lab. Clin. Med.* **123**: 372-377.
45. YAMADA, H., B. FABRIS, A. M. ALLEN, B. JACKSON, C. I. JOHNSTON & F. A. O. MENDELSON. 1991. *Circ. Res.* **68**: 141-149.
46. PINTO, J. E., P. VIGLIONE & J. M. SAAVEDRA. 1991. *Am. J. Hypertens.* **4**: 321-326.
47. DANILOV, S. M., A. I. FAERMAN, O. Y. PRINTSEVA, A. V. MARTYNOV, I. Y. SAKHAROV & I. N. TRAKHT. 1987. *Histochemistry* **87**: 487-490.
48. JOHNSTON, C. I., V. MOOSER, Y. SUN & B. FABRIS. 1991. *Clin. Exp. Pharmacol. Physiol.* **18**: 107-110.
49. FABRIS, B., B. JACKSON, M. KOHZUKI, R. PERICH & C. I. JOHNSTON. 1990. *Clin. Exp. Pharmacol. Physiol.* **17**: 309-314.
50. WEBER, K. T., Y. SUN, L. C. KATWA & J. P. M. CLEUTJENS. 1995. *J. Mol. Cell. Cardiol.* **27**. In press.
51. VOLDERS, P. G. A., I. E. M. G. WILLEMS, J. P. M. CLEUTJENS, J.-W. ARENDS, M. G. HAVENITH & M. J. A. P. DAEMEN. 1993. *J. Mol. Cell. Cardiol.* **25**: 1317-1323.
52. VAN KRIMPEN, C., R. G. SCHOE-MAKER, J. P. M. CLEUTJENS, J. F. M. SMITS, H. A. J. STRUYKER-BOUDIER, F. T. BOSMAN & M. J. A. P. DAEMEN. 1991. *Basic Res. Cardiol.* **86**(Suppl. 1): 149-155.
53. CAMPBELL, D. J. 1987. *J. Clin. Invest.* **79**: 1-6.
54. LINDPAINNER, K., M. JIN, N. NIEDERMAIER, M. J. WILHELM & D. GANTEN. 1990. *Circ. Res.* **67**: 564-573.
55. CAMPBELL, D. J. & J. F. HABENER. 1987. *Endocrinology* **121**: 1616-1626.
56. CASSIS, L. A., K. R. LYNCH & M. J. PEACH. 1988. *Circ. Res.* **62**: 1259-1262.
57. DOSTAL, D. E., K. N. ROTHBLUM, M. I. CHERNIN, G. R. COOPER & K. M. BAKER. 1992. *Am. J. Physiol.* **263**: C838-C850.
58. DOSTAL, D. E., K. N. ROTHBLUM, K. M. CONRAD, G. R. COOPER & K. M. BAKER. 1992. *Am. J. Physiol.* **263**: C851-C863.
59. KLINKSTEIN, L. B., C. E. KAEMPFER & B. U. WINTROUB. 1982. *J. Biol. Chem.* **257**: 15042-15046.
60. PEARL, L. H. & W. R. TAYLOR. 1987. *Nature* **329**: 351-354.
61. WINTROUB, B. U., L. B. KLINKSTEIN, V. J. DZAU & K. W. K. WATT. 1984. *Biochemistry* **23**: 227-232.
62. HIRAYAMA, K., K. FUKUYAMA & W. L. EPSTEIN. 1990. *Comp. Biochem. Physiol.* **96B**: 553-557.
63. REILLY, C. F., D. A. TEWKSBURY, N. M. SCHECHTER & J. TRAVIS. 1982. *J. Biol. Chem.* **15**: 8619-8622.
64. NOZAKI, Y., N. SATO, T. IIDA, K. HARA, K. FUKUYAMA & W. L. EPSTEIN. 1992. *J. Biol. Chem.* **49**: 296-303.
65. SCHECHTER, N. M., J. K. CHOI, D. A. SLAVIN, D. T. DERESIENSKI, S. SAYAMA, G. DONG, R. M. LAVKER, D. PROUD & G. S. LAZARUS. 1986. *J. Immunol.* **137**: 962-970.

66. LINDPAINTENER, K., W. LU, J. NIEDERMAJER, B. SCHIEFFER, H. JUST, D. GANTEN & H. DREXLER. 1993. *J. Mol. Cell Cardiol.* **25**: 133-143.
67. YAMAGISHI, H., S. KIM, T. NISHIKIMI, K. TAKEUCHI & T. TAKEDA. 1993. *J. Moll. Cell. Cardiol.* **25**: 1369-1380.
68. HIRSCH, A. T., C. E. TALSNESS, H. SCHUNKERT, M. PAUL & V. J. DZAU. 1991. *Circ. Res.* **69**: 475-482.
69. BAUMGARTEN, C. R., W. LINZ, G. KUNKEL, B. A. SCHÖLKENS & G. WIEMER. 1993. *Br. J. Pharmacol.* **108**: 293-295.
70. KIMURA, B., C. SUMNERS & M. I. PHILLIPS. 1992. *Biochem. Biophys. Res. Commun.* **187**: 1083-1090.
71. HASHIMOTO, K., M. HIROSE, K. FURUKAWA, H. HAYAKAWA & E. KIMURA. 1977. *Jpn. Heart J.* **18**: 679-689.
72. NODA, K., M. SASAGURI, M. IDEISHI, M. IKEDA & K. ARAKAWA. 1993. *Cardiovasc. Res.* **27**: 334-340.
73. EVERS, A. S., S. MURPHREE, J. E. SAFFITZ, B. A. JAKSCHIK & P. NEEDLEMAN. 1985. *J. Clin. Invest.* **75**: 992-999.
74. HERMAN, A. G., M. CLAEYS, S. MONCADA & J. R. VANE. 1979. *Prostaglandins* **18**: 439-452.
75. DUSTING, G. J. & R. D. NOLAN. 1981. *Br. J. Pharmacol.* **74**: 553-562.
76. NOLAN, R. D., G. J. DUSTING, J. JAKUBOWSKI & T. J. MARTIN. 1982. *Prostaglandins* **24**: 887-902.
77. GOLDSTEIN, R. H. & P. POLGAR. 1982. *J. Biol. Chem.* **257**: 8630-8633.
78. BAREIS, D. L., V. C. MANGANIELLO, F. HIRATA, M. VAUGHAN & J. AXELROD. 1983. *Biochemistry* **80**: 2514-2518.
79. AHUMADA, G. G., B. E. SOBEL & P. NEEDLEMAN. 1980. *J. Mol. Cell. Cardiol.* **12**: 685-700.
80. SATOH, K. & S. M. PRESCOTT. 1980. *Biochim. Biophys. Acta* **930**: 283-296.
81. BAUM, B. J., J. MOSS, S. D. BREUL & R. C. CRYSTAL. 1978. *J. Biol. Chem.* **253**: 3391-3394.
82. ZHOU, G., S. C. TYAGI & K. T. WEBER. 1993. *Clin. Res.* **41**: 630A.
83. WEBER, D. R., E. D. STROUD & S. M. PRESCOTT. 1989. *Circ. Res.* **65**: 671-683.
84. ALLEN, A. M., H. YAMADA & F. A. O. MENDELSON. 1990. *Int. J. Cardiol.* **28**: 25-33.
85. ALBALADEJO, P., H. BOUAZIZ, M. DURIEZ, P. GOHLKE, B. I. LEVY, M. E. SAFAR & A. BENETOS. 1994. *Hypertension* **23**: 74-82.
86. MICHEL, J.-B., A.-L. LATTION, J.-L. SALZMANN, M. L. CEROL, M. PHILIPPE, J.-P. CAMILLERI & P. CORVOL. 1988. *Circ. Res.* **62**: 641-650.
87. SMITS, J. F. M., C. VAN KRIMPEN, R. G. SCHOEMAKER, J. P. M. CLEUTJENS & M. J. A. P. DAEMEN. 1992. *J. Cardiovasc. Pharmacol.* **20**: 772-778.
88. TAN, L. B., J. E. JALIL, R. PICK, J. S. JANICKI & K. T. WEBER. 1991. *Circ. Res.* **69**: 1185-1195.
89. WEBER, K. T. 1994. *News Physiol. Sci.* **9**: 123-128.
90. VILLARREAL, F. J., N. N. KIM, G. D. UNGAB, M. P. PRINTZ & W. H. DILLMAN. 1993. *Circulation* **88**: 2849-2861.
91. BRILLA, C. G., G. ZHOU, L. MATSUBARA & K. T. WEBER. 1994. *J. Mol. Cell. Cardiol.* **26**: 809-820.
92. ZHOU, G., C. G. BRILLA & K. T. WEBER. 1992. *FASEB J* **6**: A1914.
93. SCHORB, W., G. W. BOOZ, D. E. DOSTAL, K. M. CONRAD, K. C. CHANG & K. M. BAKER. 1993. *Circ. Res.* **72**: 1245-1254.
94. SADOHIMA, J. & S. IZUMO. 1993. *Circ. Res.* **73**: 413-423.
95. KATWA, L. C. & K. T. WEBER. 1993. *J. Mol. Cell. Cardiol.* **25**(Suppl. 3): S89.
96. UNGER, T. & P. GOHLKE. 1994. *Cardiovasc. Res.* **28**: 146-158.
97. GUARDA, E., L. C. KATWA, P. R. MYERS, S. C. TYAGI & K. T. WEBER. 1993. *Cardiovasc. Res.* **27**: 2130-2134.
98. KATWA, L. C., E. GUARDA & K. T. WEBER. 1993. *Cardiovasc. Res.* **27**: 2125-2129.
99. GUARDA, E., P. R. MYERS, C. G. BRILLA, S. C. TYAGI & K. T. WEBER. 1993. *Cardiovasc. Res.* **27**: 1004-1008.

Analysis of Homozygous TGF β 1 Null Mouse Embryos Demonstrates Defects in Yolk Sac Vasculogenesis and Hematopoiesis

JULIE S. MARTIN,^a MARION C. DICKSON,^a
FRANCES M. COUSINS,^a ASHOK B. KULKARNI,^b
STEFAN KARLSSON,^b AND
ROSEMARY J. AKHURST^{a,c}

^a*Department of Medical Genetics
University of Glasgow*

*Duncan Guthrie Institute of Medical Genetics
Yorkhill, Glasgow G3 8SJ, United Kingdom*

and

^b*Developmental and Metabolic Neurology Branch
National Institute of Neurological Disorders and Stroke
National Institutes of Health
Bethesda, Maryland, 20892*

INTRODUCTION

The transforming growth factors β (TGF β s) are multifunctional regulators of cellular function. *In vitro*, they are generally potent growth inhibitors, though they can act in a stimulatory manner, *via* indirect pathways, on some cell types. The TGF β s can also induce differentiation of some cells *in vitro*, and one of their major biological effects is in modulating the extracellular matrix of responding cells.¹ Three vertebrate TGF β isoforms exist, termed TGF β 1, β 2 and β 3, respectively. *In vitro*, all three isoforms have similar qualitative effects on cells, though the sensitivity of certain cell types to different isoforms is remarkably different.^{2,3} Endothelial cells and hematopoietic cells, for example, are potently growth inhibited by TGF β 1, whereas TGF β 2 is one or two orders of magnitude less effective in this response.⁴⁻⁸

Receptors for the TGF β s were recently cloned and were shown to belong to two classes (type I and type II) of a transmembrane serine/threonine kinase family.^{9,10} They are active in an oligoheteromeric form, and the type I receptor appears to be the downstream substrate for the type II receptor. Interestingly, though TGF β 1 and 3 bind to the type I and II receptors with equal affinities, TGF β 2 is incapable of binding these receptors directly. TGF β 2 requires the presence of a third transmembrane molecule, β -glycan (the type III receptor), in order to bind

^c To whom correspondence should be addressed.

to the type II receptor.⁹ This might explain the poor activity of TGF β 2 on endothelial and hematopoietic cells, since these cell types do not express β -glycan.^{3,7,11}

TGF β 1 Gene Knockout Mice

To help elucidate the function of TGF β 1 *in vivo*, mice which have a nonfunctional TGF β 1 gene were generated by homologous recombination in embryonic stem cells.^{12,13} In the mice used for this study,¹³ the TGF β 1 gene was disrupted by insertion of a neomycin-resistance gene into the partially deleted exon 1, which disrupted the open reading frame of the gene (FIG. 1). The heterozygous TGF β 1^{null} mice were normal. Interestingly, mice bearing no functional TGF β 1 gene (homozygous TGF β 1^{null}) were born and appeared developmentally normal. These mice, however, succumb to a gross multifocal inflammatory disorder, from which they died as early as 3 weeks postpartum (p.p.).¹³⁻¹⁶

It was, perhaps, surprising that homozygous TGF β 1^{null} neonates appeared developmentally normal, since a number of studies have shown widespread expression of the TGF β 1 gene during critical stages of murine embryogenesis (see below). However, statistical analysis of the genotype ratios postpartum showed that, in fact, roughly 50% of the null mice were lost either at or before birth.¹³ Moreover, recent experiments showed that maternal TGF β 1 crosses the placenta and might be responsible for rescuing TGF β 1^{null} embryos from developmental abnormalities caused by depletion of TGF β 1.¹⁷ Thus, homozygous TGF β 1^{null} mice can be classified into two distinct phenotypes, namely, prenatal lethal and postnatal lethal.

Developmental Expression Patterns of TGF β 1 and Its Receptors

A number of groups have examined expression of TGF β 1 during mouse and human embryogenesis. Rappolee *et al.*¹⁸ showed that preimplantation mouse em-

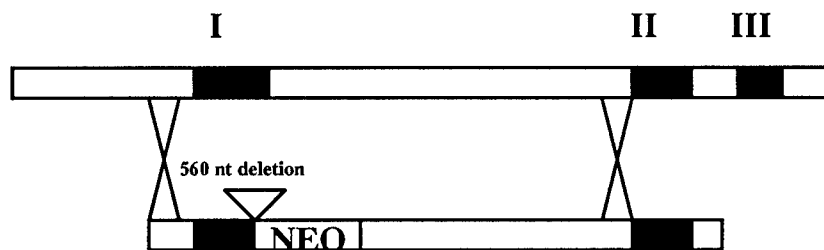

FIGURE 1. Generation of TGF β 1^{null} allele: simplified schematic diagram to show disruption of the TGF β 1 gene by homologous recombination in embryonic stem cells. The TGF β 1 gene, with exons I, II and III (blocked-in) is shown at the *top*. The targeting vector with homology over exons I and II (blocked-in), but with a 560-nucleotide deletion spanning part of the first exon and intron, and an insertion of 1.9 kb of neomycin resistance gene is shown at the *bottom*. The mutated allele will contain the deletion, a 560-nucleotide insertion containing the neomycin resistance gene, and disruption of the open reading frame of the TGF β 1 gene.

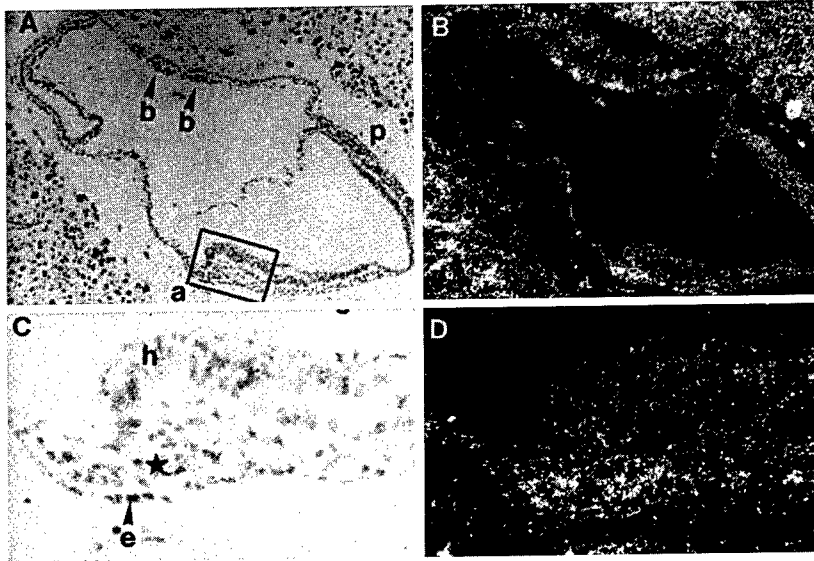

FIGURE 2. Expression of the $TGF\beta 1$ gene in the yolk sac and precardiac mesoderm of a 7.5 d.p.c. mouse embryo. (A,C) Bright-field and (B,D) dark-field views of radioactive *in situ* hybridizations with a $TGF\beta 1$ -specific probe. (C) and (D) represent the head region of the embryo (boxed-in in A), shown at higher magnification. a, anterior; b, blood islands; e, embryonic endoderm; h, neuroectoderm of head fold; p, posterior; ★, presumptive cardiac mesoderm (proangioblast progenitor cells).

bryos express $TGF\beta 1$ mRNA as detected by reverse-transcriptase polymerase chain reaction (RT-PCR). In contrast, by *in situ* hybridization we were unable to detect $TGF\beta 1$ transcripts until 7 days postcoitum (d.p.c.), when expression is seen in the blood islands of the yolk sac, the allantois and in the precardiac mesoderm of the embryo proper¹⁹ (FIG. 2).

The expression of $TGF\beta 1$ RNA in the yolk sac blood islands, allantois and cardiac mesoderm illustrates a recurrent theme of $TGF\beta 1$ gene expression during embryogenesis, that is, high level expression of the gene a) in angioblast progenitors and endothelial cells actively undergoing vasculogenesis and angiogenesis, and b) in hematopoietic tissue, at diverse stages of embryogenesis.¹⁹ The blood islands of the yolk sac are functionally distinct regions of mesodermal proliferation, induced by the underlying endoderm.²⁰ They contain the putative hemangioblast progenitors, which give rise to both endothelial and hematopoietic lineages of the yolk sac (FIG. 3). The outer hemangioblasts of the islet flatten and become endothelial cells, whereas the inner cells remain rounded and become blood cells. Eventually, the endothelial cells anastomose to form the vascular network of the yolk sac, whilst still engulfing blood cells (FIG. 3). The $TGF\beta 1$ gene is expressed in both cell lineages, at all stages of this process, including hemangioblasts and their derivative endothelial and hematopoietic cells.¹⁹ $TGF\beta 1$ RNA is also expressed in mesodermal angioblast progenitors and actively growing endothelial

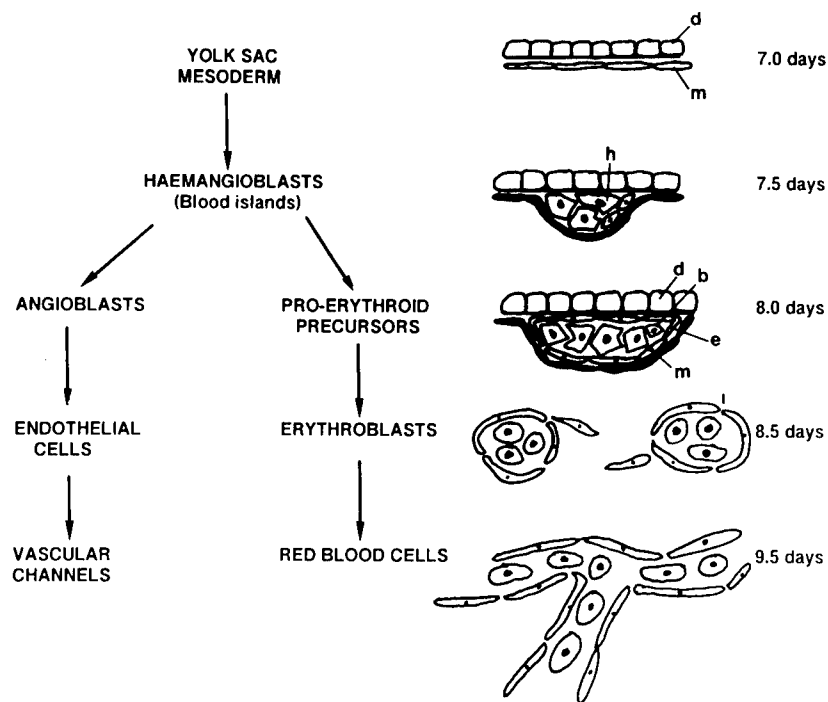

FIGURE 3. Schematic diagram to show development of the yolk sac vasculature and blood system. *Left* flow chart denotes divergence of cell lineages from the hemangioblast progenitor. *Right* cartoons show the spatial distributions of cell types within the yolk sac. b, blood cell progenitor; d, yolk sac endoderm; e, endothelial cell; h, hemangioblast; m, mesothelium.

cells of the embryo *per se*, including those of the endocardium and developing nexi of capillaries in head mesoderm and around the spinal cord.¹⁹ Similarly, the transcript is also expressed at high levels in fetal hematopoietic cells of the liver.²¹

Recent studies examined expression of the TGF β type II receptor during early murine embryogenesis. Interestingly, expression was not detected by RT-PCR until 7 d.p.c., when *in situ* hybridization and immunolocalization studies show that the receptor is only localized extraembryonically within the conceptus, *e.g.*, in the yolk sac (Christine Mummery, pers. comm.).

Developmental Analysis of the Prenatal Lethal Phenotype of Homozygous TGF β 1^{null} Embryos

Genotype analysis of adult mice and embryos was performed by polymerase chain reaction on genomic DNA.¹³ The postnatal genotype ratios of wild type (+/+):heterozygous (+/-):null (-/-) animals, obtained by crossing two heterozygous TGF β 1^{null} adults, was 1:1.5:0.5, deviating significantly from the expected

Mendelian ratio of 1:2:1. To exclude the possibility that half of the homozygous $TGF\beta 1^{null}$ animals were dying perinatally before genotype analysis could be performed, 18.5 d.p.c. fetuses from heterozygous crosses were harvested for genotype analysis by PCR. Even at 18.5 d.p.c., the genotype ratios were 1:1.5:0.5, confirming that the $TGF\beta 1^{null}$ embryos were dying *in utero*, prior to this stage.²²

To determine the gestational stage of prenatal lethality, viable embryos or fetuses from heterozygous $TGF\beta 1^{null}$ crosses were harvested for genotype analysis. At 8.5 and 9.5 d.p.c. the genotype ratios were Mendelian (1:2:1), whereas by 11.5 d.p.c. the genotype ratio of viable embryos was 1:1.5:0.5, indicating embryonic death between days 9.5 and 11.5 p.c.²²

Conceptuses from heterozygous $TGF\beta 1^{null}$ crosses were examined at 8.5 to 9.5 d.p.c. (FIG. 4), and at 10.5 d.p.c., to determine phenotypic differences between wild type and $TGF\beta 1^{null}$ animals. Analysis of 8.5 d.p.c. embryos indicated no obvious abnormalities in heterozygous or homozygous $TGF\beta 1^{null}$ embryos. However, by 9.5 d.p.c., 50% of the homozygous and 25% of the heterozygous $TGF\beta 1^{null}$ embryos showed defects in the yolk sac. The defects could be classified into two phenotypes, both independent of the other, and the extent of the abnormality, for each phenotype, was variable. The yolk sac, and in some cases the allantois, showed defects in vascularization ranging from a reduction in vessels to the presence of delicate and disorganized vessels. Additionally, or alternatively, the yolk sacs showed variable degrees of anemia. The embryos *per se* showed no specific developmental abnormalities at 9.5 d.p.c., though some were slightly developmentally retarded. By 10.5 d.p.c., the extent of retardation was more obvious (though still highly variable), and several of the $TGF\beta 1^{null}$ embryos showed signs of edema and/or necrosis.²²

Histological analysis of dissected yolk sacs from wild type or homozygous $TGF\beta 1^{null}$ embryos showed that both endothelial and hematopoietic cells were present between the mesothelial and endodermal layers of the yolk sac, and that there was no excessive proliferation of either endothelial or hematopoietic cells in the mutant compared to the control embryos. The mesothelial, endothelial and endodermal layers of the yolk sac were closely apposed in the wild type, with blood cells engulfed by discrete endothelial tubes. In contrast, in the homozygous $TGF\beta 1^{null}$ embryos, there was disruption of cellular adhesion between the two endothelial layers of the yolk sac, *i.e.*, those lining the endoderm and mesothelium, respectively. In some cases blood cells appeared to have leaked into the yolk sac cavity, indicating instability of endothelial tubes.²²

Analysis of $TGF\beta 1^{null}$ Embryos in In Vitro Culture

Analysis of the $TGF\beta 1^{null}$ embryos was confounded by the fact that only half of the homozygous $TGF\beta 1^{null}$ embryos were phenotypically abnormal (*i.e.*, $\frac{1}{8}$ of each litter). Furthermore, at 9.5 d.p.c., between 5–10% of control embryos exhibit random developmental abnormalities, further obscuring the results. Assuming that half of the $TGF\beta 1^{null}$ embryos were being rescued by maternal $TGF\beta 1$ *in utero*, we developed an *in vitro* system for culturing whole embryos from 8.5 to 9.5

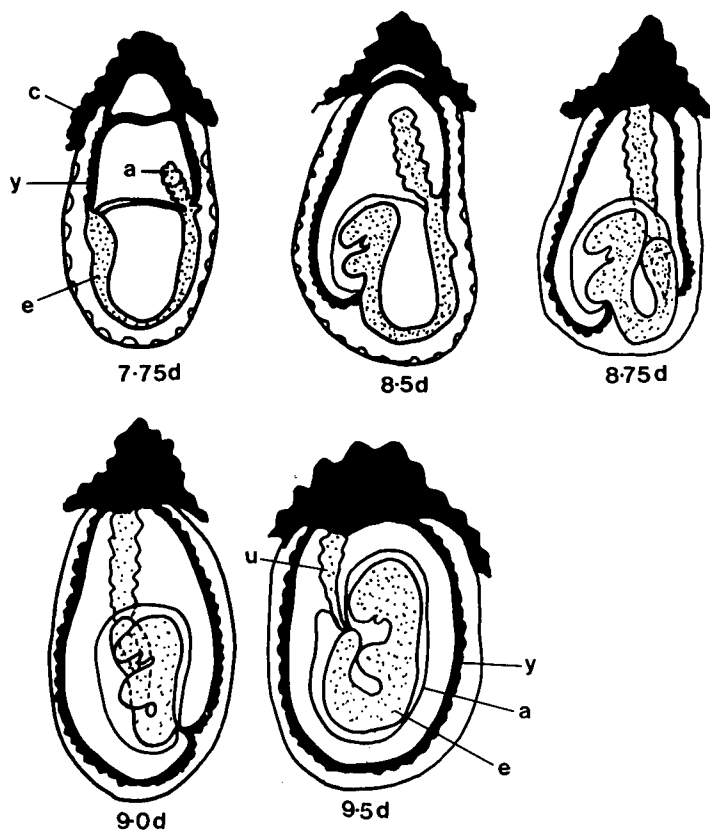

FIGURE 4. Development of the yolk sac and establishment of the chorioallantoic placental circulation in the mouse embryo. Based on a cartoon by Kaufman.³¹ The allantois (a) arises as a posterior extraembryonic mesodermal outgrowth from the primitive streak. The allantois undergoes vasculogenesis and fuses with the chorion (c) to form the umbilical cord (u), thus establishing the chorioallantoic placental circulation. The mouse embryo (e) undergoes an axial rotation or “turns,” which results in the characteristic fetal position of the embryo. During this process, the embryo also becomes surrounded by the extraembryonic membranes, including the yolk sac (y), which serves a vital placental function before establishment of the definitive placental circulation *via* the umbilical cord.

d.p.c. in TGF β -depleted medium.²³ Phenotypic analysis of cultured embryos from heterozygous TGF β 1 crosses demonstrated the aforementioned yolk sac defects in both homozygous and heterozygous TGF β 1^{null} embryos. However, the defects did not appear to be amplified in the culture system, in that still only 50% of homozygous TGF β 1^{null} embryos were phenotypically abnormal. Thus, rescue by maternal TGF β 1 might not be responsible for the dichotomy of TGF β 1^{null} phenotypes. Alternatively, maternal TGF β 1 might already have been effective in “rescuing” the null embryos prior to 8.5 d.p.c., when the culture system was initiated.

DISCUSSION

50% of homozygous $TGF\beta 1^{null}$ mice are born with no developmental abnormalities, whereas the other 50% die *in utero*. We have shown that the primary cause of prenatal lethality of $TGF\beta 1^{null}$ mice is defective endothelial and hematopoietic development, specifically within the yolk sac.²² Thus, the first cells that have been shown to express $TGF\beta 1$, during murine embryogenesis,¹⁹ are those that are phenotypically defective in the $TGF\beta 1^{null}$ embryos, suggesting a predominantly autocrine mode of action for this growth factor at these early stages. Interestingly, this also correlates with the onset of expression of the type II receptor for $TGF\beta$ in extraembryonic tissue (Christine Mummery, pers. comm.).

$TGF\beta 1$ is a potent inhibitor of proliferation of both endothelial^{24,25} and hematopoietic^{7,8,26} cells *in vitro*. Furthermore, $TGF\beta 2$ is relatively ineffective as a growth inhibitor of either of these cell types, presumably because of differential expression of receptors and accessory proteins, such as β -glycan, which bind $TGF\beta 1$ and $TGF\beta 2$ with different affinities.^{3,4,7,8} Interestingly, the homozygous $TGF\beta 1^{null}$ embryos showed no gross change in morphology which would be suggestive of uncontrolled proliferation of endothelial or hematopoietic cells, though experiments to compare cellular proliferation rates in wild-type and mutant embryos remain to be done.

The major abnormal phenotypes, which were observed in approximately half of the homozygous $TGF\beta 1^{null}$ embryos, were defects in yolk sac vasculogenesis and/or hematopoiesis. Vascular defects ranged from a reduced vascular network, to a delicate and disorganized vascular system. It appeared that the endothelial cells never formed capillary-like tubes, with tight cell junctions, since histological analysis revealed only sparse cellular connections between the endothelial monolayer juxtaposed to the endoderm, and that juxtaposed to the mesothelium. This is an interesting observation since, when microvascular endothelial cells are seeded within a three-dimensional collagen gel, $TGF\beta 1$ has the effect of inducing capillary tube formation, with the upregulation of cell adhesion molecules, such as PECAM, tube-stabilizing extracellular matrix proteins and their receptors, such as fibronectin and integrins, and the formation of tight junctions between endothelial cells.²⁷⁻²⁹ Furthermore, in this 3-d culture system, the cells are refractile to negative growth regulation by $TGF\beta$. Thus, in a culture system more reminiscent of the *in vivo* situation, $TGF\beta 1$ does not affect growth but induces differentiation. Similarly, in the $TGF\beta 1^{null}$ embryos, the predominant effect on endothelial cells seems to be inadequate differentiation rather than effects on cell growth.

A significant number of homozygous $TGF\beta 1^{null}$ embryos had anemic yolk sacs. $TGF\beta 1$ has been shown to be a potent inhibitor of both growth and differentiation of early hematopoietic progenitor cells.^{7,8,26} Thus, the $TGF\beta 1^{null}$ phenotype observed was contrary to expectations. However, the inhibitory effect of $TGF\beta 1$ on hematopoietic cells has generally been assayed by colony-forming ability *in vitro*, where potent $TGF\beta 1$ inhibition of growth may mask effects on differentiation. In contrast, in K562 cells, which are of hematopoietic origin, $TGF\beta 1$ has been shown to be a potent inducer of hemoglobin accumulation,²² a marker of differentiation. Therefore, in parallel to the observations made on yolk sac endothelial cells, the primary effect of $TGF\beta 1$ depletion on yolk sac hematopoietic

cells *in vivo* might be inadequate induction of differentiation. The abnormal phenotypes of the hematopoietic and endothelial cells, taken together, suggest that the primary function of TGF β 1 in the early embryo is not as a regulator of growth, but as an inducer of differentiation.

The yolk sac is a very important structure in early mammalian embryonic development, especially in mice where it serves an essential placental function, before the establishment of the chorioallantoic placental circulation which occurs after 9.5 d.p.c. (FIG. 4). Nutritive macromolecules are endocytosed by yolk sac endoderm, oxygen and carbon dioxide are exchanged, and the yolk sac also serves a synthetic function, biosynthesizing molecules such as α -fetoprotein, transferrin, and α -1-antitrypsin.³⁰ The primary developmental defect in homozygous TGF β 1^{null} conceptuses was restricted to the yolk sac and allantois. There appeared to be no specific developmental abnormalities within the embryos *per se*. The embryos showed variable developmental retardation and variable degrees of edema and necrosis; all likely secondary consequences of defective yolk sac development, and consequent starvation of the conceptus.

REFERENCES

1. ROBERTS, A. B. & M. B. SPORN. 1990. The transforming growth factor betas. *In* Peptide Growth Factors and Their Receptors. Handbook of Experimental Pharmacology. M. B. Sporn & A. B. Roberts, Eds. 419–472. Springer-Verlag, Heidelberg.
2. GRAYCAR, J. L., D. A. MILLER, B. A. ARRICK, R. M. LYONS, H. L. MOSES & R. DERYNCK. 1989. Human transforming growth factor-beta 3: recombinant expression, purification, and biological activities in comparison with transforming growth factors-beta 1 and -beta 2. *Mol. Endocrinol.* **3**: 1977–1986.
3. CHEIFETZ, S., H. HERNANDEZ, M. LAIHO, P. TEN DIJKE, K. K. IWATA & J. MASSAGUE. 1990. Distinct transforming growth factor- β (TGF- β) receptor subsets as determinants of cellular responsiveness of three TGF- β isoforms. *J. Biol. Chem.* **265**: 20533–20538.
4. JENNINGS, J. C., S. MOHAN, T. A. LINKHART, R. WIDSTROM & D. J. BAYLINK. 1988. Comparison of the biological actions of TGF beta-1 and TGF beta-2: differential activity in endothelial cells. *J. Cell. Physiol.* **137**: 167–172.
5. MERWIN, J. R., W. NEWMAN, D. BEALL, A. TUCKER & J. A. MADRI. 1991. Vascular cells respond differentially to transforming growth factors-beta1 and beta2. *Am. J. Pathol.* **138**: 37–51.
6. QIAN, S. W., J. K. BURMESTER, J. R. MERWIN, J. A. MADRI, M. B. SPORN & A. B. ROBERTS. 1992. Identification of a structural domain that distinguishes the actions of the type 1 and 2 isoforms of transforming growth factor β on endothelial cells. *Proc. Natl. Acad. Sci. USA* **89**: 6290–6294.
7. OHTA, M., J. S. GREENBERGER, P. ANKLESARIA, A. BASSOLS & J. MASSAGUE. 1987. Two forms of transforming growth factor-beta distinguished by multipotential haematopoietic progenitor cells. *Nature* **329**: 539–541.
8. OTTMAN, O. G. & L. M. PELUS. 1988. Differential proliferative effects of transforming growth factor-beta on human hematopoietic progenitor cells. *J. Immunol.* **140**: 2661–2665.
9. MASSAGUE, J. 1992. Receptors for the TGF β family. *Cell* **69**: 1067–1070.
10. FRANZEN, P., P. TEN DIJKE, H. ICHIO, H. YAMASHITA, P. SCHULTZ, C. HELDIN & K. MIYAZONO. 1993. Cloning of a TGF β type I receptor that forms a heterodimeric complex with the TGF β type II receptor. *Cell* **75**: 681–692.
11. MASSAGUE, J., S. CHEIFETZ, F. T. BOYD & J. L. ANDRES. 1990. TGF- β receptors and TGF β binding proteoglycans: recent progress in identifying their functional properties. *Ann. N.Y. Acad. Sci.* **593**: 59–72.

12. SHULL, M. M., I. ORMSBY, A. B. KIER *et al.* 1992. Targeted disruption of the mouse transforming growth factor- β 1 gene results in multifocal inflammatory disease. *Nature* **359**: 693–699.
13. KULKARNI, A. B., C. HUH, D. BECKER *et al.* 1993. Transforming growth factor- β 1 null mutation in mice causes excessive inflammatory response and early death. *Proc. Natl. Acad. Sci. USA* **90**: 770–774.
14. HINES, K. L., A. B. KULKARNI, J. B. MCCARTHY *et al.* 1994. Synthetic fibronectin peptides interrupt inflammatory cell infiltration in transforming growth factor β 1 knockout mice. *Proc. Natl. Acad. Sci. USA* **91**: 5187–5191.
15. MCCARTNEY-FRANCIS, N. L. & S. M. WAHL. 1994. Transforming growth factor β : a matter of life and death. *J. Leuk. Biol.* **55**: 401–409.
16. KULKARNI, A. B., J. M. WARD, A. G. GEISER *et al.* 1994. TGF- β 1 knockout mice: immune dysregulation and pathology. *In Molecular Biology of Haematopoiesis*. Vol. 3. Intercept Ltd. Andover, NH.
17. LETTERIO, J. J., A. G. GIESER, A. B. KULKARNI, N. ROCHE, M. B. SPORN & A. B. ROBERTS. 1994. *Science*. In press.
18. RAPPOLEE, D. A., C. A. BRENNER, R. SCHULTZ, D. MARK & Z. WERB. 1988. Developmental expression of PDGF, TGF-alpha and TGF-beta genes in preimplantation mouse embryos. *Science* **241**: 1823–1825.
19. AKHURST, R. J., S. A. LEHNERT, A. J. FAISSNER & E. DUFFIE. 1990. TGF beta in murine morphogenetic processes: the early embryo and cardiogenesis. *Development* **108**: 645–656.
20. MIURA, Y. & F. H. WILT. 1969. Tissue interaction and the formation of the first erythroblasts of the chick embryo. *Dev. Biol.* **19**: 201–211.
21. LEHNERT, S. A. & R. J. AKHURST. 1988. Embryonic expression pattern of TGF beta type-1 RNA suggests both paracrine and autocrine mechanisms of action. *Development* **104**: 263–273.
22. DICKSON, M. C., J. S. MARTIN, F. M. COUSINS, A. B. KULKARNI, S. KARLSSON & R. J. AKHURST. 1994. In preparation.
23. MARTIN, J. S. & R. J. AKHURST. 1994. In preparation.
24. HEIMARK, R. L., D. R. TWARDZIK & S. M. SCHWARTZ. 1986. Inhibition of endothelial regeneration by type-beta transforming growth factor from platelets. *Science* **233**: 1078–1080.
25. MULLER, G., J. BEHRENS, U. NUSSBAUMER, P. BOHLEN & W. BIRCHMEIER. 1987. Inhibitory action of transforming growth factor beta on endothelial cells. *Proc. Natl. Acad. Sci. USA* **84**: 5600–5604.
26. SING, G. K., J. R. KELLER, L. R. ELLINGSWORTH & F. W. RUSCETTI. 1988. Transforming growth factor β selectively inhibits normal and leukemic human bone marrow cell growth *in vitro*. *Blood* **72**: 1504–1511.
27. MADRI, J. A., B. M. PRATT & A. M. TUCKER. 1988. Phenotypic modulation of endothelial cells by transforming growth factor-beta depends upon the composition and organization of the extracellular matrix. *J. Cell. Biol.* **106**: 1375–1384.
28. MERWIN, J. R., J. ANDERSON, O. KOCHER, C. VAN ITALLIE & J. A. MADRI. 1990. Transforming growth factor beta modulates extracellular matrix organization and cell-cell junctional complex formation during *in vitro* angiogenesis. *J. Cell Physiol.* **142**: 117–128.
29. MADRI, J. A., L. BELL & J. R. MERWIN. 1992. Modulation of vascular cell behavior by transforming growth factors β . *Mol. Reprod. Dev.* **32**: 121–126.
30. FREEMAN, S. J. 1990. Functions of extraembryonic membranes. *In Postimplantation Mammalian Embryos: a Practical Approach*. A. J. Copp & D. L. Cockcroft, Eds. 249–265. IRL Press. Oxford.
31. KAUFMAN, M. H. 1990. Morphological stages of post-implantation embryonic development. *In Postimplantation Mammalian Embryos: a Practical Approach*. A. J. Copp & D. L. Cockcroft, Eds. 81–91. IRL Press. Oxford.

Molecular Analysis of TGF β Signal Transduction

Dominant-Inhibitory Mutations of the Type II and Type I TGF β Receptor^a

MICHAEL D. SCHNEIDER AND THOMAS BRAND

*Molecular Cardiology Unit
Departments of Medicine, Cell Biology, and Molecular
Physiology and Biophysics
Baylor College of Medicine
Houston, Texas 77030*

INTRODUCTION

In efforts to decipher fundamental mechanisms that govern the cardiac phenotype, one promise of molecular genetics is the capacity to explore proteins' function *in vivo*, through the engineering and analysis of gain-of-function or loss-of-function mutations. Limitations intrinsic to other approaches become evident in considering the multitude of biological functions ascribed to myocardial growth factors. A role for type β transforming growth factors (TGF β) in the genesis, proliferation, subsequent hypertrophy, and adaptation of cardiac muscle cells has been inferred from suggestive observational data—the intricate spatial-temporal program of growth factor expression in the heart—and, equally, from the impact of exogenous TGF β on various cardiogenic explants, pluripotent lines, or primary cell culture preparations.¹⁻⁵ Thus, the involvement of TGF β as an autocrine or paracrine factor in cardiac myogenesis, postulated from *in situ* hybridization results,⁶ has likewise been deduced from specific inductive effects of TGF β family members on progenitor cells of the axolotl,⁷ animal pole explants of *Xenopus laevis* embryos,⁸ P19 teratocarcinoma cells,⁹ and embryonic stem cells.¹⁰ Analogous conclusions regarding TGF β as an autocrine or paracrine factor in load-induced hypertrophy, drawn from the marked upregulation of TGF β after aortic banding,¹¹ gain support from the ability of TGF β to reproduce the so-called hypertrophic program of gene expression in cell culture, including preferential expression of genes associated with the embryonic myocardium.¹²⁻¹⁴ While information of these two sorts can provide a cogent rationale and indispensable data for devising alternative, more direct tests, neither line of evidence is adequate to substantiate the activity of endogenous TGF β *in vivo*, an issue that might better be addressed through inhibitors of TGF β expression or action.

For growth factors bound by receptors that contain a tyrosine kinase signaling

^a Supported by grants from the National Institutes of Health (R01 HL39141, R01 HL47567, T32 HL07706) and the American Heart Association (91-009790) to M.D.S. T.B. was a Fellow of the Deutsche Forschungsgemeinschaft.

domain, substantial success in verifying function has been achieved through the use of kinase-defective variants, which act as "dominant-negative" or "dominant-inhibitory" proteins, to disrupt signal transduction by the coexisting wild-type receptor.¹⁵⁻¹⁸ As prerequisites for signaling by the receptor tyrosine kinases are ligand-induced dimer formation and autophosphorylation, the dominant-negative phenotype is presumed to result from recruitment of the normal receptor into nonfunctional heterodimers. By contrast, TGF β and related peptides of the TGF β superfamily are recognized by a distinct series of receptor molecules harboring, instead, a serine/threonine kinase in the cytoplasmic domain.¹⁹⁻²² Though the sequential molecular events underlying TGF β receptor activation are much less completely understood than for receptor tyrosine kinases, the dimeric structure of TGF β , the apparent requirement for type I and type II receptor in tandem²³ and success in the case of the related activin type II receptor²⁴ supported the expectation that a corresponding dominant-negative receptor for TGF β might be engineered.

A Dominant-Negative Type II Receptor for TGF β

We constructed a carboxy-terminal truncation of the human type II TGF β receptor (Δ kT β RII)¹³ by deleting the cytoplasmic serine/threonine kinase domain in its entirety (shown schematically in FIG. 1A). The truncated type II receptor was transfected into neonatal rat cardiac myocytes together with TGF β -responsive luciferase reporter genes driven by the skeletal α -actin promoter or by 5' flanking sequences of the α -myosin heavy chain (activated or inhibited by TGF β , respectively). At least as measured by the induction of the skeletal α -actin promoter, neonatal rat cardiac myocytes responded equivalently to TGF β 1, β 2, and β 3, all three isoforms of TGF β found in mammals. Δ kT β RII was sufficient to block stimulation by each, whereas a similar truncation of the type II activin receptor had no effect (FIG. 1B). Conversely, Δ kT β RII was sufficient to rescue the α -myosin heavy chain reporter from inhibition by TGF β , while sparing thyroid hormone-dependent transcription of the gene. Finally, as a further criterion for specificity of the dominant-negative receptor, TGF β -dependent transcription could be restored by titrating back increasing amounts of vector encoding the full-length type II receptor protein (FIG. 1C).

FIGURE 1. A kinase-defective type II receptor for TGF β , Δ kT β RII, inhibits TGF β -dependent gene transcription in cardiac muscle cells. (A) Wild-type and truncated T β RII, illustrating predicted structural domains. *Arrowheads* denote the PCR amplification primers. (B) Δ kT β RII blocks induction of the skeletal α -actin promoter by TGF β 1, β 2, and β 3. Luciferase expression, corrected for transfection efficiency, is shown relative to the skeletal α -actin promoter in vehicle-treated, vector-transfected control cells. *Error bars* indicate standard error of the mean *Open bar*, control vector; *solid bar*, Δ kT β RII, kinase-defective T β RII; *gray bar*, Δ kAcRII, parallel truncation of the type II activin receptor. (C) Full-length T β RII restores TGF β induction of the skeletal α -actin promoter to cardiac muscle cells expressing the dominant-inhibitory receptor. (Adapted from Brand *et al.*¹³)

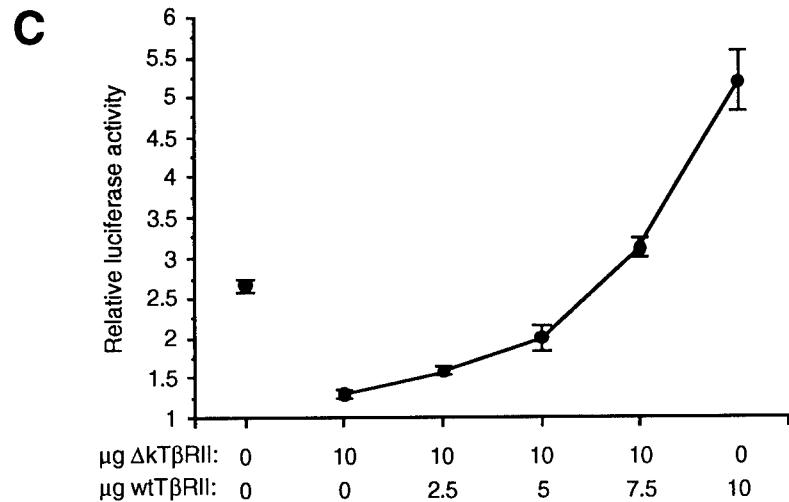
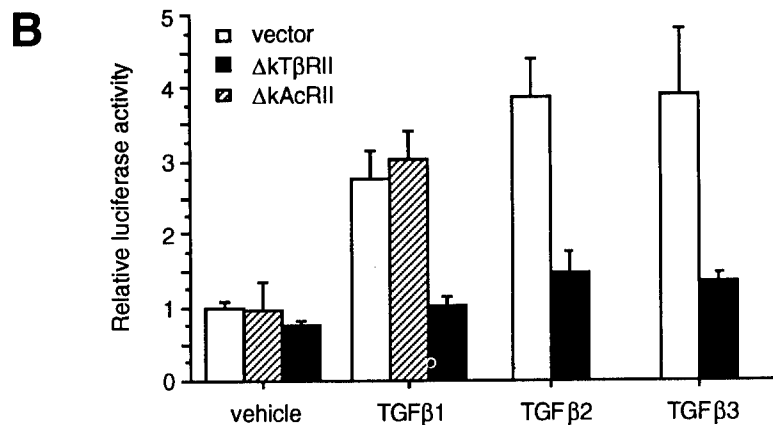
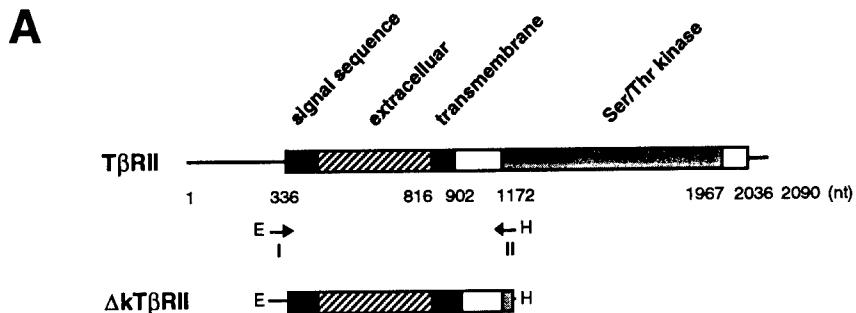

Comparative Role of the Type I and Type II Receptor

At the time these studies were initiated, molecular identification of the corresponding type I receptor for TGF β had not yet been accomplished. Six putative type I receptors soon were isolated, which shared a related but distinct cytoplasmic domain, also harboring a serine/threonine kinase motif.²⁵⁻³¹ Among them, several possess the ability to bind TGF β in the presence of the TGF β type II receptor,^{25,29,32} yet only one, designated ALK-5³⁰ or R4,³¹ has been shown to restore TGF β -dependent gene expression in cells lacking endogenous type I receptor. While there is general agreement that the type I and type II receptor form heteromeric complexes in the presence of TGF β , the comparative function of the two receptors remains a point of controversy. Must both receptors operate in collaboration, for all classes of TGF β effects? Alternatively, do separable, independent pathways exist? More specifically, does the type II receptor moderate merely growth inhibition, with gene regulation conferred exclusively or preferentially by the type I receptor?³³

To resolve these ambiguities, we first investigated the potential impact of our initial T β RII truncation in a noncardiac background—Mv1Lu mink lung epithelial cells cotransfected with a luciferase gene derived from the TGF β -responsive promoter for plasminogen activator inhibitor-1. As in cardiac myocytes, Δ kt β RII inhibited induction by TGF β , and full-length T β RII restored induction. Second, point mutations of T β RII were engineered at critical residues that are invariant among protein kinases (*e.g.*, K277A) or are conserved among the serine/threonine kinase subfamily (*e.g.*, K381A). Each of the charged-to-alanine mutations shown was sufficient to inhibit TGF β -induced gene expression, as were others, to the same extent as deletion of the entire cytoplasmic kinase domain. Third, kinase-defective truncations were engineered in two key members of the type I receptor subfamily, the bona fide type I receptor for TGF β (ALK-5)²⁸ and type I activin receptor (ALK-2).²⁷ Whereas the truncated type I TGF β receptor could inhibit TGF β -dependent expression, the corresponding mutation of ALK-2 did not; this observation agrees with recent evidence that kinase activity of T β RI is mandatory for restoring signal transduction in cells genetically deficient for the endogenous type I receptor.³⁴ Finally, a comparative titration with the type I and II receptor truncations demonstrated that Δ kt β RII was in fact more potent than Δ kt β RI as an inhibitor of TGF β -dependent gene transcription, and that the two truncations, transfected together, were similar in effect to Δ kt β RII alone.

Taken together, these findings are concordant with the interpretation that the type I and type II receptors operate in concert and are necessary in tandem for both aspects of TGF β function—growth inhibition and gene transcription.^{23,30} Given that Δ kt β RII can interdict signaling for all three isoforms of TGF β found in mammals, this conclusion suggests the further likelihood that a dominant-negative type II receptor might prove useful in the context of transgenic mice, to test more mechanistically the functions assigned to TGF β from less immediate forms of proof. In principle, forced expression of dominant-negative receptors *in vivo* offers advantages that would complement certain shortcomings of “knockout mutations” by homologous recombination:

- Immediate applicability to larger mammals, where transgenic technology exists but suitable embryonic stem cells do not;
- Targeted loss-of-function in single organs or cell types, obviating the hazard of potential systemic, indirect effects;
- Selective expression of the mutation after organogenesis is complete, minimizing the risk of embryonic lethality;
- Capacity to block effects of an entire class of growth factors, surmounting the requirement for concomitant mutation of multiple proteins with overlapping function;
- Opportunity for tissue-specific inducible expression, via tetracycline or alternative agents;³⁵ and
- Capacity to block theoretical consequences of maternally-derived growth factors.

While the importance of maternal proteins is well appreciated in the context of *Xenopus* development, this issue has received scant attention as a foreseeable impediment to loss-of-function mutations in mice. Notably, animals bearing the putative null mutation for TGF β 1 have been found to contain TGF β 1 protein, although not mRNA, attributed to transplacental transmission from the heterozygous mother (Anita Roberts, personal communication). Conceivably, this epigenetic pattern of transmission may account for the apparently normal program of development in these animals, which succumb after birth to a multifocal inflammatory disease.^{36,37}

Thus, dominant-negative receptors are potentially informative reagents, which complement other procedures to implement a loss of gene function in living cells or organisms. Appropriate precautions must be observed, of course, in their use and interpretation. Sufficient expression of the dominant inhibitor, relative to wild-type protein, must be assured. In the instance of the TGF β receptor family, certain TGF β -responsive cells apparently lack type II receptor,³⁸ a departure from the profile of receptor expression in cell types that have received the fullest attention. Several tissues—embryonic cartilage, brain, and spinal cord—lack detectable type II receptor mRNA,³⁹ and heterogeneity of endogenous receptors could complicate investigations with a given dominant inhibitor. Specificity of the dominant inhibitor is likewise a potential issue. Recent illustrations of this point include the ability of the truncated *Xenopus* activin receptor to interfere with another TGF β family member, Vg-1,⁴⁰ and, second, generalized effects of dominant-inhibitory Ras as a regulator of global gene expression.⁴¹

ACKNOWLEDGMENTS

The authors are grateful to R. J. Schwartz, M. Abdellatif, R. MacLellan, P. Paradis, J. Hawker, M.-J. Charng, and L. Kirshenbaum for helpful discussions. The authors thank H. Lin, J. Massagué, K. Miyazono, and J. Robbins for plasmids, F. Ervin for technical assistance, and R. Roberts for encouragement and support.

REFERENCES

1. PARKER, T. G. & M. D. SCHNEIDER. 1991. Growth factors, proto-oncogenes, and plasticity of the cardiac phenotype. *Ann. Rev. Physiol.* **53**: 179–200.
2. SCHNEIDER, M. D. & T. G. PARKER. 1991. Cardiac growth factors. *Prog. Growth Factor Res.* **3**: 1–26.
3. SCHNEIDER, M. D. & T. G. PARKER. 1990. Cardiac myocytes as targets for the action of peptide growth factors. *Circulation* **81**: 1443–1456.
4. MACLELLAN, W. R., T. BRAND & M. D. SCHNEIDER. 1993. Transforming growth factor-beta in cardiac ontogeny and adaptation. *Circ. Res.* **73**: 783–791.
5. ROBERTS, A. B., M. B. SPORN & A. M. LEFER. 1993. Cardioprotective actions of transforming growth factor-beta. *Trends Cardiovasc. Med.* **3**: 77–81.
6. MILLAN, F. A., F. DENHEZ, P. KONDAIAH & R. J. AKHURST. 1991. Embryonic gene expression patterns of TGF β 1, β 2 and β 3 suggest different developmental functions *in vivo*. *Development* **111**: 131–144.
7. MUSLIN, A. J. & L. T. WILLIAMS. 1991. Well-defined growth factors promote cardiac development in axolotl mesodermal explants. *Development* **112**: 1095–1101.
8. LOGAN, M. & T. MOHUN. 1993. Induction of cardiac muscle differentiation in isolated animal pole explants of *Xenopus laevis* embryos. *Development* **118**: 865–875.
9. VAN DEN EIJNDEN-VAN RAAIJ, A. J. M., T. A. E. VAN ACHTERBERG, C. M. M. VAN DER KRUIJSSEN, A. H. PIERSMA, D. HUYLEBROECK, S. W. DE LAAT & C. L. MUMMERY. 1991. Differentiation of aggregated murine P19 embryonal carcinoma cells is induced by a novel visceral endoderm-specific FGF-like factor and inhibited by activin A. *Mech. Dev.* **33**: 157–166.
10. SLAGER, H. G., W. VANINZEN, E. FREUND, A. J. M. VAN DEN EIJNDEN-VANRAAIJ & C. L. MUMMERY. 1993. Transforming growth factor-beta in the early mouse embryo: implications for the regulation of muscle formation and implantation. *Dev. Genet.* **14**: 212–224.
11. VILLARREAL, F. J. & W. H. DILLMANN. 1992. Cardiac hypertrophy-induced changes in mRNA levels for TGF-beta 1, fibronectin, and collagen. *Am. J. Physiol.* **262**: H1861–1866.
12. PARKER, T. G., S. E. PACKER & M. D. SCHNEIDER. 1990. Peptide growth factors can provoke “fetal” contractile protein gene expression in rat cardiac myocytes. *J. Clin. Invest.* **85**: 507–514.
13. BRAND, T., W. R. MACLELLAN & M. D. SCHNEIDER. 1993. A dominant-negative receptor for type-beta transforming growth factors created by deletion of the kinase domain. *J. Biol. Chem.* **268**: 11500–11503.
14. MACLELLAN, W. R., T.-C. LEE, R. J. SCHWARTZ & M. D. SCHNEIDER. 1994. Transforming growth factor- β response elements of the skeletal α -actin gene: combinatorial action of serum response factor, YY1, and the SV40 enhancer-binding protein, TEF-1. *J. Biol. Chem.* In press.
15. AMAYA, E., T. J. MUSCI & M. W. KIRSCHNER. 1991. Expression of a dominant negative mutant of the FGF receptor disrupts mesoderm formation in *Xenopus* embryos. *Cell* **66**: 257–290.
16. UENO, H., H. COLBERT, J. A. ESCOBEDO & L. T. WILLIAMS. 1991. Inhibition of PDGF beta-receptor signal transduction by coexpression of a truncated receptor. *Science* **252**: 844–848.
17. UENO, H., M. GUNN, K. DELL, A. TSENG & L. WILLIAMS. 1992. A truncated form of fibroblast growth factor receptor-1 inhibits signal transduction by multiple types of fibroblast growth factor receptor. *J. Biol. Chem.* **267**: 1470–1476.
18. MILLAUER, B., L. K. SHAWVER, K. H. PLATE, W. RISAU & A. ULLRICH. 1994. Glioblastoma growth inhibited *in vivo* by a dominant-negative *flk-1* mutant. *Nature* **367**: 576–579.
19. MATHEWS, L. S. & W. W. VALE. 1991. Expression cloning of an activin receptor, a predicted transmembrane serine kinase. *Cell* **65**: 973–982.
20. LIN, H. Y., X.-F. WANG, E. NG-EATON, R. A. WEINBERG & H. F. LODISH. 1992.

- Expression cloning of the TGF-beta type II receptor, a functional transmembrane serine/threonine kinase. *Cell* **68**: 775–785. Erratum: *Cell* **70**(6).
21. ESTEVEZ, M., L. ATTISANO, J. L. WRANA, P. S. ALBERT, J. MASSAGUÉ & D. L. RIDDLE. 1993. The *daf-4* gene encodes a bone morphogenetic protein receptor controlling *C. elegans* dauer larva development. *Nature* **365**: 644–649.
 22. XIE, T., A. L. FINELLI & R. W. PADGETT. 1994. The *Drosophila saxophone* gene: a serine-threonine kinase receptor of the TGF-beta superfamily. *Science* **263**: 1756–1759.
 23. WRANA, J. L., L. ATTISANO, J. CARCAMO, A. ZENTELLA, J. DOODY, M. LAIHO, X. F. WANG & J. MASSAGUÉ. 1992. TGFbeta signals through a heteromeric protein kinase receptor complex. *Cell* **71**: 1003–1014.
 24. HEMMATI-BRIVANLOU, A. & D. A. MELTON. 1992. A truncated activin receptor inhibits mesoderm induction and formation of axial structures in *Xenopus* embryos. *Nature* **359**: 609–614.
 25. EBNER, R., R. H. CHEN, L. SHUM, S. LAWLER, T. F. ZIONCHECK, A. LEE, A. R. LOPEZ & R. DERYNCK. 1993a. Cloning of a type-I TGF-beta receptor and its effect of TGF-beta binding to the type-II receptor. *Science* **260**: 1344–1348.
 26. HE, W. W., M. L. GUSTAFSON, S. HIROBE & P. K. DONAHOE. 1993. Developmental expression of four novel serine/threonine kinase receptors homologous to the activin/transforming growth factor-beta type-II receptor family. *Dev. Dynam.* **196**: 133–142.
 27. TEN DIJKE, P., H. ICHIO, P. FRANZÉN, P. SCHULZ, J. SARAS, H. TOYOSHIMA, C. H. HELDIN & K. MIYAZONO. 1993. Activin receptor-like kinases: a novel subclass of cell-surface receptors with predicted serine/threonine kinase activity. *Oncogene* **8**: 2879–2887.
 28. TEN DIJKE, P., H. YAMASHITA, H. ICHIO, P. FRANZEN, M. LAIHO, K. MIYAZONO & C. H. HELDIN. 1994. Characterization of type-I receptors for transforming growth factor-beta and activin. *Science* **264**: 101–104.
 29. ATTISANO, L., J. CARCAMO, F. VENTURA, F. M. B. WEIS, J. MASSAGUÉ & J. L. WRANA. 1993. Identification of human activin and TGF beta type-I receptors that form heteromeric kinase complexes with type- II receptors. *Cell* **75**: 671–680.
 30. FRANZÉN, P., P. TENDIJE, H. ICHIO, H. YAMASHITA, P. SCHULZ, C. H. HELDIN & K. MIYAZONO. 1993. Cloning of a TGF beta type-I receptor that forms a heteromeric complex with the TGF beta type-II receptor. *Cell* **75**: 681–692.
 31. BASSING, C. H., J. M. YINGLING, D. J. HOWE, T. W. WANG, W. W. HE, M. L. GUSTAFSON, P. SHAH, P. K. DONAHOE & X. F. WANG. 1994. A transforming growth factor-beta type-I receptor that signals to activate gene expression. *Science* **263**: 87–89.
 32. EBNER, R., R. H. CHEN, S. LAWLER, T. ZIONCHECK & R. DERYNCK. 1993b. Determination of type-I receptor specificity by the type-II receptors for TGF-beta or activin. *Science* **262**: 900–902.
 33. CHEN, R. H., R. EBNER & R. DERYNCK. 1993. Inactivation of the type-II receptor reveals two receptor pathways for the diverse TGF-beta activities. *Science* **260**: 1335–1338.
 34. CARCAMO, J., F. M. B. WEIS, F. VENTURA, R. WEISER, J. L. WRANA, L. ATTISAON & J. MASSAGUÉ. 1994. Type I receptors specify growth-inhibitory and transcriptional responses to transforming growth factor β and activin. *Mol. Cell. Biol.* **14**: 3810–3821.
 35. FISHMAN, G. I., M. L. KAPLAN & P. M. BUTTRICK. 1994. Tetracycline-regulated cardiac gene expression *in vivo*. *J. Clin. Invest.* **93**: 1864–1868.
 36. SHULL, M. M., I. ORMSBY, A. B. KIER, S. PAWLOWSKI, R. J. DIEBOLD, M. Y. YIN, R. ALLEN, C. SIDMAN, G. PROETZEL, D. CALVIN, N. ANNUNZIATA & T. DOETSCHMAN. 1992. Targeted disruption of the mouse transforming growth factor-beta 1 gene results in multifocal inflammatory disease. *Nature* **359**: 693–699.
 37. KULKARNI, A. B., C. G. HUH, D. BECKER, A. GEISER, M. LYGHT, K. C. FLANDERS, A. B. ROBERTS, M. B. SPORN, J. M. WARD & S. KARLSSON. 1993. Transforming growth factor beta 1 null mutation in mice causes excessive inflammatory response and early death. *Proc. Natl. Acad. Sci. USA* **90**: 770–774.
 38. MASSAGUÉ, J., S. CHEIFETZ, F. T. BOYD & J. L. ANDRES. 1990. TGF- β receptors and TGF- β binding proteoglycans: recent progress in identifying their functional

- properties. *In* Transforming Growth Factor- β s: Chemistry, Biology, and Therapeutics. K. A. Piez & M. B. Sporn, Eds. Vol. **593**: 59–72. The New York Academy of Sciences. New York.
39. LAWLER, S., A. F. CANDIA, R. EBNER, L. SHUM, A. R. LOPEZ, H. L. MOSES, C. V. E. WRIGHT & R. DERYNCK. 1994. The murine type II TGF- β receptor has a coincident embryonic expression and binding preference for TGF- β 1. *Development* **120**: 165–175.
40. SLACK, J. M. W. 1994. The inducer that never was. *Nature* **369**: 279–280.
41. ABDELLATIF, M., W. R. MACLELLAN & M. D. SCHNEIDER. 1994. p21 Ras as a governor of global gene expression. *J. Biol. Chem.* **269**: 15423–15426.

Mechanisms of Cell Transformation in the Embryonic Heart^a

JIAN-XIAN HUANG,^{b,c} JAY D. POTTS,^{c,e} ERIC B. VINCENT,^d
DANIEL L. WEEKS,^d AND RAYMOND B. RUNYAN^{b,f}

^b*Department of Anatomy
and*

*University Heart Center
University of Arizona
Tucson, Arizona 85718*

and

*Departments of ^cAnatomy and ^dBiochemistry
University of Iowa
Iowa City, Iowa 52242*

INTRODUCTION

One important event in early cardiac development is the formation of the embryonic cushions. These structures are paired, opposed, swellings which protrude into the atrioventricular (AV) canal during the tubular stage of heart development. They function as primitive heart valves during heart looping and, importantly, provide a progenitor cell population to form the atrioventricular valves and the membranous septa. At this early stage the heart is composed of two cell types, myocardial and endothelial cells. A third cell type, cushion mesenchyme, is formed by transformation of AV canal and outflow tract endothelial cells due to a stimulus from the adjacent myocardium. Beginning with the observation that exogenous transforming growth factor beta 1 (TGF β 1), in combination with normally noninductive ventricle, produces cell transformation from AV canal endothelia, we began an exploration of the mechanisms that underlie this transformation process. Our studies have revealed a critical role for endogenous TGF β 3 and several classes of signal transduction mechanisms. Recently, our studies have also led to the view that cell transformation in the heart is a recapitulation of the cell transformation process seen at gastrulation. These studies suggest a conservation of cell transformation mechanisms in the embryo and provide a new series of candidate mechanisms to be examined in the heart.

^a The work reported in this study was supported by Grants HL20220 and HL38649 to RBR and HL 42266 to DLW. EBV is a graduate fellow of the Iowa Affiliate of the American Heart Association and both RBR and DLW are Established Investigators of the American Heart Association, National Center.

^e Present address: Department of Anatomy and Cell Biology, Uniformed Services University of the Health Sciences, Bethesda, Maryland 20814.

^f Corresponding author: Raymond Runyan, University Heart Center, University of Arizona, 1501 N. Campbell Ave., Tucson, AZ 85718.

Mesenchymal Cell Formation in the Atrioventricular Canal

After fusion of the paired heart tubes, the embryonic heart is a single, looping, tube composed of an outer layer of myocardium and an inner endothelium. Between these layers is an acellular sleeve of extracellular matrix (ECM) composed of proteoglycans, collagens, and structural glycoproteins.^{1,2} Characteristic constrictions and expansions of the tube allow the identification of the single atrium and ventricle. Endocardial cushions form as a pair of opposing protrusions into the lumen of the AV canal. These masses arise by an apparent increased and localized synthesis of ECM by the AV canal myocardium.¹ A similar expansion of the ECM also takes place in the outflow tract. These areas become particularly prominent due to a loss of ECM material in the ventricular and atrial regions shortly afterwards.

At specific times in development (day 3 in the chick embryo, day 21 in man), endothelial cells of the AV canal separate from one another and hypertrophy. Though a similar transformation process takes place in the outflow tract, it has not been as well studied (available evidence suggests that the mechanisms of cell transformation will be similar). Endothelial cells of the adjacent atrium and ventricle remain unchanged. Subsequently, a subpopulation of activated AV canal endothelial cells proceed to complete epithelial-mesenchymal transformation and invade the underlying ECM. Among the changes that accompany hypertrophy and/or cell transformation are a loss of the cell-cell adhesion molecule NCAM³ and the expression of molecules such as the transcription factor *msx-1*,^{4,5} and the extracellular matrix molecules, heparan sulfate and chondroitin sulphate,⁶ fibulin,⁷ collagen I,⁸ and tenascin.⁹ The paired cushions eventually fuse to form the septum intermedium. The mesenchymal population of the AV canal goes on to participate in the remodeling and formation of the cardiac valves and the membranous septa.¹ There is some controversy as to whether other sources of cells contribute to the AV valves,¹⁰ but it is apparent that endothelial-derived mesenchyme provides a significant portion of the valvular and septal connective tissue.¹¹

A Bioassay for Epithelial-Mesenchymal Cell Transformation

Progress in understanding development in the AV canal of the heart has been greatly enhanced by the use of a three-dimensional collagen gel culture system. Derived from a protocol which used collagen gels to examine the process of cell migration,¹² collagen gels provided the structural support for a bioassay for epithelial-mesenchymal cell transformation.¹³ Through staged removal of the myocardium from gels at various times and embryonic stages, it was shown that endothelial cell transformation and mesenchymal cell invasion was induced by the myocardium. Further experiments using tissues obtained from both AV canal and ventricular regions showed that AV canal myocardium was uniquely effective as an inducer and that only AV canal endothelium was competent to respond to the stimulus.¹⁴ Experiments with tissues removed and replaced at various times indicated that the timing of the interaction was important. Thus, there is a regional and temporal specificity to both the stimulus source and the target tissue.^{1,13,14}

To directly establish the cardiac ECM as a mediator of the stimulus, extracts of ECM were isolated with EDTA and testicular hyaluronidase. ECM extract was collected that, when added to cultures of AV endothelia, produced a change in cell phenotype without cell invasion.¹⁵ Subsequent work produced both an ECM extract and a myocardium-conditioned medium, which caused a complete transformation of endothelial tissue.^{3,14,16} Continuing studies by Markwald and collaborators have focused on the identification of components in the conditioned medium that participate in the cell transformation process.¹⁷ One of these components, ES/130, is a unique protein shown to be critical to the transformation process and without homology to any other identified molecule.¹⁸

TGF β and Cell Transformation

Our focus on the role of transforming growth factor beta (TGF β) began with a survey of the effects of several growth factors on "competent" AV canal endothelial in culture. Such competent cells were produced by removal of AV canal myocardium from the surface of collagen gels after an interval sufficient to leave behind an endothelial outgrowth but before these endothelia had responded to the myocardial signal. None of the growth factors tried produced either activation or cell transformation. However, in an assay which included ventricular myocardium as a potential source of cofactor, we found both TGF β 1 or TGF β 2 to be able to stimulate cell transformation and invasion. As confirmation of this activity, we tested a blocking antibody for TGF β . This antibody produced both an inhibition of activation and an inhibition of cell transformation in cultures containing AV canal myocardium as a source of the transforming stimulus. Thus confirming the existence of an active TGF β family member in the transformation process in the heart.¹⁹

TGF β 1 was originally identified as a factor that transformed the phenotype of fibroblasts and permitted their growth in soft agar culture.²⁰ The original TGF β protein, now called TGF β 1, shares a high degree of homology with additional TGF β molecules. The TGF β gene family includes numbered members (TGF β ₁₋₅) which share at least 70% sequence homology at the nucleic acid level. These proteins have been variously found in human, pig, mouse, frog, and chicken. Though a TGF β 1 was described in the chicken, the closely related molecule, TGF β 4,²¹ appears to be the more common avian equivalent of mammalian TGF β 1.

In addition to the numbered TGF β s, a series of proteins with lesser but significant homology have been found. These include the *Drosophila* gene product, decapentaplegic;²² mullerian inhibiting substance;²³ several bone morphogenetic proteins;²⁴ Vg1;²⁵ and Vgr1 (Vg1-related) proteins.²⁶ At the time of cell transformation considered here, at least three other TGF β family members, bone morphogenetic protein 4 and activins β a and β b are known to be present in the heart²⁷ (also see FIG. 3)

There is now a body of evidence that TGF β superfamily members are involved in changes of phenotype by epithelial tissues. Kimelman and Kirschner²⁸ demonstrated that TGF β potentiates the ability of bFGF to induce mesodermal cells in *Xenopus*. Rosa *et al.*²⁹ demonstrated the ability of a blocking antibody against

TGF β 2 to inhibit the induction of *Xenopus* mesoderm by a conditioned medium obtained from XTC cells in culture. A member of the TGF β family found in *Xenopus*, Vg1, has been identified as a maternal mRNA that is only found in cells capable of inducing mesoderm formation.²⁵ Dominant negative inhibition of the activin receptor in *Xenopus* tissues has demonstrated that this member of the superfamily is critical to mesoderm formation.³⁰ In vertebrate embryos, dissolution of the müllerian duct, under the influence of müllerian inhibiting substance, is accompanied by the transformation of a population of epithelial cells into mesenchyme.³¹ Our own evidence in the developing heart is consistent with this interpretation. These data suggest that members of the TGF β family may play similar roles in regulation of cell phenotype during embryonic development.

TGF β s in the Developing Heart

TGF β s have been identified in the heart by several other laboratories as well as our own. Heine *et al.*³² demonstrated a prominent localization of TGF β 1 protein in the atrioventricular canal of the mouse embryo within well populated cardiac cushions. Akhurst and colleagues examined the distribution of several TGF β family members in mouse and human embryos, with particular emphasis on the heart.³³⁻³⁶ Using *in situ* hybridization and immunohistochemistry, they showed that TGF β 2 is prominent in the myocardium and cardiac cushions while TGF β 1 is prominent in the endothelium. Functional studies by Choy and colleagues³⁷ suggest that TGF β 1 is indirectly mitogenic for avian cardiac cushion mesenchymal cells by stimulating the production of the ECM protein, fibronectin.

Based upon our observation that a TGF β family member was functional in the cell transformation process, we set out to identify the specific member of the family involved. Since we were unable to identify TGF β 1, in a Northern blot, we obtained clones for TGF β s 2 and 3 courtesy of Drs. Jakowlew, Sporn and Roberts of the NCI. A series of RNase protection assays were performed with cardiac tissues at various stages before, during and after the time of cell transformation. These studies demonstrated that TGF β 3 was most prominent in the AV canal at the time of cell transformation and that TGF β 2 was equally, or perhaps more, prominent in the nontransforming ventricular region.³⁸ One particularly unexpected result was the observation that a control, sense riboprobe, when incubated with mRNA from the heart, was protected. This led to the conclusion that there is present in the heart an "antisense TGF β 3 mRNA" that is complementary to a portion of the TGF β 3 sequence. Using a riboprobe for this region, we demonstrated this message to be larger than 4 kb, while the normal, sense mRNA was the expected 3.0 kb. The overlap or complementary region is at least 120 bp, which is sufficiently large to form a substrate for a deaminase (next paragraph).

The presence of an antisense mRNA for TGF β 3 in the heart suggests a similarity to the antisense mRNA found for another growth factor, FGF-2 (bFGF). Kimmelman and Kirschner³⁹ first found evidence for this molecule in *Xenopus*. At the time of mid blastula transition, antisense FGF-2 is apparently released in excess to hybridize with the FGF-2 mRNA and provide a double stranded substrate for a deaminase enzyme. This enzyme modifies adenosine residues and

results in the formation of a missense mRNA.^{39,40} Though we have not shown modification of TGF β 3 mRNA, recent data suggests that antisense TGF β 3 is in excess in the heart by stage 20, well after transformation has taken place (Vincent *et al.*, unpublished). We are exploring the possibility that this is a mechanism for the inactivation of TGF β 3 mRNA when additional cell transformation is no longer needed. It is entirely possible, however, that antisense TGF β 3 functions in some other manner, and this possibility will be explored as well.

Concurrently with our RNase protection studies, experiments were undertaken to test the function of TGF β s in the heart. We took advantage of an antisense technology which had been developed by Dagle, Weeks and Walder.⁴¹⁻⁴³ These researchers developed a hybrid form of antisense oligonucleotide that contained modified internucleoside linkages (methoxyethylphosphoramidate linkages) at both the 3' and 5' ends with an internal stretch of unmodified phosphodiester bonds. This configuration has several advantages. First, the oligonucleotides are protected from exonuclease activity to considerably extend their half-life in the cell. Second, the central, unmodified portion is long enough to provide a substrate for RNase H when a DNA-mRNA duplex is formed within the cell. This enzyme specifically degrades RNA when encountered in such a duplex. Finally, the modifications to the phosphodiester backbone, a methoxyethylamidate, reduce the charge on the oligonucleotide and render it somewhat less hydrophilic. This apparently permits somewhat greater transfer into the cell.⁴²

Antisense oligonucleotides were prepared to complement the region near the AUG start site for each of the avian TGF β s as well as two nonspecific control sequences. These oligonucleotides were topically applied to AV canal explants on collagen gel cultures before the start of cell transformation. The modified antisense oligonucleotide specific for TGF β 3 proved to be uniquely capable of inhibiting normal cell transformation in these cultures. Surprisingly, unlike the blocking antibodies, the antisense oligos blocked cell transformation but not cell activation. RNase protection assays were performed to confirm the loss of TGF β 3 mRNA in the inhibited cultures. These data demonstrate a requirement for TGF β 3 in the cell transformation process in the heart.⁴⁴

One aspect that remains unclear is the source of the TGF β 3 in the heart. TGF β s have been shown to act in either a paracrine or autocrine manner. One can envision either the transfer of TGF β 3 across the ECM from the myocardium, or the autocrine release TGF β 3 by the endothelium in response to the myocardial stimulus. Further complicating this process is the knowledge that the TGF β s usually require activation from an inactive complex before they are active. Thus, one can imagine that TGF β 3 might be already present in the pericellular ECM of the endothelium and that it is activated by delivery of a protease from the muscle (or the endothelium in response to the muscle stimulus). Studies have shown that a suitable protease, urokinase type plasminogen activator, can be found in the endocardial cushions of the heart.⁴⁵ To determine the distribution of TGF β 3 in the heart we undertook an *in situ* hybridization study. Though not yet complete, it is clear that TGF β 3 message can be found in both the muscle and the endothelium before transformation takes place (Runyan *et al.*, unpublished). However, TGF β mRNA may not be translated by all tissues or (due to the presence of antisense RNA) it

may not be translatable. Thus it is equally important to examine the distribution of TGF β 3 protein in the heart.

The presence of a number of TGF β family members in the heart, and the conservation of epitopes among family members, has been the source of uncertainty in the establishment of the distribution of specific isoforms in the heart. In order to pursue studies on TGF β 3 protein in the chick, we have generated and characterized monoclonal antibodies that specifically recognize this TGF β isoform. These antibodies appear to be specific towards TGF β 3 (though not tested towards avian TGF β 4, because this protein is not yet available, they do not cross-react with mammalian TGF β 1 or β 2). FIGURE 1 depicts the pattern of TGF β 3 staining found in the stage 14–15 (pretransformation) heart. Staining is quite promi-

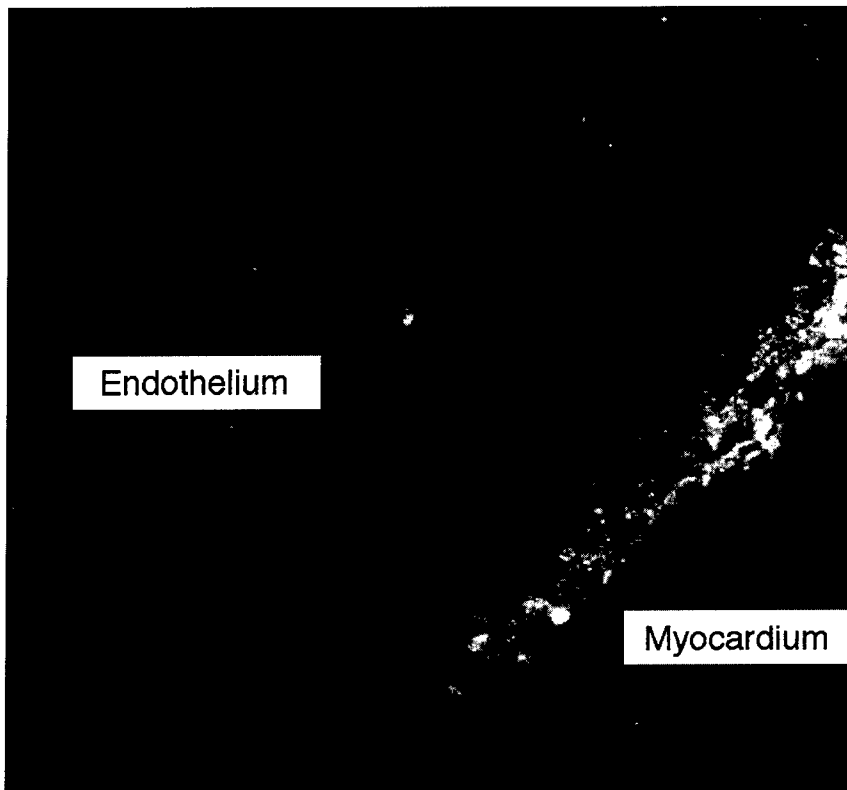

FIGURE 1. TGF β 3 protein distribution in the heart before cell transformation. This figure shows a section of a stage 14 embryo heart approximately 14–18 hr before cell transformation is observed in the AV canal. The myocardium is well stained by a monoclonal antibody to TGF β 3 but the endothelium has relatively less staining. Though the fixative included 1% cetyridinium chloride as a preservative of the ECM, no staining is seen in the ECM. TGF β 3 may be either not present in the matrix or cryptic to the antibody. Second antibody was coupled to Cy-5 fluorochrome and little or no background was seen in controls (not shown).

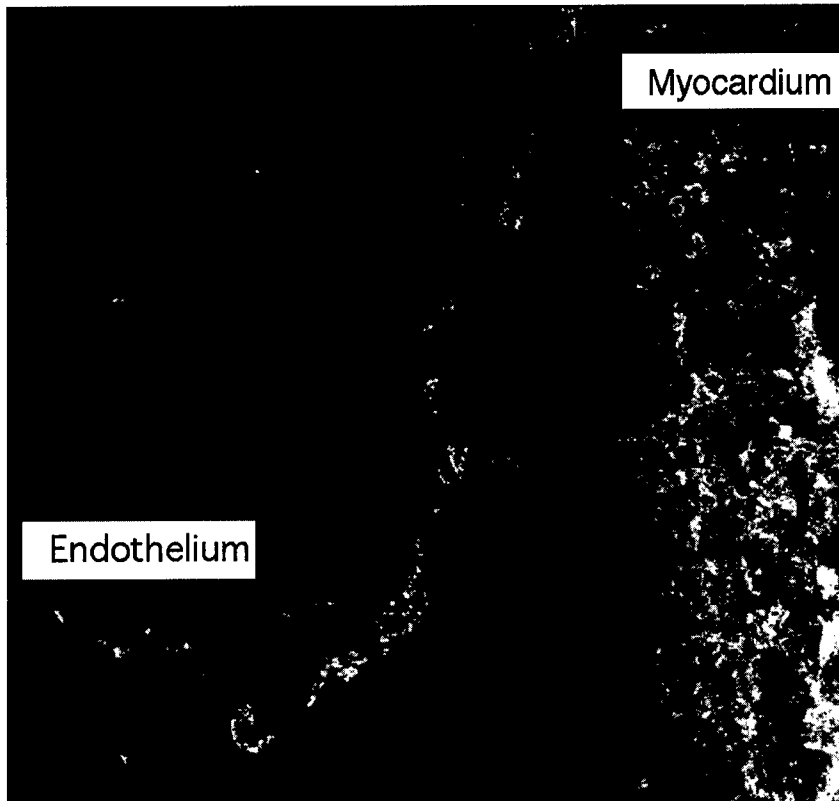

FIGURE 2. TGF β 3 protein distribution in the heart after cell transformation has begun. Staining is observed in both the endothelium and the myocardium. A transformed cell is just visible between the endothelium and the muscle in the *upper* portion of the figure and is also seen to stain. Again, this fixative preparation does not display any TGF β 3 in the ECM.

nent in the cardiac muscle but is only weakly visible in the endothelium. Despite the fact that these tissues were fixed to retain the ECM with cetylpyridinium chloride to retain the ECM, no staining can be seen in the ECM. The lack of staining in the ECM may be due to an inability to detect the inactive TGF β 3 complex or the lack of TGF β 3 transport across the ECM. Certainly, the muscle is capable of TGF β 3 synthesis, a conclusion which differs from the observations of Nakajima *et al.*⁴⁶ seen with a different antibody. FIGURE 2 shows the distribution of TGF β 3 in the stage 18 heart. In agreement with the observations of Nakajima *et al.*,⁴⁶ a significant increase of TGF β 3 staining is seen in the endocardium after the time of cell transformation. This suggests that TGF β 3 can be produced by the endothelium as an autocrine stimulus, but it remains possible that we are seeing activation of TGF β 3 previously present in the ECM. Experiments are underway to resolve the ability of this antibody to stain both active and inactive TGF β 3.

Since it appears that TGF β 3 can be produced by both tissues in the heart, other aspects of the interaction process, the activation of latent TGF β 3 or the appearance of TGF β 3 receptors at a critical time, may prove more important.

Cell Transformation in the Heart Uses Mechanisms Common to Gastrulation and Other Transformations in the Embryo

Though TGF β 3 is critical to the cell transformation process, the myocardial stimulus is a complex one. Through use of various inhibitors of signal transduction, it could be seen that the target tissue response was mediated by a number of different signal transduction mechanisms including serine/threonine and tyrosine kinases, a pertussis toxin-sensitive G protein, and an intracellular calcium flux.⁴⁷ Thus the target endothelium is apparently responding to multiple components of the ECM that, together, initiate and continue the process of cell transformation. As we continued to explore this process, our attention was drawn to the observation that the medial edge of the palatal shelves was also seen to have a prominent expression of TGF β 3.⁴⁸ This tissue also undergoes an epithelial-mesenchymal cell transformation during palatal shelf fusion. Similarly, Mitrani⁴⁹ showed TGF β 3 to be expressed at the time of gastrulation in the chick embryo. The common feature of all of these processes is that a two-dimensional sheet of cells becomes three-dimensional by cell transformation and migration of the newly formed mesenchyme. Accordingly, each of these cells might utilize similar genes to effect the transformation process. Our thought was to look for regulatory genes that might be expressed in each of these areas. Such genes might be critical to the transformation process as apart from regulation of subsequent or concurrent differentiation.

Our first candidate was the brachyury gene. Brachyury is a transcription factor that was recently cloned in the mouse.⁵⁰ This gene codes a molecule which was originally studied as an X-ray-induced point mutation produced in 1927 and known as the T mutant.⁵¹ The homozygous mutant phenotype is an embryonic lethal characterized by defective mesenchymal cell populations and a loss of posterior mesoderm.⁵² Recent expression studies showed the brachyury gene to be a prominent marker of gastrulation.⁵³ It was previously seen that T/T mutant mice had defects in cardiac mesenchymal cell formation and a misshapen heart.⁵⁴ Thus we sought to discover whether Brachyury is expressed during cell transformation in the developing heart. Using the aligned sequences of mouse, *Xenopus* and zebrafish brachyury, we designed degenerate PCR primers for the highly conserved DNA binding region of this molecule. We were able to obtain the equivalent avian portion of the molecule from a stage 17 embryonic chick heart library. Subsequent RT-PCR with nondegenerate primers showed that avian brachyury can be found in the endothelium and the mesenchyme of the AV canal as well as the muscular portion of the explant.

Despite the fact that brachyury mRNA is present in the embryonic heart, it is not in high abundance, and we were unable to extend our sequence from heart material. In contrast, we found brachyury to be much more prominent in the gastrulation stage chick embryo. Using a stage 5 whole embryo library, we were able to complete the sequence of the entire open reading frame. Whole mount *in*

situ hybridization confirmed a distribution associated with gastrulation in the chick, but the digoxigenin probe was not sufficiently sensitive to show brachyury distribution in the heart. An antibody was developed using a peptide sequence from the open reading frame, and we recently began to visualize protein in the gastrula and in the heart. At the gastrula stage, brachyury expression is first seen in cells approaching the center of the primitive streak. Cells continue to express the protein as they transform, and staining begins to disappear within a few cell lengths after mesoderm formation. Though studies in the heart are less complete, one surprise finding was an apparent nuclear localization of the antigen in myocardial cells.

In addition to brachyury, we have begun to look for other "gastrulation-specific" genes in the heart. A recent publication by Candida *et al.*⁵⁵ identified a new homeobox gene, *mox-1*, as present in both the mesenchyme of the cardiac outflow tract and in the forming mesoderm of the gastrula. We used degenerate primers selected to include the mouse *mox-1* and *mox-2* sequences and were able to identify an appropriate size band in the avian heart. This material is 96% identical to the *mox-1* homeobox region at the amino acid level and is now being used to extend the avian sequence for this molecule. Suzuki *et al.*⁴ showed previously that *msx-1* (formerly called *hox-7* or *g-hox-7*) could be found in the AV cushions

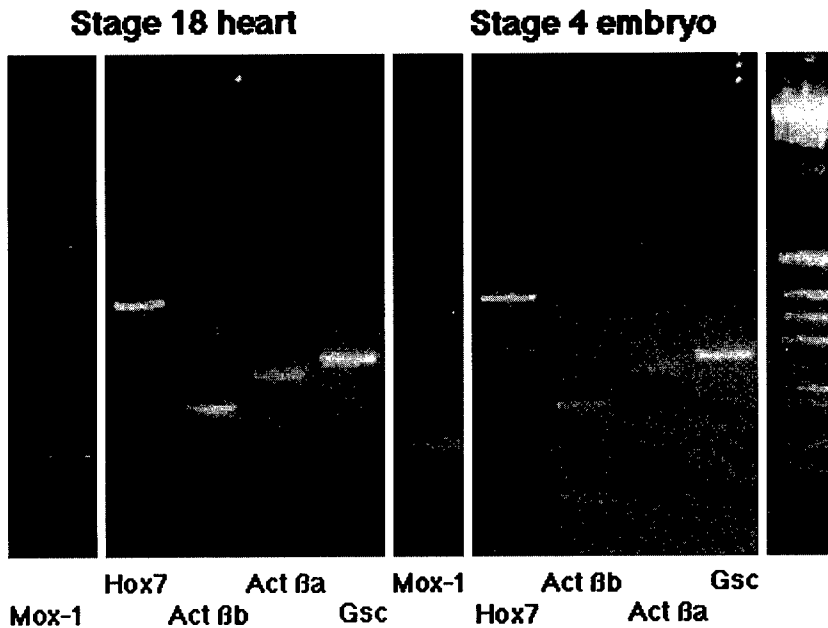

FIGURE 3. RT-PCR display of "gastrulation-specific" gene expression in both the gastrula stage chick embryo and the stage 18 heart. Probe genes include *msx-1*, activin β a (*Act β a*), activin β b (*Act β b*), *TGF β 3*, *TGF β 2*, *mox-1*, and goosecoid (*Gsc*). Heart mRNA was collected from several intact hearts and does not distinguish between myocardial, endothelial, or mesenchymal cell expression.

as well as the gastrula. By RT-PCR, we also looked for several other gastrulation-associated molecules in the heart. These included the homeobox gene *gooseoid*⁵⁶ and the TGF β -related molecules *activin β a* and *activin β b*. As shown in FIGURE 3, all these molecules can be seen in the heart and the gastrula at their equivalent stages of cell transformation. Surprisingly, we were able to detect two of these markers, *brachyury* and *gooseoid*, at stage 14, a time well before cell transformation in the heart (data not shown). This suggests that either expression is required several hours before transformation or that they function in some other process of the heart as well. One possibility to be tested is that they may also function in the process of heart looping, a folding process that has some similarity to the movements of gastrulation. This possibility as well as whether there is a role of these genes in cell transformation will be tested by antisense oligonucleotide techniques and viral transfer techniques as discussed elsewhere in this volume.

SUMMARY

The process of cell transformation in the heart is a complex one. By use of the invasion bioassay, we have been able to identify several critical components of the cell transformation process in the heart. TGF β 3 can be visualized as a switch in the environment that contributes to the initial process of cell transformation. Our data show that it is a critical switch in the transformation process. Even so, it is apparently only one of the factors involved. Others may include other TGF β family members, the ES antigens described by Markwald and co-workers^{17,18} and additional unknown substances. Observing the sensitivity of the process to pertussis toxin, there is likely to be a G-protein-linked receptor involved, yet we have not identified a known ligand for this type of receptor. Clearly, there are several different signal transduction processes involved. The existence of multiple pathways is consistent with the idea that the target endothelial cells receive a variety of environmental inputs, the sum of which will produce cell transformation at the correct time and place. Adjacent endothelial cells of the ventricle that do not undergo cell transformation are apparently refractory to one or more of the stimuli. FIGURE 4 depicts a summary diagram of this invasion process with localization of most of the molecules mentioned in this narrative.

As hypothesized here, elements of the transformation process may recapitulate aspects of gastrulation. Since some conservation of mechanism is expected in cells, it is not surprising that cells undergoing phenotypic change might reutilize mechanisms used previously to produce mesenchyme from the blastodisk. Though we have preliminary data to suggest this point, confirmation of the hypothesis by perturbation of genes such as *brachyury*, *msx-1*, etc. will be required to establish this point. The advantage of this hypothesis is that it provides, from the work of others in the area of gastrulation, a ready source of molecules and mechanisms that can be tested in the transforming heart. Whereas, perturbation of such mechanisms at gastrulation may be lethal to the embryo, such molecules and mechanisms may be responsible for the high incidence of birth defects in the heart.

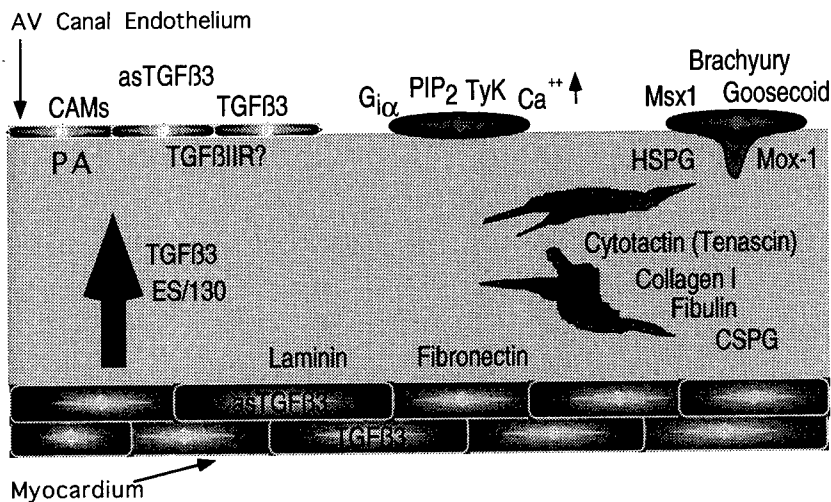

FIGURE 4. Summary of molecules known or thought to function during cell transformation in the AV canal of the heart. The cardiac muscle cells in the *bottom* of the diagram produce an extracellular matrix containing laminin and fibronectin. They also secrete an inductive, multicomponent stimulus that acts on the adjacent endothelium. One component of the stimulus is a molecule identified as ES/130. It is not yet clear whether TGFβ3 is transmitted as part of the stimulus but both TGFβ3 and antisense TGFβ3 mRNAs can be found in the muscle cells and in the endothelium. When the stimulus reaches the endothelium, a cascade of events is initiated. Cell adhesion molecules (CAMs) between endothelial cells are disrupted or downregulated. TGFβ3 is either upregulated or activated (possibly by plasminogen activator, PA), and it acts through a TGFβ receptor (the TGFβ type II receptor is indicated here). As part of the signal transduction process within the activated and hypertrophying endothelium, a G protein (G_{iα}), a tyrosine kinase (TyK), and the phosphoinositide pathway (PIP₂) all appear to be involved. An intracellular flux of calcium (Ca⁺⁺) has been observed in these cells in response to the myocardial stimulus. Cell transformation takes place and the transcriptional regulators msx-1 (formerly hox-7), brachyury, goosecoid, and mox-1 are each hypothesized to be involved. Transformation and migration of the target endothelium is marked by expression of the ECM molecules, heparan sulphate proteoglycan (HSPG), cytotactin, collagen I, fibulin, and chondroitin sulfate proteoglycan (CSPG), by the mesenchyme. Continued cell transformation may be regulated by expression of antisense TGFβ3 (asTGFβ3).

REFERENCES

1. MARKWALD, R. R., R. B. RUNYAN, G. T. KITTEN, F. M. FUNDERBURG, D. H. BERNANKE & P. R. BRAUER. 1984. Use of collagen gel cultures to study heart development: proteoglycan and glycoprotein interactions during the formation of endocardial cushion tissue. *In* The Role of the Extracellular Matrix in Development. R. L. Trelstad, Ed. 323-350. A.R. Liss. New York.
2. KITTEN, G. T., R. R. MARKWALD & D. L. BOLENDER. 1987. Distribution of basement membrane antigens in cryopreserved early embryonic hearts. *Anat. Rec.* **217**: 379-390.
3. MJAATVEDT, C. H. & R. R. MARKWALD. 1989. Induction of an epithelial-mesenchymal cell transition in embryonic chick heart correlates with an *in vivo* adheron-like complex. *Dev. Biol.* **136**: 118-128.

4. SUZUKI, H. R., B. J. PADANILAM, E. VITALE, F. RAMIREZ & M. SOLURSH. 1991. Repeating developmental expression of g-hox-7, a novel homeobox-containing gene in the chicken. *Dev. Biol.* **148**: 375–88. Published erratum appears in *Dev. Biol.* **150**: 427.
5. CHAN-THOMAS, P. S., R. P. THOMPSON, B. ROBERT, M. H. YACOB & P. J. BARTON. 1993. Expression of homeobox genes *msx-1* (*hox-7*) and *msx-2* (*hox-8*) during cardiac development in the chick. *Dev. Dynam.* **197**: 203–216.
6. FUNDERBURG, F. M. & R. R. MARKWALD. 1986. Conditioning of native substrates by chondroitin sulfate proteoglycans during cardiac mesenchymal cell migration. *J. Cell Biol.* **103**: 2475–2487.
7. SPENCE, S. G., W. S. ARGRAVES, L. WALTERS, J. E. HUNGERFORD & C. D. LITTLE. 1992. Fibulin is localized at sites of epithelial-mesenchymal transitions in the early avian embryo. *Dev. Biol.* **151**: 473–484.
8. SINNING, A. R., R. C. LEPERA & R. R. MARKWALD. 1988. Initial expression of type I procollagen in chick cardiac mesenchyme is dependent upon myocardial stimulation. *Dev. Biol.* **130**: 167–174.
9. CROSSIN, K. L. & S. HOFFMAN. 1991. Expression of adhesion molecules during the formation and differentiation of the avian endocardial cushion tissue. *Dev. Biol.* **145**: 277–286.
10. WENINK, A. C. 1992. Quantitative morphology of the embryonic heart: an approach to development of the atrioventricular valves. *Anat. Rec.* **234**: 129–135.
11. CHIN, C., R. GANDOUR-EDWARDS, S. OLTJEN & M. CHOY. 1992. Fate of the atrioventricular endocardial cushions in the developing chick heart. *Pediatr. Res.* **32**: 390–393.
12. BERNANKE, D. H. & R. R. MARKWALD. 1982. Migratory behavior of cardiac cushion tissue cells in a collagen lattice system. *Dev. Biol.* **91**: 235–245.
13. RUNYAN, R. B. & R. R. MARKWALD. 1983. Invasion of mesenchyme into three dimensional collagen gels: a regional and temporal analysis of interaction in embryonic heart tissue. *Dev. Biol.* **95**: 108–114.
14. MJAATVEDT, C. H., R. C. LEIPHERA & R. R. MARKWALD. 1987. Myocardial specificity for initiating endothelial-mesenchymal cell transition in embryonic chick heart correlates with a particulate distribution of fibronectin. *Dev. Biol.* **119**: 59–67.
15. KRUG, E. L., R. B. RUNYAN & R. R. MARKWALD. 1985. Protein extracts from early embryonic heart initiate cardiac endothelial cytodifferentiation. *Dev. Biol.* **112**: 414–426.
16. KRUG, E. L., C. H. MJAATVEDT & R. R. MARKWALD. 1987. Extracellular matrix from embryonic myocardium elicits an early morphogenetic event in cardiac endothelial differentiation. *Dev. Biol.* **120**: 348–355.
17. SINNING, A. R., E. L. KRUG & R. R. MARKWALD. 1992. Multiple glycoproteins localize to a particulate form of extracellular matrix in regions of the embryonic heart where endothelial cells transform into mesenchyme. *Anat. Rec.* **232**(2): 285–292.
18. REZAEI, M., K. ISOKAWA, N. HALLIGAN, R. R. MARKWALD & E. L. KRUG. 1993. Identification of an extracellular 130-kDa protein involved in early cardiac morphogenesis. *J. Biol. Chem.* **268**: 14404–14411.
19. POTTS, J. D. & R. B. RUNYAN. 1989. Epithelial-mesenchymal cell transformation in the embryonic heart can be mediated, in part, by transforming growth factor β . *Dev. Biol.* **134**: 392–401.
20. DELARCO, J. E. & G. J. TODARO. 1978. Growth factors from murine sarcoma virus-transformed cells. *Proc. Natl. Acad. Sci. USA* **75**: 4001–4005.
21. JAKOWLEW, S. B., P. J. DILLARD, T. S. WINOKUR, K. C. FLANDERS, M. B. SPORN & A. B. ROBERTS. 1991. Expression of transforming growth factor- β s 1–4 in chicken embryo chondrocytes and myocytes. *Dev. Biol.* **143**: 135–148.
22. PADGETT, R., D. JOHNSTON & W. A. GELBART. 1987. A transcript from a *Drosophila* pattern gene predicts a protein homologous to the transforming growth factor- β family. *Nature* **325**: 81–84.
23. CATE, R. L., R. J. MATTALIANO, C. HESSON, T. TIZARD, N. M. FARBER, A. CHEUNG, E. G. NINFA, A. Z. FREY, D. J. GASH, E. P. CHOW, R. A. FISHER, J. M. BERTONIS, G. TORRES, B. P. WALLNER, K. L. RAMACHANDRAN, R. C. RAGIN, T. F. MANGANARO, D. T. MACLAUGHLIN & P. K. DONAHOE. 1986. Isolation of the bovine and human

- genes for müllerian inhibiting substance and expression of the human gene in animal cells. *Cell* **45**: 685–698.
24. WOZNEY, J. M. 1989. Bone morphogenetic proteins. *Prog. Growth Factor Res.* **1**: 267–280.
 25. WEEKS, D. L. & D. A. MELTON. 1987. A maternal mRNA localized to the vegetal hemisphere in *Xenopus* eggs codes for a growth factor related to TGF β . *Cell* **51**: 861–867.
 26. LYONS, K. M., C. M. JONES & B. L. M. HOGAN. 1992. The TGF-beta-related DVR gene family in mammalian development. *Ciba Found. Symp.* **165**: 219–230.
 27. LYONS, K. M., R. W. PELTON & B. L. M. HOGAN. 1990. Organogenesis and pattern formation in the mouse: RNA distribution patterns suggest a role for bone morphogenetic protein-2A (BMP-2A). *Development* **109**: 833–844.
 28. KIMELMAN, D. & M. KIRSCHNER. 1987. Synergistic induction of mesoderm by FGF and TGF β and the identification of an mRNA coding for FGF in the early *Xenopus* embryo. *Cell* **51**: 869–877.
 29. ROSA, F., A. B. ROBERTS, D. DANIELPOUR, L. DART, M. B. SPORN & I. B. DAWID. 1988. Mesoderm induction in amphibians: the role of TGF β 2-like factors. *Science* **239**: 783–785.
 30. HEMMATI-BRIVANLOU, A., D. A. WRIGHT & D. A. MELTON. 1992. Embryonic expression and functional analysis of a *Xenopus* activin receptor. *Dev. Dynam.* **194**: 1–11.
 31. TRELSTAD, R. L., A. HAYASHI, K. HAYASHI & P. K. DONAHOE. 1982. The epithelial-mesenchymal interface of the male müllerian duct: loss of basement membrane integrity and ductal regression. *Dev. Biol.* **92**: 27–40.
 32. HEINE, U. I., E. F. MUNOZ, K. C. FLANDERS, L. R. ELLINGSWORTH, H.-Y. P. LAM, N. L. THOMPSON, A. B. ROBERTS & M. B. SPORN. 1987. Role of transforming growth factor- β in the development of the mouse embryo. *J. Cell Biol.* **105**: 2861–2876.
 33. LEHNERT, S. & R. J. AKHURST. 1988. Embryonic pattern of TGF beta type-1 RNA suggests both paracrine and autocrine mechanisms of action. *Development* **104**: 263–273.
 34. AKHURST, R. J., S. A. LEHNERT, A. FAISSNER & E. DUFFIE. 1990. TGF beta in murine morphogenetic processes: the early embryo and cardiogenesis. *Development*. **108**: 645–656.
 35. MILLAN, F. A., F. DENHEZ, P. KONDAIAH & R. J. AKHURST. 1991. Embryonic gene expression patterns of TGF beta 1, beta 2 and beta 3 suggest different developmental functions *in vivo*. *Development* **111**: 131–143.
 36. DICKSON, M. C., H. G. SLAGER, E. DUFFIE, C. L. MUMMERY & R. J. AKHURST. 1993. RNA and protein localisations of TGF beta 2 in the early mouse embryo suggest an involvement in cardiac development. *Development* **117**: 625–639.
 37. CHOY, M., S. OLTJEN, D. RATCLIFF, M. ARMSTRONG & P. ARMSTRONG. 1993. Fibroblast behavior in the embryonic chick heart. *Dev. Dynam.* **198**: 97–107.
 38. POTTS, J. D., E. B. VINCENT, R. B. RUNYAN & D. L. WEEKS. 1992. Sense and antisense TGF beta 3 mRNA levels correlate with cardiac valve induction. *Dev. Dynam.* **193**: 340–345.
 39. KIMELMAN, D. & M. KIRSCHNER. 1989. An antisense mRNA directs the covalent modification of the transcript encoding fibroblast growth factor in *Xenopus* oocytes. *Cell* **59**: 687–696.
 40. BASS, B. L. & H. WEINTRAUB. 1988. An unwinding activity that covalently modifies its double-stranded RNA substrate. *Cell* **55**: 1089–1098.
 41. DAGLE, J., J. WALDER & D. WEEKS. 1990. Targeted degradation of mRNA in *Xenopus* oocytes and embryos directed by modified oligonucleotides: studies of An2 and cyclin in embryogenesis. *Nucleic Acids Res.* **18**: 4751–4757.
 42. DAGLE, J., M. ANDRACKI, R. DEVINE & J. WALDER. 1991. Physical properties of oligonucleotides containing phosphoramidate-modified internucleoside linkages. *Nucleic Acids Res.* **19**: 1805–1810.
 43. DAGLE, J., D. WEEKS & J. WALDER. 1991. Pathways of degradation and mechanisms of action of antisense oligonucleotides in *Xenopus laevis* embryos. *Antisense Res. Dev.* **1**: 11–20.

44. POTTS, J. D., J. DAGLE, J. A. WALDER, D. L. WEEKS & R. B. RUNYAN. 1991. Epithelial-mesenchymal transformation of embryonic cardiac endothelial cells is inhibited by a modified antisense oligodeoxynucleotide to transforming growth factor β 3. *Proc. Natl. Acad. Sci. USA* **88**: 1516–1520.
45. MCGUIRE, P. G. & S. M. ALEXANDER. 1993. Urokinase production by embryonic endocardial-derived cells: regulation by substrate composition. *Dev. Biol.* **155**: 442–451.
46. NAKAJIMA, Y., E. L. KRUG & R. R. MARKWALD. 1994. Myocardial stimulation of TGF β expression by outflow tract endothelium in the early embryonic chick heart. *Dev. Biol.* In press.
47. RUNYAN, R. B., J. D. POTTS, R. V. SHARMA, C. P. LOEBER, J. J. CHIANG & R. C. BHALLA. 1990. Signal transduction of a tissue interaction during embryonic heart development. *Cell Regul.* **1**: 301–313.
48. FITZPATRICK, D. R., F. DENHEZ, P. KONDAIAH & R. J. AKHURST. 1990. Differential expression of TGF beta isoforms in murine palatogenesis. *Development* **109**: 585–595.
49. HARRIS, I., L. MIZRAHI, T. ZIV, G. THOMSEN & E. MITRANI. 1993. Identification of TGF-beta-related genes in the early chick embryo. *Roux's Arch. Dev. Biol.* **203**: 159–163.
50. HERRMANN, B. G., S. LABEIT, A. POUSTKA, T. R. KING & H. LEHRACH. 1990. Cloning of the T gene required in mesoderm formation in the mouse. *Nature* **343**(6259): 617–622.
51. SILVER, L. M. 1991. At the crossroads of developmental genetics: the cloning of the classical mouse T locus. *Bioessays* **12**(8):377–380.
52. KISPERT, A. & B. G. HERRMANN. 1994. Immunohistochemical analysis of the brachyury protein in wild-type and mutant mouse embryos. *Dev. Biol.* **161**: 179–193.
53. BEDDINGTON, R. S., P. RASHBASS & V. WILSON. 1992. Brachyury—a gene affecting mouse gastrulation and early organogenesis. *Development-Supplement 1992*: 157–165.
54. BAYNA, E. M., R. B. RUNYAN, N. F. SCULLY, J. REICHNER, L. C. LOPEZ & B. D. SHUR. 1986. Cell surface galactosyltransferase as a recognition molecule during development. *Mol. Cell. Biochem.* **72**: 141–51.
55. CANDIA, A. F., J. HU, J. CROSBY, P. A. LALLEY, D. NODEN, J. H. NADEAU & C. V. WRIGHT. 1992. Mox-1 and mox-2 define a novel homeobox gene subfamily and are differentially expressed during early mesodermal patterning in mouse embryos. *Development* **116**: 1123–1136.
56. DE ROBERTIS, E. M., M. BLUM, C. NIEHRS & H. STEINBEISSER. 1992. Goosecoid and the organizer. *Development-Supplement 1992*: 167–171.

Secretion of Plasminogen Activator Activity from Neonatal Rat Heart Cells Is Regulated by Hormones and Growth Factors^a

RONAL R. MacGREGOR,^b ROBERT M. KLEIN,^b AND
DEVI D. BANSAL^{b,c}

^b*Department of Anatomy and Cell Biology
University of Kansas Medical Center
Kansas City, Kansas 66160*

and
^c*Department of Biochemistry
Panjab University
Chandigarh, India*

INTRODUCTION

Growth and remodeling in most tissues begins with upregulation of specific proteases called plasminogen activators (PA). Two principal forms of PA have been characterized: tissue PA (tPA) with a molecular weight of approximately 70 kDa, and urokinase at approximately 53 kDa. Tissue PA is the form found in extracts of rat heart.¹ There are several inhibitors of PA, but the major form is PAI-1, a protein of about 50 kDa that binds and inactivates both forms of PA.² In the extracellular space, PA activates the zymogen plasminogen to form plasmin, a wide-spectrum protease. Plasmin digests matrix proteins directly, activates latent, extracellular forms of collagenases and other metalloproteinases,³ and may activate and release growth factors and cytokines bound to the matrix.^{4,5} Some of these factors may in turn restrict the release of additional PA activity by down-regulation of the rate of PA synthesis and/or upregulation of synthesis of one or more specific inhibitors (PAI) that form inactive complexes.⁶

Transforming growth factor beta (TGF β) stimulates or inhibits cell replication and other cellular functions, depending on the cell studied. In tissue interstitial matrices, TGF β stimulates synthesis and secretion of matrix components⁷ and reduces the rate of extracellular proteolysis.⁸ In the case of angiogenesis, it has been proposed⁹ that TGF β works in partnership with another growth factor, basic fibroblast growth factor (bFGF). Basic FGF stimulates release of PA that converts plasminogen to plasmin, which subsequently initiates matrix dissolution. Active enzymes in the matrix then activate latent TGF β . Active TGF β induces the formation of PAI, which decreases PA activity, inhibits the remodeling process, and thus completes a remodeling cycle.

^a Supported by the Kansas Chapter of the American Heart Association.

In hypertension, cardiac myocytes increase in volume; interstitial cells increase in number and synthesize and secrete increased amounts of matrix collagens and other matrix proteins. TGF β may participate in modulating hypertrophic responses. Myocytes and cardiac fibroblasts synthesize TGF β ,¹⁰ and have receptors for three known types of the cytokine.¹¹ In addition to growth factors of the matrix, circulating growth factors likely contribute to cardiac hypertrophy, because the fibrosis that accompanies most forms of hypertension-induced hypertrophy involves not only the hypertensive, but also the normotensive ventricle.¹²

The question of whether the PA-plasmin system plays a role in cardiac hypertrophy has not been previously addressed. Cardiac cells in culture secrete PA activity,¹³ but the effects of growth factors and cytokines on the release of PA have not been examined except for the ability of glucocorticoids to inhibit release of PA activity.¹³ To approach this question, we sought evidence that cardiac PA activity was altered *in vivo* under conditions leading to cardiac hypertrophy. We found that hypobaric hypoxia, treatment with thyroxine, and spontaneously hypertensive rats (SHR) compared to their normotensive Wistar Kyoto (WKY) control strain all correlated with higher levels of PA in heart homogenates.¹⁴ Based on these results, we initiated a study of the effects of hormones and cytokines on the release of PA activity from neonatal rat heart cells. We observed that PA secretion is regulated by numerous agents, and obtained results that suggest TGF β comprises a messenger that permits cardiomyocytes to regulate the ability of cardiac interstitial cells to release PA activity.

MATERIALS AND METHODS

Cell Isolation

Cells were isolated from the hearts of neonatal Sprague-Dawley, SHR, or WKY rats 2 to 7 days of age using the Cardiomyocyte Isolation System from Worthington Biochemical Corp. (Freehold, NJ). This procedure includes overnight incubation of minced hearts in purified trypsin, followed by addition of purified (CLSPA) bacterial collagenase and 30–60 min incubation at 37°C with gentle tumbling. Concentrations of trypsin and collagenase were doubled when cells were isolated from hearts of SHR rats.

Total Cells

To isolate total heart cells, *i.e.*, myocytes and interstitial cells, the trypsin treatment was performed in Ca-free Hank's balanced salt solution (CF-HBSS). The solution was warmed to 37°C, and then collagenase added and the [Ca] adjusted to 1.5 mM. The cells were plated into multiwell plates (Falcon/Becton Dickinson, Lincoln Park, NJ) precoated with Opticoat ECM solution (Biotecx Laboratories, Inc., Houston, TX), at a near-confluent concentration of 125,000 cardiomyocytes/cm². Plating and culture medium used in the studies (shown below in FIGURES 1–6 and TABLE 1) was similar to Waymouth's MB752/1 and contained 5% fetal bovine serum (FBS). Subsequently cells were plated and cultured using

Leibowitz's L-15 medium supplemented (sL-15) with the following: 10^{-7} M bovine insulin, 1 mg/ml bovine serum albumin, 2 mM each creatine and taurine, 2.8×10^{-4} M ascorbic acid, and Fungi-Bacti (Irvine Scientific, Santa Ana, CA).

Interstitial Cells

To isolate cardiac interstitial cells free of myocytes, the overnight incubations were in standard HBSS, and cardiomyocytes were killed by warming the tissue in the presence of Ca, and by pipetting with greater than usual force. The cells were plated at near-confluent concentrations, except in experiments involving total heart cells also, where they were plated at concentrations equivalent to the numbers of interstitial cells presumed to be present in total cell preparations seeded at 1.25×10^5 cardiomyocytes/cm². Cells were seeded into untreated multiwell plates.

Fibroblasts

Fibroblasts were obtained by plating the total cell preparation into untreated culture ware for 30 min in the presence of 5% FBS. The nonadherent cells were removed and the cultureware thoroughly rinsed to remove partially-adhered cardiomyocytes. Fibroblasts, seeded at low density, were cultured in the presence of 5 or 10% FBS until they were near-confluent.

Cell Culture and Experimental Treatments

Cells were cultured in the presence of 5% FBS. Media were changed every 2 or 3 days. When experimental substances were tested, they were added as concentrates in medium or DMSO. The vehicle was without effect. For test incubations, media were serum-free, agents were added, and the cultures were incubated for 20–24 h at 37°C. Samples of media were stored at 4°C or frozen until assayed for PA. Four to six replicate wells were tested for each conditions and each experiment was performed 2–4 times.

PA Assay

The assay was described previously.^{15,16} Briefly, standard samples of human tPA, media, or tissue extract samples were incubated at 37°C in 96-well plates with plasminogen and a chromophoric peptide substrate for plasmin (S-2251, Helena Laboratories, Beaumont, TX). Color development at 405 nm was read periodically on a plate reader, and absorbance of the samples were compared to those of the tPA standards. Data are averages \pm SEM. The significance of differences between averages are determined using the Student *t* test.

Materials

Salt solutions, L-15 medium, insulin, isoproterenol, endothelin, cortisol hemisuccinate and routine chemicals were purchased from Sigma Biochemical Co.,

St. Louis, MO. Bovine parathyroid hormone was isolated from fresh parathyroid glands.¹⁷ Human TGF β was purchased from R & D Systems, Inc., Minneapolis, MN. Anti-human uterine tPA antibody was purchased from American Diagnostica Inc., Greenwich, CT.

RESULTS

Initial studies were performed using *total cardiac cells*. Addition of isoproterenol for 20–24 h caused a dose-dependent, increased release of PA activity (FIG. 1). At 3 nM, isoproterenol caused a significant increase, and the E₅₀ was about 20 nM. Bovine parathyroid hormone also increased PA release (FIG. 2), with the E₅₀ around 4 nM; 0.8 nM had no effect.

Three of the agents inhibited the release of PA activity under both basal and isoproterenol-stimulated conditions. Cortisol, as reported earlier for dexamethasone,¹³ inhibited, with an E₅₀ of 3–10 nM for basal release, and 10–30 nM for stimulated release (FIG. 3). Endothelin was a potent inhibitor of PA release (FIG. 4) and inhibited PA release significantly at 100 pM. The E₅₀ for basal and stimulated PA release were 80 pM and 300 pM, respectively.

The most potent inhibitor of PA release from total heart cells was TGF β -1. It inhibited basal secretion significantly at 20 pM (0.5 ng/ml) from cells seeded either on unmodified plastic or on Opticoat ECM (FIG. 5), and inhibition was complete at 80 pM. Similar results were obtained when isoproterenol was present in the medium.

A previous study concluded that PA secreted from heart cells came from cardiomyocytes, and that fibroblasts contained but did not secrete activity.¹³ We reinvestigated this question by comparing the secretion of PA activity by total heart cells to that by cardiac fibroblasts. We found that fibroblasts contained and secreted as much or more PA activity than did the total cell mixture (FIG. 6). This result was confirmed by later studies showing that PA secretion by myocyte-free interstitial cells was generally equivalent to that by total cardiac cells (see below, and FIG. 7).

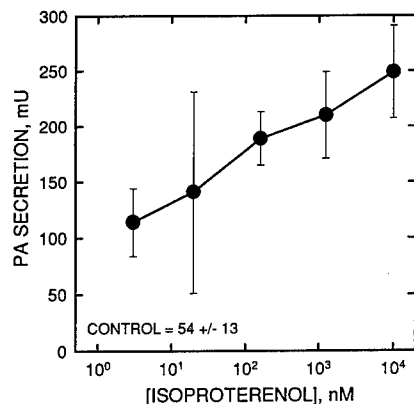

FIGURE 1. The effects of isoproterenol on secretion of PA activity by heart cells. Total heart cells from neonatal Sprague-Dawley rats were incubated 20 h in medium containing 0, 3, 20, 160, 1,250, or 10,000 nM isoproterenol. Samples of the media were assayed for PA activity, which was expressed as mU of authentic human tPA. Each data point is the average \pm SEM, and $n = 4$ for each point. The results are typical of several experiments.

FIGURE 2. The effects of parathyroid hormone on secretion of PA activity by heart cells. Total heart cells were incubated 20 h in medium containing 0, 0.8, 4, 16, 80, or 400 nM bovine parathyroid hormone. Other conditions as described for FIGURE 1.

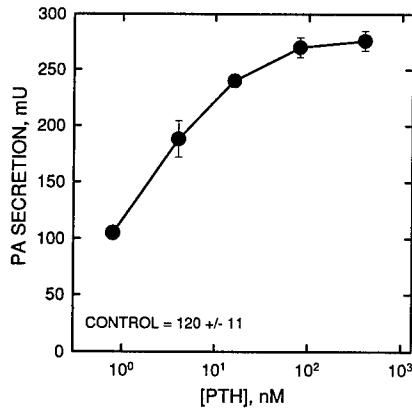

FIGURE 3. The effects of cortisol on secretion of PA activity by heart cells. Total heart cells were incubated 20 h in medium containing 0, 1.1, 3.3, 11, 33, or 100 nM cortisol hemisuccinate in the presence or absence of 1 μ M isoproterenol. Other conditions as described for FIGURE 1.

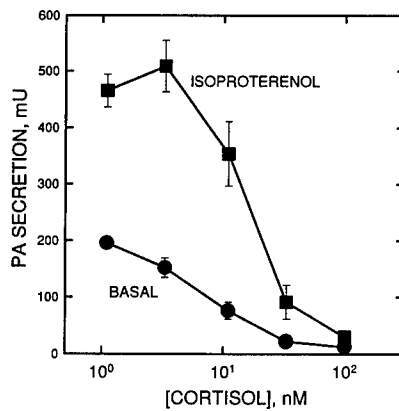
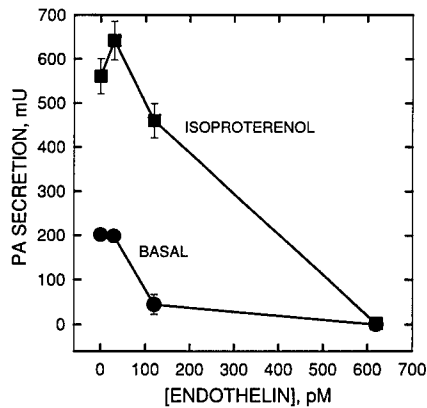

FIGURE 4. The effects of endothelin on secretion of PA activity by heart cells. Total heart cells were incubated 20 h in medium containing 0, 30, 120, 620, 2,500, or 10,000 pM porcine endothelin II in the presence or absence of 1 μ M isoproterenol. No activity was observed at 2,500 or 10,000 pM endothelin. Other conditions as described for FIGURE 1.



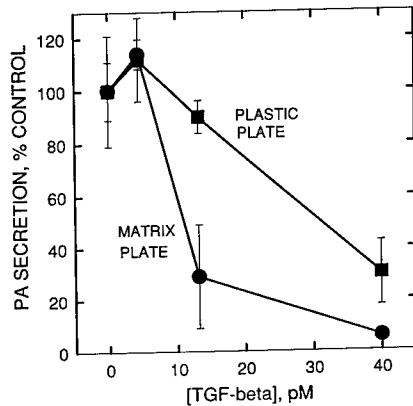

FIGURE 5. The effects of TGF β on secretion of PA activity by heart cells. Total heart cells were plated into the wells of either untreated multiwell plates or similar plates coated with Opticoat ECM. Culture was 3 days in medium with 5% FBS and 2 days with 2% FBS. The cultures were incubated 20 h in medium containing 0, 4.4, 13, or 40 pM human TGF β 1. N = 6 for each point. Actual secretion rates of PA activity under the two conditions were 2.3 ± 0.5 U for the cells on the untreated plates, and 1.0 ± 0.17 U for the ECM-coated plate. The differences in basal secretory rates were not observed in all experiments. Other conditions as described for FIGURE 1.

Since fibroblasts that primarily originate from cell replication in culture may not represent the cardiac interstitial cell population *in situ*, we modified the cell isolation procedure to allow isolation of a myocyte-free derivative of the total heart cell population. Since high intracellular [Ca] is toxic to myocytes, we used this circumstance to kill them during cell preparation.

The effects of isoproterenol and inhibitory agents on PA secretion from cardiac interstitial cells were then examined. Isoproterenol stimulated secretion of PA activity (data not shown), while cortisol, endothelin, and TGF β all inhibited release from interstitial cells (TABLE 1). Compared to its effects on the total heart cell population, cortisol was a less efficient inhibitor of PA release from interstitial cells than from total heart cells (TABLE 1), suggesting that the latter may secrete a PAI in response to glucocorticoids.

To further compare the effects of TGF β on secretion of PA activity from cardiac total and interstitial cells, we examined the effects of different concentrations of

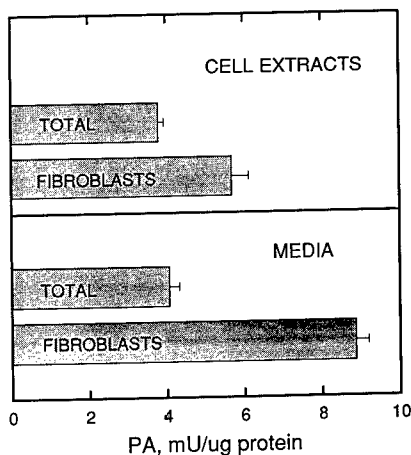

FIGURE 6. The cell content and secretion of PA activity in and from total heart cells and from cardiac fibroblasts. Cells from 7-day-old Wistar-Kyoto rats were cultured for 7 days, then Triton-x100 lysates and media were assayed for PA activity. Results were normalized to the amounts of protein in the respective cell extracts. In this experiment, the total heart cells, per well, contained 1.28 times the protein of the fibroblasts. If calculated on a per well basis, the fibroblast and total cell populations contained about the same amount of PA, but the fibroblasts secreted 2 times as much.

TABLE 1. Effects of Inhibitory Agents on Secretion of PA Activity^a

Condition	PA Secretion (mU/Well)	
	Total Heart Cells	Interstitial Heart Cells
Control	1,800 ± 220	1,980 ± 10
Cortisol, 20 nM	44 ± 44	440 ± 130
Endothelin II, 2 nM	22 ± 22	22 ± 22
TGFβ-1, 40 pM	66 ± 22	55 ± 11

^a Total heart cells and interstitial cells were isolated from 3-day-old rats, and the cells were maintained in culture for 3 days. The effects on secretion of PA activity were examined for 20 nM cortisol, 2 nM endothelin, and 40 pM TGFβ. There were 4 wells per condition. The results for all experimental groups were significantly different from the respective control conditions, $p < 0.01$.

TGFβ. Total and interstitial heart cells were cultured for 4 days, then treated overnight with 1 μM isoproterenol to increase basal secretory rates, and with 0, 8, 24, or 72 pM TGFβ. The results of the PA assays showed that the levels of PA released from the interstitial cells were much lower than those characteristic of the same cells cultured for shorter time periods (compare TABLE 1). Under control conditions of isoproterenol alone, the total cell population secreted 100 times more PA activity than did the interstitial cells (TABLE 2).

Comparison of the effects of TGFβ on total heart cells to those on cardiac interstitial cells revealed that after 4 days culture, the two cell populations responded very differently to the lowest concentration of TGFβ. Whereas 8 pM TGFβ inhibited, or had little effect upon PA release from the total cardiac cell population as expected, it unexpectedly augmented the release of PA from the interstitial cells. In the latter, 8 pM TGFβ caused a 15-fold increase in the release of PA activity. At 24 and 72 pM, however, TGFβ inhibited the elevated release with a dose response similar to that of the inhibition observed with the total heart cell population. The loss of the ability to interstitial cells to release PA activity as a function of time in culture, combined with the ability of low concentrations of TGFβ to partially restore secretory capability, were consistent with the idea

TABLE 2. Effects of TGFβ on Release of PA Activity from Isoproterenol-Treated Cardiac Total and Interstitial Cell Populations Cultured 4 Days^a

Condition	PA Secretion (U/Well)	
	Total Heart Cells	Interstitial Heart Cells
Control, exp. 1	10.2 ± 2.35	0.1 ± 0.08
TGFβ, 8 pM	9.5 ± 2.10	1.5 ± 0.5
TGFβ, 24 pM	6.8 ± 3.0	0.8 ± 0.4
TGFβ, 72 pM	0.5 ± 0.45	0

^a Total heart cells and interstitial cells were isolated from 3-day-old SHR rats, and the cells were maintained in culture for 4 days. The effects of TGFβ on secretion of PA activity were examined in the presence of 2 μM isoproterenol. There were 4 wells per condition. The results for the total heart cells were significantly different from the control group at the 72 pM level. The results for the interstitial cells were significantly different from controls at the 8 and 24 pM levels.

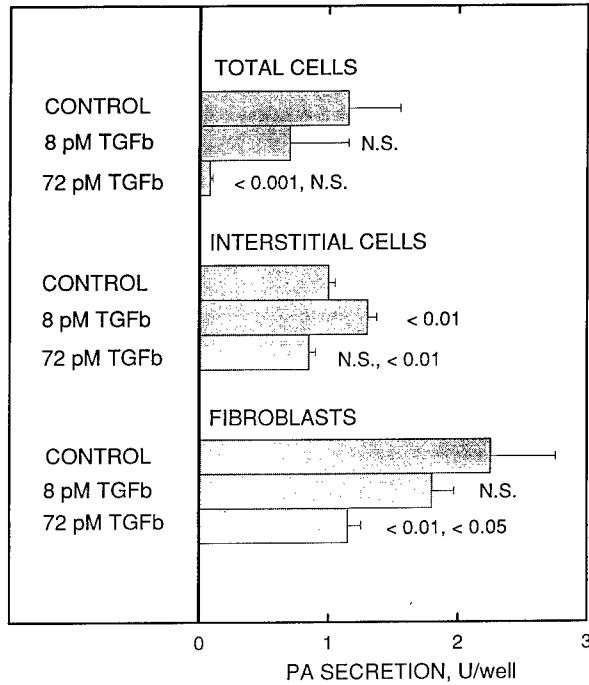

FIGURE 7. The effects of TGF β on secretion of PA activity from total cells, interstitial cells, and fibroblasts from hearts of 3-day-old WKY rats cultured in sL-15 plus 5% FBS for 2 days. Cells were treated with 8 or 40 pM TGF β and assayed for PA activity. Results are averages \pm SEM for 4 wells per group. The data for 8 pM TGF β are compared to respective controls, while those for 72 pM TGF β are compared first to controls, and then to the data for 8 pM TGF β .

that to secrete PA, cardiac interstitial cells may require continuous exposure to an active TGF β -like substance normally supplied by cardiac myocytes.

With this hypothesis in mind, we tested the effects of 8 pM or 72 pM TGF β on PA release from all 3 cardiac cell populations after only 2 days in culture. We observed that at this time, interstitial cells secreted about two-thirds the amount of PA secreted by total heart cells, and about one-half of that secreted by fibroblasts (FIG. 7). The positive effects of 8 pM TGF β on PA secretion from interstitial cells were already significant, however, while neither total cells nor fibroblasts responded positively to the cytokine. After 3 days of culture interstitial cells responded positively to 8 pM TGF β with significant increases in PA secretion as great or greater than those observed after 2 days culture (FIG. 8).

DISCUSSION

Neonatal rat heart cells secrete PA activity that is modulated in rate by several bioactive agents. Isoproterenol, a β -adrenergic agonist, was the strongest stimula-

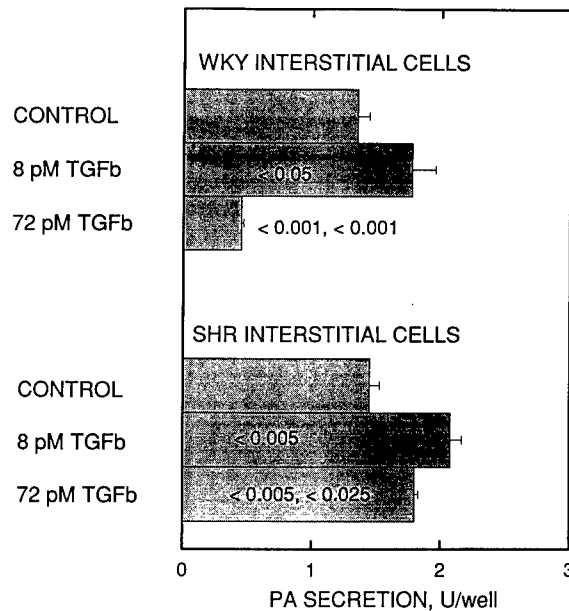

FIGURE 8. The effects of TGF β on secretion of PA activity from interstitial cells from 3-day-old WKY and SHR rats cultured in sL-15 plus 5% FBS for 3 days. Conditions for the experiments and treatment of the data are as described for FIGURE 7.

tor of release, and was effective in nanomolar concentrations. Parathyroid hormone also stimulated release at concentrations in the nanomolar range. The transduction pathway used by these agents is still uncertain, but our preliminary, unpublished studies with dibutyryl cyclic AMP suggest that secretion responds positively to increased cellular levels of cyclic AMP. Consistent with this idea is that endothelin, a vasoconstrictor and cardiac secretagogue¹⁸ that uses the phosphatidylinositol pathway,¹⁹ strongly inhibits release of PA activity.

Cortisol inhibits release of PA activity at nanomolar concentrations and is known to induce the synthesis of PAI-1 in fibroblasts.²⁰ The finding that the dose-responses of cortisol and endothelin move to higher concentrations in the presence of isoproterenol is consistent with the idea that they stimulate PAI release. The results of Mayer *et al.*¹³ are consistent with this possibility. The transduction pathway of TGF β , a third strong inhibitor of the release of PA activity, remains undefined, but this agent stimulates the formation of PAI in fibroblasts,²¹ suggesting that it is reducing the activity of secreted PA via the induction of PAI formation.

The question of whether fibroblasts and other interstitial cells of the heart secrete PA has been resolved by our study. Both nonmyocyte cell populations released PA activity, and the release was modulated by the same agents that modulated release by the total heart cell population. However, two differences between these cell populations were observed. First, the release of PA activity

by fibroblasts is stable for over a week in culture, while that by the interstitial cells decays rapidly. This may reflect differences in the cellular compositions of the two populations, or changes in the characteristics of the fibroblasts that originated from replication of the thinly-seeded cells during culture. This can be determined by examination of the properties of heavily-seeded fibroblasts, and thinly seeded interstitial cells.

The second difference between fibroblasts and interstitial cells was that the loss in ability of the latter to release PA activity could be partially reversed by the addition of 8 pM TGF β . Although the lack of requirement for TGF β on the part of fibroblasts may have been due to the development in culture of a rapid basal PA release rate or the ability to produce active TGF β , the possibility remains that an unknown cell type or substrain in either cell population is responsible for the differences in stability of the levels of PA secretion, and in their sensitivities to TGF β .

The finding that secretion of PA activity by interstitial cells decays in culture provides a possible explanation for the conclusion by Mayer *et al.*¹³ that fibroblasts do not secrete PA. The preparation of fibroblasts by this group was similar to ours. Their fibroblasts, however, were more likely to include a higher proportion of the interstitial cells because the preplating was more extensive, being used to purify the cardiac myocyte population rather than simply to generate a rapidly adherent cell population. By 5 or more days of culture as described in their study, detectable PA secretion could have ceased to occur.

In other cell types and fibroblasts from other sources,²¹ TGF β at concentrations identical to those used in this study induces the production of PAI. Whether or not this occurs in cardiac interstitial cells remains to be directly proved, but the present finding that a lower concentration of TGF β supports the formation and/or the release of PA activity is consistent with the possibility that higher concentrations induce production of PAI from the same or different cells. The remaining question is by what means does a low concentration of TGF β maintain or restore the ability of interstitial cells to secrete PA? This question is important because of its potential relationship to increasing our understanding of the roles of TGF β in the generation of cardiac hypertrophy.

Cardiac hypertrophy is an example of tissue growth and remodeling. Since our early findings described in the introduction indicated that tissue PA levels are elevated when hypertrophic stimuli are applied,¹⁴ then for TGF β to induce hypertrophy it should also induce the release of PA to the extracellular matrix space. The fact that our initial studies indicated that it was inhibitory created a contradiction to this reasoning. The discovery that low concentrations of TGF β appear to be required by heart cells that lack myocytes but not by total heart cells is not only compatible with a role of TGF β in cardiac growth and hypertrophy, but also implies that TGF β may comprise part of a physiological system for communication between and mutual regulation of cardiac myocytes and interstitial cells.

REFERENCES

1. QUAX, P. H. A., M. VAN DEN HOOGEN, J. H. VERHEIJEN, T. PADRO, R. ZEHAB, T. D. GELEHRTER, T. J. C. VAN BERKEL, J. KUIPER & J. J. EMEIS. 1990. Endotoxin induc-

- tion of plasminogen activator and plasminogen activator inhibitor type I mRNA in rat tissues *in vivo*. *J. Biol. Chem.* **265**: 15560–15563.
2. LOSKUTOFF, D. J., J. A. VAN MOURIK, L. A. ERICKSON & D. LAWRENCE. 1983. Detection of an unusually stable fibrinolytic inhibitor produced by bovine endothelial cells. *Proc. Natl. Acad. Sci. USA* **80**: 2956–2960.
 3. SAKSELA, O. & D. B. RIFKIN. 1988. Cell-associated plasminogen activation: regulation and physiological functions. *Annu. Rev. Cell Biol.* **4**: 93–126.
 4. LYONS, R. M., J. KESKI-OJA & L. MOSES. 1988. Proteolytic activation of latent transforming growth factor- β from fibroblast-conditioned medium. *J. Cell Biol.* **106**: 1659–1665.
 5. SAKSELA, O. & D. B. RIFKIN. 1990. Release of basic fibroblast growth factor-heparan sulfate complexes from endothelial cells by plasminogen activator-mediated proteolytic activity. *J. Cell Biol.* **110**: 767–775.
 6. KESKI-OJA, J., R. RAGHOW, M. SAWDEY, D. J. LOSKUTOFF, A. E. POSTLETHWAITE, A. H. KANG & H. L. MOSES. 1988. Regulation of mRNAs for type-1 plasminogen activator inhibitor, fibronectin, and type I procollagen by transforming growth factor- β . *J. Biol. Chem.* **263**: 3111–3115.
 7. SOMA, Y. & G. R. GROTENDORST. 1989. TGF- β stimulates primary human skin fibroblast DNA synthesis via an autocrine production of PDGF-related peptides. *J. Cell Physiol.* **140**: 246–253.
 8. OVERALL, C. M., J. L. WRANA & J. SODEK. 1989. Independent regulation of collagenase, 72-kDa progelatinase, and metalloendoproteinase inhibitor expression in human fibroblasts by transforming growth factor- β . *J. Biol. Chem.* **264**: 1860–1869.
 9. FLAUMENHAFT, R., M. ABE, P. MIGNATTI & D. B. RIFKIN. 1992. Basic fibroblast growth factor-induced activation of latent transforming growth factor β in endothelial cells: regulation of plasminogen activator activity. *J. Cell Biol.* **118**: 901–909.
 10. FLANDERS, K. C., N. L. THOMPSON, D. S. CISSEL, E. VAN OBBERGHEN-SCHILLING, C. C. BAKER, M. E. KASS, L. R. ELLINGSWORTH, A. B. ROBERTS & M. B. SPORN. 1989. Transforming growth factor- β 1: histochemical localization with antibodies to different epitopes. *J. Cell Biol.* **108**: 653–660.
 11. ROBERTS, A. B., N. S. ROCHE, S. WINOKUR, J. K. BURMESTER & M. B. SPORN. 1992. Role of transforming growth factor- β in maintenance of function of cultured cardiac myocytes. *J. Clin. Invest.* **90**: 2056–2062.
 12. BRILLA, C. G., R. PICK, L. B. TAN, J. S. JANICKI & K. T. WEBER. 1990. Remodeling of the rat right and left ventricles in experimental hypertension. *Circ. Res.* **67**: 1355–1364.
 13. MAYER, M., Z. FINCI & M. CHAOUAT. 1986. Suppression of plasminogen activator activity by dexamethasone in cultured cardiac myocytes. *J. Mol. Cell Cardiol.* **18**: 1117–1124.
 14. BANSAL, D. D., R. M. KLEIN & R. R. MACGREGOR. 1993. Secretion of plasminogen activator from cardiac interstitial cells of SHR and WKY rats. *Mol. Biol. Cell* **4** (Suppl.): 288A (abstract).
 15. CAMPBELL, E. E., M. A. SHITMAN, J. G. LEWIS, J. J. PASQUA & S. V. PIZZO. 1982. A colorimetric assay for releasable plasminogen activator. *Clin. Chem.* **28**: 1125–1128.
 16. BANSAL, D. D., & R. R. MACGREGOR. 1990. Secretion of plasminogen activator from bovine parathyroid cells. *Endocrinology* **126**: 2245–2251.
 17. HAMILTON, J. W., R. R. MACGREGOR, L. L. H. CHU & D. V. COHN. 1971. The isolation and partial purification of a non-parathyroid hormone calcemic fraction from bovine parathyroid glands. *Endocrinology* **89**: 1440–1447.
 18. FUKUDA, Y., Y. HIRATA, H. YOSHIMI, T. KOJIMA, Y. KOBAYASHI, M. YANAGISAWA & T. MASAKI. 1988. Endothelin is a potent secretagogue for atrial natriuretic peptide in cultured rat atrial myocytes. *Biochem. Biophys. Res. Commun.* **155**: 167–172.
 19. HILAL-DANDAN, R., K. URASAWA & L. L. BRUNTON. 1992. Endothelin inhibits adenylate cyclase and stimulates phosphoinositide hydrolysis in adult cardiac myocytes. *J. Biol. Chem.* **267**: 10620–10624.
 20. CRUTCHLEY, D. J., L. B. CONANAN & J. R. MAYNARD. 1981. Human fibroblasts produce

inhibitor directed against plasminogen activator when treated with glucocorticoids. *Ann. N. Y. Acad. Sci.* **370**: 609-616.

21. LAIHO, M., O. SAKSELA, P. A. ANDREASEN & J. KESKI-OJA. 1986. Enhanced production and extracellular deposition of the endothelial-type plasminogen activator inhibitor in cultured human lung fibroblasts by transforming growth factor- β . *J. Cell. Biol.* **103**: 2403-2410.

Intracellular Signaling and Genetic Reprogramming during Agonist-Induced Hypertrophy of Cardiomyocytes^a

H. A. A. VAN HEUGTEN,^b H. W. DE JONGE,^b
K. BEZSTAROSTI,^b H. S. SHARMA,^c P. D. VERDOUW,^d
AND J. M. J. LAMERS^b

*Departments of ^bBiochemistry and ^cPharmacology and ^dThorax
Centre, Cardiovascular Research Institute COEUR
Faculty of Medicine & Health Sciences
Erasmus University Rotterdam
P. O. Box 1738
3000 DR Rotterdam, The Netherlands*

INTRODUCTION

Cardiac myocytes stop dividing shortly after birth and subsequently the heart grows by enlargement of individual cells, a process that can be observed *in vitro* as well.¹ However, growth of individual cardiomyocytes can also be observed in the adult heart, a process called hypertrophy. Chronic hemodynamic overload of the heart by, *e.g.*, infarction, hypertension or volume or pressure overload ultimately leads to hypertrophy of the left ventricular wall. The hypertrophy process involves induction of transcription of specific contractile as well as noncontractile protein genes resulting in growth as well as change in contractile function of the cardiomyocyte.^{2,3} This allows the heart to maintain normal beat-to-beat volume under the circumstances mentioned above. Although only limited evidence was presented for their importance during *in vivo* development of hypertrophy,⁴⁻⁷ hormonal and mechanical stimuli are thought to be the initial signals that trigger the onset of cell growth. The evidence for the involvement of hormonal and mechanical signals in the induction of hypertrophy mainly comes from *in vitro* models employing cultured neonatal cardiomyocytes. Here it was shown that induction of hypertrophy is accompanied by activation of the phosphoinositide (PI) cycle and by rapid stimulation of transcription of so-called immediate early genes, transcription factors, ultimately leading to rearrangement of gene expression of structural proteins in the cardiomyocyte. Recently, studies of hypertrophy were also performed on cultured adult cardiomyocytes,⁸⁻¹¹ confirming results from the neonatal cardiomyocyte model. In this review we focus on the influence of these hormonal and mechanical signals that activate the PI cycle during development of hypertrophy in the model of cultured cardiomyocytes and the ultimate outcome

^a Parts of this work were supported by the Netherlands Heart Foundation (Grant No. 92.081) and the Netherlands Organization for Scientific Research (NWO) (Grant No. 900-516-127.)

of hypertrophic stimulation for the cardiac myocyte. The last section deals with some of our most recent results.

Some of the signals that trigger a hypertrophic response are not transduced through activation of the PI pathway. These include β -adrenergic stimulation that activates adenylate cyclase,¹² while several growth factors like fibroblast growth factor,^{13,14} insulin-like growth factor-I,^{15,16} thyroid hormone and transforming growth factor β ¹³ were also shown to activate growth-like responses. Extracellular signals that stimulate the PI cycle can also lead to growth of the cardiomyocyte, and in the last years more and more agonists of this type were identified. These include the α_1 -adrenergic agonist phenylephrine (PHE),¹⁷ angiotensin II (AngII),¹⁸ endothelin-1(ET-1)^{19,20} and α -thrombin.²¹ Furthermore, stretching of cultured cardiomyocytes leads to increased PI cycle activity and ultimately to hypertrophy.²² Increased contractile activity of cardiomyocytes also induces hypertrophy,^{23,24} but the question might be asked whether this is an independent mechanism or is transduced through increased stretching of the cells. We might even envisage β -adrenergic induction of hypertrophy as being partly the result of an increase in beating frequency of the myocytes.

Stimulation by α_1 -Adrenergic Agonist

α_1 -Adrenergic stimulation of phosphoinositide hydrolysis in cardiomyocytes is mediated through the α_{1A} -adrenergic receptor²⁵ that is coupled to phospholipase C_β through the GTP-binding protein $G_{q,11}$.²⁶ Blocking the α_{1A} -adrenergic receptor led to inhibition of α_1 -induced hypertrophy, in contrast to treatment with α_{1B} -adrenergic receptor blockers.²⁵ Blocking the $G_{q,11}$ function results in inhibition of α_1 -adrenergic-mediated hypertrophy as well.²⁶ These results directly implicate the PI cycle as an important intermediate in the signal transduction cascade leading to induction of cell growth. However, we have to be aware of the fact that α_1 -adrenergic agonist is translocated to the nucleus where the receptor is also localized,²⁷ suggesting a direct role of the receptor-agonist complex in regulation of gene expression. More distal elements of the signaling cascade involved in hypertrophy induction by catecholamines have also been identified. α_1 -Adrenergic stimulation of cardiomyocytes results in increased diacylglycerol levels.^{28,29} Probably as a result of this, activation and translocation of protein kinase C to membranes and myofilaments occurs.³⁰⁻³³ Activation of protein kinase C by phorbol ester is sufficient to give several hypertrophic responses,^{32,34,35} as was also elegantly demonstrated by protein kinase C transfection studies.^{32,36} However, activation of protein kinase C is not the only factor involved in induction of hypertrophy. Taking expression of atrial natriuretic factor (ANF) as parameter of the degree of hypertrophy (see below), it was shown that inhibition of protein kinase C activity resulted in a 75% decline in hypertrophic response to α_1 -adrenergic stimulation.²⁸ On the other hand, inhibition of Ca^{2+} /calmodulin-regulated kinases completely blocked development of hypertrophy, in agreement with the requirement for calcium of the hypertrophy process. The involvement of Ca^{2+} /calmodulin-regulated processes in induction of cell growth is further substantiated by a study in which overexpression of calmodulin led to induction of hypertrophy as well as hyperpla-

sia.³⁷ Other kinases that might be involved in transduction of the extracellular signal to the nucleus are MAP(kinase) kinases, which are thought to play an important role in growth-related processes. These MAP(kinase) kinases are activated by α_1 -adrenergic stimulation of cardiomyocytes.³⁸ However, direct evidence for the involvement of MAP kinases in the signaling pathway connecting the α_1 -adrenergic receptor to nuclear events has not been obtained. Coordinated expression of several genes takes place as a result of α_1 -adrenergic stimulation. The hypertrophic response after α_1 -adrenergic stimulation was inhibited by mutated, inactive Hras proto-oncogene³⁹ suggesting that tyrosine kinases are involved in this response, independent of activation of the PI cycle.²⁶ Early and transient responses include transcription of so-called immediate early genes, encoding known or putative transcription factors. The first proto-oncogene that was shown to be induced by α_1 -adrenergic stimulation was *c-myc*.⁴⁰ However, constitutive overexpression of *c-myc* in a strain of transgenic mice did not lead to a hypertrophic response but led to growth of the heart by hyperplasia suggesting that it is not directly involved in growth of the heart by cell enlargement.⁴¹ Other proto-oncogenes that are expressed upon α_1 -adrenergic stimulation are *c-fos*, *c-jun* and *EGR-1*.⁴² The *c-fos/c-jun* heterodimer binds to AP-1 DNA consensus sequences resulting in activation of transcription of genes containing these elements, *e.g.*, in the *ANF* gene.⁴³ The presence of *EGR-1* protein is a prerequisite for agonist-induced hypertrophy⁴⁴ as will be discussed below for *ET-1*. At a later stage of hypertrophy, protein synthesis increases,^{17,45,46} accompanied by enhanced transcription of several genes. These include the contractile protein myosin light chain-2 that is assembled into organized sarcomeric units.^{47,48} However, embryonic genes *ANF*,^{28,48,49} skeletal α -actin⁵⁰⁻⁵² and β -myosin heavy chain⁵³ were induced as well resulting in a change in phenotype of the cardiomyocyte. This change is further reflected by a lack of induction of cardiac Na^+ channel expression.⁴⁸

Stimulation by ET-1

Stimulation of cardiomyocytes with *ET-1* results in activation of phospholipase C, as was the case for *PHE*, again leading to increased inositolphosphate production⁵⁴ and diacylglycerol levels.^{19,29} This effect is probably mediated by the *ET-A* receptor.^{6,55,56} Given the important role of the PI cycle in activation of the hypertrophy process,¹¹ it is not surprising to see that the hypertrophic responses of *ET-1* and *PHE* are remarkably similar. After stimulation with *ET-1*, protein kinase C is activated³³ as well as MAP(kinase) kinase⁵⁷ and MAP kinase.^{38,57} The activation of protein kinase C by *ET-1* is necessary for induction of hypertrophy as judged by inhibition of *ET-1*-induced increase in protein synthesis after incubation with a protein kinase C inhibitor.⁵⁸ Activation of MAP kinase is partly brought about by the activity of protein kinase C isotypes that are stimutable by phorbol ester. However, as downregulation of these isozymes by prolonged incubation of cultured cardiomyocytes with phorbol ester did not result in total inhibition of *ET-1*-induced MAP kinase activity,⁵⁷ this hormone might also activate so-called atypical protein kinase C isozymes that do not require Ca^{2+} and/or diacylglycerol for activation. Moreover, as cultured cardiomyocytes contain protein kinase

C- α and - δ ,⁵⁷ isozymes that are not found in the intact adult heart,³³ the relative importance of both signaling pathways remains to be determined. As was the case for α_1 -adrenergic stimulation, incubation with ET-1 activates the immediate early gene program. Here, c-fos and EGR-1 were induced within 30 min after stimulation and decreased again after 1 hour.^{10,19,59} The expression of EGR-1 is of prime importance for development of hypertrophy; blocking translation of the EGR-1 mRNA by an antisense oligonucleotide completely inhibits ET-1-induced stimulation of protein synthesis, an indicator of hypertrophy.⁴⁴ Rearrangement of gene expression was again noticed; the transcription of the embryonic gene ANF^{19,29} as well as of the α -actin, and troponin I genes were stimulated.⁶⁰ Myosin light chain-2 gene transcription was also stimulated,⁶⁰ and increased amounts of myosin light chain-2 were assembled into organized contractile units.¹⁹ In contrast to α_1 -adrenergic stimulation, ET-1 not only increased transcription of the embryonic myosin heavy chain β -isozyme but also of the adult α -form.⁶¹ This suggests that differences in signal transduction pathways leading to hypertrophy exist between the α_1 -adrenergic agonist and ET-1. It was already shown that exposure of cardiomyocytes leads to partial homologous desensitization of the PI cycle activity, a phenomenon not present during α_1 -adrenergic stimulation.^{29,54} Whether this is the underlying mechanism that is responsible for the difference in myosin heavy chain isozyme expression as described above and the rapid decrease of ET-1-induced ANF mRNA levels²⁹ remains to be determined. During development of hypertrophy the amount of RNA in the cells increases as well as protein synthesis.^{11,20,58,60} Conflicting results were reported concerning the role of extracellular Ca^{2+} in stimulation of protein synthesis by ET-1. In one study, a Ca^{2+} blocker had no effect,⁶⁰ while the group of Suzuki and co-workers showed that the same Ca^{2+} channel blocker partly inhibited ET-1-induced increase in protein synthesis.^{20,58} On the other hand, it was shown that an increase in intracellular Ca^{2+} leads to a temporal stimulation of transcription of the myosin light chain-2, α -actin and troponin genes,⁶⁰ while ET-1-stimulated ANF release was also partially Ca^{2+} dependent.⁶² Together with the results concerning Ca^{2+} dependence of the α_1 -adrenergic induction of hypertrophy, we would like to suggest that Ca^{2+} is also important for ET-1-induced hypertrophy. In this respect it is interesting to note that we recently showed that intracellular free Ca^{2+} has a feed-forward stimulatory effect on phospholipase C when the enzyme is stimulated with ET-1 or PHE.⁶³ Although it is thought that endothelial cells are the major source of endothelin, it is important to mention that ET-1 is produced and secreted by cardiomyocytes as well,⁶⁴ suggesting that autocrine/paracrine mechanisms of induction of hypertrophy might be important too.

Stimulation by AngII

Another peptide hormone that was shown to induce hypertrophy is AngII,^{4,18} acting through the AT_1 receptor.⁶⁵ AngII provokes phospholipase C activity that is rapidly desensitized.^{66,67} However, the increase in DAG is more prolonged, and it was shown that AngII also activates phospholipase D resulting in degradation of phosphatidylcholine and formation of diacylglycerol through phosphatidic

acid.^{67,68} Probably as a result of this, protein kinase C is activated. Furthermore, cyclic-AMP levels were increased and arachidonic acid production was stimulated showing that AngII activates several signal transduction pathways at the same time. As a result of protein kinase C activation the expression of c-fos was transiently stimulated in a Ca^{2+} -dependent manner. The immediate early genes c-jun, jun-B, EGR-1 and c-myc were also transiently expressed.^{9,10,65} Again, the expression of embryonic genes was induced; ANF as well as skeletal α -actin mRNA was increased within 6 hrs of stimulation with AngII. As research into the hypertrophic effect of AngII is relatively young, studies on expression of contractile genes are not yet available. We have to keep in mind that prolonged incubation of cardiomyocytes leads to stimulation of ET-1 synthesis and secretion by cardiomyocytes.⁶⁹ This opens the possibility that part of the AngII-mediated responses are brought about by ET-1.

Stretching of cardiomyocytes also results in activation of phospholipase C and phospholipase D, and release of arachidonic acid and ultimately leads to hypertrophy.⁷⁰⁻⁷⁴ This is preceded by a short-lived increase in the inositolphosphate level and prolonged diacylglycerol accumulation, as well as protein kinase C and MAP kinase activation.⁷³ The MAP kinase activation was partially dependent on Ca^{2+} and the presence of phorbol ester-stimulatable protein kinase C,^{73,75} and although tyrosine kinases were activated,⁷³ they were not involved in activation of MAP kinases,⁷⁵ suggesting a dual pathway of activation and a role for atypical protein kinase C isozymes. The immediate early gene c-fos was induced in a protein kinase C-dependent manner,⁷³ and c-jun, c-myc and EGR-1 were induced as well.^{9,71} At a later stage of hypertrophy induction, the fetal cardiac genes ANF, β -MHC and skeletal α -actin were expressed.⁷¹ These data are reminiscent of the multiple pathways that are activated by AngII and it was indeed shown that upon stretch, AngII is released by cardiomyocytes in culture.^{76,77} The involvement of AngII in stretch-induced hypertrophy was confirmed by a study where stretch-induced hypertrophy could be blocked by an AngII receptor antagonist.⁷ Furthermore, ion-channels and contractile activity were shown not to be involved in transduction of stretch-signals to the nucleus.⁷⁸ The control of gene expression during mechanical stress was recently reviewed.⁷⁹ At this stage it is important to stress again that AngII also has an effect on ET-1 levels; AngII induces ET-1 precursor mRNA in cardiomyocytes in a protein kinase C-dependent fashion.⁶⁹ This depicts a situation where stretching of the cardiomyocytes directly activates multiple signaling pathways through the stretch-induced release of AngII followed by activation of phospholipase C by ET-1 that is produced and released by cardiomyocytes under influence of AngII.

Stimulation by Thrombin

A fourth receptor that is coupled to induction of hypertrophy through activation of the PI cycle is the thrombin receptor.^{21,80} Actually, it is a receptor for its own N-terminal peptide that is cleaved from the receptor by thrombin. Stimulation of cardiomyocytes with thrombin as well as with the N-terminal peptide leads to morphological and genetic changes that are reminiscent of hypertrophy: cells are

enlarged and contain highly organized sarcomeric units while ANF expression is induced in a dose-dependent manner. The signal transduction pathway involves both protein kinase C and tyrosine kinase activation. The relative importance of thrombin in *in vivo* induction of hypertrophy remains to be determined as cardiomyocytes are normally separated from circulating thrombin by the vessel wall.

Other Stimuli

We have to be aware of the fact that activation of phospholipase C not only occurs through G-protein-coupled receptors, but that tyrosine kinases can also lead to increased PI cycle activity through phosphorylation and activation of the phospholipase C γ -isozyme. Tyrosine kinase activity is an inherent property of a large amount of receptors, *e.g.*, the EGF, insulin, and FGF receptor families.⁸¹ Indeed, FGF activates tyrosine kinases and MAP kinases⁵⁷ and induces hypertrophy.^{13,14} Whether other receptor tyrosine kinases also induce hypertrophy remains to be determined. Hypertrophic responses like induction of ANF expression and stimulation of myosin light chain-2 gene expression can also be brought about by electrical stimulation of contraction of cardiac myocytes, independent of activation of protein kinase C or A but depending on Ca^{2+} fluxes across the membrane and calmodulin activity.⁴⁹ This suggests a role for Ca^{2+} /calmodulin-dependent kinases, as was described above. Furthermore, as many agonists like PHE and ET-1 also stimulate contraction of cells in culture, part of the hypertrophy caused by these agonists might be induced by increased contraction, as suggested by the Ca^{2+} dependence of many of the intracellular events.

Genetic Reprogramming During Cell Growth

As described above, induction of cell growth results in induction or increase in transcription of several genes.^{2,3} These agonist- or stretch-induced alterations in cardiomyocyte phenotype are reminiscent of the changes during *in vivo* cardiac remodeling following cardiac overload. These changes lead to reexpression of fetal genes, *e.g.*, β -myosin heavy chain, skeletal α -actin and ANF. The reexpression of β -myosin heavy chain leads to a larger amount of the homodimer V_1 isomyosin and results in a slower rate of ATP cycling by myosin and thus a lower rate of contraction in the hypertrophied heart. On the other hand, this improves efficiency and economy of contraction, suggesting an adaptive response.

It is important to stress that in the *in vivo* situation, enzymes that take part in Ca^{2+} homeostasis are also involved in phenotypic changes of the hypertrophied heart. For instance, the sarcoplasmic reticulum Ca^{2+} ATPase as well as its regulatory protein phospholamban are not induced or may even be downregulated during development of hypertrophy, resulting in aberrant Ca^{2+} handling in the hypertrophied heart impairing relaxation.^{82,83}

Differences in Signal Transduction and Magnitude of Hypertrophy between Agonists That Activate the PI Cycle

Only a limited number of studies have directly compared signal transduction and induction of hypertrophy of agonists that activate the PI cycle. Using the

model of cultured neonatal rat ventricular myocytes we therefore compared the effects of AngII, ET-1 and the α_1 -adrenergic agonist phenylephrine (PHE). Although the second messenger inositol (1,4,5)tris-phosphate was not detectable due to fast dephosphorylation,⁸⁴ ET-1 and PHE were equipotent in activation of the PI cycle, but the ET-1-induced production of inositol phosphates was subject to homologous desensitization.⁵⁴ The stimulation of the PI cycle by AngII is only very weak and transient.⁶⁶ On the other hand, the increase in diacylglycerol level was highest after stimulation with AngII (unpublished data), suggesting that phospholipase D was activated in this case as well, as was observed earlier.⁶⁹ Although cultured cardiomyocytes contain phorbol ester-stimulatable protein kinase C, direct activation of the kinase by the agonists was only very weak (results not shown). However, activation of other kinases is plausible as shown by the phosphorylation of a 30-kDa nonmembrane-bound protein by PHE but not by either ET-1 or AngII or by stimulation with phorbol ester.⁸⁴ Noting these large differences in signal transduction it is not surprising to see that the ultimate hypertrophic response was not the same for the three agonists. ET-1 is the strongest inducer of hypertrophy as judged by protein/DNA ratio, closely followed by PHE. In contrast, AngII gave only a very weak hypertrophic response.⁵⁹ Agonist-induced induction of hypertrophy was already apparent after 24 hrs, in contrast to the effect of protein kinase C activation by phorbol ester where the protein/DNA ratio was only increased after 48 hrs. The differences in ability to induce hypertrophy were also found when induction of transcription of the immediate genes *c-fos*, *c-jun*, *c-myc* and *EGR-1* was studied. Furthermore, the well-known induction of fetal gene expression, illustrated by expression of the ANF gene, was again weakest after stimulation with AngII. Experiments where the effect of hypertrophy on the expression is studied of proteins involved in Ca^{2+} homeostasis were performed, and remarkable similarity with the effect of *in vivo* induction of hypertrophy was noted, especially in the case of sarcoplasmic reticulum Ca^{2+} -ATPase.⁵⁹ These results indicate that induction of hypertrophy of cardiomyocytes in culture is a good model for studying signal transduction and genetic reprogramming.

REFERENCES

1. UENO, H., M. B. PERRYMAN, R. ROBERTS & M. D. SCHNEIDER. 1988. *J. Cell Biol.* **107**: 1911-1918.
2. BOHELER, K. R. & K. SCHWARTZ. 1992. *Med.* **2**: 176-182.
3. VAN BILSEN, M. & K. R. CHIEN. 1993. *Cardiovasc. Res.* **27**: 1140-1149.
4. BAKER, K. M., M. I. CHERNIN, S. K. WIXSON & J. F. ACETO. 1990. *Am. J. Physiol.* **259**: H324-332.
5. HANNAN, R. D., F. A. STENNARD & A. K. WEST. 1993. *J. Mol. Cell. Cardiol.* **25**: 1137-1148.
6. ITO, H., M. HIROE, Y. HIRATA, H. FUJISAKA, S. ADACHI, H. AKIMOTO, Y. OHTA & F. MARUMO. 1994. *Circulation* **89**: 2198-2203.
7. KOJIMA, M., I. SHIOJIMA, T. YAMAZAKI, I. KOMURO, Z. YUNZENG, W. YING, T. MIZUNO, K. UEKI, K. TOBE, T. KADOWAKI, R. NAGAI & Y. YAZAKI. 1994. *Circulation* **89**: 2204-2211.
8. CLARK, W. A., S. J. RUDNICK, J. J. LAPRES, L. C. ANDERSEN & M. C. LAPOINTE. 1993. *Circ. Res.* **73**: 1163-1176.

9. KUBISCH, C., B. WOLLNIK, A. MAASS, R. MEYER, H. VETTER & L. NEYSES. 1993. *FEBS Lett.* **335**: 37-40.
10. NEYSES, L., J. NOUSKAS, J. LUYKEN, S. FRONHOFFS, S. OBERDORF, U. PFEIFER, R. S. WILLIAMS, V. P. SUKHATME & H. VETTER. 1993. *J. Hypertens.* **11**: 927-934.
11. SUGDEN, P. H., S. J. FULLER, J. R. MYNETT, R. J. HATCHETT, M. A. BOGOYEVTCH & M. C. SUGDEN. 1993. *Biochim. Biophys. Acta* **1175**: 327-332.
12. ZIERHUT, W. & H. G. ZIMMER. 1989. *Circ. Res.* **65**: 1417-1425.
13. PARKER, T. G., S. E. PACKER & M. D. SCHNEIDER. 1990. *J. Clin. Invest.* **85**: 507-514.
14. PARKER, T. G., K.-L. CHOW, R. J. SCHWARTZ & M. D. SCHNEIDER. 1990. *Proc. Natl. Acad. Sci. USA* **87**: 7066-7070.
15. FULLER, S. J., J. R. MYNETT & P. H. SUGDEN. 1992. *Biochem. J.* **282**: 85-90.
16. ITO, H., M. HIROE, Y. HIRATA, M. TSUJINO, S. ADACHI, M. SHICHIRI, A. KOIKE, A. NOGAMI & F. MARUMO. 1993. *Circulation* **87**: 1715-1721.
17. SIMPSON, P. 1985. *Circ. Res.* **56**: 884-894.
18. BAKER, K. M. & J. F. ACETO. 1990. *Am. J. Physiol.* **259**: H610-H618.
19. SHUBEITA, H. E., P. M. McDONOUGH, A. N. HARRIS, K. U. KNOWLTON, C. G. GLEMBOTSKI, J. H. BROWN & K. R. CHIEN. 1990. *J. Biol. Chem.* **265**: 20555-20562.
20. SUZUKI, T., H. HOSHI & Y. MITSUI. 1990. *FEBS Lett.* **268**: 149-151.
21. GLEMBOTSKI, C. C., C. E. IRONS, K. A. KROWN, S. F. MURRAY, A. B. SPRENKLE & C. A. SEI. 1993. *J. Biol. Chem.* **268**: 20646-20652.
22. KOMURO, I., Y. KATOH, T. KAIDA, Y. SHIBAZAKI, M. KURABAYASHI, E. HOH, F. TAKAKU & Y. YAZAKI. 1991. *J. Biol. Chem.* **266**: 1265-1268.
23. McDERMOTT, P. J. & H. E. MORGAN. 1989. *Circ. Res.* **64**: 542-553.
24. JOHNSON, T. B., R. L. KENT, B. A. BUBOLZ & P. J. McDERMOTT. 1994. *Circ. Res.* **74**: 448-459.
25. KNOWLTON, K. U., M. C. MICHEL, M. ITANI, H. E. SHUBEITA, K. ISHIHARA, J. H. BROWN & K. R. CHIEN. 1993. *J. Biol. Chem.* **268**: 15374-15380.
26. LAMORTE, V. J., J. THORNBURN, D. ABSHER, A. SPIEGEL, J. H. BROWN, K. R. CHIEN, J. R. FERAMISCO & K. U. KNOWLTON. 1994. *J. Biol. Chem.* **269**: 13490-13496.
27. BUU, N. T., R. HUI & P. FALARDEAU. 1993. *J. Mol. Cell. Cardiol.* **25**: 1037-1046.
28. SEI, C. A., C. E. IRONS, A. B. SPRENKLE, P. M. McDONOUGH, J. H. BROWN & C. C. GLEMBOTSKI. 1991. *J. Biol. Chem.* **266**: 15910-15916.
29. McDONOUGH, P. M., J. H. BROWN & C. C. GLEMBOTSKI. 1993. *Am. J. Physiol.* **264**: H625-H630.
30. HENRICH, C. J. & P. C. SIMPSON. 1988. *J. Mol. Cell. Cardiol.* **20**: 1081-1085.
31. MOCHLY-ROSEN, D., C. J. HENRICH, L. CHEEVER, H. KHANER & P. C. SIMPSON. 1990. *Cell Regulation* **1**: 693-706.
32. SHUBEITA, H. E., E. A. MARTINSON, M. VAN BILSEN, K. R. CHIEN & J. H. BROWN. 1992. *Proc. Natl. Acad. Sci. USA* **89**: 1305-1309.
33. BOGOYEVTCH, M. A., P. J. PARKER & P. H. SUGDEN. 1993. *Circ. Res.* **72**: 757-767.
34. DUNNMON, P. M., K. IWAKI, S. A. HENDERSON, A. SEN & K. R. CHIEN. 1990. *J. Mol. Cell. Cardiol.* **22**: 901-910.
35. ALLO, S. N., P. J. McDERMOTT, L. L. CARL & H. E. MORGAN. 1991. *J. Biol. Chem.* **266**: 22003-22009.
36. KARIYA, K. I., L. R. KARNs & P. C. SIMPSON. 1992. *J. Biol. Chem.* **266**: 10023-10026.
37. GRUVER, C. L., S. E. GEORGE & A. R. MEANS. 1992. *Trends Cardiovasc. Med.* **2**: 226-231.
38. BOGOYEVTCH, M. A., P. E. GLENNON & P. H. SUGDEN. 1993. *FEBS Lett.* **317**: 271-275.
39. THORNBURN, A., J. THORNBURN, S.-Y. CHEN, S. POWERS, H. E. SHUBEITA, J. R. FERAMISCO & K. R. CHIEN. 1993. *J. Biol. Chem.* **268**: 2244-2249.
40. STARKES, N. F., P. C. SIMPSON, N. BISHOPRIC, S. R. COUGHLIN, W. M. F. LEE, J. A. ESCOBEDO & L. T. WILLIAMS. 1986. *Proc. Natl. Acad. Sci. USA* **83**: 8348-8350.
41. MATIUCK, N. V. & J. L. SWAIN. 1992. *Trends Cardiovasc. Med.* **2**: 61-65.
42. IWAKI, K., V. P. SUKHATME, H. E. SHUBEITA & K. R. CHIEN. 1990. *J. Biol. Chem.* **265**: 13809-13817.
43. KOVAČIĆ-MILIVOJEVIĆ B. & D. G. GARDNER. 1992. *Mol. Cell. Biol.* **12**: 292-301.

44. NEYSES, L., J. NOUSKAS & H. VETTER. 1991. *Biochem. Biophys. Res. Commun.* **181**: 22–27.
45. MEIDELL, R. S., A. SEN, S. A. HENDERSON, M. F. SLAHETKA & K. R. CHIEN. 1986. *Am. J. Physiol.* **251**: H1076–H1084.
46. IKEDA, U., Y. TSUTUYA & T. YAGINUMA. 1991. *Am. J. Physiol.* **260**: H953–H956.
47. LEE, H. R., S. A. HENDERSON, R. REYNOLDS, P. DUNNMON, D. YUAN & K. R. CHIEN. 1988. *J. Biol. Chem.* **263**: 7352–7358.
48. KNOWLTON, K. U., E. BARACCHINI, R. S. ROSS, A. N. HARRIS, S. A. HENDERSON, S. M. EVANS, C. C. GLEMBOTSKI & K. R. CHIEN. 1991. *J. Biol. Chem.* **266**: 7759–7768.
49. McDONOUGH, P. M. & C. C. GLEMBOTSKI. 1992. *J. Biol. Chem.* **267**: 11665–11668.
50. BISHOPRIC, N. H., P. C. SIMPSON & C. P. ORDAHL. 1987. *J. Clin. Invest.* **80**: 1194–1199.
51. LONG, C. S., C. P. ORDAHL & P. C. SIMPSON. 1989. *J. Clin. Invest.* **83**: 1078–1082.
52. BISHOPRIC, N. H. & L. KEDES. 1991. *Proc. Natl. Acad. Sci. USA* **88**: 2132–2136.
53. WASPE, L. E., C. P. ORDAHL & P. C. SIMPSON. 1990. *J. Clin. Invest.* **85**: 1206–1214.
54. VAN HEUGTEN, H. A. A., K. BEZSTAROSTI, D. H. W. DEKKERS & J. M. J. LAMERS. 1993. *J. Mol. Cell. Cardiol.* **25**: 41–52.
55. ISHIKAWA, T., L. L. OSAMU, S. KIMURA, M. YANAGISAWA, K. GOTO & T. MASAKI. 1991. *Circ. Res.* **69**: 918–926.
56. WOODCOCK, E. A., S. L. LAND & R. K. ANDREWS. 1993. *Clin. Exp. Pharmacol. Physiol.* **20**: 331–334.
57. BOGOYEVITCH, M. A., P. E. GLENNON, M. B. ANDERSSON, A. CLERK, A. LAZOU, C. J. MARSHALL, P. J. PARKER & P. H. SUGDEN. 1994. *J. Biol. Chem.* **269**: 1110–1119.
58. SUZUKI, T., H. HOSHI, H. SASAKI & Y. MITSUI. 1991. *J. Cardiovasc. Pharmacol.* **17**(Suppl. 7): S182–S186.
59. LAMERS, J. M. J., H. S. SHARMA, P. D. VERDOUW & H. A. A. VAN HEUGTEN. 1994. *Can. J. Cardiol.* **10**(Suppl. A): 49A.
60. ITO, H., Y. HIRATA, M. HIROE, M. TSUJINO, S. ADACHI, T. TAKAMOTO, M. NITTA, K. TANIGUCHI & F. MARUMO. 1991. *Circ. Res.* **69**: 209–215.
61. WANG, D. L., J. J. CHEN, N. L. SHIN, Y. C. KAO, K. H. HSU, W. U. HUANG & C. C. LIEW. 1992. *Biochem. Biophys. Res. Commun.* **183**: 1260–1265.
62. IRONS, C. E., C. A. SEI & C. C. GLEMBOTSKI. 1993. *Am. J. Physiol.* **33**: H282–H285.
63. VAN HEUGTEN, H. A. A., H. W. DE JONGE, K. BEZSTAROSTI & J. M. J. LAMERS. 1994. *J. Mol. Cell. Cardiol.* **26**: 1081–1093.
64. SUZUKI, T., T. KUMAZAKI & Y. MITSUI. 1993. *Biochem. Biophys. Res. Commun.* **191**: 823–830.
65. SADOSHIMA, J.-I. & S. IZUMO. 1993. *Circ. Res.* **73**: 413–423.
66. ABDELLATIF, M. M., C. F. NEUBAUER, W. J. LEDERER & T. B. ROGERS. 1991. *Circ. Res.* **69**: 800–809.
67. SADOSHIMA, J.-I. & S. IZUMO. 1993. *Circ. Res.* **73**: 424–438.
68. LAMERS, J. M. J., H. W. DE JONGE, V. PANAGIA & H. A. A. VAN HEUGTEN. 1993. *Cardioscience* **4**: 121–131.
69. ITO, H., Y. HIRATA, S. ADACHI, M. TANAKA, M. TSUJINO, A. KOIKE, A. NOGAMI, F. MARUMO & M. HIROE. 1993. *J. Clin. Invest.* **92**: 398–403.
70. KOMURO, I., T. KAIDA, Y. SHIBAZAKI, M. KURABAYASHI, Y. KATOH, E. HOH, F. TAKAKU & Y. YAZAKI. 1990. *J. Biol. Chem.* **265**: 3595–3598.
71. SADOSHIMA, J.-I., L. JAHN, T. TAKAHASHI, T. J. KULIK & S. IZUMO. 1992. *J. Biol. Chem.* **267**: 10551–10560.
72. YAZAKI, Y., I. KOMURO, T. YAMAZAKI, K. TOBE, K. MAEMURA, T. KADOWAKI & R. NAGAI. 1993. *Mol. Cell. Biochem.* **119**: 11–16.
73. SADOSHIMA, J.-I. & S. IZUMO. 1993. *EMBO J.* **12**: 1681–1692.
74. DASSOULI, A., J.-C. Sulpice, S. ROUX & B. CROZATIER. 1993. *J. Mol. Cell. Cardiol.* **25**: 973–982.
75. YAMAZAKI, T., K. TOBE, E. HOH, K. MAEMURA, T. KAIDA, I. KOMURO, H. TAMEMOTO, T. KADOWAKI, R. NAGAI & Y. YAZAKI. 1993. *J. Biol. Chem.* **268**: 12069–12076.
76. SADOSHIMA, J.-I., Y. XU, H. S. SLAYTER & S. IZUMO. 1993. *Circulation* **88**: I-190.
77. SADOSHIMA, J.-I., Y. XU, H. S. SLAYTER & S. IZUMO. 1993. *Cell* **75**: 977–984.

78. SADOSHIMA, J.-I., T. TAKAHASHI, L. JAHN & S. IZUMO. 1992. Proc. Natl. Acad. Sci. USA **89**: 9905-9909.
79. KOMURO, I. & Y. YAZAKI. 1993. Annu. Rev. Physiol. **55**: 55-75.
80. CHIEN, W. W., R. MOHABIR & W. T. CLUSIN. 1990. J. Clin. Invest. **85**: 1436-1443.
81. FANTL, W. J., D. E. JOHNSON & L. T. WILLIAMS. 1993. ANNU. REV. BIOCHEM. **62**: 453-481.
82. SHARMA, H. S., P. D. VERDOUW & J. M. J. LAMERS. 1994. Cardiovasc. Drugs Ther. **8**: 461-468.
83. LAMERS, J. M. J. & J. T. STINIS. 1979. Life Sci. **24**: 2313-2320.
84. DE JONGE, H. W., H. A. A. VAN HEUGTEN, K. BEZSTAROSTI & J. M. J. LAMERS. Biochem. Biophys. Res. Commun. **203**: 422-429.

Regulation of Basic Fibroblast Growth Factor (bFGF) and FGF Receptors in the Heart^a

ELISSAVET KARDAMI,^{b,c} LEI LIU,^d S. KISHORE
B. PASUMARTHI,^b BRADLEY W. DOBLE,^{b,c} AND
PETER A. CATTINI^b

^b*Department of Physiology
Faculty of Medicine
University of Manitoba
and*

^c*St. Boniface General Hospital Research Centre
Division of Cardiovascular Sciences
351 Taché Avenue
Winnipeg, Manitoba, Canada R2H 2A6*

INTRODUCTION

Cardiac myocytes lose their ability for a prompt hyperplastic and hence regenerative response soon after birth, responding to increased physiological or pathological functional demand by hypertrophy. As a consequence, irreversibly damaged myocardium as occurs after myocardial infarction becomes replaced by scar tissue, the remaining myocytes adapt to the increased workload by hypertrophy, and beyond a certain potential for compensatory responses, cardiac failure ensues. It is generally accepted that interventions aimed at reducing scar size, such as stimulation of myocardial regeneration, would improve cardiac prognosis. Although very little is known about the molecular triggers of hyperplastic and/or hypertrophic growth *in vivo*, signaling polypeptides such as growth factors have been strongly implicated in this context. A variety of growth factors have been identified in the myocardium by us and others.^{1,2} We have focused our attention on basic fibroblast growth factor (bFGF), since it is a potent stimulator of DNA synthesis not only in immature but also adult cardiomyocytes in culture.³⁻⁵ Here we will provide a brief overview of current information about bFGF and its receptors as well as our own data.

Basic Fibroblast Growth Factor in the Heart

Basic FGF (or FGF2) is an 18–25-kDa protein found in variable amounts in all tissues examined.^{6,7} It is highly conserved between species and belongs to a

^a This work was funded by grants (E.K., P.A.C.) from the Medical Research Council (MRC) of Canada and (E.K.) the Heart and Stroke Foundation of Canada. P.A.C. is an MRC Scientist.

^d Current address: Wayne State University School of Medicine, Division of Cardiology, Department of Internal Medicine, 421 E. Canfield Avenue, Detroit, MI 48201.

large family of FGF growth factors (FGF1–9) with which it shares 40–50% sequence homology; another widely studied member of this family which is also present in the heart is acidic FGF (FGF1). As is the case with several other types of signaling polypeptides, bFGF is multifunctional, a mitogen for cells of mesodermal and neuroectodermal origin, affecting differentiation, motility, gene expression and response to injury.^{6,7} Although bFGF is found in the basement membrane and extracellular matrix, its mode of secretion is unknown and is considered primarily an intracellular molecule. There are few reports of bFGF detected in the serum, raising the possibility of an endocrine activity; however, this molecule is believed to act locally, in a paracrine or autocrine fashion, presumably by binding to tyrosine kinase cell surface receptors.^{6–8} Heparan sulfate proteoglycans (HSPGs) which are integral cell membrane components are considered to act as “low”-affinity bFGF receptors and have been shown to be essential for the biological activity of bFGF in several systems.⁹ In addition, an “intracrine” mode of action has been proposed: bFGF may be capable of exerting effects on proliferation without necessarily exiting the cell, by nuclear translocation.^{10,11} It may therefore be necessary to distinguish between the potential effects of extracellular and intracellular bFGF.

Basic FGF is present in the heart at all developmental stages,¹² in the extracellular as well as intracellular space. Its function *in vivo* remains speculative, but based on its biological activity on cultured cells, several important possibilities arise. It may stimulate DNA synthesis and myocyte proliferation during development.^{3,4} It may also affect differentiation, favoring a more “fetal” program of contractile gene expression.² Its localization to the cytoplasmic face of cardiac gap junctions suggests involvement with intercellular communication.¹³ It increases in cardiac injury, indicating involvement with repair and any attempt for regeneration that might take place.^{14,15} Finally, we recently showed that bFGF may have a direct protective effect against ischemia-reperfusion injury on adult cardiomyocytes.¹⁶

Since bFGF is present in the adult heart myocyte basement membranes, lack of a measurable proliferative response by these cells may be attributed to a number of possibilities. (a) Ligand (bFGF) concentration and/or composition and subcellular localization may be inadequate or inappropriate. (b) Similarly, changes in tyrosine kinase receptor composition, concentration as well as functional coupling may preclude a response. (c) “Inhibitors” of bFGF activity on the cells may actively prevent proliferation. This function could be provided by transforming growth factor β (TGF β) and/or thyroid hormone which have been shown to cancel the bFGF-induced stimulation of DNA synthesis on myocytes and which are also present in the heart;³ alternatively, receptor dominant-negative variants may be present, effectively blocking bFGF-induced signal transduction. (d) Changes in heparan sulfate proteoglycan bFGF “receptors” concentration/composition could also prevent proliferation. (e) Myocytes may simply have irreversibly lost the ability to divide. This traditionally held opinion, however, is no longer valid, since these cells in culture can reinitiate the cell cycle, while there are reports of sparse mitotic figures *in situ*.^{5,17}

We have begun to investigate possibilities (a) to (d) in an effort to identify reversible changes that might contribute to a loss of proliferative response. To

this end, we have examined expression of FGF receptors as well as bFGF *in vivo* and *in vitro*.

FGF Receptors in Cardiac Development

Tyrosine kinase FGF receptors display a very high degree of variability. Four related gene products have been described (FGFR1–4), each with an extensive array of splice variants.⁸ Only FGFR1, the *flg* gene product, has been identified in the myocardium.^{18,19} We therefore examined expression of FGFR1 in the rat heart in development, by Northern blotting.²⁰ Levels of FGFR1 mRNA declined significantly after birth and remain relatively low, at about 20% of fetal values, for the first two weeks postpartum.²⁰ This reduction in receptor levels may contribute to or facilitate myocyte transition from a hyperplastic to a hypertrophic phenotype which occurs during this period. However, FGFR1 mRNA appeared to increase again later in development, reaching 60% of adult levels at 5–10 weeks of age.²⁰ Levels of FGFR1 mRNA in the adult heart were similar to those of brain, a tissue used as a positive control for FGFR expression (FIG. 1). Adult hearts (FIG. 1) also expressed N-syndecan, a HSPG which may act as low-affinity “receptor” for bFGF. Since, in addition to myocytes, the heart consists of many other cell types which could be the main expressors of FGF receptors, we isolated adult cardiomyocytes and investigated whether they express FGFR1 and N-syndecan

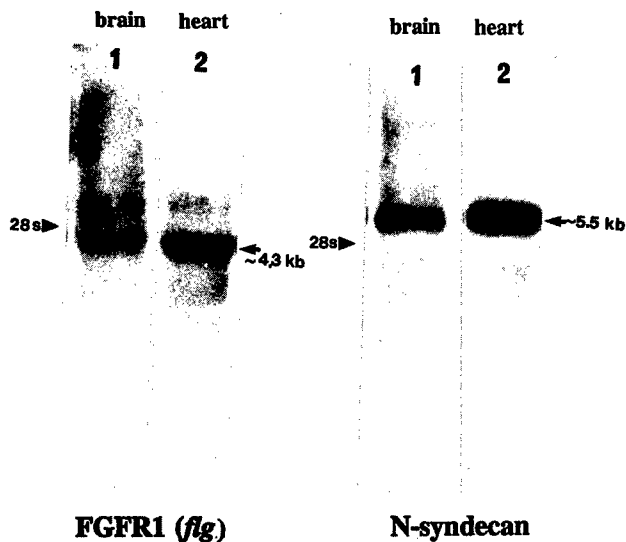

FIGURE 1. Northern blot analysis of total RNA (100 μ g/lane) obtained from adult rat heart and brain for FGFR1 (*flg*) and N-syndecan, as indicated, by hybridization with corresponding cDNAs.²⁰ Adult rat hearts were consistently found to express the FGFR1 and N-syndecan mRNAs, at 4.3 and 5.5 kb, respectively, at levels comparable to those from brain.

mRNA; levels of FGFR1 as well as N-syndecan mRNAs were found to be similar in either total heart or isolated myocytes, indicating that these cells contribute substantially to the signals obtained from whole heart RNA.²⁰

To examine whether the FGFR1 protein is present in the adult myocardium and to obtain an idea as to its relative levels compared to those of fetal hearts, we prepared membranes from the two developmental stages and examined them for expression of *flg*-like proteins by Western blotting, using a commercially available (UBI) monoclonal antibody preparation raised against the extracellular domain of FGFR1. As shown in FIGURE 2, these antibodies recognized *flg*-like antigens in both fetal and adult heart membranes; relative concentration of immunoreactive bands in the latter (after correcting for loading variations) was about 65% of the former, in agreement with the mRNA findings.²⁰ Fetal membranes expressed predominantly larger size (110–115-kDa) immunoreactive bands which were virtually absent from the adult preparations. The latter combined *flg*-like bands of 80–93 kDa which were also present in the fetal membranes. Variability in FGFR1 isoforms can be caused by alternative splicing, generating molecules with either two (82-kDa, “short” form) or three (92-kDa, “long” form) extracellular immunoglobulin-like domains.⁸ Based on findings demonstrating differential expression of FGFR1 mRNA splice variants in mouse heart development,²¹ we suggest that the different FGFR1-like forms detected in fetal versus adult myocardium reflect transitions from the “long” to the “short” FGFR1 mRNA, respectively.

Neonatal cultured myocytes have been shown to recapitulate developmental transitions occurring *in vivo*.²² These cells undergo a transition from a proliferative to a nonmitotic, binucleated phenotype after one week in culture, in the presence of low serum concentrations. They were thus used to examine possible changes in FGF receptors during these very crucial stages. Affinity cross-linking of ¹²⁵I-bFGF to the cell surface, a technique widely used to identify growth factor receptors, was employed. As shown in FIGURE 3, broad cross-linked bands around 110 and 142 kDa were detected in proliferative as well as nonmitotic cardiomyocyte cultures. After subtraction of the molecular weight of bFGF (17,000) these bands indicated receptor proteins of an apparent molecular mass of about 125 and 93 kDa. Competition with excess unlabelled bFGF resulted in complete disappearance of the cross-linked bands, demonstrating the specificity of the reaction (lane 5). Levels of the 125-kDa receptor, as estimated by densitometry and corrected for varia-

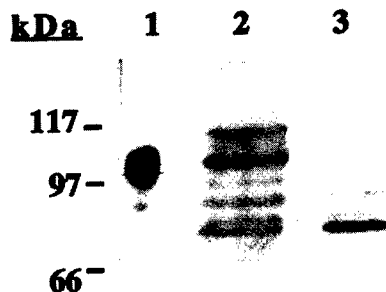

FIGURE 2. Western blot analysis of membrane preparations (50 μ g/lane) from (lane 2) fetal and (lane 3) adult rat hearts. Lane 1, purified human *flg* product (approximately 50 ng), used as a positive control. The monoclonal anti-*flg* antibody preparation used was purchased from Upstate Biotechnology, Inc. (Lake Placid, NY). Membrane preparations from rat hearts were found to express FGFR1-like antigens, in the 70–120-kDa range, at all developmental stages.²⁰

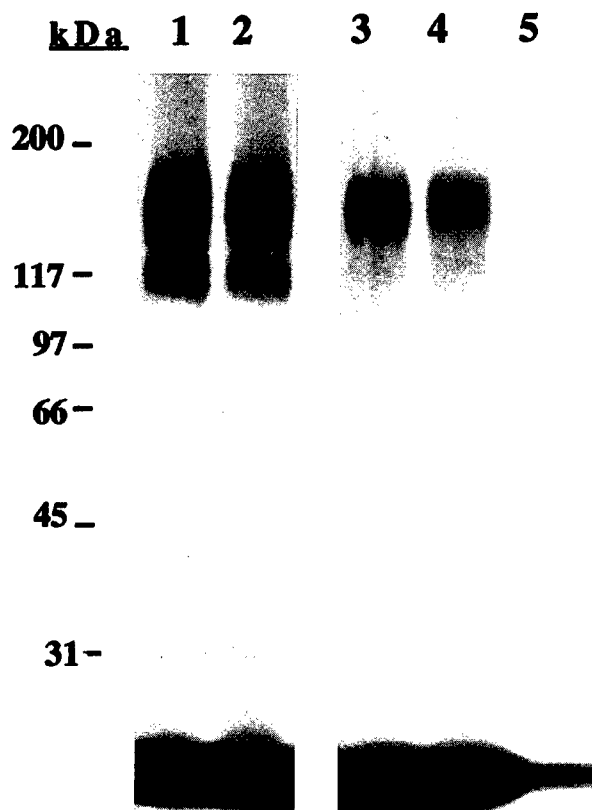

FIGURE 3. Autoradiographic analysis of affinity cross-linking of ^{125}I -bFGF onto the cell surface of cultured cardiac myocytes, using the heterobifunctional cross-linker DSS.²⁰ *Lanes 1 and 2*, two different preparations of proliferating myocytes. *Lanes 3 and 4*, two different preparations of nonmitotic myocytes. *Lane 5*, cross-linking as in lane 1 but in the presence of $3\ \mu\text{g}$ of nonlabelled bFGF. Broad cross-linked bands were detected at 110 and 140 kDa. The relative contribution of the 117-kDa band was significantly decreased in nonmitotic compared to proliferating myocytes, while there was only a slight (10%) decrease in overall concentration of cross-linked bands in the latter.

tions in protein loading, were virtually identical between proliferative and nonmitotic myocytes. Levels of the 93-kDa receptor, while always lower than those of the 125-kDa protein, decreased substantially in the nonmitotic myocytes. It appeared therefore that loss of proliferative phenotype in culture was accompanied by changes in bFGF receptor composition. It will be important to determine whether these changes contribute to or are a consequence of the nonmitotic phenotype, and whether there are differences in the signals triggered by the different receptors. Although the identity of cross-linked bands has not been established yet, it is suggested that they likely represent FGFR1-like proteins, since these were

detected in cultured myocytes by Western blotting (unpublished observations) and no other FGFR gene has been detected in these cells.

Several previous studies have indicated that heparin prevents interaction and internalization via the low-affinity bFGF receptors (HSPGs) and that any internalization of bFGF still occurring in the presence of heparin is mediated by binding to the high-affinity, tyrosine kinase, receptors.²³ Internalization of ¹²⁵I-bFGF by proliferative and nondividing myocytes, in the absence or presence of 10 μ g/ml heparin, was therefore determined. No differences were detected between the two stages. In both cases ¹²⁵I-bFGF was internalized by the myocytes via low- as well as high-affinity bFGF receptors; heparin-resistant internalization constituted approximately 50% of the total, in both proliferating and nonmitotic myocytes (unpublished observations).

Binding of bFGF to its high-affinity tyrosine kinase receptors is followed by receptor dimerization, receptor tyrosine phosphorylation and tyrosine phosphorylation of cellular substrates.⁸ We therefore examined the effect of 10-minute stimulation by bFGF on tyrosine phosphorylation of proliferating or nonmitotic myocytes. As shown in FIGURE 4, increased tyrosine phosphorylation was detectable, indicating that a signal transduction pathway had been triggered by the binding of bFGF to its receptors in both cases. In proliferating myocytes, increased phosphorylation compared to controls was seen in proteins migrating with an apparent

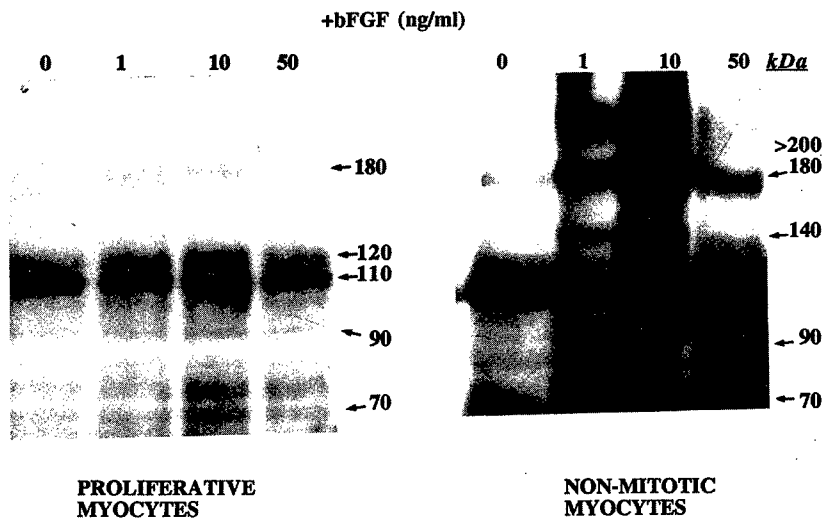

FIGURE 4. Analysis of phosphotyrosine-containing proteins in proliferating and nonmitotic myocytes, as indicated by Western blotting, using a monoclonal antibody anti-phosphotyrosine preparation from Upstate Biotechnology, Inc. Myocyte cultures were stimulated with 1, 10 and 50 ng/ml of bFGF for 10 minutes, lysed and analyzed on 7.5% polyacrylamide gels. Antigen-antibody complexes were visualized by incubation with anti-mouse rabbit immunoglobulins, followed by ¹²⁵I-protein A, as described.¹ Basic FGF induced a dose-dependent stimulation of phosphotyrosine phosphorylation in both proliferating and nonmitotic myocytes. Proteins displaying increased phosphotyrosine are indicated by *arrows*.

molecular mass of approximately 180, 110, 125 and 92 kDa, while in nonmitotic myocytes these proteins migrated with an apparent mol mass of >200, 180, 140, 90–100 kDa. It appeared therefore that certain proteins (180, 92 kDa) displayed increased phosphotyrosine content after bFGF addition in both developmental stages. However differences were also seen: increased phosphorylation of the >200- and 140-kDa bands was seen only in nonmitotic myocytes. Furthermore, phosphotyrosine levels of the 110–125-kDa broad band(s) were increased by bFGF only in the proliferating myocytes. These findings pointed at the possibility of potential differences in the signal transduction pathway(s) triggered by bFGF at the two stages. The identity of these bands is not known yet; one cannot, therefore, address the functional significance of these differences. However, since bFGF stimulates cell division in the proliferating but not the nonmitotic myocytes, it is tempting to speculate that the phosphorylation pattern observed in proliferating cells is linked to the stimulation cell division, while that of nonmitotic cells has a different end point.

In conclusion, there appears to be developmental and stage-specific regulation of FGFR abundance as well as isoform composition in the heart, in a manner supporting involvement with the transitions from a hyperplastic to a hypertrophic phenotype occurring after birth. Elucidation of the signal transduction pathways triggered by the various receptors may provide important information as to how cardiomyocyte proliferation and thus regeneration may be regulated *in vivo*.

Basic FGF Variants in the Heart: Regulation and Effects

Having been studied primarily as an 18-kDa protein, bFGF is now known to exist in higher-molecular-weight forms (20–25 kDa), the result of translation from unconventional CUG start sites.²⁴ Although both AUG- (“short”) and CUG-initiated (“long”) forms can be localized to the nucleus, the N-terminal extension of the long forms provides an additional nuclear localization signal.²⁵ Provided extracellularly, short as well as long forms of bFGF appears to bind to receptors of certain cultured cell types with similar affinity.²⁶ However, it would be important to determine these parameters specifically for the cardiac myocytes in view of the extensive variability of receptors, presenting cell-specific and stage-specific distribution.⁸ In the context of the intracellular milieu furthermore, the N-terminal extension of the longer forms may contribute to different localization, protein associations, and thus function.¹¹

We have compared bFGF accumulation and composition in immature as well as adult rat¹² or chicken (unpublished observations) hearts. High- (20–23 kDa) as well as low- (18-kDa) molecular-weight bFGF was detected in both species, in both developmental stages. In both species, overall bFGF increased in adult relative to neonatal or embryonic hearts. The most striking observation, however, was that the higher molecular weight, presumably CUG-initiated bFGF, was the predominant species in the immature myocardium, while the low-molecular-weight bFGF was predominant in the adult, suggesting an association with a hyperplastic or hypertrophic phenotype, respectively.¹²

Thyroid status exercised a profound, negative influence on the accumulation

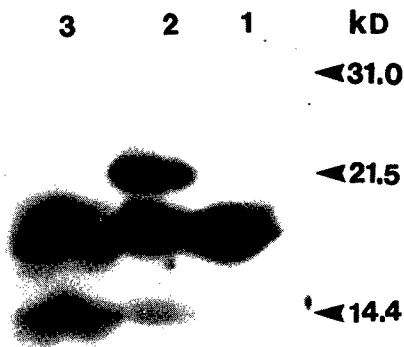

FIGURE 5. Detection of bFGFs in cultured chicken cardiomyocytes by Western blotting. Chicken myocytes were isolated from 7-day-old embryos^{3,4} and maintained for 4 days in 4% thyroid-hormone depleted fetal calf serum. Thyroid hormone (T₃; 10 nM) was then added to one-half of the cultures, and bFGF was analyzed 48 h later, after extraction and partial purification.^{1,27} *Lane 1*, recombinant human bFGF (5 ng), used as a positive control. *Lane 2*, bFGF-like peptides from "hypothyroid" myocyte cultures. *Lane 3*, bFGF-like peptides from T₃-treated myocyte cultures. Treatment with T₃ resulted in the disappearance of high-molecular-weight bFGF and the concomitant appearance of smaller immunoreactive fragments.

of high-molecular-weight bFGF in the heart, both *in vivo*¹² and *in vitro* (FIG. 5). Euthyroid rats were rendered either hyperthyroid, by daily injections of thyroxine for two weeks, or hypothyroid, by introducing propiothiouracil in their drinking water.¹² Examination of bFGF accumulation and composition revealed that hypothyroidism promoted a 5-fold increase in high-molecular-weight bFGF accumulation compared to euthyroid controls. A similar effect was seen in skeletal muscle but not in other organs such as brain or spleen, indicating a tissue-specific effect of thyroid status on bFGF accumulation. It appears that thyroid hormone may have a direct effect on myocyte bFGF variant composition. Cultured chicken cardiomyocytes, maintained in thyroid hormone-depleted serum were examined for bFGF accumulation as a function of thyroid hormone addition. As shown in FIGURE 5, low thyroid hormone levels promoted accumulation of equivalent levels of high- and low-molecular-weight bFGF, while addition of thyroid hormone resulted in complete disappearance of the high-molecular-weight species and appearance of smaller size fragments. While it is not yet known whether thyroid hormone has a tissue-specific effect on transcription, translation-initiation or posttranslational processing of bFGF, levels of this hormone in development very probably contribute to the accumulation of low-molecular-weight bFGF.

A transient increase in 21.5–22-kDa bFGF 24 hours after isoproterenol-induced cardiac injury, at a time of intense cellular infiltration and presumably proliferation in sites of myocyte degeneration was observed.¹⁴ It would therefore appear that transitions in bFGF variants occur and may play a role during cardiac development and injury, in a fashion implicating the high-molecular-weight species with a hyperplastic response.

To understand the potential role of intracellular bFGFs, we transfected primary cultures of chicken cardiomyocytes with rat bFGF cDNAs modified to yield high- (21.5–22-kDa) or low- (18-kDa) molecular-weight species.⁴ Western blotting confirmed expression of all of these bFGF forms and indicated that although percent transfection was similar in all instances, efficiency of translation for the 18-kDa bFGF was higher (over 10-fold) compared to that for the 21.5–22-kDa species;

as a consequence, only broad qualitative comparisons can be made from these experiments. Expression of either the 18- or the 21.5–22-kDa forms resulted in significant (3-fold) increase in cardiomyocyte labeling index, an 8-fold increase in total protein synthesis, but a 3-fold decrease in myosin accumulation, compared to controls. A summary of these results is shown in TABLE 1. No significant differences between the activities of the different bFGF species was detected, although they may have been masked, since the overall concentration of the 21.5–22-kDa bFGF was lower than that of the 18-kDa species. The decrease in overall myosin accumulation (and synthesis, unpublished observations) was unexpected. It did not reflect an increase in nonmuscle cells. As seen in FIGURE 6, a myocyte overexpressing the CUG-initiated form of bFGF which was localized to the nucleus (see also comments below), identified by the intense nuclear anti-bFGF fluorescence, displayed decreased (but not absent) anti-striated myosin staining. It is hypothesized that this decrease in myosin, the main structural element of myofibrils, may represent a necessary step of disorganization in preparation for the mitotic process.

Subcellular localization of bFGF in the transfected myocyte cultures was assessed by immunofluorescence microscopy. Overexpression of cDNAs yielding 21.5–22- or 18-kDa bFGF resulted in predominantly nuclear or both cytoplasmic as well as nuclear bFGF localization.^{4,27} Western blotting detection of bFGF from nuclear extracts confirmed presence of rat bFGFs in nuclei.⁴ A striking difference was detected in the morphology of nuclear chromatin: overexpression of 21.5–22-kDa bFGF was associated with the formation of multiple DNA-containing “clumps” resembling condensed chromatin (FIG. 7). This phenomenon was not observed in myocytes overexpressing the 18-kDa bFGF.⁴ In most nuclei of overexpressing cells, the pattern of chromatin clumping or fragmentation resembled somewhat that of a prophase nucleus (FIG. 7). In some instances, however, (FIG. 7c), it appeared as if chromatin has been degraded (resembling the pattern seen in apoptotic nuclei). At the very least these data indicate that high- and low-molecular-weight bFGF have different physical effects in the nucleus and thus may play a different role in the same location *in vivo*. An involvement of the 21.5–22-kDa bFGF with the processes of chromosomal condensation as well as apoptosis can also be hypothesized. It should be noted that endogenous bFGF is localized in close association with chromatin during early prophase in the chicken,²⁸ a finding offering support to the notion of this molecule participating intimately in nuclear as well as cellular division.

We have begun similar experiments using primary cultures of rat cardiomyocytes. Pattern of localization of overexpressed bFGFs was similar to that of chicken cells: The 21.5–22-kDa bFGF localized to the nucleus while the 18-kDa species was found in both nucleus and cytoplasm (FIGS. 8, 9). Chromatin “clumping” was not detectable in this case. This may reflect a species difference in the role of bFGF or may be a consequence of lower levels of expression/transfection achieved in the rat compared to chicken myocytes. The notion of a species difference is favored by the pattern of localization of endogenous intracellular bFGF which differs between chicken and rat myocytes. In the latter, bFGF was seen around the nucleus, in association with gap junctions as well as Z-lines,^{13,29} while intranuclear staining was variable. In the chicken, bFGF was not detectable

TABLE 1. Effects of Transfection with Modified bFGF cDNAs on Chicken Cardiac Myocyte Growth^a

Transfected Genes	³ H-Thymidine Incorporation (dpm × 10 ⁻²)	Labeling Index (%)	Cell Number (× 10 ⁻⁴)	PAS Positive Cells	³⁵ S-Methionine Incorporation (dpm × 10 ⁻⁴)	Relative Myosin Levels
RSVp (control)	8.42 ± 0.71	11.46 ± 2.99	13.0 ± 1.1	50.0 ± 3.7	3.78 ± 1.39	100.0 ± 14.0
RSVp.ΔmetFGF (21.5-22 kD)	18.19 ± 3.32	45.39 ± 6.80	42.0 ± 5.9	101.8 ± 8.0	31.10 ± 9.86	35.0 ± 9.0
RSVp.metFGF (18 kD)	21.75 ± 4.15	41.36 ± 2.74	32.0 ± 5.1	108.6 ± 12.0	31.11 ± 8.95	32.5 ± 12.0
RSVp.FGF (18 ± 21.5-22 kD)	15.54 ± 2.59	31.80 ± 1.28	28.3 ± 5.5	104.6 ± 18.9	25.20 ± 8.47	47.0 ± 8.0

^a Rat bFGF cDNAs were designed, encoding only 21.5-22 kDa (RSVp.ΔmetFGF), or 18 kDa (RSVp.metFGF), or 18 kDa as well as 21.5-22 kDa (RSVp.FGF) bFGF species and they were introduced into cultured embryonic chicken myocytes by gene transfer.⁴ DNA synthesis was assessed 48 h after transfection by determination of tritiated thymidine incorporation. Transfection with all forms of bFGF resulted in statistically significant (~2.6-fold) thymidine incorporation compared to controls. A combination of histochemistry and *in situ* autoradiography was used to obtain a Labeling Index (LI) (*i.e.*, the proportion of PAS positive/glycogen-granite rich cells—myocytes—that also show presence of tritiated thymidine). An overall ~3.5-fold increase in LI compared to controls was detected after transfection with all forms of bFGF. Overall cell number as well as myocyte cell number increased at least 2-fold in cultures overexpressing all forms of bFGF. PAS positive cells—myocytes—were scored in 12 random fields per coverslip (n = 4). Protein synthesis was assessed by measuring incorporation of ³⁵S-methionine into the cultures.⁴ A significant, ~8-fold, increase in protein synthesis was observed in all instances. Myosin levels, however, assessed by SDS-PAGE in combination with immunoblotting with myosin antibodies, showed a 3-fold decrease, compared to controls, in cultures overexpressing all forms of bFGF. There were no statistically significant differences between the effects of ΔmetFGF versus metFGF overexpression, in any of the parameters assessed.⁴

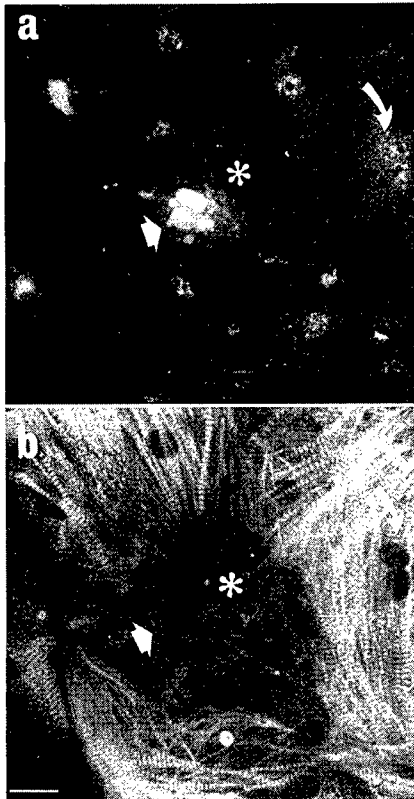

FIGURE 6. Detection of bFGF (a) and striated muscle myosin (b) by double-immunofluorescence labeling of chicken myocyte cultures transfected with RSVp. Δ metFGF, 48 h after transfection. Chicken myocytes were obtained from 5-day old embryonic hearts, and cultured as described.^{3,4} Overexpressed high-molecular-weight bFGF is localized to the nucleus (indicated by *asterisk*). Myosin content is dramatically (but not totally) reduced in the transfected myocyte, compared to its neighbours. *Bar* = 25 μ m.

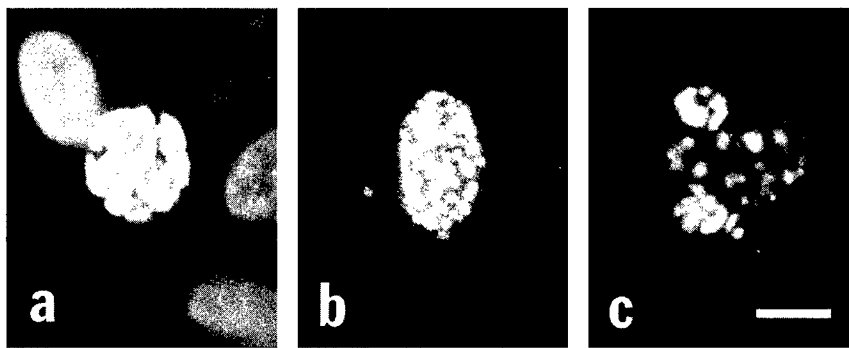

FIGURE 7. Chromatin morphology in nuclei of chicken cardiomyocytes stained with Hoechst 33342. (a) Prophase nucleus in untransfected, control cultures. (b) and (c) Nuclei overexpressing 21.5–22-kDa rat bFGF, in cultures transfected with RSVp. Δ metFGF. Overexpression of 21.5–22-kDa bFGF resulted in chromatin condensation, fragmentation, and apparently chromatin degradation in a fraction of nuclei. *Bar* = 20 μ m.

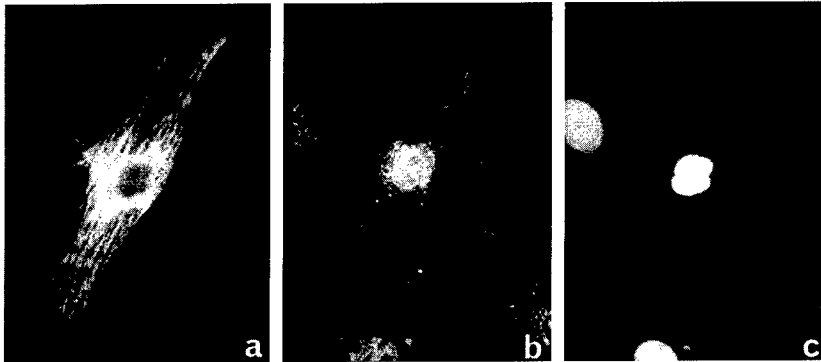

FIGURE 8. Micrographs of rat neonatal cardiomyocytes transfected with RSVp. Δ metFGF. Cells are triple-stained for (a) striated muscle myosin, (b) bFGF, and (c) nuclear DNA. High-molecular-weight bFGF is localized to the nucleus of transfected cells (endogenous bFGF is barely detectable above background at the dilution of anti-bFGF serum used). Antibodies used and conditions for immunofluorescence have been described.^{1,4}

around the nucleus or in gap junctions, but was seen inside the nucleus and Z-lines.^{28,29} In addition bFGF was found to be associated with the chromosomes during prophase and early metaphase, and with the cleavage furrow in the later stages of mitosis,²⁸ a pattern not seen in rat cells.

To examine for potential differences in the ability of high- and low-molecular-weight bFGF to stimulate DNA synthesis in rat myocytes, we performed double immunofluorescent labeling of transfected myocyte cultures for bFGF and for bromodeoxyuridine (BrdU); the latter becomes incorporated to the nuclei of cells actively synthesizing DNA. The fraction of myocytes synthesizing DNA increased by 40% or 83%, compared to controls, in cultures transfected with the 18-kDa or 21.5–22-kDa bFGF-yielding cDNAs, respectively. FIGURE 9 shows rat cardiomyocytes overexpressing the 18- or 21.5–22-kDa bFGF's (as verified by intense anti-bFGF staining) which have been counterstained for BrdU. BrdU-positive nuclei are clearly seen in the latter (FIG. 9f).

Data from both rat and chicken are consistent with the notion that the high-molecular-weight bFGF, an intracellular nuclear molecule, plays an active role in cardiomyocyte proliferation, possibly promoting chromosomal condensation (chicken) and DNA synthesis (rat). It follows that factors favoring accumulation of this particular bFGF species may also promote cell division. Of potential physiological interest is the observation that tissues express proteases that are capable of limited proteolysis of the N-terminal extension of bFGF, converting the high- to low-molecular-weight forms, and that this proteolysis is calcium dependent.³⁰

FIGURE 10 represents an attempt to integrate current evidence on the subcellular localization and possible roles of the 18 and 21.5–22-kDa bFGF, in the context of the cardiac myocyte. It is worth noting that the activity of bFGF is considered to be regulated largely at the level of bioavailability rather than de novo synthesis,⁷ a notion rendering its subcellular localization and local interactions particularly pertinent. Translation from the CUG start site will produce the 21.5–22-kDa bFGF

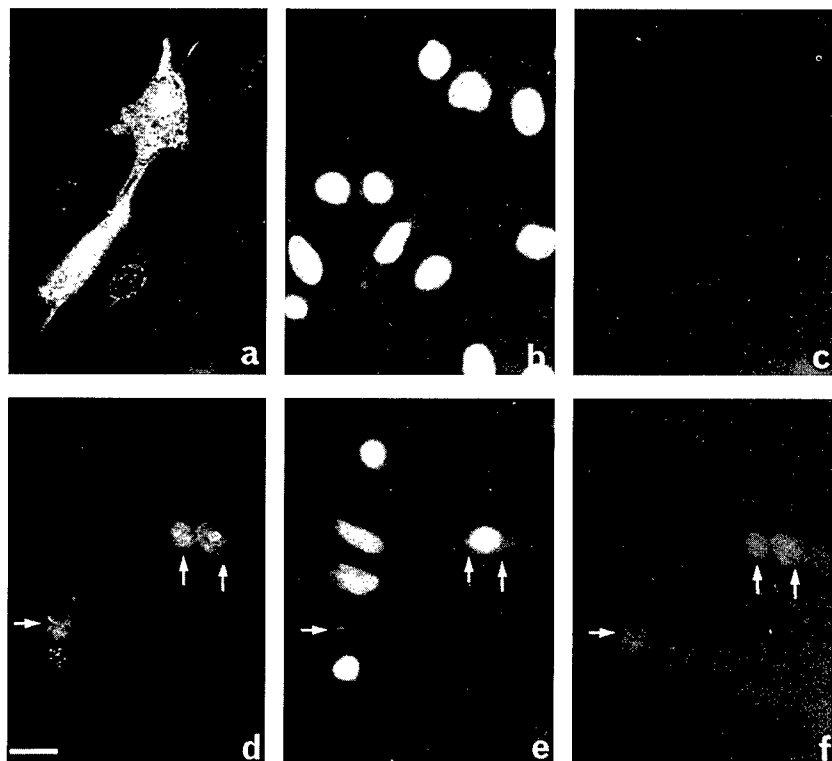

FIGURE 9. Probing for DNA-synthesizing nuclei in neonatal rat ventricular myocytes transfected with low- or high-molecular-weight bFGF genes (RSVp.metFGF or RSVp.ΔmetFGF, respectively). Cells transfected with RSVp.metFGF (a,b,c) or RSVp.ΔmetFGF (d,e,f) were stained simultaneously for bFGF (a,d), nuclear DNA (b,e), and bromodeoxyuridine (c,f). Anti-bromodeoxyuridine antibodies, detecting DNA-synthesizing nuclei, were purchased from Amersham Corp. Basic FGF was localized to the nucleus as well as the cytoplasm of cells overexpressing the low-molecular-weight bFGF; overexpressing nuclei were not stained for bromodeoxyuridine. In contrast, nuclei in cells overexpressing the high-molecular-weight bFGF displayed anti-bromodeoxyuridine reactivity. *Bar* = 20 μ m.

which will then become mainly localized to the nucleus, thereby favoring a program of gene expression related to a hyperplastic response. This form can be converted to the 18-kDa species by proteolysis; since this proteolysis is calcium-dependent³⁰ it may be linked to events associated with calcium transients, for instance, contractility or mitosis. The 18-kDa bFGF can also be produced by AUC-initiated translation. It can be targeted to several sites, such as the nucleus, where, in conjunction with other signals is likely favoring a program of gene expression more suited to a hypertrophic phenotype. An exocytotic process has been speculated as transporting bFGF to the extracellular space.³¹ There bFGF will be bound by HSPGs in the matrix as well as the cell surface. Depending on the

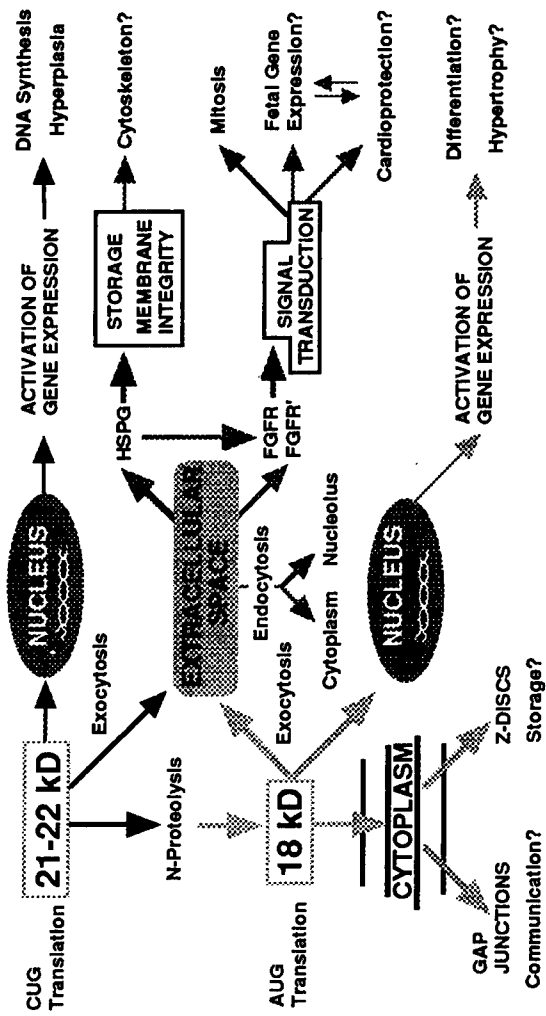

FIGURE 10. Hypothetical fate of high- and low-molecular-weight bFGF expressed by cardiac myocytes.

type of HSPG expressed at the particular time point, bFGF can remain "stored," inaccessible to the tyrosine kinase receptors, or it can be "presented" to the latter in a conformation that promotes ligand-receptor interaction and the subsequent signal transduction cascades, linked to stimulation of DNA synthesis and differentiation.³² Basic FGF can be internalized via the HSPG "receptors" and reach the lysosomal compartment,³³ or via the high-affinity receptors and reach the nucleus, where it is suggested that it will be targeted to the nucleolus and be involved in stimulation of transcription of genes encoding ribosomal RNA.¹¹ In the cytoplasm, bFGF is associated with perinuclear membrane systems (likely rough ER and Golgi), the gap junctions and the Z-lines; although an active functional/structural role in these sites cannot be excluded, these locals may serve as storage sites, "releasing" bFGF to the cytoplasm upon appropriate stimulation.

CONCLUDING REMARKS

We have identified several changes in the expression of bFGF and FGFR which may be important in regulating the transition from a hyperplastic to a hypertrophic phenotype. The abundance of FGFR declines during the very important first two postnatal weeks, an event which would be expected to make myocytes less responsive to extracellular bFGF mitotic stimulation. At the same time, thyroid hormone levels in the blood increase, an event which would also be expected to reduce the bFGF-induced mitotic response,³ either directly or indirectly, for instance, by stimulating increased TGF β expression.³⁴ Basic FGF as well as FGFR isoform transitions also occur during this time; thyroid hormone likely causes the transition from the proliferation-associated, nuclear 21.5–22-kDa bFGF to the "adult-phenotype"-associated 18-kDa species.¹² The transition to the smaller FGFR1-like form seen in adult myocytes is expected to serve a function relevant to the adult cardiac physiology. It remains to be seen whether manipulating bFGF and/or FGFR expression in the myocardium can bring about changes that would stimulate or contribute to a regenerative response by adult cardiomyocytes.

ACKNOWLEDGMENTS

The technical assistance of Robert R. Fandrich and Margaret E. Bock is gratefully appreciated.

REFERENCES

1. KARDAMI, E. & R. R. FANDRICH. 1989. Basic fibroblast growth factor in atria and ventricles of the vertebrate heart. *J. Cell Biol.* **109**: 1865–1875.
2. PARKER, T. G. & M. D. SCHNEIDER. 1991. Growth factors, protooncogenes, and plasticity of the cardiac phenotype. *Annu. Rev. Physiol.* **53**: 179–200.
3. KARDAMI, E. 1990. Stimulation and inhibition of cardiac myocyte proliferation *in vitro*. *Mol. Cell. Biochem.* **92**: 129–135.
4. PASUMARTHI, S. K. B., B. W. DOBLE, E. KARDAMI & P. A. CATTINI. 1994. Overexpression of CUG- and AUG-initiated forms of basic fibroblast growth factor in cardiac

- myocytes results in similar effects on mitosis and protein synthesis but distinct nuclear morphologies. *J. Mol. Cell. Cardiol.* **26**: 1045–1060.
5. CLAYCOMB, W. C. 1992. Control of cardiac myocyte cell division. *Trends Cardiovasc. Med.* **2**: 231–234.
 6. BASILICO, C. & D. MOSCATELLI. 1992. The FGF family of growth factors and oncogenes. *Adv. Cancer Res.* **59**: 115–165.
 7. BAIRD, A. 1994. Fibroblast growth factors: activities and significance of nonneurotrophin neurotrophic growth factors. *Curr. Opin. Neurobiol.* **4**: 78–86.
 8. JOHNSON, D. E. & L. T. WILLIAMS. 1993. Structural and functional diversity in the FGF receptor multigene family. *Adv. Cancer Res.* **60**: 1–41.
 9. RAPRAEGER, A. C., A. KRUFKS & B. B. OLWIN. 1991. Requirement of heparan sulfate for bFGF-mediated fibroblast growth and myoblast differentiation. *Science* **252**: 1705–1708.
 10. LOGAN, A. 1990. Intracrine regulation in the nucleus: a further mechanism for growth factor activity? *J. Endocrinol.* **125**: 339–343.
 11. AMALRIC, F., G. BOUCHE, H. BONNET, P. BRETHENOU, A.-M. ROMAN, I. TROUCHET & N. QUARTO. 1994. Fibroblast growth factor-2 (FGF-2) in the nucleus: translocation process and targets. *Biochem. Pharmacol.* **47**: 111–115.
 12. LIU, L., B. W. DOBLE & E. KARDAMI. 1993. Peripheral phenotype and hypothyroidism are associated with elevated levels of 21.5- to 22-kDa basic fibroblast growth factor in cardiac ventricles. *Dev. Biol.* **157**: 507–516.
 13. KARDAMI, E., R. M. STOSKI, B. W. DOBLE, T. YAMAMOTO, E. L. HERZBERG & J. I. NAGY. 1991. Biochemical and ultrastructural evidence for the association of basic fibroblast growth factor with cardiac gap junctions. *J. Biol. Chem.* **266**: 19551–19558.
 14. PADUA, R. R. & E. KARDAMI. 1993. Increased basic fibroblast growth factor (bFGF) accumulation and distinct patterns of localization in isoproterenol-induced cardiomyocyte injury. *Growth Factors* **8**: 291–306.
 15. ANDERSON, J. E. & E. KARDAMI. 1991. Distinctive patterns of bFGF distribution in degenerating and regenerating areas of dystrophic (mdx) striated muscles. *Dev. Biol.* **147**: 96–109.
 16. PADUA, R. R., R. SETHI, N. S. DHALLA & E. KARDAMI. 1993. Hearts supplemented with basic fibroblast growth factor display increased recovery from ischemia-reperfusion injury. *FASEB J.* **7**: A122.
 17. ANVERSA, P., T. PALACKAL, E. H. SONNENBLICK, G. OLIVETTI, L. G. MEGGS & J. M. CAPASSO. 1990. Myocyte cell loss and myocyte cellular hyperplasia in the hypertrophied aging rat heart. *Circ. Res.* **67**: 871–885.
 18. PATSTONE, G., E. B. PASQUALE & P. A. MAHER. 1993. Different members of the fibroblast growth factor receptor family are specific to distinct cell types in the developing chicken embryo. *Dev. Biol.* **155**: 107–123.
 19. ENGELMAN, G. L., C. A. DIONNE & M. C. JAYE. 1993. Acidic fibroblast growth factor and heart development. Role in myocyte proliferation and capillary angiogenesis. *Circ. Res.* **72**: 7–19.
 20. LIU, L., S. K. B. PASUMARTHI, R. R. FANDRICH, G. N. PIERCE, P. A. CATTINI & E. KARDAMI. 1993. Basic FGF receptors are expressed by proliferative, immature as well as differentiated cardiac myocytes. *FASEB J.* **7**: A780.
 21. JIN, Y., S. K. B. PASUMARTHI, E. M. BOCK, A. LYTRAS, E. KARDAMI & P. A. CATTINI. 1994. Cloning and expression of fibroblast growth factor receptor-1 isoforms in the mouse heart. *J. Mol. Cell. Cardiol.* **26**: 1449–1459.
 22. UENO, H., M. B. PERRYMAN, R. ROBERTS & M. D. SCHNEIDER. 1988. Differentiation of cardiac myocytes after mitogen withdrawal exhibits three sequential states of the ventricular growth response. *J. Cell Biol.* **107**: 1911–1918.
 23. MOSCATELLI, D., R. FLAUMENHAFT & O. SAKSELA. 1991. Interaction of basic fibroblast growth factor with extracellular matrix and receptors. *Ann. N. Y. Acad. Sci.* **638**: 177–181.
 24. FLORKIEWICZ, R. Z. & A. SOMMER. 1989. Human basic fibroblast growth factor gene encodes four polypeptides: three initiate translation from non-AUG codons. *Proc. Natl. Acad. Sci. USA* **86**: 3978–3981.

25. IBERG, N., S. ROGELJ, P. FANNING & M. KLAGSBRUN. 1989. Purification of 18- and 22-kDa forms of basic fibroblast growth factor from cells transformed by the ras oncogene. *J. Biol. Chem.* **264**: 19951–19955.
26. RENKO, M., N. QUARTO, T. MORIMOTO & D. B. RIFKIN. 1990. Nuclear and cytoplasmic localization of different basic fibroblast growth factor species. *J. Cell. Physiol.* **144**: 108–114.
27. KARDAMI, E., R. R. PADUA, K. B. S. PASUMARTHI, L. LIU, B. W. DOBLE, S. E. DAVEY & P. A. CATTINI. 1993. Expression, localisation and effects of basic fibroblast growth factor on cardiac myocytes. *In Growth Factors and the Cardiovascular System*. P. Cummins, Ed. 55–76. Kluwer Academic Publishers. Boston, Dordrecht, London.
28. KARDAMI, E. & L. LIU. 1991. Anti-bFGF labeling of cardiac myocytes during mitosis, *in vitro*. *J. Mol. Cell. Cardiol.* **23**(Suppl. III):S54.
29. KARDAMI, E., L. LIU & B. W. DOBLE. 1991. Basic fibroblast growth factor in cultured cardiac myocytes. *Ann. N. Y. Acad. Sci.* **638**: 244–255.
30. DOBLE, B. W., R. R. FANDRICH, L. LIU, R. R. PADUA & E. KARDAMI. 1990. Calcium protects pituitary basic fibroblast growth factor from limited proteolysis by co-purifying proteases. *Biochem. Biophys. Res. Commun.* **173**: 1116–1122.
31. D'AMORE, P. A. 1990. Modes of FGF release *in vivo* and *in vitro*. *Cancer Metastasis Rev.* **9**: 227–238.
32. AVIEZER, D., E. LEVY, M. SAFRAN, C. SVAHN, E. BUDDECKE, A. SCHMIDT, G. DAVID, I. VLODASKY & A. YAYON. 1994. Differential structural requirements of heparin and heparan sulfate proteoglycans that promote binding of basic fibroblast growth factor to its receptor. *J. Biol. Chem.* **269**: 114–121.
33. REILAND, J. & A. C. RAPRAEGER. 1993. Heparan sulfate proteoglycan and FGF receptor target basic FGF to different intracellular destinations. *J. Cell Sci.* **105**: 1085–1093.
34. YAO, J. & M. EGHBALL. 1992. Decreased collagen gene expression and absence of fibrosis in thyroid hormone-induced myocardial hypertrophy. Response of cardiac fibroblasts to thyroid hormone *in vitro*. *Circ. Res.* **71**: 831–839.

Multifactorial Regulation of Cardiac Gene Expression: an *In Vivo* and *In Vitro* Analysis^a

J. L. SAMUEL, I. DUBUS, F. FARHADIAN, F. MAROTTE,
P. OLIVIERO, A. MERCADIER, F. CONTARD, A. BARRIEUX,
AND L. RAPPAPORT^b

*U. 127 INSERM
I.F.R. Circulation
Hôpital Lariboisière
41, Boulevard Chapelle
75010 Paris, France*

INTRODUCTION

Ventricular hypertrophy observed in response to chronic arterial hypertension results from the hypertrophy of cardiomyocytes, the hyperplasia of nonmuscle cells such as fibroblasts and vascular cells and an accumulation of extracellular matrix (ECM) components leading to the development of interstitial and perivascular fibrosis. The hypertrophic process is associated with qualitative changes in the expression of genes encoding both contractile proteins specifically synthesized by striated (see review in Ref. 1) and smooth muscle cells,² and ECM proteins synthesized by nonmuscle and smooth muscle cells.³⁻⁷ The extracellular matrix is more dynamic than previously assessed.^{8,9} The primary role of cardiac ECM is to support the tridimensional organization of myocytes and capillary network (for reviews see Refs. 10,11). In other organs, ECM has been shown to modulate the morphology and the phenotype of neighboring cells¹²⁻¹⁴ and functions as receptor, protector, inactivator and storage ligand for growth factors.¹⁵ Among the ECM proteins, fibronectin serves as a bridge between cells and the collagen network^{14,16,17} and also modulates diverse cellular activities including growth, adhesion and migration during development and wound repair.¹⁴

There is increasing evidence that the changes in gene expression observed in the myocardium during pathological growth are triggered by a cascade of events including mechanical, humoral and hormonal factors.^{1,5,18,19} One hypothesis is that a primary event, which may be passive stretch, shear stress or circulating hormones such as angiotensin II, induces the local synthesis of growth factors and cytokines, which are trapped in the ECM at the site of secretion and trigger the

^a This work was supported by INSERM, CNRS, and grants from the Fondation de France, the Association Française contre les Myopathies, and the European Union (Biomed). A. Barrieux and I. Dubus were fellows from the Fondation de la Recherche Médicale and AFM, respectively.

^b Corresponding author.

phenotypic changes occurring in the responsive cells. The increased expression of several growth factors has been described in the heart and associated to tissular growth and lesion.²⁰⁻²³ Cultured neonatal cardiac myocytes are sensitive to some of these growth factors; for example bFGF or TGF β 1 elicit the reexpression of their fetal phenotype,^{19,24} and specific, as yet undefined peptides synthesized by cardiac fibroblasts stimulate their hypertrophic growth.²⁵ Moreover nonmuscle cells such as endocardial and endothelial cells have been shown to synthesize peptides which influence the contractility of the adult cardiomyocytes.^{26,27} Taken together, these data lead to the concept of a cross talk between the myocytes and other cardiac cells. Whether such a "cross talk" exists between the ventricular muscle and nonmuscle cells during the development of cardiac hypertrophy has not been investigated.

To obtain insight into the concept of cellular "cross talk" during the development of pressure overload-induced cardiac hypertrophy, we have analyzed the temporal and spatial alterations that might occur *in vivo* in the phenotype of both cardiocytes and vascular cells during the early stages of cardiac hypertrophy secondary to a sudden pressure overload. Two gene products, the β -myosin heavy chain (β -MyHC), a major contractile protein and cellular EIIIA-, EIIIB-fibronectins (FN), an ECM component, were chosen as specific markers, since i) they are synthesized by striated cardiomyocytes¹ and smooth muscle cells,^{5,6} respectively, ii) each represents the isoform expressed in fetal heart and is developmentally regulated,^{1,14,28} and iii) both are known to be absent in the normal adult rat heart but to be reexpressed during pathological cardiac growth.^{1,5,18,28} In the second part of the study we investigated *in vitro* the effects of hormones, mechanical activity and the growth factors, bFGF and TGF β on the phenotype of cultured adult cardiac myocytes.

Using *in situ* hybridization and immunolabeling approaches, we demonstrated that within the first week after aortic coarctation, the FN mRNA accumulates in the smooth muscle cells of the coronary arteries of both ventricles, whereas β -MyHC mRNA is reexpressed in the cardiomyocytes surrounding these vessels. Since the secretion of FN occurred later than β -MyHC induction, we postulate that cFN does not by itself regulate myocyte gene expression. Whether the same factors coordinate the reexpression of FN-EIIIA and -EIIIB mRNA in the smooth muscle cells and of β -MyHC in the cardiomyocytes remains unclear. Using cultures of isolated adult rat cardiomyocytes we observed that either isoproterenol or bFGF stimulates total protein synthesis, whereas contractile activity and TGF β do not. The expression of a specific gene product, β -MyHC, is under a different set of controls: the β -adrenergic agonist decreased, contractile activity dramatically increased, whereas bFGF does not modify β -MyHC mRNA levels. The multifactorial regulation of the MyHC expression is thus demonstrated in isolated adult cardiocytes and shown not to be related to total protein synthesis.

MATERIAL AND METHODS

Animals

Twenty 5-day-old female Wistar rats were submitted to a coarctation of thoracic aorta, the animals were sacrificed from 3 hours to 20 days after surgery, and

the hearts were trimmed of the great vessels, and weighed.¹⁸ Ventricles were transversely cut, and frozen in isopentane precooled with liquid nitrogen. Tissue blocks were maintained at -70°C until use for cryosectioning.

Culture of Adult Rat Cardiocytes

Adult male Wistar rats weighing 200–250 g were used. Cardiac myocytes were isolated and plated on laminin-coated 25-cm² flasks (Falcon) or 2-well Labtek chambers (Nunc) as previously described.^{29,33} The culture medium was BM86 Wissler (Boehringer Mannheim), supplemented with penicillin 100 UI/l, streptomycin 0.1 mg/l, insulin 10 pM and transferrin 5 mg/ml. The myocytes were cultured for 1–3 days in the presence or absence of 0.1 nM T3 and/or various agonists (10 nM isoproterenol, 25 ng/mL bFGF, 1 ng/ml TGF β 1, 0.1 nM angiotensin II) with daily medium changes. In some experiments, mechanical activity of the myocytes was induced by a 24-hour electrical stimulation (2 Hz).

Measure of Total Protein Synthesis

Protein synthesis in cultured myocytes was estimated by measuring the incorporation of L-[¹⁴C] phenylalanine (1 $\mu\text{Ci/ml}$ of culture medium) into total trichloroacetic acid-precipitable cellular proteins over a 24-hour incubation period.³³ Results were expressed in ¹⁴C-dpm per μg of total protein.

Immunolabelings

Cryosections (5 μm) were incubated overnight at 4°C with monoclonal antibodies directed against FN-EIIIA (kindly provided by Dr. Zardi, Italy) diluted 1/100 in PBS containing 2% rat serum, rinsed 3 times at room temperature (RT) in PBS, and incubated for 30 min at RT with biotinylated anti-mouse IgGs (1/200, Vector Laboratories). The biotinylated antibodies were revealed with a streptavidin-Texas Red complex (1/50 dilution in PBS, Amersham). After 3 washing steps, the sections were mounted in aqueous medium (Fluoprep, BioMérieux). Fluorescence was visualized using a Leitz microscope equipped with epifluorescence optics (Leica).

In Situ Hybridization

Probes

cRNA probes used for *in situ* hybridization were prepared from the chimeric plasmids containing rat α -MHC, β -MyHC,¹⁸ human FN-type I FN-EIIIA and FN-EIIB⁵ cDNAs and labeled with [³⁵S]UTP (Dupont de Nemours) as previously described.^{5,18}

Preparation of Tissue Sections and Cells

Serial cryosections (5 μm thick) and cultured myocytes were fixed in 4% paraformaldehyde for 5 min, washed in PBS (2 \times 5 min), then dehydrated in ethanol and stored at -70°C with dessicant until used for *in situ* hybridization. All the slides derived from the same set of culture were processed together for *in situ* hybridization with cRNA probes specific for α - and β -MyHC mRNAs.

In Situ Hybridization

Slides with cardiac sections or myocytes were rehydrated, fixed a second time in 4% paraformaldehyde, and washed twice in PBS. They were then treated with 20 $\mu\text{g}/\text{ml}$ proteinase K (Sigma Chemical, St. Louis, MO) in 50 mM Tris, 5 mM EDTA, pH 8.0 followed by acetic anhydride (250 $\mu\text{l}/\text{ml}$ in 0.1 M triethanolamine, pH 8.0), and dehydrated again. The radioactive antisense RNA probes diluted to 50,000 cpm/ μl in the hybridization medium^{5,18} were dispensed in 8- μl aliquots onto the section or each well of the Labtek chambers. Slides were incubated in a wet chamber at 50°C overnight. After washing under stringent conditions (50% formamide, 2 X SSC, 0.1 M dithiothreitol at 65°C for 20 min), unhybridized cRNA was digested with 20 $\mu\text{g}/\text{ml}$ RNase (Sigma Chemical) at 37°C for 30 min, and the slides were washed successively in 2 X and 0.1 X SSC at room temperature. The slides were then dehydrated and covered with Kodak NTB2 nuclear track emulsion (Eastman Kodak, Rochester, NY). After 7 to 9 days of exposure, slides were developed in Kodak D19. For each probe the controls of specificity were performed. Sense RNA probes were synthesized and labeled as antisense probes, and we verified that only a low background was obtained when each sense probe was used for *in situ* hybridization (not shown, see Refs. 5,18).

Quantitation of the Hybridization Signal

Dark-field images magnified 100-fold were recorded using a CCD videocamera (Hamamatsu C2400) and a computer (MacIntosh fx) equipped with Optilab software (Graphtek). All the slides were recorded under identical microscope lighting and camera settings as previously described.²⁹ A minimum of 100 cells from 6–10 fields were randomly analyzed per slide.

Statistical Analysis

In *in situ* hybridization experiments, the intensities of the hybridization signals with each probe are not normally distributed; therefore, the Mann-Whitney non-parametric test was used to compare the mean density at each experimental point. A significant difference was said to exist when p was less than 0.05.

RESULTS

Distribution of β -MyHC and FN mRNA in the Ventricular Wall after Aortic Stenosis

In the normal heart of 26-day-old rats neither FN mRNA (FIG. 1) nor β -MyHC mRNA^{18,28} is detectable in the ventricular wall. Thoracic aortic stenosis provides a well-defined and reproducible experimental model of cardiac hypertrophy.¹⁸ One day after surgery, the degree of hypertrophy is rather small (12%). At this stage the major changes detected in FN mRNA accumulation occurred in the blood vessels (FIG. 1). Each of the 3 FN probe type I, EIIIA or EIIIB generated a

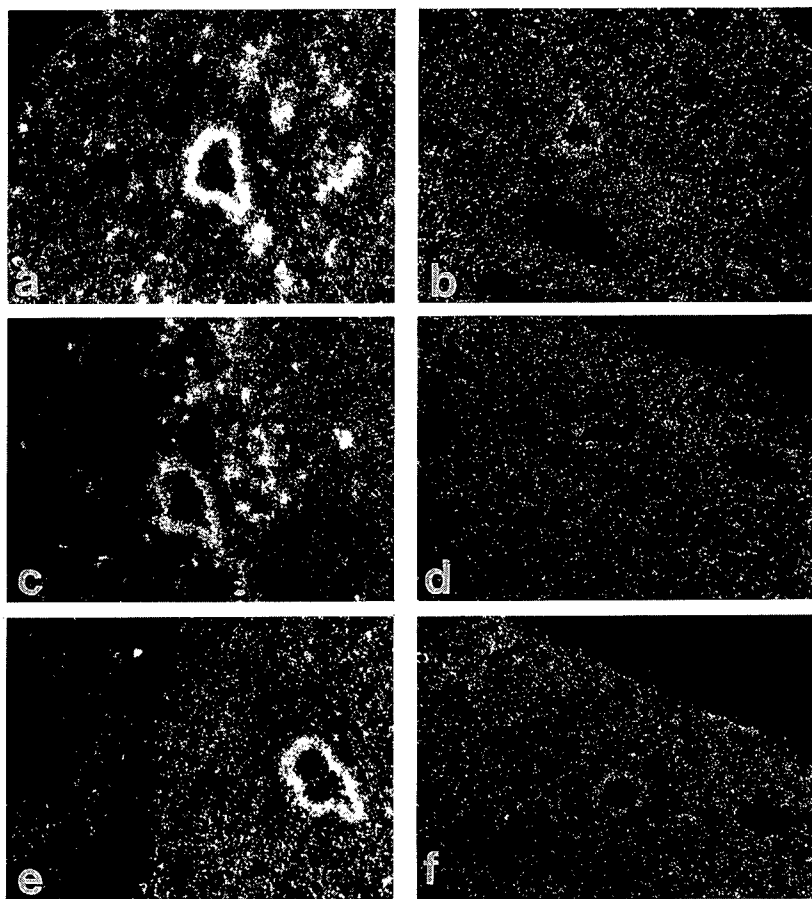

FIGURE 1. FN mRNAs accumulate within rat myocardium as early as 1 day after thoracic aortic stenosis. Serial sections from operated (a,c,e) and normal animals (b,d,f) were hybridized with FN-I (a,b), FN-EIIIA (c,d), and FN-EIIIB (e,f) probes. A strong signal is obtained with all the probes in the coronary wall of the operated animal. ($\times 100$.)

strong positive signal, mainly in the media of all arteries, of both the left and right ventricles, regardless of the size or the location of the vessels. No specific labeling was observed in the adventitial tissue. The myocardium surrounding the vessels did not react with the FN-EIIIB probe but was reactive with the FN-EIIIA probe, which gave strong, spotty signals scattered throughout the myocardial layer; the hybridization signal was not localized over the myocytes, and most probably corresponded to the interstitial tissue. At this stage β -MyHC mRNA was poorly detected and α -MyHC mRNA was the major MyHC mRNA isoform expressed by the cardiomyocytes.¹⁸

By day 5 after aortic stenosis, the degree of cardiac hypertrophy was >35%. The myocytes that surrounded the coronary arteries were the first to express β -MyHC mRNA (Ref. 18 and FIG. 2). FIGURE 2 shows that the accumulation of β -MyHC and FN mRNAs became spatially coordinated. At this time, the media of the coronary arteries still reacted strongly with the 2 FN-EIIIA and FN-EIIIB probes, but, in addition, the previously negative adventitia was now labeled with both probes (FIG. 2). Immunostaining of corresponding serial sections with antibodies specific for the EIIIA repeat failed to detect the cellular form of the FN protein in either the media or the interstitial tissue (FIG. 2). Two weeks after surgery, when cardiac hypertrophy reached more than 80%, FN mRNA was no longer detectable in the media of the coronary arteries but still accumulated strongly in the adventitia (FIG. 3). At that time, the EIIIA isoform of the protein, was detected by immunolabeling only in the media (FIG. 3). Thus it clearly emerges from FIGURES 1–3 that the distribution of the various isoforms of mRNA coding for FN observed between 1 and 15 days are spatially and temporally coordinated after imposition of pressure overload; the cellular form of FN mRNA appearing first in the media where it is expressed transiently, then in the adventitia where it is still expressed 15 days after aortic coarctation. The protein isoform encoded by EIIIA mRNA appeared later. A progressive gradient of FN expression occurs from the lumen of the arteries toward the adventitia as cardiac hypertrophy develops.

A semiquantitative analysis of the time course of accumulation and distribution of the FN mRNA is summarized in TABLE 1 and indicates that FN mRNA was transiently detected in the coronary arterial wall from day 1 to day 15 after surgery.

Modulation of Adult Cardiomyocyte Phenotype In Vitro

The spatial and temporal gradient observed between the distribution of FN mRNAs and the accumulation of β -MyHC mRNAs suggests that smooth muscle, adventitial and striated muscle cells respond to the same signal(s) that would diffuse progressively throughout the arterial and ventricular wall. It cannot be excluded, however, that the signal levels are similar throughout the tissue but that the threshold for the upregulation of the genes in these different cell types is different. Alternatively the triggers might be cell-specific. In order to identify the signal(s) responsible for the trophic responses and upregulation the β -MyHC gene in adult ventricular cells, we have investigated the effect of contractile activity and of selected putative hormones and growth factors on the induction of protein

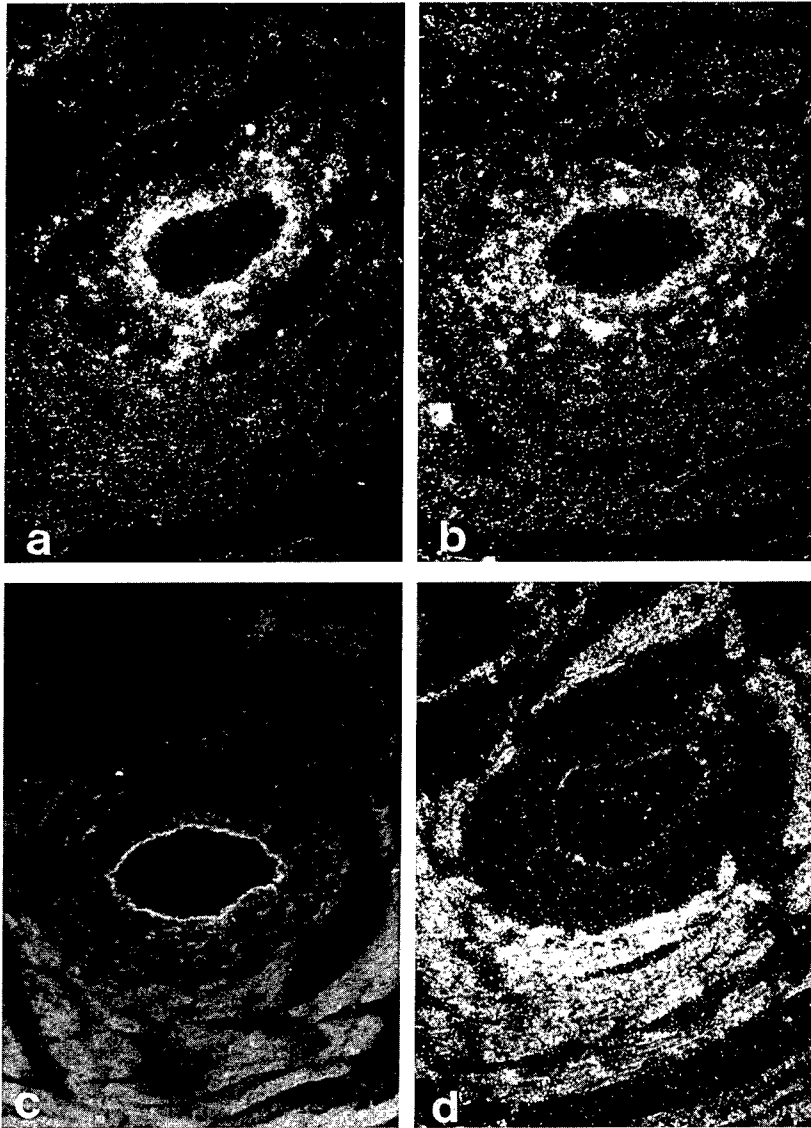

FIGURE 2. Distribution of FN and β -MyHC mRNAs in the ventricular myocardium 5 days after aortic stenosis. Serial sections from operated animals were hybridized with FN-EIIIA (a), FN-EIIIB (b) and β -MyHC (d) probes or immunolabeled with antibodies raised against FN-EIIIA (c). Note the strong hybridization signal for the two FN probes in both the smooth muscle cells and the adventitia, whereas the β -MyHC probe strongly hybridized with the surrounding cardiomyocytes. At that time the FN-EIIIA was detected only at the level of the basal membrane of the endothelium. ($\times 120$.)

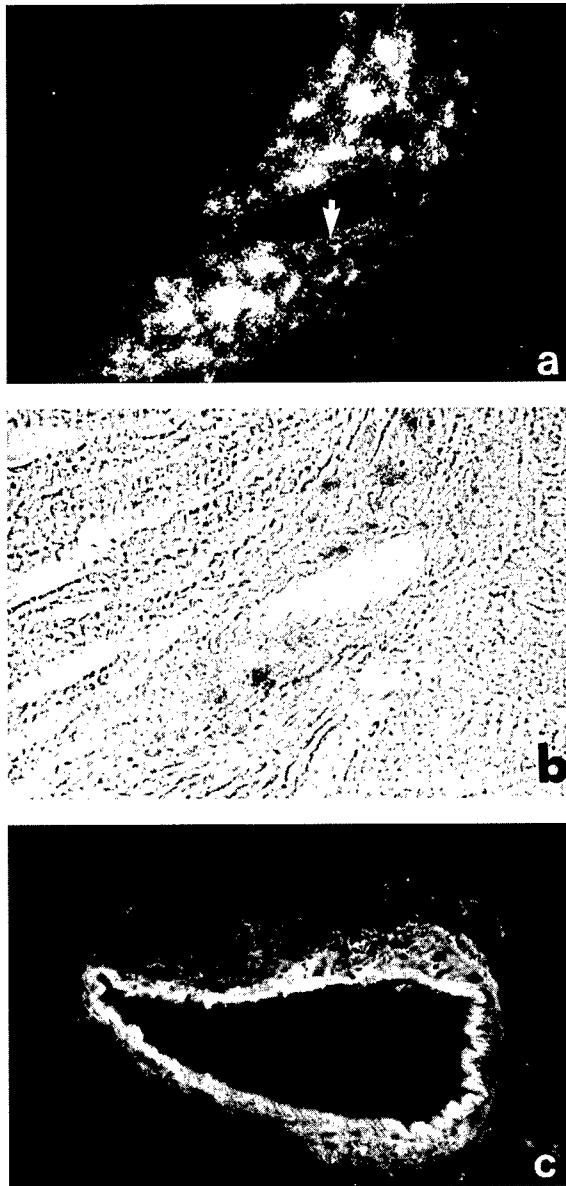

FIGURE 3. Expression of FN-EIIIA 15 days after aortic stenosis. Serial sections were either hybridized with FN-EIIIA probe (a) or immunolabeled with antibodies raised against FN-EIIIA (c); (b) is the phase contrast image of the (a) section. Note that at that time, FN-EIIIA mRNA are undetectable in the media (*arrow*), whereas they strongly accumulate in the adventitia. The protein is clearly expressed in the only media. (a,b: $\times 100$; c: $\times 200$.)

TABLE 1. Accumulation of FN mRNAs Within the Coronary Artery Wall after Imposition of a Coarctation of the Thoracic Aorta^a

Time after Surgery	Heart Hypertrophy (%)	FN-Type I	FN-EIIIA	FN-EIIIB
3 hours	ND	—	—	—
12 hours	ND	, —	—, —	—, —
1 day	23,35,29,12	±, +, ±, +	±, +, ±, +	—, +, ±, +
2 days	28	+	+	±
4–5 days	35,42,38	+, +, +	+, +	+, +
9 days	51	+	+	+
15 days	81	+	+	+

^a Each symbol represents one heart. +, ± and —, indicate high, moderate, and absent hybridization signal for 3 FN mRNA isoforms. ND: Not determined.

synthesis and expression of the myosin heavy chain isoforms in myocytes isolated from the adult rat heart. The analysis was performed at both the mRNA and protein levels, using quantitative and qualitative approaches. Quantitative *in situ* hybridization was used to evaluate the relative amounts of α - and β -MyHC isoforms and their distribution among myocytes cultured during 3–5 days in the presence of different agonists.

In a first series of experiments, cultured conditions required to maintain a cardiomyocyte phenotype close to that observed *in vivo* were defined. FIGURE 4 compares the hybridization signals obtained with myocytes cultured for 0 and 5 days. As previously shown,²⁹ at day 0 the α -MyHC probe was strongly reactive with almost all the myocytes whereas the β -MyHC probe gave a very weak signal with the majority of the cells; only very few myocytes were strongly positive with the later probe (see below, FIG. 6A,B). MyHC mRNA was distributed homogeneously throughout the entire surface of the freshly isolated adult myocytes. The percentage of myocytes expressing high levels of β -MyHC or α -MyHC²⁹ was similar to that found when the two MyHC isoforms were analyzed by immunocytochemistry.³⁰ By day 5 the signal obtained with the β -MyHC probe increased, whereas the α -MyHC signal had decreased throughout the cell population. In addition, the α - and β -MyHC signals varied from cell to cell, giving a heterogeneously labeled myocyte population. Quantitative *in situ* hybridization was shown previously to be sensitive enough to accurately measure α - and β -MyHC mRNA accumulation in the myocyte population.²⁹ The preferential expression of β -MyHC mRNA after 5 days of culture was shown to be related to the absence of T3, since the addition of physiological concentrations of T3 (1.5 nM) to the culture medium was sufficient to maintain a stable and predominant expression of α -MyHC mRNA in the whole cell population, resulting in α -MyHC mRNA levels similar to that observed in freshly plated myocytes (day 0, FIG. 5). The regulation of α -MyHC mRNA expression by T3 did not require the presence of any other molecule (neurohumoral). In contrast the downregulation of β -MyHC mRNA appears to require additional factors since the relative β -MyHC mRNA level after 3 and 5 days in culture was significantly higher than in freshly isolated myocytes even in the presence of 10^{-9} M T3 (FIG. 5). The thyroid hormone has been shown to have

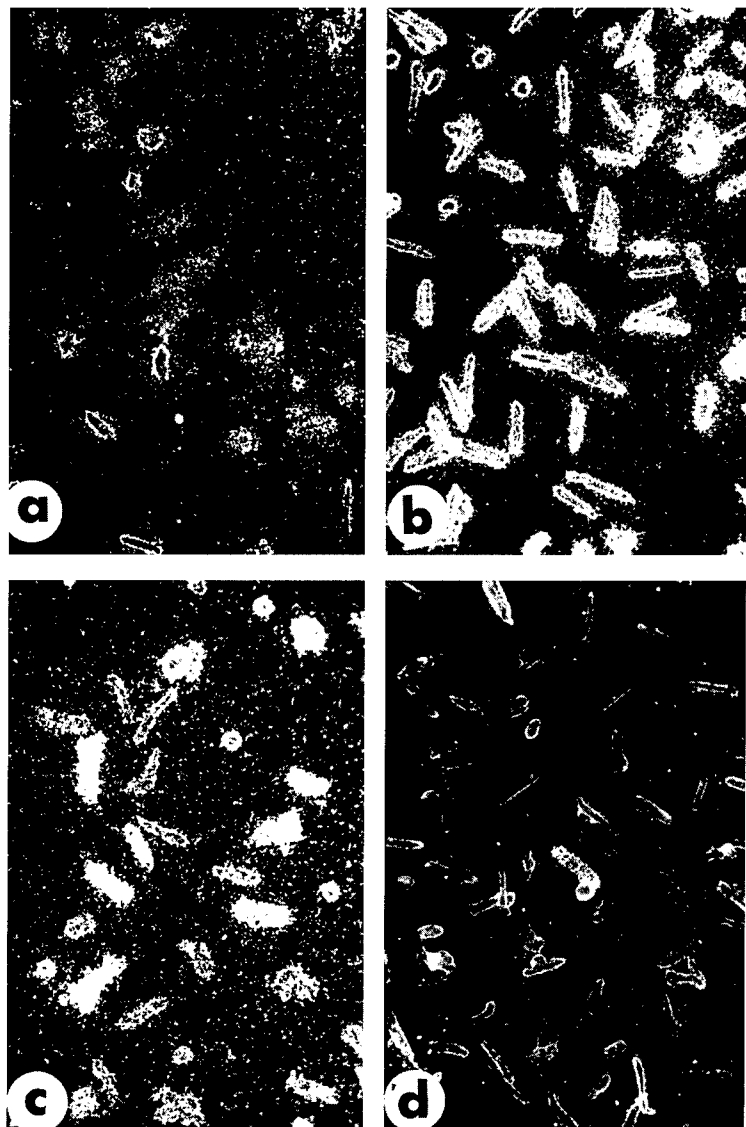

FIGURE 4. Expression of α - and β -MyHC mRNAs in cultured adult myocytes. Myocytes cultured for 5 days (a,e) or 2 hours (b,d) were hybridized with α -MyHC (a,b) or β -MyHC (c,d) probes. Note the decrease in α -MyHC mRNA signal with time in culture, while the number of cells positively labeled with β -MHC cRNA increased.

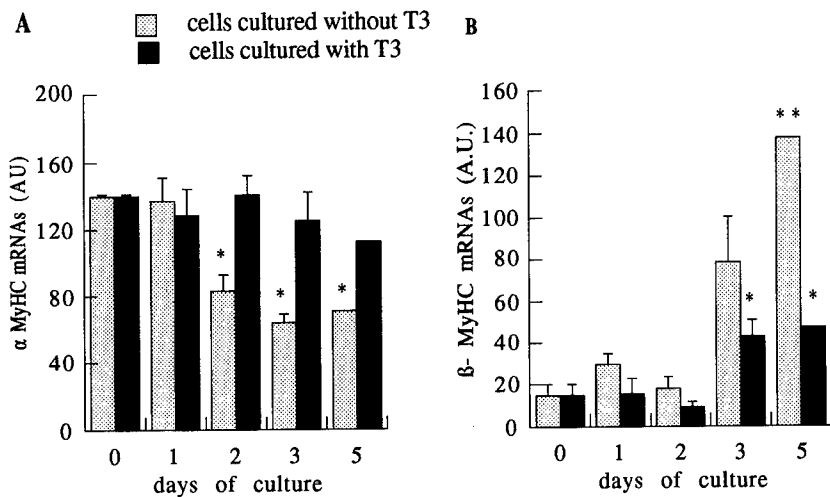

FIGURE 5. Effects of triiodothyronine (T3) and time in culture on (A) α -mRNA and (B) β -mRNA accumulations within adult cardiomyocytes. Myocytes from >4 different cultures were maintained in the presence (dark columns) or absence (grey columns) of 0.1 nM T3. mRNA levels were measured by quantitative *in situ* hybridization, as a function of time of culture. Note that the hormone prevents the decrease in α -MyHC mRNA levels but only partially prevents the increase in β -MyHC mRNA accumulations, which normally occur with time of culture * $p < 0.05$, ** $p < 0.01$ vs day 0. (Adapted from Dubus *et al.*²⁹)

no effect on protein synthesis in cultured adult myocytes²⁹ or in heterotypic non-working grafted heart.³¹

The qualitative and quantitative effects of adrenergic agonists on cardiac growth have been extensively studied using either *in vivo* or *in vitro* models of cultured immature cardiocytes. Norepinephrine induces cell proliferation and/or hypertrophy of fetal rat cardiac myocytes.³² In adult cultured myocytes low doses (10 nM) of catecholamines stimulate total protein synthesis via the β -adrenergic receptors only,³³ whereas higher doses of the β -adrenergic agonist decrease cell viability and have no trophic effect.^{33,34} Stimulation of total protein synthesis induced by a low dose of isoproterenol was not modified by the presence of T3 in the medium (a 20% increase as in the controls) (FIG. 6A). The β -adrenergic agonist had no effect on contractile protein synthesis.³³ As shown in FIGURE 6B, isoproterenol and T3 had additive effects in inhibiting the β -MyHC mRNA accumulation ($p > 0.05$ versus T3 treated cells), normally observed in adult myocytes as a function of time in culture. These results suggest that the two hormones are necessary to maintain preferential, if not exclusive, α -MyHC expression in adult rat myocytes.

Basic FGF was proposed to be one of the major signals triggering the qualitative and quantitative responses of the myocytes to pressure overload, *i.e.*, it induces hypertrophy and upregulates β -MyHC in immature myocytes.¹⁹ Exposure of adult cultured cardiomyocytes in the presence of 1 nM T3 to bFGF (25 ng/mL) for 3

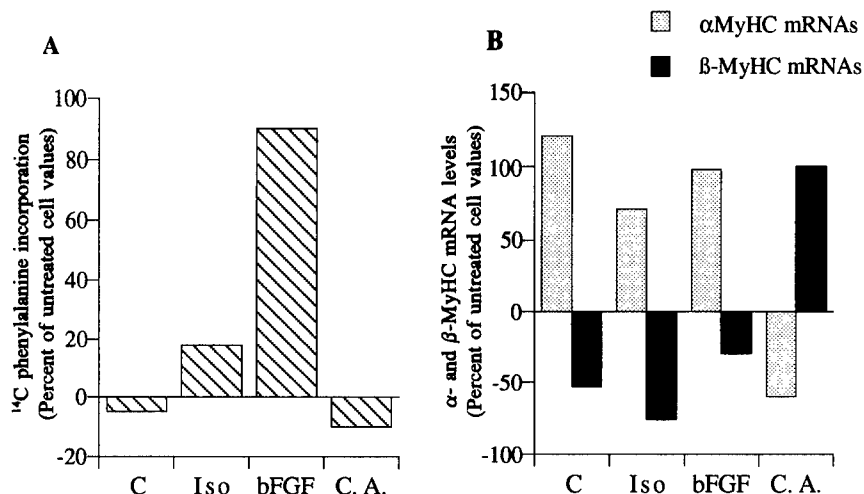

FIGURE 6. Differential effects of isoproterenol (Iso), basic fibroblast growth factor (b-FGF), contractile activity (C.A.) on (A) the protein synthesis activity and (B) α - and β -MyHC mRNA expression of adult cardiocytes cultured for 3 days. Cells were treated with 0.1 nM T3 only (C) or plus 10 nM Iso, or plus 25 ng/ml bFGF or together with a 24 h electric stimulation (2 Hz). Protein synthesis was evaluated as the incorporation of 14 C Phe/ μ g protein and mRNA levels by quantitative *in situ* hybridization. Values are given as percent of those from myocytes maintained 3 days in a T3-free medium.

days induced an 80% increase in total protein synthesis (FIG. 6A) but did not alter α - and β -MyHC mRNA expression (FIG. 6B). Preliminary results indicate that at a concentration of 1 ng/mL TGF β 1 or 10^{-10} M angiotensin II has no effect on the rate of protein synthesis in cultured adult myocytes.

Finally the effects of contractile activity induced by electric stimulation were analyzed. Total protein synthesis was unaltered by continuous contractile activity for 20 hours, whereas the pattern of MyHC isoforms was dramatically altered (FIG. 6). Indeed mechanical activity induced a 100% increase in β -MyHC and a 60% decrease in α -MyHC mRNA levels, when the myocytes are cultured in the presence of T3.

DISCUSSION

The present paper demonstrates that changes in the cardiac phenotype occurring in response to increased arterial pressure affect both muscle and nonmuscle cells in a temporal and spatial coordinated fashion. Both *in vivo* and *in vitro* experiments indicate that the cardiac gene expression is under multifactorial control.

A phenotype typical of the normal adult myocytes *in situ* is maintained in adult cardiomyocytes cultured for a few days in the presence of physiological concentrations of T3 and a β -agonist (FIG. 6). T3 alone is sufficient to maintain

adequate expression of α -MyHC while both T3 and isoproterenol work in concert to downregulate β -MyHC. *In vivo*, hypertension-induced hypertrophy is characterized by an accumulation of β -MyHC,¹ and a decrease in cardiac β -adrenergic receptor density³⁵ and cAMP levels.³⁶ Since the β -adrenergic signal pathway is shown here to be a potent inhibitor of β -MyHC expression, a decrease in adenylate cyclase activity could be involved in the long-term upregulation of β -MyHC that occurs in rodent ventricular myocardium during chronic hypertension. Numerous hormones and factors have been proposed to regulate the genomic expression of adult myocytes. The present study demonstrates that the quantitative and qualitative alterations induced in adult myocytes by extracellular stimuli are clearly distinct and are regulated by different pathways. Indeed, only bFGF dramatically increased protein synthesis, whereas myocyte stretching secondary to repetitive mechanical activity induces β -MyHC upregulation and a downregulation of α -MyHC. One important finding is that the effects of bFGF, TGF β or isoproterenol are developmentally regulated, since the data obtained with adult myocytes (this volume) differed from those previously observed in neonatal myocytes.¹⁹ In contrast, mechanical stimulation induces upregulation of β -MyHC in both mature and immature myocytes (this volume, Ref. 37) suggesting that if the factors mentioned above are involved in the mechanical response, they stimulate different intracellular pathways in neonatal and mature myocytes. These findings emphasize the importance of experimental models chosen to investigate the mechanism of cardiac genomic regulation.

Beyond basic genetic programming, several types of interactions (growth factors, cytokines, hormones, vitamin interactions with their cellular receptors, cell-cell and ECM-cell contacts) regulate the growth, shape, and state of differentiation of the cells. Signals of extracellular matrix are transduced through integrin family receptors to modulate cell motility, growth, and differentiation,³⁸ and in turn growth factors may modify the cell phenotype by altering fibronectin-integrin interaction.³⁹

The temporal and spatial gradient observed in the accumulation of FN-EIIB and EIIIA mRNAs as a result of aortic stenosis reflects the sequential stimulation first of the medial SMCs, then of the adventitial fibroblasts (FIG. 3). The reexpression of the FN-EIIB and FN-EIIB in medial SMCs is thought to represent a change towards a less mature phenotype and has been observed in hypertensive rat heart^{2,5} and in atherosclerosis.⁴⁰ The reexpression of the fetal phenotype involves also the myocyte mostly located in the vicinity of large arteries (FIG. 3) and in the inner part of the ventricles.¹⁸ Interestingly, the reappearance of the fetal form of FN mRNA in the SMCs and of β -MyHC in the striated myocytes is temporally related, the accumulation of FN mRNA preceding that of β -MyHC by only 24–48 hours. These results suggest that the same initial events regulate the reexpression of the fetal phenotype in the 3 types of cells, whether it involves the specific upregulation of one member of a multigene family such as MyHC, or the activation of a single gene resulting, via alternate splicing of its unique transcripts, in the reexpression of gene products preferentially expressed in immature SMCs. The fact that both β -MyHC and FN-EIIB and FN-EIIB mRNAs are observed in the area of coronary arteries but not at the vein level^{5,18} strongly suggests that mechanical factors induced by increased perfusion pressure (shear

stress of endothelium and/or passive stretch of cells) constitute the initial trigger for the phenotypic changes that are observed in the major cardiac cell types. This initial trigger may induce a cascade of events such as the synthesis of endothelin and/or EDRF, which would activate the secretion of growth factors, angiotensin II or ECM components responsible for the phenotypic changes of the medial smooth muscle cells,⁴¹ and then of the adventitial fibroblasts and the cardiomyocytes. Local and cell-specific signals may be involved in the cross talk between these different types of cells, but it is also possible that they all answer to the same signal but with a different time course.

It has been proposed that subtle regulations of cell-matrix interactions resulting from alterations in the ECM such as the presence of a new FN isoform and spatial distribution of integrin receptors may be responsible for changes in cell phenotype.⁴² Therefore, the changes in the phenotype of fibroblasts and cardiomyocytes after aortic stenosis could be secondary to the reexpression of FN-EIIIA by smooth muscle cells of the media and its secretion in the ECM, as previously described for cultured SMCs.¹² However, the lag time observed between the accumulation of the FN-EIIIA mRNA and the translated protein does not support this hypothesis. The temporal delay between FN mRNA and protein accumulation appears particularly long (>4 days), but a similar dissociation has been recently described for other proteins such as troponin⁴³ and suggests that translational or posttranslational control plays a role in regulating FN synthesis by SMCs and troponin synthesis by myocytes, again emphasizing a similar regulation of genomic expression in all cardiac cells, regardless of the initial programming of the differentiated function. However, since β -MyHC mRNA accumulation in the striated myocytes and FN mRNA expression in the adventitial fibroblasts occur before cellular FN deposition in the ECM, we conclude that the changes in FN expression are not the main signal of the phenotypic changes observed in the different types of cardiac cells as a result of high arterial pressure. Further information acquired from experiments using exogenous matrices of different composition and cells of different lineage may be useful in further establishing the long-term consequences of altered matrix on a cellular phenotype.

Several humoral factors have been implicated in the regulation of the cardiac genes *in vivo*. An increase in TGF β mRNA accumulation in the adult myocardium has been associated with infarction²¹ and pressure overload.⁷ The growth factor appears to affect both muscle and nonmuscle cardiac cells *in situ*. This factor has been proposed to regulate FN pre-mRNA splicing,^{44,45} *in vivo*, to selectively upstimulate cell contractility,⁴⁶ and to selectively induce tissue-specific fetal genes in neonatal cardiac muscle cells.²³ However, according to Majack *et al.*, the FN levels remain unchanged in isolated smooth muscle cells treated with TGF β ,^{47,48} and our *in vitro* experiments show that in contrast to bFGF, TGF β has no trophic effect on the adult cardiomyocytes. Angiotensin II may be one of the peptides involved directly or indirectly in the regulation of cardiac gene expression during the early phase of pressure overload-induced cardiac hypertrophy. Angiotensin II induces aortic smooth muscle cell hypertrophy⁴¹ and stimulates collagen type I⁴⁹ and FN-EIIIA + expression.^{50,51} In cultured neonatal cardiac myocytes, AII increases TGF β 1 as well as angiotensinogen gene expression,⁵² and results in a preferential expression of β -MyHC. Sadoshima *et al.* proposed that stretch-in-

duced hypertrophy of neonatal myocytes was mediated by angiotensin II production. We show that in cultured adult myocytes neither mechanical activity nor AII are able to stimulate protein synthesis, but contractile activity by itself induces upregulation of β -MyHC and downregulation of α -MyHC. It remains to be determined whether these qualitative effects are mediated via angiotensin II.

In conclusion, we have demonstrated that the imposition of pressure overload induces rapid phenotypic changes in all types of cardiac cells within the areas of mechanical stress *in vivo*. Although arterial SMCs respond first by reexpressing the fetal isoforms of FN, it is unlikely that this ECM protein is responsible for the phenotypic changes observed later in the adventitial fibroblasts and the striated myocytes. Since we have identified several factors regulating specifically quantitative and qualitative gene expression in adult myocytes, the effect of these factors on smooth muscle and adventitial cells that locally respond to pressure overload remains to be analyzed.

REFERENCES

1. BOHELER, K. R. & K. SCHWARTZ. 1992. Gene expression in cardiac hypertrophy. *Trends Cardiovasc. Med.* **2**: 176–182.
2. CONTARD, F., A. SABRI, M. GLUKHOVA, S. SARTORE, F. MAROTTE, J. P. POMIES, P. SCHIAVI, D. GUEZ, J. L. SAMUEL & L. RAPPAPORT. 1993. *Hypertension* **22**: 665–676.
3. TERRACIO, I., K. RUBIN, D. GULLBERGER, F. BALOG, W. CARVER, R. SYRING & T. K. BORG. 1991. Expression of collagen binding integrins during cardiac development and hypertrophy. *Circ. Res.* **68**: 734–744.
4. MUKHERJEE, D. & S. SEN. 1990. Collagen phenotypes during development and regression of myocardial hypertrophy in spontaneously hypertensive rats. *Circ. Res.* **67**: 1474–1480.
5. SAMUEL, J. L., A. BARRIEUX, S. DUFOR, I. DUBUS, F. CONTARD, V. KOTELIANSKY, F. FARHADIAN, F. MAROTTE, J. P. THIÉRY & L. RAPPAPORT. 1991. Accumulation of fetal fibronectin mRNAs during the development of rat cardiac hypertrophy induced by pressure overload. *J. Clin. Invest.* **88**: 1737–1746.
6. MANUYA, W. S. & P. BRECHER. 1990. Fibronectin expression in the normal and hypertrophic rat heart. *J. Clin. Invest.* **89**: 392–401.
7. VILLARREAL, F. J. & W. H. DILLMANN. 1992. Cardiac hypertrophy-induced changes in mRNA levels for TGF- β 1, fibronectin, and collagen. *Am. J. Physiol.* **262**: H1861–H1866.
8. JALIL, J. E., C. W. DOERING, J. S. JANICKI, R. PICK, W. A. CLARK & K. T. WEBER. 1988. Structural vs. contractile protein remodeling and myocardial stiffness in hypertrophied left ventricle. *J. Mol. Cell. Cardiol.* **20**: 1179–1187.
9. SILVER, M. A., R. PICK, C. G. BRILLA, J. E. JALIL, J. S. JANICKI & K. T. WEBER. 1990. Reactive and reparative fibrillar collagen remodeling in the hypertrophied rat left ventricle: two experimental models of myocardial fibrosis. *Cardiovasc. Res.* **24**: 741–747.
10. WEBER, K. T., Y. SUN, C. TYAGI & J. P. M. CLEUTJENS. 1994. Collagen network of the myocardium function. Structural remodeling and regulatory mechanisms. *J. Mol. Cell Cardiol* **26**: 279–292.
11. PELOUCH, V., I. M.C. DIXON, L. GOLFMAN, R. E. BEAMISH & N. S. DHALLA. 1994. *Mol. Cell. Biochem.* Role of extracellular matrix in heart function. *Mol. Cell. Biochem.* **129**: 101–120.
12. HEDIN, U., B. A. BOTTGER, J. LUTHMAN, S. JOHANSSON & J. THYBER. 1989. A substrate of the cell-attachment sequence of fibronectin (Arg-Gly-Asp-Ser) is sufficient to promote transition of arterial smooth muscle cells from a contractile to a synthetic phenotype. *Dev. Biol.* **133**: 489–501.

13. TERRACIO, L. & T. K. BORG. 1988. Factors affecting cardiac cell shape. *Heart Failure* **4**: 114–124.
14. HYNES, R. O. 1990. *Fibronectins*. Springer. New York, Berlin, Heidelberg.
15. RUOSLAHTI, E. & Y. YAMAGUCHI. 1991. Proteoglycans as modulators of growth factor activities. *Cell* **64**: 867–869.
16. AHUMADA, G. G. & J. E. AFFITZ. 1984. Fibronectin in rat heart: a link between cardiac myocytes and collagen. *J. Histochem. Cytochem.* **32**: 383–388.
17. ROBINSON, T. T. F., L. COHEN-GOULD & S. M. FACTOR. 1983. The skeletal framework of mammalian heart muscle: arrangement of inter- and pericellular connective tissue structures. *Lab. Invest.* **49**: 482–498.
18. SCHIAFFINO, S., J. L. SAMUEL, D. SASSOON, A. M. LOMPRÉ, I. GARNER, F. MAROTTE, M. BUCKINGHAM, L. RAPPAPORT & K. SCHWARTZ. 1989. Non synchronous accumulation of α -skeletal actin and β -myosin heavy chains during the early stages of pressure-overload-induced cardiac hypertrophy demonstrated by *in situ* hybridization. *Circ. Res.* **64**: 937–948.
19. SCHNEIDER, M. D., T. G. PARKER, S. E. PACKER, M. S. WATHEN, H. B. MARSHALL, J. M. CAFFREY & H. T. SHIH. 1990. Functional role of growth factors and cellular oncogenes in cardiac and skeletal muscle. *In Molecular Biology of the Cardiovascular System*. 63–71. Alan R. Liss Inc. New York.
20. CASSCELLS, W. & V. J. FERRANS. 1990. Growth factors in the heart. *In The Development and Regenerative Potential of Cardiac Muscle*. J. O. Oberpriller, J. S. Oberpriller & A. Mauro, Eds. 8–21. Harward. New York.
21. THOMPSON, N. L., F. BAZOBBERRY, E. H. SPEIR, W. CASSCELLS, V. J. FERRANS, K. C. FLANDERS, P. KONDAIAH, A. G. GEISER & M. B. SPORN. 1988. Transforming growth factor β -1 in acute myocardial infarction in rats. *Growth Factors* **1**: 91–99.
22. KNOWLTON, A. A., C. M. CONNELLY, G. M. ROMO, W. MAMYA, C. S. APSTEIN & P. BRECHER. 1992. Rapid expression of fibronectin in the rabbit heart after myocardial infarction with and without reperfusion. *J. Clin. Invest.* **89**: 1060–1068.
23. CUMMINS P. 1993. *In Growth Factors and the Cardiovascular System*. P. Cummins, Ed. Kluwer Academic Publisher.
24. PARKER, T. G., S. E. PARKER & M. D. SCHNEIDER. 1990. Peptide growth factors provoke “fetal” contractile protein gene expression in rat cardiac myocytes. *J. Clin. Invest.* **85**: 507–514.
25. LONG, C. S., J. H. CURTIS & P. C. SIMPSON. 1991. A growth factor for cardiac myocytes is produced by cardiac nonmyocytes. *Cell Regul.* **2**: 1081–1095.
26. BRUTSAERT, D. L., A. L. MEULEMANS, K. R. SIPIDO & S. U. SYS. 1988. Effects of damaging the endocardial surface on the mechanical performance of isolated cardiac muscle. *Circ. Res.* **62**: 358–366.
27. MEBAZZA, A., E. MAYOUX, K. MAEDA, L. D. MARTIN, E. LAKATTA, J. L. ROBOTHAM & A. M. SHAH. 1993. Paracrine effects of endocardial endothelial cells on myocyte contraction mediated via endothelin. *Am. J. Physiol.* **265**: 1841–1846.
28. FARHADIAN, F., A. BARRIEUX, S. LORTET, F. MAROTTE, P. OLIVIERO, L. RAPPAPORT & J. L. SAMUEL. 1994. Differential splicing of fibronectin pre-mRNA during cardiac ontogeny and development of hypertrophy in the rat. *Lab. Invest.* In press.
29. DUBUS, I., A. MERCADIER, O. LUCAS, F. CONTARD, O. NALLET, P. OLIVIERO, L. RAPPAPORT & J. L. SAMUEL. 1993. α -, β -MHC mRNA quantification in adult cardiomyocytes by *in situ* hybridization: effect of thyroid hormone. *Am. J. Physiol.* **265**: C62–C71.
30. SAMUEL, J. L., L. RAPPAPORT, J. J. MERCADIER, A. M. LOMPRÉ, S. SARTORE, C. TRIBAN, S. SCHIAFFINO & K. SCHWARTZ. 1983. Distribution of myosin isozyme within single cardiac cells: an immunohistochemical study. *Circ. Res.* **52**: 200–209.
31. KORECKY, B., R. ZAK, K. SCHWARTZ & U. ASCHENBRENNER. 1987. Role of thyroid hormone in regulation of isomyosin composition, contractility, and size of heterotopically isotransplanted rat heart. *Circ. Res.* **60**: 824–830.
32. MARINO, T. A., R. A. WALTER, K. D’AMBRA & W. E. MERCER. 1989. Effects of catecholamines on fetal rat cardiocytes *in vitro*. *Am. J. Anat.* **186**: 127–132.
33. DUBUS, I., J. L. SAMUEL, F. MAROTTE, C. DELCAYRE & L. RAPPAPORT. 1990. B-adrener-

- gic agonists stimulate the synthesis of noncontractile but not contractile proteins in cultured myocytes isolated from adult rat heart. *Circ. Res.* **66**: 867-874.
34. SCHLÜTER, K. D. & H. M. PIPER. 1992. Trophic effects of catecholamines and parathyroid hormone on adult ventricular cardiomyocytes. *Am. J. Physiol.* **263**: H1739-H1746.
 35. CHEVALIER, B., P. MANSIER, F. CALLENS-EL AMRANI & B. SWYNGHEDAuw. 1989. Beta-adrenergic system is modified in compensatory pressure cardiac overload in rats: physiological and biochemical evidence. *J. Cardiovasc. Pharmacol.* **13**: 412-420.
 36. BOUANANI, N., A. CORSIN, N. GILSON & B. CROZATIER. 1991. Beta-adrenoceptors and adenylate cyclase activity in hypertrophied and failing rabbit left ventricle. *J. Mol. Cell. Cardiol.* **23**: 573-581.
 37. SADOshIMA, J., J. L. TAKAHASHI, T. J. KULIK & S. IZUMO. 1992. Roles of mechanosensitive ion channels, cytoskeleton, and contractile activity in stretch-induced immediate-early gene expression and hypertrophy of myocytes. *Proc. Natl. Acad. Sci. USA* **89**: 9905-9909.
 38. HYNES, R. O. 1992. Integrins: versatility, modulation, and signaling in cell adhesion. *Cell* **69**: 11-25.
 39. FUJIO, Y., F. YAMADA, K. TAKAHASHI & N. SHIBATA. 1993. Altered fibronectin-dependent cell adhesion by PDGF accompanies phenotypic modulation of vascular smooth muscle cells. *Biochem. Biophys. Res. Commun.* **196**: 997-1002.
 40. GLUKHOVA, M. A., M. G. FRID, B. V. SHEKHONIN, T. D. VASILEVSKAYA, J. GRUNWALD, M. SAGINATI & V. E. KOTELIANSKY. 1989. Expression of extra domain A fibronectin sequence in vascular smooth muscle type is phenotype dependent. *J. Cell Biol.* **109**: 357-363.
 41. DOSTAL, D. E. & K. M. BAKER. 1993. Evidence for a role of an intracardiac renin-angiotensin system in normal and failing hearts. *Trends Cardiovasc. Med.* **3**: 67-74.
 42. YAMADA, K. M., S. AOTA, S. K. AKIYAMA & S. E. LAFLAMME. 1992. Mechanisms of fibronectin and integrin-function during cell adhesion and migration. *Cold Spring Harbor Symp. Quant. Biol. Vol. 57*: 203-212. Cold Spring Harbor Laboratory Press. Cold Spring Harbor, N.Y.
 43. SCHIAFFINO, S., L. GORZA & S. AUSONI. 1993. Troponin isoform switching in the developing heart and its functional consequences. *Trends Cardiovasc. Med.* **3**: 12-17.
 44. MAGNUSON, V. L., Y. MAUREEN, D. G. SCHATTENBERG, M. A. MANCINI, D. CHEN, B. STEFFENSEN & R. J. KLEBE. 1991. The alternative splicing of fibronectin premRNA is altered during aging and in response to growth factors. *J. Biol. Chem.* **266**: 14654-14662.
 45. BALZA, E., L. BORSI, G. ALLEMANI & L. ZARDI. 1988. Transforming growth factor β regulates the levels of different fibronectin isoforms in normal human cultured fibroblasts. *FEBS Lett.* **228**: 42-44.
 46. ROBERTS, A. B., N. S. ROCHE, T. S. WINOKUR, J. K. BURMESTER & M. B. SPORN. 1992. Role of transforming growth factor- β in maintenance of function of cultured neonatal cardiac myocytes. *J. Clin. Invest.* **90**: 2056-2062.
 47. MAJACK, R. A. 1987. Beta-type transforming growth factor specifies organizational behavior in vascular smooth muscle cell cultures. *J. Cell Biol.* **105**: 465-471.
 48. GOODMAN, L. V. & R. A. MAJACK. 1989. Vascular smooth muscle cells express distinct transforming growth factor- β receptor phenotypes as a function of cell density in culture. *J. Biol. Chem.* **264**: 5241-5244.
 49. KATO, H., H. SUZUKI, S. TAJIMA, Y. OGATA, T. TOMINAGA, A. SATO & T. SARUTA. 1991. Angiotensin II stimulates collagen synthesis in cultured vascular smooth muscle cells. *J. Hypertens.* **9**: 17-22.
 50. TAKASAKI, I., A. V. CHOBANIAN, R. SARZANI & P. BRECHER. 1990. Effect of hypertension on fibronectin expression in the rat aorta. *J. Biol. Chem.* **265**: 21935-21939.
 51. SAOUAF, R., I. TAKASAKI, E. EASTMAN, A. V. CHOBANIAN & P. BRECHER. 1991. Fibronectin biosynthesis in the rat aorta *in vitro*: changes due to experimental hypertension. *J. Clin. Invest.* **88**: 1182-1189.
 52. SADOshIMA, J., Y. XU, H. S. SLAYTER & S. IZUMO. 1993. Autocrine release of angiotensin II mediates stretch-induced hypertrophy of cardiac myocytes *in vitro*. *Cell* **75**: 977-984.

Mechanical Load and Polypeptide Growth Factors Stimulate Cardiac Fibroblast Activity

RICHARD P. BUTT, GEOFFREY J. LAURENT, AND
JILL E. BISHOP

*Division of Cardiopulmonary Biochemistry
University College London Medical School
The Rayne Institute
5, University Street
London WC1E 6JJ, United Kingdom*

Collagen Turnover and Deposition in Cardiac Hypertrophy and Cardiac Fibrosis

Collagen fibers form a network of weaves and struts in the myocardium that interconnect myocytes and capillaries, preventing slippage of adjacent muscle fibers during the cardiac cycle, coordinating the delivery of force and maintaining capillary patency during contraction.¹ Cardiac collagens are principally the type I and III fibrillar collagens, produced by cardiac fibroblasts.^{2,3} Types IV, V, VI and VIII have also been identified but represent less than 10% of the total cardiac collagen content.

During the development of cardiac hypertrophy there is an increase in collagen deposition which may lead to cardiac fibrosis, particularly if the hypertrophy is due to pressure overload.⁴⁻⁷ Excess collagen impairs the diastolic function of the heart by increasing cardiac stiffness.⁸ The relative proportion of type I collagen (compared to types I and III) may also increase,^{5,6,9} possibly contributing further to the diastolic stiffness of the heart, due to the greater tensile strength of the type I collagen fibers.

Collagen is continually synthesized and degraded in the heart, the magnitude and balance of these independent pathways determining collagen deposition. Cardiac collagen turnover is a dynamic process with fractional synthesis rates of 3-5% per day found in the ventricles of rabbits.^{10,11} 30-50% of this collagen is degraded rapidly via an intracellular pathway.¹⁰⁻¹² This degradative pathway represents an extremely sensitive mechanism whereby collagen deposition may be increased independently of changes in synthesis. Intracellular degradation occurs in addition to extracellular collagen degradation, which represents turnover of mature, cross-linked collagen, and is regulated by the metalloproteases and their inhibitors, such as tissue inhibitor of metalloprotease (TIMP).

The rates of the synthetic and degradative processes change rapidly in response to pressure overload with a sixfold increase in right ventricular collagen synthesis

two days after pulmonary artery banding accompanied by a similar fourfold increase in type I collagen $\alpha_1(I)$ mRNA levels.¹¹ Furthermore, the proportion of collagen degraded rapidly after synthesis is decreased, increasing the amount of collagen deposited in the heart. Thus transcriptional and posttranslational regulation of collagen metabolism occurs, both leading to an increase in the amount of collagen deposited.

Increased collagen deposition may occur by increasing the amount of collagen produced per fibroblast, or by increasing the numbers of fibroblasts. Collagen production per cell has been shown to increase in the right ventricle in the bleomycin model of pulmonary hypertension,¹³ as an increase in cardiac collagen synthesis occurred prior to an increase in DNA content. This has also been shown in other models of pressure overload induced cardiac hypertrophy.^{11,14,15} Increased DNA levels are due primarily to increased fibroblast replication. Thus it is clear that increased collagen production per cell and fibroblast replication occur, both representing mechanisms for increased cardiac collagen accumulation.

Although we now have data regarding the metabolic changes that occur in order to increase collagen deposition during cardiac hypertrophy induced by pressure overload, little is known of the stimuli for such changes. Here we present evidence that mechanical load and polypeptide growth factors may act synergistically to stimulate cardiac fibroblast collagen synthesis and replication.

Potential Mechanisms for Stimulating Collagen Deposition

Pressure overload causes cardiac hypertrophy, the major components of which are myocyte hypertrophy, nonmyocyte, principally fibroblast, hyperplasia, and increased collagen deposition. The mechanisms governing the increased collagen deposition in the hypertrophying and fibrotic heart are not known. Three principle hypotheses are currently being studied:

1. Increased mechanical load *per se* stimulates both fibroblast replication and collagen production per cell;
2. Autocrine or paracrine growth factors are released which stimulate fibroblast activity;
3. An increased availability of blood-borne factors stimulates cardiac fibroblast function.

These three mechanisms are not, however, mutually exclusive; mechanical load may play a role in all of them. In 1) mechanical load may directly influence cell function through cell-cell interactions, cell-matrix interactions, or cytoskeletal restructuring, with signals directed through the extensive cytoskeletal network to the nucleus.¹⁶ Mechanical load may also directly cause membrane perturbation, opening stretch-activated ion channels¹⁷ or influencing the activity of membrane-bound enzymes such as the phospholipases (phospholipase A₂, phospholipase C or phospholipase D) and nucleotide cyclases (adenylate cyclase, guanylate cyclase), which activate second messenger pathways within the cell. In 2) mechanical load may stimulate release of growth factors in an autocrine manner, for example,

platelet-derived growth factor (PDGF) is released by lung fibroblasts^{18,19} and vascular smooth muscle cells (SMC).²⁰ The release of such factors may also have paracrine effects. As another example, endothelin secretion by endothelial cells is increased in response to load²¹ and is known to stimulate vascular fibroblast replication and chemotaxis.^{22,23} Paracrine growth factors may also originate from activation of the tissue renin/angiotensin/aldosterone system (RAAS), the components of which have been demonstrated in the heart. Angiotensin has been shown to stimulate cardiac fibroblast collagen synthesis.²⁴ Growth factors may also stimulate release of other factors, for example, AII stimulates PDGF release in SMC,²⁰ and PDGF induces transforming growth factor β (TGF β) release by fibroblasts.²⁵ In 3) mechanical load may increase vessel wall permeability to blood-borne factors,²⁶ such as circulating AII²⁷ which may be elevated due to release from the kidneys in response to the hypertension. This hypothesis will not be discussed here but increased activity of RAAS has been reported and is discussed in other papers in this volume.

In Vitro Evidence Supporting a Role for Mechanical Load in Increased Collagen Deposition

We have shown *in vitro* that cardiac²⁸ (FIG. 1) and pulmonary artery²⁹ fibroblasts increase collagen production in response to mechanical load. After 24 hours of mechanical load, fetal cardiac fibroblasts, maintained in 1% or 10% fetal calf serum (FCS) did not increase collagen production compared to control levels (data not shown). After 48 hours, however, the cells subjected to mechanical load in the presence of high serum produced 75% more collagen than the control cells,

FIGURE 1. The effect of mechanical load and serum concentrations on cardiac fibroblast collagen production. Cardiac fibroblasts were grown to confluence on flexible (Flex I) or rigid (Flex II) bottomed 6-well elastin-coated culture plates and mechanically loaded using the Flexercell Strain Unit. The flexible membranes were deformed by a maximum of 20% elongation at 1.5 Hz, for 48 hours, in the presence of ascorbate and proline. After this time the media and cell layer were harvested, proteins precipitated in 67% EtOH, hydrolyzed in 6 M HCl and the collagen production determined by assessing the hydroxyproline content using an HPLC method.⁴⁵ Statistical significance was determined between control and test samples by unpaired *t*-test and results deemed significant at 95% confidence limit. All results $n = 4-6$, plotted as means \pm SEM, **★★** $p < 0.001$.

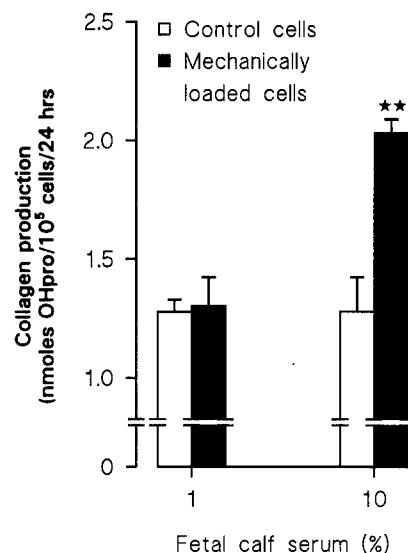

or the loaded cells maintained in 1% FCS (FIG. 1). This data implies a synergy between mechanical load and serum factors.

Another mechanism by which cardiac collagen deposition may be increased is through induction of fibroblast replication. We have shown that pulmonary artery²⁹ and lung fibroblasts^{18,19} replicate in response to mechanical load in low serum concentrations, and have preliminary data suggesting that cardiac fibroblasts also respond in this way. This indicates that fibroblast replication and collagen synthesis are stimulated through discrete pathways, the latter relying on an external supply of factors, and the former on the production of autocrine mitogenic factors or direct stimulation by mechanical load.

In Vitro Effect of Polypeptide Growth Factors on Cardiac Fibroblast Activity

The role of growth factors in the regulation of normal heart collagen or in the development of increased cardiac collagen deposition is not well characterized. These factors have been identified in the normal heart and studies have suggested that polypeptide growth factor release may be stimulated following the onset of hypertrophy.³⁰ However, interest has focused on growth factor stimulation of myocyte gene expression^{31,32} and hypertrophy³³ rather than their effects on cardiac fibroblasts.

We have studied the effects of growth factors and vasoactive agents on cardiac fibroblast activity, with respect to cell replication and collagen production. It is clear from these experiments that cardiac fibroblasts are highly sensitive target cells, able to respond to a range of classes of growth factors.²⁸

Studies on cardiac fibroblast replication have shown high sensitivity to PDGF (AB heterodimer) (FIG. 2). The responses of these cells to the other PDGF isoforms and the abundance of receptor subtypes is currently under investigation. These fibroblasts also replicate moderately in response to basic fibroblast growth factor (FGF-2), but not to insulin-like growth factor-1 (IGF-1), or to TGF β ²⁸ (FIG. 2). The vasoactive agents endothelin-1 (ET-1) and AII have also been tested, with AII, but not ET-1, producing a moderate stimulation of cardiac fibroblast replication (FIG. 2).

These agents have also been tested for their ability to stimulate cardiac fibroblast collagen synthesis (FIG. 3) with TGF β , IGF-1, PDGF, and FGF-2 all stimulating collagen production, but AII and ET-1 having no effect. These six mediators represent a diversity of classes of growth factors in terms of their discrete receptor subtypes and signal transduction pathways. The results therefore show the range of factors that are capable of stimulating cardiac collagen production.

TGF β is the most potent known stimulator of collagen production for a wide variety of fibroblast lines tested. These cardiac fibroblasts proved particularly sensitive to TGF β , with a stimulation of 120% above control levels²⁸ (FIG. 3). Our studies also showed stimulation by PDGF, the first report of increased collagen production in response to this factor. All subtypes of PDGF have previously been reported to have no effect on lung fibroblast collagen mRNA levels or protein production.³⁴ FGF-2 also stimulated collagen production by these cells, somewhat conflicting with previously published data showing collagen message levels de-

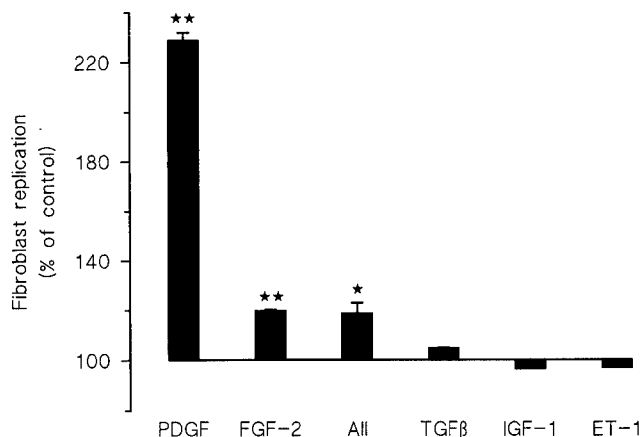

FIGURE 2. Effect of growth factors on cardiac fibroblast replication. Fibroblast replication was assessed using a rapid and convenient method of determining cell number in 96-well plates.⁴⁶ 4000 cells/well were pre-plated for 48 hours in 1% FCS. The growth factor of interest was then added in medium containing 1% FCS and serially diluted across the plate. After a further 48 hours the medium was removed, and the cells were washed in PBS and fixed in formal saline. 1% methylene blue was added for 20 minutes, washed out and the bound dye eluted with acidified alcohol (1:1, 0.1 M HCl:EtOH). Absorbance of each well was determined using a 96-well plate reader. Results are expressed as percent of 1% FCS medium control. The concentration of growth factor shown represents the dose at which a maximal effect on replication was observed (PDGF 2.6 nM, FGF-2 1.3 nM, AII 10 μ M, TGF β 3.2 nM, IGF-1 2.7 nM and ET-1 10 nM). Statistical significance was determined between 1% FCS medium control and the test samples by unpaired *t* test and results deemed significant at 95% confidence limit. All results *n* = 6, plotted as means \pm SEM, ** *p* < 0.001, + *p* < 0.05.

creasing in cardiac fibroblasts after incubation with FGF-2.³⁵ IGF-1 stimulated collagen production by the cardiac fibroblasts as previously demonstrated in monolayers of lung fibroblast³⁶ and skin fibroblasts grown in collagen lattices.³⁷

SUMMARY AND IMPLICATIONS

The regulation of collagen deposition in the heart is not fully understood. Our studies have implicated roles for polypeptide growth factors and mechanical load in stimulating both fibroblast replication and collagen synthesis. Evidence is emerging to indicate the presence of growth factors in the normal and hypertrophying heart.^{27,30,38-44} In the normal heart a balance may exist in the levels and interactions of these factors, maintaining collagen composition. Following the stimulation for hypertrophy, particularly due to pressure overload, this homeostasis may be disrupted. Mechanical load may promote enhanced growth factor production, or act synergistically with existing factors to stimulate fibroblast activity. Further work is being carried out in *in vitro* and *in vivo* models of cardiac pressure overload to determine the respective roles, the control mechanisms and signaling pathways

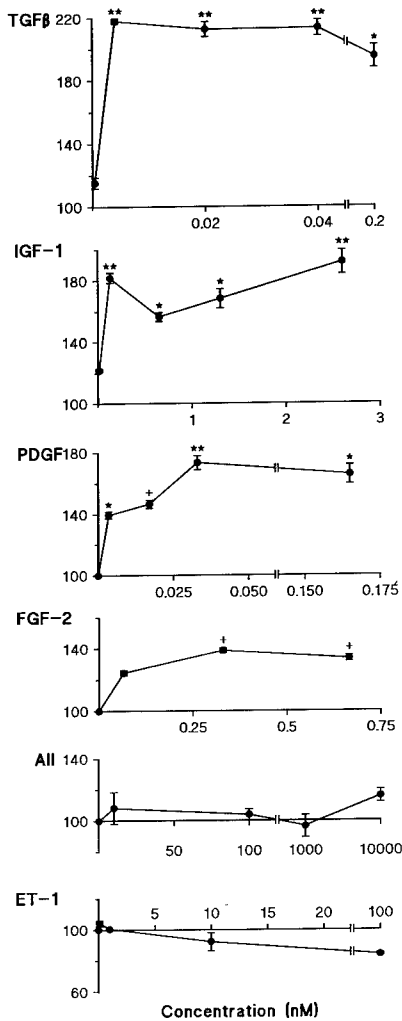

FIGURE 3. Effect of growth factors on cardiac fibroblast collagen production. Fibroblasts were grown to confluence on 12-well tissue culture plates and the collagen production determined after 24 hours of exposure to the growth factors. Collagen production was determined by assessing the OHpro content as previously described (see Fig. 1). Results are expressed as % stimulation of the 1% FCS medium control. Statistical significance was determined between control and test samples by unpaired *t* test and results deemed significant at 95% confidence limit. All results $n = 6$, plotted as means \pm SEM, $\star\star p < 0.001$, $\star p < 0.01$, $+ p < 0.05$.

of mechanical load and growth factors in the development of increased cardiac collagen deposition.

REFERENCES

1. BORG, T. K. & J. B. CAULFIELD. 1981. Fed. Proc. **40**: 2037-2041.
2. EGHBALI, M., O. O. BLUMENFELD, S. SEIFTER *et al.* 1989. J. Mol. Cell. Cardiol. **21**: 103-113.
3. EGHBALI, M., M. J. CZAJA, M. ZEYDEL, F. R. WEINER, M. A. ZERN & O. O. BLUMENFELD. 1988. J. Mol. Cell. Cardiol. **20**: 267-276.
4. JALIL, J. E., J. S. JANICKI, R. PICK & K. T. WEBER. 1991. Am. J. Hypertens. **4**: 51-55.
5. BISHOP, J. E., R. GREENBAUM, D. G. GIBSON, M. YACOB & G. J. LAURENT. 1990. J. Mol. Cell. Cardiol. **22**: 1157-1165.

6. LOW, R. B., W. S. STIREWALT, P. HULTGREN, E. S. LOW & B. STARCHER. 1989. *Biochem. J.* **263**: 709–713.
7. WEBER, K. T., J. E. JALIL, J. S. JANICKI & R. PICK. 1989. *Am. J. Hypertens.* **2**: 931–940.
8. DOERING, C. W., J. E. JALIL, J. S. JANICKI *et al.* 1988. *Cardiovasc. Res.* **22**: 686–695.
9. TURNER, J. E. & G. J. LAURENT. 1986. *Biochem. Soc. Trans.* **14**: 1079–1080.
10. TURNER, J. E., M. H. OLIVER, D. GUERREIRO & G. J. LAURENT. 1986. *Am. J. Physiol.* **251**: H915–H919.
11. BISHOP, J. E., S. RHODES, G. J. LAURENT, R. B. LOW & W. S. STIREWALT. 1994. *Cardiovasc. Res.* In press.
12. BIENKOWSKI, R. S., B. J. BAUM & R. G. CRYSTAL. 1978. *Nature* **276**: 413–416.
13. TURNER, J. E. 1988. Ph.D. dissertation. University of London.
14. SKOSEY, J. L., R. ZAK & A. F. MARTIN. 1972. *Circ. Res.* **31**: 145–157.
15. LESLIE, K. O., D. J. TAATJES, J. SCHWARTZ, M. VON TURKOVICH & R. B. LOW. 1991. *Am. J. Pathol.* **139**: 207–216.
16. INGBER, D. E. & J. FOLKMAN. 1989. *In Cell Shape, Determinants, Regulation, and Regulatory Role.* W. D. STEIN & F. BRONNER, Eds. 3–31. Academic Press. New York.
17. SACHS, F. 1991. *Mol. Cell. Biochem.* **104**: 57–60.
18. BISHOP, J. E., J. J. MITCHELL, P. M. ABSHER *et al.* 1993. *Am. J. Respir. Cell Mol. Biol.* **9**: 126–133.
19. BISHOP, J. E., R. P. BUTT & G. J. LAURENT. 1992. *J. Endocrinol.* **132**(Suppl.): 276.
20. WILSON, E., Q. MAI, K. SUDHIR, R. H. WEISS & H. E. IVES. 1993. *J. Cell Biol.* **123**: 741–747.
21. CAROSI, J. A., S. G. ESKIN & L. V. MCINTIRE. 1992. *J. Cell. Physiol.* **151**: 29–36.
22. PEACOCK, A. J., K. E. DAWES, A. SHOCK, A. J. GRAY, J. T. REEVES & G. J. LAURENT. 1992. *Am. J. Respir. Cell Mol. Biol.* **7**: 492–499.
23. DAWES, K. E., A. J. PEACOCK, A. J. GRAY, J. E. BISHOP & G. J. LAURENT. 1994. *Am. J. Respir. Cell Mol. Biol.* **10**: 552–559.
24. BRILLA, C. G., G. ZHOU & K. T. WEBER. 1993. *Circulation* **88**(Suppl.): I-294.
25. LEOF, E. B., J. A. PROPER, A. S. GOUSTIN, G. D. SHIPLEY, P. E. DICORLETO & H. L. MOSES. 1986. *Proc. Natl. Acad. Sci. USA* **83**: 2453–2457.
26. WINLOVE, C. P. & K. H. PARKER. 1993. *Eur. Respir. Rev.* **3**(16): 535–542.
27. WEBER, K. T., C. G. BRILLA & J. S. JANICKI. 1993. *Cardiovasc. Res.* **27**: 341–348.
28. BUTT, R. P., G. J. LAURENT & J. E. BISHOP. 1994. Submitted.
29. BISHOP, J. E., R. P. BUTT & G. J. LAURENT. 1993. *Eur. Respir. Rev.* **3**(16): 613–617.
30. VILLARREAL, F. J. & W. H. DILLMANN. 1992. *Am. J. Physiol.* **262**: H1861–H1866.
31. SCHNEIDER, M. D., R. ROBERTS & T. G. PARKER. 1991. *Mol. Biol. Med.* **8**: 167–183.
32. VAN BILSEN, M. & K. R. CHIEN. 1993. *Cardiovasc. Res.* **27**: 1140–1149.
33. FULLER, S. J., J. R. MYNETT & P. H. SUGDEN. 1992. *Biochem. J.* **282**: 85–90.
34. CLARK, J. G., D. K. MADTES & G. RAGHU. 1994. *Exp. Lung Res.* **19**(3): 327–344.
35. CHUA, C. C., B. H. L. CHUA, Z. Y. ZHAO, C. KREBS, C. DIGLIO & E. PERRIN. 1991. *Connect. Tissue Res.* **26**: 271–281.
36. GOLDSTEIN, R. H., C. F. POLIKS, P. F. PILCH, B. D. SMITH & A. FINE. 1989. *Endocrinology* **124**: 964–967.
37. GILLERY, P., A. LEPERRE, F. MAQUART & J. BOREL. 1992. *J. Cell Physiol.* **152**: 389–396.
38. SARZANI, R., G. ARNALDI & V. CHOBANIAN. 1991. *Hypertension* **17**: 888–895.
39. THOMPSON, N. L., F. BAZOBBERRY, E. H. SPEIR *et al.* 1988. *Growth Factors* **1**: 91–99.
40. KARDAMI, E. & R. R. FANDRICH. 1989. *J. Cell Biol.* **109**: 1865–1875.
41. SPEIR, E., Z. YI-FU, M. LEE, S. SHRIVASTAV & W. CASSCELLS. 1988. *B. B. Res. Commun.* **157**: 1336–1340.
42. CHIBA, M., S. SAKAI, M. NAKATA & H. TOSHIMA. 1990. *Circulation* **82**: III–760.
43. DONOHUE, T. J., L. D. DWORKIN, W. SLATER & V. M. CATANESE. 1990. *Clin. Res.* **38**: 240A.
44. WATANABE, H., M. NIWA, K. YAMISHITA *et al.* 1990. *Nature* **344**: 114–117.
45. CAMPA, J. S., R. J. MCANULTY & G. J. LAURENT. 1990. *Anal. Biochem.* **186**: 257–263.
46. OLIVER, M. H., N. K. HARRISON, J. E. BISHOP, P. J. COLE & G. J. LAURENT. 1989. *Cell Sci.* **92**: 513–518.

Reactive Oxygen Intermediates (ROIs) Are Involved in the Intracellular Transduction of Angiotensin II Signal in C2C12 Cells

PIER LORENZO PURI,^{a,b} MARIA LAURA AVANTAGGIATI,^{b,e}
VITO LELIO BURGIO,^b PAOLO CHIRILLO,^b
DANIELA COLLEPARDO,^b GIOACCHINO NATOLI,^b
CLARA BALSANO,^{b,c} AND MASSIMO LEVRERO^{b,d}

^bFondazione Andrea Cesalpino
and
I Clinica Medica
University of Rome La Sapienza
Rome, Italy

^cDipartimento di Medicina Interna
University of L'Aquila
L'Aquila, Italy

^dIstituto di Medicina Interna
University of Cagliari
Cagliari, Italy

INTRODUCTION

The octapeptide angiotensin II, a potent vasoconstrictor, is also a growth factor for vascular smooth muscle cells (VSMC). Angiotensin II causes hyperplasia in some smooth muscle cells in culture, such as VSMC from the aorta of spontaneously hypertensive rats,¹ from the renal arterioles of normal rats² and from injured vessels.³ In several studies angiotensin II has also been shown to stimulate hypertrophic growth of cultured VSMCs.⁴ Thus, angiotensin II directly, or in combination with other growth factors, may play an important role in the development of vascular hypertrophy and elevated arterial resistance in hypertension.

A number of recent studies *in vivo* suggest that angiotensin II may be a critical factor in mediating cardiac hypertrophy as well (reviewed in Ref. 5). Hypertrophy is the fundamental adaptive process employed by postmitotic cardiac and skeletal muscle in response to mechanical load.⁶ Using an *in vitro* model of load-induced cardiac hypertrophy, it was recently demonstrated that mechanical stretch causes

^a Address for correspondence: Pier Lorenzo Puri, Istituto I Clinica Medica and Fondazione Andrea Cesalpino, Policlinico Umberto I, Università degli studi di Roma La Sapienza, Viale del Policlinico 155, 00161 Rome, Italy.

^e Present address: Laboratory of Molecular Growth Regulation, NICHD, NIH, Bethesda 20892, Maryland.

the release of angiotensin II from cardiac myocytes and that angiotensin II acts as the initial mediator of stretch-induced hypertrophic response.⁷ Locally produced angiotensin II may therefore act as an endogenous growth factor for the myocardium. Angiotensin II stimulation induces immediate early genes such as *c-fos*, *c-jun* and *Egr1* in cardiac myocytes and nonmyocytes leading, respectively, to hypertrophy and mitogenesis.⁸ The induction of immediate early genes in general is regulated by posttranslational modification of preexisting factors and is under the direct regulation by cellular second-messenger systems.⁹ We further characterize the intracellular signal transduction pathway of angiotensin II in C2C12 mouse skeletal myoblasts, which have the capacity to differentiate into myotubes in culture¹⁰ and to form long-term differentiated grafts in adult syngeneic ventricular myocardium,¹¹ using the activation of the AP1 transcription factor as a model. AP1 (for a recent review see Ref. 12) is a family of transcriptional factors whose major component in the cells is the heterodimeric complex formed by the product of the protocongenes *c-fos* and *c-jun*.

Angiotensin II Activates TRE-Directed Transcription in C2C12 Stable Transfectants

The Jun-Fos complexes bind a cis-element termed TPA (12-*O*-tetradecanoylphorbol-13-acetate) response element (TRE), which is present in several viral and cellular promoters, including human collagenase, stromelysin, metallothionein IIa, interleukin 2, HBV enhancer I and SV40.¹² To test the ability of angiotensin II to activate transcription regulated from a TRE site we generated C2C12 cell lines stably transfected with either a wild type TRE-tk-CAT or a mutant mtTRE-tk-CAT plasmid. As shown in FIGURE 1 angiotensin II increases CAT expression from the TRE severalfold while no effect has been observed on the mtTRE-tk-CAT cell line. This stimulation is specific since it is inhibited by the selective angiotensin receptor antagonist (Sar1 Ile8)-angiotensin II (FIG. 1), and is dose dependent with a peak stimulation of 10^{-5} M (data not shown).

Angiotensin II Augments the DNA Binding Activity of c-Fos/c-Jun Heterodimers in Quiescent Undifferentiated C2C12 Myoblasts and in Differentiated C2C12 Myotubes

Modulation of TRE-directed transcription is an extremely complex phenomenon which depends on the interplay between signals modulating either the intrinsic transcriptional activity or the DNA binding activity of the different TRE binding proteins. Therefore, we explored the ability of angiotensin II to modulate AP1 binding activity in the mouse skeletal muscle cell line C2C12 (FIG. 2A). When maintained in serum rich media C2C12 myoblasts proliferate rapidly and retain an undifferentiated phenotype.¹⁴ However, when cultured in low serum media at high confluence myogenic differentiation is induced: proliferating myoblasts withdraw from the cell cycle, a battery of muscle specific gene products is induced and they subsequently fuse to form multinucleated myotubes. If C2C12 myoblasts are maintained in 0.1% of serum at very low confluence for 24 to 36 hours they do not proliferate and do not differentiate, as determined by the absence of desmin

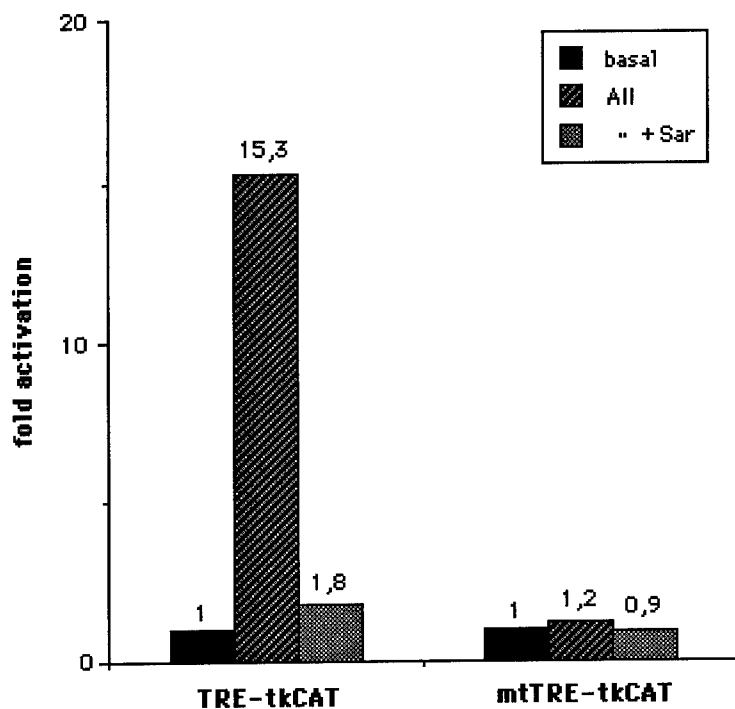

FIGURE 1. Angiotensin II activates TRE-directed transcription in C2C12 cell stable transfectants. To obtain the TRE-tk-CAT and the mtTRE-tk-CAT stable cell lines, C2C12 myoblasts were cotransfected with 5 ug of the CAT reporter plasmid and 250 ng of the neomycin resistance gene vector pAG60 by using the calcium phosphate precipitation method. After selection by G418 at 500 ug per ml, individual clones were picked up and expanded. The TRE-tk-CAT and the mtTRE-tk-CAT plasmids were derived from pBL2CATdel¹³ by inserting three copies of either a wild type or a mutated human collagenase TRE upstream from the tk promoter. Cells from both stable cell lines were plated at 2×10^6 per 10-cm dish, cultured for 24 hours, exposed to angiotensin II for 24 hours and then assayed for CAT activity as described.¹³ The results are expressed as fold activation. Experiments were repeated three to five times with at least two different preparations of DNA. Sar: (Sar1 Ile8)-angiotensin II.

expression and very low levels of DNA binding activity to muscle specific "E-box" probes (data not shown), so that they can be considered quiescent myoblasts. As shown in FIGURE 2B, actively growing C2C12 myoblasts display a high AP1 binding activity that rapidly decreases with serum starvation and is completely abolished by the addition of specific cold TRE oligonucleotides but not of unrelated cold NFkB oligonucleotides. During differentiation (FIG. 2C), AP1 activity drops at day 1 and subsequently increases to reach stable levels that are lower than those observed in cycling myoblasts. Angiotensin II strongly increases AP1 binding activity in both quiescent myoblasts (FIG. 3A) and differentiated myotubes (FIG. 3B) and the phenomenon is specific since it is abolished by (Sar1 Ile8)-

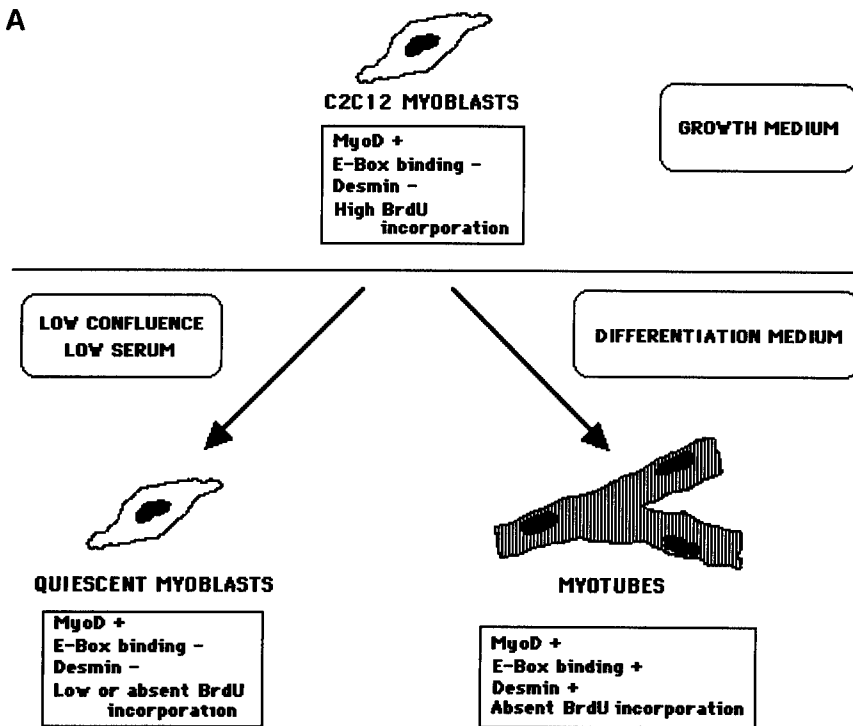

FIGURE 2. AP1 binding activity in C2C12 mouse muscle cells (A). Actively growing C2C12 cells were maintained in Dulbecco's modified Eagle's medium (DMEM) supplemented with 10% fetal bovine serum (growth medium). Quiescent myoblasts were obtained by plating the C2C12 cells at low confluence in DMEM supplemented with 0.1% fetal bovine serum. To induce differentiation, subconfluent C2C12 myoblasts were cultured with Dulbecco's modified Eagle's medium containing 1% fetal bovine serum (differentiation medium) for 48 to 72 hours. Cell extracts were prepared at the indicated time points as described elsewhere¹⁵ in actively growing, serum-starved "quiescent" (B) and differentiated (C) C2C12 cells. Protein concentrations in the extracts were determined by the method of Lowry *et al.*¹⁶ Five micrograms of cell extract were incubated with 1 μ g of poly(dIdC)-poly (dIdC), and then a large excess (2 fmol) of ³²P-5'-end-radiolabeled oligonucleotide containing a canonical TRE site (5'TCGAGTGTCTGACTCATGCTTTTCA3') was added. After 20 minutes at room temperature, the samples were subjected to electrophoresis on a 4% polyacrylamide gel with 0.25 \times TBE (1 \times TBE is 0.089 M tris-borate, 0.089 M boric acid, 0.002 M EDTA). After electrophoresis, the gel was fixed with 10% acetic acid-10% ethanol, dried and exposed to X-ray film at -70°C . The specificity of the retarded complexes was assessed by preincubating the extracts with increasing amounts of cold specific TRE or unrelated NF κ B probes.

angiotensin II. To determine the composition of the TRE-bound complexes in angiotensin II-treated C2C12 myoblasts and myotubes, cell extracts were preincubated with anti-c-Fos and anti-c-Jun antibodies that do not cross-react with other members of the Fos and Jun families. Both a polyclonal antibody directed against the N-terminal domain of c-Jun (Oncogene Science Ab-2) and a polyclonal antibody against the epitope 128-152 of c-Fos (Santa Cruz Biotechnology) were able

to reduce the TRE binding activity by 90 to 95%, suggesting that most of the TRE-bound AP1 proteins consist of c-Fos and c-Jun. A variety of control antibodies (anti-p53, anti-E1A, anti-Myc) were unable to modify the observed pattern (FIGS. 3A,B).

Angiotensin II-Dependent Increase of AP1 Binding in C2C12 Cells is Mediated by Multiple Intracellular Signaling Pathways

AP1 regulation involves both transcriptional and posttranscriptional events. Since the angiotensin II-induced increase of AP1 binding already occurs after 10 minutes of stimulation and is not affected by cycloheximide treatment at doses able to completely inhibit protein synthesis (FIG. 4A), it is likely that posttranslational modifications of preexisting AP1 proteins could be responsible for this increase. Phosphorylation and dephosphorylation of c-Fos and c-Jun have been described

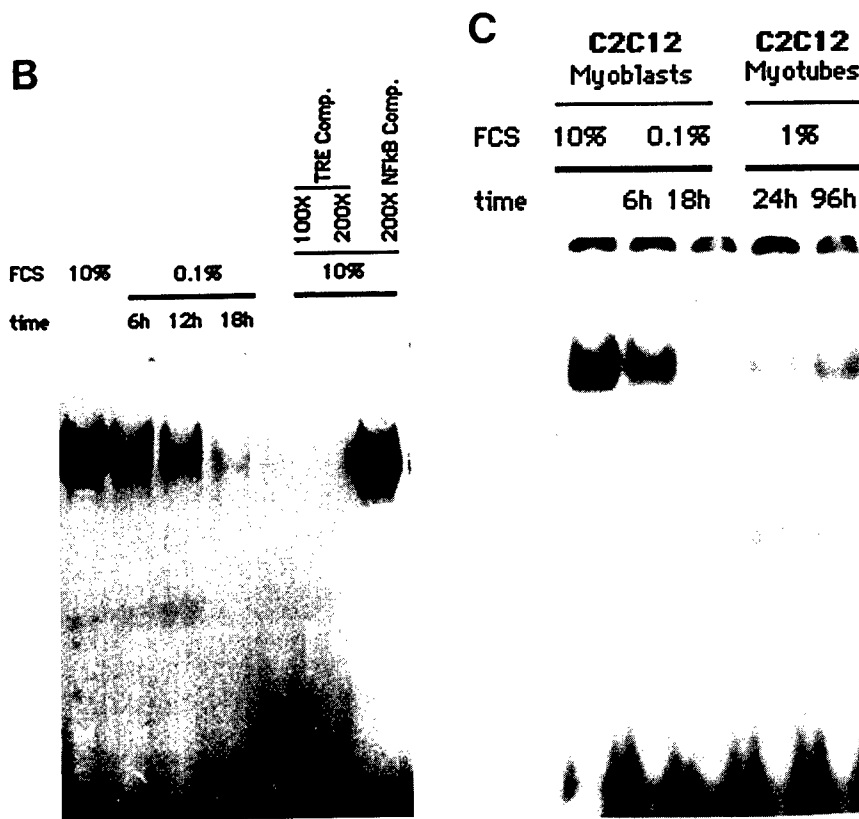

FIGURE 2. (Continued)

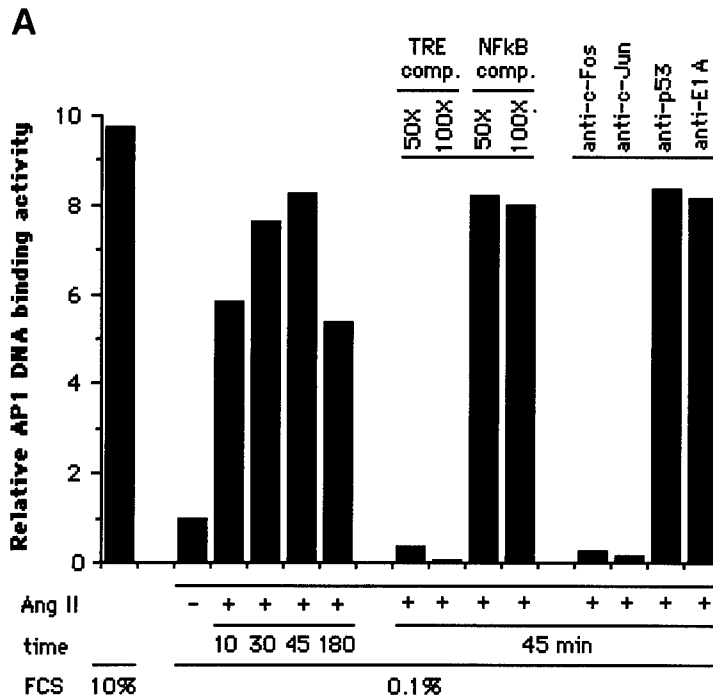

FIGURE 3. Induction of AP1 binding by angiotensin II in quiescent C2C12 myoblasts (A) and in differentiated C2C12 myotubes (B). Cell extracts were prepared and tested in gel retardation assays as described in the legend for FIGURE 2. The relative AP1 DNA binding activity was evaluated by laser densitometry analysis (Gel Scan, Pharmacia) and expressed as fold activation with respect to either unstimulated quiescent myoblasts (A and C) or unstimulated differentiated myotubes (B). The composition of the TRE-bound complexes was evaluated preincubating overnight cell extracts from angiotensin II-treated cells with 0.5 ug of anti-c-Fos and anti-c-Jun antibodies that do not cross-react with other Fos and Jun proteins. Cycloheximide was added to angiotensin II-untreated and -treated cells at the concentration of 10 ug/ml (C).

as posttranslational modifications with a critical role in AP1 function regulation. Phosphorylation of c-Jun N-terminus induced by the Ras-Raf-MAP kinase cascade augments its transactivating function,^{17,18} while the TRE-binding activity of c-Jun homodimers is upregulated by a PKC-dependent dephosphorylation of a sequence just upstream of the carboxy terminal DNA-binding domain.^{19,20} We first tested the effect of a set of different protein kinase inhibitors on angiotensin II-induced AP1 activity. HA1004 and H7 are relatively selective inhibitors of cAMP-dependent protein kinase (PKA) and protein kinase C (PKC), respectively. Staurosporine interferes with PKC function, acting on its catalytic domain, but also exerts an inhibitory activity on both PKA and pp60 v-Src tyrosine kinase. Tyrphostin 25 and genistein are specific inhibitors of tyrosin kinases, while tyrphostin 1

is an inactive analogue of tyrphostin 25. As shown in FIGURE 4B, the basal AP1 binding activity of quiescent C2C12 myoblasts was not modified by any of these inhibitors. Staurosporine, H7, tyrphostin 25 and genistein all abolish the angiotensin II-induced increase of AP1 binding while HA1004 has no effect (FIG. 4A). This result suggests that angiotensin II signaling for AP1 binding increase involves the activation of both PKC and tyrosine kinases, while the cAMP-dependent protein kinase does not seem to play a significant role.

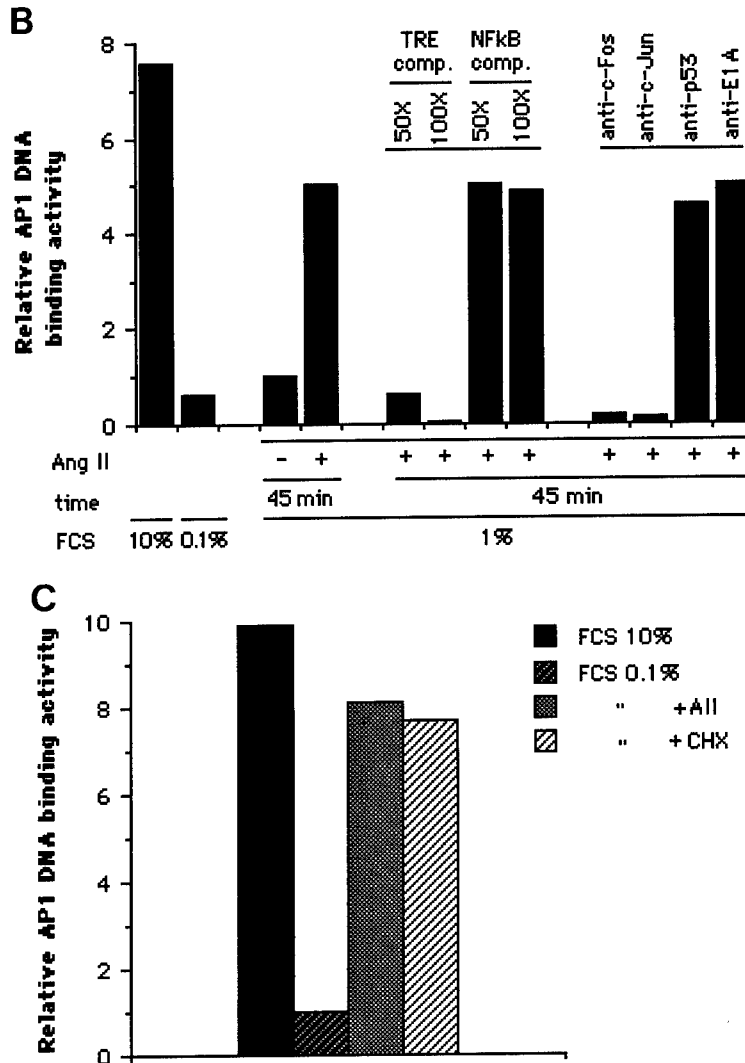

FIGURE 3. (Continued)

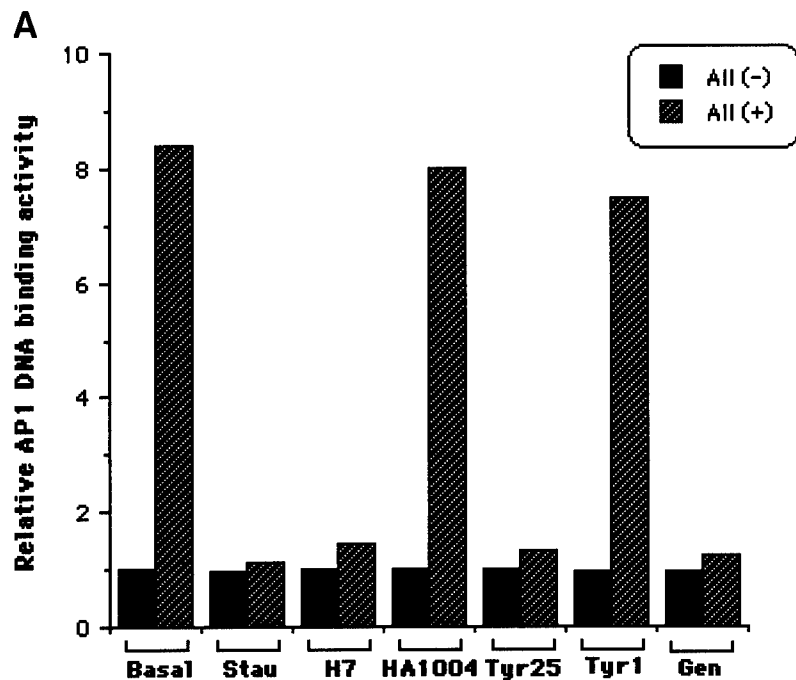

FIGURE 4. Effects of protein kinase inhibitors (A) and anti-oxidants (B) on the induction of TRE binding by angiotensin II. Cell extracts were prepared from unstimulated and angiotensin II-stimulated C2C12 quiescent myoblasts treated with different protein kinases inhibitors (A) and the cysteine derivative and glutathione precursor *N*-acetyl-L-cysteine (NAC) (B). Gel retardation assays were performed as described in FIGURE 2. HA1004 (*N*-2-guanidinoethyl-5-isoquinolinesulfonamide), H7 (1-(5-isoquinolinesulfonyl)-2-methylpiperazine), staurosporine, genistein, tyrphostin 25 and tyrphostin 1 were dissolved in dimethyl-sulfoxide (DMSO) and added to cells 2 hours before the angiotensin II stimulation at the final concentration of 75 μ M, 100 μ M, 70 ng/ml, 100 μ M, 20 μ M and 20 μ M, respectively. NAC (*N*-acetyl-L-cysteine) was dissolved in H₂O and added to cells before angiotensin II stimulation at the final concentration of 20 mM.

Reactive Oxygen Intermediates (ROIs) Are Involved in Both AP1 DNA Binding Activity and Cell Proliferation Induced by Angiotensin II

Additional regulatory mechanisms of AP1 activity involve reduction and oxidation events. Eukaryotic cells continuously produce the reactive oxygen intermediates (ROIs) H₂O₂, superoxide (O₂⁻) and hydroxyl radical (OH⁻) as side products of electron transfer reactions.²¹ A condition of oxidative stress, characterized by above normal levels of ROIs, occurs frequently in cells exposed to UV light, gamma rays or low concentrations of H₂O₂ but also upon stimulation of cells with cytokines and other natural ligands for cell surface receptors.²² While very high levels of ROIs, as produced by stimulated neutrophils, are strictly cytotoxic, due to their ability to cause irreversible damage to DNA, proteins and lipids, and to serve primarily to kill parasites in the organism, the increase of ROI levels ob-

served in many conditions seems to induce many early growth signals including a rise in intracellular pH,²³ the expression of c-Fos, c-Jun and c-Myc proto-oncogenes and the activation of transcription factors,^{22,24,25} protein kinases,²⁶ protein phosphatases²⁷ and ion channels.²⁸ AP1 genes are strongly induced by conditions causing a prooxidant state of cells. Both an increase in AP1 DNA binding,²⁹ with an even greater induction of c-jun and c-fos mRNAs,²⁹ and modulation of the c-jun transcription activation domain, mediated by a pathway including src tyrosin kinase and the Ha-Ras small guanosine triphosphate-binding protein, have been observed in response to H₂O₂ or UV.³⁰ Indeed, treatment of quiescent C2C12 myoblasts with hydrogen peroxide (H₂O₂), as a source of reactive oxygen intermediates, results in a clear dose-dependent induction of AP1 binding activity, specifically inhibited by the cystein derivative and glutathione precursor N-acetyl-L-cysteine (NAC) (FIG. 4B). Interestingly, NAC was also able to almost completely abolish the angiotensin II-induced increase of AP1 binding suggesting a role for ROIs in the transduction of angiotensin II signal. Many effects of ROIs may be involved in the induction of cell growth, and indeed oxidants stimulate growth in various cell types.²¹ As already mentioned, angiotensin II is a growth factor for several muscle cell types. To examine the effects of angiotensin II treatment on

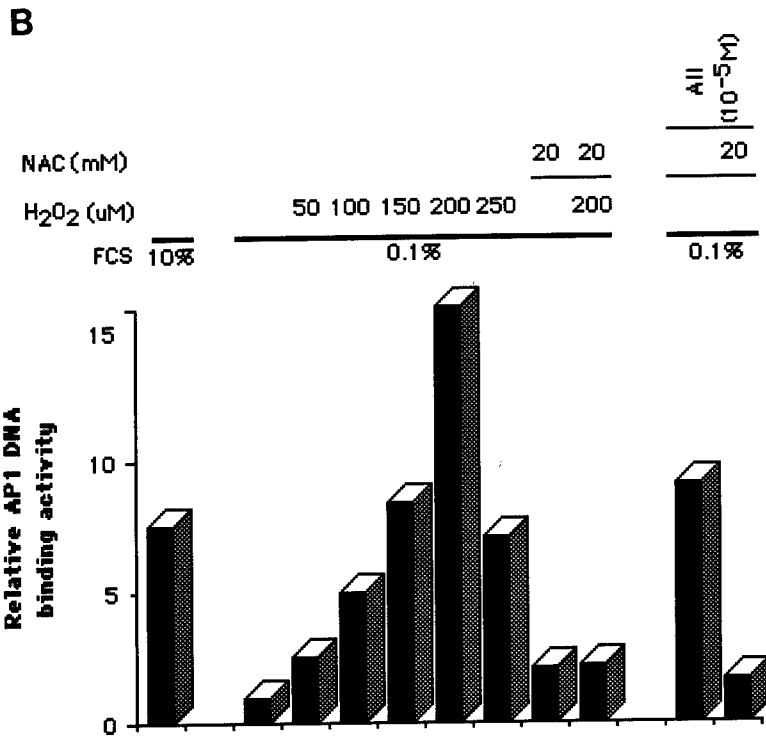

FIGURE 4. (Continued)

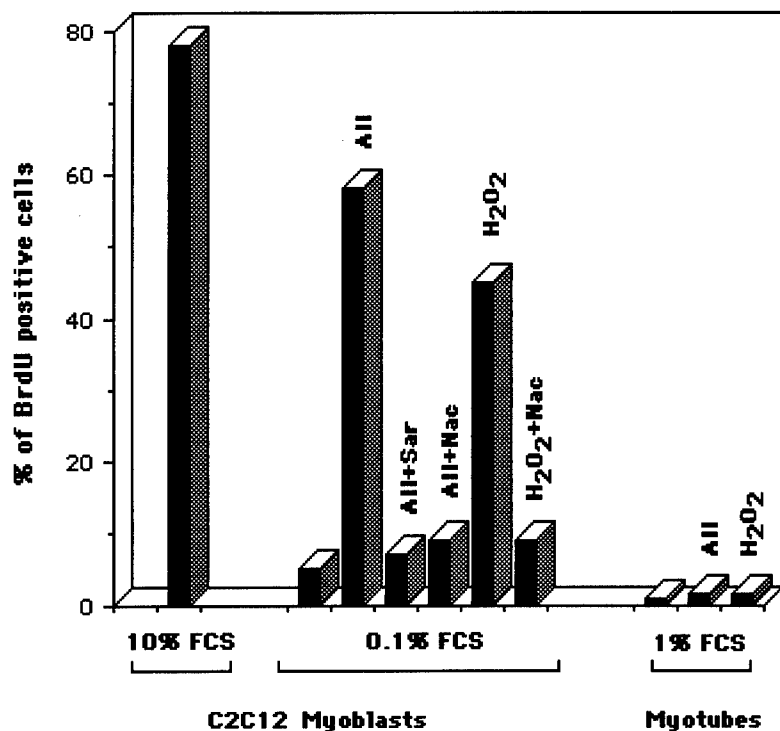

FIGURE 5. Induction of DNA synthesis by angiotensin II in quiescent C2C12 myoblasts. Cells were kept in either 0.1% serum (myoblasts) or 1% serum (myotubes) for 48 hours and then stimulated with angiotensin II at 10^{-5} M or 200 μ M H_2O_2 for 24 hours in the presence or absence of (Sar1 Ile8)-angiotensin II and NAC. Control cultures were prepared without stimulation with angiotensin II or H_2O_2 . In both preparations, BrdU (10 μ M) was added for the last 18 hours. Cells were fixed in methanol for 10 minutes at $-20^\circ C$, rehydrated in PBS and incubated in 2N HCl for 1 hour at $37^\circ C$. After neutralization in 0.1 M borate buffer (pH 8.5), cells were washed in PBS and processed for the immunohistochemical staining. Alkaline phosphatase-conjugated mouse monoclonal antibody against BrdU was used.

the rate of DNA synthesis in quiescent undifferentiated C2C12 cells and in C2C12 differentiated myoblasts, cells were labeled with the thymidine analogue BrdU. Angiotensin II has a clear mitogenic effect on undifferentiated myoblasts while it has no effects, as expected, on differentiated myotubes (FIG. 5). The induction of myoblast proliferation by angiotensin II is specifically inhibited by (Sar1 Ile8)-angiotensin II and it is almost completely abolished by NAC (FIG. 5). This result suggests that ROI generation also plays a role in the regulation of cell proliferation by angiotensin II.

CONCLUSIONS

Our results indicate that angiotensin II stimulates c-fos/c-jun heterodimers DNA binding activity in both undifferentiated C2C12 myoblasts and differentiated

C2C12 myotubes. Although AP1 activity is required in the induction of cell proliferation by growth factors, serum and TPA,³¹ angiotensin II-dependent AP1 activation in C2C12 myotubes occurs independently of DNA synthesis stimulation, suggesting that modulation of TRE containing genes by AP1 in differentiated cells might be important for other cellular responses. AP1 induction by angiotensin II involves the activation of several components of the intracellular signaling machinery, including PKC, tyrosine kinases and reactive oxygen intermediate (ROI) generation. A role for oxidative stress has been proposed in different pathological conditions such as atherogenesis and carcinogenesis.³² Increased concentrations of active oxygen species have also been measured in response to angioplasty, during the inflammatory stage of the restenosis process.³³ An important aspect of these pathological conditions is hyperplasia, and our results indicate that ROI generation also mediates the mitogenic effects of angiotensin II on quiescent C2C12 cells.

SUMMARY

Increasing evidence suggests that angiotensin II may act as a growth factor for several muscle cell types. Angiotensin II stimulation activates many immediate early response genes like c-Fos, c-Jun, c-Myc and Egr-1 in both vascular smooth muscle cells and cardiomyocytes, independently of whether a hyperplastic or hypertrophic response is taking place. In this study we report that angiotensin II significantly stimulates AP1-driven transcription in mouse skeletal muscle cells C2C12 stably transfected with a TRE-tk-CAT plasmid in a dose-dependent manner (peak stimulation at 10^{-5} M of angiotensin II). Moreover, angiotensin II increases the binding of the AP1 complex to its DNA target in both quiescent C2C12 myoblasts and in differentiated C2C12 myotubes. Most of the TRE-bound complexes in both unstimulated and angiotensin II-treated cells consist of c-jun/c-fos heterodimers. Using a set of different protein kinase inhibitors, including HA1004, H7, tyrphostin, genistein and staurosporine, we could demonstrate that the angiotensin II-induced AP1 binding increase is not mediated by the cAMP-dependent pathway and that protein kinase C and tyrosine kinases are involved. Treatment of C2C12 cells with H_2O_2 induces a dose-dependent increase in c-jun/c-fos heterodimer binding, specifically reverted by the cysteine derivative and glutathione precursor N-acetyl-L-cysteine (NAC). The observation that the induction by angiotensin II of both the AP1 DNA binding activity and DNA synthesis in quiescent C2C12 myoblasts is abolished by NAC strongly suggests a role for reactive oxygen intermediates (ROIs) in the intracellular transduction of angiotensin II signals for immediate early gene induction and for cell proliferation.

REFERENCES

1. DAEMEN, M. J. A. P., D. M. LOMBARDI, F. T. BOSMAN & S. M. SCHWARTZ. 1991. *Circ. Res.* **68**: 450–456.
2. PAQUET, J. I., M. BADOUIN-LEGROS, G. BRUNELLE & P. MEYER. 1990. *J. Hypertens.* **8**: 565–572.

3. STOFFER, G. A. & G. K. OWENS. 1992. *Circ. Res.* **70**: 820-828.
4. BERK, B. C., V. VEKSHTEIN, H. M. GORDON & T. TSUSA. 1989. *Hypertension* **13**: 305-314.
5. LINDPAINTEINER, K. & D. GANTEN. 1991. *Circ. Res.* **68**: 905-921.
6. SADOSHIMA, J., L. JAHN, T. TAKAHASHI, T. J. KULIK & S. IZUMO. 1992. *J. Biol. Chem.* **267**: 10551-10560.
7. SADOSHIMA, J., Y. XU, H. S. SLAYTER & S. IZUMO. 1993. *Cell* **75**: 977-985.
8. SADOSHIMA, J. & S. IZUMO. 1993. *Circ. Res.* **73**: 413-423.
9. RIVERA, V. M. & M. E. GREENBERG. 1990. *New Biol.* **2**: 751-758.
10. JAFFE, D. & O. SAXEL. 1977. *Nature* **270**: 725-727.
11. KOH, G. Y., M. G. KLUG, M. H. SOONPAA & L. J. FIELD. 1993. *J. Clin. Invest.* **92**: 1548-1554.
12. ANGEL, P. & M. KARIN. 1991. *Biochem. Biophys. Acta* **1272**: 129-157.
13. AVANTAGGIATI, M. L., G. NATOLI, C. BALSANO, P. CHIRILLO, M. ARTINI, E. DE MARZIO, D. COLLEPARDO & M. LEVRERO. 1993. *Oncogene* **8**: 1567-1574.
14. ALEMÀ, S. & F. TATÒ. 1994. *Semin. Cancer Biol.* **5**: 147-156.
15. NATOLI, G., M. L. AVANTAGGIATI, P. CHIRILLO, A. COSTANZO, M. ARTINI, C. BALSANO & M. LEVRERO. 1994. *Mol. Cell. Biol.* **14**: 898-898.
16. LOWRY, O. H., N. J. ROSENBROUGH, A. L. FARR & R. J. RANDALL. 1951. *J. Biol. Chem.* **193**: 265-275.
17. BINETRUY, B., T. SMEAL & M. KARIN. 1991. *Nature* **351**: 122-127.
18. PULVERER, B. J., J. M. KYRIAKIS, J. AVRUCH, E. NIKOLAKAKI & J. R. WOODGETT. 1991. *Nature* **353**: 670-674.
19. BOYLE, W. J., T. SMEAL, L. H. K. DEFIZE, P. ANGEL, J. R. WOODGETT, M. KARIN & T. HUNER. 1991. *Cell* **64**: 573-584.
20. LIN, A., J. FROST, T. DENG, T. SMEAL, N. AL-ALAWI, U. KIKKAWA, T. HUNTER, D. BRENNER & M. KARIN. 1992. *Cell* **70**: 777-789.
21. HALLIWELL, B. & J. M. C. GUTTERIDGE, eds. 1989. *Free Radicals in Biology and Medicine*. 2nd edit. Clarendon Press. Oxford, England.
22. SCHRECK, R., P. RIEBER & P. BAUERLE. 1991. *EMBO J.* **10**: 2247-2258.
23. SHIBANUMA, M., T. KUROKI & K. NOSE. 1988. *J. Cell Physiol.* **136**: 379-383.
24. MAKI, A., I. K. BEREZESKY, J. FARGNOLI, N. J. HOLBROOK & B. F. TRUMP. 1992. *FASEB J.* **6**: 919-924.
25. RAO, G. N., B. LASSEGUE, K. GRIENGLING & R. ALEXANDER. 1993. *Oncogene* **8**: 2759-2764.
26. BAUSKIN, A. R., I. ALKALAY & Y. BEN-NERIAH. 1991. *Cell* **66**: 685-696.
27. GUY, G. R., J. CAIRNS, S. BEE NG & Y. H. TAN. 1993. *J. Biol. Chem.* **268**: 2141-2148.
28. RUPPENBERG, J. P., M. STOCKER, O. PONGS, S. H. HEINEMANN, R. FRANK & M. KOENEN. 1991. *Nature* **352**: 711-714.
29. DEVARY, Y., R. A. GOTTLIEB, L. F. LAU & M. KARIN. 1991. *Mol. Cell Biol.* **11**: 2804-2811.
30. DEVARY, Y., R. A. GOTTLIEB, T. SMEAL & M. KARIN. 1992. *Cell* **71**: 1081-1091.
31. KOVARY, K. & R. BRAVO. 1991. *Mol. Cell Biol.* **11**: 4466-4472.
32. Ref. deleted.
33. CERUTTI, P. A. & B. F. TRUMP. 1991. *Cancer Cell* **3**: 1-7.
34. KONTOS, H. A., E. P. WEI, J. T. POVLISHOCK & W. CHRISTMAN. 1984. *Circ. Res.* **55**: 295-303.

Characterization of Fibroblast Growth Factor Receptor 1 RNA Expression in the Embryonic Mouse Heart^a

KISHORE B. S. PASUMARTHI,^b YAN JIN,^b
MARGARET E. BOCK,^b ARISTIDES LYTRAS,^b
ELISSAVET KARDAMI,^c AND PETER A. CATTINI^{b,d}

^b*Department of Physiology
University of Manitoba
770 Bannatyne Avenue
Winnipeg, Manitoba, Canada R3E 0W3*

and
^c*Division of Cardiovascular Sciences
St. Boniface Hospital Research Centre
751 Tache Avenue
Winnipeg, Manitoba, Canada R2H 2A6*

Basic Fibroblast Growth Factor and Receptor Isoforms in the Heart

Basic (b) fibroblast growth factor (FGF) mediates various biological responses including mitogenesis, angiogenesis and repair of tissue injury by binding to specific cell surface receptors of the tyrosine kinase family.¹ Several reports have suggested an important role for bFGF in myocardial growth, development and injury, with particular regard to myocyte cell division.²⁻¹⁰ Additional roles for this factor related to angiogenesis,¹¹ modulation of muscle gene expression,¹² cardioprotection^{13,14} and intercellular communication of heart cells¹⁵ have been reported.

The heart loses its proliferative potential during development and becomes less responsive to growth factors.¹² Although the presence of bFGF receptors in the embryonic heart is clear,^{11,16,17} the data regarding bFGF receptor RNA expression in the adult heart is controversial with studies suggesting a range of levels from high to undetectable.^{6,11,18-20}

All members of the FGF receptor family exist as short or long isoforms due to alternate splicing which can result in the presence of two (short) or three (long) extracellular immunoglobulin (Ig)-like domains in addition to the transmembrane region and intracellular tyrosine kinase domains (FIG. 1).¹ The FGFR1 gene contains an intron separating the first Ig-like domain from the remainder of the FGFR1 coding sequence and, thus, the presence or absence of the first Ig-like domain

^a This work was supported by a London Life Award and a grant from the Medical Research Council of Canada (MT12303). K. B. S. Pasumarthi is a recipient of a Heart and Stroke Foundation Studentship, A. Lytras is a recipient of a Manitoba Health Research Council Studentship and P. A. Cattini is a recipient of a Medical Research Council of Canada Scientist Award.

^d Corresponding author.

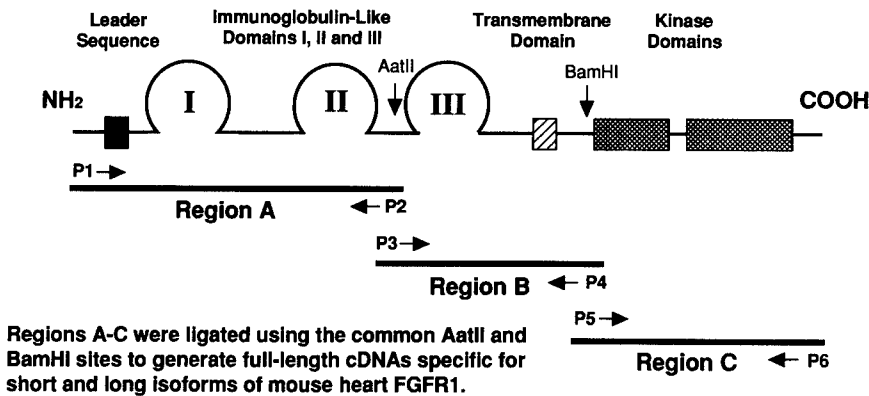

FIGURE 1. Diagram showing the structure of mouse FGFR1. The *solid box* indicates a hydrophobic leader sequence, the *three loops* (I–III) indicate the immunoglobulin-like domains in the extracellular portion of the receptor, the *striped box* indicates the transmembrane domain and the *cross-hatched boxes* represent kinase domains.¹ The *HindIII* sites in the sense primers (P1: 5'-AGATCTAAGCTTGTGGAATATCCATGGAGGTACGGAGCC-3', P3: 5'-GAGAATAAGCTTGGGAGCATCAACCACACCTACCAGC-3' and P5: 5'-GACCCCAAGCTTGGCTGGAGTCTCCGAATATGAGCTCCC-3') are indicated in *bold typeface*. The *EcoRI* sites in the antisense primers (P2: 3'-GCACCTTGCTA-GAGCGTGGCTGGG GCTTAAGGTCGT-5', P4: 3'-CCGCTCCCAGCAAGCCCGCT-TAAGACAAC-5' and P6: 3'-CGGTTGTCACCTGAGTTT GCCGCGACTCTTAAGCTA-TAG-5') are indicated by *underlining*.

mediated by alternative splicing results in long (three Ig-like domains) or short (two Ig-like domains) isoforms of FGFR1.¹ Alternate splicing in the second half of the third Ig-like domain is reported to be important for determining the ligand-binding specificities.²¹ The second half of the third Ig-like domain is contained in exon III, and three alternate exons (IIIa, IIIb and IIIc) have been described.²¹ The FGF receptor-1 (FGFR1) containing the IIIc domain (FGFR1-IIIc) is considered to be the common receptor for both acidic FGF as well as bFGF. In addition to gross differences arising from alternate splicing, variant forms of FGF receptors with minor amino acid differences have been described.^{22,23} The data also suggest tissue-specific production of FGF receptor isoforms¹ with even expression of different receptor isoforms in various tissues of the same species (mouse: brain;²⁴ neuroepithelial cells;¹⁸ A-15/NIH3T3 cells;²⁵ fibroblasts;²⁶ breast cancer cells;²⁷ rat: brain versus other tissues;²⁰ and human: placenta versus endothelial cells;²² liver cells²⁸). However, the structure of the FGFR1 receptor RNA from the heart has not been reported.

RT-PCR Cloning: Generation of Full-Length Short and Long Forms of FGFR1 cDNAs from the Embryonic Mouse Heart

We cloned two full-length cDNAs encoding short and long forms of FGFR1 from the embryonic mouse heart. Total RNA was isolated from embryonic (15-

day) Swiss Webster mouse hearts²⁹ and reverse transcribed with random hexadeoxynucleotide primers. Three overlapping regions (region A, nucleotides 1–822; region B, nucleotides 766–1528; and region C, nucleotides 1427–2526) of FGFR1 were amplified by RT-PCR using sense primers P1, P3, P5 and antisense primers P2, P4, P5, respectively³⁰ based on embryonic mouse neuroepithelial cell FGFR1 sequences (FIG. 1).¹⁸ PCR products were resolved in 1.5% agarose gels, isolated and subcloned into a modified pBS (SK + ; *Bam*HI deleted) vector using unique *Eco*RI and *Hind*III sites contained in the sense and antisense primers, respectively (FIG. 1).³¹ These overlapping regions contain sequences coding for the first and/or second Ig-like domains (region A), third Ig-like domain and transmembrane domain (region B) and the intracellular tyrosine kinase domains (region C) of mouse FGFR1 (FIG. 1). RT-PCR amplification of region A (including primer sequences) resulted in two products of 579 and 846 nucleotides, depending on whether the transcript for the short or long form of FGFR1 was amplified.³⁰ Amplification of regions B and C (including primer sequences) resulted in fragments of 790 and 1112 nucleotides, respectively. All regions (A–C) of FGFR1 were sequenced and ligated using unique restriction sites in the overlaps (*Aat*II and *Bam*HI) to generate full-length short (2259 bp) and long (2526 bp) forms of embryonic mouse heart FGFR1 cDNAs (FIG. 2).³⁰

A putative methionine codon is located at nucleotide position 58 in both short and long FGFR1 cDNAs and translation from this codon would predict peptides with molecular sizes of about 82 kDa and 92 kDa, respectively. A comparison between embryonic mouse heart and neuroepithelial FGFR1 cDNAs revealed 7 amino acid differences (FIG. 2).³⁰ The majority of sequence differences observed in the mouse heart cDNA could be found in FGFR1 sequences reported from other sources. For example, amino acids 256–258 (ILQ) and 756 (R) of our sequence differed from the reported mouse FGFR1 sequence¹⁸ but are identical to the human placenta FGFR1²² and mouse A-15/NIH3T3 FGFR1 sequences.²⁵ The long but not short FGFR1 isoform mRNA revealed a deletion of two arginine residues (equivalent to amino acids 148 and 149 in mouse brain FGFR1, FIG. 2) between the first and second extracellular Ig-like domains in one of the four independent clones. A similar deletion was reported in the short form of FGFR1 from the mouse neuroepithelial cell line¹⁸ and in the long forms from mouse brain,²⁴ a breast cancer cell line²⁷ and fibroblasts.²⁶ This two-amino acid deletion could arise from the alternative splicing of a mini-exon.³² In one of the four region A clones generated, we observed a substitution of a single nucleotide in a long but not short form of FGFR1, which results in a change of amino acid 13 from the “normal” leucine to proline.³⁰ Alterations at the level of single amino acids of FGFR1 within the same species were reported previously.³⁰ For example, amino acid 270 of mouse FGFR1 can be occupied by glycine¹⁸ or alanine,²⁵ and amino acid 765 (FIG. 2) can be occupied by glutamic acid¹⁸ or aspartic acid.²⁵ However, we cannot rule out the possibility that single amino acid changes (which can result from a single nucleotide alteration) represent errors introduced during PCR.

The significance of these changes in the amino acid sequence of mouse heart FGFR1 is unclear. However, even single alterations in the amino acid sequence could affect the receptor directly or indirectly by interfering with the structure and accessibility to functional domains. It is reported that point mutation of tyro-

Consensus	HWGKCLLFH AVLVTAITLCT ARPAPTLPDQ ▽ AQPWGVVPEV ELLLVHFGDL LQLRCLRDD VQSIMWLRDG VQLVE	75
m. brain	75
m. heart	75
Consensus	SNRTRITGEE VEVRDSIPAD SGLYACVTSS P6GSDTTYFS ▽ VNVSDALPSS EDDDDDDSS SEEKETDWTX PMRRP	150
m. brain	150
m. heart	150
Consensus	VAPYWTSPEK MEKELHAVPA AKTVKFKCPS SGTNPITLW LKNGKEFKPD HRIGGYKVRY ATWSIIMDSV VPSDK	225
m. brain	225
m. heart	225
Consensus	GNYTCIVENE YGSINHTYQL DVVERSHPRP ...AGLPAN. TVALGSNVZP MCKVYSDPQP HIQWLKHIEV NGSKI	300
m. brain HPS.....K	300
m. heart ILQ.....E	300
Consensus	GPDLNLPYVQI LKTAGVNTTD KEMEVLHLRN VSPEDAGEYT CLAGNSIGLS HHSAWLTVLE ALBERPAVMT SPLYL	375
m. brain	375
m. heart	375
Consensus	▽ EIIYCTGAP LISCHLGEVI ▽ IYKMSGTXK SDFHSQMAVH KLAksiPLRR QVTSADSSA SMNSGVLLVR PSRLS	450
m. brain	450
m. heart	450
Consensus	SSGTPH.AGV SEYELPEDPR WELPRDRLVL GKPLGEGCFG QVWLAEIAGL DKDKPNRVTK VAVKMLKSDA TEKDL	525
m. brainL.....	525
m. heartP.....	525
Consensus	SDLISEHEMH KHIGKHKNII NLLGACTQDG PLYVIVEYAS KGNLREYLQA RPPGLECYCY NPSHNPEEQL SSKDL	600
m. brain	600
m. heart	600
Consensus	VSCAYQVARG MEYLASKKCI HRDLAARNVL VTEDNVKIA DPGLARDIHH IDYKKTIMG RLPVKWMAPE ALPDR	675
m. brain	675
m. heart	675
Consensus	IYTHQSDVWS FGVLLWEIPT LGGSPYGPVP VEELPKLLKE GHRHDKPSNC TNELYMMARD CWHAVPSQRP TPKQL	750
m. brain	750
m. heart	750
Consensus	VEDLD.IVAL TS.QEYLDLS IPLDQYSFSP PDTRSSSTCSG GEDSVFSHEP LPPEPCLPKH PTQLANGLK RR	822
m. brainH.....N.....	822
m. heartR.....S.....	822

FIGURE 2. Deduced amino acid sequence of the long FGFR1 generated from embryonic mouse heart RNA. Numbers at the right indicate positions of amino acid residues. The region absent from the short FGFR1 generated from embryonic mouse heart RNA is contained within the *open triangles*. The putative transmembrane domain is contained within the *closed triangles*. A consensus sequence for mouse brain¹⁸ and heart FGFR1³⁰ is presented and mismatches are indicated. Arginines 148 and 149 were absent in 1 out of 4 long FGFR1 clones generated.

sine 766 to phenyl alanine in the FGF receptor eliminates phosphatidylinositol hydrolysis without affecting mitogenesis.^{33,34} These studies alone suggest the presence of more than one signaling pathway that might be affected by changes in receptor structure.

In Vitro Transcription and Translation: the Major Products of Short and Long Embryonic Mouse Heart FGFR1 cDNAs are 86- and 102-kDa Proteins, Respectively

Both the short and long embryonic mouse heart FGFR1 cDNAs in pBS (SK + ; BamHI deleted) were transcribed and translated in the presence of ³⁵S-methionine

using a T7 coupled reticulocyte lysate system (Promega Corp., Madison, Wisconsin).³⁰ The translated products were visualized by sodium dodecyl sulphate polyacrylamide gel electrophoresis followed by autoradiography³⁰ and revealed 86-kDa and 102-kDa proteins as the largest major products of the short and long FGFR1 cDNAs, respectively (FIG. 3). The sizes of the translated products from FGFR1 cDNAs are consistent with the predicted sizes of short and long forms of embryonic mouse heart FGFR1 based on their amino acid composition as well as the 89-amino acid deletion and absence of the first Ig-like domain in the short form predicted from the cDNA sequence (FIG. 2). In addition to the 86- and 102-kDa bands, a translated product of 74.5 kDa was generated with both the short and long FGFR1 cDNAs (FIG. 3). The size of this product is consistent with translation from the second in-frame methionine located at position 161, which is present in both the short and long forms (FIG. 2).

RNA Blot Analysis of Mouse FGFR1: FGFR1 RNA is Expressed in the Embryonic and Adult Mouse Heart

Embryonic tissues, including the heart, are in general more responsive to growth factors compared to the adult tissues which could be explained by a de-

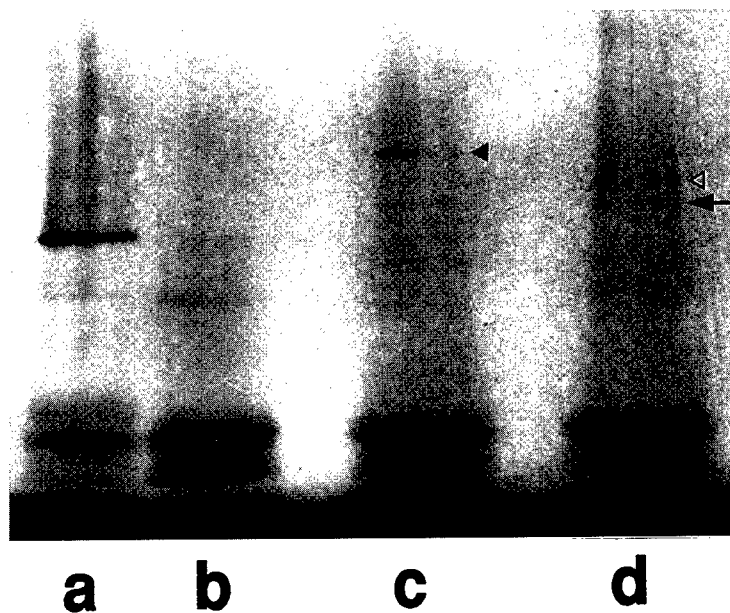

FIGURE 3. *In vitro* translation of the two FGFR1 cDNA clones. The two cDNAs were transcribed using T7 RNA polymerase and translated in rabbit reticulocyte lysates in the presence of ³⁵S-methionine. Proteins were fractionated in a 7.5% SDS-polyacrylamide gel and visualized by autoradiography. Lanes: (a) firefly luciferase (61 kDa); (b) lysate control (no template); (c) FGFR1 long form cDNA; (d) FGFR1 short form cDNA. *Open and closed arrowheads* indicate the 86-kDa and 102-kDa major products of the short and long FGFR1 cDNAs, respectively. An additional band of 74.5 kDa which is common to the short and long FGFR1 cDNAs was also observed (*small arrow*). The mobility of markers used to estimate the molecular mass of translated products included phosphorylase B (106 kDa), bovine serum albumin (80 kDa) and ovalbumin (49.5 kDa).³⁰

crease or loss of growth factor receptors in the adult tissues.¹² Expression of FGFR1 mRNA from embryonic (day-15) and adult mouse hearts was assessed by electrophoresis of total RNA (10 μ g) in a 1.5% (w/v) denaturing agarose gel containing formaldehyde³¹ followed by (Northern) blotting to nitrocellulose and sequential detection with two radiolabeled probes. The first was the (full-length) short FGFR1 cDNA which will detect both short and long FGFR1 transcripts (FIG. 2).³⁰ The second probe was a 262-bp *Dde*I fragment specific for the long FGFR1 isoform cDNA, corresponding to sequences in the first Ig-like domain which are absent from the short FGFR1 isoform transcripts (nucleotides 149–411³⁰). A single transcript of \sim 4.3 kb as estimated using the size and mobility of 28S and 18S ribosomal RNAs, was detected in embryonic and adult heart with the full-length short FGFR1 cDNA and presumably corresponds to cumulative short and long isoform RNA (FIG. 4). By densitometry, FGFR1 mRNA levels were decreased 8.5 ± 1.8 -fold ($n = 3$) in the adult versus embryonic heart. By contrast, the 4.3-kb transcript was only seen in the embryonic heart RNA using the long FGFR1 transcript-specific probe (FIG. 4). Thus, the loss of long FGFR1 isoform RNA appears to correlate with the loss of proliferative potential in the adult heart. The short isoform RNA, however, is expressed in the adult heart.

Detection of Exon III Splice in Mouse FGFR1 Transcripts: the Majority of FGFR1 Transcripts in Embryonic and Adult Mouse Hearts Contain Exon IIIc

The malignancy of prostate epithelial cells was accompanied by a switch from exclusive expression of exon IIIb (higher affinity to FGF-7) to exclusive expression of exon IIIc (higher affinity to basic FGF) in the FGFR2 gene.³⁵ We also investigated the possibility that switching from one FGFR1 isoform to another could occur during heart development as observed with exon switching and activation of FGFR2 gene during the malignancy of prostate epithelial cells³⁵ and be related to changes in the proliferative phenotype of the myocardium. The existence of three alternate exons (IIIa, IIIb and IIIc) which encode the carboxy terminal half of the third Ig-like domain has been reported for the mouse²¹ and human²² FGFR1 gene. Variant forms of FGFR1 can result due to alternate splicing of exons IIIa–c and exhibit different ligand binding affinities for bFGF.¹ The FGFR1 containing exon IIIc binds bFGF with a higher affinity (\sim 50 fold) than the FGFR1 with exon IIIb.²¹ Although it exists, FGFR1 containing exon IIIa is less abundant as well as truncated.^{21,36,37} We assessed the possibility of FGFR1 isoform switching through alternate splicing of exon III. Specifically, we examined whether FGFR1 RNA in the adult heart contains exon IIIb instead of IIIc which would be consistent with a decrease in responsiveness to bFGF. Region B, which contains the third Ig-like domain as well as the transmembrane domain, was amplified from both embryonic and adult mouse heart RNA (FIGS. 1, 5). The RT-PCR products were digested with restriction endonucleases, including *Acc*I, which generate specific patterns of fragments depending on the presence of exon IIIb or IIIc (FIG. 5). Identical results were obtained with both embryonic and adult mouse heart transcripts. Digestion of region B with *Acc*I generated fragments of 317 and 469 bp which is consistent with the presence of exon IIIc (FIG. 5). These data suggest

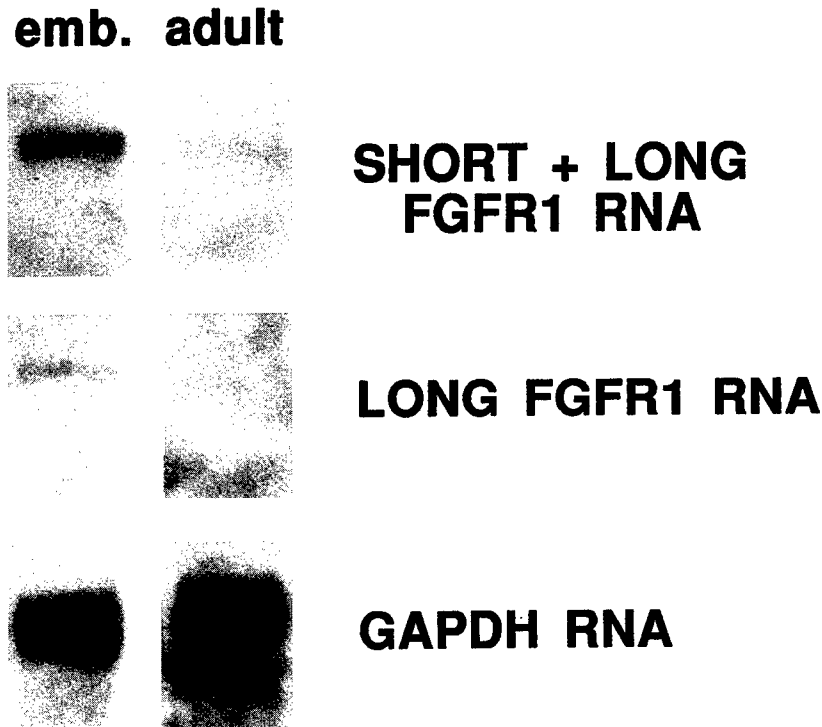

FIGURE 4. Expression of FGFR1 RNA in embryonic and adult mouse hearts. Total mouse tissue RNA ($10 \mu\text{g}$) from (a) embryonic and (b) adult heart was resolved in a 1.5% denaturing agarose gel containing formaldehyde, blotted to nitrocellulose and assessed for (i) short and long FGFR1 isoform transcripts using the short FGFR1 cDNA or (ii) long FGFR1 isoform transcripts using the 262 bp *Dde*I (nucleotides 149-411³⁰) fragment which is specific for long FGFR1 mRNAs. RNA loading was normalized by probing with a radiolabeled cDNA for glyceraldehyde-3-phosphate dehydrogenase (GAPDH; kindly provided by Dr. I. Dixon, St. Boniface Hospital Research Centre, Winnipeg, Manitoba, Canada). Probes were labeled routinely to a specific activity of $\sim 1 \times 10^9$ cpm/ μg of DNA using a random prime kit (Promega Corp., Madison, Wisconsin). Blots were hybridized at 42°C in the presence of 50% formamide for 18–24 hours and subsequently washed three times for 15 minutes in $0.1 \times \text{SSC}$ ($20 \times \text{SSC}$: 3 M sodium chloride, 0.3 M sodium citrate) with 0.1% SDS at 65°C. Transcripts were visualized by autoradiography.

that FGFR1-IIIc is the major isoform in both embryonic and adult hearts and that gross switching between the use of exon IIIb and IIIc does not occur.

Detection of FGFR1 Alternative Splice Variants of Region A in the Developing Mouse Heart: Evidence for FGFR1 Isoform Switching

Given the presence of both short and long FGFR1 isoform RNAs in the embryonic mouse heart, we assessed the possibility of isoform switching in the adult

heart by RT-PCR. Relative levels of short and long FGFR1 isoforms were determined using specific primers for region A which distinguishes the two forms since the amplified product may or may not contain a stretch of 267 nucleotides, which includes the Ig-like I domain, depending on the type of transcript (long or short) being used (FIG. 6). We amplified region A from embryonic and adult mouse heart total RNA and compared the relative levels of short (579-bp) and long (846-bp) FGFR1 isoforms (FIG. 6).³⁰ The relative level of short versus long FGFR1 isoforms was 0.5 (67% long versus 33% short) for embryonic and 5.9 (15% long versus 85% short) for adult mouse hearts at 30 cycles ($n = 2$). These data suggest there is a switch in receptor form RNA expression in embryonic (more long form) versus adult (more short form) hearts. The role for this switch is unclear as the affinity of bFGF or acidic FGF for receptors with two (short) and three (long) Ig-like domains is comparable.²² However, the possibility has been raised that homodimers and heterodimers of short and long FGFR1 could result in receptors with different affinities for FGFs.³² It has also been suggested that regulation of growth factor receptor isoforms in the heart could contribute to changes in the pattern of hyperplastic to hypertrophic growth.¹²

SUMMARY

We used reverse transcriptase-polymerase chain reaction (RT-PCR) to clone fibroblast growth factor receptor (FGFR) 1 isoforms from embryonic mouse heart

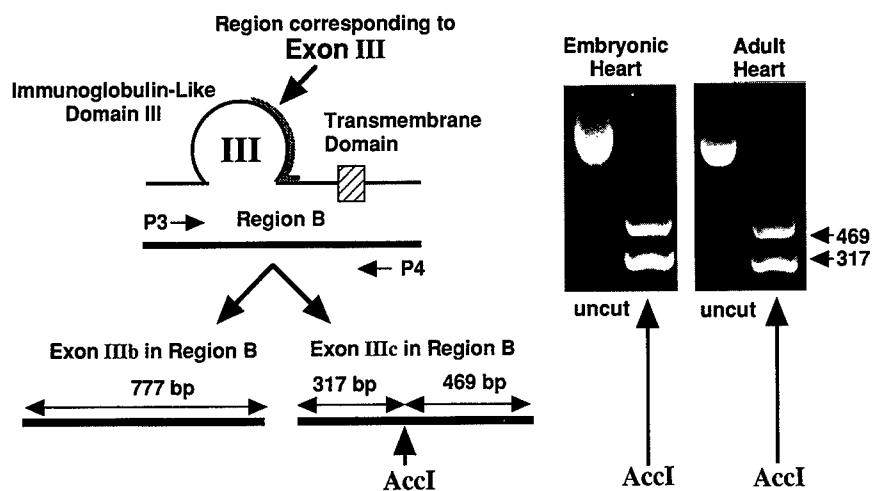

FIGURE 5. Detection of exon IIIb and IIIc sequences in transcripts from embryonic and adult mouse heart. Region B containing exon III sequences was amplified from embryonic and adult mouse heart RNA (1 μ g) using primers P3 and P4. The products were left uncut or digested with the restriction endonuclease *AccI*. The resulting fragments were fractionated in a 1.5% agarose gel and visualized by ethidium bromide staining and photography. Molecular sizes (bp) were estimated using a ϕ X174/*HaeIII* marker.

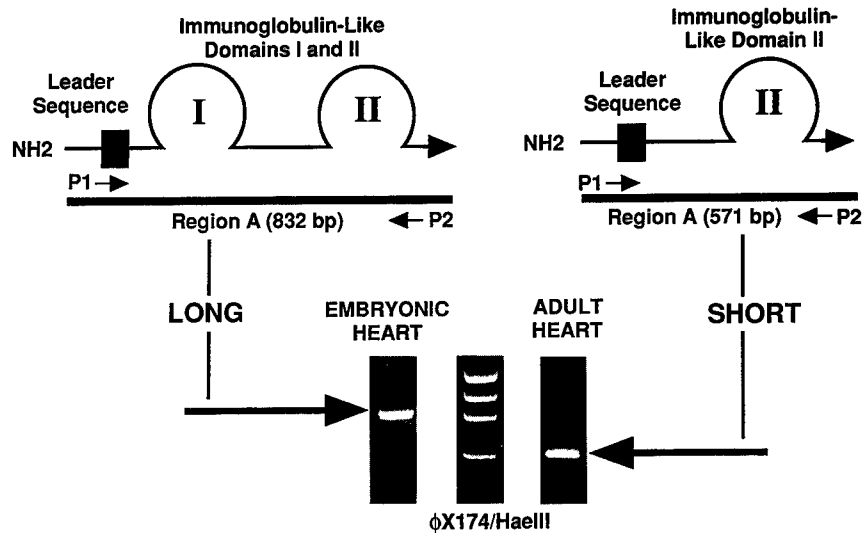

FIGURE 6. Detection of short versus long FGFR1 transcripts by RT-PCR amplification of region A. Region A in embryonic and adult mouse heart RNA (200 ng) was amplified for 30 cycles using primers P1 and P2. Amplification of region A generates 571-bp or 832-bp products depending on whether the transcript corresponds to a short or long FGFR1 isoform, respectively. Products were fractionated in a 1.5% agarose gel together with a ϕ X174/*Hae*III marker and the 872- and 603-bp bands of this marker were used to assess fragment sizes. No product was observed in embryonic and adult heart RNA samples processed in the absence of RT as a control (not shown).

and as a more sensitive method to characterize FGFR1 RNA expression in embryonic and adult mouse hearts. We describe the cloning of both full-length short (2259 base pairs) and long (2526 base pairs) FGFR1 isoform cDNAs which generated 86 and 102 kilodalton proteins, respectively, following *in vitro* translation. An assessment of FGFR1 RNA indicates that FGFR1-IIIc is the major form in both the embryonic and adult heart but there is an \sim 8.5-fold decrease in RNA levels in the adult. Differential RNA blotting as well as RT-PCR analyses are consistent with a switch in the relative expression of the short versus long FGFR1 isoforms during heart development. The long isoforms are more abundant in the embryo and the short isoforms predominate in the adult. This may be important in the regulation of growth and development of the heart.

REFERENCES

1. JOHNSON, D. E. & L. T. WILLIAMS. 1993. Structural and functional diversity in the FGF receptor multigene family. *Adv. Cancer Res.* **60**: 1-41.
2. CLAYCOMB, W. C. & R. L. MOSES. 1988. Growth factors and TPA stimulate DNA synthesis and alter the morphology of cultured terminally differentiated adult rat cardiac muscle cells. *Dev. Biol.* **127**: 257-265.
3. ANVERSA, P., T. PALACKAL, E. H. SONNENBLICK, G. OLIVETTI, L. G. MEGGS & J. M.

- CAPASSO. 1990. Myocyte cell loss and myocyte cellular hyperplasia in the hypertrophied aging rat heart. *Circ. Res.* **67**: 871–885.
4. KARDAMI, E. 1990. Stimulation and inhibition of cardiac myocyte proliferation *in vitro*. *Mol. Cell. Biochem.* **92**: 129–135.
 5. ANDERSON, J. E., L. LIU & E. KARDAMI. 1991. Distinctive basic fibroblast growth factor distribution in regenerating dystrophic (mdx) striated muscle. *Dev. Biol.* **147**: 96–109.
 6. SPEIR, E., V. TANNER, A. M. GONZALEZ, J. FARRIS, A. BAIRD & W. CASSCELLS. 1992. Acidic and basic fibroblast growth factors in adult rat heart myocytes: localization, regulation in culture and effects on DNA synthesis. *Circ. Res.* **71**: 251–259.
 7. LIU, L., B. W. DOBLE & E. KARDAMI. 1993. Perinatal phenotype and hypothyroidism are associated with elevated levels of 21.5- to 22-kDa basic fibroblast growth factor in cardiac ventricles. *Dev. Biol.* **157**: 507–516.
 8. PADUA, R. R., R. R. FANDRICH & E. KARDAMI. 1993. Increased basic fibroblast growth factor accumulation and distinct patterns of localization in isoproterenol-induced cardiomyocyte injury. *Growth Factors* **8**: 291–306.
 9. KAJSTURA, J., X. ZHANG, K. REISS, E. SZOKE, P. LI, C. LAGRASTA, W. CHENG, Z. DARZYNKIEWICZ, G. OLIVETTI & P. ANVERSA. 1994. Myocyte cellular hyperplasia and myocyte cellular hypertrophy contribute to chronic ventricular remodeling in coronary artery narrowing-induced cardiomyopathy in rats. *Circ. Res.* **74**: 383–400.
 10. PASUMARTHI, K. B. S., B. W. DOBLE, E. KARDAMI & P. A. CATTINI. 1994. Overexpression of CUG- or AUG-initiated forms of basic fibroblast growth factor in cardiac myocytes results in similar effects on mitosis and protein synthesis but distinct nuclear morphologies. *J. Mol. Cell. Cardiol.* **26**: 1045–1060.
 11. ENGELMANN, G. L., C. A. DIONNE & M. C. JAYE. 1993. Acidic fibroblast growth factor and heart development: role in myocyte proliferation and capillary angiogenesis. *Circ. Res.* **72**: 7–19.
 12. PARKER, T. G. & M. D. SCHNEIDER. 1991. Growth factors, proto-oncogenes, and plasticity of the cardiac phenotype. *Ann. Rev. Physiol.* **53**: 179–200.
 13. KARDAMI, E., R. PADUA, K. B. S. PASUMARTHI, L. LIU, B. W. DOBLE & P. A. CATTINI. 1993. Expression, localization and effect of bFGF on cardiac myocytes. *In Growth Factors and the Cardiovascular System*. P. Cummins, Ed. 55-76. Kluwer Academic Publishers. Boston, Dordrecht, London.
 14. PADUA, R. R., R. SETHI, N. S. DHALLA & E. KARDAMI. 1993. Hearts supplemented with basic fibroblast growth factor display increased recovery from ischemia-reperfusion injury. *FASEB J.* **7**: A122.
 15. KARDAMI, E., R. M. STOSKI, B. D. DOBLE, T. YAMAMOTO, E. L. HERTZBERG & J. I. NAGY. 1991. Biochemical and ultrastructural evidence for the association of basic fibroblast growth factor with cardiac gap junctions. *J. Biol. Chem.* **266**: 19551–19557.
 16. WANAKA, A., J. MILBRANDT & E. M. JOHNSON. 1991. Expression of FGF receptor gene in rat development. *Development* **111**: 455–468.
 17. PETERS, K. G., S. WERNER, G. CHEN & L. T. WILLIAMS. 1992. Two FGF receptor genes are differently expressed in epithelial and mesenchymal tissues during limb formation and organogenesis in the mouse. *Development* **114**: 233–243.
 18. REID, H. H., A. F. WILKS & O. BERNARD. 1990. Two forms of the basic fibroblast growth factor receptor-like mRNA are expressed in the developing mouse brain. *Proc. Natl. Acad. Sci. USA* **87**: 1596–1600.
 19. LIU, L., K. B. S. PASUMARTHI, R. R. FANDRICH, G. N. PIERCE, P. A. CATTINI & E. KARDAMI. 1993. Basic FGF receptors are expressed by proliferative, immature as well as differentiated cardiac myocytes. *FASEB J.* **7**: A780.
 20. YAZAKI, N., H. FUJITA, M. OHTA, T. KAWASAKI & N. ITOH. 1993. The structure and expression of the FGF receptor-1 mRNA isoforms in rat tissues. *Biochim. Biophys. Acta* **1172**: 7–42.
 21. WERNER, S., D.-S.R. DUAN, C. DE VRIES, K. G. PETERS, D. E. JOHNSON & L. T. WILLIAMS. 1992. Differential splicing in the extracellular region of fibroblast growth factor receptor-1 generates variants with different ligand-binding specificities. *Mol. Cell. Biol.* **12**: 82–88.

22. JOHNSON, D. E., P. L. LEE, J. LU & L. T. WILLIAMS. 1990. Diverse forms of a receptor for acidic and basic fibroblast growth factors. *Mol. Cell. Biol.* **10**: 4728–4736.
23. EISEMANN, A., J. A. AHN, G. GRAZIANI, S. R. TRONICK & D. RON. 1991. Alternative splicing generates at least five different isoforms of the human basic-FGF receptor. *Oncogene* **6**: 1195–1202.
24. SAFRAN, A., A. AVIVI, A. ORR-URTEREGER, G. NEUFELD, P. LONAI, D. GIVOL & Y. YARDEN. 1990. The murine *flg* gene encodes a receptor for fibroblast growth factor. *Oncogene* **5**: 635–643.
25. MANSUKHANI, A., D. MOSCATELLI, D. TALAARICO, V. LEVYTSKA & C. BASILICO. 1990. A murine fibroblast growth factor (FGF) receptor expressed in CHO cells is activated by basic FGF and Kaposi FGF. *Proc. Natl. Acad. Sci. USA* **87**: 4378–4382.
26. FASEL, N. J., M. BERNARD, N. DEGLON, M. ROUSSEAU, R. J. EISENBERG, C. BRON & G. H. COHEN. 1991. Isolation from mouse fibroblasts of a cDNA encoding a new form of the fibroblast growth factor receptor (*flg*). *Biochem. Biophys. Res. Commun.* **178**: 8–15.
27. KOUHARA, H., S. KASAYAMA, H. SAITO, K. MATSUMOTO & B. SATO. 1991. Expression cDNA cloning of fibroblast growth factor (FGF) receptor in mouse breast cancer cells: a variant form in FGF-responsive transformed cells. *Biochem. Biophys. Res. Commun.* **176**: 31–37.
28. HOU, J., M. KAN, MCKEEHAN, G. MCBRIDE, P. ADAMS & W. L. MCKEEHAN. 1991. Fibroblast growth factors from liver vary in three structural domains. *Science* **251**: 665–668.
29. CHOMCZYNSKI, P. & N. SACCHI. 1987. Single-step method of RNA isolation by acid guanidinium thiocyanate-phenol-chloroform extraction. *Anal. Biochem.* **162**: 156–159.
30. JIN, Y., K. B. S. PASUMARTHI, M. E. BOCK, A. LYTRAS, E. KARDAMI & P. A. CATTINI. 1994. Cloning and expression of fibroblast growth factor receptor 1 isoforms in the mouse heart: evidence for isoform switching during heart development. *J. Mol. Cell. Cardiol.* **26**: 1449–1459.
31. MANIATIS, T., E. F. FRITSCH & J. SAMBROOK. 1987. *Molecular Cloning: a Laboratory Manual*. Cold Spring Harbor Laboratory. Cold Spring Harbor, N. Y.
32. BERNARD, O., M. LI & H. H. REID. 1991. Expression of two different forms of fibroblast growth factor receptor 1 in different mouse tissues and cell lines. *Proc. Natl. Acad. Sci. USA* **88**: 7625–7629.
33. PETERS, K. G., J. MARIE, E. WILSON, H. E. IVES, J. ESCOBEDO, M. DEL ROSARIO, D. MIRDA & L. T. WILLIAMS. 1992. Point mutation of an FGF receptor abolishes phosphatidylinositol turnover and Ca^{2+} flux but not mitogenesis. *Nature* **358**: 678–681.
34. MOHAMMADI, M., C. A. DIONNE, W. LI, T. SPIVAK, A. M. JAYE & J. SCLESSINGER. 1992. Point mutation in FGF receptor eliminates phosphatidylinositol hydrolysis without affecting mitogenesis. *Nature* **358**: 681–684.
35. YAN, G., Y. FUKABORI, G. MCBRIDE, S. NIKOLAROPOLOUS & W. L. MCKEEHAN. 1993. Exon switching and activation of stromal and embryonic fibroblast growth factor (FGF)-FGF receptor genes in prostate epithelial cells accompany stromal independence and malignancy. *Mol. Cell. Biol.* **13**: 4513–4522.
36. JOHNSON, D. E., J. LU, H. CHEN, S. WERNER & L. T. WILLIAMS. 1991. The human fibroblast receptor genes: a common structural arrangement underlies the mechanisms for generating receptor forms that differ in their third immunoglobulin domain. *Mol. Cell. Biol.* **11**: 4627–4634.
37. PARTANEN, J., S. VAINIKKA, J. KORHONEN, E. ARMSTRONG & K. ALITALO. 1992. Diverse receptors for fibroblast growth factors. *Prog. Growth Factor Res.* **4**: 69–83.

Presence of Basic Fibroblast Growth Factor in Cultured Rat Cardiomyocytes and Its Release in Culture Medium

L. BASTAGLI,^a T. LAZZAROTTO,^b C. M. CALDARERA,^c
C. GUARNIERI,^c C. VENTURA,^d G. PEPE,^a AND P. PUDDU^a

^a*Institute of Medical Pathology and Clinical Methodology*

^b*Institute of Microbiology*

Policlinico S. Orsola

via Massarenti, 9

40138 Bologna, Italy

^c*Department of Biochemistry "G. Moruzzi"*

University of Bologna

via Irnerio, 48

40126 Bologna, Italy

^d*Institute of Biological Chemistry "A. Bonsignore"*

School of Medicine of Sassari

viale S. Pietro, 43/b

07100 Sassari, Italy

INTRODUCTION

In heart tissue it has been described that basic fibroblast growth factor (bFGF) is synthesized in endothelial and smooth muscle cells.^{1,2} Lesser data confirm that myocytes also support the formation of bFGF.^{3,4}

Speir *et al.*⁵ report the presence, in isolated fresh rat cardiomyocytes, of biologically active bFGF stimulating thymidine incorporation in the DNA of 3T3 fibroblasts and the proliferation of vascular endothelial cells. In cardiomyocytes bFGF has been localized by immunofluorescence in nuclei and has been found to be more expressed in atria than in ventricles.⁶

All these data suggest that isolated cardiomyocytes are able to synthesize bFGF in order to support regenerative and repair processes in the heart. However, the paracrine function of adult rat cardiomyocytes in terms of synthesis and release of bFGF has not been defined until now.

The aim of the present study was to assess the presence of bFGF in adult cultured rat ventricular cardiomyocytes, since in this preparation bFGF could be detected in the absence of contaminant nonmyocardial cells.

Moreover, since, in cardiac cells, tumor-promoting phorbol esters (such as phorbol myristate acetate (PMA)) have been shown to stimulate gene expression⁷ as well as DNA and protein synthesis,⁸ we also studied the effect of PMA on bFGF synthesis and its release from cardiac myocytes.

METHODS

This study was carried out using cultured cardiac myocytes prepared from male Sprague-Dawley rats (300 g).

Cell Culture

Isolated cardiac myocytes were prepared by the method of Capogrossi *et al.*⁹ The hearts were excised from anesthetized rats and immediately perfused via the aorta at 37°C with a medium buffer containing (mM): 116 NaCl, 5.4 KCl, 26 NaHCO₃, 1 NaH₂PO₄, 1 MgSO₄ and 5.6 D-glucose which had been equilibrated with a 95% O₂-5% CO₂ gas mixture (pH 7.4) (buffer A). Following this wash, a recirculating perfusion was begun with 50 ml of buffer A with an additional 50 mg collagenase (type I; Sigma) and CaCl₂ to give 50 μM. After 15–20 min, the hearts were removed and the ventricles were chopped with scissors in buffer A containing collagenase. The resulting suspension was filtered through nylon gauze and the cells were collected under gravity after 6 min. The cells were resuspended in 20 ml of buffer A containing 0.25 mM CaCl₂, and again sedimented under gravity. The myocytes were then resuspended in medium A containing 10 mM Hepes, pH 7.4, 1 mM CaCl₂ and 20 mM D-glucose (buffer B). The resulting cell suspensions were 70–80% in the rod form and were maintained upon incubation at 37°C. The cardiac myocytes were cultured, under 5% CO₂ atmosphere at 37°C, in Petri dishes (60-mm Falcon dishes, Becton Dickinson) at a density of 2×10^5 cells/dish in 3 ml/dish of M-199 medium (with Earls salts), containing 0.2% bovine serum albumin, 10^{-8} M insulin, 2.5×10^{-4} M penicillin G, 2.5×10^{-4} M streptomycin, and 10^{-5} M cytosine arabinofuranoside.¹⁰ One day after plating, the cells were treated with 0.08 μM PMA at different times. At the end of incubation the myocytes were removed and bFGF was assayed in the cells and incubation medium.

Extraction of bFGF from Cultured Cells and Media

All procedures were carried out at 4°C. Extraction buffer was added to the cells in the amount of 1 ml/5–6 mg cell proteins (extraction buffer: 2.0 M NaCl, 20 mM tris-HCl, 1% nonidet P-40, 0.5% deoxycholate, 1 mM EDTA, 1 mM EGTA, pH 7.4); the extraction buffer was added with protease inhibitors (10 μg/ml aprotinin, leupeptin, pepstatin A; 15 μM PMSF). The cells were homogenized with a pestle homogenizer and the homogenates were centrifuged (3000 rpm for 10 min). The supernatants were collected and diluted 3-fold with 10 mM tris pH 7.4. 50 μl bed volume of heparin-sepharose (Pharmacia) was added to each homogenate. The material was incubated overnight at 4°C on a rotator and then it was centrifuged (4000 rpm for 10 min). The supernatant was discarded and the pellet was added with the first wash buffer (0.60 M NaCl, 10 mM tris-HCl, pH 7.4) and then it was centrifuged (3000 rpm for 10 min). Again the supernatant was discarded and the pellet was diluted with the same wash buffer and centrifuged (3000 rpm for 10 min).

Western Blotting

The presence of bFGF in samples was detected by SDS-PAGE (15% acrylamide) followed by Western blot analysis.

After electric transfer and blocking of the nonspecific protein binding sites with 3% gelatin-1% bovine serum albumin in triethanolamine-buffered saline (TBS), the nitrocellulose membrane was incubated with a rabbit monospecific polyclonal antiserum (kindly obtained from Dr. D. A. Lappi, the Whittier Institute, La Jolla, CA) in TBS + 1% gelatin overnight at 4°C under gentle shaking. Antigen-antibody complexes were visualized by incubating the membrane with peroxidase-conjugated secondary antibody (biotin-streptavidine system, Boehringer) and developed by 4-chloro-1-naphthol (Bio-Rad).

RESULTS AND DISCUSSION

FIGURE 1 shows a representative Western blot analysis of bFGF immunoreactivity in cultured myocytes and culture media. An 18,000-D band comigrating with pure bFGF was detected in myocytes but not in culture media. However, in all

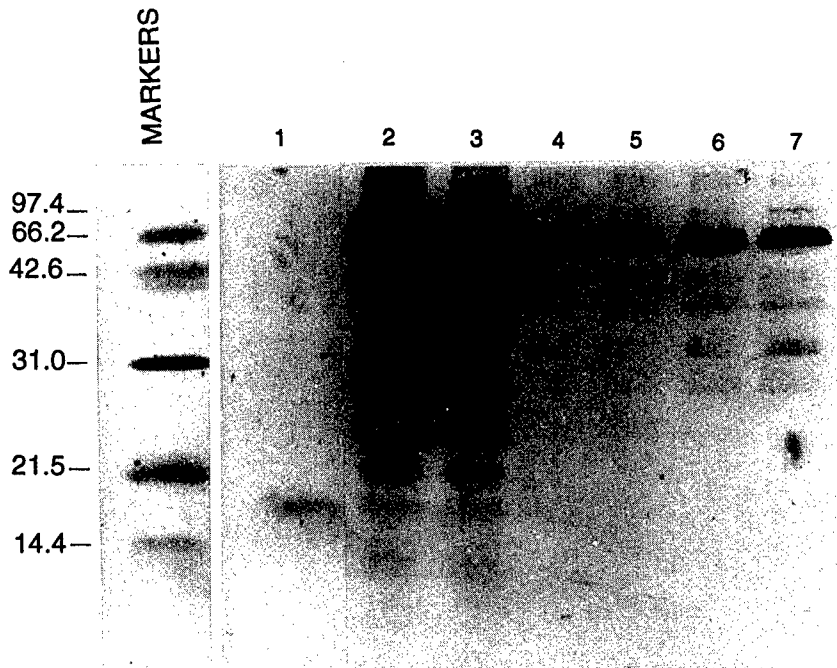

FIGURE 1. Western blot analysis of bFGF immunoreactivity in adult cultured myocytes and media. Lane 1: bFGF 60 ng. Lane 2: cardiomyocytes (30 min). Lane 3: cardiomyocytes (1 hour). Lanes 4-5: control medium (30 min). Lanes 6-7: control medium (1 hour).

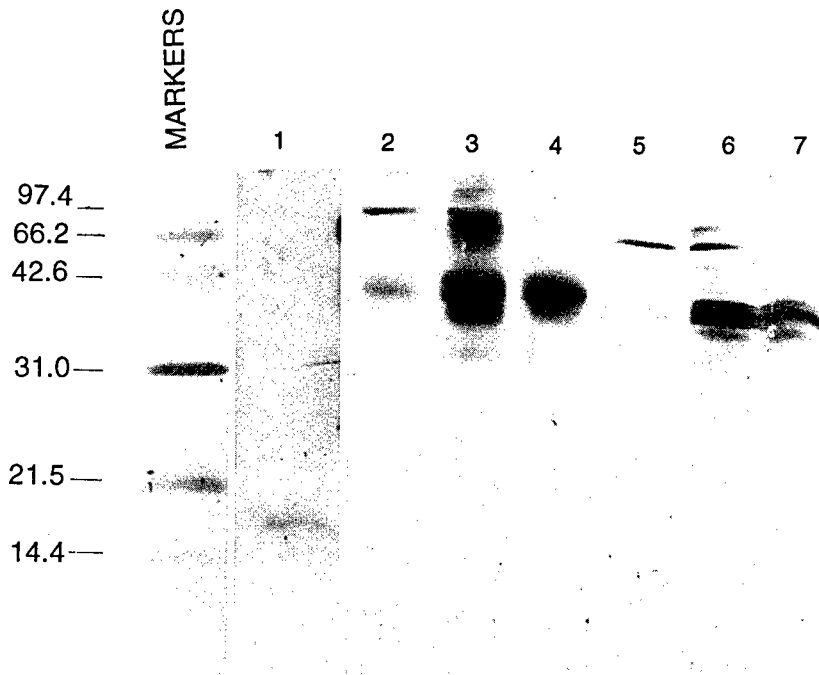

FIGURE 2. Western blot analysis of bFGF immunoreactivity in PMA-treated adult cultured myocytes and in media. *Lane 1:* bFGF 60 ng. *Lane 2:* PMA-treated myocytes (1 hour). *Lane 3:* PMA-treated myocytes (4 hours). *Lane 4:* PMA-treated myocytes (8 hours). *Lane 5:* PMA medium (1 hour). *Lane 6:* PMA medium (4 hours). *Lane 7:* PMA medium (8 hours).

instances either cells or media contained more than the 18,000-D peptide. In particular a predominant band of 65,000 D was found.

FIGURE 2 shows that PMA treatment abolished the 18,000-D band in cardiomyocytes, whereas it decreased the immunoreactive band of 65,000 and enhanced intensity of a 40,000-D band. A similar pattern was observed in the media from the PMA-treated cells.

These data indicate that an 18,000-D band corresponding to standard bFGF is present in isolated adult cardiomyocytes, whereas its occurrence seems to be blunted following PMA treatment. In the culture media the presence of bFGF immunoreactive-like peptide indicates that the myocytes would also be capable of releasing this peptide as molecular weight peptide precursors. Nevertheless, we cannot exclude that a posttranslational cross-linkage of monomeric bFGF may occur, leading to the presence of high-molecular-weight immunoreactive bands. In this regard both glutamine and lysine residues are repeated in the primary structure of the bFGF,¹¹ and therefore transglutaminase enzymes could be involved in the formation of these covalent bonds.¹²⁻¹⁴

In conclusion, PMA treatment appears to be able to modulate the distribution of bFGF immunoreactivity in adult cultured cardiomyocytes and in culture media.

REFERENCES

1. BRINDLE, N. P. J. 1993. Growth factors in endothelial regeneration. *Cardiovasc. Res.* **27**: 1162–1172.
2. GOSPODAROWICZ, D., N. FERRARA, T. HAAPARANTA & G. NEUFELD. 1988. Basic fibroblast growth factor: expression in cultured bovine vascular smooth muscle cells. *Eur. J. Cell Biol.* **46**: 144–151.
3. QUINKLER, W., M. MAASBERG, S. BERNOTAT-DANIELOWSKI, N. LUTHE, H. S. SHARMA & W. SCHAPER. 1989. Isolation of heparin-binding growth factors from bovine, porcine and canine hearts. *Eur. J. Biochem.* **181**: 67–73.
4. CUMMINS, P. 1993. Fibroblast and transforming growth factor expression in the cardiac myocyte. *Cardiovasc. Res.* **27**: 1150–1154.
5. SPEIR, E., Z. YI-FU, M. LEE, S. SHRIVASTAV & W. CASSCELLS. 1988. Fibroblast growth factors are present in adult cardiac myocytes, *in vivo*. *Biochem. Biophys. Res. Commun.* **157**(3): 1336–1340.
6. KARDAMI, E. & R. R. FANDRICH. 1989. Basic fibroblast growth factor in atria and ventricles of the vertebrate heart. *J. Cell Biol.* **109**: 1865–1875.
7. STARKSEN, N. F., P. C. SIMPSON, N. BISHOPRIC, S. R. COUGHLIN, W. M. F. LEE, J. A. ESCOBEDO & L. T. WILLIAMS. 1986. Cardiac myocyte hypertrophy is associated with c-myc protooncogene expression. *Proc. Natl. Acad. Sci. USA* **83**: 8348–8350.
8. FULLER, S. J. & P. H. SUGDEN. 1989. Protein synthesis in rat cardiac myocytes is stimulated at the level of translation by phorbol esters. *FEBS Lett.* **247**: 209–212.
9. CAPOGROSSI, M., A. A. KORT, H. A. SPURGEON & E. G. LAKATTA. 1986. Single adult rabbit and rat cardiac myocytes retain the Ca²⁺- and species dependent-systolic and diastolic contractile properties of the intact muscle. *J. Gen. Physiol.* **88**: 589–613.
10. PIPER, H. M., I. PROBST, P. SCHWARZ, F. J. HUTTER & P. G. SPIECKERMANN. 1982. Culturing of calcium stable adult cardiac myocytes. *J. Mol. Cell. Cardiol.* **14**: 397–412.
11. ESCH, F., A. BAIRD, N. LING, N. UENO, F. HILL, L. DENOROY, R. KLEPPER, D. GOSPODAROWICZ, P. BOHLEN & R. GUILLEMIN. 1985. Primary structure of bovine pituitary basic fibroblast growth (FGF) and comparison with the amino-terminal sequence of bovine brain acidic FGF. *Proc. Natl. Acad. Sci. USA* **82**: 6507–6511.
12. PUCCI, P., A. MALORNI, G. MARINO, S. METAFORA, C. ESPOSITO & R. PORTA. 1988. β -endorphin modifications by trans-glutaminase *in vitro*: identification by FAB/MS of glutamine-11 and lysine-29 as acyl donor and acceptor sites. *Biochem. Biophys. Res. Commun.* **154**: 735–740.
13. PORTA, R., V. GENTILE, C. ESPOSITO, A. FUSCO, G. PELUSO & S. METAFORA. 1988. β -lipotropin 61–76 and 61–91 fragments act as transglutaminase substrates *in vitro*. *Neuropeptides* **11**: 89–92.
14. PORTA, R., C. ESPOSITO, S. METAFORA, P. PUCCI, A. MALORNI & G. MARINO. 1988. Substance P as a transglutaminase substrate: identification of the reaction products by fast atom bombardment mass spectrometry. *Anal. Biochem.* **172**: 199–503.

Morphometry and GH/IGF-1 Axis Deficiency May Identify a Form of Dilated Cardiomyopathy Which Is Corrected by Recombinant Human Growth Hormone (rHGH)^a

A. FRUSTACI, A. ZURLO, G. A. PERRONE, A. RUSSO,
M. CALDARULO, AND M. A. RUSSO

Department of Experimental Medicine

Università La Sapienza

and

Institute of Cardiology

Università Cattolica

Rome, Italy

INTRODUCTION

Dilated cardiomyopathy (DC) includes a number of etiologically different diseases which affect myocardial structure and function often as a part of a more complex systemic disease. The diagnosis of DC is made when left ventricular (LV) dilatation and systolic dysfunction occur in the absence of coronary artery, valvular, or pericardial disease or systemic diseases.¹ A DC due to a chronic deficiency of growth hormone (GH), even as a part of a more complex picture, such as the Sheehan's syndrome, has never been reported in our knowledge. The beneficial effects of recombinant human GH (rHGH) administration suggest, *ex-adjvantibus*, a crucial role for this hormone in myocardial muscle regeneration and repair.

RESULTS AND DISCUSSION

A 49-year-old female with clinical and biochemical signs of panhypopituitarism, presented a severe DC. DC was investigated by noninvasive and invasive procedures. DC was characterized by low electrocardiographic voltages, dilatation of

^a This research was supported by MURST funds (40–60%) to MAR, 1992–93. Part of these data have been published as a full paper.²

TABLE 1. Morphometric Values and Indexes from Optical and Electron Micrographs

Parameter or Index	Before Treatment	After Treatment
1. Short axis of myocardiocytes (um)* (<i>p</i> = 0.0002)	23.5 + 6.7	38.5 + 8.2
2. Myofibrillar area (% of total cell area)* (<i>p</i> = 0.0003)	26.5 + 10.2	59.9 + 4.7
3. Nonmyofibrillar area (% of total cell area)* (<i>p</i> = 0.0003)	73.5 + 13.9	40.1 + 6.3
4. Ratio myofibrillar/ nonmyofibrillar area (#2 value/#3 value)	0.36	1.49
5. Number of mitochondria/ photographic field*	137 + 12	116 + 8
6. Mitochondrial area/ photographic field (arbitrary unit or pixels)* (<i>p</i> = 0.0001)	31626 + 258	50824 + 674
7. Mean area of individual mitochondrion (#6 value/#5 value) (arbitrary unit as in #6)* (<i>p</i> = 0.0001)	228.6 + 10.0	432.7 + 15.3

* Values represent the mean of measurement from 10 micrographs + standard deviation. Statistical significance have been calculated, when needed, for each value as indicated in the lower brackets).

cardiac chambers with secondary mitral and tricuspid regurgitation, reduced thickening and contractility of LV walls. At histology a severe vacuolar appearance of myocyte cytoplasm was revealed, and at electron microscopy a large reduction of contractile elements was documented (FIG. 1) and measured by morphometry (TABLE 1). Such myocardial damage was not sustained by coronary, valvular, or systemic diseases (hypertension, alcohol abuse, etc.). Three months of substituting opotherapy and inotropic treatment failed to induce any appreciable improvement at monthly clinical, ECG and 2D-echo-Doppler follow-up. rHGH was introduced in the treatment (4 UI/die), and because of its low levels not increased by clonidine and L-DOPA stimulation. After this, a progressive improvement of cardiac function was observed in the following three months. ECG voltages normalized and a relevant increase of myocardial mass was detected at echocardiography. After three months of rHGH therapy a new hemodynamic study showed reduction of LV end diastolic pressure with remarkable increase of cardiac output and index. Angiography showed decreased ventricular volumes with disappearance of mitral and tricuspidal incompetence and marked improvement of cardiac contractility. At biopsy, optical, electron microscopy (FIG. 1) and morphometry (TABLE 1) showed that the large myofibril-free areas of the cytoplasm after growth hormone treatment were replaced by bundles of myofibrils and by enlarged mitochondria. The withdrawal for three months of GH was followed by an impairment of cardiac conditions. Our data suggest that a GH-sensitive DC may occur during panhypopituitarism. This form of DC is identified by GH/IGF-1 axis deficiency and decreased myofibrillar content at endomyocardial biopsy, and may benefit dramatically from rHGH treatment. This case also suggests a role for GH in regeneration and repair of cellular components of myocardiocytes, especially myofibrils and mitochondria.²

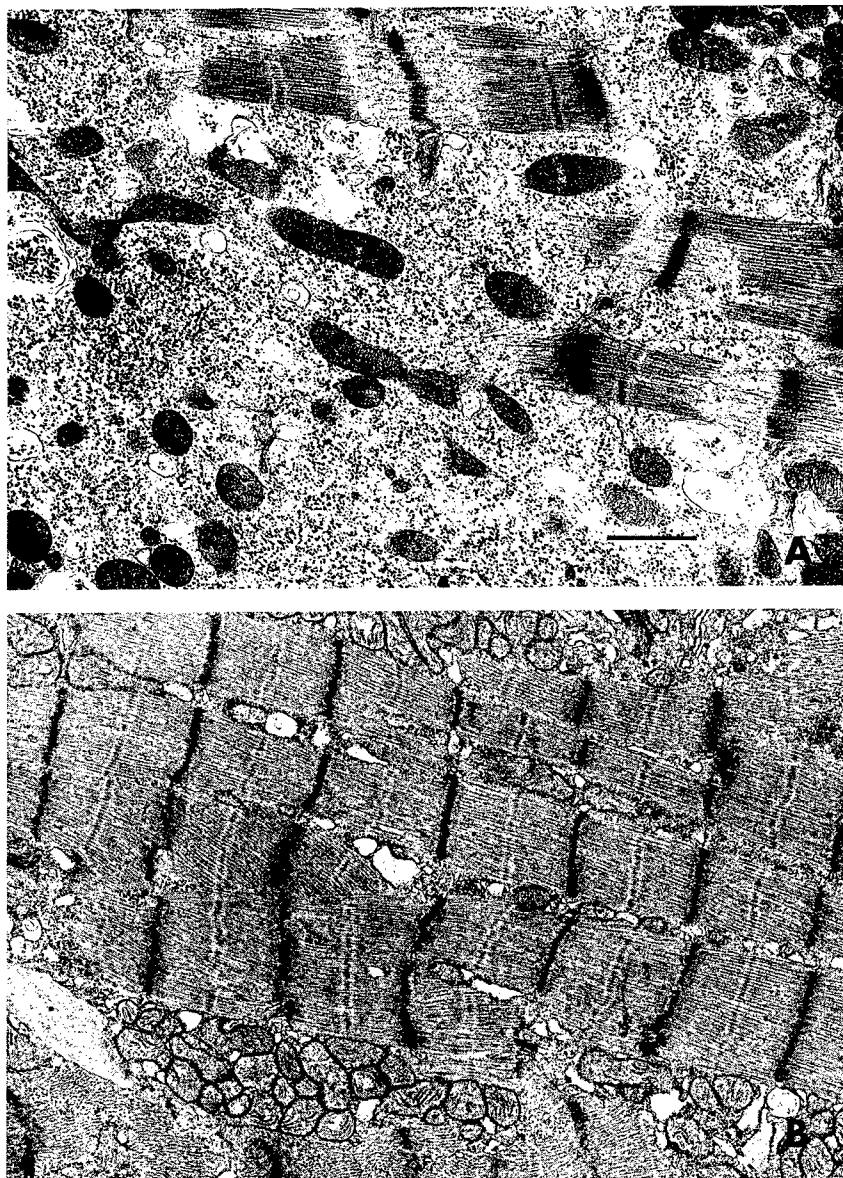

FIGURE 1. Transmission electron micrographs of endomyocardial biopsy samples before (A) and after (B) growth hormone administration. The *bar* represents 1 μ m.

ACKNOWLEDGMENT

We thank Costantino Franchi for processing the illustrations.

REFERENCES

1. Report of WHO/ISCF task force on definition and classification of cardiomyopathy. 1980. *Br. Heart J.* **44**: 672-673.
2. FRUSTACI, A. *et al.* 1992. *Am. J. Pathol.* **97**: 503-511.

Pro-Alpha2(I) Collagen and Transforming Growth Factor-Beta 1 Gene Expression in the Myocardial Hypertrophy of the Old Rat^a

G. ANNONI, B. AROSIO, D. SANTAMBROGIO, N. GAGLIANO,
AND C. VERGANI

*Cattedra di Gerontologia e Geriatria
Università degli Studi di Milano
Via Pace, 9
20122 Milano, Italy*

The connective tissue of the heart is essential for support and structural integrity of the organ and probably plays an important role in its function as an efficient pump. As in other organs, in the myocardium the connective tissue has two major components: the cells and various fibrillar extracellular proteins. Collagen is the most abundant of the extracellular proteins and types I and III collagens are the major species present in this tissue.^{1,2} Previous studies have shown that myocardial hypertrophy induced by pathological conditions of pressure overload are accompanied by cardiac fibrosis and that hypertrophy causes quantitative changes in biosynthesis and deposition of the myocardial collagen matrix.³ Since aging is a physiological condition of pressure overload-induced cardiac hypertrophy, in this study we have examined the expression of procollagen type I in the ventricular myocardium of young (2 months) and old (24 months) Sprague-Dawley rats. Moreover, the obtained results have been compared with the degree of myocardial fibrosis histologically evaluated and with the transforming growth factor- β 1 mRNA cardiac levels, a growth factor actively involved in extracellular matrix remodelling.⁴

EXPERIMENTAL PROCEDURES

Total RNA was extracted from frozen tissue by the acid guanidium thiocyanate-phenol method. For Northern analysis 20 μ g of total RNA was *denatured*, separated by electrophoresis on 1% agarose gel and then transferred to a nylon membrane. cDNA for the rat pro-alpha2(I) collagen (COL-1), transforming growth factor- β 1 (TGF β 1) and glyceraldehyde 3-phosphate dehydrogenase (GAPDH) were utilized for hybridization. Hybridization results were quantified by densitometrical scanning using a laser densitometer (Pharmacia); all the values were normalized against the relative levels of GAPDH mRNA.

^a This work was supported in part by the National Research Council's "Progetto Finalizzato Invecchiamento" Grant 93.00487.PF40.

RESULTS AND DISCUSSION

In the ventricular myocardium of young and old rats we examined COL-1 and TGF β 1 steady-state mRNA levels in order to evaluate the possible correlation between the fibrosis histologically evaluated and the regulation of these two genes. The densitometry tracing of the blots revealed a 290% increase ($p < 0.005$) in COL-1 mRNA in the ventricular myocardium of the old rats (FIG. 1); on the contrary, the TGF β 1 mRNA levels were almost identical in the two groups of animals (FIG. 2). In conclusion the histological analysis and the molecular data suggest that in old rats, myocardial hypertrophy and fibrosis are associated with an increase in COL-1 mRNA steady-state levels. The finding of similar TGF β 1 mRNA levels in the myocardium of both old and young animals suggests the absence of an active role of this growth factor and shows that pressure overload probably plays a major role in the development of these processes.

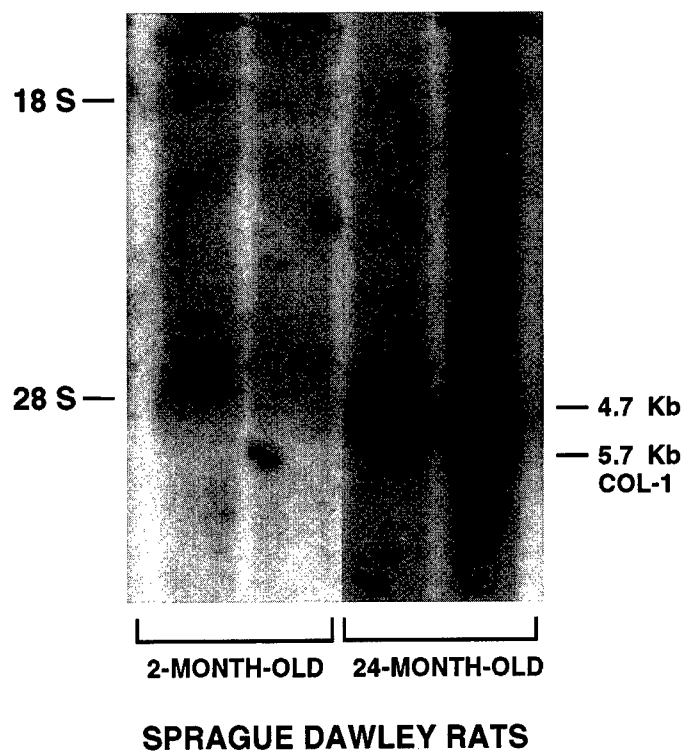

FIGURE 1. Autoradiogram of a representative Northern blot hybridization study of total RNA isolated from the ventricular myocardium of 2-month-old and 24-month-old Sprague-Dawley rats. The RNA were hybridized with a pro-alpha2(I) collagen (COL-1) probe. Densitometry scanning shows that the older animals have increased COL-1 mRNA levels (290%; $p < 0.005$) compared with young.

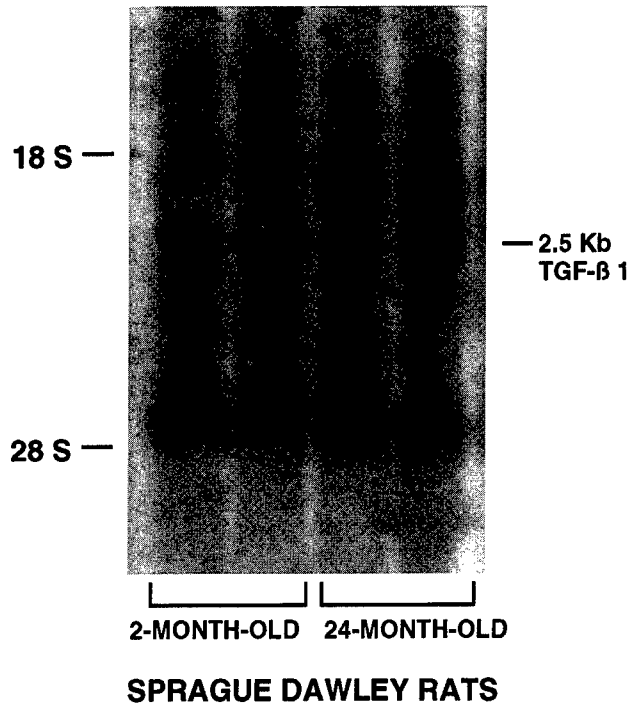

FIGURE 2. Autoradiogram of a representative Northern blot hybridization study of total RNA isolated from the ventricular myocardium of 2-month-old and 24-month-old Sprague-Dawley rats. The RNA were hybridized with a transforming growth factor- β 1 (TGF β 1) probe. Densitometry scanning shows almost identical mRNA levels in the two groups of rats.

REFERENCES

1. WEBER, K. T. 1989. *J. Am. Coll. Cardiol.* **13**: 1637-1652.
2. MEDUGORAC, I. & R. JACOB. 1983. *Cardiovasc. Res.* **17**: 15-21.
3. EGHBALI, M. E., M. EGHBALI, T. F. ROBINSON, S. SEIFTER & O. O. BLUMENFELD. 1989. *Cardiovasc. Res.* **23**: 723-729.
4. ROBERTS, A. B. & M. B. SPORN. 1990. *In Handbook of Experimental Pharmacology. Peptide Growth Factors and Their Receptors: The Transforming Growth Factor- β .* M. B. Sporn & A. B. Roberts, Eds. Vol. 1: 137-144. Springer-Verlag. New York.

Growth Hormone and Insulin-Like Growth Factor 1 in Normopituitary Patients with Various Degrees of Heart Failure

ENRICO MANGIERI, CARLO TOSTI CROCE,^a
GAETANO TANZILLI, ANTONIETTA LOMURNO,^a
MASSIMO CIAVOLELLA, FRANCESCO MANGIARACINA,
FRANCESCO BARILLÀ, AND PIETRO PAOLO CAMPA

*II Department of Cardiology
and*

*^aV Institute of Internal Medicine
"La Sapienza" University
Rome, Italy*

INTRODUCTION

Among biological systems activated in congestive heart failure, increased plasma levels of growth hormone (GH) are hypothesized to be secreted by adeno-hypophysis, in response to catecholamines¹ and atrial natriuretic factor (ANF).² Additionally, GH, through somatomedins or insulin-like growth factor-1 (IGF1), exerts a positive inotropic effect on heart muscle.³⁻⁵ The aim of the present study was: 1) to investigate the behavior of the GH-IGF1 axis in normopituitary patients with various degrees of heart failure; 2) to assess whether GH and IGF1 plasma levels are linked to ventricular mass; and 3) to investigate the behavior of the GH-IGF1 axis after clinical improvement.

MATERIALS AND METHODS

We studied 18 normotensive, normopituitary and normoglycemic patients with ages ranging 31-54 (average: 48) years undergoing heart catheterization at our institution for clinical decision making. Eight patients had primary dilated cardiomyopathy (DCM), whereas 10 presented aortic regurgitation (AR). Ten patients, 6 with DCM, were in the IV NYHA functional class, the remaining in the III class. At 2D-echocardiography, left ventricular end-diastolic (LVEDD) and end-systolic diameters (LVESD), interventricular septum (IVS) and posterior wall (LVPW) thickness, left atrial diameter (LA), and left ventricular mass index (LVMI) calculated according to Devereux, were assessed. Blood samples were collected at basal and after improvement of at least a NYHA functional class in order to determine hormone plasma levels, which were assayed through a direct immunoradiometric commercially available method (GH and IGF1). According

to cardiac index (CI) values, patients were divided into 2 groups: Group A included 10 patients with CI 2.5 L/min/m², presenting DCM in 6 cases and AR in 4; Group B included 8 patients with CI 2.5 L/min/m², presenting DCM in 2 cases and AR in 6.

STATISTICAL ANALYSIS

All data are expressed as the mean \pm standard deviation. Statistical evaluation was made by Student *t* test for paired and unpaired data. The correlation between hormones and LVMI was evaluated. A $p < 0.05$ was considered significant.

RESULTS

Patients in the III NYHA functional class had baseline GH plasma levels of 0.11 ± 0.03 ng/ml, and those in the IV NYHA functional class had significantly higher levels (4.6 ± 5.1 ng/ml, $p < 0.05$). No significant changes of GH were found in either group after clinical improvement (1.4 ± 2.3 ng/ml and 4.9 ± 6.1 , respectively). IGF1 plasma levels were 188 ± 51.6 ng/ml in Group A and increased to 254 ± 59 ng/ml after clinical improvement without any statistical difference. In Group B baseline IGF1 levels were 235 ± 70.3 (no statistical difference with baseline values of Group A). They significantly increased after clinical improvement to 338 ± 79.6 ($p < 0.001$). No significant relation was found between LVMI and hormones.

CONCLUSIONS

Our investigation revealed 1) GH plasma levels significantly increased in patients with more severe heart failure; 2) no significant relation was found by comparing LVMI and hormones in both groups; and 3) IGF1, which was lower in Group A than in Group B in basal condition, increased after clinical improvement in all patients, but the response was significant only in patients of Group B, probably due to the reduction of the hepatic stasis.

REFERENCES

1. HOLLAND, J. F., G. E. RICHARDS, S. L. KAPLAN *et al.* 1978. The role of biogenic amines in the regulation of growth hormone and corticotropin in the trained conscious dog. *Endocrinology* **102**: 1452-1457.
2. MURAKAMI, Y., Y. KATO, K. TOJO *et al.* 1988. Stimulation of growth hormone secretion by central administration of atrial natriuretic polypeptide in the rat. *Endocrinology* **122**: 2103-2108.
3. BERELOWITZ, M., M. SZABO, L. A. FROHMAN *et al.* 1981. Somatomedin-C mediates growth hormone negative feed-back by effects on both the hypothalamus and the pituitary. *Science* **212**: 1279-1284.
4. BALK, S., A. MORISI, S. GUNTHER *et al.* 1984. Somatomedins (insulin-like growth fac-

tors) but not growth hormone, are mitogenic on chicken heart mesenchymal cells and act synergistically with epidermal growth factor and fibroblast growth factor. *Life Sci.* **35**: 335-342.

5. CUNEO, C. R., P. WILMHURST, G. LOWY *et al.* 1989. Cardiac failure responding to growth hormone. *Lancet* **i**: 838-839.

Regulatory Networks of the Retinoblastoma Protein^a

WEN-HWA LEE, PHANG-LANG CHEN, AND DANIEL J. RILEY

*Center for Molecular Medicine/Institute of Biotechnology
The University of Texas Health Science Center at San Antonio
15355 Lambda Drive
San Antonio, Texas, 78245*

INTRODUCTION

The human retinoblastoma (*RB*) gene product was first identified by antibodies raised against a TrypE-human retinoblastoma (Rb) fusion protein expressed in *E. coli*.¹ These antibodies recognize a protein, termed p110^{RB}, migrating in multiple closely-spaced bands at M_r 110 to 116 kilodaltons when sized on denaturing polyacrylamide gels. The protein is absent from all the retinoblastoma lines examined thus far, which confirms that absence of Rb is important in the pathogenesis of the tumors.² Rb is a nuclear phosphoprotein that binds to DNA nonspecifically.¹ The DNA-binding activity is intrinsic to the carboxyl-terminal region,³ which also contains a bipartite nuclear localization signal.⁴

Distinct domains of the Rb have been found to be important for the protein's biologic functions (FIGURE 1). Partial proteolytic digestion of purified human Rb protein has revealed four discrete structural domains.⁵ Consistent with these results, computer-assisted analysis of the amino acid sequence of Rb protein predicts that the tertiary structure of Rb should contain several globular domains and a hydrophilic tail region. Two of the globular domains that bind viral oncoproteins have been mapped by deletion mutagenesis to the C-terminus.^{6,7} These regions are critical for several of the activities of Rb, including its phosphorylation during G₁ phase of the cell cycle,^{8,9} binding to transcription factors,¹⁰ tethering to nuclear structures,¹¹ and growth suppression in cell culture.^{12,13} Mutations within these domains are precisely those found most frequently in human tumors.^{6,7}

Although no known biologic function has yet been determined for the two N-terminal globular domains, interesting clues to their potential function have emerged. For example, when purified Rb protein was sized on a non-denaturing gel, it migrated in the form of oligomers, a property not shared by p56^{RB}, a derivative truncated at the N-terminus.⁵ Electron microscopy of purified p110^{RB} shows filamentous structures *in vitro*, which lends further support to the idea that p110^{RB} can form higher ordered structures.⁵ The structures appear to result from association

^a Work performed in the authors' laboratory was supported by grants from the NIH, the Council for Tobacco Research, and the AP McDermott Endowment Fund. DJR is the recipient of a Physician's Training Research Award from the American Cancer Society. This article is abstracted from a more complete review that will appear in the *Annual Review of Cell Biology* (1994).

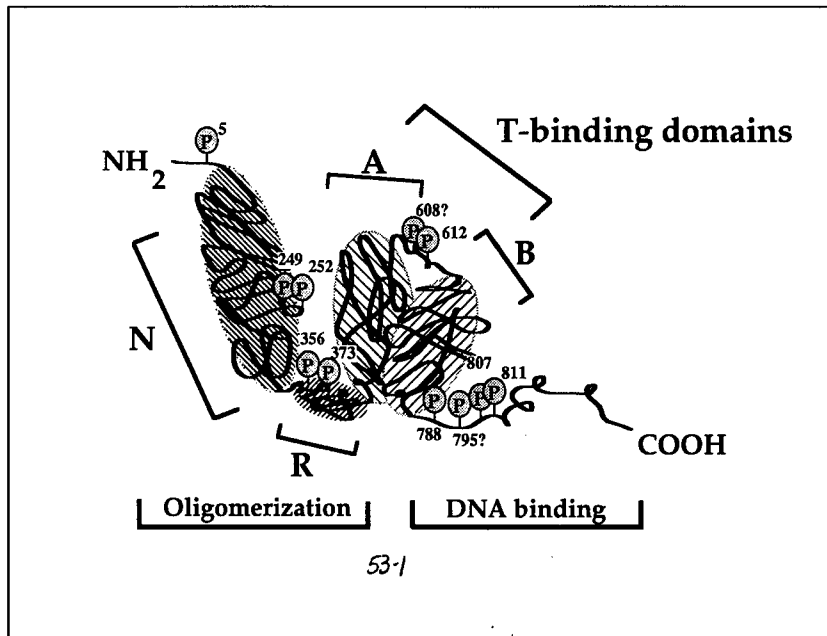

FIGURE 1. Schematic representation of the structure of the human Rb protein. Rb protein is organized into four discrete structural domains (*shaded areas*). The N-terminal domain (N) is important for oligomerization *in vitro*.⁵ Two other domains (A & B) are frequently altered in tumors and are required for the binding of E2F^{6,7} and several DNA tumor virus oncoproteins, including SV40 large T antigen.⁴⁸ Nonspecific DNA binding is intrinsic to the carboxy-terminal portion of the protein.³ Potential cdc2 phosphorylation sites are marked P, as are the amino-acid numbers of the corresponding serine or threonine residues.^{18,34}

between the N- and C-termini of the full-length Rb protein. The ability of Rb to form complex structures, when combined with its propensity to bind to nuclear matrix proteins (see below)^{14,15} and several nuclear growth-promoting proteins,^{16,17} suggests a potential mode by which Rb functions in regulating cellular activity. Rb may keep growth- and proliferation-promoting proteins “corralled” into a nuclear subcompartment until signals are appropriate for such proteins to be released so that the cell can progress beyond G₁.^{18,19} The corral created by Rb protein complexes may also function to bring these and other proteins, including some that restrict cell cycle progression or promote differentiation, to their subnuclear sites of action.^{14,19}

Regulation of Rb during the Cell Cycle

Abnormal proliferation of cells in cancer and other pathologic states is considered to be the consequence of deregulated progression through certain cell cycle checkpoints. Such checkpoints restrict progression as the cells cycle through

phases of growth, DNA synthesis, and division. They might also regulate exit from the cell cycle and commitment to differentiation.²⁰ In this framework, the inactivation of proteins involved in the checkpoints, or activating them at inappropriate times, can lead to a number of problems. Inappropriate passage of cells normally halted at the G₁/S boundary might cause them to miss precisely timed signals to exit the cell cycle for differentiation or death. Alternatively, the cells might synthesize DNA in S phase, from faulty templates, before scheduled DNA repair could be completed.

Overexpression of Rb in early G₁ represents an example of the consequence of inappropriate cell cycle control; such overexpression results in reversible G₁ arrest.^{12,21} Since Rb protein is constitutively expressed in normal cells, has a long half-life of at least 12 hours,⁹ and is present in all mammalian cells tested to date,¹ regulation of Rb in different cells must be accomplished posttranslationally. Rather than expression and degradation leading to the regulation of Rb during phases of the cell cycle, existing Rb must be activated and inactivated at appropriate times. Work determining how Rb protein is regulated to turn "on" or "off," and how it is directed to its molecular sites of action, has focused on three general mechanisms: phosphorylation, compartmentation, and association with other cellular proteins whose functions are known or under investigation.

Phosphorylation and dephosphorylation of cellular proteins are recognized as important regulatory mechanisms controlling a variety of cellular events.²² The *RB* gene product is clearly a phosphoprotein as revealed by biochemical studies of Rb prepared from cells at different stages of the cell cycle. At least five distinct electrophoretic bands migrating from M_r 110 to 116 kD have been shown to correspond to different phosphorylated forms of p110^{RB}.^{23,24}

The phosphorylation status of the Rb protein oscillates regularly during the cell cycle.^{8,9,25,26} Although Rb may exist in several subpopulations within a given cell during the same phase of the cell cycle, hypophosphorylated forms predominate in the G₀ and G₁ while more highly phosphorylated forms exist in S, G₂, and M phases. Phosphopeptide mapping has shown that Rb protein is phosphorylated on serines and threonines in at least three distinct stages: in mid-G₁, S, and near the G₂/M transition.^{9,26} Pulse-chase experiments and the phosphopeptide maps of phosphorylated p110^{RB} clearly vary in different stages of the cell cycle by the addition or subtraction of phosphate residues. This finding indicates that specific, susceptible sites are phosphorylated sequentially beginning at G₁. Dephosphorylation begins during anaphase and also continues stepwise until completion in the ensuing G₁ phase.²⁷

A primary biological function of hypophosphorylated Rb is believed to be mediation of growth inhibition in G₀ and G₁. Phosphorylation in mid G₁ is thought to inactivate a large pool of Rb, thereby overcoming its growth suppression activity. This event allows progression past G₁ and commitment to synthesis and division stages of the cell cycle. Such a line of reasoning fits with observations that the transforming proteins of some tumor viruses bind only to the hypophosphorylated form of Rb. Viral oncoproteins such as SV40 large T antigen, adenovirus E1A, and papillomavirus 16 E7 appear to function in a manner that mimics phosphorylation of Rb: they inactivate Rb at G₁ and allow cell cycle progression into S phase and beyond.²⁸⁻³⁰

G₁ Arrest by Overexpression of Rb

Direct evidence that Rb is involved in cell cycle regulation stems from single cell microinjection experiments. Injection into early G₁ cells of excess, purified, unphosphorylated Rb protein, either full-length p110^{RB} or p56^{RB}, inhibits progression into S phase.¹² The reversible G₁ arrest is seen in normal monkey kidney CV-1 cells and in human osteosarcoma Saos-2 cells expressing inactivated Rb protein. Injection of normal Rb into cells arrested in late G₁ or early S phase has no effect on DNA synthesis. These observations indicate a specific restriction point in early G₁; passage through this point commits cells to DNA synthesis and cell division. Similar experiments, using transfection of *RB* gene constructs into cycling Saos-2 cells rather than microinjection of purified Rb, also demonstrate G₁ arrest.²¹

Possible Roles for Rb in Other Phases of the Cell Cycle

Current hypotheses hold that only the unphosphorylated form of Rb, present in G₁, is active. This conclusion is largely based on data showing G₁ arrest and on the binding of growth-regulating proteins specifically with only hypophosphorylated Rb. The stepwise and sequential phosphorylation of Rb from G₁ to S and G₂, however, suggests that Rb acts at phases in addition to G₁. Thus, the first series of phosphorylations might not be a master off switch for all the functions of Rb. A recent report showed cell cycle arrest at G₂ by overproduction of Rb protein during S phase of the cell cycle. This study used a rapid, temperature-sensitive gene amplification system to overexpress murine Rb in monkey kidney BTS-1 cells specifically during S phase.³¹

Identification of proteins that interact specifically with hyperphosphorylated Rb may help advance the idea that Rb has roles in several stages of the cell cycle. Ongoing investigations are beginning to demonstrate roles for Rb in M phase, based on the tight association of Rb with other proteins that are part of the mitotic apparatus (P-L. Chen, X. Zhu, M. Mancini, W-H. Lee, unpublished data).

Interaction of Rb with Cyclin/Cdk Complexes and Protein Phosphatases

Regulators of the Rb protein, particularly kinases, are being discovered and dissected. Cdc2 kinase, a crucial gatekeeper at both G₁ to S and G₂ to M transitions, may regulate Rb function.^{32,33} Since Rb appears to be involved in restricting one or both of the same cell cycle transitions,^{12,21,31} it was logical to consider cdc2 kinase as a direct regulator of Rb protein. Indeed, cdc2 can efficiently phosphorylate the Rb protein *in vitro* on many of the same sites normally phosphorylated *in vivo*.^{18,34,35} Human cdc2 has also been shown to interact physically with Rb.^{35,36} A direct functional role for cdc2 in phosphorylating Rb *in vivo*, however, has not been demonstrated conclusively to date.

Cdc2 is only one member of a family of cyclin-dependent kinases (cdks). Other members of this family consist of one of several catalytic subunits, cdks, and one of several regulatory subunits, or cyclins. Most cdks are expressed with relative

constancy throughout the cell cycle. Their activity, however, is modulated by cell cycle-specific changes in the concentrations of specific cyclins.³⁷

Using cotransfection of cyclin and *RB* genes, it has been shown that ectopic expression of cyclins A and E can overcome Rb-mediated G₁ phase cell cycle arrest.²¹ These experiments showed that Rb is hyperphosphorylated in cells overexpressing the specific cyclins, and that phosphorylation of Rb is essential for cyclin A- and E-mediated rescue of Rb-blocked cells. Complexes of cyclins A and E with cdk might be able to phosphorylate Rb and partially inactivate it. Although the G₁ cyclins D1, D2, and D3 can also form complexes with Rb, they do not function equivalently.^{38,39} Cyclin D2-cdk2 and cyclin D2-cdk4 complexes, like cyclins A and E, can reverse the G₁ arrest caused by overexpression of Rb alone and lead to Rb phosphorylation.³⁹ The sites on Rb that cyclin D2-cdk4 complexes phosphorylate *in vitro* are identical to sites phosphorylated *in vivo*.⁴⁰ Cyclins D1 and D3, on the other hand, do not lead to phosphorylation of Rb in cultured cells.³⁹ Such observations indicate that the interaction of cyclins D1 and D3 with Rb may not be functionally significant or that their regulation of Rb does not involve phosphorylation. When interpreting these experiments, it is important to note that the data show only correlations between cyclin/ckd complexes and Rb. Direct genetic evidence—*i.e.*, creation of specific Rb or cdk mutations that abolish binding sites or sites of Rb phosphorylation—remains to be shown. Data from these mutations would be the strongest evidence to support the idea that the complexes cyclin-ckd forms with Rb are actually responsible for one level of Rb regulation.

Dephosphorylation appears to be the primary mode of Rb reactivation in G₁.²⁴ Dephosphorylation of Rb protein seems to involve protein phosphatase 1 (PP1). The catalytic subunit of PP1 binds to Rb;⁴¹ moreover, dephosphorylation of Rb in M and G₁ phases by PP1 has been demonstrated by blocking PP1 activity using specific phosphatase inhibitors.^{27,42,43} It remains to be shown whether other phosphatases may also be involved in Rb dephosphorylation.

Importance of Phosphorylation and Dephosphorylation

The phosphorylation of Rb has specific and important cellular consequences. Only hypophosphorylated Rb (1) binds well to DNA,^{1,9,44} (2) “tethers” to the nuclear structure when other cellular components are extracted by low salt/detergent solutions,¹¹ and (3) binds specifically to many other nuclear proteins.^{15,18} Phosphorylation of crucial residues on Rb apparently abolishes or weakens the interactions of Rb with other structures, thereby allowing Rb to dissociate from nuclear complexes and subcompartments at appropriate times during the cell cycle. Several avenues of research have shown that Rb exists in distinct subpopulations in a cell during a given phase of the cell cycle.⁴⁵ Perhaps it is compartmentalized with components of the nuclear matrix and other macromolecular structures in a dynamic equilibrium between various phosphorylated states.¹⁴

Proper phosphorylation of Rb depends not only on having critical serine and threonine residues available for phosphorylation, but also on sites for the binding of kinases and phosphatases. Rb point mutations that specifically alter phosphorylation sites or groups of sites will be useful to determine which phosphorylation

events are crucial for the associations of Rb with kinases and other proteins at various stages of the cell cycle. A specific point mutation of Rb at residue 706 (Cys to Phe), which prevents phosphorylation and binding to SV 40 T antigen,^{46,47} helps illustrate the concept that Rb protein conformation is important for determination of kinase binding sites. Since the Cys⁷⁰⁶ is not specifically a phosphorylation site, the Cys-to-Phe mutation might prevent phosphorylation by changing the conformation of Rb and preventing it from serving as a substrate for kinases.

Interaction of Rb with its Associated Proteins

One of the possible ways by which the effects of Rb protein are restricted to certain cell types and developmental stages is through different interactions of Rb with a network of other cellular proteins. Studies have demonstrated that exogenous oncoproteins form complexes with Rb.⁴⁸ These oncoproteins bind to the same regions of Rb protein that are often mutated in spontaneous tumors.^{6,7} A logical and prevailing theory for explaining how these oncoproteins function to transform cells postulates their binding to and inactivation of Rb, in effect mimicking inactivating mutations of the tumor suppressor.³⁰ The demonstration of direct links between positively acting oncoproteins and a negatively acting tumor suppressor launched a search to find cellular proteins that have molecular functions similar to those of exogenous oncoproteins. Several methods—passing cell extracts over an Rb-affinity column,^{18,49} screening lambda expression libraries using purified Rb protein as a probe,^{15,50} and modifications of the yeast two-hybrid system^{41,51}—have been used to identify more than thirty separate cellular proteins that bind to Rb.

The proteins characterized thus far represent a diverse group and include transcription factors,^{15,52–54} growth regulators,^{17,55} protein kinases,^{35,36,40} protein phosphatases,⁴¹ and nuclear matrix proteins.¹⁴ Novel Rb-associated proteins apparently involved in chromosome segregation during M phase are still being characterized.

Transcription Factors

The best characterized cellular Rb-associated protein is the transcription factor E2F-1.^{16,56,57} E2F binds to the same region of Rb as do the DNA tumor virus oncoproteins, and E2F-Rb complexes can be dissociated by these oncoproteins.⁵⁷ The E2F-Rb interaction has been used as a paradigm to demonstrate how Rb restrains cell cycle progression.¹⁰ E2F has been shown, for example, to activate transcription of the dihydrofolate reductase (DHFR) gene, which is active during the DNA synthetic phase of the cell cycle.⁵⁸

Since there are E2F recognition sites in the promoters of several other growth-promoting genes, it is suspected that E2F can also transactivate these genes, which include *c-myc*, *N-myc*, DNA polymerase α , and thymidate kinase.^{10,17,59,60} A recent report suggests that E2F also regulates RB gene expression *in vivo*.⁶¹ The RB gene promoter itself contains an E2F-1 recognition site and overexpression

of Rb suppresses E2F-1-mediated activation of RB transcription. E2F-1 thus participates in a feedback loop for regulation of Rb expression.

From these findings it appears that one function of Rb is to block transcriptional activation by E2F-1 and other transcription factors that play important roles in the G₁/S transition. When E2F and other transcription factors that promote cell proliferation are free, they can activate transcription of genes required for S phase and beyond. When these transcription factors are complexed with Rb and inactivated, transcription is inhibited and cell cycle progression is blocked.

Rb may also associate with intracellular signaling proteins. An Rb-associated protein, p48, which is a human homolog of yeast MS11, was recently identified.⁵⁵ MS11 is a putative negative regulator of Ras in yeast. Although functional data to implicate p48 in a mammalian cell Ras pathway have not yet emerged, a possible antagonistic interaction between Rb and Ras in human cells is being pursued.

The Nuclear Matrix

Using immunolabeling with confocal microscopy and electron microscopy, a specific association in G₁ phase between Rb and the nuclear matrix has been shown.¹⁴ The matrix serves in part as a structure to organize and compartmentalize transcription, DNA replication, and RNA processing. Such sites of organization have been characterized as "assemblies."⁶² Rb localizes not only within the assemblies, but also at the nuclear lamins and the nucleolar remnant. The latter locations are consistent with the identification of lamin A/C and UBF, a ribosomal transcription factor, as Rb-associated proteins.^{14,15} In cells expressing mutant Rb that does not bind SV40 T antigen, there is no association between Rb and the nuclear matrix.

Another nuclear matrix protein, p84 (according to sizing by SDS-PAGE), associates specifically with the N-terminal portion of hypophosphorylated Rb during G₁ phase of the cell cycle. The 84-kD protein is novel and still being characterized. It is constitutively expressed and colocalizes with splicing centers by confocal immunofluorescence.⁴¹ By its associations, then, Rb might function in RNA processing. Attributing a biologic function to the N-terminal domain of p110^{RB}, in addition to the *in vitro* function of that domain in oligomerization, will be an important step in showing that full-length Rb *in vivo* is more than just a functional C-terminal attached to a superfluous N-terminal half.

The Mitotic Process

Two other Rb-associated proteins seem to have their major functions during mitosis. One 90-kilodalton, 824-amino acid protein has 60% sequence identity with the nuc2 protein of fission yeast and the bimA protein of *Aspergillus* (P-L. Chen & W-H. Lee, unpublished data), proteins that are apparently important in metaphase spindle elongation.^{63,64} The human protein has therefore been named H-nuc (for human Nuc).

A second novel molecule, mitosin, is a 350-kilodalton phosphoprotein ex-

pressed during S and M phases of the cell cycle, but not in G₁ phase. It is phosphorylated from G₂ through M phases and degraded at the end of mitosis. During mitosis, it apparently colocalizes with centromeres/kinetichores. Preliminary studies in monkey CV1 cells indicate that overexpression of mitosin results in delayed entry into the next G₁ phase (X. Zhu & W-H. Lee, unpublished results). The protein phosphatase 1 may also link Rb to M phase functions. Because PP1 localizes specifically to chromosomes during mitosis,⁶⁵ it is interesting to suggest that dephosphorylation of Rb may occur regionally to facilitate interaction with mitotic proteins. The significance of the interactions of Rb with protein phosphatase 1, H-nuc, and mitosin during mitosis, when the majority of Rb is highly phosphorylated, needs to be explored further. Such exploration will be important in discovering more functions for Rb other than growth arrest and regulation of transcription factors in G₁. It is possible that subpopulations of Rb remain hypophosphorylated during M phase, and it is primarily with these subpopulations that mitosin and H-nuc interact.

FIGURE 2 is a schematic diagram of some of the modifications of Rb and its proposed interactions with other proteins at different stages of the cell cycle. The array of Rb-associated proteins, from transcription factors being regulated in G₁ to kinetichore domains involved in mitosis, adds a layer of complexity to the functions of Rb during the cell cycle. If the interactions between Rb and some of its associated proteins prove to be significant *in vivo*, former dogma that only the hypophosphorylated form of Rb is active may need to be reevaluated. Paradoxically, only by adding to the complexity of the interactions of Rb with its associated proteins can we productively continue to understand the functions of Rb in growth suppression, differentiation, and even, perhaps, in mitosis.

Rb-Related Proteins and Other Putative Tumor Suppressors

The search for activities of Rb protein in different cells at different times has been improved by another layer of complexity, *i.e.*, a family of proteins that share structural similarity with p110^{RB}. Two other proteins, p107 and p130, have been isolated by their interaction with adenovirus E1A.⁶⁶ A similar region of E1A is required for binding with all three of these proteins, which suggests a structural similarity between them. Amino acid sequence comparisons show a high degree of identity (53%) between p107 and p130 and a significant degree of identity (30%) between p107 or p130 and p110^{RB}.^{67,68} The sequence similarity between the three proteins is greatest in the regions that correspond to the SV40 T-binding domains in Rb. Based on these similarities, the three proteins are thought to be members of an Rb family and to have some overlapping biologic functions. Indeed, p107 has been shown to share some properties with Rb. Both inhibit E2F-mediated transcriptional activation and both can inhibit progression through G₁.⁶⁹ However, the biologic functions of p107 certainly are not identical to those of Rb. Transient growth arrest by Rb and p107 can be rescued differentially by various regulators of the cell cycle (E1A, E2F-1, and cyclins A and E for Rb, only E1A and E2F-1 for p107). Furthermore, growth arrest in cervical carcinoma cells was achieved by p107, but not by Rb. To date, no mutation of p107 has been found in human

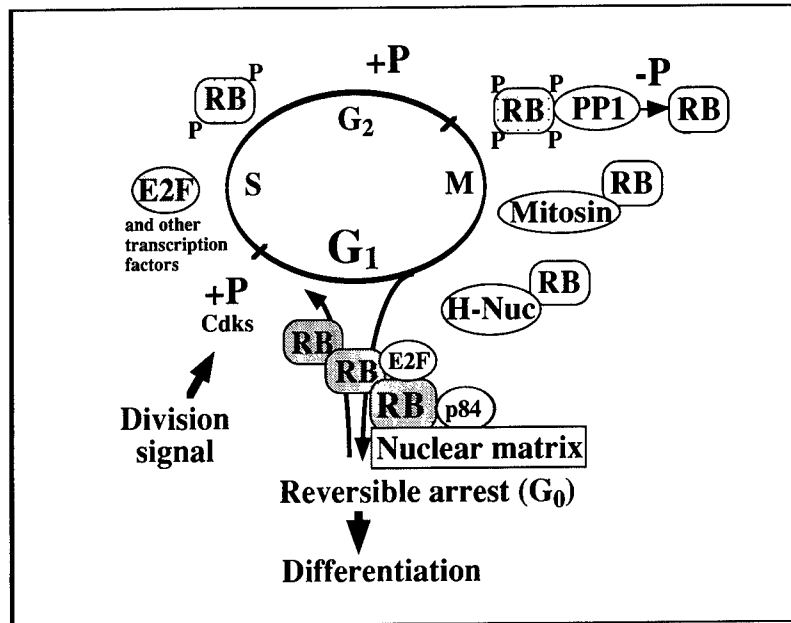

FIGURE 2. A simplified model by which Rb and its associated proteins regulate progression through the cell cycle. Hypophosphorylated Rb protein (RB) is active in G₁ phase of the cell cycle. In this form, it binds to nuclear matrix-associated proteins, including p84, and to the transcription factor E2F. It may also form oligomers that "corral" growth-promoting proteins. Phosphorylation of Rb in mid G₁, possibly by specific cdk/cyclin complexes, leads to release of E2F. The cell is then committed to progression through the rest of the cell cycle, during which Rb is further phosphorylated in S and G₂. In M phase, hyperphosphorylated Rb associates with two novel proteins, mitosin and H-nuc, and with protein phosphatase 1 (PP1). Dephosphorylation leads to reactivation of Rb in G₁. When signals are appropriate, the cell can enter G₀ and differentiate. It is important to stress that distinct subpopulations or subcompartments of Rb protein may exist in a dynamic equilibrium, and may be phosphorylated to different extents during the same phase of the cell cycle.

tumors. The true role of p107 in growth and tumor suppression therefore remains to be determined.

No functional comparisons of p130 with Rb have been reported, but p130 associates with the same E2F and some of the same cyclins and kinases as Rb.⁷⁰⁻⁷² Allelic loss of the region of chromosome 16 to which p130 maps is seen in several common tumors, and inactivating mutations of p130 may eventually be found to be essential for transformation in some of them.^{71,72}

It is attractive to think that p107 and p130 are similar enough to Rb that the three proteins have many functions that are redundant *in vivo*. Such a theory would help to explain the tissue specificity seen in tumor predisposition caused by inactivation of the *RB* gene. Patients with heterozygous germ line inactivation of the *RB-1* gene, for example, are predisposed to tumors of the retina and soft tissue, but not other tumors with any great incidence.^{73,74} Perhaps p107 and p130

substitute for Rb and act as tumor suppressors in other cells. The differences in the respective protein structures could allow association with other crucial proteins, or association with some of the same Rb-associated proteins, but with different affinities and functional consequences.¹⁹ Studies comparing Rb, p107, and p130 will undoubtedly discover more differences in their interactions with growth- and proliferation-promoting proteins than have already been established.

The functions of Rb and Rb-related proteins in tumor suppression and differentiation are remarkably specific for certain cell types and developmental stages. This specificity is probably achieved, at least in part, by the differential expression and association of other proteins that function in complexes with Rb and related proteins. We are just beginning to discover some of these other proteins and to dissect the complexities of their interaction in networks that include the retinoblastoma protein.

SUMMARY

Studies of the retinoblastoma (*RB*) gene product suggest that it may work as a fundamental regulator to coordinate pathways of cellular growth and differentiation. One known function of retinoblastoma (Rb) protein is its ability to suppress tumorigenesis. In many different cultured tumor cells, replacement of a normal *RB* gene and expression of normal Rb protein results in suppression of neoplastic properties. Moreover, in humans or experimental mice, germ line mutation of the *RB* gene leads particularly to retinoblastomas or pituitary tumors, respectively, which demonstrates that the role of *RB* in tumor predisposition is specific to certain tissues. In addition to suppressing tumor formation, Rb apparently also has roles in normal development and cellular differentiation. Recent characterizations of Rb-associated proteins and proteins within the Rb family may provide some clues to exploring the complex networks in which Rb is involved.

REFERENCES

1. LEE, W-H., J-Y. SHEW, F. D. HONG, T. W. SERY, L. A. DONOSO, L-J. YOUNG, R. BOOKSTEIN & EY-HP. LEE. 1987. The retinoblastoma susceptibility gene encodes a nuclear phosphoprotein associated with DNA binding activity. *Nature* **329**: 642-645.
2. LEE, W-H, R. BOOKSTEIN, F. HONG, L-J. YOUNG, J-Y. SHEW & EY-HP. LEE. 1987a. Human retinoblastoma gene: cloning, identification, and sequence. *Science* **235**: 1394-1399.
3. WANG, N. P., P-L. CHEN, S-H. HUANG, L. A. DONOSOS, W-H. LEE & EY-HP. LEE. 1990. DNA binding activity of retinoblastoma protein is intrinsic to its carboxyl-terminal region. *Cell Growth Differ.* **1**: 233-239.
4. ZACKSENHAUS, E., R. BREMNER, R. A. PHILLIPS & B. L. GALLIE. 1993. A bipartite nuclear localization signal in the retinoblastoma gene product and its importance for biologic activity. *Mol. Cell. Biol.* **13**: 4588-4599.
5. HENSEY, C. E., F. HONG, T. DURFEE, Y-W. QIAN, EY-HP. LEE & W-H. LEE. 1994. Identification of discrete structural domains in the retinoblastoma protein: amino-terminal domain is required for its oligomerization. *J. Biol. Chem.* **269**: 1380-1387.
6. HUANG, S., N. P. WANG, B. Y. TSENG, W-H. LEE & EY-HP. LEE. Two distinct and

- frequently mutated regions of the retinoblastoma protein are required for binding to SV40 T antigen. *EMBO J.* **9**: 1815–1822.
7. HU, Q., N. DYSON & E. HARLOW. 1990. The regions of the retinoblastoma protein needed for binding to adenovirus E1A or SV40 large T antigen are common sites for mutations. *EMBO J.* **9**: 1147–1155.
 8. BUCHKOVICH, K., L. A. DUFFY & E. HARLOW. 1989. The retinoblastoma protein is phosphorylated during specific phases of the cell cycle. *Cell* **58**: 1097–1105.
 9. CHEN, P.-L., P. SCULLY, J.-Y. SHEW, J. Y. J. WANG & W.-H. LEE. 1989. Phosphorylation of the retinoblastoma gene product is modulated during the cell cycle and cellular differentiation. *Cell* **58**: 1193–1198.
 10. NEVINS, J. R. 1992. E2F: a link between the Rb tumor suppressor protein and viral oncoproteins. *Science* **258**: 424–429.
 11. MITTNACHT, S. & R. A. WEINBERG. 1991. Phosphorylation of the retinoblastoma protein is associated with an altered affinity for the nuclear compartment. *Cell* **65**: 381–393.
 12. GOODRICH, D. W., N. P. WANG, Y.-W. QIAN, EY-HP. LEE & W.-H. LEE. 1991. The retinoblastoma gene product regulates progression through the G₁ phase of the cell cycle. *Cell* **67**: 293–302.
 13. QIAN, X.-Q., T. CHITTENDEN, D. M. LIVINGSTON & W. G. KAELIN, JR. 1992. Identification of a growth suppression domain within the retinoblastoma gene product. *Genes Dev.* **6**: 953–974.
 14. MANCINI, M., B. SHAN, J. NICKERSON, S. PENMAN & W.-H. LEE. 1994. The retinoblastoma gene product is a cell-cycle dependent, nuclear-matrix associated protein. *Proc. Natl. Acad. Sci. USA* **91**: 418–422.
 15. SHAN, B., X. ZHU, P.-L. CHEN, T. DURFEE, Y. YANG, D. SHARP & W.-H. LEE. 1992. Molecular cloning of the cellular genes encoding retinoblastoma-associated proteins: identification of a gene with properties of the transcription factor E2F. *Mol. Cell. Biol.* **12**: 5620–5631.
 16. CHELLAPPAN, S. P., S. HEIBERT, M. MUDRYJ, J. M. HOROWITZ & J. R. NEVINS. 1991. The E2F transcription factor is a cellular target for the RB protein. *Cell* **65**: 1053–1061.
 17. RUSTGI, A. K., N. DYSON & R. BERNARDS. 1991. Amino-terminal domains of c-myc and N-myc proteins mediate binding to the retinoblastoma gene product. *Nature* **352**: 541–544.
 18. LEE, W.-H., R. E. HOLLINGSWORTH, JR., Y.-W. QIAN, P.-L. CHEN, F. HONG & EY-HP. LEE. 1991. RB protein as a cellular “corral” for growth promoting proteins. *Cold Spring Harbor Symp. Quant. Biol.* **56**: 211–217.
 19. LEE, W.-H., Y. XU, F. HONG, T. DURFEE, M. A. MANCINI, Y. UENG, P.-L. CHEN & D. RILEY. 1994. The corral hypothesis: a novel regulatory mode for retinoblastoma protein function. *Cold Spring Harbor Symp. Quant. Biol.* **59**. In press.
 20. PARDEE, A. B. 1989. G₁ events and regulation of cell proliferation. *Science* **246**: 603–608.
 21. HINDS, P. W., S. MITTNASCHT, V. DULIC, A. ARNOLD, S. I. REED & R. A. WEINBERG. 1992. Regulation of retinoblastoma protein functions by ectopic expression of human cyclins. *Cell* **70**: 993–1006.
 22. HUNTER, T. 1987. A thousand and one protein kinases. *Cell* **50**: 823–829.
 23. SHEW, J.-Y., N. LING, X. YANG, O. FODSTAD & W.-H. LEE. 1989. Antibodies detecting abnormalities of the retinoblastoma susceptibility gene product (pp110^{RB}) in osteosarcomas and synovial sarcomas. *Oncogene Res.* **1**: 205–214.
 24. LUDLOW, J. W., J. AHEN, J. M. PIPAS, D. M. LIVINGSTON & J. A. DECAPRIO. 1990. The retinoblastoma susceptibility gene product undergoes cell cycle-dependent dephosphorylation and binding to and release from SV40 large T. *Cell* **60**: 387–396.
 25. DECAPRIO, J. A., J. W. LUDLOW, D. LYNCH, Y. FURUKAWA, J. GRIFFIN, H. PINWICAWORMS, C.-M. HUANG & D. M. LIVINGSTON. 1989. The product of the retinoblastoma susceptibility gene has properties of a cell cycle regulating element. *Cell* **58**: 1085–1095.
 26. DECAPRIO, J. A., Y. FURUKAWA, F. AJCHENBAUM, J. D. GRIFFIN & D. M. LIVINGSTON. 1992. The retinoblastoma-susceptibility gene product becomes phosphorylated in

- multiple stages during cell cycle entry and progression. *Proc. Natl. Acad. Sci. USA* **89**: 1795–1798.
27. LUDLOW, J. W., C. L. GLENDENING, D. M. LIVINGSTON & J. A. DECAPRIO. 1993. Specific enzymatic dephosphorylation of the retinoblastoma protein. *Mol. Cell. Biol.* **13**: 367–372.
 28. DECAPRIO, J. A., J. W. LUDLOW, J. FIGGE, J-Y. SHEW, C-M. HUANG, W-H. LEE, E. MARSILLO, E. PAUCH & D. M. LIVINGSTON. 1988. SV40 large tumor antigen forms a specific complex with the product of the retinoblastoma susceptibility gene. *Cell* **54**: 275–283.
 29. DYSON, N., P. M. HOWLEY, K. MUNGER & E. HARLOW. 1989. The human papilloma virus-16 E7 oncoprotein is able to bind to the retinoblastoma gene product. *Science* **243**: 934–937.
 30. WHYTE, P., K. J. BUCHKOVICH, J. M. HOROWITZ, S. H. FRIEND, M. RAYBUCK, R. A. WEINBERG & E. HARLOW. 1988. Association between an oncogene and an anti-oncogene: the adenovirus E1A protein binds to the retinoblastoma gene product. *Nature* **334**: 124–129.
 31. KARANTZA, V., A. MAROO, D. FAY & J. M. SEDIVY. 1993. Overproduction of Rb protein after the G₁/S boundary causes G₂ arrest. *Mol. Cell. Biol.* **13**: 6640–6652.
 32. WITTENBERG, C. & S. I. REED. 1988. Control of the yeast cell cycle is associated with assembly/disassembly of the cdc28 protein kinase complex. *Cell* **54**: 1068–1072.
 33. MYERSON, M., G. H. ENDERS, C-L. WU, L-K. JU, C. GORKA, C. NELSON, E. HARLOW & L-H. TSAI. 1990. The human cdc2 kinase family. *EMBO J.* **11**: 2909–2918.
 34. LEES, J. A., K. J. BUCHKOVICH, D. R. MARSHAK, C. W. ANDERSON & E. HARLOW. 1991. The retinoblastoma protein is phosphorylated on multiple sites by human cdc2. *EMBO J.* **10**: 4279–4290.
 35. LIN, B. T-Y., S. GRUENWALD, A. O. MORLA, W-H. LEE & J. Y. J. WANG. 1991. Retinoblastoma cancer suppressor gene product is a substrate of the cell cycle regulator cdc2 kinase. *EMBO J.* **10**: 857–864.
 36. HU, Q. J., J. A. LEES, K. J. BUCHKOVICH & E. HARLOW. 1992. The retinoblastoma protein physically associates with the human cdc2 kinase. *Mol. Cell. Biol.* **12**: 971–980.
 37. SHERR, C. 1993. Mammalian G₁ cyclins. *Cell* **73**: 1059–1065.
 38. DOWDY, S. F., P. W. HINDS, K. LOUIE, S. I. REED, A. ARNOLD & R. A. WEINBERG. 1993. Physical interaction of the retinoblastoma protein with human D cyclins. *Cell* **73**: 499–511.
 39. EWEN, M. E., H. K. SLUSS, C. J. SHERR, H. MATSUSHIMA, J-Y. KATO & D. M. LIVINGSTON. 1993. Functional interaction of the retinoblastoma protein with mammalian D-type cyclins. *Cell* **73**: 487–497.
 40. KATO, J-Y., H. MATSUSHIME, S. W. HIEBERT, M. E. EWEN & C. J. SHERR. 1993. Direct binding of cyclin D to the retinoblastoma gene product (Rb) and Rb phosphorylation by the cyclin D-dependent kinase CDK4. *Genes Dev.* **7**: 331–342.
 41. DURFEE, T., K. BECHERER, P-L. CHEN, S-H. YEH, Y. YANG, A. E. KILBURN, W-H. LEE & S. J. ELLEDGE. 1993. The retinoblastoma protein associates with the protein phosphatase type 1 catalytic subunit. *Genes Dev.* **7**: 555–569.
 42. ALBERTS, A. S., A. M. THORBURN, S. SHENOLIKAR, M. C. MUMBY & J. R. FERAMISCO. 1993. Regulation of cell cycle progression and nuclear affinity of the retinoblastoma protein by protein phosphatases. *Proc. Natl. Acad. Sci. USA* **90**: 388–392.
 43. KIM, T-A., B. R. VELASQUEZ & L. E. WENNER. 1993. Okadaic acid regulation of the retinoblastoma gene product is correlated with inhibition of growth factor-induced cell proliferation in mouse fibroblasts. *Proc. Natl. Acad. Sci. USA* **90**: 5460–5463.
 44. TEMPLETON, D. J. 1992. Nuclear binding of purified retinoblastoma gene product is determined by cell cycle-regulated phosphorylation. *Mol. Cell. Biol.* **12**: 435–443.
 45. MITTNACHT, S., J. A. LEES, D. DESAI, E. HARLOW, D. O. MORGAN & R. A. WEINBERG. 1994. Distinct subpopulations of the retinoblastoma protein show a distinct pattern of phosphorylation. *EMBO J.* **13**: 118–127.
 46. BIGNON, Y-J., J-Y. SHEW, D. RAPPOLEE, S. L. NAYLOR, EY-HP. LEE. 1990. A single

- Cys⁷⁰⁶ to Phe substitution in the retinoblastoma protein causes loss of binding to the SV40 T antigen. *Cell Growth Differ.* **1**: 647–651.
47. KAYE, F. J., R. A. KRATZKE, J. L. GERSTER & J. M. HOROWITZ. 1990. A single amino acid substitution results in a retinoblastoma protein defective in phosphorylation and oncoprotein binding. *Proc. Natl. Acad. Sci. USA* **87**: 6922–6926.
 48. CHELLAPPAN, S., V. B. KRAUS, B. KROGER, K. MUNGER, P. M. HOWLEY, W. C. PHELPS & J. R. NEVINS. 1992. Adenovirus E1A, simian virus 40 tumor antigen, and human papillomavirus E7 protein share the capacity to disrupt the interaction between transcription factor E2F and the retinoblastoma gene product. *Proc. Natl. Acad. Sci. USA* **89**: 4549–4553.
 49. KAE LIN, W. G. J., D. C. PALLAS, J. A. DECAPRIO, F. J. KAYE & D. M. LIVINGSTON. 1991. Identification of cellular proteins that can interact specifically with the T/E1A-binding region of the retinoblastoma gene product. *Cell* **64**: 521–532.
 50. DEFEO-JONES, D., P. S. HUANG, R. E. JONES, K. M. HASKELL, G. A. VUOCOLO, M. G. HONOBK, H. E. HUBER & A. OLIFF. 1991. Cloning of cDNAs for cellular proteins that bind to the retinoblastoma gene product. *Nature* **352**: 251–254.
 51. FIELDS, S. & O. SONG. 1989. A novel genetic system to detect protein-protein interactions. *Nature* **340**: 245–246.
 52. FATTAEY, A. R., K. HELIN, M. S. DEMBSKI, N. DYSON, E. HARLOW, G. A. VUOCOLO, M. G. HOROBK, K. M. HASKELL, A. OLIFF, D. DEFEO-JONES & R. E. JONES. 1993. Characterization of the retinoblastoma binding proteins RBP1 and RBP2. *Oncogene* **8**: 3149–3156.
 53. HELIN, K., J. A. LEES, M. VIDAL, N. DYSON, E. HARLOW & A. FATTAEY. 1992. A cDNA encoding an Rb-binding protein with properties of the transcription factor E2F. *Cell* **70**: 337–350.
 54. KIM, S.-J., S. WAGNER, F. LUI, M. A. O'REILLY, P. D. ROBBINS & M. R. GREEN. 1992. Retinoblastoma gene product activates expression of the human TGF- β 2 gene through transcription factor ATF-2. *Nature* **358**: 331–334.
 55. QIAN, Y.-W., Y.-C. J. WANG, R. E. HOLLINGSWORTH, JR., D. JONES, N. LING & EY-HP. LEE. 1993. A retinoblastoma-binding protein related to a negative regulator of Ras in yeast. *Nature* **364**: 648–652.
 56. BANDARA, L. R. & N. B. LATHANGUE. 1991. Adenovirus E1a prevents the retinoblastoma gene product from complexing with a cellular transcription factor. *Nature* **351**: 494–497.
 57. CHITTENDEN, T., D. M. LIVINGSTON & W. G. KAE LIN, JR. 1991. The T/E1A-binding domain of the retinoblastoma product can interact specifically with a sequence-specific DNA-binding protein. *Cell* **65**: 1073–1082.
 58. BLAKE, M. C. & J. C. AZIZKHAN. 1989. Transcription factor E2F is required for efficient expression of the hamster dihydrofolate reductase gene *in vitro* and *in vivo*. *Mol. Cell. Biol.* **9**: 4994–5002.
 59. DOU, Q.-P., P. J. MARKELL & A. B. PARDEE. 1992. Thymidine kinase transcription is regulated at the G₁/S phase by a complex that contains retinoblastoma-like protein and a cdc2 kinase. *Proc. Natl. Acad. Sci. USA* **89**: 3256–3260.
 60. PEARSON, B. E., H.-P. NASHEUER & TS-F. WANG. 1991. Human DNA polymerase α gene: sequences controlling expression in cycling and serum-stimulated cells. *Mol. Cell. Biol.* **11**: 2081–2095.
 61. SHAN, B., C.-Y. CHANG & W.-H. LEE. 1994. The transcription factor E2F-1 mediates autoregulation of RB expression. *Mol. Cell. Biol.* **14**: 299–309.
 62. WAN, K. M., J. A. NICKERSON, G. KROCKMALNIC & S. PENMAN. 1994. The B1C8 protein is in the dense assemblies of the nuclear matrix and relocates to the spindle and pericentriolar filaments at mitosis. *Proc. Natl. Acad. Sci. USA* **91**: 594–598.
 63. HIRANO, T., Y. HIRAOKA & M. YANAGIDA. 1988. A temperature-sensitive mutation of the *Schizosaccharomyces pombe* gene *nuc2+* that encodes a nuclear scaffold-like protein blocks spindle elongation in mitotic anaphase. *J. Cell Biol.* **106**: 1171–1183.
 64. O'DONNELL, K. L., A. H. OSMANI, S. A. OSMANI & N. R. MORRIS. 1991. *bimA* encodes a member of the tetratricopeptide repeat family of proteins and is required for the completion of mitosis in *Aspergillus nidulans*. *J. Cell Sci.* **99**: 711–719.

65. FERNANDEZ, A., D. L. BRAUTIGAN & N. J. C. LAMB. 1992. Protein phosphatase type 1 in mammalian cell mitosis: chromosomal localization and involvement in mitosis. *J. Cell Biol.* **116**: 1421–1430.
66. HARLOW, E., P. WHYTE, B. R. FRANZA & C. SCHLEY. 1986. Association of adenovirus early-region 1A region proteins with cellular polypeptides. *Mol. Cell. Biol.* **6**: 1579–1589.
67. EWEN, M. E., Y. XING, J. B. LAWRENCE & D. M. LIVINGSTON. 1991. Molecular cloning, chromosomal mapping, and expression of the cDNA for p107, a retinoblastoma gene product-related protein. *Cell* **66**: 1155–1164.
68. MAYOL, X., X. GRANA, A. BALDI, N. SANG, Q. HU & A. GIORDANO. 1993. Cloning of a new member of the retinoblastoma gene family (pRB2) which binds to the E1A transforming domain. *Oncogene* **8**: 2561–2566.
69. ZHU, L., S. VAN DER HEUVEL, K. HELIN, A. FATTAEY, M. EWEN, D. LIVINGSTON, N. DYSON & E. HARLOW. 1993. Inhibition of cell proliferation by p107, a relative of the retinoblastoma protein. *Genes Dev.* **7**: 1111–1125.
70. COBRINIK, D., P. WHYTE, D. S. PEEPER, T. JACKS & R. A. WEINBERG. 1993. Cell cycle-specific association of E2F with the p130 E1A-binding protein. *Genes Dev.* **7**: 2392–2402.
71. HANNON, G. J., D. DEMETRICK & D. BEACH. 1993. Isolation of the Rb-related p130 through its interaction with CDK2 and cyclins. *Genes Dev.* **7**: 2378–2391.
72. LI, Y., C. GRAHAM, S. LACY, A. M. V. DUNCAN & P. WHYTE. 1993. The adenovirus E1A-associated 130-kD protein is encoded by a member of the retinoblastoma gene family and physically interacts with cyclins A and E. *Genes Dev.* **7**: 2366–2377.
73. ABRAMSON, D. H., R. M. ELLSWORTH, D. KITCHIN & G. TUNG. 1984. Second nonocular tumors in retinoblastoma survivors. *Ophthalmology* **91**: 1351–1355.
74. HOROWITZ, J. M., S-H. PARK, E. BOGENMANN, J-C. CHENG, D. W. YANDELL, F. J. KAYE, J. D. MINNA, T. P. DRYJA & R. A. WEINBERG. 1990. Frequent inactivation of the retinoblastoma anti-oncogene is restricted to a subset of human tumor cells. *Proc. Natl. Acad. Sci. USA* **87**: 2775–2779.

Potential Approaches for Myocardial Regeneration^a

MARK H. SOONPAA, ADIL I. DAUD, GOU YOUNG KOH,
MICHAEL G. KLUG, KYUNG KEUN KIM, HE WANG, AND
LOREN J. FIELD^b

*Krannert Institute of Cardiology
Indiana University School of Medicine
1111 West 10th Street
Indianapolis, Indiana 46202-4800*

INTRODUCTION

In the mouse, contractile cardiomyocytes are apparent by day 7 of fetal development. Embryonic cardiomyocyte growth consists of hyperplasia of existing, differentiated myocytes.¹ In early neonatal life cardiomyocytes lose the ability to undergo cytokinesis, and terminally differentiate into a largely binucleate population.^{2,3} Subsequent increases in myocardial mass are due to hypertrophy. Unlike skeletal muscle, in which there is a well-defined population of undifferentiated stem cells capable of replication, the heart has no mechanism by which to increase its number of myocytes. As a result of this deficiency, natural compensations for mass loss are limited to hypertrophy. Necrotic regions of the myocardium are replaced with nonfunctional scar tissue, with a resulting loss of contractility.

While several studies indicate that adult amphibian cardiomyocytes are capable of hyperplastic growth,⁴⁻⁷ the ability of adult mammalian cardiomyocytes to divide is questionable. Conflicting results are apparent, with several groups having reported low levels of DNA synthesis or hyperplasia,⁸⁻¹² and other groups reporting virtually none.^{4,13,14} Most recently, using an unambiguous assay designed to resolve these discrepancies, our laboratory failed to detect any cardiomyocyte DNA synthesis in response to isoproterenol-induced cardiac hypertrophy in adult mice.¹⁵ Collectively, these studies suggest that the ability of the adult mammalian myocardium to regenerate is vanishingly small or nonexistent, hence the irreversible loss of myocardial function in many forms of heart disease. In this review we will discuss strategies being developed for therapeutic intervention by increasing the population of functional myocytes. This review will broadly consist of two parts: an initial section concerning genetic manipulations to increase cardiac myocyte number; and a second part describing the results of our preliminary

^a Supported by NHLBI Grants HL45453 and HL06308 (L.J.F.), and a Grant in Aid from the American Heart Association, Indiana Affiliate (G.Y.K.). This work was done during the tenure of an Established Investigatorship from the American Heart Association (L.J.F.). M.G.K. is a predoctoral fellow of the American Heart Association, Indiana Affiliate.

^b Corresponding author.

attempts to augment the cardiomyocyte population by the engraftment of exogenous cells.

Myocardial Repair by Induction of Proliferation

One method to augment cardiomyocyte number would entail inducing proliferation of cells *in vivo*. This method clearly requires the identification of the intracellular proteins which regulate cardiogenic induction, hyperplastic growth and terminal differentiation, or a combination of these. Initial attempts to identify cardiac homologues of skeletal muscle genes which directly induce the myogenic phenotype have relied on low stringency hybridization or degenerate PCR amplifications using probes based on myogenin, myoD, myf-5 and MRF4. These approaches have thus far failed to identify a cardiac determining gene.

The advent of gene transfer technologies has prompted a number of groups to attempt to induce proliferation by introducing oncogenes into cardiomyocytes. It has thus been shown that transfection with ras- or myc-expressing retroviruses¹⁶ or with the SV40 large T antigen oncogene^{17,18} can induce cardiomyocyte proliferation in embryonic and neonatal cultures. Saule and co-workers¹⁹ have shown that chick embryos infected with v-myc oncogene myelocytomatosis viruses developed cardiac rhabdomyosarcomas. The induction of rhabdomyosarcomas was highly dependent upon the age of the embryo at infection. Collectively, these studies indicate that oncogene expression can in fact induce cardiomyocyte proliferation *in vitro*. Fetal or neonatal cardiomyocytes were used in all these studies. Similar experiments using adult cardiomyocytes failed to induce proliferation, suggesting that there is a discrete temporal window through which cardiomyocytes are more susceptible to transformation.

Transgenic animals in which oncogenes are targeted to specific organs provide another approach to the study of cardiomyocyte proliferation. For example, a transgenic model which carries the polyoma virus large T oncogene driven by the metallothionein promoter has been generated by Chalifour *et al.* These animals have cardiac expression of the oncogene and exhibit severe cardiac hypertrophy.²⁰ Swain and co-workers produced transgenic mice which express relatively high levels of c-myc in the heart, resulting in a rather mild developmental hyperplasia.^{21,22} Adult transgenic hearts are 75% larger than controls and have approximately twice the number of cardiomyocytes. Hauschka and co-workers have described a transgenic model which carries a protamine-T-Ag fusion gene.²³ These animals develop right atrial tumors comprised of myofibril-containing cells. When these cells were cultured they remained mitotically active.²⁴ Our laboratory has developed several transgenic models targeting T-Ag expression to the heart. ANF-TAG mice have a fusion gene comprised of the SV40 early region driven by the atrial natriuretic factor promoter.²⁵ These mice exhibit bilateral atrial T-Ag expression, but are tumorigenic only in the right atrium. In contrast MHC-TAG mice harbor a fusion gene consisting of the SV40 early region driven by the α -cardiac myosin heavy chain promoter, which results in T-Ag expression to both atrial and ventricular cardiomyocytes.^{26,27} MHC-TAG mice typically develop bilateral atrial and ventricular tumors. Cardiac tumors from both ANF-TAG and MHC-TAG

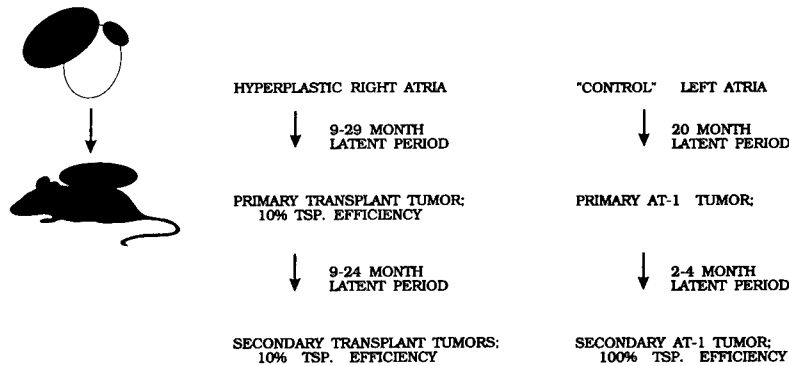

FIGURE 1. Diagram depicting derivation of AT-1 cardiomyocytes. "Control" left atria were nonhyperplastic atria from ANF-TAG mice.

mice are composed of cardiomyocytes which are both differentiated and proliferative. Initial attempts to culture primary tumor cardiomyocytes from the ANF-TAG mice failed to yield a cell line; however, a useful cell lineage was produced by transplanting tumor cells into a syngeneic host. In most instances, only 10% of the mice receiving injections of myocardial tumor cells went on to develop secondary tumors, and only after long and highly variable latencies. Subsequent passage of these tumors yielded tertiary tumors with similar growth characteristics. However, in one instance, a secondary tumor designated AT-1 (FIG. 1, Ref. 28) yielded a high frequency (>90%) of tertiary growths within a period of 2–4 months posttransplantation, suggesting the occurrence of a heritable mutation which enhanced ectopic tumor formation. Primary cultures of AT-1 cardiomyocytes are actively mitotic, exhibit spontaneous contractile activity when confluent, and ultrastructurally have a high level of differentiation typical of adult cardiomyocytes.^{28,29} AT-1 cardiomyocytes are also known to express numerous atrial-specific markers (reviewed in Ref. 30).

AT-1 cardiomyocytes have been continuously propagated as a subcutaneous tumor since 1987, but they are not a true cell line as they cannot be passaged in culture indefinitely. In an effort to produce a permanent cardiomyocyte cell line, additional culture experiments were initiated. Atrial tumors from MHC-TAG transgenic mice were placed in primary culture. These cultures gave rise to beating monolayers, which upon repeated passage developed into a highly proliferative dedifferentiated cell line designated AT-2. Collectively, AT-1 and AT-2 cardiomyocytes provide an invaluable resource for our initial efforts to study cardiomyocyte cell cycle regulators, particularly tumor suppressors, *in vitro*.

An inherent advantage of using T-Ag to induce tumorigenesis is the possibility of identifying putative cell cycle regulatory proteins by virtue of their ability to complex, or associate, with the oncoprotein. This paradigm is based on earlier studies in which the retinoblastoma gene product, pRB, was identified as an intracellular target for both T-Ag^{31,32} and the adenovirus E1A oncoprotein.³³ Retinoblastoma, a prototypical heritable childhood cancer affecting retinal cells and to

a lesser extent osteoblasts, results from mutational inactivation of the RB gene. Because loss of pRB function results in unchecked proliferation, pRB must play either a direct or indirect role in growth suppression. The interaction between a viral oncogene (*i.e.*, T-Ag or E1A) and a recessive oncogene product (*i.e.*, pRB) immediately lends itself to an attractive explanation for the transforming activities of DNA tumor virus; namely, that complex formation blocks the growth-suppressing activities of recessive oncogenes.³⁴

Given this paradigm, we initiated a series of experiments to identify the intracellular targets of T-Ag in our transgenic cardiomyocyte preparations.³⁵ We have identified four T-Ag associated proteins. Two novel proteins of mw 380 and 193 kd (designated p380 and p193, respectively) were identified as associated proteins by virtue of their ability to be co-immunoprecipitated with multiple anti-T-Ag and anti-p53 monoclonal antibodies. Subsequent studies have shown that p380 binds directly to p53. In addition, two previously described proteins, p107 and p53, were also observed to be associated with T-Ag in transformed cardiomyocytes. Interestingly, pRB was not observed to be a prominent T-Ag-associated protein in transformed murine cardiomyocytes. Subsequent studies have shown that although transcriptional regulation of p107 and p53 was roughly coincident with cardiomyocyte terminal differentiation,³⁶ it was not clear if this association was one of cause or effect. Furthermore, p53, p107 and pRB transcription was not induced by either acute myocardial overload (via aortic coarctation) or myocardial hypertrophy (via isoproterenol infusion, see Ref. 36). This result is in agreement with the absence of cardiomyocyte reactive DNA synthesis in similar models of ventricular hypertrophy.¹⁵ Finally, a fifth protein of mw 180 kd with epitopic homology to p53 was identified;³⁵ levels of this protein are dependent upon the proliferative status of cardiomyocytes both *in vitro* and *in vivo*. A schematic of these protein/T-Ag interactions is shown in FIGURE 2.

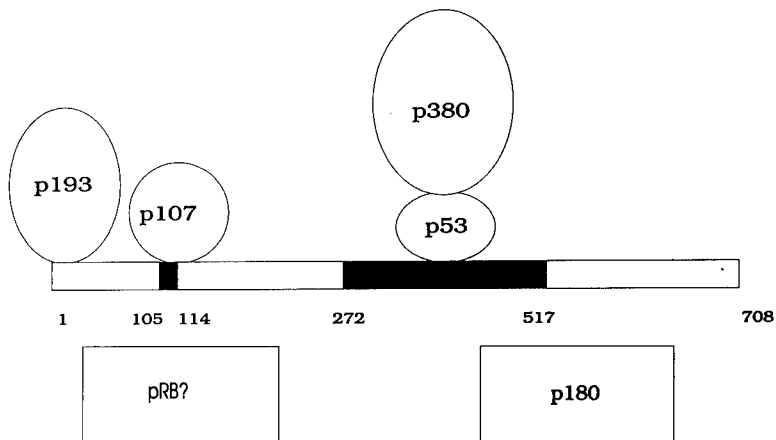

FIGURE 2. T antigen-associated proteins in cardiomyocytes are shown in the position in which they are bound. RB proteins may or may not be bound to T antigen; results are conflicting. p180 cross-reacts with p53, indicating that it has homology minimally at one epitope. p180 levels are growth regulated, being dependent upon the proliferative status of the cardiomyocytes.

Based on these collective attributes, it is our belief that the T-Ag associated and related proteins described above are likely to participate in the regulation of cardiomyocyte proliferation and/or terminal differentiation, and as such may constitute potential cellular targets for myocardial regeneration *in vivo*. Once identified and cloned, expression of such key regulatory proteins can be targeted to the heart by a variety of gene transfer approaches. The assumption here is that targeted expression of a positive growth regulator will induce cardiomyocyte proliferation. Perhaps the most promising approach to effect gene transfer in the adult myocardium is the use of tissue-specific adenoviruses. Current efforts to develop new generations of targeting viruses appear to have bypassed the temporal restraints which plagued the initial gene transfer studies which utilized this vector (Jeff Leiden, personal communication). In another approach, the actions of regulatory proteins found to have an inhibitory effect on cardiomyocyte proliferation (or alternatively those which induce cardiomyocyte terminal differentiation) might be circumvented by employing antisense strategies. Such antisense strategies might provide a means with which to block fetal cardiomyocyte terminal differentiation *in vitro*, and effectively lock the cells in a proliferative mode.

The paucity of T-Ag/Rb complexes in our transformed cardiomyocytes is of interest and deserves comment. T-Ag/p107 and T-Ag/p193 complexes are clearly much more abundant than T-Ag/pRb complexes in AT-2 cells. The inability to detect T-Ag/pRb complexes is somewhat surprising, as pRb has previously been described as ubiquitous.^{37,38} Several possibilities exist to explain this discrepancy. For example, heart tissue may not express pRb normally, hence cell lines derived from myocardium would not be expected to express the protein. Alternatively, pRb expression in the myocardium may be limited to specific developmental and/or temporal windows which may not be represented in our transformed cardiomyocyte preparations. Finally, we cannot rule out the possibility that pRb mutation was a required progression in the genesis of AT-1 and AT-2 cardiomyocytes. Experiments designed to discriminate between these possibilities are currently in progress.

Repair by Grafting of Exogenous Cells

Another method by which the population of cardiomyocytes could be increased entails direct engraftment of exogenous cells. Engraftment of healthy myocytes into a diseased heart to effect repair is dependent upon the identification of a suitable source of donor cells. Potential candidates include fetal cardiac myocytes, genetically modified skeletal myoblasts, and cardiomyocytes derived from embryonic stem cells.³⁹ We have performed a series of experiments to test the feasibility of producing stable intracardiac grafts in the adult mouse using myocytes which have been manipulated *in vitro*. Our initial study⁴⁰ utilized AT-1 cardiomyocytes; although AT-1 cardiomyocytes formed stable intracardiac grafts, their inability to form gap junctions with the host myocardium and their transformed phenotype limits their utility for engrafting experiments. An initial concern in these grafting experiments was that the host myocardium would be grossly damaged from the syringe needle or the injection pressure during cell delivery. Histological examinations failed to detect myocardial abnormalities in the preponderance of engrafted

hearts. Surface ECGs appeared normal, with no evidence of overt arrhythmia as might be caused by a circus rhythm around a graft-induced ischemic area. Plasma LDH levels showed a transient increase in the cardiac isoform, but returned to normal by one week after grafting. This transient increase probably reflected needle damage to the host, as well as damaged AT-1 cardiomyocytes. Other studies⁴¹ demonstrated that C2C12 myoblasts undergo myogenic differentiation and cell cycle withdrawal when engrafted into the myocardium of an adult mouse. Although the initial studies failed to document coupling between the nascent skeletal myotubes and the host myocardium, it was clear from subsequent experiments that the engraftment of genetically modified skeletal myoblasts could be used for long-term delivery of recombinant protein to the heart.⁴² Again, no overt damage to the host was detected. Although these studies established that cells manipulated *in vitro* could form stable intracardiac grafts, it was also evident that AT-1 cells and C2C12 myoblasts are not ideal candidates for grafts intended to physically aid in myocardial function. Based on these studies, the ideal donor cell type would be one which underwent a limited number of divisions and then withdrew from the cell cycle. An ideal cell would also need to have the contractile properties of the host heart, and would require membrane markers and junctional proteins such that it could physically and electrically couple with the host. In retrospect, the obvious choice is the embryonic or fetal cardiomyocyte.

Indeed, the most promising results to date for graft-mediated myocardial repair involved the use of fetal cardiomyocytes.⁴³ In this study, donor cardiomyocytes were isolated from fetal transgenic mice which expressed β -galactosidase under the regulation of the α -cardiac myosin heavy chain promoter. The β -galactosidase reporter facilitated the tracking of engrafted cells; stable grafts which were coupled to the host myocardium (as evidenced by ultrastructural analysis) were observed in this model. As with AT-1 and C2C12 cells, no damage was noted by histological examination or surface ECG; furthermore, plasma LDH levels were normal by one week after surgery. These studies raise the possibility that such maneuvers might be useful to effect myocardial repair.

CONCLUSION

We have described two cardiac repair strategies: induction of hyperplastic growth in existing cardiomyocytes, and grafting of exogenous myocytes. Controlled induction of cardiomyocyte proliferation will require a great deal of study to define the molecules which regulate cardiomyocyte proliferation and terminal differentiation. By analogy to other systems, the T-Ag-induced proliferation observed in our transgenic mouse models is likely to be due to T-Ag's ability to bind to and inactivate these endogenous regulatory proteins. As such, identification, characterization and molecular cloning of the myocardial targets of T-Ag should advance our understanding of this complex biological process. It is also our belief that molecular control of cardiomyocyte proliferation and terminal differentiation will likely be highly redundant, a view which is supported by the rarity of heart tumors in the general population.

We have shown that exogenous myocytes can form stable grafts in the adult

heart. The initial study with AT-1 cardiomyocytes demonstrated that cardiac grafting by cell injection was possible, but that AT-1 cardiomyocytes were a poor choice of donor cells, as they did not terminally differentiate or couple with the host. Most notably, AT-1 cardiomyocytes remained proliferative, and as such their utility is severely limited. While initial analyses failed to document physical coupling between nascent C2C12 myotubes and the host myocardium, C2C12 myoblasts did terminally differentiate. Engrafted fetal cardiac myocytes did not suffer the limitations of AT-1 and C2C12 cells, as they terminally differentiated, coupled with the host, and appeared histologically and ultrastructurally identical to host cells. Although both strategies seem to have great potential, it remains to be seen if either approach can successfully effect myocardial repair in a diseased heart.

SUMMARY

Cardiomyocytes in the adult mammal retain little or none of their developmental capacity for hyperplastic growth. As a consequence of this differentiated, nonproliferative phenotype, cardiomyocyte loss due to injury or disease is irreversible. Therapeutic intervention in end-stage diseased hearts is currently limited to cardiac transplantation. An increase in cardiomyocyte number in diseased hearts could improve function. Augmentation of the cardiomyocyte population may be achievable by the expression of regulatory proteins in the myocardium, or by intracardiac grafting of exogenous cardiomyocytes.

ACKNOWLEDGMENTS

We thank D. Field and S. H. Koh for technical assistance.

REFERENCES

1. RUMYANTSEV, P. P. 1991. Reproduction of cardiac myocytes developing *in vivo* and its relation to processes of differentiation. *In Growth and Hyperplasia of Cardiac Muscle Cells*. Bruce M. Carlson, Ed. 70–157. Harwood Academic Press. New York.
2. CLUBB, F. J. JR. & S. P. BISHOP. 1984. Formation of binucleated myocardial cells in the neonatal rat—an index for growth hypertrophy. *Lab. Invest.* **50**: 571–577.
3. BRODSKY, V. Y., B. M. CARLSON, A. M. AREFYEVA & I. A. VASILIEVA. 1988. Polyploidization of transplanted cardiac myocytes. *Cell Differ. Dev.* **25**: 177–183.
4. RUMYANTSEV, P. P. 1966. Autoradiographic study on the synthesis of DNA, RNA, and proteins in normal cardiac muscle cells and those changed by experimental injury. *Folia Histochem. Cytochem.* **4**: 397–424.
5. RUMYANTSEV, P. P. 1973. Post-injury DNA synthesis, mitosis and ultrastructural reorganization of adult frog cardiac myocytes. *Z. Zellforsch.* **139**: 431–450.
6. OBERPRILLER, J. O. & J. C. OBERPRILLER. 1974. Response of the adult newt ventricle to injury. *J. Exp. Zool.* **187**: 249–260.
7. SOONPAA, M. H., J. O. OBERPRILLER & J. C. OBERPRILLER. 1992. Stimulation of DNA synthesis by PDGF in the newt cardiac myocyte. *J. Mol. Cell. Cardiol.* **24**: 1039–1046.
8. RUMYANTSEV, P. P. & A. M. KASSEM. 1976. Cumulative indices of DNA synthesizing

- myocytes in different compartments of the working myocardium and conductive system of the rat's heart muscle following extensive left ventricular infarction. *Virchows Arch. B Cell Pathol.* **20**: 329–342.
9. NAG, A. G., T. R. CAREY & M. CHENG. 1983. DNA synthesis in rat heart cells after injury and the regeneration of myocardia. *Tissue Cell* **15**: 597–613.
 10. ANVERSA, P., D. FITZPATRICK, S. ARGANI & J. M. CAPASSO. 1991. Myocyte mitotic division in the aging mammalian rat heart. *Circ. Res.* **69**: 1159–1164.
 11. ANVERSA, P., T. PALACKAL, E. H. SONNENBLICK, G. OLIVETTI & J. M. CAPASSO. 1990. Hypertensive cardiomyopathy. Myocyte nuclei hyperplasia in the mammalian rat heart. *J. Clin. Invest.* **85**: 994–997.
 12. ANVERSA, P., T. PALACKAL, E. H. SONNENBLICK, G. OLIVETTI, L. G. MEGGS & J. M. CAPASSO. 1990. Myocyte cell loss and myocyte cellular hyperplasia in the hypertrophied aging rat heart. *Circ. Res.* **67**: 871–885.
 13. Vlieggen, H. W., A. V. G. BRUSCHKE & A. VAN DER LAARSE. 1990. Different response of cellular DNA content to cardiac hypertrophy in human and rat heart myocytes. *Comp. Biochem. Physiol.* **95A**: 109–114.
 14. KELLERMAN, S., J. A. MOORE, W. ZIERHUT, H. ZIMMER, J. CAMPBELL & A. M. GERDES. 1992. Nuclear DNA content and nucleation patterns in rat cardiac myocytes from different models of cardiac hypertrophy. *J. Mol. Cell Cardiol.* **24**: 497–505.
 15. SOONPAA, M. H. & L. J. FIELD. 1994. Assessment of cardiomyocyte DNA synthesis during hypertrophy in adult mice. *Am. J. Physiol.* **266**: H1439–H1445.
 16. ENGELMANN, G. L., M. C. BIRCHENALL-ROBERTS, F. W. RUSCETTI & A. M. SAMAREL. 1993. Formation of fetal rat cardiac cell clones by retroviral transformation: retention of select myocyte characteristics. *J. Mol. Cell. Card.* **25**: 197–213.
 17. WANG, Y.-C., N. NECKELMANN, A. MAYNE, A. HERSKOWITZ, A. SRINIVASAN, K. W. SELL & A. AHMED-ANSARI. 1991. Establishment of a human fetal cardiac myocyte cell line. *In Vitro Cell. Dev. Biol.* **27A**: 63–74.
 18. SEN, A., P. DUNNMON, S. A. HENDERSON, R. D. GERARD & K. R. CHIEN. 1988. Terminally differentiated neonatal rat myocardial cells proliferate and maintain specific differentiated functions following expression of SV40 large T antigen. *J. Biol. Chem.* **263**: 19132–19136.
 19. SAULE, S., J. P. MERIGAUD, A.-E. M. ALMOUSTAFA, F. FERRE, P. M. RONG, P. AMOUYEL, B. QUATANNENS, D. STEHELIN & F. DIETERLEN-LIEVRE. 1987. Heart tumors specifically induced in young avian embryos by the v-myc oncogene. *Proc. Natl. Acad. Sci. USA* **84**: 7982–7986.
 20. CHALIFOUR, L. E., M. L. GOMES, N.-S. WANG & A. M. MES-MASSON. 1990. Polyoma large T-antigen expression in the heart of transgenic mice causes cardiomyopathy. *Oncogene* **5**: 1719–1726.
 21. JACKSON, T., M. F. ALLARD, C. M. SREENAN, L. K. DOSS, S. P. BISHOP & J. L. SWAIN. 1990. The c-myc proto-oncogene regulates cardiac development in transgenic mice. *Mol. Cell. Biol.* **10**: 3709–3716.
 22. JACKSON, T., M. F. ALLARD, C. M. SREENAN, L. K. DOSS, S. P. BISHOP & J. L. SWAIN. 1991. Transgenic animals as a tool for studying the effect of the c-myc proto-oncogene on cardiac development. *Mol. Cell. Biochem.* **104**: 15–19.
 23. BEHRINGER, R. R., J. J. PESCHON, A. MESSING, C. L. GARTSIDE, S. D. HAUSCHKA, R. D. PALMITER & R. L. BRINSTER. 1988. Heart and bone tumors in transgenic mice. *Proc. Natl. Acad. Sci. USA* **85**: 2648–2652.
 24. GARTSIDE, C. L. & S. D. HAUSCHKA. 1991. Development of a permanent mouse cardiac muscle cell line. *In The Development and Regenerative Potential of Cardiac Muscle.* John O. Oberpriller, Jean C. Oberpriller & A. Mauro, Eds. 385–398. Harwood Academic Press. New York.
 25. FIELD, L. J. 1988. Atrial natriuretic factor-SV40 T antigen transgenes produce tumors and cardiac arrhythmias in mice. *Science* **239**: 1029–1033.
 26. STEINHELPER, M. E. & L. J. FIELD. 1991. SV40 large T-antigen induces myocardiocyte proliferation in transgenic mice. *In The Development and Regenerative Potential of Cardiac Muscle.* John O. Oberpriller, Jean C. Oberpriller & A. Mauro, Eds. 365–384. Harwood Academic Press. New York.

27. KATZ, E., M. E. STEINHELPER, A. DAUD, J. B. DELCARPIO, W. C. CLAYCOMB & L. J. FIELD. 1992. Ventricular cardiomyocyte proliferation in transgenic mice expressing α -cardiac myosin heavy chain-SV40 T antigen fusion genes. *Am. J. Physiol.* **262**: H1867–H1876.
28. STEINHELPER, M. E., N. LANSON, K. DRESNER, J. B. DELCARPIO, A. WIT, W. C. CLAYCOMB & L. J. FIELD. 1990. Proliferation *in vivo* and in culture of differentiated adult atrial cardiomyocytes from transgenic mice. *Am. J. Physiol.* **259**: H1826–H1834.
29. DELCARPIO, J. B., N. A. LANSON, JR., L. J. FIELD & W. C. CLAYCOMB. 1991. Morphological characterization of cardiomyocytes isolated from a transplantable cardiac tumor derived from transgenic mouse atria (AT-1 cells). *Circ. Res.* **69**: 1591–1600.
30. FIELD, L. J. 1993. Transgenic mice in cardiovascular research. *Ann. Rev. Physiol.* **55**: 97–114.
31. DECAPRIO, J. A., J. W. LUDLOW, J. FIGGE, J.-Y. SHEW, C.-M. HUANG, W.-H. LEE, E. MARSILIO, E. PAUCHA & D. M. LIVINGSTON. 1988. SV40 large T-antigen forms a specific complex with the product of the retinoblastoma susceptibility gene. *Cell* **54**: 275–283.
32. LANE, D. P. & L. V. CRAWFORD. 1979. T antigen is bound to a host protein in SV40 transformed cells. *Nature* **278**: 261–263.
33. WHYTE, P., K. J. BUCHKOVICH, J. M. HOROWITZ, S. H. FRIEND, M. RAYBUCK, R. A. WEINBERG & E. HARLOW. 1988. Association between an oncogene and an anti-oncogene: the adenovirus E1A proteins bind to the retinoblastoma gene product. *Nature* **334**: 124–129.
34. GREEN, M. R. 1989. When the products of oncogenes and anti-oncogenes meet. *Cell* **56**: 1–3.
35. DAUD, A. I. & N. A. LANSON, JR. 1993. W. C. Claycomb and L. J. Field: identification of SV40 large T-antigen associated proteins in cardiomyocytes from transgenic mice. *Am. J. Physiol.* **264**: H1693–H1700.
36. KIM, K. K., M. H. SOONPAA, A. I. DAUD, G. Y. KOH, J. S. KIM & L. J. FIELD. 1994. Tumor suppressor gene expression during normal and pathologic myocardial growth. *J. Biol. Chem.* **269**: 22607–22613.
37. LEE, W. H., R. BOOKSTEIN, F. HONG, L. J. YOUNG, J.-Y. SHEW & E. Y. LEE. 1987. Human retinoblastoma susceptibility gene: cloning, identification, and sequence. *Science* **235**: 1394–1399.
38. BERNARDS, R., G. M. SCHACKLEFORD, M. R. GERBER, J. M. HOROWITZ, S. H. FRIEND, M. SCHARTL, E. BOGENMANN, J. M. RAPAPORT, T. MCGEE, T. P. DRYJA & R. A. WEINBERG. 1989. Structure and expression of the murine retinoblastoma gene and characterization of its encoded protein. *Proc. Natl. Acad. Sci. USA* **86**: 6474–6478.
39. KOH, G. Y., M. H. SOONPAA, M. G. KLUG & L. J. FIELD. 1994. Strategies for myocardial repair. *Int. J. Cardiol.* Submitted.
40. KOH, G. Y., M. H. SOONPAA, M. G. KLUG & L. J. FIELD. 1993. Long-term survival of AT-1 cardiomyocyte grafts in syngeneic myocardium. *Am. J. Physiol.* **264**: H1727–H1733.
41. KOH, G. Y., M. G. KLUG, M. H. SOONPAA & L. J. FIELD. 1993. Differentiation and long-term survival of C2C12 myoblast grafts in heart. *J. Clin. Invest.* **92**: 1548–1554.
42. KOH, G. Y., S. J. KIM, M. G. KLUG, K. PARK, M. H. SOONPAA, H. WANG & L. J. FIELD. 1994. Targeted expression of TGF- β in intracardiac grafts promotes vascular endothelial cell DNA synthesis. *J. Clin. Invest.* **95**: 114–121.
43. SOONPAA, M. H., G. Y. KOH, M. G. KLUG & L. J. FIELD. 1994. Formation of nascent intercalated disks between grafted fetal cardiomyocytes and host myocardium. *Science* **264**: 98–101.

Gene Transfer in Models of Myocardial Ischemia^a

PATRICIA McDONALD, MARTIN N. HICKS,^b
STUART M. COBBE,^b AND HOWARD PRENTICE^c

*Department of Genetics
and
Department of Medicine and Therapeutics
University of Glasgow*

^b*Department of Medical Cardiology
Royal Infirmary
Glasgow, United Kingdom*

INTRODUCTION

Gene transfer into the beating myocardium has been achieved by a variety of techniques including direct DNA injection and infection with adenovirus or retroviruses. The analysis of promoter activities can be achieved through direct DNA injection despite the low transfection efficiencies obtained with this method.^{1,2} For potential therapeutic intervention cellular transduction with viral vectors has led to high-level foreign gene expression in greater than 30% of cardiomyocytes.³ Strategies aimed at conducting gene transfer in ischemic heart may open the way for the development of vectors that can drive expression of therapeutic gene products from selected promoters for application in compromised myocardium.

The technique of direct DNA injection into the myocardium has resulted in prolonged expression of foreign gene products (for durations of 6 months or more) and has been valuable in the functional dissection of tissue-specific and hormone-inducible promoters.^{4,5} Thus the relative contributions of upstream sequences to tissue-specific transcriptional activation has been determined for a variety of promoters including those for muscle-creatine kinase,⁴ cardiac TnC⁶ and β -myosin heavy chain.⁵ A comparison of transcription patterns for injected troponin C fast and cardiac troponin C promoter constructs indicated that a fast skeletal muscle specific and a heart (or slow skeletal muscle) specific promoter respectively can retain their tissue restricted activation characteristics *in vivo*.⁷ Injection of promoter constructs containing upstream sequences from the α -MHC gene resulted in thyroid hormone-inducible transcription patterns but with some apparent discrepancies from *in vitro* data.⁵ Whereas the thyroid hormone response element

^a This work was supported by grants from the Scottish Home and Health Department, the British Heart Foundation, the Medical Research Council and the Royal Society.

^c Address for correspondence: H. Prentice, Department of Genetics, University of Glasgow, Church Street, Glasgow G11 5JS, U.K.

(TRE) of the α -MHC gene is sufficient to confer thyroid hormone responsiveness in primary fetal cardiomyocytes the results from direct injection *in vivo* show a requirement for additional upstream sequences for hormone inducibility. While direct DNA injection is unlikely to be employed for extensive mutational analysis of promoter regions it is valuable for comparing activities of key promoter constructs *in vivo* with those obtained in cell culture models. In addition to studies on rats, direct DNA injection has been applied to dog and rabbit models because of a closer resemblance in terms of cardiac physiological characteristics to that of man. By direct DNA injection into dog heart it was found that levels of transcriptional activation of injected β -myosin heavy chain promoter constructs differed between right and left ventricle.⁸ The characterization of patterns of promoter activity in the hearts of large mammals may prove useful in the design of gene transfer constructs directed at alteration of cardiac phenotype in models of heart disease.

Direct DNA Injection in Ischemic/Reperfused Myocardium

With the long-term aim of exploiting suitable promoter elements to drive expression of therapeutic gene products in heart disease it is necessary to determine the extent to which ubiquitously expressed and tissue-specific promoters are activated in the ischemic myocardium. In a previous study employing direct injection of a luciferase gene construct it was found that significant luciferase gene expression was obtained at 7 days after injection into either ischemic/reperfused or nonischemic heart.⁹ We have employed constructs containing the chloramphenicol acetyl transferase (CAT) gene linked to a test promoter in addition to a Rous Sarcoma Virus (RSV) promoter-luciferase gene construct for coinjection into ischemic heart. The aim of the present study was to determine whether the ratio of CAT enzyme levels to those of luciferase would result in a consistent measure of test promoter activation. Two nontissue-specific reporter gene constructs were injected into the hearts of adult Sprague-Dawley rats that had been subjected to coronary artery ligation for a period of 15 minutes followed by reperfusion. Plasmid pSV40EP-CAT (Promega) containing the SV40 promoter and enhancer or the promoterless construct pZERO-CAT (50 μ g) (Promega) was then coinjected with pRSV-luciferase (50 μ g)⁷ into the area of transiently ischemic myocardium. Animals were sacrificed at 7 days after DNA injection and hearts removed for measurements of enzyme activity. Significant CAT activity was obtained for animals injected with pSV40EP-CAT. In contrast CAT enzyme activity was undetectable in hearts injected with pZERO-CAT. When normalized to luciferase levels the CAT activity for pSV40EP-CAT was 88.7 ± 24 compared to activity for pZERO-CAT of 2.4 ± 1.7 (in CAT units/LUC units/mg protein). The pSV40EP promoter construct is therefore expressed at levels greater than 35-fold above those for pZERO-CAT. This level of pSV40EP expression is comparable to activities obtained by direct injection into nonischemic heart (H. Prentice, unpublished observation). Thus a strong viral promoter can reproducibly drive high-level transcription in ischemic/reperfused myocardium relative to a promoterless control construct. This observation points to the feasibility of assessing relative promoter strengths in ischemic/reperfused heart.

Retrovirus-Mediated Gene Transfer in a Rabbit Model of Myocardial Ischemia

Gene transfer by the introduction of viruses into the myocardium could potentially be achieved through the preferential targeting of cardiomyocytes or of nonmyocytes. Because retroviruses selectively transduce nondividing cells, nonmyocytes in the heart represent a population of cells that could be used for exogenous expression of therapeutic gene products including secreted factors. Using a dog model of myocardial infarct it was previously found that injection of a retrovirus at 6–11 days after coronary artery occlusion will result in significant foreign gene expression when animals are sacrificed a further 7–12 days later.¹⁰ In the present study a rabbit model of myocardial ischemia was employed to investigate the degree of retroviral uptake resulting from an injection of retroviral supernatant 15 minutes after coronary artery occlusion. Infarcts were created in 9 adult rabbits by permanent coronary artery ligation. 15 minutes after coronary ligation the β -galactosidase expressing amphitropic retrovirus LNPOZ (gift from A. D. Miller) was injected into the ischemic area. The viral titer of LNPOZ was 5×10^5 colony-forming units per ml. Three injections each of 0.2 ml of viral supernatant were made per infarct. At 7 days the rabbits were euthanized and hearts removed for histochemistry and staining of tissue sections for β -galactosidase.

The presence of a region of infarct was confirmed morphologically from hematoxylin-eosin stained frozen sections from hearts of nine rabbits subjected to coronary artery ligation. Infarcted myocardial tissue from all 9 rabbits stained positive for β -galactosidase indicating successful retroviral transduction of nonmyocytes and detectable foreign gene expression. It remains to be determined whether different degrees of foreign gene expression would be obtained if the retrovirus were to be injected at one or more days after coronary artery ligation. The present observation suggests that retroviral-mediated gene transfer may be a useful method of obtaining expression of potentially therapeutic genes in nonmyocytes within the infarcted myocardium.

Future Directions for Gene Transfer into Ischemic Heart

We have demonstrated high-level expression of an SV40 enhancer/promoter construct pSV40EP-CAT following direct DNA injection into ischemic/reperfused myocardium when normalized to a coinjected viral promoter construct. The activity of pSV40EP-CAT was greater than 35-fold higher than that of a promoterless CAT construct. Direct DNA injection of ischemic/reperfused myocardium may be valuable for determining the activation patterns of tissue-specific and ubiquitously expressed promoter constructs in models of heart disease which will contribute to the creation of vectors designed to express potentially therapeutic proteins in cardiomyocytes *in vivo*. It was recently demonstrated that infusion of recombinant adenovirus into the coronary artery circulation resulted in high-level foreign gene expression in the coronary artery and in surrounding cardiac tissue with no report of an inflammatory response resulting from the viral infection.³ The introduction of viral vectors such as adenovirus into mildly ischemic heart may ultimately enable successful production of foreign proteins within cardiomyocytes in models of gene therapy for the consequences of myocardial ischemia.

Using a rabbit model of myocardial ischemia we have demonstrated that injection of an amphotropic retrovirus into a severely ischemic area of the heart results in high-level reporter gene expression at 7 days after coronary artery occlusion. Thus nonmyocytes within ischemic heart represent a useful cellular target for the expression of potentially therapeutic genes *in vivo*. In a dog model of myocardial infarct it was previously shown that transfer of the myogenic determination gene MyoD into an existing myocardial infarct can result in the conversion of nonmyocytes to the skeletal muscle phenotype.¹⁰ It may ultimately be possible to create a region of skeletal muscle to strengthen the weakened myocardium. In addition retrovirally transduced nonmyocytes may prove to be useful for production of exogenous secreted factors in the ischemic heart.

The introduction of foreign genes by viral infection of cardiomyocytes or nonmyocytes in ischemic heart holds promise for approaches aimed at achieving phenotypic alterations *in vivo*. Thus the expression of exogenous gene products in models of heart disease should open the way for strategies aimed at the production of therapeutic proteins such as angiogenic factors and other secreted factors, proteins involved in cardiac remodeling and proteins with functional consequences for the contractile apparatus.

ACKNOWLEDGMENTS

We thank the members of our laboratories for valuable criticism and advice.

REFERENCES

1. ACSADI, G., S. S. JIAO, A. JANI, D. DUKE, P. WILLIAMS, W. CHONG & J. A. WOLFF. 1991. Direct gene transfer and expression into rat heart *in vivo*. *New Biol* 3: 71–81.
2. BUTTRICK, P. M., A. KASS, R. N. KITSIS, M. L. KAPLAN & L. A. LEINWAND. 1992. Behavior of genes directly injected into the rat heart *in vivo*. *Circ. Res.* 70: 193–198.
3. BARR, E., J. CARROLL, A. M. KALYNYCH, S. K. TRIPATHY, K. KOZARSKY, J. M. WILSON & J. M. LEIDEN. 1994. Efficient catheter-mediated gene transfer into the heart using replication-defective adenovirus. *Gene Ther.* 1: 51–58.
4. VINCENT, C. K., A. GUALBERTO, C. V. PATEL & K. WALSH. 1993. Different regulatory sequences control creatine kinase-M gene expression in directly injected skeletal and cardiac muscle. *Mol. Cell. Biol.* 13: 1264–1272.
5. BUTTRICK, P. M., M. L. KAPLAN, R. N. KITSIS & L. A. LEINWAND. 1993. Distinct behavior of cardiac myosin heavy chain constructs *in vivo*; discordance with *in vitro* results. *Circ. Res.* 72: 1211–1217.
6. PARMACEK, M. S., A. J. VORA, T. SHEN, E. BARR, F. JUNG & J. M. LEIDEN. 1992. Identification and characterization of a cardiac specific transcriptional regulatory element in the slow/cardiac troponin C gene. *Mol. Cell. Biol.* 12: 1967–1976.
7. PRENTICE, H., R. A. KLONER, T. PRIGOZY, T. CHRISTENSEN, L. NEWMAN, Y. LI & L. KEDES. 1994. Tissue restricted gene expression assayed by direct DNA injection into cardiac and skeletal muscle. *J. Mol. Cell. Cardiol.* In press.
8. VON-HARSDORF, R., R. J. SCHOTT, Y.-T. SHEN, S. F. VATNER, V. MAHDAVI & B. NADAL-GINARD. 1993. Gene injection into canine myocardium as a useful model for studying gene expression in the heart of large mammals. *Circ. Res.* 72: 688–695.

9. PRENTICE, H., R. A. KLONER, Y. LI, L. NEWMAN & L. KEDES. 1993. High level RSV-luciferase expression following DNA injection into ischemic/reperfused myocardium. *J. Am. Coll. Cardiol.* **21**: 163A.
10. PRENTICE, H., R. A. KLONER, V. SARTORELLI, S. D. BELLOWES, K. ALKER & L. KEDES. 1993. Transformation of cardiac fibroblasts into the skeletal muscle phenotype by injection of a MyoD-expressing retrovirus into ischemic heart. *Circulation* **88**: I-475.

Development of Cardiomyocytes Expressing Cardiac-Specific Genes, Action Potentials, and Ionic Channels during Embryonic Stem Cell-Derived Cardiogenesis

ANNA M. WOBUS,^a J. ROHWEDEL, V. MALTSEV, AND
J. HESCHELER^b

*Laboratory of In Vitro Differentiation
Institute of Plant Genetics and Crop Plant Research
D-06466 Gatersleben, Germany*

*and
^b Institute of Pharmacology
FU Berlin
D-14195 Berlin, Germany*

INTRODUCTION

During the last decades different experimental approaches were developed for long-term cultivation of cardiac myocytes from amphibian, avian or mammalian species (see for example, Refs. 1–4; for review: Ref. 5). The numerous attempts to establish permanent cardiac cell lines resulted, for example, in one cardiac cell line from rat heart, H9c2⁶ exhibiting L-type Ca²⁺ currents but lacking many other typical ionic currents of the heart.^{7,8} Additionally, up to now, experiments to immortalize permanent clonal lines of functional cardiomyocytes were not satisfactory.^{9–11} The inability of primary myocardial cells to proliferate in culture and the lack of permanent functional myocardial cell lines require new strategies for the study of the origin, commitment and differentiation of cardiac cells.

We used a new approach for standardized differentiation of cardiomyocytes derived from pluripotent embryonic carcinoma cells (EC cells)¹² or embryonic stem cells (ES cells).¹³ EC and ES cells are permanent lines established from teratocarcinomas and from early embryos, respectively (FIG. 1). These undifferentiated embryonic cell lines were used to study the differentiation of uncommitted embryonic stem cells into the cardiomyogenic lineage and to analyze *in vitro* the expression of cardiac-specific genes, proteins, action potentials and ionic channels.^{14–19}

^a Address for correspondence: Dr. Anna M. Wobus, Institut für Pflanzengenetik und Kulturpflanzenforschung, Corrensstr. 3, D-06466 Gatersleben, Germany.

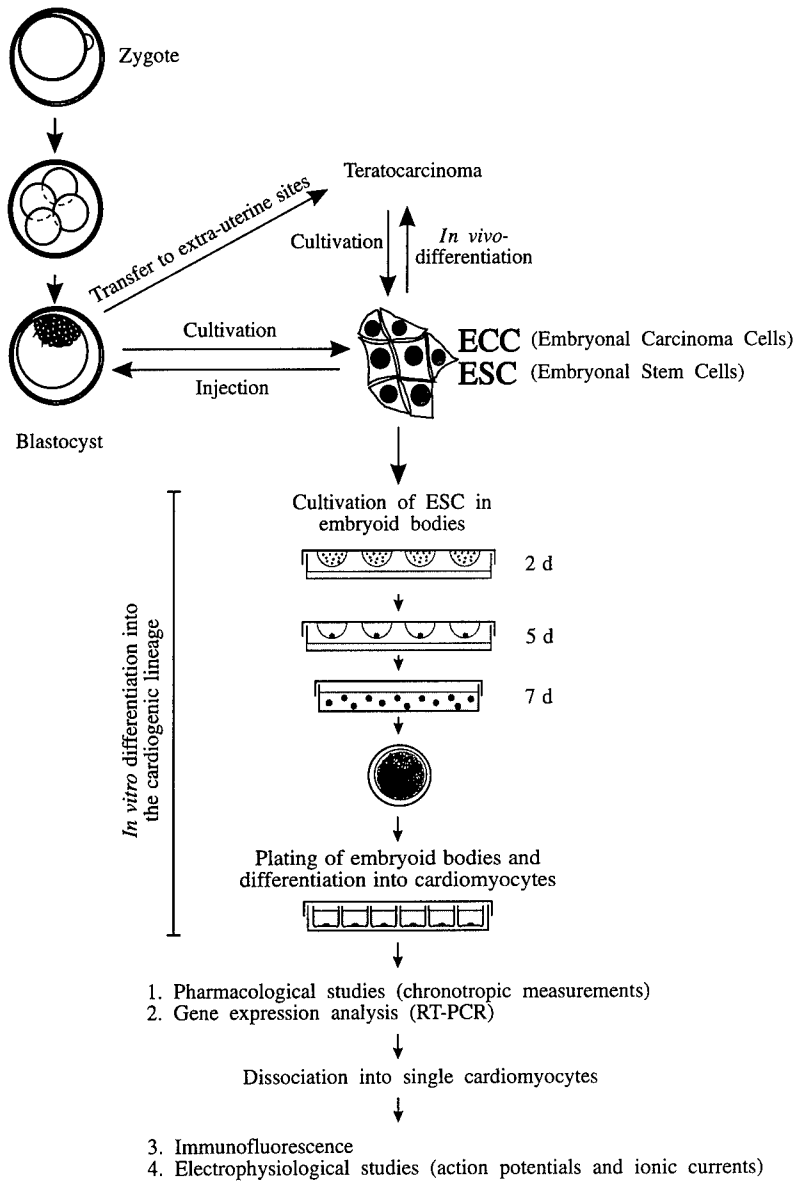

FIGURE 1. Relationship between early embryos, embryonal carcinoma cells (ECC) and embryonal stem cells (ESC) and schematic presentation of the *in vitro* differentiation assay of ESC via embryoid bodies into cardiomyocytes (RT-PCR = reverse transcriptase polymerase chain reaction).

Embryonic Stem Cells Differentiate into the Cardiomyogenic Lineage

The undifferentiated mouse embryonic carcinoma cell line P19²⁰ and the embryonic stem cell lines D3 and B117 established from the inner cell mass of mouse blastocyst²¹ and from single blastomeres of 8-cell stage embryos,¹⁵ respectively, were cultivated in embryo-like aggregates, the "embryoid bodies," in a standardized differentiation assay.¹⁵ Whereas EC cells have to be induced to differentiation with chemical inducers (for example, retinoic acid or dimethylsulfoxid²²), ES cells differentiate spontaneously into cells of endodermal, ectodermal and mesodermal origin when cultivated in embryoid bodies. After plating ES cell-derived embryoid bodies cultivated for 7 days onto adhesive substrates spontaneously beating cardiomyocytes differentiate in the embryoid body outgrowth. These cardiomyocytes were used for studying chronotropic effects of cardioactive drugs and expression of cardiac-specific genes and, after enzymatic dissociation into single cardiomyocytes, for the characterization of action potentials and ionic channels using the whole-cell patch-clamp technique (FIG. 1).

ES Cell-Derived Cardiomyocytes Respond with Heart-Specific Pharmacological Effects

Cardiac-specific receptors and signal transduction pathways were analyzed by adding cardiotropic drugs to *in vitro* differentiated cardiomyocytes. Positive chronotropic effects were induced in cardiomyocytes of all developmental stages by the β -adrenoceptor agonist (-)isoprenaline, the direct activator of the adenylyl cyclase, forskolin, the inhibitor of phosphodiesterases, isobutylmethylxanthine, the α_1 -adrenoceptor agonist, phenylephrine, and the activator of L-type Ca^{2+} channel, BayK 8644. In contrast, the β_2 -adrenoceptor agonist, clenbuterol, increased the beating frequency only after several days of cardiomyocyte differentiation. Negative chronotropic effects were induced by the muscarinic cholinergic agonist, carbachol, and by the L-type Ca^{2+} channel blockers nisoldipine, isradipine, gallopamil and diltiazem, demonstrating the involvement of voltage-dependent Ca^{2+} currents in the generation of action potentials of spontaneously beating cardiomyocytes. In all cases the specific antagonists abolished the chronotropic responses.¹⁵ Summarizing the pharmacological studies, we may conclude that in early differentiated cardiomyocytes β_1 -, α_1 -, but not β_2 -adrenoceptors, cholinergic receptors, as well as L-type Ca^{2+} channels participated in the chronotropic response. In cardiomyocytes of intermediate and terminal stage also β_2 -adrenoceptors were functionally expressed.¹⁵ The involvement of the investigated cardiac-specific agonists and antagonists in pharmacological regulation of Ca^{2+} channel and β -adrenoceptor- and cholinergic-modulated signal transduction pathway is demonstrated in FIGURE 2.

In contrast to ES cell-derived cardiomyocytes, cardiomyocyte-like cells differentiated from P19 EC cells are characterized by functional expression of adrenoceptors and Ca^{2+} channels but lack the muscarinic cholinergic response.¹⁸

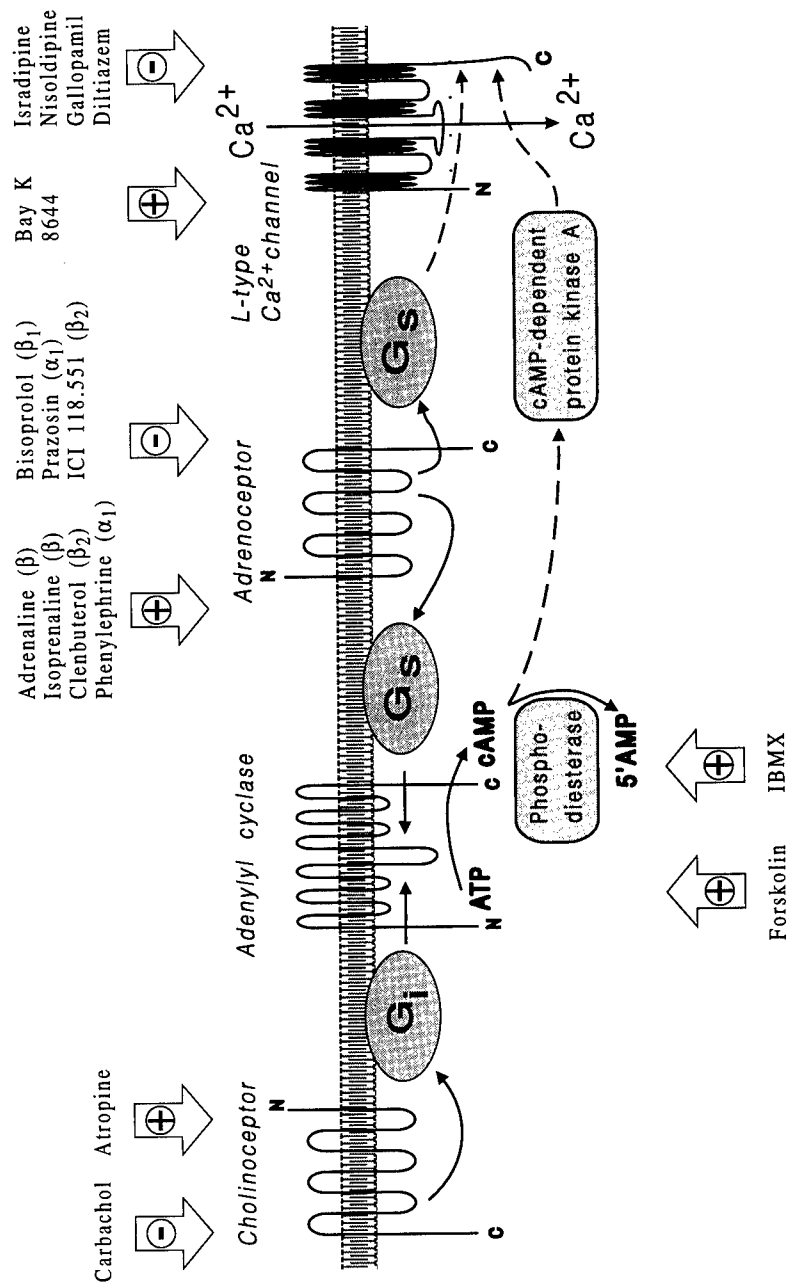

FIGURE 2. Pharmacological (chronotropic) responses of ES cell-derived cardiomyocytes and signal transduction pathways involved in Ca^{2+} current regulation (IBMX = isobutylmethylxanthine).

ES Cells Differentiate into Cardiomyocytes Expressing Action Potentials Inherent to Atrial, Ventricular and Sinusnodal Cells

The cardiomyocytes enzymatically dissociated from beating areas of embryoid body outgrowths and immunostained with monoclonal antibodies against α -cardiac myosin heavy chain (MHC) showed the characteristic morphology of embryonal and adult cardiac cells: cylindrical, tri- and multiangular shape of early differentiated stages (FIG. 3a,b) and pleiomorphic shaped cells with multiple pseudopodia-like processes after prolonged cultivation (FIG. 3c). These morphologies¹⁶ correspond to those of cardiac myocytes isolated from the adult heart.^{4,23} Similarly, the sarcomeric length of ES cell-derived cardiomyocytes (about 2 μm) was found to be in the same order of magnitude of adult mammalian heart cells.²⁴ By characterizing the action potentials of cardiomyocytes during *in vitro* differentiation, we found a characteristic pattern of action potentials dependent on the differentiation state of cardiomyocytes. This action potential pattern, indeed, was further used to define distinct developmental stages of *in vitro* cardiomyocyte development. Cardiomyocytes of early differentiation stage ("7 + 2 d" to "7 + 4 d;" = cultivation as embryoid body for 7 days and after plating for 2 to 4 days) revealed spontaneous pacemaker-like action potentials synchronous to the contractions, with amplitudes of 60 to 70 mV. During further differentiation ("intermediate stage," "7 + 5 d" to "7 + 8 d;" for explanation see above) cardiomyocytes were found to divide into cells exhibiting different types of specialized action potentials. Cardiomyocytes differentiating into terminal stage ("7 + 9 d" to "7 + 12 d;" for explanation see above) obviously showed atrial and ventricular-like types with action potentials of higher upstroke velocity, stable resting potential (about -75 mV) and loss of diastolic depolarization (FIG. 4). Similarly as described for adult atrial and ventricular cells, β -adrenoceptors prolonged the duration and increased the plateau amplitude in both atrial and ventricular action potentials. The muscarinic cholinergic agonist carbachol shortened the duration and hyperpolarized the resting potential of atrial, but not of ventricular action potentials. In ventricular-like cardiomyocytes, carbachol antagonized the β -adrenoceptor effect.¹⁶ In addition, in terminally differentiated cardiomyocytes, pacemaker-like action potentials were measured, with linear diastolic depolarizations and faster upstroke velocities. These cells presumably specialized into sinusnodal cells generating pacemaker action potentials with a frequency stimulated by adrenergic and inhibited by muscarinic receptor activation (FIG. 4).¹⁶

Cardiomyocytes Developmentally Express Cardiac-Specific Genes and All Major Heart-Specific Ion Channels

The cardiac-specific genes coding for α - and β -cardiac myosin heavy chain (MHC; α , β , see FIG. 4), atrial natriuretic factor (ANF) and the α_1 -subunit of the L-type Ca^{2+} channel ($\alpha_1\text{CaCh}$) were found to be developmentally expressed during cardiomyocyte differentiation as analyzed by RT-PCR. As shown in FIGURE 4, the α and β -cardiac MHC genes and the $\alpha_1\text{CaCh}$ gene were expressed independent of the developmental stage, and their expression coincided with the appearance

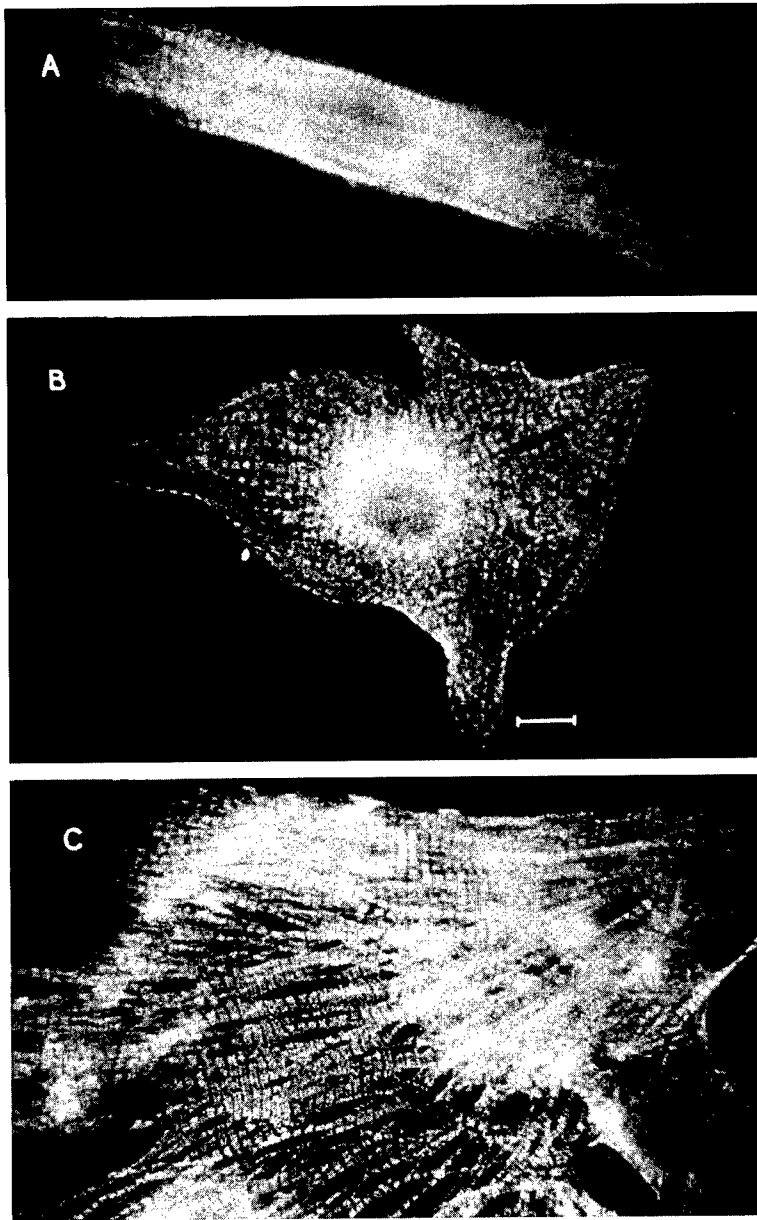

FIGURE 3. Enzymatically isolated ES cell-derived cardiomyocytes characterized by indirect immunofluorescence with monoclonal antibodies against α -cardiac myosin heavy chain: cylindrical (A), multiangular (B) and pleiomorphic morphology (C) of early (A, B) and terminally (C) differentiated cardiomyocytes.

Cardiac cell type	Early pacemaker cells	Intermediate stage cells	Atrial-like cells	Ventricular-like cells	Sinusnodal-like cells
	"6" to "7"	"7+2" to "7+4"	"7+5" to "7+8"		
Days			"7+9" to "7+18"		
Action potentials					
Ion channels	I _{Ca}				
	I _{K,to}				
	I _K				
	I _{Na}				
	I _f				
	I _{K1}				
	I _{K,ATP}				
	I _{K,ACh}				
Genes	α				
	β				
	α, CaCh				
	ANF	-----	-----		

FIGURE 4. Characteristic action potentials measured in ES cell-derived cardiomyocytes at different developmental stages compared to functional expression of respective ion channels and transcription of cardiac-specific genes (for definition and explanation see text). Both atrial and ventricular-like types of action potentials were elicited in current clamp mode by current pulse stimulation (204 pA, 3 ms).

of the first beating cells. In contrast, the atrial-specific ANF gene was found to be significantly expressed in differentiated cardiomyocytes, with weak transcriptional signals already in cardiomyocytes of the early and intermediate stage of differentiation (from "7 + 2 d" to "7 + 8 d").

Although some cardiac-specific genes, as for example, ANF and MLC-2_v, are shown to be specifically expressed in atrial and ventricular tissue, respectively,²⁵ a more detailed functional characterization of the ES cell-derived cardiomyocytes was desirable, because in the embryoid body outgrowth different cardiomyocytes representing cells with action potentials of atrial, ventricular and sinusnodal-like cell types were present (see above).¹⁶ By enzymatic dissociation using collagenase (modification of the method described in Ref. 26) we prepared single cells necessary for the application of the patch-clamp technique.^{16,19}

It was demonstrated that the various shapes of action potentials correlated with the expression of specialized types of ionic channels during differentiation. While in cardiomyocytes of early developmental stage the primitive pacemaker action potentials were generated by only two types of ionic currents, the L-type Ca²⁺ current (I_{Ca}) and the transient outwardly rectifying K⁺ current (I_{K,to}), during

further differentiation six additional types of ion currents were found. In the intermediate stage cardiomyocytes expressed the TTX-sensitive Na^+ current I_{Na} (IC_{50} -value of $1.8 \mu\text{M}$), similar to that previously reported for adult cardiomyocytes.²⁷ The density of both, I_{Ca} and I_{Na} , steadily increased during cardiomyocyte differentiation. In the intermediate stage, in addition, cells expressing the pacemaker I_{f} current were identified. In the terminal differentiation stage, a distinct pattern of distribution of ion currents specific for atrial, ventricular and sinusnodal-like cells, respectively, was measured (see FIG. 4).¹⁹ While both, atrial- and ventricular-like cells, functionally expressed I_{Ca} , $I_{\text{K, to}}$, I_{K} , I_{Na} , I_{K1} , $I_{\text{K, ATP}}$, the inwardly rectifying K^+ current ($I_{\text{K, ACh}}$), was only expressed in atrial and sinusnodal-like cells. Furthermore, sinusnodal-like cells expressed the current component important for hormonal regulation of pacemaker potentials, the I_{f} current (see Ref. 28). This current was not found in early differentiated cardiomyocytes but appeared in cells of intermediate stage and was present during terminal differentiation. Adrenaline and carbachol stimulated and inhibited I_{f} shifting the current activation curve to positive and negative potentials, respectively.¹⁹

CONCLUSIONS

Summarizing our data we may conclude that pluripotent ES cells reproduce the cardiomyocyte development from uncommitted embryonal cells to highly specialized cellular phenotypes of the myocardium. Therefore, the cellular model of ES cell-derived cardiogenesis is suggested as an *in vitro* model to study in future fundamental questions of cell and developmental biology of cardiogenesis, that is, for example: (i) the analysis of cell-cell interaction and communication during commitment and early differentiation, especially with respect to effects of growth factors and extracellular matrix proteins on cardiogenic development, (ii) the regulation of expression of tissue-specific genes and ionic currents during differentiation, which may give more insights into pathological malformations during embryogenesis, (iii) the analysis of cardiac progenitor cells and their commitment, proliferation and differentiation,⁵ (iv) the differentiation potential and differentiation pattern of "knock out" ES cells (for gene-targeting strategies, see Ref. 29), especially in the case that those cells result in periimplantational death of embryos containing inactivated genes. In addition, the finding that ES cell-derived cardiomyocytes respond with characteristic chronotropic effects to cardioactive drugs may imply that this differentiation system is an alternative *in vitro* model for pharmacological and toxicological investigations.^{15,30}

REFERENCES

1. SPERELAKIS, N. & A. J. PAPPANO. 1983. Physiology and pharmacology of developing heart cells. *Pharmacol. & Ther.* **22**: 1-39.
2. WOLLENBERGER, A. 1985. Isolated heart cells as a model of the myocardium. *Basic Res. Cardiol.* **80**(Suppl. 2): 9-14.
3. CLAYCOMB, W. C. & N. LANSON. 1984. Isolation and culture of the terminally differentiated adult mammalian ventricular cardiac muscle cells. *In Vitro* **20**: 647-651.

4. BUGAISKY, L. B. & R. ZAK. 1989. Differentiation of adult rat cardiac myocytes in cell culture. *Circ. Res.* **64**: 493–500.
5. LITVIN, J., M. MONTGOMERY, A. GONZALEZ-SANCHEZ, J. H. BISAHA & D. BADER. 1992. Commitment and differentiation of cardiac myocytes. *Trends Cardiovasc. Med.* **2**: 27–32.
6. KIMES, B. W. & B. L. BRANDT. 1976. Properties of a clonal muscle cell line from rat heart. *Exp. Cell. Res.* **98**: 367–381.
7. HESCHELER, J., R. MEYER, S. PLANT, D. KRAUTWURST, W. ROSENTHAL & G. SCHULTZ. 1991. Morphological, biochemical and electrophysiological characterization of a clonal cell (H9c2) line from rat heart. *Circ. Res.* **69**: 1476–1486.
8. SPIDO, K. R. & E. MARBAN. 1991. L-type calcium channels, potassium channels and novel nonspecific cation channels in a clonal muscle cell line derived from embryonic rat ventricle. *Circ. Res.* **69**: 1487–1499.
9. SEN, A., P. DUNNMON, S. A. HENDERSON, R. D. GERARD & K. R. CHIEN. 1988. Terminally differentiated neonatal rat myocardial cells proliferate and maintain specific differentiated functions following expression of SV40 large T antigen. *J. Biol. Chem.* **263**(35): 19132–19136.
10. JAFFREDO, T., A. CHESTIER, N. BACHNOU & F. DIETERLEIN-LIÉVRE. 1991. MC29-Immortalized clonal avian heart cell lines can partially differentiate *in vitro*. *Exp. Cell Res.* **192**: 481–491.
11. GUZMAN, R. J., P. LEMARCHAND, R. G. CRYSTAL, S. E. EPSTEIN & T. FINKEL. 1993. Efficient gene transfer into myocardium by direct injection of adenovirus vectors. *Circ. Res.* **73**: 1202–1207.
12. MARTIN, G. & M. J. EVANS. 1975. Differentiation of clonal lines of teratocarcinoma cells: formation of embryoid bodies *in vitro*. *Proc. Natl. Acad. Sci. USA* **72**: 1441–1445.
13. EVANS, M. J. & M. H. KAUFMANN. 1981. Establishment in culture of pluripotential stem cells from mouse embryos. *Nature* **291**: 154–156.
14. ROBBINS, J., J. GULICK, A. SANCHEZ, P. HOWLES & T. DOETSCHMANN. 1990. Mouse embryonic stem cells express the cardiac myosin heavy chain genes during development *in vitro*. *J. Biol. Chem.* **265**: 11905–11909.
15. WOBUS, A. M., G. WALLUKAT & J. HESCHELER. 1991. Pluripotent mouse embryonic stem cells are able to differentiate into cardiomyocytes expressing chronotropic responses to adrenergic and cholinergic agents and Ca²⁺ channel blockers. *Differentiation* **48**: 173–182.
16. MALTSEV, V. A., J. ROHWEDDEL, J. HESCHELER & A. M. WOBUS. 1993. Embryonic stem cells differentiate *in vitro* into cardiomyocytes representing sinusnodal, atrial and ventricular cell types. *Mech. Dev.* **44**: 41–50.
17. MILLER-HANCE, W. C., M. LACORBIERE, S. J. FULLER, S. M. EVANS, G. LYONS, C. SCHMIDT, J. ROBBINS & K. R. CHIEN. 1993. *In vitro* chamber specification during embryonic stem cell cardiogenesis. *J. Biol. Chem.* **268**: 25244–25252.
18. WOBUS, A. M., T. KLEPPISCH, V. MALTSEV & J. HESCHELER. 1994a. Cardiomyocyte-like cells differentiated *in vitro* from embryonic carcinoma cells P19 are characterized by functional expression of adrenoceptors and Ca²⁺ channels. *In Vitro Cell. & Dev. Biol.* **30A**: 425–434.
19. MALTSEV, V., A. M. WOBUS, J. ROHWEDDEL, M. BADER & J. HESCHELER. 1994. Cardiomyocytes differentiated *in vitro* from embryonic stem cells developmentally express cardiac-specific genes and ionic currents. *Circ. Res.* **75**: 233–244.
20. MCBURNEY, M. W. & B. J. ROGERS. 1982. Isolation of male embryonal carcinoma cells and their chromosome replication patterns. *Dev. Biol.* **89**: 503–508.
21. DOETSCHMANN, T. C., H. R. EISTETTER, M. KATZ, W. SCHMIDT & R. KEMLER. 1985. The *in vitro* development of blastocyst-derived embryonic stem cell lines: formation of visceral yolk sac, blood islands and myocardium. *J. Embryol. Exp. Morphol.* **87**: 27–45.
22. MCBURNEY, M. W., E. M. V. JONES-VILLENEUVE, M. K. S. EDWARDS & P. J. ANDERSON. 1982. Control of muscle and neuronal differentiation in a cultured embryonal carcinoma cell line. *Nature* **299**: 165–167.

23. CLAYCOMB W. C. & H. D. BRADSHAW. 1983. Acquisition of multiple nuclei and the activity of DNA polymerase α and reinitiation of DNA replication in terminally differentiated adult cardiac muscle cells in culture. *Dev. Biol.* **99**: 331-337.
24. CAPOGROSSI, M. C. & E. G. LAKATO. 1989. *In* Electrophysiology and Contractile Function. H. M. Piper & G. Isenberg, Eds. Vol. 2: 183-212. CRC Press. Boca Raton, FL.
25. CHIEN, K. R., HONG SHU, K. U. KNOWLTON, W. MILLER-HANCE, M. VAN-BILSEN, T. X. O'BRIEN & S. M. EVANS. 1993. Transcriptional regulation during cardiac growth and development. *Annu. Rev. Physiol.* **55**: 77-95.
26. ISENBERG, G. & U. KLÖCKNER. 1982. Calcium tolerant ventricular myocytes prepared by preincubation in a "KB medium." *Pflügers Arch.* **395**: 6-18.
27. BENDORF, K., W. BOLDT & B. NILIUS. 1985. Sodium current in single myocardial mouse cells. *Pflügers Arch.* **404**: 190-196.
28. DI FRANCESCO, D. 1993. Pacemaker mechanisms in cardiac tissue. *Annu. Rev. Physiol.* **55**: 455-472.
29. ROBBINS, J. 1993. Gene targeting. The precise manipulation of the mammalian genome. *Circ. Res.* **73**: 3-9.
30. WOBUS, A. M., J. ROHWEDEL, V. MALTSEV & J. HESCHELER. 1994b. *In vitro* differentiation of embryonic stem cells into the cardiogenic or myogenic lineage is specifically modulated by retinoic acid. *Roux's Arch. Dev. Biol.* **204**: 36-45.

X-Linked Dilated Cardiomyopathy

Novel Mutation of the Dystrophin Gene

W. M. FRANZ,^a M. CREMER,^b R. HERRMANN,^d E. GRÜNIG,
W. FOGEL,^c T. SCHEFFOLD, H. H. GOEBEL,^e
R. KIRCHEISEN,^b W. KÜBLER, T. VOIT,^d AND
H. A. KATUS

Department of Cardiology

^b *Department of Human Genetics*

^c *Department of Neurology*

University of Heidelberg

^d *Department of Pediatrics*

University of Düsseldorf

^e *Institute of Pathology*

University of Mainz

Germany

INTRODUCTION

Cardiomyopathies constitute a group of heart muscle diseases characterized by both contractile and electrophysiological abnormalities leading to severe heart failure or sudden death. The etiology of most cases is unknown and therefore the most frequent diagnosis is "idiopathic cardiomyopathy." Many authors have reported on kindreds with "idiopathic cardiomyopathy" transmitted as autosomal dominant, autosomal recessive, and X-linked traits.¹⁻³ A familial aggregation has been shown for 50% of the hypertrophic and 20% of the dilative idiopathic forms of cardiomyopathy suggesting a genetic cause of the disease.^{4,5} Genetic linkage analyses and positional cloning have identified mutated genes responsible for some cases of the autosomal-dominant hypertrophic cardiomyopathy, *e.g.*, the β -cardiac myosin heavy chain gene on chromosome 14q11,^{6,7} the cardiac troponin T gene on chromosome 1q31 and the α -tropomyosin gene on chromosome 15q2.⁸ Recently, genetic linkage and protein analyses identified the dystrophin gene on chromosome Xp21 as the first known disease locus responsible for isolated dilated cardiomyopathy.^{9,10}

The X-linked dilated cardiomyopathy was previously described as a rapid progressive cardiomyopathy in teenage males presenting with congestive heart failure without clinical signs of skeletal myopathy, despite elevations in serum levels of creatine kinase.³ Typically, patients die of biventricular failure within a year after the first signs of heart failure. Affected women may present atypical chest pain in their 50's or 60's, when the heart size and left ventricular function are still

^a Corresponding author: Dr. Wolfgang-Michael Franz, Department of Cardiology, Innere Medizin III, University of Heidelberg, Bergheimerstr. 58, D-69115 Heidelberg, Germany.

normal. However, slowly progressive congestive heart failure has been observed in some of these patients. The genetic defects causing DCM have only been described in maternally transmitted cardiomyopathies for mutations in mitochondrial DNA^{11,12} and for X-linked myopathies of the Duchenne, Becker and Emery-Dreifuss types.¹³⁻¹⁵ Among these, Duchenne and Becker muscular dystrophies are caused by mutations of the dystrophin gene located at Xp21.^{16,17} Cardiac involvement is very frequent in Duchenne muscular dystrophy (>80%); however only a minority (10%) of affected boys die of cardiac failure as a terminal event.^{18,19} In rare instances of Becker muscular dystrophy cardiomyopathy has been the presenting symptom.²⁰⁻²² Recently, deletions involving the dystrophin exons 48, 49, 45-53, 2-7 and 1 including the muscular promoter region were observed in patients with DCM and dystrophinopathy.²³⁻²⁵ The vast majority of patients with DMD have little or no dystrophin detectable by Western blot.²⁶⁻²⁹ This group manifests a severe myopathy, weakness and premature death due to the complications of respiratory or cardiac impairment.³⁰ By contrast, individuals with reduced levels of a semifunctional dystrophin have the milder and more variable BMD phenotype or a mild atypical myopathy.^{22,26,27,31,32} These observations suggest, that both the position of mutation and the level of expression of dystrophin determine the severity of impairment of muscle function and clinical symptoms. We here report on genetic analyses of the dystrophin gene in a family with a severe form of X-linked DCM.

MATERIALS AND METHODS

Patients

A pedigree was constructed for the affected family by interviewing the index patient (subject III-1) and living family members (FIG. 1). All available medical records were collected for three generations of family members (TABLE 1). The index patient was a 21-year-old man of normal intelligence, who presented with an episode of dyspnea, nausea and vomiting. Clinical evaluation revealed pulmonary edema, tricuspid regurgitation and tachycardia. On ultrasound the left ventricular shortening fraction was reduced to 16% (normal = 36%) and the enddiastolic diameters of the right and left ventricles were markedly enlarged to 7.9 and 3.5 cm, respectively. Impaired left and right heart functions were confirmed by heart catheterization (left ventricular ejection fraction = 20%, cardiac index = 1.5 l/min, mean pulmonary artery pressure = 35 mmHg). The coronary angiography was normal. Mild mitral and moderate tricuspidal regurgitation was observed. The endomyocardial biopsies taken from the left ventricular myocardium revealed histological changes compatible with dilative cardiomyopathy (FIG. 2). There was no evidence of inflammatory heart disease. The patient was also found to have elevated levels of serum creatine kinase, type MM (TABLE 1). On physical examination, he had normal muscle strength in all muscle groups; no elbow or ankle contractures or rigidity of the spine were present. The neurological investigation revealed normal muscle tone, no muscle atrophies, normal bilateral reflexes and no sensory deficits. Diagnostic muscle biopsies from the vastus lateralis muscle

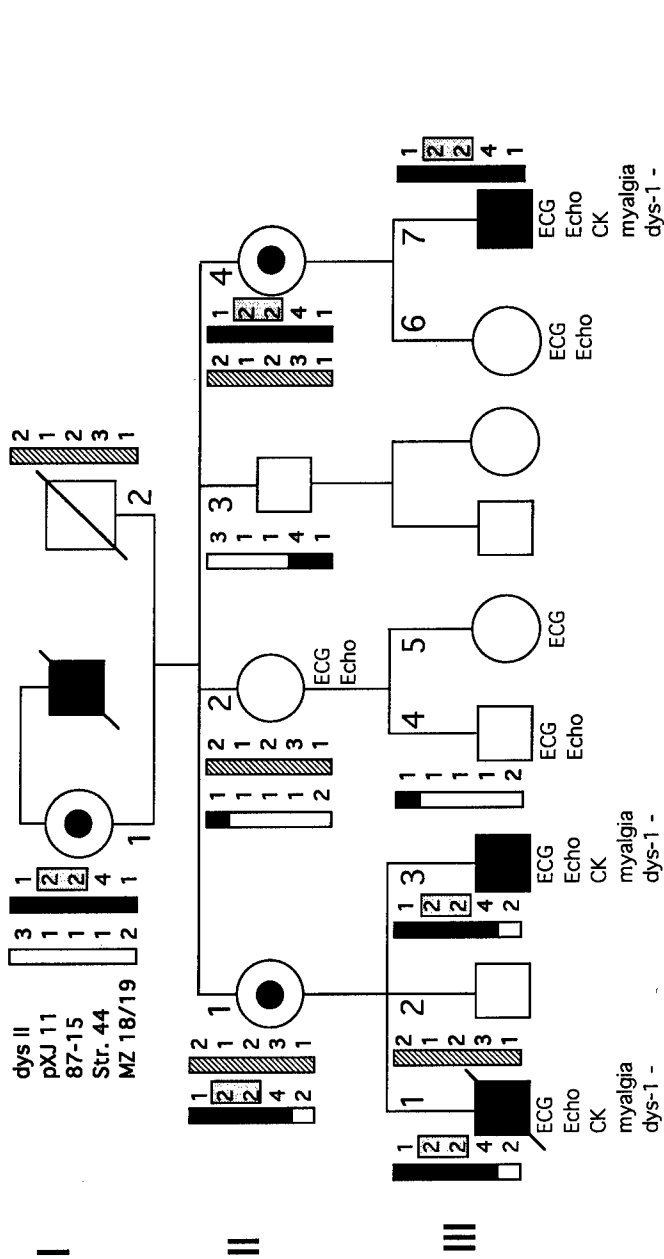

FIGURE 1. Pedigree of our family with X-linked DCM. Each individual is specified by the generation (I, II, III) and number (1-7). The five criteria, ECG and echocardiographic abnormalities, increased CK-levels, exertional myalgia and lack of reactivity with the dys-1 antibody, are listed below for each individual, respectively. Phenotypic male carriers of DCM are represented by a filled square. Heterozygous female carriers are marked with a filled dot within the circle. Crossed symbols represent death. Bars with numbers represent the allelic configuration for the 5 genomic markers (dys II, XJ1.1, 87-15, Str 44 and MZ 18/19) investigated. Open bars represent the disease unrelated Xp21 region; filled bars represent the disease related Xp21 region. Hatched bars represent the male noncarrier Xp21 region. Boxes mark the cosegregation of the alleles (XJ1.1, 87-15) with the DCM.

TABLE 1. Characterization of Family Members by Cardiological, Laboratory, Neurological and Dystrophin Analyses

Subject	Age	Sex	ECG/Block	LV-EDD	RV-Diam.	Valves	*CK U/l	Neurol.	EMG	M. Biopsy
I-1	70	f	no abn.	47 mm	no abn.	MI 2	35	no abn.	n.d.	n.d.
II-1	43	f	no abn.	45 mm	no abn.	no abn.	42	no abn.	n.d.	n.d.
II-2	46	f	iRBBB	42 mm	RV = 35 mm	TI 1	40	no abn.	n.d.	n.d.
II-3	36	m	no abn.	47 mm	no abn.	MI 1 + TI 1	43	no abn.	n.d.	n.d.
II-4	45	f	no abn.	44 mm	RV = 35 mm	MI 1 + TI 1	41	no abn.	n.d.	n.d.
III-1	21	m	LBBB	79 mm	RV < 35 mm	MI 2 + TI 2	963	Exerc. dep. myalgia	not sign.	Dys 1 neg. Dys 2 + 3 pos.
III-2	20	m	no abn.	43 mm	no abn.	no abn.	42	no abn.	n.d.	n.d.
III-3	12	m	no abn.	42 mm	RV < 35 mm	no abn.	3083	Exerc. dep. myalgia	not sign.	Dys 1 neg. Dys 2 + 3 pos.
III-4	25	m	iRBBB	50 mm	RV = 35 mm	no abn.	78	no abn.	not sign.	Dys 1 + 2 + 3 pos.
III-5	22	f	iRBBB	48 mm	no abn.	no abn.	26	no abn.	n.d.	n.d.
III-6	26	f	iRBBB	48 mm	RV = 35 mm	no abn.	27	no abn.	n.d.	n.d.
III-7	22	m	no abn.	30 mm	RV < 35 mm	no abn.	620	Exerc. dep. myalgia	not sign.	Dys 1 neg. Dys 2 + 3 pos.

* *Ck-total* (-80 U/l normal) *Ck-MB* was not significantly increased (<6% *CK*)

LV-EDD = left ventricular end diastolic diameter; normal until 55 mm, (95% percentile of normal adults)

RV-Diam. = right ventricular diameter; normal until 30 mm, (95% percentile of normal adults)

ECG = electrocardiogram-block picture:

(i)*RBBB* = (incomplete) right bundle branch block

(ii)*LBBB* = (incomplete) left bundle branch block

MI or TI = mitral or tricuspidal valve insufficiency

no abn. = no abnormalities

n.d. = not determined

Exerc. dep. = exercise dependent

not sign. = not significant

neg. = negative

pos. = positive

M. biopsy = muscle biopsy

Dys 1, 2, 3 = anti-dystrophin antibodies 1, 2, 3

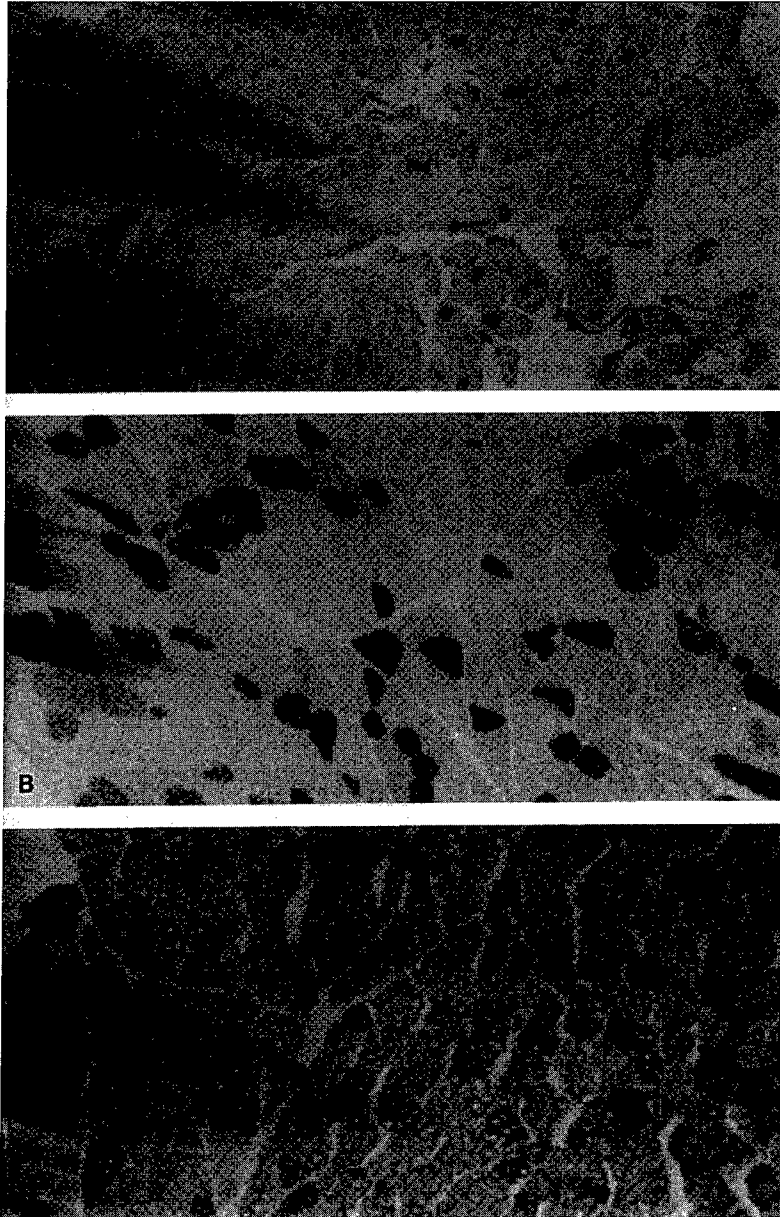

FIGURE 2. Histological analyses of heart and skeletal muscle tissue of the index patient III-1. (A) Histology of heart muscle, hematoxylin-eosin-staining ($\times 20$); (B) trichrome stain of skeletal muscle ($\times 20$); and (C) alkaline adenosinetriphosphatase (pH 10.4) of skeletal muscle ($\times 20$).

were performed. During the course in the hospital his cardiac function decreased rapidly requiring emergency transplantation. After heart transplantation in 1/94 the patient died of a septic shock.

The family history disclosed that a brother of his maternal grandmother (I-1) had died of clinically diagnosed cardiomyopathy at the age of 29 years. The youngest brother (III-3) and two maternal cousins (III-4, III-7) of the index patient had electrocardiographic abnormalities and enlarged diameters of the right ventricles on echocardiography (TABLE 1). However, only his brother (III-3) and one of his cousins (III-7) had elevated creatine kinase levels and exertional cramping myalgia since early childhood (TABLE 1). The clinical examination of these subjects did not reveal any muscle weakness. There was no muscle hypertrophy or atrophy. Peroneal- and median-nerve conduction velocities were normal in the affected male subjects, including the index patient (III-1). Electromyography of the vastus lateralis muscle revealed normal resting activity. The duration and amplitude of the motor units and recruitment patterns were also within the normal range. A muscle biopsy was performed in all four male individuals (III-1, III-3, III-4, III-7). Informed consent was obtained from all subjects. All agreed on the scientific analysis of their personal and medical data.

Sources of Tissues

Skeletal muscle was obtained by biopsy from the vastus lateralis muscle in 4 patients (III-1, III-3, III-4 and III-7) according to standard techniques.³³ Normal muscle tissue obtained from the department of orthopedic surgery served as control. Muscle from DMD patients was obtained by diagnostic needle biopsies.³⁴ Endomyocardial biopsies were obtained from the left ventricular wall during heart catheterization using a Cordis biotom, and from the explanted heart of our index patient (III-1). The tissue specimens were immediately frozen in liquid nitrogen.

Immunofluorescence and Western Blot

Immunofluorescence was carried out as previously described (FIG. 3).^{34,35} Briefly, 5 μ m cryosections were placed on a coverslip, air-dried, blocked for 5 minutes with 10% bovine serum albumine in PBS, and incubated for 2 hrs with monoclonal antibodies directed against different epitopes of dystrophin (dys) in the following dilutions: dys-1 (1:10), dys-2 (1:100), dys-3 (1:200). An anti-spectrin antibody (spec-2), diluted 1:200, served as an internal control. All monoclonal antibodies were from Novo Castra obtained from Medac Molecular Biology, Hamburg, Germany. The antibody binding in tissue specimens was detected by biotinylated anti-mouse IgG antibodies (Amersham Buchler GmbH, Braunschweig, Germany) and streptavidin-Texas red, both diluted 1:200. The coverslips were washed 3 \times 10 min between each step and mounted on Aquatex. Sections were viewed and photographed in a Zeiss III RS microscope equipped with epifluorescence. Electrophoresis was carried out by separating muscle homogenates on 4–20% sodium dodecyl sulphate (SDS) gradient gels with a 3.5% stacking gel and applying

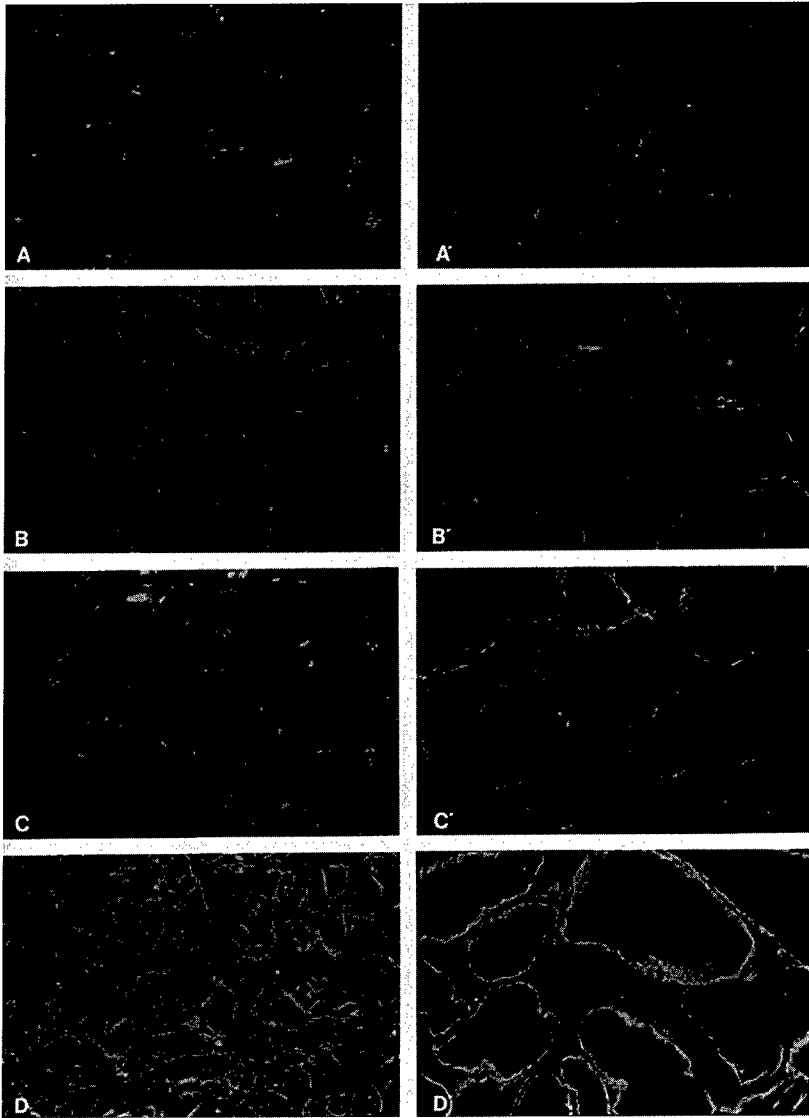

FIGURE 3. Immunohistochemical staining of heart and skeletal muscle of patient III-1. *Left panel:* explanted heart tissue stained with anti-dystrophin antibodies dys-1 (A), dys-2 (B), dys-3 (C) and with anti-spectrin antibody, spec-2 (D) as a positive control. *Right panel:* skeletal muscle biopsy stained with antibodies dys-1 (A'), dys-2 (B'), dys-3 (C'), and spec-2 (D').

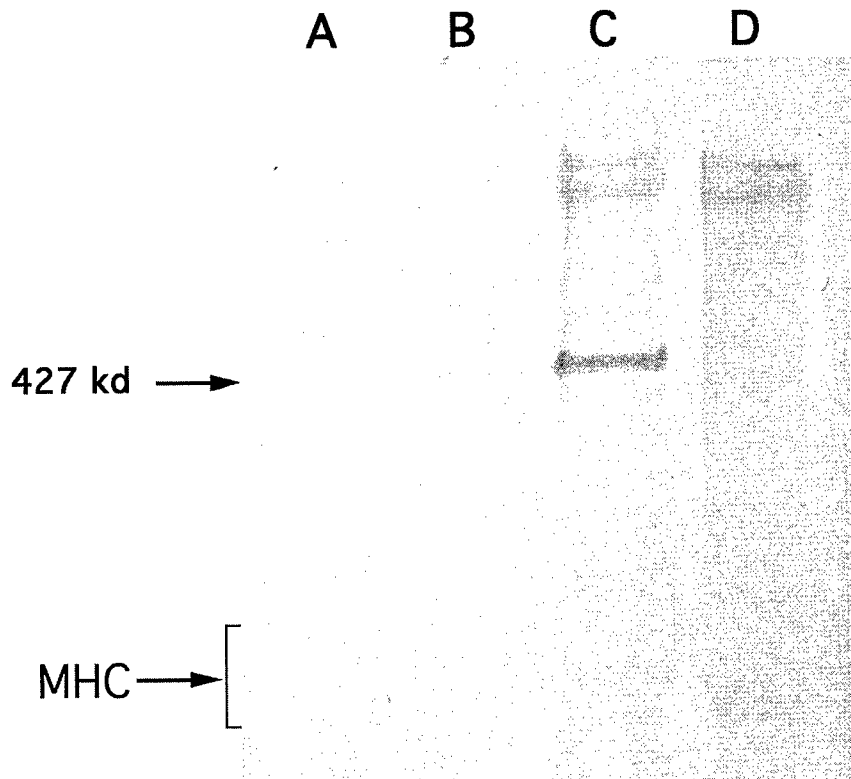

FIGURE 4. Western blot analysis of heart and skeletal muscle tissue using anti-dystrophin antibody dys-2. 100 μ g of protein is applied to each lane. *Lane A:* heart muscle of patient III-1; *lane B:* skeletal muscle of patient III-1, *lane C:* skeletal muscle of normal subject; *lane D:* skeletal muscle of a patient with Duchenne muscular dystrophy.

200 μ g of protein per lane. Western blots were probed with the same anti-dystrophin and -spectrin antibodies. Peroxidase-labeled antibodies and diaminobenzidine were used for detection.³⁴ The amount of myosin was quantitated by laser densitometry of the blots using myosin as a reference (FIG. 4).

PCR Analysis

Genomic DNA was extracted from peripheral blood leucocytes according to standard methods. DNA amplifications of 26 distinct exons and the muscle specific promoter region (PM) of the dystrophin gene were carried out by multiplex polymerase chain reactions (PCR) using the primer pairs described by Chamberlain *et al.*³⁶ and Beggs *et al.*²³ Eight additional pairs of primers, which amplify the exons 7, 21, 34, 46, 49, 53, 54 and 55, were chosen according to the cDNA sequence described by Koenig *et al.*³⁷ In addition exon 1 and the muscle specific promoter

region were amplified up to 850 bp upstream of exon 1 using 6 overlapping pairs of primers selected by the 5' DNA sequence described by Klamut *et al.*³⁸ The following polymorphic markers based on variable numbers of short tandem repeats (STR) in the dystrophin gene were assayed by PCR analysis: Dys II located in the brain promoter region,³⁹ Str 44 located in intron 44,⁴⁰ and MZ 18/19 located at the 3' untranslated region of the dystrophin gene.⁴¹ All PCR reactions were performed according to the method of Chamberlain³⁶ with the following modifications: for 25 cycles 2.5 units of CETUS Taq polymerase were used; no DMSO was added to the reaction; and PCR products were separated either on 3% NuSieve gels (axons and PM region) or on 10% polyacrylamide gels (polymorphic makers).

Southern Blot Analysis

Digestion of genomic DNA, electrophoresis and blotting on Nytran filters were performed according to standard procedures.⁴² The genomic DNA probes XJ1.1 located in intron 7,⁴³ and 87-15 located in intron 17,⁴⁴ as well as the cDNA probes 2b-3, 4-5a, 5b-6 containing the exons 10-19, 20-33 and 34-43,⁴⁵ were labeled with ³²P using the random primed labeling method.⁴⁶ Hybridizations were performed at 65°C using the buffer of Church *et al.*⁴⁷

DNA Linkage Analysis

Linkage analysis was performed using the LINKAGE (V5.03) program package.⁴⁸ Two-point LOD scores were calculated for all pairs of loci by using the LINKMAP program.⁴⁸ Two investigators analyzed the RFLP pattern identified by each specific DNA probe, independently and in a blinded fashion. The mode of inheritance was assumed to be X-linked. Penetrance was considered to be 100%, but analysis was performed at values of 90% and 95% for stringency. The disease prevalence was assumed to be 1:10,000. Allele frequency was used according to Towbin.⁹

Dystrophin mRNA Analysis by RT-PCR

Total RNA was isolated from muscle specimens according to the method of Chomczynski⁴⁹ and reverse transcribed.⁵⁰ First and second round PCR were carried out as previously described.⁵¹ The following fragments (f) were amplified using oligonucleotide primers: 30-996 (f1), 857-1409 (f2), 1367-1916 (f3), 1809-2311 (f4), 2225-2850 (f5), 2766-3486 (f6), 3416-4119 (f7), 4033-4983 (f8), 4918-5283 (f9), 5233-5744 (f10), 5619-6579 (f11), 6477-6742 (f12), 6604-7562 (f13), 7496-8344 (f14), 8251-9084 (f15), 8903-9785 (f16), 9706-10600 (f17), and 10451-11321 (f18). In the above nomenclature the first triplet codon of the reading frame ATG was located at 209-211 bp, the last TAG at 11264-11266 bp.

RESULTS

Skeletal and Heart Muscle Biopsies

HE-staining of left ventricular endomyocardial biopsies of the index patient (III-1) showed characteristics of dilative cardiomyopathy such as subendocardial and focal interstitial fibrosis, hypertrophic and atrophic myofibers, enlargement of the karyoplasma and hyperchromatic nuclei, vacuolization and reduction of myofibrils (FIG. 2a). There were no signs of myocytolysis, lymphocyte infiltration or an inflammatory process.

Skeletal muscle biopsies of the individuals III-1, III-3 and III-7 presented a mildly myopathic picture with disseminated atrophic and hypertrophic fibers, vacuolization, but no necrosis or lymphocyte infiltration (FIG. 2b). Additional histochemical analysis of the muscle tissue revealed a predominant atrophy of the slow-twitch type I fibers and a hypertrophy of the fast-twitch type II fibers (FIG. 2c). Patient III-4 presented no abnormalities in the muscle biopsy.

Dystrophin Protein Analyses

Immunofluorescence staining of heart muscle (III-1) and skeletal muscle of the index patient (III-1), his brother (III-3) as well as his maternal cousin (III-7) revealed a similar pathological dystrophin pattern: there was a complete lack of staining with the monoclonal antibody dys-1 directed against the amino acids 1181–1388 within the rod portion of the dystrophin molecule. In contrast, the antibodies directed against epitopes on both N-terminal (dys-3) and C-terminal (dys-2) sequences of the dystrophin protein showed patchy dystrophin staining of reduced intensity on the sarcolemma of skeletal and cardiac myofibers. Control stains using anti-spectrin were normal in both cardiac and skeletal muscle tissues indicating good preservation of sarcolemma in these specimens.

To determine molecular weight of the mutated dystrophin and to estimate dystrophin expression quantitatively, Western blot analysis was performed for the index patient (III-1) and three other subjects (III-3, III-4, III-7). Protein extracts from cardiac and skeletal muscle biopsies of III-1 were compared to normal skeletal muscle using the dys-2 antibody (FIG. 4). Protein extract of skeletal muscle tissue of a patient with DMD was used as negative control (FIG. 4). A significant reduction of the amount of the 427 kd dystrophin protein was observed in both cardiac and skeletal muscle extracts of patient III-1. There was no apparent change of the molecular weight detectable on SDS-gel electrophoresis (FIG. 4). No immunoreactivity of dys-1 antibody was detected in either heart or skeletal muscle homogenates. Similar findings were observed for his brother (III-3) and his cousin (III-7) in protein extracts of skeletal muscle biopsies (data not shown). Dystrophin concentration was consistently reduced to levels of approximately 20% in these individuals. In contrast, his maternal cousin (III-4) presented no quantitative or qualitative abnormalities and a regular binding to dys-1 antibody using immunoblot and immunohistochemical analysis. Since total CK and CK-MM levels were within the normal range, a dystrophinopathy of individual III-4 can be excluded.

Genetic Linkage Analysis

In order to narrow down the site of mutation in our family with dilative cardiomyopathy, genetic linkage analysis was performed. Family members (TABLE 1) presenting the following five criteria (FIG. 1) were considered as diseased: (1) echocardiographic right or left ventricular dilatation, (2) ECG abnormalities, *e.g.*, incomplete right bundle branch block, (3) increased CK-MM levels, (4) exertional cramping myalgia and (5) no reaction of skeletal and heart muscle tissue with the dys-1 antibody in Western blot and immunohistochemistry. Family members presenting ECG and echocardiographic abnormalities, but a normal CK activity in serum and no history of myalgia were considered as normal phenotypes (FIG. 1). Based on these criteria, the male subject III-4 was excluded to be affected. Allelic configurations of five different DNA loci were investigated using the polymorphic DNA probes, Dys II, XJ1.1, 87-15, Str 44, and MZ 18/19. All DNA probes used have previously been mapped within the dystrophin gene on Xp21 (see FIG. 5). Using two-point linkage analysis evidence of linkage was found for the genomic probe XJ1.1 with a pairwise LOD score of +1.93 at $\phi = 0$ (TABLE 2). The intronic probe XJ1.1 (DXS206) is known to be located in the Xp21.2 region^{52,53} within the proximal (5') portion of the dystrophin gene between exon 7 and exon 8. Autoradiographs of the XJ1.1 polymorphism demonstrated that the 3.1 kb band (allele 2) was observed in all affected males and female carriers, and was absent in all unaffected males (FIG. 2). In respect to the adjacent polymorphic marker 87-15 the female carrier (II-1) was homozygous for the allele 2, therefore not all meioses were informative. The marker 87-15 located in intron 17⁴⁴ gave a pairwise LOD score of +0.73, which does not exclude linkage with the phenotype (TABLE 2). In contrast, the other markers 5' Dys II and 3' Str 44 and MZ 18/19 revealed a negative LOD score of -99.99 at $\phi = 0$ excluding cosegregation with the disease locus. Recombinations noted with markers in the dystrophin region were with Dys II (subjects II-2, III-4), Str 44 (subject II-3) and MZ 18/19 (subjects II-1, III-1, III-3), suggesting that the mutation causing X-linked DCM lies centromeric to Str 44 and telomeric to Dys II as indicated in FIGURE 5. Thus genetic linkage analysis located the DNA region relevant for this disease 3' of the brain promoter (dys II) within the polymorphic markers XJ1.1 and 87-15 and 5' of intron 44 (Str 44). This region includes the epitope of the monoclonal Dys 1 antibody, which is located between exon 27 and 30.

Deletion Analysis of the Dystrophin Gene

To exclude an exon deletion leading to this severe type of dilative cardiomyopathy, multiplex PCR analysis and Southern hybridizations were performed. The use of the nine-primer pair PCR described by Chamberlain³⁶ and the nine-primer pair PCR described by Beggs,²³ allows a detection of approximately 98% of all known deletions including the muscular promoter region (PM) (FIG. 6A). No deletions were detectable using all 18 primer pairs plus 8 pairs of exon primers (exon 7, 21, 34, 46, 49, 53, 54, 55). In addition, 6 pairs of primers covering exon 1 and the 850 bp 5' of the muscular promoter region³⁸ showed no difference in migration

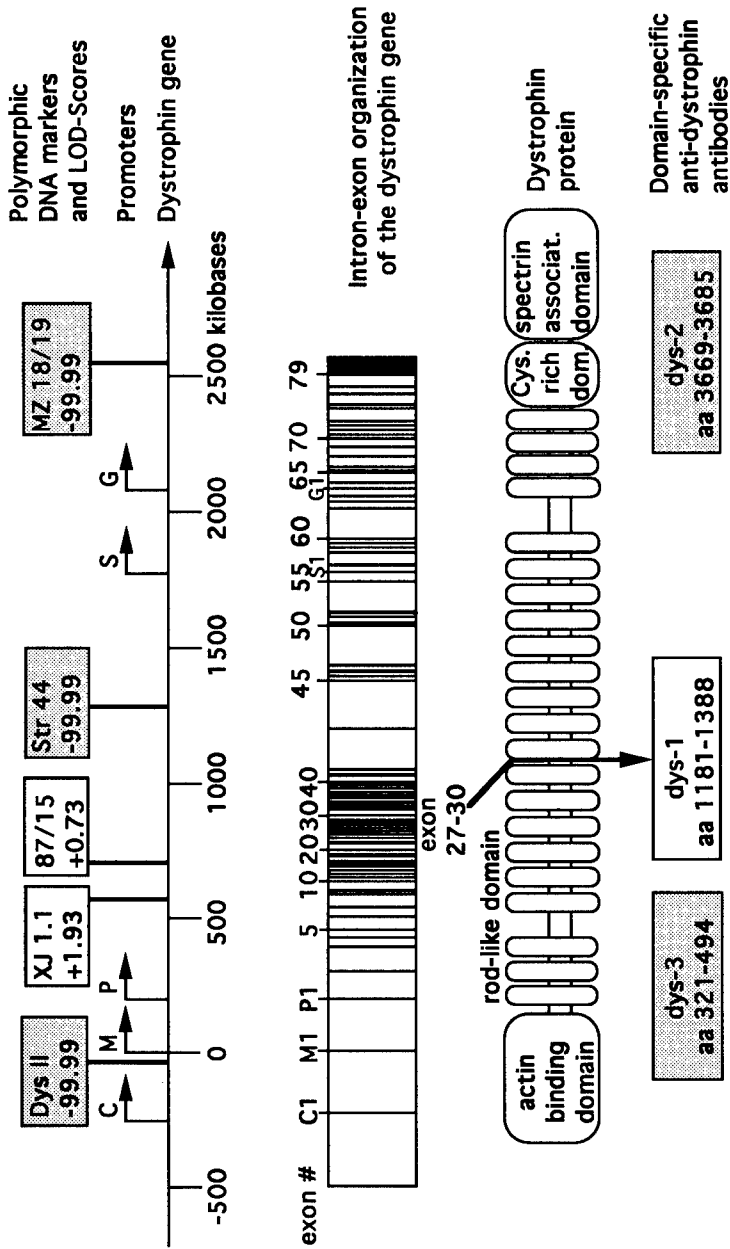

FIGURE 5. The dystrophin gene.⁶⁷ *Top line:* genomic map of the dystrophin gene spanning approximately 2.4 million bases of the short arm of X-chromosome. *Above,* polymorphic DNA markers and pairwise LOD scores for $\phi = 0$. At least five distinct promoters drive independent cell-type specific expression of dystrophin. The C (cortical)-M (muscle)- and P (Purkinje cell)-dystrophins, the "full-length" forms, each use their own first exon. The S (Schwann cell)- and G (general or glial)-dystrophin promoters encode C-terminal proteins Dp 116 and Dp 71 respectively. *Middle line:* a map of the complex exon-intron organization, in which at least 79 (plus 4 additional first) exons encode its 14 kilobase mRNA. *Bars* represent approximate relative exon positions. *Bottom line:* schematic map of the four domains, actin binding, rod-like, cysteine-rich, and spectrin-associated domain, forming the dystrophin polypeptide. *Below,* local distribution of the antigenic sites (aa = aminoacids) reacting with the domain-specific, monoclonal anti-dystrophin antibodies (dys-1, dys-2, dys-3).

TABLE 2. Pairwise LOD Scores for the Linkage of DCM with Five Genomic DNA Markers within the Dystrophin Gene at Xp21

	Recombination Frequency (ϕ)					
	0.00	0.005	0.01	0.015	0.02	0.25
Dys II	-99.99	-0.09	+0.20	+0.36	+0.47	+0.56
XJ 1.1	+1.93	+1.92	+1.90	+1.88	+1.87	+1.85
87-15	+0.73	+0.72	+0.71	+0.70	+0.69	+0.68
Str 44	-99.99	-0.39	-0.10	+0.062	+0.17	+0.25
MZ 18/19	-99.99	-2.51	-1.92	-1.58	-1.34	-1.16

compared to controls (data not shown). Thus a major deletion of an exon or of the muscle promoter was ruled out as the cause of this dystrophinopathy. In addition, Southern blot analysis using cDNA probes 2b-3, 4-5a, 5b-6, which cover the suspected genomic region from exons 10-19, 20-33 and 34-43,⁴⁵ did not show any alteration in the pattern of the affected individuals. These results exclude a major deletion in the cosegregating locus (brain promoter to intron 43) and the designated epitope region (exon 27-30) of *dys-1*, which supports a novel mutation of the dystrophin gene as the cause of this familial dilative cardiomyopathy.

Dystrophin mRNA Analysis

In order to exclude a major splice mutation within the dystrophin mRNA, reverse transcribed (RT) PCR of cardiac muscle mRNA of individual III-1 was performed using 18 overlapping pairs of primers, which amplified the whole mRNA of dystrophin from nucleotide 30 to 11380 (FIG. 7). None of these PCR products, which range from 265 to 966 bp in length, showed any difference of migration compared to normal heart control. Thus no major deletion of the dystrophin mRNA could be detected. However, deletions of a single or a few nucleotides cannot be excluded by this method.

DISCUSSION

In this paper we describe a family with inherited dilated cardiomyopathy due to a reduced expression of a mutated semifunctional dystrophin protein. All dystrophinopathic male family members with (1) right ventricular dilatation, (2) ECG abnormalities, (3) increased CK-MM levels, (4) exertional cramping myalgia and (5) loss of immunoreaction of skeletal and heart muscle tissue with the *dys-1* antibody, revealed the same XJ1.1 allelic polymorphism. A deletion of an exon or the muscular promoter region could be excluded by multiplex PCR and Southern blot analyses. In addition, a major splice-mutation of dystrophin mRNA was excluded by RT-PCR of skeletal and heart muscle tissue. Therefore, a novel mutation in the 5' portion of the dystrophin gene coding for the mid rod region may

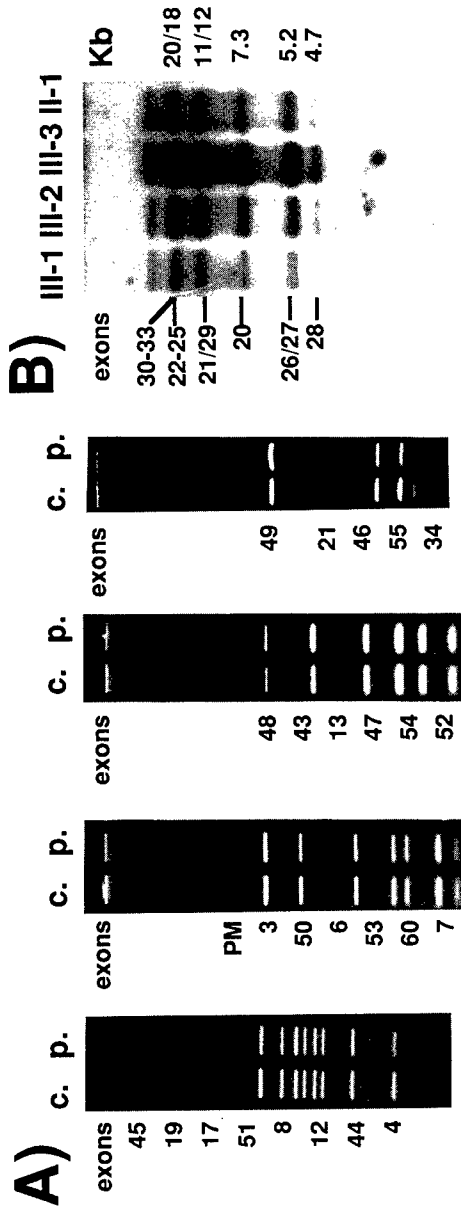

FIGURE 6. Testing for deletions of the dystrophin gene. (A) Multiplex PCR analysis of genomic DNA from the patient (p), III-1 and control (c) subject. (B) Southern blot analysis of genomic DNA from the patients III-1, III-2, III-3 and their mother II-1 using a specific dystrophin cDNA probe 4-5a.45.

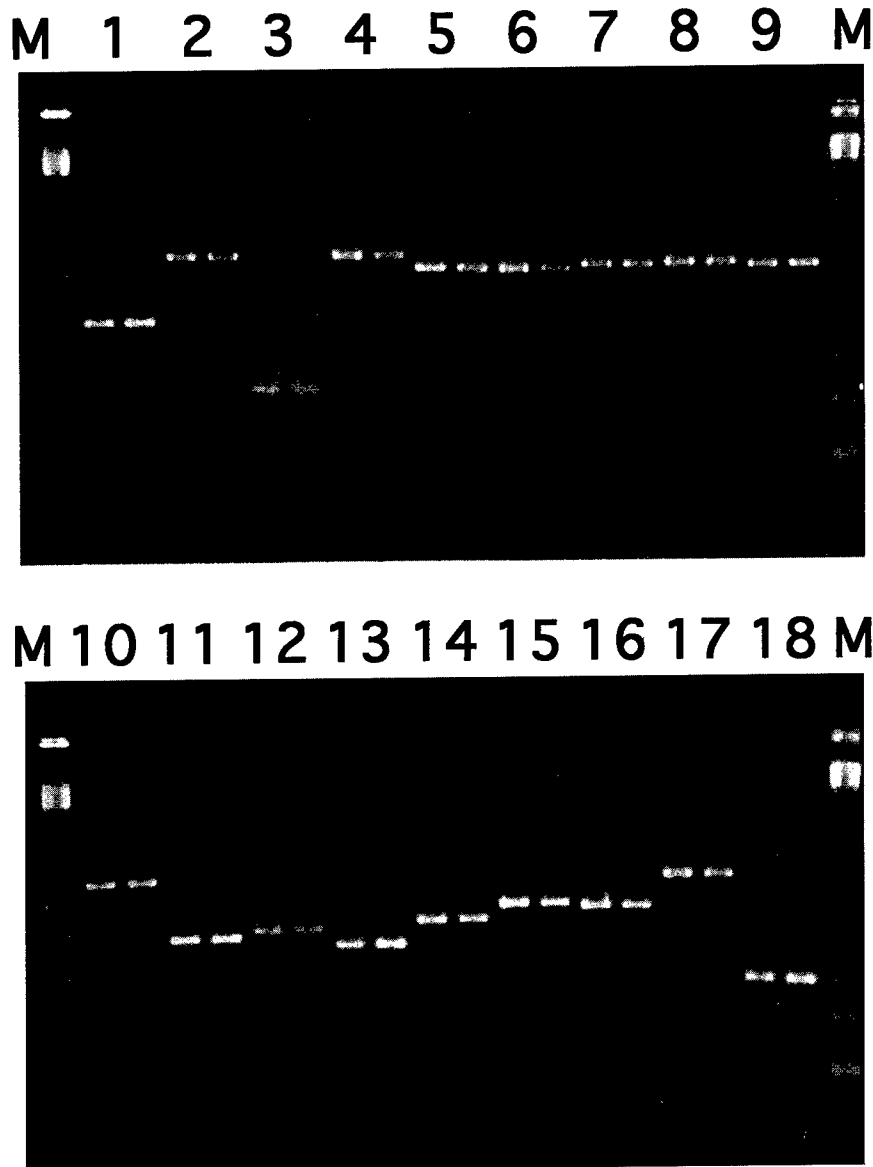

FIGURE 7. Dystrophin mRNA analysis by reverse transcribed PCR. 18 fragments covering the mRNA sequence (30 bp–11321 bp) of dystrophin were amplified from cardiac muscle mRNA of subject III-3 (*first lane*) and a normal control (*second lane*).

cause both quantitative and qualitative alterations, which phenotypically lead to this severe form of X-linked DCM.

Phenotypic Characterization of the X-Linked DCM Family

Diffuse interstitial fibrosis in the posterobasal part of the left ventricle has been described as a late but specific cardiac involvement in patients with Duchenne muscular dystrophy.⁵⁴ In our X-linked DCM family, echocardiographic enddiastolic diameters support a primary involvement of the right ventricular myocardium in contrast to DMD patients. Additional left ventricular impairment was observed, however, in the severe form of disease of the index patient (III-1). The two other affected male individuals III-3 and III-7 showed predominantly signs of right ventricular involvement such as incomplete right bundle branch block and unspecific changes of T waves in the right precordial leads V₁-V₃. A variety of ECG changes such as shortening of the PQ interval, deep Q waves in V₅-V₆ and altered T waves have been described in DMD.⁵⁴ However, the ECG changes are rather unspecific markers for this disorder. Mitral and tricuspidal regurgitations were found in the index patient (III-1) as well as in elder nondystrophinopathic members of the family and therefore were also considered as unspecific. In a recent study, early right ventricular involvement associated or not with left ventricular impairment and incomplete right bundle branch block were described as the main cardiac manifestations of Becker muscular dystrophy (BMD).²⁴ Therefore our X-linked DCM family showed phenotypic characteristics of the BMD type. BMD is known as a slowly progressive skeletal muscle disorder, marked by onset in late childhood, weakness of proximal limb girdle muscles, calf muscle hypertrophy and high levels of serum creatine kinase.⁵⁵⁻⁵⁷ It reveals a wide clinical spectrum from rapidly progressive, so-called severe, to only slight or no reductions in exercise capability, so-called mild phenotypes.^{22,31,58} Dilated cardiomyopathy may occur and in few cases can lead to refractory, rapid progressive heart failure,^{21,59-64} when transplantation is the final treatment.^{20,65} In our X-linked DCM family, skeletal muscle involvement was minor and clinical examination as well as the EMG were essentially normal. There was no muscle weakness. The only evidence of skeletal muscle disease was an elevation of CK-MM levels in the affected males (TABLE 1). Sporadic atrophy of slow-twitch type I fibers and hypertrophy of fast-twitch type II fibers were found in the muscle biopsy specimen of the affected males. It remains a possibility that muscular weakness may develop later during the life of these individuals. The present histological findings could give an explanation as well for the lack of muscle weakness, which could have been compensated by the hypertrophied fast-twitch fibers, as for the occurrence of exertional cramping myalgia during prolonged exercise, regarded as the main distress for slow-twitch skeletal muscle fibers. Two families with similar clinical findings, elevated Ck-MM levels, and genetic linkage to the dystrophin gene were described recently.^{9,10} However, in only one of these two studies, muscle biopsies were included demonstrating a similar variability in fiber size due to the presence of hypertrophic type II and atrophic type I fibers.¹⁰ Thus our study and the family reported by Muntoni exhibited only mild skeletal muscle disease but severe DCM.

The histological examination of left ventricular myocardium of our index patient showed a marked increase in connective tissue and a considerable variation in fiber size with a reduction of myofibrils, which readily explains the refractory heart failure necessitating cardiac transplantation.

The characteristic finding of our family is the symptomatic exertional cramping myalgia, which was not observed in the other DCM families with dystrophinopathy.^{9,10} Myalgia in absence of muscle weakness has been described in a few patients with BMD.^{31,58,66} These atypical forms of BMD had deletions or duplications in the proximal rod domain reaching from exon 10 to 44.³¹ Another unique finding in the affected male patients of our family was the lack of dystrophin staining using the dys-1 antibody. This antibody is directed against the mid-rod region (exons 27–30) of the dystrophin gene. Neither heart nor skeletal muscle tissue of our index patient (III-1) gave a positive reaction with this particular antibody in immunohistochemical analyses. To unravel the genetic alteration in our atypical DCM family we took the effort to further define the molecular pathology on DNA, mRNA and protein levels.

Genotypic Characterization of the X-Linked DCM Family

Using five different polymorphic markers for linkage analysis the region most likely corresponding to this disease was narrowed down to the genomic segment 3' of the brain promoter (Dys II marker) and 5' of intron 44 (Str 44 marker) (FIG. 5). The LOD score of 1.93 ($\phi = 0$) was highest for the polymorphic marker XJ1.1 (TABLE 2), the same as was described in two families by Towbin *et al.*⁹ Affected individuals of these families had significantly decreased concentrations of dystrophin only in cardiac but not in skeletal muscle. However, in our X-linked DCM family both skeletal and heart muscle tissues showed a reduction of the dystrophin molecule by 80% without changes in molecular weight on Western blot. Indirect evidence for a similar reduction of the dystrophin protein concentration in skeletal muscle tissue was shown by immunohistochemistry by Muntoni.¹⁰ However, neither Western blot analyses nor data on cardiac dystrophin protein levels were generated in this study.¹⁰ The mechanism of reduced protein expression in cardiac and skeletal muscle of this particular DCM family was successfully mapped to a deletion involving the first muscle exon and the muscle promoter of the dystrophin gene. In our DCM family a major deletion of an exon or of a promoter element was excluded by Southern blot, multiplex PCR analysis and additional amplifications of the first 850 bp of the muscular promoter region. In contrast to the two families described by Towbin, protein expression in our X-linked DCM family was reduced in skeletal (III-1, III-3, III-7) and cardiac tissue (III-1). In addition, protein data using a panel of three different antibodies (Ab) showed a constant lack of binding to dys-1 Ab in all of our affected male individuals. The lack of reaction with the dys-1 Ab cannot be explained by a disruption of the reading frame, since both the N- and C-terminal Ab (dys-2 and dys-3) did bind as expected. We conclude, that there could be a distinct sequence change of the antigenic determinant of the monoclonal dys-1 Ab. This dys-1 epitope is located in the mid-rod region between amino acids 1181 and 1388, which correspond to the exons 27 to 30 (FIG. 5). A

mutation in this area could be a possible cause for protein and/or mRNA instability leading to a reduced expression of an eventually semifunctional dystrophin protein in cardiac and skeletal muscle. Disruption of the dys-1 epitope may be caused by (1) a small in-frame deletion, (2) a point mutation leading to a conserved amino acid exchange or (3) an alternative splicing resulting in a small deletion of dystrophin mRNA. Further analysis of the mutated dystrophin gene in this family may improve our understanding of the causal relationship of dystrophin mutation and DCM and perhaps give an explanation for the predominant cardiac involvement due to this mutation. A systematic sequencing approach of the dys-1 would most likely be successful in unraveling the mutation and giving a clue to the underlying mechanism of this atypical dystrophinopathy associated with severe X-linked DCM.

SUMMARY

We report on a family with a severe form of X-linked dilated cardiomyopathy (DCM). Two brothers, the elder requiring heart transplantation, and a maternal cousin presented elevated creatine kinase levels, increased right ventricular diameters and electrocardiographic abnormalities. All complained of exertional cramping myalgia, but none had muscle weakness or a pathological electromyogram. Muscle biopsies of these individuals revealed a mild myopathic picture with atrophic type I and hypertrophic type II fibers. Immunofluorescence using N- and C-terminal antibodies (dys-2, dys-3) against the dystrophin protein showed preserved, but reduced intensity of staining of the sarcolemmal membranes. Using the same two antibodies, Western blot analyses revealed a dystrophin molecule of the expected molecular weight, which was quantitatively reduced by 80%. However, the dys-1 antibody, directed against the mid rod region of the dystrophin protein, did not react with dystrophin both on Western blot and immunofluorescence. Linkage analysis with polymorphic markers of the dystrophin gene revealed an identical haplotype at the 5' region in all affected individuals (two point lod score of 1.93, $\phi = 0$). A deletion of exons 48, 45–53, 2–7 and 1 including the promoter region of the dystrophin gene, as described in rare cases with similar clinical signs could be excluded by multiplex PCR and Southern blot analyses of this DCM family. In addition, a major splice-mutation of dystrophin mRNA was excluded by RT-PCR of skeletal and heart muscle tissue. Therefore, we conclude that a novel mutation in the 5' region of the dystrophin gene phenotypically leads to this severe form of DCM. Extensive analyses of the dystrophin gene, in particular of the sequences coding for the antigenic determinants of the dys-1 antibody in the mid rod region, may identify the molecular cause of this monogenetic form of DCM.

ACKNOWLEDGMENTS

We thank PD Dr. Schnabel from the Department of Pathology, University of Heidelberg for the contribution of the histology of the endomyocardial biopsy (Fig.

2a). We thank Prof. Dr. Meinck from the Department of Neurology, University of Heidelberg for his support and discussion of the neurological status of the individuals.

REFERENCES

1. BJÖRCK, G. & E. ORINIUS. 1964. Familial cardiomyopathies. *Acta Med. Scand.* **176**: 407-424.
2. CSANADY, M. & K. SZASZ. 1976. Familial cardiomyopathy. *Cardiology* **61**: 122-130.
3. BERKO, B. A. & M. SWIFT. 1987. X-linked dilated cardiomyopathy. *N. Engl. J. Med.* **316**: 1186-1191.
4. CLARK, C. E., W. L. HENRY & S. E. EPSTEIN. 1973. Familial prevalence and genetic transmission of idiopathic hypertrophic subaortic stenosis. *N. Engl. J. Med.* **289**: 709-714.
5. MICHELS, V. V., P. P. MOLL, A. FLETCHER, M. D. MILLER, A. J. TAJIK, J. S. CHU, D. J. DRISCOLL, J. C. BURNETT, R. J. RODEHEFFER, J. H. CHESEBRO & H. D. TAZEL-AAR. 1990. The frequency of familial dilated cardiomyopathy in a series of patients with idiopathic dilated cardiomyopathy. *N. Engl. J. Med.* **326**: 77-82.
6. TANIGAWA, G., J. A. JARCHO, S. KASS, S. D. SOLOMON, H. P. VOSBERG, J. G. SEIDMAN & C. E. SEIDMAN. 1990. A molecular basis for familia hypertrophic cardiomyopathy: an a/b cardiac myosin heavy chain hybrid gene. *Cell* **62**: 991-998.
7. GEISTERFELD-LOWRANCE, A. A. T., S. KASS, G. TANIGAWA, H. P. VOSBERG, W. MCKENNA, C. E. SEIDMAN & J. G. SEIDMAN. 1990. A molecular basis for familial hypertrophic cardiomyopathy: a b cardiac myosin heavy chain gene missense mutation. *Cell* **62**: 999-1006.
8. THIERFELDER, L., H. WATKINS, C. MACRAE, R. LAMAS, W. MCKENNAN, H. P. VOSBERG, J. G. SEIDMAN & C. E. SEIDMAN. 1994. Alpha-tropomyosin and cardiac troponin T mutations cause familial hypertrophic cardiomyopathy: a disease of the sarcomere. *Cell* **77**: 701-712.
9. TOWBIN, J. A., F. HEJTMANCIK, P. BRINK, B. GELB, X. M. ZHU, J. S. CHAMBERLAIN, E. R. B. MCCABE AND M. SWIFT. 1993. X-linked dilated cardiomyopathy: molecular genetic evidence of linkage to the Duchenne muscular dystrophy (dystrophin) gene at the Xp21 locus. *Circulation* **87**: 1854-1865.
10. MUNTONI, F., M. CAU, A. GANAU, R. CONGIU, G. ARVEDI, A. MATEDDU, M. G. MARROSU, C. CIANCHETTI, G. REALDI, A. CAO & M. A. MELIS. 1993. Brief report: deletion of the dystrophin muscle-promoter region associated with X-linked dilated cardiomyopathy. *N. Engl. J. Med.* **329**(13): 921-925.
11. ZEVIANI, M., C. GELLERA, C. ANTOZZI *et al.* 1991. Maternally inherited myopathy and cardiomyopathy: association with mutation in mitochondrial DNA tRNA^{Leu(UUR)}. *Lancet* **338**: 143-147.
12. SUOMALAINEN, A., A. PAETAU, H. LEINONEN, A. MAJANDER, L. PELTONEN & H. SOMER. 1992. Inherited idiopathic dilated cardiomyopathy with multiple deletions of mitochondrial DNA. *Lancet* **340**: 1319-1320.
13. THOMAS, N. S., H. WILLIAMS, L. J. ELSAS, L. C. HOPKINS, M. SARFARAZI & P. S. HARPER. 1986. Localization of the gene for Emery-Dreifuss muscular dystrophy to the distal long arm of the X chromosome. *J. Med. Genet.* **23**: 596-598.
14. LINDLOFF, M., P. SISTONEN & A. DE LA CHAPELLE. 1987. Linked polymorphic DNA markers in the prediction of X-linked muscular dystrophy. *Ann. Hum. Genet.* **51**: 317-328.
15. VOIT, T., O. KROGMANN, H. G. LENHARD, E. NEUEN-JAKOB, W. WECHSLER, H. H. GOEBEL, G. RAHLF, A. LINDINGER & C. NIENABER. 1988. Emery-Dreifuss muscular dystrophy: disease spectrum and differential diagnosis. *Neuropediatrics* **19**: 62-71.
16. HOFFMAN, E. P., R. H. BROWN & L. M. KUNKEL. 1987. Dystrophin: the protein product of the Duchenne muscular dystrophy locus. *Cell* **51**: 919-928.
17. KOENIG, M., A. P. MONACO & L. M. KUNKEL. 1988. The complete sequence of dystrophin predicts a rod shaped cytoskeletal protein. *Cell* **53**: 219-228.

18. PERLOFF, J. K., A. C. DE LEON & D. O'DOHERTY. 1966. The cardiomyopathy of progressive muscular dystrophy. *Circulation* **33**: 625-648.
19. HUNSAKER, R. H., P. K. FULKERSON, F. J. BARRY, R. P. LEWIS, C. V. LEIER & D. V. UNVERFERTH. 1982. Cardiac function in Duchenne's muscular dystrophy. Result of 10-year follow-up study and noninvasive test. *Am. J. Med.* **73**: 235-238.
20. CASAZZA, F., G. BRAMBILLA, A. SALVATO, L. MORANDI, E. GRONDA & E. BONACINA. 1988. Cardiac transplantation in Becker muscular dystrophy. *J. Neurol.* **235**: 496-498.
21. YAZAWA, M., S. IKEDA, M. OWA, S. HARUTA, N. YANAGISAWA, E. TANAKA & M. WATANABE. 1987. A family of Becker's progressive muscular dystrophy with severe cardiomyopathy. *Eur. Neurol.* **29**: 13-19.
22. GOLD, R., W. KRESS, B. MEURERS, G. MENG, H. REICHMANN & C. R. MÜLLER. 1992. Becker muscular dystrophy: detection of unusual disease courses by combined approach to dystrophin analysis. *Muscle & Nerve* **15**: 214-218.
23. BEGGS, A. H., M. KOENIG, F. M. BOYCE & L. M. KUNKEL. 1990. Detection of 98% of DMD/BMD gene deletions by polymerase chain reaction. *Hum. Genet.* **86**: 45-48.
24. MELACINI, P., G. A. DANIELI, G. FASOLI, C. VILLANOVA, C. ANGELINI, L. VITIELLO, M. MIORELLI, G. F. BUJA, M. L. MOSTACCIUOLO, E. PEGORARO & S. DALLA VOLTA. 1993. Cardiac involvement in Becker muscular dystrophy. *JACC* **22**(7): 1927-1934.
25. MUNTONI, F., A. MATEDDU, C. CIANCHETTI *et al.* 1993. Dystrophin analysis using a panel of anti-dystrophin antibodies in Duchenne and Becker muscular dystrophy. *J. Neurol. Neurosurg. Psychiatry* **56**: 26-31.
26. HOFFMAN, E. P., K. FISCHBECK, R. H. BROWN, JR., J. JOHNSON, R. MEDOR, J. D. LOIKE, J. B. HARRIS, R. WATERSTON, M. BROOKE, L. SPECHT, R. KUPSKY, J. CHAMBERLAIN, C. T. CASKEY, F. SHAPIRO & L. M. KUNKEL. 1988. Characterization of dystrophin in muscle-biopsy specimens from patients with Duchenne's or Becker's muscular dystrophy. *N. Engl. J. Med.* **318**: 1363-1368.
27. HOFFMAN, E. P. & L. M. KUNKEL. 1989a. Dystrophin abnormalities in Duchenne/Becker muscular dystrophy. *Neuron* **2**: 1019-1029.
28. HOFFMAN, E. P., L. M. KUNKEL, C. ANGELINI, A. CLARKE, M. JOHNSON & J. B. HARRIS. 1989b. Improved diagnosis of Becker muscular dystrophy by dystrophin testing. *Neurology* **39**: 1011-1017.
29. BULMAN, D. E., E. G. MURPHY, E. E. ZUBRZYCKA-GAARN, R. G. WORTON & P. N. RAY. 1991. Differentiation of Duchenne and Becker muscular dystrophy phenotypes with amino- and carboxy-terminal antisera specific for dystrophin. *Am. J. Hum. Genet.* **48**: 295-304.
30. EMERY, A. E. H., Ed. 1993. Clinical features. *In* Duchenne Muscular Dystrophy. 2nd edit. Vol. 24: 26-41. Oxford Monographs on Medical Genetics. Oxford University Press Inc., New York, NY.
31. GOSPE, S. M., R. P. LAZARO, N. S. LAVA, P. M. GROOTSCHOLTEN, M. O. SCOLT & K. H. FISCHBECK. 1989. Familial X-linked myalgia and cramps: a non progressive myopathy associated with a deletion in the dystrophin gene. *Neurology* **39**: 1277-1280.
32. SAKATA, C., N. SUNOHARA, I. NONAKA, K. ARAHATA & H. SUGITA. 1990. A case of Becker muscular dystrophy presenting cardiac failure as an initial symptom. *Rinsho Shinkeigaku* **30**: 210-213.
33. DUBOWITZ, V., Ed. 1985. *Muscle Biopsy: a Practical Approach*. 2nd edit. Balliere Tindall. London.
34. VOIT, T., P. STUETTGEN, M. CREMER & H. H. GOEBEL. 1991a. Dystrophin as a diagnostic marker in Duchenne and Becker muscular dystrophy. Correlation of immunofluorescence and Western blot. *Neuropediatrics* **22**: 152-162.
35. VOIT, T., K. HAAS, J. O. C. LEGER, F. PONS & J. J. LEGER. 1991b. Rapid communication: Xp21 dystrophin and 6q dystrophin-related protein. *Am. J. Pathol.* **139**(5): 969-976.
36. CHAMBERLAIN, J. S., R. A. GIBBS, J. E. RANIER, P. N. NGUYEN & C. T. CASKEY. 1988. Deletion screening of the Duchenne muscular dystrophy locus via multiplex DNA amplification. *Nucleic Acids Res.* **16**: 11141-11156.

37. KOENIG, M., E. P. HOFFMAN, C. J. BERTELSON, A. P. MONACO, C. FEENER & L. M. KUNKEL. 1987. Complete cloning of the Duchenne muscular dystrophy (DMD) cDNA and preliminary genomic organization of the DMD gene in normal and affected individuals. *Cell* **50**: 509–517.
38. KLAMUT, H. J., S. B. GANGOPADHYAY, R. G. WORTON & P. N. RAY. 1990. Molecular and functional analysis of the muscle-specific promoter region of the Duchenne muscular dystrophy gene. *Mol. Cell. Biol.* **10**: 193–205.
39. FEENER, C. A., F. M. BOYCE & L. M. KUNKEL. 1991. Rapid detection of CA polymorphisms in cloned DNA: application to the 5' region of the dystrophin gene. *Am. J. Hum. Genet.* **48**: 621–627.
40. CLEMENS, P. R., R. G. FENWICK, J. S. CHAMBERLAIN, R. A. GIBBS, M. DE ANDRADE, R. CHAKRABORTY & C. T. CASKEY. 1991. Carrier detection and prenatal diagnosis in Duchenne and Becker muscular dystrophy families, using dinucleotide repeat polymorphisms. *Am. J. Hum. Genet.* **49**: 951–960.
41. OUDET, C., R. HEILIG & J. L. MANDEL. 1990. An informative polymorphism detectable by polymerase chain reaction at the 3' end of the dystrophin gene. *Hum. Genet.* **84**: 283–526.
42. MAO, Y. & M. CREMER. 1989. Detection of Duchenne muscular carriers by dosage analysis using the DMD cDNA clone 8. *Hum. Genet.* **81**: 193–195.
43. VERELLEN-DUNOULIN, C., M. FREUND, K. DE MEYER, C. CATERRE, J. FREDERICK, M. W. THOMPSON, V. O. MARKOVIC & R. G. WARTAN. 1984. Expression of an X-linked muscular dystrophy in a female due to translocation involving Xp21. *Hum. Genet.* **67**: 115–119.
44. KUNKEL, L. M. *et al.* 1985. Analysis of deletions in DNA from patients with Becker and Duchenne muscular dystrophy. *Nature* **322**: 73–77.
45. KOENIG, M., A. H. BEGGS, M. MOYER *et al.* 1989. The molecular basis for Duchenne versus Becker muscular dystrophy. Correlation of severity with type of deletion. *Am. J. Hum. Genet.* **45**: 498–506.
46. FEINBERG, A. P. & B. VOGELSTEIN. 1983. A technique for radiolabeling DNA restriction endonuclease fragments to high specific activity. *Anal. Biochem.* **132**: 6–13.
47. CHURCH, G. M. & W. GILBERT. 1984. Genomic sequencing. *Proc. Natl. Acad. Sci. USA* **81**: 1991–1995.
48. LATHROP, G. M., J. M. LALOUEL, C. JULIER & J. OTT. 1984. Strategies for multilocus linkage analysis in humans. *Proc. Natl. Acad. Sci. USA* **81**: 3443–3446.
49. CHROMCZYNSKI, P. & N. SACCHI. 1987. Single-step method of RNA isolation by acid guanidium thiocyanate-phenol-chloroform extraction. *Analyt. Biochem.* **162**: 156–159.
50. SCHLOESSER, M., R. SLOMSKI, M. WAGNER *et al.* 1990. Characterization of pathological dystrophin transcripts from the lymphocytes of a muscular dystrophy carrier. *Mol. Biol. Med.* **7**: 519–523.
51. RININSLAND, F., A. HAHN, S. NIEMANN-SEYDE, R. SLOMSKI, F. HANEFELD & J. REISS. 1992. Identification of a new DMD gene deletion by ectopic transcript analysis. *J. Med. Genet.* **29**: 647–651.
52. THOMPSON, M. W., P. N. RAY, B. BELFALL, C. DUFF, I. OSS & R. G. WORTON. 1986. Linkage analysis of polymorphisms within the DNA fragment XJ cloned from the breakpoint of an X;21 translocation associated with X-linked muscular dystrophy. *J. Med. Genet.* **23**: 548–558.
53. RAY, P. N., B. BELFALL, C. DUFF, C. LOGAN, V. KEAN, M. W. THOMPSON, J. E. SYLVESTER, J. L. GORSKI, R. D. SCHMICKEL & R. G. WORTON. 1985. Cloning of the breakpoint of an X;21 translocation associated with Duchenne muscular dystrophy. *Nature* **318**: 672–675.
54. PERLOFF, J. K., W. C. ROBERTS, A. C. DE LEON & D. O'DOHERTY. 1967. The distinctive electrocardiogram of Duchenne's progressive muscular dystrophy. *Am. J. Med.* **42**: 179–188.
55. EMERY, A. E. H. & F. E. DREIFUSS. 1966. Unusual type of benign X-linked muscular dystrophy. *J. Neurol. Neurosurg. Psychiatry* **29**: 338–342.

56. MARKAND, O. N., R. R. NORTH, A. N. D'AGOSTINO & D. D. DALY. 1969. Benign sex-linked muscular dystrophy. *Neurology* **19**: 617-633.
57. RINGEL, S. P., J. E. CAROLL & S. C. SCHOLD. 1977. The spectrum of mild X-linked recessive muscular dystrophy. *Arch. Neurol.* **34**: 408-416.
58. KUHN, E., W. FIEHNI, J. M. SCHROEDER, H. ASSMUSS & A. WAGNER. 1979. Early myocardial disease and cramping myalgia in Becker type muscular dystrophy: a kindred. *Neurology* **29**: 1144-1149.
59. DE VISSIER, M., W. DE VOOGT & G. V. RIVIERE. 1992. The heart in Becker muscular dystrophy, fascioscapulohumeral dystrophy, and Bethlem myopathy. *Muscle Nerve* **15**: 591-596.
60. LAZZARONI, E., L. FAVARO & G. BOTTI. 1989. Dilated cardiomyopathy with regional myocardial hypoperfusion in Becker's muscular dystrophy. *Int. J. Cardiol.* **22**: 126-129.
61. SAKATA, C., H. YAMADA, N. SUNOHARA, K. ARAHATA & I. NANAKA. 1990. Cardiomyopathy in Becker muscular dystrophy. *Rinsho Shinkeigaku* **30**: 952-955.
62. BERGEAT, A., J. J. GOY & U. SIGWART. 1987. Acute pulmonary edema as the inaugural symptom of Becker's muscular dystrophy in a 19-year old patient. *Clin. Cardiol.* **10**: 127-129.
63. VRINTS, C., R. MERCELIS, E. VANAGT, J. SNOEK & J. J. MARTIN. 1983. Cardiac manifestation of Becker-type muscular dystrophy. *Acta Cardiol.* **385**: 479-486.
64. HASSAN, Z., C. P. FASTABEND, P. K. MOHANTY & E. R. ISAACS. 1979. Atrioventricular block and supraventricular arrhythmias with X-linked muscular dystrophy. *Circulation* **46**: 1365-1369.
65. DONOFRIO, P. D., V. R. CHALLA, B. T. HACKSHAW, S. A. MILLS & R. CORTELL. 1989. Cardiac transplant in a patient with muscular dystrophy and cardiomyopathy. *Arch. Neurol.* **46**: 705-707.
66. ENGLAND, S. B., L. V. NICHOLSON, M. A. JOHNSON, S. M. FORREST, D. R. LOVE, E. E. ZUBRYCKA-GAARN, D. E. BULMAN, J. B. HARRIS & K. E. DAVIES. 1990. Very mild muscular dystrophy associated with the deletion of 46% of dystrophin. *Nature* **343**: 180-182.
67. AHN, A. H. & L. M. KUNKEL. 1993. The structural and functional diversity of dystrophin. *Nature Genet.* **3**: 283-291.

***In Vivo* Definition of a Cardiac Specific Promoter and Its Potential Utility in Remodeling the Heart**

JEFFREY ROBBINS, JOSEPH PALERMO, AND
HANSJÖRG RINDT

*Children's Hospital Research Foundation
Department of Pediatrics
Division of Molecular Cardiovascular Biology
Cincinnati, Ohio 45229-3039*

INTRODUCTION

It has become apparent in the last fifteen years that the diversity of the different muscle types has its basis, at least in part, on the multitude of muscle type specific isoforms. This diversity rests upon a number of regulatory paradigms, the most common being multimembered gene families, as is seen for the myosins,¹ or alternative splicing of a primary transcript (*e.g.*, the tropomyosins).² Sometimes, a combination of these events is used to generate isoform diversity as illustrated by the myosin light chains.³ Numerous studies carried out at the cellular level during development have uncovered complex levels of control which result in well defined patterns of muscle protein isoform accumulation in the different muscle fiber types. Each muscle type is able to display a unique and characteristic profile of those proteins which underlies its functional role in the physiology of the animal.

The functional consequences of differential contractile protein isoform expression is implied by the presence of the unique isoforms, and elegant biochemical studies have been brought to bear upon the functional consequences of isoform diversity. For example, there is a large body of biochemical evidence that the speed of contraction is dependent upon the particular myosin heavy chain (MyHC) isoform that is expressed⁴⁻⁶ and, in the heart, isoform shifts are correlated with and may play a role in the heart's functional adaptation to chronic overload.⁷

Complementing the functional studies are extensive molecular data which delineate the differences between the sequences of the contractile protein isoforms. Biochemical data also demonstrate that the different isoforms can display differential activities *in vitro*. However, an *in vivo* demonstration of the functional consequences of a particular (contractile protein's) isoform switch is lacking. These switches can be induced by pleiotropic effectors such as hormonal intervention⁸ or surgically induced cardiac⁹ or systemic pressure overload. Our ability to separate the observed changes from the secondary or even other primary effects that occur in response to the global physiological changes that take place is limited.

Transgenic intervention allows one to manipulate the mammal's genetic apparatus directly, by inducing a transgene's expression while leaving the endogenous

genetic apparatus largely intact (except at the site where the transgene inserts¹⁰). By expressing an appropriate cDNA in the cardiac compartment, one can theoretically remodel the myocardium in a defined manner, and subsequently can monitor the secondary compensatory effects that occur in response to a primary genetic change. Alternatively, one can express a mutant form of the cDNA which encodes a nonfunctional protein, and create a "dominant negative" effect. One could also use the transgenic approach to ectopically overexpress a protein¹¹ or an alternative isoform in the heart in order to study isoform functionality in the context of the whole animal or organ.

A prerequisite for these kinds of studies if they are to be applied to the heart, is an understanding of the functional transcriptional sequences that are able to effect high levels of cardiac specific expression. In the last four years, we have attempted to develop suitable promoter constructs that can be used to drive expression of transgenes in the heart at levels that approach or even surpass those found for the endogenous species. We have therefore focused on the MyHC promoters as in the heart they drive transcription of the genes that encode, by mass, a highly abundant protein.

The Myosin Heavy Chains

In mammals, two MyHCs are expressed in the cardiac compartment during development and differentiation. The type of isoform present varies depending upon the particular animal, the cardiac chamber and the developmental period.¹² Additionally, the proportions may be shifted or the isoform expression patterns changed by various natural or induced physiological stimuli. As a first step in defining the transcriptional machinery which mediates the expression of these genes, we isolated and characterized the two myosin heavy chain genes that are expressed in the mouse heart.¹³ As is the case for other mammals, the two genes are closely linked (FIG. 1). Because of this linkage, the upstream boundary of the α MyHC is easily defined. Sequence analysis of this region indicated the presence of numerous potential regulatory sites which were defined based upon their homologies to other sequences that had been shown to play a role in the transcriptional regulation of muscle specific genes. Transcript specific probes were prepared and used to determine the transcriptional patterns in both the atrium and ventricle during development.¹⁴ These data are summarized in FIGURE 2. The atrium, at all stages at which it can be defined, contains >95% of the α -gene encoded product. In contrast to this, the ventricle undergoes a striking gene switch during late fetal development; the β MyHC gene is downregulated with the concomitant upregulation of α MyHC gene transcription. This pattern is maintained throughout adulthood, but the fetal pattern can be recapitulated by the induction of hypothyroidism.¹⁵ Thus, the two MyHC genes are regulated at the transcriptional level in response to a wide variety of developmental, hormonal and other physiological cues.¹⁶⁻¹⁸

Transgenic Analysis of the Myosin Promoter

Particularly striking was the presence, in the ~600 bp upstream of the gene's transcriptional start site, of at least seven highly conserved sequences found in

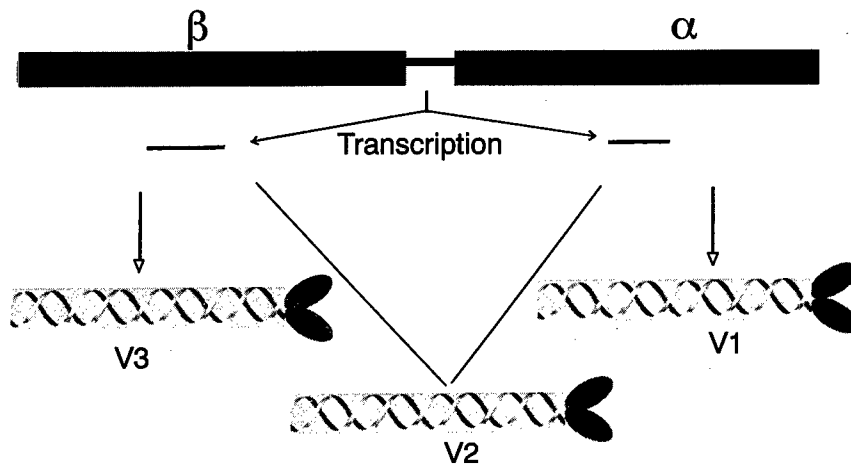
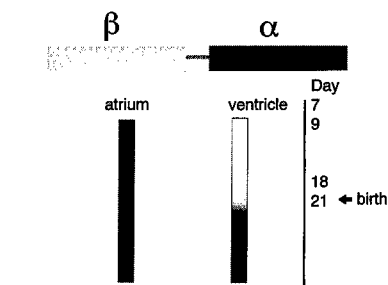

FIGURE 1. The mammalian cardiac myosin heavy chain locus. For all mammalian species for which the locus has been defined the organization is identical, with each gene producing a unique transcript. The β MyHC encodes the so-called V3 isoform, named because of its mobility on nondenaturing acrylamide gels. This isoform, which is also present in slow twitch, oxidative muscle has an intrinsically lower ATPase activity than the V1 isoform, which is encoded by the α gene. The two genes are closely linked, being separated by $\sim 4,500$ bp of sequence. The heterodimer, V2, has an ATPase activity that is intermediate between V1 and V3.

FIGURE 2. Cardiac gene transcription during mouse development. Shown in schematic form are the cardiac transcriptional patterns for the MyHC genes in the mouse heart. Unlike the larger rodents, the adult mouse ventricle contains, essentially, only the V1 isoform and beats at a rate of approximately 700 bpm (the actual rate varies between 600–750 and is strain dependent).



the cardiac MyHC genes characterized from other species. This region, shown in FIGURE 3, includes motifs that bind the GATA protein (GATTA),¹⁹ the myocyte enhancing factors 1 and 2 (MEF-1, MEF-2),^{20,21} a CArG box,²² a thyroid response element²³ and a site adjacent to it that functions in mediating thyroid hormone's effects²⁴ which we formally called TRE₂²⁵ and now refer to as "TH."

A construct, termed α -5.5 was made by linking the intergenic region to the reporter gene (*cat*) which encodes the enzyme chloramphenicol acetyl transferase (CAT). The DNA was then used to generate a series of transgenic mice. Detailed analyses showed that the intergenic region was sufficient to drive high levels of CAT in a tissue- and developmental stage-specific manner.²⁶ A limited series of deletion mutants was made in order to define the spatial limits of the gene's functional promoter: the data are summarized in FIGURE 4. The 2000 bp proximal to the start site of transcription is sufficient to drive relatively high levels of CAT in a cardiac specific manner. However, the proximal 130 bp, which contains some of the sites previously defined as playing critical roles in the gene's expression on the basis of *in vitro* transient transfection assays, is relatively inefficient at directing high levels of *cat* expression in the mouse heart.

As noted above, thyroid hormone is an efficient modulator of cardiac MyHC gene transcription and is able to essentially turn off α MyHC transcription. The effects are mediated, at least in part, via the *cis-trans* interactions that occur at the so called thyroid responsive element (TRE) which consists of the canonical sequence AGGTGA. Although α -1.3 was unable to drive high levels of *cat* expression, it was still possible that sites in the vicinity of this region played an important role within the context of the larger promoter. To study this, site directed mutations of the TRE and TH were made singly, and in combination, within the context of the entire intergenic region. Each construct was then used to generate multiple lines of transgenic mice. Subsequently, the patterns of reporter gene transcription were determined in the ventricles of the different lines under euthyroid conditions (FIG. 5). The data show that both elements are important for maintaining high levels of expression in the ventricle, although neither suffices. A mutation in the TRE as well as in TH significantly affects CAT levels in the ventricle. Surprisingly, the mutation in the TH appears to affect expression more negatively than ablation of the TRE element, which is able to bind the thyroid hormone-receptor complex. However, the double mutation is unable to drive expression, even when an increased amount of protein extract is used and the time of the assay is increased to 2 hours (FIG. 5). Quantitative determination of the CAT levels using an ELISA showed that the effect is additive, with the double mutation having a significantly lower level of expression than either of the single changes (data not shown). These results demonstrate that suitable promoter constructs are able to drive transgene expression in the heart. Using defined mutations we are also able to modulate its response to circulating levels of thyroid hormone.

The Myosin Light Chains and Their Role in Striated Muscle

The myosin light chains (MLC), classified as either alkali (MLC1, MLC3), or regulatory (MLC2), are members of the calcium binding protein family. Based

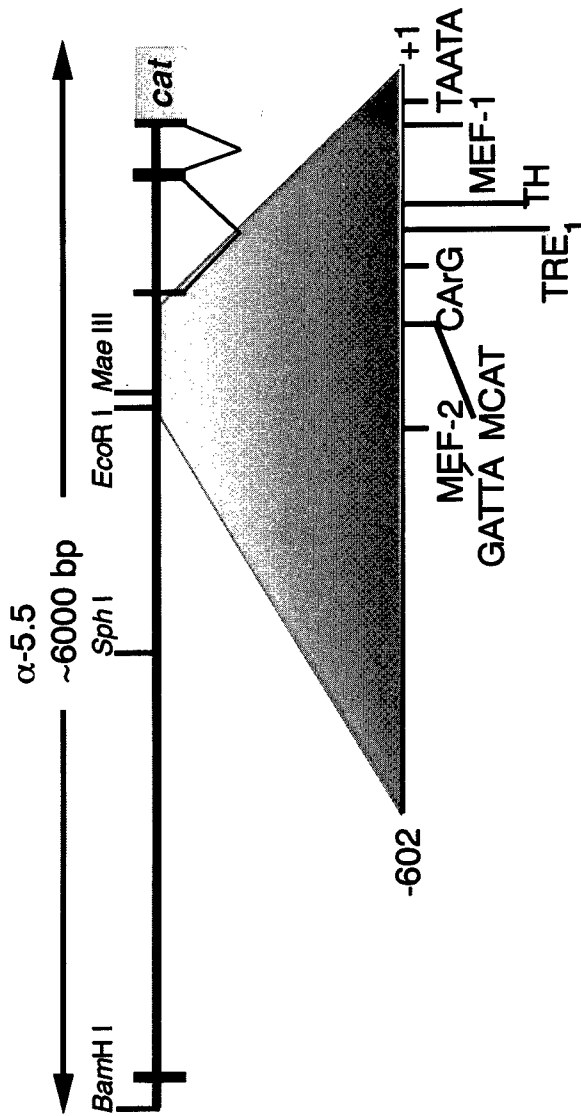

α -5.5 CTTGGGCCC TGCTGTCCCTCCTGTCACCCCTCCAGAGCCAAAGGGATCAAAAGGAGGAGGAGCCAGGACAGGAG
TRE⁻¹ CTTGGGCCCCTGC GTAGTGATCGATTGACAAAGCTGCCAAGGGATCAAAAGGAGGAGGAGCCAGGACAGGAG
TH CTTGGGCCCCTGC **TGTCCTCCTGTCACCCCTCCAGAGCCAAAGGGATACCCCTTCTTCTTAACGGACTGGAG**

FIGURE 3. Organization of the α MyHC gene's proximal upstream region. Shown is the entire intergenic region; the β MyHC sequences are located 5' of the *Bam*H I site except for the last exon (*filled box*), which encodes the 3' untranslated region (UTR). All of the transgenic constructs include the exon-intron structure that encodes the 5' UTR of the α MyHC primary transcript. The splicing events which generate the 5' UTR are shown by the *diagonal lines* linking the exons. Also shown are the relative locations of the putative regulatory regions as well as the sequences of the wild type TRE and TH elements (*bolded*). The subsequent mutations (see text) are also indicated in *bold text*.

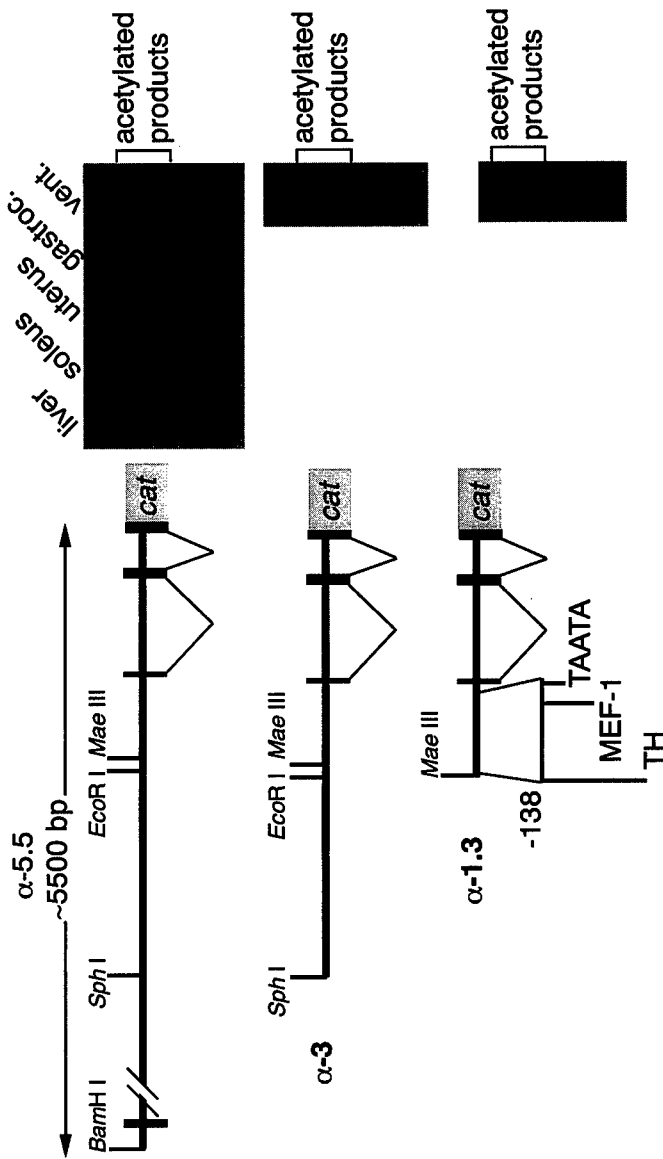

FIGURE 4. Deletion analysis of the α MyHC promoter. Restriction endonuclease digestion was used to create two deletions from the 5' end of the intergenic region. These were linked to *cat* and the constructs used to generate transgenic mice. Tissues were prepared from adult, euthyroid animals as indicated and the CAT activity measured using ^{14}C chloramphenicol and thin layer chromatography using standard methods.^{25,26} Reactions were carried out for 60 minutes using 10 μg of protein extract.

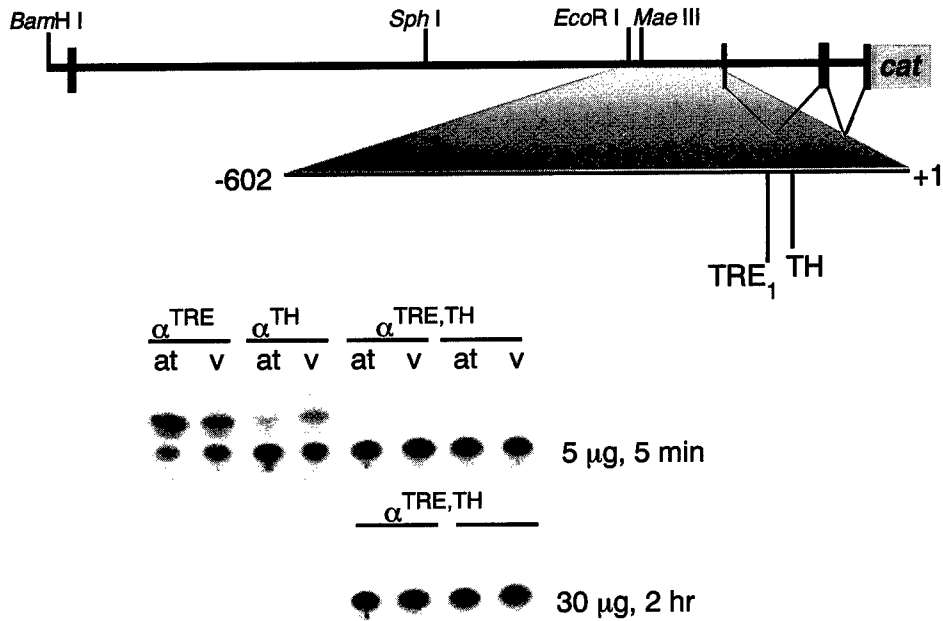

FIGURE 5. Mutation of defined elements in the α MyHC promoter. Transgenic mice were generated using either the TRE-mutated (TRE), TH-mutated (TH) or doubly mutated (TRE, TH) constructs. For the double mutation two separate lines are shown. Ventricles were collected and extracts for measuring CAT activity were prepared. The reactions were performed and analyzed by thin layer chromatography. The amount of extract and the duration of each assay is indicated.

on homology to an ancestral calcium binding domain, the family also includes calmodulin, parvalbumin and troponin C.²⁷ Sarcomeric myosin consists of a pair of 200-kDa MyHCs each of which has an alkali and regulatory light chain closely associated with the extended α -helix at the S1 hinge region (FIG. 6).^{28,29} Depending

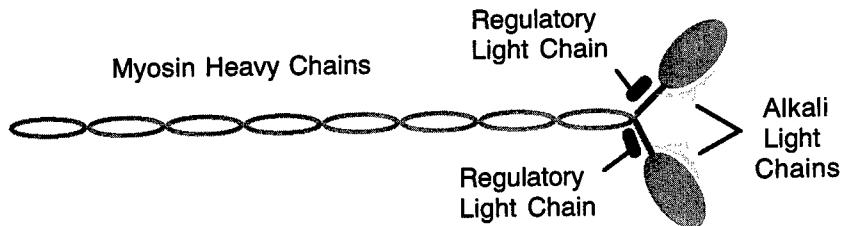

FIGURE 6. Schematic diagram of sarcomeric myosin. Antibody localization of the light chains to the hinge region of MyHC has been confirmed by X-ray crystallography of the S1 fragment of myosin,^{28,29} which shows that the light chains are wrapped around the extended α helix as it emerges from the globular head region of the MyHC.

on the particular isoform, the MLC range in size from 17–22 kDa, and their position suggests that they may function in stabilizing the hinge region; they may also aid in the power stroke of the myosin head. Recently it was shown that MyHC devoid of MLC maintains a normal ATPase activity when studied by *in vitro* motility assays, but shows a significant decrease in the velocity of sliding actin filaments. This difference can be partially restored with the addition of either MLC moiety, and reaches normal levels when both light chains are added.³⁰ However, the precise role of the light chains in the conversion of chemical energy into contractile force is still unclear.

As is the case for numerous other sarcomeric proteins, MLCs are represented by multiple isoforms expressed in specific spatial and developmental patterns which may be altered by physiologic or pathologic changes.³¹ The role of smooth muscle MLC2 in the initiation of smooth muscle contraction has shown the importance of light chain phosphorylation via the calcium/calmodulin dependent MLC specific kinase.³² However, in striated muscle the phosphorylation of MLC2 is not required for contraction and has little if any effect on actin-activated ATPase activity. In the heart, phosphorylation occurs too slowly to account for the beat-to-beat regulation of contraction. Over the last ten years, studies in intact muscle, single fibers and skinned fibers have shown that the phosphorylation of MLC2 may be important in modulating the sensitivity of the sarcomere to activation by calcium.^{33,34} While most of the data have been collected using fast twitch skeletal muscle preparations, cardiac muscle also shows a correlation between phosphorylation and increased calcium sensitivity in skinned fiber preparations as seen by a leftward shift in the force-pCa curve.³⁵ Moreover, in whole animal studies, the phosphorylation of MLC2 appears to be heart rate dependent³⁶ and is correlated with increased left ventricular pressure development during both exercise and subsequent recovery.³⁷

Initiating an in Vivo Study of MLC2

Additional observations regarding isoform switches^{38,39} and changes in MLC stoichiometry⁴⁰ during disease raises questions concerning structure/function relationships of the various MLC2 isoforms within the whole organ/animal that have not yet been addressed. The role of the regulatory MLC in the development and maintenance of sarcomeric structure *in vivo* is still unclear. As a model for studying MLC2 *in vivo*, we have utilized the α -5.5^{13,26} and α -5.5/MEF-muta⁴¹ promoters to overexpress the ventricular MLC2 isoform (MLC2v) in the heart. As an initial step, we isolated a cDNA clone from an adult mouse cardiac library that encodes the entire mouse MLC2v. The cDNA differs slightly from previously published reports,⁴² as shown in FIGURE 7. Three constructs were made using the MLC2v cDNA and the α -MyHC gene promoter (FIG. 8). Two types of sense constructs were made. The first type (MLC2v-poly A) contained the endogenous polyadenylation signal as well as a Poly A tract. This construct was driven by the α -5.5 wild type promoter. The second construct (MLC2v-sense) utilized the α -5.5 MEF-muta promoter and used the human growth hormone (hGH) polyadenylation signal. The final construct used the α -5.5 MEF-muta promoter to drive the expression of the

Mouse 2v:	MAPKKAKKRIEGGT <u>S</u> NVFSMFEEQTQIQEFKEAFTMDQNRDGFIDKNDLRDTFAAL
Rat 2v:	- S - - - - -
*Mouse 2v:	- A - LF - - - - -
Mouse 2v:	GRVNVKNEEIDEMIKEAPGPINFTVFLTMFGEKCLKGADPEETILNAFKVFDPEGKG
Rat 2v:	- - - - -
*Mouse 2v:	- - - - -
Mouse 2v:	SLKADYVREMLTTQAERFSKEEIDQMFAAFPDPVTGNLDYKNLVHIITHGEED
Rat 2v:	- - - - -
*Mouse 2v:	- - - - -

FIGURE 7. MLC2v sequence. Shown is a comparison of the amino acid sequence of the cDNA clone MLC2v with the (previously published) mouse (*Mouse 2v)⁴² and rat (Rat 2v)⁴⁴ sequences. The MLC2v clone was isolated from a λ gt11 mouse cardiac cDNA library. The resulting sequence for MLC2v differs from the rat sequence by a single residue (alanine to serine). The phosphorylated serine is *underlined*.

MLC2v-polyA

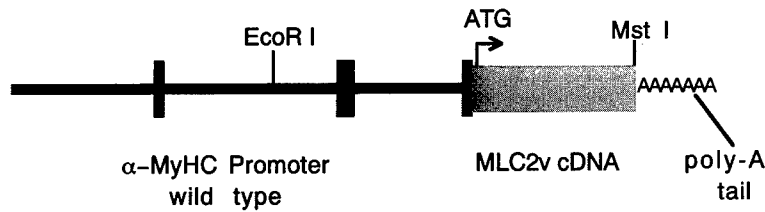

MLC2v-sense-hGH

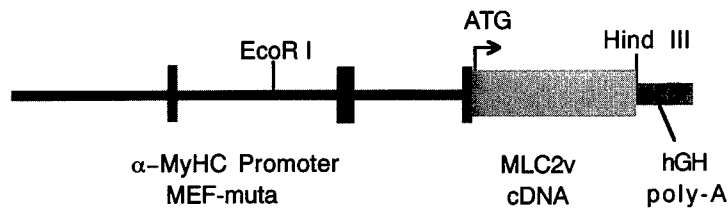

MLC2v-antisense-hGH

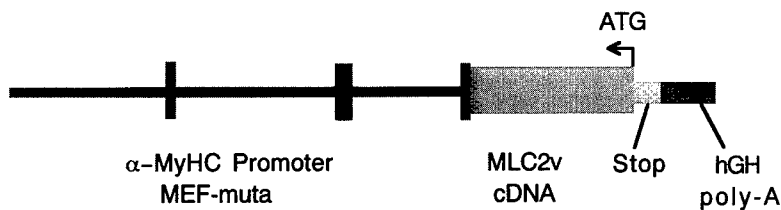

FIGURE 8. Constructs used for the generation of transgenic mice. Three constructs were made for the overexpression studies. The first construct, MLC2v-poly A, is driven by the wild type α -5.5 MyHC promoter^{13,26} and contains the full-length MLC2v cDNA, including a 70-base poly-A tail at its 3' end. The promoter includes the exon (*boxes*)-intron structure that generates the 5' UTR of the α MyHC transcript, and is joined to the MLC2v cDNA by a *Sal I/Nco I* linker containing the endogenous MLC2v Kozak consensus sequence⁴⁵ and translational start site. The next pair of constructs utilize an overexpression vector with a more potent form of the α -5.5 MyHC promoter in which the MEF-2 binding site was mutated. This promoter is three to five times stronger than the wild type when linked to *cat*.⁴¹ This vector also contains the human growth hormone polyadenylation signal preceded by a "stuffer fragment" with stop codons in all three reading frames. The MLC2v-sense-hGH construct was derived from the MLC2v-polyA construct as shown. The MLC2v-antisense-hGH construct was derived from a parental cDNA subclone and was inserted in front of the 3-stop stuffer fragment to prevent transcriptional run-on.

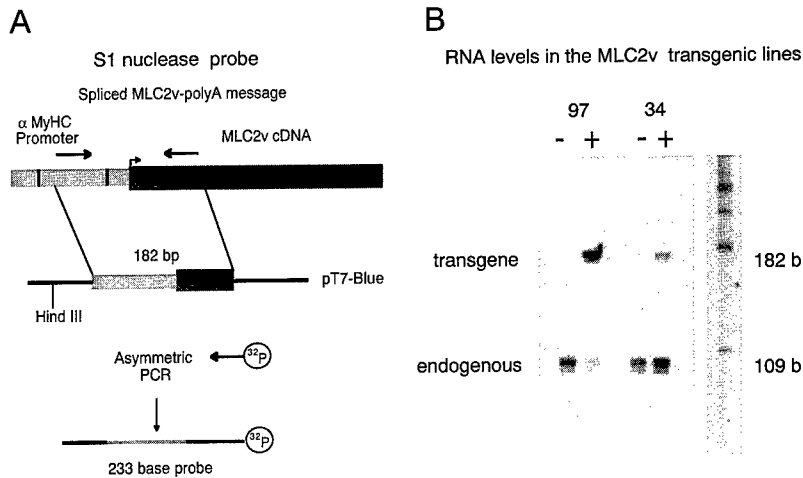

FIGURE 9. (A) S1 nuclease protection assay. S1 protection assays were used to differentiate the transgenic transcript from the endogenous MLC2v mRNA. A 182-bp fragment, spanning the junction between the α -MyHC promoter and the MLC2v cDNA was made using PCR. This fragment was then subcloned into the pT7-blue PCR cloning vector and sequenced to confirm its fidelity. The pT7-blue clone was linearized at the *Hind* III site, 51 bp from the cloning site, and used as a template for asymmetric PCR with a ^{32}P labeled oligonucleotide that was homologous to the 3' end of the insert. Differential protection from S1 digestion distinguishes the transgenic transcript which protects 182 b of the probe, from the endogenous mRNA, with which only 109 b are protected. (B) Representative S1 protection assay. Two lines of the MLC2v-poly A mice were analyzed by S1 protection to determine the level of transgene expression in the cardiac compartment. For each line, total heart RNA was isolated from a transgenic and a nontransgenic littermate, hybridized with the 233 b end-labeled probe and subjected to digestion with S1 nuclease. The results show that line 97 has the highest level of transgene expression.

MLC2v cDNA in the antisense orientation. These constructs were confirmed by sequencing and the DNA was used to generate multiple lines of transgenic mice. Subsequently, transgenic lines were analyzed by S1 nuclease protection assays to determine the level of transgene expression in the heart. Since the isoform being overexpressed is endogenous to the ventricle, it was necessary, for the sense constructs, to develop a probe that spans the junction between the promoter and the cDNA in order to differentiate the endogenous from the transgenic messages (FIG. 9A). Initial analysis of four lines generated from the MLC2v-poly A construct showed line 97 had a high level of transgene expression, and this was confirmed by Northern analysis of total heart RNA (FIG. 10). Western blot analysis using MLC2v specific polyclonal antibodies (a generous gift from K. Chien, University of California at San Diego) confirmed that the transgene's transcription results in an increase in MLC2v protein in the atrium (data not shown). Of three lines analyzed from the MLC2v-sense construct, one line also had high levels of transgenic message and an increase in MLC2v protein. The three lines generated with the antisense construct had no detectable transgenic message when analyzed via S1

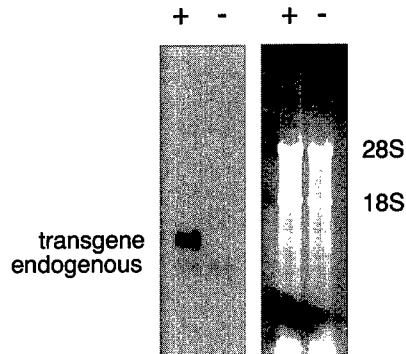

FIGURE 10. RNA levels in the MLC2v transgenic line: Northern blot analysis of line 97. Total heart RNA from a line 97 heart and a nontransgenic control were size fractionated on a methyl mercury agarose gel and transferred to ABM paper following the procedure of the manufacturer (Schleicher and Schuell). The blot was then probed with a random primed 300-bp cDNA fragment corresponding to the 3' end of the MLC2v mRNA using standard hybridization conditions.

nuclear digestion, and Western blot analysis confirmed no change in protein levels relative to controls (data not shown).

CONCLUSION

These preliminary results suggest that it will be possible to overexpress an exogenous MLC2 isoform without poisoning the sarcomeres of the myocardium. In these initial experiments, we expressed the endogenous isoform already present in the ventricle, in order to determine if stoichiometric effects must be considered. However, our promoters also drive expression in the atrium, and we are presently analyzing this compartment for the transgene's expression in order to determine if the transition from MLC2A to MLC2v/2A has any physiologic significance on muscle strip contractility or calcium sensitivity. The development of this transgenic approach in remodeling the isoform content in the different cardiac compartments, coupled with the ability to measure subtle changes in myocardial physiology,⁴³ will allow for a detailed and systematic structural study of the MLC2 family as well as providing the means for determining the role of MLC2 in both the normal and diseased heart under various physiologic conditions.

REFERENCES

1. ROBBINS, J., T. HORAN, J. GULICK & K. KROPP. 1986. *J. Biol. Chem.* **251**: 6606–6612.
2. NADAL-GINARD, B., C. W. SMITH, J. G. PATTON & R. E. BREITBART. 1991. *Adv. Enzyme Regul.* **31**: 261–286.
3. NABESHIMA, Y., Y. FUJII-KURIYAMA, M. MURAMATSU & K. OGATA. 1984. *Nature* **308**: 333–338.

4. SCHWARTZ, K., Y. LECARPENTER, J. L. MARTIN, A. M. LOMPRES, J. J. MERCADIER & B. SWYNGHEDAUW. 1981. *J. Mol. Cell. Cardiol.* **13**: 1071-1075.
5. EBRECHT, G., H. RUP & R. JACOB. 1982. *Basic Res. Cardiol.* **77**: 220-234.
6. PAGANI, E. D. & F. J. JULIAN. 1984. *Circ. Res.* **54**: 586-594.
7. ALPERT, N. R. & L. MULIERI. 1984. *Hypertension* **6**: 50-57.
8. MORRIS, E. 1993. *Circulation* **87**: 1451-1460.
9. CHASSAGNE, C., C. WISNEWSKY & K. SCHWARTZ. 1993. *Circ. Res.* **72**: 857-864.
10. GRIDLEY, T. 1991. *New Biol.* **3**: 1025-1034.
11. MINER, J. H., J. B. MILLER & B. J. WOLD. 1992. *Development* **114**: 853-850.
12. SWYNGHEDAUW, B. 1986. *Physiol. Rev.* **66**: 710-771.
13. GULICK, J., A. SUBRAMANIAM, J. NEUMANN & J. ROBBINS. 1991. *J. Biol. Chem.* **266**: 9180-9185.
14. NG, W. A., I. L. GRUPP, A. SUBRAMANIAM & J. ROBBINS. 1991. *Circ. Res.* **68**: 1742-1750.
15. IZUMO, S., B. NADAL-GINARD & V. MAHDAVI. 1986. *Science* **231**: 597-600.
16. LOMPRES, A.-M., B. NADAL-GINARD & V. MAHDAVI. 1984. *J. Biol. Chem.* **259**: 6437-6446.
17. LYONS, G. E., S. SCHIAFFINO, D. SASSOON, P. BARTON & M. BUCKINGHAM. 1990. *J. Cell Biol.* **111**: 2427-2436.
18. LOMPRES, A.-M., J. J. MERCADIER, C. WISNEWSKY, P. BOUVERET, C. PANTALONI, A. D'ALBIS & K. SCHWARTZ. 1981. *Dev. Biol.* **84**: 286-290.
19. KO, L. J. & D. ENGEL. 1993. *Mol. Cell. Biol.* **13**: 4011-4022.
20. BUSKIN, J. N. & S. D. HAUSCHKA. 1989. *Mol. Cell. Biol.* **9**: 2627-2640.
21. GOSSETT, L. A., D. J. KELVIN, T. A. STERNBERG & E. N. OLSON. 1989. *Mol. Cell. Biol.* **9**: 5022-5033.
22. MINTY, A. & L. KEDES. 1986. *Mol. Cell. Biol.* **6**: 2125-2136.
23. MAHDAVI, V., G. KOREN, S. MICHAUD, C. PINSET & S. IZUMO. 1989. *UCLA Symp. Mol. Cell. Biol.* **93**: 369-379.
24. FLINK, I. & E. MORRIS. 1990. *J. Biol. Chem.* **265**: 11233-11237.
25. SUBRAMANIAM, A., J. GULICK, J. NEUMANN, S. KNOTTS & J. ROBBINS. 1993. *J. Biol. Chem.* **268**: 4331-4336.
26. SUBRAMANIAM, A., W. K. JONES, J. GULICK, S. WERT, J. NEUMANN & J. ROBBINS. 1991. *J. Biol. Chem.* **266**: 24613-24620.
27. COLLINS, J. H. 1991. *Hum. Mol. Genet.* **1**: 727-733.
28. RAYMENT, I., R. WOJCIK, K. SCHMIDT-BASE, R. SMITH, D. R. TOMCHICK, M. M. BENNING, D. A. WINKELMANN, G. WESENBERG & H. M. HOLDEN. 1993. *Science* **261**: 50-58.
29. XIE, X., D. H. HARRISON, I. SCHLICHTING, R. M. SWEET, V. N. KALABOKIS, A. G. SZENT-GYORGY & C. COHEN. 1994. *Nature* **368**: 306-312.
30. LOWEY, S., G. S. WALLER & K. M. TRYBUS. 1993. *Nature* **365**: 454-456.
31. PETTE, D. & R. S. STARON. 1990. *Rev. Physiol. Biochem. Pharmacol.* **116**: 1-76.
32. HARTSHORNE, D. J. 1987. *Biochemistry of the contractile process in smooth muscle. In Physiology of the Gastrointestinal Tract.* 2nd edit. L. R. Johnson, Ed. 423-482. Raven Press. New York.
33. MOORE, R. L., T. I. MUSCH & J. Y. CHEUNG. 1991. *Med. Sci. Sports Exercise* **23**: 1163-1169.
34. SWEENEY, H. L., B. F. BOWMAN & J. T. STULL. 1993. *Am. J. Physiol.* **264**: C1085-C1095.
35. SWEENEY, H. L. & J. T. STULL. 1986. *Am. J. Physiol.* **250**: C657-C660.
36. FITZSIMONS, D. P., P. W. BODELL & K. M. BALDWIN. 1989. *J. Appl. Physiol.* **67**: 2447-2453.
37. FITZSIMONS, D. P., P. W. BODELL, R. E. HERRICK & K. M. BALDWIN. 1990. *J. Appl. Physiol.* **69**: 313-320.
38. CUMMINS, P. 1982. *Biochem. J.* **205**: 195-204.
39. SHI, Q., U. DANILCZYK, J. WANG, Y. P. SEE, W. G. WILLIAMS, G. A. TRUSLER, R. BEAULIEU, V. ROSE & G. JACKOWSKI. 1991. *Circ. Res.* **69**: 1601-1607.

40. MARGOSSIAN, S. S., H. D. WHITE, J. B. CAUFIELD, P. NORTON, S. TAYLOR & H. S. SLAYTER. 1992. *Circulation* **85**: 1720-1733.
41. ADOLPH, E. A., A. SUBRAMANIAM, P. CSERJESI, E. N. OLSON & J. ROBBINS. 1993. *J. Biol. Chem.* **268**: 5349-5352.
42. LEE, K. J., R. S. ROSS, H. A. ROCKMAN, A. N. HARRIS, T. X. O'BRIEN, M. VAN BLISEN, H. E. SHUBEITA, R. KANDOLF, G. BREM, J. PRICE, S. M. EVAANS, H. ZHU, W-M. FRANZ & K. R. CHIEN. 1992. *J. Biol. Chem.* **267**: 15875-15885.
43. GRUPP, I. L., A. SUBRAMANIAM, T. E. HEWETT, J. ROBBINS & G. GRUPP. 1993. *Am. J. Physiol.* **265**: H1401-H1410.
44. HENDERSON, S. A., M. SPENCER, A. SEN, C. KUMAR, M. A. Q. SIDDIQUI & K. R. CHIEN. 1989. *J. Biol. Chem.* **264**: 18142-18148.
45. KOZAC, M. 1991. *J. Biol. Chem.* **266**: 19867-19870.

Retroviral Targeting of FGF and FGFR in Cardiomyocytes and Coronary Vascular Cells during Heart Development^a

TAKASHI MIKAWA

*Department of Cell Biology and Anatomy
Cornell University Medical College
New York, New York 10021*

INTRODUCTION

Establishment of the myocardial wall is characterized by successive developmental events: 1) determination of mesodermal cells to the cardiac lineage, 2) formation of the tubular heart, 3) thickening of the wall due to both proliferation and hypertrophy of the functioning myocytes, and 4) formation of coronary vessels. Although our retroviral cell lineage studies have revealed the basic plan to establish the myocardial wall^{1,2} and coronary vasculature,³ neither the mitogen(s) regulating proliferation of embryonic myocytes nor the molecular signals defining the pattern of the coronary vascularization are well understood. This review summarizes recent work in this laboratory addressing the roles of FGF-signaling during formation of the myocardial wall and coronary vessels. Precursor cells of either myocytes or the coronary vasculature of chicken embryos were selectively targeted with replication-defective retroviruses encoding either FGF or the FGFR; the effects of altered FGF-signaling were examined at various stages of development after infection. Our data have demonstrated that 1) myocyte proliferation is directly regulated by receptor-coupled FGF-signaling during the first week of development, while later myocyte proliferation becomes FGF-independent, and 2) FGF-signaling is one of the components crucial for establishment of the myocardial wall and coronary vessels.

Retroviral Cell Tagging to Study Region-Specific Myocyte Growth in Embryonic Heart

In chicken, cardiogenic mesodermal cells lateral to Hensen's node^{4,5} become committed to myocyte lineage at HH-stages 4–6⁶ and begin to express genes necessary for muscle contraction at HH-stages 7–10.^{7–9} Fusion of the bilateral myogenic primordia forms a beating tubular heart by HH stage 10. These differentiated and beating cardiomyocytes, unlike skeletal muscle, continue to proliferate until

^a This work was supported in part by grants from AHA, NIH, and Mather's Foundation. T.M. is an Investigator of AHA (New York Affiliate).

neonatal stages in order to establish the thickened myocardial walls. The active proliferation of myocytes involved in cardiac wall thickening, including the myocardial free wall and the intraventricular septum, may be regulated developmentally as well as by local environmental cues. To follow the cardiac myocyte growth in selected regions of the myocardial wall, as well as at selected developmental stages, a replication-defective spleen necrosis retrovirus (SNV)¹⁰⁻¹² was engineered to encode the reporter gene, either cytoplasmic- or nuclear-localized β -galactosidase.^{2,13} Virus was microinjected *in ovo* into the extracellular space of either the precardiac mesoderm at HH stages 4-9, or the myocardial wall of beating hearts at stages 10-18. Infected embryos were then incubated through defined stages, up to and including hatching. Clonal growth of the progeny of individually infected myocytes was analyzed by staining of the embryos or isolated hearts in whole mount with X-gal to histochemically assess β -gal expression. FIGURE 1 summarizes the clonal analysis of myocyte growth at various regions in the myocardial wall during embryogenesis. Single precardiac cells gave rise to cone-shaped clones often extending through the entire thickness of the myocardium.^{1,2} Clone size is larger in the left ventricle than in the right.¹ In contrast, the interventricular septum consists of cones with a more axially elongated shape than those found in the lateral walls. These results suggest that each cone-shaped clone is a growth unit of the myocardial wall, and that the lateral packaging of individual clone units gives rise to the three-dimensional heart chamber.

Retroviral Vectors for In Vivo Targeting of FGF-Signaling

According to the model presented in FIGURE 1, regulation of the number and/or the size of the myocyte clone units could define wall thickness, while the shape of each unit may contribute to the overall chamber or organ shape. Early embryonic hearts express high levels of FGF1 and FGF2, as well as their high-affinity receptor (FGFR) types 1, 2 and 3.^{14,15} The expression of both FGFs and the FGFRs is developmentally regulated during heart formation.^{16,17} Thus FGF-signaling may play an important role in the establishment of heart size, thickness, and shape. To test this hypothesis, a series of viral constructs were generated to either up- or downregulate FGF-signaling. It is known that disruption of FGF-signaling in whole embryos blocks induction of the mesoderm from which myocytes arise.¹⁸ Retroviral vectors, in contrast, permit the restricted disruption of FGF-signaling to confined myocyte populations and therefore allow us to examine the effects of disrupted FGF-signaling at selected regions in the myocardial wall. The vector for stimulating FGF-signaling was designed to overexpress either the ligand or a high-affinity FGF receptor type 1, FGFR1,¹⁹ which is the dominant form of the receptor in the myocyte lineage. The virus for inhibiting the FGF signal cascade was designed to express a truncated mutant of the FGFR1 (Δ FGFR) serving as a competitive inhibitor for several FGFRs.²⁰ In addition, another construct was generated to express anti-sense FGFR1 RNA for inhibiting translation of endogenous FGFR1. All vectors were engineered to coexpress FGFR sequences and a reporter gene, *e.g.*, lacZ, thereby permitting identification of cells expressing the exogenous FGFR. Cloning steps to generate these viral

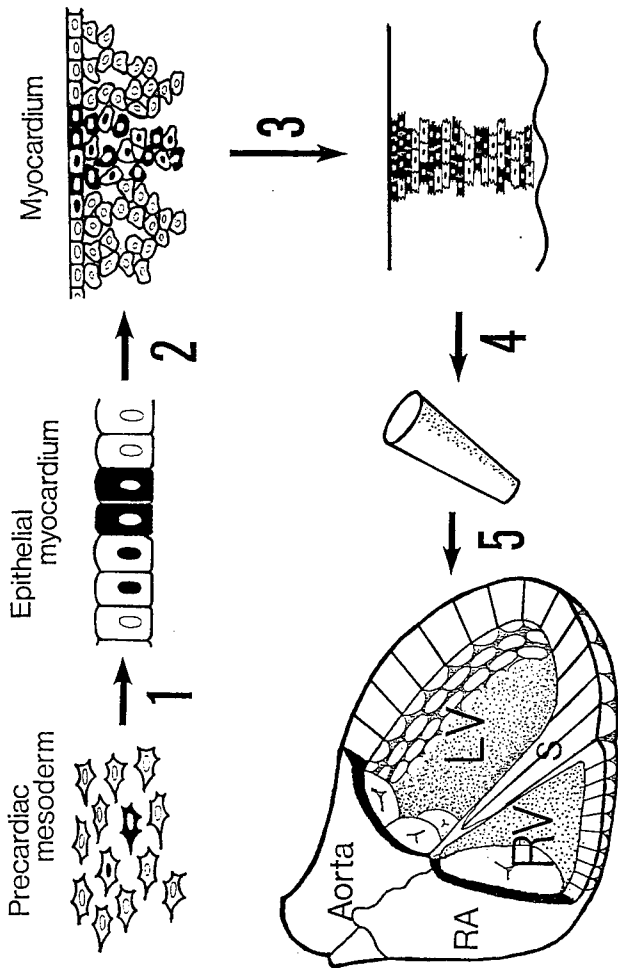

FIGURE 1. Proposed model for myocardial wall formation. Cells of the precardiac mesoderm are labeled with the retrovirus expressing cytoplasmic β -galactosidase (*black cells*) or the virus expressing nuclear-targeted β -galactosidase (*black stained nuclei*). These cells form an epithelium in the early myocardium and begin to divide (*step 1*). As the cells continue to proliferate and the myocardium develops (*step 2*), the transmural growth units become apparent. Note that the growth units contain intermingled cytoplasmic and nuclear-tagged clones. The cells then differentiate and form intercalated discs (*step 3*) and we believe that cell migrations now cease. The mature cone-shaped growth units enlarge (*step 4*) and these form the mature myocardial walls (*step 5*). *Abbreviations:* RA, right atrium; RV, right ventricle; LV, left ventricle; and S, septum. The elongated shape of the cones in the septum is not hypothetical; these have been observed experimentally. Also, note the smaller growth units in the RV as compared to the LV.

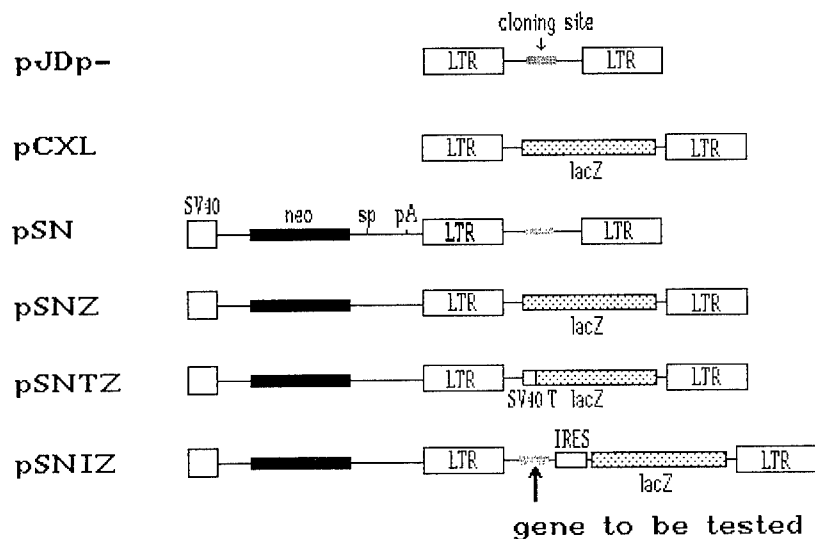

FIGURE 2. Structures of the SNV-based retrovirus vectors for cell lineage studies and gene targeting *in vivo*. The pBR322 sequences in all the constructs extend from map positions 2066 to 4361. Except pSNIZ, the cloning procedures for all plasmid DNA have been described: pJDp- (1); pCXL (13); pSN, pSNZ and pSNTZ.² pSNIZ was developed to equivalently translate two genes from dicistronic messages. The 5' noncoding region of the encephalomyocarditis virus genome, which permits entry of ribosomes to initiate translation without 5'-cap structure,³⁴ was isolated from pLZIC²⁵ by *Xba* I/*Nco* I digestion. This fragment was inserted into pCXLp- after adding a *Pst* I site to *Nco* I; this construct was designated pCXIL. The *Xba* I/*Sst* I fragment of pCXIL encoding the IRES and 5' *lac Z* was co-ligated with a *Sst* I/*Sal* I fragment of pMC1871 (Pharmacia) into pSN to generate pSNIZ. Arrow indicates the cloning sites for genes whose functions are examined *in vivo*. SV40, sp, pA and SV40T represent SV40 early promoter, SV40 splice site, SV40 poly-A signal sequence and the nuclear binding sequence of SV40 large T antigen, respectively.

vectors and pathways to coexpress dual proteins from a dicistronic proviral sequence are illustrated in FIGURES 2 and 3, respectively. In addition, proviral structures of each construct encoding FGF or FGFR transgene are presented in FIGURE 4.

FGF-Signaling Regulates Myocyte Proliferation at Early but not Later Cardiogenesis

Each virus type was introduced at E3 (HH-stages 17–18) in the beating tubular heart, which at this stage consists of differentiated myocytes. Resulting clones were examined by staining E7 and E14 hearts in whole mount with X-gal for β -gal. Colonies generated by cells expressing exogenous full-length FGFR1 (vector SNFRIZ) were indistinguishable in size and number from those infected with a control virus expressing only β -gal. In contrast, hearts infected with viruses expressing Δ FGFR1 (vector SN Δ FRIZ) or anti-sense FGFR1 (vector SN α FRIZ)

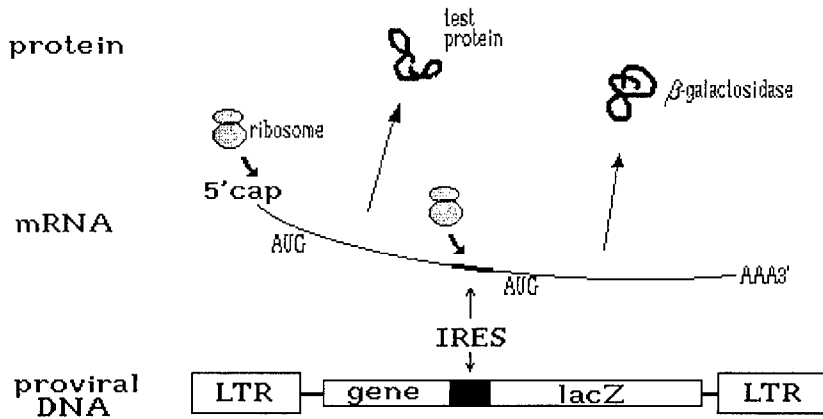

FIGURE 3. Schematic illustration of a pathway to produce two protein species from a single dicistronic mRNA. All sequences to be tested in this proposal will be inserted in pSNIZ (see Fig. 2). The gene product is translated in a 5' cap-dependent manner, while β -gal is generated cap-independently from the internal ribosome entry site (IRES).

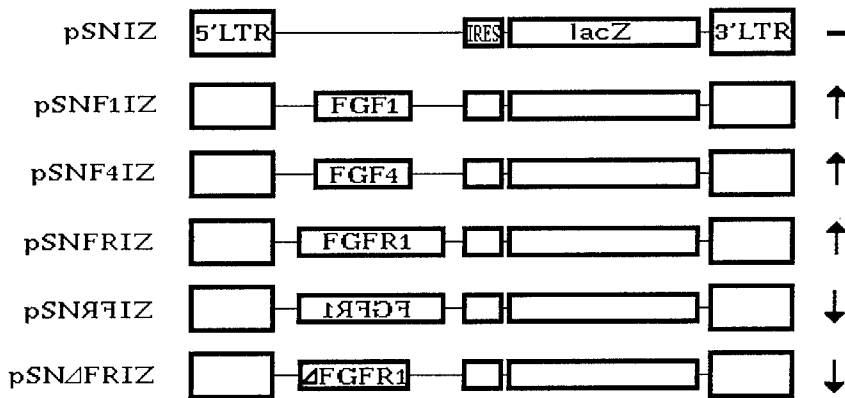

FIGURE 4. Proviral structures of the replication-defective vectors for targeting FGF-signaling. FGF1 cDNA which is fused to a secretion signal sequence of FGF4 in frame was obtained from the expression vector sp-hst/KS3:FGF⁻¹¹⁻¹⁵⁴-pMEXneo³⁶ by Sal I/Eco RI digestion, transferred to pBluescript, and then isolated by *Hinc* II/*Xba* I digestion. The fragment was inserted into pCXIZ and designated pCXF1IZ. A 0.87-Kbp fragment containing a coding region of FGF4 was isolated by partial digestion of pKoc1³⁷ with *Ava* II and *Hind* III, and then blunt-ended. After adding a *Xba* I linker, the fragment was ligated into the *Xba* I site of pSNIZ to generate pSNF4IZ. After removal of the poly(A) signal from FGFR1, full length and truncated FGFR1 of pSVcFR and pSVcTR²⁰ were transferred into the *Xba* I site of pSNIZ, and these vectors designated pSNFRIZ and pSNΔFRIZ, respectively. The construct encoding ΔFGFR1 in antisense orientation has been termed pSNα-FRIZ. Using a packaging cell line, D17.2G,¹⁰⁻¹² we generated replication-defective virions as previously described.^{1-3,13} Viral propagation, proof of helper virus-free stocks and the evidence for clonality in studies of myocardial development have been presented elsewhere.^{1,2,13} LTR and IRES indicate long terminal repeats and an internal ribosome entry site, respectively.

TABLE 1. Effects of FGFR-Disruption on Myocyte Clonal Growth^a

Transgene	Clonal Growth (Cells/Clone)	
	E3-E7	E7-E14
lacZ	49.5 ± 9.0	6.8 ± 2.6
+ FGFR1	46.5 ± 3.9	7.9 ± 2.2
+ ΔFGFR1	3.6 ± 0.5	6.5 ± 1.9
+ antisense FGFR1	13.9 ± 2.2	7.2 ± 3.5

^a Clonal growth between E3 and E7 and between E7 and E14 was examined. Individual myocytes in E3 and E7 hearts were infected with a replication-defective retrovirus encoding lacZ, FGFR1 plus lacZ, a truncation mutant of FGFR1 (ΔFGFR1) plus lacZ, and FGFR1 in antisense orientation plus lacZ. Infected hearts were fixed on E7 and E14, respectively. After staining with X-gal, the hearts were embedded in paraffin. 10 μm-thick serial sections were counterstained with hematoxylin. The nuclei surrounded by a β-gal-positive cytoplasm were counted. The standard deviation of the mean is presented. (Unpublished experiment of T. Mima and T. Mikawa.)

gave rise to colonies of significantly smaller size, *i.e.*, these had fewer cardiac myocytes. The number of myocytes per colony were counted in E7 hearts that had been infected on E3. The SNΔFRIZ- and SNαFRIZ-infected colonies contained 3–4 and 10–17 cells, respectively, while control and SNFRIZ-infected colonies had an average of 50 and 47 cells, respectively (TABLE 1). The calculated mean doubling time of the SNFRIZ-infected cells was 16–18 hr; a value consistent with prior data obtained by tritiated thymidine labeling of normal myocytes²¹ and direct cell number counts in the growing heart.²² Whereas, the doubling time of 48–64 hr and 24–28 hr were calculated for SNΔFRIZ- and SNαFRIZ-infected myocytes, respectively. In contrast, no significant change was found in clonal growth between E7 and E14, irrespective of which transgenes of FGFR were introduced (TABLE 1). These results suggest that proliferation of cardiomyocytes is regulated at least in part by FGF-signaling during the first week of chicken development but later becomes FGF-independent.

Coronary Vessels are Established by Vasculogenic Mechanisms

The embryonic chicken heart begins contraction at HH stage 10 (28 hr of incubation),²³ but for the first 6 days of embryogenesis the myocardial wall is avascular and nourished by diffusion through the endocardium.²⁴ Such diffusion is facilitated by extensive trabecular channels, which markedly increase the endocardial surface area.²⁵ Coronary vasculogenesis begins on day 6 (HH stage 29).^{26,27} Retroviral cell lineage studies in chicken embryos³ have demonstrated that: 1) precursor cells of coronary vessels begin to enter the heart on embryonic day 3 (E3) but are not present in the heart before that time, and 2) they first generate discrete channels (E7) and then link together to form a vascular network (E14). Thus, the coronary channels form by a vasculogenic mechanism, not by angiogenic outgrowth from the root of the aorta. A similar conclusion, based on serial section analysis of early embryos, was reached by Bogers *et al.* (1989).²⁶

Origin of Coronary Vascular Cells

It has been shown that the epicardial mantle begins to cover the tubular heart at HH stage 17 (E3),^{28,29} the same time that coronary precursor cells can be found

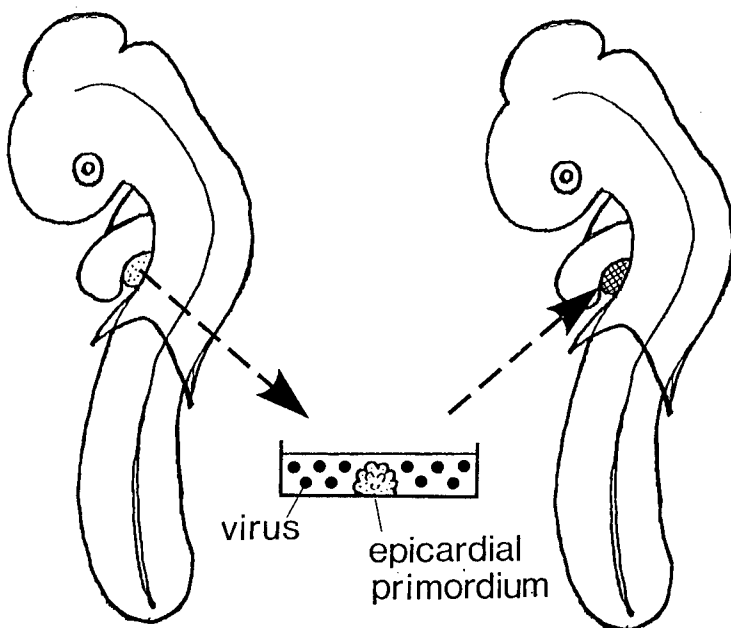
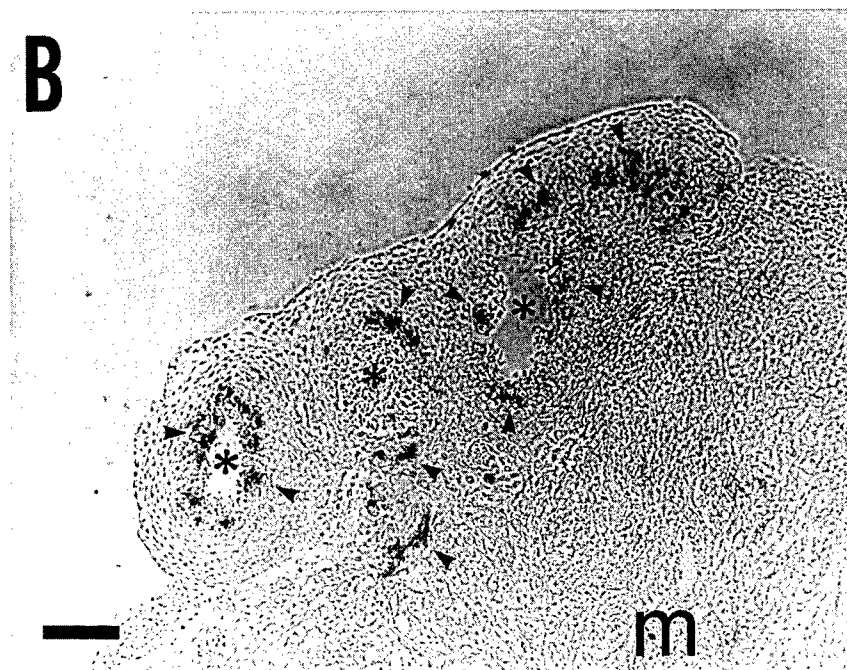
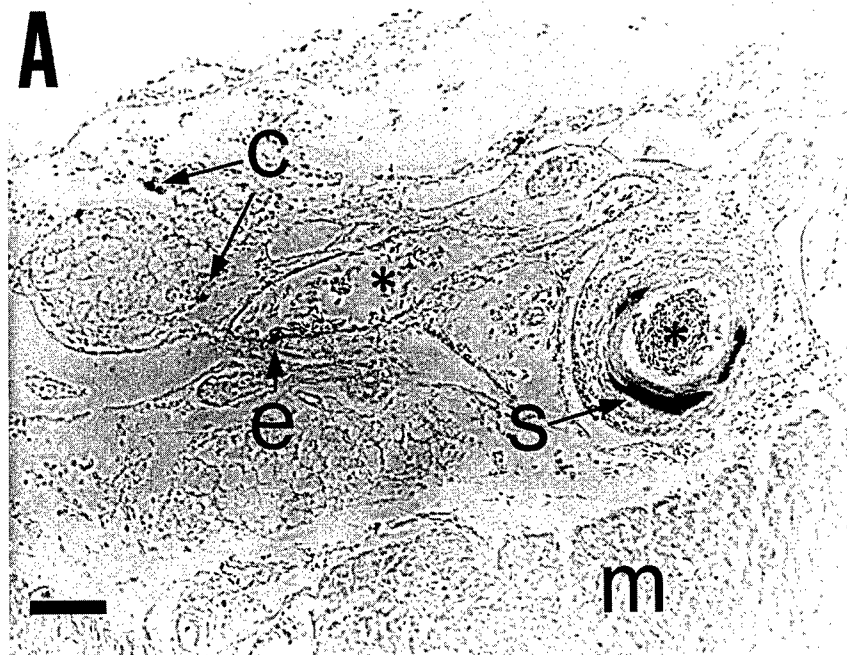

FIGURE 5. Schematic illustration of transplantation of epicardial primordium into an isochronic embryo. The epicardial primordium is isolated from a donor embryo at stages 17–18 (E3), inoculated with virus encoding a reporter, and transplanted to the epicardial cavity of an isochronic host embryo.

in embryonic heart.³ The epicardial primordium is identified based on its characteristic appearance as a grape-like cluster of cells along the dorsal mesocardium.^{28,29} Migration of coronary endothelial cells from this epicardial anlage has been shown in culture³⁰ and in chicken/quail chimera,³¹ but the origin of coronary smooth muscle and perivascular connective tissue cells remains uncertain. To address this issue, the epicardial primordium was isolated from chicken embryos at HH stages 17–18, retrovirally tagged, and back-transplanted into the epicardial cavity of isochronic embryos (FIG. 5). The fate of transplanted cells was analyzed by

FIGURE 6. Epicardial primordium was tagged with virus encoding β -gal at E3 (HH stages 17–18) and transplanted to host embryo as described in FIGURE 5. The fate of the transplanted cells was examined on E18 by staining with X-gal and histological sections (A). To test susceptibility of coronary vessel formation to FGF-signaling, virus encoding FGF was directly injected *in ovo* into the intercellular spaces of the epicardial primordium at E3 (HH stage 17–18). On E18, hearts of the infected embryos were isolated, fixed and stained with X-gal. A histological section of such a heart exhibiting rearrangement of the coronary vessel patterns (B). Asterisks mark the lumen of vessels. Arrows (A) and arrowheads (B) indicate β -gal + cells which are derived from infected epicardial primordium. Abbreviations: s, vascular smooth muscle cells; e endothelial cells; c, connective tissue cells; and m, adjacent myocardial tissues. Bar = 50 μ m.



staining of host hearts for β -gal in whole mount at E18. FIGURE 6A demonstrates one example of the transplantation that gives rise to β -gal-positive smooth muscle cells and perivascular connective tissue cells incorporated into the networking coronary vessel system. These results demonstrate that the coronary vasculature, including smooth muscle, endothelial, and perivascular connective tissue cells, are derived from the epicardial primordium and enter the tubular heart as the epicardial mantle envelopes the myocardium.

Coronary Vasculogenesis Is Susceptible to FGF-Signaling

FGF-signaling stimulates proliferation of adult vascular cells.^{32,33} To test whether coronary vasculogenesis in embryonic hearts is susceptible to FGF-signaling, a retrovirus encoding FGF and a reporter gene was introduced directly into the intercellular space of epicardial primordium at E3, and formation of the coronary vessel network was examined at E18. This precocious and ectopic expression of exogenous FGF in coronary precursor cells gave rise to abnormal branching patterns of the coronary vasculature. A histological section of such vessels containing infected cells is presented in FIGURE 6B. These results suggest that FGF-signaling may be one of the components crucial for the establishment of the branching pattern of coronary vessels in myocardial wall.

ACKNOWLEDGMENTS

Thanks are due to Dr. Mima for providing unpublished data shown in TABLE 1, Drs. Ueno and Williams for cDNA of FGFR, and Drs. Sakamoto and Terada for cDNA of FGF4. My thanks are extended to Dr. Fischman for his comments and generous support, and Lee Cohen-Gould, Li-Lin Ong and Lydia Miroff for their technical assistance.

REFERENCES

1. MIKAWA, T., A. BORISOV, A. M. C. BROWN & D. A. FISCHMAN. 1992. Clonal analysis of cardiac morphogenesis in the chicken embryo using a replication-defective retrovirus. I. Formation of the ventricular myocardium. *Dev. Dyn.* **193**: 11–23.
2. MIKAWA, T., L. COHEN-GOULD & D. A. FISCHMAN. 1992. Clonal analysis of cardiac morphogenesis in the chicken embryo using a replication-defective retrovirus. III. Polyclonal origin of adjacent ventricular myocytes. *Dev. Dyn.* **195**: 133–141.
3. MIKAWA, T. & D. A. FISCHMAN. 1992. Retroviral analysis of cardiac morphogenesis: discontinuous formation of coronary vessels. *Proc. Natl. Acad. Sci. USA* **89**: 9504–9508.
4. ROSENQUIST, G. C. 1985. Migration of precardiac cells from their origin in epiblast until they form the definitive heart in the chick embryo. *In Cardiac Morphogenesis*. 44–55. Elsevier Science Publishing, New York.
5. GARCIA-MARTINEZ, V. & G. C. SCHOENWOLF. 1993. Primitive-streak origin of the cardiovascular system in avian embryos. *Dev. Biol.* **159**: 706–719.
6. GONZALEZ-SANCHEZ, A. & D. BADER. 1990. *In vitro* analysis of cardiac progenitor cell differentiation. *Dev. Biol.* **139**: 197–209.
7. HAN, Y., J. E. DENNIS, L. COHEN-GOULD, D. M. BADER & D. A. FISCHMAN. 1992.

- Expression of sarcomeric myosin in the presumptive myocardium of chicken embryos occurs within six hours of myocyte commitment. *Dev. Dyn.* **193**: 257–265.
8. BISAHA, J. G. & D. BADER. 1991. Identification and characterization of a ventricular-specific avian myosin heavy chain, VMHC1: expression in differentiating cardiac and skeletal muscle. *Dev. Biol.* **148**: 355–364.
 9. YUTZEY, K. E., J. T. RHEE & D. BADER. 1994. Expression of the atrial-specific myosin heavy chain AMHC1 and the establishment of anteroposterior polarity in the developing chicken heart. *Development* **120**: 871–883.
 10. DOUGHERTY, J. P. & H. M. TEMIN. 1986. High mutation rate of a spleen necrosis virus-based retrovirus vector. *Mol. Cell. Biol.* **7**: 4387–4395.
 11. DOUGHERTY, J. P. & H. M. TEMIN. 1988. Determination of the rate of base-pair substitution and insertion mutations in retrovirus replication. *J. Virol.* **62**: 2817–2822.
 12. DOUGHERTY, J. P., R. WISNIEWSKI, S. YANG, B. W. RHODE & H. M. TEMIN. 1989. New retrovirus helper cells with almost no nucleotide sequence homology to retrovirus vectors. *J. Virol.* **63**: 3209–3212.
 13. MIKAWA, T., D. A. FISCHMAN, J. P. DOUGHERTY & A. M. C. BROWN. 1991. *In vivo* analysis of a new LacZ retrovirus vector suitable for cell lineage marking in avian and other species. *Exp. Cell Res.* **195**: 516–523.
 14. PATSTONE, G., E. M. PASQUATE & P. A. MAHER. 1993. Different members of the fibroblast growth factor receptor family are specific to distinct cell types in the developing chicken embryo. *Dev. Biol.* **155**: 107–123.
 15. JOSEPH-SILVERSTEIN, J., S. A. CONSIGLI, K. M. LYSER & C. VER PAULT. 1989. Basic fibroblast growth factor in the chick embryo: immuno-localization to striated muscle cells and their precursors. *J. Cell Biol.* **108**: 2459–2466.
 16. CONSIGLI, S. A. & J. JOSEPH-SILVERSTEIN. 1991. Immunolocalization of basic fibroblast growth factor during chicken cardiac development. *J. Cell. Physiol.* **146**: 379–385.
 17. OLWIN, B. B. & S. D. HAUSCHKA. 1990. Fibroblast growth factor receptor levels decrease during chick embryogenesis. *J. Cell Biol.* **110**: 503–509.
 18. AMAYA, E., T. J. MUSCI & M. W. KIRSCHNER. 1991. Expression of a dominant negative mutant of the FGF receptor disrupts mesoderm formation in *Xenopus* embryos. *Cell* **66**: 257–270.
 19. LEE, P. L., D. E. JOHNSON, L. S. COUSENS, V. A. FRIED & L. T. WILLIAMS. 1989. Purification and complementary DNA cloning of a receptor for basic fibroblast growth factor. *Science* **245**: 57–60.
 20. UENO, H., M. GUNN, K. DELL, A. TSENG, JR. & L. WILLIAMS. 1992. A truncated form of fibroblast growth factor receptor 1 inhibits signal transduction by multiple types of fibroblast growth factor receptor. *J. Biol. Chem.* **267**: 1470–1476.
 21. JETER, J. R. & I. L. CAMERON. 1971. Cell proliferation patterns during cytodifferentiation in embryonic chick tissues: liver, heart and erythrocytes. *J. Embryol. Exp. Morphol.* **23**: 403–422.
 22. DEHAAN, R. L., J. O. DUNNING, R. HIRAKOW, T. F. McDONALD, J. RASH, H. SACHS, J. WILDES & H. K. WOLF. 1968. Pacemaker rate control and mitotic activity in the embryonic heart. *In Annual Report of the Department of Embryology.* 66–84. Carnegie Institute of Washington. Washington, DC.
 23. PATTERN, B. M. & T. C. KRAMER. 1933. The initiation of contraction in the embryonic chick heart. *Am. J. Anat.* **53**: 349–375.
 24. RYCHTER, Z. & B. OSTADAL. 1971. Fate of “sinusoidal” intertrabecular spaces of the cardiac wall after development of the coronary vascular bed in chick embryo. *Folia Morphol.* **19**: 31–44.
 25. RYCHTEROVA, V. 1971. Principle of growth in thickness of the heart ventricular wall in the chick embryo. *Folia Morphol.* **19**: 262–272.
 26. BOGERS, A. J. J. C., A. C. DE GROOT, R. E. POELMANN & H. A. HUYSMANS. 1989. Development of the origin of the coronary arteries, a matter of ingrowth or outgrowth? *Anat. Embryol.* **180**: 437–441.
 27. WALDO, K. L., W. WILLNER & M. L. KIRBY. 1990. Origin of the proximal coronary artery stems and a review of ventricular vascularization in the chick embryo. *Am. J. Anat.* **188**: 109–120.

28. HO, E. & Y. SHIMADA. 1978. Formation of the epicardium studied with the scanning electron microscope. *Dev. Biol.* **66**: 579-585.
29. HIRUMA, T. & R. HIRAKOW. 1989. Epicardial formation in embryonic chick heart: computer-aided reconstruction, scanning, and transmission electron microscopic studies. *Am. J. Anat.* **184**: 129-138.
30. BOLENDER, D. L., M. D. LOSON & R. R. MORKWALD. 1990. Coronary vessel vasculogenesis. *Ann. N.Y. Acad. Sci.* **588**: 340-344.
31. POELMANN, R. E., A. C. GITTENBERGER-DE GROOT, M. M. MENTINK, R. BOKENKAMP & B. HOGERS. 1993. Development of the cardiac coronary vascular endothelium, studied with antiendothelial antibodies in chicken-quail chimeras. *Circ. Res.* **73**: 559-568.
32. NABEL, E. G. & G. J. NABEL. 1991. Gene transfer and cardiovascular disease. *TCM* **1**: 12-17.
33. NABEL, E. G., Z-Y. YANG, G. PLAUTZ, R. FOROUGH, X. ZHAN, C. C. HAUDENSCHILD, T. MACIAG & G. J. NABEL. 1993. Recombinant fibroblast growth factor-1 promotes intimal hyperplasia and angiogenesis in arteries *in vivo*. *Nature* **362**: 844-846.
34. JANG, S. K., J.-G. KRAUSSLICH, M. J. J. NICKLIN, G. M. DUKE, A. C. PALMENBERG & E. WIMMER. 1988. A segment of the 5' nontranslated region of encephalomyocarditis virus RNA directs internal entry of ribosomes during *in vitro* translation. *J. Virol.* **62**: 2636-2643.
35. GHATTAS, I. R., J. R. SANES & J. E. MAJORS. 1991. The encephalomyocarditis virus internal ribosome entry site allows efficient co-expression of two genes from a recombinant provirus in cultured cells and in embryo. *Mol. Cell. Biol.* **11**: 5848-5859.
36. FOROUGH, R., X. ZHAN, M. MACPHEE, S. FRIEDMAN, K. A. ENGLEKA, T. SAYERS, W. H. WILTROUT & T. MACIAG. 1993. Differential transforming abilities of non-secreted and secreted forms of human fibroblast growth factor-1. *J. Biol. Chem.* **268**: 2960-2968.
37. TAIRA, M., T. YOSHIDA, K. MIYAGAWA, H. SAKAMOTO, M. TERADA & T. SUGIMURA. 1987. cDNA sequence of human transforming gene *hst* and identification of the coding sequence required for transforming activity. *Proc. Natl. Acad. Sci. USA* **84**: 2980-2984.

Subject Index

- A**ctins, total, 194
Action potentials, cardiomyocytes and, 462
Acute heart failure, myocardial tissue water changes, 222
Adipocyte, adenovirus infection and, 14
Adult myocytes, extracellular stimuli and, 382
Aging, cardiac hypertrophy and, 426
Allantois, development of yolk sac and, 305
Alpha and beta adrenergic agonists, 176
Alpha-adrenergic agonist, stimulation by, 344
Alpha-myosin heavy chain, dominant-negative type II receptor for TGF β and, 310
Alpha-sarcomeric actin, 194
Alpha-smooth muscle actin, 194
ANF-TAG mice, cardiomyocyte proliferation and, 447
Angiogenesis
 morphological substrate of, 260
 transformed tissues and, 282
 vascular endothelial growth factor and, 250
 vasculogenesis and, 258
Angiotensin converting enzyme (ACE), 117
 high collagen turnover and, 289
Angiotensin peptides, 291
Angiotensin II
 growth factor therapy and, 117
 PKC activity and, 160
 stimulation by, 346
Angiotensin II signal, intracellular transduction of, 394
Annelids, 150
API binding, angiotensin II-induced increase of, 398
Arthropods, 150
AT-1 and AT-2 cells, SV40 T oncogene and, 83
AT1 cardiomyocytes, derivation of, 448
AT-1 cells, intracardiac grafts and, 268
AT₁ receptor, angiotensin II and, 165
Atrial natriuretic peptide (ANP), 213
Atrial-specific myosin heavy chain, 5
Atrioventricular canal, mesenchymal cell formation in, 318
Atrophy, disassembly of myofibrils during, 138
Avian cardiac progenitor cells, 1
- B**asic fibroblast growth factor (bFGF)
 high- and low-molecular weight, 366
 regulation of, 353
Basic fibroblast growth factor extraction, 418
Beta-adrenergic-stimulated rats, isoprenaline and, 230
Beta-myosin, hypertrophic cardiomyopathy and, 227
Beta-myosin heavy chain, hypertension-induced hypertrophy and, 382
Bombesin, DNA synthesis and, 40
Brachyury gene, cell transformation and, 324
Bradykinin, prostaglandin E₂ and, 293
BrdU (5-bromo-2'-deoxyuridine)
 bFGF and, 361
 myotubes and, 11
 transplanted hearts and, 111
- C**-fos/c-jun heterodimers, 395
C-protein phosphorylation, function of, 243
C2C12 cells
 angiotensin II signal in, 394
 cell cycle and, 10
C2C12 myoblasts, 451
Cadherins, desmosomal, 101
Calcium
 C-protein and troponin I phosphorylation and, 244
 myofibrillar structure and, 139
Calcium binding, myosin light chains and, 498
cAMP content, isoprenaline and, 230
Capillary geometry, 263
Capillary growth, 257
Cardiac compartment, MyHCs expressed in, 493
Cardiac fibroblasts, PKC activation in, 162
Cardiac growth and hypertrophy, signaling pathways for, 115
Cardiac hypertrophy
 cytokine expression during, 212
 pressure overload, 204
 reproducible rat model of, 74
Cardiac muscle factor, 4
Cardiac myocytes
 agents involved in proliferation of, 35
 hypertension and, 331
Cardiac phenotype, both muscle and nonmuscle cells and, 381
Cardiac progenitor cells, specification and commitment of, 1

- Cardiac regeneration, terminal differentiation and, 77
- Cardiac-specific genes, expression of, 462
- Cardiogenesis, early vs later, 509
- Cardiomyocyte bFGF, 419
- Cardiomyocyte differentiation, cluster-cells and, 70
- Cardiomyocyte transfer, 267
- Cardiomyocytes
adult rat, 128
cardiac-specific genes and, 462
contractile arrest of, 131
- Cardiomyopathy, Duchenne/Becker dystrophinopathy and, 109
- Catecholamines, nonbeating adult rat hearts exposed to, 178
- Cell attachment, 194
- Cell cycle, cyclin D and, 76
- Cell cycle regulation, retinoblastoma involved in, 435
- Cell orientation, repetitive mechanical load and, 28
- Cell spreading, 194
- Cell transformation, mechanisms of, 317
- Cell-matrix interactions, fibronectin isoform and, 383
- Cellular hypertrophy, nonbeating adult myocytes and, 169
- Chicken cardiomyocytes, bFGF and, 360
- Chicken N-cadherin cDNA, 130
- Chloramphenicol acetyl transferase (CAT), MyHC promoter and, 497
- Chondrocytes, *in vitro* clonal analysis and, 94
- Chronotropic effects, cardiomyocytes and, 462
- Cluster-cells, cardiomyopathic hamster, 69
- Co-cultures, cardiomyocytes from different species and ages in, 269
- Collagen content, pulmonary hypertension and, 218
- Collagen disposition, regulation of, 236
- Collagen metabolism, regulation of, 237
- Collagen turnover
cardiac hypertrophy and cardiac fibrosis and, 387
tissue repair and, 288
- Colony-stimulating factor (CSF-1), 215
- Commitment of cardiac progenitor cells, 1
- Conditioned medium, DNA synthesis and, 38
- Connective tissue
in vitro clonal analysis and, 97
repair and, 286
- Contractile activity, myosin heavy chain and, 384
- Contractile protein synthesis, 175
- Contraction, isoprenaline and, 230
- Coronary vascular cells, origin of, 511
- Coronary vessels, FGF-signaling during formation of, 506
- Creatine kinase, stretch-induced cell damage and, 23
- CUG-initiated bFGF, 359
- Culture
adult newt ventriculomyocyte in, 31
adult rat ventricular myocytes, 193
- Cultured adult cardiac myocytes, 168
- Cultured ventricular myocytes, hypertrophy and, 349
- Cushion tissue, atrioventricular canal and, 160
- Cytokines, markers of cardiac hypertrophy and, 210
- Cytoskeletal rearrangements, adult rat cardiomyocytes and, 128
- D**
Desmin
cluster-cells and, 69
SV40 T oncogene and, 86
- Desmin filaments, 87
- Desmocollins (DSC), 101
- Desmogleins (DSG), 101
- Desmoplakin, 87
- Desmosomes, 101
- Deuterostomia, 153
- Development
C-protein and troponin I phosphorylation and, 243-244
FGF receptors in, 355
FGFR1 isoforms during, 414
retroviral targeting during, 506
TGF β s in, 320
- Differentiation of cardiac progenitor cells, 3
- Dilated cardiomyopathy, GH/IGF-1 axis deficiency and, 422
- Direct DNA injection, gene transfer into beating myocardium and, 455
- Diversification of cardiac progenitor cells, 5
- DNA content, static cytometry and, 202
- DNA synthesis
adenovirus infection and, 11
bFGF and, 354
myocyte loss and, 57
newt lung epithelial cells and, 32
- Dominant-negative receptor, 310
- Duchenne and Becker carriers, 108
- Dysfunctional hearts, IGF-1-mediated hypertrophy and, 121
- Dystrophin gene, X-linked dilated cardiomyopathy and, 470
- Dystrophin protein analysis, 479

- E**
E1A oncogene, cell cycle and, 10
 Early postnatal period, new capillaries and, 264
 Echinoderms, 153
 Ejection fraction, 240
 Electron microscopy, cell-to-cell interaction and, 271
 Embryonic heart, cell transformation in, 317
 Embryonic mouse heart, FGFR1 RNA expression in, 406
 Embryonic stem cells, differentiation and, 462
 Endomyocardial biopsies, dilative cardiomyopathy and, 479
 Endothelial cell growth supplement (ECGS), DNA synthesis and, 40
 Endothelin (ET-1)
 DNA synthesis and, 40
 growth factor therapy and, 118
 Endothelin-1, stimulation by, 345
 Exogenous cells, repair by grafting of, 450
 Exon IIIc, FGFR1 transcripts and, 411
 Extracellular matrix
 mechanical stimulation of cardiac fibroblasts and, 28
 stretching of noncardiomyocytes and, 25
 synthesis of, by atrioventricular canal myocardium, 318
- F**
Fibroblast
 collagen deposition and, 388
 mechanical stimuli and, 237
 plasminogen activator and, 339
 Fibroblast growth factor receptor 1 (FGFR1) RNA expression, 406
 Fibroblast growth factor receptors, regulation of, 353
 Fibroblast growth factor signaling, development and, 506
 Fibroblast replication, effect of growth factors on, 391
 Fibrogenic phase of tissue repair, 287
 Fibronectin mRNA, beta-myosin heavy chain and, 382
 Fibrosis
 cardiac, 236
 collagen turnover and, 387
 Field-stimulating cell preparations, 173
flg gene, FGF receptors and, 355
 Formation, avian heart, 1
 Function, constrictive, 106
- G**
G₀ and **G₁** phase of cell cycle, growth inhibition in, 434
 Gastrulation, cell transformation and, 324
 Genes, MyHC locus and, 494
 Genetically manipulated mice, signaling pathways in, 122
 Genistein, 193
 Goosecoid gene, gastrulation and, 326
 Grafting, repair by, 450
 Grafts, intracardiac, 268
 Growth factor
 collagen deposition and, 388
 medial smooth muscle cells and, 383
 Growth factor therapy, signaling pathways and, 115
 Growth hormone, insulin-like growth factor 1 and, 429
 Growth hormone/IGF-1 axis deficiency, 422
- H**
Hamster
 cardiomyopathic, 66
 dilated cardiomyopathic, 207
 Heart conduction system, heart, 142
 Heart failure, GH-IGF1 axis in, 429
 Heart muscle growth, cellular mechanisms of, 149
 Hemangioblast, 303
 Hematopoiesis, yolk sac, 300
 Hemicoardates, 154
 Heparin
 bFGF receptors and, 358
 inhibition of DNA synthesis and, 42
 Hemographic transplants, 268
 Hyperplastic atrial tissue, SV40 T oncogene and, 82
 Hypertrophy
 agonist-induced, 343
 collagen disposition during, 237
 collagen turnover and, 387
 load-induced, 138
 mechanical stimulation and, 26
 potential upper limit to, 240
 thyroxine-induced, 187
 Hypertrophic cardiomyopathy (HMC), beta-myosin mutations in, 227
 Hypobaric hypoxia, 215
- I**
Immunosuppressed rats, transplantation of cardiac muscle cells in, 282
In situ hybridization studies, calcium stores and, 142
In vitro clonal analysis, 92
 Inhibitor, tyrosine kinase, 193
 Insulin-like growth factor 1
 growth hormone and, 429
 growth factor therapy and, 119
 Interstitial cells, hypertension and, 331
 Intracellular transduction, reactive oxygen intermediates and, 394
 Invertebrates, heart muscle growth in, 149

- Ionic channels, cardiomyocytes and, 462
 Ischemia, myocardial, 455
 Ischemic heart disease, ventricular remodeling in, 47
 Isoform, endogenous and transgenic messages and, 502
 Isoform switching, FGFR1, 412
 Isometric tension, Ca²⁺-dependence of, 245
 Isoprenaline, contraction and, 230
 Isoproterenol, adult myocytes and, 382
- J**E/monocyte-chemoattractant protein (MCP-1), 215
- K**inase, tyrosine, 193
 Knockout mice, TGFβ1, 301
- L**-type Ca²⁺ channel, blockers of, 462
 Long isoforms of FGF receptor, 406
- M**arathon runners, myocardial injury in, 234
 Mast cells, new capillaries and, 264
 Mechanical load
 cardiac myofibrillar structure and, 131
 fibroblast replication and collagen production and, 388
 in vitro, 169
 Mechanical performance, propionyl-L-carnitine and, 207
 Mechanical stresses, growth regulators and, 20
 Mechanisms, cellular, 149
 Mesenchymal cell formation,
 atrioventricular canal and, 318
 Mesoderm, cardiac, commitment of, 2
 MHC-TAG mice, cardiomyocyte proliferation and, 447
 Mitogen-activated protein (MAP),
 angiotensin II and, 162
 Mitosis
 differentiated amphibian cell and, 33
 DNA synthesis and, 11
 Mitotic division, DNA synthesis and, 57
 Mitotic process, retinoblastoma-associated proteins during, 438
 Molluscs, 151
 Morphological components of the stable vessel, 260
 Mox-1 gene, gastrulation and, 325
 mRNA levels, TGFβ1 probe in young and old rats and, 428
 Muscle, myosin light chain and, 499
 Muscle actins, cluster-cells and, 69
 Mutations, beta-myosin heavy chain and, 229
 Myalgia, dilative cardiomyopathy family with, 486
 Myoblasts, differentiation and, 10
 Myocardial hypertrophy, old rat and, 427
 Myocardial infarct, dog model of, 457
 Myocardial injury, marathon runners and, 234
 Myocardial ischemia, gene transfer in models of, 455
 Myocardial oxygenation, 263
 Myocardial regeneration
 hamster cardiomyocytes as model of, 65
 potential approaches for, 446
 Myocardial structure, myocardial tissue water changes and, 222
 Myocardial volume, 105
 Myocardial wall, FGF-signaling during formation of, 506
 Myocyte hyperplasia, 60
 Myocyte hypertrophy, 54
 Myocyte loss, 49
 Myocyte necrosis, 52
 Myocytes, adult rat ventricular, 193
MyoD gene, skeletal muscle differentiation and, 9
 Myofibril assembly, 131
 mechanical load and, 184
 Myofibrillar ATPase, 205
 Myoglobin, dystrophinopathic carriers and, 109
 Myosin light chain 2v sequence, 500
 Myosin light chains, striated muscle and, 495
 Myosins, muscle types and, 492
 Myotubes, multinucleated, 10
- N**eomycin-resistance gene, TGFβ1 gene and, 301
 Neural crest, *in vitro* clonal analysis and, 94
 Newt heart, stimulation of proliferative events in, 30
 Nifedipine
 capillary growth and, 264
 contractile arrest and, 133
 Nonmitotic myocytes, 357
 Null mouse embryos, yolk sac vasculogenesis and, 300
- O**ld rat, myocardial hypertrophy in, 426
 Oncoprotein, SV40 T oncogene and, 85
 Organogenesis, external mechanical forces and, 19

- P**107 and p130, retinoblastoma protein and, 439
Papillary muscle, mechanical performance of, 207
PCNA, SV40 T oncogene and, 84
Peptide hormone synthesis, connective tissue and, 291
Phorbol 12-myristate 13-acetate (PMA) bFGF synthesis and, 471
PKC activity and, 161
Phosphoinositide pathway, hypertrophy and, 344
Phosphorylation
 C-protein and troponin I, 243
 isoprenaline and, 230
 tyrosine, 358
Phosphorylation of retinoblastoma, 436
Plasminogen activator, hormones and growth factors and, 331
Plasminogen activator inhibitor-1, TGF β and, 312
Platelet-derived growth factor (PDGF), DNA synthesis and, 40
Pluripotency, *in vitro* clonal analysis and, 97
Pogonophora, 152
Posterior visceral arches, *in vitro* clonal analysis and, 93
Postmitotic cells, 9
Pressure overload
 collagen disposition and, 237
 TGF β mRNA and, 383
Pressure overload cardiac hypertrophy, 204
Pro- α 2(I) collagen, myocardial hypertrophy of old rat and, 426
Programmed cell death, 52
Proliferating cell nuclear antigen (PCNA), cluster-cells and, 69
Proliferation
 angiotensin II and, 403
 myocardial repair by induction of, 447
 myocyte, FGF-signaling regulates, 509
 PMA and, 162
 transplanted hearts and, 111
Proliferative response, bFGF and, 354
Promoters, myosin light chain isoforms and, 503
Propionyl-L-carnitine (PLC)
 papillary muscle and, 207
 pressure overload cardiac hypertrophy and, 204
Prostaglandins, bradykinin and, 293
Protein kinase C, hypertrophy and, 344
Protein kinase C activation, 161
Protein kinase C translocation, 166
Pulmonary hypertension, collagen content and, 218
- R**at cardiomyocytes, bFGF and, 361
Reactive oxygen intermediates (RIOs), angiotensin II signal and, 394
Recombinant human growth hormone (rHGH), GH/IGF-1 axis deficiency and, 422
Region-specific myocyte growth, retroviral cell tagging and, 506
Retinoblastoma gene product, 448
Retinoblastoma protein, domains of, 432
Retinoic acid (RA), DNA synthesis and, 40
Retroviral targeting, development and, 506
Retroviral-mediated gene transfer,
 infarcted myocardium and, 457
Right atria, overloaded human, 218
Right ventricular hypertrophy (RVH), 211
RT-PCR, dystrophin mRNA analysis by, 478
RT-PCR cloning, FGFR1 short and long forms and, 407
RXR α -deficient mouse, ventricular dysfunction and, 123
Ryanodine receptor, intracellular calcium release and, 144
- S**arcolemmal membranes, 188
Sarcomeres, myofibrils organized into, 138
Sarcoplasmic reticulum channels and pumps, 141
Secretion, plasminogen activator activity, 331
Serotonergic neurons, *in vitro* clonal analysis and, 94
Short isoforms of FGF receptor, 406
Shortening velocity, pressure overload and, 204
Signaling pathways
 cardiac growth and hypertrophy and, 115
 mechanical load and, 183
 phospholipase, 187
Skeletal α -actin, TGF β and, 310
Skeletal muscle biopsies, dilative cardiomyopathy and, 479
Smooth muscle cells
 in vitro clonal analysis and, 93
 medial, fibronectins in, 382
Specification of cardiac progenitor cells, 1
Static cytometry, evaluation of DNA content by, 202

- Stretch
 static, 132
 passive, 173
- SV40 T oncogene, transgenic mice expressing, 81
- T** antigen-associated proteins, retinoblastoma proteins and, 449
- Tentaculata, 152
- Terminal differentiation
 cardiac regeneration and, 72
 proliferative potential and, 80
- 12-O-Tetradecanoylphorbol-13-acetate (TPA), proliferation and, 40
- Thrombin, stimulation by, 347
- Thyroid, high-molecular weight bFGF and, 359-360
- Thyroid response element (TRE), MyHC gene and, 496
- Thyroxine
 capillary growth and, 264
 phospholipase signalling pathways and, 187
- Tissue-specific promoters, direct DNA injection and, 455
- TPA (12-O-tetradecanoylphorbol-13-acetate) response element (TRE), 395
- Transcription factor E2F-1, 437
- Transforming growth factor beta (TGF β), 215
 cell transformation and, 319
 growth factor therapy and, 118
 plasminogen activator inhibitor and, 331
- Transforming growth factor β (TGF β) receptor, 309
- Transforming growth factor β (TGF β) signal transduction, 309
- Transforming growth factor β 1 (TGF β 1), yolk sac vasculogenesis and, 300
- Transgenic mice, generation of, 501
- Transplantable tumor, 84
- Transplantation, pancreatic islet, 284
- Transplanted heart, 111
- Transplants, xenographic and homographic, 268
- Trochozoa, 150
- Troponin I phosphorylation, function of, 243
- Tumor necrosis factor-alpha (TNF- α), 215
- Tumor suppression, pocket protein, 73
- Tunicates, 154
- Tyrosine kinase, hypertrophy and, 348
- Tyrosine kinase FGF receptors, variability in, 355
- Tyrosine kinase inhibitor, 193
- V** alve leaflets, high collagen turnover and, 288
- Valvular interstitial cells (VIC), 288
- Vascular endothelial growth factor (VEGF)
 biology of, 246
 pathological angiogenesis and, 251
 physiological angiogenesis and, 250
 structure of, 247
 therapeutic angiogenesis and, 252
- Vascular endothelial growth factor isoforms, 248
- Vascular endothelial growth factor receptors, 249
- Vasculogenesis
 angiogenesis and, 258
 yolk sac, 300
 yolk sac and, 303
- Vasculogenic mechanisms, coronary vessels established by, 511
- Ventricular mechanical properties, myocardial tissue water changes and, 222
- Ventricular myosin heavy chain, 3
- Ventricular remodeling, IGF-1-mediated hypertrophy and, 121
- Ventricular volume, ejection fraction and, 240
- Vimentin, SV40 T oncogene and, 86
- W** ater changes, myocardial tissue, 222
- Wound healing paradigm, 295
- X**-linked dilated cardiomyopathy, dystropin gene and, 470
- Xenographic transplants, 268
- Y**olk sac, development of, 307
- Yolk sac vasculogenesis and hematopoiesis, 300

Index of Contributors

- A**dams, J. W., 19–29
Akhurst, R. J., 300–308
Alfarano, A., 227–229
Anger, M., 141–148
Angst, B. D., 101–104
Annoni, G., 426–428
Anversa, P., 47–64
Arosio, B., 426–428
Arrigoni-Martelli, E., 207–209
Artico, D., 111–114
Avantaggiati, M. L., 394–405
- B**ader, D., 1–8
Baker, K. M., 158–167
Baldini, A., 47–64
Balsano, C., 394–405
Bansal, D. D., 331–342
Barilla, F., 429–431
Barrieux, A., 370–386
Barsotti, A., 218–221, 222–226
Bartel, S., 230–233, 243–245
Bastagli, L., 417–421
Behnke-Barclay, M. M., 168–186
Beltrami, C. A., 111–114
Bezstarosti, K., 343–352
Biondo, B., 202–203
Bishop, J. E., 236–239, 387–393
Bock, M. E., 406–416
Booz, G. W., 158–167
Borg, T. K., 131–140
Borisov, A. B., 80–91
Brand, T., 309–316
Bunting, S., 246–256
Burgio, V. L., 394–405
Butt, R. P., 387–393
Buxton, R. S., 101–104
- C**alafiore, A. M., 218–221
Caldarera, C. M., 417–421
Caldarulo, M., 422–425
Calzolari, C., 234–235
Camaschella, C., 227–229
Campa, P. P., 429–431
Canepari, M., 204–206
Cappelli, V., 204–206
Carbone, A., 65–71
Carotenuto, A., 108–110
Cattini, P. A., 353–369, 406–416
Cesaroni, P., 65–71
Chen, J. H., 192–201
Chen, P.-L., 432–445
Chien, K. R., 115–127
Chirillo, P., 394–405
Ciavolella, M., 429–431
Clark, W. A., 168–186
Claycomb, W. C., 80–91, 267–285
Cleutjens, J. P. M., 286–299
Cobbe, S. M., 455–459
Collepardo, D., 394–405
Comi, L. I., 108–110
Contard, F., 370–386
Corsico, N., 207–209
Cousins, F. M., 300–308
Cremer, M., 470–491
Crescenzi, M., 9–18
Croce, C. T., 429–431
- D**aud, A. I., 446–454
de Bold, A. J., 192–201
De Divitiis, O., 108–110
De Feo, A., 65–71
De Jonge, H. W., 343–352
Decker, M. L., 168–186
Decker, R. S., 168–186
Delcarpio, J. B., 267–285
Di Girolamo, E., 222–226
Di Loreto, C., 111–114
Di Muzio, M., 222–226
Di Napoli, P., 222–226
Di Nardo, P., 65–71
Di Somma, S., 108–110
Dickson, M. C., 300–308
Dini, F. L., 218–221, 222–226
Doble, B. W., 353–369
Dubus, I., 370–386
- E**id, H., 192–201
Eppenberger, H. M., 128–130
Eppenberger-Eberhardt, M., 128–130
- F**arhadian, F., 370–386
Ferrara, N., 246–256
Fiaccavento, R., 65–71
Field, L. J., 446–454
Finato, N., 111–114
Fogel, W., 470–491
Franz, W. M., 470–491
Frustaci, A., 422–425
- G**agliano, N., 426–428
Gallina, S., 218–221, 222–226
Gannon, M., 1–8
Gastaldi, L., 227–229
Giugliano, M. A. M., 108–110
Goebel, H. H., 470–491
Gorza, L., 141–148
Grosso, E., 202–203
Grünig, E., 470–491
Gu, W., 72–79
Guarnieri, C., 417–421

- H**einson, H., 246–256
 Henderson, S. A., 19–29
 Herrmann, R., 470–491
 Hertig, C., 128–130
 Hescheler, J., 460–469
 Hicks, M. N., 455–459
 Huang, J.-X., 317–330
 Hunter, J. J., 115–127
Ito, K., 92–100
Janes, D. M., 168–186
 Jin, Y., 406–416
Kajstura, J., 47–64
 Karczewski, P., 243–245
 Kardami, E., 353–369, 406–416
 Karlsson, S., 300–308
 Katus, H. A., 470–491
 Katwa, L. C., 286–299
 Kim, K. K., 446–454
 Kircheisen, R., 470–491
 Klein, R. M., 210–217, 331–342
 Klug, M. G., 446–454
 Knaapen, M. W. M., 105–107
 Koh, G. Y., 446–454
 Kokott, S., 230–233
 Koller, A., 234–235
 Krause, E.-G., 230–233, 243–245
 Kübler, W., 470–491
 Kulkarni, A. B., 300–308
Lamers, J. M. J., 343–352
 Larue, C., 234–235
 Laurent, G. J., 236–239, 387–393
 Lavezzi, A. M., 202–203
 Lazzarotto, T., 417–421
 Lee, W.-H., 432–445
 Lemaire, J., 19–29
 Lembo, G., 115–127
 Levrero, M., 394–405
 Limongelli, F. M., 108–110
 Liu, L., 353–369
 Lompré, A. M., 141–148
 Lomurno, A., 429–431
 Low, R. B., 236–239
 Lytras, A., 406–416
MacGillivray, B. K., 210–217
 MacGregor, R. R., 331–342
 Magee, A. I., 101–104
 Mahdavi, V., 72–79
 Mair, J., 234–235
 Maltsev, V., 460–469
 Mancinelli, R., 207–209
 Mangiaracina, F., 429–431
 Mangieri, E., 429–431
 Manni, E., 207–209
 Maresca, P., 207–209
 Marotte, F., 370–386
 Martin, J. S., 300–308
 Martynova, M. G., 149–157
 Maturri, L., 202–203
 Matz, D. G., 30–46
 Mayr, M., 234–235
 McDonald, P., 455–459
 McKenzie, J. C., 210–217
 Melnik, N., 1–8
 Mercadier, A., 370–386
 Mesaeli, N., 187–191
 Micheletti, R., 204–206
 Mikawa, T., 506–516
 Minieri, M., 65–71
 Morano, I., 243–245
Nadal-Ginard, B., 72–79
 Nardini, V., 218–221
 Natoli, G., 394–405
 Nigro, G., 108–110
Oberpriller, J. C., 30–46
 Oberpriller, J. O., 30–46
 Olivetti, G., 47–64
 Oliviero, P., 370–386
Palermo, J., 492–505
 Panagia, V., 187–191
 Papparella, S., 108–110
 Pasumarthi, K. B. S., 353–369, 406–416
 Pepe, G., 417–421
 Perrone, G. A., 422–425
 Peruzzi, G., 65–71
 Petretta, V. R., 108–110
 Politano, L., 108–110
 Potts, J. D., 317–330
 Prentice, H., 455–459
 Price, R. L., 131–140
 Puddu, P., 417–421
 Puri, P. L., 394–405
 Puschendorf, B., 234–235
Quaini, F., 47–64
Rakusan, K., 257–266
 Rappaport, L., 370–386
 Reggiani, C., 204–206
 Reiss, K., 47–64
 Restucci, B., 108–110
 Rhodes, S., 236–239
 Riley, D. J., 432–445
 Rindt, H., 492–505
 Robbins, J., 492–505

Roetto, A., 227-229
Rohwedel, J., 460-469
Rossi, L., 202-203
Runyan, R. B., 317-330
Russo, A., 422-425
Russo, M. A., 422-425

Sacchi, A., 9-18
Samarel, A. M., 131-140
Sampaolesi, M., 65-71
Samuel, J-L., 141-148, 370-386
Santambrogio, D., 426-428
Scheffold, T., 470-491
Schlichtmann, T., 230-233
Schmitz, W., 230-233
Schneider, M. D., 309-316
Scholz, H., 230-233
Shansky, J., 19-29
Sharma, H. S., 343-352
Sharp, W. W., 131-140
Sieber-Blum, M., 92-100
Simpson, D. G., 131-140
Soddu, S., 9-18
Solerssi, R., 19-29
Sonnenblick, E. H., 47-64
Soonpaa, M. H., 30-46, 446-454
Sorrentino, V., 141-148
Spencer, R. P., 240-242
Stein, B., 230-233
Stirewalt, W. S., 236-239
Sun, Y., 286-299

Tam, S. K. C., 72-79
Tanzilli, G., 429-431
Tatò, F., 9-18
Terracio, L., 131-140
Thomas, G. R., 246-256
Tos, G. G., 227-229

Van Heugten, H. A. A., 343-352
Vandenburgh, H. H., 19-29
Ventura, C., 417-421
Verdouw, P. D., 343-352
Vergani, C., 426-428
Vettore, S., 141-148
Vincent, E. B., 317-330
Voit, T., 470-491
Volpe, P., 141-148
Vrolijk, B. C. M., 105-107

Walder, C. E., 246-256
Wang, H., 446-454
Weber, K. T., 286-299
Weeks, D. L., 317-330
Wenink, A. C. G., 105-107
Williams, S., 187-191
Wobus, A. M., 460-469

Yutzey, K. E., 1-8

Zanardi, M. C., 204-206
Zhou, G., 286-299
Zurlo, A., 422-425