

U. S. ARMY SPECIAL FORCES IN DESERT SHIELD/DESERT STORM:
HOW SIGNIFICANT AN IMPACT

A thesis presented to the Faculty of the U.S. Army
Command and General Staff College in partial
fulfillment of the requirements for the
degree

MASTER OF MILITARY ART AND SCIENCE

by

WILLIAM M. JOHNSON, MAJ, USA
B.G.S., University of Kansas, Lawrence, Kansas, 1980

FORT LEAVENWORTH, KANSAS
1996

AD BELLUM PACE PARATI

Approved for public release; distribution is unlimited.

19960819 060

REPORT DOCUMENTATION PAGE			Form Approved OMB No. 0704-0188	
Public reporting burden for this collection of information is estimated to average 1 hour per response, including the time for reviewing instructions, searching existing data sources, gathering and maintaining the data needed, and completing and reviewing the collection of information. Send comments regarding this burden estimate or any other aspect of this collection of information, including suggestions for reducing this burden, to Washington Headquarters Services, Directorate for Information Operations and Reports, 1215 Jefferson Davis Highway, Suite 1204, Arlington, VA 22202-4302, and to the Office of Management and Budget, Paperwork Reduction Project (0704-0188), Washington, DC 20503.				
1. AGENCY USE ONLY (Leave blank)	2. REPORT DATE 7 June 1996	3. REPORT TYPE AND DATES COVERED Master's Thesis, 2 Aug 95 - 7 Jun 96		
4. TITLE AND SUBTITLE United States Army Special Forces in DESERT SHIELD/ DESERT STORM: How Significant an Impact			5. FUNDING NUMBERS	
6. AUTHOR(S) Major William M. Johnson, U.S. Army				
7. PERFORMING ORGANIZATION NAME(S) AND ADDRESS(ES) U.S. Army Command and General Staff College ATTN: ATZL-SWD-GD Fort Leavenworth, Kansas 66027-1352			8. PERFORMING ORGANIZATION REPORT NUMBER	
9. SPONSORING/MONITORING AGENCY NAME(S) AND ADDRESS(ES)			10. SPONSORING/MONITORING AGENCY REPORT NUMBER	
11. SUPPLEMENTARY NOTES DTIC QUALITY INSPECTED 4				
12a. DISTRIBUTION / AVAILABILITY STATEMENT Approved for public release; distribution unlimited.			12b. DISTRIBUTION CODE A	
13. ABSTRACT (Maximum 200 words) This study investigates the contributions made by the U.S. Army Special Forces (SF) during the Persian Gulf conflict. Particular emphasis is placed on each mission performed by the SF during operations DESERT SHIELD/ DESERT STORM. Emphasis is placed initially on the building-block foundation of how a Special Forces Group (Airborne) is organized, paying particular attention to the operational A-detachment and the makeup of the SF soldier, which is paramount to this study. Brief accounts and descriptions are made of the various missions assigned to SF's coalition warfare support, which involved providing "ground truth" and close air support to the Arab-allied units, border surveillance; direct action; special reconnaissance; and combat search and rescue. This provides a base of knowledge into the myriad of operations conducted by the SF during Operations DESERT SHIELD/STORM. The study concludes by examining published quotes from key leadership within the Department of Defense which provides this study with a measurable means of determining what significance the missions executed by the SF did have on the success of DESERT SHIELD/STORM.				
14. SUBJECT TERMS Special Forces, Desert Shield/Desert Storm			15. NUMBER OF PAGES 113	16. PRICE CODE
17. SECURITY CLASSIFICATION OF REPORT Unclassified	18. SECURITY CLASSIFICATION OF THIS PAGE Unclassified	19. SECURITY CLASSIFICATION OF ABSTRACT Unclassified	20. LIMITATION OF ABSTRACT Unlimited	

GENERAL INSTRUCTIONS FOR COMPLETING SF 298

The Report Documentation Page (RDP) is used in announcing and cataloging reports. It is important that this information be consistent with the rest of the report, particularly the cover and title page. Instructions for filling in each block of the form follow. It is important to *stay within the lines* to meet *optical scanning requirements*.

Block 1. Agency Use Only (Leave blank).

Block 2. Report Date. Full publication date including day, month, and year, if available (e.g. 1 Jan 88). Must cite at least the year.

Block 3. Type of Report and Dates Covered. State whether report is interim, final, etc. If applicable, enter inclusive report dates (e.g. 10 Jun 87 - 30 Jun 88).

Block 4. Title and Subtitle. A title is taken from the part of the report that provides the most meaningful and complete information. When a report is prepared in more than one volume, repeat the primary title, add volume number, and include subtitle for the specific volume. On classified documents enter the title classification in parentheses.

Block 5. Funding Numbers. To include contract and grant numbers; may include program element number(s), project number(s), task number(s), and work unit number(s). Use the following labels:

C - Contract	PR - Project
G - Grant	TA - Task
PE - Program Element	WU - Work Unit Accession No.

Block 6. Author(s). Name(s) of person(s) responsible for writing the report, performing the research, or credited with the content of the report. If editor or compiler, this should follow the name(s).

Block 7. Performing Organization Name(s) and Address(es). Self-explanatory.

Block 8. Performing Organization Report Number. Enter the unique alphanumeric report number(s) assigned by the organization performing the report.

Block 9. Sponsoring/Monitoring Agency Name(s) and Address(es). Self-explanatory.

Block 10. Sponsoring/Monitoring Agency Report Number. (If known)

Block 11. Supplementary Notes. Enter information not included elsewhere such as: Prepared in cooperation with...; Trans. of...; To be published in.... When a report is revised, include a statement whether the new report supersedes or supplements the older report.

Block 12a. Distribution/Availability Statement.

Denotes public availability or limitations. Cite any availability to the public. Enter additional limitations or special markings in all capitals (e.g. NOFORN, REL, ITAR).

DOD - See DoDD 5230.24, "Distribution Statements on Technical Documents."

DOE - See authorities.

NASA - See Handbook NHB 2200.2.

NTIS - Leave blank.

Block 12b. Distribution Code.

DOD - Leave blank.

DOE - Enter DOE distribution categories from the Standard Distribution for Unclassified Scientific and Technical Reports.

NASA - Leave blank.

NTIS - Leave blank.

Block 13. Abstract. Include a brief (*Maximum 200 words*) factual summary of the most significant information contained in the report.

Block 14. Subject Terms. Keywords or phrases identifying major subjects in the report.

Block 15. Number of Pages. Enter the total number of pages.

Block 16. Price Code. Enter appropriate price code (*NTIS only*).

Blocks 17. - 19. Security Classifications. Self-explanatory. Enter U.S. Security Classification in accordance with U.S. Security Regulations (i.e., UNCLASSIFIED). If form contains classified information, stamp classification on the top and bottom of the page.

Block 20. Limitation of Abstract. This block must be completed to assign a limitation to the abstract. Enter either UL (unlimited) or SAR (same as report). An entry in this block is necessary if the abstract is to be limited. If blank, the abstract is assumed to be unlimited.

U. S. ARMY SPECIAL FORCES IN DESERT SHIELD/DESERT STORM:
HOW SIGNIFICANT AN IMPACT

A thesis presented to the Faculty of the U.S. Army
Command and General Staff College in partial
fulfillment of the requirements for the
degree

MASTER OF MILITARY ART AND SCIENCE

by

WILLIAM M. JOHNSON, MAJ, USA
B.G.S., University of Kansas, Lawrence, Kansas, 1980

FORT LEAVENWORTH, KANSAS
1996

Approved for public release; distribution is unlimited.

MASTER OF MILITARY ART AND SCIENCE

THESIS APPROVAL PAGE

Name of Candidate: MAJ William M. Johnson

Title of Thesis: U.S. Army Special Forces in DESERT SHIELD/
DESERT STORM: How Significant an Impact

Approved By:

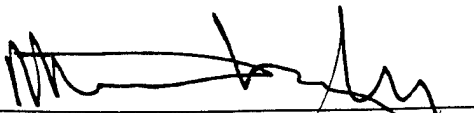
_____, Thesis Committee Chairman
MAJ Michael L. Langley, M.A.

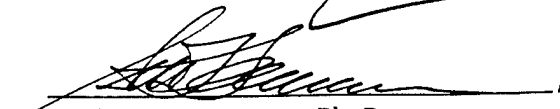
_____, Member
Arthur T. Frame, Ph.D.

_____, Member, Graduate Faculty
Michael D. Pearlman, Ph.D.

Accepted this 7th day of June 1996 by:

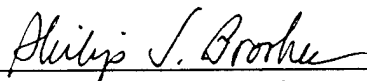
_____, Director, Graduate Degree Programs
Philip J. Brookes, Ph.D.

The opinions and conclusions expressed herein are those of the student author and do not necessarily represent the views of the U.S. Army Command and General Staff College or any other governmental agency. (References to this study should include the foregoing statement.)

ABSTRACT

U.S. Army Special Forces in DESERT SHIELD/DESERT STORM: How Significant an Impact, MAJ William M. Johnson, USA, 117 pages.

This study investigates the contributions made by the U.S. Army Special Forces (SF) during the Persian Gulf conflict. Particular emphasis is placed on each mission performed by the SF during operations DESERT SHIELD/ DESERT STORM. Emphasis is placed initially on the building-block foundation of how a Special Forces Group (Airborne) is organized, paying particular attention to the operational A-detachment and the makeup of the SF soldier, which is paramount to this study. Brief accounts and descriptions are made of the various missions assigned to SF's coalition warfare support, which involved providing "ground truth" and close air support to the Arab-allied units, border surveillance; direct action; special reconnaissance; and combat search and rescue. This provides a base of knowledge into the myriad of operations conducted by the SF during Operations DESERT SHIELD/STORM. The study concludes by examining published quotes from key leadership within the Department of Defense which provides this study with a measurable means of determining what significance the missions executed by the SF did have on the success of DESERT SHIELD/STORM.

TABLE OF CONTENTS

	Page
THESIS APPROVAL PAGE	ii
ABSTRACT	iii
LIST OF ILLUSTRATIONS	v
CHAPTER	
1. INTRODUCTION	1
2. REVIEW OF LITERATURE	23
3. RESEARCH METHODOLOGY	35
4. ANALYSIS OF SPECIAL FORCES OPERATIONS IN DESERT SHIELD	42
5. ANALYSIS OF SPECIAL FORCES OPERATIONS IN DESERT STORM	59
6. CONCLUSION AND FINDINGS	86
BIBLIOGRAPHY	111
INITIAL DISTRIBUTION LIST	116
APPENDIX	
A. FIGURES	102

LIST OF ILLUSTRATIONS

	Page
Figure 1. Organization of Special Forces	103
2. Special Forces Groups	104
3. Special Forces Company Headquarters (B Detachment) . .	105
4. Special Forces Operational Detachment "A"	106
5. Iraqi and Allied Positions on 17 January	107
6. Iraqi and Allied Positions on 23 February	108
7. Wire Diagram of Close Air Support	109
8. Enhance the Effectiveness of the Coalition	110

CHAPTER 1

INTRODUCTION

Since his special operations force commander's arrival in the gulf six months earlier he'd worked close to the front lines helping to hold the coalition together. I complimented him on the performance of his troops: they had run reconnaissance and made raids behind enemy lines, taught the Saudis, reorganized and equipped the Kuwaitis and during the fighting, served as military advisors to Arab units "they're good men."¹

Norman Schwarzkopf, It Doesn't Take a Hero

The U.S. Army Special Forces performed brilliantly during Operations DESERT SHIELD/STORM, effectively accomplishing the entire spectrum of mission capability. This was the largest scale conventional combat operation for the U.S. military since the close of the Vietnam conflict fifteen years earlier, and Army Special Forces were heavily involved in all aspects.

Significance of This Study

There has been much published since the 1991 conclusion of Operation DESERT STORM which talks of the U.S. military and the numerous operations performed. This literature has not neglected the U.S. Army Special Forces. One does not have to search long or far to find information on what Special Forces (SF) accomplished.

What this study will attempt to show, however, is another side to this already-published material, a side that is perhaps "closer" to

the action using personal notes and remembrances of actual participants from the SF units engaged in the operations.

During this study the question is the significance of the operations and missions and what role and effect did it have on the total overall scheme of maneuver and campaign plan laid by the Commander in Chief (CINC), U.S. Central Command, who at the time was General H. Norman Schwarzkopf.

This study will examine the wide range of missions conducted by the SF throughout the spectrum of conflict, beginning with the initial buildup of DESERT SHIELD in August/September 1990 and concluding with the cease-fire of DESERT STORM in February 1991. This study will look at the myriad of missions performed and the overall effectiveness it may have had. It must be noted specifically that this study looks only at the U.S. Army Special Forces in the conflict, not other elements of the U.S. Special Operations Command, which includes U.S. Navy SEALs and Special Boat Units, U.S. Air Force air and ground assets, U.S. Army Rangers and Special Operations Aviation, and Special Mission units. These units all had equally important tasks and missions during this conflict and will be mentioned only in context of their interface and support with Army Special Forces.

Background

It is necessary to understand how it came about that SF became involved in the conflict and why. Due to its unique organization and makeup of highly-qualified, senior officers and noncommissioned officers (NCOs) who are language-trained, culturally oriented trainers and leaders, SF is routinely called upon to assist in the development of a

foreign country's armed forces. This notion of training friendly forces is a logical product of the original mission for which SF was first created in 1952.

Although the creation and formation of Army Special Forces geared itself primarily to counter the Soviet threat in Eastern Europe during the Cold War, and involved the languages and cultural awareness of that region, Vietnam presented a new and unique challenge and really expanded the SF's role to that of a worldwide mission. Thus, SF officers and NCOs took on a global awareness, becoming specialists in areas of the world.

In Europe, interoperability and integration had reached workable levels four decades after World War II. In the region of the Middle East, however, there had not been four decades of togetherness and the U.S. military did not have this same level of interoperability and integration. From the outset, starting with the 2 August 1990 invasion by Iraq into Kuwait, which signaled the beginning of Operation DESERT SHIELD, General Schwarzkopf, the military representation of the U.S. within the Persian Gulf and the direct representation of the President of the United States, faced the requirement to develop and hold together a constantly changing and frail coalition of forces. Bringing this ad hoc coalition of nations to a common understanding operationally and having a reasonable chance of success was an enormous undertaking, and quite risky. This mission of ensuring interoperability of these forces and maintaining these forces consisting of Arabic and European nations, would be a task not easily performed. To accomplish this, General Schwarzkopf turned to his most flexible force to accomplish the mission, the U.S. Army Special Forces.

The U.S. Army Special Forces was then, due to its unique organizational structure and mission capabilities, the unit of choice to be selected by the Commander in Chief of Central Command, General Schwarzkopf to fulfill the necessary requirements needed to accomplish success in Operations DESERT SHIELD/STORM. To understand and gain a greater appreciation for the actions mentioned in this thesis, it is first necessary to provide a brief background into the organization of a SF unit, as it does vary quite significantly from that of conventional Army force structure.

Figure 1 illustrates a Special Forces Group consists of three "line" Special Forces Battalions, each with three "line" Special Forces companies, each with six operational A-detachments. The SF Group is commanded by a colonel (O-6), who is centrally selected by Headquarters, Department of the Army selection board. This is a highly experienced officer who had previously been a centrally selected SF battalion commander, and before that an SF company commander an A-detachment commander. In other words, this colonel has worked from the ground floor up in Special Forces.

The Group consists of approximately 1,300 officers, NCOs, and enlisted soldiers. At the group level, there is a Group Headquarters Company and Support Company, all which are geared to support the three SF battalions. The battalions are commanded by a centrally selected lieutenant colonel (O-5) and are organized into a battalion staff with an executive officer (XO), S-1 through S-5, as well as a battalion support company, consisting mainly of signal, intelligence, and other assortment of support specialties needed to support the battalions' three "line" companies.

Figure 2 shows the five active-duty Special Forces Groups, their current locations and, more significantly, the regions in the world where the unit is focused. Each group is oriented towards a specific region, carrying out the National Command Authority and that theater CINC's foreign assistance plans. This means that languages are trained for that area, exercise and frequent deployments for training are conducted, and extensive mission-area analysis of that region is studied. In the case of the Middle East region, which includes Saudi Arabia, Kuwait, and Iraq, which are pertinent to this study, the 5th Special Forces Group is the unit tasked with being knowledgeable and familiar, culture- and language-oriented towards this region. Thus it was the 5th Group which was tasked with the requirements of conducting Operations DESERT SHIELD/STORM.

In comparing the organization of a Special Forces Group with that of a conventional infantry or armor brigade, there does not seem to be major differences in the structure. Each is commanded by a colonel, with three battalions, commanded by lieutenant colonels, and an assortment of support structure present. This, however, is where all similarities cease to exist. It is at the Special Forces Company level, where the true uniqueness of SF is magnified.

The Special Forces Company (three in each battalion) is commanded by a Special Forces major and consists of a headquarters (HQ) element, called a B-detachment, and six operational detachments, called A-detachments, or A-teams, or simply refer to as operational A-detachments (ODAs). Each team consists of twelve officers and NCOs of varying skills.

Figure 3 graphically illustrates the makeup of the Company HQ, or B-detachment. The Commander and XO are officers who have previously commanded A-detachments, thus having compiled several years of experience operationally in that Group's area of operation or region of the world. Instead of a company first sergeant, each SF company has a sergeant major, who runs the day-to-day affairs of the company and is the most experienced soldier in the unit. Note also as per Figure 3, the extent of the senior-level of noncommissioned officers present. In addition to the sergeant major (E-9), the B-detachment has one master sergeant (E-8) and three sergeants first class (E-7) as well as several staff sergeants (E-6), all tasked with the responsibility of providing operational and communications support and maintaining command and control of their six ODAs. It is the mission and duty of each B-detachment to prepare, deploy, and maintain command and control with the A-teams no matter how austere or remote their base location may be. Normal SF deployments will involve the SF companies deploying to a secure, permissive, or safe environment and set up communications and a headquarters and further deploy their A-teams into the operational area.

Figure 4 portrays the makeup of the SF twelve-man A-team, or ODA. The entire 1,300 soldiers of an SF Group, to include the support elements at Group and battalion, the "line" battalions themselves, as well as the SF companies or B-detachments, are all there expressly to support, maintain, and sustain the A-detachments. It is the ODA which is the building block and foundation for all Special Forces. Each SF battalion has eighteen A-teams, meaning there are 54 ODAs in a Special Forces Group. This means there are 648 A-detachment members in that 1,300-person count of an SF Group. In actuality, each company may in

fact be able to man only five ODAs, not six, and perhaps none at the full twelve-man strength. A-teams commonly range from eight to ten soldiers, due to shortages worldwide for both Army and SF-qualified soldiers.

The A-detachment is a highly trained, language qualified (for their region), culturally sensitive team which is capable of performing all Special Forces missions in all types of weather and terrain, anywhere in the world. There are two officers on the team, the commander is a captain, who has been successful in a previous branch, usually combat arms, prior to entering SF and re-branching Special Forces. He may be a senior captain, at the six or seven year mark of his career prior to entering SF. The detachment technician is an SF warrant officer, who has previously served a minimum of six years as an NCO on an A-team. He is language qualified and has already compiled an extensive experience record prior to becoming an SF warrant officer. Many ODAs are in fact commanded by these warrant officers, who are very capable of command. The team sergeant, or operations sergeant, is a senior master sergeant with anywhere from eight to twenty years of operational experience on an A-team. Obviously, highly skilled and extremely experienced and talented. The remainder of the ODA consists of nine senior, highly trained NCOs, mainly sergeants first class and staff sergeants who, like all members, are language trained and enormously skilled. Note, as Figure 4 points out, the duplicity of skills involved: two medical specialists, two engineers sergeants, two communications specialists, and two weapons specialists. The design is to ensure that the detachment can easily become a split unit, operating in two equally capable teams, totally independent of each other. It is

these detachments which perform the wide range of missions outlined in this thesis. These teams are the operational arm of Special Forces; it is the ODA which is put deep behind enemy lines to perform whatever mission is required.

The makeup background of Special Forces would not be complete without looking closer at the individual SF soldier. It is he, after all, which all laurels of accomplishment must be placed. The fact that SF ODAs deploy to all corners of the world and accomplish a multitude of missions comes down to the fact that the SF soldier is, indeed, a cut-above. As this thesis quickly brushes through the missions and accomplishments of these fine individuals, it is important to understand the makeup fuller.

Each Special Forces soldier comes from the regular Army. He must be on his second enlistment to even "tryout" for SF. At that time he is put through an extensive assessment and selection phase, including demanding physical, mental, emotional, and psychological testing, where attrition rates can be as high as 70 percent. Only after completion of this process can a soldier continue on to the formal Special Forces Qualification Course. Officers and NCOs alike attend the same training together. The SF Qualifications Course is an intensive phased instructional and educational experience which details how to perform SF duties and functions on an A-team. Each hard-skill NCO, i.e., engineer, communications, weapons, and medical, graduates from this course as a highly-competent, in-demand specialist capable of performing at a very high standard. The SF medics, for example, undergo 54 weeks of trauma, life-support physician substitute training which includes hands-on lessons in real emergency-wards in hospitals. After one year of

training, he will graduate and join an A-team. Each individual also receives language training for his assigned unit prior to graduation as well.

What is the significance of all of this? Quite simply, that the SF soldier is not only a mature, officer or senior NCO but also is usually married and in his 30s, college educated in many instances, and very, very capable. This thesis' author was a detachment commander who had three college graduates on the ODA and three others with multiple years of college courses. The ODAs that performed the missions outlined later in this thesis are from the makeup explained above. Thus, when told of an SF mission performed, rest assured the individuals performing that mission were highly competent soldiers and very capable.

During Operations DESERT SHIELD/STORM the unique and challenging mission of ensuring that the different nations focused on a single coordinated objective was one that befitted SF. The 5th Special Forces Group (5th SFG), the Middle East being their oriented area, was given that mission, one which has come to be known as coalition warfare support teams (CSTs). In August of 1990, the term C.S.T. did not exist, and the mission was indeed vague, open ended, and left up to the creative imaginations of the on-site field commanders. The mission was to provide liaison and conduct Foreign Internal Defense (FID) operations with the Pan-Arab force, which included the Saudi Arabian land forces, the Egyptian forces, the Syrian forces, the Kuwait forces, and other member nations of the Gulf Coast Coalition. The concept of operations was quite simple in that elements of the 5th SFG would identify, locate, and link up with these coalition forces to perform the primary missions of close air support (CAS), provide for and "ground truth" to the

CINCCENT. There was a feeling that the Iraqi forces deployed in Kuwait would not hesitate to continue south into Saudi Arabia. Thus there was a true sense of urgency in deploying the SF units out to the coalition forces immediately.

The significance of this mission of coalition warfare support cannot be stressed enough. It is vital to the understanding of this thesis. Special Forces ODAs are designed to perform a wide variety of missions, mainly operating deep behind enemy lines conducting reconnaissance, direct action, and other sensitive missions. The ODA was accustomed to being a totally independent organization doing special operations missions. During the coalition warfare support mission, these ODAs operated throughout the front lines of a heavy armored battlefield, complete with artillery, tank, and mechanized fire and maneuver. This was the first time in the near 40-year history of Special Forces that A-teams performed in that magnitude on a conventional battlefield. The vast majority of the SF A-teams deployed during DESERT SHIELD/STORM were in that capacity, doing those missions previously stated. This mission, in fact, led to CSTs and five years after the Gulf conflict, is a leading Special Forces mission. In essence, the successful job done by the A-teams in the Gulf set a precedence for the future of Special Forces and their employment options. CSTs are being utilized during joint and combined exercises, and real-world deployments, such as Somalia (1993), Haiti (1995), and Bosnia (1996).

Another important aspect is the fact that the 5th SF Group was a bit different from the other SF groups, in that due to their area of responsibility being the Middle East, the 5th Group was equipped with

Desert Mobility Vehicles (DMVs) and Humm-V's in order to maneuver in the wide-open desert environments of the region. Thus the 5th Group soldiers were familiar with the desert environment and with the cultures of the Arab coalition allies. Also they had much more knowledge of conventional warfare, due to their own stock of vehicles which were utilized, maintained, and cared for in much the same way as a conventional unit cares for their organic vehicles. It should be noted that the other SF groups had no organic tactical vehicles, such as 5th Group, and thus could not have been utilized as effectively as 5th Group.

During DESERT SHIELD, the distinct danger of immediate attack provided the short-term benefits of having SF with the Arab allies; however, the training of these forces would be of long-term benefit to the allied effort as a whole. Special Forces units were placed forward along the border with Saudi Arabian Special Forces counterparts to perform a border police and early-warning detection and surveillance mission.² These combined teams were equipped with ground-to-air radios to enable them to call in close-air-support (CAS) if necessary. In addition, General Schwarzkopf was concerned that he had no reliable ground intelligence about what was happening or could happen along the entire open length of the Saudi-Kuwait-Iraq border. Therefore, border surveillance patrols with Saudi airborne and Special Forces units were established. Daylight hours were spent conducting visual reconnaissance missions from fixed border posts. At night, these teams conducted mounted patrols to deter border incursions and find refugees as well as provide early warning of enemy attack. From September to November 1990, these combined patrols were the only U.S. early warning forces (a sort

of trip wire) on the ground between the Iraqi army and the major ports and airfields of Saudi Arabia.

These combined reconnaissance patrols provided critical warning needed by the CINC. In addition, they gathered up refugees, deterred enemy patrols, and provided a means to deliver CAS to Saudi units. When the Iraqis attacked Khafji, Saudi Arabia in a significant offensive action in February 1991, these Special Forces teams assisted the Kuwait military force in urban-clearing operations to capture the remaining Iraqis and to restore internal security.

While these combined Saudi-U.S. Special Forces border patrols were securing the northern border of Saudi Arabia, the vast majority of the remaining units of 5th SFG (A) were planning to dispatch teams to support other coalition partners. The 5th SFG (A) was directed to assist in the reconstitution of the Kuwaiti Army. It was shortly after the initiation of this action that the rest of the coalition force completed their troop arrival in the country. This included the armies of Egypt, Syria, Oman, Morocco, Bahrain, United Arab Emirates, Qatar, and France. This put a great deal of pressure on the CINCCENT and his command structure and forced the need for integration and synchronization of these forces with the U.S. elements.

The 5th SF Group (Airborne) received the mission to position themselves preferably down at the battalion level of each and every coalition country's army. By the time the allied buildup was complete, the 5th Group had 106 teams assigned to nearly every single coalition battalion.³ This operation, later to be termed Coalition Warfare Support, but at the time considered simply Foreign Internal Defense

(FID), stretched the limited resources of 5th Group to a considerable degree.

The operational tasks assigned to these SF teams, were as varied as the units themselves. The SF teams initially assessed the capabilities of the units they were assigned to and tailored unit training programs. The Pan-Arab units required a great deal of assistance in calling for close air support, fighting in an Nuclear, Biological, Chemical (NBC) environment and coordinating a large-unit maneuver with nearby U.S. units. SF personnel conducted training in staff planning, combined operations, armored and mechanized warfare, human rights, the law of the land warfare, and basic civil affairs.⁴

Of course this presented a myriad of problems that the U.S. forces had to overcome. The SF units are not equipped, by doctrine, with the mobility assets to keep up with conventional units on a conventional battlefield, particularly in the desert with heavy armored forces. The 5th Group lacked sufficient vehicles to cover the wide range of units and lacked enough tactical FM radios to link them in a coherent fashion. The SF units are configured for long-range AM, burst transmissions and satellite use, not tactical conventional short-range FM communications.

During DESERT STORM, Special Forces A-teams were constantly monitoring the movement of friendly coalition forces. They especially monitored those along unit boundaries with other coalition forces; they passed information to other teams and ensured that movements were deconflicted with other allied forces. The SF teams led the way through minefields and helped coordinate the turning movement towards Kuwait City.

The SF teams moved with the first Saudi, Kuwaiti, and Egyptian units into Kuwait City itself. Despite the prohibition of U.S. units to move past 6th Ring Road in Kuwait City, they were given special permission to stay with their Arab units. "They had come this far with them and they were not about to leave at the end."⁵ Special Forces detachments took the lead in advising and assisting Kuwaiti military forces in urban clearing operations to capture remaining Iraqis and to restore internal security. The detachments worked with the Kuwaiti military to coordinate and provide basic humanitarian services, report man made obstacles, and allow coalition forces to occupy their respective embassies. Finally, Special Forces units assisted in the transition of security and restoration responsibility to the government of Kuwait.

It would not be overstating their importance by saying that these SF units provided the critical linkage and that SF was indeed a critical element in the ground offensive. The hard work and daily contact with all coalition partners ensured that the philosophy of effective coalition warfare was turned into a reality. The important heavy allied corps of Pan-Arab forces were effectively integrated into the command, control, communications, and intelligence structure of the combined forces through the actions of the SF. It is the author's contention that these corps surely would have been considerably less effective had it not been for the U.S. Army Special Forces.

In addition to this mission of coalition warfare support, the 5th Special Forces Group also was called upon to perform numerous other missions in support of the overall campaign plan. The SF teams were

inserted deep into Iraq to conduct specific, particular operations to include Special Reconnaissance and Direct Action.

The focus of this study will entail itself mainly to the aforementioned coalition support provided by SF, mainly because it involved the vast majority of the total SF operations during DESERT SHIELD/STORM. That is not to downgrade the effectiveness, bravery, and importance of the Special Reconnaissance and Direct Action missions. All these operations were infiltrations and exfiltrations conducted by Army and Air Force Special Operations aviation rotor-wing platforms and involved intense planning and execution, all at great risk.

Special Forces also participated in the planning and execution of Combat Search and Rescue (CSAR) operations during DESERT STORM. This involved SF teams working in conjunction with special operations aviation rotary-wing aircraft, infiltrating into enemy territory to recover downed allied aircrew and pilots. This mission provided much gratification as it resulted in the live recovery of a downed F-16 pilot. Obviously, this was extremely complex in nature, requiring detailed planning and execution, and was extremely dangerous.

This study will use numerous examples from the 2nd Battalion of the 5th Special Forces Group (Airborne) for several reasons, one of which was due to the fact this author was the S-3 (operations) officer for that unit and second because this unit specifically performed the coalition support role in addition to providing reconnaissance teams and doing the CSAR mission. Thus, the battalion was unique in that it was the only battalion which did each of the missions given SF during DESERT SHIELD/STORM.

It must be stated as well that it was not just the 5th SFG (A) that participated in Operations DESERT SHIELD/STORM. Elements from both the 10th Special Forces Group (Airborne) and the newly formed 3rd Special Forces Group (Airborne) also had roles. This study uses exclusively 5th SFG (A) materials as this was the SF unit that did the bulk of all missions given to SF during DESERT SHIELD/STORM. The 3rd and 10th SF Groups performed marvelously in their main missions of post-conflict stability operations which this study will not explore.

Scope

The great success of DESERT SHIELD and DESERT STORM heightened the awareness of coalition support operations that the Special Forces can accomplish to assist the conventional force. As stated in the U.S. Army's warfighting doctrine Field Manual 100-5, dated June 1993, this is indeed happening. In the areas of Special Reconnaissance and Direct Action, the SF once again reinforced its expertise and reputation in accomplishing the mission. In the mission of Combat Search and Rescue (CSAR), the SF has written doctrine, continued to exercise this mission, and due to the experience of highly skilled personnel, is a force of choice to conduct these operations. This study will examine each of the missions performed by Special Forces and will seek to determine the validity of each and, more importantly, learn of the significance to the overall campaign of each of these missions. The conclusion will then take all the activities SF performed on the whole, and examine their overall effectiveness.

Primary Question

How significant an impact did the U.S. Army Special Forces have on the overall force during operations DESERT SHIELD and DESERT STORM?

Secondary Questions

1. How were the U.S. Army Special Forces principally used during the Persian Gulf War?
2. Could other forces or agencies have had the capability to conduct the missions instead of Special Forces?
3. What is the emerging significance of the operations, particularly coalition support, to the U.S. Army Special Forces in the future?

Assumptions

United States Army Special Forces will be a viable force in the future.

Coalition Warfare will increasingly be necessary in future wars and operations other than war (OOTW).

Limitations

The focus of this thesis is U.S. Army Special Forces activities and operations in the Persian Gulf War. This research effort examines the accomplishment of these operations and the impact and effect it may have for future missions. The analysis will mainly focus on the operations conducted at the tactical level concentrating on the most recent and pertinent writings since this war. However, the relatively short time since the Gulf War may cause some informational constraint.

Definitions

Coalition Force. A force composed of military elements of nations who have formed a temporary alliance for some specific purpose (Joint Pub 1-02 dated 25 March 1994.)

Coalition Warfare. "Those tasks undertaken to facilitate the interaction of coalition partners and the U.S. military," General Carl Stiner, Army Magazine, April 1993.

Combined Operations. An operation conducted by forces of two or more allied nations acting together for the accomplishment of a simple mission (Army FM 100-5, Operations, dated June 1993.)

Direct Action. DA operations are short-duration strikes and other small-scale offensive actions by SOF to seize, destroy, or inflict damage on a specified target or to destroy, capture, or recover designated personnel or material. In the conduct of these operations, SOF may: (1) employ direct assault, raid, or ambush tactics; (2) emplace mines and other munitions; (3) conduct standoff attacks by fire from air, ground, or maritime platforms; (4) provide terminal guidance for precision-guided munitions; (5) conduct independent sabotage. (FM 31-20 U.S. Army Special Forces Operations, dated 1990).

Doctrine. Fundamental principles by which the military forces or elements thereof guide their actions in support of national objectives. It is authoritative but requires judgment in application (Joint Pub 1-02 dated 23 March 1994.).

Force Multiplier. A capability that when added to and employed by a combat force significantly increases the combat potential of that

force and thus enhances the probability of successful mission accomplishment (Joint Pub 1-02 dated 23 March 1994).

Foreign Internal Defense. FID is the participation by civilian and military agencies of a government in any of the action programs taken by another government to free and protect its society from subversion, lawlessness, and insurgency. The primary SF mission in this interagency activity is to organize, train, advise, and assist HN military and paramilitary forces. (FM 31-20, U.S. Army Special Forces Operations, dated 1990).

Liaison. That contact or inter communication maintained between elements of military forces to ensure mutual understanding and unity of purpose and action (Joint Pub 1-02 dated 23 March 1994.)

Search and Rescue. Activities designed to locate, recover, and restore to friendly control selected persons or material that are isolated and threatened in sensitive, denied, or contested areas. They focus on situations that involve political sensitivity and/or remote or hostile environments. These situations may arise from a political change, combat action, chance happening, or mechanical mishap. When directed, SF units perform combat search and rescue (CSAR) missions using collateral capabilities inherent in a DA recovery mission. SF does not employ standard CSAR procedures when executing such a mission. (FM 31-20, U.S. Army Special Forces Operations, dated February 1990).

Special Reconnaissance. SR is reconnaissance and surveillance conducted by SOF to obtain or verify, by visual observation or other collection methods, information concerning the capabilities, intentions, and activities of an actual or potential enemy. SOF may also use SR to secure data concerning the meteorological, hydrographic, or geographic

characters of a particular area. SR includes target acquisition, area assessment, and post-strike reconnaissance. (FM 31-20, U.S. Army Special Forces Operations, dated February 1990).

Unconventional Warfare. UW is a broad spectrum of military and para-military operations, normally of long duration, predominantly conducted by indigenous or surrogate forces who are organized, trained, equipped, supported, and directed in varying degrees by an external source. UW includes guerrilla warfare (GW) and other direct offensive low-visibility, covert, or clandestine operations, as well as the indirect activities of subversion, sabotage, intelligence collection, and evasion and escape (E&E). (FM 31-20, U.S. Army Special Forces Operations, dated February 1990).

Delimitations

This thesis will not delve into pre-Gulf War Special Forces operations. To do so would open up other questions that would detract from the main objective of this research. This project will focus on strictly the role of Special Forces during the Gulf War, including both Operations DESERT SHIELD and DESERT STORM. The data collected comes from open sources only. This thesis is not prescriptive in relation to a stated problem, but the conclusions bear merit for future employment considerations of Special Forces in all levels of conflict and peace.

Summary

The strength of Special Operations Forces lies in their versatility. As they demonstrated in Operation DESERT STORM, they can support conventional operations as combat multipliers, maximizing our capabilities and force potential. They also provided the "glue" that kept the coalition forces together.⁶

It is envisioned that future conflicts will arise with much less warning time. This is due to many factors, such as technological advances and the general instability of the world since the disintegration of the former Soviet Union. The important and significant contributions by Special Forces units during the conduct of the Persian Gulf War are certain to remain that way into the future. The Secretary of Defense's Final Report to Congress on DESERT SHIELD and DESERT STORM states, "Next time there might not be such a long period to develop a coalition," inferring actions taken prior to combat are a necessity.⁷ The importance of enhancing our coalition warfare capabilities is paramount for quick implementation. In light of the reduction of U.S. Armed Forces in the future, maximizing the proven synergistic potential of Special Forces in this coalition support role is prudent.

This chapter has provided the reader with a framework of the role the U.S. Army Special Forces played conducting the entire spectrum of missions during Operations DESERT SHIELD and STORM. In addition to this general framework this chapter establishes the purpose and significance of this study. The following chapter reviews existing literature on this subject, and chapter 3 explains the research and analysis methodology. Chapters 4 and 5 are the analysis portion of this thesis and chapter 6 provides the conclusion and recommendations. Hence, the framework is established for answering the research question.

Endnotes

¹H. Norman Schwarzkopf, It Doesn't Take a Hero, (New York: Bantam Books, 1992), 465.

²After Action Report, 2nd Battalion, 5th Special Forces Group, 10 March 1991.

³Author "Special Operations in Desert Storm: Separating Fact From Fiction," Special Warfare Magazine, March 1992, 3.

⁴MAJ William M. Johnson, SF, personal observations.

⁵Robert W. Riscassi, "Principles for Coalition Warfare," Joint Forces Quarterly, Inaugural Issue (Summer 1993), 71.

⁶James R. Locher III, Assistant Secretary of Defense for Special Operations and Low-Intensity Conflict, 12 November 1991.

⁷Department of Defense, Conduct of the Persian Gulf War, Final Report to Congress (Washington, D.C.: U.S. Government Printing Office, April 1992), I-49.

CHAPTER 2

LITERATURE REVIEW

Special Operations Forces can also be a significant combat multiplier when fully integrated in the corps plans. SOF units make important contributions to the corps efforts in the area of complementary reconnaissance, security, and other SOF missions. These specially trained units are enormously effective combat multipliers.¹

General Gary E. Luck, Military Review

Literature Review

The purpose of this chapter is to review existing literature on the missions and activities of Special Forces during the Persian Gulf War providing a foundation for this thesis. Four major categories of literature are discussed: Joint and Army doctrine, books, articles, and unpublished works, such as speeches, theses and papers, and an extensive network of personal after-action notes and conversations with key participants. Thoroughly researching these four categories of literature identified many works which are pertinent to this thesis.

Doctrine

The Special Forces units conduct operations throughout the spectrum of conflict from peace to war. They can be employed to accomplish tactical, operational, or strategic-level objectives. In a coalition warfare environment, such as the case in the Persian Gulf conflict, SF is significant in that it establishes a psychological

environment of national-level policy and attitudinal commitment of two or more nations to employ armed forces in combined operations to achieve shared coalition objectives. The effectiveness of combined operations is determined by the extent to which commanders and staffs are able to professionally cooperate to achieve these objectives. At the tactical level of conventional operations, soldiers and leaders interact with their coalition partners on a personal, human relations side versus political basis.

The keystone United States Army Field Manual (FM) 100-5, Operations, addresses several areas concerning Special Forces capabilities and expertise. The fact that SF covers the five principal missions of unconventional warfare, direct action, special reconnaissance, foreign internal defense, and counterterrorism.² This FM also addresses the potential problems of operations in a coalition environment. It asserts that, "few linguists have both the language expertise and depth of understanding to cross both language and doctrinal boundaries and be fully understood."³ This manual does not attempt (nor is it meant to) to tie in the capabilities that Special Forces can bring to this portion of the operational spectrum.

FM 100-5 recognizes that dedicated liaison and linguist teams are a vital resource commitment. This manual, along with Joint Pub 3.0, Doctrine for Joint Operations provides authoritative doctrine to guide commanders and their staffs in conducting joint and combined operations.

Joint Publication 3-07 Joint Doctrine for Military Operations Other Than War, basically states that Special Operations Forces validated this coalition warfare/advisory role during the Gulf War, and are recommended in the different activities of Military Operations Other

Than War (MOOTW) for utilization with this mission.⁴ Along these lines this publication alludes to the capability of Special Forces dealing with other personnel on the battlefield, such as non-governmental agencies.⁵

Joint Publication 3-05.3, Doctrine for Joint Special Operations, reflects Special Forces contributions to the Gulf War coalition:

SOF must be prepared to conduct so under conditions of coalition warfare. SOF may be required to execute unilateral operations or apply their unique characteristics to provide liaison to coalition partners and, by doing so, facilitate interoperability between U.S. and allied forces. As evidenced during Operations DESERT SHIELD and DESERT STORM, the role that SOF played in support of the campaign objectives by training, working, and going into combat with the majority of the coalition nations was one of the keys to campaign success. SOF's unique capabilities in language training, their regional orientation and forward deployment, and focus on independent small unit actions make them one of the principle forces of choice to compliment and support coalition warfare objectives.⁶

Joint Publication 3-05.3, Joint Special Operations Operational Procedures, identifies Special Forces as the only Army Special Operations Forces specifically trained to perform special reconnaissance missions.⁷ Special Forces is the responsible force to perform unconventional warfare.⁸ This doctrine sets forth doctrine and provides guidance for the joint force commander and how to best utilize Special Operations forces. The operational plans of the joint force commander, General Schwarzkopf during the Gulf War quite possibly had a significant impact on the workings of this document.

Army SOF doctrinal manuals (FM 31-20 and 100-25) have not been updated since the Gulf War. These are the keystone manuals for Special Forces in the conduct of their basic mission spectrum. These manuals

provide some technical detail as to the definition of terms and missions in which SF performs and did perform during the Persian Gulf War.

Books

Certain Victory: The U.S. Army in the Gulf War is a work of great relevance to this thesis. The overall focus is on the accomplishments of the common every day American soldier and rarely strays above the tactical level. In one particular excerpt about a Special Forces A-detachment's mission of reconstituting a Kuwaiti Armor Brigade it states, that SF "in the process became part of the glue that held the coalition together as part of the overall CENTCOM effort."⁹ This writing exemplifies that the mission performed by SF in the coalition warfare area gained recognition as a critically needed mission.

Conduct of the Persian Gulf War: Final Report to Congress, contains in its chapter on SOF a wealth of information pertinent to this thesis. It is a synthesized version of lower-level after-action reports. It provides a good foundation for fact substantiation all through the analysis and conclusion portions of this thesis.

John M. Collins, Senior Specialist in National Defense at the Library of Congress, conducted an assessment of U.S. Special Operation Forces for U.S. Senators Nunn and Cohen in 1993. Special Operations Forces: An Assessment, published in 1994, is a thorough and unrestricted study of the force. It is written to aid experts and laymen alike in their efforts to grasp the subject concerned. The author utilizes experiences from the Persian Gulf War to add to this work.

In Douglas C. Waller's book The Commandos: The Inside Story of America's Secret Soldiers, there can be found numerous accounts of the wide range of operational activities conducted by Special Forces during the Gulf War. The author uses historical background knowledge of special operations and brings us into the Gulf War-specific operations. In his closing remarks, Waller states that, although wonderfully performed missions were commonplace, "their strategic value was never realized."¹⁰ The author argues that the other portions of the research beg to disagree with Mr. Waller on this summarization, but this book does offer very noteworthy accounts of SF operations.

From Shield to Storm is a book published shortly after the conduct of the war and brings a quick responsive look at the overall effort, including small portions of SF. This book gives the reader a fairly shallow and quick broad-brush look at the coalition, in which is stated that "Special Forces personnel were assigned the more vital task of insuring smooth coordination with other allied units [Arab and non-Arab]."¹¹ The book also mentions the other SF missions conducted and generally uses a mater-of-fact approach and limits the value placing on these missions.

In General H. Norman Schwarzkopf's autobiography It Doesn't Take a Hero, he explains his operational-level planning and approaches how he led the U.S. and coalition efforts. He cites his Special Operations Commander Colonel Jesse Johnson as "one of DESERT STORM's unsung heroes."¹²

Captain (U.S. Navy) M. E. Morris' book H. Norman Schwarzkopf: Road to Triumph, contains the transcript of the Generals press brief in Riyadh, Saudi Arabia, given on 27 February 1991. He, quite bluntly,

confirms to the media as well as the world's viewers live on Cable News Network Television, what roles and missions that SF performed during the Persian Gulf War. Schwarzkopf explains that among other things, "They did a great job in strategic reconnaissance for us."¹³

In Greg Walker's book At The Hurricane's Eye U.S. Special Operations Forces from Vietnam to DESERT STORM, he applies an informed journalist's view of the accounts and usefulness of SF during the Gulf War. His buildup of background information runs over thirty years of SF activities and concludes by looking at the validity gained by SF during that time frame. Speaking of future conflicts, the author states that, "if they (wars) are to be won on the ground it will be by SOF soldiers from all the services, working together as a combined force."¹⁴

Articles

Several articles are applicable to the study of this thesis. Among these is an article published in Military Review entitled, "Coalition Warfare in DESERT STORM." The author provides an outstanding first-hand account of coalition warfare in DESERT STORM. Specifically, he states that "The linkages employed with liaison teams and with SOF augmentation teams offer a successful example for further study."¹⁵

Articles of the same quality and relevance include "Special Operations in DESERT STORM" and "Five Imperatives of Coalition Warfare" from Special Warfare Magazine.¹⁶ These articles provide a summary of the Special Operations contributions during the Gulf War. Their common theme is that they recognize the magnitude of the effort put forth by the 5th Special Forces Group in conducting its variety of missions.

These research articles bring to light fundamental principles along with their applications that have been productive to success.

Speeches, Monographs, and Lessons Learned

The following source have proven extremely valuable to this work. They have allowed the thesis development of a thorough understanding of the contributions that Special Forces had in the Gulf and how it has effected the thinking prevalent today.

"Versatility Protects SOF," made by the Assistant Secretary of Defense for Special Operations/Low Intensity Conflict James R. Locher III, presents an interesting perspective for SOF. It echoes what a valuable price special operating forces plays in all areas, particularly in coalition warfare. It is a beneficial reference for this thesis.

General Carl Stiner's testimony "USSOCOM challenges: Risk, Ambiguity, Diversity, Opportunity," to the Senate Armed Services Committee on 5 March 1992 provides an overview of the Goldwater-Nichols Act. The fundamental principle of SOF functioning as combat multipliers is extremely relevant.

In December 1992, the National Defense University sponsored a symposium entitled, "Non-traditional Roles for the U.S. Military in the Post-Cold War Era." Then Lieutenant General Wayne A. Downing, Commander of the U.S. Army Special Operations Command and now CINC USSOCOM, spoke about the SOF's role. The significance of his speech is that he talked of the future roles of Special Forces, much of it due to the validation gained during the Gulf War.

In his monograph "United States Army Special Forces: Versatile Element in the Future Security Environment," Lieutenant Colonel Stan

Florer provides great insight into the coalition capabilities of Special Forces, as well as the other missions that SF performed during the Gulf. Of particular interest to this project is that the author, now Colonel Stan Florer, is currently Director of Training and Doctrine at the United States Army John F. Kennedy Special Warfare Center and School.

In his monograph "Opening Pandora's Box: The U.S. Army in Combined Contingency Operations," Major William Gregory articulates the need to improve the U.S. Army's capability to plan and execute combined operations. It highlights this foundation by analyzing past U.S. combined operations, including DESERT SHIELD and DESERT STORM. The author asserts that the coalition having the luxury of six months of "unencumbered time in which to plan, prepare, and rehearse for combat operations,"¹⁷ may not be enjoyed by coalitions of the future. He writes of the serious ramifications of not having as much time for planning in future combined operations and exercising care in incorporating too much of the DESERT SHIELD and STORM success into future doctrine.

The author also reveals his propensity for the importance of liaison in the scheme of combined operations. He concludes with a statement that, "The Army must devote additional efforts to the identification selection and training of liaison officers in all functional areas."¹⁸ At a 1994 conference on "Standing Up Coalitions," sponsored by the National Defense University this theme was repeated again and again as extremely valid. These work substantiate a basis for this thesis: that Special Forces role in the mission of coalition support wars of the utmost importance, then during the Gulf War and now.

In his monograph entitled "Establishing Theater Command and Control in a coalition of Nations" Major Barry Maxwell is primarily oriented towards the operational and tactical levels of war. However, the issues of liaison and cultural differences, in particular the language barrier, are pertinent points towards the research of this thesis. Wartime advisory and assistance is a phrase the author uses to describe the requirement for doctrine in order to advise and assist the other members of a coalition. This monograph provides some insight into the questions identified earlier.

In his monograph entitled, "Coalitions, Command and Control: Essential Considerations," Major Joseph Moore focuses at the operational and strategic levels of war. This monograph reiterates the common deficiencies found in doctrinal manuals. This project also brings up the issue of cultural and language differences. It tells of how the U.S. supplied language trained liaison teams to coalition partners, down to battalion level, during DESERT SHIELD and STORM.

Of all the volumes of lessons learned documents, the most valuable to this thesis is the one entitled, "Roles and Missions of Special Operations Forces (SOF)." This executive summary of the role of SOF during Operations DESERT SHIELD and DESERT STORM is critical for recognized facts and for reinforcing the validity of this thesis. Many of the recommendations have yet to be implemented, particularly in expanding Special Forces doctrine "to articulate procedures to be used when supporting a U.S. commander in establishing and commanding a coalition force."¹⁹

Summary

This research of literature has brought to light some learned and qualified individuals and how their views of Special Forces Operations in the Gulf War succeeded or failed to make a lasting impression on future operations. The sources gathered provide background material, operational accounts of missions, and opinions, mixed with facts on the overall effectiveness of SF in the Gulf conflict.

Over sixty sources were assembled for research of this thesis. They provide a balanced and comprehensive summary of literature that is available and thought to be sufficient for this thesis. Research conducted does not compare the role and missions that Special Forces performed in the Gulf War with other recent operations, such as the 1983 Operation URGENT FURY, the operation in Panama JUST CAUSE, and the 1993 involvement in Somalia. The plan is to use this literature to answer the research question, "How significant an impact did the U.S. Army Special Forces have on the overall force during Operation DESERT SHIELD and DESERT STORM?" This will be the focus of the next chapter.

Endnotes

¹Luck, Gary E. "Corps Force Protection Operations." Military Review LXXII, No. 12 (December 1993), 15-25.

²U.S. Army, FM 100-5, Operations (Washington, DC: Department of the Army, 2-20, 2-21.

³U.S. Army, FM 100-5, Operations (Washington, DC: Department of the Army, 5-2.

⁴Joint Chiefs of Staff, Joint Pub 3-07, Joint Tactics, Techniques, and Procedures for Foreign Internal Defense, 20 December 1993, III-13, 14.

⁵Joint Chiefs of Staff, Joint Pub 3-07, Joint Tactics, Techniques, and Procedures for Foreign Internal Defense, 29 December 1993, IV-7.

⁶Joint Chiefs of Staff, Joint Pub 3-05, Doctrine for Joint Operations, 9 September 1993, II-15.

⁷Joint Chiefs of Staff, Joint Pub 3-05.3 Joint Special Operational Procedures, 25 August 1993, II-4.

⁸Joint Chiefs of Staff, Joint Pub 3-05.3 Joint Special Operational Procedures, 25 August 1993, II-1.

⁹Robert H. Scales, Certain Victory: The U.S. Army in the Gulf War, (Simon and Schuster, 1993), 106.

¹⁰Douglas C. Waller, The Commandos: The Inside Story of America's Secret Soldiers, (Simon and Shuster, 1994), 365.

¹¹James F. Dunnigan, From Shield to Storm High Tech Weapons, Military Strategy, and Coalition Warfare in the Persian Gulf War, (William Morrow and Company, 1992), 350.

¹²H. Norman Schwarzkopf, It Doesn't Take a Hero, (New York: Bantam Books, 1992), 465.

¹³M. E. Morris, Road to Triumph, (New York: St Martin's Paperback edition, June 1991), 262.

¹⁴Greg Walker, At the Hurricane's Eye U.S. Special Operations Forces from Vietnam to Desert Storm, 260.

¹⁵Mark B. Yates, "Coalition Warfare in Desert Storm," Military Review, Oct 93, 52.

¹⁶John Fenzel III, "Five Imperatives of Coalition Warfare." Special Warfare Magazine, July 1993, 2.

¹⁷Ibid., 35.

¹⁸Ibid.

¹⁹John Stewart, "Role, Mission of Special Operations," Executive Summary obtained from the U.S. Army Command and General Staff College Historian, 5-6.

CHAPTER 3

RESEARCH METHODOLOGY

We have the people the motivation and the reputation for unconventional thought and action. Now is the time to justify the faith our nation's leaders have placed in us by being in the forefront of change. Now is the time for us to develop new paradigms that will allow us to continue to make significant contributions to the nations security.¹

Wayne A. Downing, "Special Operations Forces: Meeting Tomorrow's Challenges Today"

The purpose of this chapter is to prepare the foundation that will be used to examine the research material found in chapters 4 and 5, which will lead to the conclusions stated in chapter 6. This chapter will serve to explain the research methodology used in this thesis and establish an outline of the criteria used for basing this evaluation.

The objective of this work is to explore the operations of the U.S. Army Special Forces during the 1990-1991 Persian Gulf conflict. In the following two chapters this paper will focus on the accomplishments and operations conducted by Special Forces during the two phases of the Gulf War, that being Operation DESERT SHIELD, which lasted from 2 August 1990 until 17 January 1991, and Operation DESERT STORM, which was initiated with the allied offensive starting at 0300 hours (EST) 17 January 1991 and lasting until the cease-fire on 28 February 1991.

In chapter 4 this paper will examine the Special Forces workings during the pre war stage of DESERT SHIELD. This will include looking at

the individual missions performed by SF during this time frame. The mission of Border Surveillance will be explained. An operation in which Special Forces detachments, operating in a combined method with the Saudi Arabian Special Forces, patrolled and monitored the entire length of the Saudi-Kuwait border.

Chapter 4 will also discuss the primary mission that the Special Forces performed during the Gulf conflict, that being Coalition Warfare.² Of all the missions performed by SF, this is the one that arguably had the biggest impact on the overall allied campaign plan.³ This mission is when Special Forces had the responsibility to provide "ground truth" and accompany the Arab coalition force into combat operations.⁴ Special Forces had the task of deploying Operational Detachment-As to each of the 104 allied coalition battalions to conduct operations during DESERT SHIELD, a monumental task.⁵ It will explain the missions SF conducted in their coalition warfare support role, giving broad treatment to this operation.

Upon conclusion of detailing the workings of SF during the DESERT SHIELD phase of the Gulf War, chapter 5 will then examine the exploits of SF activities during the armed conflict phase of the Gulf War, Operation DESERT STORM.

The first portion of chapter 5 will outline the role that SF played in coalition warfare during actual combat offensive action. The performance during this particular operation included not only the "ground truth" mission as in DESERT SHIELD, but was expanded to include the using of SF teams calling in CAS for the Arab coalition forces. This chapter will serve to explain this function and how it operated.

This thesis will also examine the missions of Special Reconnaissance and Direct Action which Special Forces teams performed. In particular, this section of the thesis will take a look at the character and makeup of the Special Forces soldier and his capabilities. This author feels it is necessary, in this chapter, to graphically exploit some of these operations in some amount of detail to give the reader a sense of understanding to the absolute quality of the individual Special Forces soldier. This underlying theme plays a significant role in the overall purpose of this thesis, thus its inclusion in this work. The exploits of the SF detachments in the conduct of these particular operations has great value in understanding the spectrum of SF capabilities utilized during the Persian Gulf War.

Chapter 5 will also examine the mission of Combat Search and Rescue and the involvement of Special Forces. This was a "very tough mission, and that was one of the Special Forces missions."⁶ This paper will detail the preparation and planning which occurred between the SF teams and the aviation assets, which resulted in the actual live combat operations of rescuing downed United States pilots in occupied, enemy territory.

Lastly, this chapter will examine briefly the role Special Forces played in the liberation of Kuwait City itself. As the SF soldiers accompanied their Arab coalition counterparts, as detailed in the Coalition Warfare sections of this paper, one of the missions involved the "clearing" of the Kuwait capital. This was a rather unique operation, in that the involvement of U.S. troops was not the desired method. Instead, it was the Arab forces which had as their task the

liberation of the capital. The only United States forces operating inside Kuwait City were the Special Forces soldiers accompanying the Arab allies, of which this author was one.⁷ This proved to be both exhilarating and thrilling to be the "liberating heroes," but extremely sensitive as to the operations involving our Arab allies.⁸ The final portion of chapter 5 examines this aspect in more detail.

The research used to examine the exploits of Special Forces during DESERT SHIELD and DESERT STORM serves as the basis or "proof" of this project. These chapters provide the raw data as to what shall be examined in this paper. The question now challenges us to quantify into arguable and usable form this raw material and point it to answering the overriding question of this thesis project--that being how significant an impact did the Special Forces operations play in the overall campaign of Operations DESERT SHIELD/STORM.

To open, it must be first necessary to understand the words "significant" and "impact," and understand the context in which this effects this work. According to Webster's II New Riverside University Dictionary, the term significant is "Having or expressing a meaning: meaningful," and also "Momentous: important."⁹ The term impact refers to "the effect or impression of one thing upon another."¹⁰

These definitions leave quite a bit to interpretation. For the purposes of this thesis, the aforementioned usages serve this research favorably. Thus the question of significant impact put in different terminology can be summarized by those actions that are deemed meaningful and leave a favorable impression, or have a positive impact on another unit or force or in this study, the overall campaign.

In essence, to answer this question of what significant impact did Special Forces play in the Gulf War, after identifying what is meant by the terms "significant" and "impact," the next step in this methodology would be to establish a measuring device or "yardstick" on how to quantify and answer the main thesis question posed.

The question becomes, How do we discover the "answers," and in what form does the proof come? The "answers" will come in the form of key and significant leaders at various levels and their mentions and thoughts of Special Forces and its impact on operations. The thoughts from the key leadership and their expressed mentions of the wide range of Special Forces missions conducted and how it may have impacted on the overall campaign will provide that "proof" and become that "yardstick" as to measure the impact and significance.

In order to quantify and "prove" the significance or insignificance that SF played in the Gulf War, where better, arguably, to look to than the key leadership from the very top levels on down to the tactical level. At these levels of command and leadership positions, with the vast responsibilities involved, decisions on the coalition level had to be made and operations structured to keep the synchronization of all forces. This, being as challenging a task as it appears, obviously was carried out successfully as the end results indicate, these key leaders' opinions and expressions of the SF's role are of immense value. From these sources, the readers can form his/her opinion as to the "answer" to the overriding question posed. The "proof," or the "yardstick" from which to measure the significant impact, will thus come from these thoughts and quotes from the key leadership during the Gulf War.

In the final chapter of this thesis, these quotes and thoughts from this key leadership will be outlined and examined. This material will then be used to form the conclusions and place in a logical sense of importance the raw materials from chapters 4 and 5. This will serve as the conclusion to this study and it will be left to the individual reader as to his/her own opinion as to the validity and significance of this study. I believe this study will prove relevant and valuable in future studies of both Special Forces and the Persian Gulf War.

Endnotes

¹Wayne A. Downing, "Special Forces: Meeting Tomorrow's Challenges Today." Special Warfare (January 1995).

²Interview with COL (R) James Kraus, 5th SFGA Commander during Gulf War.

³Ibid.

⁴Interview with COL Daniel Brownlee, 5th SFGA Operations Officer during Gulf War.

⁵Ibid.

⁶H. E. Morris, Road to Triumph, (New York: St Martins, Paperback edition, June 1991), 261, 262.

⁷Personal observations, by William M. Johnson.

⁸Ibid.

⁹Webster's II New Riverside University Dictionary. (The Riverside Publishing Company, 1988).

¹⁰Ibid.

CHAPTER 4

ANALYSIS OF SPECIAL FORCES OPERATIONS IN DESERT SHIELD

SOF personnel are trained to operate as consummate professionals with selfless dedication to the Nation, their mission, and their commanders. Their versatility, cross-cultural training, and ability to operate alone as a force multiplier often make them the force of choice. SOF provide the men and women for the tough missions.¹

U.S. Special Operations Forces,
Posture Statement, 1994

This chapter is an analysis of the missions Special Forces were tasked to perform during Operation DESERT SHIELD from the time period 2 August 1990 until 17 January 1991. All of these missions, conducted by SF during the Operation DESERT SHIELD phase were centered around the rubric of coalition warfare support. This chapter will focus on those activities and operations that SF performed exclusively during the DESERT SHIELD time frame which ended with the initiation of coalition offensive action on 17 January 1991.

On 31 August, the Headquarters, 5th Special Forces Group from Fort Campbell, Kentucky, arrived in Saudi Arabia and began its initial mission to support the Saudi Arabian lead forces.² The 1st Battalion, commanded by Lieutenant Colonel Jerry Thompson, was the first unit of the 5th Group to arrive in country. The 2nd Battalion, commanded by Lieutenant Colonel Bill "Ironman" Davis, closed its entire battalion in country on Friday, 14 September 1990, followed by the 3rd Battalion,

commanded by Lieutenant Colonel Mike Shaw.³ The 2nd and 3rd Battalions established operations at King Khalid Military City (KKMC) with the 5th Group headquarters and 1st Battalion set up in the east coast, near Dharan, operating out of the King Fahad International Airport complex.⁴

The first order of the day was to immediately organize the battalions into Forward Operating Bases (FOBs), arrange for living quarters and work spaces, and immediately set up the operations center, support center and signal center. There was a definite need to quickly acquire the use of ranges and maneuver areas to acclimatize the soldiers and to prepare them for combat. All of the Special Operations units at KKMC formed committees to develop base defense and security and evacuation plans.⁵ This was a difficult task in that the KKMC complex was totally isolated and that there was a major shortage of heavy weapons for defensive purposes. The early days after arrival were spent largely accomplishing these tasks.

Border Surveillance

As the 5th Group settled down and prepared for hostilities, the first real combined mission was initiated by joining SF teams and Saudi paratroopers/commandos to establish combined operational detachments-A, or CODA's, to conduct special reconnaissance missions along the Saudi-Kuwait border. These missions required coordination and collaboration between SF, Royal Saudi Land Forces, Saudi Arabian National Guard, Gulf Cooperative Council Units, and the border guard forces of the Ministry of the Interior.⁶ On the Saudi-Iraq border, U.S. Special Forces patrolled with the Saudi military, other coalition forces were massed

behind them followed by U.S. ground forces. They conducted border surveillance from forts called Mazekahs.⁷

On 13 October 1990, Mission SR002, which consisted of ODA-562, commanded by Captain Ken Takasaki, and Special Operations Team-A (SOT-A) 505, deployed north to become the first special reconnaissance/border surveillance unit to be actively involved in DESERT SHIELD.⁸ This element was combined with a Saudi Special Forces unit, commanded by Captain (Prince) Fahd, a graduate of the U.S. Army Special Forces and Ranger courses. This first element was responsible for surveilling the border from the border town of ArRuqi for a distance of approximately 60 kilometers. They operated from a fixed location, the border forts called mizekahs. This was a totally combined effort, to include billeting, dining, and patrolling, and in itself, was quite a success story.

The remaining border areas, stretching from the east coast of Saudi Arabia, to the tri-border area of Saudi/Iraq/Kuwait, were patrolled by these combined U.S. SF and coalition forces. These patrols utilized the HUMM-V vehicles, mounted with MK-19 machine guns, night-vision devices, communications equipment, and all the weapons assigned to the detachments. From the detachment's headquarters at the fixed border site, the area of responsibility included patrolling to the east and west of this fixed site, well coordinated with the other detachments located on each flank. The detachments communicated via both satellite and high-frequency (HF) radios back to their battalion headquarters which monitored and commanded each team. They maintained their normal TO&E equipment and their assigned vehicles.

Each of the three Special Forces battalions of the 5th Group was responsible for providing detachments to perform this mission approximately two ODAs per battalion were committed against this mission. The ODA's were usually rotated among companies within the battalion.⁹ The CINC himself stated, "These SF soldiers performed reconnaissance for us, and they let us know what was going on out there. They were the eyes that were out there."¹⁰

The conduct of this mission during the DESERT SHIELD phase was significant for several reasons. Although not much is written about the contributions that these small detachments had on the overall larger picture, interviews and AARs conducted by the actual participants point out the value was great for a variety of reasons.

Primarily, as General Schwarzkopf pointed out, these detachments were the only eyes and ears on the ground for the entire coalition force. These deployed elements provided real-time early warning to the CINC and monitored the Iraqi buildup and activities along the Kuwait-Saudi border. A very clear vision was possible of the Iraqi units, and accurate counts were able to be made and passed on.¹¹ Especially critical was the phase when the allied units did the "left hook" movement from east to west to position for the allied assault. As it turns out, these SF teams were the only eyes available to the CINC to monitor any reaction.

During the latter phases of Operation DESERT SHIELD and during the air campaign of Operation DESERT STORM, these outposts provided a means and "a target" for Iraqi deserters to move to. By providing these border surveillance teams with psychological operations tools, in the

form of leaflets and loudspeakers, they were able to "coax," and receive numerous Iraqi deserters.¹² These deserters, in turn, provided much-needed, valuable information after being passed on to the formal questioning/interrogation/debriefing by higher headquarters conventional units.

The mission of border surveillance for the 5th SFG(A) lasted from 13 October 1990 through 10 February 1991, all had been redeployed back to their battalions for re-use in another mission, namely coalition warfare.¹³ By this late date, the SF teams were replaced by the allied units who had their scouts and lead elements forward, and there was no longer a need for this to be an SF-peculiar operation. It is important to note that during the few weeks of the DESERT STORM air campaign, these teams had several shooting engagements with the enemy, some resulting in rather close calls. Captain Dan Kepper's detachment, for example, was forced to make a rather hasty exit from their Mazekah and zip away quickly in their HUMM-Vs while under intense ground fire. An Iraqi unit captured their border house by force, but the ODA, commanded by Captain Kepper, managed to escape without a loss of life or of equipment. However, damage was done to their vehicles.¹⁴ This information, in itself, proved very valuable to the deployment and tactics utilized on the small unit level by the Iraqis.

In conclusion, this mission of border surveillance did make a major significance in the larger picture, if for no other reason, it provided the only physical eyes-on means to verify the initial Iraqi movement and posturing. Thus it proved invaluable, especially in that time when the complete allied forces was in the process of re-

positioning for offensive action. The intelligence provided by the SF teams was the only means of tracking Iraqi reaction.

Coalition Warfare

with every single Arab unit that went into battle we had Special Forces troops with them. The job of those Special Forces was to travel and live right down at the battalion level with all those people and make sure they could act as the communicators with friendly English-speaking units that were on their flanks and they could also call in air strikes as necessary, they could coordinate helicopter strikes and that sort of thing. That's one of the principal roles they played and it was a very very important role.¹⁵

Coalition Warfare is a term which is most significant at the strategic or operational levels of warfare.¹⁶ At the tactical level of conventional operations, soldiers and their leaders interact with their coalition partners on a personal, human relations versus coalition basis. Special Forces noncommissioned, warrant, and commissioned officers served as the trainers, advisors, and integrating elements which enabled the effective conduct of combined and coordinated U.S.-Arab coalition operations in DESERT SHIELD and DESERT STORM.¹⁷

In essence, what General Schwarzkopf needed most from Special Forces was some semblance of "ground truth" concerning the Coalition forces' ability to fight--a very delicate matter indeed. The SOF became another "directed telescope" with enough experience to draw frank, objective conclusions and pass them in great confidence to CENTCOM.¹⁸ The linkages employed with liaison teams and SOF augmentation teams offered a successful example of how the bigger picture of coalition warfare works.¹⁹

General Swartzkopf was faced with the unique and diverse challenges of how to make the coalition of forces work and of how could

he bridge that cultural gap that existed between his forces. He chose Special Forces to achieve the synchronization in operations he required. SF personnel from the 5th Special Forces Group are trained in the language and the culture of their area of responsibility (AOR), in addition to maintaining their technical and tactical proficiency. It was logical to take this concept a step further by having these soldiers accompany the Arab coalition partners into combat. Understanding their operational environment was a key element in achieving mutual trust by the SF personnel and Arab allies. The conduct of coalition warfare was just a logical extension of SF Foreign Internal Defense (FID) capability, so SF were prepared to conduct these operations when SF hit the ground.²⁰

A logical line of questioning would be, "Why Special Forces?" What is it about SF that would make them so valuable in the coalition warfare environment, and then, what exactly was their role during DESERT SHIELD/STORM in this capacity?

Firstly, keeping the coalition was critical to the success of DESERT SHIELD and DESERT STORM.²¹ In order to legitimize the effort over there, it was critical that all the Islamic coalition allies be integrated into the defensive and offensive phases of the operation. If there had not been an effort to organize and integrate all the various countries into the coalition, I do not think we could have been successful.²² From a military standpoint, the SF presence did contribute to the integration and maximization of the coalition combat power to the extent of increasing our chances of battlefield success and bringing the ratio of forces into a more legitimate balance.²³

This idea or notion of integration cannot be underemphasized as to the immense importance it played during DESERT SHIELD/DESERT STORM. During this time frame, you have a Saudi brigade sitting here, you have got an Egyptian brigade sitting here, and you have a Syrian brigade sitting here. You have brigade and battalion boundaries, and on a map it looks real nice. In truth, the Saudis, Egyptians, and Syrians had no communication or contact with each other. The first thing SF would do is go to the right and the left, see who is there, establish contact, develop control measures, and most importantly provide coordination between the units. That was the last thing that the above-mentioned Arab coalition partners would do. They would talk only to the people in Riyadh, and to their liaison elements. In most cases, the Arab coalition partners did not know who was on their right and left and did not care. Although if you are going to conduct a defensive and later move to an offensive operation, that has to be coordinated.²⁴

Another example came on 13 January, just prior to D-Day and the air offensive launch. Airborne Intelligence platforms discovered Iraqi movements toward the Saudi border, and General Schwarzkopf ordered the 1st Cavalry Division to move to establish a defensive, to block whatever it was.²⁵ This meant that the 1st Cavalry Division had to pass through the Syrians to get into position. Coordinating a night movement requiring enormous coordination is difficult enough even for U.S. units. But to move through an edgy coalition Arab ally who has similar equipment to the Iraqis, and we have a possible movement to contact, and everybody has ammunition.²⁶ Undoubtedly, the 1st Cavalry Division would have engaged every T-62 they saw, because they would have been sure it

was the Iraqis. That would have imagined how that would have been perilous for the whole coalition.²⁷ Preventing that from happening came about only because soldiers from the 2nd battalion, 5th Special Forces Group, this author among them, literally "hand-carried" the U.S. Bradley Infantry Fighting Vehicles and M-1A1 tanks carefully through the Syrian positions.

This example of the incident of 13 January is one of many similar situations. During the massive movement from east-to-west, preparing for the "left hook" ground offensive by U.S. elements, all that was there separating young scared U.S. soldiers and Iraqi-look alike Arab allies, were those Special Forces soldiers, preventing fratricide. As Figure 1 depicts the location and original disposition of forces on 17 January, Figure 2 shows the final location prior to the ground offensive on 23 February. Little imagination is needed to see that passage-of-lines was conducted routinely and continuously through our Arab allies. Time and again, the Special Forces soldiers on the ground's proactiveness prevented not one single incident of fratricide and not one single American casualty during this time.²⁸ This was one of the most significant contributions SF made preventing those things from happening.²⁹

Why then would this valuable mission fall to Special Forces? Because SF has the senior, mature, experienced NCOs and officers who have the interpersonal skills and the negotiation capabilities. SF cultivates those skills, SF trains their men to be able to make that coalition unit capable of conducting an operation.³⁰ The SF soldiers sensitivity and respect to their coalition partners culture, religion,

political, and sociological aspects of their environment proved valuable. Living with their host unit, eating their food, speaking their language, and respecting their culture developed the rapport between the two forces that enabled them to accomplish their mission. The difficulty and magnitude of language and cultural problems are often underestimated. Even within the long-standing NATO alliance, language problems occur.³¹ There is a high potential for misunderstanding even after orders and instructions have been translated and distributed. Acronyms and specialized terminology raise the difficulty of communicating exponentially.

During DESERT SHIELD/STORM this problem was solved by Special Forces soldiers deploying down to battalion level throughout the coalition forces. Their cultural sensitivity, knowledge of all aspects of the environment facing them and their counterpart enabled them to process orders and instructions effectively. In the Annual Report to the President and Congress, then Secretary of Defense Les Aspin sums up Special Forces coalition support operations:

SOF are particularly well suited to conventional coalition warfare. One SOF contribution to the Operation DESERT STORM campaign was to extend the command and control system from the Coalition headquarters to all national elements in the field.³²

Special Forces soldiers are trained to understand and recognize the political implications their actions have. The Special Forces soldier is a careerist, carefully assessed and selected before his initial training. These mature and intelligent soldiers' training is far more extensive than their conventional counterparts. Numerous peacetime training missions and real-world contingency deployments into their AOR foster a further understanding of the political arena. In

1993 SOF deployed 13,454 men and women to 101 countries.³³ A large portion of these deployments involved Special Forces personnel. SOF are moving beyond jointness to become the most practiced of interagency military forces. Virtually all SOF activities are closely coordinated with other governmental agencies.³⁴

Special Forces soldiers are people to people experts with a vast amount of experience of working with other militaries. In addition to enhancing relationships between U.S. and host-nation military forces, SOF's language and cross-cultural skills, combined with finely attuned political sensitivities, strengthen military-to-civilian interaction."³⁵ More and more SF has been acting as the facilitator with nongovernmental organizations (NGOs) and governmental agencies to accomplish all ranges of missions.

While conducting this coalition warfare operation during the Gulf War, SF detachments were faced with a myriad of issues in anticipating and controlling psychological effects. Long isolated months in the desert, competing political agendas, rumors about atrocities being committed in Kuwait by the Iraqis, and smoke from burning oil wells were just some of the issues SF soldiers had to contend with while operating with their partners. SF soldiers had to constantly assess each situation and conversation engaged in as to never once say the "wrong" thing, or even have it be perceived as the "wrong" thing. It takes a psychologically sound and mature individual to be successful in such an environment.

Upon arriving at their assigned coalition partner's location, SF teams assessed the level of readiness and developed a training program

to include individual, collective, and leader development tasks. The training SF did with their partners had a significant impact on readiness.³⁶ Consequently, it had a positive effect for the whole coalition. The Arabs in particular were much relieved following initial intensive training in protective measures against the chemical threat Iraq possessed.³⁷ SF teams also coordinated tactical operations, provided essential information necessary to ensure operational success of coalition forces, and provided fire support coordination measures. Execution of these and other activities ensured that coalition forces were well versed in the key skills necessary to operate in a lethal and highly technical environment.³⁸

During DESERT SHIELD an SF operational detachment from the 5th SFG(A) conducted coalition support operations with the 35th Kuwaiti Armor Brigade. They trained the Kuwaitis on mine-clearing, Iraqi defensive tactics, aircraft and armored vehicle identification, and tank killing techniques. When the Kuwaitis received Yugoslavian M-84 main battle tanks, the Special Forces soldiers taught them how to operate and maintain them. When the 35th Brigade led the entire Joint Force Command-North attack back into their homeland the SF detachment went with them, not as trainers, but as advisors.³⁹ Their efforts successfully reinforced and enhanced the Kuwaitis effectiveness and credibility as a fighting force. Allowing the Kuwaitis to assure primary responsibility for the success of the effort was also of great significance to the coalition and to the U.S. effort.

This mission of coalition warfare was of immense magnitude. This author's battalion, the 2nd/5th SFG(A) alone was responsible for

the "ground truth" which entailed accurately reporting the combat power, location, equipment, capabilities, and activities of division, brigade and battalion-sized units, while also providing effective adjacent unit coordination and close-air-support to the same forces.⁴⁰ The 2nd Battalion had to "make" three line companies into four to cover all forces: Company A with the Egyptian 145th Commando Brigade; Company B with the Egyptian 3rd Mechanized Infantry Division; Company C with the Egyptian 4th Armored Division; and the provisional Company "D," with both the Syrian 9th Armored Division and the Syrian Commando Brigade.⁴¹ In total, 2nd Battalion's 18 A-detachments provided this support to over three and one-half divisions of conventional and special operations forces from four separate Arab nations.⁴²

Summary

The 2nd Battalion's activities were unprecedented. It accounted for over 8,700 enemy prisoners of war, numerous enemy personnel, tanks, and artillery positions destroyed, thousands of light weapons captured or destroyed, and significantly not one single incident of fratricide nor one single American casualty resulted.⁴³ Multiply this achievement by two other SF line battalions who accomplished equally as much as 2nd Battalion, and the results speak for themselves.

From the initial mission of performing the combined border surveillance mission to the all-encompassing coalition warfare requirement, Special Forces soldiers were extremely important and played a very significant role in the overall larger picture. The conduct of coalition warfare is not going away. Utilizing Special Forces in similar methods as in the Gulf conflict has been on the ever-increasing

rise. Every allied nation sending forces to Haiti and before that, to Somalia, had Special Forces detachments operating as a coalition support team (C.S.T.), attached.⁴⁴

Of all missions conducted during the DESERT SHIELD phase, the umbrella of coalition warfare support was the most dominant. There were numerous other activities SF performed during the DESERT SHIELD phase, namely in the areas of training intensively for Direct Action, Special Reconnaissance, and Combat Search and Rescue missions. These will be covered in chapter 5, DESERT STORM operations.

What was lacking in the Arab coalition force to make them a contributor to the overall picture U.S. Special Forces provided. SF became that valuable linkage with the U.S. command and the conventional forces. SF provide communication linkages, "ground truth," adjacent-unit coordination, close-air-support, and generally, was an American, English-speaking voice to the American, English-speaking chain-of-command and, in the final run, one simply cannot put a value price tag on a service as meaningful as that.

Endnotes

¹U.S. Special Operations Forces Posture Statement, July 1994, 43.

²Robert H. Scales, Certain Victory (Simon and Schuster, 1993), 123.

³After-Action Report, 5th Special Forces Group (Airborne).

⁴William M. Johnson personal observations.

⁵Ibid.

⁶Jerald L. Thompson, Memorandum for COMSOCENT, Subject: Coalition Warfare, 1992.

⁷Interview Special Warfare Magazine, 42. Vol 6, No. 3, July 1993, with LTC Daniel Brownlee, Commander, 1st Battalion, 5th Special Forces Group.

⁸William M. Johnson personal observations.

⁹Ibid.

¹⁰M. E. Morris, Road to Triumph (New York, NY: St Martin's Paperback edition, June 1991), 246.

¹¹Interview with MAJ Peter E. Davis, SF.

¹²Interview with CPT Kenneth Takasaki, SF.

¹³After-Action Report, 2nd Battalion 5th Special Forces Group, 10 March 1991.

¹⁴Interview with MAJ Douglas Kepper, SF.

¹⁵M. E. Morris, Road to Triumph (New York, NY: St Martin's Paperback edition, June 1991), 261-262.

¹⁶Jerald L. Thompson, Memorandum to Commander Special Operations Central Command (Subject: Coalition Warfare, 1992).

¹⁷Ibid.

¹⁸Robert H. Scales, Certain Victory (Simon and Schuster, 1993), 123.

¹⁹Mark B. Yates, "Coalition Warfare in Desert Storm." Military Review, Oct 1993, 51.

²⁰Interview Special Warfare Magazine, Brownlee, 42. Vol 6, No. 3, July 1993, with LTC Daniel Brownlee, Commander, 1st Battalion, 5th Special Forces Group.

²¹Ibid., 40.

²²Ibid., 40.

²³Ibid., 40.

²⁴Ibid., 42.

²⁵Ibid., 42.

²⁶Ibid., 42.

²⁷Ibid., 42.

²⁸After Action Report, 2nd Battalion, 5th Special Forces Group, 10 March 1991.

²⁹Interview Special Warfare Magazine, 42. Vol 6, No. 3, July 1993, with LTC Daniel Brownlee, Commander, 1st Battalion, 5th Special Forces Group.

³⁰Ibid., 43.

³¹U.S. Army. FM 100-5, Operations, (Washington, DC: Department of the Army, June 1993), 5-2.

³²Aspin's Annual Report to Congress, January 1994, 210.

³³1994 SOF Posture Statement, 22.

³⁴Report to Congress, Richard Cheney 1994, 105.

³⁵1994 SOF Posture Statement, 22.

³⁶DoD Conduct Persian Gulf War to Congress, J-9.

³⁷William M. Johnson personal observations.

³⁸Conduct of Persian Gulf War, DoD Report, J-10.

³⁹Robert H. Scales, Certain Victory: The U.S. Army in the Gulf War. Simon and Shuster, 1993), 103.

⁴⁰2nd Battalion/5th Special Forces Group After Action Review, 10 March 1991.

⁴¹Ibid.

⁴²Ibid.

⁴³Ibid.

"Interview with BG(R) Richard Potter, Deputy Commanding General,
U.S. Army Special Operations Command.

CHAPTER 5

ANALYSIS OF SPECIAL FORCES OPERATIONS IN DESERT STORM

We had already sent coalition special-operations teams deep into Iraq to watch the roads and report sightings of mobile launchers. These missions were extremely dangerous; the entire country was an armored camp--even areas that looked empty on the map turned out to be heavily patrolled by military units sent out to capture downed flyers.

H. Norman Schwarzkopf, It Doesn't Take a Hero

Introduction

This chapter is an analysis of the missions that Special Forces were tasked to perform during Operation DESERT STORM, which initiated with the Air Campaign starting at 0300 hours, 17 January 1991 and lasted until the cease fire was declared at 1200 hours, 28 February 1991. It is acknowledged that the primary mission focus of Special Forces, even during the air and ground assaults of DESERT STORM was still that of coalition warfare support.¹ This support to the Arab allied units continued all the way through until the cease fire. SF continued to build on the respect, rapport, and trust with the allied units with whom they had lived and trained with during the preceding operation, DESERT SHIELD. By the time of the allied offensive, the trust and confidence gained proved to be the key in carrying out the necessary actions which would come later during DESERT STORM.²

Coalition Warfare

The Special Forces personnel who remained with their Arab allies had established a special rapport built up during the war preparation phase of DESERT SHIELD that would be put to the ultimate test during the actual combat of DESERT STORM.³ The 2nd Bn/5th SFG(A) for instance, had its elements scattered throughout the battlefield. The three Companies of the battalion had the multiple mission to provide ground truth and close air support to the Egyptian 3rd Mechanized Infantry Division, the Egyptian 4th Armored Division, the Syrian 9th Armored Division, a Syrian Commando Regiment, and an Egyptian Commando Brigade.⁴ The Battalion had to split its battalion staff by moving a "Jump Battle Staff" forward with the Egyptian Field Army Headquarters to monitor closely the battlefield, while leaving the Battalion main headquarters in the rear at King Khalid Military City (KKMC) to collect all the incoming data, process it, and send it detailed format to the 5th Group headquarters.⁵

In addition to the mission of ground truth, the large contributing factor these Special Forces detachments had on the allied offensive, was in the area of close-air-support. This mission cannot be overemphasized. The entire Arab allied command was 100 percent relying on United States air cover and close air support, and it was the SF detachment's mission to perform. SF did the entire operation of calling in air strikes to protect the Arabs during the ground offensive. SF soldiers had the training and ground-to-air radios to perform this mission. The 5th Group had a system in place, which was exercised during DESERT SHIELD and worked extremely well during DESERT STORM.⁶ The 5th SFG(A) established a system involving SF team members positioned

down to the battalion level of the lead, in-contact units of the Arab coalition forces, responsible for calling in and directing the placement of ordinance dropped by United States Air Force fighter aircraft. The detachment would call back to their company headquarters, the B-detachment, who had assigned to them a U.S. Air Force Tactical Air Control Party, (TAC-P). This element, complete with UHF/VHF/FM radios, would immediately contact the Air Support Operations Center (ASOC), located at King Khalid Military City, who would in turn task the appropriate, or available aircraft. The ASOC would then send it to that calling TAC-P. The TAC-P would then direct the aircraft to the Special Forces team, which acted as a forward air controller, and the team at that time would take charge (Figure 3). The team members would call-in and direct the fires, usually on enemy artillery positions, but occasionally on armored vehicles and tanks.⁷

This method worked extremely well and proved timely and accurate. For instance, during the Egyptian Corps breach of the Iraqi obstacle belt on G-day, the close-air support directed by the SF soldiers with the lead elements resulted in significant enemy casualties and allowed the breach to be successful.⁸

The same can be said of the attacks on the initial targets inside of Kuwait. Special Forces teams accompanying their coalition partners the entire time, continuously provided that much-needed close air support. Many times, there seemed to be an abundance of aircraft averted, just waiting to be called to action, and quite often they came and were successful.⁹

Close-Air-Support and Ground Truth were not the only benefactor that the allied conventional force received from Special Forces. The U.S. Marine Corps (USMC) to the Arab right flank, and the U.S. Army VII Corps to the left (Figure 4) received valuable information from the SF soldiers on locations, enemy and friendly status of equipment and activities, and assisted in keeping the battle flowing. In particular, the amount of coordination between the USMC and the Syrian 9th Armored Division, as to small-unit passage-of-lines and patrolling boundaries, just inside the Kuwait boarder, was handled by one Special Forces A-detachment commanded by a Captain.¹⁰

This coordination enabled a smooth, fratricide-preventing movement by both forces, all the more impressive when you realize that the Syrians equipment and weaponry all resembled the Iraqis to the letter. The skills of the SF A-team and the rapport they had established enabled them to carry out this mission favorably.¹¹

Special Forces personnel performed as advertised: with bravery, skill, and quiet professionalism.¹² The absolute calmness and daring was quite a sight to see. Two Special Forces medical sergeants performed a combat amputation of an Egyptian soldier, while under intense indirect fire.¹³ Another brave soldier crawled into a mine-field to drag a wounded Egyptian soldier to safety, also while under artillery fire.¹⁴ One Special Forces Battalion Commander, accompanied by his S-3 and S-2 performed a Close-Quarters-Battle type operation on an Iraqi command post position and cleared the location, later receiving valorous awards for their brave action.¹⁵ In summary, the job performed by these Special Forces troops during the Coalition Warfare stage of

DESERT STORM had a significant impact on the overall success of the allied offensive.

Special Reconnaissance

We put Special Forces deep into the enemy territory. They went on strategic reconnaissance for us, and they let us know what was going on out there. They were the eyes that were out there. They did a great job in strategic reconnaissance.¹⁶

In addition to the main mission of the 5th Special Forces Group, that being coalition warfare support as previously discussed in both Chapter 4 and above, SF performed several other missions which included Special Reconnaissance. SF continued to actively support the campaign plan by inserting reconnaissance patrols hundreds of kilometers deep into Iraq.¹⁷ These teams, in support of both the XVIII Airborne Corps and the VII Corps, were emplaced principally near the highways to detect any attempt by Republican Guard reserves to counterattack or retreat.¹⁸ Training for Special Reconnaissance (SR) missions had been taking place since early October 1990. At the Group headquarters there was an element responsible for coordination and targets.¹⁹ The training was conducted outside the cities in the flat wastelands that resembled Iraq. The teams worked on their patrolling techniques, immediate-action drills, and recon procedures. Hide sites construction of a variety of different types was a primary concern.²⁰ Due to the barren terrain the teams would be operating in, the team would have to rely on underground observation posts dug rapidly during darkness.²¹ The problems soon became obvious. Where did they put the dirt and sand once it was excavated? What could they cover the hide site with once it was near completion? What materials made the best viewing ports? In the end,

these problems would be solved team-by-team as they conducted mock infiltrations and rehearsals.²²

All the SR missions conducted by SF teams during DESERT STORM took place deep inside Iraq. There were no "friendly" troops within hundreds of kilometers and, many times, there were numerous enemy in the immediate area. In addition to watching some of the key avenues and roads, Special Forces SR missions included "Scud Hunts," where the detachments would search an area for TELL launchers and SCUD missiles to report back for airpower to service.²³

All the infiltrations were conducted by rotary-wing aircraft, primarily MH-60 and MH-47 aircraft from the 3rd Battalion of the 160th Special Operations Aviation Regiment (SOAR). The pilots of the 3-160th were old hands at special operations flying. They came in 20 feet off the desert floor at 140 Knots in the dead of night and dropped their charges into isolated landing zones.²⁴ The teams poured over dozens of intelligence photos of their infiltration site.²⁵ The teams hunted for every scrap of information it could find in their area. How many people did the towns contain? Were there sheep, camels, and dogs in the area? Would there be high-tension power lines that might tangle up a helicopter landing?²⁶ There were numerous problems that had to be worked through as any error would most certainly cost lives. Thus the detailed planning for a mission of this nature was intense.

Upon infiltration, problems arose at daylight when the teams attempted to hide in terrain absolutely void of folds or vegetation. Not a hill, not a bush, not even a small depression was visible for miles. The ground was hard, usually with only a surface covering of

sand. Good hiding places were nearly impossible to find.²⁷ One detachment was surprised to find their surroundings were made up of rich farmland rather than the dry and dusty sands of King Khalid Military City.²⁸ Although the ground was softer along the Euphrates River Valley, water in the valley meant crops and people.²⁹

ARCENT still needed the intelligence in those areas mentioned and on 23 February, eight Special Forces teams flew into Iraq. Several unable to find hide sites in the barren terrain, were extracted; the Iraqis discovered others.³⁰ During one such mission, one MH-47 delivered two SF A-detachments by dropping one off, then the other successfully, however, were soon radioed by the latter team for immediate extraction, which they were, the main reasoning being the lack of absolutely no terrain feature to dig into and different terrain than that which they had planned and rehearsed for. The other team stayed on the ground three nights reporting intelligence via satellite communications.³¹ Teams that chose softer cultivated areas to dig in soon found themselves surrounded by inquisitive farmers.³² These missions took on enormous risks.

As the primary purpose of this project is to understand and show the significant impact on the overall campaign, I feel it is necessary to also understand these missions fully and the degree of difficulty they indeed had, and to, in turn, weigh that risk in the overall equation of significant contributions. Thus, this paper will briefly outline two such Special Reconnaissance missions executed by Special Forces A-detachments so that the reader can get a "feel" for the dangers involved and what benefits each may have played.

The first mission was conducted by a split detachment, comprised of three SF soldiers from 1st Battalion, Detachment A-532, and commanded by Master Sergeant Jeffrey Sims. The remaining portion of the detachment would also infiltrate into a hide-site 15 miles south of MSG Sims.³³ The team had wanted more low-level reconnaissance planes to photograph the infiltration sites just prior to D-day but the Air Force had been busy with sorties for the two Army Corps.³⁴

The infiltration, conducted on the evening before G-Day, 23 February, by MH-60 from the 160th SOAR, crossed the Iraqi border at 2100 hours and was in position north of the Euphrates River and less than 100 miles from Baghdad.³⁵ Upon touchdown at their pre-designated position at 2200 hours that night, they would have roughly five hours to prepare their hide site.³⁶ The helicopter had landed in a freshly plowed field, its furrows almost three feet deep. Boots sank into the loose dirt.³⁷ They were greeted by the eerie and unwanted sound of dogs barking from somewhere nearby. No one owning the dogs was apparently interested in their midnight howling.³⁸ In eight hours, the XVIII Airborne Corps and the VII Corps would cross the border.³⁹

By first light, after hours of hiking to their position and digging their hide site, MSG Sims and his fellow operators were in position.⁴⁰ During the night, a 50-car train rolled closely by and MSG Sims SATCOM communicated this information directly to the XVIII Airborne Corps.⁴¹

As soon as the sun shone, people came out. Farmers and sheep herders began walking within hundreds of yards of the hide-site.⁴² For the next eight hours, the team sweated out discovery as people passed by

their position. No one had expected so much foot traffic.⁴³ One sheep herder walked in front of the hide-site within a foot of the peephole. Miraculously, the herder did not notice the hide-site and walked on.⁴⁴ Another shepherd, this one with a dog, strolled dangerously near.⁴⁵

At roughly 1400 hours the team's luck got worse. A small girl and her grandfather stood frozen, staring in the direction of the hide-site. They slowly made their way to the hole. The old man tried to look inconspicuous, but inched closer to the hide-site. Then the girl bolted toward the hide-site. The old man, who appeared to be in his sixties, followed closely behind.⁴⁶ Slowly, she lifted the lid and gazed wide-eyed at the three Green Berets. The three men aimed their 9-mm pistols, equipped with silencers, right at the girl's head.⁴⁷ The team was already compromised and shooting the two civilians would serve no purpose.⁴⁸ The old man started screaming at the other shepherds now wandering several hundred yards away "Americans are here! Americans are here!" The old man and the little girl scrambled to their feet and ran away. Sims let them go.⁴⁹ Meanwhile, the team radioed for extraction due to their compromised position.

After running to another ditch, some 500 meters away, Sims knew they'd simply have to find another hole from which to make a stand.⁵⁰ Within 30 minutes, Iraqi troops began arriving by truck along the highway. The team began sniping the enemy soldiers, knocking them down one by one.⁵¹ The killing was methodical. No rifles were set on automatic. That would waste precious ammunition.⁵² Then two busloads of soldiers arrived, increasing the odds against the team's survival.⁵³ Armed civilians began sneaking across the right and left flanks.

Several village men stood on an old masonry wall surrounding a stone house nearby and waived their hands to direct the soldiers to Sim's position. The Green Berets picked off one of them.⁵⁴ But the precious firing could not protect them forever. Villagers and soldiers crept up along the irrigation ditches. The team would gun down several and the squads would retreat. But not for good. More busses carrying soldiers came.⁵⁵

Finally, one and one-half hours after they had been compromised, an F-16 Eagle roared overhead. At Sims direction, the plane dropped cluster bombs and thousand-pounders into ditches just 300 yards from Sims' position.⁵⁶

ODA 532 was rescued by a single MH-60 flown by CWO Randy Stephens and CWO John Crisufulli. It was the only daylight hot extraction carried out during DESERT STORM, with over 240 nautical miles covered by the 160th SOAR crew across enemy territory in broad daylight.⁵⁷ The extraction itself was one of intense fire-fight, as MSG Sims element all survived and got aboard the aircraft. It was a successful extraction.

The second such SR mission discussed was one led by Chief Warrant Officer Chad Balwanz, commander of detachment A-525. This eight-man team was to be inserted on a tributary of the Euphrates River with the mission to monitor traffic moving along Highway 8 from Baghdad to An-Nasiriyah.⁵⁸ After infiltration and the digging of two hide-sites, by morning the area was covered with civilian traffic, including a multitude of small children playing near the hide sites.⁵⁹ The children literally came right on top of the hide-sites, saw the team

within eyeball distance, screamed, and ran. The team obviously had been compromised.

At their new position, all seemed O.K. They would continue the surveillance and report back what they saw. At nightfall they would move further south and establish another temporary hide-site. For the next two hours the team watched the road and radioed back the vehicle movement it saw.⁶⁰

First came more children, then more adults, the adults carrying weapons, then numerous Iraqi soldiers. Four large convoy trucks came to a screeching halt along the road and deposited a company of Iraqi soldiers, Balwanz counted more than 100.⁶¹ The Iraqis opened fire and the body count against them began rising as the Iraqis reverted to human wave assaults over the open fields.⁶² In just the first ten minutes of fighting, the eight SF soldiers were able to coldly and methodically kill about forty soldiers.⁶³ This time as in the situation with MSG Sims' team, U.S. Air Force F-16's began their fire suppression on the scene. Balwanz directed the air strikes "danger close" to his team as the enemy moved closer.⁶⁴ The 160th SOAR had MH-60's on station around 2000 hours that evening to complete the extraction. Not one member of Balwanz' team was wounded or killed.⁶⁵

Together, MSG Sims ODA 532 and CWO Balwanz' ODA 525 accounted for an estimated 250 to 300 enemy dead and wounded.⁶⁶ Other special reconnaissance missions conducted in support of the ground war were not as dramatic as the two outlined. All the other teams involved got in without a fuss, dug their hides, and counted vehicles and soldiers. It is most often tedious and undiscovered by its subjects.⁶⁷

In addition to the casualties inflicted upon the enemy as noted, which is not a desirable state in a reconnaissance operation certainly, the significance can be measured positively. Such missions were not wasted efforts.⁶⁸ Even in their often too brief stay, the teams confirmed for the ARCENT Commander that no major reinforcements were landed into the Kuwait Theater of Operations.⁶⁹

The brief description and accounts of these two SR missions confirms several key points which are vital to the makeup of this paper. First, it shows the daring and calm professionalism of the Special Forces soldier and his reaction when in combat for the first time in his life. Secondly, it illustrates the character and makeup which are those traits needed in the coalition warfare mission as well. The makeup of this quality individual is what demands the trust and respect of the allied forces--which in turn provide the allied force with accurate information on the Arab ally status. Without this SF makeup, as shown in the two SR illustrations, SF could not have been successful in carrying out their wide-range of missions to provide the CINC ultimately with the proper information needed for success.

Direct Action

"Finally, they (Special Forces) also did some direct action missions, period."⁷⁰ Direct Action missions conducted by Special Forces during DESERT STORM were very limited. Those few missions exact details are either extremely sensitive or still classified. What can be discussed in this segment however are several points worthy of noting.

Firstly, the Direct Action (DA) missions were performed in the same manner as the special reconnaissance missions detailed above, in

that all were infiltrated and exfiltrated by rotary-wing special operations helicopters.⁷¹ All were conducted for precise missions and valuable targets only were chosen.

General Schwarzkopf had forbidden SF from sneaking into enemy territory before the air war started and then rejected many operations proposed after the bombing had begun.⁷² The main objective of the few DA missions that were launched and conducted involved command and control and to disrupt enemy communications. Special Forces joined British Special Air Service commandos in one operation to cut a fiber optic cable that stretched from Baghdad to Southwest Iraq.⁷³ This mission involved destroying these vital cables and took place early in the air campaign and was perilously close to Baghdad.⁷⁴ A totally successful operation, in that the infiltration and exfiltration was perfect and no enemy activity was encountered.

Another Direct Action mission involved the support requested by the two Army Corps to provide soil samples for trafficability studies. The Central Intelligence Agency had warned General Schwarzkopf's generals that the tanks and trucks they wanted to send across Southern Iraq for the Hail Mary play would become bogged down in the sandy terrain.⁷⁵ Pentagon maps for the region were incomplete.⁷⁶ General Schwarzkopf, who was desperate for detailed intelligence on the regions weather and terrain, allowed six-man SF teams to secretly helicopter into Iraq and scoop up soil samples for analysis in Riyadh.⁷⁷ The teams carried camcorders and digitized still cameras that transmitted photos back to headquarters.⁷⁸ The soil samples showed the ground was firm

enough and the pictures gave commanders a close-up view of their battlefields.⁷⁹

Another main point to understand here is that, whether the mission would be one of SR, as talked about earlier, or one of gathering soil samples in plastic containers, each would be treated equally. Each would be planned for in excruciating detail, rehearsed numerous times, and briefed in utmost detail, before being launched. Most of these missions are not overly "glamorous" as the "average" person might think. These missions require stable, mature, non-excitable individuals who will remain calm in the face of insurmountable odds and have the wherewithal to properly react to the unexpected. These traits were evident in all these DA missions as well.

What impact and overall significance did the DA missions have? I believe this is relative, in that, it may have had a large and significant impact if the soil samples collected showed exactly the opposite of the planned activities of the conventional mechanized corps. If the samples served to reinforce what had already been planned then again it would be hard to place a value on the product result.

Concerning the communication linkages destroyed, who is to say that the one particular fiber optic network did not directly or indirectly save the life of American and allied aircrewmembers, or later on, ground forces. Particularly with the DA missions, it is not easy to quantify the net gain and results, but obviously, there was some significance placed in the results of these missions, and actions were taken, directly from the results achieved by these missions.

Combat Search and Rescue

Thirdly, the Special Forces were 100 percent in charge of the combat search and rescue, and that's a tough mission. When a pilot gets shot down out there in the middle of nowhere, surrounded by the enemy, and you have the folks that are required to go in and get them, that is a very tough mission, and that was one of their (SF) missions.⁸⁰

One of the "be prepared to" missions of Special Forces from the outset of DESERT SHIELD had been Combat Search and Rescue (CSAR).⁸¹ This mission largely got overlooked in September-October due to the enormous undertaking of the coalition warfare requirements as previously discussed. The 2nd Battalion took it upon itself to train two A-detachments for this mission, just in case it would crop up later on.⁸²

In the high-threat, Iraqi-controlled territory, General Schwarzkopf firmly believed that he needed special crews to rescue downed pilots.⁸³ The mission was assigned to Special Operations as the Air Force could not offer a tangible and effective program to support the effort.⁸⁴ CSAR demanded trained aircraft, security, and medical crews. Further the mission required specialized equipment and tactics.⁸⁵

The training period was intense. The 160th SOAR, whose aircraft were equipped for deep insertions, served in the CSAR role.⁸⁶ Training for CSAR began immediately. MH-60 Blackhawks and MH-47 Chinooks were utilized, their crews creating new tactics and maneuvers.⁸⁷ Chinook crews from the 160th built security teams for CSAR operations using the Special Forces teams from 2nd Battalion.⁸⁸ CSAR tactics included the infiltration of a rescue team and a vehicle (HUMM-V) up to two hundred miles behind the lines, with the MH-47 setting down while the mobile desert vehicle made the recovery.⁸⁹

The Special Forces teams established wonderful rapport with the pilots of the 160th SOAR. The SF teams and aircrews spent long hours studying the techniques of rescuing the doomed aircrewmembers.⁹⁰ Stretchers were sawed down to fit neatly in the MH-60 aircraft. Communications devices for the SF team security members were procured and trained on.⁹¹ Methods for the medical specialist to care for the potentially injured pilots were rehearsed. Exercises, called CSAREX's, were conducted to ensure the mission could be done effectively.⁹² A CSAR Standard Operating Procedure was initiated and developed.⁹³ Intense training continued throughout DESERT SHIELD.

As the Air War began, the CSAR teams, aircraft, and aircrews positioned themselves in forward operating bases to be able to swiftly react to any call. When an American aircraft went down over Iraqi-controlled territory, rescuing a surviving pilot before capture required fast action.⁹⁴ Secretly infiltrating enemy territory, finding a downed pilot, and then racing back to friendly airspace was risky business.⁹⁵

On February 17th, a U.S. F-16 went down 40 miles behind enemy lines.⁹⁶ Engine failure caused his aircraft to crash.⁹⁷ The call came from the AWACS at 1815 hours and within minutes modified MH-60 Blackhawks from the 3-160th SOAR were in the air.⁹⁸ The two MH-60s, using night-vision devices, launched, accompanied by 2nd Battalion, 5th Special Forces Group security teams armed with AT-4 hand held rocket launchers and M-16/203 assault rifles.⁹⁹ By 2000 hours, Chief Warrant Officer Thomas Montgomery located and picked up the pilot as enemy vehicles closed in on him. Seeing the enemy, Montgomery contacted AWACS and requested support.¹⁰⁰ The pilot was rescued even though frustrated

Iraqis on the ground fired missiles after the retreating aircraft.¹⁰¹ On board jamming devices, coupled with emergency evasive action by the pilots, left the missiles far behind.¹⁰² Within minutes an F-16 was on station to destroy the enemy vehicles.¹⁰³ This was the first and only CSAR mission conducted during the hours of darkness using night-vision guidance (NVG) capabilities under zero-illumination conditions.¹⁰⁴

CSAR certainly was a bona-fide success in the eyes of one Captain "Spike" Thomas, the former Air Force Academy football star who was that rescued pilot. Although initial estimates had predicted that 40 aircraft would be lost on the opening night of the air war, only three losses occurred. During the entire air and ground war the coalition lost only 52 aircraft.¹⁰⁵ Twenty-two pilots and crew survived: 14 were captured immediately and 8 evaded capture--two for more than 24 hours.¹⁰⁶ Of seven CSAR missions launched, three were successful.¹⁰⁷ So on a grand scale, CSAR was not a major player, but on a smaller scale, to those select few who were rescued and recovered it proved immeasurable. Just the thought and knowledge by the individual pilots flying the missions had to be a comfort in just knowing that there would be efforts to recover them in the event of an emergency. In this sense, the CSAR efforts were very much as much a success as the air war, unarguably presenting wonderful results throughout.

The role SF played in the CSAR operation cannot be underestimated as well. SF soldiers accompanied every single mission flown by the 160th SOAR aircraft. The security provided, the medical expertise, and the trust and confidence in them by the aircrews had a major impact on the security and feeling of the 160th SOAR aircrews.

The crews and the SF depending on each other and performed as one element, and this was definitely a factor in the numerous successful infiltrations and exfiltrations performed.

Kuwait City

A cornerstone of the President's Gulf War objective was to restore the legitimate government of Kuwait.¹⁰⁸ Special Forces played a very key role during the operations to liberate Kuwait City. The plan for retaking the city was for the Marines to hold their positions while a vanguard of Kuwaitis, Saudis, Egyptians, and other Arab forces made the first entry into the capitol.¹⁰⁹

The only American forces that would enter the city, would be those Special Forces soldiers with the Arab units. General Schwarzkopf reviewed the plan with Colonel Jesse Johnson, Central Command's Special Forces Chief. The SF soldiers who had been attached to the Arab units throughout the campaign would accompany them into the city.¹¹⁰ One of the SF responsibilities was to remind the allies, the Kuwaitis in particular, not to retaliate against Iraqi prisoners for atrocities committed during the occupation. The U.S. did not want any war crimes on our hands.¹¹¹

U.S. Special Forces soldiers who were still with Kuwait units began to expand their role beyond that of "advising." With the help of Kuwait resistance fighters who remained in the city during the entire occupation, SF soldiers cleared areas of booby traps and minefields and otherwise assisted in the recovery.¹¹² Resistance members also guided Special Forces teams to key Iraqi headquarters buildings and torture

sites. The teams collected and evacuated five truckloads of documents indicating possible violations of the Geneva Convention.¹¹³

During the "clearance" operations of Kuwait City, the Arab coalition allies were assigned sectors, and the SF teams accompanied their counterparts throughout.¹¹⁴ This developed into a somewhat precarious predicament as international journalists were all over the city, freely moving about and sometimes seeing U.S. Special Forces with their assigned Arab coalition unit and asking questions and witnessing some incidents which obviously was not condoned by these SF soldiers or the U.S. Government.¹¹⁵ The press on a few occasions "slanted" their stories and eventually, many SF teams were withdrawn from their Arab allies and returned to base or headquarters.¹¹⁶

Totalling up all the activities which took place inside Kuwait City, Special Forces had a hand to play in quite a bit of activity. U.S. SF personnel were with the Egyptians during their securing of their sector of the city and their Embassy.¹¹⁷ The U.S. SF was also responsible for the securing of the U.S. Embassy in Kuwait City.¹¹⁸ In all of these tasks, SF performed to their usual standard of excellence.

After the cease fire, the SF soldiers remained with the Kuwait forces and assisted in the recovery and rebuilding of the city and its infrastructure.¹¹⁹ As the U.S. humanitarian assistance efforts took shape, the word was passed via SF facilitation to the coalition.¹²⁰ The coalition warfare support mission of DESERT SHIELD had run full-cycle and was back on and in the front line of importance once again. The SF team's once again provided the American decision-makers with a

communications piece and an understandable tool to enable the coalition force clear and precise understanding of the missions.

Summary

As per DESERT SHIELD, the activities and missions Special Forces performed during DESERT STORM had a major impact, I feel, on the overall campaign plan and success thereof. Even though the Direct Action, Special Reconnaissance, and Combat Search and Rescue missions conducted by SF were few, relatively speaking, in number, the results far outweighed the efforts.

Special Forces teams were indeed able to follow much of the intelligence picture desired by the CINC. They were able to successfully assist in the rescue of a downed aircrewman, saving the lives of many brave men. They provided commanders and their staffs with intelligence which was absolutely essential for future planning. SF provided soil samples which confirmed the trafficability of the region. Had the collected samples indicated "no-go" terrain, the ground war may have been very different indeed. SF performed flawlessly in its role of coalition support providing USCINCENT and his battlefield commanders with the necessary "ground truth" vital to the decision making process. The close air-support that was called in and directed by SF soldiers serving on the front lines, saved countless potential casualties of the Arab allied force. CAS enabled the coalition force to maneuver rapidly, as such sustaining relatively few casualties through the enemy obstacle belt and on to Kuwait City. The mission of providing coordination between the flanks, performed by SF soldiers proved invaluable. Not one single incident of fratricide occurred in all the chaos of the air and

ground offensives, largely due to the timeless efforts of those SF NCOs and officers being ever-proactive and nipping all potential trouble in the bud before it happened.

DESERT STORM was merely an extension of the ladder of success that SF enjoyed during DESERT SHIELD. The ground work that was laid and the foundation set during DESERT SHIELD formed the follow-on Special Forces success of DESERT STORM. The SR/DA/CSAR detachments labored long and hard to ensure mission success. All the hard work paid off with all missions assigned to SF during DESERT STORM successfully accomplished, with no friendly casualties.

Endnotes

- ¹Interview with COL James Kraus (Ret), Special Forces, 5th (SFG(A) Commander during Persian Gulf War.
- ²William M. Johnson personal observations.
- ³Ibid.
- ⁴After Action Report, 2/5th Special Forces Group, 10 March 1991.
- ⁵Ibid.
- ⁶William M. Johnson personal observations.
- ⁷Ibid.
- ⁸Ibid.
- ⁹Ibid.
- ¹⁰After Action Report, 2/5th Special Forces Group, 10 March 1991.
- ¹¹Interview with COL William J. Davis, Special Forces 2/5th (SFG(A) Commander during Persian Gulf War.
- ¹²After Action Report, 2/5th Special Forces Group, 10 March 1991.
- ¹³Interview with MAJ Peter J. Roberts, Special Forces.
- ¹⁴Ibid.
- ¹⁵Interview with LTC "Chip" Paxton, Special Forces.
- ¹⁶M.E. Morris, Road to Triumph (New York, NY: St Martin's Paperback edition, June 1991), 246, 261.
- ¹⁷Robert H. Scales, Certain Victory: The U.S. Army in the Gulf War (Simn and Schuster, 1993), 197.
- ¹⁸Ibid., 197.
- ¹⁹Greg Walker, At the Hurricane's Eye, U.S. Special Operations Forces from Vietnam to Desert Storm (Ivy Books, NY: Ballentine Books Copyright, 1994), 241.
- ²⁰Ibid., 241.
- ²¹Ibid., 242.
- ²²Ibid., 242.

²³Interview with LTC David Brownlee, Special Forces.

²⁴Robert H. Scales, Certain Victory: The U.S. Army in the Gulf War (Simn and Schuster, 1993), 198.

²⁵Greg Walker, At the Hurricane's Eye, U.S. Special Operations Forces from Vietnam to Desert Storm (Ivy Books, NY: Ballentine Books Copyright, 1994), 307.

²⁶Greg Walker, At the Hurricane's Eye, U.S. Special Operations Forces from Vietnam to Desert Storm (Ivy Books, NY: Ballentine Books Copyright, 1994), 307.

²⁷Robert H. Scales, Certain Victory: The U.S. Army in the Gulf War (Simn and Schuster, 1993), 198.

²⁸Greg Walker, At the Hurricane's Eye, U.S. Special Operations Forces from Vietnam to Desert Storm (Ivy Books, NY: Ballentine Books Copyright, 1994), 245.

²⁹Robert H. Scales, Certain Victory: The U.S. Army in the Gulf War (Simon and Schuster, 1993), 198.

³⁰Ibid., 198.

³¹William M. Johnson personal observations.

³²Robert H. Scales, Certain Victory: The U.S. Army in the Gulf War (Simn and Schuster, 1993), 198.

³³Greg Walker, At the Hurricane's Eye, U.S. Special Operations Forces from Vietnam to Desert Storm (Ivy Books, NY: Ballentine Books Copyright, 1994), 308.

³⁴Ibid., 307.

³⁵Newsweek Magazine, "Secret Warriors," 17 June 1991, 25.

³⁶Greg Walker, At the Hurricane's Eye, U.S. Special Operations Forces from Vietnam to Desert Storm (Ivy Books, NY: Ballentine Books Copyright, 1994), 244.

³⁷Ibid., 308.

³⁸Ibid., 244.

³⁹Ibid., 308.

⁴⁰Ibid., 245.

⁴¹Ibid., 309.

⁴²Ibid., 309.

⁴³Ibid., 245.

⁴⁴Ibid., 309.

⁴⁵Ibid.

⁴⁶Ibid., 310.

⁴⁷Newsweek Magazine, "Secret Warriors," 17 June 1991, 27.

⁴⁸Greg Walker, At the Hurricane's Eye, U.S. Special Operations Forces from Vietnam to Desert Storm (Ivy Books, NY: Ballentine Books Copyright, 1994), 311.

⁴⁹Ibid., 311.

⁵⁰Ibid., 246.

⁵¹Ibid.

⁵²Ibid., 246.

⁵³Ibid., 246.

⁵⁴Ibid., 312.

⁵⁵Ibid., 313.

⁵⁶Ibid.

⁵⁷Ibid., 246.

⁵⁸Ibid., 244.

⁵⁹Ibid., 247.

⁶⁰Douglas C. Waller. The Commandoes: The Inside Story of America's Secret Soldiers (Simon & Shuster, 1994), 20.

⁶¹Ibid., 22.

⁶²Greg Walker, At the Hurricane's Eye, U.S. Special Operations Forces from Vietnam to Desert Storm (Ivy Books, NY: Ballentine Books Copyright, 1994), 248.

⁶³Douglas C. Waller. The Commandoes: The Inside Story of America's Secret Soldiers (Simon & Shuster, 1994), 24.

⁶⁴Ibid., 26.

⁶⁵Greg Walker, At the Hurricane's Eye, U.S. Special Operations Forces from Vietnam to Desert Storm (Ivy Books, NY: Ballentine Books Copyright, 1994), 249.

⁶⁶Ibid.

⁶⁷Ibid.

⁶⁸Robert H. Scales, Certain Victory: The U.S. Army in the Gulf War (Simon and Schuster, 1993), 198.

⁶⁹Ibid.

⁷⁰M. E. Morris, Road to Triumph (New York, NY: St Martin's Paperback edition, June 1991), 261-262.

⁷¹2/5th SFG AAR.

⁷²Douglas C. Waller, The Commandoes: The Inside Story of America's Secret Soldiers (Simon & Shuster, 1994), 304.

⁷³Ibid.

⁷⁴Interview LTC Danial Brownlee, Special Forces

⁷⁵Newsweek Magazine, 25.

⁷⁶Ibid.

⁷⁷Douglas C. Waller, The Commandoes: The Inside Story of America's Secret Soldiers (Simon & Shuster, 1994), 304.

⁸⁰M. E. Morris, Road to Triumph, (New York, NY: St Martin's Paperback edition, June 1991), 261-262.

⁸¹William M. Johnson personal observations.

⁸²Ibid.

⁸³Robert H. Scales, Certain Victory: The U.S. Army in the Gulf War (Simon and Schuster, 1993), 194.

⁸⁴Greg Walker, At the Hurricane's Eye, U.S. Special Operations Forces from Vietnam to Desert Storm (Ivy Books, NY: Ballentine Books Copyright, 1994), 181.

⁸⁵Ibid.

⁸⁶Robert H. Scales, Certain Victory: The U.S. Army in the Gulf War (Simon and Schuster, 1993), 195.

⁸⁷Douglas C. Waller, The Commandoes: The Inside Story of America's Secret Soldiers (Simon & Shuster, 1994), 209.

⁸⁸Ibid.

⁸⁹Ibid.

⁹⁰William M. Johnson personal observations.

⁹¹Ibid.

⁹²Ibid.

⁹³Ibid.

⁹⁴Robert H. Scales, Certain Victory: The U.S. Army in the Gulf War (Simon and Schuster, 1993), 194.

⁹⁵Ibid.

⁹⁶Douglas C. Waller, The Commandoes: The Inside Story of America's Secret Soldiers (Simon & Shuster, 1994), 210.

⁹⁷Robert H. Scales, Certain Victory: The U.S. Army in the Gulf War (Simn and Schuster, 1993), 194.

⁹⁸Ibid.

⁹⁹Greg Walker, At the Hurricane's Eye, U.S. Special Operations Forces from Vietnam to Desert Storm (Ivy Books, NY: Ballentine Books Copyright, 1994), 210.

¹⁰⁰Robert H. Scales, Certain Victory: The U.S. Army in the Gulf War (Simon and Schuster, 1993), 194.

¹⁰¹Greg Walker, At the Hurricane's Eye, U.S. Special Operations Forces from Vietnam to Desert Storm (Ivy Books, NY: Ballentine Books Copyright, 1994), 210.

¹⁰²Ibid.

¹⁰³Robert H. Scales, Certain Victory: The U.S. Army in the Gulf War (Simn and Schuster, 1993), 194.

¹⁰⁴Greg Walker, At the Hurricane's Eye, U.S. Special Operations Forces from Vietnam to Desert Storm (Ivy Books, NY: Ballentine Books Copyright, 1994), 210.

¹⁰⁵Robert H. Scales, Certain Victory: The U.S. Army in the Gulf War (Simon and Schuster, 1993), 195.

¹⁰⁶Ibid.

¹⁰⁷Ibid.

¹⁰⁸Robert H. Scales, Certain Victory: The U.S. Army in the Gulf War (Simon and Schuster, 1993), 334.

¹⁰⁹H. Norman Schwarzkopf, It Doesn't Take a Hero, The Autobiography with Editors Peter Petre (New York, NY: Bantam Books, 1992), 464.

¹¹⁰Ibid.

¹¹¹Ibid., 465.

¹¹²Robert H. Scales, Certain Victory: The U.S. Army in the Gulf War (Simon and Schuster, 1993), 337.

¹¹³Ibid.

¹¹⁴William M. Johnson personal observations.

¹¹⁵Ibid.

¹¹⁶Ibid.

¹¹⁷Ibid.

¹¹⁸H. Norman Schwarzkopf, It Doesn't Take a Hero, The Autobiography with Editors Peter Petre (New York, NY: Bantam Books, 1992), 465.

¹¹⁹Interview with MAJ Peter E. Davis, Special Forces.

¹²⁰Ibid.

CHAPTER 6

CONCLUSIONS AND FINDINGS

During his famous "Hail Mary" press conference at the end of the war, Schwarzkopf had stunned his staff by publicly singling out Special Forces for praise. "It's very important that I not forget those folks," he said. This coming from a man who at first was content to leave half of the commands back in the States. Now before the operators at Ar Ar, Schwarzkopf spoke like a convert. "What you've done is never going to be made public and we can't make it public," he said solemnly. "You kept Israel out of the war."¹

H. Norman Schwarzkopf, The Commandoes

The preceding chapters of this thesis have provided the background and data in the form of information on what exactly the United States Army Special Forces performed during Operations DESERT SHIELD and DESERT STORM. Throughout the first five chapters, and in particular chapters four and five, information in reference to the answering of the primary and secondary questions posed in chapter one is found. This chapter serves to answer the research questions, to include the secondary questions corresponding with the thesis topic. In addition, this chapter serves to offer, and hopefully encourage, the potential for further research to be conducted in this area.

Before the primary question of this thesis is addressed, this work will first look at the preceding, secondary questions posed in chapter one of this thesis, which should lead to the direct answers necessary.

Secondary Questions

Question 1: How were the U.S. Army Special Forces principally used during the Persian Gulf War?

This particular question has been adequately addressed and answered in chapters four and five. The exploits and missions conducted during Operation DESERT SHIELD was briefly highlighted in chapter four. These missions included border surveillance, which involved U.S. Special Forces teams working with Saudi Arabian Special Operations teams in a truly combined manner to guard and patrol the whole length of the Saudi Kuwait border.

Chapter 4 also discusses the mission of Coalition Warfare and what Special Forces accomplished in this mission. It is pointed out here as to the vastness and significance of this mission, above all others, given to Special Forces. The 5th Special Forces Group sent 106 teams--usually 3-4 men to a team--to work with coalition force forward battalions.² They deployed to the far reaches, east and west, with the mission to ensure interoperability with out Arab coalition allies. U.S. Special Forces, simply put ,were superb in coalition warfare because they had been specially selected, trained and equipped for this unique role.³

In chapter 5, a discussion was made of the activities and missions, that Special Forces conducted during Operation DESERT STORM. These missions included coalition support, tailored towards the role played during the actual air and land offensives conducted by allied forces. This included the role Special Forces had in the close-air-support mission for the Arab allied maneuver units. Chapter 5 also

mentions the mission given to SF to provide USCINCCENT with the "ground truth."

The SF performed the missions covered were that of Special Reconnaissance, Direct Action, and Combat Search and Rescue. In describing these missions, this thesis felt it was important to detail just a few of the accounts of the bravery and skill of these Special Forces soldiers. It is an important piece with which to help illustrate the overall effectiveness question of which this thesis is about.

Despite the fact that the coalition warfare mission remained the largest operation involving the bulk of the Special Forces manpower, the conduct of the SF missions were extremely hazardous to both aircrew and SF personnel involved including infiltration deep behind enemy lines. Despite several SF missions that were compromised, none involved the loss of life of any Special Forces soldiers. The result was real-time information and intelligence for the conventional commanders to give them an "edge" on the battlefield.

In the mission of Combat and Search and Rescue, members of 2nd Battalion of the 5th Special Forces Group rescued one American F-16 pilot from behind enemy lines.⁴ Members from that battalion also provided the manning of the machine-guns on-board the penetrating special operations helicopters during all infiltration and exfiltration of the operational detachments.

Question 2: Could other forces or agencies have had the capability to conduct the missions instead of Special Forces?

This thesis points out the capabilities of the Special Forces soldier, i.e., his expertise in language, cultural orientation, and personnel maturity. Particularly in the area of coalition warfare

support and overall combined operations as conducted in the Gulf War, Special Forces was definitely the unit of choice in many areas. The thought of what could a brigade or a battalion from the 82nd Airborne Division contribute to a battalion in the Kuwaiti army should be asked? The Kuwaiti army does not have the capability to operate with them in a combined fashion. Could a battalion in the 82nd, because of differences in equipment, organization and training, it would be very difficult to fall in on a brigade in the Kuwaiti army and make them a competent fighting brigade able to conduct a combined operation? In theory, I would say yes, but that is not their primary mission and their role. That is, not a good utilization for the 82nd--their job is to be prepared to fight (close with and destroy the enemy through fire and maneuver), not to train.⁵ It is not their job to transpose that capability to another element. The same thing for the Marine Corps, it needs to be able to operate in a combined fashion, not train other people to operate as it does.⁶

In the areas of Special Reconnaissance, Direct Action, and Combat Search and Rescue, the question is also a matter of mission and resources. The specialized infiltration and exfiltration platforms available and utilized by Special Forces and other Special Operations forces are configured to be used by small, highly-trained teams. In the general-purpose, or conventional force structure, these penetrating aircraft do not exist. The small-unit of highly-skilled professionals may exist, but these forces have their missions to prepare for and it is not operating independently, deep inside the enemy's rear, totally alone and with no outside assistance. Special Forces teams thrive on these missions, it is the way these units operate. In the primary mission of

coalition warfare, Special Forces has the senior, mature, experienced NCOs and officers who have the interpersonal skills and the negotiative capabilities. Special Forces cultivates those skills, trains their guys to be able to make that coalition unit capable of conducting an operation. I don't believe the conventional forces would want to spend the resources, because everything they would have to do to support a coalition would detract from their capability to operate. I don't believe they would have the staying power or have the maturity and the experience and the interpersonal skills to be successful in providing support for a coalition. They have the job to participate in a coalition, but not to provide support in the coalition, and I think that is the difference between the conventional Army and Marine Corps and Army Special Forces.⁷ During DESERT SHIELD and DESERT STORM, it was Special Forces performing its traditional mission of advising and assisting a foreign military unit.⁸ This is not the mission of any other force in the U.S. armed forces.

Question 3: What is the emerging significance of the operations, particularly coalition support to the U.S. Army Special Forces in the future?

One can successfully argue a very good case for the operations conducted in the coalition warfare area by the 5th Special Forces Group during the Gulf War to be a model for what is happening currently in the SF community. The conduct of coalition warfare was just a logical extension of SF's FID (Foreign Internal Defense) capability, so SF was well prepared to conduct those operations.⁹ In other words Special Forces has been performing coalition warfare-type missions since its inception in 1952.

The difference, however, that DESERT SHIELD/STORM contributed to this mission is the manner in which it was conducted. The idea that SF teams deploy down to battalion-level of the conventional armor and mechanized infantry forces of allied countries to provide a command-and-control conduit, a "shadow C³I," etc., is a rather new twist to the straight-up FID mission of mainly training and letting these forces go into battle themselves. The significance of the term "coalition warfare" is that it establishes a psychological environment of national level policy and attitudinal commitment of two or more nations to employ armed forces in combined or coordinated operations to achieve coalition objectives.¹⁰

In 1995, Special Forces teams deployed to over 15 countries of the former Soviet Union to train, advise, and assist these nations' armed forces with their exercise rotation at the Joint Readiness Training Center in the United States.¹¹ The Special Forces teams deployed with these nations and participated throughout the entire exercise to include the redeployment phase. The missions were essentially the same thing the SF teams did during the Gulf War.

During the "invasion/liberation" of Haiti in 1993-1994, SF teams did the same thing with the allied peace-keeping forces rotating to this island. SF teams deployed to the host-nation, trained with, and escorted these forces to Haiti for duty as a coalition support team.¹² Current exercises and operations have similar plans, in that the utilization of Special Forces teams to assist the foreign conventional units in all those aforementioned duties is a desirable mission. Arguably, the mold set initially, as outlined in this thesis, have laid the foundation for this mission to continue on an even greater scale.

Primary Question

How significant an impact did the U.S. Army Special Forces have on the overall force during operations DESERT SHIELD and DESERT STORM?

As outlined and discussed extensively in chapter 3, the methods for answering this question will come from examining the opinions of some key leaders and their stated views and thoughts of the contributions made by SF in the Gulf conflict. Ultimately, it will be left up to the individual reader to determine his/her opinions on the overall impact SF played. Chapters 4 and 5 outline the key events and missions performed by the Special Forces units, however, there is sufficient data and relevance that each particular mission could be expanded and detailed further separately if desired. That, however, was not the purpose of this particular thesis, but instead was to look at the overall picture of SF and the role it played in the larger picture. To do this lends itself largely on speculation and opinion because hard results cannot come in the form of tabulation of points as in a sports match. Nor can it come in the form of raw data in killed-in-action of enemy battle damage reports. In other words it may be difficult to quantify statistically through hard analysis the total impact of SF operations, as viewed in the larger picture. As discussed in chapter 3, the quantifying data, or "yardstick," this thesis used, is the written word of some of the key leadership and what opinions they shared on what impact Special Forces had in the Gulf conflict.

General Gary E. Luck, currently Commander-in-Chief, United Nations Command, Republic of Korea, U.S. Combined Forces Command, Korea, was the Commanding General of the XVIII Airborne Corps during operations DESERT SHIELD/STORM. As one of the two U.S. Army Corps to participate

in this action, it was in support of his Corps that several of the Special Reconnaissance missions discussed in chapter five took place. General Luck, in reflecting on the Gulf War several years later, wrote in Military Review his views of the significance of what Special Forces can bring to the conventional battlefield.

Special Forces can also be a significant combat multiplier when fully integrated in the corps plans. SOF units make important contributions to the corps' effort in the area of complementary reconnaissance, security, and other SOF missions. These specially trained units are enormously effective combat multipliers. Working on extended operations and in the most austere conditions . . . (SF) proved extremely effective in extending the commander's eyes, maintaining liaison with factional forces and providing accurate real-time intelligence information, (SF), by virtue of their special training and language skills, also have made major contributions as liaison elements to other national forces during combined operations.¹³

It seems clear that General Luck felt that the job done by SF had a value worth mentioning and studying and educating the conventional commanders on the usefulness. His thoughts of "extending the commander's eyes, and to make important contributions to the corps' effort, [and to] have made major contributions"¹⁴ all seem to point clearly that his opinions of SF are along favorable lines. If the primary question of this thesis were to be passed directly to General Luck, the author believes his answers are given above. He, obviously from his position of high authority feels that SF had a significant impact, in fact, his opening statement of "can also be a significant combat multiplier,"¹⁵ mentions the word significant directly.

James R. Locher III, who worked for the Secretary Of Defense Dick Cheney as his assistant secretary of defense for special operations and low intensity-conflict, talked of the job Special Forces did in the Gulf War as having strategic-level implications.

The strength of special (operations) forces lies in their versatility. As they demonstrated in Operation DESERT STORM, they can support conventional operations as combat multipliers, maximizing our capabilities and force potential. They also provided the "glue" that kept the coalition together.¹⁶

The implications of this statement clearly reflects the job that Special Forces did in the coalition warfare area. The "glue" is the interoperability and the linkage discussed in this thesis. The Assistant Secretary of Defense gives it much credence by insisting that it, and SF, actually held the coalition together.

According to Admiral David E. Jeremiah, U.S. Navy, the vice-chairman of the Joint Chiefs of Staff, to "consider the variety of our Special Operations activities in the Persian Gulf . . . our forces have set a very high standard for interservice cooperation . . . thanks to some superb leadership."¹⁷ The key point to be taken from here I believe is both the verbiage, superb and cooperation namely, and the fact of the message coming from the Joint Chiefs of Staff. The Admiral seems quite pleased with the SOF and SF contributions during the conflict.

Lieutenant Colonel Mark B. Yates is a foreign area officer and was assigned to the Third Army/Army Forces U.S. Central Command (ARCENT) during the Gulf War as Chief, Coalition Warfare Division, G-3. He was responsible for those activities of coalition building and maintaining during the Gulf War. Although he has been quoted previously in this paper, I feel it is important to see what key points he makes.

"The mission assigned and performed by the 5th Special Forces Group (Airborne) proved absolutely critical. The linkages employed by (SF) augmentation teams offer a successful example for further study."¹⁸ Despite the fact that this officer was not at the highest level of

command with decision-making authority, he nevertheless served in a critical position which could oversee the battlefield and check on the results of the coalitions togetherness. The key words this author pulls from his writings are: "absolutely critical, successful, and linkages."¹⁹ If one were to pose the central issue and question of this thesis to Lieutenant Colonel Yates, I believe his response would be positive, in that he has clearly used a choice of words that underscore the word "significant." The impact that Special Forces had in keeping the coalition together, LTC Yates used the words "absolutely critical,"²⁰ to describe how he felt the performance of SF was. I believe he would feel the significance of SF was of a quality impact to the overall picture.

Throughout this thesis, quotes from various sources have been used to illustrate key points and to get a general picture and understanding of the views shared by some key leaders. However, one individual stands out from the rest, and that one would be General H. Norman Schwarzkopf. In his position as Commander-In-Chief of Central Command and the allied commander of DESERT SHIELD and DESERT STORM, he was directly responsible for receiving the strategic-level guidance from the National Command Authority, the President and the Secretary of Defense, and translating this into operational and even tactical-level successes on the battlefield. Who more than the one man trusted with this enormous task would understand and know, and "feel" what type of impact Special Forces had on that big picture, "his" big picture of fighting the operational and tactical levels of war.

Perhaps the highest praise General Schwarzkopf made to the special operations community was in a speech made at Ar Ar, Saudi Arabia

at the conclusion of the hostilities. He spoke of the successes that SOF forces made in the conflict, and closed by stating ". . . what you've done is never going to be made public and we can't make it public . . . you kept Israel out of the war."²¹ On the strategic level this appears to be a fairly convincing statement. Imagine how history would reflect differently had indeed Israel actively entered the conflict. As Commander-In-Chief, General Schwarzkopf certainly felt the activities of SF and the special operations forces on the whole, had a pretty significant impact politically.

Moving from the strategic-level of significance down to the ground-beating tactical-level, the CINC recognized the effects of Special Forces as well. "We put Special Forces deep into the enemy territory. They went on strategic reconnaissance for us, and they let us know what was going on out there. They were the eyes that were out there."²² The key points I find from this passage is the fact that he refers to SF doing that operational-level strategic reconnaissance missions for "us," meaning the entire allied force. This has to be taken in context of not only the hazards encountered (and documented in this thesis) but of the impact on intelligence gathering to benefit the force as a whole. As he quoted "Those missions were extremely dangerous, the entire country was an armed camp--even areas that looked empty on the map turned out to be heavily patrolled by military units . . . this was winter, and it was alternately freezing and wet."²³ Obviously, in the eyes and words of the allied leader for the Gulf War these missions of extreme danger were of significance to the entire coalition force, and could be accomplished only by a specially-trained force, such as SF. Special Forces teams were the unit of choice and

were selected to conduct those operations which did have a significant impact on the allied force as a whole.

How did the CINC feel about Special Forces' contributions in the area of reconnaissance? "They (SF) did a great job in strategic reconnaissance for us."²⁴ Thus, the term for "us," meaning what SF did was of benefit to the entire allied force, and what kind of effort did the Special Forces perform according to the CINC. "a great job."²⁵ This certainly looks like it did have an importance to the overall campaign.

In the area of Combat Search and Rescue, General Schwarzkopf talked of how tough a mission that was and how he selected Special Forces to conduct that mission.

The Special Forces were 100 percent in charge of the combat search and rescue, and that's a tough mission. When a pilot gets shot down out there in the middle of nowhere, surrounded by the enemy, and you're the folks that are required to go in and go after them, that is a very tough mission.²⁶

This is apparently not a mission to be given out freely to just any unit. The traits and qualities recognized as being inherently found in Special Forces made the decision to use them in this role easier. Obviously, the CINC had a great deal of confidence in SF and was not let down. Certainly, the impact on the minds of each pilot who went across into enemy territory, knowing that SF and a viable search-and rescue operation would be launched had to be significant. This author remembers CPT "Spike" Thomas, the U.S. Air Force F-16 pilot rescued from behind enemy lines and his exhilaration which was unmatched enthusiasm and thankfulness.²⁷

Lastly, to close this chapter and to end the quotes from key people, as General Schwarzkopf so aptly put, reference the SF role in coalition warfare, the CINC said,

First of all, with every single Arab unit that went into battle, we had Special Forces troops with them. The job of those Special Forces was to travel and live right down at the battalion level with all those people to make sure they could act as the communicators with friendly English-speaking units that were on their flanks, and they could also call in air strikes as necessary, they could coordinate helicopter strikes, and that sort of thing. That's one of the principal roles they played, and it was a very, very, important role.²⁸

Significance of the Thesis

To this author, the last statement made by the CINC pretty much can serve as a catch-all total summary to the primary question posed by this thesis. Special Forces did make a contribution to the allied war effort during the Gulf War. I think there is credence to the argument that the contribution made did have a significant impact on the overall campaign. The Commander-In-Chief of the entire region of the world, and the orchestrator of the combined land-sea-air campaign, General H. Norman Schwarzkopf, surely seemed to think so. The accolades were many and directed toward Special Forces. In the strategic-operational level of keeping the coalition together, the one and only unit out of the entire allied force charged with this mission was SF. As the CINC stated, "it was a very, very important role."²⁹ As history will judge the Gulf War and place it in proper perspective accordingly, the fact that the allied coalition was able to stay unified and fight as one force together was perhaps the single-most contributor to overall mission success. Arguably, the role SF played was of a significant value to making this happen and deserves whatever credit deemed just.

Conclusions

This study has shown the activities and missions that was performed by Special Forces during the 1990-1991 Persian Gulf conflict. This concluding chapter has attempted to answer the primary and secondary questions of the thesis. The "answers" given, in the form of the information data presented in chapters four and five, and the credible quotes from key leaders in this chapter serve to offer a conclusion and answer to the questions posed. Obviously, each individual will have his/her opinions and answers to the questions but this thesis has hopefully served to make all readers "aware" of what Special Forces did, and to piece it out and fit it into the overall campaign of the Gulf War in total.

There is plenty of room for further research in this area. Concerning the rest of the special operations forces, the Navy SEALs, the Army Special Operations Aviation, or the Air Force Special Operations Activities, much work can be done similar to this, in that discussions can be made as to the job done there by these forces and the overall significance they had.

There is also room to study in-depth the separate workings of each of the Special Forces missions outlined in this thesis. Particularly in the area of coalition warfare, a thesis topic could surround itself in the particular workings on a day-to-day basis on what exactly did Special Forces contribute in this area. I would encourage the examination of the topics in future thesis research.

Endnotes

¹Douglas C. Waller, The Commandoes: The Inside Story of America's Secret Soldiers (Simon & Shuster, 1994), 349.

²Special Operations in Desert Storm: Separating Fact From Fiction, Special Warfare Magazine, March, 1992.

³Ibid., 3.

⁴After-Action Report, 2nd Battalion, 5th Special Forces Group, 10 March 1991.

⁵Interview Lieutenant Colonel Brownlee, Special Warfare Magazine, July 1993, 42.

⁶Ibid., 43.

⁷Ibid., 43.

⁸"Coalition Warfare in Desert Storm, "Lieutenant Colonel Mark B. Yates, Military Review, October 1993, 50.

⁹Interview Lieutenant Colonel Daniel Brownlee, Special Warfare Magazine, July 1993, 43.

¹⁰Thompson, Jerold L., COL, SF, Memorandum for COMSOCCENT, Subject: Coalition Warfare.

¹¹Interview with BG William Tangney, Commanding General, Special Forces Warfare Command.

¹²Ibid.

¹³"Corps Force-Projection Operations," General Gary E. Luck, U.S. Army Military Review, December 1993, 23-24.

¹⁴Ibid.

¹⁵Ibid.

¹⁶Remarks by James R. Locher III, Eglin AFB, Florida, November 12, 1991.

¹⁷Remarks by Admiral David E. Jeremiah, U.S.N. Washington, D.C., December 9, 1991.

¹⁸"Coalition Warfare in Desert Storm," Lieutenant Colonel Mark B. Yates, Military Review, October 1993, 52.

¹⁹Ibid.

²⁰Ibid.

²¹Douglas C. Waller, The Commandoes: The Inside Story of America's Secret Soldiers (Simon & Shuster, 1994), 349.

²²H. Norman Schwarzkopf, The Autobiography, It Doesn't Take a Hero (New York, NY: Bantam Books, 1992), 246.

²³Ibid., 418.

²⁴M. E. Morris, Road to Triumph (New York, NY: St Martins, Paperback Edition, June 1991), 262.

²⁵Ibid.

²⁶Ibid.

²⁷Personal reflections, William M. Johnson.

²⁸M. E. Morris, Road to Triumph (New York, NY: St Martins, Paperback Edition, June 1991), 261-262.

²⁹ibid.

APPENDIX A

FIGURES

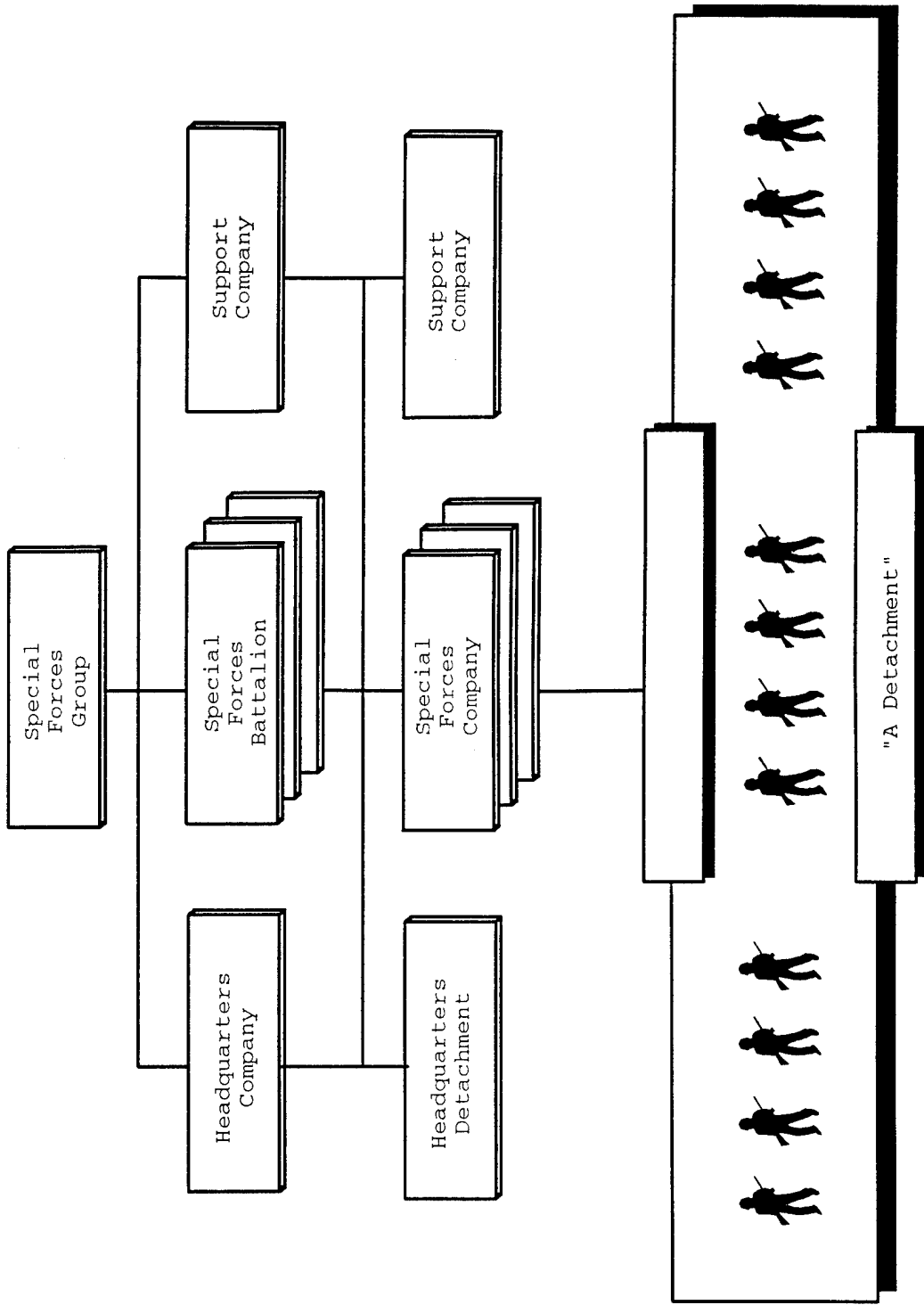

Figure 1. Organization of Special Forces.

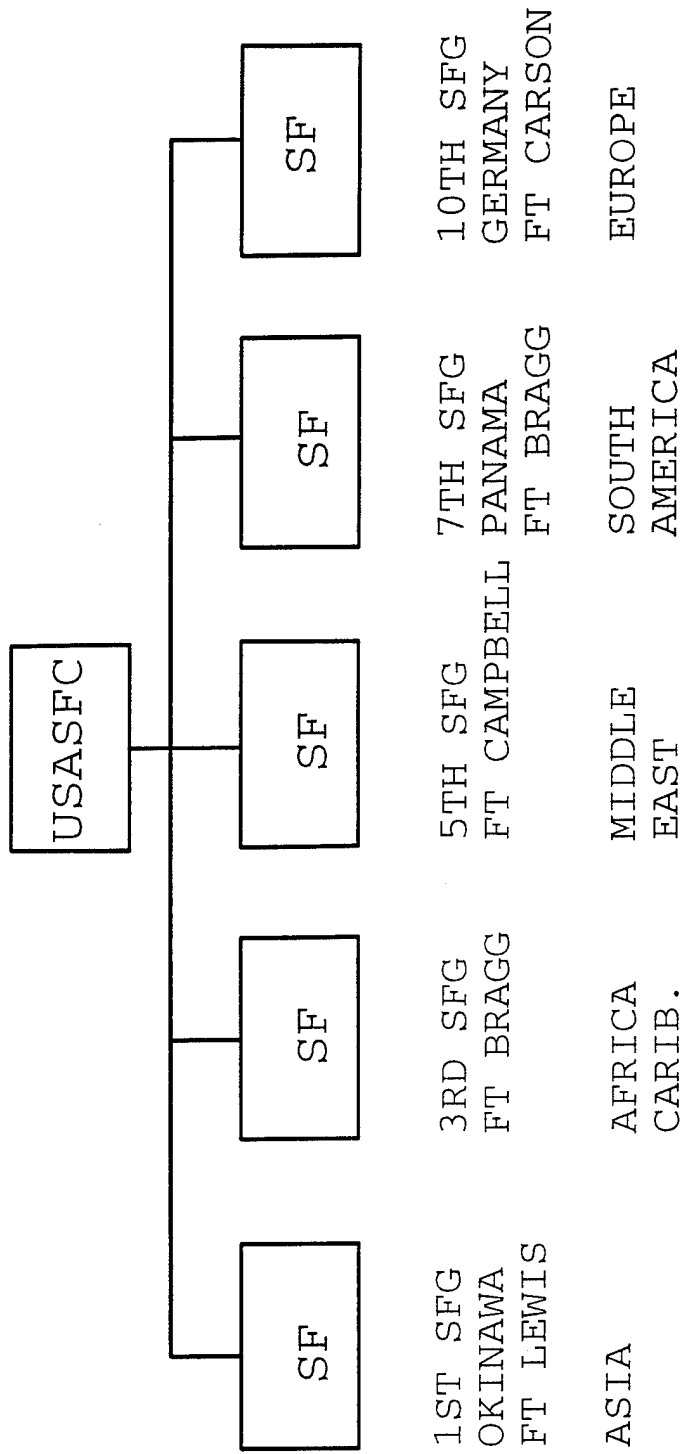

Figure 2. Special Forces Groups

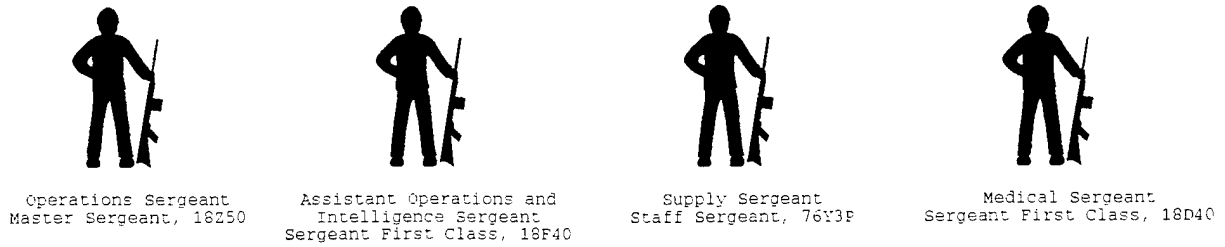
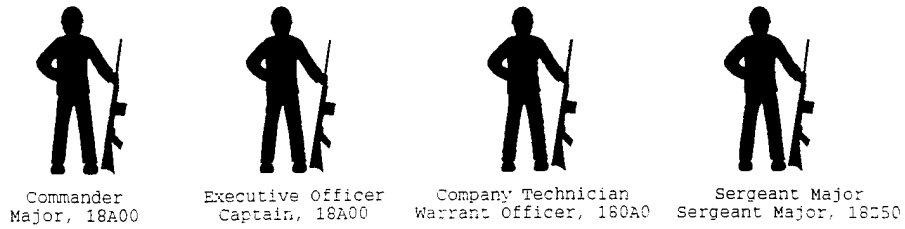

Figure 3. Company Headquarters (B Detachment), Special Forces Company.

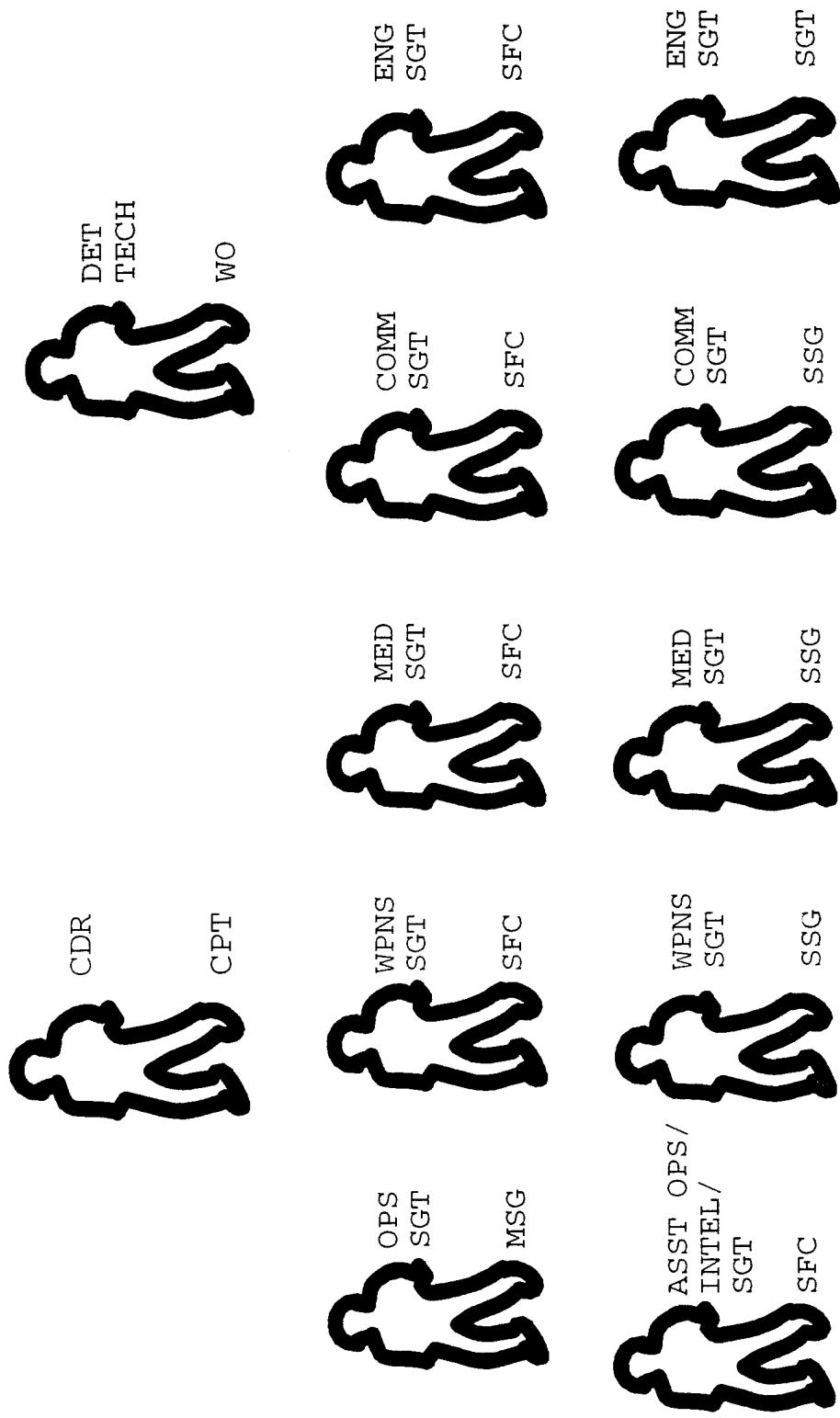

Figure 4. Special Forces Operational Detachment "A".

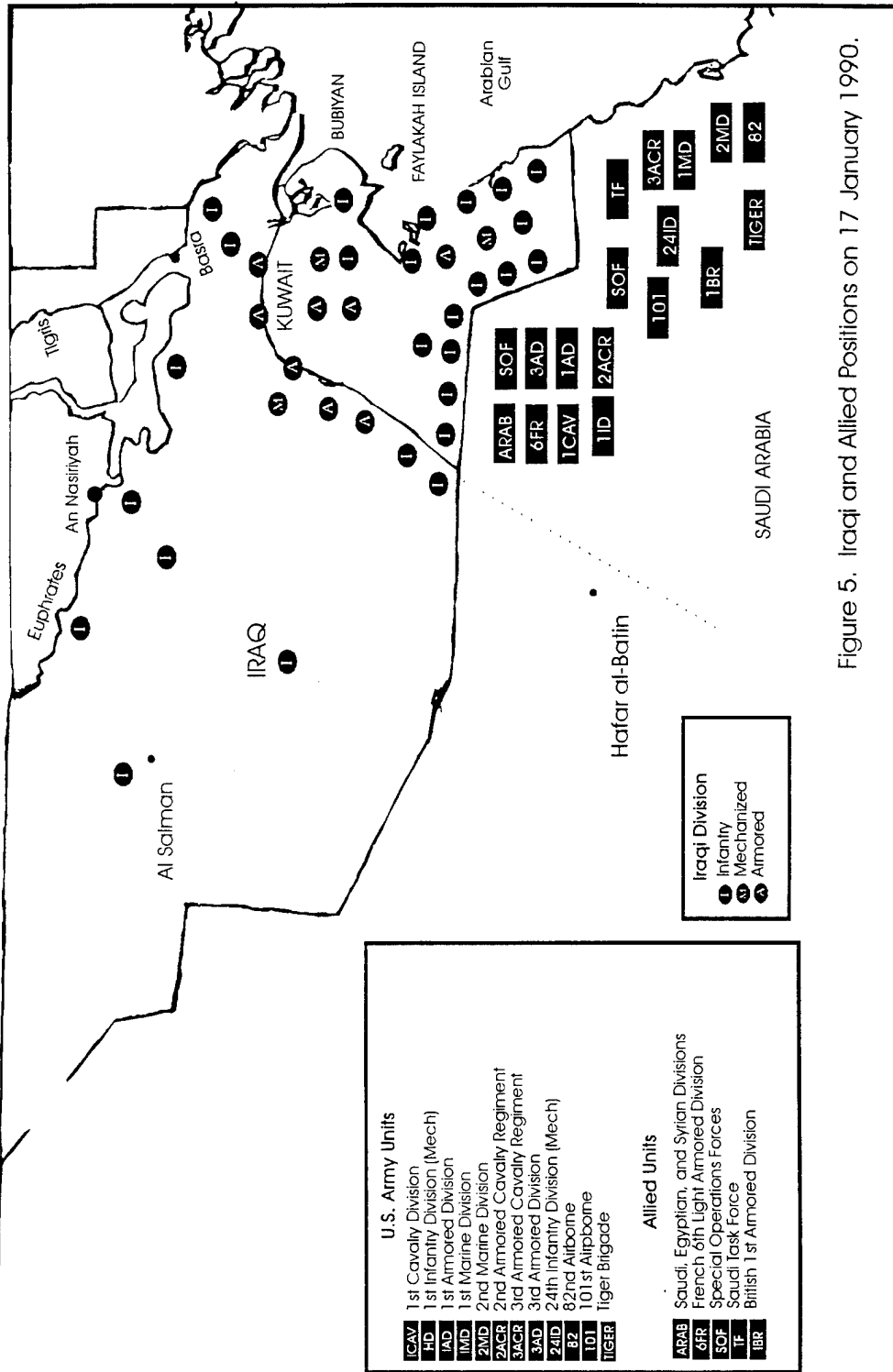

Figure 5. Iraq and Allied Positions on 17 January 1990.

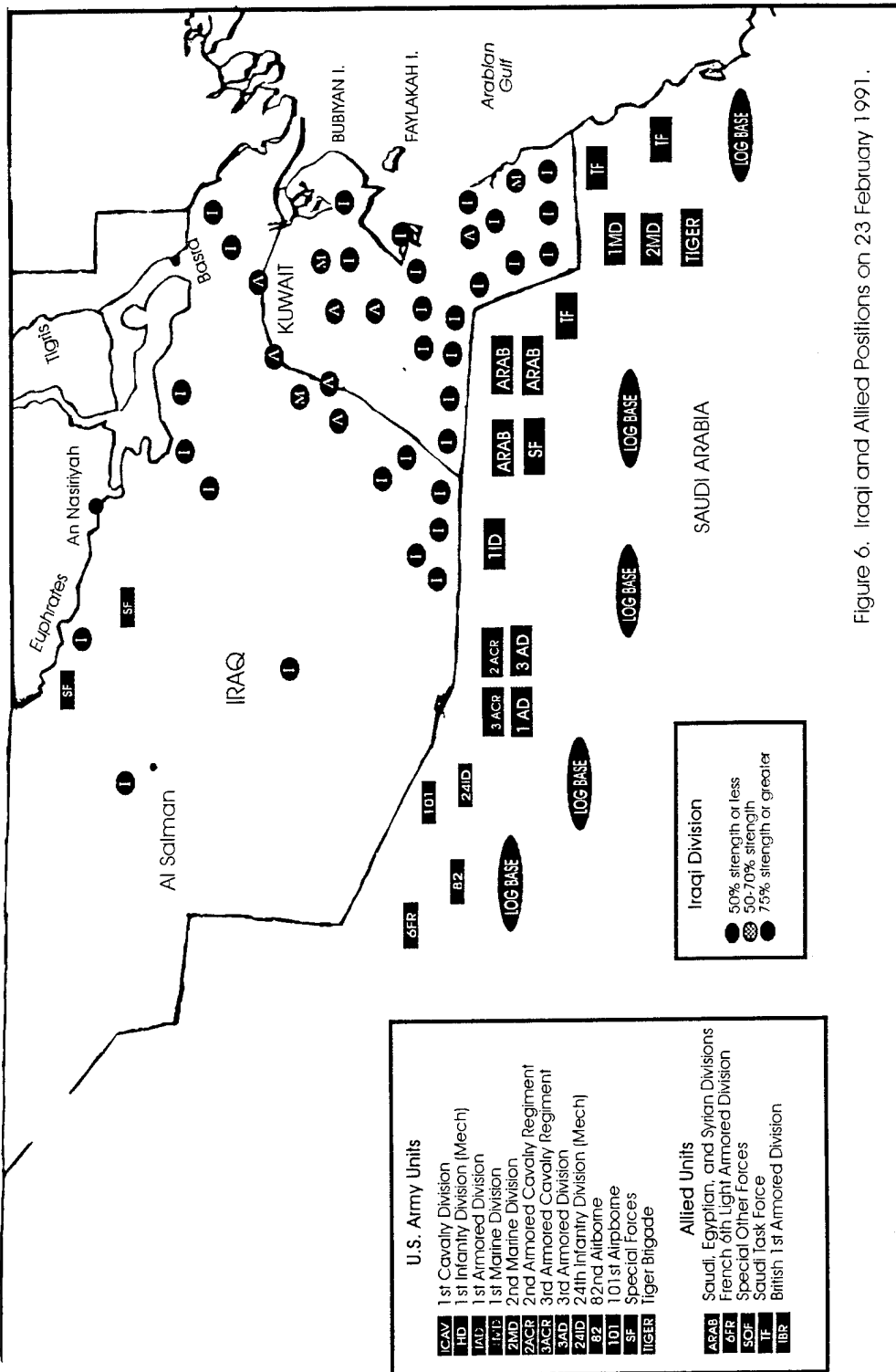
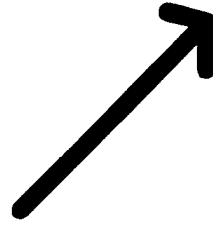

Figure 6. Iraqi and Allied Positions on 23 February 1991.

CLOSE AIR SUPPORT

(WITH EACH COALITION MANEUVER BDE/SELECTED BNS)

USSF FAC TEAM



TERMINAL GUIDANCE



USAF TAC-P W/SF B TEAM

A-10
OA-10
F-16
A-6

TASK ASOC

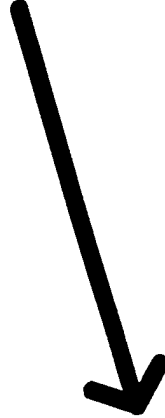

Figure 7.

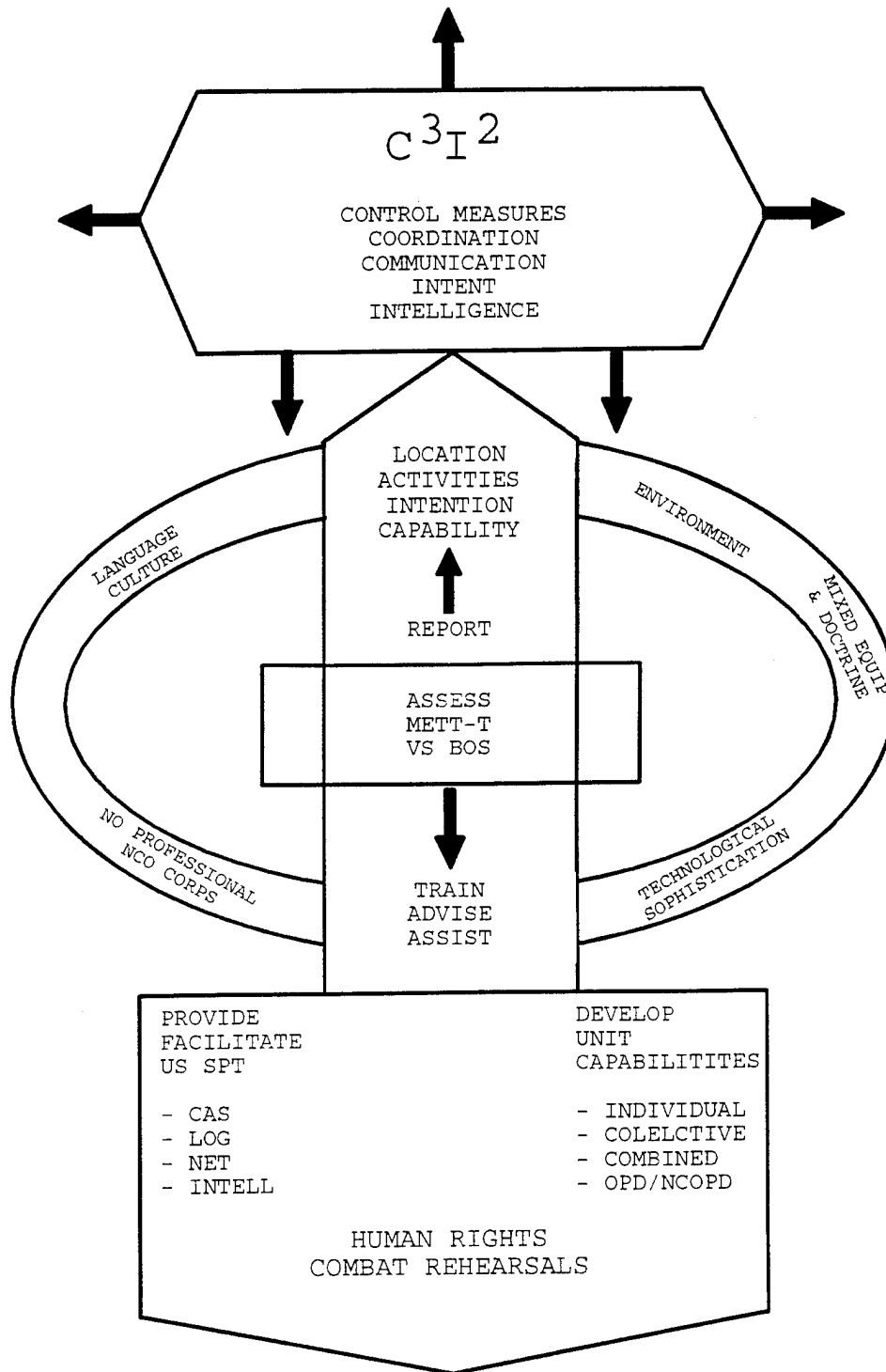

Figure 8. Enhance the Effectiveness of the Coalition.

BIBLIOGRAPHY

Government Publications

- U.S. Army. FM 100-5, Operations. Washington, D.C.: Department of the Army, June 1993.
- U.S. Army. FM 100-8, Combined Army Operations. Washington, D.C.: Department of the Army, Revised Final Draft 1 November 1993.
- U.S. Army. FM 100-25, Doctrine for Special Operations Forces. Washington, D.C.: Department of the Army, 10 December 1991.
- U.S. Army. FM 31-20-3. Foreign Internal Defense, Tactics, Techniques, and Procedures for Special Forces. Washington, D.C.: Department of the Army, 24 March 1994.
- U.S. Army. FM 31-20 Doctrine for Special Forces Operations, Washington, D.C.: Department of the Army, February 1990.
- U.S. Army. Army Special Operations Forces Reference Data, Washington, D.C.: Department of the Army, 30 June 1992.
- U.S. Army. TRADOC PAM 525-5. Force XXI Operations: A Concept for the Evolution of Full-Dimensional Operations for the Strategic Army of the Early Twenty-First Century, Washington, D.C.: Department of the Army, 1 August 1994.
- The Joint Chiefs of Staff. Universal Joint Task List. J7, The Joint Staff, 30 September 1993.
- The Joint Chiefs of Staff. User's Guide for Joint Operation Planning, 11 September 1994.
- The Joint Chiefs of Staff. JOINT PUB 1. Joint Warfare of the U.S. Armed Forces, 11 November 1991.
- The Joint Chiefs of Staff. JCS Pub 3-05. Doctrine for Joint Operations, 9 September 1993.
- The Joint Chiefs of Staff. JCS Pub 3-05.3 (Draft). Joint Special Operational Procedures, 25 August 1993.
- The Joint Chiefs of Staff. JS Pub 3-0 7.1 (Draft). Joint Tactics, Techniques, and Procedures for Foreign Internal Defense, 20 December 1993.

- U.S. Code Annotated. Title 10 Armed Forces 1 to 835, 1994 Cumulative Annual Pocket Part. West Publishing Co. Saint Paul, MN.
- U.S. Department of Defense. Conduct of the Persian War: Final Report to Congress. Washington, DC: Government Printing Office, April 1992.
- U.S. Department of Defense. Annual Report to the President and Congress. Washington, DC: Government Printing Office, January 1994.
- U.S. Department of Defense. United States Special Operations Forces Posture Statement. Washington, DC: Government Printing Office, 1994.
- National Security Strategy of the United States. Washington, DC: Government Printing Office, July 1994.
- The Institute for National Strategic Studies. Standing Up Coalitions. Washington, DC: Government Printing Office, March 1994.

Books

- Collins, John M. Special Operations Forces: An Assessment. National Defense University Press, April 1994.
- Dunnigan, James F. and Austin Bay. From Shield to Storm High Tech Weapons, Military Strategy, and Coalition Warfare in the Persian Gulf War. William Morrow and Company, 1992.
- Dunnigan, James F. How to Make War: A Comprehensive Guide to Modern Warfare for the Post-Cold War Era. William Morrow and Company, 1993.
- Graham, James R. Non-Combat Roles for the U.S. the U.S. Military in the Post Cold-War Era. National Defense University Press, August 1993.
- Pfaltzgraff, Robert L., Jr., and Richard H. Shultz, Jr. The United States Army: Challenges and Missions for the 1990's. Lexington Books, 1991.
- Morris, M. E. Captain. Road to Triumph. New York, NY: St Martin's Paperback edition, June 1991.
- Nolan, Janne E. Global Engagement, Cooperation and Security in the 21st Century. The Brookings Institute, 1994.
- Sarkesian, Sam C., and John Allen Williams. The U.S. Army in a New Security Era. Lynne Rienner Publishers, 1990.

Scales, Robert H. General. Certain Victory: The U.S. Army in the Gulf War. Simon and Schuster, 1993.

Schwarzkopf, H. Norman. The Autobiography, It Doesn't Take a Hero with Peter Petre editor. New York, NY: Bantam Books, 1992.

Swain, Richard M. "Lucky War" Third Army in Desert Storm. U.S. Army Command and General Staff College Press, Fort Leavenworth, KS.

Toffler, Alvin and Heidi. War and Anti-War: Survival at the Dawn of the 21st Century. Little, Brown and Company, 1993.

Walker, Greg. At the Hurricane's Eye. U.S. Special Operations Forces from Vietnam to Desert Storm. Ivy Books, NY: Ballentine Books Copyright 1994.

Waller, Douglas C. The Commandoes: The Inside Story of America's Secret Soldiers. Simon & Shuster, 1994.

Interviews

Davis, William J. U.S. Army Battalion Commander, 2nd Battalion, 5th Special Forces Group (Airborne), 5-6 July 1995.

Kraus, James C. U.S. Army Commander, 5th Special Forces Group (Airborne), 5-6 July 1995.

Paxton, Charles "Chip" U.S. Army Operations Officer (S-3), 3rd Battalion, 5th Special Forces Group, 14 October 1995.

Roberts, Peter J. U.S. Army Commander, C Company, 2nd Battalion, 5th Special Forces Group, 6 August 1995.

Brownlee, David U.S. Army Operations Officer, 5th Special Forces Group (Airborne), 8-9 August 1995.

Tangney, William U.S. Army Commanding General, Special Forces Command, Fort Bragg, NC, 23 October 1995.

Periodicals

Becker, John D. "Combined and Coalition Warfighting: The American Experience." Military Review, LXXIII No. 11 (November 1993): 25-29.

Brownlee, Daniel Lieutenant Colonel, Interview, Special Warfare, 6, No. 3 (July 1993): 40-44.

Downing, Wayne A. "Special Forces: Meeting Tomorrow's Challenges Today." Special Warfare, (January, 1995): 5-8.

- Fenzel, John III. "Five Imperatives of Coalition Warfare." Special Warfare, (July 1993): 2.
- Freeman, Waldo D., and Randall J. Hess. Faria Manual. The Challenges of Combined Operations." Military Review, LXXII No. 11 (November 1992): 2-11.
- Joint Forces Quarterly, Autumn 1993, 7.
- Luck, Gary E. "Corps Force Protection Operations." Military Review, LXXII #12 (December 1993): 15-25.
- Michaelis, Marc. The Importance of Communicating in Coalition Warfare. Military Review, LXXII No. 11 (November 1992): 40-50.
- Naylor, Sean D. "Haiti: The Easy Part is Over." Army Times, 4 (October 31, 1994).
- RisCassi, Robert W. "Principles for Coalition Warfare." Joint Force Quarterly, (Summer 1993): 58.
- Yates, Mark B. "Coalition Warfare in Desert Storm." Military Review, LXXIII No. 10, (October, 1993): 46-52.
- Waller, Douglas C. "Secret Warriors." Newsweek Magazine, (June 17, 1991): 20-29.
- Yaeger, Jeffrey W. "Coalition Warfare: Surrendering Sovereignty." Military Review, LXIII #11 (November 1992): 51-63.

Speeches

- Locher James R., III, "Versatility Protects Special Operations Forces," Remarks to the Association of Old Crows, Eglin Chapter, Hurlburt Field, FL, 12 November, 1991.
- Stiner, Carl W., USSOCOM Challenges: Risk. Ambiguity, Diversity, Opportunity, Prepared Statement to the Senate Armed Services Committee, 5 March 1992.

Unpublished Works

- Boykin, William G., "Special Operations and Low-Intensity Conflict Legislation: Why Was it Passed and Have the voids Been Filled?" Carlisle Barracks, PA: The Army War College, March 1991.
- Coudhry, H. M. "Coalition Warfare--Can the Gulf War-91 be the Model for the Future?" Carlisle Barracks, PA: The Army War College, 21 February 1992.

- Crevar, David N. Message from United States Army Special Operations Command (USASOC), responding to Headquarters Department of the Army (HQDA) addressing the doctrinal foundation for the coalition liaison missions performed by Army Special Operations Forces (ARSOF) during Operation DESERT SHIELD/STORM, 5 December 1991.
- Dubik, James M., and Gordon R. Sullivan. "Land Warfare in the 21st Century." Carlisle Barracks, PA: U.S. Army War College Strategic Studies Institute, February 1993.
- Florer, Hayward S. Jr. "United States Army Special Forces: Versatile Element in the Future Security Environment." Master of Military Art and Science. Thesis, U.S. Army Command and General Staff College, 1993.
- Gregory, William A. "Opening Pandora's Box: The U.S. in Combined Contingency Operations." Master of Military Art and Science Thesis, 1991. U.S. Army Command and General Staff College, Fort Leavenworth, KS 66027.
- King, Charles A. to Commander United States Army Special Forces Command, 16 March 1994. Memorandum concerning Faction Liaison team (FLT) and Coalition Support Team (CST) Training Status Matrix.
- Maxwell, Barry A. Establishing Theater Command and Control in a Coalition of Nations: Requirements for U.S. Doctrine." Master of Military Art and Science. Thesis: U.S. Army Command and General Staff College, 1992.
- Medve, John P. Integration, Interoperability, and Coalition Warfare in the New World Order. Master of Military Art and Science. Thesis: U.S. Army Command and General Staff College, 1993.
- Moore, Joseph A. Coalition Command and Control: Essential Considerations. Master of Military Art and Science. Thesis: U.S. Army Command and General Staff College, 1993.
- Pudas, Terry J. Coalition Warfare: Preparing the U.S. Commander for the Future." Newport, RI: Naval War College, 18 May 1992.
- Stewart, John Dr. Role and Missions of Special Operations. Executive Summary obtained from the USACGSC Historian.
- Thompson, Jerald L. to Commander Special Operations Command Central Command, 1992. Memorandum concerning Coalition Warfare.
- Walley, Jim. Lessons Learned Newsletter from the Gulf War pertaining to Army Special Operations Forces, (Draft) 7 April 1994.

INITIAL DISTRIBUTION LIST

1. Combined Arms Research Library
U.S. Army Command and General Staff College
Fort Leavenworth, KS 66027
2. Defense Technical Information Center
Cameron Station
Alexandria, VA 22314
3. Commander
U.S. Army Special Operations Command
ATTN: Command Historian
Fort Bragg, NC 28307
4. Commander
U.S. Army John F. Kennedy Special Warfare Center and School
ATTN: DOTD
Fort Bragg, NC 28307
5. LTC Curt L. Weimer
U.S. Army Command and General Staff College
Department of Joint and Combined Operations
Fort Leavenworth, KS 66027
6. Mr. Joseph G. D. Babb
U.S. Army Command and General Staff College
Department of Joint and Combined Operations
Fort Leavenworth, KS 66027
7. LTC Murray J. Swan, RCR
U.S. Army Command and General Staff College
Department of Joint and Combined Operations
Fort Leavenworth, KS 66027
8. LTC James A. White
U.S. Army Command and General Staff College
Department of Joint and Combined Operations
Fort Leavenworth, KS 66027
9. COL William J. Davis
709 Sherwood Drive
Carlisle, PA 17013

10. COL Glen M. Harned
3444 Flint Hill Place
Woodbridge, VA 22192
11. Major Michael L. Langley
U.S. Army Command and General Staff College
Concepts and Doctrine Development Directorate
Fort Leavenworth, Kansas 66027
12. Dr. Arthur T. Frame
U.S. Army Command and General Staff College
Department of Joint and Combined Operations
Fort Leavenworth, Kansas 66027
13. Dr. Michael D. Pearlman
U.S. Army Command and General Staff College
Combat Studies Institute
Fort Leavenworth, Kansas 66027

CERTIFICATION FOR MMAS DISTRIBUTION STATEMENT

1. Certification Date: 7 June 1996
2. Thesis Author: Major William M. Johnson
3. Thesis Title: U.S. Army Special Forces in DESERT SHIELD/DESERT
DESERT STORM: How Significant an Impact

4. Thesis Committee Members

Signatures:

MAJ Michael L. Langley

Arthur T. Frame

Michael D. Pearlman

5. Distribution Statement: See distribution statements A-X on reverse, then circle appropriate distribution statement letter code below:

A B C D E F X SEE EXPLANATION OF CODES ON REVERSE

If your thesis does not fit into any of the above categories or is classified, you must coordinate with the classified section at CARL.

6. Justification: Justification is required for any distribution other than described in Distribution Statement A. All or part of a thesis may justify distribution limitation. See limitation justification statements 1-10 on reverse, then list, below, the statement(s) that applies (apply) to your thesis and corresponding chapters/sections and pages. Follow sample format shown below:

S	-----SAMPLE-----	SAMPLE-----	SAMPLE-----	SAMPLE-----	S
A	<u>Limitation Justification Statement</u>	/	<u>Chapter/Section</u>	/	<u>Page(s)</u>
M					M
P	<u>Direct Military Support (10)</u>	/	<u>Chapter 3</u>	/	<u>12</u>
L	<u>Critical Technology (3)</u>	/	<u>Sect. 4</u>	/	<u>31</u>
E	<u>Administrative Operational Use (7)</u>	/	<u>Chapter 2</u>	/	<u>13-32</u>
	-----SAMPLE-----		SAMPLE-----		SAMPLE-----

Fill in limitation justification for your thesis below:

<u>Limitation Justification Statement</u>	<u>Chapter/Section</u>	<u>Page(s)</u>
_____ / _____	_____ / _____	_____
_____ / _____	_____ / _____	_____
_____ / _____	_____ / _____	_____
_____ / _____	_____ / _____	_____

7. MMAS Thesis Author's Signature: 

STATEMENT A: Approved for public release; distribution is unlimited.
(Documents with this statement may be made available or sold to the general public and foreign nationals.)

STATEMENT B: Distribution authorized to U.S. Government agencies only (insert reason and date ON REVERSE OF THIS FORM). Currently used reasons for imposing this statement include the following:

1. Foreign Government Information. Protection of foreign information.
2. Proprietary Information. Protection of proprietary information not owned by the U.S. Government.
3. Critical Technology. Protection and control of critical technology including technical data with potential military application.
4. Test and Evaluation. Protection of test and evaluation of commercial production or military hardware.
5. Contractor Performance Evaluation. Protection of information involving contractor performance evaluation.
6. Premature Dissemination. Protection of information involving systems or hardware from premature dissemination.
7. Administrative/Operational Use. Protection of information restricted to official use or for administrative or operational purposes.
8. Software Documentation. Protection of software documentation-- release only in accordance with the provisions of DoD Instruction 7930.2.
9. Specific Authority. Protection of information required by a specific authority.
10. Direct Military Support. To protect export-controlled technical data of such military significance that release for purposes other than direct support of DoD-approved activities may jeopardize a U.S. military advantage.

STATEMENT C: Distribution authorized to U.S. Government agencies and their contractors: (REASON AND DATE). Currently most used reasons are 1, 3, 7, 8, and 9 above.

STATEMENT D: Distribution authorized to DoD and U.S. DoD contractors only: (REASON AND DATE). Currently most used reasons are 1, 3, 7, 8, and 9 above.

STATEMENT E: Distribution authorized to DoD only; (REASON AND DATE). Currently most used reasons are 1, 2, 3, 4, 5, 6, 7, 8, 9, and 10.

STATEMENT F: Further dissemination only as directed by (controlling DoD office and date), or higher DoD authority. Used when the DoD originator determines that information is subject to special dissemination limitation specified by paragraph 4-505, DoD 5200.1-R.

STATEMENT X: Distribution authorized to U.S. Government agencies and private individuals of enterprises eligible to obtain export-controlled technical data in accordance with DoD Directive 5230.25; (date). Controlling DoD office is (insert).