

*te technical note techn*

# Mark 20 Category II/III Instrument Landing System Operational Test and Evaluation, Functional and Performance Test Report

Jesse Jones

DEFINITION STATEMENT A  
Approved for public release  
Distribution Unlimited

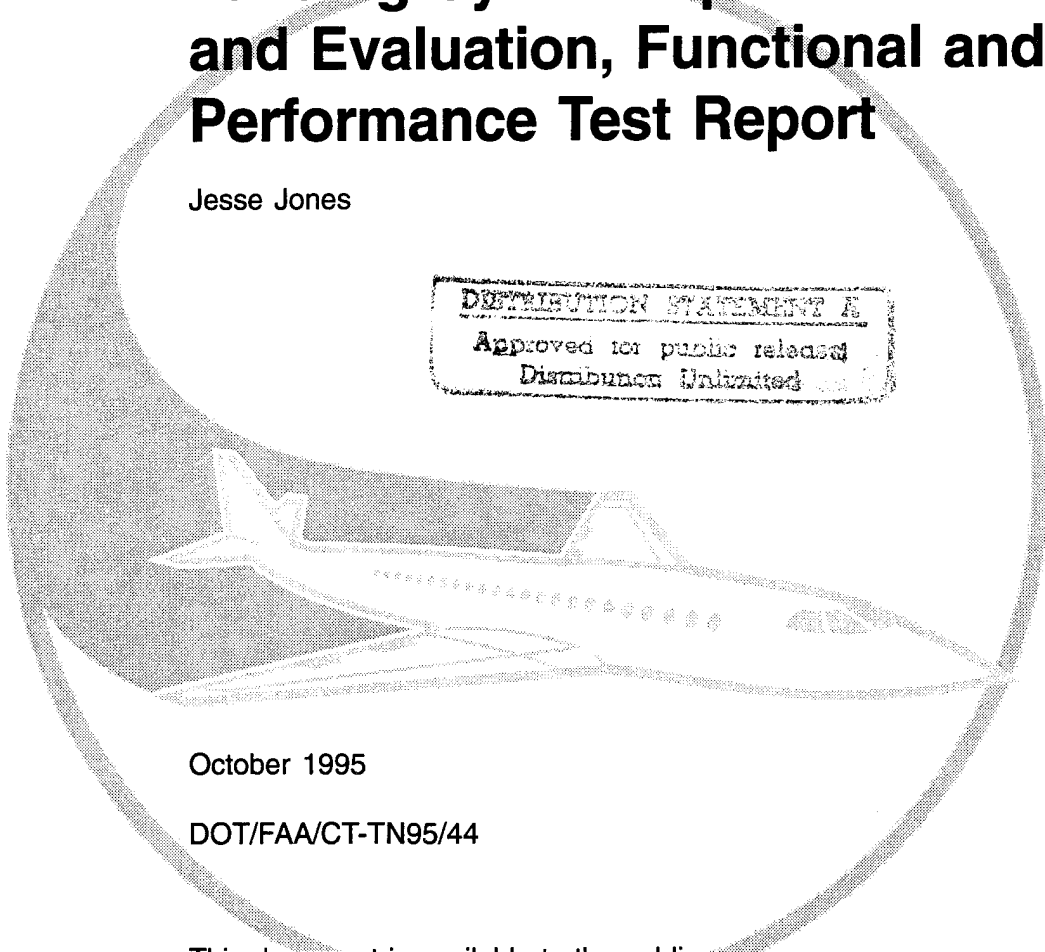

October 1995

DOT/FAA/CT-TN95/44

This document is available to the public through the National Technical Information Service, Springfield, Virginia 22161.

19960122 090



U.S. Department of Transportation  
Federal Aviation Administration

Technical Center  
Atlantic City Airport, NJ 08405

19960122 090

#### **NOTICE**

This document is disseminated under the sponsorship of the U.S. Department of Transportation in the interest of information exchange. The United States Government assumes no liability for the contents or use thereof.

The United States Government does not endorse products or manufacturers. Trade or manufacturers' names appear herein solely because they are considered essential to the objective of this report.

**Technical Report Documentation Page**

|   |  |  |   |   |           |
|---|--|--|---|---|-----------|
| 1. Report No.<br>DOT/FAA/CT-TN95/44   |  | 2. Government Accession No.                          |   | 3. Recipient's Catalog No.  |           |
| 4. Title and Subtitle<br>Mark 20 Category II/III Instrument Landing System Operational Test and Evaluation, Functional and Performance Test Report  |  |  |   | 5. Report Date<br>October, 1995   |           |
|   |  |  |   | 6. Performing Organization Code<br>ACT-360  |           |
| 7. Author(s)<br>Jesse Jones; Benjamin Bennett, Raytheon Service Co.;<br>Byron Robins, SAIC  |  |  |   | 8. Performing Organization Report No.<br>DOT/FAA/CT-TN95/44                       |           |
| 9. Performing Organization Name and Address<br>U.S. Department of Transportation<br>Federal Aviation Administration<br>Technical Center<br>Atlantic City International Airport, NJ 08405  |  |  |   | 10. Work Unit No. (TRAIS)   |           |
|   |  |  |   | 11. Contract or Grant No.   |           |
|   |  |  |   | 13. Type of Report and Period Covered<br>Technical Note<br>July 1994 - March 1995 |           |
| 12. Sponsoring Agency Name and Address<br>U.S. Department of Transportation<br>Federal Aviation Administration<br>Technical Center<br>Atlantic City International Airport, NJ 08405   |  |  |   | 14. Sponsoring Agency Code  |           |
|   |  |  |   |   |           |
| 15. Supplementary Notes<br>This effort was performed in cooperation with FAA Technical Center (ACT-360) personnel and project personnel from Raytheon Service Company in Pleasantville, New Jersey.   |  |  |   |   |           |
| 16. Abstract<br>This test report documents the results of the Operational Test and Evaluation (OT&E) Functional and Performance tests conducted on the Category II/III Mark 20 Instrument Landing System (ILS) at the FAA Technical Center, Atlantic City International Airport, Atlantic City, NJ. The Mark 20 ILS modular design is based on a new generation of microprocessors and software. With Remote Maintenance Monitoring (RMM) capability and the concept of "remove and replace" maintenance, it will provide major airway facilities throughout the U.S. with a more reliable and easily maintained system.<br><br>The report contains the system configuration, test descriptions, test equipment used, data collection and analysis methods, test results, and conclusions. Based on testing performed at the FAA Technical Center, it is recommended that the Mark 20 ILS be accepted for deployment. |  |  |   |   |           |
| 17. Key Words<br>Instrument Landing System (ILS)<br>Category II/III<br>Mark 20  |  |  | 18. Distribution Statement<br>This documentation is available to the public through the National Technical Information Service, Springfield, VA 22161 |   |           |
| 19. Security Classif. (of this report)<br>Unclassified  |  | 20. Security Classif. (of this page)<br>Unclassified |   | 21. No. of Pages<br>74  | 22. Price |

## TABLE OF CONTENTS

|   | Page |
|---|------|
| EXECUTIVE SUMMARY   | vii  |
| 1. INTRODUCTION   | 1    |
| 1.1 Purpose of Report   | 1    |
| 1.2 Scope of Report   | 1    |
| 2. REFERENCE DOCUMENTS  | 1    |
| 3. SYSTEM DESCRIPTION   | 2    |
| 3.1 Mission Review  | 2    |
| 3.2 Test System Configuration   | 2    |
| 3.3 Interfaces  | 4    |
| 4. TEST AND EVALUATION DESCRIPTION  | 4    |
| 4.1 Test Schedules and Locations  | 4    |
| 4.2 Participants  | 5    |
| 4.3 Test and Specialized Equipment  | 5    |
| 4.4 Test Objectives/Criteria  | 5    |
| 4.5 Test Descriptions   | 8    |
| 4.6 Data Collection and Analysis Method                                     | 10   |
| 5. RESULTS AND DISCUSSION   | 16   |
| 5.1 ILS Installation and Alignment  | 16   |
| 5.2 Flight Inspection   | 16   |
| 5.3 System Reliability and Maintainability                                  | 16   |
| 5.4 Remote Status and Interlock Unit  | 26   |
| 5.5 Standby Power   | 29   |
| 6. CONCLUSIONS  | 29   |
| 7. RECOMMENDATIONS  | 30   |
| 8. ACRONYMS   | 31   |
| APPENDIXES  |      |
| A. Oklahoma City Flight Inspection Field Office<br>Flight Inspection Report |      |
| B. Test Trouble Reports   |      |
| C. Stability Data   |      |

## LIST OF ILLUSTRATIONS

| Figure |  | Page |
|--------|--|------|
| 1      | Mark 20 ILS OT&E Test Setup  | 3    |
| 2      | RCSU and LCU to Subsystem Connect Diagram  | 4    |
| 3      | Locations of Boeing 727 While Airborne Localizer Approach and Far Field Monitor Data Was Collected             | 15   |
| 4      | Localizer Approach Guidance Error Plot   | 17   |
| 5      | Localizer Orbit  | 17   |
| 6      | Glide Slope Approach Guidance Error Plot   | 18   |
| 7      | Glide Slope Level Run  | 18   |
| 8      | Correlation of Temperature and Monitored Glide Slope Path RF Level for January 30, 1995                        | 19   |
| 9      | Test Configuration for Measuring VSWR, Phase, and Amplitude of Glide Slope Antennas During Ice Loading Testing | 20   |
| 10     | Far Field Monitor #1 Readings with a B727 in the Localizer Environment   | 28   |
| 11     | Far Field Monitor #2 Readings with a B727 in the Localizer Environment   | 28   |

## LIST OF TABLES

| Table |  | Page |
|-------|--|------|
| 1     | Glide Slope Antenna Measurements During Ice Loading Testing  | 21   |
| 2     | Glide Slope Clearance RF Level and SDM as SBO Level is Adjusted from 0% to 100% in 5% Increments           | 22   |
| 3     | Glide Slope Clearance RF Level and SDM as CLR SDM is Adjusted from 50% to 90% in 5% Increments             | 23   |
| 4     | Glide Slope Clearance RF Level and SDM as CLR RF Level is Adjusted from 0.00W to 0.50W in 0.05W Increments | 23   |
| 5     | Fault Diagnostic Results   | 24   |
| 6     | Log of the Position of the B727 During Far Field Monitor Testing   | 27   |
| 7     | Mark 20 Subsystem Standby Power Test Results and Requirements  | 29   |

## EXECUTIVE SUMMARY

The Federal Aviation Administration (FAA) contracted Wilcox Electric, Inc., to produce five category II/III Instrument Landing Systems (ILS) with an option to purchase more based on successful completion of testing. One system was installed for operational test and evaluation on runway 04 at the FAA Technical Center at the Atlantic City International Airport. The FAA Technical Center operational test and evaluation period was July 1994, through March 1995.

The ILS successfully passed a category III type flight check conducted by the Oklahoma City Flight Inspection Field Office and periodic flight checks conducted by the FAA Technical Center test team. The few subsystem outages that occurred during testing were easily identified and corrected. Weather effects on the Mark 20 were studied over a period of time and found to have little or no affect on operation. All subsystems exceeded their respective minimum time requirement for operating on battery standby power.

All critical test issues were addressed and resolved during the testing period. Based on testing performed at the FAA Technical Center, it is recommended that the Mark 20 ILS be accepted for deployment.

## 1. INTRODUCTION.

### 1.1 PURPOSE OF REPORT.

The purpose of this test report is to document and summarize the results of the Operational Test and Evaluation (OT&E) Functional and Performance tests conducted on the Category II/III Mark 20 Instrument Landing System (ILS) at the Federal Aviation Administration (FAA) Technical Center, Atlantic City International Airport. Integration testing was performed by ACN-100D at the FAA Technical Center and at Tamiami/Kendell Executive Airport in Miami, FL (TMB). The integration testing results are contained in a separate report.

### 1.2 SCOPE OF REPORT.

This report is prepared in accordance with the format specified in FAA-STD-024B, dated August 22, 1994. The report contains the system configuration, test descriptions, test equipment used, data collection and analysis methods, test results, and conclusions and recommendations.

## 2. REFERENCE DOCUMENTS.

|                 |   |
|-----------------|---|
| FAA-E-2852      | Category II/III Instrument Landing System with RMS, January 25, 1993.   |
| NAS-SS-1000     | NAS System Specification, Functional and Performance Requirements for the National Airspace System, General, February 1991. |
| NAS-SS-1000     | NAS System Specification, Ground to Air Element, VOL III, February 1991.  |
| OA P 8200.1     | U.S. Standard Flight Inspection Manual, Change 46, January 1991.  |
| ILS Test Plan   | Category II/III Instrument Landing System/RMS Operational Test & Evaluation/Integration Test Plan, August 1993.             |
| Test Procedures | ILS/RMS Operational Test & Evaluation, Functional and Performance Test Procedures, March 1994.                              |
| TI 6750.180     | Localizer Electronic Subsystem, Draft 10/2/94.  |
| TI 6750.181     | Glide Slope Electronic Subsystem, Draft 10/2/94.  |
| TI 6750.182     | Remote Indication & Control Equipment, Draft 10/2/94.   |
| TI 6750.183     | Link Control Unit Group, Draft 10/2/94.   |



TI 6750.184 Far Field Monitor Kit, Draft 10/2/94.

TI 6750.185 Portable ILS Signal Analyzer Group, Draft  
10/2/94.

### 3. SYSTEM DESCRIPTION.

#### 3.1 MISSION REVIEW.

An ILS provides a means for safely landing aircraft at airports under conditions of low ceilings and limited visibility. Category (CAT) II/III ILS provides highly accurate lateral and vertical guidance information, in the form of amplitude modulated radio frequency transmissions, to specialized radio reception equipment on board the aircraft. A CAT II ILS provides acceptable guidance information from the coverage limits of the ILS to 50 feet above the runway threshold, while a CAT III ILS provides acceptable guidance to, and along, the surface of the runway. The CAT II/III ILS under test is the Mark 20 system produced by Wilcox Electric, Inc. The Mark 20 ILS modular design is based on a new generation of microprocessors and software. With Remote Maintenance Monitoring (RMM) capability and the concept of "remove and replace" maintenance, it will provide major airway facilities throughout the U.S. with a more reliable and easily maintained system.

#### 3.2 TEST SYSTEM CONFIGURATION.

The Mark 20 ILS consists of a localizer, a glide slope, and inner, middle, and outer markers providing lateral, vertical, and distance to threshold guidance, respectively. The Mark 20 ILS also includes a localizer Far Field Monitor (FFM), a Link Control Unit (LCU), Remote Control and Status Unit (RCSU), and Remote Status and Interlock Unit (RSIU). Maintenance equipment provided with the Mark 20 ILS are the Portable ILS Receiver (PIR) and the Portable Maintenance Data Terminal software (PMDT).

##### 3.2.1 Localizer Subsystem Configuration.

The localizer is a Very High Frequency (VHF) dual frequency capture effect system consisting of dual course and clearance transmitters (on air and hot standby), dual integral monitoring equipment (executive and standby), dual FFMs, 14 element log periodic dipole antenna array, and a Radio Frequency (RF) distribution unit and combining unit. The localizer antenna array is located 1,005 feet from the stop end of Atlantic City International Airport, NJ (ACY) runway 04 on the extended centerline (figure 1).

##### 3.2.2 Glide Slope Subsystem Configuration.

The glide slope is an Ultra High Frequency (UHF) dual frequency capture effect system consisting of dual path and clearance transmitters (on air and hot standby), dual integral monitoring equipment (executive and standby), a three-element imaging

antenna array, and an RF distribution and combining unit. The glide slope antenna array is set back 875 feet from the threshold of ACY runway 04 with a Northwest offset of 400 feet from the runway centerline (figure 1).

### 3.2.3 Marker Beacon Subsystem Configuration.

The marker beacons are a VHF system consisting of an inner marker, middle marker, and outer marker. Each marker beacon includes a single transmitter, single monitor, and a single Yagi antenna element for the inner and middle marker, and a dual Yagi antenna configuration for the outer marker. Each marker beacon is configurable to perform as an inner, middle, or outer marker. The inner, middle, and outer marker antennas are located 1,086 feet, 3,500 feet, and 4,800 feet from the ACY runway 04 threshold, respectively. Due to property restraints, the outer marker was not positioned in a normal operating location. The inner marker is located on the extended runway centerline, the middle marker is offset by 15 feet, and the outer marker 41 feet, both to the Northwest side of the extended centerline (figure 1).

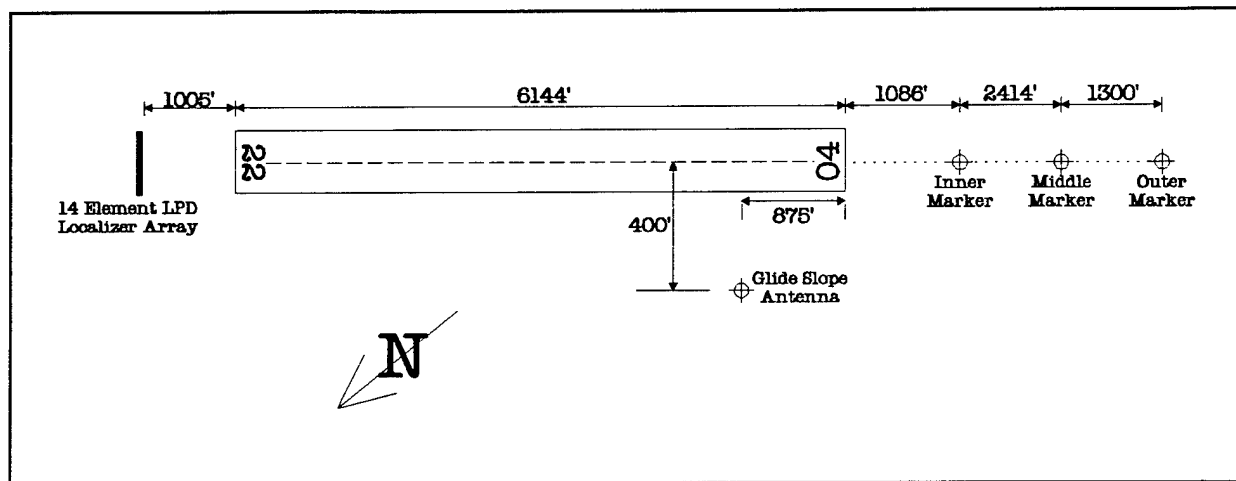

FIGURE 1. MARK 20 ILS OT&E TEST SETUP

### 3.2.4 Remote Indication and Control Equipment Configuration.

The Remote Indication and Control Equipment (RICE) consists of an RCSU and an RSIU. The RCSU is directly connected to the localizer, glide slope, and each marker beacon (figure 2). Through this connection, transmitter and monitor information for each subsystem is updated constantly at the RCSU. On/off, reset, and FFM bypass control are also provided at the RCSU. The RSIU provides category of operation indication, localizer, glide slope, and marker beacon transmitter status, interlock control and display, and FFM status and bypass control. Power and ILS status are provided to the RSIU from the RCSU. In an operational environment, the RCSU would be located in the airport tower equipment room and the RSIU in the airport control tower cab.

### 3.3 INTERFACES.

The LCU provides a communications link between the Mark 20 and its associated Maintenance Processing System (MPS). The LCU is directly connected to the localizer, glide slope, and each marker beacon (figure 2). This connection is distinct and separate from the connection from the subsystems to the RCSU. The decoder module running the MPS was developed by FAA/UNISYS and tested by ACN-100D during integration testing at the FAA Technical Center. The MPS is a remote system that is used to monitor all National Airspace System (NAS) facilities that have Remote Maintenance System (RMS) capabilities. Remote control of each subsystem is provided directly from the LCU. An operational LCU would usually be located in the airport tower equipment room. For test purposes, the LCU was located in room 306 of building 301 at the FAA Technical Center.

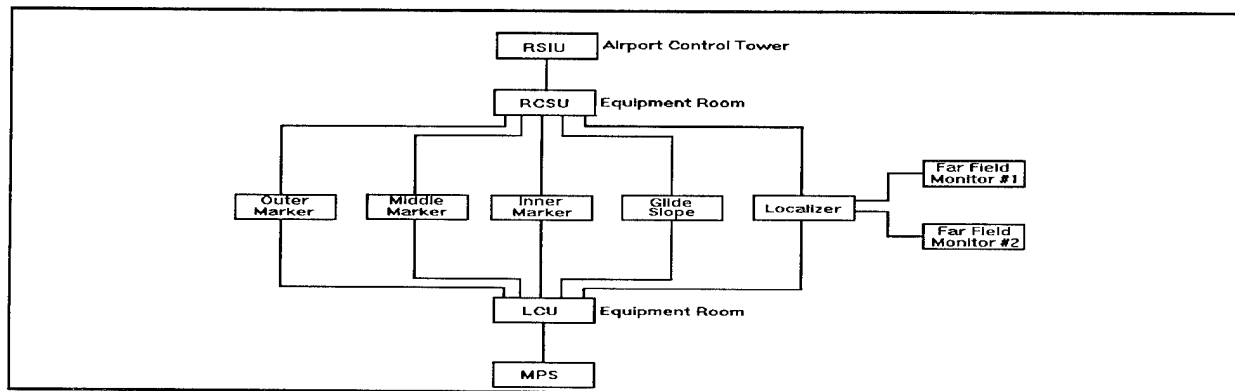

FIGURE 2. RCSU AND LCU TO SUBSYSTEM CONNECT DIAGRAM

## 4. TEST AND EVALUATION DESCRIPTION.

### 4.1 TEST SCHEDULES AND LOCATIONS.

All tests were performed at the FAA Technical Center, Atlantic City International Airport, New Jersey. The sequence of events and time frame are as follows:

| <u>EVENT</u>                           | <u>DATE</u>            |
|--|------------------------|
| Localizer antenna installation         | November-December 1993 |
| Glide Slope antenna installation       | January 1994           |
| Electronic equipment arrival           | April 21, 1994         |
| ILS RMS/Integration testing            | May-August 1994        |
| Alignment                              | May-June 1994          |
| Commissioning Type Flight Inspection   | July 12-13, 1994       |
| System Reliability and Maintainability | July 1994-March 1995   |

#### 4.2 PARTICIPANTS.

The following FAA Region and FAA Technical Center personnel participated in the Mark 20 ILS installation and test:

| <u>NAME</u>     | <u>REGION</u>    | <u>ACTIVITY</u>                              |
|-----------------|------------------|--|
| Dave Goffinet   | Great Lakes      | Installation & Alignment                     |
| Daryl Fridge    | Great Lakes      | Installation                                 |
| Mark Collins    | Great Lakes      | Installation                                 |
| R.O. Campbell   | Western Pacific  | Installation & Alignment                     |
| Simon Sohn      | Eastern          | Installation                                 |
| Reggie Carter   | Eastern          | Installation                                 |
| Robert Dunlap   | Alaskan          | Installation                                 |
| Paul Everman    | Wash.D.C.        | Installation & Alignment                     |
| Jesse Jones     | Technical Center | Installation, Alignment & Test               |
| Ben Bennett     | Technical Center | Installation, Alignment & Test               |
| Byron Robins    | Technical Center | Installation, Alignment & Test               |
| Ed Zyzys (Ret.) | Technical Center | Associate Program Manager<br>for Test (APMT) |
| Jack Townsend   | Technical Center | APMT   |

#### 4.3 TEST AND SPECIALIZED EQUIPMENT.

| <u>MODEL</u> | <u>DESCRIPTION</u>                 |
|--------------|------------------------------------|
| BIRD         | Analog Wattmeter                   |
| NARDA 3020A  | Directional Coupler                |
| HP 8508A     | Vector Voltmeter (CAL 9/22/93)     |
| HP 1725A     | Oscilloscope                       |
| Fluke 8050A  | Digital Multimeter                 |
| HP 8640B     | Signal Generator (CAL 6/17/93)     |
| HP           | Protocol Analyzer                  |
| Wilcox       | Portable ILS Receiver              |
| IBM          | Portable Maintenance Data Terminal |
|              | Instrumented Test Aircraft         |
|              | Laser Tracking System              |
|              | NIKE Radar Tracking System         |

#### 4.4 TEST OBJECTIVES/CRITERIA.

##### 4.4.1 ILS Installation and Alignment.

The purpose of the installation and alignment procedure is to verify that the Mark 20 ILS can be properly installed, aligned and made ready for a flight inspection using the draft technical documentation supplied by the contractor. The following functional requirements outlined in paragraph 4.3.1.1 of the ILS Test Plan were verified during the installation and alignment process:

a. The ILS shall broadcast lateral guidance along a fixed path, referenced to the extended runway centerline.

b. The ILS shall broadcast vertical guidance along a fixed signal path referenced to the nominal final approach path to the runway.

c. The ILS shall broadcast a morse code facility ID code except when the facility is removed from service.

d. ILS lateral guidance transmissions shall discontinue automatically if parameters monitored at the localizer exceed predefined limits.

e. ILS vertical guidance transmissions shall discontinue automatically if parameters monitored at the glide slope exceed predefined limits.

f. The NAS shall provide for the shutdown of electronic precision landing systems for the purpose of National Defense.

g. The ILS shall monitor its operational status, and certification and diagnostic test data.

#### 4.4.2 Flight Inspection.

This test demonstrates the ability of the Mark 20 ILS to meet the requirements of a Commissioning Type Inspection as set forth in the U.S. Standard Flight Inspection Manual, OA P 8200.1, Change 46, dated 1/18/91, and DOT/FAA Order 8240.47, dated 5/10/83. The following performance requirements of NAS-SS-1000 outlined in paragraph 4.3.2.1 of the ILS Test Plan will be verified by the flight inspection:

a. The ILS shall provide lateral guidance throughout the descent path from at least 18 nautical miles (nmi) from the antenna to the lowest authorized decision height.

b. The ILS shall provide lateral guidance throughout the volume of space shown in Volume III of NAS-SS-1000, figures 3.2.1.4.1.2.1.1-1 and 1-2.

c. The ILS shall provide a mean course line within limits equivalent to the following displacements from the runway center line at the ILS reference datum:

CAT II: +/- 25 feet  
CAT III: +/- 10 feet

d. The ILS shall provide vertical guidance throughout the glide path from at least 10 nmi from the antenna to the lowest authorized decision height.

e. The ILS shall provide vertical guidance throughout the volume of space shown in Volume III of NAS-SS-1000, figure 3.2.1.4.1.2.2.1-1.

f. The ILS vertical guidance signal shall be adjustable to glide path angles between 2° and 4°.

g. The ILS shall maintain the glide path angle within:

CAT II: 7.5 percent of commissioned angle.

CAT III: 4.0 percent of commissioned angle.

h. The lateral portion for ILS guidance shall be accurate to within the following at the reference datum:

CAT II: +/- 25 feet

CAT III: +/- 10 feet

i. The ILS shall broadcast a morse code facility ID signal at least six times a minute, except when collocated with Distance Measuring Equipment (DME) or a Microwave Landing System (MLS)/Precision Distance Measuring Equipment (DME/P).

j. The ILS marker beacons shall provide coverage over the following distances, measured on the glidepath and localizer course line:

Inner Marker: 500 +/- 160 feet

Middle Marker: 1000 +/- 325 feet

Outer Marker: 2000 +/- 650 feet

k. The marker beacons shall broadcast the following identification:

Outer Marker - Continuous dashes keyed at the rate of 2 per second.

Middle Marker - Alternate dots and dashes keyed at a rate of 95 dot/dash combinations per minute.

Inner Marker - Continuous dots keyed at a rate of 6 dots per second.

l. The ILS components shall discontinue operation automatically within the following time periods when their performance does not meet the required accuracy:

| <u>Guidance</u> | <u>Lateral</u> | <u>Vertical</u> |
|-----------------|----------------|-----------------|
| CAT II          | 5 seconds      | 2 seconds       |
| CAT III         | 2 seconds      | 2 seconds       |

m. The ILS shall operate in the 75 Megahertz (MHz), 108-112 MHz, and 329-335 MHz radio frequency bands.

#### 4.4.3 System Reliability and Maintainability.

The purpose of this procedure is to ensure that the ILS signal quality does not vary as a function of time (e.g., temperature variations, adverse weather conditions, etc.) and to evaluate the user's ability to restore normal operation following system failure or malfunction. There are no specific requirements outlined in NAS-SS-1000 for this procedure. However, OT&E policy requires that the system be evaluated for operational effectiveness and maintainability of equipment.

#### 4.4.4 Operation of Remote Status and Interlock Unit.

The purpose of this performance test is to monitor status and demonstrate control of the ILS from an Air Traffic Control (ATC) facility using the RSIU. The operational test will verify the following requirements as described in the ILS Test Plan:

- a. The ILS shall respond to operational control from the Airport Traffic Control Tower (ATCT).
- b. The ILS shall transmit operational status to the ATCT.

#### 4.4.5 Standby Power.

The purpose of the standby power test is to ensure that the battery power system provides for the continued, uninterrupted normal operation if the primary power fails; and upon restoration of power, that the batteries recharge in the allotted time frame. The standby power test will verify the following requirements:

- a. The ILS shall have a continuously engaged backup power supply system which enables normal operation for at least 3 hours subsequent to failure of primary AC power input.
- b. Landing facilities with backup power shall be capable of automatically switching to backup power within 1 second for those facilities serving CAT II and CAT III runways.

### 4.5 TEST DESCRIPTIONS.

#### 4.5.1 ILS Installation and Alignment.

All site preparation shall be inspected and approved prior to the commencement of the installation and alignment effort. Test team personnel shall accomplish the installation and alignment in accordance with applicable Mark 20 draft instruction books and associated FAA ILS installation procedures. Installation of the Mark 20 ILS will establish the test configuration for all testing. There are no critical issues identified for the installation and alignment process. A contractor's representative shall be on call during this process for technical assistance, if required.

#### 4.5.2 Flight Inspection.

This test shall demonstrate the ability of the Mark 20 ILS to meet the requirements of a Commissioning Type Inspection as specified in the U.S. Standard Flight Inspection Manual, OA P 8200.1, Section 217. Standard flight patterns will be flown to determine that facility performance for the required parameters meets CAT II/III tolerances. All subsystems of the Mark 20 ILS shall be in normal operation and during the inspection, configured per requirements specified in the flight inspection manual. A flight inspection aircraft with crew and appropriate equipment to record and verify ILS commissioning tolerances/limits will be required. Project personnel with appropriate equipment, including a communications transceiver, will make the required equipment configuration changes during the flight inspection. The critical issue addressed during the flight inspection will be to determine if the Mark 20 ILS can meet the requirements of a Commissioning Type Inspection.

#### 4.5.3 System Reliability and Maintainability.

##### 4.5.3.1 ILS System Reliability.

Each subsystem will be monitored throughout the test period to determine operational reliability and stability. Temperature variations and adverse weather conditions will be monitored to determine impact on each subsystem. All equipment outages will be investigated to determine probable cause. Each outage will be recorded on the Discrepancy/Failure/Improvement Form. The overall operational impact will be determined and summarized.

##### 4.5.3.2 Freezing Rain Environment on Glide Slope Antennas.

The outside temperature at the airport will be monitored for proper freezing conditions to conduct this test. Reference Voltage Standing Wave Ratio (VSWR), monitor probe voltage amplitude, and phase measurements will be obtained under normal conditions (i.e., the heaters off). Rain will be simulated (water spray) under freezing conditions and VSWR, amplitude, and phase will be measured with ice on the radomes and the heaters off. The test will be repeated with the heaters on. For safety purposes, only the lower glide slope antenna will be loaded with ice.

##### 4.5.3.3 Maintainability/Fault Diagnostics.

This phase of testing will be conducted in conjunction with the RMS/Integration testing of the ILS. Emphasis will be placed on maintainability of the system, functions of the PMDT, elements of the ILS RMS for each subsystem, and the interface to the MPS. All failures (natural and induced) will be evaluated. The adequacy of ILS technical instructions, manuals, and test equipment to provide useful and helpful trouble shooting information will be determined. Corrective maintenance actions and fault diagnostic procedures will be as stated in the



appropriate section of the draft instruction manuals. Induced faults will be nondestructive faults selected from the MK20 Maintainability Demonstration Task Population and Failure Mode Selection List used in the factory maintainability demonstration.

#### 4.5.4 Operation of Remote Status and Interlock Unit.

This test demonstrates the ability to control and monitor the status of the ILS from an ATC facility using the RSIU. The RSIU is located in the test laboratory at the FAA hanger along with the RCSU and the LCU. The RSIU was checked daily and monitored during various tests to verify:

- a. ILS category of operation indication.
- b. Far Field Monitor status indication.
- c. Far Field Monitor bypass switch.
- d. Aural/visual alarm indication and control.
- e. Runway select switch.
- f. Recognition of a localizer course alignment shift.
- g. Subsystem on/off indication.

#### 4.5.5 Standby Power.

Primary power shall be interrupted using the main Alternating Current (AC) breaker at each subsystem of the ILS and the automatic switchover to battery power observed and the elapsed time recorded. All subsystems will operate on standby power for an extended period of time. System operation will be monitored and the time period each subsystem operated on batteries (to shutdown) will be recorded. Upon restoration of primary power, the ability of each subsystem to restore batteries to a full charge condition shall be observed.

### 4.6 DATA COLLECTION AND ANALYSIS METHOD.

#### 4.6.1 ILS Installation and Alignment.

There are no specific analysis requirements for the installation and alignment of the ILS. All instructions and procedures (portions used at the FAA Technical Center) in the contractor-provided draft technical instruction books were checked for accuracy, and discrepancies reported to the program office and the contractor.

#### 4.6.2 Flight Inspection.

##### 4.6.2.1 FAA Flight Inspection.

The FAA flight inspection was performed by an aircraft and crew from the Flight Inspection Field Office (FIFO) located at Oklahoma City, Oklahoma. Commissioning flight inspection criteria and tolerances specific to ILS CAT II operation were applied for this inspection. This data was collected using the Automatic Flight Inspection System (AFIS) aboard the aircraft. Because the system was located at a test site location, the ILS

facility data was manually entered into the AFIS data base. The recorded data was analyzed by FIFO personnel using standard flight inspection report procedures. The flight inspection report is attached as appendix A.

#### 4.6.2.2 FAA Technical Center Flight Evaluations.

Periodic flight measurement missions were conducted on the Mark 20 using FAA Technical Center aircraft and data collection packages. Tracking data for these flights were collected using the FAA Technical Center NIKE radar and/or laser tracking systems. The formatted tracking data was provided to ACT-360 personnel on 9-track tapes. The tracking data was transferred to the VAX system located in building 301 using the program "trk-ibm-to-vax.exe". The tracker data was then smoothed using the program "smooth.exe". The smoothed tracker data was then translated and rotated to put the origin of the tracking coordinate system at the base of the glide slope mast using the program "trarot1.exe". A control file containing the latitude, longitude, and Mean Sea Level (MSL) elevation of the tracker and the point that the tracker data is translated and rotated to, is required to run the program.

These combined tracker and airborne data were then transferred to a local PC using Kermit. The data contained in these files are time, tracked x, tracked y, tracked z, and receiver DDM. Guidance error was then calculated from this data on an AST Premia 4/66d computer. This guidance error was calculated by converting the tracked aircraft location to a Difference in Depth of Modulation (DDM) value. The two equations used were:

$$DDM\ VALUE = \frac{0.155(ddm)}{2.8^\circ} \tan^{-1}\left(\frac{y-400}{x+6274+71}\right) \quad \text{For Localizer}$$

$$DDM\ VALUE = \frac{0.0875(ddm)}{0.32^\circ} \left[ 3^\circ - \tan^{-1}\left(\frac{z+4.42}{\sqrt{x^2+y^2}}\right) \right] \quad \text{For Glide Slope}$$

Where x, y, and z are the Cartesian coordinates of the tracked aircraft position, with the origin located at the base of the glide slope mast, the positive x-axis parallel to the runway 04 centerline and in the direction of threshold, and the positive y-axis in the direction of the runway 04 centerline. The 6274 feet added to the x coordinates and the 400 feet added to the y coordinates in the localizer calculations, are to move the origin of the tracking data to the phase center of the localizer antenna array. 4.42 feet was added to the z coordinates in the glide slope calculations and 71 feet was added to the x coordinates in the localizer calculations to compensate for the difference in the location of the tracking point and the glide slope/localizer antennas. The DDM values were calculated using the measured course/path widths of 2.8° and 0.64° for the localizer and the glide slope, respectively. The calculated DDM values are then

subtracted from the receiver DDM value to provide the guidance error. This error is then converted to micro amps and analyzed using CAT II/III tolerances provided in the U.S. Standard Flight Inspection Manual, OA P 8200.1.

#### 4.6.3 System Reliability and Maintainability.

##### 4.6.3.1 Stability During Extreme Weather Conditions.

A computer program was developed by FAA Technical Center personnel to record data serially from a Heath ID-5001 Weather Computer and the Mark 20 LCU. This program is a stand-alone program in that the Wilcox PMDT software is not required in order to collect data from the ILS.

The code was compiled and linked using Borland's Turbo C/C++ version 3.0. The source code used for this project is not ANSI C compatible.

The following weather conditions and Mark 20 monitor readings are collected:

##### **Heath Weather Station**

Outside temperature (°F)  
Instantaneous rain rate (in/hr)  
Barometric pressure (inches of Hg)  
Wind speed (MPH)  
Wind direction (degrees from true north)

##### **Localizer Executive Monitor 1 and 2 and Standby Monitor 1**

Course RF level (%)  
Course width (DDM)  
Course SDM (%)  
Course DDM (DDM)  
Course to Clearance frequency difference (kHz)  
Clearance RF level (%)  
Clearance width 1 (DDM)  
Clearance width 2 (DDM)  
Ident modulation percentage (%) (Executive monitors only)

##### **Glide Slope Executive Monitor 1 and 2 and Standby Monitor 1**

Path RF level (%)  
Path width (DDM)  
Path SDM (%)  
Path DDM (DDM)  
Course to Clearance frequency difference (kHz)  
Clearance RF level (%)

## Inner, Middle, and Outer Marker Beacons

RF level (%)  
Voltage standing wave ratio (no units)  
Ident modulation percentage (%)  
Ident keying (0 = off, 8 = keyed, 16 = continuous)

Analysis of this data involves plotting all weather and ILS parameters against time and noting unusual changes. Abrupt changes in monitored ILS parameters are compared to weather parameters to determine if a correlation exists. Extreme changes in weather over short periods of time are also noted and compared to ILS performance during that same time period to evaluate the ILS performance during varying changes in weather.

### 4.6.3.2 Ice Loading Effects on Glide Slope Antenna Elements.

The outside temperature at the airport was monitored for proper freezing conditions to conduct this test. The two parameters to be measured during this test were the antenna VSWR and RF phase on the monitor line. The VSWR was measured on the antenna feed lines to the lower and middle glide slope antennas, and the relative RF phase difference was measured between the equipment side of the antenna feed cable and the monitor return cable. These data were collected using an HP 8405A vector voltmeter. Several baseline measurements were made during varying weather conditions before the ice tests were conducted. These baseline measurements were also made immediately before loading the glide slope antennas with ice. The measurements taken with ice formed on the antennas were analyzed by comparing the data to the baseline measurements. Any significant deviation from the baseline would constitute a failure.

### 4.6.3.3 Glide Slope Clearance Monitoring.

Revision m of the localizer and glide slope monitor software was replaced with revision n. This software release addressed the glide slope clearance RF level and Sum of the Depth of Modulation (SDM) monitoring errors (deployment critical). For test purposes, the new software was initially installed in monitor #1 with revision m remaining in monitor #2. This allowed for comparison of monitor readings of both software versions as transmitter parameters were varied. Sidebands Only (SBO) level, clearance SDM, and clearance RF levels were independently stepped from their normal operating values to both high and low extreme levels. As these transmitter parameters were adjusted, the clearance RF level and SDM were recorded from both monitors. This allowed for easy data collection by the PMDT as both monitor's readings could be viewed at the same time.

#### 4.6.3.4 Fault Diagnostics Evaluation.

The data collected for this test is the result of manual diagnostics after a fault is inserted into the system. Failure of this test would be an unacceptable rate of erroneous indications of the Line Replaceable Unit (LRU) causing the system malfunctions.

#### 4.6.4 Remote Status and Interlock Unit.

##### 4.6.4.1 ILS Category of Operation Indication.

The localizer course DDM was changed to 0.050 DDM using the PMDT from the LCU. The time was measured from when the DDM change took effect and when the RSIU indication changed from CAT III to CAT II. The time was also measured between the CAT II indication and the CAT I indication. These time values were then compared to the RCSU CAT III to CAT II and CAT II to CAT I downgrade time settings.

##### 4.6.4.2 Far Field Monitor.

A computer program was developed to record FFM readings serially from the Mark 20 localizer. This program is a stand-alone program in that the Wilcox PMDT software is not required in order to collect data from the localizer. The code was compiled and linked using Borland's Turbo C/C++ version 3.0. The source code used for this project is not ANSI C compatible.

The program is hard-coded for the Mark 20 localizer PMDT port to be connected to the computers communications port 1. This program cannot be used to collect Mark 20 data remotely. The cable used to connect the computer to the localizer is a standard null modem cable. Pins 2 and 3 are switched, i.e., pin 2 of one side of the cable goes to pin 3 of the other side and vice versa. Pin 5 is used for the signal ground for DB-9 connectors and pin 7 for DB-25 connectors. The communications parameters for the localizer are no parity, eight data bits, and one stop bit. The program is hard-coded to communicate with the localizer at a data rate of 4800 baud.

To begin the program run FFM.EXE by typing "ffm" at the DOS prompt. The program will log onto the localizer and begin collecting FFM readings immediately. The FFM readings will be displayed on the screen as the data is being collected. The program is terminated by pressing any key. The collected data will include the monitored DDM and RF level as well as the date and time of the reading. This data will be recorded on disk in space delineated ASCII format. The filenames of the data collected will be the time when the file was closed, with an extension of .FF1 for FFM #1 and .FF2 for FFM #2, i.e., files that were closed at 0952 hours will be named 0952.FF1 and 0952.FF2.

The program records a DDM and RF level reading from each FFM at a rate of approximately two times per second.

Localizer approach data was collected by a Convair 580 with a Boeing 727 (B727) located at various test locations along the runway, including the ILS critical area. An approach was flown and airborne data collected while the B727 taxied from the threshold to the stop end of runway 04. A handwritten log was generated to note the time that the B727 had arrived or departed a test location. The test locations are shown in figure 3. The recorded DDM measurements for each FFM are plotted versus time and compared to flight measurements collected while the B727 was located at that position. Any abnormal disturbances discovered in the airborne data that is caused by the presence of the B727, should also be detected by the FFM in higher than normal DDM readings and the appropriate indication at the RSIU.

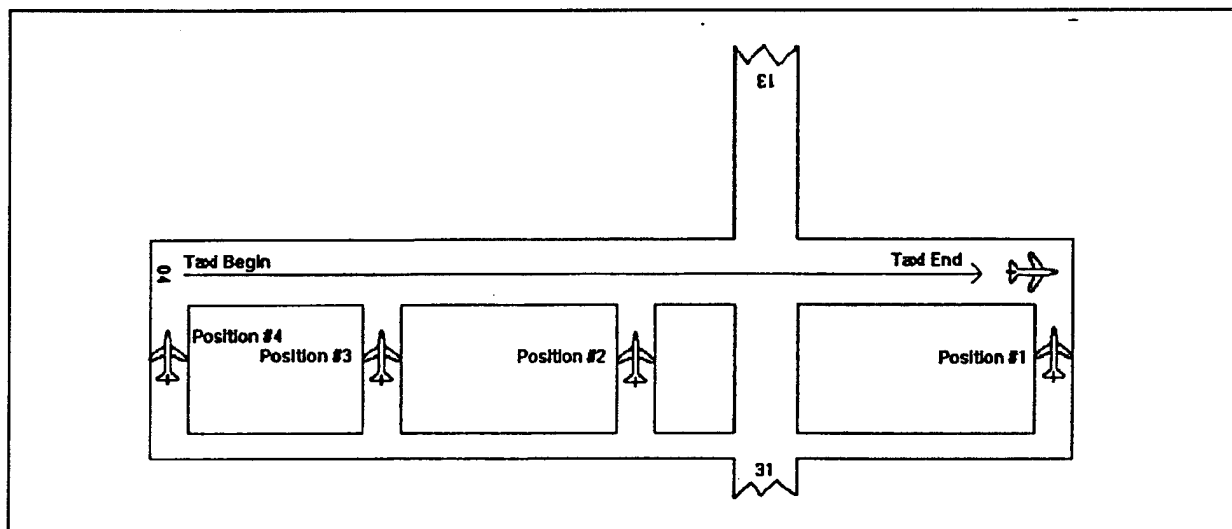

FIGURE 3. LOCATIONS OF B727 WHILE AIRBORNE LOCALIZER APPROACH AND FAR FIELD MONITOR DATA WAS COLLECTED

#### 4.6.5 Standby Power.

An AC power failure was simulated by turning off the AC power to the equipment shelters for each subsystem. The time of the induced power failure was recorded along with the switchover to battery power. Data was collected from each subsystem while operating on battery power by recording all monitor alarms that were sent to the MPS. Unacceptable results would be any monitored parameter of any subsystem going out of tolerance while operating on battery power. To verify compliance with the minimum time requirement for operating on standby power, the total time on batteries for each subsystem was obtained by recording the time that an LCU communications fault occurred. This fault is the only indication that the batteries had reached the cut off voltage. This time was then compared to the recorded AC power failure time and evaluated.

## 5. RESULTS AND DISCUSSION.

### 5.1 ILS INSTALLATION AND ALIGNMENT.

Each subsystem of the Mark 20 ILS (localizer, glide slope, marker beacons, and the FFMs) were installed by FAA region and FAA Technical Center personnel. The initial draft technical instruction books provided by the contractor were lacking in specific instructions required to complete the installation. The experience and knowledge of the F&E personnel involved in the installation allowed the process to continue. Recommended changes/additions were forwarded to the program office, AOS-240, and the contractor. Subsequent updates of the manuals resulted in acceptable manuals. The alignment process verified that the system was ready for the FAA flight inspection. The system met required flight inspection criteria.

### 5.2 FLIGHT INSPECTION.

#### 5.2.1 FAA Flight Inspection.

The Mark 20 ILS under test passed all CAT II/III commissioning flight tests conducted by the Oklahoma City FIFO. See appendix A for the flight inspection report.

#### 5.2.2 FAA Technical Center Flight Evaluation.

FAA Technical Center flight evaluations met CAT II/III flight inspection criteria. Figure 4 shows a localizer approach. Figure 5 shows a localizer orbit. Figure 6 shows a glide slope approach. Figure 7 shows a glide slope level run.

### 5.3 SYSTEM RELIABILITY AND MAINTAINABILITY.

During reliability and maintainability testing, the following LRUs were replaced due to equipment failure:

Localizer:           (1) RF relay on the transfer switch assembly  
                      (1) RMM cca

Glide Slope:        (1) Transient Suppressor Board

Marker Beacons:   (1) AC/DC converter

Test Trouble Reports (TTRs) generated during testing and their resolution are contained in appendix B.

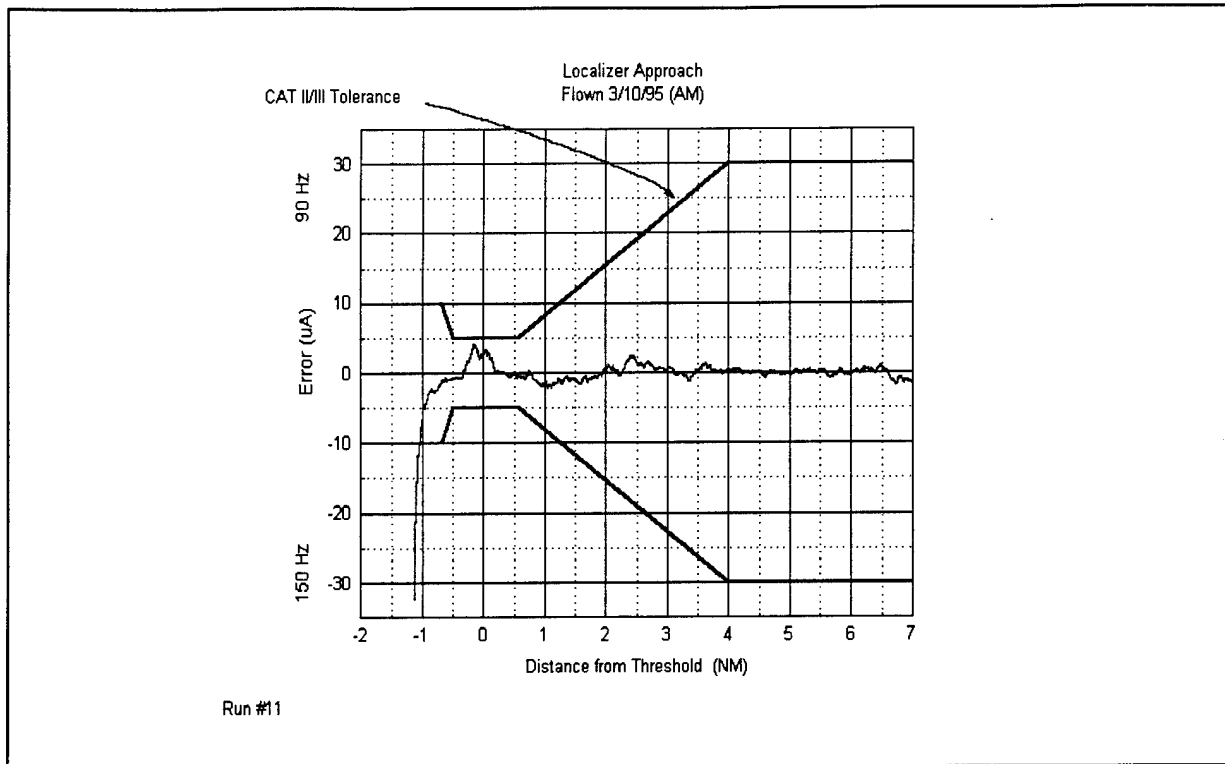

FIGURE 4. LOCALIZER APPROACH GUIDANCE ERROR PLOT

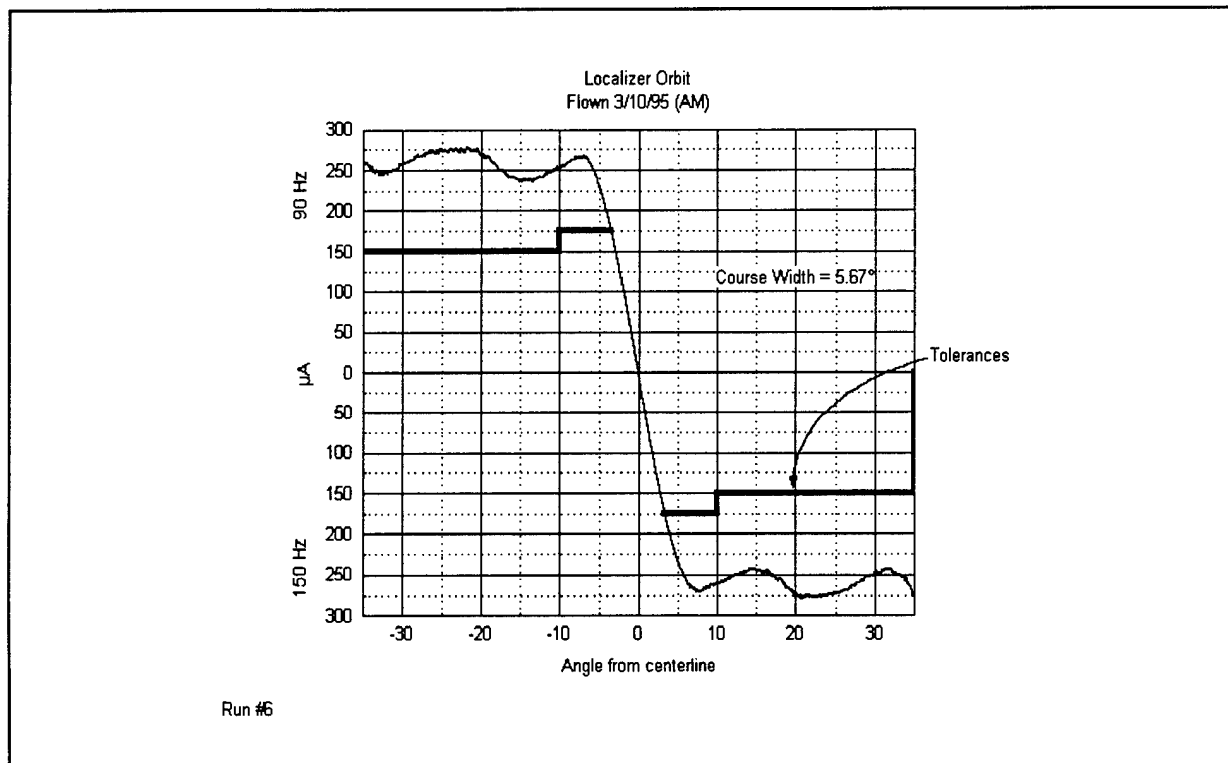

FIGURE 5. LOCALIZER ORBIT



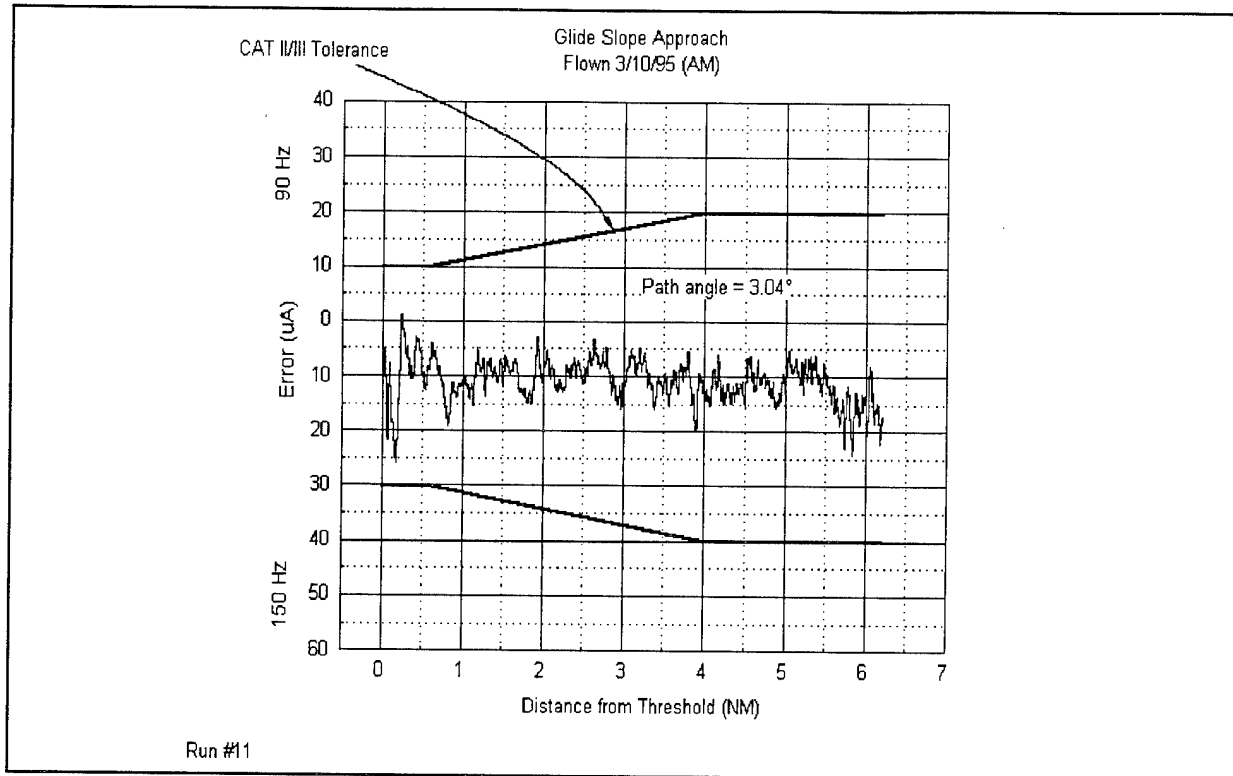

FIGURE 6. GLIDE SLOPE APPROACH GUIDANCE ERROR PLOT

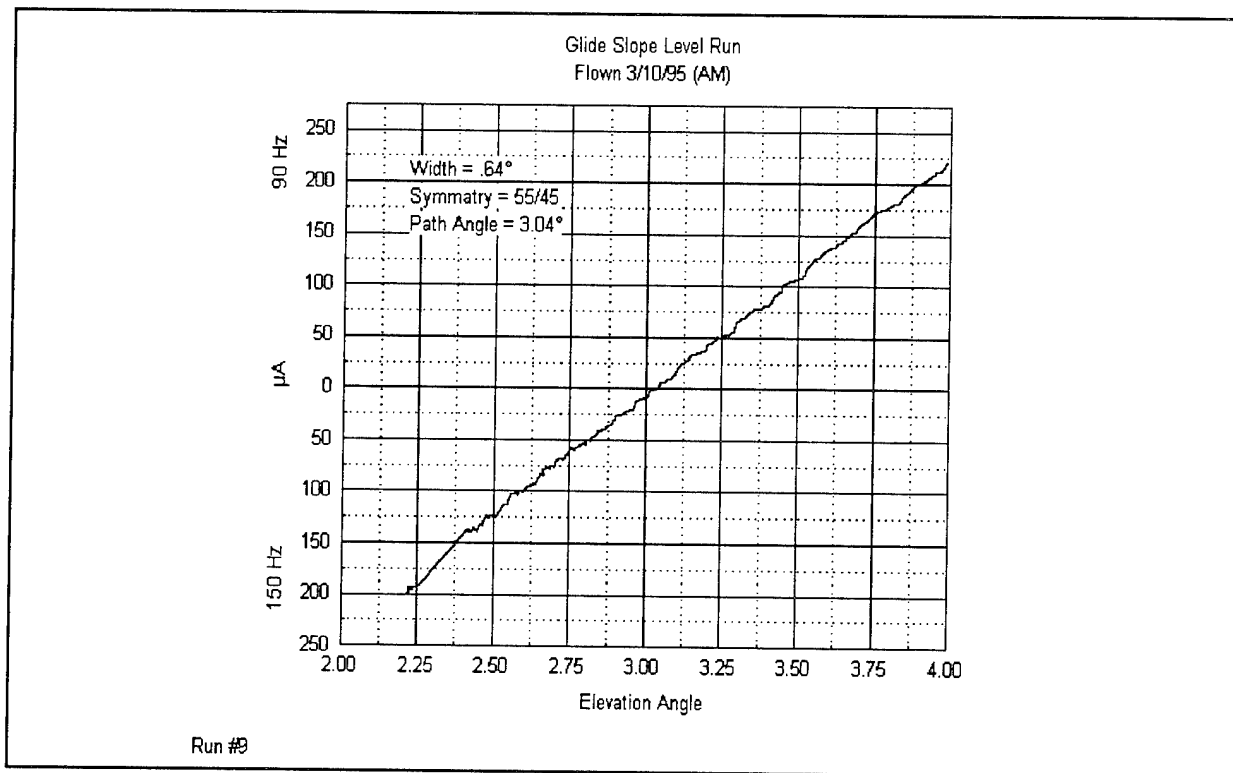

FIGURE 7. GLIDE SLOPE LEVEL RUN

### 5.3.1 Stability During Extreme Weather Conditions.

The only observed correlation between weather and the Mark 20 performance was temperature, and the course and clearance RF power for the localizer and glide slope. This correlation shows an approximate 2 percent change in RF level to a 20° Fahrenheit change in temperature. This change is relatively insignificant but could be a problem depending on the recalibration schedule. The monitors were calibrated at the test site during the summer months. Due to the change in average temperature during the winter months, the average RF levels were in the vicinity of 104 percent. The daily fluctuation in temperature varied the RF levels between 103 percent and 106 percent. At facilities with colder winter temperatures, a subsystem calibrated during the summer may drift out of RF level tolerance during the winter and vice versa. Only output power of the subsystem is affected as the impedance characteristics of exposed cable and antennas change with the temperature. This condition will not affect the quality of guidance because Carrier and Sidebands (CSB) and SBO signals are attenuated at the same rate, but some outages could occur due to RF levels exceeding alarm limits. Figure 8 shows the temperature and glide slope path RF level for January 30, 1995. The monitored weather and Mark 20 parameters for the month of January 1995 are contained in appendix C.

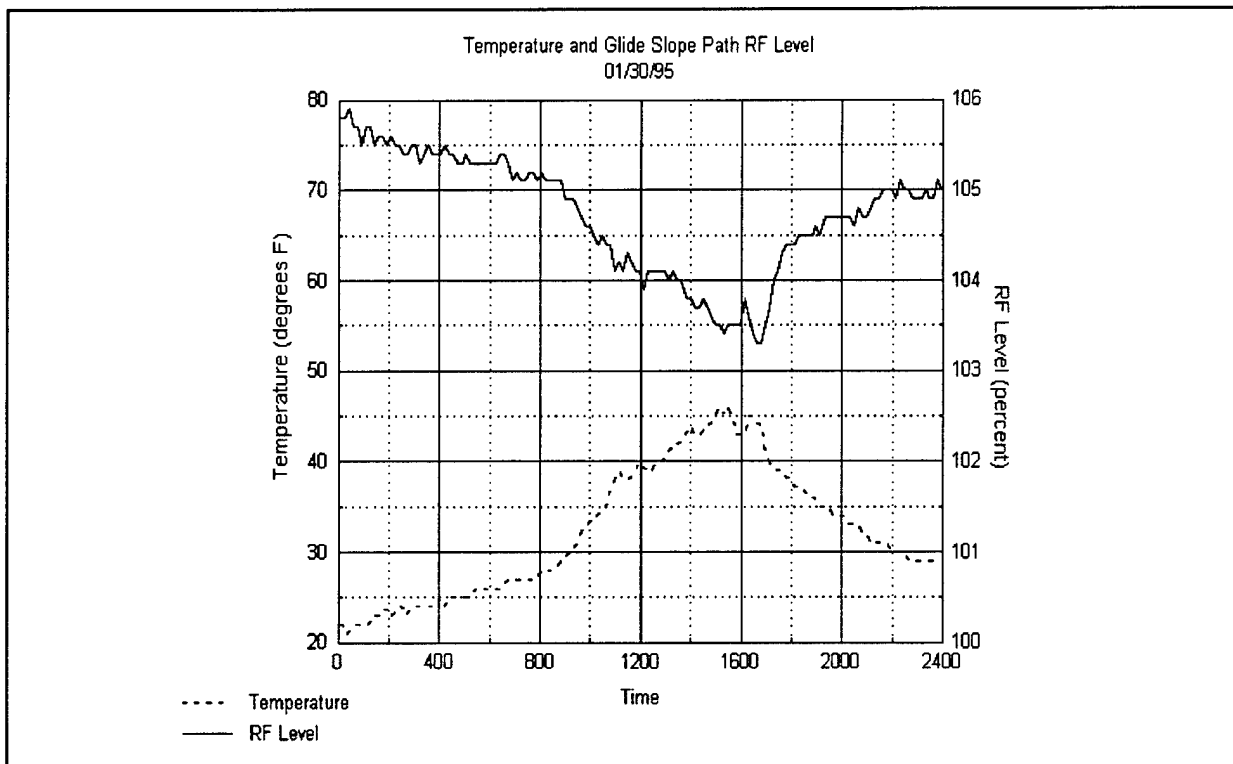

FIGURE 8. CORRELATION OF TEMPERATURE AND MONITORED GLIDE SLOPE PATH RF LEVEL FOR JANUARY 30, 1995

### 5.3.2 Ice Loading Effects on Glide Slope Antenna Elements.

Figure 9 shows the configuration for testing ice loading effects. Table 1 indicates the date, time, conditions, VSWR, phase, and magnitude of the measurements made on the antennas. This data indicates that no significant changes in measured parameters were observed during ice loading or antenna heater operation. The maximum variations from the baseline measurements were: VSWR: 0.03, Phase: 1.3°, and magnitude: 0.28 dB. Based on these measurements, it appears that the antenna heaters are not required. The data collected also indicates that antenna heater operation does not affect the radiated signal. During this testing period (8 months) no antenna heater failures occurred. Because the glide slope electronic equipment had not been delivered at the time of this test, these measurements were obtained using a signal generator for the provided signal, thus no signal in space measurements were possible and no determination of actual provided guidance can be made.

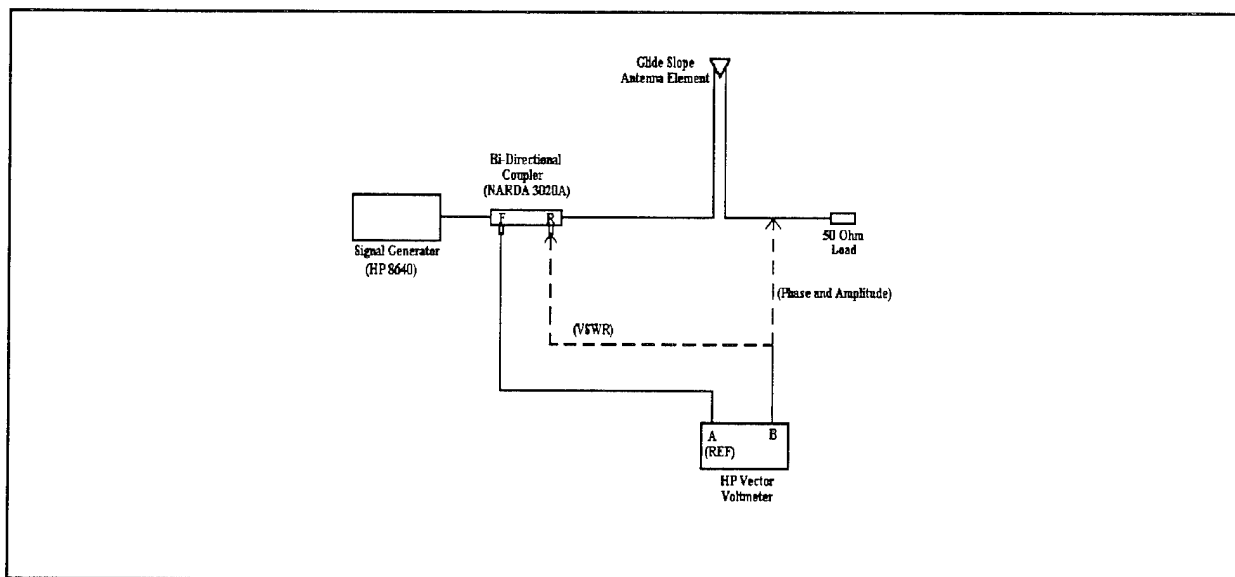

FIGURE 9. TEST CONFIGURATION FOR MEASURING VSWR, PHASE, AND AMPLITUDE OF GLIDE SLOPE ANTENNAS DURING ICE LOADING TESTING

### 5.3.3 Glide Slope Clearance Monitoring.

During the Technical Interchange Meeting held in Oklahoma City in August 1994, only one deployment critical issue was raised: the glide slope clearance detector did not compensate for SBO energy that might be present. This accounted for inaccurate Clearance RF Level and Clearance SDM monitor readings.

TABLE 1. GLIDE SLOPE ANTENNA MEASUREMENTS DURING ICE LOADING TESTING

| DATE  | CONDITIONS   | ANTENNA | VSWR  | PHASE  | MAGNITUDE |
|-------|--|---------|-------|--------|-----------|
| 01/27 | No ice on antenna. 18°F. (normal)  | Lower   | 1.157 | -22.0° | 4.93 dB   |
| 01/27 | Ice formed on antenna from hand sprayer. 18°F. Time: 0941  | Lower   | 1.165 | -22.1° | 4.90 dB   |
| 01/27 | Second reading with ice. Time: 1000  | Lower   | 1.168 | -21.9° | 4.92 dB   |
| 01/27 | Heater turned on at 1005. Measurement taken at 1045. Antenna partially de-iced ≈ 30%   | Lower   | 1.174 | -20.9° | 4.81 dB   |
| 01/27 | Antenna partially de-iced ≈ 60%. Time: 1225  | Lower   | 1.177 | -20.9° | 4.75 dB   |
| 01/27 | Antenna partially de-iced ≈ 80%. Time: 1400  | Lower   | 1.169 | -20.9° | 4.65 dB   |
| 01/31 | Heater on for 4 days. Antennas dry. 24°F. Time: 0900 (normal)  | Lower   | 1.162 | -20.7° | 4.66 dB   |
| 02/01 | Heaters on for 5 days. Antennas dry. 31°F. Time: 1340 (normal)   | Lower   | 1.187 | -21.2° | 4.72 dB   |
| 02/02 | Heaters on for 6 days. Antennas dry. 18°F. Time: 0917 (normal)   | Lower   | 1.164 | -21.1° | 4.66 dB   |
| 02/02 | Heaters on (hardwired). Water sprayed on antennas. Ice formed on reflectors and icicles hanging from sides of radomes. No ice formed on top of radomes. 18°F. Time: 0948 | Lower   | 1.17  | -21.3° | 4.67 dB   |
| 02/02 | Same conditions as above entry. Time: 1007   | Lower   | 1.171 | -21.6° | 4.65 dB   |
| 01/27 | No ice on antenna. 18°F (normal)   | Middle  | 1.080 | 30.6°  | 5.05 dB   |
| 01/27 | No ice on antenna. Heaters on for 4 hours. 18°F.   | Middle  | 1.080 | 31.1°  | 4.82 dB   |
| 01/31 | Heater on for 4 days. Antennas dry. 24°F. Time: 0900. (normal)   | Middle  | 1.090 | 31.7°  | 4.82 dB   |
| 02/01 | Heaters on for 5 days. Antennas dry. 31°F. Time: 1340 (normal)   | Middle  | 1.113 | 31.5°  | 4.92 dB   |
| 02/02 | Heaters on for 6 days. Antennas dry. 18°F. Time: 0914 (normal)   | Middle  | 1.079 | 31.3°  | 4.86 dB   |

Wilcox agreed to simultaneously pursue both a hardware and a software correction for this problem. If the software correction, which could be implemented sooner than a hardware correction, was satisfactory, it would be implemented and the effort on the hardware correction would cease.

On September 3, 1994, revision m of the localizer and glide slope monitor software was replaced with revision n. This software release addressed the deployment critical issue mentioned above. For test purposes, the new software was initially installed in monitor #1 only. This allowed for easy comparison of monitor readings of both software versions as transmitter parameters were varied. Tables 2 through 4 show the data that were collected:

Normal transmitter parameters are: Path RF Level = 2.66 Watts  
 SBO Amplitude = 55%  
 CLR RF Level = 0.20 Watts

TABLE 2. GLIDE SLOPE CLEARANCE RF LEVEL AND SDM AS SBO LEVEL IS ADJUSTED FROM 0% TO 100% IN 5% INCREMENTS

|                | Monitor #1 |           | Monitor #2 |           |
|----------------|------------|-----------|------------|-----------|
| Transmitter    | Clearance  | Clearance | Clearance  | Clearance |
| Normal (55%)   | 100.0%     | 80.0%     | 100.0%     | 80.0%     |
| SBO Level 100% | 102.6%     | 75.4%     | 117.4%     | 59.7%     |
| SBO Level 90%  | 101.8%     | 76.5%     | 113.3%     | 63.8%     |
| SBO Level 80%  | 100.8%     | 78.0%     | 109.4%     | 68.0%     |
| SBO Level 70%  | 100.2%     | 79.0%     | 105.2%     | 72.5%     |
| SBO Level 65%  | 100.1%     | 79.4%     | 103.4%     | 74.8%     |
| SBO Level 60%  | 100.1%     | 79.8%     | 101.6%     | 77.5%     |
| SBO Level 50%  | 99.6%      | 80.2%     | 98.3%      | 83.1%     |
| SBO Level 45%  | 99.4%      | 80.5%     | 96.8%      | 85.9%     |
| SBO Level 40%  | 99.4%      | 80.5%     | 95.4%      | 89.1%     |
| SBO Level 35%  | 99.3%      | 80.5%     | 94.1%      | 92.0%     |
| SBO Level 30%  | 99.2%      | 80.4%     | 92.8%      | 95.0%     |
| SBO Level 25%  | 99.2%      | 80.5%     | 91.7%      | 98.2%     |
| SBO Level 20%  | 99.2%      | 80.4%     | 90.7%      | 100.8%    |
| SBO Level 15%  | 99.3%      | 80.3%     | 89.8%      | 103.7%    |
| SBO Level 10%  | 99.3%      | 80.4%     | 89.1%      | 105.9%    |
| SBO Level 5%   | 99.4%      | 80.2%     | 88.6%      | 107.5%    |
| SBO Level 0%   | 99.4%      | 80.1%     | 88.3%      | 108.3%    |

TABLE 3. GLIDE SLOPE CLEARANCE RF LEVEL AND SDM AS CLR SDM IS ADJUSTED FROM 50% TO 90% IN 5% INCREMENTS

|                     | Monitor #1<br>(New Software) |               | Monitor #2<br>(Old Software) |               |
|---------------------|------------------------------|---------------|------------------------------|---------------|
| Transmitter Setting | Clearance RF Level           | Clearance SDM | Clearance RF Level           | Clearance SDM |
| Normal (40%)        | 100.0%                       | 80.0%         | 100.0%                       | 80.0%         |
| CLR SDM 90%         | 100.2%                       | 88.4%         | 100.7%                       | 88.2%         |
| CLR SDM 85%         | 99.8%                        | 84.5%         | 100.5%                       | 84.5%         |
| CLR SDM 75%         | 99.6%                        | 75.2%         | 99.5%                        | 75.7%         |
| CLR SDM 70%         | 99.6%                        | 70.6%         | 99.3%                        | 71.6%         |
| CLR SDM 65%         | 99.6%                        | 65.7%         | 98.9%                        | 67.0%         |
| CLR SDM 60%         | 99.5%                        | 61.1%         | 98.6%                        | 62.2%         |
| CLR SDM 55%         | 99.3%                        | 55.8%         | 98.4%                        | 57.1%         |
| CLR SDM 50%         | 99.7%                        | 51.0%         | 98.4%                        | 52.0%         |

TABLE 4. GLIDE SLOPE CLEARANCE RF LEVEL AND SDM AS CLR RF LEVEL IS ADJUSTED FROM 0.00W TO 0.50W IN 0.05W INCREMENTS

|                     | Monitor #1<br>(New Software) |               | Monitor #2<br>(Old Software) |               |
|---------------------|------------------------------|---------------|------------------------------|---------------|
| Transmitter Setting | Clearance RF Level           | Clearance SDM | Clearance RF Level           | Clearance SDM |
| Normal (0.20 W)     | 100.0%                       | 80.0%         | 100.0%                       | 80.0%         |
| CLR RF .50 W        | 145.4%                       | 80.0%         | 136.3%                       | 90.1%         |
| CLR RF .45 W        | 140.2%                       | 81.6%         | 132.6%                       | 91.3%         |
| CLR RF .40 W        | 133.1%                       | 82.5%         | 127.6%                       | 91.8%         |
| CLR RF .35 W        | 126.3%                       | 82.1%         | 121.8%                       | 90.3%         |
| CLR RF .30 W        | 118.8%                       | 81.8%         | 115.7%                       | 88.1%         |
| CLR RF .25 W        | 108.6%                       | 80.7%         | 107.2%                       | 84.0%         |
| CLR RF .15 W        | 87.9%                        | 78.1%         | 90.3%                        | 74.2%         |
| CLR RF .10 W        | 74.9%                        | 75.1%         | 79.8%                        | 65.0%         |
| CLR RF .05 W        | 57.7%                        | 68.1%         | 66.25                        | 48.5%         |
| CLR RF 0.00 W       | 26.2%                        | 41.2%         | 43.3%                        | 11.6%         |

These results demonstrate that the software correction to the glide slope clearance monitoring issue is an acceptable solution.

#### 5.3.4 Fault Diagnostic Evaluation.

Fault diagnostic testing resulted in an unacceptable percentage of erroneous LRU indications. A total of 23 faults were induced on Mark 20 subsystems with 17 correct results for a success rate of 73.91 percent. Table 5 indicates the faults that were introduced, the LRU affected, and the results of the fault diagnostics algorithm. All incorrect LRU indications at the glide slope and localizer involved faults which shutdown both transmitters such as detector faults, antenna subsystem faults, or distribution unit faults. During regression testing, all faulty LRU indications were retested, and found to be corrected.

TABLE 5. FAULT DIAGNOSTIC RESULTS

| LRU affected                                       | Fault Introduced  | Fault Diagnostics Results   |
|--|---|---|
| Localizer Audio Generator                          | Bent out pin 9 of U11   | Audio Generator   |
| Localizer AC-DC Converter #1<br>AC-DC Converter #2 | Adjusted Vadj on AC-DC converter #1 and #2, until the "on batteries" LED was illuminated. | AC-DC Converter #1<br>AC-DC Converter #2  |
| Localizer RMM cca                                  | Removed jumpers from J2   | Fault diagnostics could not be performed because the fault affected PMDT communications. The LED on the RMM card was blinking indicating a fault. |
| Localizer Transfer Switch Assembly                 | Removed CLR CSB feed line to the RF relay.  | Transfer Switch Assembly  |
| Localizer Distribution Unit                        | Disconnected the 1L antenna feed line in the DU/CU.                                       | Fault diagnostics would not run from the PMDT or the MPS.   |
| Localizer Integral Detector                        | Connected all gain jumpers to the course position detector i.e. pins 5-6, 7-8, and 9-10.  | Fault diagnostics would not run from the PMDT or the MPS.   |

TABLE 5. FAULT DIAGNOSTIC RESULTS (Continued)

|  |  |   |
|--|--|---|
| Localizer Antenna Subsystem                          | Disconnected the 1R monitor line from the DU/CU  | Fault diagnostics would not run from the PMDT or the MPS.   |
| Far Field Monitor                                    | Adjusted R83 (CHPAUD level adjust) fully clock wise.                                     | Far Field Monitor   |
| Glide Slope Audio Generator #1<br>Audio Generator #2 | Bent out pin 9 of U11.   | Audio Generator #1<br>Audio Generator #2  |
| Glide Slope Interface cca                            | Bent out pin 28 of U29.  | Interface cca   |
| Glide Slope AC/DC Converter                          | Adjusted Vadj on the AC/DC converter until the "on batteries" LED was illuminated.       | AC/DC converter   |
| Glide Slope RMM cca                                  | Removed jumpers from J2.   | Fault diagnostics could not be performed because the fault affected PMDT communications. The LED on the RMM card was blinking indicating a fault. |
| Transfer Switch Assembly                             | Removed the CLR CSB line from the RF relay.  | Transfer Switch Assembly  |
| Glide slope DU/CU Carrier power divider.             | Loosened the OUT 1 TNC connector on the CSB power divider Z1.                            | Fault diagnostics would not run from the PMDT or the MPS.   |
| Glide slope integral detector.                       | Connected all gain jumpers to the course position detector i.e. pins 5-6, 7-8, and 9-10. | Fault diagnostics would not run from the PMDT or the MPS.   |
| Glide slope antenna element.                         | Disconnected upper antenna feed line at the wattmeter body.                              | Fault diagnostics would not run from the PMDT or the MPS.   |



TABLE 5. FAULT DIAGNOSTIC RESULTS (Continued)

|                                   |   |                  |
|-----------------------------------|---|------------------|
| Marker beacon<br>Mod/PA           | Adjusted R55<br>counter clock wise<br>until the voltage<br>at R53 was at a<br>minimum.                                | Mod/PA           |
| Marker beacon<br>Mod/PA           | Adjusted R37 clock<br>wise until the<br>voltage at pin 6<br>of J2 was at a<br>minimum then<br>replaced the<br>jumper. | Mod/PA           |
| Marker Beacon<br>AC/DC Converter  | Adjusted Vadj<br>until the "on<br>batteries" LED was<br>illuminated on the<br>front panel.                            | AC/DC converter  |
| Marker Beacon<br>DC/DC converter. | Changed the alarm<br>limits for the +5V<br>supply to put the<br>monitor into<br>alarm.                                | DC/DC converter  |
| Antenna assembly                  | Disconnected the<br>antenna feed line<br>at the antenna.  | Antenna assembly |

5.4 REMOTE STATUS AND INTERLOCK UNIT.

5.4.1 ILS Category of Operation Indication.

During the test period, the RSIU accurately displayed the category of operation over varying operational conditions. The category downgrade timer was tested and found to be accurate.

5.4.2 Far Field Monitor.

Table 6 indicates the position of the B727 during testing. Figures 10 and 11 contain DDM values measured by each FFM versus time. FFM 1 is located at the inner marker and FFM 2 at the middle marker. The data collected indicate that minimal interference was detected by the FFMs. The large DDM spikes at 0921.45 and 0954.38 are when the B727 was at the stop end of runway 04 and turning to face the taxiway. The spikes, however, were not of sufficient magnitude to put the FFM into alarm. (The FFM alarm settings were set to  $\pm 0.009$  DDM and the spikes were only -0.004 and -0.005 DDM for FFM 1 and 2, respectively.) Airborne data collected indicates that no effect on provided guidance was caused by the presence of the B727 in positions 1, 2, 3, or 4 (figure 3).

TABLE 6. LOG OF THE POSITION OF THE B727 DURING FAR FIELD MONITOR TESTING

| Time    | B727 Location   |
|---------|---|
| 0915.25 | 727 in position #1  |
| 0196.45 | 727 begins to taxi forward to put the nose wheel on centerline, keeping the fuselage perpendicular to centerline.                 |
| 0196.47 | 727 nose wheel on centerline.   |
| 0921.22 | 727 begins a 180 degree pivot on centerline to return to the taxiway.   |
| 0921.45 | 727 completes the pivot and is on the taxiway.  |
| 0927.42 | 727 in position #2.   |
| 0930.53 | 727 begins to taxi forward to put the nose wheel on centerline, keeping the fuselage perpendicular to the centerline.             |
| 0931.14 | 727 nose wheel on centerline. Another 727 type aircraft is taxiing on runway 04 between the FAA B727 and the runway 04 threshold. |
| 0931.43 | The other aircraft turns off the runway to a perpendicular taxiway at the threshold of 04.  |
| 0934.16 | The B727 begins a 180 degree pivot on centerline to return to the taxiway.  |
| 0934.35 | The B727 completes the pivot, and is on the taxiway.  |
| 0936.25 | The B727 begins taxiing from position #2 to position #3 on the taxiway.   |
| 0937.16 | B727 in position #3.  |
| 0939.43 | B727 begins to taxi forward to put the nose wheel on centerline, keeping the fuselage perpendicular to the centerline.            |
| 0940.33 | The B727 begins a 180 degree pivot on centerline to return to the taxiway.  |
| 0942.29 | B727 in position #4.  |
| 0948.45 | A King Air type aircraft taxis to the threshold of runway 22 and takes off.   |
| 0949.52 | A Bonanza type aircraft taxis to the threshold of runway 22 and takes off.  |
| 0951.46 | B727 begins to taxi to centerline at threshold of runway 04.  |
| 0952.02 | B727 begins to taxi from the threshold to stop end on centerline of runway 04.  |
| 0954.38 | B727 ends taxi on centerline and turns off runway 04 at the stop end.   |

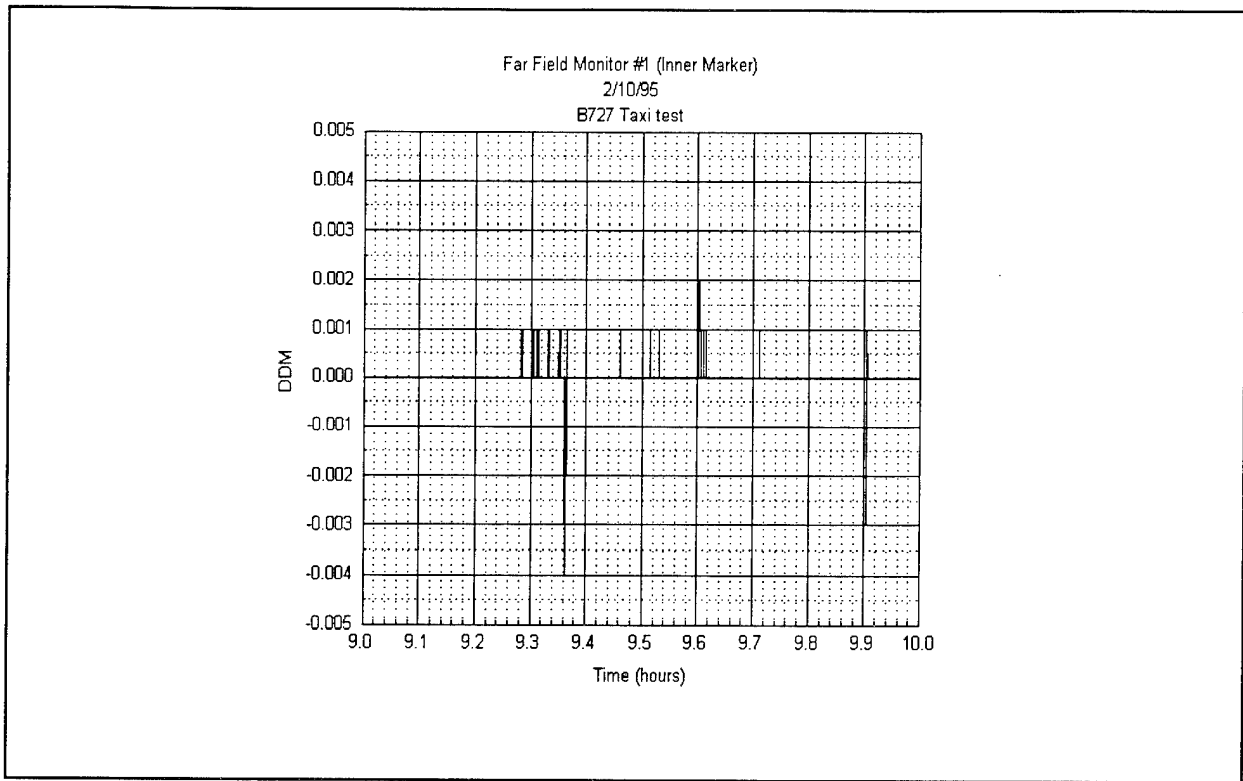

FIGURE 10. FAR FIELD MONITOR #1 READINGS WITH A B727 IN THE LOCALIZER ENVIRONMENT

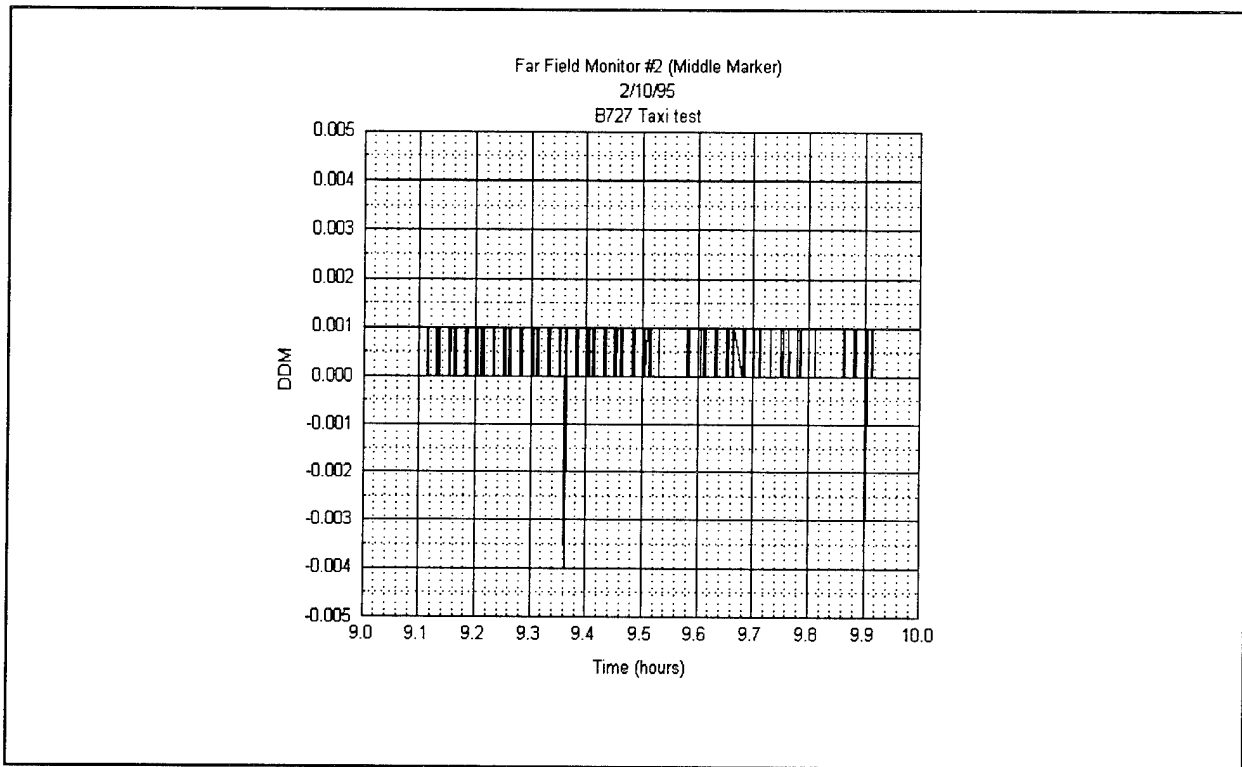

FIGURE 11. FAR FIELD MONITOR #2 READINGS WITH A B727 IN THE LOCALIZER ENVIRONMENT

## 5.5 STANDBY POWER.

All subsystems (localizer, glide slope, inner marker, middle marker, outer marker, and RCSU) exceeded the specified time operation requirement for operation on standby power. No anomalous monitor readings were observed during standby power operation. Table 7 shows the amount of time each subsystem operated on standby power and its respective requirement.

The localizer, glide slope, and RCSU subsystems recharged their respective batteries without incident. The marker beacons, however, could not recharge their batteries to full charge without shutting down. This is due to the high current draw required to recharge the batteries, which in turn overheated the power supplies and caused them to turn off. The failed power supply was returned to Wilcox for analysis.

TABLE 7. MARK 20 SUBSYSTEM STANDBY POWER TEST RESULTS AND REQUIREMENTS

| Mark 20 Subsystem | Time operated on standby power (hours) | Standby Power Requirement (hours) |
|-------------------|--|-----------------------------------|
| Localizer         | 11                                     | 4                                 |
| Glide Slope       | 16.5                                   | 4                                 |
| Inner Marker      | 172                                    | 72                                |
| Middle Marker     | 168                                    | 72                                |
| Outer Marker      | 162                                    | 72                                |
| RCSU              | 2.5                                    | 1                                 |

## 6. CONCLUSIONS.

All testing conducted on the Mark 20 Instrument Landing System (ILS) concluded in satisfactory performance of the system. Although the initial draft instruction books provided by the contractor were incomplete, subsequent revisions to the manuals resulted in an acceptable product. The alignment process outlined in the manuals verified that the system was ready for the FAA flight inspection.

The Mark 20 ILS successfully met required Category II/III criteria during the flight inspection conducted by the Oklahoma City, Flight Information Field Office (FIFO). Additional flight evaluations were conducted by the FAA Technical Center test team utilizing FAA Technical Center aircraft, flight measurement equipment, and radar/laser tracking systems. All FAA Technical Center evaluations were within Category II/III tolerances.

System reliability and maintainability were verified in that the few subsystem outages that occurred were easily identified and corrected. The Mark 20 remained operational throughout the entire test period except for interruptions to conduct required testing. The system is extremely stable. Weather conditions were recorded and analysis indicated that weather had little or no affect on operation of the system.

The Remote Status and Interlock Unit (RSIU) was monitored during various test scenarios and accurately displayed the correct category of operation. (This is the monitor/display unit that is placed in an Air Traffic Control [ATC] facility.)

All subsystems (localizer, glide slope, inner marker, middle marker, outer marker, and Remote Control and Status Unit [RCSU]) exceeded the specified time requirement for operation on standby battery power.

During the test period, there were no indications that the integration of the Remote Maintenance Monitoring (RMM) System into the ILS affected the operational effectiveness of the Mark 20.

#### 7. RECOMMENDATIONS.

Based on the results documented in this report, the Mark 20 is recommended for deployment in the National Airspace System (NAS). It is further recommended that a correction to the outer marker battery charging problem, as stated in TTR# 09, be resolved.

## 8. ACRONYMS.

|        |   |
|--------|---|
| AC     | Alternating Current                         |
| ACY    | Atlantic City International Airport, NJ     |
| AFIS   | Automatic Flight Inspection System          |
| APMT   | Associate Program Manager for Test          |
| ATC    | Air Traffic Control                         |
| ATCT   | Airport Traffic Control Tower               |
| B727   | Boeing 727                                  |
| CAT    | Category                                    |
| CLR    | Clearance                                   |
| CSB    | Carrier and Sidebands                       |
| DDM    | Difference in Depth of Modulation           |
| DME    | Distance Measuring Equipment                |
| DME/P  | Precision Distance Measuring Equipment      |
| DUCU   | Distribution Unit and Combining Unit        |
| FAA    | Federal Aviation Administration             |
| FFM    | Far Field Monitor                           |
| FIFO   | Flight Inspection Field Office              |
| ILS    | Instrument Landing System                   |
| LCU    | Link Control Unit                           |
| LED    | Light Emitting Diode                        |
| LRU    | Line Replaceable Unit                       |
| MHz    | Megahertz                                   |
| MLS    | Microwave Landing System                    |
| MPS    | Maintenance Processing System               |
| MSL    | Mean Sea Level                              |
| Mod/PA | Modulator and Power Amplifier               |
| NAS    | National Airspace System                    |
| nmi    | nautical miles                              |
| OT&E   | Operational Test and Evaluation             |
| PIR    | Portable Instrument Landing System Receiver |
| PMDT   | Portable Maintenance Data Terminal          |
| RCSU   | Remote Control and Status Unit              |
| RF     | Radio Frequency                             |
| RICE   | Remote Indication and Control Equipment     |
| RMM    | Remote Maintenance and Monitoring           |
| RMS    | Remote Monitoring System                    |
| RSIU   | Remote Status and Interlock Unit            |
| SBO    | Sidebands Only                              |
| SDM    | Sum of the Depth of Modulation              |
| TMB    | Tamiami/Kendall Executive Airport, FL       |
| TTR    | Test Trouble Report                         |
| UHF    | Ultra High Frequency                        |
| VHF    | Very High Frequency                         |
| VSWR   | Voltage Standing Wave Ratio                 |

**APPENDIX A**  
**Oklahoma City Flight Inspection Field Office**  
**Flight Inspection Report**

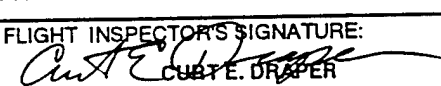
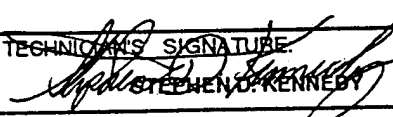
| FLIGHT INSPECTION REPORT--INSTRUMENT LANDING SYSTEM   |         |   |      |         |   |                      |              |  |                                     | REVIEW INITIALS                     |                  |                                     |                                     |                                     |      |         |       |
|---|---------|---|------|---------|---|----------------------|--------------|--|-------------------------------------|-------------------------------------|------------------|-------------------------------------|-------------------------------------|-------------------------------------|------|---------|-------|
| 1. LOCATION: ATLANTIC CITY, NJ  |         |   |      |         |   |                      |              |  |                                     | 2. IDENT: XJF                       |                  |                                     |                                     |                                     |      |         |       |
| 3. COMMON SYSTEM:   |         |   |      |         | 4. DATE / DATES OF INSPECTION: 7/12-13/94 |                      |              |  |                                     | 5. OWNER: F                         |                  |                                     |                                     |                                     |      |         |       |
| 6. TYPE OF INSPECTION   |         |   |      |         | SITE EVALUATION                           |                      | PERIODIC     |  | <input checked="" type="checkbox"/> |                                     | SPECIAL MR       |                                     |                                     |                                     |      |         |       |
|   |         |   |      |         | COMMISSIONING                             |                      | SURVEILLANCE |  |                                     |                                     | INCOMPLETE       |                                     |                                     |                                     |      |         |       |
| 7. RUNWAY NO: 04  |         | 8. FACILITY INSPECTED   |      |         | <input checked="" type="checkbox"/>       | LOCALIZER            |              | <input checked="" type="checkbox"/>  | SDF                                 | <input checked="" type="checkbox"/> | GLIDE SLOPE      | <input checked="" type="checkbox"/> | 75 MHz MARKERS                      |                                     |      |         |       |
|   |         |   |      |         | LDA                                       |                      | DME          |  | LIGHTING SYSTEM                     |                                     | COMPASS LOCATORS |                                     |                                     |                                     |      |         |       |
| 9. LOCALIZER  |         |   |      |         |   |                      |              |  |                                     |                                     |                  |                                     |                                     |                                     |      |         |       |
| FRONT COURSE  |         |   |      |         |   | COMD WIDTH: 5.60     |              |  | BACK COURSE                         |                                     |                  |                                     |                                     |                                     |      |         |       |
| TX 1  |         |   | TX 2 |         |   | CATEGORY: II         |              |  |                                     |                                     |                  | TX 1                                |                                     |                                     | TX 2 |         |       |
| OT  | INITIAL | FINAL   | OT   | INITIAL | FINAL                                     | OT                   | INITIAL      | FINAL  | OT                                  | INITIAL                             | FINAL            | OT                                  | INITIAL                             | FINAL                               | OT   | INITIAL | FINAL |
|   |         | 5.63  |      |         | 5.61                                      |                      |              |  |                                     |                                     |                  |                                     |                                     |                                     |      |         |       |
|   |         | 39.0  |      |         | 38.6                                      |                      |              |  |                                     |                                     |                  |                                     |                                     |                                     |      |         |       |
|   |         | 236/32.4  |      |         | 260/5.8                                   |                      |              |  |                                     |                                     |                  |                                     |                                     |                                     |      |         |       |
|   |         | 234/32.3  |      |         | 270/5.8                                   |                      |              |  |                                     |                                     |                  |                                     |                                     |                                     |      |         |       |
|   |         | 1/4.58  |      |         | 2/7.77                                    |                      |              |  |                                     |                                     |                  |                                     |                                     |                                     |      |         |       |
|   |         | 1/0.64  |      |         | 0/0.58                                    |                      |              |  |                                     |                                     |                  |                                     |                                     |                                     |      |         |       |
|   |         | 1/0.03  |      |         | 1/0.15                                    |                      |              |  |                                     |                                     |                  |                                     |                                     |                                     |      |         |       |
|   |         |   |      |         |   |                      |              |  |                                     |                                     |                  |                                     |                                     |                                     |      |         |       |
|   |         |   |      |         |   |                      |              |  |                                     |                                     |                  |                                     |                                     |                                     |      |         |       |
|   |         | 0/8.5   |      |         |   |                      |              |  |                                     |                                     |                  |                                     |                                     |                                     |      |         |       |
|   |         | 53.0  |      |         | 49.9                                      |                      |              |  |                                     |                                     |                  |                                     |                                     |                                     |      |         |       |
|   |         | 3R  |      |         | 1L  |                      |              |  |                                     |                                     |                  |                                     |                                     |                                     |      |         |       |
|   |         |   |      |         |   |                      |              |  |                                     |                                     |                  |                                     |                                     |                                     |      |         |       |
|   |         | S   |      |         | S   |                      |              |  |                                     |                                     |                  |                                     |                                     |                                     |      |         |       |
|   |         | -   |      |         | 18  |                      |              |  |                                     |                                     |                  |                                     |                                     |                                     |      |         |       |
| DATE:   |         |   |      | DATE:   |   |                      |              | MONITOR  |                                     | DATE:                               |                  |                                     |                                     | DATE:                               |      |         |       |
|   |         | 4.90  |      |         | 4.93                                      |                      |              |  |                                     |                                     |                  |                                     |                                     |                                     |      |         |       |
|   |         | 6.48  |      |         | 6.51                                      |                      |              |  |                                     |                                     |                  |                                     |                                     |                                     |      |         |       |
|   |         | 237/13.2  |      |         | 265/6.5                                   |                      |              |  |                                     |                                     |                  |                                     |                                     |                                     |      |         |       |
|   |         | 226/5.8   |      |         | 231/5.8                                   |                      |              |  |                                     |                                     |                  |                                     |                                     |                                     |      |         |       |
|   |         | -   |      |         | 9   |                      |              |  |                                     |                                     |                  |                                     |                                     |                                     |      |         |       |
|   |         | -   |      |         | 9   |                      |              |  |                                     |                                     |                  |                                     |                                     |                                     |      |         |       |
| 10. GLIDE SLOPE   |         |   |      |         |   |                      |              |  |                                     |                                     |                  | 11. GENERAL                         |                                     |                                     |      |         |       |
| TX 1  |         |   | TX 2 |         |   | COMD ANGLE: 3.00     |              |  |                                     |                                     |                  |                                     | SAT                                 | UNSAT                               |      |         |       |
| OT  | INITIAL | FINAL   | OT   | INITIAL | FINAL                                     | CATEGORY: II         |              |  |                                     |                                     |                  | 75 MHz MARKERS                      | <input checked="" type="checkbox"/> |                                     |      |         |       |
|   |         | 3.01  |      |         |   | ANGLE                |              |  |                                     |                                     |                  | COMPASS LOCATORS                    |                                     |                                     |      |         |       |
|   |         | 79.0  |      |         |   | MODULATION           |              |  |                                     |                                     |                  | DME                                 |                                     |                                     |      |         |       |
|   |         | 0.67  |      |         |   | WIDTH                |              |  |                                     |                                     |                  | LIGHTING SYSTEMS                    |                                     |                                     |      |         |       |
|   |         |   |      |         |   | CLEARANCE BELOW PATH |              |  |                                     |                                     |                  | 12. FACILITY STATUS                 |                                     |                                     |      |         |       |
|   |         | 2.10  |      |         |   | STRUCTURE BELOW PATH |              |  |                                     |                                     |                  |                                     | F/C                                 | G/S                                 | B/C  |         |       |
|   |         | 4/6.34  |      |         |   | PATH STRUCTURE-Z1    |              |  |                                     |                                     |                  | UNRESTRICTED                        |                                     |                                     |      |         |       |
|   |         | 5/1.68  |      |         |   | PATH STRUCTURE-Z2    |              |  |                                     |                                     |                  | RESTRICTED                          |                                     |                                     |      |         |       |
|   |         | 4/0.16  |      |         |   | PATH STRUCTURE-Z3    |              |  |                                     |                                     |                  | UNUSABLE                            | <input checked="" type="checkbox"/> | <input checked="" type="checkbox"/> |      |         |       |
|   |         | 10  |      |         |   | USABLE DISTANCE      |              |  |                                     |                                     |                  | NOTAM's:                            |                                     |                                     |      |         |       |
|   |         | 47.5  |      |         |   | SYMMETRY             |              |  |                                     |                                     |                  |                                     |                                     |                                     |      |         |       |
| DATE:   |         |   |      | DATE:   |   |                      |              | MONITOR  |                                     |                                     |                  |                                     |                                     |                                     |      |         |       |
| <p>13. REMARKS: SPECIAL INSPECTION: THIS WAS A SPECIAL INSPECTION (MAINT REQUEST) FOR EVALUATION OF A MK 20 ILS SYSTEM AS INSTALLED AT A TEST SITE LOCATION. COMMISSIONING FLIGHT INSPECTION CRITERIA AND TOLERANCES SPECIFIC TO ILS CATAGORY II OPERATION WAS APPLIED FOR THIS INSPECTION.</p> <p>GLIDE SLOPE TRANSMITTER NO 2 NOT CHECKED. INSPECTION TERMINATED, WITH MAINT CONCRRNCE, DUE TO AIRCRAFT AVAILABILITY AND HIGHER PRIORITY MISSION REQUIREMENTS.<br/>(SEE CONTINUATION SHEET FAA FORM 8240 - 15 ATTACHED)</p> |         |   |      |         |   |                      |              |  |                                     |                                     |                  |                                     |                                     |                                     |      |         |       |
| REGION: AEA   |         | FLIGHT INSPECTOR'S SIGNATURE:   |      |         |   |                      |              | TECHNICAL SIGNATURE:   |                                     |                                     |                  |                                     |                                     | AIRCRAFT NO:                        |      |         |       |
| FIFO: ACY   |         | <br>CURTIS E. DRAPER |      |         |   |                      |              | <br>STEPHEN D. KENNEDY |                                     |                                     |                  |                                     |                                     | N-69                                |      |         |       |



# FLIGHT INSPECTION REPORT--INSTRUMENT LANDING SYSTEM SUPPLEMENTAL SHEET

REVIEW INITIALS

1. LOCATION: ATLANTIC CITY, NJ

2. IDENT: XJF

3. DATE / DATES OF INSPECTION: 7/12-13/94

## 4. GLIDE SLOPE

| 4a. GLIDE SLOPE TYPE: CAP EFFECT   |         |               |          | PATH ANGLE |                  | PATH WIDTH |      | STRUCTURE BELOW PATH |      |
|--|---------|---------------|----------|------------|------------------|------------|------|----------------------|------|
|  |         |               |          | TX 1       | TX 2             | TX 1       | TX 2 | TX 1                 | TX 2 |
| 4b. DEPHASE  | ADVANCE | TX 1<br>15    | TX 2     | 3.05       |                  | 0.75       |      | 2.29                 |      |
|  | RETARD  | TX 1<br>15    | TX 2     | 3.08       |                  | 0.76       |      | 1.17                 |      |
| 4c. PATH ANGLE LOWERED TO LIMIT  |         |               |          |            |                  |            |      |                      |      |
| 4d. PATH ANGLE RAISED TO LIMIT   |         |               |          |            |                  |            |      |                      |      |
| 4e. PATH WIDTH NARROWED TO LIMIT   |         |               |          | 3.04       |                  | 0.56       |      | 2.29                 |      |
| 4f. PATH WIDTH WIDENED TO LIMIT  |         |               |          |            |                  |            |      |                      |      |
| 4g. CLEARANCE TX MODULATION DECREASED TO LIMIT - (PRIMARY TX WIDE LIMIT) |         |               |          | 3.00       |                  | 0.75       |      | 2.29                 |      |
| 4h. ATTENUATE MIDDLE ANTENNA TO LIMIT                                    |         | TX 1<br>0.4DB | TX 2     | 3.02       |                  | 0.75       |      | 1.93                 |      |
| 4i. ATTENUATE UPPER ANTENNA TO LIMIT                                     |         | TX 1<br>1.0DB | TX 2     | 2.97       |                  | 0.71       |      | 2.12                 |      |
| 4j. TRANSVERSE STRUCTURE   |         | CRS SECTOR    | FAF ALT: |            | 0.7° BELOW PATH: |            |      |                      |      |
|  |         | EDGE SECTOR   | FAF ALT: |            | 0.7° BELOW PATH: |            |      |                      |      |
| 4k. MODULATION BALANCE   |         |               |          | TX1        |                  | TX2        |      |                      |      |
| 4l. PHASING  |         |               |          | TX1        |                  | TX2        |      |                      |      |
| 4m. FRONT COURSE AREA WHERE PHASING WAS CONDUCTED                        |         |               |          |            |                  | NM         |      | MSL                  |      |
| 4n. CLEARANCE BELOW PATH   |         |               |          | TX1 S      |                  | TX2        |      |                      |      |

5. REMARKS CORRECTION FACTOR OF + 0.03 APPLIED TO REPORTED LEVEL RUN ANGLE DATA.

# FLIGHT INSPECTION REPORT--CONTINUATION SHEET

REVIEW INITIALS

1. LOCATION: ATLANTIC CITY, NJ

2. IDENT: XHF

3. FACILITY TYPE: ILS

4. DATE / DATES OF INSPECTION: 7/12-13/94

1. USEABLE DISTANCE CHECKS PERFORMED ON LOCALIZER TRANSMITTER NO 2 AND GLIDE SLOPE TRANSMITTER NO 1 ONLY.
2. LOCALIZER ALIGNMENT MONITORS CHECKED ON GROUND (RWY 04) ON TRANSMITTER NO 2 ONLY.
3. MARKER WIDTH: MM; 1137' AND IM; 626'.
4. ILS (XJF) FACILITY DATA WAS MANUALLY ENTERED INTO THE AFIS DATA BASE WITH CHANGE OF DISTANCE TO THE OUTER MARKER TO 31595' (5.2 NM) TO FACILITATE MANUAL POSITION UPDATING FOR LEVEL RUN ANGLE RESULTS (ILS 2).
5. GLIDE SLOPE MEAN SYMMETRY WAS CHECKED AT 48.7% 90HZ:  
ON PATH ANGLE; 3.01 - BELOW PATH ANGLE; 2.64 - ABOVE PATH ANGLE; 3.40 - MEAN WIDTH 0.76 DEGREES.
6. ANTENNA TILT CHECK:
 

| ANGLE | SBP  | WIDTH | SYMMETRY |       |
|-------|------|-------|----------|-------|
| 90HZ  | 2.99 | 2.10  | 0.69     | 47.8% |
| 150HZ | 2.93 | 2.09  | 0.65     | 51.4% |

# FLIGHT INSPECTION REPORT--LOCALIZER CLEARANCE PLOT

|   |           |            |                  |                    |                            |
|---|-----------|------------|------------------|--------------------|----------------------------|
| 1. LOCATION: ATLANTIC CITY, NJ          |           |            |                  | 2. IDENT: XJF      |                            |
| 3. DATE/DATES OF INSPECTION: 7/12-13/94 |           |            | 4. ANT TYPE:     |                    | 5. SITE ELEV: 67.0         |
| 6. TX: 1                                | 7. CFG: N | 8. ALT: 17 | 9. RADIUS: 10 NM | 10. WIDTH FC: 5.63 | 11. WIDTH BC: N/A          |
|   |           |            |                  |                    | CODE: FC ———<br>BC - - - - |

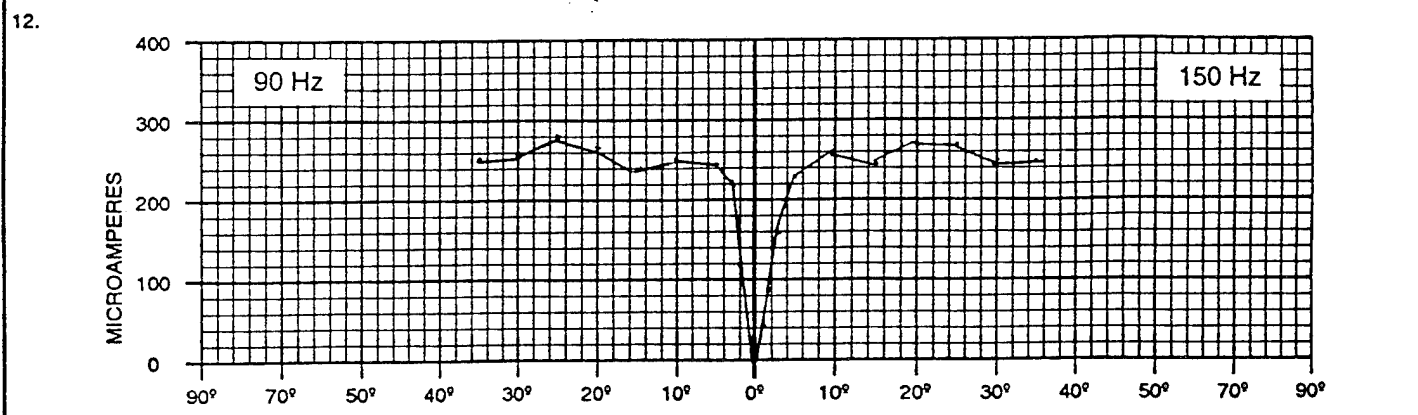

|          |           |            |                  |                    |                            |
|----------|-----------|------------|------------------|--------------------|----------------------------|
| 6. TX: 1 | 7. CFG: B | 8. ALT: 17 | 9. RADIUS: 10 NM | 10. WIDTH FC: 6.48 | 11. WIDTH BC: N/A          |
|          |           |            |                  |                    | CODE: FC ———<br>BC - - - - |

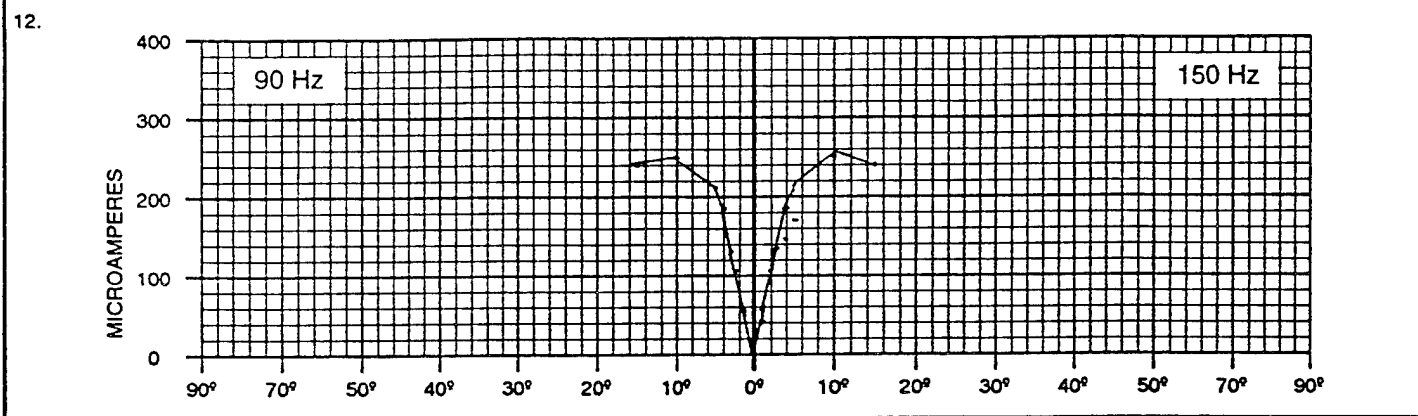

|          |           |            |                  |                    |                            |
|----------|-----------|------------|------------------|--------------------|----------------------------|
| 6. TX: 1 | 7. CFG: C | 8. ALT: 17 | 9. RADIUS: 10 NM | 10. WIDTH FC: 4.90 | 11. WIDTH BC: N/A          |
|          |           |            |                  |                    | CODE: FC ———<br>BC - - - - |

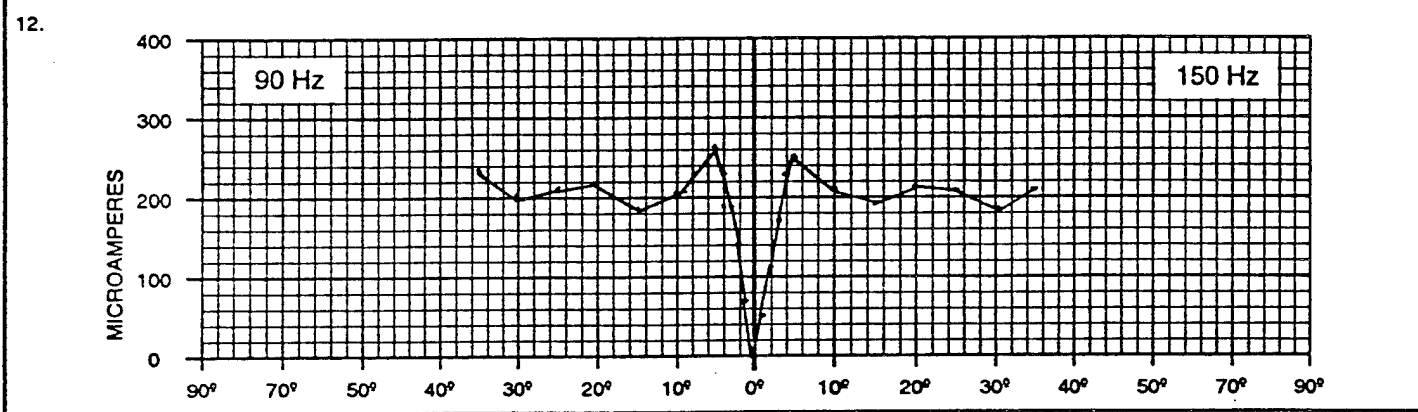

13. REMARKS: TEST SITE HAD NO BACK COURSE FOR EVALUATION.

|             |                               |   |              |
|-------------|-------------------------------|---|--------------|
| REGION: AEA | FLIGHT INSPECTOR'S SIGNATURE: | TECHNICIAN'S SIGNATURE:                         | AIRCRAFT NO: |
| FIFO: ACY   | N/A                           | <i>Stephen D. Kennedy</i><br>STEPHEN D. KENNEDY | N-69         |

## FLIGHT INSPECTION REPORT--LOCALIZER CLEARANCE PLOT

|   |           |            |                  |                    |                            |
|---|-----------|------------|------------------|--------------------|----------------------------|
| 1. LOCATION: ATLANTIC CITY, NJ          |           |            |                  | 2. IDENT: XJF      |                            |
| 3. DATE/DATES OF INSPECTION: 7/12-13/94 |           |            | 4. ANT TYPE:     |                    | 5. SITE ELEV: 67.0         |
| 6. TX: 2                                | 7. CFG: N | 8. ALT: 17 | 9. RADIUS: 10 NM | 10. WIDTH FC: 5.61 | 11. WIDTH BC: N/A          |
|   |           |            |                  |                    | CODE: FC ———<br>BC - - - - |

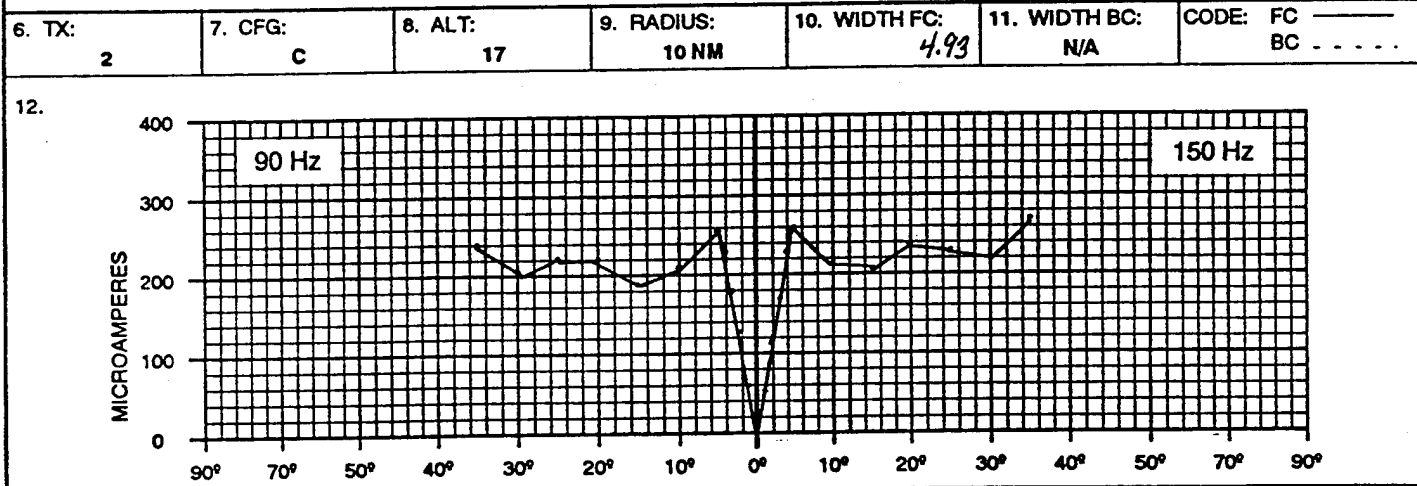
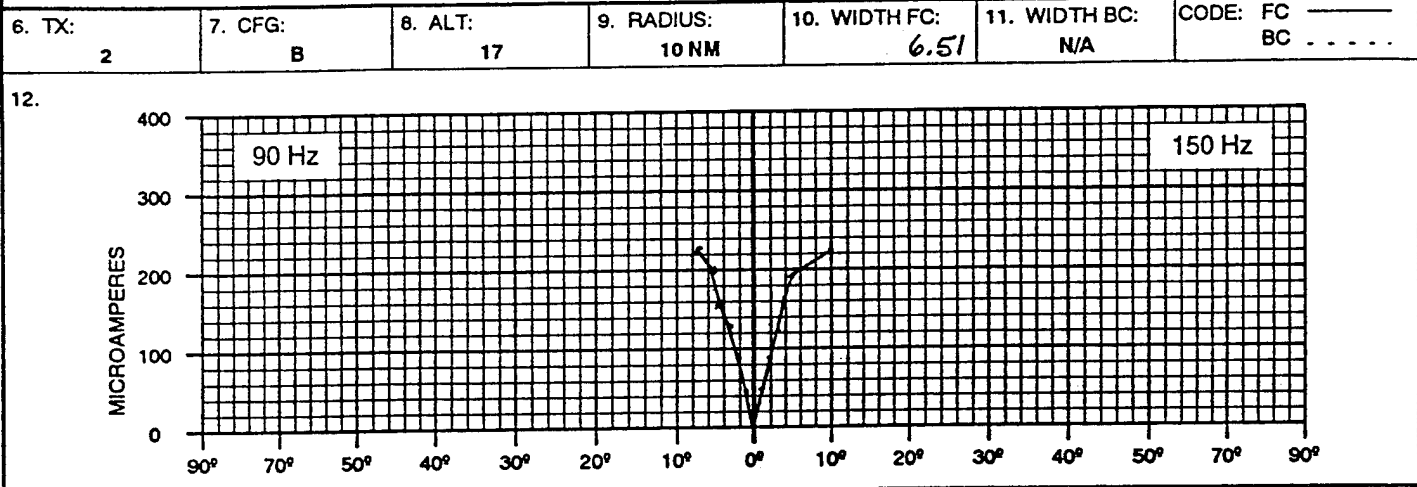
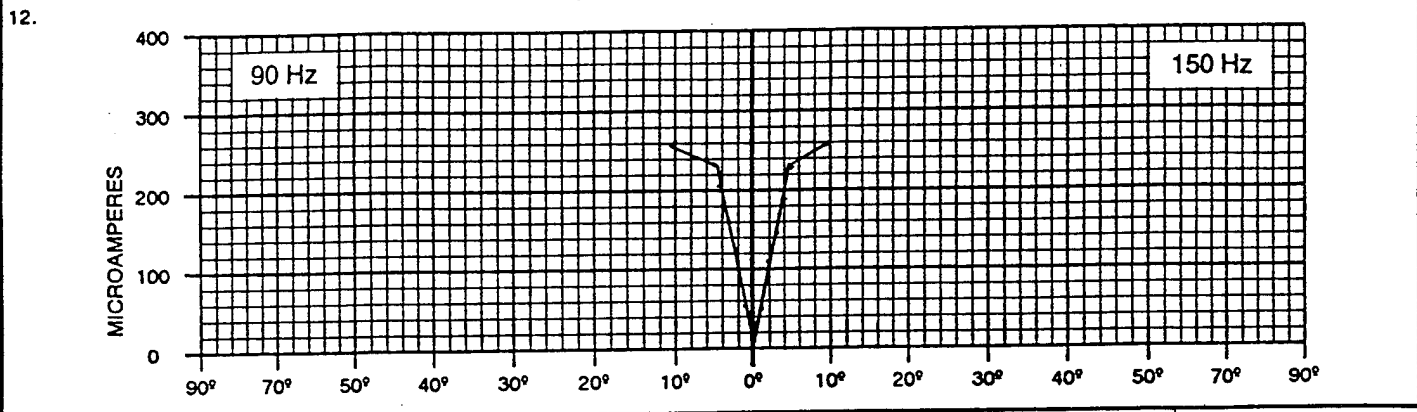

13. REMARKS: TEST SITE HAD NO BACK COURSE FOR EVALUATION.

|             |   |  |                      |
|-------------|---|--|----------------------|
| REGION: AEA | FLIGHT INSPECTOR'S SIGNATURE:<br><b>N/A</b> | TECHNICIAN'S SIGNATURE:<br><i>Stephen D. Kennedy</i><br>STEPHEN D. KENNEDY | AIRCRAFT NO:<br>N-69 |
| FIFO: ACY   |   |  |                      |

## ILS WORKSHEET

|   |                     |                              |
|---|---------------------|------------------------------|
| 1. IDENT: XJF   | 2. DATE: 7/12-13/94 | 3. TYPE CHECK: SPECIAL; SITE |
| 4. CREW: DRAPER/COLES/KENNEDY   |                     | 5. AIRCRAFT NO: N-69 /84     |
| 6. NOTES: OPERATIONAL TEST AND EVALUATION OF THE MK 20 ILS<br>INSTALLATION AT ATLANTIC CITY, NJ (KACY) RWY 04.<br><br>LIMITED COMMISSIONING PROFILE FLOWN AT MAINTENANCE REQUEST. |                     | RWY: 04                      |
|   |                     | CW: 5.60                     |
|   |                     | FREQ: 109.55                 |
|   |                     | ANGLE: 3.00                  |
|   |                     | LOC TYPE: DUAL               |
|   |                     | GND TEMP: 83                 |
|   |                     | CAT: 2                       |
|   |                     | OAT: 22                      |
|   |                     | GS TYPE: CAP EFF             |
|   |                     | BARO: 3002                   |
|   |                     | ALTITUDE:                    |

| 7. RUN # | CFG  | PA or ALN | 190 μA | PW or CW | 90 Hz SYM | FLAG or MOD | REMARKS / OTHER DATA                                |
|----------|------|-----------|--------|----------|-----------|-------------|---|
| 1        | 1N   |           |        | 5.71     | 49.8      | 38          | INITIAL NORMAL: CLEARANCES SATISFACTORY; 35 - 35    |
| 3        | 1N   |           |        | 5.59     | 49.6      | 38.6        | ADJUSTED NORMAL: CLEARANCES SATISFACTORY            |
| 4        | 1S   |           |        | 00000    |           |             | NO ANNOUNCED COURSE WIDTH - SYSTEM FAULT            |
| 5        | 1S   |           |        | 4.90     | 49.9      |             | COURSE NARROW-CLEARANCE WIDE                        |
| 6        | 1S   |           |        | 5.58     | 49.9      |             | COURSE NORMAL-CLEARANCE NARROW                      |
| 7        | 1B   |           |        | 6.59     | N/A       |             | COURSE WIDE CLEARANCE NORMAL; OT WIDE               |
| 8        | 1B   |           |        | -        | -         | -           | SYSTEM FAULT  |
| 9        | 1B   |           |        | 6.48     | 49.4      |             | COURSE WIDE CLEARANCE NORMAL                        |
| 10       | 1N   |           |        | 5.63     | 53.0      |             | NORMAL CONFIGURATION                                |
| 11       | 2S   |           |        | 4.93     | 49.5      |             | COURSE NARROW-CLEARANCE WIDE                        |
| 12       | 2S   |           |        | 5.59     | 50.1      |             | COURSE NORMAL-CLEARANCE NARROW                      |
| 13       | 2B   |           |        | 6.51     | 49.9      |             | COURSE WIDE CLEARANCE NORMAL                        |
| 14       | 2N   |           |        | 5.61     | 49.9      |             | NORMAL CONFIGURATION                                |
| 15       | 2N   |           |        | 5.67     | 49.4      |             | RF ALARM; 18NM AT LCA; USEABLE DISTANCE CHECK 10-10 |
| 16       | 2N   |           |        | 5.73     | 50.0      |             | RF ALARM; 18NM AT 4500 FT; 10-10                    |
| 17       | 2N   |           |        | N/A      | N/A       |             | APCH RF ALARM 18NM TO THRESHOLD - SAT.              |
| 18       | 2N   |           |        | 5.63     | 49.8      |             | 10NM ARC; RF ALARM; CLEARANCES SAT.                 |
| 19       | 1N   | 4.56      | 2.46   |          |           |             | SYSTEM FAULT; BAD UPDATE DATA - RECHECK             |
| 20       | 1N   | 2.99      | 1.91   | 0.92     |           |             | CHANGE DATA FOR A 6.2 NM MANUAL UPDATE              |
| 21       | 1N L | 1L        |        |          |           | 39.0        | ILS 3; LOCALIZER; Z1=2/7.7, Z2=0/0.58, Z3=1/0.15    |
|          | 1N G | 2.98      |        |          |           | 79.0        | ILS 3; G/S; Z1=4/5.366, Z2=3/0.58, Z3=7/0.17        |

## ILS WORKSHEET

|   |                     |                              |
|---|---------------------|------------------------------|
| 1. IDENT: XJF   | 2. DATE: 7/12-13/94 | 3. TYPE CHECK: SPECIAL; SITE |
| 4. CREW: DRAPER/COLES/KENNEDY   |                     | 5. AIRCRAFT NO: N-69 /84     |
| 6. NOTES: OPERATIONAL TEST AND EVALUATION OF THE MK 20 ILS<br>INSTALLATION AT ATLANTIC CITY, NJ (KACY) RWY 04.<br><br>LIMITED COMMISSIONING PROFILE FLOWN AT MAINTENANCE REQUEST. |                     | RWY: 04                      |
|   |                     | CW: 5.60                     |
|   |                     | FREQ: 109.55                 |
|   |                     | ANGLE: 3.00                  |
|   |                     | LOC TYPE: DUAL               |
|   |                     | GND TEMP: 83                 |
|   |                     | CAT: 2                       |
|   |                     | OAT: 22                      |
|   |                     | GS TYPE: CAP EFF             |
|   |                     | BARO: 3002                   |
|   |                     | ALTITUDE:                    |

| 7. RUN # | CFG | PA or ALN | 190 $\mu$ A | PW or CW | 90 Hz<br>SYM | FLAG or<br>MOD | REMARKS / OTHER DATA                                 |
|----------|-----|-----------|-------------|----------|--------------|----------------|--|
| 22       | 1N  | 1L        |             |          |              |                | ALIGNMENT MONITORS; NORMAL                           |
|          | 1N  | 9 UA      |             |          |              |                | ALIGNMENT MONITORS; 150 HZ                           |
|          | 1N  | 9 UA      |             |          |              |                | ALIGNMENT MONITORS; 90 HZ                            |
| 1-18     | TX1 |           |             |          |              |                | BEGIN GLIDE SLOPE 7/13/94                            |
| 1        | 1N  |           |             |          |              |                | SYSTEM FAULT - NO UPDATE - SEE 2                     |
| 2        | 1N  | 2.97      | 2.07        | 0.67     | 47.6         | 79.6           | INITIAL NORMAL - REFERENCE                           |
| 3        | 1N  | 3.04      |             | 6.48     | 49.4         | 78.8           | G/S STRUCTURE: Z1= 4/7.12, Z2= 9/0.60, Z3= 4/0.16    |
| 4        | 1S  | 3.01      | 2.29        | 0.56     | 51.3         | 78.9           | NARROW ALARM   |
| 5        | 1B  | 2.97      | -           | 0.75     | 49.3         |                | COURSE WIDE, CLEARANCE % MOD ALARM                   |
| 6        | 1M  | 2.99      | 1.93        | 0.75     | 46.8         |                | MIDDLE ANTENNA ATTENUATED TO ALARM - 0.4DB           |
| 7        | 1A  | 3.02      | 2.29        | 0.75     | 49.3         |                | MIDDLE ANTENNA; ADVANCE PHASE 15 DEGREES             |
| 8        | 1R  | 3.05      | 1.17        | 0.76     | 43.8         |                | MIDDLE ANTENNA; RETARD PHASE 15 DEGREES              |
| 9        | 1U  | 2.43      |             |          | 64.0         |                | SYSTEM FAULT - NO DATA                               |
| 10       | 1U  | 2.94      | 2.12        | 0.71     | 52.8         |                | UPPER ANTENNA ATTENUATED; 1DB                        |
| 11       | 1N  | 3.01      | 2.10        | 0.67     | 47.5         |                | NORMAL - LEVEL RUN                                   |
| 12       | 1N  | 2.93      | 2.09        | 0.65     | 51.4         |                | TILT CHECK - 150 HZ SIDE (LOCALIZER EXTREMITIES)     |
| 13       | 1N  | 2.99      | 2.10        | 0.69     | 47.8         |                | TILT CHECK - 90 HZ SIDE (LOCALIZER EXTREMITIES)      |
| 14       | RF  |           |             |          |              |                | USEABLE DISTANCE FROM 10 NM - 150HZ SIDE (8 DEGREES) |
| 15       | RF  |           |             |          |              |                | USEABLE DISTANCE FROM 10 NM - 90HZ SIDE (8 DEGREES)  |
| 16       | RF  |           |             |          |              |                | USEABLE DISTANCE FROM 10 NM - ON COURSE              |

## ILS WORKSHEET

|   |                     |                              |
|---|---------------------|------------------------------|
| 1. IDENT: XJF   | 2. DATE: 7/12-13/84 | 3. TYPE CHECK: SPECIAL; SITE |
| 4. CREW: DRAPER/COLES/KENNEDY   |                     | 5. AIRCRAFT NO: N-69 /84     |
| 6. NOTES: OPERATIONAL TEST AND EVALUATION OF THE MK 20 ILS<br>INSTALLATION AT ATLANTIC CITY, NJ (KACY) RWY 04.<br><br>LIMITED COMMISSIONING PROFILE FLOWN AT MAINTENANCE REQUEST. |                     | RWY: 04                      |
|   |                     | CW: 5.60                     |
|   |                     | FREQ: 109.55                 |
|   |                     | ANGLE: 3.00                  |
|   |                     | LOC TYPE: DUAL               |
|   |                     | GND TEMP: 83                 |
|   |                     | CAT: 2                       |
|   |                     | OAT: 22                      |
|   |                     | GS TYPE: CAP EFF             |
|   |                     | BARO: 3002                   |
|   |                     | ALTITUDE:                    |

| 7. RUN # | CFG | PA or ALN | 190 $\mu$ A | PW or CW | 90 Hz SYM | FLAG or MOD | REMARKS / OTHER DATA                    |
|----------|-----|-----------|-------------|----------|-----------|-------------|---|
| 17       | 1N  | 3.01      |             |          |           |             | MEAN WIDTH/SYMMETRY; ON PATH            |
| 18       | 1N  | 2.64      |             |          | 48.7%     |             | MEAN WIDTH/SYMMETRY; BELOW PATH (90HZ)  |
| 19       | 1N  | 3.40      |             |          |           |             | MEAN WIDTH/SYMMETRY; ABOVE PATH (150HZ) |
|          |     |           |             |          |           |             |   |
|          |     |           |             |          |           |             |   |
|          |     |           |             |          |           |             |   |
|          |     |           |             |          |           |             |   |

1. INSTRUMENT LANDING SYSTEM

- a. State: New Jersey
- b. City: Atlantic City
- c. Airport: Atlantic City International Airport
- d. Category of Operation: Category III
- e. Associated runway: Runway 04
- f. Approach bearing: 028.00 deg true
- h. Engineering drawing: n/a
- i. Localizer
  - 1. Latitude and longitude of antenna:  
39 deg 28' 01.03" N / 074 deg 34' 25.22" W
  - 2. Antenna Type: 14 element LPD
  - 3. Distance from stop end of runway to antenna: 1005'
  - 4. Distance from approach end of runway to antenna:  
7149'
  - 5. Distance and direction from runway centerline: on c/l
  - 6. Ground elevation at center of antenna array: 66.4' msl
  - 7. Identifier: I-XJF
  - 8. Frequency: 109.55 mhz
  - 9. Voice availability: n/a
  - 10. Course width: 5.6 deg
  - 11. Course width over threshold: 700 ft.
  - 12. Back course status: Not available
  - 13. Restrictions: None
  - 14. Remote monitor: Far field monitor
  - 15. Commissioning date: n/a
- j. Glide Slope
  - 1. Latitude and longitude of antenna:  
39 deg 27' 08.13: N / 74 deg 35; 07.27" W
  - 2. Ground elevation of antenna mast: 65.84' msl
  - 3. Elevation of runway centerline abeam glide slope  
antenna: 67.0 msl
  - 4. Frequency: 332.45 mhz
  - 5. Type of facility: Capture effect antenna system
  - 6. Distance of antenna from approach end of runway: 875'
  - 7. Distance and direction from runway c/l: 400' left
  - 8. Glide angle: 3.00 deg
  - 9. Restrictions: n/a
  - 10. Remote monitor: n/a
  - 11. Commissioning date: n/a
- k. Outer Marker
  - 1. Latitude and longitude of antenna:  
39 deg 29' 53.62" N / 074 deg 40' 20.48" W
  - 2. Ground elevation of antenna: 48' msl
  - 3. Distance from runway threshold: 4804'
  - 4. Distance from runway centerline extended: on c/l
  - 5. Locator classification: OM
  - 6. Remote monitor: n/a
  - 7. Commissioning date: n/a



**APPENDIX B**  
**Test Trouble Reports**

TTR# 01

CAT II/III ILS/RMS  
TEST TROUBLE REPORT FORM

TESTER: Ben Bennett/Paul Evermon LOCATION: ACY

TEST SCENARIO: Installation DATE: June 94

TTR CLASSIFICATION: CRITICAL:        SIGNIFICANT:        MINOR: X

**DESCRIPTION OF PROBLEM OR FAILURE:** During installation, a problem was detected with one of the FFMs. The signal from this monitor had considerable 60 Hz interference. The monitor was returned to the factory for repair. The 60 Hz interference could not be repeated at the factory and the unit appeared to be working fine under lab conditions. When the FFM was returned to ACY, the problem surfaced again. In the field it was discovered that when an audio transformer was placed in the line from the FFM to the localizer, the FFM worked fine. From this it is assumed that the FFM has a bad transformer.

**RECOMMENDED SOLUTION:** Wilcox should develop a production test procedure for the FFM to test the audio transformer in the future.

**RESOLUTION:** Wilcox has added a procedure to test the audio transformer in their production acceptance tests.

IMPROVEMENT RECOMMENDATION:

- MODIFICATION TO HARDWARE
- MODIFICATION TO SOFTWARE
- CHANGE IN TEST PROCEDURE
- CHANGE IN OPERATIONS



TTR# 03

CAT II/III ILS/RMS  
TEST TROUBLE REPORT FORM

TESTER: Ben Bennett LOCATION: ACY

TEST SCENARIO: Installation DATE: June 1994

TTR CLASSIFICATION: CRITICAL:      SIGNIFICANT:      MINOR: X

**DESCRIPTION OF PROBLEM OR FAILURE:** The "ON BATTERY" and "LOW BATTERY" LEDs do not illuminate when the "TEST" button is pressed on the RCSU.

**RECOMMENDED SOLUTION:**

**RESOLUTION:** It will be documented in the RCSU user manual that the LEDs will not light.

---

IMPROVEMENT RECOMMENDATION:            X MODIFICATION TO HARDWARE  
   or X MODIFICATION TO SOFTWARE  
        CHANGE IN TEST PROCEDURE  
        CHANGE IN OPERATIONS

TTR# 04

CAT II/III ILS/RMS  
TEST TROUBLE REPORT FORM

TESTER: Ben Bennett/Byron Robins LOCATION: ACY

TEST SCENARIO: Normal Operation DATE: June 94

TTR CLASSIFICATION: CRITICAL:        SIGNIFICANT: X MINOR:       

**DESCRIPTION OF PROBLEM OR FAILURE:** The glide slope and localizer integrity check will fail if the standby monitor alarm delay time is set too low.

**RECOMMENDED SOLUTION:** Software change to not allow a standby monitor alarm delay time too low for the integrity check to pass.

**RESOLUTION:** The PMDT software was changed to not allow the user to set the standby monitor alarm time too low.

IMPROVEMENT RECOMMENDATION:

- MODIFICATION TO HARDWARE
- X MODIFICATION TO SOFTWARE
- CHANGE IN TEST PROCEDURE
- CHANGE IN OPERATIONS

TTR# 05

CAT II/III ILS/RMS  
TEST TROUBLE REPORT FORM

TESTER: Ben Bennett LOCATION: ACY

TEST SCENARIO: Integration testing DATE: July 1994

TTR CLASSIFICATION: CRITICAL:      SIGNIFICANT: X MINOR:     

**DESCRIPTION OF PROBLEM OR FAILURE:** The localizer and glide slope manual fault diagnostics will not run after a fault has been introduced that causes both transmitters to shut down.

**RECOMMENDED SOLUTION:** Correct in software

**RESOLUTION:** Software revisions by Wilcox corrected this problem.

IMPROVEMENT RECOMMENDATION:

- MODIFICATION TO HARDWARE
- MODIFICATION TO SOFTWARE
- CHANGE IN TEST PROCEDURE
- CHANGE IN OPERATIONS

TTR# 06

CAT II/III ILS/RMS  
TEST TROUBLE REPORT FORM

TESTER: Ben Bennett LOCATION: ACY

TEST SCENARIO: Integration testing DATE: July 1994

TTR CLASSIFICATION: CRITICAL:        SIGNIFICANT: X MINOR:       

**DESCRIPTION OF PROBLEM OR FAILURE:** Auto fault diagnostics for the localizer, glide slope, and the marker beacons do not accurately identify the faulted LRU.

**RECOMMENDED SOLUTION:** Correct in software.

**RESOLUTION:** Automatic diagnostics is not as accurate as manual because in order to accurately diagnose the subsystem, faulty signals must be radiated. This can only be done manually.

IMPROVEMENT RECOMMENDATION:

- MODIFICATION TO HARDWARE
- X MODIFICATION TO SOFTWARE
- CHANGE IN TEST PROCEDURE
- CHANGE IN OPERATIONS

TTR# 07

CAT II/III ILS/RMS  
TEST TROUBLE REPORT FORM

TESTER: Ben Bennett/Byron Robins LOCATION: ACY

TEST SCENARIO: Normal Operations DATE: 8/8/94

TTR CLASSIFICATION: CRITICAL:      SIGNIFICANT: X MINOR:     

**DESCRIPTION OF PROBLEM OR FAILURE:** Localizer shut down. The executive monitor course DDM went out of tolerance causing both transmitters to shut down indicating a possible problem in the DUCU or antenna subsystems.

**RECOMMENDED SOLUTION:**

**RESOLUTION:** It has not been determined what caused this outage.

**IMPROVEMENT RECOMMENDATION:**

- MODIFICATION TO HARDWARE
- MODIFICATION TO SOFTWARE
- CHANGE IN TEST PROCEDURE
- CHANGE IN OPERATIONS



TTR# 08

CAT II/III ILS/RMS  
TEST TROUBLE REPORT FORM

TESTER: Ben Bennett/Byron Robins LOCATION: ACY

TEST SCENARIO: Standby power test DATE: 8/29/94

TTR CLASSIFICATION: CRITICAL:        SIGNIFICANT: X MINOR:       

**DESCRIPTION OF PROBLEM OR FAILURE:** The marker beacon front panel displays "on batteries" and "maintenance alert" after the batteries have been discharged and AC power restored to the system.

**RECOMMENDED SOLUTION:** The project office will have this problem corrected by Wilcox through ECP16.

IMPROVEMENT RECOMMENDATION:                    or    X   MODIFICATION TO HARDWARE  
  X   MODIFICATION TO SOFTWARE  
     CHANGE IN TEST PROCEDURE  
     CHANGE IN OPERATIONS

TTR# 09

CAT II/III ILS/RMS  
TEST TROUBLE REPORT FORM

TESTER: Ben Bennett/Byron Robins LOCATION: ACY

TEST SCENARIO: Standby power test DATE: 8/30/94

TTR CLASSIFICATION: CRITICAL:      SIGNIFICANT: X MINOR:     

**DESCRIPTION OF PROBLEM OR FAILURE:** After the batteries were discharged, AC power was restored with only one of two sets of batteries on line to reduce charge current. As a result of this condition, the outer marker AC/DC power supply shut itself down due to too much power being supplied. The AC/DC converter is not powerful enough to charge even one set of batteries after they have been discharged.

**RECOMMENDED SOLUTION:** Raise the battery cut off voltage so that the marker beacons shut down at a state of discharge that the AC/DC converter can recharge the batteries without damage. At the current cut off voltage the marker beacons remained on the air for well over 176 hours. The requirement is only 72 hours.

IMPROVEMENT RECOMMENDATION:  MODIFICATION TO HARDWARE  
 MODIFICATION TO SOFTWARE  
 CHANGE IN TEST PROCEDURE  
 CHANGE IN OPERATIONS

TTR# 10

CAT II/III ILS/RMS  
TEST TROUBLE REPORT FORM

TESTER: Ben Bennett/Byron Robins LOCATION: ACY

TEST SCENARIO: Normal Operations DATE: 9/6/94

TTR CLASSIFICATION: CRITICAL:        SIGNIFICANT: X MINOR:       

**DESCRIPTION OF PROBLEM OR FAILURE:** This is a repeat of the TTR #07. The executive monitor course ddm started to fluctuate around 8:10 pm on 5 September. It went into alarm several times but went back to normal before the 2 second alarm delay time had expired. The executive monitor remained stable until approximately 8:20 a.m. 6 September. The course ddm and course width ddm went into alarm but went back to normal before the alarm delay timer expired again. At 9:08 a.m. the course path and width ddm began to oscillate between alarm and normal. This continued until 9:30 a.m. when the course ddm remained in alarm condition until the delay timer expired causing both transmitters to shut down. No abnormal weather conditions were present at the time of shutdown.

**RECOMMENDED SOLUTION:**

**RESOLUTION:** The cause of this outage has not been determined.

IMPROVEMENT RECOMMENDATION:

- MODIFICATION TO HARDWARE
- MODIFICATION TO SOFTWARE
- CHANGE IN TEST PROCEDURE
- CHANGE IN OPERATIONS

TTR# 11

CAT II/III ILS/RMS  
TEST TROUBLE REPORT FORM

TESTER: Ben Bennett/Byron Robbins LOCATION: ACY

TEST SCENARIO: Normal Operations DATE: 11/21/94

TTR CLASSIFICATION: CRITICAL:      SIGNIFICANT: X MINOR:     

**DESCRIPTION OF PROBLEM OR FAILURE:** The inner marker AC to DC converter failed. The power was turned off for approximately 5 hours and then turned back on with no effect. The AC to DC converter from the middle marker worked in the inner marker. The converter was returned to Wilcox who will send it to Lambda for analysis.

**RECOMMENDED SOLUTION:**

**RESOLUTION:** The AC/DC converter was returned to Wilcox for analysis.

IMPROVEMENT RECOMMENDATION:

- MODIFICATION TO HARDWARE
- MODIFICATION TO SOFTWARE
- CHANGE IN TEST PROCEDURE
- CHANGE IN OPERATIONS

TTR# 12

CAT II/III ILS/RMS  
TEST TROUBLE REPORT FORM

TESTER: Ben Bennett/Byron Robbins LOCATION: ACY

TEST SCENARIO: Normal Operations DATE: 11/21/94

TTR CLASSIFICATION: CRITICAL:        SIGNIFICANT: X MINOR:       

**DESCRIPTION OF PROBLEM OR FAILURE:** Unknown failure of the RMM board on the glide slope. RMM boards were swapped from the localizer to the glide slope and the communication errors followed the RMM board to the localizer. A new spare RMM board was installed which corrected the errors.

**RECOMMENDED SOLUTION:**

**RESOLUTION:** Normal corrective maintenance.

IMPROVEMENT RECOMMENDATION:

- MODIFICATION TO HARDWARE
- MODIFICATION TO SOFTWARE
- CHANGE IN TEST PROCEDURE
- CHANGE IN OPERATIONS

TTR# 13

CAT II/III ILS/RMS  
TEST TROUBLE REPORT FORM

TESTER: Ben Bennett LOCATION: ACY Runway 04 Localizer

TEST SCENARIO: Normal Operation DATE: 02/03/95

TTR CLASSIFICATION: CRITICAL:        SIGNIFICANT:        MINOR: X

**DESCRIPTION OF PROBLEM OR FAILURE:** With transmitter #2 selected as main, the localizer would switch to transmitter #1 and remain on the air. The switch over would occur within 24 hours of start up. This anomaly only existed when transmitter #2 was selected as main.

The conditions of the fault were clearance RF level dropping to 44.8%, clearance width 1 dropping from 0.293 ddm to 0.000 ddm, clearance width 2 dropping from 0.226 ddm to 0.000 ddm, and the clearance SDM dropping from 40.7% to 0.0%.

When transmitter #2 was brought back on line, the monitors would be within alarm tolerances. This condition indicated an intermittent problem as well as prevented fault diagnostics from identifying the faulty LRU. Trouble shooting revealed that the clearance CSB RF relay on the transfer assembly was intermittent and was replaced with a new relay from the spares kit.

**RECOMMENDED SOLUTION:**

**RESOLUTION:** Normal corrective maintenance.

IMPROVEMENT RECOMMENDATION:

- MODIFICATION TO HARDWARE
- MODIFICATION TO SOFTWARE
- CHANGE IN TEST PROCEDURE
- CHANGE IN OPERATIONS

**APPENDIX C**  
**Stability Data**

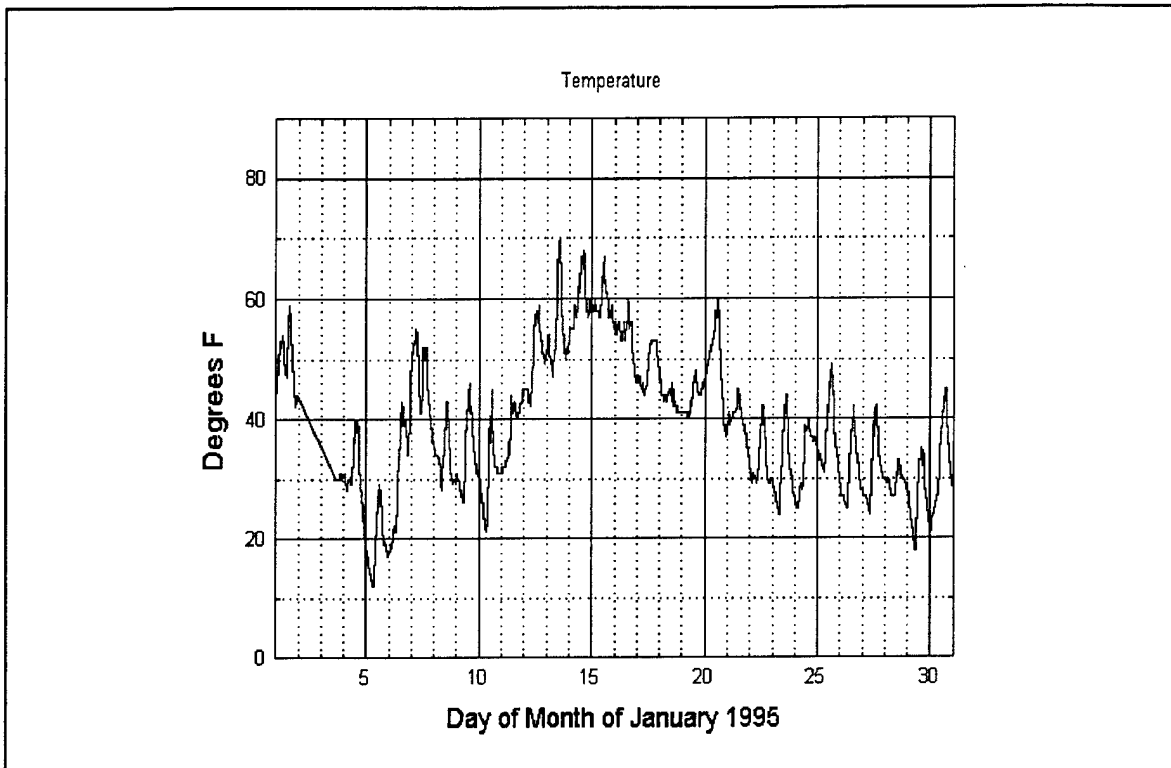

FIGURE C-1. MEASURED OUTSIDE TEMPERATURE FOR THE MONTH OF JANUARY 1995

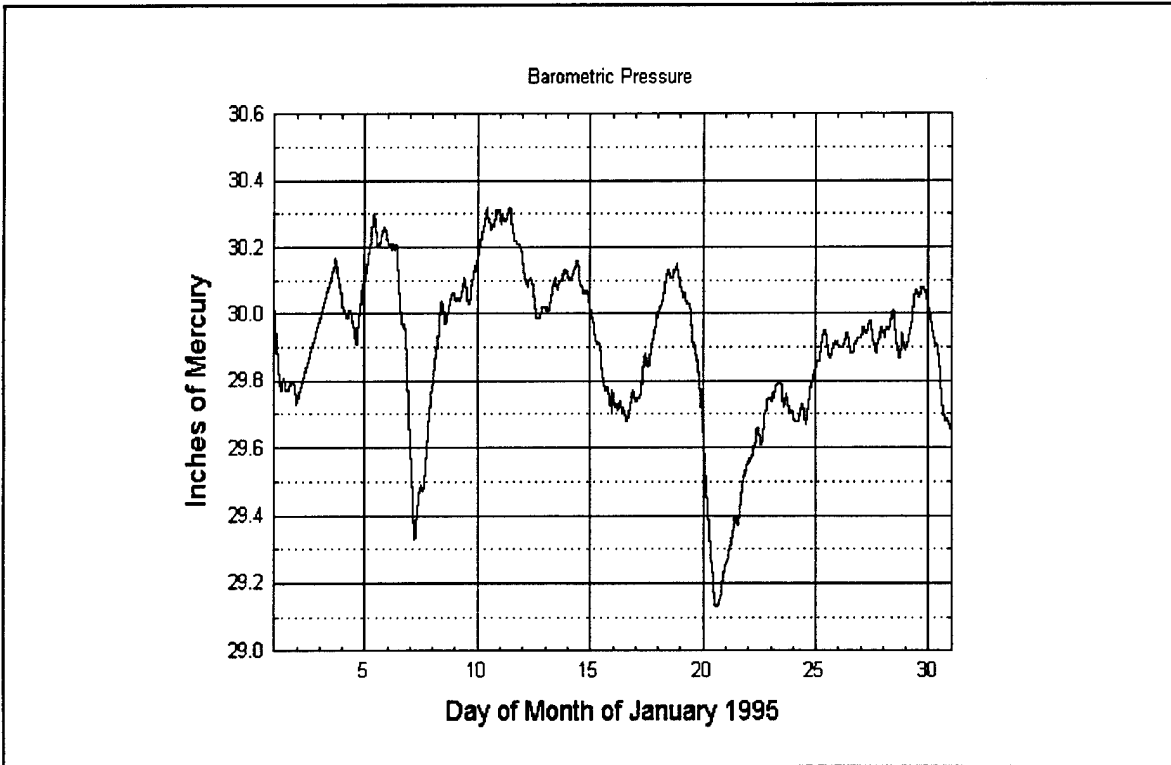

FIGURE C-2. MEASURED BAROMETRIC PRESSURE FOR THE MONTH OF JANUARY 1995



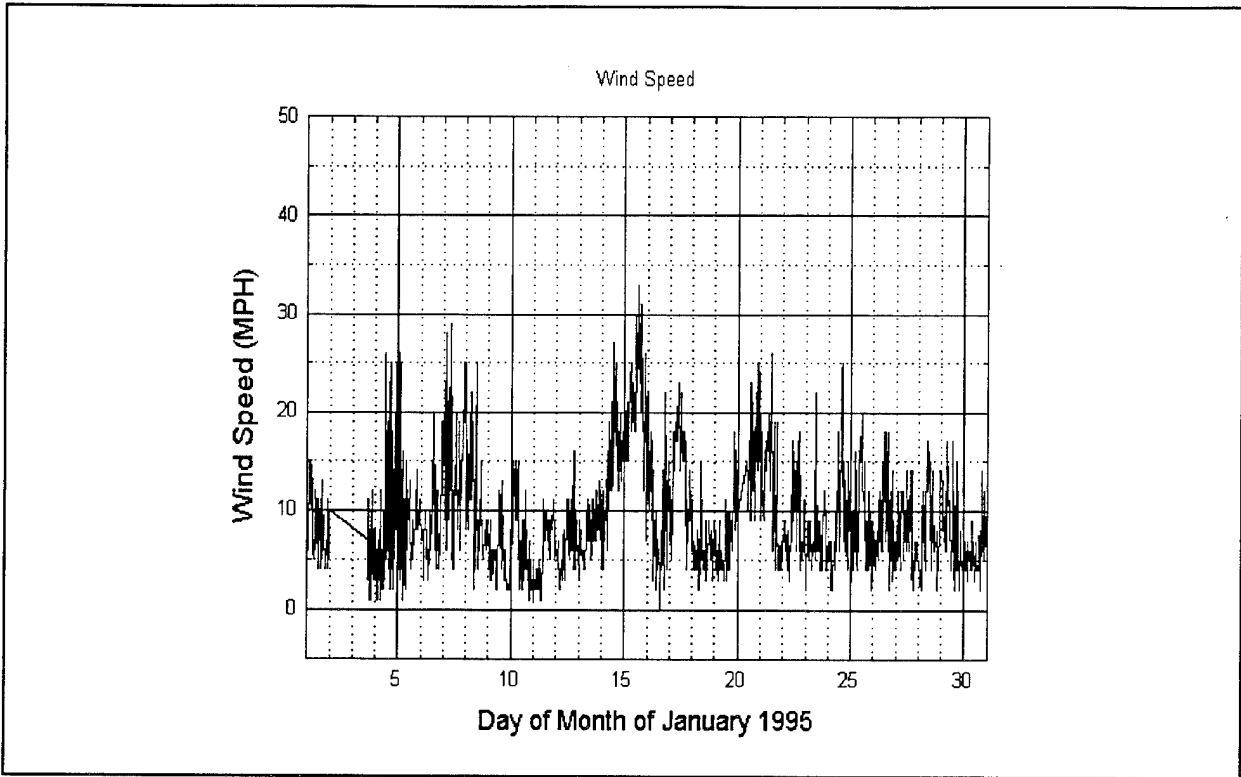

FIGURE C-3. MEASURED WIND SPEED FOR THE MONTH OF JANUARY 1995

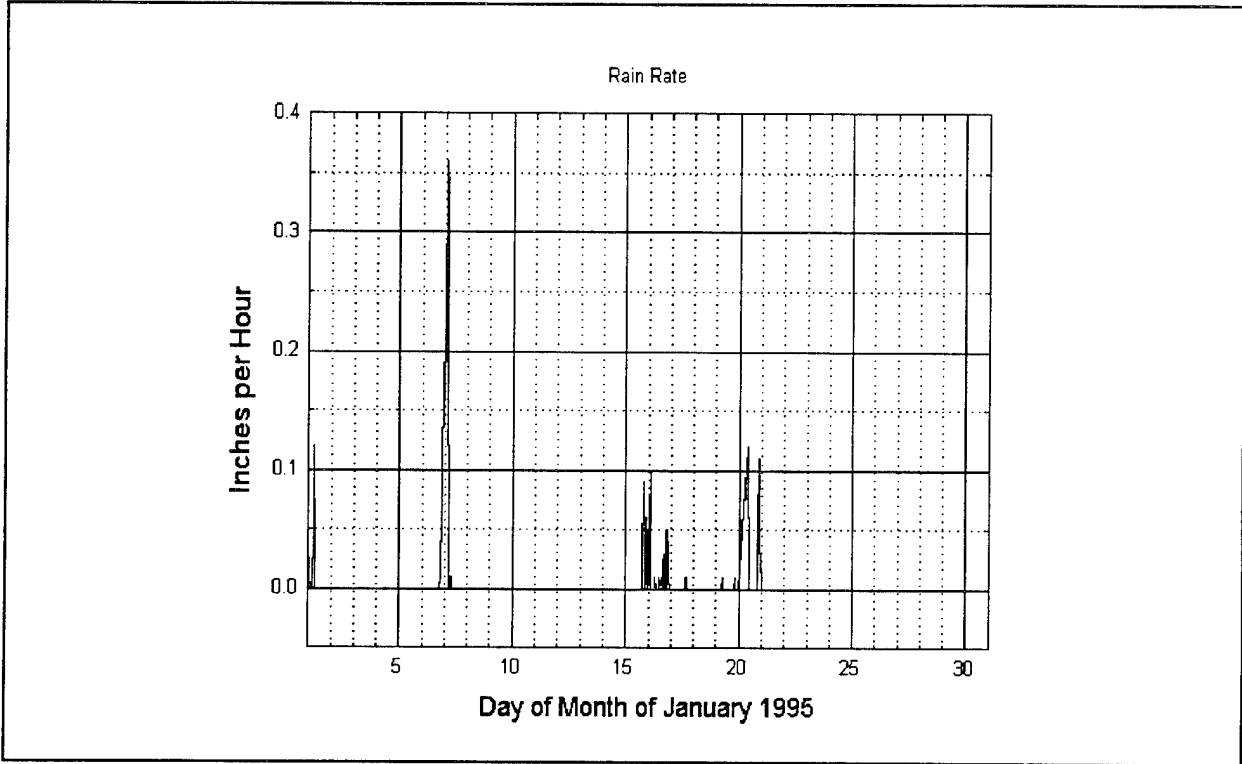

FIGURE C-4. MEASURED RAIN RATE FOR THE MONTH OF JANUARY 1995

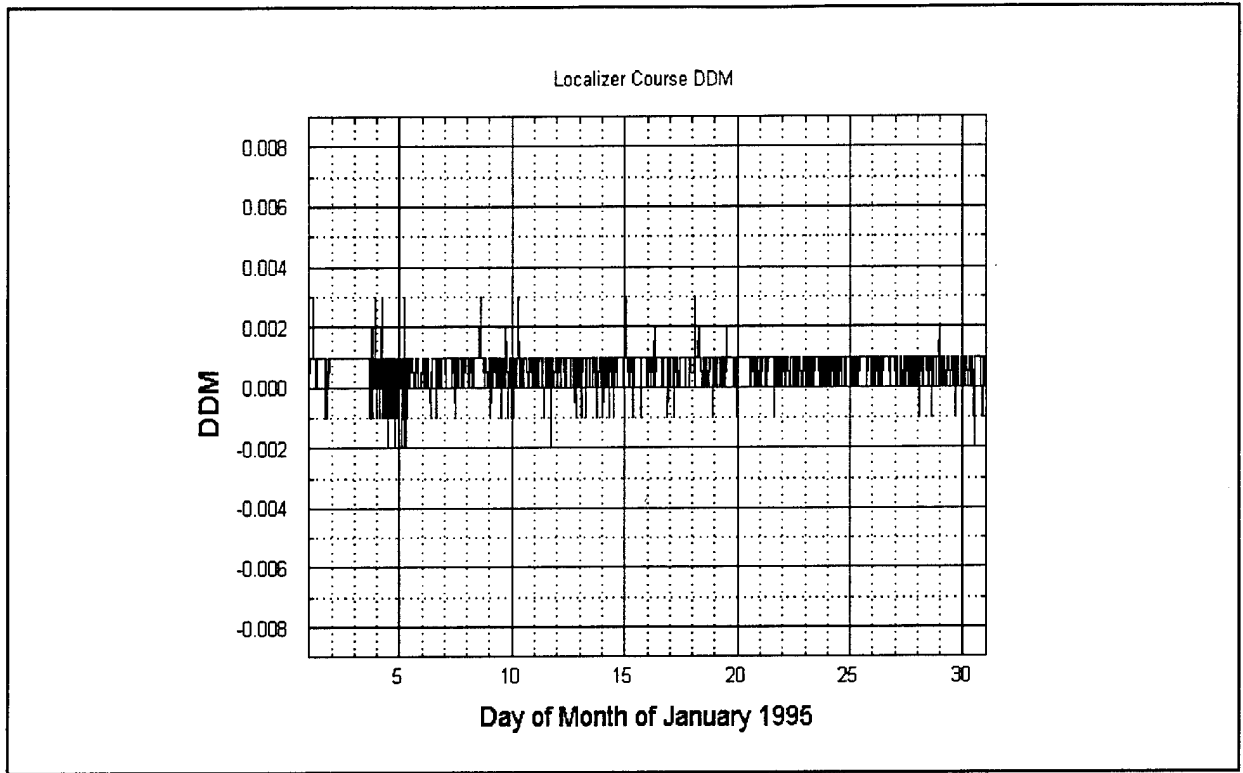

FIGURE C-5. MONITORED

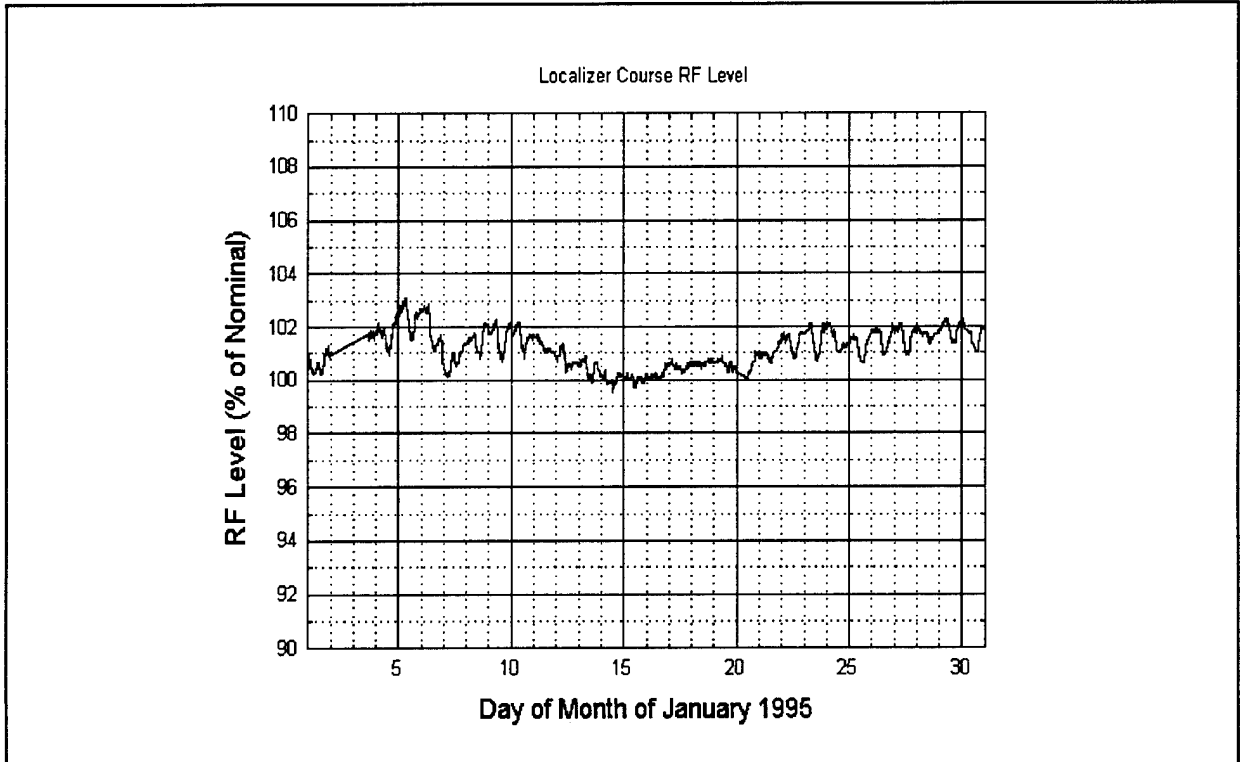

FIGURE C-6. MONITORED LOCALIZER COURSE RF LEVEL FOR THE MONTH OF JANUARY 1995

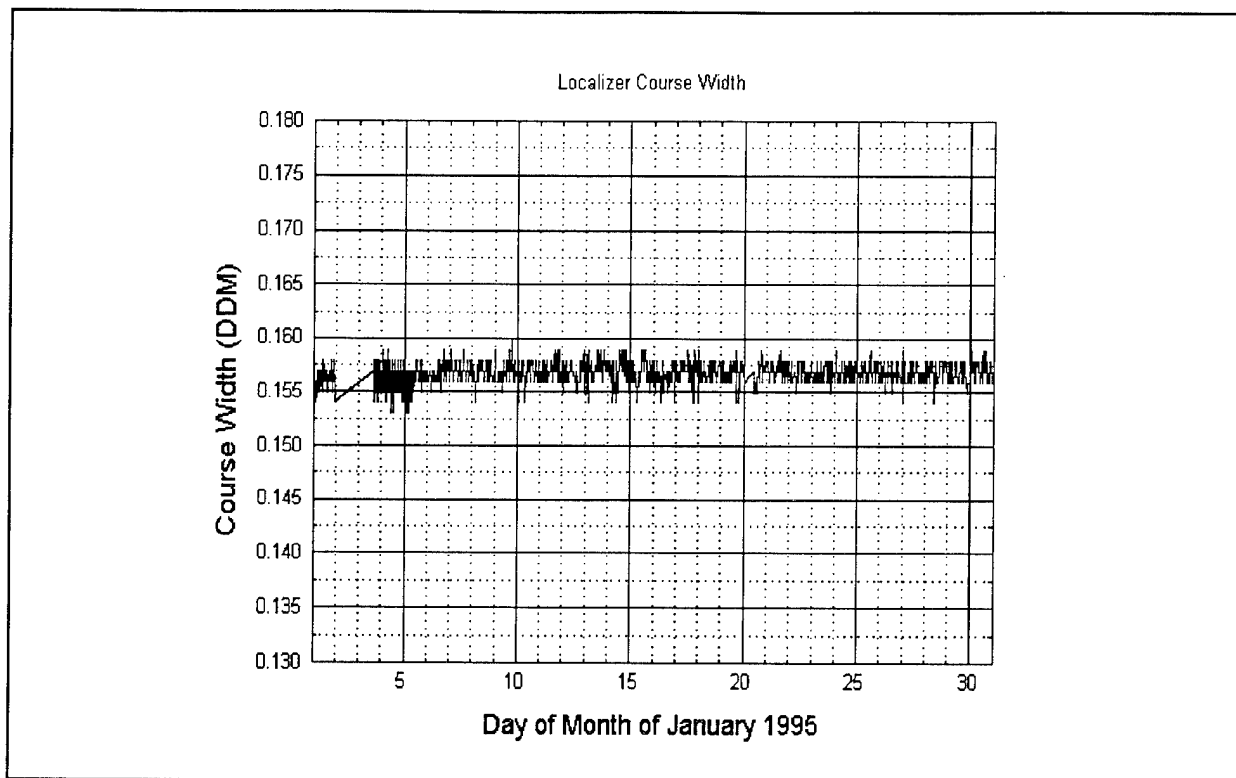

FIGURE C-7. MONITORED COURSE WIDTH FOR THE MONTH OF JANUARY 1995

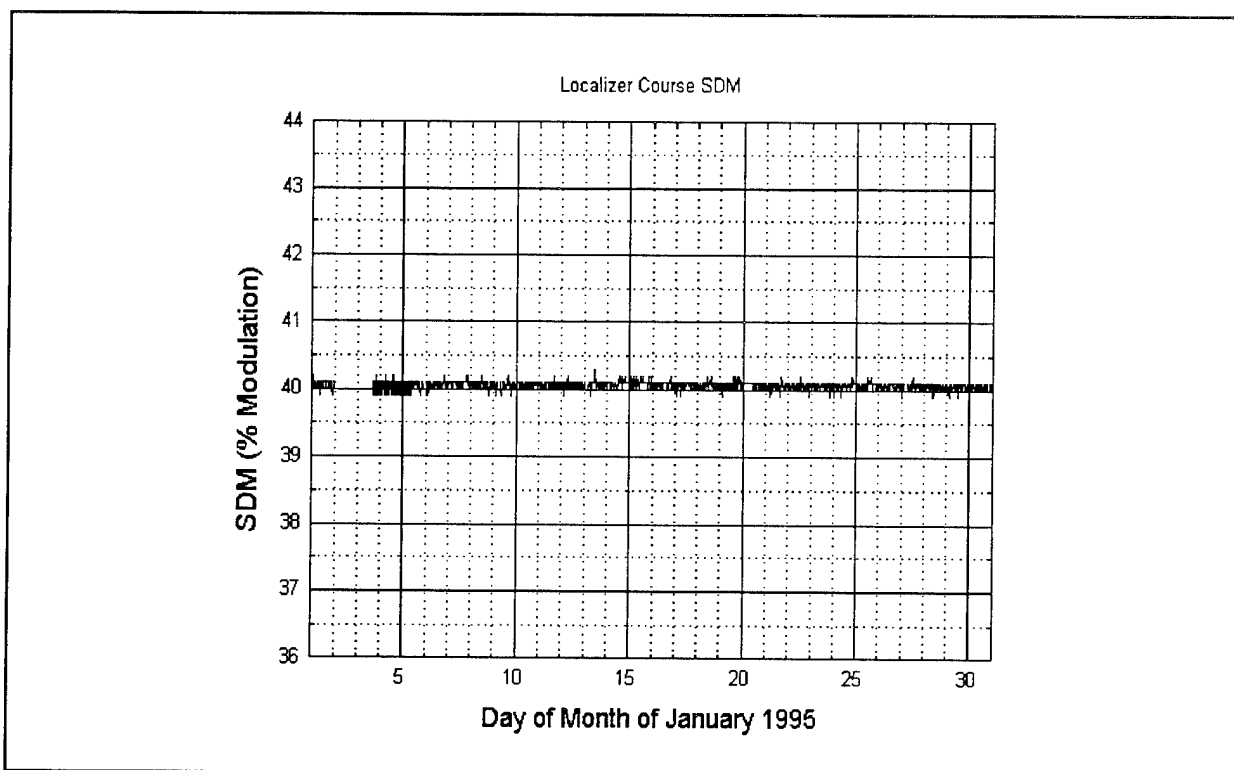

FIGURE C-8. MONITORED LOCALIZER COURSE SDM FOR THE MONTH OF JANUARY 1995

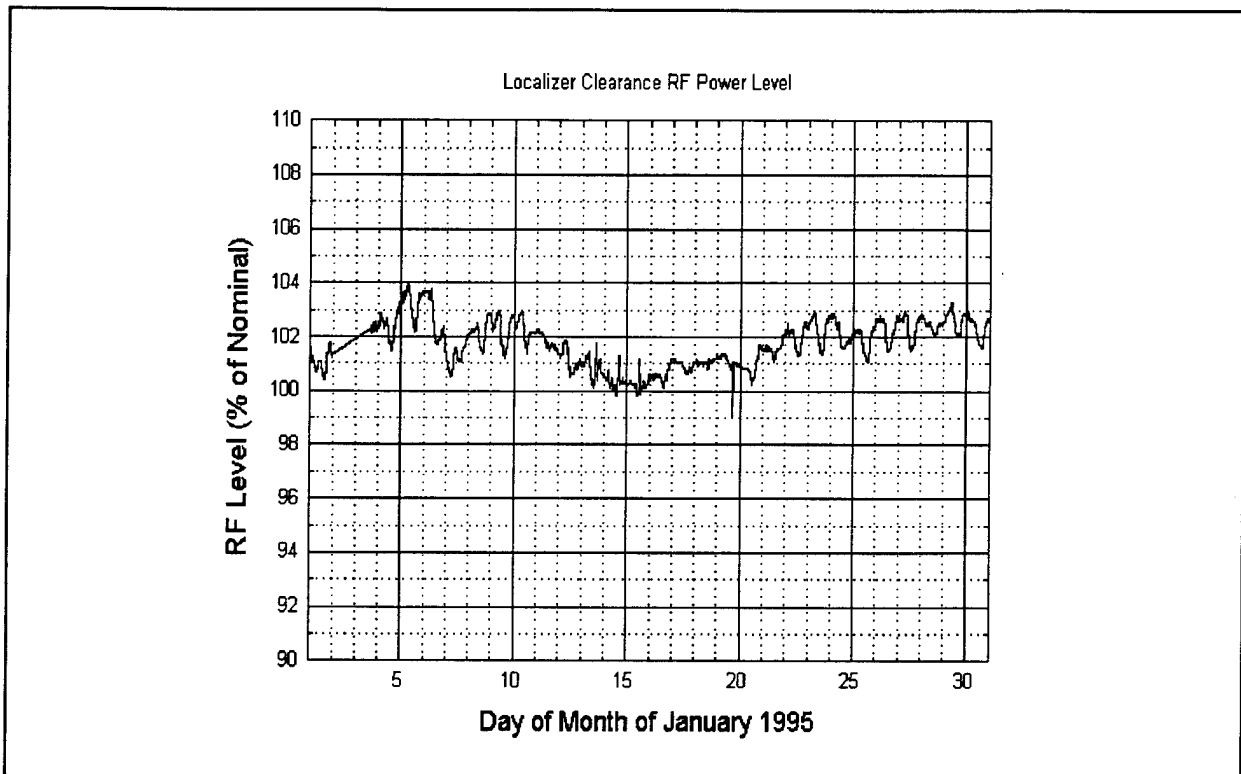

FIGURE C-9. MONITORED LOCALIZER CLEARANCE RF LEVEL FOR THE MONTH OF JANUARY 1995

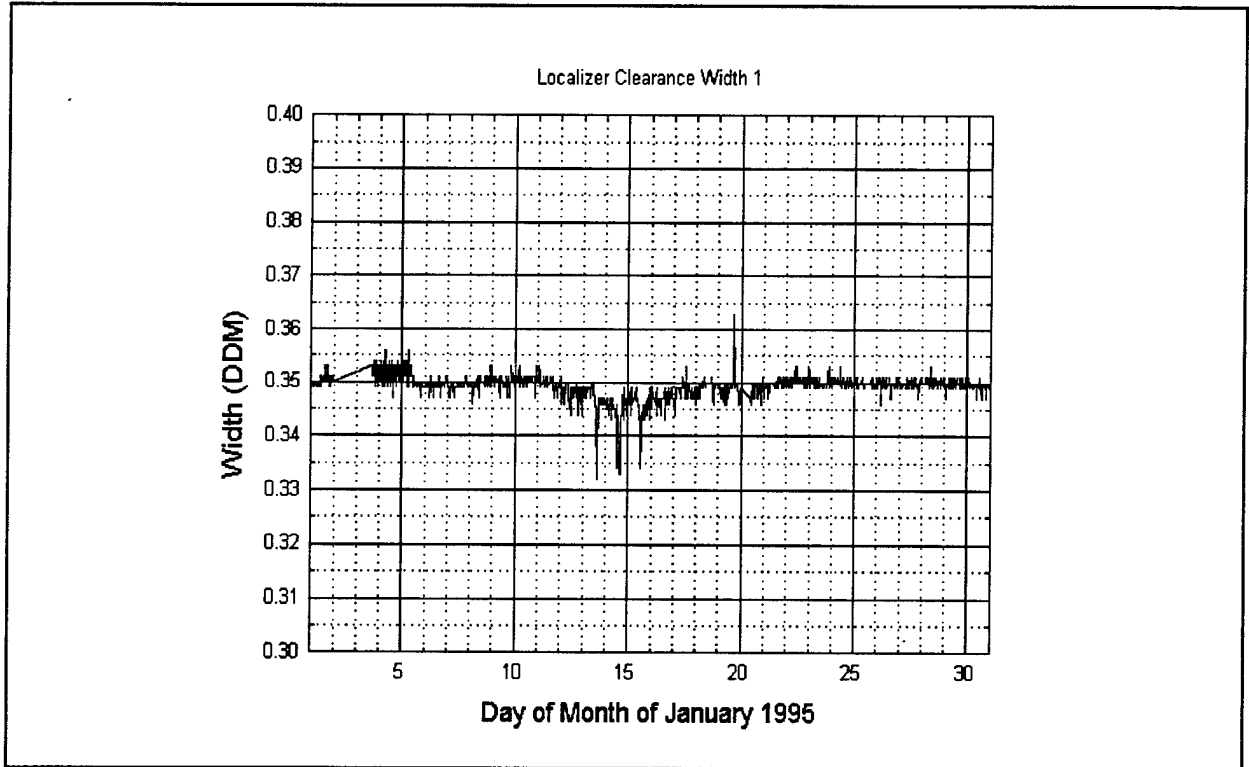

FIGURE C-10. MONITORED LOCALIZER CLEARANCE WIDTH 1 FOR THE MONTH OF JANUARY 1995

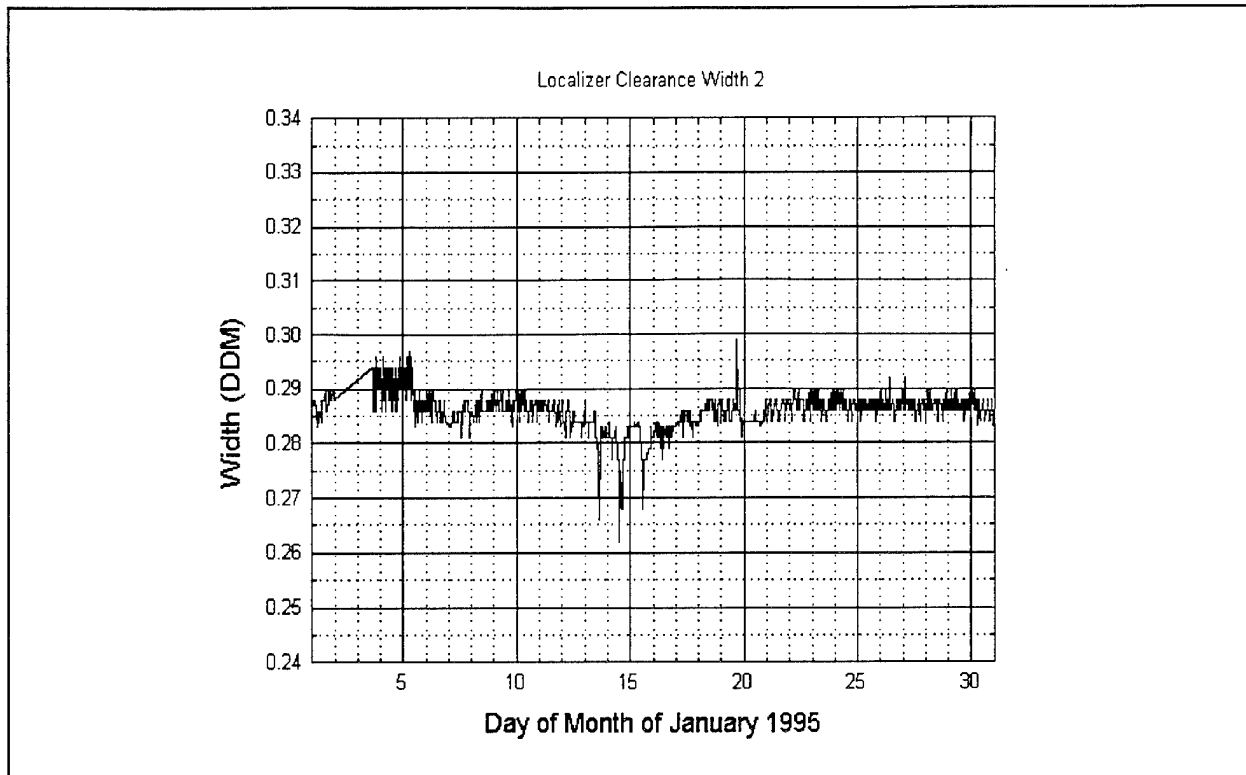

FIGURE C-11. MONITORED LOCALIZER CLEARANCE WIDTH 2 FOR THE MONTH OF JANUARY 1995

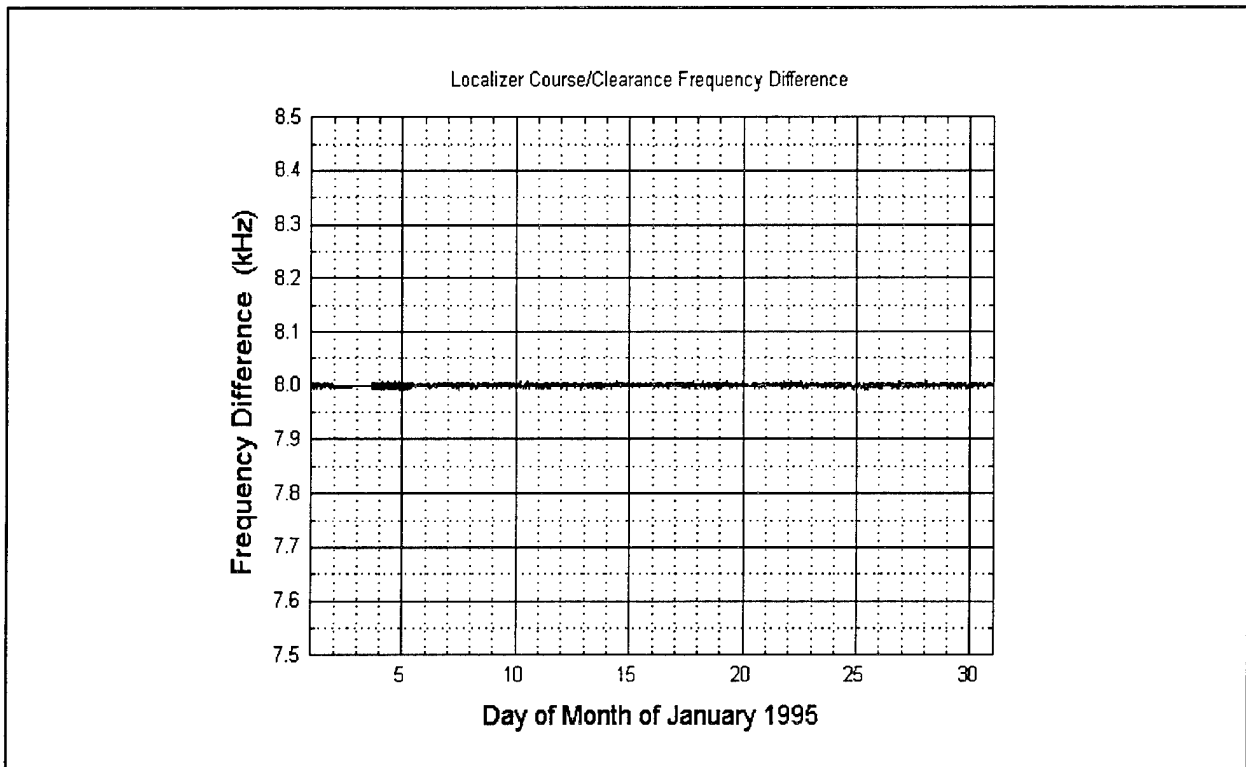

FIGURE C-12. MONITORED LOCALIZER COURSE/CLEARANCE FREQUENCY DIFFERENCE FOR THE MONTH OF JANUARY 1995

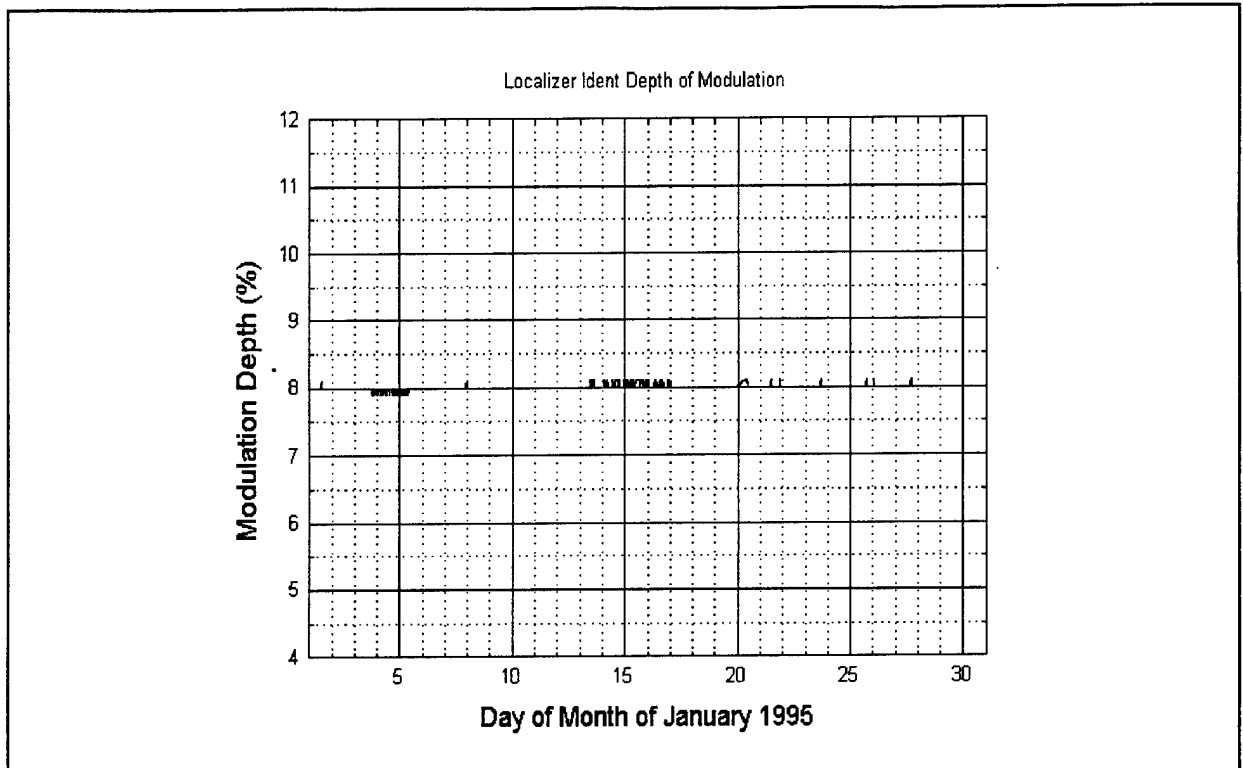

FIGURE C-13. MONITORED LOCALIZER IDENTIFICATION DEPTH OF MODULATION FOR THE MONTH OF JANUARY 1995

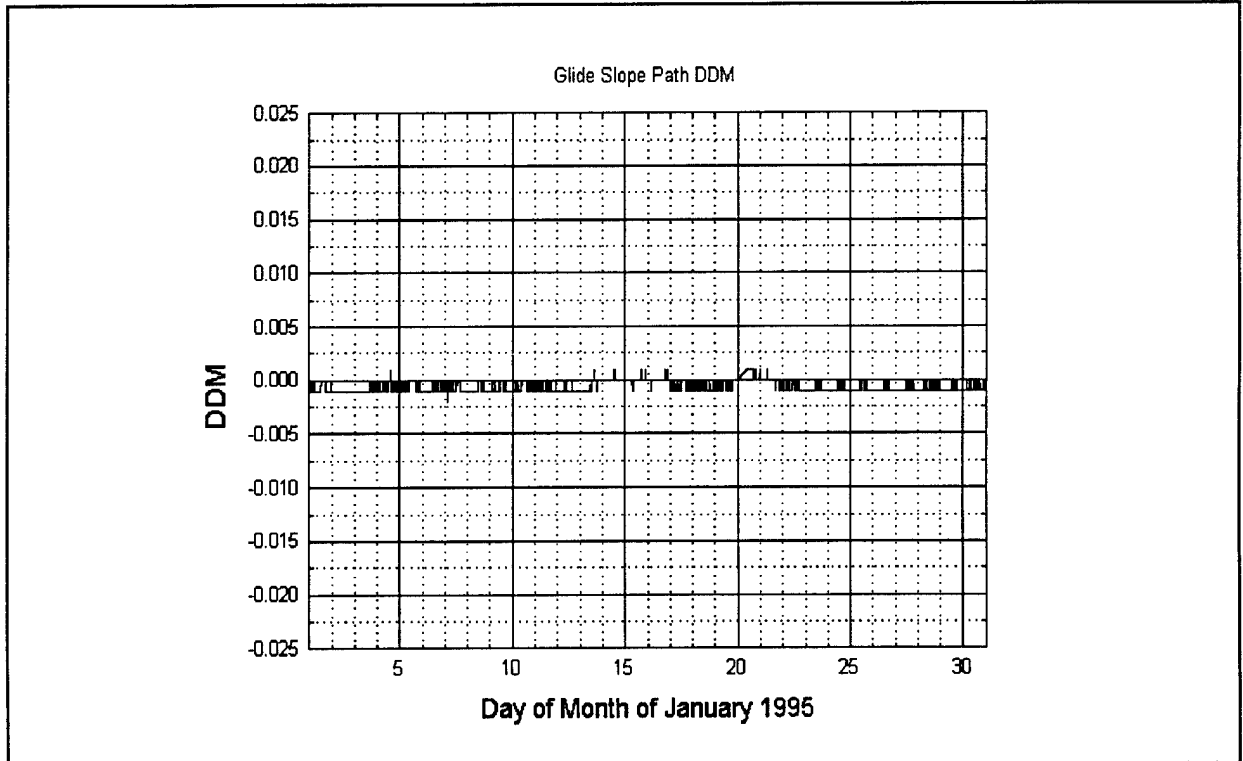

FIGURE C-14. MONITORED GLIDE SLOPE PATH DDM FOR THE MONTH OF JANUARY 1995

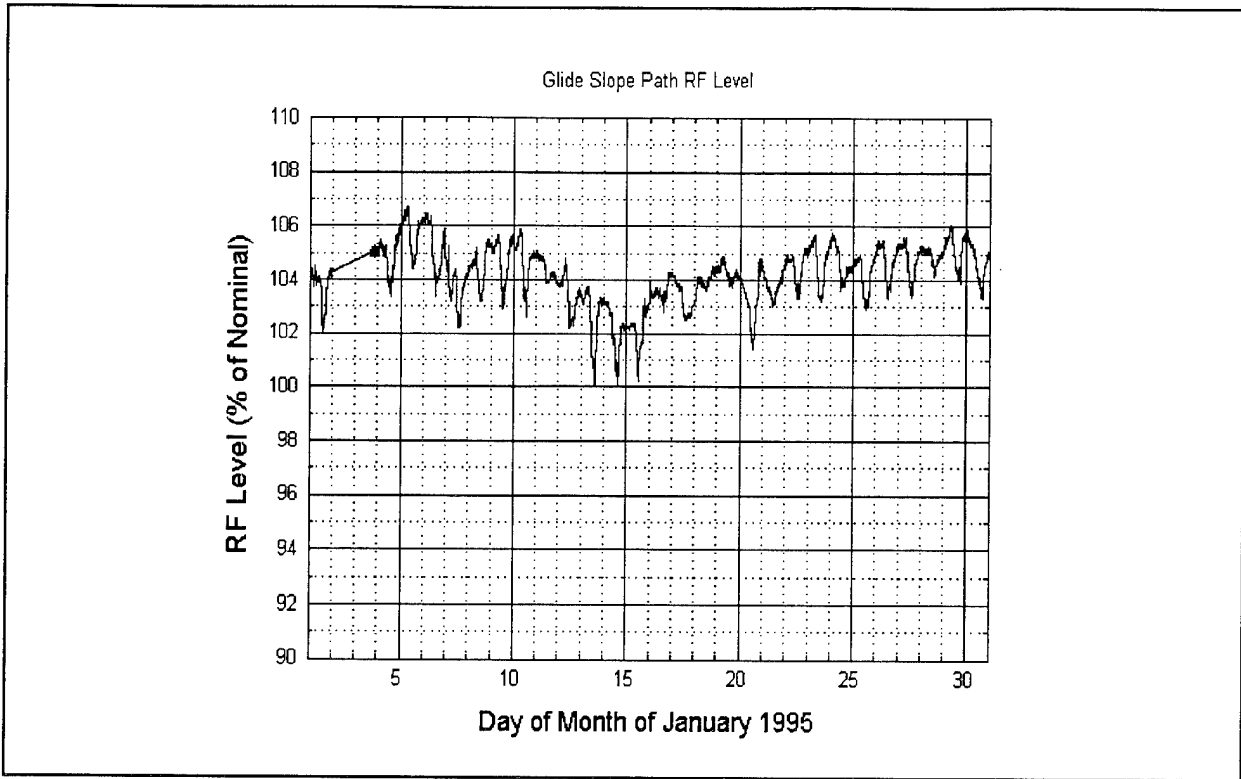

FIGURE C-15. MONITORED GLIDE SLOPE PATH RF LEVEL FOR THE MONTH OF JANUARY 1995

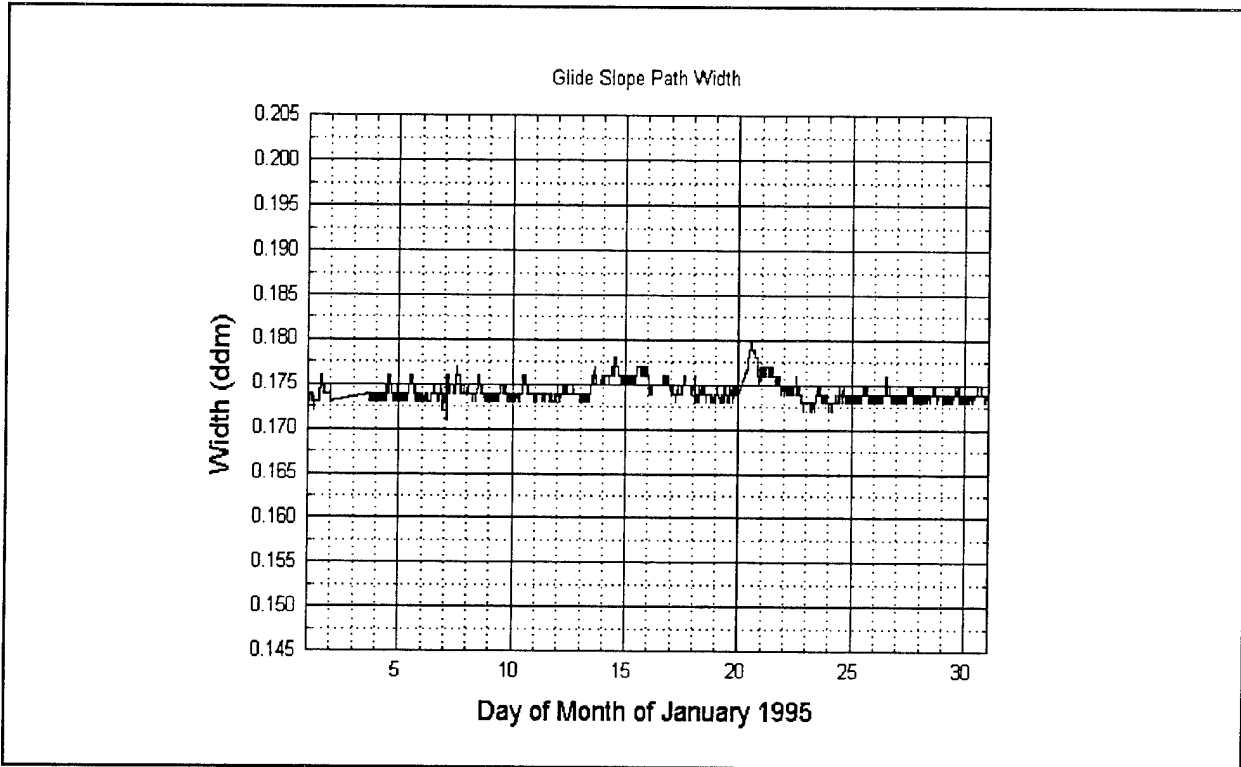

FIGURE C-16. MONITORED GLIDE SLOPE PATH WIDTH FOR THE MONTH OF JANUARY 1995

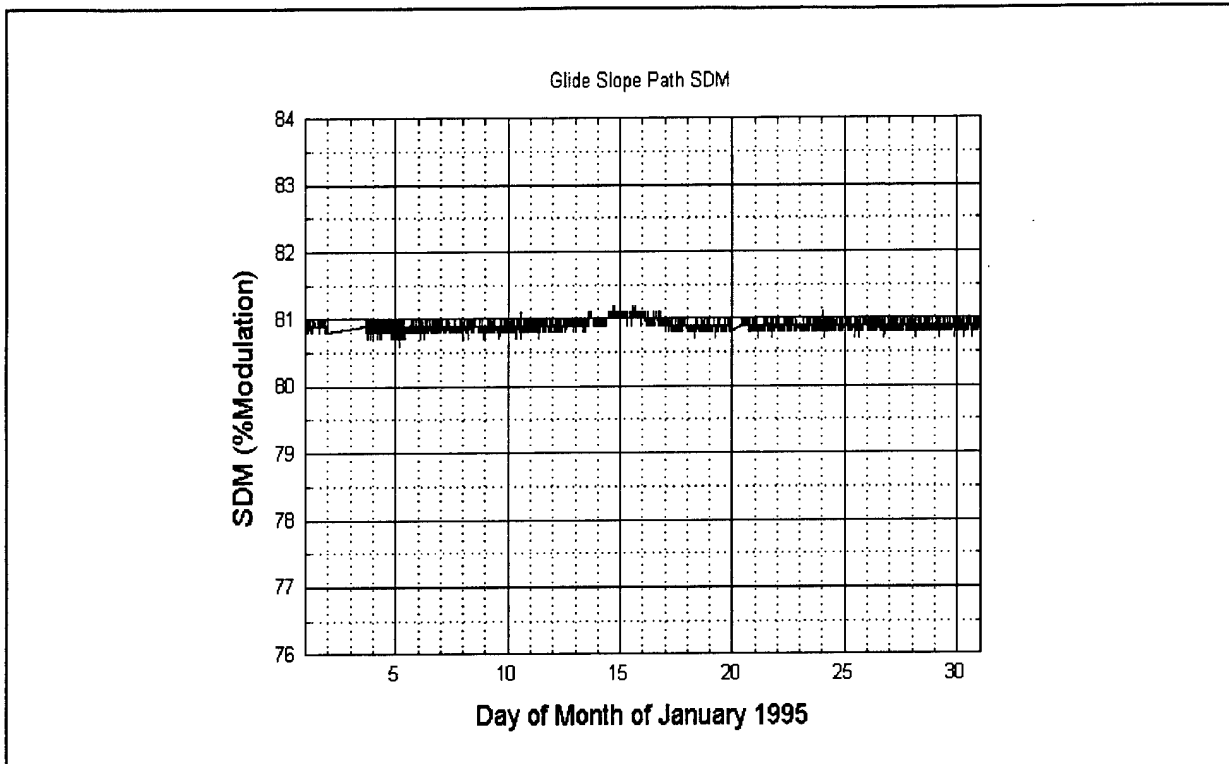

FIGURE C-17. MONITORED GLIDE SLOPE PATH SDM FOR THE MONTH OF JANUARY 1995

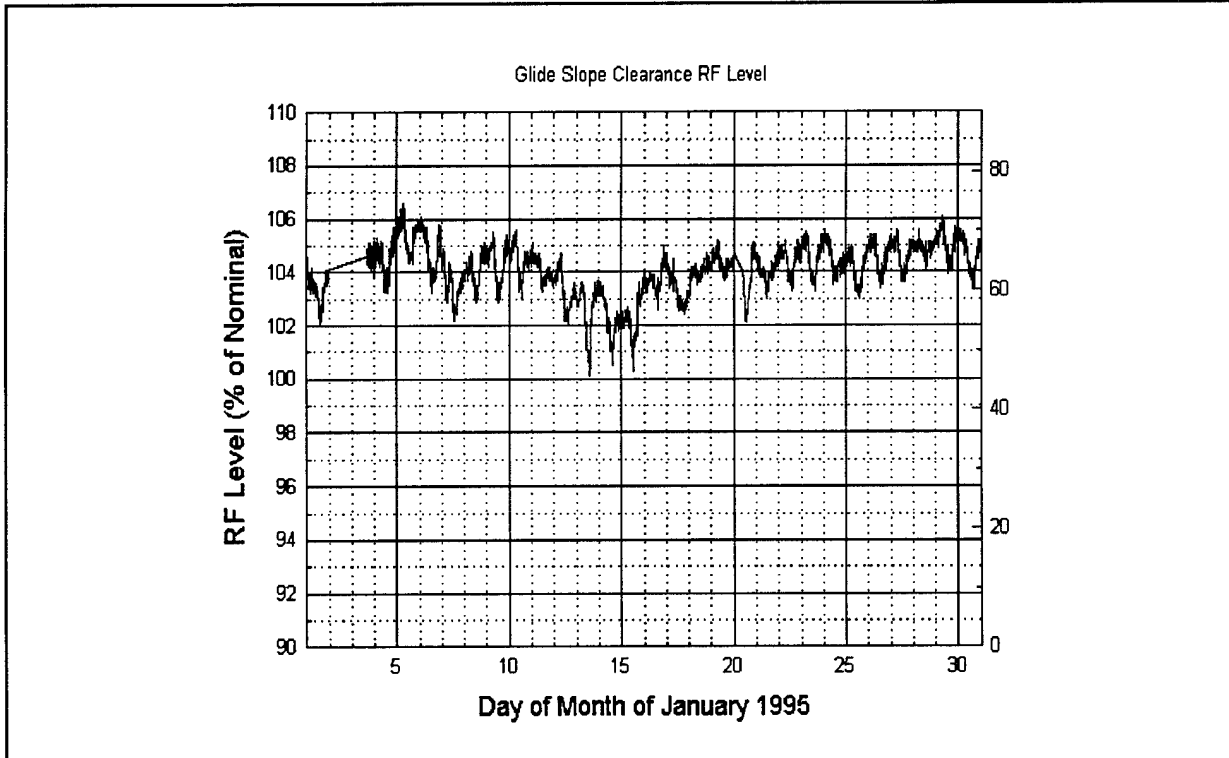

FIGURE C-18. MONITORED GLIDE SLOPE CLEARANCE RF LEVEL FOR THE MONTH OF JANUARY 1995



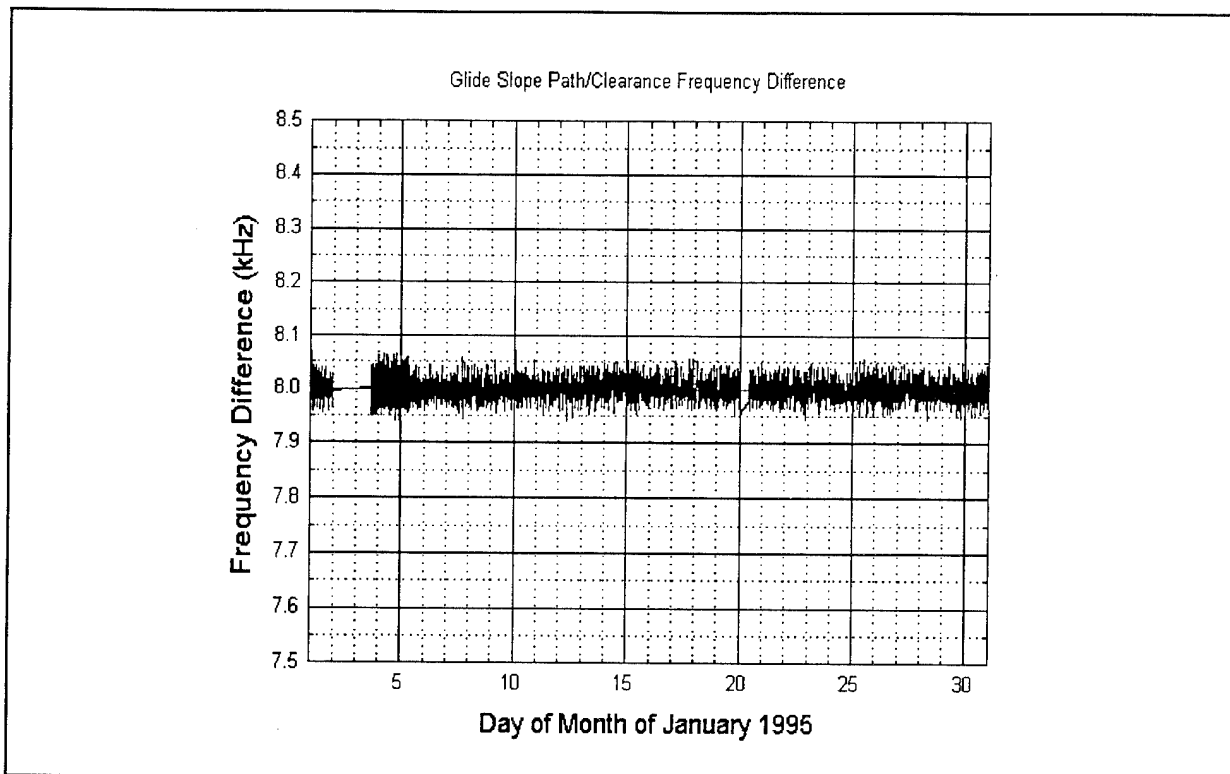

FIGURE C-19. MONITORED GLIDE SLOPE PATH/CLEARANCE FREQUENCY DIFFERENCE FOR THE MONTH OF JANUARY 1995

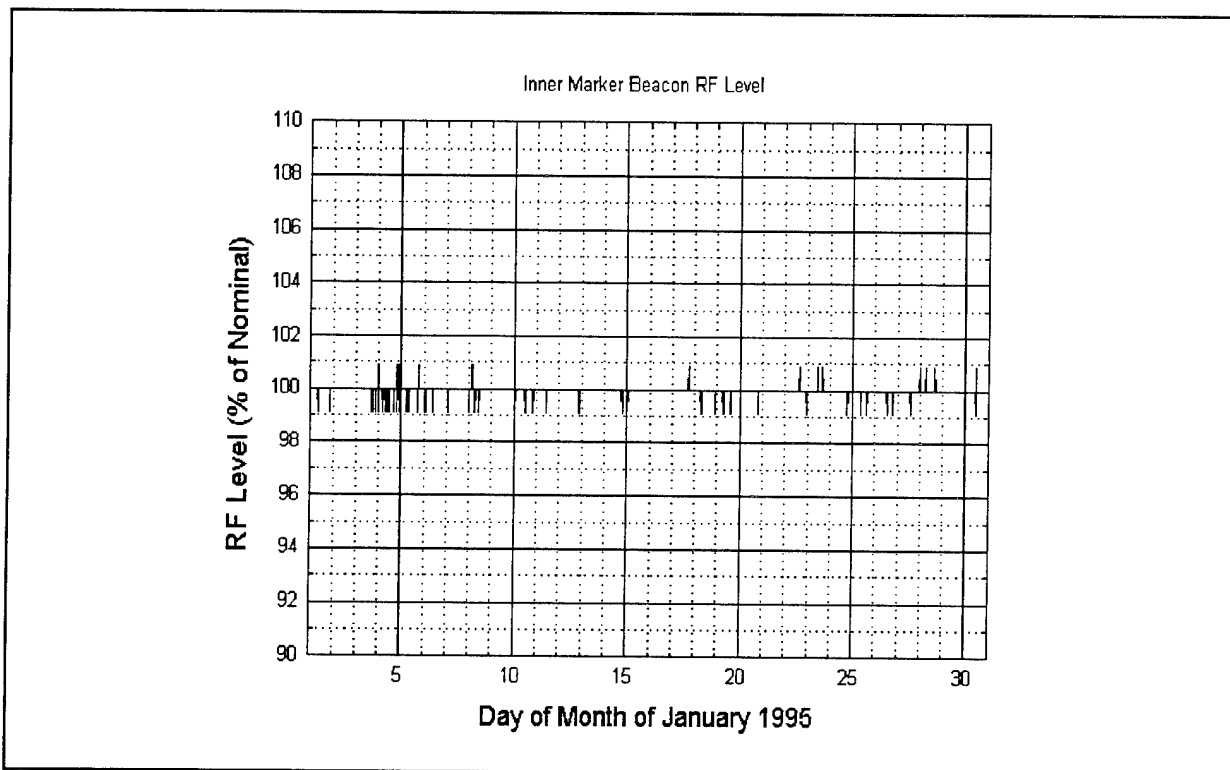

FIGURE C-20. MONITORED INNER MARKER BEACON RF LEVEL FOR THE MONTH OF JANUARY 1995

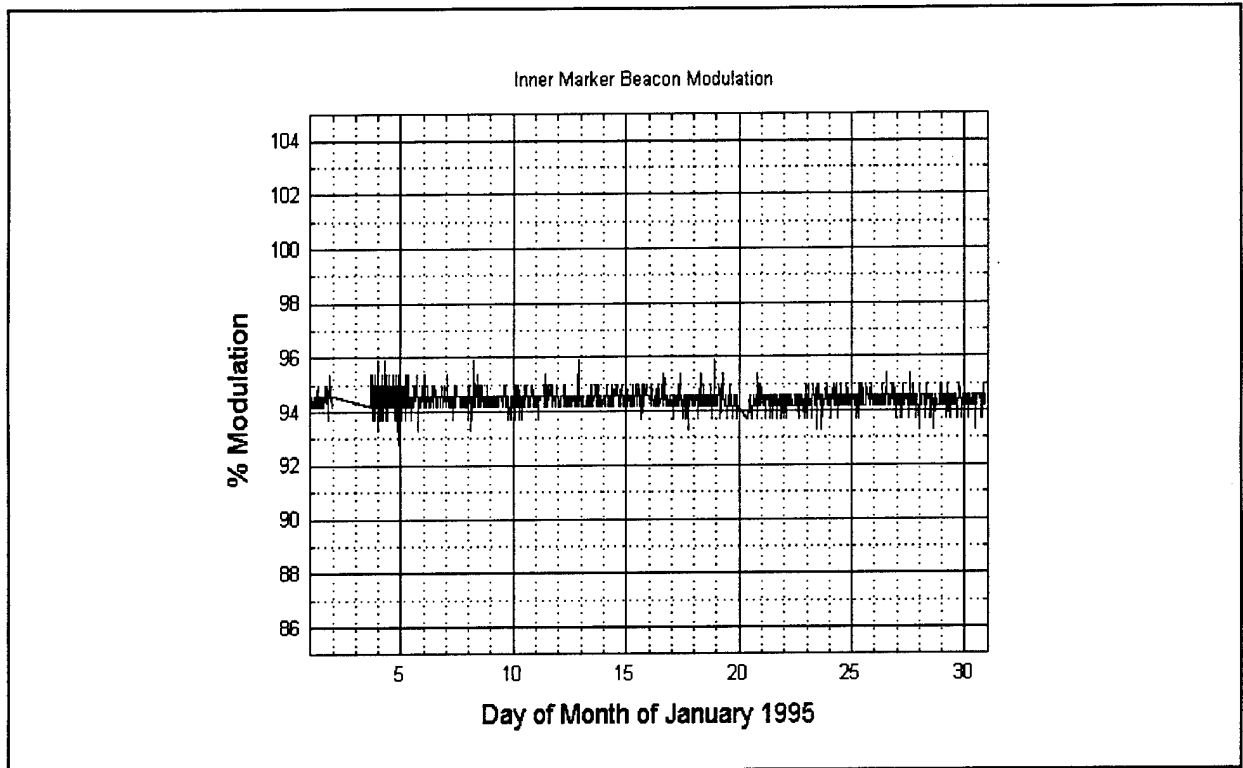

FIGURE C-21. MONITORED INNER MARKER BEACON DEPTH OF MODULATION FOR THE MONTH OF JANUARY 1995

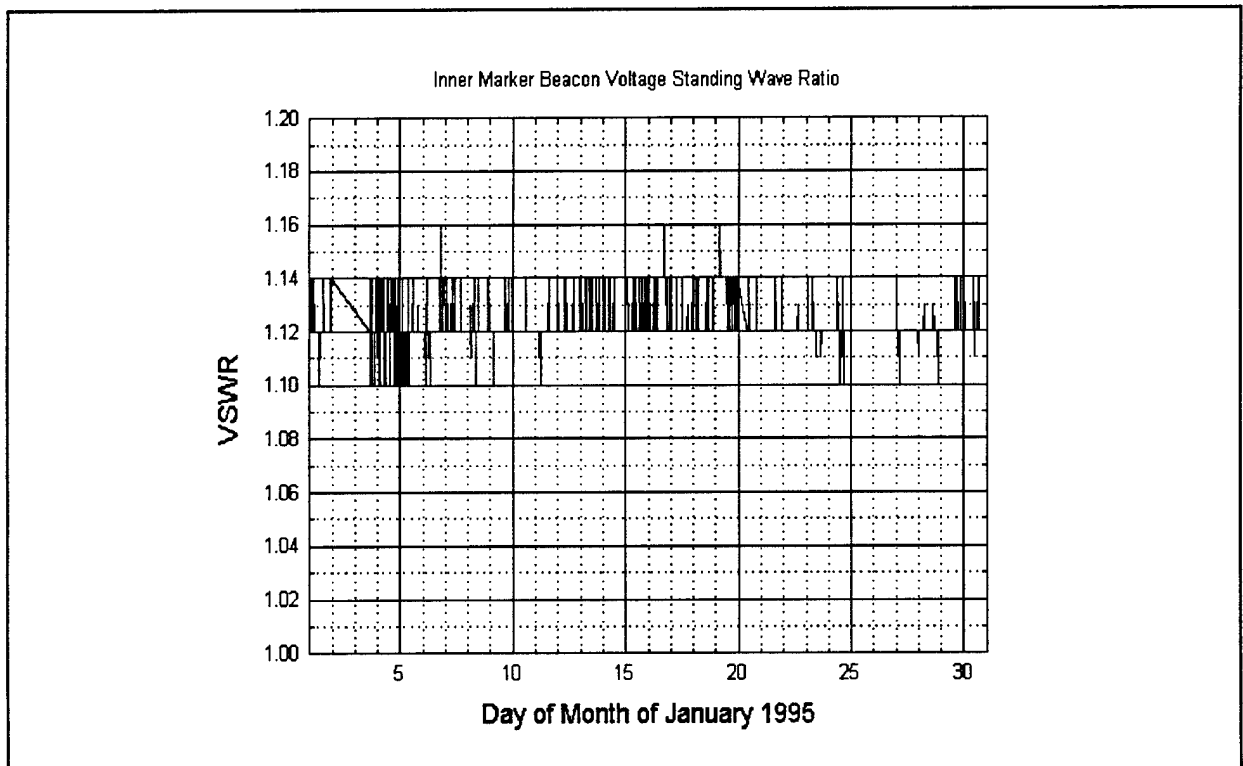

FIGURE C-22. MONITORED INNER MARKER BEACON VOLTAGE STANDING WAVE RATIO FOR THE MONTH OF JANUARY 1995

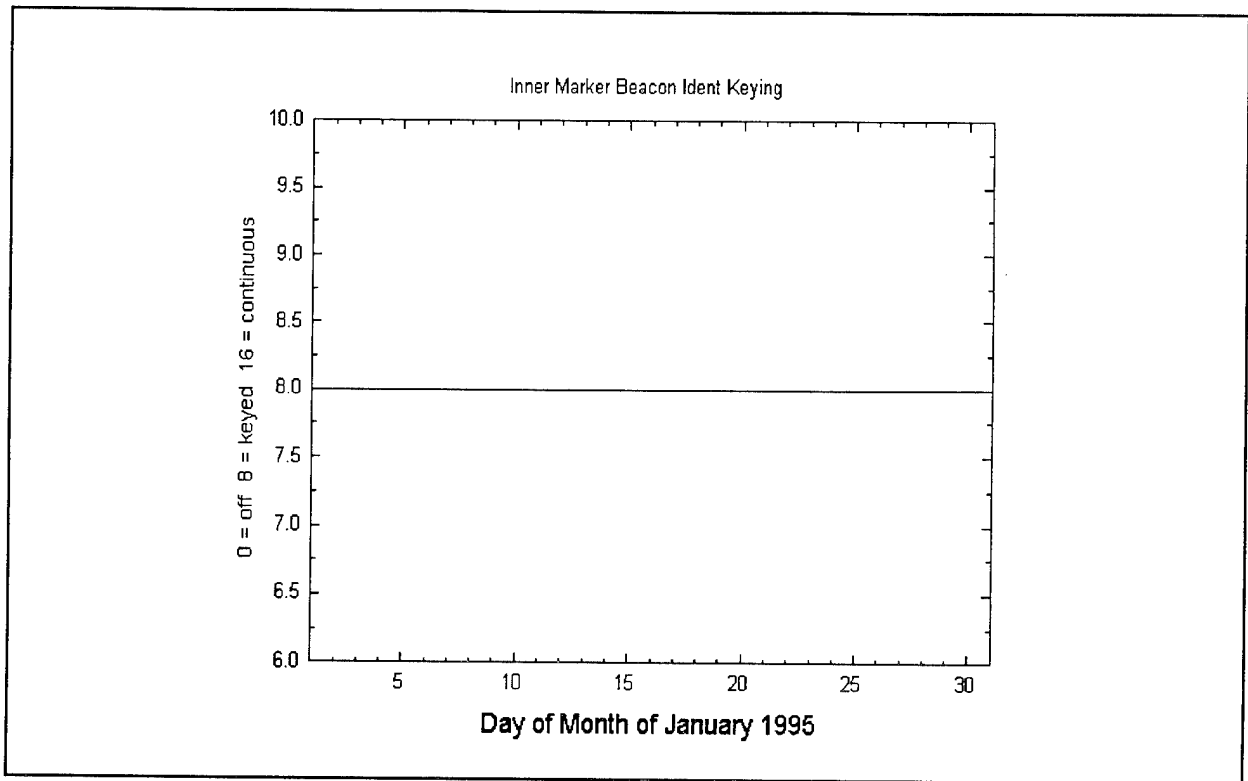

FIGURE C-23. MONITORED INNER MARKER BEACON IDENT KEYING STATUS FOR THE MONTH OF JANUARY 1995