

0291-25-001

STANDARD ARMY REFUELING SYSTEM ADAPTED TO THE BRADLEY FIGHTING VEHICLE

Scientific and Technical Report

Constantin Dumitrescu

Vitro Corporation

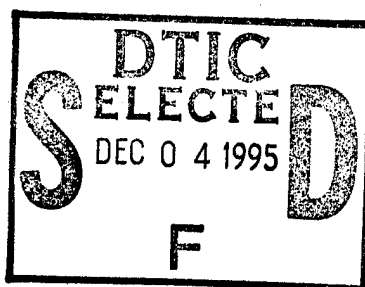

1995

19951130 067

Department of the Army
Mobility Technology Center - Belvoir
U.S. Army Tank - Automotive Command
Fort Belvoir, Virginia

DTIC QUALITY INSPECTED 5

Distribution Statement A. Approved for public release; distribution is unlimited.

REPORT DOCUMENTATION PAGE

Form Approved
OMB No. 0704-0188

Public reporting burden for this collection of information is estimated to average 1 hour per response, including the time for reviewing instructions, searching existing data sources, gathering and maintaining the data needed, and completing and reviewing the collection of information. Send comments regarding this burden estimate or any other aspect of this collection of information, including suggestions for reducing this burden, to Washington Headquarters Services, Directorate for Information Operations and Reports, 1215 Jefferson Davis Highway, Suite 1204, Arlington, VA 22202-4302, and to the Office of Management and Budget, Paperwork Reduction Project (0704-0188), Washington, DC 20503.

1. AGENCY USE ONLY (Leave blank)		2. REPORT DATE September, 1995	3. REPORT TYPE AND DATES COVERED Final	
4. TITLE AND SUBTITLE STANDARD ARMY REFUELING SYSTEM ADAPTED TO THE BRADLEY FIGHTING VEHICLE			5. FUNDING NUMBERS C: DAAK70-92-D-0002 TA: 0025	
6. AUTHOR(S) Constantin Dumitrescu				
7. PERFORMING ORGANIZATION NAME(S) AND ADDRESS(ES) Vitro Corporation Lorton, VA 22079			8. PERFORMING ORGANIZATION REPORT NUMBER 0291-25-001	
9. SPONSORING / MONITORING AGENCY NAME(S) AND ADDRESS(ES) Department of the Army Mobility Technology Center - Belvoir U.S. Army Tank - Automotive Command Fort Belvoir, VA 22060-5843			10. SPONSORING / MONITORING AGENCY REPORT NUMBER None	
11. SUPPLEMENTARY NOTES None				
12a. DISTRIBUTION / AVAILABILITY STATEMENT Distribution Statement A. Approved for public release; distribution is unlimited.			12b. DISTRIBUTION CODE N/A	
13. ABSTRACT (Maximum 200 words) Under the BRDEC Prototype Engineering Contract, DAAK 70-92-D-0002, Vitro was tasked to design and construct a Standard Army Refueling System (SARS) receiving system for a Bradley Fighting Vehicle (BFV), a retrofit kit for the BFV, and a mock-up refueling system to demonstrate the performance of the receiving system and retrofit kit. The period of performance was May 1994 to October 1995. The task was managed by the Fuel and Water Supply Division, Mobility Technology Center-Belvoir, Fort Belvoir, Virginia. Vitro analyzed the refueling characteristics of the SARS and BFV and designed a retrofit kit for the BFV that uses the existing filler point, allows gravity refueling if necessary, and requires minimum alterations. A mock-up refueling system consisting of supply, transfer, and receiving sections, including the retrofit kit, was constructed and tested.				
14. SUBJECT TERMS Standard Army Refueling System (SARS) Bradley Fighting Vehicle (BFV)			15. NUMBER OF PAGES 49	
			16. PRICE CODE N/A	
17. SECURITY CLASSIFICATION OF REPORT Unclassified	18. SECURITY CLASSIFICATION OF THIS PAGE Unclassified	19. SECURITY CLASSIFICATION OF ABSTRACT Unclassified	20. LIMITATION OF ABSTRACT SAR	

0291-25-001

STANDARD ARMY REFUELING SYSTEM ADAPTED TO THE BRADLEY FIGHTING VEHICLE

Scientific and Technical Report

Prepared by:
Constantin Dumitrescu

Vitro Corporation
Lorton, VA 22079

September, 1995

Contract DAAK70-92-D-0002
Vitro Corporation
Rockville, MD 20850-1160

Prepared for:

Department of the Army
Mobility Technology Center - Belvoir
U.S. Army Tank - Automotive Command
Fort Belvoir, VA 22060-5843

Accession For	
NTIS CRA&I	<input checked="" type="checkbox"/>
DTIC TAB	<input type="checkbox"/>
Unannounced	<input type="checkbox"/>
Justification	
By	
Distribution /	
Availability Codes	
Dist	Avail and/or Special
A-1	

Table of Contents

<u>Section</u>	<u>Title</u>	<u>Page</u>
Summary	iii
1.0	Introduction	1
1.1	Purpose	1
1.2	Task Order	1
1.3	Statement of Work	1
2.0	Background	2
2.1	Refueling Systems	2
2.2	Standard Army Refueling System	2
2.3	Bradley Fighting Vehicle	3
3.0	Analysis and Design of the Retrofit Kit	3
3.1	Physical Characteristics	3
3.2	Operating Environment	3
3.3	Refueling, Defueling Capacity	4
3.4	System Operating Parameters	4
3.5	General Considerations	4
4.0	Fabrication of the Retrofit Kit	4
4.1	SARS	4
4.2	SARS Receptacle/Adapter to BFV	5
4.3	Filler Neck and Strainer	6
4.4	Connecting Hose and Flanges of the Upper and Lower Fuel Tank	7
4.5	Pilot Valve, Bracket Support, and Sensing Line	8
4.6	Shut-off Valve, Bracket Support, and Fuel Line	8
4.7	Corrosion Prevention	9
5.0	Design and Fabrication of the Mock-up System	10
5.1	Mock-up Components	10
5.2	Supply System	10

5.3	Fuel Transfer System	12
5.4	Mock-up BFV Fuel Receiver System	13
6.0	Testing the Retrofit Kit	13
7.0	Conclusions	14
8.0	Recommendations	15

Appendix A - Figures

A-1	Schematic - Standard Army Refueling System Adapted to the Bradley Fighting Vehicle
A-2	BFV Fuel Tank Mock-up
A-3	SARS Nozzle
A-4	SARS Receiver/Adapter
A-5	Filler Point, SARS Nozzle with Control Valve and Receiver/Adapter
A-6	SARS Receiver/Adapter and Filler Point
A-7	Receiver/Adapter Placed in Filler Point
A-8	SARS Nozzle Receiver Bolted on the Elbow Adapter, and Strainer Removed
A-9	Pressure Gauge and Lower Tank
A-10	3" Connector and Vapor Hoses
A-11	Filler Neck
A-12	Filler Point with Strainer
A-13	Strainer and Fuel Line Hose
A-14	Pilot Valve, Bracket Support, and Sensing Line
A-15	Shut-off Valve Assembly
A-16	Shut-off Valve, Sensing and Fuel Lines, and Bracket Bolted to the Cover
A-17	Mock-up Supply System
A-18	Mock-up Supply Section
A-19	Control Box
A-20	Yanmar Diesel Engine Drive Pump Installed on Supply Section
A-21	3-way Ball Valve on Suction and Discharge Sections

Appendix B - Reference Documents

Appendix C - Operating Procedures

Summary

Under the BRDEC Prototype Engineering Contract, DAAK 70-92-D-0002, Vitro was tasked to design and construct a Standard Army Refueling System (SARS) receiving system for a Bradley Fighting Vehicle (BFV), a retrofit kit for the BFV, and a mock-up refueling system to demonstrate the performance of the receiving system and retrofit kit. The period of performance was May 1994 to October 1995. The task was managed by the Fuel and Water Supply Division, Mobility Technology Center-Belvoir, Fort Belvoir, Virginia.

Vitro analyzed the refueling characteristics of the SARS and BFV and designed a retrofit kit for the BFV that uses the existing filler point, allows gravity refueling if necessary, and requires minimum alterations. A mock-up refueling system consisting of supply, transfer, and receiving sections, including the retrofit kit, was constructed and tested.

The mock-up system was designed for indoor demonstrations and uses a 1.5 HP, 115V, 1 phase, small electric pump and water instead of diesel fuel. The mock-up pump size was selected for "classroom" purposes and does not provide adequate capacity to demonstrate retrofit capability. However, by testing the system with a 3 HP diesel engine driven centrifugal pump, the criteria to refuel a BFV in two minutes and defuel a BFV in under four minutes were met. This test validated the retrofit kit and confirmed that the kit would meet SARS requirements under field conditions.

1.0 Introduction

1.1 Purpose

The purpose of this report is to describe the engineering work and services for the design and construction of a Standard Army Refueling System (SARS) receiving system capable of being installed in a Bradley Fighting Vehicle (BFV).

1.2 Task Order

The source of the work is Task Order 0025, BRDEC Prototype Engineering Contract DAAK 70-92-D-0002. The task was managed by the Fuel and Water Supply Division, Mobility Technology Center - Belvoir, Fort Belvoir, Virginia.

1.3 Statement of Work

Key requirements from the Statement of Work (SOW) are as follows:

- Examine the configuration, components, performance ratings and constraints of the BFV fuel acceptance system. Compare performance characteristics and configuration with SARS requirements.
- Design a retrofit kit that will allow a SARS nozzle to provide a full load of fuel to the BFV in 2 minutes or less. The kit shall require minimum alterations to the BFV, use the existing fuel entrance for installation of a SARS receptacle and allow the SARS receptacle to be removable for refueling with a gravity nozzle.
- Construct a BFV fuel system mock-up and install a retrofit kit. Use actual BFV components apportioned the same as the BFV. Demonstrate that the kit allows filling the BFV in two minutes or less.
- The retrofit kit shall conform to Human Engineering Design Criteria in MIL-STD-1472.

2.0 Background

2.1 Refueling Systems

The U.S. Army currently uses two separate refueling systems for ground vehicles:

- Gravity Refueling System
- Pressure Refueling System

The primary functions of a refueling system are to effectively and safely store supplies of hydrocarbon fuels and transfer these supplies into vehicle fuel cells. Secondary functions include defueling, vapor return, vapor recovery, electrical bonding, electrical grounding, and automation.

Refueling systems, including the new SARS, are divided into three subsystems: supply, transfer, and receiving vehicle (see Figure A-1). The transfer process is powered by gravity or pressure.

2.2 Standard Army Refueling System

SARS is designed to support, with a minimum of risk to operating personnel, the rapid refueling of combat and combat service support vehicles and ground equipment. It is a ground based refueling system which uses the pressure refueling process. SARS is intended to provide two-minute refueling or four-minute defueling operations for any SARS refuelable vehicle, reduced fuel contamination, elimination of vapor-plume signature to the enemy detection systems, improved environmental protection, and safety improvements regarding fire and the well-being of personnel. SARS also includes provisions for nozzle pressure regulation, automatic refueling shut-off, vapor return, electrical bonding and grounding, and other performance and safety features.

The SARS maximum flow rate is 300 GPM for refueling and 150 GPM for defueling. The nozzle regulated pressure is nominally 18 PSI, and the nominal bore size of the refueling transfer interface is 2 inches. The fuel source may be any refueling supply installation which is able to supply suitable pressurized fuels.

2.3 Bradley Fighting Vehicle

The BFV fuel system was designed for gravity refueling through a port in the vehicle armor to upper and lower fuel cells. A mock-up BFV fuel system is shown in Figure A-2.

3.0 Analysis and Design of the Retrofit Kit

3.1 Physical Characteristics

The statement of work required that a retrofit kit be designed and fabricated to allow a SARS nozzle, as described in the SARS Handbook, (see Figure A-3) to interface with the vehicle and provide a full load of fuel to the BFV in 2 minutes or less. The retrofit kit should require a minimum of alteration to the existing vehicle, and the existing fuel entrance will be used for installation of the removable SARS receptacle in order to allow continued refueling using a gravity type nozzle if needed. In addition, a mock-up system of the BFV will be fabricated and incorporate a retrofit kit to demonstrate the feasibility of the SARS operating with the BFV.

3.2 Operating Environment

The retrofit kit, like the original unit, must be able to operate when exposed to harsh environmental conditions. The ambient air temperature may range from -60°F to +135°F. The unit must be designed to operate in rainfall as well as in the desert. The unit must also operate at high elevations (up to 9340 ft above sea level) and when tilted at various angles for proper "fill-level", but no fuel should be ingested into the vent return manifold.

3.3 Refueling, Defueling Capacity

The SARS refueling system must supply sufficient flow capacity and pressure at the nozzle/receiver (20 GPM to 300 GPM and 18 to 25 PSI) for ground vehicles in any environmental conditions or requirements.

For SARS defueling the supply system must maintain a negative pressure of 2.5 PSI or better at the nozzle/receiver in order to assure defueling at one half the corresponding refueling flow rate.

3.4 System Operating Parameters

A flow rate of 85 GPM and 18 PSI at the nozzle/receiver will meet the requirements for refueling in 2 minutes or less and defueling within 4 minutes for the BFV.

The location of the fuel cells and constraints for the fuel system on the vehicle were reproduced on the mock-up system and were the basis for designing the retrofit kit components to be adapted to an existing vehicle with minimum alterations.

3.5 General Considerations

Cost effectiveness, reliability, maintainability, corrosion prevention, safety, noise limits, integrated logistic support, human factors engineering, and MANPRINT were also considered in the design and modification of the vehicle fuel system.

4.0 Fabrication of the Retrofit Kit

4.1 SARS

At the start of this task order, many components of the SARS had not been manufactured, and the SARS HDBK was the only basis for design of the retrofit kit. After determining that the system could be used, design and fabrication of the prototype retrofit kit were completed. This

included replacement of the filler neck and strainer, flange connection to upper and lower tanks, and the addition of new elements. Components of the retrofit kit for the BFV to receive fuel from the SARS are:

- Receiver/Adapter
- Filler Neck
- Strainer
- Connecting Hose and Flanges of the Upper and Lower Fuel Tank
- Pilot Valve, Bracket Support and Sensing Line
- Shut-off Valve, Bracket Support, and Fuel Line

4.2 SARS Receptacle/Adapter to BFV

The receptacle for a SARS nozzle is the essential component of a fill point to which the refueling nozzle attaches for refueling/defueling services. The receptacle is the receiving half of the refueling transfer coupling and is usually installed on the vehicle's filler point. The SARS nozzle and receptacle were provided by the government and were incorporated in the system with no modifications or alterations.

The configuration of the BFV in the area of the filler point does not allow the SARS nozzle to come close to the vehicle. However, the task order requires the retrofit kit to adapt a SARS refueling nozzle to the existing fuel entrance, a gravity type entrance. Vitro designed and fabricated one specific receiver/adapter capable of being installed or removed from the vehicle in 10-15 seconds and capable of receiving the SARS nozzle (see Figures A-4 & A-5).

The receptacle was incorporated into a designed elbow adaptor between the SARS nozzle and the BFV fuel entrance. The filler neck cap is removed and the fuel line of the adaptor is

introduced into the fuel line (hose) of the receiver system (see Figure A-6). Pushing down and rotating counter-clockwise 60° (see Figure A-7), the adapter can be installed on the vehicle in 15 seconds or less.

The adapter is stainless steel with an exterior four inch pipe size elbow. A special configuration on one end allows installation of the SARS receiver unit (see Figure A-8), without alteration, and permits replacement or improvements. The other end is a standard 3 lobe bayonet from a filler cap which has been modified. Fuel from the SARS nozzle runs through the one inch tubing welded into the four inch elbow terminals. The size of the fuel line was determined in conjunction with the shut-off valves, configuration and constraints of the existing fuel system in the BFV, and safety aspects. If the fuel line were larger, the flow would increase, and the pressure on the lower tank, monitored using a pressure gauge (see Figure A-9), would rise to a dangerous level during the time in which the fuel from the lower tank is pushed up through the 3" connector hose (see Figure A-10) to fill the upper tank. Limiting the flow at this level protects the lower tank. This keeps the maximum pressure into the lower tank under 1 PSI. Even at 1 PSI or less the top of the lower tank bows approximately 1.75".

4.3 Filler Neck and Strainer

To adapt SARS to the existing fuel system and to maintain the gravity refueling system the filler neck on the upper tank was replaced. The new configuration (see Figure A-11) provided a fixture for the 1 inch fuel line which received the SARS adaptor and left space for the gravity refueling type nozzle (see Figure A-12). Connections of the filler cap flange on armor, rubber boot, clamps, and assembly hardware remained from the existing configuration.

The new filler neck contains six slots 1.5" x 8" long to allow the fuel to drain into the upper tank in the gravity refuel system and the vapor to run out from the tanks. Using SARS the vapor is recovered and returns through the double wall coaxial hose to the supply tank, incorporating all the benefits of the system. On the bottom side of the filler neck are two studs (#10-32) which hold the bracket support for the pilot valve.

A newly designed strainer (see Figure A-13) is permanently installed in the filler neck, for gravity refueling, and can be easily removed for cleaning (see Figure A-8). Only stainless steel materials were used, as with the rest of the system.

4.4 Connecting Hose and Flanges of the Upper and Lower Fuel Tank

To assure refueling of the upper tank and reduce pressure in the lower tank, the existing 2.5" hose connector was replaced with a 3" interior diameter hose (see Figure A-10), the maximum possible diameter. This was limited by the flange fixture's hole pattern on the upper and lower tanks. Increasing the diameter of the connection hose increased the flow of liquid between the tanks and reduced the pressure in the lower tank. Both flanges in the upper and lower tanks were modified to allow installation of a larger hose while respecting the pattern of the holes for screws to be installed on the tanks.

The new flange for the lower tank was changed on the mock-up system to switch the size of the vapor tube from 3/8" to 1" in diameter so that the fluid level could more easily be discerned during presentations. This change did not have an impact on the performance of the system. For future retrofit kits these flanges, like all new components, will be delivered ready to be installed by the vehicle crew.

4.5 Pilot Valve, Bracket Support, and Sensing Line

A new bracket support (see Figure A-14) is installed on the side of the filler neck for the pilot valve, which can be adjusted to the necessary level of the liquid in the tank. When the liquid reaches the valve's floating device, a pressure signal from the pilot valve is sent to the shut-off valve via the sensing line, and the refuel or defuel process is stopped. Three screws (#10-32) fix the valve on the bracket support. One .38" exterior diameter PVC clear tube (the sensing line) connects the pilot valve with the shut-off valve inside of the lower tanks. The pilot and shut-off valves (see Figures A-14 through A-16) were manufactured, adjusted and tested by Shaw Aero Devices, Inc. Modifications were made to the interior configuration and components of existing production valves of this type in order to reduce flow to 90 GPM at 18 PSI and meet the requirements of the task order.

Testing the system proved the adequacy of the modifications, adjustments, and laboratory tests by Shaw Aero Devices in conjunction with a Vitro engineer. The pilot and shut-off valves have operating temperatures between -65° F to +135°F in continuous mode and up to +250°F for 30 minutes. Internal fuel can be stored from -80°F to +160°F without damage to the valves. This data comes from drawings, data sheets, and long experience with this type of valve, which has been installed on numerous aircraft throughout the world.

4.6 Shut-off Valve, Bracket Support, and Fuel Line

The shut-off valve is supported by a bracket support bolted to one of the top covers and is located inside the main compartment of the lower tank. It is .50" from the bottom and receives fuel via a fuel line from the SARS receiver/adaptor located at the existing fuel entrance in the vehicle. One fuel resistant rubber hose, 1" inside diameter (see Figures A-15 & A-16) and 80"

long, is held fixed in the filler neck, passes through the 3" connector hose from upper to lower tank, and is connected to the shut-off valve. It can properly handle fuel at 18 to 25 PSI and 90 GPM sent by the supply system through the SARS nozzle. Using this type of fuel line, a standard rubber hose, the Vitro design proved superior to more sophisticated and expensive suggestions made by other manufacturers of different types of valves. Also, other proposed designs presented many sensing parts, and failure of one meant failure of the entire system. The installed rubber hose is much more reliable and does not require maintenance or periodical control.

Meeting SARS time and pressure requirements involved installation of a receiving section into the existing fuel system, and a refueling/defueling process from the bottom to upper level.

4.7 Corrosion Prevention

Galvanic corrosion occurs when an electric current is produced between two dissimilar metals which are in contact. The potential for galvanic corrosion increases as the difference in galvanic potentials for the two metals in contact increases.

When selecting components for the retrofit kit and the mock-up system, the potential for galvanic corrosion was considered. For each component of the system the material was identified. If there was a potential for galvanic corrosion, the pair was avoided, or measures were taken to protect against galvanic corrosion. To prevent corrosion, all the new parts of the kit are made from stainless steel and all assembly hardware (bolts, washers, nuts) are made of this same material. In the supply section the supply tank is steel hot dipped zinc protected. The same protection was provided for the fittings and piping system. Where dissimilar metals were paired, painting and galvanic protection were performed to protect against galvanic corrosion.

5.0 Design and Fabrication of the Mock-up System

5.1 Mock-up Components

The Task Order and Technical Advisor recommended design and fabrication of a mock-up system that can perform in the enclosed space of a classroom or show room, using a standard existing 20 Amp electrical outlet, and will conform with Human Engineering Design Criteria MIL-STD-1472, especially hazard and safety. Due to fire hazard, air and noise pollution, and safety in using the system in enclosed spaces, diesel fuel was replaced with water. This change reduced the cost of the installation, environmental problems with diesel fuel, cost of diesel fuel, and all hazards connected with hydrocarbon fuel.

The mock-up of the SARS adapted to a BFV represents each of the three sections in a refueling system. Each section was very carefully analyzed before the start of the design, fabrication of the components, and selection of materials.

The three sections of the Mock-up SARS-BFV refueling system are:

- supply system
- fuel transfer system
- fuel receiver system

5.2 Supply System

The supply section of the mock-up system (see Figure A-17) was designed to meet the requirements of the task and use the most reliable "off the shelf" items and materials, thus reducing cost and providing maximum performance.

A platform support was manufactured from ASTM A 36 steel, standard material for this type of application. Four supporting swivel-with-brake caster wheels assure ease of movement and hold the platform in a fixed position during demonstrations.

A 240 gallon hot-dipped galvanized ASTM storage tank, designed as an all-purpose tank for potable water at temperatures up to 160 F, is the supply tank for the system. Horizontal positioning of the tank on saddles and two tie-down rings hold it fixed on the platform. Clear nylon tubing on the side of the tank provides a safe sight level (see Figure A-18).

A straight centrifugal pump, chemical resistant to prevent corrosion, with 1-1/2 inlet (suction port) and 1-1/4 outlet (discharge port), installed on the shaft of a 1-1/2 HP maximum size electric motor (115 V, single phase, 60 Hz, using normal 20 Amps electric outlet) provides approximately 60 GPM at 18 PSI to the SARS receptacle and weighs 45 lbs. It was recognized that 60 GPM at 18 PSI was not enough to meet the task requirements for refueling the BFV in 2 minutes or less nor for defueling in under 4 minutes. However, for demonstration purposes using the mock-up, the selected pump was the largest available on the market using a single phase, 115 V motor. Using a larger pump with a heavy 3-phase motor limited the effective use of the mock-up to demonstrate the retrofit kit. The retrofit kit installed in the mock-up BFV fuel receiver was designed to perform in the SARS required time and was calibrated and tested using the required parameters, refueling in 2 minutes and defueling in 4 minutes.

A control box incorporates electric cable and a control switch (see Figure A-19). Double safety provisions are incorporated into the control box: a side hole through which the cable can be extended to the outlet, or completely retrieved inside the box, and a padlock to secure the box lid.

This will prevent unauthorized operation of the pump by unqualified personnel, personal injuries, or damage of equipment.

The piping system (see Figure A-20) maintains a 2 inch pipe size and incorporates one shut-off valve and one three-way diverting ball valve in the suction line of the pump.

A 1-1/2 inch pipe size, one shut-off valve, one 3-way diverting ball valve, and one relief valve are incorporated into the discharge line of the pump.

Changing the position of the two 3-way valves (see Figure A-21) in the system is the only step necessary in order to perform refueling or defueling of BFV tanks.

One shut-off valve regulates the supply water from the tank to the suction line of the pump. This is a safety provision and allows maintenance or repair of the pump or piping system while the tank is full. The shut-off valve in the discharge line of the pump eliminates spillage from the discharge line if the hose of the fuel transfer section is removed or damaged.

The relief valve in the discharge line (see Figure A-17) protects the pump in case of failure of a valve in the retrofit kit or improper orientation of one of the 3-way ball valves.

A bracket support installed on the side of the platform provides safe storage for the 2" fuel transfer hose during transport or periods of nonuse.

5.3 Fuel Transfer System

The transfer section of the system consists of the fuel transfer hose and SARS nozzle (see Figure A-3). For transferring fuel from the supply tank to the receiver system SARS uses a special double wall (coaxial) hose; the main 2" interior hose enhances the transfer of fuel to the SARS nozzle. An exterior (3" inside diameter) hose encloses the main hose and provides needed space between the walls of the two for vapor return from the SARS nozzle to the SARS supply

tank. However, for safety, economical, and environmental reasons the mock-up system was designed to replace diesel fuel with water. By using water the supply hose was changed to a standard 2" suction type hose with a cam-lock type fitting at one end, easily connected to the piping system of the supply section, and a special double wall (coaxial) fitting mated with the SARS nozzle at the second end. In the refueling process the return vapors from receiving tanks exit the SARS nozzle nipple. This proves that the retrofit kit works and provides recovery of vapor from the tanks.

5.4 Mock-up BFV Fuel Receiver System

The mock-up BFV fuel receiver platform (see Figure A-2) is similar to the supply system platform, built to reflect the locations of the fuel tanks in the BFV. A mock-up of the vehicle filler point armor (see Figures A-2 & A-6) is located on top of the upper tank and the filler neck as in the vehicle. The eight inch distance from the top of the lower tank to the bottom of the upper tank was also duplicated (see Figure A-10).

6.0 Testing the Retrofit Kit

To demonstrate the correct size and adjustment of the valves and full system, testing was performed using a 3 HP Yanmar diesel engine pump able to supply 80 to 90 GPM at 18-25 PSI. For 10 cycles at +75°F with 2 minute intervals between the cycles refueling was performed in 2 minutes and defueling in 3 minutes 55 seconds.

The 3 HP pump delivered 90 GPM at 25 PSI, the transfer section (hose nozzle and nozzle receiver/adaptor) handled the flow at the required pressure, thus meeting the final task order requirements: refueling in 2 minutes and defueling in 4 minutes. This test was performed three times in the presence of Fuel and Water Supply Division personnel from Fort Belvoir. Because of

noise, air pollution, and the inadmissibility of running the diesel engine in an enclosed space, the 1-1/2 HP electric pump was reinstalled in the supply section. (Tests with the 1-1/2 HP electric pump produced average refueling times of 3 min 14 seconds and average defueling times of 5 min 13 seconds.)

By installing a 3 HP electric pump to satisfy the task and SARS time requirements, the mock-up system could only be used in locations which provide 220 V, 3 phase current, and a special outlet, making the system inoperable in class rooms and many showrooms. In addition, the 3 HP electric pump weighs approximately 500 lbs.

Fort Belvoir personnel from the Fuel and Water Supply Division decided to retain the 1-1/2 HP electric pump using a 115 V, 1 phase motor, so that demonstrations could be performed in any classroom or showroom.

The SARS system retrofit kit will meet SARS requirements using supply equipment in the field.

7.0 Conclusions

Before beginning design on the retrofit kit and mock-up systems, Vitro engineers had confidence that the SARS could be adapted to the Bradley Fighting Vehicle. The retrofit kit design involved minimum alteration to the existing vehicle, uses the existing fuel entrance, and a receiver/adaptor part allows a SARS nozzle to provide refueling/defueling in the required time or a gravity type nozzle to refuel the vehicle.

Advantages of using the SARS nozzle include a very low production cost of approximately \$6,000 for the retrofit kit (receiver/adaptor, pilot and shut-off valves, filler neck

strainer, brackets and assembly hardware) depending on quantities purchased and the ease of installation on the vehicle by the crew (in eight hours or less with no special tools or facilities).

All of the design criteria were satisfied for the retrofit kit. However, time requirements were not met when using the electric pump selected for the mock-up system. The mock-up system uses a small electric pump (only 1.5 HP with a 115 V, 1 phase motor) which has unlimited access to electrical power in any civilian and military building in service. Replacement of this pump with a 3 HP diesel engine driven pump proved the retrofit kit's ability to satisfy the time conditions: refueling in two minutes or less and defueling in under four minutes.

The retrofit kit and the mock-up system were found to be safe for testing and operation by trained personnel.

Additionally, operation and maintenance of the unit will require no additional equipment or training for personnel qualified to operate and maintain this type of equipment.

8.0 Recommendations

Recommend fabrication of five retrofit kits for testing in the field. This testing will determine the feasibility of using the SARS to refuel BFVs, identify advantages and disadvantages, and determine possible interference between the bowed lower tank and the bottom of the turret basket.

Appendix A

FIGURES

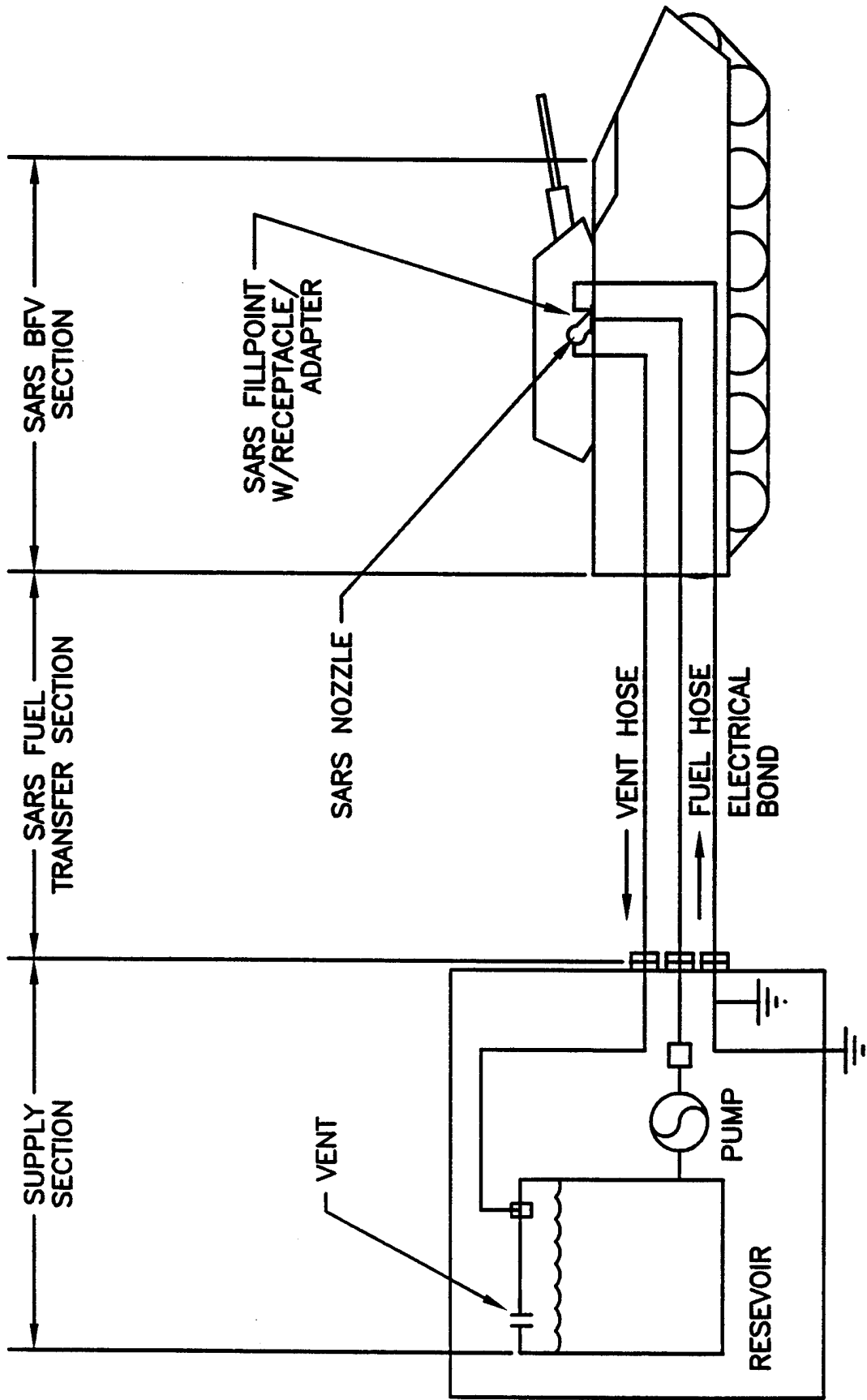

ELECTRICAL GROUND

FIGURE A-1

**SCHEMATIC--STANDARD ARMY REFUELING SYSTEM
ADAPTED TO THE BRADLEY FIGHTING VEHICLE**

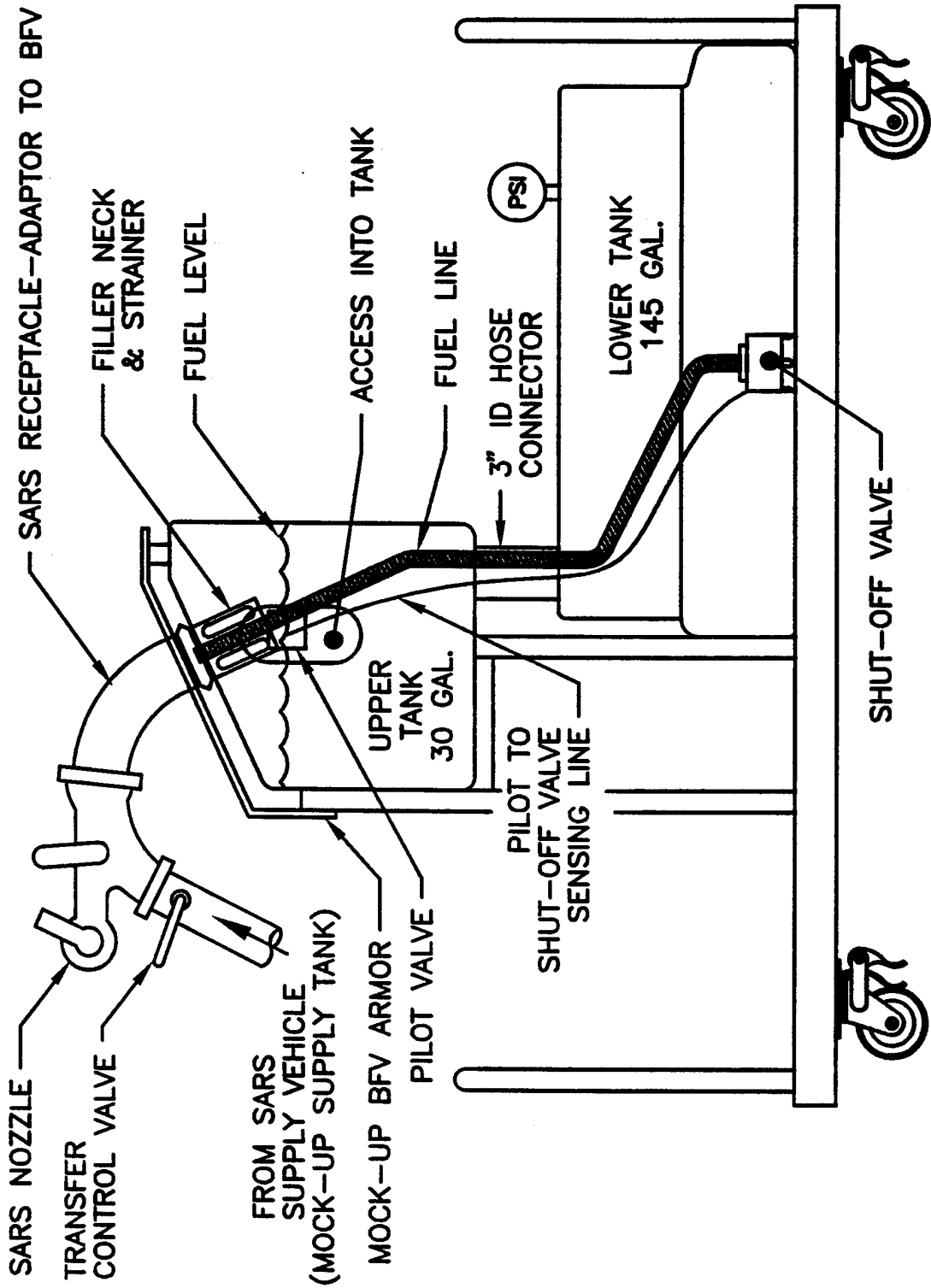
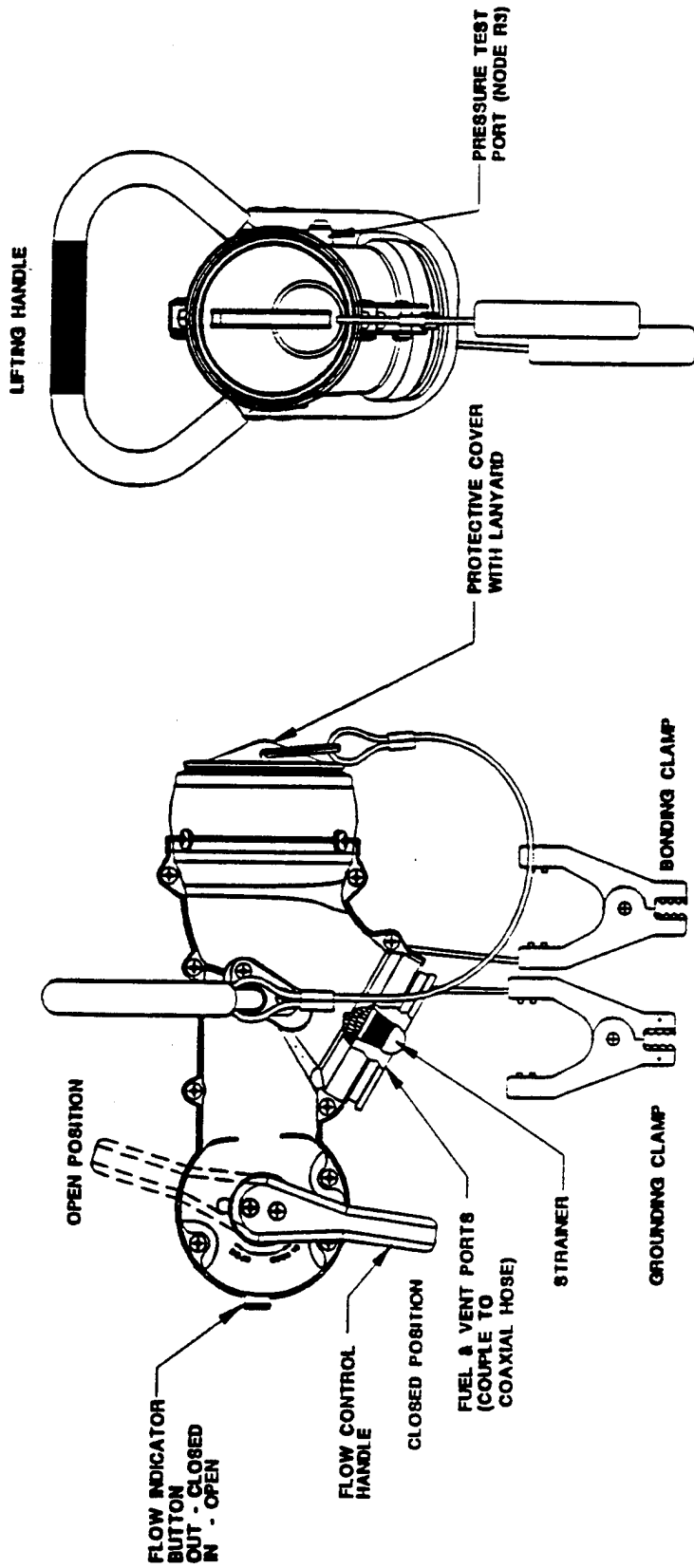

FIGURE A-2: BFV FUEL TANK MOCK-UP

NOTES

- MOCK-UP LOCATION OF TANKS AS IS IN BRADLEY FIGHTING VEHICLE
- FUEL LEVEL CONTROLLED BY PILOT VALVE WHICH SENDS A SIGNAL TO THE SHUT-OFF VALVE VIA THE SENSING LINE
- PSI GAUGE INDICATES THE PRESSURE IN THE LOWER TANK AS THE UPPER TANK FILLS UP



**FIGURE A-3
SARS NOZZLE**

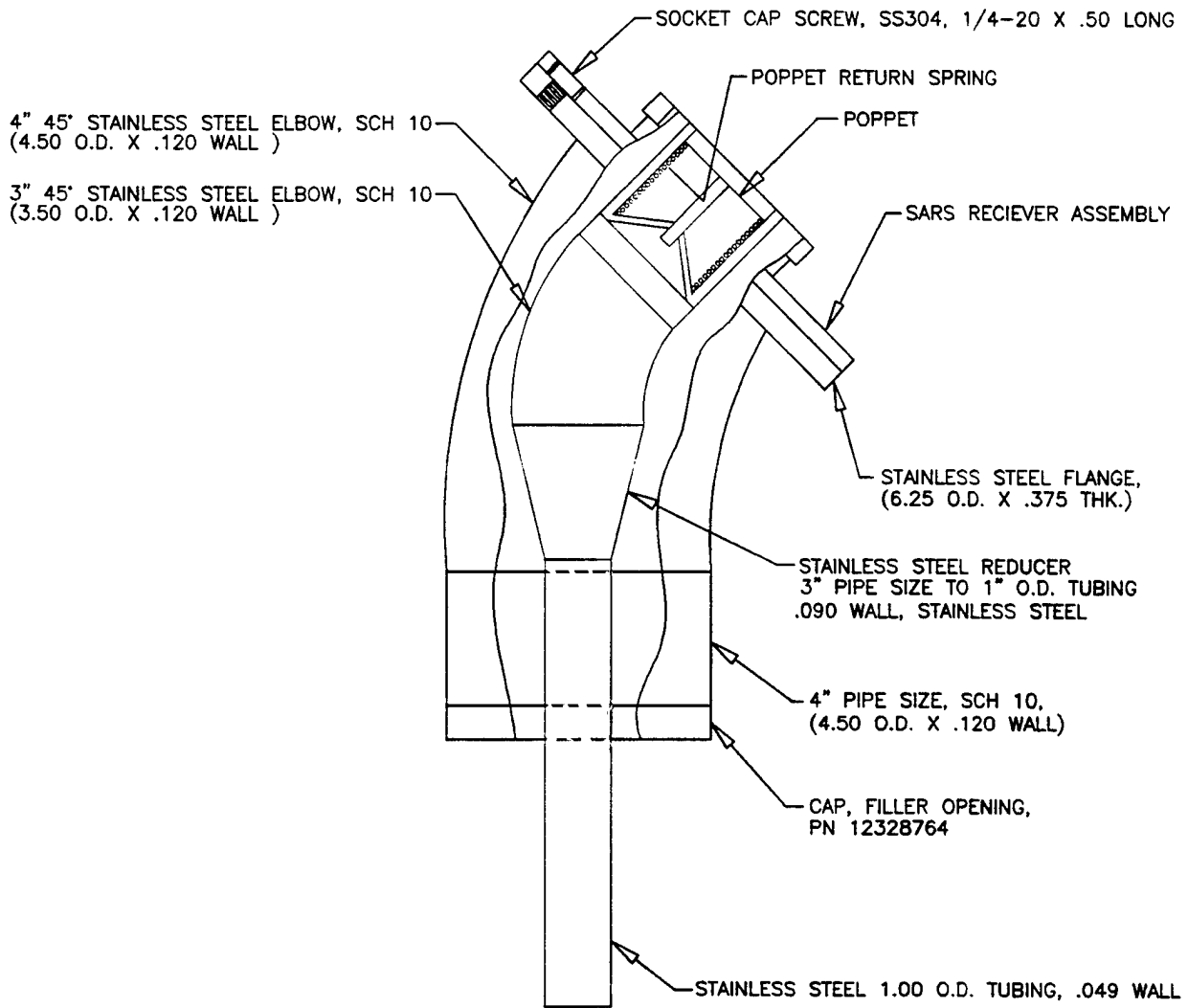

FIGURE A-4: SARS RECEIVER/ADAPTER

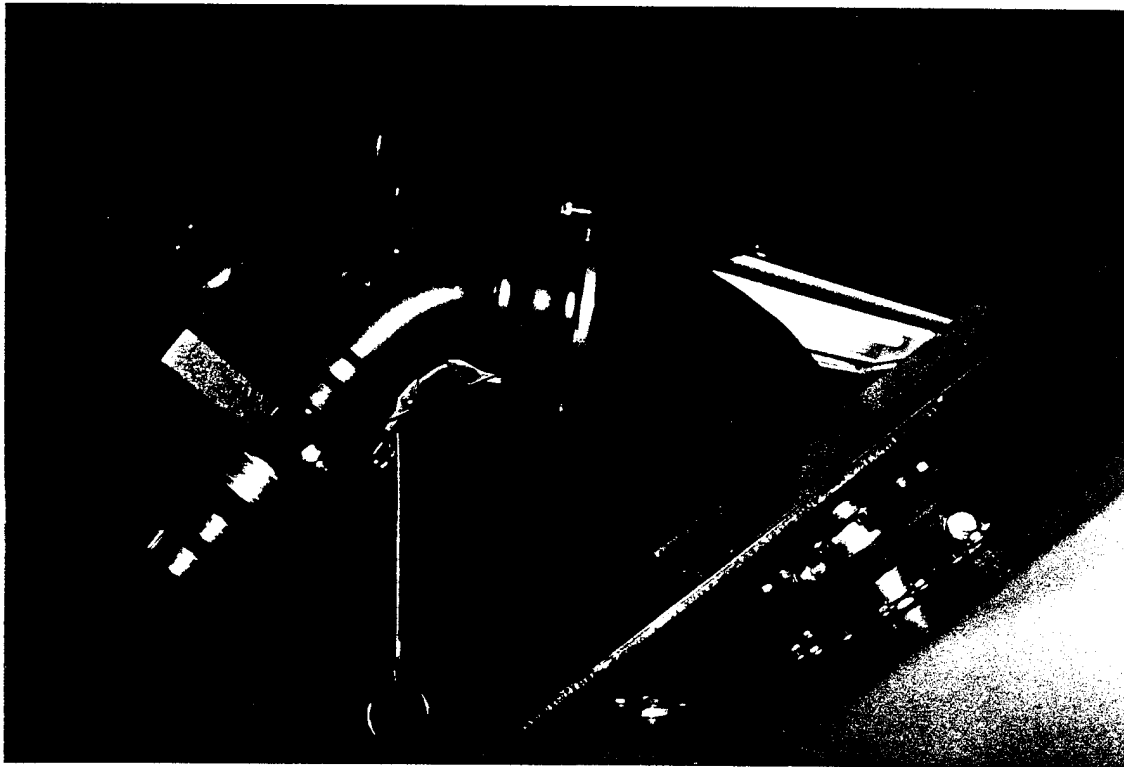

FIGURE A-5: FILLER POINT, SARS NOZZLE WITH CONTROL VALVE
AND RECEIVER/ADAPTER



FIGURE A-6: SARS RECEIVER/ADAPTER AND FILLER POINT

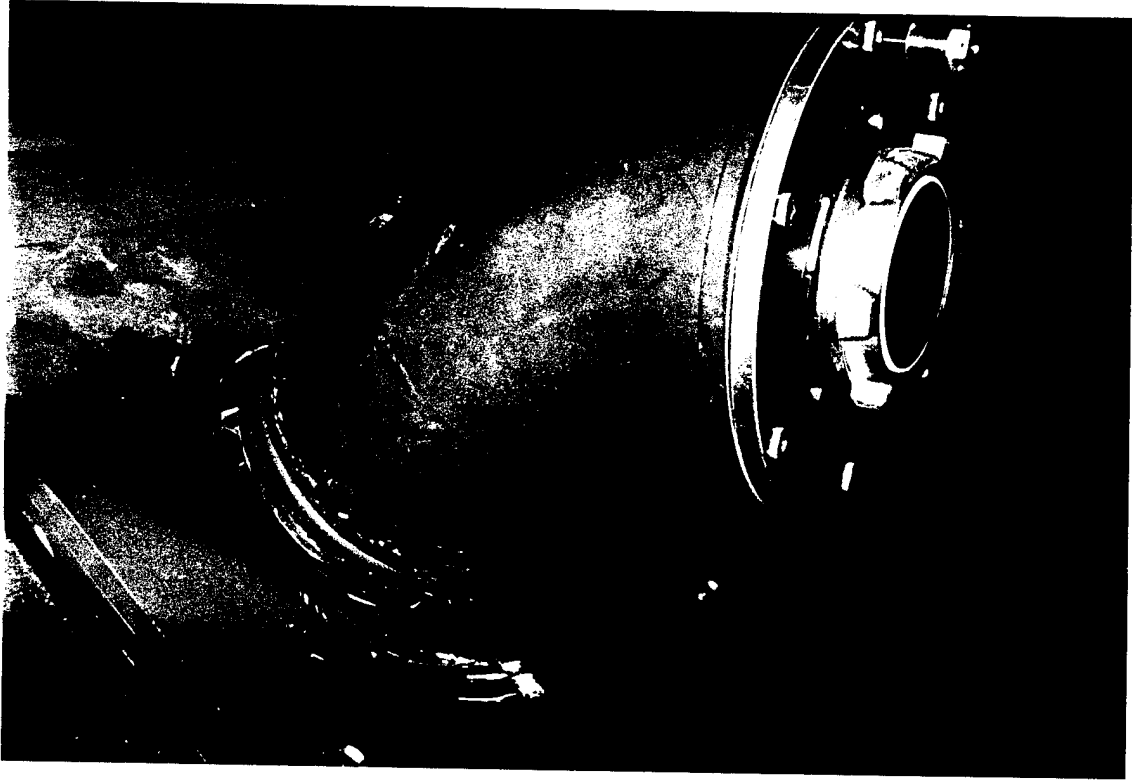

FIGURE A-7: RECEIVER/ADAPTER PLACED IN FILLER POINT

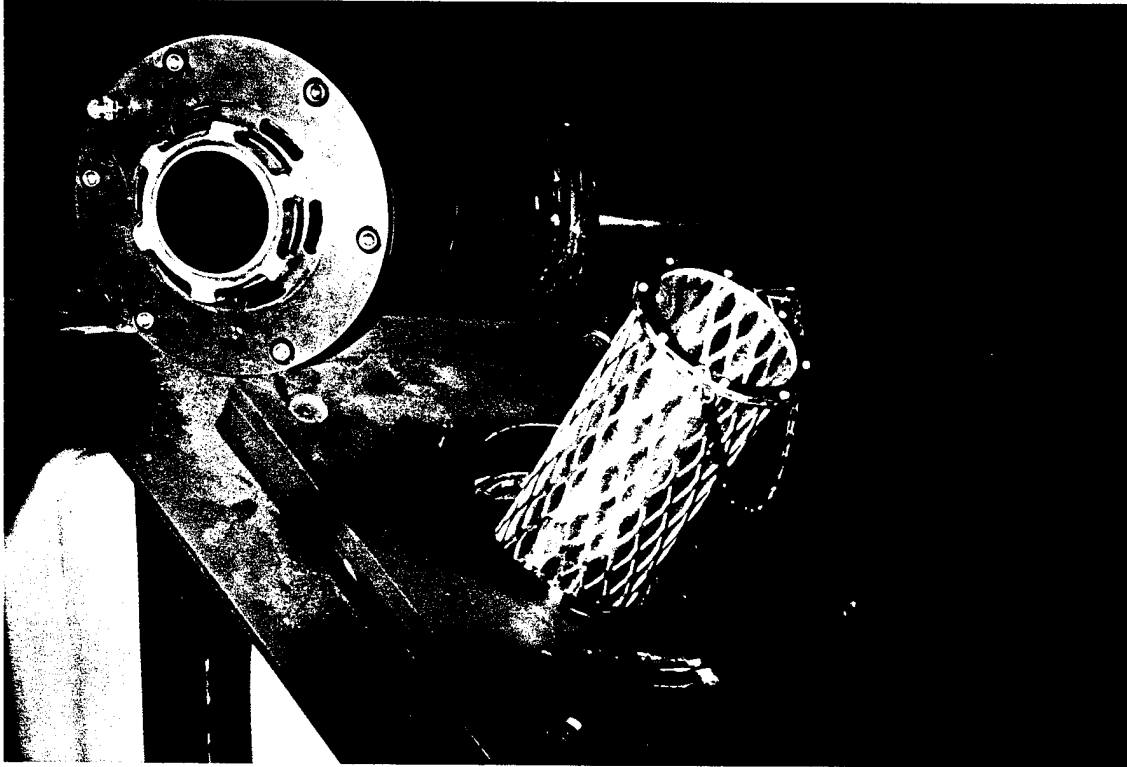

FIGURE A-8: SARS NOZZLE RECEIVER BOLTED ON THE ELBOW ADAPTER AND STRAINER REMOVED

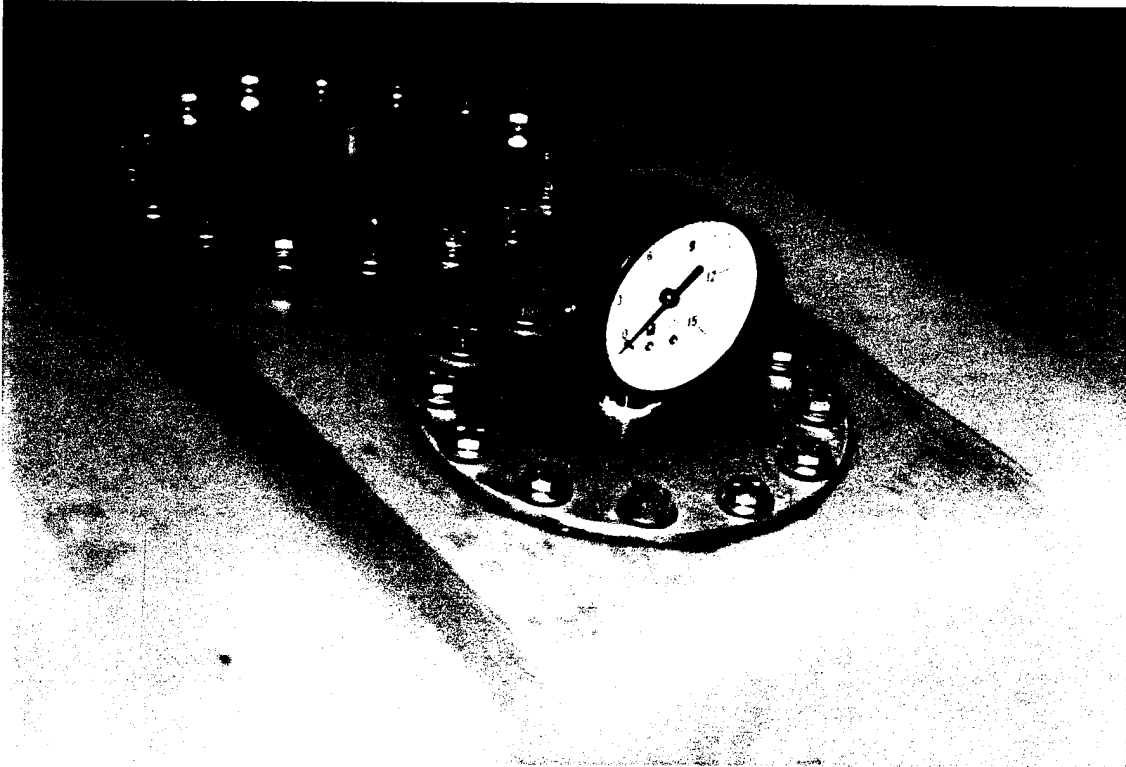

FIGURE A-9: PRESSURE GAUGE AND LOWER TANK

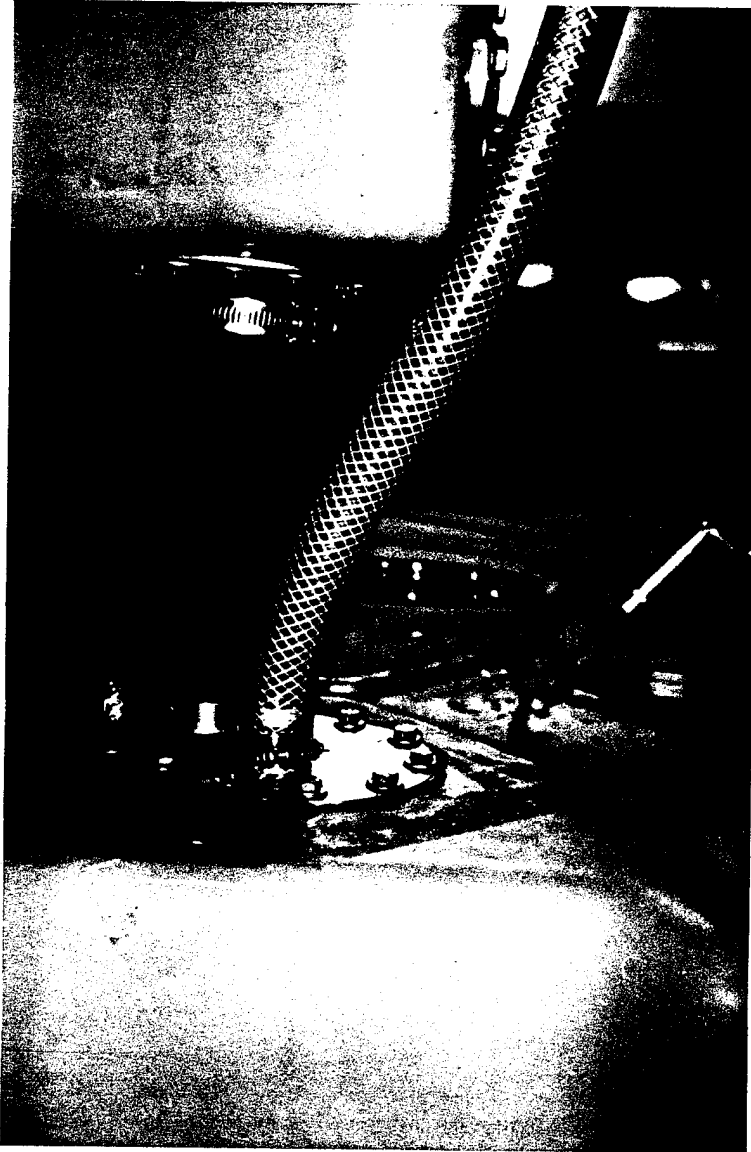

FIGURE A-10: 3" CONNECTOR AND VAPOR HOSES

A-10

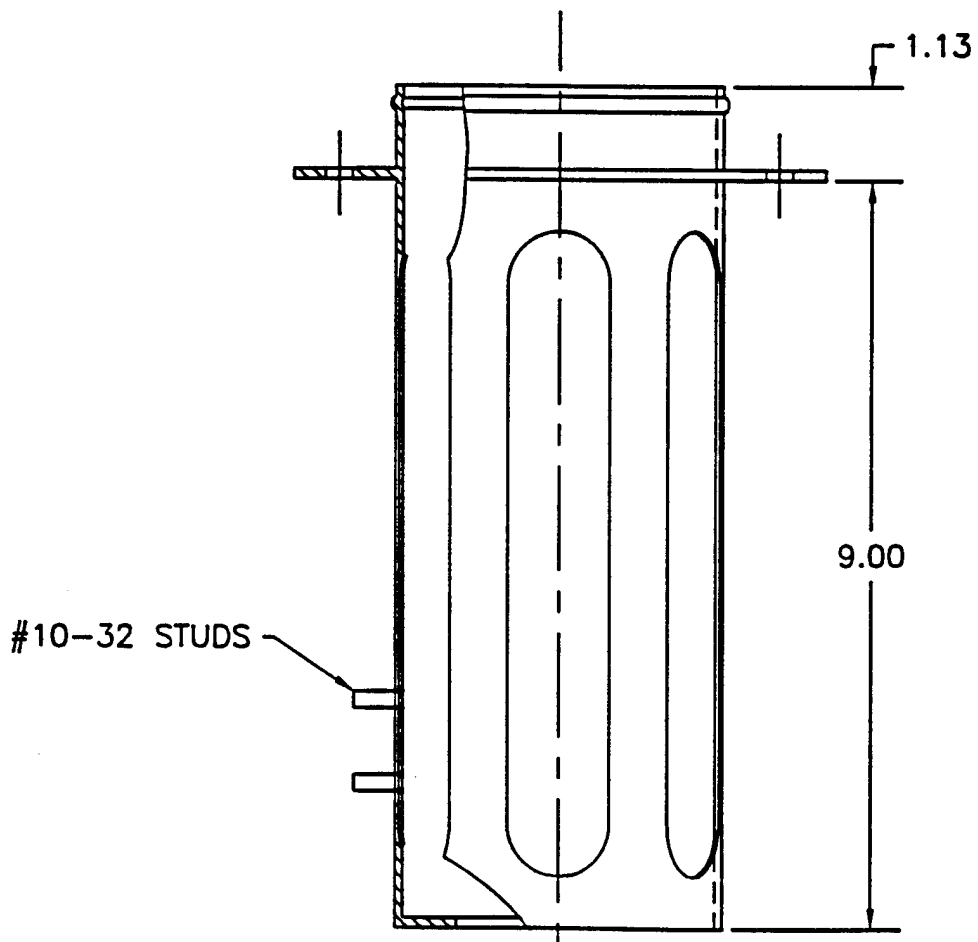
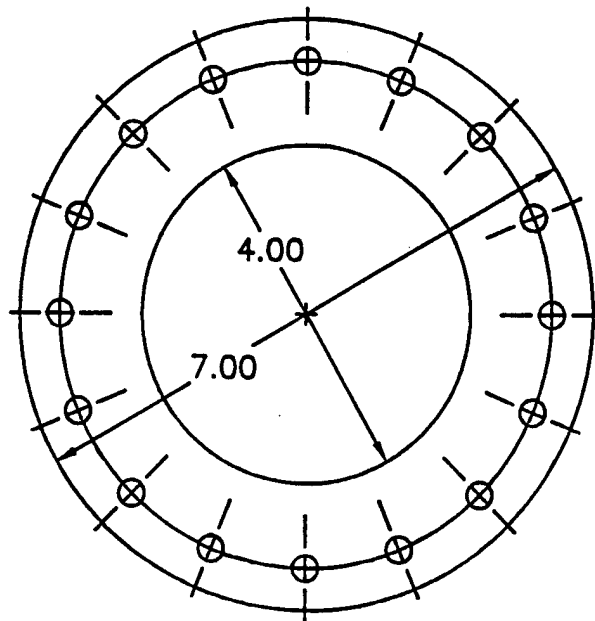

FIGURE A-11: FILLER NECK

A-11



FIGURE A-12: FILLER POINT WITH STRAINER

A-12

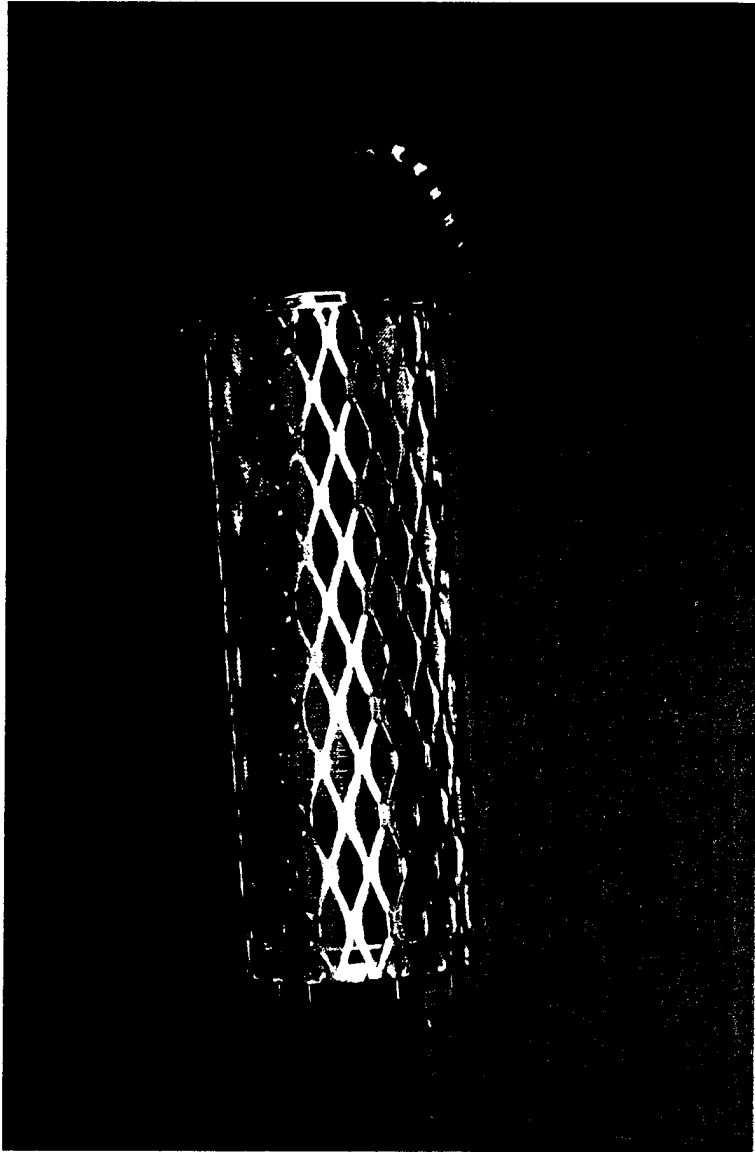

FIGURE A-13: STRAINER AND FUEL LINE HOSE

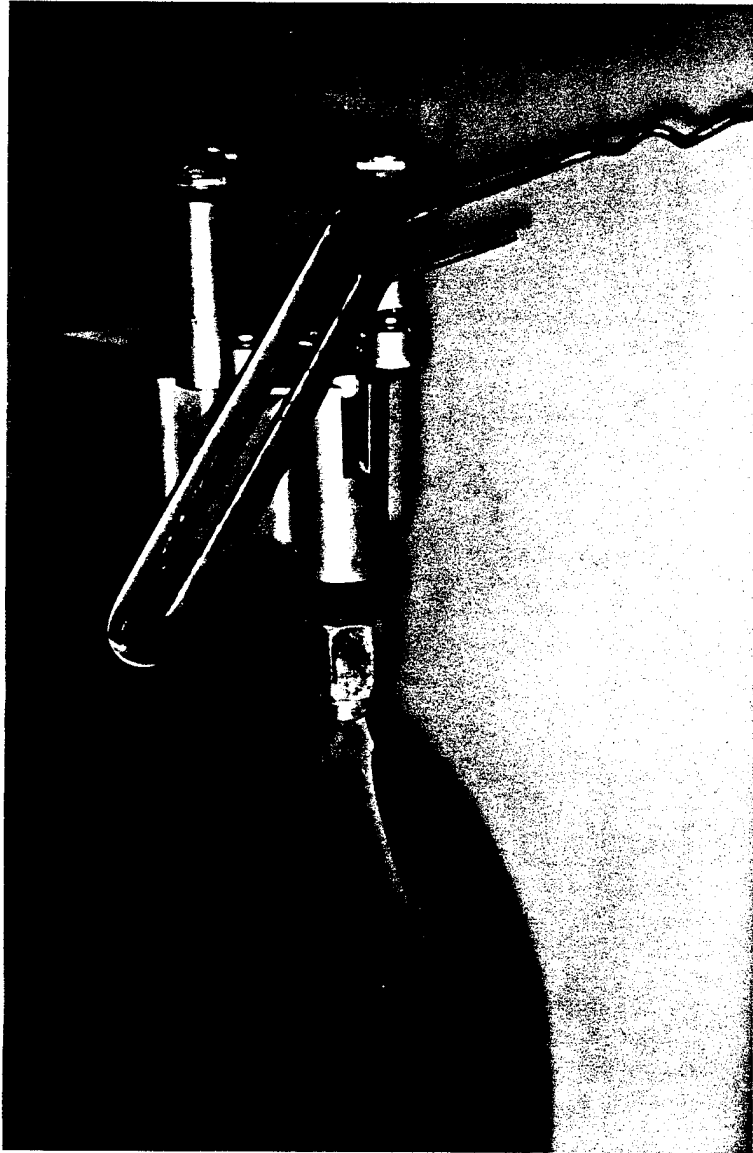

FIGURE A-14: PILOT VALVE, BRACKET SUPPORT AND SENSING LINE

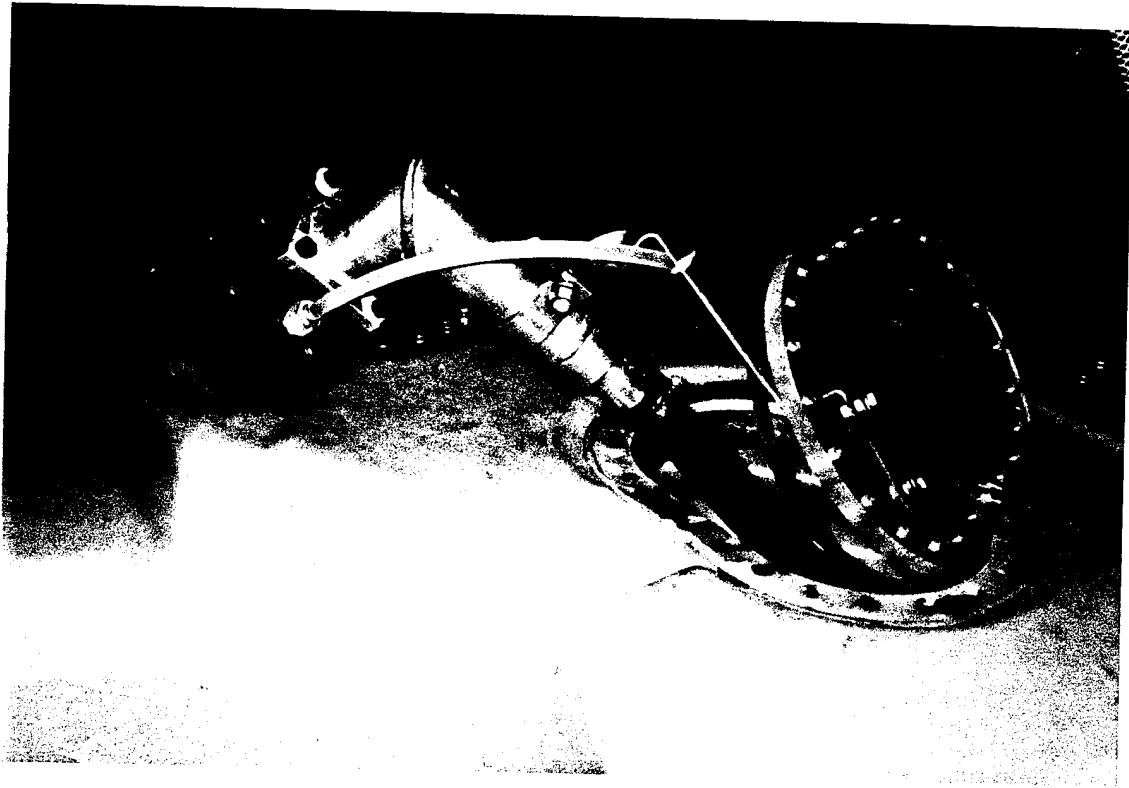

FIGURE A-15: SHUT-OFF VALVE ASSEMBLY

A-15

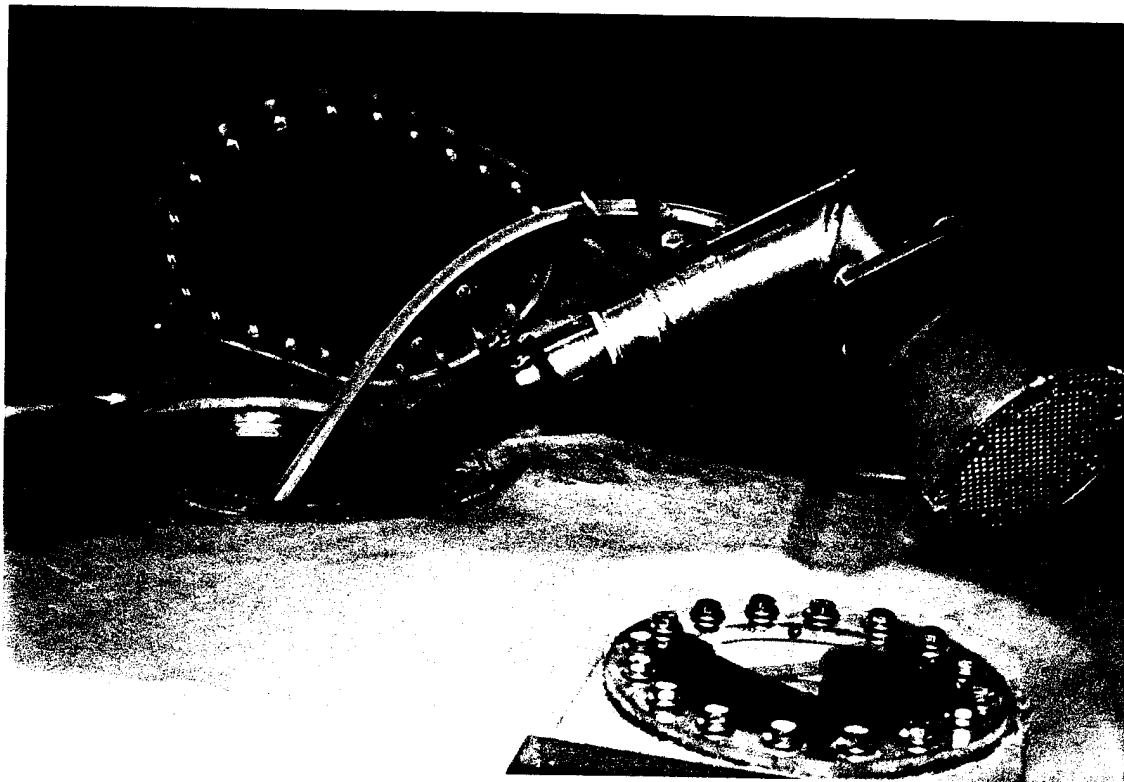

FIGURE A-16: SHUT-OFF VALVE, SENSING AND FUEL LINES
AND BRACKET BOLTED TO THE COVER

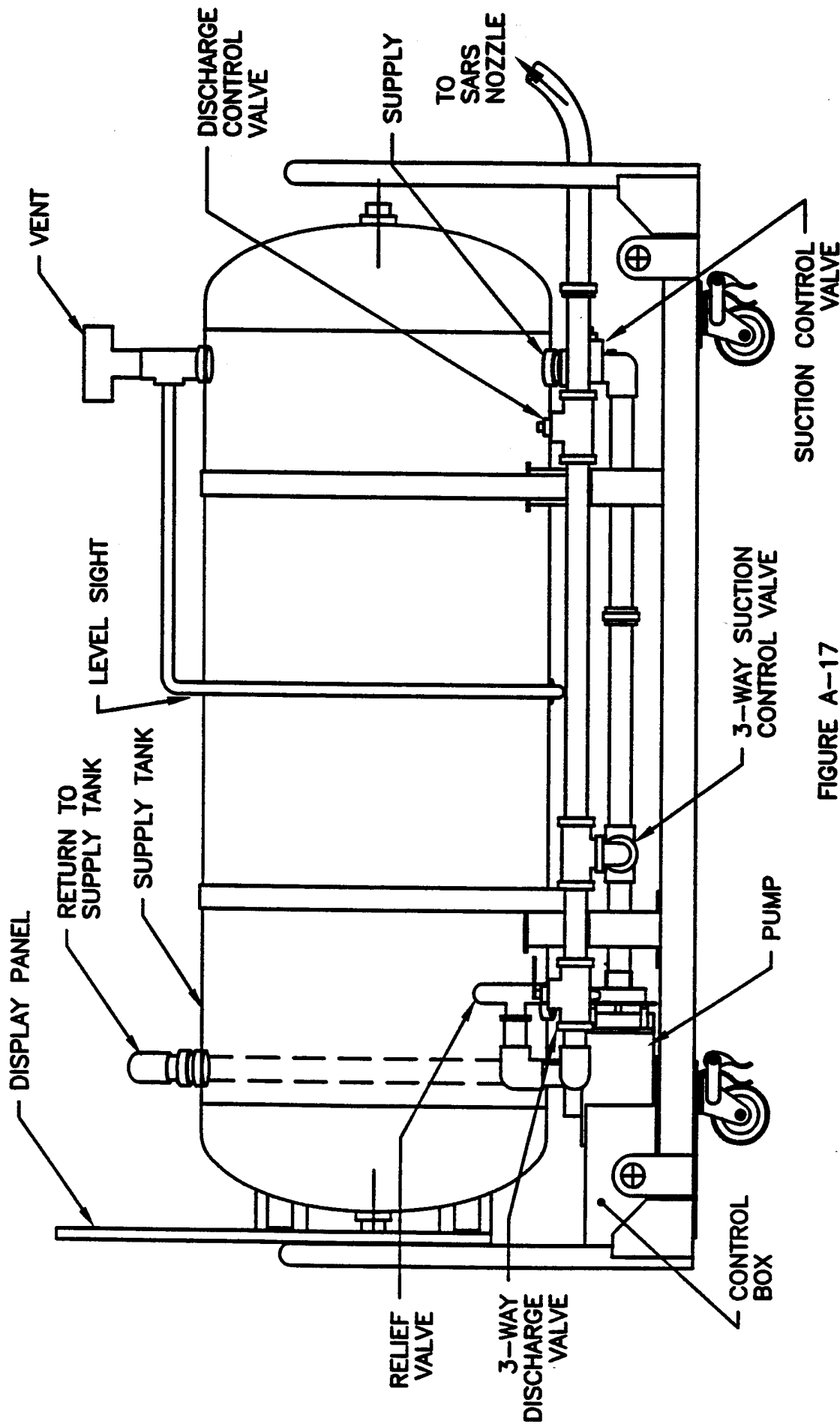

FIGURE A-17

- NOTES** - MOCK-UP SUPPLY SYSTEM PROVIDES LIQUID AT 18 PSI AND 60 GPM TO THE SARS NOZZLE USING ONE ELECTRIC PUMP (1 PHASE, 115 V, 1-1/2 HP)
- CONTROL BOX INCORPORATES ELECTRIC CABLE, AND SWITCH WITH DOUBLE SAFETY PROVISIONS: POWER CABLE RETRIEVED IN BOX AND PAD LOCK FOR BOX
 - TWO THREE-WAY VALVES INCORPORATED IN SUCTION AND DISCHARGE PIPING SYSTEM ALLOW THE SYSTEM TO REFUEL AND DEFUEL

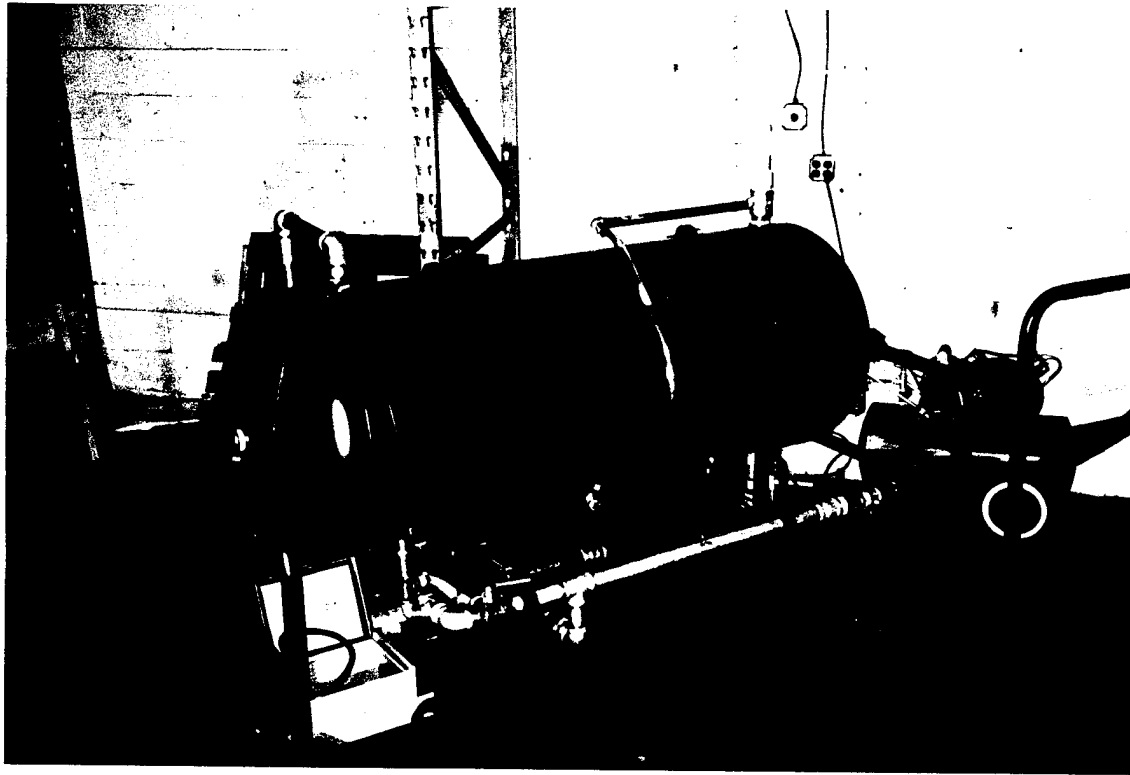

FIGURE A-18: MOCK-UP SUPPLY SECTION

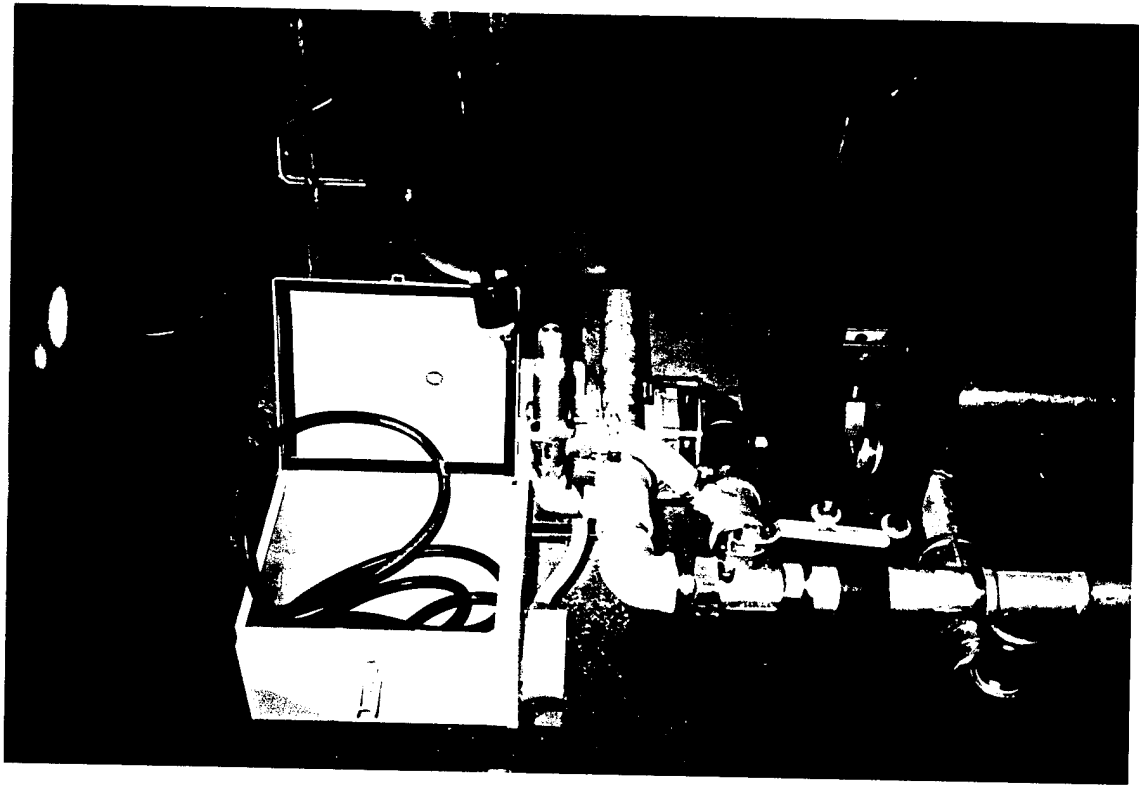

FIGURE A-19: CONTROL BOX

A-19

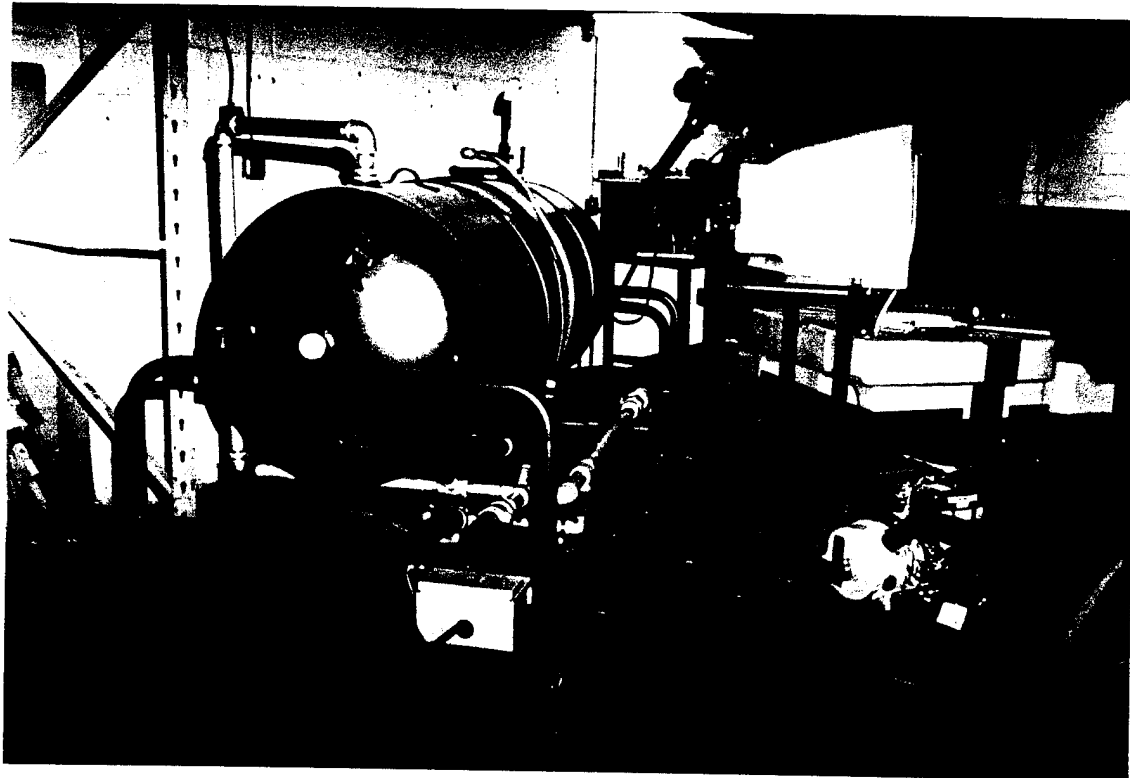

FIGURE A-20: YANMAR DIESEL ENGINE DRIVE PUMP
INSTALLED ON SUPPLY SECTION

A-20

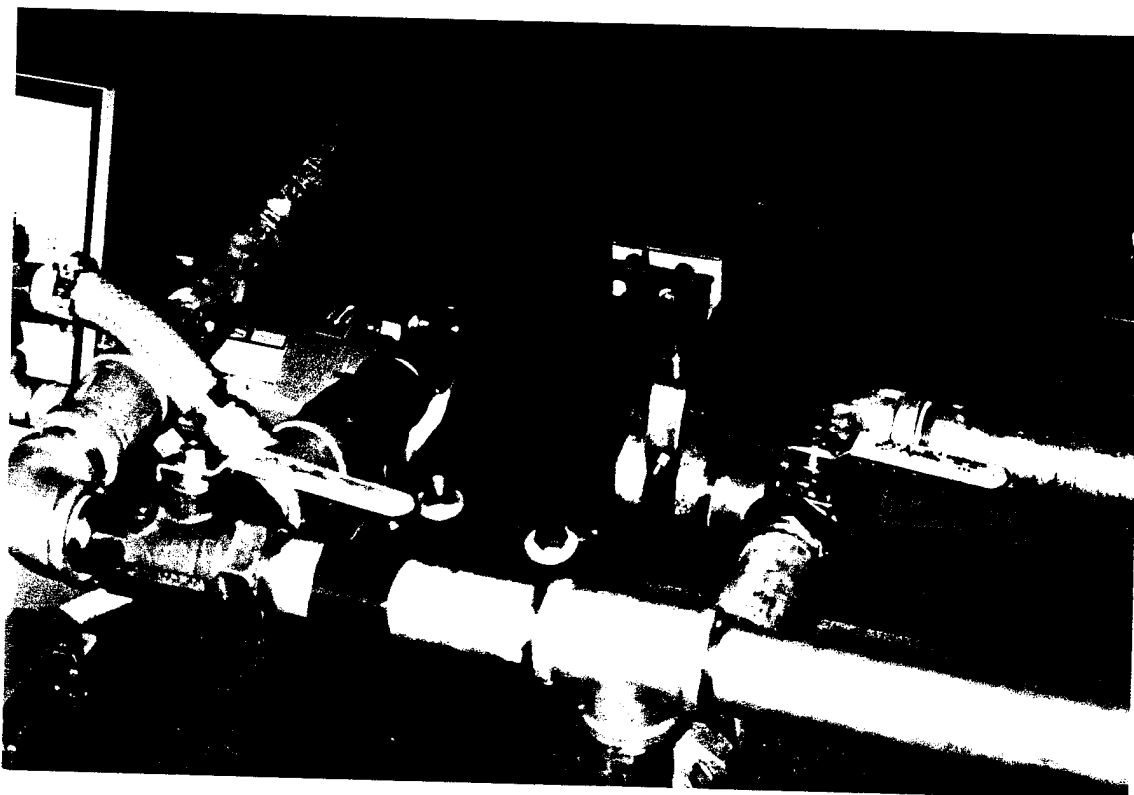

FIGURE A-21: 3-WAY BALL VALVE ON SUCTION AND DISCHARGE SECTIONS

A-21

Appendix B

REFERENCE DOCUMENTS

Appendix B

REFERENCE DOCUMENTS

1. **Data Item Descriptions (DIDS)**
 - DI-MISC-80711 Scientific and Technical Report
 - DI-MGMT-80227 Contractor's Progress, Status, and Management Report
 - DI-DRPR-81002 Conceptual Design Drawings and Associated List
2. **Military Handbook**
 - MIL-HDBK-DRAFT The Standard Army Refueling System
3. **Military Handbook**
 - MIL-STD-882 System Safety Program Requirements
 - MIL-STD-889 Dissimilar Metals
 - MIL-STD-1472D Human Engineering Design Criteria for
Military Systems, Equipment, and Facilities
 - MIL-STD-1474 Noise Limits for Army Material
 - MIL-STD-1000 Drawings
 - MIL-F-46162 Fuel, Diesel, Reference Grade
 - MS 35664 Filler Neck, Fuel cell - Military Vehicles
 - 13230E2501 Nozzle, SARS
 - 13230E2502 Housing, SARS
 - 13230E2540 Receptacle, SARS
4. **Industry Standards and Documentation**

ASTM D 975 **Diesel Fuel Grades 1-D & 2-D**
SAE AIR 868 **Test Method for Pressure Drops**
SAE AS 1284 **Standard Procedures for Surge Pressures**
SAE J 476 **Dryseal Pipe Threads**

5. **Documentation Developed under Task Order**
Developmental Design Drawings for Mock-up System
Design Drawings for Retrofit Kit of the BFV
6. **Other Documentation**
Drawings by Shaw Aero Devices, Inc.

Appendix C

OPERATING PROCEDURES

Appendix C

OPERATING PROCEDURES

The following procedures will be used to operate the SARS and BFV mock-up refueling system:

1. Roll the two platforms to a convenient distance from each other in order to provide easy handling of the supply hose from supply platform to the SARS nozzle, and lock the brake on all wheels of both platforms to hold them in stable positions.
2. Pull out the 2" delivery hose from the storage position on the supply platform, and connect the SARS nozzle to the half SARS coupling installed at the free end of the hose.
3. Remove the filler cap from the mock-up of the BFV receiving system. The operator should stand in front of the BFV armor, on the platform.
4. Place the 1" supply tube of the receiver/adaptor into the rubber hose located inside of the strainer with the elbow rotated 90° and the SARS receiver mating face oriented to the right of operator. Push the elbow down into the filler cap bayonet flange retainer and make contact with the flange.
5. Rotate the elbow 90° counter-clockwise to the end of the bayonet lobe. The mating face of the SARS receiver should be oriented toward the operator on the platform.
6. Lift the SARS nozzle with the hose and connect it to the receiver/adaptor. The nozzle should be rotated 30° counter-clockwise in order to engage the 6" lobe of the bayonet of the receiver and the hose should be located at the lower side of nozzle.
7. Open the valve located at the SARS fitting on the hose.

8. Lift the flow control handle to the open position. The flow indicator button will go inside the nozzle. The safety interlock mechanism of the nozzle prevents obscuring the flow control handle unless the nozzle is fully engaged with the receptacle bayonet. Once engaged with the receptacle and open to flow, the interlock prevents the nozzle from being disengaged until the flow control handle is fully closed and the visual flow indicator button is completely out.

REFUELING PROCESS

9. Open the control valve at the end of the discharge line (before the connected supply hose).

NOTE: FOR FUELING AND DEFUELING, POSITION THE VALVE HANDLES IN ACCORDANCE WITH DIRECTIONS ON THE LABELS AFFIXED TO THE SUPPLY TANK.

10. Open the three-way valve from the discharge line to supply position. The liquid will be delivered to the BFV receiving platform.

11. Open the three-way valve from the suction line to supply liquid from the supply tank to the pump.

12. Open the supply valve from the suction line to open the supply line from the tank to the pump.

13. Open the control box from the SARS supply platform and push out the receptacle and the electric cable through the existing hole. Pull out the electric cable to the necessary length, and connect it to a 20 amp outlet.

WARNING: MAKE CERTAIN THAT THE POWER SOURCE CONFORMS TO NATIONAL ELECTRICAL CODE (NEC) ARTICLE 250 GROUNDING. TO ENSURE A PROPER

GROUNDING, IT MUST BE TESTED BY A QUALIFIED ELECTRICIAN. WET HANDS OR STANDING ON A WET OR DAMP SURFACE, COULD CAUSE ELECTRIC SHOCK.

14. Double check all connections and valve positions.

WARNING: IN ORDER TO SAFELY USE THIS SYSTEM, FAMILIARIZE YOURSELF WITH ALL THE COMPONENTS. PROPERTY DAMAGE AND/OR PERSONAL INJURY MIGHT RESULT FROM AN INOPERATIVE ELEMENT OR INCORRECT POSITIONING OF A VALVE. THE SYSTEM IS NOT TO BE USED IN AREAS THAT REQUIRE EXPLOSION-PROOF MOTORS.

15. Push the electric switch to ON. The pump will start, and in a very short time the shut-off valve will begin to deliver liquid into the lower tank. When the upper tank is full and the liquid level has reached the level of the floating device in the pilot valve, the flow will be stopped by the shut-off valve. A specific noise will be heard at the pump and the electrical switch must be manually turned OFF.

DEFUELING PROCESS

To defuel the BFV tanks it is necessary to change the position of the three-way valve in the suction and discharge lines and to turn OFF (close) the supply valve from the supply tank.

16. The three-way valve in the suction line should be oriented to the by-pass connection between the suction and discharge lines. The transfer and supply lines in the BFV tank will be under negative pressure (2.5 PSI minimum) and the liquid will be sucked through the suction line of the pump.

17. The 3-way valve in the discharge line should be oriented to deliver through the return line into the supply tank.

18. Turn OFF the supply valve from the supply tank line.

NOTE: THIS SUPPLY VALVE MAY STAY ON WITH NO IMPACT ON THE DEFUELING TIME. TURNING THE VALVE OFF IS A SAFETY PRECAUTION TO PREVENT INADVERTENT ENGAGEMENT OF THE REFUELING PROCESS.

19. Turn ON the electric switch. The defueling process will start. When the tanks are empty, a noise from the shut-off valve and the pump will be heard, and the electric switch must be manually turned OFF.

20. If the system is needed to do other refueling/defueling, the three-way valves in the suction and discharge lines should be reoriented for the refueling process.

21. Turn ON the supply valve from the supply tank if was turned OFF.

22. Repeat step 15 to 19 for each cycle.

23. If the system is not to be used again, remove the receiver from the electric outlet, and put the electric cable and receiver back into the control box. Lock it. This will prevent accidental starting of the system by unqualified personnel and will protect the equipment.

24. Turn OFF the supply valve from the supply tank.

25. Turn OFF the two valves on the discharge line and SARS nozzle fitting.

26. Remove the SARS nozzle. Clean and dry this and store in the storage container.

27. Remove the SARS receiver/adapter (elbow) from the BFV mock-up section. Clean and store.

28. Install the filler cap on the mock-up filler neck flange to protect the interior system from dust or other unwanted materials.