

AL/CF-TR-1995-0029

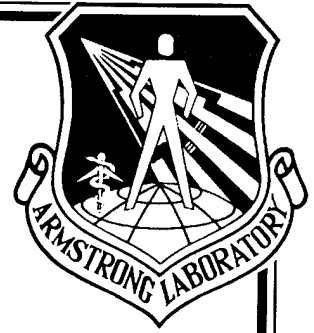

ARMSTRONG
LABORATORY

PERCEPTUAL DESIGN OF A VIRTUAL
RIGID SURFACE CONTACT

Louis B. Rosenberg

CENTER FOR DESIGN RESEARCH
STANFORD UNIVERSITY
STANFORD CA 94305

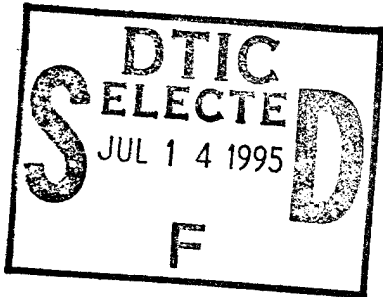

APRIL 1993

19950710 044

FINAL REPORT FOR THE PERIOD OCTOBER 1992 TO APRIL 1993

Approved for public release; distribution is unlimited

DTIC QUALITY INSPECTED 5

AIR FORCE MATERIEL COMMAND
WRIGHT-PATTERSON AIR FORCE BASE, OHIO 45433-7901

16/4

NOTICES

When US Government drawings, specifications, or other data are used for any purpose other than a definitely related Government procurement operation, the Government thereby incurs no responsibility nor any obligation whatsoever, and the fact that the Government may have formulated, furnished, or in any way supplied the said drawings, specifications, or other data, is not to be regarded by implication or otherwise, as in any manner licensing the holder or any other person or corporation, or conveying any rights or permission to manufacture, use, or sell any patented invention that may in any way be related thereto.

Please do not request copies of this report from the Armstrong Laboratory. Additional copies may be purchased from:

National Technical Information Service
5285 Port Royal Road
Springfield, Virginia 22161

Federal Government agencies registered with the Defense Technical Information Center should direct requests for copies of this report to:

Defense Technical Information Center
Cameron Station
Alexandria, Virginia 22314

TECHNICAL REVIEW AND APPROVAL

AL/CF-TR-1995-0029

The voluntary informed consent of the subjects in this research was obtained as required by Air Force Regulation 169-3.

This report has been reviewed by the Office of Public Affairs (PA) and is releasable to the National Technical Information Service (NTIS). At NTIS, it will be available to the general public, including foreign nations.

This technical report has been reviewed and is approved for publication.

FOR THE DIRECTOR



THOMAS J. MOORE, Chief
Biodynamics and Biocommunications Division
Crew Systems Directorate
Armstrong Laboratory

REPORT DOCUMENTATION PAGE

Form Approved
OMB No. 0704-0188

Public reporting burden for this collection of information is estimated to average 1 hour per response, including the time for reviewing instructions, searching existing data sources, gathering and maintaining the data needed, and completing and reviewing the collection of information. Send comments regarding this burden estimate or any other aspect of this collection of information, including suggestions for reducing this burden, to Washington Headquarters Services, Directorate for Information Operations and Reports, 1215 Jefferson Davis Highway, Suite 1204, Arlington, VA 22202-4302, and to the Office of Management and Budget, Paperwork Reduction Project (0704-0188), Washington, DC 20503.

1. AGENCY USE ONLY (Leave blank)		2. REPORT DATE April 1993	3. REPORT TYPE AND DATES COVERED FINAL - OCTOBER 1992 - APRIL 1993	
4. TITLE AND SUBTITLE Perceptual Design of a Virtual Rigid Surface Contact			5. FUNDING NUMBERS PE - 62202F PR - 7231 TA - 723100 WU - 7231000	
6. AUTHOR(S) Louis B. Rosenberg			8. PERFORMING ORGANIZATION REPORT NUMBER AL/CF-TR-1995-0029	
7. PERFORMING ORGANIZATION NAME(S) AND ADDRESS(ES) Center for Design Research Stanford University Stanford CA 94305			10. SPONSORING / MONITORING AGENCY REPORT NUMBER	
9. SPONSORING / MONITORING AGENCY NAME(S) AND ADDRESS(ES) Armstrong Laboratory, Crew Systems Directorate Biodynamics and Biocommunications Division Human Systems Center Air Force Materiel Command Wright-Patterson AFB OH 45433-7901			11. SUPPLEMENTARY NOTES	
12a. DISTRIBUTION / AVAILABILITY STATEMENT Approved for public release; distribution is unlimited.			12b. DISTRIBUTION CODE	
13. ABSTRACT (Maximum 200 words) While the state of the art in visual and auditory information display for virtual environment systems has advanced rapidly in recent years, representation of virtual force information is still in its infancy. Hindered by hardware limitations and safety considerations, most force reflection systems are unable to convincingly represent even the most basic percepts. Perhaps the most frequently distorted sensory percept is that of a rigid surface contact. Even the most forgiving users often describe virtual rigid surfaces as "mushy," "sticky," or "bouncy." This study critically examines the rigid surface contact and attempts to develop guidelines for the generation of a convincing haptic sensation. Previous attempts to create virtual rigid surfaces have focused on recreating an exact physical model of rigid contacts, which is usually not feasible due to hardware limitations. This study investigates the construction of virtual force information by modeling the <i>perceptual</i> rather than physical content, critically examining the rigid surface and attempting to extract salient perceptual features. A two-degree-of-freedom force-reflecting joystick was used to display various haptic models of a virtual wall to 7 subjects. Subjects were asked to manually explore each of the virtual wall models and use subjective rating scales to quantify the perceptual content of each. The experiment was divided into two testing sessions. The first exposed subjects to simple virtual walls modeled as basic elements, such as linear and nonlinear springs and dampers. The second test presented subjects with more complex virtual walls modeled as combinations of the simple elements from the first session. Results reveal a perceptual decomposition of the virtual wall percept enabling convincing rigid wall sensations without the need for the very high stiffnesses predicted by physical modeling.				
14. SUBJECT TERMS		Psychophysics Perceptual modeling Perceptual design Virtual surfaces		15. NUMBER OF PAGES 48
Force reflection Haptic Display Virtual reality				16. PRICE CODE
17. SECURITY CLASSIFICATION OF REPORT UNCLASSIFIED	18. SECURITY CLASSIFICATION OF THIS PAGE UNCLASSIFIED	19. SECURITY CLASSIFICATION OF ABSTRACT UNCLASSIFIED	20. LIMITATION OF ABSTRACT UL	

This page intentionally left blank.

PREFACE

This work was performed with facilities provided by NASA AMES Research Center's Human Factors Group at Moffet Field CA. Additional support was provided by Armstrong Laboratory's Crew Systems Directorate, Human Sensory Feedback Group, Wright-Patterson AFB OH. The work is part of graduate thesis work done in conjunction with the Center for Design Research, Stanford University, Stanford CA. Special thanks to Dov Adelstein and Steve Ellis for support at NASA AMES and Larry Leifer for support at CDR Stanford.

Accession For	
NTIS CRA&I	<input checked="" type="checkbox"/>
DTIC TAB	<input type="checkbox"/>
Unannounced	<input type="checkbox"/>
Justification	
By	
Distribution/	
Availability Codes	
Dist	Avail and/or Special
A1	

THIS PAGE INTENTIONALLY LEFT BLANK

TABLE OF CONTENTS

	Page
INTRODUCTION	1
Background	1
Force Reflection	1
Perceptual Design	2
The Perceptual Analysis of a Rigid Wall Contact	5
Perceptual Decomposition	7
EXPERIMENT DESIGN & METHODOLOGY	9
Overall Test Design	9
Experimental Hardware Setup	10
Test I Paradigm	11
Test I Virtual Wall Test Set	12
Derivation of the Exponential Stiffness Profile	14
Test II Paradigm	17
DATA PROCESSING	19
RESULTS	20
Raw Data	20
Processed Data	20
DISCUSSION	25
Discussion of Rating Results of Test I	25
Subjective Rating Results of Surface Rigidity (Hardness) for Test I	25
Subjective Rating Results of Initial Contact (Crispness) for Test I	26
Subjective Rating Results of Final Release (Cleanness) for Test I	27
Subjective Rating Results of Overall Rating (Wallness) for Test I	28
Discussion of Rating Results of Test II	29
Subjective Rating Results of Surface Rigidity (Hardness) for Test II	30
Subjective Rating Results of Initial Contact (Crispness) for Test II	31
Subjective Rating Results of Final Release (Cleanness) for Test II	33
Subjective Rating Results of Overall Rating (Wallness) for Test II	34
CONCLUSIONS	36
Test I Conclusions	36
Test II Conclusions	38
REFERENCES	41

LIST OF FIGURES

Figure		Page
1	Schematic of Virtual Model of Haptic Surface Contact	6
2	Subject Standing at Joystick	11
3	Virtual Wall Models Studies in Test I	12
4	Exponential Stiffness Profiles Used as Wall Models .	16
5	Virtual Wall Models Studied in Test I	18
6	Surface Rigidity Ratings for Test I for Eight Simple Virtual Wall Models	21
7	Initial Contact Ratings for Test I for Eight Simple Virtual Wall Models	21
8	Final Release Ratings for Test I for Eight Simple Virtual Wall Models	22
9	Overall Wallness Ratings for Test I for Eight Simple Virtual Wall Models	22
10	Surface Rigidity Ratings for Test II for 11 Compound Virtual Wall Models	23
11	Initial Contact Ratings for Test II for 11 Compound Virtual Wall Models	23
12	Final Release Ratings for Test II for 11 Compound Virtual Wall Models	24
13	Overall Wallness Ratings for Test II for 11 Compound Virtual Wall Models	24

INTRODUCTION

Background

While the state of the art in visual and auditory information display for virtual environment systems has been advancing by leaps and bounds in recent years, the representation of virtual force information is still in its early infancy. Hindered by hardware limitations and safety considerations, most force reflection systems are unable to convincingly represent even the most basic of haptic percepts. What is probably the most frequently distorted sensory percept attempted by virtual force reflection systems is that of a rigid surface contact. Although most of the tactual interactions we encounter in our daily lives involve contact with rigid surfaces, most force reflecting systems are unable to realistically reproduce such a percept. Virtual rigid surface contacts are often described as "mushy," "sticky," or "bouncy" by even the most forgiving users. Jex (1991), in reporting on informal "rules of thumb" derived from experience with high-performance force reflecting aircraft simulators, suggested that the ability to produce a convincing rigid wall is a primary requirement of any general purpose haptic interface. Because of the basic importance of the realistic display of haptic rigid walls for even the most primitive force reflecting virtual environments, this study critically examines the "rigid-surface-contact" percept and attempts to develop guidelines for the convincing generation of such haptic sensations.

Force Reflection

A force reflecting virtual environment system consists of force reflecting interface hardware and a computation engine. The interface hardware typically consists of a mechanical linkage in the form of a joystick or exoskeleton which couples the human operator to a source of mechanical power—either electromagnetic, electrohydraulic, or electropneumatic actuators. The computation engine governs the dynamic behavior of the interface hardware as a function of measurements from interface transducers and algorithms that describe the virtual models to be simulated. A distinguishing aspect of the display of haptic virtual information as compared to the display of visual or aural virtual information is that the same body part and interface hardware are used to transfer information back and forth

between the human and the virtual environment. Consequently, haptic information transfer is affected not only by the processing capacity of the computation engine and the comprehensiveness of the virtual model, but by the controlled dynamics of the interface linkage and of the human limb itself.

Because of the inherent physical properties of the coupled interface and human limb system, high fidelity haptic simulation of a surface contact percept presents a demanding technical challenge. The implementation of virtual haptic surfaces has been demonstrated in a variety of experimental studies (Kilpatrick, 1976; Winey, 1981; Adelstein, 1989; Minsky et al, 1990; Fasse, 1993). Acknowledged potential shortcomings of rigid wall simulations include: high frequency vibration (Ouh-young, 1990); low frequency instability (Grafiog, 1992); excessive compliance (Kilpatrick, 1976; Winey, 1981; Ouh-young et al., 1988); and stickiness (Adelstein, 1991). Stability is one problem in haptic wall implementation which has been addressed analytically (Ouh-young, 1990; Chin, 1991; Colgate et al., 1993). Recent psychophysical studies, relevant ultimately to the selection of appropriate haptic wall hardness levels, have begun to examine compliance discrimination capabilities in humans (Tan et al., 1992; Jones and Hunter, 1992).

Perceptual Design

Although previous research has addressed the generation of virtual rigid surface contacts, such work has approached the problem from primarily a dynamics and controls perspective. Although such investigations of stability and dynamics response are useful in defining limitations of force reflection hardware systems, they offer little insight into the perceptual aspects of presenting virtual force information. Recent studies have modeled virtual surfaces as linear spring/linear damper systems because such systems are convenient to analyze from a dynamics and controls perspective (Adelstein, 1989; Minsky et al., 1990; Colgate et al., 1993). These studies strive to develop virtual models which dynamically *behave* as close to a real rigid contact as hardware constraints will allow. Although it is reasonable to assume that a system which reproduces the *exact* dynamic behavior of a rigid surface contact will be *perceived* by a user exactly like a real rigid surface, it is not necessarily true that a system which *almost* behaves like a rigid surface will

be perceived as something *almost rigid*. Since hardware limitations prevent even the state-of-the-art force reflecting systems from accurately modeling stiffness values on the order of a real rigid surface, attempting to generate *similar* dynamic behaviors may not be the best approach to developing the most believable virtual percepts.

It is the belief of this author that analysis and construction of virtual force information from a *perceptual* perspective rather than a dynamics or controls perspective may result in the generation of more believable percepts within the hardware limitations of the force reflecting device. For example, it may be the case that a virtual model of a stiff linear spring is mathematically similar to a real rigid surface contact, but is perceptually very different when the stiffness value is significantly smaller than that of a real rigid surface. A linear viscous damper, on the other hand, may be physically very different than a real rigid surface contact, but it might contain strong perceptual similarities. Although dynamic analysis has led many researchers to models of rigid surfaces composed of a linear spring that is as stiff as their hardware will allow plus a small amount of added damping to enhance the stability characteristics, there is no reason to believe that such models contain particularly convincing perceptual content. The question remains, how does one model a sensory percept such as a rigid surface contact in terms of its perceptual content rather than physical qualities?

When doing a perceptual analysis of virtual sensory percepts, it is convenient to define terms such as *proximal stimulus*, *distal stimulus*, and the *perceptual hypothesis* to refer to the different stages of sensory perception. A proximal stimulus is often defined as the sensory information falling upon a receptor. A proximal stimulus may be an image falling upon the retina, a force imposed upon a muscle spindle, or a sound wave disturbing the basilar membrane of the cochlea. A distal stimulus, on the other hand, is the distant source of such sensory information. It is the reflective surface from which the visual image emanates, the weight which when lifted stretches the muscle spindles, or the bird from which the sound wave was born. Although we interact with an environment of distal stimuli, we as human beings only have access to proximal stimuli. Thus the act of perception is often described as the transduction of a proximal stimulus coupled with the guessing of what distal

stimulus most likely caused the sensation. This act of inference is often called the perceptual hypothesis and results in the generation of an internal representation of the outside world known as a percept. As long as the perceptual system is presented with enough salient sensory information in a proximal stimulus, a correct perceptual hypothesis can be made and an appropriate internal model of the actual distal stimulus will be created (Levine, 1981).

For example, a proximal stimulus might be an image falling upon your retina. Your perceptual system extracts the salient information such as edges and angles from the proximal stimulus and then might infer that the distal stimulus is a cube located across the room. This proximal stimulus might be very different from the last time you viewed that cube; lighting conditions may have changed, viewing location may have changed, it may even be a cube you have never seen before. Nevertheless you identify the object as a cube and build an internal percept. Our ability to draw the appropriate perceptual hypothesis despite changes in viewing conditions is called *perceptual constancy* and is important in allowing us to generate a robust internal model of the outside world. Clearly, some sensory information is critical for the identification and generation of the percept, while information dependent upon viewing conditions may be ignored. Because sensory perception is a complex process of inference based on certain features and not others, the key to designing a virtual percept is to ascertain which features are vital and which can be ignored.

Whether our visual system is presented with a photograph of a cube or a rough sketch of a cube, the image is likely to be identified as a cube and an appropriate internal perceptual model will be generated. In a sense, the photographic representation is analogous to physical modeling of the distal stimulus while the sketch representation is analogous to perceptual modeling of the proximal stimulus. Although a sketch contains much less sensory information than a photograph, the *sketch artist* is skilled at providing only the appropriate sensory features that assure desired perceptual analysis of the image. A good sketch can often be a more effective representation of sensory information than is a poor photograph. We can extend the analogy of the sketch and the photograph to more exotic perceptual representations such

as the virtual haptic sensations produced by force reflecting systems. Rather than producing a physically accurate (i.e., "photographic") representation of a haptic sensation, a *perceptual designer* could "sketch" haptic sensations by combining only those appropriate perceptual features which make up a desired percept. Such an approach may be more effective than "photographic" dynamic modeling of a haptic sensation, particularly in cases where force reflecting equipment lacks the fidelity to generate a realistic "photo" of the stimulus.

When developing models of a virtual sensory percept such as the *rigid surface contact*, the goal should not be to most accurately model the physical qualities of the real distal stimulus, but rather should be to provide a perceptually adequate model of the proximal stimulus. When such a model of the proximal stimulus is provided, the user can make the correct perceptual hypothesis so that the appropriate distal stimulus will be inferred. Of course, a strong understanding of the perceptual qualities of the percept being modeled is a basic requirement for the perceptual design of a convincing sensation. This study critically examines the rigid surface contact and attempts to ascertain what perceptual features are important.

The Perceptual Analysis of a Rigid Wall Contact

The first step in the perceptual design of a virtual rigid surface contact is to develop an effective decomposition of the percept into its salient sensory features. In an initial attempt to develop such a perceptual decomposition, the author spent many hours interacting with a two degree of freedom (dof) force reflecting joystick, gaining insight into the feel of a wide variety of simple virtual models and analyzing how the haptic sensations associated with such elements compare with the feel of a real rigid surface contact. The goal of such exploration was to isolate distinct and independent perceptual qualities of the real rigid wall and reveal how to reproduce such qualities through simple virtual models.

Virtual models of simple physical elements such as springs and dampers were implemented using one degree of freedom (dof) of a high performance, two axis, force reflecting joystick (Adelstein, 1989; Adelstein and Rosen, 1992).

Each axis of the joystick is powered by disk armature, permanent magnet motors, and is equipped with optical encoders to sense position, tachometers for velocity, as well as accelerometers and an interface force transducer. The motors can produce continuous forces up to a maximum of 20 N with zero cogging and negligible force ripple from DC up to 58 Hz (the first structural mode for the axis used in these experiments) at the joystick handle. The minimum friction force threshold of the passive (i.e., uncompensated) joystick is 1 N. The joystick handle's passive inertia corresponds to a mass of 0.35 kg at the hand. In these experiments, the joystick is operated under purely digital control through an A/D and D/A card with DMA on an ISA bus Intel 486DX-50 based personal computer. The digital update rate for the control algorithms used in these experiments exceeded 10 KHz.

Using this hardware, virtual haptic sensations were implemented such that a user could grab the handle of the joystick and move it to the left until the handle encountered the virtual wall model. Such an arrangement allowed for both dynamic and static interaction with the virtual sensations. For example, a virtual model of a pure linear spring was implemented so that when a user moved the handle far enough to the left, the spring was encountered and the force reflecting joystick applied an opposing force proportional to compression of the spring. Such an implementation of a virtual linear spring element is shown schematically below in Figure 1. The figure depicts the joystick handle as it is treated computationally with respect to the virtual spring that is generated by the motors in the joystick base.

Haptic Virtual Model

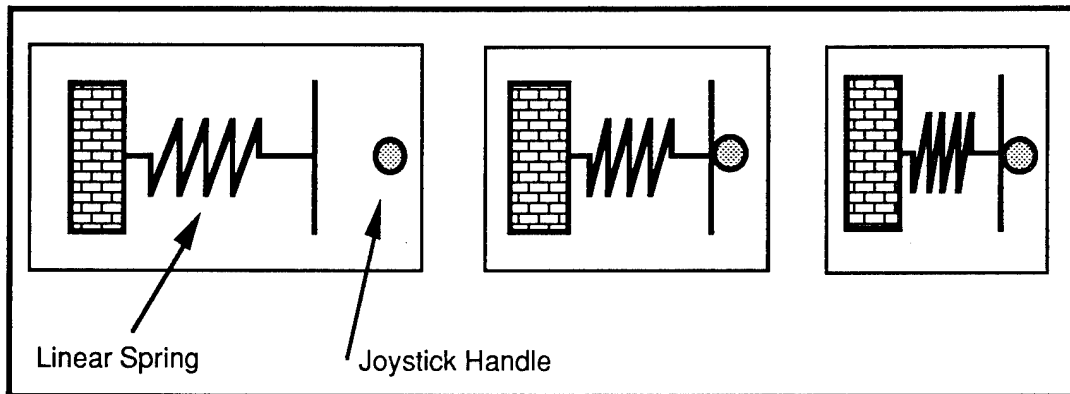

Figure 1. Schematic of Virtual Model of Haptic Surface Contact

Starting with basic virtual models such as linear springs and linear viscous dampers and expanding to nonlinear and more abstract elements, basic perceptual qualities of the virtual sensations were exhaustively compared to that of a real rigid surface contact. The real rigid surface contact was implemented by a physical hard stop that could be placed in the path of the joystick in the same location where the virtual models were presented. After extensive comparisons of many such virtual models, the following decomposition of the rigid wall contact was hypothesized.

Perceptual Decomposition

The basic percept of a rigid wall contact was found to effectively decompose into at least three perceptual parts: the initial dynamic contact with the surface, the quasi static interaction with the hard surface, and the final dynamic release from the surface. Each of these stages was found to have very distinct and independent perceptual qualities which can be described simply as the initial contact *crispness*, the rigid surface *hardness*, and final release *cleanness*. Observations revealed that if the perceptual content of any of these parts was not well represented, the overall percept of a rigid surface contact was highly distorted and the resulting percept was simply not believable. For example, interaction with a virtual model of a stiff linear spring was found to provide an adequate representation of a *hard* rigid wall when interacting in static contact with the surface; but when interacting with such a model dynamically, it was found that the initial dynamic contact had a disturbingly "mushy" or "bouncy" feel which highly distorted the overall illusion of rigidity. A virtual model of a pure linear damper, on the other hand, was found to produce a very *crisp* and abrupt force upon initial contact which can be described as more of a "thud" than a "bounce". Interaction with such a model provided a very realistic sensation of a rigid surface for the first instant of contact. After that first instant, the pure damper could not maintain the illusion of hard contact because it lacks all static rigidity and allows the joystick to sink slowly into the wall model. When pulling away from a virtual wall modeled as a pure linear damper, the percept again fails because it feels "sticky," as if pulling your hand out of a thick liquid. This sticky feeling can be eliminated by modeling a virtual damper that only produces an impedance

when velocity is toward the wall and has zero impedance when moving away from the wall. Such *directional dampers* were found to provide a *clean* final release from a virtual wall, although the initial contact sensation they produced were not as crisp as the pure linear damper. From these first few observations, initial attempts at a perceptual model of a rigid surface contact can be made. A first guess at a perceptual design of a rigid wall might be to model a boundary layer of intense directional damping to provide the illusion of crisp initial contact and clean final release followed by a stiff linear spring to provide the illusion of a hard static rigidity.

Although perceptual modeling based on personal observation is insightful, it is the subjective result of exploration rather than objective experimentation. The following empirical study was designed to systematically record the reactions of naive test subjects while interacting with various perceptual elements. The goals of this experiment were, first, to ascertain if the proposed decomposition of the rigid wall contact is a valid and useful way to analyze the percept of a rigid surface contact. Secondly, the study was intended to identify which parts of the perceptual decomposition are most important to the overall percept. Finally, the study was intended to provide insight into what simple virtual models can be used to provide the salient perceptual features. It is hoped that this study will help develop guidelines for the perceptual design of believable rigid surface contacts through the combination of basic perceptual elements. It is also hoped that the methods of perceptual design developed here will offer designers of virtual sensations a powerful alternative to physical modeling.

EXPERIMENT DESIGN & METHODOLOGY

Overall Test Design

A two degree of freedom, force reflecting joystick was used to display haptic models of various virtual walls to seven subjects. Subjects were asked to manually explore each of the virtual wall models and use subjective rating scales to quantify the perceptual content of each. For each trial, subjects interacted with a virtual wall and rated, on a scale from 1 to 7, each of the following criteria: *initial surface contact* (crispness), *surface rigidity* (hardness), *final release* (cleanness), and *overall rating* (wallness). Subjects were instructed that initial surface contact (crispness) referred to the sensation associated with the very first instant of interaction with the wall model. Surface rigidity (hardness) was described as the sensation associated with applying static pressure to the surface. Final release (cleanness) was described as the sensation associated with the instant of pulling away from the surface. Overall wallness was described as how well the model compared to a real rigid wall contact that was presented to the subject between every trial.

The experiment was divided into two testing sessions, to be referred to as Test I and Test II. Test I exposed each subject to a set of eight simple virtual wall models. Each of the virtual walls used in this test was modeled as a single basic element such as a pure linear spring or a pure linear damper. The purpose of using very simple elements in Test I was to evaluate the perceptual content of basic building blocks from which more realistic percepts could be composed. The primary goals of Test I are enumerated as follows: First, to ascertain if subjects could use the proposed decomposition to quantify the perceptual aspects of the rigid wall sensations; second, to gain insight into how basic elements might contribute to each aspect of the perceptual decomposition; and, third, to correlate relative importance of each part of the perceptual decomposition to the overall wallness ratings. Test II was run identically to Test I except that subjects were presented with a set of 11 more complex virtual wall models. Each of the virtual walls used in this test was modeled as a combination of two of the simple elements included in Test I. The primary goals of Test II were, first, to ascertain if subjects could use the proposed decomposition to quantify aspects of more realistic rigid wall

sensations; second, to gain insight into how various combinations of basic building blocks might affect the perceptual decomposition of the overall sensation; and, third, to correlate perceptual decomposition to the overall wallness ratings to understand the relative importance of the three perceptual parts.

Experimental Hardware Setup

Virtual wall models were implemented using one degree of freedom of a high performance, two axis, force reflecting joystick as previously described (Adelstein, 1989; Adelstein and Rosen, 1992). Subjects stood facing the joystick as depicted in Figure 2. The handle, which was at a height of 1 m from the floor, was grasped in the right hand. Virtual walls were aligned as shown by the shaded rectangle in Figure 2, allowing approximately 7 cm of right-to-left motion before contact was made. To eliminate spurious haptic information to the subject caused by sliding parallel along the wall surface, motion in the corresponding joystick degree of freedom (fore and aft) was blocked with a rigid clamp. To eliminate all non-haptic cues from the testing procedure, subjects were fitted with an audio headset that presented white noise that masked sounds from the force reflecting joystick mechanism. A partition was also used to prevent subjects from viewing their hands as they interacted with the joystick. To keep the rating criteria fresh in their minds, subjects were given a sheet of paper with the four criteria and rating scales. A sketch of the testing setup including the joystick mechanism and a test subject is shown in Figure 2.

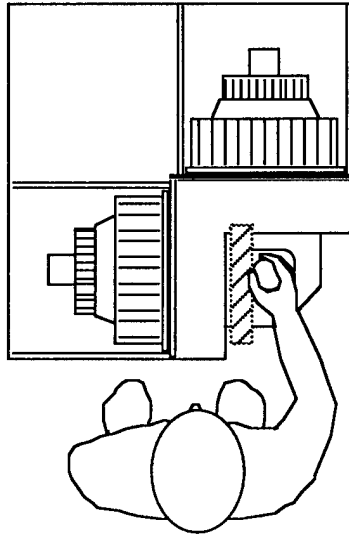

Figure 2. Subject Standing at Joystick. The subject pushes the handle to the left with the right hand to contact the virtual wall (diagonally shaded rectangle). The subject's hand and joystick handle are hidden from the subject's view during experiments.

Test I Paradigm

Subjects were exposed to a set of eight simple virtual wall models and asked to rate each wall using the four criteria described above: initial contact, surface rigidity, final release, and overall wallness. Between each virtual wall model, subjects were asked to feel a real rigid wall contact implemented by a hard stop on the same joystick device used to generate the virtual walls. The complete set of virtual wall models was presented to each subject a total of seven times, each with a random presentation order. The first three passes through the set of eight wall models were used as a training session for the subjects to familiarize them with the range of sensations they were asked to rate. During this training session, subjects were asked to concentrate on defining the limits for each rating scale so that they could spread their subjective ratings across the entire scale. Thus the best and worst limits for each scale were defined by individual subjects as the best and worst sensations that were presented in the experimental set. During the next four passes

through the set of eight virtual walls, subjects were asked to subjectively rate each of the wall models by verbally reporting their results to the experimenter. During this part of the experiment, subjects were asked to concentrate on maintaining consistent rating scales for all four of the remaining passes through the wall models.

Test I Virtual Wall Test Set

As described above, Test I involved the presentation of a set of eight simple virtual wall models. The wall models used for this test were composed of single elements such as springs or dampers. The intent was to evaluate the perceptual content of basic building blocks from which more realistic percepts could be composed. The complete set of eight virtual wall models studied in Test I along with a graphical representation of each model, is shown in Figure 3 for reference.

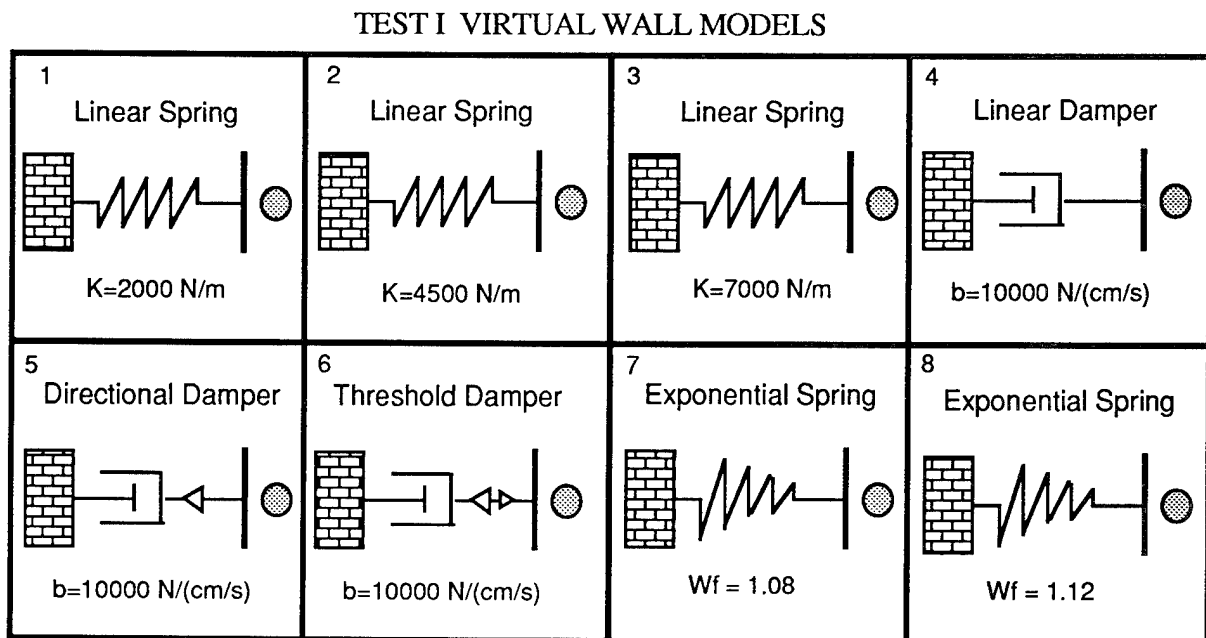

Figure 3. Virtual Wall Models Studied in Test I

The following section is a brief description of each simple element tested. Three of the virtual walls tested were composed of a pure linear spring element with stiffness of 2000 N/m, 4500 N/m, and 7000 N/m. This range was

investigated to gain insight into the effect that increasing stiffness has upon quality of the overall percept. Three of the virtual walls tested were composed of viscous dampers with a damping value of 10000 N/(cm/s). One damper model was simply a pure *linear damper* which produced an opposing force proportional to velocity. The second damper, referred to as a *directional damper*, was modeled such that it only opposed velocities in the direction toward the wall and had no effect when moving away from the wall. The third damper, referred to as a *threshold damper*, acted like a typical linear damper that turned into a directional damper when the velocity away from the wall exceeded a small threshold. The abstract notions of the directional damper and threshold damper were devised and tested in an attempt to provide damping but reduce the "stickiness" associated with heavily damped wall models.

The final two wall models tested were nonlinear springs with an exponential force Vs displacement profile. The exponential springs were derived to combat a discretization problem inherent to most force reflecting systems which limits the maximum allowable linear stiffness that can be presented. The problem arises in force reflecting systems that employ a servo loop with a digital position feedback from an encoder or A/D converter. In such systems, the maximum linear stiffness of a virtual spring that can be generated is limited by the step size of the smallest digital increment in position feedback. When stiffness becomes large enough that the force increment associated with a single digital step exceeds the user's ability to discriminate a differential change in force, the sensation is no longer perceived as a smooth linear relation, but rather as discernible incremental steps. The smallest change in force that a person can feel is often referred to by psychophysicists as a *just noticeable difference* (JND). Thus, when trying to represent a linear stiffness through force reflecting hardware that uses discrete position feedback, the fidelity of the percept is greatly corrupted when the force increase per digital step exceeds the JND in force. In addition to this limitation in the dynamic interaction with a linear virtual stiffness, static interaction with any virtual model is also corrupted when the force increment associated with a single digital step exceeds JND. Even when the joystick is in static contact with a virtual percept, if the force increment per digital step is super-threshold, a distracting vibration can be felt when the

position feedback device bounces on the edge of a pulse. Both of these effects corrupt the overall fidelity and believability of the linear spring sensation.

The question remains, can a stiffness profile be derived that maintains a force increment per digital step that is always below the user's ability to perceive a JND in force? Weber (1836) has shown that human ability to perceive a JND is not absolute, but rather varies linearly with the magnitude of the sensation. This linear variation in sensitivity with magnitude is described by a proportionality constant called a Weber fraction (W_f). Thus, when interacting with a virtual wall, users are most sensitive to small discrete jumps in force when lightly contacting the wall and are significantly less sensitive to such force increments when vigorously interacting with a surface. To take advantage of this linear variation in human sensitivity, a nonlinear spring was derived such that the force increment associated with each encoder pulse always remains below the JND in force. The effect is essentially a spring whose stiffness increases linearly with compression, resulting in an overall exponential force Vs displacement profile.

At very low force values, the Weber JND proportionality fails to hold. As a result, the initial part of the stiffness profile was derived as a purely linear spring. At the position in the force Vs displacement profile where the force increment associated with the linear spring becomes less than the force increment predicted by the Weber proportionality, the profile is smoothly transitioned to the exponential curve proposed above. Although the force profile of this virtual stiffness model is linear for very small values of displacement and exponential for larger displacements, this stiffness profile will be referred to hereinafter simply as the *exponential stiffness profile* to clearly distinguish it from the purely linear stiffness profiles.

Derivation of the Exponential Stiffness Profile

Three parameters completely describe the stiffness profile: the size of a single discrete increment of the position sensor reading D_s , the linear force increment F_t , and the Weber constant W_f . For the force reflecting joystick used in these experiments, the size of the optical encoder pulse on the motors dictated the size of the discrete position increment D_s to be 0.0175 cm. The

linear force increment is the force increase per discrete position increment to be used in the initial linear region of the stiffness profile. Ideally, this value should be the largest force that remains subthreshold to users of the system. This depends upon the friction and inertia of the system. By trial and error testing, a value of 1 oz was chosen as a conservative estimate for F_t for this system. W_f is the Weber fraction that describes the exponential part of the profile. Previous studies of manual force resolution suggest Weber fractions for upper limb force discrimination to be in the neighborhood of 10% (Tan, 1992). For this experiment, two Weber fractions ($W_f=1.08$ and $W_f=1.12$) were chosen for comparison. The variation in Weber fraction was the only difference between the two exponential stiffness models tested.

From these three parameters, the profile can be algebraically computed as follows: K is the stiffness of the linear region of the profile and can be computed from D_s and F_t as follows:

$$K = \frac{F_t}{D_s} \quad \text{Linear Stiffness}$$

Knowing the linear stiffness K , the force increment F_t and the Weber fraction W_f , the transition point X_t where the linear increments in force become smaller than the increments described by the Weber fraction JND can be found from the inequality:

$$JND > F_t \quad \text{Transition Inequality}$$

Knowing that $JND=[(W_f-1) * \text{Net Force}]$ and $\text{Net Force} = (K X_t)$, this relation can be rewritten and solved for the transition point X_t :

$$[W_f-1] K X_t > F_t$$

$$X_t = \frac{F_t}{K (W_f-1)}$$

$$X_t = \frac{D_s}{(W_f-1)} \quad \text{Transition Point}$$

Thus, for all compressions of the spring smaller than X_t , the stiffness profile is linear and is described by Hooke's law as:

$$F = K x \quad \text{for } x < X_t$$

For compressions of the spring greater than or equal to X_t , the stiffness profile is described by the exponential relation:

$$F = (K X_t) 10^{\frac{\log(Wf)}{Ds}(x - X_t)} \quad \text{for } x \geq X_t$$

Using the relations described above, Test I included two virtual walls modeled as springs with exponential stiffness profiles, both of which were computed with $F_t=1$ oz and $D_s=.0175$ cm. The only difference between the two exponential stiffness models was the Weber fractions used: $W_f=1.08$ and $W_f=1.12$. The exponential stiffness curves described by these parameters are shown below in Figure 4.

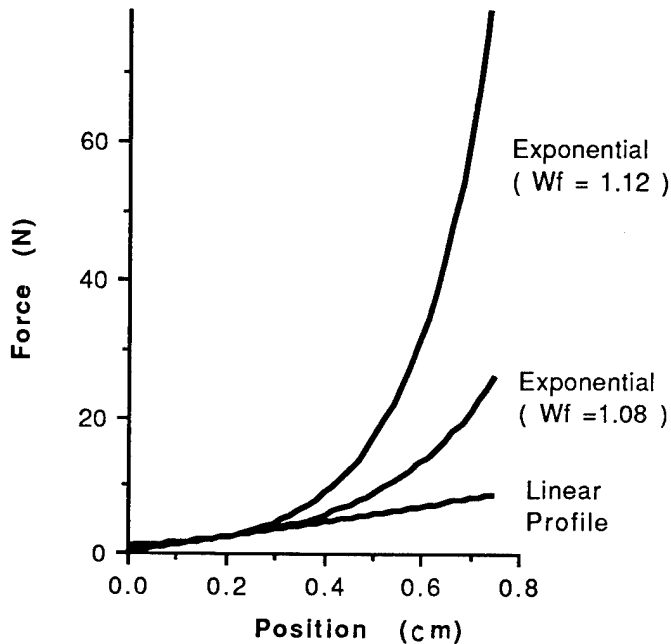

Figure 4. Exponential Stiffness Profiles Used as Wall Models

Test II Paradigm

Test II was run identically to Test I in all ways except in that a different set of virtual wall models was used. While Test I looked at basic elements in isolation, Test II investigated combinations of these basic building blocks into compound virtual wall models. Because the walls presented in Test II evoked significantly more realistic percepts than those tested in Test I, subjects had to develop new subjective rating scales for this test. To eliminate residual effects from Test I upon the subjective scales developed in Test II, subjects were required to take at least a 30-minute break between testing sessions.

In Test II subjects were presented with a set of 11 virtual walls, each of which was modeled as a combination of a stiffness and a damping element investigated in Test I. A basic question of interest was how the ratio of damping to stiffness affects the perceptual content of the wall percept. To address this issue, three of the virtual wall models were tested, each of which was composed of a linear spring element in parallel with a linear damper element. The three spring-damper systems were composed such that they had very different ratios of damping to stiffness: 0.125, 0.833, and 2.50. Also tested were two spring-damper systems implemented as a linear spring element in parallel with a directional or threshold damper element. In addition, two spring-damper models were tested in which the linear damper was contacted by the joystick before the linear spring so as to create a barrier zone of pure damping in front of the standard spring-damper model.

Test II also included spring-damper systems composed of exponential stiffnesses and various damper configurations. One virtual wall was modeled as an exponential stiffness and a light damping of 5000 N/(cm/s). Another virtual wall was modeled as an exponential stiffness and a heavy damping of 10000 N/(cm/s). The two final virtual walls were modeled as exponential stiffnesses and directional and threshold dampers of 10000 N/(cm/s). The complete set of 11 virtual wall models tested in Test II is listed, along with graphical representations, in Figure 5.

TEST II VIRTUAL WALL MODELS





<p>1 Linear Spring Linear Damper</p>  <p>$b=1000 \text{ N s/cm}$ $\frac{b}{K} = .125$ $K=8000 \text{ N/m}$</p>	<p>2 Linear Spring Linear Damper</p>  <p>$b=5000 \text{ N s/cm}$ $\frac{b}{K} = 0.83$ $K=6000 \text{ N/m}$</p>	<p>3 Linear Spring Linear Damper</p>  <p>$b=10000 \text{ N s/cm}$ $\frac{b}{K} = 2.50$ $K=4000 \text{ N/m}$</p>
<p>4 Linear Spring Directional Damper</p>  <p>$b=10000 \text{ N s/cm}$ $\frac{b}{K} = 2.50$ $K=4000 \text{ N/m}$</p>	<p>5 Linear Spring Threshold Damper</p>  <p>$b=10000 \text{ N s/cm}$ $\frac{b}{K} = 2.50$ $K=4000 \text{ N/m}$</p>	<p>6 Linear Spring Linear Damper Damping Barrier Zone</p>  <p>$b=5000 \text{ N s/cm}$ $\frac{b}{K} = 0.83$ $K=6000 \text{ N/m}$</p>
<p>7 Linear Spring Linear Damper Damping Barrier Zone</p>  <p>$b=10000 \text{ N s/cm}$ $\frac{b}{K} = 2.50$ $K=4000 \text{ N/m}$</p>	<p>8 Exponential Spring Linear Damper</p>  <p>$b=5000 \text{ N s/cm}$ $Wf = 1.12$</p>	<p>9 Exponential Spring Linear Damper</p>  <p>$b=10000 \text{ N s/cm}$ $Wf = 1.12$</p>
<p>10 Exponential Spring Directional Damper</p>  <p>$b=10000 \text{ N s/cm}$ $Wf=1.12$</p>	<p>11 Exponential Spring Threshold Damper</p>  <p>$b=10000 \text{ N s/cm}$ $Wf=1.12$</p>	

Figure 5. Virtual Wall Models Studied in Test I

DATA PROCESSING

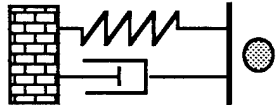
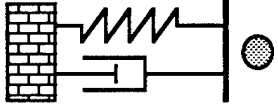
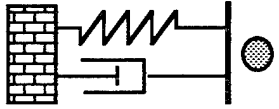
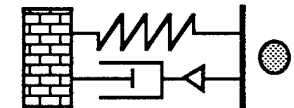
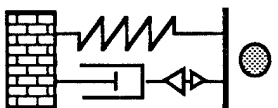
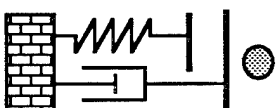
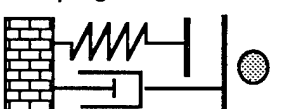
The data collected from the seven subjects in Test I and Test II consisted of whole-number subjective ratings in the range from 1 to 7. For each trial of a particular wall model, independent ratings were recorded for each of the four criteria: initial contact, surface rigidity, final release, and overall rating. Because each virtual wall model was presented four times to every subject during the rating part of the experiment, averages and standard deviations were computed to quantify the consistency of each subject's subjective ratings. Coefficients of variation were then computed for each subject's rating of a particular wall model for a particular perceptual criterion. These coefficients of variation provided general insight into how well subjects were able to use the given perceptual decomposition to assess the sensations presented.

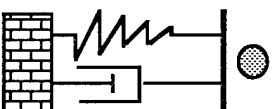
The actual raw subjective rating data were found to be inadequate for comparison across subjects because of variations in the subjects' rating scales. Each subject developed his/her own individual rating scales with unique limiting values and nonlinearities. The raw data were normalized for comparison across subjects by replacing subjective rating scores by the ordinal value of the rating scores as compared to the ratings of the complete set of wall models. This was achieved by ordering the subjective rating scores numerically from worst to best and assigning ordinal values. For Test I, ordinal values were assigned such that 1 represented the walls rated the worst of the set and 8 represented the walls rated the best of the eight-wall set. For Test II, ordinal values were assigned such that 1 represented the walls rated the worst of the set and 11 represented the walls rated the best of the 11-wall set. By using ordinal values instead of the raw subjective ratings, the subjects' relative impressions of each wall model percept were extracted independently of the actual rating scales used. This method of processing allowed for direct, meaningful comparisons of subjective rating data across all seven subjects.

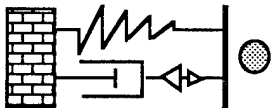
RESULTS

Raw Data

Before looking at the processed data, the reliability and repeatability of the raw data were investigated. The mean coefficient of variation of a subject's rating of a particular quality for a particular virtual wall model was found to be 0.16 for Test I and 0.24 for Test II. These values reflect relatively low variability in the subjective rating data and suggest that subjects had little trouble decomposing the overall percepts into the given perceptual elements (initial contact, surface rigidity, and final release). It further suggests that each subject had a clear conceptual model of how each virtual wall compared to the others for each of the perceptual qualities they were asked to rate. During post testing interviews, subjects reported having little trouble using the given perceptual decomposition and felt that they could clearly distinguish each quality independently of the others. When asked if there were any changes that should be made to the given decomposition to make the rating process easier, all seven subjects reported being satisfied with the decomposition, and none had any suggestions for improvements.

Processed Data

As described above, the raw rating data were normalized by replacing subjective rating scores by their ordinal values. The complete normalized rating data for all four criteria over all eight wall models of Test I are shown in graphical form in Figure 6 through Figure 9. The complete normalized rating data for all four criteria over all 11 wall models of Test II are shown in graphical form in Figure 10 through Figure 13. For all graphs, the virtual wall models are indicated by the number they were assigned previously in Figure 3 and Figure 5. Error bars which depict the standard error of means computed across seven subjects are shown on all graphs. The mean coefficient of variation for normalized ratings across all subjects for all tests was also computed and found to be 0.20. This small variation in normalized rating among subjects suggests, first, that the ordering process is a valid means of comparing data across subjects and, second, that all seven subjects had similar impressions of the sensations they experienced.

Test I Results

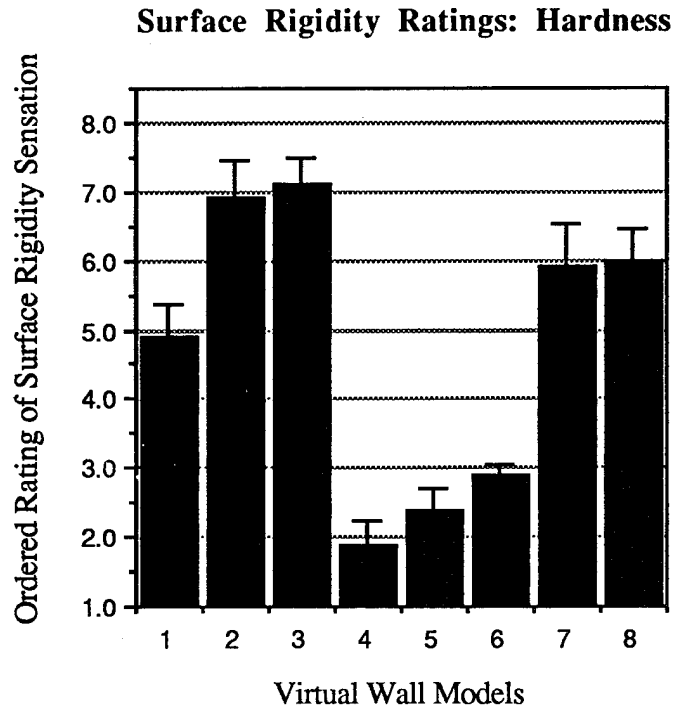

Figure 6. Surface Rigidity Ratings for Test I for Eight Simple Virtual Wall Models

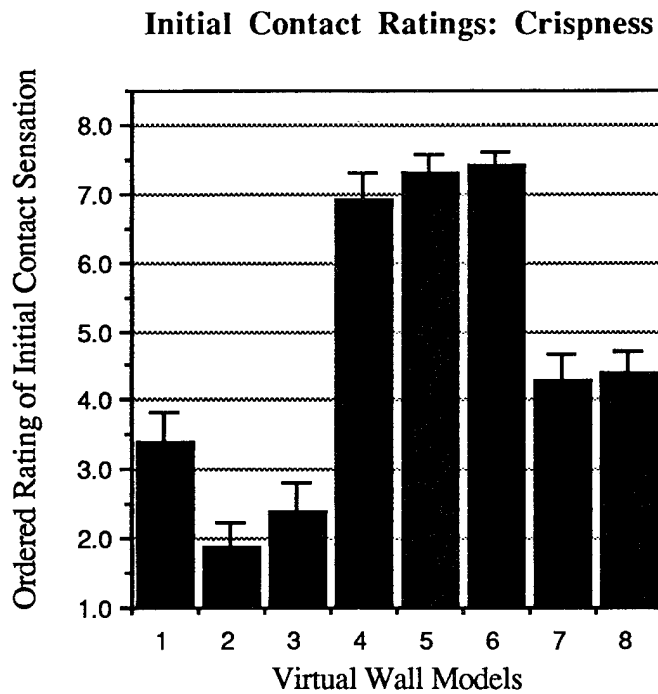

Figure 7. Initial Contact Ratings for Test I for Eight Simple Virtual Wall Models

Final Release Ratings: Clean-ness

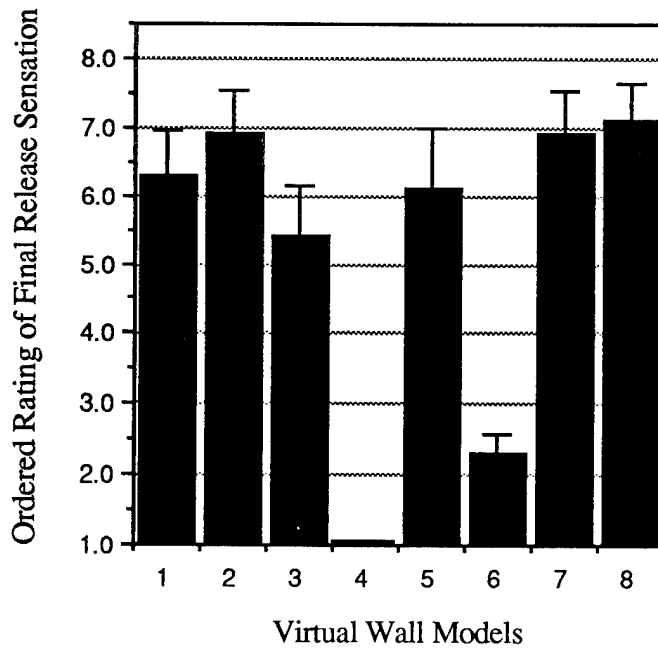

Figure 8. Final Release Ratings for Test I for Eight Simple Virtual Wall Models

Overall Ratings: Wallness

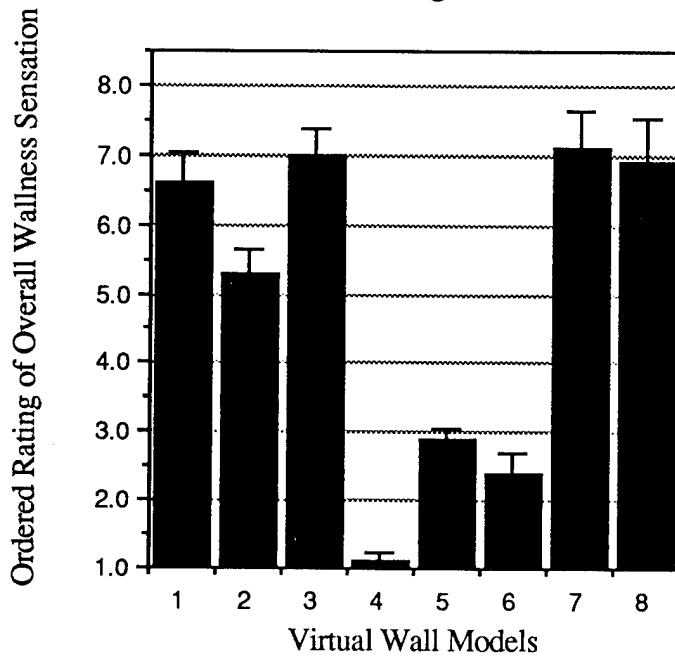

Figure 9. Overall Wallness Ratings for Test I for Eight Simple Virtual Wall Models

Test II Results

Surface Rigidity Ratings: Hardness

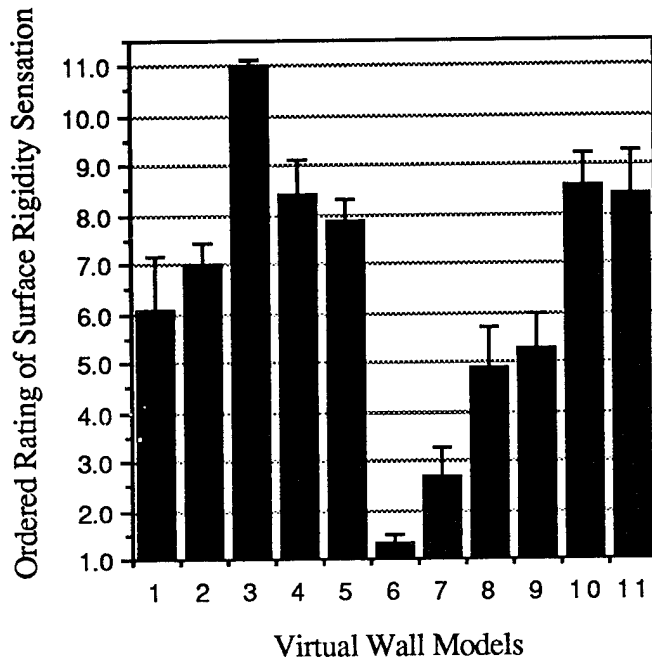

Figure 10. Surface Rigidity Ratings for Test II for 11 Compound Virtual Wall Models

Initial Contact Ratings: Crispness

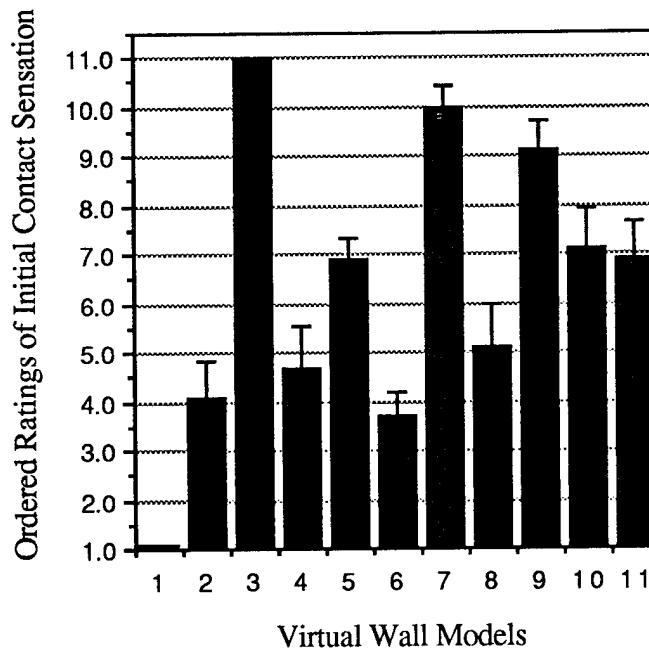

Figure 11. Initial Contact Ratings for Test II for 11 Compound Virtual Wall Models

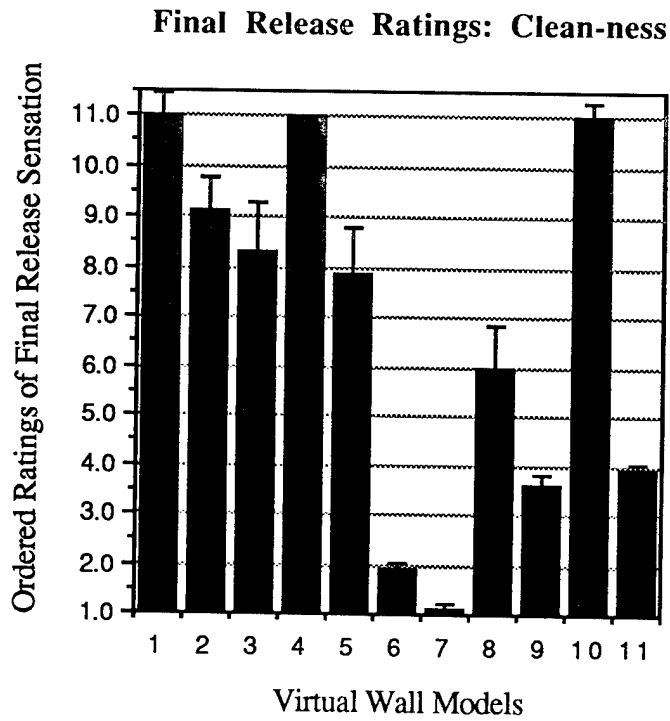

Figure 12. Final Release Ratings for Test II for 11 Compound Virtual Wall Models

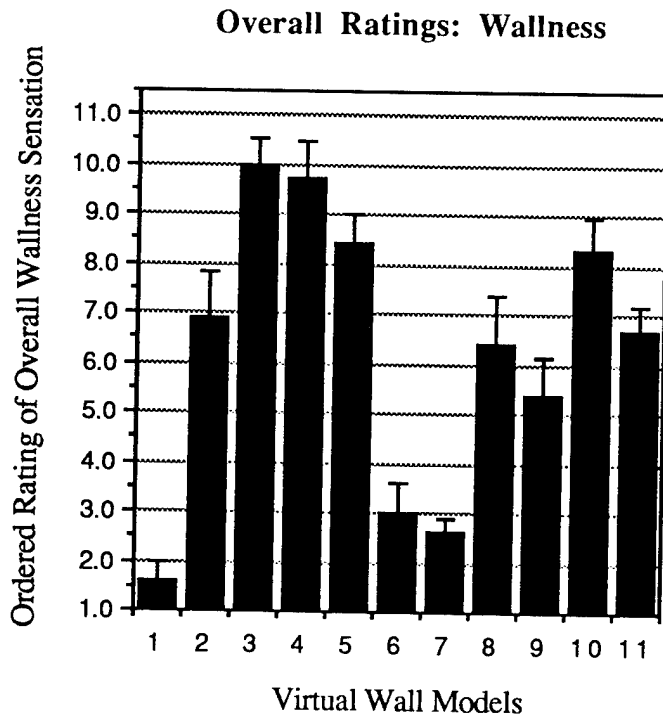

Figure 13. Overall Wallness Ratings for Test II for 11 Compound Virtual Wall Models

DISCUSSION

Discussion of Rating Results of Test I

Subjective Rating Results of Surface Rigidity (Hardness) for Test I

Turning first to the surface rigidity ratings for the eight simple virtual wall models investigated in Test I, Figure 6 clearly depicts two distinct groupings of hardness ratings. Wall models 1, 2, 3, 7, and 8 are all on the upper end of the hardness rating scale, with scores ranging between 4.9 and 7.2. The remaining wall models 4, 5 and 6 are all on the low end of the hardness rating scale, with scores ranging between 1.8 and 2.8. These results demonstrate that all seven subjects had the same strong impression that virtual walls 1, 2, 3, 7 and 8 provided the strongest sensations of surface hardness, while the remaining virtual walls 4, 5, and 6 provided the weakest sensations of surface hardness. The virtual walls 1, 2, 3, 7, and 8 which provided the strong sensations of surface hardness were all modeled as spring elements of various configurations. The virtual wall models 4, 5 and 6 which provided the poor sensations of surface hardness were all modeled as viscous dampers of various configurations.

Of the virtual walls that provided a strong sensation of hardness, wall models 1, 2, and 3 were pure linear spring elements with a wide range of stiffness values: 2000 N/m, 4500 N/m, and 7000 N/m, respectively. Despite this wide variation in stiffness values, little variation in hardness ratings was recorded. Although the lightest stiffness value of 2000 N/m did not provide as strong a sensation of hardness as the others, subject testing has revealed that a modest stiffness of 4500 N/m provided subjects with just as strong a hardness sensation as a stiffness value as high as 7000 N/m. Also providing a strong sensation of hardness, virtual wall models 7 and 8 were modeled as exponential springs with Weber fractions of 1.08 and 1.12, respectively. The hardness ratings were essentially identical for the two different Weber fractions tested. Little difference in hardness ratings was found between the exponential springs and the linear springs tested. The results suggest that both exponential stiffnesses tested were slightly better at providing the sensation

of hardness than was the 2000 N/m linear stiffness, but were not quite as good at providing a hardness sensation as the 4500 N/m and 7000 N/m linear springs.

Viscous damper virtual wall models 4, 5, and 6, on the other hand, all were found to provide a very poor sensation of hardness. Although virtual wall 4 was a pure damper, virtual wall 5 was a directional damper, and virtual wall 6 was a threshold damper, little difference in surface rigidity was noted between these variations. Of the three, the pure linear damper was the worst at providing a hardness sensation, and the nonlinear threshold damper was the best.

The results of this surface rigidity testing strongly suggest, first, that hardness is a distinct and extractable quality of a rigid wall contact sensation and that all subjects had very similar impressions of how to rate this perceptual quality. The results also strongly suggest that spring elements of various configurations provide a strong sensation of surface hardness while viscous dampers of various configurations do not. The results revealed little difference between various magnitudes of linear stiffness as well as little difference between exponential and linear stiffness profiles.

Subjective Rating Results of Initial Contact (Crispness) for Test I

Turning next to the initial contact ratings for the eight simple virtual wall models investigated in Test I, Figure 7 depicts two distinct groupings of initial contact ratings. Wall models 1, 2, 3, 7, and 8 are all on the low end of the initial contact rating scale, with scores ranging between 1.8 and 4.3. The remaining wall models 4, 5, and 6 are all on the high end of the initial contact rating scale, with scores ranging between 6.9 and 7.4. These results demonstrate that all subjects had the same strong impression that virtual walls 4, 5, and 6 provided the strongest sense of abrupt, crisp, initial contact, while the remaining virtual wall models provided the poorest sensation of initial contact. The virtual wall models 4, 5, and 6, which provided the strongest sensation of initial contact, were all modeled as viscous dampers. Although 4 was a linear damper, 5 was a directional damper, and 6 was a threshold damper, no statistically significant difference in the rated quality of initial contact

sensation was recorded. The virtual walls 1, 2, 3, 7, and 8, which provided a poor sensation of initial contact, were all modeled as spring elements. Models 1, 2, and 3 were pure linear springs of various stiffness (2000 N/m, 4500 N/m, and 7000 N/m, respectively). Of the three, the lowest stiffness value of 2000 N/m was rated the highest in initial contact sensation, while little difference was recorded between the 4500 N/m and 7000 N/m stiffnesses. The remaining wall models 7 and 8 were both modeled as exponential springs with Weber fractions of 1.08 and 1.12. No difference was recorded in initial contact rating between the two. Both of these springs showed a moderate advantage in initial contact rating over the pure linear springs, but were still far from the rating scores achieved by the linear dampers.

The results of this initial contact rating test strongly suggest that initial contact is a distinct and extractable quality of a rigid wall contact sensation and that all subjects had very similar impressions of this perceptual quality. The results also strongly suggest that pure viscous dampers of various configurations can provide a strong sensation of crisp initial contact, while various configurations of linear and nonlinear spring elements could not. An explanation of why viscous dampers can provide a stronger impression of crisp and abrupt initial contact than can spring elements stems from the simple fact that dampers are dependent upon the derivative of hand position, while springs are dependent upon hand position itself. The damper's crisp and abrupt feel is largely due to the fact that the derivative of hand position provides an element of prediction to the control of the force stick, allowing for a faster dynamic response. The incident velocity of the joystick approaching the virtual wall is a predictive indication of how hard the wall is about to be hit; thus, the control system has some lead in quickly responding with an abrupt opposing force. Spring elements have no means of predicting the contact force and thus cannot produce as strong an opposing force until the wall has already been penetrated by some amount, resulting in a bouncy rather than crisp initial contact feel.

Subjective Rating Results of Final Release (Cleanness) for Test I

Turning next to the final release ratings for the virtual wall models investigated in Test I, Figure 8 shows that wall models 1, 2, 3, 5, 7, and 8 are all

on the high end of the final release cleanness rating scale, with scores ranging between 5.4 and 7.1. The remaining wall models 4 and 6 were on the very low end of the final release cleanness rating scale, with scores ranging between 1.0 and 2.3. These results clearly demonstrate that all linear spring elements (1, 2, and 3) as well as the exponential spring elements (7 and 8) provided a strong sensation of a clean final release from the virtual wall model. In addition, virtual wall model 5, which was a directional viscous damper, provided a strong sensation of a clean final release from the wall. On the other hand, virtual wall model 4, which was a standard viscous damper, provided a very poor sensation of a clean release from the virtual wall that was often described by subjects in post-testing interviews as "sticky." Virtual wall model 6, the threshold damper, on the other hand, was rated by all subjects as being slightly better than the pure linear damper, but worse than all the other wall models.

Subjective Rating Results of Overall Rating (Wallness) for Test I

Finally we turn to the overall wallness ratings of the virtual wall models of Test I. As shown in Figure 9, virtual walls 1, 2, 3, 7, and 8 were consistently rated near the high end of the rating scale by all subjects, with scores ranging between 5.3 and 7.1. Virtual walls 4, 5, and 6, on the other hand, were consistently rated at the low end of the rating scale, with scores ranging from 1.1 to 2.8. These results demonstrate that all five spring models were given high wallness ratings, while all three damper models were given low wallness ratings.

To gain insight into what perceptual qualities are most important to the overall wallness of the percepts, the overall wallness rating results were compared with the individual perceptual quality ratings for surface rigidity, initial contact, and final release. The trend seen in the overall ratings closely matches the trend seen in the surface rigidity ratings. This result suggests that, when simple models are presented in isolation, the most important perceptual quality of a rigid wall contact percept is the surface rigidity. Although this result is insightful, it is yet unclear how the relative importance of perceptual qualities will change when simple elements are combined into compound sensations.

From these results, we can conclude that the most effective way to model a rigid wall as a single element is to use a spring element rather than a viscous damper. If we compare the overall ratings of all the spring configurations, we find that range of stiffness values of the linear springs had little measurable effect upon the overall wallness ratings. In fact, a linear spring of 2000 N/m was found to provide just as convincing an overall wall sensation as did a linear spring of 7000 N/m. The exponential springs were rated very similarly in overall rating to the linear springs.

The various configurations of viscous damper were all rated on the low end of the overall rating scale. The lowest rated wall was model 4, the pure linear damper, while the directional damper and threshold damper were rated higher. If we compare this relation between the dampers to the ratings of the individual perceptual qualities, we find the trend to match the final release ratings. It is likely that the poor final release associated with the pure linear damper resulted in its lower rating in overall wallness, although the influence of final release on overall wallness is clearly not as pronounced as is the influence of surface rigidity.

Discussion of Rating Results of Test II

Having confirmed that the proposed perceptual decomposition of the virtual wall percept into *surface rigidity*, *initial contact*, and *final release* was a reasonable and usable method of breaking down a rigid wall sensation composed of basic elements in isolation, the next step was to investigate the perceptual decomposition of compound wall models composed of multiple elements in combination. Each model studied in Test II was a combination of a spring element and a damper element tested in Test I. The basic issue addressed by Test II was the effect that various combinations of spring and damper elements have upon the perceptual decomposition of the virtual wall models.

Subjective Rating Results of Surface Rigidity (Hardness) for Test II

Turning first to the surface rigidity ratings for the 11 compound virtual wall models investigated in Test II, Figure 10 depicts a wide range of surface hardness ratings for the various wall models. Wall models 1, 2, and 3 are composed of a basic combination of a linear spring and a linear damper in parallel as shown schematically in Figure 5. The only difference among these three wall models is the ratio of damping to stiffness. Wall model 1 has high stiffness and low damping, providing a ratio of $b/k=0.125$. Wall model 2 has moderate stiffness and moderate damping, with a ratio of $b/k=0.83$. Wall model 3 has low stiffness and high damping, with a ratio of $b/k=2.5$. Comparing these three wall models, we find that damping ratio has a significant effect upon the subject's perception of surface hardness. Wall model 1, having the low damping to stiffness ratio of $b/k=0.125$, was given an average rating score of 6.1, which was the lowest of the three. Wall model 2, with a moderate damping to stiffness ratio of $b/k=0.83$, was given a slightly higher surface hardness rating score of about 7.0. Wall model 3, with the highest damping to stiffness ratio of $b/k=2.5$, was given the highest rating of the three, that is, equal to the maximum rating score of 11.0. Clearly the wall with the highest damping to stiffness ratio generated the most convincing surface hardness sensation to every subject tested. This is a particularly interesting result in light of the fact that the wall model rated best (with the high damping to stiffness ratio) had a linear stiffness of $K=4000$ N/m, while the wall with the low damping to stiffness ratio (which was rated worst of the three) had a linear stiffness of $K=8000$ N/m. Thus, a wall with significantly lower stiffness but higher damping was unanimously perceived as feeling the *hardest* of the walls tested. This is a result that could only have been derived through perceptual testing, being counter-intuitive to a physical modeling approach to a hard rigid surface.

Wall models 4 and 5 combined a linear spring element with a directional damper and threshold damper, respectively. Both wall models had a high damping to stiffness ratio of $b/k=2.5$. Despite the addition of the nonlinear damper elements, these wall models showed no advantage in surface rigidity rating from the purely linear spring-damper wall models. Wall models 6 and 7 included a linear spring-damper arrangement such that a pure

damping barrier zone existed in front of the spring element. Wall models 6 and 7 included two damping to stiffness ratios of $b/k=0.83$ and $b/k=2.50$, respectively. As seen in Figure 10, the surface rigidity ratings for these two wall models were the worst of all 11 wall models tested. Wall 6, with the lower damping to stiffness ratio, was the worst of the two with a surface hardness rating score of 1.4, while wall model 7 was rated only slightly higher with a score of 2.7.

Virtual wall models 8, 9, 10, and 11 were composed of combinations of an exponential spring element and various damper types. Wall model 8 included a moderate linear damper, wall model 9 included a strong linear damper, model 10 a directional damper, and wall model 11 a threshold damper. Wall models 8 and 9, with linear dampers, were rated 4.9 and 5.3, respectively, while wall models 10 and 11, with nonlinear dampers, were rated 8.5 and 8.3, respectively. Clearly, the use of directional and threshold dampers in combination with the exponential spring element showed a significant advantage over the use of pure linear dampers with the exponential spring for generating the surface hardness percept.

The overall results of the surface rigidity ratings of Test II suggest, first, that a damping barrier zone corrupts the illusion of surface hardness and should be avoided. The results also suggest that a high damping to stiffness ratio is more important in generating a convincing hardness sensation by a linear spring-linear damper system than is the net stiffness value used. The results also suggest that, if using exponential spring elements, the use of threshold or directional dampers evokes a better hardness sensation than do pure linear dampers. Overall, the wall model rated best in surface hardness by all subjects was the pure linear spring-damper system with the highest damping to stiffness ratio.

Subjective Rating Results of Initial Contact (Crispness) for Test II

Turning next to the initial contact ratings for the 11 compound virtual wall models investigated in Test II, Figure 11 depicts a dispersed range of initial contact ratings for the various wall models. Looking first at the linear spring-damper wall models 1, 2, and 3, we find that damping ratio has a

dramatic effect upon the subjects' perception of contact crispness. Wall model 1, having the low damping to stiffness ratio of $b/k=0.125$, was given the minimum rating score of 1.0 by all subjects tested. Wall model 2, with a moderate damping to stiffness ratio of $b/k=0.83$, was given a moderate rating score of 4.1 for initial contact crispness. Wall model 3, with the high damping to stiffness ratio of $b/k=2.5$, was given the maximum possible rating score of 11.0 by every subject.

Looking next at the rating results for wall models 4 and 5 which implement a high damping ratio using a directional damper and threshold damper, respectively, we find that neither variation of the damper design provides a better sensation of initial contact than does the pure linear damper of wall model 3. The results also demonstrate that the threshold damper provided a significantly better sensation of initial contact than did the directional damper.

Looking next at the initial contact rating results for wall models 6 and 7, which implement a damping barrier zone, we find again that damping to stiffness ratio has a dramatic effect upon the perception of initial contact crispness. Wall model 6 implemented a moderate damping to stiffness ratio of $b/k=0.83$, while wall model 7 implemented a high damping to stiffness ratio of $b/k=2.5$. The results shown in Figure 11 demonstrate that wall model 6 was rated 6.9, which was significantly lower than wall model 7 which was rated 10.0. The only difference in the models was the higher damping to stiffness ratio of wall model 7. In both cases, the wall models with damping barrier zones did not provide a superior initial contact sensation than did the pure linear spring-damper model 3.

Turning to the initial contact rating results for wall models 8, 9, 10, and 11, which implement exponential spring elements with various damper configurations, we again find the importance of damping to the crispness of initial contact sensations. Wall models 8 and 9 implement exponential springs with linear dampers of 5000 N/(cm/s) and 10000 N/(cm/s), respectively. Virtual wall model 9, with the higher damping value, attained a rating score of 9.1, which was significantly higher in initial contact sensation than wall model 8 which attained a rating score of 5.1. Wall models 10 and 11

implemented the same high damping value, but made use of directional and threshold dampers respectively. The addition of these nonlinear damper elements only corrupted the initial contact sensation, resulting in slightly lower scores of 7.1 and 6.9 as compared to the identical model with a pure linear damper which had a score of 9.1.

The overall results of the initial contact ratings of Test II suggest, first, that high damping to stiffness ratio values are of primary importance to the generation of a crisp, believable initial contact sensation. The results further suggest that directional damping, threshold damping, and damping barrier zones do not enhance the initial contact sensation. Finally, the use of exponential springs (as compared to pure linear spring elements) was found not to enhance initial contact sensation of wall models tested.

Subjective Rating Results of Final Release (Cleanness) for Test II

Turning next to the final release ratings for the 11 compound virtual wall models investigated in Test II, Figure 12 depicts a wide range of rating scores across the various virtual wall models. Virtual wall models 1, 2, and 3 consist of linear spring-damper systems of various damping to stiffness ratios. As seen in Figure 12, wall model 1, with the lowest damping to stiffness ratio, was rated best of the three in final release with a maximum rating score of 11.0. Wall model 3, with the highest damping to stiffness ratio, was rated worst of the three with a final release rating score of 8.2. This relation between damping to stiffness ratio and the cleanness of final release sensations is the inverse of what was found for surface rigidity and initial contact sensations.

Virtual wall models 4 and 5 consist of linear springs with directional or threshold dampers respectively. The directional damper was rated best with a maximum rating score for final release cleanness of 11.0, while the threshold damper was rated significantly lower with an average rating score of 7.9.

Virtual wall models 6 and 7 included a linear spring-damper arrangement such that a pure damping barrier zone existed in front of the linear spring element. Wall model 6 implemented a moderate damping to stiffness ratio of $b/k=0.83$, while wall model 7 implemented a high damping to

stiffness ratio of $b/k=2.5$. Figure 12 reveals that both such implementations of spring-damper wall models resulted in a significant degradation of the final release cleanness sensation. Wall models 6 and 7 both had very low average rating scores of 2.0 and 1.1, respectively.

Turning finally to virtual wall models 8, 9, 10, and 11, which implement an exponential spring in combination with various damping configurations, we find the following result: When the exponential spring was combined with a strong linear damping or a strong threshold damping, as used in virtual walls 9 and 11, relatively low final release cleanness rating scores of 3.7 and 4.0 were recorded. When a light damping was used as in virtual wall model 8, the final release cleanness rating was a moderately higher score of 6.0. When a directional damper was used as in wall model 10, the final release rating score was the maximum value of 11.0. This result suggests that if an exponential stiffness is used in a virtual wall model and high damping is desired to achieve a crisp initial contact sensation, then a directional damper can be used to also achieve a clean final release sensation.

Subjective Rating Results of Overall Rating (Wallness) for Test II

Finally, we turn to the overall wallness ratings of the virtual wall models of Test II. As shown in Figure 13, wall model 3 was the most favorably rated wall tested, corresponding to a linear spring-damper system with the highest damping to stiffness ratio of $b/k=2.5$. Virtual wall models 1 and 2, on the other hand, which correspond to linear spring-damper systems with moderate and low values of damping to stiffness ratio, were rated significantly lower. In fact, wall model 1, corresponding to the lowest value of damping to stiffness ratio of $b/k=.125$, was rated 1.6 in overall wallness, the lowest of all virtual walls tested. This result confirms the importance of a high damping to stiffness ratio in the perceptual design of a believable rigid wall contact percept. Comparing this result to the individual perceptual quality ratings, we find the ratings to most closely match the initial contact ratings shown in Figure 11. This correspondence suggests that initial contact sensation is of basic importance to generation of a rigid wall contact percept.

Virtual wall models 4 and 5 are spring-damper systems similar to wall model 3, except that directional and threshold dampers were implemented respectively. Figure 13 shows a slight decrease in overall wallness rating when these nonlinear damper elements were applied. Virtual wall models 6 and 7, which implemented a barrier damping zone in front of a linear spring-damper system, were rated very poorly in overall wallness by all subjects. Comparing this result to the individual perceptual quality ratings, we find the drop in ratings for walls 6 and 7 to closely match the results of the surface rigidity ratings in Figure 10 as well as the final release ratings in Figure 12. This correspondence suggests that a poor surface rigidity and poor final release sensation have a significant effect in corrupting the overall wallness of a rigid wall percept.

Virtual wall models 8, 9, 10, and 11 implement exponential spring elements with various damper configurations. Figure 13 shows that wall model 10, an exponential spring and a directional damper, was the highest rated of the four exponential walls tested. This result corresponds to the results found in the final release ratings shown in Figure 11, suggesting that final release is an important part of the overall wallness percept. Overall, the exponential springs showed no advantage over similar walls with pure linear spring elements. Because parameters used in the exponential models were chosen with little insight, future studies with exponential springs to optimize the choice of Weber fraction and linear stiffness parameters may result in better percepts.

CONCLUSIONS

Analysis of the raw data and normalized data from Test I and Test II has provided many insights into the perceptual design of a virtual wall percept. The low coefficient of variation in the subjects' raw rating scores has suggested that subjects had little trouble decomposing the overall percepts into the given perceptual qualities. The results of these tests strongly suggest that surface rigidity (hardness), initial contact (crispness), and final release (cleanness) are all distinct and extractable perceptual qualities of the rigid wall percept. The results further suggest that the subjects could clearly judge how each virtual wall model compared to the other models for each of the perceptual qualities they were asked to rate. During post-testing interviews, subjects reported having little trouble using the given perceptual decomposition and felt that they could clearly distinguish each quality independently of the others. When asked to suggest alternative perceptual decompositions, no subjects could propose any criteria beyond those they were asked to use in the rating trials. These general results lend support to the notion of perceptual design as a viable alternative to physical modeling of virtual percepts.

Test I Conclusions

The following section addresses specific results implied by the subjective rating data for each of the four rating scales investigated in Test I: *surface rigidity* (hardness), *initial contact* (crispness), *final release* (cleanness), and *overall rating* (wallness). The results of surface rigidity testing have demonstrated that various configurations of virtual spring elements were able to provide a strong sensation of surface hardness while various configurations of viscous damper elements could not. The testing also revealed that the magnitudes of linear stiffness had little effect on the overall hardness sensations reported. In fact, no difference was found in the hardness ratings of linear springs with stiffnesses of 4500 N/m and 7000 N/m. This result suggests that, when modeling rigid virtual percepts, pushing stiffness

values to upper bounds which force reflecting hardware can support is not necessarily required to extract adequate perceptual information to create the impression of rigidity.

The results of initial contact ratings have revealed that viscous damper elements of various configurations were able to provide a strong sensation of crisp initial contact, while various configurations of linear and nonlinear spring elements could not. The fact that this result is the opposite of what was revealed during surface rigidity testing confirms that surface hardness and contact crispness are two unique and distinct perceptual aspects of the overall wall percept. It has been hypothesized that the damper's crisp and abrupt feel is due to the fact that it uses the derivative of hand position which provides an element of prediction in the control of the force stick. The incident velocity of the joystick approaching the virtual wall is a predictive indication of how hard the wall is about to be hit. Thus, damping provides the control system with some lead, allowing the system to respond with an abrupt opposing force at the instant of contact. Virtual surfaces which are modeled with only spring elements have no means of predicting the contact force before the surface is penetrated. Thus, wall models with high stiffness but no damping cannot produce a strong opposing force until the wall has been penetrated by the joystick by some amount. This results in a "bouncy" rather than "crisp" initial contact feel.

Results of the final release rating trials suggest that the linear and exponential spring elements tested provided convincing final release sensations, while the pure linear damper element and nonlinear threshold damper element provided poor final release sensations. The nonlinear *directional damper* tested was shown to provide as good a final release sensation as the spring elements. Post-testing interviews have revealed that subjects describe the final release from a linear damper or threshold damper as "sticky," while they described the release from the directional damper or spring elements as "clean." These results, first, confirm that cleanness of final release is an extractable and unique perceptual quality of a rigid wall percept. The results also suggest that, if damping is desired in a virtual wall model, convincing final release sensation can be achieved through the use of a nonlinear directional damping element.

Results of the overall wallness ratings of Test I have shown that the most convincing walls tested were exponential or linear spring elements, while the least convincing walls tested were linear and nonlinear damper elements. Comparison of these results with the individual perceptual quality ratings demonstrates that the overall rating results most closely match the trend in the surface rigidity ratings. This result suggests that, for simple models, the most important perceptual quality of a rigid wall contact percept is the surface rigidity. From these results, we can conclude that the most effective way to model a rigid wall as a single element is to use a spring element rather than a viscous damper. The results further suggest that stiffness values of the linear springs have little measurable effect upon subjects' overall impression of wallness within the range tested (2000 N/m and 7500 N/m). No measurable difference was found in overall wallness ratings between linear and exponential spring elements in isolation.

Test II Conclusions

The following section addresses specific results implied by the subjective rating data for each of the four rating scales investigated in Test II. The overall results of the surface rigidity ratings of Test II suggest that, if a linear spring-damper model is used, a high ratio of damping to stiffness is of primary importance to the design of a rigid wall percept with a convincing hardness sensation. In fact, high damping to stiffness ratio was found to be more important to the design of a hardness sensation than was the net stiffness value used. The wall that was unanimously rated the hardest of the linear spring-damper systems tested was actually half as stiff as the wall rated the least hard, but had a much higher damping to stiffness ratio. This is a result that could only have been derived through perceptual testing, being counter-intuitive to a physical modeling approach to a hard rigid surface.

Other conclusions drawn from this testing were that, when using exponential spring elements in parallel with damping elements, the use of threshold or directional dampers evokes a better hardness sensation than do pure linear dampers. The results also suggest that the use of a damping barrier zone corrupts the illusion of surface hardness and should be avoided.

Finally, the results showed that, overall, the wall model rated best in surface hardness by all subjects was the pure linear spring-damper system with the highest damping to stiffness ratio.

The overall results of the initial contact ratings of Test II suggest, first, that high damping to stiffness ratio values are also of primary importance to the generation of a crisp, believable initial contact sensation. The results further suggest that directional damping, threshold damping, and damping barrier zones do not enhance the initial contact sensation. Finally, the use of exponential springs, as compared to pure linear springs, was found not to enhance initial contact sensation of wall models tested.

Although high damping to stiffness ratio was shown to be important to hardness and crispness sensations generated, this pattern was found not to follow for the final release cleanness sensations. For linear spring-damper systems, wall models with the lowest damping to stiffness ratio were rated best in final release, while wall models with the highest damping to stiffness ratio were rated worst in final release. Because this relation between damping to stiffness ratio and the cleanness of final release sensations is the inverse of what was found for surface rigidity and initial contact sensations, it poses a problem for the perceptual design of a virtual percept which satisfies all perceptual qualities of a rigid wall. The results of final release testing do show, however, that the use of a directional damper in place of a pure linear damper provides a convincing final release sensation without corrupting the hardness or crispness of the percept. Thus, these results suggest that a linear spring in parallel with a nonlinear directional damper provides a convincing sensation for all aspects of the perceptual decomposition tested. The use of a directional damper was found to have the same beneficial effect when used in parallel combination with nonlinear exponential spring elements.

The overall wallness ratings confirm the conclusions drawn above. The walls rated best in overall rating of the 11 walls tested were composed of either a linear spring and a linear damper or a linear spring and a directional damper such that the damping to stiffness ratio was the maximum value tested. Identical walls tested with low damping to stiffness ratios were rated the worst in overall wallness of the 11 walls tested. These results confirm that the

ratings reflected in the perceptual decomposition scores directly reflect the overall wallness of the total percept. This confirms that perceptual design of virtual percepts through the combination of basic perceptual elements is a viable means of constructing sensations.

Other results of the overall wallness ratings demonstrated that the use of exponential spring elements with various damper elements was rated high in overall wallness, but not as high as linear elements with high damping to stiffness ratio. Although this result does not reflect any advantage to using exponential spring elements over linear spring elements to model rigid walls, there is enough promise in exponential spring elements to consider further testing to optimize the exponential parameters, such as Weber fraction and initial stiffness, which were chosen with little insight. Because it was found that damping to stiffness ratio was so important to the sensations provided by linear systems, a similar effect should be expected with the parameters used in exponential elements.

REFERENCES

Adelstein, B.D., *A Virtual Environment System for the Study of Human Arm Tremor*, Ph.D. dissertation, Dept. of Mech. Eng., M.I.T., Cambridge MA, 1989.

Adelstein, B.D., and Rosen, M.J., "A high performance two degree-of-freedom kinesthetic interface," *Human-Machine Interfaces for Teleoperators and Virtual Environments*, NASA Conference Publication 10071, pp. 108-113, 1991.

Adelstein, B.D., and Rosen, M.J., "Design and implementaion of a force reflecting manipulandum for manual control research," in *Advances in Robotics*, ed. H. Kazerooni, Amer. Soc. Mech. Eng, New York, pp. 1-12, 1992.

Human-Machine Interfaces for Teleoperators and Virtual Environments, NASA Conference Publication 10071, pp. 108-113.

Chin, K.P., *Stable teleoperation with Optimal Performance* , Ph.D. dissertation, Dept. of Mech. Eng., M.I.T., Cambridge MA, 1991.

Colgate, J.E., Grafing, P.E., and Stanley, M.C., "Implementation of stiff virtual walls in force reflecting interfaces," Submitted to IEEE-VRAIS, Seattle WA, 1993.

Grafing, P.E., *A Study of a Haptic Interface for a Virtual Environment.*, M.S. thesis, Dept. of Mech. Eng., Northwestern University, Evanston IL, 1992.

Fasse, E.D., *On the Use and Representation of Sensory Information of the Arm by Robots and Humans*, Ph.D. dissertation, Dept. of Mech. Eng., M.I.T., Cambridge MA, 1992.

Jones, L.A. and Hunter, I.W., "Human operator perception of mechanical variables and their effects on tracking performance," in *Advances in Robotics*, ed. H. Kazerooni, Amer. Soc. Mech. Eng, New York, pp. 49-53, 1992.

Jex, H.R., "Some criteria for teleoperators and virtual environments from experience with vehicle/operator simulation," *Human-Machine Interfaces for Teleoperators and Virtual Environments*, NASA Conference Publication 10071, pp. 42-47, 1991.

Kilpatrick, P.J., *The Use of a Kinesthetic Supplement in an Interactive Graphics System*, Ph.D. dissertation, Dept. of Comp. Sci., University of North Carolina, Chapel Hill NC, 1976.

Levine, M. and Shefer, J., Fundamentals of Sensation and Perception, 2nd Edition, Pacific Grove CA: Brooks/Cole Publishing Co., 1981.

Minsky, M., Ouh-Young, M., Steele, O., Brooks, F.P., Jr., and Behensky, M., "Feeling and seeing: issues in force display," *Computer Graphics*, 24, 235-243, 1990.

Ouh-Young, M., Pique, M., Hughes, J., Srinivasan, N., and Brooks, F.P., Jr., "Using a manipulator for force display in molecular docking," *Proceedings, IEEE Int. Conf. on Robotics and Automation*, Philadelphia PA, pp. 1824-1829, 1988.

Ouh-Young, M., *Force Display in Molecular Docking*, Ph.D. dissertation, Dept. of Comp. Sci., University of North Carolina, Chapel Hill NC, 1990.

Tan, H.Z., Pang, X.D., and Durlach, N.I., "Manual resolution of length, force, and compliance," in *Advances in Robotics*, ed. H. Kazerooni, Amer. Soc. Mech. Eng, New York, pp. 13-18, 1992.

Weber, E.H., *Die Lehre vom Tastsinne und Gemeingefuhlen Braunschweig*, 1851.

Winey, C.M., III, *Computer Simulated Visual and Tactile Feedback as an Aid to Manipulator and Vehicle Control*, S.M. thesis, Dept. of Mech. Eng., M.I.T., Cambridge MA, 1981.