

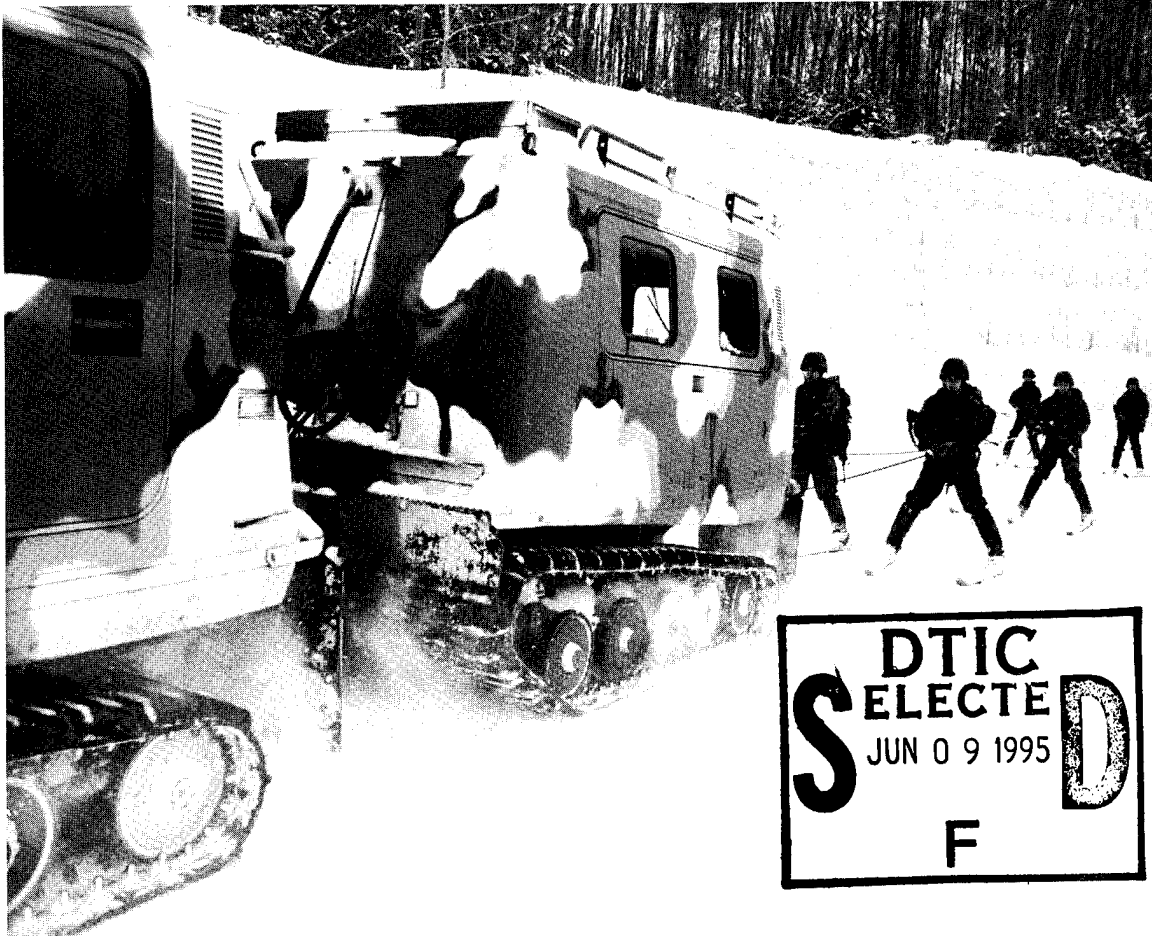

INTERNATIONAL CONFERENCE
**COLD WEATHER
MILITARY OPERATIONS**



This document has been approved
for public release and sale; its
distribution is unlimited.

BURLINGTON, VERMONT
28 FEBRUARY—2 MARCH 1995

PROCEEDINGS
Nicholas H. Collins, Editor

19950607 055

DTIC QUALITY INSPECTED 5

FOREWORD

The 1995 International Conference on Cold Weather Military Operations was held at the Radisson Hotel in Burlington, Vermont, and at the Vermont Army National Guard (VT ARNG) Mountain Warfare School (MWS) in Jericho, VT, from 28 February thru 2 March 1995. This was the first conference of this type, and was set up as a follow-on to the former NATO Winter Warfare conferences held periodically, most recently in Stockholm in 1989.

After some discussion, the co-sponsors determined that in the conference agenda some activities conducted outdoors would be highly desirable, and that the Mountain Warfare School (MWS) would be an ideal location. Also, inquiries revealed that the Radisson Hotel in Burlington was ideally suited to the needs of the conference and offered the lowest government rate. The overall cost was much more favorable than either the Boston or Washington areas, and the facilities were easily accessible to an efficient international airport.

The basis of this conference was to provide a forum for the presentation, discussion and recognition of quality accomplishments by scientists, engineers and developers in their efforts to support the combat soldier on a winter battlefield and in support operations in various cold regions environments.

The focal point of this conference was 'Winter Operations — Challenges and Opportunities.' There were more than 30 scientific papers presented, ranging from operational to innovative research and development. The Opening, Keynote and guest addresses by recognized military operational and R&D experts supplemented the conference. There were several outdoor active demonstrations of exceptional quality, providing first hand review by conference participants. Interaction and discussion revolved around a variety of exhibits on state-of-the-art research and engineering which helped to highlight the theme of the conference.

Approximately 150 attendees, representing the various uniformed services and government civilian organizations from the U.S. and ten foreign nations, took advantage of this opportunity to share technology growth, new ideas, and successful operational examples. It was a most successful conference for all who attended, and the results were gratifying.

The papers submitted to the conference coordinating staff were selected by the respective co-sponsor staffs based on chosen topic and/or operational merit. Those selected are presented here in the format of the presenter(s). These proceedings are published for the purpose of exchanging ideas, and for friendly collaboration with those nations wanting to be prepared to conduct successful operations in all manner of winter environments.



Nicholas H. Collins
Physical Scientist
U.S. Army Cold Regions Research
and Engineering Laboratory (CRREL)
Conference Coordinator

DTIC QUALITY INSPECTED 5

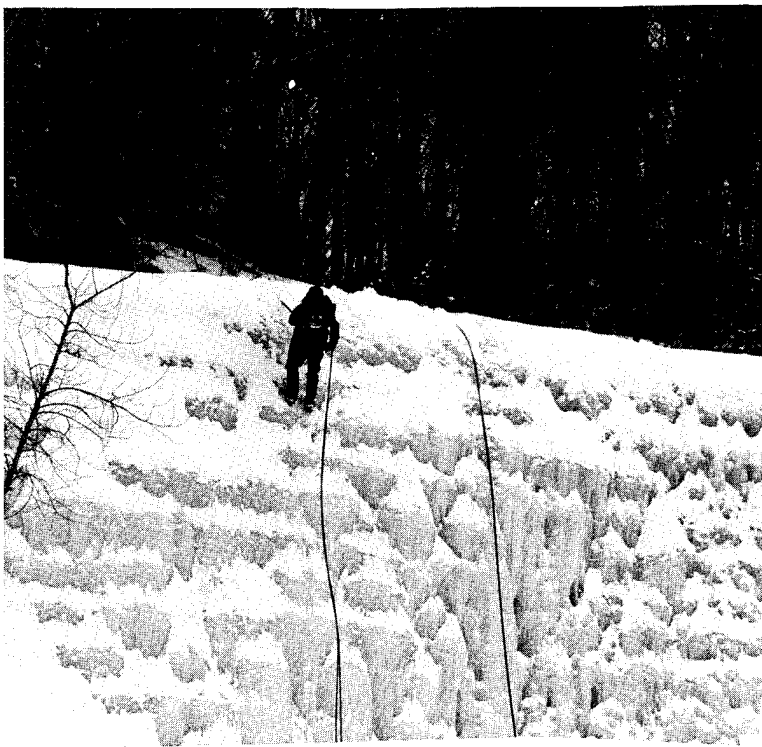

INTERNATIONAL CONFERENCE
**COLD WEATHER
MILITARY OPERATIONS**

Accession For		
NTIS	CRA&I	<input checked="" type="checkbox"/>
DTIC	TAB	<input type="checkbox"/>
Unannounced		<input type="checkbox"/>
Justification		
By <i>form 50</i>		
Distribution /		
Availability Codes		
Dist	Avail and/or Special	
<i>A-1</i>		

BURLINGTON, VERMONT
28 FEBRUARY—2 MARCH 1995

PROCEEDINGS

PREFACE

The 1995 International Conference on Cold Weather Military Operations brought together more than 150 scientists, engineers and soldiers from ten countries. There was consensus on the fact that the soldier is the most important ingredient in winter operations. Leadership and training were the two most important things that the soldier needs for success. Equipment must be highly competent and integral to training. New equipment is emerging to address some of the priority issues previously identified, but many issues remain unresolved.

The soldiers and the civilians who support the soldier who must be prepared to operate in cold weather must be proactive in identifying issues and creating a greater awareness of the impact of cold weather on military operations. Without a realistic perspective of the impact of cold, equipment, doctrine and training will be lacking and our readiness to operate effectively in winter and cold weather will be compromised. Without awareness the proponenty and resources to address even the most important winter issues will go unfulfilled. Simulation offers a new avenue to create the awareness, given that realism can be injected to the developing codes. Cooperation with international allies is an excellent means to gain expertise and leverage resources, especially from those allies who live in the northern most latitudes and mountainous regions of the earth.

Lewis E. Link, Ph.D.
Director
U.S. Army Cold Regions Research
and Engineering Laboratory (CRREL)

CONFERENCE SPONSORS

Cold Regions Research and Engineering Laboratory (CRREL)
Hanover, NH

Army National Guard Mountain Warfare School
Jericho, VT

U.S. Army Soldier System Command
Natick, MA

CONFERENCE COORDINATORS

Nicholas H. Collins
Physical Scientist
Cold Regions Research and Engineering Laboratory (CRREL)

LTC J. Michael Gately
Commander
Army National Guard Mountain Warfare School

Dr. Richard Strecker
Soldier Systems International R&D
U.S. Army Soldier System Command

CONFERENCE DESK

Carole O'Conner
U.S. Army RD & Standardization Group-UK

SFC Doris Laramee
Army National Guard Mountain Warfare School

OC Scott Beaulieu
Army National Guard Mountain Warfare School

Raymond Billman
U.S. Army Soldier Systems Command

Brian Moran
U.S. Army Soldier Systems Command

RESEARCH, DEVELOPMENT AND ENGINEERING FORUM

Dr. Walter LaBerge
Chairman, Army Science Board

MODERATOR

PANEL MEMBERS

Dr. Lewis E. Link
Director, CRREL

Jerold G. Barger
Technical Director
Cold Regions Test Activity

John Grills
Science Advisor, ALCOM

Dr. William C. Christiansen
Director, Joint Operational Test
and Information Directorate

Charles R. Williams
Executive, International Programs
U.S. Army Soldier Systems Command

There are significant technical assets that can be applied to winter operations issues. They include research, testing and training. While significant, the components dedicated to winter and cold issues represent only a small fraction of the Army's technology investment. This accentuates the need to identify and prioritize the issues most important to improving winter operability so that the available assets can be focused appropriately. Often the winter operations technical issues are not as difficult to define as it is to gain the proponentry to do something about them. This appears to be influenced by typically small (dollar wise) issues, the relatively small number of troop units that have a cold mission, and the lack of general awareness of the impact of winter and cold on military operations.

Dr. Walter LaBerge, Chairman of the Army Science Board, provided valuable insights and recommendations including increasing the role of the CINC's in arguing for cold issues, emphasizing jointness, increasing the participation in Advanced Concepts Technology Demonstrations and increasing the affordability of systems for operating in all environments. He also encouraged publishing lessons learned, examining the differences in outcomes of wargames with and without consideration of cold and winter, creating greater user support through TRADOC and FORSCOM, and defining a hard hitting slogan that will bring attention to the winter issues.

Discussions included the capabilities of modeling cold weather effects, approaches for enhancing international cooperation, and injecting cold issues more effectively into large developmental efforts such as the Soldier as a System. While models exist to estimate the impact of cold on specific operations or functions, they are commonly too sophisticated and require too much input data to be compatible with most simulations routines. The complex models must be simplified as much as practical to facilitate more realism in simulations. Through activities in NATO, bilateral agreements and joint operations, significant opportunities exist to interact internationally. Funding for significant exercises and the additional costs of participating are often a barrier.

MILITARY OPERATIONS FORUM

LTG Johnnie H. Corns, USA (Ret.)
MODERATOR

PANEL MEMBERS

BG Jerry L. Sinn
HQ, U.S. Army Materiel Command

Brigadier Janez Kavar
Territorial Defence of the
Republic of Slovenia

COL Fridolin Gigacher
Jägerschule
Saalfelden, Austria

Brigadier Reidar Melheim
Norwegian Army Materiel Command

COL Lars-Gunnar Nilsson
Försvarsmakten
Boden, Sweden

COL Pertti J. Suominen
Defense Attache
Embassy of Finland

LTC Martin Glasgow
Kommandeur Gebirgs und
Winterkampfschule
Mittenwald, Germany

The Operations panel pointed out the acute need for knowledge of winter affects on operations and great emphasis on training and leadership to cope with the affects. The risk of textbook exercises and assumptions regarding the time and assets required to conduct missions in winter are of great concern. The lack of 'winter rules' for live or simulation training tend to reinforce misperceptions about cold for those who have not had direct experience.

Strong leaders are an absolute requirement, as is adequate training of troops to function in cold. Equipment must be tailored to the environment as well as be highly maintained.

Training leaders was also emphasized as critical to success. Leaders must be careful not to get fixed on the terrain in which they train. Well trained and conditioned troops can work around some limitations in their equipment.

REGISTERED ATTENDEES

COL John Abair
HQ STARC VT
ATTN: PTS-VT
Colchester, VT 05406

Rose Acheson
U.S. Army Engineer School
ATTN: ATSE-TEC
Fort Leonard Wood, MO 65473
tel 314/596-0131 fax 314/563-4089

CPT Robert Albino
HHC, 10th Special Forces Group
Fort Devens, MA 01433
tel 508/796-3273 fax 508/796-3156

LTC Kenneth R. Allen
Alaska Army National Guard
Office of Army Aviation
PO Box 5800
Fort Richardson, AK 99505-5800
tel 907/428-6900 fax 907/428-6909

Dr. George D. Ashton
Chief, Research Division
Cold Regions Research & Engineering Laboratory
72 Lyme Road, Hanover, NH 03755
tel 603/646-4265

COL H. Atwood, Jr.
U.S. Army RD & Standardization Group-UK
PSC 802, Box 15
FPO AE 09499-1500

David Audet
U.S. Army Soldier Systems Command
ATTN: SUSD
Natick, MA 01760-5018
tel 508/651-5987

COL Palmer Bailey, USA (Ret)
305 N. Arnold Avenue
Thief River Falls, MN 56701
tel 218/681-2207

Jerold G. Barger
U.S. Army Cold Regions Test Activity
Fort Greely, AK
APO AP 96508-3110
tel 907/893-9219 fax 907/873-1990

CDT Byron Beers
Norwich University
Northfield, VT 05663

Scott Bennett
U.S. Army Soldier Systems Command
ATTN: SATNC-IC
Natick, MA0716
tel 508/651-5442 fax 508/651-4795

Dr. Amnon Birenzvig
U.S. Army Edgewood RD&E Center
ATTN: SCBRD-RTE
Aberdeen Proving Ground, MD 21010-5423
tel 410/671-2469

John R. Bouzoun
Applied Research Division
Cold Regions Research & Engineering Laboratory
72 Lyme Road, Hanover, NH 03755
tel 603/646-4585

COL Timothy Bradwell
British Liaison Office
U.S. Army Engineer School
ATTN: ATSE-LB
Fort Leonard Wood, MO 65473-6610
tel 314/563-4018 fax 314/563-4031

SFC J. Bridier
U.S. Army TRADOC
ATTN: ATCD-M
Fort Monroe, V 23651-5000

Dorothy R. Broaddus
Water Technology R&D Team
MobilityTech Center-Belvoir
ATTN: AMSTA-RBWE
10115 Gridley Road, Suite 128
Fort Belvoir, VA 22060-5843
tel 703/704-3349 fax 703/704-3360

Mark Bucksath
1st Special Forces Group
Fort Lewis, WA 98433

Robert G. Butler
U.S. Army Aviation & Troop Command
ATTN: AMCPM-PWL
4300 Goodfellow Road
St. Louis, MO 63120-1798
tel 314/263-2618 fax 314/263-2956

CPT Robert F. Buzby
USMC Mountain Warfare Training Center
MCMWTC S-3
Bridgeport, CA 93517
tel 619/932-7761 fax 619/932-7706

Dr. William C. Christiansen
Director, Joint Contact Point
ATTN: STEDP-JCP-DGP
Dugway Proving Ground, Dugway, Utah 84022
tel 801/831-3371 fax 801/831-2397

Matthew R H Clarke
SCD4, Ministry of Defence
Defence Clothing & Textiles Agency
Science & Technology Division
Flagstaff Road, Colchester, Essex
United Kingdom CO2 7SS
tel 011-44-0206-782420
fax 011-44-0206-782337

Nicholas H. Collins
Cold Regions Research & Engineering Laboratory
ATTN: CECRL-PP
72 Lyme Road, Hanover, NH 03755
tel 603/646-4470 fax 603/646-4448

Jerry C. Comati
Chief, Environmental Sciences Branch
U.S. Army RD & Standardization Group-UK
PSC 802, Box 15
FPO AE 09499-1500
tel 011-44-71-402 7331
fax 011-44-71-724 1433

SGT Michael Cornell
VT Army National Guard (VTARNG)
Colchester, VT 05406

LTG Johnnie H. Corns, USA (Ret.)
82 Westridge Drive
Churchville, VA 24421

Jan Marius de Koning
Royal Netherlands Army
PO Box 90822
2509 LV The Hague
The Netherlands
tel 011-31-70-316 4658
fax 011-31-70-316 4720

John Dente
U.S. Army CECOM
ATTN: AMSEL-RD-C2-ED-ET
Fort Monmouth, NJ 07703-5603
tel 908/544-2104 fax 908/544-2011

SGT William Deringer
Norwich University
Northfield, VT 05663

Richard Detsch
Chief, Geophysical Sciences Branch
Cold Regions Research & Engineering Laboratory
72 Lyme Road, Hanover, NH 03755
tel 603/646-4625

MSG Drummond
210th Rescue Squad, Para Rescue Team
Kulis National Guard Base
Anchorage, AK
tel 907/249-1699 fax 907/249-1505

Dr. Michel Ducharme
Defence & Civil Inst of Environmental Medicine
1133 Sheppard Avenue West
North York, Ontario, Canada M3M 3B9

SFC Robert Eddy
Minnesota Army National Guard
The Adjutant Generals Office
20 West 12th Street, St. Paul, MN 55155-2098
tel 612/231-5195 fax 612/231-5168

MG Donald E. Edwards
Adjutant General for the State of Vermont
Green Mountain Armory, Camp Johnson
Colchester, VT 05446-3004

Barbara Fossey
U.S. Army Natick RD&E Center
ATTN: SATNC-IC
Natick, MA 01760-5019
tel 508/651-4704 fax 508/651-4795

John Frim
Human Protective Systems Division
Defence & Civil Inst of Environmental Medicine
1133 Sheppard Avenue West
North York, Ontario, Canada M3M 3B9
tel 416/635-2180 fax 416/635-2132

LTC J. Michael Gately, Commander
Army National Guard Mountain Warfare School
Ethan Allen Firing Range
Jericho, VT 05465-9706
tel 802/899-2338 fax 802/899-2052

Joseph Giblo
Navy Clothing & Textiles Research Facility
(Code N3.JG)
PO Box 59, Natick, MA 01760-0001
tel 508/651-4740 fax 508/651-4683

COL Fridolin Gigacher
Austrian Army
Jägerschule
A-5760
Saalfelden, Austria
tel 011-43-6582-458 8200
fax 011-43-6582-458 7243

Oberstleutnant Martin Glagow
Kommandeur Gebirgs und Winterkampfschule
Am Hirnbichl 1, General-Kubler-Kaserne
82481 Mittenwald, Germany
tel 011-37-08823-41 400
fax 011-37-08823-41 405

v

MSG David Gouchoe
Army National Guard Mountain Warfare School
Ethan Allen Firing Range
Jericho, VT 05465-9706
tel 802/899-2338

William B. Greeley
Cold Regions Research & Engineering Laboratory
ATTN: CECRL-TE
72 Lyme Road, Hanover, NH 03755
tel 603/646-4379

John Grills
Science Advisor
Alaskan Command JO22 (ALCOM)
6-900 9th Street, Suite 110
Elmendorf AFB, AK 99506-2230
tel 907/552-7751

Dr. Murray Hamlet
USA Research Inst of Environmental Medicine
ATTN: SGRD-UE-NR
Natick, MA 01760-5007
tel 508/651-4865 fax 508/651-5298

1SG Burnell V. Haney
10th Mountain Division
ATTN: AFZS-OP
Fort Drum, NY 13602-5000
tel 315/772-6731 315/772-4080

Dr. Russell S. Harmon
Terrestrial Science, Geosciences Branch
Engineering & Environmental Sciences Div
Army Research Office ATTN: AMXRO-EN
Box 12211, Research Triangle Park, NC 27709
tel 919/549-4326 fax 919/549-4310

MAJ Dale R. Hill
Cold Regions Research & Engineering Laboratory
ATTN: CECRL-EO
72 Lyme Road, Hanover, NH 03755
tel 603/646-4202 fax 603/646-4448

LTC Russell Holden
U.S. Army Infantry Center & Ft Benning
ATTN: ATSH-WBC-C (DBS BL)
Fort Benning, GA 31905-5000

CDR David Johanson
VXE6
Antarctic Development
Point Mugu, CA 93041

Joseph B. Jones, Jr.
U.S. Army Infantry School
ATTN: ATSH-CDC
Fort Benning, GA 31905-5000
tel 706/545-6406 fax 706/545-2517

Brigadier Janez Kavar, Eng.
Territorial Defence of the Republic of Slovenia
3. PSTO Kranj, SLO-64000 KRANJ
Bleiweisova 32, Slovenia
tel 011-386-64-222 361
fax 011-386-64-222 677

CDT Kawano Kreiton
Norwich University
Northfield, VT 05663

Robert F. Kinney
U.S. Army Natick RD&E Center
ATTN: SATNC-IC
Natick, MA 01760
tel 508/651-4425 fax 508/651-4795

CPT Steve Kroone
National Defence Headquarters
ATTN: Dir of Land Requirements 5-3
MGEN George R. Pearkes Bldg
Ottawa, Canada K1A 0K2

Dr. Walter B. LaBerge
Chairman, Army Science Board

LT John Langille
Det HHC, 3/172nd Infantry (Mtn)
State Armory, 133 Elm Street
Brewer, ME 04412
tel 207/989-7450

COL Craig Lind
Norwich University
Northfield, VT 05663

Dr. Lewis E. Link, Director
Cold Regions Research & Engineering Laboratory
72 Lyme Road, Hanover, NH 03755
tel 603/646-4201 fax 603/646-4200

Dr. Ronald A. Liston
Cold Regions Research & Engineering Laboratory
ATTN: CECRL-EA
72 Lyme Road, Hanover, NH 03755
tel 603/646-4362

Joseph Mackoul
U.S. Army Natick RD&E Center
ATTN: SUSD
Natick, MA 01760-5018
tel 508/651-4140 fax 508/651-5556

MSG Mark Mahoney
210th Rescue Squad, Para Rescue Team
Kulis National Guard Base
Anchorage, AK
tel 907/249-1699 fax 907/249-1505

Gerald Malakoff
HQ,USAMC
ATTN: AMCRD-ITI
5001 Eisenhower Avenue
Alexandria, VA 22333-0001
tel 703/274-5790 fax 703/274-0554

Jim McLaughlin
U.S. Army Soldier Systems Command
Natick, MA 01760

LTC John Q. McNulty
U.S. Army Quartermaster School
U.S. Army CASCOM
ATTN: ATCL-CBQ, Fort Lee, VA 23801
tel 804/734-0307

MAJ Michael Meeks
Cold Regions Research & Engineering Laboratory
ATTN: CECRL-AK, POB 35170
Fort Wainwright, AK 99703-0170
tel 907/353-5149 fax 907/353-5142

Brigadier Reidar Melheim
Norwegian Army Materiel Command
Oslo mil/LØREN
0018 Oslo, Norway
tel 011-47-22-89 64 00
fax 011-47-22-89 64 14

LTC Bradley R. Naegle
U.S. Army TACOM
PEO, Tactical Wheeled Vehicles, Special Programs
ATTN: SFAE-TWV-SP-E
Warren, MI 48397-5000

LTC Mark Nelson, Commander
Cold Regions Research & Engineering Laboratory
72 Lyme Road, Hanover, NH 03755
tel 603/646-4202 fax 603/646-4222

COL Lars-Gunnar Nilsson
Försvarsmakten
Box 9105
961 19 Boden, Sweden
tel 011-0046-921-68300
fax 011-0046-921-68698

Carole O'Conner
Environmental Sciences Branch
U.S. Army RD & Standardization Group-UK
PSC 802, Box 15
FPO AE 09499-1500
tel 011-44-71-402 7331
fax 011-44-71-724-1433

CPT Christopher Oliver
TARDEC
U.S. Army TACOM
ATTN: AMSTA-TR-A, Warren, MI 48397-5000
tel 810/574-5849 fax 810/574-7639

Randall J. Osczevski
Defence & Civil Inst of Environmental Medicine
PO Box 2000
North York, Ontario, Canada M3M 3B9
tel 416/635-2056 fax 416/635-2104

Dr. Robert B. Oswald, Director
Research & Development Directorate
U.S. Army Corps of Engineers
20 Massachusetts Avenue NW
Washington, DC 20314
tele 202/272-0254

Richard Palmer
Cold Regions Research & Engineering Laboratory
72 Lyme Road, Hanover, NH 03755

Ronald Pawlowski
U.S. Army TECOM
Technology Development Division
ATTN: AMSTEC-CT-T
Aberdeen Proving Ground, MD 21005-5000
tel 410/278-1089 fax 410/278-9719

MAJ Andres Perez
U.S. Army CASCOM
ATTN: ATCL-MES
Fort Lee, VA 23801-6000
tel 804/734-1834 fax 804/734-0574

William Pine
Navy Clothing & Textile Research Facility
PO Box 59
Natick, MA 01760
tel 508/651-4189 fax 508/651-4783

MAJ Thomas Reaume
Officer Commanding, Parachute Company
Canadian Army
Box 10500
Canadian Airborne Centre
Edmonton, Alberta, Canada T5E 4K9

Suzanne Reeps
Navy Clothing & Textile Research Facility
Code N2 - Protective Clothing Division
PO Box 59
Natick, MA 01760
tel 508/651-4786 fax 508/651-4653

Michael Ritondo
U.S. Army TECOM
ATTN: AMSTE-TA
Aberdeen Proving Ground, MD 21005
tel 410/278-1324 fax 410/278-9184

A. J. Roberto, Jr.
Chief, Technical Resources Center
Cold Regions Research & Engineering Laboratory
72 Lyme Road, Hanover, NH 03755
tel 603/646-4204 fax 603/646-4695

Dr. Donald E. Roberts
Naval Health Research Center
Bldg 287
PO Box 85122
San Diego, CA 92186-5122
tel 619/524-1822 fax 619/524-4518

CPT Judith D. Robinson
U.S. Army Medical Dept Center & School
ATTN: MCCS-HHO
2250 Stanley Road
Fort Sam Houston, TX 78234-6100
tel 210/221-8314 fax 210/221-6489

CDT Robert Root
Norwich University
Northfield, VT 05663

CPT Paul Rosser
1st Special Forces Group
Fort Lewis, WA 98433
tel 206/967-8727

CPT David L. Ruiz
Marine Corps Systems Command
ATTN: SSCGP-MARSYSCOM
20033 Barnet Avenue, Suite 315
Quantico, VA 22134
tel 703/640-4290 fax 703/640-4287

MAJ David A. Rutledge
U.S. Army Northern Warfare Training Center
PO Box 1342
Delta Junction, AK 99737
tel 907/873-4544 fax 907/873-4117

Laura A. Ryan
U.S. Army Natick RD&E Center
ATTN: SUSD
Natick, MA 01760-518
tel 508/651-4230

CPT Karl Saad
National Defence Headquarters
ATTN: Director of Land Requirements 5-3
MGEN George R. Pearkes Bldg
Ottawa, Canada K1A 0K2

Michael M. Sawka
USA Research Inst of Environmental Medicine
Natick, MA 01760
fax 508/651-5298

Betsy Sawyer
Navy Clothing & Textile Research Facility
PO Box 59
Natick, MA 01760
tel 508/651-4189 fax 508/651-4653

LT Brent Schaffer
USMC Mountain Warfare Training Center
MCMWTC S-3
Bridgeport, CA 93517
tel 619/932-7761 fax 619/932-7706

MAJ Ralph Schutte
National Defence Headquarters
ATTN: Director of Land Requirements 5-3
MGEN George R. Pearkes Bldg
Ottawa, Canada K1A 0K2

CPT Joseph Seaquist
Minnesota National Guard
The Adjutant Generals Office
20 West 12th Street, St. Paul, MN 55155-2098
tel 612/282-4969 fax 612/282-4541

Andre G. Senecal
U.S. Army Natick RD&E Center
ATTN: SUSD
Natick, MA 01760-5018
tel 508/651-4507 fax 508/651-5274

Sally A. Shoop
Cold Regions Research & Engineering Laboratory
ATTN: CECRL-EA
72 Lyme Road, Hanover, NH 03755
tel 603/646-4321 fax 603/646-4640

Ann Marie Sibbald
National Defence Headquarters
MGEN George R. Pearkes Bldg
Ottawa, Canada K1A 0K2
tel 819/994-9630 fax 819/994-9619

BG Jerry L. Sinn
Deputy Chief of Staff for Resource Management
U.S. Army Materiel Command (AMC)
5001 Eisenhower Avenue
Alexandria, VA 22333-0001

Jay Skrocki
U.S. Army TACOM
Mobility Technology Center - Belvoir
ATTN: AMSTA-RBWP
Warren, MI 48397-5000
fax 810/574-5054

Neil E. Smedstad
U.S. Army Natick RD&E Center
ATTN: STRNC-ICCC
Natick, MA 01760
tel 508/651-4032 fax 508/651-4795

SFC Scot Southard
U.S. Army Special Operations Command
ATTN: AOFI-RI-SI
Fort Bragg, NC 28307
tel 910/432-2685 fax 910/432-1661

COL R. Stewart
U.S. Army TRADOC
ATTN: ATCD-M
Fort Monroe, VA 23651-5000

Dr. Richard Strecker
Soldier Systems International R&D
U.S. Army Natick RD&E Center
ATTN: STRNC-SURD
Natick, MA 01760-5019
tel 508/651-4660

COL Pertti J. Suominen
Defense Military, Naval and Air Attache
Embassy of Finland
3301 Massachusetts Avenue, NW
Washington, DC 20008
tel 202/298-5800 fax 202/298-6059

Andrew Vallerand
U.S. Army Natick RD&E Center
Kansas Road
Natick, MA 01760

TSgt John Vargo
Para Rescue Squad
Kirkland AFB

MGYSGT Velez
Marine Corps Systems Command
ATTN: SSCGP-MARSYSCOM
20033 Barnet Avenue, Suite 315
Quantico, VA 22134

BG Frederick D. Walker, USAF (Ret.)
541 East Grand River
East Lansing, MI 48823

Jon G. Walker
U.S. Army CASCOM (Field Services)
ATTN: ATCL-MES
Fort Lee, VA 23801-6000
tel 804/734-5062 804/734-0574

Michael Walsh
Cold Regions Research & Engineering Laboratory
ATTN: CECRL-TE
72 Lyme Road, Hanover, NH 03755
tel 603/646-4363 fax 603/646-4720

CPT Brian Weatherlow
U.S. Army Natick RD&E Center
Natick, MA 01760
tel 508/651-5377 fax 508/651-5378

CPT Jeffrey Wilkinson
Cold Regions Research & Engineering Laboratory
ATTN: CECRL-EI
72 Lyme Road, Hanover, NH 03755
tel 603/646-4657

Charles R. Williams
U.S. Army Natick RD&E Center
ATTN: STRNC-IC
Natick, MA 01760

Holli Williams
Naval Air Warfare Center - Aircraft Division
NAWA-AD, Jacksonville Road, Code 4.6.3.2
Warminster, PA 18974
tel 215/441-2688 fax 215/441-2184

Byron Young
Cold Regions Research & Engineering Laboratory
ATTN: CECRL-EA
72 Lyme Road, Hanover, NH 03755
tel 603/646-4602

Dr. Andrew J. Young
USA Research Inst of Environmental Medicine
Natick, MA 01760-5007
tel 508/651-5141 fax 508/651-5298

CDR Tom Zwollo
Assistant Naval Attache
The Netherlands Embassy
4200 Linnean Avenue, NW
Washington, DC 20008
tel 202/274-1025 202/364-7349

CONTENTS

PAPERS AND PRESENTATIONS

Materiel Challenges in Arctic and Subarctic Climates	1
Environmental Issues Guide for Heuristic Testing (Eight)	9
The Layering Principle for Cold Weather Clothing: Are We There Yet?	19
Torso Auxiliary Heating Can Maintain Extremities' Temperatures During Cold Exposure	47
Where Are the Snow Snakes	53
Ration Cold Weather Improvement Program	69
Effectiveness of a Laboratory Wave Simulator Replicating Body Heat Loss Measured Under Field Conditions	83
Winter Warrior on Battlefield 2015	93
Cold Weather Shelters	107
A Towed Snow Plow for the Small Unit Support Vehicle (SUSV)	135
Medical Research Program for Cold Weather Military Operations	145
Basic Research and Cold Weather Operations	153
Positive Temperature Coefficient Handwear and Footwear Heating Systems	163
Enhanced Mobility for Cold Regions	177
Organisation of Protection Against Avalanches in the Republic of Slovenia— Tasks of the Slovenian Army	187
Chemical/Biological Joint Contact Point	201
Trial by Adventure	213
Waterproof, Breathable Fabrics for Military Clothing Systems: An Innovative Approach to Acquisition	241
State-of-the-Art Advances in U.S. Military Cold Weather Heating Equipment	265
Cold Weather Terrain Traversal	283
Minnesota National Guard Winter Operations Program: Camp Ripley	287
The History of Feet and Fighting: Cold Weather Injuries	291
Jägerschule (Austrian Army): Winter Conditions in the Hermon-area	297
Snow Drifting Problems and Abatement	301

*In order to make this publication available as rapidly as possible,
the authors' typescripts have been reproduced as received.*

**MATERIEL CHALLENGES IN
ARCTIC AND SUBARCTIC CLIMATES**

Jerold G. Barger
U.S. Army Cold Regions Test Activity
Fort Greely, AK

MATERIEL CHALLENGES IN ARCTIC AND SUBARCTIC CLIMATES

Jerold G. Barger
U.S. Army Cold Regions Test Activity
Fort Greely, Alaska

BIOGRAPHY

Jerold G. (Jerry) Barger is Technical Director of U.S. Army Cold Regions Test Activity at Fort Greely, Alaska. A 1965 graduate of North Carolina State University, he holds a BS degree in Aerospace Engineering. His over 29 years experience in Army testing began at Aberdeen Proving Ground, MD in 1965 as a vehicle vulnerability test director, moving to a position in wheeled and tracked vehicle test administration in TECOM Headquarters in 1971. He has been employed in various technical and managerial capacities at Cold Regions Test Activity since 1973, assuming his current position of Technical Director in 1991.

ABSTRACT

This paper discusses materiel issues pertinent to military operations in cold climates, both winter and summer. While materiel developers have vastly improved operability of equipment in cold climates, the user does not benefit fully from available technology. At the same time that significant advances in technology have been achieved, new operational problems have been created by changes in Federal regulations, Army policy, and industrial practices. The U.S. Army is steadily progressing toward fielding a force which can operate under any climatic conditions, at any time of the year. While much progress has been made in the operability of mechanical equipment,

somewhat less emphasis has been placed on the individual soldier's equipment. Although a significantly improved winter uniform has been fielded, the same vapor barrier boots and Arctic mittens the soldiers were issued 30 years ago are still the standard - and no developmental progress is being made toward upgrading these basic soldier worn items. Potential adversaries have the equipment and experience to deploy and fight in the cold. The U.S. Army needs to emphasize development of cold weather equipment at least as capable as that of its potential adversaries.

KEY WORDS

Arctic, Subarctic, Natural Environmental Testing, Cold Weather, Cold Climate, Trucks, Tanks, Tactical Vehicles, Cold Weather Clothing.

INTRODUCTION COLD WEATHER TESTING

The U.S. Army Cold Regions Test Activity (CRTA) is located at Fort Greely, Alaska not merely because it is cold, but because it is colder, longer than other any military installation in the United States or Canada. More potential cold weather test time is available at Fort Greely during any winter than any other potential testing location during a 5 year period. Fort Greely offers over 678,000 acres of test and impact area

with wintertime temperatures as low as -60 degrees F. Terrain varying from broad river valleys, to tundra, to rugged arctic mountains and glaciers are available as test locations. CRTA tests equipment ranging from Main Battle Tanks and helicopter weapon systems to gloves and dog boots. Most importantly, all testing is done by experienced, military trained, MOS qualified, soldiers in the natural environment.

TESTING FACILITIES

CRTA controls a wide variety of test facilities and ranges for developmental evaluation of all types of materiel. Facilities include direct fire, indirect fire, and small arms weapons ranges, vehicle test courses, anti-aircraft missile test range, personnel obstacle courses, lakes, rivers, mountains, and glaciers. Airspace is controlled, and shared by the U.S. Air Force, over the western 80% of Fort Greely. Comprehensive instrumentation is available to measure test item performance. In addition, CRTA has extensive data and video communications capabilities to rapidly move test information to any location, including a recently completed Video Teleconferencing Center.

DEVELOPMENTAL TESTING

Developmental testing is often misconstrued as a gage on the quality of hardware. While developmental testing can fill this role, the purpose of developmental (versus operational) testing is to improve the product and to apply expertise to help the developer make his materiel the best possible within constraints of his individual program. Developmental testing is generally a test/fix/test process wherein shortcomings in equipment are identified early in

development, the tester and developer work together to improve the hardware and fix shortcomings, and the item is retested to refine the hardware and the developmental process. The end product is greatly improved, benefiting from the expertise of both the materiel developer (who has the equipment expertise) and the tester (who has the expertise on the operating environment).

CURRENT TECHNOLOGY LEVEL

The challenges of cold climate faced in World War II and the Korean Conflict have been a challenge to overcome; however, with the application of technology available today, the vast majority of problems faced then can be fully solved. For example, the operation of vehicle systems has been made relatively easy thanks to the development of synthetic lubricants, dependable antifreeze, and supplementary heating devices. Gasoline, diesel, and turbine engines can be made to start with relative ease while transmissions and gear cases filled with low temperature lubricants turn easily at the lowest temperatures likely to be encountered. The challenge for today comes in adapting the advances made since the early 1950's to current concepts and policy. The Army can no longer use air fouling high horsepower engines - loose tolerance engines which start and run well in cold climates. We also wish to take advantage of superior drive trains, transmissions, and increased mobility offered by advancing technology. Testing in the past has concentrated on temperature effects on materiel, rather than on operation in the environment. The cold chamber has been a valuable tool in perfecting equipment which can withstand temperature effects. The problem is, with advancing technology, the problems have moved from being pure temperature effects to effects of the overall

operational environment on materiel. Simply, we could take the relatively crude, by today's standards, mechanical equipment designed in 1955, add modern lubricants and apply some simple modifications, and the system would work perfectly in the cold environment. On the other hand, new technology poses new problems, and equipment designed in 1995 doesn't do nearly so well in the cold.

REGULATORY CHALLENGES

In recent years, new challenges to the materiel developer have come from various regulatory sources - primarily the Environmental Protection Agency (EPA). In an effort to meet clean air standards, the Army has developed automotive equipment and tactical vehicles which conform to emission standards dictated by the EPA. This has resulted in engine designs which incorporate much tighter tolerances in manufacture so that tighter clearances can be maintained in the engine - thereby reducing emissions in the exhaust. This condition results in serious problems for the materiel developer. As we all know, all things shrink when cold. With less room to shrink, (closer clearances), pistons tend to contact the cylinder walls in large diesel engines. This condition does not prevent starting in the cold, so cold chamber results look very good. When the close clearance engine is put under load, as in normal vehicle operation, pistons can (and do) contact the cylinder walls, causing premature and sometimes catastrophic failure. The closer tolerances also affect the valve train, causing valves to stick and pushrods to bend, again causing inoperability of the engines of some of our tactical vehicles. The answer thus far has been to increase clearances in the engine - which results in significantly higher exhaust emissions, or to warm the engines of vehicles

at no load conditions for up to three hours to stabilize engine temperatures at design operation levels - a condition unacceptable to the user. Another thorny issue regarding the engine clearance problems is that tests cannot be conducted in conventional cold chambers because of the necessity of loading the engines and the extended warm-up times being contemplated.

OTHER VEHICLE CHALLENGES

Tactical and combat vehicle problems are not limited to engine starting and the engine assembly. A current problem plaguing developers is the transmission failure rate on cross drive transmissions. These transmissions provide significantly improved performance and controllability of tracked vehicles, and are expensive. Again, close clearances and lubrication of components seem to be a problem. However, the transmission will not work properly without these close clearances - they cannot simply be increased to alleviate the cold climate problems. Some cross drive transmissions require up to 1.5 hours warm up at low load conditions (stationary) to prevent failure within the first 50 miles of operation after starting at low temperatures - a condition clearly unacceptable to the field commander. Modern production engines and vehicle systems need to be operated over a relatively narrow band of temperature (usually from about freezing to boiling point of water) to perform properly. In order to meet these conditions, a new series of fuel fired heaters is being evaluated to keep automotive systems warm overnight and when not operating. These heaters show great promise in reaching a compromise in vehicle peak performance temperatures and warm up times. U.S. designers tend to use great finesse and are very conservative in pre-

heating vehicular systems. This produces designs which are conservative in heat output and fuel consumption. To the contrary, foreign designers, particularly the Former Soviet Union, use heat and fuel prodigiously. The single T-72 tank currently at CRTA is capable of starting and reaching full operational capability within 15 minutes at extremely low temperatures. This is due to the output of an engine compartment heater of approximately 400,000 BTU/H capacity. The brute force approach of this monstrous heating system adequately heats the critical components of the vehicle, allowing rapid employment and excellent operability. Such a heater mounted in a similar U.S. Army vehicle would probably melt many critical components.

PROCEDURE VS EQUIPMENT

Test and evaluation of system of any type involves both the equipment and the documentation supplied with the equipment. In order to ensure proper function of the equipment, adequate operating and care instructions are essential. It may be a surprise to learn that up to 80% of modifications of materiel systems for use in cold climates is in the form of changes to documentation. A prime example is the M1A1/A2 Main Battle Tank system. When first tested, the M1 series has serious problems in starting, automotive operation, controllability, and weapon system operability. The materiel developer applied various hardware fixes to make the tank operable in cold climates, including trials of auxiliary generators, battery warming systems, additional batteries, and various other minor hardware additions. Such modifications would have cost the tank program in excess of \$500,000,000 to properly equip the fleet. However, through the principle of test/fix/test, and the application of

expertise of persons used to living and operating in the cold, very few actual hardware modifications were necessary. Extensive changes in starting procedure, software, and operating instructions were made over a period of almost eight years. This has resulted in a vehicle system which, if operated by the provided documentation, is fully capable of virtually immediate operation at full capability levels at any low temperature and cold climate extremes. This is typical of systems which are exposed early and frequently to cold climate testing in the natural environment. Any system, from aircraft to clothing, can benefit significantly from natural environmental testing through application of expertise of people who live and work in cold climates.

SOLDIER PERSONAL EQUIPMENT

The commodity area which enjoys the most attention at CRTA is that of soldier personal equipment. This extremely important commodity area occupies about 50% of the CRTA workload during a typical year. This, unfortunately, is not due to the dollar value of the equipment (which is generally low on a per unit basis), but to the large sample sizes necessary to accomplish meaningful testing. Usually, a minimum of 20 soldiers are provided through the TSARC process by 6th Infantry Brigade at Fort Wainwright, Alaska specifically for soldier personal equipment testing each winter. Equipment tested includes the Extended Cold Weather Clothing System, gloves, skis, ski bindings, gloves, underwear, sleeping bags, gloves, tents, and gloves. CRTA has had ongoing glove tests for almost 20 years to evaluate improved glove features and materials. Clothing and personal equipment tests are exacting, long, extensive, and among the most difficult tests to control and evaluate. CRTA works closely

with material developers, particularly Natick Laboratories and PM Soldier, on these tasks. This area of testing and evaluation is extremely complex, many factors hinging on such minor details as type of stitching in a particular fabric. Testing is further complicated by the experience and point of origin of test soldiers used in the testing.

FUTURE CHALLENGES

While the quality of knowledge about cold climate operations seems immense, it is totally overshadowed by unknown factors. The cold climate arena is plagued, as is the rest of the Army, with low funding levels to fund only a few of the many important programs to gain knowledge about cold climate operations. As an example about what we do not know and cannot yet quantify, human physiological adaptation is one important area. During 1990, CRTA conducted a short, unfunded experiment in physiological adaptation under rigidly controlled conditions. This experiment was conducted in conjunction with preparation for glove testing. Six soldiers from the 6th ID assigned to Fort Wainwright, Alaska were compared to six soldiers from the 25 ID assigned to Ft. Shafter, HI. Each participant in the exercise was identically dressed and prepared for a controlled cold exposure exercise. Results were that, under identical cold conditions at -25 degrees F, after 1 hour exposure, all 25th ID soldiers complained of being extremely cold while none of the 6th ID soldiers complained of cold. If you think as we did that it was a mental condition, the readings from instrumentation attached to fingers and toes of all participants indicated that the 25th ID soldiers had skin temperatures up to 20 degrees cooler than the 6th ID soldiers. So, there seems to be some substantiation of acclimatization. The results

cannot lead to quantification due to the limited data; however, the fact of occurrence points to further research in this area. This is but one limited example of future challenges in the quantification of cold climate effects. Much progress needs to be made in materials technology evaluation, equipment operability, and personnel limitations. Yet more data is required on food requirements and psychological adaptation to cold climate conditions - including prolonged darkness. Much attention is being given to modeling and simulation of all potential environments. Right now, insufficient data are available for effective modeling of personnel operating in an arctic or subarctic setting. The same is true of equipment in cold climates. We are about at the level of being able to guess pretty good for a particular situation with particular hardware. The testers are a long way from being able to quantify the parameters necessary for application of a successful model of the cold climate and its effects upon equipment and personnel.

SUMMARY

Testing indicates that equipment currently in the U.S. Army inventory is among the best in the world for use in cold climates. This does not mean that improvement is not necessary. While the U.S. approach to cold climate problems is different from many others, it is not always superior to other methodologies. Evaluation of materiel in the natural cold environment is essential to development of equipment which will stand the rigors of the cold weather battlefield. The best equipment can only be successfully developed to meet the needs of the American Soldier by exposing the equipment to real conditions by people who live and work in the cold. A concerted effort is required to better quantify cold environment related effects to generate

understanding which will result in equipping a cold weather fighting force which can be safe, sure, and successful. Much work in research remains to be done to successfully implement modeling and simulation for evaluation of materiel in the natural cold environment. The U.S. Army Cold Regions Test Activity stands ready to help developers and contractors to improve materiel to work well in the cold.

ENVIRONMENTAL ISSUES GUIDE FOR HEURISTIC TESTING (EIGHT)

Roger L. Williamson
U.S. Army Test and Evaluation Command (TECOM)
Aberdeen Proving Ground, MD

ENVIRONMENTAL ISSUES GUIDE FOR HEURISTIC TESTING (EIGHT)

Roger L. Williamson
U. S. Army Test and Evaluation Command (TECOM)
Aberdeen Proving Ground, MD

BIOGRAPHY

Roger Williamson is a physical scientist in the Technology Development Division at Headquarters, TECOM, located on Aberdeen Proving Ground, MD. He holds a BA in Psychology from Valparaiso University and an MA in Measurement and Statistics from the University of Maryland. In addition to eleven years at Headquarters TECOM, he spent eleven years at TECOM's Tropic Test Center in the Republic of Panama which turned his interests toward discovering and documenting effects of environments on materiel systems. Currently, he is finalizing and activating EIGHT, the environmental issues guide he designed to satisfy needs expressed to him and to support Department of Defense environmental simulation efforts. He also is leading a tri-service effort to prepare DoD and industry environmental effects program guidance that will appear as Part One of MIL-STD-810F.

ABSTRACT

This paper explains a newly established database that provides players in the materiel acquisition process with a corporate memory of the effects that various environments have on materiel system performance and reliability. A major portion of the data base is devoted to cold weather effects. The conference presentation demonstrates the data base and shows cold regions data entered from materiel tests conducted at the Army Cold Regions Test Activity in Alaska. EIGHT is a computerized knowledge base accessible by U.S. Government and other agencies. EIGHT is a very easy-to-use four-dimensional, 200K-cell, matrix of findings and supporting data. Four dimensions cover: 4 Environments, 50 Environmental Factors, 10 Analysis Areas, 100 Materiel System Types. EIGHT serves as a corporate memory for materiel system designers/testers/evaluators, providing historic test findings plus scientific background information for designing systems and modeling and simulating system effectiveness.

KEY WORDS

Environment, data base, test, technology, synthetic battlefield, models, simulation, software engineering.

DEVELOPING A DATA BASE

Determining the user's needs and meeting them are the most important parts of developing a data base. This requires systematic interviewing, designing, alpha testing hard copy versions, software engineering, and beta testing software, involving the ultimate user at every step. The eight structure evolved from fifteen years of close contact with would be users, designing and testing to meet their expectations. The RDTE community will use it because, essentially, they designed it. To help make improvements continuous, there is an option on the main menu to enter suggestions to improve the EIGHT system. EIGHT is fully documented with an end user's manual.

THE NEED FOR EIGHT

The need for documenting how various environments affect materiel system performance and reliability comes from various sources including the DoD Science and Technology thrusts listed in Table 1 and discussed in a series of DoD "white papers."

Table 1.
DoD Science/Technology Thrusts

1. Global Surveillance and Communications
2. Precision Strike
3. Air Superiority and Defense
4. Sea Control and Undersea Superiority
5. Advanced Land Combat
6. Synthetic Environments
7. Technology for Affordability
8. Soldier as a System

Of the eight DoD thrusts, number six, is the challenge of interest here. Thrust number six challenges us to: (a) develop a broad range of information and human interaction technologies (identifying critical problem areas, speeding development of cost effective solutions, and synthesizing future/present battlefields); (b) mix real and computer-simulated equipment in synthetic battlefields; (c) develop electronically linked, interactive, integrated teams of users, developers, and testers; and (d), through such synthetic environments, prepare leaders and forces for war.

Figure 1 diagrams that relationship and shows the RDTE community's approach for supporting the thrust. Note that RDTE support is taxonomic, beginning with data bases that are the *sine qua non* to models, synthesized/integrated representations, and distributed/interactive simulations. So, without valid data bases, the entire effort would have little validity.

In this manner, then, EIGHT supports more than just TECOM. It will help all combat developers by providing them with environmental effects evidence that will help them to establish performance requirements. It will help materiel system designers, testers, and evaluators by serving as a corporate memory for system planning, design, and effectiveness. Moreover, the information in EIGHT will become valuable ammunition for designing and validating modeling and simulation efforts such as "electronic battlefields" and "virtual proving grounds."

EIGHT SCOPE AND STRUCTURE

EIGHT documents the effects that various environments have on materiel system performance and reliability. Note that EIGHT focuses on the effects of environments on military systems (adverse environmental forcing functions), not on the effects of military systems on environments (environmental quality). These forcing functions include not only climatic environmental factors, but also factors induced by the item platform such as shock and vibration, constructed environmental factors such as energy-producing facilities and psychological surroundings, and combat peculiar environments such as field fortifications, smoke, and obscuration.

The term, heuristic (the "H" in EIGHT) refers to the practice of using past information to increase current performance. By its very nature, this database of comprehensive, logically organized, easily accessed, and systematically updated environmental effects information gleaned from past experience will help users perform their environmental design, test, and evaluation tasks more effectively.

Information is structured in a four dimensional matrix containing about 200,000 cells. Each cell contains an issue statement that may have one or more findings. Each finding is supported by summary data, design implications, test implications, and technical references.

Users may operate in either of two modes. In the input mode, users enter proposed findings/data, propose new levels for a matrix dimension, or suggest improvements to EIGHT system. In the output mode, users obtain information by selecting/viewing/printing/transferring approved findings/data.

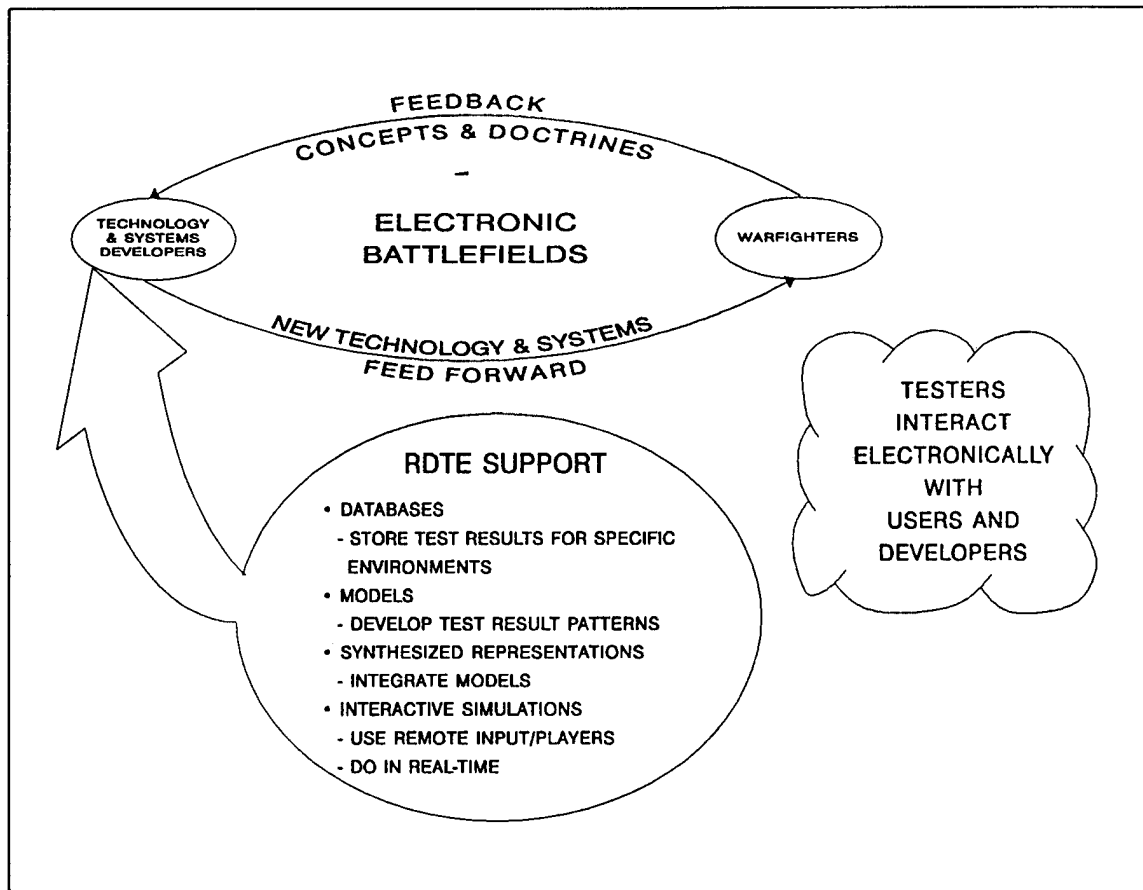

Figure 1. Synthetic environment thrust and RDTE support.

The initial EIGHT data input effort concentrates on natural environmental plus induced shock and vibration factors (about 75,600 cells). TECOM's Cold Regions Test Activity in Ft. Greely, Alaska; Tropic Test Site in Panama; and desert test facility at Yuma Proving Ground, Arizona; have entered, for the most part, findings and supporting data from past tests. Finishing touches are under way.

Data are **input** in a structured manner through a series of simple menu selections, yes/no answers, and fill-in-the-box fields. All fields have clear instructions and example inputs. Data are stored in a four dimensional matrix structure, with all entries in a common format designed to meet the needs of the EIGHT system user community. **Output** data may be located and retrieved easily via the structured matrix, by user-defined word/string searches, or a combination of both. This "structured write/flexible read" approach provides maximum speed for users who want to "zero in" on specific cells of the matrix and allows maximum flexibility for users who want to browse.

The four dimensions of the EIGHT system are as follows. **Climatic Regions (4 levels)**: areas of the world considered to be tropic, desert, cold, temperate regions. **Environmental Factors (about 50 levels)**: specific parameters of natural and induced environments, e.g., temperature, humidity, shock, vibration. **Analysis Areas (about 10 levels)**: basic design/performance/testing issue areas used to evaluate military systems, e.g., operability, vulnerability, mobility, safety. **Mission/Commodity Areas (about 100 levels)**: a classification of Army materiel systems into functional mission areas. Each mission area is further subdivided into the specific types of systems or commodities that fall into that functional area. These are

defined in "Materiel for Winning," November 1990, prepared by the U.S. Army Materiel Command, U.S. Army Training and Doctrine Command, and U.S. Army Information Systems Command. EIGHT system design and programming techniques will allow mission areas unique to other services to be added.

An issue statement is a computer-generated question formed by the four user-selected levels (one each from the four basic dimensions of EIGHT). There is one issue, then, for each of the 200,000 cells in the EIGHT system. For example, "Does **cold region temperature** affect the **operability of shelters?**" Each finding entered or retrieved falls under such an issue.

A finding is a succinctly phrased, general statement (supported by one or more sets of data within EIGHT) that describes a materiel item failure or scientific/engineering observation that falls within the scope of an issue. For example, under the issue, "Does **cold region temperature** affect the **operability of shelters?**" a finding is: "Hydraulic system components broke or leaked."

Each finding is limited to two short lines of type. These short, one-or two-line, straight-to-the-point pieces of information are the distinguishing characteristic of the EIGHT data base. It is incumbent upon the agency entering information to pull out these relevant pieces of information and lay them before persons who need them. In this way, persons who search EIGHT for information will not have to read through page after page of test or research reports to find the "good stuff" as it were.

A field of summary data supports a finding. There may be several sets of data for each finding. Generally, data are in narrative form with sufficient quantitative information to provide the user with valuable knowledge.

A field of design implications contains suggested improvements or special insights/precautions related to designing an item so that it will operate effectively in specific climatic regions or while under the influence of specific environmental factors. Some data sets may not contain design implications.

A field of test implications contains suggested improvements or special insights/precautions related to documenting particular environmental effects in specific climatic regions. Some data sets may not contain test implications. These two fields on design and test implications provide space for experts to tell the community what they think regarding the data and issue addressed in that EIGHT cell.

Each record contains information on a single point of contact (POC) for the contributing agency, entered automatically from a related data base filled out by the agency. When the POC changes, the activity merely changes the POC information in one place, and it is back-fed to all records for that agency. In this way, POC information is as current as the contributing agency makes it.

Each record also contains a technical document reference where more information may be obtained. A Defense Technical Information Center (DTIC) number may be entered into the record when available to the person entering the record.

COLD WEATHER EFFECTS ON SYSTEMS

At the present time, EIGHT contains 164 cells of cold weather effects information loaded with 472 findings and 498 sets of supporting data. All of this information is associated with a majority of the 100 or so types of materiel systems that define the fourth dimension of EIGHT, e.g., shelters, power generation equipment, missiles/rockets, mines/countermine systems, fuel handling equipment, clothing/individual equipment, food/field feeding equipment, tactical/support vehicles, battle tanks, ammunition, small arms, NBC equipment, etc., etc., etc.

The preponderance of these cold region findings are associated with hardware performance (operability) in low temperatures. Other findings cover such environmental factors as snow, ice, wind, topography, light level/path, electromagnetic radiation, acoustics, battlefield barriers, general terrain, and synergistic effects, all cutting across such analysis areas as human factors, safety, materials integrity, reliability, and mobility.

EXAMPLE OF INFORMATION IN EIGHT

Attached as EIGHT "Report C," is a printout of a complete record in the EIGHT database, showing all of the fields contained in a record. This particular record is one of eight records contained in the particular cell defined at the top of the Report, and one of 498 records currently entered into EIGHT from past test reports of systems tested at TECOM's Cold Regions Test Activity.

EIGHT allows users to search for information in single cells (i.e., choosing just one level in each of the four EIGHT dimensions). Eight also allows broader searches that would show findings and supporting data for as many cells that fell within the search criteria, allowing the user to browse broad ranges of information and print whichever findings and data are desired.

ACCESS TO EIGHT

Currently EIGHT may be accessed (to enter and read information) by U.S. Government agencies and Department of Defense contractors via Internet using an IBM-compatible PC with high-density floppy, 2Mb of RAM and 5Mb of hard disc space. Because extended memory is required for execution, XT and AT machines are not recommended.

Current plans are to establish EIGHT on the Test and Evaluation Network (TECNET) where TECNET users (Federal Government and DoD contractors) will be able to enter information into EIGHT (when provided a login code and password by TECOM) and retrieve EIGHT information (no special permission required beyond having a TECNET account). Until then, EIGHT software will be issued to TECOM and selected other Government agencies on disks that contain installation instructions, EIGHT program, and EIGHT data. TECOM will hold current data in a TECOM LAN where it will be accessible to selected users. Queries may be made to TECOM at DSN 298-1063 or commercial (410) 278-1063. Ms. Jennifer Salafia of Tri-S, Inc. will assist you in getting set up on EIGHT.

SUMMARY

Adverse environments have profound effects on military materiel system performance and reliability. The Environmental Issues Guide for Heuristic Testing contains room for about 200,000 functionally arranged and easily accessed cells of knowledge on how specific environmental factors affect specific system performance and reliability and materials integrity. Each cell may contain any number of findings. Each finding may contain any number of supporting sets of data. This information is valuable to the materiel research, development, test, and evaluation (RDTE) community members who can use such information to focus on customer needs perform their duties smarter. Modelers and simulators can use EIGHT data as ground truth information for electronic battlefields and virtual proving grounds. U.S. Government agencies and DoD contractors may enter and retrieve data through the TECOM LAN via Internet until arrangements are made to establish EIGHT on TECNET.

REFERENCES

1. U.S. Department of Defense White Paper, "Defense Science and Technology Strategy," Washington, D.C., May 1992.
2. Kramer, John, "Stratification of the Geophysical Elements of Terrestrial Combat," Informal Discussion Paper, U.S. Army Materiel Systems Analysis Activity, Aberdeen Proving Ground, MD, December 1977.
3. Williamson, Roger L., "Environmental Issues Guide Concept Plan," Methodology Investigation Final Report, U.S. Army Tropic Test Center Report No. 830102, Ft. Clayton, Canal Zone, January 1983.

[See next 2 pages for EIGHT fields/sample output.]

Report C: FINDING RECORD

1. CELL: COLD REGION, TEMPERATURE, HARDWARE PERFORMANCE (OPERABILITY),
SHELTERS (ABOVE GROUND) (INCLUDING CB)

FINDING 1 of 8

Hydraulic system components broke or leaked.

Expected Incidence: High

Data Sets: 1

Latest Data Set Date: 09/01/92

Finding Fields:

METALS, PETROLEUM / OILS / LUBRICANTS, PLASTICS / RUBBERS

DATA SET 1 of 1

Technical Data:

The Chemically and Biologically Protected Shelter (CBPS) was tested at Ft. Greely, Alaska by the Arctic Test Center in an arctic environment (-49° F to 46° F) for a period of 2 1/2 months.

Drive belts for the main hydraulic pump broke and required replacement four times during testing. Factors contributing to the damage were cold temperatures and excessive vibration of the pump while operating on internal power, which caused the belts to glaze and stiffen. Vibrations caused the adjusting slide and the main mounting for the hydraulic pump to break.

The supporting bracket broke two times during testing and was repaired. The adjusting slide and main mounting bracket were each replaced. The drive belt for the auxiliary hydraulic pump was replaced two times during testing. Both times the replacement was required because the belt became glazed during operation and slipped.

There were three incidents of hydraulic line failures during testing. The sensor line to the vehicle main hydraulic pump ruptured when the hydraulic hose separated from the fitting, causing a 3-inch tear in the protective casing. Hydraulic oil leaked from the return line of the ESS. This leak came from the crimped area of the hose connector. The hydraulic hose for the supply line of the main pump leaked at the hose connection between the ESS pod and the main pump. All three incidents are attributed to the effect of the cold environment on hoses and fittings. Replacement hoses were installed, but the return line for the ESS continued to leak. Hydraulic leaks were noted during TET PMCS, but were not initially sufficient to require adding hydraulic fluid. The leaks were in the small sensor line of the ESS, the supply line to the auxiliary pump, and the main seal of the main pump.

Material Systems:

CHEMICALLY AND BIOLOGICALLY PROTECTED SHELTER (CBPS)

01/17/95

REPORT C: Finding Record

Reference:

Final Test Report for the Preproduction Qualification Test (PPQT) of the Chemically and Biologically Protected Shelter (CBPS).

DTIC AD#:

Author Agency #: 8-ES-975-CBS-007

Activity/Entry Codes: CRTA /WMSON

Limited Distribution?: ~~Yes~~ No

Technical POC: JEROLD G BARGER

CRTA - COLD REGIONS TEST ACTIVITY

STECR-TD

DSN: (317) 873-4219

CRTA TECH DIRECTOR

COM: (907) 873-4219

Design Implications:

The leaking seals appeared to be caused by cold temperatures causing the lines and fittings to contract. An hydraulic engineer representing the manufacturer stated that weeping fluid from the hydraulic motors is normal, but pumps and hoses should show no leakage at all.

To avoid fluid leaks, use seals and connectors that do not shrink and expand because of temperature changes. To avoid cold temperature bracket beakage, use heavier gauge metals than required for temperate environment operation.

Test Implications:

To screen systems for hydraulic leaks, belt operation, and materials integrity failures, test the system in chambers early in the development cycle.

To ensure that these and other types of failures will not occur when such systems are operated under realistic field conditions, be sure to test in natural environments where cold temperatures can interact with other cold regions factors such as moisture intrusion and transportation shock and vibration to cause failures not likely to occur in chambers.

**THE LAYERING PRINCIPLE
FOR COLD WEATHER CLOTHING:
ARE WE THERE YET?**

John Frim
Human Protective Systems Division
Defence & Civil Institute of Environmental Medicine
North York, Ontario, Canada

The Layering Principle for Cold Weather Clothing: Are We There Yet?

John Frim, Ph.D.
Human Protective Systems Division
Defence and Civil Institute of Environmental Medicine
1133 Sheppard Avenue West
North York, Ontario, CANADA M3M 3B9

INTRODUCTION

Military cold weather clothing must protect the wearer against the elements of wind, snow, and rain. Concomitantly, it must provide varying amounts of insulation so as to match the amount of heat loss to the environment with the level of body heat production associated with a wide range of activities. If insulation is not adjustable, heat production can exceed heat loss, resulting in a rise in deep body temperature, an increase in sweat production, and the possible wetting of the clothing by sweat. Since moisture in clothing can greatly reduce its insulation value, prevention of excess sweating in the cold in the face of varying levels of activity is a major challenge facing designers of Arctic clothing systems.

One approach to meeting this requirement that has long been pursued is the "layering principle". In theory, the ideal cold weather clothing ensemble is made up of several layers of lesser insulation which are removed or added as needed to maintain thermal balance; in practice, success with this approach has often been difficult to achieve. First, the outer clothing layer is often the only layer that provides the essential protection against the environmental hazards, and much of the total insulation has often been associated with this layer. This effectively makes the outer layer non-optional, and its associated insulation can at times be excessive. A secondary effect of this design is that those layers that can be added or removed are beneath the outer layer, which necessitates several steps to adjust one's insulation and creates a storage problem for those inner layers which have been removed and must be kept dry. More often than not, particularly in a military setting, the logistics of adjusting insulation with such a system are simply impractical, with the result that soldiers are often wearing levels of insulation that are less than optimal.

A recent technological advance that has virtually revolutionized clothing design is the development of water-vapour-permeable water-proof materials (WVP/WPMs) which can be bonded to layers of fabric. The major benefit of these materials is that they allow water vapour to diffuse through the clothing while providing a barrier to wind and liquid water. While several varieties of such materials exist today, the most well-known is expanded polytetrafluoroethylene (PTFE) sold under the trade name "Goretex®". WVP/WPMs have found their way into a variety of clothing systems, particularly sports clothing where activity levels vary greatly and the environmental conditions range from extreme heat to extreme cold. WVP/WPMs can be used very effectively wherever there is a need in a single garment system to enhance evaporation of body sweat due to activity while keeping out external water. An excellent example of such use is the manufacture of firefighter turnout clothing [1]. While the development of WVP/WPMs is in itself important, the method of incorporation of such materials into an affective garment system design is of equal if not more importance.

WVP/WPMs have made possible the development of garment systems with unique functionalities. One of these systems is the Improved Environmental Clothing System (IECS) developed for the Canadian Forces (CF) over a period of years by Defence Research Establishment Ottawa (DREO) and recently engineered by Directorate of Clothing, General Equipment and Materials (DCGEM; now renamed Directorate of Acquisitions, Clothing, Materials, and Equipment (DACME)). The main distinguishing feature of this new system is that it comprises only three clothing layers: an inner fleece pile fabric worn next to the skin during extreme cold (literally, a warm track suit), a middle layer (combat jacket and pants) which is uninsulated but contains Goretex® for wind and water protection, and an outer insulated layer (parka and coveralls) also containing Goretex®. The IECS was designed to replace both the current wet cold and the current extreme cold clothing systems with a single system that would cover the ambient temperature range of +10 to -40°C and bring the layering principle to practical fruition in the CF.

Components and aspects of the IECS were evaluated numerous times during the various stages of its development, but it was not until 1992 that an operational and field-deployable configuration of the IECS was produced in large numbers. At that time a series of parallel field and laboratory trials were undertaken on behalf of the Directorate of Land Requirements (DLR) to evaluate and compare performance of the IECS with

the existing CF cold weather clothing ensembles [2; 3; 4]. This paper summarizes briefly the results of trials of the IECS conducted under controlled environmental conditions in the climatic chambers at the Defence and Civil Institute of Environmental Medicine (DCIEM) in Toronto, Canada.

MATERIALS AND METHODS

Subjects

Twelve military volunteer subjects were recruited for this study. Their ages ranged from 23 to 38 y, with a mean age of 29 ± 5 y (mean \pm S.D.). They were selected to be of medium build simply because of the limited range of clothing sizes available for the study. Eight subjects were used in each of two test series conducted at -10°C and -40°C . Subjects 1–8 participated in the -10°C test, while subjects 1–4 and subjects 9–12 participated in the -40°C tests.

All subjects were screened by a physician prior to their being accepted into the tests and were declared physically fit and in good health. They were briefed on the experimental procedures and they gave their written informed consent to participate. All procedures employed in these tests were passed by the DCIEM Human Use Ethics Committee.

Clothing

In essence, two clothing systems were being compared in these tests: the current clothing and the IECS. However, each of these major categories can be subdivided into sub-categories appropriate to the environmental conditions under which testing was carried out. For example, the current clothing consisted of two main configurations, current temperate (CT) and current cold (CC), while the IECS was worn either in the new temperate (NT) or extreme cold configuration. Since two levels of insulation were specified and fabricated for the outer parka and coveralls of the IECS, the extreme cold configuration was further subdivided into light parka (LP) and heavy parka (HP). Apart from the quantity of insulation and a minor change in the fiber type and weave of the outer face fabric, the LP and HP systems were functionally identical. Detailed physical characteristics of the IECS can be found in a companion study [3].

A condensed list of clothing items comprising the main clothing configurations of each system is presented below in Table 1. Clothing items of similar function are aligned

somewhat in rows. Each clothing configuration was modified slightly to be most suitable for each test condition or to meet certain test objectives. For example, the parka of ensemble **CC** was often opened and closed to allow venting, while the parka of the IECS was donned and doffed when activity increased (see below). Also, although the table indicates that the fleece layer is available for the NT configuration (and we know that soldiers wear it in this configuration), this study never used the fleece with ensemble NT.

Table 1. Partial List of Clothing Items Comprising the Various Test Ensembles

Current Clothing		IECS	
CT	CC	NT	LP / HP
undershorts tee-shirt	undershorts tee-shirt	under shorts tee-shirt	under shorts tee-shirt
	honeycomb top long johns	fleece top (as required) fleece bottom (as required)	
combat shirt combat jacket	flannel shirt sweater, scarf	middle layer jacket	middle layer jacket
combat pants		middle layer pants	middle layer pants
	parka wind pants	outer parka (as required) outer coveralls (as required)	
toque combat boots combat gloves	balaclava mukluks Arctic mittens	toque combat boots combat gloves	balaclava mukluks Arctic mittens

Note that the IECS did not include any new head, hand, or foot wear. Thus, the clothing items worn on these areas of the body during testing of the IECS were the same items that are part of the current clothing ensembles.

Experimental Design

The objective of this study was to obtain a comparison of the physiological responses to wearing the various clothing configurations under two different levels of activity and two different wind conditions, all at two different temperatures. Accordingly, a 3-factor repeated measures experimental design containing 12 cells was adopted as shown in Figure 1. Note that the same experimental design was used at both -10°C and -40°C.

However, since clothing configurations and composition of the subject samples varied between these two test temperatures, each temperature series was treated (i.e., analyzed) as a completely separate experiment. Subjects were tested in pairs at the same time of day (morning or afternoon) for four days each week for three weeks. Treatment order was counterbalanced to minimize the effects of any potential acclimation to the cold (little acclimation was expected due to the relatively short exposures and the fact that the subjects were wearing sufficient clothing to hopefully create a fairly comfortable microclimate within the clothing).

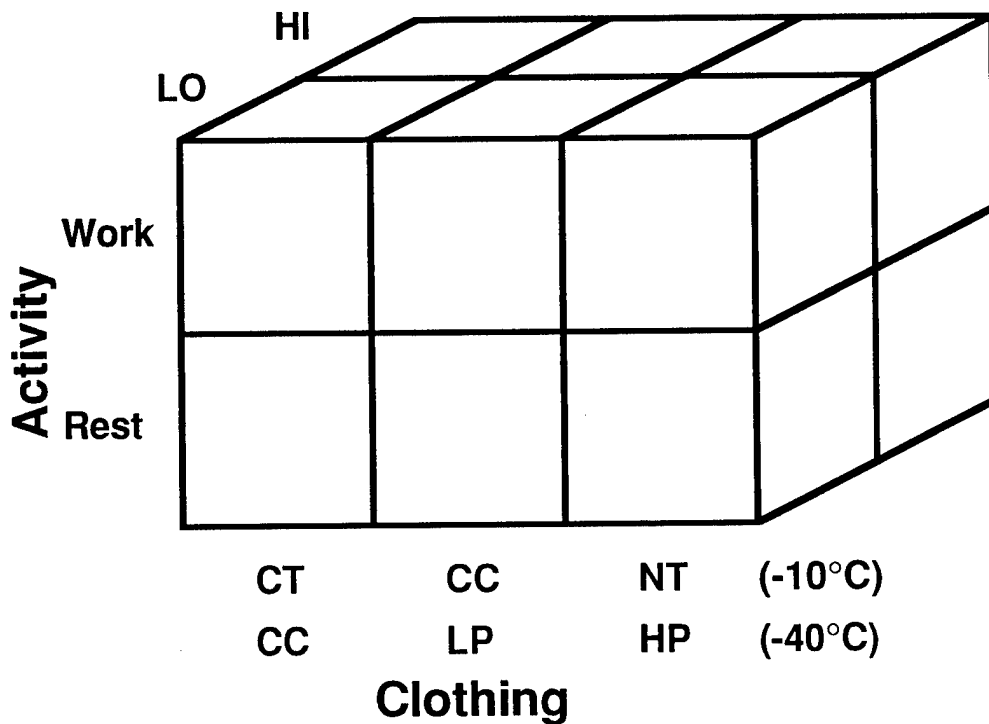

Figure 1: Graphic representation of the 3-factor repeated measures design. Each subject was exposed once to each test condition, and the -10°C and -40°C tests (of 12 cells each, as above) were treated as completely separate studies.

The main factor **Activity** consisted of two activity schedules. During **Rest**, subjects entered the environmental chamber and simply sat on a wood bench covered in a thick wool blanket with their backs to the wind. During **Work**, subjects entered the environmental chamber and spent 40 minutes of each hour working and 20 minutes resting. The work involved walking on a level treadmill at 4.5 km/h or carrying 105 mm drill rounds a distance of 2 m at a rate of 6 rounds moved per minute. The drill rounds

were placed on a rack at each end of a 2 m platform and the heights of the rack (30, 60 and 90 cm) were set to be representative of an actual weapons loading task. The three rounds were moved from one rack to the other at a cadence set by flashing lights connected to a timer. After 20 minutes, subjects switched to the other work task. This work/rest cycle was repeated twice, and the final 30 minutes comprised only 15 minutes on each work task. Note that half of the subjects began work on the treadmill while the other half began on the drill rounds task. The main factor **Wind** included a **LO** wind speed (0.4 km/h) and a **HI** wind speed (20 km/h) condition. Subjects had their backs to the wind while sitting or walking, but had to turn face into the wind while loading/unloading drill rounds from one of the racks.

The main factor **Clothing** has already been addressed briefly above. However, the rationale for the clothing selections and the two environmental temperatures should be clarified.

The “design philosophy” behind the IECS was that this single 3-layer system should replace both the current wet cold and the current extreme cold clothing systems, thereby providing proper protection under all environmental conditions ranging from +10°C (including wet cold conditions) down to the -40°C dry cold of the Arctic. Hence, the tests at -40°C were designed to assess the adequacy of the IECS insulations (**LP** vs **HP**) in extreme cold and to compare them to the current cold (**CC**) clothing configuration. Of course, not all components of the IECS would be carried at all times (clearly, one would not carry insulated parkas when temperatures are +10°C); rather, a judicious selection of items would be chosen based on the environmental conditions and operational requirements of the day. However, the implication is that one might not have the appropriate clothing items if circumstances change drastically during the day, particularly if ambient temperatures transgress the transition zone where a major change in clothing configuration would be desirable.

The design transition temperature for the IECS where one would consider wearing the inner layer fleece is about -10°C. This is also about the temperature at which one would consider wearing the insulated parka of the current clothing system. Thus, -10°C was selected as an ambient condition at which there might be a “penalty” for having chosen the clothing incorrectly. Accordingly, clothing configuration **CT** during the -10°C tests represented a situation in which inadequate insulation had been selected, as if warmer conditions had been expected but the temperature suddenly dropped to -10°C.

Similarly, configuration **CC** represented a situation in which too much insulation had been selected, as if the day had begun quite cold and then warmed up unexpectedly to -10°C . With the IECS, configuration **NT** permitted assessment of whether the fleece could be omitted down to -10°C (i.e., is the middle layer sufficient insulation during condition **Work**, and can the outer parka provide sufficient additional insulation during condition **Rest** even in high wind?).

All tests were designed to be of 150 min duration. Subjects were, of course, free to terminate any test for any reason whatsoever. Other termination criteria included rectal temperatures rising above 39°C or dropping below 35°C , rectal temperatures changing by more than $\pm 2^{\circ}\text{C}$ from the temperature at the start of the test, any skin temperature dropping below 3°C , or heart rate exceeding 80% of the age-predicted maximum heart rate ($220 - \text{age}$) for three consecutive minutes. The investigators and/or the attending physician could also terminate any test for reasons of safety.

Measurements

Rectal temperature (T_{re}) was used as an indicator of deep body temperature. Skin temperatures and local heat fluxes at 12 standard body surface sites [5] were measured with heat flux transducers. Mean skin temperature (MST) and mean heat flux (MHF) were calculated as the area-weighted average of the 12 sites according to Hardy and Dubois [5]. Additional thermistors were taped to the fingers, toes, and rear thighs for safety to prevent local frostbite. All these parameters were scanned continuously with a Hewlett-Packard data acquisition system. One-minute averages of the parameters were displayed on the screen, printed, and saved on disk for later analyses.

Subjects were weighed nude before and after each test, and the weight differences were used as an indication of fluid loss (FLOSS) during the test. A Sport Tester PE3000 heart rate monitor was used to measure and log HR. These values were also recorded by hand every 20 minutes for later statistical analyses. Throughout the tests, subjects were asked to provide subjective ratings of thermal comfort using a 13 point scale ranging from extremely hot to extremely cold, with a score of 7 representing comfort. They were asked to provide separate ratings for whole body, head, hands, and feet (-10°C series) and additionally arms and legs (-40°C series). These data were also recorded by hand every 20 minutes.

Data Analyses

All initial and final time point temperature data collected by the data acquisition system were transferred to a Macintosh computer for processing and analyses. Hand-recorded data were also entered into a spreadsheet on the Macintosh system. Heart rates, comfort scores, changes in body weights, initial and final body temperatures, as well as changes in body temperatures from start to finish of the tests were compared among the various clothing ensembles across the various test conditions. Analyses were performed with the SuperAnova statistics package (Abacus Concepts) using a repeated measures analysis of variance (ANOVA repeated, 3 within factors). Specific comparisons between clothing ensembles were done using linear means comparison contrasts. All reported statistical probabilities are based on the Greenhouse-Geiser epsilon correction for degrees of freedom as implemented in this statistics package. Results were considered significant if $p < 0.05$. Note that in this report attention is focused on the main effect of clothing and on interaction effects in which clothing was a factor (i.e., the effects of wind and activity, either singly or in combination, on the physiological variables are not considered extensively).

For the -10°C series of tests, all subjects completed 150 min of exposure under all conditions. The final time point data are, therefore, directly comparable and are probably good integrated measures of the performance of the clothing systems under the various test conditions.

Since not all subjects were able to complete the -40°C tests, statistical analyses and interpretation of the results for these tests were more complicated. In particular, "final" data from this series of tests represent physiological responses after various times of exposure; hence, they may not be directly comparable. Further, the subjective comfort and heart rate data which were collected manually at 20-min intervals could not be analyzed statistically with time as a factor beyond 60 min because of the large decrease in the number of subjects over time (from $n=7$ @ 60 min to $n=3$ @ 80-min). The statistical analyses of the comfort and heart rate data at -40°C thus represent responses during the first hour only. Averaged data are presented as the mean \pm standard error of the mean (SEM) unless stated otherwise.

RESULTS and DISCUSSION

Part A: -10°C Tests

Rectal Temperature (T_{re})

The T_{re} responses over time were quite dependent upon the test conditions. T_{re} was elevated during **Work** (the bold type refers to the entire treatment, not the individual work periods) compared with **Rest** irrespective of the clothing worn, and very definite increases in T_{re} (about 0.5°C) were observed during the first 40-min work phase. During the resting phase of the **Work** protocol, T_{re} dropped by $0.2\text{--}0.3^{\circ}\text{C}$, only to climb again with commencement of the next activity session.

The **CT** clothing configuration as worn in this study indicated the smallest overall increase in T_{re} during condition **Work**, with the major deviation in response from the other clothing ensembles beginning after about 60 min. This could be beneficial in that it may reduce the "thermal stress" of working in clothing that has excessive insulation. Clearly, changes in some of the clothing elements for ensembles **CC** and **NT** may have been able to lessen the corresponding T_{re} increases somewhat; thus, it is difficult to judge from these data alone which clothing ensemble was, in fact, better. Perhaps the most important observation is that the **NT** clothing ensemble often gave a response that was intermediate between **CC** (which may have been too insulative) and **CT** (which may have provided insufficient insulation) during the **Work** protocol. During **Rest**, ensemble **NT** appeared to maintain T_{re} better in the long term than the other two configurations of the current clothing system.

The data for the **LO** and **HI** wind conditions were qualitatively similar, the major difference being that T_{re} values at the end of the exposure during **HI** wind were about 0.2°C lower with the **CC** clothing ensemble, but only about 0.1°C lower with the **CT** and **NT** ensembles when compared to the **LO** wind condition. Overall, comparison of the **HI** and **LO** conditions indicated that the least difference between wind conditions occurred with ensemble **NT**, suggesting that the new clothing with its Goretex[®] membrane is very effective at stopping wind. As in the **LO** condition, ensemble **NT** maintained T_{re} better during **HI** wind and **Rest** than either of the current clothing ensembles, undoubtedly due to the warmth and wind protection of the outer layer.

Analysis of variance (ANOVA) performed on final rectal temperature (T_{re-f}) data after 150 min in the chamber indicated statistically significant main effects of clothing ($p < 0.01$), wind ($p < 0.05$) and activity ($p < 0.001$). There was also a highly significant

interaction between clothing and activity ($p < 0.01$), with T_{re-f} in ensemble **CC** being lowest during **Rest** ($36.97 \pm 0.06^\circ\text{C}$), but highest during **Work** ($37.65 \pm 0.05^\circ\text{C}$).

Although T_{re-i} did not differ significantly between conditions, there were small variations from day to day between and within subjects. These can be accounted for by examining changes in T_{re} (i.e., ΔT_{re}). Overall, ensemble **CT** indicated the greatest degree of cooling over time, while ensemble **NT** indicated a marginally larger positive ΔT_{re} than ensemble **CC** by the end of the exposure. The data indicate that ensemble **CT** was likely inadequate (a ΔT_{re} of -0.15°C at 150 min) while ensembles **CC** and **NT** were essentially equivalent (an average final ΔT_{re} of $< 0.1^\circ\text{C}$ for both).

ANOVA performed on ΔT_{re} at 150 min indicated a significant ($p < 0.05$) 3-way interaction between clothing, wind speed and activity, and a summary plot for these data is shown in Figure 2. The main feature of interest is that clothing ensemble **NT** performed similarly to ensemble **CC** except during **Rest** with **LO** wind, where ensemble **NT** maintained T_{re} better than the other two clothing ensembles. Ensemble **CT** clearly showed smaller increases and large decreases in ΔT_{re} .

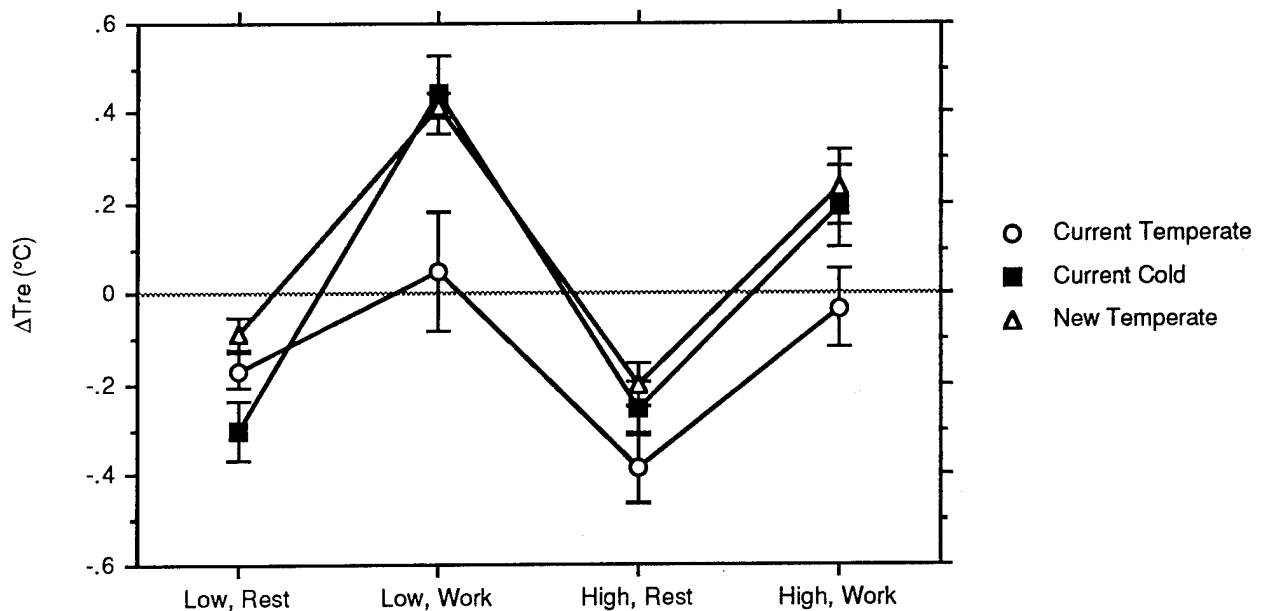

Figure 2. Mean \pm SEM final ΔT_{re} at 150 min for clothing ensembles **CT**, **CC**, and **NT** during activity protocols **Work** and **Rest** with **HI** and **LO** wind conditions.

In summary, from examination of the rectal temperature data, clothing ensemble **NT** as configured in this study provided as much or even better protection than either of the clothing ensembles based on the current clothing. Given that the IECS is a much simpler clothing system with fewer elements but more flexibility, this is a very positive result.

Mean Skin Temperature (MST)

The evolution of MST over time followed a rather expected pattern. During **Rest**, skin temperature tended to decrease along a smooth exponential-like curve, reaching lower values with **HI** wind compared with **LO** wind. Also as expected, skin temperatures decreased most with ensemble **CT**. During **Work**, a similar overall cooling trend for MST was observed, but with undulations superimposed. These undulations followed the work/rest intervals of the **Work** protocol and were somewhat more "pronounced" for the **HI** wind condition in which parkas were opened and closed (ensemble **CC**), or donned and doffed (ensemble **NT**). Keeping the **CC** parka on but open definitely kept skin temperatures warmer than donning and doffing the **NT** parka despite the noticeable rise in skin temperature after donning. Perhaps the **NT** parka should also have simply been opened and closed during this condition for a fairer comparison, but the objective was to see if the middle layer by itself would provide adequate protection during work. The fact that all subjects were able to tolerate 150 min under this test condition suggests it did.

ANOVA of the final mean skin temperature (MST_f) data indicated significant main effects of clothing ($p < 0.001$) and wind ($p < 0.001$), as well as significant 2-way clothing by wind ($p < 0.001$) and clothing by activity ($p < 0.01$) interactions. The MST_f clothing by activity interaction plot shown in Figure 3 is particularly interesting. It shows that ensemble **CT** is quite inferior to the others in being able to maintain skin temperatures at comfortable levels, especially during the **Work** condition. It also shows that whereas there is no difference between ensembles **CC** and **NT** during **Rest**, there is a clear separation of these systems during **Work**. As discussed above, the rather high value of MST_f with ensemble **CC** is likely a direct result of the insulation of the ensemble because of the requirement to always have the outer shell (an integral part of the parka) on the body. The advantage of ensemble **NT** is that wearing the outer parka during work is optional, and it provides a simple way of adjusting the insulation of the clothing to meet the changing thermoregulatory requirements of working in the cold. (Note that storage of the IECS outer parka is not a problem because it folds up into its integral

pocket and turns into a bag with shoulder straps.) As to which response is more desirable, the FLOSS data indicated 58% more sweat loss during **Work** with ensemble **CC** compared to ensemble **NT** (see below).

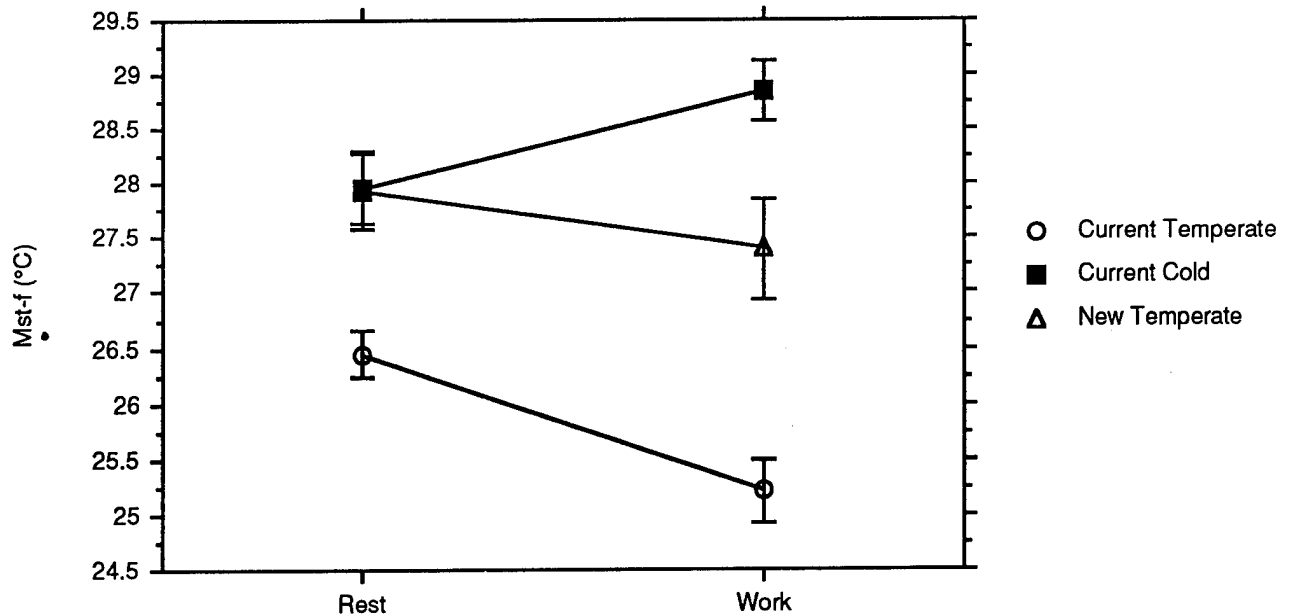

Figure 3. Mean±SEM MST-f at 150 min for clothing ensembles **CT**, **CC**, and **NT** during activity protocols **Work** and **Rest** averaged over **HI** and **LO** wind conditions.

Mean Heat Flux (MHF)

As might be expected from the MST data above, heat fluxes were greater and more variable during **Work** than during **Rest**, they were greater during **HI** wind than during **LO**, and they were greater with ensemble **CT** than with either **CC** or **NT**. Also as before, the **HI** and **LO** conditions were qualitatively similar.

The most striking feature of the MHF data was its remarkable steadiness over time and similarity across clothing ensembles during **Rest**. Time to reach steady state was somewhat longer with ensemble **CT** (about 60 min) than for ensembles **CC** and **NT** (about 15 min), and the heat loss was about 10% greater with **CT** during this time. However, MHF did eventually level off at about $95 \text{ W}\cdot\text{m}^{-2}$, which is nearly double the normal resting heat loss of a person at rest under normal room conditions.

During condition **Work**, heat fluxes were considerably higher during the work phases (0–40 min, 60–100 min, and 120–50 min) than they were during the resting phases (40–60 min and 100–120 min). During the work phases, MHF was about 20% greater with

ensemble **NT** than with ensemble **CC**, again due to the fact that with **NT** the parka was doffed during work while it was only opened with ensemble **CC**. However, during the resting phases when parkas were worn and closed, heat fluxes were much more similar.

Body Weight Changes (FLOSS)

Fluid loss (FLOSS) data showed statistically significant differences for the main effects of clothing ($p < 0.01$) and activity ($p < 0.01$), as well as a significant interaction between clothing and activity ($p < 0.01$). The latter finding is presented in Figure 4.

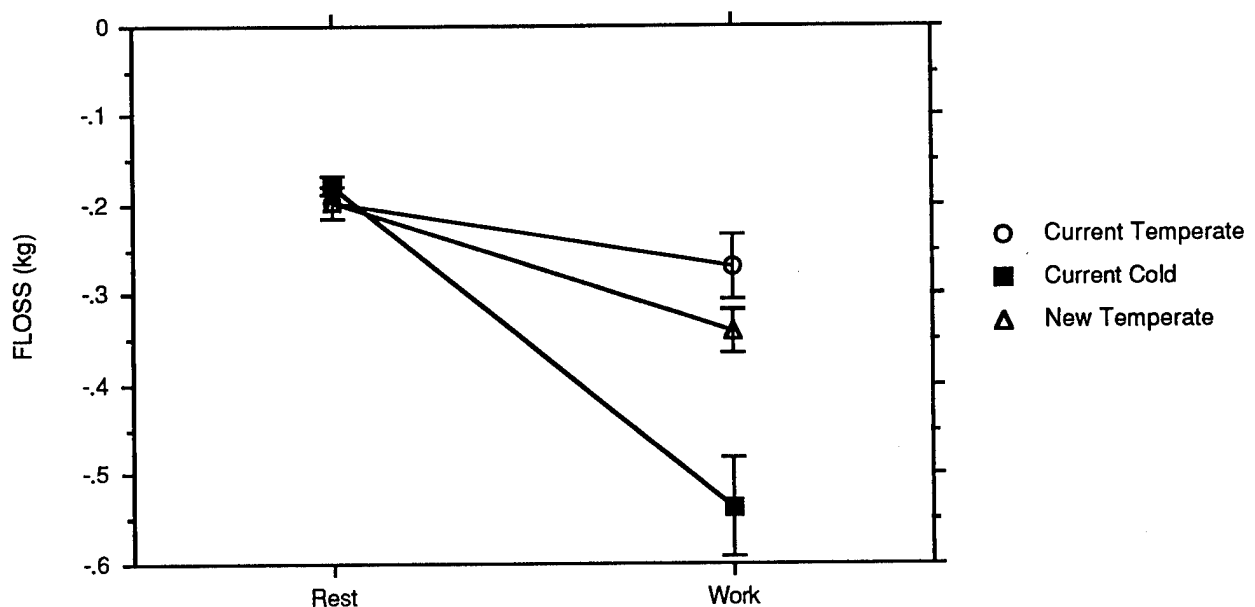

Figure 4. Fluid loss as a function of clothing and activity at -10°C . More negative values on the ordinate indicate greater fluid loss.

During condition **Rest**, fluid losses were virtually identical in all three clothing ensembles, amounting to 0.191 ± 0.009 kg over the 150 min duration of the tests. Fluid losses increased to 0.269 ± 0.036 and 0.339 ± 0.024 kg for ensembles **CT** and **NT**, respectively, during **Work** while FLOSS was 0.537 ± 0.055 kg with ensemble **CC**. Clearly, although heat losses were lower and skin temperatures were higher with ensemble **CC**, the sweat loss was considerably greater in this ensemble (58% higher than for **NT**), and that is highly undesirable in Arctic clothing. This finding indicates a significant performance advantage of the IECS over the current clothing in that the insulation level can easily be adjusted to prevent overheating and sweat-soaking of the insulation.

Heart Rate (HR)

It is not surprising that activity and time were the significant main effects influencing HR, and that there was a statistically significant interaction ($p < 0.001$) between them. The interaction plot is shown in Figure 5. HR remained at normal resting levels during condition **Rest** following a small transient elevation at 0 min related to the dressing and chamber entry activities. By comparison, HR was in the 95–105 bpm range during the work phase of condition **Work**, but dropped to almost resting values during the rest interval. Clothing, wind speed and activity also presented a statistically significant interaction although the differences (range of < 6 bpm) were too small to be of physiological significance for heart rates that were always below 110 bpm.

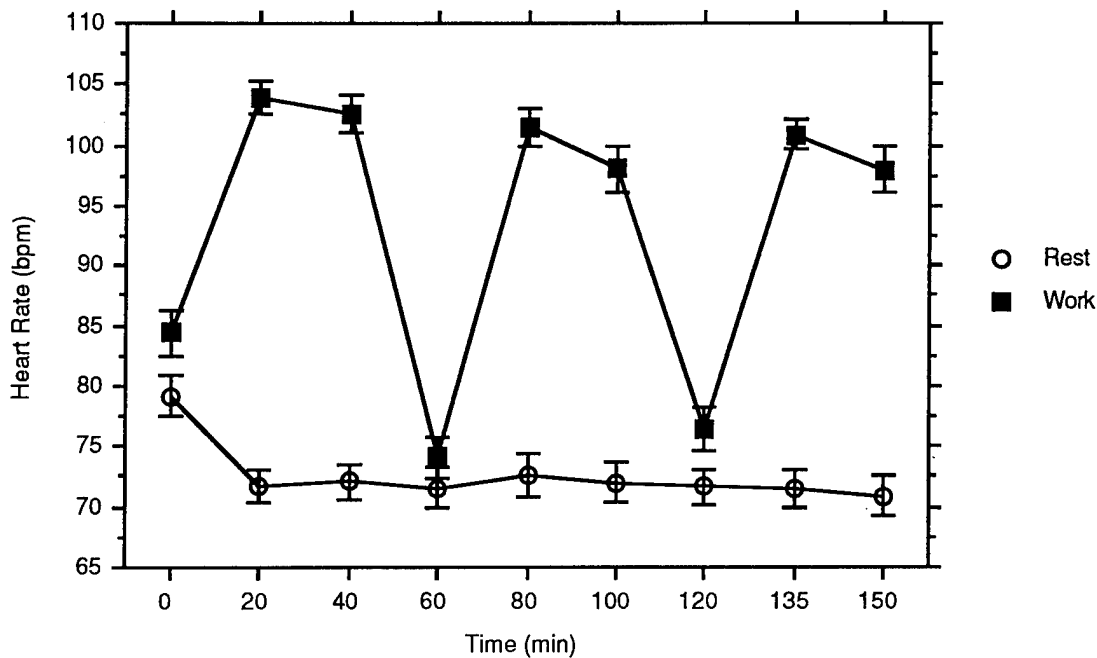

Figure 5. Heart rate vs. time for conditions **Work** and **Rest** at -10°C . Clothing and wind speed had no effect and the results are averaged over both of these factors.

Subjective Thermal Comfort

All results presented to this point can be considered objective measures of the clothing system performance. However, the ultimate objective is to develop a clothing system that is acceptable to the user, and to this end subjective assessments are important. In the -10°C test, subjective thermal comfort ratings were obtained for the head, hands, feet, and whole body even though the IECS does not include new clothing elements for

the extremities. These body parts were included to see how the clothing worn on the rest of the body would affect comfort of the head, hands and feet.

In general, thermal comfort declined over time, which is not surprising. Overall mean scores at 150 min were approximately 6.8 for the head, 6.0 for the whole body, 5.4 for the hands, and 5.3 for the feet. The influence of activity could clearly be seen in that during **Rest** the declines were quite smooth whereas during **Work** the ratings undulated in response to the cyclic activity. In the majority of cases when data were separated according to clothing, the **NT** ensemble scores were between those of ensembles **CC** and **CT**.

Because subjective thermal comfort ratings depended so much on activity with time, average values over the duration of the exposure, rather than final values, were deemed to be suitable measures of the overall comfort levels for each test. This is, in fact, the way ANOVA methods present the results that do not involve time as a factor. However, average values of thermal comfort presented below will often be higher than the lowest comfort rating given since they include comfort ratings taken early in the exposure.

Statistically, clothing had a significant main effect on all four body site comfort scores. There were also statistically significant 2-way interactions of clothing by wind (on the head, hands and feet) and clothing by activity (on the head, hands, feet, whole body), as well as a significant 3-way interaction of clothing by wind by activity (on the head and feet). This latter interaction for head comfort is plotted in Figure 6 and shows an interesting pattern. Most noteworthy is that ensemble **NT** elicited very similar comfort ratings regardless of the wind and activity conditions, demonstrating that the IECS is quite adaptable to a range of operational conditions. By comparison, ensemble **CC** was likely too warm during **LO** wind and **Work**, while ensemble **CT** did not provide sufficient protection during **H** wind and **Work**. Means comparison contrast analyses indicated that these two clothing ensembles differed significantly ($p < 0.01$) from ensemble **NT** under these two conditions.

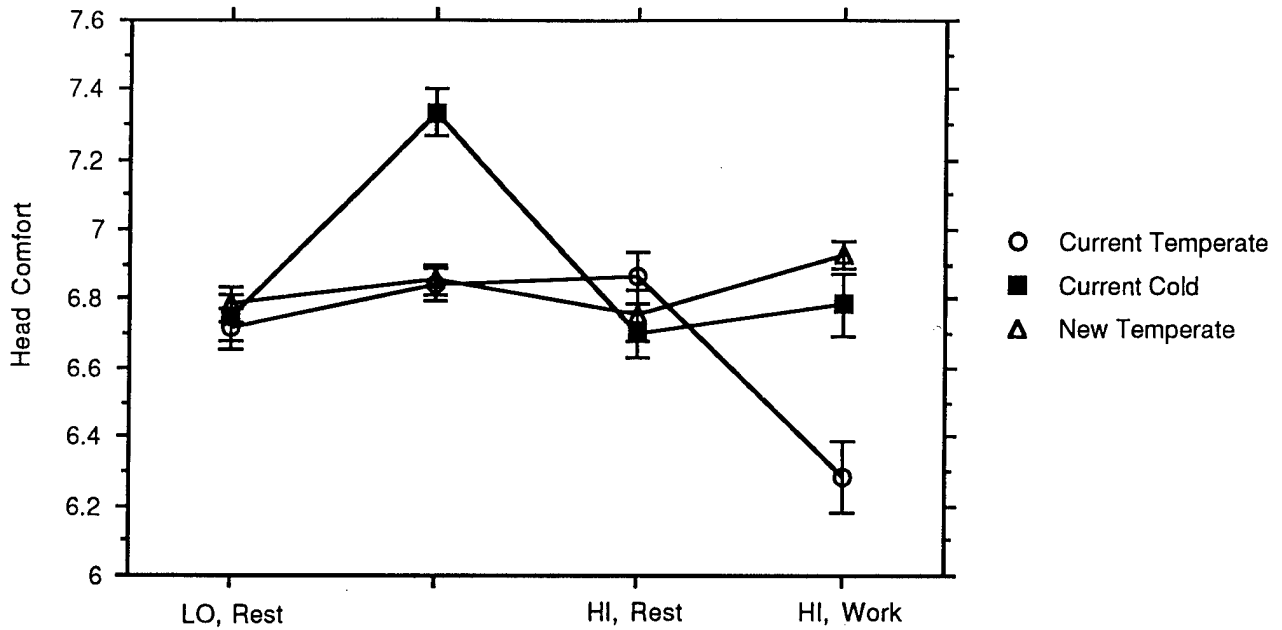

Figure 6. Head comfort with the three clothing ensembles under the various test combinations of wind (**LO**, **HI**) and activity (**Work**, **Rest**) averaged over time.

Figure 7 shows the clothing by activity interaction for whole body comfort and is further evidence of the superiority of the IECS in maintaining comfort across varying conditions. Although the rating was lower than for the head in Figure 6, it remained steady between **Work** and **Rest** (averaged here over both wind conditions). The comfort ratings with ensemble **CC** during **Rest** were comparable to those of ensemble **NT** but showed perhaps too much warmth during **Work**. This is consistent with the MST and FLOSS data presented previously. Ensemble **CT** provided lower comfort scores that even decreased between conditions **Rest** and **Work**. Contrast comparisons at the clothing by wind speed by activity interaction level indicated that ensemble **NT** differed significantly from ensemble **CC** during both wind conditions for the **Work** protocol, and from ensemble **CT** for all conditions but **Hi** wind with **Rest**.

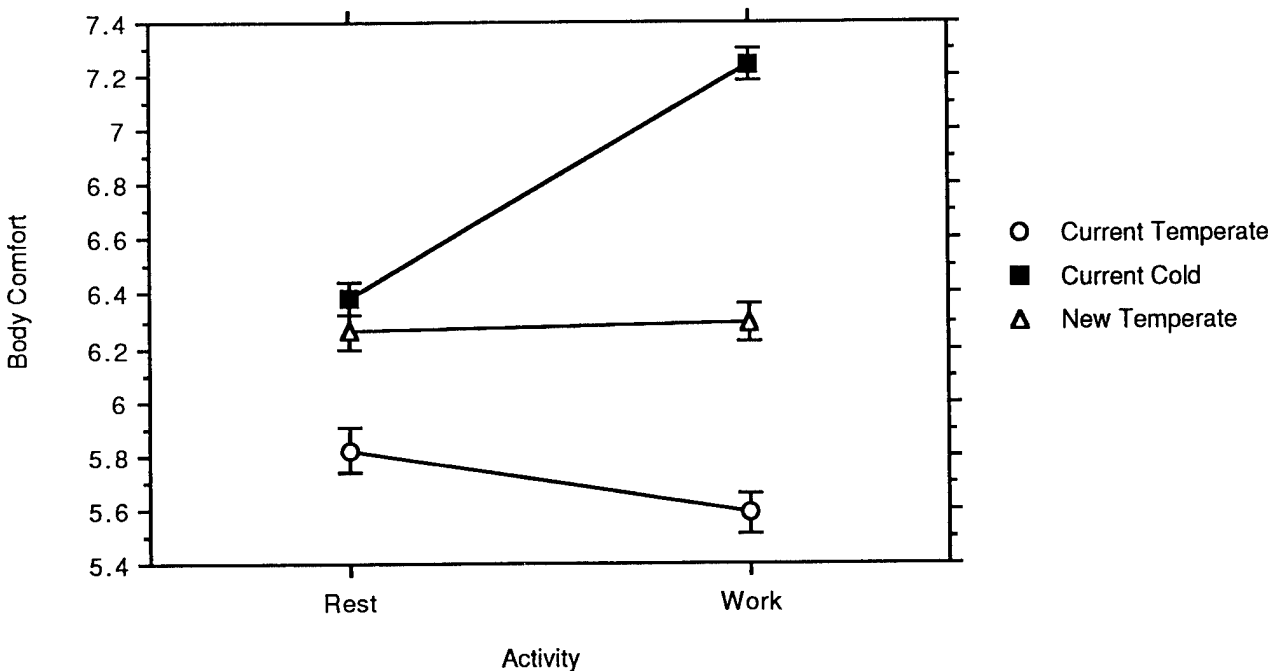

Figure 7. Whole body comfort with the three clothing ensembles under the two activity conditions (averaged over wind and time).

As a general summary of the thermal comfort results, subjects preferred the IECS over the current clothing system. It allowed simple adjustments to the insulation levels to accommodate various activity levels, and its insensitivity to wind, probably due to the Goretex® membrane, demonstrates a superior garment system.

Part B: -40°C Tests

Before discussing any specific results of the -40°C tests, a few points about the clothing ensembles used in this series should be pointed out. During the **Work** protocol and **LO** wind condition, the outer parka of the IECS was never worn. It was, however, put on during the rest phase of the **Work** protocol under the **HI** wind condition, and it was also worn during the **Rest** protocol under both wind conditions. The coveralls of the IECS were only worn during the **Rest** protocol with **HI** wind. These procedures were instituted to see if removal of the IECS parka was beneficial in preventing sweat buildup in the clothing, and at the same time to see if the inner and middle layers would provide adequate insulation during physical activity. Should these procedures indicate insufficient protection, the outer layer could, of course, be added. By comparison, the

parka of the **CC** ensemble was always worn but was opened and closed between the work and rest phases of the **Work** protocol to permit some ventilation. Thus, there was less flexibility in dressing in the **CC** ensemble. As in the -10°C tests, slight modifications to the ensembles were made for specific conditions.

Tolerance Times

A major difference between the -10°C and -40°C tests was that subjects were often unable to tolerate the extreme cold conditions for the planned 150 min duration. Of the 96 tests conducted, 56 tests or 58.33% were terminated prematurely, with about 70% of these at the request of the subject. The shortest tolerance time was 14 min and occurred during the **Work** protocol **HI** wind condition while wearing ensemble **CC**. While this short duration was likely an anomaly, the next shortest time was 56 min, and seven tests ($\approx 7\%$) lasted less than 60 min.

The mean tolerance times over eight subjects for the 12 test conditions are shown in Figure 8. The number of subjects who completed the full 150 min duration are indicated above each bar. Note that no subjects were able to tolerate 150 min with **HI** wind during the **Rest** protocol unless wearing ensemble **HP**.

Interestingly, clothing as a main factor did not have a statistically significant effect on tolerance time, suggesting that all three clothing ensembles may have provided similar levels of protection. However, inspection of the means for each clothing type under each test condition indicated that ensemble **CC** resulted in slightly shorter tolerance times during **Rest**, particularly with **HI** wind. During **Work**, ensemble **CC** resulted in tolerance times that were comparable to those with the IECS. Omitting the subject with the 14 min tolerance time from the **HI** wind **Work** condition raised the mean tolerance with ensemble **CC** to 121 minutes, only slightly exceeding the values obtained with the IECS. Considering that the IECS was frequently worn with the parka off, this is an indication that the IECS ensemble can provide more warmth overall than the current clothing. It is re-emphasized, however, that these findings were not statistically significant. Further analyses using means comparison contrasts indicated no differences between the light (**LP**) and heavy parka (**HP**) ensembles, and no differences between the current clothing and the two IECS variations, with regard to tolerance times.

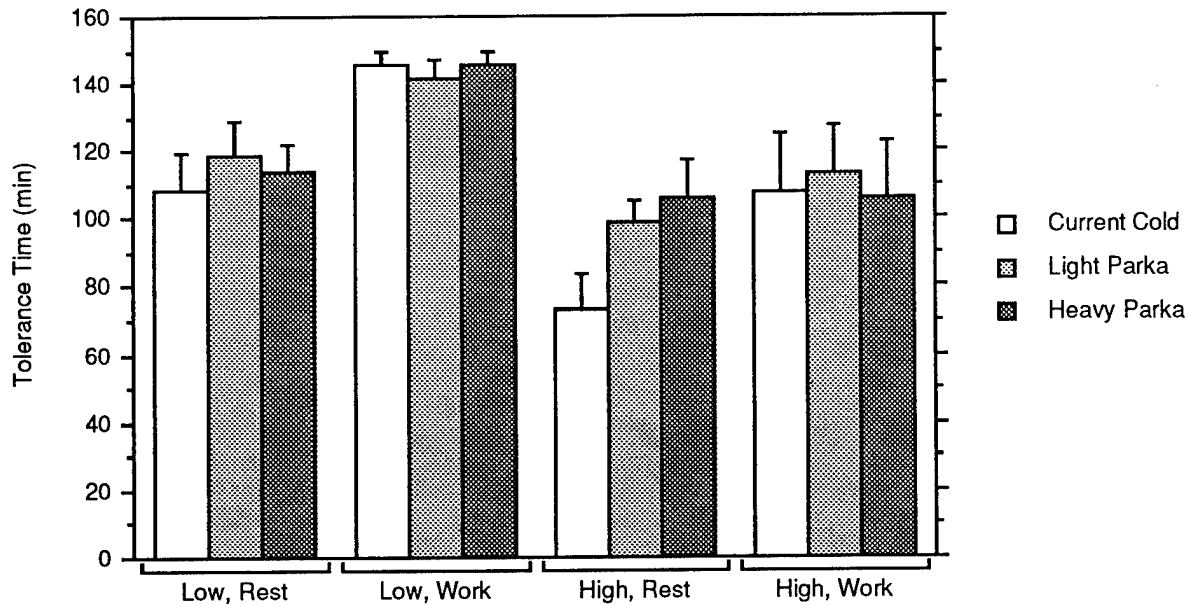

Figure 8. Mean tolerance time for the 12 test conditions at -40°C . Vertical bars depict the SEM. The abscissa labels represent wind speed and activity protocol combinations. The numbers above each bar indicate the number of subjects who tolerated the full 150 min duration.

Not unexpectedly, wind speed and activity did have statistically significant effects on tolerance times ($p < 0.01$ for both). During the **Work** protocol, more internal body heat would have been produced compared to during the **Rest** protocol, and mean tolerance times were 127 ± 5 and 103 ± 4 min, respectively (i.e., 23% longer during **Work**). Tolerance times were 27% longer in the **LO** wind condition (129 ± 4 min) than in the **HI** wind condition (101 ± 5 min), undoubtedly related to the greater convective heat removal during the **HI** wind condition.

Two notes regarding the results and analyses that follow: 1) it is re-emphasized that, due to the variations in tolerance times, "final" data comparisons involve values from widely differing exposure times; and 2) data from later times predominantly comprise the responses of the more "cold tolerant" subjects.

Rectal Temperature (T_{re})

Activity was the only statistically significant factor affecting T_{re-f} ($p < 0.001$). During the **Rest** protocol, the mean T_{re-f} averaged over all subjects, wind conditions, and clothing ensembles was $36.99 \pm 0.07^\circ\text{C}$ while during **Work** it was $37.36 \pm 0.07^\circ\text{C}$. This result is even clearer if one uses the parameter ΔT_{re} . During **Rest**, ΔT_{re} was $-0.29 \pm 0.05^\circ\text{C}$ while during **Work** the change was positive and was $0.10 \pm 0.05^\circ\text{C}$. The influence of internal heat production during activity is quite evident in these data. Note, however, that there were no significant interactions between any of the main factors for T_{re-f} .

During the **Rest** protocol of the **LO** wind condition deep body temperature remained steady for about 40 min, followed by a rather steady decrease at a rate of about $0.3^\circ\text{C}\cdot\text{h}^{-1}$. There were no major differences between the clothing ensembles during **Rest**. The effect of subjects dropping out of the test before 150 min were clearly evident in the time plots of the data as sharp steps or discontinuities in the curves, and the biasing effect of subjects with a high cold tolerance was easily seen in the final 13 min of the data with the **CC** ensemble where only two subjects remained and ΔT_{re} jumped sharply "upward" from -0.5°C to -0.2°C .

During the first work phase of protocol **Work** (0–40 min), T_{re} increased about $0.6\text{--}0.7^\circ\text{C}$ but then fell sharply about 0.2°C during the rest phase. Upon completion of the rest phase and resumption of work at 60 min, T_{re} continued to fall at least another 0.2°C over the next 15 min before there was a turnaround in response (note: the turnaround time at -10°C was about 10 min). However, there was insufficient time remaining in the work phase to restore T_{re} , and cooling again took place during the second rest period. In contrast to the -10°C study, there did not appear to be a leveling off of deep body temperature, and it is not surprising that subjects could not endure the 150 min duration. Differences in ΔT_{re} between clothing ensembles were less than 0.1°C throughout most of the exposure time.

Mean Skin Temperature (MST)

Statistical analyses of the final mean skin temperature (MST_f) data showed significant effects for all three main factors as well as for all levels of interaction. The plot for the 3-way clothing by wind by activity interaction is shown in Figure 9 and displays several interesting features. First, the **LP** and **HP** ensembles exhibited parallel changes between **Rest** and **Work** for each wind condition, but with slightly greater separation during the **HI** wind condition. This is entirely consistent with the fact that these clothing ensembles differed only in the quantity of insulation contained in the outer parka and

trousers, and that there would be a greater cooling effect with increased wind. Second, the data for clothing ensemble **CC** also showed parallel changes in MST_f between **Rest** and **Work** for each wind condition, but in the opposite direction (i.e., an increase during **Work**). Considering that the body produces more heat during activity, the drop in MST with activity in the IECS may help to reduce sweating into the clothing. Of course, these opposite responses in MST are due to the fact that the IECS parkas were removed during the working periods of the **Work** protocol, thus implementing and demonstrating the effectiveness of the layering principle.

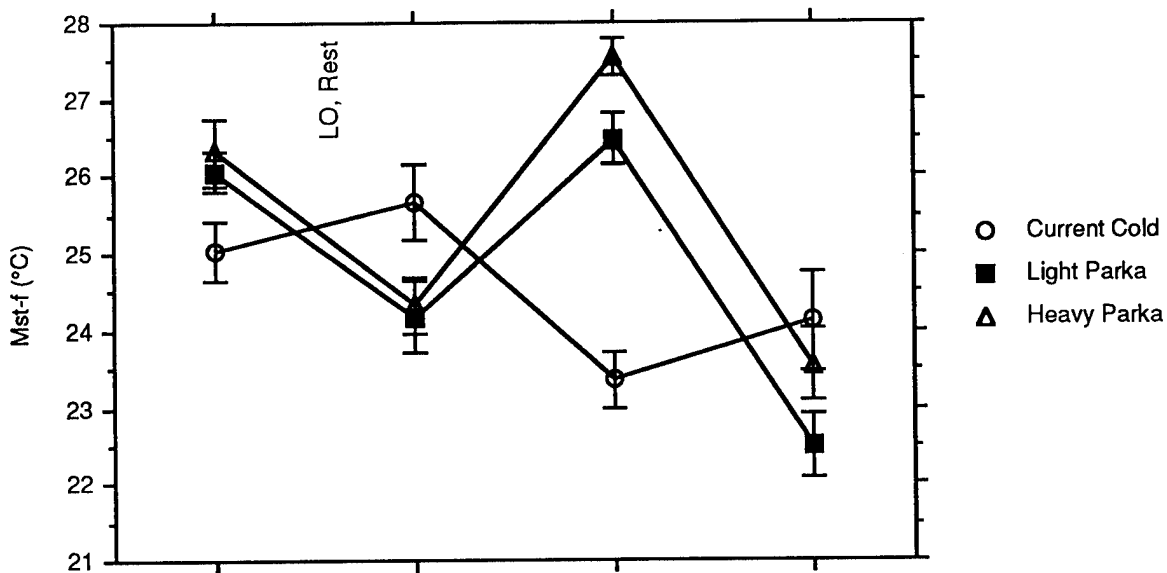

Figure 9. MST_f for clothing ensembles **CC**, **LP** and **HP** during activity protocols **Rest** and **Work** with **LO** and **H** wind conditions.

Mean Heat Flux (MHF)

Plots of MHF over time showed that whole body heat losses were less with the IECS compared to the current clothing during the **Rest** protocol, probably due to the superior insulation of the new clothing. During **Work**, heat losses were greater with the IECS because the parkas were removed for some of the time in the chamber. In general, the differences between **LP** and **HP** were less than the differences between the IECS and the current clothing. Thus, the MHF data support the idea that the IECS is an improvement over the in-service clothing.

Body Weight Changes (FLOSS)

Activity was the only factor to have a significant effect on FLOSS, but this finding is of little relevance to the objectives of this study. Overall average fluid losses were near 0.300 kg, probably because of the much reduced average durations of the -40°C exposures.

Heart Rate (HR)

As with the FLOSS data, activity was the only factor influencing HR to any great extent, a finding that does not discriminate at all between clothing systems.

Subjective Thermal Comfort

As at -10°C, thermal comfort ratings during the -40°C tests were obtained for the head, hands, feet and whole body. In addition, ratings were also obtained for the arms and legs since there were indications from the preliminary tests that these were body regions of possible discomfort. However, statistical analyses indicated very little in the way of significant effects involving clothing as a factor over the first hour of exposure (recall that analyses were limited to 60 min due to subject dropout).

Significant interaction effects between clothing and activity were found for the head, whole body and arm comfort, with the following similar results in each case: subjects were generally warmer with the IECS ensembles compared with the **CC** clothing during **Rest**, but cooler during **Work**. This finding merely points out that removal of the outer layer of clothing to adjust insulation is effective, although it may have been a little too extreme for the particular conditions. However, with the IECS one still has the option of adding a parka, trousers, or both to gain insulation, and lesser amounts can be achieved by opening several of the zippers in the clothing to promote venting. These procedures were not tried in this series of experiments, but there is no reason to believe they would not be practical and/or successful. By comparison, ensemble **CC** had far less versatility for maintaining comfort over a broad range of operational conditions.

Leg comfort depended heavily on clothing as a main effect ($p < 0.001$) as well as on the clothing by wind interaction ($p < 0.01$). The latter case is shown in Figure 10. It is quite clear that comfort ratings for the legs were not affected by wind when wearing the IECS, but they dropped considerably with ensemble **CC**. This could be attributed to the extra insulation of the IECS trousers that were worn during the **HI wind Rest** condition. Examination of the clothing by wind by activity interaction, although not statistically

significant, confirmed that ensemble **CC** showed a large drop in leg comfort during **HI** wind **Rest** which was not seen with the IECS ensembles.

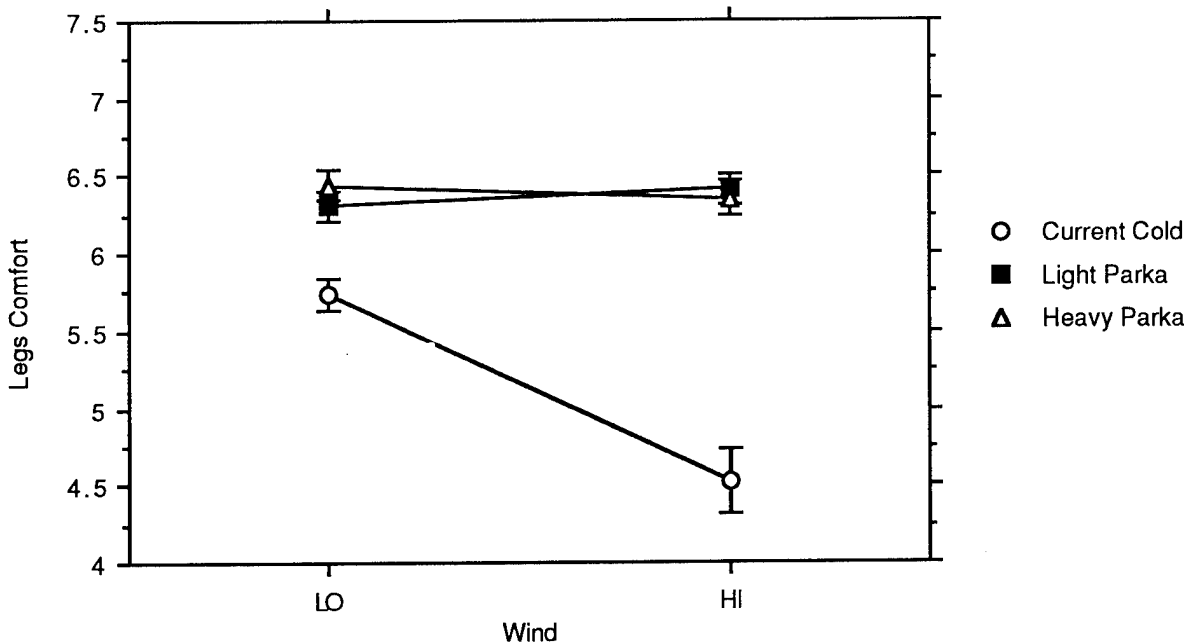

Figure 10. Clothing by wind interaction plot for leg comfort at -40°C .

A specific objective of the -40°C tests was to see if there were any statistically significant differences between the **LP** and **HP** configurations. This question was addressed by performing linear means comparison contrasts between the clothing ensembles. The contrasts were done at the clothing by wind by activity interaction level so that any differences as a function of wind and/or activity could be detected. While trends in the data were consistent with the differences in the levels of insulation, no statistically significant differences were found between these two ensembles.

CONCLUSIONS

The results of this study showed numerous instances in which the IECS demonstrated superior performance over the current in-service clothing systems. Some of these instances showed the IECS to be warmer, sometimes cooler, sometimes no change across test conditions. The point is that the IECS performed “better” than the other clothing configurations under most conditions by preventing excessive cooling during periods of inactivity and overheating during work. It was certainly well liked by the

subjects. The primary features of the clothing system that provide this improved performance are the wind-stopping water-vapour-permeable Goretex® membrane and the ease with which insulation levels can be adjusted to suit the situation.

As stated at the outset, it may not be materials themselves, but rather the clothing design and innovative approaches to incorporating new materials into these designs, that makes one ensemble superior to another. To illustrate, almost any amount of insulation can be provided in a garment system, but if the wearer is completely non-functional when fully dressed then the design is clearly poor and impractical. The flexibility, simplicity, good looks, good feel, and overall comfort of the IECS show that it is, in fact, very well designed. Perhaps the most important attribute of the IECS is that it finally brings the layering principle into practice, and it does this with no sacrifice, and possibly even some significant gains, in thermal protection against the cold.

RECOMMENDATION

The IECS as tested in this study clearly demonstrated an overall superiority over the current in-service clothing. The advantages are primarily attributable to the successful implementation of the layering principle. Several minor operational deficiencies in the clothing were already known to exist before these tests were conducted, and changes to correct these deficiencies were already underway (replace some Velcro with buttons; change brass zippers to nylon; modify pockets, etc.). However, none of these changes would be expected to alter the physiological and subjective findings of this report. Any such minor changes that would enhance the operational functionality of the clothing without significantly affecting the thermal properties are endorsed. From a thermal physiological perspective, this clothing system is recommended for further development and implementation.

REFERENCES

1. Frim J, Romet TT. Role of the moisture/vapour barrier in the retention of metabolic heat during firefighting. DCIEM No. 88-RR-40.
2. Extreme cold/cold wet weather clothing: army trial. Contract report number W7711-1-7142/01 XSE, Humansystems Inc., Milton, Ontario, L9T 1P4. October 1992.

3. Dolhan PA, Crow RM, Dewar MM, DeLong BA. A comparison of the physical properties of three prototype Arctic clothing systems. DREO Technical Memorandum 6/93.
4. Jette M, Quenneville J, Thoden J. Effects of wearing the new CF cold weather clothing on the performance of selected field tests. Contract report number W7714-1-9574/01 ST. University of Ottawa, Ottawa, Ontario. July 1993.
5. Hardy JD, Dubois EF. The technique of measuring radiation and convection. J. Nutr. 15: 461-475, 1938.

**TORSO AUXILIARY HEATING CAN MAINTAIN
EXTREMITIES' TEMPERATURES DURING COLD EXPOSURE**

Michel B. Ducharme
Dragan Brajkovic
John Frim
Human Protective Systems Division
Defence & Civil Institute of Environmental Medicine
North York, Ontario, Canada

TORSO AUXILIARY HEATING CAN MAINTAIN EXTREMITIES' TEMPERATURES DURING COLD EXPOSURE

Michel B. Ducharme, Dragan Brajkovic, and John Frim

Human Protective Systems Division, Defence & Civil Institute of Environmental Medicine,
North York, Ontario, CANADA, M3M 3B9

INTRODUCTION

Protection of the extremities has always been a concern during military operations in temperate and cold climates. This is especially true for military personnel that are often required to stay immobile or to perform delicate work in extreme cold (e.g. maintenance of vehicles, weapons and equipment; treatment of wounds; radio operation; etc.) which necessitates the removal of protective mitts in favor of working with contact gloves or even bare hands. Exposure of the hands to such conditions can result in rapid cooling of the extremities, a loss of manual dexterity, and an increased risk of cold injury. Direct heating of the hands using different technologies (e.g. electrically heated gloves, warm air or water and radiofrequency heating coils) has been attempted in the past with some success. Streets (1) observed that heating the hands and feet while sited in a -32°C environment wearing Arctic clothing can increase cold tolerance by a factor of 3 when compared to unheated gloves and boots. Inherent problems, however, are associated to direct heating: hands heating is an inefficient process; the robustness of the heating elements is susceptible to repeated flexing in the cold; and finger blood flow will remain low despite local heating if the body is cool.

Numerous studies in the past have looked at the effects of applying local auxiliary heat (indirect heating of various parts of the body) on hand comfort (2,3). However, most of these studies were done in a thermoneutral or cool environment (no less than about 14°C). Only two studies have looked at the effects of auxiliary heat on hand comfort (while barehanded) during cold exposure. Auxiliary heating of the forearms while exposed to a -18.5°C ambient environment has been found to be unsuccessful in maintaining hand comfort (4). Rapaport et al. (5) on the other hand found that hand comfort could be maintained for a one hour period while exposed to an ambient temperature of -34.4°C with the use of a full-body air-heated suit. However, such a suit is impractical for field applications.

The objective of the present study was to investigate the effect of torso heating on extremities comfort and body heat transfer during exposure to -15°C air. The working

hypothesis of the present study was that the application of auxiliary heat to the torso may trigger a vasodilatation response in the extremities with the result that a considerable quantity of heat may be delivered to the hands and possibly the feet via an increase in blood flow.

METHODS

Six healthy male subjects (mean \pm SE; 28.8 ± 2.6 y, 75.9 ± 1.0 kg, 177.7 ± 2.9 cm) were exposed one week apart to two tests (control test; CT, heating test; HT), randomly assigned, in addition to a familiarization run. During the tests the subjects wore the first two layers of the new Canadian Forces Arctic clothing ensemble (2.6 Clo) and an electrically heated vest and sat in a cold chamber for a period of 3 hours while exposed to an ambient temperature of -15°C (wind $\sim 2\text{km/h}$). Upon entering the chamber (barehanded), the subjects' finger temperature was monitored until it reached 15°C , at which point the subject was asked to put on a pair of Arctic mitts (CT) or the electrically heated vest worn by the subject was turned on (HT). The skin under the heated vest was kept close to 42°C by adjusting the power to the heaters. During the 3 hrs of exposure, the following parameters were measured: rectal temperature (T_{re}), whole-body mean weighted skin temperature and heat flow (\bar{T}_{sk} , \bar{H}) (using Hardy and Dubois 12 points system); mean skin temperature, heat flux and skin blood flow (laser doppler flowmetry) of the two middle fingers (\bar{T}_{fing} , \bar{H}_{fing} , Q_{fing}) and mean skin temperature of the two large toes (\bar{T}_{toe}). In addition, mean skin temperature and heat flow from the torso (\bar{T}_{torso} , \bar{H}_{torso}) were measured under each of the ten heaters that were fixed around the subject's torso. Statistical analyses were based on the time period between time -10 to 120 min ($n=6$). Past the 120 min mark, $n < 6$. Data are presented as mean \pm SE.

RESULTS

There was no significant difference ($p>0.05$) between CT and HT conditions for the 10 min period prior to the treatments for all the measured parameters. The following data are presented as Mean \pm S.E. for the time period t_{-10} to t_{120} where $n=6$.

Finger and toe temperatures. In CT, \bar{T}_{fing} increased for the first 7 min and then decreased to stabilize at $12.7 \pm 0.03^{\circ}\text{C}$ by t_{50} (Fig. 1). During HT, there was a rapid increase in \bar{T}_{fing} until $25.9 \pm 1.2^{\circ}\text{C}$ was reached at t_{50} where it stabilized. In CT, \bar{T}_{toe} continued to decrease until a value of $12.8 \pm 0.6^{\circ}\text{C}$ was reached after wearing the mitts for 120 min, whereas during HT, \bar{T}_{toe} continued to decrease until a value of $21.7 \pm 2.6^{\circ}\text{C}$ was reached after 120 min (Fig.2).

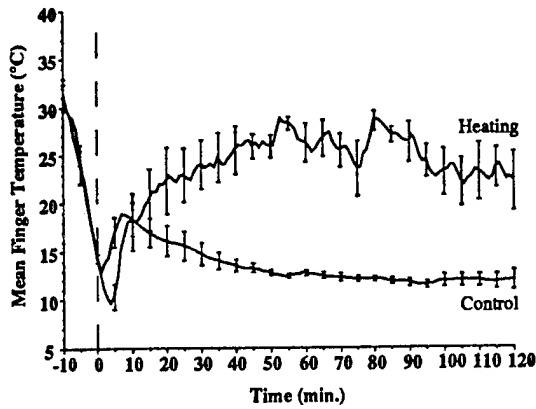

Fig.1. Mean middle finger temperatures for t_{-10} to t_{120} at -15°C ($n=6$)
[Mean \pm SE]

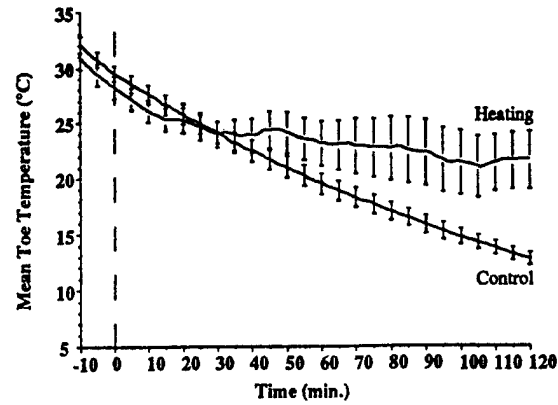

Fig.2. Mean large toe temperatures for t_{-10} to t_{120} at -15°C . ($n=6$)
[Mean \pm SE]

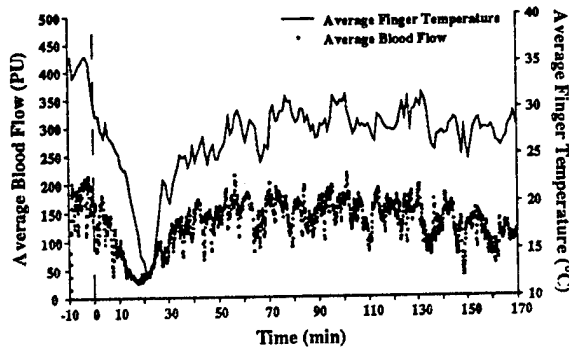

Fig.3. Example for one subject of the relationship between skin blood flows and temperatures of the middle fingers for t_{-10} to t_{170} at -15°C . ($n=6$)
[Mean \pm SE]

Finger heat flux and blood flow. In CT, \bar{H}_{fing} decreased to $42 \pm 11 \text{ W/m}^2$ by t_{20} and leveled off for the last 100 min that the mitts were worn. During HT, \bar{H}_{fing} continued to increase until $917 \pm 101 \text{ W/m}^2$ was reached at t_{40} to eventually decreased to $687 \pm 58 \text{ W/m}^2$ by the end of the exposure. On average for the 6 subjects, fingers' skin blood flow was about 5 times larger during the HT treatment (114.1 ± 20.8 Perfusion Units, PU) compared to CT (23.18 ± 5.1 PU). Figure 3 presents an example for one subject of the tight relationship between skin temperature and skin blood flow in the fingers. In this example, changes in blood flow preceded by about 4 min any changes in skin temperature.

Rectal and body skin temperatures and heat loss. In CT, T_{re} decreased from $37.15 \pm 0.08^{\circ}\text{C}$ to $36.71 \pm 0.21^{\circ}\text{C}$ over the 120 min period that the mitts were worn, whereas during HT, T_{re} did not change. In CT, \bar{T}_{sk} continued to decrease until $27.4 \pm 0.4^{\circ}\text{C}$ was reached after 120 min. During HT, \bar{T}_{sk} increased for the first 10 min and then decreased until a \bar{T}_{sk} of $30.3 \pm 0.3^{\circ}\text{C}$ was reached after 120 min. In CT, \bar{H} decreased to $159 \pm 5 \text{ W}$ by t_{20} , at which point it leveled off, whereas during HT, \bar{H} decreased to $88 \pm 8 \text{ W}$ by t_{30} and then leveled off.

It should be noted that 5 out of the 6 subjects remained in the chamber for a treatment period greater than 120 min (up to 170 min of treatment) during which time the general trend for the parameters in HT and CT remained the same. All the parameters measured were significantly higher in the heating condition (with the exception of \bar{H} , which was significantly lower) relative to the control condition ($p < 0.05$) starting at the following times (in minutes): \bar{T}_{fing} : 17; T_{re} : 27; \bar{T}_{toe} : 47; \bar{T}_{sk} : 2; \bar{H}_{fing} : 2; \bar{H} : 2. The heater power (voltage x current) required to maintain \bar{T}_{torso} at 42°C decreased from 115±5W to 103 ± 5W from time 35-120 min. However, due to the loss of some heat to the environment, the actual \bar{H}_{torso} decreased from 75 ± 4 W to 65±3 W over the same time period. The first 35 min period of heating was used to achieve a stable \bar{T}_{torso} of 42°C.

DISCUSSION AND CONCLUSION

One risk often associated with auxiliary heating is an insidious hypothermia, a slow non-symptomatic decrease in core temperature (6). In the present study, however, rectal temperature did not change during the HT condition, which let us concluded that there does not appear to be any risk of insidious hypothermia when torso heating is applied for up to 3 hours.

The application of heat to the torso region of the body can maintain finger and toe temperatures at a comfortable level for up to 3 hours during cold exposure due to an increase of skin blood flow. Auxiliary heating of the torso may be a viable approach to maintaining extremity comfort and manual dexterity for special tasks in the cold.

REFERENCES

1. Streets, D.F. 1974, Cold chamber trial of electrically heated gloves, mitts and insoles for Rapier operators and AFV crewmen, APRE Report No. 18/74.
2. Bader, M.E. and Macht, M.B. 1948, Indirect peripheral vasodilatation produced by the warming of various body areas, *J. Appl. Physiol.* 1, 215-226.
3. Lewis, T. and Pickering, G.W. 1931, Vasodilatation in the limbs in response to warming the body, *Heart* 16, 33-51.
4. Newton, J.M. and Peacock, L.J. 1957, The effects of auxiliary topical heat on manual dexterity in the cold, US Army Medical Research Laboratory - Report No. 285.
5. Rapaport, S.I., Fetcher, E.S., Shaub, H.G. and Hall, J.F. 1949, Control of blood flow to the extremities at low ambient temperatures, *J. Appl. Physiol.*, 2, 61-71.
6. Van Someren, R.N.M., Coleshaw, S.R.K., Mincer, P.J. and Keatinge, W.R., 1982, Restoration of thermoregulatory response to body cooling by cooling hands and feet, *J. Appl. Physiol.*, 53, 1228-1233.

WHERE ARE THE SNOW SNAKES

Dr. Murray P. Hamlet
Chief, Research Programs and Operations Division
U.S. Army Research Institute of Environmental Medicine (USARIEM)
Natick, MA

This presentation is an attempt to compile and categorize my observations of 25 years of cold weather deployments. I have reviewed after-action reports, interviewed Commanders, NCOs, soldiers, reviewed historical information from U.S., Finish, German, Soviet, British experiences in the cold. Although many of the issues are common sense they have nevertheless shown up repeatedly as problems. I'm sure there are more that I have not included and new equipment may have new inherent problems which have to be identified with experience. Success in cold weather deployment requires extensive, meticulous preplanning and attention to detail. Cold wind and darkness will conspire to compromise the best laid plan; so flexibility and creativity are essential for command. Small group leadership skills win in the cold.

PRE-DEPLOYMENT

1. Prepare command letters - medical, legal, and family
2. Log support - messing, water supply, power sources
3. Engineering support - vehicle maintenance, snow removal, tentage, como
4. Medical planning - injury prevention
5. Clothing issue and training
6. Send advanced party seven days ahead

SOURCES OF INFORMATION

1. After action reports - 82nd
2. ARIEM - medical issues
3. CRREL - Equipment, oversnow, ice bridges, fortifications
4. Bridgeport, CA, Camp Ripley, Ft. Drum, Ft. Wainwright, Ft. Richardson, Ft. Lewis
5. TMs, FMs, Marine Corps manuals
6. Tank and automotive command
7. Leavenworth Papers
8. In-house experience - NCOs and officers

WEATHER

1. Historical reports
2. Long and short-range forecasting sources
3. Prepare weather contingencies

DEPLOYMENT

1. Gradual exposure
2. Oversnow training
3. Clothing use
4. Fire safety - stoves - CO
5. Driving on snow and ice
6. Medical issues - cold injury, dehydration, burns, rabies
7. Shelters
8. Como problems - batteries
9. Vehicle maintenance and repair
10. Local laws - regulations - customs
11. Barracks and messing facilities

HISTORICAL PROBLEMS

1. Medivac - don't assume air
2. Snow removal
3. Water distribution
4. Command control breakdown
5. Accidents - autos, skiing
6. Mess facilities - CO and distribution
7. Tent fires
8. Sleeping in vehicles - CO
9. Mobility problems - no air - broken vehicles
10. Frozen supplies - food, medical, water
11. Mail distribution

LEADERSHIP ISSUES

1. Time and performance expectations
2. Overextending troops
3. Go to bed wet
4. Cold injuries and dental problems
5. Late arrivals - no gear or training
6. Wrong clothing
7. No hot meals
8. Poor medical surveillance
9. Dehydration

EQUIPMENT PROBLEMS

1. Metal fatigue - machetes, axes, antennas, como wire, firing pins
2. Head sets - deicing kits, plastic bags
3. Batteries - short life - keep warm
4. Frozen, cracked canteens
5. Yukon stoves - vent pipe break easily
6. Coaxial cables - crack and break
7. Land navigation compass problem
8. Skis and snowshoes need work
9. High dud rate for mortars

CHEMICAL ISSUES

1. G Agents, sarin, hydrolyzed fast - only contaminate the field for a few days.
2. Adsorption of nerve agent in charcoal increases in the cold - Cyanide it decreases.
3. Decon very difficult - get CRREL report
4. Agents not hydrolyzed on snow are easily picked up on clothing and equipment.

COMBAT TACTICS

1. Trails are easily followed and hard to camouflage
2. Target kitchens, water points, power sources, fuel depots
3. Double insulate roof of command post for IR protection
4. Small, high speed strike units are very effective
5. Force enemy to move his base camp during a predicted change in weather
6. Attack down wind when possible
7. Get and maintain indigenous shelters - don't destroy
8. Deploy and utilize thermal imaging devices
9. Make the enemy cold, wet, tired, hungry, thirsty, and confused
10. Use weather forecasting every day to your advantage
11. Keep your troops informed, warm, fed and rested
12. Make the air unfriendly - deploy stingers far forward
13. Put a lot of effort in comms, engineering and log support

NOTES FOR COMMANDERS

1. Everything you do will take longer. The senior NCO's and officers suffer the most.
2. Leadership is extremely important in the cold. You get rapid feedback for bad decisions.
3. Don't overextend the troops. Penalties are greater and consequences are more immediate.
4. Cold weather battles will be won by engineers, ie., water supply, fuel, ground transportation and road clearance.
5. Design training sessions that are realistic and can be supported.
6. Conduct your training sessions in the worst weather conditions. Schedule for the extremes.
7. The most important people in the training and performance in cold weather operations are the squad leaders.

8. Make sure the people who fit clothing know how to do it and that the men receive instructions before they go to central issue.
9. Utilize your weather people in planning operations.
10. Physical training in the cold can be done if properly warmed up and properly paced and dressed.
 - a. Clothing - don't overdress
 - b. Terrain - frozen, uneven ground increases injuries
 - c. Warm-up
11. Cold injuries
 - a. Act of individual idiosy.
 - b. Act of failure of command responsibility and function. Reason for punishment must be clear to the entire command to be effective and to preclude rumors detrimental to reporting of cold injuries.
12. Communication is extremely important in cold weather operations; often very difficult because of terrain, weather and batteries.

13. Vehicle maintenance before deployment is extremely critical - heaters and lubrication.
14. Cold areas are dark areas. Conduct military training operations in the dark.
15. The range of weapons is reduced. Firing pins break, lubrication problems, shock absorbers get solid, can't sink anchor spikes, have a high dud rate in snow, and static is a problem in mortars.
16. Gas masks are difficult to fit and seal when cold. Have the arctic kit for them and make them practice.
17. Dehydration is a major problem. Requires command influence to force drinking in the absence of thirst.
18. Ought to have one hot meal provided a day in the field.
19. Provide warming tents with hot soup; rotate personnel through the tent

RATION COLD WEATHER IMPROVEMENT PROGRAM

Andre G. Senecal
Vicki A. Loveridge
U.S. Army Natick RD&E Center
Natick, MA

RATION COLD WEATHER IMPROVEMENT PROGRAM

Andre G. Senecal and Vicki A. Loveridge

ABSTRACT

The need to continually improve and update combat operational rations was identified by the Services. The U.S. Marine Corps, the primary user of the Ration, Cold Weather (RCW), designed to sustain an individual during operations occurring under frigid conditions, has required a continuous product improvement program be undertaken for the RCW. The Army Field Feeding System-Future Study, conducted by the U.S. Army Quartermaster Center and School, Army Center of Excellence-Subsistence, indicates that an individual combat ration (i.e., RCW) will continue to be an available member of the Army's Family of Operational Rations. The individual rations require continuous improvement and added variety to enhance acceptability, increase consumption and improve nutritional intake to maintain peak performance on the battlefield.

Improvement of the RCW will be accomplished by increasing the current menu variety from 6 to 12 and improving or replacing current lesser acceptable components, either through in-house development or inclusion of non-developmental items. Primary and secondary packaging requirements will be investigated in order to improve product shelf life, reduce weight and cube, address environmental concerns, and enhance overall operational effectiveness.

Assessment of the individual components in RCW ration menus will be conducted to determine acceptability and identify customer preference. Product improvement will be performed to increase quality and acceptability. New developmental and non-developmental products will be identified for ration inclusion. Product development will target highly acceptable food items. Menu variety will be expanded and improved utilizing products such as commercial entrees, cereals (hot and/or cold), soups, beverages, snacks and deserts. Packaging systems will be evaluated for enhancing product stability and volume reduction, as well as functionality and utility. Accelerated storage and sensory acceptability studies will be conducted. Menus will be designed and approval obtained from the Office of The Surgeon General. Field studies will be conducted for customer acceptability of new menu design. Commercial Item Descriptions or performance specifications will be developed for new foods and packaging materials, and coordinated with the Services before transfer to the Defense Personnel Support Center for procurement.

INTRODUCTION

Cold weather military operations are harsh on both the individual soldier and his operational rations. Work in a cold environment has been associated with an increase in caloric requirements due to inefficiencies of locomotion on snow and ice-covered terrain coupled with the extra weight of cold weather clothing and gear (1). Although wet pack rations are more convenient to use than dehydrated rations, they are bulkier, heavier, and their water content makes them susceptible to freezing. Frozen rations contribute to reduced consumption, caloric deficit and hypohydration (1). The major concerns in cold weather feeding are providing adequate quantities of water, and enough warm and palatable food to meet energy requirements (1).

The Ration, Cold Weather (RCW) was developed in response to requirements from the U.S. Marine Corps, which annually deploys troops to Norway for cold weather training and is the responsible Service for defending the northern flank of Europe. They had found during previous cold weather training exercises that frozen, wet pack rations had accentuated problems of hypothermia and dehydration which decreased the soldiers' effectiveness in the field (6). It was determined that a critical factor in winter warfare combat effectiveness was the daily nutrient intake to support high levels of energy expenditure (2). The requirement, initiated in 1983, called for a field ration that satisfied the special demands for cold environmental operations, a 4500 kilocalorie (kcal) daily intake with lower sodium content fitting within the guidelines of AR 40-25 (3). The RCW, known as the Arctic Ration during its development, consisted of two emergency/assault food packets in combination with an Arctic supplement (4). The Marine Arctic Ration prototype was evaluated formally in the field during two NATO winter exercises

(1981 and 1984); in two rigidly controlled climatic chamber tests (1981 and 1983); informal evaluation by two Navy Seal Teams (1984); and at the U.S. Army Health Clinic, Fort Greely, Alaska (1985) (6).

Eventually, the RCW was condensed into two meal bags that provided food for 24 hours and included entrees, snacks, and a variety of flavored powders for making hot beverages. In addition, the ration contained nonfreezable components and flat, flexible and waterproof external packaging. Each menu provided sufficient kcals to satisfy the minimum energy requirements for heavy exertion in extreme cold environments (Avg. 4500 kcals - 8% protein, 32% fat, and 60% carbohydrate), Table 1. A one day supply of the RCW was significantly lighter and smaller than a 4500 kcal, one day supply for the Meal, Ready-to-Eat (MRE) (equivalent to four MREs).

Early RCW testing at the climatic chamber facilities at the U.S. Army Natick Research, Development and Engineering Center, Natick, Massachusetts, revealed dehydration problems with initial versions of the ration (5). The problems encountered by the soldiers during cold weather operations were addressed by ration reformulation. Satisfactory, but reduced levels of sodium (5 grams per ration) and protein were reformulated into the ration to reduce the daily physiological water requirements and prevent symptoms of dehydration. Furthermore, an increased number and variety of beverages was included to enhance water consumption. Other nutritional concerns addressed by the RCW include relatively high amounts of carbohydrate to replace muscle glycogen, to provide sufficient supplies of readily available energy, and to maintain effectiveness at high altitudes.

The RCW was accepted for the U.S. Marine Corps' procurement in May 1987. The Army identified limited requirement for the RCW as a special purpose item and adopted the Marine Corps Required Operational Capability in FY88. The current ration consists of six menus of

freeze dehydrated entrees and other low moisture components designed to provide lightweight, high caloric subsistence for non-resupply operations in frigid conditions. The low moisture components are suitable for utilization in extremely cold weather, since there is virtually no water to freeze. Many components can be eaten either dry or rehydrated. If all individual menu components are consumed under hydrated conditions, the water requirement is 90 ounces. Fuel tablets are provided separately for heating water in the canteen cup.

Since its inception, the RCW has undergone changes directed at its improvement. Changes that occurred between the first and second procurement included replacement of compressed entrees with loose vacuum packed varieties that resulted in reduced cost, increased rate of rehydration and acceptability. In addition, fruit soups were eliminated and spray dried coffee was replaced by the freeze dried type. During the second and third procurement, further changes occurred: Tootsie Rolls and M&Ms replaced specification candy; commercial instant soups were allowed as substitutes; and MRE crackers fortified with B vitamins were added.

The need to continually improve and update individual operational rations has been identified by the Services. These rations require continuous improvement and added variety to enhance acceptability for increased consumption and improve nutritional intake. For FY95, the RCW was identified for assessment and improvement of individual ration menus/components by the U.S. Marine Corps, the primary user of the RCW. Objectives are: a) increase of menu variety and improvement of current components, either through in-house development or inclusion of Non Developmental Items (NDI); b) investigation of innovative packaging and product configuration to minimize weight and volume, reducing processing cost, and improving producibility.

PROGRAM APPROACH

Assessment of the individual components in the RCW ration menus will be conducted to determine acceptability and identify customer preference. Product improvement will be performed to increase quality and acceptability. New developmental and non developmental products will be identified for ration inclusion. Product development will include highly acceptable food items. Menu variety will be expanded and improved, utilizing products such as commercial entrees, cereals (hot and/or cold), soups, beverages, snacks, and desserts. Packaging systems will be evaluated for reducing bulk and enhancing soldier utility. Accelerated storage and sensory acceptability studies will be conducted to ensure compliance with military requirements. Menus will be designed and approval sought from the Office of The Surgeon General. Field studies will be conducted for customer acceptability of new menu design. Commercial Item Descriptions will be developed for new foods and packaging materials and transferred to the Defense Personnel Support Center.

PROGRAM STATUS

Meetings with the U.S. Marine Corps' representatives identified food items for improvement. These items included oatmeal breakfast components, cereal bars, and beverage base powder. In addition, the U.S. Marine Corps is interested in an increase in menu variety, from six to 12. In particular, they would like the addition of more pasta dishes, which may be better than stews for high altitude performance. Other items requested for evaluation were hearty soups and a potential replacement for the Vitamin B fortified cracker.

The entree components for the RCW are similar to the Food Packet, Long Range Patrol (LRP), the Military's restricted calories ration that is designed especially for Special Forces, Long Range Reconnaissance, Rangers and other special activities troops. The freeze dehydrated entrees that are the foundation of the LRP and the RCW have traditionally been packed in a rehydration bag, then vacuum wrapped in foil making a large egg shaped component. The entree is then assembled with other ration components into either the LRP or RCW. The configuration of the entree has caused serious difficulties in the assembly process. In order to alleviate these problems and move toward a more automated packaging process, the LRP improvement program investigated brick packaging for the freeze dehydrated entree. A two year program was initiated in FY94 to make packaging changes and increase component variety by investigating available commercial dehydrated entrees. Packaging changes were required for reduction in time, cost and reconfiguration necessary to take advantage of new automated equipment now in place for ration assembly. The first year of the program identified a brick packaging system that survived rough handling tests with less than a 1% leaker rate. A producibility contract to test the reconfigured LRP assembly was awarded. Commercial entree prototypes with brick packaging were produced for testing with six new non developmental items meeting the nutritional profile of existing LRP entrees. Since the RCW and LRP utilize similar entree components the improvements that have been made under the LRP improvement program, new entree components and packaging, will be incorporated into the RCW for testing.

Changes must be nutritionally balanced to meet the Military Recommended Daily Allowance (MRDA). The nutritional means for the current six menus of the RCW ration are shown in Table 2. The overall nutritional composition of the ration exceeds the MRDA for most nutrients. However, dietitians from the U.S. Army Institute of Environmental Medicine have

expressed concern for the protein level (93 grams) of the 4500 kcal RCW, when the MRDA for a 3600 kcal ration is 100 grams. The reduction in protein occurred during earlier changes in the ration entree components. Substitution of military specification entrees with available commercial items has resulted in a substantial decrease of up to 15 grams of protein. This problem was compounded when other changes were made to the ration's composition reducing protein levels by an average of another 8 grams. The addition of new commercial entrees will require an increase in the fill weight for some entrees or the addition of suitable menu components to raise the protein levels to meet the MRDA requirements. Selection of high protein commercial items packaged under military specifications could increase the protein from an average of 26.5 grams to 34.8 grams for the entrees. The increase of 8.3 grams would bring the RCW back in line with the MRDA for protein and also improve vitamin and mineral levels.

A market survey of potential replacement items has been conducted, Table 3. The development of cold cereal/milk systems has been conducted in-house. Assembly of cold cereal with 2% dehydrated milk at a ratio of 60 grams to 30 grams was conducted by adding commercial cereals and the milk to brick type pouches with rehydration bags. The milk product utilized was a 2% coconut based product initially developed for the Navy by Natick and currently produced commercially for hikers and campers. The 2% coconut based dehydrated milk was chosen because of its acceptable flavor and a shelf life that meets military requirements. The cereal system will be field tested at Ft. Devens, Ayer, Massachusetts, in third quarter FY95. Other breakfast items such as commercial dehydrated eggs, oatmeal and cream of wheat will also be investigated for acceptability and increase of menu variety. The VO2 energy bar that will be evaluated was developed by M&M/Mars as part of a cooperative research and development agreement. The bar, fortified with medium chain triglycerides and vitamins, would help improve

the nutritional requirements of the ration providing "instant energy" during strenuous cold weather operations.

CONCLUSION

The RCW improvement project is a one year program under the Fielded Individual Ration Improvement Program for FY95. It was established at the request of the U.S. Marine Corps. Ration components such as soups, breakfast items and cereal bars will be improved through development or inclusion of commercial items. Menu variety will be expanded from six to 12. Ration components other than entrees may be varied to improve ration acceptability. MRDA nutritional requirements will be met either by entree nutrition requirements, increase in entree portion, or balance by menu components. The benefits envisioned under this program are a decrease in menu monotony and fatigue, increased consumption and nutritional intake, and enhanced combat performance.

REFERENCES

1. King, N., Mutter, S.H., Roberts, D.E., Sutherland, M.R. and Askew, E.W. Cold Weather Field Evaluation of the 18 Man Arctic Tray Pack Ration Module, the Meal, Ready-to-Eat, and the Long Life Ration Packet. *Military Medicine* 1993; 158:458-465.
2. Morgan, T.E., Hodgess, L.A., Schilling, D., Hoyt, R.W., Iwanyk, E.J., McAninch, G. Wells, T.C. and Askew, E.W. A Comparison of the Meal, Ready-to-Eat, Ration, Cold Weather, and Ration, Lightweight 30-Day Nutrient Intakes During Moderate Altitude Cold Weather Field Training Operations. USARIEM Technical Report, T5-89, 1988.
3. AR 40-25. Nutritional Allowances: Standards and Education, 15 May, 1985.
4. Mastromarino, A.C. and Loveridge, V.A. An Evaluation of the Ration, Cold Weather. April 1985. Technical Report, NATICK/TR-86/027, U.S. Army Natick Research, Development and Engineering Center, Natick, MA, 1986.
5. Roberts, D.E., Askew, E.W., Rose, M.S., Buchbinder, J., and Sharp, M.A. Evaluation of the Ration, Cold Weather During a 10-day Cold Weather Field Training Exercise. Technical Report, NATICK/TR-87/030, U.S. Army Natick Research, Development and Engineering Center, Natick, MA, 1987.
6. Carson, J.L. Technical Feasibility Test of U.S. Marine Corps Arctic Ration. USATECOM Technical Report, 8-EI-925-000-004, USA Cold Regions Test Center, Seattle, WA 1986.

TABLE 1
RATION, COLD WEATHER

MENUS

	MENU 1	MENU 2	MENU 3	MENU 4	MENU 5	MENU 6
BAG A	Oatmeal, Strawberry & Cream	Oatmeal, Apple & Cinnamon	Oatmeal, Apple & Cinnamon	Oatmeal, Maple & Brown Sugar	Oatmeal, Strawberry & Cream	Oatmeal, Maple & Brown Sugar
	Nut Raisin Mix	Nut Raisin Mix	Nut Raisin Mix	Nut Raisin Mix	Nut Raisin Mix	Nut Raisin Mix
	Cocoa Beverage Powder (2)	Cocoa Beverage Powder (2)	Cocoa Beverage Powder (2)	Cocoa Beverage Powder (2)	Cocoa Beverage Powder (2)	Cocoa Beverage Powder (2)
	Apple Cider Mix	Apple Cider Mix	Apple Cider Mix	Apple Cider Mix	Apple Cider Mix	Apple Cider Mix
	Chicken Noodle Soup	Chicken Noodle Soup	Chicken Noodle Soup	Chicken Noodle Soup	Chicken Noodle Soup	Chicken Noodle Soup
	Fruit Bars, (Fig or Blueberry)	Fruit Bars, (Fig or Blueberry)	Fruit Bars, (Fig or Blueberry)	Fruit Bars, (Fig or Blueberry)	Fruit Bars, (Fig or Blueberry)	Fruit Bars, (Fig or Blueberry)
	Crackers (2)	Crackers (2)	Crackers (2)	Crackers (2)	Crackers (2)	Crackers (2)
	Spoon	Spoon	Spoon	Spoon	Spoon	Spoon
	Accessory Packet	Accessory Packet	Accessory Packet	Accessory Packet	Accessory Packet	Accessory Packet
BAG B	Chicken Stew	Beef Stew	Chili Con Carne	Chicken A La King	Chicken & Rice	Spaghetti w/Meat Sauce
	Granola Bars (2)	Granola Bars (2)	Granola Bars (2)	Granola Bars (2)	Granola Bars (2)	Granola Bars (2)
	Oatmeal Cookie Bars (2)	Oatmeal Cookie Bars (2)	Oatmeal Cookie Bars (2)	Oatmeal Cookie Bars (2)	Oatmeal Cookie Bars (2)	Oatmeal Cookie Bars (2)
	Chocolate Covered Cookie or Brownie	Chocolate Covered Cookie or Brownie	Chocolate Covered Cookie or Brownie	Chocolate Covered Cookie or Brownie	Chocolate Covered Cookie or Brownie	Chocolate Covered Cookie or Brownie
	Orange Beverage Powder	Orange Beverage Powder	Orange Beverage Powder	Orange Beverage Powder	Orange Beverage Powder	Orange Beverage Powder
	Tootsie Rolls	Tootsie Rolls	Tootsie Rolls	Tootsie Rolls	Tootsie Rolls	Tootsie Rolls
	M&M's	M&M's	M&M's	M&M's	M&M's	M&M's
	Lemon Tea (2)	Lemon Tea (2)	Lemon Tea (2)	Lemon Tea (2)	Lemon Tea (2)	Lemon Tea (2)
	Spoon	Spoon	Spoon	Spoon	Spoon	Spoon

Accessory Packet: Coffee, Cream, Sugar, Chewing Gum, Toilet Paper (2), Matches, Closure Device (2)

TABLE 2
RATION COLD WEATHER NUTRITIONAL MEANS

NUTRIENTS	ACTUAL	MRDA
Kilocalories	4537 Kc	3600 Kc
Protein	93 Gm	100 Gm
Carbohydrates	686 Gm	440 Gm
Fat	158 Gm	160 Gm
Sodium	4878 Mg	7000 Mg
Potassium	4027 Mg	1875 Mg
Magnesium	641Mg	400 Mg
Iron	23 Mg	18 Mg
Zinc	14 Mg	15 Mg
Vitamin A	938 Re	1000 Re
Vitamin E	64 Mg	10 Mg
Vitamin C	318 Mg	60 Mg
Thiamin	5.8 Mg	1.8 Mg
Riboflavin	2.5 Mg	2.2 Mg
Niacin	24.5 Mg	24 Mg
Vitamin B6	4.1 Mg	2.2 Mg
Folate	289 Ug	400 Mg
Vitamin B12	2.1 Ug	3.0 Ug
Calcium	1276 Mg	800 Mg
Phosphorus	2240 Mg	800 Mg

TABLE 3

POTENTIAL NON-DEVELOPMENTAL ITEM COMPONENTS

ENTREES: Turkey Tetrazzini
Beef Teriyaki
Spicy Oriental Chicken
Lasagna with Meat
Sweet and Sour Pork
Beef Stroganoff

BREAKFAST: Hot Cereal
Cold Cereals with 2% Dehydrated Milk
Dehydrated Eggs

SNACKS: Beef Jerky
Meat Sticks
VO2 Energy Bar
Soups

**EFFECTIVENESS OF A LABORATORY WAVE SIMULATOR
REPLICATING BODY HEAT LOSS
MEASURED UNDER FIELD CONDITIONS**

Joseph Giblo
Navy Clothing & Textile Research Facility
Natick, MA

Background Accidental water immersion, particularly in turbulent seas, is a serious problem that threatens sailors. When immersed in cold water, body heat will be lost, despite protective garments. This heat loss is increased by wave action.

To examine the effect of wave action on human thermal responses to cold water immersion, the U.S. Coast Guard (USCG) conducted a unique field evaluation (1). Heat loss depends upon several factors, one of which is the style of the protective garment. A wet suit design allows water contact with the skin and a dry suit design does not allow water contact with the skin. The study demonstrated that when loosely-fitted, wet-suit design garments are worn, body temperature drops 1.5 to 2.0 times faster in waves than in calm seas.

The results of this study emphasized the importance of conducting water immersion studies in turbulent rather than calm water in order to more accurately determine the thermal performance of protective garments. However, field evaluations are time-consuming, expensive, and can only be conducted at specific times of the year when the required environmental conditions are expected. It is therefore more desirable to simulate a turbulent water environment in the laboratory, where controlled human and thermal manikin studies can be conducted.

Several laboratories have used agitated water for both thermal manikin and human testing. These studies, however, did not include a direct comparison with field data or measure the reproducibility of the water agitation techniques. Our laboratory focused on these areas.

We conducted a series of tests, evaluating several water agitation techniques using our unique submersible thermal manikin (2). The best technique at the time was the Compressed Air methodology.

To validate this methodology on humans, we conducted field testing at Cape May, New Jersey and compared body cooling rates measured in the field to laboratory results on the same volunteers. VIDEO - Cape May - here you can see 4 volunteers tethered with a swimmers harness to a suspended safety cable; you can observe the 1.2 meter crashing waves generated by a 41 foot CG vessel passing the volunteers at 45 to 60 second intervals; notice the waves crashing over the head and neck region and that the volunteers also had to adjust themselves in the water to prepare for the crashing waves all of which contributes to the body cooling rate. - Laboratory Compressed Air As you can see, in the laboratory, volunteers are tethered to prevent movement due to turbulence generated by the compressed air being released below them; as you can see the water is highly agitated but if you notice, the water does not wash over their head and neck regions like in the field; they are also able to maintain the survival position because they are not being battered by the periodic waves. So even though it looked like the compressed air produced simulated rough seas, body cooling was significantly higher in the Field. In the laboratory, the volunteers were able to effectively restrict water flushing through the garment and also did not have water flushing over their head and neck region (3).

Clearly, further development of a laboratory technique was still required. **SLIDE** We started by suspending a pneumatic piston from an I-beam which ran down the length of the pool chamber ceiling. A paddle was fabricated and suspended on roller bearings attached to the pool deck. The wave maker generated waves that were 0.4 meters high every 1.4 seconds. Further thermal manikin testing was conducted and a pilot human study subsequently indicated that the wave technique yielded greater body cooling rates than Compressed Air.

Purpose **SLIDE** The rest of the presentation will describe our most recent work using the wave maker. The purpose of this study was to determine the effectiveness of the wave maker to increase body heat loss compared with calm water testing and the previous field testing, and to examine the repeatability of the methodology in providing increased body heat loss.

Physical Characteristics of Volunteers **SLIDE** We utilized eight volunteers, who we tried to match with physical characteristics with our previous subjects. All subjects were fully informed of the risks, and voluntarily gave their consent to participate. As you can see from the physical character characteristics, there was no significant difference between height and percent body fat, there was a significant difference in age, weight, and body surface area between the two groups.

Test Conditions **SLIDE** Three wave and two calm water repetitions were conducted on each volunteer. Multiple trials were conducted to look at the repeatability of the test methodologies. Each cold water immersion was

scheduled to last a maximum of 90 minutes. Laboratory test conditions duplicated the ambient conditions recorded during the previous field study. Laboratory testing was conducted in a water temperature of 10°C, an air temperature of 10°C, with a wind speed of 4.5 meters per second.

Test Clothing SLIDE Test clothing was the same as that worn during the previous field study. This included the anti-exposure coverall, which is a wet suit design. The complete ensemble included cotton thermal underwear, wool socks, leather safety boots, neoprene diver's mittens, a neoprene surf cap, and a personal flotation device.

Measurements SLIDE During the cold water immersions, rectal temperature was measured using a thermistor sensor. Skin temperature and heat flow were measured at 12 sites using thermistor and heat flow sensors. Data were collected every two minutes during the test. While our target exposure time was 90 minutes, early termination criteria were: reaching a rectal temperature of 35°C, a voluntary withdrawal, or, at the discretion of the medical monitor.

SLIDE Here is a picture of two volunteers ready for immersion in waves. Note the goggles to keep water out of their eyes and the swimmers safety harness to secure them to the tether.

VIDEO - this video shows a volunteer in the NCTRF pool during a wave trial, the volunteer is tethered to prevent wandering to the sides of the pool and keep him centered in the waves, but not to restrict movement due to wave action; because of the continuous wave action, we were not able to

periodically flush great amounts of water over the head and neck region as

violently as observed in the field; note the piston and paddle operation.

Results

Exposure times SLIDE This slide shows the average exposure times for wave trials 1, 2, and 3 and calm water trials 1 and 2. During the wave trials, 30% of the early terminations were because volunteers reached the core temperature limit. The remaining subjects voluntarily withdrew due to various symptoms, such as: muscle cramps and extreme discomfort. Tolerance times were 56, 66, and 71 minutes for wave trials 1, 2, and 3, respectively. These difference were not significant. There were also no significant differences between the calm water trials.

Rectal temperature SLIDE This slide shows the average change in rectal temperature over time. Due to early termination during the wave trials, we ended statistical analysis after 50 minutes. Wave trial 1 was significantly different than wave trials 2 and 3 at 50 minutes. Core temperature decreased 0.6°C more in wave trial 1 compared with wave trials 2 and 3. There were no significant differences between the two calm water trials.

Mean Weighted Skin Temperature SLIDE This slide shows the average mean weighted skin temperature (MWST) over time. At 50 minutes, there was a significant difference between wave trials 1 and 3. There was no significant differences between wave trials 2 and 3 or between calm water trials 1 and 2 at 50 minutes.

The average MWST at 50 minutes during the first wave trial was 6°C lower than the averaged MWST during calm water trials. The difference between wave trials 1 and 3 was 1.4°C at 50 minutes.

Note the duplication of the MWST curves for wave trials 2 and 3 and calm water trials 1 and 2.

Heat Flow SLIDE This slide shows the average heat flow over time. Heat flow is the measure of energy lost by the body over time. For example, heat flow for the resting human in air, wearing your average business suit, at thermal equilibrium, would approximate 54 Watts/m². The thermal conductivity of water is approximately 20 times that of air. As you can see from this slide, measurements of heat flow with a protective garment in the water ranged from 285 to 714 Watts/m². Differences in heat flow at 50 minutes were not significant among the wave trials and averaged 466 watts/m². The average heat flow at 50 minutes was 293 watts/m² for the calm water trials, and were also not significant. The wave trials yielded 1.6 times greater heat loss than the calm water trials.

Body cooling rate, laboratory waves vs field waves SLIDE This slide shows the change in rectal temperature over time for laboratory wave trials and the previous field test conducted at Cape May. The body cooling rate for the first wave trial was similar to the field. The body cooling rate for the second and third wave trials were similar to each other, however, if you notice, it took about 15 minutes before rectal temperature began to drop and the rate of change was never as great as that of wave trial 1 and the Field.

As you can see from this slide, we were successful in duplicating our

Field results only when we tested the subjects the first time in the waves. Subsequent wave trials yielded much lower body cooling rates. Water and air temperatures were identical for all wave trials, as was the wave agitation and clothing ensemble. We postulated that there may be some kind of learning effect by the subject which prevented heat loss at the same rate as that seen during the first wave trial. This learning effect could involve posturing in the water to reduce water entry.

Conclusions SLIDE While the response to the first wave trial may approximate actual field situations, subsequent immersions may not. This has implications for researchers who use repeated measures design for evaluations in simulated rough seas. Results of this study indicate that when volunteers undergo repeated water immersions while wearing a protective garment of wet suit design, they may learn to diminish body cooling rates by reducing water flushing through the protective garment. Waves yielded 1.6 to 2.7 times faster body cooling rates than calm water. We are continuing our evaluation of the wave methodology to address some of the questions raised during this study.

References

1. Steinman, A.M., M. Nemiroff, J. Hayward, and P. Kubilis. A comparison of the protection against immersion hypothermia provided by Coast Guard anti-exposure clothing in calm versus rough seas. U.S. Coast Guard Report No. CG-D-17-85, 1985.
2. Giblo, J.W., B.A. Avellini, N.A. Pimental. Simulation of rough seas in a water immersion facility: Part I - Thermal manikin evaluation of various techniques. International Conference on Environmental Ergonomics - IV, October 1990.
3. N.A. Pimental, B.A. Avellini, J.W. Giblo, A.M. Steinman. Simulation of rough seas in a water immersion facility: Part II - Comparison of laboratory to field data. International Conference on Environmental Ergonomics - IV, October 1990.

WINTER WARRIOR ON BATTLEFIELD 2015

CPT Robert A. Albino
SPC(P) Michael J. Logan
HHC, 10th Special Forces Group
Fort Devens, MA

Captain Robert A. Albino
Headquarters and Headquarters Company
10th Special Forces Group
Fort Devens, Massachusetts 01433
Work Telephone #: DSN 256-3273/2670

6G Acorn Park 160 Ayer Road
Shirley, Massachusetts 01464-2523
Home Telephone #: 508-425-4672

Winter Warrior

On Battlefield 2015

by CPT Robert A. Albino
and SPC (P) Michael J. Logan

As Homo Sapiens overpopulate this planet, we will push our frontiers into ever more remote and inhospitable regions. However, the airless environment of undersea life presents a myriad of expensive problems to solve. The final frontier of space is even more difficult. Instead, the human species will, as it has historically done, push forward into the cold. As the human animal marches into the colder regions of this earth, he will bring with him conflict. If the United States is to protect its interests in these colder environments it must possess a specially trained and equipped soldier. 10th Special Forces Group, as a proponent for cold weather operations and equipment testing, will lead the United States in the development of such a soldier.

10th Group's interest in operations in cold weather comes both from its Mission Essential Task List (METL) and the Group's assigned region of Europe and South West Asia. Much of this region experiences heavy snowfall and over two thirds of Europe and South West Asia is mountainous. The Group METL takes its soldiers to these snowy, mountainous areas of the region. The possibility of involvement in peacekeeping

operations in the cold, mountainous terrain of former Yugoslavia brings cold weather operations to the top of Group's METL.

Cold weather training is, therefore, mission essential training for 10th Group. The recent change of the 10th Group acronym WET or Winter Environment Training to ECWT or Extreme Cold Weather Training exemplifies the renewed emphasis the Group places on cold weather training. Not only is it important that we train when and where it is cold, but also that we train when and where it is *very* cold.

As a result of a conversation between BG Potter and LTC Heinemann on cold weather operations, 10th Group selected WO1 Garcia and SPC Logan to do a research project entitled "SF Winter Warrior on Battlefield 2015." The purpose of the project was to identify technologies applicable to SF winter operations and expedite their developments so that the technologies will produce good equipment for successful SF missions. The target year for the efforts of the project to become a reality is 2015. An additional intent of the project was to raise interest in the future of cold weather military operations. LTC Stanhagen, the Group Deputy Commander assigned CPT Albino to conclude the project and bring its results closer to the near term.

Originally, LTC Heinemann envisioned the project to last only a month. However, both due to the enthusiasm of the researchers and the quality of their products, LTC Heinemann allowed the project to continue over six months. The project included visits to the U.S. Army Cold Regions Research and Engineering Laboratories at Hanover, NH and Fort Greely, Alaska; the U.S. Army Natick Research, Development and Engineering Center, MA; the Human Research and Engineering Development Center at

Engineering Center, MA; the Human Research and Engineering Development Center at Aberdeen, MD; Silicon Valley, California; the Norwegian Infantry School at Elverum, Norway and several universities local to Fort Devens such as Harvard, MIT, Boston University and Boston College.

The strength (and weakness) of this research approach was that the researchers were active duty soldiers with recent Special Forces experience on Operational Detachment Alphas or the Group's Military Intelligence Detachment. This allowed the researchers to quickly disregard equipment and technologies that did not have the potential of contributing to the accomplishment of tasks on the current METL. However, the weakness was that the researchers, although they did have college education in the core sciences, they were not scientists immersed in current laboratory techniques or latest research analysis methods. This meant that the project would eventually reach a point of diminishing returns where it should conclude and be passed to the Army's official research agencies.

An end product of the project is a book detailing technologies with applications for cold weather military operations and their subject matter expert points of contact. The other major end product is this article. The purpose of this article is to positively influence the supply and demand equation to insure that the contributions of this project are not lost. To explain: 10th Group is not the only organization with an interest in cold weather operations. Cold weather operations are part of the METL of America's Light Infantry, Ranger, and Delta Force units as well as the METL of similar units in the armed forces of our NATO allies. These units constitute several thousands of soldiers,

each with a vested interest in having state of the art equipment. It is the intent of these authors to incite interest in the concepts and equipment presented in this article so the soldiers on the ground will **demand** their chains of command **supply** them the equipment by the year 2015. Hopefully, at the same time, the end products of the *Winter Warrior on Battlefield 2015* project will, directly or indirectly, help to interest manufacturers enough to **supply** the equipment by the year 2015. Unfortunately, if the armed forces are not interested in the concepts and equipment, then the manufacturer will not design, develop, or produce the equipment and the soldiers will not have it by the year 2015. Soldiers may eventually get the equipment, although without interest now, it will be much later than 2015 and in the meantime lives may be lost.

An ally in generating the interest to get such equipment could be the United States' police type forces. As the military down sizes, our nation's emphasis will be on fighting crime rather than foreign enemies. As humans settle into the colder regions of our nation and the world, there will be, besides international conflict, all of the intranational crime problems normally associated with humans beings. Police type forces will therefore also have to operate in the cold. They too will desire state of the art equipment.

The possibilities of this cold weather equipment are considerable. The following fictionalized passage is the tip of the iceberg of the "imagineering" done by the Winter Warrior 2015 researchers and applies the some of the equipment concepts of the project in a special operations forces scenario:

Operation Winter Warrior 2015

(see figure one)... Terrorists kidnap U.S. diplomats in Norway to negotiate Middle East Peace... SOF locates terrorist's camp in Norway through a tracking device implanted in the leg of a terrorist during his time in an Israeli prison... Camp location confirmed and pinpointed via communication from indigenous wildlife...

(see figure two)... U.S. Air Force "seeded" clouds snow biogenetically engineered electronic equipment obscurants and as well as heavy snowfall on camp... Invisible lasers diminish the terrorists' vision with an effect indistinguishable from snow blindness... Assault Team begins infiltration via an under-snow tunneling vehicle...

Support teams open up with soft kill munitions... Infrasound generators blast terrorists with super low frequencies sickening and disorienting terrorists... Electromagnetic-Pulse and microwave mortar rounds further degrade and melt terrorists' unshielded electronics...

(see figure three)... Miniature drone aircraft disguised as birds effect no-reflex kill on unsuspecting terrorists guarding diplomats... Flash strobe grenades temporarily blind terrorists... Parachute fiber optics laser 2-D projectors from grenade launcher projects deceptive displays of moving friendly soldiers using the snow white landscape as a movie screen... Balloon 3-D laser projectors from mortars project holographic images of friendly soldiers onto the falling snow flakes thereby thoroughly confusing the terrorists... S-curve munitions take out terrorists hiding behind ice-crete walls... Electronic sniper scopes adjust the aim point not just for the weather, wind, and

temperature at the scope but along the entire path of the bullet... Electrified bullets stun terrorists into unconscious... Super glue foam grenades immobilize some terrorists... Sticky nets shot from grenade launchers capture other terrorists... Electrified nets shock terrorists only if they struggle...

Assault team conducts final equipment check enroute... Wearable DNA based computers controlled by (see figure "Mouth Piece Keyboard") mouthpiece keyboards and contact lens monitors allow friendlies to radio commute with a networked digital advantage... Vision enhancing optics routed to contact lenses provides friendly soldiers color night vision and the ability to intensify any light frequency from UV to IR... Motion mapping detectors that compensate for friendly movement pinpoint terrorists at close range and prevent ambush... Ear canal hearing aids/loud sound filters/radio microphones linked to sound classification software distinguishes between friendly sounds, irrelevant ambient sounds, and the all important, even if barely audible, enemy sounds...

Assault Team busts out of the ground and begins with charge by artificially intelligent robots with remote control override... Reversible jet assisted skis and forearm mounted weapons with the detachable triggers mounted to the ski pole handles allow the friendly soldiers to move and shoot effectively... Anti-noise emitters located in the heels of the boots cancel out any tell tale sounds the stealthy attackers make..... Chameleonic uniforms change pattern, color and shade as friendly soldiers attack... Individual nuclear, biological and chemical (NBC) detectors linked to a smell classification database not only gives the soldier early warning of dangerous NBC levels but gives

him the ability to track like a blood hound as well... Hand held snow density sonar discovers the snow covered footprints and ski tracks of the terrorists' escape routes...

Reactive armor on the exoskeleton-skeleton of a heavily armored friendly soldiers deflects terrorist bullets... A flechette round from a terrorist hypervelocity rifle pierces the ballistic protection inherent in the uniform fabric of a highly mobile light commando... His uniform reacts to the puncture by spraying an antiseptic type 'bandage' foam on the wound and inflating at the wound site to apply pressure and stop blood loss... The soldier's bio-feedback system registers the pain and releases non hallucinogenic painkillers into the soldier's bloodstream such that the soldier can fight his way to safety with a collapsed lung...After dispatching immediate threats, the soldier slips into unconscious and his bio-feedback system broadcasts his condition and location to rescuing friendly soldiers....His uniform chemically heats to keep the unconscious soldier warm using energy stored solarly and from excess body heat from previous periods of intense activity.....As his rescuers approach they remotely activate an infrared beacon on the unconscious soldier and find him in the white out blizzard...

The assault team quickly captures the cold, wet, sick, tired, scared, blind, wounded, and beaten terrorists....The attackers had killed only the two terrorists closest to the hostages with only the one friendly casualty....Only one terrorist escaped....with, unknown to him, a very small tracking device stuck to his clothing setting the stage for another surgical direct action mission on future objectives....

Perhaps the plot of this scenario does not seem as possible as the latest Tom Clancy novel. But that is irrelevant; the point is that the equipment is very possible, and possibly before 2015. Although some of the ideas for the equipment presented in this scenario originated with project '2015', some of the ideas have been around for years with the equipment prototypes now available. In some cases, different technologies can soon produce vastly different equipment that do the same thing. In other words, the equipment is not just possible but possible in many different ways. The Army's research laboratories, at Natick, Hanover, Fort Greely and elsewhere are hard at work making this all happen.

Interest in the researcher's work at these laboratories is the fuel that makes them go. Not in the sense that the researchers need constant boosts to their egos to inspire them, but rather in the sense that interest in their work is what generates the money that funds them. Money it seems, is not only "what makes the world go round" but is also the motor that allows the researchers to drive on from interest to ideas to workable products. The most effective and genuine interest comes from the grass roots level of the soldier on the ground. Without him passing his interest up the chain of command, the ideas presented in this article about the soldier on the ground winning and surviving in a winter environment are nothing but science fiction dreams.

Operation "Winter Warrior 2015"

Note: Terrorist Camp is 95% underground/under snow

Legend:	
●	Terrorist
○	Bunker
●	Friendly
●	Anti-vehicle Mine
●	Anti-personnel Mine
⌘	Electronic Surveillance
🌲	Trees

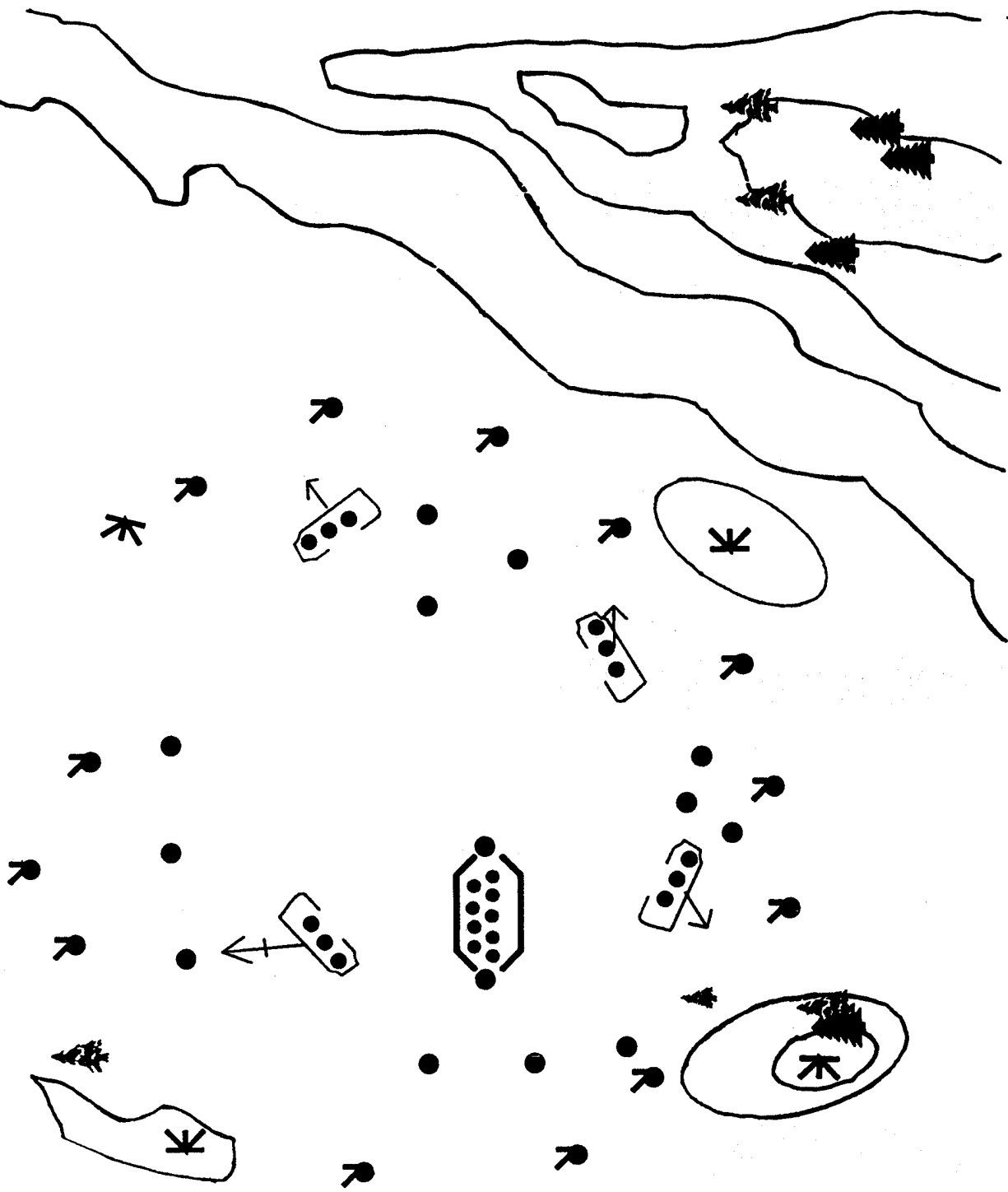

Operation "Winter Warrior 2015"

Note: Terrorist Camp is 95% underground/under snow

Legend:	
●	Terrorist
□	Bunker
○	Friendly
●	Anti-vehicle Mine
●	Anti-personnel Mine
⚡	Electronic Surveillance
🌲	Trees
Prep:	
☁	Weather(Snow)
⚡	Jamming
⚡	Microwave EMP

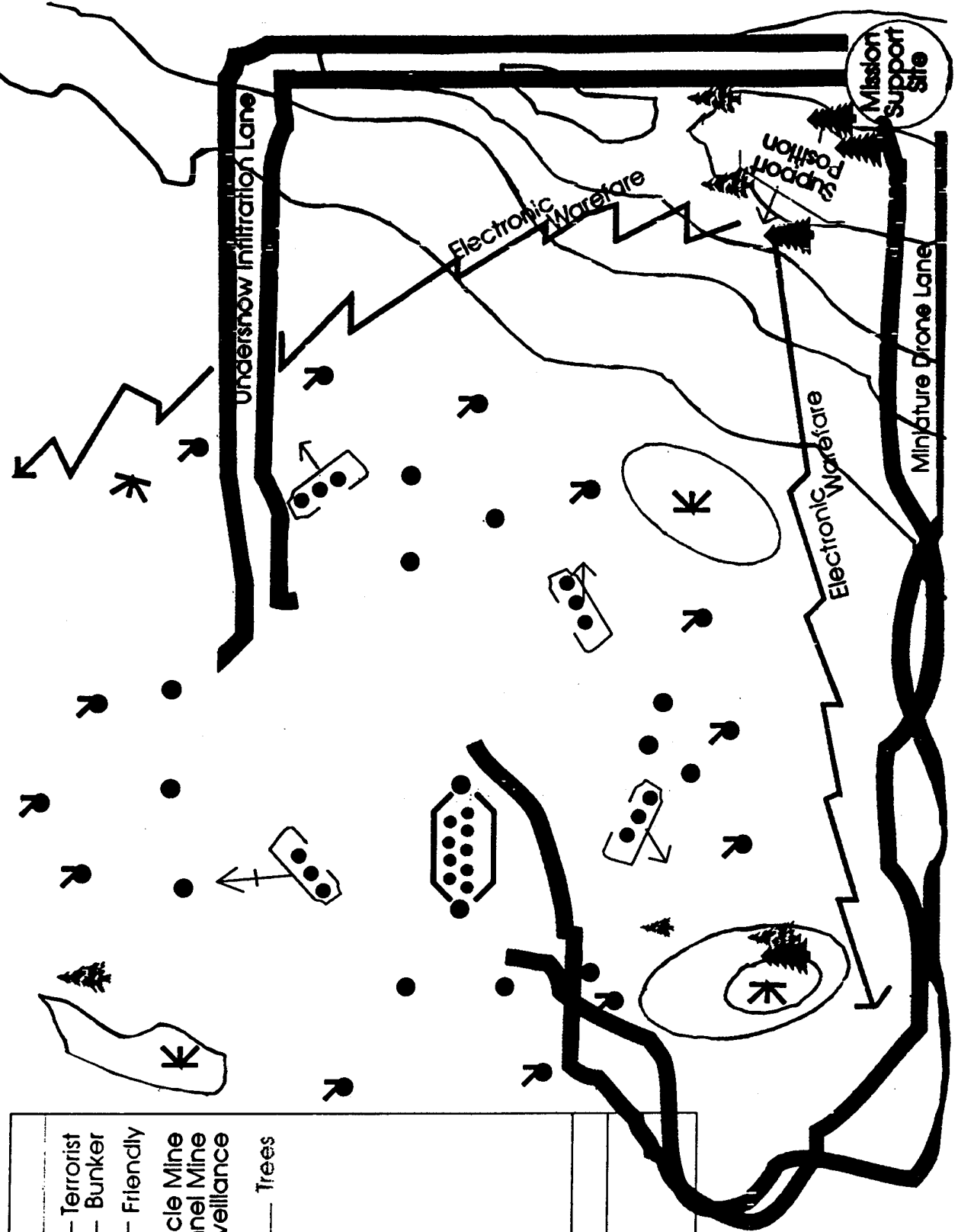
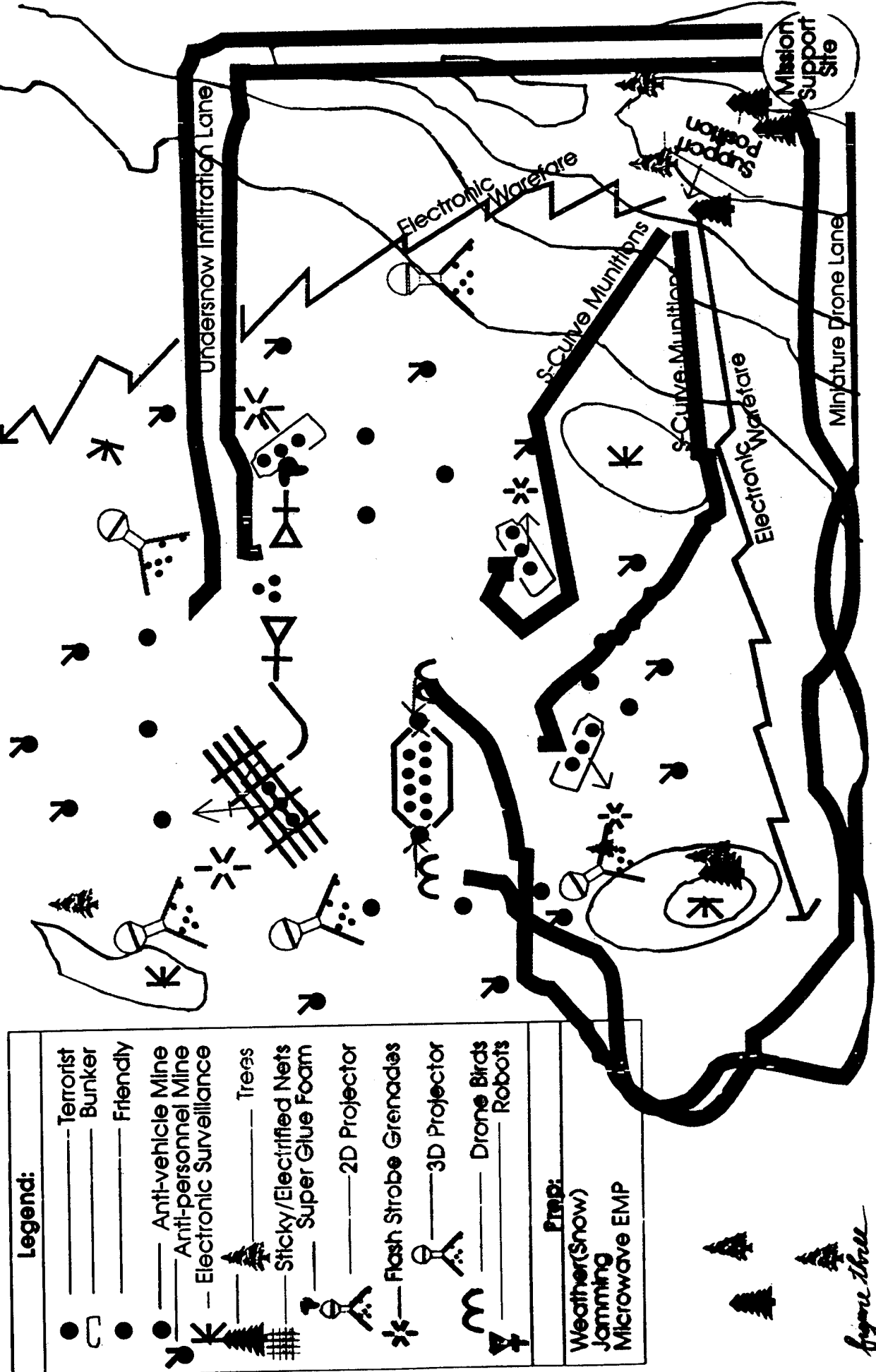

Figure 200

Operation "Winter Warrior 2015"

Note: Terrorist Camp is 95% underground/under snow



Legend:	
●	Terrorist Bunker
○	Friendly
●	Anti-vehicle Mine
●	Anti-personnel Mine
⚡	Electronic Surveillance
🌲	Trees
⚡	Sticky/Electrified Nets
⚡	Super Glue Foam
📡	2D Projector
⚡	Flash Strobe Grenades
📡	3D Projector
📡	Drone Birds
📡	Robots
Flags:	
❄️	Weather(Snow)
📡	Jamming
📡	Microwave EMP

Figure three

Mouth Piece Keyboard

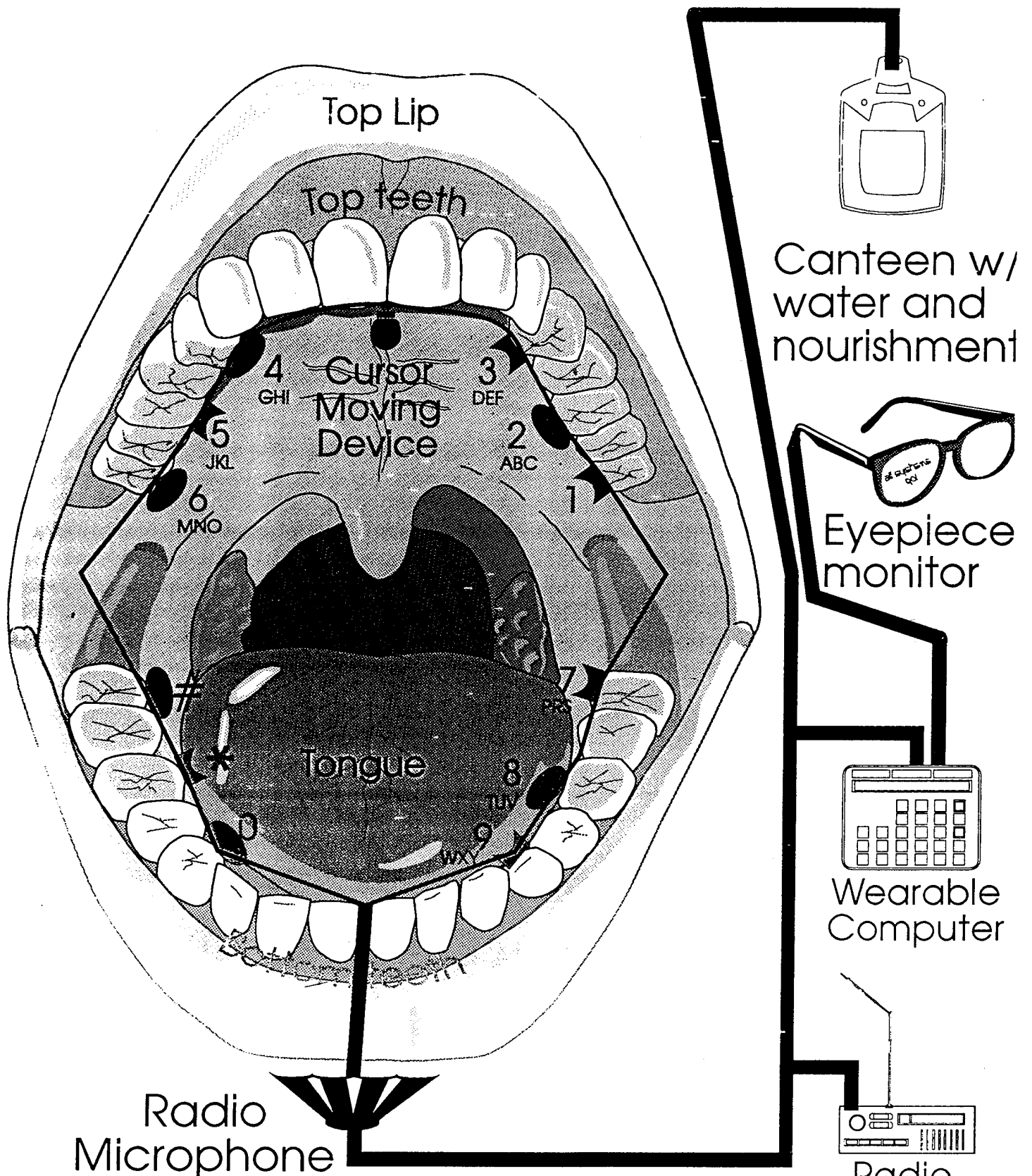

Communications Electronics Command is considering beginning the patenting / manufacturing process on this idea. To expedite call Mr. Anderson, (908) 532-4112, (DSN) 992-4112.

Radio
(on soldier's back)

COLD WEATHER SHELTERS

Laura A. Ryan
Shelters Division, Sustainability Directorate
U.S. Army Natick RD&E Center
Natick, MA

Overview of Cold Weather Shelters

by

Laura A. Ryan

Shelters Division, Sustainability Directorate

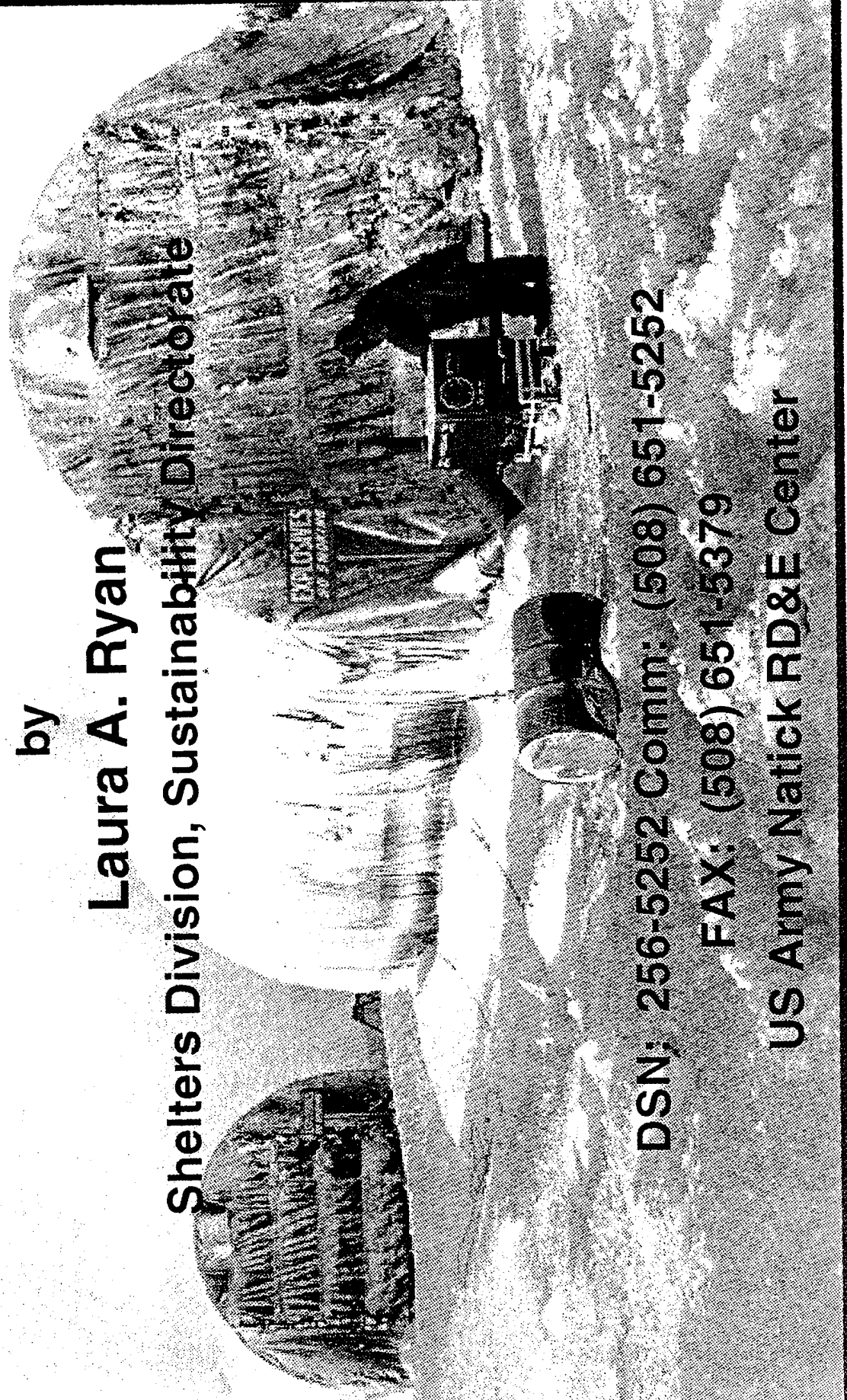

DSN: 256-5252 Comm: (508) 651-5252

FAX: (508) 651-5379

US Army Natick RD&E Center

Rigid Wall Tactical Shelters

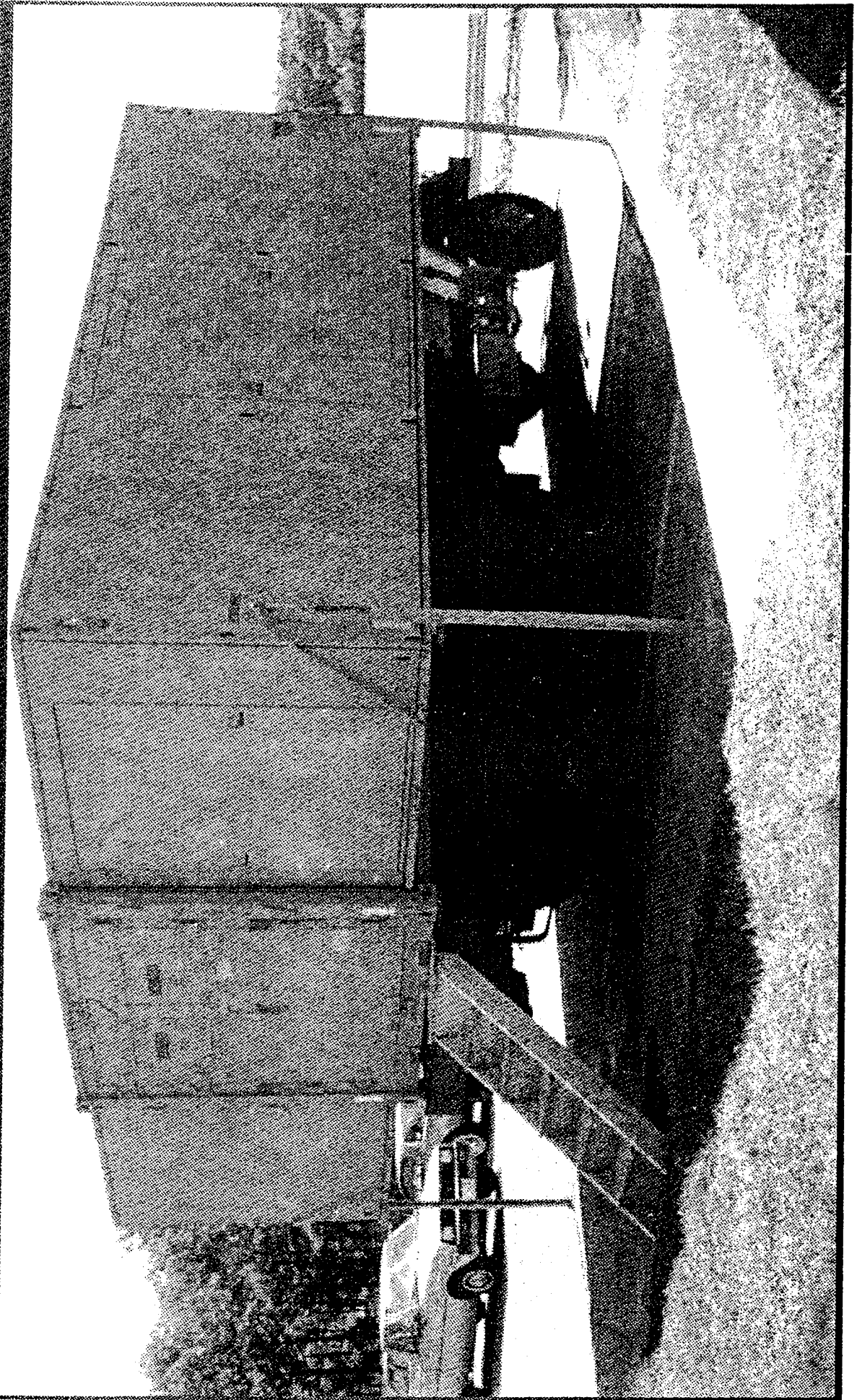

Lightweight Extreme Weather Shelter

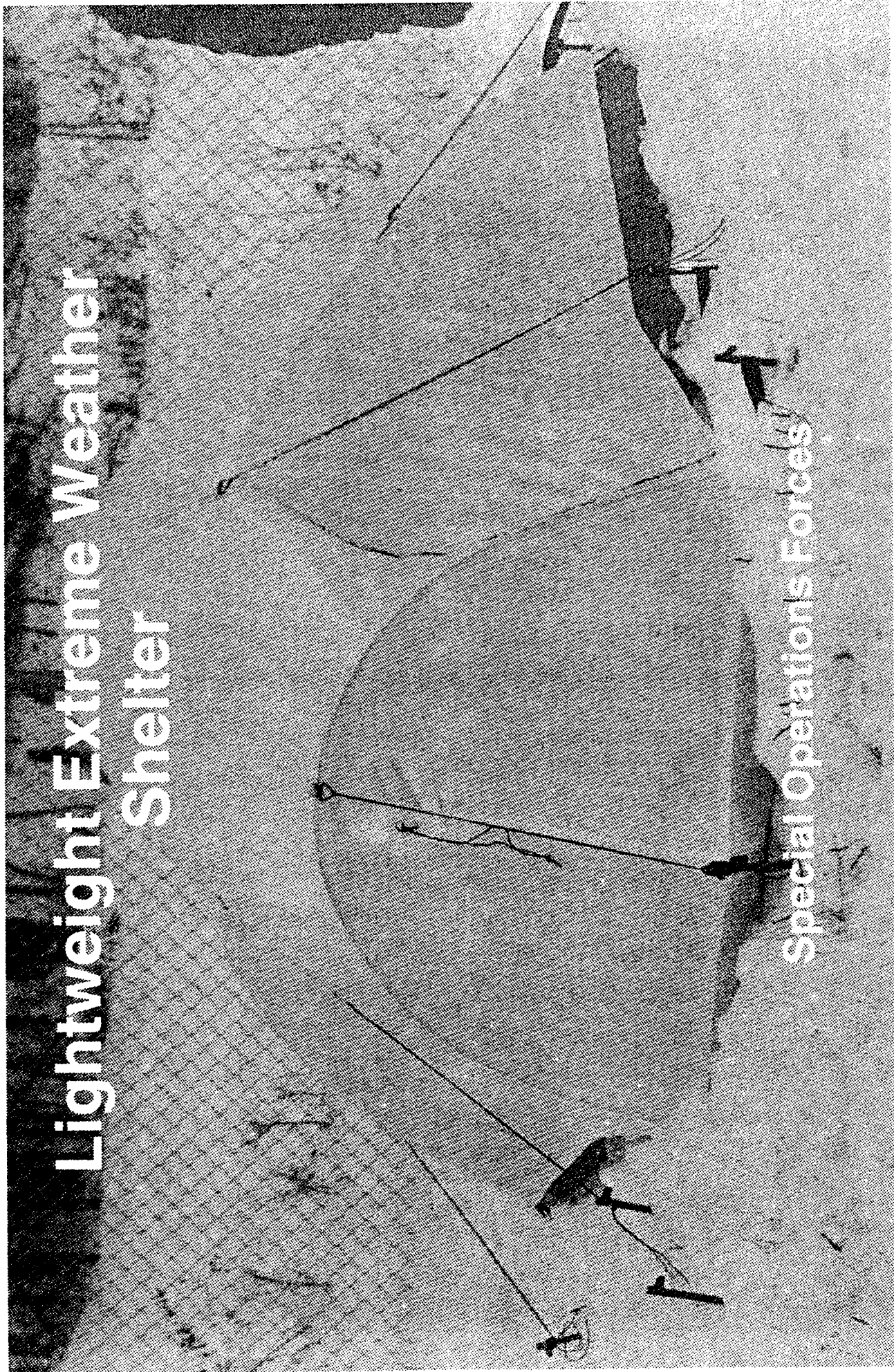

Special Operations Forces

Marine Corps Extreme Cold Weather Shelter



Soldier Crew Tent

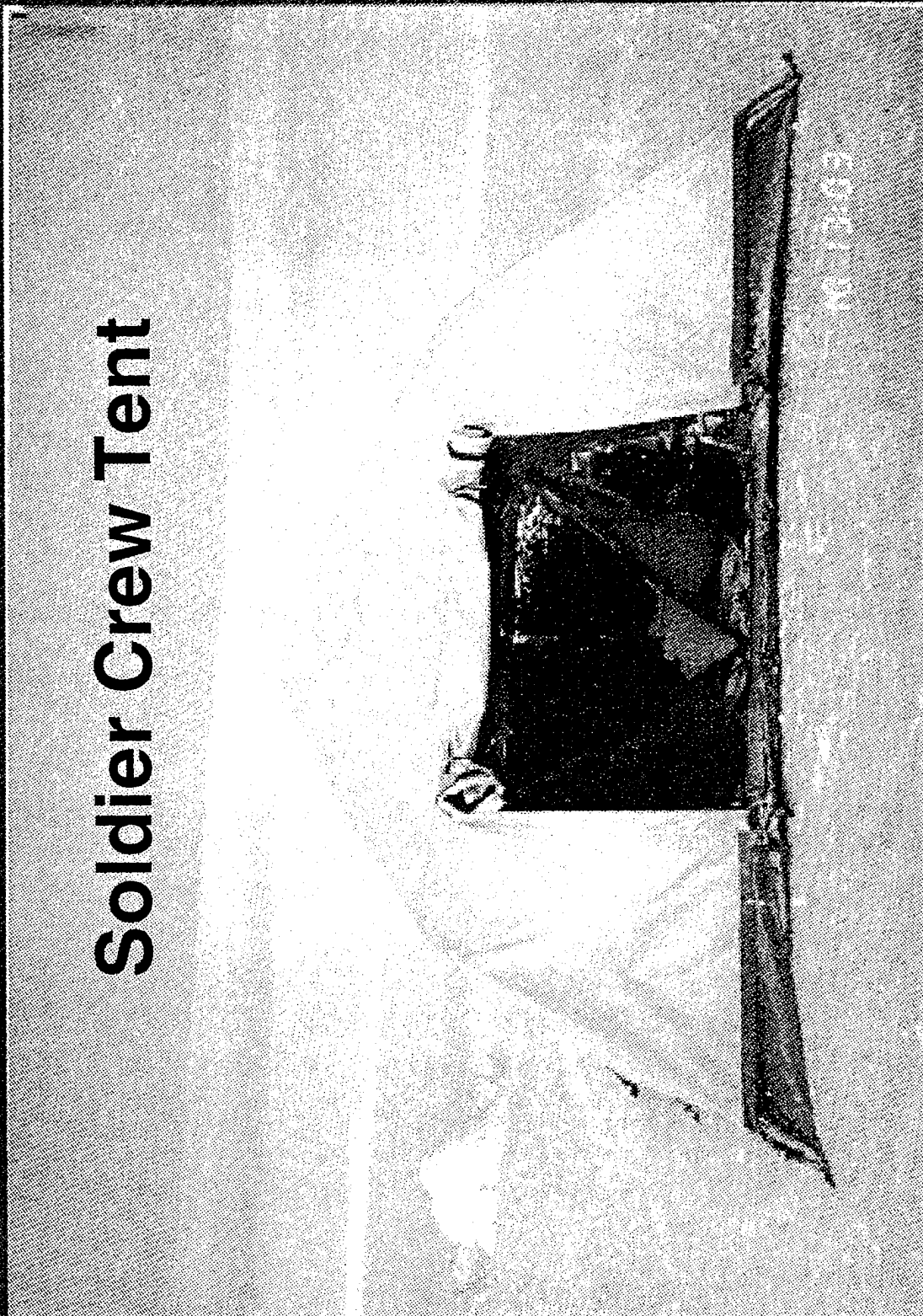

Modular Command Post System



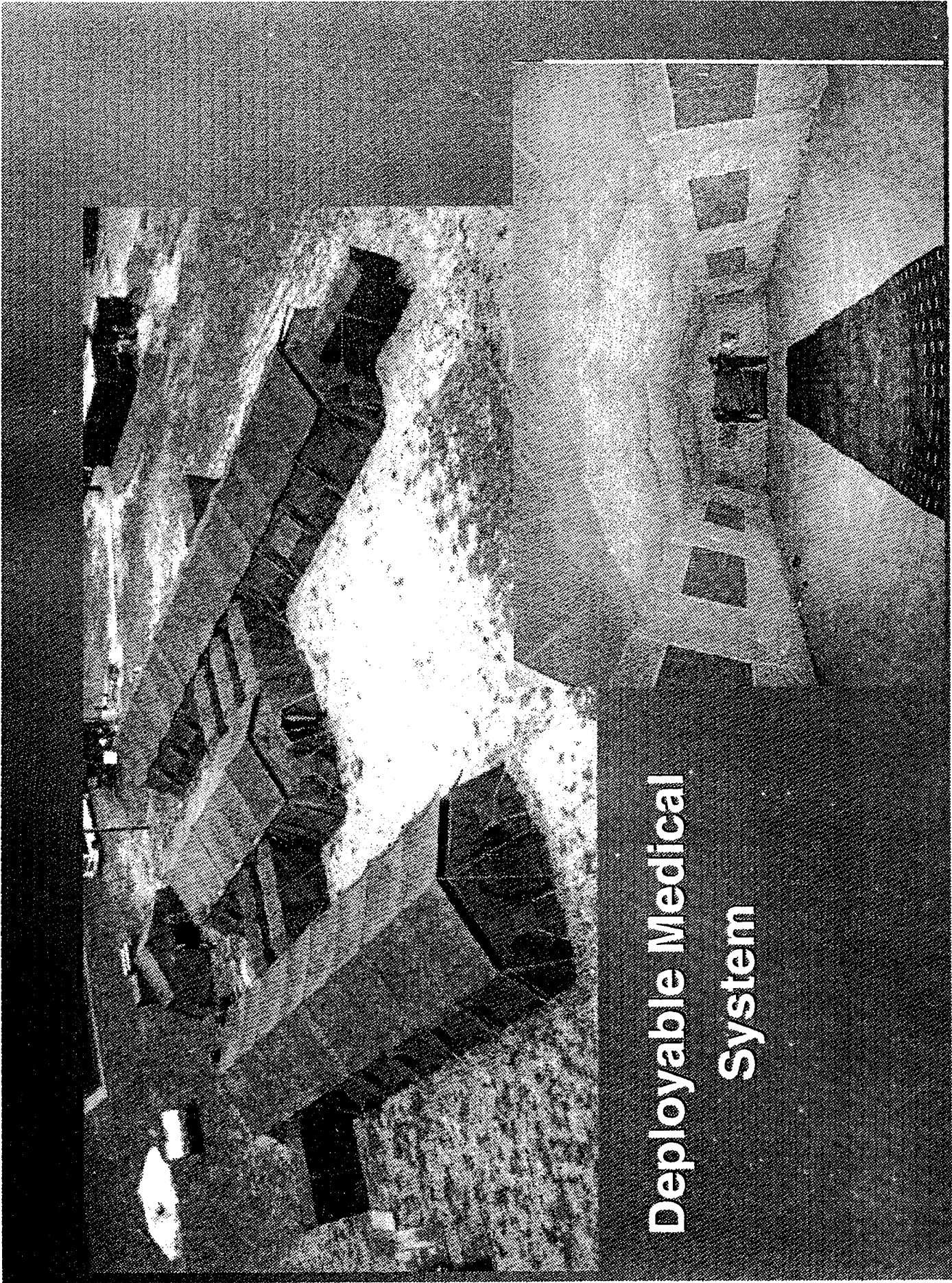

Deployable Medical System

Modular General Purpose Tent System

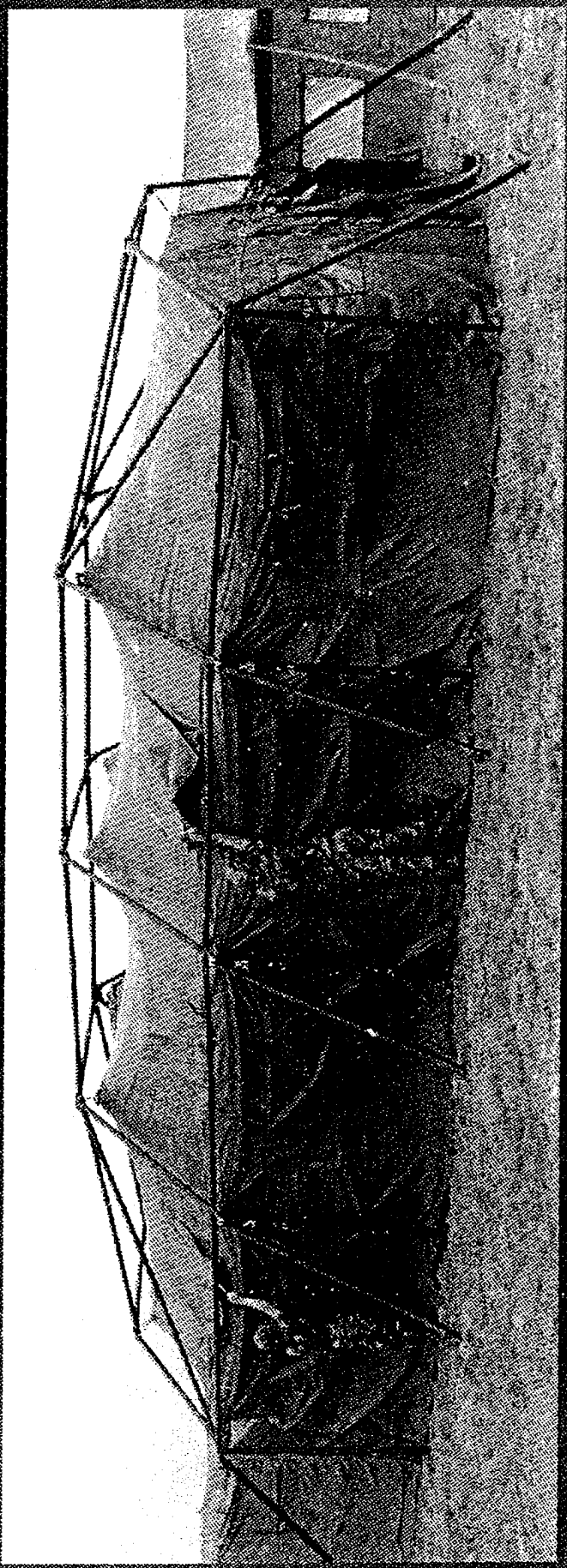

Forward Area Maintenance Shelter (FAMS)

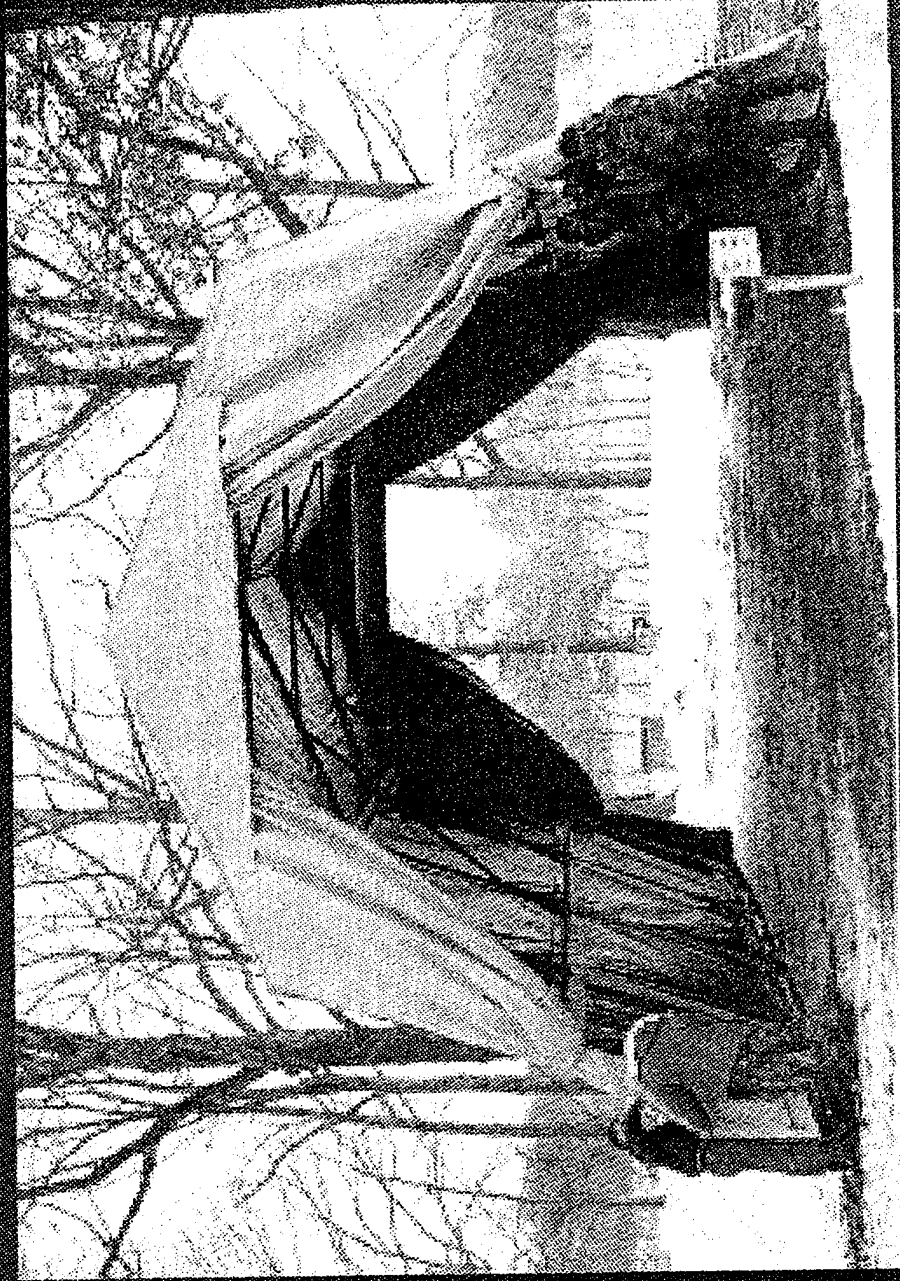

Chemical and Biological Protection

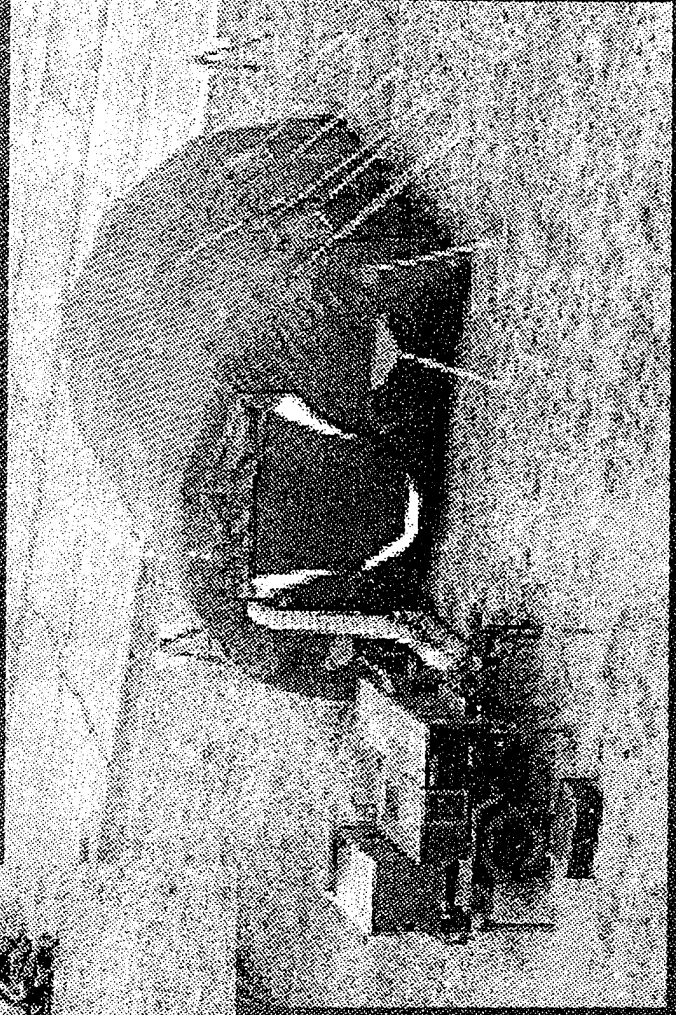

Air Beam Technology

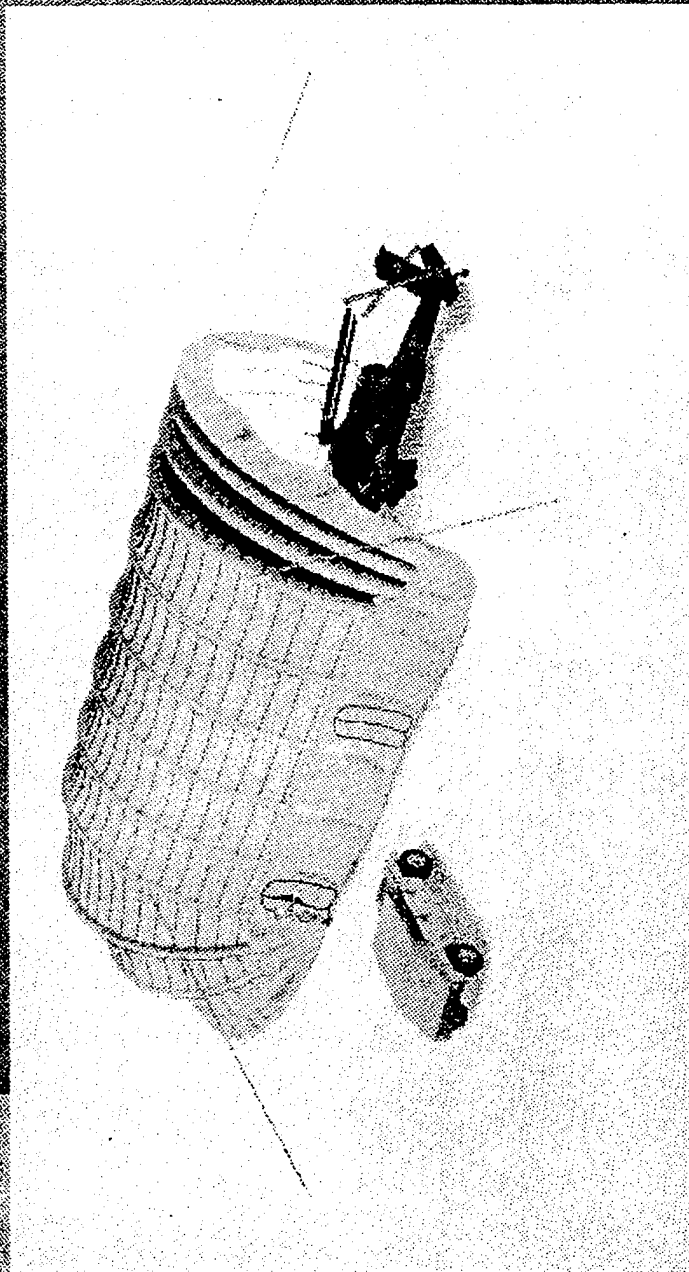
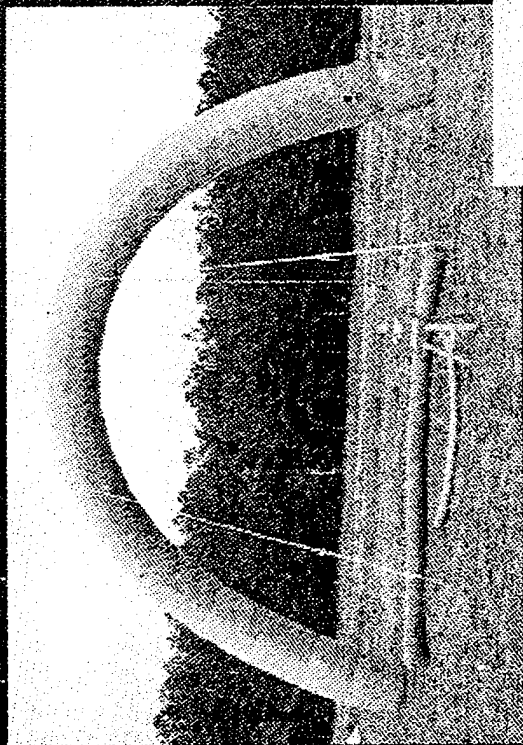

Vehicle-Mounted Shelter

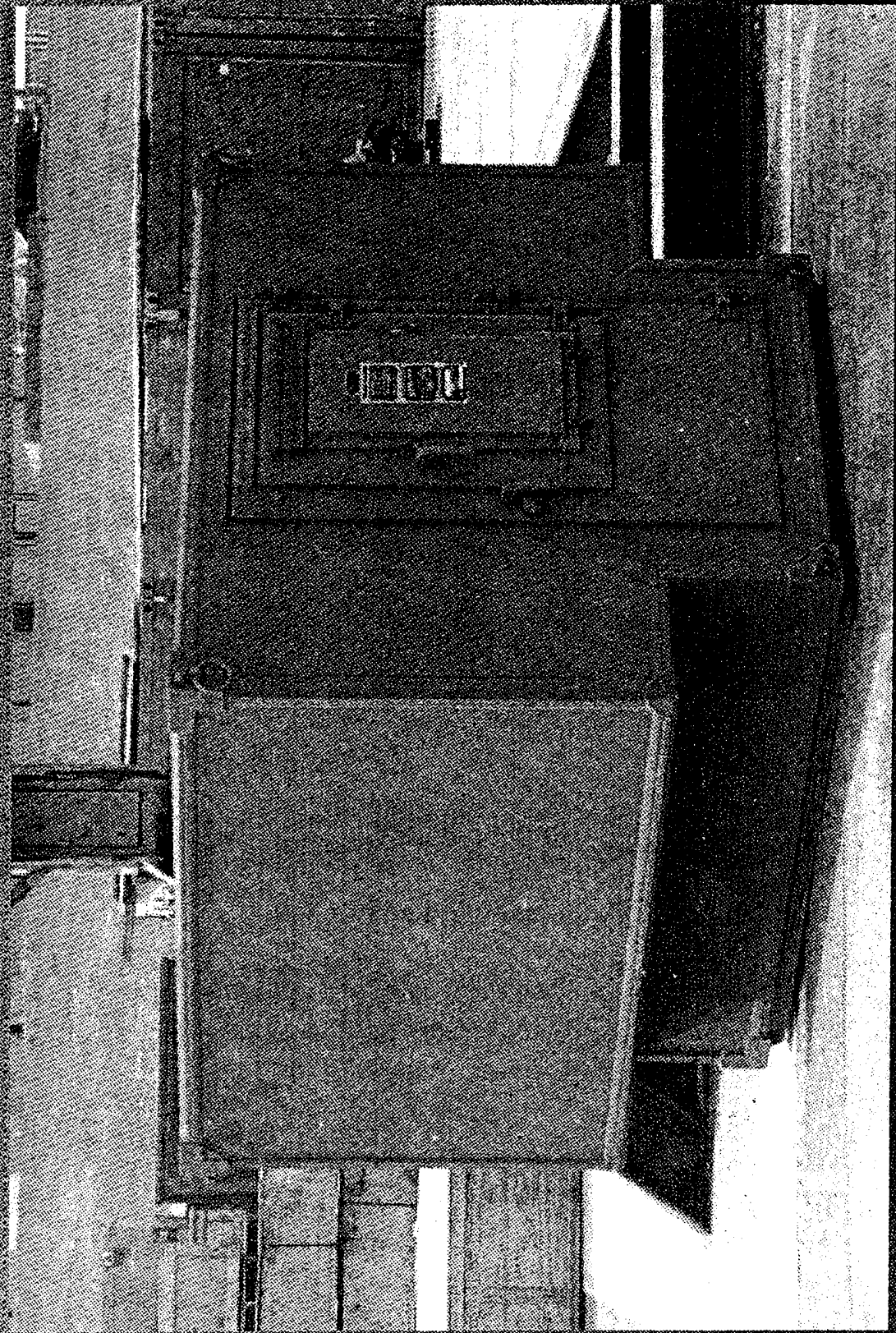

2-Man Infantry Shelter



Practical Air Shelter

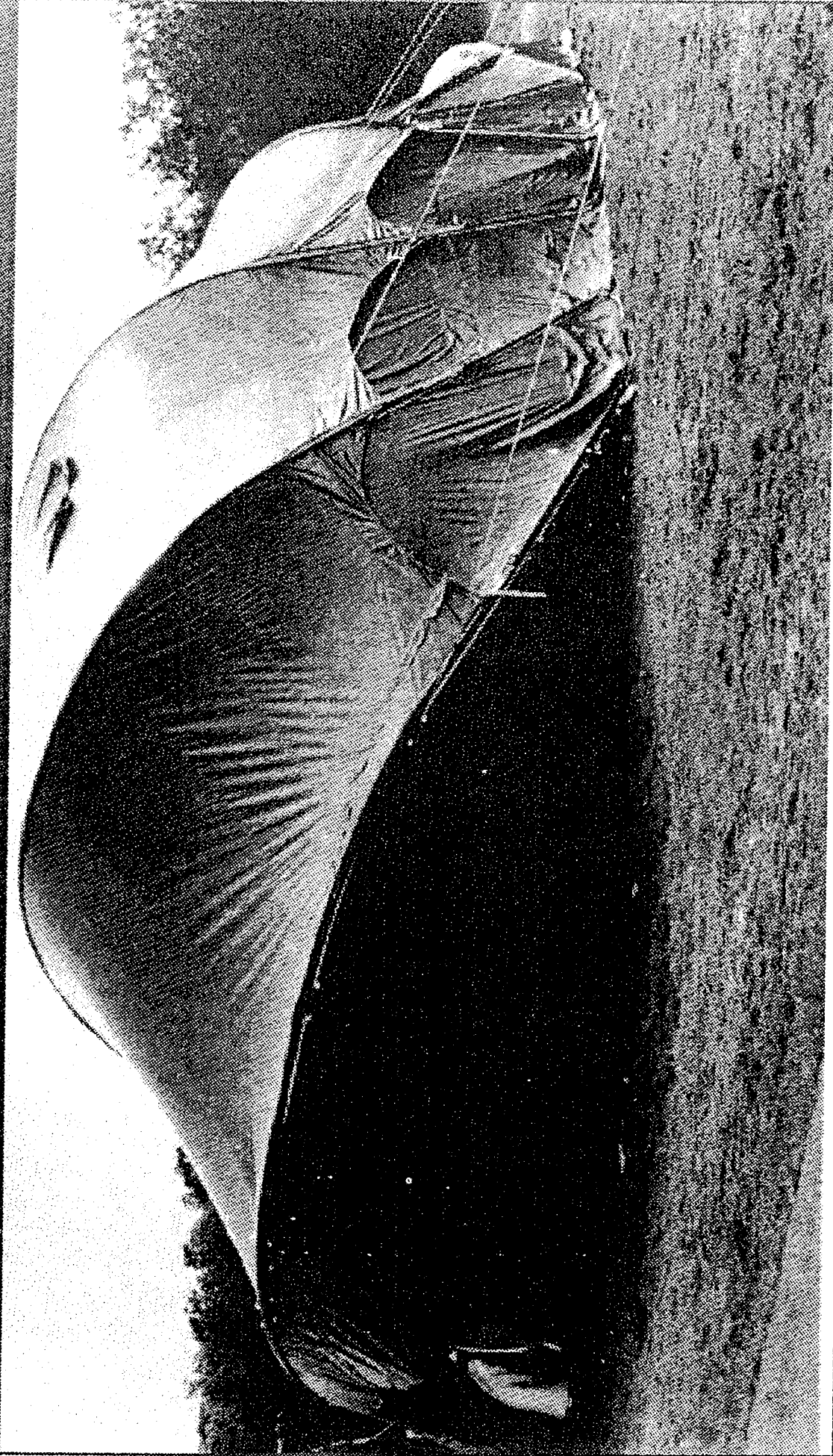

Chemically and Biologically Protected Shelter

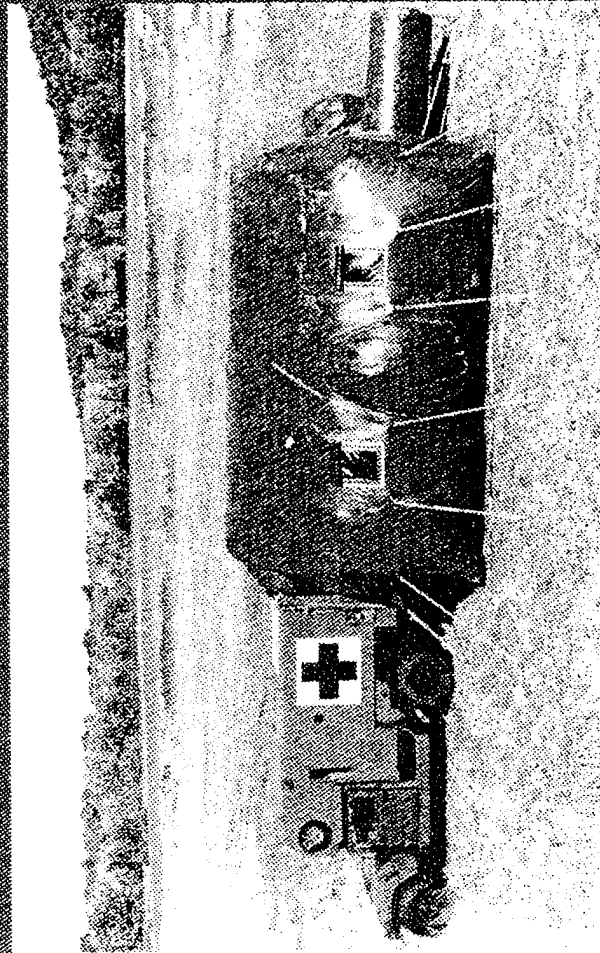

Field Hospital

**Wind Driven
Rain**

**High Wind
Testing**

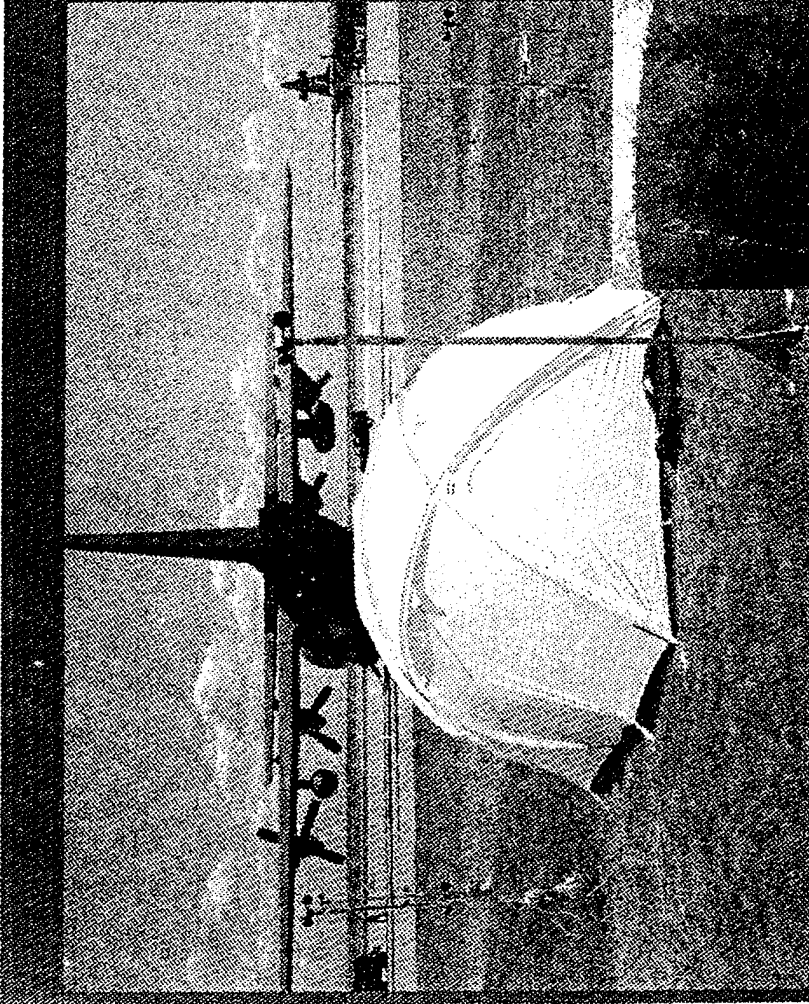

TESTING LABORATORIES

Cold Regions Research and Engineering
Laboratories, Hanover, NH

Wind Driven Rain Testing

Wind-20 mph and rain 2" ph

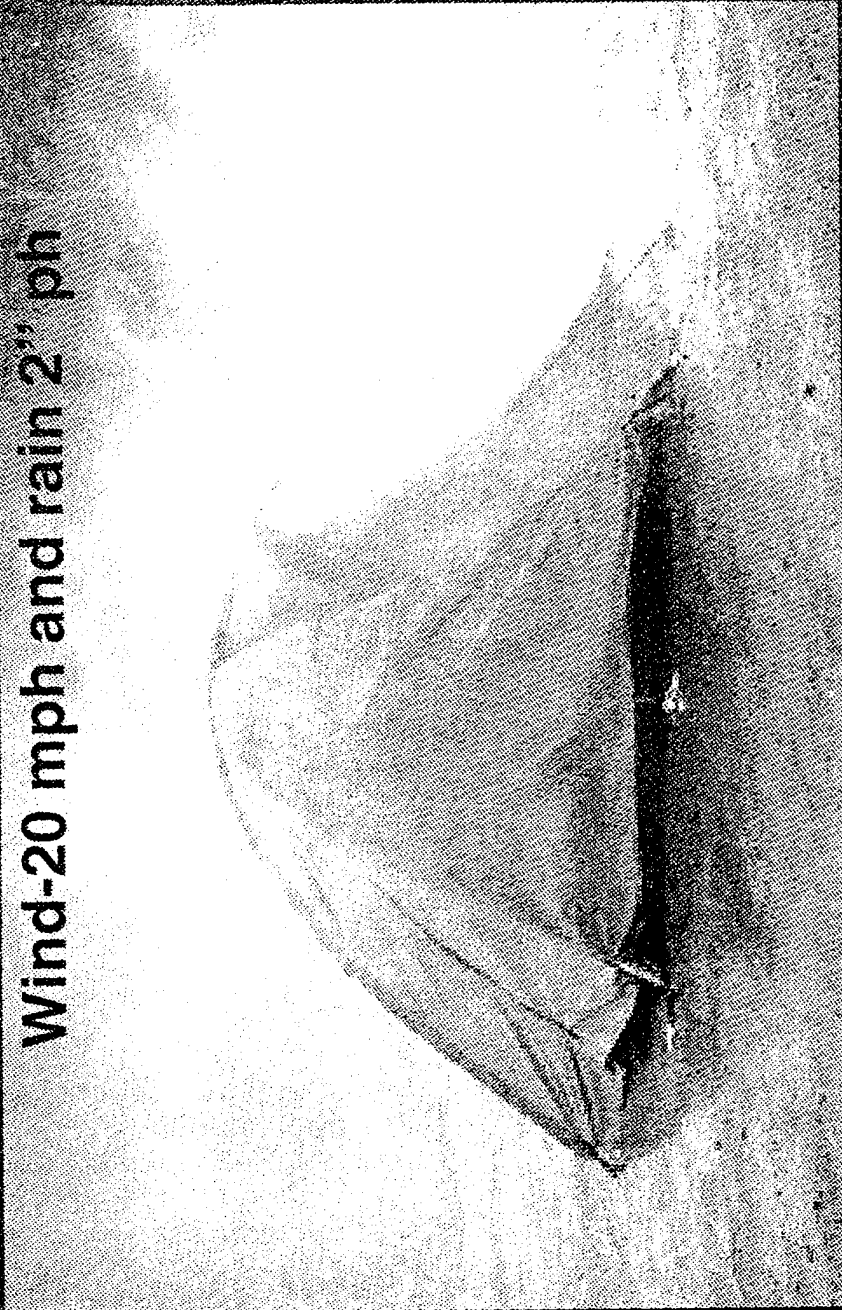

CLIMATIC CHAMBERS

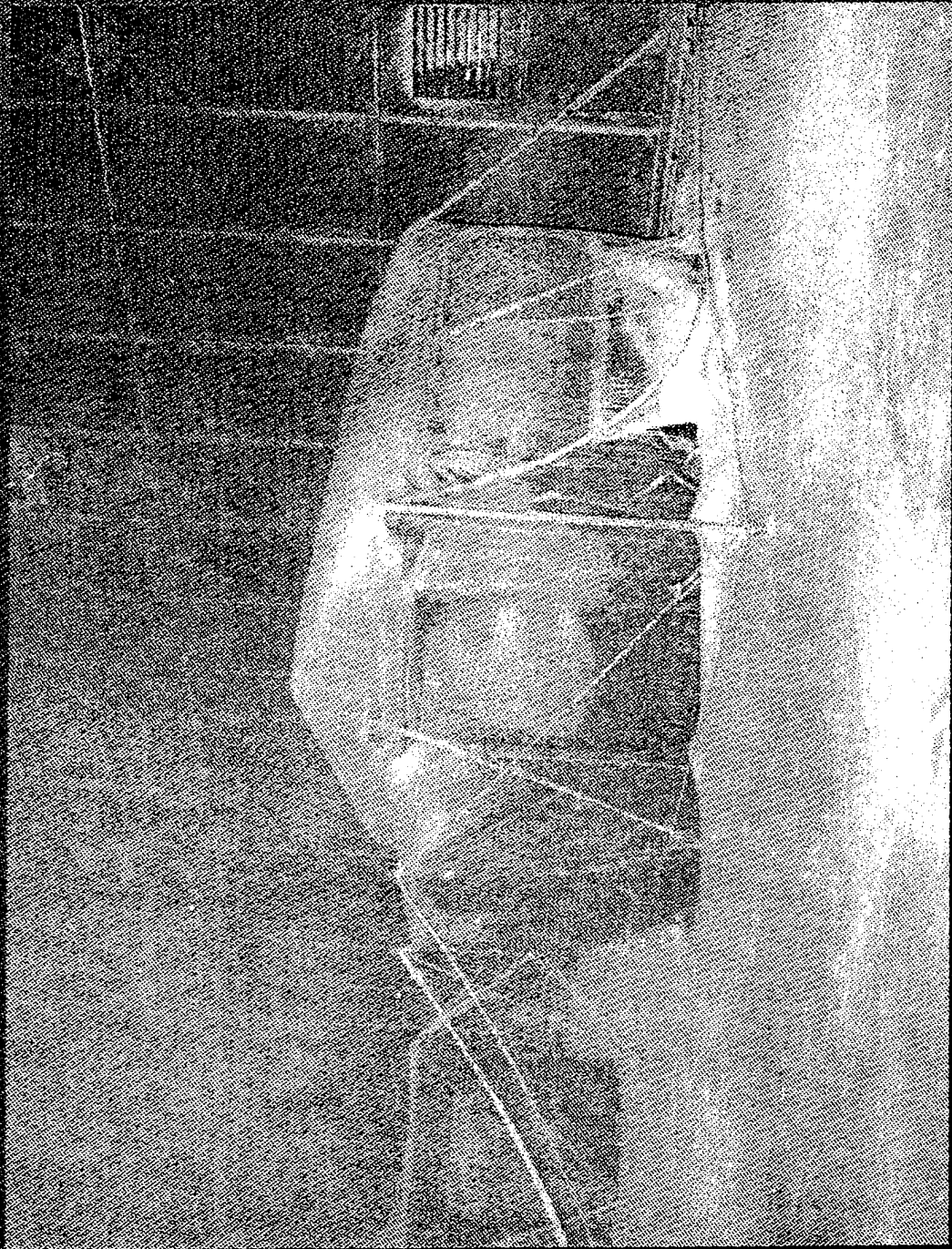

FIELD EVALUATIONS

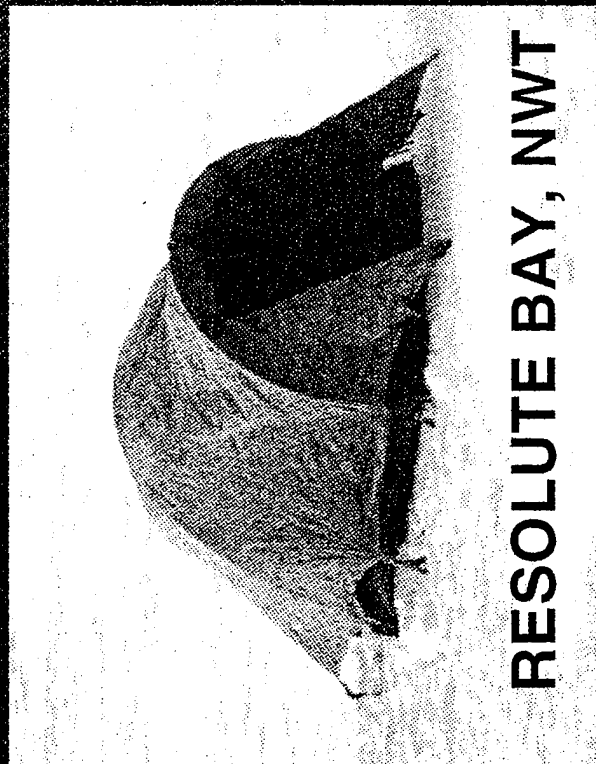
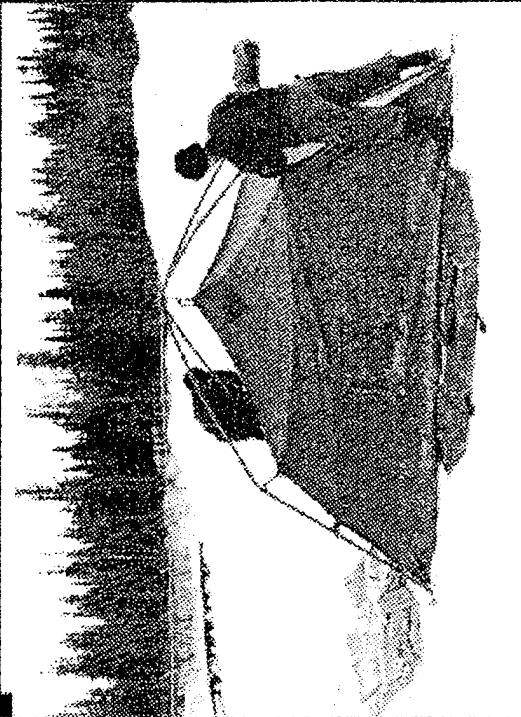

Ground Stake Evaluation



5-Man Arctic

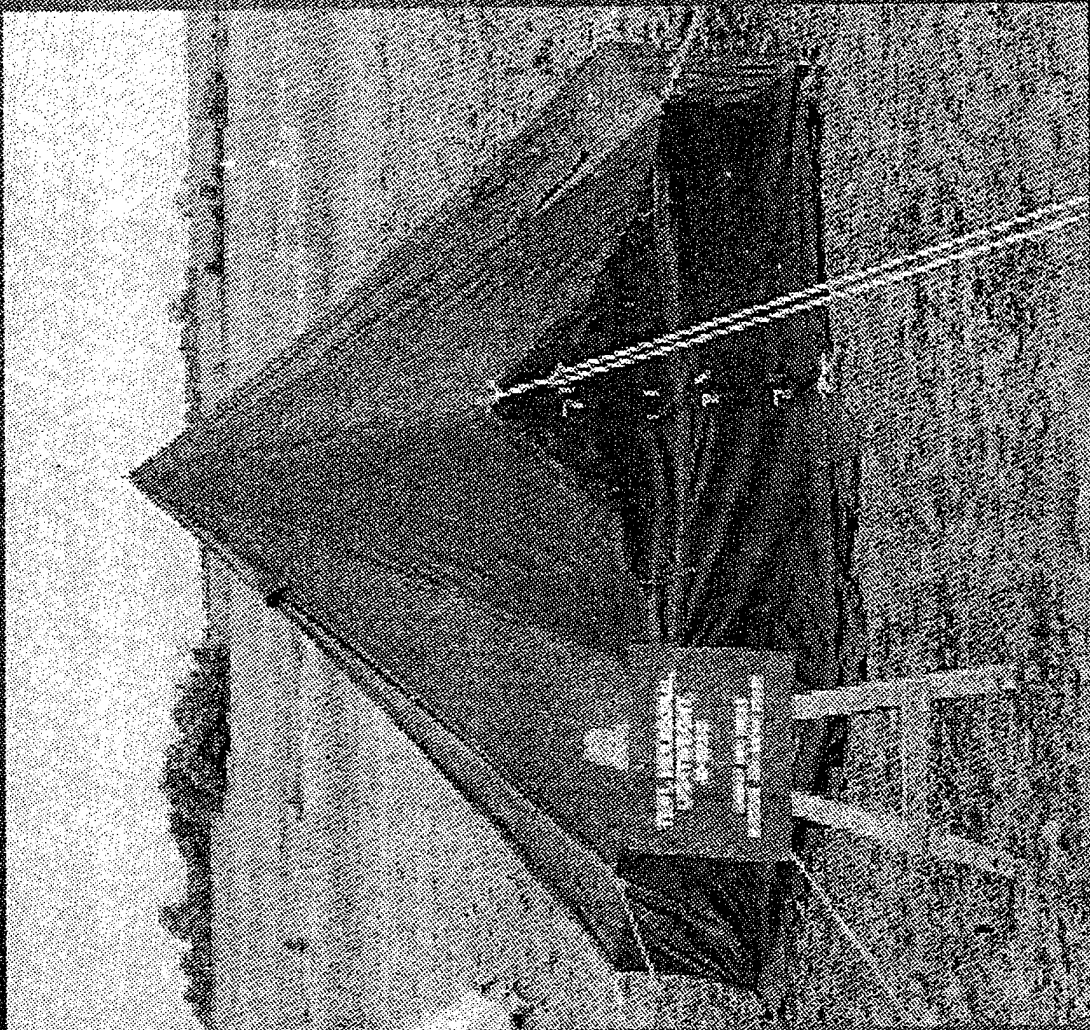

10-Man Arctic

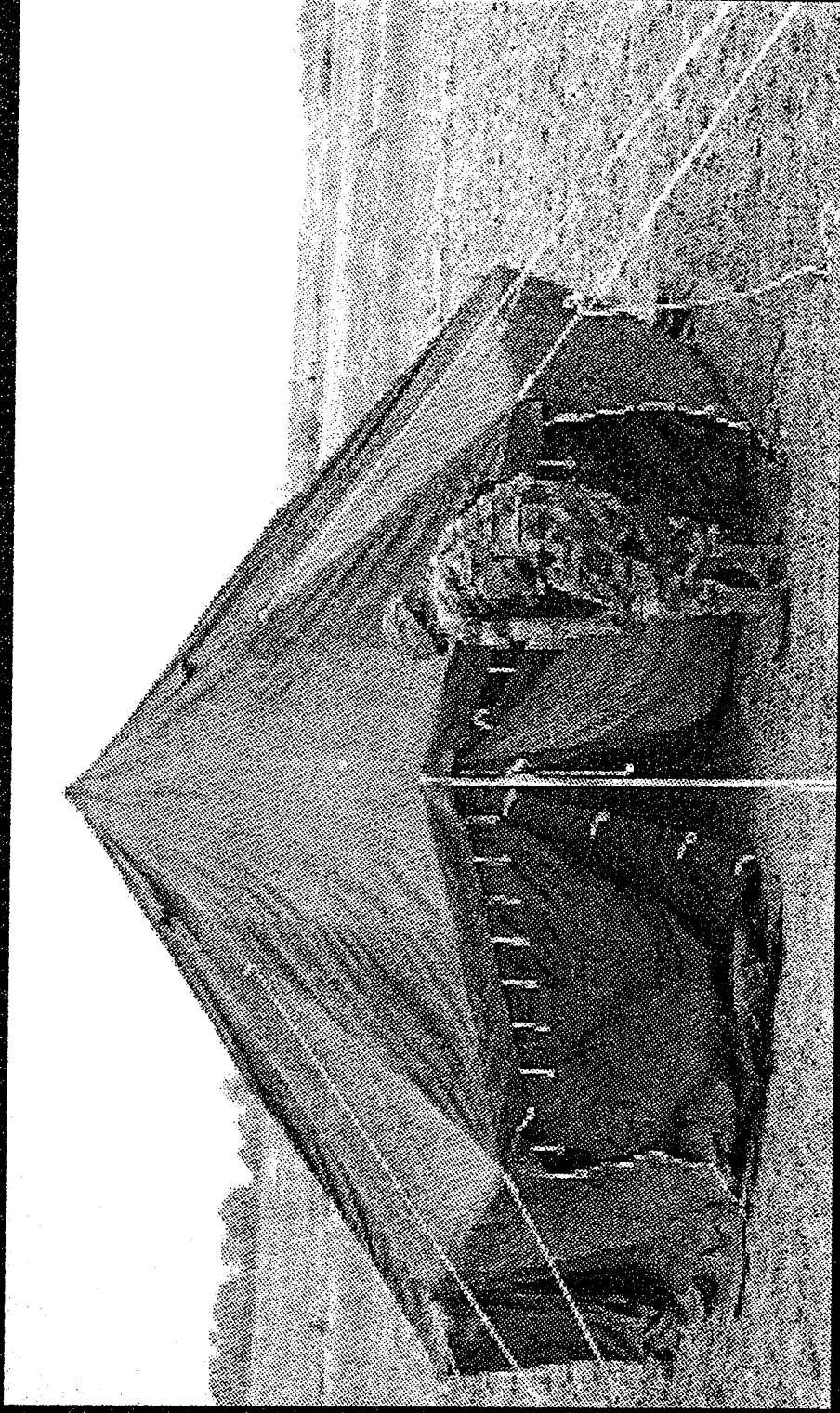

Prototype 10-Man Arctic

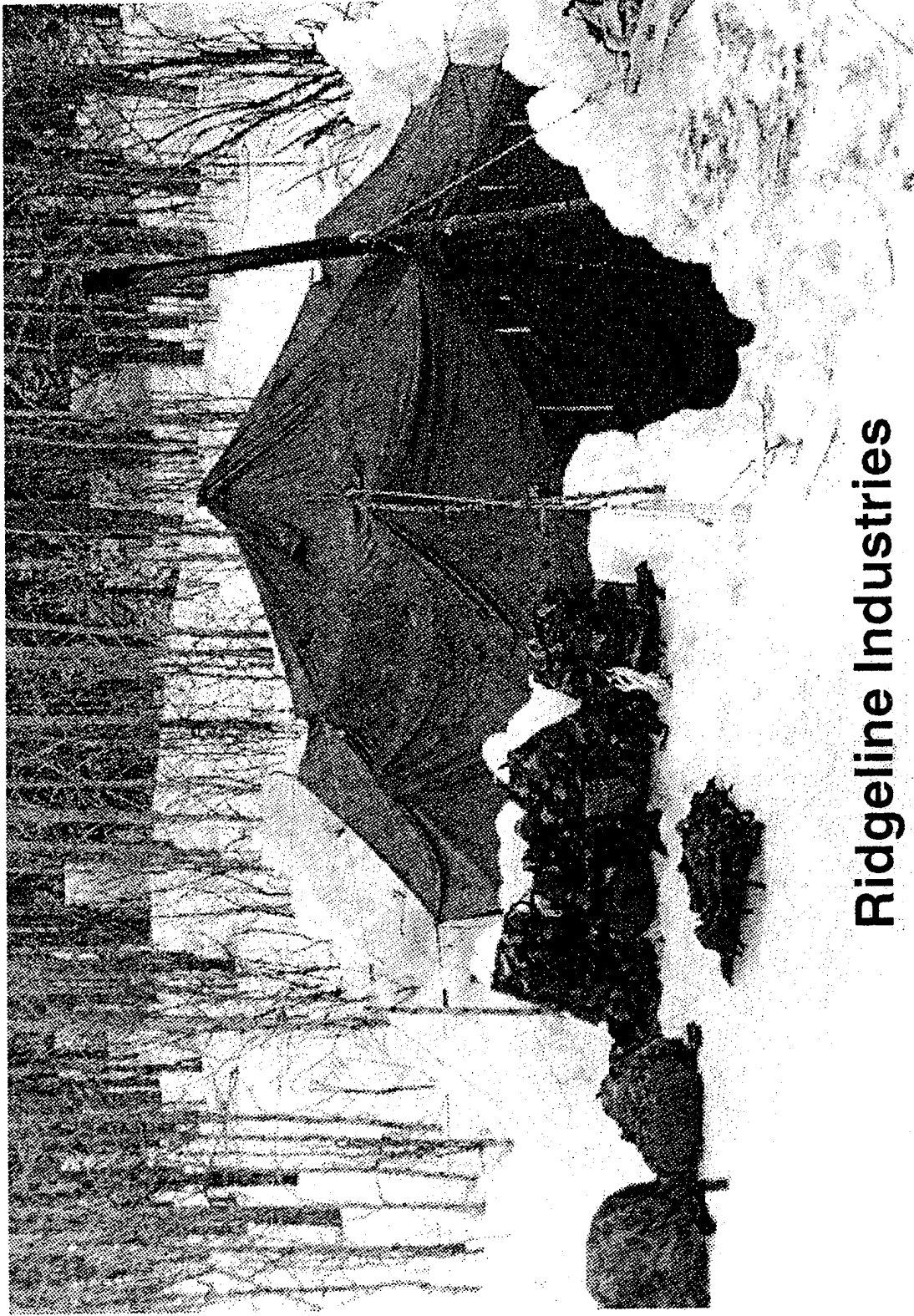

Ridgeline Industries

Prototype 10-Man Arctic

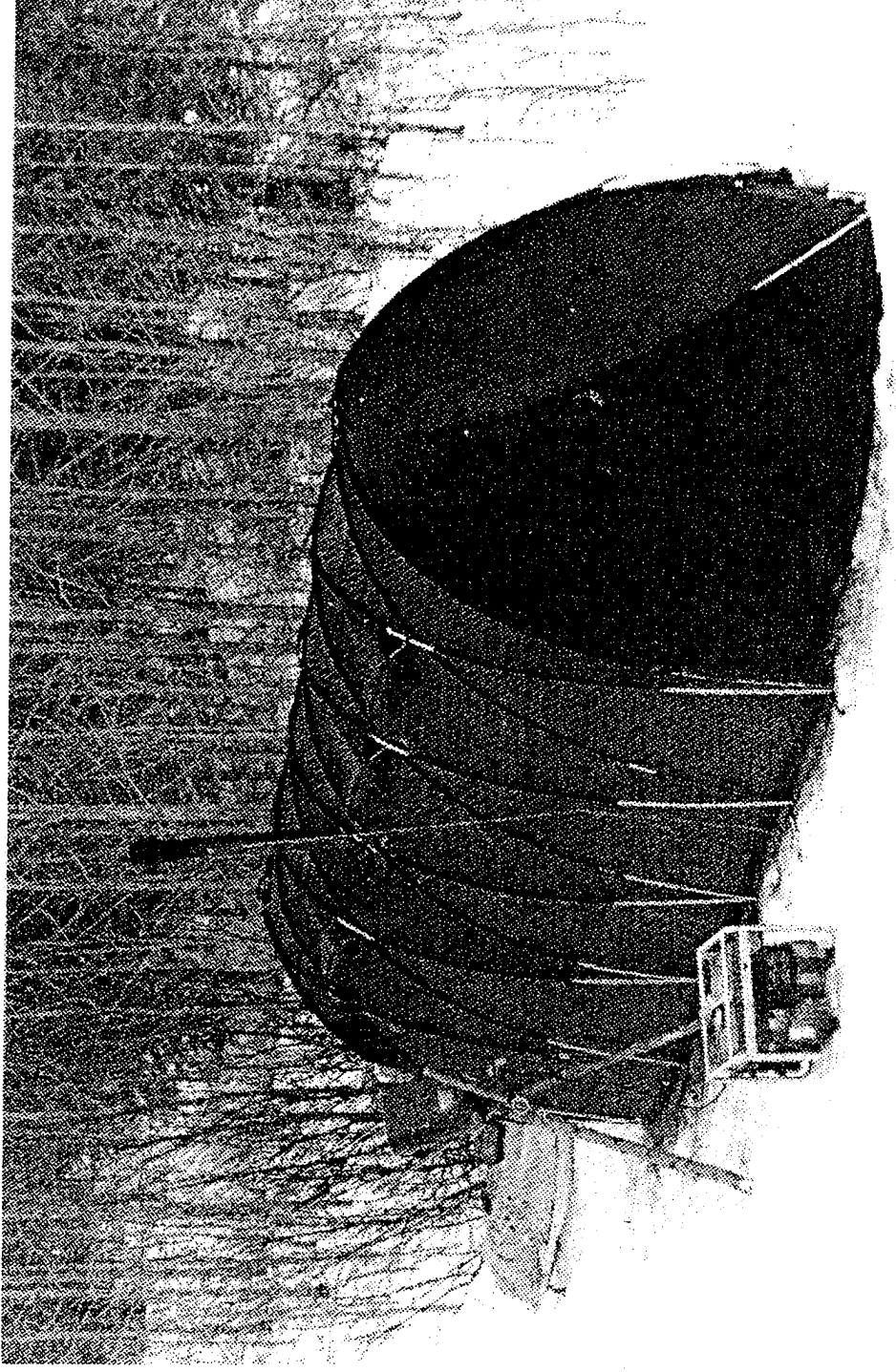

Adventure Tech, Inc.

General Purpose Tentage

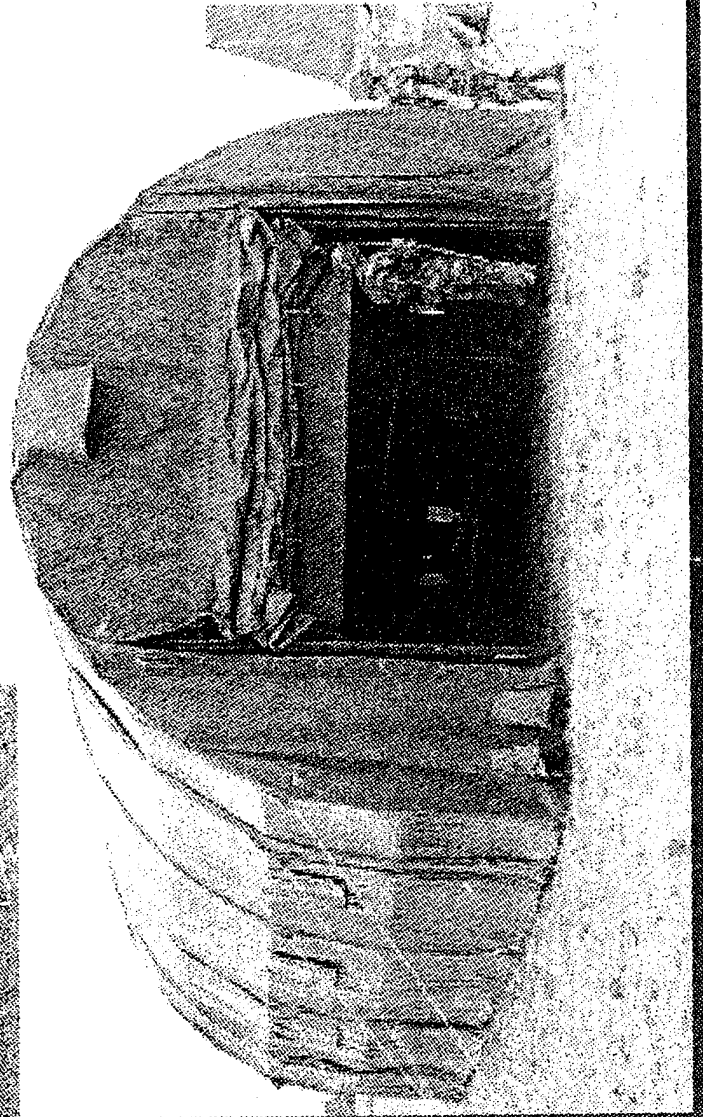
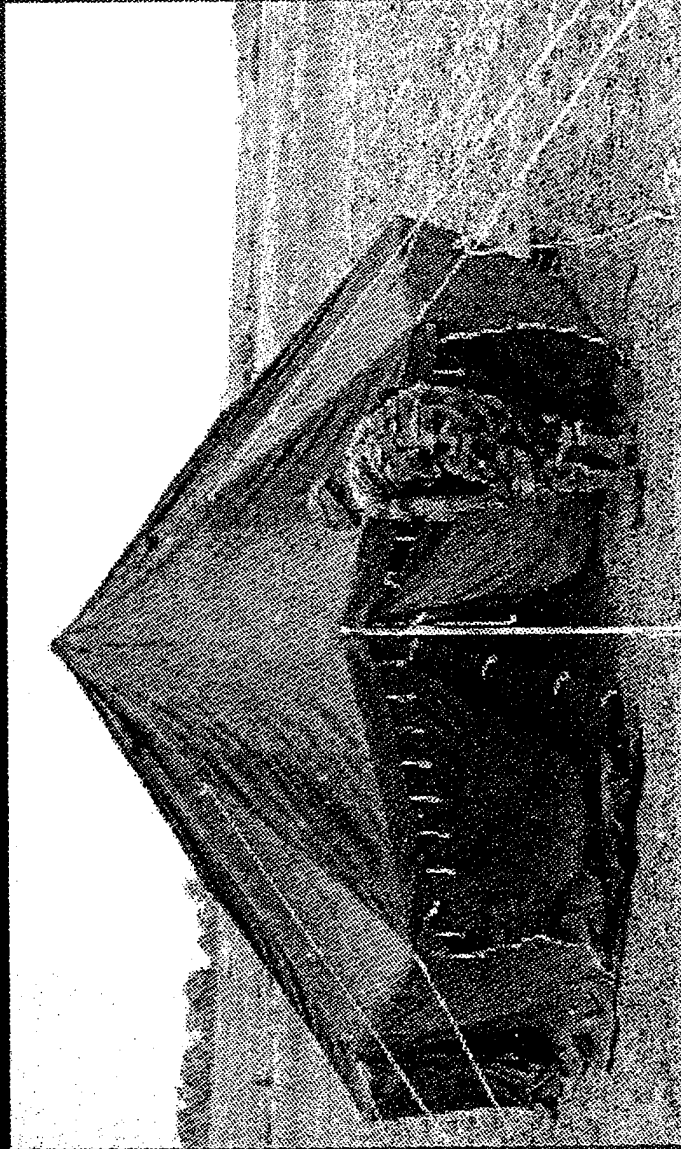

Maintenance Tents



**A TOWED SNOW PLOW FOR THE
SMALL UNIT SUPPORT VEHICLE (SUSV)**

Michael R. Walsh, PE
Cold Regions Research & Engineering Laboratory
Hanover, NH

A
Towed Snow Plow
for the
Small Unit Support Vehicle (SUSV)

Michael R. Walsh, PE

ABSTRACT

Light infantry units must conduct semiautonomous operations and limited self-resupply in remote snow covered areas. As these units are not heavily mechanized, most of their equipment is wheeled. In winter, most wheeled vehicles become immobilized once the vehicle sinkage in snow is greater than their ground clearance. Therefore, roads or paths must be open for them to operate. Since many roads and trails will not have been kept open prior to deployment, truck-mounted plows will be ineffective for clearing snow. In most instances, heavy tracked vehicles, such as dozers, are required to remove snow. These vehicles, when available, are slow, expensive, destructive, and difficult to operate in extreme cold. Therefore a snow removal method using vehicles readily available to light forces is needed.

The US Army's Small Unit Support Vehicle (SUSV) is a light-weight, low-ground-pressure tracked vehicle. A towed V-type plow assembly was proposed for this vehicle to clear pathways off-road for wheeled vehicles. A four-bar parallel linkage towing assembly was developed that bolts directly on to the SUSV's pintle hook mounting bracket. A plow was designed and constructed primarily of aluminum, has three plowing widths, and can be towed over the road on integral wheels.

This paper presents a description of the design and operation of the plow along with the results of field tests conducted in Alaska. In field trials, the SUSV successfully towed the plow through 85 cm of unbonded snow in natural terrain.

INTRODUCTION

To make use of available wheeled vehicles, any snow cover in excess of about 15 cm must be removed or compacted. Since many roads and trails will not have been kept open prior to winter deployment, truck mounted plows will be ineffective. In most instances, slow moving heavy tracked vehicles are required to

plow deep snow. Light infantry units have only one type of vehicle capable of traveling in deep snow, the Small Unit Support Vehicle (SUSV).

A towed plow for the SUSV was proposed by CRREL engineers (Fig. 1). Initial tests of $1/12$ -scale models showed that pitch control problems (plow ride up or plunging) needed to be solved prior to constructing a full scale plow. A four-bar parallel linkage towing assembly was developed which bolted on to the SUSV's pintle hook mounting bracket and attached to the plow nose. This assembly effectively controls the pitch of an attached plow while allowing freedom in the roll direction. Additionally, the only modification to the SUSV is the removal of the pintle hook (four bolts).

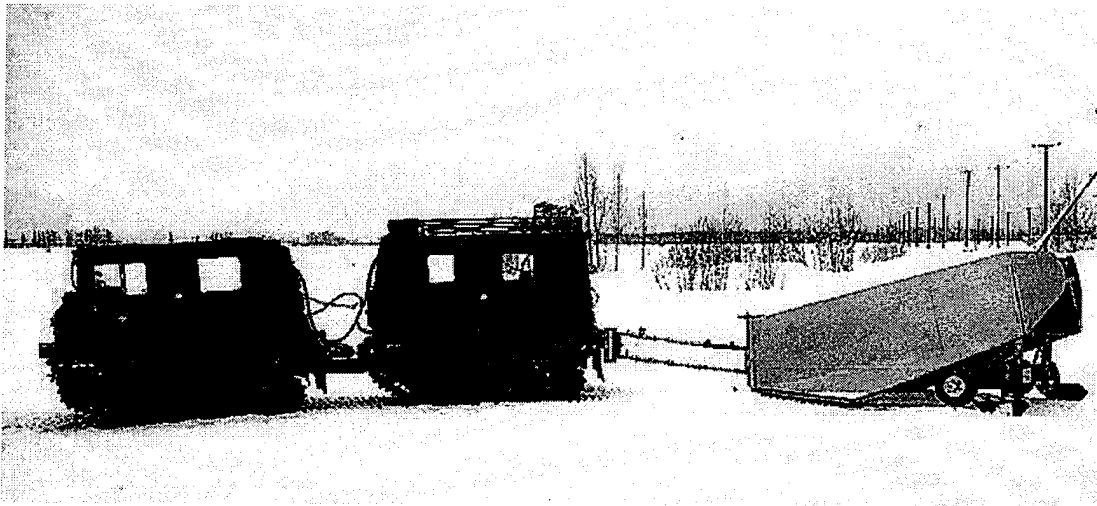

Figure 1: SUSV with plow at Ft. Wainwright

The plow is constructed primarily of aluminum. It has three plowing widths with the narrowest width allowing for over-the-road and helicopter (CH-47) transport. A tow bar that contains a pintle eye can replace the four-bar linkage so that the plow can be moved over the road by any vehicle equipped with a pintle hook. Provision had been made for quick attachment of a pintle hook to the towing SUSV.

In the winter of 1992, a SUSV successfully towed the plow through deep (maximum depth of 85 cm) unbonded snow, creating in one pass a path wide enough for a wheeled vehicle. In hard, dense, wind-blown snow, several passes were required to open a trail. No major failures occurred, although some minor problems were identified and addressed.

PLOW CHARACTERISTICS

The plow is constructed primarily of welded aluminum with steel cutting edges. A layer of ultra-high molecular weight polyethylene covers the plowing surfaces. The plow is designed to ride on three points: a front skid and two rear wheels. Three plowing widths are available: 2.1 m (fully closed), 3.1 m (half open) and 4.1 m (fully opened). These widths correspond to opening angles of 30°, 45° and 60°. They are obtained by spreading the wings using a manually operated rack and pinion spreader mechanism (Figure 2). The maximum plowed path width in one meter of snow is 2.4 m. Wing extensions (ears) fold in to facilitate shipping and reduce width for over-the-road transport or plowing in wooded areas. The plow weighs about 910 kg.

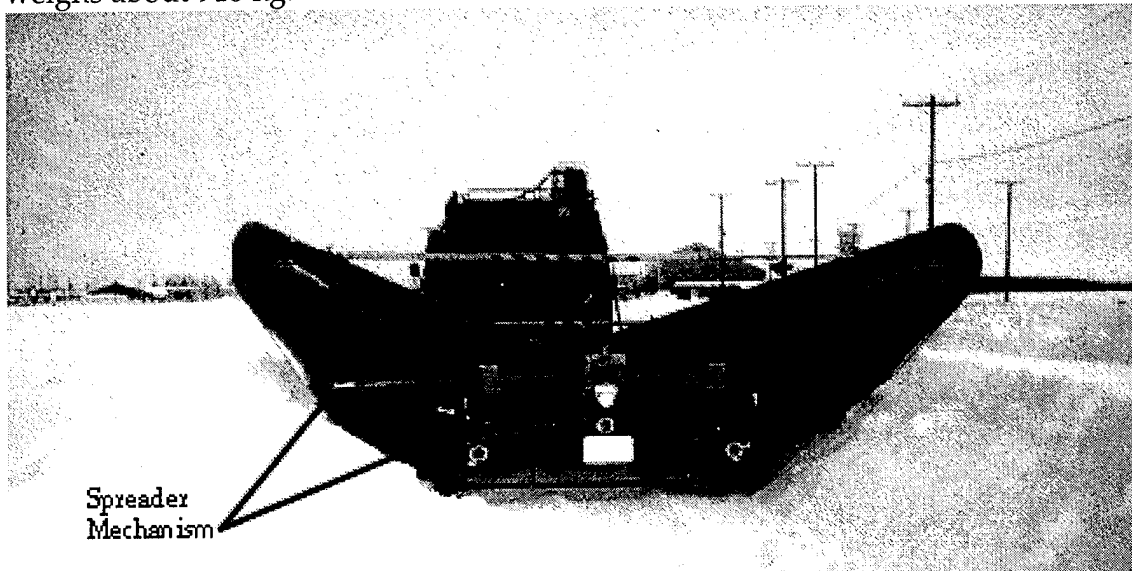

Figure 2: Rear of plow showing spreader mechanism

The four-bar linkage consists of a plow link, tractor link and upper and lower tow links. The plow link is attached to a rod on which the plow can pivot. This pivot is locked during transport. The plow link has two clevis points spaced 30.5 cm apart to which the tow links are attached. The tow links are 1.75 m in length, and have a spring-loaded takeup to allow the plow to ride over obstacles up to 16 cm in height without overstressing the mechanism. The plow links are attached to the tractor link similarly, with the same spacing between clevis points. The tractor link is bolted to the SUSV's pintle mounting bracket, and pivots in the vertical axis (yaw) and rotates in the axis of the SUSV (roll). A shear pin in the tractor link will fail at

41 kN, which is below the maximum measured drawbar capacity (44.5 kN) of the SUSV on snow.

FIELD TESTS

Field tests of the plow were performed between 13 February and 26 February 1992. These tests were conducted primarily at Fort Wainwright, Alaska. On 24 February, the plow was towed to Fort Greely, Alaska, for two days of testing. The objectives of these tests were to determine plowing capabilities of the SUSV, reliability of the plow hitch assemblies, and to identify any operational problems of the current design.

Four test areas were used at Fort Wainwright. Three relatively flat areas were the shop field, airport field, and the Tanana River firing range. They were primarily covered with undisturbed snow, although a ridge of blown snow was encountered at the airport field, and several plowed access roads were crossed at the firing range. The fourth area, Chena field, contained a depression with a 20% slope and had been subjected to extensive snowmobile traffic. In general, the undisturbed snow was 60 to 90 cm deep and not well bonded. Table 1 contains a summary of the snow data obtained during the test. More detailed data and test results are reported in Richmond and Walsh (1994).

Table 1. Summary of average snow conditions.

	<i>Date (1992)</i>	<i>Pit (number)</i>	<i>Depth (cm)</i>	<i>Avg. density (g/cm³)</i>
Ft. Wainwright				
Shop field				
	13 Feb	1	67.5	0.295
	13 Feb	2	71.5	0.189
	13 Feb	4	65.0	0.192
	14 Feb	1	67.0	0.192
	14 Feb	2	68.0	0.179
	14 Feb	3	70.0	0.186
	15 Feb	1	67.0	0.202
Chena field				
	20 Feb	1	70.0	0.205
Airport area				
	22 Feb	1	69.0	0.220
Ft. Greely				
Drop zone				
	24 Feb	1	78.0	0.379
Bolio Lake				
	25 Feb	1	62.0	0.294

Three test areas were utilized at Fort Greely. The snow cover varied from 0 to 120 cm and the snow was wind blown and very hard packed. Snow drifts were hard and dense enough so that in many places the SUSV did not break the surface, and at high speeds (> 8 kph) the plow did not dig into the snow on the first pass.

Over-the-road tests were informal and occurred when moving from one test area to another or from the shop to a test area. Additionally, the plow was towed from Fort Wainwright to Fort Greely (350 km round trip) using a Chevrolet Suburban. Otherwise, all towing occurred with the SUSV.

A set of measuring and recording instruments were installed in the rear unit of the SUSV used at Ft. Wainwright so that various vehicle and plowing parameters could be recorded. A detailed description of the instrumentation is reported in Walsh and Richmond (1992) and Osborne (1991). Table 2 presents a list of the parameters measured and the measuring devices used in these tests. The analog data was multiplexed and digitized using a data acquisition system controlled by a laptop computer. Data analysis was done at CRREL in Fairbanks, AK, and Hanover, NH.

Table 2. Test instrumentation.

<i>Parameter</i>	<i>Device</i>	<i>Location</i>
Drawbar force	Load cells, 44.8 kN cap	Top and bottom tow links
Tilt	Electronic clinometer, $\pm 60^\circ$	Interior of rear SUSV unit and top tow link
SUSV speed	Ultra-sonic speed sensor	Front of SUSV, with digital display for driver and input to digital counter in DAS

PLOW PERFORMANCE

Plow performance can be interpreted a number of ways. In this section we describe performance by reporting the forces required to pull the plow through snow and difficulties encountered in plow operation. Initial tests were conducted using narrow (1.25 cm) steel skids as the rear supports. These quickly proved inadequate and were removed. Further tests were conducted using the wheels as the rear supports.

Towing forces were analyzed by determining the horizontal and vertical components of force in each of the towing links and summing the component values for both links. The angle measured by the tilt sensor on the top link was used to determine the components. For comparison between tests, ignoring the SUSV angle affects only those tests on significant slopes. Almost all the tests were

conducted on level terrain. The horizontal and vertical component values represent the towing resistance and tongue load to the SUSV, respectively.

As space is limited, only one series of tests, those conducted at the Tanana River firing range, will be discussed in any detail. This was a fairly representative series of tests. All tests were conducted by SGT David Dillingham of the CRREL Alaska Projects Office on Ft. Wainwright. Although SGT Dillingham had experience driving a SUSV, he had never driven the vehicle with the plow attached until the day of the test.

The snow at the firing range was primarily undisturbed except for plowed access paths located about every 0.2 km leading to targets. These paths were perpendicular to the path plowed during the tests, and the banks, about 1.5 m in height, had to be climbed by the SUSV and plowed. A total of five access paths were crossed during each traverse. The terrain under the snow was rough and contained bulldozed brush as well as stumps and logs. The recorded data showed no large forces on the plow, although forces were not recorded during the entire time snow was being plowed. Plowing was done in the fully open position and some damage to the plow occurred. Plowing was generally done in low range, second gear at a speed of about 9 kph. The damage that occurred consisted of a broken weld where the left wing is attached to the pivot for opening and closing the plow. A summary of the measured forces for this series of tests is given in Table 3.

Table 3. Data summary of SUSV plow tests at Tanana River firing range.

<i>Horiz. forces (kN)</i>		<i>Vert. forces (kN)</i>		<i>Velocity (kph)</i>
<i>Max.</i>	<i>Avg.</i>	<i>Max.</i>	<i>Avg.</i>	
14.2	-7.2	4.6	2.0	0-8.0
18.1	-9.5	5.9	2.8	0-8.3
11.6	-5.8	2.8	1.6	5.1

The SUSV has about 44.5 kN of available drawbar pull in shallow snow (minimal resistance). In one test, prior to using wheels at the rear corners of the plow, a drawbar force approaching 26 kN was experienced on flat ground before the SUSV spun to a halt in 80 cm of snow. The resistance posed by deep snow in front of the SUSV and any slope which must be climbed will reduce this value. The resistance due to snow and slopes was not measured so it was not possible to determine what tractive reserve was available to the SUSV during the tests. Calculated tractive values are presented in Richmond and Walsh (1994) and Murrell and Shumate (1989).

SUMMARY

Plowing Capabilities Overall performance of the plow in unbonded snow conditions is quite good; crossing hardened snow banks and breaking out of previously plowed paths does not create an obstacle for the plow. Under normal plowing conditions at Ft. Wainwright, plowing required about 20% of the available drawbar. Climbing a moderate slope will likely require two passes, one with the plow half open and one fully open. Plow capabilities in hard dense snow are more limited. Multiple passes at half width will be necessary in the worst conditions. A device (such as a rake or ripper) for breaking up the snow before plowing may be necessary to enable efficient use of the plow in these conditions.



Figure 3: Plowed path up hill in hard, dense snow (Ft. Greely)

Driver Experience Driver experience is a critical factor when attempting to plow in difficult conditions, and trails should be scouted before attempting to plow them. However, in conditions the plow is designed to operate, minimal operator training is necessary.

Failures And Repairs A number of components failed or were damaged during field tests. The one outright failure, that of a mild steel shear pin in the tractor link, was actually encouraging as it proved that the shear pin load limiting concept worked. It should be noted that the pin that failed was much weaker than the pins used throughout the rest of the tests, and that no further failures occurred. A number of welds cracked during testing, but again, none halted testing, and these were repaired after testing concluded on the days they occurred.

Conclusions The most significant conclusion that can be drawn from the tests is that the concept of pulling a V-shaped plow behind a SUSV is feasible. For areas where plowing is difficult (slopes and hard dense snow) techniques and procedures need to be developed further. Several plow mechanisms, subsequent to these tests, have been redesigned and strengthened. These are discussed by Richmond and Walsh (1992).

The SUSV drag plow is a viable concept which will greatly facilitate winter logistics operations. Design and initial development processes have been completed at CRREL, and the system has been turned over to TACOM for final development and field deployment. Interest in the drag plow has been expressed by the Canadian Army and Hagglunds, the Swedish manufacturer of the SUSV. The plow has a US Government patent (No. 5,245,771), and patents are pending in Canada and Sweden.

LITERATURE CITED

- Osborne, M. (1991) Evaluation of the Micro-Trak Trak -Star ultrasonic speed sensor. Keweenaw Research Center, Calumet, Michigan.
- Murrell, D., and A. Shumate (1989) Addendum to comparison test in Alaska of over snow mobility systems for the M101A1/M119 towed howitzer. USA Cold Regions Test Center, APO Seattle, WA.
- Richmond, P.W. and M.R. Walsh (1994.) Design and evaluation of a towed snow plow for the small unit support vehicle (SUSV). USA Cold Regions Research and Engineering Laboratory, Hanover New Hampshire, CRREL Report 94-10
- Walsh M.R. and R.W. Richmond (1992) A low speed drag plow for use in deep snow. USA Cold Regions Research and Engineering Laboratory, Hanover, New Hampshire, CRREL Report 92-19.

**MEDICAL RESEARCH FOR
COLD WEATHER MILITARY OPERATIONS**

A. J. Young, Ph.D.
M. N. Sawka, Ph.D.
Thermal Physiology & Medicine Division
U.S. Army Research Institute of Environmental Medicine (USARIEM)
Natick, MA

MEDICAL RESEARCH FOR COLD WEATHER MILITARY OPERATIONS

A.J. Young, Ph.D. and M.N. Sawka, Ph.D.

Thermal Physiology & Medicine Division,
US Army Research Institute of Environmental Medicine
Natick, MA 01760-5007

INTRODUCTION

The US Army maintains deployment readiness to support world-wide strategic or humanitarian objectives. Cold injuries are not limited to Alaska and other circumpolar regions. In World War II, average air temperature when cold injuries occurred was 30 °F. Over 60% of the earth's land experiences January lows below 32°F, and, over 25% of the land experiences January lows below 0°F. These regions include Korea and other parts of Asia, Europe, the former Soviet states, North and South America, the Balkans, Pakistan, and India, to name but a few. Even the deserts of Africa and Southwest Asia occasionally experience near-freezing temperatures. Temperatures normally considered moderate (say 40-50 °F) can result in serious cold stress, if conditions are rainy and windy.

Cold injury degrades fighting strength. American forces experienced over 90,000 cold injuries during World War II, and 10,000 more during the Korean War. Cold injuries represented about 10% of total wounded in these wars, and resulted in 7,500,000 man days lost from combat, the equivalent of a division lost from combat for 17 months. The British evacuated 495 cold injuries (4.7% of force) from the Falklands. Cold injuries are not limited to war. During 1986 in Norway, 5% of the British force experienced cold injuries (1.5% frostbite). During exercises at Wildflecken, Germany, a battalion sized U.S. unit experienced 30 cold injuries in October 1992. In January 1993, a battalion exercising at Fort Chafe, Arkansas, experienced 60 cold injuries. Most recently, February 1995, four Rangers died apparently from hypothermia during swamp training in Florida.

HISTORY OF MILITARY CLIMATIC MEDICINE RESEARCH

The United States Army Research Institute of Environmental Medicine (USARIEM) was established in 1961 (2). USARIEM was founded as a composite of elements from former medical (Armored Medical Research Laboratory; AMRL, Ft. Knox, KY) and quartermaster (Climatic Research Laboratory; CRL, Lawrence, MA) laboratories. USARIEM was based upon the realization that both medical and clothing research should be collocated and integrated to maximize scientific return for the government's financial investment.

An important predecessor of USARIEM was the Harvard Fatigue Laboratory, at Cambridge, MA, a civilian laboratory that studied climatic problems encountered by Armed Service personnel during the First and Second World Wars (5). This laboratory pioneered the use a multidisciplinary (physiology, biochemistry, medicine, psychology) approach to study human adaptations and work capabilities at environmental extremes which USARIEM investigators

continue to employ. The Harvard Fatigue Laboratory made many important well-chronicled contributions to the war effort. After the Second World War ended, Harvard University discontinued conducting these expensive investigations. Both AMRL and CRL are considered to be descendants of the Harvard Fatigue Laboratory.

USARIEM RESOURCES

Today, USARIEM has by far the largest group of human environmental scientists located at any single institution in the world. USARIEM scientists are internationally recognized for their scientific accomplishments (7). Collectively, USARIEM has more than 1,600 scientific publications in environmental - exercise biology. This intellectual reserve combined with excellent research facilities enable USARIEM to rapidly respond to unanticipated DOD tasking. For example, during Operation Desert Shield/Storm, USARIEM conducted six tasked studies, answered 13 formal information requests, and wrote several guidance documents. Recently, USARIEM has provided written guidance for deployment to cold weather regions (1,13) in the former Yugoslavia (6).

Integration of USARIEM with US Army Natick Research, Development and Engineering Center (USANRDEC) staff provides unequalled knowledge and technical expertise in clothing systems, thermal biophysics, biomedical engineering, biophysical mathematical modeling (10,11). This consolidation of technical staff at Natick, provides an exemplary Center of Excellence. For example, Project Reliance has transferred all USAF heat stress physiology to USARIEM. Although individual universities and laboratories throughout the world might be called upon for limited problems, the special requirement of a critical mass of scientific expertise for rapid information access in time of need can only be fulfilled by scientists collocated and doing research at Natick.

Developers of military equipment (e.g. Project Manager Soldier Systems) and medical products (e.g. US Army Medical Materiel Development Activity) are dependent upon USARIEM/USANRDEC to help them minimize the thermal strain imposed by their products. Likewise, Army Center for Health Promotion and Preventative Medicine (CHPPM) is dependent upon USARIEM to perform Health Hazard Assessments for thermal stress on the NRDEC products and clothing systems. Numerous sophisticated clothing evaluation/thermal modeling efforts fulfilled for the Tri-Services provide very cost-effective benefits to the government.

Physical Facilities

Climatic Chambers: USARIEM has state-of-the art climatic control chambers for human and animal experimentation. Within the past five years, 5 of these climatic chambers have undergone complete renovation. To conduct research, scientists have 13 climatic chambers (-10° C to +50° C), one water immersion laboratory (+5° C to +45° C; 36,000 liters) and two hypobaric chambers (-35° C to +43° C; to 9,000 meters). Included is the only human-rated hypobaric chamber facility in the U.S. capable of controlling both altitude and thermal conditions, which allows the study of cold and altitude as they naturally occur (8). In addition, this hypobaric facility is the only one in the world that

can simulate conditions of barometric pressure and ambient temperature and dewpoint for elevations as high as Mt Everest (8,848 meters, 29,000 feet). High altitude research is transitioned from the USARIEM hypobaric chambers to the John Maher Pikes Peak Laboratory (14,000 feet). Another, climatic chamber at USARIEM can be used to rapidly change climatic conditions (ramps) which is useful for specific clothing and physiological studies.

Doriot Climatic Chamber Facility USARIEM scientists have access to the USANRDEC Doriot Climatic Chambers Facility which has been declared as a "National Treasure" by the U S Congress. These are the largest human research rated climatic chambers in the world. A 20 million dollar renovation of these facilities is now being completed, and when finished this facility will be worth an estimated 45 million dollars. Within this complex there are two large chambers [15 x 66 feet] that can simultaneously house 12 subjects living at simulated hot or cold extremes for indefinite periods. In addition, there are two other smaller climatic chambers. Within this complex climatic conditions can be precisely controlled -57° to +74°C with winds from 0.5 to 40 mph) and cannot be duplicated anywhere else in the United States. USARIEM uses these facilities to conduct its own medical mission as well as to support clothing developers from NRDEC and the other two services. USARIEM scientists account for ~ 75% of the use of this complex.

BIOMEDICAL RESEARCH

Human body temperature reflects the sum of gains or losses of heat by means of metabolic production, radiation, conduction/convection and evaporation. In the cold, heat tends to flow from the body. When heat loss exceeds the body's ability to produce and conserve heat, body temperature falls. Ultimately, cold injuries develop if this condition does not resolve.

Modern cold weather clothing provides substantial protection from the cold when worn correctly. Research continues to develop new technology requiring test and evaluation (10). In addition, the human thermoregulatory system can increase production of body heat and better conserve that heat within the body. Research to optimize the body's thermoregulatory defenses against cold continues. Methods may include advances in physical training (14,15) and cold acclimatization procedures (12) to enhance physical performance in cold environments. Other research approaches include the effects of altered nutritional (3,4) and medication (9) status on cold tolerance and injury susceptibility.

One topic of potential impact concerns identification of individuals with high susceptibility to cold injury. Medical risk factors for cold injury need further elucidation. Current research focuses on the role of dehydration for cold injuries, and development of hydration strategies to avoid dehydration during cold weather operations. Inquires from commanders and unit medical officers point to the need for a simple test of an individual's susceptibility to cold injury. Research will attempt to address this requirement so that susceptible individuals can be identified and steps taken to reduce their susceptibility.

FUTURE RESEARCH PLANNED FOR USARIEM'S HUMAN COLD STRESS PROGRAM

FY95 Plans:

- * Determine effects of dehydration on thermoregulation in cold.
- * Characterize mechanisms by which glycerol produces hyperhydration in cold and hot climates.
- * Determine if glycerol hyperhydration alters thermoregulatory responses to resting cold air exposure.
- * Describe epidemiological injury and illness trends for 4 companies of soldiers stationed at Arctic latitudes over a 3 year period.

FY96 Plans:

- * Determine if human cold acclimation can be induced by accelerating body heat loss but maintaining core temperature.
- * Determine if digit cold induced vasodilation responses vary with changes in core temperature.
- * Determine glycerol hyperhydration effectiveness during exercise in cold.

FY97 Plans:

- * Determine hypoxia effects on thermoregulation in cold.
- * Evaluate efficacy of glycerol hyperhydration during cold weather field operations.
- * Characterize the energetics of shivering using magnetic resonance spectroscopy.
- * Examine effects of sleep loss on thermoregulation in cold.
- * Develop test to screen for susceptibility to peripheral cold injury.
- * Delineate the relationship between Angiotensin-Converting Enzyme Genotype and susceptibility to peripheral cold injury.

REFERENCES

1. Burr, R.E. Medical Aspects of Cold Weather Operations: A Handbook for Medical Officers. Technical Note 93-4, U.S. Army Research Institute of Environmental Medicine, Natick, MA, April 1992.
2. Francesconi, R.P., R. Byrom and M. Mager. United States Army Research Institute of Environmental Medicine: First Quarter Century. The Physiologist. 29:58-62, 1986.
3. Freund, B.J., C. O'Brien and A.J. Young. Alcohol ingestion and temperature regulation during cold exposure. Journal of Wilderness Medicine. 5:88-98, 1994.
4. Freund, B.J. and M.N. Sawka. Human Fluid Balance and Dehydration During Cold Weather Military Operations. Technical Note No. T95/4, U.S. Army Research Institute of Environmental Medicine, Natick, MA. 1995.
5. Horvath, S.M. and E.C. Horvath. The Harvard Fatigue Laboratory: Its History and Contributions. Englewood Cliffs: Prentice-Hall. 1973 (182 pages).
6. Jones, B.H., P.B. Rock, M.N. Sawka, H.E. Modrow, G.C. Linsay, B. Petruccelli, M.Z. Mays, M.A. O'Mara and G.P. Krueger. Sustaining Soldier Health and Performance in The Former Republic of Yugoslavia: Guidance for Small Unit Leaders. Technical Note No. TN 93-6, U.S. Army Research Institute of Environmental Medicine, Natick, MA. 1993.
7. Pandolf, K.B., M.N. Sawka and R.R. Gonzalez, eds., Human Performance Physiology and Environmental Medicine at Terrestrial Extremes. Indianapolis, IN.: Benchmark Press, 1988. (637 pages)
8. Pandolf, K.B. and A.J. Young. Altitude and Cold. Heart Disease and Rehabilitation. 3rd Edition, M.L. Pollock and D.H. Schmidt (Eds.). Human Kinetics Publishers, Inc., Champaign, IL, pp. 309-326, 1995.
9. Roberts, D.E., M.N. Sawka, B.J. Freund and A.J. Young. Effects of Multiple-Dose Pyridostigmine Bromide on Human Thermoregulation during Exercise in Cold Air. Canadian Journal of Physiology and Pharmacology. 72:788-793, 1994.
10. Santee, W.R., L.A. Blanchard, S.K.W. Chang and R.R. Gonzalez. Biophysical Model for Handwear Insulation Testing. Technical Report T7-93, U.S. Army Research Institute of Environmental Medicine, Natick, MA, March 1993.
11. Shitzer, A., L.A. Stroschein, P. Vital, R.R. Gonzalez and K.B. Pandolf. Numerical Analysis of an Extremity in a Cold Environment Including Counter-Current Arterio-Venous Heat Exchange. Advances in Heat and Mass Transfer in Biological Systems, HTD-Vol.288. L.J. Hayes and R.B. Roemer (Eds.) New York: The American Society of Mechanical Engineers, 1994, pp.25-36.
12. Young, A.J. Homeostatic responses to prolonged cold exposure: Human cold acclimatization. Technical Report T94-11, U.S. Army Research Institute of Environmental Medicine, Natick, MA, September 1994.

13. Young, A.J., D.E. Roberts, D.P. Scott, J.E. Cook, M.Z. Mays and E.W. Askew. Sustaining Health and Performance in the Cold: A Pocket Guide to Environmental Medicine Aspects of Cold-Weather Operations. Technical Note 93-2, U.S. Army Research Institute of Environmental Medicine, Natick, MA, December 1992.
14. Young, A.J., M.N. Sawka, L. Levine, P.W. Burgoon, W.A. Latzka, R.R. Gonzalez and K.B. Pandolf. Metabolic and Thermal Adaptations to Endurance Training in Hot or Cold Water. Journal of Applied Physiology. 78:(In Press), 1995.
15. Young, A.J., M.N. Sawka, M.D. Quigley, B.S. Cadarette, P.D. Neuffer, R.C. Dennis and C.R. Valeri. Role of thermal factors on aerobic capacity improvements with endurance training. Journal of Applied Physiology. 75: 49-54, 1993.

BASIC RESEARCH AND COLD WEATHER OPERATIONS

George D. Ashton
Cold Regions Research & Engineering Laboratory
Hanover, NH

Russell S. Harmon
Engineering & Environmental Sciences Division
Army Research Office
Research Triangle Park, NC

BASIC RESEARCH AND COLD WEATHER OPERATIONS

by

George D. Ashton and Russell S. Harmon

ABSTRACT

The Army invests in basic research in cold regions via two main channels: the research program conducted by the U.S. Army Cold Regions Research and Engineering Laboratory (CRREL) at Hanover, NH; and as part of the Terrestrial Sciences research program administered by the Army Research Office (ARO) in Research Triangle Park, NC, which funds extramural research, chiefly at universities. These two programs are complementary to each other and have a common objective: to improve the Army's ability to deal with problems posed by cold weather and winter conditions. The current basic research programs are briefly described and the significance of the work related to current cold weather operations.

BASIC RESEARCH DEFINITION AND PHILOSOPHY

Basic research is one of six categories of the RDTE (Research Development Test & Evaluation) Program. Basic research is defined by AR 37-112 as "includes experimentation and scientific study in the physical, biological, and behavioral sciences. Such research is necessary to increase knowledge and understanding of science as related to national security needs. This research provides part of the scientific-technological base for later development." This is the formal definition of basic research. We further supplement this by taking the view that such research has the purpose of creating new knowledge in the sense of: "What happens and why?", "How does it happen?", and "What are the consequences?"

The need for basic research in cold region processes stems from the impact that environment has upon many different aspects of Army activities. As military technology becomes ever more complex and sophisticated, both systems and operations are increasingly influenced by the variability in natural environmental conditions. Despite continuing Army efforts to develop an all-weather/all-terrain capability, environmental conditions still constrain Army operations. In this context, special attention needs to be given to climatic extremes and adverse environments where the overall performance of systems and activities are severely restricted and the cost of full performance may be excessive. Greater knowledge and capabilities in these areas can generate large returns on investment. Thus, CRREL and ARO invest in basic research that is aimed at understanding cold climate environments and processes at a fundamental level and developing capabilities to make simulations

and predictions that will lead directly to enhanced Army systems and operational capabilities, as well as placing the Army in a position to take advantage of potential environmental weakness in adversary systems.

Applied research and exploratory development is the second of the six categories and "includes all efforts directed to solving specific military problems short of major development efforts." This paper does not specifically address applied research, but it is important, for the discussion that follows, to draw the distinction between "basic" and "applied" research. There are those who would claim that because of the "specific problem" nature of applied research, that basic research need not be relevant to specific problems, and, therefore, that researchers in this arena should be unconstrained and entirely free to pursue their scientific curiosity. We do not hold this view. Because the research undertaken by CRREL or sponsored by ARO is research on behalf of a specific client, namely the Army, it is essential that this investment be relevant to the mission of that client and directed toward basic research needs as currently perceived. For both CRREL and ARO, the basic research activity is intended to increase fundamental knowledge as well as seed scientific and far-reaching technological discovery which, at some time in the future, will enhance Army capabilities.

Note that the definition of basic research includes the word "...increase...knowledge and understanding". It is important to recognize that, at any point in time, there is a store of knowledge, partly in the form of scientific literature and partly in the form of information retained in the heads of individual researchers or research institutions, that is not broadly disseminated to the scientific community at large. Thus, we actively encourage participation in scientific meetings (workshops, symposia, conferences, etc.) and the timely publication of research results as an important means for the timely and wide dissemination and exchange of new knowledge and scientific information.

The complementary programs of ARO and CRREL deserve comment. The "in-house" program at CRREL provides a critical mass of research infrastructure, research staff, and effort intensively focusing with a short-term view on subjects directly related to current problems in cold regions research. Because CRREL is a mission-oriented research facility, it provides a knowledge base that can be readily energized and tapped on a short time frame when specific questions or problems arise that require a rapid response. By contrast, the ARO "extramural" basic research program provides a diffuse effort, with a long-range perspective, that is spread among many different universities and which has the dual advantages of the broad intellectual stimulation that characterizes the university setting and the opportunities for either highly specialized or

multidisciplinary approaches to a particular research problem. The CRREL and ARO approaches come together and are coordinated into a single, vertically integrated effort in two ways. First, the ARO extramural research program is developed and formulated through close discussion with Army laboratories. Secondly, CRREL and ARO review each other's programs on a periodic basis. This approach provides an effective means of achieving balance, direct knowledge transfer, and mutual stimulation. Within CRREL, it is important that the "in-house" basic research program be conducted in close proximity to the applied programs in the same general areas since that proximity provides a relevance that is too often lost when basic research is conducted separately. Conversely, the applied research efforts have ready access to those staff engaged in basic research, including extramural university research, since all the ARO-sponsored research efforts have one or more individuals within an Army laboratory who act as a point of contact for the project. At the minimum, this person will receive all project reports and publications, but may also choose to more closely follow progress and elect to visit an investigator during the course of the research effort. Such a situation promotes the rapid transfer of the research results into the Army.

SOME PAST SUCCESSES THAT NEEDED BASIC RESEARCH

Ripper Tooth Dozer Blade Attachment

Recently CRREL has designed and is demonstrating what appears to be a simple attachment that may be fastened to the blade of a dozer to excavate frozen earth. This is a very tough problem, particularly since frozen ground is very unlike other hard materials. Simply attaching a post to the front of the blade would not enable excavation. The success is due to having the shape of the cutter tooth appropriate to the properties of frozen ground, so that it will, in fact, dig in and rip up the frozen soil. That shape depends on a good understanding of the mechanics of cutting, which, in turn, depends on the nature of the material being cut. To properly design such a blade required first that we determined the mechanical properties of the frozen soil, its ductility, breaking behavior, and forces generated while doing the cutting.

Radial Tire Replacement for the "Lugged" Tire

The old "lugged" tire that we are so familiar with in WW II movies persisted for several decades, even though it had a lousy life duration (about 3000 miles) and really only worked in soft sand. It was thought that it should perform reasonably well in snow since snow was viewed as also being a granular material. In any case in the late 60's and early 70's CRREL was tasked to generate a mobility model for snow conditions. What was found was that the tire actually performed terribly and any number of available radial

tire configurations not only outperformed it, but also yielded higher mileage and were cheaper to produce. The "winter" tests eventually resulted in a recognition that these radial tires were better in almost all cases than the old "lugged" tires and they have been replaced throughout the Army system. How much was this worth? Count the vehicles in the Army and estimate it. Here the success did not come so much from a deliberate basic research effort, but rather from the recognition that those people knowledgeable in depth about winter material behavior (snow and frozen ground) could be expected to come up with a reasonable evaluation.

Smart Weapon Scene Generation

In the 70's our knowledge of snow largely consisted of characterizing it by the bulk properties of the snowpack, such as its overall density and depth. In the 70's it became clear that there were a great number of processes going on in the snowpack and that the snowpack evolved through the winter in response to those properties. Accordingly over the next decade or so, we explored how the snow evolves at a point in response to temperature and time. We then took these many processes and began to construct an overall model of the snowpack and now have a quite sophisticated model which is driven by the heat and mass transfer at its surfaces and yields its characteristics at later times. This model is still being improved but in the meantime has become the basis for generation of synthetic "scenes" which can then be used to explore the performance of smart weapons against a great variety of winter conditions; in fact, many more than we have time or funds to explore by actual field tests that would take years to observe. This "synthetic environment" then allows efficient evaluation of the tradeoffs and performance of smart weapon performance with greatly diminished field proof tests.

THE CRREL BASIC RESEARCH PROGRAM

The basic research program at CRREL is organized into four work packages: one each for the properties and processes of snow, ice, and frozen ground, and one to deal with energy propagation in systems in which more than one of these materials is present. Often, solution of the problems with these cold regions materials present starts from a base of knowledge that does not consider these materials and the cold aspects are simply "added on" to the behavior under warm conditions. Sometimes, however, solution of the cold situation requires more sophisticated analysis than is necessary for the "warm" equivalent situation. In these cases, the "warm" problem often becomes a simple subset of the more complicated "cold" problem.

SNOW PROPERTIES AND PROCESSES

The knowledge gaps which are being addressed here include determination of the dielectric properties of snow as a function of the liquid water content, studies of snow friction behavior, and the effects of impurities on snow processes. The relevance of this work derives from the importance of dielectric properties in the response of snow to radar sensing, the importance of friction on interactions of snow and material systems, and the persistence of NBC agents in snow. In particular, even small amounts of chemical impurities in snow may drastically affect its behavior.

ICE PROPERTIES AND PROCESSES

The knowledge gaps here center around remote detection of atmospheric icing conditions, the interrelation of mechanical and electromagnetic properties of ice, the failure of ice as a function of scale, and the evolution of the ice cover and its properties through the winter. The relevance of this work derives from the difficulty that atmospheric icing causes to air operations, particularly helicopters; the ability to remotely determine the carrying capacity of ice covers, and the use of the ice cover as either a barrier or denial tactic, and, of course the complex other interactions that occur when ice is present in the environment.

FROZEN GROUND PROPERTIES AND PROCESSES

The knowledge gaps here are the processes that cause transport of water to the freezing front when soil freezes and the effects of chemistry on that soil freezing. The relevance is to determining the forces and magnitude of frost heaving and the effects of freezing and thawing ground on mobility. This may lead to means of stabilizing thawing soils to improve mobility.

ENERGY PROPAGATION PROCESSES

The knowledge gaps here include a lack of understanding of the complex seismic-acoustic behavior of the air/snow/frozen ground/soil system, gaps in our understanding of the electromagnetic propagation in frozen soil and ice, melting snow processes that affect the snowpack behavior such as fingering of water fronts as they move through the snow pack, and the hydrologic response of the snow cover. The relevance is to such problems as smart mine performance in winter conditions, scene generation for winter conditions that enable evaluation of the performance of smart weapons, and runoff generation and effects on streamflows.

THE ARO BASIC RESEARCH PROGRAM

The cold climate basic research program executed by ARO is undertaken within the Terrestrial Sciences Program (TSP) of the Environmental Sciences Branch and is concerned with the impact of the natural environment on Army activities, ranging from mobility considerations to the management and stewardship of its installations. Presently, the primary focus of research interest for the TSP is in two broad fields: I. Hydrology and Surface Process Geomorphology and II. Snow, Ice, and Frozen Ground - although this bipartate focus and the specific topics emphasized within a particular field may shift from time to time. One long term goal of the ARO Environmental Sciences Branch, which ties together the individual Atmospheric and Terrestrial Sciences programs, is the integration of the meteorology, hydrology, and geomorphology. In particular, there is a need for the development of first-principle physical/chemical processes models, better technologies and methodologies for environmental characterization and remote sensing, and computer-based techniques for monitoring, modeling, and simulating the natural environment.

Snow, ice, and frozen ground are present either seasonally or continuously from the mid-latitudes poleward. Depending on particular conditions and equipment availability, these materials can hinder or enhance mobility. Particular research needs in this area include fundamental knowledge about the physical behavior and chemical properties of snow, ice, and frozen ground, a better understanding of processes leading to sorting by particle size and in the active layer of permafrost, and the acquisition of experimental data that will lead to the formulation of constitutive models as a function of crystal structure, temperature, loading rates, and time. Knowledge gained through this effort aids the Army in its operations in cold regions where it is often the sole presence.

Additionally, a continuous dynamic interaction takes place between solid earth materials and the most abundant fluids, water and air. The hydrology/geomorphology topic focuses on these interactions, which can profoundly affect the Army's strategy, mobility, logistics, and field operations. An improved understanding of the dynamic nature of the surface environment and its evolution through time, as well as military interaction with this environment, is essential for the continued development and improvement of Army operations and training activities. Vehicle-terrain interaction, the prediction of the response of fluvial systems to hydrologic and geomorphologic thresholds, terrain analysis and simulation, are examples of important topics of current research interest.

In the context of the Army's mission of environmental stewardship there is a need for basic research related to environmental quality. Concerns about possible environmental damage resulting from military activities - especially with respect to cold regions - requires improved techniques for site assessment, analysis, and remediation of contaminated sites. Important in this broad area are research which addresses the response of the physical landscape to modification, research which seeks to understand the fundamental nature of subsurface flow and mass transport (including first-principle-based modeling of pore liquid-soil/rock interaction, multiphase transport processes, and the issues of scale and heterogeneity effects in both porous and fractured media), and research into improved technologies for site characterization (including both remote-sensing/non-invasive and point-source sensor methodologies).

Current research projects in the cold climate are directed toward: (i) improving fundamental knowledge about the physical behavior and chemical properties of snow, ice, and frozen ground; (ii) a better understanding of processes leading to sorting by particle size and contaminant transport within the active layer of permafrost, and (iii) the acquisition of laboratory data that will lead to the formulation for materials under cold climate conditions of constitutive models as a function of crystal structure, temperature, loading rates, and time.

POSITIVE TEMPERATURE COEFFICIENT HANDWEAR AND FOOTWEAR HEATING SYSTEMS

M R H Clarke
Defence Clothing & Textiles Agency
Science & Technology Division
Ministry of Defence, United Kingdom

PAPER FOR PUBLICATION AT INTERNATIONAL CONFERENCE ON COLD
WEATHER MILITARY OPERATIONS

M R H CLARKE

1/2/95

POSITIVE TEMPERATURE COEFFICIENT HANDWEAR AND FOOTWEAR
HEATING SYSTEMS

ABSTRACT

Research is being carried out at the Science and Technology Division of the Defence Clothing and Textiles Agency to produce a portable, battery powered heating system for handwear and footwear. It is believed that heating of the extremities is sufficient to maintain performance and comfort at low temperatures (-20 deg C), provided the body core is protected by passive insulation. Hand and foot temperatures cannot be maintained by passive insulation alone because of their large surface area, which increases as more layers of insulation are added. In addition, heating of the extremities allows a reduction in the bulk of handwear and footwear, thereby improving tactility, dexterity and mobility.

The system being developed uses Positive Temperature Coefficient (PTC) polymer heating elements incorporated into gloves and insoles. The elements consist of a flexible polyester plastic film containing a carbon loaded conductive printing ink. These heaters are self regulating and can be powered by a battery carried on the wrist or ankle or by a vehicle power supply. Laboratory tests at -20 deg C have shown that the insoles can maintain a temperature of around 25 deg C, which is sufficient for thermal comfort. The hand heaters maintained a temperature of 15 deg C, which is too low to maintain thermal comfort and performance, and work is continuing to improve their design and performance. The power requirement of the heaters is around 6 watts, which would give an estimated battery duration of around 5 hours for a 150 g Lithium Sulphur Dioxide battery at -20 deg C.

Future work is planned following the modification of the hand heaters, to produce working prototype heated gloves and insoles for evaluation of performance, comfort and duration by cold chamber trials using human subjects.

INTRODUCTION

Research is being carried out at the Science and Technology Division of the Defence Clothing and Textiles Agency with the aim of producing a portable battery powered heating system for handwear and footwear, for use by service personnel in cold environments. The system could also be powered by vehicle power supplies, for example for use by tank crews or rapier missile operators.

Heating of the extremities is believed to be the best method of extending the length of time for which the performance of service personnel can be maintained at low temperatures, as it is well known that the extremities are the first parts of the body to

suffer from the effects of low temperatures (ref 1) and that the reduction in extremity skin temperature leads to reduced performance (ref 2). Passive insulation alone is insufficient to maintain the temperature of the extremities because of their large surface area, which increases as more layers of insulation are added (ref 3). The application of heat to the extremities, rather than the torso, is believed to be sufficient to maintain extremity temperature and performance, provided the torso is insulated sufficiently to prevent body cooling (ref 4), and has the advantage of reducing the power requirements by heating a smaller area and supplying the heat where it is most needed.

The use of an auxiliary heating system also has the potential to reduce the bulk of the handwear and footwear system necessary for cold operations. It is envisaged that the use of the heating system being developed would enable the serviceman to wear a heated glove of design similar to the Combat Soldier 1995 Combat glove (UK/SC/5405), rather than the current mk IV Arctic mitt inner (UK/SC/5316) and a heated insole inside the combat boot, removing the need for a thermal overboot (UK/SC/4579). The benefits of this reduction in bulk would be an increase in the wearer's tactility and dexterity with his hands, important for tasks such as firing and reloading weapons and operating electronic equipment, and increased mobility in footwear.

The third aim of the system would be to reduce the incidence of cold related injuries such as frostbite and non freezing cold injury which most often affect the extremities and can be prevented by maintaining extremity skin temperatures above the danger levels (ref 1).

THE POSITIVE TEMPERATURE COEFFICIENT (PTC) SYSTEM

The system being investigated at DCTA-S&TD uses Positive Temperature Coefficient (PTC) thin film polymer heating elements, produced by ITW Ltd (refs 5 and 6, slides 1 and 2). These consist of a pattern of conductive carbon loaded printing ink connected by a silver busbar encapsulated in a flexible polyester film. When connected to a power supply, in the form of either a battery or vehicle power supply the elements conduct electricity and heat up by resistive heating. The elements show positive temperature coefficient behaviour and at a certain temperature their resistance sharply increases therefore reducing the current flow and hence the heating effect. This means that the elements are self regulating and will not heat above the specific set temperature. This set temperature can be controlled by altering the composition of the ink used in the manufacture of the heaters.

The aim of these experiments was to test the PTC heating elements in laboratory conditions to demonstrate the temperatures that they reach and to provide an estimate of the power they use. This is important when selecting a battery power source. Although the experiment measures the temperature of the heaters and not the actual skin temperatures it does give a good idea of the temperatures that the heaters could achieve in use. The critical skin temperatures required are 21 deg C (comfort) and 15 deg C (cold) for the foot and 26 deg C (comfort) and 14 deg C (loss of dexterity) for the hand (ref 7).

EXPERIMENTAL METHOD

A PTC hand heater was tested as part of a glove and mitt assembly in order to provide a simulation of the situation in use. Four K type thermocouples were taped in position on a porcelain hand former ; on the back of the thumb, middle finger, palm and little finger, and connected to a Grant 1200 series Squirrel meter / logger. The PTC heater was lightly glued at the edges onto a glove inner, cotton interlock 5 finger sheath white (UK/SC/3354A) and this was placed over the hand former, making sure that the thermocouples were directly beneath the heater as much. A mitt, Arctic outer mk II (UK/SC/4706) was then placed over the heater and glove (slide 3).

The hand assembly was then placed in a cold chamber at $-20 (\pm 2)$ deg C and allowed to cool to below -15 deg C. The element was connected to a Metrix ITT stabilised power supply (model AX322) set to 6 volts and the temperature at each position was recorded every ten minutes for two and a half hours, until it reached a constant maximum value. The voltage and current used were recorded from the power supply every ten minutes and used to calculate the power used.

A PTC insole was tested inside a boot, again to provide thermal insulation to simulate in use conditions. Three type K thermocouples were taped onto the insole at the toe, mid foot and heel positions and the insole was placed inside a Boot, ski march (size 8 M) (UK/SC/4563). An Insole, plastic (fabric faced) (UK/SC/5012) was placed on top of the PTC insole and a wooden shoe last (size 39M) was placed inside the boot to simulate the space filled by the foot (slide 4). The boot was then placed inside the cold chamber at -20 deg C and allowed to cool to between 5 and 0 deg C. The heater was connected to the power supply set to 6.0 volts and the temperature recorded every ten minutes for four hours. The voltage and current were recorded from the power supply and used to calculate the power used by the element.

RESULTS

The graphs below show the temperatures recorded for the heaters. Figure 1 shows the PTC hand heater and Figure 2 the PTC insole. The power used by the elements stabilised at 6.3 watts for the hand heater and 5.7 watts for the insole.

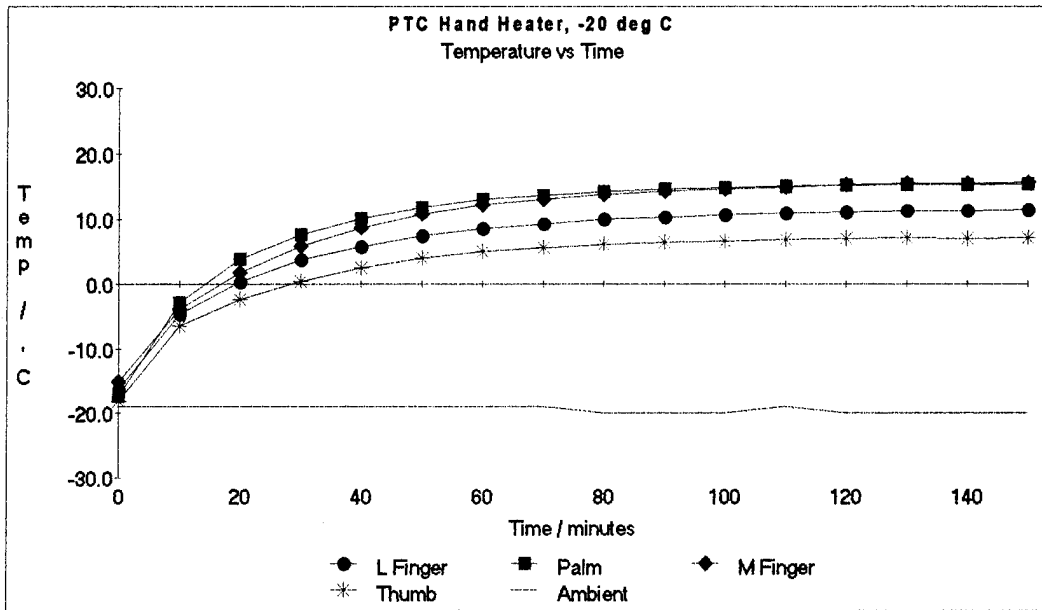

Figure 1. Temperature vs Time for PTC hand heater at - 20 deg C

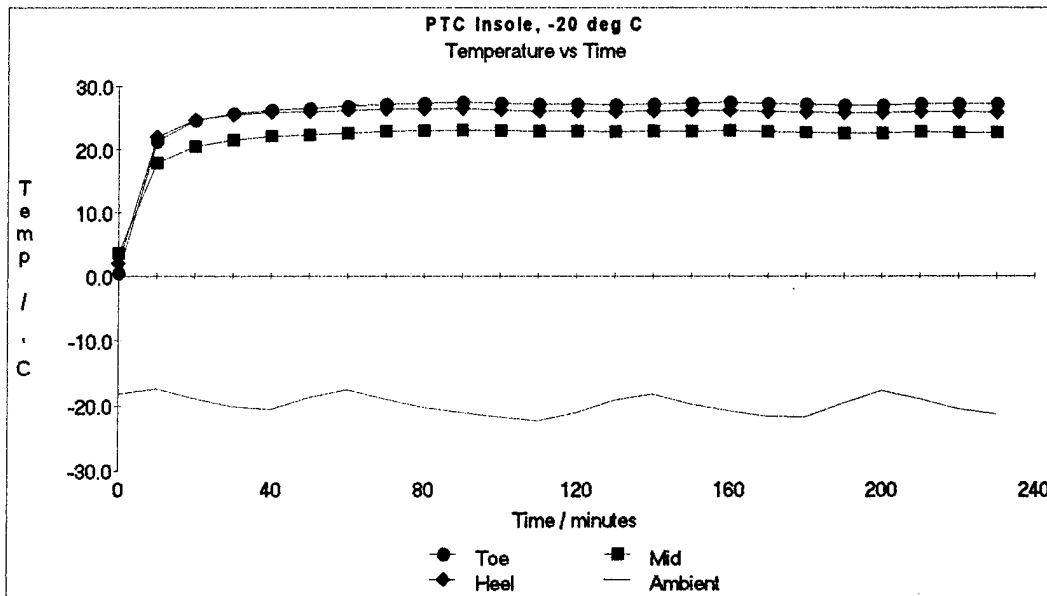

Figure 2. Temperature vs Time for PTC insole at - 20 deg C

DISCUSSION OF RESULTS

The PTC hand heater reached a maximum temperature of 15.4 deg C at the palm position and 15.6 deg C at the middle finger position but only 11.4 deg C at the little finger. This compares to the target hand skin temperature of 26 deg C for comfort and a minimum of 14 deg C to maintain finger dexterity. These results therefore

indicate that the heaters need to be modified to increase the maximum temperature by at least 5 deg C.

The thumb position was dangerously low with a maximum temperature of 7.2 deg C. This was due the physical design of the heating element which did not allow close enough contact between the heater and the hand former, and therefore indicates that the heaters will require redesign to provide better contact. In addition it is felt that the heaters need to be more flexible in order to maintain the comfort and dexterity of the wearer.

The PTC insole reached maximum temperatures of 27.5, 23.0 and 26.1 deg C at the toe, mid and heel positions respectively. These are all above the 21 deg C foot skin temperature required for comfort. The physical form of the element is believed to be suitable for incorporation into an insole such as the insole, plastic (fabric faced) (UK/SC/5012).

The table below shows the battery durations that would be expected based on the power requirements found above, assuming a single battery of 150 g for each element. Energy density values are based on the battery at -20 deg C (ref 5).

Battery type	Energy density at -20 deg C Wh / kg	Estimated duration of 150 g battery	
		Insole (5.7 W)	Hand Heater (6.3 W)
Alkaline Manganese	33	52 mins	47 mins
Nickel Cadmium (rechargeable)	19	30 mins	27 mins
Lithium Sulphur dioxide	221	5 hrs 49 mins	5 hrs 16 mins

Table 1. Estimation duration of 150 g battery at -20 deg C.

CONCLUSIONS

It has been shown that the PTC insoles have potential for use as heating elements in their present form, but that the hand heaters require some modification to increase their heating temperature and to improve the contact between the element and the user's hand. Following these modifications the elements will be lab tested under conditions which more closely simulate use in the field, using computer controlled thermal hand and foot models. The elements will then be made up into prototypes and a suitable battery selected, for testing by subjects in cold chamber experiments to determine their effectiveness at maintaining extremity function, the duration of exposure that is possible and their effects on the comfort and mobility of the wearers.

REFERENCES

1. Wilson, RA et al, "Whole body and bare hand cooling at high wind speeds" - Goodyear Aerospace Corporation Report No.AMRL-TR-70-39, September 1970
2. Fox, WF, "Human performance in the cold" - Human Factors, 1967, 9 (3), 203-220
3. Vanggaard, L, "Protection of the hands" - Proceedings 1983: Int conf on protective clothing systems, Stockholm, Sweden, 1981, 291-296
4. Haisman, MF, "Physiological aspects of electrically heated garments" - Ergonomics, 1988, vol 31, no 7, 1049-1063
5. Elton, SF, "Positive temperature coefficient electrically heated insoles - initial assessment" - SCRDE Technical Memorandum SCRDE/89/5, May 1989
6. Elton, SF & McMillan, M, "Positive temperature coefficient electrical hand and foot heaters - a continued assessment" - SCRDE Technical Report SCRDE/91/8, June 1991
7. Clarke, MRH, "Hand and footwear microclimate control devices literature survey" - SCRDE Technical Memorandum SCRDE/93/6, May 1993

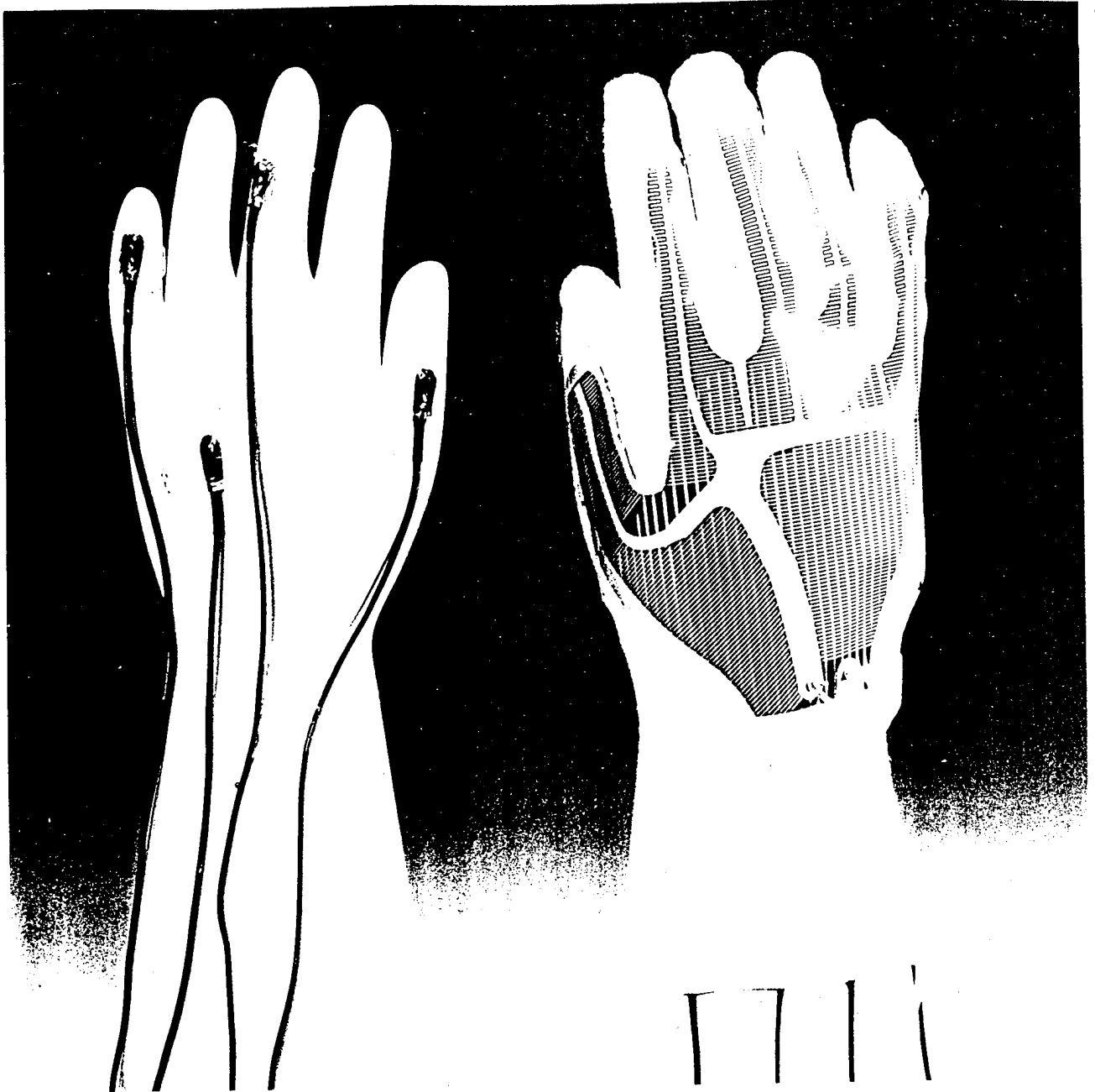

Slide 1... Positive Temperature Coefficient hand heater

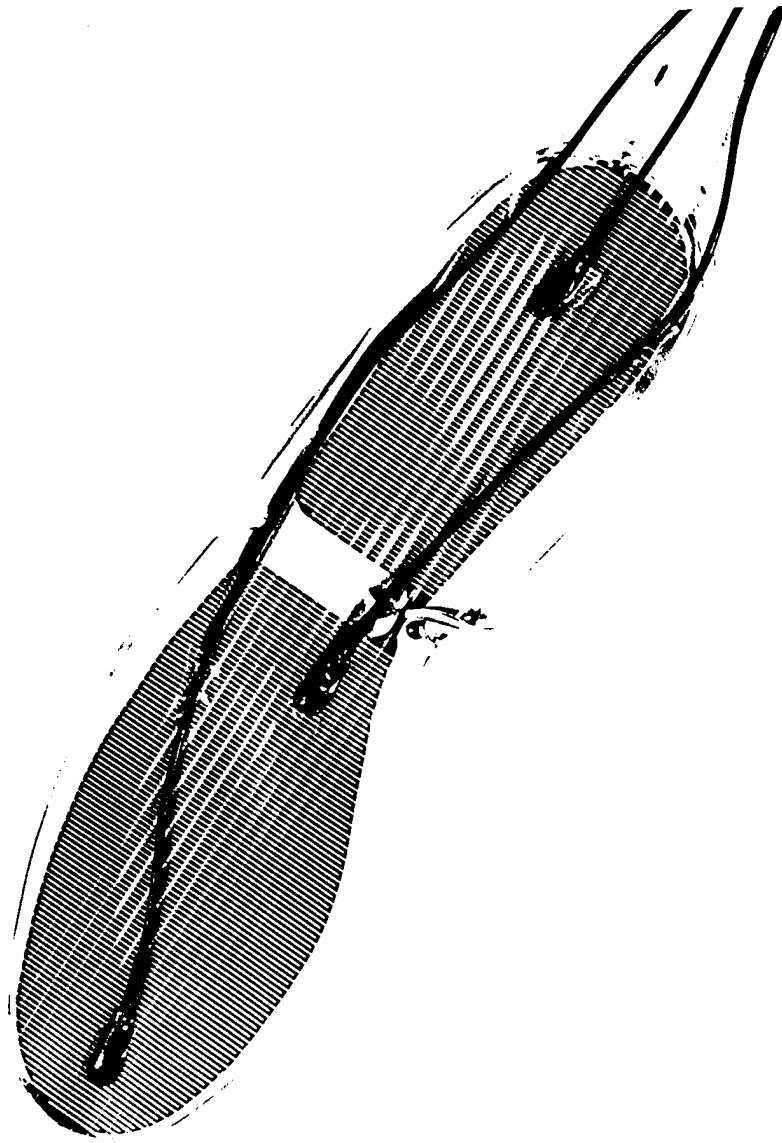

Slide 2. Positive Temperature Coefficient heated insole



Slide 3. PTC hand heater test apparatus

(Showing left to right . Grant 1200 series Squirrel meter / logger, porcelain hand former with type K thermocouples, mitt, Arctic outer, Metrix ITT power supply and PTC hand heater on glove inner)

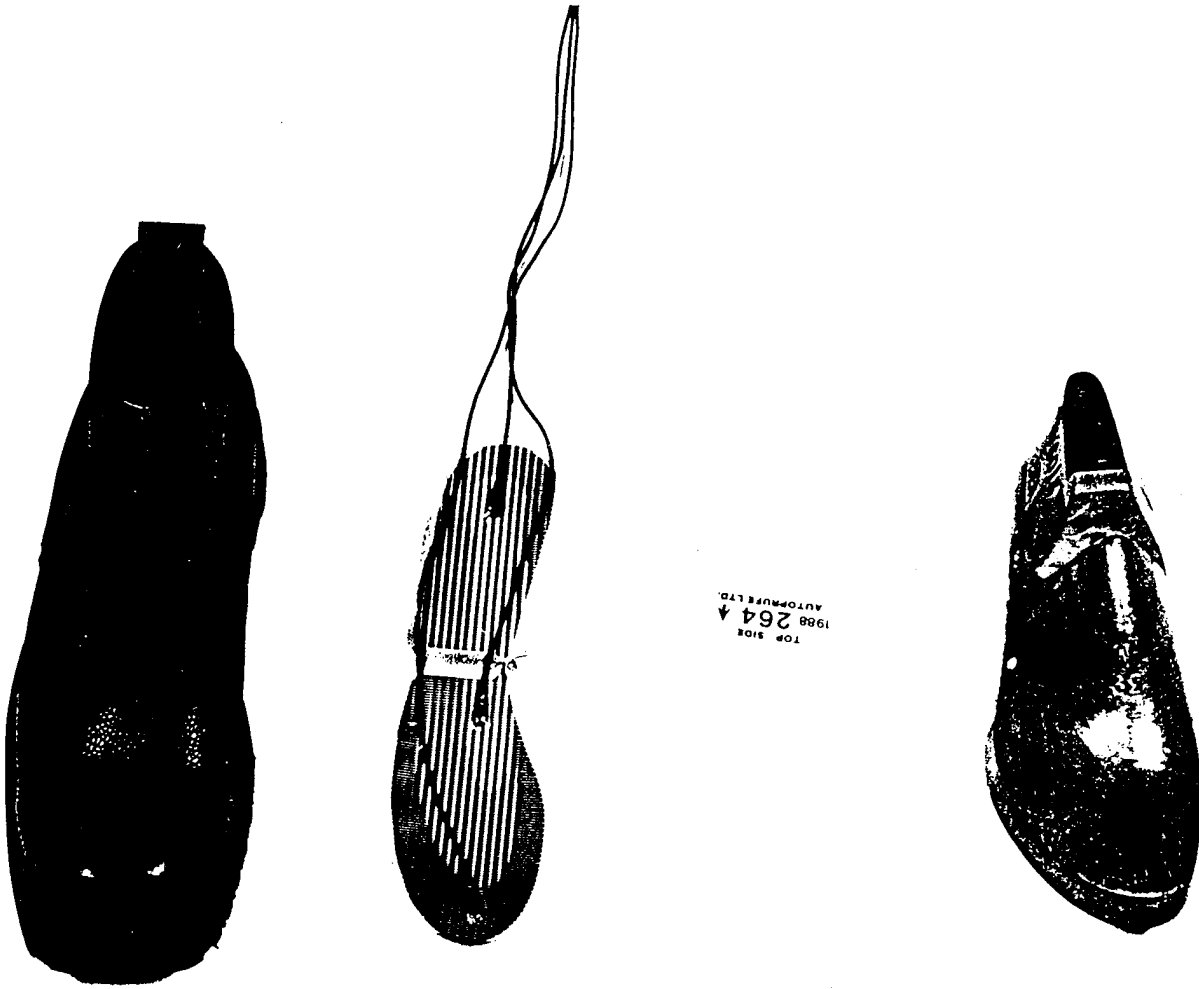

Slide 4. PTC insole in boot, ski march, components

(Showing left to right : Boot ski march, PTC insole with type K thermocouples, insole plastic fabric faced, and wooden shoe last)



Slide 5. PTC insole test apparatus

(Showing left to right PTC insole in boot, ski march (slide 4), Grant 1200 series Squirrel meter logger and Metrix ITT power supply)

EXPERIMENTAL RESULTS

PTC HAND HEATER, -20 deg C

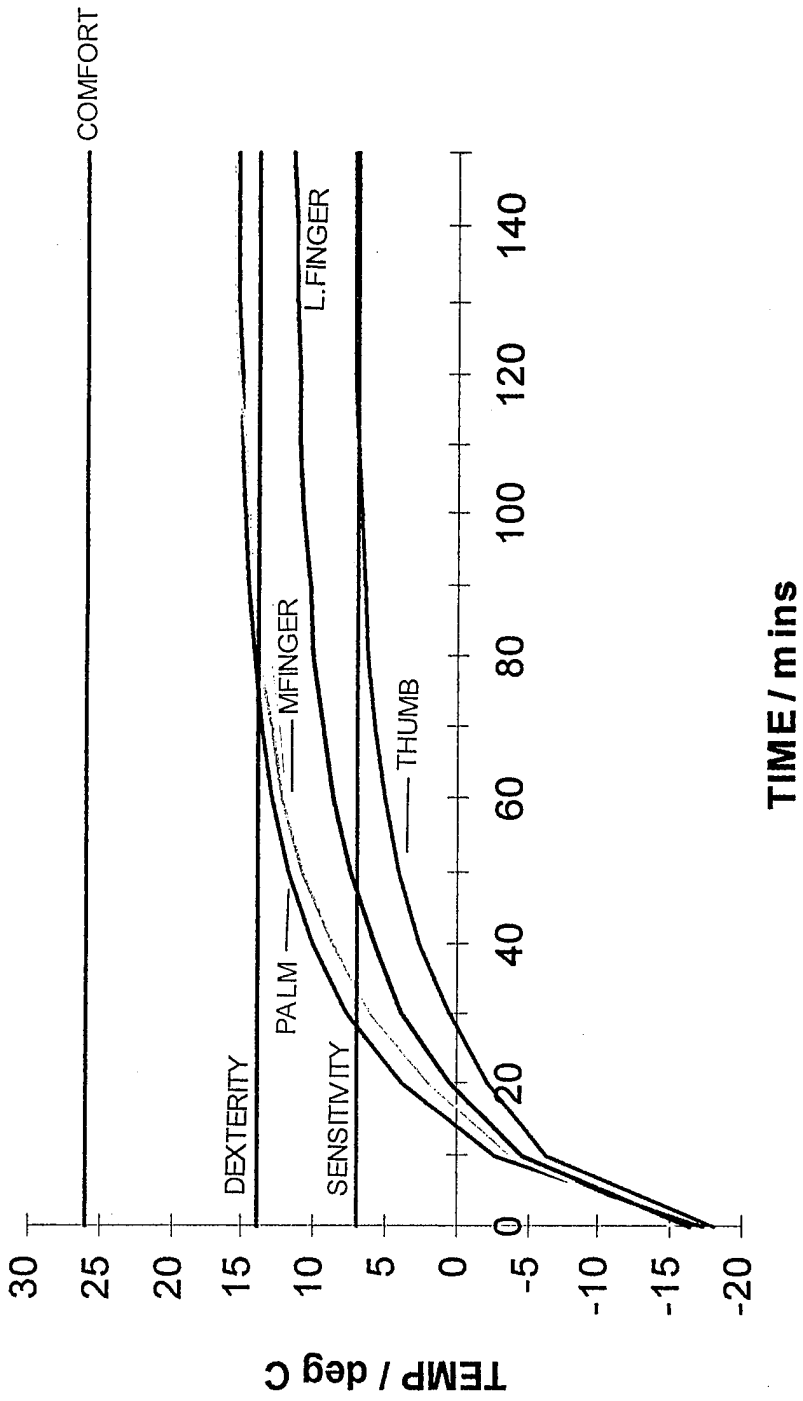

ENHANCED MOBILITY FOR COLD REGIONS

Sally A. Shoop
Cold Regions Research & Engineering Laboratory
Hanover, NH

ENHANCED MOBILITY FOR COLD REGIONS

Sally A. Shoop

U.S. Army Cold Regions Research & Engineering Laboratory, Hanover, NH

Cold temperatures affect vehicle starting and operating capability, and the presence of snow, ice and freezing or thawing ground strongly influences mobility. For example, while frozen ground can allow a vehicle to cross terrain otherwise impassable, a thawing spell can bog down most off-road or unpaved road operations.

Mobility through or over snow depends not only the vehicle's ground pressure and clearance but also the temperature history and physical properties of the snow pack. Vehicle traction on ice is a function of temperature, surface roughness and the compounds in the tire rubber.

CRREL has a very active research program on vehicle mobility in winter environments. An introduction to the impacts of cold regions on vehicle performance is presented along with a brief overview of some of CRREL's current research in these areas. Practical tips for vehicle operations in cold regions are also presented.

Enhanced Mobility for Cold Regions

Sally A. Shoop

**US Army, Cold Regions Research and Engineering Laboratory,
Hanover, NH**

Army Requirements

- **Mobility prediction**
- **Enhanced mobility through:**
 - **vehicle performance**
 - **terrain improvements**

Knowledge Base

Doctrine

- **FM 31-71 Northern Operations**
- **FM 31-70 Basic Cold Weather Manual**
- **FM 5-105 Mobility**

New Knowledge Base

Research → Tech Transfer

- **Operability**
- **Snow and Ice**
- **Freezing/Thawing Ground**

Effects of Low Temperature on Equipment Operability

- **Sluggish movement**
- **Loss of battery power**
- **Material embrittlement**
- **Fuel problems**
- **Operator problems**

Winterization of Equipment

- **Insulation**
- **Engine covers**
- **Heater installation**
- **High temperature thermostats**
- **Air intakes**
- **Arctic lubricants**
- **Tune up**

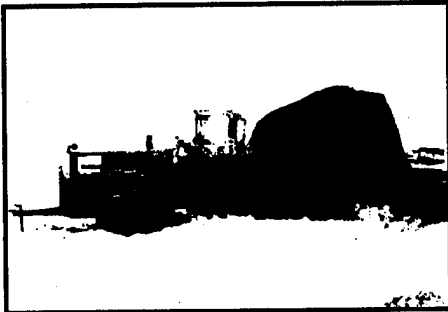

Winter Operability - Equipment Warming

Vehicle Operations at Cold Temperatures

6 Cold Regions Digest by Deborah Dlemand

- Fuels
- Batteries
- Lubricants
- Winterization
- Heating and Cold Starts
- Material Problems

Snow and Ice Mobility Influenced by

- Snow Depth
- Snow Density
- Moisture
- Snow Strength
- Temperature
- Rubber Compounds

Rules of Thumb - Snow/Ice

- Shallow Vs deep snow
 - ground pressure
 - geometry
- Over snow vehicles
 - ground pressure 1 to 3 psi
- Through snow vehicles
 - wheels: snow depth < 2/3 radius
 - tracks: snow depth < 2 time clearance

Shallow vs Deep Snow

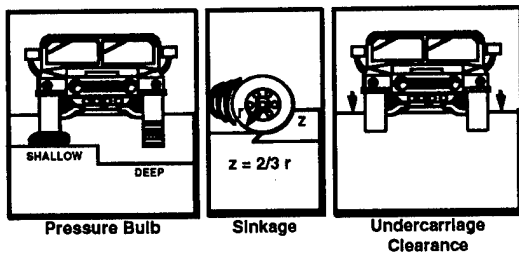

Snow/Ice cont..

- Traction Aides
- Remove Tank Pads
- Radial Tires
- Central Tire Inflation Pressure
- Anti-lock Braking Systems
- Traction Control

Snow and Ice Mobility Research

- Snow Mobility Prediction
- Traction Control for Winter Conditions
- Abrasives on Ice
- Snow Plow
- Snow Roads and Runways

Traction Prediction on Snow and Ice

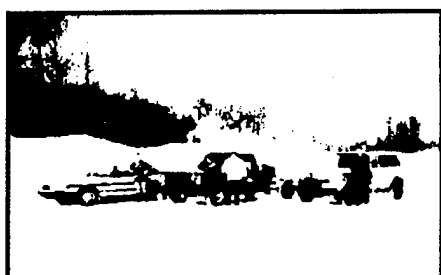
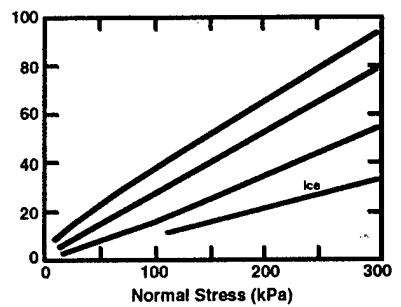

Winter Traction Testing

Traction Control Algorithms

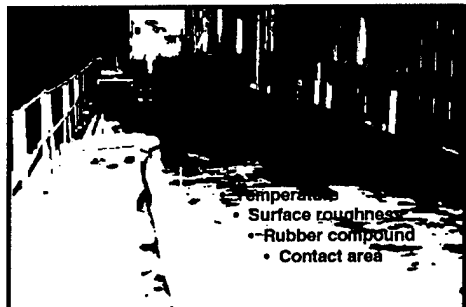
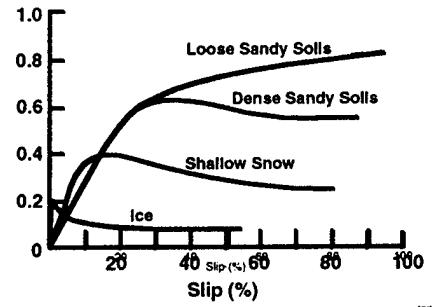

Ice Traction

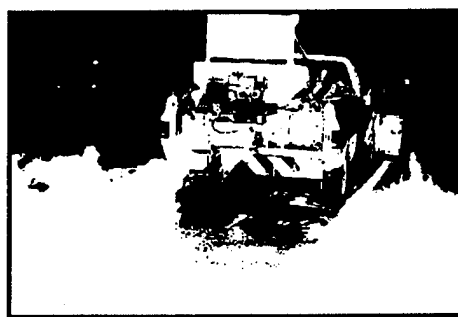

Improved Ice Friction Using Abrasives

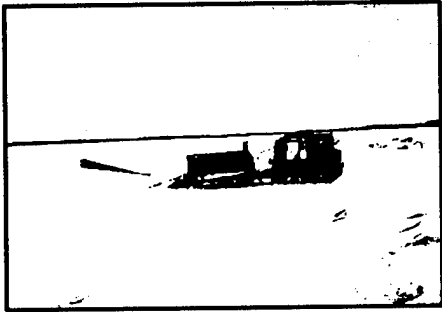

SUSV Drag Plow



Plow Path

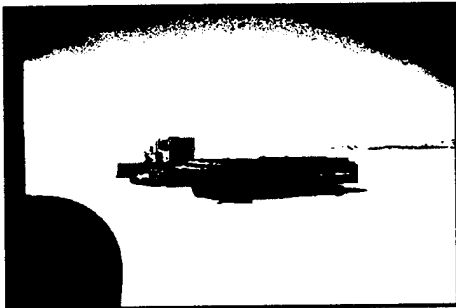

Snow, Roads and Runways



Glacial Ice Runway - Antarctica

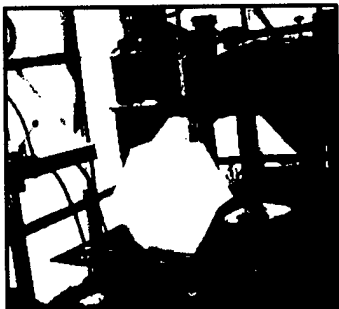

Snow Brick



Bricks for Snow Roads

Freezing/Thawing Ground Mobility

- Soil type
- Freeze and thaw depth
- Soil moisture

Thawing Soil

Critical conditions for Trafficability in Freeze/Thaw Environments

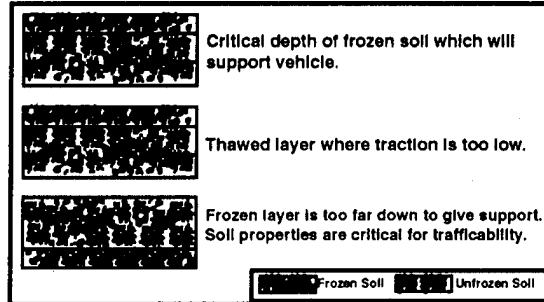

Rules of Thumb - Freeze/Thaw

- Freezing soils can increase mobility
 - 5 cm frost adequate for most soils
 - 0.5 m supports "anything" even in very wet conditions
- Thawing causes wet-slippery conditions
 - loss in traction
 - Increase in motion resistance
 - narrow, large wheels cut through mud

Research: Mobility during Freeze/Thaw

- Bearing Capacity of Frozen Ground
- Thawing Soils Mobility
- Rapid Stabilization of Thawing Soil

Bearing Capacity of Frozen Ground

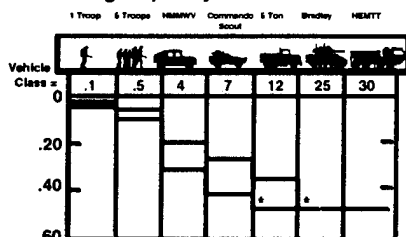

* 0.5 m frost will prevent breakthrough of most heavy equipment but mobility may be limited by crushing failure of surface material



Immobilization During Spring Thaw



Vehicle Testing in Thawing Soil

Rapid Stabilization of Thawing Ground

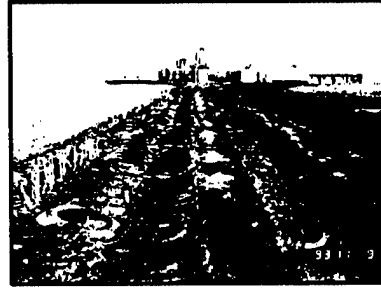

Tire Mats

Rapid Stabilization of Thawing Ground



Tire Mats

Rapid Stabilization of Thawing Ground

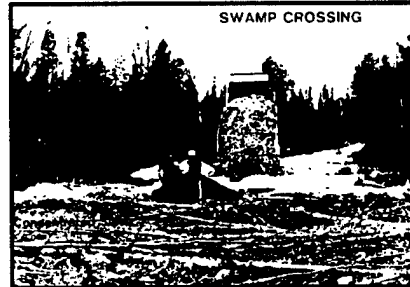

USFS Woodchunks

Summary

- Low Temperature Equipment Operability
- Rules of Thumb for Cold Regions Mobility
- Prediction and Enhancement Research
 - Snow and Ice
 - Freezing/Thawing Soil

Conclusion

- Army Cold Regions Mobility Research for
- better planning/training
 - better equipment
 - better doctrine
 - fewer surprises

Selected References

- Blaisdell, G.L and R.M. Lang. Construction of a Glacial Ice Runway and Wheeled Flight Operations at McMurdo, Antarctica. in Proc XXIII SCAR Conference, 29 August - 2 September 1994, Rome, Italy.
- Blaisdell, G.L. V. Klokov, and D. Diemand. Compacted snow runway technology on the Ross Ice Shelf near McMurdo, Antarctica. Contributions to Antarctic Research, Series 4, American Geophysical Union, submitted March, 1993.
- Blaisdell, G.L., S.L. Borland, B. Young, and W. H. Marsey. Surface friction enhancement using abrasives CRREL Report (in preparation).
- Blaisdell, G.L. and S.L. Borland. Braking traction on sanded ice. in Snow Removal and Ice Control Technology, Transportation Research Record, 1993, no. 1387, p 79-85.
- Blaisdell, G.L and Borland. Preliminary study of the effects of fines on sanded ice friction. Cold Regions Science and Technology, Vol. 21, 1992, p. 79-90.
- Diemand, D. Operations of Materiel at Extremely Low Temperatures, The Military Engineer, August, 1991.
- Diemand, D. Winter Operability: Equipment Problems and Their Remedies, Journal of Cold Regions Engineering, Vol. 6, No. 3, Sept. 1992.
- Diemand, D. : Cold Regions Technical Digest
No. 91-2 Automotive Fuels at Low Temperatures, March 1991
No. 90-1 Lubricants at Low Temperatures, December 1990.
No. 91-3 Automotive and Construction Equipment for Arctic Use: Heating and Cold Starting, April 1991.
No. 91-4 Automotive Batteries at Low Temperatures, May 1991.
No. 91-5 Automotive and construction Equipment for Arctic Use: Materials Problems, November 1991.
No. 92-1 Winterization and Winter Operation of Automotive and Construction Equipment, Sept. 1992.
- Kestler, M., K. Henry, and S. Shoop, 1994, Rapid Stabilization of Thawing Soils, Proceedings of Advanced Technology in Forest Operations: Applied Ecology in Action, Council on Forest Engineering 17th Annual Meeting, International Union of Forestry Research Organizations, Corvallis, Oregon, July, 1994, p. 291 - 306.
- Richmond, P.W., Notes for Cold Weather Military Operations, 1991, CRREL Special Report 91-30.
- Richmond, P.W. and M.R. Walsh, Design and Evaluation of a Towed Snowplow for the Small Unit Support Vehicle (SUSV), 1994, CRREL Report 94-10.
- Richmond, P.W., S.A. Shoop and G.L. Blaisdell, Cold Regions Mobility Models, 1995, CRREL Report 95-1.
- Shoop, S.A., Terrain Characterization for Trafficability, 1993, CRREL 93-6.
- Shoop, S.A., 1995, Vehicle Bearing Capacity of Frozen Peat, Canadian Geotechnical J., accepted for June 1995 issue.
- Shoop, S., Young, B., Alger, R., and Davis, J., 1994, Three Approaches to Winter Traction Testing Using Instrumented Vehicles, Subzero Engineering Conference, Brainerd, Minnesota, p. 165-171, SAE Paper 940110. Published as "Winter Traction Testing," Automotive Engineering, Vol. 102, No. 1, p. 75-78.
- Shoop, S.A., 1993, Effect of Soil Thawing on Off-Road Vehicle Traction, Proc. of the 6th International Permafrost Conference, Beijing, China, July 1993, p.559-563.
- Walsh, M.R., and P.W. Richmond, Environmental Support Systems, CRREL Develops the off-road snowplow for the SUSV, 1994, Army Battlefield Environment, Vol. 11, No. 2, Spring 1994.

**ORGANISATION OF PROTECTION AGAINST
AVALANCHES IN THE REPUBLIC OF SLOVENIA —
TASKS OF THE SLOVENIAN ARMY**

Brigadier Janez Kavar, Eng.
Territorial Defence of the Republic of Slovenia

Brigadier

Janez KAVAR , Eng.

Territorial Defence of the Republic of Slovenia

3. PŠTO KRANJ

SLO - 64000 KRANJ

Bleiweisova 32 , Slovenia

ORGANISATION OF PROTECTION AGAINST AVALANCHES IN THE REPUBLIC OF SLOVENIA - TASKS OF THE SLOVENIAN ARMY

In addition to low temperatures and the thickness of the snowcover, snow avalanches present one of the greatest problems to the execution of military operations in the winter, particularly in an alpine environment. Statistical data demonstrate that throughout history soldiers have figured most prominently amongst avalanche victims. The Carthaginian military commander Hannibal struggled against avalanches in 218 BC in his military expedition across the Pyrenees and Alps to Rome. In the area of military conflicts in the Southern Dolomites (Eastern Alps) in the First World War, around 50,000 soldiers from the Austro-Hungarian and Italian forces died in avalanches, while some estimates even speak of approximately 80,000 buried in avalanches during the period from 1915 to 1918. Following one week of snowfall in December, 1916, almost 6,000 Austro-Hungarian soldiers died in avalanches in 48 hours. And on 13 December 1916, 253 soldiers died in a single avalanche of hard-packed blocks of snow under Marmolada (3,342 m) in the Italian Dolomites. At this time, part of the Italian and Austro-Hungarian front led through land now in the Republic of Slovenia, along the Isonzo (Soča) River in the area known as the "Isonzo Front", the hinterland of which extended into the Slovenian part of the Julian Alps (Picture 1). The greatest number of victims of avalanches along this part of the front died in the area of the Vršič pass (1,611 m), where in a single day, 8 March 1916, avalanches buried 117 Russian prisoners of war and Austro-Hungarian soldiers engaged in the construction of a service road. The total number of those who died in avalanches in what is now the Slovenian part of this World War One front equalled almost 1,500 soldiers. The same area of the Slovenian mountains saw victims among the Slovenian partisans during the Second World War, although in significantly smaller numbers, as the partisan mountain warfare tactics did not require the

extended stay of such large numbers of soldiers in avalanche-prone mountainous areas. During the time when Slovenia was part of Yugoslavia, from 1945 to 1991, the majority of avalanche victims in the Slovenian mountains came from the ranks of soldiers and border guards. Many accidents also took place involving civilians, especially skiers. In March of 1937, an avalanche under Storžič (2,132 m) in the Kamnik Alps buried 9 skiers, and in January 1977 another under Begunjščica (2,063 m) in the Karawanken Alps trapped an entire school class, covering 4 students and two teachers for eternity.

The Slovenian alpine world is made up of three main mountain groups, these being the eastern part of the Julian Alps, which includes the 2,864 m high Mt. Triglav; the 120 kilometre long Karawanken mountain chain, with the 2,236 m high Mt. Stol; and the Kamniško-Savinja Alps chain, capped by the 2,558 m high Grintavec. The three mountain groups include 349 peaks over 2,000 m. The Mediterranean influence from the northernmost part of the Adriatic Sea is of fundamental significance to the occurrence of avalanches in the Slovenian part of the Julian Alps, together with many days in which snowcover and a corresponding high, maximum altitudinal location are present. In the Karawanken chain and the Kamniško-Savinja Alps the characteristic East-West orientation of the ridges, exposure to the sun and poor development of vegetation are important for the emergence of avalanche conditions. The mountainous regions of Slovenia are considered alpine areas seriously threatened by avalanches. In a relatively small area (approximately 7,000 square kilometres; the entire area of Slovenia is 20,256 square kilometres) a total of 1,246 avalanches have been registered by various studies.

In the jargon of the Slovenian armed forces, avalanches are called "the white death". They represent a constant, serious danger which is present over a fairly broad area suitable for alpine military exercises and represent a very noticeable psychological pressure in the planning of these activities, particularly for officers. This pressure is greater in the cases of officers and soldiers who are more cognisant of the principles of how avalanches start, although these individuals also have greater training in safety and rescue measures under avalanche conditions. On the other hand, a familiarity with locations susceptible to avalanches, particularly in the execution of military operations in mountainous regions, offers a plethora of opportunities for the effective blocking and destruction of an enemy's forces, arms and equipment. In this regard all the methods known for the intentional production of an avalanche, as a part of avalanche safety measures, are significant.

Safety measures planned in regard to avalanches have existed in Slovenia since 1952. The greatest thanks in this are due to the Alpine Rescue Service of Slovenia, a volunteer, civilian, public service that functions as an organisation within the Mountaineering Association of Slovenia, entrusted with and specialised in mountain rescue. This organisation was founded in 1912 and has been a member of IKAR (the International Commission for Alpine Rescue) since 1955. Later, ie after 1976, the national hydrometeorological institute became involved in organised, planned safety measures for avalanches, and particularly in the collection, analysis and transfer (publication) of data on snow conditions, working with its own network of meteorological observation stations. The task of carrying out avalanche rescue operations fell almost exclusively to the Alpine Rescue Service, operating as a part of Civil Defence, and only partially to the Yugoslav Army, which did not have sufficiently trained personnel, nor equipment, for such undertakings. In 1964 experts in Slovenia began to precipitate avalanches artificially on recreational ski slopes by bombardment. These activities were initially carried out by the Yugoslav Army, and after 1970 they were taken over by the Territorial Defence of Slovenia.

With Slovenia's gaining of independence in 1991, national-level state institutions and organisations assumed all the responsibilities related to avalanche safety. The up to date national "Law On Safety From Natural And Other Disasters", adopted in 1994, governs the avalanche safety system in its entirety. The duties that stem from the law are primarily coordinated by the Republic Safety and Rescue Administration, which operates within the Ministry of Defence, while various offices and institutions carry out these duties. The greatest number of activities in avalanche safety are carried out by the Alpine Rescue Service. The law also delineates certain responsibilities to be carried out by the Slovenian Armed Forces, in cooperation with civilian institutions, and in some exceptions independently (Picture 2). The second national law defining the duties of the Slovenian Armed Forces in avalanche safety in Slovenia is the "Law on Defence". This piece of legislation defines the duties of the armed forces related to rescue. Additionally, the responsibility of collecting data on the extent of snowcover and its characteristics have been entrusted to the Hydrometeorological Institute of the Republic of Slovenia. The "Bureau of Snow and Avalanches" is active within this institute. It is organised along the lines of "avalanche bureaus" in other alpine countries. The Bureau collects data through a network of meteorological observation stations, both permanent and seasonal. This network also includes the meteorological observation stations in the Slovenian Alps that are used by the

Slovenian Armed Forces. For the time being, this includes the meteorological observation station in the Slovenian Armed Forces alpine training centre on Pokljuka (1,347 m), in the central part of the Julian Alps, which is also used for educational purposes. Incidentally, the highest and oldest Slovenian meteorological observation station is located on Kredarica (2,551 m), again in the Julian Alps. Future plans include an expansion of the network of snow and avalanche observation stations, including stations to be used by the armed forces. The data collected in all the stations is published in the media when necessitated by the threat of avalanches. A special portion of avalanche safety duties also falls to the Slovenian police, the Ministry of Transport and Communications, the Ministry of Agriculture and Forestry and the Ministry of Environment and Physical Planning.

The greatest number of operations in avalanche safety in Slovenia are carried out by the Alpine Rescue Service of Slovenia. Within the Service, a subcommission for avalanches is active, which includes a division for avalanche-trained dogs and a division for avalanche mining specialists. At present in Slovenia, there are 30 trained avalanche dogs and 19 mining specialists in the Alpine Rescue Service, in addition to military ones. Over 500 volunteer alpine rescuers are trained in avalanche rescue techniques and work in 17 stations of the Alpine Rescue Service located in areas in close proximity to the mountains. The Alpine Rescue Service is well-equipped for avalanche rescue operations, makes use of contemporary IKAR rescue theory and principles, and collaborates in avalanche safety with related services in neighbouring Austria and Italy.

Applying previous experiences, upon its formation in 1991 the new Slovenian Armed Forces directed the necessary attention to avalanche safety in management programmes, equipment planning and performance of duties. The Slovenian Army also make use of their predecessor's professional experiences in order to guarantee effective safety measures, effective rescue response, complete cohesion, the use of the most modern theories and rescue equipment, and effective cooperation with associated civilian organisations. Despite the limitations presented by a seven-month compulsory military service, members of alpine units are trained in avalanche safety and avalanche rescue operations during a 90-hours alpine specialisation programme. Civilian experts from the Alpine Rescue Service participate in the training programmes on a permanent, planned basis, with the particular goal of ensuring complete cohesion. Once a year a course in avalanche safety together at the Slovenian Armed Forces alpine training centre is organised, this being mainly intended for civilians (skiers, alpinists, hunters, scouts).

A long-term goal of the Slovenian Armed Forces is to acquaint all its soldiers with the dangers of avalanches and to train them in related safety measures in light of the potential threat to a large portion of the country from avalanches. This training falls to the units and to the Alpine School of the Armed Forces, which with its own training staff and civilian experts has held and continues to hold alpine training courses within Slovenia's international military cooperation, under the auspices of the "Partnership for Peace" and other bilateral cooperative efforts.

The personal equipment of every member of the Armed Forces alpine units includes an electronic transmitter ("avalanche woodpecker ") and avalanche probe, in addition to protective equipment made of modern materials that make survival in extreme winter weather conditions possible. Every alpine unit has the equipment needed to determine the danger of avalanche occurrence and to carry out extensive rescue missions in avalanche conditions. The units also have traditional equipment for the intentional initiation of avalanches (a recoilless cannon and mortar), and have the ability to start avalanches artificially with mines. The artificial initiation of avalanches by bombardment falls strictly to the armed forces. The alpine units of the Armed Forces also make use of a modest number of dogs trained for avalanche conditions, and this is primarily for training purposes.

Although the number of accidents and the amount of damage due to avalanches in Slovenia does not reach the annual average in other alpine countries, the danger they pose has not been underestimated. This is one of the reasons why, in the recent past and today, Slovenian specialists have attempted to contribute something of value, through professional and research work, towards world efforts in avalanche safety.

The seventies were a period of ambitious and enthusiastic development in the equipment intended for the location of persons buried under snow. Initial work in this field was followed by the European "Pieps" and American "Skadi", whose reliability and range were fairly poor at the time.

One of the individuals searching for a new approach was France Avčín, a Slovenian scientist, university professor, alpinist, alpine rescuer, writer, hunter and electrician. With his assistant, Tone Jeglič (1), he worked to produce a very effective, though simple, transmitter working in the 100 MHz frequency range.

The concept was as follows: the frequency stability of the transmitter was not to be great, with a permitted deviation of the order of 5%. Any UKV receiver would be able to pick up the transmitter's signals without a special search, as they could be heard throughout the range. The

concept was based on the fact that many tourists, mountaineers and day-trippers could carry a pocket UKV receiver that they also use at home and thus would not need to purchase special equipment; the transmitter, on the other hand, would be so small and, at the same time, sturdy and cheap, that truly anyone interested could buy one. This piece of equipment alone would permit what is known as directional searches - radio goniometry, and the basic orientation of the position of a person buried in a large avalanche snow field could be determined immediately upon activation of the receiver. Two receivers, located in different positions, could additionally allow one to determine fairly precisely a narrow area for the search. The signal range of this electronic transmitter was several times greater than that of any contemporary transmitter. By simply disconnecting the antennae when in the vicinity of the buried individual, a final, intense search and exact locating are made possible.

Avčin and Jeglič also designed what was known as an "avalanche gun", operating in the GHz frequency range. This permits an exceptionally accurate determination of the azimuth and elevation of a person buried under an avalanche, but at the time this did not promise an early commercial application, as there was a lack of component parts. At the second symposium of the *Fundation Internationale Vanni Eingenmann*, held in Sulden in 1975, the search method using 100 MHz frequencies was not adopted because of the competition posed by already existing electronic transmitters, but the concept is still certainly worth consideration and continued effort, given the development of technology.

For some time now, science and knowledge have been international in their nature, and, with the advent of personal computers, have become relatively easily accessible. The single major obstacle to the exchange of information lies in language differences and in the specific terminology of individual fields. This is completely true for the science of snow and avalanches, and equally for avalanche rescue which requires both professional knowledge and a mastery of at least three, and up to five, world languages. With this in mind, specialised dictionaries have been compiled for the needs of the military, the air force, the navy, glacier experts and meteorologists which do not include everything needed by the soldier in an alpine unit, by the alpinist, the touring skier and the alpine rescuer. Several individuals, including Pavle Šegula (2), a delegate of the Slovenian Alpine Rescue Service to IKAR, have promoted the six-language dictionary "Snow and Avalanches" with the intention of making the extensive foreign literature accessible to Slovenian speakers. Together with colleagues from the subcommittee on avalanches and with the help of the *Fundation Internationale*

Vanni Eingenmann, Šegula worked on the conception and compilation of the dictionary on diskette, while for the needs of Slovenia he prepared a printed version of the dictionary, which he expanded to include a definition for every entry - thereby greatly enhancing the usefulness of the dictionary. With the exception of the definitions, which are intended solely for Slovenian readers, the entire dictionary is of great use to English, French, Italian, German and Spanish speakers.

The desire to produce better work in the prevention of harm brought about by avalanches in Slovenia dictated the formulation of a detailed register on avalanches in predominantly permanently settled regions. The study for the preparation of the register was conducted by Aleš Horvat (3), a forestry engineer, and France Bernot (4), a professor of geography. A study by F. Bernot and P. Šegula from 1983 which examined 192 avalanches threatening roads in Slovenia was also used as a basis for the register. The goal of this endeavour was to analyse the degree to which avalanches pose a menace to Slovenia. Existing data on the snowcover and on avalanche snow fields was examined and supplemented. The meteorological data studied included information on the height and duration of the snowcover and the intensity of snowfall. Avalanche snow fields are presented in graphic and tabular form, this at a scale of 1:10,000 in area arrangement schemes and 1:50,000 in safety and rescue. An overview is given at 1:400,000. The data is given in digital form to facilitate processing on ARC INFO computers. Additionally, the study includes an estimate of the damage caused by avalanches. All told, 1,246 avalanches were examined in the compiling of the register.

The results of this work demonstrate that avalanches pose a noticeably greater threat to Slovenia than was indicated by analyses to date. The analysis of snowfall in Slovenia points to great variety in duration, height and intensity, due to which catastrophic phenomena can appear at fairly long intervals. It is exactly this kind of temporal distribution for avalanches, particularly large-scale ones, that is the main reason for the frequently disdainful attitude towards occasional and particularly continuous avalanche safety measures. The avalanche register, drawn up to offer a basis from which to evaluate the threat presented to Slovenia, provides a good foundation for safety measures, rescue operations and land use planning, with appropriate consideration of the related conditions for its use.

The possibility of detecting avalanche victims by measuring radiated thermal energy has been the subject of numerous investigations in the past. However, there are still considerable differences in expert opinion regarding the feasibility of its practical implementation.

Modern technology, especially the use of contemporary low noise transistors, opens some new possibilities in this domain.

Milan Šval (5) of the PAP Telematika Company is developing a version of a microwave radiometer, seen in a block diagram (Picture 3), in collaboration with the Faculty of Electrical and Computer Engineering, Ljubljana, Slovenia.

The equipment consists of two identical Dicke receivers that operate in a frequency range of 1 to 4 GHz. The output of the two receivers is connected through a differential amplifier to an acoustic alarm circuit. Two antennae are mounted on a "UT 2000" universal transporting device which can be used as a sledge in snow.

Under normal conditions, both antennae will receive equal thermal energy from the ground, so that there will be no output signal.

When one of the antennae moves above a buried victim, it will receive a slightly different thermal energy compared to the other antennae, thereby activating the acoustic alarm.

Practical testing of this equipment in snow conditions will begin in February, 1995. The possibility of reducing the size of the equipment will be studied in the second phase of this project.

The project receives financial support from the Slovenian Ministry of Science and Technology.

These examples cite current professional work in avalanche safety in Slovenia, in several areas the Slovenian Armed Forces play a role.

- 1 Tone Jeglič, Faculty of Electrical and Computer Engineering, Tržaška 25, Ljubljana, SLO-61000.
- 2 Pavle Šegula, Suška 34, Škofja Loka, SLO-64220.
- 3 Aleš Horvat, Podjetje za Urejanje Hudournikov, Hajdrihova 28, Ljubljana, SLO-61000.
- 4 France Bernot, Carja Dušana 16, Ljubljana, SLO-61000.
- 5 Milan Šval, PAP-Telematika, Pivovarniška 6, Ljubljana, SLO-61000.

Sources:

- P. Šegula. Snow, Ice, Avalanches. Mountaineering Publishing House of Slovenia. 1986, Ljubljana.
- F. Mulej. Avalanches, Fatal Victims and Material Damage. 1994, Ujma 8, Ljubljana.
- A. Horvat and F. Bernot. The Threat to Slovenia by Avalanches. 1994, Ujma 8, Ljubljana.
- P. Šegula. Information Transfer in Snow Conditions and the Danger of Avalanches. 1994, Ujma 8, Ljubljana.

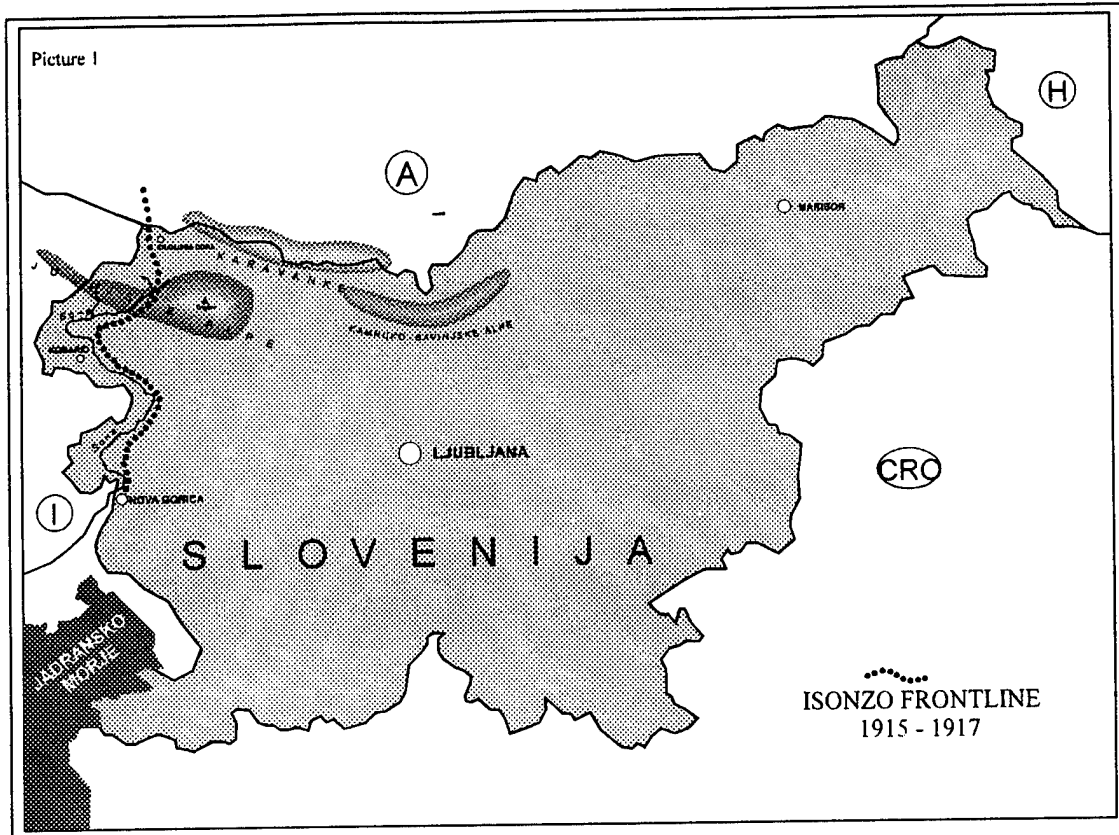

**ORGANISATION OF AVALANCHE SAFETY MEASURES
IN THE REPUBLIC OF SLOVENIA-
TASKS OF THE SLOVENIAN ARMED FORCES**

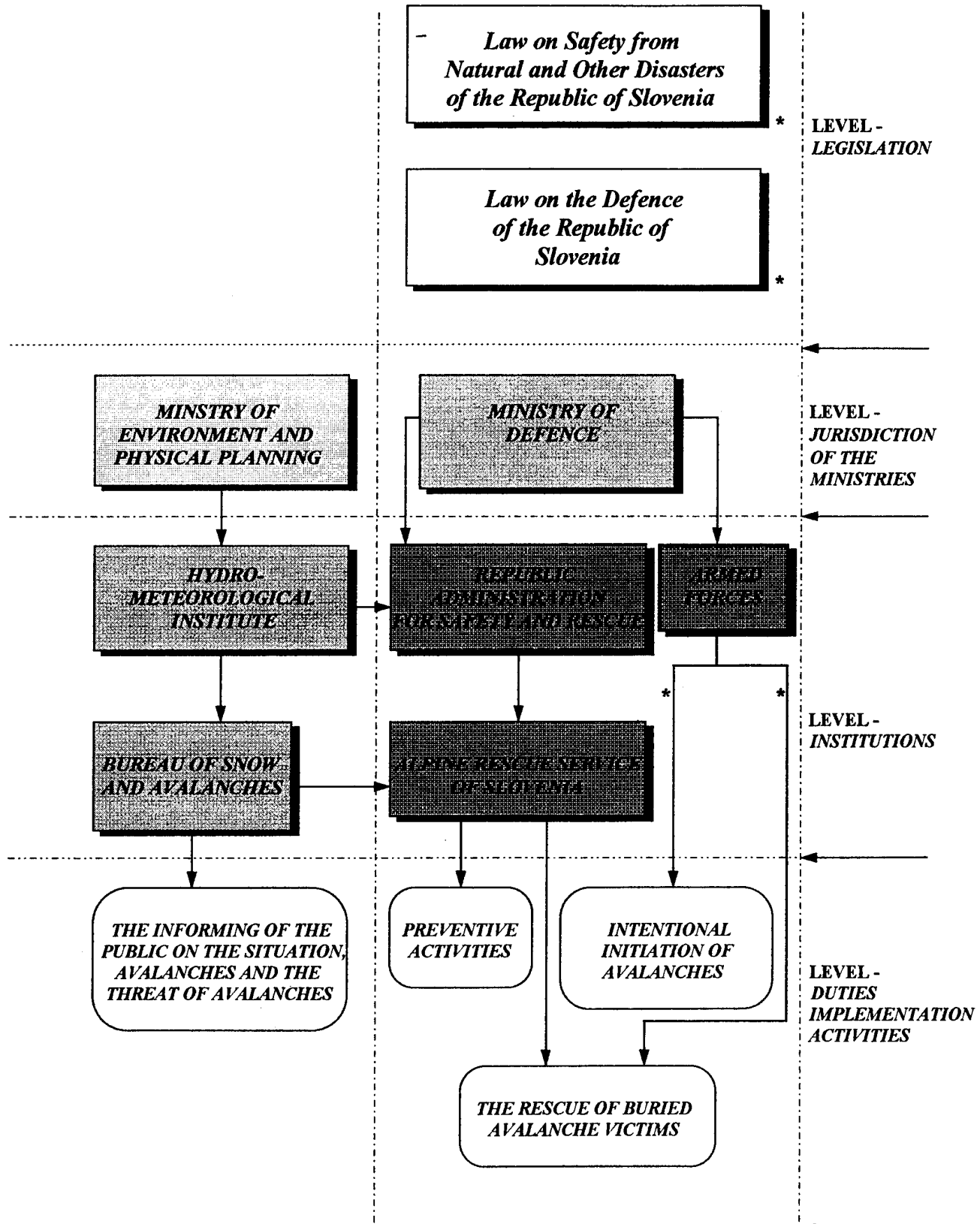

*-LEGISLATION GOVERNS THE DUTIES AND ENGAGEMENT OF THE SLOVENIAN ARMED FORCES

RADIOMETER FOR THE DETECTION OF AVALANCHE VICTIMS

BLOCK DIAGRAM :

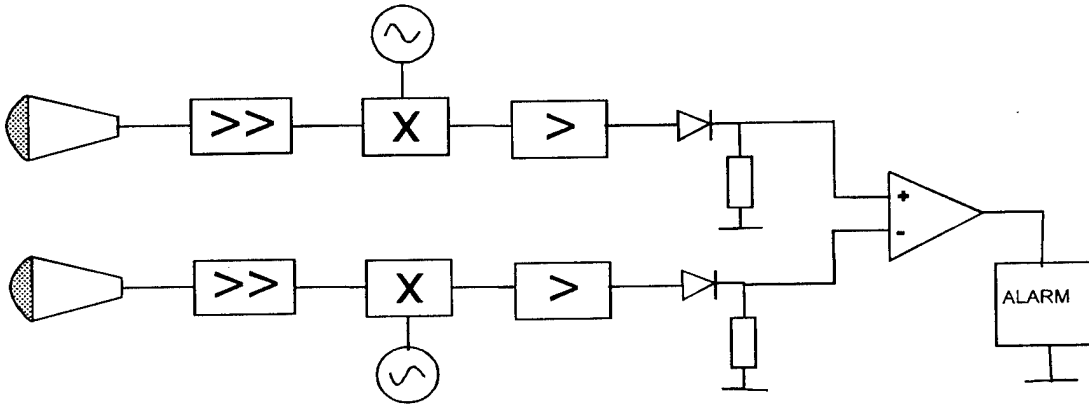

SIDE VIEW :



TOP VIEW :

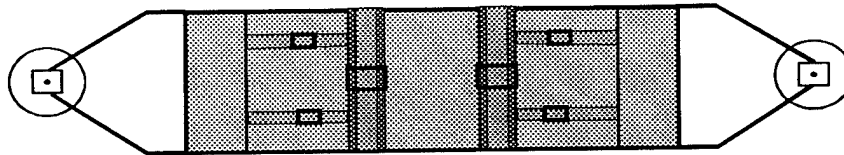

Picture 3

CHEMICAL/BIOLOGICAL JOINT CONTACT POINT

Dr. William C. Christiansen
Director
Joint Contact Point
Dugway Proving Ground, UT

Preface

The Chemical/Biological Joint Contact Point and Test (Project DO49) is a DOD directed program executed for the Joint Services and the Unified and Specified Commands (CINCs) by the Joint Contact Point Test and Information Directorate (JCP), U.S. Army Dugway Proving Ground. The mission of Project DO49 is to respond to requirements from the Services and CINCs for chemical/ biological defense information and operationally oriented data and analysis. The purpose of this pamphlet is to briefly describe available Project DO49 services and products.

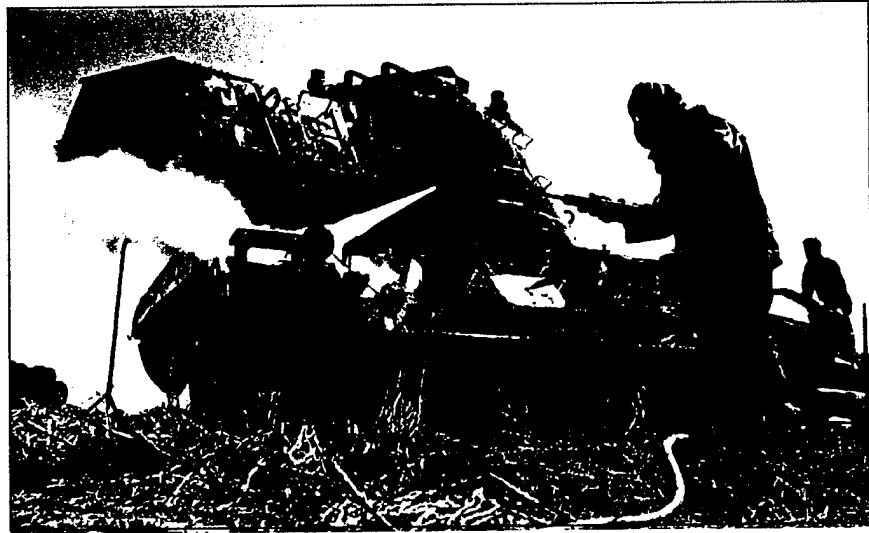

The Chemical/Biological Joint Contact and Test, Project DO49

The Chemical/Biological Joint Contact and Test (Project DO49) is an operationally oriented analysis/evaluation and test program of the Office of the Secretary of Defense (OSD) and coordinated by the Office of the Joint Staff (J-5).

In 1967 the Joint Chiefs of Staff (JCS) directed Deseret Test Center (DTC) to establish a Joint Contact Point for operational field test information on CB weapons and defense systems. Data from all sources, including laboratories and proving grounds, appropriate to the evaluation of operations were to be included. DTC was disestablished in 1973 and the Joint Contact Point mission was assigned to

Dugway Proving Ground.

At Dugway Proving Ground the program is assigned to the Joint Contact Point Test and Information Directorate, which is responsible to the CINCs and Services to:

- Provide a source of information and analysis for chemical/biological defense, with emphasis on operations.
- Respond quickly to requests from CINCs and Services and subordinate organizations for CB related information available in the Joint Technical Information Center.
- Prepare analytical studies in response to requests

that require extensive analysis and interpretation.

- Sponsor operationally oriented field/ laboratory testing of CB defense equipment, defense procedures, and doctrine; and publish appropriate reports.
- Prepare and maintain a Chemical-Biological Technical Data Source Book.

A single DOD program element in the Army RDT&E program supports Project DO49. Direct costs for use of JCP resources for DO49 tests are funded by Joint Contact Point. Direct costs for other resources are borne by the requestor.



Camouflage decontamination exercise

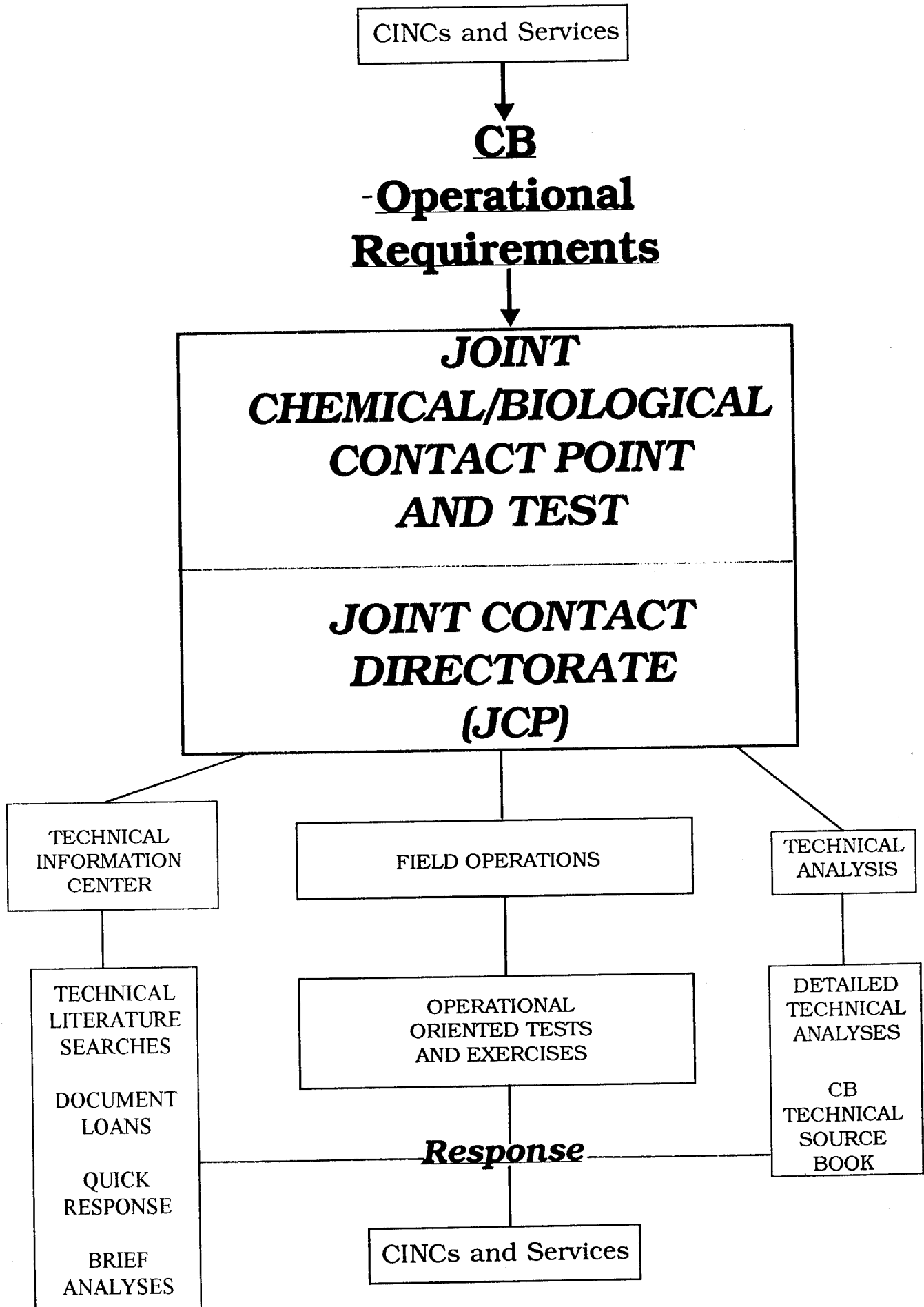

Technical Analysis and Field Operation

The Technical Analysis and Field Operation Division of JCP:

- Analyzes requirements in terms of existing information and needs for new information.
- Prepares the annual

plan of operations for Project DO49.

- Prepares reports based on technical evaluation of existing data.
- Prepares outline plans for operationally oriented tests of exercises designed to provide needed data.

- Monitors preparation of test and exercise plans.
- Monitors conduct of operationally oriented tests and exercises.
- Prepares reports of tests and exercises.

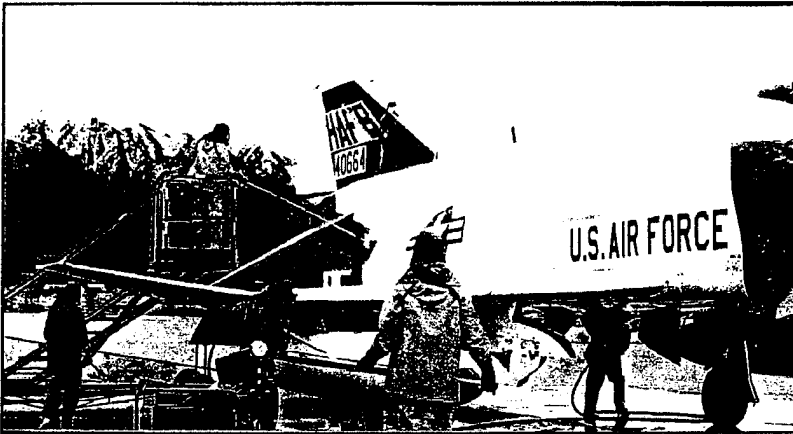

Joint Technical Information Center

The Joint Technical Information Center (JTIC) maintains a unique collection of over 60,000 documents that chronicle U.S. and Tripartite CB programs dating back to early World War II. Over 10,000 CB-related foreign intelligence citations are also contained in the collection. Through an automated BRS system, this collec-

tion can be searched to provide data/information with which to evaluate CB requirements in an operationally oriented context. Searches can be initiated using key words, authors, titles, dates, contract numbers, report numbers, corporate authors, and many other identifiers.

As of 1 October 1991, the Joint Technical Informa-

tion Center has a specialized staff member available to address phone or fax requests for CB information that can be obtained through routine search of the JTIC collection or that requires only a minimum of interpretation. DO49 customers are encouraged to take advantage of this resource.

CB Information Network (Infonet)

Preparations are well underway to transfer the entire JTIC collection to optical disk thus making this valuable resource available for automatic retrieval. Upon completion of the project (estimated FY95), autho-

rized users will not only be able to search the collection as is currently possible, but will also be able to retrieve full text, and read and copy documents of their choice at any appropriately linked computer terminal. The sys-

tem, termed INFONET, will be compatible, with INTERNET and ARPANET.

Specific information on use of INFONET will be distributed several months prior to project completion.



The Chemical/Biological Technical Data Source Book

The Chemical/Biological Technical Data Source Book provides a broad range of information appropriate for assessing requirements and capabilities for defense against chemical and biological weapons. It is a compilation and

analysis of a wide range of information and data accumulated over the past 50 years, as well as current information. Emphasis is placed on information :

- Most applicable to operation in a CB environment.

- Supporting the ability to predict hazard associated with a CB attack.
- To predict effectiveness of CB defense procedures and equipment.

This cumulative source of information is essential since all data for open-air testing of chemical weapons is pre-1969, and all data for biological weapons testing preceded 1969. Early Source Book volumes were prepared by analysts who had first-hand, extensive experience with testing, test data, and model requirements for both offensive and defensive CB systems.

These valuable, non-repeatable test and study data, a generation older than most present-day researchers and analysts, may be overlooked but for their presence in the Source Books. In the absence of intimate knowledge of enemy CB weapons capabilities, estimates must be projected from this pre-1969 data, allied with the best intelligence information available regarding enemy weapon characteristics.

Appropriate estimates, based on realistic utilization of the test data and effectiveness estimates presented in the Source Book, can identify an adequate defense and avoid unnecessary degradation of military effectiveness that may be associated with excessive CB defensive measures resulting from unsubstantiated projections of enemy offensive capability.



Combat Operations in MOPP



Source Book

The Source Book is composed of several volumes, each addressing a specific subject. A volume may consist of several parts, each published as an individual document and each part devoted to a specific agent or subject. The first nine volumes address biological or chemical agents. Volumes numbered above nine cover specific topics. The following table shows the subject of the volumes that have been published.

Volume	Title	Volume	Title
I	Introduction & Summary	VIII part 1. part 2. part 3.	Antipersonnel Bact. Diseases Tularemia Anthrax Brucellosis
II part 1. part 2. part 3. part 4.	Riot Control & Incapacitating Agents Agents CS Agents DM (Adamsite) Agent BZ Agent Cm	IX part 1. part 3.	Antipersonnel Viral, Rickettsial and Fungal Diseases Coccidioidomycosis Venezuelan Equine Encephalomyelitis
III part 1. part 2. part 3.	(Chloracetophenone) G Nerve Agents Agent GA (Tabun) Agent GB (Sarin) vol. 1, 2, & 3 Agents CG (Phosgene)	X	General Models & Parameters
IV part 1.	V Nerve Agents Agents VX	XI part 1.	General Models & Parameters
V part 1. part 2. part 3.	Blister, Blood & Choking Agents Agent H (Mustard) Agent AC (Hydrogen Cyanide) Agent CG (Phosgene)	XIII	Detection, Identification & Warning
VI part 1. part 2.	Toxin Agents Botulinum Toxin Staphylococcus Enterotoxin	XVI	Thickened Agents
VII part 1.	Anti-plant Agents Agent LNX (Orange)	XVII	Meteorological Source Book for Diffusion Model Appl.
		XVIII	Chemical/Biological Protective Equipment

Applications of Source Book Data

**The Source Book provides technical information and references
to assist users in:**

Threat Assessment	Project/Equipment Design
Operations Research Studies	Laboratory Test Support
Research Requirements	Equipment Development
Equipment Requirements	Field Test Support
Medical Requirements	Field Evaluation
Training Programs	Operational Exercises
Doctrine Development	Equipment Use Doctrine

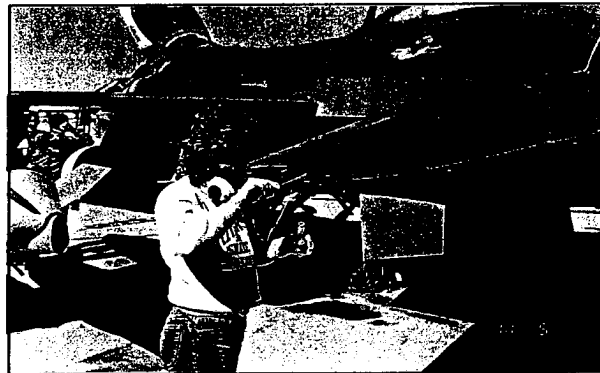

Taking swab samples



Organization

The Joint Contact Point Directorate at Dugway Proving Ground is organized by functional and mission responsibilities to optimize utilization resources and provide timely and accurate responses.

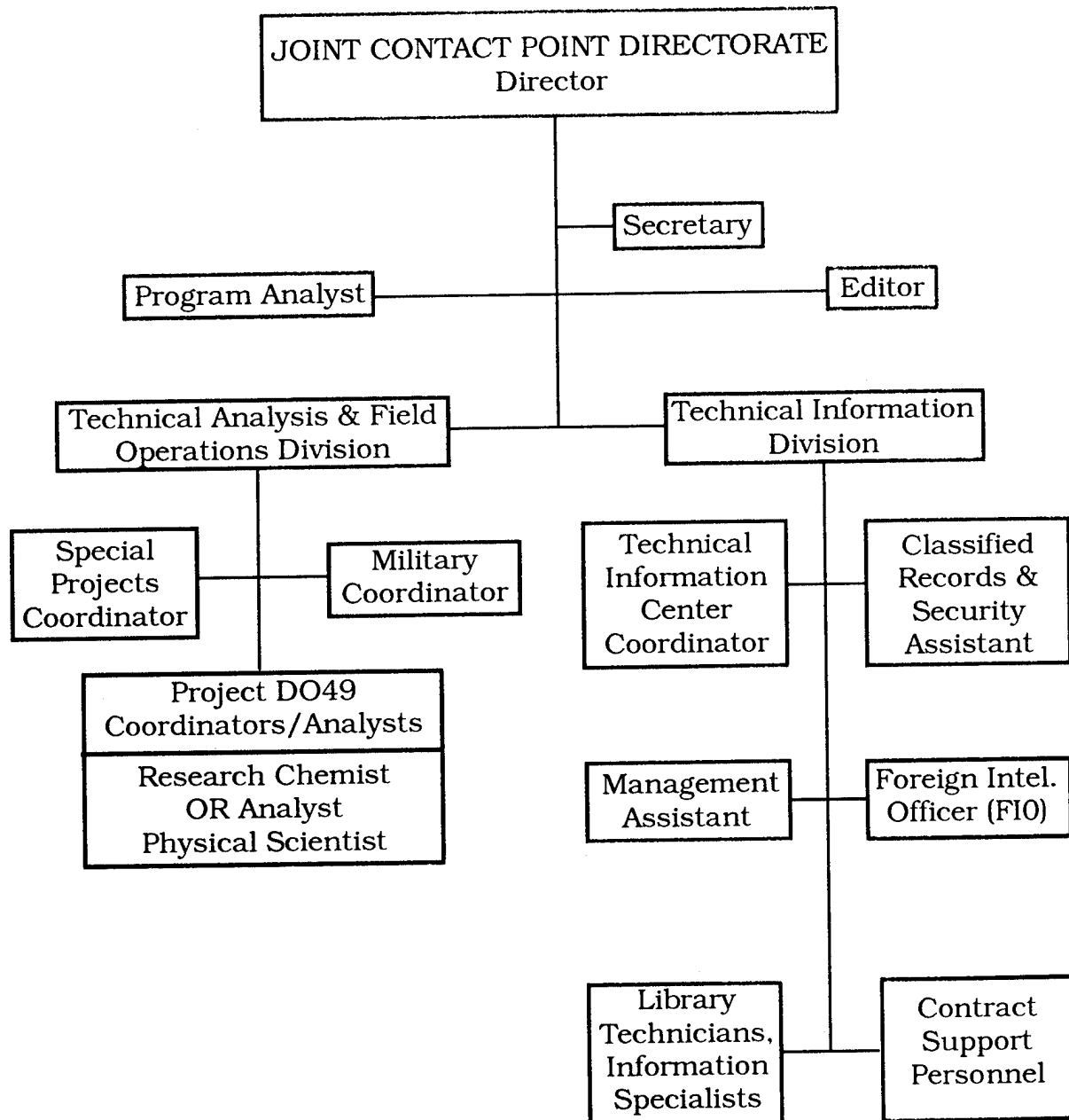

TRIAL BY ADVENTURE

Randall Oszcewski
Defence & Civil Institute of Environmental Medicine
North York, Ontario, Canada

Trial by Adventure

by

Randall Oszcewski

DCIEM

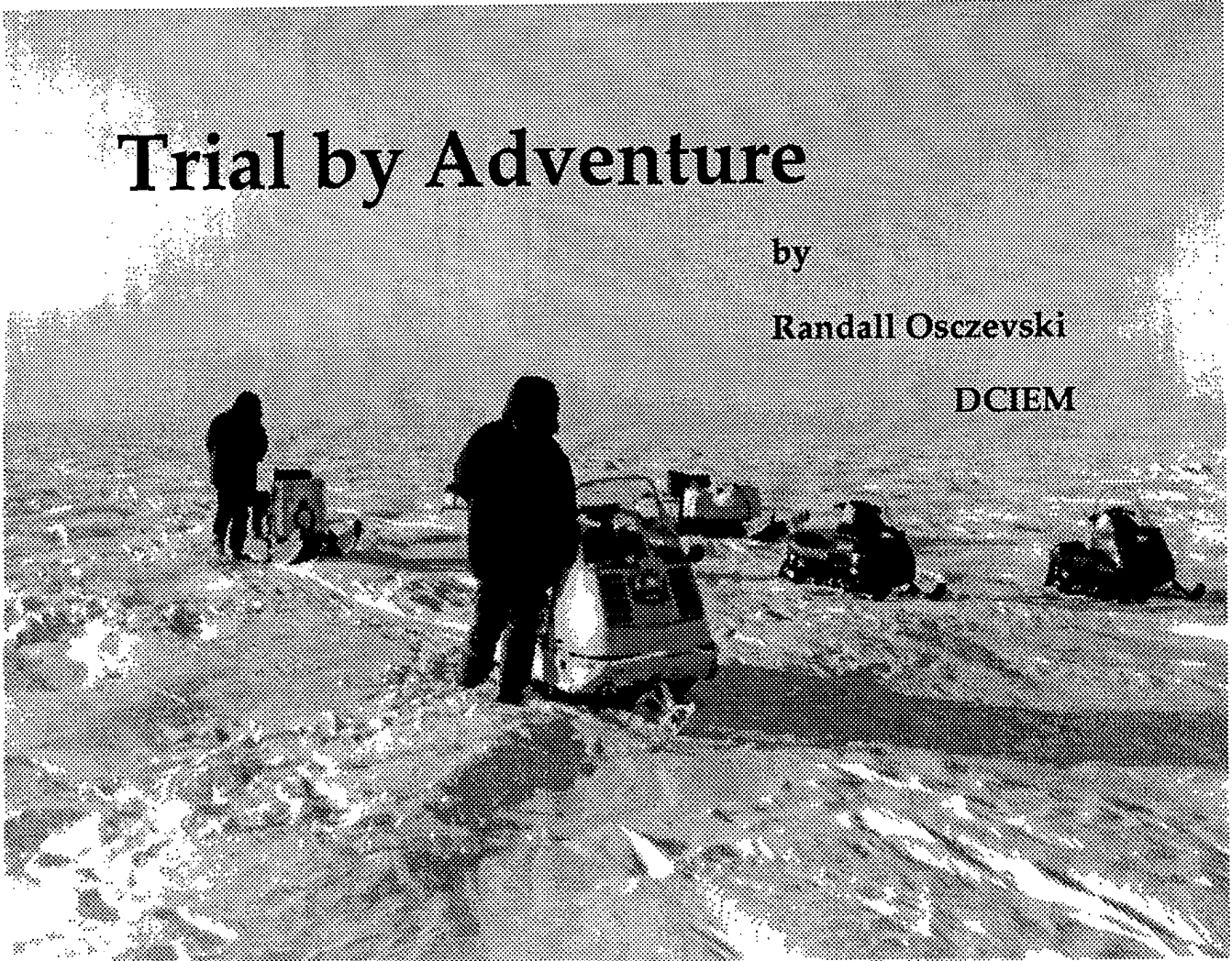

Trial by Adventure

Randall J. Oszcewski

Defence and Civil Institute of Environmental Medicine

In combat, cold injuries appear in numbers that are not usually seen in peacetime trials and exercises. Between 1986 and 1989, several experiments were carried out to examine a trial concept to provide a more rigorous peacetime test of protective equipment. A traveling system including an insulated tent, clothing and sleeping bag was developed to enable a small group to be self-supported for many days and to cover distances on the order of 1000 miles across open country, on snowmobiles. Two trials are described and the performance of the equipment and the success of the trial concept are discussed.

Trial by Adventure

Randall J. Oszcewski
Defence and Civil Institute of Environmental Medicine

INTRODUCTION

Webster's Dictionary defines adventure as:

"a: an undertaking involving danger and unknown risks

b: the encountering of risks <the spirit of adventure>. "

This entry is unsatisfactory, for it is incomplete. Adventure is not the journey, but the experience of it. As definition **b** hints, adventure is something you feel. In fact, it is an emotion, the complement of fear. Where fear is the painful expectation of impending danger, adventure is the optimistic anticipation of a new or exciting experience. Both fear and adventure can be powerful motivators, driving human beings beyond their normal limits of voluntary endurance.

In the performance of any hazardous task, individuals decide which aspect is the most important and focus on it (1). If getting the job done is most important, safety may suffer; if safety is the chief worry, task performance is likely to suffer. In combat, soldiers may ignore the pain that precedes cold injury if there are more important things to worry about. Tactics and avoiding high velocity metal objects take priority. In battle, cold injuries occur in larger numbers than expected from peacetime exercise experience and the injury rate is often proportional to the intensity of combat action (2).

In a cold weather trial or exercise, the cold is the only real enemy. Many soldiers feel that when the temperature falls below -40 ° F the danger to life and limb is at least equal to that of combat (3). Attention focuses on the cold. It becomes an honorable excuse to neglect tactical considerations and to ignore established procedures (4). Cold injuries are uncommon, and rates are related as much to the intensity of training as to the weather. As the cold deepens, troops spend more time in heated shelters and less time "soldiering". At some point, they stop being soldiers and become survivors. Unless the whole life support system fails, the consequence of inadequate clothing is often poor performance, not cold injury.

The purpose of military cold weather clothing is not simply to make soldiers comfortable or to keep them from being injured. Its purpose is to extend the range of conditions in which they can be militarily effective. Military forces can develop "delusions of adequacy" concerning their cold weather protective equipment because few cold injuries occur on peacetime exercises, where military effectiveness is of secondary importance. This delusion is shattered when they first encounter the realities of the cold battlefield. Equipment that seemed adequate in trials can fail in combat because trials do not often provide a realistic test. The problem is to identify these deficiencies in peacetime, when there is time to make corrections. We cannot ethically expose soldiers to the danger and fear that they might find on a battlefield just to produce a realistic trial. However, we can offer them adventure.

We carried out several field trials between 1986 and 1989 to test this idea and to support the development of a new cold weather clothing system for the Canadian Forces. The trials challenged the participants and exposed them to prolonged and often intense cold stress. Three to six-man teams simulated long-range patrols, traveling by snowmobile. A transport and life support system was developed to

enable them to be self-supported and to cover distances on the order of 1000 miles across open country. Independent mobility on this scale had been identified as a vital requirement for northern defence (5). We designed and built specialized equipment for these expeditions, such as an insulated tent and an extreme cold weather sleeping bag, and learned much about the conduct of extended, small-unit operations in the cold.

IMPORTANT FACTORS

Two factors were identified from previous trials as being important to the success of cold weather experiments of this kind. First, a trial must have a clearly defined and compelling goal -- one that all participants can adopt personally. The primary goal can not simply be: "to test a clothing system" or some aspect of its design. Although the experience of deadly cold can be challenging, the realities and the excruciating details of life soon take the adventure out of it. Rational people need a good reason to voluntarily endure avoidable discomfort. The attraction of a geographical goal, or some kind of record, can survive many hardships, as the history of exploration proves.

The second important factor is that any cold weather trial must take place far from settlements or heated buildings. The warmth and security of even the most austere accommodations can seem luxurious in comparison to the world outside its walls. Even though they might be a day's travel distant, warm shelters can sometimes be too close for discomfort.

TRAVEL ROUTES

The first test, named Trial Run (7, 8), took place in February of 1986 on the

west coast of James Bay. Trial Run II (9) occurred in the same area in late January and early February of 1989. In 1986, our plan was to travel from Moosonee, Ontario, at the southern end of the bay to Cape Henrietta Maria at its northern end, and then return. Moosonee is served by rail, which simplifies deployment, and has accommodations, outfitters and other services that are useful in mounting such expeditions.

In 1986 we planned to travel 690 miles, which is slightly longer than the longest unsupported snowmobile journey on record, but had to be satisfied with about two-thirds of that distance (Fig. 1) In 1989, we hoped to repeat that distance and to cross to Akimiski Island as well. The country through which we would travel was sparsely populated or wholly uninhabited, so avoiding heated buildings should have been easy. In both cases, the distance and time constraints demanded maximum effort from the participants. The lure of country rarely seen and untraveled by outsiders was also a useful incentive to travel.

Much of the planned route in each case was over landfast sea ice, which was expected to provide a safe and stable platform. On the sea ice, low winter temperatures and high wind speeds could be expected. There was also a winter snow road, made each year by tractor trains to haul supplies to the small communities near the coast. The coastal route offered a variety of snow conditions ranging from deep, soft snow in the boreal forests and coastal marshes to hard, wind-packed snow on the beaches and on the frozen surface of James Bay. We expected the river crossings to be solidly frozen in February and timed the trips to avoid the highest tides, which might flood the ice. However, we could not schedule around high winds, which caused some overflow, and high stream flow caused by melting temperatures hundreds of miles upstream.

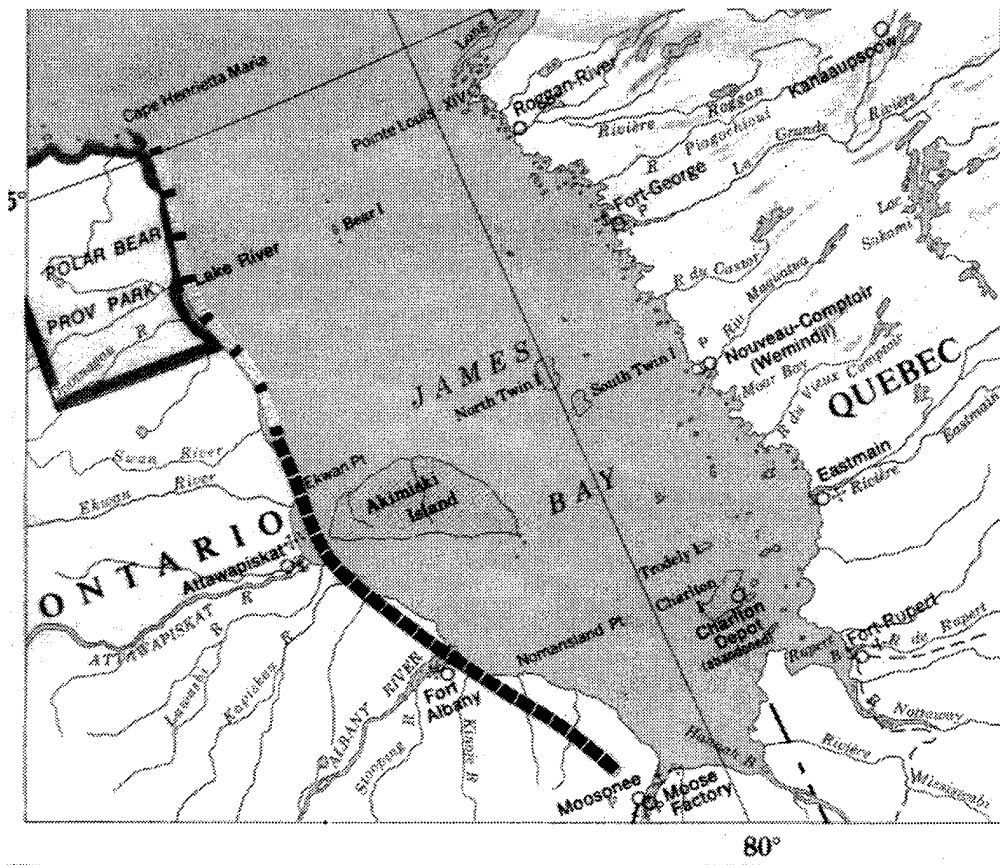

Fig. 1. Map of James Bay showing the planned route and the actual route followed by Trial Run in 1986. Trial Run II followed a similar route in 1989. Each division on the actual route line (black) is approximately equal to 8 miles.

POLAR BEARS

Part of the 1986 route was to pass through Polar Bear Provincial Park, a wilderness area so-named because it is a major winter denning area for those animals. Because of the season polar bear encounters were not expected, but could not be confidently ruled out. This added a note of realism to the exercise, for polar bears are the world's largest land carnivores. They are also one of the few animal that are known to hunt humans.

Out of respect, we carried a firearm. We also carried a trip-wire alarm that could be deployed around the tent, and a second tent so that the one we slept in would not smell like food. Later, we realized that to a polar bear, *we* smelled like food. In 1989 we carried two 303 rifles and the recommended bear defence weapon, a pump-action, 12-gauge shotgun with sights (10). Ammunition for this weapon included slugs, exploding scare cartridges and plastic slugs, designed to deter a curious bear without killing it. Fortunately we didn't have to put them to the test as no subjects presented themselves.

EXPERIENCE

We were not snowmobile enthusiasts prior to Trial Run, and we certainly aren't now. In January 1986, our combined driving experience was less than one full day. Only about four hours of this total had been acquired in the North. Some aspects of the trial remained a theoretical abstraction until late the long car drive north to the southern end of the railroad to Moosonee. Reality manifested itself in a moment of mild panic when the scale and the isolation at last began to sink in. That was when I realized that there is no sharp line between adventure and fear.

SNOWMOBILES

We borrowed two snowmobiles in 1986 and bought a third. We chose the simplest and cheapest available snowmobile, the Skidoo Elan. It is widely used in the North by the residents and has a good reputation as a utility machine. It is also light enough to be man-handled out of most difficulties. One of the borrowed machines was a Skidoo Alpine, which was twice as powerful and heavy as the Elan. Many of the spare parts were interchangeable, fortunately. For trials in 1988 and 1989, we purchased three additional Skidoo Elans.

The biggest mechanical problem we found was that half of the engine mounting bolts broke. Another problem, probably related, is the rough ride. On each trial we travelled a distance roughly equivalent to driving from Washington, D. C. to Burlington, Vermont, but on something less than an interstate highway. Because of drifting, there is a bump of some magnitude every 30 feet or so. In 500 miles there are on the order of 100,000 significant jolts. The bogie wheel suspension just does not have the travel to soak all of these up. The drivers had to kneel on the seat so that they could flex at the hips. We had "rug burns" on our knees before long. In 1989, 4 inch thick foam pads were added to the seats, which helped, although much of the time, the drivers were still on their knees.

SLEDS

Each snowmobile pulled a sledge modelled after the Inuit komatik, 16 to 18 feet long. They had ten-inch deep, two-inch wide fir plank runners shod with half-inch thick strips of ultra high molecular weight polyethylene. In tests, when loaded with 1200 lbs of concrete blocks, the Elan could pull the sled at 15 mph in six inches

of granular snow. In deep soft snow, it took only 80 lbs of force to move half a ton of sled, and on hard-packed snow, only 25 lbs. Pulling straight ahead was no problem for the small machine. The trouble came when trying to make tight turns in soft, deep snow, which sometimes caused the Elan to bog down.

In 1986 much of the load was carried in canvas tanks from the tent group toboggans used by dismounted infantry. These opened at the top and had speed lashing closures. They worked but were inconvenient, for often one had to unlash the whole thing to get something out. In 1989 we put much of the load in rugged polyethylene boxes the same width as the sleds. Nylon cargo straps were used to hold them to the sleds. To prevent lateral movements, soft, open-cell polyurethane foam pads were placed between the boxes and the deck of the sleds. Fuel cans were placed in half-height cardboard boxes, in units of three, and secured to the sled deck with a single cargo strap.

In 1986 we used long tow ropes, which made the sleds hard to control. They could also become tangled in a track. This was a problem for the Alpine which had a reverse gear. Using ropes was also hazardous as the sleds would continue to move after the snowmobile had stopped. This eventually took out all the tail lights, but more importantly, if the driver fell off the machine, which happened occasionally, the half-ton of sled could run him over. The long ropes were replaced by semi-rigid hitches in 1989, made of ultra high molecular weight polyethylene. The plastic was very strong and because it was bent into a bow shape, it deformed to minimize shock loading. Plastic was preferred over a steel tongue, which if it broke, might become a spear aimed at the driver's back.

FUEL

Each sled carried 12 plastic jerry cans holding 72 US gallons -- a load of 480 lbs when full. We learned to use wire to keep the caps from vibrating off the cans. With this fuel load, the Elan had a range of 900 miles. The Alpine used twice the fuel of the smaller machines in 1986. In 1989 the Elans averaged 12 miles/US gallon. Small amounts of gas line anti-freeze (methanol) were added now and then. In 1989, we carried several litres of methanol to fuel a heater that was supposed to keep radio batteries warm. Although the heater failed, its fuel came in handy.

One of the snowmobiles drowned when it went into a hole in the ice and sucked in an engine full of water. When we pulled it out of the steaming, black water, at - 5 °F, it became a block of ice before our eyes. This disaster threatened to end our trial. In the gathering darkness, we chipped off what ice we could and then gave the engine the equivalent of mouth-to-mouth resuscitation. Another snowmobile was run up alongside, its engine running at a high idle and its track lifted clear of the snow. The cooling shroud of the engine of this machine had been modified to take a 4 inch diameter hose. We didn't have the hose, but we improvised brilliantly. We put an outer parka over the ice-covered engine and muffler, and connected one sleeve to the cooling shroud of the running engine. This supplied 5 to 10 kilowatts of heat and dry air to an insulated enclosure around the ice-covered engine. In short order, streams of water began to run out from under the parka. Hours later, after we had emptied the crankcase of water, changed the spark plug, filters and carburetor and had run several pints of methanol throughout the fuel system, the engine started on the second pull. This success was vital to our confidence.

SNOWMOBILE STARTING

We found that these snowmobiles were easier to start in extreme cold if they were primed ten or fifteen minutes before the starter cord was pulled. The cold engine stalls after a few seconds unless it is primed again when it starts to die. It may be necessary to do this several times before it is warm enough to run on its own. Using this procedure, I was able to start the Elan snowmobiles after they had stood overnight at -44 °F. Straightening the arm while pulling the starter cord can cause an affliction identical to tennis elbow. On one of these trips, I developed this in both arms, having switched when the first had become painful.

TENT

Normally we selected camp sites that had some protection from the wind. The snow in such areas is often deep and soft. We found that it was best to unhitch the snowmobiles and use them to pack down the snow before attempting to pull the heavy sleds into the area or walk in the deep snow. In an hour or so the packed snow would set hard enough to walk on. Meanwhile, the tent could be set up and other chores performed.

A specially designed tent (11) was used in both trials. It was semi-cylindrical, 4' 1" high at the centre line, with a square floor area, measuring 8' 2.5" on a side. It comfortably housed three men in 1986 and four men in 1989 (Fig. 2). The tent was a very warm shelter for it was insulated with a layer of continuous filament polyester batting 0.8 " thick. Batting is a better insulator than a layer of air between two tent walls, particularly in gusting winds when tent walls vibrate and flap.



Fig. 2. The tent, sled and snowmobile used on Trial Run II.

Even when this tent was not heated or occupied, it was much warmer than the outside air. The interior of the tent was warmed by heat from the ground, for the ground under the snow in winter can be much warmer than the air temperature, as the lemmings and other small creatures know. This is particularly true on or near sea-ice.

Like a house, an insulated tent needs a vapour barrier to keep water from condensing in the insulation. In this case, the vapour barrier was a thin, aluminized mylar sheet to which the batting was bonded. The aluminum coating served to conceal the tent by reflecting light back into the interior. Because the vapour barrier is also an oxygen and carbon monoxide barrier, adequate ventilation is essential. This means more than having an opening at the top to let the exhaust fumes out. A heated tent is like a fireplace in a well-sealed house, it must have an opening at the top and a fresh air vent nearer the base to ensure that there is ventilation. As the tent had no floor, some air usually entered around the base of the wall, however, vents were also placed low on the wall. In a tent with sewn-in floors, a billowing floor is a sign that ventilation may be inadequate.

To stop condensation or melted frost from dripping from the ceiling onto the occupants, the inner surface of the vapour barrier was bonded to a light mesh fabric made of Nomex. This soaked up melted frost, which is abundant in the morning, and holds it to be evaporated or wicks it down to the snow floor. In 1989, the packed volume grew daily. Frost somehow made its way into the batting. This did not affect its warmth but it added about 20 lbs to the weight. If it had become a problem, I believe we could have dried it out with the hot air from one of the snowmobiles. Because other tents of this design did not accumulate frost, we suspect that the vapour barrier must have been damaged in some way.

STOVES

Cooking and heating was done with Optimus 111B stoves in 1986 and with MSR Whisperlite stoves in 1989. Both burn naphtha. The latter has the convenience of separate fuel tanks which could be changed in the tent. The tanks were refuelled outside. We replaced the O-rings of these stoves, which had leaked in cold chamber trials, with O-rings made of nitrile rubber. The plastic pump handles split longitudinally in the cold but this was only a minor inconvenience.

The stoves burned cleanly under a grill which raised the pots above the tips of the flames. This probably slowed cooking but it also prevented or reduced the formation of carbon monoxide. Any stove will produce irritating fumes and deadly carbon monoxide if the flame is cooled by a snow-filled pot. In seven nights we burned 3.7 US gal. of naphtha, which is fuel consumption rate of 1 US pint per man/night.

We ate the standard boil-in-bag rations by the light of a fluorescent lantern -- after it had warmed up enough to work. At night, breakfast bags were placed in hot water in a large vacuum flask so that they would be warm in the morning to save time. We never really solved all the problems of getting away quickly in the morning. Sometimes it was almost four hours between waking and driving off, but when the urge to get it over with became strong, we got it down to an hour and a half.

SLEEPING BAGS

We needed a sleeping bag that would provide a full night of sleep at the expected low temperatures. A small group cannot afford to keep someone up at night in shifts to keep a stove burning if it is too cold to sleep without it. This is a peacetime practice that would probably have to be sacrificed in war in favour of military effectiveness, i. e. concealment. Experiments on earlier winter exercises had shown that far more heat was lost through the compressed bottom of the bag and air mattress to the ground than through the top to the air in the tent. Heat loss could be greatly reduced by changing the distribution of insulation so that more was between our bodies and the cold ground. We experimented with warm but bulky sleeping bags that had incompressible pads. The last prototypes (Fig. 3) had a pad that was almost incompressible vertically, but could be compressed in a horizontal direction to about 40% of its original volume for stowage (12). This proved quite successful, although it was still a bit too bulky for dismounted infantry. On another trial we used it comfortably in an unheated and uninsulated tent at a temperature of -58 °F.

Moisture accumulation in sleeping bags can be a problem in long term use. After eight nights, this one typically collected about a pound of water. Most of this was probably condensed water that had evaporated from the skin, or from the breath. The outer shell collects frost, especially at the head end, which melts and soaks into the bag. In 1989 we attempted to protect the sleeping bags with Gore-Tex covers. After 8 nights it appeared that the bags with covers might have picked up more moisture than the control bag which had no protective cover. We concluded that in our tent at least, the covers were of no net benefit.

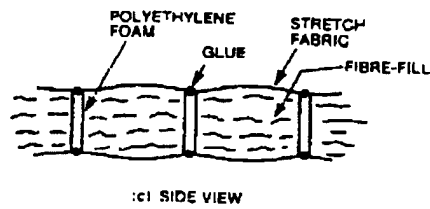
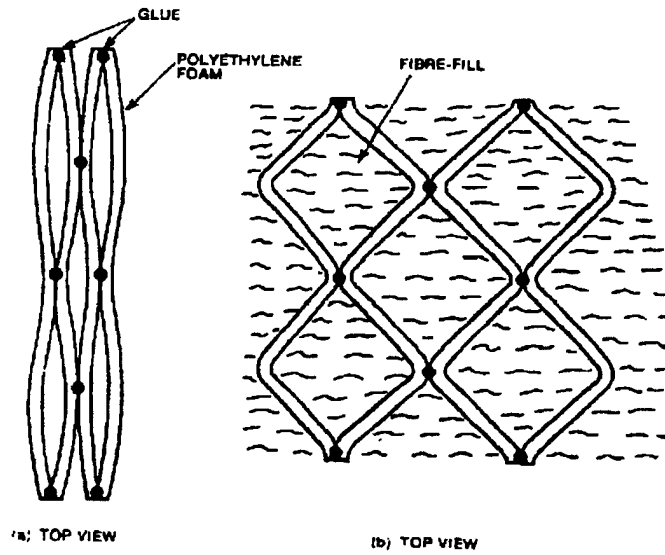
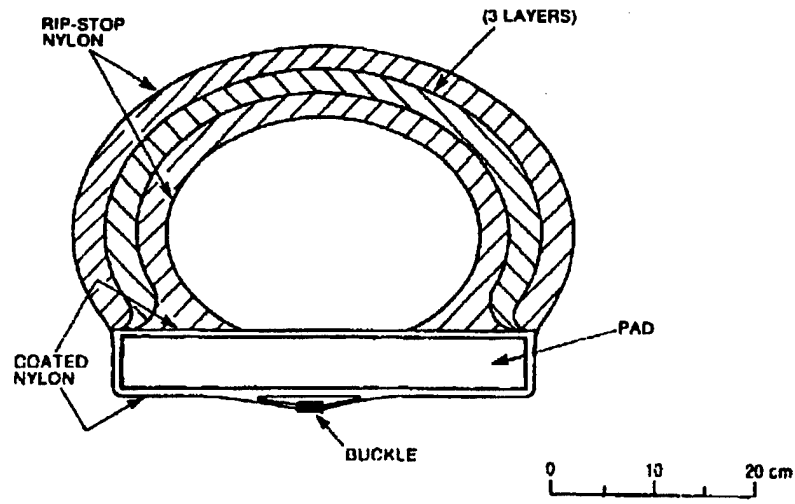

Fig. 3. The design of the sleeping bag and built-in pad.

GORE-TEX™

In the laboratory, I did some experiments to determine how permeable Gore-Tex II is at low temperatures (13). As the temperature of the fabric fell, the coating became increasingly less permeable (Fig. 4.), so that at a temperature below freezing, far less water vapour could diffuse through it. We also discovered that Gore-Tex II is often much less pliant at temperatures below -40 °F and noisy. In the laboratory, Gore-Tex does not stiffen noticeably in the cold. I believe the noise and stiffening might be caused by the freezing of the water that was absorbed by the hydrophilic coating when the clothing was last taken into a warm tent.

Gore-Tex II is "breathable" to water-vapour at normal temperatures because that molecule is polar and can diffuse through the hydrophilic coating. I wondered how "breathable" it and other "breathable" coated fabrics might be to oxygen and carbon dioxide, which are not polar. Measurements of diffusion resistance showed (Fig. 5) that many of these materials are essentially impermeable to oxygen and carbon dioxide (14). Gore-Tex II, and many of its competitors, does NOT "breathe" to any significant extent, except with regard to water vapour. The temptation to close a bivy sac or a small tent tightly in very cold weather is hard to resist. A sleeping man, in a tightly closed tent or bivy sac could partially deplete the oxygen and enrich the carbon dioxide in the enclosed air. The oxygen depletion might only be a hazard on a high mountain, but the higher carbon dioxide concentration could make it hard to get much sleep at any altitude.

CLOTHING

We used clothing similar in overall design to the recent Canadian Forces cold

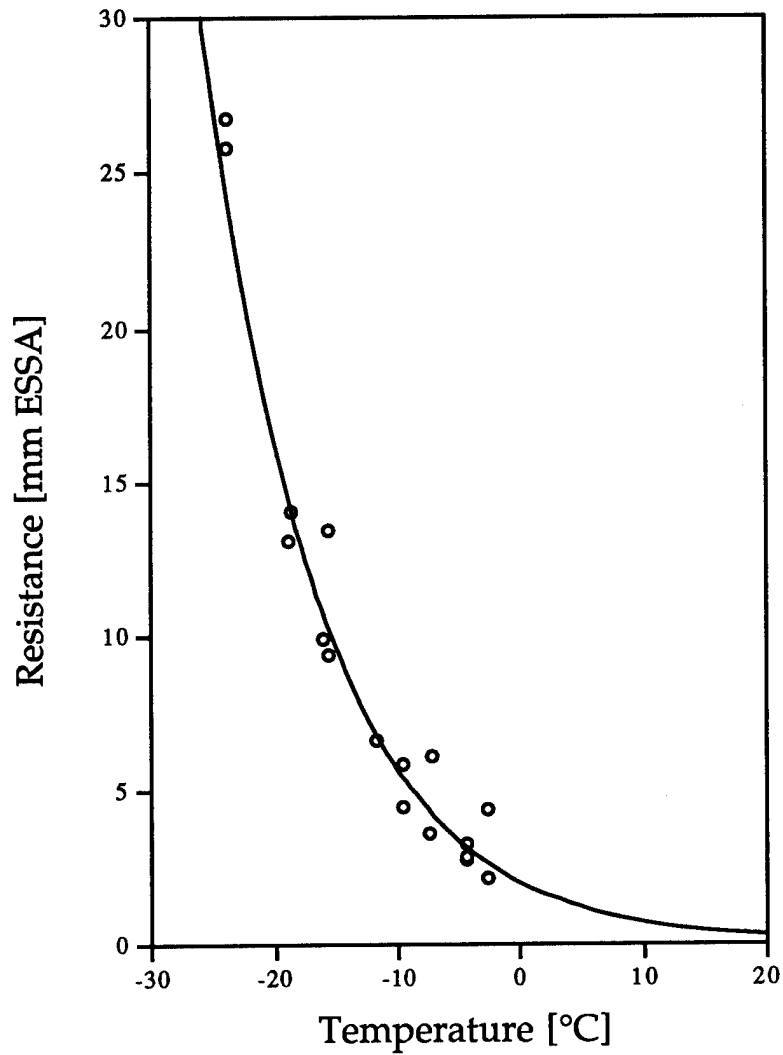

Fig. 4. The effect of temperature on the water vapour diffusion resistance of the hydrophilic component of GoreTex II adjacent to ice, in millimeters of equivalent standard still air.

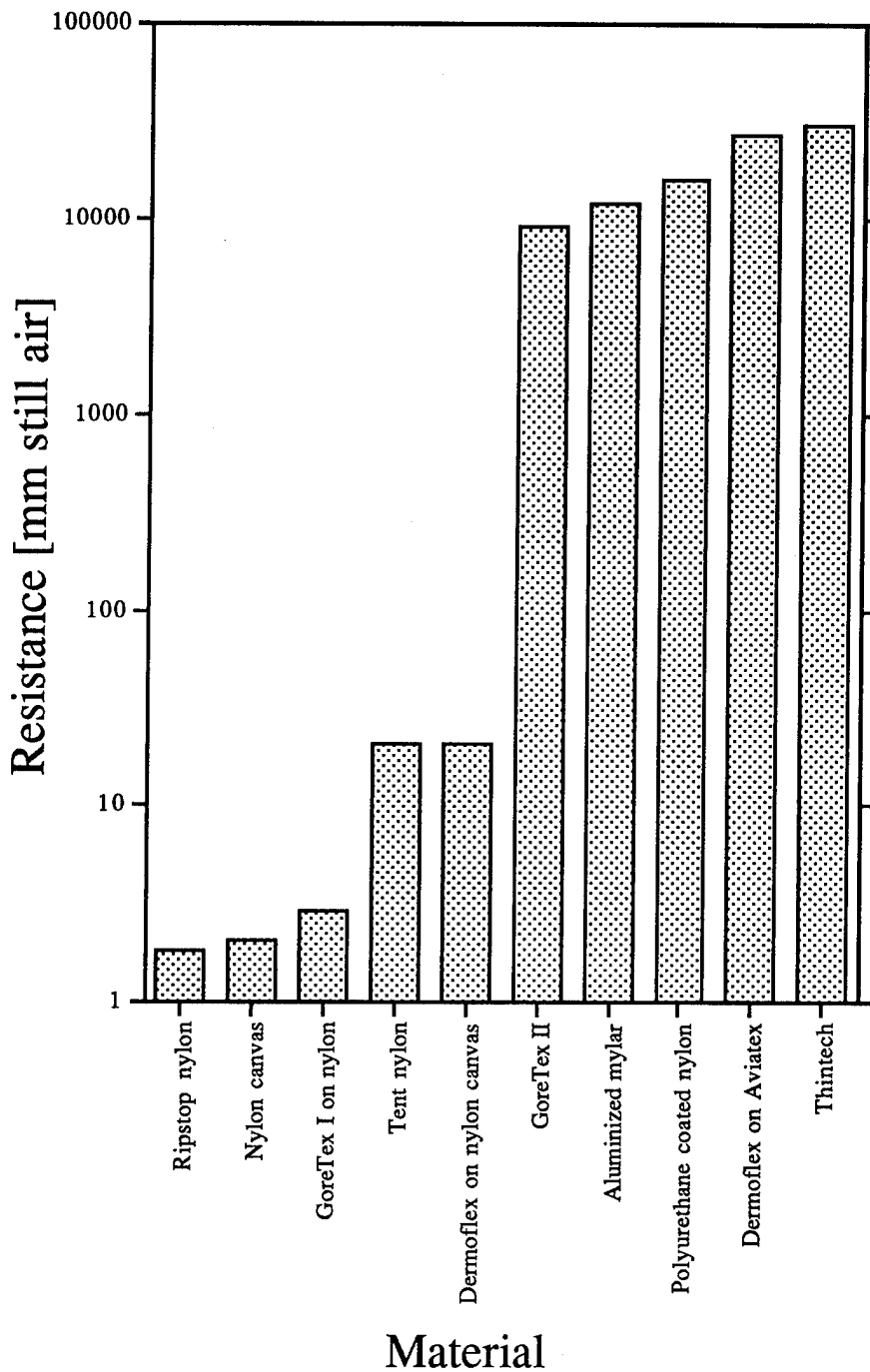

Fig. 5. Oxygen diffusion resistance of sample of ordinary and coated fabrics (14).

Note the logarithmic scale.

weather clothing, which Dr. John Frim has already described. One major difference was that the clothing shells utilized Dermoflex rather than Gore-Tex for wind and rain protection. The outer parkas and trousers were also simpler items, for they were just insulating covers meant to be conveniently removed and packed away when not needed. They were designed without pockets for this reason.

In 1989 we wore open-faced snowmobile helmets with double walled transparent visors, insulated face masks and balaclavas. An impermeable cover, fitted to the face below the eyes and over the bridge of the nose directed the humid breath away from the visor and glasses. This prevented frosting even at high work rates. The helmets were left outside to avoid the condensation problem that occurs when a cold item is taken into a heated tent. No long term problems with moisture accumulation were noticed.

WEATHER

The temperature was, on average, 18 °F colder in 1989 than it had been in 1986, averaging about -17 °F. It was also windier, at least on the ice. During travelling hours the wind normally ranged between 15 mph and 25 mph as measured at head height, which probably corresponds to meteorological reports of 25 to 45 mph. Of course, travelling on snowmobiles at around 20 mph often adds to the effective wind, especially since much of the body was above the meager protection offered by the low wind shield. Tail winds were rare, of course.

COMMUNICATIONS

HF radio communication was maintained between the field party and the

base in Ottawa, 600 miles away. A distant commercial radio-telephone system serving remote areas was available as a backup. In 1986 the field party used a military radio (AN/PRC 515) with a maximum output of 20 watts. The primary antenna was a corner-fed delta loop. Contact with the Communications Research Centre in Ottawa, which used a large log-periodic antenna at a height of 100 feet, was established on a power of 2 watts.

A crystal-controlled 10 watt transmitter (Spillsbury Communications SBX-11A) was also used successfully, both in 1986 and 1989. Less successful, was a 100 watt HF radio, powered by NiCad battery packs. Its batteries could not be kept warm and were too massive to warm up quickly. This was in contrast to the SBX-11A which was powered by alkaline D cells that could be warmed with body heat, if necessary. Field party transmissions with what should have been the more powerful radio, had to be relayed by a Ham radio operator. On one occasion, we failed to make contact by radio and had to detour to one of the small communities to use a telephone.

Brackets were affixed to the snowmobiles so that aluminum poles could be quickly erected to raise the ends of the dipole antenna. This eliminated the need for guy wires and made it easier to change frequencies. The radios and coaxial cables were kept warm in a heated, insulated box while on the move, as was a Magnavox MX 4102 satellite navigation system, a SARSAT beacon and the cameras. The coaxial cable for the radio was often frozen stiff in the morning and had to be pulled through a vent into the tent in six foot stages to be warmed and dried before being rolled. A low temperature cable is apparently available.

We had no luck with short range FM transceivers for communication

between snowmobiles. The range was too short and VOX operation was defeated by the high noise levels. The long days were largely solitary, occasionally broken by a few words shouted over the roar of the engines.

DISCUSSION

On these trials, heating fuel consumption was half of a pre-trial estimate based on fuel use during a conventional trial in similar weather, with a similar tent. This indicates that far less dependence was placed on the tent to compensate for the inadequacies of the protective clothing. On a daily basis, we were out in the weather for twice as long as long as we had been on a previous trial of cold weather equipment, or as infantry soldiers normally are on winter exercises (15). The periods during which we were continuously exposed to the cold were four times as long (8).

On our first trial, we used the latest prototypes of a clothing system that had weathered several conventional exercises and trials. We were confident that the clothing would be the least of our problems. In keeping with historical precedent, it came as a great surprise that the latter hours of each of the last five days of this trial were among the most miserably uncomfortable of our lives. Despite this discomfort, we travelled longer and farther on the last days, driven by a powerful urge to "get it over with". This drive, which has been previously described (4), was very strongly felt and very useful from the perspective of the trial.

Once we had turned south in 1989, the same urge was experienced. The ice at Ekwan Point had been too rough to consider crossing the strait to Akimiski Island as we had planned, especially as we had damaged the engine mounts. In 1986, we had

not been anxious to leave the familiarity of the snow road to travel on the sea ice along the shore, but we did eventually. Now we were not anxious to leave the now-familiar shore ice to travel across the ice bridge to an island that lay somewhere out in the whiteness, beyond our vision. By the time we reached smoother ice farther south, it was too late. We were already in return mode, and "getting it over with".

Brad Cain and I took part in both trials. We agreed that the changes to the clothing inspired by the first trial had been improvements. Although the weather conditions had been worse on the second trial, we had been less uncomfortable. Still, there had been times when we had to get off the snowmobile to warm up by running a hundred metres or so. At one point we made a 15 mile (25 km) detour to reach a heated building for a short break from the cold. A particularly painful problem was keeping the hands warm after several hours of driving, particularly the thumb on the right hand, which controls the throttle. Frostbite was limited to a few small patches on one driver's face and the loss of some skin on finger tips and around fingernails.

CONCLUSION

When compared to documented military exercises and more conventional trials carried out by the some of the same researchers, the Trial Run expeditions were far more demanding and rigorous. The participants spent much longer in cold conditions and exceeded previous levels of voluntary discomfort.

The trials also showed that independent northern patrols of the order of 1000 miles are possible, using the life-support, communications and traveling systems that had been developed.

ACKNOWLEDGEMENTS

Brad Cain (Defence & Civil Institute of Environmental Medicine), Dr Brian Farnworth (Meta Research), Dr. Lloyd Reed (Laurentian University and Science North), Alan Keefe (Defence & Civil Institute of Environmental Medicine) and L. Andre Main (AERA Technology) participated in these trials. Cain and Farnworth, in particular, contributed a great deal to the development of the systems needed to carry them out.

REFERENCES

1. Godden, D. and A. Baddeley, (1979). The commercial diver, p 156-177 of Compliance and Excellence. A Study of Real Skills, Vol. II, edited by Singleton, W.T., MTP Press Ltd., Lancaster, England.
2. Whayne, T. F. and M. F. DeBakey (1958). Cold Injury, Ground Type Surgeon General, Depart.of the Army, Washington DC. p 425.
3. Fine, B. J. and J. L. Kobrick, (1978). Human Performance Under Climatic Stress and the Myth of the "Average" Soldier: Potentially Serious Implications for Military Operations in Extreme Climates. USARIEM-M-15/78.
4. Coffey, M. F. (1953). Psychological studies of adjustment to cold on northern military exercises in winter. OAR Paper VI, 5th Defence Research Board Symposium, Canada.
5. Mobile Command Arctic Training Plan, 1980-85, FMC 3350-9 (Op Trg).
6. Oszcewski, R. J. (1985). Delusions of adequacy: protective clothing on peacetime military exercises. Presented at the Commonwealth Defence Sciences Symposium, Brighton, England, May 1985.

7. Oszcewski, R. J. (1986). Long-distance travel by snowmobile on the west coast of James Bay. Defence Research Establishment Ottawa Technical Note 86-18.
8. Oszcewski, R. J. (1986). Trial Run: A test of an unconventional concept for trials of cold weather clothing. Defence Research Establishment Ottawa Report 945.
9. Oszcewski, R. J. (1989) Trial Run II. A cold weather clothing and equipment trial conducted on the west coast of James Bay. Defence Research Establishment Ottawa, Technical Note 89-14.
10. Clarkson, P. L. (1989) The twelve gauge shotgun: a bear deterrent and protection weapon. P 55-59 of Bear-People Conflicts: Proceedings of a symposium on management strategies. Bromley, M. editor. North West Territories Dept of Renewable Resources.
11. Cain, J. B. (1985) High arctic reconnaissance tent. CDA 4, 14th Commonwealth Defence Conference on Operational Clothing and Combat Equipment, Australia.
12. Farnworth, B. ; R. J. Oszcewski, and P. A. Dolhan (1985). The development of an arctic sleeping bag, CDA-2, 14th Commonwealth Defence Conference (Operational Clothing and Combat Equipment), Australia.
13. Oszcewski, R. J. (1993). Diffusion of water vapour through cold Gore-TexTM Defence Research Establishment Ottawa Report 1202.
14. Oszcewski, R. J. (1992). The use of waterproof, breathable coated fabrics in tents: potential hazards of high altitudes. 16th Commonwealth Defence Conference (Operational Clothing and Combat Equipment), Singapore.
15. Allen, C. L. and W. J. O'Hara (1973). Energy expenditure of infantry patrols during an arctic winter exercise. Defence and Civil Institute of Environmental Medicine Report 73-R-985.

**WATERPROOF, BREATHABLE FABRICS
FOR MILITARY CLOTHING SYSTEMS:
AN INNOVATIVE APPROACH TO ACQUISITION**

Neil E. Smedstad
U.S. Army Natick RD&E Center
Natick, MA

WATERPROOF, BREATHABLE FABRICS FOR MILITARY CLOTHING SYSTEMS: AN INNOVATIVE APPROACH TO ACQUISITION

Neil E. Smedstad, U. S. Army Natick Research, Development, and Engineering Center
Natick, Massachusetts

The U. S. Army Natick Research, Development, and Engineering Center (Natick) is charged with the mission to continually improve the protective clothing systems and individual equipment for soldiers and marines in the field. For the past ten years we have relied on the use of state of the art materials that resist penetration of water, while allowing moisture vapor to pass out through the garments. The use of such materials minimizes condensation of moisture that could create a conductive cold layer next to the skin, keeps the wearer dry, and reduces the potential for cold injuries.

The first clothing system to use this "moisture management" principle was the highly successful, Extended Cold Weather Clothing System or ECWCS. Introduced to the Army in 1986, this system provides extreme cold weather protection to soldiers and marines operating in cold/wet and cold/dry conditions at ambient temperatures ranging from +40°F to -60°F. As highly successful as the system was, in nine subsequent years of use, it became evident that improvements needed to be made. The situations which lead to this decision included 1.) a sole source supplier for the basic waterproof, breathable material, and 2.) soldier and marine feedback from the field indicating use of the parka outside of the environmental envelope, i.e. higher temperatures and wetter conditions, effectively becoming the field coat of choice.

The United States Army Infantry School and the United States Marine Corps Systems Command proposed a joint Army/Marine Corps program to address these concerns and bring the ECWCS back to the state of the art. This new program is referred to as the Second Generation Extended Cold Weather Clothing System (2GECWCS).

While coordinating the requirements, we were presented with a number of challenges. First, there had very limited success in interesting potential competitors to supply the basic material in previous alternate materials programs. Second, downsizing in the Government had led to limited internal prototyping and designing capabilities. Third, Government policy changes were driving us toward "performance specifications". Finally, in order to fit production into the supply pipe line without the need for bridge buys, we were given an eighteen month time frame to complete the program.

BUILDING THE PROGRAM

Obviously an intense innovative approach was required in order to meet these lofty goals. An acquisition strategy, collaboratively developed by the Project Manager, Soldier and Natick, was devised, and was based in part on some techniques which were being considered in an on-going chemical protection program. The strategy was supported by industry and academia and encompassed a non absolute material performance specification leading to a Qualified Materials List, leveraging industry for materials and designs for the garments, comparative testing of contractor's submissions in operational testing, and a production award to the successful design contractor.

MATERIALS SPECIFICATION

The materials requirements, in the past have been perceived as being gold plated, and only attainable by one manufacturer. Part of the strategy was to dispel that contention and to present a set of parameters that reflected the minimum requirements of the Government and were consistent with normal commercial practice. Materials scientists from Natick performed a complete review of the existing military specification and concentrated on the goals of attaining the best quality materials with the most reasonable requirements. An example of recommended changes are listed in Table I.

Table I

CHARACTERISTIC	EXISTING REQUIREMENT	PROPOSED NEW 2GECWCS REQUIREMENT	TEST METHOD
Tearing Strength	Warp: 3.5 Kgf Filling: 3.2 Kgf	Warp: 3.0 Kgf Filling: 3.0 Kgf	ASTM D 2582

RATIONALE:

Reason for Change: To accommodate state-of-the-art of coated and two layers laminate materials. Expand supply base.

Why 2GECWCS Requirement is correct: Based on good performance of Wet Weather Parka & Trouser in field service.

Each material requirement was reviewed for revision or for maintaining the status quo. When the recommendations were completed, Natick convened a technical review panel to scrub the recommendations to approve, disapprove, change, and finalize each individual fabric requirement. This panel consisted of members representing Natick, and the U. S. Navy Clothing and Textiles Research Facility, the Chief of the Defense Personnel Support Center Quality Assurance Division, a representative of the Project Manager, Soldier, the former Chairman of the University of

Massachusetts, Dartmouth Textile Sciences Department, and the Materials Testing Department Manager of a large east coast mail order and retail outerwear manufacturer. This distinguished panel analyzed and approved a sensible, attainable set of requirements that adequately described the needs of the Government in terms of best commercial practice for inclusion in the Request For Proposals for the 2GECWCS are contained at Appendix A.

PARKA AND TROUSER REQUIREMENTS

Concurrently, the U.S. Army Infantry School and the U.S. Marine Corps Systems Command approved and published the operational requirements for the parka and trouser (1) (2). These requirements were developed in a meeting at the Cold Regions Test Activity in Alaska by Army and Marine Corps experts who have worn and operated in the uniform, and who have spent considerable time in cold regions, training, and training others, in such specialties as military mountaineering, search and rescue, cold weather operations, and survival. These requirements are contained in Appendix B.

DOWN SELECTING THE CANDIDATES

Natick R, D, &E Center convened a Pre-Solicitation Conference and invited industry participation. Industry was encouraged to team, combining materials companies with end item manufacturers. In order to fairly and objectively evaluate proposals for the effort, a down selection plan that incorporated materials, and end item prototype testing was developed by Natick's Behavioral Science personnel. They provided a downselection plan (3) that included identifying each services' requirements for the 2GECWCS, prioritizing the criteria for selection for each service, rating the performance of candidate systems on each criteria from test results, entering the ratings for each candidate into a decision model for comparing alternatives, and documenting the decision process and its methodology.

The development and preliminary structure of the decision model was established by review of the requirements documentation of the program, and was built using a software tool based on the Analytic Hierarchy Process (4). The initial model involved two "decision trees", one for materials and one for the end items. These trees were modified based on input from user and developer inputs, and because the structures became almost identical, the trees were merged into one tree with the understanding that it would be used in two phases. Phase I would involve materials evaluation and selection using materials data and Phase II would evaluate design attributes, and ensemble characteristics. Data points would be taken from laboratory/chamber testing, developmental field testing, and operational field testing.

The final structure of the model (Table II) had three levels. Level one represents categories of criteria for MATERIALS FACTORS, HUMAN FACTORS, AND ACQUISITION FACTORS. The second level represents the main criteria under each factor. The third level presents the sub-criteria which defines some of the second level criteria.

		Table II.	Combined Army/USMC Weight
GOAL	MATERIAL	INSULATION	.04690
		REPELLENCY	.06350
		MOISTURE PERM	.05989
	DURABILITY	TEARING	.00902
		BREAKING	.00902
		STIFFNESS	.00902
		ABRASION	.00902
		POL/DEET	.00902
		SHRINKAGE	.00902
		SURFACE	.00902
		WEIGHT	.02915
		WEIGHT/ BULK	.02786
			/BULK
	PERFORMANCE	COLORFAST	.05051
		CAMO/IR	.04402
		MOBILITY	.03448
		FLEXIBILITY	.02988
		WARMTH	.03665
		COMFORT	.01656
		POCKETS	.01907
		HOOD	.01907
		LININGS	.00918
		ACCEPTABILITY	.01052
	HUMAN FACTORS	STYLE	.00829
		NOISE	.00976
		FIT	.05537
		WEAPONS	.01587
		CLOTHING	.01664
		COMPATIBILITY	.01626
		LOAD BEAR EQUIP	.01236
VEHICLES			
EASE OF USE		.02181	
MAINTENANCE		REPAIR	.01782
LIFE CYCLE COST	LAUNDERING	.01969	
	MATERIAL COST	.01556	
	LICENSES	.01556	
	PATENTS	.01556	
	CONTRACT	.01556	
	AVAILABILITY	.05362	
	PRODUCTION	.05433	
	SHELF LIFE	.05577	
	DISPOSAL	.03598	
	ACQUISITION		

Once the decision tree was finalized, a rating questionnaire (Figure 1.) was administered to technical experts representing the material and combat developers, to rate the relative importance of first, the Level I categories, and then, Level II, and some of the Level III criteria.

When entered into the software program, the relative weights for each criterion was computed for each service. A combined weight for each criterion was also generated for use in the Phase I material selection.

A ratings scheme was established where test results for each criterion was converted to a descriptive rating of either Above Standard, Standard, or Below Standard, having a numerical value of 1.000, 0.667, or 0.333 respectively. In the case where there is a minimum value for Below Standard, a value below the minimum is considered a failure and scored as a zero. The

conversion of laboratory chamber, developmental test and operational test is based either on user requirements or technical experts judgement prior to the testing phase or on a statistical comparison with test values of the baseline or standard system (Table III).

The rating value on the particular criterion for a given offered system is then multiplied by the user's weight of importance for that criterion. The final score for the candidate system is the sum of the rating values times weights across all criteria. The candidate systems are then ranked according to the totals based on this weighted model (Table IV).

Table III.

DURABILITY	Tearing Strength (ASTM D 2582)	ABV STD > 3.3X3.3 STD 3.0X3.0-3.3X3.3 BLW STD > 2.6X2.6		
	Breaking Strength (ASTM D 5034)	ABV STD > 150X120 STD 135X100-150X120 BLW STD > 100X100		
	Shrinkage (AATCC # 96)	ABV STD < 2.5X2.0 STD = 4.0X2.0 BLW STD > 4.0X2.0		
	Physical Surface Appearance Change (Proc. "E")	STD Pass BLW STD Fail		
WEIGHT/BULK	Weight (ASTM D 3776)	ABV STD < 5.0 STD 5.0-6.0 BLW STD > 6.0		
	Stiffness (FED-STD-191 TM 5204)	ABV STD < 9.0 STD 9.0-10.0 BLW STD 10.1-12.0		
	Bulk	ABV STD STD Rating BLW STD		
	Pattern execution (Direct measure)	STD Pass BLW STD Fail		
COLOR	Color (visual match)	STD Pass BLW STD Fail		
	Colorfastness	Light (AATCC #16)	ABV STD > 3-4 STD = 3-4 BLW STD = 3.0	
		Acc. Laundering (Proc. "A")		
		Cracking (AATCC #8)	3 Colors ABV STD > 3.5 STD = 3.5 BLW STD = 3.0	
	Slack	ABV STD > 2.5 STD = 2.5 BLW STD = 2.0		
CAMOUFLAGE	Spectral Reflectance (Proc. "B")	STD = Table I BLW STD Outside of Table I		

WATER PROOFNESS & REPELLENCY	Water Permeability (AATCC #127)	Initial After Flex, 70 F After cold Flex, -40 F After Synthetic Perspiration After DEET After diesel After Weapons Lubricant After Motor oil After JP-8 After seam tape	STD Pass	
	Hydrostatic Resistance (ASTM D 3393)	Initial After Strength of coating After abrasion After DEET After diesel After weapons lubricant After Motor oil After JP-8 After high humidity	STD Pass	
	Sewer Rating (AATCC #22)		ABV STD 100, 100, 80 STD 80, 80, 80 BLW STD 80, 80, 70	
	Resistance to Organic Liquids (AATCC #118)		ABV STD > 5 launderings STD = 5 launderings BLW STD 3-4 launderings	
MOISTURE PERMEABILITY	MVTR (ASTM E 36 Proc. B & BW)	Initial After Synth. perspiration	Proc B ABV STD > 700 STD 600-700 BLW STD > 450	Proc BW ABV STD > 5000 STD 3500-5000 BLW STD > 3000

Table IV.

Contracted into Army/Marines		JGECVCS		STD 070666
EALC/WV/Coast System		MAX	1 00000	
		SCOPE	37037	FINAL
		SCOPE	COMBINED	
		SCOPE	COMBINED	
		SCOPE	COMBINED	
		SCOPE	COMBINED	
		SCOPE	COMBINED	
CONTRACTOR		SCORE	WEIGHT	FINAL
MATL	INSULAT	3.687	0.04680	0.03128
	REPEL'CY	3.792	0.04350	0.05028
	WATER PERM	1.000		
	INITIAL	1.000		
	AFT FLEXTOP	1.000		
	AFT GOLDPLEX	1.000		
	AFT SYN PERSP	1.000		
	AFT DEET	1.000		
	AFT DIESEL	1.000		
	AFT WPM LUBE	1.000		
	AFT MOT OIL	1.000		
	AFT P-8	1.000		
	AFT SEAM TAPE	1.000		
	HYDR REST	0.833		
	FAILURE	1.000		
	INITIAL	1.000		
	AFT STR COAT	1.000		
	AFT ABRASION	1.000		
	AFT DEE	1.500		
	AFT DIESEL	1.000		
	AFT WPM LUBE	0.000		
	AFT MOT OIL	1.000		
	AFT P-8	1.000		
	AFT HUMIDITY	1.000		
	SPRAY RATNG	3.687		
	ORNGC REST	3.687		
	MOISTPRM	3.834	0.05988	0.04882
	(MVTR) INITIAL	3.834		
	PROC B	1.000		
	PROC SW	0.867		
	AFT SYN PERSP	0.834		
	PROC B	1.000		
	PROC SW	0.867		
	DURABIL	1.000	0.00902	0.00902
	TEARING	3.587	0.00902	0.00902
	BREAKING	1.000	0.00902	0.00902
	STIFFNES	1.000	0.00902	0.00902
	ABRASION	1.000	0.00902	0.00902
	POL DEET	3.000	0.00902	0.00902
	SHRINKAG	3.333	0.00902	0.00902
	SURFACE	1.000	0.00902	0.00902
	WT.BULK	3.687	0.02915	0.01944
	WEIGHT	3.587	0.02798	0.01858
	BULK	1.000	0.05051	0.05051
	COLOR	1.000		
	PATTERN	1.000		
	COLOR	1.000		
	COLORFAST	1.000		
	LIGHT	1.000		
	LAUNDER	1.000		
	ACC KLUNDER	1.000		
	CROCKING	1.000		
	1 COLOR	1.000		
	BLACK	1.000		
	CAMO IR	1.000	0.04402	0.04402
	PERFORM	3.687	0.03448	0.02300
	MOBILITY	0.587	0.02988	0.01983
	FLEXIBIL	3.687	0.02888	0.02445
	COMFORT	3.687	0.01858	0.01105
	WARMTH	3.687	0.01097	0.00732
	FEEL	3.687	0.01097	0.00732
	ACCEPT	0.867	0.00818	0.00612
	POCKETS	0.667	0.01052	0.00702
	HOOD	3.687	0.00829	0.00553
	UNINGS	0.867	0.00878	0.00681
	VENTS	3.687	0.05837	0.03983
	STYLE	3.687	0.01587	0.01058
	NOISE	3.687	0.01864	0.01110
	FIT	3.687	0.01826	0.01065
	COMPATBL	3.687	0.01208	0.00824
	WEAPONS	3.687	0.02181	0.01455
	CLOTHING	3.687	0.01782	0.01189
	LOAD_SCP	3.687	0.01980	0.01313
	VEHICLES	3.687	0.01980	0.01313
	MAINTAIN	3.687	0.02181	0.01455
	EASE USE	3.687	0.01782	0.01189
	REPAIR	3.687	0.01980	0.01313
	LAUNDER	3.687	0.01980	0.01313
	ACQ_LIFECOST	3.687	0.01558	0.01038
	MAT COST	0.687	0.01558	0.01038
	LICENSES	0.587	0.01558	0.01038
	PATENTS	3.687	0.01558	0.01038
	CONTRACT	3.687	0.01558	0.01038
	AVAILABL	3.687	0.05302	0.03579
	PRODUCTN	3.687	0.05433	0.03624
	SHELF	3.687	0.05577	0.03729
	DISPOSE	3.687	0.05598	0.03740

Figure 1. Example Questionnaire

**EXTENDED COLD WEATHER CLOTHING SYSTEM
FACTOR RATING QUESTIONNAIRE**

1. RATE the IMPORTANCE of the following two categories of SELECTION FACTORS when considering materials for ECWCS (use the rating scale below):

IMPORTANT:

Make sure no two characteristics have the same exact rating! Use intermediate decimal values like 3.6 if needed.

	SLIGHTLY IMPORTANT			MODERATELY IMPORTANT				EXTREMELY IMPORTANT
	1	2	3	4	5	6	7	8
RATING								9

_____ MATERIAL FACTORS (weight durability, insulation, degradation, camouflage, static electricity, water repellency)

_____ ACQUISITION FACTORS (shelf life, repairability, disposability, material costs, producibility, material availability, licensing costs, patent costs)

Rationale for ratings:

CONFIDENCE LEVEL: Indicate your level of CONFIDENCE in your ratings above (circle number):

NOT CONFIDENT	SLIGHTLY CONFIDENT		MODERATELY CONFIDENT		EXTREMELY CONFIDENT
0.....1.....	2.....3.....	4.....5.....	6.....7.....	8.....9	

TESTING METHODOLOGY

The Natick Acquisition Center solicited industry for proposals to meet the Government needs. Contractor teams were requested to provide Government Certified Laboratory Test Reports on the submitted fabrics, yardage for verification testing, sample designs for parkas and / or trousers representing their interpretation of the design requirements of the two services, and reports indicating past performance history, past quality history, past delivery history, and indication of the ability to perform the manufacture of technically difficult specialty garments.

The data from the Government Certified Laboratory Reports was entered into the decision tree. Any test in the tree that did not specifically relate to the evaluation of the fabric remained constant for all candidates, thereby obtaining a score for the fabric only. This provided a basis to evaluate candidate fabrics against the standard where a manufacturer need not absolutely meet all requirements, but could qualify based on the weighted importance of criterion versus criterion. For example, a fabric may perform above standard against a criterion that is highly weighted and perform below standard for a factor that is not as important to the user. The resultant weighted score will qualify the material since the total score would exceed the total Standard score. Fabrics which scored equal to or above the standard were qualified to be used to manufacture test items.

A Technical Evaluation Team evaluated nine proposals based on their submissions of materials, designs, past quality performance, past delivery performance, manufacturing capability, and item cost and producibility. Three contractors qualified to make four candidate parka and trouser sets. The candidates included three new parka and trouser designs and two new fabrics as well as the standard basic shell fabric. All three provided a tariff of two hundred parkas and two hundred trousers for test.

These parkas and trousers will be tested by two independent Government test agencies, the Test and Evaluation Command (TECOM), and the Test and Experimentation Command (TEXCOM). TECOM will address all pertinent developmental issues while TEXCOM will address operational issues. Three test sites have been chosen to provide the full range of environmental conditions required of the parka and trousers. The Cold Regions Test Activity, an agency assigned to TECOM will conduct a combined developmental/operational test at Ft Greely, Alaska to assess the environmental protection in extreme cold/dry conditions. Historically, the test activity experiences temperatures as low as -60° F during the months of January and February. Forty degrees below zero is common during this time. Marines will test at the United States Marine Corps Mountain Warfare Training Center in the Sierra Nevada Mountains at Bridgeport, California. This Center traditionally experiences temperatures in the -10° to -20° F with very heavy snowfall. Following the training at the Center, the test marines will deploy for an operational exercise in Norway. United States Army soldiers will test at Ft Lewis, WA to assess the ability to protect in cold/wet conditions. This facility normally experiences temperate, but very wet conditions.

Data gathered from these field tests will be added to the materials data and run through the

downselect model. The designs for the parka and trouser assessed as the best overall and most advantageous to the Government will be awarded Production Test Quantities to produce up to 30,000 parkas and trousers for the initial fielding. The successful Contractor(s) will also deliver specifications for their product to be used by the Defense Personnel Support Center to contract for follow on supply procurement.

CONCLUSION

The 2GECWCS Parka and Trouser Program is one of the first to venture into the concept of integrated acquisition. It attempts meld into the supply system through sound planning up front, minimizing inventories of residual assets, and cutting the time frame that it takes to develop and deliver quality state of the art protective clothing and equipment to soldiers and marines. As the services continue to "right size", it only makes sense to rely on the expertise of American Industry to provide the best for our soldiers, sailor, airmen and marines.

Appendix A
2GECWCS MATERIAL REQUIREMENTS

CHARACTERISTICS	2GECWCS REQUIREMENTS	TEST METHODS
Weight	6.0 oz/sq yd max.	ASTM D 3776
Color	4 color Woodland Camouflage Pattern	Visual-match standard sample
Colorfastness to light	Equal to or better than "3-4" AATCC Gray Scale for Color Change rating after 40 hours.	AATCC #16, option "A"
Colorfastness to Laundering	Equal to or better than "3-4" AATCC Gray Scale for Color Change rating (4 cycles)	AATCC #61, option 1A & Army detergent
Colorfastness to accelerated laundering. (Black only)	Equal to or better than "3-4" on AATCC Gray Scale rating.	Test procedure "A"
Colorfastness to Crocking	4 Colors: Equal to or better than "3.5" AATCC Chromatic Transference Scale Rating.	AATCC #8
Pattern Execution	Equal to standard sample. Repeat on 27.25" +1.25", -2.5" warp.	Direct linear measure
Spectral Reflectance	See Table	Test procedure "B"
Breaking Strength (WxF)	Warp = 135 lbs, min. Filling = 100 lbs, min	ASTM D 5034
Tearing Strength (WxF)	W = 3.0 kgf, min F = 3.0 kgf, min	ASTM D #2582

Moisture Vapor Transmission Rate (MVTR). Cond 1 Proc. B & Proc BW Cond 2 Proc. B or Proc. BW	600 g/m sq/24hrs, min 3600 g/m sq/24hrs, min 600 g/m sq/24hrs, min 3600 g/m sq/24hrs, min	ASTM E 96, Procedure B <u>1</u> / & BW <u>2</u> / ASTM E 96, Procedure B <u>1</u> / & BW <u>2</u> /
MVTR, after synthetic perspiration - Cond 1 Proc. B & Proc BW Cond 2 Proc. B & Proc BW	600 g/m sq/24 hrs, min 3600 g/m sq/24hrs, min 600 g/m sq/24hrs, min 3600 g/m sq/24hrs, min	Test procedure "C" & ASTM E 96, Procedure B <u>1</u> / & BW <u>2</u> / Test procedure "C" & ASTM E 96, Procedure B <u>1</u> / & BW <u>2</u> /
Hydrostatic Resistance (HR) - Initial	No leakage (40 psi)	ASTM D 3393
HR, after strength of coating	No leakage (40 psi)	FED-STD-191 #5972 <u>4</u> / & ASTM D 3393
HR, after abrasion, (face and back)	No leakage (40 psi)	AATCC #119 <u>1</u> / & ASTM D 3393
HR, after exposure to DEET Initial exposure After Laundering	No leakage (40 psi) No leakage (40 psi) (1 cycle)	Test procedure "D" & ASTM D 3393 Test procedure "D" & "F" and ASTM D 3393

HR, after exposure to diesel Initial exposure After laundering	No leakage (40 psi) No leakage (40 psi) (1 cycle)	Test procedure "D" & ASTM D 3393 Test procedure "D" & "F" and ASTM D 3393
HR, after exposure to weapons lubricant Initial exposure After laundering	No leakage (40 psi) No leakage (40 psi) (1 cycle)	Test procedure "D" & ASTM D 3393 Test procedure "D" & "F" and ASTM D 3393
Hydrostatic Resistance after high humidity	No leakage (40 psi)	Test procedure "J" & ASTM D 3393
Stiffness	10.0 cm - maximum	FED-STD-191 #5204
Water Permeability Initial	No leakage (50 cm/10 minutes)	AATCC #127 6/
Water Permeability after flex, 70°F (warp & filling)	No leakage (50 cm/10 minutes)	Test procedure "G" & AATCC #127 6/
Water Permeability after synthetic perspiration Initial exposure After laundering	No leakage (50 cm/10 minutes) No leakage (50 cm/10 minutes) (1 cycle)	Test procedure "C" & AATCC #127 6/ Test procedure "C" & "F" and AATCC #127 6/
Water Permeability after cold flex, -40°F - Warp & Filling	No leakage (50 cm/10 minutes)	Test procedure "H" & AATCC #127 6/

Water Permeability after DEET		Test procedure "D" & AATCC #127 <u>6</u> / Test procedure "D" & "F" and AATCC #127 <u>6</u> /
Initial exposure	No leakage (50 cm/10 minutes)	
After laundering	No leakage (50 cm/10 minutes) (1 cycle)	
Water Permeability after diesel		Test procedure "D" & AATCC #127 <u>6</u> / Test procedure "D" & "F" and AATCC #127 <u>6</u> /
Initial exposure	No leakage (50 cm/10 minutes)	
After laundering	No leakage (50 cm/10 minutes) (1 cycle)	
WP, after weapons lubricant		Test procedure "D" & AATCC #127 <u>6</u> / Test procedure "D" & "F" and AATCC #127 <u>6</u> /
Initial exposure	No leakage (50 cm/10 minutes)	
After laundering	No leakage (50 cm/10 minutes) (1 cycle)	
Spray Rating		
After laundering	Equal to or better than 90,90,80 after 5 laundering	Test procedure "F" & AATCC #22
Resistance to Organic liquids		
After laundering	No wetting by n-tetradecane after 5 laundering	Test procedure "F" & AATCC #118
Physical Surface appearance changes after laundering		Test procedure "E"
After laundering	No changes in physical surface appearance after 20 laundering	
Dimensional Stability, Warp x Filling		FED-STD-191 #5552
	Warp - 4.0% (max.) Filling - 2.0% (max.)	

Water Permeability after Seam Tape	No leakage (50 cm/10 minutes)	Test procedure "K"
---------------------------------------	----------------------------------	--------------------

1/

The back side of the test cloth shall face the water, the free stream air velocity shall be 550 ± 50 FPM as measured 2 inches above the fabric specimen. The air flow shall be measured at least 2 inches from any other surface. The test shall be run for 24 hours and weight measurements shall be taken at only the start and completion of the test. At the start of the 24 hour test period, the air gap between the water surface and the back of the specimen shall be $3/4 \pm 1/16$ inch. Five initial and three after synthetic perspiration specimens shall be tested.

2/ The back side of the test cloth shall face the water. The free stream air velocity shall be 550 ± 50 FPM as measured

2 inches below the fabric specimen. The air flow shall be measured at least 2 inches from any other surface. The test shall be run for 2 hours and weight measurements shall be taken at only the start and completion of the test. Five specimens shall be tested. The specimen shall be sealed in any manner which prevents wicking and/or leaking of water out of the cup.

3/ The water pressure shall be applied to the face side of the test cloth.

4/ Except that the specimens shall be stretched at 20 pounds.

5/ The abrasion test shall be conducted in multidirectional mode using the face side of the test cloth as the abradant. A load of 6 pounds shall be applied to the abradant. The test shall be completed at 10,000 cycles.

6/ The water permeability shall be measured as specified in Method 5516 of FED-STD-191, except that the face side of the test cloth shall contact the water. The hydrostatic head shall be 50 centimeters and shall be held for 5 minutes. The report shall only include measurement of the appearance of water drops. Leakage is defined as the appearance of water any place within the 4-1/2 inch diameter test area. The test may be performed using any device which tests the same specimen area at the equivalent pressure. In cases of dispute, the apparatus described in Method 5516 of FED-STD-191 shall be used.

TEST PROCEDURES

A - Accelerated laundering test. The test procedure shall be in accordance with FED-STD-191 test method 5614, except the following deviations shall apply: Five (5) specimens containing

predominantly Black print, each 4-1/2 inches by 3 inches, shall be cut from the test fabric and then folded in half, with the face side out, to form a bag 2-1/4 by 3 inches. Machine stitch the open edges together (seam allowance no more than 1/4 inch) to form a bag leaving an opening (approximately one inch in length). Through the opening add 35 stainless steel spheres. Close the bag by stapling or stitching. Place the bag in a stainless steel cylinder (one bag per cylinder) without the color transfer cloth, add 50 ml of P-D-245, Type II detergent solution (0.5 percent by weight detergent solution) and 100 stainless steel spheres and close tightly. Place the stainless steel cylinder in a preheated Launder-Ometer set at a water bath temperature of 160 ± 50 F. Agitate cylinder for one (1) hour maintaining a constant temperature. At the end of the laundering cycle, remove the bag from cylinder and rinse each bag thoroughly in a beaker, in running tap water at 100 ± 50 F for five (5) minutes with occasional stirring or hand squeezing. Remove excess water by squeezing in hand (not extracting) and then dry bag in automatic tumble dryer set on permanent press cycle, 150° - 160° F for fifteen (15) minutes (more than one bag can be dried together). If the bag breaks open to release the contained spheres at any time during the test, the test shall be considered invalid and another bag specimen shall be prepared and tested. Remove all spheres from the bag and evaluate each face of the bag without pressing or ironing the bag. Each face of the laundered bag shall be compared to the original sample (unlaundered) in accordance with AATCC Evaluation Procedure 1 for evaluation of Gray Scale for Color Change and the rating shall be based on the portion of the Black print exhibiting the most color loss. The lower of the two ratings of each bag shall be recorded as the result for the bag. Failure of any of the five (5) bags to meet the required rating, shall be considered a test failure.

B - Spectral reflectance test. Reflectance data shall be obtained from 600 to 860 nm relative to a barium sulfate standard, the preferred white reference standard. Other reference white standards may be used provided they are calibrated to an absolute white; e.g., Halon, magnesium oxide or vitolite tile. The spectral bandwidth at 860 nm shall be less than 26 nm. Reflectance measurements shall be made using either the monochromatic or polychromatic mode of operation of a spectrophotometer. When the polychromatic mode is used, the spectrophotometer shall operate with the specimen diffusely illuminated with the full emission of a source that simulates either CIE Source A or CIE Source D65. Each shade of the pattern shall be measured as a single layer of cloth backed with six layers of outer shell material of the same shade. Readings will be taken on a minimum of two different areas and the data averaged. The specimen shall be viewed at an angle no greater than 10 degrees from normal with specular component included. Photometric accuracy shall be within 2 nm. The standard aperture size used in the color measurement device shall be 1.0 to 1.25 inches in diameter. Any color having spectral reflectance values falling outside the limits at four or more of the wavelengths specified in the following table shall be considered a test failure.

Spectral Reflectance Requirements
Reflectance Values (percent)

Wavelength Nanometers	Black 357		Light Green 354		Dark Green 355 and Brown 356	
	Min.	Max.	Min.	Max.	Min.	Max.
600			8	20	3	13
620			8	20	3	13
640			8	20	3	13
660			8	20	3	13
680			8	36	3	22
700		20	14	60	6	46
720		30	26	78	20	60
740		33	40	90	30	80
760		33	50	92	32	88
780		34	55	92	32	90
800		34	55	92	32	90
820		35	55	92	32	90
840		35	55	92	32	90
860		35	55	92	32	90

C - Water permeability and moisture vapor transmission rate after perspiration test. The specimen, 8 inches by 8 inches, shall be cut and exposed to synthetic perspiration as follows: The synthetic perspiration solution shall be made up in a 500 ml glass beaker by combining 3.0 grams sodium chloride, 1.0 gram trypticase soy broth powder, 1.0 gram normal propyl propionate, and 0.5 gram of liquid lecithin. Add 500 ml of distilled water, add a magnetic stirring bar, and cover the beaker. Place the beaker on a combination hot plate/magnetic stirrer apparatus. While stirring, heat the solution to 50°C until all ingredients are dissolved. While stirring, cool the solution to 35°C, remove cover, and dispense immediately with a pipette or other suitable measuring device. Dispense 2 ml of perspiration solution at 35°C onto the center of an 8 inch by 8 inch by 1/4 inch glass plate. Place the specimen on the glass plate with the knit side facing the glass. Dispense an additional 2 ml of the synthetic perspiration solution onto the center of the specimen. Place an 8 inch by 8 inch by 1/4 inch glass plate on top of the specimen with a 4 pound weight positioned in the center. After 16 hours, remove the specimen (do not rinse) and air dry the specimen before testing. Test the specimen for water permeability or moisture vapor transmission rate, as applicable.

D - The specimen, 8 inches by 8 inches, shall be laid flat, face side up, on a glass plate, 8 inches by 8 inches by 1/4 inch. Three drops of the test liquid (i.e., DEET, diesel) shall be applied to the center of the specimen. A glass plate of the same dimensions shall be placed on the specimen and a four (4) pound weight placed in the center of the glass plate of the assembly. After 16 hours, remove the specimen and test immediately for hydrostatic resistance or

water permeability, as applicable.

E - Physical surface appearance laundering test. Place 2 + 0.2 pounds of the finished, test cloth and, if needed, ballast in an automatic washing machine set on permanent press cycle, high water level and warm (100 + 100F, -00 F) wash temperature. Each sample unit, 48 inches in length by full width, shall be cut in half across the width of the fabric. one half of the sample unit (24 inches) will be laundered and the other half retained for final evaluation (unlaundered). Place 0.5 ounces (14 grams) of detergent conforming to Type II of P-D-245 into the washer. The duration of each laundering cycle shall be 30 + 5 minutes. After laundering, place sample and ballast in an automatic tumble dryer set on permanent press cycle, 150°-160° F, and dry for approximately 15 minutes. Conduct 20 laundering and drying cycles. After each drying cycle, examine both sides of the cloth for changes in physical surface appearance. Sample shall show no changes in physical surface appearance when compared to the unlaundered sample. The laundering equipment, washer and dryer, shall be in accordance with AATCC test method 135.

F - Procedure E except for the sample size and the evaluation for physical surface appearance shall be used to launder samples for one (1) cycle prior to testing for spray rating and resistance to organic liquids and to launder synthetic perspiration, DEET, diesel, weapons lubricant, motor oil and J-8 contaminated samples for one (1) cycle prior to testing for hydrostatic resistance and water permeability, as applicable.

G - Water Permeability after flex (700F) test. one specimen, eight (8) inches by twelve (12) inches, shall be cut from the sample unit with the eight (8) inch dimension in the indicated direction (warp or filling as applicable). The specimen shall be conditioned and flexed as specified in Method 2017 of FED-STD-101 except the specimen shall not be aged, the short edges shall not be heat sealed or otherwise joined, and the specimen shall be flexed for 1500 cycles. Two six (6) inch by eight (8) inch specimens shall be cut from the eight (8) inch by twelve (12) inch flexed specimen and tested for water permeability.

H - Water permeability after cold flex test. The water permeability after cold flex test shall be as specified in procedure G except that the eight (8) inch by twelve (12) inch specimen shall be mounted on the flex test apparatus, placed in a test chamber at the specified temperature for one hour, and then flexed in the test chamber at the specified temperature. At the end of the flexing cycle, the specimen shall be removed from the test chamber and conditioned prior to testing for water permeability.

J - High humidity test. Three (3) specimens, four (4) inches by four (4) inches, shall be tested and shall be laid flat, back side up on a supporting plate and the assembly placed in a desiccator containing water in the lower portion. The water level shall be approximately one (1) inch below the specimens. The lid of the desiccator shall be put in place and the desiccator placed in a circulating air oven having a temperature of 160 OF \pm 2 OF for a period of seven (7) days. At the end of the aging period, each specimen shall be removed from the desiccator and tested

immediately in accordance with ASTM D-3393 with the water pressure being applied to the face side of the material.

K - Water permeability after seam tape. A square sample of material, 24 inches by 24 inches, shall be cut with one diagonal of the specimen parallel to the warp direction of the material. The square sample shall then be cut in half to form two (2) rectangular pieces of dimensions 12 inches by 24 inches. The two (2) rectangular pieces shall be superimposed with face sides together and then seamed along one, 24 inch long dimension. The bias seam (relative to the fabric) shall be constructed as a Type SSa-1 seam using a Type 301 stitch, size B thread of V-T-285, 10 to 13 stitches per inch and a 1/4 (max.) seam allowance. The seam shall then be seam taped with a suitable seam tape compatible with the material. The seam tape shall be one (1) inch (\pm 1/16 inch) wide and shall be applied over the sewn seam on the back side of the material as one continuous piece. The taped, seamed test sample shall be cooled for a minimum of one (1) hour prior to further testing. The test sample shall be laundered for five (5) cycles in accordance with Test Procedure E and then visually examined for any sign of tape lifting, curling, bubbling, puckering or separation along the tape edges or tape width (the occurrence of any of these visual defects shall be considered a test failure). Three (3) test samples shall be prepared and evaluated. Two (2), eight (8) inch by eight (8) inch, test specimens (maximum) shall be cut from the center 16 inch square area of each test sample; the seam taped seam shall be centered in each test specimen. Five (5) test specimens shall then be tested for water permeability in accordance with AATCC #127 6/ with the seam centered in the test area and using a 50 centimeter hydrostatic pressure head held for a period of 10 minutes.

Appendix B
2GECWCS PARKA AND TROUSER REQUIREMENTS

REQUIREMENT	ARMY	MARINE CORP
Environmental Protection	Provide wet and cold environmental protection at temperature ranges down to 60 deg F. Environmental Protection Range using current ECWCS under garments.	Function in a wet/cold and dry/cold environment in the temperature range of +40 deg F to -25 deg F. Maximum protection from snow and rain. Maintain or enhance the current cold weather protection of the user.
Waterproofness	Water resistant ('83 SN-CIE) Provide waterproof front and underarm vent closures. (ORD)	Waterproof in design. Maintain MVTR
Compressed bulk	Latest materials technology (less bulky than current ECWCS Parka)	Achieve at least a 15% compressed bulk reduction (25%0 desired) when compared to the current standard item. (system
Weight	= < the standard system	Achieve at least a 15% weight reduction (25%0 desired when compared to the current standard item. (system)
Lower Cargo Pockets, Pockets	Must be compatible/usable while wearing LBE/ITLBV	Pockets (generic) must be accessible while wearing LBE. Exterior pockets (generic) must be oriented to allow natural anatomic entry of hands.
Hood	Rolled and stowed, compatible with a fur ruff	Stowable hood
Hung Lining	Investigate Elimination	Investigate Elimination
Snow Skirt	Retain	Retain

Field durability See Note 3 of COIC	=> current parka or provide for 120 days field life, whichever is the more restrictive criterion	Minimum service life of 120 days under combat conditions
Comply with applicable health, safety, and HFE design requirements	Yes (ORD). Materials not harmful to skin and do not constitute a flame thermal hazard ('83 SN-CIE).	Yes, = < current standard system
ILS	To be supported in the same manner as existing like systems. No additional burdens on the support system. No training strategy or devices required. '83 SN-CIE states "Require no user maintenance other than normal care, cleaning, or replacement of damaged components, Repairable by using unit"	Require no user maintenance other than normal care and cleaning
MANPRINT	Shall present no significant MANPRINT issues	Shall present no significant MANPRINT issues.
Fit	5th% female to 95th% male Soldier	5th% female to 95% male Marine
Concept	Use as a layering system with ventilation openings. Function Homogeneously with other items of combat clothing and equipment. Function as the protective layer of ECWCS.	Use as a layering system with ventilation openings. Function Homogeneously with other items of combat clothing and equipment. Function as the protective layer of ECWCS.
Don/Doff	Easily donned and doffed (*83 SN-CIE)	Easily donned and doffed
Shelf life	5 year shelf life ('83 SN-CIE)	Minimum shelf life of 5 years
Resistant to mold and mildew	Yes ('83 SN-CIE)	Yes
Resistant to POL's	Yes, when practical	Yes, when practical

Launderable	= to or better than current standard	SHIPBOARD
Ventilation (Heat Burden Reduction)	provide ease of use for underarm ventilation, reduce heat burden, and be compatible when used with LBE	provide ease of use for underarm ventilation, reduce heat burden, and be compatible when used with LBE
Special pockets		Waterproof interior "map pocket
Trousers		Trousers must have external pockets. They shall accommodate either suspenders or a belt.
Drying	Quick Drying	Quick Drying
Camouflage	Compatible with approved camouflage patterns. Possess maximum IR signature reduction. ('83 SNCIE)	Compatible with approved camouflage patterns. Possess maximum IR signature reduction. ('83 SNCIE)
Semi-permanently attached name tape	Yes	Yes
Compatible with current NBC ensemble	Yes ('83 SN-CIE)	Yes
Compatibility	Compatible with components/subsystems of IIFSP ('83 SN-CIE). Compatible with the developmental Modular Field Pack if ready.	Compatible with components/subsystems of IIFSP. Compatible with the developmental Modular Field Pack if ready.

REFERENCES

- (1) U. S. Army Infantry School and Center, Operational Requirements Document for a Second Generation Extended Cold Weather Clothing System Parka and Trousers, 2 November 1993, and amended 30 November 1993
- (2) U. S. Marine Corps Systems Command, Operational Requirements Document for Cold Weather Clothing and Equipment, no date
- (3) Sampson, J., Second Generation Extended Cold Weather Clothing System (2GECWCS) Downselection Plan, 23 December, 1993
- (4) Saaty, T. L., Multicriteria Decision Making - The Analytic Hierarchy Process, RWS Publications, Pittsburgh, PA, 1992.

**STATE-OF-THE-ART ADVANCES IN
U.S. MILITARY COLD WEATHER**

Joseph Mackoul
U.S. Army Natick RD&E Center
Natick, MA

**STATE-OF-THE-ART ADVANCES
IN U.S. MILITARY
COLD WEATHER HEATING EQUIPMENT**

INTRODUCTION

The U.S. Military is developing a Family of Space Heaters (FOSH) utilizing the latest technological advances in combustion, thermoelectrics and safety controls to provide heat for soldiers, supplies and equipment in tents and shelters in the field during cold weather conditions. The goals of the FOSH program are to replace currently fielded heaters which are antiquated, unsafe and inefficient; provide improved heat distribution and tentage habitability conditions; and to satisfy the heating requirements of new tentage developments and applications recently introduced in the military supply system.

CURRENT MILITARY TENT HEATING EQUIPMENT IN THE FIELD

The predominant sources of heat for military tents over the past 50 years have been the World War II vintage M-41 and Yukon tent heaters. They have the capability to operate without the

use of electrical power, burn liquid and solid fuels, and are simple, rugged and inexpensive. These heaters, with their unique capabilities, have served the military well in the past. However, today they are ill-equipped to meet the latest military tent heating requirements. They utilize antiquated burner technologies which, by today's standards, have serious safety and operational deficiencies, are inefficient, and require excessive maintenance. The M-41 and Yukon heaters were designed in the 1940's and 50's to burn gasoline which will no longer be available in the field due to the conversion to diesel fuel and JP-8. They operate very poorly with diesel fuel, creating excessive levels of smoke and soot output and require many hours of continuous maintenance. If left unattended, the soot produced in these heaters serves to plug up the stack, put out the flame, and create explosive pockets of unburned fuel vapors. Safety hazards also exist due to the inherent design of these burners. They operate by means of the vaporization of an open pool of raw fuel, making them very susceptible to accidental fires.

Another major drawback for these heaters is the poor distribution of heat which produces uncomfortable living conditions in military tents. These heaters transfer heat through radiation and natural convection in which all the heat

rises to the top of the tent, leaving the bottom part cold. This makes for poor tent habitability conditions and inefficient fuel consumption. On a cold day in a General Purpose Tent, the temperature at head level can be 50°F higher than the temperature at lower leg level. This is the crucial for several reasons. The soldier sleeps in the bottom part of the tent and the most difficult parts of the body to keep warm are the lower legs and feet.

In addition, since the 1940's and 50's, several new tentage developments, sizes, materials and applications have been introduced into the military supply. This change increases the military's tent heating requirements far beyond the capabilities of the current tent heaters. For example, with the introduction of the Modular Command Post System (MCPS) tent (which houses expensive computer equipment), a heater is needed which can: (a) operate outside the tent to free up valuable floor space; (b) provide completely automatic unattended operation to eliminate the need of a fireguard and an operator to make constant heater adjustments; (c) utilize modern "state-of-the-art" safety controls to prevent loss of life and valuable mission equipment; and (d) provide accurate control of heat output and effective heat distribution to allow full performance of mission functions.

Additionally, with the introduction of the Soldier Crew Tent and other (3-5 man) tents in the field, a need exists for heaters with greatly reduced size, weight and heat output.

The deficiencies of the current tent heating equipment and its inadequacies for meeting the new tent heating requirements has created a serious void in the military tent heating capability. As a result the soldier is forced to utilize improper and unsuitable heating equipment adversely affecting his/her safety, health and morale. The FOSH program was established to fill this void by replacing the current deficient heaters, overcoming the safety hazards and meeting the heating requirements of new tentage developments.

MARKET INVESTIGATION

Prior to the initiation of the FOSH program, Natick conducted a worldwide market investigation in an effort to identify possible commercial heater candidates that could meet the new military tent heating requirements. The results of the market investigation revealed that no commercial heater exists with the capability to meet all the minimum military tent heating requirements. These requirements, found to vary greatly from

those in the commercial sector, include:

a. Operation without the use of external electrical power - to support operation in remote locations where no electrical power is available and to eliminate the need to transport a generator in the field for heating purposes.

b. A multi-fuel capability including all types of liquid fuels (diesel, jet fuel, gasoline) and solid fuels (wood and coal) - to allow essential operation of the heater with any fuel available to the soldier in the field.

c. Operation in all cold weather conditions including Arctic temperatures down to -60F - to support worldwide deployment including regions in the Arctic.

d. Vented products of combustion - to allow continuous operation in an enclosed shelter without presenting a health hazard.

e. Simple to operate and easily maintained - to be easily operated by the soldier without requiring tedious maintenance procedures that will burden the soldier and take him/her away

from primary mission activities.

f. Lightweight, highly mobile, rugged and inexpensive - to support rapid deployment, ease of transport and withstand rigorous field conditions unique to the military. Also to be affordable by the military in large quantities.

A breakdown of the market investigation's results shows that the vast majority of commercially available heaters require electrical power for the operation of fans, pumps, ignition systems and safety controls. Only a small percentage of commercially available heaters qualified as nonpowered heaters. When the requirements for multi-fuel operation and venting of the products of combustion are applied to this small group, all but a few candidates are eliminated. Popular devices like the kerosene heaters, Coleman^R stoves, propane heaters, camping and RV equipment are eliminated from possible consideration. Finally, when the requirements to be lightweight, portable, rugged, simple to operate and inexpensive are added, no commercial heater candidate survived.

R-TUBE VAPORIZING BURNER TECHNOLOGY

As a result of the market investigation, a unique vaporizing burner technology was identified. The technology appeared to offer great advantages over the current burner designs and had potential for meeting the full scope of the military requirements. This burner technology is known as the vaporizing "r-tube" burner technology, named because its vaporizing tube forms the shape of an "r". A schematic of this burner design in comparison to the M-41 is attached (see ENCL 1). This burner technology was developed by a company in Canada that supplied heaters for the marine industry in which several requirements are similar to those of the military - operation without electrical power, multifuel operation, simple, rugged and inexpensive. In-house testing of a prototype showed that it could burn diesel and other fuels with a much safer, cleaner and more efficient combustion process. Many of the safety hazards associated with the current heaters are eliminated due to the inherent design of the r-tube which allows the fuel vaporization process to take place entirely within the confines of the tube itself. This prevents the pooling of raw fuel during operation and allows the means to restrict and/or stop the flow of fuel during overfiring or flame out conditions. In contrast, the M-

41 fuel vaporization process takes place in an open bowl at the bottom of the pot, resulting in the exposure of a pool of raw fuel during operation and no means to restrict or stop the flow of fuel during overfiring or flameout conditions. The end result is that the pot overfills, creating an uncontrollable or runaway fire condition which has been the cause of many tent fires in the field. Another advantage of the r-tube burner is its multi-stage combustion process allowing for much cleaner and more complete combustion of fuels. Fuel entering the r-tube is first converted to a gas in a separate step and then mixed with air for combustion, whereas in the M-41 the combustion process takes place in a single stage directly above the open pool of fuel. As a result of the market investigation and subsequent evaluation, the vaporizing r-tube burner technology was selected to be utilized in three of the heaters of the FOSH program.

FOSH DESCRIPTION

In the early planning stages of the FOSH program, an inventory of military tentage was undertaken to gain knowledge of the latest tent sizes, materials and applications in the supply system. A heat transfer analysis was conducted on the most

commonly used tents in the field to determine the heating loads required to maintain 50°F - 60°F in the tents over the spectrum of anticipated climatic conditions. The results of this effort were used to determine the sizes and types of heaters needed in the FOSH to best meet the military's latest requirements. A brief summary sheet showing the results of the heat transfer analysis and final FOSH configuration is attached (see ENCL 2).

The FOSH consist of four heaters - Space Heater Small (SHS), Space Heater Medium (SHM), Space Heater Arctic (SHA) and Space Heater Convective (SHC). The heaters can be further subdivided into two types; the nonpowered radiant type consisting of the SHM, SHA, and SHS and the selfpowered convective type consisting of the SHC. A Thermoelectric Fan (TEF) device also forms part of the FOSH and is used with all the nonpowered heaters (SHS, SHM & SHA) to circulate heated air inside a tent. A more detailed description of these items is as follows:

NONPOWERED HEATERS (SHS, SHM, & SHA)

The nonpowered radiant heaters operate inside a tent without any electrical power and provide heat by means of radiation and natural convection. For the sake of standardization, commonality of components, reduction of spare parts and familiarization of

operation, all of the nonpowered heaters utilize the same burner technology, multi-fuel control valve design, sight glass, telescoping exhaust stack and flue cap. As discussed above, the vaporizing r-tube burner technology, common to the SHS, SHM and SHA, allows these units to overcome the major combustion and safety problems that have existed over the past 50 years in the nonpowered combustion industry. The multi-fuel control valve design, common to all the nonpowered heaters, is a newly developed item that provides a new capability to compensate for dissimilar fuel viscosities and maintain a consistent flow rate among the various types of liquid fuels encountered in the field (DF-2, DF-1, DF-A, JP-5, JP-8, JP-4, and gasoline). The r-tube burner combined with the new valve give all the nonpowered heaters the capability to operate in temperatures ranging from 60°F to -60°F. The addition of a sight glass allows the operator to view the flame in order to monitor and make adjustments to the heater. Previously, the soldier had to open the top lid of the combustion chamber during operation; a procedure which was the cause of many fires in the field.

The SHM, otherwise known as the H-45 heater, is a 45KBTU heater that is designed to provide heat for the General Purpose

and TEMPER tents. Development of this heater was completed in 1991 and over 20,000 units have been manufactured to date. This heater is now replacing the old M-41 heater in the field. It weighs approximately 70 pounds with all accessories and is 24" in diameter by 24" high.

The SHA is a 35KBTU heater that completely self-stores all its accessories and is designed to provide heat for the 10-man Arctic tent and other tentage with floor area between 100 and 200 square feet. The SHA will replace the Yukon heater in the field. Development of this heater is scheduled for completion in the 3QFY97. It shall weigh approximately 50 pounds and be 18"H x 10"W x 24"L.

The SHS is a 15KBTU heater that also has a self-storing capability and is designed to provide heat for the Soldier Crew Tent (5-man tent) and other tentage with floor area between 80 and 100 square feet. There currently is no heater in the field to meet this requirement. Development for this heater is scheduled for completion in the 3QFY97. It shall weigh approximately 30 pounds and be 16"H x 9"W x 16"L.

THERMOELECTRIC FAN (TEF)

The TEF is designed for use with all the nonpowered heaters to produce more uniform heating of tents resulting in more comfortable living/working conditions, improved health and morale, and significant fuel savings. The TEF is a silent, lightweight, compact ruggedly designed unit 12" in diameter and 10" high that is simply set on top of any of the nonpowered heaters when in use. It has a built-in thermoelectric module which converts heat from the top surface of the heater into electricity to power a 450 CFM fan. The fan blows air downward over the heater to the bottom of the tent, thus improving air circulation and providing more even distribution of heat throughout the entire shelter. Improved heat distribution as a result of the circulating fan allows operation of the heaters at lower outputs, thus reducing fuel consumption. The TEF will be fielded with the SHA and SHS in the 3QFY97.

SELFPOWERED HEATER (SHC)

The SHC is a unique 35KBTU thermoelectric heater that provides forced hot air circulation in the MCPS and other military tentage without the need for an external power supply

(i.e. a field generator). The development effort for the SHC represents the first ever successful attempt to integrate thermoelectrics and combustion into a fieldable heater prototype that delivers clean, breathable hot air to military tentage and shelters. The thermoelectric heater generates its own electrical power (approximately 180 watts) through the use of thermoelectric modules located in the combustion chamber, converting waste heat into electrical energy. The electricity generated is used to power the blowers, pumps, ignition system, safety system, and control devices. The heater can be operated either inside or outside the tent and can burn multiple liquid fuels (DF-2, DF-1, DF-A, JP-5, & JP-8). The heater is started with a single switch and operation is completely automatic due to built-in diagnostics, safety and temperature controls. The generation of electrical power within the SHC makes possible the use of "state-of-the-art" combustion technology and controls to provide much cleaner and more efficient combustion of fuels over the currently fielded heaters, resulting in significant reduction in fuel costs and maintenance requirements.

CONCLUSION

The efforts of the FOSH program will result in the fielding of heating equipment that represents a vast improvement over currently fielded items. No longer will the soldier be required to utilize mismatched, deficient heating equipment and make-shift provisions which has resulted in injury, loss of life, and/or destruction of valuable mission equipment. The state-of-the-art heating equipment being developed in the FOSH program will serve to improve the soldier's overall quality of life, directly improving his/her safety, health, morale and war fighting capability.

NON-POWERED R-TUBE BURNER TECHNOLOGY

R-TUBE BURNER

PREVIOUS VAPORIZING BURNER

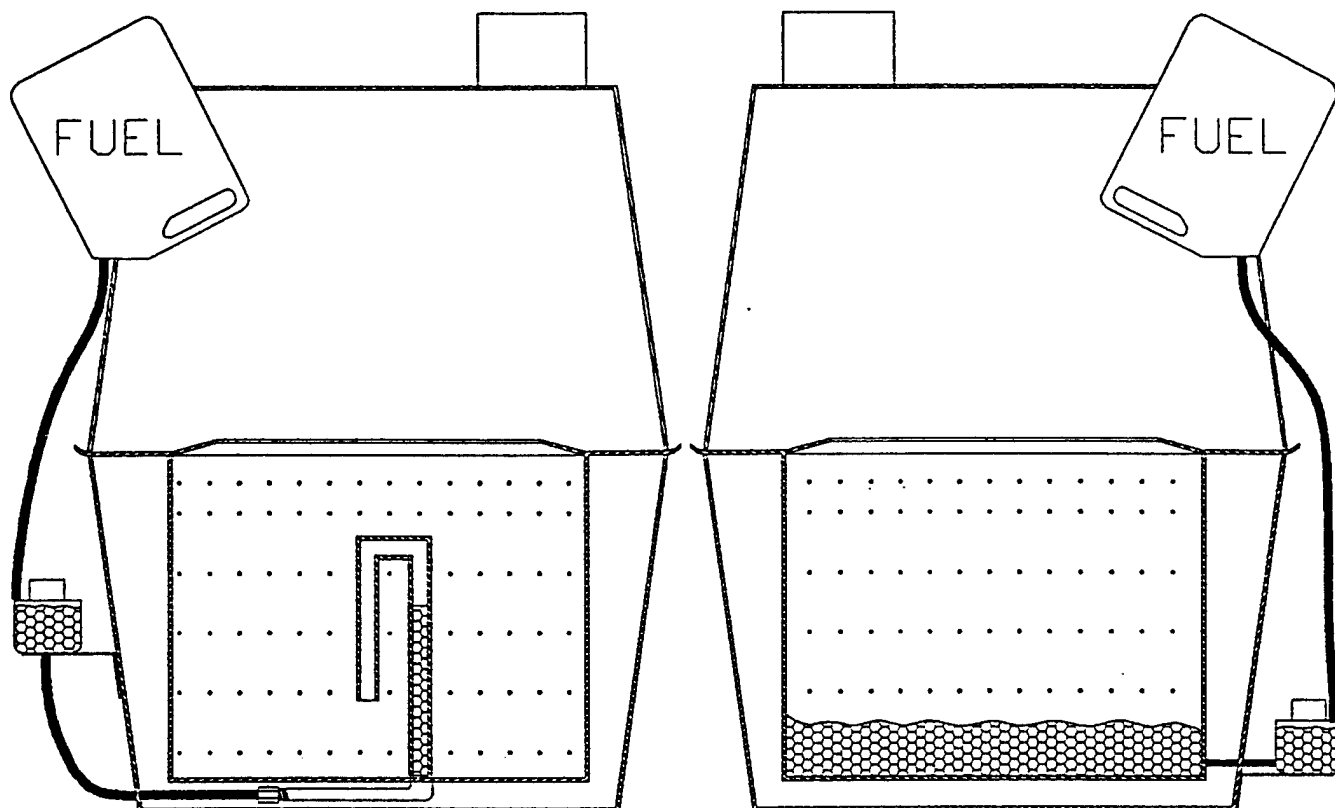

R-TUBE BURNER ADVANTAGES:

1. GREATLY INCREASED SAFETY
2. AUTOMATIC FUEL SHUT-OFF, SELF CONTAINED
3. CLEAN COMBUSTION OF DIESEL FUEL
4. GREATLY REDUCED MAINTENANCE REQUIREMENTS
5. MORE EFFICIENT OPERATION WITH ALL FUELS
6. LOW COST, SIMPLE, RUGGED

NEW MULTI-FUEL CONTROL VALVE ADVANTAGES:

1. GREATLY IMPROVED CONTROL OVER FUEL FLOW RATE
2. ACCOMMODATES VARIOUS FUEL VISCOSITIES
3. INCREASED DURABILITY
4. STANDARDIZATION

FOSH DESIGN CRITERIA

<u>TENT</u>	<u>FLOOR AREA</u> (ft 2)	<u>HEAT LOAD (-30F)</u> (KBTU/HR)
1) FIVE SOLDIER CREW TENT (FSCT)	110	10
2) GP SMALL	200	43
3) GP MEDIUM	512	95
4) TEMPER (16 ft)	320	46
5) SICPS	121	34
6) ARCTIC 5 MAN	113	25
7) ARCTIC 10 MAN	200	34

FOSH PROFILE

<u>HEATER</u>	<u>DESCRIPTION</u>	<u>FUEL</u>	<u>TENTS</u>
SPACE HEATER MEDIUM (SHM)	REPLACES M-41 RADIANT NON-POWERED	ALL LIQUID & SOLID	#2,3&4
SPACE HEATER ARCTIC (SHA)	REPLACES YUKON RADIANT NON-POWERED	ALL LIQUID & SOLID	#6&7
SPACE HEATER SMALL (SHS)	RADIANT NON-POWERED OR CONVECTIVE SELF POWERED	ALL LIQUID	#1
SPACE HEATER CONVECTIVE (SHC)	CONVECTIVE SELF POWERED	ALL LIQUID	#5
THERMOELECTRIC FAN (TEF)	FOR USE ON SHM & SHA	N/A	#2,3,4,6&7

COLD WEATHER TERRAIN TRAVERSAL

David Audet
U.s. Army Natick RD&E Center
Natick, MA

MAJ David A. Rutledge
U.S. Army Northern Warfare Training Center
Delta Junction, AK

MAJ Dunston
Marine Corps Mountain Warfare Training Center
Bridgeport, CA

TRAINING ISSUES

ISSUE 95-T-_: Military ski training of normal infantry soldiers requires a boot/binding combination that allows for both cross country and downhill techniques.

ACTION STATUS: INITIAL

ACTION: The training methodologies presently endorse two different teaching progressions. One is the use of a double plastic boot and plate binding using alpine techniques. The other uses a flexible boot with a Nordic cable binding which allows for extended cross country movement over level or rolling terrain and downhill movement using the telemark or Alpine techniques.

LEAD AGENCY:

Commander
NRDEC
ATTN: STRNC-ICC (Mr. Dave Audet)
Natick, MA 01760-5018
DSN 256-

SUPPORT AGENCY:

Commandant, USANWTC
ATTN: APVR-GNW (MAJ Rutledge)
501 2nd St. #2900
Ft. Greely, Alaska
APO AP 96508-2900
DSN 317-873-4306/4107

Commanding Officer
Marine Corps Mountain Warfare Training Center
Box 5002
ATTN: MAJ Dunston
Bridgeport, CA 93517-5002
DSN 985-7296

BATTLE LAB: Dismounted Battlespace

Executive Summary w/Milestones Applicable

1. History: In an Mountainous/Arctic environment mobility is critical in order to fight and win. The training methodology that provides the greatest potential for mobility in this environment is the diagonal stride/ Nordic downhill (telemark) ski progression.

2. General: The ski march boot or vapor barrier boot with a cable binding combination provides for the forefoot to flex and pressure to be applied to the ball of the foot. Using Nordic Downhill skiing techniques with this boot/binding combination allows an instructor to accelerate the skill progression required to teach a soldier to ski. This method of skiing is focused solely on mobility. There is no requirement in most theaters to move large numbers of soldiers over steep (> 35 degrees) glaciated terrain. Although there surely will be a need to have reconnaissance troops and special operations forces move over this terrain in limited numbers in order to guide larger units to more negotiable terrain as well as provide advance reconnaissance the number of soldiers involved with this type of operation is limited in scope. Therefore, the focus of training should provide for two ski mobility methodologies that have different applications based on mission requirements. Additionally there needs to be a doctrinal/training philosophy prioritization that does two things: the first is to consolidate doctrinal philosophy that delineates between the two skiing methodologies based on mission requirements, and the second is to determine what gear is to be used in which mission profile.

PREPARED BY: U.S. Army Northern Warfare Training Center/MAJ Rutledge/DSN 317-873-4306 and U. S. Marine Corps Mountain Warfare Training Center/MAJ Dunston/DSN 985-7207/7296.

ISSUE STATUS: REVIEW

TARGET COMPLETION DATE: TBD

**MINNESOTA NATIONAL GUARD
WINTER OPERATIONS PROGRAM:
CAMP RIPLEY, MN**

CPT Joseph Seaquist
SFC Robert Eddy
Minnesota National Guard Academy
Camp Ripley, MN



**MINNESOTA NATIONAL GUARD
WINTER OPERATIONS PROGRAM
CAMP RIPLEY, MN**



1. Presented by CPT Joseph Seaquist and SFC Robert Eddy
 - ✓ Representing Minnesota National Guard Winter Operations Program.

2. Mission Statement
 - ✓ To train selected individuals and units in those skills necessary to accomplish their mission of fighting and defeating a threat force while deployed in a cold weather environment.

3. History
 - ✓ 1967 - Instructor Team organized
 - ✓ 1969 - First batallion-sized unit trained
 - ✓ 1973 - First Winter Operations Course
 - ✓ 1986 - National Guard Bureau named Camp Ripley as the primary winter training site for National Guard units nationwide and named the Winter Operations Instructors as subject matter experts.
 - ✓ 1967-1995 - Over 113,000 soldiers trained

4. Training and Unit Support
 - ✓ Winter Operations Course
 - ✓ Cold Weather Maintenance Course
 - ✓ Air Crew Survival Course
 - ✓ Mobile Training Teams
 - ✓ Annual Training Assistance
 - ✓ Leader Orientation / Planning Guidance

These courses are generic to most units. Unit needs and missions are used to customize the training as needed.

5. Camp Ripley, MN

◆ Climate

- ✓ Average annual snow fall of 44".
- ✓ Average temperature of 12 F with recorded lows of -46 F.

◆ Terrain

- ✓ 53,000 acres of level plain to rolling hills
- ✓ Bounded on north and east by rivers

◆ Facilities and Equipment

- ✓ Housing for 3700
- ✓ Winter clothing for 2500
- ✓ Equipment to support a Separate Infantry Brigade (M) and an Armor Battalion.
- ✓ Airport facilities support C130s on either a paved or tactical runway.
- ✓ World-class Biathlon Course
- ✓ Modern automated ERETS ranges
- ✓ Tank/Bradley ranges, Tables VII, VIII, and XII
- ✓ Artillery, 105 mm to 203 mm, MLRS maximum range to 20 K

MINNESOTA NATIONAL GUARD ACADEMY

PO BOX 180, CAMP RIPLEY

ATTN: WINTER OPERATIONS

LITTLE FALLS MN 56345-0180

(612) 632-7214 DSN: 871-7214

FAX: EXT 7799

**THE HISTORY OF FEET AND FIGHTING —
COLD WEATHER INJURIES**

CPT Judith Robinson
U.S. Army Medical Department Center & School
Fort Sam Houston, TX

THE HISTORY OF FEET AND FIGHTING

COLD WEATHER INJURIES

PRESENTED BY CPT JUDITH D. ROBINSON

History verifies why we need to keep cold weather injuries at the forefront of our preparations for potential military operations. It also reminds us that without basic leadership problems will still arise regardless of our level of scientific knowledge or the technology made available to our troops.

Our first documented lesson of the interaction between cold, feet and the clothing worn can be found in Xenophon's, March of the 10,000, where he wrote of his mercenaries crossing Armenia in winter; "Men were left behind who had lost their toes by frostbite. It did seem good to take off the shoes at night, but if any slept with their shoes on, the straps worked into the feet. Flavius Vegetius Renaus further made it explicit in "On Things Military" in 390 A.D.; "The soldier who must endure cold without proper clothing is not in a state to have good health or to march."

But perhaps the best known cold disaster is Napoleon's retreat from Moscow in 1812. Napoleon left for Moscow 100,000 strong and reached safety with only 10,000. His surgeon to the imperial guard, Larrey, believed "that the only reason which forced soldiers to stay behind... was frostbite of feet and hands."

Larrey published his experiences and they were widely translated and yet when the British and French invaded the Crimea in 1854, 20% of the total patient evacuations at the siege of Sevastopol were frostbite casualties

Then in WWI, British and ANZAC forces invade the Gallipoli peninsula. The offensive stalls and when a snowstorm hits in November, 1915, it finds the soldiers without proper protection or clothing, no proper instruction, and poor leadership. There were 2,000 cases of cold injury of the feet and 200 soldiers froze to death. WWI with its static trench warfare saw the introduction of "Trench Foot", a non-freezing cold injury. It was a major problem for the Allies, especially the British with 115,000 cases. They combatted the problem by instituting rigorous foot discipline of cleanliness, dry socks, platoon inspections, and self-care.

In 1942, when we enter WWII we discover the Japanese had landed in the Aleutian Islands off Alaska. The weather was fierce and the terrain was impossible. The troops were badly equipped and clothed. Early on they "hunkered down" into their foxholes and trench foot and frostbite were major problems once again. By 1943, the ratio of cold injury to wounded in action was 1:1.

When we go to Europe in 1944 we find we had still not learned our lessons. Cold injuries began to increase at geometric rates. Down in the battalions, cold injury was costing us more casualties than the Germans and it correlated exactly with the intensity of fighting. George Patton and his staff had anticipated the problem; in April, 1944 he stated in a letter of instruction, "Officers are responsible... He must look after his men's feet, see that they have properly fitting shoes in good condition. That their socks fit. He must anticipate change of weather and see that proper clothing and footgear is obtained." And as the winter campaign into Germany was underway in November, 1944 his Third Army Operations Order read: "The most serious menace confronting us today is not the German Army, which we have practically destroyed, but the weather, which may well destroy us through the incidence of Trench Foot." His philosophy was clear, "Soldiers must look after themselves, particularly in wet or cold weather. This applies particularly to trench foot which can largely be prevented if the soldier will massage his feet and put on dry socks. He is not responsible for the arrival of dry socks, but if they arrive - he is responsible for putting them on or for the field expedient methods of drying them out."

But, is it not fair to say that in snow, cold and mud cold injuries are simply inevitable? If we compare the figures from the winter campaign of 1944-45 in Italy it can shed some interesting light on this question. The British 10th Corps fought in the same place in the same weather as the US Fifth Army, yet the British casualty figures were much less than the American figures. Why? Because the British had attended to good clothing, good discipline, and good command emphasis.

We had developed better cold weather clothing and had stockpiled them in France. So what happened to us in Germany? It was a planning and logistic failure. General Omar Bradley, the Commanding General of the 12th Army Group, tells us in his 1951 autobiography, "When the rains came in November with a blast of wintry cold, our troops were ill-prepared for winter time campaigning. During our race to the Rhine, I had deliberately by-passed shipments of winter clothing in favor of ammunition and gasoline. We now found ourselves caught short, particularly in bad-weather foot wear. We had gambled and were now paying for the bad guess." Bradley pleaded with Eisenhower for more and more infantry replacements. Soldiers were wrapping their boots and feet in blanket shoes to try to avoid cold injury. The hospitals were filled with cases of frostbite and trench foot. The real cost was added up after the war. It was found that 90% of the cold weather casualties in the combat forces were in the infantry. They had an average hospital stay of 87 days, half of the cases went back the United States and only 2% ever went back into combat. In the war altogether we had lost 84,000 soldiers to cold weather injuries.

Then in June, 1950 we went to fight in Korea and to learn our lessons again. General MacArthur was well aware of the potential cold injury problem and issued good, specific orders to do the personal care we have been discussing. We also had better clothing and equipment. But, when we went into battle with the Chinese Army at the Chosin Reservoir we had our own "Retreat From Moscow" as the Marine Corps and Army Troops fought their way south to evacuation at Hungnam. At least half of the walking wounded in action were

frostbite cases. Here is where "lessons learned" on foot care needed to be enforced to the maximum. So the results of lessons forgotten again crippled soldiers and meant that many soldiers would never fight again. Again we found that it correlated directly with the intensity of combat and that it was the soldier down in the battalion that had the most trouble. Only 20% of the Army was in the battalions, but they took four times as many cold injury casualties as the Army as a whole.

Korea gave us two new pieces of data. The first was that in extreme cold, the casualties rates go down. No one is outside, vehicles don't run, weapons freeze, and the men do whatever they can to stay warm. The second was that black soldiers are at increased risk. Korea was the first time the black soldier was integrated into the combat units and they suffered in-proportionately from cold injury. We are still trying to sort out this data and why this seems to be the case. But, it is important that they, their commanders, and medics are extra alert to the potential problem.

In 1964 we find ourselves immersed in Vietnam and begin to walk through cold rice paddy water. Now we have another cold wet injury, a version of trench foot, known as "paddy foot", "immersion foot", or "prune foot". The increased capillary permeability and the absorbed water in the skin causes a pitting edema and dull pain. So, we go back to foot care, to command inspections, dry socks and all that dull stuff we keep forgetting.

There are field training exercises and training conducted in cold weather environments and the literature is full of papers that report the continued problem with cold weather injuries. The new non-permeable Arctic Thermal Boot causes another non-freezing injury known as "Thermal Boot Syndrome". But when the British go to the Falkands in 1982 we find that they too forgot the lessons of the past. Group Captain Mike Fisher reported, "The boots were standard, not waterproof and water came in over the top. 20% of the casualties were Trench Foot." Captain Steven Hughes, Regimental Medical Officer of the Parachute Regiment found one case of Trench Foot per platoon of 20 men. He had to set up Feet R&R Centers." On the other hand, Sergeant George Matthews of the Royal Marines, who trained regularly in Norway, said "I had my guy's boots straight off every day, powdering them and putting on dry socks. I didn't have one guy with trench foot in my troop". When the British won they found over 40% of the Argentine soldiers had frostbite from a total neglect of elementary foot care. For the British the final count was that 11% of 680 evacuated casualties were Trench Foot cases.

It is imperative that we learn from the past and do not repeat these mistakes, for if we do not it is truly the soldiers, sailors, airmen and marines who we support that will suffer.

**WINTER CONDITIONS
IN THE HERMON-AREA (ANTILIBANON)**

COL Fridolin Gigacher
Jägerschule
Saalfelden, Austria

J Ä G E R S C H U L E
K o m m a n d o
WALLNER-Kaserne
5760 SAALFELDEN

SAALFELDEN, 24 February 1995

Briefing on
Winter Conditions in the HERMON-area
(Antilibanon)

1. TOPOGRAPHY

The Hermon mountain ridge extends in a Northeast - Southwest direction with the highest point 2814 m. This ridge stands alone in the area and is subject to constant strong winds blowing from the West.

2. CLIMATE

The elevated regions of the Golan experience heavy rain and snowfalls during the winter period.. Strong West winds blow constantly with speeds of 100 mph (160 km/h) having been measured. Lowest temperatures recorded in the Hermon area were 8,60 F (-13oC).

3. STAGES OF WINTER

Winter is comprised of three stages: the November - December period which is characterised by heavy rain and ice storms; the January - February period with heavy snowfalls; and the March period with icy conditions as a result of warm days and cold nights however not so severe as the November - December stage.

4. ICE STORMS

The ice storms (freezing rain) conditions make travel in the Hermon area extremely hazardous both on foot and by vehicle. All exposed vehicles and equipment are sheathed in ice. Water proof clothing is necessary for personnel working in the area as wet clothing coupled with high winds will have severe effects on the body.

5. SNOW STORMS

The snow in the Hermon region has higher water content than that found in most mountain regions of Europe or North America. This, coupled with the high winds creates unusual packed snow coastings on buildings and vehicles. The western sides of ridges and the tops of ridges tend to have little snow while depressions and the eastern sides of ridges experience heavy drifting. In the Aarne area roads were covered with drifts up to five meters deep. One drift on the eastern side of the Hermon ridge was measured at 60 Meters.

Lack of uniformity in snow distribution makes travel by ski or oversnow vehicles a demanding task even for skilled persons.

6. PERSONAL FACTORS

Severe wind-chill-effects are experienced by personnel in exposed locations. In sheltered locations the drifting snow can isolate them in buildings.

Positions which are occupied permanently should be stocked to be selfsufficient for up to one month in food, water and fuels.

A medical officer should be stationed with any troops in the Hermon area.

The effects of solar radiation of high elevations are severe. Sunglasses, sun barrier creams/lotions, and headcoverings are needed, as are anti-chapping creams or ointments to counteract the effects of dry air at altitudes.

Communications to all positions are important to maintain morale of isolated personnel and to counteract psychological effects of being out-off by storms.

7. ACCOMMODATION

Insulated buildings are needed for all personnel and to protect material subject to freezing. Personnel cannot live in tents - this point was strongly stressed by IDF

8. SNOW CLEARANCE

The most effective way of clearing roads was found to be by means of a bulldozer with an angled blade. A combination of cutting and packing snow drifts was used to open roads on the sides of the mountain. An armoured personnel carrier with a dozer blade was tried and found useful in some areas. Snow blowers were limited by their inability to climb and blow snow simultancously but were useful on level sections where snow depth was not too great. An elevator type of blower unit which can be attached to a bulldozer was found to be effective. (Caterpillar was reported to make such an attachment.) Clearance of roads in the Hermon area took from 1 1/2 to 2 weeks time after storms.

9. VEHICLE RECOMMENDATIONS

IDF used oversnow vehicle to reach positions immediately after snow storms. The Type favoured was the KAESSBOHRER PISTEN-BULLY which was designed for use on skiing slopes.

Armoured personnel carriers and the cargo version of the APC were used in the area but were not held in much favour owing to their heavy ground pressure and their tendency to side-slip during icy conditions. The cargo version performed better than the armoured. Some problems of throwing tracks were also reported when traversing rocky terrain laterally.

All wheeled vehicles need tire chains when operating on snow-covered roads and must be of the four or six wheel drive type.

NOTE: In discussions it was stated that IDF did not occupy positions on the top of Mt Hermon continuously during the winter 1973-1974 owing to the severe weather conditions.

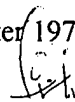

(FRIDOLIN GIGACHER)

SNOW DRIFTING PROBLEMS AND ABATEMENT

Dr. James Lever
Robert Haehnel
CPT Jeff Wilkinson
Cold Regions Research & Engineering Laboratory
Hanover, NH

Snow Drifting Problems and Abatement

Problem Statement:

Snow drifting pertains to wind transport of loose fallen snow that can present problems for both base and tactical commanders. It reduces visibility and can deposit on roadways and avenues of approach. This complicates both planning and execution of operations. Snowdrifts can cause structural failure, obscure observation ports, render access-ways inoperable or inundate barriers. The intent of snowdrift modeling is to be able to predict the depth, location, and rate of accumulation of drifts relative to structures.

CRREL Capability:

The Army's Cold Regions Research and Engineering Laboratory, Hanover, NH., has developed the capability to model common snow drifting problems. Currently we possess a recirculating wind tunnel for small-scale modeling (about 1:200). A larger tunnel is under construction and will be operable in April of 1995. The wind tunnel uses glass oxide beads about the size and consistency of table salt as the modeling media. They replicate the gross formation of drifts reasonably well. A moiré photography and computer imaging method has been developed. It produces a three-dimensional image of the contours similar to both topographical maps and computer terrain outputs. With this system we are able to calculate drift volumes, locations and rates of accumulation. (See Figure)

Modeling methods were verified by studying geometric shapes such as cylinders, cubes and simple steps in our wind tunnel and in the field. We have also examined drifts developed by simple groups of elevated buildings. We can investigate changes in drift patterns due to building location or shape alterations. This capability is directly applicable to base layout and building design; however, it can also assist in tactical operations.

Operations:

Snow transport mechanisms change as wind speed increases. Creep occurs as winds exceed a threshold velocity, thereby providing enough energy for particles to rollover one another. A saltation layer (a few inches thick) forms as the wind speed increases. The snow particles are ejected from the surface, carried downwind, splash back into the surface knocking other particles loose and continuing the process. High winds cause the typical turbulent diffusion or "white out" condition. The proportion of snow being transported by each of these mechanisms is determined by wind speed, snow hardness, and particle size.

Snow fences are a current method of drift control. To be used effectively they must be properly sited and sized. To protect an avenue of approach the fences need to be located upwind of the traveled way at least 35 times the height of the fence and roughly perpendicular to the prevailing winds. The height of the fence will determine the amount of snow that can be stored. The required storage volume is determined from available local meteorological data. Snow fences can be placed in depth if necessary to

provide enough storage if materials or signature is a problem. Other military applications are listed below:

Mobility:

- Improving trafficability: Proper drift control will free horizontal assets for other missions.

Countermobility:

- Speed Bumps: Small wind rows could be encouraged to grow as a disrupting obstacle. Their relatively shallow depth reduces signature and proper employment mimics natural formations called "sastrugi."
- Discouraging trafficability: If the threat is primarily wheeled vehicles, drifts could be encouraged to grow in depressions and on high-speed avenues of approach.

Survivability:

- Security Fences: Standard wire fences quickly become engulfed during heavy snow drifting.
- Sensors: Remote detection devices can become inoperable if the field of vision is obscured.
- Concertina Wire Fences: Standard and non standard wire obstacles may become inundated during heavy drifting.
- Fighting Trenches: Excavated lines of communication can fill and become unusable without overhead protection or continuous maintenance.

Sustainability:

- Entrances: Proper location or protection of portals is critical for continued operations.
- Exterior Storage: Proper placement of equipment is essential for retrieval or servicing.
- Air Handling Units: High volume intakes can ingest significant amounts of snow or the openings can become blocked by drifted snow.

Problem Survey:

We now have the capability to solve real problems. We would like your input on specific areas of concern. What are real time issues facing you?

Future

Our long-range focus is to produce a computer modeling method. This could be incorporated into a military computer terrain model showing topography before and after drifting.

Points of Contact:

CRREL
72 Lyme Road
Hanover, NH 03755-1290

603-646-4100, Fax 4477
DSN 220-(extension)

Dr. James Lever, 4309 (jlever)
Robert Haehnel, 4325 (rhaehnel)
Capt. Jeff Wilkinson, 4657 (jwilkins)

email address (mailid)@crrel41.crrel.usace.army.mil

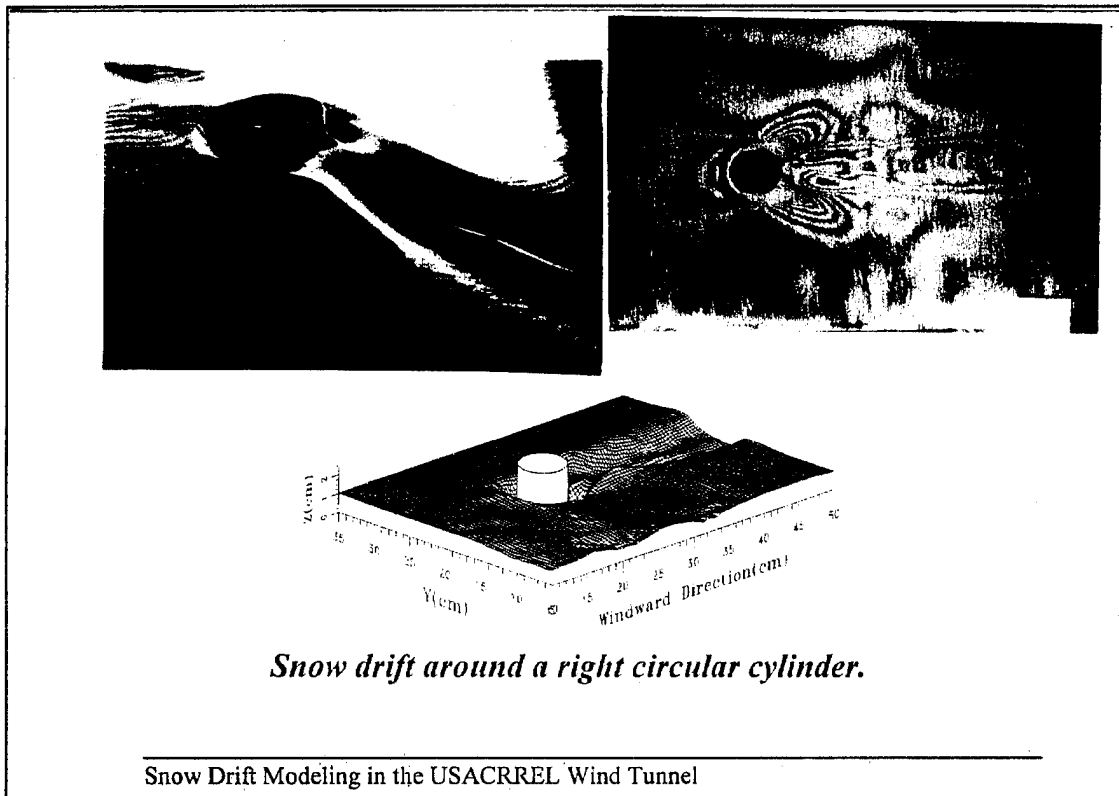

Figure

- Top left: Photo of model cylinder in atmospheric wind tunnel.
- Top right: Moiré photo of same cylinder.
- Bottom: Computer generated surface plot of model cylinder and drift formation.