

DTIC  
SELECTE  
APR 18 1995  
S  
C  
D

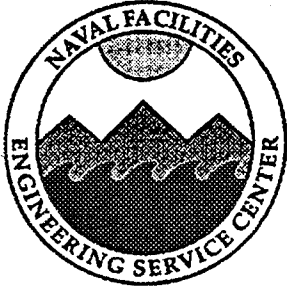

NAVAL FACILITIES ENGINEERING SERVICE CENTER  
Port Hueneme, California 93043-4328

---

---

## Technical Report TR-2039-OCN

### DESIGN GUIDE FOR PILE-DRIVEN PLATE ANCHORS

by

James Forrest, Ph.D, Robert Taylor, and Lora Bowman

March 1995

19950414 119

Sponsored by:  
Commander  
Pacific Division  
Naval Facilities Engineering Command  
Pearl Harbor, HI 96860-7300

FOR QUALITY ENGINEERING

METRIC CONVERSION FACTORS

Approximate Conversions to Metric Measures				Approximate Conversions from Metric Measures			
Symbol	When You Know	Multiply by	To Find	Symbol	When You Know	Multiply by	To Find
in	inches	*2.5	centimeters	mm	millimeters	0.04	inches
ft	feet	30	centimeters	cm	centimeters	0.4	inches
yd	yards	0.9	meters	m	meters	3.3	feet
mi	miles	1.6	kilometers	km	kilometers	1.1	yards
						0.6	miles
in <sup>2</sup>	square inches	AREA	square centimeters	cm <sup>2</sup>	square centimeters	0.16	square inches
ft <sup>2</sup>	square feet	6.5	square meters	m <sup>2</sup>	square meters	1.2	square yards
yd <sup>2</sup>	square yards	0.09	square meters	km <sup>2</sup>	square kilometers	0.4	square miles
mi <sup>2</sup>	square miles	0.8	square kilometers	ha	hectares (10,000 m <sup>2</sup> )	2.5	acres
	acres	2.6	hectares				
		0.4					
oz	ounces	MASS (weight)	grams	g	grams	0.035	ounces
lb	pounds	28	kilograms	kg	kilograms	2.2	pounds
	short tons	0.45	tonnes	t	tonnes (1,000 kg)	1.1	short tons
	(2,000 lb)	0.9					
tsp	teaspoons	VOLUME	milliliters	ml	milliliters	0.03	fluid ounces
Tbsp	tablespoons	5	milliliters	l	liters	2.1	pints
fl oz	fluid ounces	15	milliliters	l	liters	1.06	quarts
c	cups	30	milliliters	l	liters	0.26	gallons
qt	quarts	0.24	liters	m <sup>3</sup>	cubic meters	35	cubic feet
pt	pints	0.47	liters	m <sup>3</sup>	cubic meters	1.3	cubic yards
gal	gallons	0.95	liters	°C	Celsius temperature	9/5 (then add 32)	Fahrenheit temperature
ft <sup>3</sup>	cubic feet	3.8	liters				
yd <sup>3</sup>	cubic yards	0.03	cubic meters				
		0.76	cubic meters				
°F	Fahrenheit temperature	TEMPERATURE (exact)	Celsius temperature				
		5/9 (after subtracting 32)					

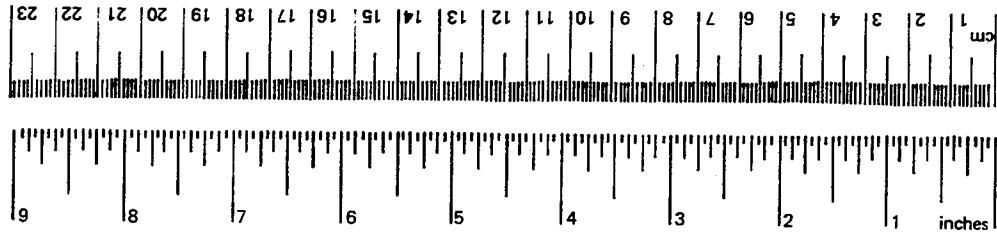

\*1 in = 2.54 (exactly). For other exact conversions and more detailed tables, see NBS Misc. Publ. 286, Units of Weights and Measures, Price \$2.25, SD Catalog No. C13.10-286.

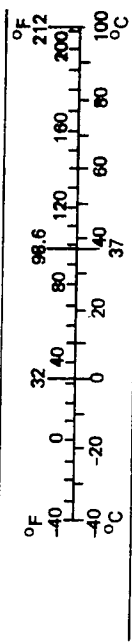

REPORT DOCUMENTATION PAGE			Form Approved OMB No. 0704-018	
Public reporting burden for this collection of information is estimated to average 1 hour per response, including the time for reviewing instructions, searching existing data sources, gathering and maintaining the data needed, and completing and reviewing the collection of information. Send comments regarding this burden estimate or any other aspect of this collection information, including suggestions for reducing this burden, to Washington Headquarters Services, Directorate for Information and Reports, 1215 Jefferson Davis Highway, Suite 1204, Arlington, VA 22202-4302, and to the Office of Management and Budget, Paperwork Reduction Project (0704-0188), Washington, DC 20503.				
1. AGENCY USE ONLY (Leave blank)	2. REPORT DATE March 1995	3. REPORT TYPE AND DATES COVERED Final; Oct 1992 - Sept 1994		
4. TITLE AND SUBTITLE <b>Design Guide for Pile-Driven Plate Anchors</b>		5. FUNDING NUMBERS PR - 42-083		
6. AUTHOR(S) James Forrest, Ph.D., Robert Taylor, and Lora Bowman				
7. PERFORMING ORGANIZATION NAME(S) AND ADDRESS(ES) Naval Facilities Engineering Service Center Port Hueneme, CA 93043-4328		8. PERFORMING ORGANIZATION REPORT NUMBER TR-2039-OCN		
9. SPONSORING/MONITORING AGENCY NAME(S) AND ADDRESSES Commander Pacific Division Naval Facilities Engineering Command Pearl Harbor, HI 96860-7300		10. SPONSORING/MONITORING AGENCY REPORT NUMBER		
11. SUPPLEMENTARY NOTES				
12a. DISTRIBUTION/AVAILABILITY STATEMENT Approved for public release; distribution is unlimited.		12b. DISTRIBUTION CODE		
13. ABSTRACT (Maximum 200 words)  A user guide is presented for designing and installing plate anchors in the sea bottom using conventional pile driving techniques. This permits use of low cost, highly efficient, mooring anchors to meet a broad range of mooring requirements, including hurricane moorings for ships or other floating structures. This technique is particularly appropriate for heavily congested or confined areas. The anchors are suitable for various bottom deposits, including soft organic silts, overconsolidated clays, dense sands, glaciated soils and corals. Vibratory and impact diesel hammers may be used with a retrievable follower section to insert the anchors into the bottom. They are then pull-tested either horizontally or vertically up to the design loads. This approach provides versatile, easily fabricated anchors, suitable for a variety of situations, that can be installed with readily available marine construction assets.				
14. SUBJECT TERMS Anchors, pile-driven plate anchors (PDPA)			15. NUMBER OF PAGES 56	16. PRICE CODE
17. SECURITY CLASSIFICATION OF REPORT Unclassified	18. SECURITY CLASSIFICATION OF THIS PAGE Unclassified	19. SECURITY CLASSIFICATION OF ABSTRACT Unclassified	20. LIMITATION OF ABSTRACT UL	

**PREFACE**

The Naval Facilities Engineering Service Center (NFESC), formerly the Naval Civil Engineering Laboratory (NCEL), was tasked by the Naval Facilities Engineering Command (NAVFAC) to develop guidance for the design, sizing, and installation of high capacity pile-driven plate anchors (PDPA) that are installable with Navy equipment and personnel. A 2-year engineering investigation (EI) program was started in FY91 in conjunction with PACDIV, Code 102 funded prototype anchor installations. Plate anchors were driven and load-tested in San Diego Harbor and a multi-point fleet mooring was installed at the Naval Inactive Ship Mooring Facility (NISMF) at Middle Loch, Pearl Harbor, Hawaii. Data secured from several series of model tests under the EI program and from prototype anchor installations were used primarily for performance verification and enhancement of concepts developed over the past 20 years by the Foundation Engineering Division of the former NCEL.

This document provides guidance on the selection, configuration, and installation of low cost, highly efficient plate anchors, particularly suitable for moorings in heavily congested or confined areas. Direction is provided on obtaining required site information and on selection of anchor size and drive depth. Guidance is presented on system configuration, equipment selection, and installation procedures. Example problems of sizing anchors for two different types of seafloors are included. Additional information on the various aspects of plate anchor technology can be found in the References.

Accession For	
NTIS CRA&I	<input checked="" type="checkbox"/>
DTIC TAB	<input type="checkbox"/>
Unannounced	<input type="checkbox"/>
Justification	
By _____	
Distribution /	
Availability Codes	
Dist	Avail and/or Special
A-1	

## CONTENTS

	Page
<b>CHAPTER 1. SELECTION OF ANCHOR TYPE</b> .....	1
1.1 ANCHOR FUNCTIONING .....	1
1.2 WHEN TO USE PILE-DRIVEN PLATE ANCHORS .....	1
<b>CHAPTER 2. DETERMINING SEAFLOOR CONDITIONS</b> .....	7
2.1 SITE DATA REQUIREMENTS FOR PILE-DRIVEN PLATE ANCHORS ..	7
2.2 SEAFLOOR SOIL TYPES .....	7
2.2.1 Sands (Cohesionless) .....	7
2.2.2 Muds, Silts, and Clays (Cohesive) .....	8
2.2.3 Coral .....	8
2.2.4 Rock .....	8
2.3 DETERMINATION OF SEAFLOOR SOIL PROPERTIES .....	8
<b>CHAPTER 3. SELECTING THE ANCHOR SIZE</b> .....	11
3.1 OPTION 1 - GRAPHICAL APPROACH .....	11
3.1.1 Cohesive Soil (Clay or Mud) .....	11
3.1.2 Cohesionless Soil (Sand) .....	12
3.2 OPTION 2 - ANALYTIC APPROACH .....	13
<b>CHAPTER 4. HOLDING CAPACITY OF CHAIN</b> .....	21
4.1 ANCHOR CHAIN IN COHESIONLESS SOIL (SAND) .....	21
4.2 ANCHOR LINE IN COHESIVE SOIL (MUD) .....	21
<b>CHAPTER 5. SELECTING ANCHOR DRIVEN DEPTH</b> .....	27
5.1 KEYING DISTANCE IN COHESIVE SOIL .....	27
5.2 KEYING DISTANCE IN COHESIONLESS SOIL (SAND) .....	28

	<b>Page</b>
<b>CHAPTER 6. MOORING LAYOUT</b> .....	31
6.1 ANCHOR LOCATION IN CLAYS AND MUDS .....	31
6.2 ANCHOR LOCATION IN SANDS .....	32
<b>CHAPTER 7. STRUCTURAL DESIGN</b> .....	35
7.1 STRUCTURAL DESIGN OF THE ANCHOR .....	35
7.2 FOLLOWER DESIGN .....	35
7.2.1 Sizing the Follower .....	35
7.2.2 Follower-Anchor Connection .....	36
7.2.3 Additional Follower Details .....	36
7.3 CHAIN-WIRE COMBINATION .....	36
7.4 SELECTING THE PILE DRIVER .....	37
7.4.1 Driving In Cohesive Soil .....	37
7.4.2 Vibratory Hammer in Cohesionless Soil .....	37
7.4.3 Impact Hammer in Cohesionless Soil .....	38
7.5 HAMMER CAPACITY .....	38
<b>CHAPTER 8. INSTALLATION</b> .....	45
<b>CHAPTER 9. PROOF TESTING THE ANCHOR</b> .....	47
<b>CHAPTER 10. REFERENCES</b> .....	51
<b>APPENDIXES</b>	
A - List of Symbols .....	A-1
B - Examples .....	B-1

## **CHAPTER 1**

### **SELECTION OF ANCHOR TYPE**

#### **1.1 ANCHOR FUNCTIONING**

The concept of operation for a pile-driven anchor is illustrated in Figure 1-1. The anchor is connected to a structural member called a follower and driven vertically into the seafloor using a pile-driving hammer. The follower is retrieved, and the anchor chain buoyed off. The anchor is then pull-tested, either vertically, or horizontally, to "key" it; that is, rotate the plate so the anchor resists pull-out forces by mobilizing the bearing capacity of the soil.

Wide flexibility may be used in the plate anchor fabrication. One anchor configuration that has been used successfully consists of a steel plate welded onto a section of structural steel beam to which a padeye is attached, see Figure 1-2. Except for the keying flap, recommended for soft and cohesive soils to enhance keying, the same types of anchor configuration can be used for all types of soils. The keying flap is a hinged plate which generates minimal soil resistance during penetration but opens up to reduce vertical anchor movement during keying.

#### **1.2 WHEN TO USE PILE-DRIVEN PLATE ANCHORS**

Pile-driven plate anchors (PDPA), direct embedment anchor type, are particularly suitable for moorings at sites with complex seafloor conditions, or in heavily congested or confined areas where there is close proximity of other moored vessels or bottom obstructions, such as utility cables. In such situations, conventional drag anchors or mooring dolphins are generally not adequate. A comparison of different anchor-type applications is shown in Table 1-1. Usage factors for pile-driven plate anchors are in Table 1-2.

Table 1-1  
Comparison of Anchor Type Applications

Parameter	Anchor Type <sup>a</sup>			
	Drag Embedment	Deadweight	Pile	Direct Embedment
<b>Seafloor Material Type</b>				
Soft clay, mud	+	+	-	+
Soft clay layer (0 to 20 ft thick over hard layer)	-	+	+	+
Stiff clay	+	+	+	+
Sand	+	+	+	+
Hard glacial till	-	+	-	+
Boulders	o	+	o	o
Soft rock or coral	o	+	+	-
Hard, monolithic rock	o	+	-	o
<b>Seafloor Topography</b>				
Moderate slopes, < 10 degrees	+	+	+	+
Steep slopes, > 10 degrees	o	o	+	+
<b>Loading Direction</b>				
Omni-directional	o	+	+	+
Uni-directional	+	+	+	+
Large uplift component	o	+	-	+
<b>Lateral Load Range</b>				
To 100,000 lb	+	+	-	+
100,000 to 1,000,000 lb	+	-	+	+
Over 1,000,000 lb	+	o	+	+

<sup>a</sup>See Reference 1 for further details.

**Key:**

- + = Functions well
- = Normally not a good choice
- o = Does not function



Table 1-2  
General Usage Factors for Pile-Driven Plate Anchors

Positive Factors
<ol style="list-style-type: none"><li>1. Easily adapted to broad range of situations.</li><li>2. Very high capacity achievable.</li><li>3. Standard off-the-shelf components.</li><li>4. Installable with readily available marine construction equipment.</li><li>5. Resists loads in any direction, including uplift.</li><li>6. Functional in sand, mud, clay, coral, and over-consolidated soils.</li></ol>
Negative Factors
<ol style="list-style-type: none"><li>1. Cannot use in competent rock seafloors.</li><li>2. Capacity falls off once maximum exceeded.</li><li>3. Anchor is not recoverable in normal practice.</li></ol>

For further information on selection and design of anchors, see Handbook of Marine Geotechnology, Chapters 1, 4, 5, and 6 (Ref 2), or NAVFAC Design Manual DM-26 (Ref 3).

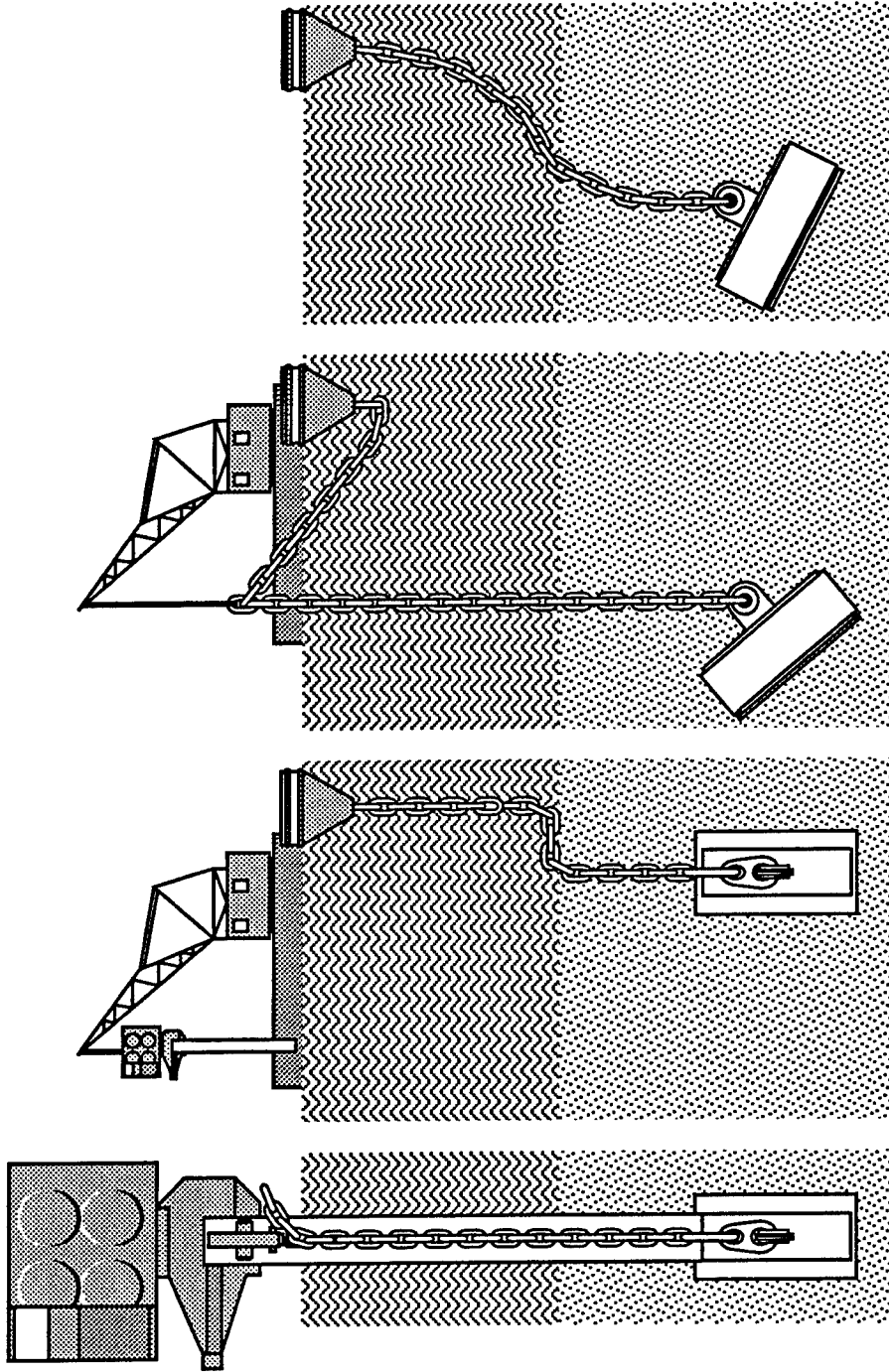

**d) Anchor established**

**c) Proof load to set anchor**

**b) Recover driver and follower**

**a) Drive anchor**

Figure 1-1  
Driven plate anchor: concept of operation.

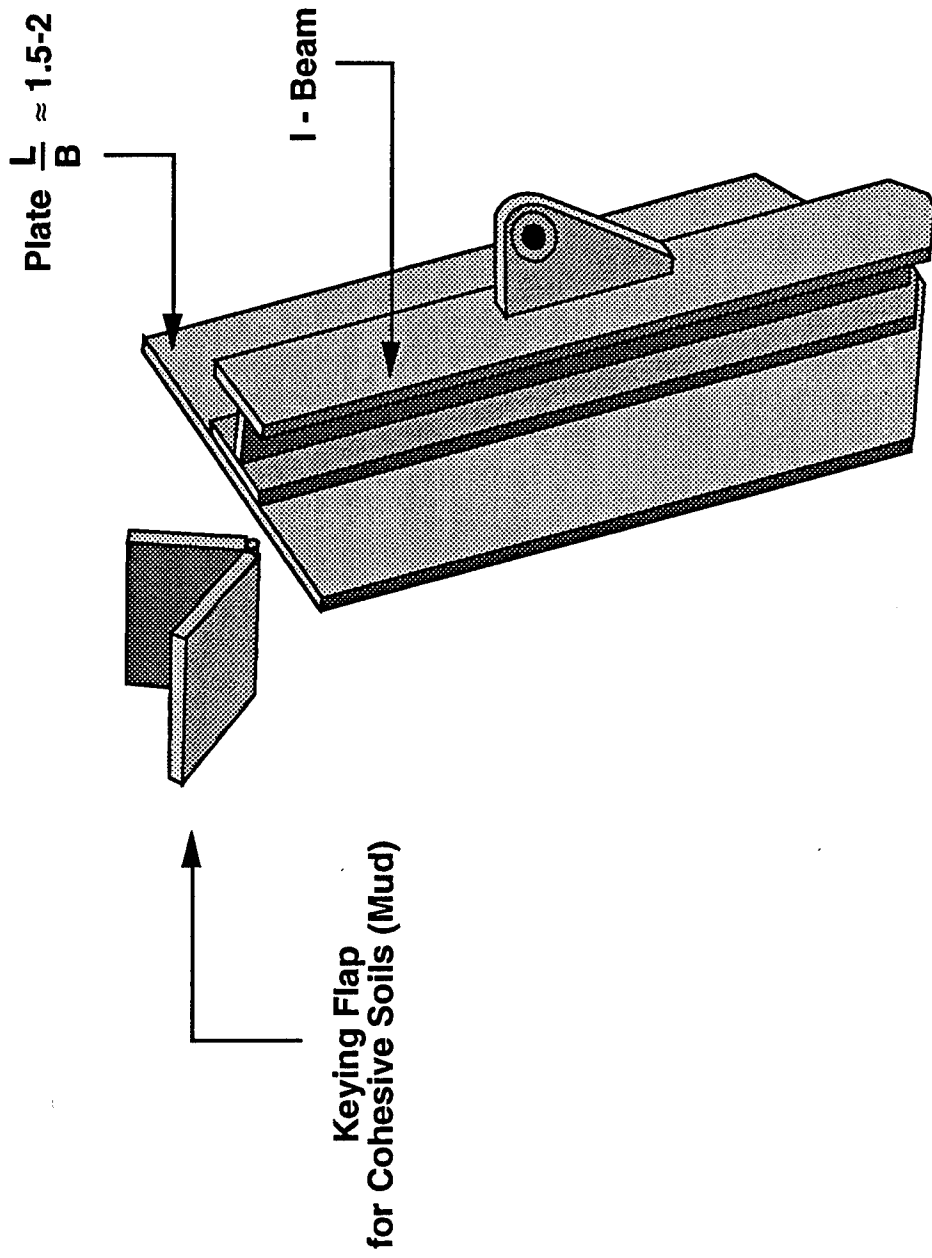

Figure 1-2  
Driven plate anchor configuration.

## CHAPTER 2

### DETERMINING SEAFLOOR CONDITIONS

#### 2.1 SITE DATA REQUIREMENTS FOR PILE-DRIVEN PLATE ANCHORS

- Site Bathymetry
- Site Topography
- Engineering Properties of Soil to Expected Anchor Depth
- Depth To Intact Rock

#### 2.2 SEAFLOOR SOIL TYPES

##### 2.2.1 Sands (Cohesionless)

Characteristics:

- Free draining
- More than 90 percent of grains visible to naked eye (larger than #200 sieve or 0.074 cm diameter)
- Non-plastic, segregates readily
- Difficult to collect samples, sample washes out during retrieval, sampler cutting edge occasionally damaged from stones or abrasive materials

Information required:

- Effective Weight of the Soil,  $\gamma_b$
- Friction angle, ( $\phi$ )
- Mineral types (quartz, calcareous)

### **2.2.2 Muds, Silts, and Clays (Cohesive)**

Characteristics:

- Soil is plastic, may resemble putty or modeling clay
- Less than 10 percent of grains visible to the naked eye (at least 90 percent smaller than the #200 sieve)

Information required:

- Undrained shear strength,  $S_u$
- Atterberg limits
- Soil sensitivity,  $S_t$
- Effective weight of the soil,  $\gamma_b$

### **2.2.3 Coral**

Characteristics:

- Identified by rock dredge sample

Information required:

- Compressive strength or hardness

### **2.2.4 Rock**

Not appropriate for pile-driven anchors.

## **2.3 DETERMINATION OF SEAFLOOR SOIL PROPERTIES**

From literature and local sources, such as Public Works Centers, universities, and commercial geotechnical consultants (see Table 2-1).

From personal contacts. Sounding, sampling and testing, see Handbook of Marine Geotechnology, Chapters 2, 3, and 8 (Ref 2), or Seafloor Soil Sampling and Geotechnical Parameter Determination Handbook (Ref 4).

Table 2-1  
Sources of Marine Geological and Geotechnical Data

Source	Location
Universities and Government Organizations	
Lamont-Doherty and Geological Observatory of Columbia University	Palisades, NY 10964
National Geophysical and Solar-Terrestrial Data Center, Environmental Data Service, NOAA	Boulder, CO 80302
Chief of Operations Division, National Ocean Survey, NOAA	1801 Fairview Avenue East Seattle, WA 98102
Chief of Operations Division, National Ocean Survey, NOAA	1439 W. York Street Norfolk, VA 23510
Naval Oceanographic Office National Space Technology Laboratories	Code 3100 NSTL Station, MI 39522
Scripps Institution of Oceanography	La Jolla, CA 92093
Chief Atlantic Branch of Marine Geology	USGS, Bldg 13 Quissett Campus Woods Hole, MA
Chief Pacific Arctic Branch of Marine Geology, USGS	345 Middlefield Road Menlo Park, CA 94025
Woods Hole Oceanographic Institution	Woods Hole, MA

Source	Location
<b>Journals and Conference Proceedings</b>	
Journals of Geotechnical Engineering	American Society of Civil Engineers
Marine Geotechnology	Pergamon Press, NY
Canadian Geotechnical Journal	National Research Council of Canada Ottawa, Canada
Geotechnique	Institution of Civil Engineers London
Ocean Engineering	Pergamon Press, NY
Offshore Technology Conference	Houston, TX
Conference on Civil Engineering in the Oceans (1 through 4)	American Society of Civil Engineers

## CHAPTER 3

### SELECTING THE ANCHOR SIZE

Anchor capacity is the maximum load that can be applied at the shackle prior to anchor pullout. Plate anchor capacity is dependent upon both the size of the plate and the strength of the soil. This guide presents two options for determining the required plate size. Under Option 1, the plate size for a specific anchor capacity may be selected using design curves presented in Section 3.1. These curves were developed by the procedures outlined under Option 2 (see Section 3.2). For situations falling outside the plots of Option 1 or if greater precision is required, the techniques of Option 2 should be used.

Under Option 2, the plate size is determined using simplified anchor capacity equations and parameter values presented in Section 3.2. Work by the Naval Facilities Engineering Service Center (NFESC), formerly the Naval Civil Engineering Laboratory (NCEL), has shown that this approach is sufficiently accurate for design and generally conservative.

#### 3.1 OPTION 1 - GRAPHICAL APPROACH

##### 3.1.1 Cohesive Soil (Clay or Mud)

- Estimate required ultimate load capacity,  $F_u$ . This should be at least equal to the design load, reduced by the contribution of the anchor line in the bottom (see Chapter 4), multiplied by a factor of safety (FS). A safety factor of 2 is recommended for most applications.
- Select tentative size of anchor based on experience, etc.
- Select depth of keyed anchor. Refer to soil profile information and Chapter 5, dealing with keying distance prediction. As an initial approximation, a vertical keying distance of  $2L$ , where  $L$  is the length of the driven plate, may be used. Then the design (keyed) depth will be the driven depth (to the tip of the anchor) minus  $2L$ .
- Select size of plate from Figure 3-1. Enter size of plate, with the soil shear strength at the selected design depth of the anchor, and proceed upward to the required ultimate capacity, then read off the required plate area along the left axis. Repeat this until the required area of the plate agrees with the original assumption for anchor size.



- Finalize drive depth. For the selected anchor, determine the predicted keying distance from Figure 5-1. The final point drive depth is then the design depth plus the keying distance determined from Figure 5-1.

Figure 3-1 applies only for anchors keyed at depths of five or more plate widths, and only to marine (saturated) soil conditions. Capacity is based on a load capacity factor (Section 3.2) of 12. For other situations with cohesive soils, Option 2 (see Section 3.2) must be used. Note: Figure 3-1 provides the ultimate load capacity so the factor of safety is only 1.0.

### 3.1.2 Cohesionless Soil (Sand)

- Estimate required ultimate load capacity,  $F_u$ . For primarily horizontal loading, this should be the design horizontal load, reduced by 20 percent, to account for the contribution of the anchor line in the bottom, multiplied by a factor of safety. The expected ultimate mooring capacity,  $T_m$ , is then given by the relationship:

$$T_m = 1.25 F_u.$$

For situations involving primarily vertical loading, the contribution of the anchor chain is ignored. A safety factor of 2 is recommended for most applications.

- Select a trial anchor size. Select one of the anchor sizes presented in Figures 3-2, 3-3, or 3-4. These figures provide ultimate (keyed) anchor capacity, versus the ratio of keyed depth to anchor plate length. These figures provide capacities for three different plate sizes, in sands of three different densities: loose, medium dense, and dense.
- Select trial depth of keyed anchor. Refer to soil profile information and Chapter 5, dealing with keying distance prediction. As a first approximation, a vertical keying distance of 1.5 L may be used, where L is the length of the driven plate.
- Determine capacity of anchor from Figures 3-2, 3-3, or 3-4. Go to the appropriate figure, depending upon sand density, and determine the capacity of the selected anchor at the trial depth. Vary the plate size or design depth until the desired capacity is provided. For anchor sizes or situations other than those represented by Figures 3-2, 3-3, or 3-4, Option 2 in Section 3.2 must be used. Again, the factor of safety included in the figures is only 1.0.
- Finalize drive depth. For the selected anchor, refer to Figure 5-2 to confirm keying distance. The point drive depth is then the design depth plus the keying distance from Figure 5-2.

### 3.2 OPTION 2 - ANALYTIC APPROACH

Where conditions differ from the assumptions included in Figures 3-1 through 3-4, Option 2 must be used. This approach is based on simplified load capacity equations. Vertical anchor capacity may be determined as shown below.

Cohesive soils (clay or mud) (Ref 5).

$$F_u = A c N_c \quad (3.1)$$

Cohesionless soils (sand) (Ref 6).

$$F_u = A (\gamma_b D N_q) \quad (3.2)$$

where:

$F_u$  = Ultimate anchor holding capacity

$A$  = Area of the plate

$c$  = Cohesive strength of the soil

$\gamma_b$  = Effective (buoyant) weight of the soil

$D$  = Embedded depth of the (keyed) anchor

$N_c$  = Bearing capacity factor for cohesive soil, see Figure 3-5 (Ref 6)

$N_q$  = Bearing capacity factor for cohesionless soils, see Figure 3-6 (Ref 7)

Figures 3-5 and 3-6 show load capacity factor versus keyed depth ( $D$ ), normalized by plate width ( $B$ ) for cohesive and cohesionless soils, respectively. To use these curves, one first selects a tentative size of anchor and trial depth, and calculates the relative embedment depth. Then the appropriate value for  $N_c$  or  $N_q$  is selected from Figure 3-5 or 3-6. These values are then used in the appropriate equation to determine capacity.

Equation 3.1 may be used for both short term or long term loading. To account for soil disturbance and other irregularities, such as eccentricity of loading, a maximum load capacity factor of 12 is recommended for all marine (saturated) situations. Nevertheless, in both normally consolidated soils or over-consolidated clay, if the keyed depth to width ratio ( $D/B$ ) is 6 or greater, long term load capacity factors in excess of 15 are noted. For non-saturated conditions see "special conditions" (Ref 6).

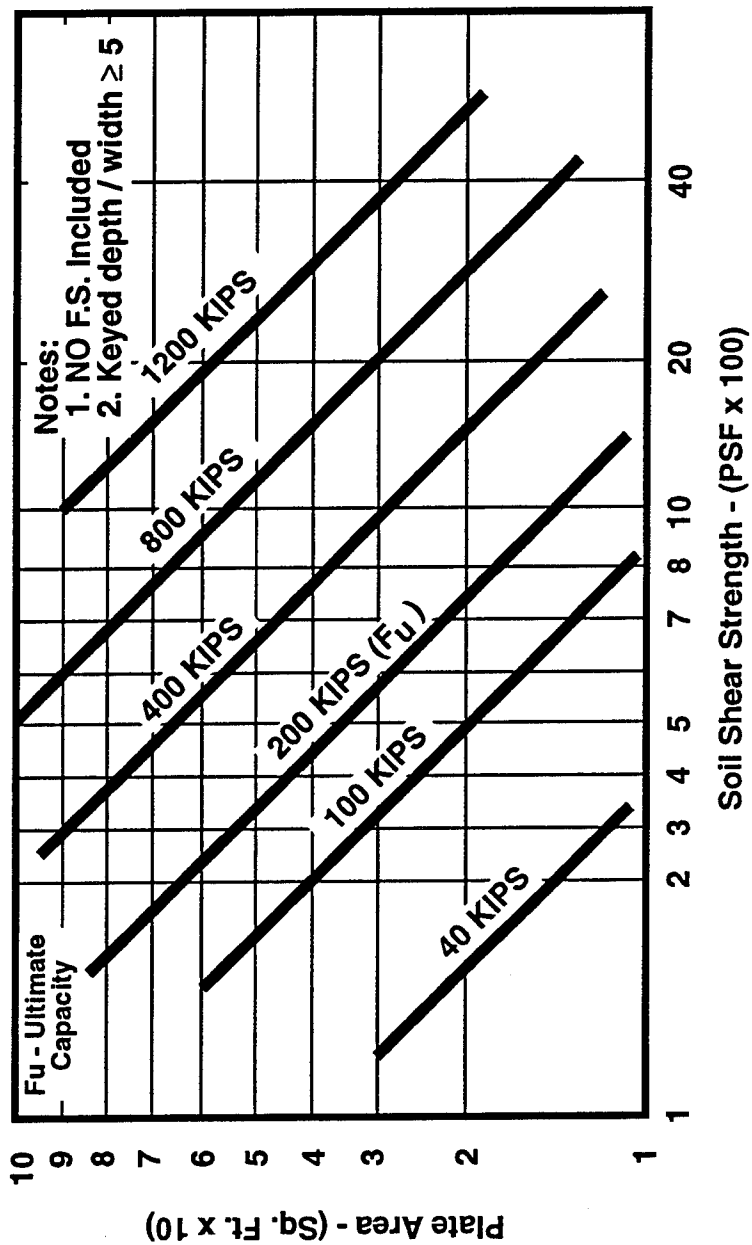

Figure 3-1  
 Required plate area for anchors in cohesive soil.

Buoyant Unit Weight 50 pcf. - Friction Angle = 30 deg.

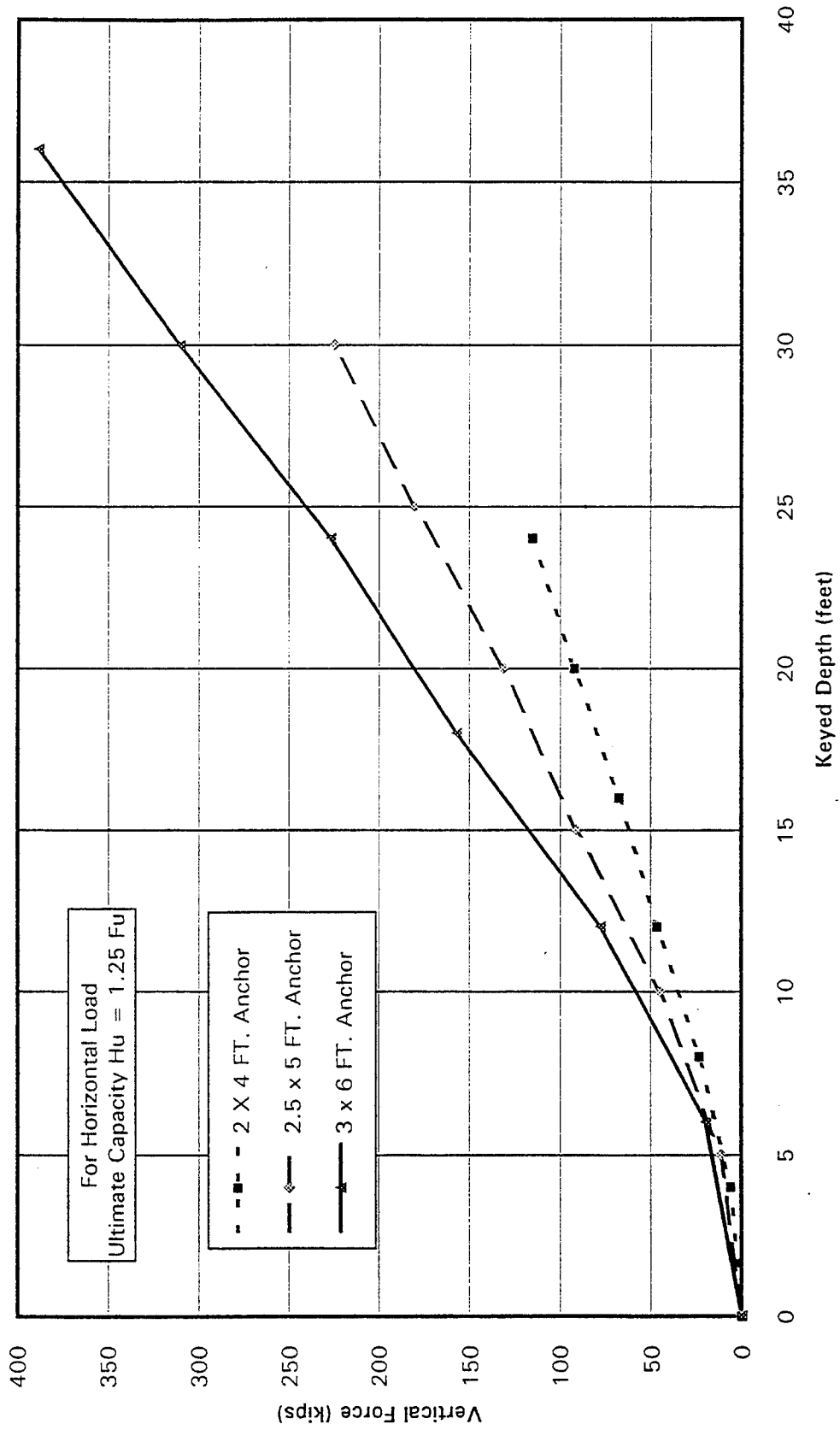

Figure 3-2  
Plate area capacity in loose sand.

Buoyant Unit Weight 60 pcf. - Friction Angle = 36 deg.

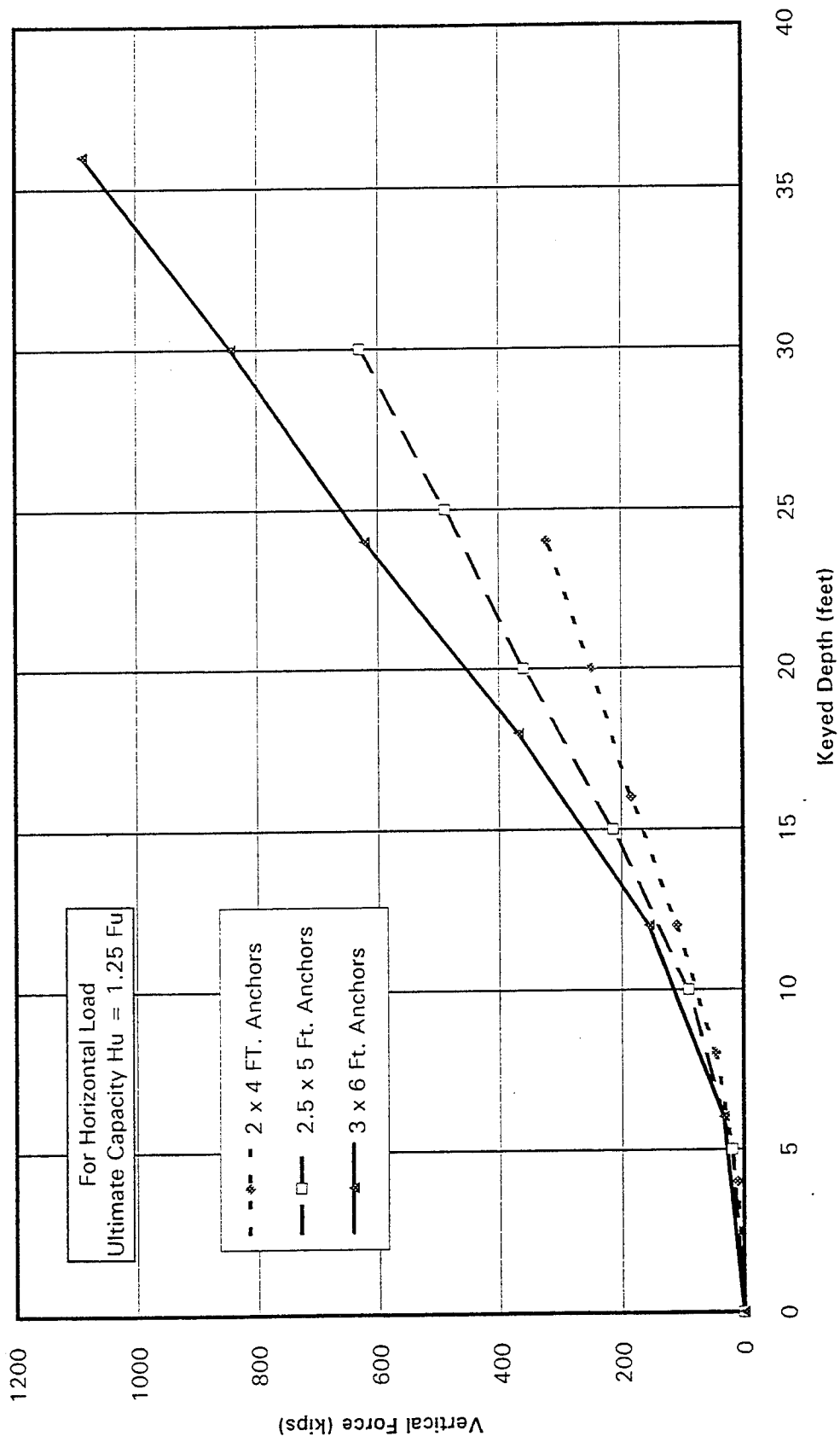

Figure 3-3  
Plate area capacity in medium dense sand.

Buoyant Unit Weight 70 pcf. - Friction Angle = 40 deg.

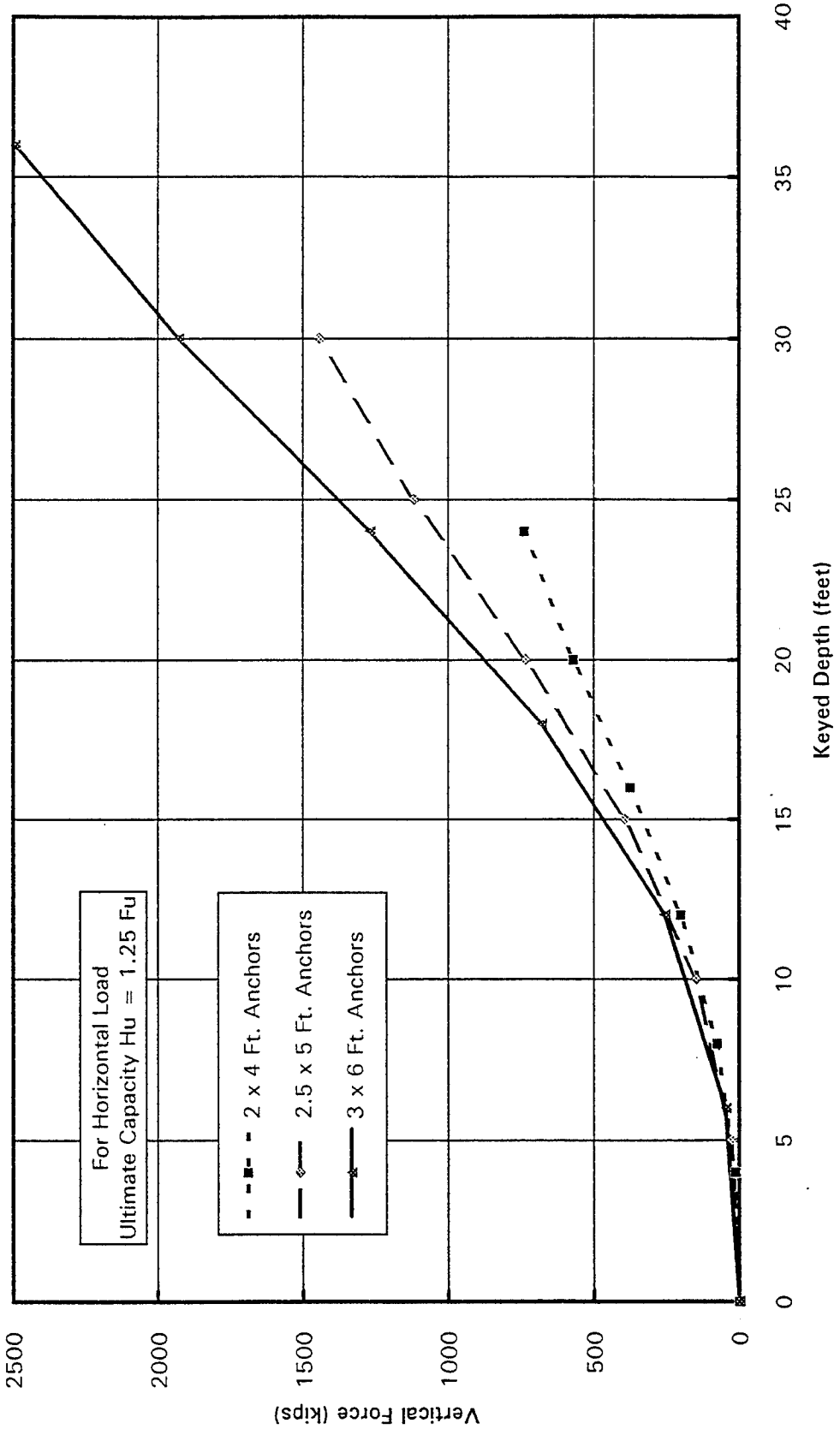

Figure 3-4  
Plate area capacity in dense sand.

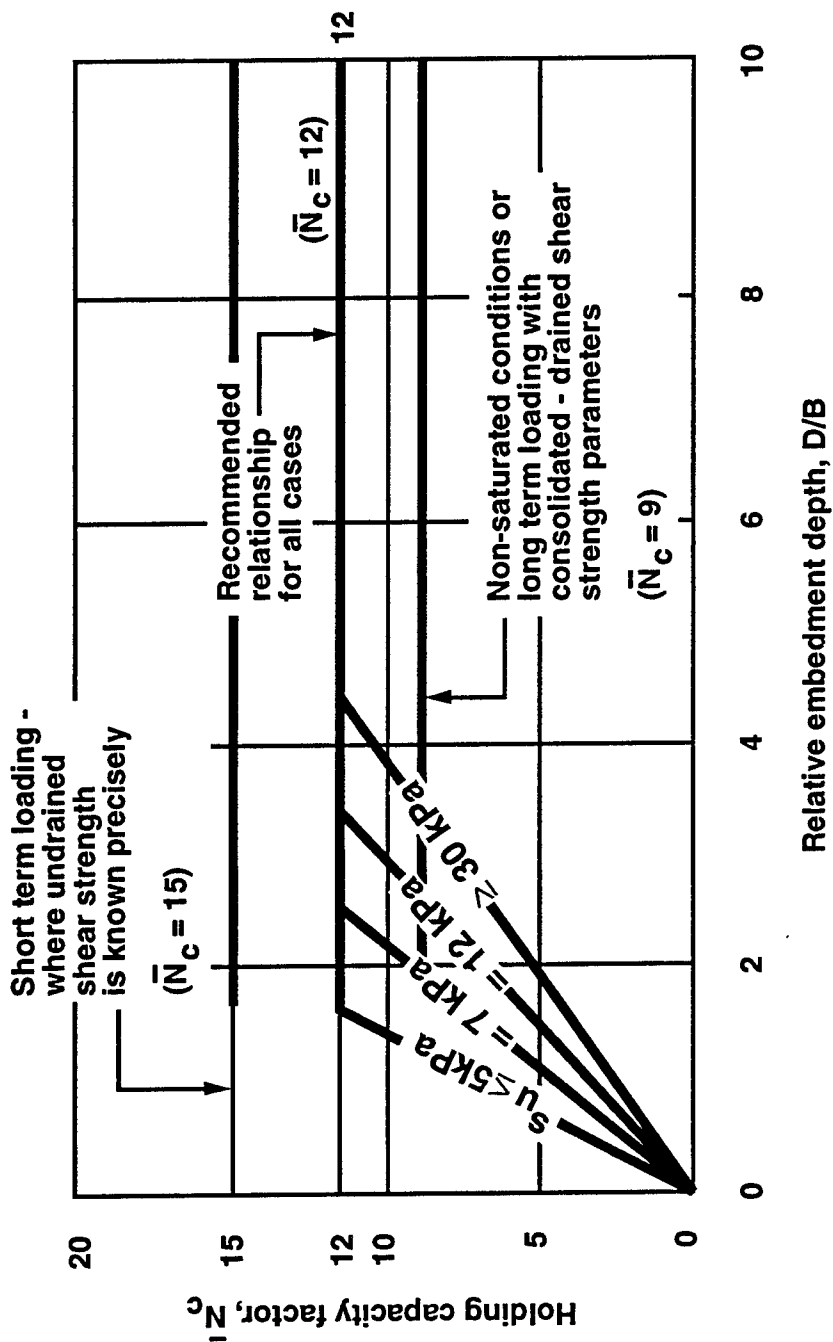

Figure 3-5  
Holding capacity factors for cohesive soils (see Beard, 1980).

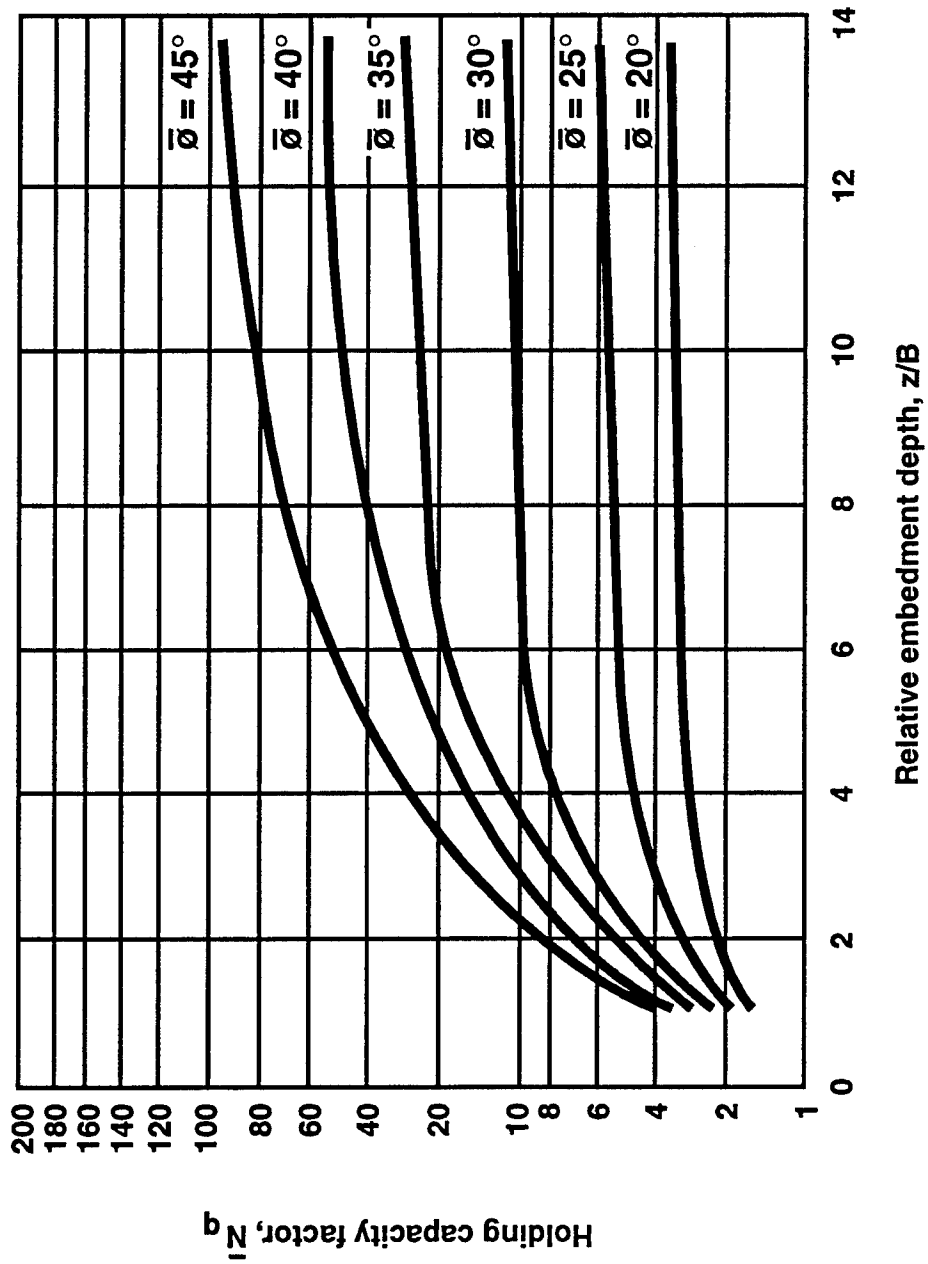

Figure 3-6  
Holding capacity factors for cohesionless soils (see Forrest, 1992).



## CHAPTER 4

### HOLDING CAPACITY OF CHAIN

The anchor line can contribute significantly to the ultimate capacity of a driven plate anchor under horizontal loading. However, for vertical loading situations, the contribution of the anchor line is ignored. The anchor line follows a catenary from the mooring buoy to the "daylight" point, or point at which it enters the bottom (see Figures 4-1(a) and 4-1(b)). Thereafter, it follows a curved path down through the mud to the anchor shackle. The path of the anchor line in the seabed depends upon the depth of the anchor, the type of anchor line, the anchor line tension, and angle at the mudline, all of which depend upon the layout of the mooring. In order to determine the various geometric parameters (shown in Figure 4-1(b)) for clay or mud and the contribution of the anchor line, a computerized procedure has been developed (Ref 8). A few solutions for typical situations in cohesive soils are presented below to show trends. There is no currently available analysis procedure for sands.

#### 4.1 ANCHOR CHAIN IN COHESIONLESS SOIL (SAND)

Under horizontal load, anchor chain can conservatively be assumed to contribute an additional 25 percent to the short-term plate anchor capacity (Ref 9). (Recent work indicates the long-term chain capacity can provide an increase in capacity up to 80 percent of that of the anchor alone.) Therefore, the ultimate horizontal capacity,  $H_u$ , may be increased by 25 percent to account for the contribution of the chain. The horizontal capacity at the mudline is then given by the expression:

$$H_u = 1.25 F_u$$

where  $F_u$  is ultimate anchor capacity. The anchor size is then based upon this value, divided by an appropriate factor of safety.

#### 4.2 ANCHOR LINE IN COHESIVE SOIL (MUD)

The various combinations of soil strength, design load, chain or wire size, water depth, etc., are too numerous to be presented here. A few typical cases for anchor chain in a typical harbor deposit are depicted in Figures 4-2 and 4-3. These figures show the reduction of chain tension in a soft harbor silt (mud), with a strength increase of 10 psf per foot of depth for a 300 and 500 kip horizontal design load, respectively, at the mudline. The chain profiles in the bottom, for a number of different chain angles at the mudline, are shown with superimposed contours of chain tension. For example, look at Figure 4-2; assuming the anchor chain enters

the mud at an angle of 5 degrees, by the time it penetrates to a depth of 50 feet (horizontal distance  $X_1$ , in Figure 4-2 of about 165 feet), the tension on the anchor chain has decreased from greater than 300 kips, to less than 225 kips. Once the chain trajectory has reached a vertical orientation, it no longer contributes to the horizontal capacity, so the plots are not continued into this range.

When an anchor is proof-loaded horizontally in soft deposits, it is desirable to insert wire between the anchor shackle and the anchor chain to enhance keying (see Chapter 7). Figure 4-4 provides an indication of the change in anchor line geometry and anchor line contribution to capacity, due to a 40-foot length of cable at the anchor shackle. This figure has contours of shackle tension and mudline angle superimposed on a cross-section of the bottom, as opposed to the anchor line profiles shown in Figures 4-2 and 4-3. Nevertheless, using Figure 4-4, it may be seen that the shackle tension at a depth of 50 feet and horizontal distance of 140 feet, is increased from about 225 kips, as provided by Figure 4-2, to about 250 kips, by the addition of the 40 feet of 3-inch wire at the anchor. For such situations, the reduction in anchor line resistance must be balanced against the increased anchor capacity, due to the wire allowing the anchor to key at a greater depth. For analysis of other situations, the anchor line analysis program is required.

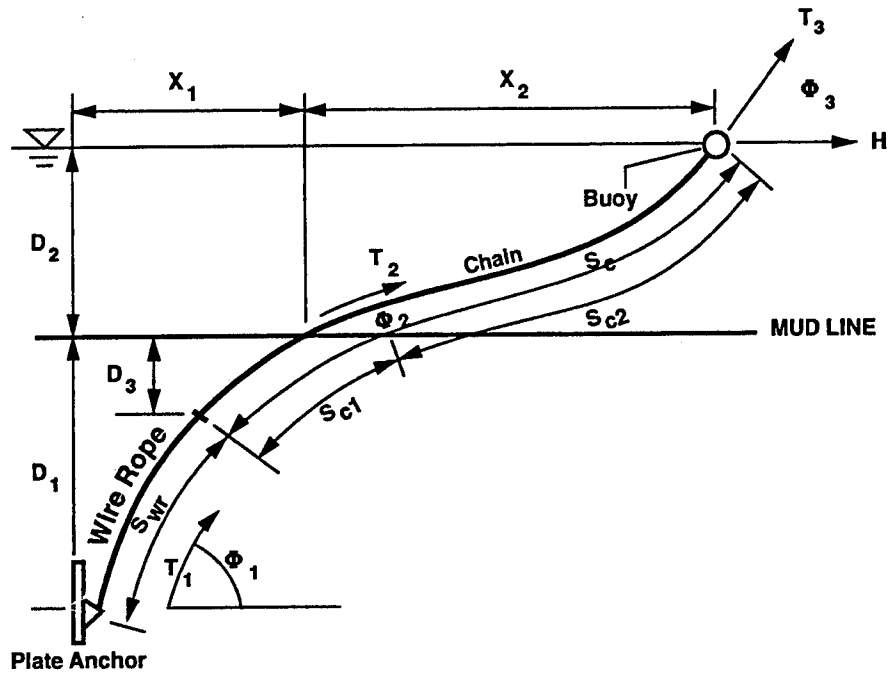

(b) Configuration of Driven Plate Anchor

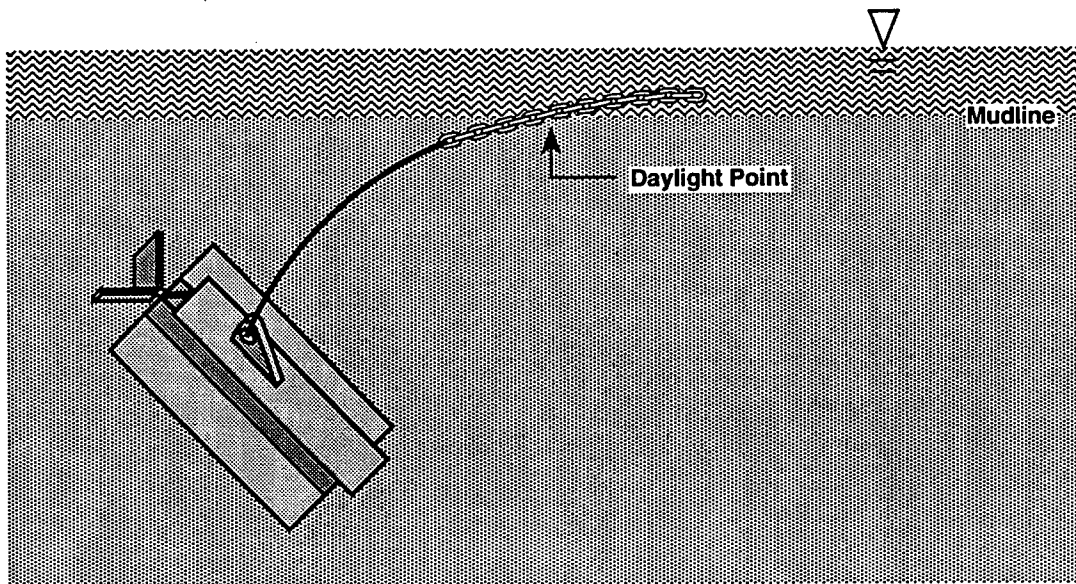

(b) Mooring Line Nomenclature

Figure 4-1  
Pile-driven plate anchors.

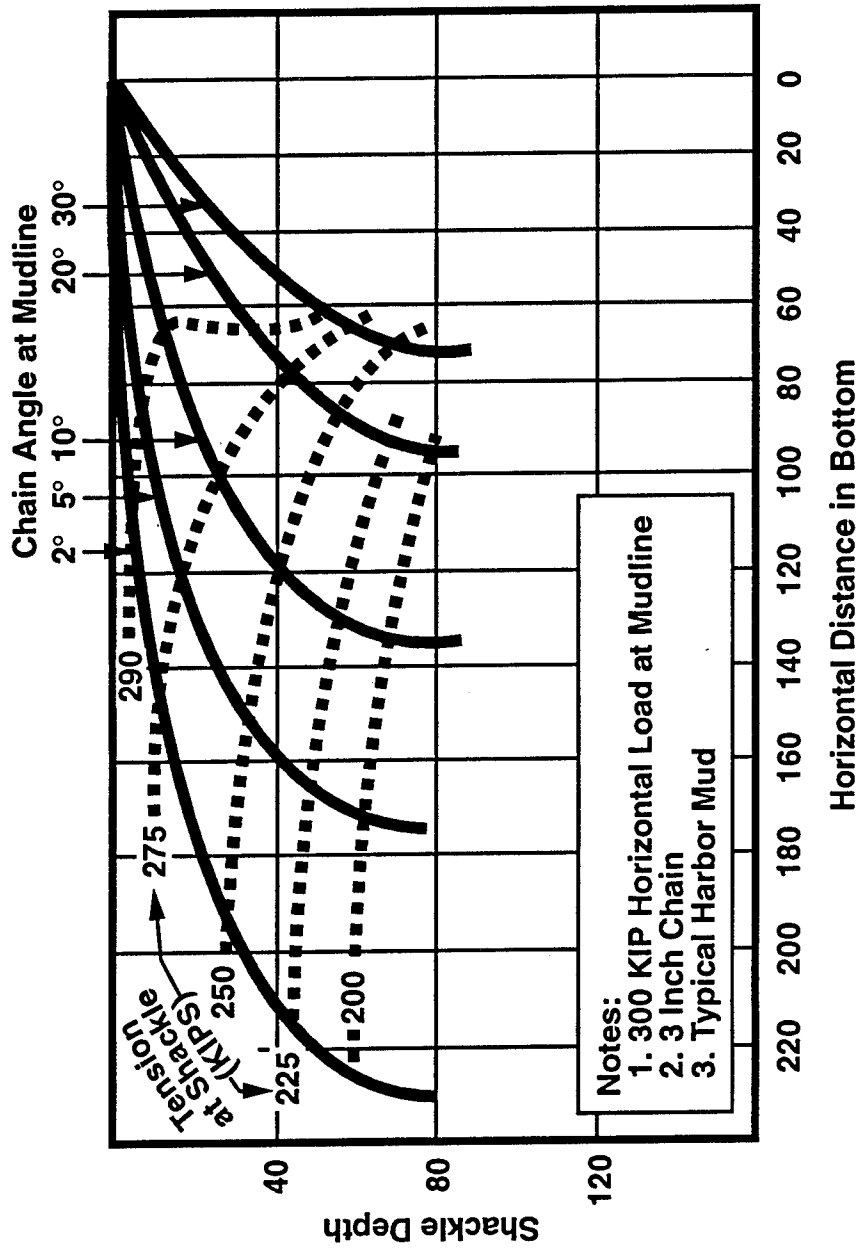

Figure 4-2  
 Chain profile and tension for 300-kip horizontal load.

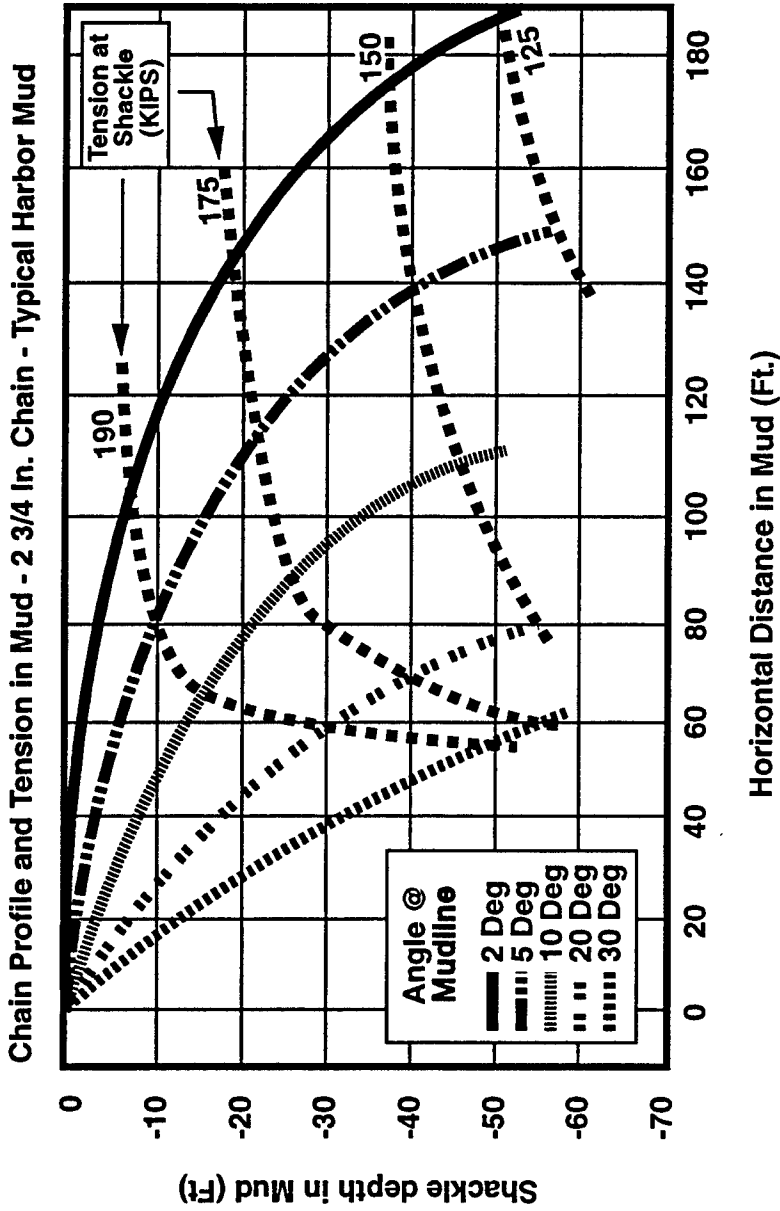

Figure 4-3  
Chain profile for 200-kip horizontal load.

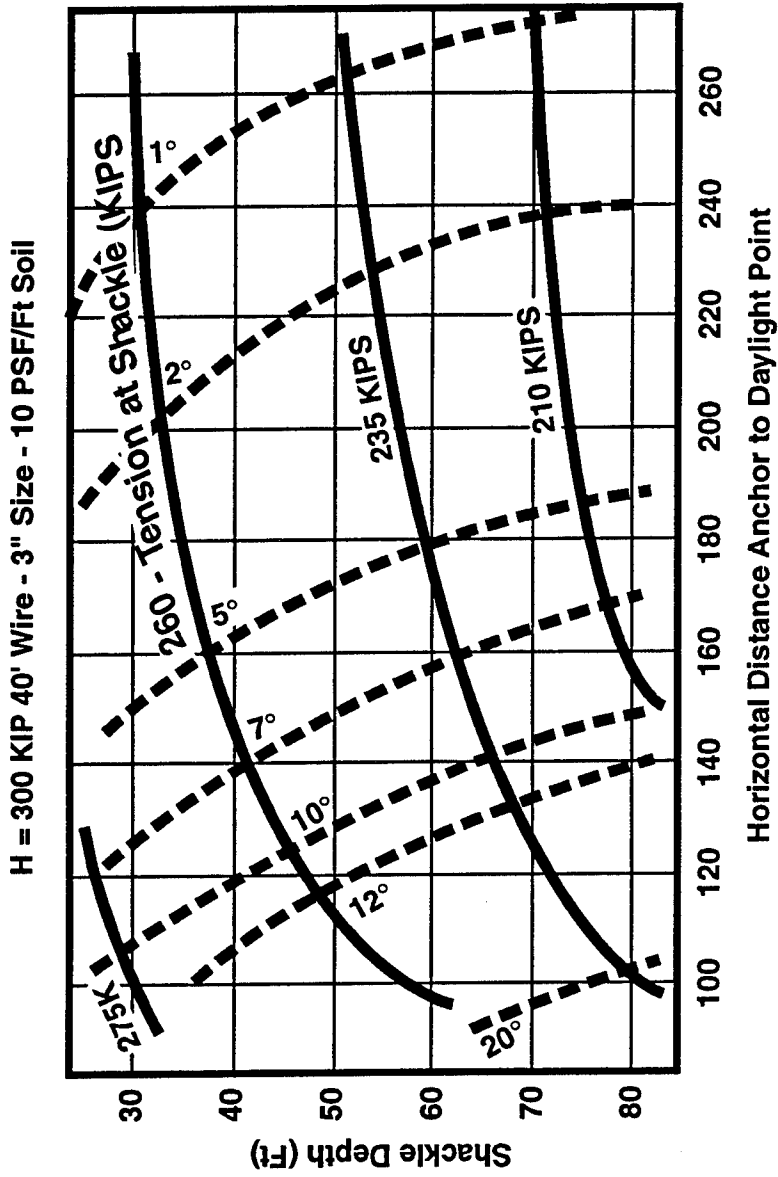

Figure 4-4  
Tension at shackle for 300-kip horizontal load.

## CHAPTER 5

### SELECTING ANCHOR DRIVEN DEPTH

Drive depth selection is based on the following criteria:

1. Required anchor capacity
2. Soil profile
3. Anchor follower handling capabilities
4. Drivability considerations
5. Keying distance
6. Environmental conditions such as the potential for scour, stability of slopes, future dredging, etc.

Items 1 and 2 are discussed in Chapters 2 through 4. The size and keyed depth are selected to meet capacity requirements of the soil profile at the site. However, plate anchors must be "keyed." During keying, the embedment depth is reduced, so the keying distance must be added to the design depth to determine the driven depth. The anchor drive depth should be a compromise between factors of size and drivability to optimize handling and equipment requirements.

#### 5.1 KEYING DISTANCE IN COHESIVE SOIL

Keying behavior can be scaled by normalizing keying arm length and required keying distance by plate length ( $L$ ). Keying distance relationships in soft cohesive soils may be estimated from Figure 5-1. Keying distance ratios in Figure 5-1 fall into three different categories:

- Category 1. Above the "B" envelope: Vertically loaded anchors in soft soils without keying flaps.
- Category 2. Between the "B" and "A" envelopes: Vertically pulled anchors with keying flaps and horizontally loaded anchors without flaps, with wire at the anchor shackle to enhance cutting into the seafloor.

- **Category 3.** Below the "A" envelope: Anchors with keying flaps and a suitable length of wire attached to the anchor, loaded horizontally in stages.
- **Procedure.** From the geometry of the anchor, the ratio of the keying arm to the plate or fluke depth is determined. The keying arm length is the shortest distance from the point of attachment of the shackle and the near surface of the plate. Entering Figure 5-1 with the keying arm ratio, the ratio of vertical keying distance to plate length is selected using the appropriate envelope. By multiplying this ratio by the plate length, the keying distance is determined.

## 5.2 KEYING DISTANCE IN COHESIONLESS SOIL (SAND)

Keying behavior can be scaled by normalizing keying arm length and keying distance by plate length ( $L$ ). An envelope of keying depth ratio versus scaled keying arm length for cohesionless soil is presented in Figure 5-2. By providing a reasonable length of keying arm (distance between the anchor shackle and the plate), an anchor in sand can be made to key in a relatively short distance.

- **Procedure.** The procedure for determining the keying distance is similar to that outlined above for cohesive soils, except that Figure 5-2 for cohesionless soils is used.



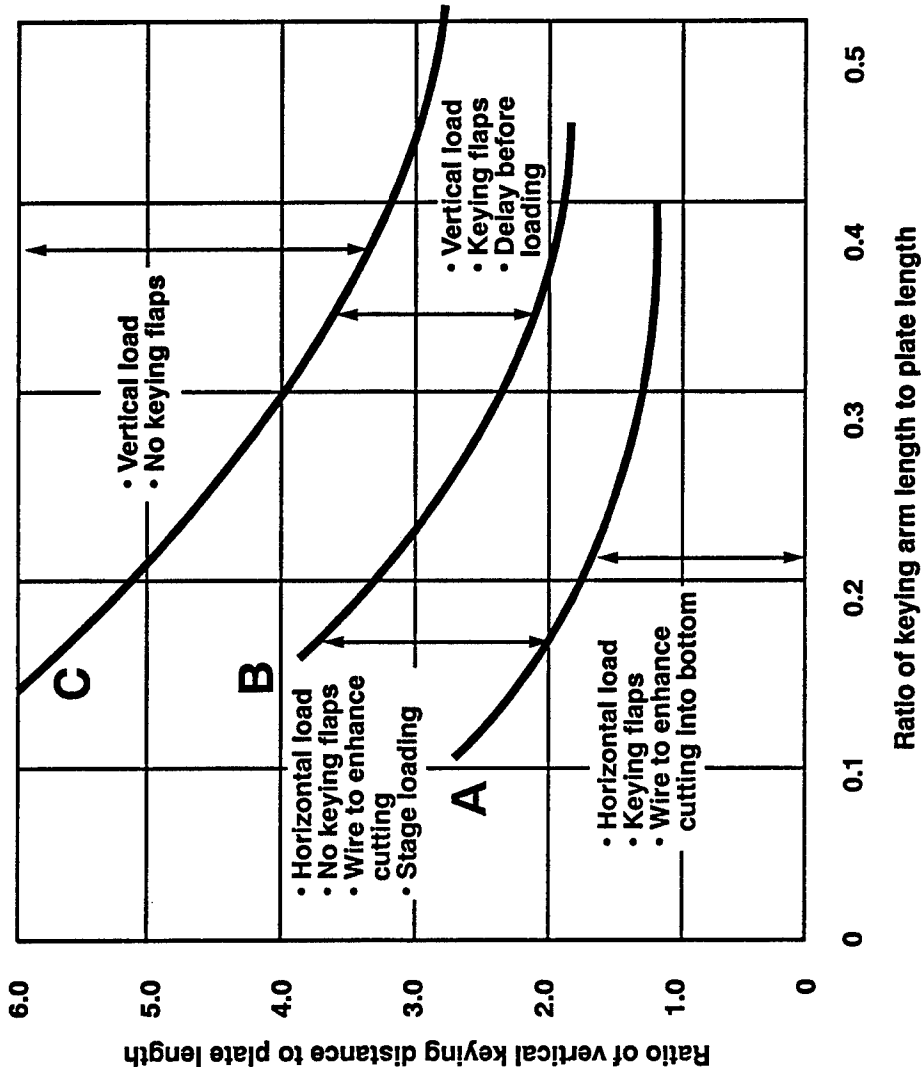

Figure 5-1  
Keying distance ratios for soft cohesive sediments.

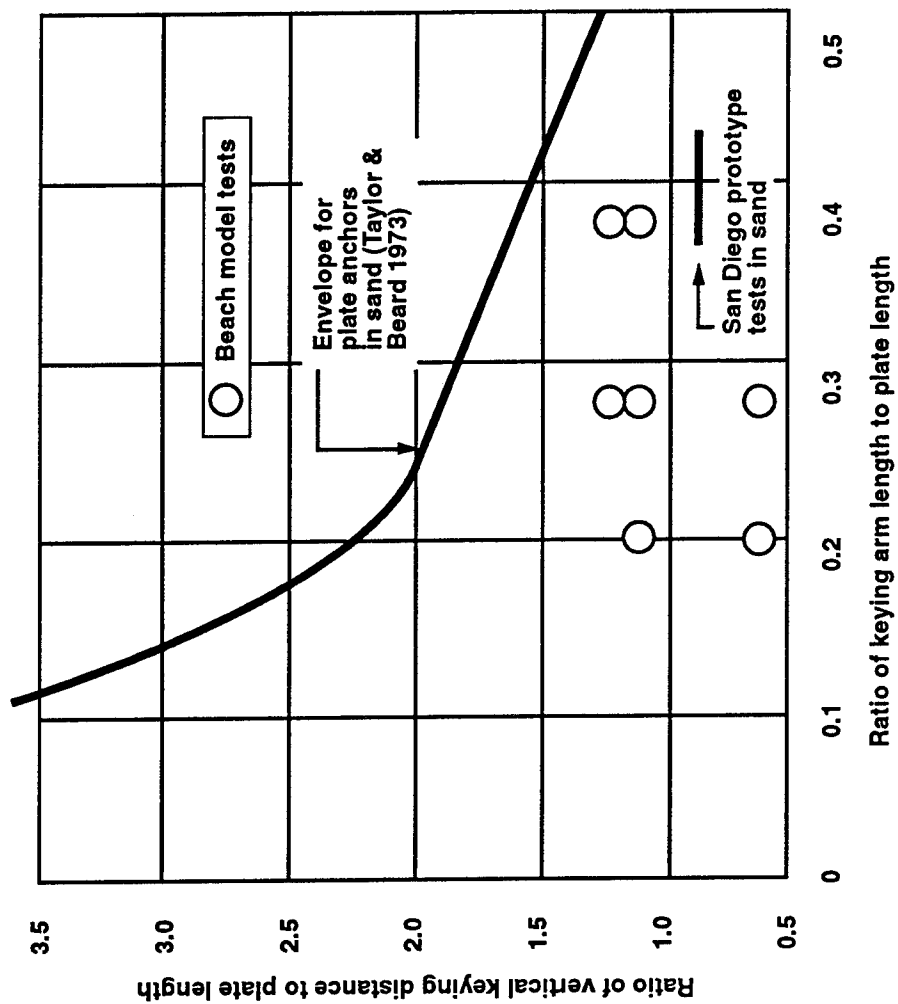

Figure 5-2  
Keying distance ratios for cohesionless soils.

## CHAPTER 6

### MOORING LAYOUT

#### 6.1 ANCHOR LOCATION IN CLAYS AND MUDS

For a mooring to function properly, the mooring buoys must maintain their prescribed locations under design load. This requires knowing where to install the plate anchors and selecting the correct length of anchor line to the buoy, which in turn requires taking proper account of the length, distance, and the amount of anchor line cutting through the soil under load. Because of the large number of combinations of soil strength, design load, chain and wire size, water depth, etc., required anchor locations in soft cohesive soils require an anchor line analysis such as referred to in Chapter 4. The relationships previously presented in Figures 4-2 through 4-4 show horizontal distance ( $X_1$  in Figure 4-1) in a typical harbor mud for different anchor line angles at the mudline. These figures were developed to show the reduction in anchor line tension and the horizontal distance for anchor lines in silt (mud), with a strength increase of 10 psf per foot of depth. Contours of shackle line tension have been superimposed on anchor line profiles for two different design horizontal loads at the mudline (and different chain sizes) in Figures 4-2 and 4-3. Although Figure 4-4 is in a different format from Figure 4-2, it provides an indication of the change in anchor line tension and anchor position (see Section 4.2), due to a 40-foot length of wire between the anchor shackle and the chain. The analysis of the complete mooring, including the anchor chain from the mud line to the mooring buoy, can be provided by the analytical chain model program. A preliminary version of this program has been used to develop contours of horizontal distance between the anchor and the buoy, and contours of wire tension at the anchor for horizontally loaded mooring buoys at Pearl Harbor. These contours are superimposed onto a chart showing shackle depth versus chain length in Figure 6-1. The relationships in Figure 6-1 are for a 200-kip horizontal mooring load on a mooring buoy, a 40-foot length of 2-3/4-inch wire between the anchor and the anchor chain, and a water depth of 25 feet. The plots were developed for a plate anchor (with an area of 60 ft<sup>2</sup>) embedded in mud, with a strength increase of 10 psf per foot with depth. Figure 6-1 combines the chain length  $S_{c1}$  below the mudline with the catenary length  $S_{c2}$  over the horizontal distance  $X_2$  (see Figure 4-1(b)). The length of chain required to provide a prescribed horizontal spacing between the anchor and the mooring buoy under load ( $X_1$  plus  $X_2$ , Figure 4-1) may be selected, and the load at the shackle may be determined by going into Figure 6-1 with a specific anchor depth. Figure 6-1 is shown here only as representative data that can be derived using the anchor chain model. The latest version of the model (Ref 8) uses an iterative solution technique that solves for mooring leg geometry at a specific design load, given one of three boundary conditions:

1. Specified horizontal anchor to buoy spacing.

2. Specified total leg anchor line length.
3. Specified chain angle at the seafloor.

## **6.2 ANCHOR LOCATION IN SANDS**

For sands, there is no analysis currently available for the anchor line in the sea bottom. One approach for this case is to assume the anchor chain cuts negligibly into the bottom under applied load and treat the anchor chain as a catenary between the mudline and the buoy. The chain program (Ref 8) can handle this situation by merely adding the length of chain that extends from the mudline down to the shackle.

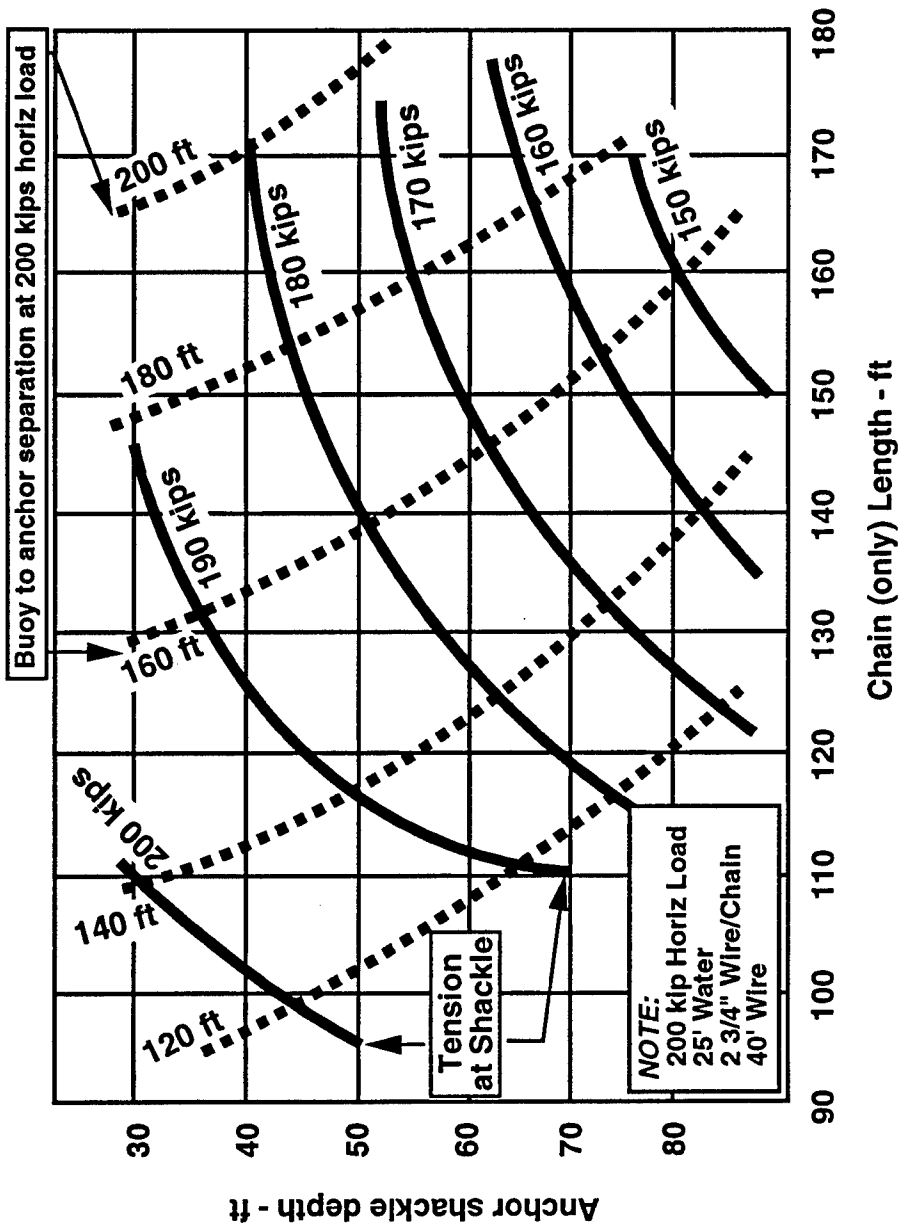

Figure 6-1  
 Chain tension - length relationships: 200-kip horizontal load and 40 feet of wire on anchor.

## CHAPTER 7

### STRUCTURAL DESIGN

#### 7.1 STRUCTURAL DESIGN OF THE ANCHOR

Soil stresses on the plate anchor may be estimated by distributing the ultimate anchor capacity,  $F_u$ , uniformly over the plate area. The anchor is analyzed for moment and shear using conventional structural design procedures (Ref 10). Typical anchor designs that have been used by NCEL are shown in Figure 7-1 and in Figure 7-2 (NCEL Drawing 92-6-1F). These anchors are designed to approach the yield limit for A36 steel at ultimate loads in the range of 300 to 400 kips. Options for increasing anchor structural capacity include increasing the size of the beam; increasing plate thickness; using higher strength steel; changing the length to width ratios; or adding reinforcing struts. A very efficient means of providing high capacity anchors would be to use hollow sections made up of bent plates, as are used for modern drag anchors (Ref 11).

#### 7.2 FOLLOWER DESIGN

##### 7.2.1 Sizing the Follower

The follower is a structural member of sufficient length and stiffness to conduct the pile driving forces from the hammer down to the plate anchor in order to drive it to the required depth. The maximum load on the follower may be taken as the maximum anchor penetration resistance, see Section 7.4. The column tables in the American Institute of Steel Construction (AISC) manual can be used to provide rough guidance on follower design (Ref 10). These tables give allowable static loads on concentrically loaded sections of A36 and A50 steel, with a factor of safety of about 2 for values of the ratio of unrestrained follower length to radius of gyration ( $l/r$ ) up to 200. Because driving impact loads occur too quickly for buckling to develop, the load at the follower-anchor interface can be up to twice the allowable loads in the AISC manual. For  $l/r$  ratios greater than those covered by the tables in Reference 10, allowable load on the follower may be estimated by using double the allowable stress determined by Equation E2.2, page 5-42, of the 1989 version of the AISC manual.

For example, if an A36 steel W14x145 section is to be used for a follower, then the table on page 3-22 of the AISC manual shows an allowable concentric load of 435 kips for a follower length of 40 feet (an  $l/r$  ratio of 121). Doubling this would allow for a driving resistance up to 870 kips. For greater follower lengths, Equation E2.2 can be used. For a (unsupported) follower length of 95 feet, Equation E2.2 gives an allowable stress of about 1900 psi. Doubling this and multiplying by the cross sectional area of 42.7 in.<sup>2</sup> provides the requirement that the maximum anchor driving resistance should not exceed 160,000 pounds.

The required follower length can sometimes be reduced if using a vibratory hammer adapted for driving underwater. A design for a follower that has been used for installing mooring anchors in Pearl Harbor is shown in Figure 7-3. This figure corresponds with NCEL drawing 92-8-1F.

### **7.2.2 Follower-Anchor Connection**

The follower must maintain contact with the anchor during driving. This has been accomplished by welding plates onto the follower that slip over the web of the structural beam of the anchor, see Figure 7-4. Rectangular or box beam section guides as shown in Figure 7-4 have been found satisfactory, or reinforced plates as shown in the follower design in Figure 7-3 (NCEL Drawing 92-8-1F) may be used. These restraining arms should extend a minimum distance of 2 feet down the web of the structural beam and fit fairly snug between the flanges. Contact between the anchor and follower during setup can be maintained through a turnbuckle attached to a padeye near the top of the follower; see Figure 7-5. The anchor line is attached through a quick release (pelican hook) to the turnbuckle, which is tightened to keep the anchor and chain in place against the follower.

### **7.2.3 Additional Follower Details**

As shown in Figure 7-3, the follower should have padeyes welded near both ends for lifting, for use in connecting the anchor to the follower, and for attaching the anchor chain during anchor installation. A double padeye at the top end permits attaching the turn buckle and pelican hook. Plates welded outside the flanges near the end of the follower (see Figure 7-3) can be used to provide a larger contact area between the follower and the anchor beam flanges during driving. The follower design in Figure 7-4 is for a 12-inch structural beam and a nominal follower length of 75 feet. The size and/or length of the structural member can be modified to suit the specific conditions.

Recent experience in plate anchor installation has shown that when the follower needs to be extended for a particular site, "butted and bolted" connections are very sensitive to vibration during installation procedures. The connection of the two I beam ends of the follower should be bolted and welded to securely butt the two ends together. During past installations, follower connections that were only bolted failed in a shearing of the bolts, resulting in the loss of the follower section that was buried in the seafloor.

## **7.3 CHAIN-WIRE COMBINATION**

For anchors in soft cohesive soil that are to be loaded horizontally, it is beneficial to place a section of wire between the anchor and the anchor chain. For near-horizontal mooring loads, this enables the anchor line to cut into the bottom to achieve a keyed orientation at a greater embedment depth. The length of wire rope must be selected so that it always remains buried below the mud line during service, so that it experiences minimal corrosion and abrasion. The anchor chain that extends up through the mud line should be cathodically protected to inhibit corrosion.

## 7.4 SELECTING THE PILE DRIVER

Assumption: that penetration continues as long as the anchor resistance,  $R$ , is less than the total weight of the anchor, follower and hammer, plus the maximum dynamic force,  $P$ , of the hammer (Ref 1). The resistance,  $R$ , is estimated from the deep foundation theory, using bearing capacity factors and the generated side friction. Three cases are considered.

### 7.4.1 Driving in Cohesive Soil

The maximum driving resistance,  $R$ , in soft muds, is expected to be about half the ultimate vertical load capacity,  $F_u$ , (as determined by conventional bearing pile analysis) of an unkeyed anchor. This could be up to the full value of the (unkeyed) vertical capacity for stiffer clays. In either case the resistance is due to end bearing and side friction on the anchor and side friction on the follower.

If a more precise estimate of driving resistance is required it may be estimated as follows:

$$R = c [N_c A_t + A_a] + A_f c' \quad (7.1)$$

where:

- $c$  = undisturbed soil shear strength
- $N_c$  = bearing capacity factor with a maximum value of 9
- $A_t$  = area of the anchor tip
- $A_a$  = lateral surface area of the beam-plate anchor
- $A_f$  = lateral surface area of the follower
- $c'$  = disturbed strength of the soil

### 7.4.2 Vibratory Hammer in Cohesionless Soil

The maximum driving resistance,  $R$ , is expected to be only about 30 percent of the ultimate vertical load capacity,  $F_u$ , of the unkeyed anchor-follower combination. In this case, the side friction on the follower is essentially zero. If a more precise estimate of driving resistance,  $R$ , is required, it may be estimated using the following equation:

$$R = A_t N_t q + A_a B p_a \quad (7.2)$$

where

- $N_t$  = bearing capacity factor ranging from 30 for loose sands, to 120 for very dense sands
- $q$  = overburden stress at the anchor tip due to the submerged weight,  $\gamma_b$ , of the overlying soil
- $B$  = Beta-coefficient ranging from 0.3 for loose sand, up 1.0 for very dense sand
- $p_a$  = average effective overburden pressure on the anchor due to  $\gamma_b$ , and the other terms are as defined earlier



### 7.4.3 Impact Hammer in Cohesionless Soil

The driving resistance will normally be less than the ultimate anchor capacity,  $F_u$ . Here, the side friction on the follower and the anchor must be included along with the end bearing on the anchor. If a more precise estimate of driving resistance,  $R$ , is required, it may be estimated using the following equation:

$$R = A_t N_t q + A_a B p_a + A_f B p_f \quad (7.3)$$

where:

$p_f$  = average effective overburden pressure on the buried length of follower due to  $\gamma_b$   
and the other terms have been defined above

### 7.5 HAMMER CAPACITY

Once the maximum resistance to driving,  $R$ , is determined, a hammer is selected to provide a dynamic force greater than the difference between  $R$  and the static weight,  $W$ , of the anchor-follower system. In most situations, particularly in cohesionless soils, it is preferable to use an impact hammer for driving the anchor. A vibratory hammer can then be used if necessary, during extraction of the follower. A vibratory hammer may also be adapted for driving underwater to permit using a shorter follower if the soil is extremely soft.

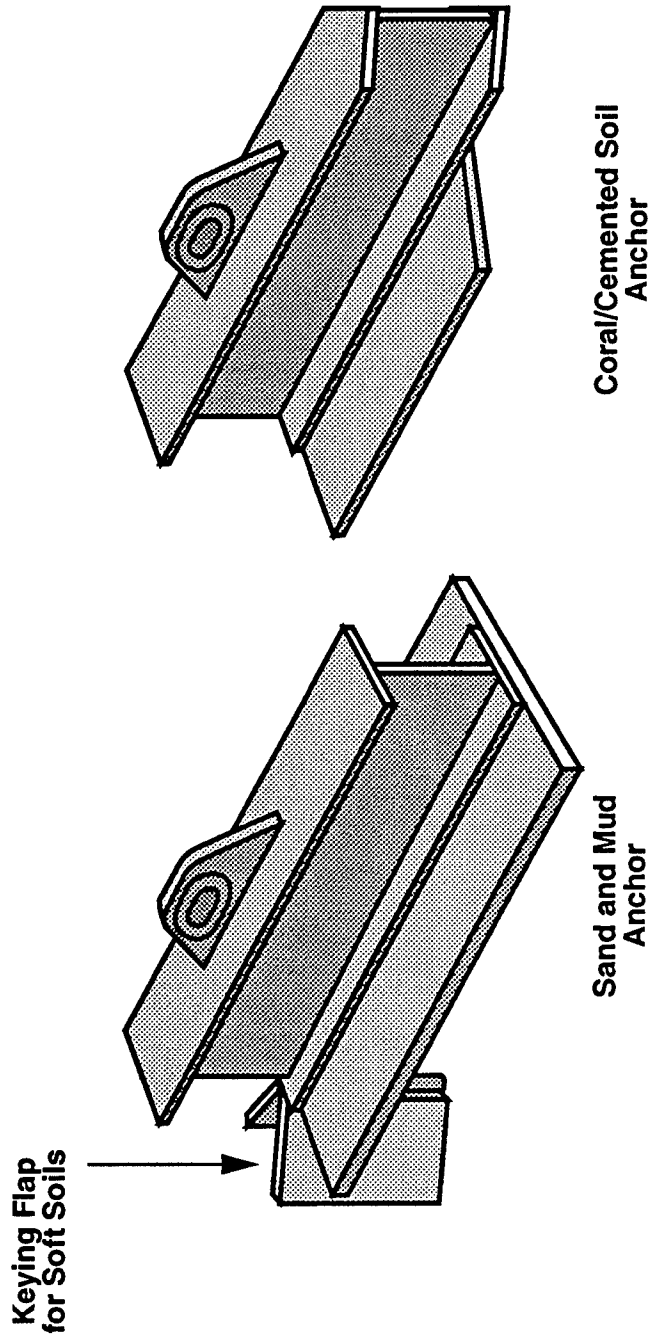

Figure 7-1  
Typical configuration for clay, sand, and coral anchors.

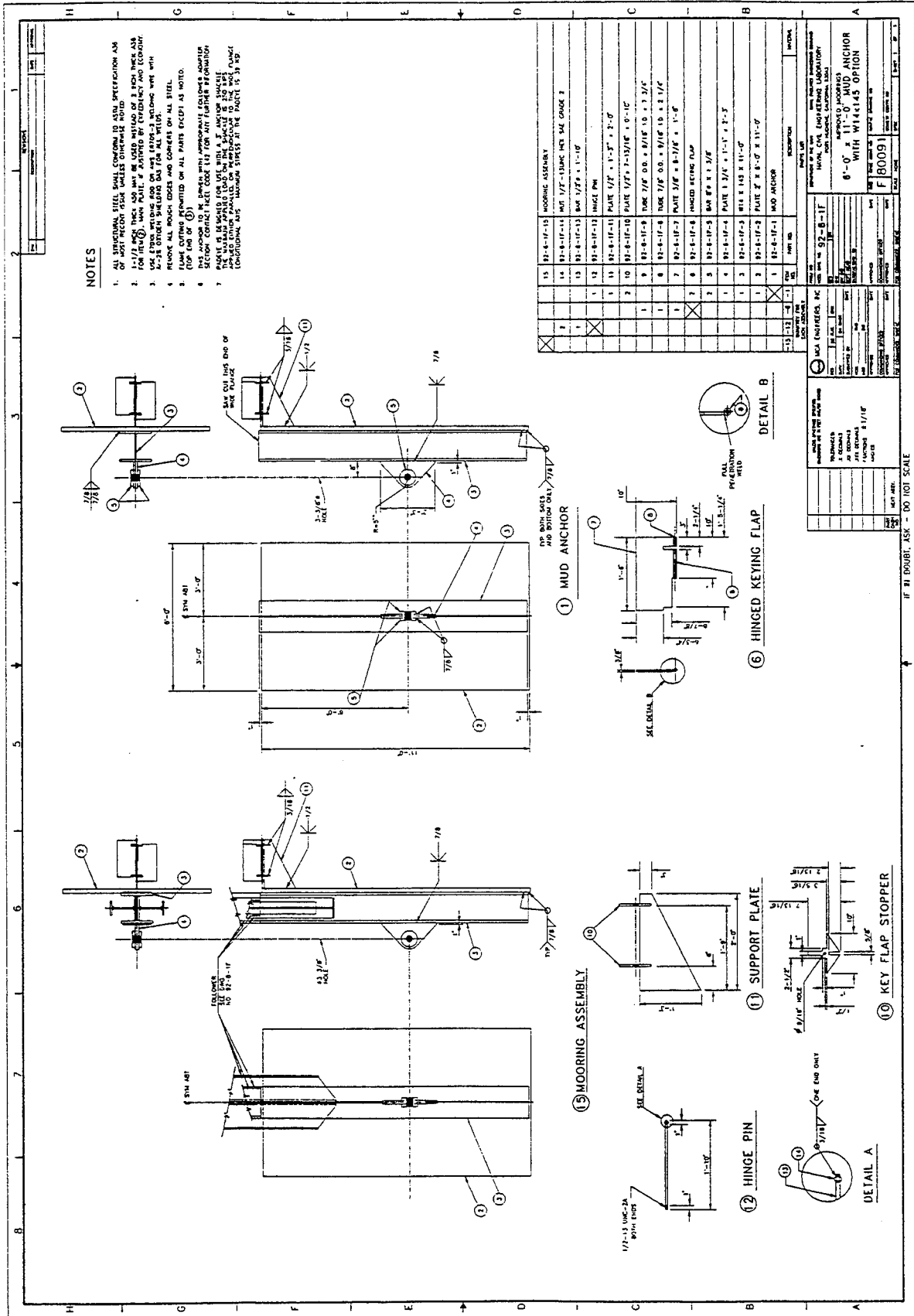

Figure 7-2  
Mud anchor (NCEL drawing 92-6-1F).

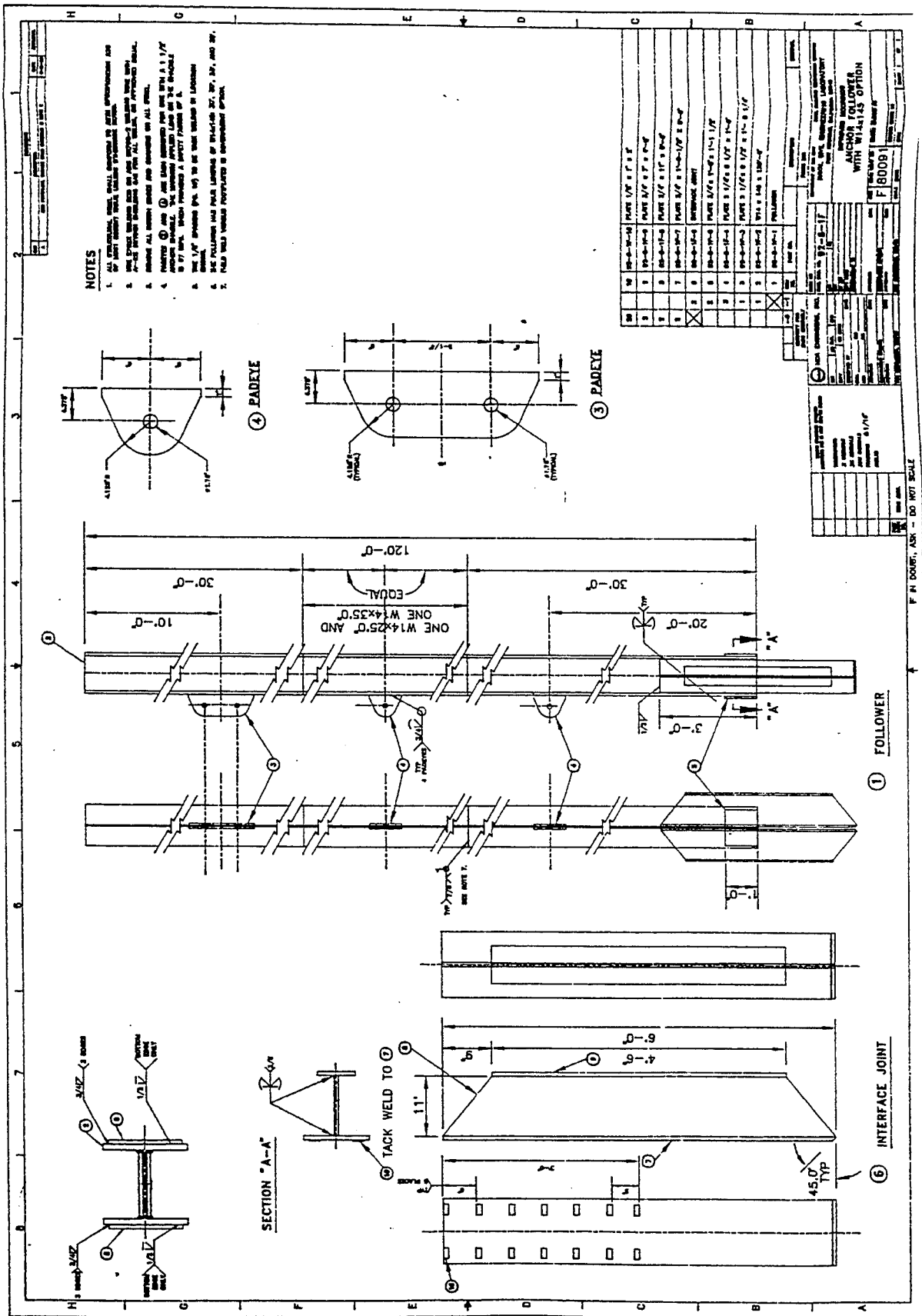

Figure 7-3  
Anchor follower (NCEL drawing 92-8-1F).

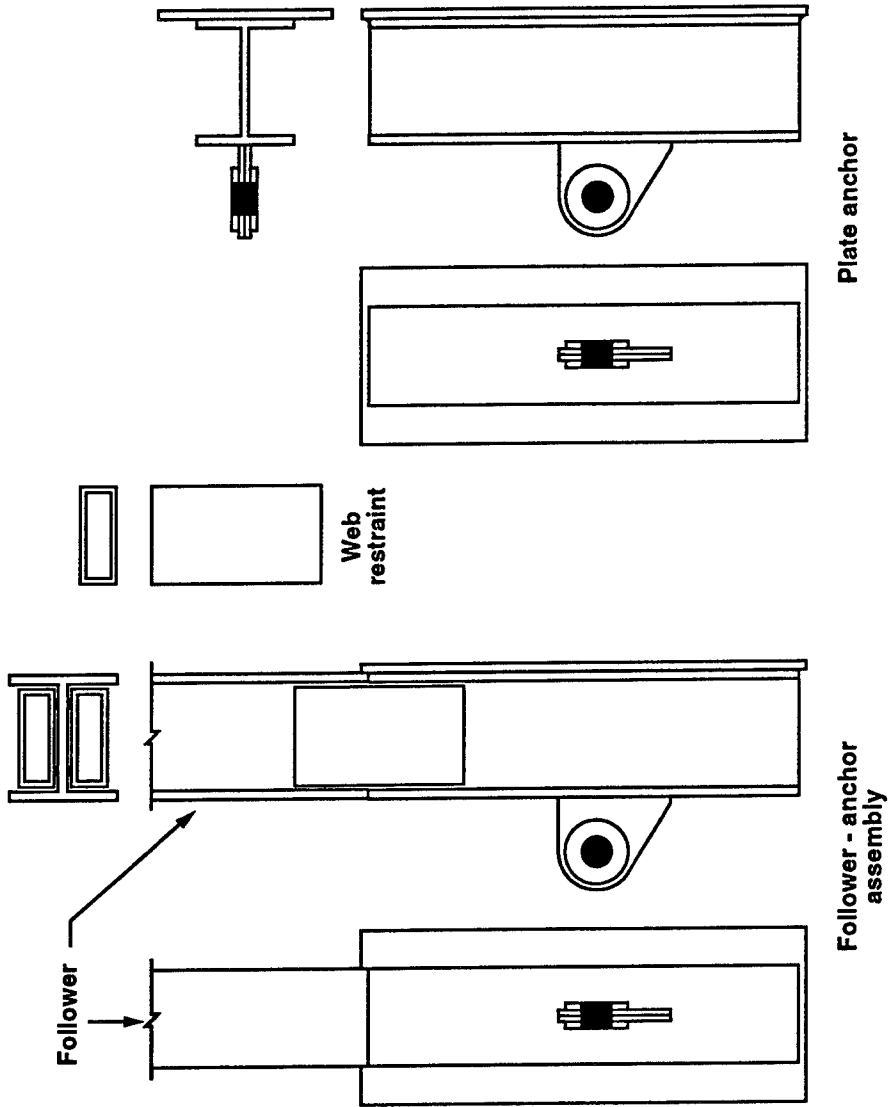

Figure 7-4  
Plate anchor and follower connection.

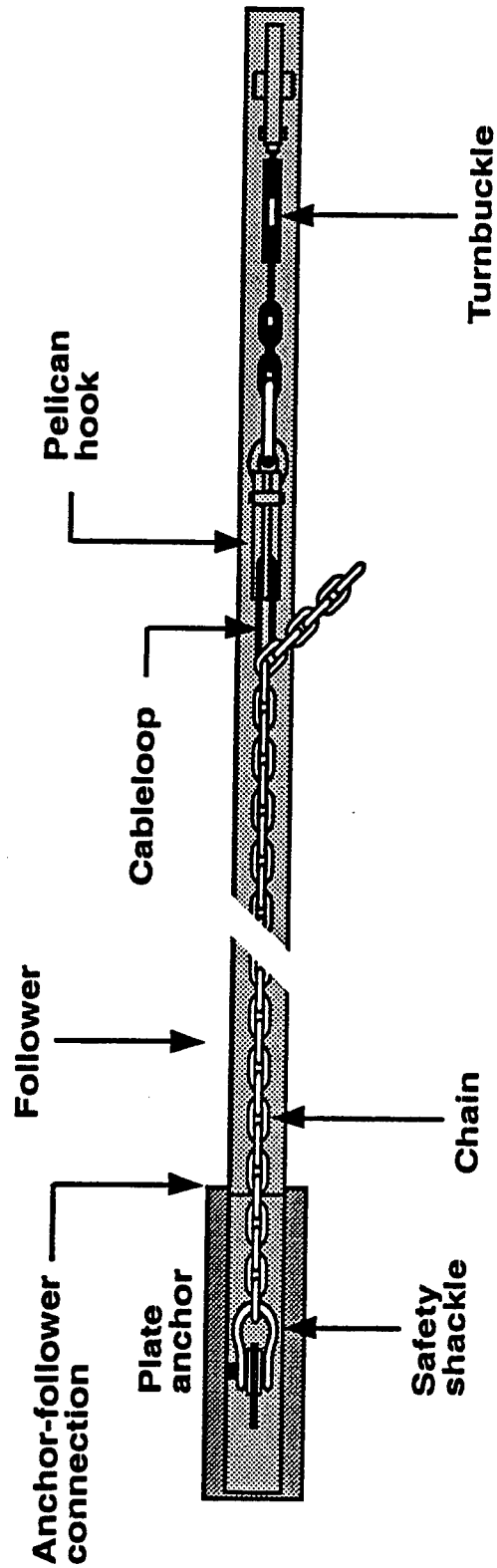

Figure 7-5  
Anchor-follower assembly.

## CHAPTER 8

### INSTALLATION

The following installation sequence has been found satisfactory.

1. Lay out the follower on blocking on the deck so that the shackle for attaching the pelican hook and turnbuckle are on top.
2. Line up the anchor so that the padeye faces up and slide the anchor into the follower connection until it seats against the end of the follower.
3. Stretch out the anchor chain along the follower and pass a loop of cable through one of the chain links and over the pelican hook on the follower (see Figure 7-5).
4. Tighten the chain, using the turnbuckle through which the pelican hook is attached to the follower.
5. The follower-anchor assembly is lifted by the crane through a strap, to the upper lifting eyes on the follower. The assembly unit is lifted to and put over the driving side of the deck. (An option that is available if a vibratory hammer is used, is to connect the hammer and the follower once the anchor is secured, then lift the whole assembly by the hammer. This simplifies lining up the vertical axis of the hammer with the follower, and requires handling only one assembly).
6. The anchor and follower are inserted through a template on the side of the barge to ensure straight driving (not used with submersible hammer). The chain is facing away from the barge. For a horizontally loaded mooring leg in soft soil, the anchor (and therefore the barge) must be oriented so that the padeye is pointing in the direction of the intended service load. In sands and stiff clay, the anchor orientation is unimportant since the anchor will see only the vertical component of the load.
7. The anchor assembly is then lowered vertically and seated on the seafloor.
8. The hook is released from the follower and used to place the hammer on the follower. During this operation, it is critical that the barge remain in position so that the template can keep the follower vertical. As soon as the pelican hook reaches deck level, the end of the chain should be tied off to the deck and the pelican hook tripped to release the anchor chain, so that it is free from the follower during the continuance of driving. The released chain will rest on the bottom and be pulled down into the mud with the advancing anchor.

9. The anchor is then driven to its required depth and the follower retrieved. Any vibratory or impact hammer having sufficient capacity (see Section 7.4) can be used to drive the anchor. A vibratory hammer adapted to perform underwater can permit a reduction in the required follower length, however, it must be an extremely large vibratory hammer to drive the anchor and follower into most soils. Once driven to design depth, the follower can be pulled out with the aid of a vibratory hammer.

10. The anchor may be pull-tested at this time, or the anchor chain buoyed off for later testing (it is recommended that the soil be allowed to setup overnight before testing in soft soils).



## CHAPTER 9

### PROOF TESTING THE ANCHOR

Proof testing may be carried out either vertically or horizontally, using a crane or other barge-mounted pulling equipment, respectively. The applied proof test load should be increased up to the design load, which should typically not exceed 50 percent of the ultimate capacity of the anchor. For sands, loading can be carried out immediately following driving, and it is of minor importance whether the anchor is set horizontally or vertically, as the anchor chain remains vertical throughout most of its embedded depth. For soft clays or muds, it is preferable to set the anchor by slowly pulling horizontally in the direction of the design load, permitting the anchor line to cut into the seafloor. Horizontal loading typically initiates earlier keying and smaller keying depths, which are desirable for large anchors in soft soils.

For anchors driven into sensitive cohesive soils, it is better not to execute proof testing immediately after driving. Keying distances can be shortened considerably by permitting the soil to regain some of its strength prior to pull-testing. Rocker has shown that pull testing small anchors after 1 hour, instead of 15 minutes, decreased keying distances by about one half in sensitive clays (Ref 12). Two benefits are derived by waiting for the soil to regain some of the strength lost due to disturbance. First, the skin friction at the anchor increases and the anchor line tension is higher before the anchor starts to move. This causes the chain and wire to cut deeper into the seabed and achieves an anchor line configuration corresponding to a partially keyed anchor at the outset. Secondly, the resisting couple that causes the anchor to key can be larger due to the increased skin friction. This larger couple causes the anchor to key faster. Consequently, it is beneficial to discontinue loading whenever the anchor starts to move, and to wait for a strength gain before recommencing loading. This results in a greater keyed depth which generally means a greater soil strength, and thereby a higher anchor capacity.

When load-testing between a symmetric pair of anchors in soft harbor deposits, the following procedure has been used effectively. A schematic of the loading-chain pulling sequence during a typical proof test is shown in Figure 9-1. The loading and measurement sequence are as follows:

1. Locate the barge with loading mechanism between opposing anchors and connect the anchor lines up to the loading mechanism.
2. Pull in line until all the slack is out of the anchor lines (position A in Figure 9-1) and the barge is located approximately mid-way between anchors.
3. Slowly increase tension on the anchor lines while monitoring the amount of line pulled in and the tension being measured (region B in Figure 9-1).

4. At some stage of the loading, the first anchor will break loose (position C in Figure 9-1) and start to key. This will cause the tension in the anchor line to fall off, as depicted in Figure 9-1. This temporary loss of capacity will cause the barge to move away from the keying anchor. This way it is known which anchor is keying.

5. As soon as the anchor line tension falls off, monitor the amount of chain pulled in until the tension starts to build up again (see distance E in Figure 9-1). This provides an estimate of the keying distance, and therefore the final keyed depth of the anchor.

6. Continue slowly increasing the tension on the anchor lines until the second anchor keys (position E in Figure 9-1). Monitor the length of chain pulled in (see distance F in Figure 9-1) until the tension starts to build up again. The distance G represents the anchor movement during the keying process and provides assurance that the anchor has keyed at the required depth.

7. Continue to increase tension (region G in Figure 9-1) until the required proof load (see position F in Figure 9-1) has been reached.

8. Stop pulling in chain and monitor tension. In soft soils, there should be a gradual drop in load due to soil consolidation. If the anchor is properly seated, the load decrease should not be more than 10 percent of the maximum load after about 10 minutes.

In sands, and even in stiff clays, it may be desirable to apply a load slightly in excess of the desired proof test load to verify the anchor capacity. Under these conditions, dynamic effects may result in an increase in anchor capacity from that available under quasi-static loading. It is important to monitor anchor keying distances. If keying distances start to exceed the fluke length of the anchor under proof load, it is an indication that the anchor is pulling out.

Most of the same elements used for horizontal pulling of anchors in soft soil are also used for pulling anchors in harder seafloor deposits. Principal differences include:

- Only one anchor is pulled at a time.
- The pull test can be done with the barge crane, provided it has the capacity to pull the design load.
- The anchor line is all chain, wire is generally not included.
- The anchor requires proofing up to only 80 percent of the design load, because of chain effects.

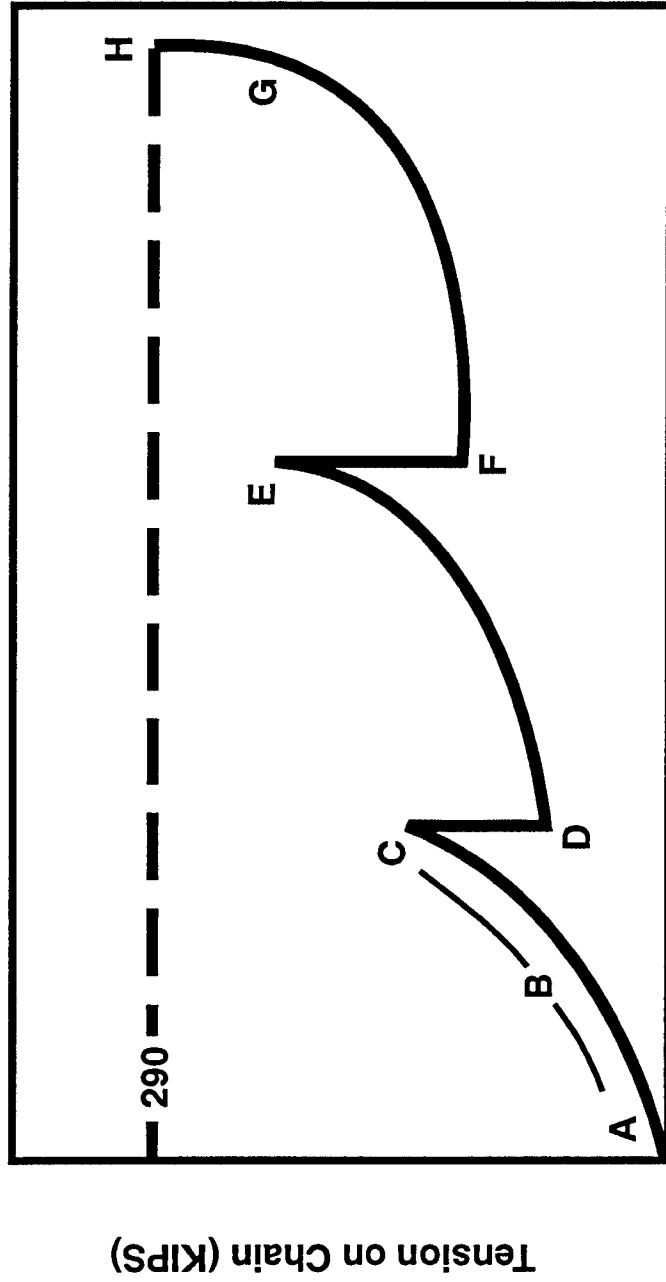

Chain Pulled In

Figure 9-1  
Tension - chain recovery relationship  
between symmetrical anchor pairs (typical).

## CHAPTER 10

### REFERENCES

1. Naval Civil Engineering Laboratory. Technical Note N-1133: Specialized anchors for the deep sea, by J.E. Smith, R.M. Beard, and R.J. Taylor, Port Hueneme, CA, Nov 1970.
2. \_\_\_\_\_. Handbook for marine geotechnical engineering, by K. Rocker, Port Hueneme, CA, Mar 1985.
3. Naval Facilities Engineering Command. NAVFAC Design Manual DM-26, Harbor and Coastal Facilities, Washington, DC.
4. Naval Civil Engineering Laboratory. Seafloor soil sampling and geotechnical parameter determination handbook, by H.J. Lee and J.E. Clausner, Port Hueneme, CA, Aug 1979.
5. R.M. Beard and H.J. Lee. "Holding capacity of direct embedment anchors," in Proceedings of the Civil Engineering in the Ocean/III, Vol 1, Specialty Conference of the American Society of Civil Engineers and the University of Delaware, New York, NY, Jun 1975.
6. Civil Engineering Laboratory. Technical Report R-882: Holding capacity of plate anchors, by R.M. Beard, Port Hueneme, CA, Oct 1980.
7. J.B. Forrest. "Driven plate anchors for Navy moorings," paper presented at the MTS '92 Conference of The Marine Technology Society, Washington, DC, Oct 19-21, 1992.
8. S. Bang and R. Taylor. "Static mooring line configuration analysis tool," paper presented at the MTS '94 Conference of The Marine Technology Society, Washington, DC, Sep 7-9, 1994.
9. Naval Civil Engineering Laboratory. Technical Note N-1635: Drag embedment anchor tests in sand and mud, by R.J. Taylor, Port Hueneme, CA, Jun 1982.
10. American Institute of Steel Construction. AISC manual of steel construction, Ninth Edition, Chicago, IL, 1989.
11. Naval Civil Engineering Laboratory. Technical Note N-1522: Design guide for drag embedment anchors, by R. Taylor and P.J. Valent, Port Hueneme, CA, Jan 1984.
12. Civil Engineering Laboratory. Technical Note N-1491: Reduction of embedment anchor capacity due to sediment disturbance, by K. Rocker, Port Hueneme, CA, Jul 1977.

## Appendix A

### LIST OF SYMBOLS

A	=	Area of the anchor plate.
$A_t$	=	Area of the anchor tip.
$A_a$	=	Lateral surface area of the beam-plate anchor.
$A_f$	=	Lateral surface area of the follower.
B	=	Width of the anchor plate.
B'	=	Beta-coefficient ranging from 0.3 for loose sand up to 1.0 for very dense sand.
c	=	Cohesive strength of the soil.
c'	=	Disturbed strength of the soil.
D	=	Embedded depth of the (keyed) anchor.
$F_u$	=	Ultimate anchor holding capacity.
$F_u/(DA)$	=	Plate area factor for cohesionless soil.
$H_d$	=	Design horizontal tension at the mudline.
L	=	Length of the anchor plate.
$p_a$	=	Average effective overburden pressure on the anchor due to $Y/b$ .
$P_f$	=	Average effective overburden pressure on the buried length of follower due to $Y/b$ .
q	=	Overburden stress at the anchor tip due to the submerged weight of the overlying soil.
$N_c$	=	Holding capacity factor for cohesive soils.
$N_q$	=	Holding capacity factor for cohesionless soils.
$N_t$	=	Bearing capacity factor ranging from 30 for loose sand to 120 for very dense sand.
R	=	Maximum anchor driving resistance.
$T_d$	=	Design tension on the anchor chain.
$T_m$	=	Horizontal anchor capacity at the mudline.
$\gamma_b$	=	Effective (buoyant) weight of the soil.
$\phi$	=	Friction angle of the soil.

## **Appendix B**

### **EXAMPLES**

A few examples of selecting anchor size using the design curves are presented below. No attempt is made to cover all the aspects of the system, such as anchor location or specific structural design. These issues are either discussed elsewhere or are beyond the scope of this version of the guide. Only Option 1 will be used in the examples.

#### **HORIZONTAL MOORING LOAD OF 200 KIPS OVER SOFT MUD**

A plate anchor must be designed and installed in a mud bottom for a horizontal design mooring load on the buoy of 200 kips. The water depth is 25 feet and the harbor bottom is a soft silt with a shear strength increasing at the rate of 10 psf per foot.

##### **Estimate Required Ultimate Load Capacity, $F_u$ .**

The horizontal load on the buoy is 200 kips, assume a load reduction of 25 kips due to the anchor line in the mud. Using a factor of safety of 2, the required ultimate capacity at the anchor shackle is 350 kips. USE OPTION 1.

##### **Select Tentative Length of Anchor Plate**

Based on experience, select a 10-foot-long anchor.

##### **Select Anchor Design Depth**

Assume a 90-foot long W section of A36 steel at 145-lb/ft is available for the follower. With a 25-foot water depth, a 90-foot follower can insert a 10-foot-long anchor to a mud depth of 75 feet without the hammer going into the water. For a first case, assume an all chain anchor line and keying flaps on the anchors. Assume a ratio of keying arm to plate length of 0.3. Using Figure 5-1, an approximate keying distance of 3 times the plate length is found, producing a keying distance of 30 feet. Therefore, a reasonable choice of design depth is 75 minus 30, or 45 feet. At a depth of 45 feet, the mud has a shear strength of 450 psf.

##### **Determine Anchor Plate Area**

Going into Figure 3-1, with a soil strength of 450 psf and a required anchor capacity of 350 kips, an anchor plate area of about 70 ft<sup>2</sup> is required. For an anchor length of 10 feet, this would require a plate width of 7 feet.

## **Finalize Design**

Check keyed depth to plate width ratio:  $45/7 = 6.5$ , which is greater than the 5 requirement. Check keying arm length. Since the thickness of the W12 X 145 is about 15 inches, and the padeye extends the shackle out roughly another 9 inches, the keying arm is about 2 feet. This provides a keying arm to plate length ratio of about 0.4. Referring to Figure 5-1, this should insure keying well within the 30 feet assumed. Assume the anchor line is to consist of 2-3/4-inch chain. Then from Figure 4-3, as long as the mooring setup is such that the chain angle at the mudline is flatter than about 25 degrees, the tension at the anchor shackle is less than 175 kips, providing a safety factor of at least 2.

If the anchor is in close quarters, this will require a higher line angle. Thus, the anchor must have greater capacity. This can be achieved by keying the anchor quickly (to get stronger soil and a greater keyed depth) or by using a greater area. Assume a 40-foot length of 2-3/4-inch wire at anchor. This will allow the anchor line to cut into the soil and insure quicker keying and a higher line angle. In this case, a keying distance (see Figure 5-1) of 1.5 L or 15 feet will be achieved. Therefore, a reasonable choice of design depth is 75 minus 15 feet, or 60 feet. At a depth of 60 feet, the mud has a shear strength of 600 psf. Proceeding as with the previous problem, but using a soil strength of 600 psf, a plate area of only 50 ft<sup>2</sup> is required. Therefore, a 10- by 5-foot anchor plate, or some other similar combination is possible. Referring to Figure 6-1, it is noted that as long as the horizontal buoy to anchor spacing is at least 160 feet, the tension at the anchor will not exceed 175 kips (at a depth of 60 feet), which provides the safety factor of 2 required. If a tighter spacing is needed, the anchor can be made wider to maintain a safety factor of 2, without affecting the rest of the design (except the anchor structural design).

## **HORIZONTAL MOORING LOAD OF 200 KIPS OVER A DENSE SAND BOTTOM**

A plate anchor must be designed and installed in a sandy bottom to withstand a horizontal design load of 200 kips at the mooring buoy. The water depth is 35 feet and the harbor bottom is a dense sand.

### **Determine Ultimate Load**

Assuming the chain takes up 20 percent of the design horizontal load, and using a safety factor of 2, the required ultimate load is  $(0.8 \times 200) \times 2 = 320$  kips. USE OPTION 1.

### **Select a Trial Anchor Size**

Select the 2- by 4-foot anchor size presented in Figures 3-2, 3-3, or 3-4.

### **Select Anchor Design Depth**

Assume a 60-foot long W section of A36 steel at 145 lb/ft is available for the follower. With a 35-foot water depth, a 60-foot follower could drive a 4-foot long anchor 31 feet without the hammer going into the water. Assume an all-chain anchor line. From Figure 5-2, an approximate keying distance of 1.5 by plate length is assumed, leading to a keying distance of

6 feet. A reasonable choice of design depth for this case is something less than 31 minus 6 feet. Select a driving depth of approximately 26 feet, and thus a design depth of 20 feet.

#### **Determine Capacity of Anchor From Figure 3-4**

Going into Figure 3-4 at a design depth of 20 feet shows an ultimate load of over 500 kips. In this case, the required capacity of 320 kips can be provided by the 2- by 4-foot anchor at a design depth of about 16 feet.

#### **Finalize Drive Depth**

For the selected anchor (and a keying distance as suggested by Figure 5-2 of 6 feet), the drive depth is 16 plus 6, or 22 feet.



## DISTRIBUTION LIST

AF / ROBERTS, TALLAHASSEE, FL  
AFESC / AL/EQ-TIC (FL 7050), TYNDALL AFB, FL  
ATLANTIC RICHFIELD CO / RE SMITH, DALLAS, TX  
BETHLEHEM STEEL CO / ENGRG DEPT, BETHLEHEM, PA  
BING YEN AND ASSOCIATES, INC / IRVINE, CA  
BLAYLOCK ENGINEERING GROUP / T SPENCER, SAN DIEGO, CA  
CAL STATE UNIV / C.V. CHELAPATI, LONG BEACH, CA  
CALIFORNIA / DEPT BOATING/WATERWAYS (ARMSTRONG), SACRAMENTO, CA  
CBC / CODE 155, PORT HUENEME, CA; CODE 430, GULFPORT, MS; PWO (CODE 400),  
GULFPORT, MS  
CHESNAVFACENGCOM / CODE 112.1, WASHINGTON, DC; CODE 402 (FRANCIS),  
WASHINGTON, DC  
CHEVRON OIL FLD RSCH CO / ALLENDER, LA HABRA, CA  
COMCBLANT / CODE S3T, NORFOLK, VA  
COMFAIR / MED, SCE, NAPLES, ITALY, FPO AE  
COMFLEACT / PWO, NAF, FPO AP; PWO, FPO AP; SCE, FPO AP  
COMNAVACT / G.T. CLIFFORD, LONDON, UK, FPO AE; PWO, LONDON, UK, FPO AE  
DILLINGHAM CONSTR CORP / (HD&C), F MCHALE, HONOLULU, HI  
EDWARD K NODA & ASSOC / HONOLULU, HI  
KING SAUD UNIV / AL-SHAURANI, RIYADH,  
LONG BEACH PORT / ENGRG DIR (ALLEN), LONG BEACH, CA  
LOS ANGELES COUNTY / PW DEPT (J. VICELJA), HARBOR CITY, CA  
MARATHON OIL CO / GAMBLE, HOUSTON, TX; COLLINS, HOUSTON, TX  
MARCORBASE / CODE 405, CAMP LEJEUNE, NC; MAINT OFFR, CAMP PENDLETON, CA; PAC,  
PWO, FPO AP  
MARCORPS / FIRST FSSG, ENGR SUPP OFFR, CAMP PENDLETON, CA  
MC CLELLAND ENGRS, INC / LIB, HOUSTON, TX  
MC DERMOTT, INC / E&M DIV, NEW ORLEANS, LA  
NAS / PWO, SIGONELLA, ITALY, FPO AE; SCE, NORFOLK, VA  
NAS ADAK / CODE 114, FPO AP  
NAVCAMS / MED, SCE, NAPLES, ITALY, FPO AE; SCE, WAHIAWA, HI  
NAVPHIBASE / SCE, SAN DIEGO, CA  
NAVSTA / ENGRG DIR, PWD, ROTA, SPAIN, FPO AE; PWO, GUANTANAMO BAY, CUBA,  
FPO AE  
SAN DIEGO PORT / PORT FAC, PROJ ENGR, SAN DIEGO, CA  
SHELL OIL CO / E. DOYLE, HOUSTON, TX  
SUBASE / SCE, PEARL HARBOR, HI  
USDA / FOR SVC, EQUIP DEV CEN, SAN DIMAS, CA; FOREST PROD LAB (JOHNSON), MADISON, WI;  
OCEAN ENGRG DEPT, ANNAPOLIS, MD  
VENTURA COUNTY / DEPUTY PW DIR, VENTURA, CA