

REPORT DOCUMENTATION PAGE

Form Approved
OMB No. 0704-0188

Public reporting burden for this collection of information is estimated to average 1 hour per response, including the time for reviewing instructions, searching existing data sources, gathering and maintaining the data needed, and completing and reviewing the collection of information. Send comments regarding this burden estimate or any other aspect of this collection of information, including suggestions for reducing this burden, to Washington Headquarters Services, Directorate for Information Operations and Reports, 1215 Jefferson Davis Highway, Suite 1204, Arlington, VA 22202-4302, and to the Office of Management and Budget, Paperwork Reduction Project (0704-0188), Washington, DC 20503.

1. AGENCY USE ONLY (Leave blank)	2. REPORT DATE August 1994	3. REPORT TYPE AND DATES COVERED Technical (6/1/93-5/31/94)
4. TITLE AND SUBTITLE High Field Electrostrictive Response of Polymers		5. FUNDING NUMBERS N00014-91-J-1078
6. AUTHOR(S) Z. Ma, J.I. Scheinbeim, J-W. Lee and B.A. Newman		8. PERFORMING ORGANIZATION REPORT NUMBER #32
7. PERFORMING ORGANIZATION NAME(S) AND ADDRESS(ES) Polymer Electroprocessing Laboratory Department of Mechanics and Materials Science College of Engineering, Rutgers University P.O. Box 909 Piscataway, NJ 08855-0909		
9. SPONSORING / MONITORING AGENCY NAME(S) AND ADDRESS(ES) Dr. JoAnn Milliken Office of Naval Research Arlington, VA 22217-5000		10. SPONSORING / MONITORING AGENCY REPORT NUMBER
11. SUPPLEMENTARY NOTES Accepted for publication in Journal of Polymer Science: Part B: Polymer Physics Edition		
12a. DISTRIBUTION / AVAILABILITY STATEMENT Approved for public release; distribution unlimited Reproduction in whole or in part is permitted for any purpose of the United States Government.		12b. DISTRIBUTION CODE

S D T I C
E L E C T R I C
M A R 2 0 1 9 9 5
S G D

13. ABSTRACT (Maximum 200 words)

It is well known that electrostrictive strains are proportional to the square of the applied electric field. It therefore appeared reasonable to assume that for some polymeric materials, a large acoustic thickness response, d_T , ($d_T = \frac{dS}{dE}$) might be obtained by application of high dc bias fields, ~ 20 MV/m, to a film while driving the film with an ac signal to access the high slope region of the electrostrictive strain vs. applied field curve. Previous studies of crystallizing poly(vinylidene fluoride) (PVF₂) from solution under high electric fields have demonstrated that gel-like samples of PVF₂ with high content of the plasticizer tricresyl phosphate (TCP) could be subjected to electric fields as high as ~ 100 MV/m. Using this type of heavily plasticized PVF₂, d_T values ~ 4 Å/V were obtained. Values of 9 Å/V were obtained for a certain class of thermoplastic elastomer (i.e., a polyurethane). These d_T values are considerably greater than those obtained from conventional piezoelectric ceramic materials. In addition, large elastic strains ($> 3\%$) were observed as a function of applied dc field.

14. SUBJECT TERMS			15. NUMBER OF PAGES
17. SECURITY CLASSIFICATION OF REPORT Unclassified			16. PRICE CODE
18. SECURITY CLASSIFICATION OF THIS PAGE	19. SECURITY CLASSIFICATION OF ABSTRACT	20. LIMITATION OF ABSTRACT	

19950317 165

OFFICE OF NAVAL RESEARCH

Contract N00014-91-J-1078

R&T Code 4132046

Technical Report No. 32

HIGH FIELD ELECTROSTRICTIVE RESPONSE OF POLYMERS

by Z. Ma, J.I. Scheinbeim, J-W. Lee and B.A. Newman

Prepared for Publication
in
Journal of Polymer Science
Polymer Physics Edition

Polymer Electroprocessing Laboratory
Department of Mechanics and Materials Science
College of Engineering
Rutgers University
Piscataway, NJ 08855-0909

Accession For	
NTIS CRA&I	<input checked="" type="checkbox"/>
DTIC TAB	<input type="checkbox"/>
Unannounced	<input type="checkbox"/>
Justification	
By	
Distribution /	
Availability Codes	
Dist	Avail and/or Special
A-1	20

August 1994

Reproduction in whole or in part is permitted for any purpose of the United States Government.

This document has been approved for public release and sale; its distribution is unlimited.

High Field Electrostrictive Response of Polymers

MA ZHENYI, JERRY I. SCHEINBEIM,* JAR WHA LEE, and BRIAN A. NEWMAN

Polymer Electroprocessing Laboratory, College of Engineering, Rutgers University, Piscataway, New Jersey 08855-0909

SYNOPSIS

It is well known that electrostrictive strains are proportional to the square of the applied electric field. It therefore appeared reasonable to assume that for some polymeric materials, a large acoustic thickness response, d_T , ($d_T = \frac{dS}{dE}$) might be obtained by application of high dc bias fields, ~ 20 MV/m, to a film while driving the film with an ac signal to access the high slope region of the electrostrictive strain vs. applied field curve. Previous studies of crystallizing poly(vinylidene fluoride) (PVF₂) from solution under high electric fields have demonstrated that gel-like samples of PVF₂ with high content of the plasticizer tricresyl phosphate (TCP) could be subjected to electric fields as high as ~ 100 MV/m. Using this type of heavily plasticized PVF₂, d_T values ~ 4 Å/V were obtained. Values of 9 Å/V were obtained for a certain class of thermoplastic elastomer (i.e., a polyurethane). These d_T values are considerably greater than those obtained from conventional piezoelectric ceramic materials. In addition, large elastic strains ($> 3\%$) were observed as a function of applied dc field. © 1994 John Wiley & Sons, Inc.

Keywords: electrostriction • electrostrictive strain • thermoplastic elastomer • polyurethane

INTRODUCTION

The application of an electric field to any material can displace charge and lead to field-induced elastic strains. If the sign of the strains are unchanged on reversal of the electric field, this property is termed electrostriction and it occurs in all materials whether crystalline or not.¹ Although the property of electrostriction has been well known for inorganic materials for many years, the phenomenon is still not well understood. In a recent review,² the phenomenological and physical origins of electrostriction in a wide variety of solids was discussed by V. Sundar and R. E. Newnham. It is interesting to note that even though polymeric materials are classical dielectric materials, recent studies of electrostriction in polymers have been restricted to the single example of poly(vinylidene fluoride) PVF₂.³

Several years ago we carried out studies of the effects of the addition of plasticizers, on the ferroelectric, piezoelectric, and pyroelectric properties of PVF₂^{4,5} and its copolymers. The presence of plasticizer significantly modifies the elastic modulus and dielectric constant of the polarized films.⁴ Although the plasticizer resides in the amorphous regions of these semicrystalline polymers, our work has shown that the addition of large amounts of plasticizer results in a decrease in crystallinity, which can lower the elastic modulus to a desired level, but also reduces the piezoelectric response of the material,⁵ because the polarization resides in the crystalline regions. In addition, our studies of the oriented crystallization of both PVF₂ and nylon-11 from solution under high applied electric fields⁵⁻⁷ have shown that these polymers, in a heavily plasticized state ($\sim 65\%$ plasticized by weight), can sustain very high electric fields (~ 100 MV/m).

The thickness coefficient for a material, d_T , may be defined as the change in strain in the thickness direction with respect to a change in applied electric field ($d_T = \frac{dS}{dE}$), that is, the slope of the strain versus

* To whom correspondence should be addressed at Polymer Electroprocessing Laboratory, Department of Mechanics and Materials Science, Rutgers University, Busch Campus, P.O. Box 909, Piscataway, New Jersey 08855-0909.

Journal of Polymer Science: Part B: Polymer Physics, Vol. 32, 2721-2731 (1994)
© 1994 John Wiley & Sons, Inc. CCC 0887-6266/94/162721-11

applied electric field curve. A good value of d_T for a piezoelectric ceramic currently used in transducer applications with low applied field, such as lead zirconium titanate (PZT), would be $\sim 5 \text{ \AA/V}$. The thickness coefficient, d_T , at room temperature is $\sim 0.25 \text{ \AA/V}$ for PVF₂ and $\sim 0.03 \text{ \AA/V}$ for the odd-numbered nylons. The nylon values at room temperature are extremely low because it is below the glass transition temperature (T_g).

For some special end-use applications, we were interested in designing a material having an elastic modulus $\sim 10^7 \text{ N/m}^2$, together with a thickness coefficient, $d_T \sim 5 \text{ \AA/V}$. For PVF₂, the amount of TCP required to reduce the modulus to the desired level (10^7 N/m^2) decreased the film crystallinity to below 10% and resulted in a greatly reduced piezoelectric thickness coefficient because 80% of the polar crystals responsible for the piezoelectric activity were no longer present. Given this difficulty, we looked for alternative methods to achieve the required properties. It was apparent that no piezoelectric material, polymeric or otherwise, would satisfy the requirements of high piezoelectric constant and low elastic modulus, and this led us to consider using the property of electrostriction of polymers.

In general, the thickness strain, S ($S = \text{change in thickness/original thickness}$), as a function of applied electric field can be expressed as a series expansion:

$$S = dE + ME^2 + \gamma E^3 + \dots \quad (1)$$

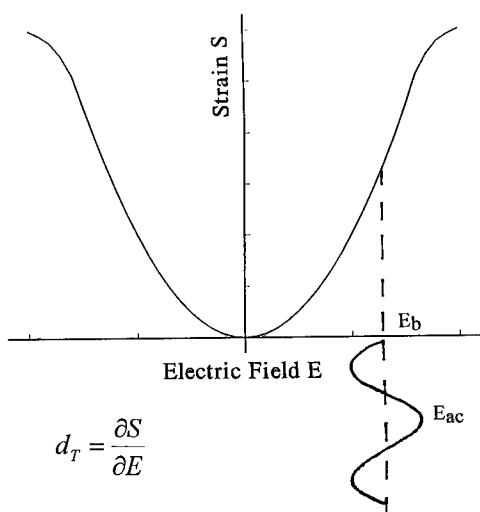

Figure 1. Schematic diagram of electrostrictive response curve.

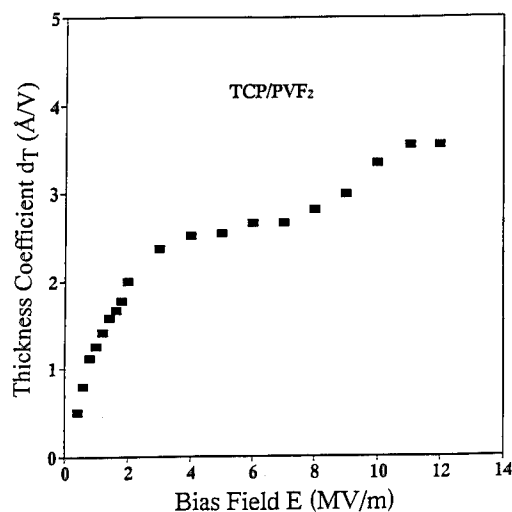

Figure 2. Variation of thickness coefficient (d_T) with applied bias field for a plasticized (65%) polyvinylidene fluoride (PVF₂) film.

The first term is the piezoelectric response, and the second term characterizes the electrostrictive response. The thickness coefficient, d_T , is defined as the derivative of the strain (S) with respect to the applied electric field (E).

$$d_T \equiv \frac{\partial S}{\partial E} = d_{(E=0)} + 2ME \quad (2)$$

where M is the electrostrictive coefficient. Because our early work had shown that polymers can have extremely high dielectric strength, even in a gel- or liquid-like state,⁵ it occurred to us that it might be possible to apply a large enough dc bias field to an appropriate low crystallinity, low modulus polymer film to access the high d_T region of the electrostrictive curve. This concept is shown schematically in Figure 1, where E_b is the large dc bias field and E_{ac} is the superimposed ac driving signal.

Films of PVF₂, heavily plasticized with tricresyl phosphate (TCP) to achieve an elastic modulus between 10^7 N/m^2 and 10^8 N/m^2 , were prepared and sent to BBN, Cambridge, MA, for measurement of d_T . These films exhibited high values of d_T , as shown in Figure 2. At the highest field, the data showed some scatter, but values of d_T approaching 4 \AA/volt (i.e., comparable with PZT) were observed. The initial plasticizer content of 65% by weight made the samples difficult to handle and to measure accurately, because plasticizer was continually extruded from the system during the measurement process; however, the feasibility of the idea was established.

Because the high field electrostrictive properties of polymers of any kind, whether crystalline or not, have not been explored, and to avoid the difficulties of dealing with a polymer/plasticizer system, we decided to examine a different class of polymers, the thermoplastic elastomers, which can have a low elastic modulus without the use of plasticizer. These materials consist of a block copolymer comprising a crystallizable component and a noncrystallizable component. The crystallizable component can phase separate, the crystals acting as physical cross-links to hold the liquid-like amorphous matrix component together, to produce an elastomer, as shown schematically in Figure 3. The elastic modulus of these materials is controlled by the percentage of the crystallizable component and the processing conditions, because processing controls the degree of phase separation and, therefore, crystallinity. In this paper, we present the results of our study of the electrostrictive response of a particular polyurethane elastomer. The polyurethane elastomers may be considered to be block copolymers consisting of alternating polyurethane and polyol segments, the polyurethane and polyol segments being designated as hard and soft segments, respectively, because the hard segment is below its crystalline melting point and the amorphous soft segment is above its glass transition temperature at normal use temperatures. In view of the fact that very few previous studies of the high field electrostrictive behavior of the polymeric materials had been made, and because our preliminary work with BBN had indicated that very large values were attainable for d_T , we decided to design and construct three quite independent types of apparatus to measure the strains induced by E_{ac} as a function of the bias field or just by E_b to confirm our preliminary experiments. These methods were:

- (a) a modification of the experimental method used by BBN to measure d_T as a function of E_b . This method utilized an accelerometer to determine thickness strains and was (commonly) used successfully to measure d_T for ceramic materials such as PZT. We modified this apparatus so that it was more appropriate for measurement of a soft polymer.
- (b) a utilization of a double-beam interferometer method that had been used successfully to determine electrostriction in ceramic materials with great accuracy.
- (c) an air gap capacitor apparatus.

Using these three independent types of apparatus, we measured the electrostrictive strain as a function

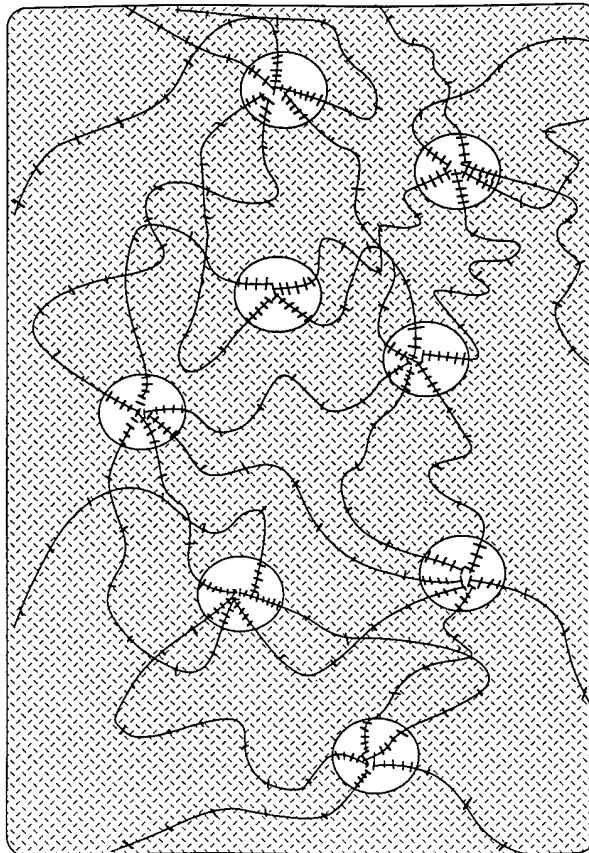

Figure 3. Schematic diagram of thermoplastic elastomer structure.

of applied electric field, and the corresponding thickness coefficient, d_T , as a function of applied electric field for both unoriented and uniaxially oriented polyurethane films. The influence of water content on these results was also investigated.

EXPERIMENTAL

The polyurethane film (PU) used was processed by Deerfield Urethane, Inc. using a Dow polyurethane (PT6100S). The 25- μm thick films were cut into 25 \times 25 mm square samples. Oriented samples were prepared by drawing to two, three, or four times the original length at room temperature and then annealing at 100°C for 2 h at fixed extension.

To measure the thickness coefficient, d_T , of the polymer film as a function of the applied electric field, the first apparatus constructed measured the acceleration of the upper film surface using a commercial accelerometer. Figure 4 shows a schematic representation of this system that was based on the

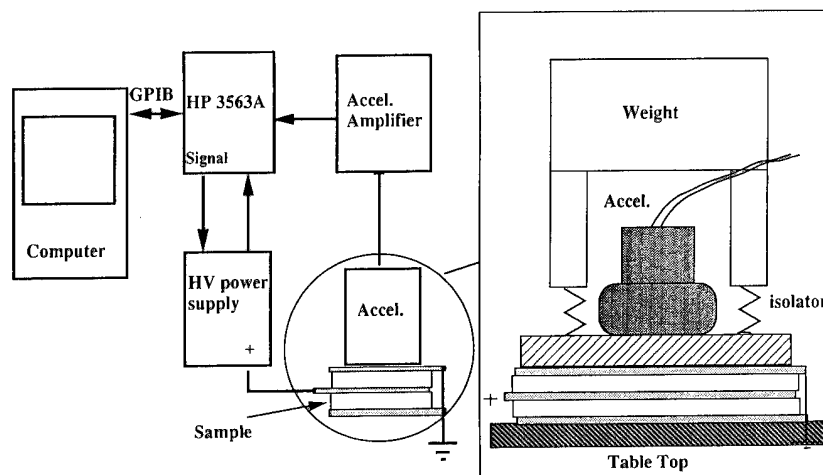

Figure 4. Schematic diagram of accelerometer apparatus used to measure the thickness coefficient d_T .

BBN design⁸ used for the preliminary measurements. Two layers of film were placed between three Tin foil electrodes. The inner layer of Tin foil was used as the high voltage electrode; in this way, the electric field was confined inside the sample sandwich. An accelerometer was attached to a flat plate spacer with a 750-g weight on the plate to ensure good sample to accelerometer contact. A dynamic isolator was used to separate the weight and sample's motions to increase the frequency response of the system. This arrangement was useable over the required end-use frequency range of 10–1000 Hz. The samples were excited by a small ac signal (V_{ac}) with the response (d_T) measured as a function of dc bias voltage (E_b). The outputs were processed using an HP 3563A system analyzer, which rejected most of the noise. The top weight of the system was variable. To measure the effects of water content and sample atmosphere the accelerometer apparatus and samples were placed in a vacuum chamber. The whole system was controlled using an IBM computer.

To confirm our results, we also constructed an entirely different experimental apparatus to measure the thickness response, d_T , a double beam laser interferometer. This method was previously described by Pan and Cross⁹ and a schematic representation is shown in Figure 5.

For the interferometer measurements, samples were cut into strips of 10×5 mm and gold electrodes 5×3 mm \times 200 Å thick were evaporated onto opposing sides. The gold acted both as electrodes and reflecting mirrors. Two sample clamps were used to hold the sample flat and perpendicular to the laser

light. In response to any thickness change of sample under the applied electric field, the recombined light reflected from both sample surfaces produces a change of phase and therefore a change in the set of interference fringes observed. This change is recorded with a resolution of better than 10 Å,⁹ depending on film surface flatness. The signals (corresponding to a change in sample thickness) are then converted into the thickness coefficient, d_T .

A third experimental apparatus for measuring static sample strain as a function of applied electric field is shown schematically in Figure 6. The sample sandwich was placed between two glass plates each of which was gold coated (by evaporation) on one side. The air-gaps shown in Figure 6, formed two parallel plate capacitors. As the sawtooth voltage waveform was applied, the sample thickness changed, changing the air-gap distances, producing a change in the capacitance values. The capacitance changes were recorded by an impedance analyzer; the data was stored in the computer. Two air-gap capacitors were used to insure that the top glass slide did not tilt.

RESULTS AND DISCUSSION

We first measured the polyurethane films as processed by Deerfield. A typical result for d_T as a function of the applied dc bias electric field obtained by using the accelerometer method is shown in Figure 7. The applied ac signal (V_{ac}) was $\sim 50 V_{rms}$ at a frequency of 250 Hz. The thickness response was

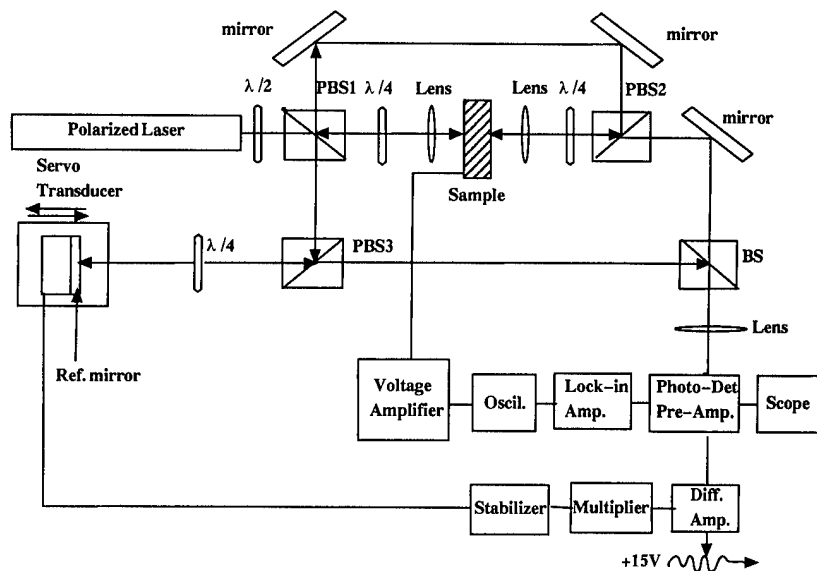

Figure 5. Schematic diagram of double-beam laser interferometer apparatus.

found to be independent of frequency over the measurement range (10–1000 Hz). The value of the thickness coefficient, d_T , increased linearly with increased electric field, which implied that the response was electrostrictive in nature. The value of the electrostrictive constant, M , obtained from the linear portion of Figure 7 is $M \approx 2.6 \times 10^{-17} \text{ m}^2/\text{V}^2$. The value tended to reach a plateau (saturation) at an applied field on the order of 15–20 MV/m. The corresponding d_T value saturated at $6.2 \text{ \AA}/\text{V}$. These results were about 20 times larger than the largest d_T coefficient of any piezoelectric polymer known. The dc bias field could easily be increased to 40 MV/

m for these films without causing dielectric breakdown.

On the basis of our previous studies of piezoelectric polymers, we believed that the effects of the electric field might be more significant if the polymeric chains were oriented into the plane of the film. This is done before polarizing piezoelectric polymers, both PVF_2 and the odd-numbered nylons, to facilitate dipole reorientation into the field direction by rotation about the long axis of the polymer chains. Therefore, we studied the effect of draw ratio on the saturation values of d_T of the polyurethane films. These results are shown in Figure 8a and b. Figure

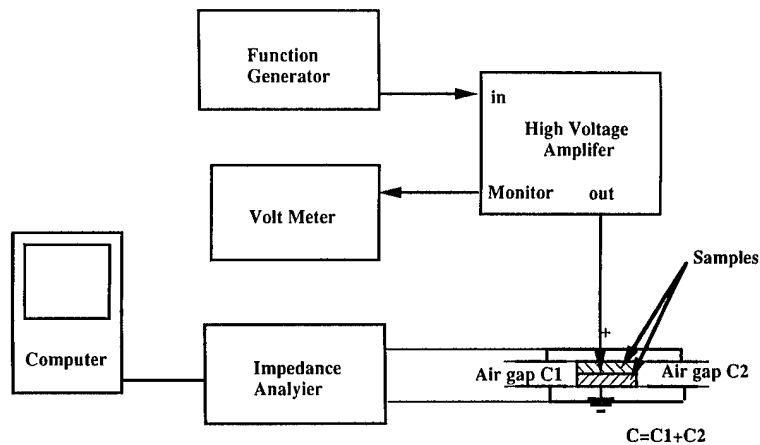

Figure 6. Schematic diagram of apparatus used to measure the static thickness change as a function of applied bias field.

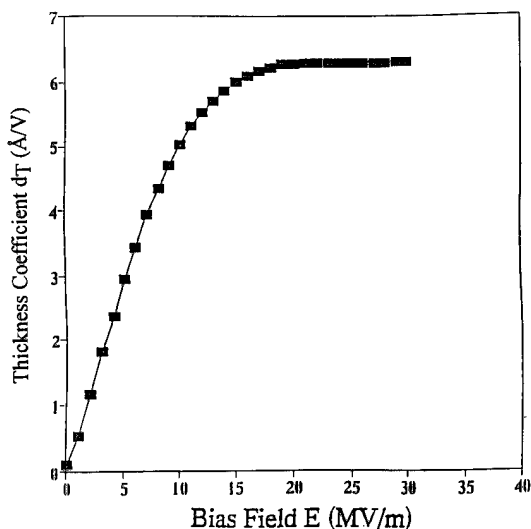

Figure 7. Variation of thickness coefficient (d_T) with an applied bias field for a polyurethane thermoplastic elastomer.

8a shows the thickness coefficient of the polyurethane films as a function of bias field at different draw ratios. Figure 8b shows the saturation value of d_T with draw ratio. It should be noted that the value of d_T peaked at 9 Å/V at a draw ratio of 3 : 1. The reduced response seen as the draw ratio exceeded 3 : 1 may be caused by crystallinity changes resulting from high uniaxial orientation. Studies of crystallinity and phase separation changes produced by drawing and annealing will be reported in future publications.

The increase in response with uniaxial orientation suggested the presence of some dipole reorientation phenomenon and led us to study the existence of any dipole switching in the crystalline regions or bias field induced orientation in the amorphous regions. The sample with a draw ratio of 3 : 1 was studied using a 1000 S period saw tooth shaped electric field waveform. We measured the current density, J , versus the electric displacement, D , and the results are plotted in Figure 9. Figure 9a shows the J vs. E curves obtained, which exhibit a broad peak around 40 MV/m; Figure 9b shows the electric displacement, D (which is equal to the time integrated current density) vs. E curve, which shows a D - E hysteresis loop with an apparent remanent polarization (value of D at $E = 0$), P_r , of approximately 456 mC/m². As the electric field was continually cycled, the peak height in the J - E curve and the corresponding apparent P_r values gradually decreased. If the sample was left without an applied

electric field for several hours, the response was seen to recover to its original value.

Because such a large remanent polarization would imply a much larger dipole density than was present in this material, it seemed unlikely that the phenomenon observed could be accounted for in terms of any intrinsic dipole switching mechanism. In addition, it is known that polyurethanes can absorb moisture from the surrounding atmosphere. This led us to examine the D - E hysteresis behavior and the value of P_r as a function of water content. At zero humidity, the broad peak on the J - E curve disappeared and the P_r value decreased to a range of 0–20 mC/m². Because the apparent dipole switching peak depended on the moisture absorbed by the film, the d_T accelerometer apparatus was placed in a vacuum chamber (10^{-5} torr for 1 day) that was back filled with dry nitrogen. Figure 10 shows the thickness response of the dried polyurethane that was observed to maintain the previously measured high

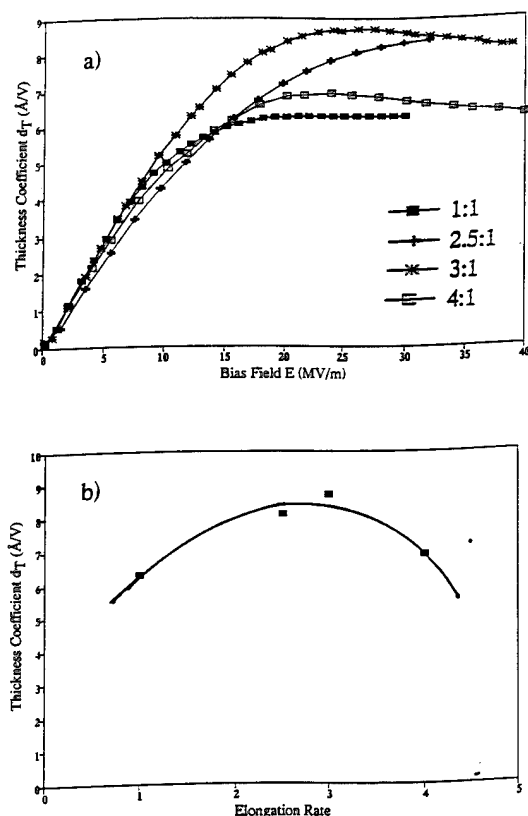

Figure 8. (a) Variation of thickness coefficient (d_T) with applied bias field for polyurethane films as a function of draw ratio; (b) saturation value of thickness coefficient (d_T) as a function of draw ratio.

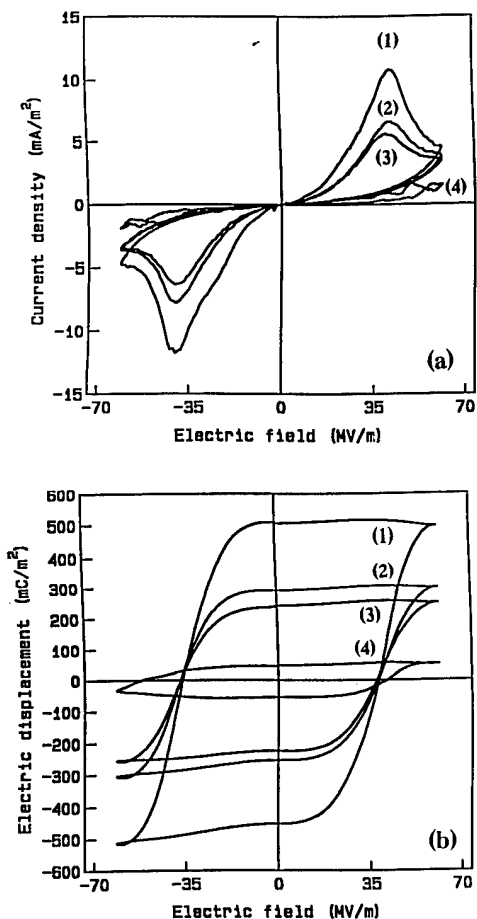

Figure 9. (a) Current density J vs. electric field for oriented polyurethane film with or without humidity; (b) electric displacement D vs. electric field E for oriented polyurethane film.

d_T value. Although the lack of moisture drastically changed the J - E and D - E hysteresis behavior, it did not appear to diminish the d_T response.

Figure 11 shows the thickness response change with applied bias field under different reduced pressures. The d_T response was observed to increase as the pressure decreased from one atmosphere to 10^{-5} torr: the saturation value of d_T increased from 5.8 to 7.8 Å/V. The reduction in pressure reduced the amount of moisture in the film and may have also reduced any measurement error produced by air trapped between the metal foil electrodes and the samples.

While using the accelerometer apparatus, we began to consider the effect of the spring isolation weight with regard to possible sample constraint. This consideration was, not surprisingly, triggered by the fact that d_T was observed to decrease when

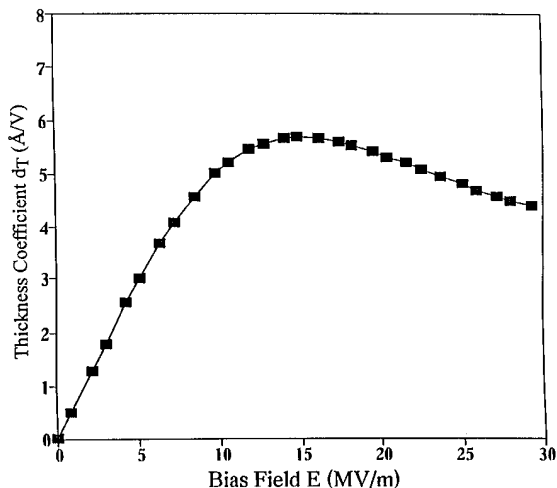

Figure 10. Variation of thickness coefficient (d_T) with an applied bias field for a polyurethane film at zero humidity.

the weight was increased. This increase in weight produced an increase in normal force that increased the frictional force on the film as it expanded laterally during the electric field-induced decrease in thickness. Because Poisson's ratio of the urethane elastomer is ≈ 0.5 at zero applied field, the material is incompressible and one should expect a correlation between lateral constraint and change in thickness coefficient. The variation in d_T with weight load was also studied and the results are shown in Figure 12. d_T was measured at an applied bias field of 12.5 MV/m using a 50 V_{rms} ac signal and a frequency of 250

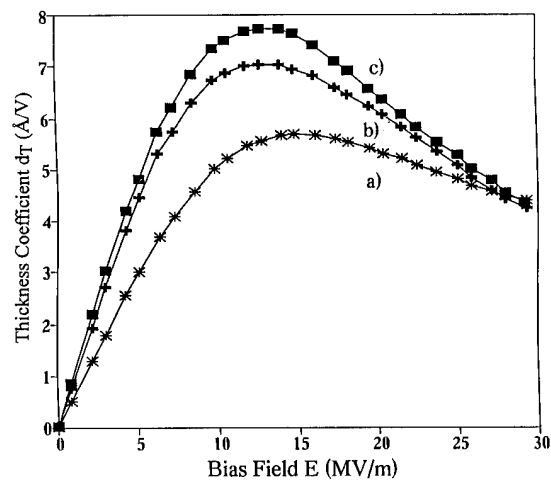

Figure 11. Variation of thickness coefficient (d_T) with an applied bias field for polyurethane under different pressure (a) atmosphere; (b) 10^{-3} torr; (c) 10^{-5} torr.

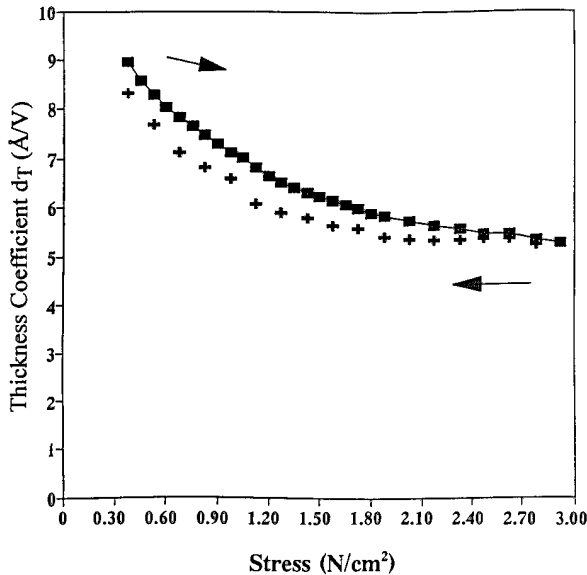

Figure 12. Variation of thickness coefficient as a function of preloaded stress at a bias field of 12.5 MV/m.

Hz. The results show that d_T decreased from ~ 9 Å/V with increasing compressive stress and approached a stable value at ~ 5 Å/V. This we believed to be due to sample constraint resulting from the frictional forces produced by the weight.

Because the d_T value apparently decreased with increased sample constraint, we chose a method to measure the thickness response that minimized this constraint. The laser interferometer apparatus was used to measure the polyurethane thickness variation as a function of applied electric bias field because it can be used to examine a free-standing film. The result of d_T vs. bias field, E_b , is shown in Figure 13. As expected, d_T increased linearly with increasing bias field. The electrostrictive coefficient, M , was also determined and a value of $1.8 \times 10^{-17} \text{ m}^2/\text{V}^2$ was obtained. This value of M is smaller than the value obtained using the accelerometer apparatus ($M \approx 2.6 \times 10^{-17} \text{ m}^2/\text{V}^2$). Even though in this apparatus the films are free standing and only clamped at the ends, it should be noted that the gold electrodes are also a restraint to the lateral expansion and may reduce the thickness response of the polyurethane film. To further confirm our results and reduce the restraint on lateral expansion, we designed a third measurement method to measure the strain response, S , directly in the thickness direction.

Measurements were carried out using a double capacitance dilatometer (Fig. 6). The results are shown in Figure 14 and indicated hysteresis behavior

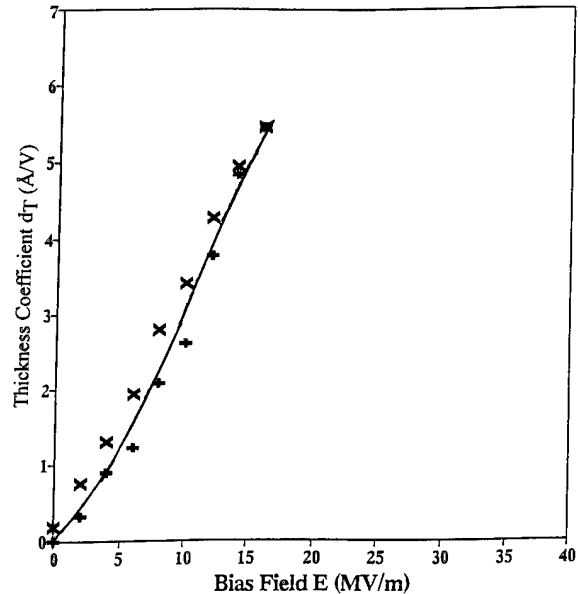

Figure 13. Variation of thickness coefficient with applied bias field measured by the laser interferometer.

similar to that which occurs in ceramic materials.² As the electric field increases there is a corresponding decrease in film thickness. It was also observed that the strains were fully recovered as the electric field decreased to zero. The maximum observed strain is $\sim 3\%$ and the corresponding value of d_T is ~ 20 Å/V. These results are much larger than the previous measurement results due to the minimization of surface constraint.

Figure 15 shows the static strain as a function of applied electric bias field obtained experimentally

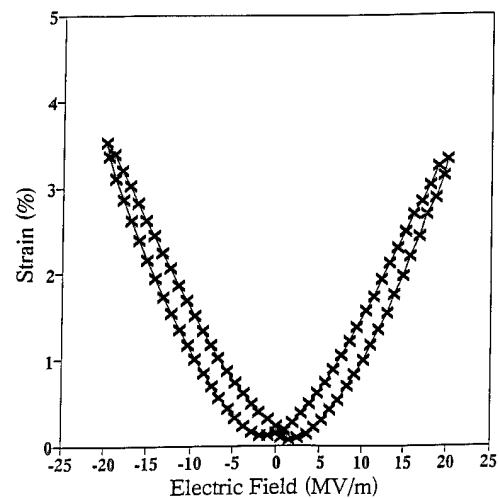

Figure 14. Variation of strain with applied bias field measured by capacitance method.

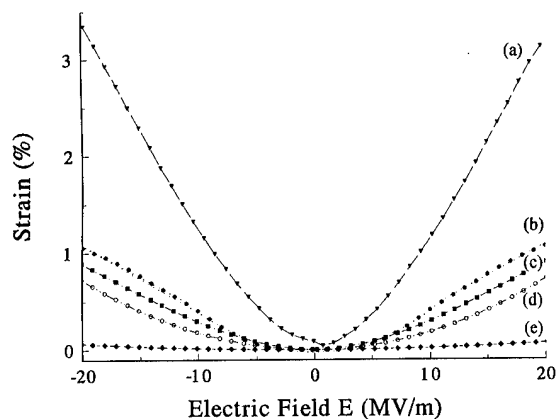

Figure 15. Variation of strain with applied dc bias field for: (a) less constrained films using the capacitance measurement system; (b) electrode films using the capacitance measurement system; (c) unelectrode films using the accelerometer measurement system; (d) electrode films using the laser interferometer system; (e) for unconstrained film predicted using Maxwell (electrode) attraction.

using all these methods together with the calculated Maxwell strains caused by electrode attraction. An examination of this data shows that at lower electric fields, the observed strains are proportional to the square of the applied electric field and the thickness coefficient is proportional to the applied electric field ($d_T = 2ME$), confirming the electrostrictive nature of the response. At higher electric fields, the strains exhibit a linear relationship to the electric field, corresponding to a constant thickness coefficient. It is also observed that the strains are fully recovered as the electric field decrease to zero. Curves (a) and (b) in Figure 15 show the strains obtained using the capacitor measurement. For curve (a), the maximum observed strain is $\sim 3\%$ and the corresponding value of d_T is $\sim 20 \text{ \AA/V}$. These results are much larger than the previous measurements, presumably due to the minimization of the surface constraint. To compare this method with the laser interferometer method, we coated the film surfaces with 200 \AA gold electrodes on each side and repeated the capacitor measurements. The strain response obtained is shown in curve (b), which has a maximum observed strain of 1.05% , and a corresponding value of d_T is $\sim 6.9 \text{ \AA/V}$. Curves (c) and (d) are obtained from the integration of the d_T vs. E data measured by the accelerometer and laser interferometer methods, respectively. As discussed previously, these data were obtained from constrained films, and it can be seen that curves (c) and (d) are consistent with that of curve (b) (i.e., when the surface is constrained, the

electrostrictive response is much less). Curve (e) shows the calculated Maxwell strain, the elastic strain induced by the attractive forces between electrodes. This strain is much smaller than our measured results and is about 10% of the strain measured by the laser interferometer method. The contribution of electrode attraction to the electrostriction coefficient is $\sim 1.7 \times 10^{-18} \text{ m}^2/\text{V}^2$. After subtraction of the Maxwell contribution, the electrostriction coefficient is $1.63 \times 10^{-17} \text{ m}^2/\text{V}^2$ for curve (b), $2.4 \times 10^{-17} \text{ m}^2/\text{V}^2$ for curve (c), and $3.3 \times 10^{-17} \text{ m}^2/\text{V}^2$ for curve (d). We also compared our results with a simplified model¹⁰ introduced by Anderson et al. The mechanical stress in a homogeneous dielectric from a uniform electric field had been calculated by energy minimization, where the polarizable point dipoles were assumed to be separated by equal distances. The calculated electrostriction coefficient, M , is $1.3 \times 10^{-17} \text{ m}^2/\text{V}^2$, which is of the same order of magnitude as our measured results for the constrained films, but not for the unconstrained films.

Figure 16 shows the d_T values obtained as a function of applied bias field for: (a) less constrained films measured using the capacitance measurement system, (b) films with evaporated electrodes measured using the capacitance measurement system, (c) films measured using the accelerometer measurement system, (d) films with evaporated electrodes measured using the laser interferometer system, and (e) calculated using Maxwell (electrode)

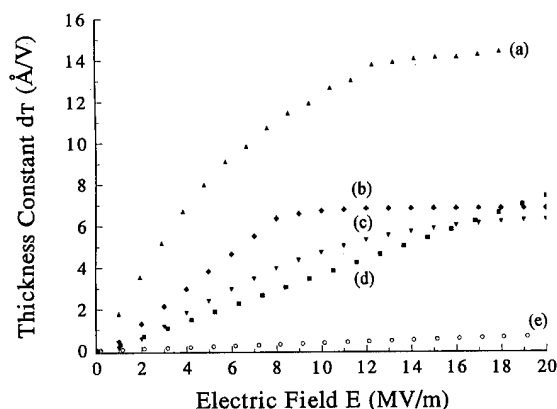

Figure 16. Thickness constant with applied dc bias fields for: (a) less constrained films using the capacitance measurement system; (b) electrode films using the capacitance measurement system; (c) unelectrode films using the accelerometer measurement system; (d) electrode films using the laser interferometer system; (e) for unconstrained film predicted using Maxwell (electrode) attraction.

attraction. It is obvious that the least constrained film (Fig. 16a) exhibits the largest measured value of d_T and the largest static strains (Fig. 15a). For films with significantly greater degrees of constraint (Fig. 16b, c, d). The measured values of d_T and the static strains (Fig. 15b, c, d) are significantly less.

To obtain an estimate of the constraint resulting from a 200 Å layer of gold on the opposing surfaces of the polyurethane film, we used a simple model of a three-layer composite and assumed that the lateral strain on electrodes and film was equal, and that the moduli and Poisson's ratio of the gold electrodes and polymer film were independent of field. This latter assumption is, of course, more likely to be true for the gold than the polymer. It is also assumed that the elastic strains in the sample do not vary across the thickness of the sample (uniform strain). With these assumptions, it can be shown that the resulting strain in the thickness direction for the polymer film, resulting from an electrostriction stress, σ is given by:

$$S = -\frac{\sigma}{E_1} \left[1 - \frac{4\nu_1^2}{2(1-\nu_1) + (1-\nu_2) \frac{t_1 E_1}{t_2 E_2}} \right] \quad (3)$$

where E_1 , ν_1 , and t_1 are the elastic modulus, Poisson's ratio, and thickness of the polymer film, and E_2 , ν_2 , and t_2 are the corresponding values for the gold electrodes.

Assuming plausible values for these constants ($E_1 = 1.9 \times 10^7$ N/m², $E_2 = 7.85 \times 10^{10}$ N/m², $\nu_1 = 0.5$, $\nu_2 = 0.42$, $t_1 = 25 \times 10^{-6}$ m, and $t_2 = 2 \times 10^{-8}$ m) we find

$$S = -\frac{\sigma}{E_1} K_{\text{constraint}} \quad (4)$$

where $K_{\text{constraint}}$ is a correction factor produced by the surface constraint, and $K_{\text{constraint}} \sim 0.15$ for the values listed. This implies that the measured values for strain and thickness coefficient, d_T , are $\sim 15\%$ of the values expected for a truly unconstrained film. Therefore, the differences in the curves shown in Figure 15b, c, d and Figure 16b, c, d mostly likely arise from differences in surface constraints. The most unconstrained case (Fig. 15a and Fig. 16a) exhibits much larger values (strains approximately three times greater at higher field) but still much less than the theoretically derived strain for a truly unconstrained film. In fact, it was observed that the Maxwell (electrode) attractive force was sufficiently

great to give rise to a constraint even in this case. However, considered as a source of the observed electrostrictive strains, the Maxwell attractive force gives rise to only comparably small values of strain (Fig. 15e and Fig. 16e).

CONCLUSION

We examined the thickness response, d_T , obtained from a soft polymeric material, a polyurethane, using three quite separate measurement techniques. Under high dc bias field, we discovered an extremely high value of the thickness coefficient, d_T , and also that extremely high static strains could also be produced by simply changing applied voltage. Because d_T increased linearly with increasing bias field, and because the static strains (which could not be explained on the basis of electrode attraction) increased with the square of the bias field, electrostriction is suggested as the basis for the enormous response. It is also suggested that the large electrostrictive response measured is in fact greatly reduced by the surface constraints imposed by the necessity to utilize a surface conductive layer as electrodes. Further studies are being carried out to further investigate and determine the effects of surface constraint on the measured electrostrictive response, and also to determine the molecular origins of the observed phenomenon. It is apparent that these materials offer great promise in applications as acoustic projectors and transducers, and, because of the large rapid strains produced, as artificial muscle and actuator devices.

The authors would like to thank Bill Watters, BBN, Cambridge, Massachusetts for running the plasticized PVF₂ films. Some support from DARPA/ONR for this work became available in 1991 and also this work was supported in part by CAFT.

REFERENCES AND NOTES

1. M. C. Lines and A. M. Glass, *Principles and Applications of Ferroelectrics and Related Materials*, Oxford Press, New York (1977).
2. V. Sunder and R. E. Newnham, *Ferroelectrics*, **135**, 431 (1992).
3. T. Furukawa and N. Seo, *Jpn. J. Appl. Phys.*, **29**(4) 675 (1990).
4. B. A. Newman, J. I. Scheinbeim, and A. Sen, *Ferroelectrics*, **57**, 229 (1984).

5. A. Sen, J. I. Scheinbeim, and B. A. Newman, *J. Appl. Phys.*, **56**, 2433 (1984).
6. S. C. Mathur, A. Sen, B. A. Newman, and J. I. Scheinbeim, *J. Mater. Sci.*, **23**, 977 (1988).
7. J. I. Scheinbeim, S. C. Mathur, and B. A. Newman, *J. Polym. Sci., Part B, Polym. Phys.*, **24**, 1971 (1986).
8. Private discussion with Bill Watters of BBN.
9. W. Y. Pen and L. E. Cross, *Rev. Sci. Instrum.*, **60**(8), 2701 (1989).
10. R. A. Anderson, *Phys. Rev. B.*, **33**(2), 1302 (1986).

Received April 12, 1994

Accepted August 2, 1994