

THE UNITED STATES ARMY MODERNIZATION PLAN

UPDATE (FY95-99)

LAND FORCE DOMINANCE

THRU

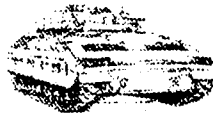

DTIC
SELECTED
DEC 08 1994
S F D

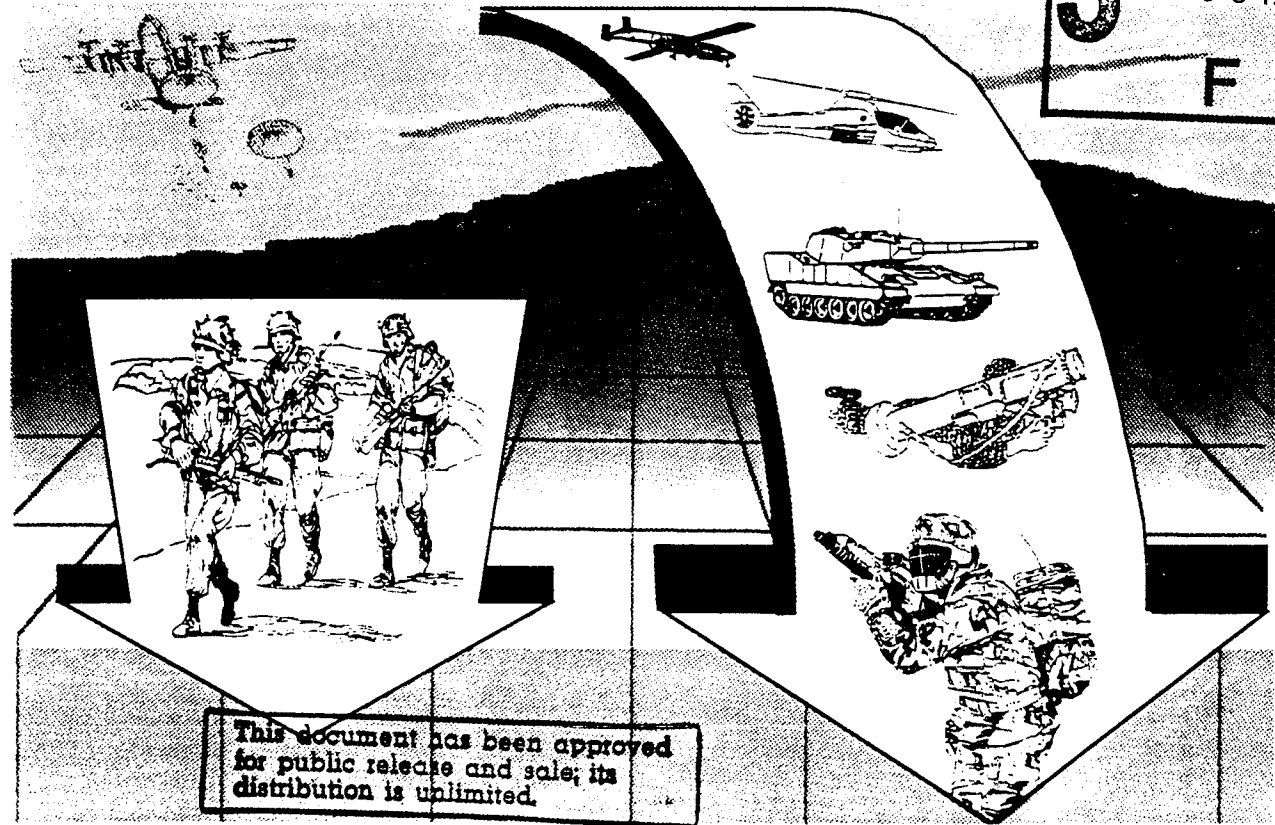

Modernization Objectives

- Project & Sustain
- Protect The Force
- Win The Information War
- Conduct Precision Strike
- Dominate The Maneuver Battle



DEPLOY TO
CONTINGENCIES

1994 1201030

MAY 1994

DTIC QUALITY INSPECTED 8

REPORT DOCUMENTATION PAGE

Form Approved
OMB No. 0704-0186

Public reporting burden for this collection of information is estimated to average 1 hour per response, including the time for reviewing instructions, searching existing data sources, gathering and maintaining the data needed, and completing and reviewing the collection of information. Send comments regarding this burden estimate or any other aspect of this collection of information, including suggestions for reducing this burden, to Washington Headquarters Services, Directorate for Information Operations and Reports, 1215 Jefferson Davis Highway, Suite 1204, Arlington, VA 22202-4302, and to the Office of Management and Budget, Paperwork Reduction Project (0704-0186), Washington, DC 20503.

1. AGENCY USE ONLY (Leave blank)		2. REPORT DATE 26 MAY 1994	3. REPORT TYPE AND DATES COVERED INTERIM	
4. TITLE AND SUBTITLE THE UNITED STATES ARMY MODERNIZATION PLAN UPDATE (FY 95-99)			5. FUNDING NUMBERS	
6. AUTHOR(S) DAMO - FD - LTG JAYM GARNER, - ADCSOPS-FD DAMO - FDQ - COL Greene				
7. PERFORMING ORGANIZATION NAME(S) AND ADDRESS(ES) OFFICE OF THE DEPUTY CHIEF OF STAFF FOR OPERATIONS AND PLAN - FORCE DEVELOPMENT PENTAGON, WASHINGTON, DC 20310-0460			8. PERFORMING ORGANIZATION REPORT NUMBER	
9. SPONSORING / MONITORING AGENCY NAME(S) AND ADDRESS(ES) SAME AS 7			10. SPONSORING / MONITORING AGENCY REPORT NUMBER	
11. SUPPLEMENTARY NOTES supersedes previous update January 1993 THE ARMY MODERNIZATION PLAN VOLUME II Annex A-P				
12a. DISTRIBUTION / AVAILABILITY STATEMENT DISTRIBUTION STATEMENT A			12b. DISTRIBUTION CODE	
13. ABSTRACT (Maximum 200 words) (OPTIONAL) This edition/updates of the Army Modernization PLAN reflects the impacts of the DOD Bottom Up Review, new Defense Planning Guidance, restated National Military Strategy, newly published Joint & Army doctrinal manuals, the effects of the continued decline in fiscal resourcing and force structuring effects on the Modernization Goals and objectives. This volume charts the changes the Army faces as we continue to modernize the force. These changes are reflected by modernization objective and outlines future projections by functional area.				
14. SUBJECT TERMS			15. NUMBER OF PAGES 325	
			16. PRICE CODE	
17. SECURITY CLASSIFICATION OF REPORT UNCLASS	18. SECURITY CLASSIFICATION OF THIS PAGE UNCLASS	19. SECURITY CLASSIFICATION OF ABSTRACT UNCLASS	20. LIMITATION OF ABST SAR	



DEPARTMENT OF THE ARMY
WASHINGTON, D.C. 20310-5200



May 26, 1994

SUBJECT: Army Modernization

America's Army must respond to the crises of today and tomorrow. It must be power-filled, versatile, and able to respond worldwide with such overwhelming, technically superior force as to render any potential adversary impotent and minimize our cost in soldiers' lives.

In the year since the last Army Modernization Plan was published, much has changed and this update reflects the impact of those dynamics: the Department of Defense Bottom-Up Review, a restated National Military Strategy, new Defense Planning Guidance, publication of key Joint and Army doctrinal manuals, continued decline in fiscal resourcing, and force structure reductions. These forces of change are amplified by international uncertainty, global weapons and technology proliferation, and the fact that on a daily basis the Army has thousands of soldiers deployed to over 70 countries, along with our standing commitment of 125,000 forward deployed soldiers. The bottom line is that change is constant and the Army must respond accordingly.

Our Nation must have a modern, power projection Army to ensure America's vital interests can be protected. Today, we are at a threshold of a new era and we must proceed into it decisively. The Industrial Age is being superseded by the Information Age, or Third Wave. The Army's total force, military and civilian personnel of the National Guard, Reserve, and active forces, is well-configured to fight and win in the late Industrial Age. Transition to Third Wave warfare can only be guaranteed by ensuring our modernization vision of Land Force Dominance is retained. That vision is supported by the five modernization objectives: rapidly project and sustain forces, protect committed forces, win the information war, conduct precision strikes, and dominate the maneuver battle. These objectives, the adequate funding of their components, and an ever present focus on the soldier are imperative as the Army builds toward the force of the next century--Force XXI.

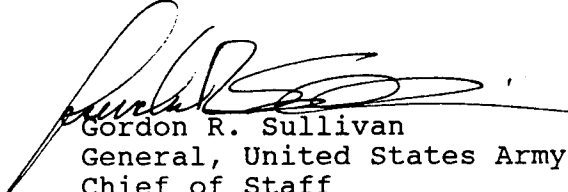
Gordon R. Sullivan
General, United States Army
Chief of Staff

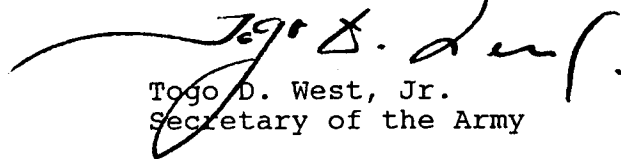
Togo D. West, Jr.
Secretary of the Army

19941201 030



THE UNITED STATES ARMY MODERNIZATION PLAN UPDATE (FY 95-99)

AMERICA'S ARMY

"America's Army relies on a technological edge...to overmatch our adversaries. To maintain this edge, we must continue to modernize."

Togo West
Secretary of the Army

TABLE OF CONTENTS

<u>CHAPTER</u>		<u>PAGE</u>
	EXECUTIVE SUMMARY	1
1	CLOSE COMBAT - HEAVY	1-1
2	CLOSE COMBAT - LIGHT	2-1
3	COMMAND, CONTROL, COMMUNICATIONS AND COMPUTERS (C4)	3-1
4	ENGINEER AND MINE WARFARE	4-1
5	AIR DEFENSE	5-1
6	TACTICAL WHEELED VEHICLES	6-1
7	FIRE SUPPORT	7-1
8	THEATER MISSILE DEFENSE	8-1
9	INTELLIGENCE AND ELECTRONIC WARFARE	9-1
10	LOGISTICS	10-1
11	SOLDIER MODERNIZATION	11-1
12	AVIATION	12-1
13	NUCLEAR, BIOLOGICAL AND CHEMICAL	13-1
14	INFORMATION MISSION AREA INFRASTRUCTURE	14-1
15	MEDICAL	15-1
16	TRAINING	16-1
17	SPACE EXPLOITATION	17-1
18	BATTLEFIELD DIGITIZATION	18-1
	GLOSSARY	G-1

Prepared By:

ODCSOPS-FD
ATTN: DAMO-FDQ
The Pentagon
Washington, DC 20310-0460



1994

**THE UNITED STATES ARMY
MODERNIZATION PLAN
UPDATE**



EXECUTIVE SUMMARY

"To be prepared for war is one of the most effectual means of preserving peace."

George Washington
1st Annual Address To Congress
8 January 1790

Section I

Introduction

This volume is an update to the 1993 Army Modernization Plan. It charts the changes the Army has experienced over the past year as we continue to modernize the force. The azimuth for modernization has not wavered in spite of the increased pace of reductions to both force structure and the Army budget. These reductions have had dramatic programmatic impacts. Some weapon system programs or modifications have been terminated, while many others have been deferred or stretched into the out years. Innovative approaches to modernization are being implemented, such as horizontal technology integration (HTI), the Army's Enterprise Strategy, and Digitization of the Battlefield. The Army Modernization Plan, in conjunction with the Army Science and Technology Master Plan (ASTMP), is being charted to ensure that the nation has an Army capable of establishing and maintaining **Land Force Dominance**.

**Modernization Vision
Ensuring Land Force Dominance**

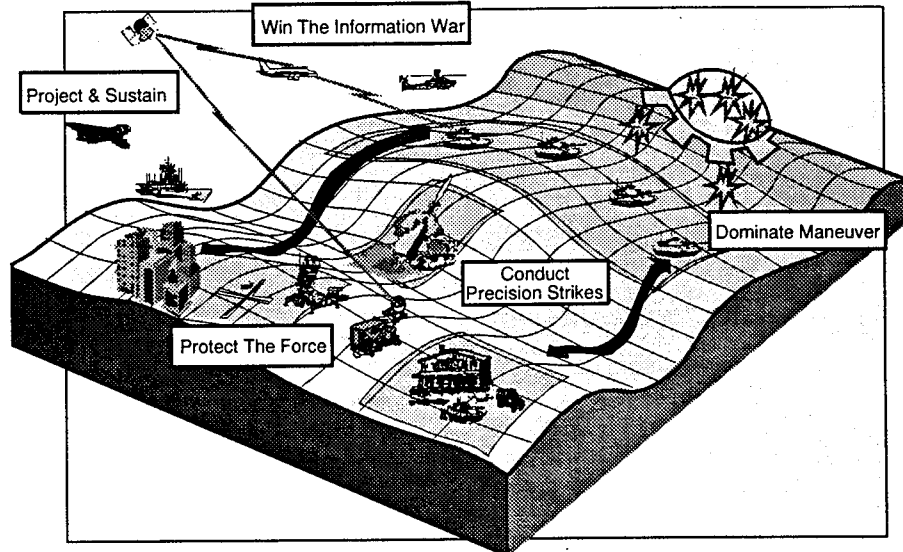

Accession For	
NTIS	<input checked="" type="checkbox"/>
CRA&I	<input type="checkbox"/>
DTIC	<input type="checkbox"/>
TAB	<input type="checkbox"/>
Unannounced	<input type="checkbox"/>
Justification
By	
Distribution /	
Availability Codes	
Dist	Avail and/or Special
A-1	

"The real issue is how to exploit American science and technology for decisive military purposes. How can we defeat our enemies with the least cost in American lives and treasure?"

GEN William E. DePuy

Why Modernize?

The current National Military Strategy requires the Army to win America's wars decisively, while minimizing casualties. At the same time the Army is experiencing continuous down-sizing in an increasingly fiscally constrained environment. Thus, modernization of the remaining force gains increasing importance. This is because the success of military operations and the level of casualties is directly linked to our overall warfighting capability.

Warfighting capability of a coalition force can be reflected in various manners. It can be measured by the "force exchange ratio" (FER), which is the ratio of enemy losses to that of coalition losses. It can also be measured as it directly relates to casualty estimates and achievement of military objectives. The bottom line is that poor warfighting capability equates to a reduced ability to generate decisive force, which in turn causes a high casualty rate and fewer opportunities to achieve military objectives.

This chart graphically portrays the relative warfighting capabilities of US force mixes against a threat force and shows the relationship of casualties to capabilities. The analysis used numerous simulated conflicts in various regions of the world and then validated them through comparisons with historical campaigns. As the FER increases toward the point of "decisive force" (FER \geq 5.0), casualties decline dramatically and military objectives are achieved consistently. The results of the analysis suggest that US military forces should be structured, designed, equipped and rapidly deployable to achieve an FER of 5.0 or greater in order to meet the National Military Strategy warfighting success criteria.

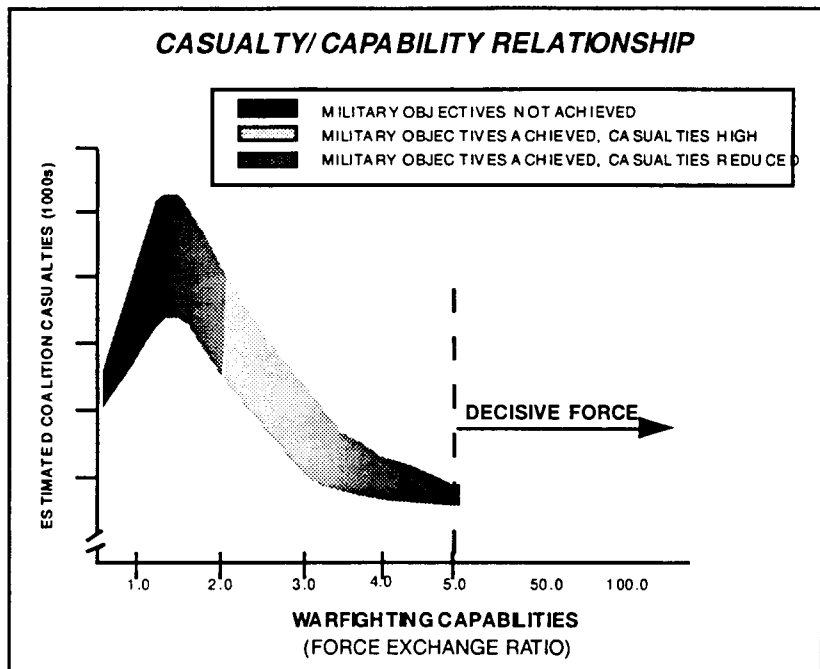

Funding for force modernization correlates directly to warfighting capability. Decrements to funding earmarked for modernization programs reduces capability and increases our inability to protect the force, resulting in increased casualties. From 1989 through the 1999 POM the Army's RDA budget reflects a decline of \$12.5 billion. Prudent management of declining RDA funds is imperative.

Forces of Change

Since the publication of the 1993 Army Modernization Plan a number of actions have altered the manner in which the Army pursues its modernization efforts. Creation of a new Defense Planning Guidance document, the Department of Defense Bottom-Up Review, a pending National Military Strategy, key doctrinal changes, force structure issues, and innovative force modernization thrusts are among the more significant factors. Some of these forces of change are discussed below.

IMPACTS ON ARMY MODERNIZATION

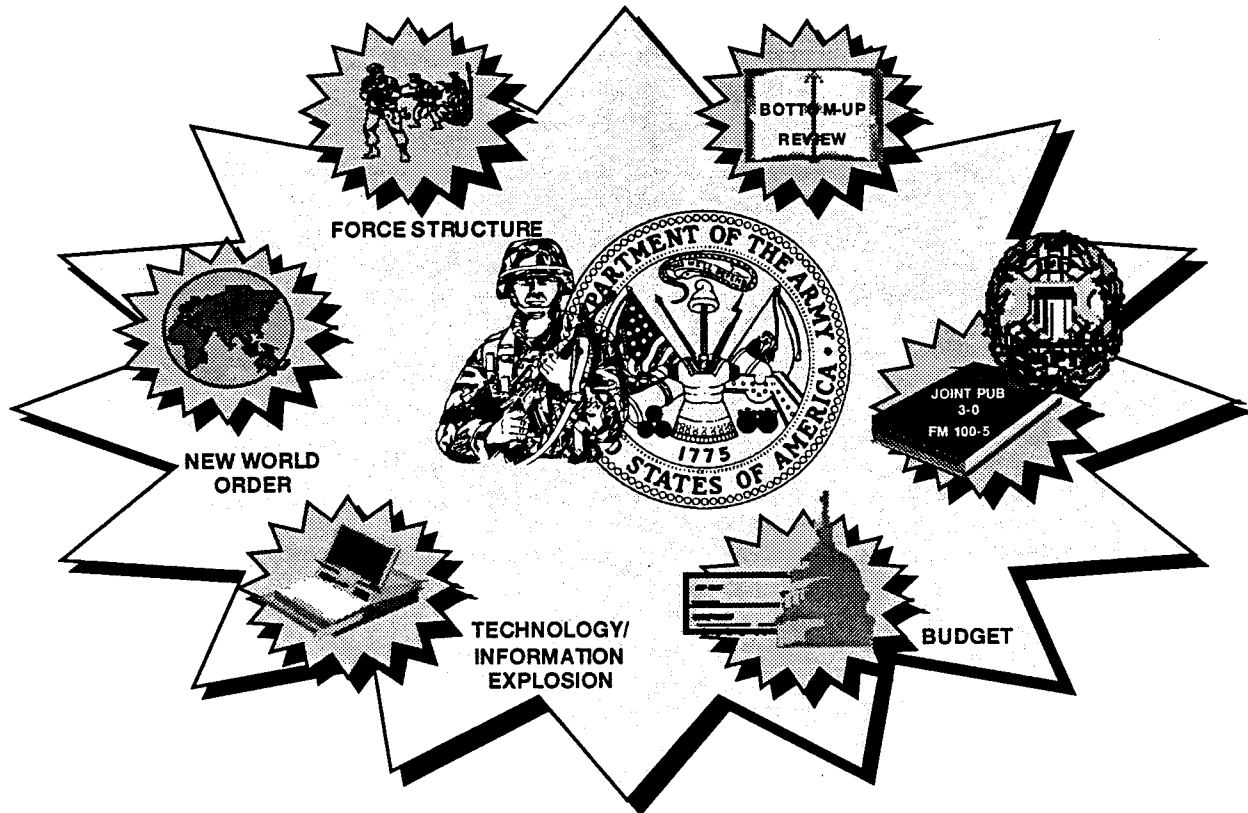

• **Bottom-Up Review (BUR).** The BUR, as initiated by the Secretary of Defense, and completed in September 1993, had as its purpose to "define the strategy, force structure, modernization programs, industrial base, and infrastructure needed to meet new dangers and seize new opportunities." The BUR identified four dangers to the United States.

- Spread of nuclear, biological, and chemical weapons
- Aggression by major regional powers or ethnic and religious conflict
- Potential failure of democratic reform in the former Soviet Union and elsewhere
- Potential failure to build a strong and growing US economy

NEW DANGERS

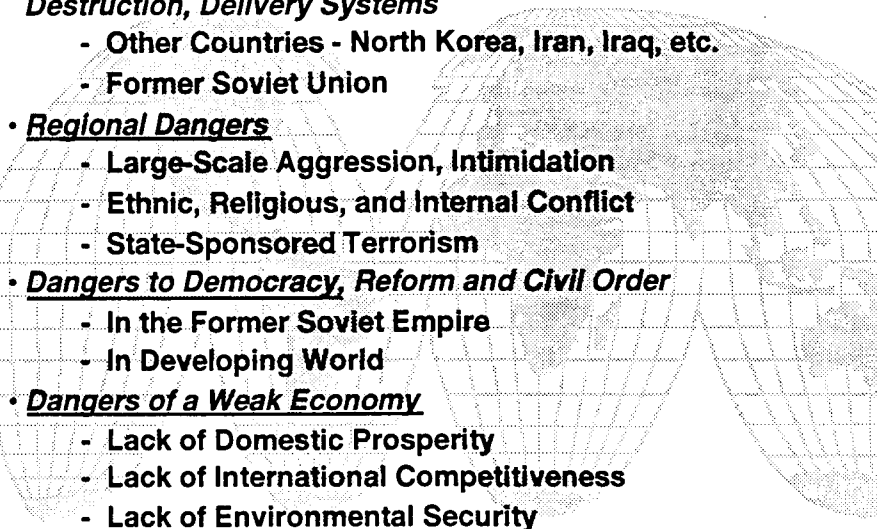

Bottom
Up
Review

- 
- **Proliferation of Nuclear Weapons and Other Weapons of Mass Destruction, Delivery Systems**
 - Other Countries - North Korea, Iran, Iraq, etc.
 - Former Soviet Union
 - **Regional Dangers**
 - Large-Scale Aggression, Intimidation
 - Ethnic, Religious, and Internal Conflict
 - State-Sponsored Terrorism
 - **Dangers to Democracy, Reform and Civil Order**
 - In the Former Soviet Empire
 - In Developing World
 - **Dangers of a Weak Economy**
 - Lack of Domestic Prosperity
 - Lack of International Competitiveness
 - Lack of Environmental Security

Through the use of scenarios the BUR recommended a force structure of 10 active Army divisions, 5-8 reserve component divisions and 15 enhanced readiness brigades. More detailed discussion of force structure implications can be found on page 9. This force, in concert with other Service forces, was determined to be sufficient to "fight and win two nearly simultaneous major regional conflicts." The scenarios placed a significantly increased requirement for force projection from CONUS as we continue to withdraw forces from overseas bases. Emphasis was given to early entry capabilities through an albeit smaller forward presence, pre-positioning equipment afloat, giving priority to anti-armor enhancements, and protecting the force against the threat from proliferation of ballistic and cruise missiles.

• Doctrinal Developments

Joint and Army doctrines drive the Army's modernization vision, hence the Army Modernization Plan. Our concept for waging war is to overwhelm an enemy throughout the depth and breadth of the battlefield by executing simultaneous operations. Through control of space and the skies overhead, and the conduct of decisive joint and multinational land combat operations, we deny an enemy at every point—physically and psychologically -- the ability to maintain a coherent operational plan or to respond appropriately to battlefield conditions. The Army of the future must maintain an overmatching capability to ensure land force dominance. To achieve this end, the Army must field high payoff technologies which support the five modernization objectives of **Project and Sustain the force; Protect the Force, Win the Information War; Conduct Precision Strikes** throughout the battlefield, and **Dominate the Maneuver Battle.**

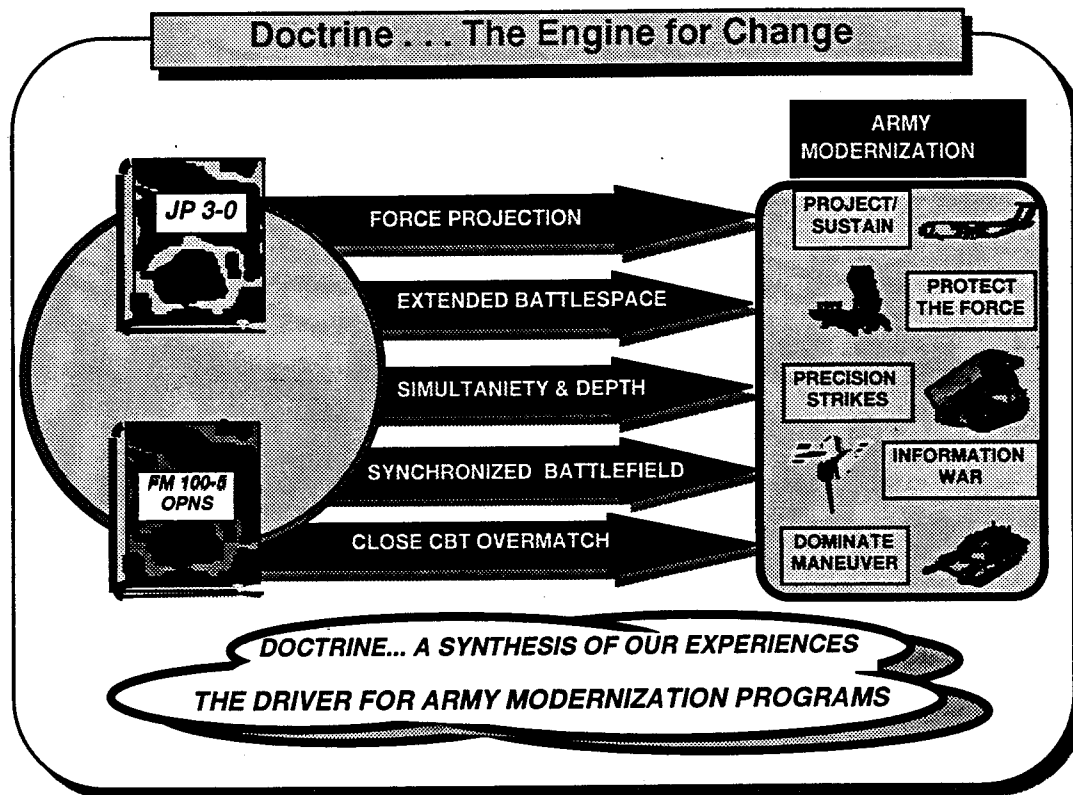

A significant difference from last year is the revision and publication of key doctrinal documents at both the Joint and Army Departmental levels. Joint Publication 3-0 (Doctrine for Joint Operations) was approved by the Chairman of the Joint Chiefs of Staff in September 1993 and Army Field Manual (FM) 100-5 (Operations) was published in June 1993. These operational documents were developed concurrently. Army doctrinal thinking both fed and took direction from the emerging joint warfighting doctrine. Together, they serve as the cornerstones and set forth how we will conduct military operations in support of our National Military Strategy with a versatile, deployable, agile and lethal force. These operational doctrines are the keys to determining how the Army will organize, train, and equip its forces. Army doctrine then directly affects subordinate doctrine, training, leader development, force design, and equipment acquisition programs.

•• JOINT PUBLICATION 3-0, Doctrine for Joint Operations

On 9 September 1993, the Chairman of the Joint Chiefs of Staff approved the Nation's cornerstone joint warfighting doctrine, Joint Pub 3-0. This publication establishes the fundamental principles and operational concepts for joint operations, as well as the doctrinal basis for U.S. military participation in multinational and interagency operations. While its primary focus is on joint warfighting, the publication also addresses those military operations that do not include the use or threat of use of force, doctrinally referred to as "military operations other than war". It provides operational and organizational guidance for the exercise of command by joint force commanders (JFCs) through their subordinate commanders, and guides development of combatant command strategy and the planning and execution of joint campaigns and major operations. Of significance, Joint Pub 3-0 emphasizes the role of land and naval force commanders in the conduct of joint operations. Within their JFC-defined areas of operations (AOs), land and naval force commanders are typically designated as "supported" commanders, and exercise "general direction" over "supporting" forces, defining the priority, effects, and timing of "supporting" operations within their AOs. In essence, the JFC has decentralized various aspects and dimensions of the joint battle to subordinate land and naval force commanders, empowering them to integrate and synchronize the operations of the elements of the joint force within their AOs. This very powerful operational concept ensures that land battles are fought and won decisively and as an entity with

all the power available to the joint force, as opposed to fighting separate dimensional battles and relying on time and attrition to secure an elusive victory.

FM 100-5 * DOCTRINE IMPACT**

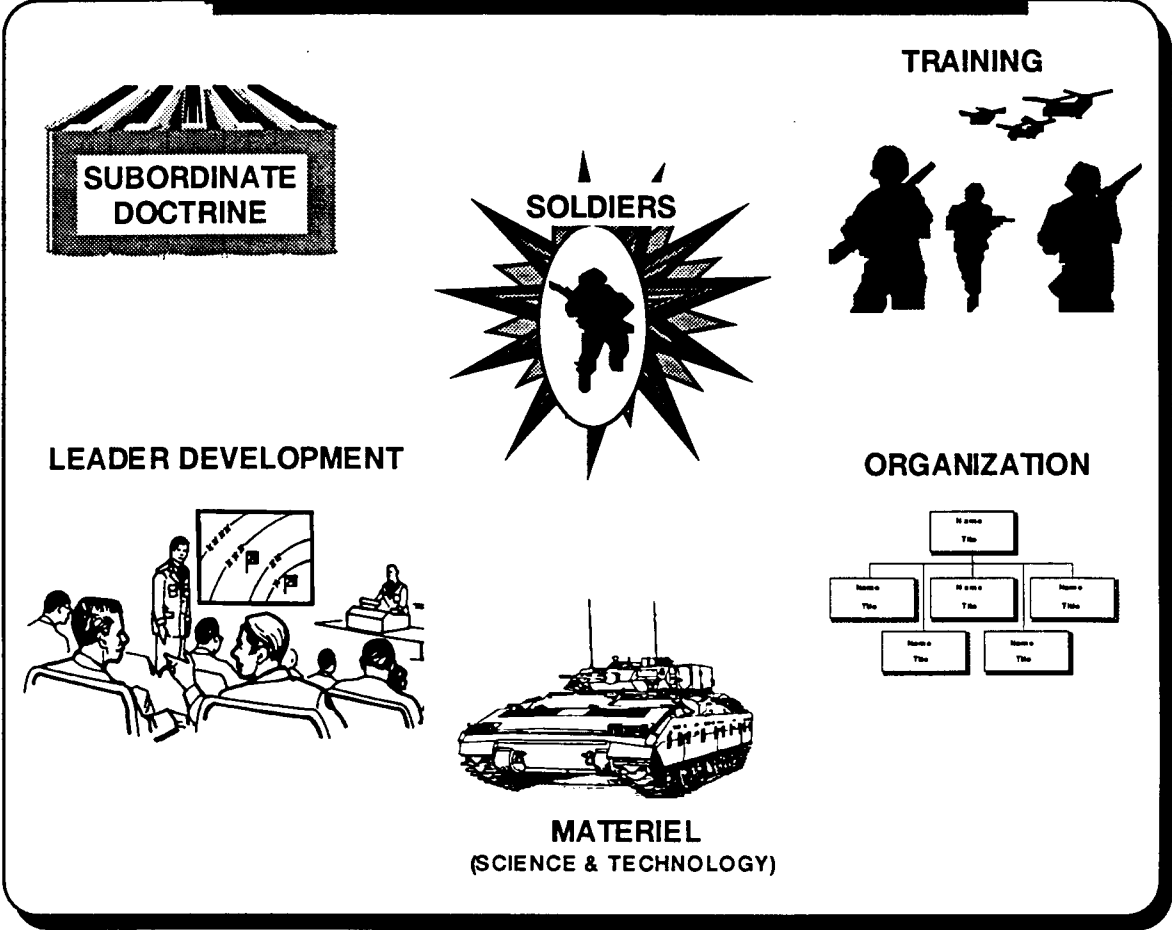

.. FM 100-5, OPERATIONS - THE 1993 VERSION

The 1993 operational doctrine reflects Army thinking in a new strategic era. It calls for a force projection Army that can build and sustain decisive combat power in any region worldwide. It recognizes that the Cold War has ended, hence the grand strategy of the United States has changed. Many of the principles and fundamentals of AirLand Battle, which were validated during Operations JUST CAUSE and DESERT STORM, have been retained. The doctrine reflects a strong shift toward increasingly joint operations, as intended in the Goldwater-Nichols Act of 1986 and described in Joint Pub 3-0, and acknowledges an expanded battlefield framework and wider inter-Service/interagency cooperation and dependence. Inherent, also, is the increasing recognition of not only joint operations, but multinational operations as well.

.. AREAS OF SIGNIFICANT CHANGE

- **Force Projection.** Force projection is a central theme of FM 100-5, Joint Pub 3-0, the BUR, and the emerging National Military Strategy. Army forces have always been required to rapidly deploy from CONUS in support of national objectives. But this requirement has increased significance as we return more forces from overseas bases and become a more CONUS based force. Army doctrine addresses the challenge of getting the right mix of armored, light and special operations forces into distant, and, in many cases, immature theaters. Emphasis is placed on the importance of force mobilization, deployment, redeployment and demobilization in an increasingly short notice environment. An airborne brigade can be dropped anywhere in the world within 96 hours; an entire light division can be air lifted to any trouble spot in approximately 500 sorties. With a combination of air and sealift a complete division with its Corps support package can be in theater within 12 days. Within 30 days 2 Armored Divisions with their Corps slices arrive and within 75 days a 5 Division Corps, made up of heavy and light forces with warfighting and support equipment, is on the ground ready for operations.

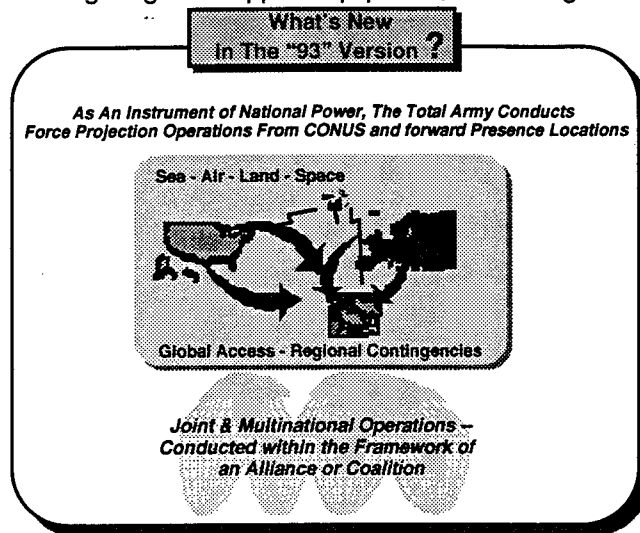

- **Joint and Combined/Multinational Operations.** Army forces (ARFOR) are employed by Joint Force Commanders in support of joint force objectives. The FM captures the essence of the ARFOR commander's operational requirements and considerations. The ARFOR commander will be required to place greater emphasis on the integration of air, land, sea, space, and special operations capabilities within the ARFOR area of operations. This requires the commander to be able to capitalize on technology enhancements throughout the multi-dimensional battlespace.

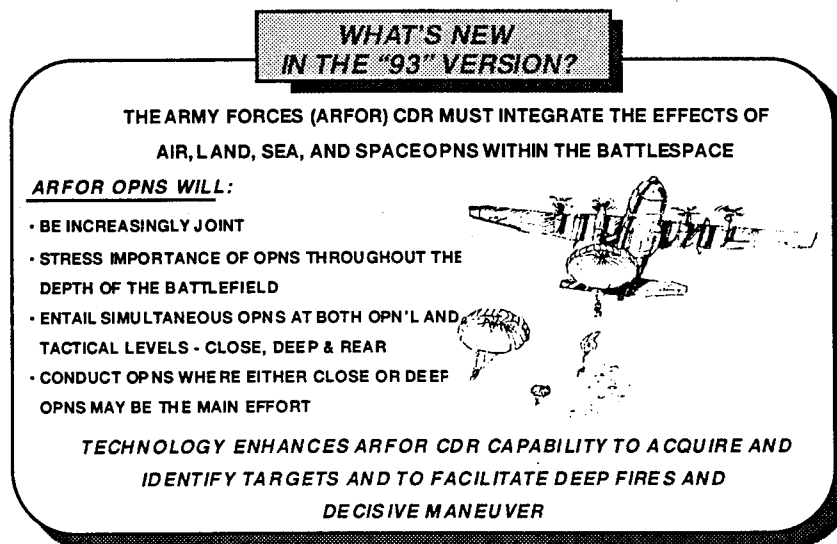

EXECUTIVE SUMMARY

- **Simultaneous Attack/Close, Deep and Rear Operations.** The ability to prosecute a campaign in a synchronized manner throughout the depth of the battlefield is vital for success. To that end, the battlefield framework has been realigned to represent a more comprehensive view of operations. Successful modernization programs such as Army TACMS have been pivotal in providing a commander with versatility and immediate response. Army TACMS is the most accurate, most rapid, and most responsive weapon on the battlefield - plus it is all weather. It epitomizes the ability to synchronize operations and carry the attack throughout the battlespace.

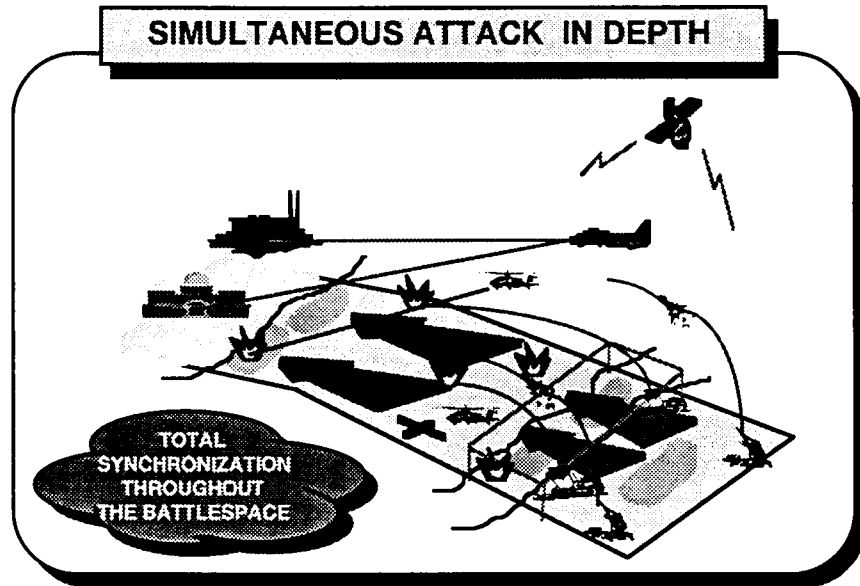

- **Operations Other Than War (OOTW).** For the first time, our warfighting doctrine has been expanded to include military operations other than war. FM 100-5 recognizes that Army forces must operate across the spectrum of military operations – peace, conflict and war. National authorities will continue to call upon the Army to perform missions other than direct combat. These include peacekeeping, humanitarian assistance, and domestic support operations. The primacy of focus for Army actions continues to be on winning the nation's wars, but our new doctrine challenges leaders to understand the concept for decisive victory during diplomatic and humanitarian activities and to translate that understanding into conditions for success as in Operations PROVIDE COMFORT, PROVIDE HOPE, and the aftermath of Hurricanes Iniki and Andrew.

**Operations Other Than War...
the Army as the force of choice**

Types of Operations:

- Arms Control
- Combatting Terrorism
- Counterdrug Opns
- Nation Assistance
- NEO
- Civil Support Opns
- Peace Opns



**DOMESTIC
SUPPORT
OPNS**



**NATION TO NATION
ASSISTANCE / AGREEMENTS**

Six Principles

- Objective
- Unity of Effort
- Security
- Restraint
- Perseverance
- Legitimacy

Recent Examples:

Hurricane Andrew/Iniki
Midwest Floods
Task Force Los Angeles
Operation Restore Hope
Operation Provide Comfort
Operation Southern Watch
Operation Sea Angel
MFO (Sinai Observer Force)
UN Support in Yugoslavia



**HUMANITARIAN
ASSISTANCE**

- **Versatility.** Based on the expanding role envisaged for Army forces, the four tenets of AirLand Battle – agility, depth, initiative, and synchronization – have been expanded to include a fifth – **versatility**. Attention is now focused on the essential nature for Army forces to organize in response to the wide variety of operational possibilities, ranging from war through peacetime activities. The demands for a more versatile, flexible force are increasing, given the evolving roles in military operations other than war.

America's Army has a mission...

**Berlin Wall is down, but the world is still troubled.
4 dangers--regional, nuclear weapons, economic, to democracy**

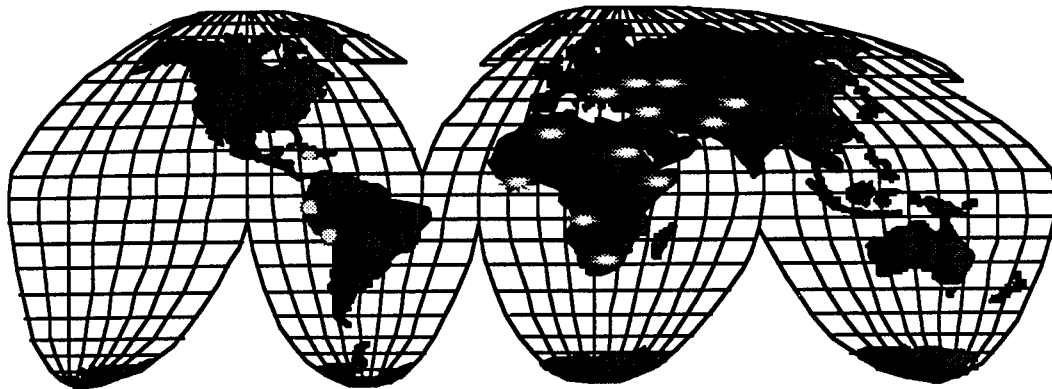

...and we're doing the job at home and abroad. US stationed soldiers are training, conducting disaster relief operations, counterdrug operations.

On any given day, there are 14,184 soldiers serving in 72 countries supporting national policy through nation assistance, peacekeeping, counterdrug operations. Plus 125,000 soldiers forward stationed in Europe, Korea, Panama.

"Peace, like war, can succeed only where there is a will to enforce it, and where there is available power to enforce it."

Franklin D. Roosevelt
October, 1944

• Force Structure

Organizational structure is never stagnant and continues to evolve. The robust Army designed to confront the Soviet Union and Warsaw Pact in Central Europe proved itself in Panama and on the battlefields of Southwest Asia. However, the operational environment is dynamic. The Cold War environment has been replaced by an ill defined, less structured environment of regional conflicts spanning the continuum of operations. To meet this challenge, the Army of tomorrow will be significantly different from the Army that fought and won, as part of a joint/multinational coalition, Operation DESERT STORM and the Cold War. The force will be smaller and must be more versatile in order to emphasize rapid response capabilities. It will possess the building blocks necessary to fight as part of a joint and multinational force. It will be primarily a CONUS based force, but forward deployed forces in Europe and Korea will continue to be a critical part of the structure.

The recently completed Bottom-Up Review and Defense Planning Guidance have directed further reductions to Army force structure. The Army will transition into a combat force structure of 10 fully

EXECUTIVE SUMMARY

structured active component divisions, 5 to 8 reserve component divisions, and 15 reserve component enhanced readiness brigades. A significant amount of the combat support and combat service support structure to sustain the force will continue to be provided by the reserve components. Additionally, the inherent capabilities of the reserve component structure will augment the Total Army's capability to conduct selected operations other than war by supporting civil authority missions such as disaster relief and nation building.

A smaller Army with a variety of worldwide missions will require a very capable force. The Army will continue to leverage technology to increase lethality, deployability, and versatility. Weapon systems possessing increased ranges, improved accuracy, and more sophisticated munitions will increase the combat power of both mechanized and light forces. Enhancements in command and control systems will permit "split-based operations" by reducing unit deployment requirements and retaining information processing at home station. Through total asset visibility (TAV), supply managers will know the locations of all assets throughout the supply system. TAV permits managers to rapidly locate, distribute, and/or divert critical supplies to priority units. Information products will be passed via long range, reliable communications to the deployed commander. Digitization of the battlefield will increase the commander's ability to understand the enemy and friendly situation, thus lifting the fog of war and assisting in bringing all available combat power to bear at the decisive moment of the battle. The commander will be better able to synchronize the combat function of Battle Command because deciders will be deciding, shooters shooting, and supporters supporting, based on their shared perspective of the battlefield.

The Army will modify the echelon above division (EAD) structure to meet the needs of a force projection Army. The emphasis will be to develop a tailorable headquarters capability, which can effectively support joint and multinational operations. Additionally, a capability will be required to rapidly tailor combat service support packages for unique missions across the range of military operations. Part of the solution will be to increase force package tailoring through the development of new designs and greater modularity.

• **Army Initiatives.** Two key initiatives that assist in bringing 21st Century technology and concepts to the Army are Louisiana Maneuvers and TRADOC's Battle Labs.

•• **Louisiana Maneuvers (LAM).** Now in its second year, LAM provides a way for the Army to investigate the future. We cannot wait for war to investigate the possibilities of new doctrine, organizations, or technology. LAM provides a means for the senior Army leadership to focus on critical growth issues, make policy decisions, and guide the allocation of resources. To make informed decisions, we need to experiment, and LAM affords that capability. We cannot afford the time or the dollars to place large formations of soldiers and expensive prototypes in the field simply to test hypotheses. Instead we are investigating the future through the use of simulations. LAM has been a catalyst to force the development of distributed interactive simulations (DIS) and to link virtual, constructive, and live simulations. Eight issues have been recognized for exploration during FY 94. They are reflected in the figure below, along with the proponent organizations.

FY 94 LOUISIANA MANEUVERS ISSUES	
<u>Proponent</u>	<u>Issue</u>
TRADOC	- Holistic Review of C4I - New Technologies - More Lethal, Survivable, Deployable Forces - Continuous Operations - Weapons of Mass Destruction
FORSCOM	- Deployment
USASSDC	- Exploitation of Space
AMC	- Sustainment

•• **Battle Labs.** TRADOC has organized six Battle Labs (shown below) to identify, develop, and experiment with new warfighting concepts and new capabilities offered by emerging technologies. The Battle Labs are charged with examining the latest concepts in battlefield organization, tactics, doctrine, and technological capabilities. They experiment with new ideas and evaluate the capabilities offered by new technologies for their impact on the battlefield of the future through the use of Advanced Warfighting Experiments (AWE), Advanced Warfighting Demonstrations (AWD). Battle Labs have already paid dividends to the force by proving the concepts and accelerating the development of both the 2d Generation Forward Looking Infra-Red (FLIR) and Total Asset Visibility (TAV). Battle Labs are at the forefront of reform and will be the mechanisms to rapidly test and field new technologies.

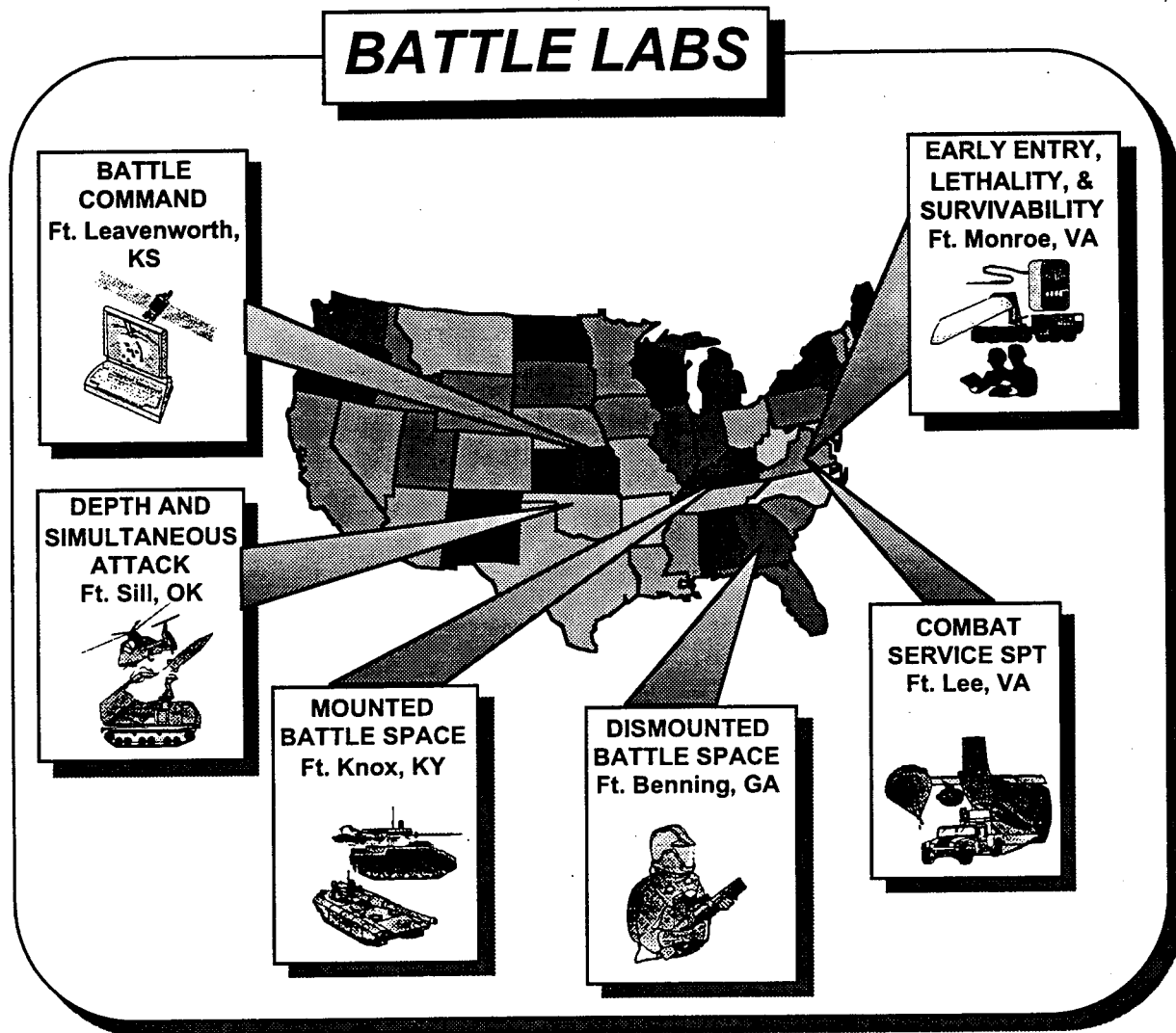

The Army is refining the organizational roles at battalion, brigade, and division levels, as well as EAD and EAC. The question to be answered is how will technology affect the role of each organization in its relationship to another. Will our ability to "see the battlefield" alter those relationships? The future Army structure will be the result of two main factors - leveraging technology and determining how the organization fits into doctrinal requirements.



Section II

Army Modernization Program Direction

"A true power projection Army centers around full integration of the microprocessor."

GEN Gordon R. Sullivan

Force XXI

Modernization of our forces is a constant process and is generally one of evolution. But, evolutionary or even revolutionary changes imply that the Army is headed in a specific direction. Indeed, that is the case. We are at the threshold of a new era – Third Wave Warfare, which dictates that the nation's Army evolve into a new force for a new century – Force XXI.

Much work has already been done, as we lead into the next century. Further definition and refinement of the parameters of Force XXI continues. The Army's senior leadership and major commands must wrestle with a whole host of issues that include doctrine, the size and shape of the force in a changing international and domestic environment, full integration of digital technology, and realistic, challenging training that provides validated feedback. The extensive use of simulation systems, the identification of key issues in the Louisiana Maneuvers process, the testing in the Battle Labs, and the execution by actual field units are all key parts of the process.

All indications are that we are on the right track. Innovation, such as integrating key technologies horizontally across the force, is providing tremendous payoffs that are critical to execute a lethal, synergistic campaign plan that ensures victory with the least cost of our soldiers' lives. The Information Age is upon us with all its implications for the mission of the United States Army. To ignore it or fail to prepare for it and incorporate it will spell disaster. We will have ignored past lessons and prepared for past conflicts, rather than those of the future. Force XXI is the process that will ensure America's Army maintains Land Force Dominance – well into the 21st Century.

Increasing threat capabilities demand greater weapons accuracies, increased speed and mobility, all the while maintaining positive, dynamic command and control of our forces engaged in combat. These increases in capability are required to ensure overwhelming force, minimum loss of life, and ultimate success on the battlefield. To that end the Army has consistently invested a large portion of its resources in critical, modern technologies, as reflected in the ASTMP. Industry has responded by providing solutions to the Army's combat requirements, thus permitting our forces to qualitatively modernize.

Today we are on the verge of a major technological transformation - the conversion of an Army that uses analog platforms to one that is digitally based, whose shooters and C2 platforms are capable of passing digital information at phenomenal rates throughout the depth and breadth of the battlefield. Our Army needs to cross this "digital threshold" in order to accomplish the following:

- We must stay ahead of the threat. Digital technology is readily available to potential adversaries on the open market.
- Equip systems with digital technology that can be improved through future insertions on a much more economical basis.

- Provide an overall reduction in operational costs with digital platforms that have greater system reliability and maintainability.
- Maintain the industrial production base for major systems. As platforms are converted from analog to digital, current production facilities are used. This keeps the production lines "warm" and maintains the critical core of scientists and engineers that build tanks, infantry fighting vehicles, armored C2 systems, howitzers, attack helicopters, etc. Retooling and/or restarting costs of production lines is minimized and critical job skills are maintained.
- Modernization of the Army's existing platforms, wherever feasible, to maximize sunk investment costs.

Having accomplished the above the Army is then in the position of being able to tie disparate digital platforms together with an architecture that allows us to operate in "real" or "near real" time with common situational awareness.

• Horizontal Technology Integration (HTI)

Horizontal Technology Integration (HTI) is a new strategy for modernization. It is defined as, *the application of common enabling technologies across multiple systems to improve the warfighting capability of the force.* It is the simultaneous integration of technology into different types of weapon systems that fight together as units or task forces, providing exponential improvement to the force. It is a process that supports an integrated battlefield architecture. Just as the "Big 5" weapons systems (Blackhawk and Apache Helicopters, Abrams Tank, Bradley Fighting Vehicle, and PATRIOT) comprised the Army's modernization framework to execute the AirLand Battle doctrine of the 1970s and 80s, HTI can assure the Army of a much more synchronized, versatile, and lethal force throughout the 1990s and beyond.

•• Enabling Strategies - The Army has identified several enabling strategies which provide vast improvement and enhanced capability to the force. Currently, "Own the Night", "Battlefield Combat Identification" and "Digitization of the Battlefield" have been identified as strategies through which the HTI process can be implemented.

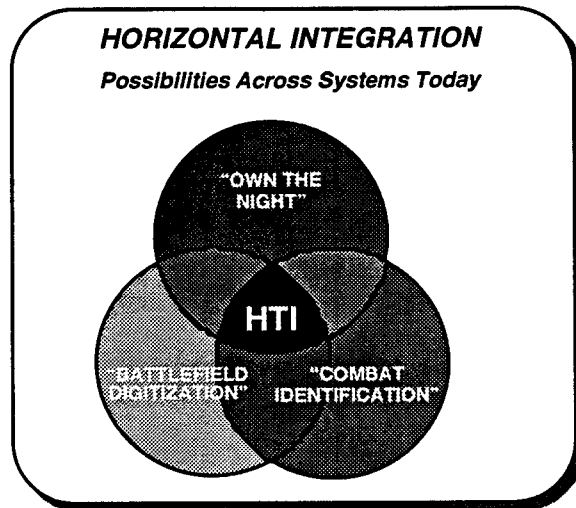

•• Technology Exploitation/ Economic Benefits - HTI provides an approach to modernization which aggressively exploits leading-edge technologies and permits the Army to optimize scarce modernization funds by ensuring "across the force" development of requirements and supporting acquisition strategies. HTI breaks away from traditional vertical "stovepipe" processes of individual system requirements and looks instead at the overall force requirements on the battlefield. Past modernization programs at times produced incompatible systems with mismatched capabilities. Warfighters, in turn, did not have the same view of the battlefield and were unable to fully synchronize their actions. HTI integrates dissimilar weapon systems (tanks, armored vehicles, artillery, aircraft, command and control vehicles) with common technology through either new acquisitions, Pre-Planned Product Improvements (P3I), or system-component upgrades.

• **Combat Identification**

This program is essential in a high paced, increasingly lethal combat environment. Reduction of fratricide, greater situational awareness, and increased lethality by using weapons to their maximum effectiveness are primary benefits of effective combat identification. Passive and active means are being investigated.

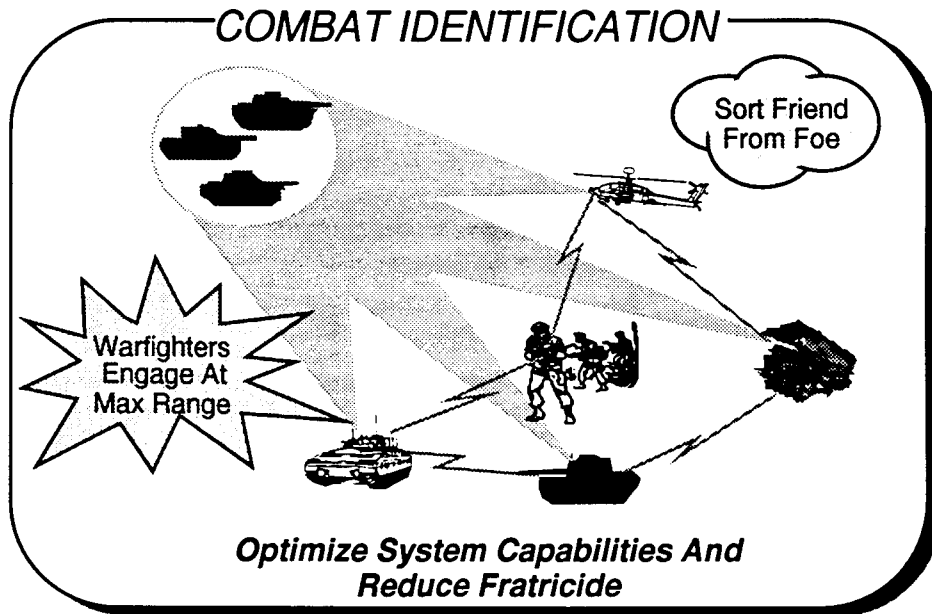

• **Own The Night**

Operations JUST CAUSE and DESERT STORM proved both the value of night operations and the superior capabilities enjoyed by the United States forces. As with other aspects of these operations, our success is not lost on our potential adversaries. We must continue to ensure that our forces "own the night", which in turn means that we must maintain our advantage on our all weather, all environment capability. Our ability to see an adversary through smoke, haze, dust, and darkness, when he has a lesser ability, means greater effectiveness, speed of maneuver, surprise and reduced loss of life.

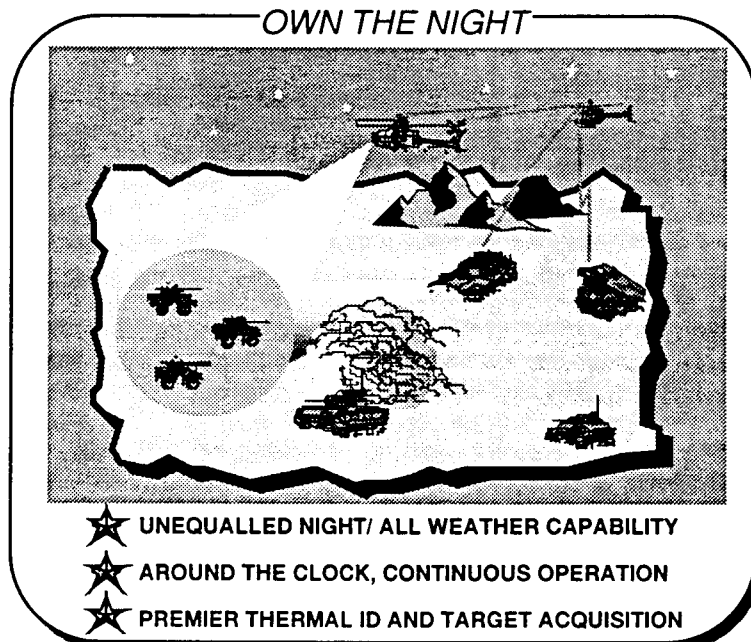

• Digitizing the Battlefield

•• What is a "Digitized Battlefield" - A "Digitized Battlefield" is one where the applications of digital technologies to acquire, exchange and employ timely digital information throughout the battlespace are tailored to the needs of each force element.

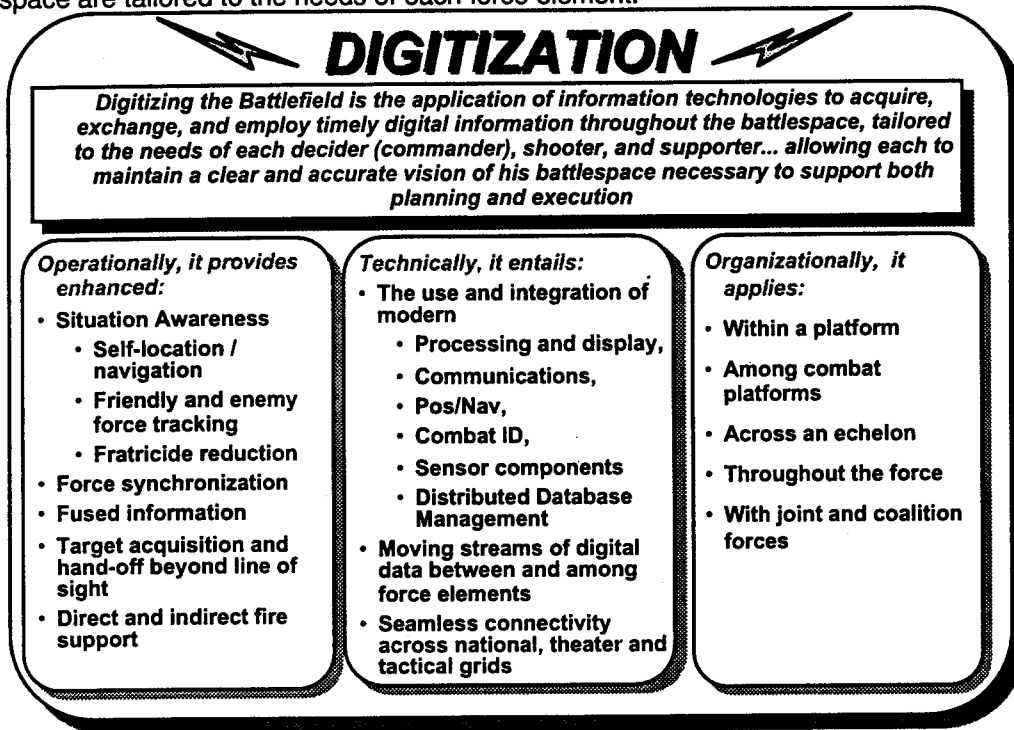

Digitization allows deciders, shooters, and supporters at all levels to maintain clear and accurate pictures of their respective battlespace. Fusion of information technologies permits the commander to increase the tempo of operations, expand the force's battlespace, and exploit fleeting opportunities. This common picture will be presented via graphic displays, such as icons, resulting in "shared situational awareness" for selected battlefield operating systems, command and control nodes, and the individual soldier. From this a commander gains the ability to employ forces in a highly mobile, synergistic, overwhelming manner with a high degree of confidence based on fused digital data - a common "picture" - from across the battlefield. We call this the Digitized Battlefield. The importance of this concept cannot be overemphasized. It is the wave of the future and is reflected in many of the applicable chapters of this volume. The Army objective is to field a digitized brigade in FY96, a digitally capable division in FY97, and to digitize the contingency corps by FY 99. Execution of these efforts will lead us to the Army of the future -- Force XXI.

"Unless soldiers, statemen...and politicians understand what lies ahead, we may find ourselves fighting the wars of the past, rather than those of tomorrow."

Alvin and Heidi Toffler
War and Anti-War, 1993

Operational Considerations - From an operational perspective digitizing the battlefield will ensure that we can create a synergistic effect, through near-real-time command and control and rapid force synchronization throughout the depth of the battlespace, and an overwhelming operational tempo that is faster than the enemy's ability to react.

DIGITIZE THE BATTLEFIELD TO ENSURE...

***The Right Force To The Right Place
At The Right Time***

***HE NEVER HAD
A CHANCE!!!***

***Decisive
Victory***

***IN THE BATTLE -
SHOOTERS SHOOTING***

***IN CONTROL -
DECIDERS DECIDING***

***IN SUSTAINMENT -
SUPPORTERS SUPPORTING***

***Inside The Enemy's Decision Cycle...
Repetitive!
Consecutive!
Relentless!***

TOTAL SYNCHRONIZATION THRU DIGITIZATION

• CONTROL THE BATTLESPACE • CONTROL THE TEMPO • CONTROL THE ENVIRONMENT

- Command and control nodes at all levels will be able to ensure maximum synchronization and unity of effort by capitalizing on the availability of a common perspective of the battlefield, to include enemy and friendly locations. Commanders will be able to instantly transmit and receive orders and graphics, thus ensuring that the initiative is never relinquished to the enemy.

"Rapidly is the essence of war."

Sun Tzu Wu
500BC

DIGITAL PLATFORMS

Give Us The Ability To:

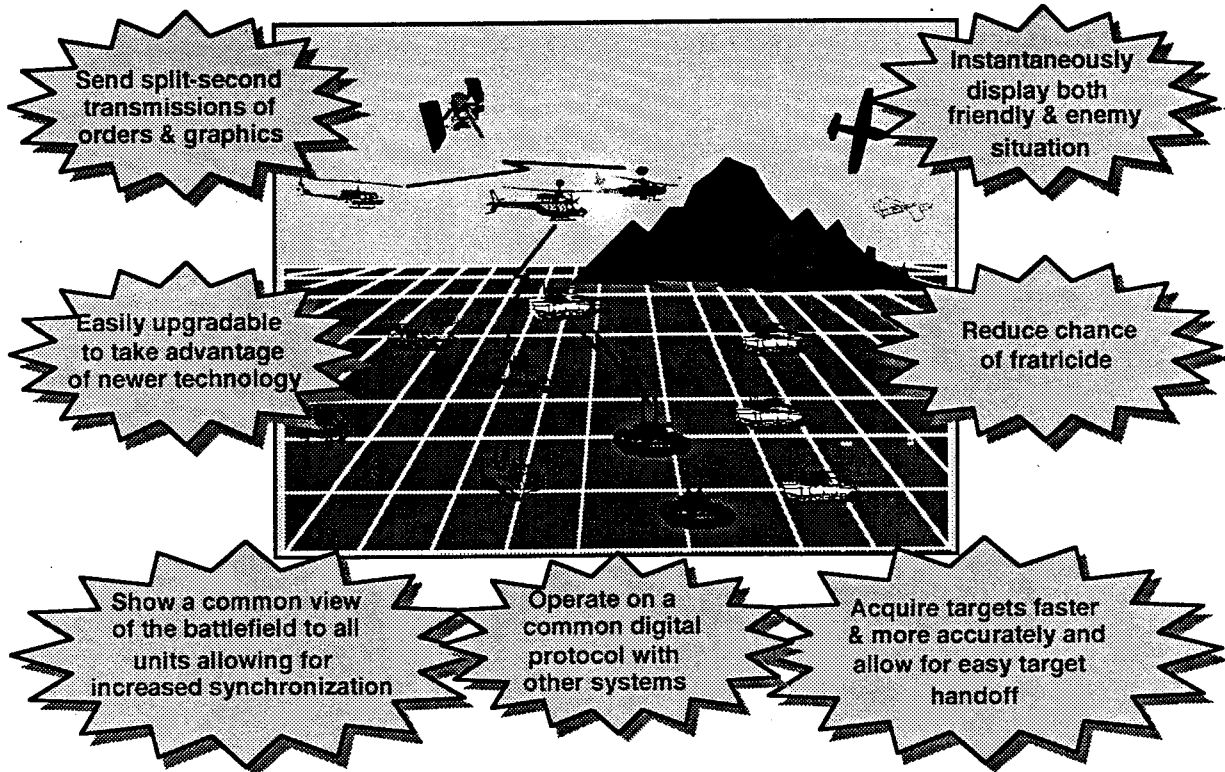

- To a "shooter" (e.g., tank, aviator, artilleryman, infantryman, etc.) this shared situational awareness will assist in bringing every killing system to bear on the enemy with precision and overpowering operational tempo, regardless of weather or daylight conditions. This will minimize friendly casualties, whether from enemy fires or fratricide, while at the same time dramatically increasing enemy losses by bringing maximum firepower into the fight.

- Our sustainment capability of the fighting force will be significantly enhanced by the availability of real-time knowledge of critical supplies and ammunition (e.g., TAV), thus permitting resupply of the maneuver force on the move. Indeed, the sustainment base is more responsive to the point of becoming part of the maneuver battle - increasing our force's tooth and shortening its tail.

•• **Reliability/Flexibility Considerations** - Use of digital technologies has other advantages. Reliability is increased exponentially since the microchip is much less susceptible to failure, thus reducing mean time between failures. Miniaturization permits greater capability, while reducing cube and weight. Digital technologies also lend themselves to open-ended architectures, which facilitates future upgrades. Improved capabilities become relatively inexpensive by using plug-in cards, microchips, and software updates. Additionally, significant strides can be made toward early insertion of standardized protocols and systems in P31 and new system acquisition programs.

•• **Current Efforts** - A special task force (STF) for digitization was formed in November 1993. Its charter was to review and address the issues impacting the Army's digitization efforts. The STF findings and recommendations were reported to the Army leadership in December 1993. The initial thrust is being continued by a follow-on STF, announced on 14 January 1994 by the Secretary and Chief of Staff, Army. It has the responsibility to accomplish the following:

- Act as a "bridge" between the initial effort and assist in the formation of a permanent organization, the Army Digitization Office (ADO).
- Determine the hardware and software requirements for each Battlefield Operating System.
- Ensure proper analysis/assessments are undertaken to validate the requirements.
- Prepare an acquisition strategy for inclusion in the FY96-01 POM.

The ADO, under the supervision of the Vice Chief of Staff, will ensure program implementation and execution, as well as the required analysis, for hardware and software as they become available for testing and fielding. The ADO will be comprised of a multi-disciplined membership that will include doctrinal thinkers, technical experts, scientists, engineers, and procurement specialists. Most importantly, the ADO will lay the foundation that will enable the creation of Force XXI.

• **The Army Enterprise Strategy** - The Army Enterprise Strategy establishes a method for how the Army, as a whole, integrates its efforts in C4I. Stemming from joint and Army doctrines, it codifies what the Army must do to ensure command and control superiority and sets forth Army requirements as a component of a joint or combined force. It addresses the Army's need to organize, train, and equip the force, as well as the manner in which C4I functional requirements are established to sustain the force. Battlefield operating systems will benefit from this holistic approach to C4I. Appropriate chapters of this document incorporate the application of this strategy to the modernization of the force.

The Army Enterprise Strategy

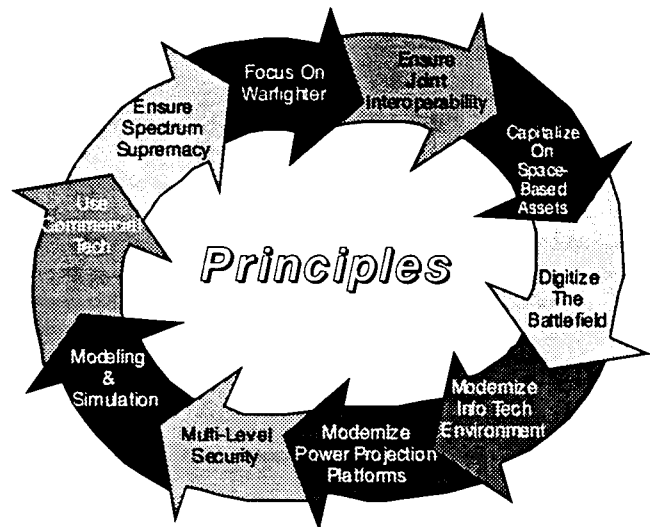

In summary, the Army is a changed and changing force, whether in doctrine, force structure, training, or equipment. Regardless of the dynamism of the changes, combat capabilities must be preserved and enhanced. Our emphasis, in the direction of the Army's modernization program, is to ensure maximum combat capability through the efficient introduction and use of technology across the force.

"The Army must continue to adapt to ensure success in a rapidly changing strategic environment."

FM 100-5
Operations



Section III

MODERNIZATION OBJECTIVES

"The soldier should always be furnished completely with arms and ammunition."

Napoleon I
Maxims of War, 1831

Five specific objectives continue to set the course for the Army to retain overmatching technological capabilities as the force is continuously modernized:

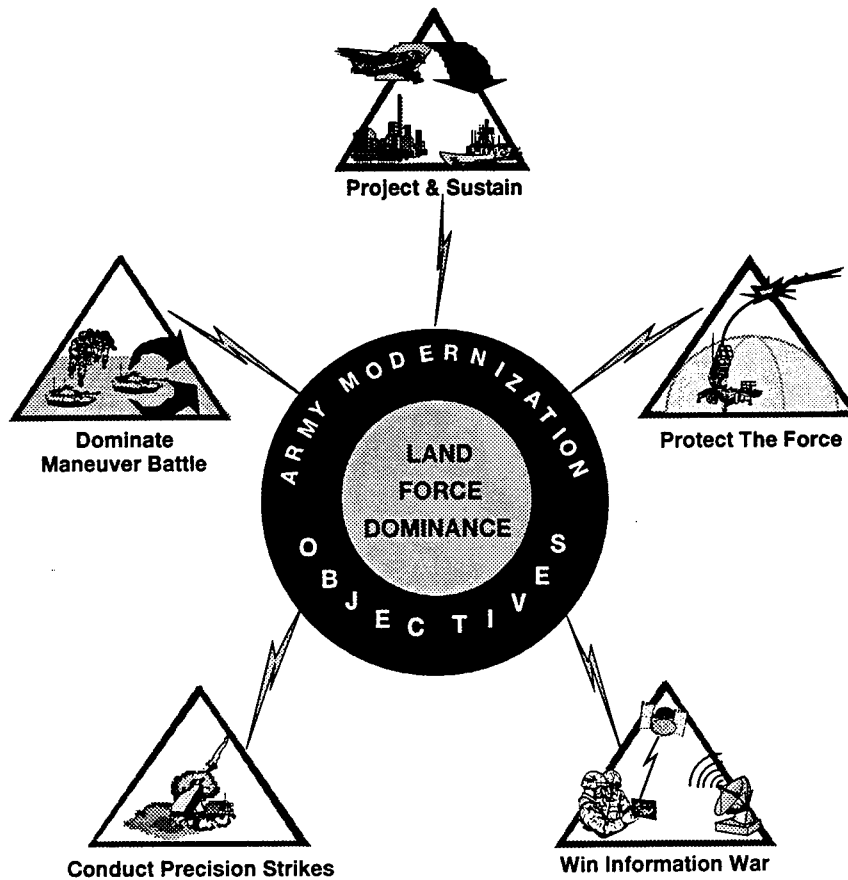

The tables in this section depict the FY95 budget requests for specific areas within each of the Modernization Objectives. The projection through the remainder of the current POM (FY95-99) is shown by bar chart. This leads to the Force Package Assessment, which portrays, by percentage, the level of fill for the major requirements in support of each Objective at the conclusion of FY99. Army Force Packages consist of prioritized units earmarked for deployment, with Force Package I having the highest priority. Detailed requirements and assessments are located in succeeding chapters of this update.

PROJECT AND SUSTAIN

America's Army

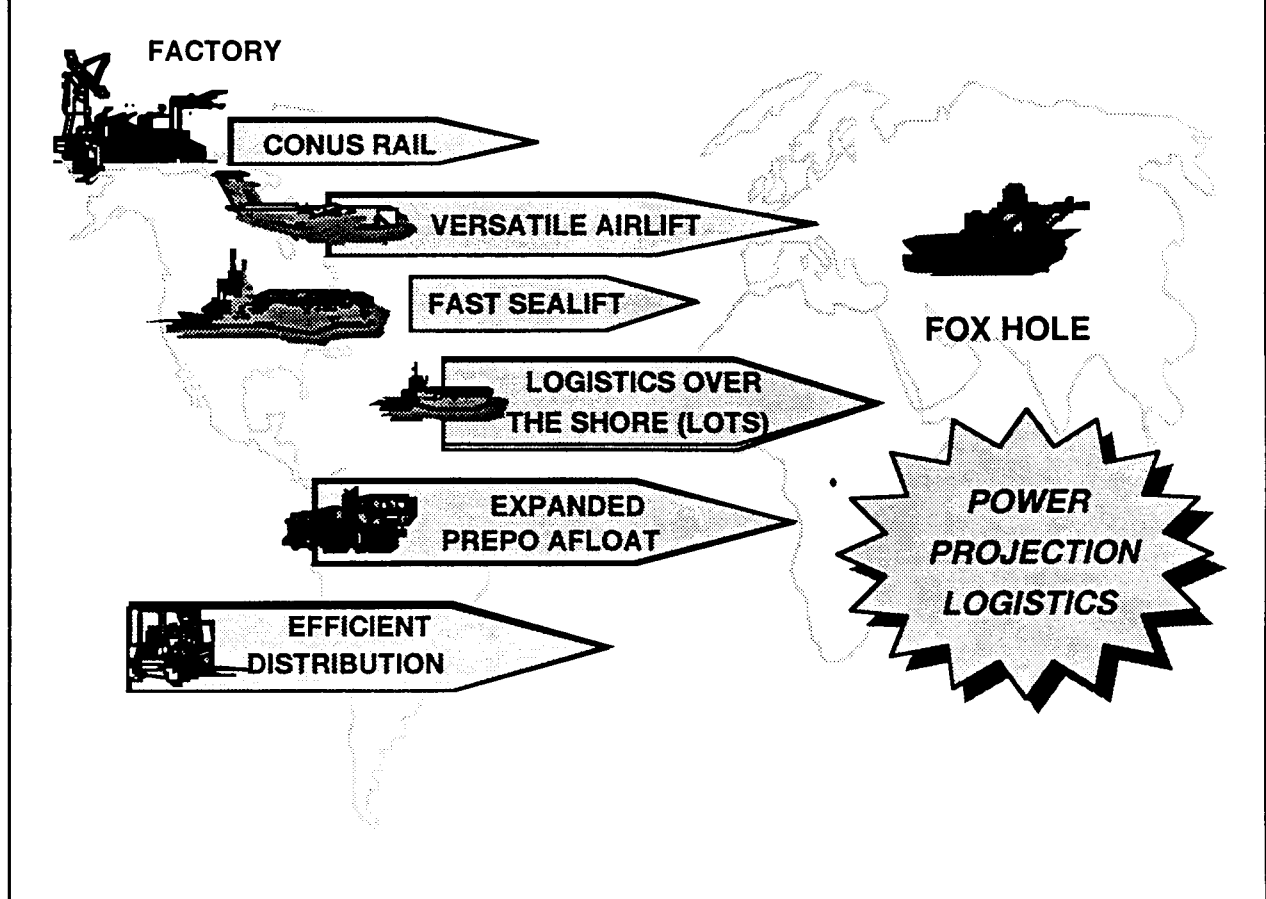

More than at anytime in the last half century America's Army has become CONUS based with a much diminished forward presence. Crisis response places increasingly heavy premiums on our ability to project and sustain forces on short notice for extended periods of time. We must place increasing emphasis in this area. The Achilles Heel in this modernization objective is sufficient air and sea lift assets. The Army continues to be a staunch advocate of both the C-17 and Fast Sea Lift programs of the Air Force and Navy, respectively. Continuation of these programs is vital and of high priority for the Army and the Nation. The first of five vessels that make up the heavy brigade set of pre-positioned afloat equipment has been loaded. When completed in 1995 the Army will be able to provide a much more rapid, robust capability to the Theater Commander.

The ability to project and sustain our forces is truly a Total Army effort. The initial sustainment capability of the active force must be augmented by the combat support and combat services support found in the Reserve Components. Increased efforts to modernize these forces are essential.

WHAT THE MINI-POM BUYS FOR PROJECT & SUSTAIN

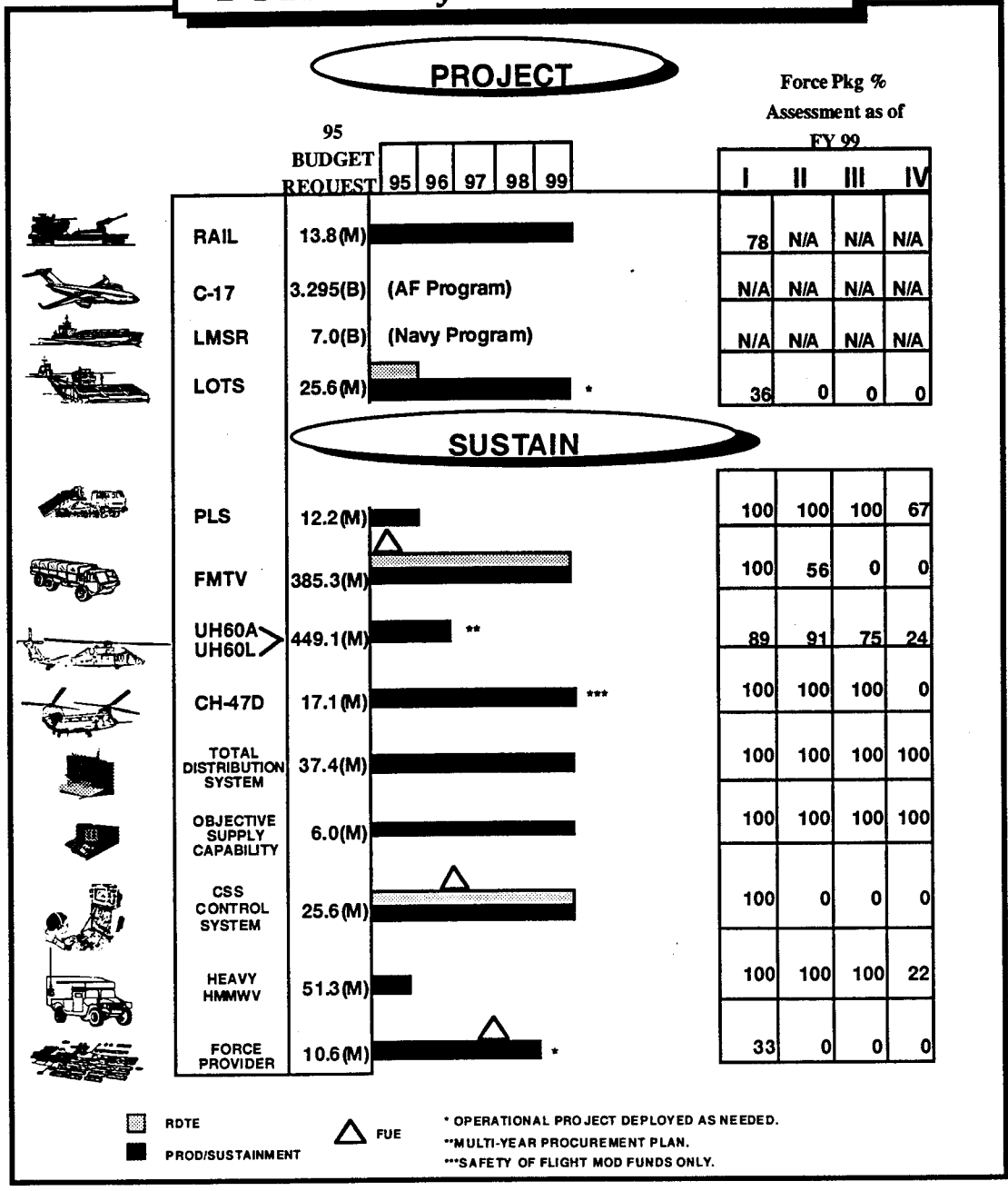

In summary, the Army's ability to project and sustain its force is stretched to its maximum capability for the foreseeable future. Careful consideration has been given to ensure the most capability is provided within budgetary constraints. Strategic lift capability is crucial to ensure our nation's warfighters reach the theater and can conduct sustained combat operations. Finally, any future funding decrements will adversely impact the Army's ability to execute its portion of power projection and force sustainment called for by the nation's National Military Strategy.

PROTECT THE FORCE

America's Army

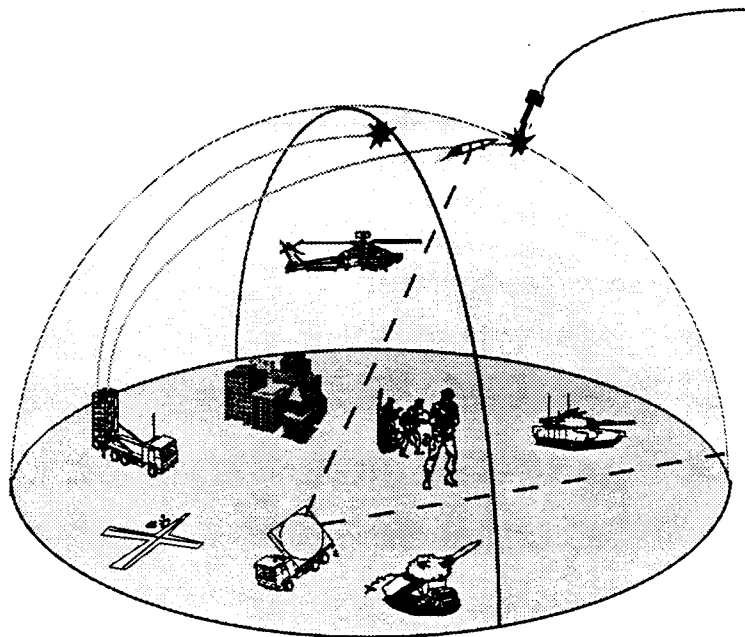

DECISIVE VICTORY WITH MINIMUM LOSS OF LIFE

Protection of our force is crucial and yet is also becoming more challenging. Proliferation of weapons of mass destruction, along with cruise and tactical ballistic missile technologies, is rampant. The increasing missile threat brings with it corresponding nuclear, biological and chemical (NBC) employment threat against our forces. Thus, a high premium must be placed on a viable, maneuverable, rapidly deployable missile defense. Coupled with the NBC threat are the improvements in NBC protection to ensure our soldiers' effectiveness under any condition. Long range, highly responsive counterfires are integral to effective force protection. Combat identification between friendly and hostile forces is imperative to take advantage of the maximum effectiveness of long range weapon platforms and prevention of fratricide.

WHAT THE MINI-POM BUYS FOR PROTECT

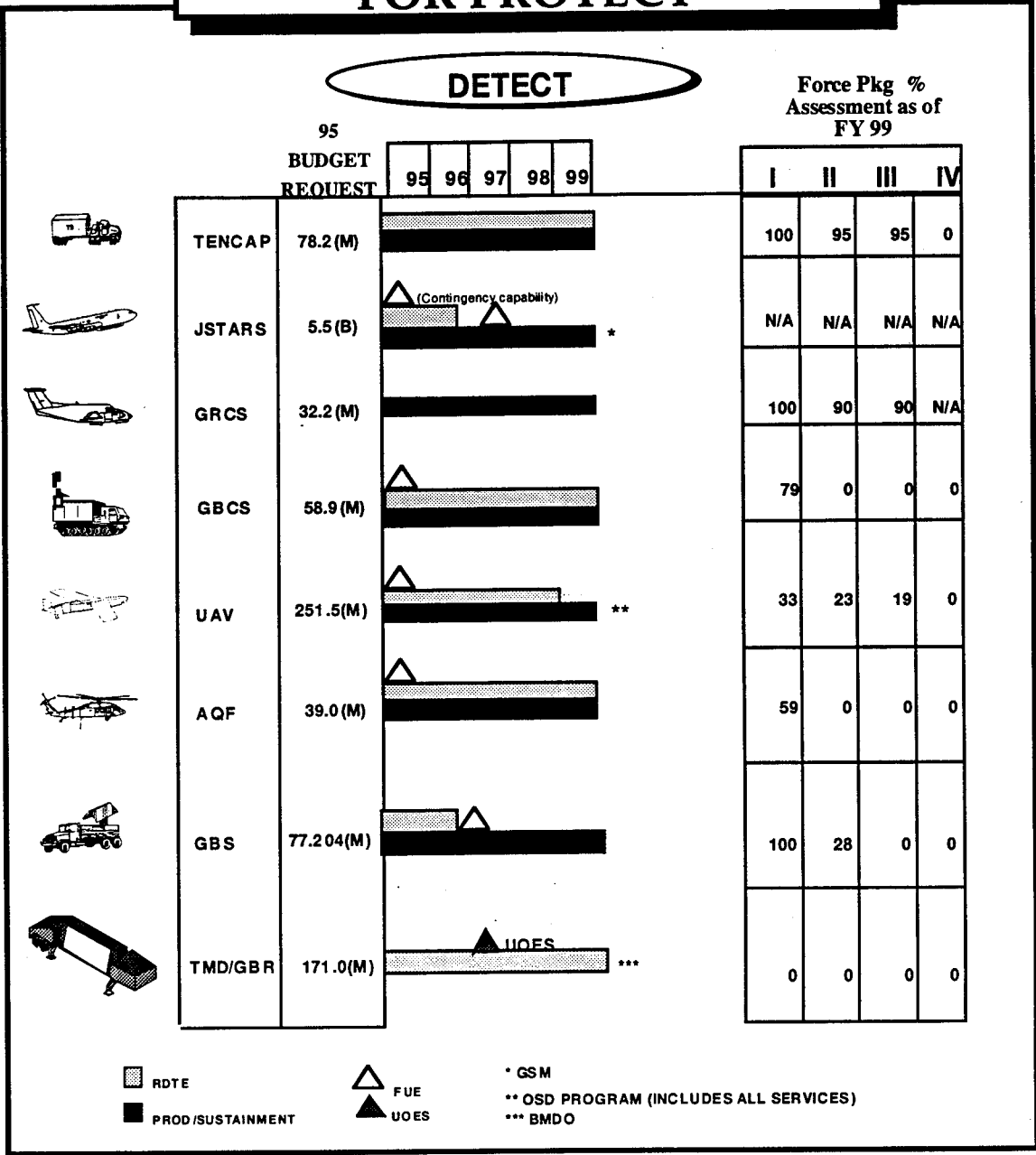

WHAT THE MINI-POM BUYS FOR PROTECT

INTEGRATE

Force Pkg %
Assessment as of
FY 99

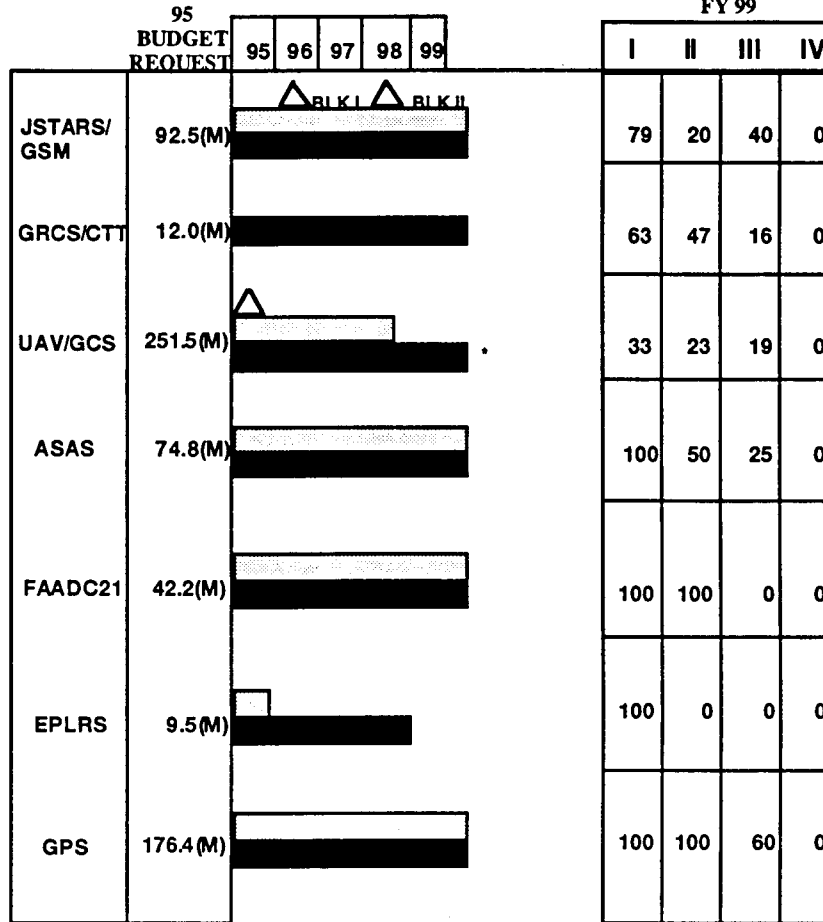

□ RDTE

△ FUE

■ PROD/SUSTAINMENT

*UAV AIR VEHICLES SAME \$ WITH GCS. OSD FUNDED.

WHAT THE MINI-POM BUYS FOR PROTECT

DESTROY

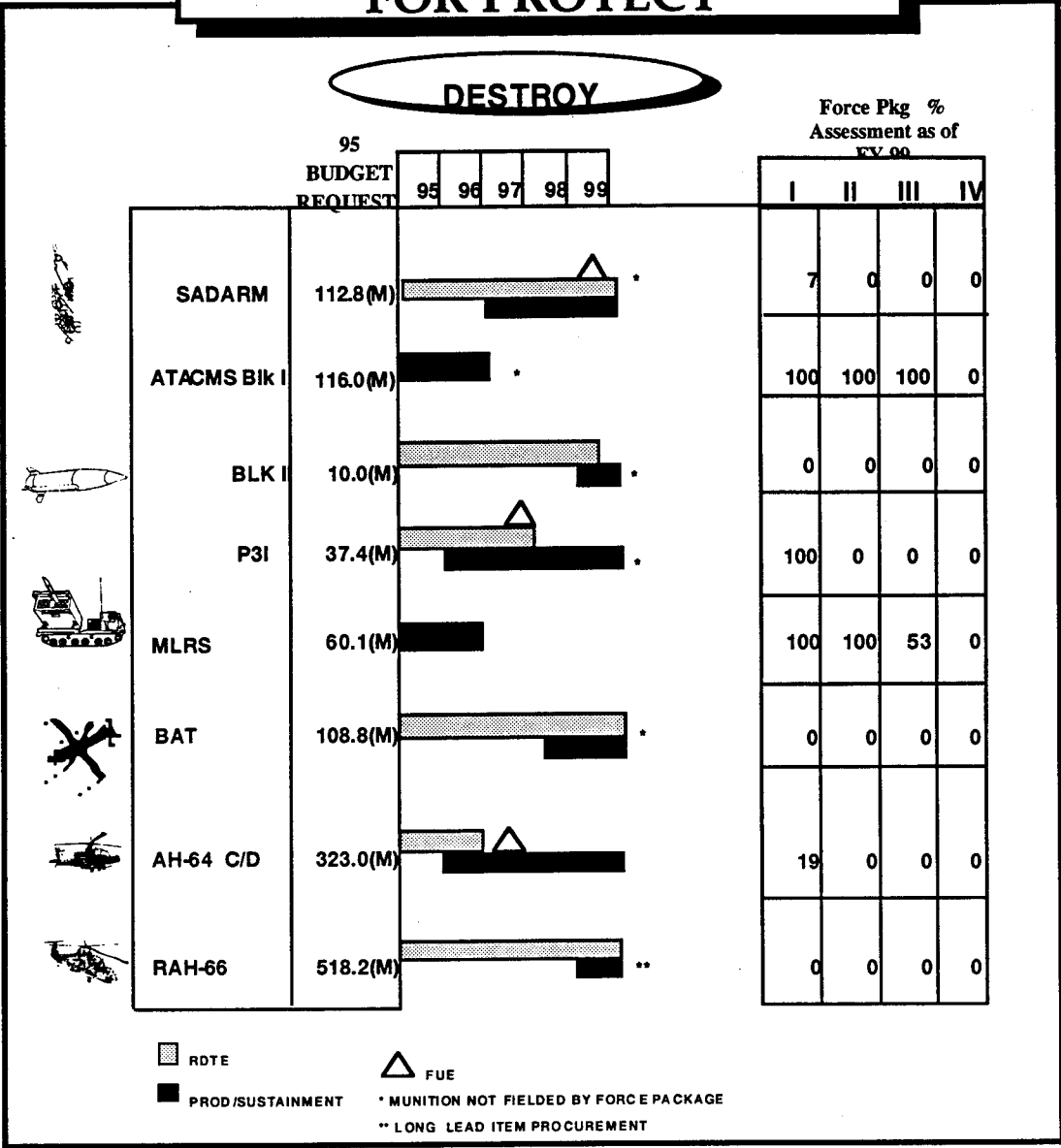

WHAT THE MINI-POM BUYS FOR PROTECT

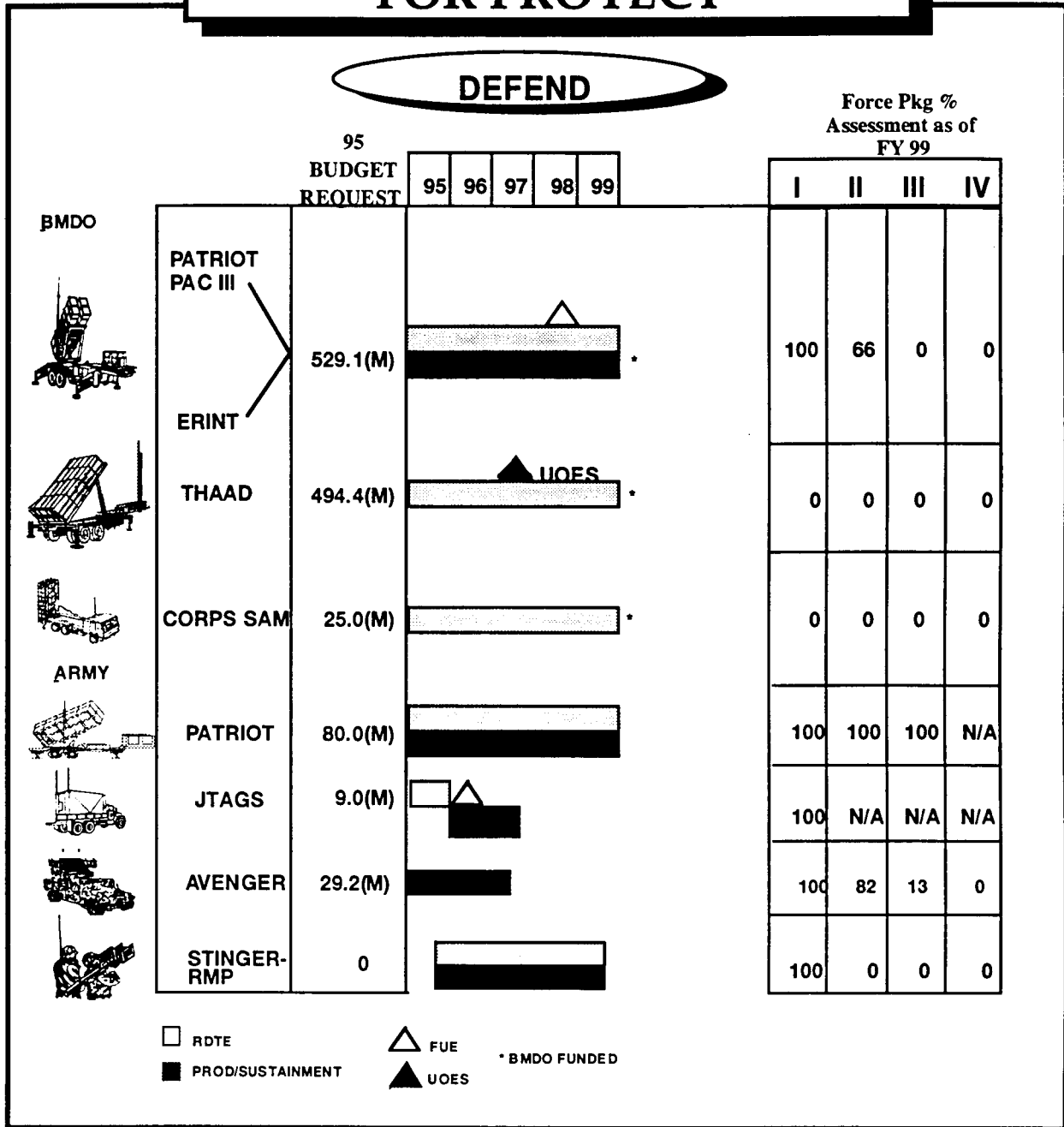

WHAT THE MINI-POM BUYS FOR PROTECT

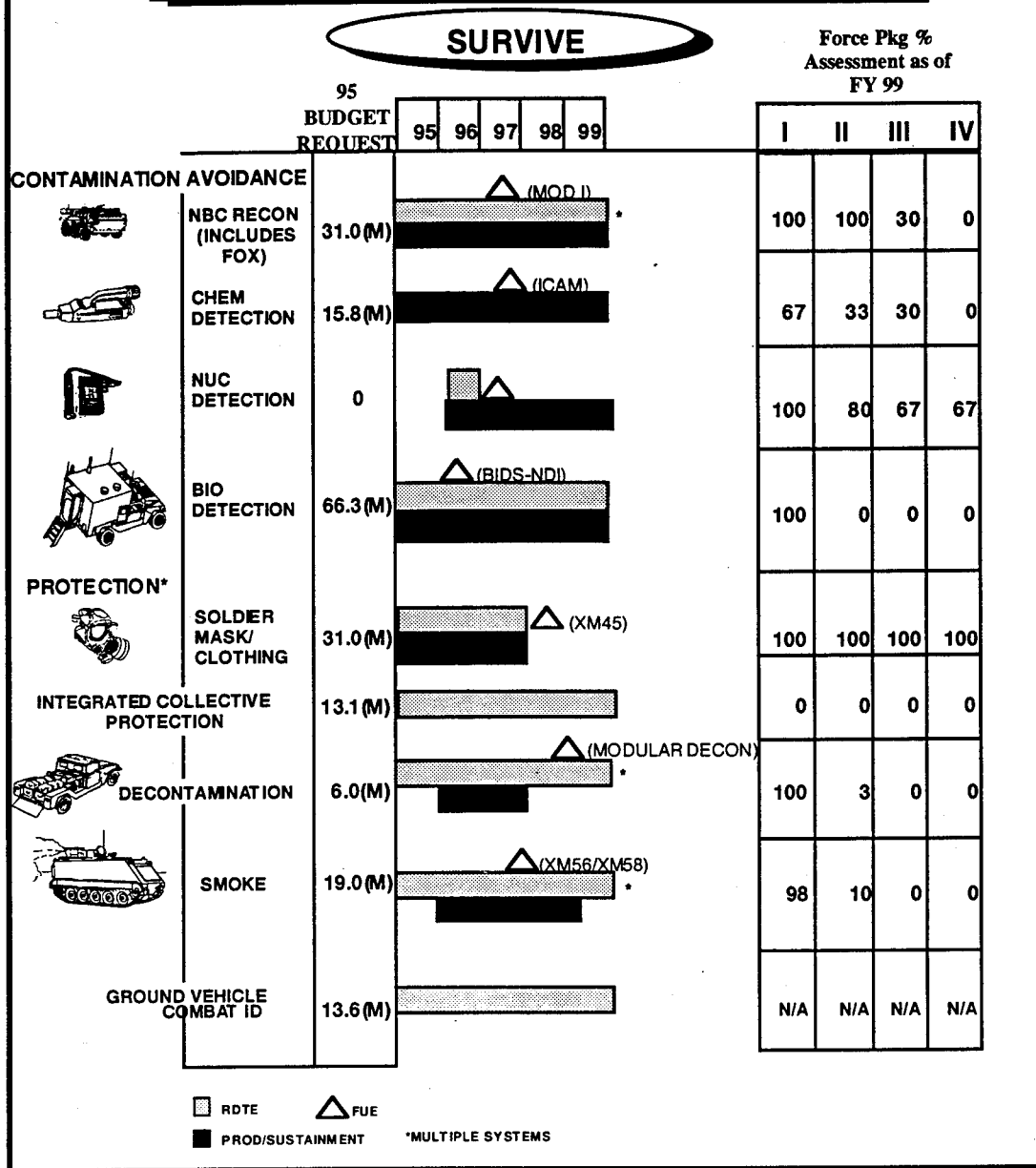

In summary, our Army must survive the perils of the battlefield in order to win our nation's wars. Careful consideration has been applied to ensure that we have a well balanced program to ensure survival against the majority of current and future threats. Deep cuts in funding have resulted in killing some programs and delaying others.

Our ability to protect the force is on the verge of being broken. We cannot absorb further funding shortfalls.

WIN THE INFORMATION WAR

America's Army

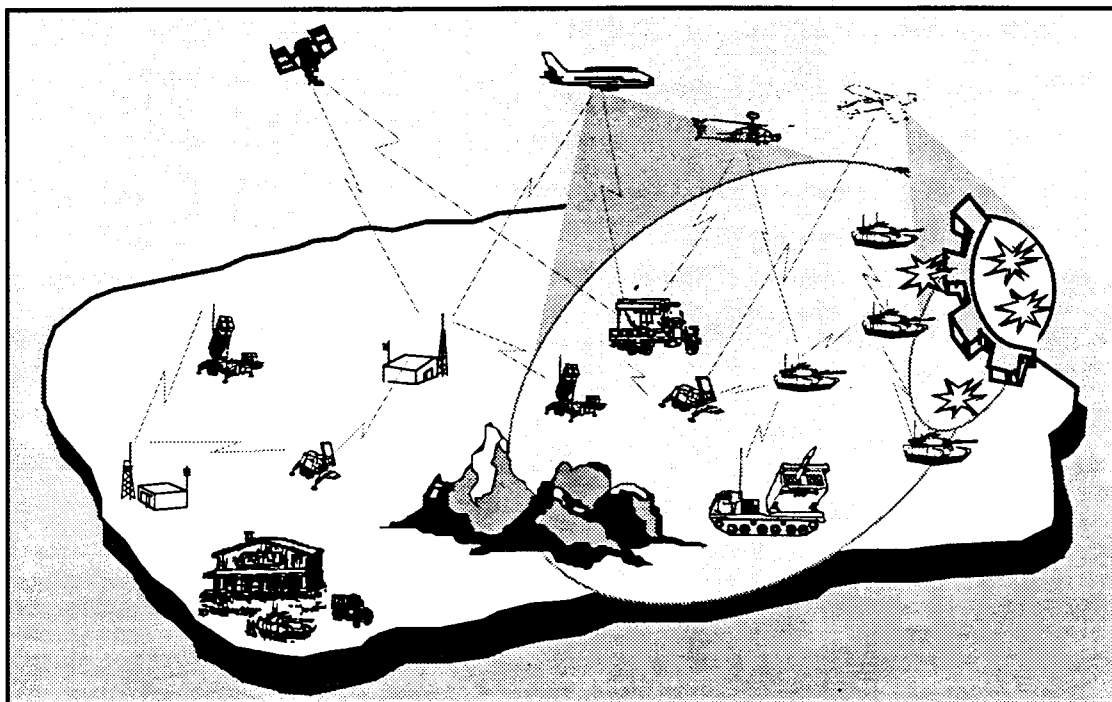

**NEAR REAL TIME
DIGITAL DATA FROM SENSOR TO SHOOTER**

Winning the Information War hinges upon our having superior C2 systems, protecting them from exploitation and degradation, and attacking the adversary's comparable C2 and decision support mechanisms. It emphasizes the use of proven tools of destruction, electronic warfare, OPSEC, deception, and PSYOPS to affect the adversary's ability to perform command and control. These same tools provide a basis for examining our own potential vulnerabilities and developing and employing countermeasures to adversary capabilities. The Army will Win the Information War by developing an advantage by building superior C2 systems and conducting Information Warfare to maintain the advantage.

WHAT THE MINI-POM BUYS FOR WIN THE INFORMATION WAR

SENSORS

Force Pkg %
Assessment as of
FY 99

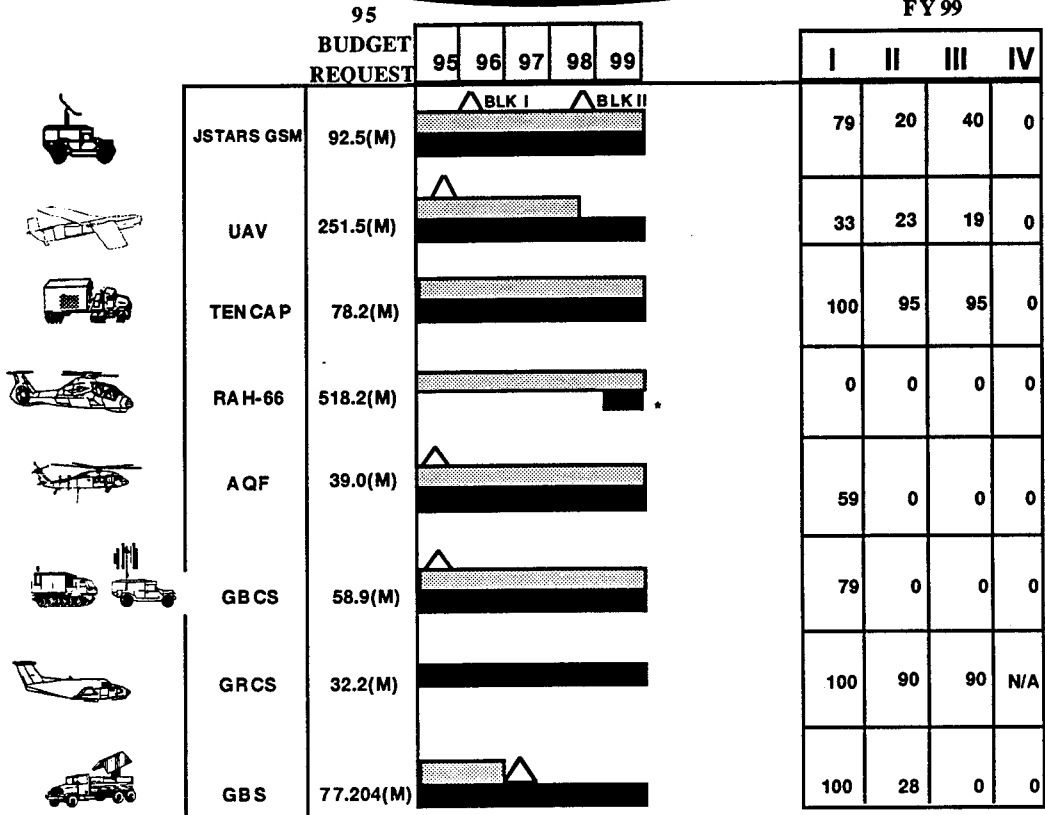

EW SYSTEMS

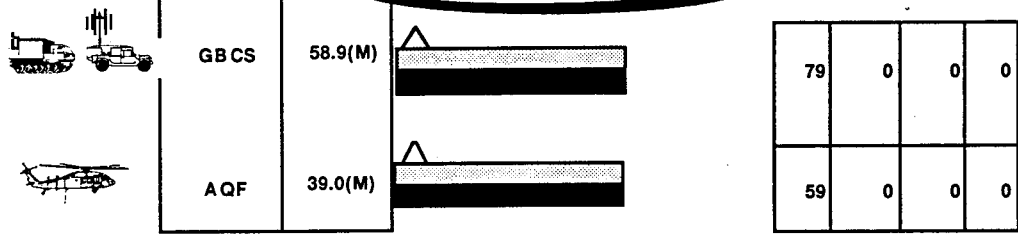

 RDTE
  FUE
 PROD/SUSTAINMENT
 * LONG LEAD ITEM PROCUREMENT.

WHAT THE MINI-POM BUYS FOR WIN THE INFORMATION WAR

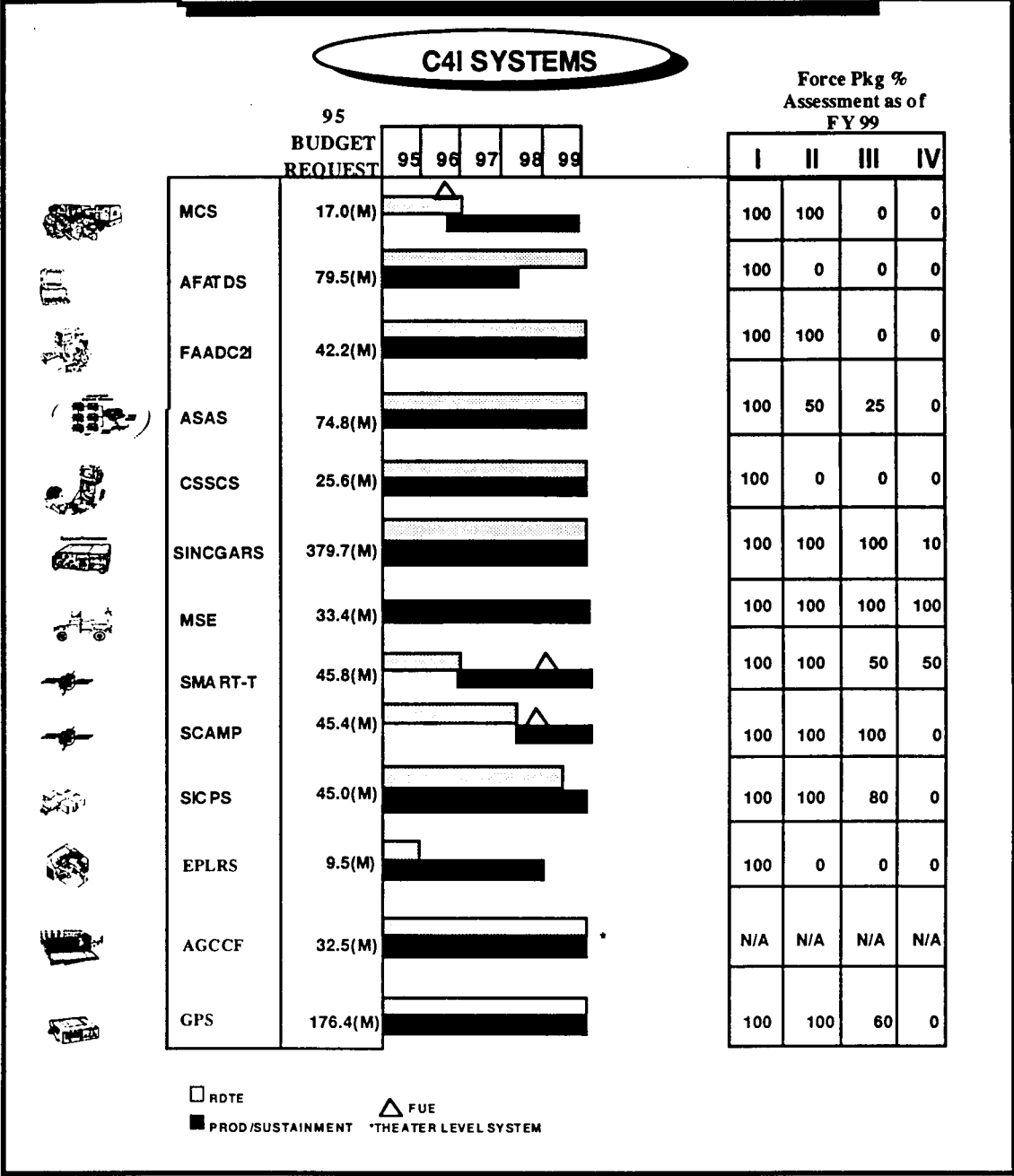

In summary, digital technology is revolutionizing the Army's ability to win the information war. Digitizing the battlefield permits the commander to bring overwhelming force in a rapid, synchronized manner to ensure defeat of the threat. Data gathering throughout the range of military operations is crucial to ultimate success and Land Force Dominance.

CONDUCT PRECISION STRIKES

America's Army

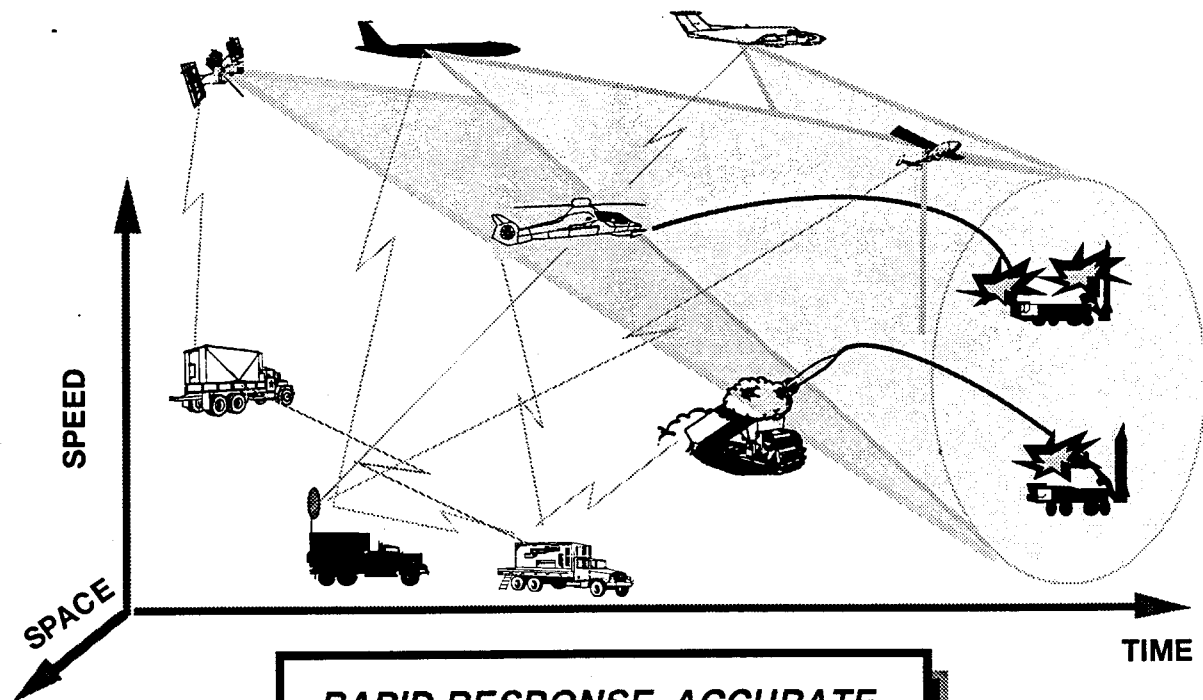

**RAPID RESPONSE, ACCURATE
ALL WEATHER CAPABLE**

The Army must be able to conduct deep attacks against the threat. These attacks will be against weapons of mass destruction, sensors, command and control nodes, command posts, and weapon systems. Keys to the location and destruction of these targets are near-real time intelligence coupled with weapons systems armed with smart and brilliant munitions and longer ranging capabilities.

WHAT THE MINI-POM BUYS FOR CONDUCT PRECISION STRIKES

C4I SYSTEMS

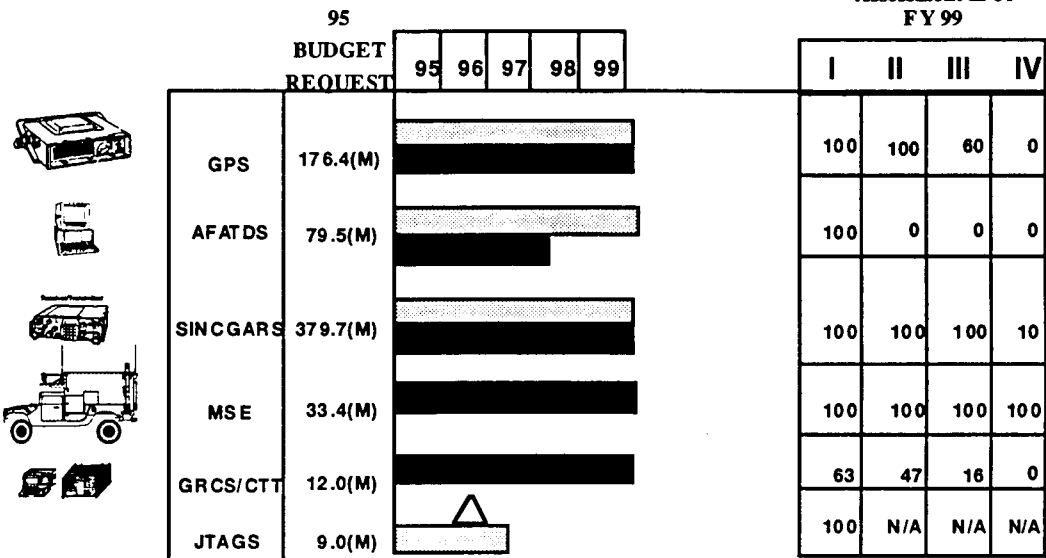

SENSORS

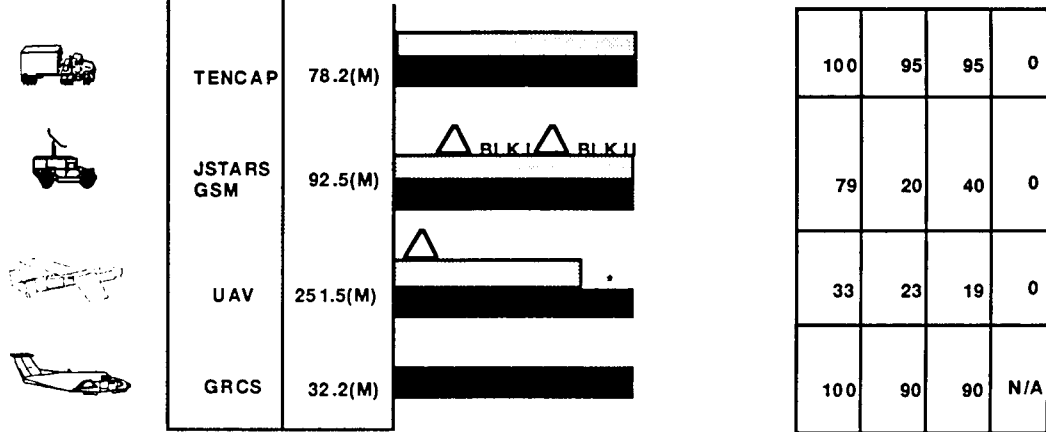

□ ROTE

█ PROD/SUSTAINMENT

△ FUE

*OSD PROGRAM (includes all services)

WHAT THE MINI-POM BUYS FOR CONDUCT PRECISION STRIKES

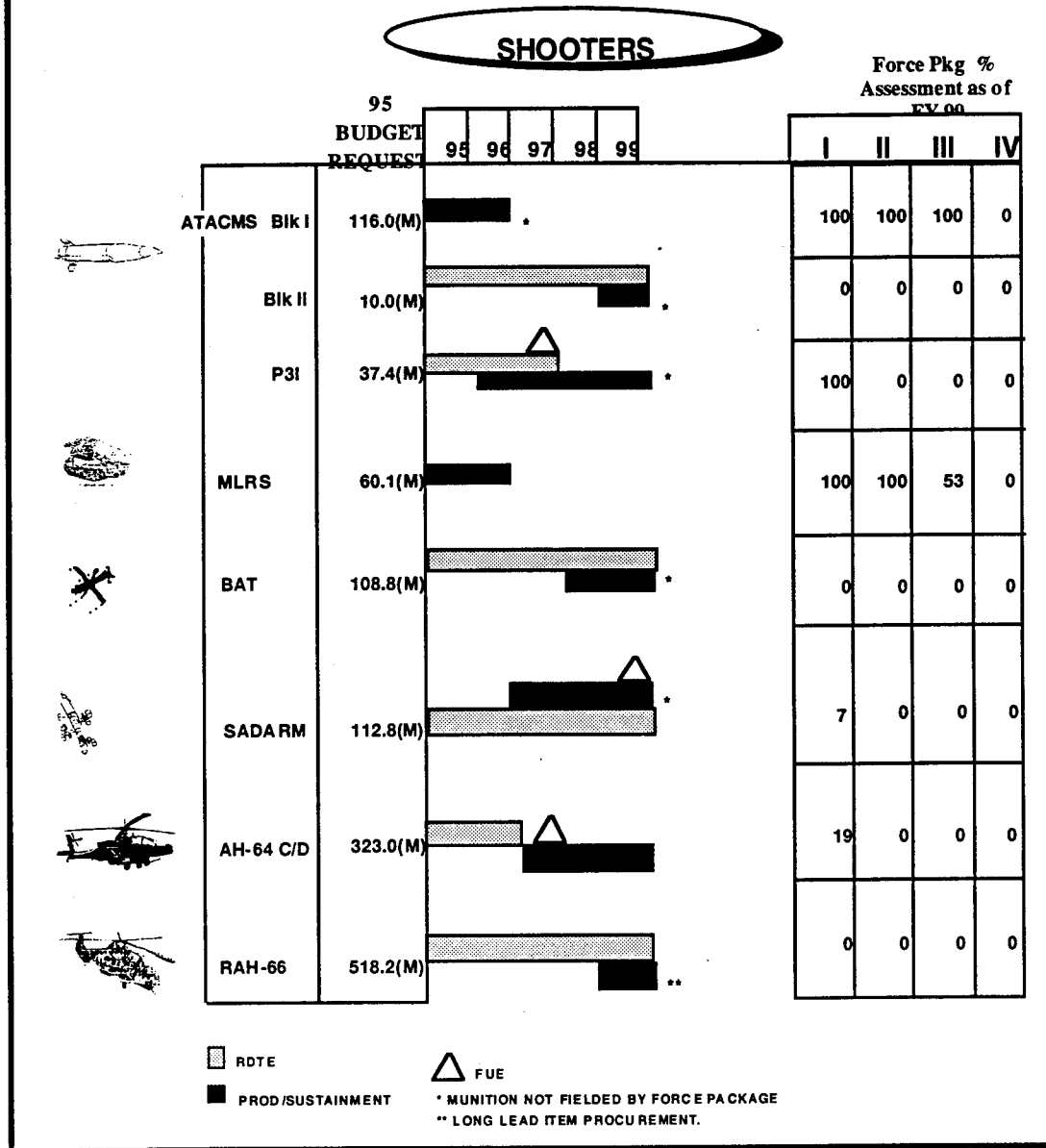

In summary, modernizing our capability to conduct precision strikes throughout the depth of the battlefield is of paramount concern. Early destruction of threat forces ensures early success on the battlefield and translates into saving soldiers' lives, while meeting the goals set forth in our National Military Strategy.

DOMINATE THE MANEUVER BATTLE

America's Army

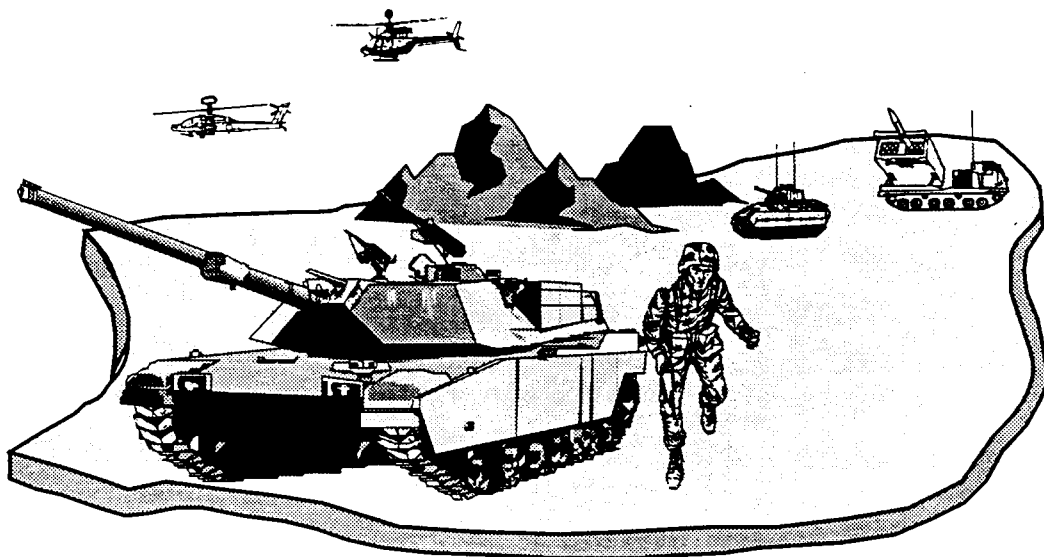

RELENTLESS, OVERWHELMING COMBAT POWER

Rapid, decisive victory is the essence of Land Force Dominance. Future upgrades or modifications to existing systems and the development and introduction of new platforms must ensure that our forces can bring overwhelming force and complete destruction of the threat combat power. Initiative, depth, agility, synchronization, and versatility continue to be the hallmarks of the future Army. To accomplish this, we must emphasize increases in range and lethality, as well as incorporation of real-time fused intelligence.

Horizontal technology integration (HTI) is one of the primary methods the Army will use in its modernization effort. **Second Generation Forward Looking Infra Red (FLIR) optics, Combat Identification, and Digitization of the Battlefield** are the first candidates for HTI. Operation DESERT STORM and the Army's continued evaluation in its Battle Labs point clearly to the increased combat power and survivability of our forces, when these candidate systems are fielded.

Access to these systems' capabilities permits commanders the opportunity to focus their combat power, destroy enemy forces and minimize the loss of soldiers' lives.

WHAT THE MINI-POM BUYS FOR DOMINATE MANEUVER

MANEUVER

Force Pkg %
Assessment as of
FY 99

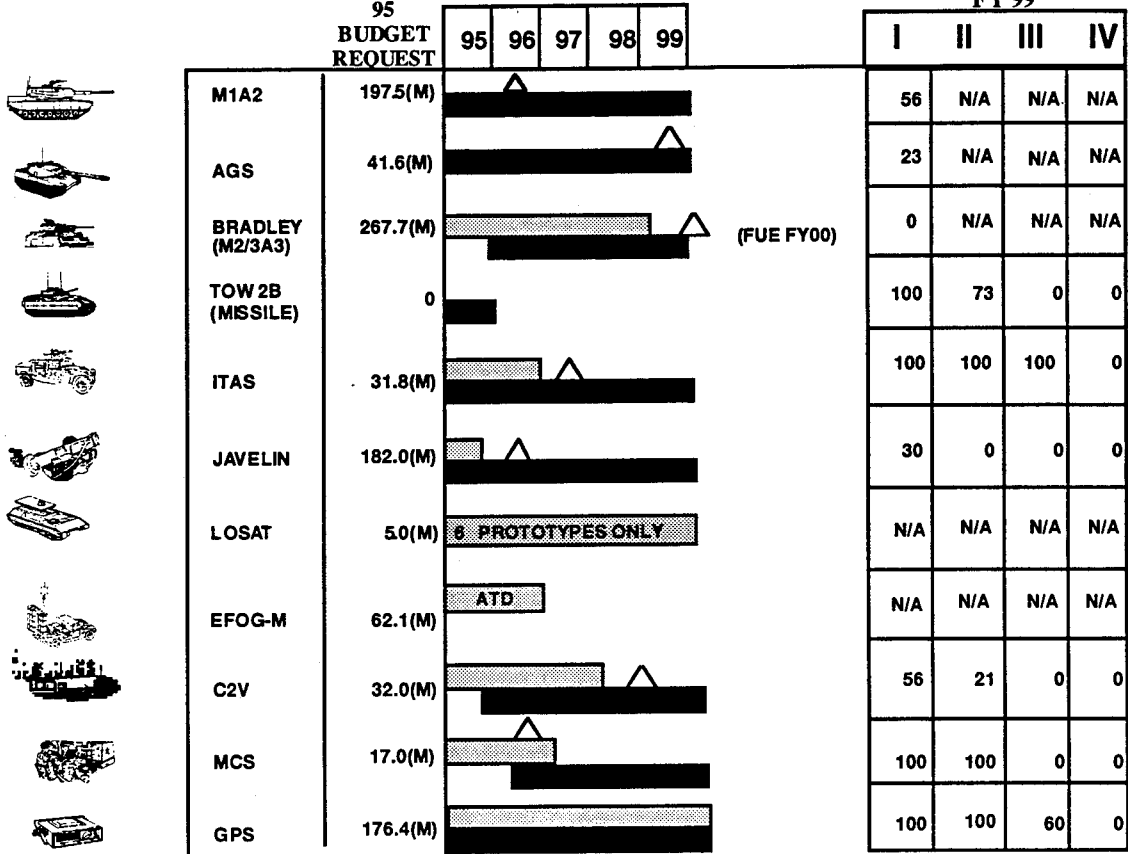

AVIATION



RDTE
 PROD/SUSTAINMENT
 FUE
 * RETRO FIT & MODS.
 ** LONG LEAD ITEM PROCUREMENT.

WHAT THE MINI-POM BUYS FOR DOMINATE MANEUVER

FIRE POWER

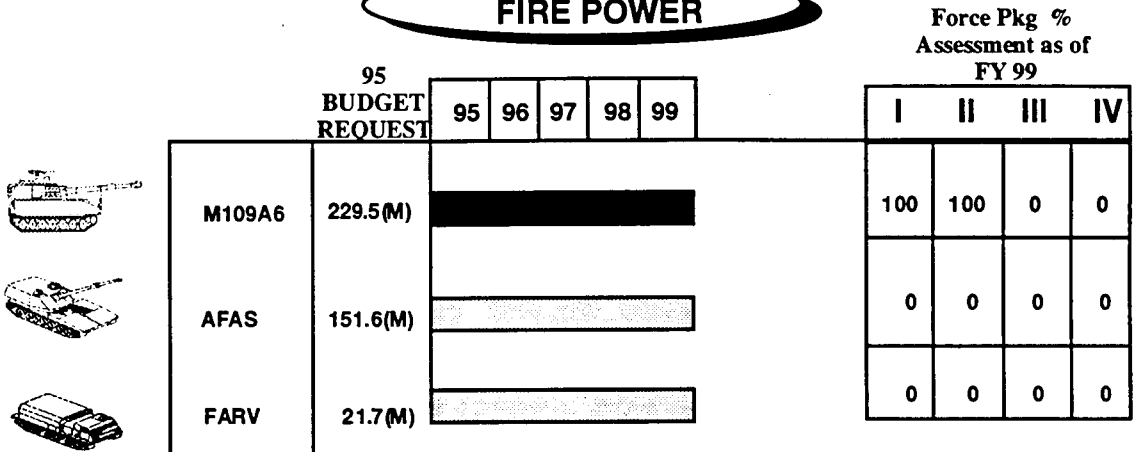

MOBILITY/COUNTERMOBILITY

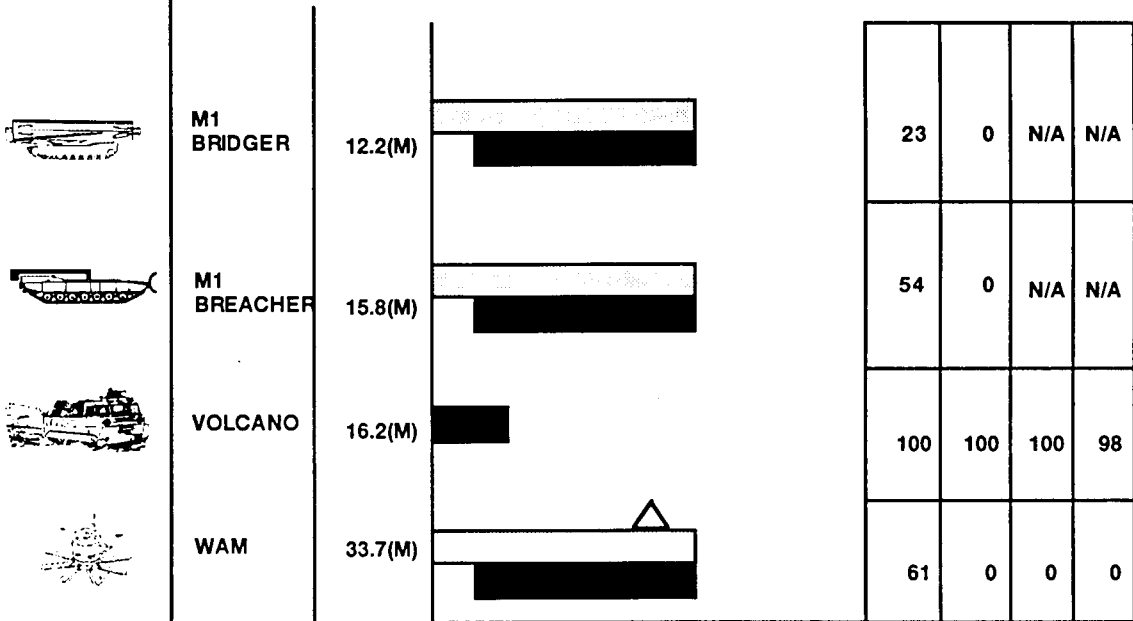

RDTE
 PROD/SUSTAINMENT
 FUE

In summary, the ability to successfully dominate the maneuver - to place soldiers on the ground and seize military objectives, results in Land Force Dominance. Striking the enemy in depth, using speed and agility can only be assured with a balanced funded modernization plan.

Conclusion

"Again and again we have owed peace to the fact
that we were prepared for war."

Theodore Roosevelt
June 1897

The chart below reflects our nation's paradigm of war. As a nation, with one exception, we have expended few resources and given even less thought to the necessity and readiness of our armed forces until we are faced with an immediate crisis or war. This has had three significant impacts.

- Between periods of conflict the military has fallen into a mode of unpreparedness, resulting in national humiliation, as witnessed by OPERATION DESERT ONE.

- When the nation is committed to war it has required a tremendous up-front investment of resources.

- We experience a tragic loss of our nation's most precious resource - the lives of our servicemen and women.

The one exception to this paradigm was during the decade of the 1980s, when the nation committed to a time of sustained modernization. This period culminated in OPERATION DESERT STORM. US forces engaged the fourth largest army on the planet and inflicted such a resounding defeat that the Iraqi army was reduced to being the second largest army within its own borders. This overwhelming and decisive victory was achieved within 100 hours and with the fewest number of American casualties ever experienced on a field of battle of this magnitude.

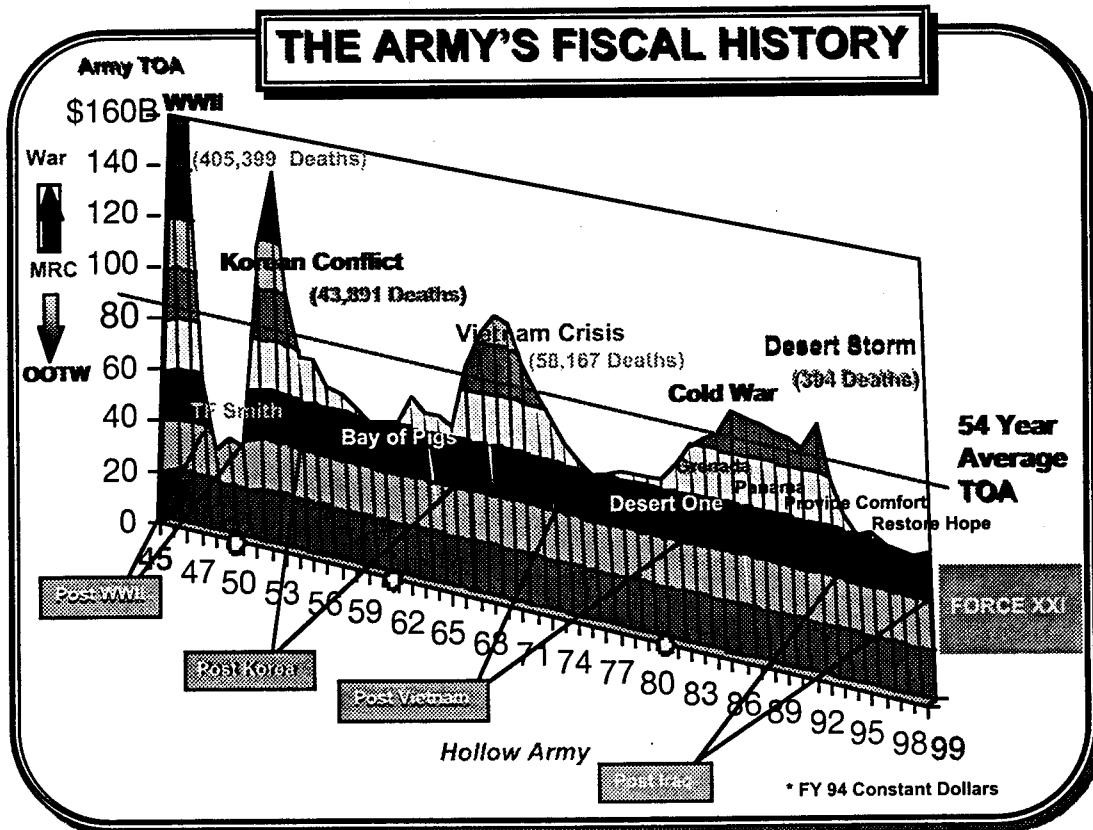

EXECUTIVE SUMMARY

The Army is committed to a modernization azimuth pointed toward ensuring our nation possesses the most modern, well trained, and ready force in the world. It is a daunting challenge, given the continuing decline in Army TOA and the corresponding impact on RDA. Tough decisions have been made to reduce force structure, cancel many programs and delay or stretch out others. As future budgetary decisions are exercised, great care must be taken or the Army may find itself at risk as we attempt to provide the forces and equipment necessary to carry out our National Military Strategy. Our nation demands an Army that is capable of projecting **Land Force Dominance**. It must be capable of engaging any enemy on the battlefield and winning decisively and quickly with the minimum number of casualties. The leaders of today's Army remain committed to ensuring this objective is met. Continuation of the current fiscal trend requires intense, error-free management – if the mistakes of the past are to be avoided.

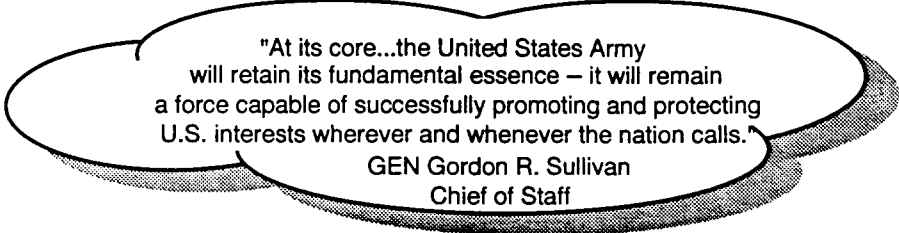

"At its core...the United States Army will retain its fundamental essence – it will remain a force capable of successfully promoting and protecting U.S. interests wherever and whenever the nation calls."

GEN Gordon R. Sullivan
Chief of Staff

CHAPTER 1

CLOSE COMBAT - HEAVY

SECTION 1

INTRODUCTION

This chapter updates Annex A of the 1993 Army Modernization Plan. There have been no major changes in the roles, missions, and capabilities of the Army's heavy forces since the publication of that Plan. There have been changes in force composition as a result of the OSD Bottom Up Review which calls for a reduction to 10 Active Army Divisions. Additionally, modernization strategies for specific weapon systems have been modified or canceled to adjust for the most recent budgetary constraints of the 1995-1999 mini-POM. Despite these changes the Army remains committed to achieving Land Force Dominance now and well into the 21st Century.

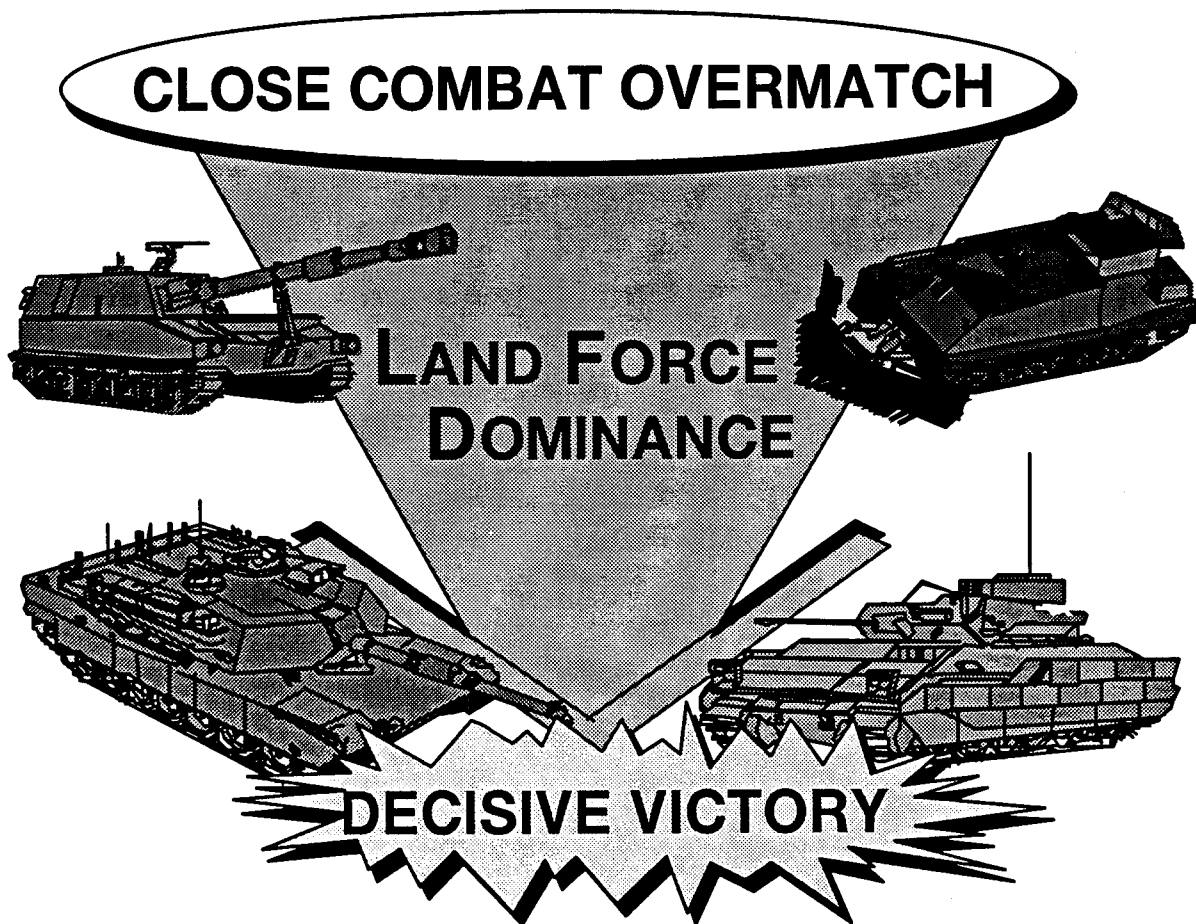

SECTION 2

WARFIGHTING CONCEPT

Forward Looking Warfighting Doctrine.

The Army's doctrine continues to evolve, encompassing a changing world political environment, US national interests, and joint and multinational operations - all focused on forces maintaining technological superiority in systems and capabilities. As articulated in FM 100-5, Operations, published in June 1993, and Joint Publication 3-0, promulgated by the Chairman of the Joint Chiefs of Staff in September 1993, Army doctrine emphasizes exploiting emerging technology to our advantage. The intent is to bring to bear an overwhelming force against an adversary and avoid a grinding battle of attrition. The Army is to do so by:

- Finding the enemy while our forces are dispersed over a wide area.
- Massing quickly to fight a highly synchronized battle.
- Rapidly moving to dispersed locations.
- Rapidly refitting and reconstituting.

Priority of our most modern and capable equipment will be to our contingency forces. New advanced technologies plus, low observable and lighter armored vehicles are essential to meet the deployability demands of our force projection Army and the future battlefield. Although the Main Battle Tank and Infantry Fighting Vehicle (IFV) remain the current primary mounted systems, newer and more revolutionary technologies must be incorporated into these platforms to ensure America's **Land Force Dominance**.

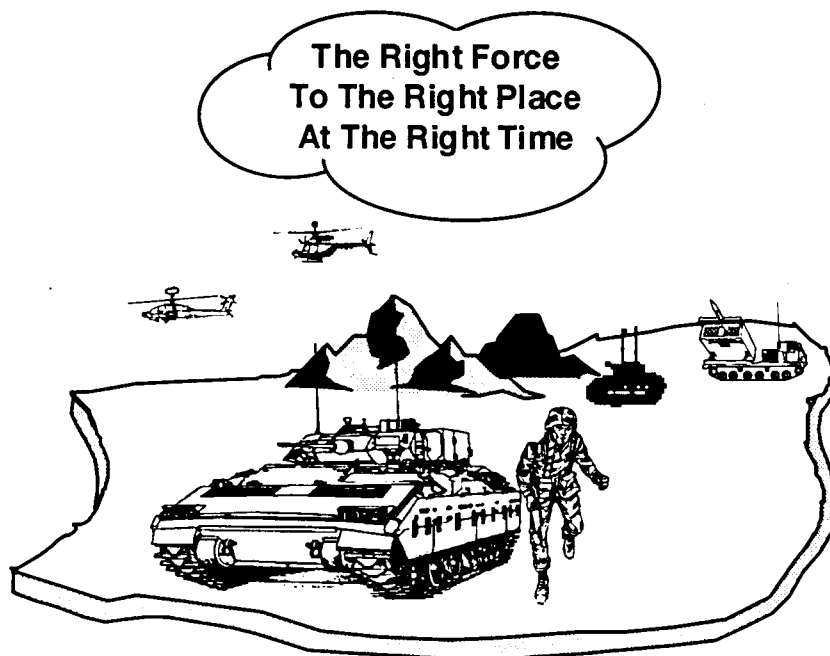

Figure 1-1

SECTION 3

CURRENT PROGRAM ASSESSMENT

Assessments of Heavy Force capabilities and systems to perform armor, cavalry, mechanized infantry, and scout missions are based on the functional areas of: command and control, weapons and munitions, reconnaissance and security, and support and sustainment.

Significant Changes - As the assessment charts indicate, the only significant change is in the Mobility/Counter Mobility area. There are no other changes in the Heavy Forces Assessment since the release of the January 1993 Modernization Plan.

Ratings and their definitions are as follows:

RED—No capability exists, or it is incapable of defeating threat or providing required support.

AMBER—A limited capability or quantity exists to perform the mission.

GREEN—Adequate capability or quantity exists to perform the mission.

HEAVY FORCE CAPABILITIES ASSESSMENT				
	DEFICIENCIES	NEAR TERM (FY94-95)	MID TERM (FY96-99)	FAR TERM (FY00 -08)
COMMAND & CONTROL	<ul style="list-style-type: none"> - SLOW INFORMATION TRANSFER - OUTDATED TECHNOLOGY - RELIABILITY - POSITION / NAVIGATION 	AMBER	AMBER	GREEN
WEAPONS AND MUNITIONS	MOBILITY: <ul style="list-style-type: none"> - LACK OF DEPLOYABILITY BY AIR - HIGH FUEL CONSUMPTION - LACK OF MOBILITY IN SUPPORT VEH. 	AMBER	AMBER	GREEN
	LETHALITY: <ul style="list-style-type: none"> - LACK OF DIRECT FIRE KILL CAPABILITY AT EXTENDED RANGES - LACK OF LONG RANGE DAY/NIGHT FIRE CONTROL & OBSERVATION SIGHTS - STATE OF THE ART TECHNOLOGY - MANPOWER INTENSIVE 	AMBER	AMBER	GREEN
	SURVIVABILITY: <ul style="list-style-type: none"> - COMBAT ID SYSTEM - ARMOR PROTECTION - PERFORMANCE RELIABILITY 	AMBER	AMBER	GREEN
RECONNAISSANCE AND SECURITY	<ul style="list-style-type: none"> - NO STATE OF THE ART RECON. VEH. - LIMITED OBSERVATION, INFORMATION COLLECTION, & INDIRECT FIRE CONTROL - LIMITED NBC RECONNAISSANCE - LACK OF COMBAT POWER TO CONDUCT SECURITY OPERATIONS AT DIVISION 	AMBER	AMBER	AMBER
SUPPORT AND SUSTAINMENT	<ul style="list-style-type: none"> - INADEQUATE RECOVERY CAPABILITY - AVLB UP GRADE - INSUFFICIENT NUMBER OF HVY EQUIPMENT TRANSPORTERS 	RED	AMBER	AMBER

Figure 1-2

HEAVY FORCE SYSTEMS ASSESSMENT

	DEFICIENCIES	NEAR TERM (FY94-95)	MID TERM (FY96-99)	FAR TERM (FY00 - 08)
ARMOR	<ul style="list-style-type: none"> - SLOW INFORMATION TRANSFER - LACK OF DEPLOYABILITY BY AIR - NEED FOR GREATER LETHALITY AT EXTENDED RANGES - GREATER SURVIVABILITY (COMBAT ID) 	AMBER	GREEN	GREEN (AMBER)**
MECHANIZED INFANTRY	<ul style="list-style-type: none"> - INFANTRY FAMILY OF VEH NEEDS TO KEEP PACE WITH THE ABRAMS - SLOW INFORMATION TRANSFER - NEED FOR GREATER LETHALITY AT EXTENDED RANGE, DAY OR NIGHT. - GREATER SURVIVABILITY (COMBAT ID) - GREATER LETHALITY FOR AT SYSTEMS 	AMBER	AMBER	GREEN (AMBER)**
CAVALRY AND SCOUT	<ul style="list-style-type: none"> - NO STATE-OF-THE ART RECON. VEH - LIMITED OBSERVATION, INFORMATION COLLECTION, & INDIRECT FIRE CONTROL - LACK OF COMBAT POWER TO CONDUCT SECURITY OPERATIONS AT DIVISION. - LIMITED NBC RECONNAISSANCE. 	AMBER	AMBER	AMBER
FIRE SUPPORT	<ul style="list-style-type: none"> - TARGET ACQUISITION - RATES OF FIRE - NEED FOR GREATER LETHALITY AT EXTENDED RANGES - COMMAND AND CONTROL 	AMBER	AMBER	GREEN
MOBILITY / COUNTER-MOBILITY	<ul style="list-style-type: none"> - QUICKLY DETECT, BREACH, AND CROSS OBSTACLES AS PART OF THE ABRAMS AND BRADLEY TEAM. 	RED	RED*	AMBER
COMMAND & CONTROL	<ul style="list-style-type: none"> - SLOW INFORMATION TRANSFER - OUTDATED TECHNOLOGY - RELIABILITY - POSITION / NAVIGATION 	AMBER	AMBER	GREEN
MUNITIONS	<ul style="list-style-type: none"> - GREATER LETHALITY AT EXTENDED RANGES. - GREATER CAPABILITY AGAINST SPECIALTY TARGETS. 	GREEN	AMBER	AMBER

* Denotes Changes

** If today's potential enemies (N. Korea, Iraq, Iran, etc.) modernize one generation during the far term, this period would be rated Amber for both Armor and Mechanized Infantry...one generation of threat modernization acutely degrades warfighting outcomes.

Figure 1-3

Mobility/Counter Mobility - Mid-term rating changed from AMBER to RED. FUE for bridger and breacher were slipped from FY 98 and FY 97 to FY 00 and FY 99, respectively. Programs were stretched in the mini-POM as a result of reduced availability of funding.

SECTION 4

RESEARCH DEVELOPMENT, AND ACQUISITION STRATEGY

The Army's Research, Development and Acquisition (RDA) strategy succeeds only via continuous modernization actions. Continuous modernization has served well in the past and remains our roadmap for the future as well. The RDA goal is to equip the American soldier with world-class equipment in sufficient quantity and in the shortest possible time, so our soldiers can win decisively, quickly and with minimum loss of life.

Continuous modernization means that our goal for each major weapon system (e.g., Main Battle Tank, Howitzer, etc.) that makes up our key warfighting capability, is to have either a system in production, being upgraded, or a replacement next generation system in development. A break in this process results in erosion of critical skills, lapse in the fielding process, diminished industrial base, stagnant technology, increased fleet aging, and dulling of our warfighting edge vis-a-vis potential opponents. Continuous modernization is the means by which we sustain our forces, capabilities, and our entire acquisition system - its people, supporting industrial base, infrastructure, and programs.

DoD's current acquisition philosophy allows more time to develop and evaluate new technologies and make decisions regarding them. This reduces concurrency in development programs and causes retention of existing equipment. It increases emphasis and investment in science and technology programs which lead to a broad range of advanced technology demonstrations. Technological advances must be incorporated into systems more often through upgrades rather than by initiating new systems.

Thus, the Army's RDA strategy requires that we continue to modernize by upgrading and initiating selective new starts. Although we will reduce the number of new weapons produced, the need to maintain technological superiority will drive us to increase S & T efforts to develop new and innovative technologies. Leap-ahead technologies that overmatch any potential adversary represent a key combat force multiplier for our smaller force. The United States Army must maintain its technological advantage and constantly reinvest into those advantages to provide superior equipment for our soldiers.

Science and Technology. S&T activities have been focused on solving post-Cold War deficiencies associated with our inability to rapidly project force. A major goal of several related Advanced Technology Demonstrations (ATD) is to show the feasibility and operational payoffs of more deployable combat vehicles.

Eight Science and Technology Objectives (STOs) directly support heavy force modernization. In addition to the STOs for the ATDs, there are three additional ones relating to human factors, hypervelocity guidance, and target acquisition/recognition/target identification missile seeker.

Land vehicle demonstrations related to lighter "heavy" forces have been grouped under an umbrella program, the Advanced Vehicle Technologies (AVT) Top Level Demonstration, which involves several different agencies whose activities are coordinated and integrated horizontally through an office at the Tank-Automotive and Armaments Command. The principal ATDs under AVT are summarized below:

- **Composite Armored Vehicle.** This investigates the use of composite materials as the primary vehicle structural material. Issues include producibility, reparability, nondestructive testing, ballistic and structural integrity. The demonstrator will also address the integration of signature reduction techniques and light weight armors.

- **Hit Avoidance.** This demonstrates the effectiveness of a protective system of threat warning sensors (e.g., laser, radar), countermeasures (jammers, decoys, obscurants), and associated architecture to defeat threats from all aspects (e.g., horizontal, top, or bottom).

- **Crewman's Associate.** This addresses the impact of crew size on the weight of combat vehicles by investigating ways to reduce the number of the crew members needed to effectively operate a combat vehicle.

- **Target Acquisition.** This will investigate the transfer of Comanche-style target acquisition techniques to ground vehicle applications. The demonstrator will feature 2d generation FLIR technology with an automatic pan feature that identifies potential targets to the crew. This aided target recognition capability will shorten engagement times, reduce fratricide, and extend the battlespace.

The chart on the next page depicts a commitment to continuous modernization. Some programs, however, have had to be stretched out in the modernization process due to funding constraints in the most recent POM. LOSAT has been restructured as an S&T program looking at integrating it on an AGS chassis. NLOS-CA, renamed Enhanced Fiber-Optic Guided Missile, has been restructured as an S&T program under a provisional Advanced Concept Technology Demonstration. Stinray is not funded after FY 94. Figure 1-2 depicts the Heavy Force's acquisition strategy to meet these requirements in the future. Those systems identified with an asterisk have had adjustments since the January 1993 Modernization Plan.

RDA STRATEGY

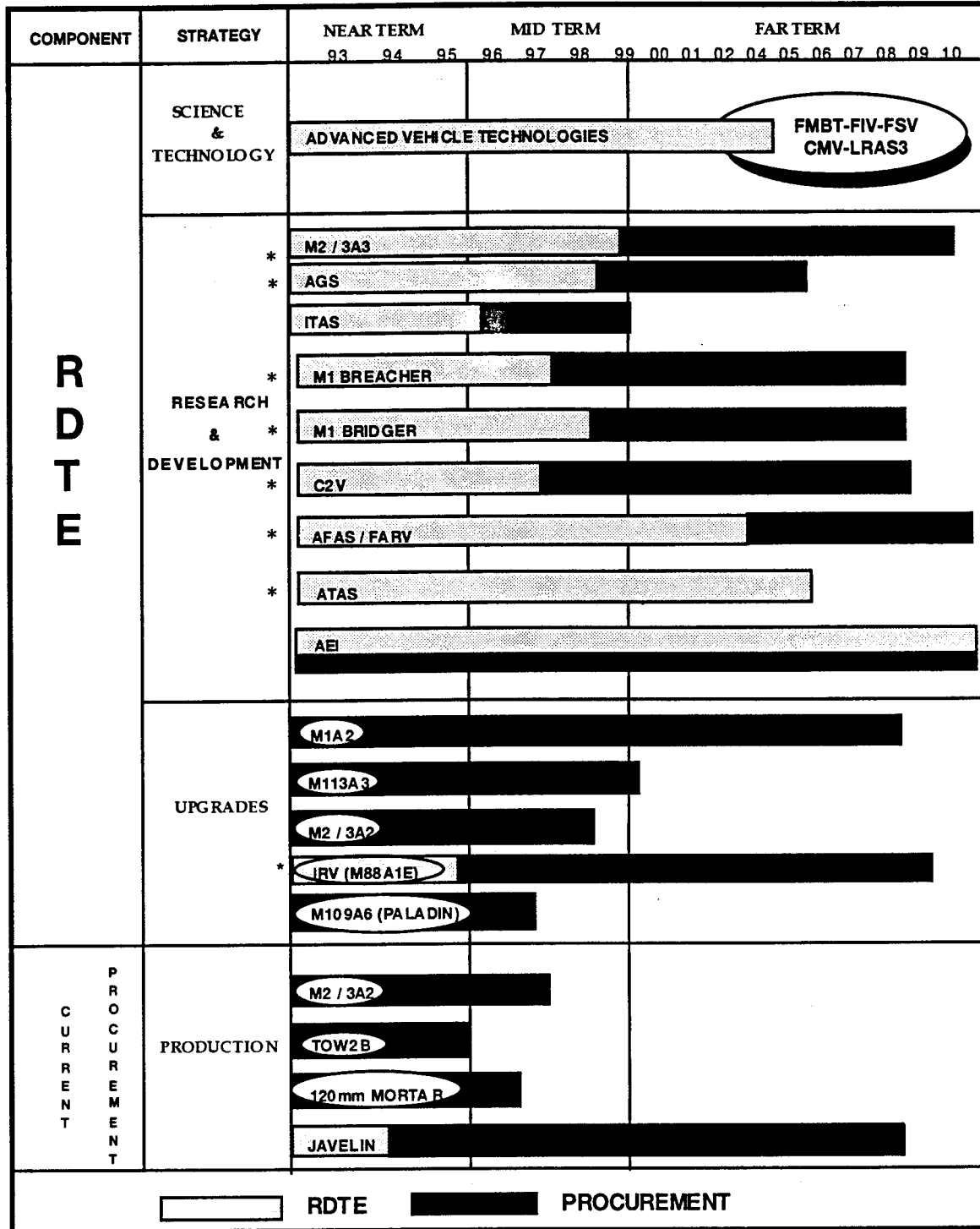

* Indicates adjustment since 1993 Mod Plan.

Figure 1-4

Changes in Research and Development Programs that Support the Heavy Force Modernization/Acquisition Strategy.

Infantry/Cavalry Fighting Vehicle(M2/3A3). Funding constraints moved FUE date from 1998 to 2000. FUE: FY00.(From FY98)

Non-Line of Sight - Combined Arms (NLOS-CA). Procurement delayed indefinitely due to rescheduling in the mini-POM. FUE: N/A(Procurement delayed indefinitely)

M1 Breacher. Will be stretched out due to funding constraints. Since no similar vehicle is currently fielded, breaching minefields will be labor intensive until it is procured. FUE: FY00. Procurement delayed from FY96 vs 98.

Heavy Assault Bridge. Procurement delayed in constrained environment. Weight limited AVLB will continue to slow fast moving operations. FUE: FY99. Procurement delayed from late FY95 to FY97.

Command and Control Vehicle (C2V). Follow on to M-577 will field in FY98. Key to digitized battlefield, it will slow by one year the fielding of the objective TOE. FUE: FY98. Procurement delayed from FY96 to FY97.

Tank Main Armament System (TMAS). TMAS program consists of ATAS & AEI and ISA technical improvement programs for new tank armament systems. It has been slowed due to R&D and funding constraints. Will revert to RDTE effort for FMBT, and upgraded ammunition. FUE: FY01 for selected program elements (changed from FY96).

STINGRAY. Laser detection system technology will not be pursued due to funding constraints. New technology remains available when funding permits. FUE: N/A(Procurement delayed indefinitely)

The following upgrade programs support the Heavy Force Modernization/Acquisition Strategy.

Improved Recovery Vehicle (M88A1E1). Funding constraints slowed initial production; 70 Ton Recovery Vehicle is testing well and will be ready by 1996. FUE: FY96 (From FY95).

Unfunded Program Issues. All unfunded programs are listed below. The only changes are to the M2/3A3 upgrade and NLOS-CA.

M1A2. The Abrams upgrade program is currently fully funded in Phase I. Phase II of the program is only 75% funded. Lack of a fully funded phase II will restrict fielding of the M1A2 to selected FP 1 units. The goal is to fill all Contingency Corps Heavy Forces.

M2/3A3. Funding for the Bradley IFV upgrade program has been identified in the POM. This reflects a change from the 1993 Modernization Plan. The goal is to fill all Contingency Corps Heavy Forces.

M113A3. Reduced funding for the M113A3 upgrade program means only 54% of FP 1 requirements being met. Additional funding is required to meet the goal of filling all FP 1 units.

EFOG-M. The Enhanced Fiber Optic Guided-Missile (EFOG-M) is an important part of a proposed Advanced Concept Technology Program (ACTD) program. If successful, 12 fire units and 236 missiles will become part of a residual capability within FORSCOM.

M1 Bridger/Breacher. Current POM funding for the Heavy Assault Bridge and M1 Breacher does not provide quantities sufficient to fill FP1 units— our goal. This program will require both additional funding and the allocation of 500 more Abrams chassis to correct the shortfall.

Improved Recovery Vehicle (M88A1E1). The current POM does not provide sufficient funding for the M88A1E1; our goal is to field the M88A1E1 to all armor, engineer, and maintenance units in FP 1.

Training Devices. Insufficient funding in the POM for Conduct of Fire Trainer (COFT), upgrades, Platoon Gunnery Trainers (PGT), and Tank Weapons Gunnery Simulation Systems and Precision Gunnery Systems (TWGSS/PGS) negatively impacts our capability to train and modernize heavy forces. The greatest impact will be felt by National Guard units that are converting from M60A3 to M1 tanks. The POM does not cover the cost of upgrading 26 COFTs.

MOUNTED FORCE MODERNIZATION PLAN

	DEFICIENCIES	NEAR TERM (FY94-95) SOLUTIONS	MID TERM (FY96-99) SOLUTIONS	FAR TERM (FY00-08) SOLUTIONS
COMMAND & CONTROL	<ul style="list-style-type: none"> •Slow information transfer •Outdated technology •Reliability •Position/Navigation 	<ul style="list-style-type: none"> •GPS •SINCGARS 	<ul style="list-style-type: none"> •C2V •IVIS •Digital Architecture 	<ul style="list-style-type: none"> •Digital Architecture*
WEAPONS & MUNITIONS	MOBILITY: <ul style="list-style-type: none"> •Lack of deployability by air •High fuel consumption •Lack of mobility in support veh 	<ul style="list-style-type: none"> •M1 A1 Fielding •M2/3A2 Fielding •M1 13A3 Fielding 	<ul style="list-style-type: none"> •AGS •M1 A1 Fielding •M2/3A2 Fielding •M1 13A3 Fielding 	<ul style="list-style-type: none"> •M1 A1 Fielding •M2/3A2 Fielding •AGS
	LETHALITY: <ul style="list-style-type: none"> • Lack of direct fire kill capability at extended ranges • Lack of long range day/night fire control & observation sights • update technology • manpower intensive 	<ul style="list-style-type: none"> •M1 A1 Fielding •M2/3A2 Fielding •M1 13A3 Fielding •TOW 2B •120MM Mortar •AEI •M109A6 Fielding 	<ul style="list-style-type: none"> •AGS •M1 A2 Fielding •M2/3A2 Fielding •M1 13A3 •JAVELIN •M109A6 Fielding 	<ul style="list-style-type: none"> •M1 A1 Fielding •M2/3A2 Fielding •AGS •AFAS •FARV •JAVELIN
	SURVIVABILITY: <ul style="list-style-type: none"> • Combat ID system • Armor protection • Performance reliability 	<ul style="list-style-type: none"> •M1 A1 Fielding •M2/3A2 Fielding •M1 13A3 Fielding •M109A6 Fielding 	<ul style="list-style-type: none"> •AGS •M1 A1 Fielding •M2/3A2 Fielding •M1 13A3 Fielding •M109A6 Fielding 	<ul style="list-style-type: none"> •M1 A1 Fielding •M2/3A2 Fielding •AGS •AFAS •FARV
RECONNAISSANCE & SECURITY	<ul style="list-style-type: none"> • No state-of-the-art recon veh • Limited observation, info collection, & direct fire control • Limited NBC reconnaissance • Lack of combat power to conduct security operations at division 	<ul style="list-style-type: none"> •M2/3A2 •M1 A1'S Div Sq Dn •HMMWW Scout 	<ul style="list-style-type: none"> •AGS •M2/3A3 •M1 A1'S Div Sq Dn •HMMWW Scout 	<ul style="list-style-type: none"> •FSV •LRAS3
SUPPORT & SUSTAINMENT	<ul style="list-style-type: none"> • Inadequate recovery capability • AVLB upgrade • Insufficient number of hvy equipment transporter 		<ul style="list-style-type: none"> •IRV •Breacher •Hvy Aslt Bridge 	<ul style="list-style-type: none"> •IRV •Breacher •Hvy Aslt Bridge
<p>* In the period FY96-99, the Army will field architecture in the Corps Contingency Force. The majority of the platforms will be analog with digital applique; however, some platforms (mostly Abrams M1A2) will be fully digital. As the Army continues digitization into the far term, more systems will be fully digital.</p>				

Figure 1-5

SECTION 5

TRAINING

Tough Realistic Training

In future years, more than at any other time in our Army's history, training must depend on training devices, simulation, greater innovation, and superb leadership. Several events cause these changes:

- Downsizing the Army
- Doctrinal advancements
- Army budget reductions
- Advancement in training technologies

The Combined Arms Training Strategy (CATS) achieves the maximum training value from existing OPTEMPO, ammunition, range and maneuver areas, and the integration of simulation and simulators. CATS establishes "proficiency gates" throughout the training process; these are used by commanders to assess training proficiency and optimize training resources.

Training Aids Devices Simulators and Simulations (TADSS) permits training for tasks that require frequent repetition or that are too expensive or too hazardous to personnel and equipment to train in the field.

TADSS is used to validate proficiencies prior to on-equipment training and before conducting qualification events or field training exercises that consume OPTEMPO and full-caliber ammunition.

The heavy force's training strategy sets forth our training device strategy for the near, mid and far terms. It is based on training devices, embedded trainers, and distributed training to support our mission. The near term strategy contains part-task appended trainers for gunner, maneuver and driver training. The mid term strategy contains devices that begin to integrate gunner, maneuver and driver training. In the far term, we introduce and field embedded training devices: for example, a precision laser engagement system and conduct-of-fire trainer (COFT). Further depending on the capabilities of the on-board computer network in future vehicles, a close combat tactical trainer (CCTT) capability may be embedded and linked to a central computer system which would drive the simulation.

Training Simulators And Devices. The primary focus of training device modernization for the heavy force is to allow individuals, crews, and units to attain and maintain the highest levels of proficiency at the most affordable cost. Current and future training devices for heavy forces are:

Tank Conduct of Fire Trainer (UCOFT/MCOFT). The UCOFT trains the gunner and TC as a team in simulated battlefield environment. The team is faced with increasingly difficult scenarios based on computer assessments of their skills. The M1A2 software upgrade to the UCOFT is currently in development.

Guard Unit Armory Device Full-Crew Interactive Simulation Trainer-Armor (GUARD FIST-I). The GUARD FIST-I is a tank-mounted training device for crew collective training. Computer generated imagery is presented concurrently through color video monitors; these are mounted in front of

driver, gunner, and tank commander vision ports and at an external instructor station. The crew simulates loading, firing, and driving with full crew interaction. GUARD FIST-I is to be fielded in 4QFY94.

Tank Precision Gunnery In-bore Device (TPGID). The TPGID is a 35mm subcaliber inbore device mounted in the Abrams tank gun tube that replicates main gun firing and allows full crew interaction using the tanks fire control system. The TPGID effectively engages targets to 2,000 meters.

Thru-Sight Video (TSV). The TSV is used for after action reviews (AAR) for gunnery and tactical training and remedial training. TSV consists of a TV camera linked to the gunner's primary sight and an equipment package; it records the gunner's sight picture. TSV is scheduled to be fielded in FY94.

Interim Thermal Signature Target (ITST). This device trains mounted crewman using thermal sight techniques to engage targets during limited visibility. To be used in the interim until a standard, thermal integrated target system is procured. We are scheduled to produce ITST in FY95.

Tank Weapons Gunnery Simulation System/Precision Gunnery System (TWGSS/PGS). TWGSS/PGS is a vehicle-mounted gunnery training system which simulates main gun and coaxial machine gun firing. It is based on an eye-safe laser system and reflectors, and is compatible with the MILES training device used in combined arms exercises. TWGSS/PGS is used with M1, M1A1, and M1A2 tanks, AGS, and 25mm, TOW and coax for M2/M3 series BFV. It is scheduled for fielding in FY95.

Precision Range Integrated Maneuver Exercise (PRIME) Laser Range. This enhances the capabilities of M1 and M2/M3 MILES, Laser Target Interface Device(LTID), and Automated Tank Target System (ATTSS) pop-up targets. It supports tank/IFV gunnery and tactical training of crews and units. Fielding began in FY93.

Main Tank Gun/Weapons Effects Signature Similar (MTG/WESS). This device is a more cost effective and realistic means of simulating the flash, bang, and smoke of the tanks main gun; it is used for force-on-force tactical engagement exercises.

Simulation Networking (SIMNET). This is a program which feeds technological information to an objective system program and provides training and combat development capabilities. Two mobile versions are use. The program includes training developments, combat developments, and increased training capabilities.

Close Combat Tactical Trainer (CCTT). CCTT will provide a means to train and sustain collective tactical tasks and skills in the conduct of simulated crew through battalion task force level tactical operations. It is scheduled for 3QFY98.

Service School Seminar Trainer (JANUS-A). JANUS is a computer generated tactical simulation model that allow control of elements from brigade to individual systems. Fielding began in FY93.

SECTION 6

CONCLUSION

Given the uncertain and explosive nature of the world in which we live, the Nation's Heavy Forces are central to our capability of ensuring peace and stability. We have been reminded of this most recently in the deployment to Somalia. This event, coupled with the release of the Bottom-Up Review which ties the Army end strength to 10 divisions, means that the Army's heavy forces must be more lethal to compensate for the reduce aggregate strength. The Army's modernization strategy adjusts to these realities by continuing to field world class hardware through limited acquisition of new and upgraded weapons platforms and by synchronizing the Heavy Forces through the revolutionary concept of Battlefield Digitization.

The tank and the infantry fighting vehicles continue to be the power brokers of mounted, combined arms operations. The M1A2 tank provides needed upgrades in armament, fire control, inertial POS/NAV and a situational display. The M2A3 provides similar improvements and a 2d generation FLIR. Both of these vehicles are needed to ensure Force Package 1 units have modern, reliable systems, as their current systems will be 5-10 years old when the new vehicles are fielded. In addition, we are in danger of losing a critical component of the production base. Should the situation arise where we must fight two MRCs, the industrial production base will be vital to our success.

Similarly, the M109A6, Paladin, provides an improved digital capability to the Field Artillery and fills a void until a completely new vehicle, AFAS, can be fielded. The Paladin's increased range, accuracy and rapid rate of fire are necessary to support the rapid, non-linear battlefield of the next century.

These increases in capability not only provide better lethality and survivability on the future battlefield, but allows for the implementation of a more vital concept, Battlefield Digitization. This initiative provides a common and shared view of the battlefield among each of the elements of the fight. The improved command and control (C2) and improved force synchronization provide a synergistic effect that will overwhelm future opponents. As such, this capability is vital to a force that is tasked to do more with less. The upgraded M1A2, M2A3, and M109A6 will interact with a new production vehicle, the C2V, to provide the essential platforms necessary for the digitized battlefield. The C2V, the replacement for the M577, will provide the command and control integration necessary for the commander on the battlefield. While interim measures on some vehicles (e.g., appliques) may provide a partial solutions, the advantages of the digitized battlefield will not be fully realized until the objective requirements are met.

Implementation of our Heavy Force modernization strategy will ensure this nation has the capability to respond with overwhelming combat power both now and into the next century. Our modernization strategy provides the Heavy Force with the necessary capabilities to continue to be the most dominant land force in the world, able to win decisively with minimum casualties on any battlefield.

CHAPTER 2

CLOSE COMBAT LIGHT

SECTION 1

INTRODUCTION

The purpose of this chapter is to provide an update to Annex B, Close Combat - Light, of the 1993 Army Modernization Plan. The annex addresses modernization of the US Army's Light Forces and is focused on the remainder of the 20th Century and the beginning of the 21st.

The roles and missions of the Light Forces will not change in the foreseeable future. The National Military Strategy recognizes an increasing role for the nation's light forces capabilities. This is further reflected in the recently published Joint Publication 3-0 (Doctrine for Joint Operations) and the Army's FM 100-5 (Operations). During the period of the Cold War the Army depended on the versatile capabilities of light forces to meet the challenge of crisis action. Changes in the threat, down sizing of the force, and changes in the Army's modernization philosophy are causing continual assessment and trade off analyses with respect to modernization and future capability requirements. In the future light forces must be more lethal, survivable, and sustainable.

The Army's Light Forces possess a unique balance of capabilities and strengths different from other elements, such as Heavy Forces or the U.S. Marine Corps. The Light Forces are the only forces in America's arsenal that can execute and sustain a forced entry using airborne and/or air mobile operations in support of a land campaign. The joint force commanders employ Light Forces in the terrain for which they are best suited, such as cities, mountainous regions, and jungles. Also, Light Forces will retain the primary dominance in specialized missions such as, counter insurgency, disaster relief, and peace keeping operations. Deployability is the hallmark of the Army's Light Forces. They can be deployed via airlift anywhere in the world within 48 hours – significant strength and firepower that may spell the difference between victory and defeat. An entire Light Division can be deployed in approximately 500 sorties, a unique capability possessed by no other force in America's arsenal.

Since the publication of the Close Combat Light Annex in 1993 there have been several adjustments in light force requirements, organizations, and equipment. Organizational changes have triggered other adjustments in the numbers and types of systems required. Continuing funding reductions are increasing risk - not only in capabilities, but in materiel programs and in fundamental research. Although the basic modernization programs for Light Forces described in the original annex remain unchanged, adjustments during Fiscal Years 93 and 94 are reflected principally in Section 6 of this update.

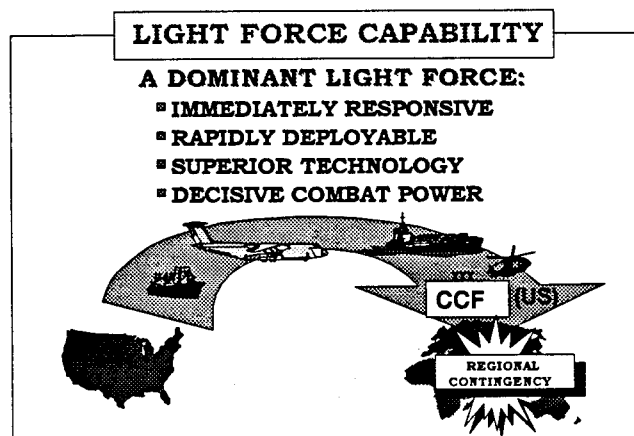

CLOSE COMBAT LIGHT

SECTION 2

WARFIGHTING CONCEPT

The end of the Cold War has produced significant changes in Army warfighting doctrine. In the new world order, the battlefield is a joint and often combined and/or coalition environment. Joint Publication 3-0 and Field Manual 100-5, Army Operations, provide the capstone doctrine for the future Army. They form the doctrinal foundation for conducting operations across the operational continuum. Light Forces remain the Nation's most deployable and crisis responsive combat force. They are organized, trained, equipped, and ready to rapidly meet the new uncertainties of an evolving world order and provide the Army the capability to operate on restrictive terrain (forested, mountain, jungle, desert, and urban).

Since the demise of the Cold War, the Army has given added resources and emphasis to increase the lethality, mobility, survivability, and sustainability of Light Forces. A complete list of all development and procurement of equipment destined for Light Forces would be too lengthy to include in this Modernization Plan update. However, shown below are systems that the Army is procuring that are critical to Light Forces. For instance, Javelin (AAWS-M) doubles the engagement range and provides a new top-attack anti-tank capability to light infantry and engineer platoons. The Improved Target Acquisition System (ITAS), similar to Javelin, gives light anti-tank units a significantly greater acquisition range by incorporating a 2d Generation FLIR. These new systems, when committed in battle with other important systems like the AGS and Comanche, will empower Light Forces to achieve decisive victory quickly with minimal casualties under all conditions. Individual soldier upgrades mentioned in the Soldier chapter of this Modernization Plan will have a significant benefit in Light Forces, such as Land Warrior and 21st Century Land Warrior (21CLW).



Figure 2-1

A Light Force is defined as all those combat, combat support and combat service support units that participate in and support the dismounted close battle. The definition includes light, airborne, air assault, Ranger, and mountain infantry, long range surveillance, Alaskan Scouts, combat engineers that support light combat forces, military police, special forces, civil affairs, and psychological operations units.

Light Forces require a sustained modernization strategy. They need organic mobility and adequate transportation to carry unit and individual combat and sustainment loads. The light combat soldier need better protection in extreme environments on the battlefield. Many of these requirements are addressed in the Land Warrior and 21st CLW programs and rapid force projection initiative.

The successfully completed Soldier Integrated Protective Ensemble (SIPE) Advanced Technology Demonstration (ATD) has resulted in a dual follow-on effort. The Land Warrior development program will take the most successfully demonstrated capabilities from SIPE, and using off-the-shelf technologies, provide the first fielded soldier system in FY 99. The 21st Century Land Warrior (21st CLW) Top Level Demonstration program will integrate and demonstrate less mature, more far-reaching technologies to provide more advanced capabilities than Land Warrior. 21st CLW and its core ATD, the GEN II Soldier ATD, will provide the link of the individual soldier into the digitized command and control network, providing greatly increased situational awareness and accurate target hand-off capabilities, enhancing the overall survivability and lethality of not only the individual, but of the unit as well. The synergistic effect of all the components will provide the edge for our soldiers to dominate all regional conflicts and be the cornerstone of the future force projection Army.

The Light Force requires an upgraded capability to breach obstacles and has a critical need to detect and defeat booby traps and command detonated mines. Recent approval of the Countermine Top Level Demonstration will provide the means to rectify current light force shortfalls in breaching and in mine and booby trap detection and protection. A required capability assessment for this area is being conducted during this fiscal year by the Dismounted Warfighting Battle Lab in conjunction with the Fort Belvoir Research and Development Center to explore technologies for light force countermine detection and protection. A concept for individual mine avoidance will be demonstrated in 21st CLW using a thermal weapon sight, in conjunction with the soldier's computer, for in-stride mine avoidance.

Light Forces need to be able to see and kill at greater distances and with greater lethality in a force projection Army. Extended acquisition and engagement ranges are required if light initial entry forces are to dominate the maneuver battlefield. This shortfall is being addressed in programs such as Land Warrior, 21st CLW, Javelin, and the laser countermeasure system.

There is an insufficient capability to rapidly collect and process information, particularly in operations other than war. Continued development of new C3I systems and next generation night vision systems, including the FLIR technologies that support them, will begin to correct this shortfall at the turn of the century. These efforts will assist in integrating the soldier into the digitized battlefield.

- Position location devices are essential not only for navigation but also for situational awareness and combat identification.
- Night vision devices must be enhanced through the use of next generation FLIR technologies.
- Video capture will provide near-real time battlefield intelligence from the individual soldier to higher echelons.

Sensor-to-shooter intelligence is critical if we are to maintain the overmatching technological edge in battle. The direct fire battle requires fire support assets that effectively engage, attrit, and canalize forces not yet in direct fire contact. Infantry mortar capabilities will be enhanced for precision firing in support of maneuver in the close battle.

The Light Force continues to have a requirement for a single munition capable of defeating multiple targets. The Multiple Purpose Individual Munition (MPIM) has the potential of satisfying this requirement. The MPIM will provide the light forces with the capability to defeat light armor, and personnel in earth and timber bunkers and masonry buildings. In an attempt to streamline the acquisition process, the Army and USMC have entered into a joint SRAW/MPIM program. This effort should produce a cost effective system that provides the Light Force a manportable, fire-and-forget, multipurpose, light antiarmor weapon system.

CLOSE COMBAT LIGHT

The Light Force requires a robust training base that makes full use of technology. If the Army is to maintain a high level of readiness, reductions in operating expenditures that impact on training time and resources must be balanced with an increased investment in simulators and simulations. Current and projected funding is inadequate to correct this near term shortfall.

SECTION 3

CURRENT PROGRAM ASSESSMENT

As stated in the 1993 annex, the Training and Doctrine Command has recently developed and enhanced the concept based requirements system capitalizing on the six new Battle Labs. The Dismounted Battlespace Battle Lab at Fort Benning, GA has the lead for light force modernization. Its mission is to define the capability requirements of Dismounted Battlespace and integrate them in the combined arms force.

Modernization Strategy. An aggressive strategy to modernize the Light Force is required. In order to support the National Military Strategy we must exploit the inherent rapid deployability of light forces and make them more lethal, survivable and sustainable.

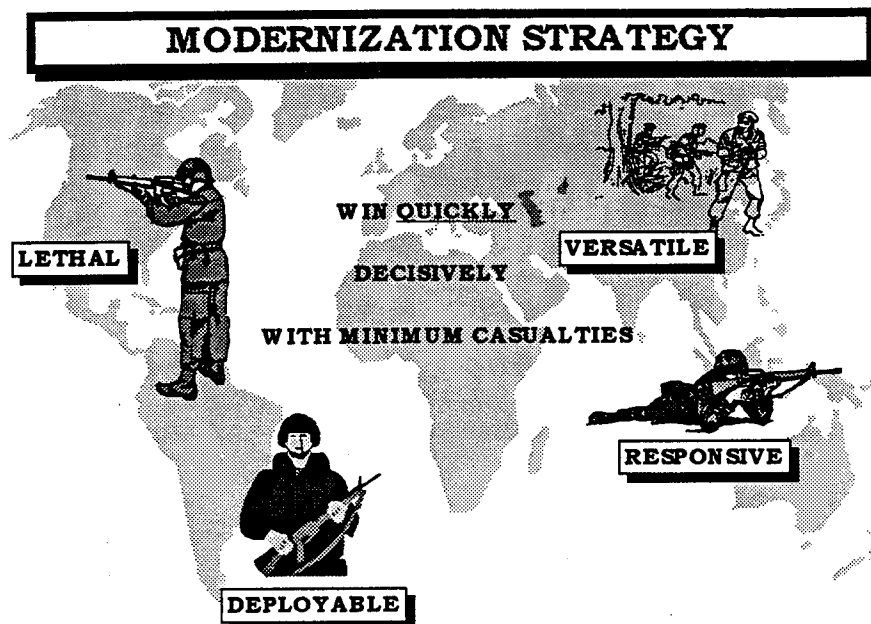

Figure 2-2

Light Force Assessment

Figure 2-3 summarizes the Light Force assessment. The following ratings were used in the assessment:

RED - No capability exists, or it is incapable of defeating threat or providing required support.

AMBER - A limited capability or quantity exists to perform the mission.

GREEN - Adequate capability or quantity exists to perform the mission.

CLOSE COMBAT LIGHT ASSESSMENT

Objectives	Deficiencies	Near Term (FY94-95)	Mid Term (FY96-99)	Far Term (FY00+)
Project and Sustain the Force	-Deploy external support -Logistics distribution -Load carrying	AMBER	AMBER	AMBER
Protect the Force	-Acquisition by enemy -Combat ID -Ballistic protection -Negotiate mines & booby traps -Area denial -Rapid fighting position construction	AMBER	GREEN	GREEN
Win the Battlefield Information War	-Inadequate communications -Position location -Inadequate remote sensor	AMBER	GREEN	GREEN
Conduct Precision Fires	-Effect extended close battle -Inadequate range, lethality & accuracy -Inadequate indirect fires	AMBER	AMBER	GREEN
Dominate the Maneuver Battle	-Anti-armor -Probability of kill -Single use systems -Deployable direct fire support	AMBER	AMBER	GREEN

Figure 2-3

SECTION 4

RESEARCH, DEVELOPMENT AND ACQUISITION STRATEGY

The key to successful implementation of Army Research, Development and Acquisition (RDA) strategy is the concept of continuous modernization. The RDA strategy goal is to equip the American soldier with world-class equipment in sufficient quantities and in the shortest possible time, so that the American soldier can win decisively, quickly, and with minimum casualties. Continuous modernization is the means for sustaining our forces, capabilities, and our entire acquisition system: people, supporting industrial base, infrastructure and programs.

The new Department of Defense acquisition approach increases emphasis and investment in Science and Technology programs which lead to a broad range of Advanced Technology Demonstrations (ATD) and Top Level Demonstrations (TLD), conducted by the material developer community, and Advanced Warfighting Demonstrations (AWD), conducted by the TRADOC battle labs in conjunction with Louisiana Maneuvers. Technological advances will be incorporated more often into systems through upgrades rather than through initiation of new systems.

During the fiscal years 1994 and 1995 the Dismounted Battlespace Battle Lab will be conducting the Continuous Operations AWD, which is focused on Light Forces and will support the AWDs of the other battle labs on Light Force issues. Additionally, the modernization of the Light Force is being addressed in the upcoming 21st Century Land Warrior TLD and the Rapid Force Projection Initiative.

Science and Technology. S&T activities for light forces have been focused on solving two post-Cold War deficiencies by means of two umbrella programs or Top Level Demonstrations, which involve several different agencies. The Rapid Force Projection Initiative (RFPI) will demonstrate new technologies and tactics for light forces to improve their warfighting capabilities against armor. The 21st Century Land Warrior (21st CLW) will exploit the commercial electronics revolution to give dismounted soldiers a technical edge over their adversaries.

RFPI will examine a variety of precision, stand-off killers, forward located sensors (manned, unmanned, aerial, and ground), the necessary command and control system to transmit targeting information and an automated fire support element. One of the key aspects of this program is that it maintains constant airlift, so the force does not become less deployable as its anti-armor capabilities increase. A separate program, utilizing many components from RFPI, has been proposed as an Advanced Concepts Technology Demonstration (ACTD). Key differences of this ACTD from the top level demonstration include a smaller set of killers, larger scale, free play field exercise to let the user evaluate tactics, techniques and doctrine, and a residual capability left in the hands of a FORSCOM unit after the demonstration.

Unprogrammed Areas. The following Light Force systems are unfunded or partially funded. Forfeiture of these systems and/or similar systems will significantly impact on the modernization of the Light Forces of the future.

- **Anti-Armor Weapon System - Medium (AAWS-M):** Missiles - Although the POM provides for procurement of AAWS-M (Javelin) missiles, the cut in total recommended funding of the program results in significant increases in missile and command launch unit (CLU) costs and limits the availability of missiles for live-fire training, and does not eliminate the obsolete Dragon from the force, leaving those units at risk. The limited funding approved will cause a production dip in FY00 and 01.

- **Mortars**

(1) Decreased funding for the improved mortar ballistic computer will allow fielding to Force Package 1 and Force Package 2, but not to the remainder of the total Army Force, creating significant compatibility, capability, and training concerns.

(2) RDTE-Lack of funding does not allow research and development work to go forward on the Mortar Fire Control System (MFCS) until FY01. This upgrade will "digitize" mortar units and significantly decrease employment times and increase accuracy.

- **Objective Individual Combat and Crew Served Weapons.** Although RDTE funding is provided, the procurement tails are not currently funded. Unless funding for procurement of the objective systems are made available, the survivability of our individual combat soldier will be at greater risk.

- **Advanced Night Vision Systems.** The RDTE is funded to a limited extent, but no procurement funding has been identified to complete the acquisition action. This will have a significant impact on warfighting by undercutting the Army's goal of Owning the Night.

- **Combat Protection Systems (STINGRAY and OUTRIDER).** The STINGRAY program is the most developed of all Service programs and is providing the basis for future systems. The decrement to RDTE for the STINGRAY creates a problem in taking the prototypes through the ADT process and moving the technology through EMD to fielding. This affects the development of the OUTRIDER program as well. It may result in a significant delay in the fielding of US systems in a proliferating environment of competitive foreign systems. The lack of procurement funding puts our combat soldiers and their equipment at high risk.

The chart below reflects minor adjustments (indicated by an asterisk) to the Close Combat Light Systems Assessments.

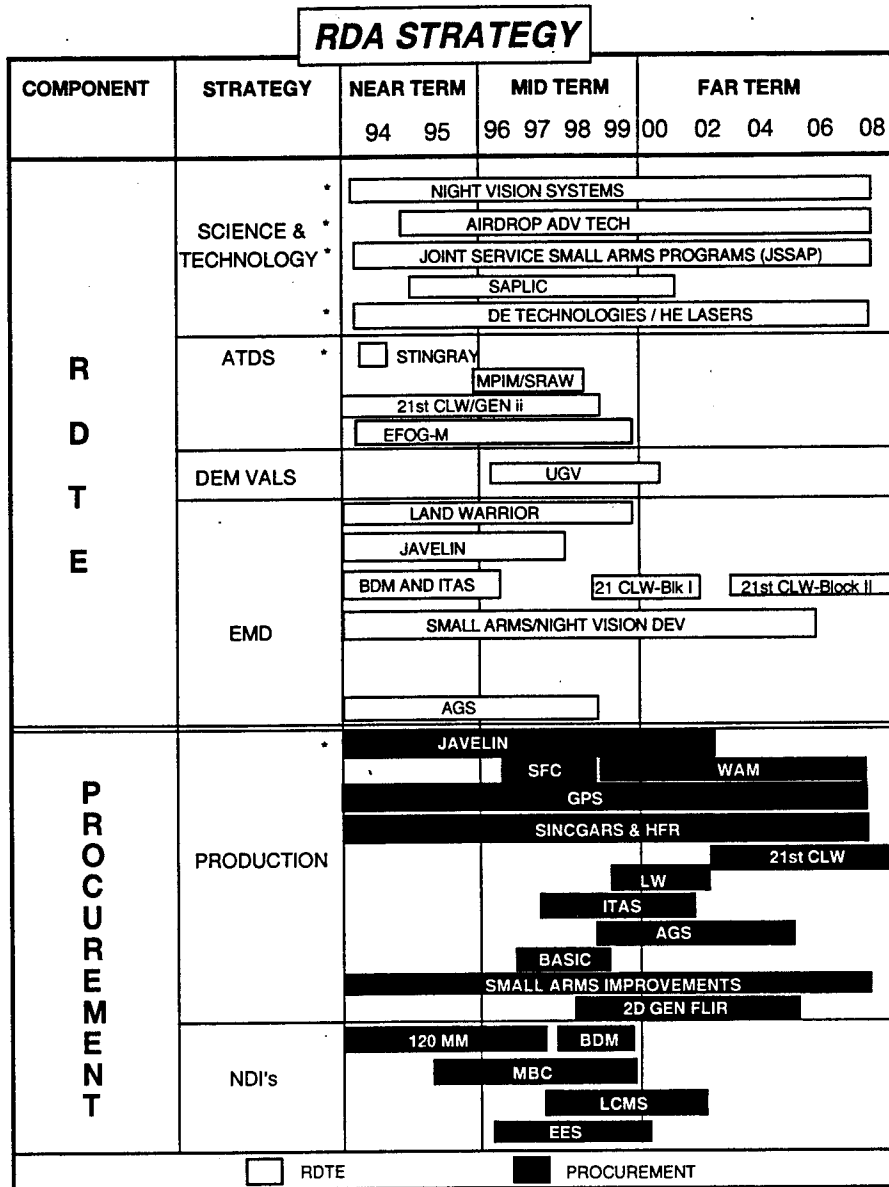

Figure 2-4

SECTION 5

TRAINING

Training is fundamental to victory. Training will always be the foundation of Army warfighting capabilities. As such, it will remain the key to combat-ready Light Forces. Effective Army modernization through the exploitation of technology is inexorably linked to rigorous, continuous training. We cannot effectively exploit the advanced technology base unless we match our materiel acquisitions with advancements in our training base.

The training emphasis will continue to be on combat-ready units. The training will be METL based, multi-echelon and assisted by the Combined Arms Training Strategy (CATS). The CATS is a descriptive, notional, annual training program which integrates optimum combinations of full-scale live-fire training with training aids, devices, simulators, and simulations (TADSS).

Computer networking and distributed training will bring the school house expertise to the soldier in the field. Future battles will be fought to a great extent by soldiers that were trained with a significant mix of TADSS as well as unique training ammunition.

Simulations used to drive command post exercises (CPX) will see improvements in their ability to replicate the consequences of command decisions. These CPX drivers will be delivered by smaller, less expensive computers allowing for increased opportunities to train. In some cases the computers used for these exercises will be the same tactical computers used during warfighting. Our simulations capabilities will enhance training and combat developments. In the future they will also enhance our ability to rapidly respond to crises by giving commanders expanded intelligence and data linked tools for rapid mission planning and rehearsal of contingencies.

The failure to support the training device programs for systems funded for development and fielding is equivalent to not fielding the basic capability. Systems that soldiers cannot be trained on to proficiency, are in essence not employable capabilities. Consistent with major program funding and fielded equipment and systems, the following future training devices will be required to support the Light Force.

- Laser Countermeasure System-Tactical Engagement Simulator (LCMS-TES)
- Stingray Tactical Engagement Simulator
- JANUS
- Javelin Training Devices: a missile simulation round (MSR), a field tactical trainer (FTT), and a basic skills trainer (BST)
- Precision Gunnery Training System (PGTS) consisting of the TOW Gunnery Trainer, the TOW Field Tactical Trainer (TETT), the Improved TOW Vehicle Field Tactical Trainer (ITVETT), the Dragon Gunnery Trainer (DGT), and the Dragon Field Tactical Trainer (DFTT) (required funding of the Javelin program would eliminate the requirements for DGT and DFTT since the Dragon would leave the inventory)
- Machine Gun recoil Amplifier, .50 Caliber M2
- M21 .22 Caliber Rimfire Adapter (RFA)
- 5.56 mm Short-Ranger Training Ammunition (SRTA)/M2 Bolt
- Location of Miss and Hit (LOMAH) System
- Short-Range Training Round (SRTR) 81-mm and 60-mm

SECTION 6

CONCLUSION

The intent of modernization is to correct current shortfalls while preventing future ones, thereby enhancing tomorrow's warfighting capability. Science and technology must continue to provide our Light Forces with both evolutionary and revolutionary advancements in capability. Tough realistic training as a combined arms force will still be the cornerstone to our success on the battlefield.

Our strategy is to retain and enhance the world's most capable military force. We must nurture a force that is CONUS-based, lethal, survivable, and sustainable. It must be deployable on short notice to deter aggression, defeat an adversary, or provide disaster relief; and capable of sustained humanitarian and military assistance. An investment in the Army today is an investment in the country tomorrow.

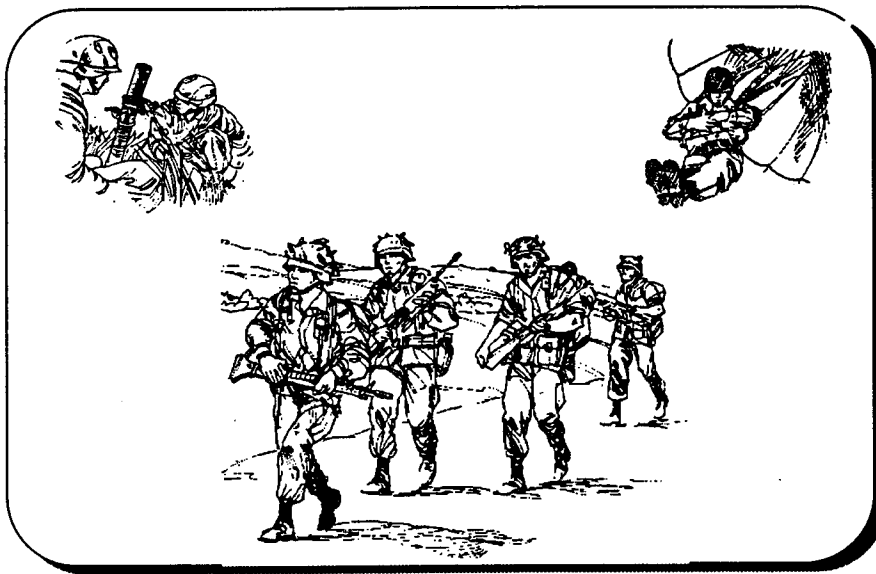

US ARMY LIGHT FORCES
"Meeting the challenge"

CHAPTER 3

COMMAND, CONTROL, COMMUNICATIONS AND COMPUTERS (C4)

SECTION 1

INTRODUCTION

This chapter updates Annex C of the 1993 Army Modernization Plan. The original annex, which this update addresses, remains valid where changes are not indicated. The roles, missions, and capabilities of the Army's command, control, communications, and computer (C4) systems have not changed since publication of the Modernization Plan. There have been changes in force composition and modernization consistent with changing security commitments and declining resources. There are instances where fielding schedules and research and development for some systems or modification programs have been drawn out over an expanded time frame. Indeed, some efforts have had to be unfunded or canceled altogether. This chapter will highlight the changes and present an azimuth for the future. This chapter is also retitled to more correctly portray the interaction of computers with C3 systems. Specific computer terminals are key components of future tactical C2 and communications systems and are included in Annex C of the Modernization Plan and are updated in this chapter. Other computer systems contribute more to sustaining base applications and are covered in Annex N (Information Mission Area) of the Modernization Plan and Chapter 14 of this update.

Under the overarching modernization objectives, C4 programs will help America's Army win today's battles by combining leveraging technologies to dominate the battlefield and meet the information needs of the warfighters. The thrusts of C4 modernization support battlefield commanders by providing and transmitting information globally—clearly required of a power projection force.

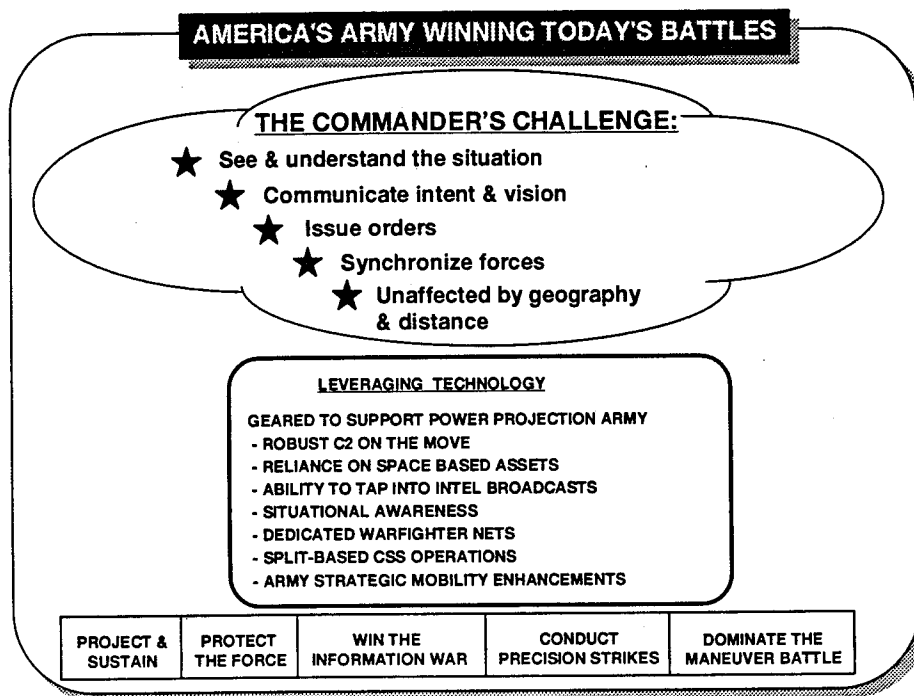

SECTION 2

WARFIGHTING CONCEPT

The warfighting concept for C4 continues to evolve. In the past, stove-piped systems were developed and operated independently. Today these systems are giving way to a totally integrated, seamless architecture. Apparent to the user is complete integration of C4 systems requiring global interconnectivity from the sustaining base through the theater to the tactical commanders.

The actions listed in Figure 3-1 depict transitioning C4 modernization from one of Cold War requirements to one better able to support and sustain a Post Cold War environment. As previously stated, this post Cold War Army will be structured to project combat power quickly to anywhere in the world to further US national objectives. The Force Projection Army Command and Control (FPAC2) plan depicted in the following figure graphically displays key features of the current C4 modernization goals.

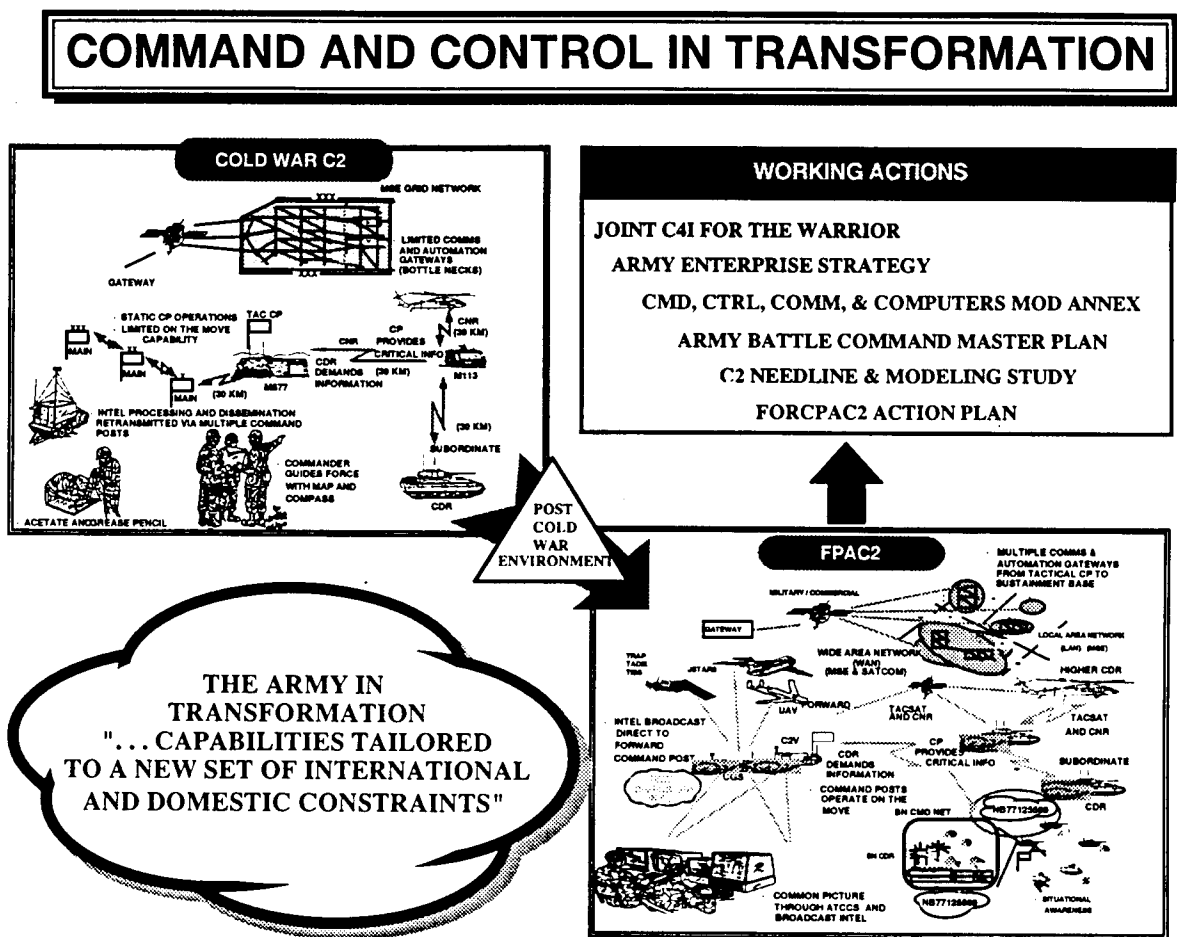

Figure 3-1

Split-based operations are the hallmark of a power projection Army. Such an Army depends on a modern, robust communications and information system in order to achieve land force dominance regardless of where that force might be projected. Technological advances dictate a continuing effort and challenge to modernize while at the same time ensuring that the following warfighting imperatives remain the drivers of C4 modernization:

- **Deployability.** C4 systems and organizations must move rapidly and while many are in the Reserve Components not all systems or units are as technologically advanced as they must be. Modernization focus needs to shift to key reserve component units once active contingency forces are upgraded.

- **Compatibility.** C4 equipment must be used in joint and combined operations, yet we have a number of communications systems that are old and cannot interoperate. The focus will be towards developing a common operating environment for automated C2 systems and the development of interoperable, antijam data transport systems.

- **Standardization.** Standardizing protocols and procedures for shared use of jointly controlled (usually national) resources paves the way for international standardization critical to successful coalition operations.

- **Mobility.** C4 assets operate under the "split base" mode of operations during CONUS-based (or home station) marshaling, strategic and operational deployments, tactical employments, and during the early phase of all contingencies. When units deploy without their sustaining base they must be supported from outside the tactical theater.

- **Expandability.** From the commencement of operations through mobilization to the conduct of battles, C4 assets must be capable of responding quickly and reaching maturity and robustness in very short order.

- **Range Extension** capabilities must be improved.
- **Survivability** and more protection is necessary.
- **Integration** and the interconnection of C4 information systems must be improved.

- **Technology Advancement.** As technology advances, C4 systems and equipment must remain sustainable and modern to keep US forces ahead of potential adversaries, improve deployability and mobility capabilities, and provide for unforeseen digital data and voice communications requirements. This is one of our cardinal azimuths.

- **Responsive to infrastructure changes and data volume increases.** Digitizing the battlefield through development of the M1A2, advanced Bradley, C2V and other digital systems requires enhancement of the data transport means. Communication systems must be capable of rapid digital data transmissions which are necessary for battlefield interconnectivity and increased demands on C4 system capacity.

- **Force Projection Installations.** To conduct force projection operations, the Army must be capable of rapidly mobilizing, deploying and conducting operation. Mobilization, deployment, and split-based operations will be conducted in CONUS from several specially selected installations. The Army must ensure that tactical C2 systems are interoperable with the force projection installation's C4 infrastructure.

- **Frequency spectrum efficiencies.** More and more dependence on the electromagnetic spectrum by an increasing pool of weapon systems continues to stress an already overcrowded spectrum. Civilian users also compete for the same spectrum. This problem is compounded by the likelihood of deploying to nations which have differing rules for Radio Frequency (RF) spectrum management and differing allotments of frequencies provided by the host country. New technologies are necessary to expand the shared use of the spectrum, such as Demand Access Multiple Assigned (DAMA), which depend on future satellite radios and packetizing networks.

- **Digitizing the Battlefield.** Provides an integrated digital information network that supports warfighting systems and assures C4 decision cycle supremacy. Also permits the commander the ability to employ forces in a highly mobile, synergistic manner with a high degree of confidence based on digital data - a common picture of the battlefield and enabled by today's advanced technologies in computers, telecommunications, mass memories and displays. Battlefield Digitization provides a heretofore unmatched level of battle coordination, and keeps commanders and soldiers fully informed. The importance of this concept cannot be overemphasized. The Army's objective is to digitize a brigade by FY96, followed by a division in FY97, and a digitized corps in FY99.

- **Adaptable to battlefields with significant enemy interference and interdiction.** Threat forces, regardless of sophistication, have the means to intercept and deny friendly communications. Electronic Counter-Measure (ECM) technology is relatively cheap and quite effective even at low levels of sophistication. Daily reports of increased proliferation and availability of technology and ECM equipment indicates an electronic threat could be encountered practically anywhere in the world. The Army's deploying forces must be able to contend with such threats. Technologies providing low probability of intercept and low probability of detection of emissions complement frequency hopping, while communications systems having direct sequencing, spread spectrum techniques help eliminate enemy interference and interdiction.

SECTION 3

CURRENT CAPABILITY ASSESSMENT

The chart below depicts the current command, control, communications and computer capability assessment. It provides a snapshot assessment of capabilities needed to win the information war. There are no significant changes from the assessment made in Annex C of the 1993 Army Modernization Plan.

	DEFICIENCIES	NEAR TERM (FY94-95)	MID TERM (FY96-99)	FAR TERM (FY00-08)
COMBAT NET RADIO (IHFR, SQUAD RADIO, SINCGARS)	<ul style="list-style-type: none"> •POOR RELIABILITY •LACK OF SECURE EQUIPMENT •TOO HEAVY •MAINTENANCE INTENSIVE •LIMITED ANTI-JAM •SHORTAGES 	AMBER	AMBER	GREEN
DATA DISTRIBUTION	<ul style="list-style-type: none"> •LIMITED CAPABILITY •INCREASING DEMAND BY OTHER BOS SYSTEMS •DIGITIZATION OF WEAPONS 	RED	AMBER	AMBER
AREA COMMON USER SYSTEM	<ul style="list-style-type: none"> •DEPLOYMENT IS RESOURCE INTENSIVE •LIMITED MOBILITY •LIMITED RANGE •MANPOWER INTENSIVE •POOR SURVIVABILITY •INSUFFICIENT DATA THRUPUT 	AMBER	GREEN	AMBER
C2 ON THE MOVE	<ul style="list-style-type: none"> •NO CURRENT CAPABILITY FOR MOBILE COMMAND POST •COMMAND SYSTEMS NON EXISTENT •NO MOBILE SATCOM ON ARMY VEHICLES •TOO MANY ANTENNAS REQUIRED •POS/NAV LIMITED 	RED	AMBER	GREEN
RANGE EXTENSION	<ul style="list-style-type: none"> •DOES NOT CONFORM TO JCS STDS •LIMITED SATELLITE AVAILABILITY •OBSOLETE HF RADIO ANTENNAS & AND NO DATA CAPABILITY •SATCOM EQUIPMENT TOO BIG •NEED WARFIGHTERS NET 	RED	AMBER	GREEN
C4 AUTOMATION	<ul style="list-style-type: none"> •LIMITED USE ON THE MOVE •INCOMPATIBILITIES •OBSOLETE TECHNOLOGY 	RED	RED	AMBER

* The deficiencies listed under CNR do not apply to SINCGARS which, if rated separately, would be rated **GREEN** for Near, Mid, and Far terms.

Figure 3-2

SECTION 4

CURRENT PROGRAM ASSESSMENT

Several changes in acquisition strategy have occurred since the Modernization Plan was last published. These changes were, in large measure, results of efforts to reshape the force and competing efforts to reduce weapon system outlays and budgets. Key to maintaining momentum in C4 modernization is a clear focus on objectives and goals.

PLGR. Procurement and fielding for force package (FP) 1, 2, and part of 3 are in progress. PLGR will provide the initial GPS capability to the Army. Future GPS systems will be embedded in other systems (i.e., GPS/SINGARS embedding).

ATCCS Systems Evolving into Army Battle Command System (ABCS). The ABCS concept envisions standard, modular, systems support and applications support software supporting a "tailorable" set of applications software. There will exist a set of ABCS common, common support, and commercial off-the-shelf software applications along with functionally unique applications software. Combined, these applications will create, access, and update force level information and provide the capability to generate a common picture of the battlefield and enhance situational awareness. The ABCS Operational Requirements Document is awaiting approval by HQDA.

ARMY TACTICAL COMMAND AND CONTROL SYSTEM REVIEW "ATCCS IN TRANSFORMATION"

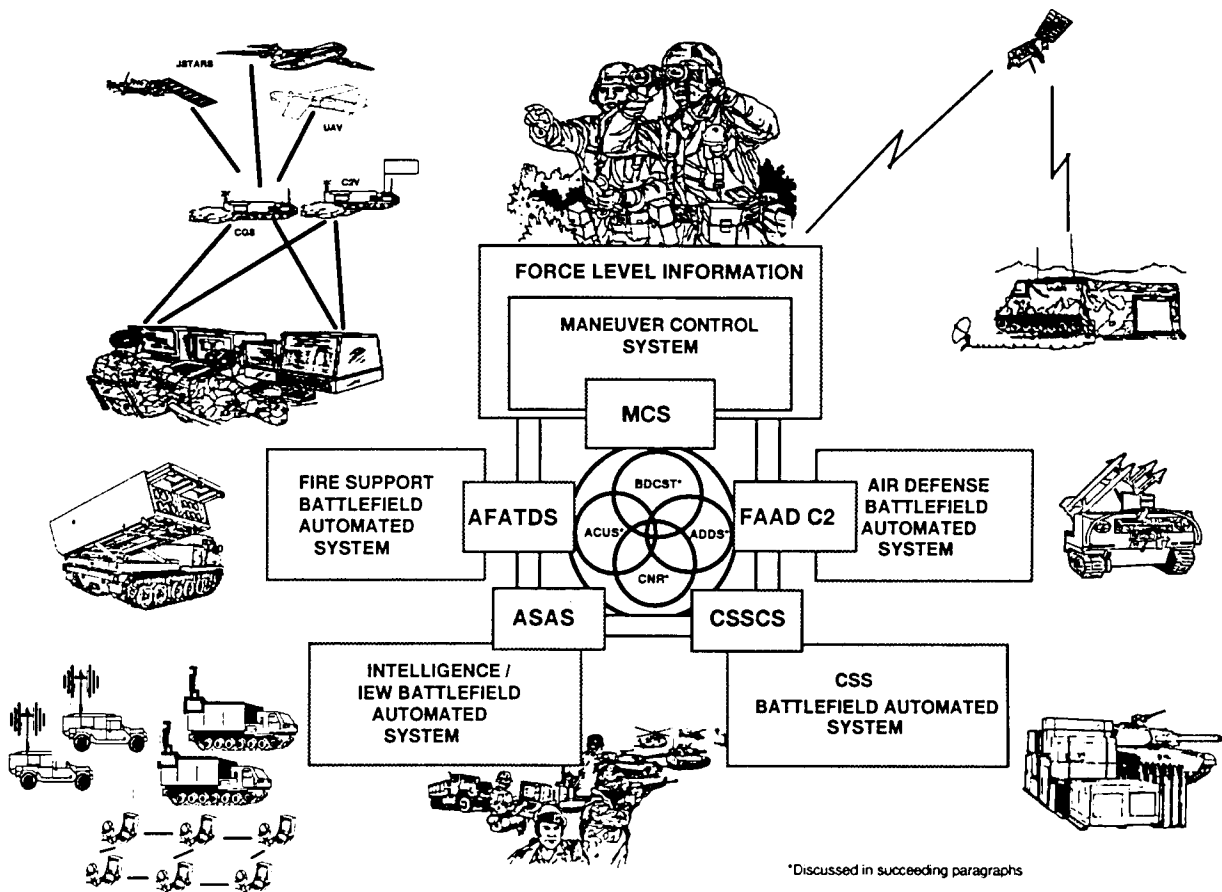

Figure 3-3

Broadcast (BDCST). The Army is moving to broadcast nets for rapid and wide dissemination of perishable combat information in order to immediately and simultaneously update key command nodes across the battlefield. Broadcast nets help to improve efficiency of combat communications by transmitting information without the need for responses by the recipients. Such broadcast nets would support functions such as air defense, sensor-to-shooter links, and early warning. Examples include the Commander's Tactical Terminal-Hybrid (CTT-Hybrid), which support the Guardrail common sensor system, and certain of the Joint-STARS broadcasts to area ground station modules within Army units.

Army Data Distribution System (ADDS). EPLRS, JTIDS, SINCGARS internet controllers (INC). Current TRADOC needline studies are examining the total requirement for data transport means and methods. Results will drive the mix of EPLRS, JTIDS, and advanced SINCGARS with INC that are needed to digitize the battlefield.

Combat Net Radio (CNR). Stretching out SINCGARS FP 3 fielding; begin SIP development. SINCGARS fielding to reserve component forces (Force Package 3) not considered round-out to active units has been slowed. However, offsetting this is the development of improved SINCGARS radios which focuses on data distribution improvements and integration of GPS technology to promote situational awareness.

Area Common User System (ACUS). The ACUS is composed of the tri-service tactical communications system (TRITAC), found in echelons above corps, and the Mobile Subscriber Equipment (MSE), found in echelons of corps and below. The TRITAC and MSE equipment provide the switching, transmission, control, and terminal equipment for their respective areas. TRITAC systems are being upgraded with the technological capabilities of the MSE system. Upgrades to both systems are being validated and documented in a System Improvement Plan.

Maneuver Control System (MCS). MCS will be the primary automated decision support system for the tactical maneuver commander and staff. In conformance with the ABCS concept, MCS will also evolve to a common operating environment and supporting tailorable applications. It will provide the functional applications (both Command and Unique) necessary to satisfy information requirements for a specific operation, develop and distribute plans and orders, provide estimates for future operations, and provide the ability to effectively control current combat operations. A request for proposals (RFP) is being developed for version 12 of MCS.

QEAM Program terminated. A total of 6,500 10 meter masts have been purchased and will be distributed to Force Package 1 units beginning 1st Qtr FY 95. Funds are not available for additional buys.

C2V FUE accelerated by 1-2 years. The C2V program was accelerated to an FUE of FY98 to accommodate earlier fielding of 467 vehicles to FP 1 heavy units. The program is entering a Milestone I/II ASARC 1QTR FY94. Pending the ASARC decision, the program will enter the engineering & manufacturing development (EMD) phase with a production of six (6) C2V prototypes for use in technical and operational testing. Testing is scheduled to be accomplished in FY95.

SICPS to FP 1 only. SICPS provides a family of command posts which will house the Army Tactical Command and Control System (ATCCS), corps through battalion. A limited procurement production contract has been awarded to begin in FY95 which authorizes 251 shelters to be fielded to FP 1 units over a period of three years to support near term fielding of ATCCS. The SICPS IOTE is scheduled for FY94 at Ft. Hood, Texas. A competitive follow-on production contract will be awarded in FY94 for additional quantities of SICPS required for the ATCCS program.

Combining AWIS/STACCS. STACCS is a theater-level C2 automation system in support of Echelons Above Corps. AWIS mission is modernization of the strategic C4 system in support of NCA, CINCS, etc. STACCS currently operates as a secret-level WWMCCS and is capable of running C2 software developed for WWMCCS and AWIS. AWIS, STACCS, and the theater level CSSCS will be combined into a single program called AGCCS in late FY 94 and early FY 95 and will directly support the Joint GCCS program efforts, as well as C4I for the Warrior (C4IFTW) and the Enterprise Strategy (described in sections 5 and 6).

SECTION 5

RESEARCH, DEVELOPMENT AND ACQUISITION STRATEGY

Constrained resources continue to challenge the Army's modernization vision. Strategy changes have concentrated on modernizing smaller portions of the force in the near term. Specifically, the contingency corps will be the focus of C4 modernization efforts in the budget and mid-term POM years with the remainder of the force modernization stretched over time. This allows the force to maintain the industrial base by challenging manufacturers to continually modernize capabilities, while ensuring the total force is modernized in the long term. Warfighting capabilities are increased, with the emphasis on modernizing those forces most likely to be called into action early in a contingency operation.

Reserve component forces continue to be modernized by funding dedicated exclusively to their missions. The focus on this funding is to modernize those forces (in many cases combat support and combat service support units) that would be activated in the early stages of operations.

To maintain a forward vision and to continually expand capability and improve efficiency, new systems are being introduced into the C4 modernization strategy. Some specific key programs are:

Combat Survivor Evader Locator (CSEL). This is a handheld device capable of providing near realtime, secure data messaging, geopositioning, and voice (line-of-sight) capability. It is principally a space-based over-the-horizon system that will serve thousands of simultaneous users at relatively low cost. Anticipated applications include world-wide executive level communications, survivor radio, special operations missions, intelligence use, logistics tracking, and law enforcement.

Army Battle Command System (ABCS). This is a new concept definition which incorporates ATCCS, theater, and strategic level C4 into a fully integrated, seamless entity. Features include shared use of software and hardware where applicable and automatic routing of information through the communications systems available to a distributed, but universally accessible data base.

Software configurable radio. Advances in software design are allowing manufacturers to develop a radio that is fully configured by software programming. In its idealistic, purest form, this will lead to a single radio for virtually all applications. Radios are programmed by insertion of software to accomplish specific missions. This ensures the capability for unlimited interoperability and unprecedented levels of communication system standardization and flexibility.

Advanced Warfighting Demonstrations (AWD). Investigation of promising technologies that may lead to further enhancements to the C4 architecture are constantly being pursued.. Examples are: Extremely High Frequency Applique, Advanced Satellite Technology & EHF Communications (ASTEC), Expert Communications Link Manager, and airborne video data links.

Advanced Technology Demonstrations (ATD). These also play key roles in defining what can be accomplished in the future. Some of the more important ones are cited below:

- The Combined Arms Command and Control (CAC2) ATD will provide the foundation for digitizing the battlefield at the fighting unit level. It will demonstrate the technology for near-term automated transfer of digital C3 data for the tactical maneuver forces. Proof-of-concept simulations with the Battle Labs will be used to refine functionality, establish communications capabilities, and establish operational utility. The capability will be demonstrated on operational platforms, starting with the NTC 94-07 battlefield synchronization exercise.

- The Survivable Adaptive Systems (SAS) ATD will demonstrate C2-on-the-move and survivable C3 systems of dispersed assets supported by multimedia connectivity, to support expanded command post dispersion and complement common user systems to provide long-haul/inter-echelon connectivity.

- The Digital Battlefield Communications project will provide an evolutionary communications capability for fielded tactical units and split-based operations worldwide. It will leverage the evolving commercial communications infrastructure, demonstrating increased and more flexible use of bandwidth to support multimedia operations, seamless or internetted tactical communications, and the communications to perform command and control operations while on the move.

- The Battlefield Combat Identification ATD will provide mid-to-far term integrated combat identification solutions for the ground forces, with emphasis on situational awareness and positive target identification.

- The Multiband Multimode Radio project is part of a tri-Service/ARPA effort to demonstrate flexible, reprogrammable, multiband tactical data radio technology.

To facilitate future direction and program strategies, TRADOC's Signal Center at Ft Gordon has embarked on a study to determine the battlefield needs for data communications capabilities. The study will model various force mixes in different contingency settings to determine the amount of data to be transmitted, received, and manipulated. The study will then determine whether current systems and proposed densities are sufficient to handle the load. If not, recommendations will be made to ensure programs are properly structured to address the shortfall. This will result in a solid azimuth for supporting a truly digitized battlefield.

SECTION 6

TRAINING

Training and Leader Development

As automated systems and technological developments are fielded, innovative training programs must be in place. Training must approximate combat operations. C4 and training devices used for garrison tasks must be the same or similar to those used in combat.

Although command post exercises (CPX) and tactical exercises without troops (TEWT) will continue to be the center piece for C4 training, constrained resources require more emphasis on simulations, devices, and embedded training. Future C4 equipment will have embedded training and will be capable of interfacing with the family of simulations and the National Simulation Center.

Simulations

C4 training will stress the use of computer simulations. Simulations will be used to conduct resident institutional instruction in tactics at the various schools and by commanders conducting unit training for their staffs and their subordinate commanders and staffs. The number of controllers required to utilize the simulations will continue to be reduced. Training simulations will allow training in functions and tasks that previously were difficult or impossible due to various constraints. Computer simulations will allow exercises to be replayed with different decisions to learn which tactics and techniques provide the best results. Tactical automation will be used for garrison application which will reduce or eliminate the requirement for separate sustainment training program on the tactical automation devices. Embedded training will facilitate both individual and collective training in units.

The National Simulation Center (NSC) is a centralized facility for training and integrating high quality C4 simulations. The NSC manages development and fielding of training and analytical simulations Army-wide. A host agency exists for research and analysis of the tactical applications of combat development products. NSC will be the focal point for application of battle training simulations for C4 training.

Family of Simulations (FAMSIM) is the overall command, control, and synchronization training program. It includes combat, CS, CSS C4 synchronization trainers (hardware and software) which supports training of echelons from company through EAC. Family of Simulations will:

- Train C4 tasks at all echelons.
- Be embedded in the ATCCS.
- Allow home station training.
- Use common data structures and linkages. Linkage is the interface which allows two or more simulations to share data, act on data, and share the results of the action, e.g., a CONUS based division could participate in an exercise with a Corps forward deployed in Western Europe.

SECTION 7

CONCLUSION

The past year was a hallmark for C4 systems modernization. SINGARS radios are achieving over 10,000 hours of reliability before failure; EPLRS are performing beyond expectations in trials with the 24th MX; Corps and Division Warfighter net radios are being fielded; MSE fielding was completed, and PLGRs are being produced and fielded in quantity. Funding decrements and force downsizing present challenges to accomplishing existing programs and visions for the future. As the Army explores methods for cost containment, more and more programs will be refocused. Many of the vertically developed programs will be abandoned for jointly developed alternatives. Less and less of the force will be modernized with cutting edge technology, relying on upgrading existing systems. The end result needs to be an Army capable of executing its missions across the warfighting spectrum described in the National Military Strategy.

C4 AZIMUTH

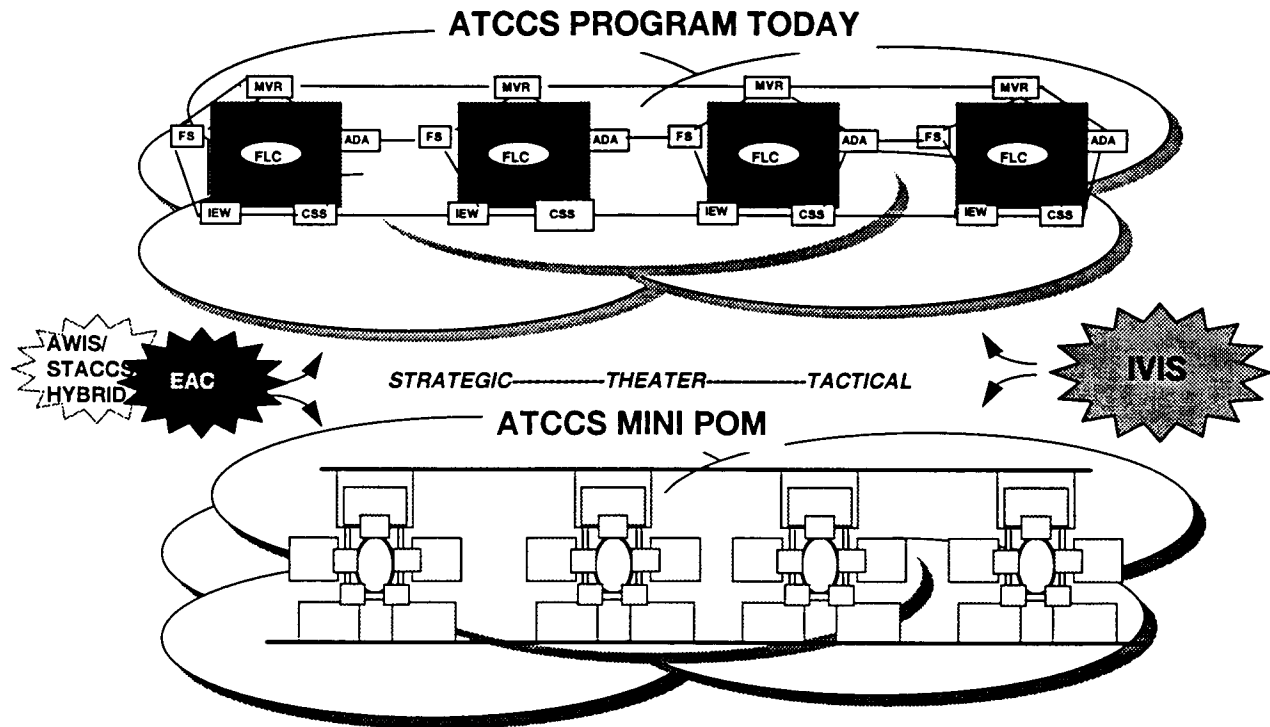

Figure 3-4

As the key architecture of warfighting C4, ATCCS is undergoing change to keep pace with a changing world and changing demands on our Army. As long as changes are focused and controlled, preparedness for conflict anywhere in the world will be assured. We have made great strides to achieving the goal of totally digitizing the battlefield! With continued emphasis and reasonable refocusing of programs in view of declining resources, we remain very optimistic that our vision of the future will be a reality.

CHAPTER 4

ENGINEER & MINE WARFARE

SECTION 1

INTRODUCTION

This chapter updates Annex D of the 1993 Army Modernization Plan. US Army Engineer roles, missions, and required capabilities remain unchanged. As stated in the 1993 Modernization Plan "engineers do not get well." That trend only continues to get worse as we face changes in national strategy and reduction in modernization budgets. Fielding schedules and research and development for nearly all engineer systems are now longer. As a result, engineer modernization focus is to field technological overmatching systems to the Contingency Corps wherever possible. The current program still has shortfalls that must be resolved in future programs. These shortfalls include tactical bridging, demolitions and selected countermine systems. Current methods of executing these missions are antiquated and leave US Army commanders with gross deficiencies in mobility/countermobility support leaving the maneuver commander with multiple deadly risks to counteract. Our minimal engineer modernization efforts do not provide robust overmatching capability to execute even one of the two Major Regional Contingencies (MRCs) as outlined in the current Defense Planning Guidance.

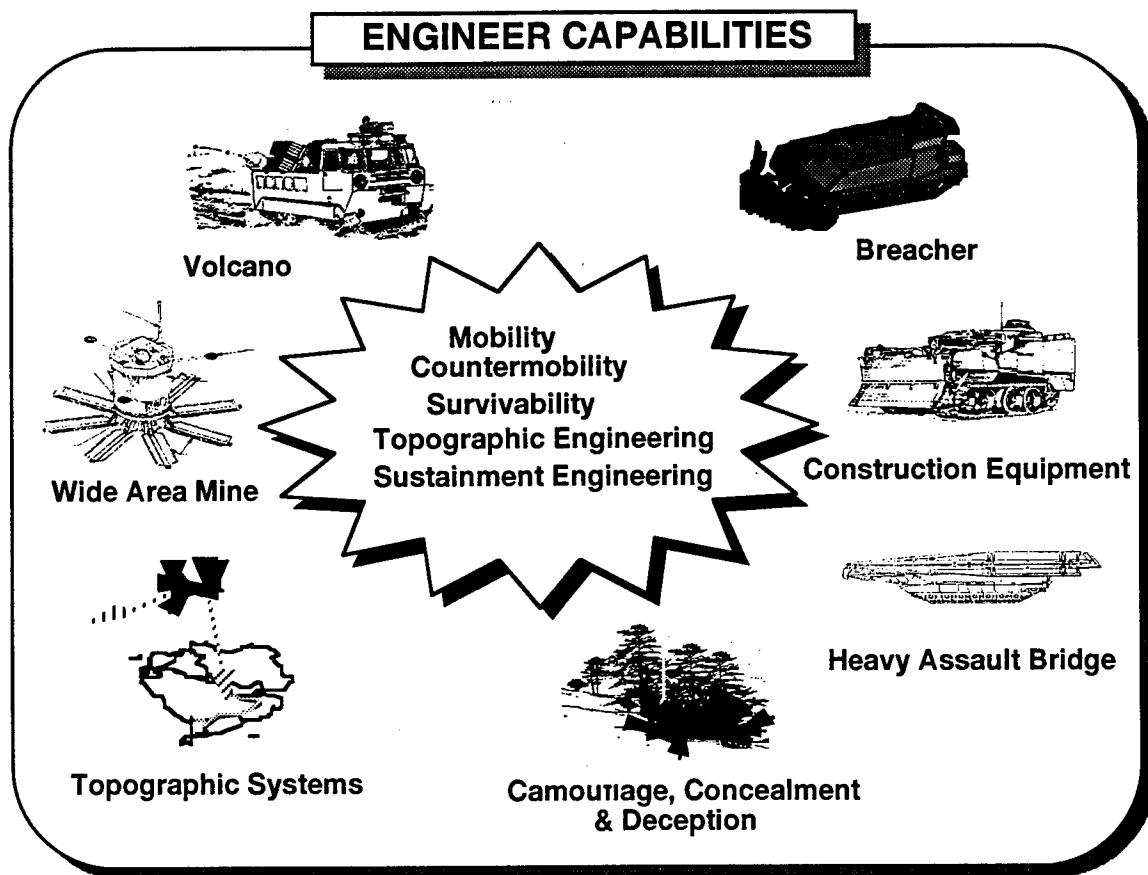

SECTION 2

WARFIGHTING CONCEPT

How to employ engineer forces needs emphasis as we enter this new strategic era. The vacuum created by the dissolution of the former Soviet Union and Warsaw Pact has unleashed ethnic and international rivalries that had previously been kept in check. To capitalize on this economic and military chaos, the world's arms markets are opening wide to proliferate an immense variety of systems to anyone with sufficient resources. With enough money, many nations can now become modernized opponents. The face of battle can change even during a conflict by an enemy's acquisition of sophisticated weapons and new technologies. The end result is an extremely volatile world with access to the most lethal weapon systems man has ever made.

Regional powers have or are rapidly acquiring armored vehicles, helicopters, and missile systems which can threaten early entry forces. Emerging missile technologies and long range artillery will be used to target our forces, command and control nodes, ports, road networks, and airfields. Many of these regional powers are located in geographic areas for which we do not have topographic data bases and which do not contain the minimal infrastructure needed to support or sustain our operations. Fortunately, hardware alone will not make a quality enemy force.

This volatile security environment must be overcome by successfully employing the basic tenets of Army Operations - initiative, agility, depth, synchronization, and versatility. Army Warfighting Doctrine laid out in FM 100-5, Operations, sets the framework for the US Army - to deter war and, if deterrence fails, by providing Army forces capable of achieving decisive victory as part of a joint team on the battlefield. To support these tenets, the Engineer must integrate and synchronize its doctrine, training, organizations, leaders, equipment and soldiers with the maneuver and support forces to achieve success on the battlefield. This support must cover the full spectrum of the operational continuum from war (where our objective is to fight and win), to conflict (where our objective is to deter war and resolve conflict), to peacetime (where our objective is to promote peace). The engineer supports Army Operations through its battlefield operating systems of mobility, countermobility, survivability, sustainability and topographic support. The success of the Army's Warfighting Doctrine depends on robust engineer capabilities.

Engineers, like no other battlefield component, provide the resources and direct actions which allow commanders to dominate the maneuver battlefield. Freedom of maneuver is created by detecting and neutralizing mines and other obstacles, crossing gaps, providing combat roads and trails, and performing Forward Aviation Combat Engineering (FACE) operations. Enemy forces are denied freedom of maneuver by disrupting, turning, fixing or blocking their movement, and by employing smart mines which will destroy his maneuver forces. In other words, a force projection army must:

COUNTER THE ANTI-PERSONNEL AND ANTI-TANK MINE

PROBLEM. The emerging standoff minefield detection systems will partially solve this problem. These systems will be available in limited quantities, but will not warn us of every potential minefield. **Small isolated mining remains very difficult to detect.**

DEFEAT COMPLEX OBSTACLES. This normally includes mines. Current mine breaching systems such as the Mine Clearing Line Charge (MCLIC) and the Battalion Countermine Set (BCS) are marginally effective against today's sophisticated landmines and cannot defeat complex obstacles. The Breacher will provide this capability, **but will only be fielded in limited quantities.**

OVERCOME MAN-MADE OR NATURAL GAPS. The current Armored Vehicle Launched Bridge (AVLB) is incapable of crossing the M1 tank at its maximum span and cannot keep up with the force. The redesigned AVLB will be capable of crossing the M1 tank but still cannot keep up with the supported force. The Heavy Assault Bridge (HAB) will accommodate the M1 vehicles and keep up, but will be in short supply. The impact of M1/Heavy Equipment

Transporter (HET) combinations will demand greater capacities for follow-on bridging. Follow-on bridging is currently limited to the Medium Girder Bridge and World War II vintage Bailey Bridge. Both bridges are manpower intensive, logistically burdensome and cannot cross the M1/HET combination. **There is no system programmed to address this deficiency.**

USE OBSTACLES TO DOMINATE THE ENEMY MANEUVER

BATTLEFIELD. Current conventional and scatterable mines are inadequate for this task. VOLCANO provides the commander a dynamic capability. New smart mines, like the Wide Area Mine(WAM), are critical, particularly for early entry forces. The means to create explosive obstacles have not kept up with technology; **current demolitions, which are logistically burdensome, are still WW II vintage.**

PROTECT ITS DEPLOYED UNITS. To protect US forces requires construction to harden, camouflage, and conceal critical command and control nodes, weapon systems, and logistic nodes. Engineers must accomplish these tasks quickly with little host nation infrastructure support. Robust engineer forces and systems are a necessity for these complex mission requirements. Engineers also protect soldiers and systems that conduct **precision strikes** through camouflage, hardening, and concealment because these systems exert such immense impact on enemy operational centers of gravity.

SUSTAIN ITSELF. Paramount to this requirement is the logistical throughput and survivability provided by engineer tactical construction equipment. Current construction equipment averages over 20 years old. The current funding line is inadequate to address this problem. To sustain our forces engineers must construct or repair ports to accommodate our RORO ship fleet, airfields to accommodate the nations C-17/C-5/C-141 air fleet, roads, and infrastructure to enable joint forces to operate and sustain. Engineers must upgrade, maintain, or construct lines of communication and facilities, produce construction materials, and perform area damage control so US forces can successfully operate in unfavorable terrain and under unfavorable conditions.

MAXIMIZE USE OF TERRAIN. Engineer forces provide terrain reconnaissance through observation, digital terrain data, and exploitation of multi-spectral imagery. Expedient terrain information (e.g., maps, studies, and terrain IPB products) provides early deploying units with the latest visual images of the area of operations. This requires precise, up-to-date knowledge of the terrain and the effects of the terrain on enemy and friendly forces. Fielding of the Digital Topographic Support System (DTSS) and Quick Response Multicolor Printer (QRMP) provide commanders hard-copy terrain products and are a start toward terrain digitization, however, much remains to be accomplished.

OPERATIONS OTHER THAN WAR. Engineers have the versatility to provide the necessary construction, power distribution, temporary bridging, road restoration, and other essential support functions to accomplish this element of our national strategy.

PROVIDE COMBAT ENGINEERS WITH THE SAME MANEUVER, PROTECTION, AND COMMAND AND CONTROL CAPABILITIES AS THE COMBINED ARMS TEAM. The M1 Breacher and HAB are critical first steps toward this end, but many critical deficiencies still exist in mobility and protection for the engineer force. Engineers fight effectively as an integral part of the close combat team. (Needs for close combat fighters are discussed in Annex A - Heavy Forces, and Annex B - Light Forces of the basic 1993 Modernization Plan and Chapters 2 and 3 of this update.)

SECTION 3

CURRENT PROGRAM ASSESSMENT

This section assesses the US Army's ability to execute the EMW program during the Near (FY 94-95), Mid (FY 96-99) and Far (FY00-08) terms. The program to modernize the Engineer force is based on the following mission areas:

Mobility. Enhances friendly freedom of maneuver by providing countermine/counterobstacle capability, conducting gap/river crossings, constructing combat roads/trails, and performing forward aviation combat engineering (FACE).

Countermobility. Impedes enemy freedom of maneuver by enhancing battle space with obstacles and mines.

Survivability. Reduces friendly force vulnerability through rapid construction of fighting positions, protective emplacements, and camouflage/concealment.

Sustainment Engineering. Supports force projection by maintaining, upgrading, or constructing lines of communications and facilities, area damage control, and producing construction materials.

Topographic Engineering. Provides commanders with terrain analysis and topographic products that allows them to use terrain most effectively.

ASSESSMENT AND MODERNIZATION FIX

Figure 4-1, on the next page, identifies each EMW mission area, its ratings in the near, mid, and far terms, and appropriate comments concerning the current Program Objective Memorandum (POM). Changes from the initial modernization plan are asterisked. The ratings and their definitions are as follows:

- **RED** - No capability exists, or what exists is incapable of defeating the threat or providing the required support.
- **AMBER** - A limited capability or quantity exists to perform the mission.
- **GREEN** - Adequate capability or quantity exists to perform the mission.

MISSION AREA	NEAR TERM	MID TERM	FAR TERM	COMMENTS
MOBILITY				
Countermine/Counter Obstacle				
Detection	Red	Amber	Amber	ASTAMDS fielded in far term
Breaching	Red	Amber	Amber	Breacher is critical; too few fielded No funds to replace Clear Lane Marking Systems
Marking	Red	Red	Red	
Clearing	Amber	Amber	Amber	Dismounted capability only
Gap Crossing				
Assault Gap Crossing	Red	Red	Amber	Too few HAB/AVLB 70 fielded Improved Ribbon Bridge and Heavy Dry Support Bridge unfunded
Bridging	Red	Red	Red	
Combat Roads&Trails/FACE	Amber	Amber	Amber	Fielding DEUCE in near term
COUNTERMOBILITY				
Mine Warfare				
Scatterable	Amber	Amber	Amber	Insufficient production funding
Smart	Amber	Amber	Amber	Added category in sufficient quantity
Conventional	Amber	Amber	Amber	Deteriorating stock/Logistic Burden
Obstacle Development				
Explosive Obstacles	Amber	Amber	Red	No developmental program Obsolescence - current stock-Log Burden
Non-Explosive Obstacles	Green	Green	Green	
SURVIVABILITY				
Camouflage & Concealment	Amber	Amber	Green	Multispectral/Ultra Lightweight Camouflage Net System-GP fielded
Fortifications				
Individual	Amber	Amber	Amber	Soldier fighting cover unfunded
Vehicle	Amber	Amber	Amber	ACE System Improvement Phases/DEUCE
Shelters	Amber	Amber	Amber	Too Few Fielded
SUSTAINMENT				
Construction Equipment	Amber	Amber	Red	No investment strategy
TOPOGRAPHIC				
Strategic	Amber	Red	Red	No funds for TSS upgrade
Operational	Amber	Amber	Red	Programmed improvements not funded
Tactical	Amber	Amber	Red	Lack of wide band ATCCS

Figure 4-1

MOBILITY

Presently mobility systems are inadequate to support maneuver forces. Heavy forces leap-ahead modernization has surpassed the mobility systems capability to support. Current capabilities can only support gap crossings for military load class 70 traffic under caution conditions. Countermine capability is severely restricted by the lack of a stand off mine detection system. Current capability relies upon hand-held mine detector or the mine probe.

Countermine / Counter Obstacle. Funding cuts in the M1 Breacher in FY97 reduces the procurement quantity. Deletion of countermine capabilities to defeat magnetic mines and the decision not to provide light armor forces self extraction capability will, in the near term, reduce the versatility and flexibility of our combined arms maneuver force. No funding for an improved Cleared Lane Marking System (CLAMS) changes this area to red.

Gap Crossing. Deleted the tactical bridging program in both Research, Development, Testing, and Evaluation (RDTE) and Other Procurement Army (OPA). Current fixed bridge systems (M4T6, Medium Girder, and Bailey) were designed for the M60 tank, not the M1 tank. They are over two decades old and restrict mobility (maximum military load class 60). Killing the Tactical Bridging Program "which included procurement of Improvement Ribbon Bridge transporter only (not the bridge bays) and Heavy

Dry Support Bridge," prevents fixing this deficiency. Funding cuts for the Heavy Assault Bridge (HAB) in FY96 flattens the Army procurement program spikes in those years and reduced procurement quantities. Current intentions are to stretch these programs into the next POM cycle and Extended Planning Annex in order to meet the Army's procurement objectives in the out years.

Combat Roads & Trails/FACE. Capability improves with the fielding of the Deployable Engineer Universal Combat Earthmover (DEUCE). Provides a self-propelled dozing capability that replaces the dozer-tractor-trailer combination and enhances mobility of light forces in the mid-term.

COUNTERMOBILITY

Mine Warfare. Have added the Smart category in the mine warfare mission area. Includes development and procurement of Wide Area Mine (WAM), Command and Control (C2) WAM, and Intelligent minefield. Reduction of class V Volcano procurement quantities results in inadequate reload capability for Force Package 1. Some maneuver forces will not be able to quickly employ tactical minefields in offensive and defensive operations.

Obstacle Development. Deleting the development and fielding of all future modernized demolition condemns engineers to World War II technology. Demolition methods and materials will require an extensive use of manpower, training, logistics, safety procedures, and time.

SURVIVABILITY

The DEUCE will be employed in the survivability mode by light forces. This system solves the current problem created by the heavier, larger ACE which breaks the light division's airlift cap hindering deployments.

SUSTAINMENT ENGINEERING

Did not obtain funding for an investment strategy of \$25 million year to modernize the Tactical Construction Equipment (TCE) fleet. One quarter of the fleet is obsolete now. By the far term assessment will be red.

TOPOGRAPHIC ENGINEERING

Missions are now categorized as Strategic, Operational, and Tactical due to doctrinal changes emerging from the US Army Engineer School. Assessment remains the same. The DTSS coupled with the Quick Response Multi-colored Printer and programmed planned product improvements focus on providing a multi-spectral imagery capability down to division level in the near term.

SUMMARY

Today's Engineer force relies on overaged, nonmaintainable systems in insufficient numbers to support heavy maneuver force operations in both MRCs. The modernization gap between combat functions of maneuver and mobility/survivability is extremely wide now and continues to widen. The modernization strategy and the adjustments outlined here provide marginal improvement. The procurement of the Heavy Assault Bridge and M1 Breacher, ASTAMIDS, WAM, DEUCE, and digital topographic capability provides the framework to develop a more responsive, efficient, and flexible Engineer Force. Funds committed yield insufficient production and an overall capability of **AMBER** and getting worse.

SECTION 4

RESEARCH, DEVELOPMENT AND ACQUISITION STRATEGY

Demolition and bridging technology bases have not continued in the new program. An acceptable risk has been determined for the current demolition programs and technologies and future developments have not been funded at this time. Current demolition materials (mostly World War II technology) are heavy and bulky, placing a high demand on transportation and material handling assets. Most demolition missions require highly trained engineers. Inherent risk exists in the use of demolitions by non-trained personnel thus requiring the need for highly trained key personnel. There is an acceptable risk in the current means of transporting, handling, and storing demolitions. The industrial technical base was recently regenerated in the US after a 10 year hiatus. The ability to quickly modernize these industries in the future will be costly and delay the availability of a critical asset.

The bridging technical base, as a result of program changes, will go dormant in 1995. Reliance on other nations for technical expertise in tactical bridging may be required in the future. Our aging lines of communication bridging does not permit our wide and heavy M1-Heavy Equipment Transporter (HET) tandem to cross while loaded. Future modernization will rely almost exclusively on our current allies and their defense industries to support our technical needs.

Engineer and Mine Warfare (EMW) Science and Technology Program. Science and Technology (S&T) initiatives focus on leveraging current technologies and maturing others to insert into existing systems to improve operational capabilities and correct deficiencies. The program is divided into two parts. The first consists of Science and Technology Objectives (STO), ATD, and Top Level Demonstrations (TLD), which are DA recognized research efforts expected to provide major technology advancements. The other part is made up of selected technology demonstrations and research efforts directed by the research laboratories.

SCIENCE AND TECHNOLOGY OBJECTIVES (STO)

Battlefield Visualization Technologies develop and demonstrate rapid 3-D battlefield visualization capabilities and dynamic terrain and environment capabilities that can operate in a field environment to create high resolution, geometrically correct 3-D battlefield scenes; demonstrate and apply the use of these developments in a virtual reality environment for tactical and training applications.

Mine Hunter Killer demonstrates an infra-red detection scheme on a combat vehicle which applies a mounted forward looking microwave detection device and a brassboard directed energy/explosive neutralizer. These are then integrated into a single system which demonstrates the ability to both detect and kill mines at a standoff range.

Digital Terrain Data Generation and Update Capability develops software, special processor cards, and techniques to provide the field commander with the ability to update digital terrain information provided by the DMA or to develop his own, high resolution database of an area of critical interest not covered by DMA.

Low Cost, Low Observable (LCLO) Multispectral Technology demonstrates the ability to execute and evaluate LCLO systems operating across the threat waveband to reduce signature and increase mobility of friendly assets on the battlefield.

Vehicle-Terrain Interaction develops technologies required to provide accurate and reliable high-resolution mobility predictions, assessments, and representations.

LOC - Construction Materials and Methods provide the capability for rapid construction and repair of the in-theater transportation and facilities infrastructure to sustain a deployed force with limited engineer resources.

Field Fortifications develop technology required for expedient protective systems that will reduce manpower, material, and logistic requirements for survivability missions.

Hyperspectral Exploitation uses hyperspectral sensors to provide a capability to rapidly identify targets and militarily significant manmade and natural features from remotely sensed imagery and hyperspectral data, especially for deep tactical targets and over denied areas.

Smart Weapon Operability Enhancement (SWOE) develops analytical infrared and basic millimeter wave models to robustly simulate geographical and time/weather driven characters of environmental scenes; develops a validated multi-sensor scene generation capability to allow quantitative consideration of environmental conditions in the design, test, and evaluation of smart weapon and automatic target recognition devices; and extends the scene generation capability to encompass radio frequency band future weapon systems employed in global operations.

Vehicle Mounted Mine Detector will demonstrate technologies including x-ray backscatter imaging, ground sonar and nuclear explosive detectors to use on a vehicle mounted system to detect mines.

ADVANCED TECHNOLOGY DEMONSTRATIONS (ATD)

Close-In Man Portable Mine Detector ATD demonstrates four hand-held brassboards, each using different technologies to detect metallic and non-metallic mines.

Intelligent Minefield (IMF) ATD conducts breadboard component demonstrations of communication links between control stations, smart local controllers and sensors and demonstrates common component modules which would link WAM and other mines to create an IMF.

Off Route Smart Mine Clearance ATD demonstrates the ability to protect combat and support vehicles from top attack, anti-tank smart standoff mines.

TOP LEVEL DEMONSTRATIONS (TLD)

The Army and US Marine Corps are co-sponsoring a Top Level Demonstration (TLD) on Countermine Technologies as part of Science and Technology Thrust 5 initiatives. This TLD focuses on integrating countermine capabilities with C3I linkage to maintain Army and Marine mobility, survivability, and agility.

- Expand the Lodgement (Light Forces)
- Breakout from the Beach (Medium Forces)
- Movement to Contact (Heavy Forces)
- Assault on Objective (Heavy Forces)

Pacing technologies that will be shown include:

- Sensors – IR, Microwave, Multi-spectral
- Seismic and Acoustic Decoys
- Explosive and Directed Energy Neutralization
- Information Processing
- Robotics

SECTION 5

TRAINING

The Engineer mission area has always sought modern, state of the art training simulators/ devices for use by engineer soldiers and the Army at large. We have learned from past experience that realistic, tough training is the most effective way to prepare soldiers for the rigors of combat, especially in the areas of mine laying and clearing. Our land based forces must be able to prosecute operations across the spectrum of conflict in an unimpeded fashion.

All engineer and mine warfare training devices continue in the program. Procurement of Volcano and WAM training devices has been reduced from those amounts stated in the 1993 Modernization Plan and are discussed below:

Devices being developed are:

M970 CEV 165mm Subcaliber Trainer. Trains the main gun firing and targeting procedures on the CEV using inexpensive 40mm ammunition. Fielding: training base - FY91, Army Wide - complete 1QFY94.

Mine Effects Simulator (MES). MILES II training mine that uses a radio frequency link to provide real-time casualty and damage assessment. The MES can be dispensed by the GEMSS, FLIPPER or by hand. Testing at CMTC 1QFY94.

MES - VOLCANO. Gives MES capability to the M88 VOLCANO training canister. Fielding date has not been determined.

WAM Trainer (MILES II). MES capable mine. Issue to the combined training centers and local training and audiovisual centers in FY97.

VOLCANO-WAM MES. MES capable Wide Area Mine (WAM) using reloadable VOLCANO delivery. Fielding FY98.

MOPMS-MES. Gives MES and reload capability to the M136 MOPMS trainer. Fielding is planned in FY98.

OPFOR/CONV MES. MES capable Opposing Force and Conventional Mines. Fielding is planned for FY99.

Breacher Embedded Training P3I. Allows training in simulated combat environments. Distributed Information Systems (DIS)-compatible and allow interactive training with systems such as the Close Combat Tactical Trainer and the virtual brigade. FY99.

APOBS Inert Trainer. Allows soldiers to practice needed skills to create a footpath through an antipersonnel minefield. Scheduled fielding FY94.

Improved Inert MICLIC Trainer. An inexpensive and improved trainer that overcomes many current shortcomings and offers a more effective and versatile tool by which to sustain MICLIC training.

MDI Inert Trainer. (Modernized Demolitions Initiator) Allows soldiers to train safely on the use of new MDI system with both standard and special purpose military demolitions. Fielding FY 94.

Crane Simulator. A NDI, universal cab crane simulator. Fielding - FY97.

HAB Trainer. For individual and crew, based on the current M1 Drivers Trainer with control and software modifications. Fielding - FY98.

Engineer Combined Arms Tactical Trainer (ENCATT). Stand-alone Divisional Engineer tactical unit trainer. A simulation-based system, using engineer equipment, dynamic terrain and semi-automated forces. Trains battalions, companies and platoons in realistic combat scenarios. Collocated and interactive with the Close Combat Tactical Trainer. Platoon configured mobile units will support reserve component training. Fielding FY2004.

Explosive Minefield Breacher Trainer (EMBT). The EMB is in the concept phase and will replace the MICLIC. It is envisioned that the trainer will be a multipurpose system capable of being used for individual, unit, Force-on-Force, and institutional training. A fielding date has not been determined.

SECTION 6

CONCLUSION

The CINCs' capability for warfighting and operations other than war is highly dependent on a modernized engineer force which is versatile, robust, and highly proficient. Army modernization in the Engineer and Mine Warfare mission area is **AMBER** and getting worse in the mid and far terms. As a result, the Army's ability to execute its warfighting doctrine is at risk.

CHAPTER 5
AIR DEFENSE
SECTION 1
INTRODUCTION

This chapter updates Annex E of the 1993 Army Modernization Plan. The roles, missions, and capabilities of the Army's Air Defense Forces have not changed. There have been changes in force composition and modernization as the Army experiences a continued draw down of structure and funding. There are instances where fielding schedules and research and development for some systems or modification programs have been drawn out over an expanded time frame. Some modernization efforts have been canceled. This chapter will attempt to capture this dynamic period of change and present an azimuth for the future. The original annex, which this update addresses, remains valid where changes are not indicated. For more in-depth discussion of the changes occurring in the Theater Missile Defense area, see Chapter 8, Theater Missile Defense, of this update.

The mission of Air Defense Artillery is to employ ground-based air and missile defenses that protect friendly forces and assets from aerial surveillance and attack. Operation Desert Shield/Storm (ODS) demonstrated how devastating attacks from the air can rapidly destroy an enemy force that has no credible air defense capability. It also demonstrated the tremendous battlefield and political impacts of cruise and tactical ballistic missiles. ODS lessons reinforce the need for a credible air and missile defense capability.

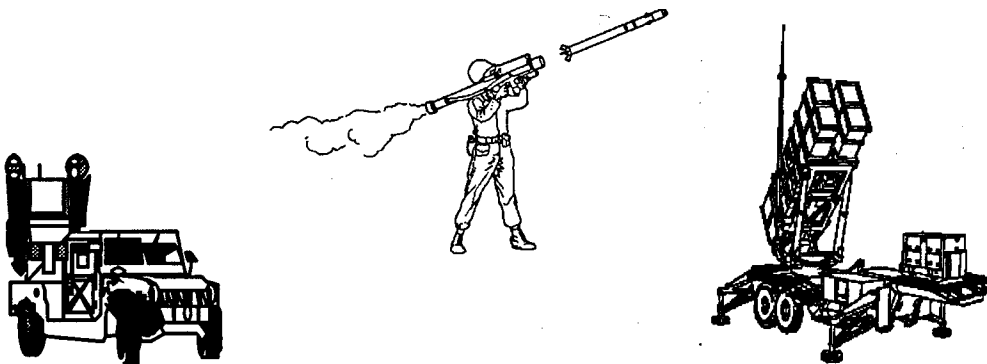

Modernization of Air Defense Artillery is key to continued protection of military and civilian assets in both theater and strategic arenas well into the next century.

SECTION 2

WARFIGHTING CONCEPT

INTRODUCTION

The concept of how to fight and defeat current and future aerial systems that represent potential air threats to US forces and critical assets throughout the world remains as described in the Modernization Plan. Potential adversaries have access to state-of-the-art technologies, from ever expanding sources. The importance of air power was underscored during Operation Desert Shield/Storm by the Joint air arms of the US and Allied forces. The lessons learned in the use of aviation, precision guided munitions, and sustained air operations (and conversely, how to defend against them), must be incorporated in all future warfighting concepts.

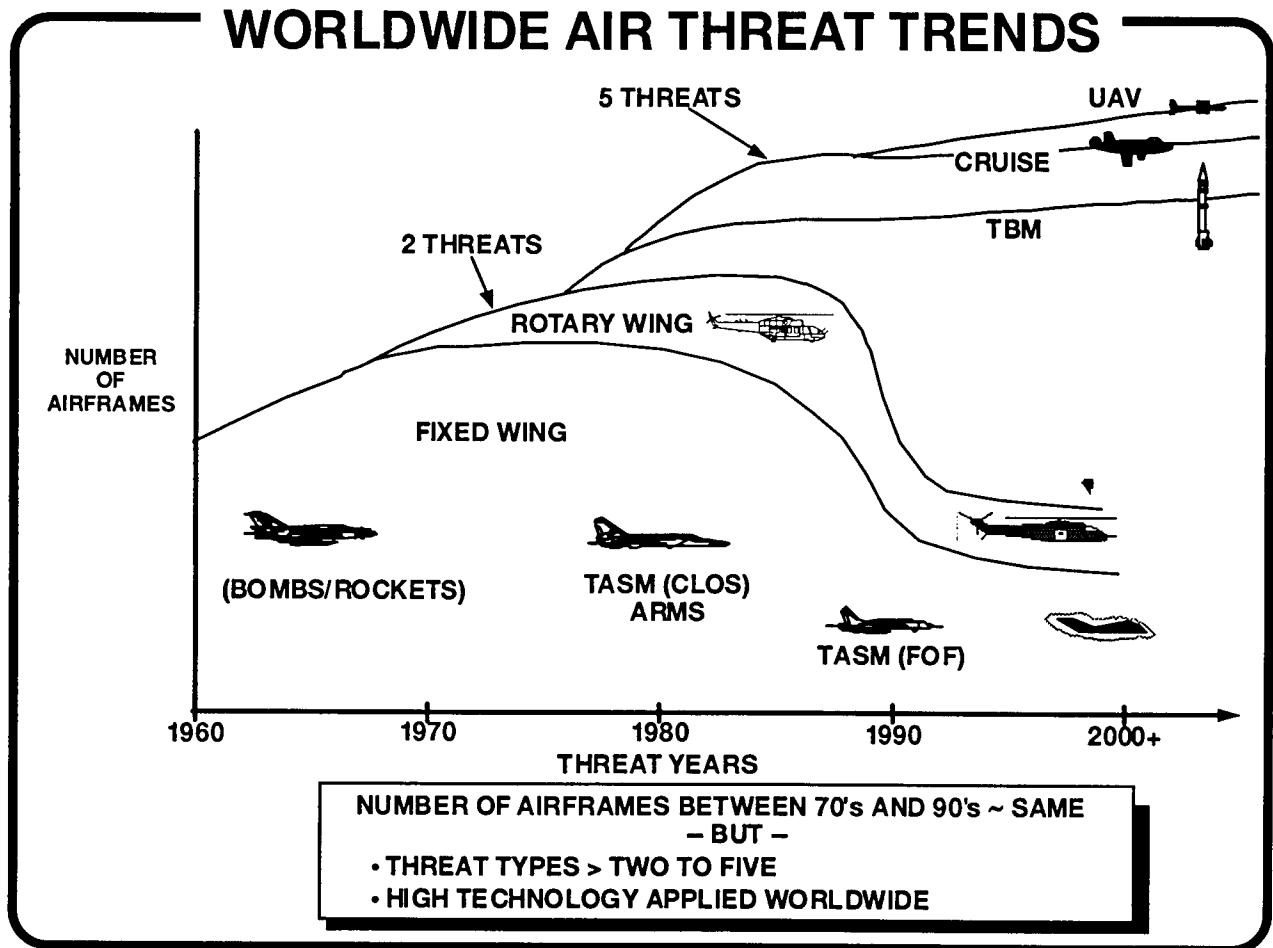

Figure 5-1

Air Threats. The primary aerial threats that must be countered by air defense forces are graphically depicted in Figure 5-1. The Joint air arm can be expected to deal effectively with the fixed wing threat; however, there must exist a synergy between defensive counter-air and ground-based air defense artillery to effectively counter the entire threat spectrum. Priority targets for ground-based air defense are tactical ballistic missiles (TBMs), unmanned aerial vehicles (UAVs), cruise missiles (CMs), tactical air-to-surface missiles (TASMs), fixed wing (FW) aircraft leakers and helicopters (rotary wing - RW). For a relatively small sum of money anyone can procure from the expanding world weapons

market a "Poor Man's" Air Force. Figure 5-2 depicts the variety of aerial threat systems that can be bought given \$50M.

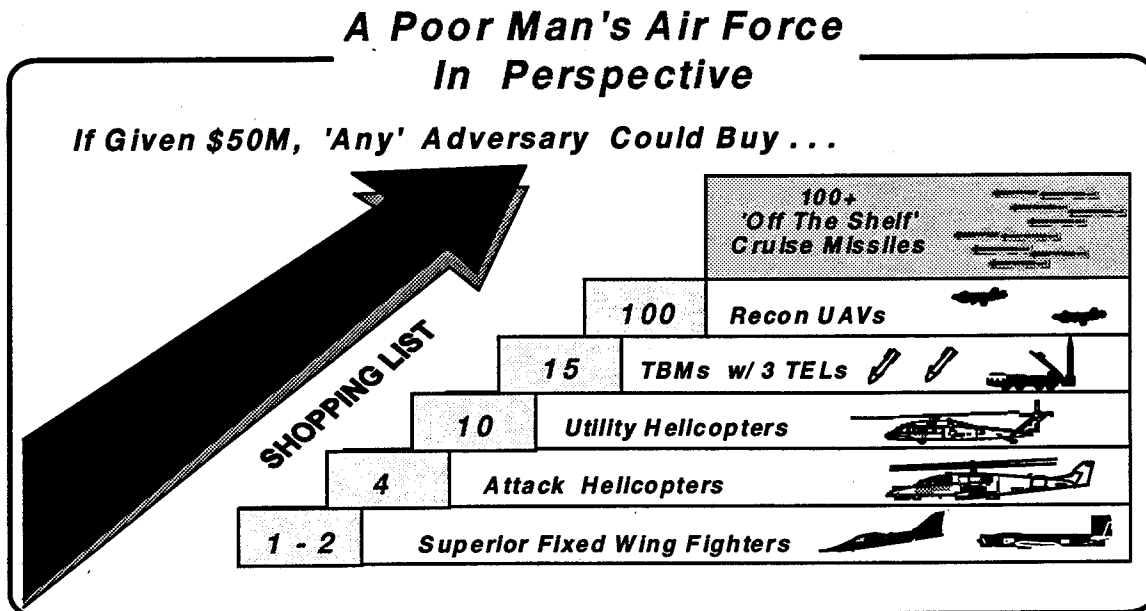

Figure 5-2

Potential Threat Regions. US forces may find themselves in regional conflicts most anywhere around the globe. Figure 5-3 shows some potential locations and principal air threats.

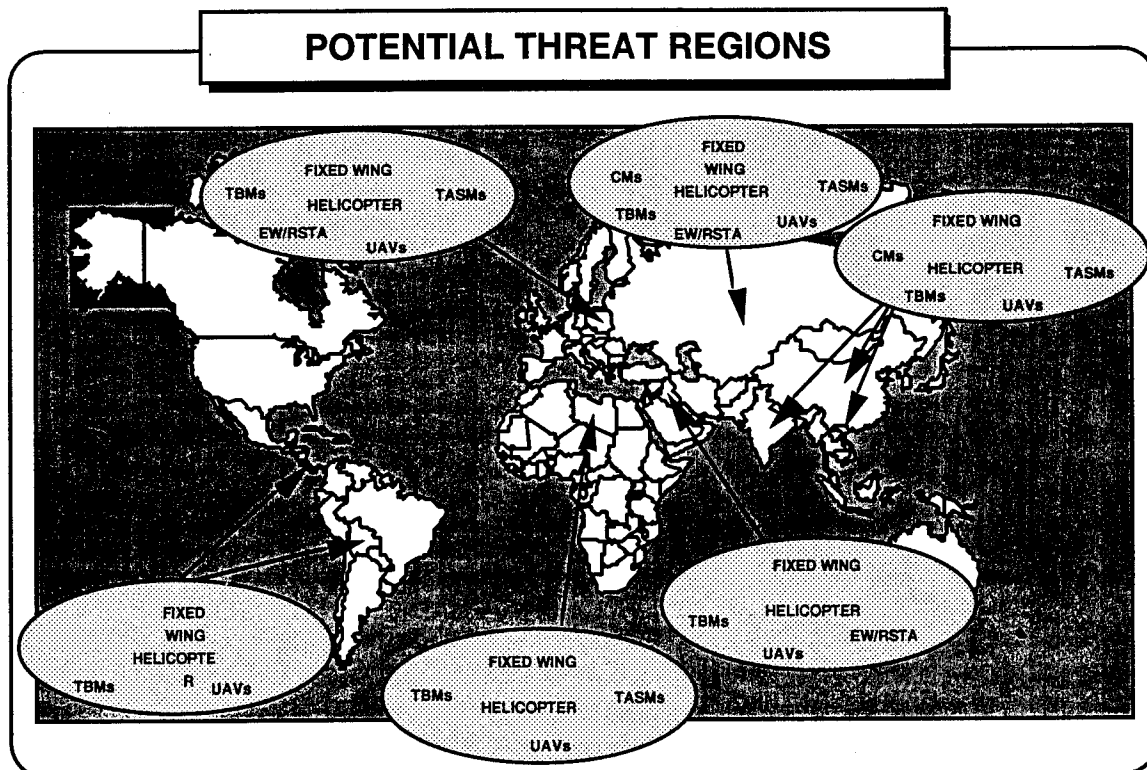

Figure 5-3

Joint Doctrine. Joint Pub 3-0, Doctrine for Joint Operations, charges air defense forces to participate in the aerospace defense mission through synchronized, integrated joint campaigns and major operations, with the overall goal of increasing the total effectiveness of the joint force, while projecting focused capabilities that present no seams or vulnerabilities for an enemy to exploit. Early entry forces should deploy with sufficient organic and supporting air defense capability to preserve freedom of action and protect the force and equipment from potential or likely threats. The Joint Force Commander (JFC) will normally seek to secure air and maritime superiority early in the conduct of joint operations. Additionally, the JFC will seek to achieve superiority immediately in C4I. Control of space operations is a necessary precursor to C4I superiority. The JFC will use space assets to observe and assess the enemy's intentions, capabilities, and actions, while concurrently depriving the enemy the ability to use his space based assets to seek similar information about friendly forces. The neutralization of the enemy's weapons of mass destruction (WMD) is also a key goal of the JFC. It is not only the sheer killing power of these WMD that has the greatest effect. The strategic, operational, psychological, and political impact of WMD can affect strategic objectives and operational campaign design. Finally, joint forces need to consider interoperability with multinational forces. Warfare of the future argues that the US will seldom operate unilaterally in the future.

Army Doctrine. FM 100-5, published in June 1993, focuses on the integration of Army operations into the Joint/Combined force to implement National Military Strategy and on the fundamentals of force protection. Protection of the force during early entry operations is a key element of our National Military Strategy and an essential objective of Army modernization. Once in theater, Army forces must have freedom to maneuver to achieve the goal of Land Force Dominance. Effective, versatile, and synchronized air defense capabilities will provide the required freedom to maneuver.

ADA Mission. The ADA mission is to employ ground-based air and missile defenses to protect the force and designated geopolitical assets from aerial attack and surveillance through all phases of contingency operations. Inherent in this mission is ensuring that the ground commander can dominate battlespace to achieve decisive victory by winning quickly with minimal casualties.

Combat Operations. In armed conflicts, Air Defense Artillery forces are required throughout the battlefield, theater of operations, and theater of war, while simultaneously maintaining strategic protection of the United States (see Figure 5-4).

INTEGRATED AIR DEFENSE

- POST 2000 TIMEFRAME -

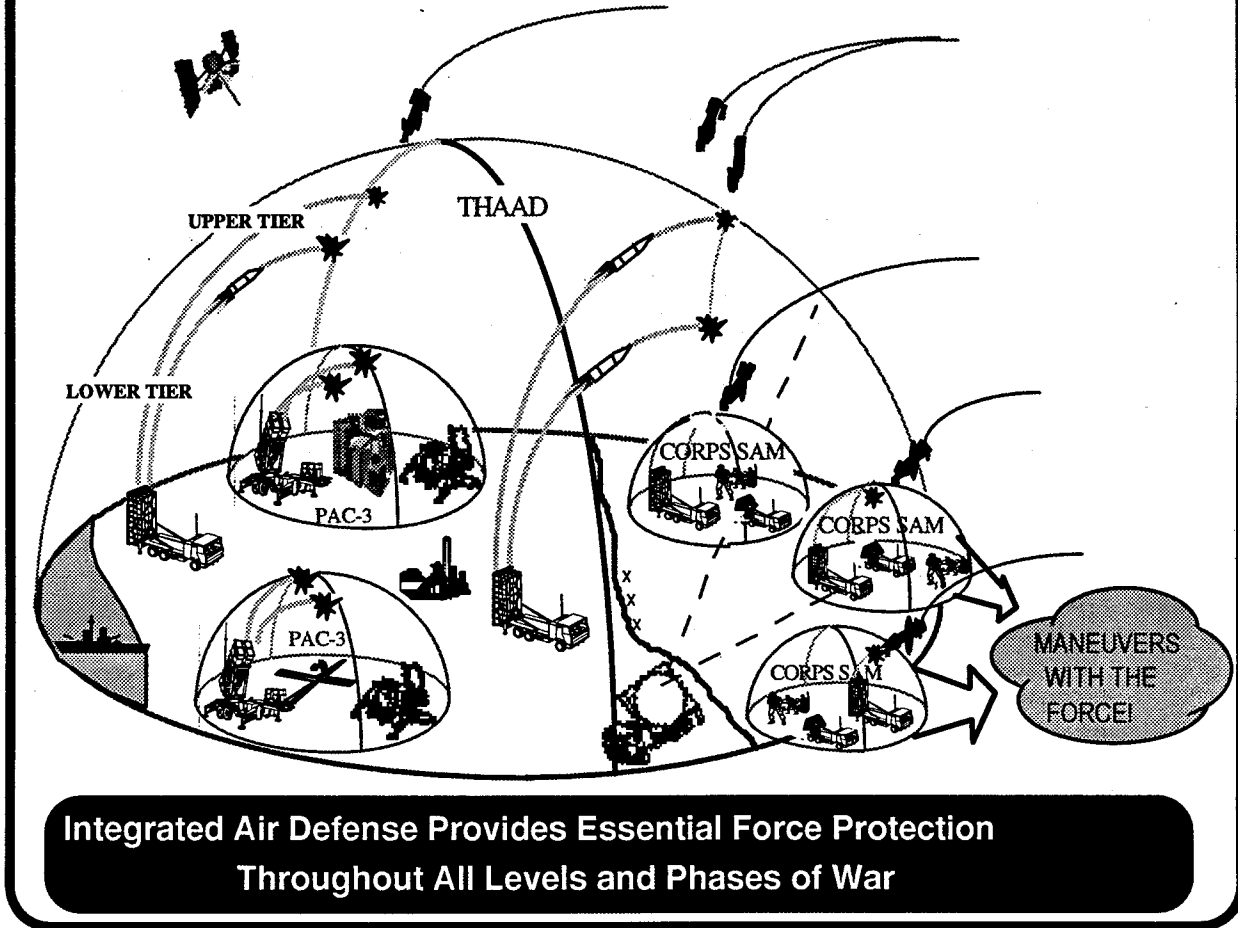

**Integrated Air Defense Provides Essential Force Protection
Throughout All Levels and Phases of War**

Figure 5-4

Once force projection operations are initiated, Air Defense Artillery forces provide requisite force protection, in synergy with other joint and combined air defense elements, from entry through redeployment operations. Early deployment of missile defense and counter-RSTA capability is crucial to the success of early entry operations. Deploying forces are most vulnerable during the initial stages of the build-up. Tactical missile defense forces protect the lodgement, geopolitical assets, and the debarking forces against ballistic and cruise missiles. Counter-RSTA units deny the enemy targeting information which is key to sustaining a productive air or missile attack. Corps and divisional Air Defense Artillery units compliment theater tactical missile defense forces by providing protection against short range tactical missiles, fixed wing leakers, helicopters, and by limiting observation by UAVs. As the joint force expands the lodgement area, Air Defense artillery units continue protecting the force and geopolitical assets, and deny enemy reconnaissance throughout the area of operations. Once decisive operations begin, Air Defense Artillery units focus on limiting or denying reconnaissance and targeting by UAVs and defeating attacks by aircraft, and theater missiles. During post-conflict and redeployment operations, Air Defense Artillery forces concentrate on providing force security and preventing surprise, permitting unimpeded reconstitution and facilitating unopposed embarkation of forces no longer required.

Strategic Defense. ADA forces will also have the specified operational mission of National Missile Defense – neutralizing the threat of accidental, unauthorized, or limited strikes against the US with ICBMs and SLBMs; and Anti-Satellite (ASAT) operations – negating low-earth-orbit threat satellites. Land based weapons, sensors, and command and control systems will be fully integrated into a tiered architecture to defend against ballistic missiles. ASAT weapons will negate the enemy's ability to utilize his satellite assets for military gain.

Tailoring the ADA Force. Air Defense Artillery (via the TAA-01 and mini-POM processes) has tailored its systems and the ADA force to counter those threats to the contingency force best addressed by ground-based systems. The Air Force has no capability against TBMs in the terminal phase due to detection difficulties and inadequate kill potential, and has limited capability against CMs, UAVs, TAsMs, and RW aircraft. Cruise missiles and TAsMs, particularly low-altitude missiles, are difficult to detect and kill due to the clutter of the earth's background when viewed from an aircraft. The UAV and RW aircraft threats operate at altitudes and locations where air-to-air combat is doctrinally avoided. This "tailoring" of our ground-based air defense force is being done with the intent of being synergistic and complementary to Air Force capabilities rather than redundant and duplicative.

SUMMARY

To achieve **Land Force Dominance**, Air Defense Artillery must provide force protection so tactical forces have freedom to maneuver throughout the joint battle area. At Corps and Theater level, control of the air environment must be maintained while protecting critical operational level warfighting capabilities. Air defense forces at Theater Strategic level must protect APODs and SPODs and key geopolitical and population centers. Air defense forces must be strategically deployable and sustainable and possess the flexibility to support all types of contingency operations. At the strategic level, air defense elements will protect the US against ballistic missiles and provide an anti-satellite capability to protect the Theater Commander's ability to move undetected and unhindered.

SECTION 3

CURRENT PROGRAM ASSESSMENT

INTRODUCTION

This section provides assessments of the updated Program Objective Memorandum (POM) FY94 - FY99 resourced forces and the resulting modernization priority changes. The program assessments are based on the threat capabilities, Army/Joint Doctrine, the modernization level of forces programmed to be available in the near-, mid-, and far-term, and established ADA missions/requirements. As a result of reductions in near- and mid-term funding programmed for air defense, previous program assessments are no longer entirely valid. Therefore, new priorities for mid-, and far-term ADA modernization have been established based on updated program assessments.

Requirements. Air Defense missions and requirements as depicted in Figure 5-5 remain essentially unchanged.

ADA MISSIONS/REQUIREMENTS		
MISSION AREAS	MISSION	REQUIREMENTS
FORWARD AREA AIR DEFENSE (FAAD)	<ul style="list-style-type: none"> • ENSURE FREEDOM TO MANEUVER • PROTECT THE FORCE • COUNTER-RSTA 	<ul style="list-style-type: none"> • STRATEGIC/TACTICAL MOBILITY • SURVIVABILITY COMMENSURATE WITH THE FORCE • HIGH FIREPOWER/LETHALITY; • EXTENDED RANGE • C3I - ACQUISITION AND ID; ACTIVE/PASSIVE, INTEGRATED, DISTRIBUTED
CORPS AREA AIR DEFENSE (CAAD)	<ul style="list-style-type: none"> • FREEDOM TO MANEUVER • PROTECT THE FORCE • COUNTER-RSTA • COUNTER UNCONVENTIONAL WARHEADS • SUPPORT DEEP OPERATIONS 	<ul style="list-style-type: none"> • STRATEGIC/TACTICAL MOBILITY • SURVIVABILITY • LETHALITY; • EXTENDED RANGE • DETECT, CLASSIFY, ID, ENGAGE THREAT TM PLATFORMS AND FW LEAKERS • ASSET TM DEFENSE • C3I - ACQUISITION - ACTIVE/PASSIVE, INTEGRATED DISTRIBUTED WITH FAAD/TAAD ELEMENTS
THEATER AREA AIR DEFENSE/THEATER STRATEGIC AIR DEFENSE (TAAD/TSAD)	<ul style="list-style-type: none"> • CONTROL AIR ENVIRONMENT • PROTECT THE FORCE • CONDUCT DEEP OPERATIONS • COUNTER-RSTA • PROTECT CITIES/GEOPOLITICAL TARGETS (TSAD UNIQUE) • PROTECT APOD/SPODS • COUNTER UNCONVENTIONAL WARHEADS 	<ul style="list-style-type: none"> • STRATEGIC/TACTICAL DEPLOYABILITY • SURVIVABILITY • HIGH FIREPOWER/LETHALITY; • EXTENDED RANGE • DETECT, CLASSIFY, ID, ENGAGE TMS • LAYERED ASSET TM DEFENSE • C3I - ACQUISITION - ACTIVE/PASSIVE, INTEGRATED WITH CAAD/JOINT ELEMENTS
STRATEGIC	<ul style="list-style-type: none"> • PROTECT UNITED STATES • COUNTER UNCONVENTIONAL WARHEADS • ASAT 	<ul style="list-style-type: none"> • DETECT, CLASSIFY, ID, ENGAGE ICBM/SLBMS • HIGH SYSTEM EFFECTIVENESS/ AVAILABILITY • HIGH LETHALITY; EXTENDED RANGE • C3I: INTEGRATED WITH NATIONAL ASSETS • DENY USE OF SATELLITES

Figure 5-5

Current Assessment (FY93). The assessment of our current forces (Figure 5-6) becomes the basis for establishing our near-term (FY94-95) priorities (Figure 5-7).

CURRENT ASSESSMENT (FY94)			
MISSION AREAS	REQUIREMENTS	CAPABILITIES	PROBLEM AREAS
FORWARD AREA AIR DEFENSE (FAAD)	<ul style="list-style-type: none"> • STRATEGIC/TACTICAL MOBILITY • SURVIVABILITY • HIGH FIREPOWER/LETHALITY • EXTENDED RANGE • INTEGRATED C3I 	<ul style="list-style-type: none"> • STRATEGICALLY DEPLOYABLE WITH SUPPORTED FORCE • BSFV PROVIDES PROTECTION FOR TEAMS WHILE MOUNTED AND CAN MANEUVER WITH FORCE • AVENGER PROVIDES INCREASED FIREPOWER/MANEUVERABILITY • COMBINED ARMS INITIATIVE: ATAS ON OH-58C 	<ul style="list-style-type: none"> • MANPADS/BSFV TEAMS NOT SURVIVABLE DURING ENGAGEMENTS • STINGER/AVENGER OUTRANGED BY STANDOFF HELICOPTER AND UAV • THREAT DEVELOPED COUNTER TO STINGER BREAKS DEFENSES • CANNOT DETECT, ID, ENGAGE LRCS & MASKED TARGETS • RSTA ACQUISITION AND KILL SHORTFALL • LIMITED FIREPOWER • ACQUISITION CAPABILITY IS BINOCULARS ONLY • VOICE COMMUNICATIONS ONLY – NO DATA EXCHANGE • AIRCRAFT IDENTIFICATION VISUAL; INHERENT FRATRICIDE PROBLEM • COLLATERAL TM COVERAGE, AT BEST, FROM CORPS PATRIOT FIRE UNITS
CORPS AREA AIR DEFENSE (CAAD)	<ul style="list-style-type: none"> • STRATEGIC/TACTICAL MOBILITY • SURVIVABILITY • HIGH FIREPOWER/LETHALITY • EXTENDED RANGE • DETECT/CLASSIFY/ID ENGAGE TMS • ASSET TM DEFENSE • INTEGRATED C3I 	<ul style="list-style-type: none"> • CAPABLE TBM COVERAGE • CORPS GAINS ORGANIC TBM UNITS • IMPROVED PATRIOT EMPLACEMENT/GUIDANCE CAPABILITIES 	<ul style="list-style-type: none"> • STRATEGIC DEPLOYMENT LIMITED BY AVAIL ASSET & SIZE OF PATRIOT/HAWK EQUIPMENT • LIMITED CAPABILITY TO DETECT/ENGAGE LRCS TARGETS • TM DETECTION/ENGAGEMENT RANGE LIMITED • CANNOT ASSURE UNCONVENTIONAL WARHEAD KILL • LIMITED MOBILITY • INSUFFICIENT FIRE UNITS TO PROTECT ALL CRITICAL ASSETS • HAWK/CHAPARRAL MANPOWER INTENSIVE - LIMITED FIREPOWER
THEATER AREA AIR DEFENSE/THEATER STRATEGIC AIR DEFENSE (TAAD/TSAD)	<ul style="list-style-type: none"> • STRATEGIC DEPLOYABILITY • SURVIVABILITY • HIGH FIREPOWER/LETHALITY • EXTENDED RANGE • DETECT/CLASSIFY/ID ENGAGE TMS • LAYERED ASSET DEFENSE • INTEGRATED C3I 	<ul style="list-style-type: none"> • CAPABLE TBM COVERAGE • IMPROVED PATRIOT EMPLACEMENT/GUIDANCE CAPABILITIES 	<ul style="list-style-type: none"> • CANNOT ASSURE UNCONVENTIONAL WARHEAD KILL/UNABLE TO PREVENT COLLATERAL DAMAGE • STRATEGIC DEPLOYABILITY LIMITED BY AVAIL ASSETS & SIZE OF PATRIOT EQUIPMENT • LIMITED CAPABILITY TO DETECT/ENGAGE LRCS TARGETS • TM BATTLESPACE LIMITED • LIMITED ASSET DEFENSE; CANNOT PROVIDE AREA COVERAGE OVER THE FORCE
STRATEGIC	<ul style="list-style-type: none"> • DETECT, CLASSIFY, ID ENGAGE ICBM/SLBMs • HIGH SYSTEM EFFECTIVENESS/ AVAILABILITY • HIGH LETHALITY; EXTENDED RANGE • C3I: INTEGRATED WITH NATIONAL ASSETS • DENY USE OF SATELLITES 		<ul style="list-style-type: none"> • CANNOT PROTECT U.S. AGAINST ICBM/SLBMs • CANNOT MEET ASAT REQUIREMENTS

Figure 5-6

NEAR-TERM PRIORITIES (FY94-95)
<ul style="list-style-type: none"> • CAPABLE TACTICAL MISSILE DEFENSE • INCREASED LETHALITY AGAINST MASS DESTRUCTION WARHEADS • CAPABLE ADA TO SUPPORT MANEUVER FORCES • IMPROVED AND INTEGRATED C3I - ALL ECHELONS • IMPROVED STRATEGIC DEPLOYABILITY • EARLY WARNING AND POSITIVE IDENTIFICATION

Figure 5-7

Near-Term Assessment (FY94-95). While significant research and development efforts to resolve ADA shortfalls continue throughout the near-term, few capabilities are fielded to solve these deficiencies. Notable exceptions – Light and Special Division Interim Sensor (LSDIS) and FAAD C3I – begin fielding in early FY94 to our early entry forces. The introduction of LSDIS and FAAD C3I systems enhances the acquisition and command and control capabilities of these FAAD Forces and lead the Army's effort to "digitize the battlefield". However, budget reductions have reduced the total procurement quantity of both the LSDIS and FAAD C3I systems. Many FAAD units, therefore, are no longer funded to receive the enhanced capabilities and will remain constrained to visual early warning and voice-tell passing/receiving of track data. Additionally, funding reductions delay the fielding of GBS to the mid-term (FY96-99) while also reducing the systems to be procured. Stinger Block I software RDTE continues and the Block I hardware mods are cut into the ongoing production efforts. All funding for RDT&E on Non-Cooperative Target Recognition (NCTR) systems has been deleted.

In the CAAD, TAAD, and TSAD areas, funding for PATRIOT PAC-3 and THAAD remains steady. The fielding of the PATRIOT remote launch capability and other PATRIOT modifications begins to extend PATRIOT battlespace. Funding for major Corps-SAM work is delayed until FY98. NMD will be kept in the tech base only, and no funding is made available for ASAT work.

The updated assessment of our near-term forces becomes the basis for developing new mid-term (FY96-99) priorities (Figure 5-8).

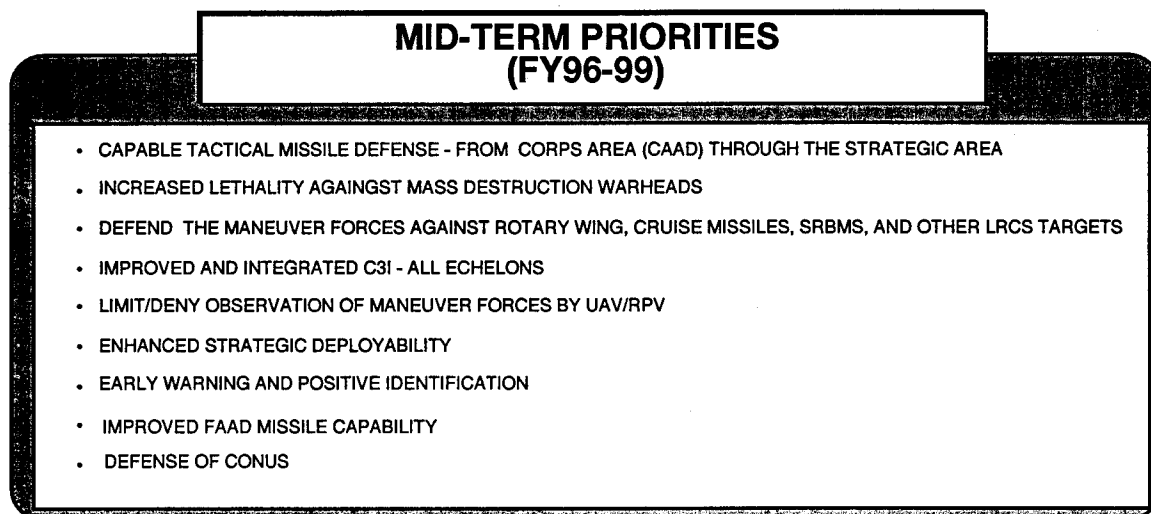

Figure 5-8

Mid-Term Assessment (FY96-99). The remaining products of current and near-term RDT&E finally begin to be fielded in the mid-term. With current funding levels, GBS will begin fielding and FAAD C3I will complete fielding. A reduced fielding of AVENGER will be completed in the mid-term. Reduced Stinger funding allows the Block I retrofit of only 600-700 missiles per year in FY96-99. Budget reductions have terminated funding for the Non-Cooperative Target Recognition (NCTR) program. AVENGER modifications have been reduced. In the FAAD arena there will be some AC units without FAAD C2 and/or GBS. The only weapon system available to address the myriad of threat will be the Stinger (RMP). The resulting Stinger-only force, with limited sensor capabilities and no organic means of positively identifying air vehicles, has significant shortcomings in dealing with a technically sophisticated UAV and rotary wing threat.

PATRIOT Advanced Capability (PAC-3) improvements to the radar and missile increases battlespace and improves lethality against the ballistic missile threat. Reduction in the size of the launcher (still an unfunded requirement) maintains PATRIOT's high demand on airlift to get to the conflict. A THAAD User Operational Evaluation System (UOES) will be fielded in late FY96. Although the THAAD UOES is not an objective system, it will be available for contingency deployment to add vertical and horizontal depth to the Army's ability to kill threat ballistic missiles. PAC-3 and THAAD, operating in an enclave, provide two-tiered asset and area coverage. The OSD Bottom Up Review has delayed all major Corps SAM work until FY98, pushing the Army capability to defend Corps maneuver forces from cruise missile, TASM, and short range TBM attack deeper into the first decade of the 21st Century. Corps SAM is also vital to 21st Century maneuver operations as it will kill threat UAV/RPVs and deny enemy observation and targeting of maneuver forces.

In the strategic realm, budget reductions and the recent OSD Bottom-Up Review will keep NMD in technical development. Additionally, funding for the anti-satellite program has been terminated.

The updated mid-term assessment drives the new far-term (FY00-08) priorities, shown in Figure 5-9.

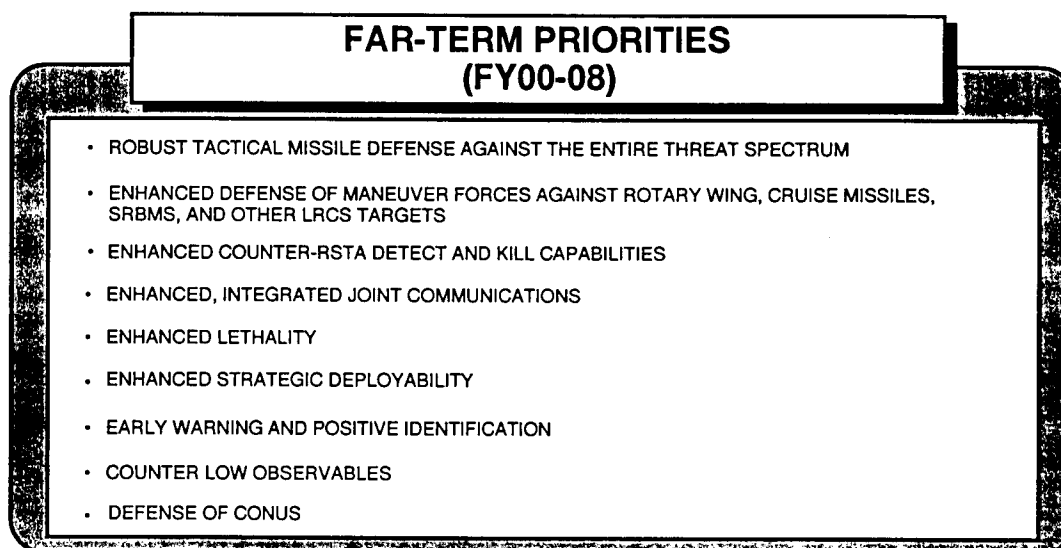

Figure 5-9

Far-Term Assessment (FY00-08). Overall, air defense in the CAAD/TAAD/TSAD areas improves throughout the far-term. The introduction of the Corps SAM system provides enhanced mobility and TBM/UAV/CM defense, allowing extended coverage of the maneuver units. Additionally, THAAD, PAC-3, and Corps SAM units in TAAD enclaves provide the objective upper/lower tier TBM defense. The procurement of the objective THAAD system results in a viable upper tier defense capability in the TAAD/TSAD areas. WMD warhead lethality improves as well. However, air defense deficiencies in the FAAD and strategic arenas remain. Stinger upgrades designed to defeat the hovering helicopter at extended range in clutter are unfunded. Most of the Stinger missiles are rapidly passing shelf life expectancy, further eroding force capabilities. Not all forces will be equipped with sensors and automated C2. There will still be no capability to engage satellites, and NMD will not be fielded.

SUMMARY

ADA has experienced a 43% reduction in funding from the original POM FY94-FY99. This has had a profound impact, particularly on the planned modernization in the FAAD arena. Funding no longer supports NCTR, upgrades to all STINGER, automation and sensor fielding to all units, and desired AVENGER upgrades. Consequently, the FAAD modernization program nearly ceases in the mid-term and capabilities fielded will remain into the far-term. Funding levels remain steady in the Corps, Theater and Theater Strategic arenas and most programs (excepting ASAT , Corps SAM, and NMD) have remained relatively unchanged from the original POM. Figure 5-10 summarizes the capabilities and shortfalls through our budget and POM periods. These assessments constitute the foundation of our material program priorities. Ratings that have changed are asterisked.

ASSESSMENT SUMMARY				
MISSION AREAS	THREAT	NEAR (FY94-95)	MID (FY96-99)	FAR (FY00-08)
FAAD FORWARD AREA AIR DEFENSE	RW	AMBER	AMBER	AMBER
	FW*	GREEN	GREEN	AMBER **
	CM	RED	RED	RED**
	EW	AMBER	AMBER	GREEN
	RSTA/UAV	AMBER	AMBER**	RED**
CAAD CORPS AREA AIR DEFENSE	TBM	RED	AMBER	GREEN
	CM	RED**	RED**	GREEN
	FW*	GREEN	GREEN	GREEN
	EW	AMBER	AMBER	GREEN
	RSTA/UAV	AMBER	AMBER	GREEN
TAAD THEATER AREA AIR DEFENSE	FW*	GREEN	GREEN	GREEN
	TBM	RED	AMBER	GREEN
	CM	RED**	RED**	GREEN
	RSTA	GREEN	GREEN	GREEN
TSAD THEATER STRATEGIC AIR DEFENSE	FW*	GREEN	GREEN	GREEN
	TBM	RED	AMBER	GREEN
	CM	RED**	RED**	GREEN
	RSTA	GREEN	GREEN	GREEN
STRATEGIC	SATELLITES	RED	RED	RED
	ICBM/SLBM	RED	RED**	RED**
	FW*	GREEN	GREEN	GREEN
	CM	RED**	RED**	GREEN

*LEAKERS ** DENOTES CHANGES
 GREEN: ADEQUATE CAPABILITY OR QUANTITY EXISTS TO PERFORM THE MISSION.
 AMBER: ALIMITED CAPABILITY OR QUANTITY EXISTS TO PERFORM THE MISSION.
 RED: NO CAPABILITY EXISTS, OR IT IS INCAPABLE OF DEFEATING THREAT OR PROVIDING REQUIRED SUPPORT.

Figure 5-10

SECTION 4

RESEARCH, DEVELOPMENT, AND ACQUISITION STRATEGY

INTRODUCTION

This section outlines the impact of recent FY95-99 budget reductions on our air defense Research, Development, and Acquisition strategy. The FAAD area has felt the greatest impact of the budget reductions with NCTR funding being eliminated and AVENGER, FAADS C2, Stinger, and GBS funding being reduced. Our goal now is to get "the greatest bang for the limited bucks" that are available for air defense modernization.

Acquisition Strategy Guidelines. Our ADA acquisition strategy in this era of austere budgets and reduced force structure requires that we very selectively modernize by upgrading in the near-term, continue doing research on high payoff technologies, and initiate new starts that provide a leap-ahead in capabilities designed to overmatch the future threat.

Air Defense Funding. Figure 5-11 provides the new ADA RD&A Army POM funding profile. This reflects a 46% reduction in FY95-99 funding from the original Army POM. Figure 5-12 provides the Ballistic Missile Defense Organization's (BMDO) funding profile for THAAD, GBR, PAC-3, and Corps SAM.

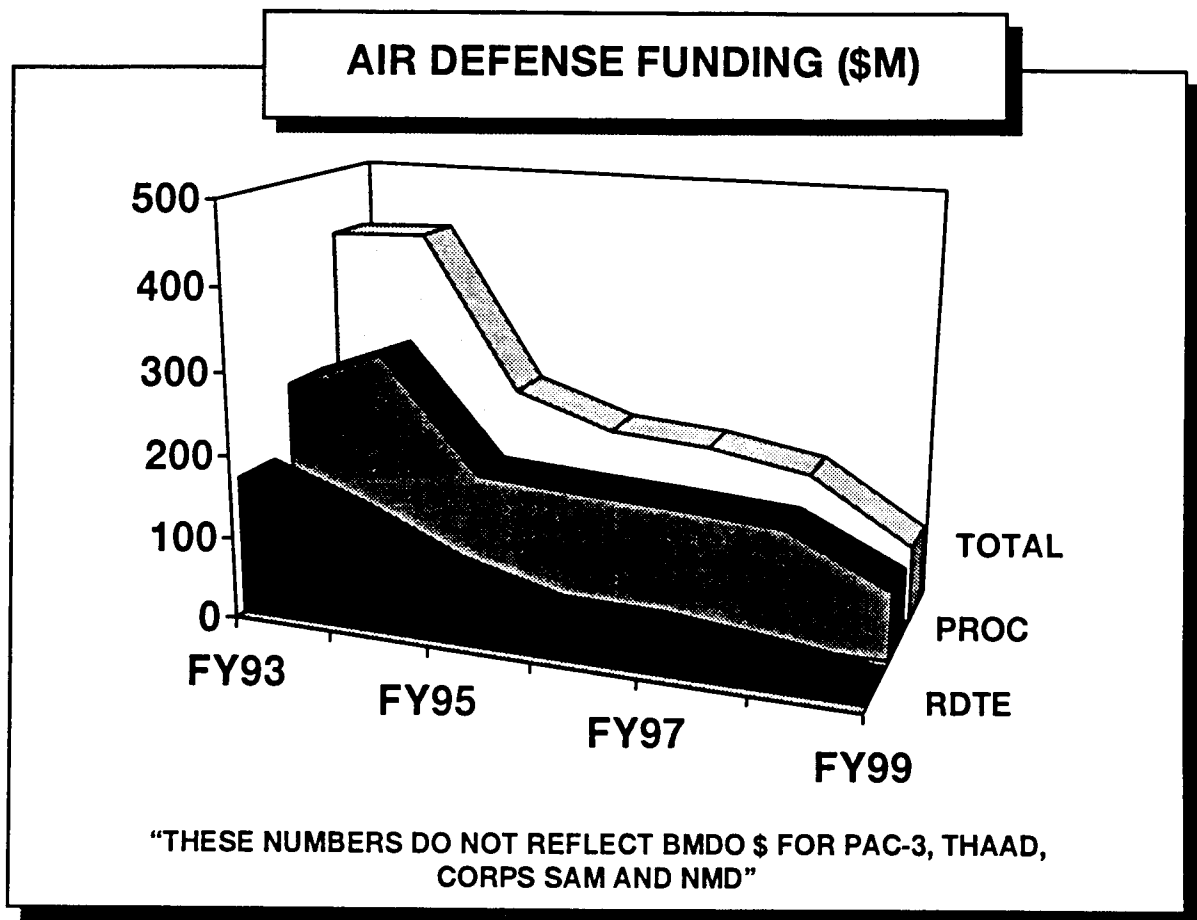

Figure 5-11

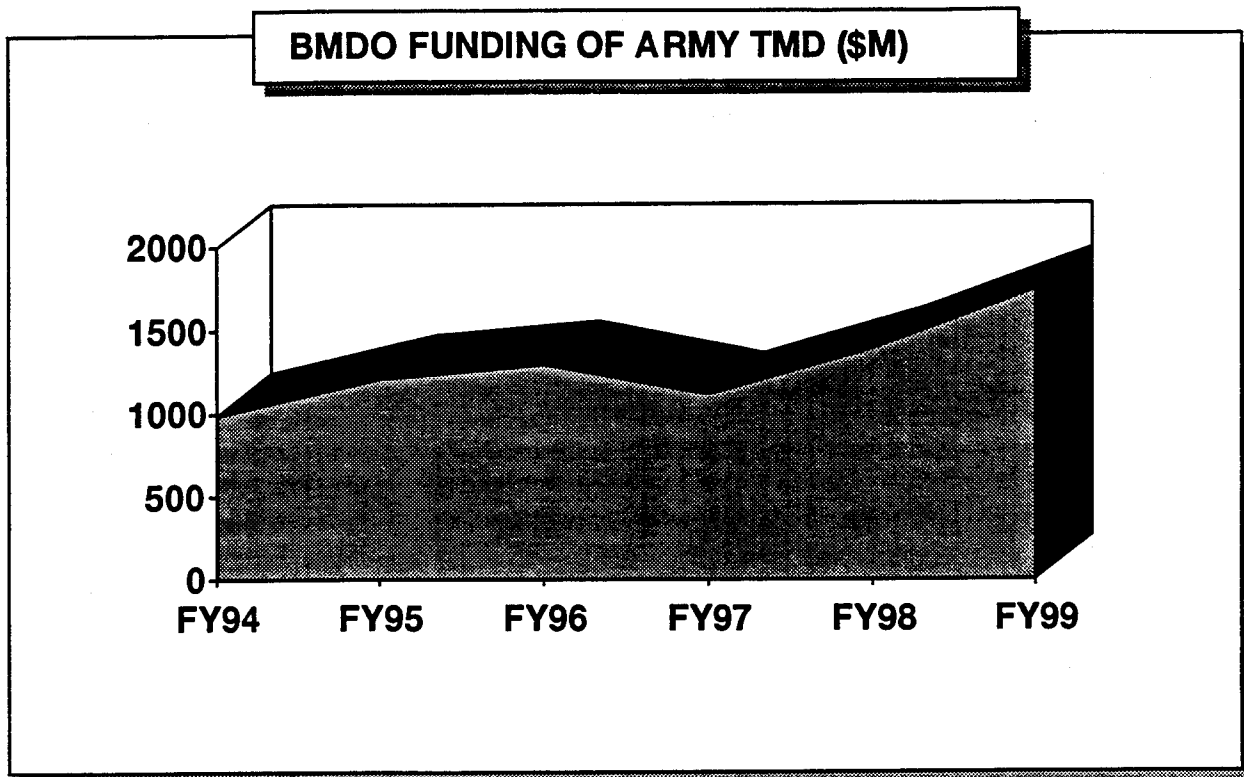

Figure 5-12

WHAT THE NEW BUDGET CHANGES

Stinger. Funding (FY95 and out) for Block I has been reduced. Block I RDTE is funded as is retrofit of approximately 3500 missiles.

Bradley Stinger Fighting Vehicle. A Bradley Turret Study was funded through FY93 to research the feasibility and cost associated with modifications that will allow the STINGER Team to fire while "buttoned up" inside the Bradley. No funding to continue the study (beyond FY93) and/or procure any turret modifications as a result of the study exists in the updated POM.

Avenger. Funding reductions (FY95 and out) cancel the five year multi-year procurement contract after the fourth year and reduces P31 to the point where only the Heavy HMMWV and some Environmental Control Unit/Prime Power Unit modifications remain affordable. A Complementary Missile Study is ongoing (funded only through FY94) and may eventually lead to a new missile for the AVENGER. No funding to continue the study beyond FY94 and/or procure/field any complimentary missile that might come from this study exists in the updated POM.

Chaparral. It is a mature system that has evolved over time with several technical modifications. It is being totally phased out of the Active Army and will be partially replaced in the ARNG by the fielding of the AVENGER system. Updated POM funding reductions in FY95 removes money programmed to support the retrofit of 622 E-Type missiles with the Rosette Scan Seeker. No further modifications are budgeted in the POM.

HAWK. HAWK is being retired from the Active Army and transferred to the Army National Guard at a faster rate than anticipated. There are no funds programmed in the POM for continued upgrades. Consequently, HAWK will remain in its current configuration in the foreseeable future.

PATRIOT. The centerpiece of the Army's Corps and Theater level forces, PATRIOT funding in the POM has not changed. PATRIOT PAC-3, the next step in the modernization process, is further discussed in Chapter 8.

Theater High Altitude Area Defense (THAAD). This system received strong support in the OSD Bottom Up Review. See Chapter 8 for more detailed discussion.

Corps Surface to Air System. The OSD Bottom Up Review delayed all major Corps SAM work until FY98. With the hastened transfer of HAWK to the National Guard, and an evolving threat capability to protect our Corps maneuver forces against the SRBM, CM, UAV/RPV, TASM, and FW/RW threat is reduced. See Chapter 8 for a more detailed discussion.

National Missile Defense (NMD). The OSD Bottom Up Review decided to keep NMD in technical development only. See Chapter 8 for a more detailed discussion.

Air Defense Sensors. In the FAAD arena, material solutions to our greatest existing deficiency, the absence of a sensor, begin fielding in 4Q93.

Light and Special Division Interim Sensor. No change.

FAAD GBS. Recent budget reductions will delay fielding of GBS from FY95 to FY96 and places integration testing of GBS and FAAD C2 programmed for FY95 in jeopardy. Funding reductions also will reduce procurement by at least 17 systems (three Bns worth), thus impacting on our ability to equip all AC units with GBS. LSDIS freed up by the fielding of GBS may be fielded to the AC units now not programmed to receive the reduced quantity of GBS, thus ensuring that all AC units receive at least some type of sensor (However, LSDIS does not address far term threat capabilities. GBS is the far term solution.)

Non-Cooperative Target Recognition (NCTR). The updated budget canceled this program.

Horizontal Technology Integration. Air Defense is an active participant in ongoing Horizontal Technology Integration (HTI) efforts, particularly in the area of digitization of the battlefield. The ongoing JTIDS procurement effort demonstrates the effects of how an unsuccessful HTI effort drives the cost of the system up dramatically. In this case numerous Army participants in the JTIDS effort have pulled out as a result of budget reductions leaving air defense as primarily the only user. The cost per JTIDS has therefore increased significantly. Conversely, air defense expects to see substantial cost savings in the ongoing HTI effort to provide second generation FLIRs to our AVENGER and Chaparral systems.

Digitized Battlefield. Efforts to digitize the FAAD arena are underway. FAAD C2 will fully integrate FAAD C2 systems, sensors, and weapons to optimize the collective capabilities of allocated resources contributing to the digitized battlefield. Within the distributed architecture design, FAAD C2 will integrate external sensor and intelligence data and other told-in information on a near real time basis; filter, accurately correlate and fuse all relevant information received; and allow distribution of the pertinent information to all designated battlefield users and ADA weapons (via SINCGARS or ADDS). Reductions in funding for FAAD C2 and JTIDS will result in fewer ADA units receiving this required capability. Present funding levels support FAAD C2 fielding to most, but not all AC FAAD units. Digitization exists throughout our existing HAWK and PATRIOT units and will be imbedded in all THAAD and Corps SAM development efforts. (Further discussion of these initiatives is contained in Chapter 8).

FAAD Command and Control (C2) Budget reductions will delay all Block II (integration of EPLRS) RDT&E thus causing fielding delays of up to two years for Block II. Additionally, budget reductions will reduce the total planned procurement of 19 systems by at least 4, meaning that not all AC units will receive FAAD C2.

HIMAD C3I. Funding for PATRIOT and TBM BM/C4I is adequate for continuation of planned improvements, however, HAWK and AN/TSQ-73 Post Deployment Support Software (PDSS) were not funded for FY94.

Advanced Technology Demonstrations (ATDs) and Advanced Warfighting

Demonstrations (AWDs). The Army continues to place increasing emphasis on ATDs and AWDs to enable the user to develop more informed requirements and to enable the material developer to reduce risk prior to the initiation of full-scale system development. The Elevated Integrated Sensor technology demonstration will address affordable options for the passive vehicle-mounted infrared search-track technology. During FY93 two of the four ATDs completed by the Army directly supported the air defense mission area: the Advanced Air Defense Electro-Optical System (AADEOS) and the Multi-Role Survivable Radar (MRSR). The Elevated Integrated Sensor technology demonstration will address affordable options for passive, vehicle-mounted, infrared search-track technology. Capabilities developed in these ATDs provide a sound baseline on which to build future Army and tri-Service efforts. Of the ongoing 28 ATDs (to be followed up with AWDs), the air defense mission area will benefit from many, to include: Multisensor Aided Targeting-Air, Radar Deception and Jamming, Bistatic Radar for Weapons Location, Survivable Adaptive Systems, Combined Arms Command and Control, Battlefield Combat Identification, and the Fiber Optic Guided Missile.

CINCs' TMD Experiment Program. Begun in FY89, this program provides the CINCs with a yearly threat based opportunity to develop their tactics, techniques, and procedures and long term theater architecture requirements for TMD. See Chapter 8 for a more detailed discussion.

Unfunded Requirements. Recent budget reductions have increased the number of unfunded requirements in the air defense arena. At this point in time, deficiencies exist in the following areas: FAAD engagement capabilities, lethality, and survivability; low cost effective defense against cruise and anti-radiation missiles; an anti-satellite capability; and, the ability to passively detect and identify targets beyond visual range.

SUMMARY

This section focused on the impact of recent budget reductions on the material aspects of existing air defense modernization plans. A few systems have been terminated. Others have had funding reduced and/or shifted to later years, while others remain fully funded. Of greatest concern now is the increase in unfunded requirements. As work begins on POM FY96-01, air defense modernization plans will be reevaluated. Although it is recognized that materiel alone cannot win a battle, victory in any future conflict will result from a skillful blend of materiel with sound tactics and doctrine, balanced organizations, and well trained soldiers and leaders.

SECTION 5

TRAINING

The Air Defense Artillery training strategy remains unchanged from the original modernization plan. It incorporates the training principles of FM 25-100 and FM 25-101 and the six Army imperatives. It also embodies the Army's Combined Arms Training Strategy (CATS). Since the soldier is the key to America's victory in war, his/her training is monumentally important to winning decisively with minimal casualties. Our focus is on training ADA soldiers to operate effectively as members of the combined arms forces on the future battlefield. In this era of reduced budgets, simulations play an ever important part in the maintenance of tactical and technical skills while reducing the actual cost to train the soldier. Air Defense continues to pursue distributed interactive simulations (DIS) for collective task training and imbedded system training devices that are compatible with DIS. The AVENGER is the one ADA weapon system currently not adequately funded for training devices. As a result, fire units are having to be fielded to TRADOC and AMC to support operator and maintainer training rather than being fielded to TOE units. Key to the training strategy is the ability to provide necessary simulators and simulations for echelon training from the individual soldier through the theater level in dynamic, interactive environments. The ADA training strategy and CATS are the confluent forces which drive ADA training and modernization requirements.

SECTION 6

CONCLUSION

Air Defense Artillery is linked directly or indirectly to all five objectives of the Army Modernization Vision. ADA's most critical contributions are in its ability to protect the force and assist in winning the information war, thus permitting the achievement of the remaining three Army Modernization Objectives. The level of force protection ADA can provide is dependent on the level of modernization achieved by the programmed forces and how well they are trained and led. This update of Annex E reiterates that the existing air and missile threat is very real and expected to increase (particularly in the cruise missile and TBM arenas) and that commanders' expectations as to what ADA must be able to accomplish have not changed. This means that deficiencies in current and projected ADA forces must be resolved if we hope to continue to adequately protect the force. Budget reductions have necessitated that our ADA modernization priorities be relooked and realigned to best take advantage of the limited amount of funding available. Priorities for the mid- and far-term now primarily focus on:

- ensuring the ability to effectively counter the growing TBM and Cruise Missile threat with PATRIOT system upgrades and the fielding of THAAD and Corps SAM.
- ensuring our early deploying FAAD forces are world-class by equipping them with modern sensors, automated Command and Control capabilities, and improving their mobility and survivability on the battlefield.

A number of deficiencies in the air defense mission area are corrected over the period covered by this modernization plan, however, a number still remain through the mid- and far-term:

- without the internal battery upgrade, STINGER missiles will exceed their shelf life by the year 2005.
- unless exiting deficiencies in the STINGER system are corrected, our forward area forces with unmodified missiles will remain incapable of engaging most stand-off and masked helicopters
- unless a method is developed that will allow our STINGER teams to fire from within the BSFV, and unless greater protection is provided for our AVENGER and non-BSFV aligned STINGER teams, our FAAD forces remain vulnerable to the effects of most indirect and direct fire weapons
- unless alternative technology is developed, ADA forces remain vulnerable to ARMs because of the continued requirement to radiate to track and engage targets.
- unless the technology is developed and fielded, the continental US will remain vulnerable to attack by ICBMs and the enemy (if they possess the technology) will be able to utilize their satellites unimpeded to enhance their warfighting capabilities.

As work begins this spring on building POM FY96-01 and a new Army Modernization Plan, these deficiencies will become our focal point for attempting to garner additional modernization funding for Air Defense Artillery.

CHAPTER 6

TACTICAL WHEELED VEHICLES

SECTION 1

INTRODUCTION

This chapter updates Annex F of the 1993 Army Modernization Plan. As downsizing continues, Tactical Wheeled Vehicles (TWV) remain the backbone of the Army's warfighting support and sustainment structure. The requirement continues for a modern tactical fleet which possesses the mobility, agility, and endurance to support the soldier on battlefields located in any region and climate with minimal required maintenance.

Current Army force structure reductions marginally impact upon the types and mix of vehicles required. This update focuses on the significant requirements reduction, reduced funding and Army program decisions since publication of Annex F, with revised capability and overall fleet health implications. Specifically, it addresses funding decisions made in the Program Objective Memorandum (POM).

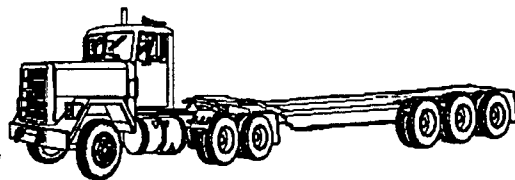
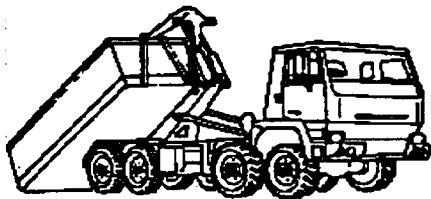
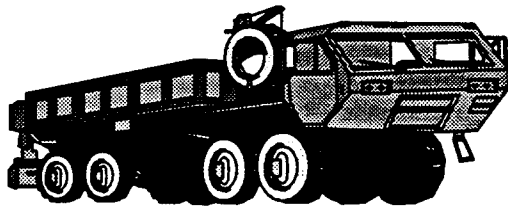
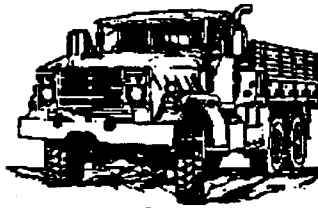
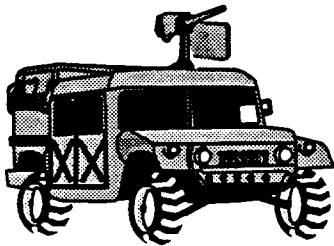

**TWV Fleets Provide The Backbone In The
Warfighting Support And Sustainment Structure**

SECTION 2

WARFIGHTING CONCEPTS

TWV, more than ever before, are crucial to the execution of successful campaign plans. The Army's dependence upon large numbers of capable TWV was well demonstrated in Operation Desert Storm. TWV now serve as weapons platforms, communication system platforms, means for medical evacuation, major weapon system rearm/refuel vehicles, tank transporters and innumerable unit mobility and resupply vehicles. Trucks provide the agility necessary to support maneuver warfare, and are truly one of the Army's premier combat multipliers!

The High Mobility Multipurpose Wheeled Vehicle's (HMMWV) size lends itself to rapid air deployment and containerization for surface deployment. The Family of Medium Tactical Vehicles (FMTV) also facilitates surface deployment as it overcomes the current medium fleet lifting and tie-down limitations through the addition of four telescoping lifting beams and distinct tie-down points. The FMTV is also compatible with commercial flatracks and can be stowed in container cells onboard commercial container vessels. Preparation for airlift of the FMTV is easier and quicker than the current fleet. FMTV can be prepared for air transport in approximately nine minutes by one person. By comparison, the current fleets takes approximately 45 minutes.

TRANSPORTABILITY						
	AIR (TWV PER FRAME)			SEA	RAIL	CONTAINER SHIP
	C130	C141	C5			
HMMWV	3	6	16	YES	YES	YES
LMTV	1	3	8	YES	YES	YES
MTV	1	3	8	YES	YES	YES

Figure 6-1

As the Army downsizes, the requirements for TWV will be reduced on a fairly proportional basis. Figure 6-2 updates TWV Procurement Objective changes associated with Army downsizing since Jan 1993. Some requirements have increased in recognition of the vehicles' importance to mission accomplishment and doctrine changes. Increases in truck units, Heavy Equipment Transporter (HET) doctrine, engineer support and expanded use of the HEMTT contributed to these larger requirements. Reduced procurement objectives necessitated a reassessment of current and planned acquisitions and other fleet management initiatives. Fewer requirements permit the earlier retirement of selected over-age vehicles, lower unresourced needs, and reduce the associated maintenance burden.

MINI-POM PROCUREMENT OBJECTIVES		
FLEET	PROCUREMENT OBJECTIVE	DELTA
LIGHT		
HMMWV	104,800	- 274
CUCV	12,987	- 2,013
MEDIUM		
LMTV	41,835	- 5,499
MTV	45,763	- 8,953
HEAVY		
HEMTT	13,135	+ 535
PLS	3,329	- 71
M915 LINE HAUL	4,639	+ 672
ENGINEER TRACTORS	3,086	+ 894
HET	2,100	+ 308
TOTAL	231,674	- 14,401

Figure 6-2

SECTION 3

CURRENT PROGRAM ASSESSMENT

This section presents an update of current TWV fleet capabilities measured against battlefield requirements and the current and programmed assets to satisfy those requirements.

Retirement Program Update. The 1989 Tactical Wheeled Vehicle Modernization Plan (TWVMP) established a vehicle retirement policy and an execution program. This program was designed to eliminate selected vehicles with performance deficiencies to effect a reduction in Operation and Support (O&S) costs, and to capitalize on advantages derived from reducing the variety of makes and models of vehicles. The criteria established remains unchanged. The chart below displays the Army's updated goals based on the current force structure as well as the status in meeting retirement goals.

PROJECTED RETIREMENT SCHEDULE					
<u>ITEM</u>	<u>FY90-93 OBJECTIVE</u>	<u>ACTUAL</u>	<u>FY94</u>	<u>FY95</u>	<u>FY96</u>
M880	22,898	15,826	7,072	0	0
GAMA GOAT	5,996	5,918	78	0	0
M151	17,504	33,314	6,756	0	0
2.5 TON GAS	1,881	1,372	509	0	0
2.5 TON MF	2,952	11,171	6,364	6,364	6,364
5 TON OLDER	500	3,446	5,749	5,749	5,749
GOER	1,176	1,163	13	0	0
M746	117	46	71	0	0
M123	1,000	299	701	0	0
LINE HAUL	800	132	514	0	0
CUCV	14,632	0	4,632	10,000	10,560

Figure 6-3

The Line Haul Tractor and the Commercial Utility Cargo Vehicle (CUCV) are being retained above previous ANNEX F levels since the National Guard and US Army Reserve components did not reduce forces as quickly as anticipated. The CUCV will be retained to fill selected HMMWV shortages and normal CUCV requirements. The Line Haul Tractor requirements have increased due to a greater number of truck unit authorizations in Total Army Analysis (TAA) 01, most of which are in the USAR.

The Army has declared the M880, M151, GAMA Goat, GOER and M746 obsolete. As a result, these items will no longer be captured in Continuing Balance System-Expanded (CBS-X). In order to maintain visibility of these items, it is important that they continue to be reported in this database. The Army is working on a solution to this visibility problem.

TWV Fleet Assessment

Reduced funding continues to have a negative impact on the military effectiveness and modernization scorecard of the TWV fleet.

Assessment Methodology. The Army is continually assessing the capabilities and ownership characteristics of its TWV fleet via studies, analyses, mission area reviews, and operational lessons learned. The ratings and their definitions are as follows:

RED - No capability exists, or vehicle is incapable of defeating threat or providing required support.

AMBER - A limited capability or quantity exists to perform the mission.

GREEN - Adequate capability or quantity exists to perform the mission.

ASSESSMENT OF THE FLEET - 1994				
CATEGORY	ON HAND	NEAR (94-95)	MID (96-99)	FAR (00-08)
LIGHT	148,107*			
HMMWV	75,678	GREEN	GREEN	AMBER
CUCV	57,525	AMBER	AMBER	RED*
SUSV	1,076	GREEN	GREEN	AMBER
M151	6,756	RED	RETIRED	RETIRED
M880	7,072	RED	RETIRED	RETIRED
ASV	0	RED	GREEN	GREEN
MEDIUM	123,939*			
2-1/2 TON	60,928	RED	RED	RED
LMTV	0	RED	GREEN	GREEN
5 TON	63,011	AMBER	AMBER	AMBER
MTV	0	RED	GREEN	GREEN
HEAVY	21,619*			
PLS	0	GREEN	GREEN	GREEN
HEMTT	12,501	GREEN	GREEN	AMBER
HET (OLD)	698	AMBER	RED	RED
LINE HAUL	5,153	GREEN	GREEN	RED
LET	1,745	GREEN	GREEN	AMBER
MET	840	AMBER	AMBER	RED
M 123	682	RED	RETIRED	RETIRED

* Denotes Change

Figure 6-4

The Heavy fleet's increase in on-hand assets is the result of fielding the M916A1, M915A2 and HEMTTs procured with congressionally provided O&S supplemental funding and USAR and National Guard procurements.

The CUCV rating has changed from **GREEN** to **RED** in the far-term as a result of the deletion of the CUCV rebuy. In the year 2000 and beyond, all current CUCV assets will be beyond their Economic Useful Life (EUL).

Light Fleet Assessment

The overall condition of the light fleet is currently at an acceptable level to meet mission requirements. To keep the light fleet at this level, future procurements of HMMWVs and CUCVs to continue replacing aging assets is required. With the FY95 mini-POM program cuts and OSD kill of the CUCV rebuy, this will not be possible in the foreseeable future.

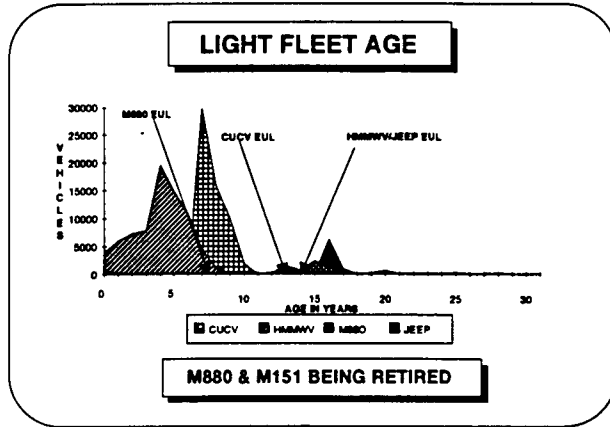

Figure 6-5

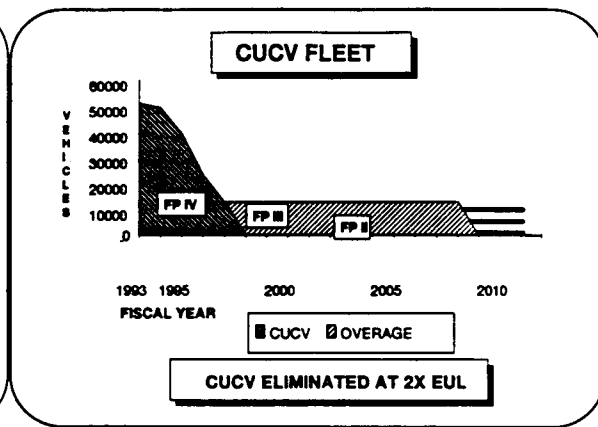

Figure 6-6

Age of Fleet. Lack of CUCV replacement is a major shortfall beyond FY94. M151s and M880s, components of the retirement program, are beyond EUL (Figure 6-5).

CUCV. Figure 6-6 shows that the current CUCV fleet will meet all Force Package (FP) requirements. Force Package 1 requirements do not exist for the CUCV; All FP 1 requirements are for the more capable HMMWV. In FY98 and beyond, all CUCV requirements will be filled by assets above EUL.

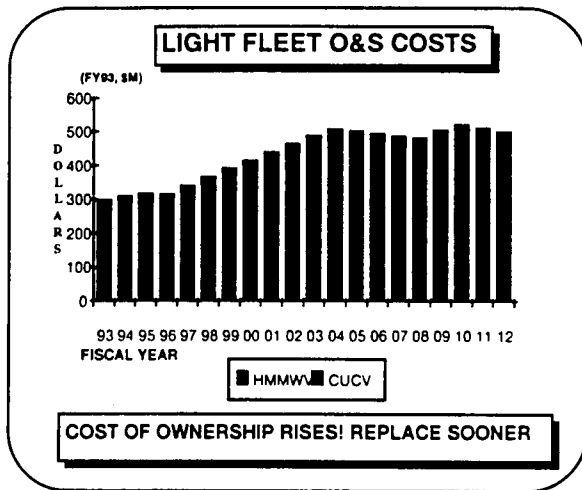

Figure 6-7

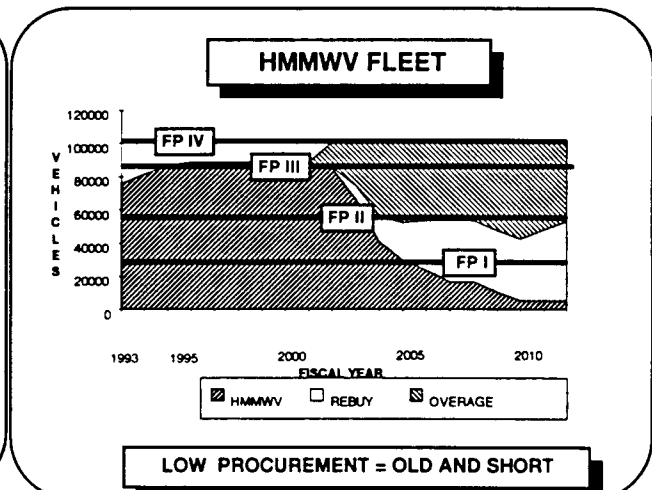

Figure 6-8

Operation & Support Costs (O&S). In Figure 6-7 O&S costs double from FY93 to FY01 as a result of increased aging of the HMMWV fleet.

HMMWV. (Figure 6-8). POM funding allocations permit procurement of 97 percent for heavy variant. With many HMMWVs in the Contingency Corps having over 100,000 miles and no further buys, the HMMWV will require an upgrade. As a minimum, a power train update will be required. The

funding necessary to support this requirement is currently under study. An A1 version of the light HMMWV will begin production in January 1994. It will incorporate many of the components used in the Heavy HMMWV. The POM also procures the high mobility trailer (companion trailer for the HMMWV) for FP 1.

Medium Fleet Assessment

FMTV. FMTV replaces 2 1/2- and 5-ton trucks Army-wide. Funding allows 100 percent of FP 1 and 20 percent of FP II through FY99. Despite the introduction of the FMTV and the initiation of an Extended Service Program (ESP) for National Guard and USAR 2 1/2 ton vehicles, the 2 1/2 ton fleet will continue to retain its **RED** assessment and the 5 ton fleet will remain **AMBER** for the older series trucks until the 21st Century.

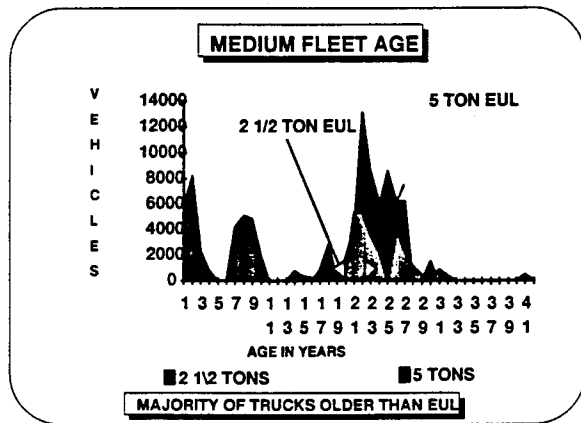

Figure 6-9

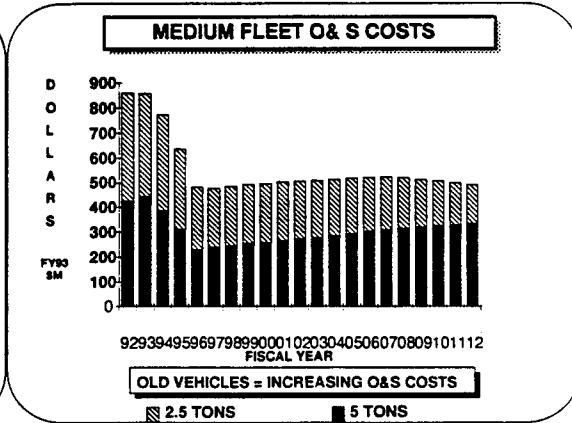

Figure 6-10

Major budget cuts to both the FMTV program and ESP during the FY95 mini-POM will force retention of trucks exceeding their EUL, resulting in higher O&S costs to maintain these substandard vehicles (Figures 6-9 and 6-10). The overall reduction trend in O&S costs are more due to retirements than to the introduction of new vehicles to this fleet.

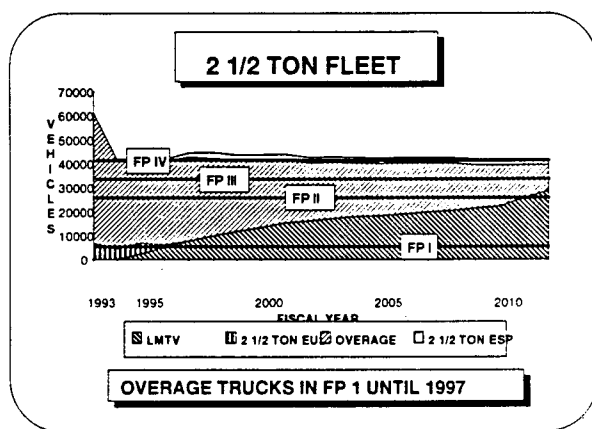

Figure 6-11

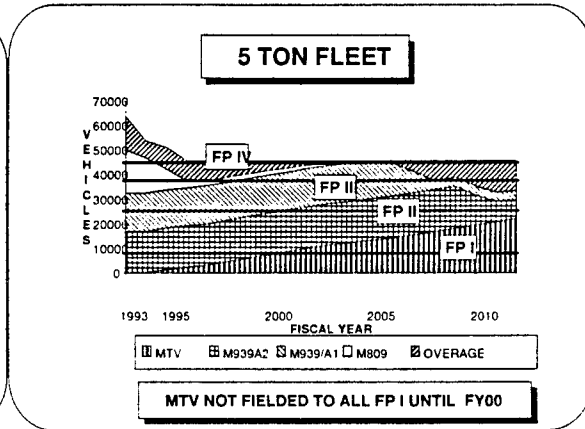

Figure 6-12

2 1/2 Ton including the Light Medium Tactical Vehicle (LMTV). As depicted in Figure 6-11, all FP 1 units will not be fielded with the LMTV until FY97. This is the same year when the newest 2 1/2 tons become over-age. Force Packages II through IV will be filled with substandard vehicles. The rate of FMTV procurement does not meet the Army's redistribution goals due to lack of funding.

TACTICAL WHEELED VEHICLES

5 Ton including the Medium Tactical Vehicle. (MTV) Figure 6-12 reflects that all FP 1 units will be filled in FY99 as opposed to FY03 as shown in Annex F. This is accomplished as a result of the lowering of FP 1 requirements rather than as a result of increased procurement of MTV. The level of fill with assets within EUL drops below the goal after 2007 as the first M939 series trucks reach their EUL.

Heavy Fleet Assessment

Heavy Fleet Age. (Figure 6-13). The introduction of the PLS and HETS, combined with recent M915A2/M916A1 procurements keep the Heavy fleet average age well below EUL. Over the twenty-year time horizon, however, this condition will decline, as out-year procurements are limited to HEMTT replacements—or the new Family of Heavy Tactical Vehicles (FHTV). The Project Manager for Heavy Tactical Vehicles is continuing to study an acquisition strategy for a FHTV as stated in Annex F.

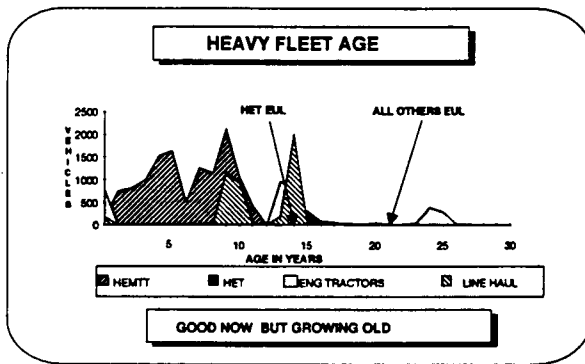

Figure 6-13

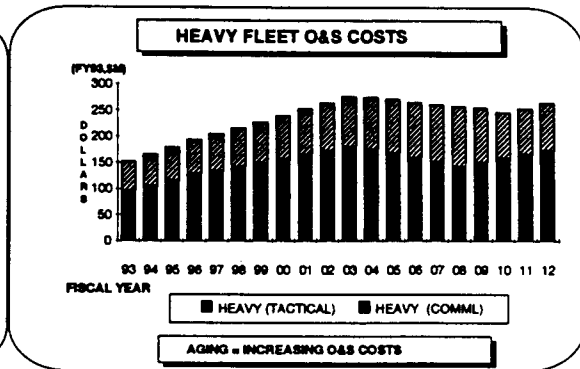

Figure 6-14

Heavy Fleet O&S Costs. Figure 6-14 reflects the revised heavy fleet O&S costs over time. Starting out with a relatively young fleet, its age is reflected in a growing O&S cost tail, which begins to abate when new HEMTTs are fielded in FY03. Operation and support costs expectedly increase as vehicles exceed EUL.

The Palletized Load System (PLS). Procurement of PLS trailers, the last component of the five-year multi-year contract, ceases in FY95. Funding allows for 100 percent of FPs I through III for trucks and trailers and 100 percent fill of FPs I and II for flatracks. As Figure 6-15 shows, the PLS production run also meets 50 percent of FP IV as a result of the lowered PLS requirements.

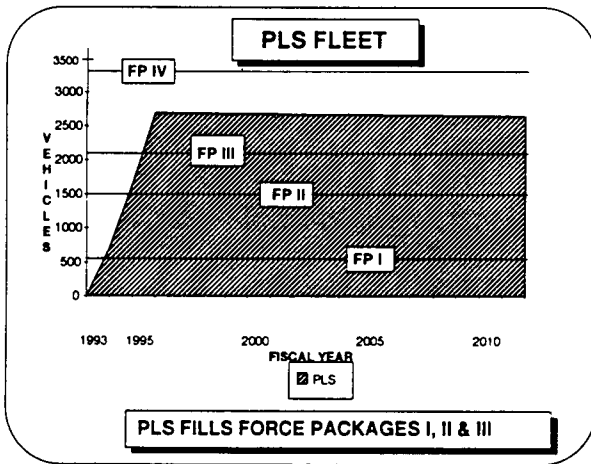

Figure 6-15

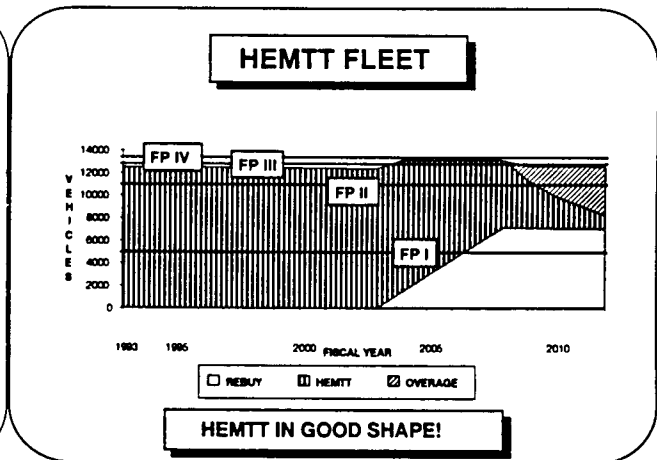

Figure 6-16

HEMTT. Force structure reductions and PLS fieldings combined now provide capable HEMTT assets to fill FPs I through IV until HEMTTs begin to go over-age in 2005 (Figure 6-16). This capable fleet is in good shape and is expected to remain so for some time.

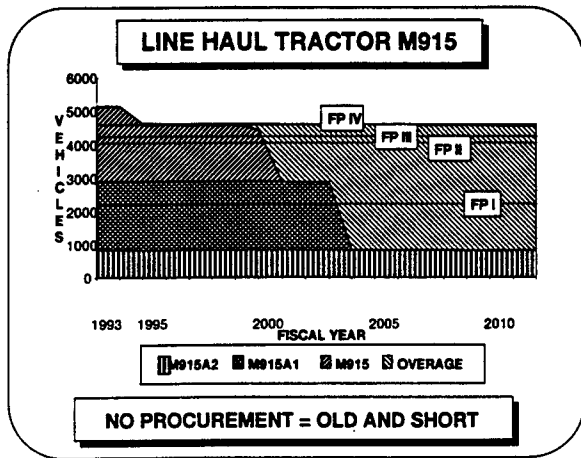

Figure 6-17

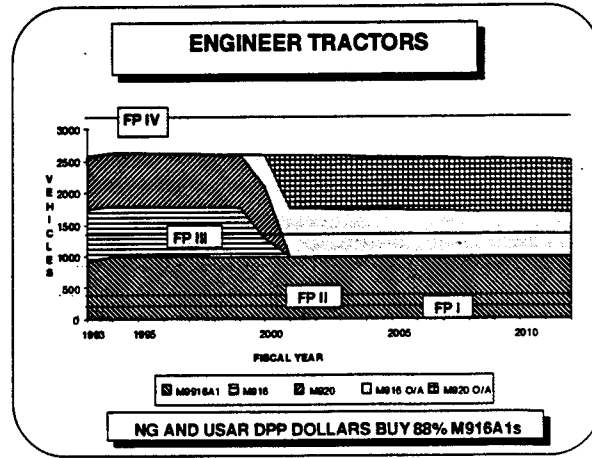

Figure 6-18

Line Haul Tractor (M915). Figure 6-17 depicts the Army's rapidly declining capability levels beginning in FY00.

Engineer Tractors (M916 and M920). National Guard and Army Reserve Dedicated Procurement Program (DPP) dollars are responsible for 88 percent of the M916A1 procurement (Figure 6-18). Thus, some of these new assets will be distributed to fill FP III and FP IV requirements.

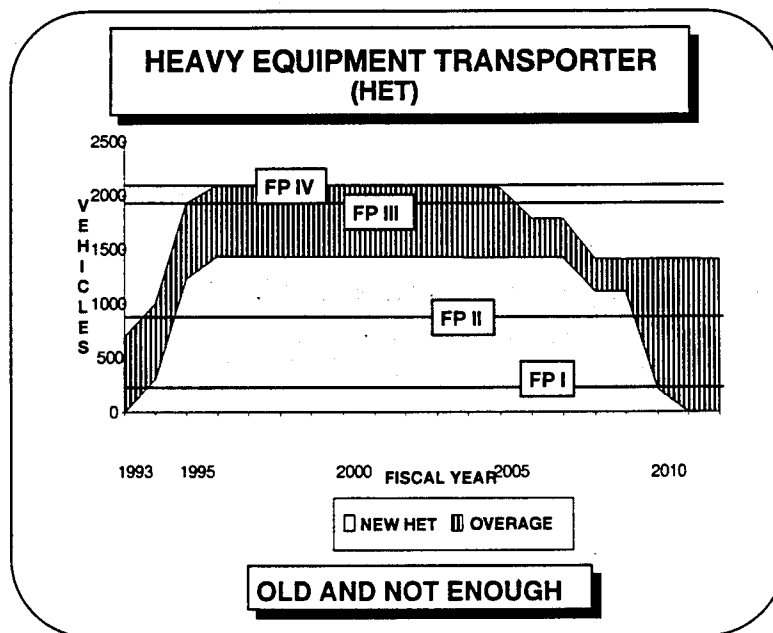

Figure 6-19

Heavy Equipment Transporter (M1070). Currently funded production of the 70-ton HET fills FP I, II and a portion of III based on revised requirements.

Heavy Repair Vehicle (HRV). Congress provided FY94 funding to support R & D for the HRV. The HRV uses a PLS chassis as the base for the system. It will replace the current M113 tracked

TACTICAL WHEELED VEHICLES

maintenance vehicles. The HRV will improve the support provided by unit mechanics and DS repairers in armor and mechanized battalions as well as in the DS maintenance support units. The HRV is not currently funded.

Trailer Assessment

ASSESSMENT OF THE TRAILER FLEET - 1994				
CATEGORY	ON HAND	NEAR (84-95)	MID (96-99)	FAR (00-08)
LIGHT HMT M101/A1 M101A2 M105/A1 M105A2 M107 M149/A1 M149A2 CHASSIS TBLR*	74,416	GREEN AMBER GREEN AMBER GREEN RED RED GREEN GREEN	GREEN AMBER GREEN AMBER GREEN RED RED GREEN GREEN	GREEN RED GREEN AMBER GREEN RETIRED* RETIRED* GREEN GREEN
MEDIUM HEMAT M979 M1034 M1048 M1061 M1073 M707/689 M720 M832 M840 M1022	8,051	GREEN GREEN GREEN AMBER GREEN GREEN GREEN RED RED AMBER GREEN	AMBER GREEN GREEN GREEN GREEN GREEN GREEN RED RED AMBER GREEN	GREEN GREEN GREEN AMBER GREEN AMBER GREEN RED RED RED GREEN
SEMITRLR LOW/FLAT M269 LB M270 LB M871/M872	19,477	AMBER AMBER GREEN	AMBER AMBER GREEN	RED AMBER GREEN
SEMITRLR VAN M128/M129 M313 M373 ELEC VANS	5,201	RED AMBER GREEN GREEN	AMBER AMBER GREEN GREEN	GREEN RED GREEN GREEN
SEMITRLR TANKER M131 SER M900 SER M1062 M1098	3,803	RED GREEN GREEN GREEN	RED GREEN GREEN GREEN	RETIRED GREEN GREEN GREEN

CHASSIS DENSITIES NOT INCLUDED IN ON-HAND QUANTITIES

* Denotes Changes

Figure 6-20

Trailers. With the exception of a few specific trailers (e.g., the HET), trailer funding has historically come from Congressional budget marks. The trailer fleet suffers from being short against requirements (qualitatively and quantitatively), having too many models, and being severely over-age with excessive O&S burdens.

SUMMARY

Figure 6-21 describes what the Mini-POM funding profile does and does not do for each fleet category. Figure 6-22 summarizes major Congressional directions on Army TWV programs and how the Army has addressed them.

LIGHT FLEET		MEDIUM FLEET	
DOES	DOES NOT	DOES	DOES NOT
<p>PROCURE HMMWV AND HEAVY HMMWV</p> <p>REBUY THE HMMWV BEYOND POM</p> <p>PROCURE THE ASV</p>	<p>PROCURE AT ECONOMIC RATE</p> <p>PROCURE TOTAL REQUIREMENT</p> <p>REBUY THE CUCV</p>	<p>PROCURE FMTV</p>	<p>PROCURE VANS, TANKERS, AND TRAILERS UNTIL SECOND 5-YEAR MULTI-YEAR</p> <p>PROCURE ESP FOR ACTIVE ARMY</p>
HEAVY FLEET		TRAILERS	
DOES	DOES NOT	DOES	DOES NOT
<p>PROCURE PLS</p> <p>PROCURE HEMTT</p>	<p>PROCURE PLS FLATRACKS TO MEET JCS REQUIREMENTS</p> <p>PROCURE SUFFICIENT QUANTITY TO MEET ALL REQUIREMENTS</p> <p>MEET CONGRESSIONAL DIRECTION FOR HET PROCUREMENT</p> <p>PROCURE HEAVY COMMERCIAL TRACTORS</p> <p>PROCURE HET ESP</p>	<p>PROCURE SUPPLY VAN</p> <p>PROCURE HIGH MOBILITY TRAILER (HMT)</p> <p>PROCURE FMTV TRAILERS</p> <p>PROCURE M1081 TRAILERS AND M1022 DOLLY SETS</p> <p>PROCURE M871 SEMI-TRAILERS</p>	<p>PROCURE OTHER TRAILERS</p> <p>PROCURE SUFFICIENT QUANTITIES</p>

Figure 6-21

Replacing the CUCV with the HMMWV would allow for a single fleet of light trucks to be maintained and supported by the Army. However, funds for the HMMWV are not sufficient for replacement of the CUCV.

The medium fleet is already inadequate to meet the Army's needs. Current funding does not permit procurement of all variants of the FMTV to achieve pure fleetings by installation. Units receiving the FMTV will have to retain older 2 1/2 and 5 ton vehicles to meet their mission requirements until all authorized FMTV variants are received. This will happen when vehicles from the second 5-year multi-year contract are fielded. Meanwhile, current over-age 2 1/2 tons must be maintained at ever-increasing O&S costs to the user.

PLS was envisioned as a system consisting of trucks, trailers and flatracks. Sufficient quantities of trucks and trailers are being procured to support approximately 90 percent of Army requirements for the Maneuver Oriented Ammunition Distribution System (MOAD). Insufficient PLS flatrack procurement

(1/3 the requirement), however, renders the Palletized Load System capable of supporting only a limited contingency.

The funding profile provides for procurement of the FMTV trailer, however the trailer is procured and fielded in the second FMTV 5-year multi-year contract. Until FMTV units receive these trailers, they will have to retain older, less capable, lower capacity, trailers to meet mission requirements.

Shortages for M871 trailers remain. Over-age M127s, which carry only half the load of an M871, will continue to be substituted.

CONGRESSIONAL DIRECTION		
<u>PROGRAM</u>	<u>LANGUAGE</u>	<u>ARMY MOD PLAN</u>
CUCV	PROVIDE FOR CUCV REPLACEMENT	LACKS DOLLARS TO COMPLY
HMT	EVALUATE OFF-THE-SHELF	COMPLIES
FMTV	HIGHLIGHTS FMTV IMPORTANCE	PROCURES
2-1/2 TON ESP	CRITERIA = 50% FMTV COST, 80% LIFE	ESTABLISHED
HET	BUY OUT HET	LACKS DOLLARS TO COMPLY
PLS	ACQUIRE INTERMODAL FLATRACKS	COMPLIES

Figure 6-22

Congressional direction would have more funds placed in the CUCV program than is available for this lower priority system. In the case of the HMT, FMTV, 2 1/2 ton and PLS, the dollars in the POM and EPA simply do not provide the funds to procure the required quantity of vehicles.

SECTION 4

RESEARCH, DEVELOPMENT, AND ACQUISITION STRATEGY

Modernizing TWV

The Army is modernizing the TWV fleet by leveraging commercial technology where it makes sense. This reduces its research and development (R&D) expenditure by tailoring commercial technology to meet unique military needs. The idea is to encourage the use of "dual-use" technology in which the military "spins on" technology from the defense industrial base. The concept of dual-use technology encourages collaboration and saves time and money by leveraging common research and development in many aspects of ground mobility.

National Automotive Center (NAC). The Army established the NAC to serve as a catalyst linking government, industry, and academia. The center strives to promote advanced automotive technology development with emphasis on dual-use technology for ground vehicles by fostering basic automotive research, technology development, manufacturing development and professional development.

The NAC has encouraged dual-use technologies through the use of the Broad Agency Announcement to leverage commercial R&D projects which have potential military applications and Cooperative Research and Development Agreements (CRDAs) to promote collaborative R&D. In conjunction with the Department of the Army Domestic Technology Transfer Office, the NAC has developed model CRDAs between the Army and General Motors Corporation and the Army and Ford Motor Company, which were signed in September 1993. These ground-breaking agreements will also serve as prototypes for future CRDAs between the Army and other companies in any industrial sector conducting R&D applicable to Army needs.

Science and Technology. The majority of the Army's TWV requirements can be met by technology embedded in the commercial truck industry. Advanced technologies are applicable for tactical vehicles that operate in unique military conditions (i.e., adverse environmental conditions, hostile fire, and with austere maintenance facilities). The US Army Tank Automotive Research Development and Engineering Center (TARDEC) is advancing technologies that improve vehicle mobility, performance, durability, vehicle weight reduction, maintenance time, and support costs. These technologies are pursued for integration into existing or new systems. Technologies currently being investigated include, but are not limited to:

- Automation of crew functions to include robotics cargo handling, ammunition handling, and refueling.
- Electronic Tow Bar Capability which substitutes an "electronic tether" in place of a physical coupling for convoy operations where line of sight between vehicles is constantly available.
- Obstacle Avoidance technologies include monitoring headway, maintaining a safe distance between vehicles and providing limited short term vehicle path control during periods of driver inattention.

TWV Procurements

TWV programs took a share of the reductions in the Army's procurement account. Planned acquisitions of TWV were significantly reduced and, in some cases, terminated. Figure 6-23 notes the timing of planned TWV procurements. Also noted are those programs which have been cut since Annex F was published in Jan 1993. These cuts reduce the acquisition of more capable TWV, increase the

Army's cost of ownership, and in some cases mean a departure from compliance with Congressional guidance.

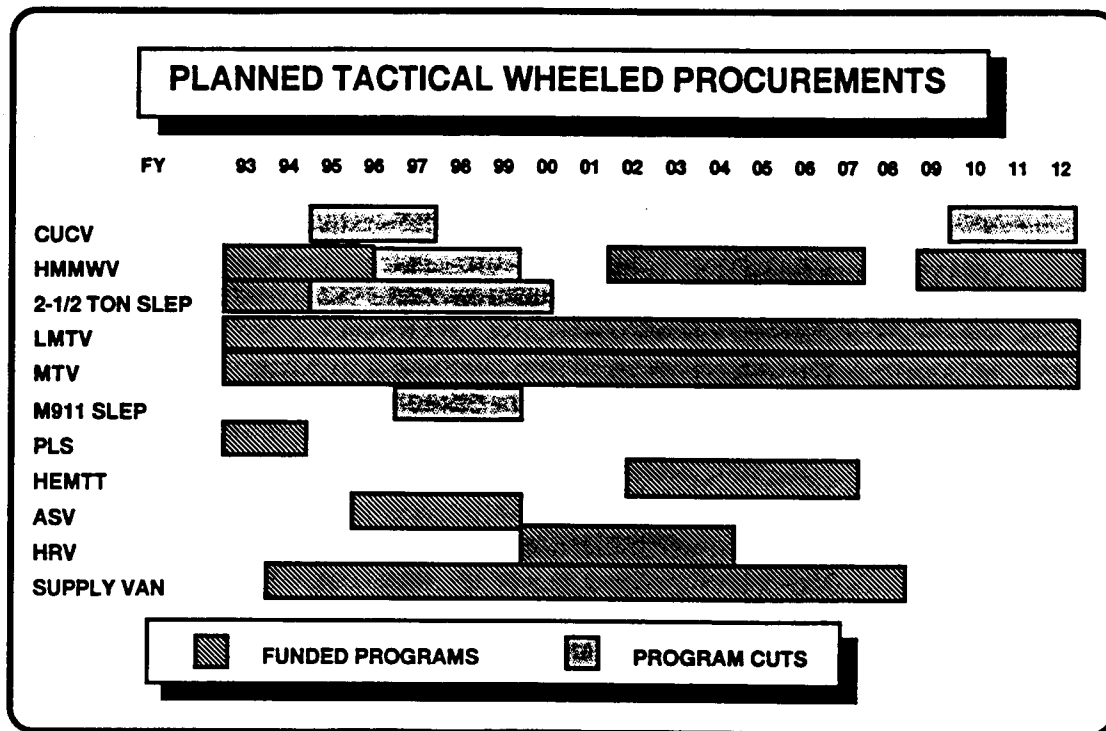

Figure 6-23

The following paragraphs note the revised programs and impact of budget reductions.

CUCV. A near-term rebuy of the CUCV was terminated. This, coupled with its 2010 - 2012 replacement, will leave the Army with the choice of either retaining about 12,000 CUCV, which will average 27 years of age in the year 2012, or disposing of them with no provision for light transport vehicles to many units.

HMMWV. Termination of the HMMWV line fills requirements to just over FP III needs. This curtailment prohibits pure fleetings all units in the divisions. Inability to replace the oldest HMMWV drives up the long-term cost of ownership, and may result in the potential loss of the production base for this vehicle.

2 1/2 Ton Extended Service Program (ESP). Reductions in TWV procurement dollars, coupled with reduced medium fleet requirements, necessitated a complete reassessment of medium fleet modernization options. At the heart of the reassessment was the realization that reduced 5-ton requirements would result in older 5-ton vehicle retirements, thus improving the 5-ton fleet health and permitting a shift in emphasis to the 2 1/2 ton. This resulted in a strategy to fully modernize the Contingency Corps with all FMTV variants, followed by focus on FMTV procurements for the 2 1/2 ton LMTV variant. This strategy made a 2 1/2 ton ESP program less attractive than before. The Army is focusing on ESP as a customer program for the National Guard and Reserve assets.

FMTV. The FMTV program was decremented in FY97-99 during the recent mini-POM. The 2 1/2 ton fleet remains RED beyond the turn of the century. Although FMTV is currently in low rate initial production, only Force Package I units, those having the highest priority, will be equipped with this modern family of trucks by the 21st Century. Without added funds there is a potential for retaining up to

10,000 current 2 1/2 ton trucks to the year 2012. At that time vehicles as old as forty-three (43) years of age will still be in use at a time when the first FMTV vehicles are nearing replacement age.

M911 Extended Service Program. The planned ESP for the current Heavy Equipment Transporter (HET) tractor has been terminated. This was being relied upon to remanufacture and upgrade current assets to partially fill the gap between HET requirements and programmed acquisitions. Program termination will result in the retention of commercial tractors, which in 2012 will average 25 years of age or 1.8 times their EUL.

Procurement Funding Level

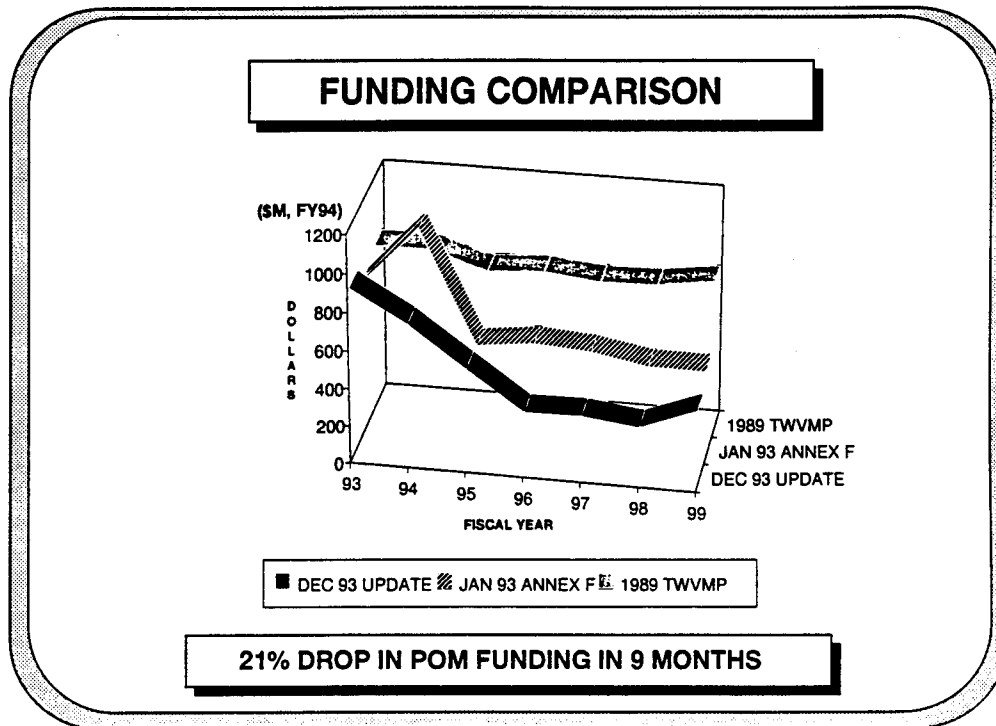

Figure 6-24

During the development of the TWV Modernization Plan (TWVMP) in 1989, the Army committed to a level funding strategy (\$800M ± 15 percent) to procure TWV at the historical average of 4.6 percent of total Army procurement dollars. It was recognized then that this level of funding was inadequate to acquire the requisite number of TWV and to retire them when it was most economical to do so. Later, in January 1993, Annex F to the AMP reduced the level of resourcing in the near term, FY93-99, by 21 percent. The mini-POM further reduced the level of funding for the same FY93-99 time period by an additional 21 percent. These cumulative reductions, in an already under resourced account, far exceed requirements reductions and, unfortunately, coincide with a point in time when a large portion of the medium fleet is due for replacement.

SECTION 5

TRAINING

The TWV training objective is to provide skilled vehicle operators, maintainers and leaders in sufficient numbers and requisite skills to ensure effective use of TWVs in support of our forces. To gain training payoffs, we rely heavily on simulators and distributed driver training packages.

Training Simulators/Devices. High quality simulators are employed to improve driving skills and to raise safety consciousness. Additionally, we use training devices for maintenance training.

- **Training Simulators.** Ten non-system Driver Skill Trainers (DST) were fielded in the 3rd Quarter FY93 to the US Army Transportation School and the Motor Transport Operator Course at Fort Leonard Wood, MO. The DST teaches basic driving skills and reinforces hands-on vehicle operation by providing realistic skill enhancement training in difficult to replicate terrain, weather and light conditions, and in prohibitively unsafe emergency reaction maneuvers. It employs computer-generated visual scenarios and math models to create realistic driving environments. A post fielding training effectiveness analysis will assess DST training payoffs and will develop requirements for future fieldings.

- **Training Devices.** A generic non-system panel trainer for wiring, lighting, application of DC circuits, diesel engine maintenance and hydraulic system maintenance is currently used to support training of maintenance procedures for new and emerging TWVs. All new vehicles will have built-in-test and built-in-test-equipment (BIT/BITE) software for the transmission and engine.

Driver Standardization Program. To facilitate Army wide standardized training, clear and concise Distributed Training Packages (DTP), published as training circulars, provide field commanders with driver selection, training and testing guidance. DTPs are MOS-immaterial and contain risk assessment matrices, lesson plans, sample training schedules, instructional aids lists, paper viewgraphs, training area designs, written exams, hands-on performance tests, related reference list and, where appropriate, corresponding training video programs.

SUMMARY

Army training strategists and planners are faced with significant challenges as a result of force and funding reductions and the introduction of new and complex TWVs. These challenges are being met by the use of cost effective training simulators/devices and distributed training packages in the Army Driver Standardization Program. Collectively these ensure that competent operators, maintainers and leaders, are trained to effectively employ and support TWV assets.

SECTION 6

CONCLUSION

This update of the Army Modernization Plan confirms the goals, objectives and general fleet direction noted in Annex F and in its predecessor, the 1989 TWVMP. Changes articulated here are principally the result of reduced force structure and funding levels. The goals of TWV modernization, namely, to provide capable TWV to meet battlefield requirements, at an affordable cost of ownership, while improving fleet supportability characteristics, remain unchanged.

Reduced quantitative requirements have served to alleviate some of the deficiencies noted in Annex F. The major deficiencies which exist now are (by fleet):

Light Fleet:

- Shortage of HMMWVs (though reduced) to meet expanded operational requirements.
- Increasing age of CUCV assets.

Medium Fleet:

- Shortage of 5 ton vehicles with improved mobility levels.
- Retention of old 2 1/2 ton payload class of trucks resulting in operational deficiencies and significant O & S cost drain.

Heavy Fleet:

- Shortage of new HETS and forced retention of older assets.
- Inability to fully implement the MOADS doctrine with significant shortages of flatracks.

"Graying" of the TWV Fleet

FLEET AVERAGE AGE 1993 vs END POM				
VEHICLE	ECONOMIC LIFE	MAX FLEET AVG AGE OBJECTIVE	FLEET AVERAGE AGE	
			1993	2008
CUCV	12	6.5	7.7	21.0
HMMWV	17	7	4	12.6
SUSV	15	7.5	5.2	17.5
M151	15	7.5	15.7	N/A
M880	7	3.5	15.1	N/A
2-1/2 TON	20	10	23.7	18.4
5 TON	22	11	13.1	13.2
PLS	20	10	N/A	13.1
HEMTT	20	10	6.1	10.6
ENG TRACTORS	20	10	10.7	22.4
HET	14	7	14.7	18.2
M123	14	7	24.4	N/A
TOTAL FLEET AGE	16.9	8.5	11.7	4.5

Figure 6-25

Figure 6-25 is a reflection of the average ages of specific vehicles. It displays the Economic Useful Life (EUL) of each vehicle, the ideal or "objective age" and the current (1993) average as well as the projected fleet age in 2008 based on planned procurements. The total fleet average age increases by 24 percent, from 11.7 years to 14.5.

The Army has a set of reasonable modernization goals to acquire capable, cost-effective TWV. We use analytical tools to make informed decisions about life expectancies, modernization efforts and risks. Acquisition programs are in place to acquire required capabilities, and to reduce the O&S cost burden. However, resources are not available to maintain an adequate level of TWV fleet modernization.

CHAPTER 7
FIRE SUPPORT
SECTION 1
INTRODUCTION

This chapter updates Annex G of the 1993 Army Modernization Plan. It assesses the current state of Army Fire Support, outlines modernization plans and provides a "snapshot" appraisal of fire support capability over the next few years. Our Army faces a serious challenge of conflicting demands over the next five to ten years. As we turn to technology to maintain the war fighting capability of our ever decreasing force, the funding available to acquire the needed technology is becoming more scarce. This update reflects the reductions in the FY95-99 mini-POM and is a report of how that challenge is affecting fire support modernization.

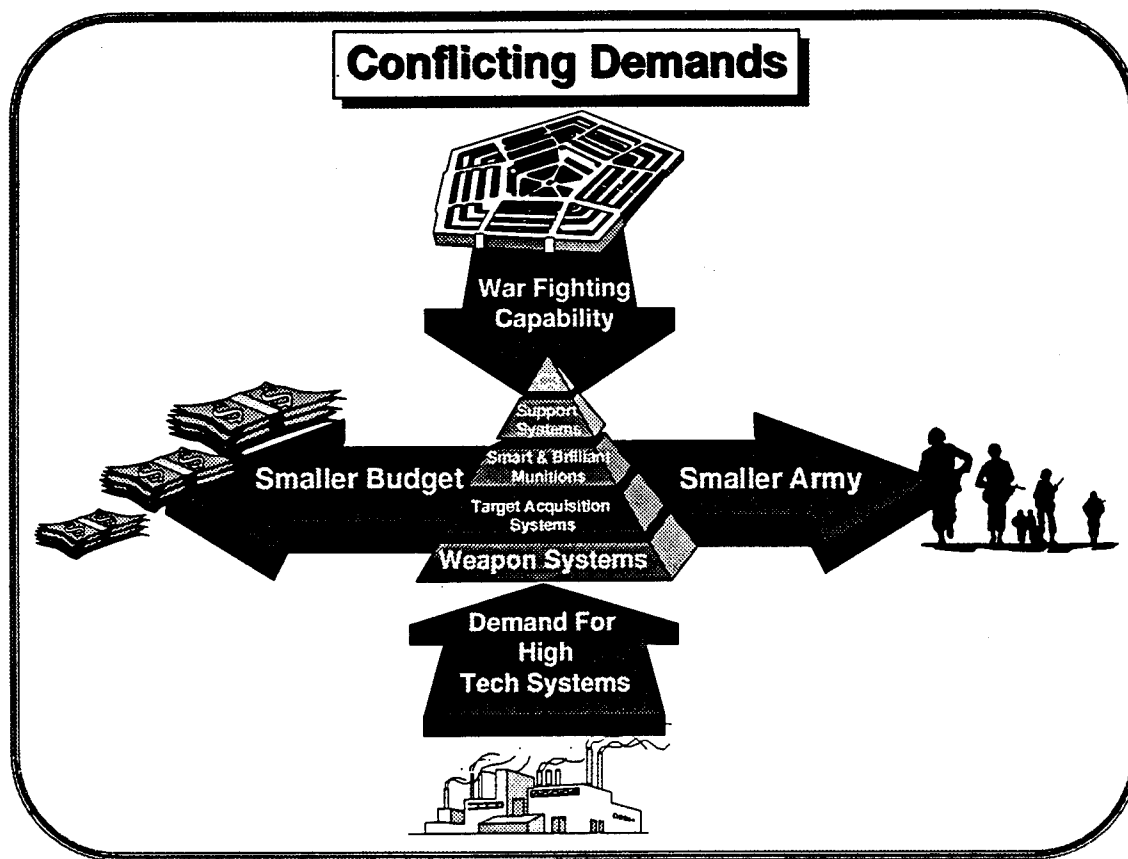

The Fire Support Annex of the Army Modernization Plan published in January 1993 articulated a vision for modernizing fire support. Though the general thrust of the 1993 Modernization Plan remains constant, much has changed in the last year. Leadership, doctrine, and strategy have begun to reshape the direction of our force, but the most immediate impact on our modernization program has been the shrinking defense budget. Every program in the Fire Support Mission Area has been examined – some were altered little, some changed drastically, and some were terminated. It is through this lens of fiscal constraint that this update must be viewed.

SECTION 2

WARFIGHTING CONCEPT

While specific programs have changed in this update, the concept of "Fighting with Fires" remains as a viable warfighting philosophy. It emphasizes the need to integrate and synchronize fires and maneuver to achieve quick, decisive victory on extended, joint battlefields. It embodies the tenets of Army operations – initiative, depth, agility, synchronization and versatility.

FIGHTING WITH FIRES

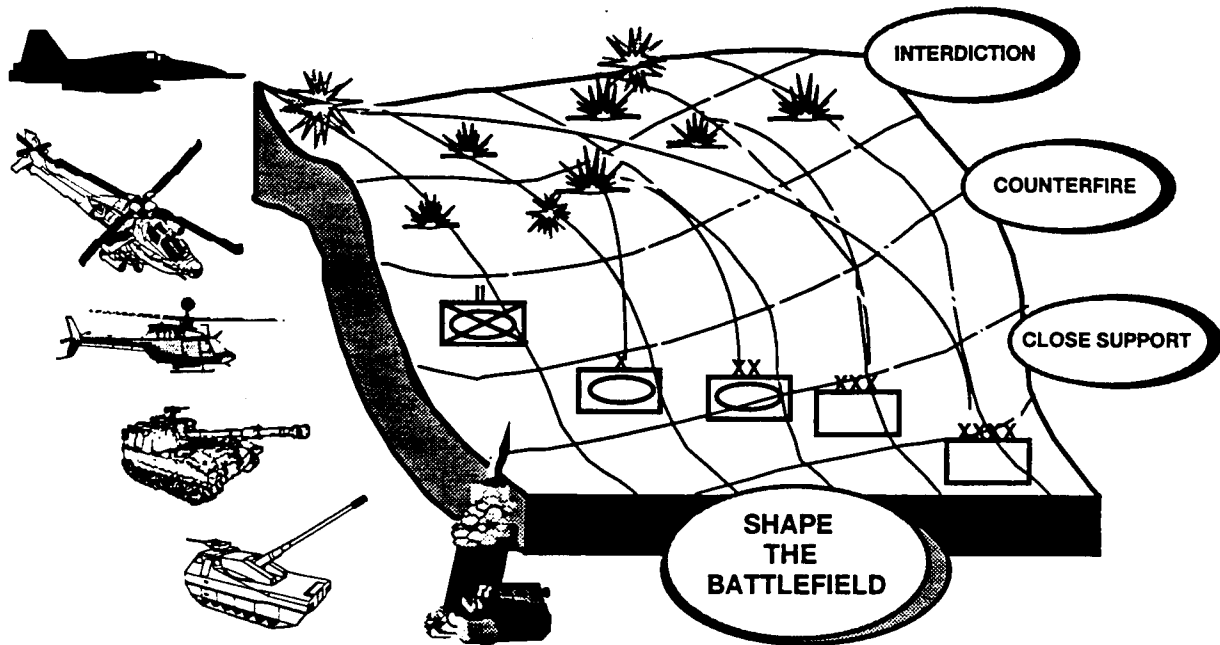

- FIRES THROUGHOUT THE BATTLEFIELD
- COMMANDERS AT ALL ECHELONS FIGHT FIRES
- SYNCHRONIZED DELIVERY FROM A COMPLEMENTARY FAMILY OF ATTACK SYSTEMS
- FIRES EXTEND THE BATTLE IN TIME, SPACE AND PURPOSE

Figure 7-1

"Fighting with Fires" is the application of technology in a synchronized manner throughout the depth of joint battlefields. The Land Component Commander (LCC) must have the ability to plan, apportion, and execute fires, whether delivered by fixed or rotary winged aircraft, Navy warships or surface-based mortars, rockets, missiles, or cannons.

"Fighting with Fires" is focused combat power. Once applied, there is no rest for the enemy. The commander uses all available options to kill the right things at the right place and at the right time. Phased, echeloned fights, are replaced by battles which extend, in time and space, throughout a theater. Complementary capabilities of systems within the Army and among the Services are orchestrated. Centers of gravity are held hostage throughout the depth of battlefields because we are able to see the enemy in real-time, strike when and where we choose, and kill when we strike. Commanders can achieve all this when they "Fight with Fires."

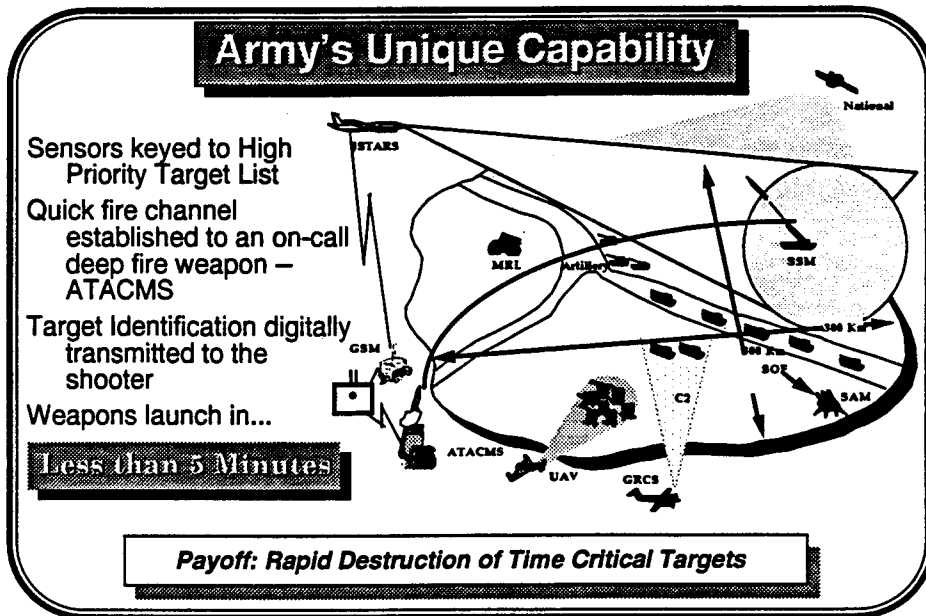

Figure 7-2

The Army's ability to fight with fires at ever increasing depth gives it a unique capability. With designated target acquisition assets searching for high priority targets and execution decentralized to an MLRS battalion with ATACMS, missiles can arrive on target over 200 kilometers deep less than 12 minutes after acquisition—day or night, in any weather. Only ATACMS and ATACMS P3I, linked with dedicated sensors, provide the reliable responsiveness necessary to destroy high value, fleeting targets at depth.

The technology for deep fires has not yet reached its full potential. ATACMS can be stretched to even greater range; smarter precision munitions are right around the corner; sensors are becoming increasingly more capable; and the digital command and control that ties it all together is becoming more responsive.

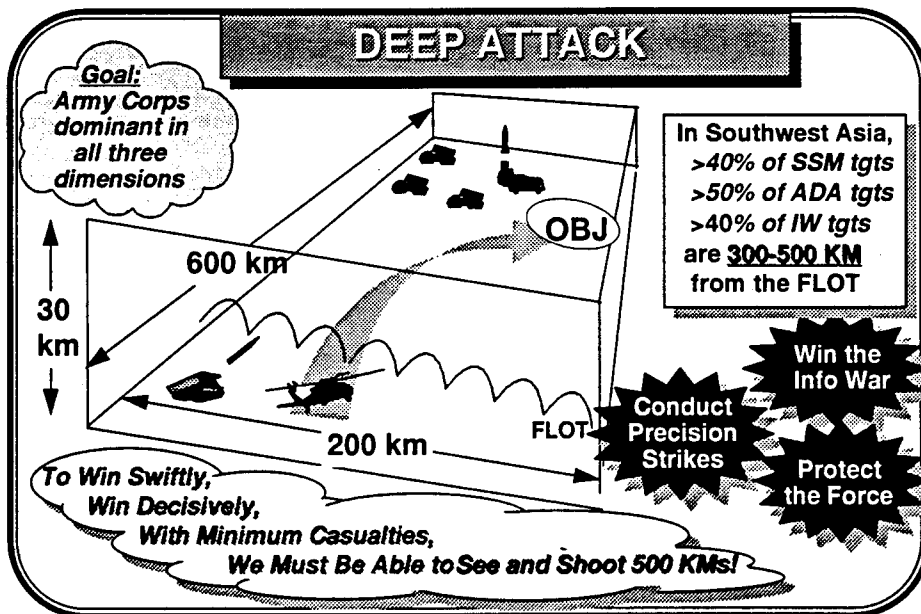

Figure 7-3

FIRE SUPPORT

Successfully "Fighting with Fires" requires the close integration of four major sub-systems:

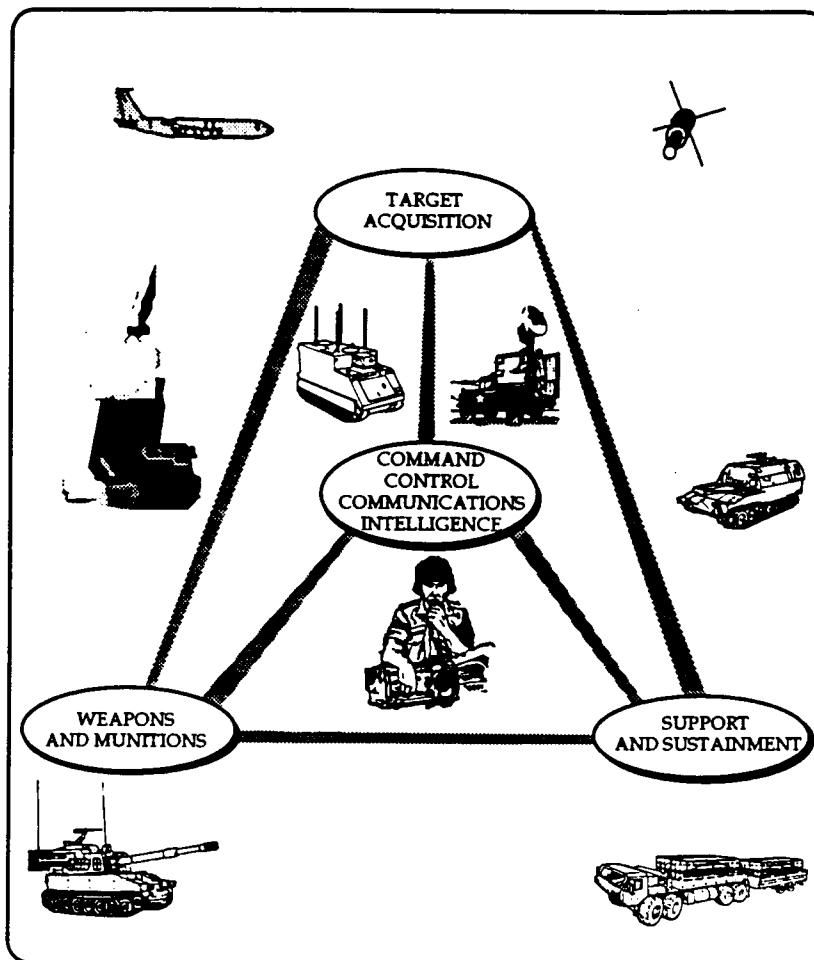

Figure 7-4

- **Target Acquisition.** Target acquisition systems find the target. This includes systems ranging from target acquisition radars, to fire support vehicles, to theater and national assets. All these systems and equipment perform the key task of target location and identification.

- **Command, Control, Communications and Intelligence.** C3I is the "brain" of the fire support system. The C3I system collates information for decision-making, technical data computation and logistical support.

- **Support and Sustainment.** This subsystem ensures we are supplied with the ammunition, transport, survey, maintenance and meteorological support required to deliver fires.

- **Weapons and Munitions.** Weapons and munitions are the heart of our fire support system. Without highly capable cannon, missile and rocket systems no amount of effort can win the battle.

The future battlefield will place new demands on the fire support system of systems. Fires will become even more important than before as our force becomes smaller. Only by leveraging technology can we ensure our fire support system of systems is up to the challenge.

SECTION 3

CURRENT PROGRAM ASSESSMENT

INTRODUCTION

The field artillery "System of Systems" provides a framework for accomplishing fire support's assigned roles:

- **Close Support** – the engagement of enemy forces that threaten the close fight. Close support fires enhance the capabilities of our own direct fire systems, suppress the capabilities of enemy direct fire systems, and directly contribute to the destruction of enemy close combat forces.
- **Counterfire** – the total effort to defeat threat indirect fire systems consisting of proactive and reactive attacks on threat indirect fire weapons, on his observation and target acquisition assets, and on his logistics base.
- **Interdiction** – fires that destroy, disrupt or delay threat forces at depth. Since these fires strike the threat before it can engage our forces, interdiction is the most desired fire support. With interdiction, we are not joined in close combat; rather we apply our combat power in what is essentially a one-sided battle.

This section addresses the capability of our fire support system of systems to accomplish its major roles during near (FY94-95), mid (FY96-99) and far (FY00-08) terms.

The ratings used are:

GREEN – Adequate capability or quantity exists to perform the mission.

AMBER – A limited capability or quantity exists to perform the mission.

RED – No capability exists, or it is incapable of defeating threat or providing required support.

ASSESSMENT AND MODERNIZATION "FIX"

Within each of the roles for field artillery, specific systems have been planned to address identified deficiencies. Some are supported in the current Program Objective Memorandum (POM) / Extended Planning Annex (EPA); others will require additional resources. Systems keyed to deficiencies and arrayed in the time periods planned for procurement are described below.

Close Support. (Figure 7-5)

- Current situation. Current command and control systems are adequate to control today's systems, but are difficult to support and have high operational and support costs. Today's close support weapons are aging, outranged, outnumbered, manpower intensive, and of questionable survivability given the development and proliferation of smart munitions available to the highest bidder.

CLOSE SUPPORT

DEFICIENCY	SOLUTIONS		
	NEAR TERM FY 94-95	MID TERM FY 96-99	FAR TERM FY 00-08
RATING	AMBER	AMBER	GREEN
OUTRANGED	M109A5 HOW* M109A6 PALADIN*	M109A5 HOW* M109A6 PALADIN*	HICAP AFAS/FARV * LT WT 155 HOW
MUNITION LETHALITY		105mm DPICM *	ERA HICAP
SLOW RATE OF FIRE	M109A6 PALADIN*	M109A6 PALADIN*	AFAS/FARV *
SUSTAINABILITY	M109A5 HOW* M109A6 PALADIN* FAASV *	M109A5 HOW* M109A6 PALADIN* BRADLEY FISTV*	AFAS/FARV * LT WT 155 HOW
SURVIVABILITY	M109A5* M109A6 PALADIN*	M109A5* M109A6 PALADIN* BRADLEY FISTV*	AFAS/FARV * LT WT 155 HOW
MANPOWER INTENSIVE			AFAS/FARV * LT WT 155 HOW
STRATEGIC DEPLOYABILITY			LT WT 155 HOW
TACTICAL MOBILITY			AFAS / FARV* LT WT 155 HOW
TARGET ACQUISITION		BRADLEY FISTV* LLDR	BRADLEY FISTV *
INADEQUATE FS AUTOMATION	IFSAS* FSAC*	AFATDS *	AFATDS*
* SUPPORTED IN CURRENT POM/EPA			

Figure 7-5

Near Term Assessment: AMBER

In the near term, we will complete fielding of the M119 towed howitzer to the active component and 105mm Rocket Assisted Projectile (RAP) ammunition to improve deployability and lethality for light forces. For the heavy force not programmed to receive the Paladin, the M109A5 155mm self-propelled howitzer is being developed with automotive and armament improvements to increase reliability and range, and a collective NBC system to improve survivability. IFSAS and AFATDS will begin to displace TACFIRE and LTACFIRE, giving commanders the responsive digital links needed for close support.

Mid Term Assessment: AMBER

Mid-term improvements are keyed to continued fielding of the Paladin which introduces semi-autonomous, shoot-and-scoot tactics and greatly improved survivability, responsiveness, and range. Additionally, DPICM munitions for 105mm cannons will complete development. AFATDS is fielded in growing quantities to replace the aging TACFIRE C2 system. Improvements to target acquisition include a Bradley FISTV. Light forces need the Lightweight Laser Designator Rangefinder (LLDR), but it is unfunded.

Far Term Assessment: GREEN

Far term improvements center on replacing the close support weapon for both heavy and light forces. The heavy force finally receives the AFAS howitzer and the FARV ammunition carrier. The introduction of automatic ammunition handling and loading provides a quantum leap in rate of fire to offset the improved quality and quantity of threat artillery. AFAS and FARV, the centerpieces of fire support modernization, will reduce manpower requirements and exploit technology to improve reliability, responsiveness, and survivability. Paladin will be fielded to lower priority units, allowing older M109s to

be retired. Although not currently funded, the Army is cooperating with the USMC to define a requirement for a lightweight 155mm towed howitzer to increase lethality for light forces without increasing manpower or logistical requirements. To complement new weapons, improved, more lethal, longer range projectiles are being designed (ERA and HICAP).

Counterfire. (Figure 7-6)

- **Current situation.** Today's counterfire capability is marginal in each of the four system of systems areas. Command and control systems do not possess adequate processing capability, and radars require software changes to capitalize on technological advancements. Both C3I and Target Acquisition systems must improve in the areas of deployability, mobility, and survivability. The ability of standard munitions to defeat modern self-propelled artillery remains marginal. The increased emphasis on contingency operations requires improved deployability in our weapon systems plus smart munitions to reduce logistical requirements.

COUNTERFIRE

DEFICIENCY	SOLUTIONS		
	NEAR TERM FY 94-95	MID TERM FY 96-99	FAR TERM FY 00-08
RATING	AMBER	AMBER	AMBER
TARGET ACQUISITION CAPABILITY	Q-36 PIP * UAV-SR *	UAV-CR	FIREFINDER P3I
INADEQUATE RANGE	MLRS *		MLRS ERR* AFAS *
LETHAL MUNITIONS		SADARM *	SADARM* SADARM P3I
FIRE CONTROL TECHNOLOGY	MLRS DEEP BATTLE MODS(V6)*	MLRS IFCS*	MLRS IFCS* MLRS ILMS
* SUPPORTED IN CURRENT POWEPA			

Figure 7-6

Near Term Assessment: AMBER

Near term improvements center on the product improvements to downsize the AN/TPQ-36 to improve strategic and tactical mobility, increase survivability, reduce crew size, and improve processing. The fire control system for MLRS is being improved to support the ATACMS missile (Battle Modifications (V6)) and prepare for terminally guided payloads. The inability to continue funding for MLRS launchers will leave the reserve components with a serious counterfire deficiency. The M110 howitzer will continue in service for the foreseeable future. Short-range UAV provides a leap ahead in target acquisition capability.

Mid Term Assessment: AMBER

Mid-term improvements center on increasing lethality with the introduction of SADARM. This provides a quantum leap in counterfire efficiency and effectiveness. Additionally, the planned introduction of UAV-Close Range improves accuracy and depth of target acquisition.

Far Term Assessment: AMBER

In the far term, we must further improve, or replace, the existing MLRS fire control to maintain system reliability. The initial fielding of AFAS and the fielding of extended range rockets will give field artillery the "reach" to protect the force at even greater range. Firefinder P3I and SADARM P3I, currently unfunded, would further enhance this capability.

Interdiction Fires. (Figure 7-7)

- Current situation. During DESERT STORM the highly successful use of ATACMS demonstrated the Army's ability to execute interdiction fire at depth. The volume of fire and short time lines required mandate a surface-to-surface system immediately responsive to ground commanders. Improving this high-payoff capability is one of the Army's five modernization objectives (Conduct Precision Strikes) and is also a key contributor to the attack operations pillar of Theater Missile Defense (see Chapter 8). The emphasis on contingency operations dictates an even more lethal, deployable deep strike capability to protect our forces during entry into a theater of operations.

INTERDICTION FIRES

DEFICIENCY	SOLUTIONS		
	NEAR TERM FY 94-95	MID TERM FY 96-99	FAR TERM FY 00-06
RATING	AMBER	AMBER	GREEN
RANGE	ATACMS *	ATACMS P3I*	ATACMS EN ATACMS P3I* MLRS ERR *
COUNTER FORCE	ATACMS *	ATACMS P3I*	ATACMS EN
MOVING, HARD TGT KILL			ATACMS II * SADARM P3I BAT* BAT P3I *
TARGET ACQUISITION	UAV-SR * JSTARS* GRCS*	JSTARS* GRCS* UAV-CR	
ANTI-EMITTER CAPABILITY			
MET/VELOCIMETER	MMS* MVS*	MVS*	TAMSS
FIRE CONTROL	MLRS IFCS* MLRS DEEP BATTLE MODS* FDDM*	MLRS IFCS *	MLRS IFCS*
STRATEGIC DEPLOYABILITY			HIMARS
RESPONSIVENESS			MLRS ILMS
* SUPPORTED IN CURRENT POWEPA			

Figure 7-7

Near Term Assessment: AMBER

Near term solutions include the continued procurement of ATACMS, Joint Surveillance and Target Attack Radar System (JSTARS), Guard Rail Common Sensor (GRCS), and the completion of deep battle modifications to MLRS launchers. TSSAM RDTE is completed and the technology is put "on the shelf". This, in conjunction with the projected procurement of the Unmanned Aerial Vehicle-Short Range (UAV-SR) , initiates the enhancement of our current capability to conduct accurate, responsive interdiction fires.

Mid Term Assessment: AMBER

In the mid-term, ATACMS P3I, with a range twice that of ATACMS, is produced to attack soft, sitting interdiction targets. Coupled with continued acquisition of responsive sensors, the Army's deep strike capability becomes more robust.

Far Term Assessment: GREEN

By the far term, our fire support modernization strategy produces a lethal deep strike force. Improvements to smart munitions (BAT and SADARM) and procurement of ATACMS P3I and ATACMS Block II (with a 13 BAT payload) can be well underway. Extended Range Rockets become available to increase the capability of the MLRS system. Additional funding is needed, however, for enhancements to meteorological systems, Firefinder radar, the M270 launcher mechanical system, and warheads for attack of emitters to further increase our capability. Acquisition of HIMARS is needed to improve strategic and operational mobility of early deploying deep strike forces. Finally, our currently funded systems do not allow us to engage critical targets to the depth allowed by current treaties. The Enhanced ATACMS, if developed, would give the joint task force commander that capability.

SUMMARY

SUMMARY OF RATINGS IN FIRE SUPPORT ROLES			
ROLE	RATING		
	NEAR TERM FY 94-95	MID TERM FY 96-99	FAR TERM FY 00-08
CLOSE SUPPORT	AMBER	AMBER	GREEN
COUNTERFIRE	AMBER	AMBER	AMBER
INTERDICTION FIRES	AMBER	AMBER	GREEN

Figure 7-8

While today's fire support systems are impressive, the requirement to keep pace in a changing world requires that we modernize continually. It is a given that the future field artillery force will be smaller and resources will be constrained. For fire support to remain effective, it must be more lethal, more survivable, and more deployable. This smaller force, well trained and well led, can achieve decisive victory. Overmatching technology ensures it can do so with minimum casualties. The modernization strategy outlined here gives the Army an ability to "fight with fires" and win.

SECTION 4

RESEARCH, DEVELOPMENT AND ACQUISITION STRATEGY

The development and improvement programs outlined in this section play a significant role in meeting future fire support needs and attaining our goal of "a trained and ready Army that can execute the National Military Strategy." The full, comprehensive RDA program for fire support is displayed on the accompanying charts. Programs with significant changes since the 1993 Army Modernization Plan are highlighted with asterisks and addressed in following paragraphs.

RESEARCH, DEVELOPMENT, TEST & EVALUATION

Science and Technology. The Science and Technology (S&T) program provides the technological foundation for Army modernization. The Science and Technology objectives, unchanged significantly from last year, are updated in the Science and Technology master plan. Similarly, ATDs, JFTDs and TDs, provide demonstration of technologies. They are also outlined in the S&T master plan. The Joint Precision Strike Demonstration continues to provide a worthwhile platform for demonstrating the Army's near-term capabilities in the precision strike arena. It, coupled with Depth and Simultaneous Attack Battle Lab at Ft. Sill, are helping define the way ahead in this critical area.

A number of S&T programs support fire support modernization. Twelve STOs are approved, as well as three ATDs, as summarized below:

- **Bistatic Radar ATD.** Employs bistatic radar (physically separated transmitter and receiver) to detect and track mortars, artillery, and rocket for counterfire and registration. This technology could be available for a Firefinder P3I.

- **Precision Guided Mortar Munition.** See Chapter 2.

- **Joint Precision Strike Demonstration.** This demonstration is designed to develop and demonstrate an Army adverse weather, day/night, end-to-end, sensor-to-shooter precision strike capability which reduces precision strike timelines from hours to minutes; provides measurable improvements in target location, identification, weapon effectiveness, and combat assessment; and near-real time cross-sensor cueing, data dissemination, seamless sensor-to-shooter connectivity and dynamic retargeting.

In addition to these ATDs, there are several relevant demonstration programs that address fire support deficiencies. "Hit avoidance" technologies, discussed in Chapter 1, have been evaluated to address top-attack protection needs of AFAS and FARV. Advanced submunition sensor technology will demonstrate technology to increase the footprint of SADARM to provide a capability to attack moving targets. The Multi-Platform Launcher has two objectives. First, it will explore inexpensive, strap-on guidance for MLRS rockets to improve accuracy. Second, methods to improve deployability and flexibility of the launcher will be investigated. The Lightweight 155mm Howitzer demonstration will include advanced fire control and other candidate improvements to make the howitzer more responsive and deployable.

Upgrades. Many fielded systems can have their service life extended by upgrading existing capabilities. While many of these programs remain unfunded, several are moving toward fielding.

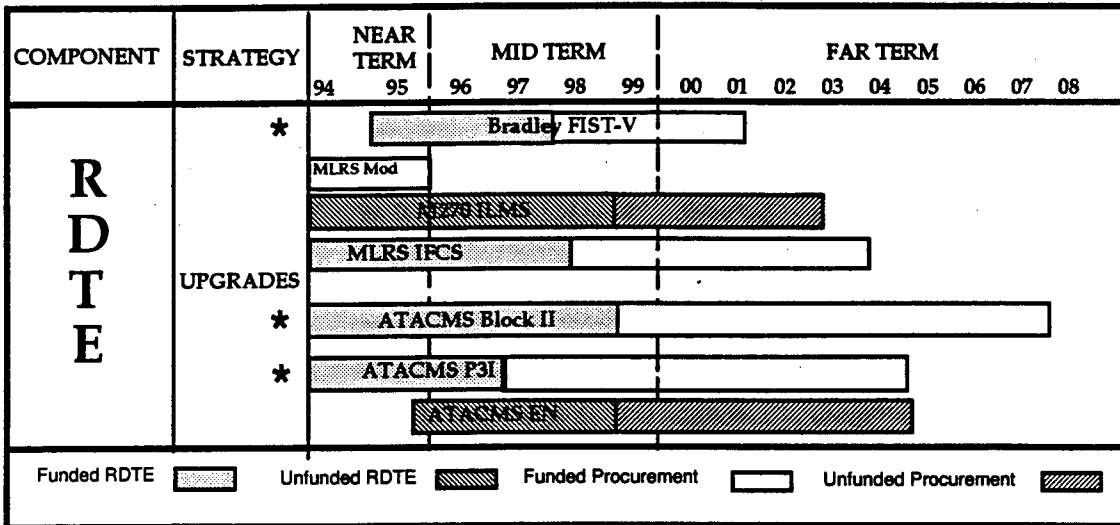

Figure 7-9

- **Bradley Fire Support Team Vehicle (BFISTV).** The BFISTV is a Bradley converted to a FS configuration. It replaces the M981 FIST-V and provides the mobility required to keep pace with our Bradley / M1-mounted forces. It incorporates a navigation and direction system; an integrated sight system that provides day/night/all weather visibility, range finding and designation; and, an improved automatic target hand-off system. Fielding has been shifted from FY96 to FY99 due to funding shortfall.

- **ATACMS Pre-Planned Product Improvement (P3I)** (Formerly ATACMS ER). ATACMS P3I, now fully funded, is a modification of the current basic missile. The payload has been reduced to approximately 275 bomblets, allowing the missile to fly over twice its present range. Global Positioning System (GPS) capability will be added to improve missile accuracy. Future improvements include integration of BAT P3I. Fielding will occur in FY97.

- **ATACMS Block II.** With the Army withdrawal from TSSAM, ATACMS Block II fulfills the Corps Commander's need to destroy moving armored targets at depth. The payload per each ATACMs round is 13 standard BATS. When available BAT P3I munitions will be loaded. ATACMs Block II fielding will occur in FY00.

Demonstrations and Validations. There has been one additional system included for Dem/Val since last year.

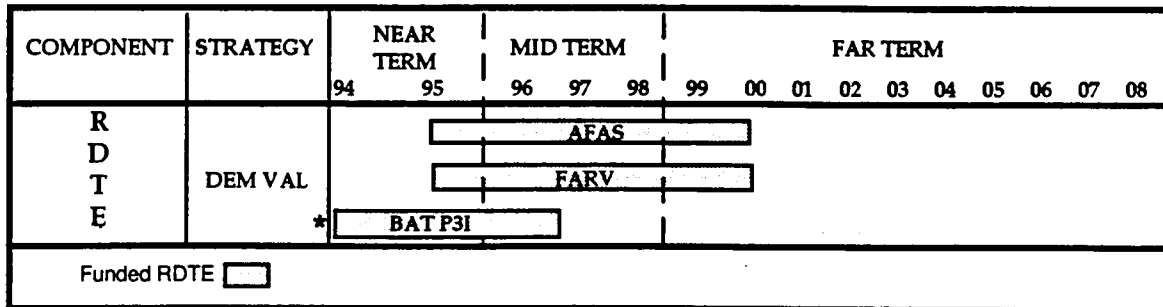

Figure 7-10

- **Brilliant Anti-armor Submunition Preplanned Product Improvement (BAT P3I).**

BAT P3I increases the effectiveness of basic BAT. It incorporates improved seeker technology, software, and warhead enhancements to attack additional targets, add robustness against countermeasures, and improve its capabilities during degraded weather. Funded to be carried in ATACMS P3I beginning FY2002, it adds versatility and flexibility to the deep fires program.

Engineering and Manufacturing Development (EMD). All following systems planned for entry into EMD during the POM/EPA period continue to be resourced. One has had programmatic changes.

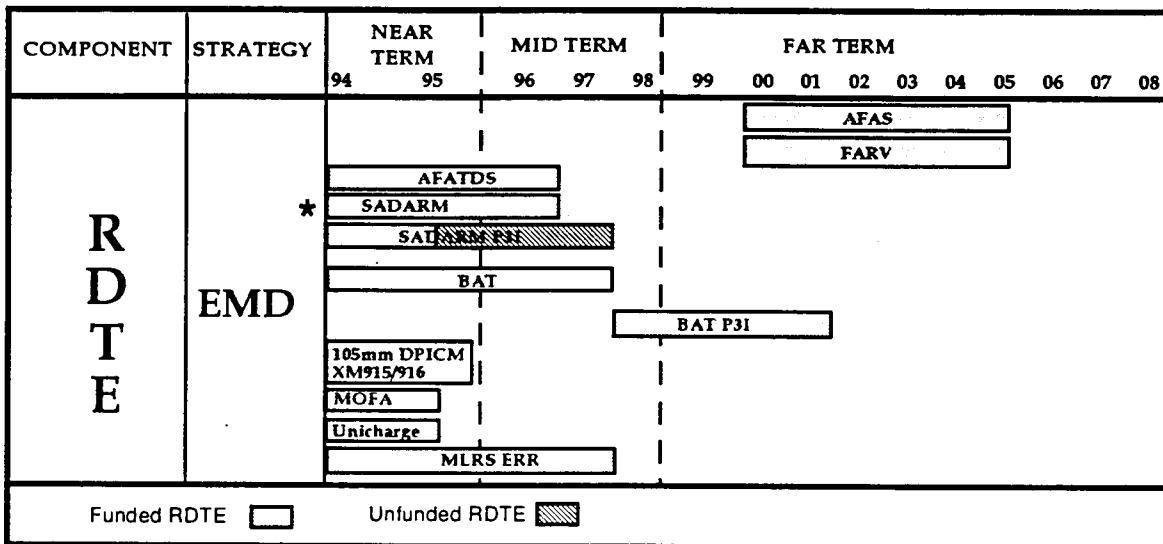

Figure 7-11

- **SADARM (155mm and MLRS).** The 155mm SADARM projectile contains two SADARM submunitions in a base ejecting carrier, uses the M577 mechanical or M762 electronic time fuse, and is delivered in the same manner as other 155mm munitions. The MLRS SADARM warhead is integrated with an existing or extended range MLRS rocket motor and fired from the existing MLRS rocket pod container. Each warhead contains six SADARM submunitions. The dispense system deploys the submunitions over the target area. EMD was recently extended 27 months to increase reliability.

PROCUREMENT

The payoff for RD&A is putting quality equipment in the hands of soldiers. Whether new production or a non-developmental item, the goal is to ensure tomorrow's field artilleryman receives the best equipment.

Production. Most of the systems shown are resourced, but the scheduled procurement for some has been modified within the last year.

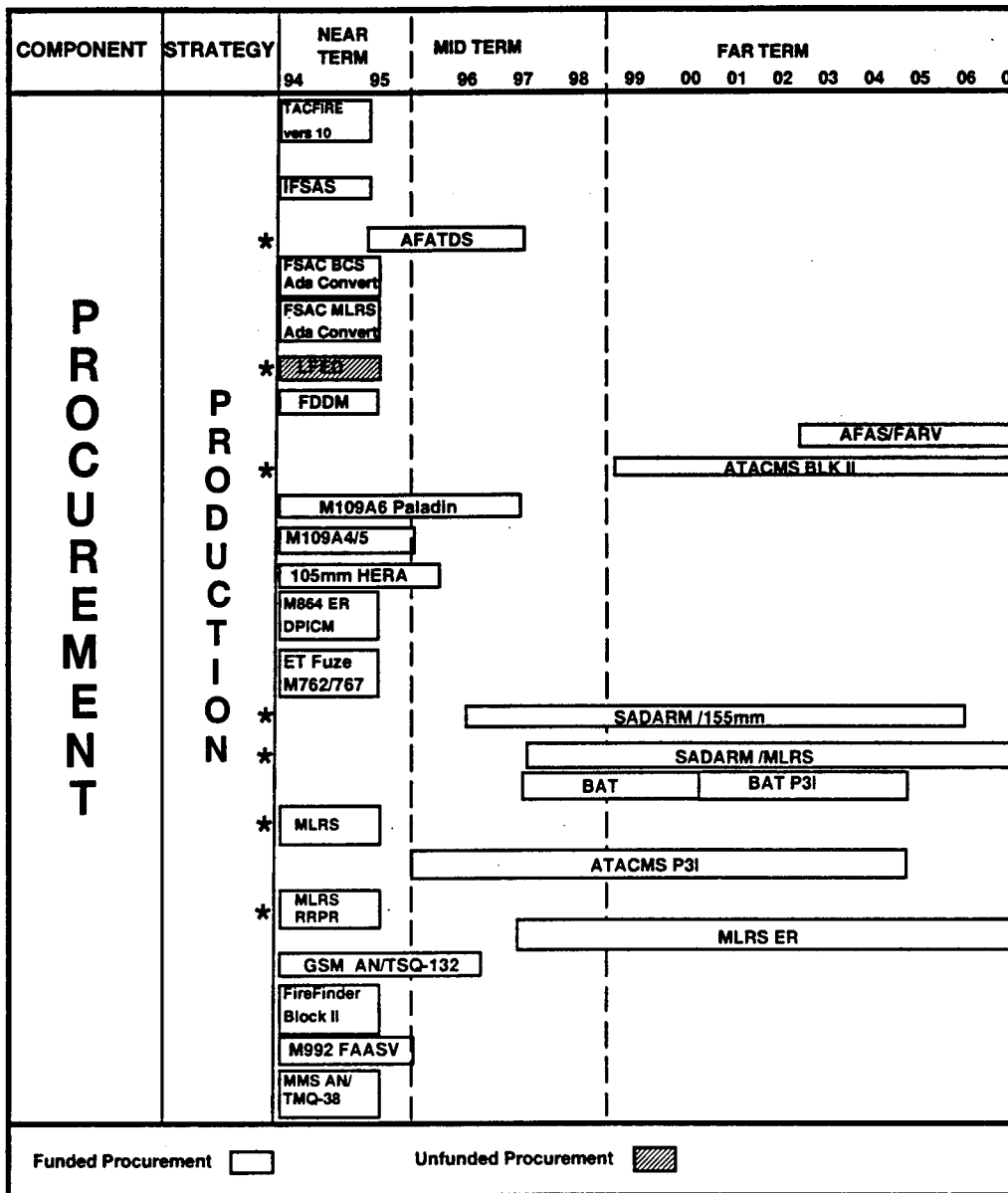

Figure 7-12

- **Advanced Field Artillery Tactical Data System (AFATDS).** EMD for version 1 will be completed and production will start in FY94. Subsequent versions will continue in EMD until FY96. Curtailment of funding currently allows fielding of Force Package 1 only.

- **Lightweight Forward Entry Device (LFED).** The LFED will be used by platoon forward observers and field artillery aerial observers to compose, edit, transmit, receive, store, display messages and process data used in the conduct of fire support operations. The LFED is approximately half the size of the FED fielded to our heavy divisions. It is an unfunded program due to the Mini-POM prioritization.

- **Sense and Destroy Armor (SADARM).** Production and fielding have slipped 27 months since publication of the last Modernization Plan because of unforeseen problems during technical tests. Fixes have been identified. The program will be further modified as technical fixes are applied.

- **Multiple Launch Rocket System (MLRS).** Funding for procurement of the MLRS launcher ends after FY94. This combat proven system will remain the backbone for long-range counterfire within the active component. Fiscal constraints currently preclude fielding to the entire force, as projected in the 1993 Modernization Plan.

- **MLRS Extended Range Rocket (ERR).** The MLRS ERR offers greater range, improved accuracy, and reduced M77 grenade dud rates. The warhead payload is reduced, but accuracy is increased by incorporating a low level wind measuring device and a "soft launch". While RDTE has remained on track, production has been delayed two years because of funding priorities within the POM.

Non-Developmental Items (NDI). If equipment already developed can meet fire support requirements, it will be procured "off the shelf". This normally means modern equipment reaches our soldiers more quickly. Two changes have occurred over the last year.

- **Howitzer, Lightweight, Towed, 105mm, M119A1.** Production funding for the M119A1 was terminated in FY93.

- **Muzzle Velocity System. (MVS)** Procurement has been delayed until late FY94 as materiel developers select the most capable system.

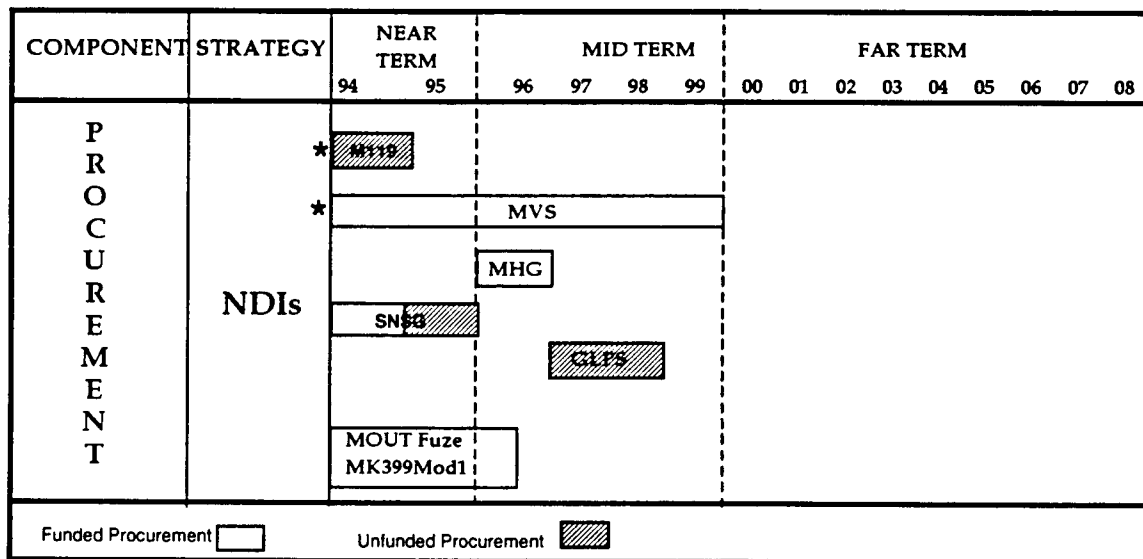

Figure 7-13

SUMMARY

In a period of uncertainty, efforts must be directed toward doing business smarter, with up-to-date technology, and with even more cost effective performance. The Fire Support Modernization Plan capitalizes on previous investments and attempts to leverage the most affordable technology. It uses a mixture of new systems and technological upgrades of existing systems. This plan describes not only systems being fielded, but those still in development. While it is a plan for the near term, it also describes, more importantly, what is planned for the future.

SECTION 5

TRAINING

In addition to training simulators and devices discussed in the 1993 AMP, the following "stand alone" device is now under development:

- **Fire Support Combined Arms Tactical Trainer (FSCATT).** FSCATT will integrate the training of the gunnery team. It will consist of a target acquisition subsystem, fire direction center subsystem, a weapon subsystem, FIST-V module, and drivers station. FSCATT will provide connectivity to the close combat tactical trainer (CCTT). It will be issued to each active division artillery/brigade and armored cavalry regiment (ACR) and each reserve battalion and ACR.

SECTION 6

CONCLUSION

As we move toward the next century two conflicting forces will challenge our attempt to modernize. The smaller Army must become more dependent on high technology systems if it is to retain the combat capability necessary to ensure Land Force Dominance. Unfortunately, increased technology – often at significant cost – is required just as our economy is becoming more constrained. Costly high technology is demanded at exactly the time it is least affordable. The rapid pace at which technology is changing complicates the problem even more. New systems quickly become obsolete and require upgrades or replacement, if the Army is to maintain its technological edge.

This chapter, in consonance with Annex G, proposes a balanced, affordable approach that, if adequately funded, will continue to overmatch our potential adversaries. In the near term the POM provides for the most critical modernization – improvements to cannon and rocket systems, continued fielding of the ATACMS missile, and upgrades to our fire support vehicle. As the end of the century approaches, and continuing to 2005, the Army will complete its planned procurement of Paladin, ATACMS, AFATDS, Bradley FISTV, Firefinder improvements, and SADARM. Fiscal constraints, however, will allow only partial fielding of even the most critical systems – Paladin, MLRS, and AFATDS.

With the current funding, there will remain a serious shortfall in resources for a number of key fire support systems and programs until the end of the century. In close support the majority of the cannon force will still be equipped with the aging M548. Even after AFAS is fielded most of the cannon fleet will still be using the 1960 vintage M109 chassis. There are also growing concerns in the counterfire arena. Despite our best effort, it will be on the edge of inadequacy. There will be a shortage of MLRS launchers, the obsolete M110 howitzer could still be in the inventory, and funds have not been identified for HIMARS, extended range rockets, or Firefinder P3I. For interdiction fires, we have made great strides, but we still lack an RF-emitter killer.

"Fighting with Fires" into the next century will require continual modernization if our smaller force is to maintain the technological edge America expects. The Army's five modernization objectives provide the guide for a balanced distribution of limited resources. If they are closely followed, fire support modernization will keep pace with the rest of the Army.

CHAPTER 8

THEATER MISSILE DEFENSE

SECTION 1

INTRODUCTION

This chapter serves to update Annex H of the 1993 Army Modernization Plan (AMP) and reflects the most recent fiscal constraints as a result of the FY95-99 mini POM. Army Theater Missile Defense (TMD) capabilities, as updated in this chapter, continue to fulfill Army Modernization Plan objectives and thus improve the ability of CINCs to achieve quick, decisive victory with minimum casualties. TMD Protects the Force from the threat of Theater Missiles (TMs). This helps CINCs Project and Sustain the Force safely, by defending Aerial Ports of Debarkation (APOD), Sea Ports of Debarkation (SPOD), lines of communication (LOC), C3I facilities and other infrastructure against TM interdiction. Winning the Information War allows TMD forces to Conduct Precision Strikes against enemy missile launch capabilities, helping the CINC Dominate Maneuver by protecting maneuver forces from being canalized, destroyed en masse, or being interdicted in deep/rear areas. This chapter provides an update of the programs that comprise this key building block of – **LAND FORCE DOMINANCE**.



Other chapters of this Modernization Plan describe the changes in the individual materiel programs which provide improved Army TMD capabilities. These are found primarily in the Air Defense, Fire Support, Aviation, Intelligence and Electronic Warfare (IEW), NBC Defense, and Command, Control, and Communications (C3) chapters and will not be repeated here. However, as in the basic AMP, the capabilities represented by all those individual programs do not provide a comprehensive picture of what is required or what will be attained when the programs are synergistically integrated and examined in the context of the TMD Operational Concept. Therefore, this chapter addresses and updates the Army TMD integration effort to evolve into a system-of-systems with some reasonable balance of capabilities among the four TMD pillars indicated in Figure 8-1. The original Annex, which this update addresses, remains valid where changes are not indicated.

TMD OPERATIONAL PILLARS

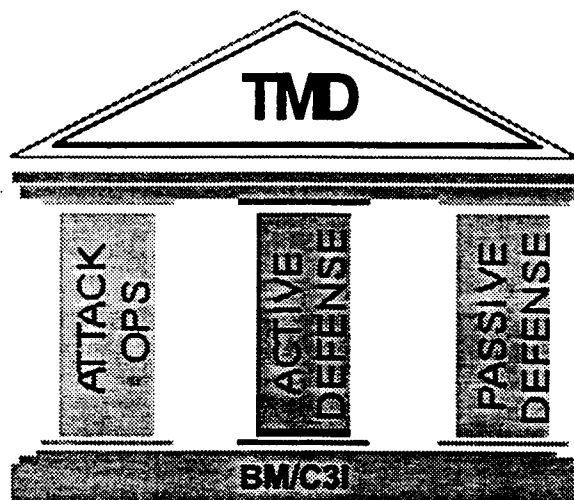

Figure 8-1

Since the January 1993 publication of the Army Modernization Plan (AMP), the importance of Theater Missile Defense has been underscored and/or effected by several events:

- The Strategic Defense Initiative Organization (SDIO) has been renamed the Ballistic Missile Defense Organization (BMDO) and the National Command Authority missile defense emphasis has shifted from strategic to theater operations. Congress has directed that Theater Missile Defense take priority in BMDO funding and efforts. This change in emphasis is an effort to provide ballistic missile protection for our forces in the field - where the threat exists today.
- There has been a **JCS study of Service roles and missions (Feb 93) which validated the current delineation of responsibilities** of the Services and also recommended a review of Theater Air Defense to ensure that we have the appropriate mix and quantities of air and missile systems. A detailed Mission Area Analysis to comprehensively review Theater Air Defense requirements, capabilities, and deficiencies has been completed and should be published soon. Additionally, the 8 August 1993 Joint Military Net Assessment states that **"our current theater ballistic missile defense capability is inadequate"**.
- In addition to the operational counters to the theater missile threat, counter proliferation efforts have taken on increased significance within DoD and a more formal structure has been established to oversee, coordinate and enhance counter proliferation efforts, particularly against Weapons of Mass Destruction (WMD).
- There is a new emerging National Military Strategy to address the four dangers identified in the post-Cold War world. There was a DoD review of Theater Missile Defense as a part of the Bottom Up Review (BUR) which studied the force structure and modernization options necessary to support the National Military Strategy. As a result of this review, a robust Theater Missile Defense program of \$12 Billion in FY95 - 99 was selected to deal with this threat. Impacts on individual programs are still being determined.
- The Deputy Secretary of Defense and the Under Secretary of Defense for Acquisition have identified Theater Missile Defense as an important area for the NATO Alliance, and an area in which there are opportunities for increased Allied cooperation. The NATO Armaments Directors were told that discussions on TMD cooperation should include, at a minimum, the need for interoperability of missile defenses Allied countries may deploy, and should also explore potential cooperation including cooperative R&D on BMD technology; cooperative development, production or deployment of TMD interceptors, sensors, and BM/C3I; and sharing space-based

sensor and other early warning information to improve the effectiveness of Theater Missile Defenses.

- The role of space based weapons has been reevaluated, and treaty limitations on other systems are being reviewed.
- The Western European Union (WEU) has begun an initiative to establish requirements for a European Theater Missile Defense capability. As part of this concept, there would be a universal early warning and surveillance system.
- The Army Science Board in their 1993 Summer Study of "Missile Defense Programs" concluded that TMD capability is of vital importance to the Army and it is essential for employment of land forces in future contingencies. Many of the ASB's recommendations will form the basis for the continuing evolution of Army TMD capabilities.

There has been no change required in the Army's basic concept for Theater Missile Defense as a result of the activities listed above. The four pillar concept, including Passive Defense, Active Defense, Attack Operations, and the BM/C3I that links the other efforts into a coherent whole, remains valid.

Virtually all operational scenarios envision the deployment of Army TMD forces as part of joint (and multinational) forces as described in Joint Publication 3.0 Doctrine For Joint Operations, Army publications FM 100-5, Operations and FM 100-7, Army in Theater Operations (Draft). Joint Doctrine (and its supporting tactics, techniques, and procedures) is being developed and will be detailed in Joint Publication 3-01.5, Doctrine for Joint Theater Missile Defense. Conceptually, primary emphasis in this chapter is given to TMD operations as part of an Army component in joint or multinational contingency operations. This chapter, therefore, focuses only on any updates in concept, development, production, and fielding of Army TMD forces, and provides the impact of those changes on Army Theater Missile Defense.

SECTION 2

WARFIGHTING CONCEPT

If uncountered, theater missiles, particularly those armed with weapons of mass destruction, place limits on US National Military Strategy options. Our ability to project US forces into theater contingency operations is threatened by these missiles. Army doctrine (FM 100-5, Operations) recognizes that our forces are most vulnerable during initial entry operations. The Army Science Board 1993 Summer Study concluded that TMD capability is of vital importance to the Army **because theater missiles could cause the Army to be denied access to the battlefield.** Therefore, deploying US forces must possess the inherent means necessary to defend themselves against the theater missile threat (See Figure 8-2).

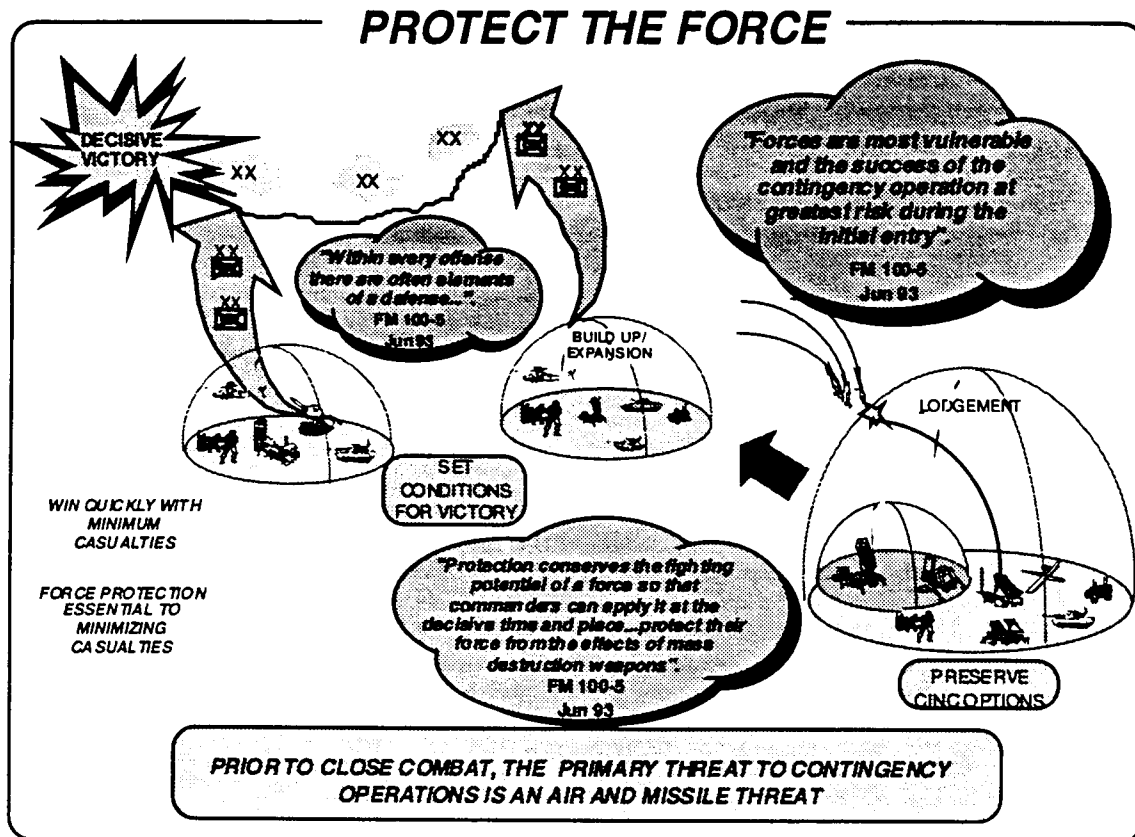

Figure 8-2

The TMD mission is to Protect the Force from threat TM attacks. The force includes U.S., allies, and others included in areas of vital interest to the United States. The theater missile threat consists of both tactical ballistic (TBM) and aerodynamic (TAM) missiles. The theater ballistic missile threat consists of very short range (VSRBM <100 Km), short range (SRBM >100 <1000 Km), and medium range tactical ballistic missiles (MRBM >1000 <3000 Km). Numerically, the vast majority of these missiles are in the very short and short range categories that are particularly threatening to deployed forces in the maneuver and Corps support areas of the battlefield. Tactical Aerodynamic Missiles (TAM), include Cruise Missiles (CM), Tactical Air-to-Surface Missiles (TASM), and Anti-Radiation Missiles (ARM), as well as Unmanned Aerial Vehicles (UAV), and an array of long range multiple launch rockets, all of which again provide stressing threats to maneuver forces.

Continued proliferation of missile technology and availability of cheap off-the-shelf components can result in a "poor man's air force" equipped with a large number of accurate and lethal theater missile threats. For example, availability of systems or technologies for inertial navigation (\$30-35K), global

positioning systems (\$4.5K), and air platforms and propulsion systems (\$300-500K), enables Third World countries to develop or procure stressing cruise missile capabilities. For less than \$500K a country can deploy a lethal cruise missile threat. The tactical missile threat to deployed forces is expected to more than double by the year 2000.

The four pillar TMD operational concept to deal with this threat remains valid and encompasses the synergistic capability of four operational pillars as shown in Figure 8-3.

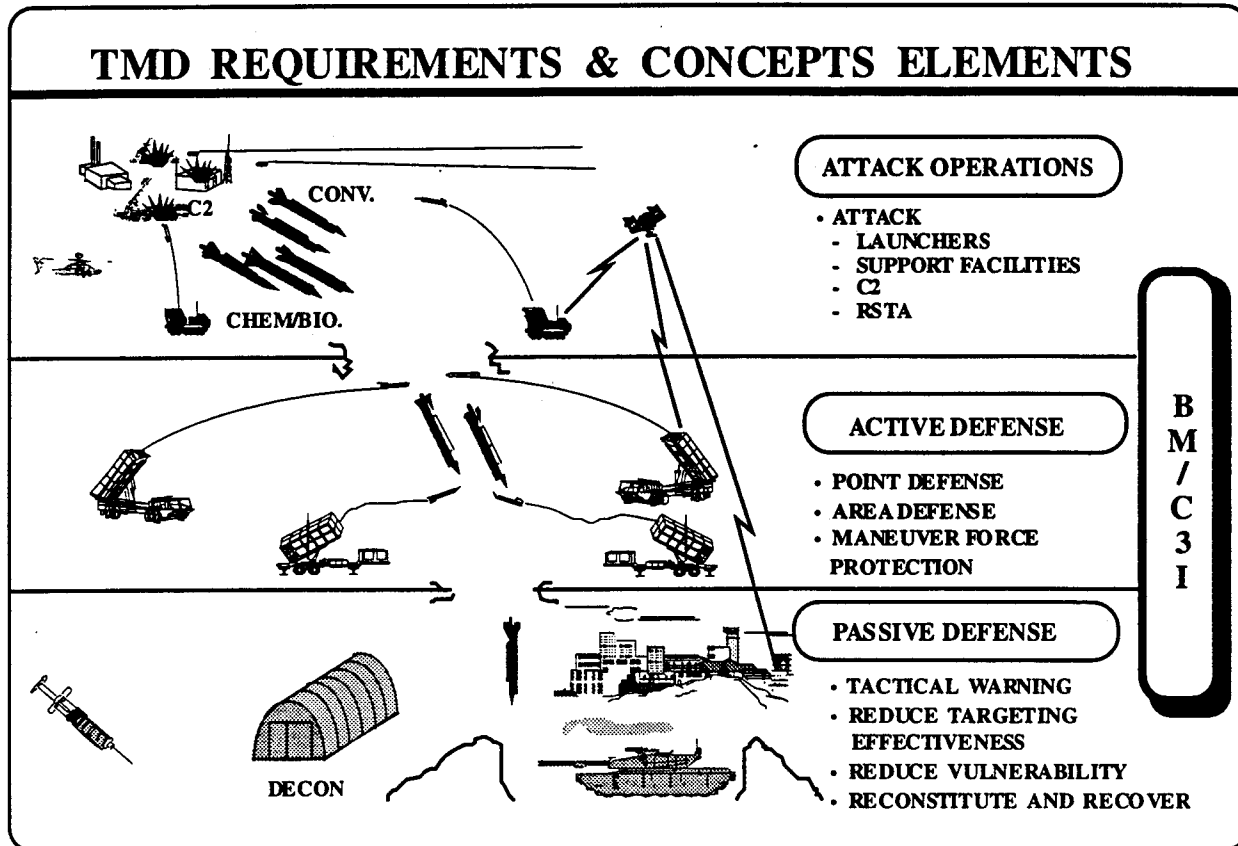

Figure 8-3

Each of the four pillars has an important role in TMD:

- **Attack Operations.** Prevents launch of TMs by attacking launchers, BM/C3, Reconnaissance, Intelligence, Surveillance, and Target Acquisition (RISTA) and logistics support, and includes actions of air, ground, sea, space, and Special Operations Forces (SOF).
- **Active Defense.** Provides protection by destroying missiles in flight.
- **Passive Defense.** Reduces the probability and minimizes the effects of TM attack.
- **BM/C3I.** Coordinates Attack Operations, Active Defense, and Passive Defense and integrates the TMD systems into combat operations.

The capabilities required to defend against theater missiles are as stated in the original AMP. What is changing is the increased awareness of the threat posed by these missiles and by the proliferation of missile technology. This has resulted in a consensus on the need to develop robust Theater Missile Defense architectures and vigorously engage in counter proliferation activities. In addition to ballistic missiles, The Army Science Board, in its 1993 Summer Study, drew attention to the growing importance of the Cruise Missile, Unmanned Aerial Vehicle, and Remotely Piloted Vehicle threat (See Figure 8-4).

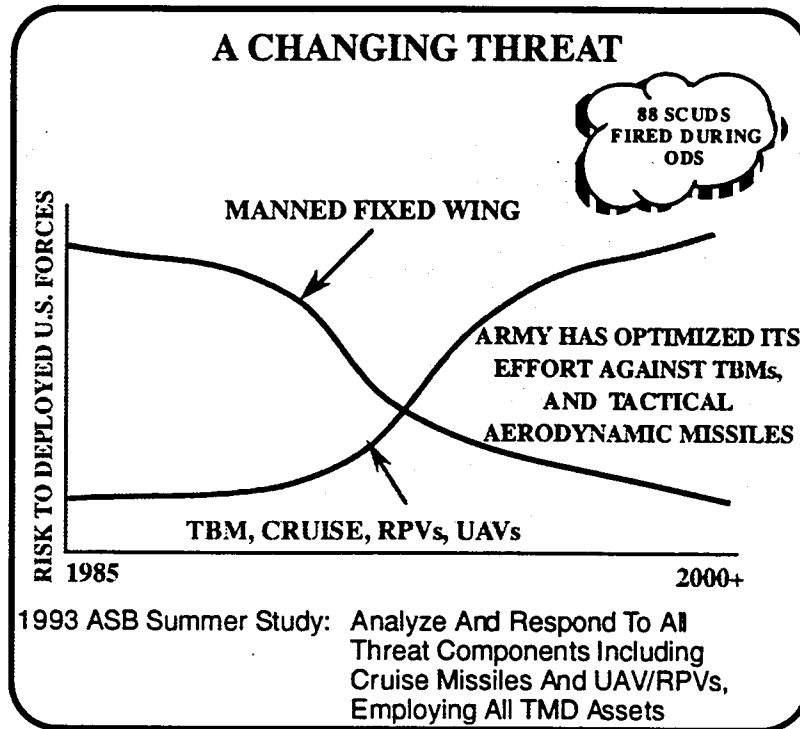

Figure 8-4

SECTION 3

CURRENT PROGRAM ASSESSMENT

The original AMP assessment considered the TMD capabilities for each TMD pillar. Capabilities were assessed **Red**, **Amber**, or **Green** using the following criteria:

- **Red** - No capability exists, or it is incapable of defeating threat or providing required support.
- **Amber** - A limited capability or quantity exists to perform the mission.
- **Green** - Adequate capability or quantity exists to perform the mission.

A review of the assessments, taking into account the DOD Bottom-Up Review and other activities mentioned in Section 1, using 1994-1995 as the near term, and 1996-1999 as the mid-term, showed no significant change in the overall assessment for any of the Army TMD elements. The assessment of the four pillars is based on assessments of individual programs encompassed by those pillars without repeating the detailed assessment of the individual programs presented in other respective annexes— Air Defense; Command, Control, and Communications; Intelligence and Electronic Warfare; Fire Support; etc.

TMD CAPABILITIES ASSESSMENT			
	NEAR-TERM	MID-TERM	FAR-TERM *
ACTIVE DEFENSE	AMBER	RED	GREEN
ATTACK OPERATIONS	AMBER	AMBER	GREEN
PASSIVE DEFENSE	RED	AMBER	AMBER
BM/C3I	AMBER	AMBER	AMBER

* This assessment projects to the far term (see Figure 8-5) based on continued funding and development of several systems across the pillars, e.g., Corps SAM. Shortfalls listed are those that exist entering the far-term (FY2000).

Figure 8-5

ACTIVE DEFENSE

Enemy missiles will become increasingly capable of denying access to airfields and ports essential to force projection operations. Active Defense will be required to destroy those missiles not suppressed or destroyed during Attack Operations. A detailed assessment of Army air and missile defense capabilities is in Annex E, Air Defense, of the AMP and in Chapter 5 of this update.

The DOD Bottom-UP Review (BUR), *Forces for a New Era*, addressed Ballistic Missile Defense as a key modernization issue. Given the present and projected threat of potential adversaries acquiring ballistic and cruise missiles, and possibly arming them with weapons of mass destruction, the BUR selected program reaffirmed emphasis on Theater Missile Defense because the threat exists today. Theater Missile Defense will be a robust \$12 Billion program between FY95-99. BMDO's TMD program will include the following active defense capabilities:

- **PATRIOT Advanced Capability-Level 3 (PAC-3):** PATRIOT was originally fielded to defeat the high-intensity Cold War aircraft attack expected in Central Europe. It was modified in the late 80's to meet the requirement to kill tactical ballistic missiles, and was successfully used in combat in 1991. Additional modifications (PAC-3), will improve the lethality and range of the Army's PATRIOT Anti-Missile system and improve capability against longer range threats. PATRIOT will provide the lower tier of a layered ballistic missile defense by killing the shorter range (endoatmospheric) ballistic missiles at lower altitudes. PAC-3 will also enhance PATRIOT performance against air breathing threats.

THEATER MISSILE DEFENSE

- Theater High-Altitude Area Defense (THAAD): THAAD will work together with PATRIOT in layered defenses to defend dispersed assets over wide areas and population centers against TBM attacks. THAAD will counter more advanced threats anticipated in the future. THAAD will defeat longer range (exoatmospheric) missiles at greater ranges, minimizing the effects of weapons of mass destruction on the ground and defending a larger area.
- Corps SAM will have the mission of protecting Army and USMC forces from theater ballistic missiles, tactical aerodynamic missiles, and other airborne threats in the 21st Century. It will provide protection for the maneuvering forces of the Army Corps and the USMC MEF; Corps SAM will also be capable of fighting as a lower tier TBM system with THAAD in the corps or theater army rear. Major work on this system has been delayed until 1998 with technology and concept demonstrations to be conducted beforehand.

Considering the BUR results, the near-term assessment for Active Defense remains **Amber** due to PATRIOT capabilities. Fielding PAC-3 and the THAAD User Operational Evaluation System (UOES) improves Active Defense in the mid term, however, it does not improve capabilities against the full range of threat improvements. **There is no mid-term capability dedicated to protect the maneuver force against the short-range TBM and increasing cruise missile threat.** This shortfall necessitates development of Corps SAM, a joint Army-USMC requirement, which provides strategic deployability, tactically mobile force protection, and high fire power. Active Defense becomes **Green** only when Corps SAM and the Joint Tactical Information Distribution System (JTIDS) are fielded in the long term. Failure to field JTIDS or a JTIDS-equivalent system would cause Active Defense to remain **Amber** in the long-term. Failure to field Corps SAM would cause Active Defense to go **Red** in the long term.

Figure 8-6 summarizes the mid-term active defense capabilities and shortfalls as we understand them today.

ACTIVE DEFENSE		
CAPABILITIES		SHORTFALLS
FY 94 -95	FY 96 - 99	
<ul style="list-style-type: none"> • LOWER TIER ASSET DEFENSE AGAINST TBMs 	<ul style="list-style-type: none"> • EXTENDED LOWER TIER TBM ENGAGEMENT CAPABILITY • COMMON TMD BM/C3I CAPABILITY • LIMITED TWO-TIERED TBM AREA DEFENSE 	<ul style="list-style-type: none"> • LACKS ADEQUATE CM/UAV/RPV/ ARM CAPABILITY • INADEQUATE FORCE STRUCTURE, STRATEGIC DEPLOYABILITY AND TACTICAL MOBILITY TO COVER MANEUVER FORCES • DOES NOT ACHIEVE JOINT, INTEGRATED BM/C3I

Figure 8-6

ATTACK OPERATIONS

The Army currently has limited capability to conduct effective and responsive deep strike TMD operations. Current target acquisition and sensor capabilities and the absence of a system capable of delivering sufficiently lethal counter fires or interdiction at the extended ranges required for TMD make this area **AMBER**. To resolve this shortfall, the mid-term focus will place priority on improving Attack Operations target acquisition capabilities and extending the range capability of surface-to-surface missile systems and attack helicopters. The mid-term Attack Operations force has improved airborne systems, such as UAV Short Range (which begins fielding in the near term), and ground-based SIGINT systems with enhanced capabilities against modern signal environments, but target acquisition remains inadequate through the long term. ATACMS P3I and Apache Longbow improve the deep strike capabilities of attack systems, but because of the shortfall in target acquisition, TMD Attack Operations remains **AMBER** in the

mid-term. Currently programmed sensor systems will allow Attack Operations to become **GREEN** in the far-term.

Remaining problem areas include the inability to detect, classify, identify, and engage the TM threat to the limits of the INF treaty. Although ATACMS P3I will significantly improve the range at which TMD targets can be attacked, the need to extend surface to surface missile fires deeper, beyond the range of ATACMS P3I, to INF treaty limits is paramount to the ability to successfully prosecute Attack Operations. Army near- and mid-term programs are absolutely essential to defeat the TM threat, yet they lack necessary capabilities to ensure the degree of success desired. In the foreseeable future, Attack Operations of all Services require complementary Active and Passive Defenses to ensure necessary degrees of force protection. The near- and mid-term Attack Operations capabilities and shortfalls are shown in Figure 8-7.

ATTACK OPERATIONS		
CAPABILITIES		SHORTFALLS
FY 94 -95	FY 96 - 99	
<ul style="list-style-type: none"> • SURFACE TO SURFACE FIRES TO ATACMS BLOCK I RANGE • ALL WEATHER DAY/ NIGHT CAPABILITY TO ATACMS BLOCK I RANGE 	<ul style="list-style-type: none"> • SURFACE TO SURFACE FIRES TO ATACMS P3I RANGE • APACHE LONGBOW • DETECTION OF TM ELEMENTS TO JSTARS LIMITS • SHORT RANGE UAVs • ALL WEATHER DAY/NIGHT CAPABILITY TO ATACMS P3I RANGE • BAT SUBMUNITION (LIMITED CAPABILITY VS TM TARGETS) • IMPROVED FDDM C2 TIMELINES 	<ul style="list-style-type: none"> • DOES NOT PROVIDE SURFACE TO SURFACE FIRES TO INF TREATY LIMITS • FAILS TO DETECT, CLASSIFY, AND IDENTIFY TM ELEMENTS AT OPERATIONAL DEPTHS • LACKS ALL WEATHER NIGHT CAPABILITIES BEYOND ATACMS P3I RANGE CAPABILITY • LACKS SMART SUBMUNITIONS TO IMPROVE LETHALITY AGAINST TM ELEMENTS • NO REAL TIME TARGETING

Figure 8-7

PASSIVE DEFENSE - PROTECT THE FORCE

A principal objective of the Army Modernization Plan is to Protect the Force. The goal of Passive Defense is cost-effective survivability enhancements to protect the force. The programs to accomplish this are being directed, managed, and executed by the Army Branches whose Battlefield Operating Systems (BOS) are being addressed.

Problems in the development of near- and mid- term Attack Operations and Active Defense systems preclude complete protection from all theater missile threats. Missiles not neutralized by Attack Operations or Active Defense means are capable of causing unacceptable casualties and severe consequences for the commander's plan. These shortfall realities demand that we develop inexpensive systems and procedures that increase the protection of our soldiers against the effects of missile-delivered weapons, including WMD.

The assessment of Passive Defense remains **RED** in the near term due to shortcomings in Tactical Warning and NBC Defense capabilities. Passive Defense becomes **AMBER** in the mid term as a result of the fielding of a biological agent detection capability, an improved immunization capability, and

the fielding of the Joint Tactical Ground Stations (JTAGS) which allows in-theater processing of Defense Support Program (DSP) data more quickly and efficiently than currently done from a central CONUS location. Passive Defense remains **AMBER** in the far term due to the **AMBER** state of individual and collective NBC protection. The Passive Defense capabilities and shortcomings are shown in Figure 8-8.

PASSIVE DEFENSE		
CAPABILITIES		SHORTFALLS
FY 94 -95	FY 96 - 99	
<ul style="list-style-type: none"> • LIMITED DEGREE OF PROTECTION FOR FIXED AND MOBILE ASSETS (SUSCEPTIBILITY & VULNERABILITY REDUCTION) 	<ul style="list-style-type: none"> • PROVIDE TACTICAL WARNING FOR THEATER CRITICAL ASSETS AND FORCES • BIOLOGICAL AGENT DETECTION AND AN IMPROVED VACCINE 	<ul style="list-style-type: none"> • LEAVES HIGH DEGREE OF SUSCEPTIBILITY AND VULNERABILITY IN THEATER CRITICAL ASSETS & FORCES • NO STANDOFF MULTI-AGENT CB DETECTION CAPABILITY

Figure 8-8

BATTLE MANAGEMENT/COMMAND, CONTROL, COMMUNICATIONS, AND INTELLIGENCE

Command, Control, and Communications program updates are addressed in Chapter 3 and Intelligence and Electronic Warfare updates are discussed in Chapter 9. Current assessments revealed that TMD Command and Control remains **AMBER** in both the near- and mid-term.

Active defense and attack operations requirements continue to stress the Army's current C3I architecture. C3I systems will need to provide more interoperability for joint and multinational operations and provide for rapid distribution of large volumes of processed data which is critical to Winning the Information War. The initial fielding of JTIDS (air-to-ground), further fielding of the Standard Theater Army Command and Control System (STACCS) and the Army Tactical Command and Control System (ATCCS) (including ASAS Block I), and the incorporation of JTAGS, and UAV-Short Range permits BM/C3I to remain **AMBER** in the mid term.

Current and future TMD requirements may greatly exceed the capability of available communication architectures, placing a viable TMD BM/C3I in jeopardy. The continued fielding of JTIDS allows BM/C3I to keep pace with the threat and keeps BM/C3I **AMBER** in the far term. Figure 8-9 summarizes the capabilities and shortfalls of Army TMD Battle Management/ Command, Control, Communications, and Intelligence.

COMMAND AND CONTROL		
CAPABILITIES		SHORTFALLS
FY 94 -95	FY 96 - 99	
<ul style="list-style-type: none"> • LIMITED JOINT C2 CAPABILITY 	<ul style="list-style-type: none"> • MINIMUM JOINT INTERFACE / INTEROPERABILITY 	<ul style="list-style-type: none"> • DOES NOT PROVIDE FULL JOINT, COMBINED, AND ALLIED INTEROPERABILITY • DOES NOT PROVIDE JOINT/ COMBINED INTEGRATION ACROSS THE FOUR PILLARS

Figure 8-9

Since success on the battlefield depends on the ability to rapidly employ all Army and other Service assets, we must continue developing and fielding a coherent and joint interoperable, flexible and responsive TMD BM/C3I architecture. Communications systems which provide near real-time distribution of large volumes of processed data are essential to joint command, allied interoperability, and effective TMD operations. The Army Science Board recommended development of an Army TMD/TAD BM/C3I technical information architecture as part of a theater wide technical information architecture for WINNING THE INFORMATION WAR.

The complexity of TMD operations, involving a system-of-systems, crossing not only Battlefield Functional Mission Areas, but joint and multinational interfaces as well, identifies this operational area as a high payoff battlefield capability that may be achieved with Horizontal Technology Integration and digitization.

Digitization remains the key to tying the pieces of the TMD battlefield into an integrated system of systems within the Army and then into the joint and multinational arenas. Digitization will allow the seamless passage of intelligence from strategic, operational, and tactical levels in time to provide alerting of all forces for passive operations, cueing of active systems for Protection of the Force, and targeting launchers and infrastructure for Precision Strikes.

SUMMARY

The assessment of TMD capabilities clearly showed the need for improved BM/C3I to accomplish the TMD operational mission. The enabling technologies that resolve the BM/C3I shortfalls will synergistically improve Army TMD capabilities and therefore, improve the warfighting capabilities of the force. Technology enhancements in battlefield identification, position location and navigation, tactical C2, digitization, next generation FLIR, survivability suites, and hit-to-kill technologies can all provide potential substantial contributions if horizontally incorporated into Army TMD systems. Vertical integration of these advances into Army TMD systems, such as ATACMS, PATRIOT, THAAD, Fox NBC Reconnaissance Vehicles, and JSTARS, will further enhance Army TMD operations capabilities.

All of the programs discussed in this assessment provide important contributions to TMD operations. There are some specific programs, however, that remain critical to TMD. Without future funding of these programs, effective TMD will be seriously jeopardized. These programs are:

- Corps SAM
- ATACMS P3I
- JTAGS
- UAV-Short Range

SECTION 4

RESEARCH, DEVELOPMENT AND ACQUISITION STRATEGY

This section updates the Research, Development and Acquisition actions necessary to acquire the required TMD capabilities. This section does not restate the RD&A strategies cited in other functional area annexes, it links those strategies that will ultimately yield the desired TMD capabilities.

The nature of the current threat and the fiscal constraints imposed on the Department of Defense have resulted in a DOD acquisition approach which increases emphasis and investment in Science and Technology programs. The resulting technological advances will be incorporated more often into systems through upgrades rather than through start ups of new systems.

ACTIVE DEFENSE

In the near term, active defense acquisition strategy focuses on improving current PATRIOT PAC-2 TMD capability in both lethality and range (defended battlespace). PATRIOT PAC-3 will be the Army's near term lower tier TMD system, capable of asset defense. Two PAC-3 candidate missile technologies were evaluated - multimode and ERINT. The Army has recommended selection of the ERINT candidate as the future PAC-3 missile, but will continue multimode development for a period of time as a risk mitigation measure. THAAD is also in development as an upper tier, area defense system. When acquired and fielded, PAC-3 and THAAD will provide two-tiered, near leak proof active defense for deployed forces and geopolitically important assets. Research and development efforts aimed at improving missile lethality are in progress for both PATRIOT and THAAD. Sled tests, flight tests, constructive simulations (e.g., PATRIOT/ERINT Engagement Lethality Simulation - PEELS) and hardware-in-the-loop testing collectively contribute to evolutionary refinements to missile and kill vehicle development to counter WMD warheads.

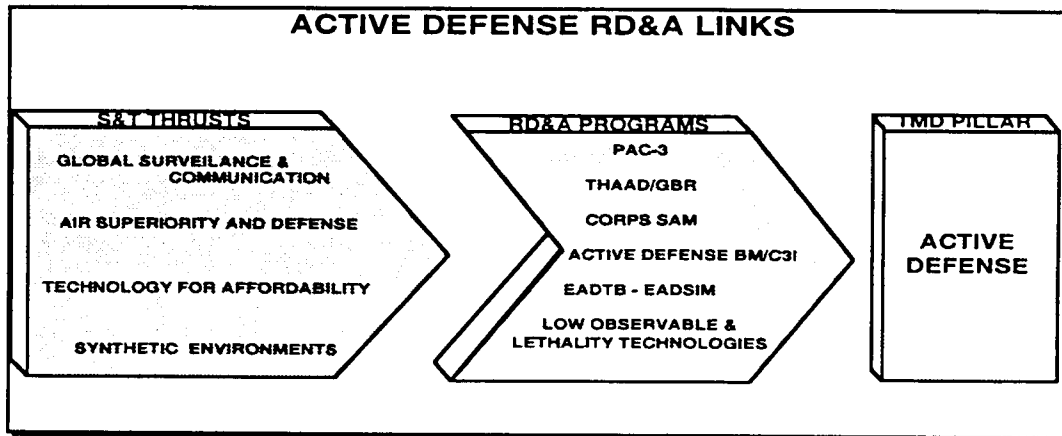

Figure 8-10

In the far-term, Corps SAM is the Army's active defense acquisition priority. Detection of low observable, slow moving, low altitude cruise missiles and UAVs will be vital to the desired performance of Corps SAM. High priority needs to be attached to technology programs that address early detection/tracking of in-flight Cruise Missiles/UAVs, and detection of ballistic missile launches, to enable active defense interceptors to be cued to achieve early engagement. Technologies to improve lethality of interceptors will also be necessary to ensure kill of weapons of mass destruction. **BUR delay of Corps SAM development will impact the Army's ability to protect the force.**

ATTACK OPERATIONS

The Fire Support, Aviation and IEW Annexes/Chapters detail RD&A strategies which contribute to the conduct of Attack Operations as an element of TMD. Like Active Defense, in a joint and multinational context, many other non-Army organizations and systems participate. Significant technologies and developments that yield improved TMD attack operations capabilities are in the Precision Strike S & T

Thrust. The Army Science and Technology program Joint Precision Strike Advanced Technology Demonstration (ATD) is designed to develop and demonstrate an Army adverse weather, day/night, end-to-end sensor to shooter precision strike capability which: reduces precision strike timelines from hours to minutes; provides measurable improvements in target location, identification, weapon effectiveness and combat assessment; and provides near-real-time cross sensor cueing, data dissemination, seamless sensor-to-shooter connectivity and dynamic retargeting.

The Army S&T program Bistatic Radar for Weapons Location ATD provides an anti-radiation missile survivable radar to detect short range tactical ballistic missiles with accuracy consistent with current and future TMD requirements.

Though not specifically noted, joint, allied and multinational capabilities are certainly a consideration, and technologies to improve interoperability will have significant payoff for TMD attack operations. As is the case for all technology and systems developments, cost/resource reduction (life cycle costs) can be improved by exploiting promising technologies during the developmental processes.

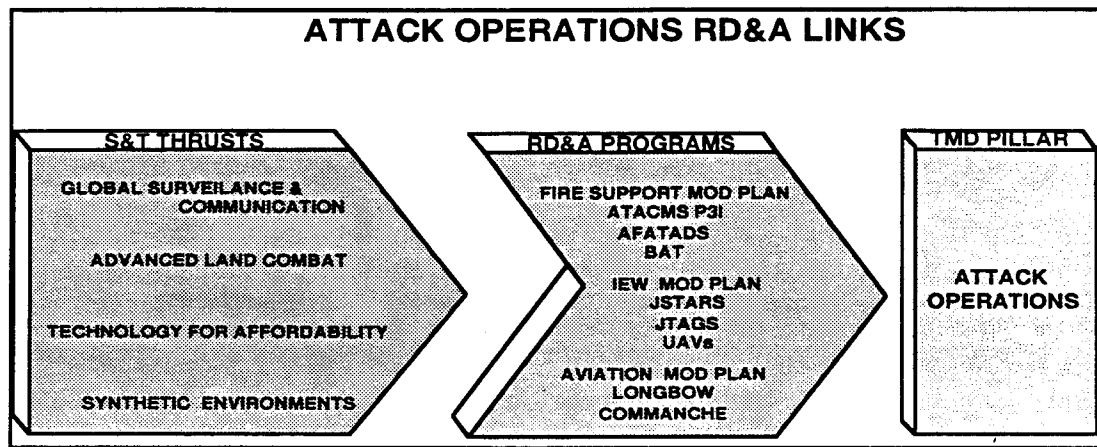

Figure 8-11

PASSIVE DEFENSE

The effective application of Passive Defense Measures to Protect the Force is critically reliant on warning to reduce susceptibility and vulnerability. Development of materiel that contributes to Passive Defense is distributed throughout the Army and contributions are not contained in any single functional modernization annex. There are also implications for using developments and technologies for resource reduction purposes and for simulation and training.

Critical emerging technologies supporting TMD Passive Defense, particularly regarding WMD and NBC defense, contribute to the following specific areas:

- **Contamination avoidance:** Includes detection, reconnaissance and warning. Priority for technological advances is in remote/standoff detection, both passive (IR), and active (laser). Bio agent detection capability is also a critical technological area, particularly advancements using antibody reactivity and laser induction. The Army S&T program in biodetection research and technology will provide point and standoff biological agent detection with enhanced sensitivity to toxics, improved logistics, and increased environmental operating ranges.
- **Protection:** Includes both individual and collective protection systems. Technological azimuth is to reduce weight and reduce logistical resupply requirements. Promising developments are being pursued in light weight materials that also provide laser/ballistic protection, and in regenerating filter systems. The Army S&T programs, Soldier Integrated Protective Ensemble (SIPE) and 21st Century Land Warrior-Generation II ATDs, provide a modular, head-to-toe individual fighting soldier system to include advanced lightweight impermeable membrane chemical protection against toxic vapors and liquids. The S&T

program in medical research and technology for soldier protection and treatment includes biological efforts in vaccines, toxoids, and antisera (anti-toxin); chemical efforts in topical skin protectant, nerve agent antidote auto injectors, anti-convulsant auto injector, skin decontamination kit, and nerve agent pretreatment (Pyridostigmine).

- Decontamination: The intent is reduced logistics burden and manpower expended to maintain combat power. Technology advances are being pursued in sorbent, self-stripping coatings for equipment.
- Smoke/Obscuration: Countering threat RISTA capabilities is the objective of the smoke/obscuration program to maximize force protection. In view of current and future threat sensors and platforms, IR and Millimeter Wave defeating (multispectral) smokes may provide a very cost effective technology to leverage against directed energy and UAV threats.

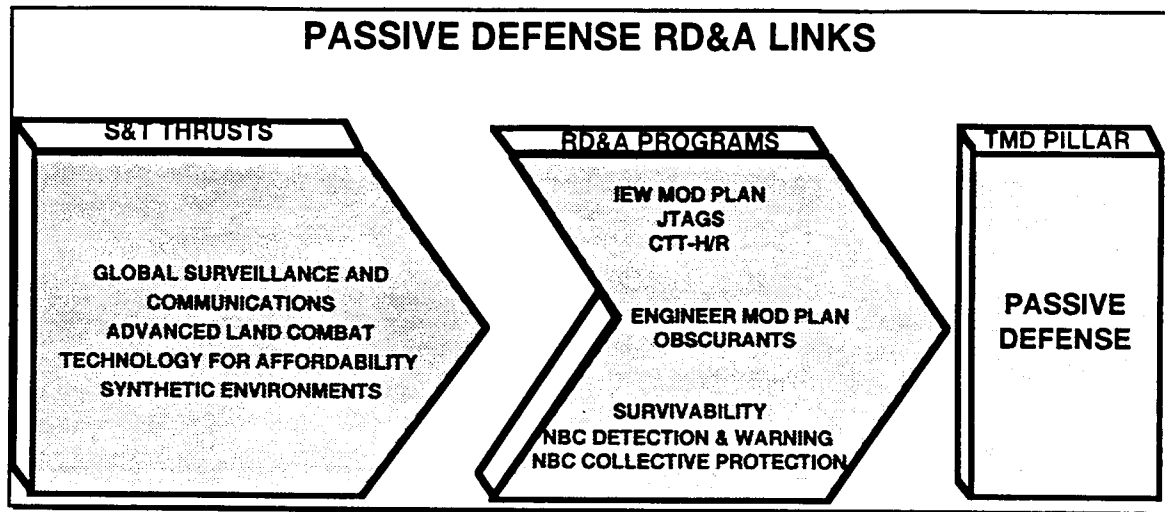

Figure 8-12

BATTLE MANAGEMENT / COMMAND, CONTROL, COMMUNICATIONS, AND INTELLIGENCE (BM/C3I)

RD&A activities in BM/C3I are focused by the following considerations:

- In addition to seamless intelligence operations between joint elements, continued efforts must be made for integration to provide a seamless passage of TMD intelligence in multinational TMD operations from Strategic, to Operational, to Tactical levels of TMD operations.
- TMD operations require attention to intelligence preparation during peace and crisis, as well as war. Information on technology availability and capabilities is necessary to plan for and prepare forces for TMD operations and to enable counter proliferation efforts.
- During war, IEW collection, analysis, and dissemination must be agile enough to provide Battle Damage Assessment (BDA) in time for dynamic retargeting of attack operations targets.

The C3 and IEW Annexes/Chapters provide considerable detail about the impressive technology and development activities which ultimately support the Global Surveillance and Communications Thrust. C3I capabilities are embedded within and without Army functional area systems. they are linked not only to the Surveillance and Communications, the Precision Strike, and Air Superiority and Defense Thrusts. Other significant contributions in BM/C3I for TMD operations are represented by Joint Exercises and experiments that demonstrate a capability to match a technology development with an operational need.

The use of Extended Air Defense Simulation (EADSIM), the Extended Air Defense Test Bed (EADTB), Louisiana Maneuvers, and Joint Precision Strike/Warbreaker Advanced Distributed Simulations type programs contribute to exploiting the use of simulations for requirements and concept development efforts, focus on the technology base, improving acquisition procedures, and achieving training and readiness enhancements.

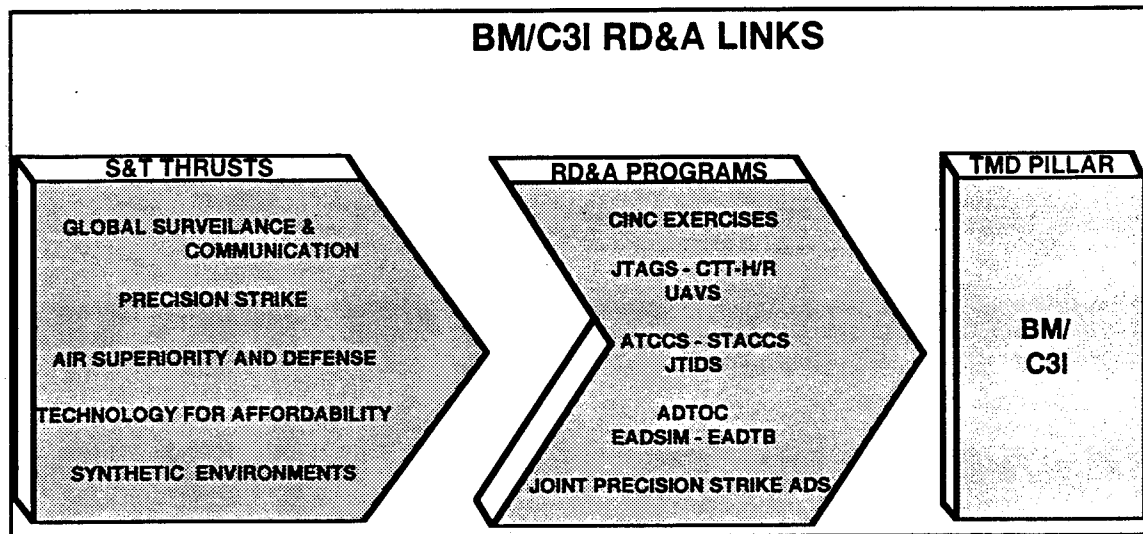

Figure 8-13

SUMMARY

This section focused on RD&A activities related to development of TMD capabilities. Except for some Active Defense developments, most of these developments are not TMD unique and have multiple applications within the Battlefield Functional Mission Areas. A large number of the programs are embedded in non-TMD activities. Nevertheless, they are critical to the overall conduct of successful TMD operations. As such, they should remain visible and be traceable to TMD capabilities, and be linked, in their larger context, to support from the DoD S&T Thrusts.

Army modernization efforts are supported by the science and technology strategy reflected in the Army Science and Technology Base Master Plan. In addition to basic research and exploratory development, this master plan provides the advanced development path for the rapid insertion of new technologies into new Army TMD systems or product improvements to existing systems. TMD has been established as a priority for technologies that will lead to the development of critically needed capabilities in Army systems and product improvements to enhance TMD operations.

The series of "linked" exercises termed Louisiana Maneuvers (LAM) will enable the Army to look at which technology developments will change the TMD battle the most. How to leverage new technologies for enhanced theater missile defense is proposed as an FY95 LAM objective. The LAM will be used to help determine how to protect the forward deployed force, given fewer ground based air defense forces and a proliferation of tactical ballistic missiles and air breathing platforms. Additional hardware in the loop (HWIL) simulations, emphasizing validation with flight and field test data will allow the Army to focus scarce resources to those science and technology programs, system improvements, and new system developments that can provide the greatest improvement in TMD operations. This link between the Army scientists at the laboratories, the soldier as represented by the combat developer or user, and the materiel developer will provide the most efficient use of Army modernization resources.

The exploitation of simulations, Louisiana Maneuvers, and Battle Labs in evaluating the mix of technology upgrades and new starts, will reduce the cost and time required for acquisition and testing, and consequently, maintain the technological advantage for LAND FORCE DOMINANCE.

SECTION 5

TRAINING

The use of simulations is becoming increasingly important with reduced budgets mandating the reduced use of resources. In the TMD arena, the use of simulations is also necessary to create the linkages and environments that can exercise the entire scope of TMD operations. This training needs to continue with increased emphasis on the integration and execution of the TMD elements. TMD operations must be incorporated into the Army's Combat Training Centers (CTCs), and the Battle Command Training Program (BCTP) must continue to insert TMD operations as an integral part of their exercises.

The Louisiana Maneuvers (LAM) offer opportunities to consider current and future Army TMD strategies. As part of LAM, TMD and related areas will be examined in detail to provide a full spectrum of insights in doctrine, training, leader development, organizations, materiel, and soldiers (DTLOMS). This capability will enable the Army to look at what technology developments, or changes in tactics, techniques, or procedures will change the TMD battle the most and then train to take advantage of those tactics, techniques and procedures which provide the synergy to win the TMD battle.

The TMD experiments program is a BMDO funded, HQDA administered program intended to explore current capabilities to conduct TMD operations; improve capabilities where possible; explore "off the shelf" and "quick fix" solutions to improve TMD; leave capabilities in theater where possible; and make TMD an integral/integrated part of standard warfighting operations/procedures in the theater. The experiments include simulation efforts and data collection. They have been planned and conducted in conjunction with scheduled theater exercises in PACOM/USFK (Ornate Impact) and EUCOM (the executed portions of Optic Needle) with Space Command support. The exercises also involve CONUS players from TRADOC and USASSDC as well as national level (DIA, NSA, ARPA). The program works in all four pillars and exercises the entire attack operations systems from sensors to shooters.

Through the TMD-related CINC experiments/exercises, leaders have gained valuable experience in detailed TMD planning and capabilities such as the development of CENTCOM's Joint Tactics, Techniques, and Procedures (JTTP) for TMD. These planned exercises and experiments offer senior Army leaders insight to TMD tactics, techniques and procedures. The scope of these CINC experiments/exercises allows joint and multinational interfaces so that Theater CINC and Service component requirements and concepts can be developed, tested, and exercised. TMD Experiments/Exercises for FY94 will be conducted in Ornate Impact II (PACOM), Optic Needle II (EUCOM), and Optic Cobra (CENTCOM). The overall design of each theater experiment explores the ability of the U.S. command and its components to implement the four pillars of TMD: Active Defense, Passive Defense, Attack Operations, and BM/C3I. The experiments focus on the following areas of joint TMD operations: warning and cueing, collection management, intelligence dissemination, analysis and target development, target dissemination, and attack planning and execution. The experiments are designed to provide potential improvements to the current architectures and evaluation of those architectures. The Army must also participate in Theater Air and Missile Defense and Precision Strike Advanced Distributed Simulation (ADS) demonstrations to define and demonstrate the extent and importance of the Army role in TMD.

As the complexity of TMD warfare increases, so must the realism in TMD training and leader development. The development of new simulations and use of existing ones for TMD training enhances the tactical and technical competence of all soldiers. It is important that the Army also aggressively pursue the incorporation of TMD operations in joint and multinational exercises and simulations such as ARPA's Warbreaker, not only to develop and exercise Army capabilities, but to learn more about the non-Army elements which play a role in TMD operations, and to teach joint and multinational elements the role that the Army can play in joint and multinational TMD operations.

SECTION 6

CONCLUSION

The Army TMD mission is to protect U.S. forces, allies, and other important countries and areas of vital interest to the U.S. from theater missile attacks. TMD operations are urgent, high priority operations that could determine success or failure during future air, land, and naval operations. The Army Science Board expressed the concern that enemy theater missiles could cause the Army to be denied access to the battlefield. This update of the Army Modernization Plan addressed key Army TMD programs and activities that provide us modernized and improved TMD capabilities and described the most recent modernization plans for each of the four pillars of the TMD operational concept. Updated assessments of current and programmed TMD capabilities addressed operations against the TM threat expected in the near-term (FY94-95) and mid-term (FY96-99), and identified shortfalls. Projections were made for the long-term (beyond 2000). Operational emphasis was given to TMD deployments as part of an Army component in joint or multinational contingency operations.

As our potential adversaries continue to acquire modern technology to update their Theater Missile systems at a rapid pace, it is clear that U.S. TMD capabilities must be upgraded through a continuous modernization program, inserting cutting edge technologies to bring about technologically superior TMD capabilities. To this end, high priority needs to be attached to programs that address early detection/tracking of Tactical Aerodynamic Missiles and detection of ballistic missile launches, to enable active defense interceptors to be cued, passive defenses to be warned, and launcher locations and infrastructure to be designated for attack operations. This is especially critical when attempting to counter WMD.

The complete theater missile threat (TBM, CM, UAV etc.) is expected to more than double by the year 2000. It is necessary to protect the key assets in the Theater Support area. The THAAD Upper Tier and PATRIOT Lower Tier will adequately counter the longer range portion of the TBM threat spectrum. It is important, however, not to lose sight of the fact that the vast majority of the world's missiles are in the VSR category and were designed to pursue tactical objectives. As such, they will be targeted against our Land Forces. **Today we have no protection against this threat, therefore, we must develop and field Corps SAM.** Corps SAM will provide an enhanced capability against this projected threat. It is imperative that the Army protect the force!

Locating and destroying missile systems on the ground and in the air, preventing or minimizing the damage caused by missiles that escape destruction by Attack Operations and Active Defense systems, and integrating all these capabilities with efficient BM/C3I systems contribute to Land Force Dominance by Protecting the Force and Conducting Precision Fires. The incentives for investing in these activities translate to the lives of our soldiers, and should be pursued with vigor and determination.

CHAPTER 9

INTELLIGENCE AND ELECTRONIC WARFARE

INTRODUCTION

SECTION 1

This chapter updates Annex I of the 1993 Army Modernization Plan. The roles, missions, and capabilities of the Army's Intelligence and Electronic Warfare force have not changed. There have been changes in force composition and modernization as the Army experiences a continued draw down of structure and funding. There are instances where fielding schedules and research and development for some systems have been drawn out over an expanded time frame. The original annex, which this update addresses, remains valid where changes are not indicated. This chapter captures the changes during this dynamic period and shows the impact of the changes on the azimuth for the future.

Intelligence systems support all the Army modernization objectives with emphasis on Win the Information War, Protect The Force, and Conduct Precision Strikes. The IEW portion of the Army Modernization Plan details and provides the rationale for the major programs that comprise this key building block of **Land Force Dominance** as shown in the chart below.

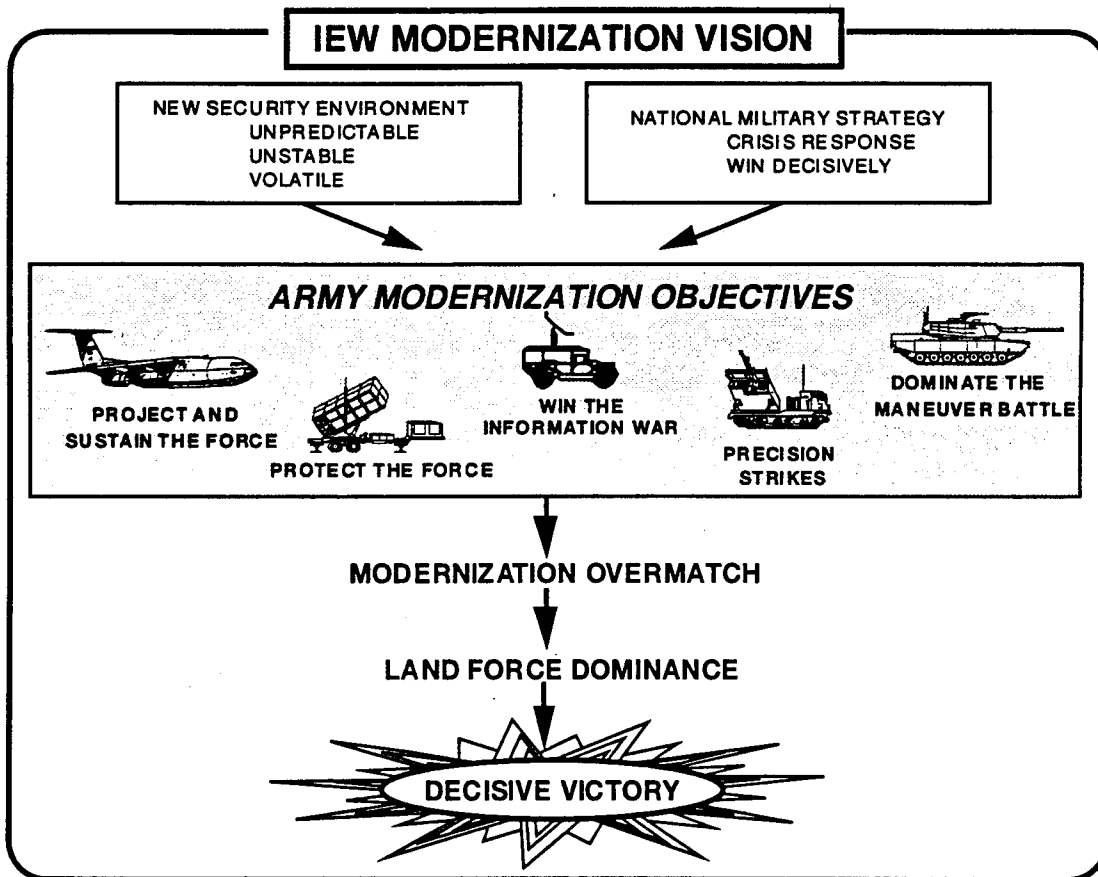

The IEW Modernization Plan is based on the objective architectures contained in the Army Intelligence and Electronic Warfare Master Plan (AIMP); they fully support all Battlefield Operating Systems (BOS) and the Army modernization vision. The capabilities provided by this plan are compatible with and augmented by the National Foreign Intelligence Program: General Defense Intelligence, Consolidated Cryptologic, and Foreign Counterintelligence Programs.

SECTION 2

WARFIGHTING CONCEPT

The overall warfighting concept for Intelligence and Electronic Warfare (IEW) has not changed. The continuing objective is to create a seamless structure of intelligence, from national to maneuver battalion level, in order to provide the intelligence essential to executing all tactical missions in support of joint military operations requirements contained in the National Military Strategy. Doctrinal concepts are in accordance with the 1993 revisions to FM 100-5, Operations, and JCS Publication 3-0, Doctrine for Joint Operations. IEW systems will also contribute to the evolving DoD information warfare concept. The evolution of ground and airborne intelligence collection systems toward commonalty in sensor packages and the addition of a near-real-time imagery capability from multiple sensors for our tactical commanders, require redistribution of personnel and skills. These requirements are incorporated into a new force design that coincides with the IEW modernization process.

Mission Area Warfighting Objectives.

The mission of Army intelligence is to provide timely, accurate, and relevant intelligence and electronic warfare support to tactical, operational, and strategic commanders across the continuum of military operations. This reduces uncertainty and risk to US forces, and facilitates effective application of force and forces. The functions and users of IEW support are shown in Figure 9-1.

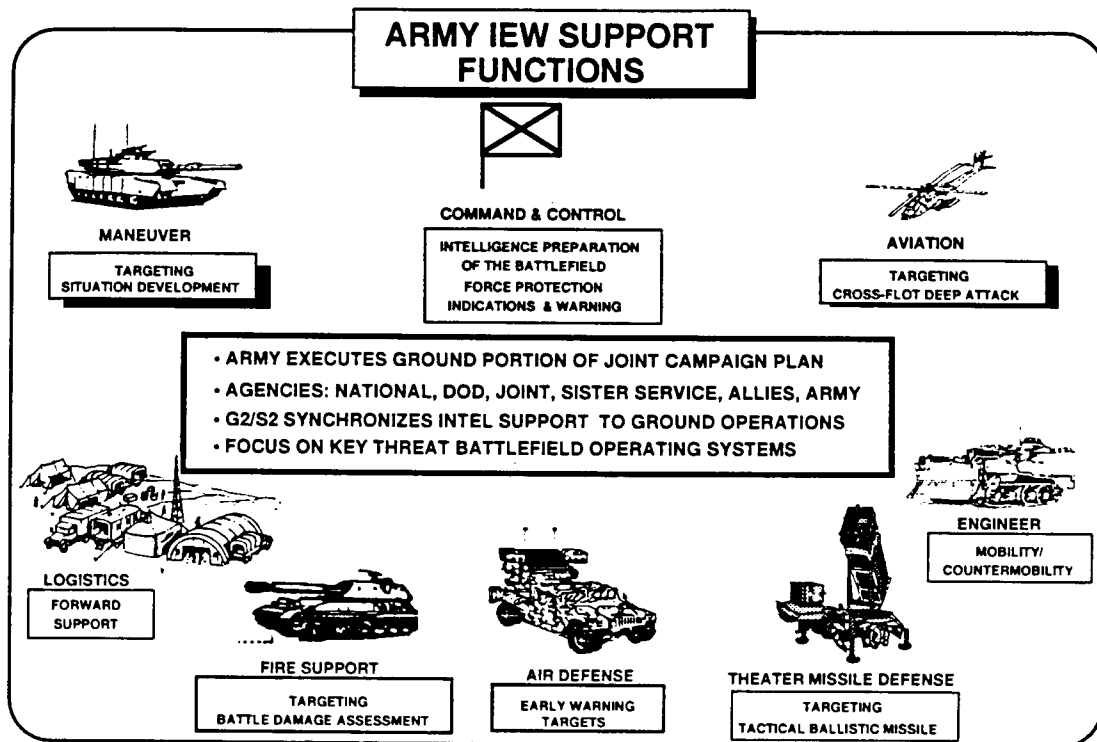

Figure 9-1

The Army does not fight alone, but as part of a joint team. It integrates its efforts in unified operations with its sister Services, with other national agencies, and often with allied and coalition forces. By doing so, the Army's operational capabilities are enhanced, victory comes quicker, and friendly casualties are reduced.

IEW must support the commander at each echelon. The resolution, time lines, and focus of intelligence requirements are different at each level necessitating organic support to ensure sensor-to-shooter links are responsive to the commander. Figure 9-2 provides the concept of focused intelligence required to support warfighters.

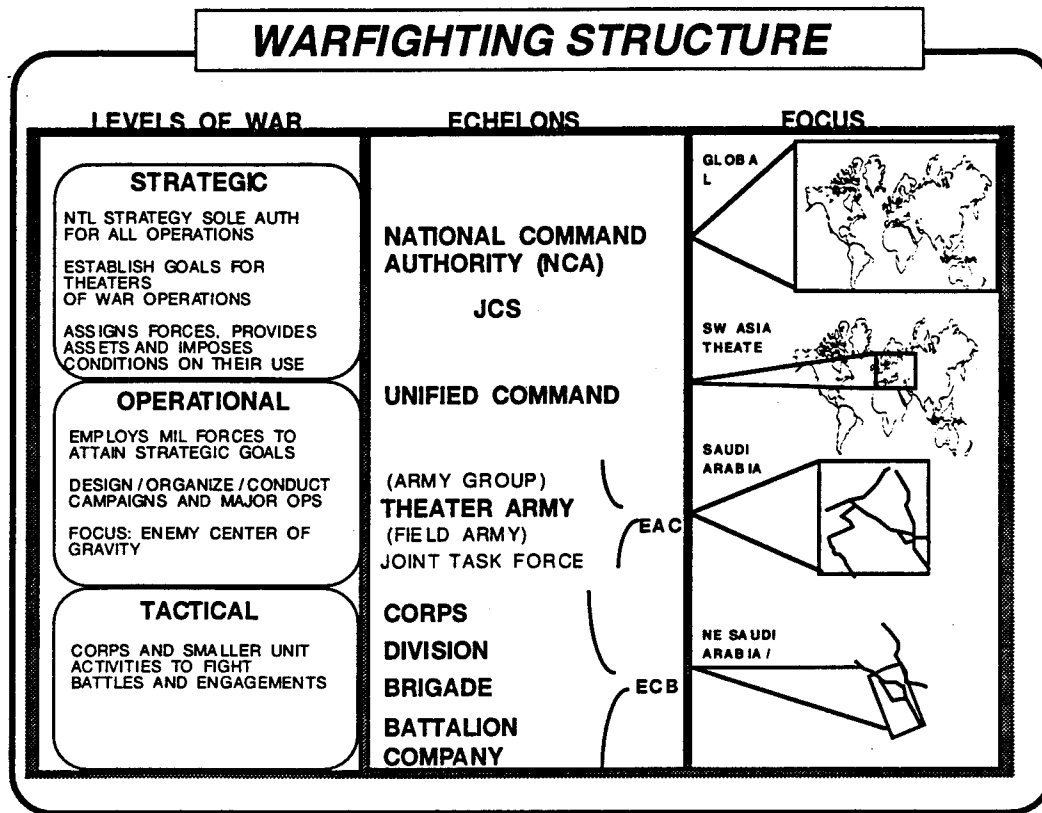

Figure 9-2

Within this warfighting structure of focused intelligence—at the tactical level—the IEW systems also simultaneously support the close, deep, and rear battles as depicted in Figure 9-3. This demands the flexibility and overall technological advantage inherent in the objective IEW architecture of this plan.

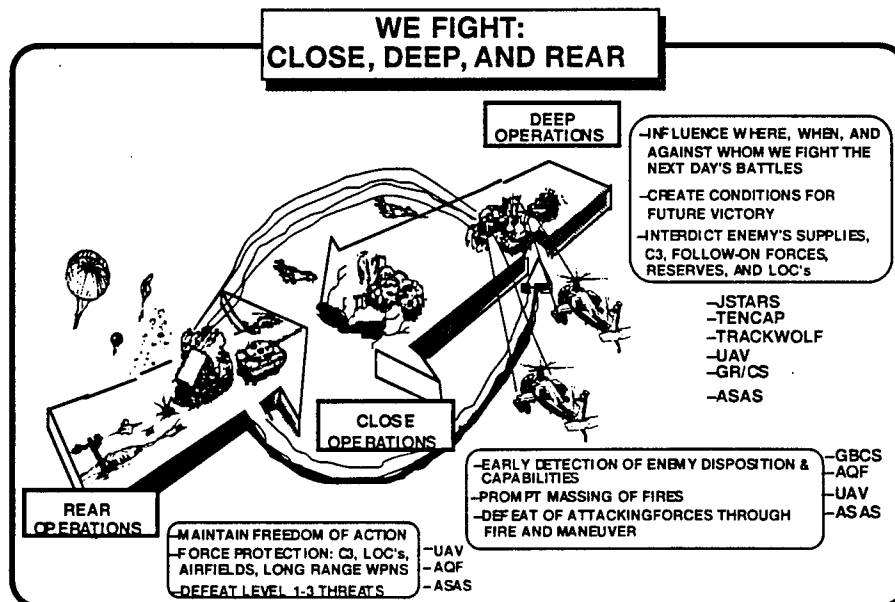

Figure 9-3

INTELLIGENCE AND ELECTRONIC WARFARE

SECTION 3

CURRENT PROGRAM ASSESSMENT

The IEW mission area is evaluated by intelligence function and collection disciplines. When graded on a red, green, and amber basis, the importance of the current path of modernization is evident. The assessments of IEW architectures, in present, near- and far-term periods, are summarized in Figure 9-4. The near term (FY96 - 99) SIGINT/EW assessment has been reevaluated from **GREEN** to **AMBER** based on funding reductions which will lengthen the time to field GBCS and AQF, and delay performance upgrades to GRCS. The Processing/Dissemination present evaluation (FY94 - 95) has been upgraded from **RED** to **AMBER** based on the procurement and imminent fielding of all 12 Block I ASAS systems. ASAS Block I incorporates the efforts of all tactical intelligence automation efforts (Joint Tactical Fusion, Artificial Intelligence Balanced Technology Initiative, Warrior, Joint Deployable Intelligence Support System)

IEW FORCE ASSESSMENT				
	DEFICIENCIES	PRESENT (FY94 - 95)	NEAR TERM (FY96 - 99)	LONG TERM (> FY00)
SIGINT/EW	<ul style="list-style-type: none"> - SINGLE FUNCTION SYSTEMS - OLD PLATFORMS W/ HIGH O&S COSTS - DATED TECHNOLOGY - LIMITED TARGETING 	AMBER	AMBER* • GBCS • GRCS • AQF	GREEN
IMINT	<ul style="list-style-type: none"> - LACK ORGANIC FOFLOT CAPABILITY AT CORPS/ DIV - LACK SID FOR NATIONAL/ THEATER FOR ALL DIV 	RED	AMBER	GREEN
HUMINT/CI	<ul style="list-style-type: none"> - LACK DIGITIZED COMMS FOR LRSU - LIMITED CAPABILITY TO FUSE C//IPW INTO ALL-SOURCE PRODUCT 	GREEN	GREEN	GREEN
PROCESSING/ DISSEMINATION	<ul style="list-style-type: none"> - LACK AUTOMATED ALL-SOURCE FUSION SYSTEM - INABILITY TO OPERATE IN JOINT ENVIRONMENT 	AMBER* • ASAS	AMBER	GREEN
* Denotes Changes				

Figure 9-4

IEW's contributions to the battlefield dynamics (early entry, lethality & survivability, depth and simultaneous attack, mounted and dismounted battlespace, and battle command) are considerable. IEW modernization provides a balanced, versatile, and expansible force. As we traverse this process, we complete the transition from single discipline to multi-discipline collection preprocessing, processing and analysis systems; from predominately manual to predominately automated all source fusion, analysis and production processes; and from limited to full capability to provide intelligence coverage and timeliness in support of military operations. And we do it with significantly fewer systems and greatly enhanced interoperability, as shown in figure 9-5.

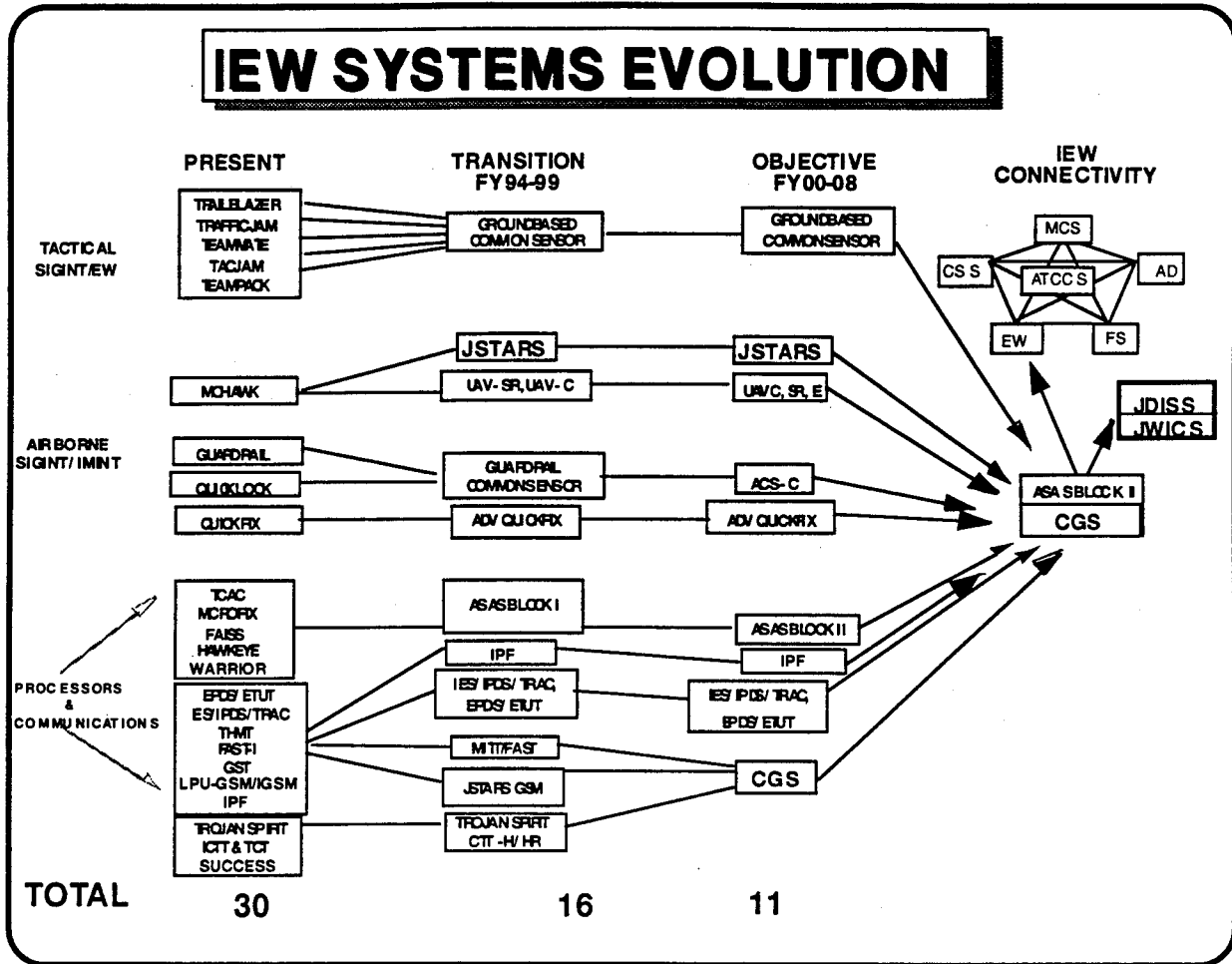

Figure 9-5

The Army has greater collection and exploitation capabilities against modern communications systems, it can accomplish rapid dissemination of near-real-time imagery to all echelons, and is capable of more flexible and rapid deployment. IEW sensors and ground stations will all connect into the ASAS fusion system which in turn will provide the connectivity with the other Army command and control systems and the joint intelligence systems. This Army IEW concept for building toward the future is illustrated in Figure 9-6.

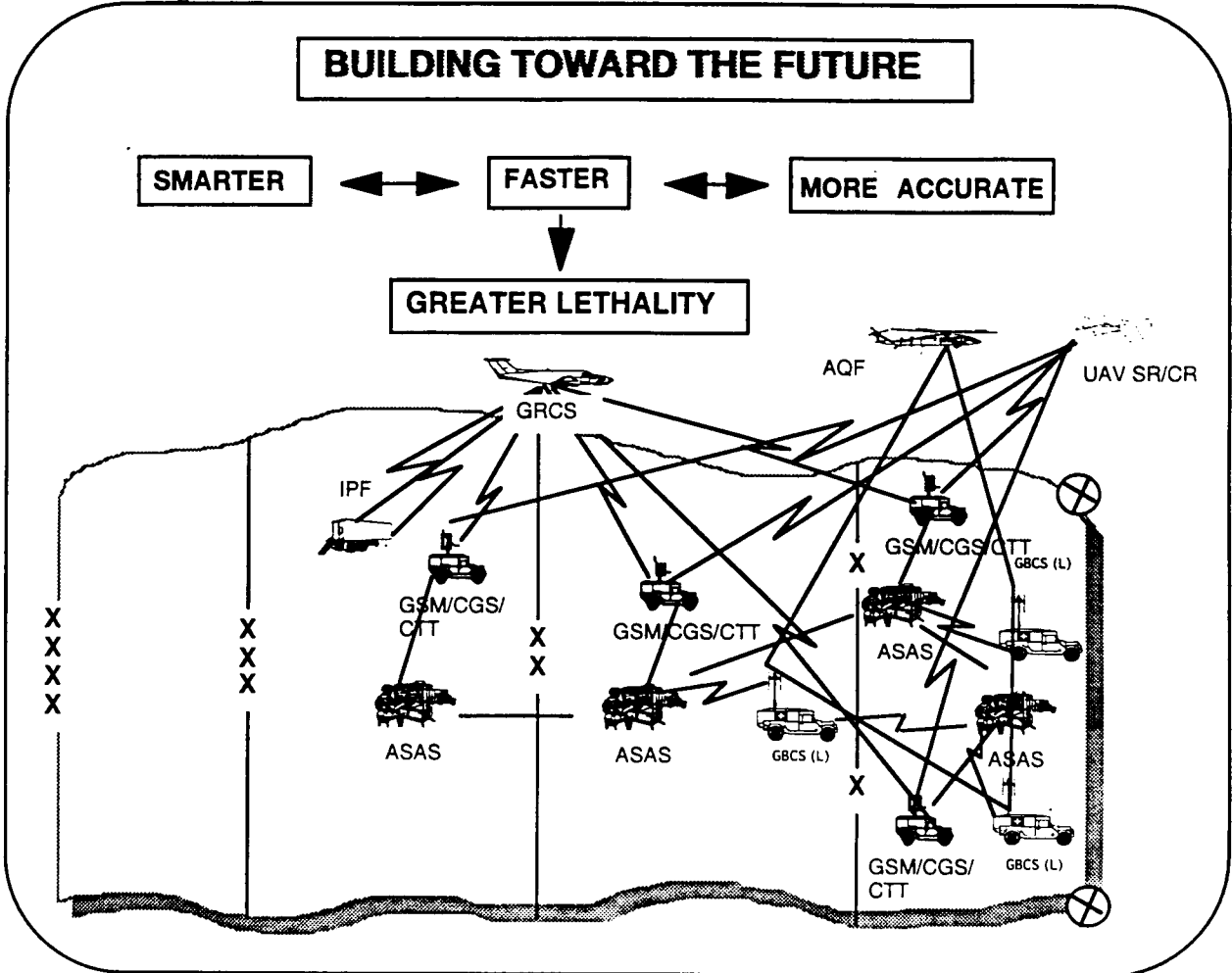

Figure 9-6

SECTION 4

RESEARCH, DEVELOPMENT, AND ACQUISITION STRATEGY

The RDA strategy for IEW underwent only minor changes during the Program Objective Memorandum updating—mini POM—process during the year. The major changes for the IEW Flagship systems—due to reductions in funding—were reflected in the Basis of Issue for the UAVs and the Ground Based Common Sensor (GBCS).

The IEW RDA strategy is portrayed by year in Figures 9-7 and 9-8.

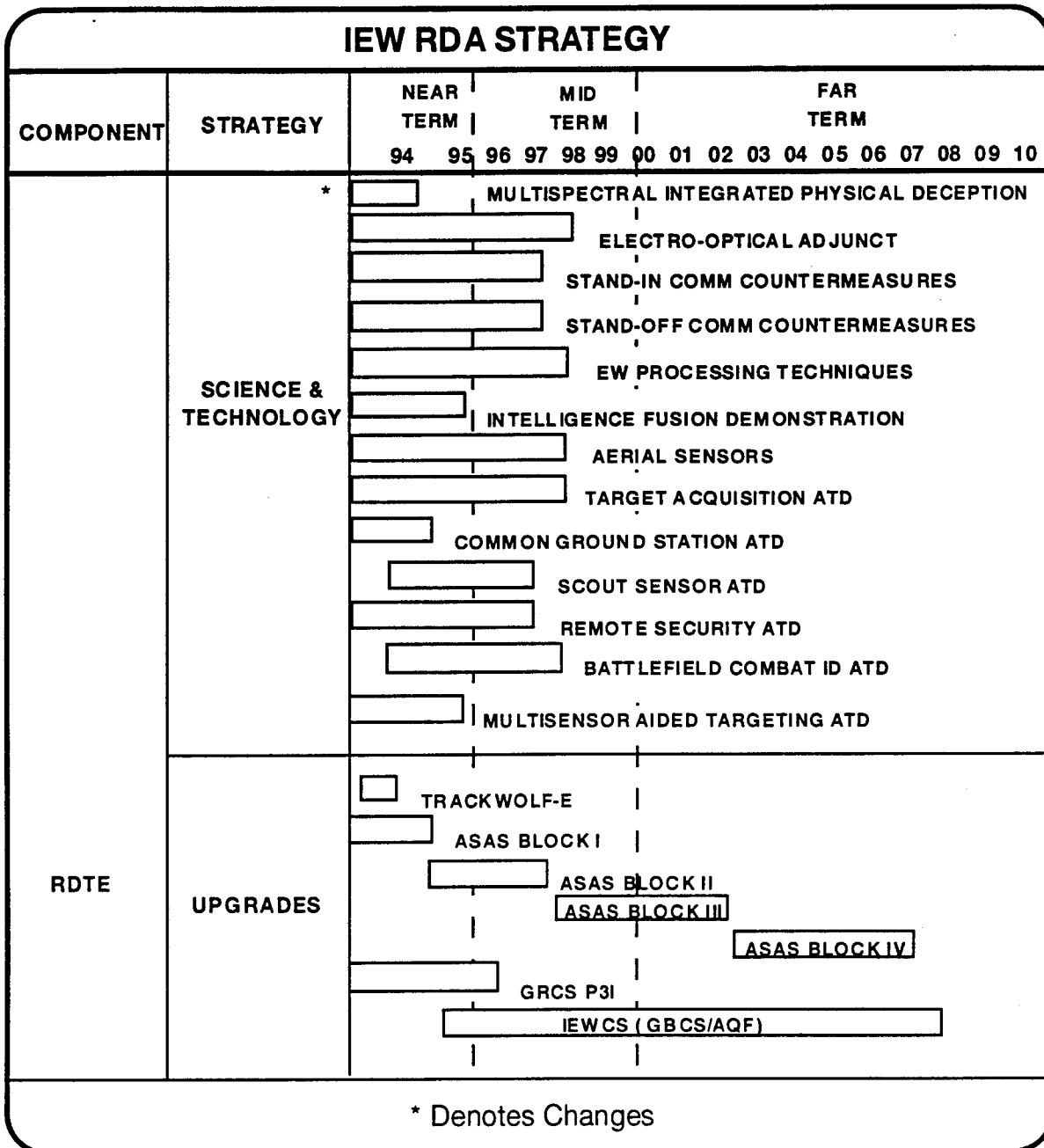

Figure 9-7

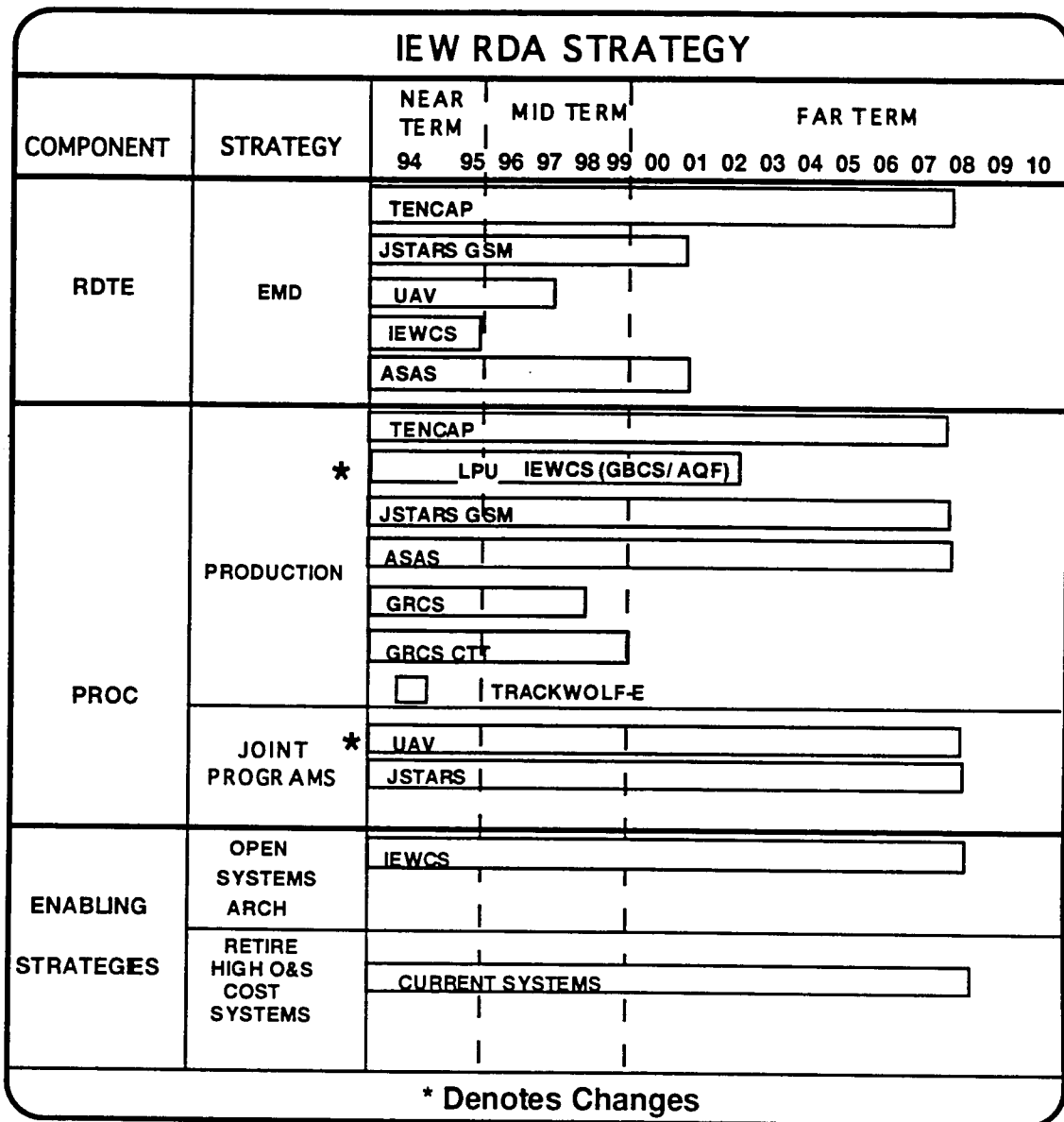

Figure 9-8

UAV-Short Range Basis of Issue. Initial basis of issue was 2 baseline systems per corps and selected EAC MI brigades and 1 per division and ACR. This has been changed to 2 baseline systems per corps and selected theater MI brigade; one baseline system per heavy, airborne, and air assault division; and one per heavy ACR.

UAV-Close Range Basis of Issue. Initial basis of issue was 5 baseline systems per division and 3 per separate brigade. This basis has been changed to 5 baseline systems per light division and ACR; and three baseline systems per heavy division and ACR, the airborne and air assault divisions, and one per separate brigade.

GBCS Basis of Issue. The initial basis of issue was 6 baseline systems per division and 4 per separate brigade and ACR. The adjusted basis of issue is six GBCS are fielded to each heavy division; four to each light division, separate brigade and ACR.

Tactical Deception. The deception program was terminated during the Mini-POM. Multispectral Integrated Physical Deception effort will be terminated at the end of FY94.

Figure 9-9 below displays funding impacts and changes to the RDA strategy. The extent to which we are able to accomplish the IEW program strategy objectives is also depicted.

IEW MISSION AREA		
	<u>CURRENT (FY94 - 95)</u>	<u>NEAR (FY96 - 99)</u>
TENCAP:	<p>DOES</p> <ul style="list-style-type: none"> -- National Imagery Cap. to Select Corps / EAC MI Bde; Begin Fielding MITT/ FAST. <p>DOES NOT</p> <ul style="list-style-type: none"> -- Provide Total ASARS Cap. (TRAC) -- Replace EPDS with TEP. 	<p>DOES</p> <ul style="list-style-type: none"> -- National Imagery Cap. to FP1, 2, & 3 Corps / EAC MI Bde's & FP2 Corps; MITT/FAST to all Div.
JSTARS:	<p>DOES</p> <ul style="list-style-type: none"> -- Contingency Cap. > Desert Storm. -- Initiate Block I M (5 ton) GSM Procurement. <p>DOES NOT</p> <ul style="list-style-type: none"> -- Complete FP 2 or 3 fielding 	<p>DOES</p> <ul style="list-style-type: none"> -- 54 GSM's - Field Contingency Corps; Capability to some of FP 1 & 2 Div/ Corps -- Initiate CGS (Common Ground Station) Procurement.
UAV: (Defense Agency / JPO Funding)	<p>DOES</p> <ul style="list-style-type: none"> -- Initiate UAV-Short Range Procurement. <p>DOES NOT</p> <ul style="list-style-type: none"> -- Complete UAV-CR Fielding to Contingency Corps -- Develop / Acquire Army Unique Payloads. 	<p>DOES</p> <ul style="list-style-type: none"> -- Complete UAV-SR to Contingency Corps -- Capability to FP 2 and 3 -- Initiate UAV-C R Fielding to Contingency Corps
GR/CS	<p>DOES</p> <ul style="list-style-type: none"> -- Field GRCS to XVIII ABN Corps. <p>DOES NOT</p> <ul style="list-style-type: none"> -- Upgrade Korean system to full SIGINT cap -- Initiate ACS RDTE. 	<p>DOES</p> <ul style="list-style-type: none"> -- Field GRCS to III Corps -- Field DASR to XVIII Corps -- Field CTT-H capability to FP 1, 2, and 3
GBCS	<p>DOES</p> <ul style="list-style-type: none"> -- Open Sys. Architecture / RDTE. <p>DOES NOT</p> <ul style="list-style-type: none"> -- Complete GBCS to FP2 or 3 	<p>DOES</p> <ul style="list-style-type: none"> -- Field GBCS to Contingency Corps -- Begin Fielding GBCS to FP2
AQF	<p>DOES</p> <ul style="list-style-type: none"> -- AQF RDTE <p>DOES NOT</p> <ul style="list-style-type: none"> -- Field AQF to FP2 or 3. 	<p>DOES</p> <ul style="list-style-type: none"> -- Field Contingency Corps
ASAS	<p>DOES</p> <ul style="list-style-type: none"> -- Begin Fielding Block I; Initiate Block II RDTE. <p>DOES NOT</p> <ul style="list-style-type: none"> -- Begin Fielding Block II. 	<p>DOES</p> <ul style="list-style-type: none"> -- Complete ASAS Block I (12 Systems). -- Initiate ASAS Block II Procurement.

Figure 9-9

Figure 9-10 provides the percentages of each force package which the current program will equip for each of the IEW Flagship systems. Contingency corps capability will be fully available prior to the end of the decade with follow on force fielding not completed until after the turn of the century.

PERCENTAGE FORCE PACKAGE FIELDING				
		Near Term (94-95)	Mid Term (96-99)	Far Term (>00)
UAV-SR	FP 1	10	78	100
	FP 2	0	40	100
	FP-3	0	40	100
	FP-4	0	0	0
UAV-CR	FP 1	0	10	100
	FP 2	0	0	100
	FP-3	0	0	100
	FP-4	0	0	100
GRCS	FP 1	75	100	100
	FP 2	0	90	100
	FP-3	0	90	100
	FP-4	N/A	N/A	N/A
ASAS BLOCK I	FP 1	78	100	N/A
	FP 2	50	50	N/A
	FP-3	25	25	N/A
	FP-4	0	0	N/A
BLOCK II	FP 1	0	0	100
	FP 2	0	0	100
	FP-3	0	0	100
	FP-4	0	0	0
JSTARS GSM BLOCK I	FP 1	10	79	N/A
	FP 2	0	20	N/A
	FP-3	0	40	N/A
	FP-4	0	0	0
BLOCK II	FP 1	0	0	100
	FP 2	0	0	100
	FP-3	0	0	100
	FP-4	0	0	0
AQF	FP 1	0	59	100
	FP 2	0	0	0
	FP-3	0	0	0
	FP-4	0	0	0
GBCS	FP 1	10	79	100
	FP 2	0	0	40
	FP-3	0	0	40
	FP-4	0	0	0

Figure 9-10

The force capabilities provided by second generation modernization give us a more balanced and capable force. Modernized systems are: more deployable, technologically robust, and capable of providing near-real-time intelligence to the accuracy required by our newest weapons systems. New technology is being inserted throughout the intelligence disciplines.

The Army Science and Technology Master Plan is meeting the IEW technology requirements to correct identified shortfalls in the operational capability of currently programmed systems. It will improve our geolocation accuracy, expand frequency range and the capability to exploit low probability of intercept signals, improve target classification and cross system cueing capabilities, and provide for an on-the-move operational capability. The Advanced Technology Demonstration for Joint STARS, and the Advanced Warfighting Demonstrations, Joint Precision Strike and Common Ground Station will expedite the transition of new technology capabilities into the Army force structure.

SECTION 5

TRAINING

The IEW training objective is to provide well trained soldiers, crews, units, and leaders to maximize the effectiveness of future IEW systems. This vision has five guiding tenets depicted in Figure 9-11. Collectively these IEW tenets comprise the training strategy to ensure an understanding of the capabilities of IEW systems and how to employ them on the battlefield to find, fix, and kill the enemy.

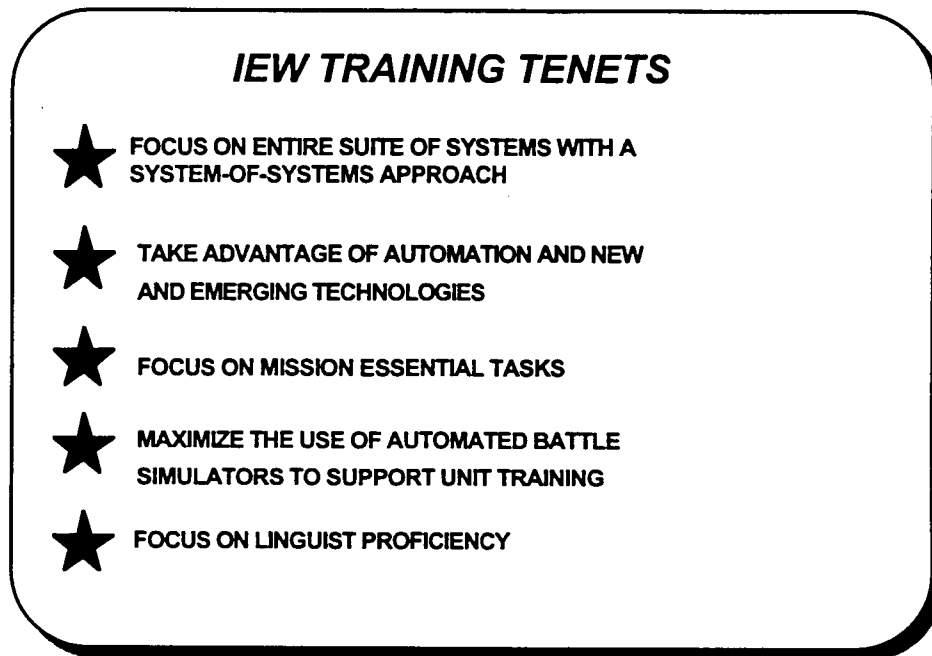

Figure 9-11

The training focus is on an integrated, system-of-systems approach to training that reduces reliance on institutional training and places more emphasis on unit and displaced training, the exploitation of simulators, embedded training, and training devices, and the enhanced use of artificial intelligence and other emerging training technologies. The Intelligence Center and School has assigned additional training responsibilities to its 111th MI Brigade. It has introduced an Integrated Field Training Exercise (IFTX), which provides the student in each course of instruction with hands-on experience with all tactical intelligence systems and Tactical Operations Center intelligence activities at maneuver brigade, division, and corps echelons.

The expanded use of simulation training has many positive implications. Intelligence capabilities will be replicated in support of FTX/CPXs like Battle Command Training Program (BCTP) at Ft Leavenworth and the National Training Centers. Realistic simulation ensures intelligence systems are full participants in Louisiana Maneuvers, Joint Precision Strike Demonstration and the Battle Labs.

SECTION 6

CONCLUSION

The IEW Modernization Plan facilitates the development of an Army Intelligence organization that provides timely, accurate, and relevant intelligence and electronic warfare support to tactical, operational, and strategic commanders across the continuum of military operations. This reduces uncertainty and risk to US forces, and facilitates the effective application of force and forces. Intelligence support is down-sized, but more capable, deployable, and sustainable. It brings the tactical intelligence capability to a level where the information collected and disseminated is accurate enough to maximize current weapons capabilities. It ensures that the flow of intelligence is sufficient and in the right form to meet the requirements of the Army warfighter supporting Joint operations. By increasing the capability of a smaller force, supporting effective employment of smart weapons, and providing accurate and timely intelligence, this Army IEW program is fundamental to the lethal, deployable and versatile Army which can apply decisive force on the battlefield to win swiftly with minimum casualties. The bottom line...

- One family of UAV to fix targets
- One airborne system to look deep
- One ground collection system that does it all
- One common ground station that receives it all
- One all source analysis system that fuses it all

The changes to the IEW force and its capabilities across the duration of the program, summarized in Figure 9-12, contribute dramatically to a smaller, more lethal force and **adequately support the National Military Strategy.**

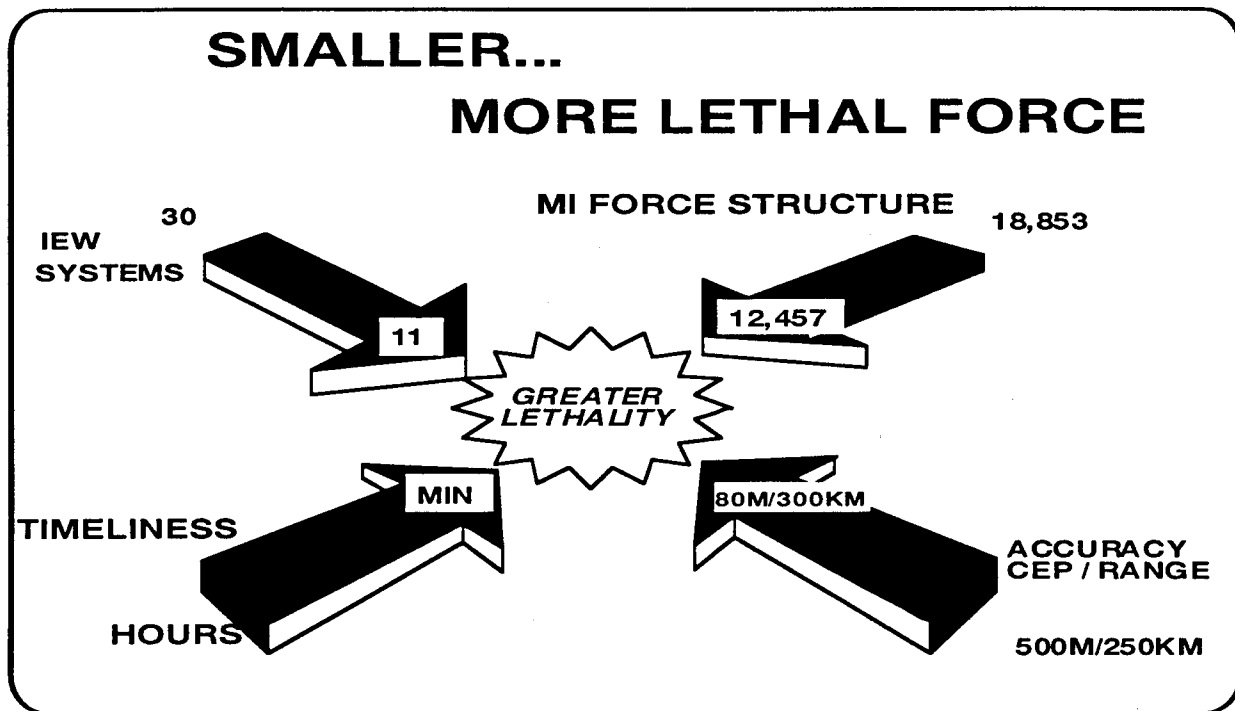

Figure 9-12

CHAPTER 10

LOGISTICS

SECTION 1

INTRODUCTION

This chapter updates Annex J of the 1993 Army Modernization Plan. The Army's logistics modernization objective of **PROJECT AND SUSTAIN THE FORCE** has not changed. There have been changes in force composition and modernization as the Army experiences a continued draw down of structure and funding. The original annex, which this update addresses, remains valid where changes are not indicated. This chapter provides the rationale only for those major changes.

Our logistics requirements remain unchanged:

- Upgrade CONUS rail.
- Obtain versatile airlift.
- Expand prepo afloat.
- Increase sealift capability.
- Efficiently distribute sustainment.
- Upgrade logistics-over-the-shore.
- Improve soldier quality of life.

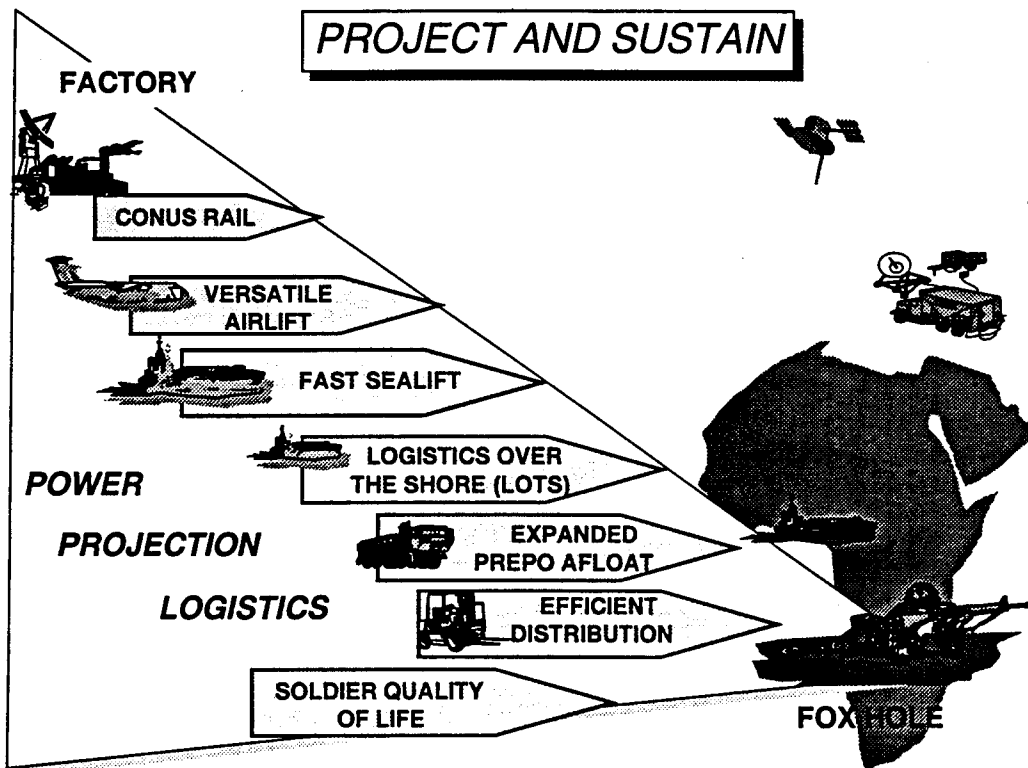

SECTION 2

WARFIGHTING CONCEPT

The Total Distribution Program (TDP) is a significant new logistics modernization initiative to support the Force Projection warfighting concept. TDP will bridge the seams between strategic, operational, and tactical logistics to provide total visibility of all assets from industrial base to the end user using assured communications, automatic identification technology (AIT), and effective distribution management practices.

Emerging concepts for split operations of Combat Service Support elements can further enhance the logistical support of Force Projection Operations. In split CSS Operations, deploying CSS elements will employ downsized automation devices that are linked by communications to large scale automation processors which remain in CONUS garrisons. The resulting reduction in equipment and personnel will significantly enhance the mobility and responsiveness of the deployed CSS management elements.

TDP and split operations require assured communications between the forward area and CONUS. This element of the Army Enterprise Strategy, the Army C4I vision for the future, is critical to the successful logistical support of Force Projection Operations.

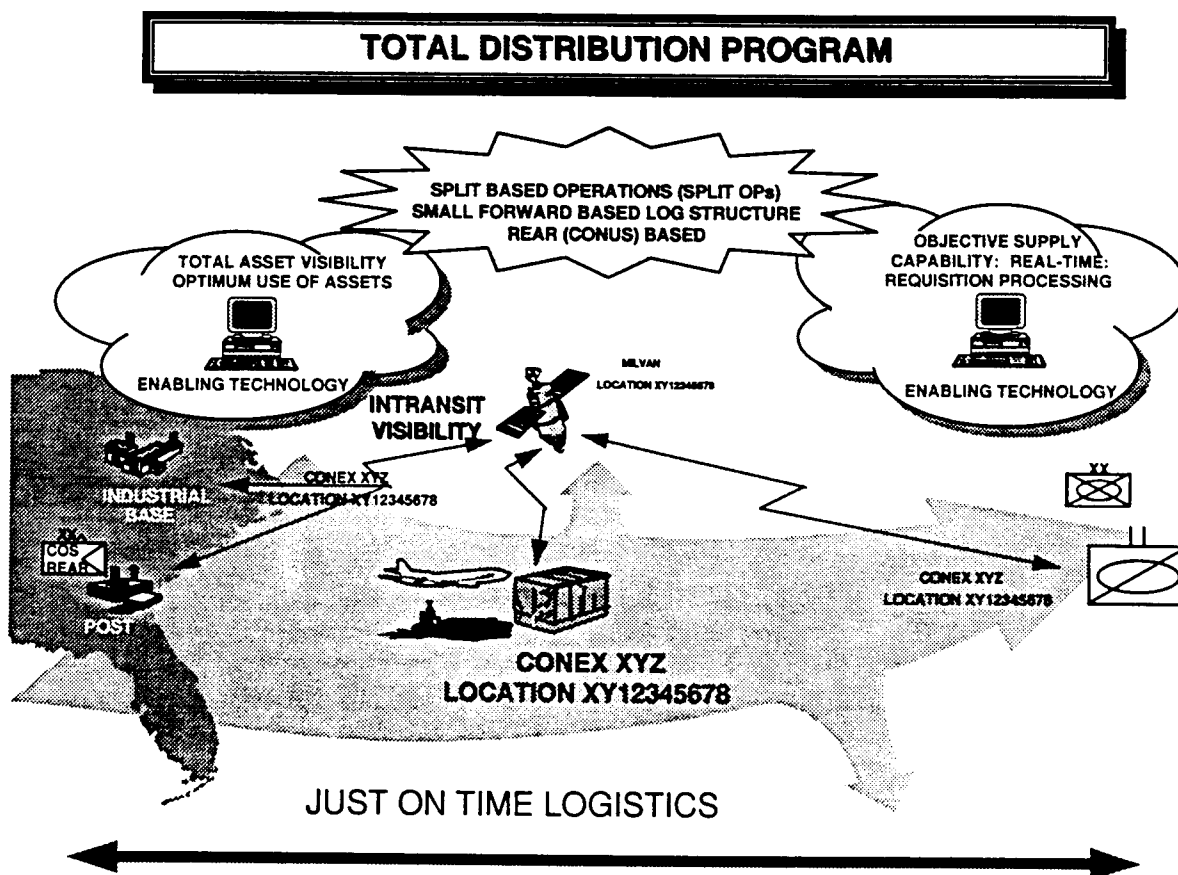

Figure 10-1

SECTION 3

CURRENT PROGRAM ASSESSMENT

Charts in this section reflect the logistics assessment. Information on the charts differing from the original annex are annotated with an asterisk. Detailed explanations are in section 6. The ratings and their definitions are as follows:

RED—No capability exists, or is incapable of defeating threat or providing required support

AMBER—A limited capability or quantity exists to perform the mission

GREEN—Adequate capability or quantity exists to perform the mission

PROJECT

ASSESSMENT	NEED	SYSTEM	PAYOFF	YEAR(S)	LEVEL
AMBER	VERSATILE AIRLIFT	C-17	ACCESS TO 6000+ MORE AIRFIELDS	FY93-06	STRATEGIC
AMBER*	RAPID SEALIFT* (WAS RED)	LMSR *	24 KNOT RO/RO SHIP	FY93-02	STRATEGIC
AMBER	FLEXIBLE LOGISTICS-OVER-THE-SHORE (LOTS)	100T CRANES CAUSEWAYS TUGS,* LCUS, LCMS, BOATS	INCREASED LOTS FLEXIBILITY	FY93-99	STRATEGIC OPERATIONAL
AMBER	MILITARILY USEFUL RAILCARS	70-100T RAILCARS*	SUFFICIENT RAIL CARS TO DEPLOY FORCE TO PORTS	FY93-08	STRATEGIC
AMBER	IMPROVED AIRDROP DELIVERY	MATERIEL & PERSONNEL DELIVERY SYSTEMS LOW ALT RETRO RKT SYSTEM*	INCREASED AIRCRAFT SURVIVABILITY DECREASED DROP ZONE DISPERSION.	FY94-08	TACTICAL
* Denotes Changes					

Figure 10-2

The overall assessment of the five components of **PROJECT** has been upgraded from **RED/AMBER** to **AMBER** due to the following changes:

Rapid Sealift Capability. Improves from **RED** to **AMBER** due to increase in sealift capability during FY94-95. Five container ships will be converted during FY95-96 to Large Medium Speed Roll-on Roll-off (LMSR) ships for both pre-positioned sets and surge requirements. A total of 19 LMSR will be available by FY00. As of Jan 94, 29 Maritime Administration-owned Ready Reserve Force (RRF) RO/RO ships will be available. Procurement of seven additional RRF are projected to be accomplished during FY94-95.

Logistics-Over-The-Shore (LOTS) Assessment. Remains **AMBER** with further definition of LOTS roles/capabilities and issues as shown in Figure 10-3, below:

	SYSTEM	RQMT	EXISTING	POM	MINI-POMCHANGES OR COMMENT
S H I P D I S C H A R G E	RO/RO DISCHARGE CAUSEWAY	6	NONE	3	NO PLUS-UP OR CUT SHORT 3 (SEE FERRY BELOW)
	TUGS 100 FT 128 FT	11 6	25 0	NONE NONE	NO PLUS-UP OR CUT IN PRODUCTION
	CRANES 100-250 TON	6	NONE	2	KILLED IN MINI-POM
S H I P M O V E M E N T S H O R E	LACV-30	26	26	26 IN SLEP KILLED	LACV-30 STRUCTURE AND SLEP FUNDING ZEROED
	TUGS 45 FT 65 FT PUSHER	0 0 7	2 15 NONE	NONE NONE KILLED 4	RETAIN IN LIEU OF PUSHERS RETAIN IN LIEU OF PUSHERS 2 FOR USAR IN DPP
	LCUS LCU-2000 LCU-1600	35 13	35 13	NONE NONE	
	LCMs LCM-8-MOD0 LC M-8-MOD1	0 77	28 96	NONE NONE	
	LARC -LX	23	23	NONE	NO PLUS UP FOR LARC-LX SLEP
	LSVs	6	5	NONE	ONE FY 94 DELIVERY
	CAUSEWAYS FERRY PIER	8 5	NONE NONE	16 4 (EST)	RESTRUCTURE CONTRACT FOR FEWER FERRIES AND MORE RO/ROs STILL SHORT 1
C M D & L O G I S T I C S	CHI BOATS	23	NONE	KILLED	KILLED
	FERRY HARBOR	1	3	NONE	
	PATROL BOATS	10	8	NONE	RETAIN AS SUB FOR CHI BOATS
	J/Q/T BOATS	1/0/0	6/2/1	NONE	RETAIN AS SUB FOR CHI BOATS
	FMS	3	3	NONE	

Figure 10-3

LOTS has three primary roles as shown in the above chart: ship handling and discharge; ship to shore movement, and command/control/logistics. Key components of LOTS are: Landing Craft (LC), causeways, cranes, tugs, and Lighter Amphibians (LARC-LX). The lack of modern 100-250 Ton Cranes, Pusher Tugs, some shortage of causeway systems, and other modern equipment are the remaining problem areas facing watercraft modernization. The Lighter, Air Cushion Vehicle (LACV-30) will be eliminated from the force structure with units inactivated by the end of FY94. The SLEP for the LACV-30 was killed based on analysis that the system could not be upgraded to meet 50-Ton capacity requirement, that it is very expensive to operate, and it provides limited capability. The amphibian

mission will be picked up by the LARC-LX. Causeways include causeway ferries, roll-on, roll-off discharge platforms, and floating causeways. Research and development is directed at the reduction of operating costs and the improvement of current systems with less risky technical options. This strategy will increase the efficiency of LOTS operations. However, this capability will remain amber since sufficient modernized equipment will not be procured to meet ASMP requirements.

Rail Cars Assessment. Remains **AMBER** with additional issues. There are shortages of heavy lift rail cars. With outloading problems experienced in Operation Desert Storm, as recognized by a General Accounting Office (GAO) audit on rail deployment, the Army has a continuing need to acquire various types of militarily useful flatcars to effectively meet deployment requirements. The GAO highlighted the fact that the number and types of rail cars most often used for transporting military equipment is rapidly declining. The Army has a program in place to procure rail cars. Funding continues throughout the POM.

Airdrop Delivery Systems Assessment. Remains **AMBER** even with the elimination of low altitude retro-rocket systems. However, the technology is to be completed and documented in FY 94 and placed "on the shelf" for possible future use. Enhancements to airdrop equipment are required to: increase probability that materiel delivered will land in a usable condition, increase survivability of aircraft and crews, and increase accuracy and weight capacity of delivery systems.

The overall assessment and all sub-elements of **SUSTAIN** remain **AMBER**. One of the program elements, efficient data transmission, is renamed Process/Transmit Logistics Information. There have been changes within the components which are highlighted with an asterisk and discussed in the paragraphs below:

SUSTAIN

ASSESSMENT	NEED	SYSTEM	PAYOFF	YEAR(S)	LEVEL
AMBER	EFFICIENT DISTRIBUTION *	PETROLEUM DISTRIBUTION SYSTEM *	IMPROVED DEPLOYABILITY	FY93-08	OPERATIONAL
AMBER	PROCESS/ TRANSMIT LOG INFO	STACOMP CTASC-II LOGTECH *	IMPROVED ASSET MGT VISIBILITY AND SPLIT OPERATIONS	FY93-08	OPERATIONAL TACTICAL
AMBER	MANAGEMENT CAPABILITY	SAAS MOD SAAS ATP ASIS ULLS, SAMS	ASSET VISIBILITY AND CONTROL	FY94-08	TACTICAL
AMBER	EMERGENCY DISTRIBUTION	CH47D + UH60A/L	RAPID AIR RESUPPLY	FY93-99	OPERATIONAL TACTICAL
AMBER	IMPROVE CBT LIVING	FORCE PROVIDER	INCREASE CBT EFFECTIVENESS	FY93-98	STRATEGIC OPERATIONAL TACTICAL
AMBER	ACCURATE INFORMATION	CSSCS *	REAL-TIME LOGISTICS INFO	FY93-02	OPERATIONAL TACTICAL
AMBER	EFFICIENT TRANSPORTATION	FMTV, PLS *	GREATER PAY-LOAD CAPACITY	FY93-08	TACTICAL
AMBER	EFFICIENT DISTRIBUTION	TOTAL DISTRIBUTION PROGRAM *	ASSET VISIBILITY, INTRANSIT AND CONTROL *	FY93-08	STRATEGIC OPERATIONAL TACTICAL
AMBER	RAPID RESUPPLY	OBJECTIVE SUPPLY CAPABILITY	REDUCED ORDER/ SHIP TIME	FY93-08	OPERATIONAL TACTICAL
AMBER	TRANSPORTATION MANAGEMENT	DAMMS-R,WPS, TCACCIS, CFM, DAMMS-MPM, AALPS, AND STRADS	IMPROVED MOVEMENT CONTROL	FY93-97	STRATEGIC OPERATIONAL

* Denotes Changes

Figure 10-4

Distribution and Dispensing of Petroleum, Oils, and Lubricants Assessment. There has been a reduction in RDTE and the elimination of Arctic Enhancements. Soldiers will continue with current equipment.

Process/Transmit Logistics Information. Formerly Efficient Data Transmission Assessment, continues **AMBER** with reduction in STACOMP procurement stretched and termination of CTASC-II program after FY95. CTASC-II Block II, a component of split operations, will be fielded to the contingency corps. The Block I version of CTASC-II will extend through the remainder of the Army.

Force Provider Assessment. **AMBER** rating in near to far terms. While there were no decrements in the POM there is still a lack of adequate soldier collective support systems. Force Provider is an air transportable system which contains, in one modular package, all materiel necessary to provide quality food, billeting, and hygiene services for 550 persons. Six 550 person modules can be combined to form a 3,300 person Brigade-size system. It provides rest and refit facilities for soldiers who have been denied such facilities due to sustained operations. The system is packaged and stored ready for operations and is designed to provide support above organic capability. Additionally, Force Provider

may be used as an Intermediate Staging Base and for other operations to include troop movement, reconstitution, disaster relief, humanitarian assistance and peacekeeping support. This capability will alleviate the current need to perform numerous support missions on an adhoc task force basis.

Combat Service Support Control System (CSSCS) Assessment. The overall assessment remains **AMBER**, however, reduced level of procurement results in limited distribution to only Contingency Corps units.

Efficient Transportation Assessment. There has been a major revamping of the Army's tactical wheeled vehicles program including the FMTV and PLS. Details are contained in Chapter 6 (Tactical Wheeled Vehicles) of this update.

The overall assessment of the **CORE** support components remains **AMBER** with the following changes:

CORE SUPPORT TO THE FORCE

ASSESSMENT	NEED	SYSTEM	PAYOFF	YEAR(S)	LEVEL
AMBER	AMMUNITION *	M1A1 105MM ARTY, 155MM SADARM VOLCANO/WAM TRG UNIQUE *	IMPROVED LETHALITY AND SUSTAINIBILITY	FY93-98	STRATEGIC OPERATIONAL TACTICAL
AMBER	MHE*	FORKLIFT *	EFFICIENT HAND- LING OF MATERIEL	FY93-08	TACTICAL
AMBER	TACTICAL ELECTRICAL POWER *	TACTICAL QUIET GENERATOR*	EFFICIENT, DEPENDABLE, ELECTRICAL POWER	FY94-08	TACTICAL
AMBER	AUTOMATED DIAGNOSTIC TEST EQUIPMENT*	IFTE *	MOBILE GENERIC TEST EQUIPMENT	FY93-08	TACTICAL
AMBER	TEST EQUIP MODERNIZATION*	TMDE MODERNIZATION*	MORE ACCURATE VERSATILE TMDE	FY93-08	TACTICAL
AMBER	COMBAT MEDICAL EQUIPMENT*	DEPMEDS*	TIMELY UPGRADE/ REPLACEMENT OF COMBAT MEDICAL EQUIPMENT	FY93-95	TACTICAL
AMBER	HOT FOOD	CONTAINER KITCHEN	PROVIDING FOOD RATIONS DAILY	FY93-98	TACTICAL
AMBER	SHELTER	RIGID WALL SHELTER TENTAGE	PROTECTION	FY93-08	OPERATIONAL TACTICAL
AMBER* new	EXPLOSIVE ORDNANCE DISPOSAL *	EOD *	SURVIVABILITY, SECURITY, PERSONNEL SAFETY *	FY93-08*	OPERATIONAL TACTICAL *
AMBER* new	FORWARD REPAIR & RECOVERY*	SECM HRV IRV *	INCREASED SAFETY AND, PAYLOAD *	FY95-98 00-04 95-00 *	TACTICAL*
* Denotes Changes					

Figure 10-5

Ammunition Assessment. Remains **AMBER**. The Army continues to support ammunition modernization procurement for such items as 120mm tank rounds, 155mm SADARM and WAM. However, the FY95-99 POM reflects reduced resourcing support for modern war fighting ammunition, training ammunition, and munitions industrial production base.

SADARM and EOD now are added to the chart in Figure 10-5.

Explosive Ordnance Disposal (EOD). This has been added as a tenth component and is rated **AMBER** due to lack of capability to rapidly clear mass quantities of unexploded ordnance (UXO). The EOD program includes the use of the following robotic and directed energy technology to remotely clear areas of UXO: Remote Controlled Reconnaissance Monitor (RECORM), Remote Ordnance Neutralization System (RONS), and the Mobile Ordnance Disrupter System (MODS).

Forward Repair and Recovery. This has been added as an eleventh component and is rated **AMBER** due to the following reasons:

- **Shop Equipment Contact Maintenance.** Current S-250 equipped vans provide limited on-board repair tools and equipment. Current M880-series trucks and CUCVs are over-aged and lack mobility required by unit maintainers and forward DS teams. Heavy HMMWV chassis with shelter to provide relief commencing in FY95 (see Chapter 6).

- **The Heavy Repair Vehicle.** Current M113 tracked maintenance vehicles provide limited on-board storage for repair modules and diagnostic tools. Wheeled HRV will improve the support provided by unit mechanics and DS repairers in Armor and Mechanized Battalions and their DS maintenance support units (see Chapter 6).

- **Improved Recovery Vehicle.** Provides safe recovery and evacuation of armored weapons and heavy equipment. (see Chapter 1).

Materiel Handling Equipment (MHE) Assessment. This remains **AMBER** with the elimination of the ATLAS developmental program, based on fielding an NDI ATLAS equivalent five years sooner, and reduced buy of the Front Side Loader Forklift, and no acquisition of container handlers.

Hot Food Assessment. Near term remains **AMBER**. Mid and far terms downgraded from **GREEN** to **AMBER** because additional resources are required as a result of a change in the Army field feeding standard. New standard specifies one A/B ration per day vice one A/B every third day. Compo 1 maneuver battalions are fully resourced to the new standard. Procurement of components (less Kitchen Company Level) to implement standard in the remainder of the force are not programmed.

The following systems were reduced proportionally in the mini-POM to correspond with reductions in the base force. Overall ratings remain unchanged.

Tactical Electrical Power Assessment. Reduced diesel power generator procurements. Therefore, gas powered generators will see continued use.

Automated Diagnostic Test Equipment.

Test Equipment Modernization.

Deployable Medical System (DEPMEDS).

The following chart depicts the overall logistics systems assessment over time. The changes discussed previously are highlighted with an asterisk.

LOGISTICS SYSTEMS ASSESSMENT				
	NEED	NEAR TERM (FY94-95)	MID TERM (FY96-99)	FAR TERM (FY00-08)
PROJECT	- VERSATILE AIRLIFT	AMBER	AMBER	GREEN
	- RAPID SEALIFT	RED	AMBER *	GREEN
	- FLEXIBLE LOGISTICS-OVER-THE-SHORE (LOTS)	AMBER	AMBER	AMBER
	- MILITARILY USEFUL RAILCARS	AMBER	AMBER	GREEN
	- IMPROVED AIRDROP DELIVERY	AMBER	AMBER	GREEN
SUSTAIN	- EFFICIENT DISTRIBUTION	AMBER	GREEN	GREEN
	- EFFICIENT DATA TRANSMISSION	AMBER	GREEN	GREEN
	- MANAGEMENT CAPABILITY	AMBER	GREEN	GREEN
	- EMERGENCY DISTRIBUTION	AMBER	GREEN	GREEN
	- IMPROVE COMBAT LIVING	AMBER	AMBER *	AMBER *
	- ACCURATE INFORMATION	AMBER	GREEN	GREEN
	- EFFICIENT TRANSPORTATION	AMBER	GREEN	GREEN
	- RAPID RESUPPLY	AMBER	GREEN	GREEN
- TRANSPORTATION MANAGEMENT	AMBER	GREEN	GREEN	
CORE	- AMMUNITON	AMBER	AMBER	AMBER
	- MHE	AMBER	AMBER	AMBER
	- TACTICAL ELECTRICAL POWER	AMBER	GREEN	GREEN
	- INTEGRATED MAINTENANCE TEST EQUIPMENT	AMBER	AMBER	GREEN
	- TEST EQUIP MODERNIZATION	AMBER	AMBER	GREEN
	- COMBAT MEDICAL EQUIPMENT	AMBER	GREEN	GREEN
	- HOT FOOD & SHELTER	AMBER	AMBER *	AMBER *
	- DEPMEDS	AMBER	GREEN	GREEN
	- EOD	AMBER *	AMBER *	GREEN *

Figure 10-6

SECTION 4

RESEARCH, DEVELOPMENT AND ACQUISITION STRATEGY

This section discusses systems that have major changes as a result of the mini-POM. System changes are indicated with an asterisk (*) in the RDA chart at Figure 10-7.

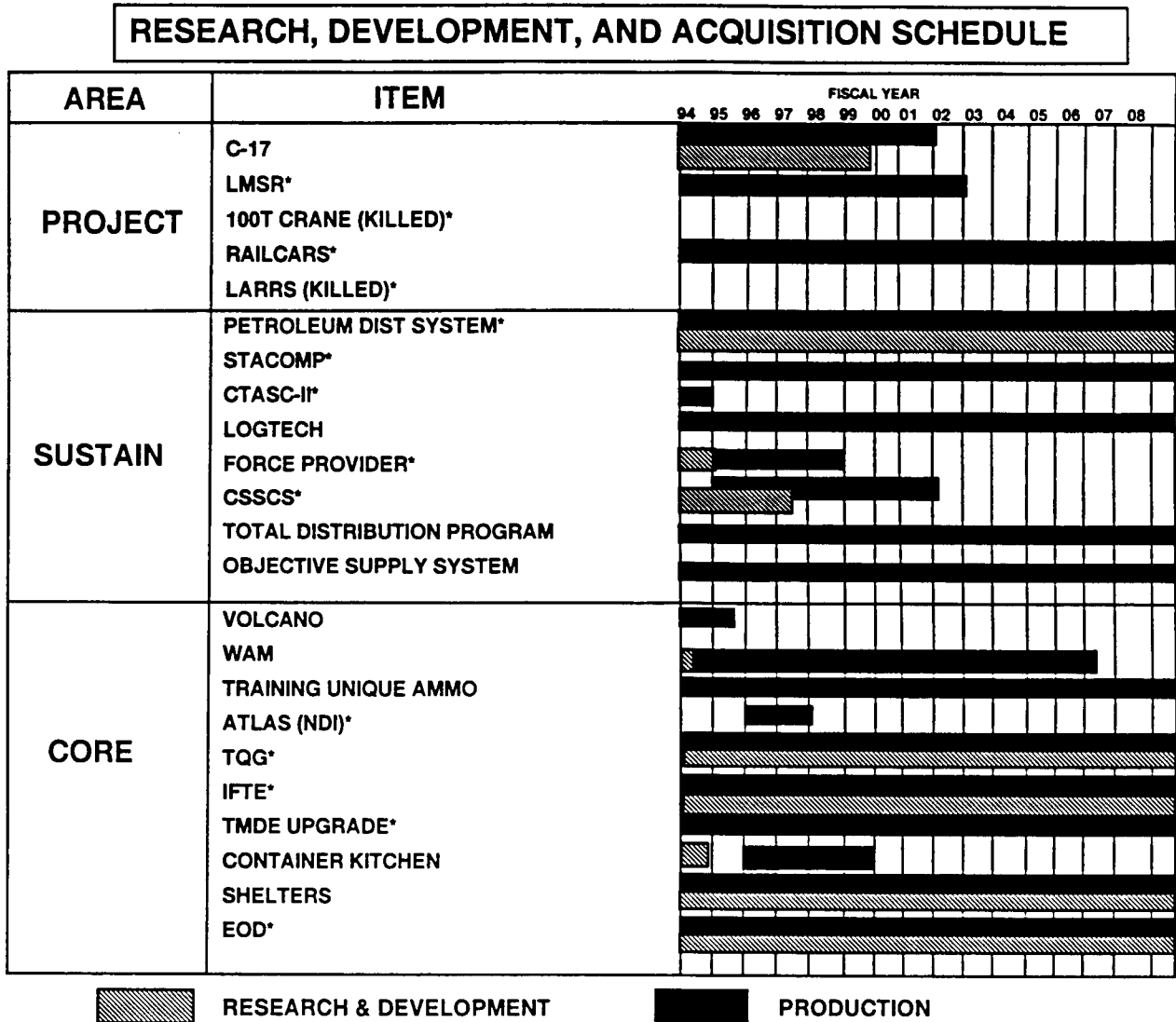

Figure 10-7

Logistics-Over-The-Shore (LOTS). Acquisition Strategy: 100-ton Crane acquisition has been canceled. Pusher tugs will be procured for the reserves. The mini-POM eliminated the funding for the procurement of 100-250 Ton Cranes, Small Pusher Tugs and Coastal Harbor Inland (CHI) boats. It also eliminated the funds from the LACV-30 SLEP that were recommended to be reprogrammed for the LARC-LX upgrade and procurement of other LOTS and rail equipment. Presently, the Army can perform limited LOTS operations in support of a single MRC. The Army will employ Host Nation and ally support in addition to leasing necessary equipment to meet the shortfalls. Even with these limitations available, assets can satisfy the requirements of a single MRC.

Rail Cars. Acquisition Strategy: DoD has a validated requirement for 2306 militarily useful flatcars of which the Army requirement is 2189. The Army currently has 566 flatcars, each with 140 Ton capacity. The rest of the Army's fleet of flatcars (403) will be retired from the inventory by Dec. 31, 1993 because of safety deficiencies. The Army has allocated funds to buy approximately 1000 rail flatcars over the FY93 to FY99 period. At the end of the POM the Army will have filled 78% of its contingency corps requirements. This is an improvement. 1827 of the rail cars support Contingency Corps installations.

Airdrop. Acquisition Strategy: Funding cuts resulted in termination of Low Altitude Retrorocket System (LARRS) R&D and procurement and possible delay in completion of development of the Guided Precision Airdrop System.

Petroleum Distribution System. Acquisition Strategy: Due to reduction of the RDTE for petroleum distribution equipment to the FY93 level, sustainment for petroleum items was reduced to approximately \$3M a year. Procurement of the Arctic Enhancements was eliminated. Soldiers will continue with current equipment.

STACOMP and CTASC-II. Acquisition Strategy: Reduction in procurement of STAMIS Tactical Computers (STACOMP) fills the Contingency force and 60% of FP II. This stretches out modernization. The Corps Theater ADP Service Center - Phase Two (CTASC-II) program has been eliminated after FY95, completing FP I through FP III with Block I and FP I with Block II.

Force Provider. Acquisition Strategy: Twelve of 36 objective modules are funded; no change from previous modernization plan.

Combat Service Support Control System. Acquisition Strategy: Current resourcing will allow fielding to 37% of the Contingency Force by FY2000 due to reduction in procurement dollars. Remaining Contingency Corps Force Package (FP) II and III CSS commanders will continue to use less efficient, slower (often manual) information management tools. Milestone III (Full Scale Development) has been rescheduled for January 1995. The first procurement will probably occur towards the end of FY95.

ATLAS. Acquisition Strategy: The All-Terrain Lifter, Articulated System (ATLAS) program is being replaced by Non-developmental item (NDI) program and will result in production for Contingency Forces in FY95/96. There is also a reduced buy of the Front Side Loader Forklift.

Tactical Quiet Generator. Acquisition Strategy: 100% Force Package (FP) I, 60% FP II, 0% FP III. The systems were reduced proportionally in the mini-POM to correspond with the reduction of base forces.

Test Measurement and Diagnostic Equipment Integrated Family of Test Equipment (IFTE). Acquisition Strategy: There is a reduction in Integrated Family of Test Equipment (IFTE) program that slows FP I fielding to FY95 and FP II to FY97. This delay in IFTE standardization throughout the total force will increase costs for training and support items. The Base Shop Test Facility and Contact Test Set are in full scale production which started in 1993. The award was completed in July 1992. Initial Operational Test and Evaluation has been completed. First Unit Equipped took place in FY93. Electro-optical capability will be added to IFTE in FY96.

TMDE Modernization. Acquisition Strategy: There is a reduction in the program corresponding to reduced force structure. The program reduces TMDE obsolescence and provides state of the art equipment, primarily NDI. The program is designed to upgrade older and replace worn-out test equipment. Cost savings are generated and readiness enhanced through the upgrading of test equipment.

Deployable Medical System (DEPMEDS). Acquisition Strategy: There is approximately a 15% reduction in the program except for FY95 and FY96 where additional funds were decremented. This results in decreased sustainment/modernization of DEPMEDS.

Ammunition. Acquisition Strategy: The government - owned ammunition base has been reduced from 16 active plants in 1991 to 9 today – with planned plant closure and facility divestiture continuing throughout the POM period. The ammunition production base provides for the manufacture of ammunition items requested by all the services; minimally supports plant downsizing and closure plans; and inadequately supports reduction of DOD backlog of ammunition demilitarization items. The Army will continue to seek additional funding for these areas. All war reserve procurements in the mini-POM are modern ammunition items, which are covered in separate annexes and/or chapters under their respective fighting system program modernization. Training will be supported through procurements and drawdown from war reserve stocks for selected items..

Explosive Ordnance Disposal (EOD) - Equipment Upgrade. Current Capability: Various items of hand emplaced tools and equipment are used to render safe and dispose of unexploded ordnance (UXO) one at a time.

Requirement. A capability to rapidly and remotely conduct reconnaissance of hazardous areas, perform physical operations, record EOD procedures, and rapidly engage multiple quantities of UXO.

Acquisition Strategy. Continue to develop and procure tools and equipment to provide for the conduct of EOD operations remotely and safely as a force multiplier to the EOD soldier. Quantities procured will be deployed to all force packages, EOD units and the training base. Current funding will not field these systems in a timely manner and avoid technology obsolescence. This decrements the sustainment capability of equipment, e.g. remote firing devices, cavity demolition containers, shop sets, de-armor kits, and ferrous metal locators. Robotics Ordnance Neutralization Devices are not supported. The Army's High Technology Integration Program should provide capability insight without further EOD specific research.

Two Advanced Warfighting Demonstrations/Experiments are logistical in nature. The Early Entry Lethality and Survivability (EELS) Battle Lab will conduct advanced Airdrop for Land Combat that encompasses a high altitude delivery with GPS based guidance. The Combat Service Support (CSS) Battle Lab will conduct Total Distribution Logistics decision support system simulation and field training exercise.

SECTION 5

TRAINING

The mini-POM has affected Logistical training programs significantly. Training efforts will have to be diffused over many different systems - the more modern Contingency Corps systems as well as the older ones in forces other than the Contingency Corps. This is time consuming for the training base as well as the gaining units which will have to assure up-to-date training of their forces. Efforts to further reduce training time are being made by embedding training and tutorials in the newer automated systems (e.g., CSSCS and STACOMP).

SECTION 6

CONCLUSION

The chart below addresses the impacts of funding shortfalls.

FY95 - 99 MINI-POM

DOES PROVIDE	VS	DOES NOT PROVIDE
POWERED CAUSEWAYS TO REPLACE LAMP-H		100 TON CRANE, PUSHER TUGS, LARC-LX UPGRADE
FORCE PROVIDER @33%		67% OF FORCE PROVIDER
IFTE FORCE PACKAGE (FP) I @55%		45% OF FP I & 100% OF FP II & III
STACOM FP I - 100%, FP II - 60%		33% OF FP II AND 100% OF FP III
CSSCS FP I - 100%		100% OF FP II, III, AND IV
MHE - NDI FOR CCF.		BEYOND CCF
CONTAINERIZED KITCHEN FOR CONTINGENCY CORPS		CONTAINERIZED KITCHEN FOR FP II AND FP III
TQG FP I 100% FP II 60%		FP II - 40% FP III 100%
RAILWAY CAR, FLAT, 100T CCF-78%		CCF - 22%, FP II & III

Figure 10-8

As a result of the mini-POM the majority of modernization programs funded will maintain the Contingency Corps as the most modern, most capable Corps in the world. Other force packages will employ less technologically advanced systems.

CHAPTER 11

SOLDIER MODERNIZATION

SECTION 1

INTRODUCTION

This chapter updates Annex K, Soldier, of the 1993 Army Modernization Plan. The roles, missions and capabilities of the Army's Soldier System have not changed. However, changes in force composition and modernization continue to affect structure and funding requirements. This chapter will capture refinements in the Soldier modernization process that have occurred through FY93. The original annex remains valid where changes are not indicated.

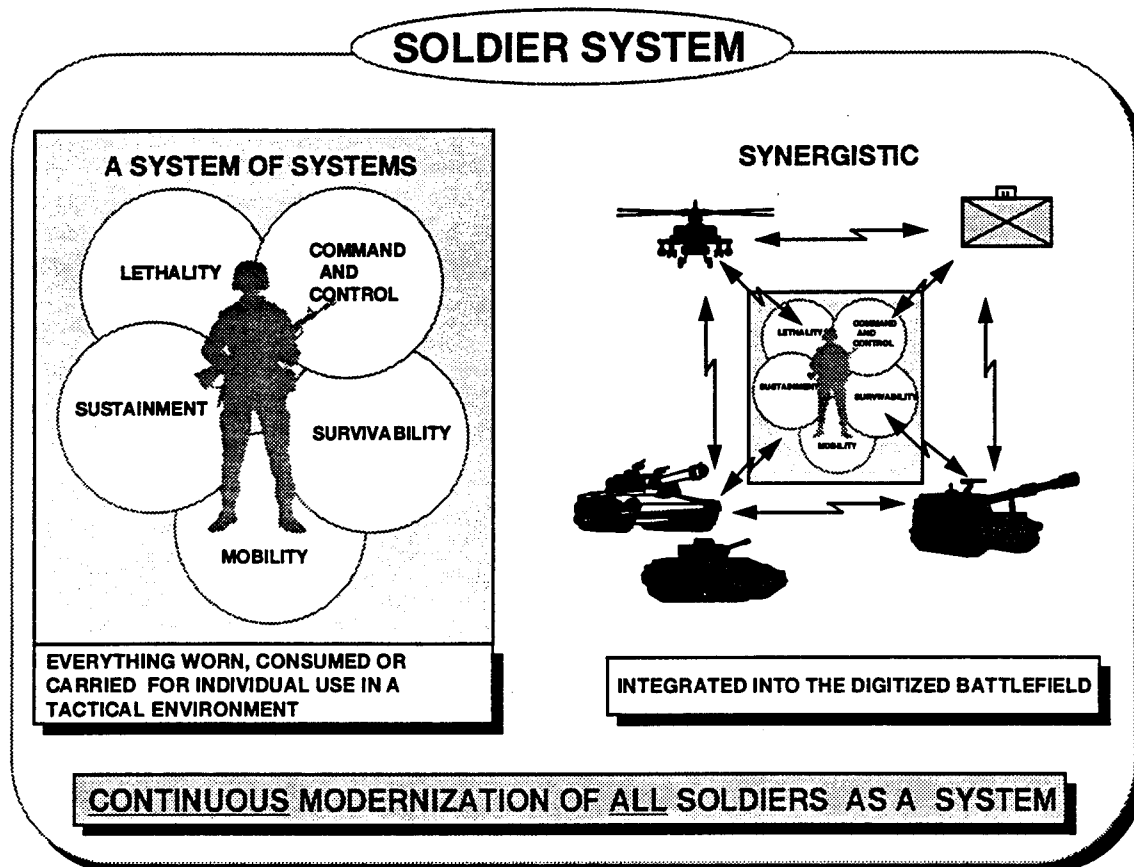

SECTION 2

WARFIGHTING CONCEPT

The recently revised FM 100-5, published in June 1993, and Joint Publication 3.0, published in September 1993, provides new challenges and missions for the individual soldier (peacekeeping and humanitarian missions). The number of soldiers available to participate in missions other than war is greatly reduced as the force continues to build down. Protection of U.S. soldiers and selective targeting and control of destabilizing elements without injury to local populace is of paramount importance. The Soldier System must employ the latest technologies and equipment to make the soldier more survivable and capable. Continued enhancements to the Soldier System are key in the successful completion of all missions.

Even though the soldier will fight more and more as part of a joint and/or combined operation team, there are no major changes in how we fight the Soldier System. As indicated in Annex K of the Modernization Plan, the Soldier System includes all individual items used by soldiers in the tactical environment. This "philosophical" system is varied and tailored according to the needs of each type soldier (Dismounted, Mounted, Air, various MOS's, etc.).

An integrated threat assessment, Volume I, for dismounted soldiers was completed in Aug 93. Volume II, the revised System Threat Assessment Report (STAR) is scheduled for Sep 94.

The system approach to soldier modernization has two objectives: (1) to optimize and integrate all soldier capabilities, and (2) to allow the Soldier to fully access the digitized battlefield.

SECTION 3

CURRENT PROGRAM ASSESSMENT

Soldier Integrated Protective Ensemble (SIPE) Advanced Technology Demonstration (ATD) (Oct-Dec 92) demonstrated the technological feasibility and operational benefit of component and subsystem integration. The SIPE ATD demonstrated and assessed, in an operational environment, the potential of new capabilities and/or enhanced operational effectiveness. The technologically mature, high payoff capabilities identified in SIPE are being pursued through tailored modernization strategies (Figure 11-1) in order to field as fast as technology will allow. Some of the operational payoffs are: improved survivability, improved engagement performance, faster response to changes in mission/situation, improved mission duration or effective mission truncation, interoperability of system components, and potential reduction in weight and bulk.

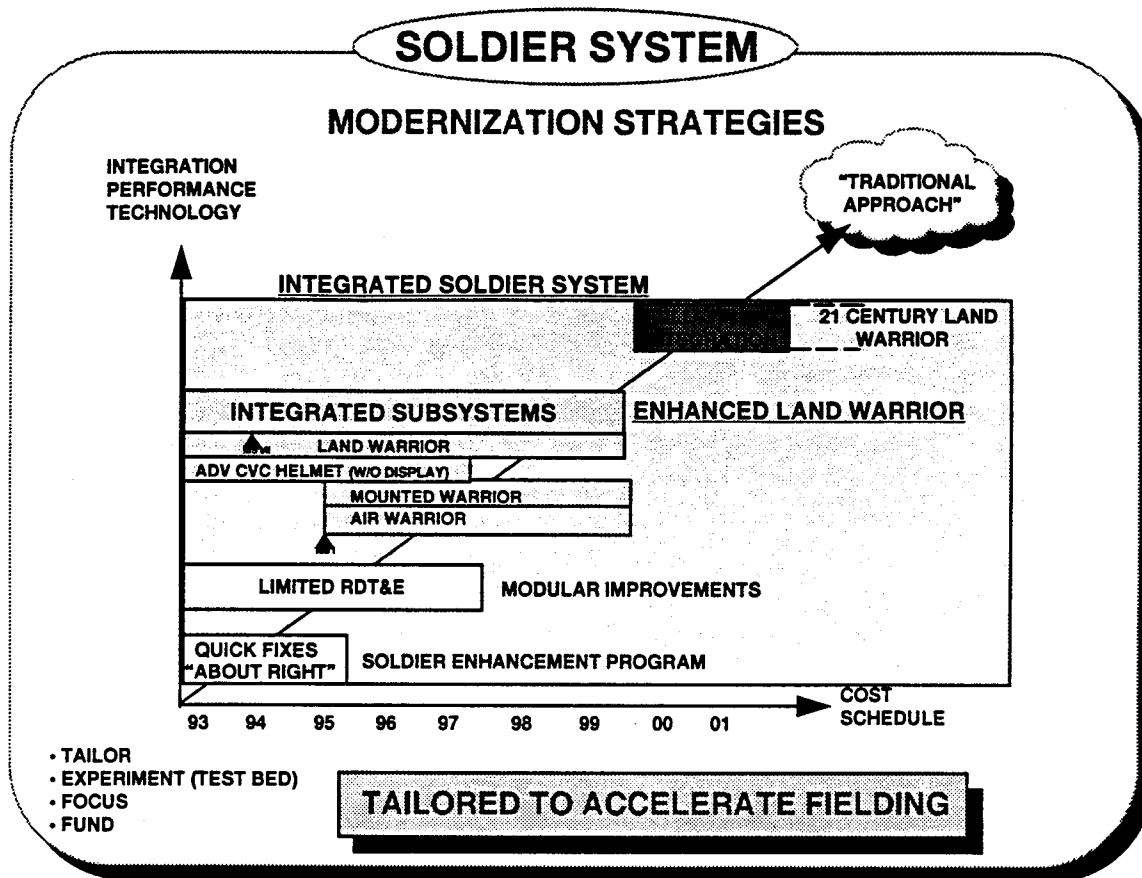

Figure 11-1

The Soldier Enhancement Program (SEP), congressionally initiated and funded for Research, Development, Test and Evaluation (RDT&E), continues to provide a quick response mechanism (less than 3 years from program approval to production) to meet urgent soldier needs with the best of off-the-shelf technologies. Beginning in FY94, SEP RDT&E and procurement is funded entirely by the Army. When ready or near-ready solutions to Army needs are available, SEP provides expeditious evaluation and adoption for procurement. An example of this is the Combat Medic Vest System, which went from a far-term (extended POM) program to mid-term (POM years) program.

Other modular improvements such as small arms, body armor and chemical protective equipment require more extensive development, testing and certification prior to fielding. The Joint Service Lightweight Integrated Suit Technology (JSLIST) is a joint Service coordinated effort to standardize the chemical protective clothing with the Army and Marine Corps as co-proponents.

THE ENHANCED LAND WARRIOR PROGRAM (ELW). The Enhanced Land Warrior program is in Concept Exploration. It includes programs for Soldiers with three types of missions.

- **Land Warrior (LW)** (formally TEISS) for dismounted combat soldier, is the lead program and the technology carrier for the ELW program as a whole. Some of the technologies being incorporated in LW will have application in the Mounted and Air Warrior systems, which will be configured optimally to meet the unique operational needs of these different groups of soldiers. It has an approved Mission Need Statement (MNS). Completion of the Land Warrior trade-off analysis will lead to a Milestone I/II decision in the second quarter FY94. LW will field the first integrated soldier capability before the end of this decade. See Figure 11-2 below.

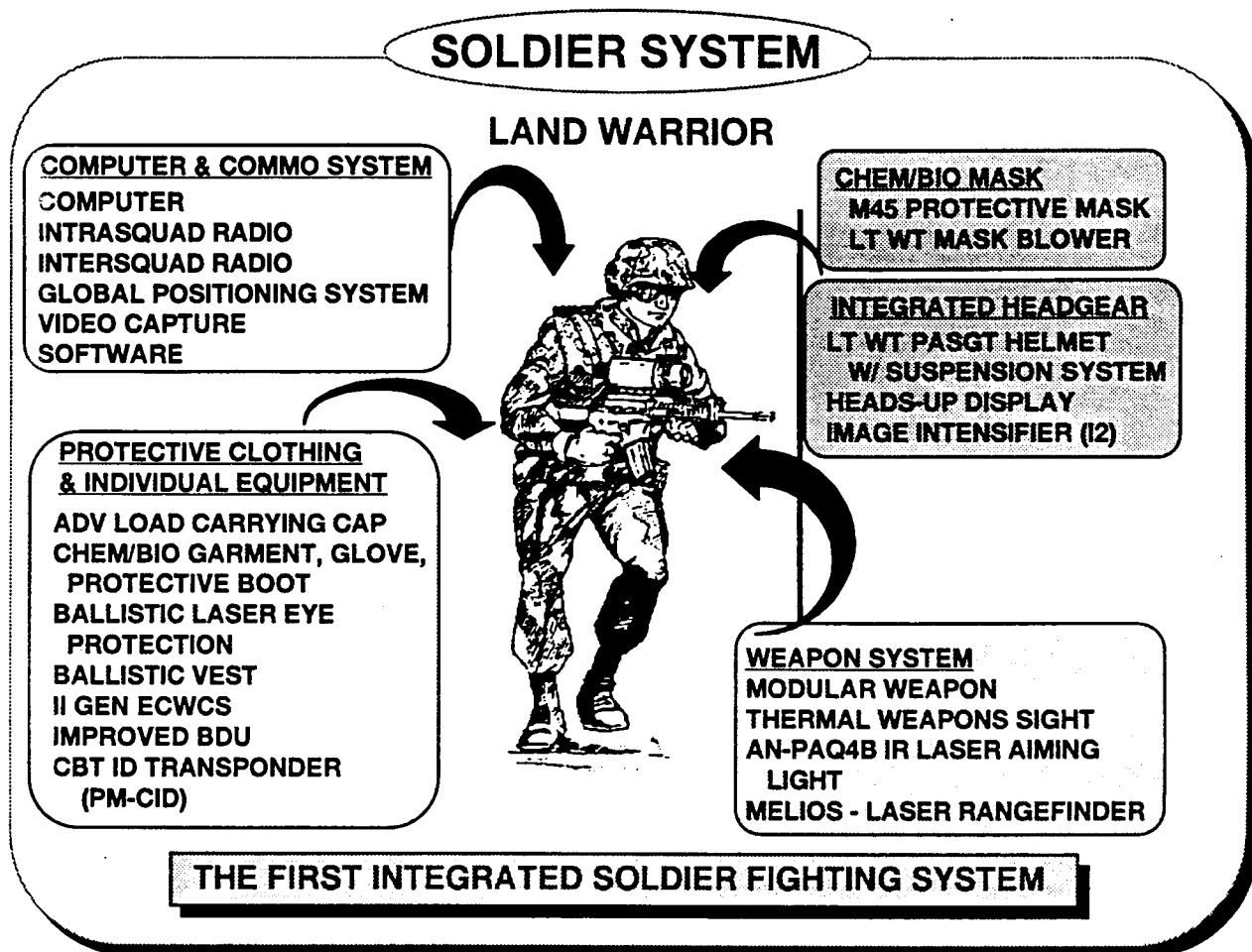

Figure 11-2

- **Mounted Warrior.** (Formally Mounted Armor Crewman Ensemble) for mounted crewmen, consists of the advanced Combat Vehicle Crewman helmet, helmet-mounted display and an advanced uniform ensemble.

- **Air Warrior.** (Formally Aircrew Integrated Ensemble) for air crewmen will be technologically compatible with the Mounted Warrior to the maximum extent and will be a joint Army/Navy program. The

Enhanced Integrated Soldier System (TEISS) objective/Block II Soldier.

The Soldier Test Bed (Figure 11-3) concept will help to accelerate the modernization process by putting modular subsystems as they become available into the hands of real soldiers, and obtaining real data under real conditions. The intent is to supplement formal approaches to testing as both a "sanity check" and as a means to rapidly refine requirements definition. If it's feasible, we buy it and field it to soldiers quicker.

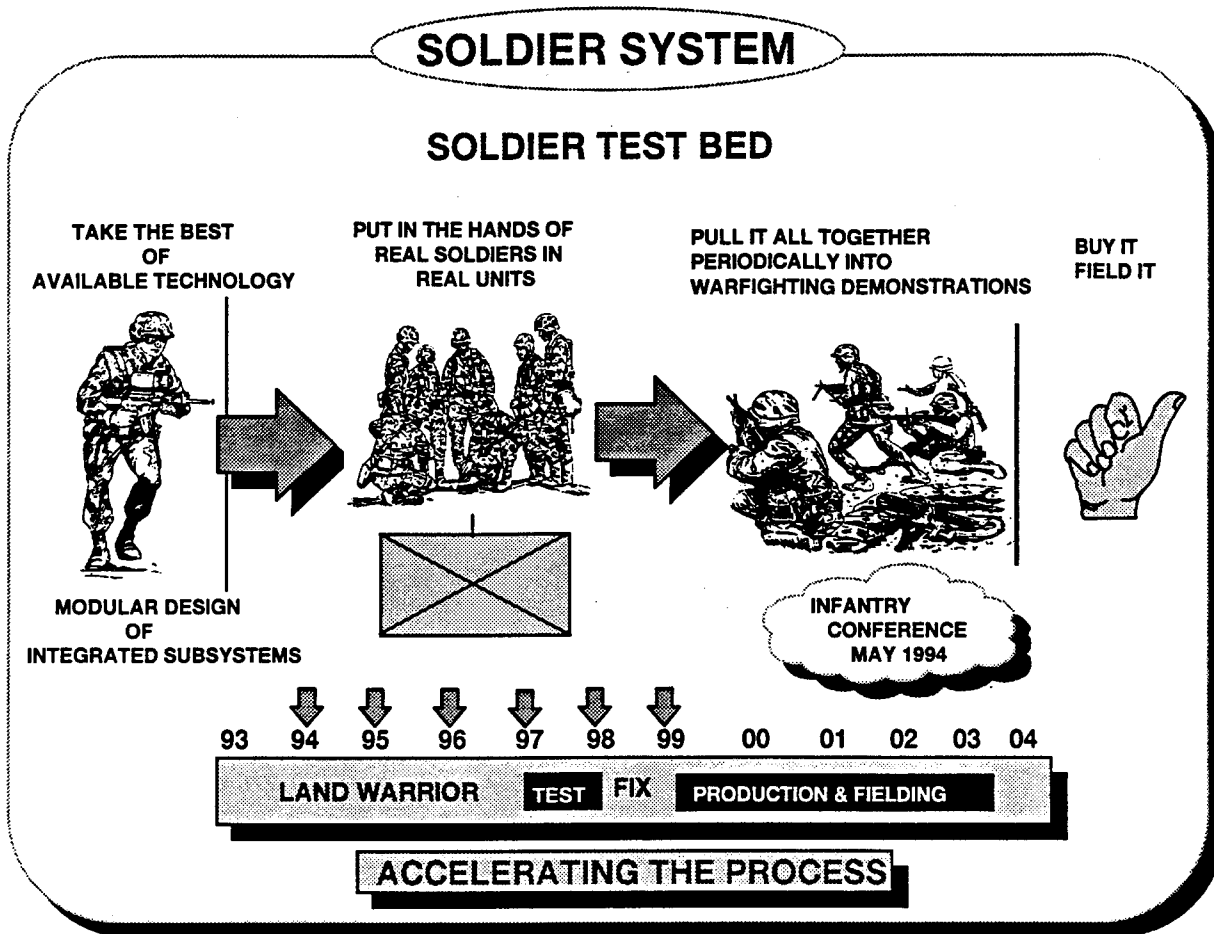

Figure 11-3

Assessment of Soldier System is changed only in that the length of the near, mid, and far term modernization timelines are prolonged. The application of technology to multiply the effectiveness of reduced forces will take longer.

SECTION 4

RESEARCH, DEVELOPMENT, AND ACQUISITION STRATEGY

The Thrust 5, Block II Soldier was formally approved and institutionalized as 21st Century Land Warrior (21CLW) Top Level Demo (TLD). The 21CLW TLD will further develop and demonstrate immature, high risk technologies needed to meet full operational requirements in the next decade. The 21CLW replaces the Enhanced Integrated Soldier System (TEISS) objective/Block II Soldier.

Soldier Enhancement Program completed 15 programs in FY 93. Total new starts for FY 94 is 39, bringing the total ongoing SEP programs to 69.

The Land Warrior (LW) program was initiated to develop and produce the first integrated Soldier System. LW has an approved Mission Needs Statement, is a Non-Developmental Item integration effort, augmented with some developmental items. It incorporates items being developed in a number of ongoing programs.

The GEN II ATD and 21st CLW (TLD) were initiated to demonstrate technologies on a system framework as a precursor to the development and acquisition of a 21st CLW system.

SOLDIER ENHANCEMENT PROGRAM	
FY93 COMPLETIONS	
Self-Heating Meal	Knee Pads
M24 Sniper Rifle Optic	Laser Target Pointer
M249 Assault Pack	Soldier's Knife/Sheath
.50 Cal MG Soft Mount	Improved Shelter
.50 Cal SLAP TC	CVC Helmet Improvements
Rifle/Carbine Dust Cover	Neckgaiter
Cbt Ration Enhancements	Mounted Crew Equipment Bag
Hot Weather BDU Cap	

Figure 11-4

SOLDIER ENHANCEMENT PROGRAM, FY94 NEW STARTS

Fighting Position Excavator	Dim Tracer, 5.56mm
Lt. Wt. Chemical Overgarment	SFC Revetment Kit
HMMWV Mount, M249	Ind Soldier Enhanced Rations
Multi-Faith/Vegetarian Rations	Inconspicuous Body Armor
SA Alt Commercial Lubricant	Stun Hand Grenade, No. 20
Lt. Wt. Underwear	Improved Frames for ALICE Pack
Dual Mount, M2, MK19	Enhanced Incendiary Grenade
Cold Weather Parka/Trouser	40mm High Velocity Tracer
Tool Inventory Software	Imp Poncho Liner
FEA Body Armor Study	Add on Pouches for ALICE
Combat Medic Vest Systems	Extreme Cold Weather Mittens
Stabilized Binoculars	Extended Cold Weather Gloves

Figure 11-5

SECTION 5

TRAINING

Training requirements for the individual soldier are of two types: training to develop and enhance warfighting skills and training for new equipment which is being integrated into the force. Conventional methods used to achieve the former will be enhanced by employment of the latest technology in computer based simulators. Training for the latter is accomplished by building on the common skills developed in the use of earlier equipment and by designing in, wherever possible, embedded training in new equipment.

A contract was placed (1QFY93) to build 38 simulators for the Close Combat Tactical Trainer (CCTT). The CCTT, which includes a dismounted Infantry capability, is a follow-on to the Simulations Networking (SIMNET) project.

Envisioned as a combined arms tactical trainer, CCTT will provide training for the total combined force. It will train collective tasks (crew through battalion) as well as leader tasks for command, control, communication, and maneuver. It is anticipated that the CCTT will be both a unit and institutional level trainer. This program is closely tracking the LW project in an effort to find methods of training integration between the two programs. Operational testing is scheduled for FY96 and First Unit Equipped for FY99. Operational testing is scheduled for FY96 and First Unit Equipped for FY99.

SECTION 6

CONCLUSION

As force size and structure change, and new missions for the soldier evolve, conclusions of the original Soldier Modernization Plan remain valid. Some near term equipment improvements have been Type Classified and others move toward that milestone. The name TEISS has changed to Land Warrior which will be joined by Mounted Warrior for mounted soldiers and Air Warrior for air crews under the umbrella program of Advanced Land Warrior. The 21st CLW Top Level Demonstration (TLD) is planned near the end of the decade to showcase the capabilities made possible by technological progress in the interim. This will enable commanders the opportunity to evaluate the tactical merit of these capabilities for inclusion in the Soldier System in the next century.

Fielding of modernized soldier equipment under the Central Funding and Fielding (CFF) program slowed during FY93 as funding was reallocated to urgent needs associated with the changing force structure and world situation. A return to funding levels consistent with the modernization of the soldier will be pursued in the next POM.

The United States soldier remains the cornerstone of the current and future force projection Army. Adequate funding is critical to develop the capabilities demonstrated in SIPE into the fully hardened, militarized, fieldable equipment package, "Land Warrior." This will ensure mission accomplishment, while preserving our nation's most precious resources - her sons and daughters.

CHAPTER 12
AVIATION
SECTION 1
INTRODUCTION

This chapter updates ANNEX L of the 1993 Army Modernization Plan. Changes have been brought about by initiatives to restructure Aviation to account for Army of Excellence deficiencies (Aviation Restructure Initiative), updated funding guidance contained in the September 1993 mini-Program Objective Memorandum (POM) and the results of the Aviation Functional Area Analysis completed in September 1993.

Our business demands that we fight as a team, both inter- and intra-Service. The continuing evolution of Joint, Army and Aviation doctrines have been woven into the strategy of the Aviation Modernization Plan. This document along with FM 100-5 and Joint Publication 3-0 integrate doctrine, modernization strategies, and joint warfare into a cohesive structure that is essential to victory.

The original annex remains valid where changes are not indicated.

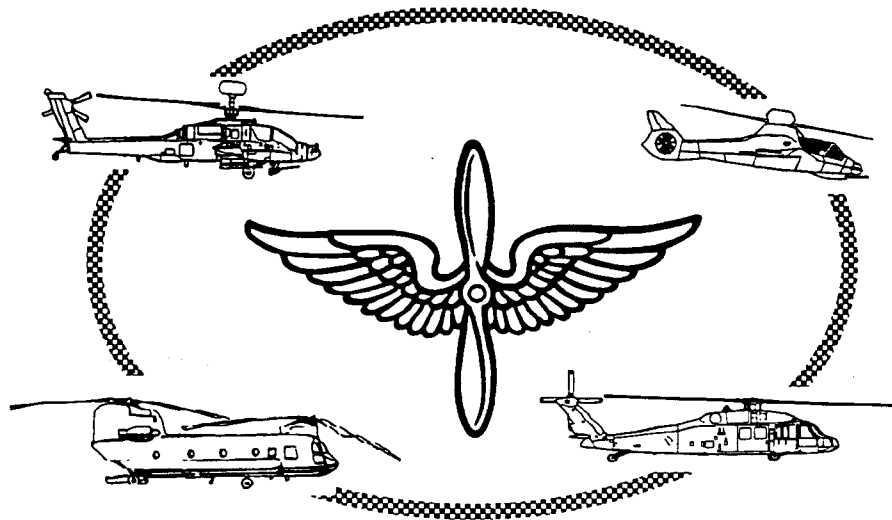

SECTION 2

WARFIGHTING CONCEPT

The continued evolution of doctrine places increasing emphasis on the role of aviation forces including early entry. The potential has been realized for maneuver by combat aviation. The helicopter can overcome ground system limitations by gaining a high degree of battlefield observation, killing at great stand-off ranges, avoiding vulnerability in close terrain, easily crossing terrain obstacles, and being able to self-deploy. During strategic deployment to an actual or potential regional conflict, self-deployment or early strategic air and/or sea lift of aviation forces could be decisive. Having the means for day/night and adverse weather reconnaissance and security at great distances from a lodgment area is crucial in the early days. Aviation can operate throughout the depth of the battlefield in support of maneuver elements, enhancing all missions through modernized aircraft and more offensive-minded doctrine.

Operational Roles and Missions. The versatility of aviation encompasses missions throughout the range of military operations. Aviation operations are shown below.

AVIATION OPERATIONS

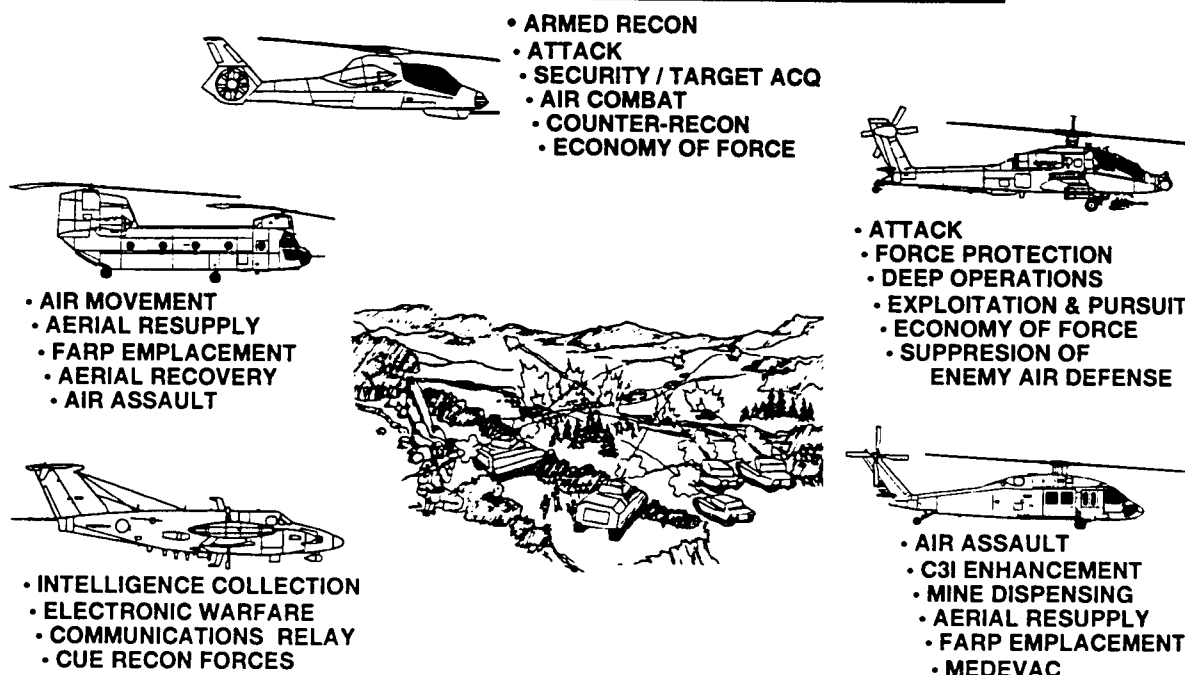

Figure 12-1

Joint and Combined Operations. Joint operations are a certainty in future conflicts. Depending on the theater, mission, and level of conflict, the mix of joint forces will vary. Although Army Aviation units will continue to operate as part of the Army component of the Unified Command, Specified Command, or Joint Task Force, it is certain that Army Aviation forces will be required to communicate with, support, or be supported by sister Services. We are presently addressing interoperability issues, working doctrinal manuals, and tactics, techniques, and procedures that support joint warfighting.

Warfighting Requirements

Force Design. The Total Army Analysis-2001 (TAA-01), completed in 1993, identified the force structure required to meet the National Military Strategy of a **Power Projection Army**. Results of the DOD "Bottom Up Review" and the recently published Defense Planning Guidance will cause a downsizing of the TAA-01 force.

The future holds many changes to structure and force design for aviation. The **Aviation Restructure Initiative (ARI)** was undertaken to correct the deficiencies in the Army of Excellence (AOE) design. Principle warfighting deficiencies identified concerned insufficient maintenance and support personnel to maintain optempo. Shortcomings were found in manning the C2 headquarters and lack of assistant crew chiefs/door gunners for assault and general support UH-60 aircraft. ARI standardizes combat organizations throughout the force and creates utility organizations consistent with unit mission requirements.

ARI has changed the Army Modernization Plan, Annex L, significantly. The design goals below reflect some of the changes. The ultimate objective, however, remains the same—reduce the various types of rotary wing aircraft, thereby reducing operating and support costs. These goals reflect the continued strategy of replacing older, technologically obsolete aircraft with fewer, more capable aircraft.

MODERNIZATION DESIGN GOALS

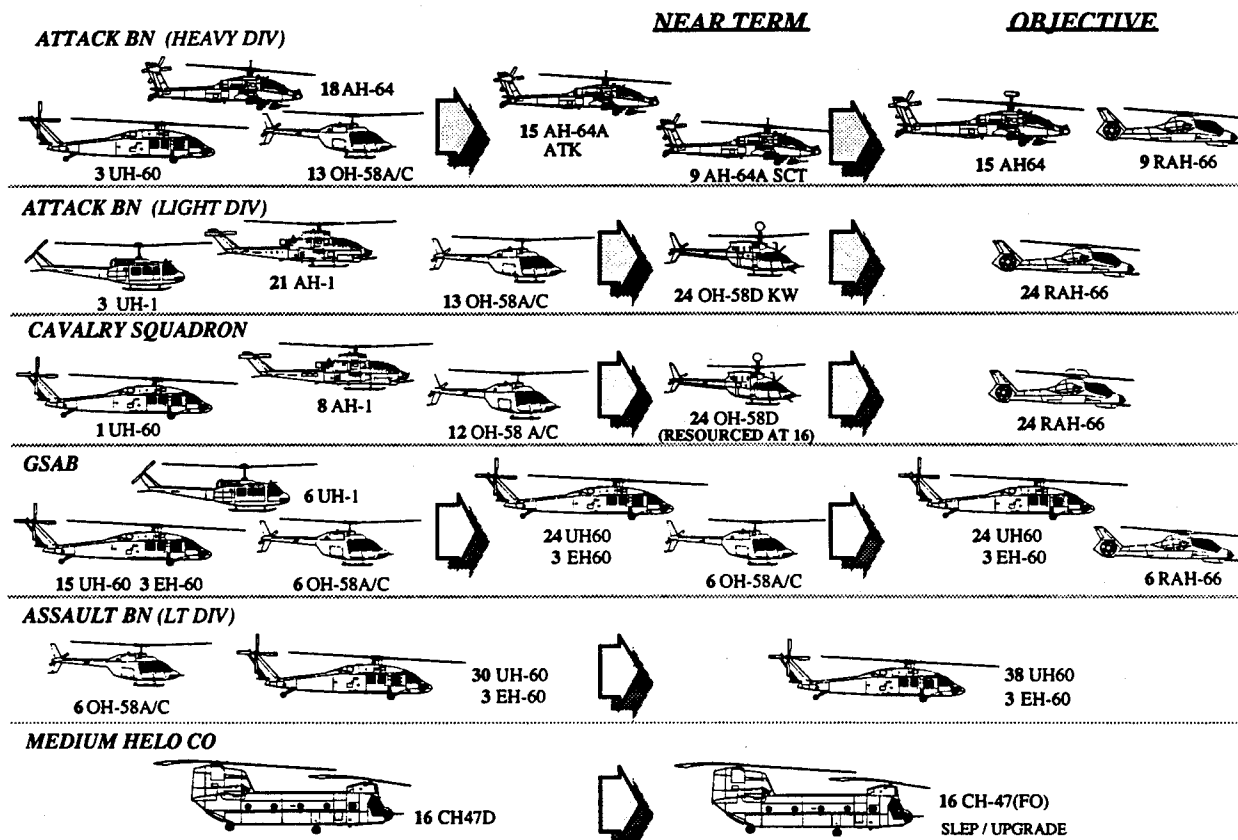

Figure 12-2

The objective rotary wing fleet requirements under the TAA-01 force structure are shown in Figure 12-3. Aircraft quantities are broken down by Table of Organization and Equipment (TOE), float/attrition, and Table of Distribution and Allowance (TDA)/training aircraft. Float requirements are based on Army regulations. AH-64 requirements reflect "without" RAH-66 as scout/ "with" RAH-66 as scout. The last RAH-66 will be fielded to attack battalions in Heavy Divisions/Corps (last FUE FY2014).

The AH-64 will act as an interim scout until the RAH-66 is fielded. Ongoing analysis may further impact these requirements.

OBJECTIVE FORCE (FY15)	AIRCRAFT TYPE			
	AH-64	RAH-66	UH-60 *	CH-47
TOTAL TOE	760 / 485	1173	1569	360
FLOAT/ATTRITION	190 / 125	299	400	92
TDA / TRAINING	74 / 49	117	157	36
TOTAL AIRCRAFT REQUIREMENT	1024 / 659	1589	2126	488

* Does not include 131 LUH Special Operations and SEMA Aviation Not Included

Figure 12-3

Future Mission Requirements. There is no change from the AMP on the future mission requirements for Army Aviation Rotary Wing Fleet. Army Aviation's modernization requirements replace older, technologically obsolete helicopters with fewer, more capable systems. As the chart below depicts, the ultimate goal is to reduce the number, types and models of aircraft. Using this graph, the composition of the fleet can generally be determined by fiscal year. It is evident that while the RAH-66, AH-64D Longbow and additional acquisition of the UH-60L displace older aircraft at the turn of the century, a large portion of the Rotary Wing Fleet will consist of Vietnam-era aircraft through the rest of the decade..

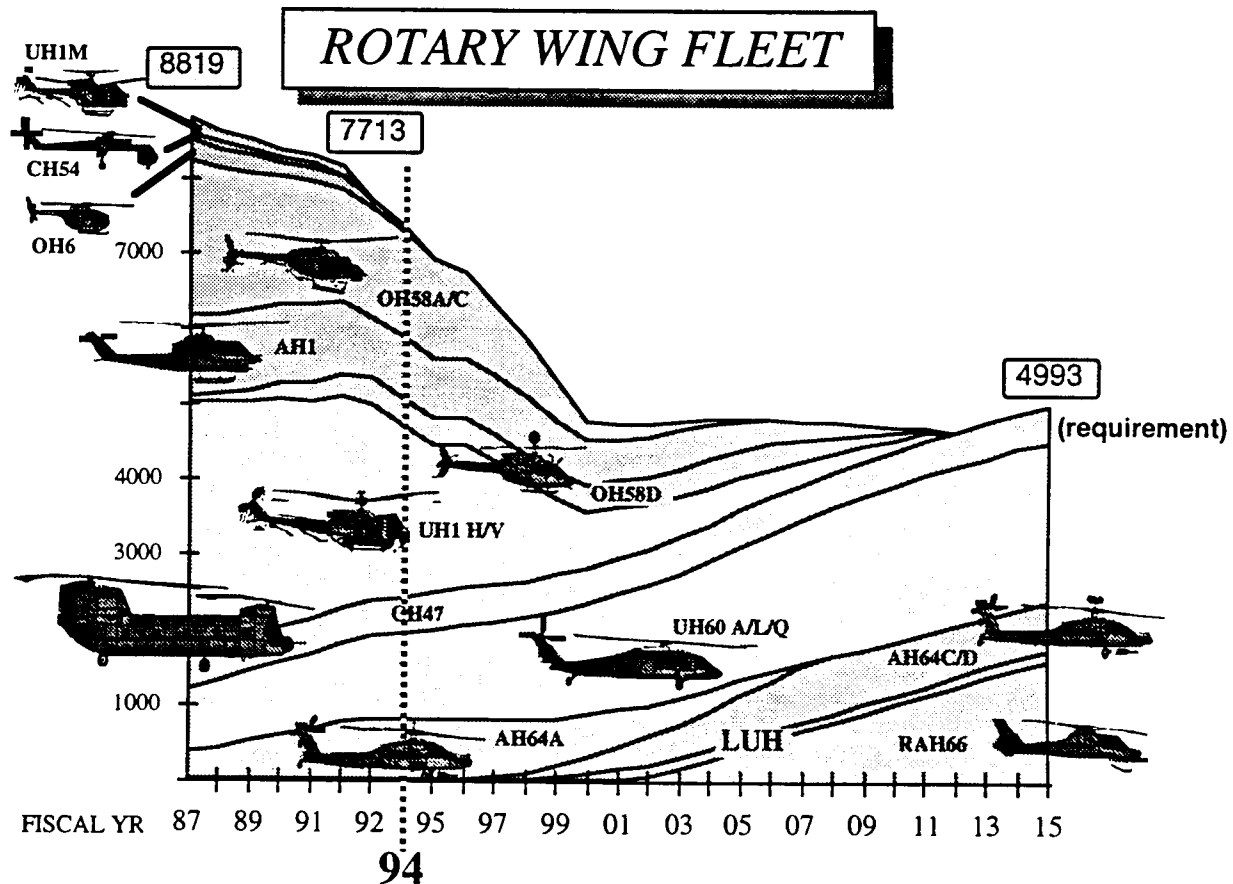

Figure 12-4

There is a change to the AMP in the Fixed Wing Fleet. The new "Fixed Wing Investment Strategy" calls for replacing the current fleet of twenty different aircraft with four airframes. This strategy will reduce the fleet by 40%; save RDT&E, APA, OMA, and training costs; create an effective and efficient fleet; and improve the Army's warfighting capability. The four types of aircraft will be: a C-XX Short Range Utility (C-12) type aircraft for personnel and limited cargo hauling); a C-XX Medium Range Utility aircraft; a C-XX Long Range transport aircraft (C-26 Gulfstream-type aircraft) and a Multi-Mission Medium Tactical Transport (M3T2) aircraft (for intra-theater cargo, the High Capacity Air Ambulance mission and the Aerial Common Sensor mission).

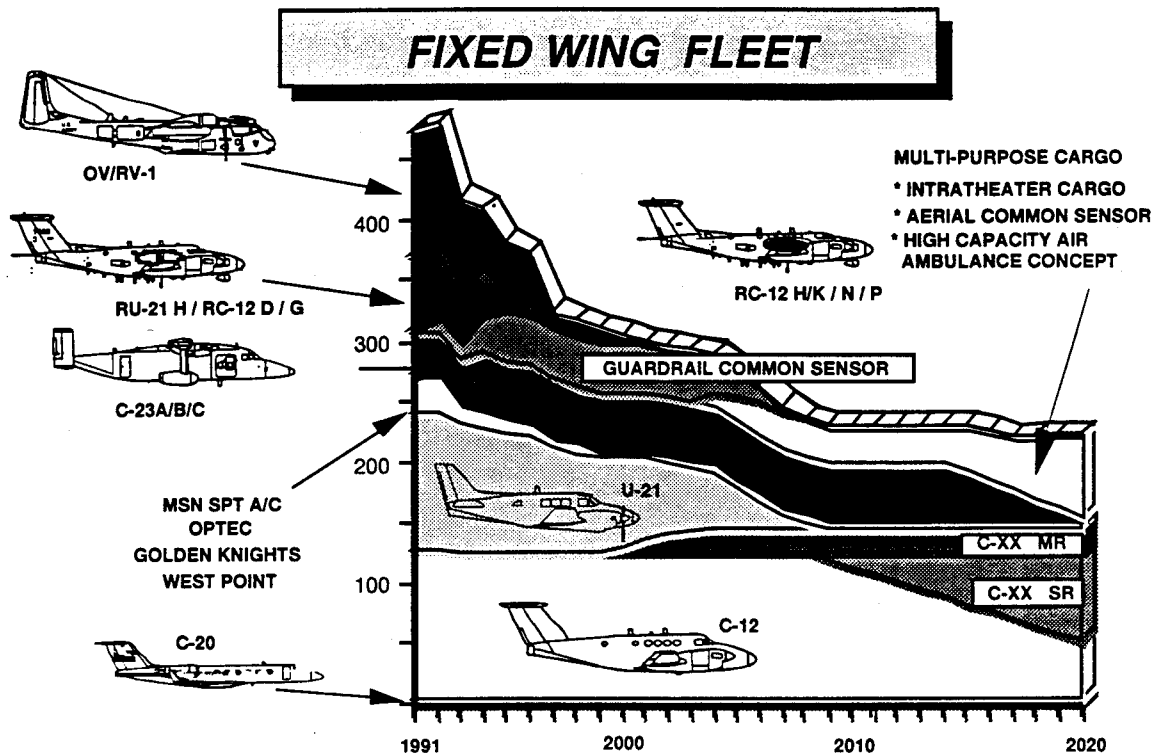

Figure 12-5

SECTION 3

CURRENT PROGRAM ASSESSMENT

This section assesses the warfighting requirements described in Section 3. A **RED/ AMBER/ GREEN** rating scheme is used as defined below.

RED -- The system is incapable of defeating threats or providing required support.

AMBER -- A limited capability/quantity exists.

GREEN -- Adequate capability/quantity exists.

Mission Assessment. Warfighting capability in each of our major mission areas for the present, POM, and EPP (Extended Planning Period) is shown below. The percent of modernized aircraft by force package and an assessment of overall warfighting capability based upon the 4 corps/20 division force is provided.

Reconnaissance/Security. The AH-1 and OH-58A/C are **RED**. Both aircraft lack the capabilities to successfully operate at night and in reduced visibility, flight performance necessary for global operations, and adequate targeting sensors. The OH-58D Kiowa Warrior is **AMBER**, but presently accounts for less than 50 percent of the cavalry squadron fleet. While it improves reconnaissance and security operations, it does not offer requisite self-deployability, range, speed, or payload for global operations. This mission continues to be conducted by 1960's technology AH-1 and OH-58A/C aircraft in the near to mid-term. The introduction of the RAH-66 in the far term will solve reconnaissance/security deficiencies.

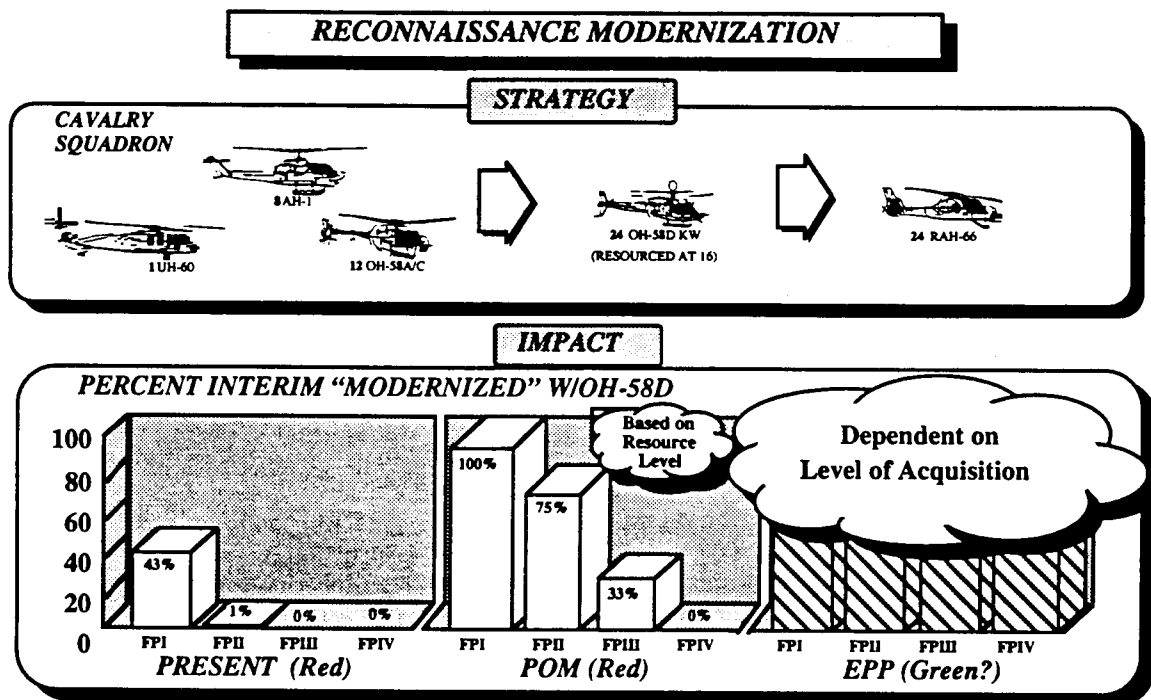
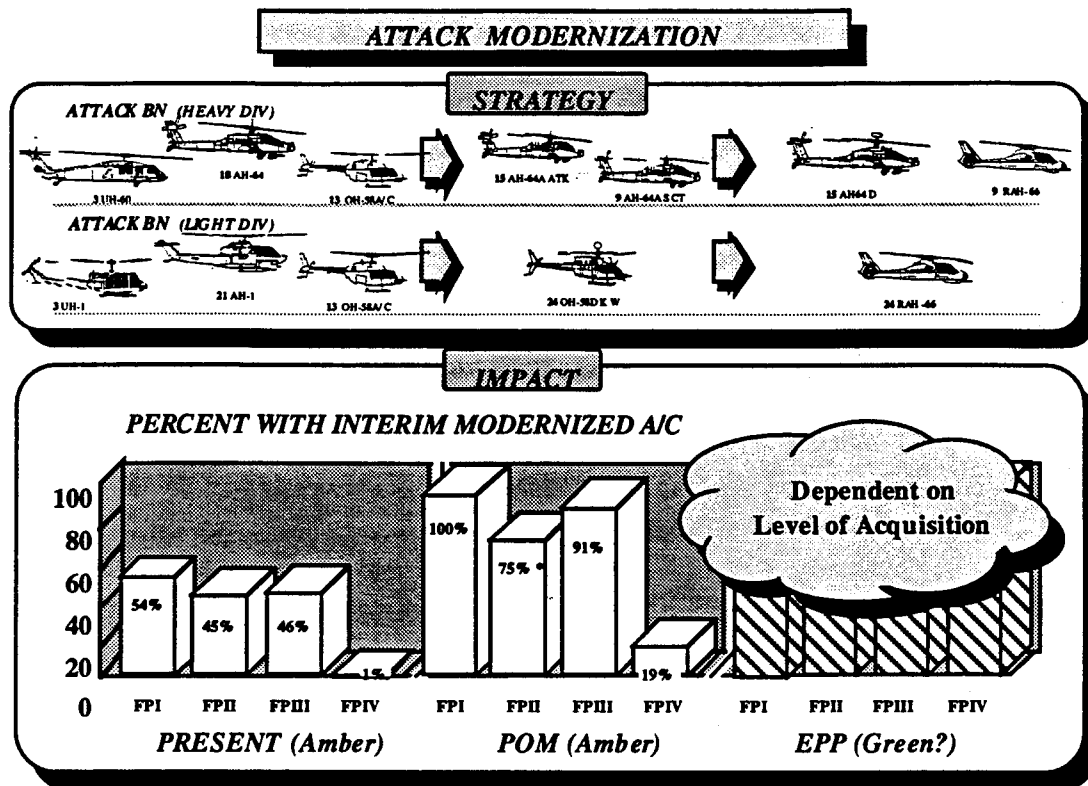

Figure 12-6

Attack. The attack mission is assessed **AMBER**. It is performed by two different aircraft teams: AH-1/OH-58A/C (assessed **RED**) and the AH-64A/OH-58A/C (assessed **AMBER** due to the OH-58 scout). The AH-1/OH-58A/C is assigned to light/heavy divisions and echelon above corps (EAC) attack battalions, these aircraft are only marginally survivable, supportable, and maintainable. Each aircraft entered service during the Vietnam era. Only a few AH-1F C-NITE aircraft possess a target acquisition

system capable of limited night/adverse weather combat operations. Flight performance limits the ability of the AH-1 to carry sufficient weapon payloads in the high/hot environments typical of Southwest Asia. The OH-58A/C target acquisition is limited to the pilot's eyesight and is severely limited in performance. In the mid-term, attack battalion capabilities are significantly improved under the Aviation Restructure Initiative. However, shortfalls in interim modernized aircraft, the range/speed/payload limitations of the OH-58D, and the less than optimized design of the AH-64 serving in the scout role, lead to an **AMBER** rating in the mid-term. Introducing the AH-64C/D and Comanche, in the far term, provides a tremendous increase in combat capability for attack roles.



* Force Package imbalance due to past fielding priorities and new Force Package alignment. Fielding plans within the POM address this issue.

Figure 12-7

Utility. The current utility fleet is rated **AMBER**. The UH-1H/V are old airframes, possessing inadequate lift, speed and range for operations in high/hot environments. The UH-60A/L is a solid performer with excellent deployability, sustainability, and maintainability. The utility fleet is also considered **AMBER** in the Mid-term. UH-60 improvements are required to extend communications range, improve navigational accuracy, and provide self-protection. Additional UH-60 procurements are also required to replace aging UH-1H and UH-1V. The UH-60Q is a concept under development to fully meet MEDEVAC mission requirements.

UTILITY MODERNIZATION

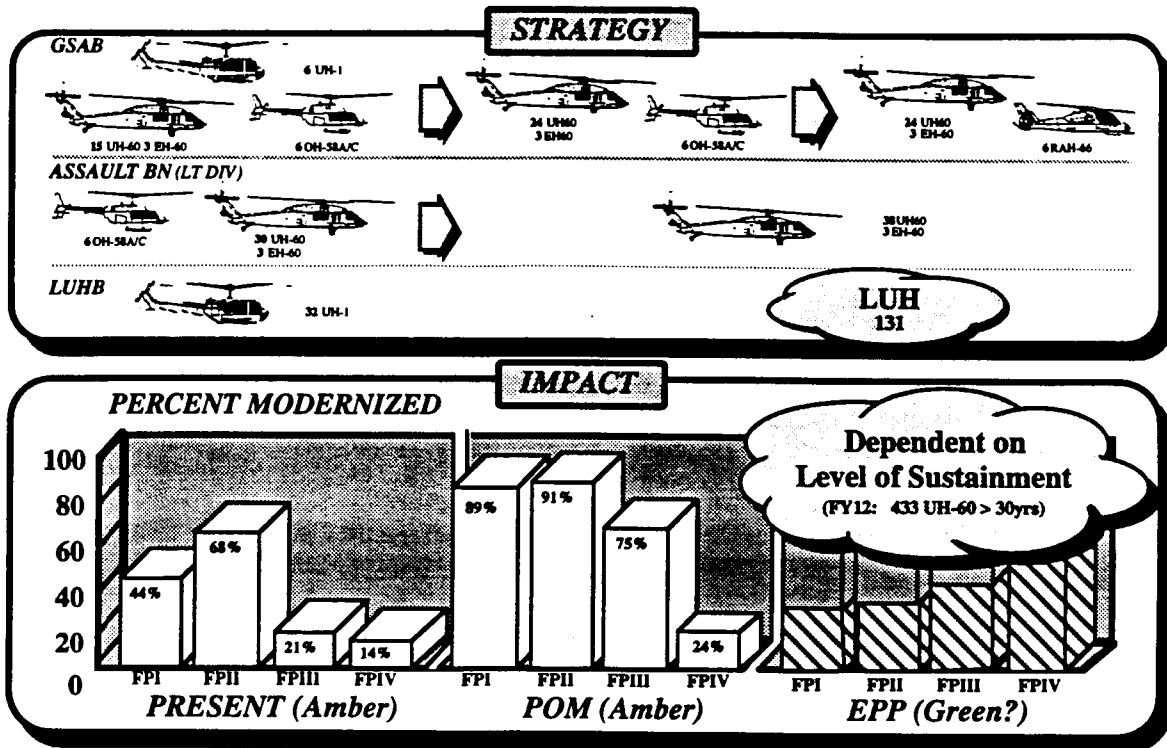

Figure 12-8

Cargo. The CH-47D provides adequate capability into the mid term. Minor enhancements are required to improve supportability, payload, communication range and connectivity, and navigation accuracy in the near term. However, in FY02 our cargo fleet begins to exceed its projected useful life. A replacement for the CH-47D is not envisioned until the FY2015/2020 timeframe. This "National Rotorcraft Transport (NRT)" is projected to be a national/joint program. An upgrade/SLEP is the only option to extend CH-47D useful life until this timeframe. Studies and analysis of possible upgrades/SLEP options are ongoing.

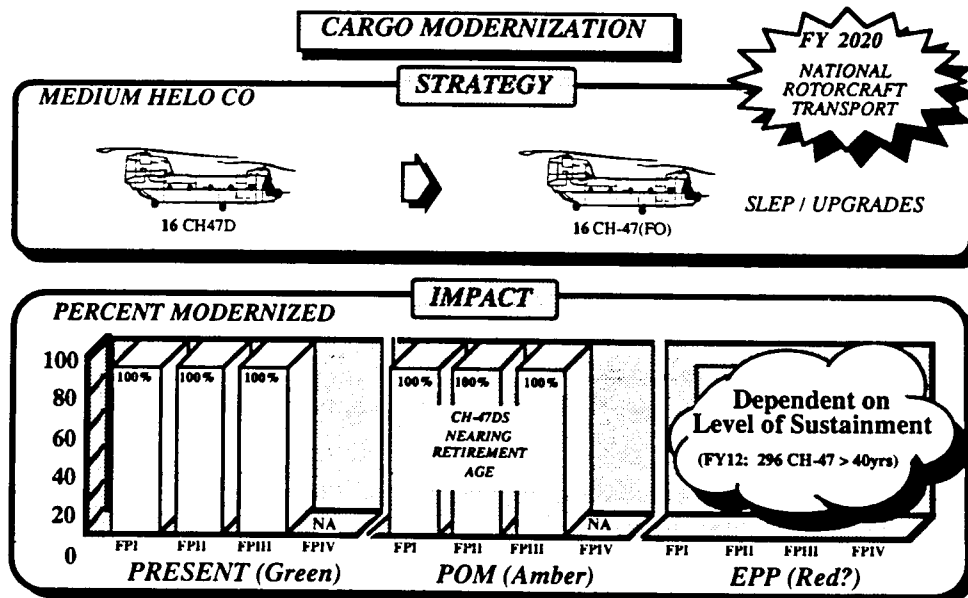

Figure 12-9

Fixed Wing. Present/POM-AMBER. The U-21 is **RED**. The U-21 fleet is approaching 30 years in service and began phased retirement in FY93. The C-12 is **AMBER**. A cockpit upgrade is needed to standardize the fleet and to improve long range navigation communication, and weather avoidance, and support new federal aviation regulations requiring a mode-S transponder for traffic avoidance. The C-12 will begin to reach its planned useful life in FY09. The fixed wing fleet is assessed at **GREEN** in the EPP given funding for the C-XX and multi-purpose cargo programs.

Intelligence and Electronic Warfare (IEW). The Special Electronics Mission Aircraft (SEMA) assessment is contained in the IEW chapter of this Modernization Plan update.

Special Operations Aircraft (SOA). The SOA fleet includes the AH-6/MH-6, MH-60, and MH-47 helicopters. The assessment of SOA aircraft capability is classified.

CONCLUSION. The figure below summarizes aviation capabilities by major mission area for current, POM, and EPP periods. The obsolete AH-1/OH-58A/C and an inadequate number of OH-58D result in "RED" assessments for reconnaissance/security for the current and POM periods. The aging utility and cargo fleets face potential obsolescence in the outyears.

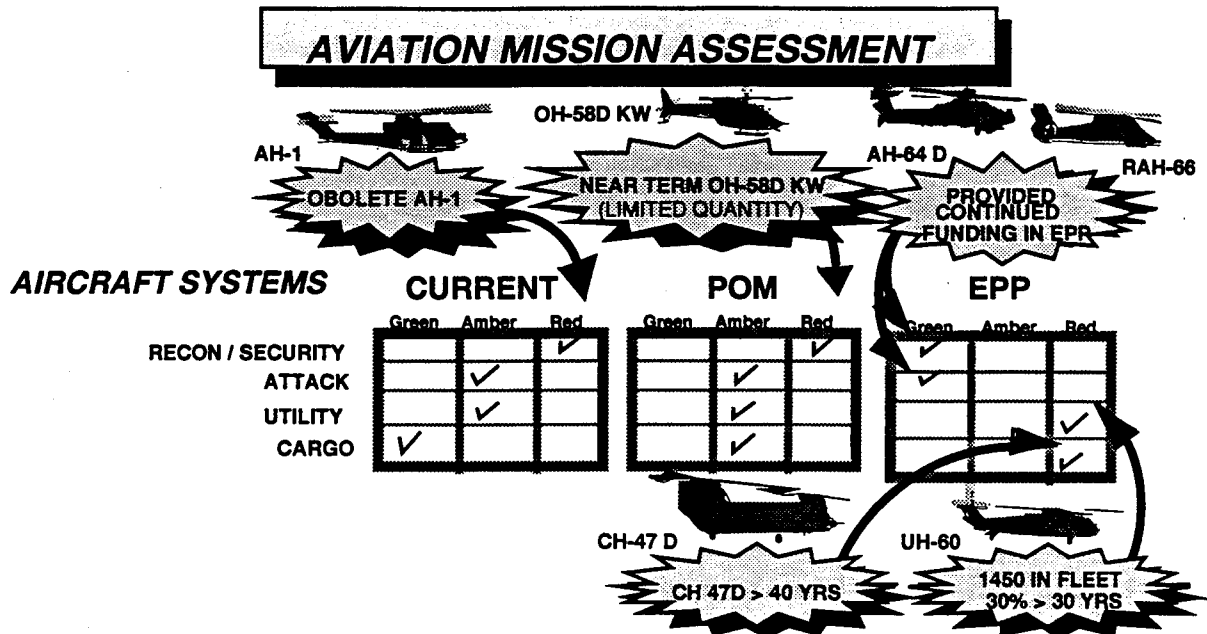

Figure 12-10

SECTION 4

RESEARCH, DEVELOPMENT, AND ACQUISITION STRATEGY

Aviation RDA Strategy. The Research, Development, and Acquisition (RDA) strategy for Army Aviation forms a continuous cycle for modernization. Aircraft are sustained with safety upgrades and Engineering Change Proposals (ECP). Materiel Changes (MC) counter advances in opposing force capabilities and insert new technologies to maintain our technological edge. New systems acquisitions are initiated to replace old and technologically obsolete aircraft. Investment strategy as outlined in basic annex has not changed, however, due to implementation of ARI and decreasing availability of funds some programs have been slipped and total buys altered (i.e., UH-60 procurement ends in FY96 requiring the retention of significantly more UH-1s than previously anticipated). The results of this strategy are graphically portrayed below. The procurement objective for each aircraft (formulated from the baseline POM/EPP) is shown inside each box. Any number above the box represents the requirement to resource the 4 Corps/20 Division TAA-01 force (shown only if different from the procurement objective). Decision points for major materiel changes or new product developments are indicated by the triangles. Converging lines indicate the replacement and retirement of existing systems. The outyear programs shown on the far right represent Aviation's "advanced concepts/systems."

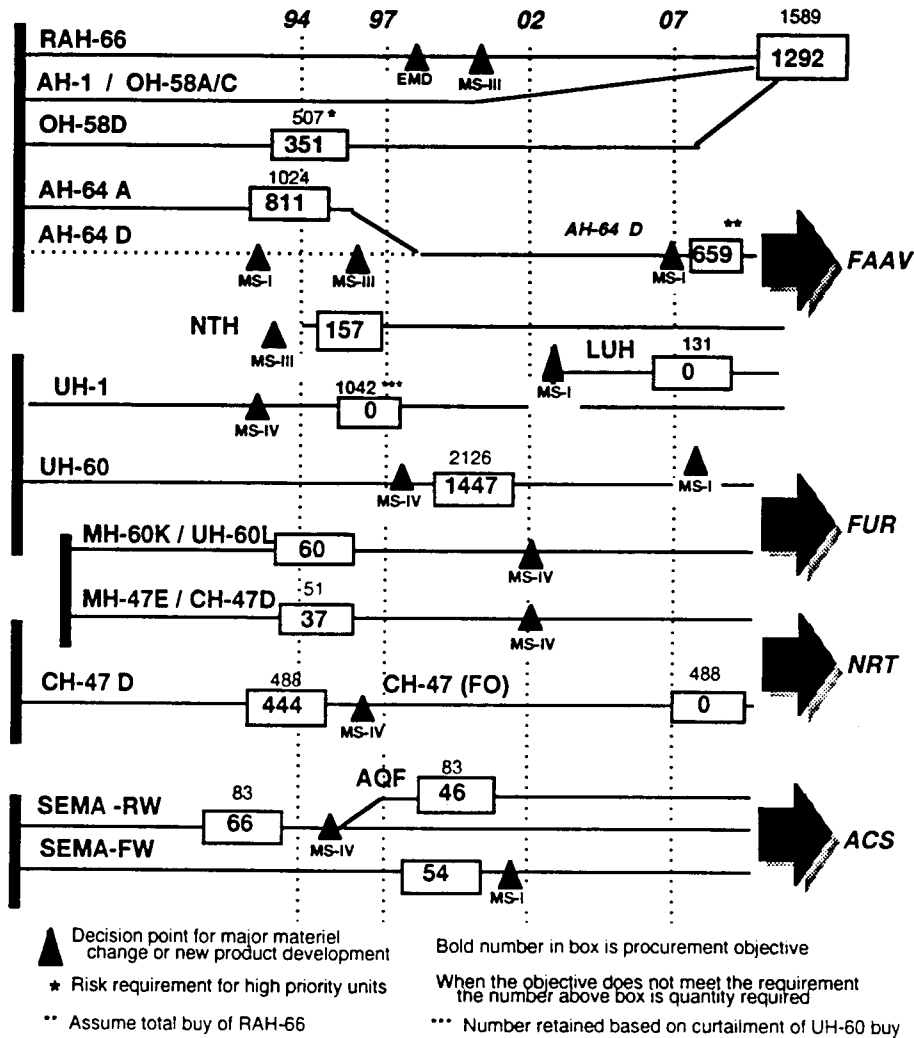

Figure 12-11

The impact of our modernization strategy and ARI are clear. The AH-1, OH-58A/C, and eventually the OH-58D are replaced by the RAH-66. The AH-64 requirement is reduced from 763 to 659 by FY 2010, as the RAH-66 displaces AH-64s serving as interim scouts in the attack battalions (AH-64 useful life, attrition, and sustainment needs (ORF, RCF, TDA) will more than account for this reduction by this timeframe). The UH-1 is displaced by the LUH (given funding), the New Training Helicopter (in the training role), and the UH-60 L/Q (in the General Support Aviation Battalion and MEDEVAC role). The requirement to SLEP/upgrade CH-47Ds at the turn of the century is unfunded.

Rotary Wing Acquisitions. The chart below reflects where we are going within fiscal responsibility (compared with Figure 12-4, Future Mission Requirements). The major difference is that we must maintain the UH-1 well into the 21st Century due to the curtailment of the UH-60 procurement.

As a result of force structure changes, the total number of airframes should decrease.

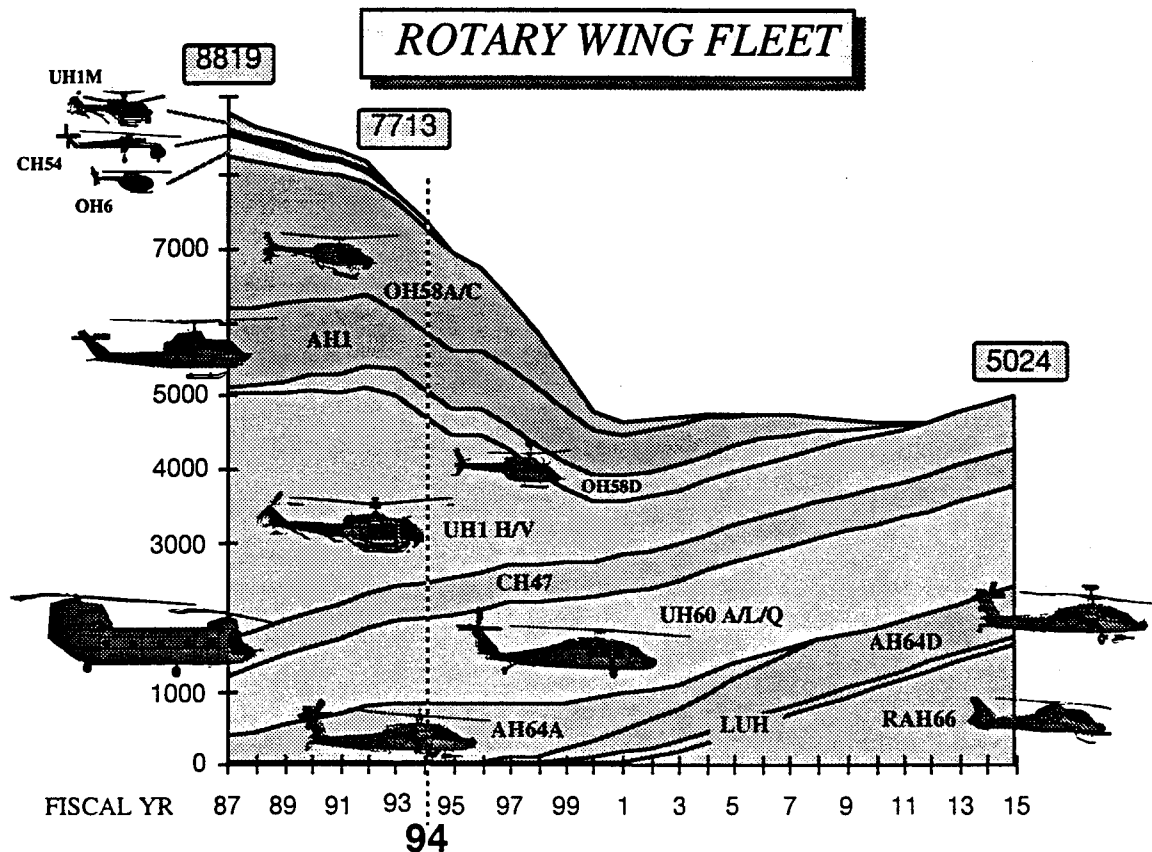

Figure 12-12

Aviation Science and Technology Program Overview. Each modernization program reflected in Annex L to the AMP has a planned major decision point at which time the system(s) receives one or more major upgrades, thus, infusing new technology and capabilities into the system through the materiel change process. The decision point may reflect the initiation of a new system development as a function of the changing threat, mission requirement, and/or retirement of an existing fleet due to age and obsolescence. The Aviation Science and Technology (S&T) strategy assures that appropriate supporting S&T programs and demonstrations are in place to support the AMP strategy.

Science and Technology (S&T) has historically provided the competitive advantage that allowed success on the battlefield. The Aviation Modernization Plan is strongly committed to maintaining technological superiority. Using the tenets of the Army Science and Technology Master Plan (ASTMP),

the Aviation Modernization Plan will incorporate high-leverage areas that have a comparative advantage and make the modernization plan strategically sound.

The Aviation S&T program includes advanced technology demonstrations (ATDS) for the key subsystem and component areas of the rotorcraft.

- **The Joint Turbine Advanced Gas Generator (JTAGG) II and III.** These are technology demonstrations (TD) in support of OSD Integrated High Performance Turbine Engine Technology (IHPTET) program will provide turbine engine benefits of a 40% reduction in specific fuel consumption and a 120% increase in power to weight.

- **The Rotorcraft Pilot's Associate (RPA).** This ATD will develop and demonstrate revolutionary improvements in combat helicopter mission effectiveness through the application of Artificial Intelligence (AI) for Cognitive Decision Aiding (CDA) and integration of advanced pilotage, target acquisition, armament and fire control, communications, controls and displays, navigation, sensors, survivability and flight control technologies. The RPA real-time cognitive decision and task aiding system will include route planning, data fusion of off-board and on-board intelligence and targeting sources, targeting and weapons manager, internal and external situation assessment, communication planner, and a cockpit information manager. The RPA ATD technology is targeted for the AH-64 Apache, Apache Longbow, RAH-66 Comanche, and Special Operations Aircraft.

- **The Multi-Sensor Aided Targeting-Air (MSAT-Air).** This ATD will demonstrate automatic target acquisition, recognition, tracking and hand-off in an operational environment. A prototype second generation FLIR and POP Longbow FCR will be integrated into a UH-60 testbed helicopter. Multi-sensor fusion provides a viable technical solution to robust ATR. Comanche will incorporate a FLIR/MMW multi-sensor suite. MSAT-Air is being coordinated with PEO Aviation and the Army Aviation Center to facilitate transition of the multi-sensor fusion capability to the Comanche development program and as a potential upgrade to Apache.

- **The Advanced Image Intensification ATD.** This will develop and demonstrate an advanced night vision goggle for night pilotage and driving, to significantly enhance operational effectiveness and reduce workload. AI2 will demonstrate night pilotage goggles with a 50% improvement in field of view for Army utility, cargo and current scout aircraft applications with resolutions as good as or better than 3rd generation goggles. AI2 will also demonstrate integrated flight symbology. The ATD will demonstrate and quantify, in an operational environment, the increase in user effectiveness and workload reduction associated with pilotage of current scout, utility, and cargo aircraft. The larger field of view and good resolution of AI2 also make it a candidate for night driving applications.

- **The Advanced Helicopter Pilotage Project.** This is intended to develop a robust, turreted dual-spectral, wide-field-of-view night pilotage sensor with the required helmet-mounted display, and will demonstrate its performance in flight evaluations. Army aviation is limited in its ability to fly NOE at night by the capability of our current pilotage sensors. A robust, wide field-of-view sensor with improved resolution and dual spectral capability (FLIR and image intensification) permits flight under a wider range of conditions than a current single-sensor pilotage sensors. Components developed under this project – thermal imaging detector/dewar, scanner, and image intensifier – are being provided to the Comanche effort, supporting Comanche risk reduction.

Technology demonstrations will be preliminary funded to support the National Transport Rotorcraft (NTR) program initiative. NTR will develop a national cargo/commuter concept and development strategy employing Integrated Process and Product Development (IPPD) techniques and methods. NTR TDs will address airframes, structures, rotors and transmissions. In FY95, the S&T program initiates and establishes the National Rotorcraft Center (NRC) to improve this nation's global competitive edge in rotorcraft and retain our military supremacy in this critical arena. The NRC will be the Executive Agent for government/industry partnership that combines government laboratories, academic

research and industry capabilities to expedite the development and incorporation of dual use rotorcraft technologies. The Army's Combined Arms Weapon System (TACAWS) rotorcraft/missile integration ATD for air-to-air and air-to-ground applications will demonstrate lightweight, multi-role, fire and forget missile capability.

In addition to the above, the longer term Aviation S&T efforts will support attack rotorcraft upgrades developing and integrating advanced pilotage and man-machine technologies in support of crew station and cockpit enhancements. Concepts will be developed for improved mission effectiveness and survivability through employment of nearly autonomous UAVs as part of a complimentary rotorcraft manned and unmanned team. Technology demonstrations will develop the optimum trade-off between UAV autonomy and pilot/operator control workload.

The Aviation Battle Lab Support Team (ABLST) has been involved with numerous Advanced Warfighting Demonstrations (AWD). ABLST has provided support and participated in every Battle Lab demonstration performed this past year. The ATACMS Live Fire Exercise in October 1992 by the D&SA Battle Lab evaluated aviation's concept for attack operations in a Joint Theater Missile Defense scenario while showing its ability to pass digitized information across the battlefield. The dismounted Battle Lab's Night Fighting Concept Exploration Program in November examined the compatibility of ground lasing systems with aviation sensors. The Mounted Battle Space Lab demonstrated the interoperability of the IVIS with ATHS with the goal of horizontally integrating the battlefield. Under the auspices of the D&SA Lab, aviation observed Operation Desert Capture and its intelligence gathering mission. Future demonstrations include Operation Optic Needle, IVIS/IDM hardware, JSTARS/IDM, Deep Battle CEP, and night fighting exercises.

Core Programs. Essential to the support and sustainment of the Army's major aircraft programs are our "core" programs. These programs provide required mission and support equipment, as well as upgrades or new technologies that ensure mission and operational supportability requirements are met. The core programs include Aviation Survivability Equipment (ASE), Aviation Electronics (avionics), Aviation Ground Support Equipment (AGSE), Aviation Life Support Equipment (ALSE). Changes to the core programs from the January 1993 Modernization Plan are discussed below.

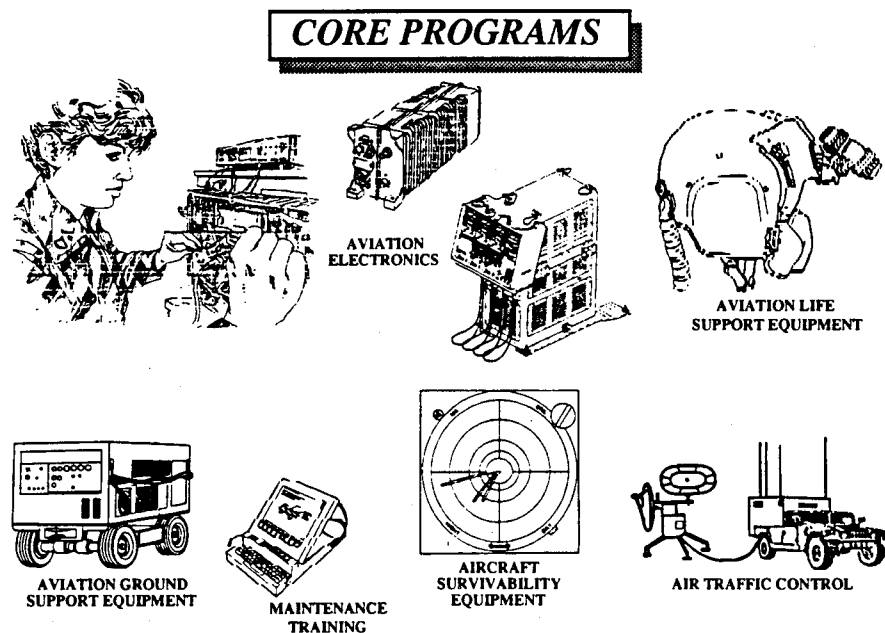

Figure 12-13

• **Aircraft Survivability Equipment (ASE).** The AN/APR-48 Radar Frequency Interferometer (RFI) will only be fielded to Longbow Apache aircraft due to funding shortfalls.

- **Aviation Electronics.** Mini-POM funding reductions have resulted in the termination of the Obstacle Avoidance System (OASYS) and the Flight Data Recorder (FDR) and the deferral of procurement for the Aviation Mission Planning Station until beyond FY00. In addition, avionics funding does not fully resource Force Package I or the requirement to "digitize the battlefield" within the combined arms team by the year 2000. The Aviation Electronics program has been restructured to initiate the development and acquisition of the minimum programs required to meet aviation's digitization of the battlefield requirements. This includes GPS, High Frequency Nap-of-the-Earth (HFNOE) communications, Have Quick II (HQII), Improved Data Modem (IDM), Army Aviation command and Control System (A2C2S), and Aviation Mission Planning System (AMPS). This effort will focus on the Force Package I and modernized aircraft.

- **Aviation Ground Support Equipment (AGSE).** Mini-POM funding reductions result in the deferred acquisition of Advanced Boresight Equipment (ABE), Standard Aircraft Towing System (SATS), Portable Engine Test System (PETS), and Aircraft Decontamination, Deicing and Cleaning System (ADDCS). In addition, the Unit Maintenance Aerial Recovery Kit (UMARK) and Battle Damage Assessment and Repair (BDAR) kits are delayed until FY99. The Flexible Engine Diagnostic System (FEDS) is unfunded.

- **Aviation Life Support Equipment (ALSE).** The Mini-Pom reduces RDTE on the Aircrew Integrated Ensemble (AIE), Aircrew Integrated Helmet System Pre-program Product Improvement (AIHS P3I), Laser Protection, and NBC Protection.

- **Air Traffic Services.** Mini-POM funding reductions will permit only limited acquisition of tactical ATC, including delayed and limited procurement of the Tactical Airspace Integration System (TAIS).. TAIS would have provided the A2C2 node of the Army Tactical Command and Control System (ATCCS), allowing for the tactical Air Traffic Service (ATS) component of the digital battlefield. Modernization/upgrade of fixed base facilities in preparation for the National Airspace System (NAS) integration will continue on a stretched basis.

Enabling Strategy Areas

O&S Cost Reductions. The Engine Component Improvement Program (CIP) benefits users of the T700, T55, T53 series turbine engines and the GTCP-36 series Auxiliary Power Unit. Future propulsion systems, such as the T800, will be included in the CIP as they are fielded. The CIP has been virtually cut in half by the Mini-POM, eliminating all support for the T53 and restricting the level of support for the T700, T55, and GTCP-36. Efforts to eliminate EMI/EMP deficiencies in the T700 and T55 engine component qualifications will be stretched out.

Retirements. The Aviation Restructure Initiative accelerates the retirement of OH-58A/C, UH-1, AH-1, and OH-6 aircraft. Approximately 2000 of these aircraft are retired in the POM as a result of ARI and force structure cuts.

Mini-POM Issues

Comanche is the Army's highest priority modernization program. Funding in the mini-POM for Comanche was insufficient to support planned Initial Operational Capability (IOC) date of January 2003. During the OSD Bottom-Up Review, the Comanche program was estimated to have a \$700M shortfall. This shortfall was addressed through a three step process. First, the Budget Estimate Submit (BES) provided \$99M. Secondly, OSD, through the Program Decision Memorandum process gave the program \$354M and thirdly, the program has been "streamlined" with OSD's help. This "streamlining" includes relief from select, excessive regulatory practices and provides for a fully funded program.

Funding for the initiation of the Advanced Cargo Aircraft or Improved Cargo Helicopter (ICH, CH-47 follow-on upgrade) program was eliminated. The CH-47D airframes will start exceeding 40 years of

age in 2002. Research and Development funding is needed for technology insertions required to extend the CH-47D fleet service life.

The mini-POM eliminated UH-60 procurement after completion of the multi-year buy in FY96, reducing the total acquisition by 124 aircraft. This decision will require continued use of the UH-1 and impede our strategy to reduce the aging aircraft inventory. The current mini-POM does not fund the MEDEVAC fleet (UH-60Q).

There is no RDT&E program to support either upgrades to existing training aids, devices, simulators, or simulations or to develop and procure new training systems which capitalize on the latest advances in image generation, pre-mission rehearsal capabilities, and hardware/firmware advances. Funding for our simulation strategy is centered on the Advanced Rotary Wing Aircraft (ARWA) program. This unfunded program is critical to offset the training, safety, and readiness issues associated with the continued decrease in OPTEMPO flying hours and to support increasing distributed interactive simulation requirements.

SUMMARY

The intent of the Aviation RDA strategy is sound. The RAH-66 Comanche remains one of the Army's highest priorities. The AH-64C/D continues to receive Army and Congressional support. The UH-60L is a proven performer. The CH-47D program is nearly complete and is ready to enter the next stage to sustain it into the next century. The OH-58D Kiowa Warrior capability provides major contributions to early entry and light forces survivability and lethality during the transition to the RAH-66. The SOA and IEW portions of the program are funded in their respective segments of the total budget and POM. The termination of the UH-60L buy at the end of FY96 will require the Army to fly the obsolete UH-1 for the foreseeable future. No RDA dollars are available to upgrade these UH-1s. Lack of funding in the "core" programs has resulted in severely impacting several programs including Have Quick II, IDM, Obstacle Avoidance System, Voice Altitude Warning System and Flight Data Recorder. The loss of these programs and their integration in the fight will degrade Aviation's capability.

SECTION 5

TRAINING

INTRODUCTION

To properly synchronize forces in joint and combined operations requires considerable training. The changing threat, fiscal constraints, and force reductions require more effective management and use of our resources. We continue to emphasize three central themes to guide the development of our training.

- **Standardization** of procedures where it makes sense. Establishment of tasks, conditions, and standards for proficiency throughout Aviation training programs.
- **Decentralization** of training execution to the appropriate level of the Aviation force.
- **Sustainment** of individual and collective skills by developing and distributing necessary and useful training support.

The training and leader development strategy for Army Aviation is depicted below.

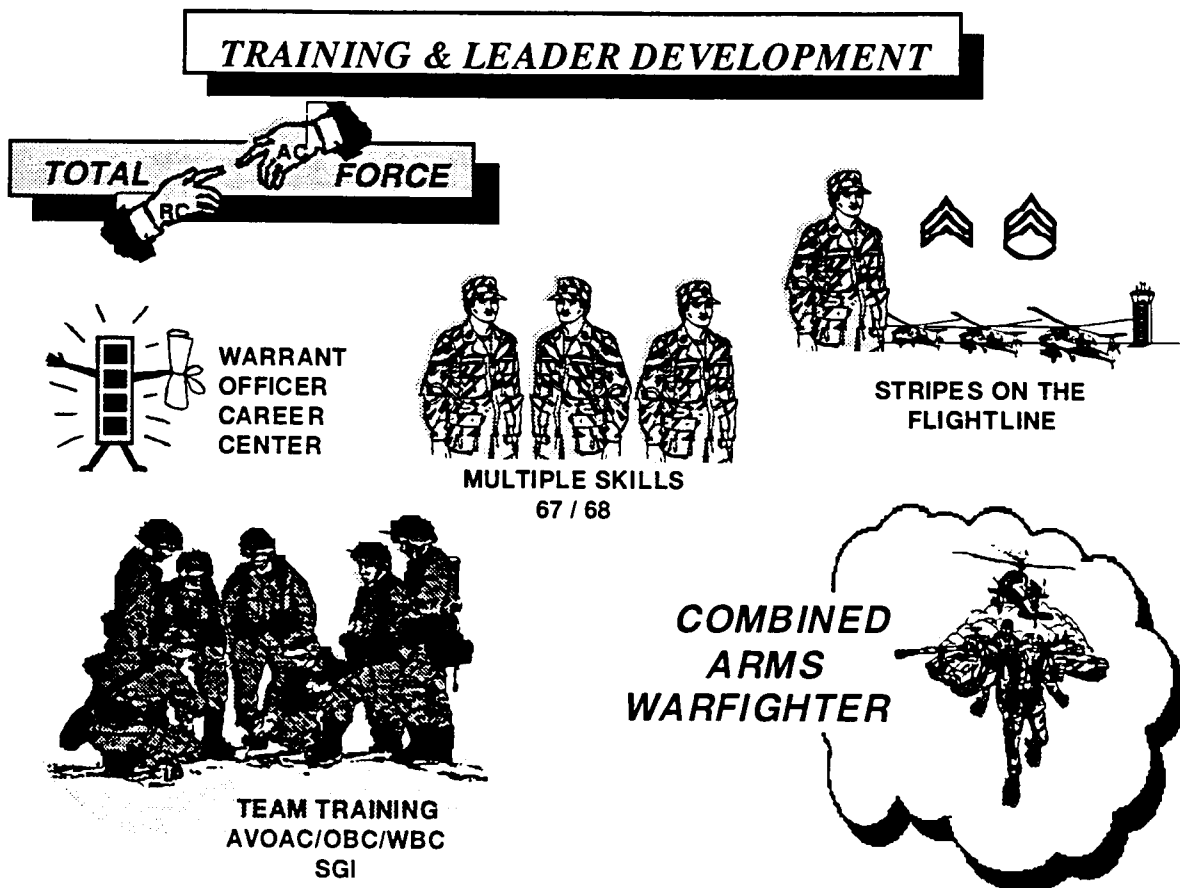

Figure 12-14

This strategy continues to emphasize individual, crew, and collective training, and includes initiatives to enhance combat effectiveness despite declining resources. Both Active and Reserve Component training bases provide vital support to our training and leader development strategy. Institutional initiatives include:

- Reconfiguring Initial Entry Rotary Wing (IERW) to a dual-track system consisting of a UH-1 common core followed by either a UH-1 or OH-58A/C tactical track.
- Procurement of a more cost effective training helicopter. The first of a planned buy of 157 TH-67 Creek was delivered in the first quarter of FY94.
- The assignment of highly skilled, noncommissioned officers to conduct maintenance at the unit level.
- Pre-command training for battalion and brigade commanders.
- Establishment of the Warrant Officer Career Center.
- Consolidation of Military Occupational Specialties to provide multi-skilled soldiers in support of our high technology systems.

Simulators and Simulations. As aircraft and weapons become more complex and sophisticated, their operating costs are certain to increase. The lack of adequate training areas, limited firing ranges, limited eyesafe laser ranges, and reduced flying hour programs will also restrict training. To compensate individual, crew, and unit training must increasingly focus on simulation. Army Aviation's simulator and simulation strategy is based on current and planned aviation systems, tactics, and doctrine to field the necessary training aids, devices, simulations, and simulators to support operational units and the institution.

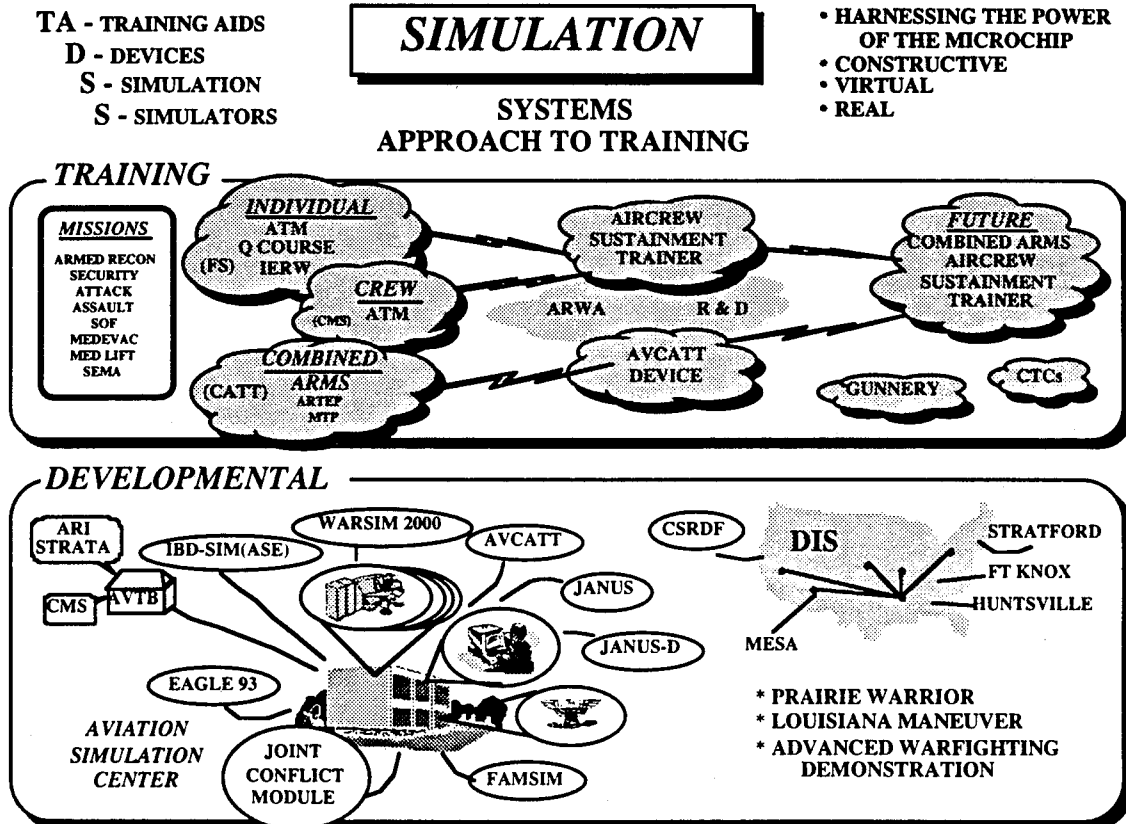

Figure 12-15

- **Individual and Crew Training Simulation.** Individual training will be provided through Computer-Based Instructional systems which include authoring stations for software development and rapidly reconfigurable part-task trainers for system switchology training. Crew training will be provided by flight simulators, combat mission simulators, embedded training devices, and area weapons scoring systems. Crew training simulators will be fixed-base/full-motion at the institution and non-motion/mobile in the units. In addition, composite maintenance trainers are being incorporated to facilitate trouble shooting and enhanced rapid repair and return to service.

- **Collective Training Simulation.** The Aviation Combined Arms Tactical Trainer (AVCATT) is the aviation component of the CATT family of collective training simulators. Army aviators will experience task loading and achieve unit cohesiveness by fighting collectively in the AVCATT. The use of embedded training devices, the Aircraft Survivability Equipment Trainer (ASET) IV system, Multiple Integrated Laser Engagement System/Air Ground Engagement System (MILES/AGES) II, and the Tactical Engagement Simulation System (TESS) at Combat Training Centers will further enhance the collective training capability of our units.

- **Leader Development.** New leadership development initiatives include the Aircraft Survivability Equipment (ASE)/Electronic Warfare Officer Course (EWOC), Aviation Test Bed Training, and Janus/Brigade and Battalion Simulation Integration Planning. The ASE/EWOC course will provide aviation commanders with the necessary expertise to minimize risk and accomplish the unit's mission in a hostile air defense environment. The Aviation Test Bed Training and Janus/Brigade and Battalion Simulation Integration Planning will be used for command and control leader training and provide important stepping stones to field training exercises and combat training center exercises.

Science and Technology Initiatives. Technology has historically provided the competitive advantage that allowed success on the battlefield. The Aviation Modernization Plan is strongly committed to maintaining technological superiority. Using the tenets of the Science and Technology Master Plan, the Aviation Modernization Plan will incorporate high-leverage areas that have a comparative advantage and make the modernization plan strategically sound.

The near term aviation-related Advanced Technology Demonstrations (ATD) are Rotorcraft Pilot's Associate, Radar Deception and Jamming, and Multi-Sensor Aided Targeting. Rotorcraft Pilot's Associate ATD program objective (FY93-97) is to establish revolutionary improvements in combat helicopter mission effectiveness through the application of artificial intelligence for cognitive decision aiding and integration of advanced pilotage, target acquisition, armament and live fire control communications, cockpit controls and displays, navigation, survivability and flight control technologies. The Multi-Sensor Aided Targeting ATD will demonstrate fusion of multiple sensor and processor modules with advanced algorithms in an automated target acquisition suite. The Radar Deceptions and Jamming ATD will demonstrate enhanced aircraft survivability and lethality through the integration of avionics and advanced Aircraft Survivability Equipment (ASE) sensors. Fusion of avionics and ASE sensor data will provide a consolidated sensor report to a knowledge-based expert system for situation assessment and response planning.

The Aviation Battle Lab Support Team (ABLST) has been involved with numerous Advanced Warfighting Demonstrations (AWD). ABLST has provided support and participated in every Battle Lab Demonstration performed this past year. The ATACMS Live Fire Exercise in October 1992 by the D&SA Battle Lab evaluated Aviation's concept for attack operations in a Joint Theater Missile Defense scenario while showing its ability to pass digitized information across the battlefield. The dismounted Battle Lab's Night Fighting Concept Exploration Program in November examined the compatibility of ground lasing systems with aviation sensors. In December, the Mounted Battle Space Lab demonstrated the interoperability of the IVIS with ATHS with the goal of horizontally integrating the battlefield. Under the auspices of the D&SA Lab, aviation observed Operation Desert Capture and its intelligence gathering mission. Future demonstrations include Zen Regard, Operation Optic Needle, IVIS/IDM hardware, JSTARS/IDM, Deep Battle CEP, and night fighting exercises.

Improvements must be made in modeling during simulations with regard to Aviation, in particular its armed reconnaissance role.

Future Battlefield Distributed Simulation-Developmental (BDS-D). Army aviation simulation development programs must be integrated into BDS-D to ensure that the benefits of distributed interactive simulation complement warfighting. Advanced concepts, tactics, techniques, and procedures can be developed using man-in-the-loop simulation and networking to other simulation facilities.

Advanced Rotary Wing Aircraft (ARWA). This technology base program upgrades the capability of the Aviation Test Bed. The resultant products may be inserted in to the Family of Aircrew Sustainment Trainers (FAST) and the AVCATT. The ARWA program will upgrade test bed capabilities to replicate mission equipment packages of modern aircraft in a realistic electronic battlefield environment. ARWA goals include the development of aviation devices capable of conducting large portions of Force Development Test and Experimentation (FDT&E).

Simulation 2000. By the year 2000, the Army will construct and demonstrate a robust variety of synthetic environments to significantly improve simulation at all levels. Included will be the networking of manned virtual simulators, live simulation at combat training centers, and constructive models like Warfighters' Simulation 2000 (WARSIM 2000). These efforts will fully network the corps level simulated battlefield.

CONCLUSION

Advances in technology, networking, and software will increase effective joint/combined arms training with simulation/simulators. The training strategy leverages the technologies and enhancements described below to offset the drawdown in training resources.

SECTION 6

CONCLUSION

The Army's evolving military strategy shifts emphasis from forward stationing to a **Power Projection Army**. Aviation's modernization strategy supports this shift in focus through evolving doctrine, the **Aviation Restructure Initiative**, and aircraft **modernization programs**. Our investment strategy is a balanced one, featuring improvements in both warfighting systems and training. Warfighting improvements entail sustaining existing capabilities, technology infusion, or the retirement of old systems and new system procurement. The training strategy leverages the power of the computer to improve combat readiness in an environment of scarce resources.

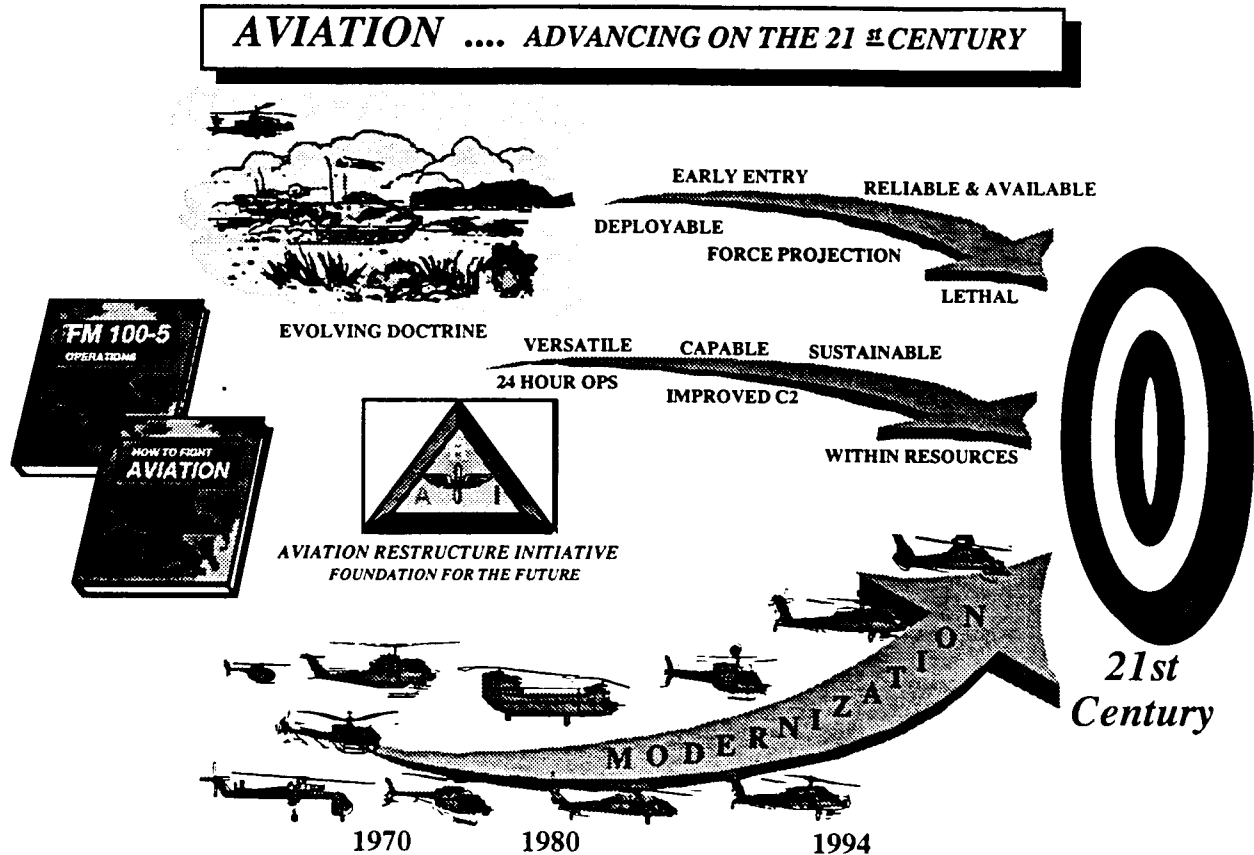

Figure 12-16

Aviation is a central force in the combined arms team. Air maneuver and air movement have become essential for successful combat operations, making aviation uniquely suited to meeting the challenges of the 21st Century.

CHAPTER 13

NUCLEAR, BIOLOGICAL AND CHEMICAL

SECTION I

INTRODUCTION

This chapter updates Annex M of the 1993 Army Modernization Plan. The roles, missions, and capabilities of the Army's NBC defense battle staff and its chemical forces (NBC recon, smoke, decontamination) have not changed. The Army expects to activate a Biological Detection Company in 1996 to provide a first-time ever capability to protect deployed units from biological weapons attack. There have been changes in force composition and modernization as the Army experiences a continued draw down of structure and funding. There are instances where fielding schedules and research and development for some systems or modification programs have been drawn out over an expanded time frame. Indeed, some efforts have had to be placed in the unfunded requirements arena or canceled altogether. This chapter will attempt to capture this dynamic period of change and present an azimuth for the future. The original Annex M, which this update addresses, remains valid where changes are not indicated. The chart below summarizes the linkage of NBC systems with the Army Modernization objectives and support to the nation.

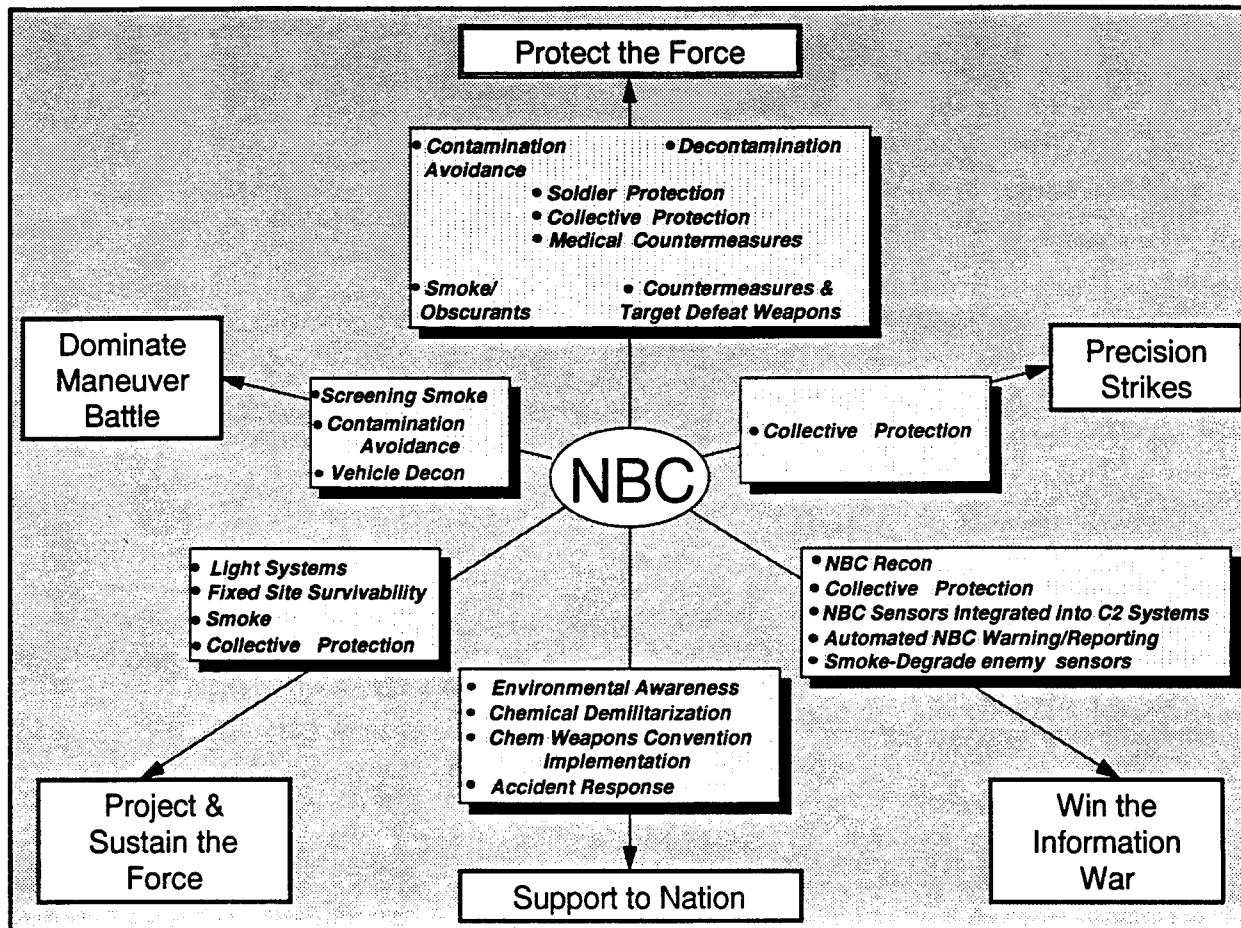

Threat. The threat of "weapons of mass destruction" use has grown dramatically over the past two decades. The potential for use of NBC weapons in regional conflicts is high. Nuclear and biological weapons are becoming more widespread in today's world. Five nations have declared nuclear weapons arsenals and many other nations have active nuclear weapon development programs. Some experts believe that North Korea may already have a nuclear capability. Since 1969, the "chemical weapons club" has expanded from six to twenty plus nations. A number of *threat* nations acquired sophisticated chemical weapons arsenals and refused to sign the multinational Chemical Weapons Convention (CWC) treaty this year. Modern industrial processes create many products that are in themselves very lethal and can be used as weapons. Several countries have active biological weapons programs, in spite of the Biological Weapons Convention of 1972. Biological agents, including toxins, are extremely potent and provide the widest area coverage of any weapon system. The biological weapons threat has the capability to exceed nuclear weapons in its potential breadth, lethality, and uncontrollability. The 1993 DoD Bottom-up Review lists as the first of the four dangers to U.S. interests, "the proliferation of nuclear, biological and chemical weapons, as well as those associated with the large stocks of these weapons that remain in the former Soviet Union."

Our National Military Strategy demands that we have a decisive force with technological superiority to both reduce risk and swiftly and decisively terminate conflicts with minimum loss of life. The NBC modernization plan provides a key element in achieving this superiority through survivability enhancements which mitigate the effects of NBC Weapons of Mass Destruction (WMD) on soldiers and units. A DoD task force on counter proliferation of WMD identified NBC Defense as a critical component of the national counter proliferation effort.

This plan supports our joint warfighting doctrine as well. Joint Pub 3.0, Doctrine for Joint Operations (Sep 93), notes that the principle of war entitled "Security" results from the "measures taken by commanders to protect their forces." It further states that protection of the force is a key concern of a combatant Joint Force Commander (JFC) and that the JFC must protect the force from "enemy maneuver and firepower, including the effects of mass destruction weapons."

The need for a viable NBC defense program remains essential to our nation. It is an essential element of our National Military Strategy, our joint operations doctrine and the Army's **Protect the Force** modernization objective.

"I believe that one of our greatest challenges as a nation...will be to prevent the proliferation of weapons of mass destruction and the building of massive armaments in the hands of people who are prepared to use them—not just nuclear, but biological and chemical..."

PRESIDENT BILL CLINTON
November 19, 1992

SECTION 2

WARFIGHTING CONCEPT

"The one (threat) that scares me to death - perhaps even more so than attack of nuclear weapons and the one we have less capability against - is biological weapons."

**GEN COLIN POWELL
30 March 1993**

The NBC mission area warfighting concept remains unchanged since the publication of the AMP. It consists of three major elements: NBC defense, smoke/obscurants, and target defeat (TD) weapons (which includes flame, incendiary and anti-materiel concepts).

- **NBC defense** is based upon the fundamentals of **contamination avoidance, protection, and decontamination**. These form a functional hierarchy which protect the force, sustain combat power, and minimize NBC-related casualties -- all of which are essential to gain/maintain **Land Force Dominance**. Contamination avoidance is the cornerstone of NBC defense. Our units attempt to avoid contamination, if at all possible, thereby avoiding NBC casualties, performance degradation, and decontamination requirements. If units cannot avoid contamination, they must take protective action - use individual and collective protection equipment. If individuals or units become contaminated, they must decontaminate both themselves and their equipment to prevent the spread of contamination and gain relief from the operational, physiological, and psychological degradation of protective systems.

- **Smoke/obscurants** increase the effectiveness of our Army's weapons systems while at the same time degrade an adversary's. Advanced obscurants counter threat reconnaissance, intelligence, surveillance, and target acquisition (RISTA), top attack smart munitions, and directed energy weapons systems (DEWS). Smoke/obscurants provide instantaneous vehicle survivability enhancement capabilities, support our deception operations and conceal both forces and fixed sites.

- **Target Defeat** (formerly titled "Flame/Incendiary & Non-Lethal" -- or "FINL") weapons offer a multi-pronged, innovative approach to meet warfighting challenges. Flame/Incendiary weapons give individual soldiers greater capabilities to defeat hardened targets, such as "bunkers." These weapons are especially effective in military urban operations. Temporary disabling technology systems degrade and defeat enemy vehicles and logistic supplies both in close terrain and deep in enemy territory. Non-lethal anti-materiel weapons provide mission kill capabilities against armored vehicles/equipment without causing injury and minimizing lethal "weapons" in operations other than war, such as for crowd control. Funding constraints have resulted in unfunding Riot Control Agents and reducing anti-materiel weapons to a "tech watch."

MODERNIZATION STRATEGY. The NBC modernization strategy remains focused on lightweight, readily deployable, easily maintained NBC defense equipment. Program revisions and current funding restraints have caused changes in our modernization strategy as discussed below. Changes on the accompanying charts are asterisked and italicized.

- **Contamination Avoidance.** The FY94 President's Budget provides additional funding for the DoD Biological Defense Program to accelerate the development and fielding of the following: a

NUCLEAR, BIOLOGICAL AND CHEMICAL

non-developmental point biological agent detector system in the mid-term, an improved (P3I) system and an Army standard system in the far-term; a non-developmental long-range standoff sensor in the mid term; and Army standard short and long-range standoff sensors in the far term. Program restructuring and funding constraints cause the unit level nerve/blister agent detector/alarm to slip from the near to mid term and the real-time automatic warning/reporting of nuclear/chemical contamination to slip from the mid to far term.

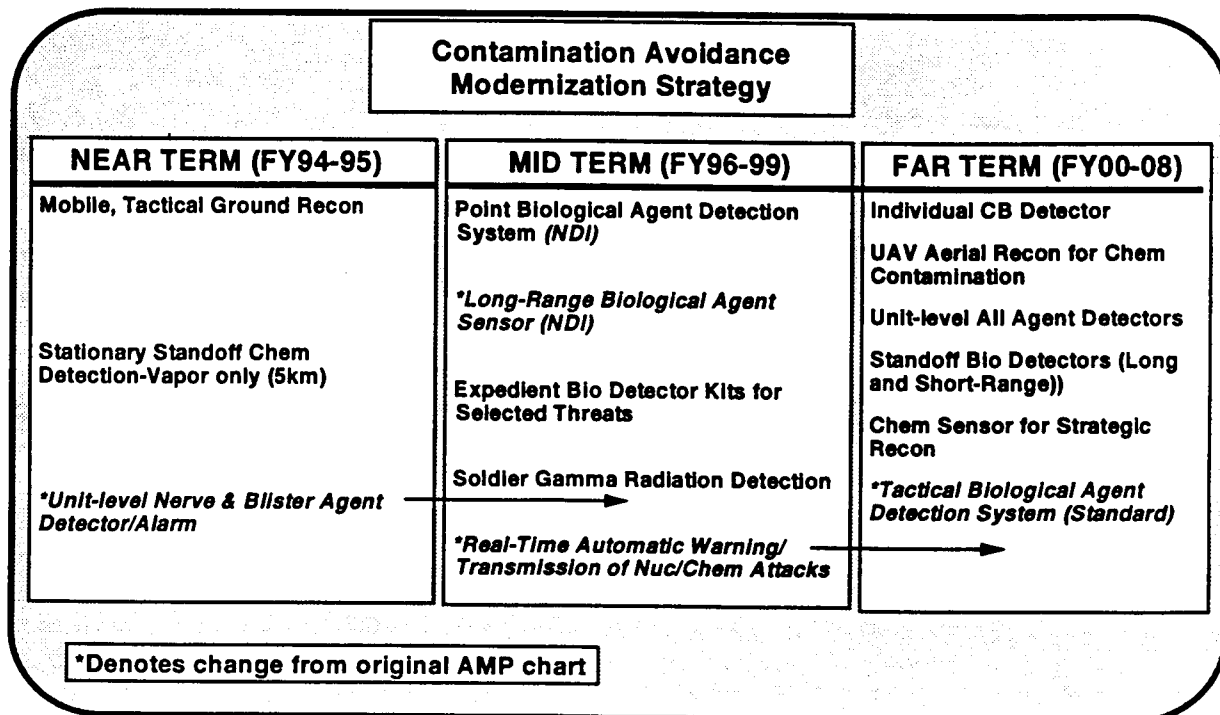

Figure 13-1

• **Protection.** The Protection modernization strategy remains unchanged as outlined in Figure 13-2 below.

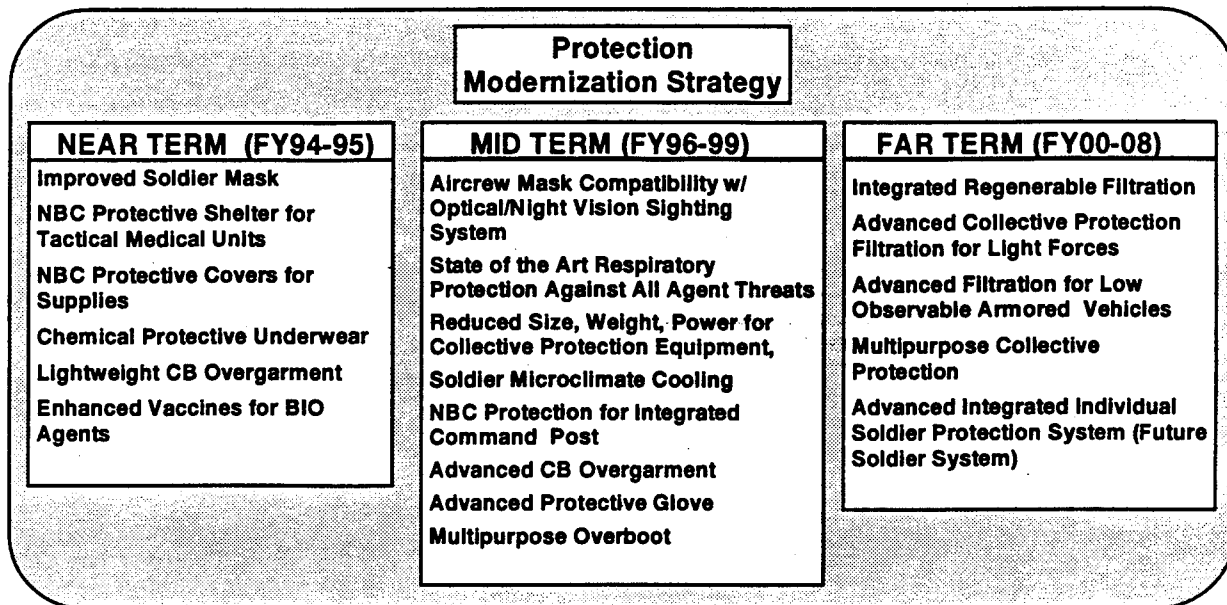

Figure 13-2

• **Decontamination.** Technical challenges in developing environmentally and operationally acceptable decontaminants and solvents cause the effective non-corrosive decontaminant and the decon system for electronics/avionics to slip beyond the far term.

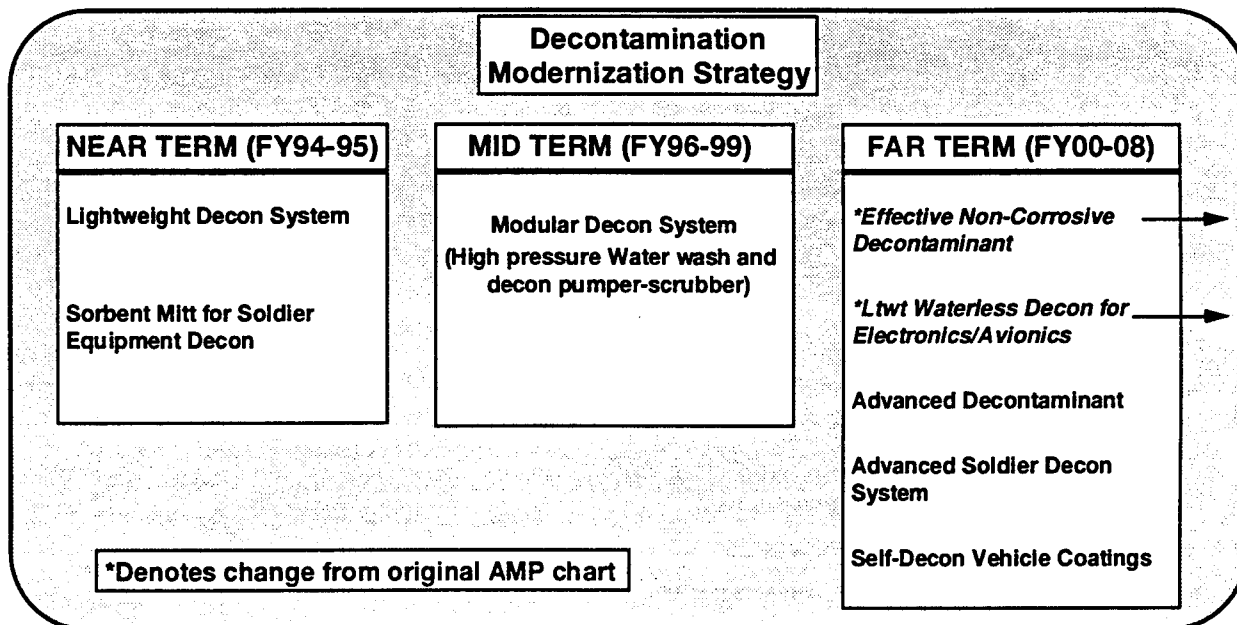

Figure 13-3

• **Smoke/Obscurants.** Funding constraints have caused delays in development of projected multi-spectral smoke capabilities beyond the far term and the light vehicle self-protection capability from the mid to far term.

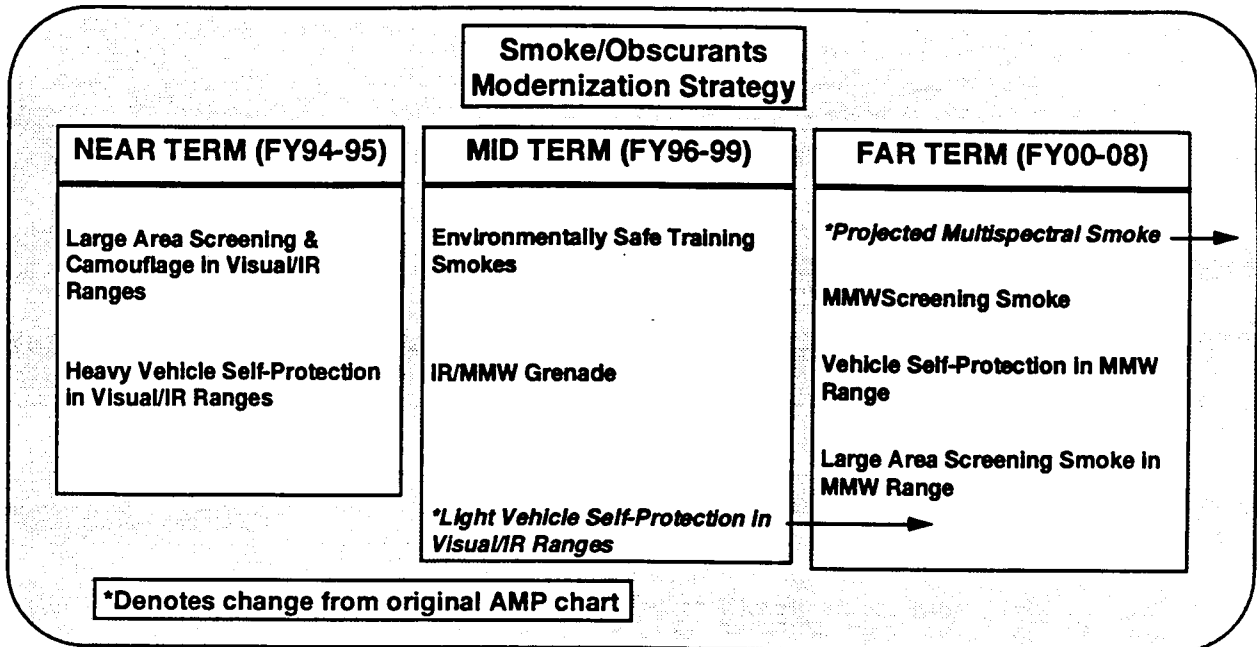

Figure 13-4

• **Target Defeat Weapons.** Funding cuts have caused improved shoulder-fired flame weapon and riot control delivery systems to slip from the mid to far term, as shown in Figure 13-5.

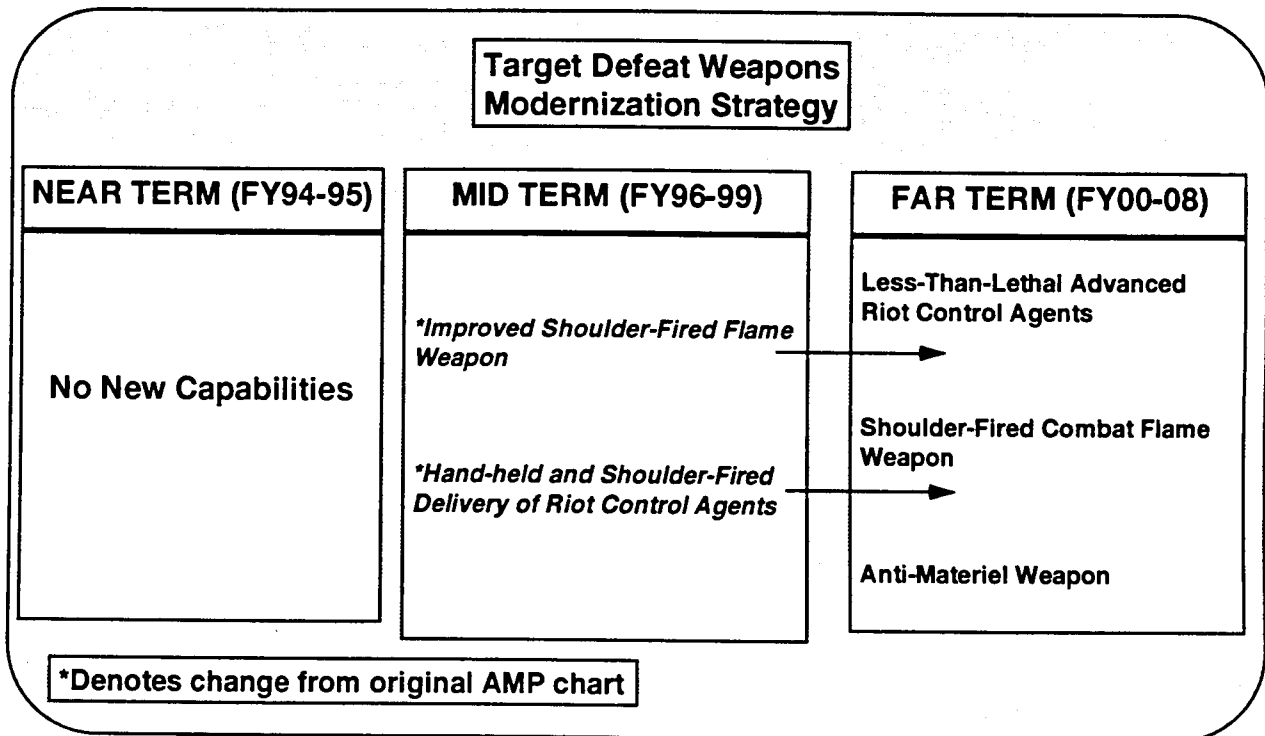

Figure 13-5

• **Smoke/Obscurants.** Funding cuts for both mechanized and projected multi-spectral smoke cause a downgrade in this area from **GREEN** to **AMBER** in the far term. See Figure 13-7 for a summary.

DEFICIENCIES	NEAR TERM (FY94-95)	MID TERM (FY96-99)	FAR TERM (FY00-08)
<ul style="list-style-type: none"> - Limited capability to screen infrared (IR) sensors - No millimeter wave region screening capability - No light vehicle self-screening smoke system - No multi-spectral smoke munitions - Limited projected smoke capability - No large area multi-spectral smoke system - Limited hvy vehicle self-protection smoke system 	AMBER	AMBER	AMBER* ↓
* Denotes Changes			

Figure 13-7

• **Target Defeat (TD) Weapons.** There is **no change** in the assessment of this area. TD continues in the **RED** category due to a lack of anti-material weapons and inadequate flame munitions. Figure 13-8 shows a summary assessment for this area.

DEFICIENCIES	NEAR TERM (FY94-95)	MID TERM (FY96-99)	FAR TERM (FY00-08)
<ul style="list-style-type: none"> - Limited flame/incendiary delivery capability - No Non-lethal weapon system 	RED	RED	RED

Figure 13-8

SUMMARY

Funding reductions will have little impact on the mission area through the mid-term. However, with the exception of protection, the assessment for the far term shows a negative trend which can only be corrected with increased funding in the mid-term, especially for the area of contamination avoidance.

SECTION 4

RESEARCH, DEVELOPMENT AND ACQUISITION (RDA) STRATEGY

The overall NBC RDA strategy remains unchanged. However, program revisions due to funding constraints have resulted in a number of changes within the components of our strategy. Those changes are discussed below and highlighted with italics and asterisks on the accompanying charts.

Paramount to NBC materiel modernization is a strong science and technology investment. The Army Science and Technology Master Plan (ASTMP) is the Army's strategic plan for science and technology. This SecArmy/CSA approved, resource-constrained plan is based on the Army leadership's vision of the future Army. The ASTMP serves as top-down guidance from Headquarters, Department of the Army, to all Army science and technology organizations.

The goal in NBC defense science and technology is to maximize the use of scarce resources by pursuing new technologies that enhance current warfighting capabilities, reduce/eliminate battlefield deficiencies and are shown to be cost effective. Resources are being prioritized for technologies in biological agent defense, stand-off detection and modeling and simulation of NBC environments and systems. Efforts in flame/incendiary and non-lethal technologies have been significantly reduced and refocused to provide far term, leap-ahead capabilities.

RESEARCH, DEVELOPMENT, TESTING AND EVALUATION (RDT&E)

- **Advanced Technology Demonstration (ATD).** The NBC defense science and technology strategy is planning for one formal ATD for biodetection in FY 96-99. This ATD will highlight advanced biological detection and contamination avoidance capabilities for unit detection/warning and reconnaissance applications. Unit detection and warning capabilities will be enhanced by the addition of a generic module for detection and identification of biological threat agents. Reconnaissance capabilities will be demonstrated for a stand-off biolaser detector. The Flame/Incendiary device ATD has been deleted due to a funding shortfall.

In addition to the technology demonstrations and the proposed ATDs, there are currently four science and technology objectives (STOs) in the FY 94 ASTMP for the NBC defense program. A STO states a specific, measurable, major technology advancement to be achieved by a specific year. The STOs are CB filtration, advanced respiratory protection, biodetection, and antibody development.

- **Demonstration Validation (Dem Val).** A number of programs have been ~~deleted~~. Others have been added to update the program. Rationale for changes are shown in the following table. Figure 13-9 provides an overview of the Dem Val strategy.

Dem Val Strategy Changes

System	Remarks
RESPO 21	Change--transition direct from 6.3A to 6.4
Advanced Integrated Collective Protection (AICPS)	Add
Individual Soldier Detector	Add
Bio Detector	Add
Long-Range Standoff (S/O) Bio Detector	Add
Short-Range Standoff (S/O) Bio Detector	Add
Projected Directed Energy Neutralization System (PDENS)	Add
Electro-Optical Smoke	Add
Catalytic Sorbent	Add

Advanced Modular Decon	Add
Chemical Standoff Laser	Delete—Funding cut
Self-strip Coating	Delete—Funding cut
Large Area Mech Projected Smoke	Delete—Funding cut

• **Engineering, Manufacturing and Design (EMD):** There have been a number of changes in this area as shown in the following table and Figure 13-9.

EMD Strategy Changes

System	Remarks
Short Range Bio Standoff Detector	Add
Long-Range Bio Standoff Detector	Add
XM45 Aircrew Protective Mask	Delete: program transitions from 6.3b to Production
Chemical Standoff Laser	Delete—funding cut
Multipurpose Decontaminant	Delete—return to tech base
Multipurpose Integrated Chem Agent Det (MICAD)	Delete-funding cut; program buy back pending
Self-Strip Coating	Delete—funding cut
Large Area Mechanized Projected Smoke System	Delete—funding cut

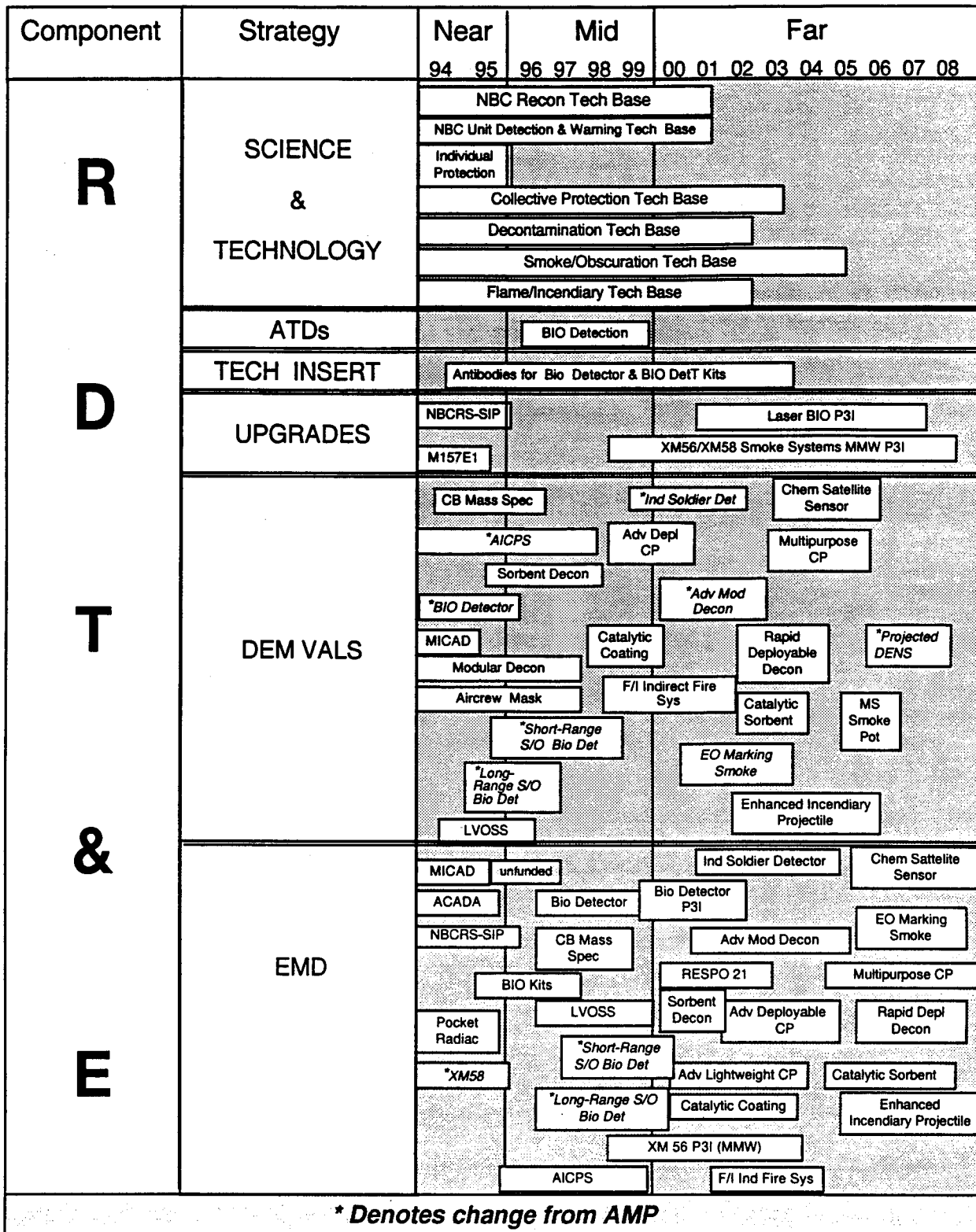

Figure 13-9

PROCUREMENT

As a result of increased funding for the Biological Defense Program, production and NDI efforts are added for biological detection systems. A change in user requirements for mechanized smoke is shown with the addition of the XM58 smoke system, a mechanized version of the XM56 multi-spectral smoke system. System deletions due to program terminations and funding cuts include: Chemical Agent Detector Network (CADNET), Multipurpose Integrated Detector/Alarm (MICAD), Chemical Laser Standoff Detector, Advanced Airborne Radiac System (AARS). The NBCRS SIP is at risk due to funding cuts in R&D. The following tables and Figure 13-10 summarize these and other changes.

NDI Strategy Changes

System	Remarks
Long-Range Bio Standoff Detector	Add--funded by OSD
Biological Integrated Detection System (BIDS)	Add--funded by OSD

Production Strategy Changes

System	Remarks
Long-Range Bio Standoff Detector	Add--funded by OSD
Short-Range Bio Standoff Detector	Add--funded by OSD
BIDS (P3I & Army Standard))	Add--funded by OSD
Biological Detector	Restructure: BIDS component; delete chem module
XM58 Mechanized Smoke	Add-spin-off from XM56 Smoke Generator program
Chem Agent Detector Network (CADNET)	Delete-program terminated
Advanced Airborne Radiac System (AARS)	Delete--funding cut
XM1101 Large Area Mech Projected Smoke	Delete--funding cut
Multipurpose Decontaminant	Delete--return to tech base
M157 Smoke Generator	Delete--funding cut; program buy-back pending
Advance Airborne Radiac System	Delete--funding cut
Improved Chemical Agent Monitor	Reduced buy

Component	Strategy	Near	Mid	Far							
		94 95	96 97 98 99	00 01 02 03 04 05 06 07 08							
R	SCIENCE & TECHNOLOGY Selected products listed as examples only and do not reflect actual dates of execution	Recon Tech Base									
		CB Mass Spectrometer			LWT Standoff Chem Sensor				Chem Satellite Sensor		
		Unit Detection & Warning Tech Base									
		Individual Soldier Detector			Rapid Bio Detector				Adv Bio Laser Standoff Detector		
		Collective Protection (CP) Tech Base									
		Multipurpose CP System			Advanced LWT CP System						
		Individual Protection Tech Base									
		RESPO 21									
		Decontamination Tech Base									
		Sorbent Decon			Catalytic Decon				Rapid Deployable Decon		
Smoke/Obscurant Tech Base											
Multispectral Smoke			Smart Wpns Defeat Smoke		Adv Radar Countermeasures			Combat ID Smoke			
Flame/Incendiary Tech Base											
Flame/Incendiary Warhead											
D	ATDs (Proposed)	BIO Detection			*Adv CB Decon			*MS Wpn Defeat			
					*NBC Oracle						
	TECH INSERT	Antibodies for Bio Detector & BIO Det Kits									
T	UPGRADES	NBCRS-SIP			Laser BIO P3I						
		M157E1			XM56/XM58 Smoke Systems MMW P3I						
&	DEM VALS	CB Mass Spec		*Ind Soldier Det			Chem Satellite Sensor				
		*AICPS			Adv Depl CP		Multipurpose CP				
		Sorbent Decon			*Adv Mod Decon						
		*BIO Detector									
		MICAD		Catalytic Coating			Rapid Deployable Decon		*Projected DENS		
		Modular Decon			F/I Indirect Fire Sys			Catalytic Sorbent		MS Smoke Pot	
		Aircrew Mask			*Short-Range S/O Bio Det			EO Marking Smoke			
		*Long-Range S/O Bio Det			Enhanced Incendiary Projectile						
		LVOSS									
		E	EMD	MICAD unfunded		Ind Soldier Detector			Chem Satellite Sensor		
ACADA				Bio Detector		Bio Detector P3I		EO Marking Smoke			
NBCRS-SIP				CB Mass Spec		Adv Mod Decon					
BIO Kits				RESPO 21		Multipurpose CP					
Pocket Radiac				LVOSS		Sorbent Decon		Adv Deployable CP		Rapid Depl Decon	
*XM58				*Short-Range S/O Bio Det		Adv Lightweight CP			Catalytic Sorbent		
				*Long-Range S/O Bio Det		Catalytic Coating			Enhanced Incendiary Projectile		
				XM 56 P3I (MMW)							
AICPS				F/I Ind Fire Sys							
* Denotes change from AMP											

Figure 13-10

THE DIGITIZED BATTLEFIELD

The digitized battlefield offers unique opportunities to provide tactical commanders real-time NBC attack/hazard information. Our modernization strategy envisions NBC sensors linked to digital communications systems and NBC hazard analysis software to provide a real-time, automatic NBC warning and reporting system from platoon through division. NBC systems which contribute to this vision are the following:

- **Nuclear, Biological and Chemical Reconnaissance System-System Improvement Program (NBCRS - SIP).** Sensor, communications and automation upgrades, along with the Global Positioning System (GPS) installation, will allow NBC recon elements to transmit critical NBC reconnaissance information in real-time to battlefield commanders, thus improving our ability to more closely synchronize maneuver with contamination avoidance.

- **Multipurpose Integrated Chemical Agent Detector (MICAD) Network.** MICAD offers the capability to integrate platoon level chemical and radiological sensors with the tactical command and control communications system to provide automatic NBC attack and hazard information in real-time. This will greatly improve the sharing of NBC information among commanders and staffs, enhancing the ability to synchronize the battle under NBC conditions.

- **Chemical Standoff Detector.** A lightweight chemical sensor, capable of identifying agent clouds 3-5 kilometers away, and mounted in a Remotely Piloted Vehicle with digital transmission equipment, provides another capability to the commander to extend his view of the NBC battlefield. This complements the ground-based NBCRS and greatly improves our ability to avoid NBC contamination and limits the operational degradation inherent under NBC battlefield conditions.

- **The Automated Nuclear, Biological, and Chemical information System (ANBACIS).** A system currently under development by PM, Operations Technical Data Systems (OPTADS) and the U.S. Army Chemical School. ANBACIS is designed to increase the effectiveness, reliability, and speed of the chemical operations at battalion level and higher, to include: improving the speed of transmission of NBC warnings and reports and assisting in the planning of NBC reconnaissance, decontamination and smoke operations. ANBACIS is part of the Standard Army Command and Control System (STACCS) and is being integrated into the Maneuver Control System.

All of these systems are under-funded or unfunded. Additional R&D funds are required to ensure these systems are available at the appropriate time for integration into the digitized battlefield.

SUMMARY

The NBC RDA strategy remains unchanged despite funding cuts. It provides capabilities which overmatch the NBC threat and protects the force while reducing the number of end items, manpower and logistics requirements, and cost. This strategy focuses on products which will provide versatility, deployability and survivability, contributing to **Land Force Dominance**.

SECTION 5

TRAINING

There have been significant developments in our efforts to integrate both the battlefield effects of NBC weapons and the effectiveness of our modernized NBC defense systems into battle simulations and war games. Some of these developments are described below.

- **TRADOC Battle Labs.** TRADOC established the Battle Labs to study and experiment with issues related to the five battlefield dynamics. Battle Labs integrate new technologies into the required capabilities of the force projection Army. Battle Labs focus on horizontal integration of technology. Because of this, NBC issues span all Battle Lab areas. Biological defense and defense from weapons of mass destruction (WMD) are postured with the Dismounted Warfighting Center Battle Lab, which is charged with soldier survivability. The Mounted Warfighting Battle Lab studied Vehicle Engine Exhaust Smoke Systems (VEESS) and recommended that VEESS remain an important survivability enhancement for the combat force. The Mounted Battle Lab is also the focal point for the Army's "digitizing the battlefield efforts", electronically linking weapons systems and commanders to permit increased battlespace awareness. The Battle Command Battle Lab continues to monitor the improvements in the automated NBC warning/reporting and planning software (ANBACIS), and anticipates its incorporation into the Maneuver Control System. The Early Entry, Lethality, and Survivability Battle Lab is studying 2K and 10K early entry force structures with organic NBC elements as a means of enhancing survivability of the force. The CSS Battle Lab is preparing to review the fog-oil (SGF-2) packaging and distribution on the battlefield. The Depth & Simultaneous Attack Battle Lab has indicated an interest in less-than-lethal weaponry.

- **Louisiana Maneuvers (LAM).** The Army Chief of Staff has established the Louisiana Maneuvers as a process for transforming our forward deployed Army to the force projection Army of the 21st Century. LAM enables senior leadership to identify issues, opportunities and policy, focusing on Army Warfighting capabilities and responsibilities. Simulations, war games and exercises are tools for focusing on the issues. Ten issues have been slated for investigation in FY94. Among these is the issue "Weapons of Mass Destruction", or WMD. The WMD issue explicitly requires a thorough evaluation of current doctrine, equipment and training in light of the mission of the future force projection Army. The results of this investigation should provide both useful insights on the effectiveness of our current modernization program and provide a basis for refining the program.

SECTION 6

CONCLUSION

"Whether or not gas will be employed in future wars is a matter of conjecture, but the effect is so deadly to the unprepared that we can never afford to neglect the question."

***General John J. Pershing
1920***

The NBC modernization strategy reinforces the Army's modernization vision and its objectives. Scarce resources are focused on the most promising technology insertions and leap-ahead technologies to provide horizontal integration of NBC capabilities across all mission areas to **Protect the Force**. Funding shortfalls in the NBC modernization program will significantly delay the development and fielding of the following capabilities: improved NBC reconnaissance, chemical agent mobile standoff detection, digitized automatic warning and reporting network, and both projected and mechanized multi-spectral smoke.

Our conclusion remains unchanged from the AMP: Additional investment in all components of the NBC mission area is essential to deter the proliferation of WMD, and to maintain an overmatch capability that will ensure **Land Force Dominance** on the future NBC battlefield.

"The use of weapons of mass destruction can have an enormous impact on the conduct of all operations. Not only do the sheer killing and destructive power of these weapons create the battlefield effect, but the strategic, operational, psychological, and political impacts of their use affect campaign designs."

FM 100-5, Operations, June 1993

CHAPTER 14

INFORMATION MISSION AREA INFRASTRUCTURE

SECTION 1

INTRODUCTION

This chapter updates Annex N of the 1993 Army Modernization Plan.

The National Military Strategy calls for the Army to conduct joint and combined military operations across a continuum of potential operations. This mandate ranges from peacekeeping and disaster relief operations to Land Force Dominance in both global contingency and major regional conflict scenarios.

PROJECT and SUSTAIN

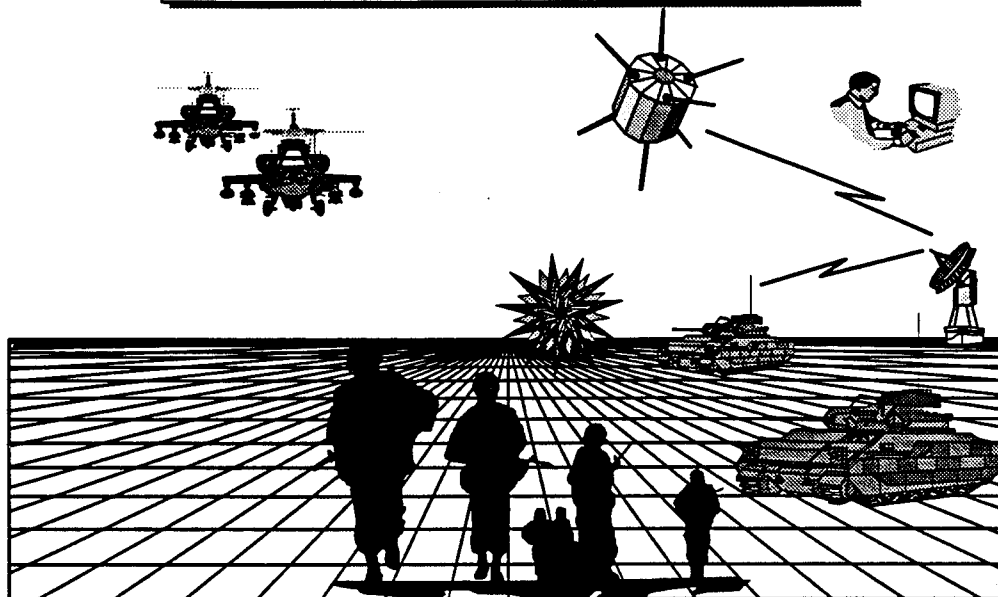

A primary key to Land Force Dominance is the modernization objective, "Project and Sustain." The IMA Infrastructure supports this objective and also lends enabling capabilities which serve to "Win the Information War." The IMA Infrastructure is also at the hub of the Army's Enterprise Vision – A strategy for the integration of Army Command, Control, Communications, Computers and Intelligence (C4I) capabilities into the force multiplier which is at the vanguard of modern warfighting doctrine and technology – Information Dominance. C4I capabilities are key to high technology warfare which will be played out through a modernized force projection on the digitized battlefield.

The Enterprise approach is holistic and leverages the operational synergy that information dominance brings to the warfighter. The current IMA Infrastructure Annex (N) of the Army Modernization Plan (AMP) primarily addresses the sustaining and strategic aspects of information technology modernization. The operational/tactical aspects of information automation and technology modernization

are addressed by the Command, Control, Communications, and Computers (C4) Annex of the AMP. Other information modernization and automation capabilities are discussed in the Logistics (Annex J) and Intelligence and Electronic Warfare annexes. It is the intent of the IMA Infrastructure Update to begin addressing the evolving modernization and integration of Army C4I assets under the overarching vision and strategy which is the **Enterprise Strategy**.

The Enterprise Strategy Will:

- **Unify the C4I Community toward a Common Goal**
- **Establish a structure to guide the system development process**
- **Develop economic, functional and technical guidelines and criteria to aid resource managers in making C4I system assessments**
- **Provide a broad systems perspective across DoD**

Support US Army Warfighters into the 21st Century

Figure 14-1

The Enterprise vision seeks to develop the integrated information architecture to support the Army within reduced manpower and funding levels. Consolidation of redundant functions, increasing overall system throughput, and merging existing "stovepipe" C4I systems will assist in the development of a streamlined global information infrastructure. The objective C4I architecture will deliver a "global information grid" to the joint and combined warfighter, the access to which will be facilitated by veritable "plug-in" capability.

Figure 14-2 lays out the principles of the Army Enterprise Strategy that provide a framework for C4I Horizontal Technology Integration (HTI):

Enterprise Principles

- **Focus on the Warfighter**
- **Enforce Joint Interoperability**
- **Capitalize on Space Based Assets**
- **Digitize the Battlefield**
- **Modernize Power Projection Platforms**
- **Optimize the Information Technology Environment**
- **Implement Multilevel Security**
- **Ensure Spectrum Supremacy**
- **Acquire Integrated Systems Using Commercial Technology**
- **Exploit Modeling and Simulation**

Figure 14-2

• **Focus on the Warfighter.** The overarching principle of Enterprise which is the lens through which the other nine Enterprise principles are focused in order to ensure that technology and resources are integrated into a suite of modern warfighting capabilities.

• **Ensure Joint Interoperability.** Provide C4I systems that interoperate in joint and combined operations.

• **Capitalize on Space-based Assets.** Assured access to mission-essential military and commercial space-based systems.

• **Digitization of the Battlefield.** Provide an integrated digital information network that supports warfighting systems and assures C2 decision cycle superiority.

• **Modernize Power Projection Platforms.** Turn Army installations into modern platforms to support efficient peacetime-transition-wartime operations to include training, mobilization, deployment, split-based operations, and redeployment.

• **Optimize the Information Technology Environment.** Provide more efficient information support for combat and peacetime operations.

• **Implement Multi-Level Security.** Provide ability to access and exchange information at needed levels of classification using a single objective C4I system.

• **Ensure Spectrum Supremacy.** Provide warfighter with electromagnetic spectrum supremacy to maximize the benefits of maneuver and tempo in conjunction with firepower.

• **Acquire Integrated C4I Systems Using Commercial Technology.** Provide warfighter with synchronized C4I capabilities that leverage commercial technology.

• **Exploit Modeling and Simulation.** Provide warfighter with cost effective training, testing, and rapid prototyping through state-of-the-art modeling and simulation.

C4I Integrated Work Station

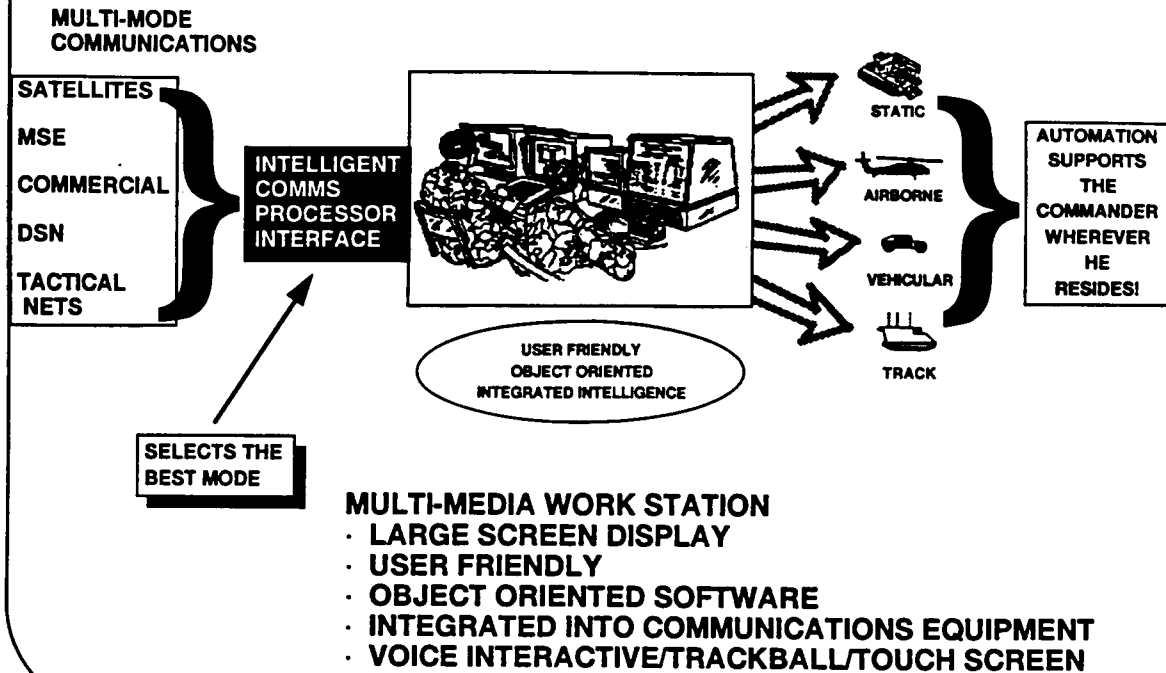

Figure 14-3

The Enterprise Strategy serves to leverage Horizontal Technology Integration across all battlefield operating systems. The commander will attain the objective C4I battlefield automation capability to synchronize and execute the mission inside an adversary's decision loop. Integrated C4I workstations (Figure 14-3) will enable the warfighter to "pull" and use the appropriate information and communications to execute synergy and dominance within the battlespace.

SECTION 2

WARFIGHTING CONCEPT

The on-going technology revolution continues to drive and redefine military strategy, doctrine, and requirements. Lessons from Operations DESERT SHIELD/DESERT STORM helped to clarify the need for a strong CONUS-based infrastructure from which to project and sustain warfighting capabilities. Force projection doctrine depicts the Army installation as a power projection platform from which forces will mobilize, deploy, and remain in contact from the area of operations. Credible crisis response requires the capability to project military power to end conflicts rapidly on terms favorable to the US and its allies.

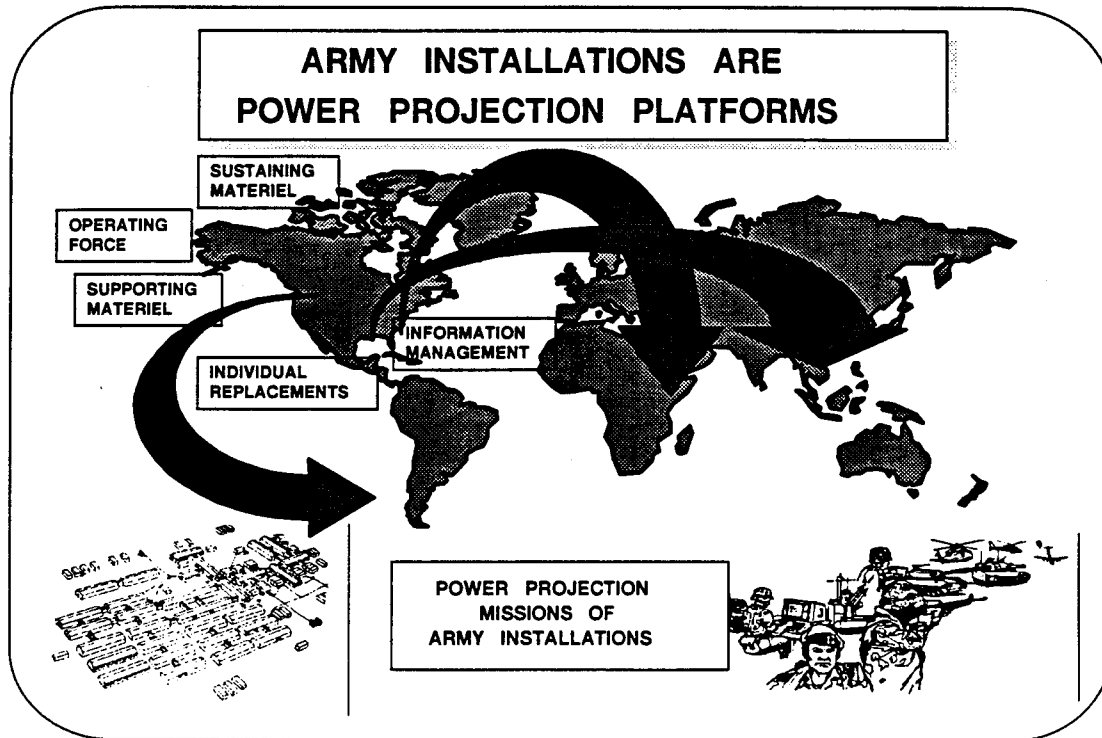

Figure 14-4

Warfighting capabilities afforded by the C4 assets of the IMA infrastructure will make possible split-based operations, which support the Enterprise principle, "Focus on the Warfighter." Under this framework, assured and enhanced communications allow selected logistics functions to be accomplished from either CONUS or a forward presence location. Split-based operations will allow the Army to deploy only those functional capabilities which are absolutely necessary to provide materiel management support to the deployed force. This strategy is fundamental to rapid deployment of modular, tailorable units to any geographic area of operations. Deployed materiel management cells will rely heavily on information management technology and command, control and communications (C3) systems that provide real time electronic transmission of logistics data and message and voice communications. The assured communications and automation links from the deployed materiel management cell (MMC) back to the supporting MMC in CONUS are essential to implementing a National Military Strategy predicated on force projection.

Long haul communications capabilities will be provided by both military communications satellite links and commercial satellite capabilities which may be required for surge augmentation. These strategic lines of communication (LOC) will provide global connectivity for the deployed peacekeeper or warfighter. The global communications and information grid will provide the infrastructure for operational support capabilities. The ability to plug-out/plug-in to the global grid will permit the deployed commander to decide and synchronize operational courses of action based on near real-time intelligence, logistics and sustainment information, as required.

IMA infrastructure systems and automated information management capabilities (Figure 14-5) leverage the synchronization of operations necessary to conduct complex joint and combined operations. Standard interfaces and interoperable C4I systems will be developed and enforced in accordance with the tenets of the Army Enterprise strategy and the C4I For The Warrior (C4IFTW) concept of operations directed by the Joint Chiefs of Staff.

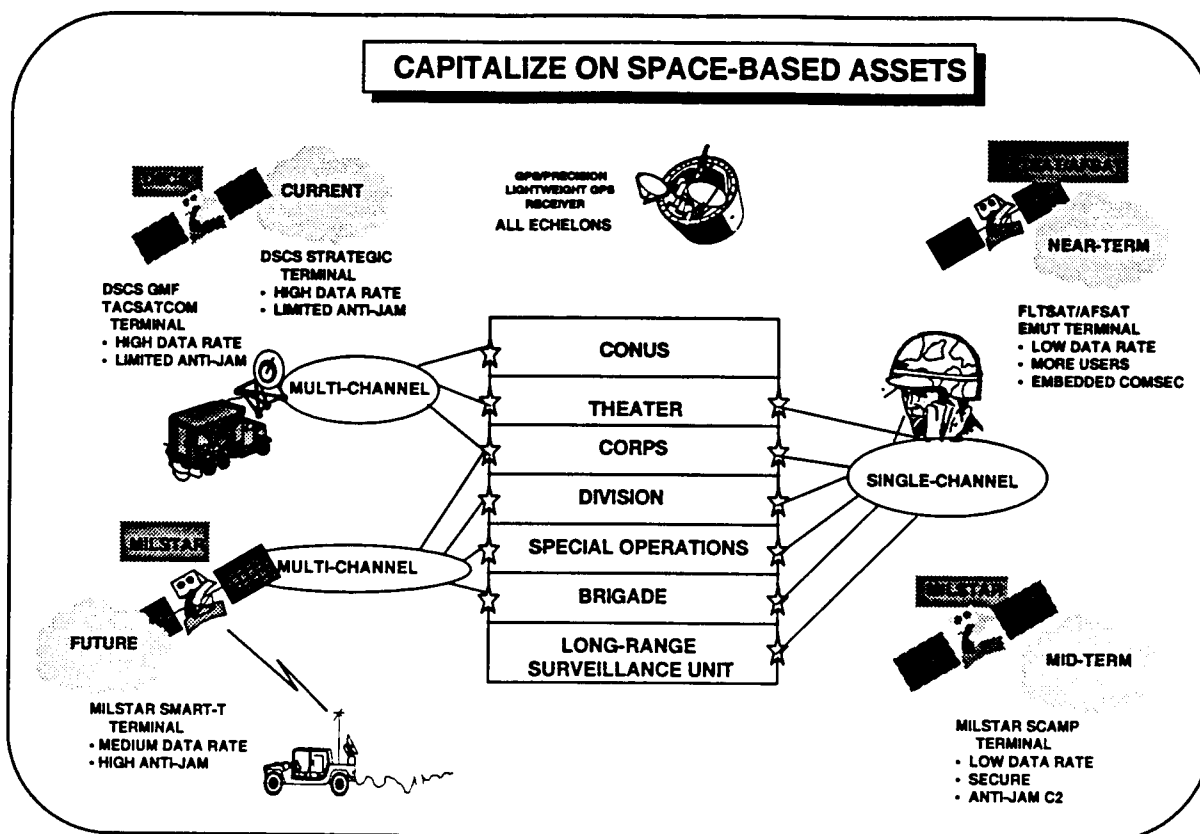

Figure 14-5

In addition to combatant C4I needs, the IMA infrastructure supports the functional "business needs" of the warfighter both in garrison and when deployed. Sustaining Base Information Services (SBIS) will field the modernized installation infrastructure under an open systems environment designed to leverage standards and economies in managing and operating the Army's physical plant. A modern and efficient information management base is essential to leveraging the power projection platform capability of Army installations. One of the key lessons from Desert Storm was that many of the administrative functions previously perceived to be non-combat related were critical to the sustainment of the deployed forces. Business functions related to medical services, payroll, war reserve stockpile and spare parts management, transportation and legal services, etc. are necessary to sustain the deployed

warfighter or peacekeeper. All these functions were required to equip the forces during the buildup and to sustain high degrees of morale and combat readiness once deployed. Telecommunications services between deployed Commander-In-Chief elements and their CONUS-based support functions at Army installations became mission critical.

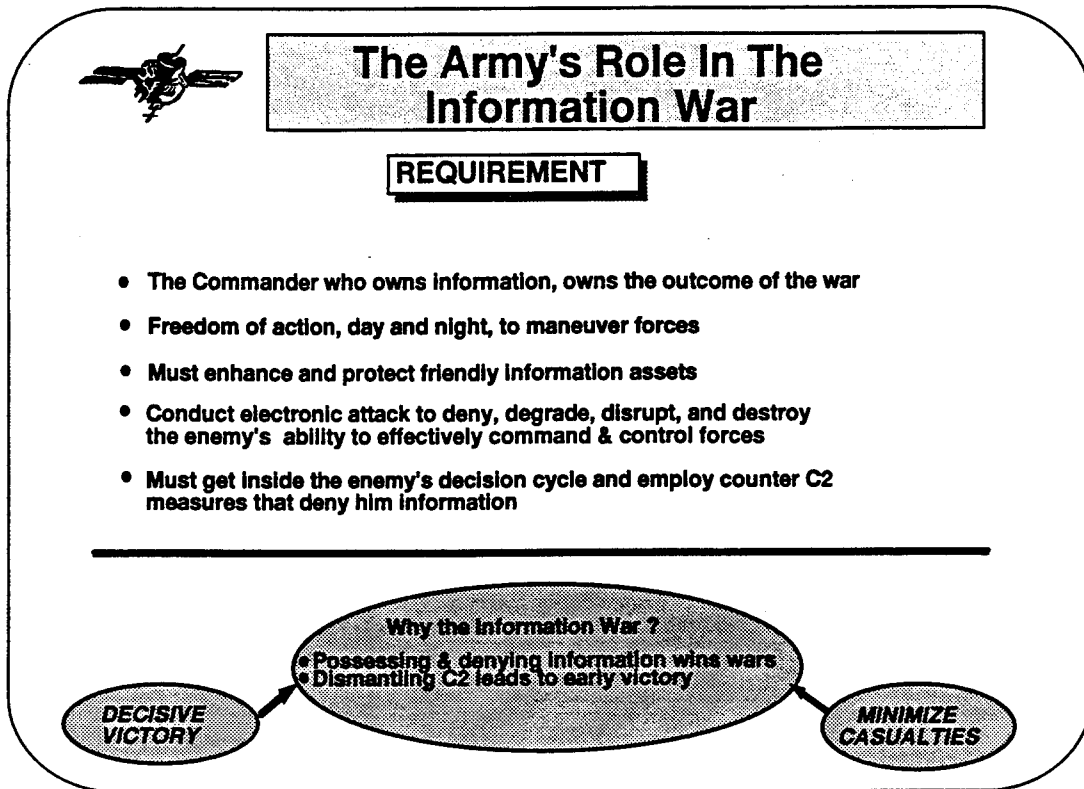

Figure 14-6

Administrative information is vital to decisions on force readiness and deployability. The commander is compelled to react within a compressed time/operations continuum facilitated by modern information management and decision support systems. Modern IMA infrastructure capabilities give the warfighting commander the capability to operate inside of the adversary's information/decision loop. Information dominance is a warfighting enabler of the highest order.

SECTION 3

CURRENT PROGRAM ASSESSMENT

IMA Infrastructure programs for the near-term continue to reflect the Army's dedication to modernizing the force projection capabilities of Army installations. These installations are the power projection platform from which forces are mobilized and deployed and are also the CONUS logistics base for the deployed warfighter under the doctrine of split-based operations.

The Power Projection C4 Infrastructure (PPC4I) program initiative is modernization of the information infrastructure at Army installations. PPC4I focuses on modernizing the "backbone" information processing and transfer capabilities vital to the daily operation of these installations. More importantly, the PPC4I program initiative focuses modernization resources on those installations from which warfighters must maintain optimum readiness and be able to mobilize and deploy under force package strategy and guidance. IMA infrastructure programmed improvements will allow the Army to better support the National Military Strategy for force projection by providing continuous, more responsive information flow from the National Command Authority to the battlefield. PPC4I includes the following modernization initiatives:

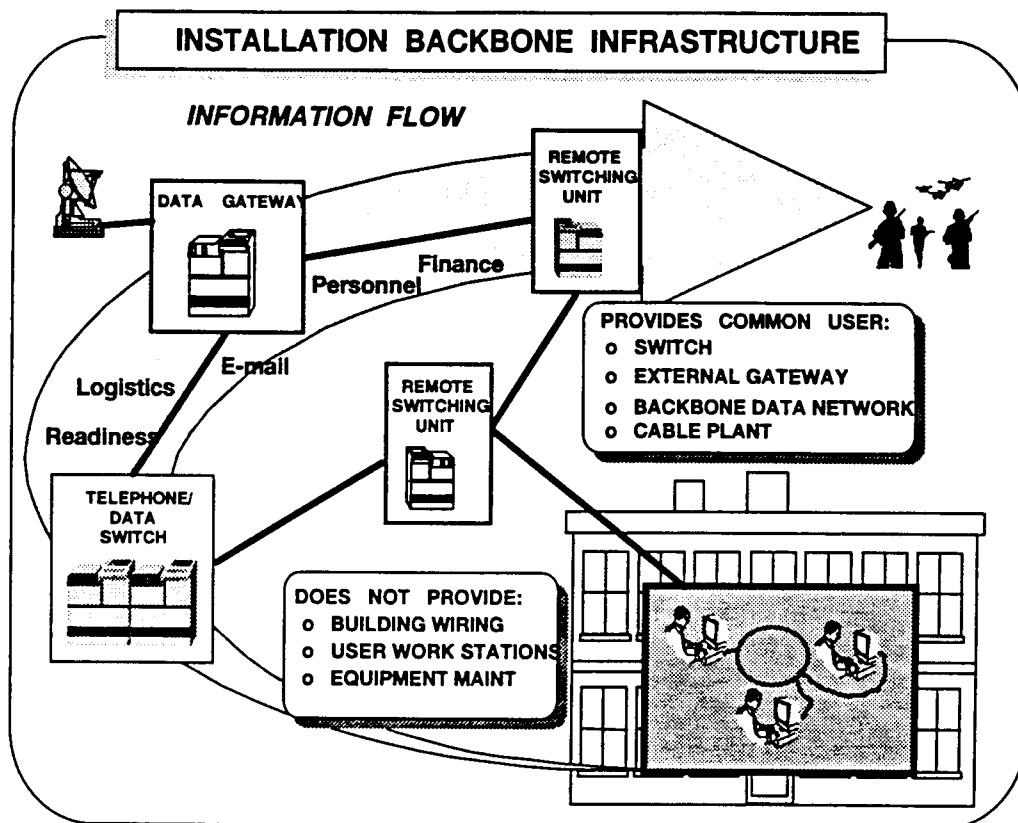

Figure 14-7

- **Sustaining Base Information Services (SBIS).** SBIS begins the transition of existing sustaining base information services to an open systems (non-proprietary) operating environment. A funding shortfall has impacted the program in the mid to far term. This is primarily due to the Joint Applications Development Process which has surfaced an increased level of detail and resources needed for developing software applications.

- **Installation Support Module (ISM).** ISM provides application and database software to installation commanders for use in performing operational functions.

- **Major Army Command Telephone Modernization Program (MTMP).** MTMP replaces analog with modern digital technology telephone switches.

- **Outside Cable Rehabilitation (OSCAR).** OSCAR replaces obsolete wire cable at Army installations with upgrades and fiber optic transmission media.

- **Common User Installation Transport Network (CUITN).** CUITN supports automation users by engineering and providing the hardware and transmission media to interconnect users behind the communications gateway interface to higher level communications networks like the Defense Data Network and Defense Information Systems Network. Revision of investment strategy allows the capability to be fielded in support of early deployers.

- **Army Gateway Program (AGP).** AGP supplies software and hardware to connect installation users to the Defense Information Systems Network.

- **Reserve Component Automation Systems (RCAS).** RCAS provides the Army National Guard and the Reserve Component with automation capabilities for daily operations. Also provides unit administration and mobilization command and control. A funding shortfall has impacted the program. Current funding profile will affect system fielding and delay improvements to the enhanced mobilization capability.

- **Joint Computer-Aided Acquisition and Logistic Support (JCALS).** JCALS electronically acquires, integrates and provides access to technical and engineering data required to support the materiel acquisition process. A funding shortfall has impacted the program.

- **Defense Message System-Army (DMS).** DMS extends military messaging service down to installation user level.

IMA ASSESSMENT SUMMARY

PROGRAM	DEFICIENCIES	NEAR TERM FY94-FY95	MID TERM FY96-FY99	FAR TERM FY00-FY08
SBIS	FUNDING SHORTFALL	GREEN	AMBER*	AMBER*
ISM	NONE	GREEN	GREEN	GREEN
MTMP	FUNDING SHORTFALL	AMBER	AMBER	AMBER
OSCAR	FUNDING SHORTFALL	AMBER	AMBER	AMBER
CUITN	FUNDING SHORTFALL	AMBER*	AMBER	AMBER
AGP	NONE	GREEN	GREEN	GREEN
RCAS	FUNDING SHORTFALL	AMBER*	AMBER*	AMBER*
JCALs	FUNDING SHORTFALL	AMBER*	AMBER*	AMBER*
DMS-ARMY	MULTI-LEVEL SECURITY PRODUCT REQUIRED	AMBER	AMBER	GREEN
RED: INADEQUATE CAPABILITY/RESOURCES TO PERFORM MISSION AMBER: LIMITED CAPABILITY/RESOURCES TO PERFORM MISSION GREEN: ADEQUATE CAPABILITY/RESOURCES TO PERFORM MISSION * Denotes Changes				

Figure 14-8

SECTION 4

HORIZONTAL TECHNOLOGY INTEGRATION

C4I supporting systems provide the strategic, command and control, and sustainment information underpinnings for a force projection Army. C4I also provides the communications and transmission media that link the multi-tiered command and control structure from the White House to the foxhole.

One of the key approaches for achieving Army modernization objectives is through Horizontal Technology Integration (HTI). Army planners and materiel developers will leverage technology to improve existing capabilities by high pay-off technology insertions to existing sustaining base and battlefield information systems. The charts below cite some of the key considerations as we look at HTI.

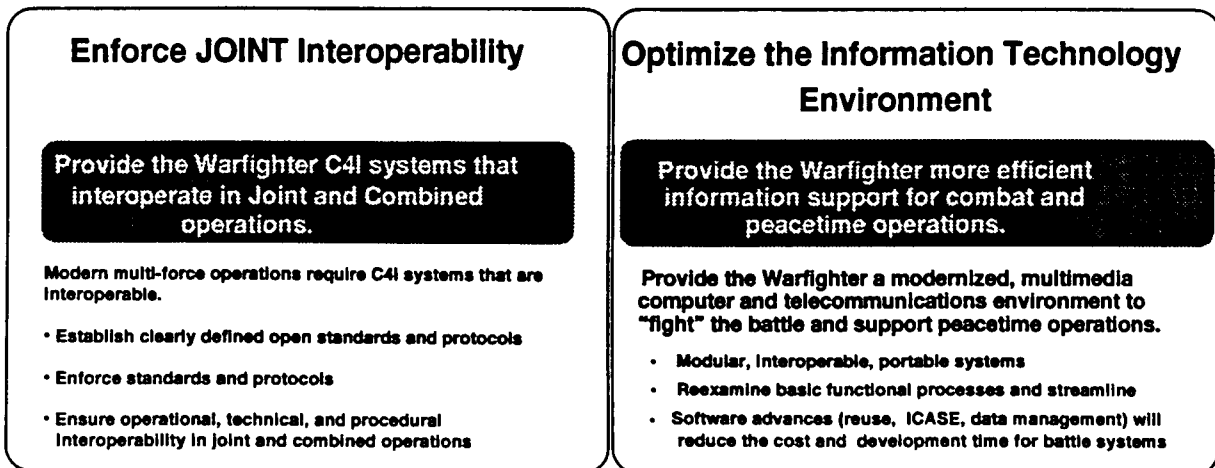

Figure 14-9

Figure 10

Information is critical to the successful conduct of warfare. Information dominance is a pre-eminent battlefield necessity. The intelligence and situation awareness leveraged by C4I systems are key enabling capabilities which engage the lethality and effectiveness of other battlefield operational systems. Better information collection and management help determine when specific battlefield operations are necessary and will indicate the best and safest means of conducting them. A mature C4I information architecture will be predicated on requirements and systems solutions which will be horizontally engineered and integrated across all battlefield operational weapons platforms and the C2 systems which govern their use. Development and enforcement of C4I systems standards and protocols are vital to HTI across the battlefield in both joint and combined operations.

C4I HTI permits a shared awareness of the tactical situation down to the crew level throughout the combined arms team. Real time force synchronization is enhanced by automated C2 and the capability to deliver highly accurate, massed fires from dispersed locations. Decisive maneuver will be facilitated and fratricide greatly reduced.

Information technologies bring an additional capability for meeting the uncertain and multiple threats of the post cold war era. In the conduct of Operations Short of War, as well as wartime operations, United States informational technologies will provide a unique contribution to multilateral operations that no other nation will likely be able to provide. For operational effectiveness in the context of land force dominance, Army information technologies will be leading the way for the execution of coalition deterrent or warfighting efforts.

SECTION 5

RESEARCH, DEVELOPMENT & ACQUISITION STRATEGY

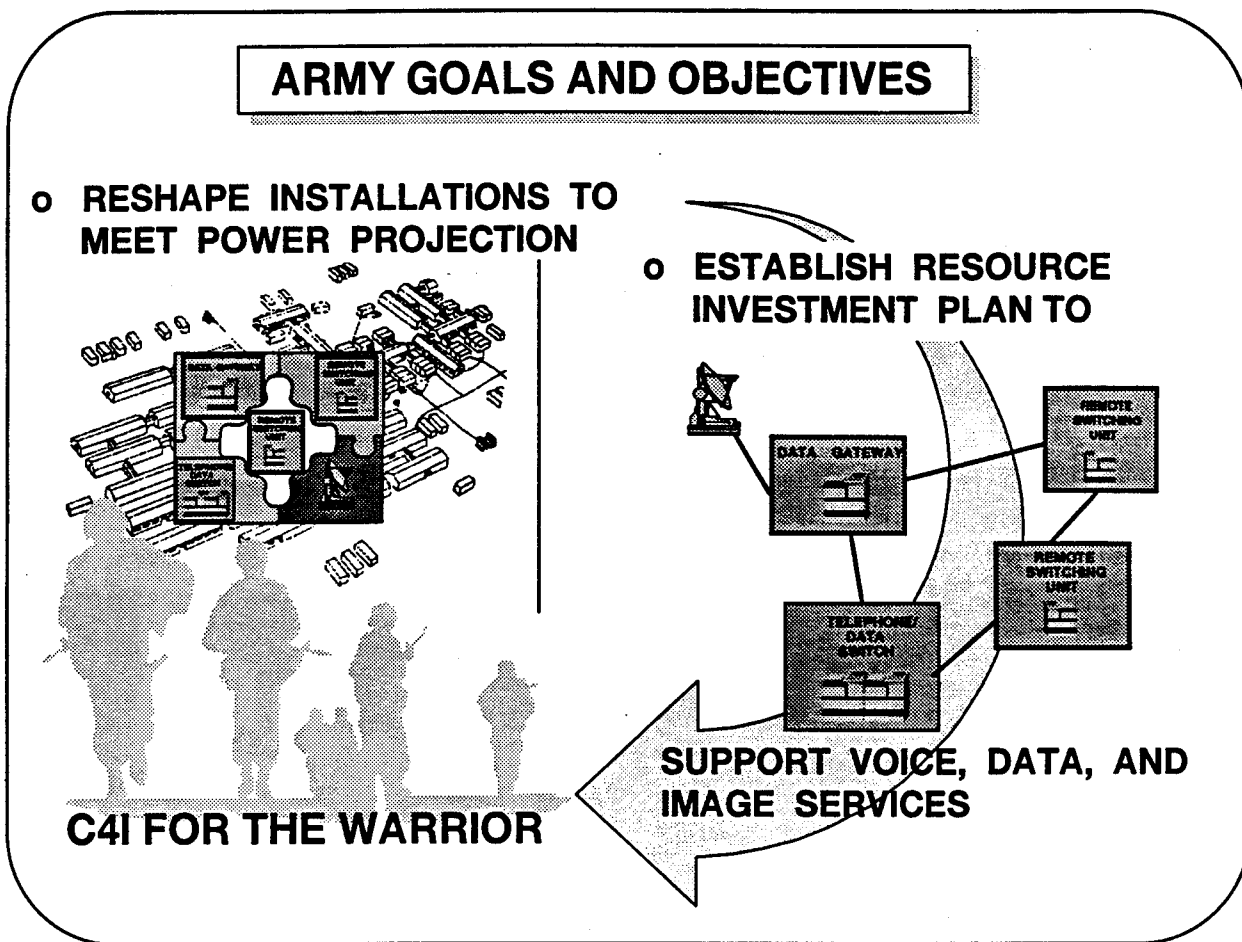

Figure 14-13

As the size of the Army is reduced and many forward deployed units return to CONUS, IMA infrastructure systems and services become more critical to Army readiness. High priority is being given to IMA Infrastructure initiatives which can enhance productivity and readiness as overhead is reduced. Opportunities that maximize return on investment through high productivity and efficiency must be pursued. The application of modern information technology and standards is a key ingredient and enabler for a modern and ready Army.

A research, development & acquisition (RDA) strategy based on continuous modernization ensures that Army forces will have leading edge technology to leverage the capability to win quickly and decisively with minimal casualties and materiel expenditures. IMA Infrastructure RDA initiatives support this strategy of continuous modernization chiefly through the use of commercial-off-the-shelf/non-developmental item (COTS/NDI) acquisitions. The COTS/NDI acquisition strategy serves both IMA infrastructure requirements developers and materiel developers well, since information technology advances are accelerating far ahead of established procurement cycles.

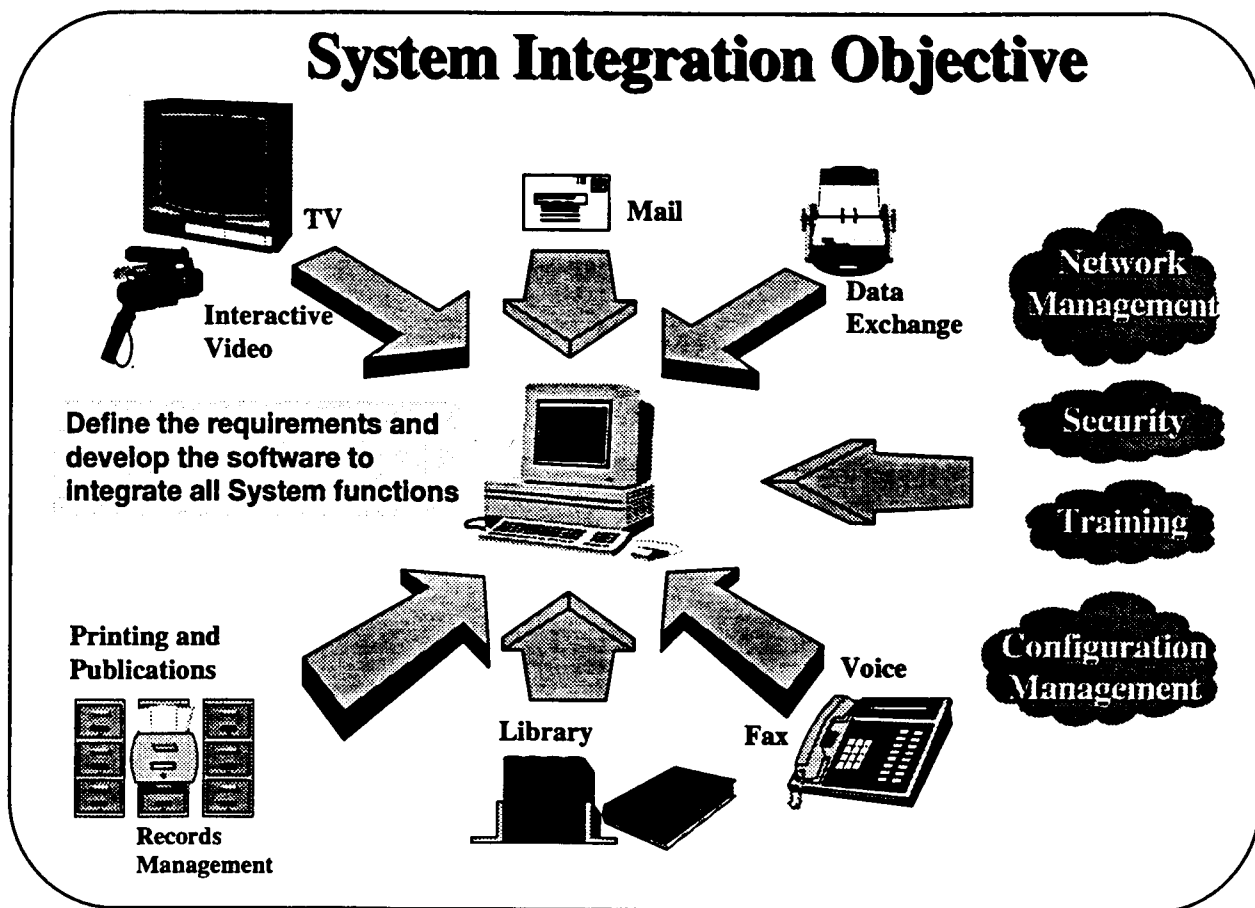

Figure 14-14

A key goal of the IMA Infrastructure acquisition strategy is the on-line integration of information management capabilities. Technology is driving the convergence of formerly stand-alone capabilities (Figure 14-14) to integrated, interactive information management. The systems integration objective capability will enable Army users to access and employ fused capabilities involving data, voice, and video through near real-time telecommunications networking.

With the advent of an environment characterized by a less recognizable threat coupled with austere fiscal constraints, the Department of Defense has set the stage for the Services to explore and evaluate new technologies which will provide leap-ahead capability to existing weapons and information/telecommunications systems. In the Army, this has been manifest as the Battle Labs concept where solutions to requirements are explored and evaluated for technology insertion opportunities. Battle Labs focus on opportunities for horizontal technology integration (HTI) across battlefield operating systems because weapons and information systems must interoperate to generate battlefield synergy in combined and joint operations.

Prototype force projection and battlefield capabilities will be developed through modeling and simulation among the networked Battle Labs. The Battle Labs exploit leading edge technology by "wargaming" advanced technology and warfighting demonstrations. Virtual prototyping of simulated capabilities is planned to demonstrate the value of HTI without "bending metal" or entering into expensive and protracted RDA cycles. This methodology will also guide materiel developers to the best NDI/COTS materiel solutions. Promising leap-ahead technologies will be evaluated for further materiel development consideration as well as the resources to integrate these capabilities into the warfighting force.

The near-term IMA Infrastructure RDA strategy is implemented by the following PPC4I programs discussed in Section 3, Current Program Assessment:

RDA STRATEGY

COMPONENT	STRATEGY	94	95	96	97	98	99	00	01	02	03	04	05	06	07	08	
PROCUREMENT	OFF-SHELF/ NDIs *	ARMY GATEWAY PROGRAM-AGP															
		MACOM TELEPHONE MOD PLAN-MTMP															
		OUTSIDE CABLE REHABILITATION-OSCAR															
		COM USER INSTALL TRNSPRT NTRK-CUITN															
		SUSTAINING BASE INFO SERVICES-SBIS															
		ITP															
		DEFENSE MESSAGE SYSTEM-DMS															
		RESERVE COMP AUTO SYSTEM-RCAS															
		JOINT CALS-ICALS															

Figure 14-15

- * Sustaining Base Information Services - Requirements will be accommodated by a Department of Defense initiative after FY99.
- * ITP (Installation Transition Processing) - This program transitions to SBIS after FY95.

SECTION 6

TRAINING

The modern Army requires trained and qualified military and civilian information resource managers who can manage the utilities of the IMA infrastructure as an integrated entity and who are committed to support the functional users. The continued merging of the IMA disciplines and underlying technologies makes it incumbent upon the Army to recruit, train, and employ skilled information managers and technicians. IMA curricula at DoD, Army, Senior Service Schools, and participating colleges and universities are available to develop a cadre of civilian and military IMA professionals and leaders.

Skills associated with the development, operation, and maintenance of information systems change rapidly. Through the use of embedded training capabilities like on-line training tutorials and computer-assisted instruction, functional users become more responsible for training and proficiency with software application programs. The historical training, education, and career development distinctions between automators, communicators, visual information managers, records managers, and library managers continue to blur as associated technology and management requirements become more integrated.

Both Career Program 34 and the Signal Center curriculum at Fort Gordon, GA are dedicated to training and developing the personnel who will lead and provide support for the Army's information age transition. The IMA Infrastructure training and professional development community will:

- Recruit and retain qualified information technology managers and specialists.
- Provide enhanced IMA leadership qualities.
- Provide state-of-the-art training.
- Provide trained IMA professionals to the Army Acquisition Corps.

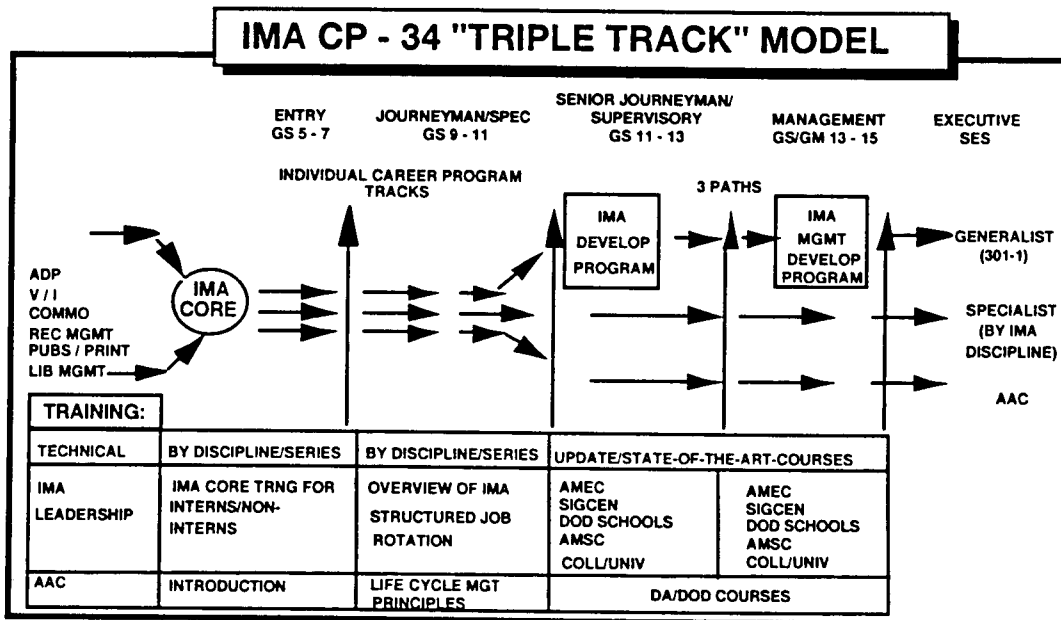

Figure 14-16

Training and Modeling and Simulation

Information and telecommunications technologies have made available advanced modeling and simulation techniques which are revolutionizing how the Army trains and develops its requirements and materiel solutions. Through their application, these technologies will allow the Army to model, simulate and practice/train battlefield capabilities on a microprocessor-based "virtual battlefield". Louisiana Maneuvers (LAM) is a Chief of Staff initiative designed to transition the Army through the current post Cold War period of rapid change. LAM, serving as a laboratory and testing site for senior Army leadership, will rely on virtual reality technology to provide the warfighter with cost effective training, testing, and rapid prototyping of battlefield capabilities.

The technologies and functional capabilities germane to the IMA Infrastructure will enable LAM to meet its objectives. Powerful three-dimensional graphic workstations in conjunction with high bandwidth capacity telecommunications will link Battle Labs and simulation centers from geographically distributed sites. The Defense Simulation Internet provides this support currently. TRADOC is developing the TRADOC Simulation Internet for Battle Lab connectivity in an objective distributed, interactive simulation environment.

The Army is also participating in the National Information Superhighway initiative. This top priority national initiative will revitalize the national economic and information infrastructure by networking centers of commerce, manufacturing, education/training, health care and multi-media services and utilities. This vast undertaking is targeted to prepare the nation for a robust and globally competitive economy, which is a top DoD priority in the interest of the national security. The Army is preparing to interface with the "Electronic Superhighway" as an innovative and viable example of dual use technology.

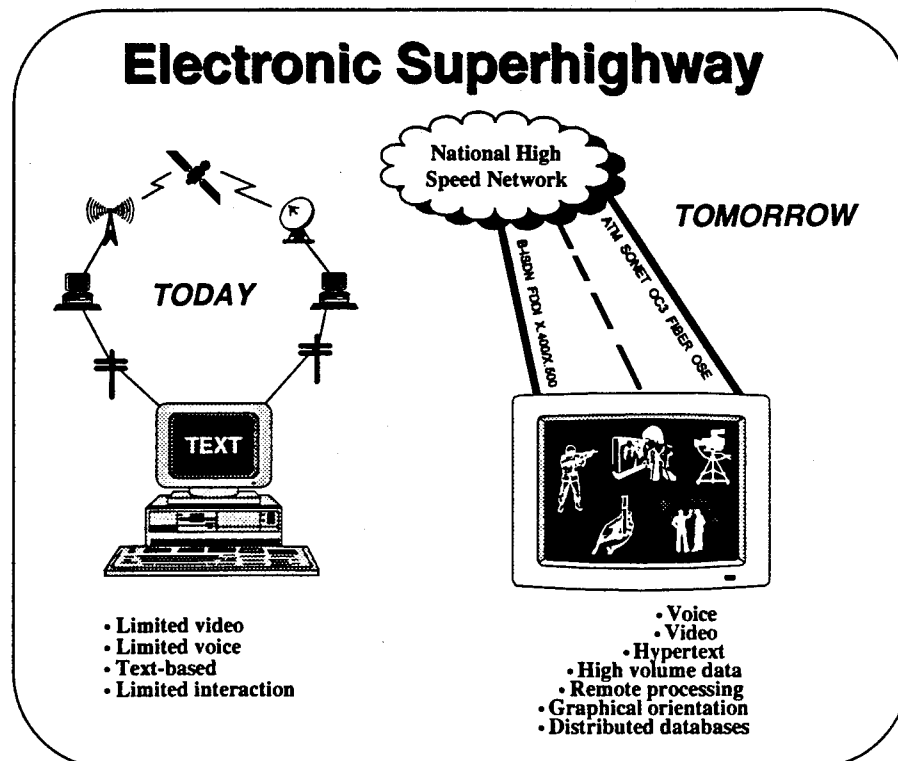

Figure 14-17

SECTION 7

CONCLUSION

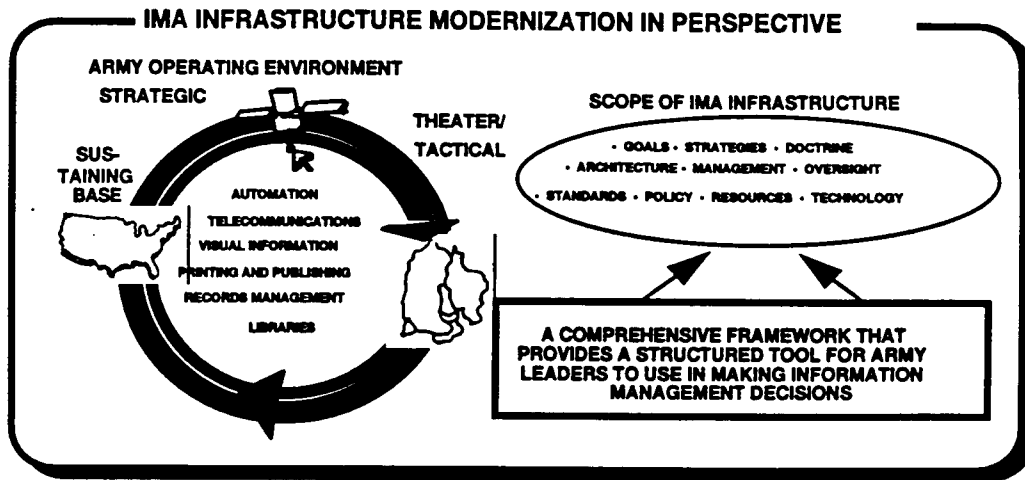

Figure 14-18

The vast power of the microprocessor and the accelerating tempo of telecommunications is propelling change at unprecedented velocity. The information age is exerting powerful influences on all domains of military science and battlefield capability. The Army has a great stake in the outcome of mastering C4I technologies because information dominance will be both a potent warfighting deterrent and the pre-eminent force multiplier on current and future battlefields. Advanced technology is redefining the terrestrial battlefield to encompass operational realities associated with the need to dominate "battlespace". Battlespace reaches across the electromagnetic spectrum and into the domain of space-based telecommunications assets. The advanced technology battlefield is where these interdependent, operational capabilities will play out. The **Enterprise Strategy** is the acknowledgment that the modern Army must interoperate its information, intelligence, and weapons systems in order to leverage the battlefield synergy that advance technology can provide.

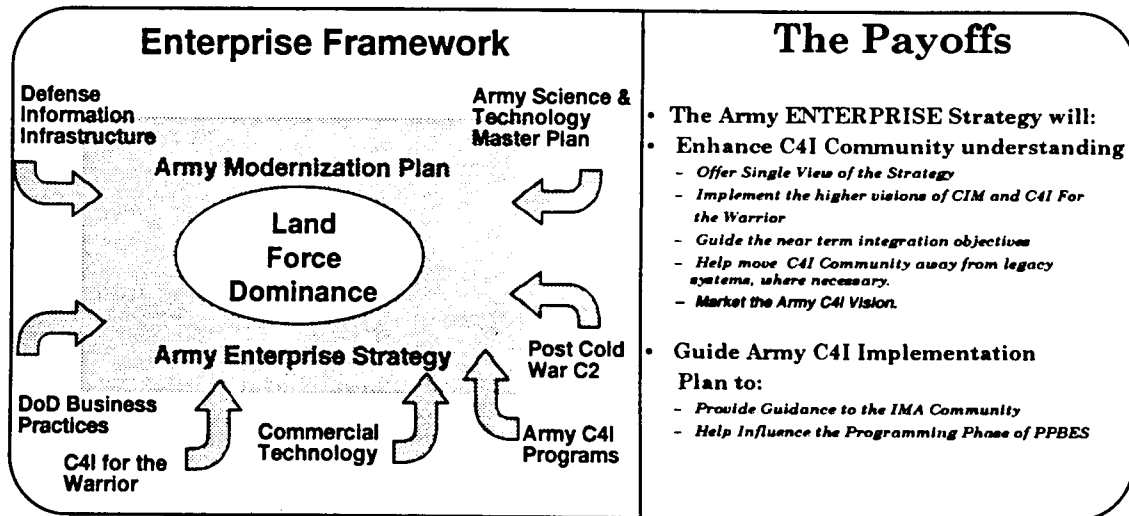

Figure 14-19

CHAPTER 15

MEDICAL

SECTION 1

INTRODUCTION

This document updates Annex O of the US Army Modernization Plan (AMP), Volume II, January 1993. The mission of the US Army Medical Department (AMEDD) has not changed. It continues to support the Army modernization objectives to project, sustain and protect the force. The following information provides updates to the war fighting concept; current program assessment; research, development, and acquisition strategy; and training. New information on Horizontal Technology Integration (HTI) is provided in Section 4. Some of the time frames for fielding, research, development, and acquisition provided in the initial AMP have changed as a result of recent decrements to the budget and force structure. These changes are provided in the subsequent sections using the current, available data.

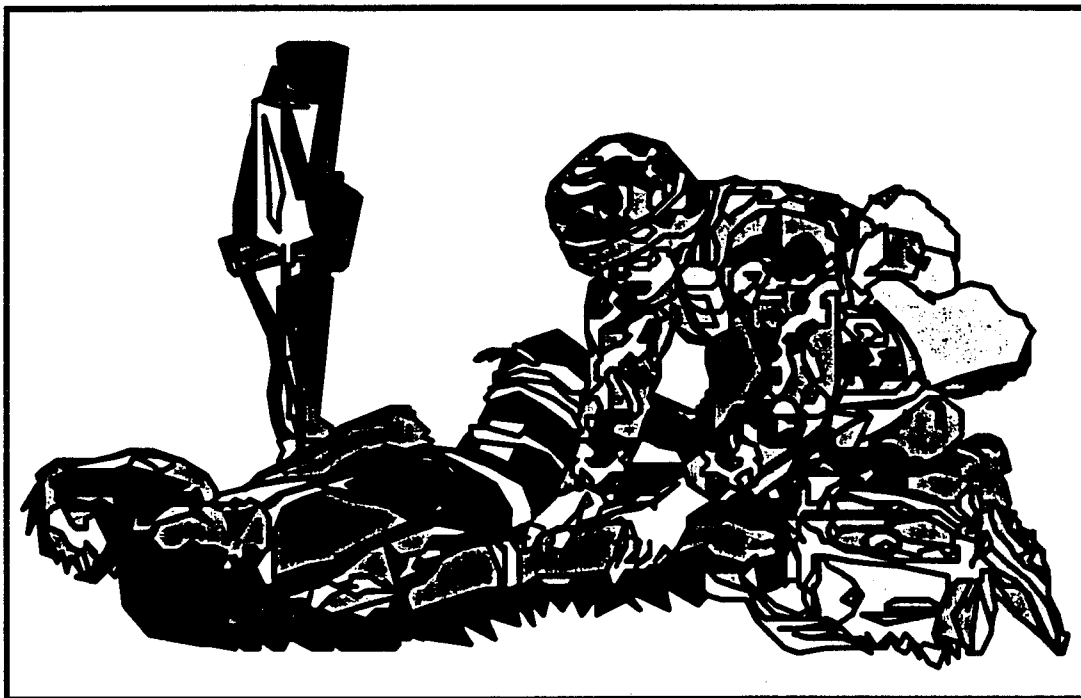

SECTION 2

WARFIGHTING CONCEPT

The nature of modern warfare creates unique challenges for medical protection of the soldier and for the delivery of health service support (HSS) on the extended battlefield. The medical challenge begins before the soldier deploys with the requirement to immunize the soldier against infectious disease and to enhance rapid acclimatization to extreme climates and "jet lag." It influences the battle with pretreatment for chemical and biological threat agents and countermeasures for operational stress and the health hazards of combat systems. The greatest medical challenge will be to simultaneously provide HSS to deploying forces; provide HSS to the CONUS base, and establish a medical support system within the theater. The HSS system of the future will be rapidly tailorable to meet these challenges. This system will be designed to support extremes ranging from low profile/low density forces, through operations other than war, to support of a corps and multiple corps organizations requiring long term sustainment. The health care delivery system must provide medical units with the flexibility and versatility required to meet the challenges of future combat operations. The medical force of the future will provide the soldier state-of-the-art medical/surgical treatment and evacuation.



Figure 15-1

The following capabilities are additions and/or significant changes to the medical operational capability requirements in Annex O of the AMP. They outline newly assimilated concepts and technologies and reinforce the need for smaller, faster organizations in support of force projection.

- **Protection.** Medical science and technology programs enhance warfighting capabilities by providing biomedical technologies, information and materiel, which (1) increase the ability to project the force to all parts of the world, by providing immunization against endemic disease and extreme climates (2) protect the force from disease, illness, and injury by providing medical countermeasures to environmental threats, operational stress, health hazards of combat systems, and aggressor weapons systems (to include conventional, biological, chemical, and directed energy), and (3) sustain the force through medical intervention and treatment for battle and non-battle injuries.

- **Enhancing Casualty Survival.** Early deployment of hospitals and forward medical units is required to provide prompt medical care and to prevent unnecessary casualty evacuation. Prompt resuscitation and restoration of physiological stability decreases morbidity. Adequacy of far forward resuscitation frequently determines survival; the current weight and cube of medical facilities prevents this.

Initiatives associated with the modernization of field combat medical units in Force Package 1 (i.e., oxygen generation, small volume resuscitation fluids, blood substitutes, lightweight shelter systems) will result in decreases of unit weight and cube.

- **Command, Control, Communications, Computers, and Intelligence (C4I).** A requirement exists for a seamless communications architecture and joint doctrine to fully meet the AMEDD's needs. Medical command and control, medical regulating, medical intelligence, and telemedicine are encumbered by the lack of both joint doctrine and integrated communications capabilities across the continuum from the theater of operations to the sustaining base. AMEDD access to satellite communications for long-haul information transfers is essential to state-of-the-art medical care available to the soldier. Joint medical regulating and communication systems that fully encompass all echelons of patient evacuation and accountability need to be developed. Automated health care documentation and patient tracking are critical to an effective medical support package.

- **Telemedicine, Telesurgical Presence, and Virtual Reality.** There is inadequate capability in the field for expert consultation for professional, medical personnel, as well as continued professional training. Consultation must include the ability for consultants to review x-rays, CT scans, pathology specimens, and to observe the patient. Access to expert consultation must be included in state-of-the-art medical treatment. Early development of telepresence surgery through the use of overhead relay communications coupled with mechanical, hydraulic, and electrical devices will provide a surgeon, stationed rearward with the necessary audio and visual information, to assist the surgeon at a remote field location. Virtual reality also provides a unique, precise, realistic training device which can emulate HSS requirements for all medical components on the battlefield.

- **HSS in Operations Other Than War (OOTW).** The ability to effectively employ medical support in contingency operations requires specialized Medical Equipment Sets (MES). An MES for OOTW is under development by the AMEDDC&S and USAMMA and is expected to be fielded in late FY95.

SECTION 3

CURRENT PROGRAM ASSESSMENT

An updated assessment of HSS capabilities is depicted in figure 15-2. Significant changes are asterisked and discussed on the next page. As in the AMP, the parameters of the analysis were constrained to address battlefield needs in doctrine, training, leader development, organizations, and materiel to include science and technology. The assessment was further constrained to materiel enhancements or requirements that are essential to providing health care on the battlefield.

MODERNIZATION OBJECTIVE	WARFIGHTING CAPABILITY	NEAR (FY94-95)	MID (FY96-99)	FAR (FY00-08)
PROJECT AND SUSTAIN	FAR-FORWARD SURGICAL SUPPORT	GREEN*	GREEN	GREEN
PROJECT AND SUSTAIN/ PROTECT THE FORCE	PATIENT EVACUATION PLATFORMS	AMBER*	AMBER*	AMBER*
PROJECT AND SUSTAIN	ENHANCING CASUALTY SURVIVAL	AMBER*	AMBER*	AMBER*
PROJECT AND SUSTAIN/ PROTECT THE FORCE	PREVENT / MINIMIZE ENDEMIC DISEASE/ENVIRONMENTAL INJURY	AMBER	AMBER	AMBER
PROJECT AND SUSTAIN	COMMAND, CONTROL, COMMUNICATIONS, COMPUTERS, AND INTELLIGENCE	RED*	AMBER*	AMBER*
PROJECT AND SUSTAIN	PROVIDE MEDICAL MATERIEL AND BLOOD	AMBER	GREEN*	GREEN*
PROJECT AND SUSTAIN/ PROTECT THE FORCE	DEVELOP NBC AGENT PREVENTIVE AND TREATMENT MEASURES	N = RED* B = RED C = AMBER	N = RED* B = RED C = AMBER	N = RED* B = AMBER C = AMBER
PROJECT AND SUSTAIN/ PROTECT THE FORCE	TELEMEDICINE, TELE-SURGICAL PRESENCE, AND VIRTUAL REALITY	AMBER*	AMBER*	GREEN*
PROJECT AND SUSTAIN/ PROTECT THE FORCE	PROVISION OF HEALTH SERVICE SUPPORT IN AN NBC ENVIRONMENT	N=RED* B=RED* C=RED*	N=RED* B=RED* C=RED*	N=RED* B=AMBER* C=AMBER*
PROJECT AND SUSTAIN/ PROTECT THE FORCE	PROVIDE CARE FOR NON-BATTLE INJURIES AND DISEASE IN OPERATIONS OTHER THAN WAR	AMBER	AMBER	GREEN
PROJECT AND SUSTAIN/ PROTECT THE FORCE	DIAGNOSIS AND TREATMENT CAPABILITIES FOR DIRECTED ENERGY INJURIES	AMBER	AMBER	AMBER
PROJECT AND SUSTAIN/ PROTECT THE FORCE	PROVIDE TREATMENT TO DENTAL PATIENTS	AMBER	AMBER	GREEN*

Green - Adequate capability or quantity exists to defeat the threat and perform the mission.
 Amber - A limited capability or quantity exists to defeat the threat and perform the mission.
 Red - No capability exists, or it is incapable of defeating the threat.

Figure 15-2

Far Forward Surgical Support.

Near Term - **GREEN**; Mid Term - **GREEN**; Far Term - **GREEN**

Rationale: Far forward surgery is rated **GREEN** during the near term based on the acquisition time required to procure the lightweight shelter and support equipment. Improved far forward surgical support is projected to be available to Force Package 1 by FY95. Fielding was originally planned to occur in FY96.

Patient Evacuation Platforms. (New objective)

Near Term - **AMBER**; Mid Term - **AMBER**; Far Term - **AMBER**

Rationale: Currently there are no programmed resources for the modernization of the medical air and ground evacuation fleet.

Enhancing Casualty Survival.

Near Term - **AMBER**; Mid Term - **AMBER**; Far Term - **AMBER**

Rationale: There are insufficient resources available to continue the modernization of field combat medical units in Force Package 1 or to sustain these units once modernized.

Command, Control, Communications, Computers, and Intelligence (C4I). (New Objective)

Near Term - **RED**; Mid Term - **AMBER**; Far Term - **AMBER**

Rationale: C4I is rated **RED** during the near term because AMEDD access to satellite communication for long haul information transfers is non-existent. This is critical for effective medical support packages. Additionally, communication shortfalls of tactical high frequency radios and switchboards in field medical units was substantiated during the most recent AMEDD Functional Area Assessment as warranting a **RED** rating during the near term. The VCSA directed the Signal Center and School to work with AMEDD on resolving the problem.

Medical Materiel and Blood.

Near Term - **AMBER**; Mid Term - **GREEN**; Far Term - **GREEN**

Rationale: The mid and far terms have been upgraded from **AMBER** to **GREEN**. Oxygen, fluid production, blood substitutes, and small volume resuscitation fluids capabilities are scheduled to be available by mid term.

Develop NBC Agent Preventive and Treatment Measures.

Near Term - **RED**; Mid Term - **RED**; Far Term - **RED**

Rationale: The nuclear medical defense subset of this capability has been downgraded from **AMBER** to **RED** in the near, mid, and far terms. Acceptable products suitable for military fielding to protect individuals from radiation do not exist nor is a technological breakthrough for full protection anticipated during the far term. The development of a drug to prevent gastrointestinal, bone marrow, and central nervous injury is not foreseeable in the far term. A product to mitigate vomiting, a primary effect of radiation which interferes with the soldier's ability to complete the mission, will be fielded in the mid term.

Telemedicine, Telesurgical Presence, and Virtual Reality. (New Objective)

Near Term - **AMBER**; Mid Term - **AMBER**; Far Term - **GREEN**

Rationale: Advanced Technology Assisted Health Service Support (ATAHSS) remains an evolving, dynamic concept. Resourcing and requirement issues are unresolved.

Provision of Health Service Support in an NBC Environment.

Near Term - **RED**; Mid Term - **RED**; Far Term - **RED**

Rationale: **RED** in the near and mid terms for chemical and biological is due to non-medical resourcing issues pertaining to medically acceptable protective suits, advances in medical materiel decontamination, collective protection shelters for patient protection and treatment, and improved patient decontamination methods. **RED** in the near, mid, and far terms for nuclear is due to the nonavailability of any type of Nuclear Protective Shelter for HSS.

Provide Care for Non-Battle Injuries and Disease in Operations Other Than War.

Near Term - **AMBER**; Mid Term - **AMBER**; Far Term - **GREEN**

Rationale: Near and mid term ratings remain unchanged because technology does not provide modernized dental equipment that would significantly reduce the weight and cube of dental organizations. Decreased weight, size and maintenance requirements would enable dental units to project and sustain the force farther forward in a more efficient manner.

SECTION 4

RESEARCH, DEVELOPMENT, AND ACQUISITION STRATEGY

Figure 15-3 provides a road map of various medical modernization methods.

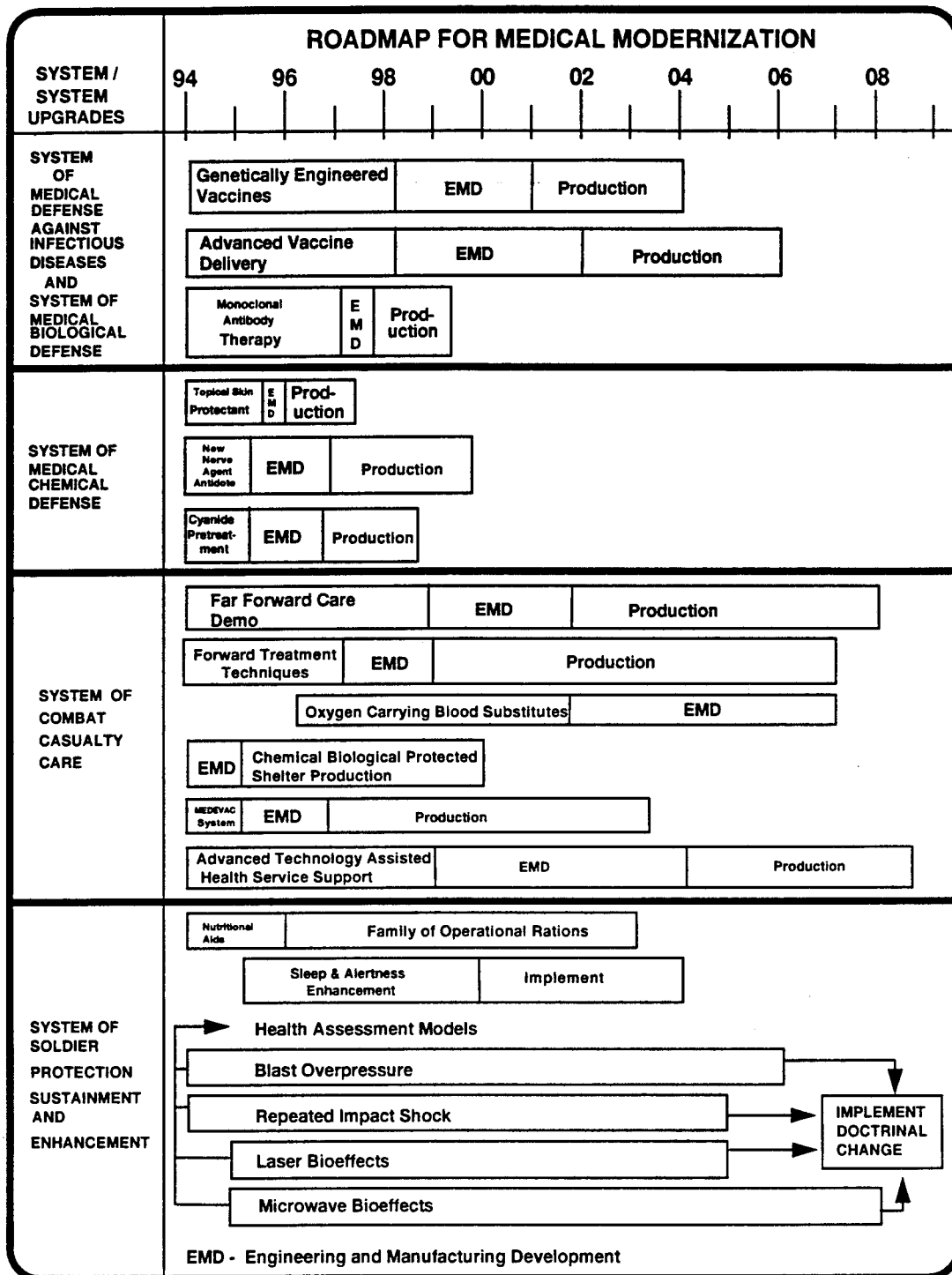

Figure 15-3

The number one near and mid term medical support equipment modernization issue for the AMEDD is the modernization of the medical evacuation (MEDEVAC) system through integration of enhanced platforms and medically specific interior designs. Treatment of the sick and wounded; transportation of medical equipment, supplies, personnel; and enroute combat medical care will be improved resulting in decreased morbidity and mortality.

The UH-60Q MEDEVAC helicopter, in combination with developing concepts for a high-capacity air ambulance (fixed wing) and Forward Surgical Teams (FST) are envisioned to provide the Army with a significant increase in far forward medical support capability. This growth in HSS is accomplished through the use of advanced technology and integration of state-of-the-art medical, navigational, and mission equipment, into existing airframes to extend the range of medical support and evacuation.

The Army Medical Department, in coordination with the Infantry and Armor Schools and the US Army Medical Materiel Development Agency (USAMMDA) has initiated development of the Armored Evacuation Vehicle (AEV) requirements. The USAMMDA will construct Proof of Principle (POP) models of the medical treatment compartments for potential vehicle solutions based on a draft requirements document provided by the US Army Medical Department Center and School. Estimated completion of the models is April 1994.

The Chemical/Biological Protected Shelter (CBPS) is in full scale development and has been undergoing technical testing at Dugway and Yuma Test Centers since 4th Quarter, FY93. Five prototypes have been completed to support technical and operational testing. Production dollars to support fielding CBPS were approved beginning in FY95.

Advanced Technology Assisted Health Service Support (ATAHSS) is a developmental concept which proposes that advanced emerging technologies be threaded through the entire HSS system. By enhancing already existing capabilities, providing replacement for outdated technology, and inserting new capabilities, significant decreases in morbidity and mortality can occur. ATAHSS encompasses, but is not limited to advances in therapeutic equipment, communication devices, and telemedical technology. Medical data and visual images archived by ATAHSS will be incorporated into technology-mediated simulations and used to provide realistic training to health care providers at all levels. Resourcing issues will impact directly on the success of ATAHSS.

Medical materiel modernization efforts encompass the research and development of medical materiel, through a drug and vaccine industrial base, for countering potentially mission aborting infectious diseases as well as chemical biological warfare agents. Many DoD drugs and vaccines are not normally developed by the US pharmaceutical industry because there is little financial incentive. Additional efforts of the medical program include technologies and techniques supporting far-forward casualty treatment; individual sustainment (self aid devices and techniques) to reduce the severity of battle and non-battle injuries; topical skin protectants; oxygen carrying blood substitutes; and miniature and filmless medical imaging (x-rays) technologies. The modernization strategy also addresses nutritional and physiological approaches to minimize the impact of military operational and environmental stresses which degrade the capabilities of, or render inoperable, the human component of combat systems.

The ability of research, development and acquisition (RDA) programs to protect, sustain, and project the force is directly correlated to resourcing levels. Figures 15-4 through 15-7 reflect the ability to accomplish these objectives.

FIELD MEDICAL HOSPITAL PROGRAM (FY94-99)		
DOES		DOES NOT (FY94-99)
NEAR (FY94-95)	MID (FY96-99)	
<p>Sustain and modernize 53 percent of field units in Force Package 1</p> <p>Procure new technology medical materiel for 53 percent of field medical units in Force Package 1</p> <p>Support continued fielding (TPF, NET) associated with DEPMEDS/MF2K configuration</p>	<p>Sustain and modernize 85 percent of field medical units in Force Package 1</p> <p>Procure new technology medical materiel for 85 percent of field medical units in Force Package 1</p>	<p>Procure any additional DEPMEDS-equipped hospitals</p> <p>Sustain and modernize 15 percent of field medical units in Force Package 1</p> <p>Procure new technology medical materiel for 15 percent of field medical units in Force Package 1</p> <p>Sustain and modernize any field medical units in Force Packages 2 and 3</p>

Figure 15-4

NUCLEAR, BIOLOGICAL, AND CHEMICAL PROGRAM (FY94-99)		
DOES		DOES NOT (FY94-99)
NEAR (FY94-95)	MID (FY96-99)	
<p>Store biological defense vaccines</p> <p>Continue to produce biological vaccines (anthrax, botulinum toxoid, Q-fever, and encephalitis)</p> <p>Continue to produce botulinum antitoxin</p> <p>Procure patient chemical wraps</p> <p>Perform operational studies</p> <p>Procure NBC resuscitative devices</p> <p>Procure XM-28 (NBC collective protection) for contingency corps Force Package 1</p>	<p>Store biological defense vaccines</p> <p>Expand production of biological defense vaccines (for additional vaccines and increased production rates)</p> <p>Procure vital signs monitor</p> <p>Procure powered ventilator</p> <p>Procure multichambered autoinjector</p> <p>Procure anti-radiation medications</p> <p>Procure chemical biological protected shelter for contingency corps Force Package 1</p>	<p>Procure NBC collective protection for the remainder of the force</p>

Figure 15-5

SCIENCE AND TECHNOLOGY BASE PROGRAM (6.1-6.3A, FY94-99)	
DOES	DOES NOT
<p>Support the President's objective to maintain defense technology</p> <p>Resource medical science and technology base at 0 percent real growth</p> <p>Provide for an integrated, resource-constrained and balance mid-through long-term investment strategy reflecting:</p> <ul style="list-style-type: none"> • Next generation and future warfighting capability needs • Key emerging technologies • Systemic issues • Supporting capabilities <p>Align resources with Army Operational Capability Requirements</p> <p>Support Executive and Lead agent responsibilities</p> <p>Anticipate decreasing mid-term HIV requirements</p>	<p>Sustain core capability</p> <ul style="list-style-type: none"> ① Combat Casualty Care ② Infectious Disease ③ Chemical and Biological Research <p>Resource HIV growth to meet congressional direction</p>

Figure 15-6

FULL SCALE DEVELOPMENT PROGRAM (6.3B-6.4, FY94-99)	
DOES	DOES NOT
<p>Support vaccine development, testing and regulatory approval of programs (GP120) targeted against HIV disease</p> <p>Development programs required to field medical materiel that is technologically current, low weight, low cube, less power consumptive,</p> <p>Support rapid identification and diagnosis, toxoid and vaccine development testing and regulatory approval to develop countermeasures for biological warfare agent threats to U.S. Forces</p> <p>Development targeted against endemic disease identified as threats to deployment or significantly impacting training U.S. Forces Development and testing of topical skin protectant, drugs, drug delivery systems, and packaging technologies for protecting and treating U.S. Forces against chemical warfare agent threats identified as a validated threat</p>	<p>Provide for development of polyvalent vaccines or drug therapies</p> <p>Provide for the fielding of a silver nylon burn dressing, thorough analysis and testing of medical interior for an armored aid station, development, testing and regulatory approval of more effective burn treatment or integration of expert systems for field medical evaluation and care</p> <p>Provide for the development of a Staphylococcal Enterotoxin B toxoid, a purified anthrax vaccine or development of a Brucellosis vaccine</p> <p>Provide for development of vaccines to protect against dengue and leishmaniasis</p> <p>Provide for development of an advanced anticonvulsant or testing of reactive antivesicant barrier creams</p> <p>Provide for development of crew alertness monitors and hazardous gas monitors</p>

Figure 15-7

SECTION 5

TRAINING

AMEDD modernization training continues to optimize the potential of technological advancements in military and civilian environments. Modernization training prepares AMEDD leaders and soldiers to accomplish their mission by providing training on the operation and maintenance of new equipment, new doctrine, and new organizational changes. The following provides an update to Annex O of the AMP on the development and testing of training devices and simulations.

- **Multiple Integrated Laser Engagement Simulation System (MILES) Casualty Cards.**

The MILES Casualty Cards (GTA 8-11-14) were fielded in January 1993. An official evaluation of the cards will be provided in a future update to the AMP as the information becomes available. The cards are available through local Training Support Centers or Visual Information Support Centers.

- **Interactive Videodiscs (IVD).** IVD production for the AMEDD is a coordinated and continuous effort among the teaching divisions, the Directorate of Training Development, and the Health Sciences Media Division at the US. Army Medical Department Center and School (AMEDDC&S). At the request of one of the teaching divisions, generic video data discs are being developed which will facilitate the production of subject specific interactive videodiscs.

- **Satellite Training.** Funds are not available at this time.

- **Telemedicine Training.** The implementation of ATAHSS, currently being tested with rapid prototyping exercises and deployments, bears implications for training. Prior to full implementation of the system, users at all points of the interface with the system must be knowledgeable and competent in the performance of tasks associated with its use. Data collected and archived during operations will be available for incorporation into realistic training simulations that can be linked across sites via electronic highway assets.

SECTION 6

CONCLUSION

The AMEDD's current doctrine and organizational design was based on a forward deployed, prepositioned, extensive host nation support NATO warfight scenario. As a result of the lessons learned in JUST CAUSE and DESERT STORM and the introduction of a new National Military Strategy and Army operational concepts, (along with a significant downsizing of the total force), the AMEDD has conducted an extensive analysis of required and current capabilities. The current Medical Force 2000 (MF2K) organizational design, HSS, revised doctrine in FM 100-5, medical materiel assemblages and evacuation platforms, training and leader development requirements compel modification, modernization, and further development and acquisition of overmatching technologies.

The major initiatives currently being worked by the AMEDD to support a CONUS based force projection Army are the development of a FST, Contingency Hospital, ATAHSS, and enhanced air and ground medical evacuation platforms. These initiatives will allow the AMEDD to protect, sustain, and project the force by maintaining a medical presence with the soldier, preserving the health of the command, clearing the battlefield of casualties, providing state-of-the-art medical care within the operational environment, and returning as many soldiers to duty as possible. Bill payers have been identified for organizational structures. The AMEDD requires assistance in funding and procurement of enhanced evacuation platforms and ATAHSS. These critical pieces of the HSS battlefield system, if not corrected, could negate or severely degrade the performance and potential of the remaining HSS assets. The ultimate result would be no advancement in our continued battle against mortality and morbidity.

CHAPTER 16

TRAINING

SECTION 1

INTRODUCTION

This chapter updates Annex P of the 1993 Army Modernization Plan. The Army focuses its training programs through the Training Mission Area (TMA). The TMA provides the training aids, devices, simulators and simulations (TADSS) critical to attaining the Army's modernization objectives. The TMA provides the appropriate mix of TADSS to allow Army components to train to standard. These TADSS provide "high payoff" simulations-based training supporting the DoD vision of the future battlefield environment.

TRAINING FOR THE FUTURE

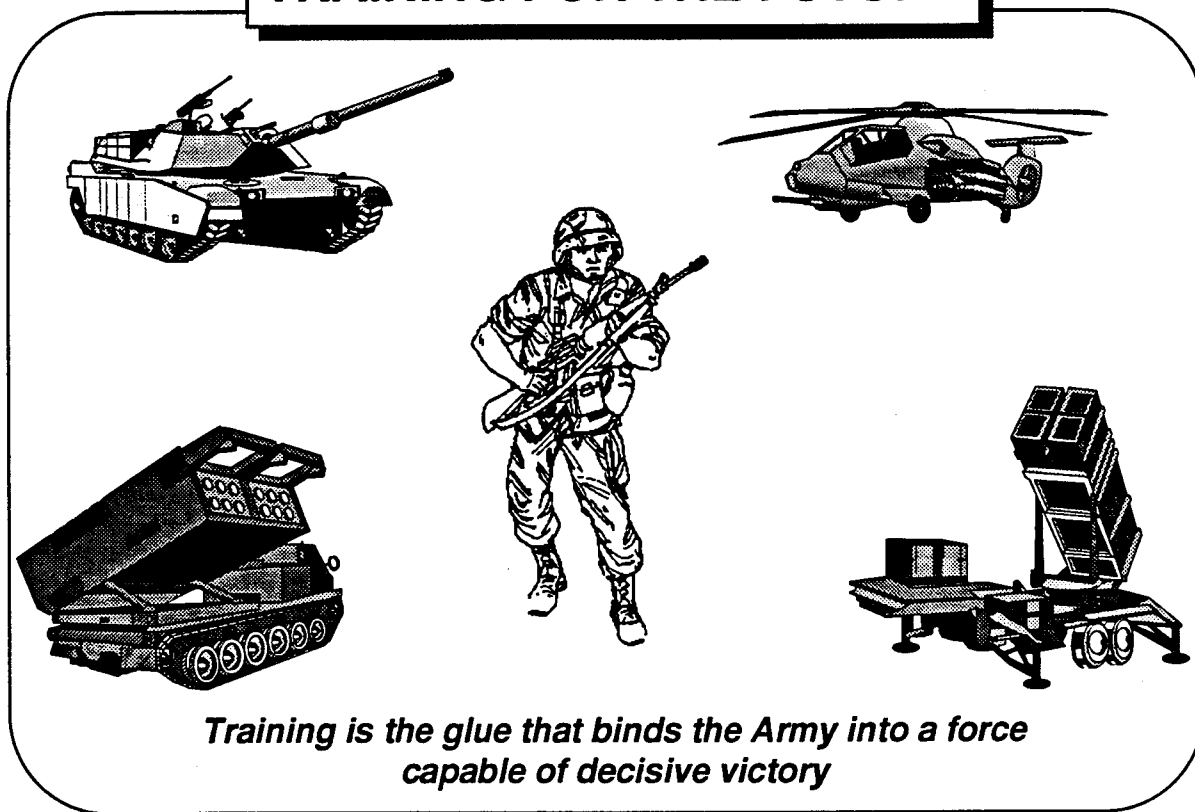

Training is the glue that binds the Army into a force capable of decisive victory

SECTION 2

WARFIGHTING CONCEPT

The TMA supports the Army's mission to organize, train, equip and provide decisive forces capable of rapid deployment to and immediate engagement in any location and situation, by providing realistic simulation-based training.

Key elements of the TMA are:

- **Combined Arms Tactical Trainers (CATT).** A network of simulations and simulators that replicate vehicles and weapon systems of the combined arms team.
- **Family of Simulations (FAMSIM).** Provide realistic battlefield environments for commanders and staffs to practice the execution of command and control, synchronization and employment of combat arms assets without incurring the high cost of field training exercises.
- **Combat Training Centers (CTC).** The TMA provides the TADSS and instrumentation systems used at the CTCs, the Army's premier practice fields.
- **Nonsystem Training Devices (NSTD).** These critical home station and individual/crew training devices and simulators enable soldiers, leaders and units to conduct demanding training on tasks that would otherwise be too costly or hazardous to train.
- **Training Ammunition.** Training Ammunition enables AC\RC units to achieve training standards with individual/ crew served weapons and also provides ammunition support for the training base.
- **Land, Ranges, Targets, and Environmental.** Range instrumentation, targetry and devices to support MCA approved range projects and Army range modernization requirements, identified in the Army Range and Training Land Master Plan, are developed and procured by the TMA.

SECTION 3

CURRENT PROGRAM ASSESSMENT

The following Figures graphically represent the significant changes to the Training Mission Area Programs:

TRAINING ASSESSMENT OF TRAINING MISSION AREA PROGRAMS				
MAJOR TMA PROGRAMS	DEFICIENCIES	NEAR TERM FY 94-95	MID TERM FY 96-99	FAR TERM FY 00-08
CATT	No Man-in-the loop modeling capability to support DOD DIS initiatives No Bn/TF level Battle level Battle Distributive Simulation-Developmental capability to exploit new technology No network simulation capability for the Bn/TF to do combined arms training w/EN, AV, ARTY, and ADA forces No acquisition developmental strategy savings through prototype simulations No combined arms weapon system prototyping and evaluations No combined arms doctrinal evaluation base	AMBER	AMBER	AMBER
FAMSIM	Lack of standardized protocol inhibits linking of simulations, simulators, and range instrumentations in support of DIS Unable to adequately support acquisition and testing requirements per Defense Science Board recommendation	AMBER	AMBER	GREEN*
CTC	No objective assessment of Lt Inf Live Fire (JRTC Live Fire Instrumentation) (NTC Live Fire Expansion) No objective assessment of F-O-F and Live Fire in urban environment (JRTC MOUT Instrumentation) No objective assessment of Air/Ground operations (CTC integration of AGES II) Limited capability to exercise modern systems on instrumented battlefield at NTC, JRTC, and CMTC (ALB-F) Antiquated, inefficient, high (OPTEMPO) threat vehicle at NTC (M113 OCV) Inability to fully exercise modernized systems in Live Fire at NTC (NTC Live Fire Mod)	AMBER	AMBER	GREEN*
* Denotes Changes				

Figure 16-1

TRAINING ASSESSMENT OF TRAINING MISSION AREA PROGRAMS				
MAJOR TMA PROGRAMS	DEFICIENCIES	NEAR TERM FY 94-95	MID TERM FY 96-99	FAR TERM FY 00-08
TRAINING AIDS, DEVICES, SIMULATORS, AND SIMULATIONS (TADSS)	Not replacing MILES as fast as it ends life cycle; Not enough MILES AGES II to fully integrate Army Aviation at CTCs RC Impact: No GUARDFIST Bradley for Total Force	AMBER	GREEN*	GREEN*
FIRE SUPPORT	No Homestation SAWE-RF	AMBER	AMBER	AMBER
COUNTER MOBILITY/ SURVIVABILITY	No NBC Training Devices	RED	RED	RED
INTELLIGENCE	Inadequate IEW training devices: IEWTPT is only partially system funded	AMBER	AMBER	AMBER
COMBAT SERVICE SUPPORT	No effective means to train mobility/ countermobility tasks	RED	RED	RED
RANGE INSTRUMENTATION, TARGETRY, AND DEVICES	Shortage of Standard range targetry (RETS/PRETS) No Engagement Skill Training Device (EST) No Installation Instrumented Range Capability (PRIME) No capability to engage realistic thermal targets (AITST)	AMBER	AMBER	AMBER

Figure 16-2

TRAINING ASSESSMENT OF TRAINING MISSION AREA PROGRAMS				
MAJOR TMA PROGRAMS	DEFICIENCIES	NEAR TERM FY 94-95	MID TERM FY 96-99	FAR TERM FY 00-08
TADSS- OTHER PROGRAMS LAM	No mechanism to effectively take charge of the process and simultaneously maintain combat readiness during an accelerated build-down of the U.S. Army	AMBER	AMBER	AMBER
DIS	Unable to provide capability to execute OSD lead responsibilities for implementation of DIS architecture development Unable to provide capability beyond DIS demo's Unable to provide DIS utility to training, combat development and other functions	AMBER	AMBER	GREEN*
TNG AMMO	Cannot resource entire requirement at present funding levels during Mid Term	GREEN	RED*	RED*
LAND ACQUISITION (NTC)	Inadequate Maneuver Space: Less Maneuver flexibility Less battle area depth Limited CS/CSS depth	AMBER	AMBER*	AMBER*

* Denotes Changes

Figure 16-3

SECTION 4

RESEARCH, DEVELOPMENT, AND ACQUISITION STRATEGY

As the Army becomes a smaller, CONUS based power projection force, the training aids, devices, simulators and simulations (TADSS) developed and procured through the Training Mission Area (TMA) become more critical to Army readiness. The primary means of acquiring most TADSS are through normal research, development and procurement. However, some training requirements can and have been met by procuring off-the-shelf and non-developmental items. The TMA is now beginning to look toward science and technology efforts to leverage emerging technologies. Modernization of our Army through the promotion of new technologies will increase the lethality, versatility, deployability, survivability, and affordability of Army weapons systems. Technologies that will improve training and achieve a higher level of training readiness must be developed to ensure our soldiers are the most capable and highly trained Army on the battlefield. TADSS contributes to a wide range of capabilities to include:

- Upgrading and fielding MILES Army-wide.
- Instrumenting the Army's premier practice fields--the Combat Training Centers.
- Providing a network of simulators for vehicles and weapons that will allow units to conduct and sustain combined arms tactical training with crew through battalion-level simulated exercises.
- Providing commanders and staffs battle simulations depicting realistic battlefield environments to allow routine practice of command and control, synchronization, and employment of combined arms and assets.
- Providing devices that realistically train tasks that would be otherwise too costly, difficult, or unsafe to train using actual equipment.

The sophistication, complexities, escalating operating costs, and increased lethality of modern weapon systems, as well as the need to learn how to synchronize a fast-moving, dispersed battle, create the demand for simulation-based training that can replace or augment traditional field and range training. Simulation-based training is developed to train commanders and staffs from brigade through echelons above corps. The training vision for the year 2000 and beyond is to produce a seamless simulation environment that allows actual combat systems, manned simulators, and other simulations to exercise on a virtual battlefield. The simulated warfighting environment can be packaged or scaled to address a variety of uses, to include connecting smaller segments of simulation into larger, synchronized environments when required.

TADSS provides soldiers and commanders training through free and natural interaction with simulated environments, instructional features, and complementary collective training strategies that facilitate learning while retaining warfighting skills. In the future, materiel developers must embed training capabilities into weapon systems.

Streamlining the weapon system acquisition process necessitates incorporating training requirements early in the process. The emphasis on MANPRINT, Embedded Training (ET), value engineering, and top-down training strategies dictate the necessity to describe complete training systems. Common technology challenges exist for weapon training and training system development for a total training system package.

Shared weapon training requirements for the future include tactical proficiency, ET, semiautomated forces, seamless simulation, and expert battle management. Additionally, ET, SAF, and seamless simulation are examples of shared future technology challenges, as are the following:

- **Large-scale, real-time networking.** Long haul data network services to allow broad engagement scenarios with equipment and crews at geographically separate sites.
- **Knowledge representation.** Artificial intelligence that builds from a knowledge base by representing expert knowledge with a rule structure.
- **Low-cost computer image generation.**
- **Rapidly reconfigurable terrain data bases that allow development of geo-specific terrain photo-based images.**
- **Modular design.** Test beds using modular hardware and software simulator designs require rapid prototype simulators and advanced artificial intelligence technologies.

Training Research and Development, Future Acquisition Strategy

Fiscal constraints and the reduction of our force structure will cause technologies that have high payoffs in training to receive priority for funding. Development of new systems will slow down, and emphasis will be on upgrading current systems with new technology that provide key combat force multipliers for our forces. Training technology initiatives must be examined and prioritized in a similar manner. The future training technology initiatives that have high payoffs (i.e., reduce training time and resource consumption, such as OPTEMPO, ammunition, training land, and ranges and significantly improve training) and provide a key training force multiplier should receive high priority for funding. These future training technology initiatives should support new weapon systems or system upgrades whenever possible. This becomes a truly high payoff when training technologies and system development and upgrades combine to provide both training and combat force multipliers.

We will continually examine ways and means to improve Army training. Exploitation of innovative technologies that significantly improve training and training readiness must be encouraged and incorporated into the training environment. Our challenge is to have the most technologically combat trained and deployable force in the world. The Army must look to research and development initiatives to identify technology that may offset decreasing force structure and ensure the means of providing realistic and dynamic training to our soldiers—today and tomorrow.

SECTION 5

TRAINING

The major objective of Army training in connection with modernization is the integration of systems and non-systems training technology, development and integration within the three categories of simulation. Additionally the application of technology will off-set the restrictions imposed upon training by high technology weapons systems, safety, environmental sensitivities and higher training costs. In meeting these objectives, training technology will better serve and support Army readiness in the 21st Century.

The integration of systems and non-systems training aids, devices, simulators and simulations (TADSS) affects the requirement development process, acquisition management, and resourcing. Our intent is to optimize the available research, development and acquisition dollars to field the most effective possible training technology concurrent with the fielding of new battlefield technology.

The Army seeks greater standardization in systems TADSS across all battlefield operating systems (BOS). This ensures a consistent approach to training technology and equitable investment in TADSS for individual, collective, institutional and unit training. In developing TADSS standards, the unique requirements inherent in each BOS will be recognized and supported. A major objective will be to develop and institutionalize embedded TADSS.

Non-systems TADSS will be developed to integrate system training devices and to provide sub-systems for training systems involving multiple devices.

The Army continues to seek training technology to support and integrate all three components of OSD's simulation architecture (live, virtual and constructive). The ultimate objective is to fully integrate the three categories into seamless, interactive training networks which will not only enhance training quality, but also provide the greatest return on investment.

The three critical factors that force the Army to consider innovative application of training technology to achieve training readiness standards are:

- Expanding capabilities of Army modernized weapons and battlefield systems which make traditional field training with these systems impractical.
- Increasing environmental sensitivities and resulting restrictions to conventional field training.
- Increasing costs of conducting conventional field training.
- Increased safety awareness.

To mitigate those factors, the Army's approach to training technology must be integrated and focused.

SECTION 6

CONCLUSION

The National Military Strategy calls for an Army that is deployable, lethal, versatile, and capable of conventional deterrence. Our Army must have the ability to win wars decisively, swiftly, and with minimum casualties. Land Force Dominance is required to ensure quick, decisive victory. The U.S. Army, to achieve **Land Force Dominance**, must continually field high payoff technologies that provide capabilities to quickly project and sustain and protect the force, win the information war, conduct precision strikes throughout the extended battlefield, and dominate the maneuver battle. Investments in enhanced capability weapons systems do not necessarily ensure readiness—leaders must be trained to employ the systems, soldiers must be trained to operate them, using tough and realistic training.

Only by maintaining a well-trained and ready total force can we meet the expectations of the American people have of America's Army. Training brings into balance those functions we must do well. Training is the imperative that bonds all other Army imperatives into a coherent whole. Good training retains quality people; brings doctrine to life; melds new force structure into combat ready units; makes soldiers and units proficient with new equipment; and develops competent, confident leaders.

This Training Annex is a "road map" for future actions concerning training—its course charted by the Combined Arms Training Strategy (CATS). CATS provides guidance on how the total force trains and the resources required for training. CATS describes the transition from a TADSS-supported, high OPTEMPO/live fire training program to a TADSS-based training program that uses significantly lower levels of OPTEMPO/live fire. CATS calls for a mix of field training and simulators for individual training and simulations for unit training at company level through echelons above corps. In accordance with CATS, units organize for training as they would organize for combat. This strategy enhances combined arms and service support operations, and minimizes the time needed to train Army units to the standards of their mission essential task list—before they deploy to combat.

The Training Mission Area (TMA) programs support a holistic approach to Army training. Each program contributes a critical piece to the Army's integrated training system and offers necessary linkages to combat readiness. Additionally, these programs support a synergistic effect; each interacts with other training programs to provide an exponential benefit. All TMA programs must be sufficiently resourced to ensure training readiness of the Army.

Bottom line: The Army faces significant changes in the future. These changes will challenge our capability to train; we must train more effectively and efficiently. The maturing of current technologies and emergence of new concepts offer opportunities to improve the training of soldiers, leaders, and units. At the same time, constrained resources will demand that we reshape the current training strategy to preserve the progress we have made, take advantage of new opportunities, and reduce the strain on dollars and manpower. This Training Annex describes the anticipated future training environment, a training strategy for that environment, and provides the plan to carry out this strategy.



CHAPTER 17 SPACE EXPLOITATION



SECTION 1 INTRODUCTION



The 1993 Army Modernization Plan (AMP) did not include an Annex on Space Exploitation, but for over 40 years the Army has played a key role in space. Support for operational missions is provided through exploitation of existing space assets and the application of space products to enhance command and control as well as other warfighting capabilities. The major applications areas of space products have been communications, navigational aids, intelligence, weather, missile warning, and imagery. This chapter addresses Army space related activities to support the warfighter.

Space surveillance, navigation, and communication capabilities enable CINCs to project and sustain the force safely and more efficiently, getting the right forces and equipment to the right place on time. Space intelligence and imagery capabilities contribute to the conduct of precision strikes against opposing forces and critical assets. Space exploitation helps protect the force from the threat of theater ballistic missiles (TBMs) by providing surveillance, detection, tracking, and early warning. These same capabilities help the Army win the information war, dominate the maneuver battlefield, and contribute to precision strike and sustaining the force.

Space has become an integral component of the Army's technological and operational evolution. Army space activities include efforts to maintain the technological edge, to use research and development to gain more leverage from national investments in space systems, and to influence the design of future space systems. The Army goal is to make the use of space a standard part of the planning for all appropriate Army operations and an integral part of the execution of all missions. This normalization of space provides the best utilization of technological capabilities to support warfighters, and is consistent with the principle of the Army's Enterprise Strategy to **Capitalize on Space Based Assets**.

Army space policy is derived from the National Military Strategy and the DOD Space Policy. It directs the Army to:

- Capitalize on emerging space systems' capabilities.
- Exploit space activities that contribute to the successful execution of Army missions.
- Support assured access to space and use of space capabilities to aid strategic, operational, and tactical missions.

To accomplish this Space vision, the Army has been developing the concepts; identifying and documenting requirements; and has begun the training of a cadre of space experts. Exploiting space requires a management strategy and an acquisition strategy that facilitate and commit to the integration of emerging space capabilities with existing and programmed capabilities. In addition, the Army must continue to capitalize on national and joint programs, as well as domestic commercial and international space systems. This must be done while preserving the options to support initiatives that may satisfy not only common user requirements, but also any Army unique requirements for space.

US Army space utilization has become an important component in the conduct of all phases of land warfare. The Army will continue to develop the use of space capabilities to improve the execution of its missions across the operations continuum in a global environment requiring a force projection Army. Modernization of Army space capabilities, as presented in this chapter, contribute to fulfilling Army Modernization Plan objectives and thus, improve the ability of CINCs to achieve quick, decisive victory with minimum casualties.

The Army needs to continue development of capabilities to execute Army missions which support the National Military Strategy areas of Strategic Defense, Forward Presence, Crisis Response, and Reconstitution. Army strategic roles supported by space exploitation are depicted in Figure 17-1.

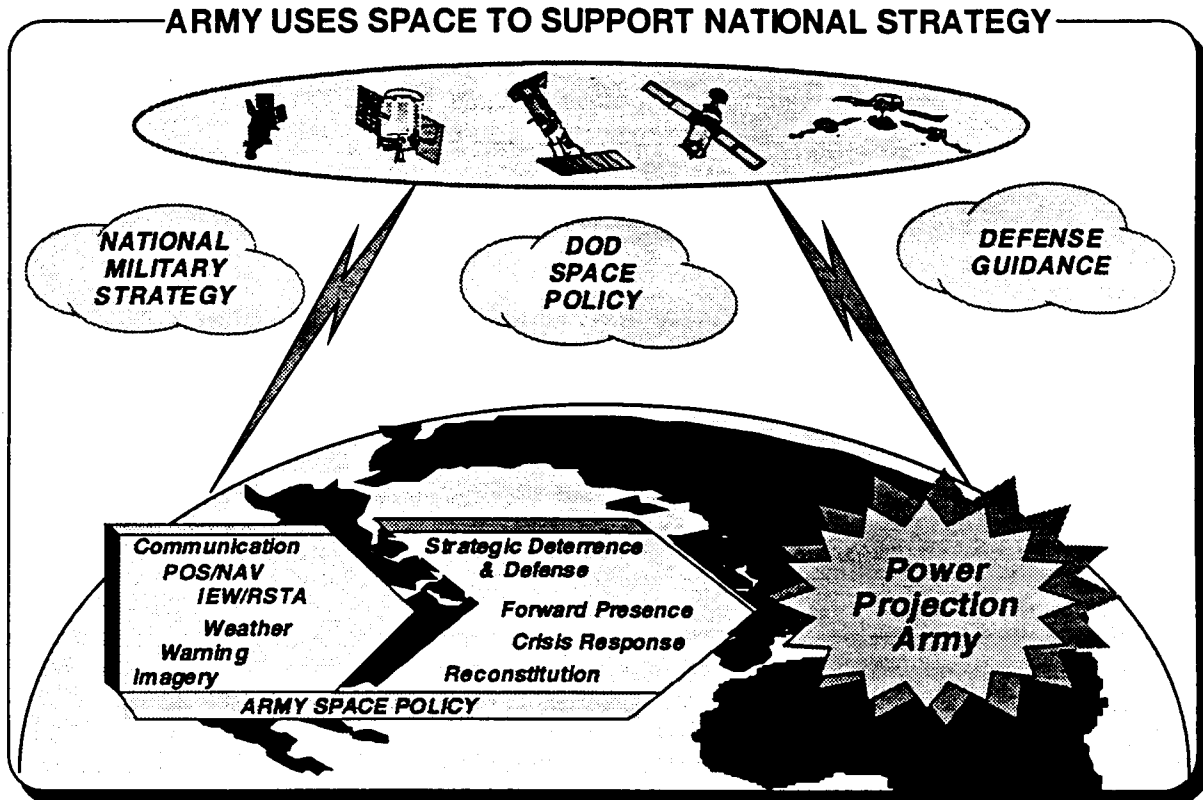

Figure 17-1

The Army does not have a separate "Space Exploitation" mission area. Space functions and products are integrated into other mission areas and battlefield operating systems. Army space exploitation can be grouped in six functional capabilities: communications; position and navigation, intelligence and electronic warfare, weather, warning; and imagery. Other chapters of this Modernization Plan describe the individual modernization programs which provide improved Army functional area capabilities exploiting space. The details of these programs will not be repeated here, however, programs in these functional areas will be assessed to explain the important role that Army space exploitation plays on today's, - and tomorrow's, battlefield. Army exploitation of space systems is discussed below by functional capability:

Communications. Global and theater wide instantaneous communications provide flexibility, agility, and efficiency in all phases of operations. Space based communications capabilities provide range extension for theater terrestrial communications networks and allow interconnection of widely separated force enclaves. These capabilities are required to meet the demands of Army operations on today's battlefield including split based operations, an increased operations tempo, C2 on the move, and a warfighters network providing an unprecedented situational awareness. Space based Military Satellite Communications (MILSATCOM) assets, augmented by civil SATCOM, enable this capability. The Army coordinates and manages the Ground Mobile Forces use of the Defense Satellite Communications System (DSCS) for the warfighting CINCs. Command, Control, and Communications program updates are also addressed in Chapter 3.

Position and Navigation (POS/NAV). The Global Positioning System (GPS) enables rapid setup and automatic orientation of the new tactical ground mobile forces Tri-band SATCOM terminals that will provide rapidly deployable DSCS and commercial satellite communications for the force projection Army. GPS hand held and vehicle installed receivers provide precise position location. Uses of GPS include route planning, surveying for fire support, and navigation for weapon systems, helicopters, and ground vehicles. GPS also provides timing for communication circuits. This is especially critical for high speed data communication. The introduction of GPS into combat net radios will also enhance situational awareness.

The use of small lightweight GPS receivers provides confidence, speed, and flexibility in mobile non-nuclear warfare. The capability to contribute to the overall situational awareness, including combat identification, has added new dimensions to the warfighters horizon. GPS integration into smart weapons enhances the Army's precision strike capabilities. Other position and navigational updates are discussed in Chapter 3.

Intelligence and Electronic Warfare (IEW). The Army's Tactical Exploitation of National Capabilities (TENCAP) program is focused on tactical applications of national space systems that were designed to support strategic requirements. Downlinking of strategic systems to tactical levels provides an accurate and current enemy picture (imagery, communications, and electronic signatures) during both planning and execution. Secondary dissemination and broadcast capabilities supported by space assets provide a continuing situation awareness through all phases of operations. Intelligence and Electronic Warfare updates are also discussed in Chapter 9. National capabilities have also supported numerous humanitarian efforts to include Hurricane Andrew and the recent midwest flood relief efforts.

Weather. Tactical Defense Meteorological Satellite Program (DMSP) downlinking provides accurate theater weather to support planning in real time to support execution. Accurate meteorological data at target sites is required data for long range acquisition and engagements. Current Army capabilities are through commercial satellites and receivers.

Warning. Overhead coverage, such as the Defense Support Program (DSP) satellites, allows surveillance of enemy missile systems, cues active theater missile defenses, provides targeting information to attack operations forces through the Joint Tactical Ground Stations (JTAGS), and allows all forces to take passive defense measures.

Imagery. Current map products are not available for many areas of the world that a Force Projection Army may be sent. Space based sensors, including national assets, can provide the most current electro-optical (EO), infrared (IR), synthetic aperture radar (SAR), and multi-spectral images (MSI) of ground operations areas. When processed with elevation data, up to date broad area mapping products can be supplied by topographic engineer units. These products enhance terrain analysis and enable limited mission planning and rehearsal.

Processed imagery data is used by multiple intelligence systems and, when combined with data from other assets, contributes to the Intelligence Preparation of the Battlefield (IPB). Engineer and mine warfare modernization updates, including production and dissemination of imagery, that are linked to space capabilities are also discussed in Chapter 4.

The United States Army Space and Strategic Defense Command (USASSDC) is the organization that serves as the proponent and integrator of space activities for the Army. USASSDC is made up of the Army Space Command (ARSPACE) and the Army Strategic Defense Command (SDC). ARSPACE serves as the Army component for US Space Command, and provides the Army input for planning DOD space system support of military operations. ARSPACE also conducts the Army Space Exploitation Demonstration Program which executes operational space demonstrations to operational units. USASSDC ensures Army access to space resources to enhance accomplishment of Army missions and is the focal point for the Army space research and development technology base. HQ TRADOC is the user representative in the combat development arena.

SECTION 2

WARFIGHTING CONCEPT

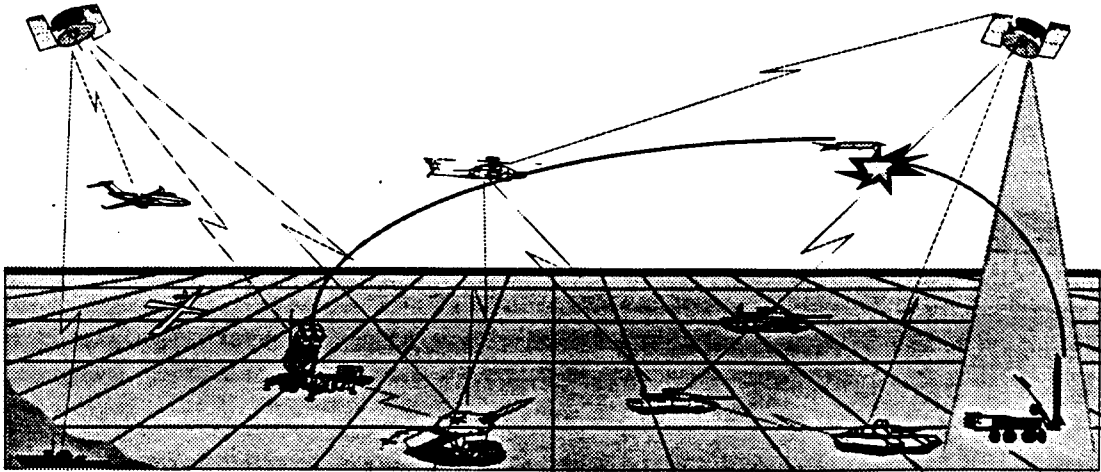

Throughout history, the victor on the battlefield has been the military force that has controlled the "high ground". From that vantage point, armies could not only observe the entire battlefield, but they could also maintain a defensible position while attacking their foes below.

In tomorrow's battles the "high ground" will continue to be equally important. The "high ground", however, is no longer confined to the highest hill or geographical objective. Tomorrow's "high ground" extends into space – and includes all the tremendous advantages of "space-age" technology.

While the Army is a land force, it is dependent on support from sea, air, and space assets to accomplish its missions. Many current space systems were designed and justified to support strategic rather than tactical requirements. In times of crisis, however, they have been adapted and tailored to satisfy some of the Army's operational and tactical requirements. These systems have made valuable contributions to Army operations. The delivery of timely space products to land forces was an essential ingredient of the Desert Storm victory.

Space capabilities are becoming an integral part of Army planning and operations. The architectures and activities that support Army warfighting will include a significant contribution from Army space activities/programs. In the future we must not just exploit existing space assets but, rather, we must prioritize and assert the land warfighter's space application requirements to influence the design of tomorrow's spacecraft. In so doing the Army will maximize the effect of space products and more fully achieve the force enhancement potential of space assets.

Since 1987, Army space policy has been to enhance the Army's ability to conduct full-dimensional operations using space system capabilities. Army Doctrine (FM 100-5, Operations, dated June 1993) recognizes the contributions of space applications to force projection. Space Support to Army Operations, FM 100-18 (Draft), dated September 1993, describes the capabilities and employment of space systems that enhance the Army's execution of strategic, operational, and tactical missions across the range of military operations. Space support to the warfighter will contribute in all phases of force projection deployments (Figure 17-2) and in all phases of operations from war to operations other than war.

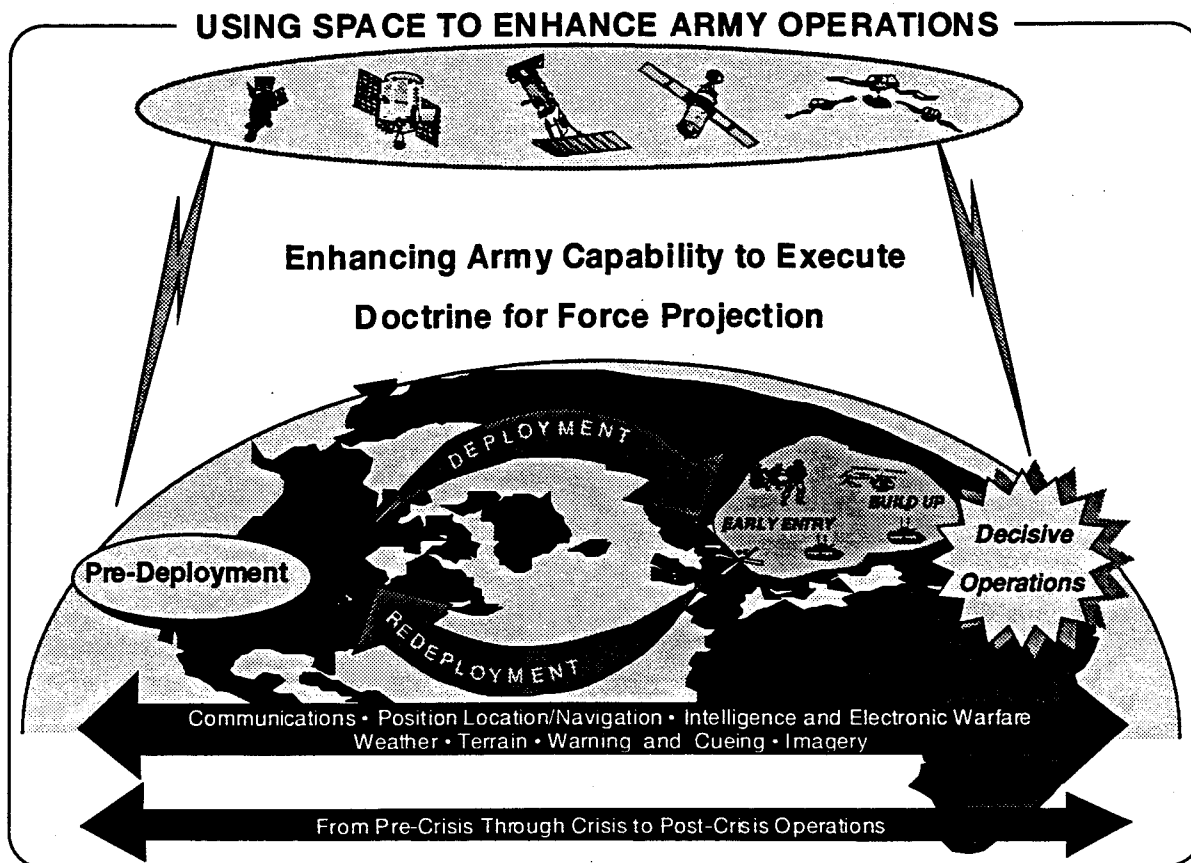

Figure 17-2

PEACETIME

Operations Other Than War. In addition to day-to-day support for peacetime operations, space applications provide support to the warfighter in the performance of missions other than war. Space applications contribute to peacekeeping, humanitarian assistance, disaster relief and other operations short of war as demonstrated in Somalia, Hurricanes Iniki and Andrew, and the Andean Ridge. In peacetime, peacekeeping, nation assistance, and security assistance are all supported by communications, imagery, mapping, and meteorology from space assets. In Somalia, the 10th Mountain Division faced vast stretches of poorly mapped, poorly trafficable terrain with little host nation infrastructure. The void was partially filled by using mapping products developed from space based systems, including TENCAP capabilities. These were provided to the division from the Army Space Exploitation Demonstration Program shortly before deployment. The units were equipped with Small Lightweight GPS Receivers (SLGRs) updated to 15 meter accuracy and multi-spectral imagery converted to hard copy products. Commercial International Maritime Satellite (INMARSAT) terminals were used to overcome the shortfall in immediately available inter-theater communications to support medical, administrative, and logistic needs in the field. A new small tactical receiver for Defense Meteorological Satellite Program (DMSP) data and civil satellite data was shipped to the division and provided the Joint Task Force in Somalia with timely, high resolution weather imagery.

Counter-Drug Operations benefit from space enabled capabilities of overhead surveillance in near real time, accurate position location to support intercepts, and instantaneous communications to operate inside the trafficker's decision loop.

The role of space exploitation and utilization of space products in operations other than war also sets conditions for the Army's transition to crisis response.

SPACE EXPLOITATION

CONFLICT

Pre-crisis. In the pre-crisis phase of operations the primary space contributions are in communications, surveillance and warning, mapping, and meteorological support. Space capabilities will be incorporated into training and preparation phases to enable Army forces to train the way they would fight. Training and exercises are enhanced by bringing enemy and environmental conditions expected in war to CONUS exercises/simulations. Collection and archiving of imagery supports the rapid production of up-to-date maps for many areas of the world.

In today's environment, responding to crises will normally be done in concert with allies. Space capabilities are key to support these activities. Global communications allow proper coordination for international operations. Global communications also allow proper force tailoring for the anticipated mission and improved joint/combined training/exercises of forces. Alliance support activities include continuous surveillance and warning to decrease vulnerability.

The use of space by potential enemies to enhance their warfighting must also be addressed by the warfighter. Space denial against either space based or ground based systems may be necessary when facing such an adversary. Control of space will be a key element of maintaining and sustaining a favorable air situation and will become an increasing requirement for the warfighter to Win The Information War.

Pre-deployment. During the pre-deployment phase of force projection, the Army notifies, mobilizes where necessary, prepares, and conducts training for those forces designated by the National Command Authority to meet the theater CINC's requirements. These forces rely upon specific, predictive, and timely intelligence as the foundation for effective force generation and deployment preparations. Through space assets, ground commanders can "see" the theater from the first day of the crisis. Space assets allow the intelligence preparation of the theater through near real time intelligence, mapping, and weather capabilities.

Using space exploitation, tactical forces will be able to "learn" the battlefield at home station during pre-deployment training. Army exploitation of National Technical Means (NTM) through the Tactical Exploitation of National Capabilities (TENCAP) program provides intelligence information, allowing CONUS-based units to conduct intelligence preparation of the battlefield and anticipate warfighting requirements. Commanders use this data to tailor combat forces and logistics support packages to meet the threat. This information also allows units to war game operations prior to and during deployment to reduce their unfamiliarity with the situation. Using LANDSAT and commercial topographic systems, Army engineer units can exploit the most current topographical data to update maps, create image maps where no maps exist, or create rough substitutes where digital mapping data does not exist, and disseminate them to deploying forces prior to departure from home station. Through the use of DMSP and commercially available satellite weather systems, staff weather officers and teams contribute to development of courses of action for deployment and operational planning.

Deployment / initial entry. Global satellite communications provide commanders continuous, positive command and control of split based operations from home station through operational activities in theater, and ultimately for redeployment. Global communications provide flexibility and agility in force packaging, enroute final planning, and combined with GPS provide real time cargo tracking for planning of the logistics build-up. Immediate intelligence updates are available to deploying forces through UHF SATCOM, even when they are split and on the move from CONUS to a theater of operations. Early entering forces benefit from GPS by having immediate survey and position location information. They also benefit from the combined battlefield range extension achieved through communications and RSTA capabilities which prevent surprise. TENCAP systems are designed to support split-based operations with the necessary integrated communications and tactical mobility to support this phase of any operation. During the vulnerable early phases, DSP provides early warning of enemy missile attack, and cues shooters.

Decisive operations. An unparalleled situational awareness can be achieved by the Army's aggressive use of space applications and assets. This is a key element of digitizing the battlefield as discussed in Section 4. This situational awareness pays its biggest dividends in the decisive operations

phase of warfighting. Through space, the commander has continuous, secure inter and intra-theater communications to enhance agility, flexibility, depth, synchronization, and precision attack. A full spectrum of intelligence capability in real time enhances warning, agility, and precision attack so that the commander can move against an enemy at a point in time predetermined by his campaign plan or tied to specific enemy actions enabling the commander to strike at enemy vulnerabilities. Weather data from space and terrain imagery allow intelligence preparation of the battlefield, enable exploitation of weather conditions to best advantage, and provide intelligence for poorly or uncharted terrain. As in other phases, overhead coverage allows surveillance of enemy missile systems, cues theater missile defenses, and warns forces to take passive defense measures.

The communications range extension capabilities provided via satellite were critical to command and control during the decisive operations phase of Desert Storm. Without satellite radios, the commander's scheme of maneuver may not have been supported.

Redeployment. Continuous intelligence update of potential threats during vulnerable redeployment protects forces from surprise. Continuous communications allows positive control and reorientation to any new crisis even during redeployment. Exact knowledge of unit equipment and location and status of supplies provides the ability to redirect forces on the move or smooth recovery at home station enabling a faster return to readiness for the next mission.

Summary. Enhancement of Land Force capabilities through the delivery of tailored space and space related products will remain an Army priority in order to cope with the new dangers in the post-Cold War, post-Soviet Union world. Exploitation of space technologies is vital to the success of Army operations in peace and war. Space capabilities and products can provide the warfighter a critical operational edge by reducing the fog of war. Space capabilities enable the creation of an unparalleled situational awareness through all phases of force projection. Space applications can allow the commander to see deep, read the battle in real time, and apply maneuver and fires more quickly than the enemy can react. Improved initiative, agility, depth, synchronization, and versatility will enhance the commander's warfighting abilities.

U.S. and allied operational success in DESERT STORM was directly linked to successful space exploitation. The aggregate of national, civil, and commercial space systems during Desert Storm provided a critical combat multiplier which was aggressively exploited. The use of satellites for warning of ballistic missile launches, alerting of active defense missile batteries, and position location and communications extension to support maneuver added new dimensions to the Desert Storm battlefield. If this capability were not available in the future through lack of funding, priority, or institutional commitment, the Army would lose much of its demonstrated flexibility, agility, tempo, and depth. Continued development of space capabilities to meet battlefield requirements and the normalization of space utilization are imperative to achieve land force dominance. Space exploitation will assist smaller U.S. forces in maintaining a technological overmatch against potential enemies.

SECTION 3

CURRENT PROGRAM ASSESSMENT

Army space capabilities were assessed **RED**, **AMBER**, or **GREEN** using the following criteria:

- **RED** - Incapable of defeating threat or providing required support.
- **AMBER** - Marginal due to effectiveness or quantity.
- **GREEN** - Capable of defeating the threat or providing required support.

This section provides an assessment of the capability to meet operational requirements for Army space activity. The overall review includes fiscal years 1994 and 1995 as the near-term, 1996 - 1999 as the mid-term, and post 2000 for the far-term projections. The rating is based on assessments of individual programs encompassed by space utilization without repeating the detailed assessment of the individual programs presented in other respective chapters— Air Defense; Command, Control, and Communications; Intelligence and Electronic Warfare; Fire Support; etc. This assessment (Figure 17 - 3) projects to the far-term, and is based on continued funding and uninterrupted development of several systems. Additional reductions in research and development budgets and programs, and any failure to replace and/or modernize existing space assets, however, will reduce the warfighting capabilities of our deployed forces. For some functions, commercial space systems may be available to supplement or support non-military operational missions.

SPACE CAPABILITIES ASSESSMENT			
	NEAR TERM (FY94-95)	MID TERM (FY96-99)	FAR TERM (FY00-08)
COMMUNICATIONS	AMBER	AMBER	AMBER
POSITION/NAVIGATION	AMBER	GREEN	GREEN
IEW	AMBER	AMBER	GREEN
WEATHER	AMBER	GREEN	GREEN
WARNING	AMBER	AMBER	AMBER
IMAGERY	AMBER	AMBER	GREEN

Figure 17-3

Communications. Satellite communications capability is critical to a largely CONUS based, power projection Army. The range extension capabilities of space are necessary to support the requirements of Army operations on today's battlefield. These requirements are being driven by a global strategy and operations doctrine that envisions split based operations and units widely dispersed on the battlefield.

Communications satellites receive signals from user terminals and retransmit them to other ground stations. These systems provide communications links and eliminate the need for miles of cable or numerous ground relay stations. The Army uses military and commercial communications satellites to provide this significant capability. Satellite communications carry a large portion of intercontinental, intertheater and a significant portion of the intratheater traffic at division level and above. Some tactical intratheater users are also supported. During a crisis, however, the demand for satellite communication exceeds current capabilities. Increased access to channels in the satellite communications system is required, and will be improved by 1996 when Demand Assigned Multiple Access (DAMA) is operational. DAMA will provide improved satellite channel access through the use of an automatic controller which optimizes channel utilization.

The Defense Satellite Communications System (DSCS) provides the wide band, high capacity communications for the large volume of information required to operate and support deployed units. DSCS supports tactical communications through the Ground Mobile Forces Satellite Communications (GMFSC) program. The Army has about 200 GMFSC terminals that connect to other Army communication systems such as Mobile Subscriber Equipment (MSE) to provide connectivity between dispersed units. The Army does significant amounts of RDT&E associated with DSCS ground terminals. Army interoperability and data throughput capabilities will be enhanced by the ongoing GMF Modification-in-Service program.

Missile defense and joint precision strike requirements continue to stress the Army's current C4I architecture. As mid-term technical and tactical capabilities of the threat continue to improve, C4I systems will need to provide more interoperability for joint and combined operations and provide for rapid, seamless distribution of large volumes of processed data which is critical to winning the information war.

These improvements will maintain communications as **AMBER** in the mid-term. As space utilization becomes normalized, however, requirements continue to increase, and the rate of increase in requirements is exceeding the rate of increase in capacity. As a result, communications remain **AMBER** through the far-term. Army satellite communications far-term improvements will be focused on providing improved C2 for mobile operations (MILSATCOM on the move), and the addition of reliable secure communications in all weather conditions. MILSTAR, the next generation of military communications satellites, will provide highly survivable, jam-resistant, worldwide, secure, joint service communications to strategic and tactical forces. The Army MILSTAR program is focused on Corps, Division, and Special Operations Forces. Any continuing shortfall will be in capacity as opposed to capability.

Command, Control, and Communications program updates are also addressed in Chapter 3.

Position and navigation (POS/NAV). The GPS constellation of NAVSTAR satellites has become increasingly important to Army operations. Use of Small Lightweight GPS Receivers (SLGR) provided confidence, speed, and flexibility in DESERT STORM. Continued proliferation and use of these devices and the precision location GPS receivers now being fielded will enhance the Army's overall combat, combat support, and combat service support capabilities bringing this area to a **GREEN** rating in the mid-term. GPS information is also programmed to be incorporated into combat net radio communications and embedded in a wide variety of Army systems. The availability of this information and the ability to distribute it on the battlefield will aid in achieving better situational awareness and in fratricide avoidance. The resulting capabilities will maintain a **GREEN** posture for this application through the far-term.

Intelligence & Electronic Warfare. The Army is now limited in conducting effective and responsive deep precision strike operations at least partially due to limited target acquisition and sensor capabilities, – therefore, overall near term IEW/RSTA must be rated **AMBER**. The priorities for resolution during the mid-term focus on improving the tactical commander's ability to "see" his area of interest and his ability to target the enemy force.

The mid-term force has improved space systems with enhanced capabilities against modern signal environments and with improvements in satellite imagery, downlinking, and communications. Target acquisition remains **AMBER**, as requirements evolve. In the long term, US Army space capabilities will further enable far-term Joint Precision Strike by providing real time space data downlinks to the tactical level along with the improved processing and dissemination capability which enables the data to be fused with information obtained from other RSTA sources. Providing an accurate enemy picture (imagery, communications, and electronic signatures), during both planning and execution, will satisfy Army requirements in this critical area and bring the far-term assessment to **GREEN**.

Space exploitation will also be key to future ability to monitor the critical areas of Weapons of Mass Destruction (WMD) proliferation and treaty compliance. The availability of this information will allow better preparation of Army forces for potential contingencies.

Intelligence and Electronic Warfare updates are discussed in Chapter 9. Precision strike/fire support updates are provided in Chapter 7.

Weather. The Army is dependent upon weather conditions in planning and conducting operations. Defense Meteorological Satellite Program (DMSP) downlinking provides accurate theater weather in real time and accurate meteorological data at target sites for long range engagements. Currently, commercial receivers provide data/imagery from civil and allied weather satellites. The fielding of small commercial weather terminals will provide improved capability at the unit level. The addition of DMSP receivers and processors will provide an encrypted, assured source of weather data and imagery that will bring the mid-term assessment of this area to **GREEN**.

Improvements desired for the far-term provide tailored weather and environmental/topographical products for tactical units to augment intelligence preparation of the battlefield and aid in decision making. The far-term requirements will be satisfied by the integration of weather receivers into the appropriate Army systems. This will provide a capability to merge DMSP data with terrain information to enhance battle planning and execution. This integration will maintain capabilities **GREEN** for the far-term.

Warning. A principal objective of Army modernization is to protect the force. Army space capabilities to warn the force can provide a cost-effective survivability enhancement to protecting the force. Space based warning enhances all four pillars of the Army's Theater Missile Defense capabilities (TMD). Overhead coverage allows surveillance of enemy missile systems, cues active theater missile defenses and attack operations forces, and allows forces to take passive defense measures. Shortfalls in capabilities today result in an **AMBER** rating in light of the proliferating threat of theater missiles. Required improvements will allow us to better warn threatened areas and populations, engage at greater ranges, and give us the opportunity to engage enemy launchers more effectively by providing shooters more precise launch point locations (Figure 17 - 4).

Protection of the force is enhanced in the mid-term through the use of Defense Support Program (DSP) data processed by Joint Tactical Ground Stations (JTAGS). JTAGS is a transportable system which will provide in-theater stereo processing of DSP data. This capability, combined with additional fielding of communications capabilities in the far-term, maintain only an **AMBER** assessment for warning. Sensor shortfalls, including DSP, preclude a **GREEN** assessment. These shortfalls are primarily related to the short range ballistic missile threat and the increasing threat from hard to see cruise missiles, UAVs, and RPVs.

SPACE ENHANCES THEATER MISSILE DEFENSE

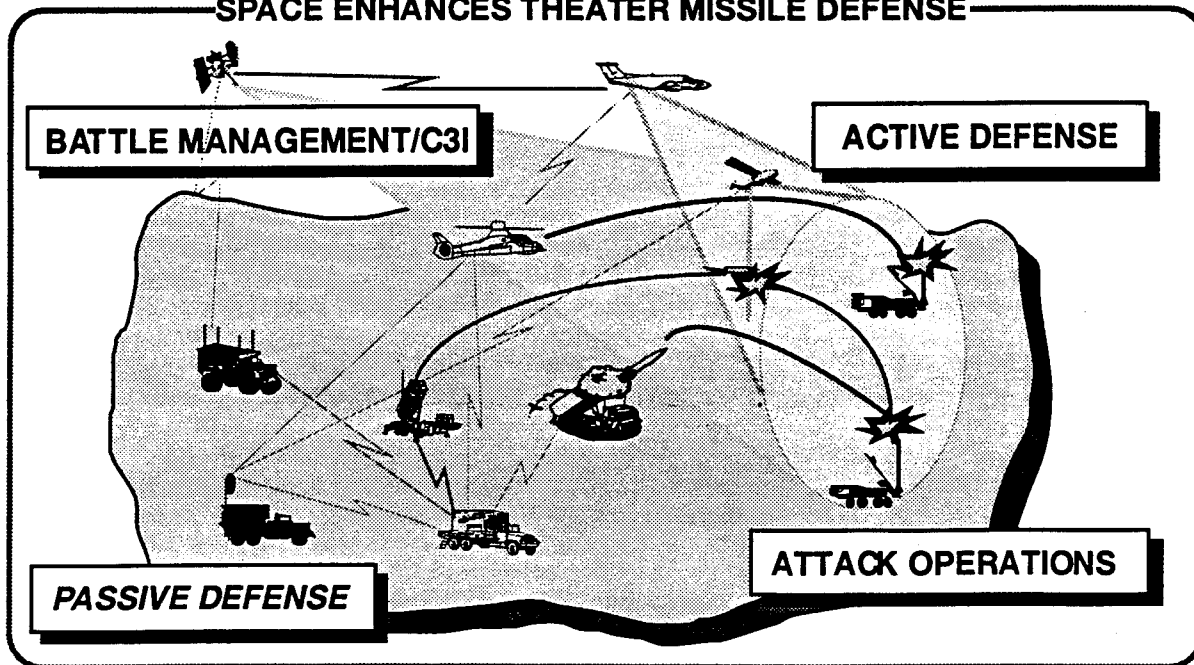

Figure 17-4

With the termination of the next generation early warning systems (i.e., Follow-on Early Warning System), the Army must aggressively participate in defining requirements for the follow-on system. The ability of this replacement system to satisfy Army theater warning requirements will impact the far-term rating of this area.

Imagery. Although there has been a proliferation of space based imagery in the last several years, capability in this area is currently **AMBER**. The availability of imagery in the near term is limited by the number of areas mapped to date or that have topographic data available to transfer the images into mapping products. With the availability of LANDSAT and SPOT imagery, large area low resolution (10 meter) data is available.

The Army is a leader in the exploitation of multi-spectral imagery. Data from LANDSAT and SPOT satellites is fused to provide broad area mapping products to support contingency operations when our soldiers are going into areas where maps either do not exist, or they are too old to be of any use. However, LANDSAT 4 and 5 are nearing the end of their useful lives and LANDSAT 6 failed to achieve orbit due to a launch mishap. Additional satellite ground processing capabilities will allow LANDSAT and SPOT data to be used in a full Mission Planning and Rehearsal system, a tool that will significantly enhance planning and training, but imagery through the mid-term remains **AMBER** due to the loss of LANDSAT 6.

In the long term, Army requirements could be satisfied by the addition of a high resolution multi-spectral sensor (HRMSI) on the LANDSAT 7 satellite. This sensor would be able to provide stereo images and reduces the need for a topographic database to produce mapping products. Continued support for the broad area coverage to be provided by LANDSAT 7 is necessary or the DOD will be dependent on foreign sources for unclassified imagery. Loss of this program or its ground processing station would inhibit Army operations and reduce the far-term assessment from **GREEN** to **AMBER**. In addition, continued increases in the demand for imagery will cause increased demand for dissemination systems. This would include requirements for the processing of data from commercial systems in the field. The distribution portion of the topographic engineering capability is rated **RED** in the far-term because capability is not programmed to keep up with increased demand.

SECTION 4

DIGITIZED BATTLEFIELD

"I'm very bullish on space. I want the Army to stay in space. The Army is in space, and we're remaining in space. I get a lot of technology out of it... And I cannot have a digitized battlefield without space-based platforms."

CSA Gordon Sullivan
4 October 1993

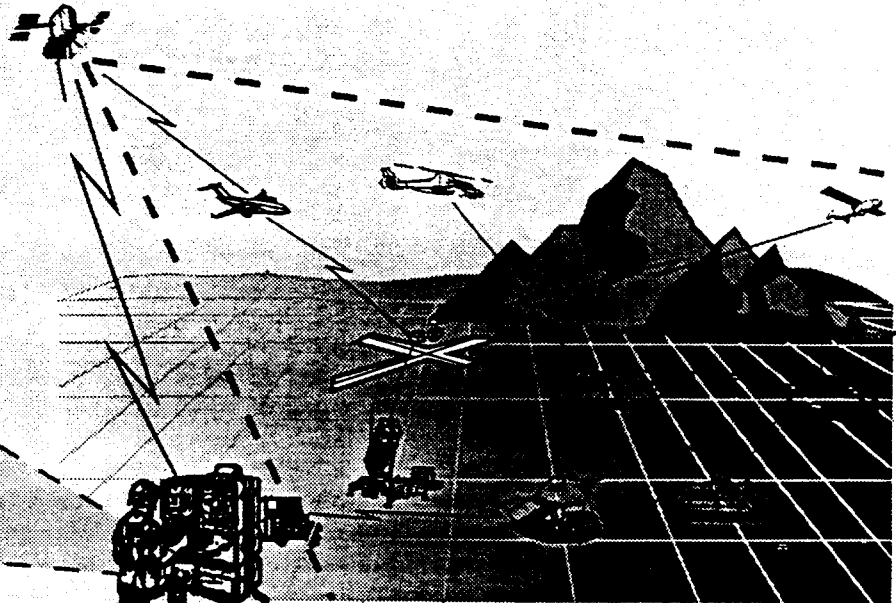
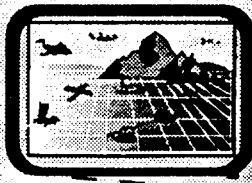

As clearly put by the Chief of Staff of the Army, space assets are key to achieving the digitized battlefield. The Army's need is for a horizontally integrated battlefield network of information nodes using leading edge technologies. The horizontal integration of information nodes involves the exchange of real time information and data across mission areas to establish friendly force dominance over enemy forces. There is a heavy reliance on satellite transmissions for command and control, data, surveillance, targeting and weapon system information capabilities to be converted to digital networks. Conversion to digital communications is necessary for the Army to maintain technological superiority on future battlefields.

The Army is the greatest current and future user of space exploitation products. Satellites, including but not limited to GPS, have had a profound impact. Space systems are key to the whole concept of the integrated, digital battlefield. The continued development of Global Position and Navigation System technology and embedding of this capability in several Army combat platforms will be a Horizontal Technology Integration with real warfighting capabilities payoff. Embedded GPS receivers with digital communications will result in an enhanced situational awareness and command and control. Improved combat identification and improved agility and flexibility of forces will consequently provide fratricide reduction. Future battlefield systems will demand effective and adequate support from space systems in order to achieve the enhanced situational awareness provided by digitization, a major combat multiplier.

Connecting sustainment bases to the battlefield provides updated resource information to logisticians and field commanders to make key operational decisions. The ability to remain linked to command posts, intelligence sensors and subordinate commanders by satellite provides the commander great flexibility and agility. Satellite broadcasts of intelligence, weather and other important information direct from the broadcast source to users, and integrated common user communications systems enable a shared situational awareness which permits real time force synchronization and the capability for swift, decisive maneuver.

The Army's "vision" of the digitized battlefield is a ground force operating in a combined arms, joint task force setting. The integrated ground force C4I and weapon systems information network would operate as an integral part of the joint network of land, air, and sea forces which would, in turn, be linked to a global network enabled by the exploitation of space.

SECTION 5

RESEARCH, DEVELOPMENT AND ACQUISITION STRATEGY

Space and space related capabilities can support the entire spectrum of Army operations. Although additional training in use of all available space capabilities is still required, the use of space to enhance the warfighting capability of deployed forces has been demonstrated. Space related systems will supplement, complement, and in some cases, replace existing and programmed systems. The goal for the Army is the normalization of space exploitation across the range of military operations.

The Army is and will continue to be the most extensive user of space products. The Army has made a considerable investment in developing space applications for our warfighters. In the past, however, with the exception of TENCAP programs, the Army has not had the ability to influence the design of satellite products in a meaningful way. This section reviews the Research, Development and Acquisition (RDA) programs to acquire the required space capabilities and influence future space products. This section does not restate the RDA strategies cited in other functional area annexes, it highlights those space related strategies that will ultimately yield the desired capabilities.

The nature of the current threat and the fiscal constraints imposed on the defense department have resulted in a DOD acquisition approach which increases emphasis and investment in Science and Technology programs. The resulting technological advances will be incorporated more often into systems through upgrades rather than through start ups of new systems. This is consistent with the Army's overall strategy for the current, mid-term, and far-term exploitation of space (Figure 17-5). In the near term, the goal is to leverage off existing satellites and space assets. Acquisition implications for this period mean that the Army will procure receivers to accept usable data and information from existing networks and capabilities. In the mid-term, the focus shifts to the leveraging of systems that are currently in advanced development. This input to final development will allow the Army to plan to process and use information and capabilities that will be made available to it. This translates to procurement of processors to take advantage of capabilities available through mid-term space assets. The Army should drive space related research and development to provide Army tailored products to meet specific Army requirements for the 21st Century. The Army will need to influence satellite design and operation so that it has direct access to the required information and capabilities.

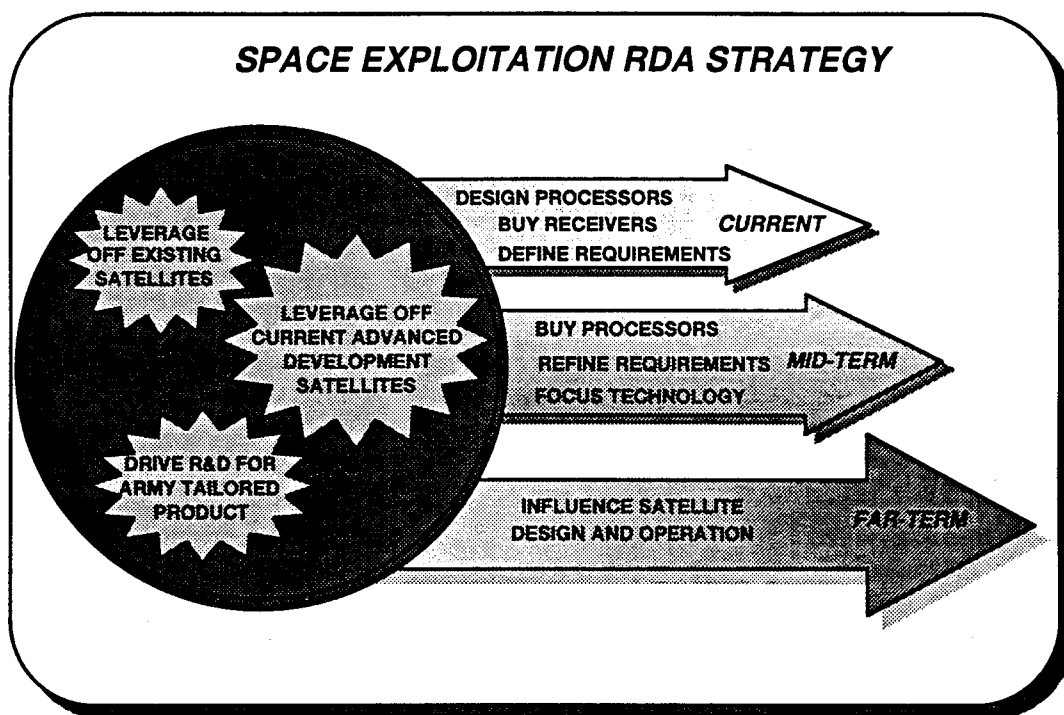

Figure 17- 5

SPACE EXPLOITATION

The Army Research, Development and Acquisition Strategy operates within the framework of the seven Department of Defense Science and Technology Thrusts. Modernization of the Army's space utilization capabilities focuses on exploitable gains in global surveillance and communication, precision strike, air superiority and defense, simulation and other synthetic environments for training and readiness, and technologies which lower the costs of development, production and sustainment. The Army space RDA strategy, through the Army Science and Technology Master Plan (ASTMP), identifies programmatic links to enabling technologies which contribute to the implementation of the Army Modernization Strategy.

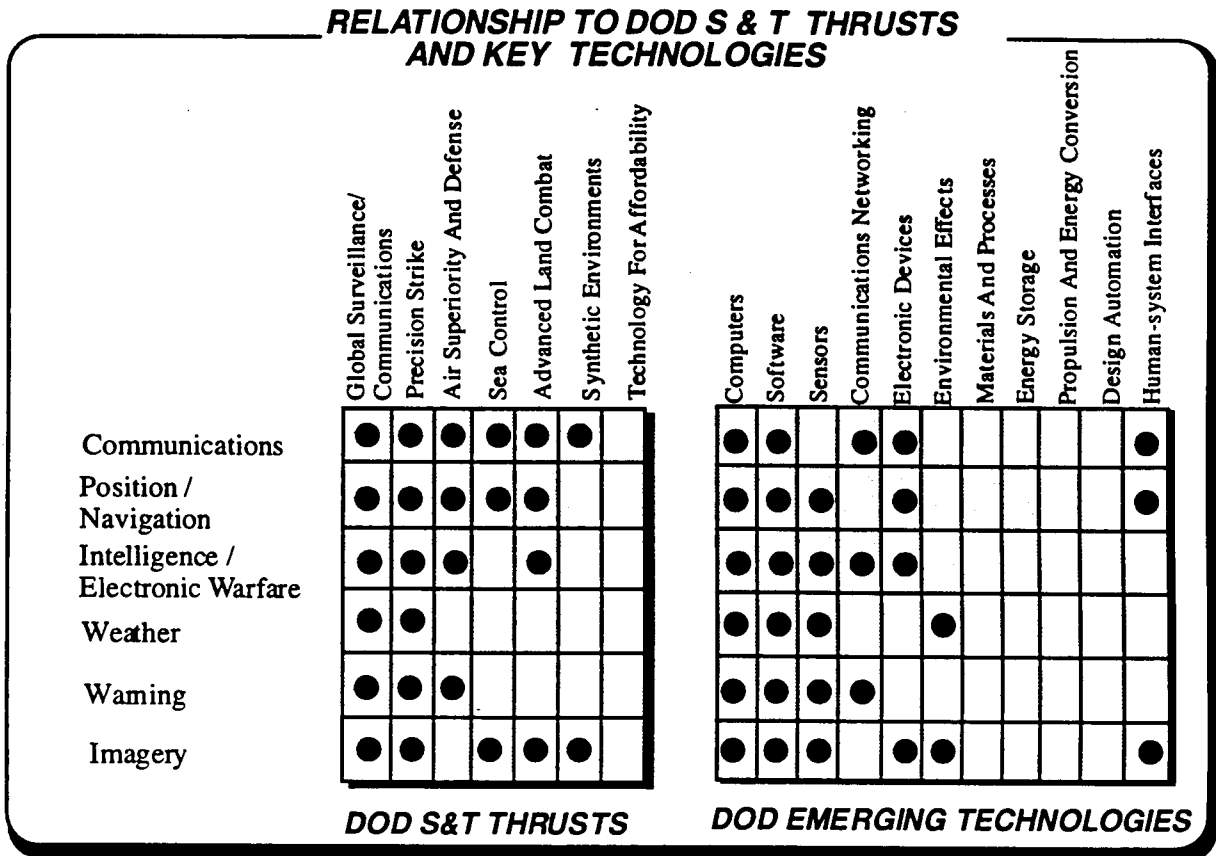

Figure 17-6

The focus for technology development and modernization of space assets is on exploiting space for the tactical commander. The Army Space and Strategic Defense Command is currently developing meaningful proposals for additional Science and Technology Objectives (STOs) and Advanced Technology Demonstrations (ATDs). These will be submitted for Army Science and Technology Working Group (ASTWG) approval along with FY96 POM funding. This will provide additional resources to the Army Science and Technology program to support space applications exploratory and advanced technology development. Any approved STOs and ATDs will be incorporated in the FY95 ASTMP update and integrated into the AMP Space Exploitation Annex. This provides added value to the current Army acquisition strategy for space related materiel developments that includes using non-developmental items (NDI), commercial off-the-shelf equipment (COTS), and commercial, civil, and tactically oriented satellites to improve warfighting capabilities.

A program of Army Space Exploitation Demonstrations (ASEDP) is being conducted to increase the Army's awareness and exploitation of space capabilities and to show the value added of Army space modernization programs. This series demonstrates new technologies for possible further development, and assists in refining requirements for further documentation.

Demonstration and evaluation of space based capabilities is also part of the series of "linked" exercises termed Louisiana Maneuvers (LAM) and the TRADOC Battle Labs which are assessing battlefield dynamics. This is a process which will enable the Army to look at which technology developments will have the greatest impact on the battlefield. Additional hardware in the loop (HWIL) simulations, emphasizing validation with flight and field test data will allow the Army to focus scarce resources to those science and technology programs, system improvements, and new system developments that can provide the greatest improvement in warfighting operations. This link between the Army scientists at the laboratories, the soldier as represented by the combat developer or user, and the materiel developer will provide the most efficient use of Army modernization resources. The linkages among Army space program modernization, functional areas modernization, and battlefield dynamics is shown in Figure 17-7.

**RELATIONSHIP TO ARMY MOD PLANS
AND BATTLEFIELD DYNAMICS**

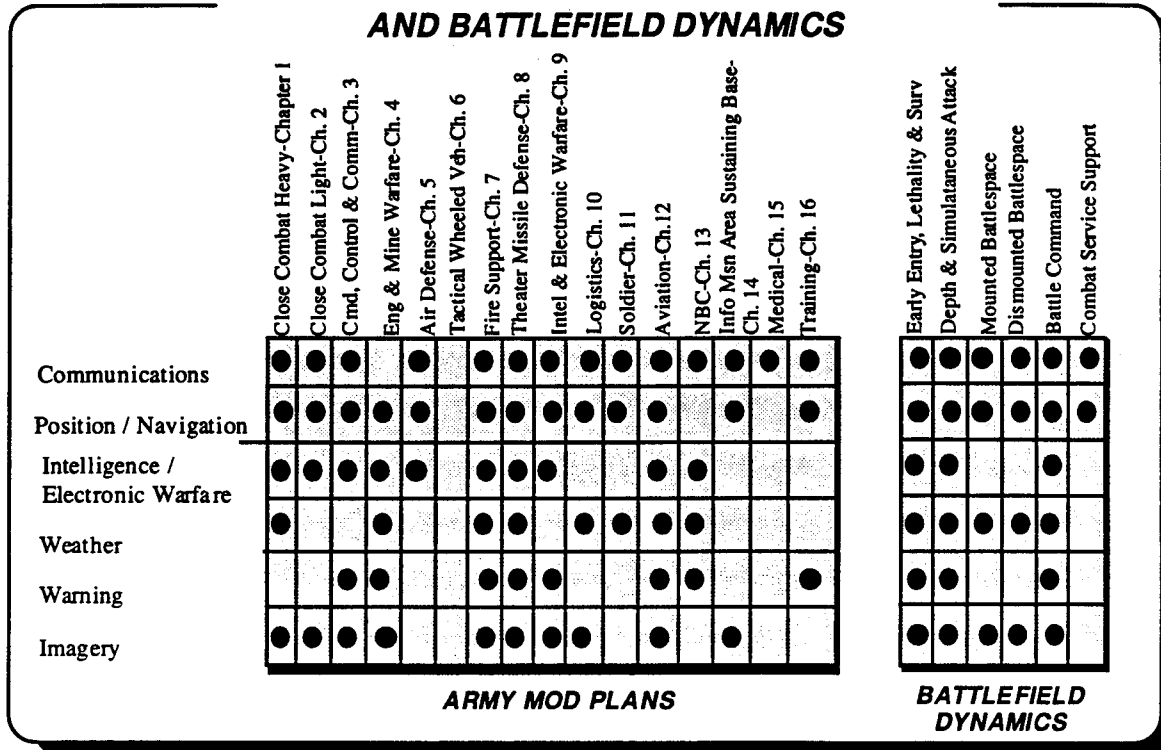

Figure 17-7

Development of a credible and robust space exploitation capability requires pursuit of potential opportunities from any and all non-Army sources. Space assets are frequently national or joint assets and doctrine for Army use of space has as a basic tenet that the Army will exploit non-Army space capabilities. Sharing and leveraging of RDT&E resources with NATO and major non-NATO allies also offers potential that should be explored.

The capability for use of space by potential enemies to enhance warfighting is also a concern that must be considered. Use of space assets must be denied to such an adversary. Space denial operations and capabilities are wide ranging and may be necessary to preserve the commander's ability to Win the Information War. National policies concerning space denial operations and denial of data from U.S. space systems to potential or actual enemies are presently being developed.

SPACE RELATED RDA PROGRAMS

Specific space related modernization programs in each related functional area are depicted in Figure 17- 8:

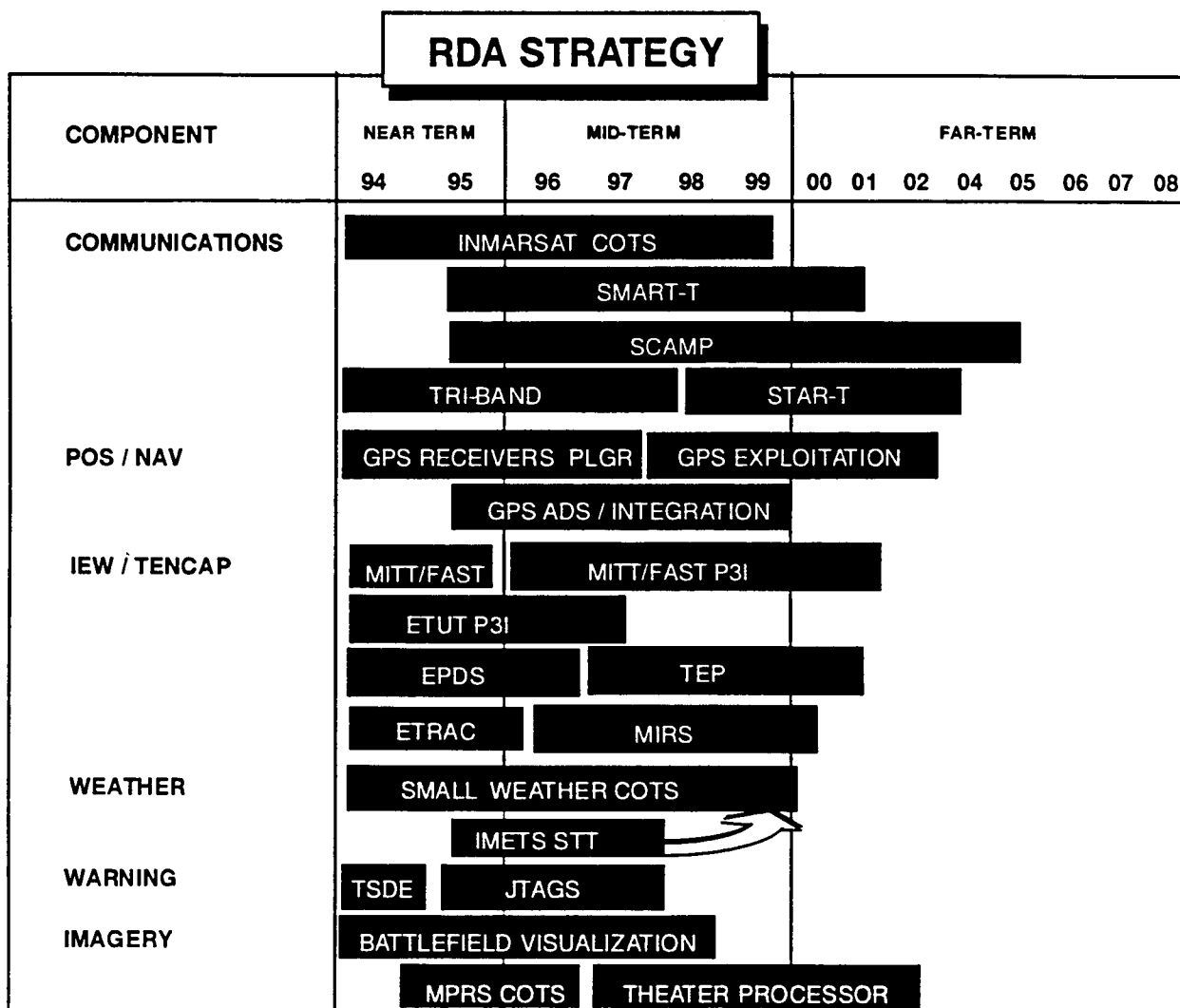

Figure 17- 8

Communications. Space based communications systems allow high data rate information exchange both within a theater of operations and inter-theater. With no line of sight constraints, the battlefield can be extended, op tempo can be increased, and depth of maneuver can be expanded to overwhelm an enemy on the battlefield. The current initiative to develop and field a mobile command and control on the move system with SATCOM downlinks will remedy deficiencies identified in Desert Storm. Anti-jam and low probability of intercept features of these systems will also offer additional operational security.

MILSTAR, the next generation of military communications satellite, intends to use the Extremely High Frequency (EHF) band which offers the advantages of anti-jam, spot beams to specific geographic locations, security and small user antennas. In addition to enabling the use of low probability of intercept (LPI) and low probability of detection (LPD) techniques, this satellite spectrum (above 30 GHz) increases the capacity for satellite communications. EHF provides a band of over 2 GHz on which there is no congestion. This provides a unique opportunity to achieve standardization and interoperability in communications.

The SCAMP and SMART-T terminals are being developed to implement the EHF capability of MILSTAR. SHF is also being investigated as a possibility. It also has the potential to transition to demand assigned multiple access (DAMA) control. Six prototype Tri-Band terminals are now being fielded. These will be modified, based on user experience, and fielded as STAR-T beginning in 1998.

The Army is responsible for the development, acquisition, and logistics of most satellite user and control terminals except those used exclusively in Air Force aircraft or on Navy ships. The GMF Modification-In-Service program will improve satellite channel utilization, correct Army/Air Force interoperability problems, provide enhanced anti-jam capability, modernize electric components, and improve deployability of selected GMFSC terminals. Easily deployable Enhanced Manpack UHF terminals and INMARSAT commercial off the shelf terminals will contribute to enhancing the warfighters early entry capabilities through the use of space.

POSITION AND NAVIGATION (POS/NAV)



With the GPS constellation completed, the Army is currently fielding the Precision Location GPS Receiver (PLGR) with an error of less than 15 meters. Current Combat Identification initiatives to reduce fratricide depend on GPS data to provide friendly locations. Situation awareness and friendly identification will be enhanced with an embedded capability in all vehicles/ individual equipment. Additional GPS Exploitation programs will provide tactical commanders with rapid and accurate survey support and precise position (Differential GPS) and azimuth determination (ADS) using GPS and Advanced Communications Technology Satellites (ACTS). The Army provides support for GPS receiver development and the Joint Program Office.



Intelligence & Electronic Warfare. The Army TENCAP program is currently fielding the Mobile Integrated Tactical Terminal (MITT) and the Forward Area Support Terminal (FAST) to Divisions and select brigades. These systems provide secondary imagery and SIGINT receive capabilities and enable limited analysis of national and theater intelligence data.

Evolutionary development will continue with the modernization of the Enhanced Tactical User Terminal (ETUT) and Electronic Processing and Dissemination (EPDS) at Corps. Two Enhanced Tactical Radar Correlators (ETRAC) will be fielded to corps in FY95 and FY97, and a new Mobile Imagery Receive System (MIRS) will be fielded to corps in FY00. EPDS will be replaced by the Tactical Elint Processor (TEP) in FY01.

All TENCAP systems are interoperable, based on common DODISS standards, and directly interface with other Army communications and tactical display processors. The incorporation of more robust multiwave flexible communications will expand these interoperable capabilities. Further improvements include downsizing of TENCAP systems to enhance rapid deployment and the provision of graphic display software for rapid situation assessment of the battlefield.

Space exploitation IEW RDA efforts also include:

- Graphic situation displays that integrate information derived from imagery assessments and SIGINT and then transmit this data over narrow band width communications links so that the

SPACE EXPLOITATION

receiver can overlay this information on a map background to provide a "picture" of the battlefield.

- Workstations that can exploit multi-spectral imagery and perform both spatial and spectral exploitation of hyper-spectral imagery to add a new dimension to mapping, targeting and situation assessment for the commander.
- Multi-source digital mapping and display capabilities, including all weather day/night sensors and camouflage-penetrating, and foliage penetrating sensors, and the potential capability for detection of minefields and NBC weapons.
- Integrated target detection and simultaneous reporting to force control and weapon control authorities.
- Rapid automated analytical capabilities, using on board processors and software and advanced processors to handle greater volume of data and shorten decision cycles. This will provide real time support to tactical users and support declining intelligence manpower resources.

Additional RDA information on intelligence modernization programs that are linked to space capabilities are provided in Chapter 9.

Weather. Meeting the objective of tailored real time weather and environmental/topographical products for tactical units requires improved processing capabilities, development of Army-unique sensor suites, communications standards for space platforms, advanced ground stations/receivers capable of receiving, processing, fusing, and interpreting weather and environmental data, and better means of dissemination. Some interim capability can be achieved by fielding of COTS weather terminals at corps headquarters with receive terminals at division and separate brigade level.

The Integrated Meteorological System (IMETS) begins low rate initial production in FY94. It will initially use the commercial weather receiver, WRAASE, to receive non-encrypted weather imagery and data from U.S. civil and foreign satellites which are vulnerable to being turned off during conflicts. The mid-term IMETS will include a DMSP receiver and processor. This will provide an encrypted, U.S. owned, assured source of weather data and imagery. A pre-planned product improvement, beginning in 1996, will field the Small Tactical Terminal to receive direct downlink data from DMSP. Far-term improvements include the capability to merge this data with terrain information to produce integrated environmental effects, models/simulations and virtual reality displays that will enhance battle planning and execution.

Warning. The Gulf War demonstrated the necessity for missile defense/warning. With the technology to produce "Scud"-like missiles proliferating around the world, the threat of missile attack is escalating, making highly effective missile defense and warning more crucial than ever. Future force projection operations are increasingly likely to involve threats that have offensive missile systems. The Army Science Board, in their 1993 study of missile defense programs, concluded that a Theater Missile Defense (TMD) capability is of vital importance to the Army because theater missiles could cause the Army to be denied access to the battlefield. TMD is essential for employment of land forces in future contingencies.

The Army's ability to warn forces of tactical ballistic missile launch is dependent upon space based early warning data such as Defense Support Program (DSP) data. This warning then initiates passive force protection actions, active anti-missile defenses, and counter attack operations against missile launchers. Fielding of the Joint Tactical Ground Station (JTAGS) will provide direct DSP downlink mobile ground stations for a theater commander who can then process and disseminate near real time warning of theater ballistic missile launches. JTAGS will simultaneously process data from up to three DSP satellites to provide timely and accurate launch point location for attack operations, impact area prediction for local passive defense warnings, and in flight position information for cueing active defenses. The prototype Tactical Surveillance Demonstration Enhancement (TSDE) terminal is currently available for contingencies and is used for Joint Precision Strike advanced technology demonstrations. Development and evaluation of follow-on systems to DSP are important for force protection and precision strike against these critical mobile targets. The development of these systems is currently under review.

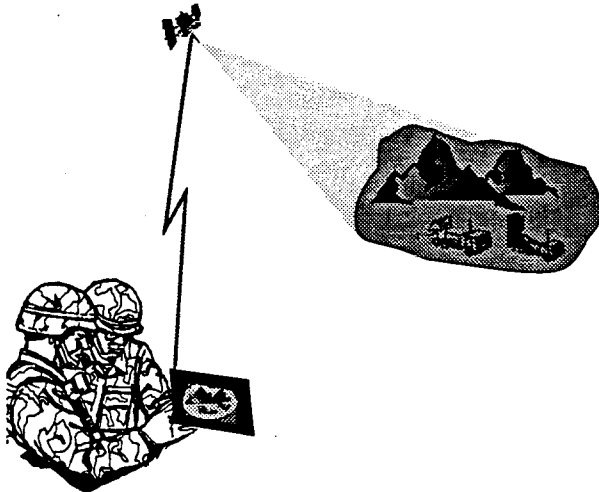

Imagery. In the area of mapping, charting and geodesy, the Digital Topographic Support System (DTSS) is already in low rate initial production. Its introduction will greatly improve our mapping support to tactical units and provide an ability to deal with short notice, unanticipated requirements. A DTSS upgrade that will allow processing of multi-spectral imagery and production of hardcopy MSI is currently under consideration. LANDSAT 7 with High Resolution MSI (HRMSI) will further enhance mapping support. The Battlefield Visualization program will demonstrate the technologies to provide tactical commanders the capability to integrate various image products with digital terrain and MSI data to simulate the appearance of the terrain along a planned course with the Mission

Planning Rehearsal System (MPRS). Terrain reconnaissance and other tactical missions can be planned and rehearsed. Near real time threat data may also be portrayed with a 3-D perspective view.

Additional RDA information on engineer and mine warfare modernization programs, including production and dissemination of imagery, that are linked to space capabilities are provided in Chapter 4.

Summary. This section focused on RDA activities related to development of space capabilities. Evolving space technology must be considered when designing and developing next generation systems or improvements to existing systems. A large number of capabilities are embedded in Army systems. Embedding space technology advances into new generations of Army equipment will permit economies of scale and order of magnitude increases in flexibility for ground support equipment. The building of both ground and space based components capable of being custom figured, integrated, or interchanged with other systems or to meet specific mission requirements will also increase force flexibility by reducing the number of different systems that must accompany a deployment. The research and development programs that ultimately provide future capabilities are presented in the Army Science and Technology Master Plan. They are also linked, in their larger context, to the DOD S&T Thrusts and emerging critical technologies.

The efficient integration of these technologies will be enhanced by improved acquisition strategies and processes. This process will take advantage of simulations and prototyping to ensure maximum enhancement of warfighting capabilities as return on investment. Additional leveraging of joint, national, and allied investments will also result in more efficient acquisition of Army capabilities through the exploitation of space.

SECTION 6

TRAINING

The integration of space systems and space products into Army operations is a continuing process. Increasing involvement in space activities, requires continued development and expansion of space training and education programs. General space awareness training and education must be integrated in the education and training programs for all members of the Army team. Army commanders and staff will require knowledge of the space systems and capabilities that are available to support military operations. Even more critical, is the know how to obtain support in order to effectively and efficiently capitalize on available information and capabilities. The Army's Combat Training Centers (CTCs), Pre-Command Training Courses (PCC), and the battle command training programs need to continue to insert space based capabilities as an integral part of their exercises, and place increased emphasis on the integration and execution of these elements. The Army Space Exploitation Demonstration Program (ASEDP) provides a means of infusing space technology and normalizing space utilization throughout the Army.

The use of simulations is becoming increasingly important with reduced budgets mandating the reduced use of resources. In the space exploitation arena, the use of simulations is also necessary to create the linkages and environments that can exercise the entire scope of offensive and defensive operations. The speed at which space products are integrated and the determination of the value added by space exploitation is enhanced by the application of the Battle Labs and Louisiana Maneuvers (LAM) process. The Battle Labs evaluated a commercial space package in 1993 as an issue in evaluation of command and control systems. The result is projected fielding of commercial space terminals in numerous space support areas to provide a gap filler of space exploitation products until the fielding of objective systems in those areas. The terminals consist of satellite receivers for INMARSAT, a small weather terminal, multi-spectral imagery printing, and the Mission Planning Rehearsal System.

The Louisiana Maneuvers (LAM) offer opportunities to consider current and future Army strategies and capabilities. **Army Exploitation of Space Assets** is a LAM issue for 1994. As part of LAM, space exploitation is being examined in detail to provide a full spectrum of insights and a foundation for decision making in doctrine, training, leader development, organizations, materiel, and soldiers (DTLOMS) as they relate to space. This "exercise" enables the Army to examine the functions of a force projection Army, identify current and future shortfalls, and formulate potential space exploitation concepts and capabilities to enhance the warfighting capabilities of a force projection Army. This process allows the Army to look at what technology developments, or changes in tactics, techniques, and procedures will change the battle the most and then train to provide the synergy to win with minimum casualties. Appropriately mature technologies and high value added applications can be embedded with proponent AMC and TRADOC agencies, and the use of space can be normalized throughout the Army from doctrine to weapons development.

The examination of the space exploitation issue will be accomplished through warfighter's surveys, live exercises, constructive simulations and analytical models to determine the value added of space concepts and possible applications to the ground commander. In developing the LAM Issue Evaluation Plan (IEP), it became clear that the issue of space exploitation is very broad and complex and has impacts across all battlefield operating systems (BOS). The IEP is a roadmap to coordinate and implement the Army Exploitation of Space Assets issue, and develop recommendations to make the Army space capable and literate.

The evaluation of the Exploitation of Space issue will address four sub-issues:

- Evaluate and refine concepts and capabilities for employing space products in support of Army combat forces including, but not limited to communications, intelligence, mapping, weather, missile warning and tactical imagery.
- Horizontally integrate promising space applications across battlefield operating systems.

- Assess and quantify value-added to mission potential of land forces from timely delivery of relevant space products.
- Define an investment strategy that will ensure the Army becomes "space literate" and "space capable".

LAM ISSUE EVALUATION PROCESS

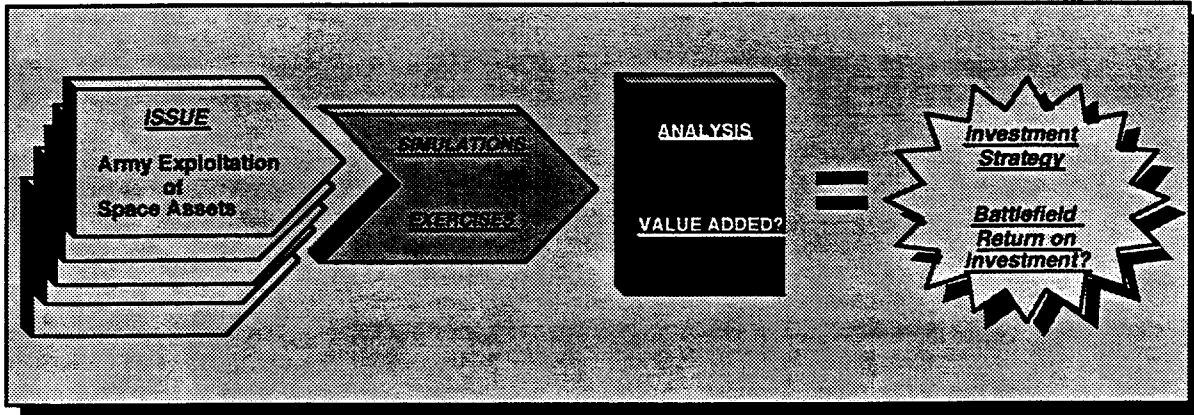

Figure 17-9

Through a program of CINC experiments/exercises every year, leaders gain valuable experience in detailed planning using space based capabilities. These planned exercises and experiments offer senior Army leaders additional insight to tactics, techniques and procedures. The scope of these CINC experiments/exercises allows joint and combined interfaces so that theater CINC and Service component requirements and concepts can be developed, tested, and exercised. The Army must also participate in the theater air and missile defense and precision strike Advanced Distributed Simulation (ADS) demonstrations to define and demonstrate the extent and importance of the Army role in space for these key operational areas.

Summary. As the complexity of warfare increases, so must the realism in training and leader development. The development of new simulations and use of existing ones for training enhances the tactical and technical competence of all soldiers. The development of a corps of space-smart personnel is critical to the Army's continued use of space and exploitation of space products. The Army must also aggressively pursue the incorporation of space based capabilities and ground based space related activities into joint and combined exercises and simulations such as ARPA's Warbreaker. This would not only develop and exercise Army capabilities, but also provide opportunities to learn more about the non-Army elements which play a role in these operations, and conversely, to teach joint and combined elements the role that the Army can play in joint and combined operations while exploiting space based capabilities.

SECTION 7

CONCLUSION

Although Space Exploitation is not a specified functional area for the Army, all Army operations are becoming more dependent on the use of space capabilities. This Chapter to the update of the Army Modernization Plan summarizes key Army space related programs and activities that provide the Army modernized and improved warfighting capabilities. Many of the space capabilities summarized are in programs presented in detail in other chapters. This chapter also provides updated assessments of current and programmed capabilities against the threat expected in the near-term (FY95-96), mid-term (FY97-99), projected to the far-term (Post 2000) and identified shortfalls.

As our potential adversaries continue to acquire modern technology to update their systems, it is clear that Army access to and exploitation of space capabilities must be upgraded through a continuous modernization program, inserting high leverage technologies to bring about superior capabilities from space to the Army warfighter. These long term needs will be met by efforts that are planned and programmed today.

High priority needs to be attached to programs that address early detection and warning of theater missile threats to enable active defense interceptors to be cued, passive defenses to be warned, and launcher locations and infrastructure to be designated for attack operations. The entire system to accomplish this will be enabled by timely use of space based sensor data.

Given the realities of reduced funding and force structure, the development plans defined in this document must carefully consider investments in technology that result in less manpower intensive capabilities; enhance affordability by reducing development, production, and life cycle support costs, make effective use of simulations; provide interoperability for joint and combined operations, provide useful information for the deciders; and enhance lethality of shooters. Modernization of any space based element of the system normally requires very long lead times for development and implementation. Early investment decisions are required along with improved acquisition processes to speed implementation, even to meet far-term (Post 2000) requirements. The investment in these activities has considerable warfighting payoff and should be pursued with vigor and determination.

CHAPTER 18

BATTLEFIELD DIGITIZATION

SECTION 1

INTRODUCTION

"Any military...has to perform at least four key functions with respect to knowledge. It must acquire, process, distribute, and protect information, while selectively denying or distributing it to its adversaries and/or allies...a key to many, if not most, of tomorrow's victories."

Alvin and Heidi Toffler
War and Anti-War

THE ARMY VISION

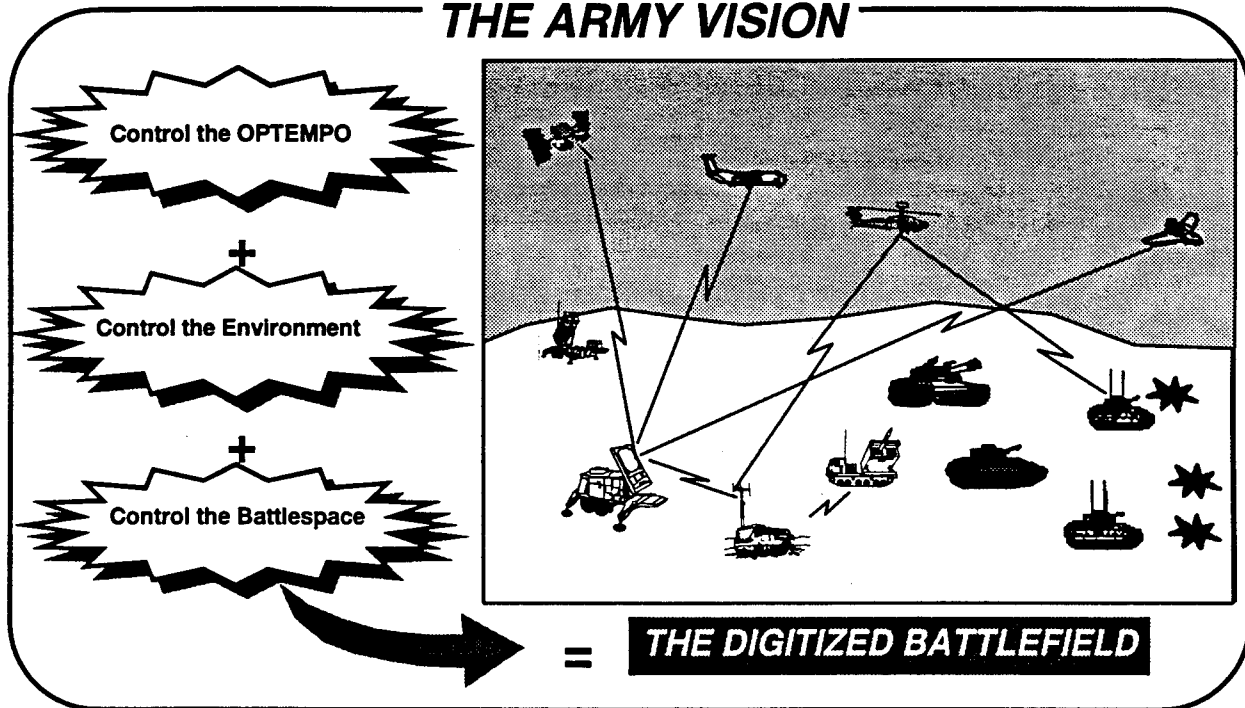

As the Army reorganizes to a smaller Post-Cold War structure, its mission remains fixed: deter war and if deterrence fails, provide forces capable of achieving decisive victory as part of a joint team on the battlefield, anywhere, anytime. This results in a dilemma: How does the Army maintain the edge to fulfill its mission in the face of greatly reduced resources? The answer is in leveraging America's technological advantage to provide the tools to secure an overwhelming edge on the battlefield, even as force structure and major weapons acquisitions are reduced.

SECTION 2

WARFIGHTING CONCEPT

In layman's terms, the Army is connecting the elements at the forward edge of the battlefield with computers in a Wireless Local Area Network arrangement so they may transmit text and graphical data in near real time. Digitization allows the warfighter to communicate vital battlefield information instantly, rather than through slow voice radio and even slower liaison efforts. No longer will the brigade or battalion commander be required to consume valuable time having his subordinate commanders report to the Tactical Operations Center (TOC) in the middle of the night. Operations orders and overlays can be "E-mailed" to the lower headquarters. Coordination at contact points may be replaced by digitally exchanging control measures using "John Madden"-like pens and observing, in near-real time, the position of the other unit on the digital display. The goal then is to integrate this technology, which is already well developed in the civilian marketplace, into the force as a whole, so that all systems will be tied together in a seamless architecture. This simple concept is a challenging one for the Army, as it must bring together disparate systems and make them compatible and interoperable. The arcane world of communications standards and protocols becomes a priority for the warfighter and communicator alike.

Difficult though it may be, battlefield digitization offers two major advantages for the Army on tomorrow's battlefield. The first of these is a shared situational awareness among all friendly elements. This provides each of the systems and their command cells with a common view of the fight.

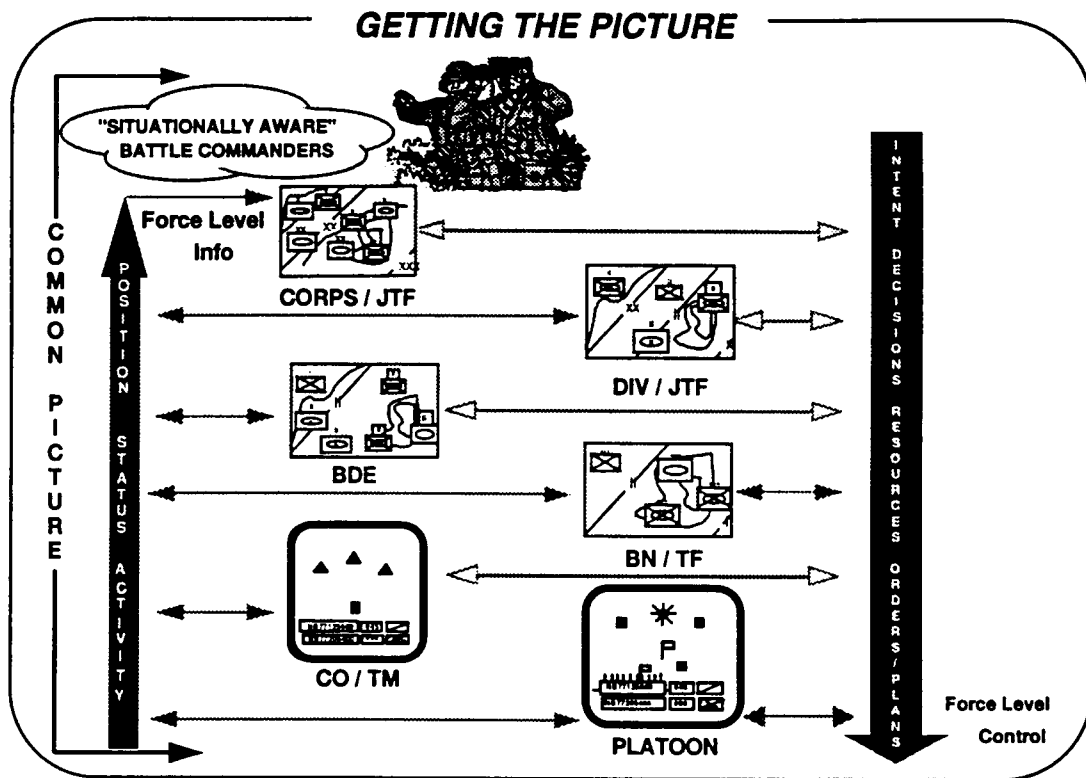

On a system level, the integrated display, will provide the crew, pilot or individual soldier a display of friendly unit locations, enemy locations, friendly graphics, and support information such as ammo and fuel status. This situational awareness may be transmitted to and shared by all elements in the unit. For example a tank platoon leader can monitor the location of all his elements as well as track their logistical status. Any enemy sightings made by members of his platoon are displayed on the platoon leader's CID (Commander's Integrated Display) making command and control much easier. Additionally, each vehicle

has a common picture, significantly reducing the possibility for fratricide. In the future, Combat Identification technology packages may be inserted to further reduce the chances of friendly fire accidents. Additionally, the display could include maps of the terrain, and the ability to receive satellite imagery. All this will provide the battlefield leader the information to make rapid decisions and get inside the enemy's decision cycle.

In addition to a shared situational awareness, real time force synchronization will vastly multiply the combat power brought to bear on the enemy. Digitization ensures that the common picture viewed by the front-line unit is shared by combat support and service support elements. Furthermore, that picture is transmitted instantaneously – and without error. The enemy convoy sensed by the friendly infantry unit will be displayed immediately in the supporting artillery TOC. Since the target will be tied into a position/location system, the grid will be extremely accurate. The combination of instantaneous communication and grid accuracy will result in rapid target servicing.

Another aspect of synchronization involves the principle of mass. This principle enjoins the commander to place his forces at the critical place on the battlefield at the decisive time. By having a common picture of the battlefield, in near-real time, the commander can move his forces quickly and adjust his direction of attack or defensive positions while on the move. Essentially, he can mass on the move, a great advantage in gaining and keeping the initiative.

Rapid response to targets and rapid force massing are just two aspects of synchronization. Another is the incorporation of all the systems into the close, deep, and rear battles. Once they are digitized, all units can share information that will allow combat support and service support units to rapidly enter the fight. In the close fight, engineers, artillery, and air defense artillery (ADA) units can position themselves to respond instantly to support. Real time intelligence can flow to the commander of the close fight to gauge his progress and the enemy reactions, even though they may be out of his line of sight. For example, aviation assets can screen past the Forward Line of Troops (FLOT) and relay that image in near-real time to Bde and Div TOCs. Combat Service Support units may monitor ammunition and fuel levels in near real time as well. With the latest advances in self-diagnostics, the Battalion Motor Officer may know that a vehicle needs a new generator within minutes of a malfunction occurring. Such advances will greatly streamline the resupply process, instead reacting to logistical reports, logisticians will better be able to anticipate requirements, eliminating costly delays in resupply. Coincidentally, the battlefield commander will have near-real time knowledge of his logistic capability, and will be able adjust for any constraints. He will also be linked to the deep precision strike systems, and coordinate his actions with the target results of those systems. In sum, this real time force synchronization will allow the battlefield commander a degree of information and hence, control, that is unprecedented in modern warfare. He will be able to react to enemy actions faster, get into the enemy's decision cycle, and destroy the enemy's battle plan.

SECTION 3

CURRENT PROGRAM ASSESSMENT

For the past few years the Army's plan to integrate digital technologies into its weapon systems has been to embed the technology into a platform as it is produced on the assembly line. This process of taking platforms from analog to digital began with the M109A6 Paladin, and has been extended to the M1A2 Abrams Tank, the M2A3 Bradley, and the Apache Longbow programs. The Army refers to these digitized platforms as "embedded systems."

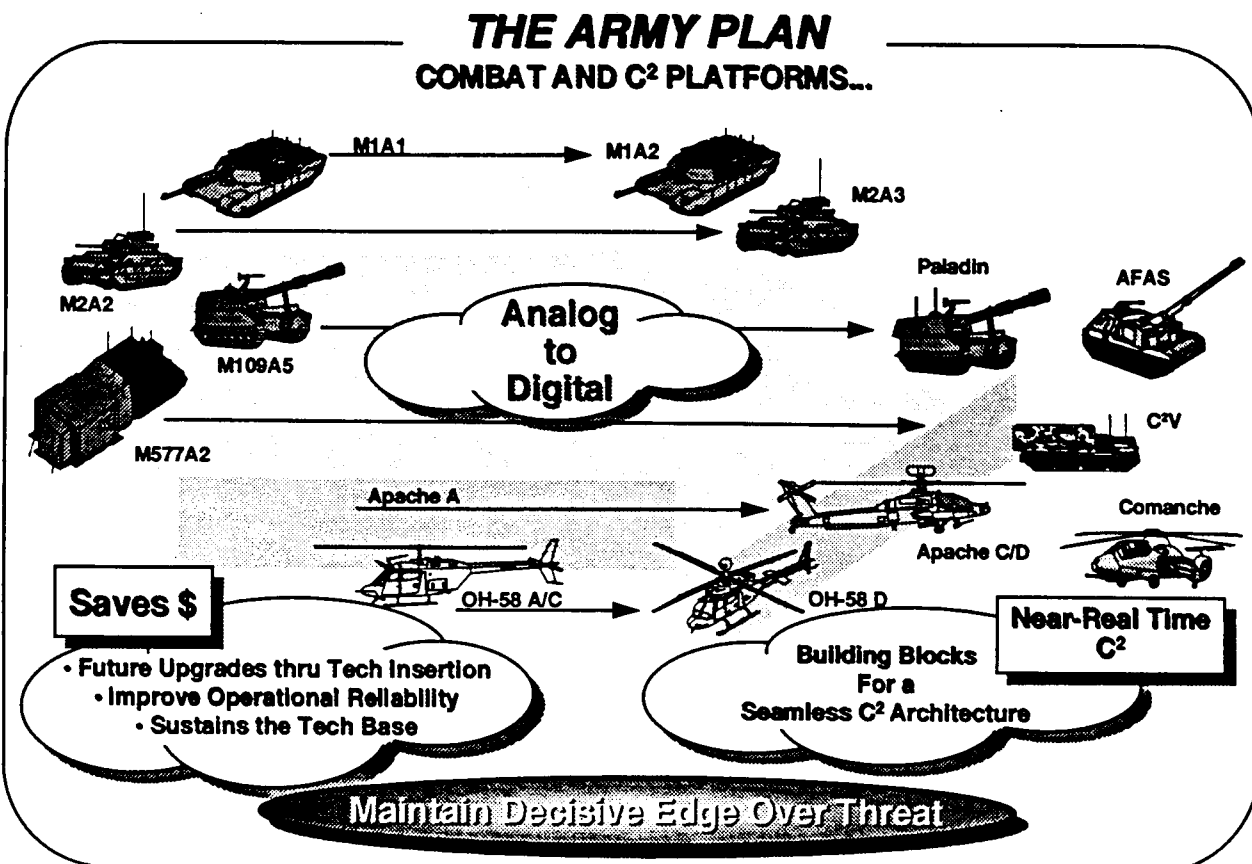

This strategy will bring digitization to the force, however, given current fiscal constraints it will take too long to provide this capability throughout the Army. Because of limited procurement, it is estimated that the Army will not complete fielding the "embedded" digitized platforms to Force Package 1 units until 2015 – and the entire Army until 2025. As a partial solution, the Army has decided to leverage the civilian sector and bring available digital information to the rest of the Force quickly. An "applique" solution has been chosen to integrate a communications interface, a computer unit and a position/navigation device into selected combat vehicles. The applique program will compliment the Army's major improvement program of procuring "embedded" systems, by allowing us to begin passing digital information to combatants and to selected combat support and combat service support units.

**THE APPLIQUE SOLUTION-
MOVING DIGITS TO THE PLATFORM**

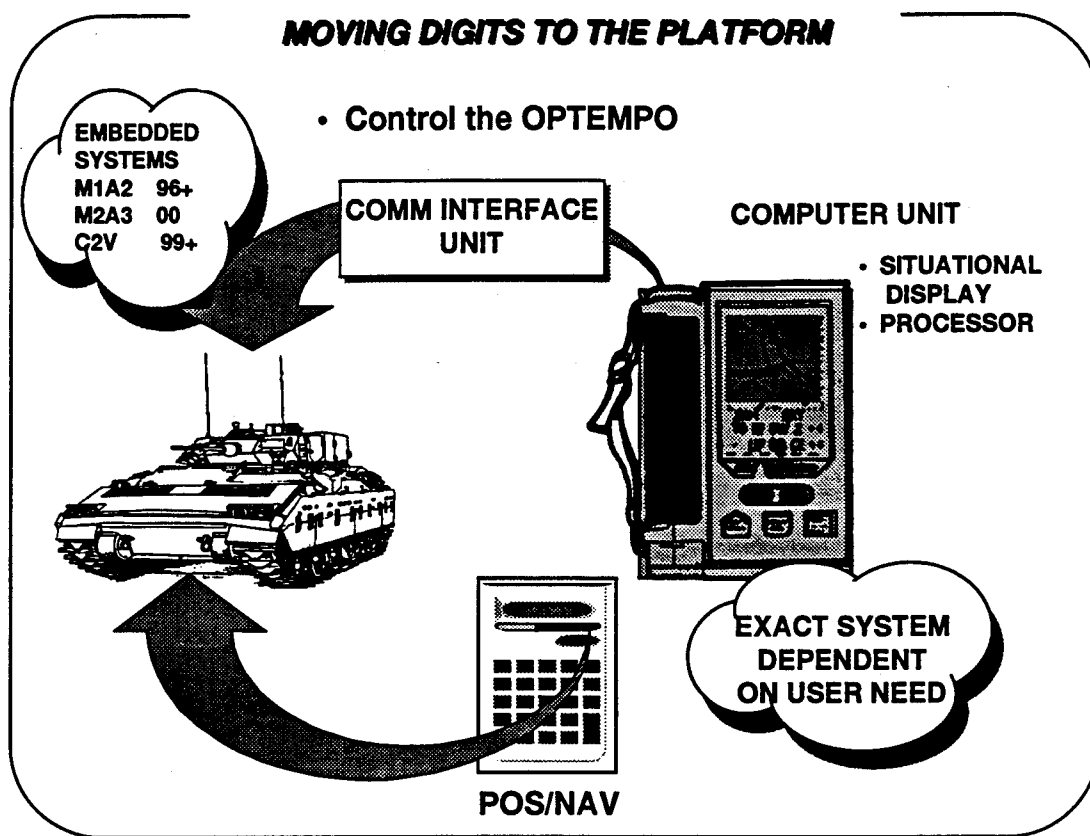

The Army's plan is to field a digitized Brigade in 1996, a digitized Division by 1997 and the CONUS Contingency Corps by 1999. To make this a reality, in January 1994, the Army Chief of Staff, announced the formation of the Digitization Special Task Force. The Task Force will construct "the nerve system that will enable us to build Force XXI." Force XXI is the 21st Century Army that will be digitized and redesigned to harness the power of Information Age Warfare. The Task Force will work with TRADOC to determine the requirements, hardware, software and communications architecture to provide the foundation for Force XXI. The Digitization Special Task Force will hand-off its work to the Army Digitization Office (ADO) in June 1994. The ADO will then have the responsibility of designing and implementing an architecture that will include a mixture of embedded and applique systems.

SECTION 4

RESEARCH DEVELOPMENT AND ACQUISITION STRATEGY

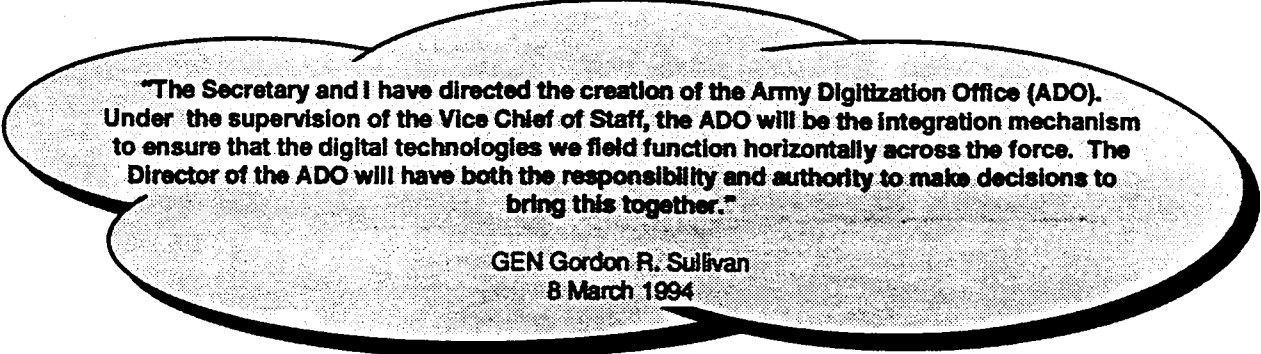

"The Secretary and I have directed the creation of the Army Digitization Office (ADO). Under the supervision of the Vice Chief of Staff, the ADO will be the integration mechanism to ensure that the digital technologies we field function horizontally across the force. The Director of the ADO will have both the responsibility and authority to make decisions to bring this together."

**GEN Gordon R. Sullivan
8 March 1994**

The Army has two major aspects to its RDA strategy. The first involves the development of the applique for platforms and soldiers that do not have an embedded digital capability. The second involves evolving the embedded systems to ensure full compatibility with the applique, software and communications means used for the digitized battlefield. To manage this effort the Army has established the Digitization Special Task Force and the follow-on Army Digitization Office.

The Task Force has the following missions to accomplish by June 1994:

- Draft the actual hardware/software requirements for each Battlefield Functional Area (BFA)
- Draft an acquisition strategy plan for the FY 96-01 POM
- Solidify program funding estimates
- Draft a digital architecture, to include actual standards and protocols
- Conduct hardware, software, and communications trade-off analyses
- Conduct an initial technology assessment
- Coordinate an Army Digitization Office charter

The Task Force is composed of members from TRADOC, the Army Staff, the Army Materiel Command and the Operations and Testing Command. When the Task Force reports out the above mentioned products to the Secretary of the Army and Chief of Staff, the Army Digitization Office will then assume direction of the digitization effort. The Army Digitization Office has coordinating authority with the Program Executive Offices, and the Army Materiel Command, as well as TRADOC. This will allow for the horizontal integration necessary to bring digitization along quickly. In addition, the ADO will allocate funding to ensure a coherent solution is developed. In the near future, the Task Force will provide the funding estimates needed for the FY 96-01 POM. While they will not spend the funds directly, the Task Force and subsequent ADO will ensure the funding levels for the concerned offices will support the Army's digitization plans.

MANAGEMENT CONCEPT



Challenge of Digitization:
 Move fast; buy cheap; expect growth; accept change;
and
 integrate across platform, system, and BOS boundaries

Management Options

- Traditional
 - Define/lock in requirements
 - Appoint PM
 - Test, pass, then field

OR

- Innovative
 - Evolve integrated requirements
 - Involve user & multiple PMs
 - Experiment, refine, enhance

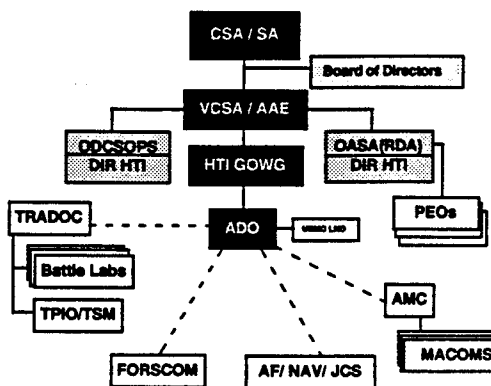

FORM AN ARMY DIGITIZATION OFFICE (ADO)
 • Authority to coordinate actions of user & multiple PEOs
 • Flexibility to move quickly
 • Technical expertise to assess/integrate/trade-off

The role of the Army Digitization Office is not to usurp any of the agencies involved in the digitization effort, but to act as an integrator and maintain direction over the effort to ensure high quality solutions that can harness technology quickly and enforce standards. For instance, TRADOC will remain the Army's requirements developer and the PEOs will develop the hardware, software and communications to facilitate digitization. The coordination authority delegated to the ADO by the Secretary of the Army and Chief of Staff will allow the process to move more quickly, since it will serve as a single focal point to integrate these efforts. Initially, the ADO will focus on the brigade and below effort, since higher echelons already possess some digital technology. As mentioned previously, this involves two major areas of concern: coordinating the development of an applique and evolving embedded systems to ensure compatibility and future growth potential.

The applique is a system that will facilitate the exchange of digital information to selected ground and air elements that do not possess an embedded digital capability. It encompasses the wheeled, tracked, and air platforms as well as the individual soldier. The applique will consist of a computer unit (similar to a notebook computer), a communications interface, and a position/navigation device. In developing an acquisition strategy, the Army desires to leverage off of the civilian sector to ensure the most up to date technology is available to the Army. This concept is exemplified in the following figure, whereby the Army will investigate the use of commercial off the shelf (COTS) units.

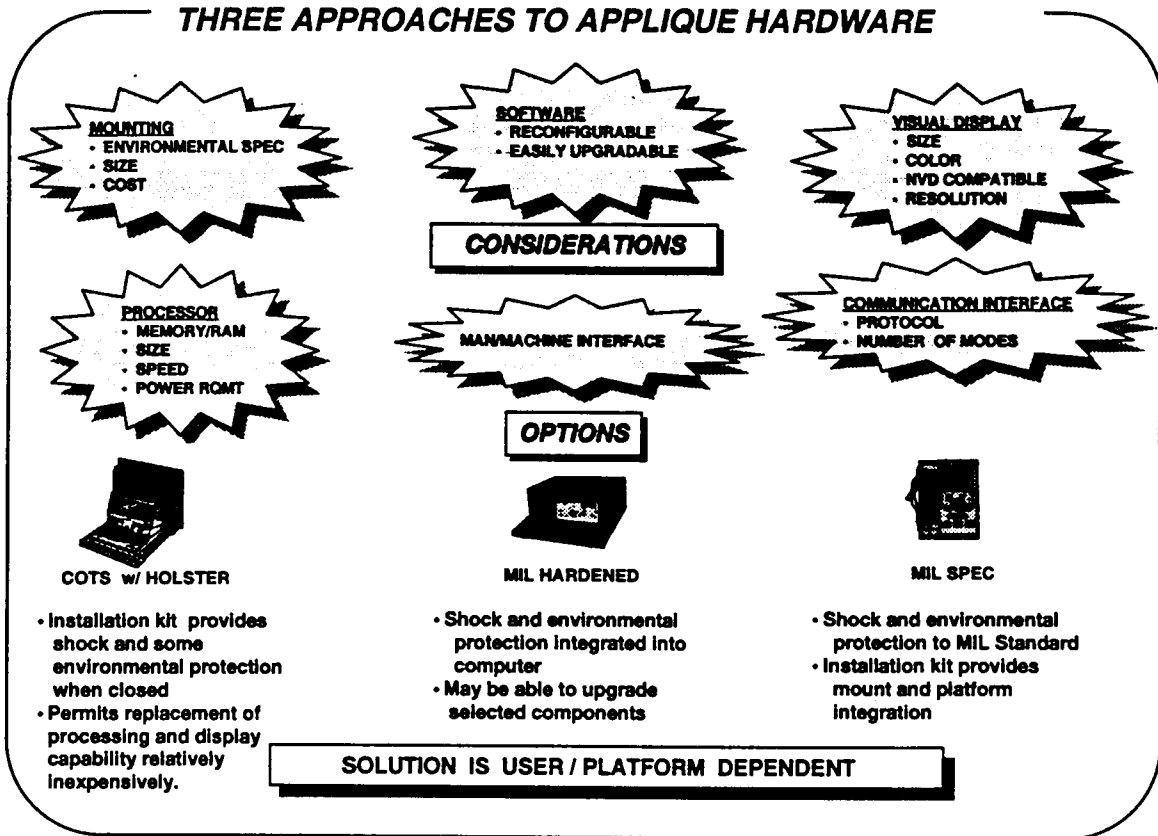

Using COTS will prove the most inexpensive option and allow the Army to upgrade every 3 to 5 years to acquire the latest technology. If that is not possible, using a mil-hardened box that can exchange circuit cards would be the next best option. Finally, the Army sees the full MILSPEC unit as most expensive and the longest to acquire. In the long run, the Army may find it necessary to use variations of all three types, depending on the ruggedness required for specific platforms.

In addition to the computer unit, the Army must confront the communications challenge inherent in exchanging large amounts of digital information. Currently, the Army is using the SINCGARS radio as its primary data hauler at brigade and below. Increasing evidence suggests that the present radio may not have the capacity to carry the required amount of data necessary to maintain situational awareness. As a result, the Army is evaluating a number of possible replacements including the SINCGARS Improvement Program (SIP) and dedicated data radios such as EPLRS and the newer packet technology radios. Clearly, as digitization becomes an important part of the way the Army fights, the requirements for digital information exchange will greatly increase and the "communications pipes" need to be large enough to accommodate that information. Cost will be a major driver in the selection of a data capable radio.

The third component of the applique, and perhaps most important, is the software used by Brigade and Below units to facilitate digital communications. Currently, there are two major efforts that are being used by the Army. The first is the M1A2 software used in the tank for situational awareness. The second is the Battalion and Below Command and Control (B2C2) developed by the Army for situation awareness at brigade and below. As the exact requirements become more focused the Army will select a software package for each and ensure the gateways and interfaces are present to allow the current software to evolve together. It is also important that the software have the capability to interface with ATCCS to ensure a seamless digital architecture. As a result, the Army will examine the design of the Maneuver Control System software as well as the software at brigade and below to ensure a seamless interface.

SECTION 5

TRAINING

The integration of digitization into the force will not happen until each soldier is familiar with the tactics, techniques and procedures needed for utilizing digital information. Training for the digitized battlefield will mean focusing on two major challenges. The first is training leaders and soldiers on proper use of the equipment. The second is adjusting soldiers and leaders to the new responsibilities that digitization permits. These two factors will form the basis of the training requirements for the Digitized Battlefield.

Training on the computer information systems that enable the digitized battlefield will mean reformatting institutional and unit training. The 3rd Wave Mission Need Statement (MNS) does not call for new Military Occupational Specialties (MOS) for digitization. As a result, soldiers and leaders will have to be instructed on this equipment as part of their normal training. TRADOC has already developed training for M1A2 crewmen and is preparing plans for incorporating training at the other levels. To assist with this training, digitized platforms, both applique and embedded, in the future will have the ability to incorporate simulation training as part of the software package. This will allow units to conduct realistic training in their vehicles instead of in a specialized training simulation.

SECTION 6

CONCLUSION

As Desert Storm revealed, advanced technology combined with well trained soldiers, and competent leadership can achieve an overwhelming victory on the battlefield. If this edge is to continue, especially in a vastly smaller Army, modernization is critical. Digitization is a key component to synchronizing all assets into the fight. It promises to retain the advantage America has over its possible threats. Preliminary results of Janus warfighting simulations show a marked improvement in the ability of digitized forces to mass combat power quickly and increase the loss exchange ratio in the Army's favor. It becomes imperative, therefore, to transition from a simulation environment to actual combat systems.

The method of using a combination of embedded and applique systems will allow the Army to field this technology quickly to the force. The Army Digitization Office will ensure that the software, hardware, and communications components are interoperable. In the future, the Army Battle Command System concept will ensure that the brigade and below effort is properly integrated with the ATCCS to provide the commander with a seamless digital architecture down to the individual soldier.

As the Army moves toward Force XXI, digitization may provide the means to make the force design changes to provide for greater lethality, survivability and tempo on the battlefield. More importantly, a digitized Force XXI will ensure that decisive victory with minimum casualties continues to be the hallmark of the Army's warfighting doctrine.

GLOSSARY OF ACRONYMS, BREVITY CODES & ABBREVIATIONS

1Q	First Quarter (in the FY)
2Q	Second Quarter (in the FY)
3Q	Third Quarter (in the FY)
4Q	Fourth Quarter (in the FY)
A2C2	Army Airspace Command and Control
AADEOS	Advanced Air Defense Electro-Optical System
AALPS	Automated Airlift Planning System
AAMP	Army Aviation Modernization Plan
AAMS	Advanced Anti-tank Missile System
AAMWD	Air-to-Air MEP/Weapons Demonstration
AAO	Army Acquisition Objective
AARS	Advanced Airborne Radiac Sensor
AAWS-M	Anti-Armor Weapons System - Medium
ABMOC	Air Battle Management Operation Center
ABO	Agents of Biological Origin
ABS	Anti-Lock Braking System
ABT	Air Breathing Threat
AC	Active Component
ACA	Advanced Cargo Aircraft
ACADA	Automatic Chemical Agent Detector Alarm
ACAPS	Artillery Communications/Aural Protective
ACCP	Army Correspondence Course Program
ACE	Armored Combat Earthmover
ACES	Arrow Continuation Experiments
ACPM	Aircrew Protective Mask
ACQ	Armored Cavalry Regiment Acquisition
ACR	Armored Cavalry Regiment
ACS	Aerial Common Sensor
ACS-C	Aerial Common Sensor-Corps
ACTEDS	Army Civilian Training, Education and Developmental System
ACUS	Area Common User System
AD	Active Defense
AD	Advanced Development
AD	Air Defense
ADA	Air Defense Artillery
ADAM	Area Denial Artillery Munition
ADAM	Area Denial/Antipersonnel Munition
ADCATT	Air Defense Combined Arms Tactical Trainer
ADDS	Army Data Distribution System
ADI	Air Defense Initiative
ADKEM	Advanced Kinetic Energy Missile
ADO	Army Digitization Office
ADR	Air Defense Reticle
ADTOC	Air Defense Tactical Operations Center
ADV	Advanced
AEI	Armament Enhancement Initiative
AFAS	Advanced Field Artillery System
AFATDS	Advanced Field Artillery Tactical Data System
AFCS	Automated Fire Control System
AFFS	Advanced Firefinder System (Formerly ATACS)
AGP	Army Gateway Program
AGS	Armored Gun System
AGSE	Aviation Ground Support Equipment
AHE	Ammunition Handling Equipment
AHFWS	Army High Frequency Electronic Warfare System

AHM	Anti-Helicopter Mine
AHP	Advanced Helicopter Pilotage
AI	Artificial Intelligence
AICP	Advanced Integrated Collective Protection
AIE	Aircrew Integrated Equipment
AIHS	Aircrew Integrated Helmet System
AIMP	Army Intelligence and Electronic Warfare Master Plan
AIMS	Advanced Integrated Man-Portable System
AISI	Automated Integrated Survey System
ALB	Airland Battle
ALC	Advanced Land Combat
ALO	AirLand Operations
ALSE	Aviation Life Support Equipment
AMC	Army Materiel Command
AMCCOM	Armaments and Munitions Chemical Command
AMCS	Aircrew Microclimatic Conditioning System
AMEC	Army Management Engineering College
AMEDD	Army Medical Department
AMEV	Armored Medical Evacuation Vehicle
AMM	Army Modernization Memorandum
AMMIT1-H	Aerial Multi-Mission Integrated Test Bed - First Generation - Helicopter
AMP	Army Modernization Plan
AMSS	Aircrew Modular Survival System
AMT	Army Modernization Training
AMV	Armored Maintenance Vehicle
ANBACIS	Automated Nuclear, Biological and Chemical and Computers
ANVIS	Aviator's Night Vision Imaging System
AO	Attack Operations
AOR	Area of Responsibility
AP	Anti-Personnel
AP	Armor Piercing
APA	Aircraft Procurement - Army Advanced Pilot's Aid
APC	Armored Personnel Carrier
APD	Advanced Physical Deception
APOBS	Anti-Personnel Obstacle Breaching System
APOD	Aerial Port of Debarkation
APSP	Advanced Pilotage System Program
APT	Advanced Platform Technologies
APU/ECU	Auxiliary Power Unit/Environmental Control Unit
APU	Auxiliary Power Unit
AQF	Advanced Quick Fix
AQL	Advanced Quick Look
ARCAD	Advanced Riot Control Agent Device
ARDEC	Armament Research, Development, and Engineer
ARF	Airborne Relay Facility
ARH	Anti-Radiation Homing
ARI	Army Research Institute
ARL	Aerial Reconnaissance Low
ARL	Army Research Laboratory
ARM	Anti-Radiation Missile
ARMADILLO	Army Anti-Radiation Missile Defense,
ARO	Army Research Organization
ART	Advanced Rotorcraft Transmission
ARTEP	Army Training and Evaluation Program
ASARS	Advanced Synthetic Aperture Radar System
ASAS	All Source Analysis System
ASAS CHS	All Source Analysis System Common Hardware and Software

ASAT	Anti-Satellite
ASBREM	Armed Services Biomedical Research Evaluation and Management Committee
ASD(HA)	Assistant Secretary of Defense for Health Affairs
ASE	Aircraft Survivability Equipment
ASEMA	Advanced Special Electronics Mission Aircraft
ASET	Aircraft Survivability Equipment Trainer
ASIS	Ammunition Surveillance Information System
ASL	Authorized Stockage List
ASM	Air-to-Surface Missile
ASM	Armored Systems Modernization
ASMP	Army Strategic Mobility Plan
ASTAMIDS	Aerial Standoff Minefield Detection System
ASTMP	Army Science and Technology Master Plan
ASV	Armored Security Vehicle
AT	Anti-Tank
ATACMS	Army Tactical Missile System
ATACMS-EN	Army Tactical Missile System Enhancement
ATACMS-ER	Army Tactical Missile System Extended Range
ATACS	Advanced Target Acquisition Counter-Fire System
ATAHSS	Advanced Technology Assisted Health Service Support
ATAM	Air-to-Air Missile
ATAS	Advanced Tank Armament Systems
ATAS	Air-to-Air STINGER
ATBMP	Army Technology Base Master Plan
ATC	Air Traffic Control
ATCCS	Army Tactical Command And Control System
ATCOM	Aviation and Troop Command
ATD	Advance Technology Demonstration
ATE	Automatic Test Equipment
ATG	Antenna Transceiver Group
ATGM	Anti-Tank Guided Missile
ATLAS	All-Terrain Lifter Articulated System
ATM	Advanced Trauma Management
ATM	Anti-Tactical Missile
ATMDPO	Army Theater Missile Defense Project Office
ATNAVICS	Air Traffic Navigation, Integration and Coordination System
ATP	Allied Technical Publication
ATR	Automatic Target Recognition
ATS	Air Traffic Services
ATD	Advanced Technology Transition Demonstration
AUIB	Aircrew Uniform Integrated Battlefield
AVCATT	Aviation Combined Arms Tactical Trainer
AVCATT	Aviation Combined Arms Team Trainer
AVIM	Aviation Intermediate Maintenance
AVLB	Armored Vehicle Launched Bridge
AVOAC	Aviation Officer Advance Course
AVTB	Aviation Test Bed
AWACS	Airborne Warning and Control System
AWIS	Army WWMCCS Information System
AWMP	Army Watercraft Master Plan
BADS	Biological Agent Decontamination System
BAI	Battlefield Air Interdiction
BAS	Biological Agent Simulant
BASIC	Body Armor Set, Individual Countermine
BAT	Brilliant Anti-Armor Submunition
BBS	Brigade/Battalion Battle Simulation
BC	Biological/Chemical (Bio/Chem)
BCIS	Battlefield Combat Identifications Systems

BCS	Battalion Countermine Set
BCS	Battery Computer System
BCTP	Battle Command Training Program
BCU	Battery Computer Unit
BDA	Battle Damage Assessment
BDA/PSA	Battle Damage Assessment/Post Strike Assessment
BDM	Bunker Defeat Munition
BDO	Battle Dress Overgarment
BDS-D	Battlefield Distributed Simulation - Development
BDU	Battle Dress Uniform
BE	Brilliant Eyes
BEP	Battery Electronic Pack
BEW	Blast Effect Weapons
BFA	Battlefield Functional Area
BFMA	Battlefield Functional Mission Area
BFSV	Bradley Fire Support Vehicle
BFV	Bradley Fighting Vehicle
BICES	Battlefield Information Collection and Exploitation System
BIDS	Biological Integrated Defense System
BIT	Built-in Test
BITE	Built-in Test Equipment
BLAPP	Ballistic/Laser Armor Protective Posture
BLEPS	Ballistic Laser Eyeware Protective System
BLK	Block
BM	Ballistic Missile
BM/C3	Battle Management/Command, Control, and Communications
BM/C3I	Battle Management/Command, Control, Communication, and Intelligence
BOIP	Basis of Issue Plan
BOS	Battlefield Operating System
BPS	Ballistic Protective System
BRDEC	Belvoir Research, Development & Engineer
BRM	Bridge and Road Munition
BSFV	Bradley Stinger Fighting Vehicle
BST	Basic Skills Trainer
BSTF	Base Shop Test Facility
BTI	Balanced Technology Initiative
BUCS	Backup Computer System
BVR	Beyond Visual Range
BW	Biological Warfare
BWC	Biological Weapons Convention
C-RISTA	Counter-Reconnaissance, Intelligence, Surveillance, and Target
C/B	Chemical/Biological
C2	Command and Control
C2E	Command and Control Element
C2I	Command, Control, and Intelligence
C2V	Command and Control Vehicle
C3	Command, Control and Communications
C3I	Command, Control, Communications, and Intelligence
C4	Command, Control, Communications, Computers
C4I	Command, Control, Communications, Computers, and Intelligence
CAA	US Army Concepts Analysis Agency
CAAD	Corps Area Air Defense
CAAM	Computer Assisted Artillery Meteorology
CAC	Combined Arms Center
CACPT	Combined Arms and Command Post Trainers
CADNET	Chemical Agent Detector Network
CAI	Combined Arms Initiative
CAI	Computer Aided Instruction

CAL	Caliber
CALS	Computer Acquisition And Logistics Support
CALS	Computer-Aided Acquisition and Logistics Support
CAM	Chemical Agent Monitor
CAM	Commercial Assets Mobilization Program
CANE	Combined Arms in a Nuclear/Chemical Environment
CAPS	Communications/Aural Protective System
CAS	Close Air Support
CASCOM	Combined Arms Support Command
CATS	Combined Arms Training Strategy
CATT	Combined Arms Tactical Trainer
CAV	Composite Armor Vehicle
CB	Chemical / Biological
CBDA	Chemical and Biological Defense Agency
CBI	Computer-based Instruction
CBMS	Chemical Biological Mass Spectrometer
CBRS	Concept Based Requirements System
CBW	Chemical/Biological Warfare
CCD	Close Combat Decoy
CCTT	Close Combat Tactical Trainer
CD-ROM	Compact Disk, Read-only Memory
CDA	Central Design Activity
CE	Chemical Energy
CECOM	Communication & Electronics Command
CED	Concept Exploration & Validation
CEE	Commercial Equivalent Equipment
CENTCOM	Central Command
CEP	Circular Error Probable
CEP	Concept Evaluation Program
CEV	Combat Engineer Vehicle
CFE	Combined Forces Europe
CFM	Conus Freight Management System
CFM	Cubic Feet per Minute
CFT	Captive Flight Trainers
CFV	Cavalry Fighting Vehicle
CGC	Combat Gap Crosser
CGS	Common Ground Station
CHAALS	Communications High Accuracy Airborne Location System
CHCS	Composite Health Care System
CHEM	Chemical
CHEMSIM	Chemical Simulation
CHS	Army Command and Control Common Hardware/Software
CI	Counter Intelligence
CI/IPW	Counterintelligence/Interrogation of Prisoners of War
CID	Criminal Investigation Division
CIE	Clothing & Individual Equipment
CIM	Corporate Information Management
CINC	Commander In Chief
CIVADMIN	Civil Administration
CLAMS	Clear Lane Marking Systems
CLASS	Closed Loop Artillery Simulation System
Class IV	Construction Materials
CLO	Counter Low Observables
CLU	Command Launch Unit
CM	Cruise Missile
CMD	Command
CMI	Computer Managed Instruction
CMISE	Corps Military Intelligence Support Element

CMO	Civil Military Operations
CMS	Combat Mission Simulator
CMST	Collection Management Support Tools
CMTC	Combat Maneuver Training Center
CMV	Combat Mobility Vehicle
CNR	Combat Net Radio
CO	Company
COA	Course Of Action
COE	Cab Over Engine
COFT	Conduct of Fire Trainers
COMINT	Communications intelligence
COMMZ	Communication Zone
COMPO	Component
COMPUSEC	Computer Security
COMSEC	Communication Security
CONOPS	Continuous Operations
CONUS	Continental United States
CONUSA	Continental US Army
CONV	Conventional
CORPS SAM	Corps Surface-to-Air Missile
COTS	Commercial Off The Shelf
CP	Career Program
CP	Command Post
CPE	Collective Protection Equipment
CPX	Command Post Exercise
CRDEC	Chemical Research, Development and Engineering Center
CRIS	Civil Reserve Information Services
CS	Combat Support
CSC	Combat Stress Control
CSD	Combat Support Decoy
CSP	Common Synthetic Aperture Radar Processor
CSS	Combat Service Support
CSSCS	Combat Service Support Control System
CSSTSS	Combat Service Support Training Simulation System
CTASC-II	Corps/Theater Automatic Data Processing Service Center II
CTC	Combat Training Center
CTIS	Central Tire Inflation System
CTOC	Corps Tactical Operations Centers
CTS	Computerized Tomography Scanner
CTT	Commander's Tactical Terminal
CTT-H	Commander's Tactical Terminal-Hybrid
CTT-H/R	Commander's Tactical Terminal-Hybrid/Receiver
CUCV	Commercial Utility Cargo Vehicle
CUITN	Common User Installation Transport
CVC	Combat Vehicle Crewman
CVDOS	Combat Vehicle Defensive Obscuration System
CW	Chemical Warfare
CWC	Chemical Weapons Convention
D/NAPS	Day/Night Adverse Weather Pilotage System
D2	Data Distribution
DA	Department of the Army
DAM	Decontamination Agent, Multi-purpose
DAMMS-R	Department Of Army Movements Management System-Redesign
DAP	Decontamination Apparatus, Portable
DARPA	Defense Advanced Research Project Agency
DASM	Deep Attack SMART Munitions
DBOF	Defense Business Operations Fund
DCC	Digital Cartographic Capability

DDR&E	Director Of Defense Research And Engineering
DE	Directed Energy
DEA	Data Exchange Annex
DEM	Demonstration
DEM VAL	Demonstration Validation
DENS	Directed Energy Neutralization System
DEPMEDS	Deployable Medical Systems Development System
DEW	Directed Energy Warfare
DF	Direction Finder(ing)
DFLP	Defense Foreign Language Program
DFTT	Dragon Field Tactical Trainer
DGT	Dragon Gunnery Trainer
DIA	Defense Intelligence Agency
DIS	Distributed Information System
DIS	Distributed Interactive Simulation
DISC4	Director of Information Systems
DITS	Dismounted Infantry Training Strategy
DMD	Digital Message Device
DMRD	Defense Management Review Decision
DMS	Defense Message System
DNBI	Disease and Nonbattle Injuries
DoD	Department of Defense
DOE	Department of Energy
DPG	Defense Planning Guidance
DPI	Data Processing Installations
DPICM	Dual Purpose Improved Conventional Munitions
DS	Direct Service
DS	Direct Support
DS-2	Decontamination Solution #2
DSA	Depth and Simultaneous Attack
DSCS	Defense Satellite Communications System
DSETS	Direct Support Electrical Test Set
DSP	Defense Support Program
DSS	Device Simulation And Simulator
DST	Driver Skill Trainer
DT&E	Developmental Test and Evaluation
DTLOMS	Doctrine, Training, Leader Development, Organization, Materiel, Soldiers
DTOC	Division Tactical Operations Center
DTSS	Digital Topographic Support System
DTSS	Digitized Terrain Support System
E-O	Electro-Optic
EA	Electronic Attack
EAC	Echelons Above Corps
EAC-CIP	Echelon Above Corps Communications Improvement Program
EADSIM	Extended Air Defense Simulation
EADTB	Extended Air Defense Test Bed
ECBRS	Enhanced Concept Based Requirement System
ECM	Electronic Countermeasures
ECP	Engineering Change Proposal
ECWCS	Extended Cold Weather Clothing System
ECWSS	Extended Cold Weather Sleep System
ED	Engineering Development
EDI	Electronic Data Interchange
EELS	Early Entry, Lethality, and Survivability
EES	Expedient Excavation of Soils (EES) System
EFP	Explosively Forward Penetrator
EFVS	Electronic Fighting Vehicle System
EIDS	Electronic Information Delivery System

ELINT	Electronic Intelligence
EMB	Explosive Minefield Breacher
EMBT	Explosive Minefield Breacher Trainer
EMD	Engineering & Manufacturing Development
EMFCS	Enhanced Mortar Fire Control System
EMP	Electro-Magnetic Pulse
EMW	Engineer and Mine Warfare
ENCATT	Engineer Combined Arms Tactical Trainer
EO	Electro-Optics
EO/FLIR	Electro-Optic/Forward Looking Infrared
EO/IR	Electro-Optic/Infrared
EOD	Explosive Ordnance Disposal
EP	Electronic Protection (Old ECCM)
EPA	Environmental Protection Agency
EPA	Extended Planning Annex
EPDS	Electronic Processing and Dissemination System
EPLRS	Enhanced Position Location Reporting System
EPMS	Enlisted Personnel Management System
EPP	Electric Power Plant
EPW	Enemy Prisoners of War
EQUIP	Equipment
ERA	Extended Range Artillery Projectile
ERDEC	Edgewood Research, Development and Engineering Center
ERFS	Extended Range Fuel System
ERINT	Extended Range Intercept Technology
ERR	Extended Range Rocket
ES	Electronic Warfare Support (Old ESM)
ESSS	External Stores Support System
ET	Electronic Time
ET	Embedded Trainer
ETC	Electrothermal Chemical
ETP	Exportable Training Packages
ETRAC	Enhanced Tactical Radar Correlator
ETUT	Enhanced Tactical User's Terminal
EUCOM	European Command
EUL	Economic Useful Life
EUSA	Eighth US Army (Korea)
EW	Electronic Warfare
F/I	Flame/Incendiary
FA	Field Artillery
FAA	Federal Aviation Administration
FAAD	Forward Area Air Defense
FAADC3I	Forward Area Air Defense C3 Intelligence System (includes software)
FAADS	Forward Area Air Defense System
FAAPS	Field Artillery Ammunition Processing System
FAAR	Forward Area Alerting Radar
FAASV	Field Artillery Ammunition Support Vehicle
FAAV	Future Attack Air Vehicle
FACE	Forward Aviation Combat Engineering
FAISS	FORSCOM Automated Intelligence Support System
FAMSIM	Family of Simulations
FARP	Forward Arming and Refueling Point
FARV	Future Armored Resupply Vehicle
FASCAM	Field Artillery Scatterable Mines
FAST	Fire Control Radar
FAST-I	Forward Area Secondary Imagery Dissemination and Tactical Related
FDA	Food and Drug Administration
FDC	Fire Direction Center

FDDM	Fire Direction Data Management
FDS	Fire Direction System
FED	Forward Entry Device
FEWS	Future Early Warning System
FFSV	Future Fire Support Vehicle
FHTV	Family of Heavy Tactical Vehicles
FIFV	Family of Infantry Fighting Vehicles
FINL	Flame/Incendiary and Non-Lethal
FIST-V	Fire Support Team Vehicle
FLIR	Forward Looking InfraRed
FLO/FLO	Float-On Float-Off
FLOT	Forward Line Of Friendly Troops
FLT	Flight
FM	Field Manual
FMBT	Future Main Battle Tank
FMF	Flexible Manufacturing Facility
FMS	Foreign Military Sales
FMTV	Family of Medium Tactical Vehicles
FMVSS	Federal Motor Vehicle Safety Standards
FO	Forward Observer
FOF	Force on Force
FOFLOT	Forward Of Forward Line of Friendly Troops
FOMOA	Force Modernization Analyzer
FOR	Family of Operations Rations
FORSCOM	Forces Command
FORTAS	Forward Observer Remote Target Acquisition System
FOV	Family of Vehicles
FP	Force Package
FP I	Force Package I
FP II	Force Package II
FP III	Force Package III
FP IV	Force Package IV
FROG	Free Rocket Open Ground
FS	Fire Support
FSAC	Fire Support ADA Conversion
FSCoord	Fire Support Coordinator
FSD	Full Scale Development
FSE	Fire Support Element
FSIC	Forward Sensor Interface and Control
FSS	Fast Sealift Ships
FST	Forward Surgical Team
FSTS	Future Fire Support Training Strategy
FSV	Fire Support Vehicle
FSV	Future Scout Vehicle
FTT	Field Tactical Trainer
FTX	Field Training Exercise
FTX/CPX	Field Training Exercise/Command Post Exercise
FUE	First Unit Equipped
FUR	Future Utility Rotorcraft
FW	Fixed Wing
FY	Fiscal Year
G-2	Intelligence Staff Office/Officer (Division/equivalent and above)
GA	Georgia
GATOR	Air delivered AP/AV target activated munition system
GBCS (H)	Ground Based Common Sensor (Heavy)
GBCS (L)	Ground Based Common Sensor (Light)
GBCS	Ground Based Common Sensor

GBI	Ground Based Interceptor
GBR	Ground Based Radar
GBS	Ground Based Sensor
GCS	Ground Control Station
GEMSS	Ground Emplaced Mine Scattering System
GFR	Group Feeding Ration
GLPS	Gun Laying And Positioning System
GMD	Global Missile Defense
GMFSC	Ground Mobile Forces Satellite Communications
GMP	Good Manufacturing Practices
GND	Ground
GPALS	Global Protection Against Limited Strikes
GPM	Gallons per Minute
GPS	Global Positioning System
GRCS	Guardrail Common Sensor
GSE	General Supply Equipment
GSM	Ground Station Module
GSR	Ground Surveillance Radar
GST	Ground Station Terminal
GSTS	Ground-Based Surveillance and Tracking System
GTA	Graphic Training Aids
GUARD FIST-I	Guard Unit Armory Device Fully-Crew Interactive Simulation Trainer-Armor
HA	Heavy Armor
HAB	Heavy Assault Bridge
HACR	Helicopter Active Control Rotor
HATMD	High Altitude Theater Missile Defense
HAWK	Homing All the Way Killer
HD MET	Heavy Duty Medium Equipment Transporter
HDSB	Heavy Dry Support Bridge
HE	High Explosive
HE WAM	Hand Emplaced Wide Area Mine
HEAT	High Explosive Anti-Tank
HEED	Helicopter Emergency Egress Device
HELO	Helicopter
HEMAT	Heavy Expanded Ammunition Trailer
HEMMS	Hand Emplaced Minefield Marking System
HEMMT	Heavy Extended Mobility Tactical Truck
HET	Heavy Equipment Transporter
HF/DF	High Frequency/Direction Finder(ing)
HFR	High Frequency Radio
HGSS	Hellfire Ground Support Simulator
HHV	Heavy HMMWV Variant
HICAP	High Capacity Projectile
HIMAD	High to Medium Altitude Air Defense
HIMARS	High Mobility Artillery Rocket System
HIP	Howitzer Improvement Program (Now Paladin)
HIPAS	High Performance Armament System
HIRSS	Hover Infrared Suppressor System
HIV	Human Immunodeficiency Virus
HMD	Head Mounted Display
HMMH	High Mobility Materials Handler
HMMWV	High Mobility Multipurpose Wheeled Vehicle
HMT	High Mobility Trailer
HOS	Helicopter Oxygen System
HOW	Howitzer
HPM	High Powered Microwave
HQDA	Headquarters, Department Of The Army

HSLSS	Health Service Logistics Support System
HSPR	Harness, Single Point Release
HSS	Health Support Service
HTI	Horizontal Technology Integration
HUD	Heads-Up Display
HUMINT	Human Resources Intelligence
HUMINT/CI	Human Resources Intelligence/Counterintelligence
HVG	Hypervelocity Gun
HVT/HPT	High Value Target/High Pay-off Target
HVY	Heavy
HYEX	Hydraulic Excavator
I & S	Intelligence and Surveillance
I2	Image Intensifier
IBAHRS	Inflatable Body and Head Restraint System
ICAM	Improved Chemical Agent Monitor
ICBM	Intercontinental Ballistic Missile
ICC	Information and Coordination Central
ICLAMS	Improved Cleared Lane Marking System
ICM	Improved Conventional Munition
ICOFT	Institutional Conduct of Fire Trainer
ICTT	Improved Commander's Tactical Terminal
ICW	Interactive Courseware
ID	Identification
ID	Infantry Division
IDIQ	Indefinite Delivery/Indefinite Quantity
IES	Imagery Exploitation System
IEW	Intelligence and Electronic Warfare
IEWCS	Intelligence and Electronic Warfare Common Sensor
IFCS	Interim Fire Control System
IFCST	Institutional Fire Control System Trainer
IFF	Identification Friend or Foe
IFR	Instrument Flight Rules
IFSAS	Fire Support Automation System
IFTE	Integrated Family Of Test Equipment
IFV	Infantry Fighting Vehicle
IGRV	Improved Guard Rail Five
IGSM	Interim Ground Station Module
IHFR	Improved High Frequency Radio
IHPTET	Integrated High Performance Turbine Engine Technology
IKP	Instructor and Key Personnel
ILMS	Improved Launcher Mechanical System
IM	Information Management
IM	Insensitive Munitions
IMA	Information Mission Area
IMETS	Integrated Meteorological System
IMINT	Imagery Intelligence
IMT	Institutional Maintenance Trainer
IMTS	Improved Moving Target Simulator
INFOSEC	Information Systems Security
INT	Internal Intelligence
IOC	Initial Operating Capability
IPB	Intelligence Preparation of the Battlefield
IPDS	Imagery Processing and Dissemination System
IPE	Individual Protective Equipment
IPF	Integrated Processing Facility
IPR	In-Progress Review
IPW	Interrogation of Prisoners of War

IR&D	Independent Research and Development
IR	Infrared
IR/EO	Infrared/Electro-Optics
IRB	Improved Ribbon Bridge
IRBT	Improved Ribbon Bridge Transporter
IRCM	Infrared Countermeasures
IRDSS	Infrared Defeating Smoke System
IRS&T	Infrared Search and Track
ISDN	Integrated Services Digital Network
ISE	Intelligence Support Element
ISM	Installation Support Module
ISO	International Standardization Operation
ISP	Interim System Production
ISU	Integrated Sight Unit
ITACS	Improved Army Tactical Communications System
ITAS	Improved Target Acquisition System
ITP	Installation Transition Processing
ITS	Integrated Training System
ITST	Interim Thermal Signature Target
ITVFTT	Improved TOW Vehicle Field Tactical Trainer
IVIS	Inter-Vehicular Information System
JAART	Joint Attack of Artillery
JAAT	Joint Air-Attack Team
JCALS	Joint Computer-aided Acquisition
JCS	Joint Chiefs of Staff
JIC	Joint Intelligence Center
JIF	Joint Interrogation Facility
JMEC	Joint Materiel Exploitation Center
JPO	Joint Program Office
JRTC	Joint Readiness Training Center
JS-LIST	Joint Service-Lightweight Integrated Suit Technology
JSEAD	Joint Suppression of Enemy Air Defense
JSTARS	Joint Surveillance and Target Attack Radar System
JTAGG	Joint Turbine Advance Gas Generator
JTAGS	Joint Tactical Ground System
JTD	Joint Technology Demonstration
JTF	Joint Task Force
JTIDS	Joint Tactical Information Distribution System
JTMD	Joint Theater Missile Defense
KE	Kinetic Energy
KIAS	Knots Indicated Air Speed
LAM	Louisiana Maneuver
LAMPSS	Large Area Mobile Projected Smoke System
LAN	Local Area Network
LAPES	Low Altitude Parachute Extraction System
LARRS	Low Altitude Retro Rocket System
LBSS	Lightweight Battlefield Surveillance System
LCC	Land Component Commander
LCMS	Laser Counter-Measures System
LCSS	Land Combat Support System
LCSS	Lightweight Camouflage Screening System
LCU	Lightweight Computer Unit
LDS	Lightweight Decontamination System
LEAP	Lightweight Exo-Atmospheric Projectile
LET	Light Equipment Transporter
LET	Launch Effects Trainer
LFX	Live Fire Exercises
LIBC	Lightweight In-stride Breaching Capability

LIC	Low Intensity Conflict
LIEC	Lightweight In-Stride Extraction Capability
LLADI	Low Level Air Defense Interface
LLDR	Lightweight Laser Designator/Range Finder
LLTV	Low Light Level Television
LMSR	Large Medium Speed Roll-On/Roll-Off
LMTV	Light Medium Tactical Vehicle (21/2 Ton FMTV)
LOC	Line Of Communication
LOGMARS	Logistics Application Of Automated Markings And Reading Symbols
LOGTECH	Logistics Technology
LOMAH	Location Of Miss And Hit
LONGARM	Long Range Artillery Missile
LONGFOG	Long Range Fiber Optic Guided Missile
LONGRAM	Long Range Artillery Missile
LOS-F-H	Line-of-Sight Forward Heavy
LOS-R	Line-of-Sight Rear
LOSAT	Line-of-Sight Antitank
LOTS	Logistics Over-The-Shore
LP	Liquid Propellant
LPC	Launch Pod Container
LPI	Low Probability Of Intercept
LPU	Limited Procurement Urgent
LR53	Long Range Advanced Scout Surveillance
LRAMRP	Long Range Army Materiel Requirements Plan
LRC	Lesser Regional Conflict
LRCS	Low Radar Cross Section
LRF	Laser Rangefinder
LRIP	Low Rate Initial Production
LRRDAP	Long Range Research, Development, and Acquisition Plan
LRSU	Long Range Surveillance Unit
LSCAD	Lightweight Standoff Chemical Agent Detector
LSDIS	Light And Special Division Interim Sensor
LSP	Logistic Support Platform
LT	Laser Transmitter
LTACFIRE	Light Tacfire
LTR	Light Tactical Raft
LTWT	Lightweight
LUH	Light Utility Helicopter
LVAD	Low Velocity Air Drop
LVOSS	Light Vehicle Obscuration Screening System
MA	Multichambered Autoinjector
MACOM	Major Army Command
MANPADS	Man Portable Air Defense System
MANPRINT	Manpower and Personnel Integration
MANTECH	Manufacturing Technology
MAPS	Modular Azimuth Positioning System
MAST	Mobile Aircrew Sustainment Trainer
MBT	Main Battle Tank
MCA	Military Construction, Army
MCAP	Mine Clearing/ Armor Protection Kit
MCD	Missile Countermeasure Device
MCM	Material Change Management
MCOFT	Mobile Conduct of Fire Trainer
MCS	Maneuver Control System
MCS	Mobile Camouflage System
MDA	Missile Defense Act of 1991
MDEP	Management Decision Package
MDI	Modernized Demolition Initiator

MDMS	Multiple Delivery Mine System
MDS	Meteorological Data System
MDS	Modular Decontamination System
MEDEVAC	Medical Evacuation
MEDLOG	Medical Logistics
MEP	Mission Equipment Package
MES	Mine Effects Simulator
MESAR	Multifunction Electronically Scanned Adaptive Radar
MET	Medium Equipment Transporter
MET	Meteorological
METL	Mission Essential Task List
METT-T	Mission, Enemy, Troops, Terrain, and Time
MF2K	Medical Force 2000
MFOM	Mlrs Family Of Munitions
MGB	Medium Girder Bridge
MHE	Material Handling Equipment
MHG	Meteorological Hydrogen Generator
M	Military Intelligence
MICAD	Multi-purpose Integrated Chemical Agent Detector
MICLIC	Mine Clearing Line Charge
MICOM	Missile Command
MILES	Multiple Integrated Laser Engagement System
MILES/AGES	Multiple Integrated Laser Engagement System/Air-to-Ground Engagement
MILSPEC	Military Specification
MIRS	Miniaturized Imagery Receive System
MIRV	Multiple Independently Targeted Re-Entry Vehicle
MITLA	Microcircuit In Logistics Applications
MITT	Mobile Integrated Tactical Terminal
MLC	Military Load Class
MLRS	Multiple Launch Rocket System
MLS	Microwave Landing System
MLS	Multilevel Security
MMLS	Mobile Microwave Landing System
MMS	Meteorological Measuring System
MMS	Multi Mode Seeker
MMW	Millimeter Wavelength
MNS	Mission Need Statement
MOADS	Maneuver Oriented Ammunition Distribution System
MOE	Measures of Effectiveness
MOFA	Multi-Option Fuze Artillery
MOPMS	Modular Pack Mine System
MOPP	Mission-oriented Protective Posture
MOS	Military Occupational Specialty
MOUT	Military Operations In Urban Terrain
MP	Military Police
MPIM	Multi-Purpose Individual Munition
MPTT	Maintenance Part Task Trainer
MQS	Military Qualification Standards
MRBM	Medium Range Ballistic Missile
MRC	Major Regional Contingencies
MRDC	Medical Research & Development Command
MRE	Meal, Ready-to-Eat
MRLS	Multiple Rocket Launcher System
MRSR	Multi-Role Survivable Radar
MRT	Missile Round Trainer
MS	Milestone or Multispectral
MSAT-AIR	Multi-Sensor Aided Targeting - Airborne

MSCS	Multi-Spectral Camouflage System
MSE	Mobile Subscriber Equipment
MSEP	Multi-Sensor Electronic Package
MSGGL	Multisalvo Smoke Grenade Launcher
MSL	Missile
MSR	Missile Simulation Round
MSTK	MOS Specific Tool Kit
MSX	Midcourse Space Experiment
MTADS	Mass Tactical Aerial Delivery System
MTG/WESS	Main Tank Gun/Weapons Effects Signature Similar
MTI	Moving Target Indicator
MTI/SAR	Moving Target Indicator/Synthetic Aperture Radar
MTI/SLAR	Moving Target Indicator/Side Looking Airborne Radar
MTMP	MACOM Telephone Modernization Plan
MTOE	Modified Table of Organization and Equipment
MTP	Mission Training Plan
MTV	Medium Tactical Vehicle (5 Ton FMTV)
MVS	Muzzle Velocity System
MWD	Military Working Dogs
NAAK	Nerve Agent Antidote Kit
NAI/TAI	Named Area of Interest/Target Area of Interest
NAS	National Airspace System
NASA	National Aeronautics And Space Administration
NATO	North Atlantic Treaty Organization
NAV	Navigation
NBC	Nuclear, Biological, and Chemical
NBCCS	NBC Contamination Survivability
NBCRS	NBC Reconnaissance System (XM93 FOX)
NBCWRS	NBC Warning and Reporting System
NCA	National Command Authority
NCOES	Noncommissioned Officer Education System
NCTR	Non-Cooperative Target Recognition
NDI	Non Developmental Item
NET	New Equipment Training
NG/FS	Next Generation/Future System
NLOS-CA	Non-Line of Sight-Combined Arms
NMD	National Missile Defense
NMS	National Military Strategy
NOE	Nap-Of-the-Earth
NOT	New Organizational Training
NRDEC	Natick Research, Development & Engineering
NRT	Near Real Time
NSTD	Nonsystem Training Device
NTC	National Training Center
NTH	New Training Helicopter
NUC	Nuclear
NWNPT	Nuclear Weapons Non-Proliferation Treaty
O&M	Operations and Maintenance
O&S	Operation and Sustainment
O&S	Operations and Support (Costs)
OASYS	Obstacle Avoidance System
OB	Order of Battle
OCONUS	Outside Continental United States
OD	Ordnance Disposal
ODCSOPS	Office of the Deputy Chief of Staff for Operations and Plans
ODS	Operation DESERT SHIELD/STORM
OICCSW	Objective Individual Combat and Crew Served Weapons
OICW	Objective Individual Combat Weapon

OMA	Operation and Maintenance, Army
OMT	Organizational Maintenance Trainer
OPA 1	Other Procurement, Army
OPFOR	Opposing Force
OPNS	Operations
OPSEC	Operations Security
OPTEMPO	Operational Tempo
ORD	Operational Requirements Document
OSA	Operational Support Airlift
OSC	Objective Supply Capability
OSCAR	Outside Cable Rehabilitation
OSCR	Operating And Support Cost Reduction
OSD	Office of the Secretary of Defense
OSE	Open Systems Environment
OT	Operational Test
OUTS	Operational Unit Transportable System
P2C4I	Power Projection Command, Control, Communications, Computers and Intelligence
P3I	Pre-Planned Product Improvement
PAC	PATRIOT Advanced Capability
PAC-2	PATRIOT Advanced Capability-2
PAC-3	PATRIOT Advanced Capability-3
PACOM	Pacific Command
PADS	Position Azimuth Determining System
PAM	Penetration Augmented Munition
PASGT	Personnel Armor System Ground Troop
PATRIOT	Phased Array Tracking To Intercept Of Target
PCAS	Persistent Chemical Agent Simulant
PD	Passive Defense
PDENS	Projected Energy Neutralization System
PDM	Pursuit Deterrent Munition
PE	Protective Equipment/Protective Entrance
PEF	Process Engineering Facility
PENAIDS	Penetration Aids
PEO	Program Executive Office/Officer
PERF	Performance
PGT	Platoon Gunnery Trainer
PGTS	Precision Gunnery Training System
PH	Probability of Hit
PHID	Positive Hostile Identification
PK	Probability Of Kill
PKG	Package
PLL	Prescribed Load List
PLS	Palletized Loading System
PLT	Platoon
PM	Program/Project/Product Manager
PM-SDR	Project Manager-Soldier
POL	Petroleum, Oil, And Lubricants
POM	Program Objective Memorandum
POSNAV	Position Navigation
POST	Passive Optical Seeker Technology
PPBES	Planning, Programming, Budgeting, and Execution System
PRIME	Precision Range Integrated Maneuver Exercise Laser Range
PROD	Production
PSI	Pounds per square inch
PSYOP	Psychological Operations
QM	Quartermaster
QRMP	Quick Reaction Multicolor Printer

QRP	Quick Response Program
R & D	Research and Development
RAAM	Remote Anti-Armor Mine
RAM	Reliability, Availability, Maintainability
RAP	Rocket Assisted Projectile
RB	Ribbon Bridge
RC	Reserve Component
RC-TRANSMOD	Reserve Component Transition To Modernization
RCAS	Reserve Component Automation System
RCD	Riot Control Device
RCS	Radar Cross Section
RCU	Radio Control Unit
RD&A	Research, Development, and Acquisition
RD&J	Radar Deception and Jamming
RDT&E	Research, Development, Test and Evaluation
REFLUPS	Resuscitative Fluids Production and Reconstitution System
RESPO 21	Respiratory Protection System 21
RF	Radio Frequency
RFA	RimFire Adapter
RFAM	Radio Frequency Attack Munition
RFI	Radio Frequency Interference
RFI	Radio Frequency Interferometer
RFP	Request for Proposal
RFPNLOS	Rapid Force Projection Non-Line-Of-Sight
RISTA	Reconnaissance, Intelligence, Surveillance and Target Acquisition
RLPG	Regenerative Liquid Propellant Gun
RLW	Ration, Lightweight
RMP	Reprogrammable Microprocessor
RO/RO	Roll-On/Roll-Off
ROC	Regional Operation Center
ROC	Required Operational Capability
ROI	Return on Investment
ROW	Rest of the World
RPA	Rotorcraft Pilot's Associate
RPV	Remotely Piloted Vehicle
RRPR	Reduced Range Practice Rocket
RRS	Remote Relay System
RSCAAL	Remote Sensing Chemical Agent Alarm
RSTA	Reconnaissance, Surveillance and Target Acquisition
RTS	Radiation Training System
RTS	Regional Training Site
RW	Rotary Wing
S&T	Science and Technology
S-2	Intelligence Staff Office/Officer (Brigade/equivalent and below)
S/SU	Systems/Systems Upgrades
SAAS	Soldier as a System Program
SAAS	Standard Ammunition Automated System
SAAS-ATP	Standard Army Ammunition System-Ammunition Transfer Point
SAAS-MOD	Standard Army Ammunition System-Modified
SACLS	Semi-Active Command Line-Of-Sight
SADARM	Sense And Destroy Armor
SAILS	Standard Army Installation Logistics System
SAMP	Small Arms Master Plan
SAMS	Standard Army Maintenance System
SAPLIC	Small Projected Line Charge
SAR	Synthetic Aperture Radar
SARSS-O	Standard Army Retail Supply System-Objective
SATCOM I	Satellite Communications Ground Equipment (Tactical)

SATCOM	Satellite Communications
SATS	Small Arms Training Strategy
SAVA	Standard Army Veronicas Architecture
SAW	Squad Automatic Weapon
SAWE	Simulated Area Weapons Effects
SAWE-RF	Simulation of Area Weapon Effects-Radio Frequency
SBIR	Small Business Innovative Research
SBIS	Sustaining Base Information Services
SCPE	Simplified Collective Protection Equipment
SDC	Sample Data Collection
SDI	Strategic Defense Initiative
SDIO	Strategic Defense Initiative Organization
SEAD	Suppression of Enemy Air Defense
SEE	Small Emplacement Excavator
SEMA	Special Electronic Mission Aircraft
SEP	Soldier Enhancement Program
SF	Stock Funded
SFC	Soldier Fighting Cover
SFTS	Synthetic Flight Training System
SGC	Smoke Generator Carrier
SGI	Small Group Instructor
SGL	Smoke Grenade Launcher
SGS	Smoke Generator Set
SHIMM	Self-Heating Individual Meal Module
SHORAD	Short Range Air Defense
SHTU	Simplified Handheld Terminal Unit
SIAGL	Survey Instrument Azimuth Gyroscope Lightweight
SIC	Survey Information Center
SICPS	Standardized Integrated Command Post System
SID	Secondary Imagery Dissemination
SIF	Selective Identification Feature
SIGINT	Signals Intelligence
SIGINT/EW	Signals Intelligence and Electronic Warfare
SIGSEC	Signals Security
SIMLM	Single Integrated Medical Logistics Manager
SIMNET	Simulation Networking
SINCGARS	Single Channel Ground and Airborne Radio System
SIP	System Improvement Phase
SIPE	Soldier Integrated Protective Ensemble
SKOS	Sets, Kits, and Outfits
SLAM	Selectable Lightweight Attack Munition
SLBM	Submarine Launched Ballistic Missile
SLEP	Service Life Extension Program
SLGR	Small Lightweight Global Positioning System Receiver
SMB	Standoff Minefield Breacher
SME	Subject Matter Expert
SMR	Simulated Missile Round
SM	Service Member
SNSG	Survey North Seeking Gyro
SOA	Special Operations Aviation
SOAR	Special Operations Aviation Regiment
SOCOM	Special Operations Command
SOF	Special Operations Force(s)
SOUTHCOM	Southern Command
SPACECOM	Space Command
SPADOC	Space Defense Operations Center
SPH	Self-Propelled Howitzer

SPOD	Sea Port Of Debarkation
SRBM	Short Range Ballistic Missile
SRTA	Short-Range Training Ammunition (M2 Bolt)
SRTR	Short-range training round
SSDC	Space and Strategic Defense Command
STACCS	Standard Theater Army Command and Control System
STACOM	Stamis Tactical Computer
STAFF	Smart Target Activated Fire and Forget
STAMIS	Standard Army Management Information System
STANAG	Standardization Agreement (NATO)
STAR	System Threat Assessment Report
STARBET	Structure/Airframe for Rotorcraft in Battlefield Environment Technology
STARSFIARS	Standard Army Supply Finance And Accounting Reporting System
STB	Super Tropical Bleach
STE-ICE	Simplified Test Equipment-Internal Combustion Engine
STF	Special Task Force
STO	Science and Technology Objectives
STP	Soldiers Training Publication
STPT	Stinger Troop Proficiency Trainer
STRAC	Standards for Training Requirements and Ammunition Committee
STRADS	Strategic Deployment System
STRAP	System Training Plan
SUSV	Small Unit Support Vehicle
SWD	Sun, Wind, & Dust
SWS	Sniper Weapons System
SYS	Systems
TA	Target Acquisition
TAA	Total Army Analysis
TAA-99	Total Army Analysis - 1999
TAAD	Theater Area Air Defense
TACACCIS	Transportation Coordinator Automated Command And Control Information System
TACAWS	The Army Combined Arms Weapon System
TACCIMS	Theater Automated Command and Control Information Management System
TACCS	Tactical Army Combat Service Support Computer System
TACFIRE	Tactical Fire Direction Computer
TACFIRE	Tactical Fire Control System
TACOM	Tank Automotive Command
TADSS	Training Aids, Devices, Simulators and Simulations
TAIS	Tactical Airspace Integration System
TAMSS	Target Area Meteorological Sensor System
TAS	Target Acquisition System
TASM	Tactical Air-To-Surface Missile
TAV	Total Asset Visibility
TB	Traversing Beam
TBD	To Be Determined
TBESC	Tech Base Executive Steering Committee
TBIS	Technology Base Investment Strategy
TBM	Tactical Ballistic Missile
TBMD	Tactical Ballistic Missile Defense
TCAC	Technical Control and Analysis Center
TCP	Tactical Cryptologic Program
TCT	Tactical Commander's Terminal
TD	Technology Demonstrations
TDA	Table of Distribution and Allowance
TDAC	Tactical Data Acquisition and Correlation
TDAP	Total Distribution Action Plan
TDFD	Time Delay Firing Device

TDP	Technical Data Package
TDS	Total Distribution System
TDI	Tank Device Trainer
TECH INTEL	Technical Intelligence
TEISS	The Enhanced Integrated Soldier System
TEMOD	TMDE Modernization
TENCAP	Tactical Exploitation of National Capabilities
TEP	Tactical Electronic Processor
TERCOM	Terrain Contour Matching
TES	Tactical Engagement Simulator
TF	Task Forces
TFTT	TOW Field Tactical Trainer
TGT	TOW Gunnery Trainer
THAAD	Theater High Altitude Area Defense
THMT	Tactical High Mobility Terminal
TIBS	Tactical Information Broadcasting System
TIP	Treaty Implementation Plan
TM	Theater Missile
TMA	Training Mission Area
TMD	Tactical Missile Defense
TMD	Theater Missile Defense
TMDE	Test and Measurement Diagnostic Equipment
TMDI	Theater Missile Defense Initiative
TMMMC	Theater Medical Materiel Management Center
TOA	Total Obligational Authority
TOC	Tactical Operations Center
TOE	Table of Organization and Equipment
TOW	Tube-Launched, Optically Tracked, Wireguided-Missile
TPF	Total Package Fielding
TPFDL	Time Phased Force Deployment List
TPGID	Tank Precision Gunnery In-bore Device
TPT	Troop Proficiency Trainer
TQG	Tactical Quiet Generator
TRAC	Tactical Radar Correlator
TRADOC	Training and Doctrine Command
TRANSCOM	Transportation Command
TROJAN SPIRIT	TROJAN Special Purpose Integrated Remote Intelligence Terminal
TSAD	Theater Strategic Air Defense
TSAM	Theater Surface-To-Air Missile
TSM-S	TRADOC Systems Manager-Soldier
TSM-SDR	TRADOC Systems Manager-Soldier
TSS	Topographic Support System
TSSAM	Tri-Services Stand-Off Attack Missile
TSV	Thru-Sight Video
TTCS	Tactical Terminal Control System
TTP	Tactics, Techniques, and Procedures
TUGV	Tactical Unmanned Ground Vehicle
TVS	Tactical Vehicle Simulator
TVT	Television Tapes
TW/AA	Tactical Warning/Attack Assessment
TWGSS	Tank Weapons Gunnery Systems
TWV	Tactical Wheeled Vehicle
TWVMP	Tactical Wheeled Vehicle Modernization Plan
TWVULDP	Tactical Wheeled Vehicle Useful Life Determination Program
UAV	Unmanned Aerial Vehicle
UAV-C	Unmanned Aerial Vehicle-Close
UAV-CR	Unmanned Aerial Vehicle-Close Range
UAV-E	Unmanned Aerial Vehicle-Endurance

UAV-SR	Unmanned Aerial Vehicle-Short Range
UCOFT	Unit Conduct of Fire Trainer
UGV	Unmanned Ground Vehicle
UH	Utility Helicopter
ULCANS	Ultra Lightweight Camouflage Net System
ULLS	Unit Level Logistics System
UMC	Upgrade, Maintain and Construct
UOES	User Operational Evaluation System
USAADASCH	United States Army Air Defense School
USAIC	United States Army Intelligence Center
USAIS	United States Army Infantry School
USAMRDC	United States Army Medical, Research and Development Command
USAREUR	US Army Europe
USFK	US Forces Korea
USMC	US Marine Corps
UTARS	Utility Aircraft Requirements Study
UV	Ultraviolet
V	Volt
VAC	Volts of Alternating Current
VAL	Validation
VEESS	Vehicle Engine Exhaust Smoke System
VEMMS	Vehicle Emplaced Minefield Marking System
VIDS	Vehicle Integrated Defense System
VOLCANO	Multiple Mine Delivery System
VTC	Video Teleconference
VTOL	Vertical Take-Off and Landing
VVS	Vans, Vehicles and Shelters
WAM	Wide Area Mine
WAN	Wide Area Network
WAND	Wide Area Neutralization Device
WCC	Weapons Control Computer
WOLF	Work Order Logistics Files
WPNS	Weapons
WPS	Worldwide Port System
WTCV	Wheel Tactical and Combat Vehicle

