

AD-A283 125

GE

Form Approved  
OMB No. 0704-0188

Public reporting burden  
gathering and mainte  
collection of informat  
Davis Highway, Suite



response, including the time for reviewing instructions, searching existing data sources,  
ormation. Send comments regarding the burden estimate or any other aspect of this  
quarters Services, Directorate for Information Operations and Reports, 1215 Jefferson  
dget, Paperwork Reduction Project (0704-0188), Washington, DC 20503.

1. AGENCY USE ONLY (Leave blank)

4. REPORT DATE  
April 1993

3. REPORT TYPE AND DATES COVERED  
FINAL

4. TITLE AND SUBTITLE

The Cold War - An Assessment of  
Strategy

5. FUNDING NUMBERS

6. AUTHOR(S)

Chris T. Anzalone  
Lt Col, US AF

7. PERFORMING ORGANIZATION NAME(S) AND ADDRESS(ES)

AIR WAR COLLEGE  
325 CHENNAULT CIRCLE  
MAXWELL AFB AL 36112-6427

8. PERFORMING ORGANIZATION  
REPORT NUMBER

Unnumbered AWC research  
paper

9. SPONSORING/MONITORING AGENCY NAME(S) AND ADDRESS(ES)

N/A

DTIC  
S ECTE D  
AUG 11 1994  
G

10. SPONSORING/MONITORING  
AGENCY REPORT NUMBER

N/A

11. SUPPLEMENTARY NOTES

PAPER IS WRITTEN TO FULFILL ACADEMIC RESEARCH REQUIREMENTS FOR AN IN-RESIDENCE  
SENIOR SERVICE PROFESSIONAL MILITARY SCHOOL.

12a. DISTRIBUTION/AVAILABILITY STATEMENT

APPROVED FOR PUBLIC RELEASE; DISTRIBUTION IS UNLIMITED

12b. DISTRIBUTION CODE

13. ABSTRACT (Maximum 200 words)

See page iii

14. SUBJECT TERMS

Cold, War, Assessment, Strategy

15. NUMBER OF PAGES

34

16. PRICE CODE

17. SECURITY CLASSIFICATION  
OF REPORT  
UNCLAS

18. SECURITY CLASSIFICATION  
OF THIS PAGE  
UNCLAS

19. SECURITY CLASSIFICATION  
OF ABSTRACT  
UNCLAS

20. LIMITATION OF ABSTRACT  
UL

**AIR WAR COLLEGE  
AIR UNIVERSITY**

**THE COLD WAR  
AN ASSESSMENT OF STRATEGY**

by  
**Chris T. Anzalone  
Lt. Col., USAF**

**A RESEARCH PAPER SUBMITTED TO THE FACULTY  
IN  
FULFILLMENT OF THE CURRICULUM  
REQUIREMENT**

**FOR: Professor S. Cochran**

**MAXWELL AIR FORCE BASE, ALABAMA**

**APRIL 1993**

**94-25284**



*L/692*

Accession For	
NTIS CRA&i	<input checked="" type="checkbox"/>
DTIC TAB	<input type="checkbox"/>
Unannounced	<input type="checkbox"/>
Justification	
By _____	
Distribution /	
Availability Codes	
Dist	Avail and/or Special
<b>A-1</b>	

**94 8 10 069**

## DISCLAIMER

This study represents the views of the author and does not necessarily reflect the official opinion of the Air War College or the Department of the Air Force. In accordance with Air Force Regulation 110-8, it is not copyrighted, but is the property of the United States government.

Loan copies of this document may be obtained through the interlibrary loan desk of the Air University Library, Maxwell Air Force Base, Alabama 36112-5564 (telephone 205- 953-7223 or DSN 493-7223).

## ABSTRACT

**TITLE:** The Cold War: An Assessment of Strategy

**AUTHOR:** Chris T. Anzalone, Lieutenant Colonel, USAF

The first Cold War is over. This conflict between ideologically opposed superpowers represented a classic war of resources. Leverage was gained by the side who could introduce a better technology, create a new political or economic alliance, or maintain the national economic base necessary to sustain a high technology force structure in the nuclear era. The major difference between this Cold War and traditional wars was that the military instrument of power was held in check by nuclear technology and its associated delivery vehicles. Moreover, nuclear warfare imposed a set of constraints never realized in past conflict. The consequence of a nuclear exchange between the superpowers was manageable at first, but rapidly escalated until the means clearly did not justify the ends. The fact that a nuclear exchange was avoided is a tribute to proper strategy.

The U.S. grand strategy of the Cold War was "Containment". Just how to contain the Soviet Union, its ideology and its military force, was the ultimate challenge of U.S. strategists. Consequently, six distinctly different containment strategies were advanced to meet the national objectives. Five of the six, including The New Look, Flexible Response, and Detente, were defensive in nature and did not sufficiently provide the means to achieve their objectives. The final strategy - Reagan's "peace through strength" initiative - was the first offensive strategy properly resourced.

## BIOGRAPHICAL SKETCH

Lieutenant Colonel Chris T. Anzalone (M.B.A., Florida Technological University) has been a study of Soviet strategy and tactics since he was stationed at RAF Lakenheath in 1979. Initially assigned as a Weapons System Officer in F111F, he also served as an Electronic Warfare Officer on the EF-111 test team. It was in this capacity that he co-authored the first MCM 3-1 tactics manual for the EF-111 weapon system. Next, he served on the Air Staff, responsible for advanced avionics technology for the F-22 and other tactical platforms. During this tour he served as Assistant Executive Officer to the Vice Chief of Staff. He commanded a Navigator Training Squadron in 1991.

Lieutenant Colonel Anzalone is a Distinguished Graduate of Squadron Officers School, and completed Air Command and Staff College. He is a member of the Air War College, class of 1993.

## TABLE OF CONTENTS

I. INTRODUCTION .....	1
II. ASSESSMENT OF STRATEGY .....	3
UNITED STATES STRATEGY .....	3
THE INITIAL STRATEGY OF CONTAINMENT .....	3
NSC-68: A CHANGE IN STRATEGY .....	4
THE NEW LOOK .....	5
FLEXIBLE RESPONSE .....	7
DETENTE AND CONFRONTATION .....	9
PEACE THROUGH STRENGTH .....	11
III. INSIGHTS GAINED FOR FUTURE APPLICATION .....	14
MULTIPLE ADMINISTRATIONS = MULTIPLE OBJECTIVES .....	14
PERSONALITIES ARE IMPORTANT .....	14
CONSENSUS ON THE THREAT IS IMPORTANT .....	15
CENTERS OF GRAVITY .....	17
IS THE DEFENSE THE BEST OFFENSE? .....	17
NATIONAL RESOURCES MUST COMPLIMENT PLANS .....	18
ENDS MUST JUSTIFY MEANS .....	20
POWER TOOLS IMPLY A NEW STYLE OF WAR .....	22
IV. CONCLUSION .....	23
NOTES .....	25
APPENDIX: COLD WAR HISTOGRAM .....	26
REFERENCES .....	27

## INTRODUCTION

The Cold War, a global conflict lasting over 45 years, was a product of the post-WWII struggle for power between the U.S. and USSR. Both superpowers suffered severe psychological, political and economic costs that in the end crippled the Soviet Empire, and left lasting scars on America.

The period of conflict between the United States and the Soviet Union was a total war between two ideologically opposed nations. "War is nothing but a duel on a larger scale" . . . it is "the act of force to compel our enemy to do our will".<sup>1</sup> This specific contest of wills could be viewed as a threat to global stability, or an opportunity for each superpower to advance their respective ideologies beyond their borders. In the Cold War, hostilities ensued when one superpower attempted to fill the vacuum of power left by the defeated Germany and Japan in direct confrontation of the other's vital interests. Moreover, the power gained in this "new world order" was defended by new weapons of mass destruction. A technology directly threatening the viability and national will of the two warring nations. The nuclear weapon, and the means to employ it, would significantly alter the strategic resource equations for the remainder of the century.

The style of war was indeed different because every instrument of national power was energized by both warring nations except the traditional one - direct military confrontation. The atomic bomb and the thought of mass destruction had clearly placed the military arm in check (as long as both sides feared its use). Additionally, under the umbrella of the strategic stalemate, evolved a new doctrine of "limited war" through indirect military confrontation between a client state and a major superpower. These "limited wars", or wars by proxy, can be viewed as major battles within this Cold War construct; thus the Berlin crisis, the Korean War, the Cuban Missile crisis, the Vietnam War, and the War in Afghanistan, among others, are direct subsets of the Cold War. Moreover, the strategies that evolved within the battlefields of the European and Asian theaters were governed by the overarching Cold War strategies, and subject to similar constraints.

In 1949, George Kennan, an expert in Soviet relations, understood the consequences of this vision when he professed to a National War College

audience that "I would rather wait thirty years for a defeat of the Kremlin brought about by the tortuous and exasperatingly slow devices of diplomacy than to see us submit to the test of arms a difference so little susceptible to any clear and happy settlement by those means".<sup>2</sup> Louis Halle, a Cold War historian, arrived at a similar conclusion twenty years later that "total war is not necessarily one in which every weapon and device is used without limitation." The character of the Cold War can be defined "as a war for total objectives in which the parties are limited" in their means of producing victory.<sup>3</sup>

Given this new construct, a study of Cold War strategy is a classic examination of how or how not to efficiently allocate ends to means in the nuclear era. Resources are indeed the key. Moreover, power relationships between the two superpowers are dependent on the actual national resources available for Cold War strategists. To borrow from Clausewitz, victory could not be realized until the correct resources are brought to bear against the "center of gravity" of the opponent. "War in general, and the commander in any specific instance, is entitled to require that the trend and designs of policy shall be consistent with these means."<sup>4</sup> Until the Reagan era, the national and military strategies of both nations were defensive in nature and focused away from centers of gravity. The Soviets were rarely able to assume the offensive during the war, limited by economic inefficiencies and technology inferiority. On the other hand, the U.S. was initially self-constrained by ambiguous plans and objectives as well as limited resources. After, the correct mix of national resources was applied to aid in the demise of the Soviet economy and subsequently the Communist Party of the Soviet Union, the U.S. prevailed.

Containment was the overarching grand strategy of the United States. Containment began as a strategy to stall the expansion of Soviet political influence. The initial author of Containment, George Kennan, advanced the strategy assuming severe resource constraints. After Kennan, the objectives and plans to implement the strategy were altered during every new political administration. The changes were made to reflect new perceptions of "the threat", new relative power positions, and new approaches to matching ends to means. Consequently, during the Cold War, the U.S. policy makers advanced six different strategic formulas to implement containment.



This essay will offer a view of these Cold War strategies. First, we will examine the various American national strategies of the Cold War. 5 Next, the respective strategies will be assessed and strategic flaws identified in an attempt to gain insights into the nature of the first Cold War.

Key questions addressed in this paper are: Was the Cold War an escalation of arms to some future direct military conflict, or merely an idea to rationalize the foreign policy of Containment? Or more importantly, is this a new "style" of war in a modern world? Was the strategy of Containment flawed? Did Containment work? What were the constraints to strategy? What were their impacts? Do resources drive the grand strategy, or the strategy drive the resources? Or, were the resources assumed? How do you design a strategy that initiates the offense without employing the military instrument of power? How do you resource such a strategy? And finally, how do you define victory?

The answers to these questions differentiate "hot wars" from "cold wars". The stakes of the war were high. Thus, gaining insights from the strategies that worked, as well as those that failed, may offer strategists the means to avoid a protracted cold war in the future.

#### ASSESSMENT OF STRATEGY

U.S. STRATEGIES - AFFORDABLE DEFENSE OR COSTLY OFFENSE. The United States, at the onset of Cold War, fashioned defensive strategies in an attempt to "hold the perimeter". The problem was that the perimeter was around the largest continent. Conventional resources could never be sufficiently resourced to achieve the task against a military superpower. Thus, new schemes were devised to achieve the required resources - through non-military means - to defend against the Soviet perimeter. Each U.S. President experimented with varying means to this end, but not until forty years later would they have committed sufficient national resources to achieve the offensive.

THE INITIAL CONCEPT OF CONTAINMENT. In an attempt to establish a post-WWII peaceful world order, the Truman administration remained politically and economically engaged in Europe and the Far East. As the threat of Soviet expansion materialized, U.S. foreign policy evolved to adapt. Initially, Truman advanced ambiguous objectives and self-imposed limitations on resources in the early days of the Cold War. The result was

a "band-aid" foreign policy and a weakened military that allowed for uncontested Soviet expansion of influence into Europe and the Far East. This directly influenced the course of the Chinese civil war and the loss of China to Communism. This first "domino" in the chain would haunt the U.S. in Korea, Taiwan, and Indochina.

The initial concept of containment was published by George Kennan.  
6 The U.S. finally had stated objectives and a plan, but remained resource limited. Indeed, the strategy remained defensive and oriented on Europe. (SEE Fig. 1) Kennan stated the fundamental goals of US foreign policy should be to protect the security of the nation and advance a world order in which the nation can contribute to peace and provide an environment more favorable to the interests of the US. He believed that not all parts of the world were equally vital to American security. He advocated a "strongpoint defense" focused on the Atlantic community, the Mediterranean nations and Middle east, as well as Japan and the Philippines as key to American interests.<sup>7</sup> His objectives were: "1) restoration of the balance of power in Europe; 2) a split between the Soviet Union and its chief instrument for projecting power beyond its borders, the international Communist movement; and, 3) through a combination of inducements, alter Moscows view of the outside world as hostile, and make possible a negotiated mutual withdrawal of Soviet and American forces from the forward positions they had occupied after World War II.<sup>8</sup>

The plan to achieve the objectives centered around the use of Marshall Plan aid to strengthen European Recovery, expand propaganda and psychological warfare techniques, increase economic aid to countries maintaining democratic ideals, deploy naval forces in the Mediterranean as a show of force and discourage Soviet aspirations in the region, and finally impose economic containment.<sup>9</sup>

The resources to carry out the plan were predominantly diplomatic and financial. The military was still important as a check to Soviet conventional force in Europe, but were not postured for such a contingency. Allies were considered important and prevalent. He believed that politics, psychology, and economics played a dominant role in dealing with the Soviets, and that excessive reliance on the military could be destabilizing. "Remember", Kennan said in 1947, ". . . as things stand

# FIGURE 1 KENNAN'S CONTAINMENT STRATEGY 1947-1948\*

**GOAL: AN INTERNATIONAL ORDER MORE FAVORABLE TO THE INTERESTS OF THE U.S.**

**PATIENCE & FIRMNESS STRATEGY  
STRONGPOINT DEFENSE PITCHING US  
STRENGTHS AGAINST SOVIET WEAKNESS**

**THREAT = USSR POLITICAL POWER**

## OBJECTIVES

1. RESTORE BALANCE OF POWER TO NATIONS THREATENED BY USSR
2. REDUCE SOVIETS ABILITY TO PROJECT INFLUENCE BEYOND ITS BORDERS
3. MODIFY THE SOVIET CONCEPT OF INTERNATIONAL RELATIONS TOWARD A VIEW OF NEGOTIATING DIFFERENCES

## NATIONAL SECURITY POLICY

- NSC 58/2 - ELIMINATE SOVIET POWER IN EAST BLOC SATELLITES
- NSC 48/2 - EXPLOIT THROUGH POLITICAL, PSYCHOLOGICAL, & ECONOMIC MEANS ANY RIFTS BETWEEN CHINA & USSR
- NSC 20/4 - ENCOURAGE NEGOTIATIONS VIA UNITED NATIONS RESOLUTIONS

## FOREIGN POLICY

TRUMAN DOCTRINE  
ECONOMIC RECOVERY OF EUROPE VIA MARSHALL PLAN

## RESOURCES US ADVANTAGE

**POLITICAL**  
POST-WWII PROMINENCE  
POST WAR SECURITY ALLIANCES  
ACTIVE LEADERSHIP

**ECONOMIC** US ADVANTAGE

US US\$  
GNP (APPROX)\*\* \$300B \$100B

MARSHALL PLAN AID

**TECHNOLOGICAL** US MONOPOLY

ATOMIC BOMB OFFSETS USSR CONVENTIONAL STRENGTH

**PSYCHOLOGICAL** US ADVANTAGE

STRONG NATIONAL WILL IN US  
WIDESPREAD DISAFFECTION IN USSR

**MILITARY** USSR ADVANTAGE

	US	USSR
1945 FORCES	12,300,000	11,300,000
WARHEADS	2	0
DEL SYS	28	0

	US	USSR
1947 FORCES	670,000	2,800,000
WARHEADS	50	0
DEL SYS	50	0

## PLAN/CONCEPT

- MARSHAL PLAN AID TO HELP RESTORE CONFIDENCE IN WESTERN EUROPE
- NEGOTIATE DISPUTES VIA DIPLOMACY
- SHIFT EMPHASIS IN JAPAN FROM CONTROL TO REHABILITATION TO ESTABLISH A SELF-CONFIDENT NATION
- MILITARY USED AS A DETERRENT, A SOURCE OF ALLIED SUPPORT, & PREPARE FOR WAR
- AVOID DIRECT MILITARY CONFRONTATION  
NAVAL PRESENCE IN MEDITERRANEAN  
ASYMMETRICAL ESCALATION  
NO FIRST USE OF ATOMIC WEAPON
- EXPLOIT TENSIONS BETWEEN THE CPSU AND OTHER COMMUNISTS
- ENCOURAGE NATIONALISM IN SOVIET UNION & SOVIET BLOC
- BEGIN COVERT ACTIVITIES
- POSITIVE AND NEGATIVE REINFORCEMENT TO SOVIET BEHAVIOR

## KEY ACTORS

PRESIDENT	H. TRUMAN
AUTHOR	GEORGE KENNAN
SEC STATE	MARSHALL/ACHESON
SEC DEF	FORRESTAL/JOHNSON

\* MULTIPLE SOURCES, PREDOMINANTLY GADDIS. STRATEGIES OF CONTAINMENT

\*\* GNP EST USING FY66 DOLLARS

today, it is not Russian military power which is threatening us, it is Russian political power ... ." 10

In Europe, the first stage of Containment did work. The Soviet expansion was halted and a firm security alliance established. Kennan correctly identified the threat, and the center of gravity, but his strategy relied too much on the psychological and diplomatic instruments of power. Success, in this case, could only occur over tens of years, at best.

NSC-68: A CHANGE IN STRATEGY? The Soviets detonated an atomic weapon earlier than expected. The arms race had begun. In reaction to the new threat, Truman began a comprehensive national security policy scrub. The resulting document authored by Paul Nitze, NSC-68 (See Fig. 2), institutionalized contain-ment as a policy and recommended a major departure from Kennan's initial concept to reflect the perceived change in the threat.

NSC-68 defined the objectives of containment as an effort "by all means short of war to block the further expansion of Soviet power, expose the falsities of Soviet pretensions, induce a retraction of Kremlin control and foster the seeds of destruction within the soviet system . ."11 Nitze advocated a global perimeter defense- not a strongpoint. Further, he believed that changes in the balance of power would only occur as a result of economic maneuvers or military action. To achieve the objectives of containment, Nitze's plan was to use a host of psychological, political, economic, and military measures. He viewed the inadequacy of conventional military force as a detriment to global containment - merely a bluff. Nitze's overall goal, given fiscal guidance by President Truman, was to safeguard our national interests via economic means. 12

NSC-68 came closer to matching the resource requirements with the strategy, but ignored the Soviet's Achilles Heel - their economy, and did not specify a formula for victory over the Soviets. The drafters of NSC-68 further erred when they expanded the national objective from war against Russia to war against Communism. NSC-68 fostered recognition "by this government, the American people, and all free peoples, that the cold war is in fact a real war in which survival of the free world is at stake". Further, Western interests were expanded to Asia for the first time as NSC-68 argued "the assault on free institutions is worldwide . . .and a defeat anywhere is a defeat everywhere".13 This alteration seemed subtle, but in

# FIGURE 2 NSC-68 (NITZE) CONTAINMENT STRATEGY 1950-1953\*

## GOAL: ECONOMICALLY SAFEGUARD NATIONAL INTERESTS

SYMMETRICAL RESPONSE STRATEGY  
PERIMETER DEFENSE TO DRAW  
THE LINE ON COMMUNIST EXPANSION

THREAT = USSR MILITARY POWER AND  
FORCES IN EAST EUROPE

COMMUNIST CHINA

### OBJECTIVES

1. BY ALL MEANS SHORT OF WAR, BLOCK SOVIET EXPANSION
2. EXPOSE FALSITIES OF SOVIET PRETENSIONS
3. INDUCE A RETRACTION OF KREMLIN CONTROL AND FOSTER THE SEEDS OF DESTRUCTION WITHIN THE SOVIET SYSTEM

### RESOURCES

**POLITICAL** US ADVANTAGE  
CONGRESSIONAL & UN SUPPORT  
ALLIANCES WITH 41 NATIONS/NATO  
SUCCESSFUL BERLIN ACTION  
UNSUCCESSFUL ASIAN POLICY  
ECONOMIC

US ADVANTAGE US USSR  
GNP (APPROX)\*\* \$400B \$150B

MARSHALL PLAN AID CONTINUES

**TECHNOLOGICAL** US ADVANTAGE  
ATOMIC BOMB DEVELOPED IN USSR  
SMALL STOCKPILES: US H-BOMB

**PSYCHOLOGICAL** US ADVANTAGE  
WEST ECONOMIC RECOVERY GAINS  
STALINS REPRESSION CONTINUES

**MILITARY** USSR ADVANTAGE  
1950 US USSR

DEF \$	\$12 B	\$30B
FORCES	1.6 - 2 mill	5 mill
WARHEADS	450	1
DEL SYS	450	0
1952		
DEF \$	\$30B	\$31B

WARHEADS	1010	4
DEL SYS	755	0

### NATIONAL SECURITY POLICY

NSC135/3 - RESIST SOVIET POLITICAL  
WARFARE, STAND FIRM WITH ALLIES

NSC 48/5 - ENDORSED RESTRICTIONS ON  
KOREAN CONFLICT & PROVIDED ACTION  
AUTHORITY TO DETER RED CHINESE

NSC 68 - INSTITUTIONALIZED CONTAINMENT  
AND PROVIDED BETTER MEANS OF  
COUNTERING SOVIET EXPANSION  
& WAR BY PROXY

### FOREIGN POLICY

TRUMAN DOCTRINE  
FLEXIBLE BUT LIMITED RESPONSE  
IN KOREA

### PLAN/CONCEPT

- CONTINUE EUROPEAN RECOVERY PLAN
- KEEP DIPLOMATIC CHANNELS OPEN BUT DISCOURAGE NEGOTIATIONS UNTIL KREMLIN CHANGES POLICY
- INCREASE MILITARY SPENDING FOR AIR DEFENSE OF CANADA AND US, & SURFACE DEFENSE OF SEA LINES OF COMMUNICATION
- AVOID DIRECT MILITARY CONFRONTATION
- ESCALATION OF ARMED FORCES IN EUROPE & ASIA - FORWARD PRESENCE
- PRODUCE THE H-BOMB
- INCREASE PSYCHOLOGICAL AND ECONOMIC PRESSURE ON THE SOVIETS
- ENCOURAGE STRONG ALLIANCES
- INITIATE A PUBLIC AWARENESS CAMPAIGN
- LARGE TAX INCREASE TO FUND PLAN (COST EST = \$50B FOR DEFENSE ALONE)

### KEY ACTORS

PRESIDENT	H. TRUMAN
AUTHOR	PAUL NITZE
SEC STATE	ACHESON
SEC DEF	MARSHALL/LOVETT

\* MULTIPLE SOURCES, PREDOMINANTLY  
GADDIS. STRATEGIES OF CONTAINMENT

\*\* GNP EST USING FY66 DOLLARS

effect ignored the real enemy and allowed the Soviets to conduct a new "limited" war-by-proxy in Korea, and eventually Southeast Asia. Finally, they attempted to recommend a means to resource the strategy through tax hikes, public awareness campaigns, additional Alliance structures, and more defense dollars. It was this "price tag" that soured Truman from approving the strategy.

Korea validated the objectives of NSC-68 and further showcased the resource limitations of the U.S. The original objective in Korea to repel the armed intruders back behind the 38th parallel and restoration of international peace suited the defensive strategy of containment. However, when the decision was made to cross the line and "liberate" the North, the U.S. attempted the strategic offense, but against the wrong enemy. As Acheson eloquently stated the day the Chinese attacked - "We are fighting the second team, whereas the real enemy is the Soviet Union".<sup>14</sup> Once committed, Truman was unready for unrestricted war against the Soviets and the Chinese simultaneously. Further, he was unwilling to employ nuclear weapons to achieve an end. Truman was clearly resource constrained from assuming the offensive at this point in time.

THE NEW LOOK. The basic principles of NSC-68 formed the foundation for Eisenhower's New Look strategy (See Fig. 3). Central to the strategy, advanced by John Foster Dulles, was the concept of regaining the initiative lost during the Korean War years, while simultaneously lowering costs. The overall aim of the strategy was to "maintain the security of the US and the vitality of its fundamental values".<sup>15</sup> Similar to NSC-68 in theory, it advocated the use of deterrence to hold the defensive perimeter around the communist world, but when the Soviets crossed the line, they suffered the consequence of a nuclear response. To make nuclear deterrence credible, Eisenhower approved NSC162/2 which stated the US policy that nuclear weapons will be considered equal to conventional means when dealing with the Communists. It also argued that the US was unable to meet all its defense needs without the support of its allies.<sup>16</sup> Unlike NSC-68, it reintroduced Kennan's concept to drive wedges between the Soviets and their European satellites.

The plans to achieve these objectives were quite different. First, deter general war through a strong and uncertain nuclear force.

# FIGURE 3 EISENHOWER'S NEW LOOK STRATEGY 1953-1961\*

**GOAL: MAINTAIN SECURITY OF US AND THE VITALITY OF ITS FUNDAMENTAL VALUES**

**BOLDNESS STRATEGY - MASSIVE RETALIATION  
PERIMETER DEFENSE WITH  
STRATEGIC ASYMMETRY**

**THREAT - USSR POLITICAL POWER & AGGRESSIVE  
INTENT OF INTERNATIONAL COMMUNISM**

## OBJECTIVES

1. BY ALL MEANS SHORT OF WAR, BLOCK SOVIET EXPANSION
2. EXPOSE FALSITIES OF SOVIET PRETENSIONS
3. INDUCE A RETRACTION OF KREMLIN CONTROL AND FOSTER THE SEEDS OF DESTRUCTION WITHIN THE USSR
4. REGAIN INITIATIVE WHILE LOWERING ECONOMIC COSTS

## NATIONAL SECURITY POLICY

NSC162/2 - THE US WILL CONSIDER NUCLEAR WEAPONS EQUAL TO CONVENTIONAL MEANS WHEN DEALING WITH COMMUNISTS

NSC 68 - INSTITUTIONALIZED CONTAINMENT AND PROVIDED BETTER MEANS OF COUNTERING SOVIET EXPANSION & WAR BY PROXY

MASSIVE RETALIATION

## FOREIGN POLICY

EISENHOWER DOCTRINE  
LIBERATION OF EASTERN EUROPE

## RESOURCES US ADVANTAGE

**POLITICAL**  
EAST GERMAN & POLISH REVOLT  
UNCERTAINTY OF USSR LEADERSHIP  
ACTIVE US LEADERSHIP  
EXPANDING ALLIANCES  
**ECONOMIC**

US ADVANTAGE    US    USSR  
GNP\*\*    1955    \$508B    \$185B  
APPROX 1961    \$575B    \$272B

**TECHNOLOGICAL**    UNCERTAIN

SOVIETS LAUNCH SPUTNIK  
EXPANDING NUCLEAR ARSENALS

**PSYCHOLOGICAL**    US ADVANTAGE

MCCARTHYISM DRIVES PUBLIC AGENDA  
SOVIETS STRESS AGRI-ECONOMY

**MILITARY**    US ADVANTAGE

	US	USSR
1955		
DEF \$	\$30 B	\$30B
FORCES	2.8 - 3.5 mill	5.7 mill
WARHEADS	4123	102
DEL SYS	1639	28
1961		
DEF \$	\$50B	\$40B
FORCES	2.5 mill	3 mill
WARHEADS	6388	365
DEL SYS	1803 TRIAD	129

## PLAN/CONCEPT

- RELY ON THE NUCLEAR DETERRENT OF MASSIVE RETALIATION - AN ASYMMETRICAL AND FLEXIBLE ARMED RESPONSE
- REDUCE CONVENTIONAL FORCES
- ENCOURAGE STRONG AND LASTING ALLIANCES - SEATO & KOREA/TAIWAN
- MILITARY USED AS A DETERRENT, A SOURCE OF ALLIED SUPPORT, & PREPARE FOR WAR

- PSYCHOLOGICAL WARFARE - PROMOTE LIBERATION OF EASTERN EUROPE AND CHINA
- EXPAND COVERT OPERATIONS
- ATTEMPT NEGOTIATIONS WITH THE USSR AND CHINA

## KEY ACTORS

PRESIDENT	EISENHOWER
AUTHOR	JOHN DULLES
SEC STATE	JOHN DULLES/HERTER
SEC DEF	WILSON/MCELROY/GATES
ADVISORS	KENNAN

\* MULTIPLE SOURCES, PREDOMINANTLY GADDIS. STRATEGIES OF CONTAINMENT

\*\* GNP EST USING FY66 DOLLARS

Intercontinental bombers were produced, and research on a missile force was conducted. Second, deter conventional conflict through strong alliances. By 1958, Washington had assumed explicit obligations to defend some 45 countries from attack, and implicitly many more.<sup>17</sup> This system of alliances and military strategy were consistent with Eisenhower's overall strategy to seek maximum deterrence at minimum cost. Deterrence allowed this global "shielding" given limited resources. The third element dealt with psychological warfare. Dulles advanced his policy of East Europe liberation through constraint running public commentaries on the difficulties of Communist rule and the advantages of freedom. A propaganda campaign was initiated in printed and broadcast text. A fourth element of the plan complemented the third and centered on the use of covert action. Political propaganda, economic warfare, assistance to underground resistance factions, and deception plans were all implemented. The CIA executed major coup attempts in Iran and Guatemala, counter-insurgency operations, and U-2 overflights. The fifth element of the plan was an attempt at negotiations with the Soviets and Communist China. 18

The New Look formally institutionalized Containment, but the resources to contain "communism" were revised. Deterrence, through massive nuclear retaliation, as well as a strong alliances, formed the essence of establishing a "psychological perimeter". The strategy was sound, but for it's assumptions. First, it assumed first use of nuclear weapons within most confrontational scenarios. This threat was a "paper tiger" and not credible. There was no question that it achieved the economies sought, but it was unimpressive to both adversaries and allies. Further, it did not allow an offensive option vice direct nuclear attack on the Soviet homeland. Second, the New Look had no provisions to exploit economic strengths or deal with revolutionary communist factions in the Third World. Covert activities were expanded, but they served mainly to shore up the defenses, than offer an offensive solution.

Eisenhower, deriving strategy from a Clausewitzian approach, correctly assessed that the means did not match the ends to implement Containment. His goal of greater deterrence at less cost, was realized. A defensive perimeter was established by erecting an invisible nuclear fence. Did these means justify the ends? The short peace would only remain



viable until the American nuclear monopoly was toppled. Sputnik invalidated the New Look strategy opening the door for further unconventional confrontations.

FLEXIBLE RESPONSE. The 1960's represented the greatest period of direct superpower conflict during the Cold War. The spectrum of conflict was vast - from direct confrontation during the Cuban Missile crisis and the Soviet invasion of Czechoslovakia in 1968, to Communist expansion of influence into the third world and the Vietnam War. Further, ICBM's were introduced into the resource equation that complicated the perception of the threat. The New Look strategy, dependent on the use of nuclear weapons, was clearly unwieldy in these situations.

President Kennedy, surrounding himself with Truman era Cold warriors and "wiz kids"<sup>19</sup>, fashioned a new strategy of flexible response (See Fig. 4) to offer strategists more options. Kennedy's objectives placed less emphasis on reducing costs and greater emphasis on reducing risks. He envisioned options for action at all levels, from diplomacy, covert action, to general war. He desired flexibility to respond without automatic escalation, and believed in deterrent strength.

The objectives of the strategy were 1) deter all wars, general or limited, conventional or nuclear, large or small; 2) convince all potential aggressors that any attack would be futile; 3) provide backing for the diplomatic settlements of disputes; and, 4) insure the adequacy of bargaining power to end the arms race. <sup>20</sup>

The plan for implementing Flexible Response gave first priority to decreasing the reliance on nuclear weapons. Further, they emphasized a stronger NATO military force. Seeing the greater "bang for the buck" of strategic missile forces and the need to maintain strategic superiority, they also expanded the procurement of ICBMs and SLBMs. <sup>21</sup>

The greatest test of the flexible response strategy came in the Vietnam War under the Johnson administration. The assumptions were that adequate force could be applied with precision and discrimination. Further, the defense of Southeast Asia was crucial to the world order, and that direct conflict between the superpowers must be avoided.

# FIGURE 4 FLEXIBLE RESPONSE STRATEGY 1962-1969\*

**GOAL: PRESERVE AND PROTECT A WORLD OF DIVERSITY**

FLEXIBILITY OF STRATEGIC CHOICE  
BALANCE OF POWER STRATEGY  
SYMMETRICAL RESPONSE

THREAT = USSR POLITICAL IDEOLOGY, CBMS,  
AND CONVENTIONAL FORCES IN EUROPE

## OBJECTIVES

1. DETER ALL WARS, GENERAL OR LIMITED, NUCLEAR OR CONVENTIONAL
2. CONVINCED ALL ADVERSARIES THAT ATTACK WOULD BE FUTILE
3. PROVIDE BACKING FOR DIPLOMATIC SETTLEMENTS OF DISPUTES
4. ENSURE ADEQUACY OF BARGAINING POWER TO END THE ARMS RACE

## NATIONAL SECURITY POLICY

NSC 68 - INSTITUTIONALIZED CONTAINMENT AND PROVIDED BETTER MEANS OF COUNTERING SOVIET EXPANSION

## MILITARY POLICY

FORWARD PRESENCE  
DETERRENCE/EXTENDED DETERRENCE  
CONVENTIONAL AND NUCLEAR FORCE OPTIONS

## FOREIGN POLICY

FREE WORLD SECURITY  
STEM COMMUNIST INFLUENCE IN VIETNAM  
EXPAND DIALOGUE WITH SOVIET UNION

## RESOURCES UNCERTAIN

**POLITICAL**  
CUBAN MISSILE CRISIS - US GAINS  
SOVIET CZECH INVASION  
US INVOLVEMENT IN VIETNAM  
HOT LINE & TEST BAN/SALT TALKS  
SOVIET SET BACKS IN THIRD WORLD

**ECONOMIC** US ADVANTAGE USSR  
GNP 1967 \$762B \$372B  
(APPROX)\*\*

**TECHNOLOGICAL** US ADVANTAGE

NO CLEAR FIRST STRIKE CAPABILITY  
SOVIET STRATEGIC ARSENAL EXPANDS

**PSYCHOLOGICAL** USSR ADVANTAGE

ANTI-VIETNAM SENTIMENT RUINS

NATIONAL FOREIGN POLICY CONSENSUS

**MILITARY** US ADVANTAGE

1968	US	USSR
DEF \$	\$80 B	\$55B
FORCES	3.5 million	3.7 million
WARHEADS	4982	1316
DEL SYS	2332	1001
ICBM	1054	732
SLBM	656	110
BOMBERS	622	159

## PLAN/CONCEPT

- BOLSTER CONVENTIONAL AND UNCONVENTIONAL MILITARY CAPABILITIES; EXPAND NATO FORCES
- CREDIBLE ICBM & SLBM BUYS; 200% BOOST IN DELIVERABLE MEGATONNAGE
- NEW EFFORTS TO SOLIDIFY ALLIANCES; FIRST STRIKE AN OPTION
- EXPAND NON-MILITARY ELEMENTS OF CONTAINMENT; \$29 B FOR "ALLIANCE FOR PROGRESS" IN LATIN AMERICA; EXPAND THE PEACE CORPS
- EFFECTIVELY MANAGE DOMESTIC RESOURCES VITAL TO DEFENSE

## KEY ACTORS

PRESIDENT	KENNEDY/JOHNSON
AUTHOR	WALT ROSTOW
SEC STATE	DEAN RUSK
SEC DEF	MACNAMARA/CLIFFORD
NSC	MCGEORGE BUNDY
ADVISERS	TAYLOR/NITZE

\* MULTIPLE SOURCES, PREDOMINANTLY GADDIS. STRATEGIES OF CONTAINMENT

\*\* GNP EST USING FY66 DOLLARS

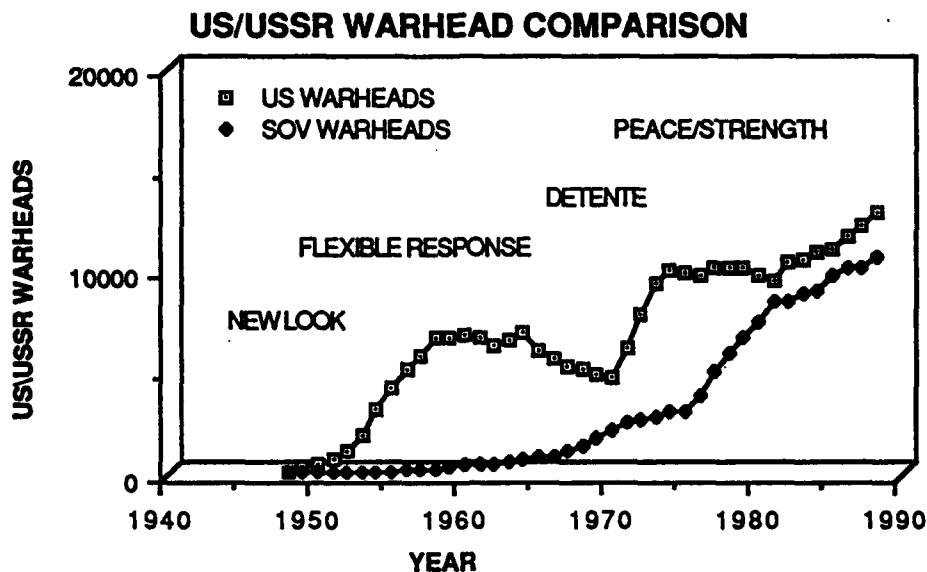

Figure 5. Comparison of US/USSR Nuclear Warheads (Source: *Historian of the Department of Defense*, various years)

Similar to Korea, the selection of force was constrained by the reality of keeping the war limited. Nuclear weapons and strategic build-ups could involve the Chinese or Soviets. A war by proxy strategy was used by the Soviets which altered the resource balance. The end result was a US psychological, military and political defeat that gave the Soviets greater leverage in the overall Cold War.

The overall problem with this strategy was that the plan for implementation, nor the resources matched the objectives or the perception of the threat. The Kennedy/Johnson administrations bolstered conventional and unconventional military forces (getting more bang for the buck) and established military options across the spectrum of conflict, but to what end? The aim to deter all general or limited war was violated by the Cuban Missile crisis and the Vietnam War. The second objective to convince adversaries that attack would be futile meant little to the Vietcong. Further, diplomatic victories, especially with the Soviet Union were rare. The final objective to assure adequacy of bargaining power to end the arms race was actually reversed. The Soviets, during this period, managed to achieve strategic arms parity - an impressive feat in such a short time with grave resource implications. (See Figs. 5 and 6 for a comparison of strategic arms and delivery vehicles.)

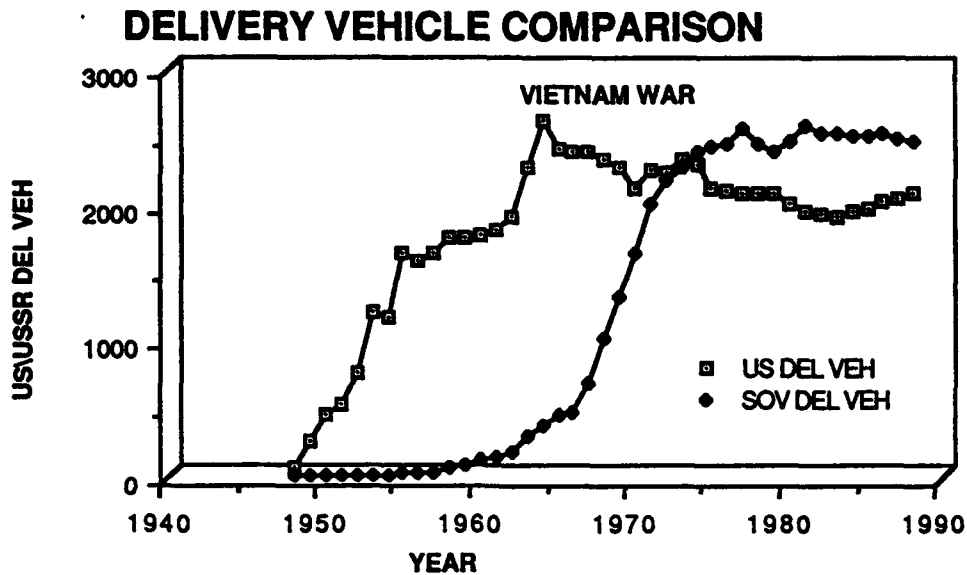

Figure 6. Comparison of US and USSR Delivery Vehicles (Source: *Historian of the Department of Defense*, various years)

How does one account for such a disconnect between plans and objectives? Indeed, the means, and the plan to achieve these means, overshadowed the ends. This disconnect in strategy was grossly flawed and placed blinders on the strategic decision makers. The consequence was conflict. The resulting decline in international stature and domestic upheaval permitted the Soviets to attempt a Cold War offensive in the subsequent decade. Hence, this period represented the "low point" of the Cold War from an American perspective and mandated a fundamental review of national strategy.

**DETENTE.** The Nixon administration, spearheaded by Dr. Kissinger, implemented a radical shift in Cold War strategy. The new strategy, called detente (See Fig. 7), assumed strategic parity with the Soviet Union. It further assumed the Soviets were willing to negotiate an end to the Cold War. The reason for the shift was because Kissinger desired to counteract the relative slide in U.S. power. Specifically, he wanted to reverse the psychological and political damage created by the demise in the war in Vietnam. As a result, the Cold War strategy of detente looked more like the original strategy promoted by Kennan twenty years prior. The military and economic tools of national power were held in check by a

FIGURE 7

**DETENTE'  
1970-1979\***

**GOAL: AN INTERNATIONAL ORDER MORE FAVORABLE TO THE INTERESTS OF THE U.S.**

DEFENSE IN PLACE - NEGOTIATE AN END TO COLD WAR  
ASYMMETRICAL RESPONSE - LESS UTILITY FOR NUCLEAR WEAPONS  
SET LIMITS ON RESPONSE - SUFFICIENCY

THREAT - SOVIET ACTION NOT IDEOLOGY

**OBJECTIVES**

1. CONTAIN THE INFLUENCE AND POWER OF THE SOVIET UNION
2. CONVINCING SOVIETS THAT IT IS IN THEIR OWN INTERESTS TO BE CONTAINED
3. ENSURE ADEQUACY OF BARGAINING POWER TO END THE ARMS RACE
4. INTEGRATE SOVIETS INTO STABLE WORLD ORDER

**NATIONAL SECURITY  
POLICY**

PD-59/ STRATEGIC ARMS LIMITATIONS

**NATIONAL MILITARY  
POLICY**

NUCLEAR DETERRENCE  
EXTENDED DETERRENCE  
FLEXIBLE RESPONSE  
FORWARD BASING

**FOREIGN POLICY**

CONGRESS BECOMES ACTIVE  
NIXON DOCTRINE  
VIETNAMIZATION  
CARTER DOCTRINE

**RESOURCES  
UNCERTAIN**

**POLITICAL**  
LEGITIMATE SOVIET POST WWII CLAIMS  
SOVIET INDIA & EGYPT PACTS  
US COURTS CHINA  
CONTINUED BILATERAL ARMS TALKS  
US PULLS OUT OF VIETNAM

**ECONOMIC**      US ADVANTAGE      USSR  
US  
GNP 1970      \$1,000B      \$500B  
(APPROX)\*\*

**TECHNOLOGICAL**      UNCERTAIN  
NO CLEAR FIRST STRIKES SUPERIORITY  
STRATEGIC PARITY

**PSYCHOLOGICAL**      USSR ADVANTAGE  
VIETNAM DOMESTIC UPHEAVAL  
SOVIET PROPAGANDA INCREASES

**WATERGATE**      US ADVANTAGE  
**MILITARY**

1971	US	USSR
DEF \$	\$78 B	\$64B
FORCES	3.5 mil	3.7 mil
WARHEADS	6054	2409
DEL SYS	2249	2005

ICBM	1054	1447
SLBM	656	401
BOMBERS	555	157

**PLAN/CONCEPT**

- ENGAGE THE SOVIETS IN SERIOUS NEGOTIATIONS ON SUBSTANTIVE ISSUES
- USE CONCEPT OF "LINKAGE" - LINK ARMS TALKS TO THIRD WORLD POLICY, ECONOMIC INDUCEMENTS TO BEHAVIOR
- EXPLOIT LINKS TO INTERNATIONAL COMMUNIST NATIONS & SOVIET RIVALS
- REDUCE AMERICAN COMMITMENTS IN THE WORLD; PULL OUT OF VIETNAM
- MAINTAIN ALL TREATY COMMITMENTS
- PROVIDE NUCLEAR SHIELD FOR NATIONS VITAL TO US SECURITY
- FURNISH MILITARY AND ECONOMIC AID IN ACCORDANCE WITH TREATIES
- MILITARY STRATEGY BASED ON AMBIGUOUS THREATS AND UNCERTAINTY
- INTEGRATE SOVIET ECONOMY INTO INTERNATIONAL SYSTEM; GRAIN SALES, MFN STATUS AS INDUCEMENTS

**KEY ACTORS**

PRESIDENT	NIXON/FORD/CARTER
AUTHOR	KISSENGER
SEC STATE	ROGERS/KISSENGER
SEC DEF	LAIRD/SCHLESINGER/BROWN
NSC	KISSENGER/BREZINSKI

\* MULTIPLE SOURCES, PREDOMINANTLY GADDIS, STRATEGIES OF CONTAINMENT

\*\* GNP EST USING FY66 DOLLARS

public soured on the idea of America at war. The arms race had continued reflecting escalating means with little hope of ending the race. Nuclear weapons, given parity, were reaching decreasing practical utility. Diplomacy, in his view, was the best vehicle for remedying the situation.

The overall objectives of detente were to "contain" the power and influence of the Soviet Union. But unlike previous strategies, apply a new combination of pressures and inducements, that if successful, would convince the Soviets that it is in their best interests to be "contained". Further, like Kennan, the goal reflects the aim of integrating the Soviet Union into the existing world order to facilitate peaceful equilibrium and insure the adequacy of bargaining power as an end to the arms race.<sup>22</sup>

To implement the strategy of detente, Kissinger devised a plan focused on active diplomacy. First, engage the Soviets in serious negotiations on issues of mutual security. To achieve this end he introduced the concept of "summitry". Second, Kissinger advanced the concept of "linkage" whereby arms talks would be linked to third world policy, and economic inducements coupled to political behavior. Further, he planned to exploit links to other international communist nations, especially Soviet rivals. China became the focus of an intense economic and political exchange between nations. Third, to signal American compliance, the U.S. would maintain all treaty commitments, but pull troops out of Vietnam. The concept of extended deterrence to shield allied nations remained vital to U.S. security interests. Next, to better balance the international balance of power, the U.S. would furnish economic and military aid to key Third World nations and allies. These tenets of the plan were formalized within the Nixon Doctrine. Fifth, in an attempt to introduce uncertainty in U.S. response to Soviet aggression, Kissinger formed a military strategy around an ambiguous threat that conveyed the notion that the risks were kept high and incalculable. This signalled a shift back to asymmetrical response. Conventional military forces would be cut, and nuclear force modernization would be financed. <sup>23</sup>

Detente required major philosophical adjustments to U.S. policy toward the Soviet Union. First, it required a recognition of "multi-dimensional" nature of power in the world. This multipolar view of the world pitted economic forces against military strength, and nationalism against ideology. The assumptions also embraced the concept of

"trilateralism" that emphasizes the economic might of Japan and Germany. Similarly, it loosened tensions with the Soviets by accepting the current state of the World Order (i.e. the post-WWII Eastern Europe boundaries were legitimate). A second requirement was a shift in defense strategy from superiority to sufficiency. Given sufficiency, it is in the interests of both sides to exhibit mutual restraint. <sup>24</sup> Hence, Kissinger viewed detente as a strategy of mutual restraint, coexistence, and ultimately cooperation. <sup>25</sup>

Detente was fashioned as a means to resuscitate an America in decline and reestablish a defensive foundation from which to negotiate an end to the Cold War. To achieve this end, the administration had to appease both the adversary and the U.S. Congress. America's only relative strength versus the Soviets was economic. Hence, the strategy allowed major concessions in territory and prestige in an effort at peaceful coexistence.

This radical shift in strategy resulted in few successes and many failures. Opening the door to China, the superpower summits, the Arab-Israeli War of 1973, and the ABM and SALT negotiations formed the basis of success. On the other hand, the SALT talks were derailed when Congress amended many of the original initiatives. Further, in an effort to balance the global power equation, the administration backed Third World nations with military and economic aid. The problem was they backed the losing cause. Nixon supported the white government of South Africa, infused massive resources into Iran, failed to keep Cyprus independent of Greek/Turkish domination in 1974, and supported the losers in Angola, and Pakistan.

Finally, the objectives, and the plan to achieve them, could be perceived as an effort to sue for peace in the Cold War, in lieu of further conflict and arms escalation. Arms would be capped, and economies intertwined thereby fashioning a world order satisfying both political entities. Peace did not prevail, but Kissinger did succeed in reestablishing American influence and prestige. Detente ultimately failed when the Soviets, now uncontained, sent troops into Afghanistan.

PEACE THROUGH STRENGTH, President Carter, and ultimately Reagan, revised the U.S. strategy as a consequence of Afghanistan. To counter "the focus of evil in the modern world . . .". <sup>26</sup> , Reagan abandoned detente

FIGURE 8

# REAGAN'S STRATEGY 1980-1988\*

GOAL: PEACE THROUGH STRENGTH

OFFENSIVE - CAN FIGHT & WIN NUCLEAR WAR  
BALANCE OF POWER STRATEGY  
SYMMETRICAL CONTAINMENT

THREAT = USSR = EVIL EMPIRE

## OBJECTIVES

1. CONTAIN SOVIET EXPANSION AND MODERATE SOVIET INTERNATIONAL BEHAVIOR
2. ENCOURAGE CHANGE IN SOVIET SYSTEM TOWARD GREATER LIBERALISM
3. NEGOTIATE SECURITY ISSUES IN THE U.S. INTERESTS

## NATIONAL SECURITY POLICY

NSDD-75 - CONTAIN SOVIET EXPANSION

### NATIONAL MILITARY POLICY

NUCLEAR DETERRENCE/CONVENTIONAL RETALIATION  
EXTENDED DETERRENCE  
TECHNOLOGICAL SUPERIORITY  
FORWARD BASING

### FOREIGN POLICY

REAGAN DOCTRINE - ROLL BACK SOVIET INFLUENCE IN THE THIRD WORLD  
STRATEGIC ARMS REDUCTION

## RESOURCES

POLITICAL US ADVANTAGE

STRONG LEADERSHIP  
SOVIET/AFGHAN INVASION  
US INVOLVEMENT IN THIRD WORLD  
START TALKS & SUMMITS

ECONOMIC US ADVANTAGE

GNP 1980 US \$ 3187B  
1989 3847B  
(APPROX)\*\*

TECHNOLOGICAL US ADVANTAGE

STRATEGIC MODERNIZATION & SDI

PSYCHOLOGICAL US ADVANTAGE

AFGHANISTAN SOURS SOVIET PUBLIC SDI CAUSES FEAR OF FIRST STRIKE

MILITARY US ADVANTAGE

1987	US	USSR
DEF \$	\$228 B	\$207B
FORCES	2.2 m ill	4.4 m ill
WARHEADS	13873	11044
DEL SYS	1957	2511

ICBM 10 00 1418

SLBM 640 928

BOMBERS 317 165

## PLAN/CONCEPT

- ENERGIZE A HUGE MILITARY BUILD-UP; STRATEGIC FORCE MODERNIZATION - \$2.1 TRILLION APPORTIONED OVER 7 YEARS
- CREDIBLE DETERRENT; ENGAGE IN SDI RESEARCH
- REJECT SALT II TREATY; NEGOTIATE ARMS REDUCTIONS IN THE U.S. INTERESTS
- EXPLOIT DIFFERENCES BETWEEN THE CPSU AND EASTERN EUROPE PARTIES
- MAINTAIN STRONG ALLIANCES; EXPAND TACTICAL NUCLEAR WEAPONS IN EUROPE
- TAKE ADVANTAGE OF US TECHNOLOGICAL SUPERIORITY TO ENGAGE IN AN ARMS RACE OF INDEFINITE DURATION AND COST
- SUPPORT RESISTENCE GROUPS IN AFRICA AND AFGHANISTAN WITH ECONOMIC AND MILITARY AID

## KEY ACTORS

PRESIDENT	RONALD REAGAN
SEC STATE	HAIG/SCHULTZ
SEC DEF	WEINBERGER
NSC	COLIN POWELL
ADVISERS	NITZE

\* MULTIPLE SOURCES, PREDOMINANTLY GARIOFF, DETENTE AND CONFRONTATION, THE MILITARY BALANCE 1987 (LONDON)

\*\* GNP EST USING FY87 DOLLARS



and cooperative coexistence, and began a unilateral campaign to rebuild the military and economic might of the United States. He surrounded himself with advisors who were noted for strong ideological attitudes against the Soviet Union.<sup>27</sup> Reagan quickly fashioned a Cold War strategy around the previous concepts of containment, but clearly more confrontational in employing multiple means of national power. His slogan "peace through strength" epitomized the new direction (See Fig. 8).

Reagan employed the economic superiority of the U.S. and crafted an unprecedented military build-up to shift the balance of power toward the favor of the U.S. (See Fig. 9). The plan of attack emphasized patience and stalled negotiations until the U.S. military and political base had gained in relative strength. This had merit for the Soviets were overextended economically through maintenance of the arms race, and the need to sustain their troops in Afghanistan.

### US STRATEGIC MILITARY SPENDING COMPONENT

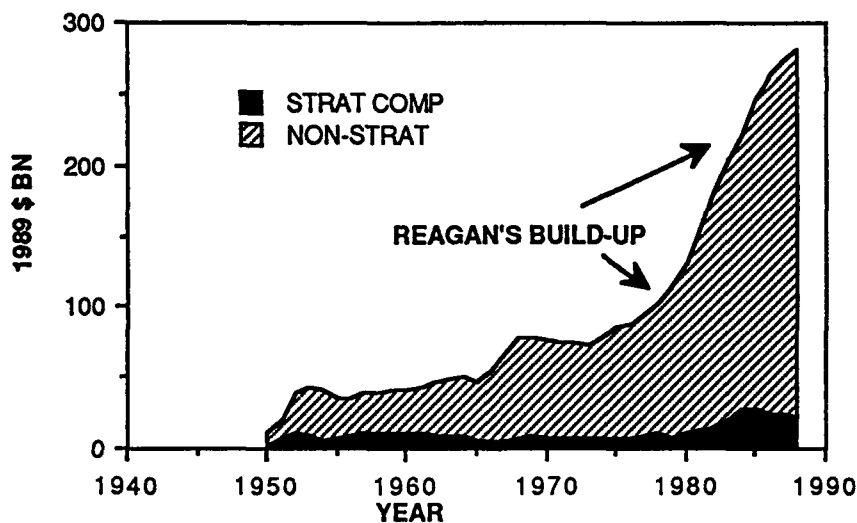

Figure 9. The Reagan resource build-up.

(Source: *Annual Report of the Secretary of Defense*, various years.)

The objectives of Reagan's strategy were documented in National Security Decision Directive (NSSD) - 75. It established three long-term aims: 1) contain the Soviet expansion and moderate Soviet international behavior; 2) encourage, by the limited means at the disposal of the administration, change in the Soviet political and economic system toward

greater liberalism; and, 3) negotiate agreements that were in the best interests of the United States.<sup>28</sup> Containment had been reinstated as policy, and an ultimate plan to win the Cold War had been given national guidelines.

Initially, Reagan rejected the SALT II treaty, and expanded theater nuclear forces in Europe. His plan supported communist resistance movements in the Third World. Strong Alliances were to be maintained and "shored up" with conventional force. Further, psychologically, politically, and economically exploit differences between the Communist Party of the Soviet Union and Eastern Europe satellites, namely Poland, East Germany and Czechoslovakia. The showcase of the plan was an effort to take advantage of the U.S. technological superiority. The concept was to engage the Soviets in an arms race of indefinite duration and cost. Reagan energized a conventional and nuclear force modernization program totalling nearly \$2.1 trillion apportioned over seven years. The key military technology advanced - the Strategic Defense Initiative (SDI) - created a fundamental shift in military doctrine and strategy that affected both sides. Military doctrine would shift away from deterrence based on parity toward superiority in both nuclear and non-nuclear regimes. Only after these initiatives were credible would negotiations (from strength) occur. 29

The change in military doctrine and the abandonment of arms control signalled to the Soviets that America would not offer a means for them to prevail in a contest of weapons. Further, through SDI, Reagan laid down an economic challenge. If the Soviets were to keep pace with the U.S. technological advances, they would have to move into areas yet undiscovered by soviet scientists, and accomplish this feat under grave economic stress.

In short, this strategy was the first one to actually match required national resources with national objectives, ends with means. The strategy clearly placed the Soviets within a strategic dilemma; how do they maintain the offensive in the Cold War without economic collapse? Moreover, by trading guns for butter, how could they maintain political control over a starving population, and nationalistic forces in their satellites?

Reagan, for the first time, offered an offensive solution - properly resourced by all national means. He achieved his, and Kennan's, objectives. But unlike Kennan, he used economic, technological, and military means as opposed to political and psychological. The difference in means reflects the impact of the nuclear arms race on the strategic equation - an area Kennan did not have to deal with in 1947. In sum, Reagan successfully pit the strength of the United States against the Soviet weakness - their economy. His strategic timing was noteworthy for he correctly assessed that for the first time in the Cold War, the Soviets had declined in both absolute and relative power. He capitalized on their vulnerabilities even at the expense of the U.S. economy, and directly contributed to the demise of the USSR.

#### INSIGHTS GAINED FOR FUTURE APPLICATION

An examination of Cold War strategy produces many lessons for students of strategic thought. As we have seen in this unprecedented superpower struggle for power, there are right ways and wrong ways to advance a national strategy. The consequences of flawed strategy are potentially disastrous. Placing the world at risk of a nuclear holocaust may well be viewed by historians in the 21st century as the most unstable means to achieve political aims, and place this period of history as a new chapter in human barbarism. The fact that a nuclear exchange was avoided is also a tribute to proper strategy. Besides these overarching comments, what specific insights could be gained from this period of conflict?

##### 1. MULTIPLE ADMINISTRATIONS EQUAL MULTIPLE OBJECTIVES.

U.S. leaders advanced six different strategies to achieve an end to the Cold War. Each administration prior to Reagan seemed to experiment with finding the correct national means to solve this problem. The respective strategist's examined the problem given their individual view of the threat and their respective resource environment. The result was six different sets of objectives and views of the threat. Fig 10 compares the various approaches.

In retrospect, the objectives appear ambiguous and clearly defensive in nature. How does one "expose falsities of Soviet pretensions", as

detailed by Nitze in NSC-68? Moreover, how do you know when you have "convinced the Soviets it is in their interests to be contained", or when you have "ensured the adequacy of bargaining power . . .", as documented in detente? How do you measure your progress in achieving these objectives? How do you know when you've achieved objectives?

Unachievable objectives were resident in most strategies. The lesson is clear. One must coherently communicate and resource the aims of national strategy. If the means are not affordable, the national objectives should be revised. If properly advanced, the result is a method to rally popular support and define the realistic means to an end, exemplified by Reagan. If communicated or resourced poorly, the result is means that support a plan not in the interest of the United States, as we saw in the era of flexible response.

2. PERSONALITIES ARE IMPORTANT! Each of the various administrations approach to containment tended to be determined, not through rational strategic planning sessions, but more through a determination to do something different from previous administrations. For example, the New Look was a reaction to Truman's "no win war" in Korea. The flexible response strategy grew out of Democratic complaints of Eisenhower's reliance on nuclear weapons. Further, the Nixon doctrine reflected Republican beliefs that LBJ overcommitted the nation in Vietnam. The Carter "human rights" campaign was in reaction to the perceived amorality of Kissinger. And finally, Reagan promised to "close the window of vulnerability" left open by Carter.<sup>30</sup> These personality biases directly influenced the structure of the Cold War grand strategy and complicated the fragile attempts to achieve a victory.

Similarly, the key advisors to the Presidents influenced the strategy. Kennan, Nitze, Dulles, Rostow and Kissinger advanced the strategy from the Department of State. Should the State Department advocate national security strategies for war, the National Security Council, or the Department of Defense? Whose responsibilities is it to develop non-military means of attack? Will they be effective if advocated by the State Department? Will they ever be properly resourced? Will creation of a National Economic Council complicate security matters? In my view, the National Security Council should develop the grand strategy. All other agencies should be members of, or subordinate to the National Security

**Strategy.** The absence of this "unity of effort" may result in reduced options toward stemming a protracted Cold War II.

**3. CONSENSUS ON THE NATURE OF THE THREAT IS IMPORTANT!**

Planners keyed on proper political interpretation of the adversary. During the Cold War the threat was perceived as:

Kennan	USSR political power
Nitze/NSC-68	USSR military power
New Look	USSR political power & international communism
Flexible Response	USSR ideology, ICBMs, & forces in Europe
Detente	Soviet behavior & ideology
Reagan	USSR leaders and military power

Given these fundamental differences in "the threat", it is no wonder that different plans were formulated. Moreover, attempting to contain military power is much easier to plan than containing international communism. One means of interpreting the variance in perspective is that each respective administration "reacted" to the immediate security situation when they came to office. New assessments were framed within the initial construct and varied only when a new president was elected or when a new technology was introduced into the resource equation.

## **KENNAN**

**PATIENCE & FIRMNESS STRATEGY  
STRONGPOINT DEFENSE PITTING US  
STRENGTHS AGAINST SOVIET WEAKNESS**

**THREAT = USSR POLITICAL POWER**

1. RESTORE BALANCE OF POWER TO NATIONS THREATENED BY USSR
2. REDUCE SOVIETS ABILITY TO PROJECT INFLUENCE BEYOND ITS BORDERS
3. MODIFY THE SOVIET CONCEPT OF INTERNATIONAL RELATIONS TOWARD A VIEW OF NEGOTIATING DIFFERENCES

## **NSC-68**

**SYMMETRICAL RESPONSE STRATEGY  
PERIMETER DEFENSE TO DRAW  
THE LINE ON COMMUNIST EXPANSION**

**THREAT = USSR MILITARY POWER AND  
FORCES IN EAST EUROPE**

1. BY ALL MEANS SHORT OF WAR, BLOCK SOVIET EXPANSION
2. EXPOSE FALSITIES OF SOVIET PRETENSIONS
3. INDUCE A RETRACTION OF KREMLIN CONTROL AND FOSTER THE SEEDS OF DESTRUCTION WITHIN THE SOVIET SYSTEM

## **NEW LOOK**

**MASSIVE RETALIATION  
PERIMETER DEFENSE WITH  
STRATEGIC ASYMMETRY**

**THREAT = USSR POLITICAL POWER &  
AGGRESSIVE INTENT OF INTERNATIONAL  
COMMUNISM**

1. BY ALL MEANS SHORT OF WAR, BLOCK SOVIET EXPANSION
2. EXPOSE FALSITIES OF SOVIET PRETENSIONS
3. INDUCE A RETRACTION OF KREMLIN CONTROL AND FOSTER THE SEEDS OF DESTRUCTION WITHIN THE USSR
4. REGAIN INITIATIVE WHILE LOWERING ECONOMIC COSTS

## **FLEXIBLE RESPONSE**

**FLEXIBILITY OF STRATEGIC CHOICE  
BALANCE OF POWER STRATEGY  
SYMMETRICAL RESPONSE**

**THREAT = USSR POLITICAL IDEOLOGY,  
ICBMS, AND CONVENTIONAL FORCES  
IN EUROPE**

1. DETER ALL WARS, GENERAL OR LIMITED, NUCLEAR OR CONVENTIONAL
2. CONVINCING ALL ADVERSARIES THAT ATTACK WOULD BE FUTILE
3. PROVIDE BACKING FOR DIPLOMATIC SETTLEMENTS OF DISPUTES
4. ENSURE ADEQUACY OF BARGAINING POWER TO END THE ARMS RACE

## **DETENTE**

**DEFENSE IN PLACE - NEGOTIATE AN END TO  
COLD WAR  
LESS UTILITY FOR NUCLEAR WEAPONS  
SET LIMITS ON RESPONSE - SUFFICIENCY**

**THREAT = SOVIET ACTION NOT IDEOLOGY**

1. CONTAIN THE INFLUENCE AND POWER OF THE SOVIET UNION
2. CONVINCING SOVIETS THAT IT IS IN THEIR OWN INTERESTS TO BE CONTAINED
3. ENSURE ADEQUACY OF BARGAINING POWER TO END THE ARMS RACE
4. INTEGRATE SOVIETS INTO STABLE WORLD ORDER

## **PEACE THROUGH STRENGTH**

**OFFENSIVE - CAN WIN NUCLEAR WAR  
BALANCE OF POWER STRATEGY  
SYMMETRICAL CONTAINMENT**

**THREAT = USSR = EVIL EMPIRE**

1. CONTAIN SOVIET EXPANSION AND MODERATE SOVIET INTERNATIONAL BEHAVIOR
2. ENCOURAGE CHANGE IN SOVIET SYSTEM TOWARD GREATER LIBERALISM
3. NEGOTIATE SECURITY ISSUES IN THE U.S. INTERESTS

**FIGURE 10. THE GRAND OBJECTIVES.**

Future applications are obvious. First, variance in grand strategy in both national objectives and definition of the threat to national interests should be resisted without first resourcing the change in strategy. Ideas are cheap and immediate; however, resourcing them, especially to win a Cold War, are borne by generations. Similarly, from a planners perspective, it was easier to adjust resources to accommodate small changes in objectives. Radical changes required radical restructuring of required resources and major alterations of plans. In most cases, a single term administration can not implement a severely altered strategy. The greatest success in the Cold War came from multi-term administrations who offered long-term strategic coherency.

#### 4. CENTERS OF GRAVITY WERE IDENTIFIED BUT RARELY ATTACKED.

What is the formula for victory? Ultimately, the leader who devised an offensive strategy to commit non-military resources against the opponents center of gravity while, at the same time protecting his, would prevail.

On the Soviet side, their strategic center rested on the political mechanism for holding all the forces of nationalism and fragmentation in check - the Communist Party of the Soviet Union. The mechanism for undermining the political strong hold on the satellite nations, and dissolve the glue that bound their domestic republics together was to attack the Soviet economy while providing inducements for nationalism. Non-military means were the only choice.

The U.S. center of gravity was national will. The Soviets were much more successful at reaching this element during the Cold War. For example, Khrushchev's campaign of deceit, and Breshnev's propaganda following the Vietnam War directly influenced American strategists. Moreover, self-imposed attacks from "McCarthyism" and Watergate aided the Soviet effort. The lesson? Strategists must attempt to protect their center of gravity while applying the greatest national means against the opponents to achieve victory. Reagan was the only President who mastered this principle. Second, over reliance on military means for victory in the nuclear era could only lead to military conflict - not strategic victory. Avenues of economic warfare, and non-lethal weapon technology must be explored at greater length to avoid further Cold Wars, or come to quicker victories.

5. IS THE DEFENSE THE BEST OFFENSE? Containment was a defensive strategy. Were there better alternatives? Yes, given a large short-term price tag, otherwise no. Was it successful? Yes, from the perspective that it kept the opponent from scoring a large number of points. On the other hand, the Cold War was a low scoring contest. Indeed, military power, especially nuclear forces, were successfully kept in check. However, failures of containment abounded. The Korean war, Castro's rise to power in Cuba, the Cuban Missile Crisis, the fall of South Vietnam and Cambodia, Communist insurgency in Angola, Mozambique and Nicaragua, and Soviet influence in Syria, Iraq, Libya, Egypt, and Somalia are numerous examples of an "uncaged" bear.

The lesson, in this case, is when one sets a defensive strategy based on balance of power equations, one must assume a low scoring, drawn out contest. The American way of war runs contrary to the protracted nature of this assumption. If politicians place this nation at war, albeit a Cold War, they must attempt to take the offensive at the earliest juncture. Had Truman or Eisenhower properly resourced an offensive strategy, would we have been subject to the nuclear arms race? On the other hand, did America have the political and economic means to sustain the offensive in the 1950's? Finally, if an offensive is unachievable in the short term, national objectives must be reexamined.

6. NATIONAL RESOURCES MUST COMPLIMENT STRATEGIC PLANS. The Cold War was a war of resources. Leverage was gained by the side who could introduce a better technology, create a new political or economic alliance, or maintain the national economic base necessary to sustain a high technology force structure in the nuclear era.

Basic to the study of the Cold War is the nature of the arms race. Weapons of mass destruction proliferated laterally and horizontally at unprecedented levels. Initially, the Americans possessed a monopoly on the atomic bomb and the means to deliver them. The Soviets closed the "gap" during the Vietnam era, when U.S. resources were diverted to the Southeast Asian war effort. Weapons diversity expanded, causing new kinks in military strategy. The result was a high-tech battlefield, with tactical nuclear weapons expanding into most conventional means of delivery. On the strategic side, air transportable delivery systems expanded to missile, sea-based, and space based schemes. Complex



command and control, intelligence, and communication systems, as well as air defenses sprung up to support the strategic arsenals.

Similarly, security alliances expanded as a means of providing a "nuclear umbrella" to those states feeling threatened by the great powers. The NATO alliance and Marshall Plan were implemented to shore up war torn Western Europe. The former created a lasting security process, the later, an economic stimulant. During this era, the Warsaw Pact was created, the SEATO, CENTO and ANZUS treaties signed as well as a host of bilateral security arrangements. All in all the United States introduced over 50 agreements to help balance regional power. <sup>31</sup> Shifts in alliances during the cold war implied a great political victory or embarrassment. For example, the U.S. politicians lamented over the "loss of China" in 1948, only to see China shift against Soviet-style Communism in the 1970's. Further, the expulsion of Soviet "advisors" by Egypt after the Arab-Israeli War was a great embarrassment to Soviet leaders. Finally, the United Nations grew in international preeminence, but was stalled in its initiatives by the veto votes and power politics of the two superpowers.

The side who possessed the strongest national will and public sentiment also gained resource leverage over the other. The Soviets had the advantage due to the nature of their political control mechanisms, specifically the Communist Party. But transporting this style of government abroad was often perceived as suppressive. Americans had a strong anti-Communist resolve (thanks to McCarthyism in the 1950's) initially, but lost it during Vietnam. Further, nuclear weapons had grave impacts on the psychology of the warring nations populace. Faced with national extinction, civil defense programs arose and propaganda weapons and deceit flourished.

Of great significance, when viewing national resources during the Cold War, was the health and wealth of the economy. Clearly, the means to execute global strategies encompassing large investments in expensive weapon systems was focused in the economic instrument of power. In this domain, the United States possessed the greatest leverage. Paul Kennedy's thesis in his work "The Rise and Fall of Great Powers" is of significance at this juncture. Simply put, great powers in relative decline instinctively respond by spending more on "security", thereby diverting needed resources away from domestic "investment", and causing a long term

economic dilemma. <sup>32</sup> In both superpower nations, one could easily apply this axiom. Soviet leaders, in an attempt to maintain military parity with the West, devoted a large share of natural and industrial resources to its war machine. The result was a relative decline in domestic economic product that, in the end, formed the demise of the Marxist ethic. On the other hand, the United States employed the economic tool as a means to its end, invoked superior financial and technological institutions and outperformed the Soviets in the international marketplace. The result, however, was a looming federal deficit, and an international trade posture in decline. In this context, the Cold War caused grave damage to both powers. Gaddis notes that due to the Cold War, a new criteria for defining a superpower has emerged. Now the interrelationship between military strength and economic vitality as well as the skill in which the government keeps them in balance is paramount. <sup>33</sup>

The methodology for strategic planning under a Cold War construct mandates that the planner identify available resources and clarify resource constraints. Second, they must properly interpret national objectives. In essence, they must clarify ends and match ends to means before they formulate a strategic plan. In the Cold War, most strategies fell far short of required resources. For example, Nitze, when advocating NSC-68, assessed a \$40 billion shortfall, that was never funded. And in the early 1960's, MacNamara was convinced he could make up the \$14 billion shortfall to implement flexible response by streamlining measures. <sup>34</sup> In these cases, resources were assumed to implement strategy. In the other asymmetrical strategies, resources determined the strategy. Eisenhower placed restrictions to means within his objectives. Further, Kissinger and Kennan recognized limitations to available resources and advocated use of diplomatic and psychological means. Finally, in the case of Ronald Reagan, the strategy determined the resources. He borrowed funds that grossly inflated the national debt in exchange for a winning balance of resources (See Fig 11). The result was a decisive victory, but also a large bill to pay in succeeding generations.

The lesson is simple. If a strategy is based on balancing power with long term application, it is acceptable to assume or underestimate resources. Also, defensive strategies are implied. If you base your

strategy on balancing actual resources and short term victory, you must be prepared to pay the bill.

7. ENDS MUST JUSTIFY MEANS. Nuclear warfare imposed a set of constraints never realized in past conflict. Specifically, the burden of long term environmental and psychological damage beyond the borders of the warring nations. The consequence of a nuclear exchange between the superpowers was manageable at first, but rapidly escalated until the means clearly did not justify the ends.

The Cold War was indeed a war for high stakes. The military strategy of the war assumed gradual escalation to a nuclear contest. Given doctrines of "Mutual Assured Destruction" and Nuclear Superiority, the threat of an attack on the "homeland" was real. Further, given strategies that advocated first use of nuclear means of destruction, compounded by the minute warning times associated, risked the viability of a nation on the "trigger finger" of the political leaders. Because of this great risk, both sides sought to deter direct military confrontation at all costs. Both sides also believed they could survive and win a nuclear duel. But at what costs - national extermination?

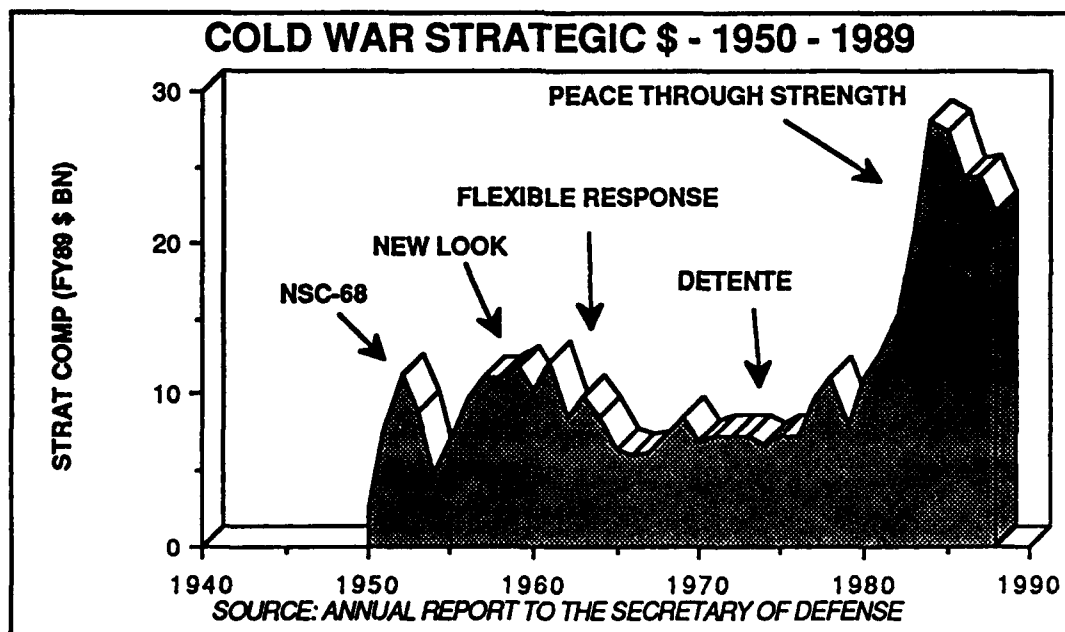

Fig. 11. US Strategic Expenditures in the Cold War

The actual costs of the Cold War are unmeasurable. Some Congressional estimates indicate over a \$3 trillion price tag in the U.S. alone. The economic and political costs were detrimental to the Soviet Union causing collapse. The similar costs to the U.S. are yet to be measured. Further, loss of life also occurred in Korea, Vietnam, Angola, Afghanistan, Cambodia, Nicaragua, Czechoslovakia, and the Middle East, to name a few. Last, the psychological cost to a generation are intangible but significant.

The stakes of conflict are further compounded by moral factors. The dilemma is acute. What happens if a nuclear duel had occurred? What about the post war damage to the people, the environment, and the planet? The small nuclear devices dropped against the Japanese as well as nuclear accidents like Cherynobal caused worldwide repercussions and lasting scars. How do the leaders communicate the risk to the public? Schlesinger argues that two sets of books were kept. One scale of values for internal policy, another for foreign affairs.<sup>35</sup> Couple this with the trends on both sides to over exaggerate the threat to rationalize large defense, intelligence, and arms budgets, the result was a growing feeling of "hatred" between nations and public insecurity. Did the means of confrontation really justify the ends?

Above all, the strategists who realized resource shortfalls and designed their strategy around asymmetrical response were most dangerous. The New Look and Detente strategies offered policy makers two options; small conventional response or nuclear exchange. The intermediate options were not funded to gain a peace dividend from WWII, Korea and Vietnam. When means drive ends, strategic options are minimized. Had the U.S. maintained an asymmetrical response strategy, would Reagan have used nuclear weapons to win the Cold War? Who would be considered the victor? Is this morally acceptable?

A parallel is now being drawn between the asymmetrical strategies of post-WWII, Korea and Vietnam strategists after a Cold War "peace dividend". The resulting military instrument of power to President Clinton will mirror that of the New Look and Detente. The problem? During these periods, the United States actually declined in relative power until regional instability and conflict prevailed. Secondly, strategic options were reduced to limited conventional means or nuclear response. The later never

employed in the past. To compensate for the lack of military options, other national tools for fighting subsequent Cold Wars must be developed (e.g. economic or political warfare tools) to avoid repeating the loss of life and prestige of the Korean or Vietnam Wars.

8. "POWER TOOLS" USED IMPLY A NEW STYLE OF WAR. The Cold War was a global war. The great power confrontation began in Europe but quickly spread horizontally into Asia and the Third world. World War II had left immense turbulence in "colonial nations" as well as states overrun by attacking forces. Consequently, "traditional social orders lay smashed, colonial regimes had been discredited, underground nationalist parties had flourished, and resistance movements had grown up, committed not only to military victory but political transformation." <sup>36</sup> This turbulence could be viewed as a threat to global stability, or an opportunity for the superpowers to advance their respective ideologies globally.

Aid programs were introduced by both superpowers to counterbalance regional actors against each other. The European Recovery Plan and aid to Greece and Turkey under the Truman doctrine are prime examples. In this context, economic, humanitarian and military aid was offered to nations either opposing Communism or supporting it. Consequently, Cold War battlefields emerged in East Asia, Southwest Asia, the Middle East, Africa, and Central America, as well as Europe. The intensity of conflict varied between regions from Communist revolutionary uprisings, like in China, to covert operations supporting anti-Communists in Central America. Countries like India and Egypt artfully exploited both superpowers for aid during the Cold War. Because of this unique global characteristic and means of employing national resources during the Cold War, one could easily discard the notion that this was merely an extension of World War II.

During the Cold War, the Soviets primarily relied on political (Communist Party), diplomatic (peaceful coexistence), political-military (use of client states), and psychological (Berlin Blockade and propaganda) instruments of power. These were wielded in a defensive fashion, and noticeably lacking economic means. The United States employed political (Truman, Eisenhower, Carter, Reagan Doctrine), economic (Marshal Plan and reconstitute Japan, and Trilateralism), psychological (Nuclear weapons and covert operations), political-military (NATO and international

alliances) and diplomatic (Berlin Airlift, SALT, INF, NPT, START Treaties) to enforce the Soviet perimeter. Again, the tools and the strategy were defensive, in principle, and failed to attack the Soviet weakness - their economy, or their center of gravity - the Communist Party. The formula did not work initially, but as both sides experimented with this new "style" of war by non-military means, the solution for victory would be found.

The Cold war can teach us a valuable lesson in creating multiple options, non-military in nature, that can attack an adversary without crossing his borders with a large army or bombing his allies or his capital. This was an ideological war, but the difference between ideologies was political and economic views. In the post-Cold War world order, strategists must fashion effective political and economic warfare "tools" for national leaders to counter adversaries short of employing military force, or suffer the consequence.

## CONCLUSION

### A POLITICAL, PSYCHOLOGICAL WIN

Within this Cold War construct, how do you define a winner? Clausewitz defines a range of success, some do not involve an opponents outright defeat. They range from destruction of the enemy's forces, the conquest of his territory, to a temporary occupation or invasion, to projects with an immediate political purpose, and finally passively surviving enemy attacks. Any one of these could serve to overcome the enemy's will.<sup>37</sup> In the nuclear era, the only options within this range are preemptive attack and annihilation of your enemy, or political projects. The former, given the risks, was deemed last resort by Cold War leaders. The latter, interpreted as achieving your political objectives, is hard to measure against six distinct grand strategies. One interpretation could be that the winner is the nation that could maintain the balance of power in their favor to the point of the adversary's collapse. Another could be the nation that met their political aims identified at the onset of war, or the objectives stated prior to the final contest. A final and more realistic approach is the nation that successfully avoided the risks of general war, and successfully toppled the adversary from superpower status without the use of direct military means. Given these interpretations, the U.S. did

prevail with a political and psychological victory. Moreover, nuclear exchange and general war between the superpowers was averted.

The post-war expansion of influence by the Soviets and subsequent increase of power did demand positive action. War was initiated, but resource limitations on both sides thwarted any immediate offensive options. Various strategies were implemented with differing results. The strategic mistakes made on both sides cost many lives, and undoubtedly, the nature and style of warfare had changed. Victory in the Cold War, is found in non-military means, whether it be psychological, economic, political or diplomatic. On the other hand, the military instrument is required to protect one's own center of gravity. More importantly, correctly resourcing the national strategy is essential. This aspect bears greater study by senior military officials for one could envision similar strategies to win a potential economic contest with Japan and/or a United Europe, as well as devising the means to fight the war on drugs. These are obviously issues of national defense, but resource constrained in the use of armed force - like the Cold War.

STRATEGIC OBJECTIVE: DETER GENERAL WAR

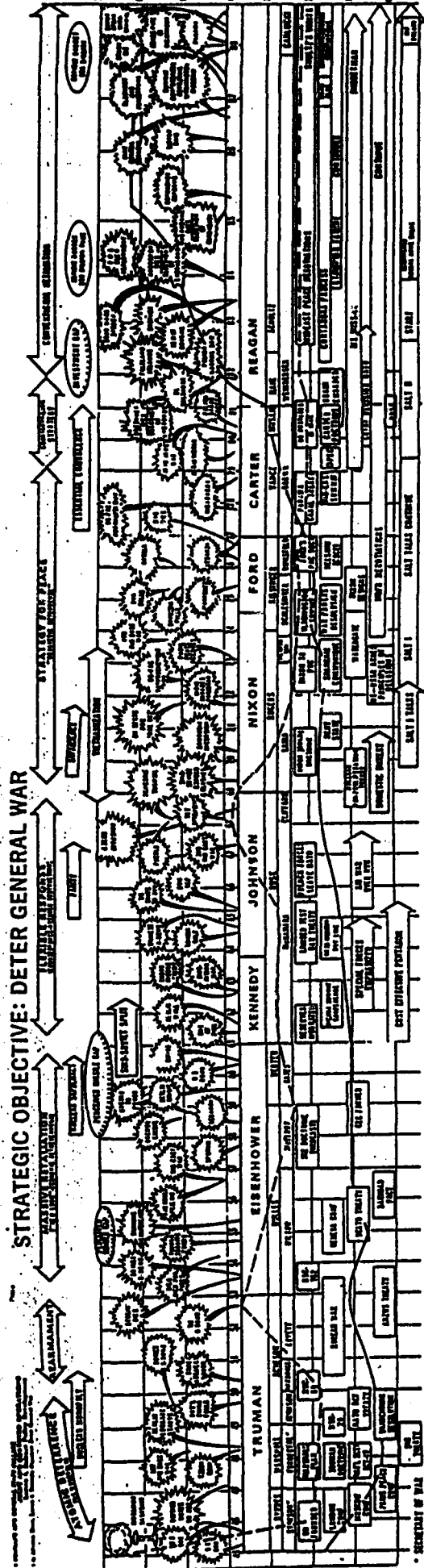



## ENDNOTES

- 1 Clausewitz, Carl von, *On War*, Edited and Translated by Micheal Howard and Peter Paret, Princeton University Press, Princeton N.J., 1984.
- 2 Kennan, George, National War College lecture, Dec 21, 1949, Kennan Papers, Box 17.
- 3 Halle, Louis. *The Cold War as History*, New York, 1991, p. 152.
- 4 Clausewitz, Carl von, *On War*, Edited and Translated by Micheal Howard and Peter Paret, Princeton University Press, Princeton N.J., 1984.
- 5 Analysis of strategies based on the model proposed in Air War College 1993 curriculum and outlined by William P. Snyder in his article, "Strategy: Defining It, Understanding It, Making It", Air University Press, 1 June 1991, rev. February 1992. For a classic discussion on Nuclear Strategies, see Freedman, Scott, *The Evolution of Nuclear Strategy*, p.141.
- 6 "Comments on the General Trend of U.S. Foreign Policy", *Kennan Papers*, Princeton Univ. Press, Aug. 20, 1968.
- 7 IBID
- 8 See Gaddis, *Strategies of Containment*, pp. 27-30. Also, reference Gaddis, *Strategies of Containment*, pp.36-51, and 63 for resource constraints.
- 9 U.S. Economic containment was formalized in legislation in 1949 - the Export Control Act intending to cut the Soviets off from any commodity which could contribute to the Soviet war making ability, and empowered the President to exercise trade controls. Up until this time, the idea of economic warfare was merely a concept. Also note, the U.S. had been the prime supplier of arms to the Soviet Union during WWII under Lend-Lease.
- 10 IBID, and National War college lecture, Dec. 18, 1947.
- 11 NSC-68, April 14, 1950, FR: 1950,I, pg 9, 12, 25-26, 28, 252-3.
- 12 "History of the Joint Chiefs of Staff," vol IV. 1950-1952, and Public Papers of the President: Harry Truman, 1950 (Washington:1965) p. 492.
- 13 NSC-68, April 14, 1950. pp 264, 283, 285, 291-2.
- 14 Acheson meeting with JCS, Dec 3, 1950.
- 15 See NSC 5602 in the national Archives, "Basis of National Security Policy", Feb. 1956. Also, Gaddis, J.. *Strategies of Containment*, p.136.
- 16 NSC 162/2, Oct. 30, 1953, p. 22.
- 17 Gaddis, J.. *Russia, the Soviet Union, and the United States*, p.230.
- 18 IBID, p.159.
- 19 Secretary of Defense McNamara used quantitative analysis techniques to estimate the Soviet threat, thereby dispelling any missile and bomber gaps. Further, Acheson, Rusk and Nitze, architects of NSC-68 became influential advisors to the President. Walt Rostow became the chief planner.
- 20 Reference Pres. Kennedy's message to Congress, Mar. 28, 1961.
- 21 By 1964, the administration had increased the strategic weapon stockpile by 150%, constructed 10 of 29 additional Polaris submarines, and 400 of 800 additional Minutemen missiles. For specific details see Jerome Kahn, *Security in the Nuclear Age*, Wash. DC, 1975, p. 85.
- 22 Kennedy also expanded the non-military elements of containment. Specifically, provide \$20 billion to Latin America under the Alliance for Progress initiative, the establishment of the Peace Corps.
- 22 Gaddis, J.. *Strategies of Containment*, p.289.
- 23 Conventional military forces were cut, and nuclear force modernization were financed. Planning for the B-1 bomber, the Trident submarine and the cruise missile

were initiated at the expense of 50 Air Force squadrons, 7 Army divisions, and nearly 500 ships. Finally, integrate the Soviet economy into the international system by expanding agricultural sales and bartered goods. See Gaddis, pp.300-308.

24 Dixon, Peter W., *Kissenger and the Meaning of History*, N.Y. , 1978, pp. 89.

25 For an insight into Kissenger's perspective from a primary source, see Kissenger, Henry. *White House Years*, pp. 116-119.

26 Lewis, Anthony, "Reagan on War and Peace", *New York Times*, Oct. 20, 1980.

27 General Haig was made Secretary of State, and Casper Weinberger played a key role in defense. Even pre-detente Cold warriors like Walt Rostow and Paul Nitze were placed in charge of arms control.

28 NSDD-75 remains classified but positions taken from it have been confirmed in interviews. See Garthoff, *Detente and Confrontation*, pp. 1012.

29 Garthoff, Raymond L. pp 1016-1120.

30 Deibai and Gaddis, p.9.

31 Approximately 51 Post WWII treaties were signed by Truman and Eisenhower.

32 Kennedy, Paul. *The Rise and Fall of the Great Powers*, intro.

33 See Gaddis, *Strategies of Containment*, Chap 9.

34 Gaddis, *Strategies of Containment*, p.93, 226-7.

35 Sclesinger discusses his views of morality in nuclear conflict through essay in Deibai and Gaddis, *Containing the Soviet Union: A Critique of U.S. Policy*, Pergammon-Brassey International Defense Pub, Washington, 1987.

36 Kolko, Gabriel, *Politics and War*, p.28.

37 Clausewitz, pg. 94.

## REFERENCES

- Addington, Larry H. The Patterns of War Since the Eighteenth Century. Bloomington, Indiana: Indiana University Press, 1984.
- Ambrose, Stephen E. "The Presidency and Foreign Policy", Foreign Affairs, Winter 1992.
- Blair, Clay. The Forgotten War: America in Korea, The Times Books, New York, 1987.
- Brzezinski, Zbigniew. "The Competitive Relationship", Caging the Bear, ed by Charles Gati, Bobbs-Merill Co., Indianapolis, 1974.
- \_\_\_\_\_. "The Cold War and It's Aftermath", Foreign Affairs, Fall 1992.
- \_\_\_\_\_. Game Plan: A Geostrategic Framework for the Conduct of the U.S. -Soviet Contest, Atlantic Monthly Press, 1987.
- Catuda, H. M. Soviet Nuclear Strategy From Stalin to Gorbachev, Humanities Press Intl., Atlantic Highlands, N.J., 1988.
- Clausewitz, Carl von. On War. Indexed Edition, Princeton University Press, Princeton N.J., 1984.
- Cox, Micheal. Beyond the Cold War: Superpowers at the Crossroads?, University Press of America, Lantham, MD, 1990.
- Deibei and Gaddis. Containing the Soviet Union: A Critique of U.S. Policy. Washington, Pergammon-Brassey International Defense Pub., 1987.
- Dixon, Peter W. Kissenger and the Meaning of History, New York, 1978.
- Fleming, D. F. Cold War and It's Origins: 1917- 1960, Doubleday, Garden City, N.Y., 1961.
- Forrestal, James. The Forrestal Diaries, Walter Mills, New York, 1951.

- Freedman, Scott . The Evolution of Nuclear Strategy. Little & Co. Glenview, Il, 1988.
- Gaddis, John Lewis. Russia, The Soviet Union and the United States: An Interpretive History, 2nd Ed.. New York: McGraw Hill Inc., 1990.
- \_\_\_\_\_. The United States and the End of the Cold War. New York: Oxford University Press, 1992.
- \_\_\_\_\_. Strategies of Containment. New York and Oxford: Oxford University Press, 1982.
- Garner, Lloyd. Architects of Illusion: 1941-1949. Quadrangle Books, Chicago Il., 1970.
- Garthoff, Raymond L., Detente and Confrontation: American-Soviet Relations from Nixon to Reagan. Brooking Inst., Wash. D.C., 1985.
- Gati, Charles. Caging the Bear: Containment and the Cold War. Bobbs- Merrill Co., New York, 1974.
- Gastegger, Curt. "Modern Warfare and Soviet Strategy", Survey, Oct, 1965.
- Halle, Louis J. The Cold War as History. New York: Harper & Row, Publishers, Inc., 1991.
- Hammond, Paul. The Cold War Years: US Foreign Policy Since 1945, Harcourt, Brace & World Inc. , 1969.
- Hyland, William G. The Cold War: Fifty Years of Conflict. New York: Random House, 1991.
- Kennan, George. "The Sources of Soviet Conduct", Foreign Affairs, 1947.
- Kennedy, Paul. The Rise and Fall of the Great Powers: Economic Change and Military Conflict from 1500 to 2000. Vintage Press, New York, 1987.
- \_\_\_\_\_. "Preparing for the 21st Century: Winners and Losers", The New York Review, Feb. 11, 1993.

- La Feber, Walter. America, Russia, and the Cold War: 1945-1990. 6th Ed. New York: McGraw-Hill Inc., 1991.
- Lambeth, Benjamin & Lewis, Kevin. "The Kremlin and SDI", Foreign Affairs, Spring, 1988.
- Larson, Deborah W. Origins of Containment: A Psychological Explanation, Princeton Univ. Press, 1985.
- Lippmann, Walter. The Cold War: A Study in United States Foreign Policy, Harper & Row, New York, 1947.
- Luttwak, Edward. The Grand Strategy of the Soviet Union. Simon & Schuster, New York, 1983  
\_\_\_\_\_. The Pentagon and the Art of War. Simon & Schuster, New York, 1985.
- McNamara, Robert S. Out of the Cold: New Thinking for American Foreign and Defense Policy in the 21st Century, Simon and Schuster, New York, 1989.
- Medhurst, Ivie, Wander, Scott. "Rhetoric and Cold War: A Strategic Approach", Cold War Rhetoric, Greenwood Press, N.Y., 1990.
- Mintz, Alex (editor). The Political Economy of Military Spending in the U.S., Rutledge Press, New York, 1992.
- Morgenthau, Hans J., The Strategy for Power and Peace, 5th ed., Alford A. Knopf Press, New York, 1973.
- Nye, Joseph S., Jr. Bound To Lead: The Changing Nature of American Power, Harper-Collins, New York, 1991.
- Paret, Peter. Makers of Modern Strategy. New Jersey: Princeton University Press, 1986.
- Pipes, Richard. Survival is not Enough: Soviet Realities and America's Future, Simon and Schuster, New York, 1984.
- Pipes, Richard. "Why the Soviets Think They Could Fight and Win a Nuclear War", Commentary, July 1977.

Rees, David. The Age of Containment: The Cold War, 1945-1965, St. Martin's Press, London, 1967.

Simmons. The Strained Alliance: Peking, Pyonyang, Moscow and the Politics of the Korean Civil War, New York, 1975.

Snyder, William P. "Strategy: Defining It, Understanding It, Making It", Air University Press, 1 June 1991, rev. Feb. 1992.

Stalin, J.V. Works, Stanford University Press, Vol III, 1967.

Tonelson, Alan. "What is the National Interest", The Atlantic Monthly, July, 1991.

Ulam, Adam B. Expansion and Coexistence: The History of Soviet Foreign Policy, 1917 - 1967, Preager, New York, 1968.

U.S. Policy Toward the Soviet Union: A Long term Western Perspective, The Atlantic Council's Working Group on US-Soviet Relations, edited by Andrew Goodpaster, Walter Stoessel, Jr., and Robert Kennedy, University Press of America, Lantham, MD., 1988.

Wirls, Daniel. Buildup: The Politics of Defense in the Reagan Era, Cornell Univ. Press, 1992.