

ADA279181

U. S. Department of Commerce Charles Sawyer, Secretary
National Bureau of Standards A. V. Astin, Acting Director

X-ray Protection Design

Harold O. Wyckoff and Lauriston S. Taylor

Accession For	
NTIS GRA&I	<input checked="" type="checkbox"/>
DTIC TAB	<input type="checkbox"/>
Unannounced	<input type="checkbox"/>
Justification	
By _____	
Distribution _____	
Availability Codes	
Dist	Avail and/or Special
A-1	



National Bureau of Standards Handbook 50
Issued May 9, 1952

For sale by the Superintendent of Documents, Washington 25, D. C.

Price 20 cents

Preface

This Handbook contains primary factual data and basic principles necessary for designing shielded X-ray installations, based on the recommendations of the National Committee on Radiation Protection (see NBS Handbook 41, Medical X-ray Protection up to Two Million Volts). It considers the protection requirement for persons working with the equipment and for persons in adjoining areas. It discusses typical cases, giving a variety of examples to illustrate the application of the fundamental principles and recommendations, and carrying out detailed calculations showing how to arrive at the optimum conditions providing sufficient protection for safe operation with the most economical form of radiation shielding. Practical criteria for the choice of barrier materials, location of X-ray equipment, etc., are included. Full use of the recommendations of the National Committee on Radiation Protection is made in this Handbook, but it is not an official report of that committee.

National Bureau of Standards Handbook 41, prepared by the National Committee on Radiation Protection, gives the essentials of protection design, but does not go into the details of the solution of actual problems encountered. Therefore it seems desirable to provide a more detailed discussion regarding the application of the basic information to specific problems.

A. V. ASTIN, *Acting Director.*

Contents

	Page
Preface.....	III
1. Introduction.....	1
2. Basic principles of protection design.....	3
3. Computations for the useful beam.....	4
4. Computations for the scattered radiation.....	12
5. Computations for the direct radiation (leakage radiation)....	13
6. Secondary protective barriers.....	15
7. Protective materials.....	15
8. Distance protection.....	16
9. Examples.....	17
10. Fluoroscopic protection.....	20
11. Radiographic protection.....	21
12. Film protection.....	22
13. 250-kvp deep therapy.....	23
14. One-million-volt therapy.....	28
15. Discussion.....	34
16. References.....	36

X-RAY PROTECTION DESIGN

Harold O. Wyckoff and Lauriston S. Taylor

1. Introduction

Although many publications dealing with X-ray protection, including the comprehensive-handbook type, have appeared, none has yet undertaken the explanation of certain assumptions and recommendations nor included detailed design specifications. The present paper discusses X-ray protection recommendations and gives sample design problems and methods of computing barriers for real installations. It is hoped that architects and designers of buildings and rooms in which X-rays will be used for fluoroscopy, radiography, or therapy will find this publication a very real aid to their planning. The data, graphs and tables are taken from National Bureau of Standards Handbook 41, Medical X-ray Protection up to Two Million Volts [1].¹

In general, rules and recommendations in the field of X-ray protection cannot be considered final. They are based on the best data available at the time, and may require revision as our knowledge increases. In Handbook 41 the absorption curves and tables for the useful radiation may be considered final, as far as they go. No important changes in these may be reasonably anticipated. On the other hand, the absorption data for scattered radiation are incomplete, and rough approximations based on fragmentary data must be used. In such a case estimates are made in the safe direction, but the final results are not affected too seriously as the magnitudes of the differences are usually small. Rules are included in Handbook 41 concerning the maximum permissible radiation leakage through the tube housing. With but few exceptions, modern, commercially available X-ray tube housings meet these requirements; in fact, a number of them allow smaller leakages. The computations suggested in this report may therefore yield larger barrier thicknesses than are required. Although these considerations are not usually economically important in the low-voltage region, they may

¹ Figures in brackets indicate the literature references at the end of this paper.

assume considerable importance in the high-voltage region (1,000,000 volts and above).

For the present, protection recommendations must be based on the limited data available. Additional changes may be expected in the future as X-ray equipment design is improved or X-ray techniques are altered, and a more detailed analysis of the equipment and operating conditions for a particular installation may permit some reduction of the barrier requirements from those obtained by the general rules included here. However, the methods indicated in Handbook 41, and explained in more detail in this paper, are known to be safe for modern equipment.

X-ray protective barriers can be divided into two types: one providing protection against the *useful beam*, and usually spoken of as a primary protective barrier; and one providing protection against the *secondary and direct radiation*, and called a secondary protective barrier. The *useful beam* is that part of the radiation from the target that passes through the tube-housing aperture, cone, or diaphragm. *Direct radiation*² is that radiation escaping through the tube housing itself, whereas *secondary radiation* is radiation that originates in an irradiated material. The latter includes *scattered* radiation and *fluorescent* radiation. Thus, if the X-ray tube is fixed in position, only that portion of the wall or floor struck by the useful beam will require a primary protective barrier, whereas all other areas will require secondary protective barriers. However, if the tube may be aimed in every direction, all walls must be considered as primary protective barriers. As is shown later, the secondary barrier will be approximately one-half the thickness of the primary barrier for the same target distance.

The permissible exposure rate for X-rays is set at 0.30 r (300 mr) per week, measured in air [2]. This exposure may be distributed uniformly over the working time in a week or may be obtained in larger short-time exposures, provided the total does not exceed 0.30 r in any one week. For computing the thicknesses of protective barriers, it is customary to assume uniform exposure over the working hours of the week, and not to permit the existence of radiation levels exceeding this rate in occupied space. For computation purposes, in Handbook 41 and in this Handbook,

² *Direct radiation* is frequently referred to as *leakage radiation*; these terms will be used interchangeably in this paper.

the workweek is taken as six 8-hr days, or 48 hr. The value of 0.30 r/week then corresponds to 0.050 r/day, or 6.25 mr/hr, or 10^{-4} r/min. It should be noted that this is not a tolerance dose, because it is not known that the body can tolerate any radiation. However, at such exposure levels no ill effects to the individual have been revealed to date that indicate the need for revision to a lower level requirement. Additional information acquired in the future may result in changes in the above figures.

2. Basic Principles of Protection Design

It is possible to make several general statements regarding X-ray protection design that will be helpful in the preliminary consideration of a new installation.

1. *The major portion of the protection should be as near to the tube as possible.* The required barrier thickness is not reduced by such an arrangement, but the area of the protection barrier is reduced so that the saving in total volume of barrier varies approximately as the square of the distance of the barrier from the target. It is usually recommended that a large amount of this protection be incorporated in the tube housing if this is compatible with the mechanical design requirements for mobility. It is not economically desirable, however, to reduce the direct (leakage) radiation level below about one-tenth that of the scattered radiation. One might think that if the useful X-ray beam is not restricted in direction, then as far as the requirements for the barriers struck by the useful beam are concerned, there will be no saving because of the use of a tube housing. A tube housing with some shielding is required, however, to limit the radiation to the therapeutic or diagnostic field. While small portions of the body may be given the very high exposures required for therapy, a comparable dosage to the whole body might be lethal.

2. *It is desirable to restrict the directions of the useful beam.* In such cases where this is possible, only the barrier that may be struck by the useful beam need be treated as a primary protective barrier. The others may be treated as secondary protective barriers, and, as shown later, need be only approximately half the thickness of the corresponding primary protective barrier. Restriction of the direction of the useful beam will allow reduction of weight of doors, the amount of

baffing around openings in the treatment room, the number of sheets of lead glass in the observation window, etc., as these will then be secondary barriers. If they must be part of the barrier system, openings should be located as far as practicable from the X-ray target. In addition, it is often possible to restrict the tube motion so as to allow the useful beam to be projected only into unoccupied space. Examples are included later to show the marked saving resulting from these considerations.

3. *It is usually considered advisable to compute all barrier thickness requirements for a full 8-hour day.* If it is planned to use an installation for only 4 hr/day, it does not follow that the barrier thicknesses may be reduced by a factor of 2. For example, a 20-in. wall surrounding a million-volt unit could be reduced only 2 in. by halving the operation time. The extra cost is not two-eighteenths greater for the thicker wall, but a much lower figure, as the major expense is for the form work, which is nearly equal in the two cases. Special conditions may permit a reduction in the barrier thickness because of a reduced working time, but the assumption should be clearly stated on the design layout, and thoroughly understood by operating personnel when the installation is completed and in use.

4. *Lead is the major protective material in the low-voltage range and is also used in the high-voltage range when space is limited.* Concrete, because of its structural strength, has been favored in the high-energy region, where the absorption is principally a mass effect, provided the installation space is not limited and weight not restricted. In some cases of low-voltage installations where the tube motion is restricted, ordinary plaster walls may be sufficient for scattered radiation. Steel may be useful and economical for mobile barriers in low-potential installations and for doors in high-voltage installations. Further information on protective materials is presented below.

3. Computations for the Useful Beam

There are numerous experimental data in the literature from which radiation attenuation curves for various materials may be obtained for the *useful beam*. In the lower-energy region, where the principal process for attenuation is the photoelectric effect, these data are in essential agreement. For higher energies (up to the maximum considered here)

the Compton effect becomes most important. In this region, care must be exercised to use attenuation curves obtained under broad-beam conditions because only in such cases are practical operating conditions duplicated. Radiation attenuation is less for broad-beam than for narrow-beam conditions where no radiation scattered by the absorber is measured. Use of narrow-beam attenuation data may lead to an *under-estimation* of the barrier requirements.

The curves of figures 1, 2, 3, and 4, which satisfy the broad-beam conditions, are chosen from the literature. The voltage waveform, direction of the X-ray beam with respect to the

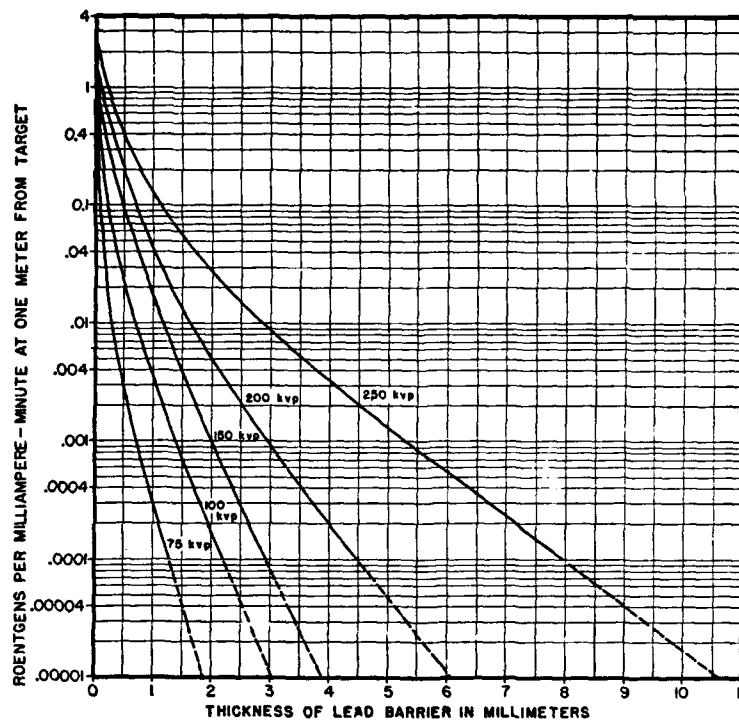

FIGURE 1. Attenuation in lead of X-rays produced by potentials of 75- to 250-kvp.

The curves were obtained with a half-wave generator and with a 90-degree angle between the electron beam and the axis of the X-ray beam. The filter was 3 mm of aluminum for the 150-, 200-, and 250-kvp curves and 0.5 mm of aluminum for the 75- and 100-kvp curves. Direct-current potentials require 10-percent-thicker barriers than for the pulsating potentials given above [3].

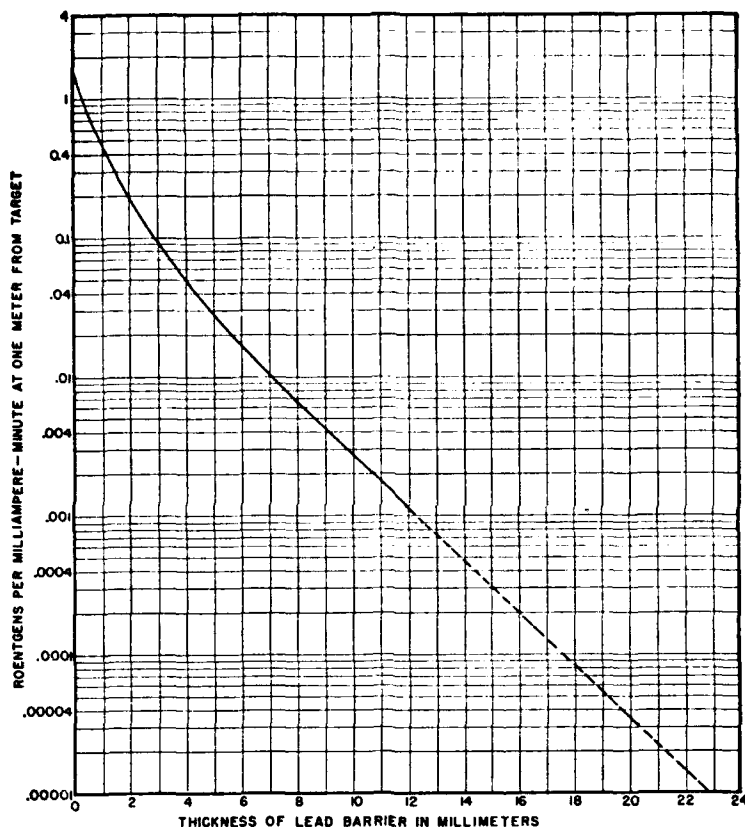

FIGURE 2. Attenuation in lead of X-rays produced by a potential of 400 kvp.

The curves were obtained with a half-wave generator and with a 90-degree angle between the electron beam and the axis of the X-ray beam. The filter was 0.4 mm of tin, 0.75 mm of copper, 2 mm of aluminum, plus the inherent filtration of the tube (4).

electron beam, and inherent filtration for each curve are listed below the corresponding figure. All these factors are important and should not be overlooked in the design of adequate, yet economical protection. The ordinates of the curves give the dosage rate of the useful beam beyond the barrier in roentgens per minute at a point 1 m from the target for a target current of 1 ma. The abscissas are thickness of the specified barrier material that reduces the dosage rate of the 1-ma beam, as shown by the ordinates. Barrier re-

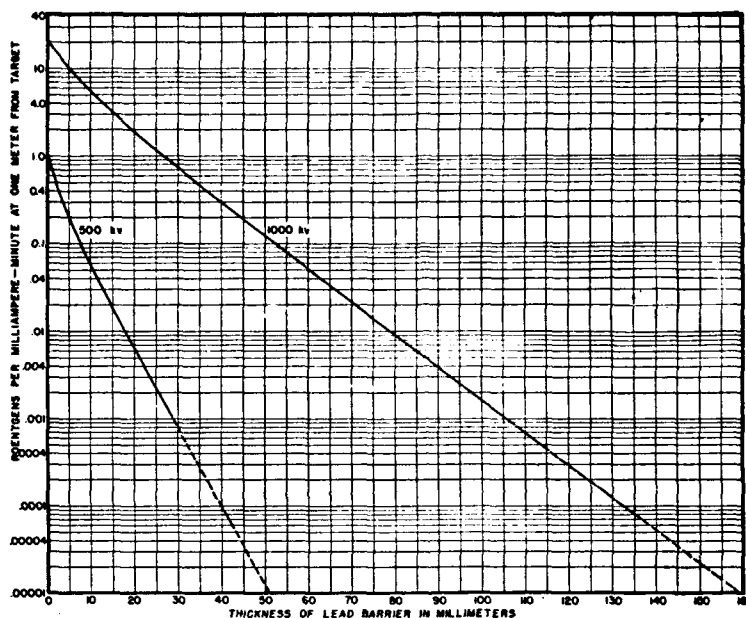

FIGURE 3. Attenuation in lead of X-rays produced by potentials of 500 and 1,000 kv.

The curves were obtained with a direct-current generator and with an angle of zero degree between the electron beam and the axis of the X-ray beam. The inherent filtration was 2.8 mm of tungsten, 2.8 mm of copper, 2.1 mm of brass, and 18.7 mm of water [5].

quirements at other distances and radiation outputs are computed on the basis of the dosage rate at 1 m. If the tube current is increased above 1 ma, the barrier requirements will be increased; if the distance between the tube and the point to be protected is increased, the barrier requirements will be decreased.

The figures, therefore, indicate directly the barrier thickness required to reduce the dosage rate to the permissible value of 10^{-4} r/min for 1 ma and at 1 m from the target. By simple calculations the graphs may be used also for other conditions. For instance, if the actual distance is 2 m, the distance factor reduces the radiation intensity by 4, and the barrier needs therefore only to reduce the radiation to 4×10^{-4} r/ma-min at 1 m. On the other hand, if the actual current is 10 ma, the dosage rate is 10 times that for 1 ma, and the

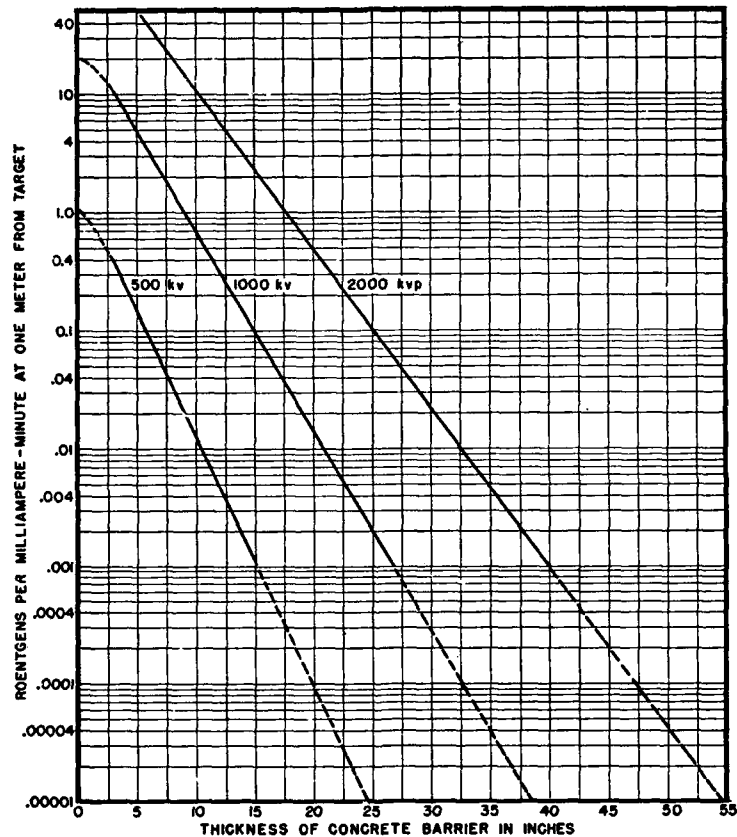

FIGURE 4. Attenuation in concrete of X-rays produced by potentials of 500 kv, 1,000 kv, and 2,000 kvp.

The 500- and 1,000-kv curves were obtained with a direct-current generator [5]; the 2,000 kvp was obtained with a resonance generator [6]. All data were obtained with an angle of zero degree between the electron beam and the axis of the X-ray beam. The filter at 500 and 1,000 kv was 2.8 mm of tungsten, 2.8 mm of copper, 2.1 mm of brass, and 18.7 mm of water; and at 2,000 kvp was 1.6 mm of tungsten, 5.1 mm of copper, and 6.8 mm of water. If the density of the concrete used in an installation is different from that of the above curves (147 lb/ft³), the abscissa should be corrected by a factor of 147 divided by the density of the concrete used.

barrier must be such as would reduce the radiation from a 1-ma beam to $1/10 \times 10^{-4}$, or 10^{-5} r/min. In general, the required lead equivalent of the barrier may be obtained from the appropriate curve by using as the ordinate the dosage rate \dot{Y}_u , where

$$Y_u = 9.7 \frac{C^2}{i} \times 10^{-6} \quad (1)$$

and C is the distance in feet between the target and the nearest position to be occupied by personnel during the exposure, and i is the target current in milliamperes.

For example, suppose it is necessary to reduce the radiation to the permissible level at a point 8 ft from a target with a tube current of 10 ma at 100 kv. Here $C=8$ and $i=10$ in eq 1 gives

$$Y_u = \frac{(8)^2(9.7)10^{-6}}{10} = 6.2 \times 10^{-5}$$

Using the ordinate value 6.2×10^{-5} (approximately 0.00006) on the 100-kv curve in figure 1, it is found that the lead barrier must be 2.4 mm thick.

Tables 1, 2, 3, 4, and 5 show the barrier requirements obtained according to eq 1 from the figures 1, 2, 3, and 4 for a number of typical conditions. Approximate half-value layers of lead and concrete, where available, are also included for each tube potential, by which the barrier requirements for target currents other than those listed may be computed. For instance, if a target current of 5 ma is used at 100 kv with a target-to-personnel distance of 10 feet, the barrier

TABLE 1. Primary protection-barrier requirements for 10 ma at the pulsating potentials¹ and distances indicated

Target distance	Lead thickness with peak of—				
	75 kv	100 kv	150 kv	200 kv	250 kv
<i>ft</i>	<i>mm</i>	<i>mm</i>	<i>mm</i>	<i>mm</i>	<i>mm</i>
2	2.2	3.4	4.3	6.7	11.8
3	2.0	3.1	4.0	6.2	10.9
5	1.7	2.7	3.6	5.5	9.6
8	1.5	2.4	3.2	4.8	8.5
10	1.3	2.2	3.0	4.5	8.1
15	1.1	1.9	2.6	4.0	7.1
20	1.0	1.7	2.4	3.6	6.4
50	0.5	1.1	1.7	2.4	4.3
Approximate HVL thickness measured at high filtrations...	.18	0.24	0.3	0.5	0.8
Radiation filter (mm of Al).....	.5	.5	3.0	3.0	3.0

¹ X-rays excited by direct-current potentials require approximately 10 percent greater thickness than those given here for pulsating potential.

will have to stop only one-half as much as the radiation delivered at the 10 ma target current. This does not mean that the barrier can be reduced by one-half, but that it can be reduced by one half-value layer (HVL) of lead (where the half-value layer is defined as the thickness of a material required to reduce the emergent radiation to one-half the dosage rate of the incident radiation). In table 1 the HVL thickness for 100-kv radiation is given as 0.24 mm of lead.

TABLE 2. Primary protective-barrier requirements for 400-kvp pulsating potential with reflection target¹

Target distance	Lead thickness with target current of—		
	1 ma	3 ma	5 ma
<i>ft</i>	<i>mm</i>	<i>mm</i>	<i>mm</i>
5	16.5	20	22
8	14.0	17.0	18.5
10	12.5	15.5	17.0
15	11.0	13.5	14.5
20	9.5	11.5	13.0
50	5.5	8.0	9.0
Approximate HVL thickness measured at high filtration.....	2.0	-----	-----

¹ Radiation filter: 0.4 mm of tin, plus 0.75 mm of copper, plus 2 mm of aluminum.

TABLE 3. Primary protective-barrier requirements for 500-kv constant potential with transmission target¹

Target distance	Barrier thicknesses with target current of—					
	1 ma		3 ma		5 ma	
	Lead	Concrete ²	Lead	Concrete ²	Lead	Concrete ²
<i>ft</i>	<i>mm</i>	<i>in.</i>	<i>mm</i>	<i>in.</i>	<i>mm</i>	<i>in.</i>
5	36	18.0	42	20.5	44	21.5
8	31	16.0	37	18.5	39	19.5
10	29	15.0	35	17.5	37	18.5
15	25	13.5	31	16.0	33	17.0
20	22	12.5	28	14.5	30	16.0
50	14	8.5	19	11.0	21	12.0
100	8	6.0	13	8.0	15	9.5
Approximate HVL thickness measured at high filtration.....	-----	-----	3.0	1.5	-----	-----

¹ Radiation filter: 2.8 mm of tungsten, plus 2.8 mm of copper, plus 2.1 mm of brass, plus 1.87 mm of water.

² The density of this concrete is 147 lb/ft³.

The barrier requirements for the reduced tube current will then be $2.2 - 0.24 = 2.0^3$ mm of lead. Similarly, a change in tube current by a factor of 4 ($=2^2$) or 8 ($=2^3$) would involve an increase or decrease of 2 or 3 HVL in the barrier requirements, depending upon whether the current was raised or lowered from the tabulated value of 10 ma by those factors.

TABLE 4. Primary protective-barrier requirements for 1,000-kv constant potential with transmission target ¹

Target distance	Barrier thicknesses with target current of—					
	1 ma		3 ma		5 ma	
	Lead	Concrete ²	Lead	Concrete ²	Lead	Concrete ²
<i>ft</i>	<i>mm</i>	<i>in.</i>	<i>mm</i>	<i>in.</i>	<i>mm</i>	<i>in.</i>
5	123	30.5	131	32.5	136	33.5
8	113	28.0	120	29.5	125	30.5
10	107	27.0	115	28.5	120	29.5
15	97	24.5	105	26.5	110	27.5
20	91	23.0	99	25.0	103	26.0
50	69	18.5	77	20.5	82	21.0
100	53	15.0	61	17.0	66	18.0
Approximate HVL thickness at high filtration	-----		8	1.8	-----	

¹ Radiation filter: 2.8 mm of tungsten, plus 2.8 mm of copper, plus 2.1 mm of brass, plus 18.7 mm of water.

² These concrete thicknesses are for a concrete density of 147 lb/ft³.

TABLE 5. Primary protective-barrier requirements for 2,000-kvp pulsating potential with transmission target ¹

Target distance	Concrete thicknesses ² with target current of—		
	0.5 ma	1.0 ma	1.5 ma
<i>ft</i>	<i>in.</i>	<i>in.</i>	<i>in.</i>
5	42.5	45.0	46.5
8	39.5	42.0	43.5
10	38.5	40.5	42.0
15	35.5	38.0	39.5
20	34.0	36.0	37.5
50	28.0	30.0	31.5
100	23.5	25.5	27.0
Approximate HVL thickness measured at high filtration	-----		2.3

¹ Radiation filter: 1.6 mm of tungsten, plus 5.1 mm of copper, plus 6.8 mm of water.

² These concrete thicknesses are for a concrete density of 147 lb/ft³.

³ Because of the tolerances of rolled lead, it is not necessary to carry the final results beyond the nearest 0.1 mm of lead.

4. Computations for the Scattered Radiation

Unfortunately, there are very few data available on the attenuation of scattered and direct radiation. It has been pointed out by several authors, however, that the 90-degree scattered radiation measured at 1 m from the scatterer does not exceed 0.1 percent of the incident radiation for most practical situations (table 6). For larger-angle scattering the amount scattered is certainly less than 0.1 percent, but it may be considerably larger for angles smaller than 90 degrees. Fortunately, most scattering is 90 degrees or greater, or has to pass through the scatterer. The latter possibility serves to reduce the intensity of the scattered beam. Thus, for most practical cases, the scattered radiation measured at 1 m from the scatterer does not exceed 0.1 percent of the incident beam.

TABLE 6. Radiation scattered at 90 degrees to the useful beam

X-ray tube potential	Literature reference	Field size	Percentage of incident beam scattered ¹
75 kvp.....	[7]	25 by 18 cm.....	0.1
80 kvp.....	[8]	8-cm diam.....	.002
		25-cm diam.....	.028
		35-cm diam.....	.073
200 kvp.....	[7]	15-cm diam.....	.04
200 kvp.....	[9]	6 by 8 cm.....	.034
		10 by 15 cm.....	.09
		20 by 20 cm.....	.22
1 Mvp.....	[10]	20 by 20 cm.....	.076

¹ Measured at 1 m from the scatterer.

As absorption curves are not available for this scattered radiation, it is customary to use the same absorption curve for the scattered radiation as for the useful beam when the X-ray potential is less than 500 kv, and the 500-kv curve for all higher X-ray tube potentials. (Any error is in the safe direction.) The low-filtration part of the attenuation curves may be used for such computations. It should be noted that such scattering results from the Compton effect, but because the spectral distribution of the radiation is not known, the Compton equation cannot be used rigorously[11]. The above recommendations are therefore only an approximation, but the figure of 0.1 percent and the use of the recommended absorption curve provide ample barrier thicknesses under most practical conditions, even for fairly small angle scattering.

As the dosage rate must be reduced to 10^{-4} r/min at posi-

tions to be occupied by personnel, the radiation in roentgens per milliamper minute at 1 m from the target required to give such levels of scattered radiation is given by

$$S_{500} = \frac{9d^2D^2}{i} \times 10^{-4} \quad (2)$$

for X-ray tube potentials of 500 kv or below.⁴ Here D is the distance in feet between the target and scatterer, and d is the distance between the scatterer and the position in occupied space. For 1,000-kv potentials, since the output is roughly 10 times as great as for 500 kv, the ordinate should be computed by the relation

$$S_{1000} = \frac{9d^2D^2}{i} \times 10^{-5} \quad (3)$$

(The 500-kv absorption curve is used to determine the barrier thickness.) For 2,000 kvp, the output is 60 times larger than that for 500 kv, and the ordinate (the 500-kv absorption curve is used to determine the barrier thickness) should be obtained from the relation

$$S_{2000} = \frac{1.5d^2D^2}{i} \times 10^{-5} \quad (4)$$

The abscissa corresponding to the ordinate values of eq 2, 3, or 4 on the appropriate absorption curve gives the barrier thickness required for protection against scattering.

5. Computations for the Direct Radiation (Leakage Radiation)

The amount of direct radiation is considerably reduced by the protection incorporated in the tube housing. Most manufacturers have incorporated sufficient barrier in the tube housing to reduce the direct radiation to a maximum of 1 r/hr (0.017 r/min) at 1 m from the target for therapeutic-type tube housings, and to 0.10 r/hr (0.0017 r/min) at 1 m from the target for diagnostic-type tube housings. These radiation levels are for the maximum rated current for the maximum rated X-ray tube potential. Although it is true that the relative hardness of the radiation from the target depends upon the direction of the radiation compared

⁴A point in occupied space must have a dosage rate of 10⁻⁴ r/min or less. The dosage rate at 1 m from the scatterer, because of the inverse-square law, is thus $d^2 \times 10^{-4} / 3.28^2$, where 3.28 is the number of feet per meter. In order to produce this rate, the incident beam at the slab must be 1,000 times larger, or $1000 \times d^2 \times 10^{-4} / 3.28^2$. At 1 m from the target, the rate must then be $1000 \times d^2 \times D^2 \times 10^{-4} / 3.28^2 \times 3.28^2$. In order to obtain the same units as the ordinate of the attenuation curves, the rate is divided by the current giving eq 2.

to that of the electron beam, there has been no extensive survey of these variables. The suggestion has been made, therefore, that the direct (leakage) radiation be assumed to be of the same hardness as the useful beam after relatively high filtration. The "straight" (high filtration) portion of the appropriate curve may thus be used for such computations. For therapeutic tube housings that meet the specifications listed above, the extra attenuation required is

$$\frac{1720}{C^2}, \quad (5)$$

and for a diagnostic installation is

$$\frac{172}{C^2}, \quad (6)$$

where C is the target-to-personnel distance in feet. These equations are obtained by noting that the dosage rates at 1 m are, respectively, 160 and 16 times the permissible dosage rate. Table 7 shows the number of half-value layers necessary to obtain the reductions required at different distances. The half-value layer for any specific X-ray tube potential used may be obtained from the proper column in table 1, 2, 3, 4, or 5. For instance, if the distance, C , from target-to-

TABLE 7. *Half-value layers of protective material required to reduce the leakage radiation to the permissible level*¹

Distance	Number of half-value layers	
	Diagnostic Tube	Therapeutic Tube
3	4.2	7.5
4	3.4	6.7
5	2.8	6.1
6	2.3	5.5
7	1.8	5.1
8	1.5	4.7
9	1.0	4.3
10	0.8	4.1
12	0	3.6
15	-----	2.9
17	-----	2.6
20	-----	2.1
25	-----	1.5
30	-----	0.9
40	-----	0

¹ This presupposes that the tube is surrounded by an adequate tube shield, and hence the table represents additional barrier requirements.

personnel is 10 ft for a 250-kvp therapy tube, table 7 indicates that approximately 4.1 HVL are required. The 250-kvp column of table 1 shows the HVL thickness to be 0.8 mm of lead. The required reduction is thus obtained with 4.1×0.8 , or 3.3 mm, of lead.

6. Secondary Protective Barriers

The rules given above for scattered radiation (eq 2, 3, and 4), and for direct (leakage) radiation, may be used to compute the secondary protective barrier thickness for each of the two separate effects. If the barrier thicknesses so computed separately are nearly equal (or differ by less than 3 HVL), then 1 HVL of lead should be added to the larger single-barrier thickness to obtain the required total.⁵ But if one of the thicknesses is more than 3 HVL greater than the other, the thicker one alone is adequate.⁶

7. Protective Materials

Most attenuation data of interest for protection design have been obtained for lead, although a few curves, such as figure 4, have been given for concrete at the higher X-ray potentials. Sometimes the experimental attenuation data is presented in the form shown in tables 8 and 9, taken from "Recommendations of the British X-ray and Radium Protection Committee"[12]. In using these tables the equivalent lead thickness is first determined as indicated above. In the row corresponding to this lead thickness and the column corresponding to the X-ray tube potential, the thickness of concrete (table 8) or iron (table 9) may be obtained. For instance, if a computation indicates that a 200-kvp machine requires 4 mm of lead, a barrier of 260 mm of concrete or 55 mm of steel would give the same protection. It should be noted that such conversion tables are only applicable when the waveform and radiation filter of the machine for which the protection is to be designed closely approximates those of the machine with which these data were obtained. Note that curves obtained with constant potential X-rays can be used with safety for installations having generators of other wave forms.

⁵ Each of the two effects thus produce a permissible dose. Together they produce twice the permissible dose. This radiation can be reduced to the permissible level by the addition of 1 HVL.

⁶ The larger thickness will permit transmission of the permissible level from one effect, plus not more than one-eighth (3 HVL) of the permissible level from the other effect. This one-eighth excess is negligible in view of other conservative approximations that are involved.

TABLE 8. Concrete equivalents of lead¹ at different X-ray tube potentials

Lead thickness	Tube potential			
	150 kvp	200 kvp	300 kvp	400 kvp
	Millimeters of concrete ²			
<i>mm</i>				
1	80	75	56	47
2	150	140	89	70
3	220	200	117	94
4	280	260	140	112
6	-----	-----	200	140
8	-----	-----	240	173
10	-----	-----	280	210
15	-----	-----	-----	280

¹ Computed from British X-ray protection recommendations [12].² Density 2.35 g/cm³.TABLE 9. Iron equivalents¹ of lead at different X-ray tube potentials

Lead thickness	Tube potential						
	150 kvp	200 kvp	300 kvp	400 kvp	600 kvp	800 kvp	1,000 kvp
	Millimeters of iron						
<i>mm</i>							
1	11	12	12	11	10	9	8
2	25	27	20	18	16	14	13
3	37	40	28	23	19	17	16
4	50	55	35	28	23	20	18
6	-----	-----	48	38	30	26	23
8	-----	-----	60	45	36	31	28
10	-----	-----	75	55	42	36	32
15	-----	-----	-----	75	55	48	43
20	-----	-----	-----	-----	70	60	55
50	-----	-----	-----	-----	-----	125	110

¹ From British X-ray protection recommendations [12].

8. Distance Protection

In some installations it is possible to depend upon distance alone to give proper protection. Under such circumstances the air absorption is often important. Here, again, complete data on the air absorption are lacking. Table 10 is computed for both inverse-square and air-absorption reduction of the useful beam radiation indicated, and for a dosage rate with zero barrier thickness, as indicated on the curves of figures 1, 2, 3, and 4. The air-absorption coefficient was chosen for a photon energy equal to one-half of that of the maximum X-ray photon energy.

9. Examples

Next several sample design problems will be considered, to bring out the principles outlined above. The first example is that shown in figure 5. A *fixed* therapeutic-type X-ray

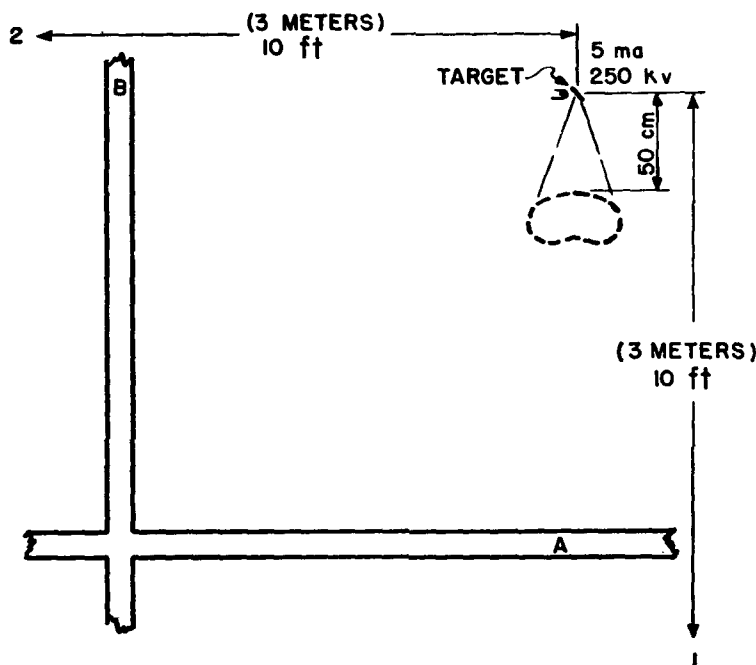

FIGURE 5. Fixed therapeutic-type X-ray tube installation showing necessary dimensions for protection computations.

The steps in the computations are listed in table 11. The target current is the average value for a 48-hr week.

tube is to be operated 16 hr/week⁷ at 15 ma and 250 kvp. The patient will be located 50 cm (1.6 ft) from the target. The personnel to be protected by the barriers will be located at positions 1 and 2. The barrier requirement for wall A is determined from eq 1 for the useful beam; $C=10$ ft, $i=5$ ma,⁸ $Y_u=10^2/5 \times 9.7 \times 10^{-6}=1.9 \times 10^{-4}$ r/ma-min at 1 m.

⁷ This restriction must be thoroughly understood by operating personnel (see principle 3, p. 4).

⁸ All the equations derived in this paper are based on a 48-hr work week. A target current of 15 ma for 16 hr will produce the same amount of radiation as a target current of 5 ma when the tube is operated for 48 hr. Five milliamperes is thus the target current to be used for the solution of this problem.

TABLE 10. Distance protection

Target current ma	Distance ¹ for—																																																																																																																																																																																																					
	50 kv	75 kv	100 kv	150 kv	200 kv	250 kv	400 kv	500 kv	1,000 kv	2,000 kv																																																																																																																																																																																												
0.005	15	20	25	30	35	40	45	50	55	60	65	70	75	80	85	90	95	100	105	110	115	120	125	130	135	140	145	150	155	160	165	170	175	180	185	190	195																																																																																																																																																																	
.01	30	40	50	60	70	80	90	100	110	120	130	140	150	160	170	180	190	200	210	220	230	240	250	260	270	280	290	300	310	320	330	340	350	360	370	380	390	400	410	420	430	440	450	460	470	480	490	500	510	520	530	540	550	560	570	580	590	600	610	620	630	640	650	660	670	680	690	700	710	720	730	740	750	760	770	780	790	800	810	820	830	840	850	860	870	880	890	900	910	920	930	940	950	960	970	980	990	1,000	1,010	1,020	1,030	1,040	1,050	1,060	1,070	1,080	1,090	1,100	1,110	1,120	1,130	1,140	1,150	1,160	1,170	1,180	1,190	1,200	1,210	1,220	1,230	1,240	1,250	1,260	1,270	1,280	1,290	1,300	1,310	1,320	1,330	1,340	1,350	1,360	1,370	1,380	1,390	1,400	1,410	1,420	1,430	1,440	1,450	1,460	1,470	1,480	1,490	1,500	1,510	1,520	1,530	1,540	1,550	1,560	1,570	1,580	1,590	1,600	1,610	1,620	1,630	1,640	1,650	1,660	1,670	1,680	1,690	1,700	1,710	1,720	1,730	1,740	1,750	1,760	1,770	1,780	1,790	1,800	1,810	1,820	1,830	1,840	1,850	1,860	1,870	1,880	1,890	1,900	1,910	1,920	1,930	1,940	1,950	1,960	1,970	1,980	1,990	2,000
.025	45	60	75	90	105	120	135	150	165	180	195	210	225	240	255	270	285	300	315	330	345	360	375	390	405	420	435	450	465	480	495	510	525	540	555	570	585	600	615	630	645	660	675	690	705	720	735	750	765	780	795	810	825	840	855	870	885	900	915	930	945	960	975	990	1,005	1,020	1,035	1,050	1,065	1,080	1,095	1,110	1,125	1,140	1,155	1,170	1,185	1,200	1,215	1,230	1,245	1,260	1,275	1,290	1,305	1,320	1,335	1,350	1,365	1,380	1,395	1,410	1,425	1,440	1,455	1,470	1,485	1,500	1,515	1,530	1,545	1,560	1,575	1,590	1,605	1,620	1,635	1,650	1,665	1,680	1,695	1,710	1,725	1,740	1,755	1,770	1,785	1,800	1,815	1,830	1,845	1,860	1,875	1,890	1,905	1,920	1,935	1,950	1,965	1,980	1,995	2,010	2,025	2,040	2,055	2,070	2,085	2,100	2,115	2,130	2,145	2,160	2,175	2,190	2,205	2,220	2,235	2,250	2,265	2,280	2,295	2,310	2,325	2,340	2,355	2,370	2,385	2,400	2,415	2,430	2,445	2,460	2,475	2,490	2,505	2,520	2,535	2,550	2,565	2,580	2,595	2,610	2,625	2,640	2,655	2,670	2,685	2,700	2,715	2,730	2,745	2,760	2,775	2,790	2,805	2,820	2,835	2,850	2,865	2,880	2,895	2,910	2,925	2,940	2,955	2,970	2,985	3,000
.05	90	120	150	180	210	240	270	300	330	360	390	420	450	480	510	540	570	600	630	660	690	720	750	780	810	840	870	900	930	960	990	1,020	1,050	1,080	1,110	1,140	1,170	1,200	1,230	1,260	1,290	1,320	1,350	1,380	1,410	1,440	1,470	1,500	1,530	1,560	1,590	1,620	1,650	1,680	1,710	1,740	1,770	1,800	1,830	1,860	1,890	1,920	1,950	1,980	2,010	2,040	2,070	2,100	2,130	2,160	2,190	2,220	2,250	2,280	2,310	2,340	2,370	2,400	2,430	2,460	2,490	2,520	2,550	2,580	2,610	2,640	2,670	2,700	2,730	2,760	2,790	2,820	2,850	2,880	2,910	2,940	2,970	3,000																																																																																																				
.1	180	240	300	360	420	480	540	600	660	720	780	840	900	960	1,020	1,080	1,140	1,200	1,260	1,320	1,380	1,440	1,500	1,560	1,620	1,680	1,740	1,800	1,860	1,920	1,980	2,040	2,100	2,160	2,220	2,280	2,340	2,400	2,460	2,520	2,580	2,640	2,700	2,760	2,820	2,880	2,940	3,000																																																																																																																																																						
.25	450	600	750	900	1,050	1,200	1,350	1,500	1,650	1,800	1,950	2,100	2,250	2,400	2,550	2,700	2,850	3,000	3,150	3,300	3,450	3,600	3,750	3,900	4,050	4,200	4,350	4,500	4,650	4,800	4,950	5,100	5,250	5,400	5,550	5,700	5,850	6,000	6,150	6,300	6,450	6,600	6,750	6,900	7,050	7,200	7,350	7,500	7,650	7,800	7,950	8,100	8,250	8,400	8,550	8,700	8,850	9,000																																																																																																																																												
.5	900	1,200	1,500	1,800	2,100	2,400	2,700	3,000	3,300	3,600	3,900	4,200	4,500	4,800	5,100	5,400	5,700	6,000	6,300	6,600	6,900	7,200	7,500	7,800	8,100	8,400	8,700	9,000	9,300	9,600	9,900	10,200	10,500	10,800	11,100	11,400	11,700	12,000	12,300	12,600	12,900	13,200	13,500	13,800	14,100	14,400	14,700	15,000	15,300	15,600	15,900	16,200	16,500	16,800	17,100	17,400	17,700	18,000	18,300	18,600	18,900	19,200	19,500	19,800	20,100	20,400	20,700	21,000	21,300	21,600	21,900	22,200	22,500	22,800	23,100	23,400	23,700	24,000	24,300	24,600	24,900	25,200	25,500	25,800	26,100	26,400	26,700	27,000	27,300	27,600	27,900	28,200	28,500	28,800	29,100	29,400	29,700	30,000																																																																																																				
1	1,800	2,400	3,000	3,600	4,200	4,800	5,400	6,000	6,600	7,200	7,800	8,400	9,000	9,600	10,200	10,800	11,400	12,000	12,600	13,200	13,800	14,400	15,000	15,600	16,200	16,800	17,400	18,000	18,600	19,200	19,800	20,400	21,000	21,600	22,200	22,800	23,400	24,000	24,600	25,200	25,800	26,400	27,000	27,600	28,200	28,800	29,400	30,000																																																																																																																																																						
2	3,600	4,800	6,000	7,200	8,400	9,600	10,800	12,000	13,200	14,400	15,600	16,800	18,000	19,200	20,400	21,600	22,800	24,000	25,200	26,400	27,600	28,800	30,000	31,200	32,400	33,600	34,800	36,000	37,200	38,400	39,600	40,800	42,000	43,200	44,400	45,600	46,800	48,000	49,200	50,400	51,600	52,800	54,000	55,200	56,400	57,600	58,800	60,000																																																																																																																																																						
2.5	4,500	6,000	7,500	9,000	10,500	12,000	13,500	15,000	16,500	18,000	19,500	21,000	22,500	24,000	25,500	27,000	28,500	30,000	31,500	33,000	34,500	36,000	37,500	39,000	40,500	42,000	43,500	45,000	46,500	48,000	49,500	51,000	52,500	54,000	55,500	57,000	58,500	60,000																																																																																																																																																																
5	9,000	12,000	15,000	18,000	21,000	24,000	27,000	30,000	33,000	36,000	39,000	42,000	45,000	48,000	51,000	54,000	57,000	60,000	63,000	66,000	69,000	72,000	75,000	78,000	81,000	84,000	87,000	90,000	93,000	96,000	99,000	102,000	105,000	108,000	111,000	114,000	117,000	120,000	123,000	126,000	129,000	132,000	135,000	138,000	141,000	144,000	147,000	150,000	153,000	156,000	159,000	162,000	165,000	168,000	171,000	174,000	177,000	180,000	183,000	186,000	189,000	192,000	195,000	198,000	201,000	204,000	207,000	210,000	213,000	216,000	219,000	222,000	225,000	228,000	231,000	234,000	237,000	240,000	243,000	246,000	249,000	252,000	255,000	258,000	261,000	264,000	267,000	270,000	273,000	276,000	279,000	282,000	285,000	288,000	291,000	294,000	297,000	300,000																																																																																																				
10	18,000	24,000	30,000	36,000	42,000	48,000	54,000	60,000	66,000	72,000	78,000	84,000	90,000	96,000	102,000	108,000	114,000	120,000	126,000	132,000	138,000	144,000	150,000	156,000	162,000	168,000	174,000	180,000	186,000	192,000	198,000	204,000	210,000	216,000	222,000	228,000	234,000	240,000	246,000	252,000	258,000	264,000	270,000	276,000	282,000	288,000	294,000	300,000																																																																																																																																																						
15	27,000	36,000	45,000	54,000	63,000	72,000	81,000	90,000	99,000	108,000	117,000	126,000	135,000	144,000	153,000	162,000	171,000	180,000	189,000	198,000	207,000	216,000	225,000	234,000	243,000	252,000	261,000	270,000	279,000	288,000	297,000	306,000	315,000	324,000	333,000	342,000	351,000	360,000	369,000	378,000	387,000	396,000	405,000	414,000	423,000	432,000	441,000	450,000	459,000	468,000	477,000	486,000	495,000	504,000	513,000	522,000	531,000	540,000	549,000	558,000	567,000	576,000	585,000	594,000	603,000	612,000																																																																																																																																				

By using this ordinate value on the 250-kv curve (fig. 1) a barrier requirement of 7.3 mm is found. (This value might, alternately, have been figured from table 1. Here it is found, for the same voltage and distance *but at 10-ma tube current*, that 8.1 mm of lead is required. As the current is only 5 ma, or half that given in the table, the barrier may be reduced by 1 HVL of 0.8 mm. Thus, the final required thickness is $8.1 - 0.8 = 7.3$ mm.)

The secondary barrier (B) may be computed by the use of tables 1 and 7, figure 1, and eq 5. The following factors are to be considered:

- (1) Direct (leakage) radiation from the target through the tube enclosure.
- (2) Scattered radiation from the patient.
- (3) Scattered radiation from the useful beam striking wall A.

These factors will now be considered in detail.

(1) Table 7 indicates that 4.1 HVL are required for a distance of 10 ft with a therapeutic-type X-ray tube. However, the unit is only operated for one third of the 48 hr each week, so 1.6 HVL⁹ must be subtracted from this requirement. As the HVL thickness for 250-kvp radiation is 0.8 mm of lead (table 1), the required attenuation is obtained by $(4.1 - 1.6) \times 0.8 = 2.0$ mm of lead.

(2) Scattered radiation from the patient is obtained from eq 2, where $d = 10$ ft and $D = 1.6$ ft. Thus

$$S = \frac{(10)^2 \times (1.6)^2 \times 9 \times 10^{-4}}{5} = 0.046 \text{ r/ma-min}$$

at 1 m from the target. Using this ordinate value on the 250-kvp curve (fig. 1), a lead requirement of 1.6 mm is found.

(3) Scattering from the wall A would be computed in the same manner as that from the patient but with $D = 10$ ft, $d = 14$ ft. Thus

$$S = \frac{100 \times 196}{5} \times 9 \times 10^{-4} = 3.5 \text{ r/ma-min}$$

at 1 m. Again referring to the 250-kvp curve in figure 1, it is seen that for an ordinate value of 3.5, the lead thickness is negligible. Radiation scattered from the patient and not from the wall A thus determines the barrier thickness.

⁹ A reduction of 3 in the radiation is obtained by 1.6 HVL.

The rule for secondary barriers requires, if the scattered and direct radiation requirements do not differ by at least 3 HVL (as these do not), that the final secondary protective barrier thickness be obtained by adding 1 HVL to the larger thickness. A barrier of 0.8+2.0, or 2.8 mm, of lead is therefore required for barrier B. It is interesting to note that a saving of over 50 percent (from 7.3 to 2.8 mm) is possible in barrier B by restricting the motion of the tube so that the useful X-ray beam cannot be pointed at it. Such restriction may not always be possible or desirable but the possibility should not be overlooked in the design planning. Calculations such as above may be conveniently tabulated for ease in keeping track of all of the factors involved. Table 11 shows a summary of the data for the first sample problem.

TABLE 11. Steps in barrier computation for figure 5

D is the target-to-patient distance; *d* is the patient-to-personnel-position distance; *C* is the target-to-personnel-position distance.

Barrier	Personnel position	Primary protective barrier	Secondary protective barrier							Recommended barrier thickness	
			Scatter				Direct (leakage)				
			<i>D</i>	<i>d</i>	Dosage rate ¹	Barrier	<i>C</i>	Number of HVL ²	Barrier		
A.....	1	mm 7.3	ft 1.6	ft 10		mm 1.6	ft 10		mm 2.5	mm 2.0	mm 2.8
B.....	2				0.046						

¹ Roentgens per milliamper-minute at 1 m.

² 1 HVL equals 0.8 mm of lead.

10. Fluoroscopic Protection

Fluoroscopes are required to have a lead-glass barrier with a lead equivalent of 1.5 mm for the useful beam, so that a structural barrier for primary protection is not required. In addition, the type of tube used for this work does not permit a continuous current of more than 5 ma at 100 kvp. Equation 2, figure 1, and tables 1 and 7 may be used to compute the secondary protective barrier when the target-patient distance is 2 ft. Table 12 lists the major results of the computation, and the wall thickness requirements, for fluoroscopic application only. Actually, some tube housings allow the escape of smaller amounts of direct radiation than the maximum specified in Handbook 41. The fluoroscopic

table may in some cases attenuate the scattered radiation. Under these combined conditions the barrier requirements may be 0.2 to 0.3 mm of lead less than given in table 12.

TABLE 12. Secondary barrier requirement computations for fluoroscopic machines operating at 100 kvp

Secondary protective barrier							
Scattering				Direct			Recom- mended Barrier thickness
<i>d</i>	<i>D</i>	Dosage rate ¹	Barrier	<i>C</i>	Number of half val- ue layers	Barrier	
<i>ft</i>	<i>ft</i>		<i>mm</i>	<i>ft</i>		<i>mm</i>	<i>mm</i>
6	2	0.026	0.5	6	2.3	0.55	0.8
8	2	.046	.35	8	1.5	.35	.6
10	2	.072	.25	10	0.8	.2	.5
12	2	.10	.2	12	0	-----	.45
15	2	.16	.15	15	0	-----	.4
20	2	.29	.1	20	0	-----	.3

¹ Roentgens per milliamper-minute at 1 m.

11. Radiographic Protection

Radiographic equipment does not have a self-contained primary protective barrier as do the fluoroscopic units so this must be provided in the floor and walls. In addition, a large number of radiographic tube stands incorporate extreme flexibility of the tube housings so that primary protective barriers must be required for all walls and the floor. The useful beam will not, however, generally strike the walls above 7 ft from the floor so primary barriers may be limited to this height. On the other hand, the weekly exposure (in milliamper-minute) of a radiographic equipment is substantially limited by the time required to arrange the patient for radiography rather than by the permissible tube loading. Statistics for a few high-output, general-purpose, 100-kvp radiographic units indicate that current averaged over a week is equivalent to not more than $\frac{1}{2}$ ma at 100 kvp. This corresponds to reductions of 5 HVL below that given in table 1. The correct working values for primary protective barriers around a general-purpose radiographic unit are shown in table 13. It may be noted that the difference between the barrier requirements for 10 ma and $\frac{1}{2}$ ma do not differ by 1.2 mm (5×0.24 mm) for all target distances.

The reason for this difference is that the HVL thickness for small absorber thicknesses is less than 0.24 mm of lead.

TABLE 13. Primary barrier requirements for radiographic machines operating at 100 kvp¹

Target distance	Barrier for—	
	10 ma	1/3 ma
<i>ft</i>	<i>mm</i>	<i>mm</i>
5	2.7	1.5
8	2.4	1.2
10	2.2	1.1
15	1.9	0.8
20	1.7	.7
50	1.1	.2

¹ The tube current for a busy installation averaged over 1 week is taken as 1/3 ma (see text).

12. Film Protection

Undeveloped photographic film requires even more protection than do personnel. Total exposures of the order of 0.15 mr of 100-kvp radiation over a portion of the film may produce undesirable shadows. The permissible dosage rate for personnel is 0.1 mr/min. If films are placed in radiation having such a dosage rate, they will receive their maximum permissible exposure of 0.15 mr in 1.5 min. Table 13, which gives the barrier requirements for personnel protection, may thus be used to obtain the barrier thickness required to protect films from useful beam radiation emitted by a radiographic machine. This table gives the thicknesses required for 1.5-min exposures; for 3-min exposures one half-value layer must be added; for 6-min exposures, two half-value layers, etc. Table 14 indicates the values so obtained for an

TABLE 14. Barrier requirements for photographic-film protection against 100-kvp radiation¹

Target distance	Exposure time and lead-barrier thickness					
	15 min	30 min	60 min	120 min	8 hr	32 hr
<i>ft</i>	<i>mm</i>	<i>mm</i>	<i>mm</i>	<i>mm</i>	<i>mm</i>	<i>mm</i>
5	2.3	2.6	2.8	3.0	3.5	4.0
10	1.9	2.1	2.3	2.5	3.0	3.5
15	1.6	1.8	2.0	2.2	2.7	3.2
20	1.4	1.6	1.8	2.0	2.5	3.0

¹ See text for conditions.

average current of $1/3$ ma. These values are valid for a high-workload radiographic unit when the useful beam can be pointed directly at the film. Approximately one-half this thickness (depending upon the target-to-patient distance) is required if the beam can never be pointed at the stored film.

13. 250-kvp Deep Therapy

Let us now consider a 250-kvp deep-therapy installation. At the time such equipment is supplied by the manufacturer, its X-ray beam may be pointed in any direction. Unless there are restrictions placed on the mechanical motion of the tube, all walls, floor, and ceiling should be primary protective barriers. As the beam cannot be pointed at all of these walls for the full 48-hr week, it is worthwhile to consider the proportion of time each protective barrier may be struck by the useful beam. If it is possible to obtain all treatment conditions without directing the beam toward any one given barrier, a mechanical restriction may be incorporated in the tube motion. This barrier then becomes a secondary protective barrier with a consequent reduction of the required thickness.¹⁰ Even if no such restrictions are permissible, it may still be possible to assign maximum times of irradiation of general areas. It may be possible to state, for instance, that the beam will be pointed toward the ceiling for a maximum of one-eighth of the time. Then the primary protective barrier thickness computed for the ceiling may be reduced by 3 HVL ($1/8 = 1/2^3$). For design purposes it should be assumed that the machine will operate at its full rating of 250 kvp and 15 ma whenever used.

Figure 6 shows a suggested plan for a 250-kvp 15-ma therapy installation. The letters indicate the protective barriers, and the figures indicate the positions of personnel to be protected. Where personnel may occupy any position along the opposite side of a barrier, that position should be chosen for computation purposes for which the least attenuation is obtained, that is, for which radiation is normal to the surface. Positions 1, 8, and 9, located in the hallway, are considered to be positions for limited occupancy of not more than 6 hr/week. As the hall is narrow it is not con-

¹⁰ However, if secondary barrier computations are used to determine a protective barrier, the restrictions imposed to make the wall a secondary barrier should be listed in the operating instructions for the equipment and in all protection surveys of the installation. Removal of these restrictions without increasing the protective barrier produces a radiation hazard.

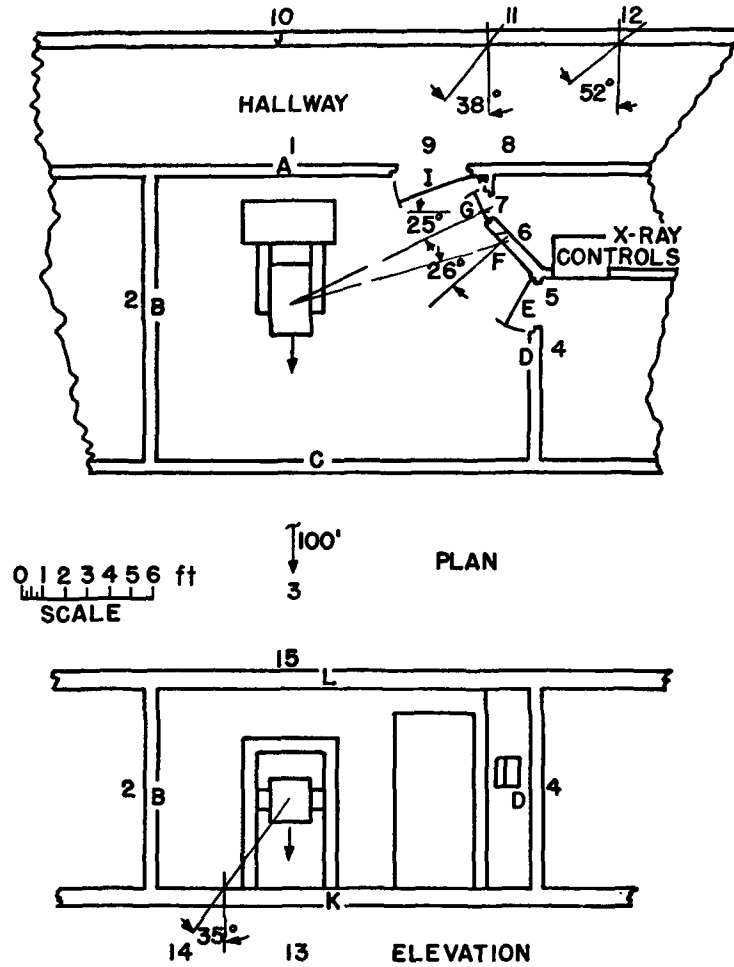

FIGURE 6. Plan and elevation views of sample 250-kvp therapy installation.

Steps in the computations are given in tables 15 and 16.

sidered possible that desks may be located there at some future date. All other positions are considered for 48 hr/week occupancy. Wall J, which has no doors opening into the hallway within the length that might be struck by the

useful beam, is a concrete wall having a lead equivalent of 1.6 mm measured at 250 kvp. There are no mechanical restrictions in the tube motion so all walls, ceiling, and floor require primary protective barriers. It may be assumed, however, for this installation that the beam will not be pointed towards the ceiling for more than one-eighth of the time. Three half-value layers may be subtracted from the ceiling primary protective barrier requirement for a 48-hr week. In accordance with basic principles outlined earlier, the X-ray tube is positioned as far as practicable from the doors, E, G, and I, and the observation window, F.

Windows in outside walls, while often considered desirable for psychological and architectural reasons, may give inadequate shielding. If they were included in this plan, they would have to be provided with baffles having the lead equivalent required for wall C.

Table 15 lists the steps in the computation for each position, column 1, and the corresponding barrier, column 2. The distance between the target and personnel position measured from the scale drawing, figure 6, is shown in column 3. Column 4 shows the barrier requirements for a 10-ma-target current and a 48-hr week, either obtained from table 1 or computed from eq 1 and the 250-kvp curve of figure 1. In the installation considered here the target current is 15 ma instead of 10 ma, so that the radiation output will be 1.5 times as large. The additional barrier required to compensate for this increase is that required to reduce the radiation by one-third. Such a reduction is obtained by approximately 0.6 HVL. The HVL thickness for 250-kvp radiation is 0.8 mm of lead according to table 1. The barrier requirement for 15 ma, column 5, is thus obtained by adding 0.6×0.8 or approximately 0.5 mm to the requirement for 10 ma, column 4. The fraction of the 48-hr week during which the beam is pointed toward a given position or during which personnel are located at that position (work factor) is indicated in column 6. If, for instance, the work factor is $\frac{1}{3}$, 3 HVL (0.8 mm each) are subtracted from column 5 to obtain column 7, (radiation path length in barrier). If the work factor is 1, columns 5 and 7 are the same. The approximate angle with the normal at which the radiation penetrates the barrier is indicated in column 8. Where the angle is not zero degrees, the radiation path through the barrier is greater than the thickness. The true thickness may be obtained by multiplying the path length by the trigono-

metric cosine of the angle. The resulting thickness is listed in column 9. Positions 10, 11, and 12 receive protection from barriers A and J, I and J, and H and J, respectively. For structural reasons barrier J already has a lead equivalent of 1.6 mm. For these positions (10, 11, and 12) the barrier A should have a lead equivalent of 8.0—1.6, or 6.4 mm; barrier I of 5.2—1.6, or 3.6 mm; and barrier H of 4.9—1.6, or 3.3 mm. As these values are less than or equal to those required for positions 1, 8, and 9, the latter will determine the barrier thicknesses for A, H, and I.

The floor directly below the X-ray machine will require the largest amount of protection, as is indicated by the requirement for position 13. At position 14 the requirement is 2.0 mm less than for position 13. The floor protection can therefore be made up of two layers; one of 7.0 mm thickness over the entire floor, and another of 2.0 mm in a 2- or 3-ft-radius circle, with its center directly below the X-ray tube target.

TABLE 15. Primary-barrier protection for therapy installation shown in figure 6

Personnel position	Barrier	Target distance	Computation for barrier					
			10 ma	15 ma	Work factor	Lead oblique thickness	Angle	Lead-barrier thickness
1	2	3	4	5	6	7	8	9
		<i>ft</i>	<i>mm</i>	<i>mm</i>		<i>mm</i>	<i>Degrees</i>	<i>mm</i>
1	A	6	9.2	9.7	$\frac{1}{8}$	7.3	0	7.3
2	B	7	8.8	9.3	1	9.3	0	9.3
3	C	100	2.7	3.2	1	3.2	0	3.2
4	D	12	7.7	8.2	1	8.2	10	8.1
5	E	12	7.7	8.2	1	8.2	0	8.2
6	F	11	7.9	8.4	1	8.4	26	7.6
7	G	10	8.1	8.6	1	8.6	25	7.7
8	H	12	7.7	8.2	$\frac{1}{8}$	5.8	55	3.3
9	I	10	8.1	8.6	$\frac{1}{8}$	6.2	43	4.5
10	A+J	13	7.5	8.0	1	8.0	0	8.0
11	I+J	17	6.8	7.3	1	7.3	37	5.8
12	H+J	20	6.4	6.9	1	6.9	51	4.3
13	K	8	8.5	9.0	1	9.0	0	9.0
14	K	9	8.2	8.7	1	8.7	37	7.0
15	L	7	8.8	9.3	$\frac{1}{8}$	6.9	0	6.9

For purposes of illustration, it may be worthwhile to consider the savings obtained by restricting the motions of the X-ray tube. Let us assume that mechanical restrictions of

the tube do not permit the useful beam to strike walls D, H, A, doors E, G, I, and window F. These walls, doors, and windows then require only secondary protective barriers and necessitate separate computation. All other barriers remain the same.

Table 16 lists the principal steps in the computation of the secondary protective barriers. It may be assumed that the patient is the principal scattering object and is located 1.6 ft from the target (column 4). The distances will depend somewhat upon the orientation of the tube, but the minimum distance will be obtained for a vertical beam. These distances are tabulated in column 3. The insertion of values from columns 3 and 4 and a current of 15 ma into eq 2 gives the dosage rate of the scattered radiation that is listed in column 5. The barrier requirements, column 6, for those dosage rates are then obtained from the 250-kvp curve, figure 1.

The barrier requirements for the direct radiation are obtained in the following manner. The number of half-value layers required for each distance, C, is obtained from table 7. The number of half-value layers is multiplied by 0.8 (the HVL thickness for 250-kvp radiation) to obtain the direct radiation barriers of column 9.

The oblique thickness of the barrier (the radiation path length in the barrier) required to reduce both scattered and direct (leakage) radiation to permissible limits for each position may be obtained by use of the rules suggested in the section on secondary barriers. As columns 6 and 9 do not differ by 3 HVL ($3 \times 0.8 = 2.4$ mm), 1 HVL must be added to the larger to obtain column 10. Column 11 gives the work factor for each position. For a work factor of $\frac{1}{8}$, 3 HVL must be subtracted from column 10 to obtain the required oblique thickness. Here again, it should be noted that for thin barriers the HVL thickness is less than 0.8 mm. For instance for a lead-barrier thickness of 3.7 mm the HVL thickness, as determined from figure 1, is more nearly 0.6 mm of lead. The true barrier thickness, column 14, may be obtained as before from the angle of the radiation with the barrier normal, column 13, and the oblique thickness, column 12.

It is seen by comparing the results of tables 15 and 16 that a saving of 2.2 to 4.6 mm of lead can be realized by restricting the motion of the tube in the manner postulated.

14. One Million-Volt Therapy

Figure 7 shows a suggested arrangement for a 1-million volt, 3-ma unit that is to be operated 48 hr/week. The treatment room is located in the corner of the bottom floor of the building. The tube is restricted in motion so that the X-ray beam can be pointed only at the most distant points of occupied space and never toward adjoining rooms, above the horizontal, or toward the observation window. This arrangement is in accordance with the suggestions of principle 2. The observation window is located at a corner of the room to provide a maximum view of the treatment room with limited area of the window. The X-ray control is placed near this window so that the operator can see both the control and the patient from a single position during the treatment. A maze is provided so that the entrance door may be of light weight. This reduces mechanical difficul-

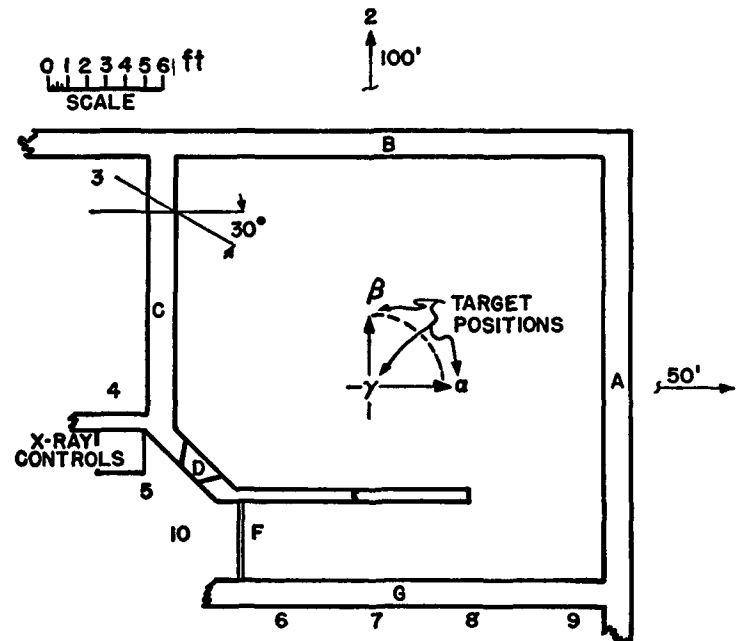

FIGURE 7. Plan view of a 1-million-volt 3-milliampere X-ray unit. The steps in the computations are listed in tables 17 and 18.

TABLE 16. Secondary-barrier protection for installation shown in figure 6

The useful beam is restricted so that it cannot strike walls A, D, E, F, G, H, and I.
 D, Target-to-patient distance, d, Patient-to-personnel-position distance.
 C, Target-to-personnel-position distance.

Barrier	Personnel position	d	D	Scatter		Direct		Oblique thickness	Work factor	Required oblique thickness	Angle	Recommended lead thickness	
				Dosage rate†	Lead barrier	C	Number of half-value layers‡						Lead barrier
1	2	3	4	5	6	7	8	9	10	11	12	13	14
A	1	6	1.6	0.0055	3.4	6	5.5	4	5.2	1/4	2.8	0	2.8
B	4	12	1.6	.022	2.1	12	3.6	4	3.7	1	3.7	10	3.7
C	5	12	1.6	.022	2.1	12	3.6	2.9	3.7	1	3.7	0	3.7
D	6	11	1.6	.019	2.3	11	3.8	3.0	3.8	1	3.8	28	3.8
E	6	10	1.6	.015	2.3	10	4.1	3.3	4.1	1	4.1	23	3.7
F	7	10	1.6	.022	2.1	12	3.6	2.9	3.7	1/4	1.9	55	1.1
G	8	12	1.6	.015	2.4	10	4.1	3.3	4.1	1/4	2.1	43	1.5
H	9	10	1.6	.028	2.0	13	3.3	2.6	3.4	1	3.4	0	3.4
I	10	13	1.6	.044	1.6	17	2.9	2.1	2.9	1	2.9	37	2.3
A+J	11	17	1.6	.061	1.4	20	2.1	1.7	2.5	1	2.5	61	1.6
H+J	12	20	1.6										

† 1 HVL equals 0.8 mm of lead.

‡ Roentgens per milliamperem-minute at 1 m.

ties attendant with heavy doors and is usually cheaper. In accordance with information under principle 4, the protection material is to be concrete.

As the distance between the axis of rotation of the X-ray machine and the target is appreciable, the target cannot be assumed to be at a fixed position for all orientations. Three limiting positions of the target are marked on figure 7. It is possible to pivot the X-ray tube through a quarter hemisphere, about a vertical axis through an angle of 90 degrees from α to β , and about a horizontal axis through an angle of 90 degrees from horizontal to a vertically downward position, γ . For position α , the beam is directed toward wall A, for position β , toward wall B, and for position γ , toward the floor. The numbered positions indicate possible locations of personnel. For computation of the thickness of barriers, the extreme positions have been chosen where radiation is normal to the barrier, since the barrier thickness required is a maximum there. Other positions along a given wall might require less protection, but it is usually economically impractical to vary the thickness of a wall. The cost of extra form work to produce this varying thickness for concrete walls is usually larger than the saving in wall material. A few positions, such as 5, 6, 8, 9, and 10, were chosen because (1) they represented possible critical points when the radiation could be scattered around the maze, (2) they were behind different X-ray absorbing materials, or (3) the total protective barrier thickness changed abruptly. Position 11 is on the floor above, a minimum distance of 20 ft from the target.

Walls A and B are primary protective barriers for tube positions α and β , respectively. The required thicknesses can be obtained directly from table 4. They are listed in table 17, column 4. As the secondary-barrier requirements for these walls will be much less than the primary barrier requirements, secondary-barrier computations are not required.

The secondary-barrier requirements for all other barriers are obtained from the direct (leakage) and scattered-radiation barrier requirements by the use of the secondary-barrier rules. The major steps in the computation are listed in table 17. The principal scatterer was assumed to be the patient located 1.6 ft (D) from the target. Distances from patient to occupied space, d , were measured from the scale drawing. The insertion of the proper values of d , D , and i

TABLE 17. Steps in barrier computation for figure 7

Tube position	Barrier	Per-sonnel position	Pri-mary barrier thickness	Secondary-barrier thickness (concrete)										Angle	Re-quired true thick-ness
				Scatter			Direct			Oblique thick-ness					
1	2	3	4	d	D	Dose rate ¹	Barrier	C	Number of half-value layers	Barrier	11	12	13	14	
			in.	ft.	ft.		in.	ft.		in.	ft.	ft.	Degrees	in	
a	A C D E+G E+G E+G E+G E+G E+G E+G E+G	1	21	22	1.6	0.037	8	20	2.1	3.8	9.8	30	8.5		
		2	21	18	1.6	0.025	8.5	17	2.6	4.7	10.3	30	10.3		
		3	21	17	1.6	0.022	9	16	2.7	4.9	10.8	30	9.3		
		4	21	16	1.6	0.019	9	15	2.9	5.2	10.8	45	7.6		
		5	21	13	1.6	0.013	10	12	3.6	6.5	11.8	15	11.3		
		6	21	12	1.6	0.011	10	12	3.6	6.5	11.8	0	11.8		
		7	21	14	1.6	0.015	9.5	14	3.1	5.6	11.3	30	9.6		
		8	21	17	1.6	0.022	9	16	2.7	4.9	10.8	60	5.4		
		9	21	20	1.6	0.031	8	20	2.1	3.8	9.8	0	9.8		
		10	21	14	1.6	0.015	9.5	14	3.1	5.6	11.3	30	9.6		
		b	B C D E+G E+G E+G E+G E+G E+G E+G E+G	2	18	14	1.6	0.015	9.5	16	2.9	5.2	11.3	30	9.6
3	18			14	1.6	0.015	9.5	13	3.4	6.1	11.3	15	10.9		
4	18			15	1.6	0.017	9	14	3.1	5.6	10.8	0	10.8		
5	18			18	1.6	0.025	8.5	17	2.6	4.7	10.3	15	9.9		
6	18			17	1.6	0.022	9	16	2.7	4.9	10.8	0	10.8		
7	18			18	1.6	0.025	8.5	17	2.6	4.7	10.3	15	9.9		
8	18			20	1.6	0.030	8.5	19	2.3	4.1	10.3	45	7.8		
9	18			17	1.6	0.022	9	16	2.7	4.9	10.8	45	7.6		
10	18			20	1.6	0.031	8	20	2.1	3.8	9.8	0	9.8		
11	18			17	1.6	0.022	9	17	2.6	4.7	10.8	45	7.6		
c	C D E+G E+G E+G E+G E+G E+G E+G E+G E+G			3	18	13	1.6	0.012	10	13	3.4	6.1	11.8	15	11.8
		4	18	12	1.6	0.011	10	12	3.6	6.5	11.8	15	11.3		
		5	18	13	1.6	0.012	10	13	3.4	6.1	11.8	15	11.3		
		6	18	12	1.6	0.011	10	12	3.6	6.5	11.8	0	11.8		
		7	18	13	1.6	0.012	10	13	3.4	6.1	11.8	15	11.3		
		8	18	16	1.6	0.019	9	16	2.7	4.9	10.8	45	7.6		
		9	18	13	1.6	0.012	10	13	3.4	6.1	11.8	45	7.6		
		10	18	13	1.6	0.012	10	13	3.4	6.1	11.8	45	7.6		
		11	18	22	1.6	0.037	8	20	2.1	3.8	9.8	0	9.8		

¹ Roentgens per milliamper-minute at 1 m.

(3 ma) into eq 3 gives the dosage rate of table 17, column 7. The ordinate of figure 4 for 500-kv radiation corresponding to each of the dosage rates is the barrier thickness required for scattered-radiation protection, column 8.

The radiation reduction required for leakage radiation is next considered. The distances, C (column 9), between target and occupied space are obtained from the scale drawing, figure 7. Column 10 gives the number of half-value layers required for leakage-radiation protection. They were obtained from table 7 for the different values of C . The product of 1.8 in. of concrete (the HVL thickness for 1,000-kv radiation) and the number of half-value layers gives the barrier requirement for direct radiation, column 11.

As the scattered-and direct-radiation barrier requirements do not differ by 3 HVL (5.4 in.) 1 HVL must be added to the larger requirement to obtain the length of the path through the barrier, column 12. The true thickness of the barrier, column 14, is then obtained by multiplying the oblique thickness by the trigonometric cosine of the angle, column 13.

Either because of the three orientations of the tube or because several personnel positions were chosen for some of the barriers, there are a number of different required thicknesses listed in table 17 for each barrier. Barriers A and B are determined, of course, by the primary protective-barrier requirements. For all other barriers, which shield personnel from scattered and direct radiation, the maximum thickness is chosen for the recommended design. Barrier C, for instance, includes in table 17 requirements for 8.5, 10.3, 9.6, 10.9, 7.6, and 11.8 in. of concrete. The value recommended for design purposes is obviously 11.8 in. of concrete. Similar reasoning may be used for barriers D, E, and G. The requirement for barrier F is obtained only for position α -10 where barrier E also helps to attenuate the radiation. The required thickness computed for these two barriers combined is 5.4 in. of concrete, but 8.3 in. of concrete have already been recommended for barrier E because of position γ -10. The thickness recommended for barrier F is therefore zero. There are also several positions where E and G act together to reduce the radiation. The sum of recommended values

for E and G acting separately is 17.9 in. of concrete. This value is greater in every case than the true thickness required for E and G acting together. The recommended wall thicknesses obtained by this sort of reasoning are listed in table 18.

TABLE 18. Recommended barrier thickness for figure 7

Barrier	Reference table 17	Recommended concrete thickness
A-----	$\alpha-1$	21
B-----	$\beta-2$	18
C-----	$\gamma-4$	11.8
D-----	$\gamma-5$	11.3
E-----	$\gamma-10$	8.3
F-----	$\alpha-10$	0
G-----	$\alpha-8$	9.6
H-----	$\alpha-11$	9.8

¹ If the observation window is to use water for attenuating the radiation, the water thickness should be 11.3 x 2.35, or 26.6 in. thick. If lead glass alone is to be used, it should have a lead equivalent of 24 mm.

Before leaving the above problem, the possibility of other sources of scattered radiation increasing the barrier requirements should be investigated. For example, wall B might act as a scatterer that could produce radiation hazard at position 3. For this case, d is 13 ft and D is 8 ft. According to eq 3 the scattered radiation must be reduced to

$$\frac{8^2 \times 13^2 \times 9}{3} \times 10^{-5}, \text{ or } 3.2 \times 10^{-1}, \text{ r/ma-min,}$$

by the barrier. The 500-kv curve in figure 4 shows that 3.5 in. of concrete is required. As 3.5 in. is less than the value of 11.8 in. indicated in table 18, barrier C is not increased by the new condition.

Another case which requires additional investigation is that of multiple-scattered radiation. With the tube in position α , radiation could be scattered from wall A to wall G and then scattered again to position 10. The first scattering, as the useful beam will be of small dimensions, will be only 0.1

percent of the useful beam. The second scattering to 10 comes from a large portion of wall G. Under similar conditions such second scatterings have been found experimentally to be approximately 10 percent of the incident first scattering. As the output of the tube is 20 r/ma-min at 1 m, the useful beam incident on wall A is

$$\frac{20 \times 3 \times 3.28^2}{8^2} = 10 \text{ r/min,}$$

where 3.28 is the conversion factor from meters to feet. At wall G, a mean distance of the order of 15 ft from the center of the useful beam on wall A, the scattered beam would be

$$\frac{10 \times 3.28^2}{1000 \times 15^2}, \text{ or } 5 \times 10^{-4}, \text{ r/min.}$$

(The 1,000 is the 0.1-percent factor noted above.) At position 10 the second scattered beam will be

$$\frac{5 \times 10^{-4} \times 3.28^2}{10 \times 12^2}, \text{ or } 4 \times 10^{-6}, \text{ r/min.}$$

As this is only 4 percent of the permissible dosage rate, this scattered radiation will not require additional attenuation.

15. Discussion

The foregoing computations were based on certain assumptions that may not always be true. These computations provide adequate protection, but they may in some cases provide overprotection. In order to be on the safe side and because of the somewhat limited data now available, protection was computed for a large work factor, a large radiation field, the maximum permissible direct radiation, and safe assumptions of the quality of the direct and scattered radiations. These assumptions will now be examined to determine, if possible, where future additional information or changes in tube housing protection may provide more economical design.

Probably the factor giving the most overprotection is the assumption that all walls, ceiling, and floor may be struck by the useful beam for 8 hr/day. In some cases, as already outlined, it is possible to place a work factor of less than 1 on areas that are less likely to receive the useful beam radiation. If the treatment techniques can be further limited or if adequate statistics were available to give more realistic work factors for all barriers, the protection requirements could be further decreased. In the limiting case where the useful beam does not strike a certain barrier, the examples just computed indicate that the barrier may be reduced by 0.4 to 0.5 of the thickness required for full-time irradiation by the useful beam. Depending upon the distance between target and personnel, this saving could be perhaps 3 to 8 HVL.

There is sometimes a question as to how much shielding should be incorporated in the tube housing. For tube housings fulfilling the requirements for diagnostic and therapeutic purposes, tables 12, 16, and 17 show that the wall requirements for direct radiation protection differ by less than 3 HVL from that for the scattered-radiation protection. According to the secondary-barrier rule, it is not economical to make this difference more than 3 HVL. From the computations performed earlier, the direct (leakage) radiation could be reduced to a negligible factor for secondary-barrier computations if the tube-housing leakage were reduced by a factor of 4 to 10. Actually, most commercial diagnostic tube housings meet this requirement. In order to meet this new requirement instead of the old one the estimated difference in tube-housing weight would be an increase of from 2 to 4 lb for diagnostic units and perhaps 100 lb for 2,000-kvp therapy units. Secondary-barrier requirements could then be reduced by 1 HVL.

There are not yet sufficient data to judge the amount of overprotection provided by the scattered-radiation computations. Complete surveys of the scattered radiation versus angle will of course be important only when the tube housing has a restricted motion. For high-voltage therapeutic units the effective high voltage of the scattered radiation is also important. The data of table 6 indicates reduction in scattered radiation that may result from a smaller field size.

16. References

- [1] National Bureau of Standards Handbook 41, Medical X-ray protection up to two million volts (Superintendent of Documents, Government Printing Office, Washington 25, D. C., 15 cents).
- [2] National Bureau of Standards Handbook 47, Recommendations of the International Commission on Radiological Protection and of International Commission on Radiological Units (Superintendent of Documents, Government Printing Office, Washington 25, D. C., 15 cents).
- [3] C. B. Braestrup, Radiology **43**, 206 (1944).
- [4] C. B. Braestrup, private communication.
- [5] H. O. Wyckoff, R. J. Kennedy, and W. R. Bradford, J. Research NBS **41**, 223 (1948) RP1920.
- [6] G. Singer, C. B. Braestrup, and H. O. Wyckoff, Am. J. Roentgenol. **56**, 771 (1946).
- [7] H. Behnken, Fort auf dem geb. der Roent. **41**, 245 (1931).
- [8] C. B. Braestrup, Radiology **38**, 207 (1942).
- [9] C. B. Braestrup, Radiology **31**, 206 (1938).
- [10] C. B. Braestrup and H. O. Wyckoff, Radiology **51**, 840 (1948).
- [11] L. S. Taylor, Radiology **34**, 425 (1940).
- [12] Recommendations of the British X-ray and Radium Protection Committee, 7th Revised Report (Oct. 1948), 32 Welbeck St., London, W. 1.