

AD-A269 600

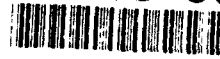

**S** DTIC  
ELECTE  
SEP 14 1993 **D**  
**A**

POR 7157

**MINOR SCALE EVENT**

Test Execution Report

Test Directorate  
HE Simulation Division  
New Mexico Operations Office  
Defense Nuclear Agency  
Kirtland Air Force Base, NM 87115-5000

30 January 1986

Project Officer's Report

CONTRACT No. DNA 001-85-C-0396

Approved for public release  
distribution is unlimited

Prepared for  
Director  
DEFENSE NUCLEAR AGENCY  
Washington, DC 20305-1000

93 9 14 022

93-21314

Sally

# DISCLAIMER NOTICE

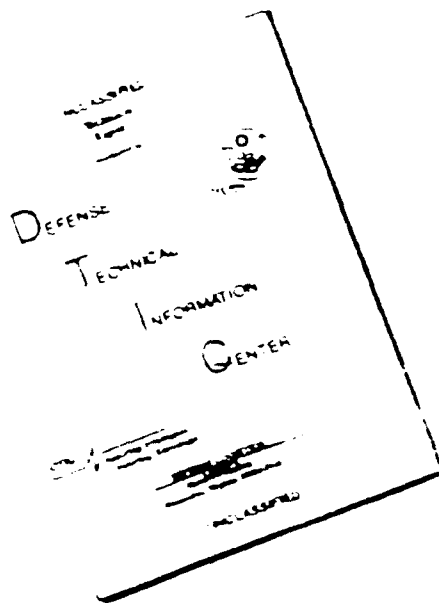

THIS DOCUMENT IS BEST  
QUALITY AVAILABLE. THE COPY  
FURNISHED TO DTIC CONTAINED  
A SIGNIFICANT NUMBER OF  
PAGES WHICH DO NOT  
REPRODUCE LEGIBLY.

Accession For	NTIS CR&I	
DTIC T/E	DTIC T/E	
Unannounced	Unannounced	
Justification	Justification	
By		
Distinction/		
Availability Codes		
Dist	A-1	
Special		

DTIC REPORT NUMBER 1

Director  
 Defense Nuclear Agency  
 ATTN: [REDACTED] TITL  
 Washington, DC 20305-1000

Director  
 Defense Nuclear Agency  
 ATTN: [REDACTED] TITL  
 Washington, DC 20305-1000



UNCLASSIFIED

REPORT DOCUMENTATION PAGE				
1. REPORT SECURITY CLASSIFICATION <b>UNCLASSIFIED</b>		2. RESTRICTIVE MARKINGS		
3. SECURITY CLASSIFICATION AUTHORITY <b>N/A since Unclassified</b>		4. DISTRIBUTION AVAILABILITY STATEMENT <b>Approved for public release; distribution is unlimited.</b>		
5. SECURITY CLASSIFICATION DOWNGRADING SCHEDULE <b>N/A since Unclassified</b>		6. MONITORING ORGANIZATION REPORT NUMBER(S) <b>POR 7157</b>		
7a. NAME OF PERFORMING ORGANIZATION <b>Test Directorate HE Simulation Division</b>	7b. OFFICE SYMBOL (if applicable) <b>NMHE</b>	7c. NAME OF MONITORING ORGANIZATION <b>Director Defense Nuclear Agency</b>		
8a. ADDRESS (City, State, and ZIP Code) <b>New Mexico Operations Office Defense Nuclear Agency Kirtland Air Force Base, NM 87115-5000</b>		8b. ADDRESS (City, State, and ZIP Code) <b>Washington, DC 20305-1000</b>		
9a. NAME OF FUNDING SPONSORING ORGANIZATION	9b. OFFICE SYMBOL (if applicable)	10. PROGRAM ELEMENT IDENTIFICATION NUMBER <b>DNA 001-85-C-0396</b>		
9c. ADDRESS (City, State, and ZIP Code)		11. SOURCE OF FUNDING NUMBERS		
		PROGRAM ELEMENT NO	PROJECT NO	TASK NO
12. TITLE (Include Security Classification) <b>MINOR SCALE EVENT, Test Execution Report</b>				
13. PERSONAL AUTHOR(S) <b>Major Michael G. Evinrude, USMC, Test Group Director</b>				
13a. TYPE OF REPORT <b>Project Officer's Report</b>	13b. TIME COVERED FROM <b>831001</b> TO <b>860130</b>	13c. DATE OF REPORT (Year, Month, Day) <b>860130</b>	13d. PAGE COUNT <b>322</b>	
14. SUPPLEMENTARY NOTES				
15. COSAT CODES			16. SUBJECT TERMS (Continue on reverse if necessary and identify by block number)	
FIELD	GROUP	SUB-GROUP		
16	1		<b>Hardened Mobile Launcher Ground Motion Ejecta</b>	
18	3		<b>Nuclear Weapons Effects Dust Effects Debris Hemispherical Charge High Explosives Airblast</b>	
17. ABSTRACT (Continue on reverse if necessary and identify by block number) <b>MINOR SCALE was a high explosive (HE) test sponsored by the Defense Nuclear Agency. It was detonated at 1220 hours on 27 June 1985 on the White Sands Missile Range, NM. The explosive charge consisted of 4744 tons of ammonium nitrate fuel oil (ANFO) poured in bulk into a 44-foot (13.4-m) radius fiberglass hemisphere. The resulting airblast provided the scaled equivalent airblast of an 8 KT (33.44 TJ) nuclear device. The primary objective of the test was to provide an airblast and ground shock environment for Department of Defense (DoD) sponsored experiments. These experiments were designed to determine the response of tactical and strategic weapon systems, communications equipment, vehicles, and a variety of structures to this environment. A secondary objective was to provide a simulated precursor environment for several other experiments. A third objective was to provide a thermal environment (in addition to airblast) for several experiments.</b>				
18. DISTRIBUTION AVAILABILITY OF ABSTRACT <input type="checkbox"/> UNCLASSIFIED UNLIMITED <input checked="" type="checkbox"/> SAME AS RPT <input type="checkbox"/> DTC USERS		19. ABSTRACT SECURITY CLASSIFICATION <b>UNCLASSIFIED</b>		
20. NAME OF RESPONSIBLE INDIVIDUAL <b>Major Michael G. Evinrude, USMC</b>		21. TELEPHONE (include Area Code) <b>(505) 844-4651</b>	22. OFFICE SYMBOL <b>NMHE</b>	

DD FORM 1473, 84 MAR

43 APR edition may be used until exhausted.  
All other editions are obsolete.

SECURITY CLASSIFICATION OF THIS PAGE

UNCLASSIFIED

~~UNCLASSIFIED~~  
~~SECURITY CLASSIFICATION OF THIS PAGE~~

18. SUBJECT TERMS (Continued)

Cratering  
Precursor  
MINOR SCALE

Section

1

2

~~SECURITY CLASSIFICATION OF THIS PAGE~~

MINOR SCALE TEST EXECUTION REPORT  
TABLE OF CONTENTS

<u>Section</u>		<u>Page</u>
1	INTRODUCTION	1
1.1	GENERAL	1
1.2	TEST OBJECTIVES	1
1.3	TEST FACILITIES	1
	1.3.1 Testbed	4
	1.3.2 Explosive Charge Container	4
	1.3.3 ANFO Mixing	13
	1.3.4 Explosive Operations	13
1.4	SPECIAL ENVIRONMENT	16
	1.4.1 Thermal Radiation Source (TRS)	16
	1.4.2 Thermal Precursor Simulation	21
2	TEST REQUIREMENTS, PLANNING, AND ORGANIZATION	24
2.1	TEST REQUIREMENTS	24
2.2	TEST PLANNING	24
	2.2.1 General	24
	2.2.2 Project Officers Meetings	29
	2.2.3 Security	30
	2.2.4 Environmental Assessment and Archeological Survey	30
	2.2.5 Public Affairs Plan	30
	2.2.6 Safety	31
	2.2.7 Aircraft Operations	35
2.3	GROUND ZERO (GZ) SELECTION	38
2.4	TEST GROUP STAFF ORGANIZATION	38
	2.4.1 Test Group Director	38
	2.4.2 Technical Director	39
	2.4.3 Program Directors	40
	2.4.4 Test Group Engineer (TGE)	41
	2.4.5 Instrumentation Engineer (IE)	41

TABLE OF CONTENTS (Continued)

<u>Section</u>	<u>Page</u>	<u>Section</u>
2.4.6	41	
2.4.7	41	
2.4.8	42	
3	43	
TECHNICAL SUPPORT	43	
3.1	43	
EXPLOSIVES	43	
3.1.1	43	
Introduction	43	
3.1.2	43	
Ammonium Nitrate and Fuel Oil (ANFO)	43	
3.1.3	45	Apper
ANFO Mixing Plant	45	A
3.1.4	45	B
Quality Control	45	C
3.1.5	45	D
Charge Weight and Density	45	E
3.2	48	F
PRECURSED RADIAL	48	G
3.3	48	H
INSTRUMENTATION	48	I
3.3.1	48	J
Cable Systems and Plan	48	K
3.3.2	52	L
Data Recording Systems/Facilities	52	M
3.4	52	N
DIAGNOSTICS	52	
3.5	56	
PHOTOGRAPHY	56	
3.5.1	56	
Technical Photography	56	
3.5.2	56	
Documentary Photography	56	
3.6	56	
METEOROLOGY AND MICROBAROGRAPH MEASUREMENTS	56	
4	57	
EXPERIMENTS	57	
5	67	
CONSTRUCTION AND FIELDING ACTIVITIES	67	
5.1	67	
TESTBED CONSTRUCTION	67	
5.2	69	
PRECURSED RADIAL	69	
5.3	69	
CONSTRUCTION OF LARGE SCALE STRUCTURES	69	
5.4	69	
FIELDING ACTIVITIES	69	
5.5	69	
PRE-D-DAY ACTIVITIES	69	
5.6	80	Figur
D-DAY ACTIVITIES	80	1.1
5.6.1	80	1.2
Hold Criteria	80	1.3
5.6.2	80	1.4
Event Day Countdown	80	1.4

TABLE OF CONTENTS (Continued)

<u>Page</u>	<u>Section</u>	<u>Page</u>
41	5.6.3 Helium Bags	91
41	5.6.4 Reentry Plan	91
42		
43		
43	APPENDICES	
43		
45	<u>Appendix</u>	
45	A ACRONYMS AND ABBREVIATIONS	97
45	B OPERATIONS REQUIREMENT AND DIRECTIVES	101
48	C STATEMENT OF ENVIRONMENTAL CONSIDERATION	119
48	D PUBLIC AFFAIRS PLAN	125
48	E INFORMATION BROCHURE	139
52	F SAFETY PLAN 151	151
52	G ANFO MIXING PLANT	213
56	H MYLAR BAG DRAWINGS	227
56	I ENGINEERING DRAWING LIST	237
56	J MINOR SCALE PRECURSED PROCEDURES AND MYLAR BAG DEPLOYMENT	249
56	K MINOR SCALE HOLD CRITERIA AND PROCEDURES	265
57	L H + 24 HOUR REPORT	275
67	M HELIUM BAG PROBE DATA	277
67	N REENTRY PLAN	293
69		
69		
69	LIST OF FIGURES	
69		
80	<u>Figure</u>	
80	1.1 Test site location	2
80	1.2 White Sands Missile Range, NM	3
	1.3 Aerial view of admin park	5
	1.4 Ground zero location	6



LIST OF FIGURES (Continued)

<u>Figure</u>		<u>Page</u>	<u>Figure</u>
1.5	MINOR SCALE testbed	7	5.7
1.6	Charge container	8	5.8
1.7	Segmented hemisphere - 4800 ton	9	5.9
1.8	Segmented hemisphere - sections and details	10	5.10
1.9	Segmented hemisphere - sections and details	11	
1.10	Segmented hemisphere - foundation and detail	12	5.11
1.11	First ANFO Leak	14	5.12
1.12	Second ANFO Leak	14	5.13
1.13	TRS units	20	5.14
1.14	Helium envelope for dusty precursed radial MINOR SCALE	22	
2.1	MINOR SCALE master schedule	26	
2.2	Aerial view of McDonald Ranch House	31	
2.3	MINOR SCALE hazardous experiments	37	
2.4	MINOR SCALE fielding organization	39	
3.1	Unloading ammonium nitrate at Socorro, NM	44	<u>Table</u> 1.1
3.2	ANFO being emptied from hopper into truck at ANFO plant	44	1.2
3.3	ANFO being pumped into hemisphere during filling operation	45	1.3
3.4	Fuel oil content by load number	47	1.4
3.5	Sieve number versus percent retained	49	2.1
3.6	Site plan for the helium envelope for dust precursed radial	50	2.2
3.7	Deployment dolly concept for MINOR SCALE gas bag	51	2.3
3.8	Test bed layout - GZ area	53	3.1
3.9	Test bed layout - south instrumentation park	54	3.2
3.10	Test bed layout - north instrumentation park	55	4.1
5.1	ANFO plant under construction showing large I beams and timbers	68	5.1
5.2	Mylar bag in crate on dusty radial	70	5.2
5.3	Norway Valhall II Experiment #7410 under construction with hemisphere in background	71	5.3
5.4	Aerial photograph of the United Kingdom House preshot	71	5.4
5.5	Aerial photograph of the UK house, postshot	72	
5.6	ANFO Plant	73	

LIST OF FIGURES (Continued)

<u>Page</u>	<u>Figure</u>	<u>Page</u>
7	5.7 ANFO fiberglass container	74
8	5.8 Experiment #3040, key worker shelter showing stairwell construction on the north side	74
9	5.9 Backfilling north Instrumentation Park, 3/4 complete	75
10	5.10 Lightning damage to cables and cable ends on cable run going to east Instrumentation Park during lightning storm	75
11		
12	5.11 Damage to cable inside instrumentation trailer at east Instrumentation Park during lightning storm	76
14	5.12 MINOR SCALE GZ at T-60 minutes, 27 June 1985	90
14	5.13 MINOR SCALE airblast bubble	92
20	5.14 MINOR SCALE ejecta	93
22		
26		
31		
37		
39		

LIST OF TABLES

<u>Page</u>	<u>Table</u>	<u>Page</u>
44	1.1 Unit assignment for MINOR SCALE	18
44	1.2 Nozzle spacing	18
45	1.3 TRS arrival times	19
47	1.4 TRS burn times	21
49	2.1 MINOR SCALE milestones	25
50	2.2 MINOR SCALE hazardous operations	33
51	2.3 Hazardous materials summary	36
53	3.1 MINOR SCALE ANFO plant output	46
54	3.2 Daily ANFO production	47
55	4.1 MINOR SCALE experiment list	58
68	5.1 Scale comparison	68
70	5.2 MINOR SCALE 45-day countdown	77
71	5.3 MINOR SCALE countdown	81
71	5.4 MINOR SCALE time line	94
72		
73		

SECTION 1  
INTRODUCTION

1.1 GENERAL.

MINOR SCALE was a high explosive (HE) test sponsored by the Defense Nuclear Agency (DNA). It was detonated at 1220 hours on 27 Jun 1985. The planned explosive charge consisted of 4440 tons (4400 Mg) of ammonium nitrate-fuel oil (ANFO) poured in bulk into a 44 foot radius fiberglass hemisphere. The resulting airblast provided the equivalent airblast (scaled) of an 8 kt (33.44TJ) nuclear device. The detonation of this charge provided an airblast and ground motion environment that was used by a variety of agencies to collect basic explosive environment data or to test systems against a simulated nuclear environment.

In addition to the basic blast, one series of experiments measured the effects of a simulated precursor environment. These experiments were placed in one of eight helium filled bags that provided the precursor near the ground.

Another series of experiments were placed near Thermal Radiation Sources (TRSs) and were subjected to a combined airblast/thermal environment. TRS units were used previously on both the MILL RACE and DIRECT COURSE events. MINOR SCALE had seven TRS units placed on the testbed at overpressures ranging from 12 psi (83 kPa) to 3.4 psi (23 kPa). Appendix A gives a list of acronyms and abbreviations used in this report.

1.2 TEST OBJECTIVES.

The primary objective of the test was to provide an airblast and ground shock environment for Department of Defense (DOD) sponsored experiments. These experiments were designed to determine the response of tactical and strategic weapon systems, communications equipment, vehicles, and a variety of structures to this environment. A secondary objective was to provide a thermal environment (in addition to airblast) for several experiments. A third objective was to provide a simulated precursor environment for several other experiments.

1.3 TEST FACILITIES.

The test was conducted at White Sands Missile Range (WSMR), approximately 20 miles (30 km) south of the northern boundary (see Figures 1.1 and 1.2) at the Permanent High Explosive Test Site (PHETS). Ground zero (GZ) was the same

# HIGH EXPLOSIVE TEST LOCATION

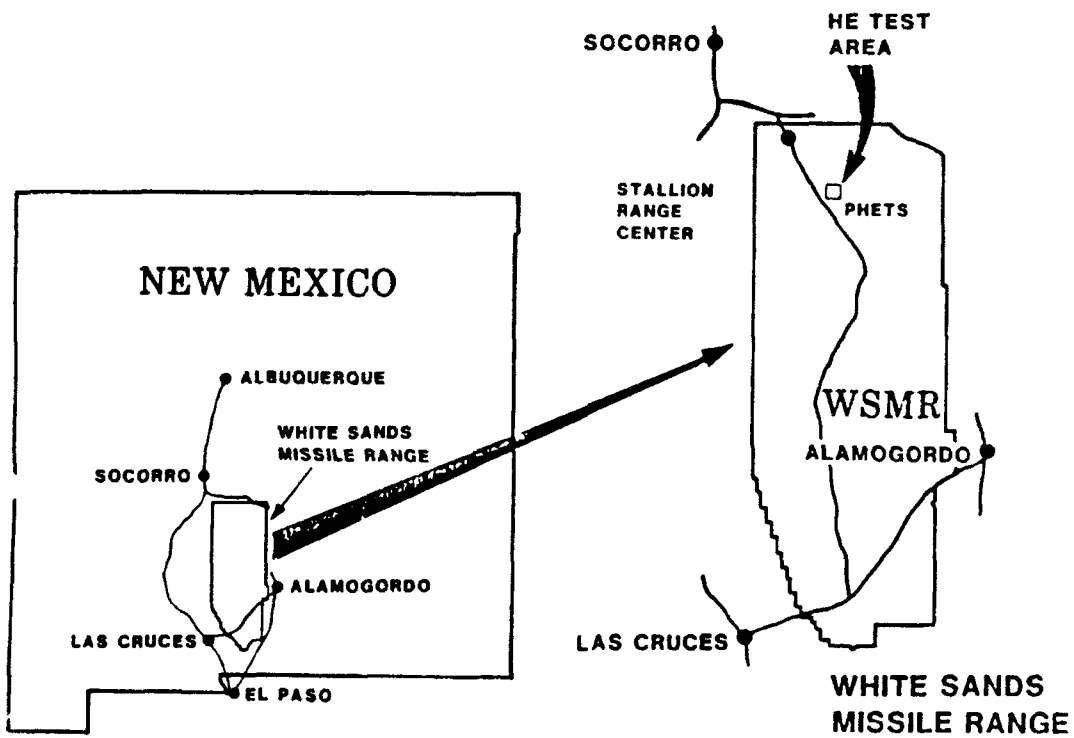

Figure 1.1. Test site location.

ATION

DO

SANDS  
E RANGE

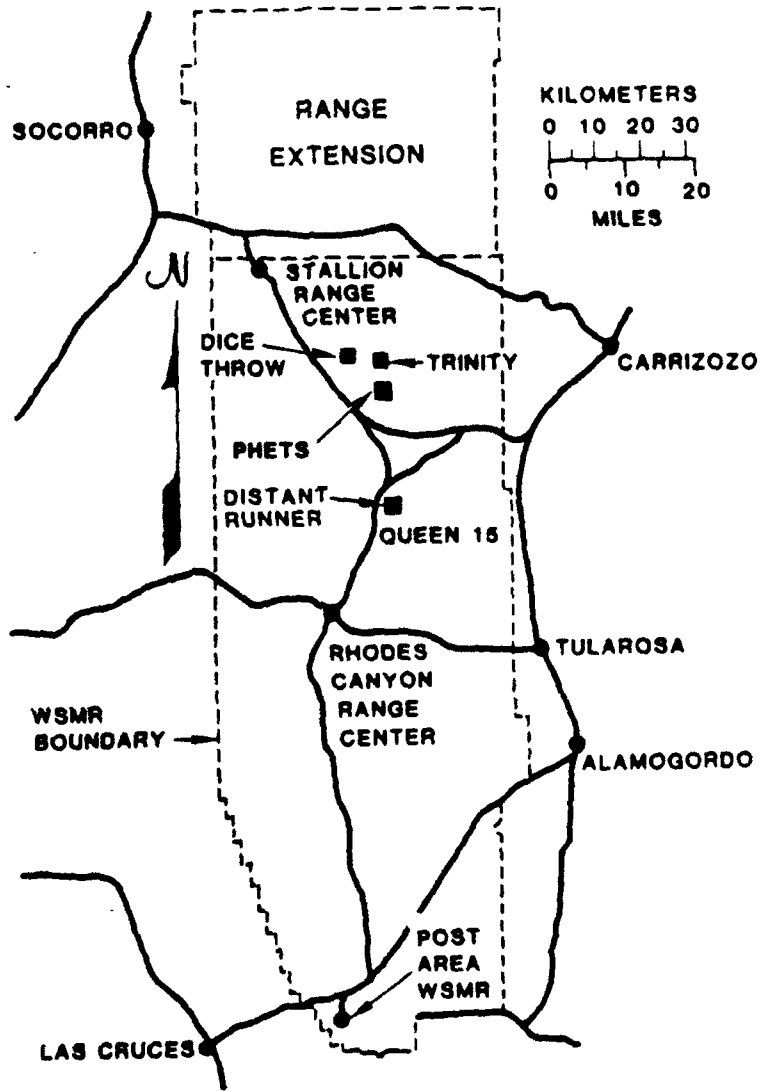

Figure 1.2. White Sands Missile Range, NM.

location as the GZ for DIRECT COURSE. This location allowed the reuse of nearby roads, the instrumentation parks, the three DIRECT COURSE instrumentation radials, and most of the diagnostic camera bunkers.

#### 1.3.1 Testbed.

The MINOR SCALE testbed consisted of four instrumented radials (one precursor radial), four separate unmanned instrumentation parks, a timing and firing park, and an administration park (Figure 1.3). About 175 experiments were located on the testbed. Figure 1.4 shows the overall layout of the testbed, and Figure 1.5 shows the layout of the major experiment groups.

#### 1.3.2 Explosive Charge Container.

The charge was designed to contain 4880 tons (4436 Mg) of ammonium nitrate-fuel oil (ANFO) poured into a fiberglass hemisphere. The design was an adaptation of the DIRECT COURSE charge container concept with a smaller (less than one percent) container to charge ratio. The ANFO was manufactured as a small prill of ammonium nitrate, similar to lawn fertilizer. The fuel oil was then mixed in with the prills and absorbed, creating the ANFO.

The container was a segmented fiberglass hemisphere 44 feet in radius. The base of the hemisphere consisted of 24 identical segments and the top (or cap) consisted of 12 segments as shown in Figure 1.6. A cross section of each segment (Figures 1.6 A, B, and C) can be described as follows: the inner surface was 1/4 inch of fiberglass. The core consisted of 3 inches of cardboard. The outer layer was a different thickness depending on the height above the ground. At ground level the fiberglass was 3/4 inch thick; at the top of the hemisphere it was 1/4 inch thick. Individual segments were assembled by placing an additional quarter inch fiberglass patch on the inner and outer surfaces along each joint.

The entire structure rested on a wooden, circular frame that sat on 25 vertical, buried, wooden piles. The interior ground area was covered by a polyethylene sheet to prevent the absorption of ground moisture. The engineering drawing of the fiberglass hemisphere are shown in Figures 1.7 through 1.10.

In March 1985 the hemisphere fabrication contractor arrived at WSMR and started the erection of the 36 panels of the hemisphere container. Erection was completed on 8 April 1985. Continuous ANFO loading into the sphere began June 17, 1985. The ANFO was about 4 feet high against the walls at 1700 hours June 18. At 1600 hours on June 21 visual observation of the container indicated no problems. At

ation allowed the reuse of nearby  
TEST COURSE instrumentation radials,

of four instrumented radials (one  
entation parks, a timing and firing  
About 175 experiments were located  
out of the testbed, and Figure 1.5

4880 tons (4436 Mg) of ammonium  
hemisphere. The design was an  
concept with a smaller (less than  
was manufactured as a small print)  
The fuel oil was then mixed in

hemisphere 44 feet in radius.  
cal segments and the top (or cap)  
A cross section of each segment  
lows: the inner surface was 1/4  
es of cardboard. The outer layer  
bove the ground. At ground level  
the hemisphere it was 1/4 inch  
cing an additional quarter inch  
ong each joint.

n, circular frame that sat on 25  
und area was covered by a poly-  
moisture. The engineering draw-  
es 1.7 through 1.10.  
n contractor arrived at MSNR and  
sphere container. Erection was  
into the sphere began June 17,  
alls at 1700 hours June 18. At  
ainer indicated no problems. At

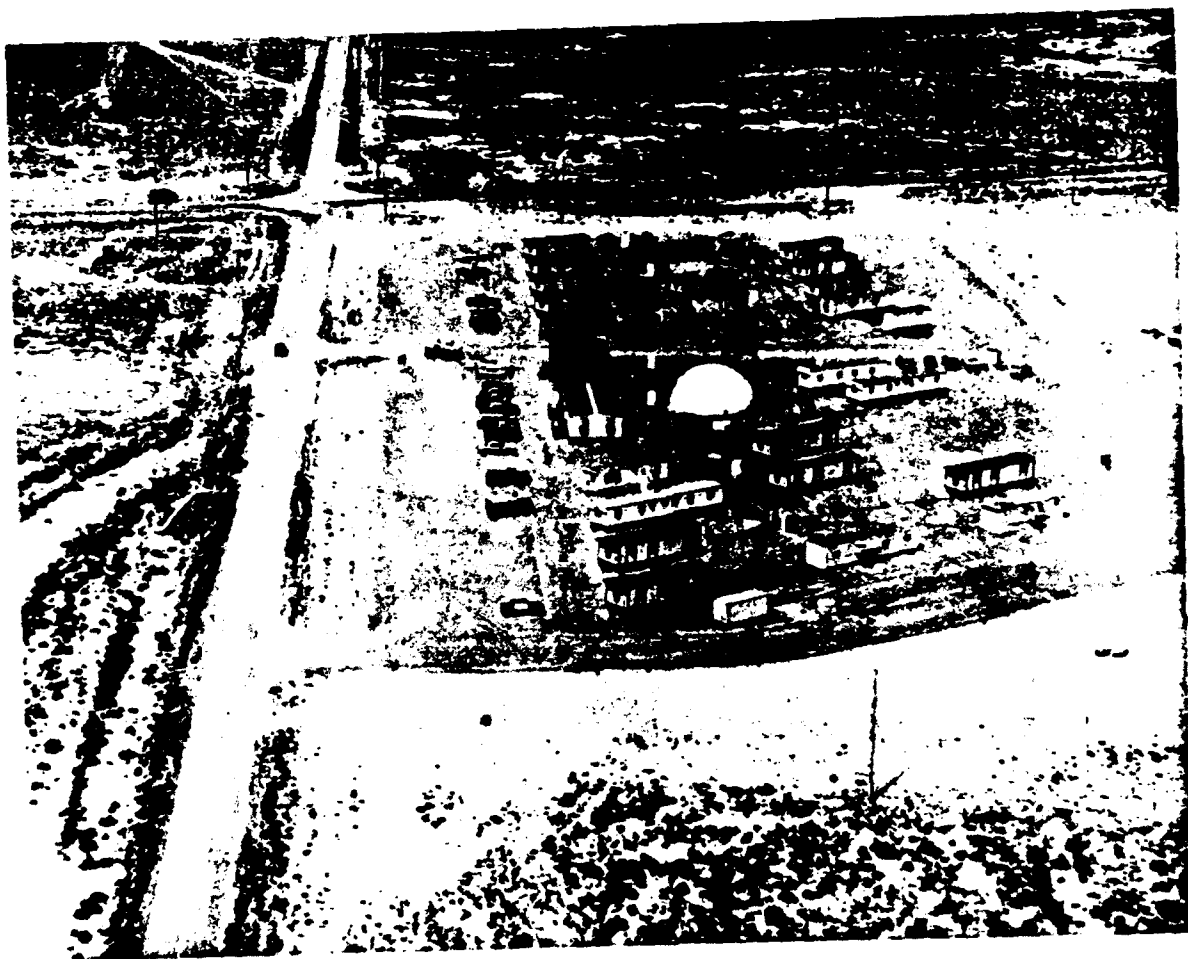

Figure 1.3. Aerial view of admin park.

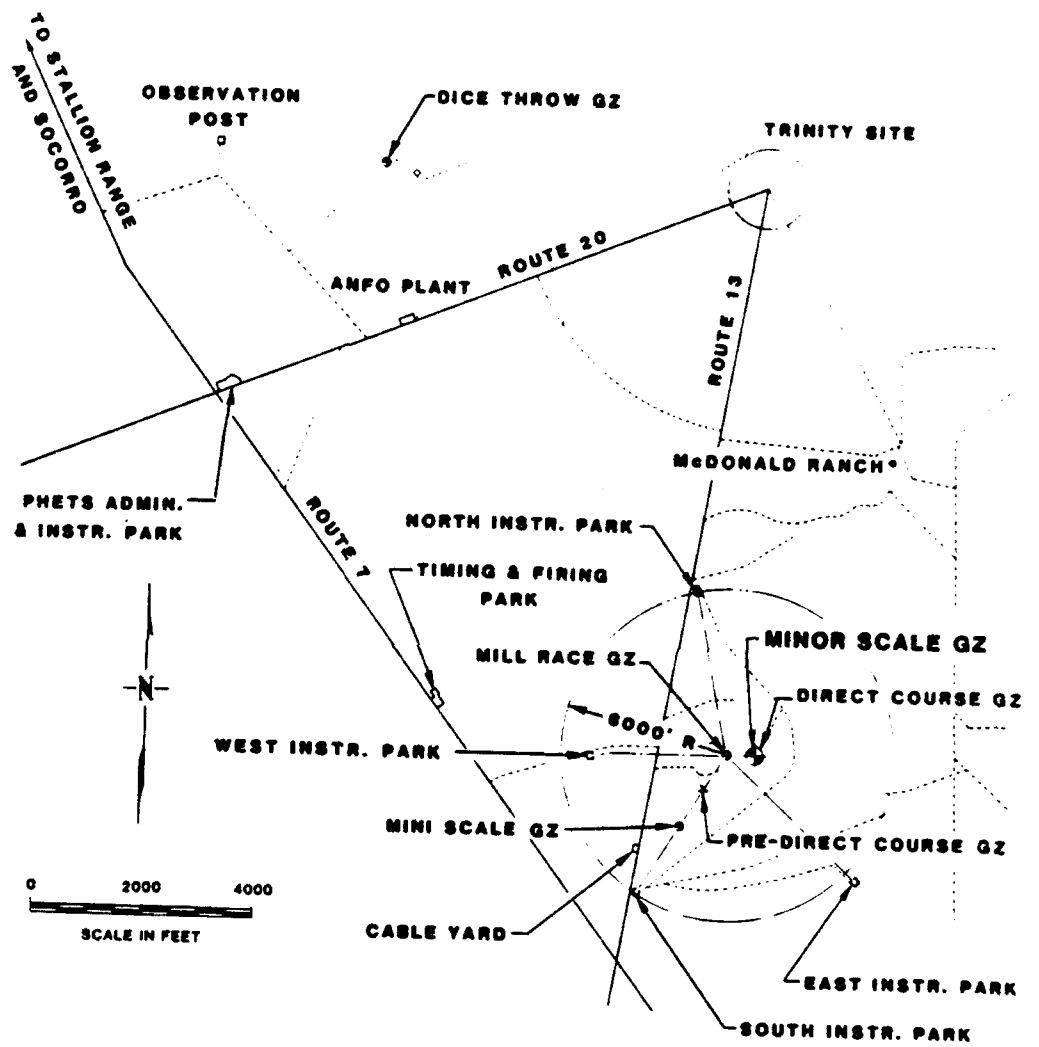

Figure 1.4. Ground zero location.



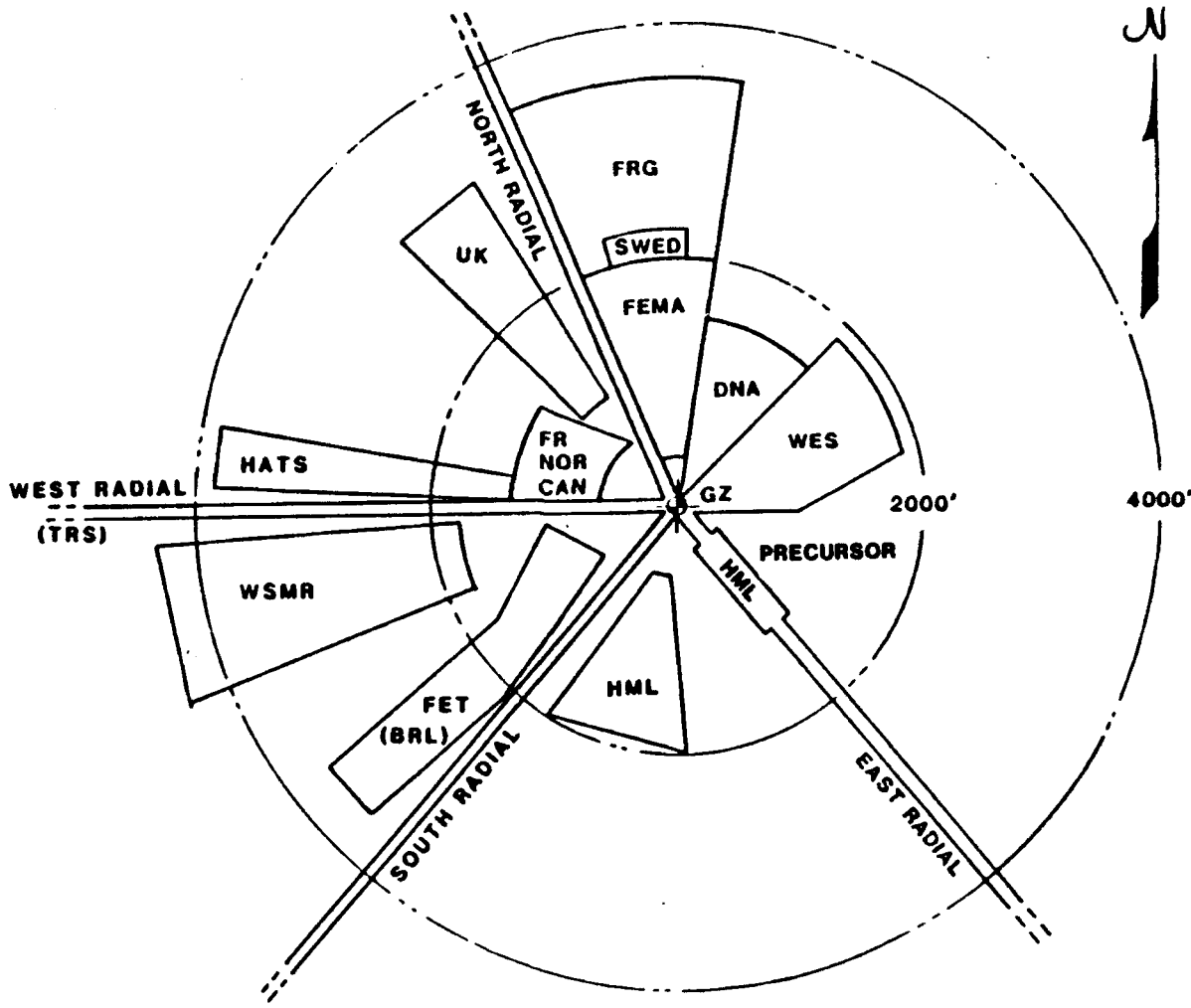
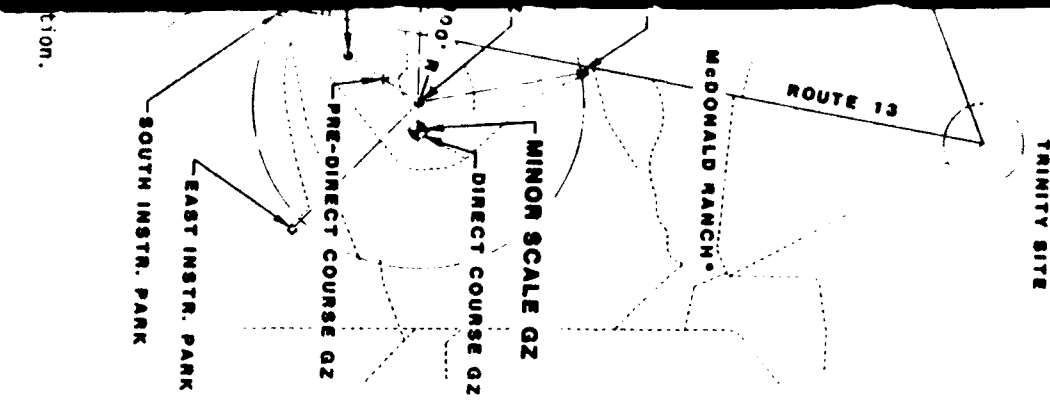
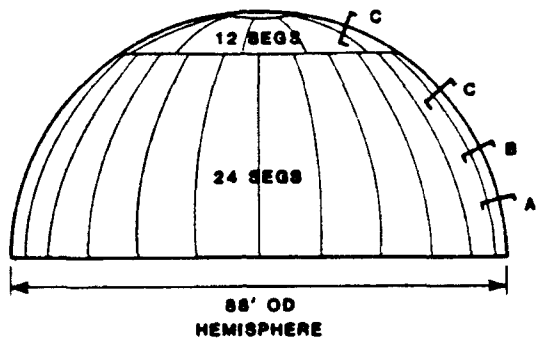
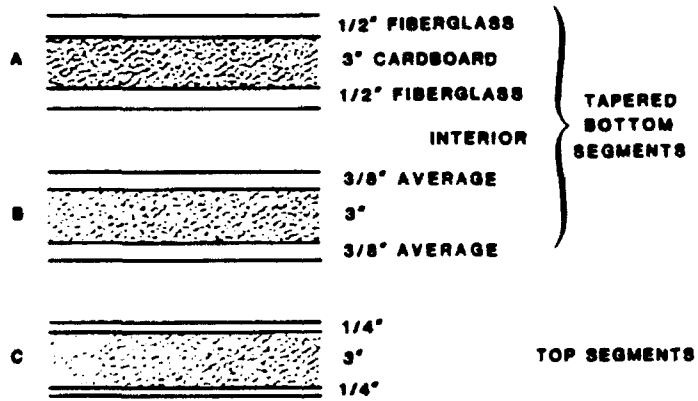

Figure 1.5. MINOR SCALE testbed.



**SEGMENT CROSS-SECTIONS**



**JOINT CROSS-SECTIONS**

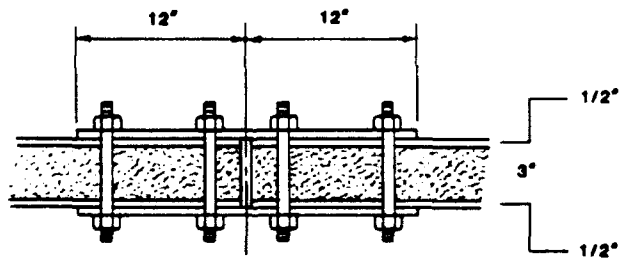

Figure 1.6. Charge container.

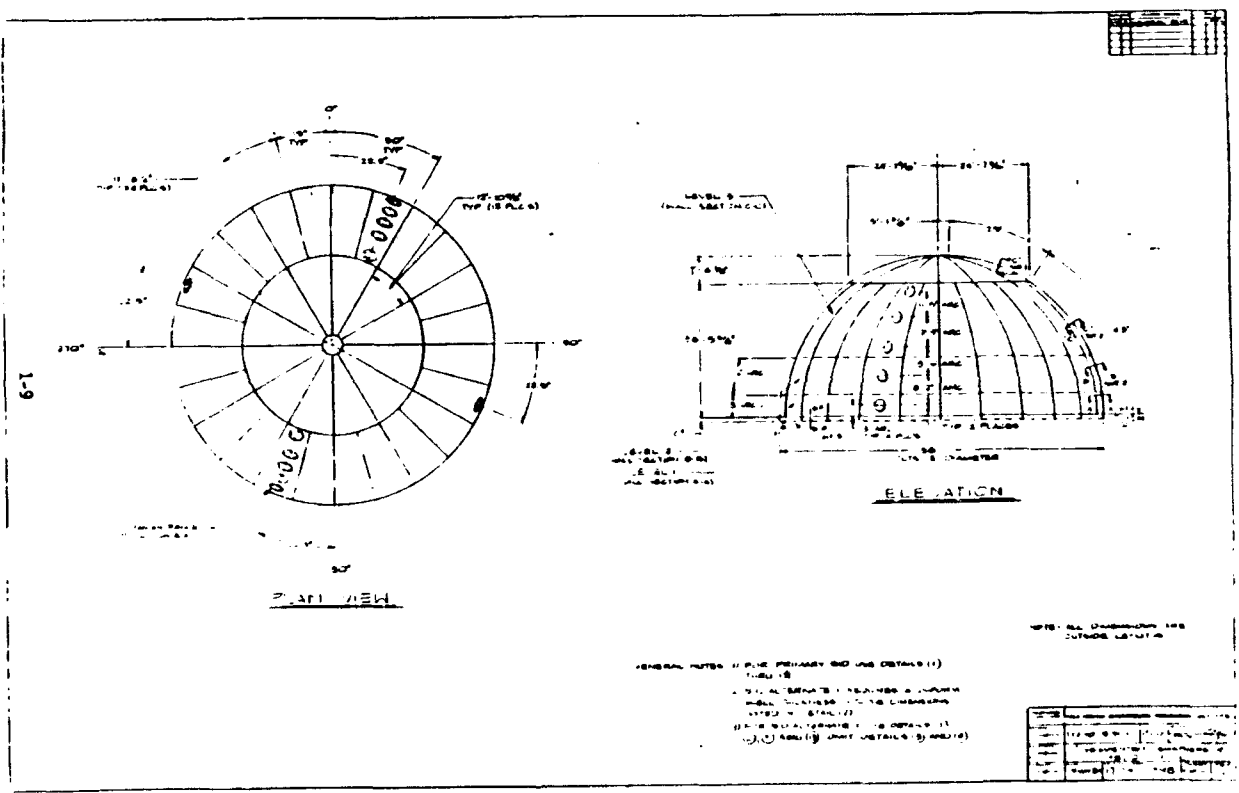
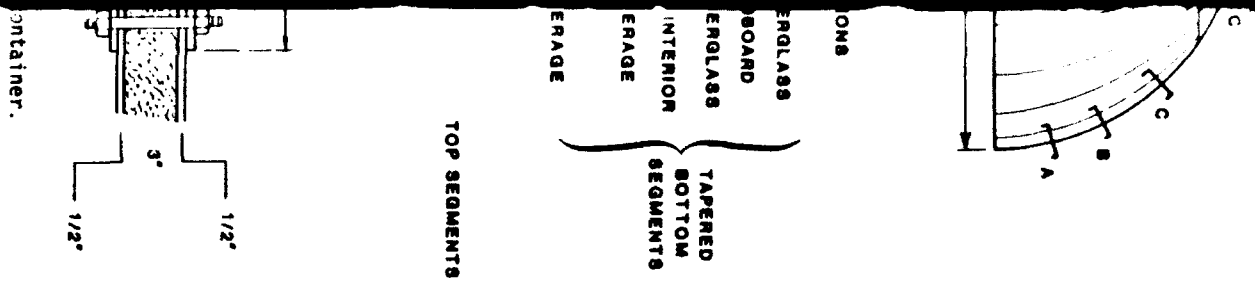

Figure 1.7. Segmented hemisphere - 4800 ton.

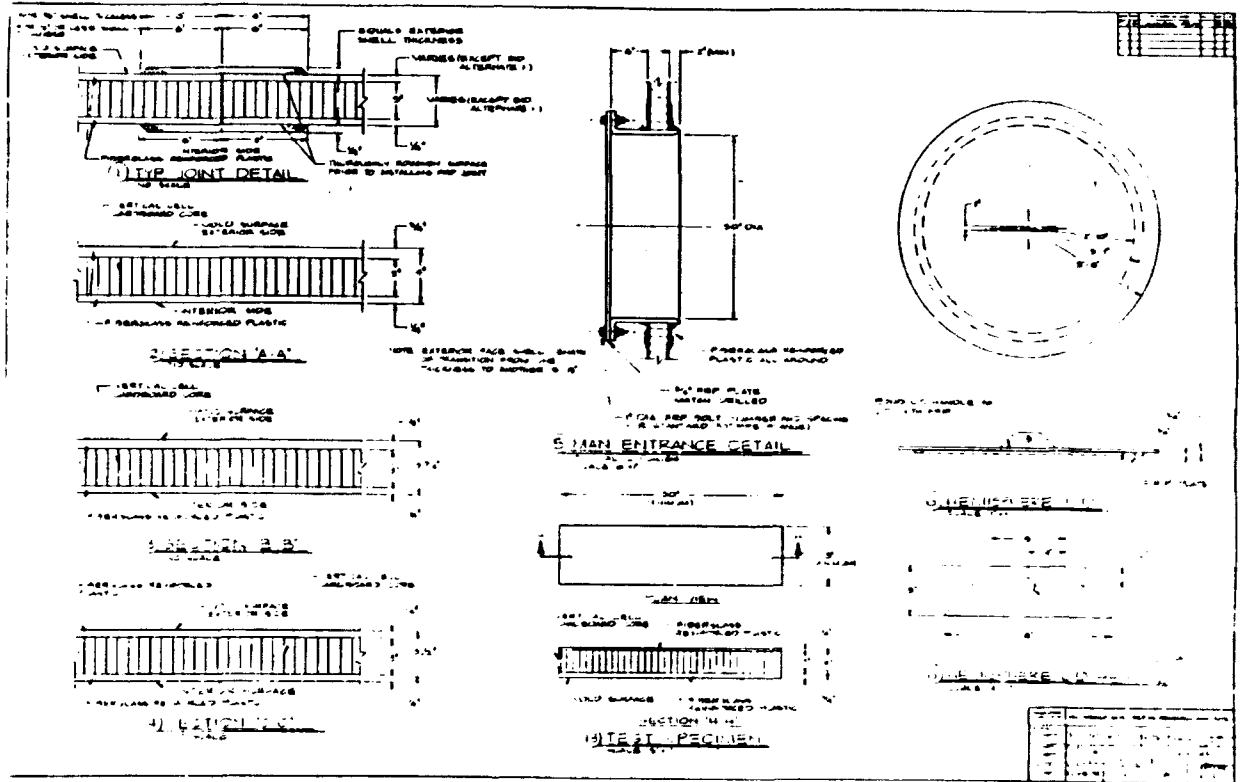
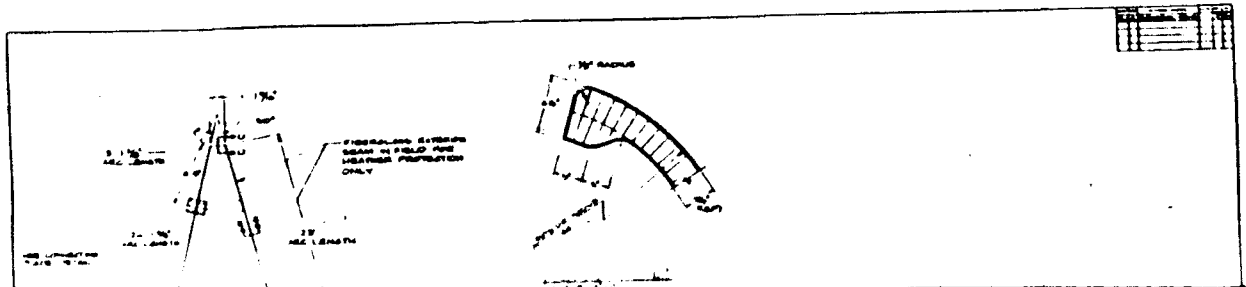

Figure 1.8. Segmented hemisphere - sections and details.



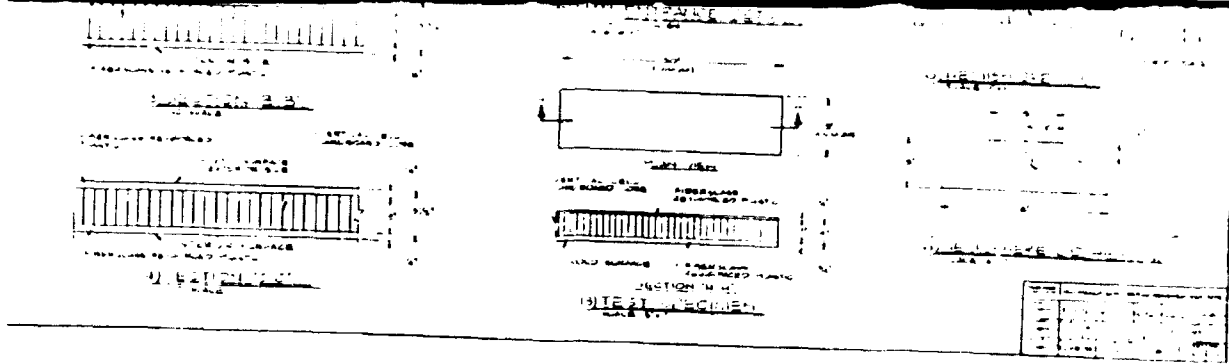

Figure 1.8. Segmented hemisphere - sections and details.

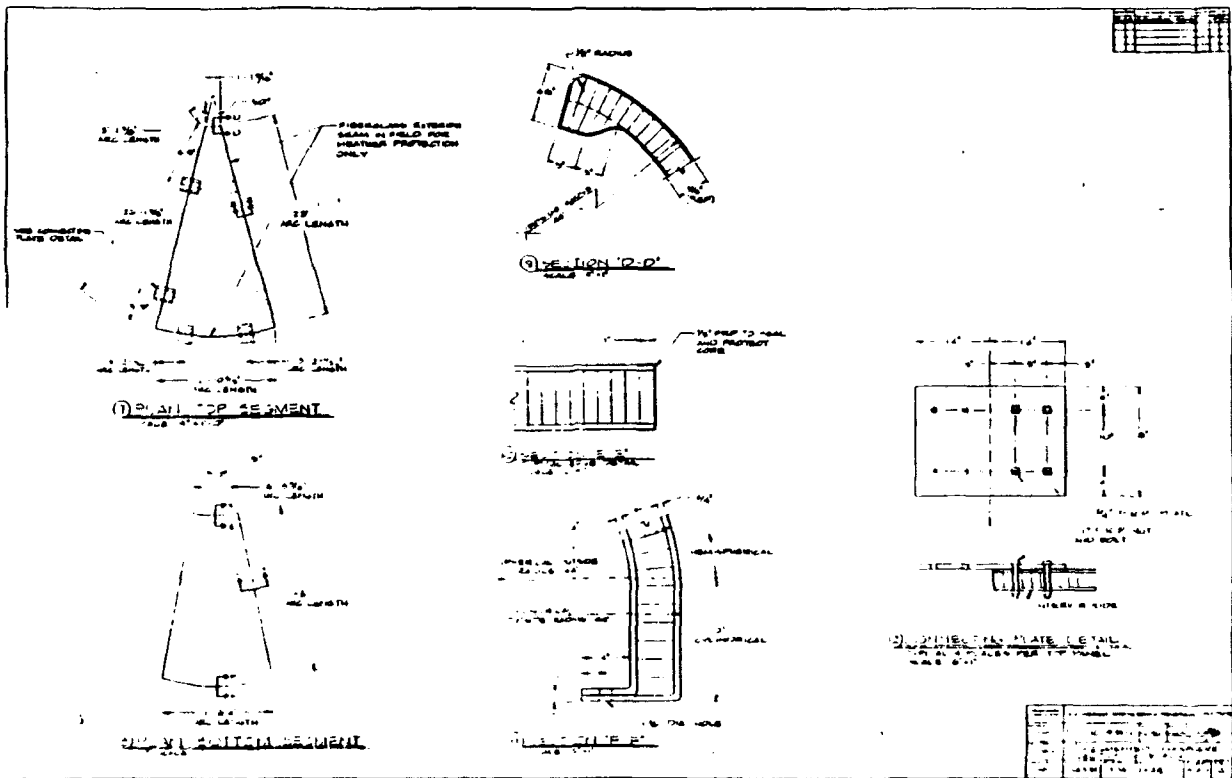

Figure 1.9. Segmented hemisphere - sections and details.

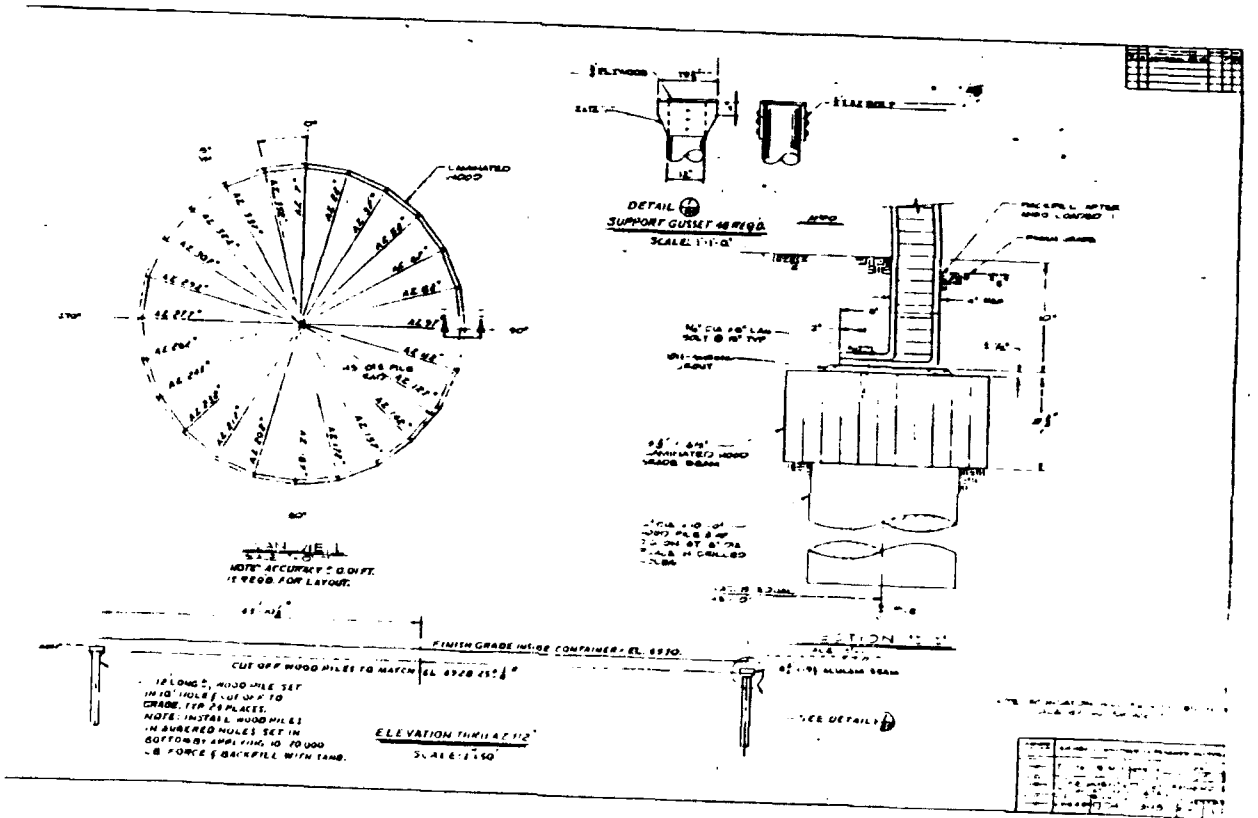

Figure 1.10. Segmented hemisphere - foundation and detail.

2000 hours an inspection showed the edge of the field-applied fibreglass about 10 feet up the sides of the container. On Sunday, June 2, loading because ANFO was behind the ANFO at the top of the container would impact the schedule. At 1800 hours, a 17.5° crack near the container. As the crack continued to 172.5°. The crack continued with about a 2-inch separation at detonation.

At 0145 hours Monday joint at radial 172.5° opened and the crack onto the radial. See Figure 1.12 for ANFO, estimated at 120 tons a was left in place for the detonation.

### 1.3.3 ANFO Mixing.

A mixing plant (Blasting Agent) was set up for Explosives Test. The mixing plant. Fuel oil delivered to the trucks carrying the ammonium nitrate loaded into trucks from the trucks used to transport the plant. The raw material for ammonium nitrate and 100 lbs of explosive operator. After completion of the booster charge was emulsified in fibreglass container.

2000 hours an inspection showed small (less than 1/8 inch) cracks had developed at the edge of the field-applied fiberglass joints. The cracks ran from the ground to about 10 feet up the sides of the hemisphere.

On Sunday, June 23rd, about 1600 hours a decision was made to stop loading because ANFO was being added very slowly due to the necessity to distribute the ANFO at the top of the container. Continuation of loading at this slow rate would impact the schedule. Approximately 4744 tons were in place at this time.

At 1800 hours, a loud sharp "crack" was heard by NMERI technicians working near the container. As they watched, a very large crack began to form at radial of 172.5°. The crack continued to open for about 30 minutes and then stabilized with about a 2-inch separation. See Figure 1.11 for picture one hour prior to detonation.

At 0145 hours Monday 24 June, a crack developed in the container. The joint at radial 172.5° opened to about 6 inches, followed immediately by ANFO spilling out of the crack onto the ground. A second crack later developed at the 52.5° radial. See Figure 1.12 for picture one hour prior to detonation. The spilled ANFO, estimated at 120 tons at the 172.5° radial and 100 tons at the 52.5° radial, was left in place for the detonation at 1220 hours plus 0.03 seconds on 27 June 1985.

#### 1.3.3 ANFO Mixing.

A mixing plant to add diesel oil to ammonium nitrate to make ANFO (Blasting Agent) was set up on the North Range, WSMR, in support of MINOR SCALE High Explosives Test. The mixing plant is located 1.45 miles east of route 7, on route 20. Fuel oil delivered to the mixing plant in trucks was discharged into the auger carrying the ammonium nitrate from the hopper to elevators. The ANFO was gravity loaded into trucks from the elevators for delivery to the hemisphere at GZ. The trucks used to transport the ANFO were appropriately marked, as well as the mixing plant. The raw material for the ANFO, at the mixing plant, was limited to 100 tons of ammonium nitrate and 100 tons of diesel fuel oil.

#### 1.3.4 Explosive Operations.

After completion of the fiberglass container and prior to ANFO 1' the booster charge was emplaced at ground level in the center of the fiberglass container.

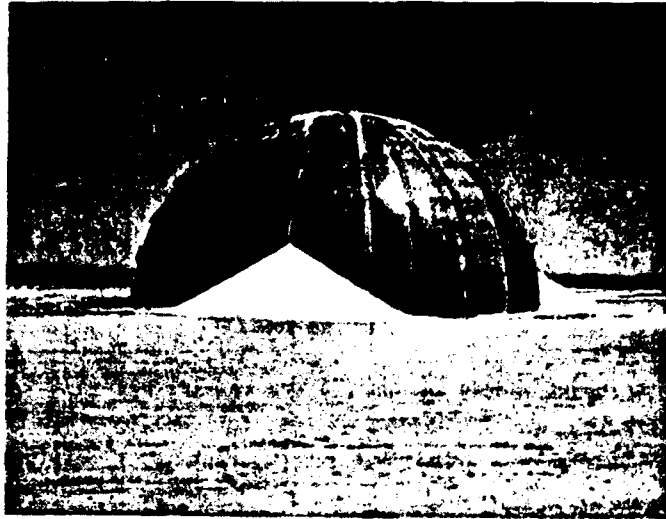

Figure 1.11. First ANFO leak.

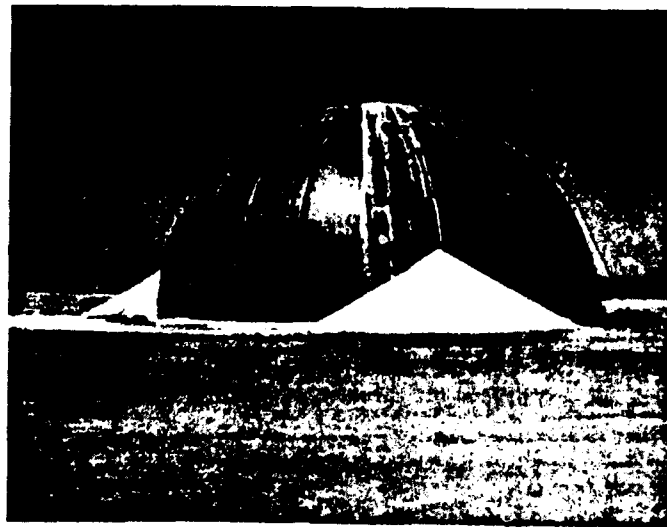

Figure 1.12. Second ANFO leak.

A. The hemispherical shells were emplaced in a confined detonation container and tied

B. All were loaded into a container which was delivered to the test site and pneumatically filled there, wearing sea level.

loading operation during daylight hours.

ANFO Weapons Center (NSWC) fuel oil content track actual characteristics important for both

C. E by NSWC, consisted of a booster weighing 400 lbs. Four 60-foot aluminum tubes were attached to the booster from a detonation from the booster. The arming consisted of a fiberglass hemispherical shell mounted inside the tubes and tied off once the

Arming holders at the test site. The detonation cables, pre-positioned at Sandia National Laboratories, were located on the test site.



A. The booster, consisting of 310 pounds of Octol, was constructed in a hemispherical shape approximately 25 inches in diameter. Two sub-booster pellets were emplaced in the Octol booster. Each sub-booster had two lengths of flexible confined detonating cord (FCDC) attached and was extended outside of the fiberglass container and tied off during the remainder of the charge loading operation.

B. ANFO Loading. 4744 tons of ammonium nitrate-fuel oil mixture (ANFO) were loaded into the 88-foot diameter, honeycombed, fiberglass hemisphere. The ANFO was delivered to the test site in bulk form from the mixing plant in hopper trucks and pneumatically discharged into the hemisphere. Two workmen inside the hemisphere, wearing self-contained breathing apparatus, distributed the ANFO to insure a uniform level. This process continued until loading was terminated. The entire loading operation required approximately 10 days to complete. Loading was conducted during daylight hours, except for the evening of 22-23 June.

ANFO quality control was monitored by personnel from the Naval Surface Weapons Center (NSWC). Samples of ANFO were taken from each load and analyzed for fuel oil content and particle size. Each load was weighed on a platform scale to track actual charge weight. Particle size and particle size distribution are important for both charge density/weight results and ANFO sensitivity.

C. Booster System/Pre-Arming. The MINOR SCALE booster system, supplied by NSWC, consisted of a 25-inch diameter OCTOL (75/25 HMX/TNT) hemisphere main booster weighing nominally 310 pounds and containing 2 CH-6 sub-booster pellets. Four 60-foot aluminum sheathed, flexible, confined, detonating cords (FCDC) transfer detonation from the exploding bridgewire detonators to the Octol hemisphere. Pre-arming consisted of placing the Octol hemisphere and sub-booster assembly inside the fiberglass hemisphere prior to charge construction. The FCDC lines were pre-positioned inside during assembly and exited the hemisphere through the bottom and were tied off once the detonator holders were attached.

Arming consisted of attaching the four TC234 detonators to the detonator holders at the end of the FCDC lines and enabling the Arming and Firing (A&F) System. The detonators and firing system were designed, supplied, and operated by Sandia National Laboratory Albuquerque (SNLA), Division 7132. Four 300-foot "C" cables, pre-positioned in the structure, attached the detonators to the X-unit located on the test pad. This unit was connected to the A&F system located in the

Timing and Firing (T&F) Van, approximately 6000 feet away in the West Instrumentation Park. The A&F system consisted of an arm panel with an "Arm/Safe" key switch and monitor lights, a high voltage panel, an interlock panel, two power supplies, and a cable lock box with key. The system was locked out until after final arming by the two keys in the system.

#### 1.4 SPECIAL ENVIRONMENTS.

##### 1.4.1 Thermal Radiation Source (TRS).

1.4.1.1 Introduction. A policy decision by HQ DNA was made in October 1984 that a TRS environment would be provided as part of the basic test environment for approved U.S. experiments. Seven U.S. units would be fielded. The U.K. could participate with their TRS unit on a non-interference (with DNA units) basis. DNA would furnish fuels and test bed construction on a cost reimbursable basis.

At the HQ DNA MINOR SCALE Experiment Proposal Review in March 1984, requirements to field seven TRS units were identified and approved. One U.S. unit was later withdrawn from the event at the request of the experimenter. TRS experiments are listed by experiment number and TRS unit number in Table 1.

Science Applications International Corp. (SAIC), Albuquerque, the developer of the TRS system used on MILL RACE, proposed substantial modifications to the TRS system that were to improve performance of the units. The modifications included shortening LOx lines to the nozzles, pre-cooling the LOx plumbing, placing DIRECT COURSE unit components in modular frames, and converting the pilot flame fuel from propane to Hydrogen. Flexibility of positioning the nozzle modules to fit the experiment requirements was retained. During November of 1984 SAIC was contracted by the Defense Nuclear Agency to modify the seven TRS units as proposed. The scope of contract is given in DNA Contact DNA001-85-C-0100.

1.4.1.2 Construction and Testing. Due to the poor performance of the TRS units on the DIRECT COURSE event (see TER for DC) additional help was enlisted from two national laboratories. The Oak Ridge and Los Alamos National Laboratories were brought on board the project prior to the design review to provide consultation assistance to FCDNA and SAIC in avoiding potential difficulties in the compressed schedule getting to the MINOR SCALE event.

ORNL provided representatives at monthly review meetings. Their representatives had expertise in the areas of cryogenics design, and instrumentation. ORNL was prepared to investigate issues arising by experiment or calculations.

LANL provided  
tives offered expertise in  
The character  
Radiant Power  
Spectrum:  
Maximum Flux:  
Duration:  
Nozzle Spaci  
LOx pre-cool  
To support t  
to the DIRECT COURSE co  
capacity. Two tanks, v  
equal length to all noz  
increased LOx capacity  
pressure Nitrogen be  
collector bottles was  
SAIC produc  
modular frames. After  
their Albuquerque faci  
wide, 7.5 feet tall.  
a complete dry unit is  
The first  
The components were p  
March 1985.  
Unit one  
a wind protection fe  
nozzle spacings were  
1.4.1.3 Fielding  
MINOR SCALE.  
The unit  
consisted of eight  
Aluminum honey comb  
pit wall and the un-

LANL provided representatives at monthly meetings. Their representatives offered expertise in shock hardening and structure design.

The characteristics that the modified TRS units were to have were:

Radiant Power:	60-100 megawatts/nozzle
Spectrum:	2600 K Quasi-grey body
Maximum Flux:	55 Calories/centimeter squared/second
Duration:	0.6-4.0 seconds
Nozzle Spacing:	1-5 meters
LOx pre-cooldown:	All nozzles

To support the pre-cool down system two 100 gallon LOx tanks were added to the DIRECT COURSE components along with an increased high pressure Nitrogen gas capacity. Two tanks, vise one large tank, were used to keep LOx lines short and equal length to all nozzles plus balance the weight of the total modular unit. The increased LOx capacity along with the pre-cool down flow dictated that more high pressure Nitrogen be available in each unit. To accomplish this the number of collector bottles was increased from four to six.

SAIC produced the design drawings and contracted the fabrication of the modular frames. After fabrication SAIC assembled the components into the frames at their Albuquerque facility. The final size of the frames is 40 feet long, 8.5 feet wide, 7.5 feet tall. All components are internal to the frame. The total weight of a complete dry unit is near 10 tons.

The first frame was completed and delivered to SAIC on 11 February 1985. The components were placed into the frame and the complete unit arrived at KAFB on 1 March 1985.

Unit one (the first unit completed) was tested in a temporary pit inside a wind protection fence. The test series consisted of 18 four nozzle events. Two nozzle spacings were used. Unit one was moved to WSMR on 18 March 1985.

1.4.1.3 Fielding and Instrumentation. Table 1.1 shows the units assigned to MINOR SCALE.

The units were placed in steel walled free standing pits. The pit floor consisted of eight concrete anchors, and 1-2 feet of gravel for water drainage. Aluminum honey comb was placed at the perimeter of each pit between the top of the pit wall and the unit blast plates for blast overpressure cushion/seal.

Table 1.1. Unit assignment for MINOR SCALE.

<u>Unit Number</u>	<u>Pit Number</u>	<u>Experiment Number</u>	<u>Agency</u>
1	6	1300	NEL (WSMR)
2	1	1320	NEL
3	5	1325	NEL
4	2	1375	NEL
5	3	5107	NATIC
6	4	5109	HDL

Unit number corresponds to the order of production by SAIC.

Four active calorimeters were placed on the GZ side of each unit for diagnostics monitoring of unit performance. The sensors were located aligned with each nozzle and placed seven feet away at six feet elevation. The active calorimetry was fielded, recorded and data reduced by BRL.

The TRS control system was capable of monitoring each unit in the areas of:

- Nitrogen gas pressure
- Pilot flame operation
- Control communication status

Table 1.2 indicates the nozzle spacing used on each unit.

Table 1.2. Nozzle spacing.

<u>Unit Number</u>	<u>Experiment Number</u>	<u>Nozzle Spacing</u>
1	1330	19'9", 6'11", -6'11", -19'9"
2	1320	7'0", 3'6", -3'6", -7'0"
3	1325	11'6", 3'9", -3'9", -11'6"
4	1375	11'6", 3'9", -3'9", -11'6"
5	5107	11'6", 3'9", -3'9", -11'6"
6	5109	11'6", 3'9", -3'9", -11'6"

4.4.1.4  
WSMR for ex

directly  
system an  
days to  
tion tes  
flows, c

flows we  
burn us

damaged  
was lat-  
others.

nozzle  
were re

units ■  
listed

Runs.  
nit.

4.4.1.4 Dry Runs. Table 1.3 indicates the actual dates of arrival at KAFB and WSMR for each unit.

Table 1.3. TRS arrival times.

<u>Unit Number</u>	<u>Arrive KAFB</u>	<u>Arrive WSMR</u>
1	01 Mar 85	18 Mar 85
2	18 Mar 85	25 Mar 85
3	25 Mar 85	01 Apr 85
4	01 Apr 85	08 Apr 85
5	08 Apr 85	15 Apr 85
6	15 Apr 85	22 Apr 85
7	22 Apr 85	N/A

Upon arrival at WSMR each unit was installed into its pit by crane directly from the transporting truck. BFECNV connected the unit into the control system and bolted on the 3/8 inch thick blast plates. This action took two to three days to complete. After installation was completed all unit subsystems were function tested. This testing consisted of pilot flame burns, LOx flows, LOx A1 cold flows, control system communication drills.

After all six units were individually tested, collective LOx A1 cold flows were conducted. On three occasions prior to the first MFP a total system hot burn using event timing was successfully executed.

On the 12 June 1985 collective burn one nozzle module on unit 1 was damaged by the failure of the graphite nozzle block early in the burn sequence. It was later determined that slight cracks had gone undetected in that unit and four others.

Unit 1 was put back into service within 24 hours by moving a complete nozzle module from unit 7 at KAFB into unit 1 at WSMR. All cracked graphite nozzles were replaced prior to the next test of the system.

The TRS system participated on both MFPs and Dress Rehearsal with all units burning hot and for the event durations. The burn times for each unit are listed in Table 1.4. Figure 1.13 shows one of these burns.



Figure 1.13. TRS units.

Unit Number

1  
2  
3  
4  
5  
6

1.4.1.5 Event Results. All 28 pi TRS controller. All nozzles burned levels of heat were delivered to each TRS units experienced bla

No damage was sustained by any unit.

1.4.1.6 Post Event Tests and Reco the units. All fuels were purged fr to KAFB. The first three units were

The last three units arrived at KAFB 1.4.2 Thermal Precursor Simulat

The thermal precursor sim the blast wave propagation. The t ground and the surface air near the heated surface air faster and create face. The thermal precursor simulate layer of helium gas at the time of d in helium than in air, the shockwave duced a simulated precursor. The The bags covered a total area approx in Figure 1.14. The first bag be positioned two feet above the speci bags were buried in the ground to pr

Table 1.4. TRS burn times.

<u>Unit Number</u>	<u>Burn Duration</u>
1	2.0 sec
2	4.5 sec
3	1.3 sec
4	1.3 sec
5	3.0 sec
6	4.3 sec

1.4.1.5 Event Results. All 28 pilot flames ignited on command from the central TRS controller. All nozzles burned for the prescribed duration and the planned levels of heat were delivered to each target.

TRS units experienced blast over pressures ranging from 3.5 to 11.0 psi. No damage was sustained by any unit.

1.4.1.6 Post Event Tests and Recovery. No post event testing was performed on the units. All fuels were purged from the units and they were prepared for transit to KAFB. The first three units were moved to the KAFB TRS site on 24 July 1985. The last three units arrived at KAFB on 7 August 1985.

1.4.2 Thermal Precursor Simulation.

The thermal precursor simulated the effects of a thermal ground layer on the blast wave propagation. The thermal flash from a nuclear device heats the ground and the surface air near the detonation. The blast wave travels through the heated surface air faster and creates a precursor of the shock wave near the surface. The thermal precursor simulated this environment by providing a two foot high layer of helium gas at the time of detonation. Since pressure waves advance faster in helium than in air, the shockwave moved faster in the helium environment and produced a simulated precursor. The helium was contained beneath eight mylar bags. The bags covered a total area approximately 400 feet wide by 950 feet long as shown in Figure 1.14. The first bag began 400 feet from ground zero. The bags were positioned two feet above the specially-prepared dusty surface. The sides of the bags were buried in the ground to prevent excessive helium loss.

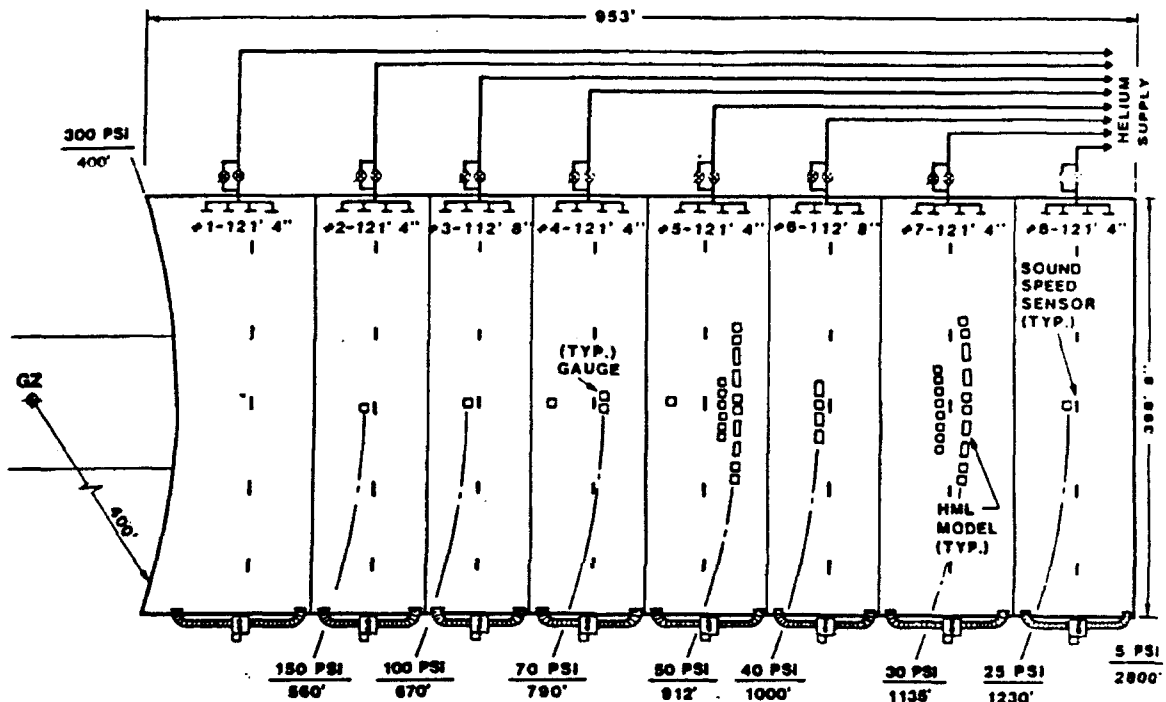
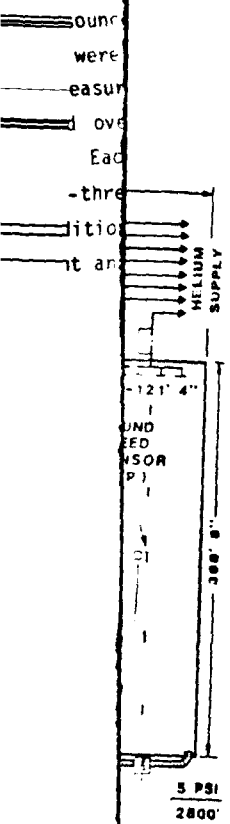

Figure 1.14. Helium envelope for dusty precursed radial MINOR SCALE.

For  
 microphone sou  
 of a system f  
 covers were p  
 protection sys  
 To  
 precursor. It  
 to this enviro





Forty sound velocity probes which contained high voltage spark gaps and microphone sources were installed on the precursed radial. The spark gaps were part of a system for measurement of helium concentration in the helium bag. Plastic covers were placed over each spark gap probe during calibration, as a personnel protection system. Each cover was marked "Danger High Voltage" and "Do Not Remove".

Twenty-three experiments were designed to measure the properties of the precursor. In addition, eight hardened mobile launcher (HML) models were subjected to this environment and their responses were recorded.

SECTION 2  
TEST REQUIREMENTS, PLANNING, AND ORGANIZATION

2.1 TEST REQUIREMENTS.

The purpose of DNA sponsored HE simulation tests is to provide a testbed for a simulated nuclear airblast ground shock and thermal radiation effects. The airblast and thermal pulse environments are used to evaluate target response of military and civilian structures, equipment, and systems, investigate (study) phenomenologies, validate predictive techniques and expand experimental data bases.

Recent HE test programs include:

- a. PRE-DICE THROW-shaped charge development program at WSMR in 1974-5,
- b. DICE THROW-600 ton ANFO surface stacked charge at WSMR in 1976,
- c. MISER'S BLUFF, Phase I-multiburst charge development program at WSMR in 1977.
- d. MISER'S BLUFF, Phase II-120 ton ANFO stack-charge, and six 120 ton ANFO stacked charges multiburst tests at Planet Ranch, AZ in 1978,
- e. MILL RACE 600 ton ANFO surface stacked charge at WSMR in 1981,
- f. PRE-DIRECT COURSE height-of-burst concept development program using 24 tons of ANFO at WSMR in 1982, and
- g. DIRECT COURSE-609 tons of ANFO, 166 foot height-of-burst shot at WSMR October 26, 1983.

The current MISTY CASTLE test series continued with the third test in the series, MINOR SCALE detonated 27 June, 1985 at WSMR. MINOR SCALE was an 8 kt (scaled) nuclear airblast equivalent test with a hemispherically shaped charge.

2.2 TEST PLANNING.

2.2.1 General.

In December 1983 Headquarters DNA sent letters requesting experiment proposals to the appropriate US and foreign government agencies. A DNA proposal review panel selected the participants for the test in April 1984. Technical support plans were submitted from April-July 1984. The first project officer's meeting (POM) was held in July 1984, the second in September 1984, and the third in November 1984. Numerous additional project officers meetings were held at the permanent high explosive test site (PHETS) on the White Sands Missile Range (WSMR), New Mexico,

during April  
Figure 2.1 :

—  
PI  
Re  
Pr  
  
Pr  
Aj  
F  
S  
I  
S  
E  
T

-----  
Requirem  
submitte  
WSMR. W  
support

during April, May and June 1985. Table 2.1 shows the major MINOR SCALE milestones. Figure 2.1 shows the MINOR SCALE master schedule.

Table 2.1. MINOR SCALE milestones.

Activity	
Planning meeting	29-30 November 1983
Request for experiment proposals	12 December 1983
Proposals review meeting -- foreign countries	16 April 1984
Proposal review meeting	24-26 April 1984
Approval letter to experimenters	10 May 1984
First Project Officers Meeting (POM)	23-27 July 1984
Start of test bed construction	September 1984
Initial cost estimates provided	30 August 1984
Second POM	24-28 September 1984
Experiment construction began	Fall of 1984
Third POM	29 November - 5 December 1984
Start erection of charge container	11 March 1984
Completion of cable installation	10 May 1985
MFP + 1	12 June 1985
Start ANFO loading	14 June 1985
MFP + 2	18 June 1985
Dress rehearsal	22 June 1985
MINOR SCALE executed	27 June 1985

To obtain approval for use of WSMR for MINOR SCALE a new Operational Requirements document (OR) 96315, in the MISTY CASTLE test series was prepared and submitted to WSMR. The OR described detailed support requirements requested from WSMR. WSMR approved the proposed site for MINOR SCALE and provided for use of WSMR support facilities for FCDNA. Seven Operations Directives (OD) were issued. The

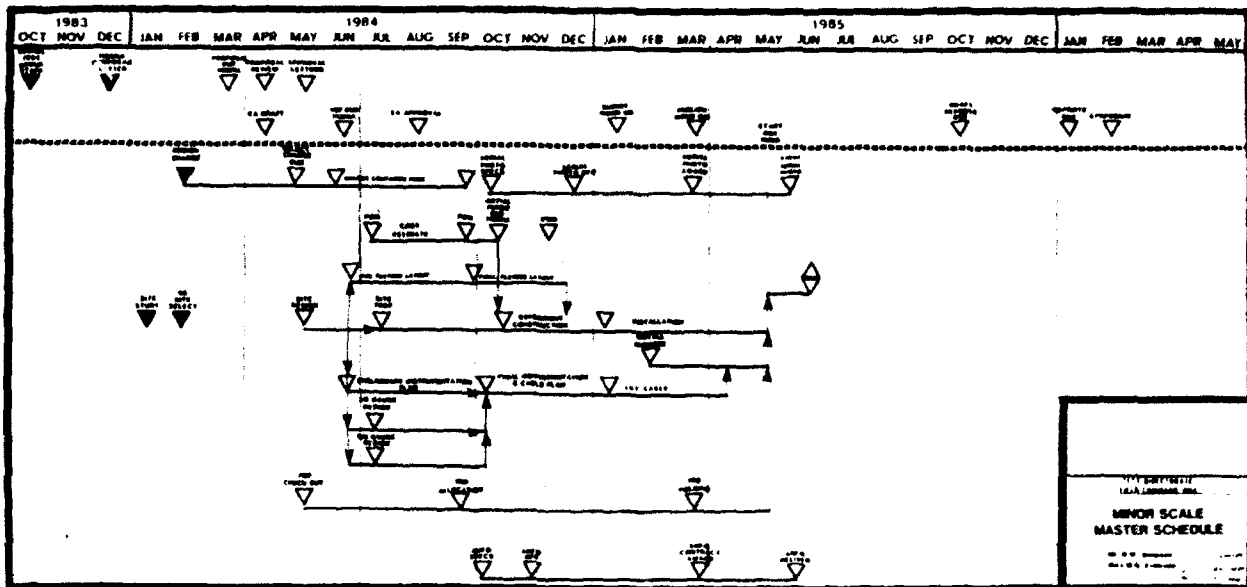

Figure 2.1. MINOR SCALE master schedule.

following Operational Directives are contained in ANFO Event; (2) 96315B, Laser Test; (3) 96315C, Ground Check; (5) 96315E, Project Check. The MINOR SCALE effort, MSNR test code 96315B, 852 Aircraft. Each OD defines the National Range Programs Directorate (NRP) one for the MINOR SCALE Event and one for Appendix B.

Following the assignment of staff proceeded to select agencies to perform the following areas:

Airblast and Thermal Measurements

The Ballistic Research Laboratory (BRL) measured the time of arrival, the amplitude, and the free field pressure. BRL also recorded the free field pressure.

Ground Motion Measurements

The U.S. Army Waterways Experiment Station (WES) recorded the ground motion data and the airblast induced ground motion data and the Charge Container.

The University of New Mexico

provided the design of the container system and the Charge Container.

Quality Control of the ANFO

Pre-arming of the Charge.

The Naval Surface Weapons Center (NSWC) provided the ANFO fuel oil content, particle size distribution, and installed the pre-arming the charge.

Arming and Firing

Sandia National Laboratories (SNL) provided the charge arming and firing support and firing interface equipment were provided.

following Operational Directives are contained in Appendix B: (1) 96315A, 4800 Ton ANFO Event; (2) 96315B, Laser Test; (3) 96315C, ANFO Mix and Loading; (4) 96315D, Ground Check; (5) 96315E, Project Checks; (6) 96316A, Aircraft Flights; and, (7) 96316B, B52 Aircraft. Each OD defines the support WSMR directorates were to provide to the MINOR SCALE effort. WSMR test coordination for MINOR SCALE was provided by the National Range Programs Directorate (NR-PD). Two operational requirements (OR) one for the MINOR SCALE Event and one for Aircraft Support were issued. They are in Appendix B.

Following the assignment of a MINOR SCALE Test Group Staff (TGS), the staff proceeded to select agencies to provide technical support in the following areas:

Airblast and Thermal Measurements.

The Ballistic Research Laboratory (BRL) was selected to provide the free-field airblast measurements on the test site from 4000 psi to 1/4 psi. They measured the time of arrival, the amplitude and waveforms of the airblast overpressure. BRL also recorded the free field thermal environment produced by TRS units.

Ground Motion Measurements.

The U.S. Army Waterways Experiment Station (WES) obtained the free field airblast induced ground motion data and documented the ground shock phenomena.

Charge Container.

The University of New Mexico Engineering Research Institute (NMERI) provided the design of the container system and supervised the construct. of the charge container.

Quality Control of the ANFO Filling Operation, Booster Placement and Pre-arming of the Charge.

The Naval Surface Weapons Center (NSWC), Dahlgren, Virginia monitored the ANFO fuel oil content, particle size distribution and the net charge weight. In addition they supplied and installed the booster system, and were responsible for pre-arming the charge.

Arming and Firing.

Sandia National Laboratories, Albuquerque (SNLA), Division 7132, provided the charge arming and firing support. Firing cables, X-unit, and the timing and firing interface equipment were provided and exercised during each dry run.

Far Field Airblast Damage Predictions and Barograph Measurements.

SNLA, Division 7111, provided predictions of airblast propagation and synoptic patterns based on meteorological conditions. This was to help avoid offsite damage effects, to measure small pressure amplitudes in selected, representative locations verifying predictions, and to provide factual data for any damage claim adjustments.

Meteorology Support.

This combined effort by SNLA, Division 7111 and the WSMR Meteorological Team of the Atmospheric Science Laboratory provided wind direction and velocity, air temperature, and humidity as a function of altitude through rawinsonde balloon launches. This information in predicting far field airblast damage and was essential in making the "go" decision for test execution. An SNLA tethered sonde recording system was used to record barometric conditions from ground surface to 1500 feet.

Documentary Photography.

The WSMR contractor, Dynallectron Corporation, provided documentary photographic support to participating agencies and FCDNA. Over \_\_\_\_\_ still photographs (black and white, color and slides) were taken to document progress and test results. Motion picture documentary film (4,600 feet) was taken of the testbed activities and experiment installation for the primary purpose of producing a documentary movie.

Technical Photography.

The majority of technical photography coverage of blast effects on testbed experiments was provided by WSMR (STEWS-NR-DO). The Denver Research Institute (DRI) and Norway also provided technical photographic coverage.

Diagnostics.

Optical diagnostic coverage of the detonation, shockwave and cloud was provided by WSMR (STEWS-NR-DO). Diagnostics of the ANFO detonation was done by AFWL (NTEO) and DRI.

Anthropomorphic Mannikins.

The Life Sciences Division of Los Alamos National Laboratory fielded and conducted damage assessment on mannikins for those experimenters evaluating blast hazards on humans.

Engin

Tech.

support, testbed  
some experimenter

Logis

Logis

system, the FCDN  
and White Sands I  
tic requirements

Tech

TRI,

Document, the ch  
ble and organize

2.2.2 Proj

Proj

of planning and  
mation between  
agency personnel  
fielding comment  
menter requirem  
POM a review of  
third POM, appr  
cost estimates

POM

date and were l  
test. The purp  
plan test activ

- 
- 
- 
- 
- 
- 
-

Engineering Support.

Tech. Reps., Inc., (TRI), Albuquerque, NM, provided engineering field support, testbed layout drawings, design of TRS pits, and construction drawings for some experimenters.

Logistic Support.

Logistic support was provided from several sources. The FCDNA supply system, the FCDNA Acquisition Office (FCA), local purchase agreements in Socorro, and White Sands Missile Range (WSMR) were used to provide the broad range of logistic requirements for the test.

Technical Reports.

TRI, Albuquerque, NM, prepared the camera-ready copies for the Program Document, the changes thereto, and the Test Execution Report. TRI will also assemble and organize the camera-ready copies from the MINOR SCALE Results Symposium.

2.2.2 Project Officer Meetings.

Project Officer Meetings (POMs) are held periodically during the course of planning and executing a high explosive test to facilitate the exchange of information between experiment project officers, and the Test Group Staff and support agency personnel. Three POMs were held (July, September, and November 1984) before fielding commenced to accomplish all planning and design. At the first POM experimenter requirements and the scope of experiments were established. At the second POM a review of all support design and test bed layout was conducted; and at the third POM, approval of all design plans were supposed to be obtained. Reimbursable cost estimates were prepared following the second and third POMs.

POMs at the test site commenced three months before the original test date and were held two weeks apart initially with increased in frequency up to the test. The purpose of these POMs was to exchange test preparation information and to plan test activities. Specifically, topics discussed included:

- Construction schedule
- MFPs
- Staff and experimenter status reports
- Countdowns
- Re-entry plan
- Recovery plan
- Administrative matters

2.2.3 Security.

Security concerns were significantly greater in MINOR SCALE than on DIRECT COURSE or MILL RACE. Approximately 25 percent (over 50) of the experiments were classified either pre and/or post event. This required significant operational security (OPSEC) planning prior to fielding, and positive security controls on the test site before and after the event. The FCDNA CI detachment provided assistance during the entire OPSEC effort by providing planning guidance to concerned experimenters. In addition to OPSEC planning, there was positive control of the test site, or portions thereof, for personnel safety and during dry runs and event day. Security plans were published in the MINOR SCALE.

2.2.4 Environmental Assessment and Archeological Survey.

Although there is a WSMR Environmental Impact Assessment for National Range Operations, the assessment does not cover large HE tests. DNA therefore contracted with Kaman-TEMPO, to have an Environmental Assessment (EA) prepared for the previous large HE test, MILL RACE, which was detonated 16 September 1981. Another EA was prepared for MINOR SCALE and published 4 September 1984 by Kaman Tempo. A "Finding of No Significant Impact" Statement is contained in Appendix C.

In preparing the MINOR SCALE EA, special consideration had to be given to the impact of the MINOR SCALE and follow-on tests on McDonald Ranch (Figure 2.2) and any archaeological sites in the test operating areas.

To determine that no archaeological sites would be damaged by test activities, WSMR contracted to have an archaeological survey conducted of the area within a radius of 12,000 feet (3,658 meters) from GZ for MILL RACE. No significant archaeological sites were found within the test area. The PRE-DIRECT COURSE test site did not have to be re-surveyed because it was totally within the original MILL RACE surveyed area. Because the DIRECT COURSE GZ was 1000 feet east of MILL RACE, the original archeological survey area had to be expanded. WSMR contracted with Eastern New Mexico University (ENMU), Portales to survey the area. The report identified no archeological sites within the DIRECT COURSE area of activity. The MINOR SCALE EA also showed the archeological sites in the test area.

2.2.5 Public Affairs Plan.

A Public Affairs Plan (Appendix D) describes policies, objectives, and responsibilities, and provided guidance for the conduct of public activities in connection with the MINOR SCALE test. An Information Brochure (Appendix E) was prepared for distribution immediately before the event.



Fi

- 2.2.6 Safety.
- A. Respo  
The [
- mate responsibility  
FCDNA conducted test:  
Test Group Director  
Directorate Safety F  
safety issues with 1  
Eac'  
1.  
2.  
jeopardizing other  
3.  
4.  
requirements.  
5.



F than on  
experiments  
operational  
pils on the  
assistance  
d experi-  
the test  
vent day.

ational  
herefore  
red for  
1981.  
y Kaman  
fx C.  
e given  
e 2.2)

y test  
e area  
ficant  
test  
MILL  
FACE,  
with  
port  
The

nd  
in  
15



Figure 2.2. Aerial view of McDonald Ranch House.

2.2.6 Safety.

A. Responsibilities.

The Director, Test Directorate, Field Command, DNA (FCT) has ultimate responsibility for the safety of all operations, personnel, and equipment on FCDNA conducted tests. The Safety Program was the responsibility of the MINOR SCALE Test Group Director (TGD). The Test Directorate Safety Engineer implemented Test Directorate Safety Programs and was responsible for coordination of all MINOR SCALE safety issues with the Chief, Safety Office, WSMR, for the TGD.

Each agency was responsible for:

1. The safe conduct of its operations at WSMR.
2. Coordination of hazardous activities with the TGD to prevent jeopardizing other experimenters and their equipment.
3. Reporting all accidents to the TGD.
4. Knowledge of, and compliance with, the DIRECT COURSE safety requirements.
5. Preparation of Safety Standard Operating Procedures.

**B. Hazardous Materials and Operations**

The MINOR SCALE test operation had a variety of materials and operations that were potentially hazardous. The generated hazards were minimized by cooperation between agencies, by making all personnel aware of them, and by use of good judgment in working with hazardous items and operations. In addition, there were natural hazards which exist because of the locale and environment. Some of the more serious potential hazards that were dealt with at the MINOR SCALE testbed are listed below:

**1. Natural Hazards.**

A summary of hazards which might be encountered at WSMR was provided to all personnel assigned to, or visiting, the MINOR SCALE testbed.

**2. Construction Hazards.**

During site preparation and construction of the many structures, hazards were minimized by proper use of personnel protective equipment and instruction in safe operation and use of equipment.

a. All applicable OSHA regulations were complied with and enforced during site work.

b. The use of hard hats, safety glasses and proper safety shoes were required at the work site.

c. Work areas were surveyed and fire extinguishers placed to assure protection against fire hazards.

d. First aid equipment was available and easily accessible at the site.

**3. Electrical Storms.**

Electrical storms are quite common in the WSMR area. To protect against personnel injury and equipment damage potential gradient meters were supplied for use in determination of the approach of electrical storms. Explosive handling and LOX transfer operations were terminated whenever an electrical storm came within 5 miles of the hazardous operation.

**4. MINOR SCALE Testbed Hazards.**

This event involved hazards which were unique to HE simulation testing. Table 2.2 displays the hazardous operations which were identified for this event. Specific Safety Standing Operating Procedures for each operation were prepared by the respective experimenters and the TGSO and were approved by the WSMR

DMA  
Exp.  
No.

F-1

F-2

F-3

F-4

F-5

F-6

Table 2.2. MINOR SCALE hazardous operations.

Annex No.	DNA Exp. No.	Description of Operation	Hazard	Type Hazard	Hazard Class		Comments	Agency
					Pre	Post		
F-1		Assembly of fiberglass charge container	Mechanized equipment; aerial lifts; lower panel sections weigh 2840 pounds	C	2	3	Major construction operation; personnel hazard from falling objects/working at heights; maneuvering with heavy loads	Molded Fiberglass
F-2		ANFO mixing plant operation	Ammonium nitrate mixed with diesel oil on site to make ANFO, blasting agent	X,C	3	4	Standard ANFO handling; heavy truck traffic; augers, elevators, hoppers	Contractor
F-3		Main booster emplacement & main charge construction	310 lb. octal booster, 4 FCDC lines, 4800 tons ANFO	X,E,C.	2	3	The octal booster and FCDC lines will be installed inside the fiberglass charge container, then ANFO loaded by pneumatic bulk trucks	NSMC/NMERI
F-4		Pre-arming, Arming, and detonation	OH-4 Sub-boosters and detonators connected to AMF system	X,E	2	3	As part of firing countdown, detonators installed, AMF system hooked up and armed; postshot-safe system, inspect testbed	SRLA/NSMC
F-5	8720	Helium sound velocity probes	3500 volt spark gap gages; helium high pressure gas system	E,S	2	3	Hazard only during gage testing; once prerursed helium bag emplaced, gage inaccessible	SAIC
F-6	8707	Laser field operations	100 joule-pulsed wave laser	R	2	3	Hazard only during calibration tests; special procedures in effect	ORI

Table 2.2. MINOR SCALE hazardous operations.  
(Continued)

Annex No.	DWA Exp. No.	Description of Operation	Hazard	Type Hazard	Hazard Class		Comments	Agency
					Pre	Post		
F-7	7500 7501 8709	Blast gauge stations	10 blast gauges with 500 mCi sources	R	2	2	Sources stored until installed on testbed; postshot, ensure integrity, remove and ship to DRES	DRES
F-8	8202	Pyrotechnic ejecta	10 artificial ejecta bowling balls each with 2 lb pyrotechnic and electric match	X,E	3	3	Bowling balls placed 50-100' from GZ, fired at zero time; recovered	DRI
F-9	8704	Streak X-ray	Kevex 30 kv X-ray tube; internal high voltage	R,E	2	3	Calibration tests, special procedures in effect	TRM
F-10	8706	Automatic dust tube catcher	54 gm datasheet, 54 mini-caps	X,E	3	3	Gauges placed in precursed bag area	DRI
F-11	8717	Soil characterization	Troxler surface moisture-density gauge with gamma and neutron source	R	3	3	Gauge used pre- and postshot; not on testbed during event	WES
F-12	8722	Holography	12 m joule ruby laser/3 mv gallium arsenide laser	R,E	3	3	Lasers internal to gauge, wholly contained	TRM
F-13	1220/ 1221	Hardened shelter	Sulfur hexafluoride	G	3	3	Used for pre- and postshot test only; not on testbed during shot	WES
F-14	TR8		Gaseous oxygen and hydrogen, liquid oxygen	G,F,E	2	2	Servicing of 8 systems, warm tests, postshot safing of systems	SAIC/BPEC

Safety Office.  
at the site of e  
testbed. Figure  
fying access re

permitted until  
was authorized  
WSMR Safety an  
specified in w  
MINOR SCALE Sa  
Field Command,  
Safety Plan is  
2.2.7 At  
Se

rized below:

surements uti  
and recovery  
of Stallion  
Mockingbird  
a pass thro-  
minutes the

and recover-  
pattern ar  
27,000 ft A-

recovery p  
tern ar  
ft AGL.

the GZ ar  
tudes.

Safety Office. Applicable portions of the approved SOP's were posted conspicuously at the site of each operation.

Table 2.3 presents a summary of hazardous materials included in the testbed. Figure 2.3 located hazardous experiments within the testbed layout, specifying access restrictions.

Postshot reentry into the test bed by experimenter personnel was not permitted until the postshot safety teams had completed their surveys and reentry was authorized by the TGD. The postshot safety assessment teams included DNA and WSMR Safety and Environmental Health personnel. Postshot reentry procedures were specified in writing and distributed to the appropriate personnel. The complete MINOR SCALE Safety Plan dated February 1985 is on file at the Test Directorate, Field Command, Defense Nuclear Agency, Kirtland AFB, New Mexico 87115. The basic Safety Plan is located in Appendix F.

#### 2.2.7 Aircraft Operations.

Several organizations participated in the event with aircraft as summarized below:

a. Particle Measuring Systems Inc. conducted cloud sampling measurements utilizing a Beech Barron from T+4 minutes through T+90 minutes. Launch and recovery was at Socorro airport. The aircraft entered the range in the vicinity of Stallion Range Center at 5000 ft AGL and proceeded to a holding orbit south of Mockingbird Gap. Following the detonation it passed over GZ at 1000 ft AGL and made a pass through the dust cloud climbing to 15,000 ft AGL. At approximately T+90 minutes the aircraft exited the range in the vicinity of Stallion Range Center.

b. Aerial photography was taken from two RF-4B aircraft. Launch and recovery points were Holloman AFB. The RF-4B aircraft were vectored to their pattern around GZ from a holding orbit in the range extension at T+2 minutes and 27,000 ft AGL.

c. Radar imagery was taken from two RF-4B aircraft. Launch and recovery points were Holloman AFB. The RF-4B aircraft were vectored to their pattern around GZ from a holding orbit in the range extension at T+2 minutes and 27,000 ft AGL.

d. The U-2 and SR-71 aircraft obtained airborne radar imagery of the GZ area after detonation. The flight path was over WSMR airspace at high altitudes.

Table 2.3. Hazardous materials summary.

Type of Hazard	Quantity	Location	Duration of Hazard
<b>EXPLOSIVES</b>			
ANFO	4000 tons	MSGZ	Hemisphere loading - shot
OCTOL (75/25 NH <sub>4</sub> /TNT)	310 lbs	MSGZ	Hemisphere loading - shot
CB-6	1/2 lbs	MSGZ	Hemisphere loading - shot
TC-234 Detonators (4):			
PETN	1000 mg	MSGZ	Final arming - shot
RDX/EXON	15.54 gm	MSGZ	Final arming - shot
FCBC (4)	240 ft	MSGZ	Hemisphere loading-shot
Pyrotechnic (408 mg/ 60% teflon)	20 lbs	Ejecta Pads	Late time install - recovery
Electric Matches	160 mg	Ejecta Pads	Late time install - recovery
Detasheet	54 gm	Exp 0706	One month prior - recovery
HN-70 Mini-cap Dets	54	Exp 0706	One month prior - recovery
<b>RADIATION</b>			
Promethium 147	5000 mCi	Exps. 7500, 7501, 0709	Late time - recovery
Cesium 137	0 ± 1 mCi	Test Bed	Used pre- and postshot
Americum 241	40 ± 10% mCi	Test Bed	Used pre- and postshot
Lasers	(2) 100 Joule pulsed	Laser Bunkers	Calibration and during shot
X-Ray Tube	3 Rv/634 roentgen/hr	Exp. 0704	Calibration and during shot
Lasers	Ruby (12 mJoule) and gallium arsenide	Exp. 0722	Gauge installation - recovery
<b>PRESSURE GAS</b>			
Sulfur Hexafluoride	120 lb bottle	Exp. 1220-1221	Pre- and postshot use
Nitrogen	(32) 255 cu ft @ 2500 psi	(4)/IRS	First field test-postshot
<b>FLAMMABLES</b>			
Hydrogen	(8) 300 cu ft @ 2500 psi	(1)/IRS	First field test - postshot
Oxygen	(8) 250 cu ft @ 2500 psi	(1)/IRS	First field test - postshot
LOR	(8) 275 liter (8) 1500 gal	(1)/IRS (1)/IRS	First field test - postshot First field test - postshot
Diesel Fuel	Numerous vehicles	IRS Test Articles	Positioned late-time - postshot Inspection and removal
Nitromethane	(3) 55 gal drums	Exp. 0065, 66, 67	Drums positioned late time

**UNCONTROLLED ACCESS RESTRICTIONS**  
 A 100' RADIUS WILL BE A CONTROLLED ACCESS ZONE  
 CONTROL WILL BE IN EFFECT DURING LOADING  
 AND UNLOADING OPERATIONS

**UNCONTROLLED ACCESS RESTRICTIONS**  
 A 100' RADIUS WILL BE A CONTROLLED ACCESS ZONE  
 CONTROL WILL BE IN EFFECT DURING LOADING  
 AND UNLOADING OPERATIONS

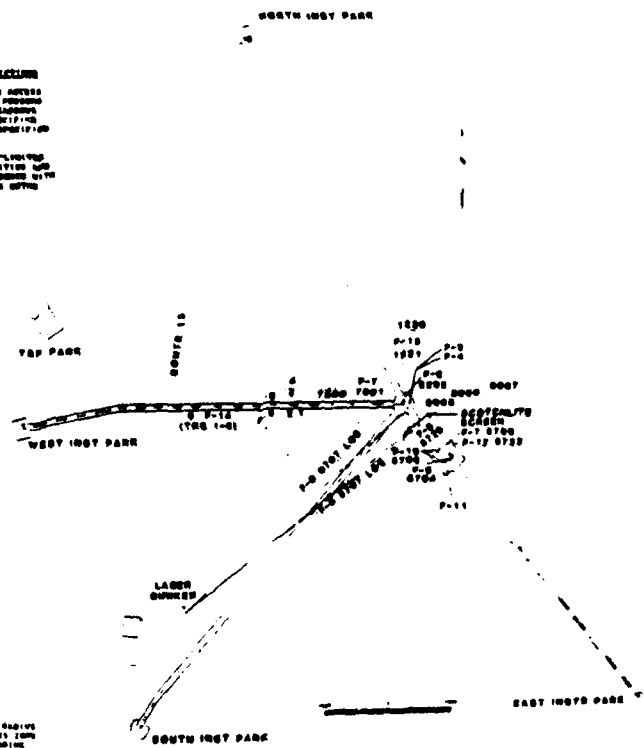

**1. UNCONTROLLED ACCESS RESTRICTIONS**  
 A 100' RADIUS WILL BE A CONTROLLED ACCESS ZONE  
 CONTROL WILL BE IN EFFECT DURING LOADING  
 AND UNLOADING OPERATIONS

**2. UNCONTROLLED ACCESS RESTRICTIONS**  
 A 100' RADIUS WILL BE A CONTROLLED ACCESS ZONE  
 CONTROL WILL BE IN EFFECT DURING LOADING  
 AND UNLOADING OPERATIONS

**3. UNCONTROLLED ACCESS RESTRICTIONS**  
 A 100' RADIUS WILL BE A CONTROLLED ACCESS ZONE  
 CONTROL WILL BE IN EFFECT DURING LOADING  
 AND UNLOADING OPERATIONS

**4. UNCONTROLLED ACCESS RESTRICTIONS**  
 A 100' RADIUS WILL BE A CONTROLLED ACCESS ZONE  
 CONTROL WILL BE IN EFFECT DURING LOADING  
 AND UNLOADING OPERATIONS

**5. UNCONTROLLED ACCESS RESTRICTIONS**  
 A 100' RADIUS WILL BE A CONTROLLED ACCESS ZONE  
 CONTROL WILL BE IN EFFECT DURING LOADING  
 AND UNLOADING OPERATIONS

**6. UNCONTROLLED ACCESS RESTRICTIONS**  
 A 100' RADIUS WILL BE A CONTROLLED ACCESS ZONE  
 CONTROL WILL BE IN EFFECT DURING LOADING  
 AND UNLOADING OPERATIONS

**7. UNCONTROLLED ACCESS RESTRICTIONS**  
 A 100' RADIUS WILL BE A CONTROLLED ACCESS ZONE  
 CONTROL WILL BE IN EFFECT DURING LOADING  
 AND UNLOADING OPERATIONS

**8. UNCONTROLLED ACCESS RESTRICTIONS**  
 A 100' RADIUS WILL BE A CONTROLLED ACCESS ZONE  
 CONTROL WILL BE IN EFFECT DURING LOADING  
 AND UNLOADING OPERATIONS

**9. UNCONTROLLED ACCESS RESTRICTIONS**  
 A 100' RADIUS WILL BE A CONTROLLED ACCESS ZONE  
 CONTROL WILL BE IN EFFECT DURING LOADING  
 AND UNLOADING OPERATIONS

**10. UNCONTROLLED ACCESS RESTRICTIONS**  
 A 100' RADIUS WILL BE A CONTROLLED ACCESS ZONE  
 CONTROL WILL BE IN EFFECT DURING LOADING  
 AND UNLOADING OPERATIONS

**11. UNCONTROLLED ACCESS RESTRICTIONS**  
 A 100' RADIUS WILL BE A CONTROLLED ACCESS ZONE  
 CONTROL WILL BE IN EFFECT DURING LOADING  
 AND UNLOADING OPERATIONS

**12. UNCONTROLLED ACCESS RESTRICTIONS**  
 A 100' RADIUS WILL BE A CONTROLLED ACCESS ZONE  
 CONTROL WILL BE IN EFFECT DURING LOADING  
 AND UNLOADING OPERATIONS

**13. UNCONTROLLED ACCESS RESTRICTIONS**  
 A 100' RADIUS WILL BE A CONTROLLED ACCESS ZONE  
 CONTROL WILL BE IN EFFECT DURING LOADING  
 AND UNLOADING OPERATIONS

# MINOR SCALE HAZARDOUS EXPERIMENTS

Figure 2.3. MINOR SCALE hazardous experiments.

e. An F-14 aircraft obtained a post event damage assessment of the GZ area through photo/thermal imagery. Launch and recovery were at Kirtland AFB, NM. The aircraft entered the range in the vicinity of Stallion Range Center at 1500 ft AGL at approximately T+20 minutes. It conducted a figure 8 pass over GZ and exited the range in the vicinity of Stallion Range Center. Time on station was approximately thirty minutes.

f. There were no classified items associated with these flight operations.

2.4.2

g. An on-site aircraft coordination meeting was held on 12 March and the final flight operations meeting was held 4 June 1985.

### 2.3 GROUND ZERO (GZ) SELECTION.

The decision to use the DIRECT COURSE GZ for MINOR SCALE was arrived at by weighing the technical requirements for the event against the cost savings gained from the reuse of the three DIRECT COURSE instrumentation radials and instrumentation parks. The technical considerations were satisfied in September 1984 when a determination was made that diagnostic ground motion measurements were not going to be a major objective of the MINOR SCALE event. If ground motion measurements had been determined to be a major objective, the MINOR SCALE GZ would have had to have been located at an undisturbed site, resulting in additional testbed construction costs.

### 2.4 TEST GROUP STAFF ORGANIZATION.

The organization of the DIRECT COURSE test group staff (TGS) is shown in Figure 2.4. Test Group Staff duties were as follows:

#### 2.4.1 Test Group Director.

- a. Responsible for formulation of the DIRECT COURSE test program:
  - (1) Planning of the test to include objectives, financing, management, scheduling, and defining all aspects of the test program.
  - (2) Assist the Technical Director in preparing the scientific experiment plan and testbed layout.
  - (3) Supervise the preparation of operational plans for the fielding, execution and recovery phases of the test program.
- b. Responsible for fielding, execution and recovery of the DIRECT COURSE Program:
  - (1) Direct the fielding aspects of the program onsite to include scheduling, construction, photography and recording systems.



- (2) Formulate and direct the safety and security plans for the test series and appoint Safety and Security Officers.
- (3) Plan, control, and report the expenditure of funds.
- (4) Establish requirements for and direct logistic support.
- (5) Coordinate details for the HE and TRS sources with the agencies responsible for these technical functions.
- (6) Prepares the Test Execution Report.

2.4.2 Technical Director.

- a. Responsible for formulation of the DIRECT COURSE technical program:
  - (1) In coordination with experimenter agencies and the Test Group Director (TGD), modify as necessary the technical experiments using current best practices in order to obtain the quality of data required to achieve the objectives of Deputy Director Science and Technology (DDST) approved goals.
  - (2) Prepare a detailed technical plan to accomplish the scientific program and assist the TGD in preparing a schedule to assure timely execution of the test.

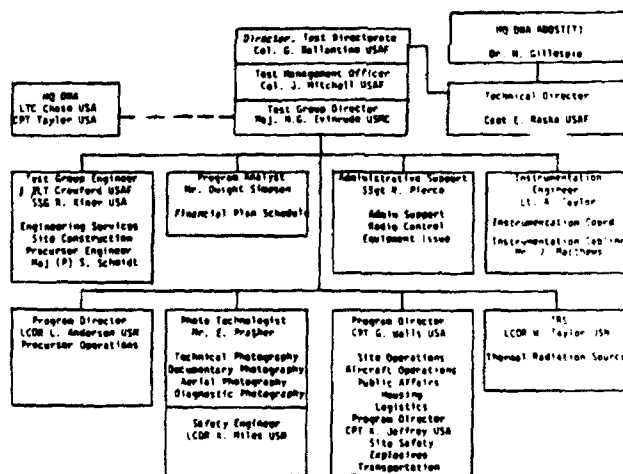

Figure 2.4. MINOR SCALE fielding organization.

- (3) Prepare the Program Document.
  - (4) Evaluate the effect of safety restrictions on the achievement of the scientific objective(s).
  - b. Responsible for fielding and execution of the DIRECT COURSE technical program:
    - (1) Serve as an advisor on the TGS and support the TGD during fielding.
    - (2) Supervise and coordinate the technical activities of the test and advise the TGD concerning management of the technical activities of the experiments in the field.
    - (3) Monitor the state-of-readiness of the technical experiments, monitor installation of experiments and make recommendations for adjusting the schedule as necessary.
    - (4) Coordinate impact on technical activities concerning funds, schedules, test support, field operations, and relationships with other agencies with the TGD and other staff members. Coordinate with the DDST and cognizant HQ DNA Project Officers.
    - (5) Formulate changes in the technical plan as necessary to achieve the scientific objectives and approve minor adjustments in the scope of the technical experiments. Coordinate major changes or adjustments of funding levels with the TGD and the cognizant HQ DNA Project Officers prior to submittal to DDST for approval.
    - (6) Monitor the construction and instrumentation of all experiments, ensuring that all experimenters modifications conform to current best practice.
    - (7) Review the Symposium and Project Officers' Reports.
- 2.4.3 Program Directors.
- a. Assist the TGD as required in planning and executing the DIRECT COURSE test program in areas of assigned responsibilities.
  - b. Assist in developing the testbed designs and determining construction requirements.
  - c. Develop operational, engineering, technical, and administrative plans, as directed.

- 2.4.4 d. Coordinate during Test Group
  - a. Provide and provide
  - b. Assist in the experiments
  - c. Perform with recovery
  - d. Coordinate Instrumentation
- 2.4.5 a. Performance management
  - b. Coordinate the instrumentation layout
- 2.4.6 Program
  - a. Development
  - b. Preparation
  - c. Production and Safety
- 2.4.7 a. Development
  - b. Oversee and Com

ement  
chni-  
uring  
test  
ical  
nts,  
ions  
ds,  
ips  
rs.  
rs.  
ve  
the  
ges  
nt  
or  
i-  
to  
-  
-  
e

- d. Coordinate and monitor the activities of experimenters/agencies during the planning, fielding, executing, and recovery of the test.
- 2.4.4 Test Group Engineer (TGE).
  - a. Provide engineering support in the planning, fielding, executing, and preparation of the testbed.
  - b. Assist in the test site and testbed design to include instrumentation and administration parks, and determine construction requirements and schedules for all aspects of the test.
  - c. Perform engineering design and construction management associated with preparing test site, experiment installation, and site recovery.
  - d. Coordinate the construction support effort associated with the test.
- 2.4.5 Instrumentation Engineer (IE).
  - a. Perform instrumentation and cable planning, and instrumentation park management for the DIRECT COURSE test program.
  - b. Coordinate requirements and oversee instrumentation support during the planning, fielding, and execution phases of the test. This will include determining experimenter requirements, configuring instrumentation vans, designing cable layouts, performing cable coordination functions, providing for instrumentation maintenance, and laying out the instrumentation parks.
- 2.4.6 Program Analyst (PA).
  - a. Develop and maintain the event test schedules.
  - b. Prepare progress status reports as required.
  - c. Provide financial management for the event, including preparation of basic testbed and reimbursable cost estimates, maintenance of budget and financial plans, and cost accounting.
- 2.4.7 Safety Officer (SO).
  - a. Develop and coordinate preparation of event safety plans.
  - b. Overall coordination of approval and enforcement of safety procedures for the Test Group Director and the Director of the Field Command Test Directorate.

2.4.8

Administrative NCOIC.

- a. Perform all administrative duties required to support the event.
- b. Perform as a Project Net Operator in Test Control during dry runs and event countdown.
- c. Act as the Test Group Staff Vehicle Control Officer and assist in staff billeting.

3.1 EXPLOSIVES.

3.1.1 Introduction  
The Naval

Command, Defense Nuclea

(1) Monito

(2) Monito

(3) Procur

cords.

(4) Emplac

(5) Provi

Sandia National Labora

arming and firing sup

Anchorage, Alaska, and

was unloaded (Figure

nitrate was then deli

delivered to the mix

nitrate from the hop

elevator to the truck

(Figure 3.3).

3.1.2 Ammonium

ANFO was

inexpensive, and can

and TNT had been est

by a competitive bid

tions, modified sl

tests, were used on

simpler sieve size

bulk density. The

single (industrial)

available in the pa

SECTION 3  
TECHNICAL SUPPORT

3.1 EXPLOSIVES.

3.1.1 Introduction.

The Naval Surface Weapons Center (NSWC) was requested by the Field Command, Defense Nuclear Agency, to provide the following services:

- (1) Monitor ANFO fuel oil content and particle size distribution,
- (2) Monitor charge weight,
- (3) Procure the main booster assembly and flexible, confined detonating cords,
- (4) Emplace booster and pre-arm charge, and
- (5) Provide technical advise on explosive operations.

Sandia National Laboratories Albuquerque (SNLA) was requested to provide the charge arming and firing support. The ANFO was supplied by Alaska Explosives Limited, Anchorage, Alaska, and was delivered to the rail head in San Antonito, NM where it was unloaded (Figure 3.1) into 25-ton capacity bulk carrier trucks. The ammonium nitrate was then delivered to the mixing plant (Figure 3.2) at WSMR. Fuel oil was delivered to the mixing plant and discharged into the auger carrying the ammonium nitrate from the hopper to the elevator. The ANFO was gravity loaded from the elevator to the trucks which then transported the ANFO to the charge container at GZ (Figure 3.3).

3.1.2 Ammonium Nitrate and Fuel Oil (ANFO).

ANFO was selected as the explosive because it is readily available, inexpensive, and can be formed into the desired shape. The comparability of ANFO and TNT had been established during the PRE-DICE THROW test. The ANFO was procured by a competitive bid through a Government contract. The MINOR SCALE ANFO specifications, modified slightly from the PRE-DICE THROW, DICE THROW, and MISERS BLUFF tests, were used on PRE-DIRECT COURSE, DIRECT COURSE and MINOR SCALE and included a simpler sieve size distribution and an increase in the allowable ammonium nitrate bulk density. The density increase was allowed in that the industry has gone to a single (industrial) grade of prill instead of the explosive and industrial grades available in the past.

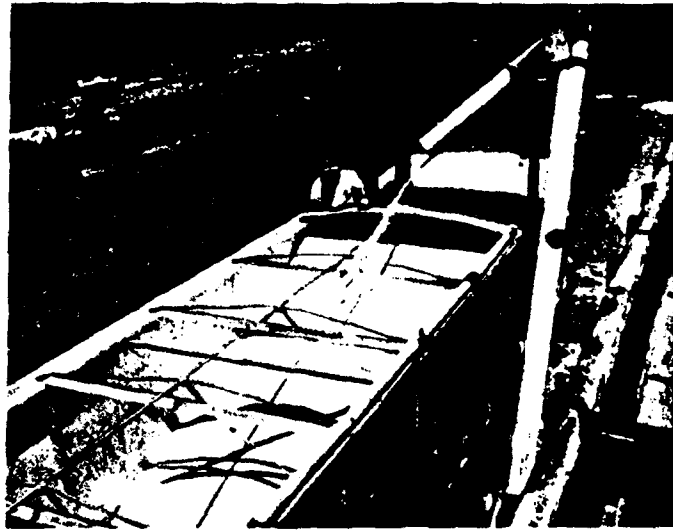

Figure 3.1. Unloading ammonium nitrate at Socorro, NM.

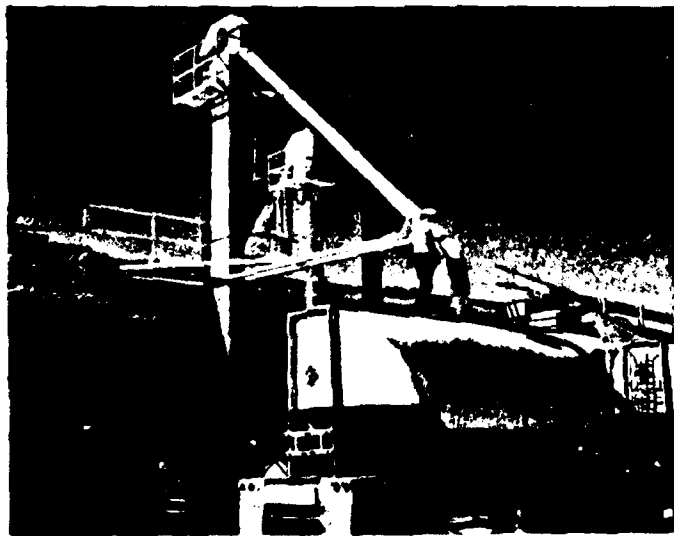

Figure 3.2. ANFO being emptied from hopper into truck at ANFO plant.

Figure 3.

3.1.3 ANF  
In  
drawings shown  
meters east of  
plant is capabl  
over an 80 hour

3.1.4 Qua  
Tal  
plant, ANFO and

As  
analyzed one s  
cated an avera  
charge. The F

3.1.5 Ch  
18  
day period.



Figure 3.3. ANFO being pumped into hemisphere during filling operation.

### 3.1.3 ANFO Mixing Plant.

In May 1985 an ANFO mixing plant was installed in accordance with the drawings shown in Appendix G. The plant was installed at WSMR, approximately 2,000 meters east of the Administrative Park on Route 20, to the north of the road. The plant is capable of providing a mixed ANFO charge at a rate of 50 to 70 tons an hour over an 80 hour period.

### 3.1.4 Quality Control.

Table 3.1 presents the load and truck number, time in and out, the ANFO plant, ANFO and Fuel Oil weight, and measured oil content for the MINOR SCALE event.

As part of the production quality control, the ANFO was obtained and analyzed one sample from every 10,000 pounds of material supplied. The data indicated an average fuel oil content of  $5.6 \pm 0.4\%$  at the ANFO plant and 5.2% from the charge. The Fuel Oil content by loads is shown in Figure 3.4.

### 3.1.5 Charge Weight and Density.

186 truck loads of ANFO, totaling 4,744.13 tons, was loaded over a ten day period. The daily production is shown in Table 3.2. The U.S. Standard Sieve





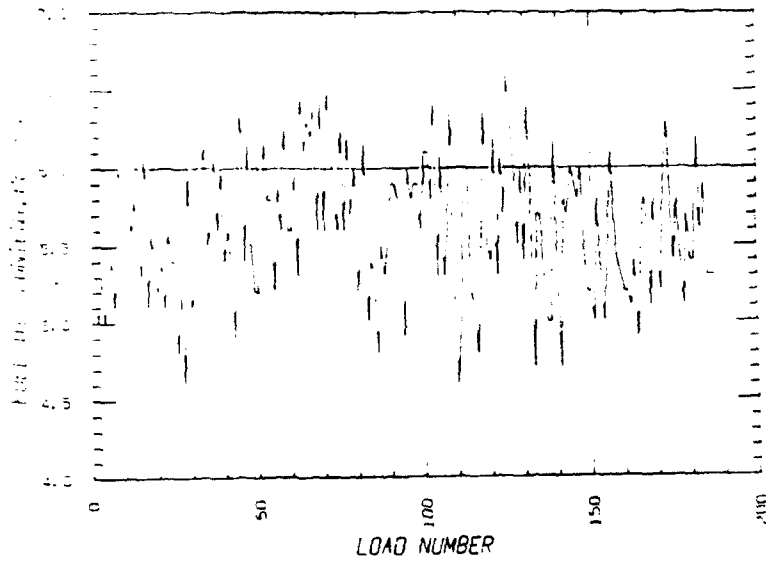

Figure 3.4. Fuel oil content by load number.

Table 3.2. Daily ANFO production.

DAY	TIME WORKED (hours)	OUTPUT (tons)	RATE (tons/hour)
165	4.82	82.94	17.21
167	8.70	239.28	27.51
168	11.61	437.83	37.70
169	12.76	610.09	47.80
170	12.92	720.15	55.75
171	13.05	841.53	64.47
172	17.93	1063.79	59.32
173	13.84	609.03	44.02
174	4.50	139.49	30.97
TOTAL	100.13	4744.13	47.38

number versus the percentage retained on the Sieve are shown in Figure 3.5 for the MINOR SCALE plant, the MINOR SCALE charge and for comparison the MINI SCALE 2 charge.

### 3.2 PRECURSED RADIAL.

The thermal precursor was designed to simulate the effects of a heated ground layer on the blast wave propagation. The thermal flash from a nuclear device heats the ground and the surface air near the detonation. The blast wave travels through the heated surface air faster and creates a precursor on the shock wave near the surface. The thermal precursor was to simulate this environment by providing a thin surface layer of helium gas at the time of detonation. Since pressure waves advance faster in helium than in air, the shockwave will move faster in the helium environment and produce a simulated precursor. The helium was contained beneath eight mylar sheets. The sheets will cover a total area of 400 feet wide by 900 feet long. The front sheet will begin 400 feet from ground zero. The sheets were positioned two feet above the specially-prepared dusty surface. The sides of the sheets were buried in the ground to prevent excessive helium loss. The site plan for the bag layout is shown in Figure 3.6. A sketch of the bag deployment concept is shown in Figure 3.7. Further details of the bags are given in Appendix H.

### 3.3 INSTRUMENTATION.

#### 3.3.1 Cable Systems and Plan.

The multipurpose cable system used on MINOR SCALE (1) connected recorders to sensors at experiment stations to record data, (2) provided electrical power to the instrumentation parks, and (3) transmitted timing signals. The cable system was designed to minimize crossed cables, to minimize the amount of cable used (shortest runs possible), and to minimize the number of connection points reducing unwanted noise. To accomplish these objectives, multiple pair, unspliced trunk cables were laid parallel to each other adjacent to each of the primary airblast gaugelines.

Trunk cables were terminated at junction boxes located in close proximity to designated experiments. Single twisted pair or four conductor cable fanned out from the junction box directly to the sensor. Power cables ran directly to each instrumentation park from sub-stations. Instrumentation power was conditioned through motor-generator sets.

3.5 for the  
MINI SCALE 2

s of a heated  
nuclear device  
wave travels  
lock wave near  
y providing a  
pressure waves  
n the helium  
ined beneath  
e by 900 feet  
s were posi-  
f the sheets  
plan for the  
ept is shown

ted record-  
trical power  
able system  
cable used  
ts reducing  
iced trunk  
rv airblast

se proxim-  
able fanned  
tly to each  
conditioned

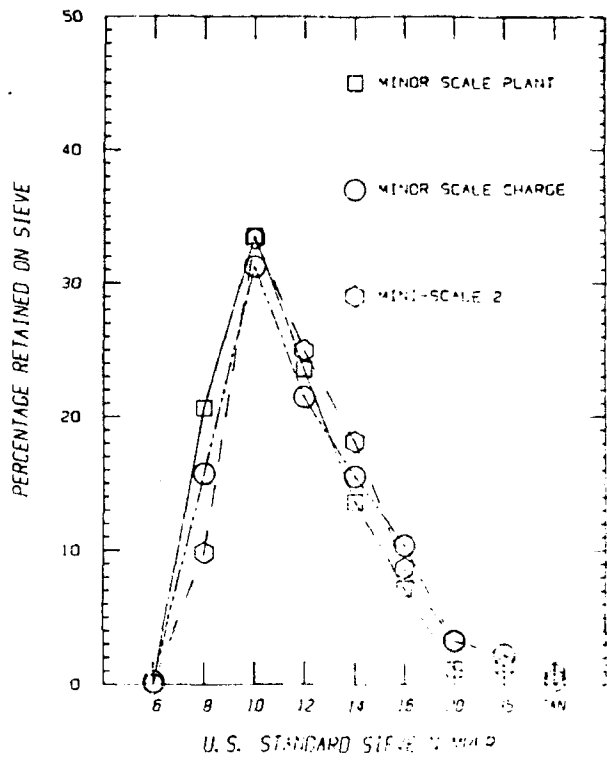

Figure 3.5. Sieve number versus percent retained.

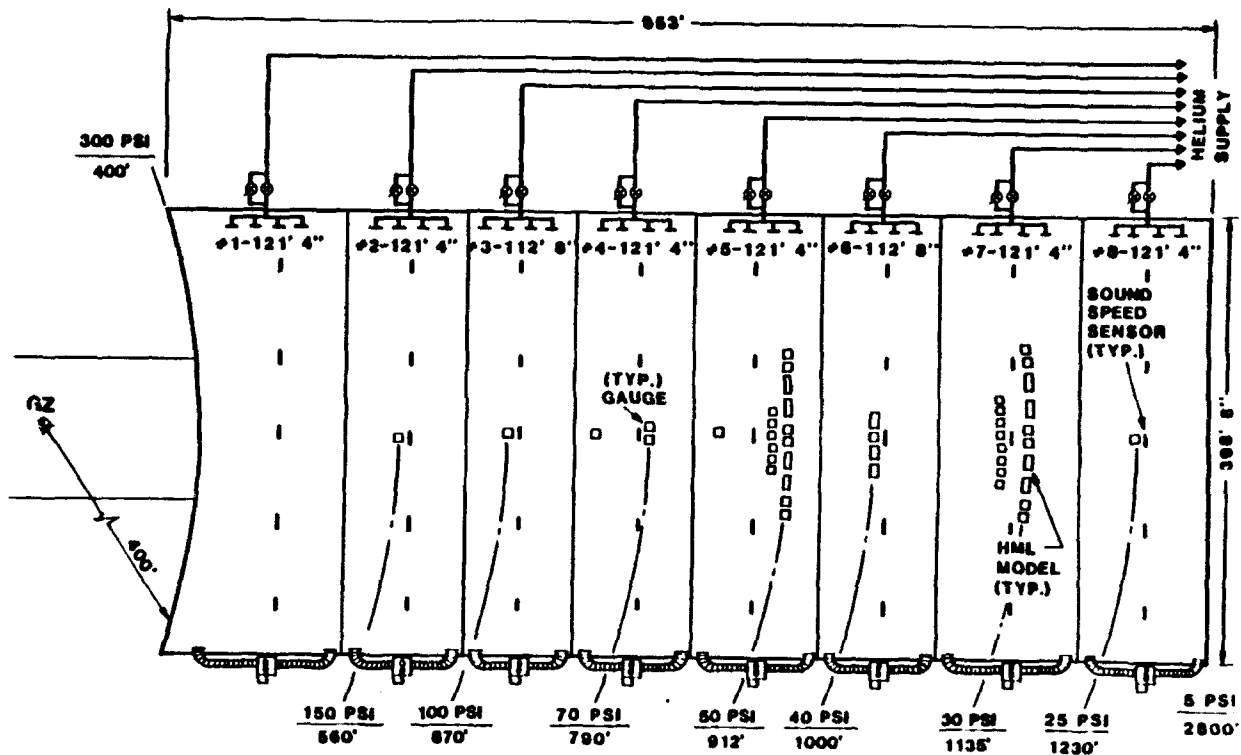
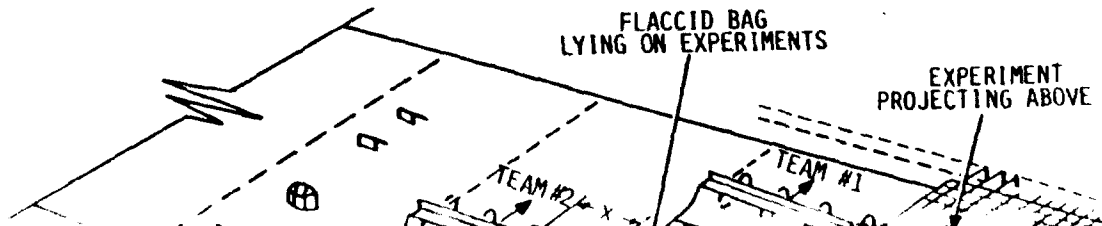

Figure 3.6. Site plan for the helium envelope for dust precursed radial.



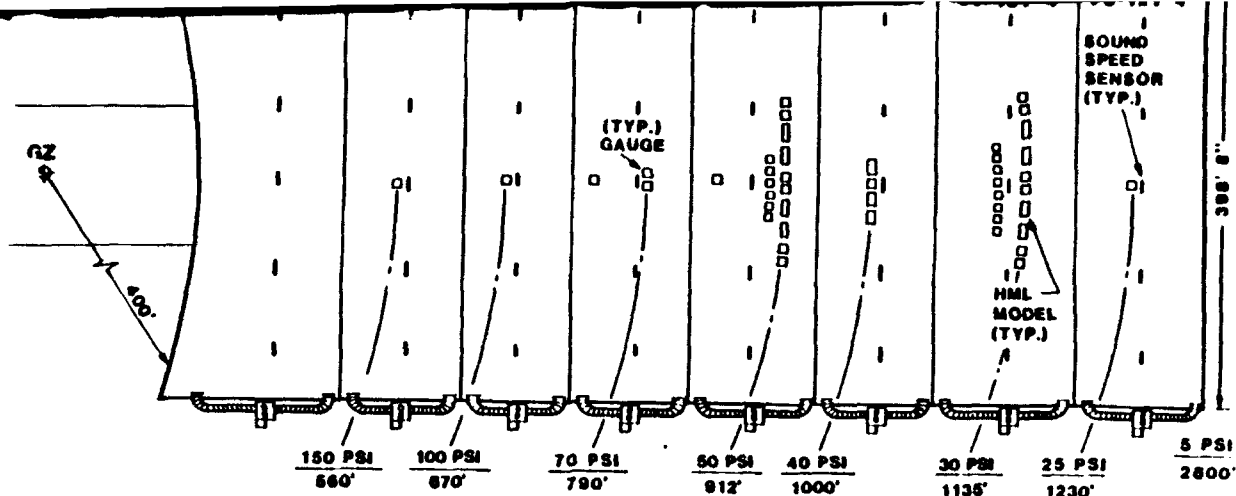

Figure 3.6. Site plan for the helium envelope for dust precursed radial.

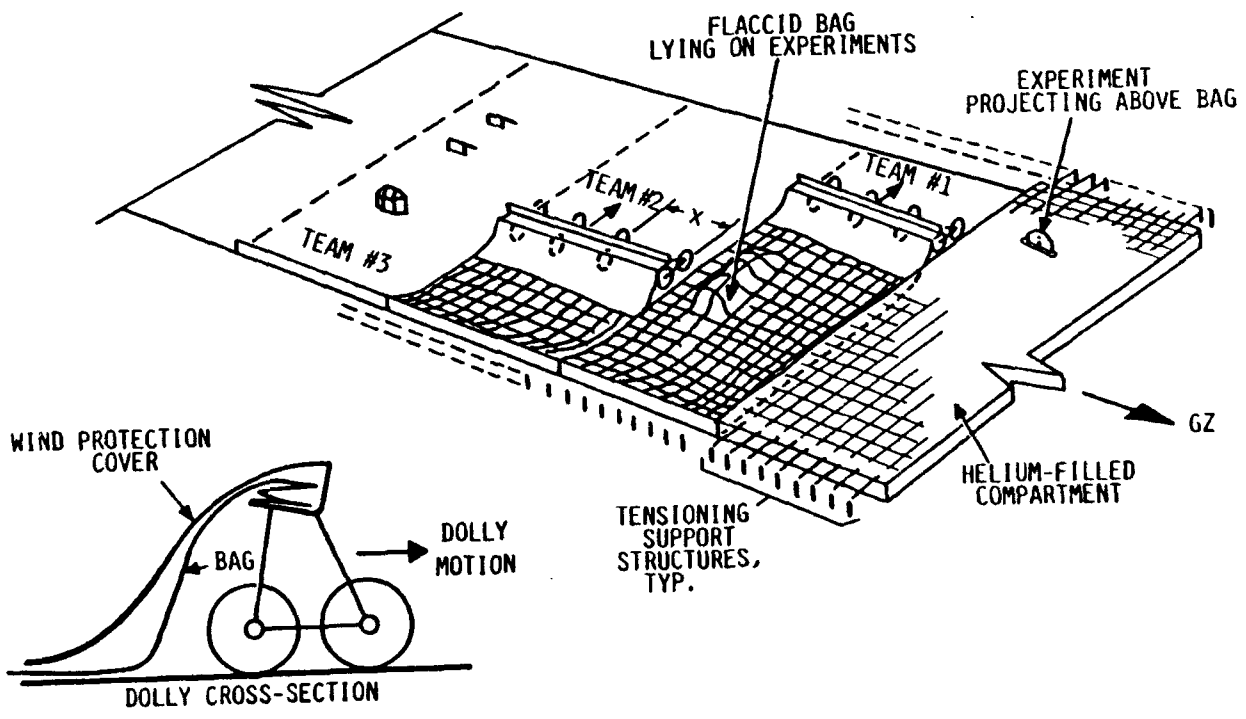

Figure 3.7. Deployment dolly concept for MINOR SCALE gas bag.

Figure 3.8 through 3.10 show the cable layout on the MINOR SCALE test-bed. The total amount of cable used on MINOR SCALE including cable for telephones was 6,703,200 feet.

#### 3.3.2 Data Recording Systems and Facilities.

A combination of analog and digital instrumentation was used on MINOR SCALE. The digital instrumentation was located in buried ground-shock isolated bunkers at relatively close distances from GZ. The bunkers were not manned at event time and the instrumentation was remotely controlled.

The analog instrumentation was located in instrumentation trailers in the four instrumentation parks. The expected overpressures at the instrumentation parks required that the trailers also not be manned at event time. A monitoring system was used to determine if the analog tape recorders began running at the required times. The instrumentation trailers were placed in semi-buried shelters and the instrumentation trailer shelters were constructed based on designs from the U.S. Army Civil Engineering Research Laboratory (CERL).

#### 3.4 DIAGNOSTICS.

The diagnostic measurements used to record the environment produced by the MINOR SCALE are described in the MINOR SCALE Program Document and the results are recorded in the MINOR SCALE Symposium Proceedings. A brief summary of the diagnostics fielded is as follows:

1. Charge Breakout - WSMR fielded medium-speed cameras along the north, west and south radials.
2. Shockwave Optics - WSMR fielded cameras along the north, west and south radials.
3. Aerial Optics - The USMC provided two RF-4C aircraft.
4. Free-field Airblast - BRL fielded gages along all four radials.
5. Free-field Ground Motion - WES fielded gages along the north radial.
6. Detonation Velocity - (a) AFWL fielded measurements along multiple radials within the charge. (b) DRI fielded fiber optic cable measurements along multiple radials within the charge.
7. TRS Calorimetry - BRL provided measurements of the heat environment produced by the TRSs.
8. Weather Support - SNLA and ASL provided support in the areas of weather prediction and documentation of weather conditions at event time.

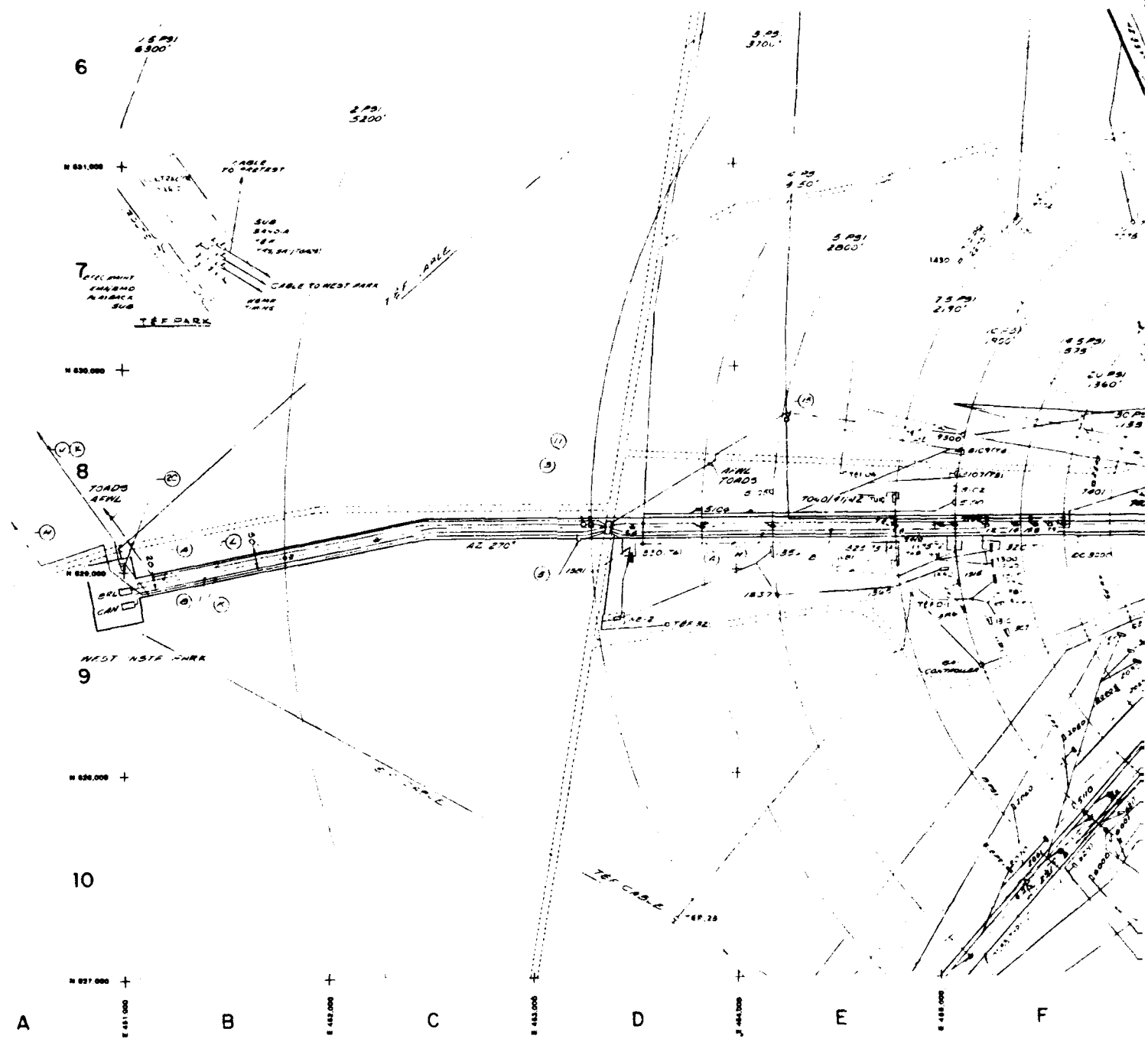







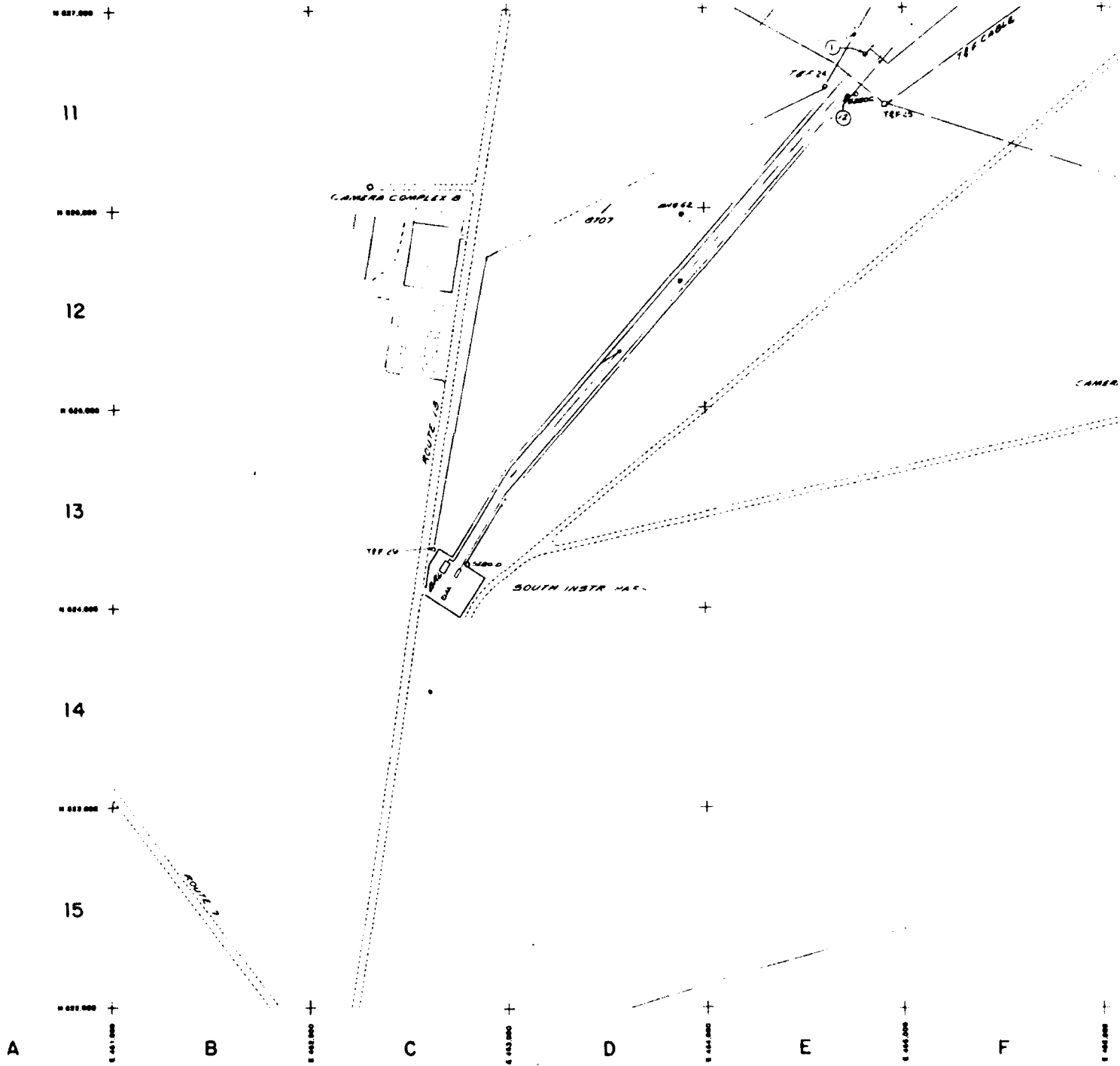

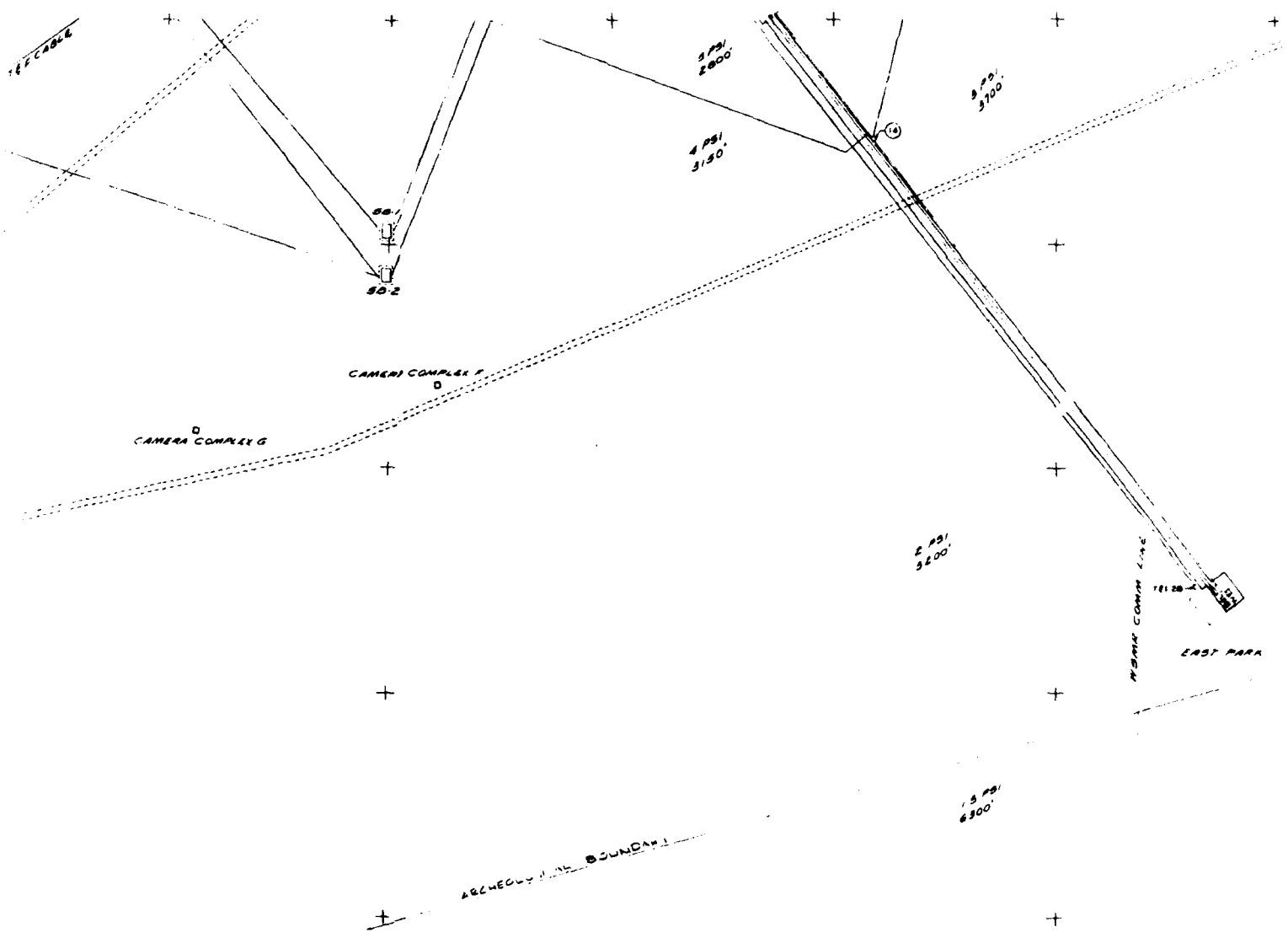

F    +    G    +    H    +    I    +    J    +    K

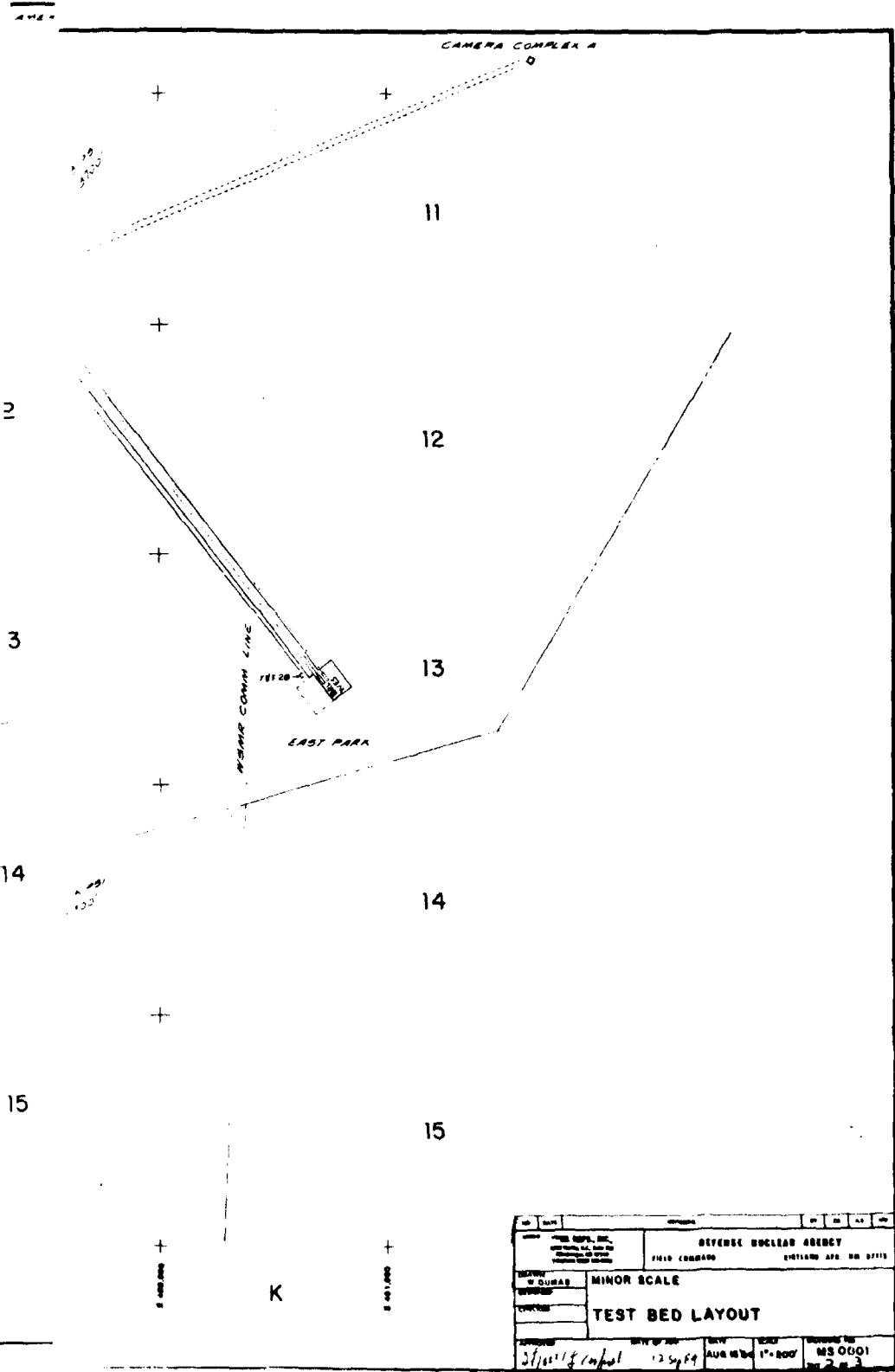

THE MAPS, INC. 1000 N. 10th St. Grand Rapids, MI 49503		DEFENSE BUCKLER AGENCY FIELD COMMAND DUNLAP AFB, MS 37113	
DRAWN BY W. GUMAS	MINOR SCALE		
CHECKED BY	TEST BED LAYOUT		
DATE OF PLOT 2/11/54	DATE 12 Sep 54	SCALE 1" = 200'	DRAWING NO. MS 0001 OF 2 OF 3

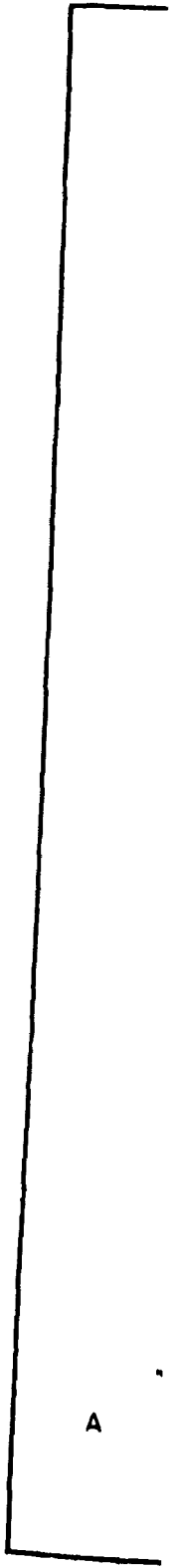

N 638,000 +

2

N 638,000 +

3

N 634,000 +

4

N 630,000 +

5

N 626,000 +

A

E 451,000

B

E 452,000

C

E 453,000

D

E 454,000

E

E 455,000

F

E 456,000  
E 457,000

E 458,000  
E 459,000



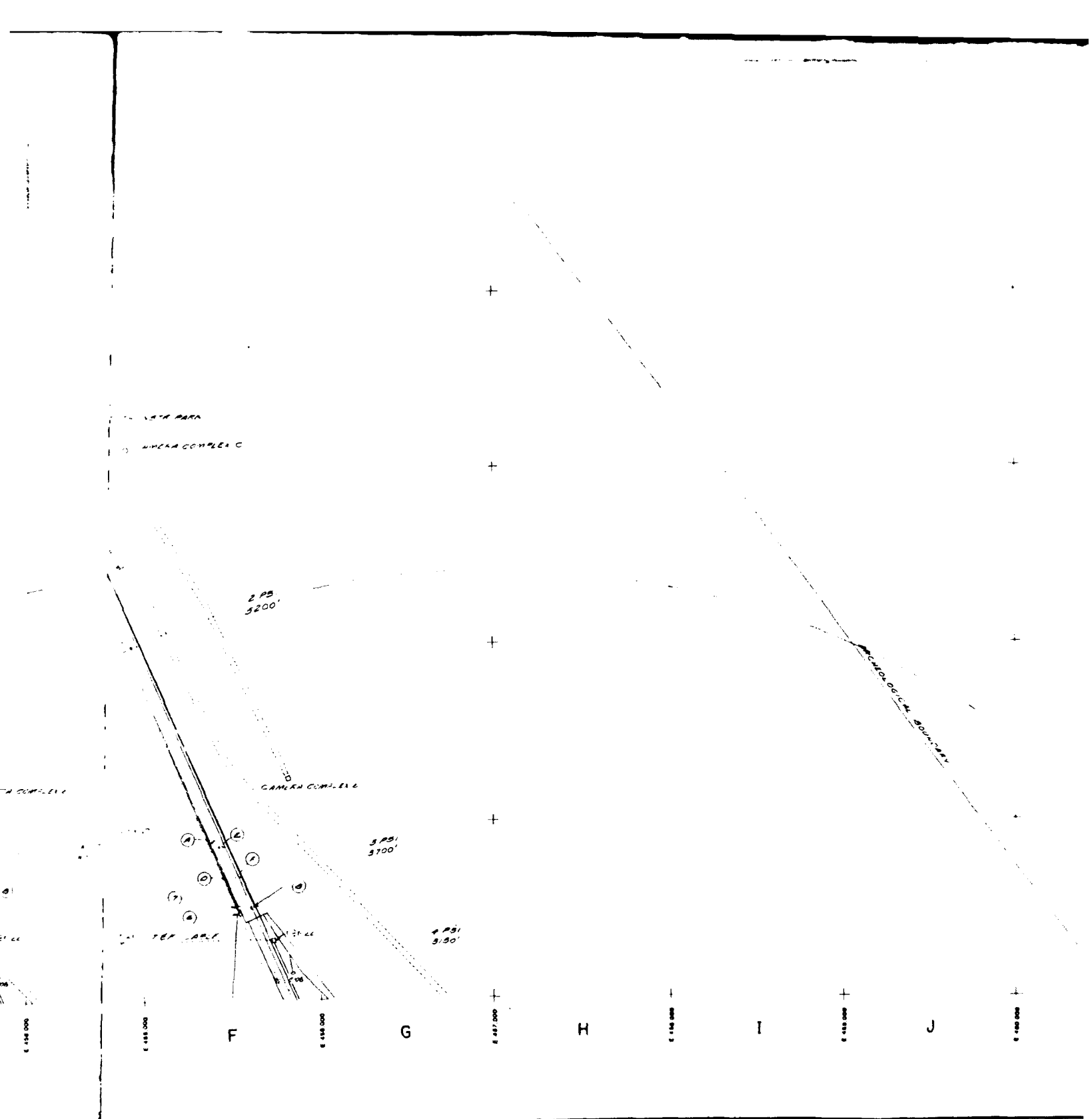
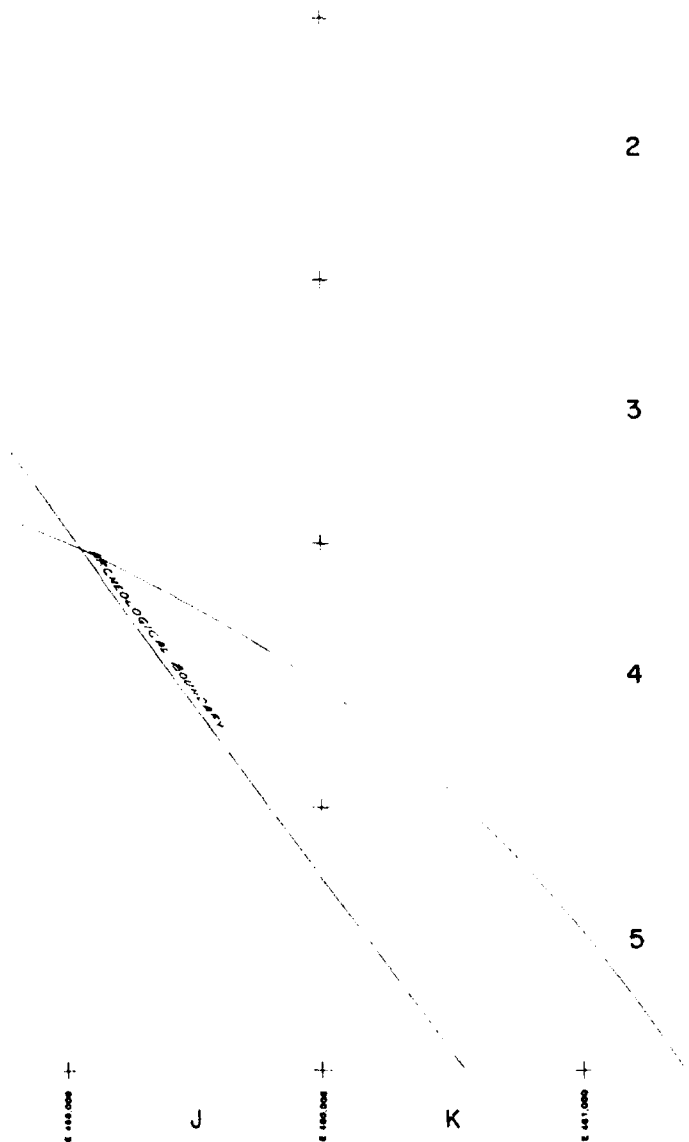

Figure 3.10. Test



TITLE: PPL, INC. 4000 BENTLEY AVE. S.W. ALBUQUERQUE, NM 87105		DEFENSE NUCLEAR AGENCY FIELD CODE: 4000 DISTRICT: 400 07115	
DRAWN BY: W. DUMAS	MINOR SCALE		
<b>TEST BED LAYOUT</b>			
DATE: 11/18/84 BY: [Signature]	DATE: AUG 16 1984	SCALE: 1"=200'	DRAWING NO.: MS 0001 SHEET 3 OF 3

layout -

55

Figure 3.10. Test bed layout - north instrumentation park.

## SECTION 4

### EXPERIMENTS

MINOR SCALE had 178 experiments with 2,213 channels of recorded information. The experiments are listed in Table 4.1 in the order of the assigned DNA experiment number. An explanation of the column headings follows:

DNA # - DNA Experiment Number

Agen - Agency sponsoring and/or funding experiment

Experiment Title - Abbreviated title of experiment

PSI - Requested PSI level

TRS - Thermal Radiation Source exposure indicated by "Yes" or "No"

Icam - Number of internal cameras. A 'D' preceding camera indicates a DRI fielded camera, a 'T' is an experimenter fielded camera, and 'A' is an aerial camera. An \* indicates film is classified.

Ecam - Same as "I cam" except it is an external camera

Chan - No. of channels needed

Amp - No. of amplifiers needed

Gage - Passive or active gage

Bunker - Self recording

Dum - Anthropomorphic Manniken

TSP Date - Date of latest revision to TSP

Remarks - Amplifying information

For each experiment the objective, justification, description, pretest data, simulation test programs and predictions are stated in the MINOR SCALE Program Document (POR 7156). Experiment results, conclusions and recommendations are given in the MINOR SCALE Results Symposium Project Officer Report (POR 7158).

For reporting purposes and in an effort to logically group experiments, three broad categories of experiments are provided: (1) phenomenology, (2) structures and (3) systems.



Table 4.1. MINOR SCALE experiment list.

This listing was printed 3/27/1985

0000	Open Experiment Title	Psi	TR5	Ican	Ecan	Chan	App	Sage	Agm	Bunker	Dus	Dest	TSP	Date	Remarks	0000	Am
1000	AFSC AFBL Near Field Seismic		No	0	0	24	0	24	AFBL	Self	0	No	26JUN84	8 sites; 5-75km from 61		1300	mm
1200	Aray BELVOIR Land Mines	750	No	0	0	2	2	2	BRL	NP	0	No	1AUG84	18 mines; 23" spacing		1301	mm
1201	Aray BELVOIR Land Mines	1000	No	0	0	2	2	2	BRL	NP	0	No	1AUG84	18 mines; 23" spacing		1302	mm
1202	Aray BELVOIR Land Mines	1500	No	0	0	2	2	2	BRL	NP	0	No	1AUG84	18 mines; 23" spacing		1303	mm
1220	Aray MES Hardened Shelter	30	No	2	0	3	3	3	MES	NP	0	No	JULY84	Frame, fabric/buried 4'		1304	mm
1221	Aray MES Hardened Shelter	100	No	2	0	7	7	7	MES	NP	0	No	JULY84	Concrete/buried 4'		1410	mm
1200	Aray CECOM S-200 Shelter	10	No	0	1	10	10	10	MES	NP	0	Yes	13MAY85	2.5 ton truck/roadside		201	mm
1201	Aray CECOM S-200 Shelter	0	No	0	1	10	10	10	MES	NP	0	Yes	13MAY85	2.5 ton truck/roadside		202	mm
1300	MSNR AIS 1	12	No	1	2	14	14	14	MSNR	WB1	1	Yes	27SEP84	45 tilt/running		203	mm
1305	MSNR AIS 1	12	No	1	2	17	17	17	MSNR	WB1	1	Yes	27SEP84	Side on/running		204	mm
1306	MSNR AIS 2	12	No	1	2	14	14	14	MSNR	WB1	1	Yes	27SEP84	Head on/running		205	mm
1307	MSNR AIS 3	12	No	0	1	4	4	4	MSNR	WB1	0	Yes	14MAY85	Side on/running		206	mm
1310	MSNR AMB 1	11	No	1	2	12	12	12	MSNR	WB1	1	Yes	27SEP84	Side on/running		207	mm
1315	MSNR AFS 1	18	No	1	2	20	20	20	MSNR	WB1	1	Yes	27SEP84	Side on/running		208	mm
1320	MSNR ALS 1	12	T1	1	2	12	12	12	MSNR	WB1	1	Yes	27SEP84	Side on/running		209	mm
1325	MSNR AFS 1	7.4	T3	1	2	20	20	20	MSNR	WB1	1	Yes	27SEP84	Side on/running		210	mm
1330	MSNR AMB 2 (vehicle)	3.4	T6	0	2	27	27	27	MSNR	WB2	0	Yes	14MAY85	Side on/running		211	mm
1333	MSNR AMB 3 (vehicle)	3.4	No	0	2	20	20	20	MSNR	WB2	1	Yes	14FEB85	Side on/running		212	mm
1336	MSNR AMS 1	5	No	1	2	9	9	9	MSNR	WB2	0	Yes	27SEP84	In a vehicle/operating		213	mm
1337	MSNR AMS 2	5	No	0	2	3	3	3	MSNR	WB2	1	Yes	27SEP84	On loose sanikin		214	mm
1338	MSNR AMS 3	2.2	No	1	1	9	9	9	MSNR	WB2	0	Yes	27SEP84	In a chopper		215	mm
1340	MSNR ARH 1	12	No	0	0	3	3	3	MSNR	WB1	0	Yes	27SEP84	Inside 1300/ 4"x6"x8"		216	mm
1345	MSNR ACH 1	7.4	No	0	1	3	3	3	MSNR	WB2	1	Yes	27SEP84	On loose sanikin		217	mm
75	MSNR Combined Experiments	10	T2	0	2	9	9	9	MSNR	WB1	5	Yes	27SEP84	Dummies with equipment		218	mm

Tab

Table 4.1. MINOR SCALE experiment list (Continued).

This listing was printed 3/27/1985

Experiment Title	Psi	TR5	Ican	Ecan	Chan	App	Base	Agon	Donor	Due	Dest	TSP	Date	Remarks		
Medical System 1 5-75km from 62																
Reader & Detector 23" spacing	1388	MSNR	Chemical System (2 units)	9.3	No	0	2	3	3	3	MSNR	WB2	0	Yes	18DEC84	Head on/operating
Amplifier 23" spacing	1381	MSNR	Reader & Detector	3.4	No	0	1	3	3	3	MSNR	WB2	1	Yes	18DEC84	Loose tanks/near 1338
Detector 23" spacing	1382	MSNR	Amplifier	12	No	0	0	3	3	3	MSNR	WB1	0	Yes	18DEC84	In 1385
Generators buried 4'	1383	MSNR	Detector	12	No	0	1	3	3	3	MSNR	WB1	0	Yes	18DEC84	Near 1385
Assault Fuel Sys buried 4'	1386	MSNR	Generators	18	No	0	5	16	16	16	MSNR	WB1	0	Yes	14FEB85	3 generators
162 Tank: STA 2 truck/roadside	1618	USMC	Assault Fuel Systems	7.5	No	0	2	4	4	4	BRL	HP	0	Yes	3JUL84	Filled with water
BWP Tracked APC truck/roadside	2811	BRL	162 Tank: STA 2	35	No	0	1	8	8	8	BRL	SP	2	Yes	4JAN85	Classified, post-test
BRM-2 Armored t/running	2821	BRL	BWP Tracked APC: STA 3	36	No	1	1	9	9	9	BRL	SP	4	Yes	4JAN85	Classified, post-test
BTR-60 Wheeled moving	2838	BRL	BRM-2 Armored Car: STA 4	26	No	1	1	7	7	7	BRL	SP	3	Yes	4JAN85	Classified, post-test
BWP Tracked APC moving	2631	BRL	BTR-60 Wheeled APC: STA 4	26	No	1	1	7	7	7	BRL	SP	4	Yes	4JAN85	Classified, post-test
BWP Tracked APC moving	2832	BRL	BWP Tracked APC: STA 4	26	No	1	1	5	5	5	BRL	SP	4	Yes	4JAN85	Classified, post-test
BTR-60 Wheeled moving	2833	BRL	BWP Tracked APC: STA 4	26	No	1	2	6	6	6	BRL	SP	4	Yes	4JAN85	Classified, post-test
ZIL-157 Cargo moving	2848	BRL	BTR-60 Wheeled APC: STA 5	28	No	1	2	6	6	6	BRL	SP	4	Yes	4JAN85	Classified, post-test
BRM-2 Armored moving	2858	BRL	ZIL-157 Cargo Trucks: STA 6	11.5	No	0	3	5	5	4	BRL	SP	3	Yes	4JAN85	Classified, post-test
ZIL-157 Cargo moving	2851	BRL	BRM-2 Armored Car: STA 6	11.5	No	1	3	6	6	6	BRL	SP	3	Yes	4JAN85	Classified, post-test
BAZ-66 Cargo moving	2868	BRL	ZIL-157 Cargo Trucks: STA 7	8	No	0	3	2	2	2	BRL	SP	3	Yes	4JAN85	Classified, post-test
BAZ-66 Cargo moving	2861	BRL	BAZ-66 Cargo Trucks: STA 7	8	No	0	3	3	3	3	BRL	SP	3	Yes	4JAN85	Classified, post-test
FEMA ORNL Ltut. B operating	2878	BRL	BAZ-66 Cargo Trucks: STA 8	6.5	No	0	3	3	3	3	BRL	SP	3	Yes	4JAN85	Classified, post-test
FEMA ORNL Ltut. B skin	3888	FEMA	ORNL Ltut. Blast Doors	50	No	0	0	0	0	0			0	No	29JUN84	2 doors flush to ground
FEMA ORNL Ltut. I	3881	FEMA	ORNL Ltut. Blast Doors	100	No	0	0	0	0	0			0	No	29JUN84	2 doors flush to ground
FEMA NES Broad K 4'x6'x28"	3882	FEMA	ORNL Ltut. Blast Doors	200	No	0	0	0	0	0			0	No	29JUN84	2 doors flush to ground
FEMA NES Broad K skin	3818	FEMA	NES Broad Keyworker Shel	60	No	0	0	10	10	10	NES	HP	0	No	OCT84	1/4 scale; burned
equipment	3811	FEMA	NES Broad Keyworker Shel	175	No	0	0	10	10	10	NES	HP	0	No	OCT84	1/4 scale; burned

Table 4.1. MINOR SCALE experiment list (Continued).

This listing was printed 3/27/1983

0000 Aqon	Experiment Title	Psi	TRS	Ican	Ecan	Chan	App	Gage	Aqon	Dunker	Doa	Dest	TSP	Bate	Remarks	0000 Aqon	Es
3828	FEMA MES Joint CD Model Shel	14.5	No	0	0	10	10	10	MES	NP	0	No	AUG84	1/4	scale; near 7399		
3830	FEMA MES 15 Psi Blast Shelter	15	No	0	0	10	10	10	MES	NP	0	No	AUG84	1/4	scale; flush buried	6010	DOE
3831	FEMA MES 15 Psi Blast Shelter	50	No	0	0	10	10	10	MES	NP	0	No	AUG84	1/4	scale; flush buried	6011	DOE
3840	FEMA MES Keyworker Shelter	75	No	3	0	100	100	100	MES	NP	3	No	OCT84	32"x36"x10'H	Buried 4'	6012	DOE
3841	FEMA MEST Test		No	0	0	0	0	0	MES	NP	0	No	NOV84		Test on 3840 structure	6014	DOE
5100	HBL MATS-1, S-650	10	No	2	2	33	33	33	HBL	NP	0	Yes	24JUL84		Outriggers	6015	DOE
5102	HBL MATS-4, S-657	10	No	0	1	0	0	0	HBL	NP	0	Yes	24JUL84		End-on orientation	6210	HW
5104	HBL MATS-6, S-200 C/B	4	No	0	1	1	1	1	HBL	NP	0	Yes	24JUL84		End-on orientation	6211	HW
5105	HBL MATS-7, S-200 C/B	5	No	0	1	0	0	0			0	Yes	24JUL84		Side orientation	6220	HW
5107	HBL MATS-3, HMMW/CCCI	10	TS	0	3	15	15	15	HBL	NP,MP	0	Yes	24JUL84		Anchored	6221	HW
5100	Army Matich-1 ISO Shelter	4	No	0	1	6	6	6	MES	NP	0	Yes	14SEP84		Anchored	6230	HW
5109	Army Matich-2 ISO (Hardened)	10	T4	1	2	25	25	25	MES	NP	0	Yes	14SEP84		Anchored/Wires through TRS	6231	HW
5110	Army Matich-3 SES	10	No	1	2	21	21	21	HBL	SP	0	Yes	9JAN85		Side on/anchored	6232	HW
5200	ARDC Weapons Secur. Container	10	No	0	2	6	6	6	HBL	NP	0	Yes	23JUL84		82"x78"x43" steel cage	6234	HW
5240	BNW Best Electrical Effects		No	0	0	3	3	3	EMA	Self	0	No	12JUN84		2 vans/3 comm links	7000	UK
5200	BNW Best Electri. Res.	1-00	No	0	1	14	14	14	BNW	SP	0	No	16JUN84		00, 20psi, 3500', SP	7002	UK
5300	LAML Ionospheric Response	<.1	No	0	0	0	0	0			0	No	29JUN84		HF Radar	7034	UK
5302	LAML RFB Waves		No	0	0	0	0	0			0	No	29JUN84		Satellite Magnetometer	7040	UK
5303	LAML Electron Content Receiver		No	0	0	0	0	0			0	No	19OCT84		Receive satellite signal	7041	UK
6000	DOE HNL Rob/Load/Resp/Brav	0	No	0	1	30	30	30	FC	S01	0	Yes	7Feb85		Ideal/102"x24"x12"H	7042	UK
6001	DOE HNL H./L./R./B.(45 deg.)	10	No	0	1	17	17	17	FC	S01	0	Yes	7Feb85		Ideal/102"x24"x13"H	7050	UK
6002	DOE HNL Loads/Response	30	No	0	1	19	19	19	FC	S01	0	Yes	7Feb85		Ideal/114"x24"x11"H	7053	UK
6003	DOE HNL Full Size Segment	30	No	0	0	22	22	22	DOE	Self	0	Yes	7Feb85		Ideal/100"x144"x66"H	7070	UK
6004	DOE HNL Loads/Response	50	No	0	1	6	6	6	FC	S01	0	Yes	7Feb85		Ideal/114"x24"x11"H	7071	UK

Table

Table 4.1. MINOR SCALE experiment list (Continued).

This listing was printed 3/27/1985

Experiment Title	Psi	TRN	Ican	Ecan	Chan	App	Geop	Apn	Shutter	Duo	Dust	TSP	Gate	Remarks
6810 DOE NWL Resp/Load/Gravity	30	No	0	0	48	48	48	FC	S01	0	No	7Feb85	Real/114"x24"x11" H	
6811 DOE NWL Loads/Response	30	No	0	0	6	6	6	FC	S01	0	No	7Feb85	Real/114"x24"x11" H	
6812 DOE NWL R./L./Grav/Trench	50	No	0	0	48	48	48	FC	S01	0	No	7Feb85	Real/114"x24"x11" H	
6814 DOE NWL R./L./Gravity	40	No	0	0	14	14	14	FC	S01	0	No	7Feb85	Real/114"x24"x11" H	
6815 DOE NWL Resp/Gravity	50	No	0	0	1	1	1	FC	S01	0	No	7Feb85	Real/114"x24"x11" H	
6210 NWL NWL Mobile Resp/Gravity	0	No	0	1	27	27	27	FC	S02	0	Yes	4Feb85	Ideal/169"x24"x19" H	
6211 NWL NWL Mob/Resp/Grav(45 deg)	11	No	0	1	27	27	27	FC	S02	0	Yes	4Feb85	Ideal/169"x24"x19" H	
6220 NWL NWL Response/Gravity	30	No	0	1	20	20	20	FC	S02	0	Yes	4Feb85	Ideal/110"x46"x12.4" H	
6221 NWL NWL Response	50	No	0	1	7	7	7	FC	S02	0	Yes	4Feb85	Ideal/110"x46"x12.4" H	
6230 NWL NWL Response/Grav/Load	30	No	0	0	43	43	43	FC	S02	0	No	4Feb85	Real/110"x46"x12.4" H	
6231 NWL NWL Response/Grav/Load	50	No	0	0	43	43	43	FC	S02	0	No	4Feb85	Real/110"x46"x12.4" H	
6232 NWL NWL Response	50	No	0	0	7	7	7	FC	S02	0	No	4Feb85	Real/110"x46"x12.4" H	
6234 NWL NWL Resp/Gravity	40	No	0	0	15	15	15	FC	S02	0	No	4Feb85	Real/110"x46"x12.4" H	
7000 UK UK001 FS House	7.7	No	3	4	61	61	61	WNER	NP	0	Yes	2JUL84	Pre & post serial photos	
7002 UK UK005 1/3 Scale House	7.7	No	1	1	14	14	14	WNER	NP	0	Yes	2JUL84		
7036 UK UK036 Passive Airblast Res.	4	No	0	0	0	0	6			0	No	21NOV84	18"x4'	
7040 UK UK040 Launch Tubes	7.5	TUK	0	1	2	2	2	SRL	NP	0	Yes	NOV84	12 Tubes	
7041 UK UK041 Clothing	7.5	TUK	0	3	7	7	14	SRL	NP	4	Yes	NOV84	6 sets	
7042 UK UK042 Radooes	7.5	TUK	0	1	3	3	3	SRL	NP	0	Yes	NOV84	10 Panels	
7050 UK UK1/1 Steel&Concrete Lock	10-90	No	0	0	0	0	0			0	No	NOV84	10 Blocks each type	
7053 UK UK1/3 I Beams	4-10.5	No	0	0	0	0	0			0	No	NOV84	10 each, 26' tall	
7070 UK UK6/1 Full Scale Shelter	11	No	0	0	1	1	1	SRL	NP	0	No	NOV84	Half buried/borned	
7071 UK UK6/2 Full Scale Shelter	45	No	0	0	1	1	1	SRL	NP	0	No	NOV84	Half buried/borned	

Table 4.1. MINOR SCALE experiment list (Continued).

This listing was printed 3/27/1985

0000	Agon	Experiment Title	Psi	TR5	Icaa	Ecaa	Chan	Asp	Sage	Agon	Bunker	Dun	Dust	TSP	Date	Remarks	0000	Agon
7072	UK	UK6/3 Full Scale Shelter	20	No	0	0	1	1	1	BRL	NP	0	No	NOV84	Half buried/bermed			
7075	UK	UK7 Model Shelter	11	No	0	0	0	0	0			0	No	NOV84	Sand base cover; 24 each		7402	NORW
7076	UK	UK7 Model Shelter	20	No	0	0	0	0	0			0	No	NOV84	Sand base cover; 24 each		7410	NORW
7077	UK	UK7 Model Shelter	45	No	0	0	0	0	0			0	No	NOV84	Sand base cover; 24 each		7500	CANA
7080	UK	Four-man Battle Trench	20	No	0	0	0	0	0			0	No	NOV84	20'x3'x6.5' deep		7501	CANA
7081	UK	Four-man Battle Trench	30	No	0	0	0	0	0			0	No	NOV84	20'x3'x6.5' deep		7502	CANA
7100	FRB	E-52 Gauges	7.5-20	No	0	0	14	14	7	MES	NP	0	No	20JUN84	Even spacing in psi		7520	CANA
7150	FRB	Nitroethane Storage	20	No	0	1	2	2	2	MES	EP	0	Yes	20JUN84	Water in drums		8010	DNB
7151	FRB	Nitroethane Storage	10	No	0	1	2	2	2	MES	EP	0	Yes		Water in drums		8011	DNB
7152	FRB	Nitroethane Storage	5	No	0	0	2	2	2	MES	EP	0	No		Water in drums		8012	DNB
7153	FRB	Nitroethane Storage	600	No	0	0	1	1	1	MES	EP	0	No		Water in buried pipes		8020	DNB
7156	FRB	Nitroethane Storage	750	No	0	0	1	1	1	MES	EP	0	No		Water in buried pipes		8050	DNB
7157	FRB	Nitroethane Storage	600	No	0	0	1	1	1	MES	EP	0	No		Water in buried pipes		8060	FRB
7170	FRB	Antenna	5	No	0	1	0	0	0			0	Yes	20JUN84	CLASSIFIED POST-TEST		8063	DNB
7171	FRB	Antenna	6.5	No	0	1	0	0	0			0	Yes	20JUN84	CLASSIFIED POST-TEST		8066	DNB
7172	FRB	Antenna	8	No	0	1	0	0	0			0	Yes	20JUN84	CLASSIFIED POST-TEST		8067	DNB
7180	FRB	Tracked Vehicle I	14.5	No	0	1	7	7	7	MES	NP	1	Yes	20JUN84	CLASSIFIED		8200	DNB
7181	FRB	Tracked Vehicle II	14.5	No	0	1	13	13	13	MES	NP	1	Yes	20JUN84	CLASSIFIED		8201	DNB
7200	FR	Blast valves/Blast door	50	No	1	0	0	0	0	BRL	NP	0	No	30OCT84			8202	DNB
7201	FR	Blast valves/Blast door	50	No	1	0	3	3	3	BRL	NP	0	No	30OCT84			8210	DNB
7300	SHED	Buried Structure	86	No	0	0	7	7	7	BRL	SP	0	No	21AUG84	Concrete structure A		8220	DNB
7399	SHED	Joint CB Shelter	14.5	No	2	0	19	19	19	MES	NP	2	No	23AUG84	Norway-Sweden joint test		8250	DNB
7400	NORW	Communication Shelter	10	No	0	0	0	0	0			0	No	03JUN84	2 FRP cylinders		7250	DNB
7401	NORW	Communication Shelter	25	No	0	0	0	0	0			0	No	03JUN84	2 FRP cylinders			

Tab

Table 4.1. MINOR SCALE experiment list (Continued).

This listing was printed 3/27/1985

Experiment Title	DMA	Age	Exp	Title	Psi	TR5	Ican	Ecan	Chan	App	Gage	Apn	Dunker	Dun	Dust	TSP	Date	Remarks
7402 NORM Communication Shelter	50	No	0	0	0	0	0	0	0	0	0	0	0	0	No	0	8JUN84	2 FRP cylinders
7410 NORM VALHALL II	150	No	T	14	0	60	60	60	NORN	Self	0	0	0	No	0	0	8JUN84	Sees-buried; 50' x 52'
7500 CANA Beta Gauge	50	No	0	0	0	0	0	2	DRES	WP	0	0	No	0	0	0	26NOV84	Near 7520
7501 CANA Beta Gauge	150	No	0	0	0	0	0	2	NORN	Self	0	0	No	0	0	0	26NOV84	Near 7410
7502 CANA Beta Gauge	300	No	0	0	0	0	0	0	0	0	0	0	No	0	0	0	26NOV84	1 inactive gauge
7520 CANA Ship Stiffened Panels	50	No	0	0	20	20	20	DRES	WP	0	0	0	No	0	0	0	14SEP84	8' x 15' panel
8010 DMA TIC Cloud Phenomenology	No	0	T	3	0	0	0	0	0	0	0	0	No	0	0	0	27JUN84	3 ground sites
8011 DMA TIC Low Level Dust	No	0	T	1	0	0	0	0	0	0	0	0	No	0	0	0	27JUN84	Old Adesa Park
8012 DMA TIC Dust Transmission	No	0	T	1	0	0	0	0	0	0	0	0	No	0	0	0	27JUN84	8 targets on mountain
8020 DMA Dust-Induced RF	No	0	0	14	14	14	SAI	GAP	0	0	0	0	No	0	0	0	9JUL84	Record 8 RF bands
8050 DMA TSC on Wave Backscatter	No	0	2	4	4	0	HNL	BUS	0	0	0	0	No	0	0	0	2JUL84	35,95,140,225 GHz
8060 DMA MES Experimenter's BR	5-800	No	0	0	26	26	26	MES	EP	0	0	0	No	0	0	0	26NOV84	Support for HNL
					44	44	44	MES	EP									Support for precursor
8065 DMA MES Nitroethane	150	No	0	0	0	0	0	0	0	0	0	0	No	0	0	0		Tethered barrel
8066 DMA MES Nitroethane	100	No	0	0	0	0	0	0	0	0	0	0	No	0	0	0		Tethered barrel
8067 DMA MES Nitroethane	20	No	0	0	0	0	0	0	0	0	0	0	No	0	0	0		Tethered barrel
8200 DMA DRI Optical Diagnostics	10-75	No	0	0	4	0	0	0	0	0	0	0	0	Yes	0	0	7SEP84	Ejecta on debris radials
8201 DMA DRI Stereo Diagnostics	10-75	No	0	0	4	0	0	0	0	0	0	0	0	Yes	0	0	7SEP84	30 photography
8202 DMA DRI Pyrotechnic Ejecta	>2000	No	0	0	0	0	0	0	0	0	0	0	0	No	0	0	7SEP84	10 Bowling Balls
8210 DMA SRI RF Transmiss. (96GHz)	10	No	0	0	7	7	7	SRI	EB1	0	0	0	No	0	0	0	22JUN84	Receiver Array
8220 DMA MES Debris Collection	No	0	0	0	0	0	0	0	0	0	0	0	0	Yes	0	0	2JUL84	3 Radials/6 pads/15 pits
8230 DMA MVERI Sand Columns/diagl.	>2000	No	0	0	0	0	0	0	0	0	0	0	0	No	0	0	27JUN84	
8250 DMA SGL Artificial Ejecta	>2000	No	0	0	0	0	0	0	0	0	0	0	0	No	0	0	9JUL84	10 devices in crater

Table 4.1. MINOR SCALE experiment list (Continued).

This listing was printed 3/27/1985

DNM	Agee	Experiment Title	Psi	TRG	Ican	Ecan	Chan	Ang	Sege	Agee	Dunker	Due	Dust	TSP	Date	Remarks
8270	DNM	SEA Debris Mitigation	.5-1k	No	0	0	0	0	0	0	0	0	No	29NOV84	4 concrete boms	8790
8511	DNM	In Situ Cloud Sampling		No	0	0	0	0	0	PWS	Self	0	No	JUN84	Filters on Beech Baron	9001
8520	DNM	Multi-Spectral Imagery		No	0	0	0	0	0			0	No	26JUN84	8 aircraft	9001
8620	DNM	Weather Characterization		No	0	0	12	12	12	SHLA	Self	0	No	16OCT84	Pre-vent explosions	9011
8700	DNM	Dusty, Precur. Dist Line	22-300	No	0	0	69	69	69	BRL	ETI	0	No	30NOV84	900'x400' dust + hel joo	910
8781	DNM	H-Tech Greg Measurements	15-150	No	0	0	42	42	42	BRL	ETI	0	No	24JUL84	11 stations	
8782	DNM	H-Tech Seob Measurements	15-150	No	0	0	50	50	50	BRL	ETI	0	No	24JUL84	11 stations	
8783	DNM	SOLI Laser Doppler Veloc.	30	No	0	0	23	23	20	SOL	Self	0	No	20NOV84		
8784	DNM	TRN Streak I-ray	30,50	No	0	0	6	6	6	BRL	ETI	0	No	10SEP84	30,50	
8786	DNM	DRI Dust Catchers	30,50	No	0	0	6	6	6	BRL	ETI	0	No	19SEP84	3 hqts/location;30,50	92
8787	DNM	DRI Laser Photography	2.2	No	0	0	33	33	0	DRI	Self	0	No	19SEP84	Four lasers	93
8788	DNM	SRI I-ray Absorption	30	No	0	0	7	7	1	SRI	EBI	0	No	13SEP84		92
8789	DNM	DRES I-ray Attenuation	30,50	No	0	0	18	18	18	BRL	ETI	0	No	20NOV84	30,50	94
8710	DNM	ISI Surface Recess. Photo	30,50	No	T 3	0	0	0	0			0	No	20AUG84	30,50	94
8715	DNM	GBL Drag Bodies	30,50	No	0	0	20	20	20	GBL	Self	0	No	25OCT84	30,50	94
8717	DNM	MES Soil Characterization		No	0	0	0	0	0			0	No	14SEP84	Soil samples in precursor	94
8718	DNM	TRN Shear Gauges	15-150	No	0	0	11	11	11	BRL	ETI	0	No		Mounted in 8701	94
8719	DNM	TRN Cine Flash Microscope	30,50	No	0	T 3	6	6	6	BRL	ETI	0	No	21NOV84	30,50	94
8720	DNM	SAI Helium Concentration	27-320	No	0	0	1	1	40	SAI	T&F	0	No	20NOV84	HeI in bag/40 places	94
8722	DNM	TRN Holography	30	No	0	0	4	4	4	BRL	ETI	0	No	20NOV84		94
8723	DNM	GBL Passive Gauges	30,50	No	0	0	0	0	6			0	No	25OCT84	6 I-beams	94
8724	DNM	Soil Scour Character.		No	0	0	0	0	0			0	No	20NOV84	Soil samples in precursor	94
8750	DNM	Negative Pressure Gauges	30,50	No	0	0	0	0	0	BRL	ETI	0	No		6" high; 4 stations	94
790	DNM	ISI Zebra Cameras		No	0	25	0	0	0			0	No	30NOV84	Precursor zebra board	94

Table 4.1. MINOR SCALE experiment list (Continued).

This listing was printed 3/27/1985

Experiment

ISI Tower (Shockwave Isotopes  
Fireball Hirsch Baron  
Aerial Opt  
Free Field Explosions  
    Jst Hel Jaa

Free Field  
B. Detonation; 30,50

IC Charge Qu  
TRN Calor  
C TRN System  
    Testbed W  
LA Offsite W  
LA Microbaro in precursor  
E Explosive/WI

0 places  
in precursor  
ations  
ra board

DNAO Agen	Experiment Title	Psi	TRN	Icao	Ecao	Chan	Ang	Gage	Agon	Bamber	Dun	Dust	TSP	Date	Remarks
8791 DMR	ISI Tower Cameras	No	0	4	0	0	0	0	0	0	0	No	30NOV84		Precursor Tower
9000 USNR	Shockwave Optics	No	0	21	0	0	0	0	0	0	0	No			Shockwave on 3 radials
9001 USNR	Fireball Optics	No	0	4	0	0	0	0	0	0	0	No			3 views
9010 USMC	Aerial Optics	No	0	A 0	0	0	0	0	0	0	0	No			RF-4
9100 BRL	Free Field Airblast	2-500	No	0	0	33	33	33	BRL	SP	0	No			South radial
						36	36	36	BRL	WP					West radial
						33	33	33	BRL	WP					North radial
						31	31	31	BRL	EP					East radial
						10	10	10	BRL	Other					2 north; 0 south
9200 MES	Free Field Ground Motion	1-4000	No	0	0	90	90	90	MES	WP	0	No	26NOV84		North radial
7300 AFML	Detonation Velocity	10000	No	0	0	200	200	200	AFML		0	No	6AUG84		Gauges in ANFO
9310 NSMC	Charge Quality		No	0	0	0	0	0			0	No			ANFO Quality Control
9400 BRL	TRN Calorimetry	3.4-12	Yes	0	0	32	32	32	BRL	WP	0	No			Data for TRN units
9405 SAIC	TRN System	3.4-12	Yes	0	T 0	0	00	00	SAI	T & F	0	No	6DEC84		0 TRN units
9410 FC	Testbed Weather	10-150	No	0	0	15	15	15	FC	T & F	0	No			3 weather stations
9415 SHLA	Offsite Weather		No	0	0	5	5	5	SHLA		0	No			Weather data
9416 SHLA	Microbarographs		No	0	0	6	6	6	SHLA		0	No			Overpressure in tons
9500 FBI	Explosive Debris Analysis		No	0	0	0	0	0			0	No	21SEP84		Air & soil samples



Table 4.1. MINOR SCALE experiment list (Concluded).

This listing was printed 3/27/1983

DMA Experiment Title	Psi	TR5	Icam	Ecam	Chan	App	Bope	Agem	Bunker	Duo	Dust	TSP	Bate	Remarks
Number of DMA experiments			170											
Total number of internal cameras			34											
Total number of external cameras			213											
Number of gauges			2277											
Number of amplifiers needed			2261											
Number of channels needed			2213											
Number of dummies needed			75											

5.1

ments s  
eras us  
drawing  
experin  
channel

earth  
struct  
142°)  
new on  
Highwa  
testbe  
and F  
Februa

cordi  
compl  
tals  
Apri  
insta

May.  
sche  
used  
were  
meth  
Tab

fram

SECTION 5  
CONSTRUCTION AND FIELDING ACTIVITIES

5.1 TESTBED CONSTRUCTION.

MINOR SCALE required a major effort to field the 178 technical experiments shown in Table 4.1. There were a total of 213 external cameras, and 54 cameras used within various structures. Appendix I gives a list of all the engineering drawings that support MINOR SCALE. Seventy-five dummies were fielded for various experiments by the Lovelace Foundation. Two thousand two hundred and thirteen channels of information were recorded from 2,277 gauges using 2,261 amplifiers.

The basic testbed design was finalized during the summer of 1984 and earth moving operations began in the fall. Three airblast radials which were constructed for DIRECT COURSE were reused for MINOR SCALE and a fourth radial (azimuth 142°) and instrumentation park were added. Existing roads were improved and several new ones were added. A reinforced concrete cable crossing was constructed on WSMR Highway Route 13. During January 1985, above average rain and snowfall on the testbed caused delays which were made up by working 70 hour weeks in late January and February. The major testbed construction and improvements were completed in February 1985.

Installation of diagnostic airblast gage mounts and ground motion recording stations and construction of the ANFO mixing plant began in March and were completed in late May. Emplacement of experiment technical camera mounts and pedestals began in April and scaffolding for diagnostic shockwave cameras was emplaced in April-May time frame. Optical targets for diagnostic and experimenter cameras were installed in early time.

The ANFO plant was started in March (see Figure 5.1) and completed in May. Initial plant start-up problems caused a one week delay of the ANFO delivery schedule. When ANFO loading began, a temporary system of weighing the trucks was used from 14-17 June. A single axle at a time was weighed and five or six readings were required. After installation of an adequate set of scales on 18 June, both methods were used for a time to obtain comparison data between the techniques. Table 5.1 provides the comparison between the two methods.

The Thermal Radiation Source (TRS) pit liners were changed from wood frame construction to steel in January 1985. The first TRS unit was shipped from

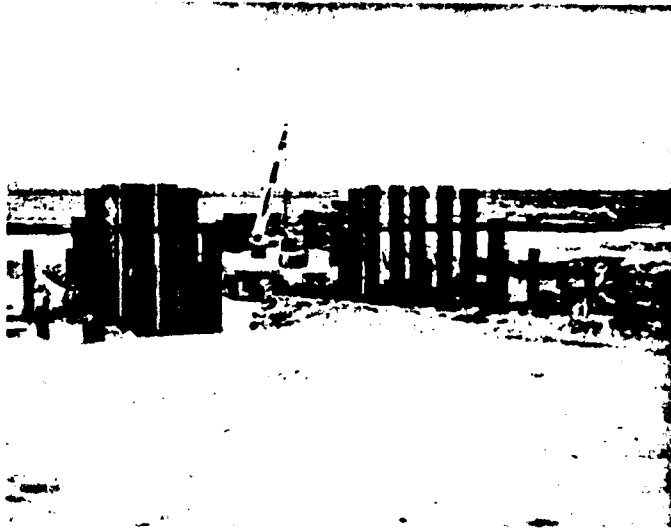

Figure 5.1. ANFO plant under construction showing large I beams and timbers.

Table 5.1. Scale comparison.

Truck Number	Old Scale	New Scale	$\frac{\text{Old-New}}{\text{New}} \times 100$
1	--	--	
2	17.16	17.36	-1.15
3	20.61	20.67	-0.29
4	20.08	20.28	-0.99
5	22.53	22.06	2.13
6	16.38	16.93	-3.25
7	15.17	15.23	-0.39
8	20.33	20.03	1.50
		AVERAGE	-0.35%

Kirtland Air Force Base (KAFB), New Mexico to test site in March. The first 27 hour TRS countdown was conducted on 15-16 May.

Instrumentation trailer shelters were started in April and completed in early May. Three hundred new digitizers were delivered in early May, 200 in late May, and the last 100 were delivered in early June.

5.2

man  
tes  
tie  
8  
ce

5.3  
11  
(F-  
an  
5.

ga  
a  
st  
tr  
i  
p  
w  
R

c  
t  
t  
s  
t

in  
in

PRECURSED

The first

ture of the

te. The last

nails was st

on 25 June a

for deployi

CONSTRUCT

Among th

ure 5.3), the

5.6), the AN

backfilling the

FIELDING

The Ball

as a result

of 61 gauge

to replace

KAFB TRS site

ns of 20 pair

. AEWES suff

ound. The

ement weather

In earl

r and alarm s

ed. The alarm

siren. The co

e electrical

no reports of

PRE D-DAY

The sc

in Table 5.2

se of the cri

5.2 PRECURSED RADIAL.

The first 5 bags for the precursed radial arrived in early May. The manufacture of the last bag by Sheldahl was completed in late May and shipped to the test site. The last bag arrived the week of 3 June. Placement of the envelope tiedown nails was started the week of 3 June. The deployment of the bags started at 8 p.m. on 25 June and completed 0630 shot day 27 June (see Figure 5.2). The procedures for deploying the bags over the precursed radial are shown in Appendix J.

5.3 CONSTRUCTION OF LARGE SCALE STRUCTURES.

Among the major fielding efforts were the construction of Norway Valhall II (Figure 5.3), the United Kingdom house (Figures 5.4 and 5.5), the new ANFO plant (Figure 5.6), the ANFO container (Figure 5.7), FEMA key worker shelter (Figure 5.8), and backfilling the instrumentation bunkers and instrumentation parks (Figure 5.9).

5.4 FIELDING ACTIVITIES.

The Ballistic Research Laboratory (BRL) suffered severe damage to their gauges as a result of the lightning storm on 28 April (see Figures 5.10 and 5.11). a total of 61 gauges (39 pressure and 22 calorimeter) were lost. BRL had sufficient spares to replace the pressure gauges. Twenty-five calorimeters were obtained from the KAFB TRS site and calibrated by BRL. In addition to the gauges, BRL also lost 13 runs of 20 pair cable on the east radial. All cable and connectors were replaced. AEWES suffered damage to 10 amplifiers in the east park but no cable damage was found. The 2 TRS weather stations and interconnecting cable were damaged. Replacement weather stations from the KAFB TRS Site were quickly installed.

In early May New Mexico Tech personnel installed the field unit, recorder and alarm system to monitor electrical storm activity in the vicinity of the testbed. The alarm system consisted of a flashing red light which was later changed to a siren. The completed system was in operation the week of 3 June. There was a severe electrical storm in the testbed area at 1700 hours 12 June. However, there were no reports of damage to any gauges.

5.5 PRE D-DAY ACTIVITIES.

The schedule of the MINOR SCALE 45 day countdown as of 7 May 1985 is given in Table 5.2. In May the readiness data was changed from 13 June to 25 June because of the criticality of the following items:

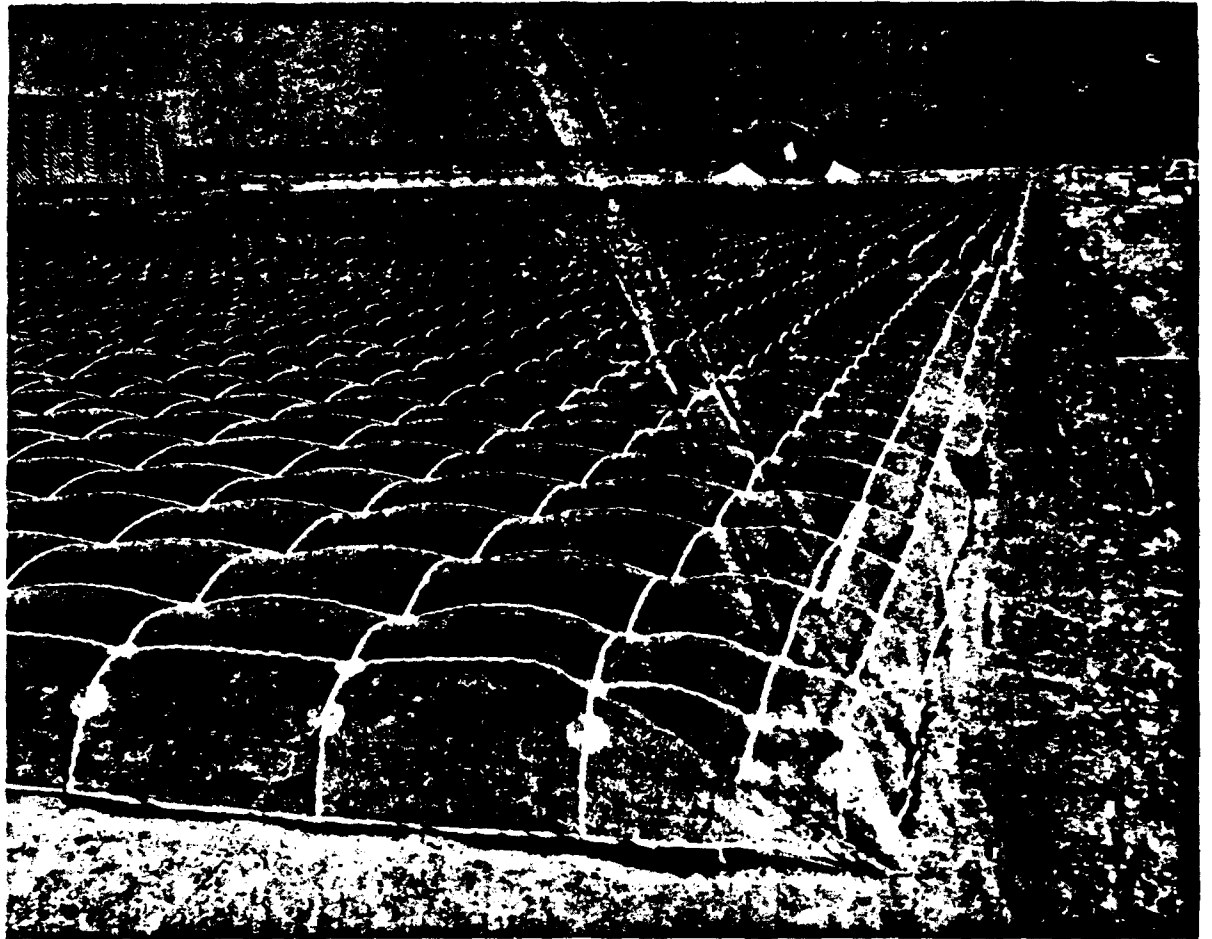

Figure 5.2. Mylar bag in crate on dusty radial.



Figure 5.3. Norway Valha hemisphere i



Figure 5.4. Aerial ph

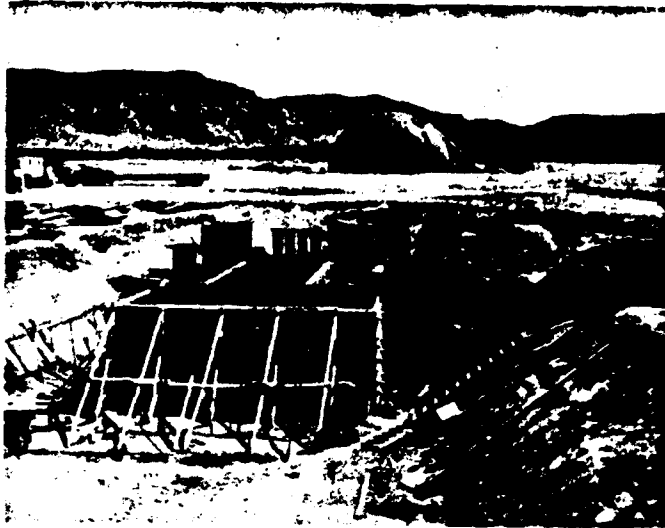

Figure 5.3. Norway Valhall II Experiment #7410 under construction with hemisphere in background.

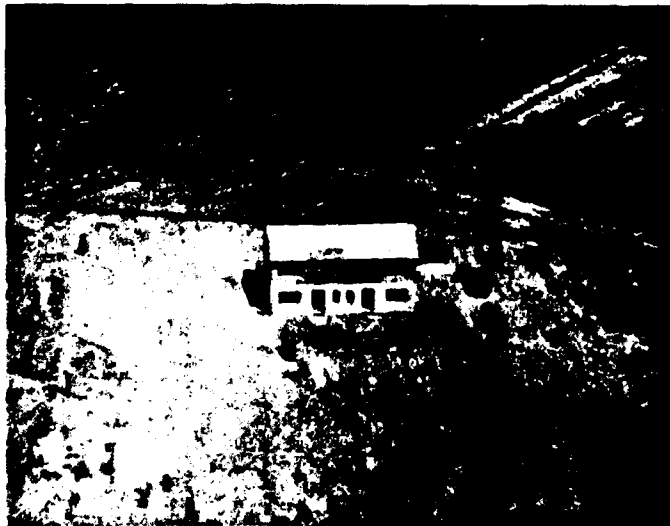

Figure 5.4. Aerial photograph of the United Kingdom House preshot.

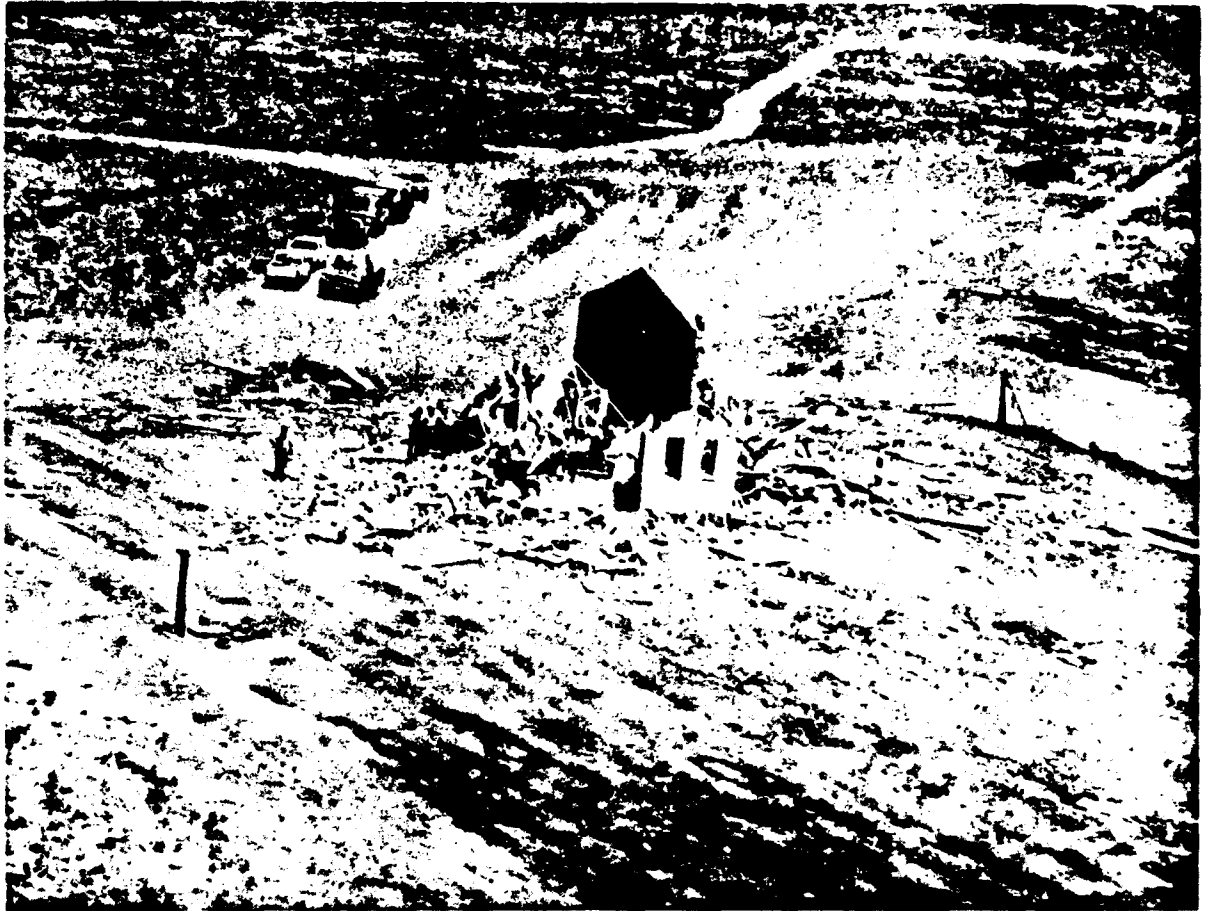

Figure 5.5. Aerial photograph of the UK house, postshot.

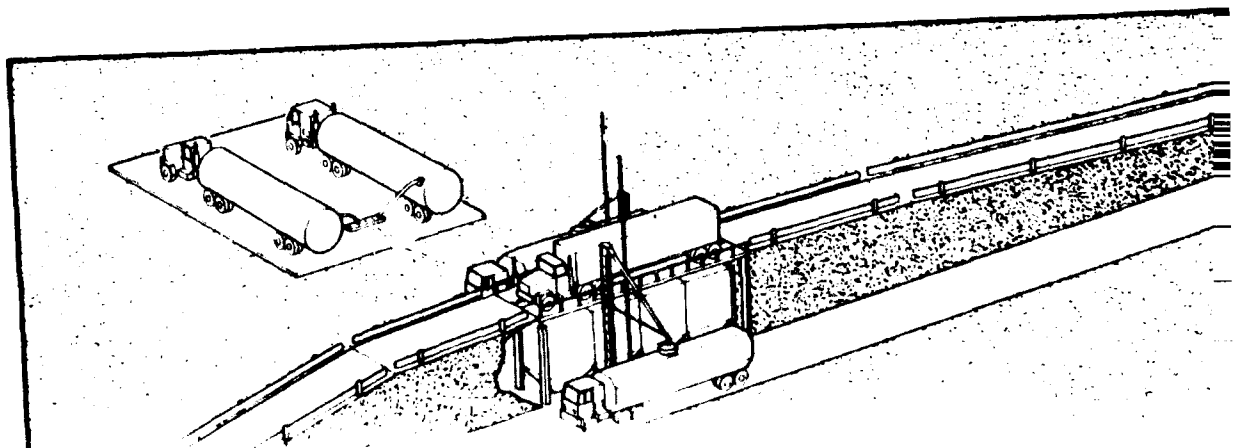



Figure 5.5. Aerial photograph of the UK house, postshot.

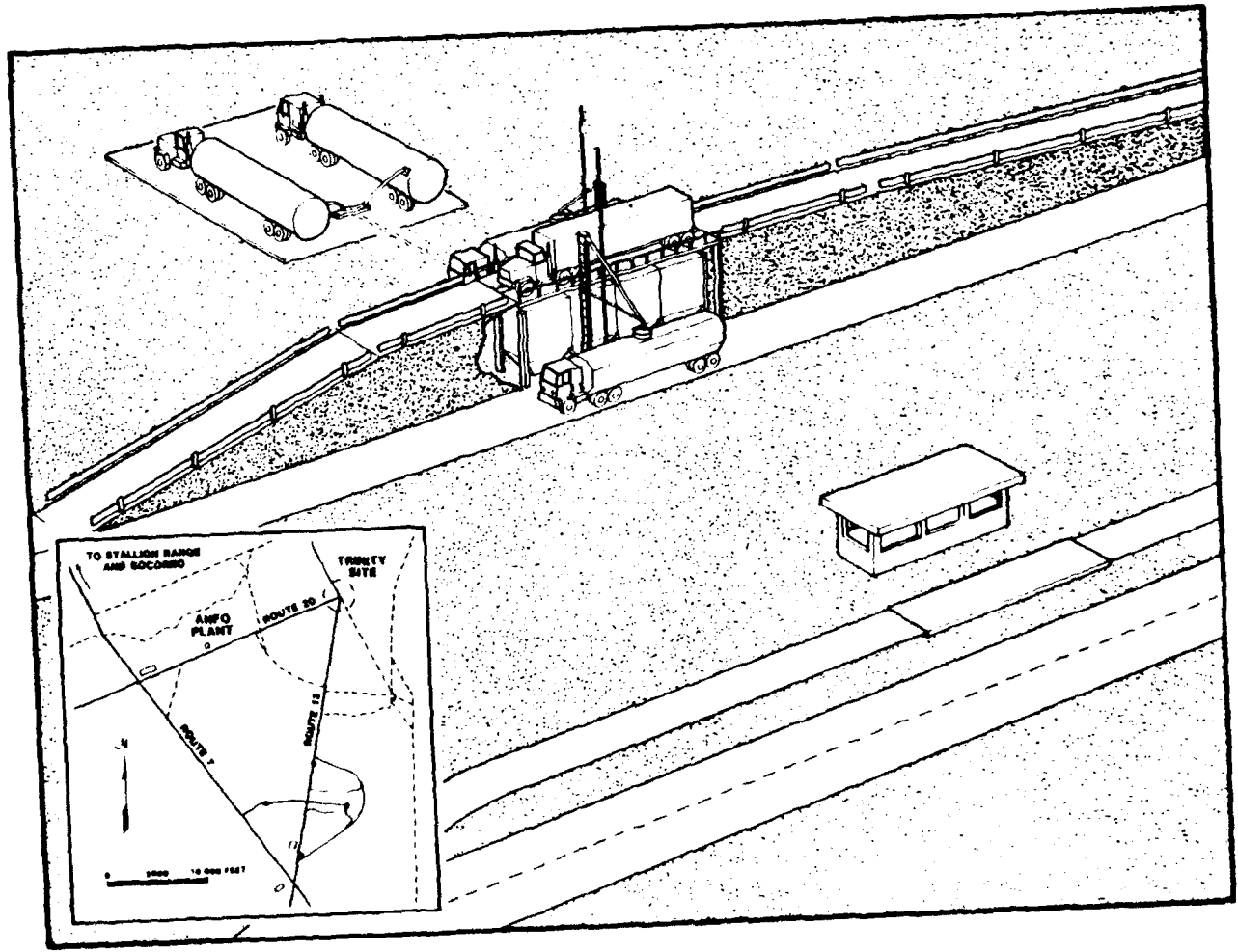

Figure 5.6. ANFO Plant.



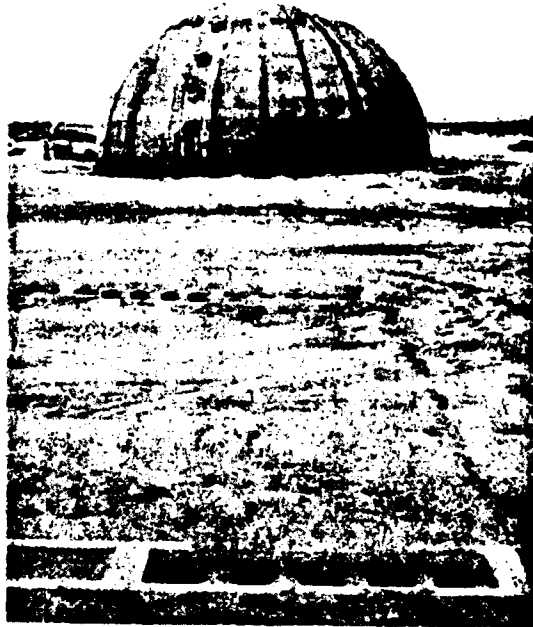

Figure 5.7. ANFO fiberglass container.

Figure

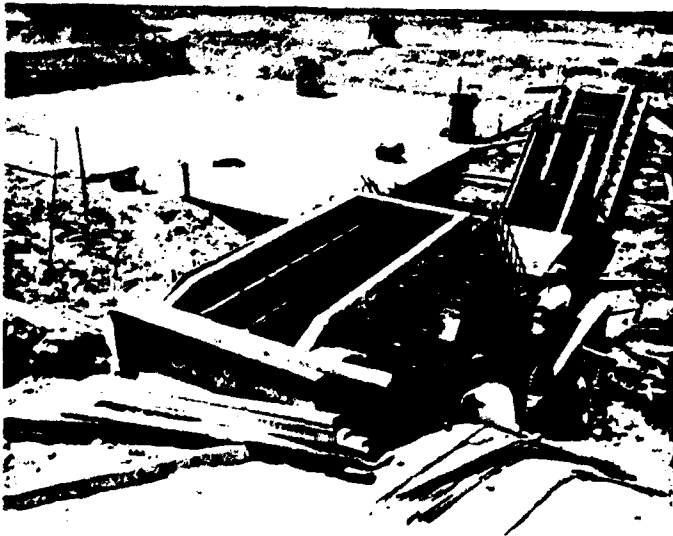

Figure 5.8. Experiment #3040, key worker shelter showing stairwell construction on the north side.

Figure 5.1



Figure 5.9. Backfilling north Instrumentation Park, 3/4 complete.

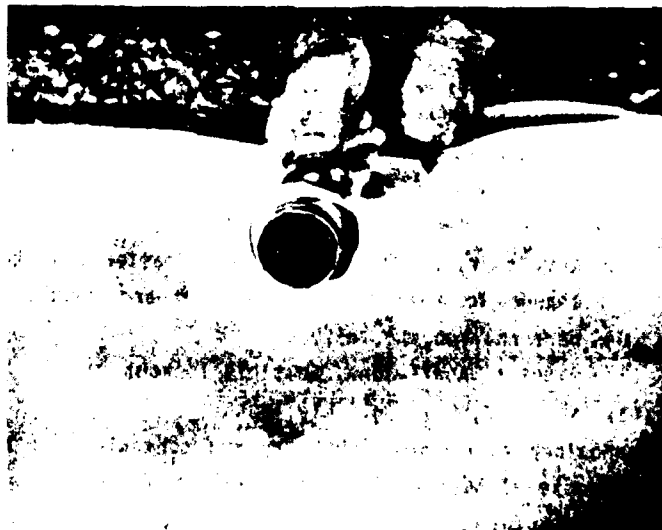

Figure 5.10. Lightning damage to cables and cable ends on cable run going to east Instrumentation Park during lightning storm.



Figure 5.11. Damage to cables inside instrumentation trailer at East Instrumentation Park during lightning storm.

- a. Construction.
- b. Digital instrumentation deliveries.
- c. Weather delays. A severe thunderstorm struck the testbed over the weekend of 27-29 April damaging 61 gauges.
- d. Range lockouts. Coordination with WSMR-NR showed the following schedule of events that would impact MINOR SCALE construction or experiment placement one or two half-days a week.
  - (1) Navy test, April-May, east-west pattern, lockout. this could change to a north-south pattern and result in a lockin for personnel on the testbed.
  - (2) Patriot, April-June, possible lockout.
  - (3) Sgt York, May, possible lockout.

The mandatory full power (MPF) dry run scheduled for 11 June was postponed to 12 June because of high winds which were a problem to the TRS units. The MPF was conducted with a zero time of 1110 hours. The countdown was exercised from

Date Scheduled
D-45 (11 May 1985)
D-41
D-40
D-38
D-31
D-30
D-28
D-28
D-27
D-27
D-22
D-22
D-21
D-20
D-20
D-18
D-18
D-18
D-18
D-15
D-15
D-14

Table 5

Table 5.2. MINOR SCALE 45 day countdown.  
(Date: 7 May 1985)

<u>Date Scheduled</u>	<u>Date Accomplished</u>	<u>Event</u>	<u>Activity</u>
D-45 (11 May 1985)		Start signal dry runs on request by experimenter	IE
D-41		Project Officers Meeting (POM) at 1330 hrs	TGD/Project Officers
D-40		TRS collective burn	TRS/SAIC
D-38		TRS collective burns	TRS/SAIC
D-31		Aerial survey flight	PD
D-30		MINOR SCALE test put on WSMR 30 day schedule	WSMR (NR-PD)
D-28		Commence scheduled daily signal dry runs	IE
D-28		Start observation point (OP) construction	TGE
D-27		Project Officers Meeting (POM) at 1330 hrs	TGD/Project Officers
D-27		Test observer info package distributed	PD
D-22		Complete diagnostic camera installation	WSMR
D-22		Verify ANFO plant operational	PD
D-21		Project Officers Meeting (POM) at 1330 hrs. Report status of experiments for upcoming mandatory full participation (MFP) No. 1 to TGD.	TGD/Project Officers
D-20		Countdown meeting with Range Control	TGD
D-20		Check status of security for GZ	TGSO
D-18		Deliver main booster assembly (MBA)	PD
D-18		ANFO loading begins	AFWL/NMERI
D-18		GZ security begins	PD
D-15		Complete technical camera installation	WSMR/DRI
D-15		Project Officers Meeting at 1300 hrs (MFP procedures review)	TGD/TD/IE Project Officers
D-14		Conduct MFP No. 1 at 1000 hrs. (TRS hot test, aircraft participation, pull film in all cameras)	TGD

Table 5.2. MINOR SCALE 45 day countdown (continued).

<u>Date Scheduled</u>	<u>Date Accomplished</u>	<u>Event</u>	<u>Activity</u>	<u>Date Scheduled</u>
D-13		MFP classified film review	PT	D-3
D-12		Project Officers Meeting (MFP debrief) at 1330 hrs	TD/Project Officers	D-3
D-11		Review technical film coverage with experimenters	TD/WSMR/Expermnt.	D-3
D-8		Conduct MPF No. 2 at 1000 hrs (if required). (TRS hot test, pull film as required).	TGD	D-2
D-7		Project Officers Meeting at 1330 hrs. (MFP debrief, report readiness for dress rehearsal).	TD/Project Officers	D-2
D-7		MINOR SCALE put on 7 day schedule	WSMR (MR-PD)	D-2
D-7		Start McDonald Ranch protective measures	TGE	D-2
D-7		OP construction completed	TGE	D-1
D-7		Aerial photos (helicopter)	PT/WSMR	D-1
D-7		Meteorology detonation (0900 & 1500)/ MET rocket launch (1200)	SNLA/ASL	D-1
D-6		Meteorology detonation (0900 & 1500)/ MET rocket launch (1200)	SNLA/ASL	D-1
D-6		Submit status of OP preparations	PD	D-1
D-6		Adjust cameras as necessary and report readiness of cameras to TGD	WSMR/DRI/ SNLA	(25 Jun)
D-6		WSMR countdown briefing at 1000 hrs	TGD	D+
D-5		Meteorology detonation (0900 & 1500)/ MET rocket launch (1200)	SNLA/ASL	D+
D-4		Meteorology detonation (0900 & 1500)/ MET rocket launch (1200)	SNLA/ASL	D+
D-4		Complete ANFO loading. Report charge readiness to TGD.	PD	D+
D-3		MINOR SCALE test coded in WSMR scheduling system	WSMR	D
D-3		Dress rehearsal at 1000 hrs. (TRS hot test/aircraft participation).	TGD	D

Table 5.2. MINOR SCALE 45 day countdown (continued).

<u>Date Scheduled</u>	<u>Date Accomplished</u>	<u>Event</u>	<u>Activity</u>
D-3		Meteorology detonation (0958 & 1500)/ MET rocket launch (1400)	SNLA/ASL
D-3		Weather evaluation	TGD/TD/ SNLA
D-3		Project Officers Meeting at 1330 hrs (dress rehearsal critique)	TGD/Project Officers
D-2		Initiated helium delivery	PD
D-2		Weather evaluation	TGD/TD/ SNLA
D-2		Project Officers Meeting at 1330 hrs (experiment status to TGD)	TGD/Project Officers
D-2		TRS fueling starts	TRS/SAIC
D-2		Begin bag deployment	PD/NMERI
D-1		Load cameras	WSMR/DRI/ SNLA
D-1		Meteorology detonation (0900 & 1500)/ MET rocket launch (1200)	SNLA/ASL
D-1		Helium trucks arrive	PD
D-1		TRS liquid oxygen fill (10 hrs)	TRS/SAIC
D-1		Final decision on event status	TGD/TD
D-1		Aerial photos (helicopter)	PT/WSMR
D-0		Event (see event countdown)	
(25 June 1985)			
D+1		Aerial photos (helicopter)	PT/WSMR
D+1		Quick Look Meeting (1030)/24 hour report	TGD/TD
D+3		Aerial reconnaissance flights	PD
D+5		Aerial reconnaissance flights	PD
D+6		Begin film review	TD/PT/PD
D+7		TRS removal starts	TRS/SAIC
D+10		TRS removal starts	TRS/SAIC
D+25		Complete film mailing	WSMR
D+40		Gauge mount removal	TGE/ WSMR EOD
D+45		Precursor Quick Look Meeting	PD/TD

the T-3 hour point through T+1 minute. Several minor problems were identified with the countdown sequence and several small procedural problems were encountered. These were resolved prior to MFP #2.

- a. 204 of 214 technical cameras were operational with 189 operating properly.
- b. The T&F van ran well except for a couple of bad monitors.
- c. The following experiments did not participate because of minor problems: 1200-1202, 7300, 8704, 8708, 8719, 8720, and 8990.
- d. Most of the experiments that participated in the MFP did not have all data channels operating.
- e. Of the five precursor camera back drops (zebra sails) which were raised, one was torn by the wind. Damage was minor and the sail was repaired. All sails were later reinforced at the point of failure.
- f. All seven TRS units operated.

MFP #2 was scheduled and executed on 17 June 1985. Most of the data channels for the experiments were operational. The dress rehearsal occurred on 22 June as scheduled. Winds prevented the deployment of the mylar bags on 23 and 24 June. Deployment of the bags started at 2049 the night of 25 June 1985. Two bags were completely deployed and one was partially deployed the evening of 25.26 June. The remaining bags were deployed the evening of 26-27 June.

#### 5.6 D-DAY ACTIVITIES.

##### 5.6.1 Hold Criteria.

The first draft of the Hold Criteria was published in January 1985. After a thorough review by the appropriate Headquarters, DNA personnel, the Field Command staff and project agencies concerned, the final criteria and procedures were published on 2 May 1985. Appendix K contains the criteria and procedures.

##### 5.6.2 Event Day Countdown.

The MINOR SCALE countdown schedule is given in Table 5.3. Zero time was scheduled to be 1000 25 June 1985. This time could not be met because high winds on the testbed prevented the deployment of the bags. On 25 June the zero time was rescheduled for 1000 hours 27 June. At T-150 minutes (0730 27 June 1985) the Test Group Director placed the countdown in a "hold" status in order that the filling of the bag with helium could be completed (see Figure 5.12 for aerial view at T-150 minutes) and because weather conditions (focusing) were unsatisfactory. The T-150

+/- T  
T-40T  
T-20T  
T-20T  
T-20  
T-16  
T-10  
T-8T  
T-7T  
T-7T  
T-6T  
T-6  
T-5  
  
T-E  
T-E  
  
T-  
T-  
T-  
  
T

Table 5.3. MINOR SCALE countdown.

14 Jun 85

EV	+/- TIME	EVENT	ACTIVITY
Begin b	T-40hrs	Begin bag deployment.	NMERI
HOLD Drive	T-20hrs	HOLD Point, if required.	TGD/TD
Weathe	T-20hrs	Weather & OPSEC evaluation.	TGD/TD/PD
Commenc	T-20hrs	Commence TRS fueling.	TRS/SAIC
Begin	T-16hrs	Begin second day bag deployment.	NMERI
Intern	T-10hrs	Internal roadblocks activated.	TGSO
Commenc	T-8hrs	Commence TRS unit checkout.	TRS/SAIC
HOLD P	T-7hrs	HOLD Point, if required.	TGD/TD
Commenc	T-7hrs	Commence LOX toff.	TRS/SAIC
Meteor	T-6hrs	Meteorology Balloon Launch.	WSMR ASL
Start	T-6hrs	Start Signal Dry Runs for WSMR NR/00.	IE
Estab	T-5hrs	Establish communications with Range Control.	NET OPERATOR (NO)
Make	T-5hrs	Make "GO" decision based on weather. Announce wind speed.	TGD/TD/NO
Estab	T-5hrs	Establish communications with trailers and bunkers.	NO
WES NP1	( )	BRL WP ( )	WB 1 ( )
WES NP2	( )	Canada ( )	WB 2 ( )
BRL NP	( )	BRL SP ( )	SB 1 ( )
NMERI	( )	EMA ( )	SB 2 ( )
		WES EP ( )	E3 1 ( )
		BRL EP ( )	T&F ( )
min Star	T-270min	Start signal dry runs for experimenters.	IE
HOLD	T-240	HOLD Point, if required.	TGD/TD
Comm	T-240	Commence local countdown broadcast on the hour. Announce "T-4 hours". Announce wind speed.	NO
Anno	T-240	Announce "Commence helium fill".	PD



Table 5.3. MINOR SCALE countdown (continued).

+/- TIME	EVENT	ACTIVITY	+/- TIME	Pho
T-210	Meteorology balloon launch.	WSMR ASL	T-120	Pho
T-210	Establish communications with all sites and trailers (use checkoff list). (Sites will respond in sequence. Respond with "_____ is on the air").	NO		Soc
	Millers Watch (5260) ( )	Atom (8010) ( )		Ho1
	Rt 13 South (5260) ( )	Hilltop (8010) ( )		El
	GUS (8050) ( )	Jim (8010) ( )	T-120	Anr
	GAP (8020) ( )	DRI ( )		Es
	SNLA (8620) ( )	LANL (5300's) ( )	T-120	Es
	McDonald's Ranch ( )	TIC (8012) ( )		
	WES NP1 ( )	BRL WP ( )		T-110
	WES NP2 ( )	Canada ( )		In
	BRL NP ( )	BRL SP ( )		te
	NMERI ( )	EMA ( )		T-105
		WES EP ( )		Sa
		BRL EP ( )		T-90
		WB 1 ( )		Bl
		WB 2 ( )		T-90
		SB 1 ( )		He
		SB 2 ( )		T-75
		EB 1 ( )		Cc
		T&F ( )		A'
		Ploss Site ( )		T-70
		Worley Site ( )		Cr
		Sail Hoist Crew ( )		a
		Risinger Site ( )		S
T-180	Open range net. Announce "T-3 hours". Announce wind Speed.	NO		H
T-178	Report readiness of technical cameras to Test Control.	WSMR/DRI	T-70	w
T-175	Helium fill status report given to Test Control.	PD/SAIC	T-66	A
T-150	HOLD Point, if required.	TGD/TD	T-66	B
T-150	Commence TRS unit final checkout.	TRS/SAIC	T-65	
T-150	Announce "30 minute warning for completion of signal dry runs".	IE		
T-150	Make "GO" decision based on weather conditions/Blast Focusing. Report test status to WSMR Range Control.	TGD/TD		
T-150	Experimenters commence clearing the testbed.	TGSO/ Project Officers		
T-126	Announce "Meteorology detonation in 5 minutes".	SNLA		
T-122	Announce "Meteorology detonation in 1 minute".	SNLA		
T-121	Meteorology detonation (10 second countdown).	SNLA		
T-120	Announce "T-2 hours". Announce wind speed and direction.	NO		
T-120	Helium fill status report given to Test Control.	PD/SAIC	T-62	



Table 5.3. MINOR SCALE countdown (continued).

+/- TIME	EVENT	ACTIVITY	+/- TIME	EV
T-62	Announce "Meteorology detonation in 1 minute".	SNLA	T-42	Helium
T-61	Meteorology detonation (10 sec countdown).	SNLA	T-40	Announc
T-60	Announce "T-1 hour". Commence countdown on range net in 10 minute intervals. Announce wind speed and direction.	NO	T-35	WB57 a
T-60	Report TRS readiness status.	TRS/SAIC	T-35	Report
T-60	Uncover WSMR classified e:periments.	WSMR-TE	T-30	HOLD P
T-60	Final readiness check. Respond with "_____ is ready for the event."	NO	T-30	Announ
	Millers Watch (5260) (✓)	Atom (8010) (✓)	T-30	RF-4 a
	Rt 13 South (5260) (✓)	Hilltop (8010) (✓)	T-30	Arming
	GUS (8050) (✓)	Jim (8010) (✓)	T-30	Author
	GAP (8020) (✓)	EMA (✓)	T-25	Helium
	SNLA (8620) (✓)	DxI (✓)	T-25	Report
	McDonald's Ranch (✓)	LAML (5300's) (✓)		to T&I
	Ploss Site (✓)	Worley Site (✓)		
	Sail Hoist Crew (✓)	TIC (8012) (✓)		
		TRS (✓)		
		TIC (8011) (✓)		
		T&F (✓)		
		WSMR T&F (✓)		
		Admin External (✓)		
		Risinger Site (✓)		
T-55	PMS aircraft launch.	PMS	T-24	Conf
T-55	Helium status report given to Test Control.	PD/SAIC	T-20	Annou
T-55	Begin switch to helium reserve tanks.	PD/SAIC	T-20	Lift
T-55	Announce "Commence radar avoidance around testbed until T-20 min."	NO	T-19	Conf
T-51	Surface wind report to TGD. Net operator announces conditions.	WSMR ASL/ SNLA/TRS	T-18	Conf
T-50	Announce "T-50 minutes". Announce wind speed and direction.	NO	T-16	Helium
T-50	Arming party enters testbed.	SNLA/NSWC	T-15	HOLD
T-46	Blast focusing report made to Test Control.	SNLA	T-15	Conf
T-45	HOLD Point, if required.	TGD/TD	T-15	Mann
T-45	Complete switch to helium reserve tanks.	PD/SAIC		with
T-45	TRS/WSMR/SAIC/Trailer/Bunker Operators and sail hoist crew depart testbed.	TRS/WSMR/ SAIC		SNLA
T-45	Request permission from Range Control to arm charge.	NO		EMA
				DRI
				TRS

Table 5.3. MINOR SCALE countdown (continued).

ACTIVITY  
 NLA  
 us  
 NLA  
 40  
 ft  
 S/SAIC  
 MR-TE  
 T-30  
 aft  
 (-)  
 (-)  
 (-)  
 arm  
 (-)  
 (-)  
 (-)  
 (-)  
 (-)  
 (-)  
 MS  
 MS a  
 T-2  
 S/SAIC  
 S/SAIC  
 ar av  
 )  
 )  
 9070  
 SMR ASL/  
 high NLA/TRS  
 4114  
 )  
 tatu  
 NLA/NSWC  
 nt,  
 NLA  
 RF-4  
 30/TD  
 tati  
 l per/SAIC  
 )  
 20) S/WSMR/  
 AIC  
 )

+/- TIME	EVENT	ACTIVITY
T-42	Helium status report given to Test Control..	PD/SAIC
T-40	Announce "T-40 minutes".	NO
T-35	WB57 aircraft launch.	NASA
T-35	Report "Testbed is clear except for arming/safety party".	TGSO
T-30	HOLD Point, if required.	TGS/TD
T-30	Announce "T-30 minutes".	NO
T-30	RF-4 aircraft launch.	USMC
T-30	Arming party requests permission from TGD to arm charge.	SNLA/NSWC
T-30	Authorize arming of charge.	TGD
T-25	Helium status report given to Test Control.	PD/SAIC
T-25	Report arming complete. Arming party departs GZ and returns to T&F van. Notify Range Control.	SNLA/NSWC/ NO
T-24	Confirm PMS aircraft is in holding orbit.	Cherokee/NO
T-20	Announce "T-20 minutes".	NO
T-20	Lift radar avoidance around testbed.	WSMR-NR
T-19	Confirm aircraft status at Kirtland AFB (F-14 and F-4C) (AV 244-9070).	NO
T-18	Confirm high altitude aircraft status at Beale AFB (AV 368-4114/2186).	NO
T-16	Helium status report given to Test Control.	PD/SAIC
T-15	HOLD Point, if required.	TGD/TD
T-15	Confirm RF-4 and WB57 aircraft are in holding orbit.	Cherokee/NO
T-15	Manned station personnel accountability check. Respond with "All personnel at _____ are in position."	NO
	SNLA (8620) ( )	Ploss Site ( )
	EMA ( )	Worley Site ( )
	DRI ( )	Risinger Site ( )
	TRS ( )	TIC (8011) ( )
		PMS Aircraft ( )
		T&F ( )
		WSMR T&F ( )
		Admin External ( )

Table 5.3. MINOR SCALE countdown (continued).

+/- TIME	EVENT	ACTIVITY	+/- TIME
T-12	Report testbed status to Range Control. Confirm range "GREEN".	NO	T-90s
T-10	Announce "T-10 minutes". Begin countdown announcements at 1 minute intervals.	NO	T-75s
T-10	Helium status report given to Test Control.	PD/SAIC	T-70s
T-9	Announce "T-9 minutes".	NO	T-65s
T-8	Announce "T-8 minutes".	NO	T-60s
T-7	Announce "T-7 minutes".	NO	T-50s
T-7	Announce "Meteorology detonation in 5 minutes".	SNLA	T-45s
T-6	Announce "T-6 minutes".	NO	T-40s
T-6	Request permission from Test Control to ready firing panel.	SNLA	T-30s
T-6	Direct "Ready the firing panel".	NO	T-20s
T-6	Helium status report given to T&F.	PD/SAIC	T-10s
T-6	Surface wind report to T&F.	TRS	T-5se
T-6	Confirm range green.	NO	T-4se
T-5	HOLD Point, if required.	TGD/TD	T-3se
T-5	Announce "T-5 minutes". Final T&F sequencing begins.	NO	T-2se
T-5	Establish ready-hold communications with NR.	TD	T-1se
T-5	Confirm firing panel ready. Arming Complete.	TD	T-0
T-4	Announce "T-4 minutes".	NO	T+30s
T-3	Announce "T-3 minutes".	NO	T+30s
T-3	Turn off tether sonde transmissions.	SNLA	T+31s
T-2.5	Start recorders.	T&F	T+40s
T-2.5	Ignite TRS burners.	TRS TD	T+50s
T-2	Announce "T-2 minutes".	NO	T+60s
T-2	Meteorology Detonation (NO countdown).	SNLA	T+1m

Table 5.3. MINOR SCALE countdown (continued).

ACTIVITY	+/- TIME	EVENT	ACTIVITY
NO	T-90sec	Announce "T-90sec."	NO
NO	T-75sec	Announce "Turn off power to helium system."	NO
PD/SAIC	T-70sec	TRS pressurization.	TRS
NO	T-65sec	Confirm helium system deenergized.	PD/SAIC
NO	T-60sec	Announce "T-60 seconds". Start 10 second countdown intervals.	NO
NO	T-50sec	Announce "T-50 seconds".	NO
SNLA	T-45sec	Confirm high voltage.	TD
NO	T-40sec	Announce "T-40 seconds".	NO
SNLA	T-30sec	Announce "T-30 seconds".	NO
NO	T-20sec	Announce "T-20 seconds".	NO
PD/SAIC	T-10sec	Announce "T-10 seconds".	NO
TRS	T-5sec	Announce "5".	NO
NO	T-4sec	Announce "4".	NO
TGD/TD	T-3sec	Announce "3".	NO
NO	T-2sec	Announce "2".	NO
TD	T-1sec	Announce "1".	NO
TD	T-0	DETONATE CHARGE.	T&F
NO	T+30sec	Announce "T+30 seconds".	NO
NO	T+30sec	Safe firing system.	SNLA
SNLA	T+31sec	DRI reports status.	DRI
T&F	T+40sec	Announce "T+40 seconds".	NO
RS TD	T+50sec	Announce "T+50 seconds".	NO
NO	T+60sec	Announce "T+1 minute".	NO
SNLA	T+1min	Meteorology balloon launch. Turn on tethersonde.	WSMR ASL/ SNLA

Table 5.3. MINOR SCALE countdown (continued).

+/- TIME	EVENT	ACTIVITY	+/- TIME
T+1	Report safing of firing system.	T&F	T+4hr Close
T+1	Commence Phase I reentry from T&F park.	TGSO	T+6hr Quiet
T+1	Notify ASL to launch meteorology rocket.	NO/SNLA	T+24hr 24
T+2	Announce "T+2 minutes". Terminate range count.	NO	
T+2	Report test execution and safe firing system to Range Control.	TGD	
T+2	Manned station personnel accountability check.	NO	
	Millers Watch (5620) ( )    Atom (8010) ( )    TRS ( )		
	Rt 13 South (5260) ( )    Hilltop (8010) ( )    TIC (8011) ( )		
	GUS (8050) ( )    JIM (8010) ( )    T&F ( )		
	GAP (8020) ( )    DRI ( )    WSMR T&F ( )		
	SNLA (8620) ( )    LANL (5300's) ( )		
	McDonald's Ranch ( )    TIC (8012) ( )		
T+3	Direct Phase II reentry party to proceed to staging areas.	TGSO	
T+3	Notify aircraft (F-14 and F-4C) at Kirtland AFB of event execution. (AV 244-9070)	NO	
T+4	Notify high altitude aircraft of event detonation (AV 368-4114/2186).	NO	
T+5	Reset halon fire protection systems.	Trailer Oprs	
T+10	Commence Phase II reentry.	TGSO	
T+15	Safety party reports progress.	TGSS	
T+30	Report to WSMR Range Control testbed safe and security controls are being established.	NO	
T+30	Set internal roadblocks/lift external roadblocks.	TGSO/WSMR Security/NO	
T+60	Commence Phase III reentry.	TGSO	
T+60	Press proceeds to Admin Park.	DNA/WSMR PAO	
T+90	Press interview.	TBD	
T+4hr	Lift internal roadblocks. Commence Phase IV reentry.	TGSO	

Table 5.3. MINOR SCALE countdown (continued).

<u>+/- TIME</u>	<u>EVENT</u>	<u>ACTIVITY</u>
T+4hr	Close Range Net.	NO
T+6hr	Quick Look Reports.	Project Officers
T+24hr	24 hour report.	TGD/TD



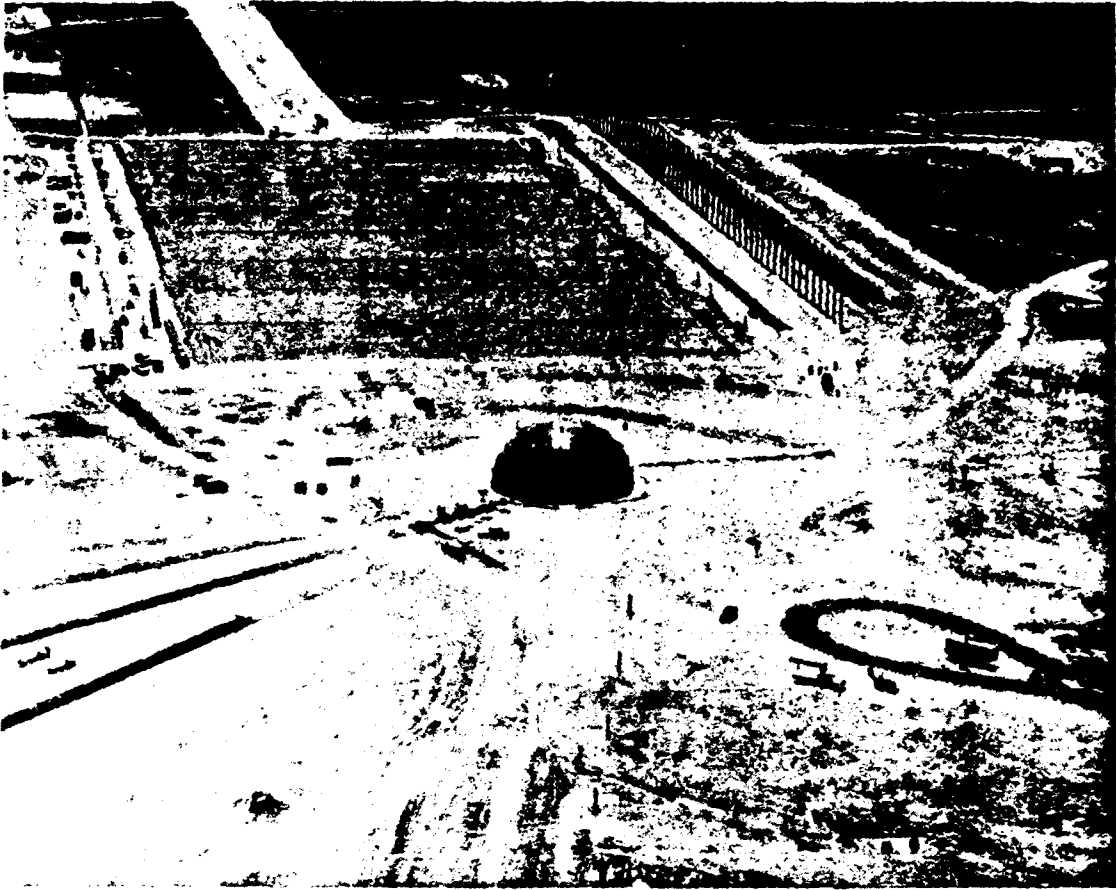

Figure 5.12. MINOR SCALE GZ at T-60 minutes, 27 June 1985.

countdown was resumed at 0930. The trouble with bag 1 and hold was called that time (T-65 minutes). At 1136 8. At T-20 minutes (1155), there was a disconnect problem. The countdown was disconnected. The pressure was 857.2 + 7.2°C and ambient soundspeed: 161 contained in Appendix L.

5.6.3 Helium Bags.  
The helium bags were deployed using the procedures used in deploying the data.

5.6.4 Reentry Plan.  
Appendix N is the reentry plan for the reentry.

Phase I was the safety survey. Four hazards were of concern: explosive radioactive sources. Included in the staging of security forces.

Phase II was the establishment of classified experiments, manning of recovery of classified technical files, and been declared safe.

Phase III contained "Other" security controls were established. recovery, VIP tour, installation of other support personnel requiring access to the testbed could be made outside of the established barricade

countdown was resumed at 0930. The new zero time of 1200 noon. At 1055 there was trouble with bag 1 and hold was called till 1110. The countdown was restarted at that time (T-65 minutes). At 1136 (T-24 minutes) dust devils destroyed bags 1 and 8. At T-20 minutes (1155), there was a 5 minute hold because of a helium truck disconnect problem. The countdown was resumed at 1200 with a 1220 zero time. The detonation took place at 1220 + 0.031 seconds. Figure 5.13 and 5.14 show the detonation. The pressure was 857.93 pascals, the temperature +24.8°C, dew point +7.2°C and ambient soundspeed 1161 ft/sec. The H+24 hour report of the event is contained in Appendix L.

#### 5.6.3 Helium Bags.

The helium bags were deployed as shown in Table 5.4. Appendix J gives the procedures used in deploying the bags and Appendix M gives the helium bags probe data.

#### 5.6.4 Reentry Plan.

Appendix N is the reentry plan for MINOR SCALE. There were four phases for the reentry.

Phase I was the safety sweep of the testbed immediately after the shot. Four hazards were of concern: explosives, TRS, high pressure helium, and experiment radioactive sources. Included in this phase was the air sampling team and the staging of security forces.

Phase II was the establishment of security safeguards/controls for the classified experiments, manning of the instrumentation parks and bunkers, and the recovery of classified technical film. This phase commenced when the testbed had been declared safe.

Phase III contained "Other Priority Activity" which occurred as soon as security controls were established. These other activities include precursor radial recovery, VIP tour, installation of road barriers, and diagnostic film recovery.

The reentry Phase IV was for all other experimenters, photographers and other support personnel requiring testbed access. Access control was relinquished at this time. Internal roadblocks were lifted as Phase IV commenced. In Phase IV access to the testbed could be made by any route. However, all vehicles were parked outside of the established barricades around sensitive areas.



Figure 5.13. MINOR SCALE airblast bubble.



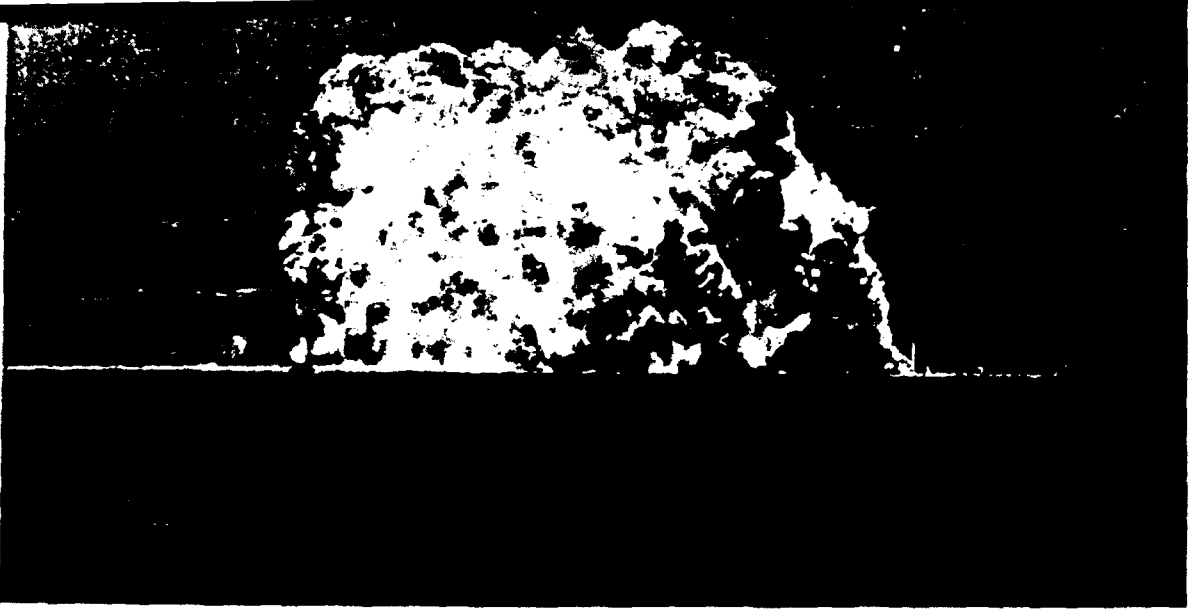

Figure 5.13. MINOR SCALE airblast bubble.



Figure 5.14. MINOR SCALE ejecta.

Table 5.4. MINOR SCALE bag time line.

Start deploying Bag 2	2049	25 June 1985 Tuesday
Finish deploying Bag 2	2251	
Start deploying Bag 1	2325	
Finish deploying Bag 1	0115	26 June 1985 Wednesday
Start deploying Bag 3	0308	
Finish deploying Bag 3	0308	
Bag 3 deployment halted by wind (delay)	0406	
Resume deploying Bag 3	2100	
Start deploying Bag 4	2110	
Finish deploying Bag 3	circa 2230	
Finish deploying Bag 4	circa 2305	
Start deploying Bag 6	2325	
Start deploying Bag 8	2355	26 June 1985
Finish deploying Bag 6	0110	27 June Thursday
Start deploying Bag 5	circa 0155	
Finish deploying Bag 8	0200	
Start deploying Bag 7	0355	
Finish deploying Bag 5	0435	
Finish deploying Bag 7	0630	
Helium checkout NMERI/SAIC	0800	
Start helium flow into Bag 1	0920	
Helium flow started into all bags	0931	
Original zero time	1000	
All bags nominally full	1053	
Switch over to helium skids	1134	
Dust devils destroy Bags 1 & 8	1136	
Test execution	1220	27 June 1985

ing Pha  
xperime  
ocument  
optical  
ay  
sday

During Phase IV the following major activities were conducted:

- Experiment Recovery.
- Documentary and Motion Picture Photography.
- Optical Instrumentation Film Recovery.



APPENDIX A  
ACRONYMS AND ABBREVIATIONS



APPENDIX A  
ACRONYMS AND ABBREVIATIONS

AFWL	Air Force Weapons Laboratory	EOD	explosive ordnance disposal	km
AGL	above ground level	EPA	Environmental Protection Agency	KT
ANFO	ammonium nitrate fuel oil	Exp	experiment	kV
ASL	Atmospheric Sciences Laboratory	FC	Field Command	LANL
BMO	Ballistic Missile Office, USAF	FCA	FCDNA Acquisition Office	LCDR
BFEC	Bendix Field Engineering Corporation	FCDC	flexible confined detonating cord	LOX
BIS	booster initiation system	FCDNA	Field Command, Defense Nuclear Agency	m
BMD	US Army Ballistic Missile Defense Command	FE	facility engineer	MBA
BRL	Ballistic Research Laboratory	FEMA	Federal Emergency Management Agency	MCD
CAN	Canada	FET	foreign equipment tests	MET
CERF	Civil Engineering Research Facility	FIDU	fiducial (signal)	MFP
CI	Curie	FR	French	mg
CI	Counter Intelligence	FRG	Federal Republic of Germany	MICOM
CSL	Chemical Systems Laboratory	GBL	GB Laboratories, Inc.	min
DDST	Deputy Director Science & Technology	GZ	ground zero	MMC
DNA	Defense Nuclear Agency	HATS	hardened tactical shelter	MV
DoD	Department of Defense	HDL	Harry Diamond Laboratories	MX
DOE	Department of Energy	He	helium	N
DRES	Defense Research Establishment-Suffield	HE	high explosive	NCEL
DYN	Dynatron	HML	hardened mobile launcher	NCO
E	East	HOB	height of burst	NOR
EA	environmental assessment	Hr	hour	NM
EBW	exploding bridgewire	HQ	headquarters	NMERI
EDL	engineering drawing list	HV	high voltage	NO
EMP	electromagnetic pulse	I Cam	internal cameras	NOSC
ENMU	Eastern New Mexico University, Portales	IE	instrumentation engineer	NR
E Cam	external cameras	ISI	Information Science, Inc.	NRP
		KAFB	Kirtland Air Force Base	NSWC
		KCF/H	thousand cubic feet/hour	NTS
				OD
				OP
				OPSE
				OR

meter  
 ton  
 volts  
 Alamo al  
 ommar Agency  
 id ox  
 i  
 boos  
 er cing cord  
 eoloclear  
 atory  
 igrar ent  
 Army l  
 nutes  
 tin-M  
 livol  
 sile y  
 -th  
 al Ci  
 abora  
 rcommi  
 way  
 Mexi  
 Mexi  
 Instit  
 t oper  
 val Oc  
 itiona  
 itiona  
 ival S  
 vada  
 erati  
 sserva  
 erati  
 erati

km kilometer  
 KT kilo ton  
 kV kilovolts  
 LANL Los Alamos National Laboratory  
 LCDR Lt Commander, USN  
 LOX liquid oxygen  
 m milli  
 MBA main booster assembly  
 MCD master countdown  
 MET meterological  
 MFP mandatory full participation  
 mg milligrams  
 MICOM US Army Missile Command  
 min minutes  
 MMC Martin-Marietta Corp.  
 MV millivolts  
 MX missile X  
 N North  
 NCEL Naval Civil Engineering Laboratory  
 NCO noncommissioned officer  
 NOR Norway  
 NM New Mexico  
 NMERI New Mexico Engineering Research Institute  
 NO net operator  
 NOSC Naval Ocean Systems Center  
 NR national range  
 NRP national range programs  
 NSWC Naval Surface Weapons Center  
 NTS Nevada Test Site  
 OD operations directives  
 OP observation point  
 OPSEC operational security  
 OR operations requirement

OSHA Occupational Safety and Health Administration  
 PA program analyst  
 PAO public affairs officer  
 PD program director  
 PHETS permanent high explosive test site  
 PMS particle measurement systems  
 POM project officer meeting  
 POR project officer report  
 ppm parts per million  
 pps pulses per second  
 psi pounds per square inch  
 PVC polyvinylchloride  
 R roentgen  
 S South  
 SAIC Science Applications, International Corp.  
 SEA Scientific and Engineering Associates  
 sec seconds  
 SF sulfur hexafluoride  
 SNLA Sandia National Laboratories, Albuquerque  
 SO safety officer  
 SOP standard operating procedure  
 SRC Stallion Range Center  
 SRII Stanford Research Institute, International  
 SSI Scientific Service, Inc.  
 SWED Sweden  
 T time  
 TD technical director  
 TER test execution report  
 TERA Terminal Effects Research and Analysis

T&F	timing and firing	TSP	twisted shielded part
TGD	test group director	TSP	technical support plan
TGE	test group engineer	UK	United Kingdom
TGS	test group staff	US	United States
TGSO	test group security officer	USMC	United States Marine Corp
TGSO	test group safety officer	V	volts
TIC	Technology International Corporation	VIP	very important persons
Tm	team	W	West
TOADS	time of arrival diagnostic system	WES	Waterways Experiment Station
TRI	Tech. Reps., Inc.	WSMR	White Sands Missile Range
TRS	thermal radiation source		

fon

OPER

APPENDIX B

OPERATION REQUIREMENT AND OPERATIONS DIRECTIVES

OR 96315	MINOR SCALE Event
OD 96315A	4,800 Ton ANFO Event
OD 96315B	Laser Test
OD 96315C	ANFO Mix and Loading
OD 96315D	Ground Shock
OD 96315D	Project Tests
OD 96316A	Aircraft Flights



5A  
020

OD NO. 96315A

OD NO: 96315A	DISTRIBUTION		REVISION NO:
PARAGRAPH 1020			OR TEST DESIGNATOR(S): None
AA. . . . .	1	<u>AIR FORCE</u>	
AFC . . . . .	0	AD-RUC. . . . .	1
HSHM-MHC-PR . . . . .	1	6585TG/RUM	
ASNC-TWS. . . . .	9	HAFB, NM 88330 . . . . .	1
DELAS-DP . . . . .	1	6586 TS/DOS	
IS-G . . . . .	4	HAFB, NM 88330 . . . . .	0
NR-AO . . . . .	5	Armt Div	
NR-CE . . . . .	0	ATTN: AD-TZP, Eglin AFB,	
NR-CF . . . . .	1	FL 32542 . . . . .	0
NR-CR . . . . .	6	Field Command, DNA. . . . .	
NR-D . . . . .	6	ATTN: FCTOU	
NR-CS . . . . .	2	Kirtland AFB, NM 87115-5000. . . . .	5
NR-CS-DMA . . . . .	1	. . . . .	
NR-PD . . . . .	3	TE . . . . .	0
NR-PR . . . . .	1	. . . . .	
PL-P. . . . .	0	. . . . .	
DP-F. . . . .	1	. . . . .	
SD . . . . .	1	. . . . .	
. . . . .		NONTS . . . . .	0
. . . . .		. . . . .	
. . . . .		. . . . .	
. . . . .		. . . . .	
. . . . .		. . . . .	
. . . . .		. . . . .	
. . . . .		. . . . .	
. . . . .		. . . . .	
. . . . .		. . . . .	



OR/OD No. 96315A	SECURITY CLASSIFICATION		REVISION No.
UDS PARAGRAPH: 1052			DATE:
PROGRAM TITLE: MC SERIES			
	ITEM	Classification	Declassification Date
G.	RECOVERY AID (Information)	N/A	
1.	Radar Look Angle at ground impact point	"	
2.	Radar range to ground impact point	"	
3.	Optical Instrument look angle at impact point	"	
4.	Telemetry look angle to loss of signal	"	
H.	OTHER ITEMS	"	
1.		"	
2.		"	
3.		"	
NOTE: The following provide classification level and downgrading instructions.			
1. CONFIDENTIAL DF, FCTOU, 30 Apr 85, subject: Classified Film from MFP.			
2. Ltr, FCTOU, 1 May 85, subject: Mission Classified Optical Instrumentation Film.			

PAGE 2 of  
 STEWS NR-P Form 16  
 1 Mar 79

NATIONAL RANGE USERS  
 HANDBOOK

PREVIOUS EDITIONS OF THIS FORM ARE OBSOLETE



NO: 96315A		<b>OPERATIONS DIRECTIVE</b>	REVISION NO:
UDS PARA			OR TEST DESIGNATOR(S): None
1100	PROGRAM AND TEST INFORMATION		
	a. Program Information		
	(1) User: Defense Nuclear Agency.		
	(2) Sponsor: NR-P, telephone, 678-1622.		
	(3) Priority: 3.		
	b. Test Information		
	(1) User Test Conductor: Maj. Michael G. Evinrude, Field Command, DNA telephone 679-4183.		
	(2) User Control Point: Admin Park, Permanent High Explosive Test Site, telephone 679-4183.		
	(3) Range Control Point: Stallion, Console 11, telephone 679-4430.		
	(4) OR Test Designator/OD Comparison		
	TEST DESIGNATOR	OD	Test Title
	None	96315A	4,800 Ton ANFO Event
		96315B	Laser Test
		96315C	ANFO Mix and Loading
		96315D	Ground Checks
		96315E	Project Tests
	(5) Test Description: MINOR SCALE will be a high explosive (HE) event designed to provide a blast, thermal and shock environment for Department of Defense (DOD), US Government agencies and foreign government sponsored target response experiments. For selected experiments, eight Thermal Radiation Sources (TRS) placed at varying distances from ground zero (GZ) will augment the blast and shock environment providing thermal radiation. The TRS will operate just prior to the main detonation. Execution is currently scheduled for 25 June 1985. MINOR SCALE will detonate 4,800 tons of ammonium nitrate and fuel oil (ANFO) placed at ground level. Target response experiments will be included in this test. Test objectives are to:		
	(a) Record blast and shock environment.		
	(b) Record damage to weapons, shelters and systems.		

NO: 96315A		<b>OPERATIONS DIRECTIVE</b>	REVISION NO:
CDS			OR TEST
PARA			DESIGNATOR(S): None
		<p>(c) Record synergistic effects of blast and thermal environments.</p> <p>(d) Increase weapons effects data base.</p>	
1800	<p><b>OPERATIONAL HAZARDS</b></p> <p>The operational hazards associated with this test are specified in the Operational Hazards Form (STEWS-NR-P Form 1) serial numbers MS-1 thru MS-10 dated 25 March 1985.</p>		
2000	<p><b>TEST OPERATIONAL CONCEPTS/SUMMARIES</b></p>		
a.	<p>Test Events</p>		
	EVENT NO.	+TIME	EVENT
	1	-8 CD	User submits schedule to Range Scheduler.
	2	-1 WD	User briefs WSMR support elements.
	3	-8 Hr 30M	WSMR starts master countdown (MCD). See MCD beginning on page A-1.
	4	+ASAP	NR project engineer submits Post-Test Counterorder (PTC) to WSMR support elements, as necessary, for deviations to test support.
b.	<p>Ground Safety Operational Concepts/Summaries</p> <p>(1) The MINOR SCALE Safety Plan, dated Feb 85 will cover operations for this test.</p> <p>(2) Roadblocks for the high explosive event (see map on following page):</p> <p>(a) Block Road 13 at the Mine Site to southbound traffic.</p> <p>(b) Block Road 7 at the telephone at Mockingbird Gap to northbound traffic.</p> <p>(c) Block Road 13 approximately 1.3 miles northeast of Pond Site to northeast bound traffic.</p> <p>(d) Block Road 20 approximately 0.7 miles west of the intersection of Road 7 and 20 to eastbound traffic.</p> <p>(e) Block Road 7 at the intersection of Road 7 and the Observation Point Road to southbound traffic.</p>		

OD NO: 96315A	<b>ROAD BLOCK MAP</b>	REV NO:
TITLE: M C Series		TEST DESIGNATOR: None

NO:  
CDS  
PARA  
2100

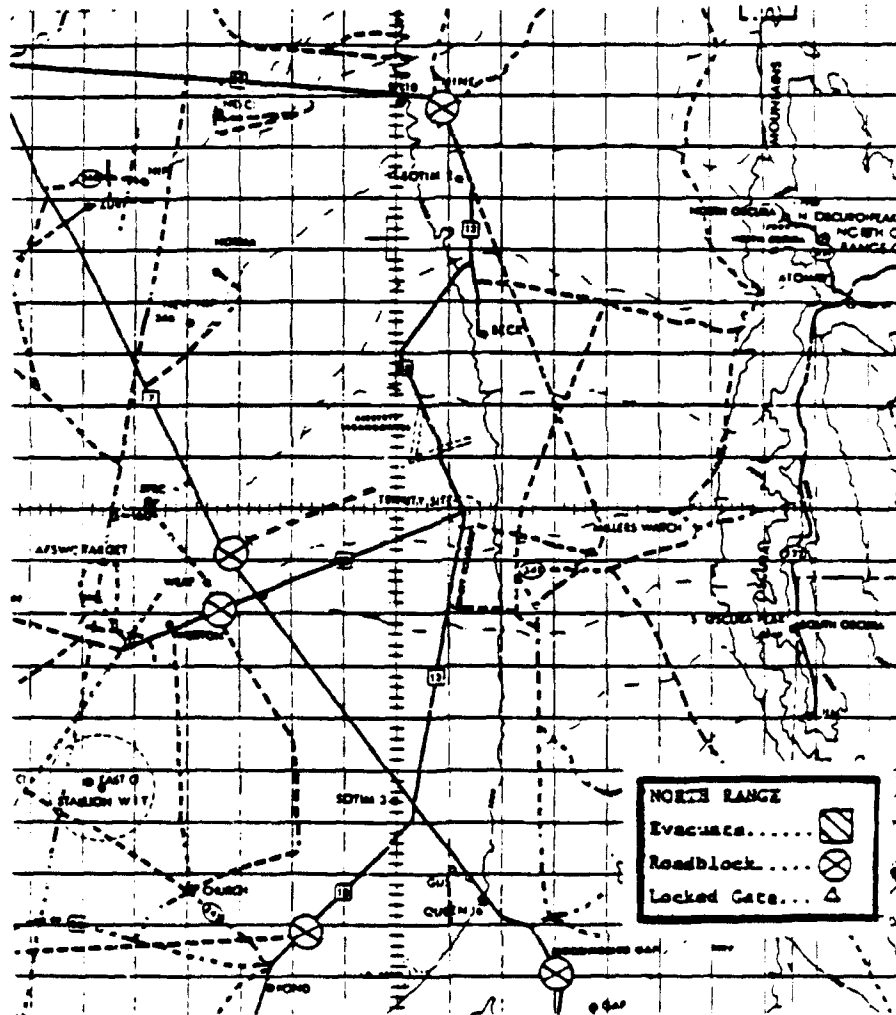

27C

3

NO: EDS PARA	96315A	<b>OPERATIONS DIRECTIVE</b>	REVISION NO: OR TEST
			DESIGNATOR(S): None
2100	<b>MEASUREMENTS AND DATA</b>  <b>Fixed Cameras</b> (1) Sites/Assignments: See pages of this document beginning with page B-1. (2) Support: (a) Provide coverage of equipment and structures under the influence of a high pressure shockwave. (b) Provide coverage of the detonation fireball, shockwave expansion, cloud formation and rise.		
2700	<b>GROUND COMMUNICATIONS</b>  a. A point to point voice net will be provided between trailer A (Test Control) in the Administration Park and the timing and firing trailer in the Timing and Firing Park. b. The Stallion local command net will be provided to trailer A. c. An outdoor public address system will be provided at the observation point. d. Telephones will be provided as requested.		
3200	<b>METEOROLOGY</b>  a. <b>Forecasts</b> (1) Standard WSMR 24 hour forecasts will be available. An updating of all forecast data can be obtained from the duty forecaster at 678-1032/2605. (2) Forecasts of high surface winds (in excess of 20 knots) and/or electrical storms in the test vicinity will be provided from D-15 days through event execution to the test representative (679-4183).  b. <b>Observations</b> (1) <b>Surface</b> (a) A mobile meteorological tower will be provided at the Administration Park to obtain standard WTH data at 25, 50, and 75 feet with readout in the administration trailer. (b) Anemometer recordings will be provided in the administration trailer.		

315A

MEASUREMENTS  
Fixed Camera  
1) Sites  
2) Support  
a) Provide high pressure  
b) Provide formation

GROUND COMMUNICATIONS  
A point to point in the Administration Park and the timing and firing trailer  
The Stallion local command net  
An outdoor public address system  
Telephones

METEOROLOGY  
Forecast  
(1) Standard WSMR 24 hour forecast  
(2) Forecasts of high surface winds and/or electrical storms  
Observations  
(1) Surface  
(a) Administration Park meteorological tower  
(b) Anemometer recordings

NO: 96315A		<b>OPERATIONS DIRECTIVE</b>			REVISION NO:																																																																																			
UDS PARA					OR TEST		DESIGNATOR(S): None																																																																																	
3400	(2) Upper Air: Data will be obtained from rawinsonde balloon releases at Stallion Site at D-3, T-6 hour, T-3 hour, T-1 hour and T-0. Data will be collected from surface to 6 km MSL. WTH data in 150 meter increments will be provided to the on-site representative.																																																																																							
	<b>OTHER TECHNICAL SUPPORT</b>																																																																																							
	Frequency Control and Analysis																																																																																							
	(1) Station Plan: HAFB (1).																																																																																							
	(2) Frequency Protection Plan																																																																																							
	<table border="1"> <thead> <tr> <th>NOMENCLATURE OR FUNCTION</th> <th>FREQ (MHz)</th> <th>REPC (+MHz)</th> <th>AEB (kHz)</th> <th>RFA</th> </tr> </thead> <tbody> <tr> <td>A/G Comm</td> <td>139.05</td> <td>-</td> <td>-</td> <td>CAL AA III</td> </tr> <tr> <td>A/G Comm</td> <td>141.45</td> <td>-</td> <td>-</td> <td>CAL AA III</td> </tr> <tr> <td>A/G Comm</td> <td>139.10</td> <td>-</td> <td>-</td> <td>CAL AA III</td> </tr> <tr> <td>A/G Comm</td> <td>139.25</td> <td>-</td> <td>-</td> <td>CAL AA III</td> </tr> <tr> <td>A/G Comm</td> <td>166.00</td> <td>-</td> <td>-</td> <td>CAL AA III</td> </tr> <tr> <td>Exp Diag</td> <td>0.106</td> <td>0.01</td> <td>-</td> <td>WS 40127</td> </tr> <tr> <td>Exp Diag</td> <td>0.200</td> <td>0.01</td> <td>-</td> <td>WS 40127</td> </tr> <tr> <td>Exp Diag</td> <td>2500</td> <td>1.00</td> <td>-</td> <td>WS 40127</td> </tr> <tr> <td>Exp Diag</td> <td>9086.616</td> <td>1.00</td> <td>-</td> <td>WS 50020</td> </tr> <tr> <td>Exp Diag</td> <td>96000</td> <td>100,000</td> <td>200,000</td> <td>WS 40121</td> </tr> <tr> <td>Exp Diag</td> <td>140,500</td> <td>100,000</td> <td>200,000</td> <td>WS 40121</td> </tr> <tr> <td>Exp Diag</td> <td>255,000</td> <td>100,000</td> <td>200,000</td> <td>WS 40121</td> </tr> <tr> <td>Instrumentation</td> <td>149.15</td> <td>-</td> <td>16</td> <td>WS 40112</td> </tr> <tr> <td>Exp Diag</td> <td>220.3</td> <td colspan="4">User must obtain proper authorization before</td> </tr> <tr> <td>Exp Diag</td> <td>50.3</td> <td colspan="4">frequencies can be scheduled for use at WSMR.</td> </tr> </tbody> </table>						NOMENCLATURE OR FUNCTION	FREQ (MHz)	REPC (+MHz)	AEB (kHz)	RFA	A/G Comm	139.05	-	-	CAL AA III	A/G Comm	141.45	-	-	CAL AA III	A/G Comm	139.10	-	-	CAL AA III	A/G Comm	139.25	-	-	CAL AA III	A/G Comm	166.00	-	-	CAL AA III	Exp Diag	0.106	0.01	-	WS 40127	Exp Diag	0.200	0.01	-	WS 40127	Exp Diag	2500	1.00	-	WS 40127	Exp Diag	9086.616	1.00	-	WS 50020	Exp Diag	96000	100,000	200,000	WS 40121	Exp Diag	140,500	100,000	200,000	WS 40121	Exp Diag	255,000	100,000	200,000	WS 40121	Instrumentation	149.15	-	16	WS 40112	Exp Diag	220.3	User must obtain proper authorization before				Exp Diag	50.3	frequencies can be scheduled for use at WSMR.			
	NOMENCLATURE OR FUNCTION	FREQ (MHz)	REPC (+MHz)	AEB (kHz)	RFA																																																																																			
	A/G Comm	139.05	-	-	CAL AA III																																																																																			
	A/G Comm	141.45	-	-	CAL AA III																																																																																			
	A/G Comm	139.10	-	-	CAL AA III																																																																																			
	A/G Comm	139.25	-	-	CAL AA III																																																																																			
	A/G Comm	166.00	-	-	CAL AA III																																																																																			
	Exp Diag	0.106	0.01	-	WS 40127																																																																																			
	Exp Diag	0.200	0.01	-	WS 40127																																																																																			
	Exp Diag	2500	1.00	-	WS 40127																																																																																			
Exp Diag	9086.616	1.00	-	WS 50020																																																																																				
Exp Diag	96000	100,000	200,000	WS 40121																																																																																				
Exp Diag	140,500	100,000	200,000	WS 40121																																																																																				
Exp Diag	255,000	100,000	200,000	WS 40121																																																																																				
Instrumentation	149.15	-	16	WS 40112																																																																																				
Exp Diag	220.3	User must obtain proper authorization before																																																																																						
Exp Diag	50.3	frequencies can be scheduled for use at WSMR.																																																																																						
3500	<b>Medical</b>																																																																																							
	Medical support will be provided from D-18 through event day.																																																																																							

NO:
UDS
PARA

4100

4200

5300

15A

NO: 96315A		<b>OPERATIONS DIRECTIVE</b>	REVISION NO:
U DS			OR TEST
PARA			DESIGNATOR(S): None
4100	<b>DATA PROCESSING</b>	Data reduction of detonation, dust phenomenology, shock wave expansions, cloud formation, detonation velocity, uniformity of detonation, shock wave separation, and fireball characteristics will be provided. The user is requested to work closely with data analysis personnel during the data reduction period to assure the reports are complete and in an acceptable format.	
4200	<b>DATA DELIVERY AND DISPOSITION</b>	Three tabulated copies of all upper air data and copies of all anemometer charts will be sent to the following addressee:  Commander, Field Command Defense Nuclear Agency ATTN: FCTT (CPT Raska) Kirtland AFB, NM 87115-5000	
5300	<b>SUPPLY/STORAGE/SERVICES</b>	Security: Security support will be provided from D-57 through D+15 days.	

TA PROCES

reduct  
ud form  
aration  
quested  
duction  
rmat.

TA DELIV

ree tabu  
arts wil

UPPLY/STC

ecurity:

NR-P Form  
111

OD NO: 96315A		MASTER COUNTDOWN & OPERATION LOG		REVISION NO:		PRIORITY: 3		SERVICE: 0		PAGE 1 OF 4	
UDS PARAGRAPH 2000				OR TEST DESIGNATOR(S): NONE		OPN TITLE: 4,800 Ton ANFO Event					
OPN INDEX:		TEST DATE:		RANGE CONTROLLER:							
EVENT NO	RESP ELEM	EVENT	T+TIME	ACTUAL TIME	STATUS		REMARKS				
					G	R					
		STARTS TEST									
1	NR-CR	Mans Range Control Complex.	-08H 30M								
2	NR-CR	Conducts communications checks. Provides time check.	-08H 00M								
3	User	Conducts Thermal Radiation Source (TRS) unit checks.	-08H 00M								
4	User	Commences liquid oxygen (LOX) fill.	-07H 00M								
5	ASL	Launches Sotim 3 met balloon.	-06H 00M								
6	User	Sets internal test bed roadblocks and evacuates nonessential personnel.	-06H 00M								
7	NR-CR	Checks command net, ready/hold and fire command inhibit circuits with user.	-04H 00M								
8	NR-CR	Provides standard countdown to event and two minute plus count.	-04H 00M								
9	ASL	Launches Sotim 3 met balloon.	-03H 00M								
10	NR-CR	Verifies readiness of technical cameras.	-03H 00M								

112

STEWS-NR-P Form 25(Rev)  
1 Aug 78

Replaces STEWS-NR-P Form 25, 1 Jul 73, which is obsolete.

STEWS-NR-P SOP 70-10c

OD NO: 96315A		MASTER COUNTDOWN & OPERATION LOG (Continuation)		REVISION NO:		PAGE 2 OF 4	
UDS PARAGRAPH 2000				OR TEST DESIGNATOR(S): NONE			
EVENT NO	RESP ELEM	EVENT	T+TIME	ACTUAL TIME	STATUS		REMARKS
					G	R	
11	NR-CR	Obtains FO-NOGO status from user based on weather evaluation.	-02H 30M				
12	User	Conducts met detonation.	-02H 00M				
13	NR-CR	Directs SD-P to set external roadblocks.	-01H 45M				
14	User	Verifies Adm and Instrumentation Parks evacuated of nonessential personnel.	-01H 15M				
15	ASL	Launches Sotim 3 met balloon.	-01H 05M				

7	NR-CR	Checks command net, ready/hold and fire command inhibit circuits with user.	-04H 00M			
8	NR-CR	Provides standard countdown to event and two minute plus count.	-04H 00M			
9	ASL	Launches Sotim 3 met balloon.	-03H 00M			
10	NR-CR	Verifies readiness of technical cameras.	-03H 00M			

STEWS-NR-P Form 25 (Rev) 1 Aug 78  
 Replaces STEWS-NR-P Form 25, 1 Jul 73, which is obsolete.  
 STEWS-NR-P SOP 70-10c

OD NO: 96315A		MASTER COUNTDOWN & OPERATION LOG (Continuation)			REVISION NO:		PAGE 2 OF 4	
UDS PARAGRAPH 2000					OR TEST DESIGNATOR(S): NONE			
EVENT NO	RESP ELEM	EVENT	T+TIME	ACTUAL STATUS		REMARKS		
				TIME	C		R	
11	NR-CR	Obtains GO-NOGO status from user based on weather evaluation.	-02H 30M					
12	User	Conducts met detonation.	-02H 00M					
13	NR-CR	Directs SD-P to set external road-blocks.	-01H 45M					
14	User	Verifies Adm and Instrumentation Parks evacuated of nonessential personnel.	-01H 15M					
15	ASL	Launches Sotim 3 met balloon.	-01H 05M					
16	User	Conducts met detonation.	-01H 00M					
17	User	Verifies TRS ready.	-01H 00M					
18	NR-CR	Verifies overflight protection.	-01H 00M					
19	NR-CR	Verifies and announces radar avoidance of test bed.	-01H 00M					
20	User	Conducts arming of charge.	-40M 00S					
21	User	Completes arming and verifies GZ clear	-20M 00S					
22	NR-CR	Lifts radar avoidance of test bed.	-20M 00S					

STEWS-NR-P Form 25-1 (Rev) 1 Aug 78  
 Replaces STEWS-NR-P Form 25-1, 1 Jul 73, which is obsolete.  
 STEWS-NR-P SOP 70-10c

113



OD NO: 96315A		MASTER COUNTDOWN & OPERATION LOG (Continuation)			REVISION NO: OR TEST DESIGNATOR(S):	PAGE 3 OF 4
UDS PARAGRAPH 2000		T-TIME	ACTUAL STATUS	REMARKS		
EVENT NO	BSP ELEM		G R			
23	NR-CR			-15M 00S		
a.	THS	Obtains status: Comm/Tim/Data Ckts				
b.	RUM	Airspace				
c.	DP-F	Ground Safety				
d.	User	Test Conductor				
24	NR-CR	Verifies roadblocks set.		-15M 00S		
25	NR-CR	Announces Range Status. HOLDS IF RED.		-12M 00S		
26	User	Confirms firing panel ready.		-08M 00S		
27	NR-CR	Confirms command net and ready/hold circuits with Test Director.		-05M 00S		
28	User	Evaluates weather. HOLDS IF RED.		-04M 00S		
29	User	Ignites TRS burners.		-03M 30S		
30	User	Conducts met detonation.		-02M 00S		
31	User	Detonates charge.		00M 00S		
32	ASL	Launches Sotim 3 met balloon.		+01M 00S		
33	User	Verifies safing of firing system.		+01M 00S		
34	User	Verifies test bed safe and security controls established.		+30M 00S		
35	NR-CR	Directs SD-P to lift external roadblocks and set internal roadblocks.		+30M 00S		

STENS-NR-P Form 25-1 (Rev) 1 Aug 78 Replaces STENS-NR-P Form 25-1, 1 Jul 73, which is obsolete. STENS-NR-P SOP 70-10c

OD NO: 96315A		MASTER COUNTDOWN & OPERATION LOG (Continuation)			REVISION NO: OR TEST DESIGNATOR(S):	PAGE 4 OF 4
UDS PARAGRAPH 2000		T-TIME	ACTUAL STATUS	REMARKS		
EVENT NO	BSP ELEM		G R			

30	User	Conducts met detonation.	-02M 00S			
31	User	Detonates charge.	00M 00S			
32	ASL	Launches Sotim 3 met balloon.	+01M 00S			
33	User	Verifies safing of firing system.	+01M 00S			
34	User	Verifies test bed safe and security controls established.	+30M 00S			
35	NR-CR	Directs SD-P to lift external roadblocks and set internal roadblocks.	+30M 00S			

STWS-NR-P Form 25-1 (Rev) 1 Aug 78 Replaces STWS-NR-P Form 25-1, 1 Jul 73, which is obsolete. STEWS-NR-P SOP 70-10c

OD NO: 96315A		MASTER COUNTDOWN & OPERATION LOG (Continuation)				REVISION NO:	PAGE 4 OF 4
UDS PARAGRAPH 2000						OR TEST DESIGNATOR(S): NONE	
EVENT NO	RESP ELEM	EVENT	T+TIME	ACTUAL TIME	STATUS	REMARKS	
36	NR-CR	Lifts internal roadblocks.	+04H 00M				
37	NR-CR	Terminates operation. Releases supporting elements.	+06H 00M				
		TEST COMPLETE					

STWS-NR-P Form 25-1 (Rev) 1 Aug 78 Replaces STWS-NR-P Form 25-1, 1 Jul 73, which is obsolete. STEWS-NR-P SOP 70-10c

36 NR-CR Lifts internal roadblocks.  
 37 NR-CR Terminates operation. Releases supporting elements.

115

OD 96315A

OR TEST DESIGNATOR: None

EXP. #	CAMERA STATION	CAMERA TYPE	FPS	LENS (mm)	EXP. #	CAMERA STATION	CAMERA TYPE	FPS	LENS (mm)
1220	F-3762	LOCAM	400	10	2040	F-3842 **	LOCAM	400	13
	F-3763	LOCAM	400	10		F-3843 **	LOCAM	250	3
1221	F-3764	LOCAM	400	10	2050	F-3844 **	LOCAM	400	13
	F-3765	LOCAM	400	10		F-3846 **	LOCAM	400	13
1280	F-3823	LOCAM	400	13		F-3847 **	LOCAM	400	13
1291	F-3824	LOCAM	400	13		F-3848 **	LOCAM	250	3
1300	F-3762 *	LOCAM	400	13	2051	F-3849 **	LOCAM	400	13
	F-3767 *	LOCAM	400	13		F-3850 **	LOCAM	400	13
	F-3768 *	LOCAM	250	6		F-3851 **	LOCAM	400	13
1405	F-3772	LOCAM	400	13	2060	F-3853 **	LOCAM	400	13
	F-3773 *	LOCAM	400	13		F-3854 **	LOCAM	400	13
	F-3774 *	LOCAM	250	6		F-3855 **	LOCAM	400	13
1306	F-3775 *	LOCAM	400	13	2061	F-3857 **	LOCAM	400	13
	F-3776 *	LOCAM	400	13		F-3858 **	LOCAM	400	13
	F-3777 *	LOCAM	250	6		F-3859 **	LOCAM	400	13
1307	F-3938 *	LOCAM	400	13	2070	F-3861 **	LOCAM	400	13
	F-3939 *	LOCAM	400	13		F-3862 **	LOCAM	400	13
1310	F-3778 *	LOCAM	400	13		F-3867 *	LOCAM	400	13
	F-3779 *	LOCAM	400	13	3040	F-3864	LOCAM	400	5.7
	F-3780 *	LOCAM	250	6		F-3865	LOCAM	400	5.7
1315	F-3781 *	LOCAM	400	13		F-3866	LOCAM	400	5.7
	F-3782 *	LOCAM	400	13	3100	F-3867	LOCAM	400	13
	F-3783 *	LOCAM	250	6		F-3868	LOCAM	400	13
1320	F-3784 *	LOCAM	400	13		F-3869	LOCAM	400	10
	F-3785 *	LOCAM	400	13		F-3870	LOCAM	400	10
	F-3786 *	LOCAM	250	6	3102	F-3875	LOCAM	400	13
1325	F-3787 *	LOCAM	400	13	3104	F-3875	LOCAM	400	13
	F-3788 *	LOCAM	400	13	3105	F-3876	LOCAM	400	13
	F-3789 *	LOCAM	250	6	3107	F-3877	LOCAM	400	13
1330	F-3790 *	LOCAM	400	13		F-3878	LOCAM	400	13
	F-3791 *	LOCAM	400	13		F-3879	LOCAM	400	13
1336	F-3917 *	LOCAM	400	13	3108	F-3880	LOCAM	400	13
	F-3918 *	LOCAM	400	13	3109	F-3881	LOCAM	400	13
	F-3919 *	LOCAM	250	6		F-3882 *	LOCAM	400	13
1357	F-3814 *	LOCAM	400	13		F-3883	LOCAM	400	10
	F-3815 *	LOCAM	400	13	3110	F-3818 **	LOCAM	400	13
1365	F-3813 *	LOCAM	400	13		F-3819 **	LOCAM	400	13
1375	F-3816 *	LOCAM	400	13		F-3820	LOCAM-L	250	6
	F-3817 *	LOCAM	400	13	5200	F-3864	NOVA-L	1000	13
1380	F-3794 *	LOCAM	400	13		F-3865	NOVA-L	1000	13
	F-3795 *	LOCAM	400	13		F-3866	48	24	40
1381	F-3796 *	LOCAM	400	13	5200	F-3869 **	NOVA-L	2000	13
1382	F-3867 *	LOCAM	400	13	6000	F-3891 **	NOVA-L	2000	13
1386	F-3871	LOCAM	400	13	6001	F-3893 **	NOVA-L	2000	13
	F-3872	LOCAM	400	13	6002	F-3895 **	NOVA-L	2000	13
1610	F-3821	LOCAM	400	25	6004	F-3895 **	NOVA-L	2000	13
	F-3822	LOCAM	400	13	6210	F-3909 **	NOVA-L	2000	13
2011	F-3823 **	NOVA-L	2000	3	6211	F-3910 **	NOVA-L	2000	13
2021	F-3829 **	NOVA-L	2000	8	6220	F-3913 **	NOVA-L	2000	13
	F-3829 **	LOCAM	400	3	6221	F-3770 **	NOVA-L	2000	13
2030	F-3837 **	LOCAM	400	3	7000	F-3931	NOVA-L	1000	13
	F-3838 **	LOCAM	250	6		F-3932	NOVA-L	1000	13
2031	F-3833 **	LOCAM	400	6		F-3933	NOVA-L	1000	13
	F-3834 **	LOCAM	250	6		F-3934	NOVA-L	1000	13
2032	F-3835 **	LOCAM	400	6		F-3935	NOVA-L	2000	13
	F-3836 **	LOCAM	250	6		F-3936	NOVA-L	2000	13
2033	F-3830	LOCAM	400	3		F-3937	NOVA-L	2000	13
	F-3831 **	LOCAM	400	3		F-3938	NOVA-L	2000	13
	F-3832 **	LOCAM	250	6		F-3939	NOVA-L	2000	13
2040	F-3841 **	LOCAM	400	13	7002	F-3940	NOVA-L	2000	13
					7040	F-3941	NOVA-L	2000	3
						F-3880	LOCAM	400	13
						F-3940	LOCAM	400	13
						F-3949	NOVA-L	1000	13

\* See Note 1 on page 2 of this document.  
 \*\* See Note 2 on page 2 of this document.

DD 96315A

OR TEST DESIGNATOR: None

None

EXP. #	CAMERA STATION	CAMERA TYPE	FPS	LENS (mm)	EXP. #	CAMERA STATION	CAMERA TYPE	FPS	LENS (mm)
7040	F-3950	NOVA-L	1000	13	9000	F-3750	4C	2500	500
	F-3951	NOVA-L	1000	13		F-3751	4C	2500	500
7100	F-3956	NOVA-L	1000	13		F-3752	4C	5000	100
7151	F-3957	NOVA-L	1000	13		F-3760	100	100	135
7179	F-3958 **	LOCAR	400	13		F-3761	100	120	135
7171	F-3961 **	LOCAR	400	13	9001	F-3753	NYCRN	10000	100
7172	F-3962 **	NOVA-L	2000	13		F-3754	NYC-WF	20000	75
7180	F-3963 **	LOCAR	400	13		F-3914	NYC-WF	20000	75
7131	F-3964 **	LOCAR	400	13		F-3755	NYCRN	10000	150
7200	F-3966	LOCAR	400	5		F-3756	NYC-WF	20000	75
7201	F-3967	LOCAR	400	5		F-3915	NYC-WF	20000	75
7199	F-3968	LOCAR	400	5		F-3757	NYCRN	10000	150
	F-3969	LOCAR	400	5		F-3758	NYC-WF	20000	100
8050	GUS SITE	4E	6	50		F-3716	NYC-WF	20000	150
8050		4E	6	50	9010	F-4021	NOVA-L	6000	75
8791	F-3975	FII-WF	10000	250		F-4022	NOVA-L	6000	75
	F-3976	FII-H	10000	250		F-4023	NOVA-L	3000	50
	F-3977	FII-H	10000	250		F-4025	LOCAR	400	25
	F-3978	FII-H	10000	250					
	F-3979	FII-H	10000	250					
	F-3980	FII-H	10000	250					
	F-3981	FII-H	10000	250					
	F-3982	FII-H	10000	250					
	F-3983	FII-H	10000	250					
	F-3984	FII-H	10000	250					
	F-3985	FII-H	10000	250					
	F-3986	FII-H	10000	250					
	F-3987	FII-H	10000	250					
	F-3988	NOVA-H	10000	250					
	F-3989	NOVA-H	10000	250					
	F-3990	NOVA-H	10000	250					
	F-3991	NOVA-H	10000	250					
	F-3992	NOVA-H	10000	250					
	F-3993	NOVA-H	10000	250					
	F-3994	NOVA-H	10000	250					
	F-3995	NOVA-H	10000	250					
	F-4001	4C	2500	250					
	F-4002	4C	2500	250					
	F-4003	4C	2500	250					
	F-4004	100	300	250					
	F-4005	100	300	250					
8790	F-3997	FII-H	10000	25					
	F-3998	4C	2500	50					
	F-3999	4C	2000	50					
	F-4000	100	200	50					
9000	F-3732	4C	2500	500					
	F-3733	4C	2500	500					
	F-3734	4C	2500	500					
	F-3735	4C	2500	500					
	F-3736	4C	2500	500					
	F-3737	4C	2500	500					
	F-3738	4C	5000	100					
	F-3739	4C	2500	500					
	F-3740	4C	2500	500					
	F-3741	4C	2500	500					
	F-3742	4C	2500	500					
	F-3743	4C	2500	500					
	F-3744	4C	2500	500					
	F-3745	4C	2500	500					
	F-3746	4C	5000	500					
	F-3747	4C	2500	500					
	F-3748	4C	2500	500					
	F-3749	4C	2500	500					

1  
2  
3

APPENDIX C

STATEMENT OF ENVIRONMENTAL CONSIDERATION

1. Letter 23 Oct 1984 DNA to Assistant Secretary of Defense.
2. Title page "Environmental Assessment of the MINOR SCALE High-Explosive Test"
3. Finding of No Significant Impact from Major General Grayson O. Tate, Jr. USA Deputy Director, WSMR



LEEE

DEFENSE NUCLEAR AGENCY  
WASHINGTON, D.C. 20305

23 OCT 1984

MEMORANDUM FOR ASSISTANT SECRETARY OF DEFENSE (MANPOWER, INSTALLATIONS  
AND LOGISTICS)(ENVIRONMENTAL POLICY)  
COMMANDER, FIELD COMMAND, DEFENSE NUCLEAR AGENCY (FCP)

SUBJECT: Environmental Assessment for the MINOR SCALE High-Explosive Test

1. Reference DoD Directive 6050.1, Environmental Effects in the United States of DoD Actions, 30 July 1979.
2. Attached (Enclosure 1) is the Environmental Assessment for a High Explosive test at White Sands, New Mexico. *The findings of the Environmental Assessment show that the program will not have a significant effect on the quality of human environment.*
3. Based on a review of the above findings and the guidelines contained in the reference, I have determined that an Environmental Impact Statement is not necessary for this event. A Finding of No Significant Impact is attached (Enclosure 2).

FOR THE DIRECTOR:

  
 THOMAS P. JEFFERS  
 Director for Logistics & Engineering

2 Enclosures  
as

ENVIRC  
MINOR

Frank  
Kennet  
KAMAN  
816 S1  
Santa

4 Sept

Final

Prepa

Direc  
DEFEN  
Washi

KT-84-011(R)

ENVIRONMENTAL ASSESSMENT OF THE  
MINOR SCALE HIGH-EXPLOSIVE TEST

Frank W. McMullan  
Kenneth E. Gould  
KAMAN TEMPO  
816 State Street  
Santa Barbara, California 93102

4 September 1984

Final Report for Period 6 February 1984 - 30 April 1985

CONTRACT NUMBER DNA 001-84-C-0154

THIS WORK SPONSORED BY THE DEFENSE NUCLEAR AGENCY  
UNDER RDT&E RMSS CODE B3450 84466 H R 00002 25904D

Prepared for:

Director  
DEFENSE NUCLEAR AGENCY  
Washington, D.C. 20305

■ TA  
- E

3 OCT 1984

■ C

■ C

■ C

St

■ ar. LATIONS

(FCP)

■ r Explosive Test

ne United States

■ a High  
■ rta Environmental  
ffect on the

contained in  
Statement is not  
is attached

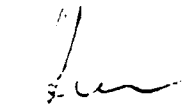

Engineering

for

IUCL

in,



## Finding of No Significant Impact

### 1. NAME OF PROPOSED ACTION

MINOR SCALE High-Explosive Test

### 2. DESCRIPTION OF PROPOSED ACTION

Field Command, Defense Nuclear Agency, proposes to conduct a high explosive test program 3.5 miles south of the Trinity Complex, White Sands Missile Range (WSMR), New Mexico to record blast and shock phenomena; record damage to weapons, shelters, and systems; record effects of combined blast and thermal phenomena; and increase the weapons effects data base. The proposed plan is to detonate a charge of explosives equivalent to 4000 tons of TNT, which would simulate the blast and shock from an 8 KT nuclear surface burst. The planned ground zero (GZ) is within a few hundred meters of several smaller scale detonations in 1981, 1982, 1983, and 1984.

Following the test the rubble will be removed; temporary structures and recoverable cabling will be salvaged and removed; and the crater filled. Alternate locations were considered but were discarded because of the availability of the required geologic characteristics at WSMR. Further, the proposed site is remote from population centers and is located on a national range dedicated to large scale testing.

### 3. ANTICIPATED ENVIRONMENTAL EFFECTS

The proposed construction and test bed will result in the temporary disturbance of about 480 acres of land. The effects of the explosion include airblast, thermal, noise, ground shock, crater formation, ejecta, missiles, and chemical by-products. Airblast dominates the other explosion phenomena. Damage or destruction of plants and animals (mostly rodents and lizards) can be expected within 1400 meters from the explosion of the 4800 ton ANFO charge. Ground level dust and other air pollutants from the diffusion of the explosion cloud will be well within the most restrictive air quality standards. No endangered species will be affected by the program. Known archaeological sites will not be affected.

Finding of No Significant Impact  
(continued)

4. FINDING AND CONCLUSION

The proposed action will not significantly affect the quality of the human environment and is not controversial. Therefore, an Environmental Impact Statement will not be prepared for the proposed action.

FOR THE DIRECTOR:



GRAYSON D. TATE, JR.  
Major General, USA  
Deputy Director  
(Operations and Administration)



APPENDIX D  
PUBLIC AFFAIRS PLAN

PUBLIC AFFAIRS PLAN

for

MINOR SCALE

1. SITUATION:

a. MINOR SCALE is a Department of Defense high explosive (HE) test sponsored by the Defense Nuclear Agency (DNA) and conducted by Field Command, DNA (FCDNA). The test objectives are to:

(1) Provide an air-blast and ground-shock environment for Department of Defense (DOD) weapon systems, communication equipment, aircraft, vehicles, and a variety of structures.

(2) Provide a thermal environment for select experiments.

(3) Record air-blast, ground shock, and dust phenomenologies.

(4) Record damage to DOD-sponsored experiments.

(5) Record combined thermal/blast effects.

(6) Increase weapons effects data base.

b. MINOR SCALE will consist of a testbed array surrounding an explosive charge. The charge will consist of a 4800 ton mixture of ammonium nitrate and fuel oil (ANFO) placed in a hemispherical container at ground level. There will be approximately 300 experiments on the test bed being sponsored by 10 U.S. agencies and six foreign governments.

c. MINOR SCALE will be conducted at DNA's Permanent High Explosive Test Site (PHETS) which is in the northern portion of White Sands Missile Range (WSMR), N.M., about 18 miles south of Stallion Range Center. The nearest communities are San Antonio, N.M., to the northwest and Three Rivers, N.M., to the southeast. Each is about 30 miles distant with a very small population. Socorro, N.M., with a population of about 9,000, is 40 miles to the northwest and Carrizozo, N.M., with a population of about 4,000, is about 40 miles to the east.

. SCOP  
-articipa  
. OBJE  
llay po  
nd,  
. PURP  
uidance  
ent  
MINOR SC  
25,  
. EXECI  
a. (  
  
companies  
among th  
public a  
  
ive  
public a  
and  
understar  
ere  
connectic  
10  
scheduling  
test or p  
est  
General, nge  
coordinat  
est  
the Test to  
  
on.  
est  
to

2. SCOPE: This plan is applicable to all DOD agencies and activities participating in or supporting the MINOR SCALE test program.

3. OBJECTIVES: To gain public understanding of the need for the test and to allay possible public alarm in connection with the MINOR SCALE test.

4. PURPOSE: To announce policies, objectives, responsibilities, and provide guidance for the conduct of public affairs activities in connection with the MINOR SCALE test program.

5. EXECUTION:

a. Concept of Operations:

(1) Since a number of government agencies and government-sponsored companies will be involved in MINOR SCALE, close coordination and cooperation among the commands and agencies will be required to assure the success of the public affairs effort attached to these tests.

(2) The Commanding General of WSMR is responsible for conducting public affairs and community relations activities designed to achieve public understanding of the need for the tests and the absence of hazards in connection with the MINOR SCALE test program. Release of information on the scheduling, postponement, completion, success or failure of any particular test or project phase will be coordinated with the range commander (Commanding General, STEWS-PA, WSMR). Release of information will be by WSMR PAO in coordination with Headquarters, DNA. Coordination will be effected through the Test Group Director, FCDNA, to HQ DNA.

(3) The WSMR commander will be solely responsible for the release of information concerning matters involving mishaps or matters pertaining to ground safety on WSMR. The Defense Nuclear Agency will provide information and assistance concerning any mishaps relating to MINOR SCALE to the WSMR Commander. The above requirement stems from a DOD directive which states, in part, "The release of public information regarding the safety aspects of (testing) operations requires special attention. The possible hazards and margins of safety are matters of public concern. It is essential, therefore, that such information be released to the public by the single source that is most knowledgeable."

b. Plan of Operations:

(1) The WSMR commander will ensure, for public affairs purposes, there is continuous liaison between WSMR and the MINOR SCALE Test Group Director so that maximum informational support, within the capabilities of the WSMR PAO, can be provided.

(2) The WSMR PAO will ensure the continuation of public information and community relations programs designed to allay public apprehension as to possible hazards and margins of safety during all phases of MINOR SCALE.

(3) Based on past experience with similar projects, the public affairs effort will consist of a series of news releases and announcements detailing various phases of the test program, monitoring public attitudes, and answering press queries. If requested, WSMR PAO personnel, with FCDNA representation, should conduct face-to-face discussions with community leaders and media representatives prior to the event.

(4) It is essential that timely announcements be given the press prior to and following the test in an effort to avoid speculation and apprehension on the part of the public. Pre-test announcements (See Para. 7) will be placed as required to meet news media deadlines. The WSMR PAO will coordinate all releases of information as specified in paragraph 5.a.(2).

(5) Press announcements detailing mishaps or serious injuries to project personnel will be provided by the WSMR PAO as soon as possible following the incident and in accordance with current directives. A sample news release describing such an occurrence is not provided because of the many variables which occur.

(6) News media may attend the event, however, due to classification of the experiments after the blast, news media photography will not be permitted. News media representatives will not be permitted to bring photographic equipment to the observation point without authorization from WSMR Security. Video tape and still photography support will be provided to the news media. Specifically, WSMR Public Affairs Office (PAO) will produce video tape and still photographs of preparation for MINOR SCALE and the detonation. WSMR PAO will coordinate with HQDNA PAO as to content of the video tape and still photography. Video tape and still photographs will be available for release to the media within one hour after the detonation. HQDNA PAO and WSMR PAO will approve any material released to the media. One copy of material released to the media will be sent to OASD(PA) by express mail or other overnight delivery service.

(7) Binoculars will not be allowed on the range to view the event for reasons of security.

(8) The test will not be open for public viewing. Attendance at the observation point on shot day will be by invitation only.

6. COORDINATION: Direct communication is authorized between WSMR PAO and the MINOR SCALE Test Group Director on matters concerning technical information, the success or failure of the test, or scheduling. Release approval, content of releases and coordination among WSMR, FCDNA, and HQDNA will be handled as described in paragraph 5.a.(2).





7. ENCLOSURES: The following enclosures are intended as models for the release of information under the circumstances indicated:

Enclosure 1 -- Initial test announcement, to be released as soon as PA plan is approved.

Enclosure 2 -- Additional pre-test announcement, to be released about one week before the explosion, with an approved photograph showing test preparations.

Enclosure 3 -- Announcement of successful test, to be released within four hours of the explosion, with an approved photograph and video-tape of the explosion.

Enclosure 4 -- Announcement of unsuccessful test.

Enclosure 5 -- Questions and answers.

INITIAL PRE-TEST ANNOUNCEMENT

(To be released as soon as PA plan is approved)

WHITE SANDS MISSILE RANGE, N.M., (DATE) -- Preparations for a unique high-explosive test program, known as MINOR SCALE, are underway in the northern portion of White Sands Missile Range.

The purpose of MINOR SCALE is to expose military hardware, vehicles, and structures to an air-blast and ground-shock environment. Test officials said there should be approximately 300 experiments, sponsored by 10 U.S. agencies and six foreign governments, on the test bed.

The test, scheduled for June 1985, involves the detonation of 4800 tons of ammonium nitrate and fuel oil (ANFO). The ANFO will be placed in a 88 foot diameter hemispherical container at ground level.

The program is sponsored by the Defense Nuclear Agency (DNA), with Field Command, DNA, Albuquerque, conducting the test.

The test site is about 30 miles northwest of Three Rivers, N.M., and 40 miles west of Carrizozo, N.M. An environmental assessment has determined there will be no significant environmental effects from the test.

Marine Corps Major Michael G. Evinrude of Field Command, DNA, is the test group director. The WSMR project engineer for MINOR SCALE is Lee Meadows of the National Range Operations Directorate.

Encl 1

SECOND PRE-TEST ANNOUNCEMENT

(To be released about seven days before the explosion with cleared/approved photographs of test bed preparations).

(WSMR PAO will need 40 each black and white 8X10 photographs)

WHITE SANDS MISSILE RANGE, N.M., (DATE) -- Crews are placing 4800 tons of a mixture of ammonium nitrate and fuel oil (ANFO) into a 88 foot diameter hemispherical container in preparation for next week's MINOR SCALE test.

The purpose of MINOR SCALE is to expose military hardware, vehicles and structures to an air-blast and ground shock environment. There will be approximately 300 experiments, sponsored by 10 U.S. agencies and six foreign governments, on the test bed.

The test site is in the northern portion of the missile range, about 30 miles northwest of Three Rivers, N.M., and 40 miles west of Carrizozo, N.M. An environmental assessment has determined there will be no significant environmental effects from the test.

MINOR SCALE is sponsored by the Defense Nuclear Agency (DNA), with Field Command, DNA, Albuquerque, conducting the test. Marine Corps Major Michael G. Evinrude is the Test Group Director. The WSMR project engineer for the test is Lee Meadows of the National Range Operations Directorate.

SUCCESSFUL TEST

(To be released with approved video tape and black and white still photographs of the explosion).

(WSMR PAO will need seven each 60- to 90-second videotapes and 40 each 8X10 black and white still photographs to accompany the release.)

WHITE SANDS MISSILE RANGE, N.M., (DATE) -- The Defense Nuclear Agency (DNA) successfully detonated a 4800 ton high explosive charge in the northern portion of White Sands Missile Range today at (TIME).

The purpose of the test, called MINOR SCALE, was to expose military hardware, vehicles, and structures to an air-blast and ground-shock environment. Approximately 300 experiments, sponsored by 10 U.S. agencies and six foreign governments, were on the test bed.

Marine Corps Major Michael G. Evinrude, test group director for Field Command, DNA, said the event was a success. However, the effect of the explosion on the test objects will not be known until sponsoring officials can examine their experiments.

Encl 3

ANNOUNCEMENT OF UNSUCCESSFUL TEST

WHITE SANDS MISSILE RANGE, N.M., (DATE) -- A Defense Nuclear Agency (DNA) high-explosive detonation, designed to provide an air-blast and ground-shock environment for experiments on the test bed, was termed unsuccessful today by officials of the MINOF. SCALE program at White Sands Missile Range.

WSMR officials said there were no personal injuries or property damage associated with today's test failure.

Marine Corps Major Michael G. Evinrude, DNA test group director, said the test was determined unsuccessful because (brief outline of reason).

Officials have begun a detailed, on-site investigation to determine the reasons for the failure.

- 1. Q: Wh  
A: In  
cl
- 2. Q: Ho  
AN  
A: Tr  
a  
a  
a
- 3. Q: W  
A: E  
=
- 4. Q:  
A:
- 5. Q:  
A:
- 6. Q:  
A:

Encl 4

Encl ≡

QUESTIONS AND ANSWERS

1. Q: Why is photography not allowed?  
A: Individual or press photography is not allowed because of numerous classified experiments on the test.
2. Q: How much did the MINOR SCALE program cost? How much of that was for ANFO?  
A: The cost to prepare the test bed, provide diagnostic instrumentation and logistical support, is 7 million. Cost to test and evaluate the approximately 300 experiments is estimated at 30 million, ANFO cost approximately 1.1 million.
3. Q: What type of experiments are on the test bed?  
A: Experiments on MINOR SCALE range from measurement of air and ground shock waves caused by the blast to recording and documenting the blast and thermal effects on different types of shelters, buildings, antenna systems, a wide range of military equipment and protective clothing, and equipment on anthropomorphic mannikins. Pictures of most of the experiments are displayed at the Observation Post.
4. Q: How much TNT is 4800 tons of ANFO comparable to?  
A: 4800 tons of ANFO is equivalent to 4000 tons of TNT.
5. Q: What size nuclear explosion is MINOR SCALE comparable to?  
A: MINOR SCALE was designed to simulate the airblast effect from an eight kiloton nuclear detonation.
6. Q: Why do you use ANFO?  
A: ANFO is being used because it is currently the most cost effective explosive available. It is also very safe to handle. Research programs are ongoing to determine if more suitable and cost effective explosives can be developed.

Encl 5

7. Q: Is ANFO harmful to the environment? How do you return the area to pre-test conditions? 14. Q  
A: Upon detonation most of the ANFO is consumed leaving little residue. After salvagable test articles and other materials are removed from the test bed, all debris is picked up and put in a sanitary landfill. 15. C
8. Q: How do you get 4800 tons of ANFO to explode all at once? Can it happen accidentally? .  
A: A 100 pound octal booster is centered in the ANFO to uniformly ignite it. Accidental detonation of the ANFO is extremely remote. 16.
9. Q: How many simulated nuclear explosions have been conducted at WSMR?  
A: DNA has conducted three previous nuclear simulation tests at WSMR: DICE THROW in 1976, MILL RACE in 1981, and DIRECT COURSE in 1983.
10. Q: Have you scheduled more tests like this for WSMR? 17.  
A: Yes, more tests are currently scheduled at WSMR starting in 1986 and each year following.
11. Q: Why did you establish the Permanent High Explosive Test Site at WSMR?  
A: The Permanent High Explosive Test Site (PHETS) was established at WSMR to provide a cost effective, reusable high explosive test facility. 18.
12. Q: Can we go down to see the test bed either before or after the explosion?  
A: The test bed will be closed the day before execution because of final test preparations. Post test observations will not be allowed until the day after detonation due to safety and security considerations. 19-
13. Q: How far away will the blast be heard?  
A: Atmospheric conditions greatly affect how far and where the blast can be heard. On MILL RACE for example, the blast was heard several hundred miles away. Towns adjacent to WSMR will likely hear the blast.

How is a test  
The high explosive  
The thermal  
nuclear weapon  
How long before  
Observation  
About 40 seconds  
ground zero  
What is ANFO  
ANFO is an  
an explosive  
fuel oil.  
Why is MINOR  
The test has  
lightening  
Lightening  
Why is the  
The test name  
plans for  
in June 86  
Why is MINOR  
continue  
MINOR SCALE  
Future tests  
SCALE.

14. Q: How is a test like this related to nuclear weapons?  
A: The high explosive test simulates the blast from a nuclear weapon, and the thermal radiation source simulates the thermal radiation from a nuclear weapon.
15. Q: How long before we hear the blast and feel the shockwave at the observation point?  
A: About 40 seconds as the Observation Post is approximately 8 miles from ground zero and sound travels 1060 feet per second.
16. Q: What is ANFO?  
A: ANFO is an acronym which stands for Ammonium Nitrate Fuel Oil. It is an explosive composed of Ammonium Nitrate (Fertilizer) containing 6% fuel oil.
17. Q: Why is MINOR SCALE scheduled in the Summer and not the Fall?  
A: The test has been scheduled for June 84 to minimize the chances of lightening affecting test bed equipment such as recording gauges. Lightening storms are more frequent in the July-October time frame.
18. Q: Why is the test called MINOR SCALE?  
A: The test name MINOR SCALE has no special significance. There are no plans for a test called MAJOR SCALE. The next test to be conducted in June 86 is called MISTY PICTURE.
19. Q: Why is MINOR SCALE larger than DIRECT COURSE? Will future tests continue to get bigger?  
A: MINOR SCALE was planned to simulate the battlefield environment. Future tests are not projected to get bigger than MINOR SCALE.



ity?

at

y

ollowed

roperty

irs Office

APPENDIX E  
INFORMATION BROCHURE

# Information Brochure

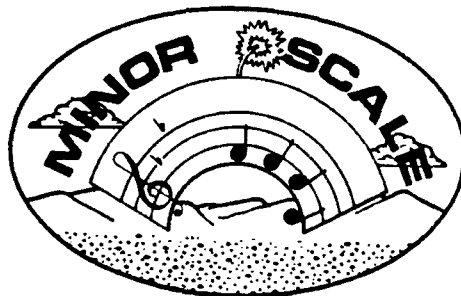

**Test Directorate  
Field Command  
Defense Nuclear Agency  
Kirtland AFB, NM**



#### INTRODUCTION

MINOR SCALE is the third test in the Misty Castle Series of large scale high explosive (HE) tests sponsored by the Defense Nuclear Agency to be conducted at White Sands Missile Range (WSMR), New Mexico. It is currently scheduled for June 1985. The explosive charge will consist of 4,880 tons of an ammonium nitrate & fuel oil (ANFO) mixture poured in bulk into a 44 foot radius fiberglass hemisphere. The resulting overpressure will simulate the equivalent airblast of an 8 kiloton nuclear device. The detonation of this charge will provide an airblast and ground motion environment which will be used by a variety of agencies to collect basic explosive environmental data or to test systems against a simulated nuclear environment.

The test bed is sponsored by Defense Nuclear Agency (DNA), with Field Command, DNA (FCDNA) as its operations agency tasked with executing the event. Participation was opened to all Department of Defense (DoD) and federal government agencies, plus selected foreign countries. Experiment selection screening by a DNA technical review committee occurred in March 1984. Since then, agencies with approved experiments have gone through an experiment definition and planning process with FCDNA in order to locate the experiments where they will receive the desired effects.

In addition to the experiments associated with the overpressure environment, one series of experiments will be conducted to measure the effects of a simulated precursor environment. The thermal flash from a nuclear device heats the ground and the surface air near the detonation. The blast wave travels through the heated surface air faster and creates a precursor on the shock wave near the surface. The thermal precursor will simulate this environment by providing a thin surface layer of helium gas at the time of detonation. Since pressure waves advance faster in helium than in air, the shockwave will move faster in the helium environment and create a simulated precursor.

Another series of experiments will be placed near thermal radiation sources (TRS) so they can be subjected to a combined airblast/thermal environment. TRS units were used on both of the two previous MISTY CASTLE events - MILL RACE and DIRECT COURSE.

A TRS unit consists of a linear array of four upward-directed nozzles, each of which produces a flame approximately two meters in diameter and six meters high. The radiant heat is produced by a chemical reaction between liquid oxygen and aluminum powder. Each nozzle directs 5 liters/sec of liquid oxygen and 5 kg/sec of aluminum powder into the air, where the reaction takes place, releasing about 50 megawatts of radiant heat.

The eight TRS units will be placed at various overpressures on the MINOR SCALE testbed. The four nozzles will be spaced to provide specific heat environments for the individual experiments, ranging from about 10 to 40 calories/sec/cm<sup>2</sup>.

#### OBJECTIVES

The primary objective of the test is to provide an airblast and ground shock environment for DoD sponsored experiments. These experiments are designed to determine the response of tactical and strategic weapon systems, communications equipment, vehicles, and a variety of structures to this environment. A secondary objective is to provide a thermal environment (in conjunction with the airblast) for several experiments. A specific objective is to provide a simulated precursor environment.

#### EVENT DESCRIPTION

The test will be conducted at MSNR, approximately 20 miles (30 km) south of the northern boundary (see Figures 1 and 2) at the Permanent High Explosive Test Site (PHETS). Ground zero (GZ) is the same location as GZ for DIRECT COURSE, as shown in Figure 2. This location allows the reuse of nearby roads, the instrumentation parks, the three DIRECT COURSE instrumentation radials, and most of the diagnostic camera bunkers. However, because of the larger explosive charge, several changes will be made.

The airblast at the instrumentation parks will be too strong for the standard instrumentation trailers. Therefore, two things will be done. A series of hardened bunkers will be placed near the charge at the 10 psi overpressure level to perform remote recordings. Bermed structures similar to quonset huts will be placed at the instrumentation parks. These structures will be large enough to contain two instrumentation trailers each. The trailers will then be configured to operate remotely, i.e., they will be unmanned during the test.

The closest unprotected site is the DIRECT COURSE administrative park, now designated the Timing & Firing (T&F) park. This is where the timing and firing trailer and several other manned instrumentation trailers will be located. This park is about 11,000 ft west of GZ.

The administrative park for MINOR SCALE is now located on the northeast corner of the intersection of Route 7 and Route 20.

The Observation Point for MINOR SCALE will be approximately 1.6 miles north of the new administrative park, in the old DICE THROW area. An ANFO mixing plant will be constructed to the north of Route 20, approximately 2 miles east of the MINOR SCALE administrative park.

The MINOR SCALE testbed consists of four instrumented radials (one precursor radial), four instrumentation parks, a T&F park, and an administrative park. Nearly 200 experiments will be located on the testbed. Figure 3 shows the layout of the testbed. Fielding MINOR SCALE requires the services of over 400 personnel: skilled construction workers, technicians, program managers, and scientific personnel with a wide range of expertise. Instrumentation on the testbed will consist of:

- Active and Passive Gauges: over 2300
- Recording Channels: over 2200
- Recording Cable: 7 million feet
- External Experiment Response Cameras: 223
- Internal Experiment Response Cameras: 57

## HIGH EXPLOSIVE TEST LOCATION

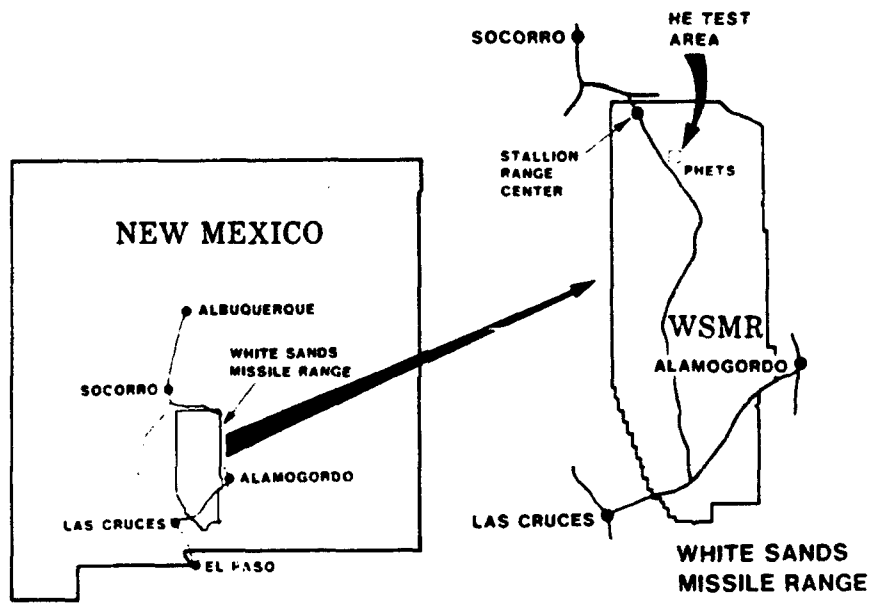

Figure 1. PHETS location.

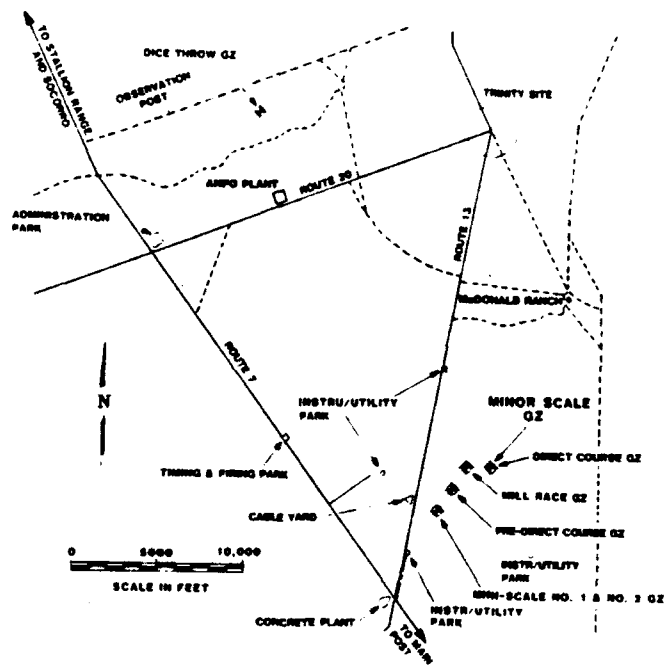
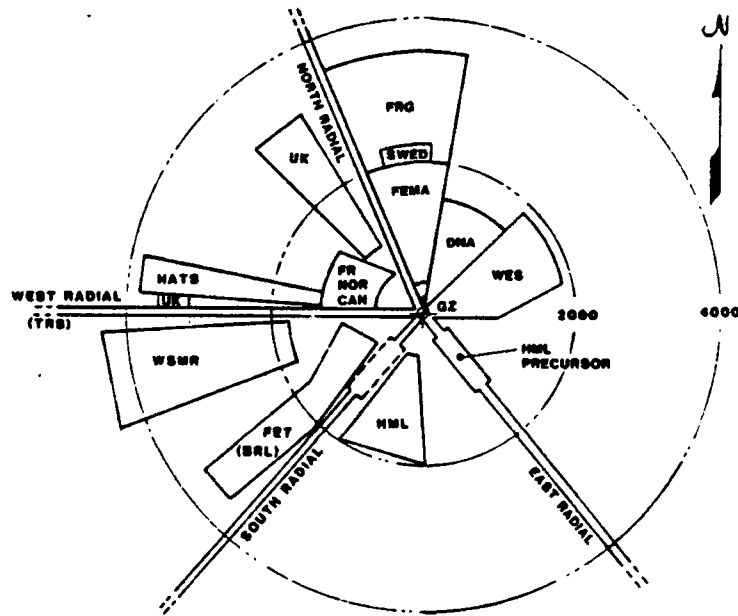

Figure 2. PHETS area with GZ shown.

WEST R  
(TRB)



### MINOR SCALE EXPERIMENTS

Figure 3. Testbed layout.

PERSONNEL

Field Command, Defense Nuclear Agency

MAJ Mike Evinrude, USMC	Test Group Director
Capt Ed Raska, USAF	Technical Director
LCDR Kurt Mathews, USN	Technical Director (TRS)
LCDR Larry Anderson, USN	Program Director (Precursor)
LCDR William Taylor, USN	Program Director (TRS)
Mr. Dwight Simpson, DoD Civ	Program Analyst
CPT Greg Walls, USA/CPT Ken Jeffrey, USA	Program Directors
LT Steve Crawford, USAF	Test Group Engineer
MAJ Stan Schmidt, USA	Test Group Engineer (Precursor)
SSG Ronald Kiner, USA	Asst Test Group Engineer
Mr. Ray Harrison, CIV	Testbed Engineer
LT Doug Taylor, USN	Instrumentation Engineer
Mr. Jim Wilson, CIV	Instrumentation Coordinator
Mr. Jim Mathews, CIV	Cable Coordinator
LCDR Ken Miles, USN	Safety Officer
Mr. Emory Prather, DoD CIV	Photo Program Director
SSgt Ronald Pierce, USAF	NGCIC Administration

Headquarters, Defense Nuclear Agency

LTC Emory Chase, USA Project Officer

Aberdeen Research Center, APG

Mr. John Keeler, CIV Technical Advisor

White Sands Missile Range

Mr. Lee Meadows, CIV	Program Coordinator
Mr. Jim Kilcrease, CIV	Asst Program Coordinator
Mr. Glyn Zumwalt, CIV	Upgrade Facility Engineer

FIELDING SUPPORT AGENCIES

Air Force Weapons Laboratory

Charge Diagnostics Airblast Predictions

Ballistic Research Laboratory, APG

Free Field Airblast Data Recording

Airblast Predictions

Bendix Field Engineering Corp

Timing and Firing Data Recording  
Cable Coordination Thermal Radiation Source

Molded Fiberglass

ANFO Container

Naval Surface Weapons Center, Dahlgren

Main Booster Assembly ANFO Quality Control



<u>New Mexico Engineering Research Institute</u>	Container Assembly and Erection
<u>KWFO Loading</u>	
<u>ANFO Mix Plant Construction</u>	
<u>Sandia National Laboratories, Albuquerque</u>	Far Field Blast Monitoring and Meteorology
<u>Booster Initiation System</u>	
<u>Science Applications International, Inc</u>	
<u>Thermal Radiation Source</u>	
<u>Technical Reports, Inc</u>	Engineering Services
<u>Technical Documentation</u>	
<u>Waterways Experiment Station, Vicksburg</u>	
<u>Free Field Ground Motion Recording</u>	
<u>White Sands Missile Range</u>	Construction
<u>Photography</u>	Ground/Flight Safety
<u>Meteorology</u>	Logistics Support
<u>Security</u>	Public Affairs
<u>Surveying</u>	
<u>US Marine Corps - Third Marine Air Wing</u>	
<u>Aerial Photography</u>	

EXPERIMENTERS AND CONTRACTOR SUPPORT

Aeromet Corp.  
 Boeing Aerospace Company  
 Cortez III, Services Corp.  
 Defense Nuclear Agency (SPSS, RAAE, RAAE, SPAS, SPTD)  
 Denver Research Institute (DRI)  
 Electro Magnetic Applications, Inc. (EMA)  
 Federal Bureau of Investigation (FBI)  
 Federal Emergency Management Agency (FEMA)  
 GE Laboratories (GBL)  
 Goodyear Aerospace Corp.  
 H-Tech Labs, Inc.  
 Information Science, Inc. (ISI)  
 Kaman Science, Inc. (KSC)  
 Los Alamos National Laboratory (LANL)  
 Los Alamos Technical Associates (LATA)  
 Lovelace Foundation  
 Martin Marietta Corp.  
 National Technical Systems (NTS)  
 Oak Ridge National Laboratory (ORNL)  
 Particle Measuring Systems, Inc. (PMS)  
 Physics International Inc. (PII)  
 Physical Science Lab. (PSL) Los Crustis  
 Research & Development Associates (RDA)  
 Sandia National Laboratory (SNLA)  
 Science Applications International Corp. (SAIC)  
 Science and Engineering Associates (SEA)  
 S-Cubed  
 SRI International (SRII)  
 Spectron Development Labs, Inc. (SDLI)  
 Technology International Corp. (TIC)

Technology Service Corp. (TSC)  
 TERRA, New Mexico Institute of Mining and Technology  
 TRW Space & Technology Group (TRW)  
 US Air Force Geophysics Laboratory (AFGL)  
 US Air Force Ballistic Missile Office (BMO)  
 US Army Armament Research and Development Center (ARDC)  
 US Army Behavior Research & Development Center  
 US Army Ballistic Missile Defense Command (BMDC)  
 US Army Ballistic Research Laboratory (BRL)  
 US Army Communications and Electronics Command (CECOM)  
 US Army Chemical Systems Lab. (CSL)  
 US Army Engineer Waterways Experiment Station (WES)  
 US Army Harry Diamond Laboratories (HDL)  
 US Army Materiel Command (AMC)  
 US Army Natick Research and Development Center  
 US Army Nuclear and Chemical Agency (USANCA)  
 US Army Test and Evaluation Command (TECOM)  
 US Army White Sands Missile Range (WSMR)  
 USMC  
 US Naval Civil Engineering Laboratory (NCEL)

FOREIGN EXPERIMENTERS

Canada  
 Federal Republic of Germany  
 France  
 Norway  
 Sweden  
 United Kingdom

### MILESTONES

Experiment Proposal Review at HQDNA	16 - 17 APR 84
First POM	23 - 27 Jul 84
Testbed Construction Begins	Aug 84
Cost Estimates Mailed to Experimenters	31 Aug 84
Second POM	24 - 28 Sep 84
Third POM	26 - 30 Nov 84
Experiment Installation	Oct 84 - May 85
Installation of Instrumentation Bunkers	Jan 85 - Mar 85
TRS Installation	Mar 85 - Apr 85
MFP #1	29 May 85
MFP #2	6 Jun 85
Dress Rehearsal	10 Jun 85
MINOR SCALE Readiness	13 Jun 85
Experiment Final Reports	Jan 86
Results Symposium	Feb 86



APPENDIX F  
MINOR SCALE SAFETY PLAN

# MINOR SCALE SAFETY PLAN

Sec

FEBRUARY 1985

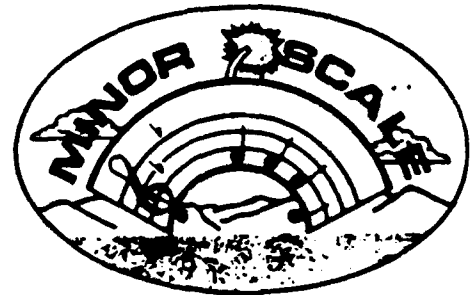
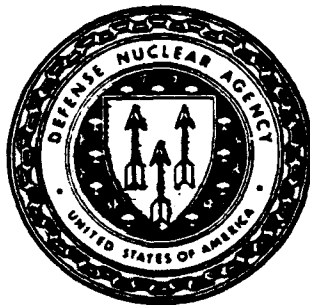

TEST DIRECTORATE

FIELD COMMAND

DEFENSE NUCLEAR AGENCY

KIRTLAND AFB, NEW MEXICO

87115

PREPARED BY:

*Walter J. Hogan*

Walter J. Hogan, Safety Consultant  
Tech. Reps., Inc.

REVIEWED BY:

*Kenneth K. Miles*

Kenneth K. Miles  
LCDR, USN  
Test Directorate Safety

REVIEWED BY:

*James D. ...*

WSMR Safety Office

APPROVED BY:

*Michael G. Evinrude*

Michael G. Evinrude  
MAJ, USMC  
Test Group Director

TABLE OF CONTENTS  
(To Appendix F)

Section	Page No.
<b>I INTRODUCTION</b>	<b>155</b>
A. Purpose . . . . .	155
B. Scope . . . . .	155
C. Application . . . . .	161
D. Responsibilities . . . . .	161
E. References . . . . .	162
<b>II DEFINITIONS</b>	<b>163</b>
A. Hazard Classifications . . . . .	163
B. Limited Access Zone . . . . .	163
C. Controlled Access Zone . . . . .	163
D. Test Bed . . . . .	163
E. Agency Project Officer . . . . .	163
<b>III PROCEDURES</b>	<b>164</b>
A. General . . . . .	164
B. Participating Agencies . . . . .	164
C. Personal Protective Equipment . . . . .	164
D. Medical Emergencies . . . . .	165
E. Explosives . . . . .	165
F. Hydrogen . . . . .	166
G. Liquid Oxygen (LOX) . . . . .	166
H. Air Traffic . . . . .	167
I. Electric Power . . . . .	167
J. Electrical Storms . . . . .	167
K. Fire Protection and Reporting . . . . .	167
L. Design Safety Factors . . . . .	168
M. Vehicles . . . . .	168
N. Controlled Access Zones and Limited Access Zones . . . . .	168
O. Postshot . . . . .	168
<b>IV EXPERIMENT HAZARDS AND ACCESS RESTRICTIONS</b>	<b>170</b>
A. General . . . . .	170
B. Natural Hazards . . . . .	170
C. Aircraft Support . . . . .	170
D. MINOR SCALE Test Bed Hazards . . . . .	170

INTRODUCTION

- A. Purpose
- B. Scope
- C. Appl
- D. Respo
- E. Refe

DEFINITIONS

- A. Haza
- B. Limi
- C. Cont
- D. Test
- E. Agen

PROCEDURES

- A. Gene
- B. Part
- C. Per
- D. Mer
- E. Exp
- F. Hyd
- G. Lid
- H. Air
- I. Ele
- J. Ele
- K. Fire
- L. Des
- M. Vel
- N. Col
- O. Po

EXPERIMENT HAZARDS AND ACCESS RESTRICTIONS

- A. Ge
- B. Na
- C. A
- D. M

AGENCY

**LIST OF ILLUSTRATIONS**  
(For Appendix F)

<u>Figure</u>		<u>Page No.</u>
1	Location of Permanent High Explosive Test Site (PHETS) . . . . .	156
2	PHETS Area and MINOR SCALE Operations. . . . .	157
3	MINOR SCALE Test Bed . . . . .	158
4	MINOR SCALE Charge Container . . . . .	159
5	TRS Layout . . . . .	160
6	MINOR SCALE Test Bed Layout (Controlled and/or Limited Access Zones). . . . .	169

**LIST OF TABLES**  
(For Appendix F)

<u>Table</u>		
1	MINOR SCALE Hazardous Operations . . . . .	171
2	Hazardous Materials Summary. . . . .	173

**ANNEXES**  
(For Appendix F)

Annex A	MINOR SCALE Organization	179
Annex B	WSMR Summer Hazards	182
Annex C	Protective Measures, MINOR SCALE Safety Plan	199
Annex D *	Emergency Reporting	
Annex E *	SNLA Division 7132 Safe Operating Procedure for MINOR SCALE (Limited Distribution)	
Annex F *	Safety Standing Operating Procedures (Limited Distribution)	
	F-1 Assembly of Fiberglass Charge Container	
	F-2 ANFO Mixing Plant Operation	
	F-3 Main Booster Emplacement and Main Charge Construction	
	F-4 Pre-Arming, Arming (Firing System Hook-up) and Detonation	
	F-5 Helium Sound Velocity Probes	
	F-6 Laser Field Operations	
	F-7 Blast-Gauge Stations	
	F-8 Pyrotechnic EJECTA	
	F-9 Streak X-Ray	
	F-10 Automatic Dust-Tube Catchers	
	F-11 Soil Characterization	
	F-12 Holography	
	F-13 Hardened Shelter	
	F-14 Thermal Radiation Source	
Annex G *	Reentry Procedures (Limited Distribution)	

\* not included in this POR.



SECTION I  
INTRODUCTION

A. PURPOSE.

This Safety Plan establishes the MINOR SCALE Event Safety Program. MINOR SCALE is a Defense Nuclear Agency (DNA)-sponsored, large scale, high explosive field test with the purpose of exposing structures, shelters, military systems and equipment to blast and thermal phenomena simulating the detonation of a nuclear weapon. Four thousand eight hundred tons of ammonium nitrate fuel oil (ANFO), which produces an airblast equivalent to four thousand tons of TNT or 8 kiloton nuclear, will provide the blast and shock environment. Eight arrays of a nozzle-dispensed aluminum powder and liquid oxygen mixture will provide a thermal radiation source (TRS) for selected experiments to evaluate the synergistic effects of blast and thermal radiation phenomena. The charge will be placed in a fiberglass hemisphere, 88 feet in diameter (Figures 1 through 5).

DOO, federal government agencies, and selected foreign countries are the participants. Over 180 individual experiments will be conducted. Typical experiments are:

- Blast and thermal effects on above surface and partially buried shelters, blast shelters, and industrial buildings.
- Blast and thermal effects on various radomes and antennas.
- Blast and thermal effects on anthropomorphic dummies.
- Blast and thermal effects on military communication and protective equipment.
- Phenomenology diagnostic measurements.
- Cloud measurements using various techniques.
- Blast and thermal effects on various armored vehicles.
- Blast effects on propagation of electromagnetic signals (radar, communications) in airborne systems.
- Remote pressure sensing (air/ground).

B. SCOPE.

The Safety Program for MINOR SCALE is designed to provide an active, functioning mechanism with the goal of identifying actual and potential hazards to personnel and equipment. Section I delineates responsibilities and identifies the

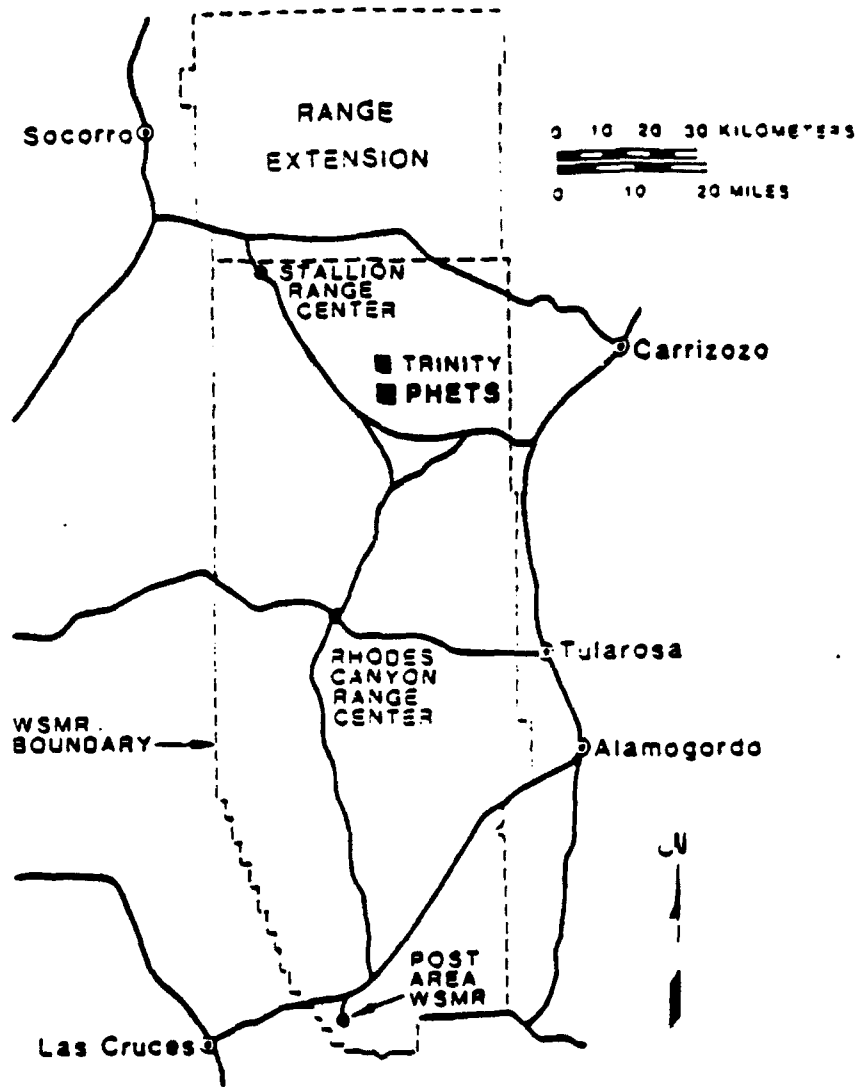

Figure 1. Location of permanent high explosive test site (PHETS).

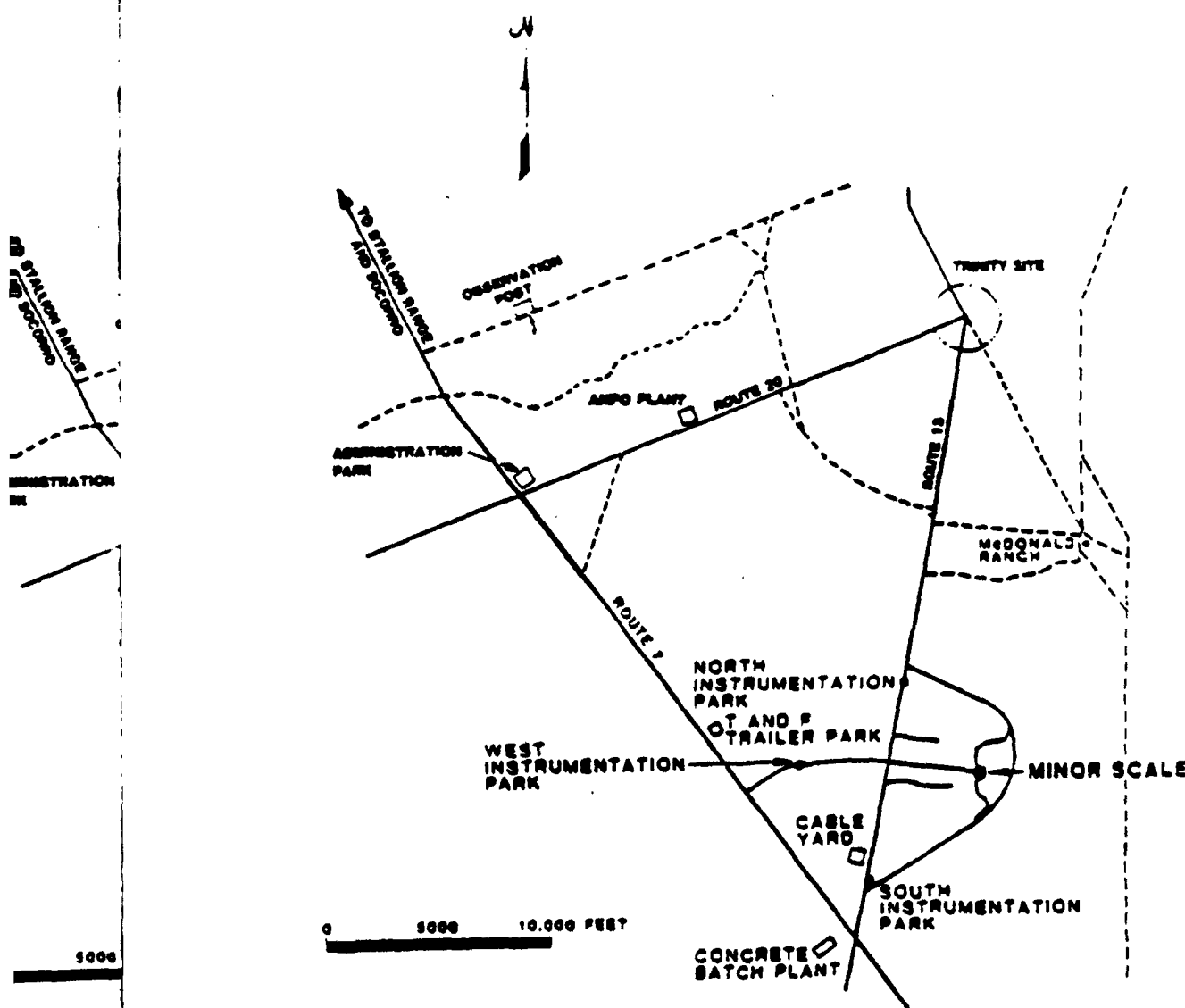

Figure 2. PHETS area and MINOR SCALE operations.

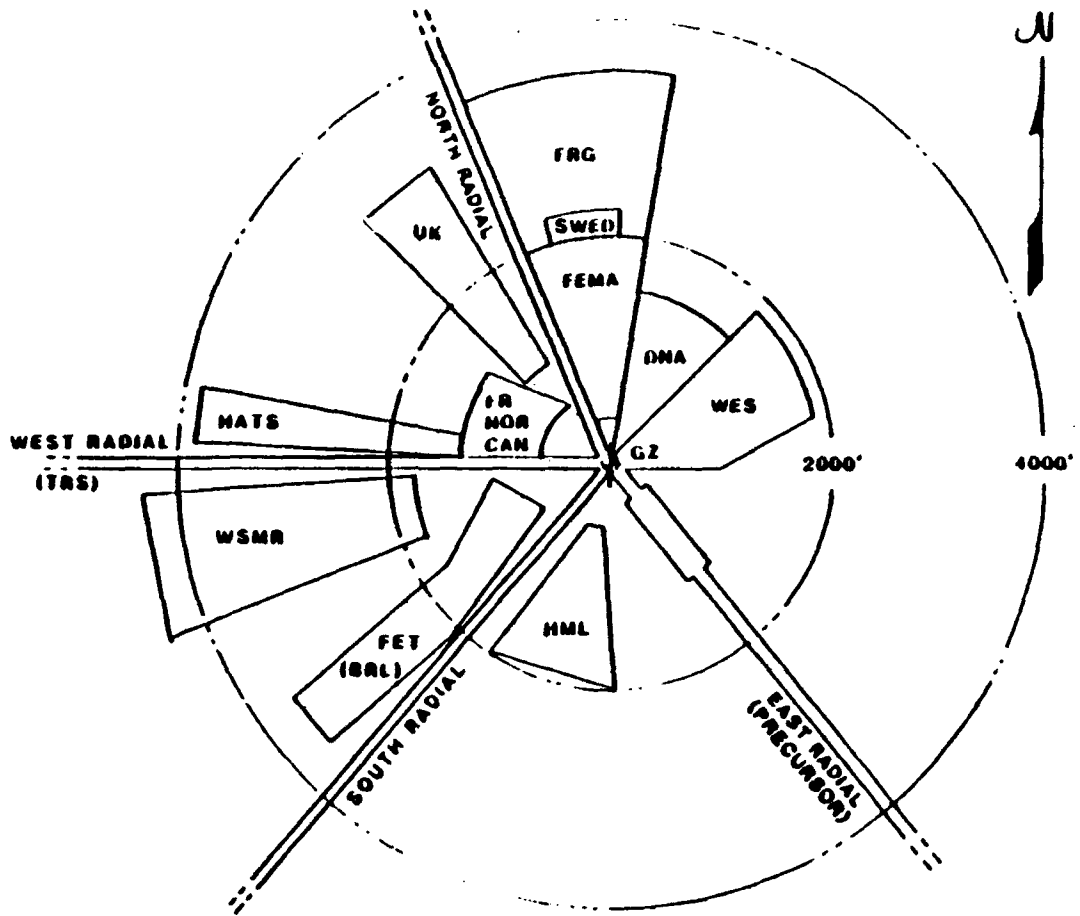

Figure 3. MINOR SCALE testbed.

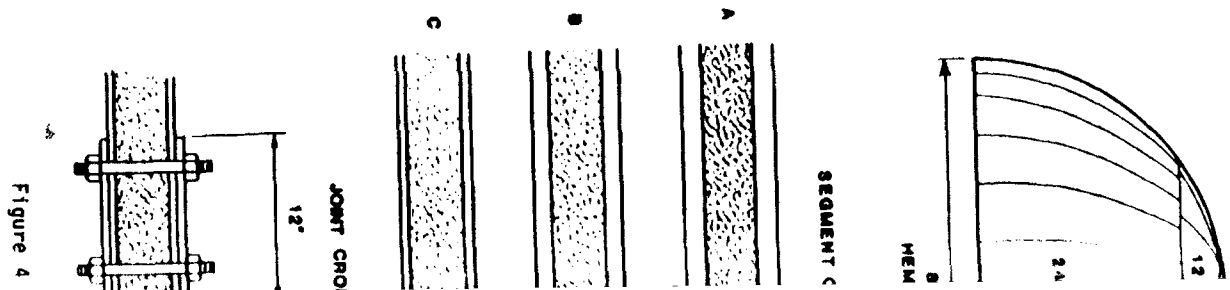
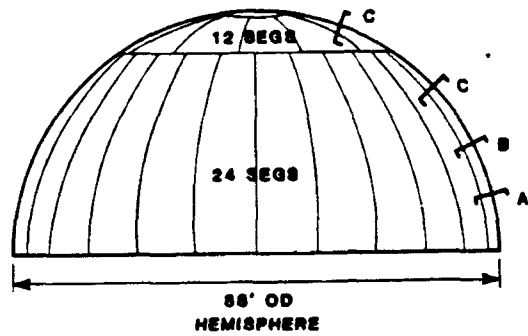
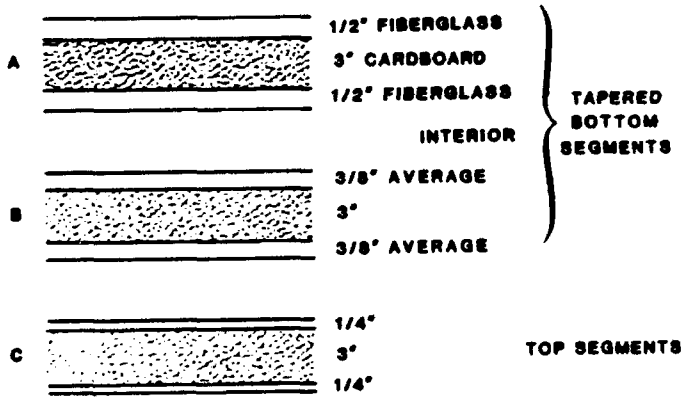

Figure 4



**SEGMENT CROSS-SECTIONS**



**JOINT CROSS-SECTIONS**

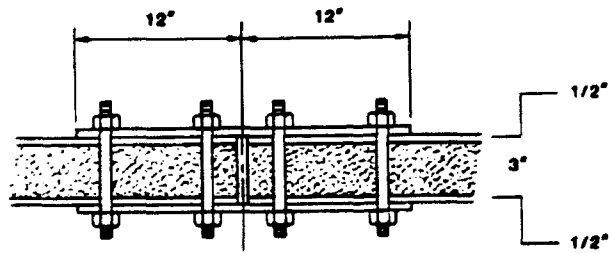

Figure 4. Charge container.

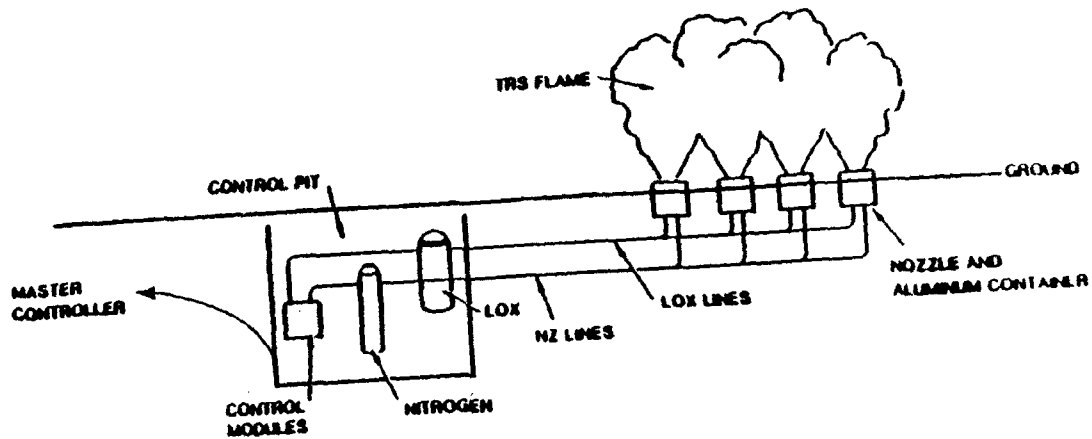

Figure 5. TRS Layout.

160

participants for the event. Section II contains classification and access restrictions. Section III contains specific instructions for the test bed. Section IV lists specific procedures for the experiment layout. Additional attached annexes. Annex A lists the participants related with the Summary of Hazards for MSMR. Annex B is the Summary of Hazards for MSMR. Annex C is the Summary of Operating Procedures and the Sandia National Laboratory Arming and Standby Procedures. Annex D lists emergency procedures. Annex E establishes the Safety Standing Operating Procedures for hazardous operation. Annex G\* establishes procedures for the test bed postshot.

C.

APPLICATION.

All participating organizations contained herein. The Test Group Director Chief, Safety Office, MSMR, may permit variations are necessary for successful execution. Adequate alternate safety procedures will be documented. When a conflict exists between the Instructions, MSMR Regulations, or those of a agency, the procedure providing the more stringent will be followed. Questions of technical interpretation will be referred to the Test Group Director (TGD) for resolution.

D.

RESPONSIBILITIES.

The Director, Test Directorate, is responsible for the safety of all DOD equipment. The MINOR SCALE Safety Program is the responsibility of the Test Directorate Test Group Director (TGD). The Test Directorate Test Directorate Safety Programs and its responsibilities are summarized in the Test Directorate SCALE safety issues with the MSMR, Safety Office. Each MINOR SCALE agency shall be responsible for:

1. The safe conduct of its operations.
2. Coordination of hazardous activities and their equipment.

\* not included in this POR.

participants for the event. Section II contains definitions pertaining to hazards classification and access restrictions. Section III identifies general procedures for the test bed. Section IV lists specific hazards and access restrictions associated with the experiment layout. Additional information is provided in the attached annexes. Annex A lists the participating experimenter Project Officers. Annex B is the Summary of Hazards for WSMR. Personnel locations on the test bed are summarized in Annex C. Annex D\* lists emergency procedures. Annex E\* is a copy of the Sandia National Laboratory Arming and Firing procedures. Annex F\* contains the Safety Standing Operating Procedures (SOP), approved by WSMR, for each hazardous operation. Annex G\* establishes requirements and priorities for reentry into the test bed postshot.

C. APPLICATION.

All participating organizations shall comply with the policies contained herein. The Test Group Director (TGD), with the concurrence of the Chief, Safety Office, WSMR, may permit variations if, in his judgment, such variations are necessary for successful execution of the test. In such cases, adequate alternate safety procedures will be published as a supplement to this document. When a conflict exists between the requirements of this document, FCDNA Instructions, WSMR Regulations, or those of a participating agency or DOD contract agency, the procedure providing the more stringent or higher degree of protection will be followed. Questions of technical interpretation will be referred to the TGD for resolution.

D. RESPONSIBILITIES.

The Director, Test Directorate, Field Command, DNA (FCT) has ultimate responsibility for the safety of all DOD/FCDNA operations, personnel, and equipment. The MINOR SCALE Safety Program is the responsibility of the MINOR SCALE Test Group Director (TGD). The Test Directorate Safety Engineer (FCTS) implements Test Directorate Safety Programs and is responsible for coordination of all MINOR SCALE safety issues with the WSMR, Safety Office for the TGD.

Each MINOR SCALE agency shall be responsible for:

1. The safe conduct of its operations at WSMR.
2. Coordination of hazardous activities with the TGD to prevent jeopardizing other experimenters and their equipment.

\* not included in this POR.

3. Reporting all accidents to the TGO.
4. Knowledge of, and compliance with, the requirements of this plan.

E.

REFERENCES.

1. WSMR Regulation 385-15, Safety Standing Operating Procedures, 22 August 1983.
2. Department of the Army Materiel and Readiness Command Regulation 385-100, Safety Manual, 17 August 1981.
3. CFR Title 29, Part 1926, Subpart U, Blasting and Use of Explosives.
4. WSMR USERS HANDBOOK, Volume II, 1 October 1980.
5. MINOR SCALE Operational Requirement.

A. HAZ  
Ca  
 tive measures c  
Ca  
 or extensive d  
 by limiting p  
 and/or remote l  
Ca  
 and/or test sy  
 mum use of pro  
Ca  
 tests system c

B. LI  
 A  
 directly invo  
 specified hazz

C. CI  
 S  
 sonnel which  
 determined by

D. I  
 T  
 experiment em

E. A  
 T  
 instrumentati  
 ing agency.



SECTION II  
DEFINITIONS

A. HAZARD CLASSIFICATIONS.

Category I - Catastrophic. So hazardous that no preventive or protective measures can be taken to reduce this hazard below a calculated risk.

Category II - Critical. Could result in injury or illness to personnel or extensive damage to experiments and/or test system components unless controlled by limiting personnel access, or by using special protective clothing/equipment and/or remote handling devices.

Category III - Marginal. Potential hazard to personnel, experiments, and/or test system components which can be controlled by special handling and minimum use of protective clothing/equipment.

Category IV - Negligible. No hazard to personnel, experiments, or tests system components.

B. LIMITED ACCESS ZONE.

A zone in which access to work areas is restricted to those persons directly involved in handling the hazardous items and/or participating in the specified hazardous operation (normally for a specified time).

C. CONTROLLED ACCESS ZONE.

Similar to "Limited Access Zone", but allows those activities and personnel which have minimum interference with the specified hazardous operation, as determined by the TGD.

D. TEST BED.

The area surrounding ground zero (GZMS) which encompasses all experiment emplacement, instrumentation trailer parks, laser and camera bunkers.

E. AGENCY PROJECT OFFICER.

The individual charged with the field responsibility of installation, instrumentation, and recovery of experiments fielded on MINOR SCALE by his sponsoring agency.

SECTION III  
PROCEDURES

A. GENERAL.

The policies set forth in this section are established to assist the TGD in fulfilling his responsibilities and to insure safe execution of the tests.

B. PARTICIPATING AGENCIES.

1. The Project Officer (PO) for each agency participating on MINOR SCALE shall be responsible for the safety of his personnel and for the safe conduct of his agency's operations at the MINOR SCALE Site. Project officers are listed in Annex A. Each Project Officer with hazardous operations shall prepare a Standing Operating Procedure (SOP) for hazardous operations on MINOR SCALE and shall assist the TGD in modifying the plan, if necessary, so that it meets the approval of the TGD and the WSMR, Safety Office. The PO shall also assist the TGD in preparation of any reports or forms pertinent to his experiments that may be required by WSMR.

2. The agency's SOP shall identify procedures which are required for the safe conduct of the agency's operation and which are to be followed by agency personnel during the fielding, test, and experiment recovery phases. It shall emphasize hazardous materials and/or conditions that may be encountered during any phase, and shall provide detailed procedures to be followed in order to cope with such hazards. Each SOP will be approved by the TGD and the WSMR, Safety Office. Approved SOP's are included in Annex F of this document.

3. Agency contractors and subcontractors will be considered to be a part of that agency. It shall be the responsibility of the agency PO to assure that such contractors and their personnel conform to the requirements of this document.

C. PERSONAL PROTECTIVE EQUIPMENT.

All participating agencies shall provide their personnel with the necessary personal protective equipment for use during those operations in which personnel hazards exist. This equipment shall meet requirements and specifications of the Department of Labor and shall include items such as hard hats, safety shoes, protective goggles, and special equipment for specific tasks (e.g., nonstatic clothing, face shields, etc.).

D. MEDICAL EMERGENCIES.

The TGD will arrange for, and publish, procedures for handling major medical emergencies. Participating agencies shall provide first aid supplies appropriate for the hazards involved in fielding their experiments. First aid supplies shall be maintained in a conspicuous and convenient location. A First Aid kit will be available at the GZ construction trailer. In the event personnel require transportation to the hospital, call the Socorro Ambulance (Annex D). Until EMT's are available at Stallion, staff personnel trained in first aid will stabilize injured personnel, and if determined to be acceptable, use a suitable vehicle for transport to meet the dispatched ambulance either at Stallion or enroute. During charge construction and event execution and reentry, a WSMR ambulance and medics will be on site.

E. EXPLOSIVES.

Explosives used at WSMR will be handled, transported, and stored in compliance with Department of the Army Materiel and Readiness Command Regulation 385-100, Safety Manual; and CFR Title 29, Part 1926, Subpart U, Blasting and Use of Explosives, whichever is more applicable. The TGD has jurisdiction over all explosives related to MINOR SCALE and he shall be notified prior to their arrival at WSMR. A WSMR safety representative shall be included on the access lists for all explosives areas and shall be included as a member of the Pre-arming and Arming Parties, and Postshot Assessment Team.

1. Transporting. The transportation on WSMR of all explosives related to DIRECT COURSE is under the jurisdiction of the TGD. All explosives transported on WSMR must be carried in vehicles complying with Chapter 22 of DARCOMR 385-100 for transporting explosives. Approved vehicles must carry appropriate fire fighting equipment, including Class B-C portable fire extinguishers, explosives tie-downs, and other safety equipment. When carrying explosives, the vehicle must display the appropriate "EXPLOSIVES" signs. Explosives shall not be transported into or out of the test bed complex until after the agency Project Officer has developed plans for these operations and they have been approved by the TGD. Separation of personnel from potentially hazardous explosives will be based upon quantity-distance tables of DARCOMR 385-100.

NOTE: The TGD may permit transportation of 2 kilograms or less of explosives and the detonator on the same vehicle provided the detonator is carried in its shipping container and physically separated from the explosive.

2. Storage. The TGD will arrange for appropriate explosive storage magazines for use by DNA agencies and contractors. Requirements for storage shall be made known to the TGD at least two weeks before explosives are due to arrive at WSMR.

3. Instrumentation. An explosive that is instrumented shall be handled in the same manner as one having detonators. When not in use, the instrumentation leads shall be connected together and grounded to the container.

F. HYDROGEN.

The TGD shall be notified of hydrogen deliveries to the MINOR SCALE test bed at least two working days before deliveries are to be made. TRS pits require hydrogen servicing. Areas containing hydrogen tanks will be designated Limited Access Zones during and after the tanks are serviced.

G. LIQUID OXYGEN (LOX).

The TGD shall be notified at LOX deliveries to the MINOR SCALE test bed at least two working days before deliveries are to be made.

At least two persons qualified to handle LOX shall be suited in protective clothing for each handling operation. One member of the crew performing the LOX handling or transfer operations shall be designated to have full authority over all personnel and equipment in the immediate vicinity and shall be responsible for the safety of these personnel during the time required for the handling or transfer. Operations shall be performed only in open areas where good ventilation can be maintained. The area around LOX transfer points will be inspected to assure there are no oils or grease which could be stepped on. Boots will be inspected for oil/grease. System materials which will come into contact with LOX shall have ductility and impact resistance suitable for the temperatures involved. Head, face, hand and foot protection, as prescribed by the approved SOP, shall be worn during all operations involving LOX. Any oil/grease will be cleaned from boots and the area before LOX is used. LOX will not be used to blow clothes or body parts clean of dirt or moisture. Personnel protection and handling procedures shall conform to Paragraph 6-6 of AFR 127-101. In addition to the requirements of AFR

127-101, fresh  
handling and tr  
less of  
ided the  
Physically  
tted to the  
d approval. storage  
irement for age shall  
stshot oper arrive at  
orm 46-e mus  
shall be  
instru-  
ational Elec  
picious plac  
urer's instr MINOR SCALE  
ads. ground RS pits  
ppendix K, esignated  
eference dur  
or all elec  
shall be use test bed  
shall include  
trailer is in protec-  
cate the ungr ming the  
J. Eity over  
ible for  
for use in dr trans-  
and transfer tion can  
5 miles of ar assure  
K. cted for  
all have  
Fire extingu Head,  
phase when ne be worn  
and types of onts and  
tion 420-3. v parts  
reported by s shall  
of AFR

127-101, fresh air breathing equipment shall be maintained in readiness during LOX handling and transfer operations.

H. AIR TRAFFIC.

Flight plans for all air traffic related to MINOR SCALE shall be submitted to the TGD for review and forwarding to WSMR Flight Safety for coordination and approval. Because of the varied and continuing operations at WSMR, the requirement for advance approval of flight plans applies to dry runs and pre- and postshot operations, as well as shot day activities. A National Range STEWS-NR-P Form 46-e must be submitted to the WSMR Range Program Office for each flight.

I. ELECTRIC POWER.

All electrical systems shall conform to the requirements of the National Electric Code. High voltage signs shall be posted in appropriate, conspicuous places. Generators shall be operated in accordance with the manufacturer's instructions and shall be operated only by qualified personnel. Generator pads, grounding, and fuel supply systems shall comply with WSMR Regulation 420-3, Appendix K, Paragraph 2. All instrumentation trailers using a floating ground reference during operations must be equipped with a positive earth grounding system for all electrical components, including power sources. This earth ground system shall be used at all times except during test operations. The grounding system shall include a red and green light warning system to visually identify whether the trailer is in the grounded or ungrounded configuration. The red light shall indicate the ungrounded configuration.

J. ELECTRICAL STORMS.

The TGD shall be responsible for supplying potential gradient meters for use in determination of the approach of electrical storms. Explosive handling and transfer operations shall be terminated whenever electrical storms come within 5 miles of any hazardous operation.

K. FIRE PROTECTION AND REPORTING.

The TGD shall arrange for fire protection for MINOR SCALE facilities. Fire extinguishers will be provided to agencies for the duration of the fielding phase when necessary to meet the requirements of WSMR Regulation 420-3. Locations and types of fire extinguishers shall be as prescribed in Appendix N, WSMR Regulation 420-3. Any fire, regardless of type or size, shall be reported. Fires may be reported by any of the following means:

1. Telephone: Dial 679-4434.
2. Radio: Any radio net having a base station with telephone communication.
3. Messenger: If neither telephone nor radio is available, a messenger shall proceed to the nearest telephone or fire station.

L. DESIGN SAFETY FACTORS.

Following is a tabulation of minimum safety factors to be used in the design of test items:

Item	Factor of Safety for Personnel	Basis
Handling Equipment	4	Material Yield Strength
Cryogenic Systems and Materials	5	Material Yield Strength

Note: Application of safety factor where personnel are involved is: Load or pressure x safety factor = minimum design load or pressure. Where loads or pressures are to be test related only (that is, induced by the test), no factor of safety is required.

M. VEHICLES.

Speed limits on WSMR numbered roads shall be as posted by WSMR. The maximum speed limit on all roads within the MINOR SCALE test bed shall be 25 miles per hour.

N. CONTROLLED ACCESS ZONES AND LIMITED ACCESS ZONES.

Controlled Access Zones and/or Limited Access Zones have been developed on the basis of information provided by participating agencies. A Test Bed Layout indicating the location of the hazardous operations is shown in Figure 6.

O. POSTSHOT.

Postshot reentry into the test bed by experimenter personnel shall not be permitted until the Postshot Assessment Team has completed its survey and reentry is authorized by the TGD. The Postshot Assessment Team shall include representatives from the WSMR Radiation Protection Office and Safety Office. Postshot Reentry Procedures and experiment recovery requirements are specified in Annex G.



SECTION IV  
EXPERIMENT HAZARDS AND ACCESS RESTRICTIONS

A. GENERAL.

A variety of hazards will exist at the MINOR SCALE test bed. The MINOR SCALE-generated hazards can be minimized by cooperation between agencies, by making all personnel aware of them, and by use of judgment in working with hazardous items. In addition to these hazards, there are natural hazards which exist because of the locale and environment. This section identifies the more serious hazards that will be encountered at the MINOR SCALE test bed.

B. NATURAL HAZARDS.

Annex B is a summary of hazards which might be encountered at WSMR. All personnel assigned to, or visiting, the MINOR SCALE test bed should be provided with a copy of this information.

C. AIRCRAFT SUPPORT.

Several organizations will support the event with aircraft as summarized in the supplement to the OR.

D. MINOR SCALE TEST BED HAZARDS.

This event involves hazards which are unique to the type of burst simulated and to the different types of experiments which make up the Test Bed Layout.

Table 1 displays the hazardous operations which have been identified for this event. These operations are summarized in this section. Specific safety Standing Operating Procedures for each operation will be approved by the WSMR Safety Office and included as Annex F. Applicable portions of the approved SOP's will be posted conspicuously at the site of each operation in accordance with the provisions of Reference 1. SOP's will be numbered NR-PD (Operation Number 1 through 14), coinciding with ANNEX F - Operation Number 1-14.

Table 2 presents a summary of hazardous materials included in the test bed. Figure 6 locates hazardous experiments within the Test Bed Layout, specifying access restrictions. Hazardous operations are summarized below:

1. Container Construction. The container will be a segmented fiberglass hemisphere 44' in radius. The base of the hemisphere will consist of 24 identical segments and the top (or cap) will consist of 12 segments as shown in



MINOR SCALE test bed. The MINOR action between agencies, by making agreement in working with hazardous natural hazards which exist because notifies the more serious hazards d.

h might be encountered at WSMR. SCALE test bed should be provided

event with aircraft as sum-

ique to the type of burst simu- make up the Test Bed Layout. ons which have been identified this section. Specific safety will be approved by the WSMR portions of the approved SOP's operation in accordance with the ed NR-PD (Operation Number 1 er 1-14.

materials included in the test the Test Bed layout, specifying zed below:

er will be a segmented fiber- hemisphere will consist of 24 st of 12 segments as shown in

Table 1. MINOR SCALE hazardous operations.

Agency No.	OMB Reg. No.	Description of Operation	Hazard	Type Hazard		Hazard Class		Comments	Agency
				Pre	Post	Pre	Post		
F-1		Assembly of fiberglass charge container	Mechanized equipment; aerial lifts; lower panel sections weigh 2000 pounds	C	2	3	Major construction operation; personnel hazard from falling objects/hurling at heights; manoeuvring with heavy loads	Divided fiberglass	
F-2		AMFO mixing plant operation	Ammonium nitrate mixed with diesel oil on site to make AMFO, blasting agent	B,C	3	4	Standard AMFO handling; heavy truck traffic, augers, elevators, hoppers	Contractor	
F-3		Main booster emplacement & main charge construction	310 lb aerial booster, 4 FCBC lines, 4000 tons AMFO	B,C,C	2	3	The aerial booster and FCBC lines will be installed inside the fiberglass charge container, then AMFO loaded by pneumatic bulk trucks	ORNL/MSMBI	
F-4		Pre-arming, arming, and detonation	CG-4 Sub boosters and detonators connected to AMF system	B,E	2	3	As part of firing count down, detonators installed, AMF system boomed up and armed; positive safe system, inspect test bed	SMR/MSMBI	
F-5	0770	Helium sound velocity probes	3500 volt spark gap gases; helium high pressure gas system	E,B	2	3	Hazard only during gage testing, once processed helium bag employed, gage inaccessible	SMR	
F-6	0701	Laser field operations	100 joule pulsed wave laser	B	2	3	Hazard only during calibration tests, but special procedures in effect	SMR	

Table 1. MINOR SCALE hazardous operations (Concluded).

Annex No.	DHA Exp. No.	Description of Operation	Hazard	Type Hazard		Hazard Class		Comments	Agency
				Pre	Post	Pre	Post		
F-7	1500 1501 0700	Blast gauge stations	10 blast gauges with 500 mCi sources	0	2	2	Sources stored until installed on test bed; postshot, insure integrity, remove and ship to DRES	MS	
F-8	0302	Pyrotechnic ejecta	10 artificial ejecta (bullet balls each with 2 lb pyrotechnic and electric match)	A,E	3	3	Boiling balls placed 50-100' from G/, fired at zero time; recovered	MS	
F-9	0300	Stream X-ray	Excess 30 hr X-ray tube; internal high voltage	0,E	2	3	Calibration tests, special procedures in effect	MS	
F-10	0300	Automatic dust tube catcher	54 gm detasheet, 54 mini-caps	A,E	3	3	Gauges placed in precursored bag area	MS	
F-11	0311	Soil characterization	Treadle surface moisture density gauge with gamma and neutron source	0	3	3	Gauge used pre- and postshot; not on test bed during event	MS	
F-12	0722	Holography	12 mJoule Ruby laser/3 mJoule gallium arsenide laser	0,E	3	3	Lasers internal to gauge, wholly contained	MS	
F-13	1220/ 1221	Hardened shellor	Sulfur hexafluoride	0	3	3	Used for pre- and postshot test only, and on test bed during shot	MS	
F-14	T05		Gaseous oxygen and hydrogen, liquid oxygen	0,F,E	2	2	Servicing of 0 systems, warm tests, postshot safing of system	AIC/DRE	

172

TYPE OF HAZARD	QUANTITY
<b>EXPLOSIVES</b>	
AmD	4000 tons
DTIC (75/25 mm/101)	310 lbs
CR-6	1/2 lbs
TC-234 Detonators (41)	
PCFB	1000 mg
801/ELDM	15.54 gm
Pyrotechnic (40R mag/40R tetram)	240 ft
20 lbs	20 lbs
Electric Matches	160 mg
Detasheet	54 gm
30-70 Mini-cap bolts	54
<b>RADIATION</b>	
Plutonium 107	5000 mCi
Cesium 137	0.2 mCi
Americium 241	40 ± 10% mCi
Lasers	(2) 100 Joule pulsed
X-ray Tube	3 Rv/520 reentgon/hr
Lasers	Ruby (12 mJoule) and Gallium arsenide
<b>PRESSURE GASES</b>	
Sulfur hexafluoride	120 lb bottle
Nitrogen	(32) 255 cu ft @ 2500 psi
<b>FLAMMABLES</b>	
Hydrogen	(0) 300 cu ft @ 2500 psi
Oxygen	(0) 250 cu ft @ 2500 psi
LOX	(0) 275 liter (0) 1500 gal
Diesel fuel	Hummers vehicles
Methylmethane	(3) 55 gal drums

Table 2. Hazardous

Table 2. Hazardous material summary.

Type of Hazard	Quantity	Location	Duration of Hazard
<b>EXPLOSIVES</b>			
ANFO	4800 tons	MSG2	Hemisphere loading - shot
OCTOL (75/25 HMX/TNI)	310 lbs	MSG2	Hemisphere loading - shot
CN-6	1/2 lbs	MSG2	Hemisphere loading - shot
TC-234 Detonators (4):			
PETN	1000 mg	MSG2	Final arming - shot
RDX/EXON	15.54 gm	MSG2	Final arming - shot
FCBC (4)	240 ft	MSG2	Hemisphere loading-shot
Pyrotechnic (40% mag/60% tolfon)	20 lbs	Ejecta Pads	Late time install - recovery
Electric Matches	160 mg	Ejecta Pads	Late time install - recovery
Batasheet	54 gm	Exp 8706	One month prior - recovery
IN-70 Mini-cap Bets	54	Exp 8706	One month prior - recovery
<b>RADIATION</b>			
Promethium 147	5000 mCi	Exps. 7500, 7501, 8709	Late time - recovery
Cesium 137	8 ± 1 mCi	Test Bed	Used pre- and postshot
Americum 241	40 ± 10% mCi	Test Bed	Used pre- and postshot
Lasers	(2) 100 joule pulsed	Laser Bunkers	Calibration and during shot
X-Ray Tube	3 Kv/630 roentgen/hr	Exp. 8704	Calibration and during shot
Lasers	Ruby (12 mjoule) and gallium arsenide	Exp. 8722	Gauge installation - recovery
<b>PRESSURE GAS</b>			
Sulfur Hexafluoride	120 lb bottle	Exp. 1220-1221	Pre- and postshot use
Nitrogen	(32) 255 cu ft @ 2500 psi	(4)/TR5	First field test-postshot
<b>FLAMMABLES</b>			
Hydrogen	(8) 300 cu ft @ 2500 psi	(1)/TR5	First field test - postshot
Oxygen	(8) 250 cu ft @ 2500 psi	(1)/TR5	First field test - postshot
LOR	(8) 275 liter (8) 1500 gal	(1)/TR5 (1)/TR5	First field test - postshot First field test - postshot
Diesel Fuel	Numerous vehicles	TR5 Test Articles	Positioned late-time - postshot inspection and removal
Nitromethane	(3) 55 gal drums	Exp. 8865, 66, 67	Drums positioned late time

Figure 4. A cross section of each segment can be described as follows: the inner surface will be a 1/4 inch of fiberglass. This outer layer will be different thicknesses depending on the height above the ground. At ground level the fiberglass will be 3/4 inch thick; at the top of the hemisphere, it will be 1/4 inch thick. Individual segments will be erected by a special hydraulic fixture, bolted together, and sealed with an additional quarter inch fiberglass patch on the inner and outer surfaces along each joint.

The entire structure will rest on a wooden, circular frame that sits on 25 vertical, buried, wooden poles. The interior ground area will be covered by a mylar sheet to prevent ground moisture from getting into the ANFO. (Annex F-1)

2. ANFO Mixing. A mixing plant to add diesel oil to ammonium nitrate to make ANFO (Blasting Agent) will be set up on the North Range, WSMR, in support of MINOR SCALE High Explosives Test. The mixing plant will be located 1.45 miles east of route 7, on route 20. Fuel oil delivered to the mixing plant in trucks will be discharged into the auger carrying the ammonium nitrate from the hopper to elevators. The ANFO will be gravity loaded into trucks from the elevators for delivery to the hemisphere at GZ. The trucks used to transport the ANFO will be appropriately marked, as will the mixing plant. The raw material for the ANFO, at the mixing plant, will be limited to 100 tons of ammonium nitrate and 100 tons of diesel fuel oil. (Annex F-2)

3. Explosive Operations. After completion of the fiberglass container and prior to ANFO loading, the booster charge will be constructed at ground level in the center of the hemisphere fiberglass container.

a. The booster, consisting of 310 pounds of Octol, will be constructed in a hemispherical shape approximately 28 inches in diameter. Two CH-6 sub-booster pellets will be emplaced in the Octol booster. Each sub-booster will have two lengths of flexible confined detonating cord (FCDC) attached that will be extended outside of the fiberglass container and tied off during the remainder of the charge loading operation.

b. ANFO Loading. 4,800 tons of ammonium nitrate-fuel oil mixture (ANFO) will be loaded into the 88-foot diameter, honeycombed, fiberglass hemisphere. The ANFO will be delivered to the test site in bulk form from the mixing plant in hopper trucks and pneumatically discharged into the hemisphere. Two workmen inside the hemisphere, wearing self-contained breathing apparatus,

distrib  
the he  
days t

Surfac  
analyz  
form :  
butior  
Annex

plied  
main  
lets.  
trans  
spher  
assem  
lines  
botto

holde  
tem.  
Sandf  
cable  
local  
Timi  
tion  
and  
and  
by t

Syst

high  
test

distribute the ANFO to insure a uniform level. This process will continue until the hemisphere is full. The entire loading operation will require approximately 10 days to complete, working daylight hours only.

ANFO quality control will be monitored by personnel from the Naval Surface Weapons Center (NSWC). Samples of ANFO will be taken from each load and analyzed for fuel oil content and particle size. Each load is weighed on a platform scale to track actual charge weight. Particle size and particle size distribution are important for both charge density/weight results and ANFO sensitivity. Annex F-3 is the ANFO Loading SOP.

4. Booster System/Pre-Arming. The MINOR SCALE booster system, supplied by NSWC, consists of a 27.5-inch diameter OCTOL (75/25 HMX/TNT) hemisphere main booster weighing nominally 310 pounds and containing 2 CH-6 sub-booster pellets. Four 60-foot aluminum sheathed, flexible, confined, detonating cords (FCDC) transfer detonation from the exploding bridgewire detonators to the Octol hemisphere. Pre-arming consists of placing the Octol hemisphere and sub-booster assembly inside the fiberglass hemisphere prior to charge construction. The FCDC lines are pre-positioned inside during assembly and exit the hemisphere through the bottom and are tied off once the detonator holders are attached.

Arming consists of attaching the four TC234 detonators to the detonator holders at the end of the FCDC lines and enabling the Arming and Firing (A&F) System. The detonators and firing system are designed, supplied, and operated by Sandia National Laboratory Albuquerque (SMLA), Division 7132. Four 300-foot "C" cables, pre-positioned in the structure, attach the detonators to the X-unit located on the test pad. This unit is connected to the A&F System located in the Timing and Firing (T&F) Van, approximately 6000 feet away in the West Instrumentation Park. The A&F System consists of an arm panel with an "Arm/Safe" key switch and monitor lights, a high voltage panel, an interlock panel, two power supplies, and a cable lock box with key. The system is locked out until after final arming by the two keys in the system.

The Arming SOP is provided as Annex F-4. The SMLA SOP No. 02700 8502, System Description and Detailed Procedures, is provided as Annex E.

5. Helium Sound Velocity Probs. Forty sound velocity probes in which high voltage spark gaps and microphone sources will be installed on the MINOR SCALE test bed precursed radials. The spark gaps are part of a system for measurement of

helium concentration in the helium bag. Plastic covers will be placed over each spark gap probe during calibration, as a personnel protection system. Each cover will be marked "Danger High Voltage" and "Do Not Remove". (Annex F-5)

6. Laser Field Operations. Two 100 joule ruby lasers, Holobeam Laser, Inc., Model 810 will be mounted in manned bunkers 5038 feet from GZ along the west radial. The laser beams will be aimed at diffuse screening targets behind the leading edge of the helium bag and GZ. Laser operating personnel, observers and guards must wear protective glasses during operation. The lasers will be locked out when not in operation. (Annex F-6)

7. Blast-Gauge Stations. Ten blast-gauge stations will be installed on two radials of the MINOR SCALE test bed. Each station will incorporate a beta densitometer gauge, Amersham Corp. promethium-147 beta source, 500 mCi. The beta densitometer gauges will be calibrated and used to measure the blast-wave density for the MINOR SCALE HIGH explosive blast test. A no access area will be roped off around each blast-gauge station and posted with radiation warning signs visible to personnel approaching from any direction. (Annex F-7)

8. Pyrotechnic Ejecta. Ten bowling balls, five buried at 5 feet on ten foot intervals starting at 50 feet from edge of hemisphere, and five buried at 2 feet on ten foot intervals starting at 60 feet from edge of hemisphere will be placed on test bed. Each ball contains approximately two pounds of a 40% magnesium and 60% teflon pyrotechnic wax based mixture which will be initiated by an Atlas M-100 Electric match containing 16 mg of Class C pyrotechnic material. The pyrotechnics will be fired on test runs and at event zero time through the timing and firing system (1/2 amp, 50 ms signal). Storage, handling and transportation will be in accordance with regulations for explosives. A limited access zone will be established during tests and final installation of devices. (Annex F-8)

9. Streak X-Ray. A Kevex X-ray tube, 631 roentgens/hr @ one meter, 30 kv @ 9-10 ma will be emplaced in an underground vault on the test bed with two sails projecting above ground level. The X-ray source transmits from one sail to detectors on the other sail. Sails are 4-6 inches apart. Area will be roped off during calibration. (Annex F-9)

10. Automatic Dust-Tube Catchers. Nine dust-tube catchers will be emplaced in the test bed. Each dust-tube catcher contains 54 gms detasheet and M-70 mini-cap detonators. The dust-tube catchers will be placed at 50 and 30 psi

stations within the precursor bag area. Each station will have three pedestals, one above the bag and two below the bag. The area within 50 feet of each tube will be designated a limited access zone during loading and arming of the explosive matrix. (Annex F-10)

11. Soil Characterization. A soil test gauge, Troxler soil characterization gauge with 8 mCi Cesium-137 and 40 mCi Americium-241 sources, will be used pre- and post-shot to take soil samples on MINOR SCALE test bed. When not attended the system will be properly secured. (Annex F-11)

12. Holograph. A holograph apparatus will be emplaced underground on the test bed with two sails extending 6 inches above ground. The holograph gauge contains two internal lasers, a ruby pulsed 12 mJoule laser, and a 3 mw continuous wave gallium arsenide laser. Both lasers are wholly contained within the gauge apparatus. Since the laser beams emit only between the 2 inch gap between the sails, there is no eye hazard to personnel for normal operations. High voltage components will be locked out and/or disconnected when internal components are exposed. (Annex F-12)

13. Hardened Shelter. Small quantities of sulfur hexafluoride will be released 10 meters upwind to two hardened shelters (1220 and 1221). Concentration outside and inside the shelter will be measured. The SF<sub>6</sub> concentration is not expected to exceed 10 ppm. Pre- and post-blast tests are required. Sulfure Hexaflouride is a nonflammable, nontoxic inert gas. It is used as a tracer gas by EPA and other regulatory agencies in tests to study air movement in open air studies. (Annex F-13)

14. TRS Operations. Eight Thermal Radiation Source (TRS) installations will be located on the test bed. Each site will consist of a pit containing a control system and regulators, and a supply of powdered aluminum, hydrogen and oxygen. The four burners for each pit will be buried approximately 40 feet from the service pits. These systems will be serviced and maintained in accordance with the TRS Standing Operating Procedures. The pit areas will be designated Limited Access Zones. The TRS units will be monitored by the TRS Central Control System in the TRS Instrumentation Van (West Instrumentation Park) and fired as part of the event timing and firing system. (Annex F-14)

Military vehicles and other equipment will be located along the west radial between 1720' and 3500' from GZ. Some of these test articles will contain

diesel fuel to run their engines during the test. The diesel fuel in test articles requiring TRS support will not ignite.

Three 55 gallon drums of nonsensitized nitromethane will be enplaced on the test bed (see 8065, 8066, and 8067 on Figure 16). These drums will be stored and transported as a flammable liquid.



ANNEX A  
MINOR SCALE ORGANIZATION

FCOMA Test Group Staff

Test Group Director	Maj Mike Evinrude
Technical Director	Capt Edward Raska
Test Group Engineer	Lt Stephen L. Crawford
Asst Test Group Engineer	SSG Ron Kiner
TRI Design Engineer	Mr. Ray Harrison
TRI Construction Inspectors	Huey Lewter and Vance Porter
Instrumentation Engineer	Lt Allen D. Taylor
Cable Coordinator	Mr. Jim Mathews
Program Analyst	Mr. Dwight Simpson
Program Director	CPT Charles G. Walls
Program Director	CPT Ken Jeffrey
Program Director (TRS)	LCDR William Taylor
Technical Director (TRS)	LCDR Kirk Mathews
Safety Officer	LCDR Kenneth Miles
Photo Program Director	Mr. Emery Prather
Administration	SSgt Ron Pierce

WSMR Support

Project Officers	Mr. Lee Meadows Mr. Jim Kilcrease
Stallion Range Facility Engineer	Mr. Glen Zumwalt
Safety (Ground) (Flight)	Mr. Mike Moody Mr. C. Garcia
Radiation Protection Officer	Mr. George Wenz

Agency Project Officers

Air Force Geophysics Laboratory	John Cipar	Agency
Air Force Weapons Laboratory	ILT Eisenhart	Techno
Belvoir Research & Development Center	Bill Comeyne	Techno
Boeing Aerospace Co.	Glen Jones	TRW Sp
Defense Research Establishment Subfield (DRES) Canada	Dave Ritzel	UK Sci
Denver Research Institute	John Wisotski	UK Atc
Federal Emergency Management Agency	Bettge	U.S. A
GB Laboratories	George Burghart	U.S. A
Goodyear Aerospace Corp.	E. Mueller	U.S. /
Harry Diamond Laboratories	Lou Belliveau	Har
HQDNA	LTC Gilbert Ullrich	Key
H-Tech Laboratories, Inc.	Bruce Hartenbaum	FRE
Information Science, Inc.	Walt Dudziak	DM/
Los Alamos National Laboratory	Dwight Rickel	So'
Martin Marietta Corporation	Joe Hollon	Del
Naval Civil Engineering Laboratory	John Mathews	U.S. /
New Mexico Engineering Research Institute Sand Columns Charge Construction	Ken Benson	White
New Mexico Institute of Mining & Technology	Bruce Schneider	
Norwegian Defense Construction Service	W. Rison	
Oak Ridge National Laboratory	Mr. Arnfinn Jenssen	
Particle Measurement Systems	C. Chester	
Royal Swedish Fortification Administration	Dr. Knollenberg	
SAIC/ALBQ	Dr. Bengt Vretblad	
SAIC/MASS	John Dishon	
SRI International	Dan Baxter	
Sandia National Laboratory, Albuquerque	Marshall Cross	
Science & Engineering Associates	Alan Burns	
Spectron Development Labs, Inc.	Richard Heinze	
	Jack Reed	
	Larry Skenandore	
	George Burghart	
	James Keller	
	Dr. O. Modarress	

lect Of

Agency Project Officers

Technology International Corp.	W. Boquist
Technology Service Corp.	B. Radza
TRW Space & Technology Group	Ralph Wuerker Dick Batt
UK Scientific Research Development Branch	Dr. Stealey
UK Atomic Weapons Research Establishment	Tony Wood
U.S. Army Armament Research & Devel. Center	Fred Schumann
U.S. Army Ballistic Research Lab	George Teel John Sullivan
U.S. Army Engineer Waterways Experiment Station	
Hardened Shelter	G. L. Cane
Keyworker Shelter	Bill Huff
FRG Experiments	Jim Watt
DNA Experiments	Jim Ingram
Soil Characterization	Bruce Phillips
Debris Collection	Kim Davis
U.S. Army Natick Research & Devel. Center	J. Fanucci
White Sands Missile Range (STEMS-TE-NP)	John O'Kumma

ANNEX B

WSMR SUMMER HAZZARDS



# SUMMER RECREATION HAZARDS

**White  
Sands  
Missile  
Range  
New Mexico**

appr  
Seri  
is n  
sunb  
pers  
dama  
sun  
expe  
  
lonc  
of  
crar  
eicl  
tre  
  
In  
per  
the  
coo  
sal  
Thi  
  
is  
att  
bra  
ove  
of

## HEAT INJURIES

The sunny, warm weather of the Southwest can become a hazard if not approached with caution. Heat can injure our bodies in several ways. Serious bodily injury and loss of manhours can occur if proper judgement is not used.

Excessive exposure to the ultraviolet rays of the sun can result in sunburn. A bad sunburn may not only be uncomfortable, but can cause a person to become very ill. Repeated exposure to the sun may produce skin damage and be a cause of skin cancer. Unexposed skin should be exposed to the sun no longer than 10 to 15 minutes initially. After the first few days the exposure time may be gradually lengthened until the skin is conditioned.

Heat Cramps may result from exposure to high temperature for a relatively long time, particularly if accompanied by heavy exertion, with excessive loss of salt and moisture from the body. Heat cramps are characterized by the cramping of muscles of either the skeletal system or the intestines. In either case, the condition may be relieved in a few hours under proper treatment, although soreness may persist for several days.

A loss of salt and water from the body may also lead to heat exhaustion. In this condition, the person becomes pale, weak, dizzy, confused and perspires freely. Treatment is aimed at promoting the return of blood to the heart (by elevating the feet), cooling the patient (by moving him to a cool place, fanning him, etc.), and by increasing the salt intake. Encourage salty foods or fluids (carbonated beverages have a high sodium content). This same treatment can be used in the treatment of heat cramps.

Heat stroke is the most serious of the three types of heat injury, and is often fatal. Heat stroke is a medical emergency and requires immediate attention. It is caused by damage to the heat-regulating mechanism of the brain, and is characterized by an extremely high body temperature (often over 108 degrees Fahrenheit); profound coma; hot, red, dry skin; and absence of sweating. Pulse and respirations are rapid and convulsions may occur.

The prime objective of treatment is to lower the body temperature as quickly as possible. Move the patient to a cool or shady place, and remove all outer clothing. If possible, immerse the patient in cool or ice water; if not, sprinkle him with water, fan to hasten evaporation and get him to a hospital immediately.

Will salt tablets decrease the danger of heat injuries? Recent studies have shown that when a normal diet is consumed, the ingestion of up to 3 additional salt tablets does not reduce the incidence of heat injuries. When more than 3 salt tablets a day were consumed, the incidence of all 3 types of heat injury increased. Excessive salt intake can cause symptoms of gastrointestinal distress, muscular soreness, fatigue and decreased work capacity. Excessive consumption of salt must be avoided; the goal is a balance of salt and water, with neither too much nor too little. Salt tablets are not recommended for oral undiluted consumption by the Surgeon General.

Heat injuries can be avoided by observing the following rules:

1. Acclimatize yourself, i.e., gradually expose yourself to the heat and sun over a period of several days.
2. Reduce physical activity during the heat of the day and observe WBGT (Wet Bulb Globe Temperature) restrictions of outdoor work.
3. Drink more water and use extra salt in cooking (Persons on sodium restricted diets should check with their private physician before altering their sodium intake).
4. Keep yourself in good physical condition; any illness may lower your resistance to heat stress. Alcohol also may compromise your resistance to heat injury.
5. Be alert to the signs and symptoms of heat injury in both yourself and those you are working or playing with outdoors. If you recognize these signs or symptoms then take the proper first aid measures and seek immediate medical care if the condition warrants emergency attention. A video tape on heat injury and its treatment is available for loan from Environmental Health, MUSAHC, 678-1331.

organ  
Black  
The d  
Weste  
plagu  
to hu  
Cauti  
been  
of fi  
facti  
impr  
sant  
pose  
the  
of t  
dise  
the  
burr  
The  
any  
cont  
hav  
the  
to  
to  
and  
cat  
who

## PLAGUE

Virtually everyone has heard of the disease caused by the bacterial organism Yersinia pestis. In the middle ages the disease was known as the Black Death and killed an estimated one fourth of the population of Europe. The disease is called plague and can be found in wild animals throughout the Western United States.

New Mexico routinely leads the nation in the number of cases of human plague, however, plague in New Mexico has historically been more of a threat to human health during the warmer months in the northern half of the state. Caution is indicated in southern New Mexico as well. Cases of plague have been documented in both wild animals and humans in this area, also.

Plague is not the great killer it once was in terms of the huge number of fatalities associated with the disease. This decline is due to several factors: The discovery and use of a wide variety of antibiotic drugs, improvements in the early diagnosis of the disease, vast improvements in sanitation and rodent control, and individual awareness as to the hazard posed by wild animals that may be carriers of the disease. This drop in the number of fatalities is not indicative of any lessening of the seriousness of the disease, however. Plague is still a virulent, potentially lethal disease.

Plague is perpetuated in nature by bloodsucking fleas which transmit the bacteria from one animal to another. Fleas live in the fur, nests and burrows of their hosts and most will parasitize more than one kind of mammal. The wild rodent is by far the predominant reservoir of wild plague, however, any mammal that can be a host for the fleas that carry the pathogen can contract the disease. Predatory animals commonly show positive evidence for having contracted the disease either from infected flea bites or from eating the infected flesh of their prey. Domestic dogs and cats are also susceptible to fleas, therefore they are also vulnerable to plague. Dogs do not seem to get noticeably sick from plague but it may kill cats. Because of this and other environmental hazards (i.e., rabies), one should not allow dogs and cats to run free. Many human cases of plague may directly be linked to a pet who roamed free, contracted the disease from a wild source and brought it home.

When plague is introduced into dense populations of susceptible rodents the disease spreads rapidly, killing many animals and leaving their fleas without a source of blood. These fleas, searching for a new meal, will readily leave the sick and dying rodents and infest and bite a new host. For this reason, the handling of sick or dead rodents should be strictly avoided as should any area known to be heavily inhabited by rodents. The killing of wild rodents by untrained personnel using poison or snap traps also may increase the risk of human plague because of the transfer of infected fleas.

Humans can also contract plague by direct contact with the infected blood or tissues of a sick or dead animal. Hunters and trappers who skin, clean or otherwise handle rabbits, carnivores, or rodents can get plague if infected body fluids enter a cut or abrasion. Recently a fatality in southern New Mexico was directly linked to the skinning of a plague infected bobcat by the deceased.

Humans are highly susceptible to plague. The incubation period ranges from two to six days and in rare instances may be longer. Normal symptoms include a high fever, chills and headache. Lymph glands in the groin, armpits and neck become swollen and tender. The disease is typically severe, with a definite onset.

If plague bacillus invades the lungs it produces a pneumonia characterized by high fever, headache, difficulty in breathing, shortness of breath and a cough productive of bloody sputum. This form of the disease typically has a shorter incubation period, is highly communicable and may be spread to other persons when the patient coughs or sneezes. The fatality rate in untreated pneumonic plague is estimated to be 95 percent. Death occurs after a short illness of one to three days.

Plague is well established in New Mexico among wild rodents and rabbits. It is technically and practically impossible to eradicate the disease from the wild at this time. Individual education and precautions are therefore indicated in the prevention of this disease in the human community. The following are recommended plague prevention measures an individual should take:

bedd  
rabbi  
meat,

their  
wear  
thor

junk  
Do n

espe

the  
Clin

and

pair  
mill  
rocl  
clai  
is  
tre

The  
on

the



ents  
with-  
ily  
s  
s  
as.  
f  
ced  
es  
s  
r-  
e.  
er-  
ly  
ter  
ts.

1. Restrain pets and keep them and their living quarters (kennels and bedding) treated with flea powder. Keep dogs and cats away from wild rodents, rabbits and their nests and burrows. Do not feed pets raw rabbit or rodent meat, viscera, skins, etc.

2. Avoid contact with wild animals and their fleas. Stay away from their burrows and nests. Do not handle sick or dead animals. Hunters should wear rubber gloves during skinning and cleaning operations. Cook wild game thoroughly before eating.

3. Discourage rodents by keeping your home and yard free of trash, junk and garbage. Store animal feed in rodent proof containers or buildings. Do not snap trap or poison wild rodents.

4. See your physician immediately about any unexplained illness, especially one having sudden onset of high fever.

5. Report any observed unusual die-off of a number of wild rodents in the same general location to Environmental Health, McAfee US Army Health Clinic.

#### V E N O M O U S   A R T H R O P O D S

The following are some of the important poisonous arthropods (insect and insect-like animals) which may be encountered in this area:

CENTIPEDE. A segmented, wormlike creature with from 15 to more than 100 pairs of legs. Each segment has one pair of legs (in contrast to the harmless millipede, which has two pairs of legs per segment). Lives under logs, boards, rocks, and in dwellings where it can gain entrance. It is provided with poison claws located behind the mouth, connected to large poison glands. The bite is painful, much like the sting of a bee, but otherwise is not serious. For treatment, use cold compresses.

SCORPION. Scorpions are straw colored and have eight legs and two pincers. The scorpion's tail contains a stinger. The severity of scorpion stings depends on the type of scorpion.

The sting of most New Mexico scorpions is not serious. The sting of these scorpions produces a local reaction with pain, swelling and bruising.

Treatment consists of cleansing the wound, applying a cool compress, and getting a tetanus shot.

The more dangerous scorpion, the Centuroides, is found only in the Lordsburg area of New Mexico. This small type produces a neurotoxin venom and the sting can be quite serious.

Symptoms associated with the sting of a Centuroides includes restlessness, muscle cramps, involuntary drooling, and uncontrolled urination and defecation. The victim may also have difficulty breathing, and venom can cause blurred vision and temporary blindness.

The initial treatment for a Centuroides sting is the application of a cool compress to the wound and immediate transportation to a medical facility. This allows professional treatment of any complications while pain medication and tetanus shot can be given. (Provided by Jim Knight, wildlife specialist at New Mexico State University.)

TARANTULA SPIDER. Very large hairy spider. About 30 species live within the limits of the United States, mostly here in the Southwest. The bite of any of our Southwestern tarantulas is entirely harmless. The bite has been described as "painful as a couple of pin stabs" and has essentially the same effect. Cleansing of the wound is all that is needed. Tarantulas should not be indiscriminately killed as they are one of nature's very efficient pest controllers eating many different types of annoying insects.

BLACK WIDOW SPIDER. Average-sized spider with a shiny black body. Usually has distinctive red hour-glass marking on underside of abdomen; however, exact design may vary, with occasionally two or more distinct triangles or blotches or sometimes only an irregular longitudinal area. Found in darker corners of barns, stables, shacks, outdoor latrines, wood piles, basements, etc.

Symptoms include severe abdominal pain with "board-like" rigidity of the abdominal muscles. An occasional fatality has been reported. The only first aid measure to be taken is local cleansing of the bitten area; keep the patient as quiet as possible and obtain medical aid as soon as possible.

The s  
in this ar

BEEES  
painful  
greatly f  
lethal do  
to bee st  
tolerance

WASP  
hornets.  
are found  
in holes

ANT  
the dang  
harveste  
attack s  
bare-mou  
at lengt

REA  
have bee  
John A.

1.  
site of  
to spec  
or may  
subside  
necessa

2.  
swellin  
The sym  
or thro  
Medica

## STINGING INSECTS

The stinging insects belong to the order Hymenoptera. Those present in this area include the following:

BEEES. Both honey bees and bumble bees are found in this area and inflict painful stings. The pain is due to the injected venom. The severity is greatly increased in the case of multiple stings; it has been estimated the lethal dose for an adult is 500 bee stings within a short time. Tolerance to bee stings, however, may develop in those long exposed to stings. This tolerance disappears when exposure is discontinued.

WASPS. The term "wasp" generally includes wasps, yellow jackets, and hornets. These insects build their nests of "pap" (wood pulp) or mud, which are found beneath eaves, on porches, in outbuildings, shrubbery, trees, or in holes in the ground.

ANT. Certain species of stinging ants are quite formidable because of the danger of a mass attack by hordes of these ants. In this area the red harvester ant may be encountered. They have a vicious sting and readily attack small animals and man if the unwitting victim disturbs their low, bare-mound-like nests. Small children could be in great danger if exposed at length to these ants. They should be told never to play near ant mounds.

REACTIONS TO STINGS. Three general types of reactions to insect stings have been described. The names given below to these reactions were coined by John A. Flumo of the US Department of Agriculture.

1. Hymenopterism Vulgaris: There is pain, redness, and swelling at the site of the sting. The severity of these manifestations varies from species to species. The pain, redness, and swelling may last for only a few minutes, or may persist for up to a few days. This reaction is not serious and subsides without treatment, although an ice pack may be used. It is not necessary for a physician to be consulted.

2. Hymenopterism Intermedia: This type of reaction includes considerable swelling beyond the actual site of the sting; for example, an entire arm. The symptoms last for several days. If the insect has stung the tongue, neck, or throat, there may be enough swelling to impair breathing or swallowing. Medical aid should be obtained if this reaction occurs.

3. Hymenopterism Ultima: This reaction is also known as anaphylactic shock. It may result from only one sting. The patient goes into shock quite rapidly; the breathing is shallow, pulse and heartbeat are faint or indetectable, sweating occurs, and the patient loses consciousness. The body may break out in hives. A physician is needed at once, for this reaction often terminates fatally, sometimes in a matter of minutes.

The last two reactions indicated the person is allergic to the venom of the stinging insect. The occurrence of a Hymenopterism Intermedia reaction may mean the patient is likely to demonstrate Hymenopterism Ultima in the future, perhaps with the very next sting. The particular type of insect responsible must be strictly avoided; desensitization injections by an allergist may be feasible.

PREVENTIVE MEASURES. If nests of wasps, bees, or ants are found on WSMR, they should be left alone and the Pest Management Section of Facilities Engineering should be contacted. Rapid disposal of garbage, especially fruit, around quarters, yards, and picnic areas is very important, since some kinds of wasps and bees will gather around this sort of garbage. Watermelon seems especially attractive to yellow jackets. Certainly everyone should use the refuse facilities provided in public parks, but few people realize that this procedure may be a matter of life or death.

#### VECTORS OF DISEASE

Certain creatures, while not themselves poisonous, may carry diseases to man. Some important ones in New Mexico are:

TICKS. The Rocky Mountain Wood Tick may carry the organisms that cause Rocky Mountain Spotted Fever, as well as Colorado Tick Fever. Therefore, its bite should be carefully avoided. Wear high boots and keep socks outside trouser legs when walking through known tick-infested areas, especially thick woods and high grass. Before retiring at night, and after leaving a tick-infested area, carefully search your body and clothing for the tiny, flat, leathery insects.

NOTE: When engorged with blood, they are a good deal larger, perhaps the size of a bean. If the tick has already imbedded his mouth parts in the skin, remove the tick immediately. Several methods may work: you may simply

gently p  
with ker  
To apply  
the mout

FLI

of anima  
Househol  
closed f  
Filth f

their pi

MO

light t  
the bra  
Use of  
collars  
encoura  
time.

wading

BA

carrier  
of rabi  
to life  
been fo  
alive,  
to dis  
inatal;

I

Engine  
to the  
bat sh  
of suc  
DO NOT  
sick c

gently pull it off with the fingers (or tweezers, if available); or douse it with kerosene, gasoline, lighter fluid, tincture of iodine, etc. **WARNING:** To apply heat may cause an engorged tick to burst. It is important to remove the mouth parts with the tick.

**FLIES.** Flies are significant vectors of disease. Keeping yards free of animal feces is imperative if fly populations are to be minimized. Household refuse as well as garden waste should be bagged and secured in closed plastic bags and placed out for pickup by refuse collection personnel. Filth flies can be more than just a nuisance and require all personnel to do their part in keeping WSMR clean and fly-free.

**MOSQUITOES.** Two species of mosquitoes are in this area (proven by mosquito light trap collections) which can transmit encephalitis, an inflammation of the brain. This danger is aside from their characteristic as biting pests. Use of screen bed nets, insect repellent, rolled-down cuffs and buttoned-up collars will provide a significant amount of protection. Personnel are also encouraged to ensure water is not allowed to stand for extended periods of time. Standing water sources such as birdbaths, overwatered yards and children's wading pools are favorite breeding places for mosquitoes.

**BATS.** In this vicinity approximately ten per cent of the bats are carriers of rabies. Most of these carriers eventually become ill and die of rabies. When a bat is found ill with rabies, it may look dead, but "come to life" when disturbed. Such a bat may be found on the ground, and have been found in the post swimming pools. If, on the other hand, a bat is found alive, and "roosting" somewhere (on a porch, for instance), it is best not to disturb it. Chances are it is not infected. Bats should not be indiscriminately killed as they are one of nature's best insect pest controllers.

If a sick or dead bat is found, Pest Management personnel at Facilities Engineering should be notified; they will pick up the animal and deliver it to the Post Veterinarian for laboratory examination. Anyone picking up a bat should use heavy gloves and put the specimen in a paper sack. Collection of such specimens should not be attempted by inexperienced persons. **TO REPEAT: DO NOT ATTEMPT TO CAPTURE BATS OR OTHER WILD OR STRAY ANIMALS.** Many of the sick or dead bats collected at WSMR have been proven to be rabid. Rabies

have also been found in dogs, cats, skunks, and coyotes in this area. Rabies in man is always fatal. The last human death from rabies in Dona Ana County was in 1949. Let's not have any more.

### P O I S O N O U S S N A K E S

The following are some of the important poisonous snakes which may be encountered in this area:

RATTLESNAKES. Over a dozen species of rattlesnakes are found in the Southwest. They are pit vipers (so called because of a small, deep pit found between the nostril and eye on each side of the head) and all possess the distinctive rattle at the end of the tail. The larger species of rattlesnakes feed principally upon small mammals; the smaller species mostly upon lizards. Species identification among rattlesnakes may be difficult, but it is often important. The venoms show significant differences that can influence treatment and prognosis.

Western Diamondback Rattlesnake. Two light, diagonal stripes on the side of the head, the posterior one extending to an angle of the mouth. The tail is distinctly ringed with black and gray or white, and the black rings are as wide as or wider than the pale ones. General coloration is buff, gray, brown or reddish with diamonds that are less clear-cut, often appearing dusty with indistinct light edges. The belly is cream to pinkish buff sometimes clouded with gray. Average length is 3 to 5 1/2 feet; maximum is 7 feet.

Prairie Rattlesnake. Light diagonal strip behind eye is narrow; body blotches are rectangular, usually with narrow light edges. General ground coloration is often greenish-gray or olive-brown. Average length is 3 to 4 feet; maximum a little under 5 feet.

Mojave Rattlesnake. This snake is very similar to the western diamondback and prairie rattlesnakes in pattern and general appearance. The general color is often greenish or olive and the average length 30 to 40 inches; maximum is about 4 feet.

sna  
sna  
not  
of

dry  
Of  
500

roc

tra  
rar

fo

as  
ca

in  
ly  
ti

ne

th  
sv  
er  
al  
bi

WESTERN CORAL SNAKE. Coral snakes are much smaller than the rattlesnake. They are small snakes but are considered dangerous. The head is small and not distinct from the neck. The body is slender and elongate, not tapered. The tail is blunt. Coral snakes have color patterns made up of complete rings of yellow (or white), black and red (coral).

HABITAT:

Western Diamondback Rattlesnake. Inhabits many types of terrain from dry, sparsely wooded rocky hills to flat desert and coastal sand dunes. Often in agricultural land and near towns. Generally avoids elevations above 5000 feet in the United States but may be found up to 8000 feet in Mexico.

Prairie Rattlesnake. Inhabits dry grassland and rocky hills; on open rocky mountain slopes to at least 9000 feet.

Mojave Rattlesnake. Occurs very largely in desert and prairie-desert transition zones. Decidedly a lowland snake in the northern part of its range; frequents arid mountains in Mexico.

Western Coral Snake. Inhabits grassland and dry open woods; sometimes found along streams and occasionally in suburban areas.

FIRST AID TREATMENT OF SNAKEBITE:

1. Remain Calm. It is imperative that the individual bitten as well as the individual rendering first aid remain as calm as possible. Hysteria can drastically hamper the patient's chance for a speedy recovery.

2. Limit Activity. Immobilize the bitten extremity and have the bitten individual lie down and remain as quiet as possible. This action is particularly crucial in discouraging extensive systemic venom transport and associated tissue destruction.

3. Transport To Medical Treatment Facility. The bitten individual may need definitive care which can only be rendered in a medical facility.

4. If Medical Attention Is More Than One Hour Away:

a. Apply a loosely constricting band (at least 2 inches wide) between the bite and the trunk of the body, 2-3 inches above the bite or above the swelling if it has already occurred. The veins distal to the band should be enlarged but a pulse should be palpable in the extremity. A finger should be able to slip between the band extremity or the band is too tight. Loosen the band for five minutes every twenty minutes.

b. Incising the bite should only be done when a serious bite has occurred. Large amounts of venom are injected in perhaps less than 20% of those bitten so the chances of getting a severe bite are not great. If incision is done, it should be accomplished by making a short, shallow (1/8 - 1/4 inch) incision through each fang mark with a sterile blade along the longitudinal axis of the limb. Do not crosscut the wound. Suction should be applied by devices constructed for such purposes and not by mouth. When in doubt don't incise the bite.

c. Steps 4a or 4b, if they are warranted by the isolation of the bitten individual and the perceived severity of the bite, should be undertaken as quickly as possible after the bite. Incision and suction are of particularly dubious value if done more than twenty minutes after the bite.

#### 5. DON'TS.

a. DON'T PANIC.

b. DON'T CONSUME ANY ALCOHOL.

c. DON'T PACK THE EXTREMITY IN ICE. An icebag applied to the site of the bite may prove helpful in slowing the spread of the venom and alleviating pain but the entire extremity should not be immersed in ice.

d. DON'T INJECT ANTIVENIN IN THE FIELD. Antivenin may cause fatal anaphylactic shock in sensitive individuals and should only be administered, when indicated, in a medical treatment facility.

e. DON'T RISK A SECOND BITE TO KILL THE SNAKE.

f. DON'T APPLY A COMPLETE TOURNIQUET UNLESS THE BITE IS FELT TO BE SO SEVERE THAT THE LOSS OF THE BITTEN LIMB MUST BE ACCEPTED TO SAVE THE INDIVIDUAL'S LIFE.

g. DON'T HARASS, TEASE OR HANDLE SNAKES. A very small portion of snakebites involve strikes by an unseen snake. In most instances, if you avoid confrontation so will the snake.

#### P O I S O N O U S P L A N T S

Throughout man's history, plants have served as a major source of food, shelter and healing principles. Many of the nutritional and medical properties of plants were discovered through a trial and error process with countless people suffering the toxic effects of plants before the desirable



effects were isolated. The toxic effects of plants range from mild skin or gastrointestinal irritation to serious conditions involving the cardiovascular and nervous systems. Deaths have followed the consumption of some plants.

Today, most edible plants are clearly identified in the market so that we no longer have to select them in their natural state. As a result, most toxic reactions to plants result from accidental ingestion. Unfortunately, most of these accidents occur in infants and small children, making plants one of the leading causes of childhood poisoning. Both indoor and outdoor plants can be dangerous if eaten.

#### OUTDOOR PLANTS:

CASTER BEAN. Chewing just a few seeds of this large, attractive, shrub-like herb, the source of castor oil, can cause death. The tick-like, mottle seeds and to a lesser extent, the leaves - contain ricin phytotoxin, which causes burning of the mouth and throat, nausea, vomiting, severe stomach pains, diarrhea, excessive thirst prostration, dullness of vision and uremia. Death from uremia may occur within 12 days of eating the seeds. Swallowing the hard-coated seeds whole is not dangerous, but chewing one to three seeds can be fatal to a child; four to eight seeds, to an adult.

JIMSONWEED. Also known as Jamestown weed, thornapple, stinkweed, and datura. Although the leaves and seeds have been used as a source of drugs, poisonings are common. Children who suck the flowers, eat the seeds, or make "tea" from the leaves have been poisoned, and cornpickers working in fields where jimsonweed grows have suffered transient effects on their eyes from the plant dust. Effects of poisoning are dry mouth, pupil dilation, redness of skin, headache, hallucinations, nausea, rapid pulse, elevated blood pressure, delirium, convulsions, coma and death.

LARKSPUR (DELPHINIUM). The wild varieties of this subspecies of the crowfoot or buttercup family, are a leading cause of death among range cattle, and the tall, flowering herbs can be fatal to humans, too, if eaten in large quantities. Toxicity of the plant decreases as the plant grows older. The alkaloids can cause stomach upset and nervous excitement or depression.

MUSHROOMS. Mushroom-hunting, even by the knowledgeable, can be a deadly sport. There are several thousand species of mushrooms in the United States. Some are always poisonous; others are poisonous only in certain seasons, or locations, when eaten raw, or during a particular stage of maturity. Their effects also vary from individual to individual. One person may be severely poisoned by eating a mushroom species that another eats with impunity. In some people, the combination of alcohol and mushrooms is like the combination of alcohol and Antabuse. In others, taking drugs like hydroxychloroquine may make a harmless mushroom highly toxic. Most important to the mushroom hunter - There is no sure way of distinguishing between the harmless mushroom and the poisonous toadstool! The differences between them are minute and subtle, and the poisonous and edible forms may grow in the same area, even in the same fairy ring. Nor does cooking destroy the toxins. Mushrooms of the Amanita genus, such as the Sly Agaric and deadly Amanita, cause about 90% of the deaths due to mushroom poisoning. One or two bites can be fatal, and 50 to 90% of those who are poisoned die.

BLACK NIGHTSHADE. Black nightshade is a weed found throughout the United States. Blue nightshade, also known as deadly nightshade and climbing nightshade, is a woody vine or shrub found in damp places. Both species contain solanine in all parts; with the highest concentrations in the unripened fruit. Solanine is extremely toxic, and small amounts can be deadly. Symptoms of poisoning are stomach pain, a fall in temperature, paralysis, dilated pupils, vomiting, diarrhea, shock, circulatory and respiratory depression and loss of sensation.

OLEANDER. A fragrant evergreen shrub or tree that grows up to 25 feet tall; the oleander is found in the south and in California, where it has been planted as a headlight screen on the median strips of freeways. Its twigs, and green or dry leaves, and flowers contain the cardiac glycosides, neriodide and oleandroside, which act like digitalis but are much more toxic. Just one of the smooth, leathery leaves is enough to kill an adult. Using an oleander branch as a skewer to roast meat on an open fire can transfer a fatal dose of the poison to the meat. Children have also been poisoned by sucking the nectar from the plant's flowers, and honey made by bees that have visited the flowers is poisonous. Symptoms of oleander poisoning include severe abdominal pain, nausea, vomiting, bloody diarrhea, dizziness, slowed pulse, hypotension, hypothermia, cyanosis, cardiac irregularities, marked dilation of the pupils, convulsions, respiratory paralysis and coma.

IND  
plants c  
The foll  
and gard

Caladium  
Elephant  
Dumbcane  
Dieffenb

English

Rhodode  
Azalea

Poinse

Hydran  
Lily o

Mornir

Ligus

Aloe

INDOOR PLANTS/HOUSE PLANTS. Even the most common house and garden plants can be poisonous. Many contain toxic substances in beautiful disguise. The following is a partial list of dangerous plants commonly found in houses and gardens in the United States:

<u>PLANT</u>	<u>TOXIC PART</u>	<u>SYMPTOMS</u>
Caladium Elephant Ear (Philodendron) Dumbcane Dieffenbachia (mother-in-law plant)	All Parts	The effect of these plants is widely variable. Symptoms may include immediate pain, burning, redness and swelling of the lips, tongue and throat. The symptoms produced may be as a result of an allergy or a true chemical burn. Blister formation may occur.
English Ivy	All parts, esp. berries and leaves	Symptoms vary widely. Irritation of the lips, tongue and throat, vomiting soon after eating, stomach pain and diarrhea may be seen.
Rhododendron Azalea	Flowers and leaves	Watering of mouth, eyes, nose; energy loss, vomiting, loss of coordination, progressive paralysis.
Poinsettia	Leaves, stem and sap	Symptoms vary widely. Irritation of lips, tongue and throat, vomiting soon after eating, stomach pain and diarrhea may be seen.
Hydrangea Lily of the Valley	Leaves, bulbs, Whole plant	Nausea, vomiting and diarrhea, irregular heart-beat, stomach upset.
Morning Glory	Seeds	Hallucination, exhilaration, delusions, blurred vision, stupor and possible coma.
Ligustrum or Privet	Berries	Stomach cramps and possible death.
Aloe Vera	Sap	Symptoms vary widely. Irritation of the lips, tongue and throat, vomiting soon after eating, stomach pain and diarrhea may be seen.

<u>PLANT</u>	<u>TOXIC PART</u>	<u>SYMPTOMS</u>
Asparagus Fern Moses-in-a-Basket/Boat	Berries Fleshy Parts	Symptoms may be a result of allergy or a true chemical burn and might include redness, swelling, pain, itching and blister formation.
Geranium	Leaves	Symptoms may be a result of allergy or a true chemical burn and might include redness, swelling, pain, itching and blister formation.
Wandering Jew	Leaves	Symptoms may be a result of allergy or a true chemical burn and might include redness, swelling, pain, itching and blister formation.

The dangers of childhood plant poisoning could be greatly reduced if adults would take these few precautions:

1. Know the names of the plants in your house, yard, and neighborhood. If you are unsure of the identity of a plant, take a sample to your nursery for a correct identification.
2. Teach your children about the dangers of eating plants. Point out those plants in your area which you know to be particularly harmful.
3. Put houseplants out of the reach of infants and toddlers. Make older brothers and sisters aware of the importance of keeping the little ones away from the plants.
4. Keep the number of the Health Clinic and Poison Crisis Center near your phone. Call if your child has eaten or chewed on a plant, even if you believe that the plant is non-toxic. New information is available daily and it is better to be safe than sorry.
5. Keep a one ounce container of syrup of ipecac in your home. Syrup of ipecac will cause your child to vomit and is much safer than salt water or other home remedies. It should only be used under the direction of the Poison Center or your physician.

NOTE: The information in the "Poisonous Plant" section of this booklet has been taken from "The Perils in Plants," Emergency Medicine, May 1970 and "Toxic Plants of New Mexico", Poison, Drug Information and Medical Crisis Center, University of New Mexico, Albuquerque, New Mexico.

## ANNEX C

### PROTECTIVE MEASURES, MINOR SCALE SAFETY PLAN

#### 1 INTRODUCTION

The MINOR SCALE high explosives event will involve several hundred people preparing experiments, instrumentation, a test bed and a 4800-ton charge of ammonium nitrate and fuel oil (ANFO). Heavy construction equipment will be used for erecting buildings, digging bunkers, and laying cable to support numerous experiments to be fielded by agencies of the U.S. and other governments. It is important to recognize the potential for injury in such a large effort being accomplished to meet a deadline. Supervisors from DNA and the specific agencies involved should be alert to potential problem areas, recognize them if present and take action to correct them immediately.

#### 2. RESPONSIBILITIES

##### 2.1 DNA Staff.

The MINOR SCALE Test Group Director and his staff will insure that all agencies involved with the MINOR SCALE event are aware of and practice safe operations at all times. Specific areas for which they are responsible for safety include lightning protection, explosives safety and protection from detonation effects. These will be specifically addressed herein.

2.2 Other Agencies and Organizations.

Supervisors must insure that their personnel are qualified to do the job involved. Heavy equipment operators must be properly trained and licenced (when required) to operate the specific equipment involved. Supervisors must be aware of unsafe practices, observant to detect them and take corrective action immediately if detected.

3. LIGHTNING PROTECTION

Lightning storms are not uncommon in the northern desert area of WSMR and, at times, can be extremely intense. Lightning can injure or kill personnel and can damage or destroy electric/electronic equipment. If weather radar or visual sightings confirm thunder storm cells within five miles of the test bed, operations on sensitive equipment and explosives/blasting agents should cease. Personnel should take precautions to avoid being struck by moving away from likely targets such as large metallic objects. One safe place is inside a rubber tired vehicle.

Experiment protection and explosive charge protection are discussed separately and are not covered in this Annex.

4. EXPLOSIVES MONITORING

ANFO will be mixed approximately four miles northwest of the test bed. Fuel oil will be mixed with ammonium nitrate prills and the mixture will then be transported by truck to the hemispherical fiberglass shell and pneumatically loaded. ANFO is classified as a blasting agent because it is insensitive to most methods of initiation such

as bla  
it is  
4800  
availa  
the he  
ANFO.  
above  
ANFO  
must  
1).  
5.  
shock  
with  
perso  
than  
roug  
km)  
deto  
litt  
rock  
clos  
(DR)  
mis!

as blasting caps, fire, impact and electrical stimulation. However, it is prudent to observe stringent safety measures when working with 4800 tons of blasting agent. A lightning warning system will be available at both locations. Temperature sensors will be implanted in the hemisphere to warn of any unforeseen rise in temperature of the ANFO. The fuel oil in the ANFO could flash and burn at temperatures above 140°F if a spark or other flame producing device were present. ANFO will also react with pyrite bearing ores, e.g., copper, and these must be kept away from, or insulated from contact with ANFO (Reference 1).

## 5. DETONATION EFFECTS

### 5.1 General.

MINOR SCALE detonation effects of interest include blast, ground shock, ejecta, missiles and dust. Blast is by far the most important with regard to personnel safety. Ground shock is not dangerous to personnel beyond 2300 ft (700 m) and there will be no personnel closer than 4750 ft (1400 m). Ejecta will be limited to 3-4 crater radii, or roughly 787 ft (240 m). Missiles can be thrown as far as 2.5 miles (4 km) (Reference 2). However experience from MILL RACE, which was detonated 1080 ft (330 m) from the planned MINOR SCALE GZ, indicates little missile activity. The soil in this area contains very few rocks. There will be three groups of people 2.5 miles (4 km) or closer for the MINOR SCALE detonation. The Denver Research Institute (DRI) people will be at 4750 ft (1448 m) and will be protected from missiles by four feet of earth. Personnel at the Timing and Firing

(T&F) Park will be 11,500 ft (3505 m) from GZ and will be inside windowless vans which will provide sufficient protection from the possibility of a missile travelling this distance. The personnel at McDonald Ranch will be at 11,610 (3539 m) from GZ and will not be protected except for hard hats. However; the chance of being struck by a missile is extremely remote because of past experience at the GZ area with missiles and the fact that the ranch is at the outer limits of possible missile range.

#### 5.2 Blast.

Blast generates overpressures and noise which, at close ranges, are quite destructive. These effects decrease with range, and varying degrees of protection are required depending on the range involved. Figure 1 relates predicted overpressure to range for the MINOR SCALE detonation. The threshold of eardrum rupture for humans is 5 psi (34.5 kPa) overpressure (Reference 3). This pressure is predicted to occur at 2800 ft (853 m). No one will be this close to GZ. Ear injury (hearing loss) can occur at overpressures as low as 0.29 psi (2kPa). This overpressure is predicted to occur at 22,000 ft. The blast also generates flying debris which, for MINOR SCALE, can be expected to occur out to 1.24 miles (2 km). Flying dust and sand could occur as far as 2.5 miles (4 km) depending on surface conditions.

### 6. SPECIAL CONSIDERATIONS FOR CLOSE-IN PERSONNEL

#### 6.1 Denver Research Institute (DRI) Bunkers.

DRI will to have four persons located 4750 ft (1448 m) from GZ. They will be nearer to GZ than anyone else and will be located inside

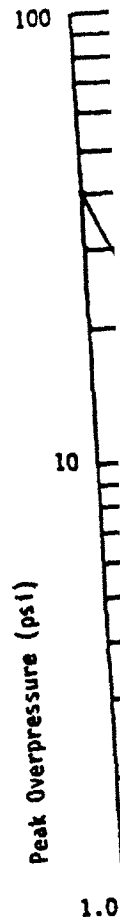



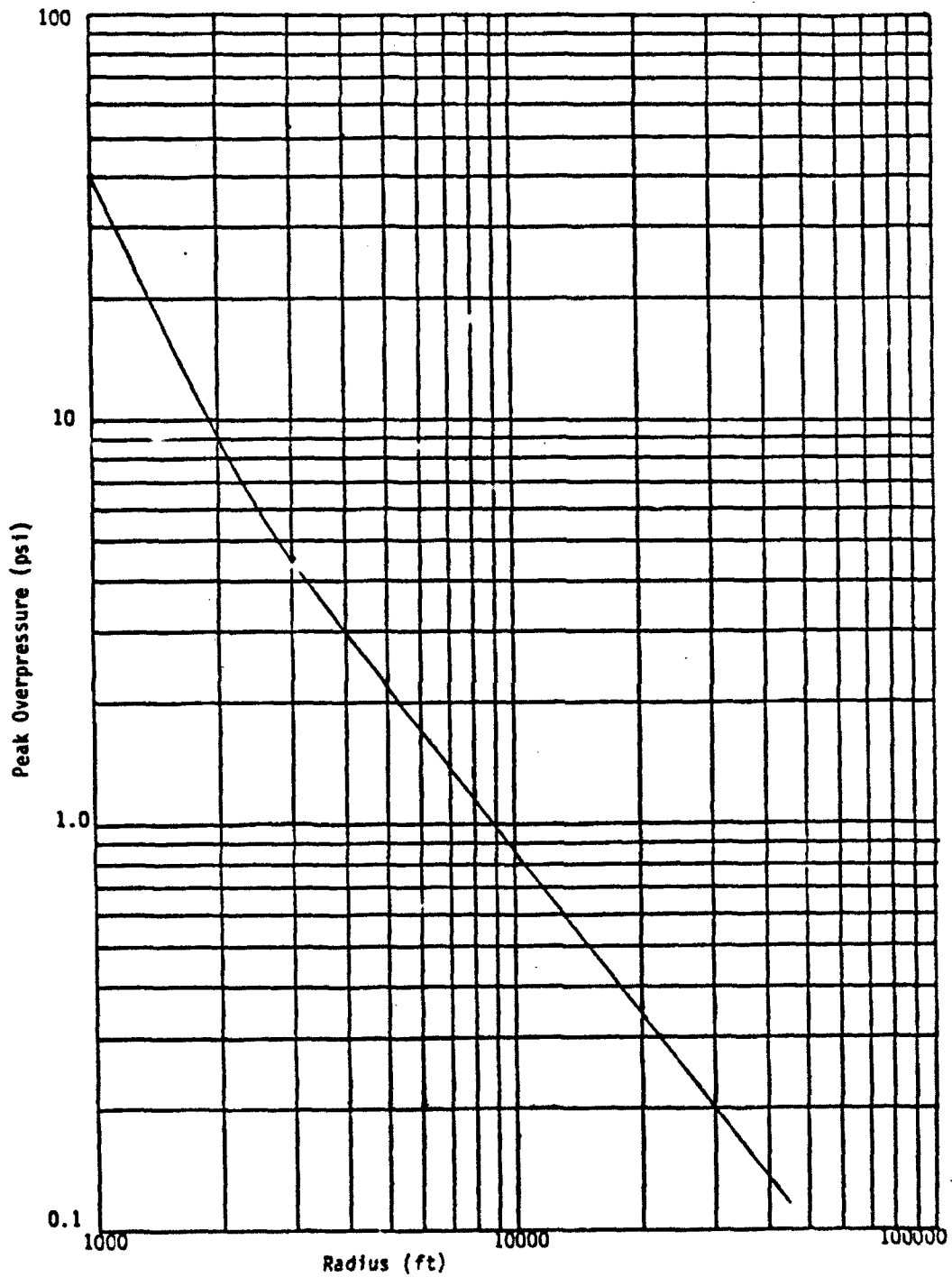

Figure 1. MINOR SCALE Overpressure vs Radius  
203

two reinforced wood bunkers. The bunkers will be side by side roughly southwest of GZ and will be elevated about 10 ft above ground level. Each bunker will contain a laser system as described in experiment #8707. The bunkers are 9X23X9 ft, with the 23 ft length oriented approximately in line with GZ. A 10x10x4 ft thick earth berm will be constructed over the rear half of each bunker to protect persons inside from falling debris.

The bunkers have a rectangular opening in the end towards GZ, one is 8X12 in and the other is 12X14 in. These apertures are needed for the lasers to shoot through. These apertures will be closed and locked after the lasers are fired and before the blast wave reaches the bunkers. This action is time sensitive because the lasers must fire for approximately 30 ms after the detonation and the blast wave will arrive 3.2 s after detonation.

One bunker has a small rectangular opening in the rear plus a small hole low in one side. The other bunker has two 14X14 in openings in the rear. These openings will be sealed in such a manner that they will not allow overpressure to enter. Air conditioner hoses inlets are provided.

The doors on both bunkers will be refurbished. In addition, a locking bar will be installed to secure the doors from the inside, with four brackets for the bar on each door, two brackets mounted on the door and one on each side of the door.

The construction of the bunkers is laminated 2X6 boards with 3/4 in plywood on the outside and 3/8 in plywood on the inside. Against a 2.2 psi overpressure, the front wall has a factor of safety of at

least th  
replaced  
section  
sure.

Tal  
of 170  
in the  
cm/s<sup>2</sup>

causing

0

force

ment b

non-es

The pe

size

locke

0.1 p

the r

(Ref

will

capa

has

oper

gl

for

least three. One of the bunkers had a 3X5 ft section removed and then replaced in the wall towards GZ. The steel plates securing this section are sufficient to withstand the predicted 2.2 psi overpressure.

Table 1 provides information on detonation effects. Ground shock of  $170 \text{ cm/s}^2$  is not sufficient to knock a person down; however persons in the bunkers are advised to sit or crouch. Levels approaching  $500 \text{ cm/s}^2$  are needed to knock a person down or into something possibly causing injury.

Overpressures of 2.2 psi will generate a substantial shock or force on the front wall of the bunkers. It is important that equipment be well secured and that personnel be sitting or crouched. All non-essential items will be removed from the bunker before shot day. The peak overpressure inside the DRI bunkers will be a function of the size of the openings in the bunkers. If the aperture is closed and locked when the blast wave arrives, pressure rise should be less than 0.1 psi. If the aperture remains open a peak of 0.15 is possible. If the rear door is not secured peak overpressure could approach 0.3 psi (Reference 4 and 5). Hard hats should be worn. Sound pressure levels will be sufficient to cause hearing loss and hearing protectors capable of at least 28 dB attenuation should be worn. If the aperture has not closed, a substantial amount of debris will penetrate the opening possibly causing equipment damage or injury. The wrap-around glasses used for protection against laser light should be sufficient for eye protection.

Table 1. MINOR SCALE Effects

	Range	OP <sup>1</sup>	Duration	Ground Shock	SPL <sup>2</sup>
	(ft)	(psi)	(s)	(cm/s <sup>2</sup> )	(dB)
DRI Bunkers	4,750	2.20	0.68	170	188
T&F Park	11,500	0.70	~ 0.8	48	166
McDonald Ranch	11,600	0.69	~ 0.8	48	165
Gus Site	14,780	0.50	~ 1.0	36	164
Millers Watch	19,000	0.35	> 1.0	26	162
Admin Park	24,288	0.24	> 1.0	18	158
Observ. Point	29,300	0.19	> 1.0	10	156

1. Overpressure.
2. Sound pressure level.

#### 6.2 Timing and Firing (T&F) Park.

There are plans for five instrumentation type trailers and 10 people to be located at the T&F Park which is the same area as the old Administration area. Detonation effects are shown in Table 1. The two effects of interest are the static overpressure and the sound pressure level. The overpressure will be sufficient to knock objects

off of tables or racks and possibly shake florescent light tubes out of their sockets. Objects not well secured to the walls or ceiling could also break loose and cause injury or damage. Ordinary glass windows will probably break (80 percent probability), Reference 3. Vehicle glass is much more resistant to overpressure; however vehicles should be parked perpendicular to the blast wave and windows should be left open to lessen the likelihood that the glass will break. Persons in the trailers should wear hard hats, eye protection (glasses are sufficient) and hearing protection.

### 6.3 McDonald Ranch.

Sandia National Laboratories, Albuquerque (SNLA) plans to monitor overpressure at McDonald Ranch with one person. Other instrumentation will document blast and shock data. Range to GZ is 11,600 ft (3539 m) and the overpressure is forecast to be 0.69 psi (45.7 kPa). Table 1 shows effects of interest for McDonald Ranch. There are two effects of concern. The first is the static overpressure which may pick up sand or dust and throw it at sufficient velocity to cause eye injury. The second is the sound pressure level which is well above the 160 dB limit recommended by Reference 2. Therefore persons in this area will wear eye and hearing protection. Glasses are sufficient if the flying sand cannot bypass the glasses and reach the eye at high velocity. Ear plugs or other approved hearing protection must also be worn. Persons in this area should not stand in or behind any of the ranch buildings or any object which could generate debris from the impact of the blast wave. Ordinary window glass has an 80 percent probability

of breaking, Reference 3. Flying missiles (rocks) are a slim possibility and should be watched for. The McDonald Ranch structure will be protected by reinforcing roof beams and removing all windows and doors.

#### 6.4 GUS Site.

GUS Site is located on Route 7 roughly south of GZ at about 14,780 ft. Table 1 shows predicted detonation effects.

The effects of concern are static overpressure and sound pressure level. Overpressures of 0.5 psi could knock poorly secured items off tables, racks, ceilings or walls inside trailers. ordinary window glass has a 15 percent probability of breaking, Reference 3. Personnel in trailers or outside should wear eye protection (glasses are sufficient), hard hats and hearing protection. There is little chance of flying missiles; however sand and dust could be a problem. Vehicles in the area should have their windows open.

#### 6.5 Miller's Watch.

Miller's Watch is located north, northeast of GZ at 19,000 ft. Table 1 shows detonation effects. It is planned to have one instrumentation van for experiment no. 5260 at Miller's Watch and one south southwest of GZ at about the same range. The chance of flying missiles, sand or dust is remote at this range. Sound pressure levels exceed safe levels however, and hearing protection should be worn along with hard hats. There is a 10 percent probability that ordinary window glass will break.

#### 6.6 Administration Park.

The Administration Park is located 23,000 ft northwest of GZ at

the intersection of Routes 7 and 20. There will be numerous administration trailers, vehicles, personnel and possibly instrumentation trailers. The sound pressure level is predicted to be just under 160 dB such that hearing protection will not be required at this location. However the sound will be loud and those persons with sensitive ears may want to cover their ears or wear hearing protection. Overpressure levels, see Table 1, are low enough that there is only a 7 percent probability of window breakage. However there will be many windows subject to this overpressure so breakage should be expected. To minimize breakage, the following guidance will be followed:

1. Trailers with windows will be parked end-on to GZ if possible.
2. All windows will be partially open.
3. Windows facing GZ ( $90^{\circ}$ ) or offset  $70^{\circ}$  from facing GZ have the greatest risk of breakage, so efforts to minimize this condition should be taken.
4. Windows facing GZ or offset  $70^{\circ}$  from this orientation will be taped to minimize the possibility of flying glass.
5. Cracked or loose glass will be replaced/repared before the event.

There should be no danger from dust, debris or flying missiles. There will be dust concentrations under the detonation cloud so if the cloud moves northwest over the Administration Area, dust can be expected, however concentrations will not be dangerous and they will be relatively shortlived.

#### 6.7 Observation Point

The Observation Point (OP) is the location where all observers and non-essential experimenters will be placed to view the detonation. The location is what once was the west instrumentation park for the 1976 DICE THROW event. As shown in Table 1, the range is close to 5 miles, the predicted overpressures is 0.19 psi and predicted sound pressure level is 156 dB. Ground shock will be noticeable but not dangerous to persons standing or seated. Overpressure will be noticeable but not dangerous. The sound pressure level is below that required for hearing protection; however the noise will be loud. In fact, meteorological conditions could amplify the sound levels under the right circumstances. Therefore it is recommended that ear plugs be given to everyone for their use.

#### 6.8 Security Guards

Security guards will be deployed early in the morning on event days at WSMR. These guards secure all avenues of approach to the test bed and adjacent areas to insure no unauthorized entry. Specific guard locations have not yet been designated. The following guidance will be followed when specific locations are designated:

- Security guards between 12,000 and 22,000 feet should have eye and hearing protection.
- Security guards beyond 22,000 feet require no special protection.



REFERENCES

1. Letter, Kaman Tempo to Field Command, Defense Nuclear Agency, ATTN FCTT, 23 January 1985.
2. McMullan, F and Gould, K, Environmental Assessment for the MINOR SCALE High Explosive Test, Kaman Tempo, Santa Barbara, CA, 4 September 1984.
3. Gould, K, High Explosive Field Tests, Explosion Phenomena and Environmental Impact, DNA6187F, Defense Nuclear Agency, 1 October 1981.
4. Operation UPSHOT-KNOTHOLE, Project 3.9, Field Fortifications, WR728, HQ, Defense Nuclear Agency, December 1954.
5. Crawford, R. E. et al, The Air Force Manual for Design and Analysis of Hardened Structures, AFWL-TRJ-74-102, Air Force Weapons Laboratory, October 1974.

Let  
ATTN  
McM  
SCA  
4 S  
Gou  
Env  
198  
Ope  
WR7  
Cra  
An  
We



APPENDIX G  
ANFO MIXING PLANT

214

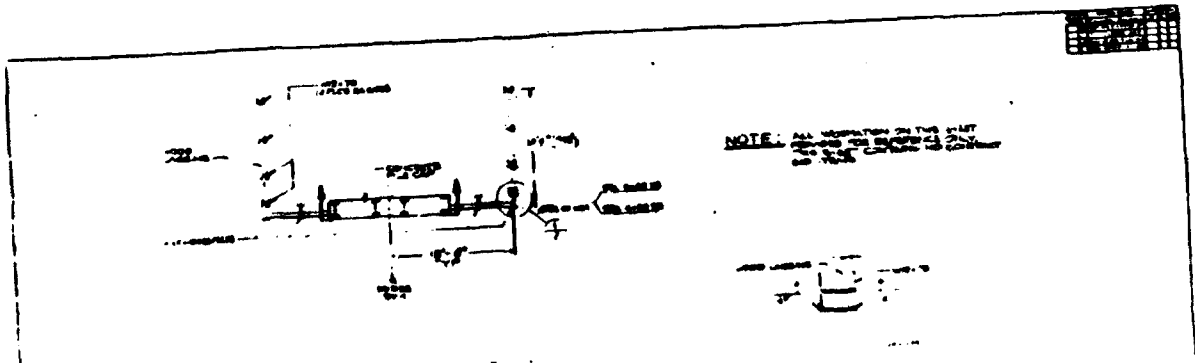
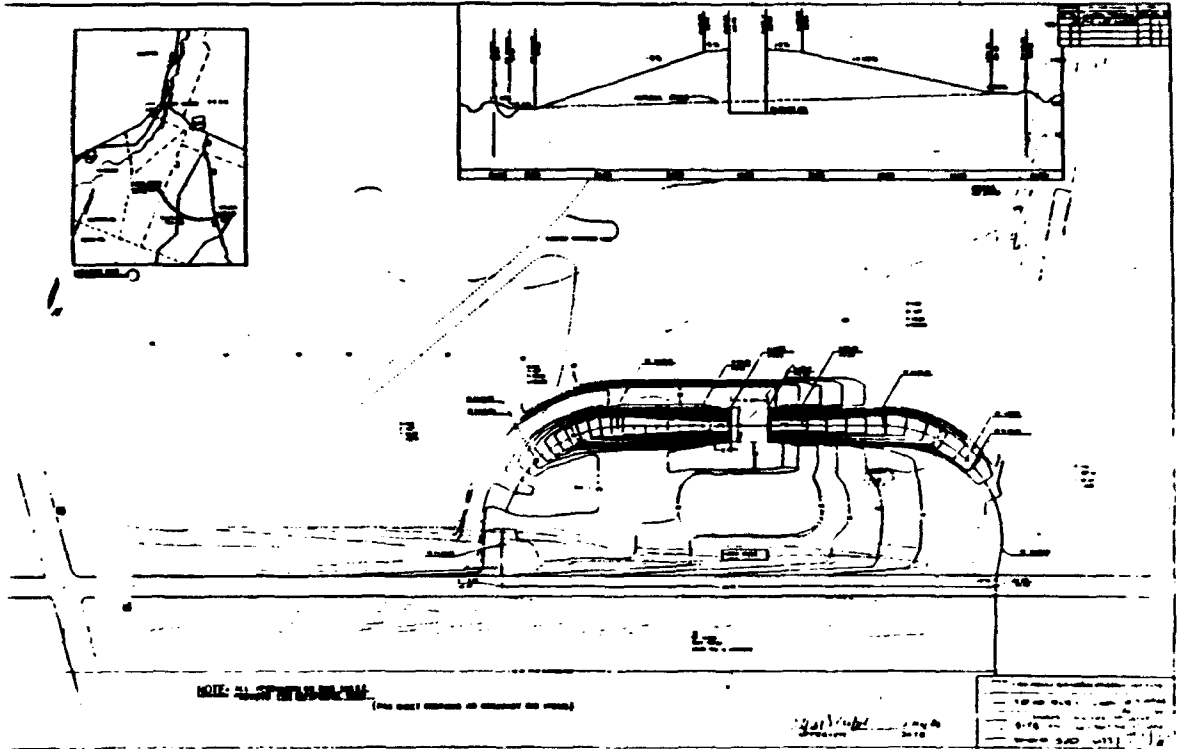

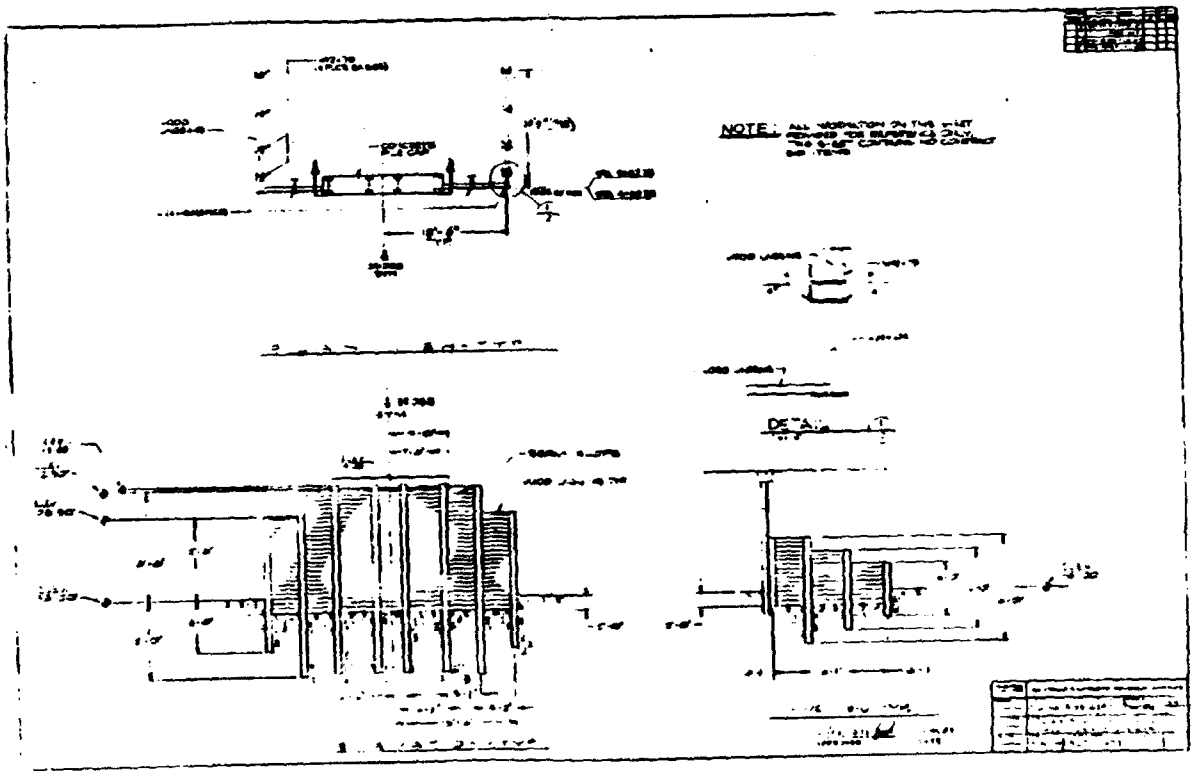
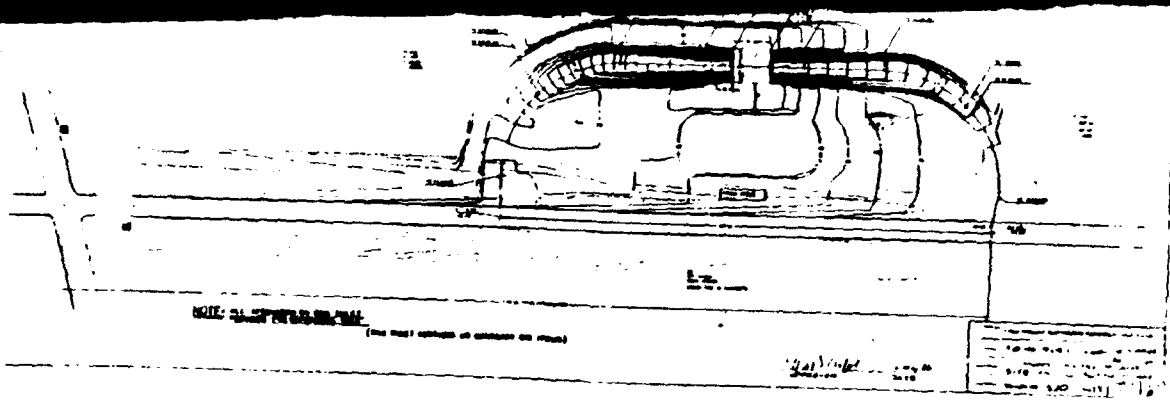

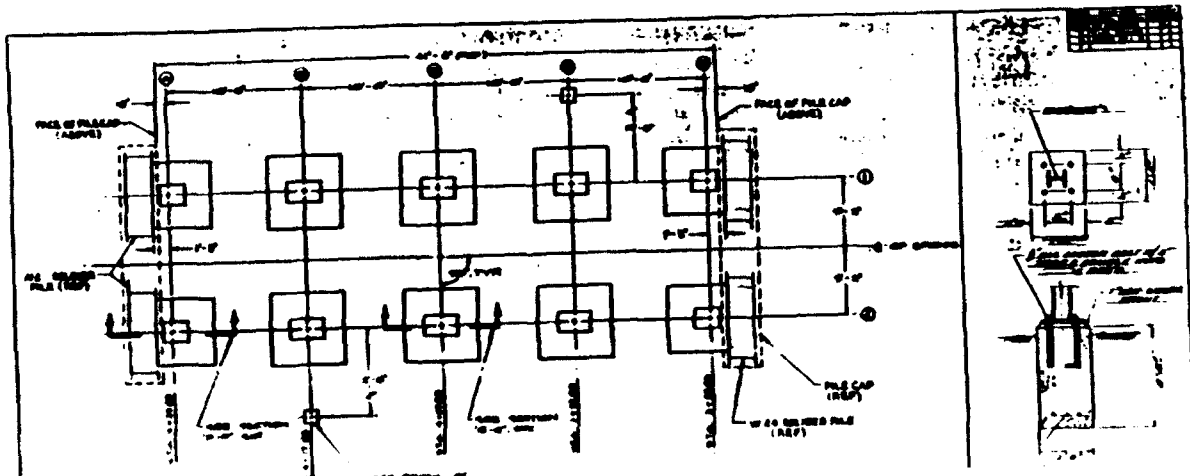
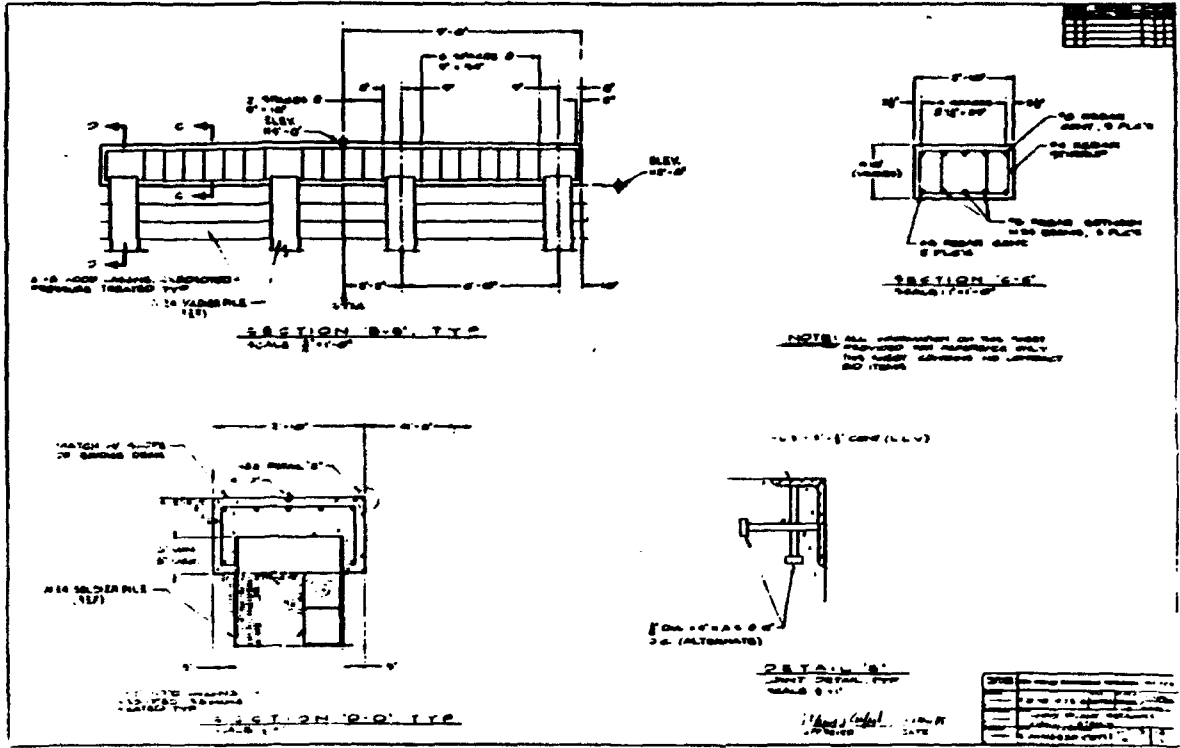

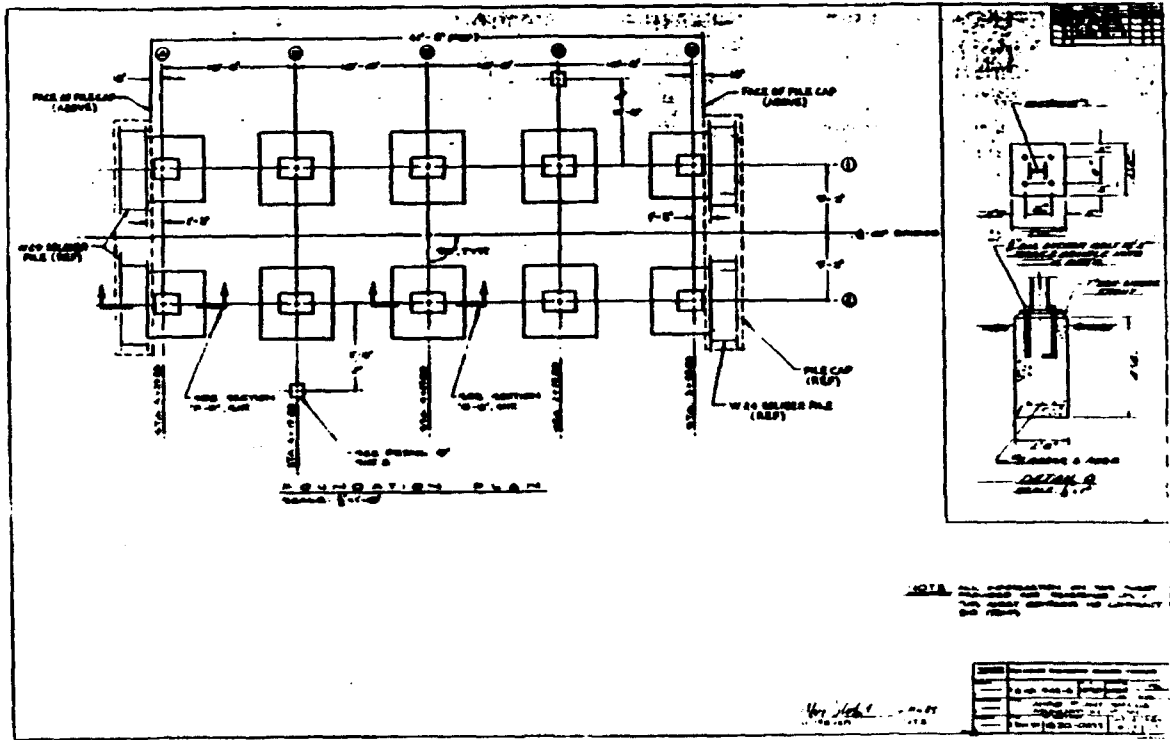
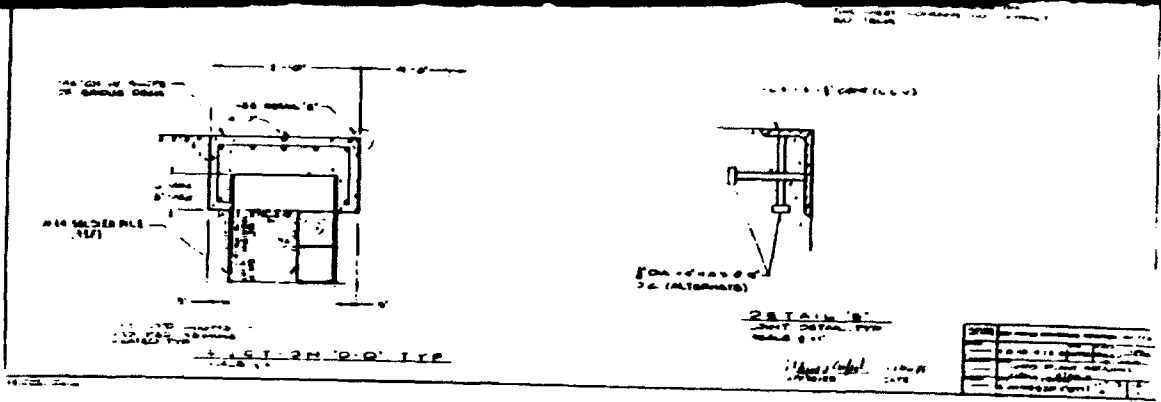

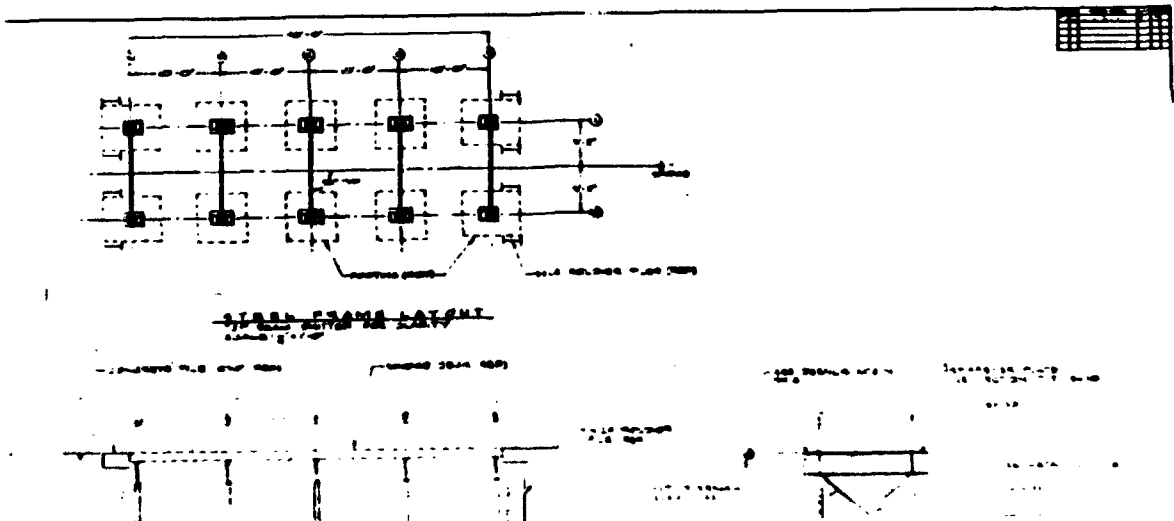
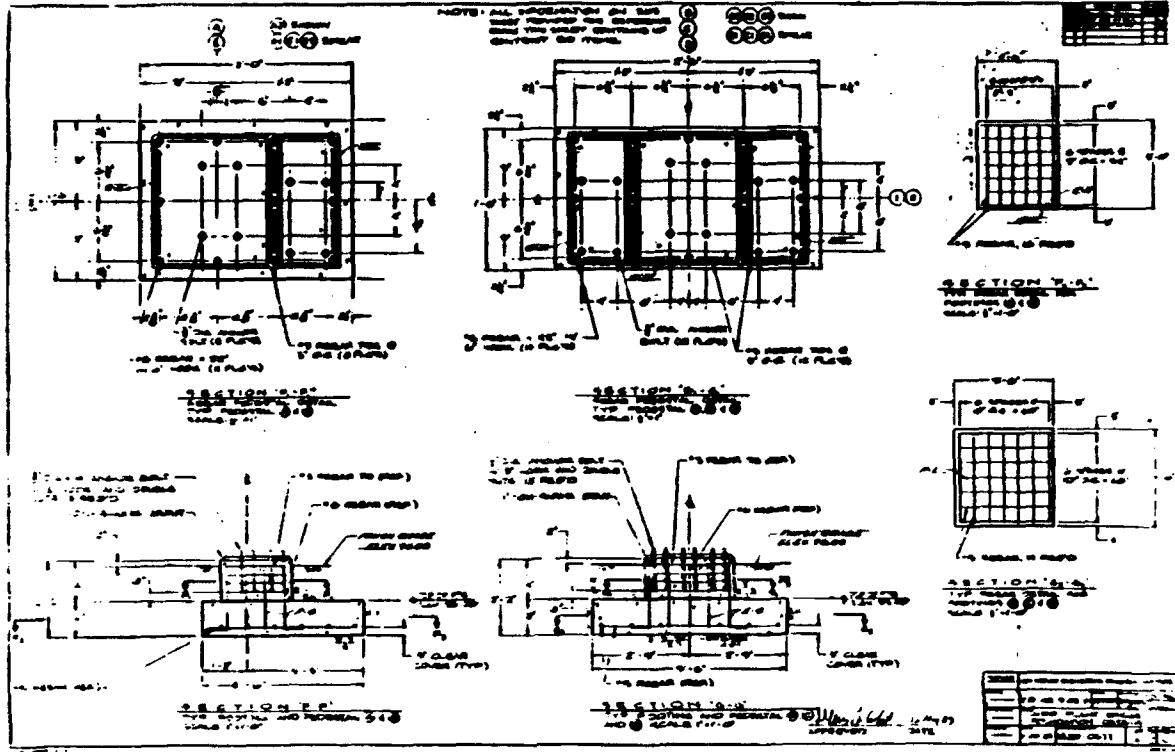



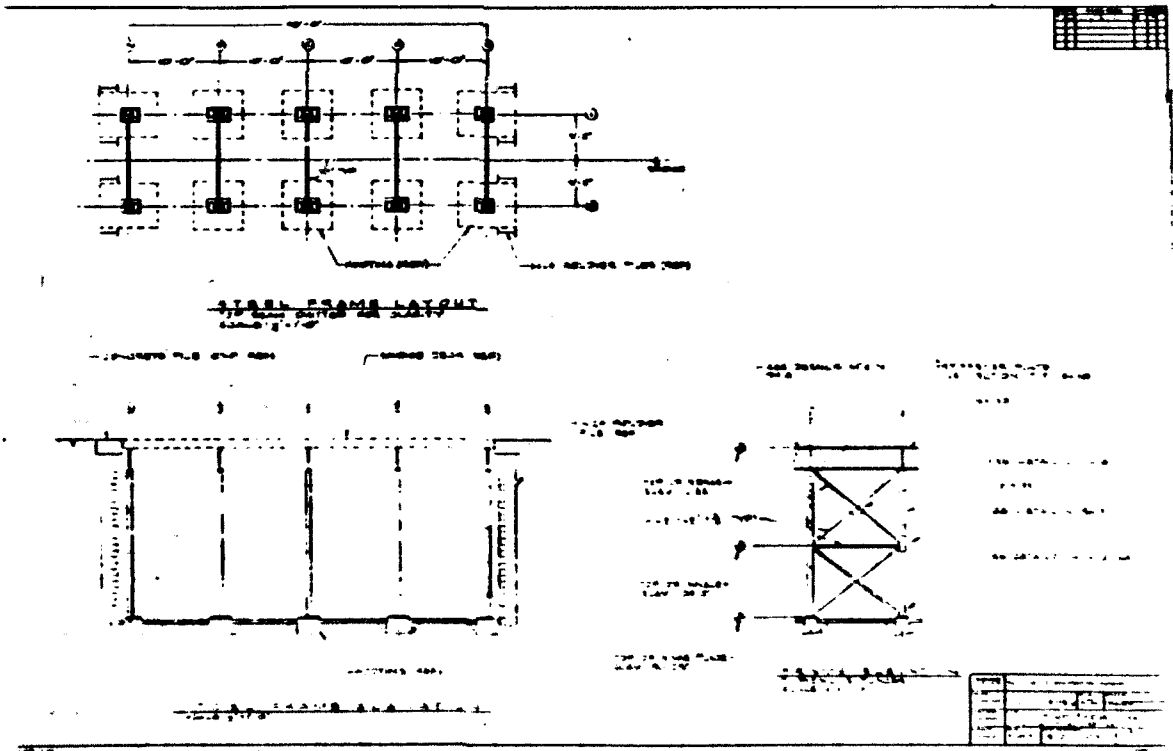
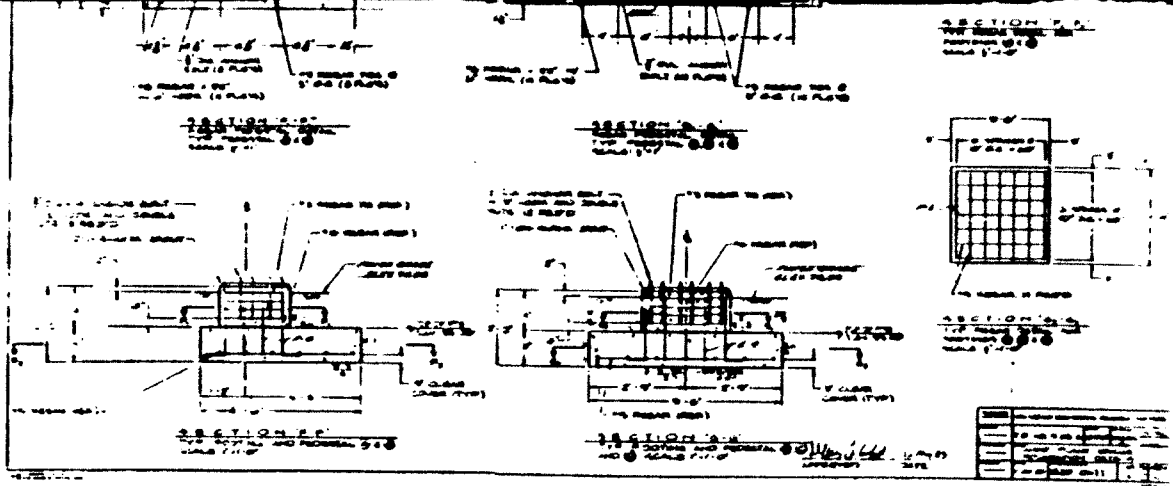

220

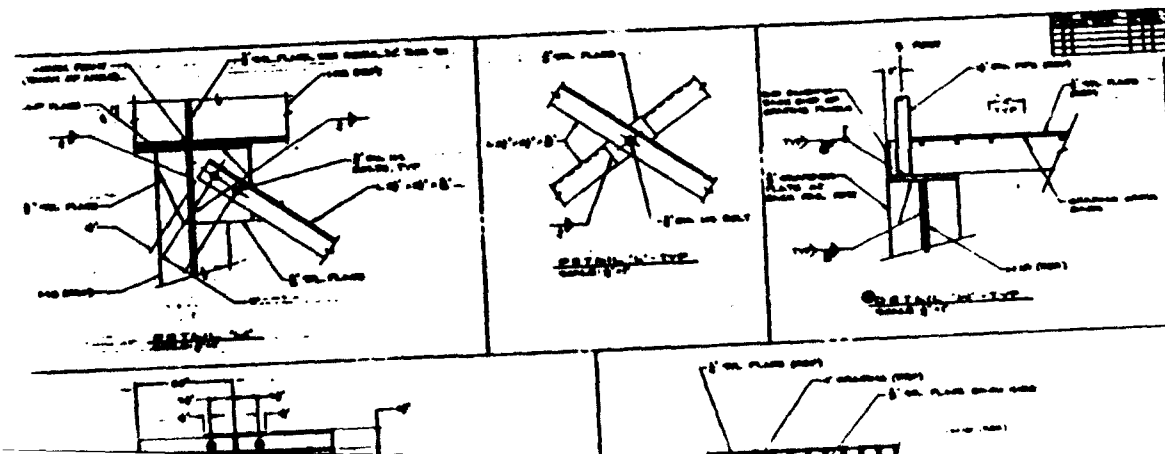
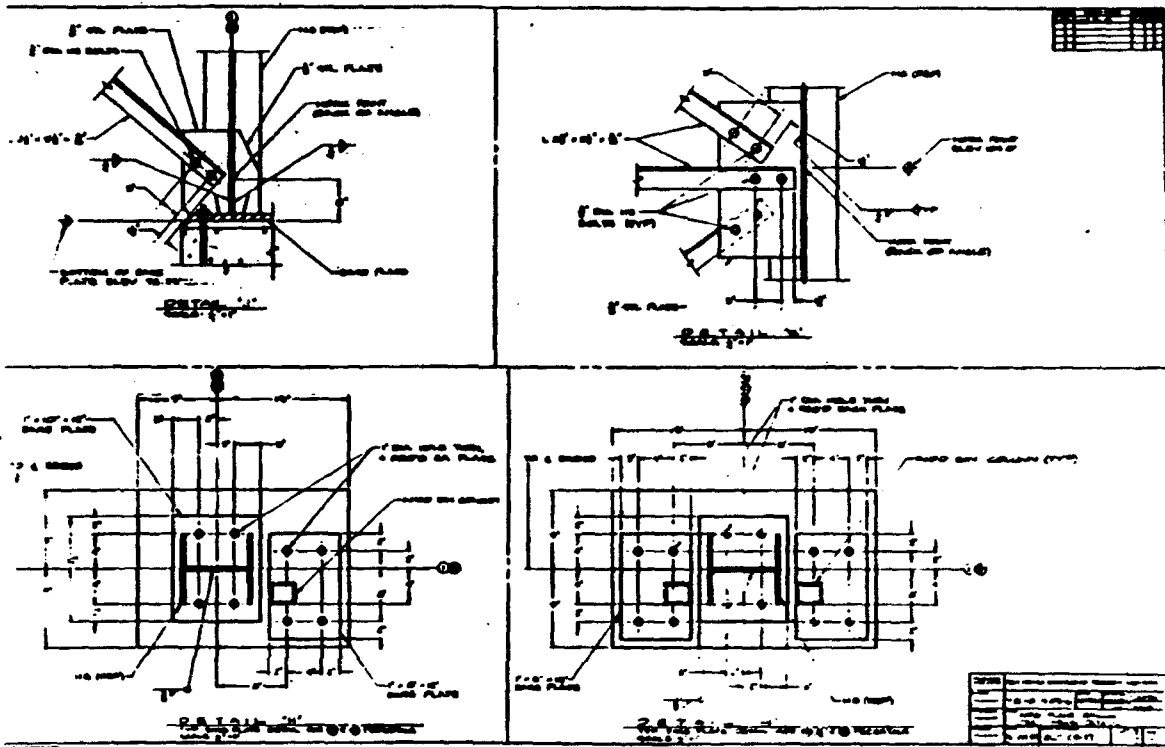

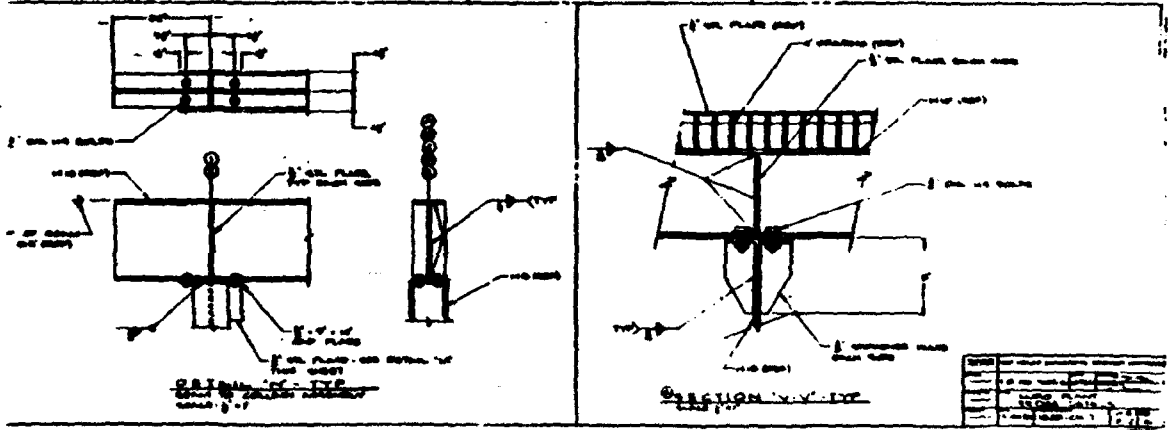
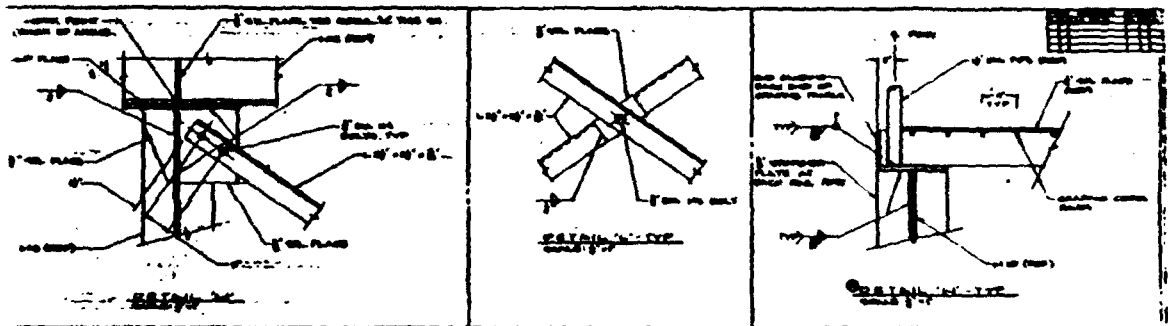
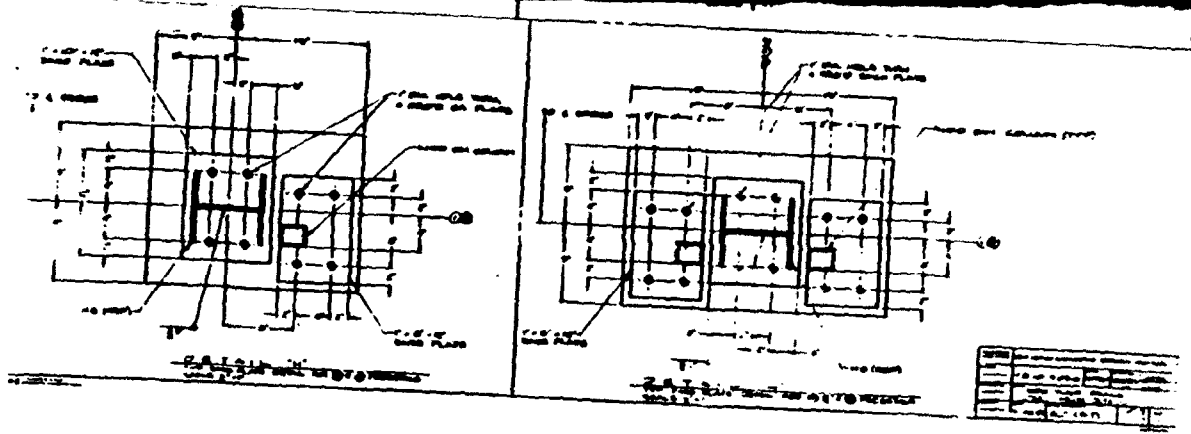

222

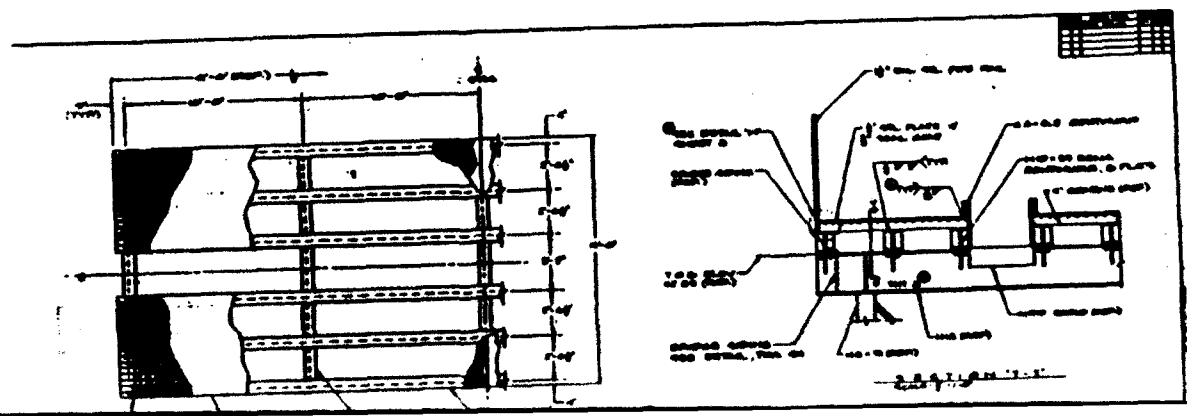
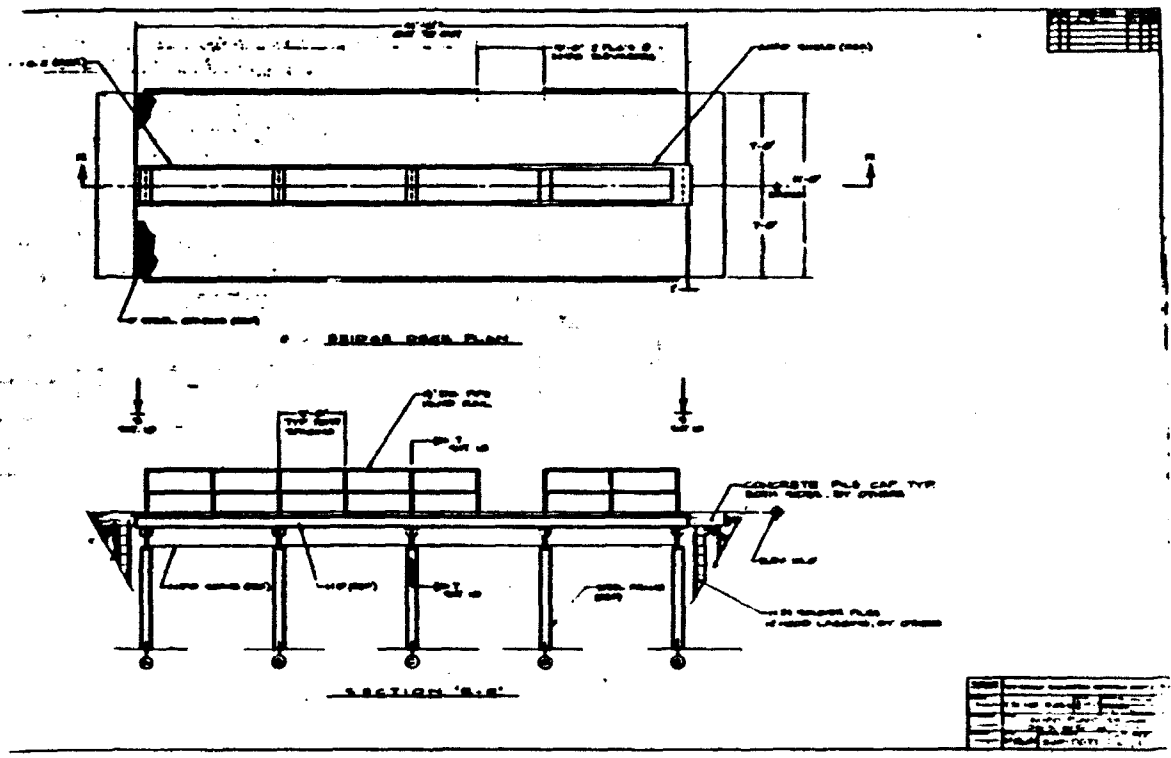

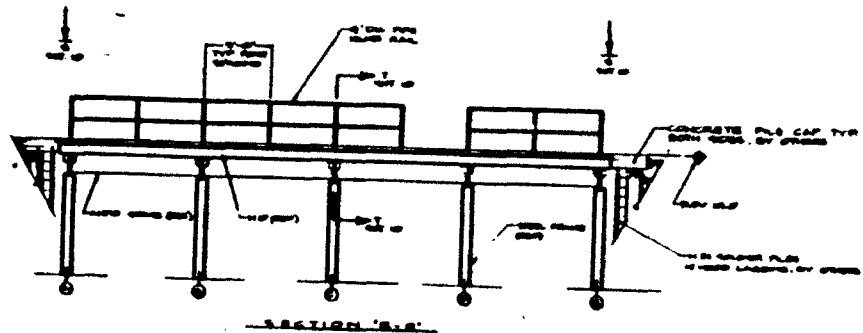

SECTION 'A-A'

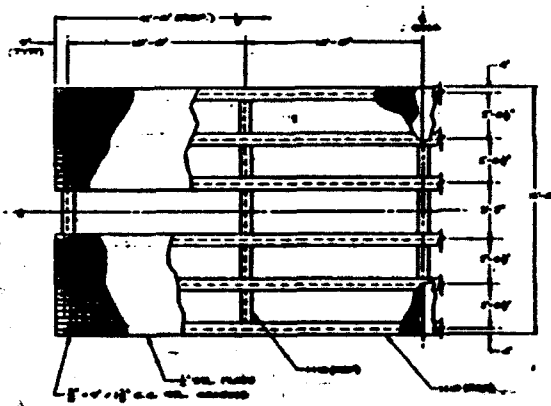
SECTION 'B-B'

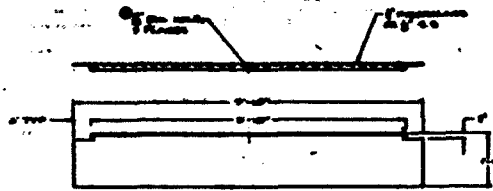

SECTION 'C-C'

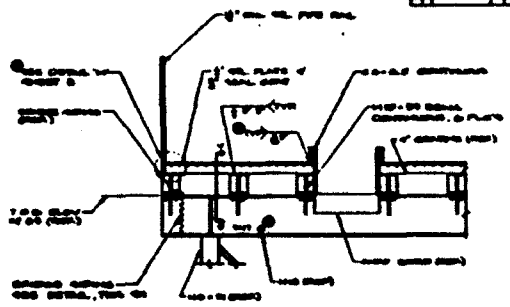

SECTION 'D-D'

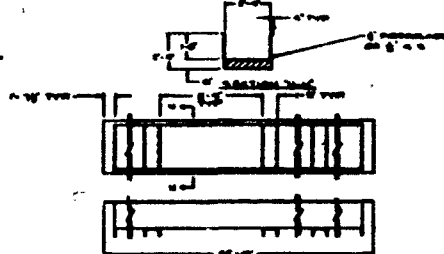

SECTION 'E-E'

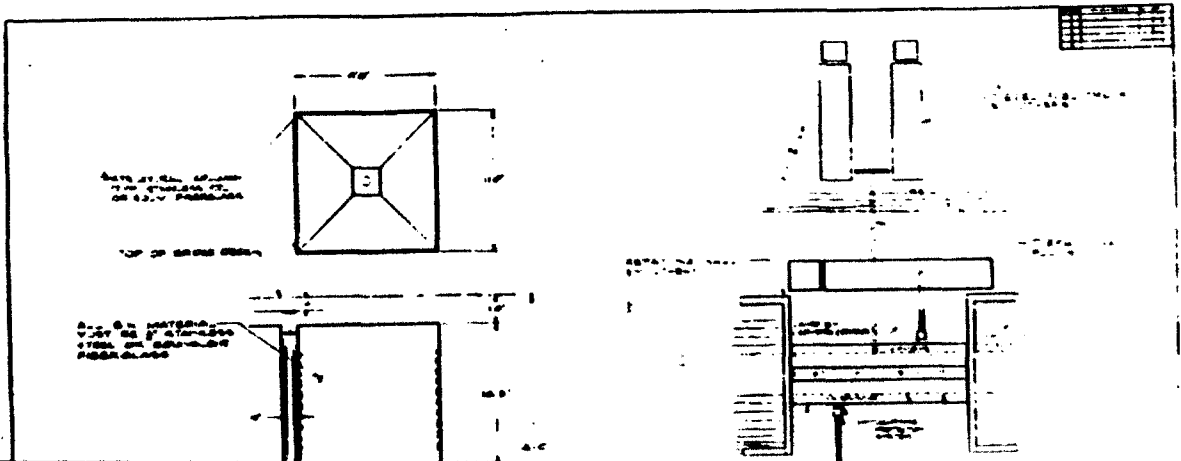
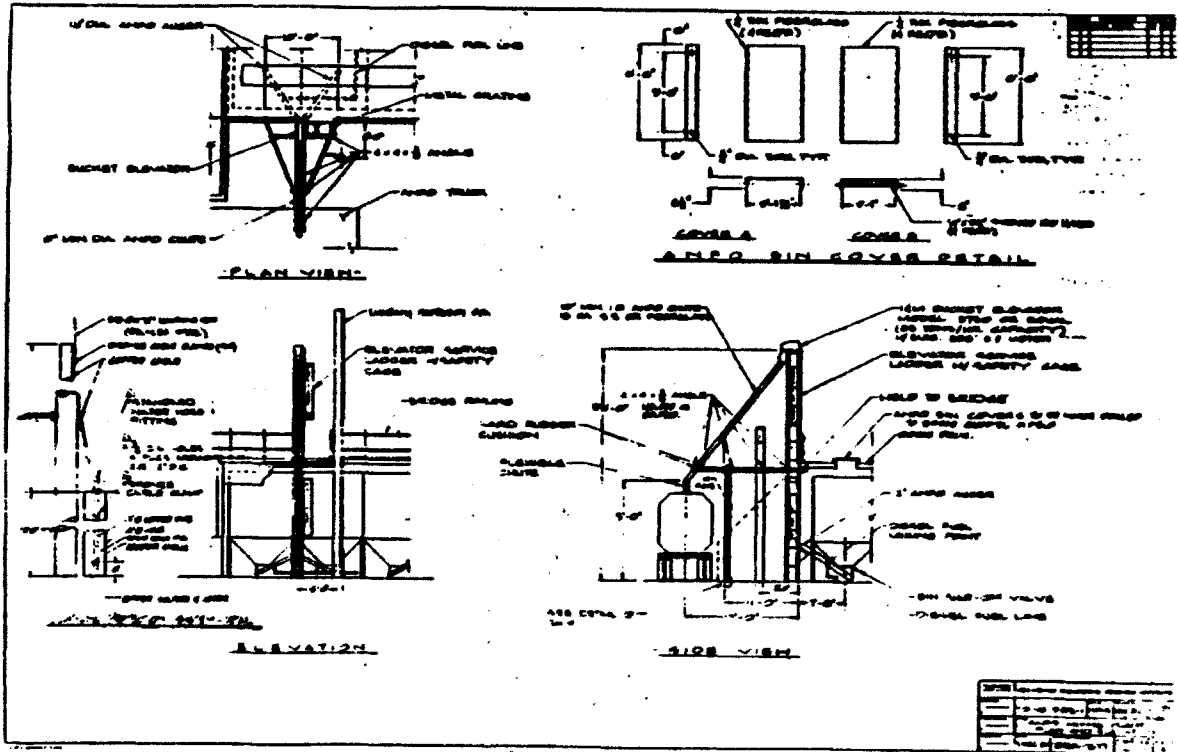

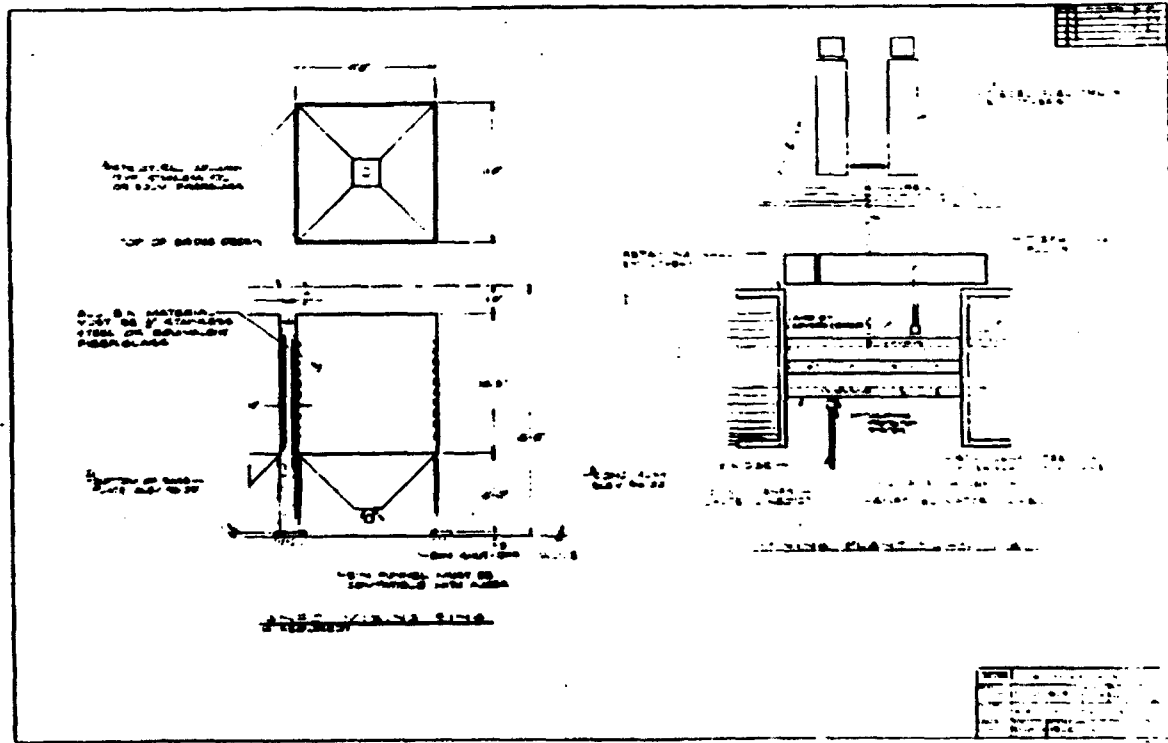
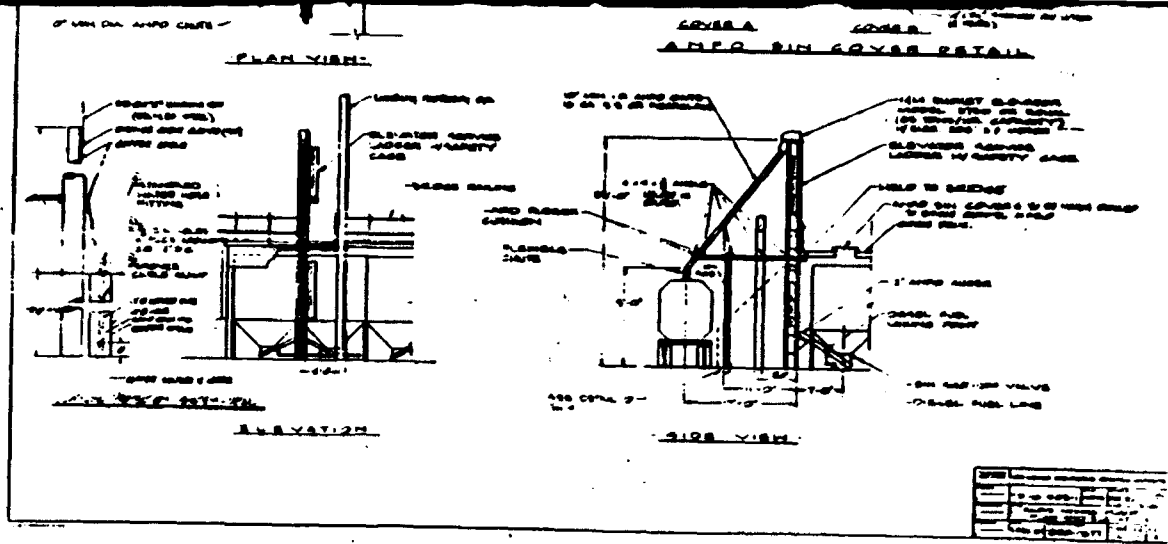



APPENDIX H  
MYLAR BAG DRAWINGS

228

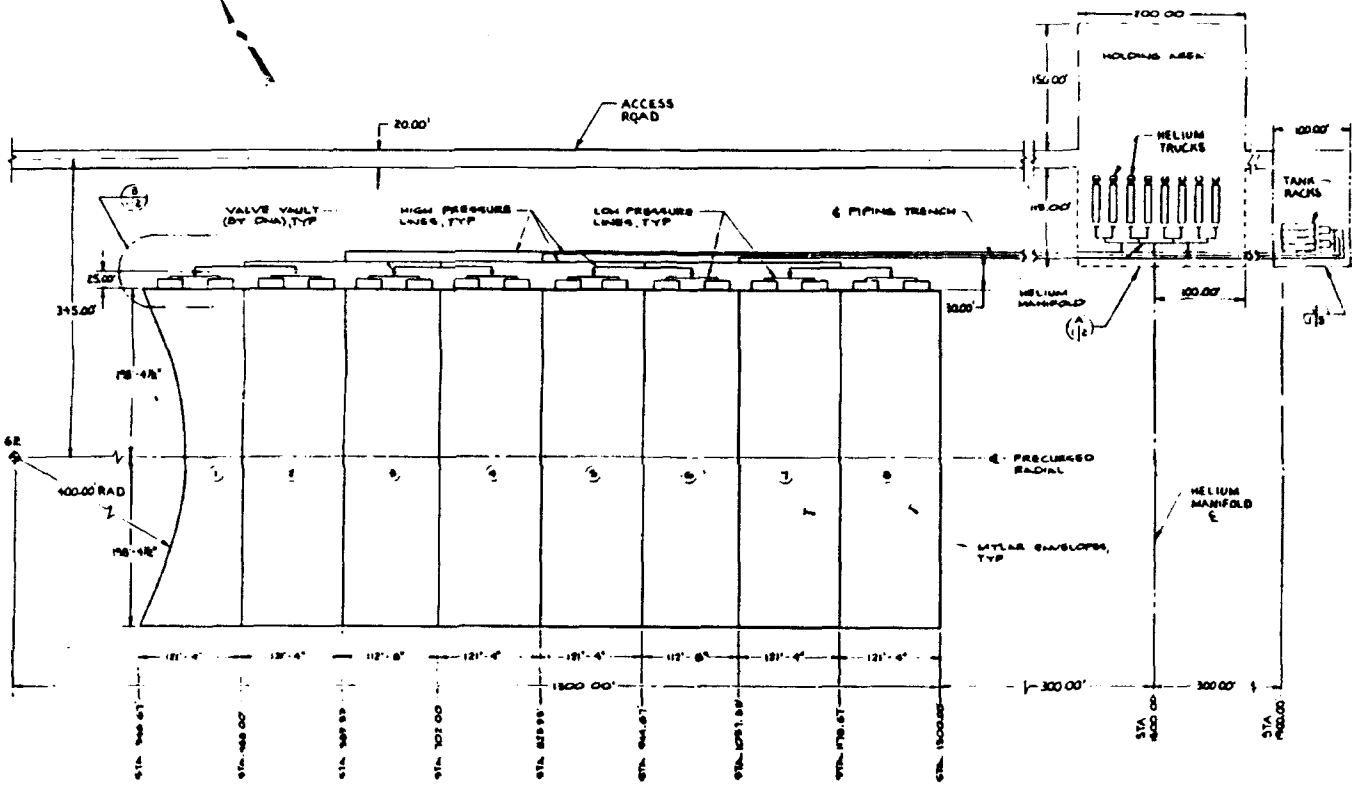

SITE PLAN LAYOUT

229

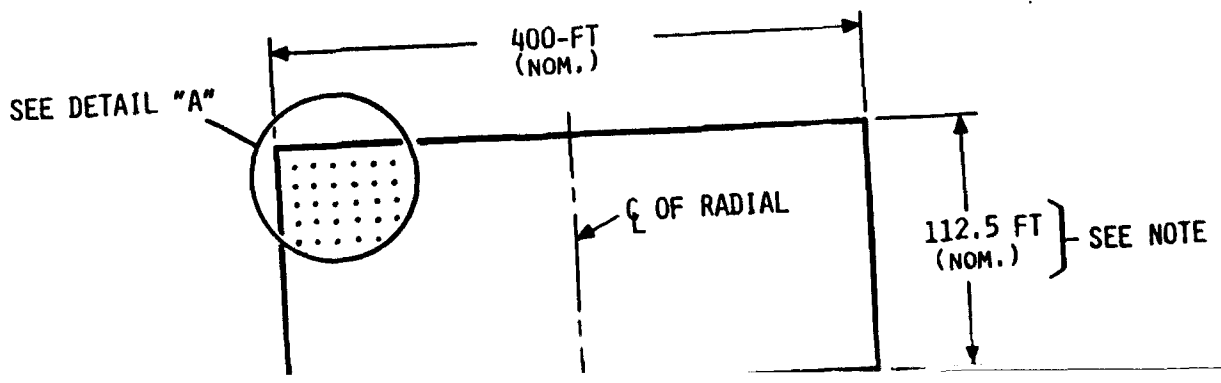

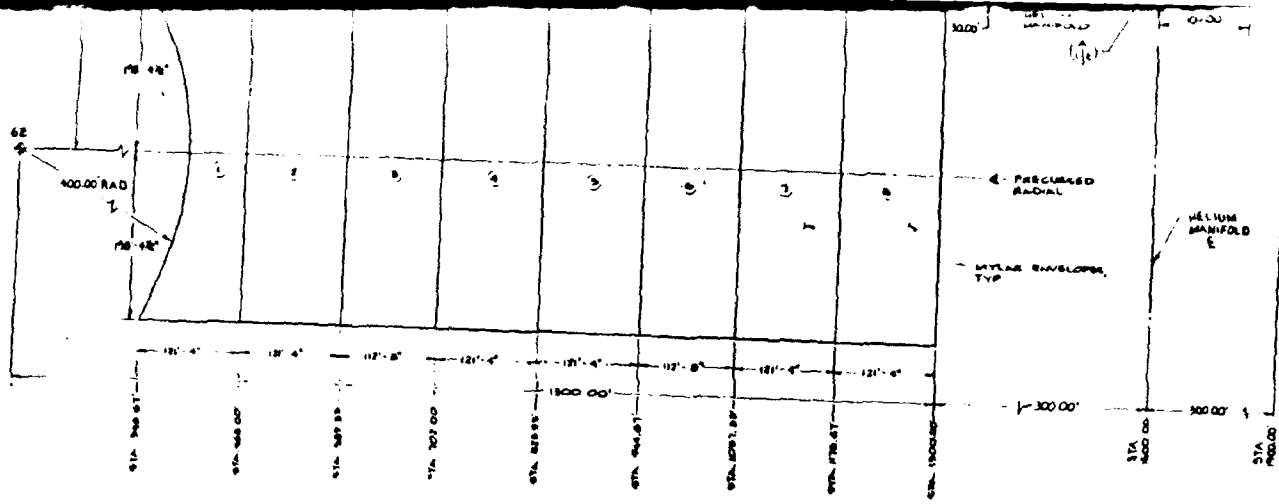

SITE PLAN LAYOUT

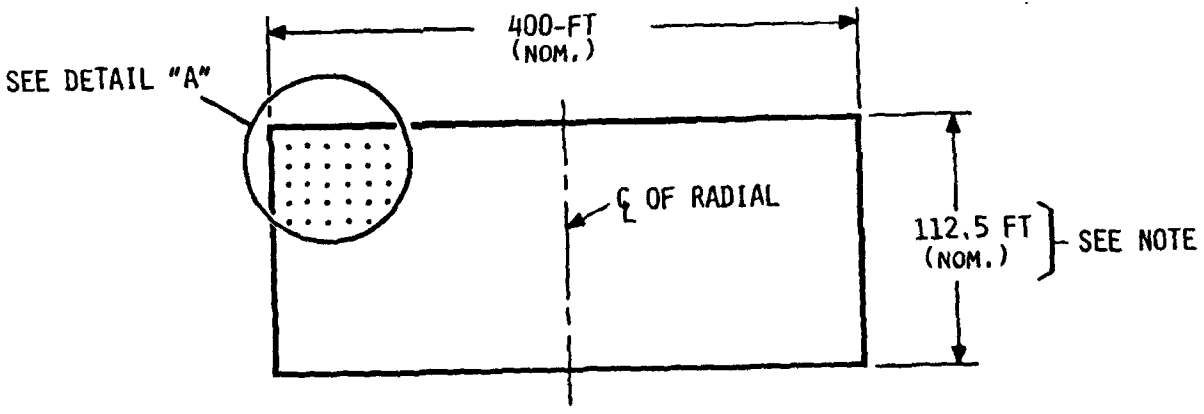

PLAN VIEW (NTS)

INDIVIDUAL COMPARTMENT PLAN FOR MINOR SCALE GAS BAG



WIND LOAD GUSSETS  
 (TRIANGULAR MEMBRANES  
 BONDED TO TOP MEMBRANE  
 AND TIE-DOWN CORD, TO  
 RESIST WIND LOADS,  
 TYP. EA. WAY,  
 SEE DETAIL "C")

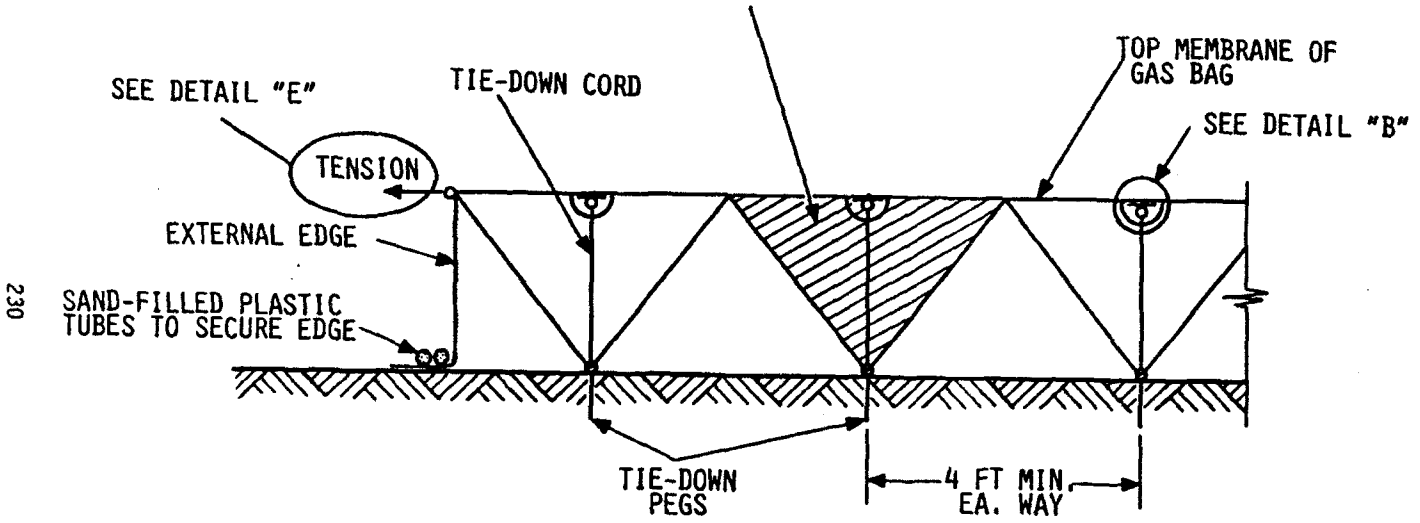

ELEVATION  
 (NTS)

DETAIL "A"

MINOR SCALE GAS BAG COMPARTMENT  
 CROSS-SECTION



230

REINFORCING YARN IN  
 MYLAR MEMBRANE

TENSILE CORDS BONDED  
 TO TOP OF MEMBRANE

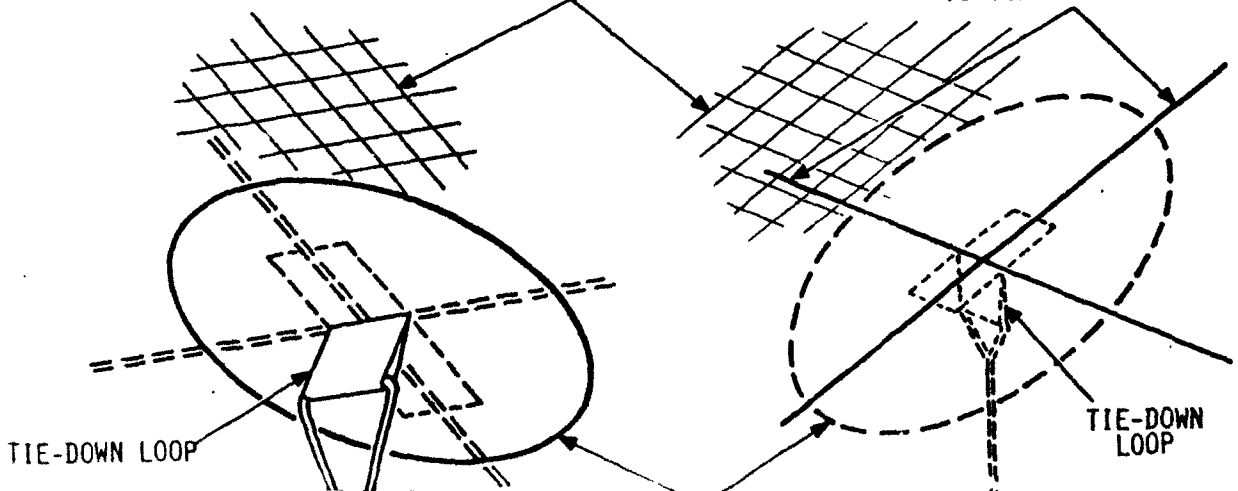

231

SAND-FILLED PLASTIC TUBES TO SECURE EDGE

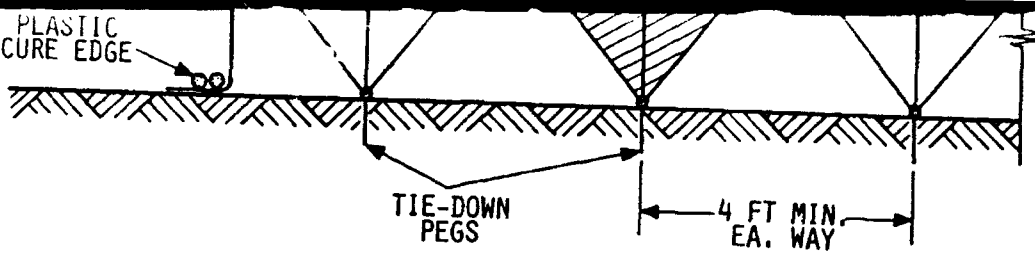

TIE-DOWN PEGS

4 FT MIN. EA. WAY

ELEVATION  
(NTS)

DETAIL "A"

MINOR SCALE GAS BAG COMPARTMENT  
CROSS-SECTION

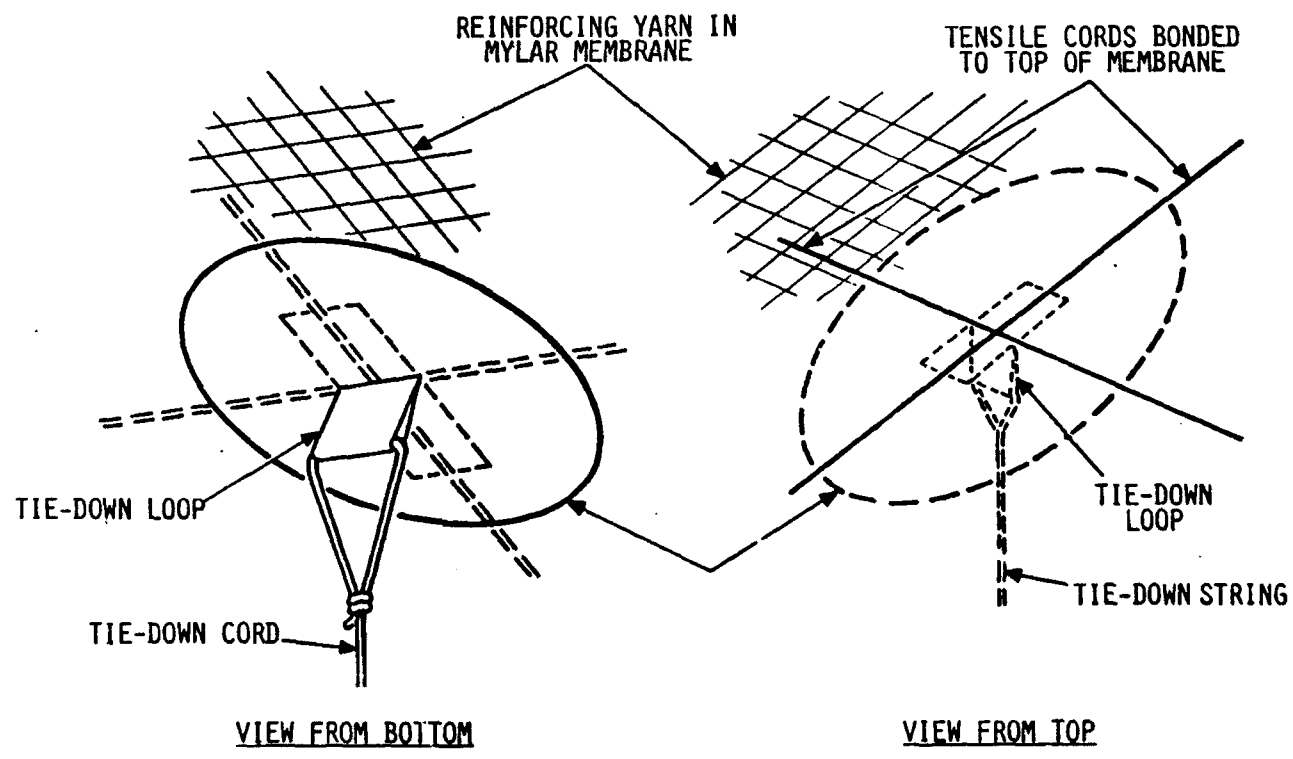

VIEW FROM BOTTOM

VIEW FROM TOP

DETAIL "B"

MINOR SCALE GAS BAG  
LOAD PATCH DETAILS

(SEE DETAIL "C" FOR RELATIONSHIP TO WIND LOAD GUSSETS)



232

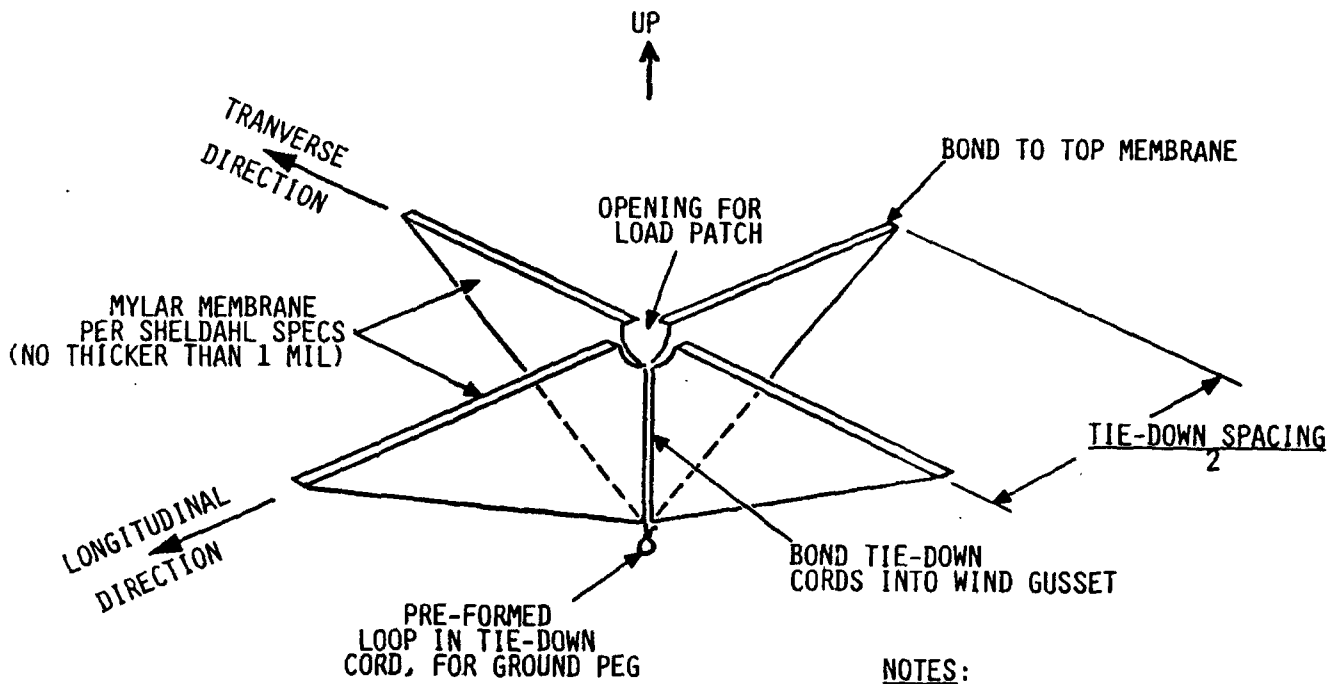

- NOTES:**
1. WIND GUSSETS MAY NOT BE NEEDED IN BAG INTERIOR
  2. IF PLASTIC MEMBRANE GUSSETS ARE UNACCEPTABLE, DIAGONAL CORDS MIGHT SUFFICE.

**DETAIL "C"**

MINOR SCALE GAS BAG  
WIND GUSSET DETAILS  
(REFER TO DETAIL "B")



233

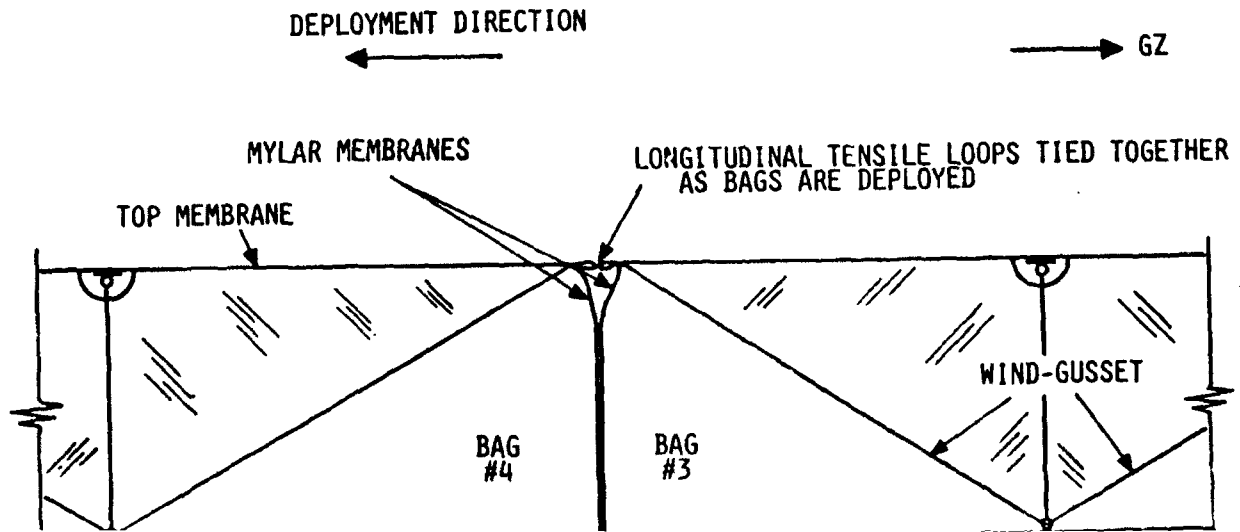

LONGITUDINAL  
DIRECTION

PRE-FORMED  
LOOP IN TIE-DOWN  
CORD, FOR GROUND PEG

BOND TIE-DOWN  
CORDS INTO WIND GUSSET

NOTES:

1. WIND GUSSETS MAY NOT BE NEEDED IN BAG INTERIOR
2. IF PLASTIC MEMBRANE GUSSETS ARE UNACCEPTABLE, DIAGONAL CORDS MIGHT SUFFICE.

DETAIL "C"

MINOR SCALE GAS BAG  
WIND GUSSET DETAILS  
(REFER TO DETAIL "B")



DEPLOYMENT DIRECTION

→ GZ

233

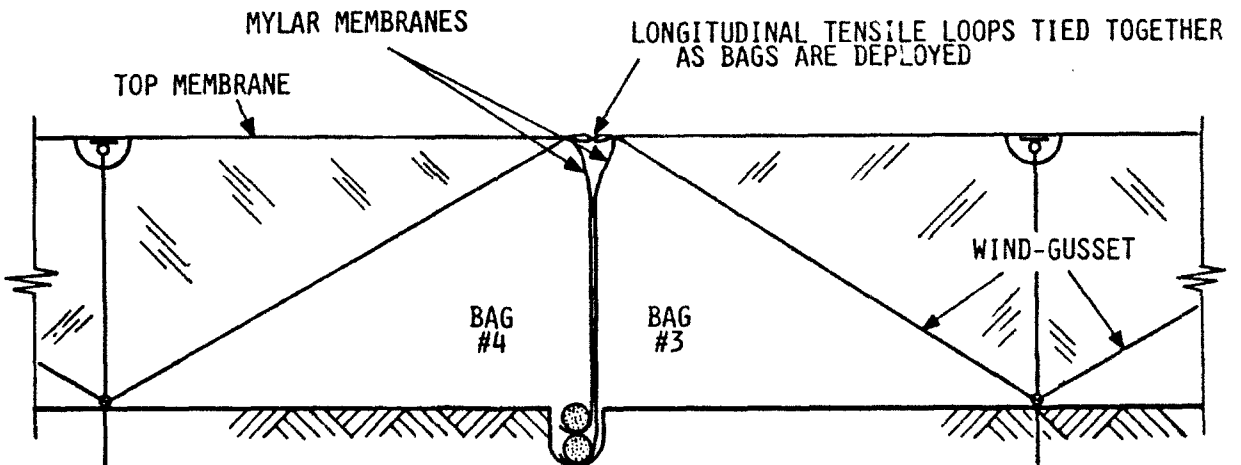

ELEVATION  
(NTS)

DETAIL "D"

MINOR SCALE GAS BAG  
INTERCOMPARTMENT DETAILS



NOTE: THIS SCHEME COULD BE APPLIED TO BOTH SIDES OF BAGS, OR TO ONE SIDE WITH OTHER SIDE TETHERED.

234

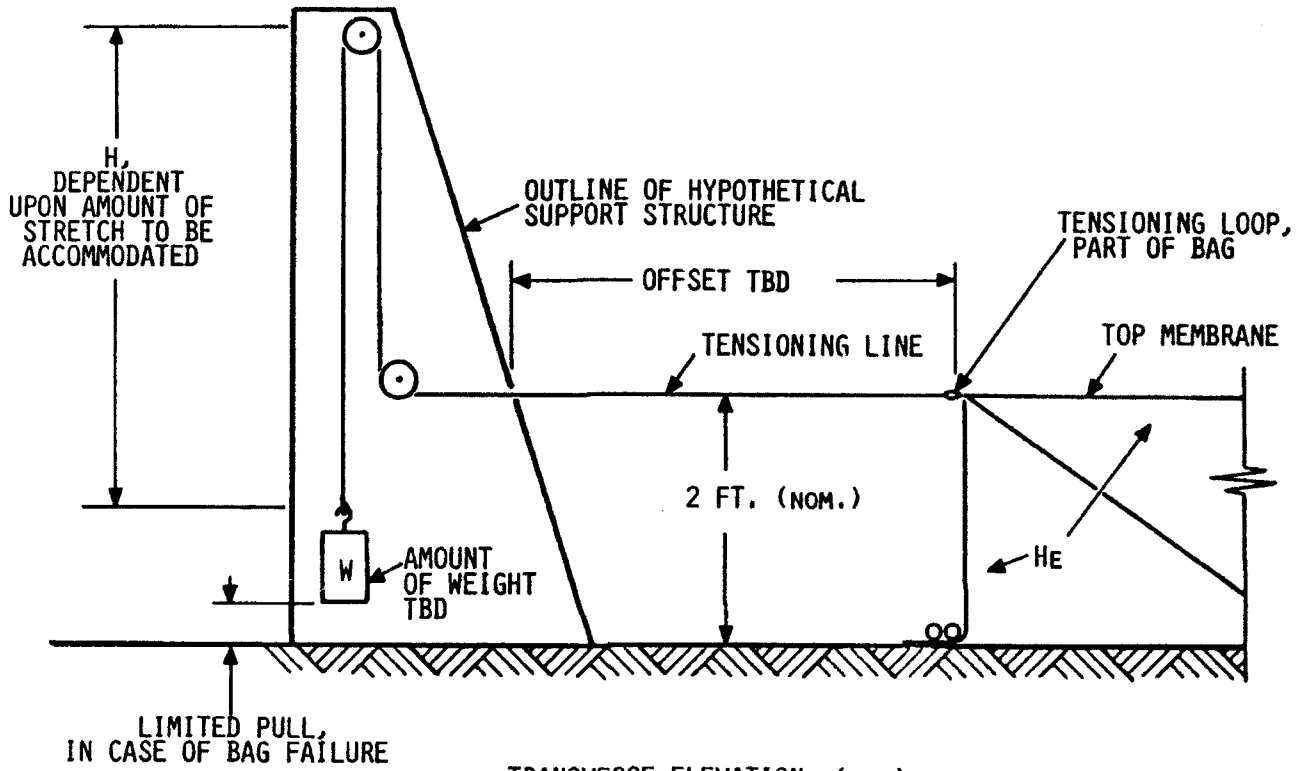

TRANSVERSE ELEVATION (NTS)  
(SEE DETAIL "F" FOR LONGITUDINAL ELEVATION)

DETAIL "E"  
MINOR SCALE GAS BAG  
TENSIONING SCHEME



RIGID FRAMEWORK  
ADEQUATE TO RESIST  
BENDING INDUCED BY  
FAILURE OF ONE BAG

USE SAME  
SCHEME AS  
SHOWN IN  
DETAIL "E"  
FOR SIDES

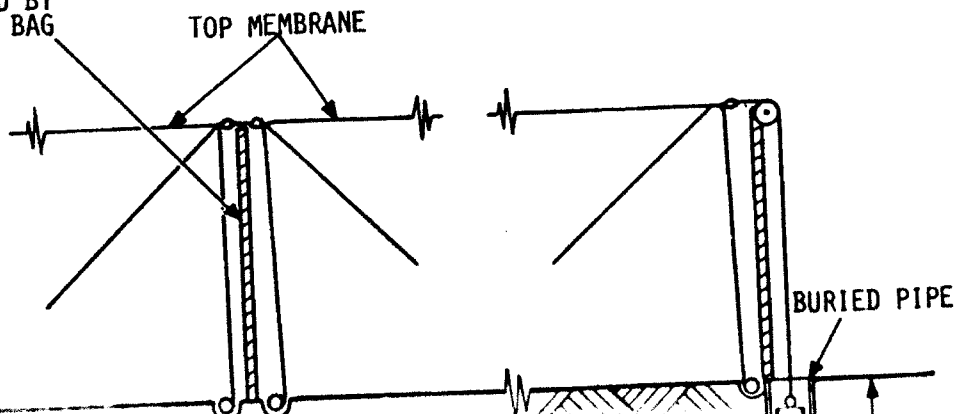



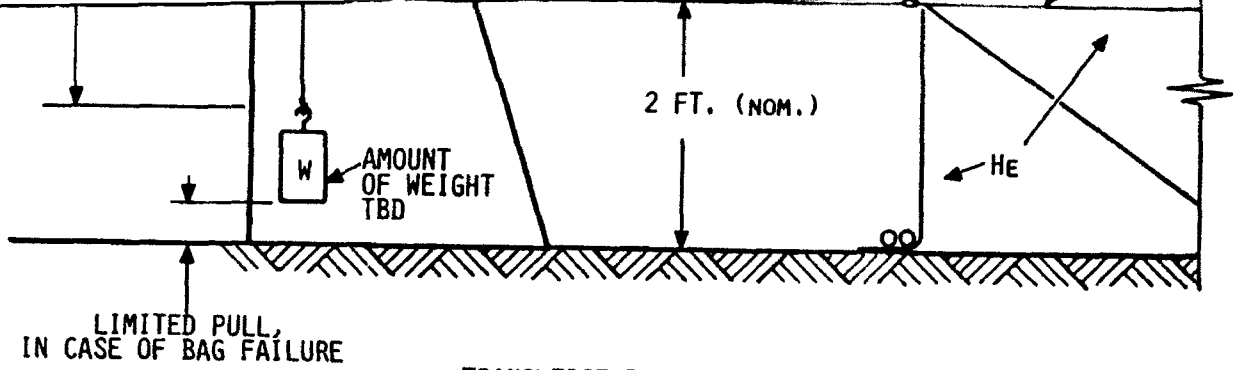

TRANSVERSE ELEVATION (NTS)  
 (SEE DETAIL "F" FOR LONGITUDINAL ELEVATION)



DETAIL "E"  
 MINOR SCALE GAS BAG  
 TENSIONING SCHEME

235

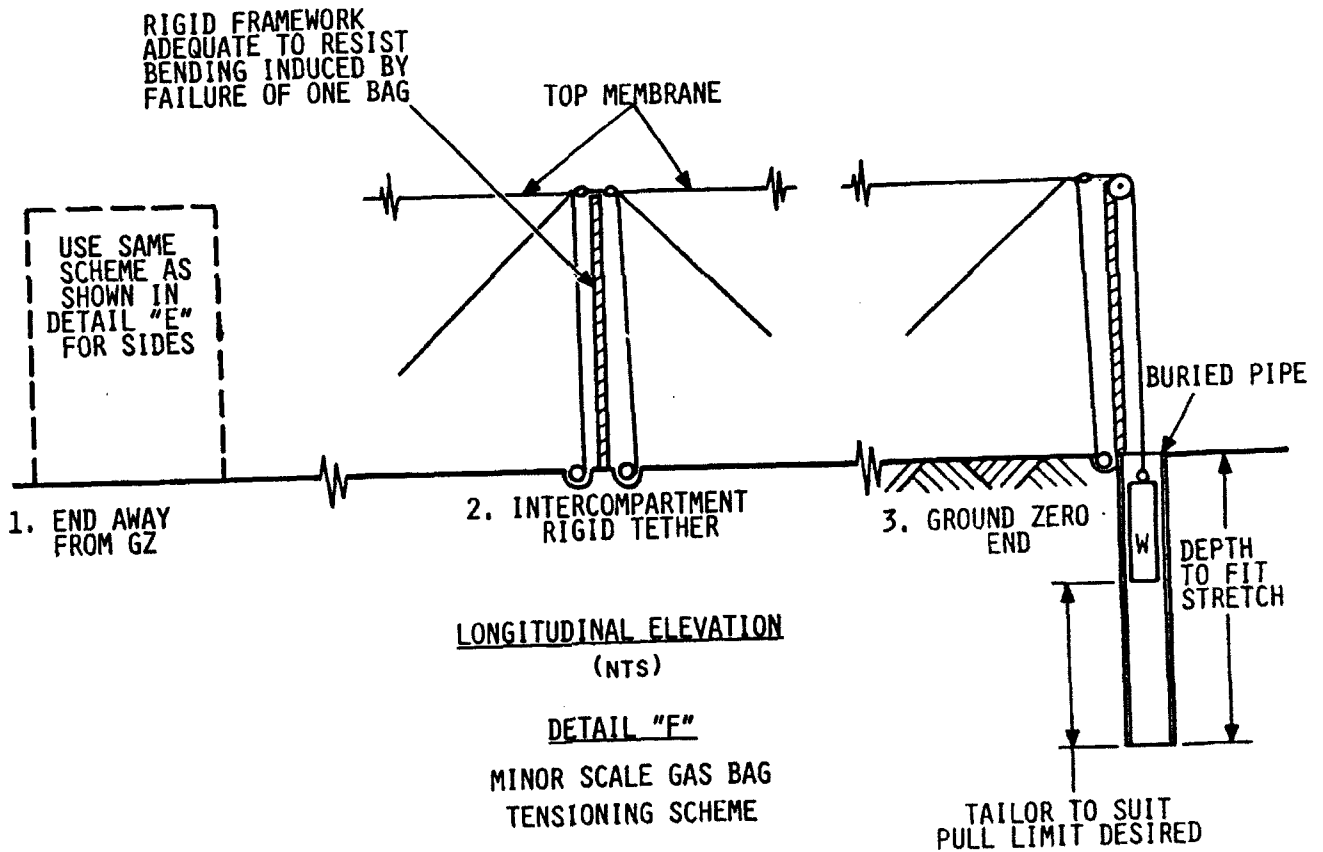

LONGITUDINAL ELEVATION  
 (NTS)

DETAIL "F"  
 MINOR SCALE GAS BAG  
 TENSIONING SCHEME





APPENDIX I  
ENGINEERING DRAWING LIST

EN

MINOR SCALE

ENGINEERING DRAWING LIST (EDL)

DWG. No.	SHT. NO.	TITLE	AGENCY	DATE	REV.
MS0001	1	Test Bed Layout	TRI/DNA	15 AUG 84	7
MS0001	2	Test Bed Layout	TRI/DNA	15 AUG 84	7
MS0001	3	Test Bed Layout	TRI/DNA	15 AUG 84	7
MS0003	1	Secondary PWR Distribution Block Diagram	TRI/DNA	19 FEB 85	
MS0003	2	Secondary PWR Distribution Electrical Specs.	TRI/DNA	19 FEB 85	
MS0003	3	Transformer Pad Layout & Berm Details	TRI/DNA	19 FEB 85	
MS0004	1	T&E Units 1 thru 7 Pit Construction Details	TRI/DNA	5 FEB 85	3
MS0004	2	T&E Units 1 thru 7 Pit Construction Details	TRI/DNA	20 FEB 85	1
MS0005	1	North Inst Park Layout	TRI/DNA	4 MAR 85	1
MS0005	2	East Inst Park Layout	TRI/DNA	4 MAR 85	1
MS0005	3	South Inst Park Layout	TRI/DNA	4 MAR 85	1
MS0005	4	West Inst Park Layout	TRI/DNA	4 MAR 85	1
MS0005	5	T&E Park Not Used Layout	TRI/DNA		
MS0006	1	GZ Area Grading Plan	TRI/DNA		
MS0007	1	Generator Pit Excavation & Details	TRI/DNA	13 JUNE 85	
MS0500	1	Helium Bag Layout	TRI/DNA	14 DEC 84	3

DWG. No.

MS0500

MS0500

MS0500

MS0500

MS0500

MS0500

MS0500

MS0500

MS0500

MS0500

MS0500

MS0500

MS0500

MS0501

MS0502

MINOR SCALE

ENGINEERING DRAWING LIST (EDL)

DWG. No.	SHT. NO.	TITLE	AGENCY	DATE	REV.
MS0500	2	Helium Bag Bag No. 1 Details	TRI/DNA	14 DEC 84	3
MS0500	3	Helium Bag Bag No. 2 Details	TRI/DNA	14 DEC 84	3
MS0500	4	Helium Bag Bag No. 3 Details	TRI/DNA	14 DEC 84	1
MS0500	5	Helium Bag Bag No. 4 Details	TRI/DNA	14 DEC 84	3
MS0500	6	Helium Bag Bag No. 5 Details	TRI/DNA	14 DEC 84	3
MS0500	6A	Helium Bag Bag No. 5 Grid w/Exp Overlay	TRI/DNA	14 MAY 85	1
MS0500	7	Helium Bag Bag No. 6 Details	TRI/DNA	14 DEC 84	1
MS0500	8	Helium Bag Bag No. 7 Details	TRI/DNA	14 DEC 84	3
MS0500	8A	Helium Bag Bag No. 7 Grid w/Exp Overlay	TRI/DNA	14 MAY 85	
MS0500	9	Helium Bag Bag No. 8 Details	TRI/DNA	14 DEC 84	2
MS0500	10	Helium Bag Penetration Details	TRI/DNA	6 MAR 85	1
MS0500	11	Helium Bag Penetration Details	TRI/DNA	7 MAR 85	1
MS0500	12	Helium Bag Penetration Details	TRI/DNA	6 Mar 85	1
MS0501	1	Remote Site Locations	TRI/DNA	5 FEB 85	
MS0502	1	BRL Gages -- Line 1 Layout	TRI/DNA		

MIMOR SCALE

ENGINEERING DRAWING LIST (EDL)

DWG. No.	SHT. NO.	TITLE	AGENCY	DATE	REV.
MS0502	2	BRL Gages -- Line 2 Layout	TRI/DNA		
MS0502	3	BRL Gages -- Lines 3 & 4 Layout	TRI/DNA		
MS0503	1	DPR Exp's/Cable Layout	TRI/DNA	28 MAR 85	6
MS0504	1	DPR Helium Dist/Sensors/Cable Layout	TRI/DNA	28 MAR 85	5
MS0504	2	DPR Helium Dist/Sensors/Cable Helium Supply Park Site Plan & Layout	TRI/DNA	25 APR 85	1
MS0505	1	Dust Suppressant Areas	TRI/DNA	22 MAY 85	
MS0505	2	Dust Suppressant Areas	TRI/DNA	22 MAY 85	
MS1200	1	Army Exp. 1200/01/02 Site Plan & Layout	TRI/DNA	13 MAR 85	
MS1220	1	Army/VES Exp. 1220 Layout & Excavation Plan	TRI/DNA	29 JAN 85	1
MS1221	1	Army/VES Exp. 1221 Layout & Excavation Plan	TRI/DNA	29 JAN 85	1
MS1280	1	CBCOM Exp. 1280/81 Layout & Details	TRI/DNA	16 APR 85	1
MS1300	1	VES Exps. 1300 Thru 1385 Site Plan & Dust Suppressant Areas	TRI/DNA	14 MAY 85	
MS1320	1	VSMR Exp. 1320 & TRS No. 1 Layout	TRI/DNA	5 FEB 85	
MS1325	1	VSMR Exp. 1325 & TRS No. 5 Layout	TRI/DNA	15 FEB 85	
MS1330	1	VSMR Exp. 1330 & TRS No. 6 Layout	TRI/DNA	15 FEB 85	
MS1345	1	VSMR Exp. 1345 & TRS No. 7 Layout	TRI/DNA	15 FEB 85	

DWG. No  
MS1375  
MS1610  
MS1610  
MS2011  
MS3000  
MS3010  
MS3020  
MS3030  
MS3040  
MS3040  
MS3040  
MS5100  
MS5280  
MS6000  
MS6000

MINOR SCALE

ENGINEERING DRAWING LIST (EDL)

DWG. No.	SHT. NO.	TITLE	AGENCY	DATE	REV.
MS1375	1	USMC Exp. 1375 & TRS No. 2 Layout	TRI/DNA	15 FEB 85	1
MS1610	1	USMC Exp. 1610 Layout	USMC/DNA	17 JULY 84	2
MS1610	2	USMC Exp. 1610	USMC/DNA	17 JULY 84	
MS2011	1	BRL Exp. 2011 Thru 2070 Site Plan	TRI/DNA	23 APR 85	4
MS3000	1	FBPA Exp. 3000/01/02 Site & Excavation Plan	TRI/DNA	14 MAR 85	
MS3010	1	FBPA Exp. 3010/11 Site Plan & Bern Details	TRI/DNA	4 MAR 85	1
MS3020	1	FBPA Exp. 3020 Site Plan & Bern Details	TRI/DNA	14 MAR 85	
MS3030	1	FBPA Exp. 3030/31 Site & Excavation Plan	TRI/DNA	14 MAR 85	
MS3040	1	FBPA Exp. 3040 Site Plan Foundation/Excavation Plan	TRI/DNA	10 NOV 84	2
MS3040	2	FBPA Exp. 3040 Details	C of E/ DNA		2
MS3040	3	FBPA Exp. 3040 Details	C of E/ DNA		2
MS5100	1	HDL Exp 5100/01/04/05/08/10 Layouts	TRI/DNA	13 MAR 85	2
	2	HDL Exp. 5107 & TRS No. 3 Layout	TRI/DNA	15 FEB 85	2
	3	Army Exp. 5109 & TRS No. 4 Layout	TRI/DNA	15 FEB 85	2
MS5280	1	BMD Exp. 5280 Site Plan & Layout	TRI/DNA	25 APR 85	
MS6000	1	BOE Exp. 6000/01/02/03/04 Layout		4 MAR 85	1
MS6000	2	BOE Exp. 6010/11/12/14/15		13 MAR 85	2

MINOR SCALE

ENGINEERING DRAWING LIST (EDL)

DWG. No.	SHT. NO.	TITLE	AGENCY	DATE	REV.
MS6003	1	BOEING Exp. 6003 Layout & Sections	BOE/DNA	4 MAR 85	1
MS6003	2	BOEING Exp. 6003 Sections	BOE/DNA	4 MAR 85	1
MS6003	3	BOEING Exp. 6003 Sections	BOE/DNA	4 MAR 85	1
MS6210	1	MM Exp. 6210 Layout & Details	MM/DNA	5 MAR 85	C
MS6211	1	MM Exp. 6211 Layout & Details	MM/DNA	5 MAR 85	C
MS6220	1	MM Exp. 6220 Layout & Details	MM/DNA	5 MAR 85	
MS6221	1	MM Exp. 6221 Layout & Details	MM/DNA	5 MAR 85	
MS6230	1	MM Exp. 6230 Layout & Details	MM/DNA	5 MAR 85	
MS6232	1	MM Exp. 6232 Layout & Details	MM/DNA	5 MAR 85	1
MS7000	1	UK Exp. 7000/02 Site Plan & Dust Suppressant Layout	TRI/DNA	22 MAY 85	
MS7040	1	UK Exp. 7040/41/42 Site Plan, Raft, TRS No. 8 & Conc. Apron Layout	TRI/DNA	20 MAR 85	1
MS7040	2	UK Exp. 7040/41/42-TRS Pit Excavations & Retaining Wall Details	TRI/DNA	20 MAR 85	1
MS7040	3	Figure No. UKA/1-TRS Layout	UK/DNA	20 MAR 85	1
MS7040	4	Figure No. UKA/2-TRS Target Details	UK/DNA	20 MAR 85	1

DWG. No.
MS7050
MS7053
MS7070
MS7075
MS7100
MS7150
MS7150
MS7170
MS7200
MS7200
MS7300
MS7300
MS7399
MS7399
MS7399



MINOR SCALE

ENGINEERING DRAWING LIST (EDL)

DWG. No.	SHT. NO.	TITLE	AGENCY	DATE	REV.
MS7050	1	Airblast Dynamic Effects Lockers (7050)	UK/DNA	22 MAR 85	2
MS7053	1	UKA/4 Airblast Dynamic Effects I-Beams (7053)	UK/DNA		1
MS7070	1	UK Exp 7070/71/72 Site Plan, Layout/Excavation/Berm	TRI/DNA	9 APR 85	
MS7075	1	UK Exp 7075/76/77 & 7080/81 Site Plan & Excavation Details	TRI/DNA	9 APR 85	
MS7100	1	FRG Exp. 7100, Anchor Block & Gage Mount Details	FRG/DNA	23 FEB 85	
MS7150	1	FRG Exp 7150/51/52 & 7155/56/57 Site Plan	TRI/DNA	1 MAY 85	4
MS7150	2	FRG Exp 7150/51/52 & 7155/56/57 Layout & Details	TRI/DNA	23 FEB 85	
MS7170	1	FRG Exp. 7170 Site Plans & Details	FRG/DNA	23 FEB 85	
MS7200	1	FR Exp. 7200/01 Layout/Excavation/Berm	TRI/DNA	2 APR 85	2
MS7200	2	FR Exp. 7200/01 Joint Detail	TRI/DNA	23 APR 85	1
MS7300	1	SWED Exp 7300 Layout, Plan & Sections	SWED/DNA	17 APR 85	
MS7300	2	SWED Exp 7300 Details	SWED/DNA	17 APR 85	
MS7399	1	SWED Exp. 7399 Site Plan Foundation/Excavation Plan	TRI/DNA	19 OCT 84	1
MS7399	2	SWED/NORW Exp. 7399 Layout	SWED/DNA	19 OCT 84	
MS7399	3	SWED/NORW Exp. 7399 Reinforcement Plans & Sections	SWED/DNA	19 OCT 84	

MINOR SCALE

ENGINEERING DRAWING LIST (EDL)

DWG. No.	SHT. NO.	TITLE	AGENCY	DATE	REV.	DWG. No.
MS7399	4	SWED/NORW Exp. 7399 Reinforcement Sections	SWED/DNA	19 OCT 84		MS7410
MS7399	5	SWED/NORW Exp. 7399 Plans & Sections	SWED/DNA	19 OCT 84		MS7410
MS7399	6	SWED/NORW Exp. 7399 Reinforcement Plans & Sections	SWED/DNA	19 OCT 84		MS7410
MS7399	7	SWED/NORW Exp. 7399 Plans & Sections	SWED/DNA	19 OCT 84		MS7410
MS7399	8	SWED/NORW Exp. 7399 Reinforcement Sections	SWED/DNA	19 OCT 84		MS7410
MS7400	1	NORW Exp 7400/01/02 Site Plan & Excavation Details	NORW/DNA	20 JULY 84	2	MS7410
MS7410	1	NORW Exp. 7410 Foundation/Excavation Plan	TRI/DNA	11 OCT 84	1	MS7410
MS7410	2	NORW Exp. 7410 Plan & Section	NORW/DNA		C	MS7410
MS7410	3	Light Machine Gun Bunker	NORW/DNA		B	MS7410
MS7410	4	Light Machine Gun Bunker	NORW/DNA		B	MS7410
MS7410	5	Shelter	NORW/DNA		B	MS7410
MS7410	6	NORW Exp. 7410	NORW/DNA		B	MS7410
MS7410	7	Observation Bunker	NORW/DNA		B	MS7410
MS7410	8	Observation Bunker	NORW/DNA		B	MS7500
MS7410	9	Generator & Expansion Chamber	NORW/DNA		A	MS7520
MS7410	10	Generator & Expansion Chamber	NORW/DNA		A	MS7520
MS7410	11	Open Firing Position Shuttering	NORW/DNA		A	MS7520
MS7410	12	Open Firing Position Shuttering Reinforcement	NORW/DNA		A	MS7520

MINOR SCALE

ENGINEERING DRAWING LIST (EDL)

DWG. No.	SHT. NO.	TITLE	AGENCY	DATE	REV.
MS7410	13	Covered Trench/LMSB	NORV/DNA		A
MS7410	14	Covered Trench/LMSB	NORV/DNA		A
MS7410	15	Burster Slab	NORV/DNA		A
MS7410	16	Ventillation	NORV/DNA		A
MS7410	17	Instrumentation	NORV/DNA		A
MS7410	18	Photo Support	NORV/DNA		A
MS7410	19	D300 mm Stl. Tube	NORV/DNA		A
MS7410	20	D200 mm Stl. Tube Periscope	NORV/DNA		A
MS7410	21	Air Inlet Blast Attenuators	NORV/DNA		A
MS7410	22	Air Inlet	NORV/DNA		A
MS7410	23	NORV Exp. 7410 Air Inlet	NORV/DNA		A
MS7410	24	Observation Tower	NORV/DNA		A
MS7410	25	T-Shaped Tower	NORV/DNA		A
MS7410	26	Cable Penetration and Gage Mnt.	NORV/DNA		A
MS7410	27	Casting Piece for Instr. Table	NORV/DNA		A
MS7410	28	Instr. Table	NORV/DNA		
MS7500	1	CAMA Exp. 7500/02 Layout & Details	TRI/DNA	20 MAR 85	
MS7520	1	CAMA Exp. 7520 Foundation & Excavation Plan	TRI/DNA	11 OCT 84	3
MS7520	2	Stiffened Panel Mounting Foundation	CAMA/DNA		
MS7520	3	Reinforcing Details & Access & Cover	CAMA/DNA		

MINOR SCALE

ENGINEERING DRAWING LIST (EDL)

DWG. No.	SHT. NO.	TITLE	AGENCY	DATE	REV.
MS7520	4	General Layout & Footing Floor Plan	CMAA/DNA		
MS8010	1	TIC Exp. 8010 Layout & Details	TRI/DNA	4 MAR 85	2
MS8011	1	TIC Exp. 8011 Details	TRI/DNA	24 MAY 85	1
MS8012	1	TIC Exp. 8012 Layout & Target Details	TRI/DNA	29 APR 85	
MS8050	1	TSC Exp. 8050 Site Plan & Layout	TRI/DNA		
MS8200	1	DNA Exp's. 8200/01/02/10/20/50/70 Site Plan	SEA/DNA		B
MS8200	2	DNA Exp's. 8200/01/02/10/20/50/70 Plans & Details	SEA/DNA		D
MS8200	3	DNA Exp. 8270 Details	SEA/DNA		A
MS8200	4	DNA Exp. 8270 Details	SEA/DNA		
MS8200	5	DRI Exp. 8200/01 Camera Shelter Details	TRI/DNA	6 MAR 85	
MS8200	6	Layout	SEA/DNA		
MS8210	1	DNA Exp. 8210 Layout	SEA/DNA	20 MAR 85	
MS8210	2	DNA Exp. 8210 Ant Mast Anchor Details	TRI/DNA	20 MAR 85	
MS8220	1	DNA Exp. 8220 Layout		24 APR 85	1
MS8220	2	DNA Exp. 8220 Ejecta & Debris Exp. P17			

DWG. No.
MS8220
MS8505
MS8551
MS8620
MS8703
MS8703B
MS8703B
MS8703B
MS8703B
MS8704
MS8706
MS8707
MS8707
MS8707
MS8707

MINOR SCALE

ENGINEERING DRAWING LIST (EDL)

DWG. No.	SHT. NO.	TITLE	AGENCY	DATE	REV.
MS8220	3	DWA Exp. 8220 Pit Assembly			
MS8505	1	DWA Exp. 8505 Site Plan & Layout	TRI/DNA		
MS8551	1	SRI Exp. 8551 Excavation	TRI/DNA	13 JUNE 85	
MS8620	1	DWA Exp 8620 Site Plan & Layout	TRI/DNA	18 APR 85	2
MS8703	1	DWA Exp. 8703 Excavation	TRI/DNA		1
MS8703B	1	DWA Exp. 8703B Site Excavation Plan Exp. Layout & Details	SPEC/DNA	15 JAN 85	3
MS8703B	2	DWA Exp. 8703B Sections & Details	SPEC/DNA		3
MS8703B	3	DWA Exp. 8703B Sections & Details	SPEC/DNA		3
MS8703B	4	Section & Details	SPEC/DNA		3
MS8704	1	TRV Exp. 8704 Layout & Details	TRI/DNA		
MS8706	1	DRI Exp. 8706 Details	TRI/DNA	9 APR 85	
MS8707	1	DRI Exp. 8707 Site Plan	TRI/DNA	22 MAR 85	
MS8707	2	DRI Exp. 8707 Details	TRI/DNA	22 MAR 85	1
MS8707	3	DRI Exp. 8707 Laser Bunker Cover Details	TRI/DNA	25 APR 85	1
MS8707	4	DRI Exp. 8707 Laser Bunker Cover Framing Details	TRI/DNA	25 APR 85	

MINOR SCALE

ENGINEERING DRAWING LIST (EDL)

DWG. No.	SHT. NO.	TITLE	AGENCY	DATE	REV.
MS8707	5	DRI Exp. 8707 Camera Enclosure Framing Details	TRI/DNA	6 MAY 85	1
MS8709	1	DNA Exp. 8709 Layout & Vault Details	TRI/DNA	29 APR 85	
MS8713	1	DNA Exp. 8713 Layout	NTS/DNA		
MS8715	1	DNA Exp. 8715/8723 Layout	DNA	13 MAR 85	2
MS8719	1	DNA Exp. 8719 Cine Flash Microscope Plain View	TRI/DNA	22 APR 85	1
MS8719	2	DNA Exp. 8719 Cine Flash Microscope Side View	TRW/DNA		
MS8777	1	DNA Exp. 8777 Site Plan & Layout	TRI/DNA		
MS8777	2	DNA Exp. 8777 Experiment Details	TRI/DNA		
MS8790	1	DNA Exp. 8790 Layout	TRI/DNA	9 APR 85	3
MS8790	2	Zebra Boards Layout & Details	TRI/DNA	30 APR 85	2
MS8790	3	Zebra Boards Details	TRI/DNA	30 APR 85	
MS8790	4	Zebra Boards Details	TRI/DNA	30 APR 85	
MS8790	5	Zebra Boards Details	TRI/DNA	30 APR 85	
MS8790	6	Details	TRI/DNA	2 MAY 85	
MS8990	1	KSC Exp. 8990 Layout	TRI/DNA	15 MAY 85	

APPENDIX J  
MINOR SCALE PRECURSOR PROCEDURES  
INCLUDING  
MYLAR BAG DEPLOYMENT

## MINOR SCALE PRECURSOR PROCEDURES

### I. PRE-DEPLOYMENT PREPARATIONS.

A. The helium distribution system was installed during construction of the precursed radial. It was flow tested on nitrogen on 15 June 1985 (D-10). During the flow test, NMERI monitored the high pressure line and corrected one leak discovered. A second high pressure leak test was performed on 25 June to find any leaks caused by driving over the line, and in the connections to the helium trucks. Several leaks were corrected. The perforated helium distribution bars were not to be installed until just after the dolly passed on deployment of the bags. No water diversion berms were constructed around the valve vaults as they were on the high side and were not backfilled until late time.

B. The air movement system (closed bag recirculation, gas mixture exhaust, and air intake) was installed during construction of the precursed radial. NMERI installed fans and louvers before 4 June so they could be tested for remote operation. The fan motors initially installed became inoperative, and had to be replaced with dust-proof motors. A sand-bag berm was constructed by FE around each fan box to protect it from water damage.

C. Mylar bags were delivered to the site by Sheldahl as scheduled, and were stored in the cable yard. NMERI and FCDNA jointly inspected the contents of the shipping crates by D-10, and custody of the bags was then given to NMERI for pre-deployment staging.

numbe  
Tensi  
posit  
drive  
the  
other  
not  
prio  
flus  
aug  
driv  
nail  
con  
nail  
gru  
nail  
the  
sh  
fr  
sp  
sh  
fr  
it  
g



D. The tension loops on the exterior perimeter of the bags were numbered by Sheldahl to match up with the corresponding tension spikes. Tension spikes (side stakes) were driven on line with tie-down nails and positioned 6 feet outside the perimeter of the radial. Spikes were driven to leave 6 inches exposed above the ground. FE actually drove the side stakes at locations established by contract surveyors. Every other side stake was to have its number shown on a tape flag; this was not done. Spikes were driven after dust placement was complete, just prior to bag deployment.

E. Tie-down nails were surveyed in position and driven surface flush by NMERI starting about 4 June until completed on 22 June. FE augmented the NMERI crew as needed to meet this schedule. Nails were driven on 51 3/4 inch centers to add tolerance for bag placement. The nail survey layout held the center point of each bag constant. The control grid layout developed by NMERI is attached. NMERI did not paint nailheads (they were covered by dust), but provided each worker with a grubbing stick (combined with string puller) to help him find buried nails.

F. A trench 6 inches deep was dug with a trenching machine around the bag perimeter. Trenching was coordinated to avoid severing shallowly-buried cables. Laborers pitched any rocks or hard clods away from the excavated soil windrow, and cleaned out the trench to the specified depth. Double soil windrows left by the trencher had to be shoveled into a single windrow. The windrow had to be on the side away from the future bag. Perimeter trench locations were surveyed to take into account the effective bag shrinkage caused by reducing the nail grid to 51 3/4 inches. Trenching was done between D-6 and D-4.

G. Similar trenches were dug at each bag interface. Laborers removed the rocks and hard clods by hand since truck traffic over the dust was discouraged. Windrows of soil were placed on the side of the trench away from 6Z, except as follows. Since bags #5 and 7 were to be placed last, after 1-4, 6, and 8 were in place, windrows for the trench at the 5/6 interface and the trench at the 7/8 interface were placed on the side towards 6Z. That way bag joints on both edges of bags 5 and 7 could be made up from inside those bags. This trenching was also done between D-6 and D-4.

H. Flood lighting for night work was pre-arranged as follows. Eight mobile light carts were borrowed from other commands or rented to be on site by 21 June. Sources were:

Kirtland -- 2 carts  
Rental -- 4 carts  
Holloman -- 3 carts

Typical arrangement of the carts is shown on the attached sketch. Carts were moved around to best light the work area. Rental carts could not be moved with the light stanchions up, as jacking legs had to be used. Carts were not brought onto the dust. Fueling and towing the carts was done by FE.

I. Every test object which protruded through the bag had a tailored polyurethane skirt installed at the two foot height. A Sheldahl representative visited the site on 18 June to verify that penetrations were as designed. Skirts were installed by the Sheldahl crew from 22-24 June. This was scheduled to happen earlier, but experimenters were not ready. One-quarter mil mylar was to be installed by Spectron on the leading and trailing edges of the 8703 blast wings,

but wa  
this e  
J  
the te  
worked  
experi  
8701/0  
K  
the su  
experi  
screer  
L  
arrivi  
each.  
and s  
other  
laid  
by 16  
their  
and i  
the s  
bag,  
NHERI  
with  
mana

but was not available at the needed time. The prefabricated skirt for this experiment was carefully taped across these 3 inch spans.

J. During his 18 June visit, the Sheldahl representative inspected the test objects for sharp surfaces likely to puncture the bag, and worked out protective cushioning measures satisfactory to the experimenter(s) involved. Experiments of particular concern were 8701/02, 8709, and 8710.

K. Prior to bag deployment, sleeve sockets were inserted by DRI at the surveyed locations of the under-bag Scotchlite screens for experiment 8707. They also hand-dug a four inch deep slot at each screen to hold the screen height above grade to 20 inches.

L. Helium reserve skids (four jumbo tube trailer equivalents) arrived on site on 14 June. The full skids weighed about 52,000 pounds each. FE arranged for two cranes to lift these skids from their lowboys and set them on the ground. They were set tightly adjacent to each other at the 10 psi line, and their 6Z ends were protected with sandbags laid by FE. They survived the blast nicely in this fashion.

M. A total of 33 jumbo helium tube trailers arrived at White Sands by 1600 on D-1. The MINOR SCALE Helium Truck Management Plan details their movements.

N. A supply of backup materials was staged by D-2 at the storage and laydown area on the east side of the radial. This supply included the spares furnished by Sheldahl under contract, the extra (ninth) 6Z bag, and four pallets of sandbags (about 500 total bags) staged on the NMERI cargo truck.

O. Two porta-johns were placed in the storage area prior to D-2, with provision for their removal on the morning of D-0. The PHETS manager arranged for this.

P. Prior to bag deployment, NMERI accomplished crew training for both experienced and new deployment personnel. Training was held on 18 June. Separate documentation lists the topics covered. Crew members were trained in all aspects of bag deployment to enable their flexible utilization.

Q. NMERI laid out the tension straps with bungee and poker-chip tensioners on D-2. No S-hook was used; instead, the string was tied to the tension loop on the bag. Standard plastic poker chips were furnished for tensioners. Hole enlargement due to wear was not a problem during the MINOR SCALE deployment period.

R. Add-on bogey wheels permitting lateral movement of the empty dolly were tested by NMERI before D-2. They worked successfully, although about 15 minutes was needed each time to install and remove them.

S. The wind curtain on each dolly was replaced by NMERI before D-2 with a similar design using a heavier fabric and a board weight.

T. NMERI hosted training on 19 June in the proper use of the self-contained breathing apparatus. Sheldahl sent two volunteers. Only persons trained in use of the breathing apparatus would have been permitted to enter the helium environment if emergency repairs were needed. NMERI also furnished an ice vest for cooling individuals entering the helium environment. No one actually entered the helium environment on MINOR SCALE.

U. NMERI modified the deployment dollies before D-2 to add a brace in the frame above each wheel. This brace can be used as a step to reach up into the dolly bed.

V. The folded mylar membranes for bags #1 and 2 were laid out on

top of the  
weather.  
were ret  
schedule  
were set  
subsequ  
M.  
the site  
informa  
winds an  
X.  
before  
tractor  
not blo  
fine an  
accurac  
areas,  
same di  
1. The  
deploy  
distrib  
uncont  
within  
to min  
"windc  
to ad  
truck

top of their deployment dollies and covered to protect them from weather. This was done by NMERI on the morning of D-2. The neobranes were returned to their crates when high winds prevented deployment on schedule. The boxes containing mylar neobranes for bags #3 through 8 were set on the ground on the east (starting) side of the radial for subsequent loading onto the dollies.

W. During the two week period prior to D-0, a record of winds at the site was made using the remote-reading anemometer at GZ. This information was analyzed by SNLA to find any correlation between site winds and SNLA predictive data.

X. Scarification of the dust surface was accomplished by FE forces before each bag was deployed. They used a drag drawn by a garden tractor. This was done when winds were low, so the fine material was not blown away. Winds arising after scarification did blow away some fine material. Scarification should be done in daylight for safety and accuracy. Scheduled start was the morning of D-2 for bag #1 and 2 areas, and bag #3,4,6, and 8 areas were to be completed by sunset the same day. Scheduled start for bag #5 and 7 areas was the morning of D-1. These were actually done during the evening of D-1 concurrent with deployment of other bags. Dust within 20 feet of the perforated helium distribution headers was not to be scarified, in order to minimize uncontrolled dust pickup and scattering by the helium in-flow. Also, within 5 feet of the west edge of bag #1, dust was not to be scarified to minimize the amount of dust which would adhere to the clear mylar "window".

Y. Just before the bags were deployed over the HML models, BMD was to add moisture to the model soil bins. They were to bring a water truck along the west edge of the radial and use a garden-type hose to

spray the soil bins. This was not done, as moisture content was determined to be satisfactory without it.

## II. BAG DEPLOYMENT.

NOTES: (1) The time sequence for bag deployment is discussed in other documentation and is not repeated here.

(2) Time allowed for helium fill is indicated in the MINOR SCALE countdown, along with detailed helium status reporting times.

A. The following deployment crew precepts were to be observed by NMERI:

1. Two crews were to be staffed to enable concurrent deployment of two bags.
2. Each individual was to be cross-trained to understand the rudiments of each bag deployment task to which he might be assigned.
3. Notwithstanding (2), each individual was to be assigned his initial job in advance. This was to include familiarization with his team and his explicit role on that team (e.g., was he to tie two rows of nails or three?).
4. The NMERI Project Manager was to be responsible for managing the successful deployment of these bags. He was not to assume duties which would distract him from this management function.
5. There were to be enough go-fers.
6. There were to be enough relief personnel to spell other crew members during the continuously-advancing bag deployment cycle. Normal crew rest was to be taken between bags.
7. There were to be people (both night and day) whose job it

was t  
monit  
away  
assi  
memb  
tear-  
were  
MINO  
D-1  
wer  
side  
unde  
ther  
excr  
to  
wer  
sel  
the  
was  
to  
pli

was to patrol the perimeter of the bags, adjusting tension straps, monitoring bag condition, fixing any tears within reach, and chasing away unauthorized people or wild animals. These people were not assigned, as all hands were used on the bag deployment.

B. Sheldahl provided four mylar technicians per crew to tape the membrane to test object skirts and to repair tears. Finger-hole sized tears were to be taped by NMERI as the dolly advanced; any larger tears were to be fixed by Sheldahl.

C. The following bag deployment procedures were new, unique to MINOR SCALE, or warrant clarification:

1. Bags 5 and 7 were not to be deployed before the night of D-1 due to experiment longevity. As many of the other bags as possible were to be deployed during the night of D-2.

2. One implication of (1) is that for bags #5 and 7, two side-filling crews were needed.

3. During deployment of bag #1, DRI personnel were to enter under the dolly to place their four under-bag Scotchlite screens in their prepositioned holders. This proved so easy to do that DRI was excused, and this job was handled by on-lookers.

4. NMERI was to plan optimal dolly alignment to avoid having to shift the dolly to miss experiments. Detailed experiment locations were provided for the congested areas of bags #5 and 7 to enable selection of wheel paths. In bag #3, the dolly was to ride up and over the berm which protects the Tech Reps experiment. Instead, the dolly was modified to bridge across the experiment. Empty dollies were moved to their next starting position by backing down the next bag to be placed. This allowed a test of the wheel paths, and avoided having to

turn the dollies around.

5. The bag tie-down strings for MINOR SCALE terminated in slip knots to be tightened over the nail heads. These knots were held in place with a drop of Duco cement. NHERI provided each worker with a bent screwdriver with a machined slot in the blade to ease the fatigue of sliding these knots tight over the nail heads.

6. Permission was granted by the Safety Officer for deployment personnel to wear light, flat-soled shoes (e.g., tennis or boat shoes) to minimize disturbance of the dust surface. The tie-down personnel accordingly were not directed routinely to smooth out the dust as the bag advanced. If they noticed ruts or gouges deeper than about 1/4 inch, they were to try to pat them smooth with a vertical hand motion. A lateral sweeping motion was not desired. In fact, foot traffic disturbed the soft dust surface so extensively that leveling became impractical.

7. There were no inter-bag tensile loop connections to be made on MINOR SCALE. The bags were expected to bulge together when inflated from the intended internal overpressure of 0.01 to 0.02 inches of water. They did bulge together satisfactorily.

8. Individual experimenters were asked to stand by as the bag passed their experiment, to confirm for themselves that it was not disturbed by the bag deployment crew, and to accomplish last minute tasks such as removing lens coverings. Once their business was finished, they were asked to stand off the radial. LCDR Anderson explained this policy at successive Project Officer Meetings; enforcement was the duty of the NHERI dolly supervisor. A white line was to be established using an athletic field striping machine for spectators to stand behind; this was not done. Spectator control was

not a part

experiment

Phillips a

bag deploy

repairs as

because bi

clear wyl

this proc

extra car

not to sp

window be

prior to

deployed

bags was

East sid

underway

carls pr

of this

positio

passage

III. C

A.

highly



not a particular problem.

9. Repair of the dust surface in front of selected experiments was to be accomplished by Dr. George Ullrich and Bruce Phillips and their designees. As much as possible, this was done before bag deployment. FE provided manual landscape rollers and crew to make repairs as directed. At least two soil repair crews were planned because bags #5 and 7 were to be deployed concurrently.

10. Special care was to be taken with the embedding of the clear mylar "window" on the west end of bag #1. As with other bag ends, this process started from the middle and worked to the edges, taking extra care to avoid wrinkles in the fabric. Trench fillers took care not to spill dirt on the clear fabric. In spite of this care, the window became muddy on the inside when moisture condensed on the mylar prior to bag inflation.

11. Bags #5 and 7 were to be placed in between bags already deployed. As a consequence, all traffic and logistic support for these bags was to come from the west (finishing) end and none from the sides. East side light carts were to be repositioned after deployment was underway to aid more effectively. This proved unnecessary as the west carts provided adequate light. NMERI was to evaluate other consequences of this sequencing, such as its possible effect on dolly wheel positioning. In fact, one dolly cart module had to be removed to allow passage.

### III. CONTINGENCY ACTIONS

A. Successful deployment of the MINOR SCALE bags was known to be highly dependent on having wind speeds of 10 knots or below. While the

prevailing conventional wisdom is that such conditions are most likely during the hours of darkness, exceptions are commonly observed. Likewise, the conventional wisdom is that high winds are most likely during the afternoon, yet calm afternoons are occasionally encountered. In order to deal with these contingencies, the NMERI bag deployment crew was berthed in the Admin Park. That way when winds came up, the crew could retreat for a few hours of sleep to be ready to go again when the winds died down.

B. When strong winds arose during the deployment of the bags, the NMERI supervisor was to take contingency actions of graduated severity:

1. The first response was to cease tying strings to nails, and have each crew member grab and hold onto two adjacent load patches. Crew members had learned the proper technique for holding onto the load patches during their training. Everybody was then to hunker down and wait for the gust to pass.

2. If the first response was insufficient, the next action was to place sandbags in the tray of the deployment dolly and along the edge on the ground. PVC wind frames were placed to prevent the ayilar from blowing against the dolly. This technique was used during the deployment of bag #3, and the bag survived in this position during winds which lasted about 14 hours.

3. If it appeared that the bag was in grave danger of being lost, the senior NMERI supervisor on the scene was prepared to give the order to have the Sheldahi technicians cut the bag with scissors along the line of ties last secured. The bag was to be folded, weighted with sandbags, and cut beyond the weights. The billowing remainder was to be stuffed back under the wind frame on the dolly. Later, after the wind had subsided, the remainder of the bag would have been laid. A tape

splice across  
The effect we  
would have be  
recirculation  
inside the b  
vertical wal  
C. Inf  
over 10 knot  
in a state o  
inflation ph  
whether to c  
the bags.  
been quicker

#### IV. HELIUM

A. A  
the heliua  
checkoff in  
and key all  
the checki

- 1.
- 2.
- 3.
- 4.
- 5.
- 6.

splice across the entire width of the bag would not have been attempted. The effect would have been to reduce the length of the bag. Helium would have been introduced into the isolated section using the recirculation system. Since the recirculation outlets are only 6 feet inside the bag, there was not enough mylar material to try for a vertical wall at the splice.

C. Inflation of the bags would not have been attempted in winds over 10 knots. The bags are known to be extremely vulnerable to damage in a state of partial inflation. If high winds had arisen during the inflation phase, a judgment call would have been made by LCDR Anderson whether to continue inflation, or to use the exhaust fans to evacuate the bags. If the bags were more than 75 percent full, it would have been quicker to complete filling them than to evacuate them.

#### IV. HELIUM FILL PROCEDURES

A. A detailed checkoff procedure was developed by SAIC describing the helium fill procedures to be followed. A copy is attached. The checkoff included identification of who is responsible for each step, and key milestone times in the countdown. The major phases included in the checklist are as follows:

1. Verify system controls are working.
2. Pressurize helium distribution system and watch for leaks.
3. Confirm helium/air recirculation system is working.
4. Check remote operation of helium reserve skids.
5. Visually inspect mylar bags.
6. Begin helium flow:
  - a. Increase rate stepwise to 100 KCF/H.

b. When 75% full, reduce flow to 50 KCF/H.

c. When 90% full, reduce flow to 30 KCF/H.

7. Bolt covers down on valve boxes.

8. Depart the 6Z area.

B. The helium fill procedures were based on filling all 8 bags concurrently. It was anticipated that this would take about 80 minutes. This was found to be about right in practice. The intended pressure inside each bag was 0.02 inches of water, which was not normally to be exceeded.

C. It was considered a possibility to deliberately exceed the target helium concentration, in order to minimize the subsequent draw from the helium reserve skids. This was an option which was kept available if the likelihood of a same-day postponement had seemed much greater than an overnight delay. As circumstances developed, this option was not employed.

D. The target helium concentration was expressed in terms of sound speed. The target was 2300 to 2400 feet per second. The reason for expressing it in sound speed was to avoid the conversion problems caused by varying temperature and humidity. In order for the target to be met, the average of the 5 sound speed gauges in each bag had to fall within 2300-2400 fps, and all 8 bags had to meet this criterion. If the operator had reason to believe a particular sound speed gauge was giving a spurious reading, he was to zero it out and compute the bag average on the gauges remaining. If the controls did not achieve this precise range, exceeding 2400 fps was preferred over not making at least 2300 fps. As circumstances developed, an average of about 2000 fps was reached in surviving bags 2-7.

E. We planned to use the recirculation system continuously during

ifla  
oneq  
E.  
down  
S  
ner  
he  
pow  
ol  
17  
ulc  
irt  
ve  
nel

bag inflation and the period prior to shot execution to keep the helium environment well mixed. This was inadvertently not done.

F. A command was given by the Net Operator at T-90 seconds in the countdown to turn off power to the helium system. When this command was heard, SAIC activated a relay to turn off the ignition switch on the 60 KW generator which powers the system. At this, the sound speed display and the bag control displays showed meaningless characters, indicating that power had been successfully turned off. SAIC reported back to Test Control by T-80 seconds that this had occurred. In order to restore power in the event of a hold occurring after this time in the countdown, it would have been necessary to re-enter the test bed and manually restart the generator. A delay of 20 minutes or so would have been involved, during which time the bags would gradually have lost pressure and helium. This was not necessary.



APPENDIX K  
MINOR SCALE HOLD CRITERIA AND PROCEDURES

## MINOR SCALE DELAY/HOLD CRITERIA

### INTRODUCTION

The purpose of this document is to establish the hold criteria that will be used during the countdown for the MINOR SCALE event scheduled for 13 June 1985. There are approximately 200 experiments on MINOR SCALE. It is next to impossible to expect that all of these experiments will be installed and properly running at the scheduled execution time. Therefore, we must establish a series of criteria to decide, in advance, under what conditions we will hold the event to correct problems and under what conditions we will continue the countdown in spite of problems. Since there are many million of dollars worth of experiments, it must be an organizational decision to develop and approve of the hold criteria.

### GENERAL DEFINITIONS

**Experiment:** an activity that has been given an experiment number by the Technical Director. The most recent experiment list will have the numbers for all the experiments on MINOR SCALE.

**Delay:** a decision to change the shot day before the countdown has begun.

**Hold:** a decision to change the shot time or shot day after the countdown has begun. The countdown will begin with the start of the deployment of the precursor bag (approximately 6 p.m. on D-2).

### DELAY CRITERIA

A delay will not be considered for any single experiment, i.e. one HML model or one Army vehicle. However, if any of the following diagnostics experiments is not functional then a delay will be initiated: the airblast measurements (Exp. 9100), the shockwave cameras (Exp. 9000), and the charge detonation velocity measurements (Exp. 9300).

The event will be delayed if any of the following conditions occur.

- a. Less than 90% of the experiment will be ready at the schedule shot time.
- b. The TRS units will not be ready. This implies that less than five of the units will be operating. If five of the seven units are operational, then the remaining two units will be considered only as experiments that aren't ready and will be counted under the experiment percent.
- c. The precursor bag will not be ready. If any bag is not ready, then the precursor is not ready.
- d. Weather that prevents proper conditions for shot execution, i.e. recent rains that have left the dusty precursor too damp to dry in time for the scheduled execution.
- e. The Timing & Firing system is not functioning properly.
- f. The instrumentation system is not functioning properly.
- g. The explosive charge is not ready.

h  
cannot  
do not  
the sh

HOLD CR

Di  
holds.  
Items

a  
helium  
diatel  
and the  
sidere

b

c

damage  
recomm

precur  
being

greate

of the

d  
ing eq  
determ

status  
less w

e  
sound

1  
site t  
time.



h. Foreign satellite coverage: several experiments are classified and cannot be uncovered if a surveillance satellite is overhead. Therefore, if we do not have an adequate window to uncover the classified experiment, execute the shot, and then cover the damage, the shot will be delayed.

#### HOLD CRITERIA

During the countdown many situations will have to be considered as potential holds. Some of the items will require rescheduling of the event for a later date. Items that will be considered for a hold are listed below:

a. If the precursor environment is in imminent danger of failing (loss of helium concentration due to major bag rupture), the test will be executed immediately, consistent with safety criteria. In this situation satellite coverage and the status of other experiments, including TRS experiments, will not be considered.

b. Obviously, all the items that can cause a delay can also cause a hold.

c. Weather conditions:

(1) Upper air conditions that would lead to blast focusing that might damage surrounding communities: Jack Reed of SNLA will provide the GO/NO GO recommendation during the ocuntdown.

(2) Wind conditions that prevent continuing the deployment of the precursor bag. These conditions could occur during the period when the bag is being deployed. Winder greater than 10 mph will delay the deployment.

(3) The wind is too high at shot time to fire the TRS units. Winds greater than eight mph are considered too high.

(4) Heavy cloud cover, rain, or lightning that prevents continuation of the countdown.

d. Instrumentation status: the analog recorders and the digital recording equipment will be monitored during the countdown. If, at any time, it is determined that any of the following conditions exists a hold will be initiated:

(1) Less than 90% of the active data will be recorded.

(2) Less than 90% of the precursor data will be reocrded.

(3) Less than 90% of the HML data will be recorded. Some experiments' status will not be monitored. Therefore, their status will be assumed good unless we know it is bad.

e. Precursor status: each of the eight bags must be within the desired sound speed range of 2300 to 2400 feet per second.

The final decision on executing the event will, of course, be made on the site by the Technical Director based on the best information available at the time.

2 May 1965

HINOR SCALE HOLD PROCEDURES

POINT IN COUNTDOWN	EXPECTED DURATION OF PROBLEM	ACTIONS TO BE TAKEN	POINT IN COUNTDOWN
T-48 hrs to T-28 Hrs	<8 hrs	1. Continue countdown to T-28 hrs. 2. Use "Non-tested Experimenter Call Sheet" to pass word. 3. Hold at T-28 hrs until problem solved.	T-150 min to T-62 min
	>8 hrs	1. Reschedule shot. 2. Use "Agency Call Sheet" to inform world. 3. Start count at T-48 hrs.	
T-28 hrs to T-7 hrs	<8 hrs	1. Continue countdown to T-7 hrs. 2. Use "Non-tested Experimenter Call Sheet" to pass word. 3. Hold at T-7 hrs. until problem solved.	T-62 min to T-6 min
	>8 hrs	1. Reschedule shot. 2. Use "Agency Call Sheet" to inform world. 3. Start count at T-28 hrs.	
T-7 hrs to T-240 min	<4 hrs	1. Continue countdown to T-240 min. 2. Use "Non-tested Experimenter Call Sheet" to pass word. 3. Hold at T-240 min until problem solved.	T-62 min to T-6 min
	>4 hrs	1. Reschedule shot. 2. Use "Agency Call Sheet" to inform world. 3. Secure TRS. 4. Start count at T-6 hrs.	
T-240 min to T-150 min	<4 hrs	1. Continue countdown to T-150 min. 2. Use "Non-tested Experimenter Call Sheet" to pass word. 3. Hold at T-150 min until problem solved.	T-62 min to T-6 min
	>4 hrs	1. Reschedule shot. 2. Use "Agency Call Sheet" to inform world. 3. Deflate helium bag. 4. Secure TRS. 5. Start count at T-6 hrs.	

2 May 1985

MINOR SCALE HOLD PROCEDURES

POINT IN COUNTDOWN	EXPECTED DURATION OF PROBLEM	ACTIONS TO BE TAKEN
T-158 min to T-62 min	<2 hr	<ol style="list-style-type: none"> <li>1. Continue countdown to T-62 min.</li> <li>2. Use "Non-tested Experimenter Call Sheet: to pass word.</li> <li>3. Hold at T-62 min until problem solved.</li> </ol>
	2 hrs to 4 hrs.	<ol style="list-style-type: none"> <li>1. Evaluate status of experiments (generators, etc.)</li> <li>2. Use "Non-tested Experimenter Call Sheet: to pass word.</li> <li>3. Perform appropriate adjustments.</li> <li>4. Continue countdown to T-62.</li> <li>5. Hold at T-62 until problems solved.</li> </ol>
	>4 hrs	<ol style="list-style-type: none"> <li>1. Reschedule shot.</li> <li>2. Use "Agency Call Sheet" to inform world.</li> <li>3. Deflate helium bag.</li> <li>4. Secure TRS.</li> <li>5. Start count at T-6 hrs.</li> </ol>
T-62 min to T-45 min	<1.5 hr.	<ol style="list-style-type: none"> <li>1. Continue countdown to T-45 min.</li> <li>2. Use "Non-tested Experimenter Call Sheet: to pass word.</li> <li>3. Hold at T-45 min until problem solved.</li> </ol>
	1.5 hr. to 4 hr.	<ol style="list-style-type: none"> <li>1. Evaluate status of experiments.</li> <li>2. Use "Non-tested Experimenter Call Sheet: to pass word.</li> <li>3. Cover classified experiments, if necessary.</li> <li>4. Send PMS aircraft to refuel.</li> <li>5. Start count at T-60 min.</li> </ol>
	>4 hr.	<ol style="list-style-type: none"> <li>1. Reschedule shot.</li> <li>2. Use "Agency Call Sheet" to inform world.</li> <li>3. Deflate helium bag.</li> <li>4. Secure TRS.</li> <li>5. Cover classified experiments.</li> <li>6. Start count at T-6 hrs.</li> </ol>

2 May 1985

MINOR SCALE HOLD PROCEDURES

POINT IN COUNTDOWN	EXPECTED DURATION OF PROBLEM	ACTIONS TO BE TAKEN	POINT IN COUNTDOWN
T-45 min to T-30 min	<1.5 hr.	<ol style="list-style-type: none"><li>1. Continue countdown to T-30 min.</li><li>2. Use "Non-tested Experimenter Call Sheet: to pass word.</li><li>3. Hold at T-30 min until problem solved.</li></ol>	T-15 min to T-4
	1.5 hr to 4 hrs.	<ol style="list-style-type: none"><li>1. Recharge helium reserve system.</li><li>2. Send PMS aircraft to refuel.</li><li>3. Cover classified experiments, if necessary.</li><li>4. Evaluate status of experiments.</li><li>5. Use "Non-tested Experimenter Call Sheet: to pass word.</li><li>6. Start count at T-60 min.</li></ol>	
	>4 hrs.	<ol style="list-style-type: none"><li>1. Reschedule shot.</li><li>2. Use "Agency Call Sheet" to inform world.</li><li>3. Deflate helium bag.</li><li>4. Secure TRS.</li><li>5. Send PMS aircraft home.</li><li>6. Start count at T-6hr.</li></ol>	
T-30 min to T-15 min	<1.5 hr.	<ol style="list-style-type: none"><li>1. Continue countdown to T-15 min.</li><li>2. Use "Non-tested Experimenter Call Sheet: to pass word.</li><li>3. Hold at T-15 min until problem solved.</li></ol>	
	1.5 hr to 4 hr.	<ol style="list-style-type: none"><li>1. Disarm charge.</li><li>2. Recharge helium reserve system.</li><li>3. Send PMS aircraft to refuel.</li><li>4. Cover classified experiments, if necessary.</li><li>5. Use "Non-tested Experimenter Call Sheet: to pass word.</li><li>6. Evaluate status of experiments.</li><li>7. Start count at T-60 min.</li></ol>	
	>4 hrs.	<ol style="list-style-type: none"><li>1. Disarm Charge.</li><li>2. Reschedule shot.</li><li>3. Use "Agency Call Sheet" to inform world.</li><li>4. Deflate helium bag.</li><li>5. Secure TRS.</li><li>6. Cover classified experiments.</li><li>7. Send PMS aircraft home.</li><li>8. Start count at T-6 hrs.</li></ol>	

2 May 1985

MINOR SCALE HOLD PROCEDURES

POINT IN COUNTDOWN	EXPECTED DURATION OF PROBLEM	ACTIONS TO BE TAKEN
T-15 min to T-4 min	<1.5 hr.	<ol style="list-style-type: none"><li>1. Continue countdown to T-4 min.</li><li>2. Use "Non-tested Experimenter Call Sheet: to pass word.</li><li>3. Hold at T-4 until problem solved.</li></ol>
	1.5 hr to 4 hrs	<ol style="list-style-type: none"><li>1. Safe firing panel, if necessary.</li><li>2. Disarm charge.</li><li>3. Recharge helium reserve system.</li><li>4. Send PMS aircraft to refuel.</li><li>5. Cover classified experiments, if necessary.</li><li>6. Evaluate status of experiments.</li><li>7. Use "Non-tested Experimenter Call Sheet: to pass word.</li><li>8. Start count at T-60 min.</li></ol>
	>4 hrs.	<ol style="list-style-type: none"><li>1. Safe firing panel, if necessary.</li><li>2. Disarm charge.</li><li>3. Reschedule shot.</li><li>4. Use "Agency Call Sheet" to inform world.</li><li>5. Deflate helium bag.</li><li>6. Send PMS aircraft home.</li><li>7. Secure TRS.</li><li>8. Cover classified experiments.</li><li>9. Start count at T-6 hrs.</li></ol>

2 May 1985

MINOR SCALE HOLD PROCEDURES

POINT IN COUNTDOWN	EXPECTED DURATION OF PROBLEM	ACTIONS TO BE TAKEN	POINT IN COUNTDOWN
T-4 min to T-2.5 min	<1.5 hr	<ol style="list-style-type: none"><li>1. Safe firing panel.</li><li>2. Reset TRS, if necessary.</li><li>3. Use "Non-testbed Experimenter Call Sheet: to pass word.</li><li>4. Start count at T-10 min.</li></ol>	T-2.5 min to T-0
	1.5 hr to 4 hrs.	<ol style="list-style-type: none"><li>1. Safe firing panel.</li><li>2. Disarm charge.</li><li>3. Recharge helium reserve system.</li><li>4. Send PMS aircraft to refuel.</li><li>5. Cover classified experiments, if necessary.</li><li>6. Evaluate status of experiments.</li><li>7. Use "Non-testbed Experimenter Call Sheet: to pass word.</li><li>8. Start count at T-60 min.</li></ol>	
	>4 hrs.	<ol style="list-style-type: none"><li>1. Safe firing panel.</li><li>2. Disarm charge.</li><li>3. Reschedule shot.</li><li>4. Use "Agency Call Sheet" to inform world.</li><li>5. Deflate helium bag.</li><li>6. Send PMS aircraft home.</li><li>7. Secure TRS.</li><li>8. Cover classified experiments.</li><li>9. Start count at T-6 hrs.</li></ol>	

2 May 1985

NINOR SCALE HOLD PROCEDURES

POINT IN COUNTDOWN	EXPECTED DURATION OF PROBLEM	ACTIONS TO BE TAKEN
T-2.5 min to T-0	<1.5 hr.	<ol style="list-style-type: none"><li>1. Stop recorders.</li><li>2. Safe firing panel.</li><li>3. Use "Non-testbed Experimenter Call Sheet: to pass word.</li><li>4. Start count at T-10 min.</li></ol>
	1.5 hr to 4 hrs.	<ol style="list-style-type: none"><li>1. Safe firing panel.</li><li>2. Disarm charge.</li><li>3. Reset TRS.</li><li>4. Send PMS aircraft to refuel.</li><li>5. Recharge helium reserve system.</li><li>6. Cover classified experiments, if necessary.</li><li>7. Evaluate status of experiments.</li><li>8. Rewind recorders.</li><li>9. Use "Non-testbed Experimenter Call Sheet: to pass word.</li><li>10. Start count at T-60 min.</li></ol>
	>4 hrs.	<ol style="list-style-type: none"><li>1. Safe firing panel.</li><li>2. Disarm charge.</li><li>3. Reschedule shot.</li><li>4. Deflate helium bag.</li><li>5. Secure TRS.</li><li>6. Cover classified experiments.</li><li>7. Send PMS aircraft home.</li><li>8. Rewind recorders.</li><li>9. Use "Agency Call Sheet" to inform world.</li><li>10. Start count at T-6 hrs.</li></ol>





APPENDIX L  
H+24 HOUR REPORT

SUBJECT: MINOR SCALE H PLUST 24 HOUR REPORT

1. The 4800 ton ANFO event, MINOR SCALE, sponsored by the Defense Nuclear Agency was executed at 12:20:00.031 MDT on 27 June 1985 at the Permanent High Explosive Test Site at White Sands Missile Range. The first impression from the visual evidence, (i.e. crater size, the debris, the structural damage), is that the charge detonated at predicted. There is some initial evidence of jetting. The charge container had developed two ruptures and approximately 100+ tons of ANFO had spilled from each rupture.
2. At this time nothing is known of the actual data. The following operational items have been assessed. 35 of 39 DRI cameras operated. 196 of 204 WSMR cameras operated. 5 cameras have not been recovered at this time. All analog recorders ran. Approximately 90% of the digital channels recorded data.
3. The dusty precursor area encountered the following problems: 2 of the 8 bags (the first and the last) were destroyed by a dust devil wind approximately 40 minutes prior to execution. The remaining six bags appeared to have an average sound velocity of 2062 feet per second. The highest was 2141 and the lowest was 1928.
4. All seven of the TRS units operated properly. At first glance it appears they provided the proper fluence conditions for each experiment.
5. All scheduled aircraft experiments flew and they appeared to meet their general objectives.
6. The crater size was 345 feet in diameter (including the crater lip) and 80 feet in depth. The depth was about twice as deep as the predictions.

JAMES E. MIMS, LTC, FCTO, 4-7866  
GEORGE A. BALLANTINE, FCT, 4-4222

APPENDIX M  
HELIUM BAG PROBE DATA

34/2/1

1107 TAB

# HELIUM BAG PROBE LAYOUT

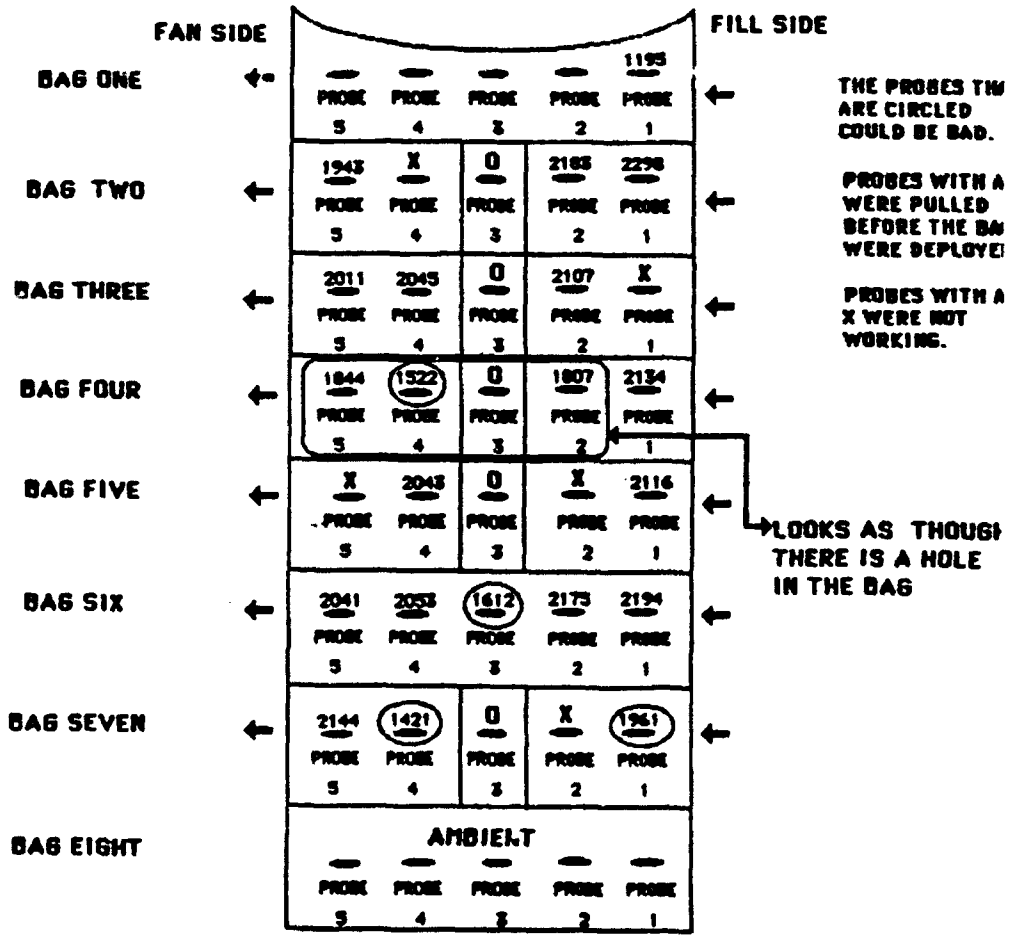

COUNT = 1 , TIME = 06:00:39, AMBIENT = 1124

	PROBE 1	PROBE 2	PROBE 3	PROBE 4	PROBE 5	AVERAGE
BAG 1	1124	1123	1123	1124	1124	1124
BAG 2	1123	1122	0	1123	1124	1123
BAG 3	1123	1122	0	1123	1122	1123
BAG 4	1122	1123	0	1120	1124	1124
BAG 5	1125	0	0	1126	0	1126
BAG 6	1122	1124	1124	1123	1123	1123
BAG 7	1125	1125	0	1123	1123	1124
BAG 8	0	1124	1123	1123	1123	1123

COUNT = 2 , TIME = 08:09:27, AMBIENT = 1124

	PROBE 1	PROBE 2	PROBE 3	PROBE 4	PROBE 5	AVERAGE
BAG 1	1124	1125	1125	1125	1126	1125
BAG 2	1127	1123	0	1121	1125	1124
BAG 3	1126	1125	0	1120	1125	1126
BAG 4	1125	1127	0	1120	1129	1125
BAG 5	1127	0	0	1125	0	1126
BAG 6	1127	1127	1127	1130	1128	1128
BAG 7	1127	1123	0	1129	1127	1127
BAG 8	0	1129	1126	1127	1133	1129

COUNT = 3 , TIME = 09:15:23, AMBIENT = 1161

	PROBE 1	PROBE 2	PROBE 3	PROBE 4	PROBE 5	AVERAGE
BAG 1	1151	1150	1153	1148	1145	1149
BAG 2	1154	1152	0	1138	1148	1148
BAG 3	1151	1153	0	1160	1155	1154
BAG 4	1156	1154	0	773	1157	1156
BAG 5	1156	0	0	1157	0	1157
BAG 6	1155	1154	1155	1148	1154	1153
BAG 7	1155	1149	0	1159	1181	1159
BAG 8	0	1148	1151	1158	1164	1155

COUNT = 4 , TIME = 09:27:31, AMBIENT = 1151

	PROBE 1	PROBE 2	PROBE 3	PROBE 4	PROBE 5	AVERAGE
BAG 1	1905	1173	1176	1169	1167	1319
BAG 2	1673	1167	0	1088	1169	1274
BAG 3	1254	1180	0	1183	1169	1197
BAG 4	1162	1178	0	905	1182	1174
BAG 5	1279	0	0	1180	0	1230
BAG 6	1157	1178	1177	1165	1173	1170
BAG 7	1178	1159	0	1179	1183	1175
BAG 8	0	909	1169	1181	1185	1178

COUNT = 5 , TIME = 09:30:58, AMBIENT = 1161

	PROBE 1	PROBE 2	PROBE 3	PROBE 4	PROBE 5	AVERAGE
BAG 1	2091	1722	1180	1171	1168	1466
BAG 2	2108	1185	0	1085	1170	1387
BAG 3	1697	1182	0	1184	1174	1309
BAG 4	1330	1181	0	905	1183	1231
BAG 5	1193	0	0	1183	0	1188
BAG 6	1214	1182	1182	1170	1180	1186
BAG 7	1185	1160	0	1184	1187	1179
BAG 8	0	909	1172	1187	1187	1182

COUNT = 6 , TIME = 09:34:54, AMBIENT = 1161

	PROBE 1	PROBE 2	PROBE 3	PROBE 4	PROBE 5	AVERAGE
BAG 1	2035	1915	1422	1172	1170	1543
BAG 2	2005	1833	0	1092	1171	1526
BAG 3	1606	1572	0	1440	1177	1449
BAG 4	1476	1232	0	921	1209	1306
BAG 5	1539	0	0	1182	0	1361
BAG 6	1595	1390	1236	1170	1183	1315
BAG 7	1284	948	0	1186	1187	1219
BAG 8	0	909	1172	1188	1189	1183

COUNT = 7 , TIME = 09:39:01, AMBIENT = 1161

	PROBE 1	PROBE 2	PROBE 3	PROBE 4	PROBE 5	AVERAGE
BAG 1	1397	1342	1648	1465	1474	1705
BAG 2	2242	1962	0	1085	1172	1615
BAG 3	1740	1703	0	1399	1272	1529
BAG 4	1523	1455	0	986	1250	1409
BAG 5	1654	0	0	1278	0	1466
BAG 6	1729	1565	1290	1276	1214	1415
BAG 7	1472	948	0	1325	1292	1363
BAG 8	0	909	1174	1187	1192	1184

COUNT = 8 , TIME = 09:42:35, AMBIENT = 1161

	PROBE 1	PROBE 2	PROBE 3	PROBE 4	PROBE 5	AVERAGE
BAG 1	2047	1985	1979	1638	1657	1861
BAG 2	2194	2009	0	1093	1333	1712
BAG 3	1835	1772	0	1630	1325	1641
BAG 4	1586	1573	0	1227	1420	1492
BAG 5	1721	0	0	1556	0	1639
BAG 6	1777	1751	1780	1416	1208	1586
BAG 7	1504	948	0	1292	1259	1332
BAG 8	0	909	1229	1285	1325	1290

COUNT = 9 , TIME = 09:49:03, AMBIENT = 1161

	PROBE 1	PROBE 2	PROBE 3	PROBE 4	PROBE 5	AVERAGE
BAG 1	2078	2047	1966	1618	1523	1846
BAG 2	2162	2015	0	1097	1474	1687
BAG 3	1915	1844	0	1487	1269	1629
BAG 4	1660	1627	0	1161	1353	1433
BAG 5	1832	0	0	1386	0	1609
BAG 6	1935	1849	1771	1457	1307	1634
BAG 7	1696	993	0	1294	1256	1415
BAG 8	0	909	1220	1259	1307	1262

COUNT = 10 . TIME = 09:53:07. AMBIENT = 1161

	PROBE 1	PROBE 2	PROBE 3	PROBE 4	PROBE 5	AVERAGE
BAG 1	2102	2047	2018	1862	1599	1926
BAG 2	2155	2049	0	1087	1707	1750
BAG 3	1989	1887	0	1706	1380	1741
BAG 4	1703	1785	0	1252	1521	1590
BAG 5	1971	0	0	1842	0	1907
BAG 6	2128	2019	2019	1758	1683	1921
BAG 7	1754	948	0	1552	1453	1586
BAG 8	0	909	1732	1599	1299	1543

COUNT = 11 . TIME = 09:53:54. AMBIENT = 1161

	PROBE 1	PROBE 2	PROBE 3	PROBE 4	PROBE 5	AVERAGE
BAG 1	2162	2126	2072	1842	1597	1960
BAG 2	2204	2091	0	1093	1311	1725
BAG 3	2053	1956	0	1713	1369	1743
BAG 4	1787	1777	0	1207	1500	1568
BAG 5	1975	0	0	1540	0	1813
BAG 6	2112	2021	1932	1795	1357	1945
BAG 7	1829	948	0	1456	1393	1556
BAG 8	0	909	1771	1448	1301	1507

COUNT = 12 . TIME = 10:02:16. AMBIENT = 1161

	PROBE 1	PROBE 2	PROBE 3	PROBE 4	PROBE 5	AVERAGE
BAG 1	2186	2144	2072	1909	1830	2028
BAG 2	2215	2108	0	1092	1603	1795
BAG 3	2032	1987	0	1308	1470	1941
BAG 4	1918	1905	0	1245	1571	1680
BAG 5	2029	0	0	1045	0	1007
BAG 6	2152	2069	1978	1820	1713	1946
BAG 7	1930	948	0	1531	1305	1595
BAG 8	0	909	1795	1424	1297	1505



COUNT = 13 , TIME = 10:13:35. AMBIENT = 1161

	PROBE 1	PROBE 2	PROBE 3	PROBE 4	PROBE 5	AVERAGE
BAG 1	2214	2105	2037	1993	1949	2060
BAG 2	2215	2102	0	1084	1879	1820
BAG 3	2120	1995	0	1850	1760	1931
BAG 4	1870	1850	0	1400	1777	1724
BAG 5	2084	0	0	1982	0	2033
BAG 6	2215	2129	2029	1907	1851	2026
BAG 7	2024	948	0	1794	1241	1686
BAG 8	0	909	1881	1819	1769	1823

COUNT = 14 , TIME = 10:21:28. AMBIENT = 1161

	PROBE 1	PROBE 2	PROBE 3	PROBE 4	PROBE 5	AVERAGE
BAG 1	2151	2107	2117	1907	1853	2028
BAG 2	2187	2108	0	1096	1896	1822
BAG 3	2086	1985	0	1819	1825	1929
BAG 4	1858	1884	0	1398	1542	1671
BAG 5	2075	0	0	1963	0	2019
BAG 6	2134	2122	2025	1904	1893	2028
BAG 7	2020	948	0	1799	1389	1736
BAG 8	0	909	1824	1808	1784	1805

COUNT = 15 , TIME = 10:28:27. AMBIENT = 1161

	PROBE 1	PROBE 2	PROBE 3	PROBE 4	PROBE 5	AVERAGE
BAG 1	2195	2088	2055	2011	1991	2068
BAG 2	2262	2117	0	0	1741	2107
BAG 3	2103	1989	0	1075	1813	1946
BAG 4	1860	1874	0	1420	1701	1719
BAG 5	2086	0	0	2027	0	2057
BAG 6	2180	2096	2051	1945	1813	2018
BAG 7	2000	948	0	1850	1581	1810
BAG 8	0	909	1858	1856	1680	1728

COUNT = 16 , TIME = 10:34:37, AMBIENT = 1161

	PROBE 1	PROBE 2	PROBE 3	PROBE 4	PROBE 5	AVERAGE
BAG 1	2383	2277	2191	2061	2015	2185
BAG 2	2252	2157	0	0	1954	2121
BAG 3	1755	2074	0	1894	1875	1900
BAG 4	1920	1927	0	1401	1739	1759
BAG 5	2162	0	0	2013	0	2088
BAG 6	2164	2098	2080	1948	1973	2032
BAG 7	2092	948	0	1888	1756	1915
BAG 8	0	909	1912	1883	1649	1815

COUNT = 17 , TIME = 10:41:31, AMBIENT = 1161

	PROBE 1	PROBE 2	PROBE 3	PROBE 4	PROBE 5	AVERAGE
BAG 1	2297	2277	2128	2051	1954	2155
BAG 2	2215	2155	0	0	1968	2113
BAG 3	1790	2118	0	1924	1903	1934
BAG 4	2147	1988	0	1412	1856	1851
BAG 5	2142	0	0	2019	0	2081
BAG 6	2170	2098	2084	1953	1846	2030
BAG 7	2141	947	0	1911	1823	1960
BAG 8	0	909	1945	1920	1804	1890

COUNT = 18 , TIME = 10:48:37, AMBIENT = 1161

	PROBE 1	PROBE 2	PROBE 3	PROBE 4	PROBE 5	AVERAGE
BAG 1	2328	2225	2205	2061	1979	2174
BAG 2	2192	2151	0	0	1991	2111
BAG 3	1752	2119	0	1753	1740	1741
BAG 4	2129	2041	0	1447	1700	1891
BAG 5	2135	0	0	2035		2085
BAG 6	2134	2163	2082	1960	1951	2046
BAG 7	2135	948	0	1935	1879	1983
BAG 8	0	909	1968	1931	1864	1921

COUNT = 19 , TIME = 10:53:11 , AMBIENT = 1161

	PROBE 1	PROBE 2	PROBE 3	PROBE 4	PROBE 5	AVERAGE
BAG 1	2350	2313	2227	2078	2003	2194
BAG 2	2179	2142	0	0	2017	2108
BAG 3	1717	2036	0	1967	1973	1938
BAG 4	2088	2063	0	1474	1931	1894
BAG 5	2126	0	0	2073	0	2101
BAG 6	2164	2107	2080	1992	1999	2068
BAG 7	2133	948	0	1965	1937	2012
BAG 8	0	909	1974	1931	1900	1942

COUNT = 20 , TIME = 11:01:52 , AMBIENT = 1161

	PROBE 1	PROBE 2	PROBE 3	PROBE 4	PROBE 5	AVERAGE
BAG 1	2353	2320	2237	2086	2025	2204
BAG 2	2166	2135	0	0	2019	2107
BAG 3	1723	2096	0	1991	2008	1954
BAG 4	2099	2073	0	1501	1982	1914
BAG 5	2146	0	0	2099	0	2123
BAG 6	2150	2118	2096	2029	2039	2090
BAG 7	2146	948	0	2010	2015	2037
BAG 8	0	909	2016	1991	1943	1983

COUNT = 21 , TIME = 11:06:17 , AMBIENT = 1161

	PROBE 1	PROBE 2	PROBE 3	PROBE 4	PROBE 5	AVERAGE
BAG 1	2339	2308	2232	2088	2031	2200
BAG 2	2173	2137	0	0	2025	2112
BAG 3	1722	2094	0	2015	2027	1965
BAG 4	2068	2060	0	1510	2004	1821
BAG 5	2142	0	0	2099	0	2121
BAG 6	2170	2126	2045	2063	2051	2015
BAG 7	2133	948	0	2033	2019	2064
BAG 8	0	909	2024	2001	1954	1993

COUNT = 22 , TIME = 11:19:18, AMBIENT = 1161

	PROBE 1	PROBE 2	PROBE 3	PROBE 4	PROBE 5	AVERAGE
BAG 1	2386	2341	2000	2109	2062	2180
BAG 2	2201	2142	0	0	2053	2132
BAG 3	2100	2105	0	2057	2068	2083
BAG 4	2055	2098	0	2000	2025	2045
BAG 5	2135	0	0	2099	0	2117
BAG 6	2187	2157	1686	2059	2051	2028
BAG 7	2137	948	0	2088	2025	2063
BAG 8	0	909	2035	2016	1964	2012

COUNT = 23 , TIME = 11:27:03, AMBIENT = 1161

	PROBE 1	PROBE 2	PROBE 3	PROBE 4	PROBE 5	AVERAGE
BAG 1	2366	2352	881	2140	2101	2240
BAG 2	2300	2188	0	0	2083	2190
BAG 3	887	2136	0	2047	2057	2031
BAG 4	2078	2133	0	1541	2024	1944
BAG 5	2120	0	0	2084	0	2102
BAG 6	2182	2175	1590	2059	2053	2032
BAG 7	2166	948	0	2034	2031	2037
BAG 8	0	909	2080	2063	2055	2066

COUNT = 24 , TIME = 11:37:47, AMBIENT = 1161

	PROBE 1	PROBE 2	PROBE 3	PROBE 4	PROBE 5	AVERAGE
BAG 1	2339	2300	881	2069	2050	2190
BAG 2	2204	2175	0	0	2091	2157
BAG 3	1170	2100	0	2027	1914	1810
BAG 4	2051	2110	0	1538	1974	1938
BAG 5	2111	0	0	2070	0	2095
BAG 6	2184	2166	1687	2055	2026	2024
BAG 7	2193	948	0	2080	2010	2094
BAG 8	0	909	1277	1267	1240	1262

COUNT = 25 . TIME = 11:39:03. AMBIENT = 1161

	PROBE 1	PROBE 2	PROBE 3	PROBE 4	PROBE 5	AVERAGE
BAG 1	2231	2225	882	2033	2001	2138
BAG 2	2211	2176	0	0	1951	2112
BAG 3	1183	2116	0	1937	1921	1789
BAG 4	2041	2113	0	1526	1998	1920
BAG 5	2101	0	0	2073	0	2088
BAG 6	2150	2162	1686	2057	2047	2020
BAG 7	2211	948	0	2078	2008	2099
BAG 8	0	909	1194	1216	1204	1205

COUNT = 26 . TIME = 11:41:23. AMBIENT = 1161

	PROBE 1	PROBE 2	PROBE 3	PROBE 4	PROBE 5	AVERAGE
BAG 1	1693	2131	882	2003	1921	1937
BAG 2	2218	2167	0	0	2064	2150
BAG 3	1172	2113	0	1957	1955	1789
BAG 4	2051	2113	0	1526	1996	1922
BAG 5	2109	0	0	2073	0	2092
BAG 6	2177	2166	1687	2055	2043	2020
BAG 7	2216	948	0	2073	2011	2102
BAG 8	0	909	1204	1211	1191	1202

COUNT = 27 . TIME = 11:44:25. AMBIENT = 1161

	PROBE 1	PROBE 2	PROBE 3	PROBE 4	PROBE 5	AVERAGE
BAG 1	1713	2113	882	1990	1923	1935
BAG 2	2195	2164	0	0	2017	2122
BAG 3	1178	2107	0	1973	1934	1772
BAG 4	2049	2111	0	1522	1994	1911
BAG 5	2109	0	0	2071	0	2090
BAG 6	2189	2158	1688	2052	2037	2028
BAG 7	2225	948	0	2055	2002	2097
BAG 8	0	909	1194	1214	1200	1203

COUNT = 19 . TIME = 11:48:00, AMBIENT = 1161

	PROBE 1	PROBE 2	PROBE 3	PROBE 4	PROBE 5	AVERAGE
BAG 1	1814	1845	1981	1196	1825	1829
BAG 2	2232	2164	0	0	2057	2168
BAG 3	1173	2100	0	1999	1907	1795
BAG 4	2042	2102	0	1522	1994	1912
BAG 5	2105	0	0	2067	0	2086
BAG 6	2173	2166	1686	2052	2035	2022
BAG 7	2223	948	0	2065	1974	2097
BAG 8	0	909	1192	1210	1181	1194

COUNT = 29 . TIME = 11:51:03, AMBIENT = 1161

	PROBE 1	PROBE 2	PROBE 3	PROBE 4	PROBE 5	AVERAGE
BAG 1	0	0	0	0	0	0
BAG 2	2255	2162	0	0	2000	2142
BAG 3	336	2105	0	2043	1933	2015
BAG 4	2062	2105	0	1431	1933	1914
BAG 5	2105	0	0	2051	794	2073
BAG 6	2137	2154	1523	2055	2028	2035
BAG 7	2218	948	0	2042	1930	2032
BAG 8	0	909	1184	1202	1190	1192

COUNT = 30 . TIME = 11:54:03, AMBIENT = 1161

	PROBE 1	PROBE 2	PROBE 3	PROBE 4	PROBE 5	AVERAGE
BAG 1	0	0	0	0	0	0
BAG 2	2403	2123	0	0	1927	2191
BAG 3	1122	2074	0	210	1900	170
BAG 4	2107	2105	0	210	1932	2011
BAG 5	2105	0	0	2051	794	2073
BAG 6	2191	2162	1686	2057	2032	2022
BAG 7	2211	948	0	2055	2023	2026
BAG 8	0	0	0	0	0	0

COUNT = 31 , TIME = 11:50:17, AMBIENT = 1161

BAG	PROBE 1	PROBE 2	PROBE 3	PROBE 4	PROBE 5	AVERAGE
BAG 1	0	0	0	0	0	0
BAG 2	2452	2133	0	0	1275	1295
BAG 3	886	2064	0	1370	1225	2010
BAG 4	2065	2107	0	1520	1984	1919
BAG 5	2126	0	0	2047	734	2087
BAG 6	2203	2164	1691	2063	2037	2022
BAG 7	2207	948	0	2053	2019	2025
BAG 8	734	309	1192	0	0	1192

COUNT = 32 , TIME = 12:00:04, AMBIENT = 1161

BAG	PROBE 1	PROBE 2	PROBE 3	PROBE 4	PROBE 5	AVERAGE
BAG 1	0	0	0	0	0	0
BAG 2	2381	2211	0	0	1064	2135
BAG 3	887	2052	0	1637	2020	2027
BAG 4	2057	2101	0	1517	1224	1912
BAG 5	2116	0	0	2049	734	2082
BAG 6	2124	2173	1695	2023	2037	2020
BAG 7	2321	948	0	2041	2027	2026
BAG 8	734	309	1192	0	0	1192

COUNT = 33 , TIME = 12:02:56, AMBIENT = 1161

BAG	PROBE 1	PROBE 2	PROBE 3	PROBE 4	PROBE 5	AVERAGE
BAG 1	0	0	0	0	0	0
BAG 2	2345	2207	0	0	2010	2133
BAG 3	887	2052	0	2020	2020	2040
BAG 4	2053	2116	0	1512	1224	1912
BAG 5	2116	0	0	2040	734	2082
BAG 6	2122	2175	1690	2022	2045	2027
BAG 7	2247	948	0	2055	2040	2114
BAG 8	734	309	1207	0	0	1207

COUNT = 34 . TIME = 12:08:19. AMBIENT = 1161

	PROBE 1	PROBE 2	PROBE 3	PROBE 4	PROBE 5	AVERAGE
BAG 1	0	0	0	0	1513	1513
BAG 2	2329	2321	0	0	1993	2181
BAG 3	887	2083	0	2021	2020	2048
BAG 4	2086	2136	0	1517	1929	1932
BAG 5	2107	793	0	2047	1835	1986
BAG 6	2134	2171	1573	2057	2047	2026
BAG 7	1836	948	0	2071	2072	1993
BAG 8	794	909	1212	0	0	1512

COUNT = 35 . TIME = 12:08:21. AMBIENT = 1161

	PROBE 1	PROBE 2	PROBE 3	PROBE 4	PROBE 5	AVERAGE
BAG 1	0	0	0	0	1320	1320
BAG 2	2300	2207	0	0	1909	2139
BAG 3	887	2120	0	2017	2021	2053
BAG 4	2123	2120	0	0	1947	2063
BAG 5	2107	1396	0	2043	734	2043
BAG 6	2175	2173	1575	2051	2041	2023
BAG 7	1959	947	0	2096	2080	2014
BAG 8	0	309	1205	0	0	1205

COUNT = 36 . TIME = 12:10:20. AMBIENT = 1161

	PROBE 1	PROBE 2	PROBE 3	PROBE 4	PROBE 5	AVERAGE
BAG 1	0	0	0	0	1331	1331
BAG 2	2332	2204	0	0	1971	2169
BAG 3	987	2120	0	2015	2025	2050
BAG 4	2113	2067	0	1965	1917	1982
BAG 5	2107	1114	0	2045	784	2043
BAG 6	2175	2168	1567	2050	2040	2021
BAG 7	1974	948	0	2109	2098	2027
BAG 8	0	309	1199	0	0	1199



COUNT = 37 . TIME = 12:12:13. AMBIENT = 1161

	PROBE 1	PROBE 2	PROBE 3	PROBE 4	PROBE 5	AVERAGE
BAG 1	0	0	0	0	1335	1335
BAG 2	2303	2199	0	0	1329	2144
BAG 3	887	2113	0	2015	2019	2049
BAG 4	2324	1824	0	1467	1391	1977
BAG 5	2103	794	0	2041	793	2072
BAG 6	2170	2162	1671	2053	2043	2020
BAG 7	1908	948	0	2126	2108	2047
BAG 8	793	909	1206	0	0	1206

COUNT = 38 . TIME = 12:13:56. AMBIENT = 1161

	PROBE 1	PROBE 2	PROBE 3	PROBE 4	PROBE 5	AVERAGE
BAG 1	0	0	0	0	1218	1218
BAG 2	2225	2207	0	0	1893	2103
BAG 3	887	2111	0	2013	2015	2046
BAG 4	1982	1932	0	1005	1872	1715
BAG 5	2101	793	0	2041	794	2071
BAG 6	2137	2156	1623	2053	2039	2014
BAG 7	1359	948	0	2144	2121	2075
BAG 8	794	909	1211	0	0	1211

COUNT = 39 . TIME = 12:15:49. AMBIENT = 1161

	PROBE 1	PROBE 2	PROBE 3	PROBE 4	PROBE 5	AVERAGE
BAG 1	0	0	0	0	1209	1209
BAG 2	2225	2137	0	0	2049	2130
BAG 3	986	2109	0	2041	2011	2054
BAG 4	1313	1643	0	1005	1854	1604
BAG 5	2101	793	0	2043	794	2072
BAG 6	2134	2171	0	2051	2047	2113
BAG 7	1508	947	0	2161	2136	1935
BAG 8	793	1646	1214	0	0	1630

COUNT = 400, TIME = 13:11:54, AMBIENT = 1101

	PROBE 1	PROBE 2	PROBE 3	PROBE 4	PROBE 5	AVERAGE
BAG 1	0	0	0	0	1105	1135
BAG 2	2298	2103	0	0	1943	2141
BAG 3	886	2107	0	2045	2011	2054
BAG 4	2134	1807	0	1522	1844	1827
BAG 5	2116	794	0	2043	793	2080
BAG 6	2134	2175	1612	2053	2041	2015
BAG 7	1961	948	0	1421	2144	1942
BAG 8	793	909	1216	0	0	1216

---

APPENDIX N  
REENTRY PLAN

21 June 1985

SUBJECT: MINOR SCALE Reentry Plan

1. Phase I.

Phase I is the safety sweep of the testbed immediately after the shot. Four hazards are of concern: explosives, TRS, high pressure helium, and experiment radioactive sources. Included in this phase is the AIR sampling team and the staging of security forces.

A. Sweeping GZ Area.

Start Point: T&F Park.

Route: South on route 7 to West Park Drive. East to route 13, route 13 to Security Ave, east to dismount point.

<u>VEHICLE</u>	<u>OCCUPANTS</u>	<u>NAME</u>	<u>FUNCTION</u>
(R) W-1	NSWC/SNLA	Mike Swisdak	Check and report clear of explosives.
	FCDNA/WSMR Safety	LCDR Smith Mike Moody	Coordinate and report on explosive/RADSAFE status.
(R) S-1	WSMR RADSAFE	Ray Quast LCDR Miles	Sweep for radioactivity in 7500 area and precursor.
	Bureau of Alcohol, Tobacco, and Firearms	D. Gardner (+1)	Obtain ground/air samples at GZ. Pick up air samples at <u>PSI stations.</u>
*N-29	SAIC	Wayne Grove Billy Schaeffer	Dust collection.
**S-34	SAIC	John Cockayne Didier Rault	Dust collection.

\*From McDonald's Ranch

\*\*From GUS Site

B. Sweep TRS Radial to GZ.

Start Point: T&F Park/Admin Park/Reentry Point.

Team 1: Down route 7 to West Park Drive, West Park Drive to route 13, route 13 to Security Ave, Security Ave to security access point.

Team 2: Down route 7 to West Park Drive, West Park Drive to route 13.

W - South on route 7 to West Park Drive, West Park Drive to route 13, route 13 to Security Ave., Security Ave to GZ area.

<u>VEHICLE</u>	<u>OCCUPANTS</u>	<u>NAME</u>	<u>FUNCTION</u>
(R) W-3	FCDNA/BFEC/SAIC (Tm. #1)	LCDR Taylor Dace Harrall Jerry Stoughton	Safe TRS systems (1,2,5).
(R) W-4	FCDNA/BFEC/SAIC (Tm. #2)	LCDR Mathews Ed Welsh Carl Bloemker	Safe TRS systems (6,UK, 3,4). Cover UK Exp. 7041.
(MP-R)(R) W-5	WSMR Sec./Photo (W/Tm. #2)	PFC Allen C. Brady	Photography and security for Exp. 7041.
(R) W-6	FCDNA PD WSMR Security	CPT Walls L. Ferriquey	Direct reentry procedures.
W-7	FCDNA	Maj Brake L. Holmes D. Early	Oversee security procedures.

NOTE: 1300 Series TRS units will be safed first.

C. Safe High Pressure Helium.

Start Point: Route 20 west of route 7.

Route: Down route 7 to T&F Park. Pick up SAIC personnel. Down route 7 to route 13, north to South Instrumentation Park. East on South Park Road to dismount point.

<u>VEHICLE</u>	<u>OCCUPANTS</u>	<u>NAME</u>	<u>FUNCTION</u>	
S-2	NMERI/SAIC	Bruce Schneider	Secure helium reserve. Open truck park valves.	
		John Dishon	Inspect VBI-8.	(C-R)
(R) S-3	NMERI/SAIC	Paul Reining	Verify system depressurized.	(R)
		Jerry Lattery		(R)
		R. Spake	Later, verify 8791 camera tower is safe for entry.	(R)
				(R)
				(R)
				(R)
				(R)
				(R)
				(MP-R)

D. Security Staging.

Start Point: Reentry point on route 7.

Route: W - South on route 7 to West Park Drive. East to West Instrumentation Park.

S - South on route 7 to route 13. North to South Instrumentation Park.

N - East on route 20 to route 13. South on route 13 to North Instrumentation

Park.

	<u>VEHICLE</u>	<u>OCCUPANTS</u>	<u>NAME</u>	<u>FUNCTION</u>
(C-R)	S-10	CORTEZ III		Establish South internal roadblock.
(R)	S-4	FCDNA TD/PD	Maj Raska Dr. Gillespie LCDR Anderson Capt Lutton	Supervise Precursor recovery.
(R)	S-32	WSMR-DYN	R. Halferty T. Gilmora B. Thum	Photography for Tech Director Dr. Ullrich.
(R)	*S-5	BMO/AFWL/HQDNA	Lt. Emery Lt. Eisenhart Lt. Morgan Maj Burton Lt. Anderson Dr. Ullrich	Cover Precursor models.
(R)	S-6	WSMR-DK	D. Brown T. Cao D. Saenz	Photography Precursor.
(R)	S-7	BMO/AFWL/SAIC	Lt. Cooper Lt. Wert Lt. Miller Lt. Matthews D. Baxter	Cover Non-Precursed models.
(R)	S-8	WSMR-DK	S. Townsley T. Parsley C. Abston	Photography Non-Precursor.
(MP-R)	S-9	WSMR Security	SGT Jackson SP4 Sandy SP4 Grondin SP4 Eisel	Security for HML models.

\* - PICK UP DR. ULLRICH AT ADMIN PARK (INTERSECTION OF ROUTE 20/7).

D. Security Staging (Cont'd).

Start Point: Reentry point on route 7.

Route: W - South on route 7 to West Park Drive. East to West Instrumentation Park.

	<u>VEHICLE</u>	<u>OCCUPANTS</u>	<u>NAME</u>	<u>FUNCTION</u>	
(C-R)	W-41	CORTEZ III		Establish west internal roadblock.	(R)
(R)	W-8	BRL	Sullivan Vigil Deel Schallhorn Be liveau Seaward	Cover Exp's. 2011, 2030, 2031, 2040, 2050, 2060.	(R)
	W-9	BRL	Jones Stone Cooper Matthevs Stravbridge Pfeffer	Cover Exp's. 2021, 2032, 2033, 2051, 2061, 2070.	(R)
	W-10	BRL	Harrison Sanders Prosser Renner Keck Lucas Grabulis	Cover experiments.	(R)(P)
(R)	W-11	BRL/WSMR-DK	Ethridge T. Moore J. Salazer	Photograph experiments.	
(MP-R) (R)	W-12	WSMR-DK/SECURITY	T. Gomez T. Vasquez SP4 Henry PV2 Meeks	Photograph/secure FET experiments.	(R) (R)
	W-13	BRL/LANL	K. Harris Dr. Richmond	Photograph/recover mannikins.	(MP-



D. Security Staging (Cont'd).

Start Point: Reentry point on route 7.

Route: W - South on route 7 to West Park Drive. East to West Instrumentation Park.

<u>VEHICLE</u>	<u>OCCUPANTS</u>	<u>NAME</u>	<u>FUNCTION</u>
(R) W-14	WSMR-TE/DK/LANL	O'Kuma Dutchover Trevino Herring Fletcher	Cover Exp's. 1300, 1305, 1315, 1320.
(R) W-15	WSMR-TE/DK	Briones Fritz Torres Yoachim	Cover/Photograph Exp's. 1306, 1307, 1310, 1383.
(R) W-16	WSMR-TE/FT. BLISS	Wyley Davis Darbro 30 Soldiers	Cover all experiments.
(R)(R) W-17	WSMR-TE/DK/LANL	Williams Lopez Newton Hyland Yalverton	Cover experiments 1365, 1380, 1386. Enter West Bunker #1.
(R) W-18	WSMR-TE/DK/LANL	Gomez Morgan Hicks SP5 Adams PFC Morris	Cover/Photograph Exp. 1357. Enter West Bunker #2.
(R) W-19	WSMR-TE	Fritz Rex	Transport coffins and generator.
(R) W-20	WSMR-TE/DK/FT. BLISS	Hutchison Niesser Kelly 10 Soldiers	Cover/Photograph Exp. 1330, 1381.
(MP-R) W-21	WSMR-DK WSMR SECURITY	Golightly SP4 Grondin PFC Miller PV2 Massucci PV2 Lewis	Photograph/Secure 1300 series experiments.
W-22	WSMR-DK	Callaway Highman	Photograph WSMR Exp's.

D. Security Staging (Cont'd).

Route: N - East on route 20 to route 13. South on route 13 to North Instrumentatic Park.

	<u>VEHICLE</u>	<u>OCCUPANTS</u>	<u>NAME</u>	<u>FUNCTION</u>
(C-R)	N-28	CORTEZ III		Establish north internal block.
(R)	N-1	WES	J. Watt W. Huff L. Carre J. Ray B. Benson	Cover Exp. 7170/71/72.
(R)	N-2	WES	T.C. Falls T. Slawson S. Woodson A. Harris D. Lee R. William	Cover Exp. 7180/81.
(MP-R)(R)	N-3	WSMR-DK WSMR SECURITY	A. Saclowski R. Christman SP4 Warmbier	Photography for Exp. 7170-81. Security for Exp. 7170-81.

2. P  
F  
exper  
class  
safe.

to d

VEHI  
PART  
INST

B.

VER  
PAB  
PAB

2. Phase II.

Phase II is the establishment of security safeguards/controls for the classified experiments, manning of the instrumentation parks and bunkers, and the recovery of classified technical film. This phase commences when the testbed has been declared safe.

A. Establish Security Safeguards/Control Areas for US Classified Experiments.

Start Point: West and South Instrumentation Parks.

Routes: (W) East to route 13. South on route 13 to Security Avenue. East to dismount points.

(S) East on South Perimeter Drive to dismount points.

<u>VEHICLE</u>	<u>OCCUPANTS</u>	<u>NAME</u>	<u>FUNCTION</u>
PARTICIPANTS ARE THOSE LISTED UNDER PHASE I(C) STAGED AT THE WEST AND SOUTH INSTRUMENTATION PARKS.			

B. Establish Security Safeguards/Control Areas for Foreign Classified Experiments.

Start Point: North Park.

Route: South on North Perimeter Drive to dismount points.

<u>VEHICLE</u>	<u>OCCUPANTS</u>	<u>NAME</u>	<u>FUNCTION</u>
PARTICIPANTS ARE THOSE LISTED UNDER PHASE I(C) STAGED AT THE NORTH INSTRUMENTATION PARK.			

C. Instrumentation Park Support Personnel.

Start Point: Reentry point on route 7.

Route: N - East on route 20 to route 13. South on 13 to North Park.

S - South on route 7 to route 13. North on route 13 to South Park.

W - South on route 7 to West Park Drive. East on West Park Drive to West Park.

<u>VEHICLE</u>	<u>OCCUPANTS</u>	<u>NAME</u>	<u>FUNCTION</u>	
S-11	WES	G. Williams H. Mayfield	Recover instrumentation data in East Park.	(R)
(R) S-12	WES	J. Stout	Recover instrumentation data in East Park.	(R)
(R) S-13	SRI	A. Burns J. Tanzi	Recover instrumentation data in East Bunker #1.	
(R) S-14	BRL/BENDIX/WSMR-IS	Nancy Syzmanski Kash Winningham Vince King Sam Acevedo Fred Apache	Recover instrumentation data in South Park.	(R)
(R) S-15	BRL/BENDIX	George Teel Leo Wolf	Supervisor data recovery operations.	
(R) S-16	BRL/BENDIX/WSMR-IS	Wayne Denton Roger Peterson Jim Bernhardt Alan Doty Shawn Still	Recover instrumentation data in East Park.	
(R) S-17	BENDIX/MMC/PCDNA/ WSMR SECURITY	Scott Crawford Larry Murner J. Swain LTC Brown SP4 Goodmiller	Recover instrumentation data in South Bunker #2.	
(R) S-18	BENDIX/BOEING/PCDNA/ WSMR SECURITY	Mary Jo Sifuentes Bill Fenner Mary Clobes Maj Reynolds PFC Geraghty	Recover instrumentation data in South Bunker #1.	
(R) W-24	BRL/BENDIX/WSMR-IS	Larry Barnes Allison Wilkie Bob Peterson Jr. Tafoya Ron Umpleby	Recover instrumentation data in West Park.	
(R) H-4	WES	D. Biggs F. Shirley	Recover instrumentation data in North Park. (#50027)	

Instrum

CLE

C. Instrumentation Park Support Personnel (Cont'd).

	<u>VEHICLE</u>	<u>OCCUPANTS</u>	<u>NAME</u>	<u>FUNCTION</u>
-5	N-5	WES	J. Ingram J. Day	Recover instrumentation data in North Park.
-6	N-6	WES	F. Leaks G. Bonner	Recover instrumentation data in North Park.
-7	(R) N-7	WES/WSMR-IS	H. Parks J. Stoll D. Foster R. Contreves	Recover instrumentation data in North Park (#50028).
-8	(R) N-8	BRL/BENDIX/WSMR-IS	Ellis Frith Steve Bichl Rob Bitting Sonny Gavi Riviera	Recover instrumentation data in North Park.
N-9	(R) N-9	NMERI	Jack Babcock Steve Montoya	Recover instrumentation data in North Park. Then proceed to TOADS bunker to recover data.
*N-10	*N-10	WES	J. Ferguson J. Brogan C. Cox M. Holloway	Activate playback computer.

\*DESTINATION ADMIN PARK.

D. Recovery of Technical Film.

Start Point: Reentry point on route 7.

Routes: N - South on route 7 to route 20. East on route 20 to route 13.  
South on route 13 to North Perimeter Road. South on North  
Perimeter Road to dismount point.

W - South on route 7 to West Park Road. East on West Park Road to  
route 13.

<u>VEHICLE</u>	<u>OCCUPANTS</u>	<u>NAME</u>	<u>FUNCTION</u>
W-25	WSMR-DYN	C. Gallegos	Supervise overall film recovery operations.
W-26	WSMR-DYN/DO/ISI	J. Cox Vic Dixon	Film recovery superviso
W-27	WSMR-DYN	W. Dudziak G. Baker B. Davis	Pull film on Exp. 2011, 2021, 2030-2033, 6000- 6002, 6004, 6210-6211 6220-6221.
W-28	WSMR-DYN	A. Garcia H. Thomas	Pull film on Exp. 1300, 1305, 1306, 1310, 1320, 1383.
W-29	WSMR-DYN	B. Montoya R. Bridges	Pull film on Exp. 1307, 1315, 1325, 1355, 1365, 1375, 1380, 1386.
W-30	WSMR-DYN	C. Yates S. Aragon	Pull film on Exp. 2040, 2050, 2051, 2060, 2061 2070, 5110.
W-31	WSMR-DYN	B. Walters C. Williams	Pull film on Exp. 1330, 1357, 1381.
N-11	WSMR-DYN	B. Arenas R. Chitty	Pull film on Exp. 7170- 7172, 7180-7181, 3040; 7150-7151, 1220-1221; 1280-1281, 1610, 5200, 7399, 5108.

NOTE: Film in internal cameras will not be pulled until the experimenter arrives.

3. Phase III.

Phase III covers "Other Priority Activity" which should occur as soon as security controls are established. These other activities include precursor radial recovery, VIP tour, installation of road barriers, and diagnostic film recovery.

A. Precursor Radial/Time Sensitive Experiment Recovery.

Start Point: Reentry point on route 7.

Route: S - South on route 7 to route 13. North on route 13 to South Perimeter Drive. East on South Perimeter Drive to dismount point.

M - South on route 7 to route 20. East on route 20 to route 13. South on route 13 to North Perimeter Road. South on North Perimeter Road to dismount point.

W - South on route 7 to West Park Road. East on West Park Road to route 13. West Radial Road to dismount point.

<u>VEHICLE</u>	<u>OCCUPANT</u>	<u>NAME</u>	<u>FUNCTION</u>
S-19	TRW	Daniel Kwoh Ken Beach Harry Rungaldier	Safe X-Ray tubes. Recovery X-Ray film (Exp. 8704).
S-20	WSMR-DK	J. Ralls	Photography for Exp. 8705
S-21	DRI	R. Bjarason L. Smith V. Brown	Safe Exp. 8706 (Dust Catchers).
S-22	MHC	J. Hollon J. Garber R. Sanchez J. Pohlen	Evaluation of soil conditions. (Precursor)
S-23	SDL	D. Krause T. Hoeft D. Modarress	Safe Exp. 8703.  (Access to bunker only)
S-24	WES	B. Phillips J. Schumacker T. Rayborn	Soil characterization (Exp. 8717).
(R) S-25	GBL	George Burghart Dave Shear	Recover 8715/8723 experiments.
S-26	MHC	T. Fisher J. Dzielak D. Chappell J. Bruce	Evaluation of soil conditions. (Non-Precursor)

3. Phase III (Cont'd).

A. Precursor Radial/Time Sensitive Experiment Recovery (Cont'd).

<u>VEHICLE</u>	<u>OCCUPANT</u>	<u>NAME</u>	<u>FUNCTION</u>
S-27	TRW	R. Wuerker M. Wickham R. Rohr B. Flory	Recover film from Exp. 8719.
S-28	BOEING	Matt House Bud Barrett Jerry Randolph	Recover self-recording system in Exp. 6003.
S-33	DRES	J. Funk T. Watson D. Saint	Recover instrumentation data in East Park.
(R) W-42	DRES	R. Campbell	Recover instrumentation data in West park. Proceed to Exp. 7501.
W-32	DRES	D. Ritzel G. Rude	Safe/inspect 7500-7501.
W-33	NORWAY	A. Jenssen O. Krest E. Helseth A. Rinnan	Recover Exp. 7410.
(MP-R) (R) W-34	WSMR-DK	B. Nowell A. Medina R. Baca B. Yancey PFC Brown	Photography of Exp. 7500-7520 7410.
	WSMR SECURITY		Security for Exp. 7410.
N-12	SEA	Keller, Jim Gordon, Tim Stockton, Jerry Wheeler, Bruce	Erect barriers/assessment for 8270 and other debris/ejecta experiments. Safe Exp. 8202 (Bowling Balls).
N-17	NMERI/AFWL	K. Benson P. Roupas W. Thompson B. Henny W. Baker L. Voelker G. Weis	Supervise crater/ejecta barrier installation.
N-13	WES	L. Davis W. McMahon	Ejecta recovery (Exp. 8220).
N-14	WES	D. Hale G. Phillips S. Scott	Ejecta recovery (Exp. 8220).
N-15	WSMR-DK	R. Clark	Photography for Exp. 8220.



P To  
art  
Data:  
LE  
R6

B. VIP Tour.

Start Point: Observation Point.

Route: See attached map.

<u>VEHICLE</u>	<u>OCCUPANTS</u>	<u>NAME</u>	<u>FUNCTION</u>
(R) M-16	PCDNA WSMR HQDMA	TBD	Tour Trinity, McDonald Ranch, and testbed.

# MINOR SCALE VIP TOUR

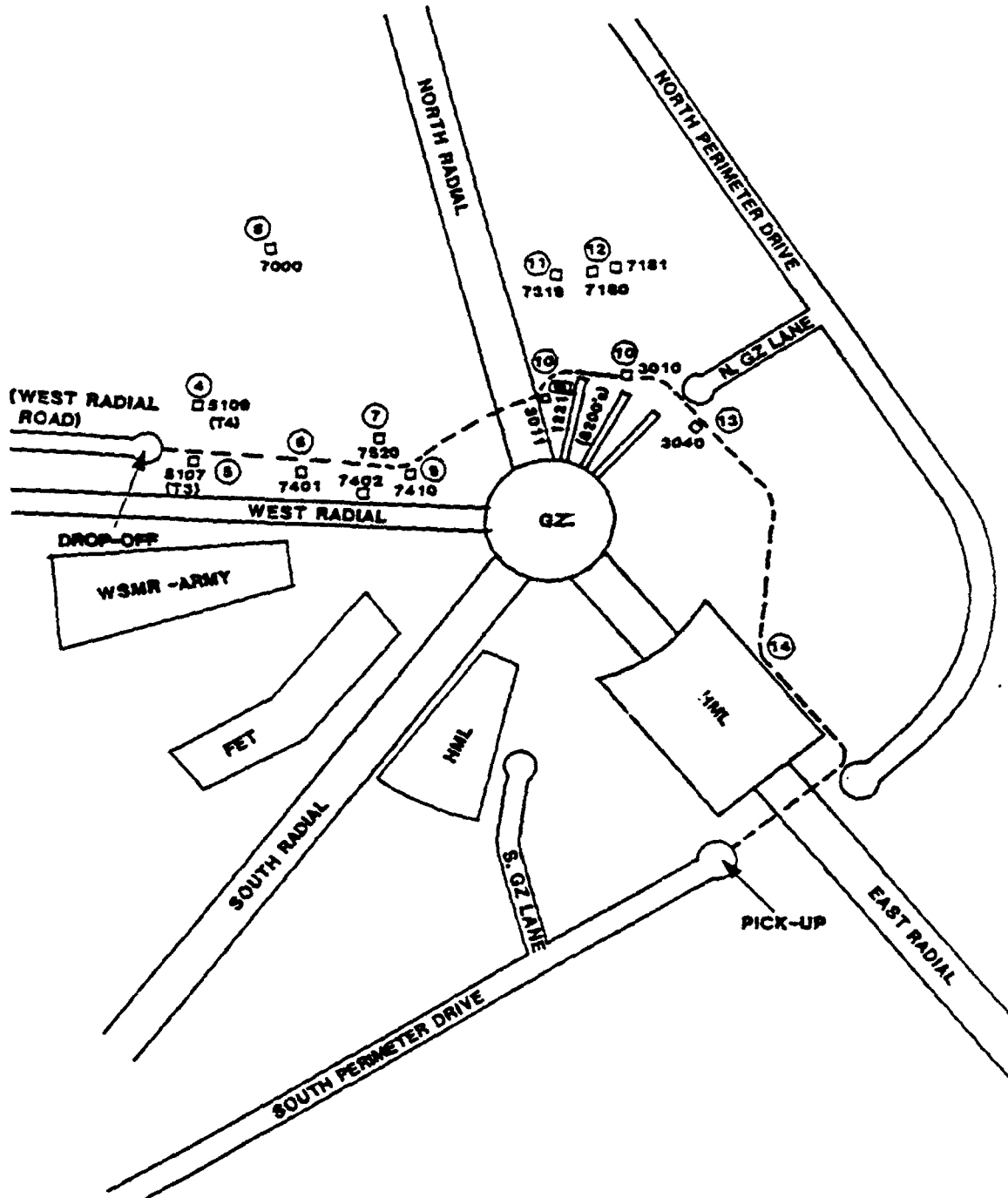

C. Installation of Road Barriers/Cordons.

Start Point: Route 7 reentry point.

Route: N - East on route 20 to route 13. South on route 13.

S - South on route 7 to route 13. North on route 13 to South Perimeter Drive.

W - South on route 7 to West Park Drive. East on West Park Drive to route 13.

	<u>VEHICLE</u>	<u>OCCUPANTS</u>	<u>NAME</u>	<u>FUNCTION</u>
(R)	S-35	FCDNA/WSMR-IS	Maj Schmidt Larry Meeks Jeff McGinnis Pete Vigil Clarence Williams SSG Kiner	Erect precursor barrier.
(R)	S-36	FCDNA/WSMR-IS	Lt Crawford Louis Flores Lendell Smith James Elwood Charles Townsend	Erect non-precursor and FET barriers.

D. Other Time Sensitive Experiments.

Start Point: Route 7 reentry point.

Route: N - East on route 20 to route 13. South on route 13.

Drive. S - South on route 7 to route 13. North on route 13 to South Perimeter

route 13. W - Wouth on route 7 to West Park Drive. East on West Park Drive to

<u>VEHICLE</u>	<u>OCCUPANTS</u>	<u>NAME</u>	<u>FUNCTION</u>
W-35	WSMR-TE	Harold O'Neill Richard Lee Vince Maties Norb Slavoki Larry States	Assessment team for 1300 series.
W-36	WSMR-TE	Mika Cieslak Peter Sakalas Richard Ess J.D. Johnson (Marine)	Assessment team for 1300 series.
W-37	WSMR-TE	Lanny Schlosberg Richard Downing John Brand	Assessment team for 1300 series.
W - 38	WSMR-TE	Mathew Foss Paul Deluca Donna Shandle CPT Kujawski	Assessment team for 1300 series.

E. Diagnostic Film Recovery.

Start Point: Route 7 reentry point.

Route: N - East on route 20 to route 13. South on route 13.  
 S - South on route 7 to route 13. North on route 13 to South Perimeter Drive.  
 W - South on route 7 to West Park Drive. East on West Park Drive to 13

<u>VEHICLE</u>	<u>OCCUPANTS</u>	<u>NAME</u>	<u>FUNCTION</u>
S- 30	WSMR-DYN	J. Herrera E. Baca	Recover Exp. 8791 film.
S- 31	WSMR-DYN	L. Harbron J. Torres	Recover Exp. 9000/9001 film.
W- 39	WSMR-DYN	R. Torres J. Flores	Full film on Exp. 5100, 5102, 5104, 5105, 5107, 5109.
W- 40	WSMR-DYN	D. Holland J. Oliver	Full film on Exp. 7000, 7002, 7040, 7200-7201.
* N- 21	WSMR-DYN	D. Gallegos	Supervise diagnostic film recovery.
N- 22	WSMR-DYN	J. Armijo	Field supervisor.
N- 23	WSMR-DYN	R. Cardwell M. Pino	Recover Exp. 8790 film.
:			
N- 24	WSMR-DYN	L. Anaya G. Padilla	Recover Exp. 8790 film.
N- 25	WSMR-DYN	B. Perkins E. Gonzalez	Recover overview camera film (Exp. 8790).
N- 26	WSMR-DYN	R. Aerts D. Griego W. Harper	Recover Exp. 9000/9001 film.
N- 27	WSMR-DYN	P. Lopez S. Haley	Recover Exp. 9000/9001 film.

\* - FROM MILLERS WATCH

4. Phase IV.

This reentry phase is for all other experimenters, photographers, and other support personnel requiring testbed access. Access control is relinquished at this time. Internal roadblocks will be lifted as Phase IV commences.

Routes: Access to the testbed may be made by any route. However, ALL vehicles must park outside of the established barricades.

During Phase IV the following major activities will be underway:

- Experiment Recovery.
- Documentary and Motion Picture Photography.
- Optical Instrumentation Film Recovery.

## DISTRIBUTION LIST

### DEPARTMENT OF DEFENSE

#### DEFENSE NUCLEAR AGENCY

ATTN: DR ULLRICH (DFSP)  
ATTN: LT COL ULLRICH (RAAE)  
ATTN: LTC CHASE (NANF)  
ATTN: MAJ APO (SPSD)  
ATTN: MR. KENNEDY (TDTR)  
ATTN: MR. MILLER  
ATTN: SPWE  
ATTN: TDTD

#### DEFENSE NUCLEAR AGENCY

ATTN: TEST CONSTRUCTION DIV

#### DEFENSE NUCLEAR AGENCY

ATTN: CAPT BRUMBURGH (TDTT)  
ATTN: CAPT LUTTON (TDTT)  
ATTN: CPT JEFFREY (NMHE)  
ATTN: CPT WALLS (NMHE)  
ATTN: NMEN  
ATTN: NMENIN  
ATTN: NMENCE (LTC SCHMIDT)  
ATTN: NMHE (MAJ EVINRUDE)  
ATTN: TDTM (MR SIMPSON)  
ATTN: TDNM-F (LCDR SMITH)  
ATTN: TDTT (LT COL LEE)  
ATTN: LCDR ANDERSON (NMHE)  
ATTN: LCDR TAYLOR (NMHE)  
ATTN: LT CRAWFORD (NMHE)  
ATTN: MR PRATHER (NMHE)  
ATTN: TDNM-CF

#### FIELD COMMAND DEFENSE NUCLEAR AGENCY

ATTN: CI-FCDNA  
ATTN: FCSS (MR HIER)

### DEPARTMENT OF THE ARMY

#### DIVISION ENGINEER

ATTN: NNDED-PM MR ROMEO

#### HARRY DIAMOND LABORATORIES

ATTN: DELHD-NW-EA MR BELLIVAEU  
ATTN: DELHD-NW-EA MR. SHUMAN  
ATTN: DELHD-RT-CB MR WELLMAN  
ATTN: HATS PROJECT OFFICER

#### U S ARMY ARMAMENT SCH & DEV CENTER

ATTN: SMCAR-LCN-C(D) MR SCHUMANN

#### U S ARMY BALLISTIC RESEARCH LAB

ATTN: AMXBR-TBD MR SULLIVAN  
ATTN: AMXBR-TBD MR TEEL

#### U S ARMY BELVOIR R&D CTR

ATTN: STRBE-NNT MR COMEYNE  
ATTN: STRBE-NNT MR WEINHOLD

#### U S ARMY CHEMICAL SYSTEMS LAB

ATTN: DRDAR-CLW-E MR ZURAW

#### U S ARMY COMM-ELECTRONICS CMD

ATTN: AMSEL-ED-SS MR ANTISELL

#### U S ARMY ENGR WATERWAYS EXPER STA

ATTN: MR DAVIS  
ATTN: MR HUFF  
ATTN: MR INGRAM  
ATTN: MR JACKSON  
ATTN: MR KEIGER  
ATTN: MR PHILLIPS  
ATTN: MR SLAWSON  
ATTN: MR WATT

#### U S ARMY MATERIAL COMMAND

ATTN: AMCDE-SSE MR BASSETT

#### U S ARMY NATICK RSCH DEV & ENGRG CTR

ATTN: STRNC-ICCC MR PENTHENY  
ATTN: STRNC-UE DR FANUCCI

#### U S ARMY NUC & CHEMICAL AGENCY

ATTN: MONA-WE DR RENNEN

#### U S ARMY WHITE SANDS MSL RANGE

ATTN: STEWS-EH-R  
ATTN: STEWS-NR-DO-P MR DIXON  
ATTN: STEWS-NR-PD MR MEADOWS  
ATTN: STEWS-TE-N MR BRIONES  
ATTN: STEWS-TE-N MR O'KUMA

#### USAMICOM/DRSMI-FAOB

ATTN: AMSMI-YIT MR BLANCHARD

### DEPARTMENT OF THE NAVY

#### NAVAL CIVIL ENGINEERING LAB

ATTN: CODE L64 MR MATTHEWS

#### NAVAL POSTGRADUATE SCHOOL

ATTN: DR WOELER

### DEPARTMENT OF THE AIR FORCE

#### AIR FORCE GEOPHYSICS LAB/LWH

ATTN: MR CIPAR

#### AIR FORCE WEAPONS LABORATORY

ATTN: NTED (LC WERT)  
ATTN: NTED (LT EISENHART)  
ATTN: NTED (MR AUBREY)

#### BALLISTIC MISSILE OFFICE

ATTN: LT COOPER (MGEM)  
ATTN: LT EMARY (MGEM)  
ATTN: LTCOL COLLINS (MGEM)  
ATTN: LTCOL FURBEE (MGEM)

### DEPARTMENT OF ENERGY

#### LOS ALAMOS NATIONAL LABORATORY

ATTN: MR BERNHARDT  
ATTN: MR OLSEN  
ATTN: MR RICHMOND  
ATTN: MR RICKEL  
ATTN: MR TATE

#### SANDIA NATIONAL LABORATORIES

ATTN: MR CHURCH