

AD-A256 343



4

AL-TR-1992-0060

ARMSTRONG  
LABORATORY

DTIC  
ELECTE  
OCT 16 1992  
S C D

# PURITY ANALYSIS OF MNG AND CHEMICAL ANALYSIS OF MNG AND MNNG IN BIOLOGICAL SAMPLES

W.T. Brashear  
P.P. Lu  
M.M. Ketcha

MANTECH ENVIRONMENTAL TECHNOLOGY, INC.  
P.O. BOX 31009  
DAYTON, OH 45431-0009

APRIL 1992

FINAL REPORT FOR THE PERIOD MAY 1991 THROUGH NOVEMBER 1991

Approved for public release; distribution is unlimited.

DEFENSE TECHNICAL INFORMATION CENTER



9227155

2698

92 1 15 010

424884

AIR FORCE SYSTEMS COMMAND  
WRIGHT-PATTERSON AIR FORCE BASE, OHIO 45433-6573

## NOTICES

When U S Government drawings, specifications, or other data are used for any purpose other than a definitely related Government procurement operation, the Government thereby incurs no responsibility nor any obligation whatsoever, and the fact that the Government may have formulated, furnished, or in any way supplied the said drawings, specifications, or other data, is not to be regarded by implication or otherwise, as in any manner licensing the holder or any other person or corporation, or conveying any rights or permission to manufacture, use, or sell any patented invention that may in any way be related thereto.

Please do not request copies of this report from the Harry G. Armstrong Aerospace Medical Research Laboratory. Additional copies may be purchased from:

National Technical Information Service  
5285 Port Royal Road  
Springfield, Virginia 22161

Federal Government agencies and their contractors registered with Defense Technical Information Center should direct requests for copies of this report to:

Defense Technical Information Center  
Cameron Station  
Alexandria, Virginia 22314

### TECHNICAL REVIEW AND APPROVAL

AL-TR-1992-0060

The experiments reported herein were conducted according to the "Guide for the Care and Use of Laboratory Animals," Institute of Laboratory Animal Resources, National Research Council.

This report has been reviewed by the Office of Public Affairs (PA) and is releasable to the National Technical Information Service (NTIS). At NTIS, it will be available to the general public, including foreign nations.

This technical report has been reviewed and is approved for publication.

FOR THE COMMANDER



ERIK K. VERMULEN, Colonel, USAF, BSC  
Director, Toxicology Division  
Armstrong Laboratory

## REPORT DOCUMENTATION PAGE

Form Approved  
OMB No. 0704-0188

Public reporting burden for this collection of information is estimated to average 1 hour per response, including the time for reviewing instructions, searching existing data sources, gathering and maintaining the data needed, and completing and reviewing the collection of information. Send comments regarding this burden estimate or any other aspect of this collection of information, including suggestions for reducing this burden to Washington Headquarters Services, Directorate for Information Operations and Reports, 1215 Jefferson Davis Highway, Suite 1204, Arlington, VA 22202-4302, and to the Office of Management and Budget, Paperwork Reduction Project (0704-0188), Washington, DC 20503.

<b>1. AGENCY USE ONLY (Leave Blank)</b>	<b>2. REPORT DATE</b> April 1992	<b>3. REPORT TYPE AND DATES COVERED</b> Final Report, May - November 1991	
<b>4. TITLE AND SUBTITLE</b> Purity Analysis of MNG and Chemical Analysis of MNG and MNNG in Biological Samples		<b>5. FUNDING NUMBERS</b> Contract F33615-90-C 0532 PE 62202F PR 6302 TA 630201 WU 63020174	
<b>6. AUTHOR(S)</b> W.T. Brashear, P.P. Lu, M.M. Ketcha		<b>8. PERFORMING ORGANIZATION REPORT NUMBER</b>	
<b>7. PERFORMING ORGANIZATION NAME(S) AND ADDRESS(ES)</b> ManTech Environmental Technology, Inc. P.O. Box 31009 Dayton, OH 45431-0009		<b>10. SPONSORING/MONITORING AGENCY REPORT NUMBER</b> AL-TR-1992-0060	
<b>9. SPONSORING/MONITORING AGENCY NAME(S) AND ADDRESS(ES)</b> Armstrong Laboratory, AI/OET Wright Patterson AFB, OH 45433 6573		<b>11. SUPPLEMENTARY NOTES</b>	
<b>12a. DISTRIBUTION/AVAILABILITY STATEMENT</b> Approved for public release; distribution is unlimited.		<b>12b. DISTRIBUTION CODE</b>	
<b>13. ABSTRACT (Maximum 200 words)</b> Currently <i>N</i> -methyl <i>N'</i> -nitroguanidine (MNG) is being considered by the Air Force Armament Laboratory for use in explosive formulations. The Toxic Hazards Research Unit (THRU) has been asked to develop a mammalian toxicity profile of MNG that includes the analysis of chemical impurities, and an assessment of the potential for the metabolism of MNG to 1-methyl-3-nitro-1-nitrosoguanidine (MNNG). Potential <i>in situ</i> gastric conversion of MNG to MNNG is a toxicological concern because MNNG is both mutagenic and carcinogenic. <i>N</i> -methyl- <i>N'</i> -nitroguanidine was analyzed by high performance liquid chromatography and small amounts of guanidine, methylguanidine, and nitroguanidine were detected. The conversion of MNG to MNNG was investigated by dosing Fischer 344 rats orally with MNG. Gastric contents, feces, and urine were analyzed from these animals. No evidence of conversion of MNG to MNNG was detected in any of the samples analyzed.			
<b>14. SUBJECT TERMS</b> MNG, <i>N</i> -methyl <i>N'</i> -nitroguanidine; MNNG, 1-methyl-3-nitro-1-nitrosoguanidine; Metabolism of MNG; gastric conversion of MNG to MNNG; HPLC analysis of MNG, MNNG, and other guanidines		<b>15. NUMBER OF PAGES</b> 23	<b>16. PRICE CODE</b>
<b>17. SECURITY CLASSIFICATION OF REPORT</b> UNCLASSIFIED	<b>18. SECURITY CLASSIFICATION OF THIS PAGE</b> UNCLASSIFIED	<b>19. SECURITY CLASSIFICATION OF ABSTRACT</b> UNCLASSIFIED	<b>20. LIMITATION OF ABSTRACT</b> UL
NSN 7540 01-280 5500		Standard Form 298 (Rev. 2-89) Prescribed by ANSI Std. Z39-18 298 102	

## PREFACE

This is one of a series of technical reports describing results of experimental laboratory programs conducted in the Toxic Hazards Research Unit, ManTech Environmental Technology, Inc. This document serves as a final report on selected toxicity studies of *N*-methyl-*N*-nitroguanidine (MNG). The research described in this report began in May 1991 and was completed in November 1991. It was performed under Department of the Air Force Contract No. F33615-90-C-0532 (Study No. F01). Lt Col James N. McDougal served as Contract Technical Monitor for the Toxicology Division, Occupational and Environmental Health Directorate, Armstrong Laboratory, Wright-Patterson Air Force Base, OH.

The animals used in this study were handled in accordance with the principles stated in the Guide for the Care and Use of Laboratory Animals, prepared by the Committee on Care and Use of Laboratory Animals of the Institute of Laboratory Animal Resources, National Research Council, Department of Health and Human Services, National Institute of Health Publication #86-23, 1985, and the Animal Welfare Act of 1966, as amended.

The authors gratefully acknowledge Daniel L. Pollard of ManTech Environmental for his great assistance and beneficial discussions. Also, acknowledgement is given to Robert J. Greene of ManTech Environmental for his assistance in the development of the ultraviolet high performance liquid chromatography method.

UNCLASSIFIED

Accession For	
NTIS GRA&I	<input checked="" type="checkbox"/>
DTIC TAB	<input type="checkbox"/>
Unannounced	<input type="checkbox"/>
Justification	
By	
Distribution/	
Availability Codes	
Dist	Avail and/or Special
A-1	

## TABLE OF CONTENTS

SECTION	PAGE
List of Figures .....	3
List of Tables .....	4
Abbreviations .....	5
1 INTRODUCTION .....	7
2 MATERIALS AND EQUIPMENT .....	8
Test Material .....	8
Guanidine Compounds .....	8
Reagents .....	9
Equipment .....	9
3 EXPERIMENTAL SECTION .....	11
Sample Clean-Up Procedures .....	11
Chromatographic Separations .....	12
4 RESULTS .....	13
Analysis of Residue MNG and MNNG in the Biological Samples .....	13
Purity Analysis of Air Force Armament Laboratory MNG .....	14
5 DISCUSSION .....	17
6 REFERENCES .....	18
QUALITY ASSURANCE STATEMENT .....	19

## LIST OF FIGURES

FIGURE		PAGE
1	Chemical Structures of Guanidine Compounds .....	8
2	HPLC Fluorescence System .....	10
3	Analysis of Biological Samples for MNNG by HPLC with UV Detection .....	11
4	Analysis of Air Force Armament Laboratory MNG by HPLC with UV Detection .....	15
5	Analysis of Air Force Armament Laboratory MNG by HPLC with Fluorescence Detection .....	16

**LIST OF TABLES**

<b>TABLE</b>		<b>PAGE</b>
1	Analysis of Residue MNG and MNNG in Biological Samples .....	13
2	Evaluation of the Method .....	13
3	Purity Analysis of Dosed MNG from the Air Force Armament Laboratory .....	14
4	Method Evaluation (II) .....	15

## ABBREVIATIONS

C	Celsius
F-344	Fischer 344
g	Gram
G	Guanidine
h	Hour
HPLC	High performance liquid chromatography
i.d.	Inside diameter
kg	Kilogram
m	Meter
M	Moles/liter
mg	Milligram
mM	Millimoles/liter
MG	Methylguanidine
mL	Milliliter
mm	Millimeter
MNG	<i>N</i> -Methyl- <i>N'</i> -nitroguanidine
MNNG	1-Methyl-3-nitro-1-nitrosoguanidine
MWCO	Molecular weight cut off
N	Normal solution
NG	Nitroguanidine
nm	Nanometer
ODS	Octadecylsilane
UV	Ultraviolet
$\lambda_{em}$	Emission wavelength
$\lambda_{ex}$	Excitation wavelength



**µg**

**Microgram**

**µL**

**Microliter**

**µm**

**Micrometer**

## SECTION 1

### INTRODUCTION

An analytical method suitable for the study of *N*-methyl-*N'*-nitroguanidine (MNG, CAS 4245-76-5) was developed to detect and quantitate possible impurities in the MNG sample supplied by the U.S. Air Force Armament Laboratory. The synthetic route for the synthesis of MNG involves the methylation of nitroguanidine (NG) with methylamine (Patrick and Cady, 1990). Among the likely impurities are guanidine (G, CAS 113-00-8), methylguanidine (MG, CAS 471-29-4), NG (CAS 556-88-7), and 1,2-dimethyl-3-nitroguanidine. Because guanidine compounds are not volatile, MNG samples were analyzed by high performance liquid chromatography (HPLC). Nitroguanidine, MNG, and 1-methyl-3-nitro-1-nitrosoguanidine (MNNG), which have a nitro substituent, were analyzed by HPLC with ultra violet (UV) detection. Guanidine and MG, which could not be detected via HPLC with UV detection, were analyzed by HPLC with fluorescence detection (Kobayashi et al., 1987).

The evaluation of the mammalian toxicity of MNG also includes the analysis of possible metabolites of MNG. Although the metabolism of MNG is not well documented, the intragastric nitrosation of MNG to MNNG is of toxicological concern because MNNG is both mutagenic and carcinogenic (Endo et al., 1974). It is well known that MNNG can be synthesized from MNG and sodium nitrite under acidic conditions (McKay and Wright, 1947). Because of this, the intragastric conversion of MNG-like compounds has been proposed as a possible etiologic factor in human gastric cancer (Endo et al., 1975). This risk could also be exacerbated by diets high in nitrates or nitrites. To investigate the possible conversion of MNG to MNNG, five nonfasted male Fischer 344 (F-344) rats (7 to 10 weeks old) were dosed orally with 0.5 g/kg of body weight of MNG. Six hours after dosing, the rats were sacrificed. Urine, gastric contents, and feces were removed and quick frozen at -70 °C for HPLC analysis for MNG and MNNG.

SECTION 2  
MATERIALS AND EQUIPMENT

**TEST MATERIAL**

*N*-methyl-*N'*-nitroguanidine was obtained from the Air Force Armament Laboratory at Eglin Air Force Base, FL.

**GUANIDINE COMPOUNDS**

Guanidine compounds used as analytical standards were purchased from Aldrich Chemical Co., (Milwaukee, WI). The compounds obtained were G hydrochloride, MG hydrochloride, NG, MNG, and MNNG. The chemical structures of these compounds are shown in Figure 1. These chemicals were used without further purification.

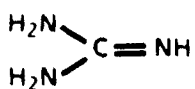

Guanidine  
(G)

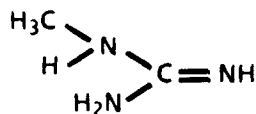

Methylguanidine  
(MG)

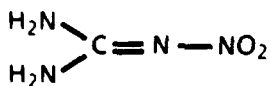

Nitroguanidine  
(NG)

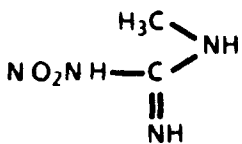

*N*-methyl-*N'*-nitroguanidine  
(MNG)

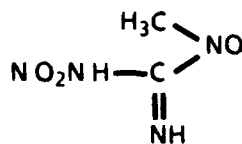

1-methyl-3-nitro-1-nitrosoguanidine  
(MNNG)

**Figure 1. Chemical Structures of Guanidine Compounds.**

## REAGENTS

High performance liquid chromatographic-grade methanol was obtained from Fisher Scientific (Fairlawn, NJ) and ninhydrin and acetonitrile were obtained from Aldrich Chemical Company (Milwaukee, WI). Sodium hydroxide was obtained from Mallinckrodt (Paris, KY) and sodium octanesulfonate was obtained from Eastman Kodak Chemical Company (Rochester, NY).

## EQUIPMENT

Samples for HPLC analysis were prepared using a tabletop centrifuge (Clay-Adam Co., NY), a 0.2- $\mu$ m-pore syringe filter (Supelco, Bellefonte, PA), and YM-membrane filters with molecular weight cut off (MWCO) ranges of 30,000 and 10,000 (Amicon, Beverly, MA).

High performance liquid chromatographic analysis was performed using a Waters M-6000 HPLC pumping system equipped with a Waters model UK6 injector (Waters, Milford, MA). A Brownlee Spheri-5 octadecylsilane (ODS, Alltec Associates Inc., Deerfield, IL) reversed-phase column (220 mm x 4.6 mm i.d.) was used for the chromatographic separation of NG, MNG, and MNNG. This system used a Kratos 773 Spectroflow UV monitor as a detector (Kratos Analytical Inc., Ramsey, NJ).

A Brownlee Spheri-5 ODS reversed-phase column (220 mm x 4.6 mm) used for the reversed-phase ion-pair HPLC method was used for the chromatographic separation of G and MG. The reaction system for postcolumn derivation was equipped with a mixing tee (Supelco, Bellefonte, PA), and a Waters 6000A HPLC pump. A mixing column (2 cm x 0.4 cm) was filled with 0.5 mm glass beads, and the reaction coil consisting of a Teflon knit coil (3 m x 0.5 mm i.d.) coupled to a stainless steel tube (5 m x 0.5 mm i.d.). These materials were supplied by Supelco (Bellefonte, PA). The reaction coil was immersed in a heating bath (GCA Scientific, Chicago, IL). A Perkin-Elmer LS-5 fluorescence spectrophotometer (Perkin-Elmer Corp., Norwalk, CT) was used to detect the fluorophore with an excitation wavelength of 395 nm and an emission wavelength of 500 nm. The diagram of this system is depicted in Figure 2.

Both the UV and fluorescence signals were acquired and processed with Nelson Analytical System software (Model 2600, Cupertino, CA) using an IBM/AT personal computer for data management.

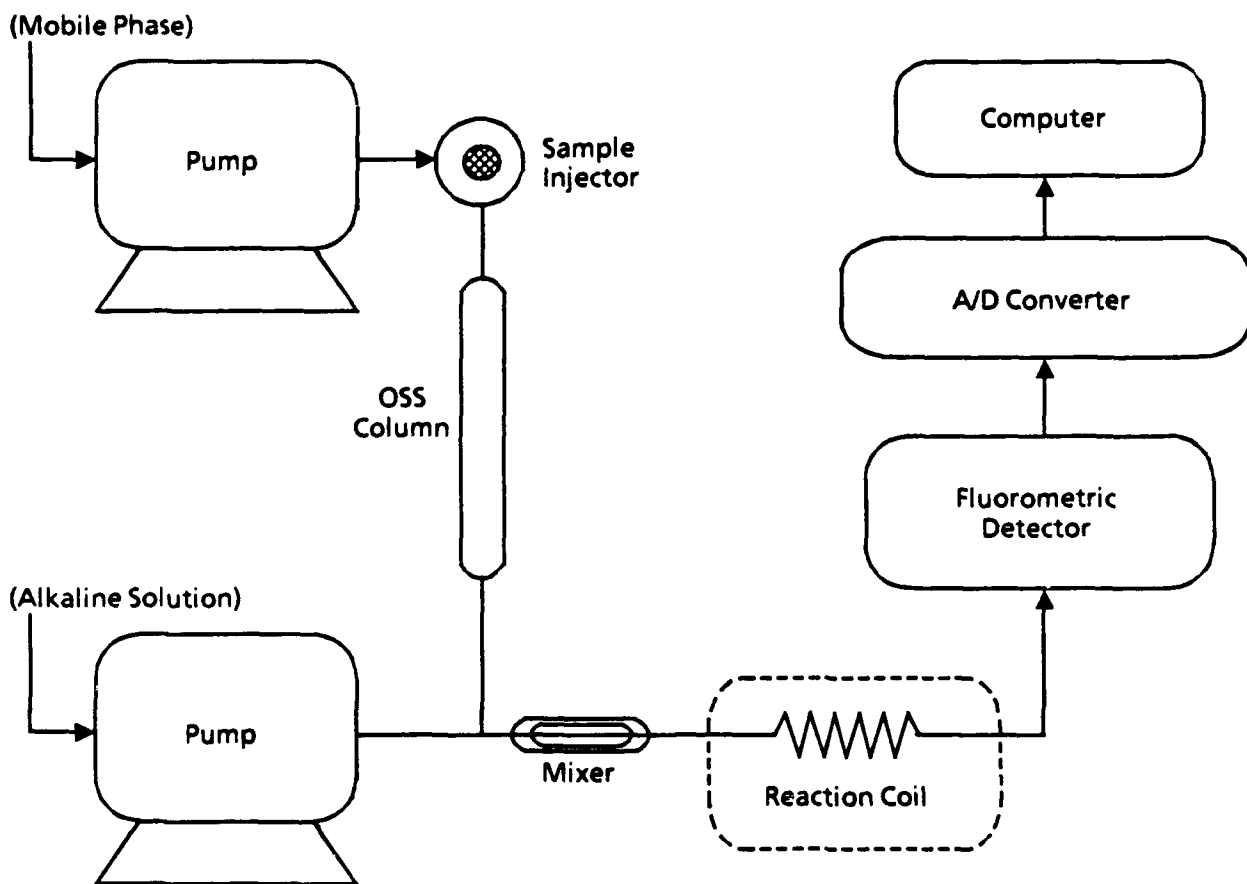
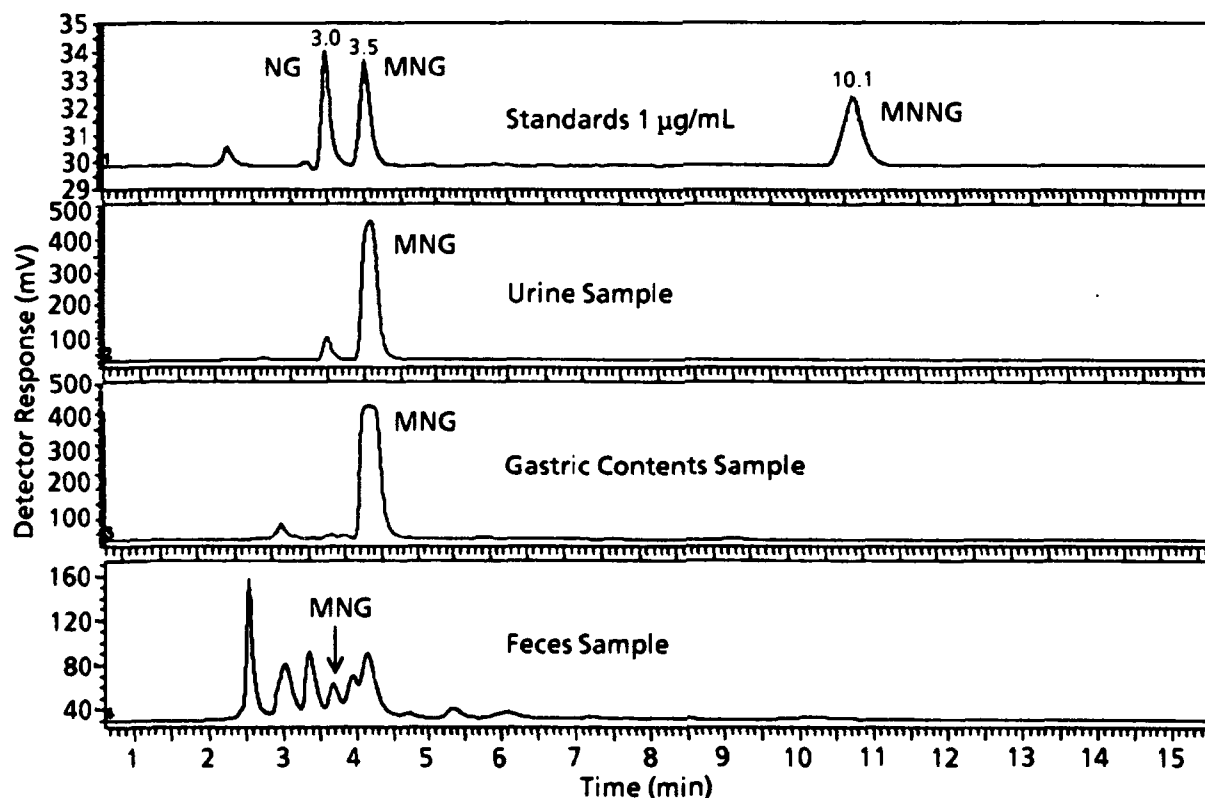

**Figure 2. HPLC Fluorescence System.** Sample eluting from HPLC column was mixed with 0.5 NaOH and passed through a heated reaction coil. The fluorescence adduct formed by the reaction of a guanidine compound with ninhydrin was detected via fluorescence.

SECTION 3  
EXPERIMENTAL SECTION

**SAMPLE CLEAN-UP PROCEDURES**

**Samples of Feces and Gastric Contents:** Samples of the feces and gastric contents, approximately 0.3 g in weight, were placed in 10-mL test tubes and 0.9% sodium chloride solution was added to dilute each sample by a factor of 10. The sample was homogenized by stirring with a magnetic stirrer for 1 h, and then centrifuged for 20 min. The supernatant of the samples was first filtered by a 0.2- $\mu$ m-pore syringe filter, and then with a 30,000 MWCO membrane centrifugation filter. For the analysis of higher concentrations of the MNG in gastric contents, the filtered supernatant of the samples was further diluted by a factor of 20 with deionized water (H<sub>2</sub>O). The diluted samples were directly analyzed by HPLC. Aqueous MNG standards were used to quantitate the level of MNG in the gastric contents instead of MNG-spiked control samples of the gastric contents (Figure 3).



**Figure 3.** Analysis of Biological Samples for MNNG by HPLC with UV Detection. The x axis is retention time in minutes, and the y axis gives the detector response in millivolts. Top panel: Aqueous standards of NG, MNG, and MNNG. Second panel: Rat urine showing presence of MNG. Third panel: Gastric contents showing presence of MNG. Bottom panel: Feces showing presence of small amounts of MNG.

**Urine samples:** A 1.0 mL urine sample was transferred into a 2-mL glass vial containing 125  $\mu$ L of 1N hydrochloric acid. The acidified sample was vortexed for 1 min and allowed to stand at room temperature for 20 min. The samples were then centrifuged for 30 min. The supernatant of the urine samples was filtered first by a 0.2- $\mu$ m-pore syringe filter followed by filtration with a 10,000 MWCO membrane centrifugation filter. The filtered samples were extracted twice with 1.0 mL aliquots of ethyl acetate and combined. The samples were evaporated to dryness and reconstituted with 1 mL of 10% methanol MeOH/H<sub>2</sub>O. A 20- $\mu$ L aliquot of the reconstituted sample was used for HPLC analysis of MNNG.

For analysis of high concentration of the MNG in the urine, the urine samples were diluted by a factor of 100 with deionized H<sub>2</sub>O, and were directly analyzed by HPLC. Aqueous MNG standards were used to quantitate the level of MNG in the diluted urine samples instead of the MNG spiked in the control urine (Figure 3).

### **CHROMATOGRAPHIC SEPARATIONS**

The mobile phase for HPLC analysis for UV detection of NG, MNG, and MNNG was 90% H<sub>2</sub>O and 10% MeOH with flow rate of 1.0 mL/min. However, two different mobile phases were used for the isocratic ion-pair fluorescence HPLC analysis of G and MG. Solvent System I was used for G and MG analysis, and System II was used for a retention time check:

#### **Solvent System I**

Mobile Phase: 10% MeOH, and 20% acetonitrile (CH<sub>3</sub>CN), 5.0 mM ninhydrin and 12.0 mM octanesulfonate; flow rate is 1.5 mL/min, reaction temperature 82 °C; 0.5 M sodium hydroxide (NaOH) with flow rate 0.5 mL/min;  $\lambda_{ex}$  = 395 nm and  $\lambda_{em}$  = 500 nm.

#### **Solvent System II**

Mobile Phase: 10% MeOH, and 10% CH<sub>3</sub>CN, 5.0 mM ninhydrin, and 10.0 mM octanesulfonate; flow rate 1.5 mL/min, reaction temperature 75 °C; 0.5 M NaOH, flow rate 0.5 mL/min;  $\lambda_{ex}$  = 395 nm and  $\lambda_{em}$  = 500 nm.

## SECTION 4

### RESULTS

#### ANALYSIS OF RESIDUE MNG AND MNNG IN THE BIOLOGICAL SAMPLES

Residue MNNG was not detected in any of the samples of feces, gastric contents, or urine above the detection limit (Table 1). The detection limits of the MNNG-spiked control samples are listed in Table 2. A large amount of test material MNG was detected in the gastric contents of the rats sacrificed 6 h after dosing. A small amount of MNG was detected in the samples of feces, and a large amount of MNG was found to be excreted in the urine. The MNG levels in feces, gastric contents, and urine for five animals are listed in Table 1. Some pertinent chromatograms of these analyses are shown in Figure 3. High performance liquid chromatographic with UV detection gave retention times of 3.0 min for NG, 3.5 min for MNG, and 10.1 min for MNNG.

**TABLE 1. ANALYSIS OF RESIDUE MNG AND MNNG IN BIOLOGICAL SAMPLES**

Rat No.	Feces (µg/g)		Gastric Contents (µg/g)		Urine (µg/mL)	
	MNG	MNNG	MNG	MNNG	MNG	MNNG
#7	120	<2.5	11,280	<2.0	8015	<5.0
#8	20	<2.5	6,600	<2.0	5403	<5.0
#9	76	<2.5	5,320	<2.0	7800	<5.0
#10	125	<2.5	7,740	<2.0	4592	<5.0
#11	102	<2.5	14,220	<2.0	6051	<5.0

**TABLE 2. EVALUATION OF THE METHOD**

Analyte	Samples	Detection Limit <sup>a</sup>	Recovery (%)	Correlation Coefficient
MNNG	Feces	2.5 µg/g	92	0.974
	Gastric Contents	2.0 µg/g	103	0.981
	Urine	5.0 µg/mL	N/A	0.998
MNG	Feces	5.0 µg/g	105 <sup>b</sup>	0.984

<sup>a</sup> The signal to noise level is larger than 3.

<sup>b</sup> Spiked MNG was selected having similar concentration to that detected in the samples of feces.

The detection limit, recoveries, and linearity of the calibration curves were evaluated to validate the method. These data were obtained with the control samples spiked with different concentrations of MNG and MNNG. The detection limit of MNNG is 2.0 µg/g in the gastric contents,



2.5 µg/g in the feces, and 5.0 µg/mL in the urine. The percentage of MNNG recovered in the samples of feces and gastric contents at lower spiking levels (5.0 µg/g) is also listed in Table 2. The percentage recovery of MNNG in urine was not given because MNNG is not stable in urine and is known to react with nitrogenous bases (McKay and Wright, 1947). In addition, Table 2 also lists the correlation coefficients of the pertinent calibration curves to evaluate the linearity of the calibration curves.

#### PURITY ANALYSIS OF AIR FORCE ARMAMENT LABORATORY MNG

An HPLC method using an ODS reversed phase column and a UV detector was developed to analyze Air Force Armament Laboratory for NG and MNNG. A 0.25% of NG impurity was detected in the USAF MNG (Table 3). No MNNG was detected in the USAF MNG above its detection limit (Table 4). The HPLC analysis of the USAF MNG and standards of NG, MNG, and MNNG are shown in Figure 4.

A reversed-phase ion-pair HPLC method was developed to analyze G and MG (Kobayashi, et al. 1987). The system employed a postcolumn derivatization with a fluorometer as a detector. A small amount of G and MG impurities were detected in the MNG (Figure 5) and the quantitation results are listed in Table 3. The presence of large amounts of MNG in the solutions (up to 10 mg/mL) did not interfere with the fluorescence detection. The identification of G and MG peaks was performed by matching their retention times to the standards, employing two mobile phases with different selectivity and spiking the standards in the samples. High performance liquid chromatography with fluorescence detection gave retention times of 7.8 min for G and 8.7 min for MG using Solvent System I.

The detection limit, and linearity of the calibration curves were evaluated to validate the methods, and the results are listed in Table 4. Because only the aqueous solutions were involved in the purity study, the methods provide sufficient sensitivity in the detection of low levels of the impurities. In addition, the lowest correlation coefficient of the calibration curves was 0.9994; therefore, accurate results of quantitation can be anticipated.

**TABLE 3. PURITY ANALYSIS OF DOSED MNG FROM THE AIR FORCE ARMAMENT LABORATORY**

NG	NG/MNG (%)	0.25 ± 0.053 <sup>a</sup>
MG	MG/MNG (%)	0.055 ± 0.003 <sup>b</sup>
G	G/MNG (%)	0.0016 ± 0.0002 <sup>b</sup>
MNNG	MNNG/MNG (%)	<0.05

<sup>a</sup> t-test with nine samples at 95% confidence limit.

<sup>b</sup> t-test with five samples at 99% confidence limit.

TABLE 4. METHOD EVALUATION (II)

Impurity	Detection Limit g/g <sub>MNG</sub>	Correlation Coefficient
NG	$<5.0 \times 10^{-4}$	0.9995
MG	$3.0 \times 10^{-6}$	0.9996
G	$2.0 \times 10^{-6}$	0.9994
MNNG	$<7.0 \times 10^{-4}$	0.9998

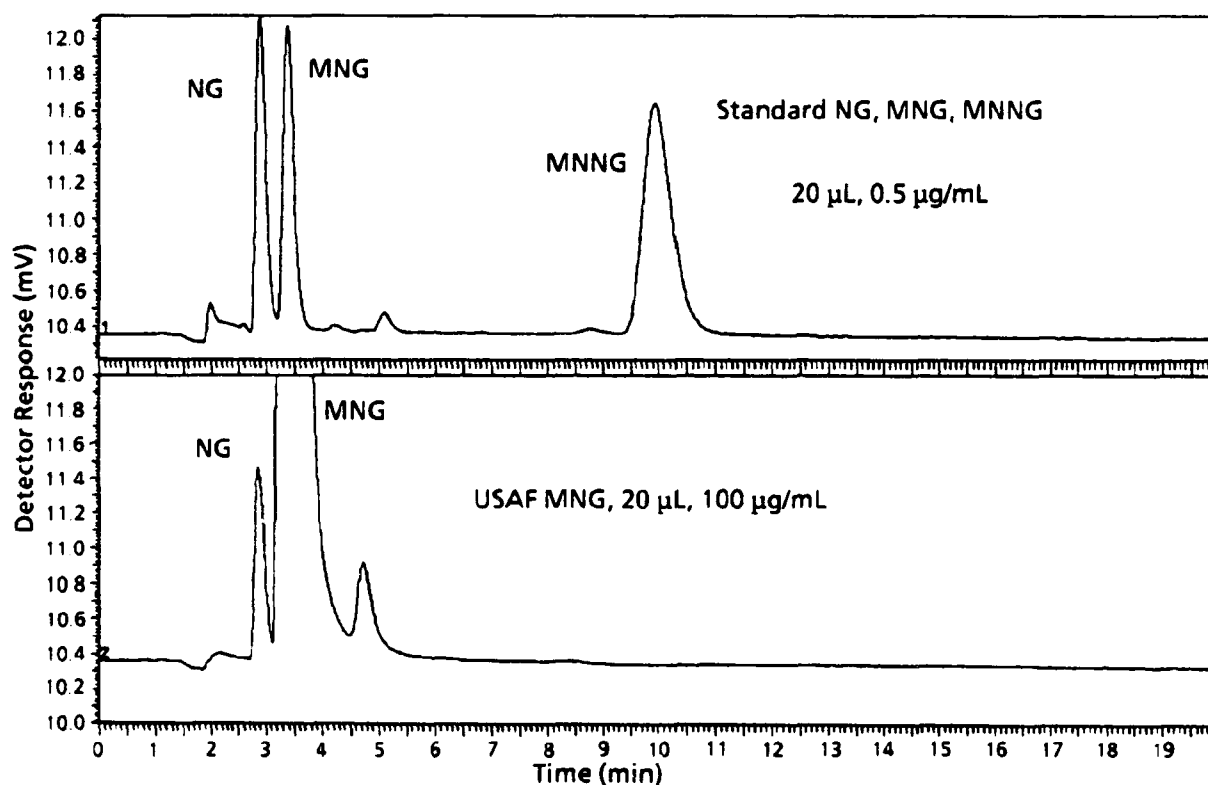
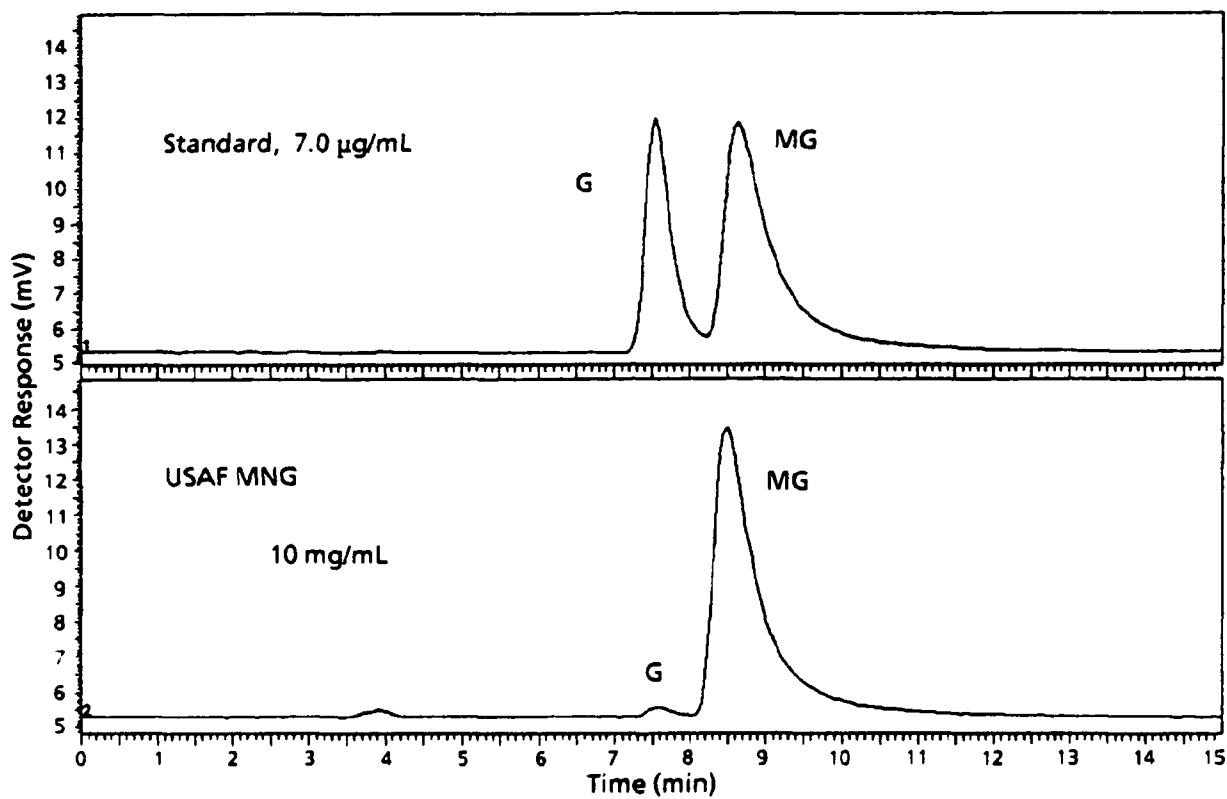

Figure 4. Analysis of Air Force Armament Laboratory MNG by HPLC with UV Detection. Top panel: Aqueous standards of 0.5 μg/mL NG, MNG, and MNNG. Bottom panel: Expanded chromatogram showing small amount of NG in Air Force MNG.



**Figure 5. Analysis of Air Force Armament Laboratory MNG by HPLC with Fluorescence Detection.** Top panel: Aqueous standards of 7.0 µg/mL G, and MG. Bottom panel: Chromatogram of 10 mg/mL Air Force MNG showing small amounts of G and MG.

## SECTION 5

### DISCUSSION

The analysis of Air Force Armament Laboratory MNG covered two separate areas. One was the analysis of the chemical purity of the MNG sample, and the second was the evaluation of the potential for the intragastric conversion of MNG to the known carcinogen MNNG.

The first objective was addressed by the HPLC analysis of MNG. High performance liquid chromatography analysis was done with UV detection to quantitate the amount of NG and MNNG. A significant finding was that MNNG was not detected in the Air Force Armament Laboratory MNG sample. This question is of toxicological concern because MNNG is a known carcinogen. Calculations based on the limits of detectability indicated that the level of MNNG was less than 0.1% by weight. The UV HPLC analysis also indicated that the MNG was 0.25% NG by weight. The presence of NG was not toxicologically significant and because MNG is synthesized by methylating nitroguanidine it was most probably due to unreacted starting material. High performance liquid chromatography with fluorescence detection was used to analyze the Air Force Armament Laboratory MNG for G and MG. A fluorescence-detection technique was employed because these guanidine compounds do not absorb at a usable UV wavelength. The HPLC fluorescence method determined that the Air Force MNG contained 0.0016% G and 0.055% MG (by weight). The presence of trace amounts of G and MG was not of toxicological concern.

The analysis of gastric contents, urine, and feces in male F-344 rats did not detect the intragastric conversion of MNG to MNNG. None of the samples analyzed indicated that MNG is converted to MNNG under the conditions investigated. The limit of detectability for MNNG was less than 2.0 µg/g for gastric contents, 5.0 µg/mL for urine, and 2.5 µg/g for feces. The intragastric conversion of MNG to MNNG is of toxicological concern because MNNG is a known carcinogen. Under acidic gastric conditions, MNG could be converted to MNNG especially in the presence of nitrites. Kinetic studies of the conversion of amides to nitrosamides have demonstrated that MNG can be nitrosated to MNNG in the presence of nitrite (Mirvish, 1975). Nitrite can come from diet or from the environment, but it may also originate from the bacterial reduction of nitrate (Sander and Schweinsberg, 1972). Epidemiological studies have associated the consumption of nitrate-rich drinking water with a high incidence of gastric cancer (Hill and Hanksworth, 1973). Thus, exposure to MNG may present the potential of conversion to MNNG. Further research into this question may be addressed by the coadministration of MNG and nitrite, or MNG and nitrate to test animals.

## SECTION 6

### REFERENCES

Endo, H., K. Takahashi, and H. Aoyagi. 1974. Screening of compounds structurally and functionally related to *N*-methyl-*N'*-nitro-*N*-nitrosoguanidine, a gastric carcinogen. *Gann* 65:45-54.

Endo, H., K. Takahashi, N. Kinoshita, T. Utsunomiya, and T. Baba. 1975. An approach to the detection of possible etiologic factors in human gastric cancer. *Gann Monogr. Cancer Res.* 17:17-29.

Hill, M.J. and G. Hanksworth. 1973. Bacteria, nitrosamines and cancer of the stomach. *Br. J. Cancer* 28:562-567.

Kobayashi, Y., H. Kubo, and T. Kinoshita. 1987. Post-column derivatization system for the fluorometric determination of guanidine compounds with ninhydrin by reversed-phase ion-pair high-performance liquid chromatography. *J. Chromatogr.* 400:113-121.

McKay, A.F. and G.F. Wright. 1947. Preparation and properties of *N*-methyl-*N*-nitroso-*N'*-nitroguanidine. *J. Am. Chem. Soc.* 69:3028-3030.

Mirvish, S.S. 1975. Formation of *N*-nitroso compounds: Chemistry, kinetics, and *in vivo* occurrence. *Toxicol. Appl. Pharmacol.* 31:325-351.

Patrick, M.A and H.H. Cady. 1990. Development of the phase diagram of the methylnitroguanidine/ammonium nitrate system. Los Alamos National Laboratory, Los Alamos, NM. August Interim Report No AFATL-TR-90-78. Eglin AFB, FL: Munitions Division, Air Force Armament Laboratory.

Sander, J. and F. Schweinsberg. 1972. Wechselbeziehungen zwischen nitrat, nitrit und kanzerogenen *N*-nitrosoverbindungen. *Zbl. Bakt. Hyg. B.* 156:299-340.

## QUALITY ASSURANCE

The study, "Purity Analysis of N-methyl-N'-nitroguanidine (MNG) Test Substance and Chemical Analysis of MNG and 1-Methyl-3-nitro-1-nitrosoguanidine in Biological Samples," was conducted by the ManTech Environmental Technology, Inc., Toxic Hazards Research Unit under the guidance of the Environmental Protection Agency's Good Laboratory Practices Standards, 40 CFR 792. No claim will be made that this was a "GLP" study as no attempt was made to adhere to the strict requirements of those standards.

Various phases of this study were inspected by members of the Quality Assurance Unit. Results of the inspections were reported directly to the Study Director at the close of each inspection.

<u>DATE OF INSPECTION</u>	<u>ITEM INSPECTED</u>
June 11, 1991	Study data
November 18 - December 11, 1991	Data and Final Report
January 17, 1992	Final report

The Quality Assurance Unit has determined through review process that this report accurately describes those methods and standard operating procedures required by the protocol and that the reported results accurately reflect the raw data obtained during the course of the study. No discrepancies were found that would alter the interpretations presented in this Final Report.

  
M. G. Schneider  
QA Coordinator  
Toxic Hazards Research Unit

Date April 1, 1992