

# Naval Submarine Medical Research Laboratory



NSMRL Special Report SF90-3

3 OCTOBER 1990

AD-A241 770



Proceedings Sixth Tripartite Conference on Submarine Medicine  
and

IEP B-52

FRANCE UNITED KINGDOM UNITED STATES

held at the  
Naval Submarine Medical Research Laboratory, Groton, CT  
on 1 June - 4 June 1987

Edited by

Paul K. Weathersby, CAPT MSC USN  
and  
Jeanne C. McNary

DTIC  
ELECTE  
OCT 21 1991  
S B D

Released by:

R. G. Walter, CAPT DC USN  
Commanding Officer  
Naval Submarine Medical Research Laboratory

91-13551



Approved for public release; distribution unlimited

91 1018 027

# DISCLAIMER NOTICE

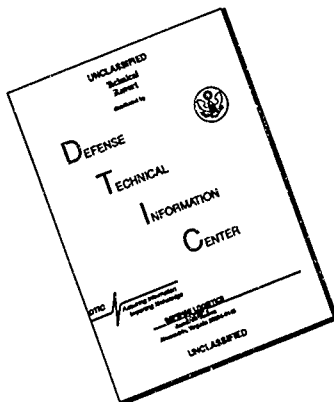

THIS DOCUMENT IS BEST QUALITY AVAILABLE. THE COPY FURNISHED TO DTIC CONTAINED A SIGNIFICANT NUMBER OF PAGES WHICH DO NOT REPRODUCE LEGIBLY.

PROCEEDINGS SIXTH TRIPARTITE CONFERENCE

ON

SUBMARINE MEDICINE AND IEP B-52

FRANCE      UNITED KINGDOM      UNITED STATES

1 JUNE - 4 JUNE 1987

Edited by:

Paul K. Weathersby, CAPT MSC USN

and

Jeanne C. McNary

Approved and Released by

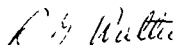

R. G. WALTER, CAPT DC USN  
Commanding Officer  
NAVSUBMEDRSCHLAB

Approved for public release; distribution unlimited

PROCEEDINGS SIXTH TRIPARTITE CONFERENCE ON  
SUBMARINE MEDICINE AND IEP B-52

	PAGE
I. INTRODUCTION .....	i
II. AGENDA .....	ii
III. LIST OF CONFERENCE ATTENDEES .....	v
IV. SUMMARY OF CONFERENCE	
Submarine Escape and Rescue .....	1
Submarine Air Quality .....	10
Clinical Issues .....	15
Psychological Issues .....	18
Appropriate NATO STANAGs .....	20
Concluding Activities .....	21
V. Appendices - full papers	
1. Joint IEP B52/AngloFrench DRG Area 8 (Submarine Medicine) Project Officers Statement .....	22
2. Presentation Remarks by Surgeon CDR C. J. Kalman .....	23
3. DSRV-MOSUB Pressurized operations - the UK scenario by CDR R. Whiteside, .....	25
4. The RN MOSUB Scenario, Standards of Air Purity by Surgeon CDR C. J. Kalman .....	32
5. U.S. Scenario for DSRV Escape Under Pressure by CDR Carson and CDR Adkisson .....	47
6. Pressurized Rescue by G. Masurel .....	53
7. Decompression Analysis for Submarine Rescue by CDR P. K. Weathersby, J. R. Hays, B. L. Hart, S. Survanshi. L. D. Homer, and CAPT E. T. Flynn .....	72
8. Prophylactic Drugs by Surgeon CDR C. J. Kalman .....	75
9. Atmosphere Profiling of Organics on Submarines: The UK Approach by P. R. Dibben .....	81
10. U.S. ACM Revision by J. Thill .....	83
11. BR1326 - Air Purification in Submarines by C. Adams ..	86
12. Revealing the Presence of Phenols in a Submarine Atmosphere by PCA Clair, M. Abran and PCA Dumas .....	104

13.	Submarine Air for Divers by CDR P. K. Weathersby, CAPT E. T. Flynn and R. S. Lillo .....	109
14.	Royal Navy Experience with Molecular Sieve CO <sub>2</sub> Removal Plant by C. Adams .....	114
15.	Pollution of the Atmosphere of Submarine Hazards Due to Air Regeneration Systems by H. Bodilis and MCA L. Giacconi .....	120
16.	Impact of Low O <sub>2</sub> on Fire Safety in Submarines by H. W. Carhart .....	128
17.	The Naval Submarine Medical Research Laboratory's Studies of Human Responses to Fire-retardant Atmospheres by CAPT D. R. Knight .....	150
18.	Use of Halon 1301 (Freon 13 B1) on Board French Submarines by H. Bodilis and MCA L. Giacconi .....	161
19.	Additivity of Hydrocyanic Acid and Carbon Monoxide Incapacitating Effects on Animal Models by J. Hee ....	165
20.	Passive and Active Exposure to Cigarette Smoke Under Controlled Conditions by J. Hee .....	175
21.	Particulate and Gaseous Pollution from Tobacco Smoking Influence of Various Removing Devices by J. Hee .....	186
22.	Why is Smoking not Allowed on Board French Submarines? by MCA Giacconi .....	195
23.	Proposed U.S. Policy Guidance Concerning Tobacco Smoking on Submarine by CAPT R. L. Bumgarner .....	204
24.	Use of Containers to Provide Life Support Stores to Distressed Submarines by H. Bodilis and MCA L. Giacconi .....	208
25.	An Introduction to Submarine Psychiatry Outline by P. F. Giannandrea, M.D. ....	218
26.	Comprehensive Contextual Analysis of Conflict Within the Submarine Community by P. A. Rogers .....	224

INTRODUCTION

The 6th Tripartite Conference on Submarine Medicine and Information Exchange Program B-52 were held at the Naval Submarine Medical Research Laboratory, Groton, CT, USA, on 1-4 June 1987. Over 40 people participated bringing medical and operational expertise from submarine forces of France, the United Kingdom and the United States. Observers were present from two allied countries expecting to increase their involvement with submarines: Canada and Australia. Observers were also present from the US National Academy of Science panels forming an external study of submarine atmospheres.

This volume contains a summary of the technical presentations and a flavor of the vigorous discussion they provoked. Full manuscripts were kindly provided by many of the speakers, and these papers are enclosed.

We are grateful to CAPT D. Knight, MC, USN, LCDR J. Bowman, MSC, USN, Dr. K. Bryant, Mr. J. Parker, and Ms. D. Johnson for assembly of these materials.

DTIC  
copy  
TFO

Accession For	
NTIS GRA&I	<input checked="" type="checkbox"/>
DTIC TAB	<input type="checkbox"/>
Unannounced	<input type="checkbox"/>
Justification	
By _____	
Distribution/	
Availability Codes	
Dist	Avail and/or Special
A-1	23

AGENDA

Mon 1 June

0830 Welcome, Opening US: CAPT Harvey  
0835 Opening Remarks CAPT Bumgarner  
UK: SURG CDR Kalman  
FR: MCA Giacomoni

SUBMARINE ESCAPE and RESCUE  
Chairman SURG CAPT Pearson

DSRV - MOSUB Pressurized Operations  
0845 UK Scenario: CDR Whiteside  
0925 UK Sub Air Quality: SURG CDR Kalman  
0940 US Scenario: CDK Carson, CDR Adkisson  
1015 COFFEE  
1030 Discussion on Operations  
  
Decompression Requirements  
1045 UK Experiments (Islander II): Dr. Withey  
1100 US Experiments (AIRSAT 5,6): Mr. Parker  
1115 LUNCH

Decompression Requirements (continued)  
Chairman: CDR Adkisson  
1300 Fr Experiments: M. Masurel  
1315 US Statistical Analysis: CDR Weathersby  
1330 US Procedures Selection: CAPT Harvey  
1345 Discussion on Decompression

Escape Complications  
1400 UK Survival after escape (Mk IX SEIS): SURG CAPT Pearson  
1425 Canada Experience with exposure: Dr. Ackles  
1440 UK Drugs with escape: SURG CDR Kalman  
1500 UK Depressurization systems: Dr. Withey  
1520 Discussion on Escape  
1540 Future Plans  
  
1830 Reception and no-host dinner

Tuesday, 2 June

SUBMARINE AIR QUALITY  
Monitoring and Control  
Chairman: CDR Weathersby

0830 UK Atmospheres Profiling/Hydrocarbons:  
Mrs. Dibben, SURG CDR Kalman  
0920 US CAMS-II Evaluation: Dr. Wyatt

0930 COFFEE  
0945 US Atmosphere Control Manual: Mr. Thill  
1005 UK Atmosphere Control Manual: Mr. Adams  
1025 Fr Atmosphere Control: M. Dumas  
1030 US Procedures for Submarine Divers: CDR Weathersby  
1050 Fr Molecular Sieve Applications: M. Bodilis  
1115 LUNCH

Monitoring and Control

Chairman: CAPT Knight  
1340 UK Molecular Sieve Applications: Mr. Adams  
1355 Fr Equipment pollution hazard: M. Bodilis  
1410 Discussion on analysis and control  
1430 COFFEE

Fire Emergencies on Submarines

1440 US Laboratory Experiments: Dr. Carhart (read by CAPT Knight)  
1510 US Low O2 Proposal: Capt Knight  
1525 Fr HALON 1301 use: M. Bodilis  
1535 Fr HCN, CO Interactions: M. Hee  
1600 Discussion on fire

Wednesday, 3 June

CLINICAL ISSUES

Smoking

Chairman: CAPT Bumgarner

0830 Fr Controlled studies: M. Hee  
0845 UK Research on CO/Smoking: Dr. Smith  
0910 Fr Devices for smoke removal: M. Hee  
1005 US Position on smoking: (Capt Bumgarner)  
1015 COFFEE  
1030 Fr Position on smoking: MCA Giacomoni  
1040 Discussion on smoking  
Other clinical  
1115 US Computer Diagnosis: Dr. Moeller  
1135 Discussion of clinical issues  
1200 LUNCH  
1400 TOUR of U.S. Atmosphere Control/Analysis Equipment  
Bldg. 88 SUBASE (Host: CWO Thaden, USN)  
CAMS-I CO/H2 burner  
CO2 scrubber Oxygen generator  
1540 Fr Life support stores: M. Bodilis  
NATO STANAGS 1184 and 1206  
1555 US Position: CAPT Bumgarner  
1610 UK Position: SURG CDR Kalman  
1625 Fr Position: MCA Giacomoni



Thursday, 4 June

0830 Perspective Submarine Psychological Problems: CAPT Scott  
0845 Introduction to Submarine Psychology: Dr. Giannandrea, LCDR MC  
0930 Submariner Psychological Screening Process: Dr. Wallace  
0950 Effects of Exposure to Suicide Within Submarine Service: Dr. Bryant  
1035 Comprehensive and Contextual Analysis of Conflict Within Submarine  
Community: Dr. Rogers, LT MSC

1130 General Discussion  
1215 Research Recommendations  
1245 Plans for next meeting  
1300 Secure

ATTENDEES:

United States

CAPT R. Bumgarner, MC, USN	Naval Medical Command (Project Officer)
CAPT H. Scott, MC, USN	Naval Hospital, Groton
CDR G. Adkisson, MC, USN	Submarine Development Group One
CDR J. Carson, MC, USN	Submarine Development Group One
LCDR R. Barnes, USN	Submarine Development Group One
CDR R. Garrahan, USN	Naval Sea Systems Command (SEA-00C3)
Mr. J. Thill	Naval Sea Systems Command (SEA-56Y14)
Mr. J. Lawrence	Naval Sea Systems Command (SEA-PMS-393)
Mr. K. Tondreau	Naval Sea Systems Command (SEA-PMS-395)
LT P. O'Brien, USN	Chief of Naval Operations (OP-231)
Mr. T. Daley	Naval Ship System Engineering Station
CDR A. Manalaysay	Naval Medical Research and Development Command
Mr. D. Chandler	Naval Medical Research Institute
CAPT E. T. Flynn	Naval Medical Research Institute
Dr. J. Wyatt	Naval Research Laboratory
CDR H. Schwartz, MC, USN	Navy Experimental Diving Unit
CAPT C. Harvey, MC, USN	Submarine Medical Research Laboratory
CAPT D. Knight, MC, USN	Submarine Medical Research Laboratory
CDR P. Weathersby, MSC, USN	Submarine Medical Research Laboratory
Dr. A. Callahan	Submarine Medical Research Laboratory
Dr. G. Moeller	Submarine Medical Research Laboratory
Mr. J. Parker	Submarine Medical Research Laboratory
LCDR D. Southerland, MC, USN	Submarine Medical Research Laboratory
Dr. K. Bryant	Submarine Medical Research Laboratory
LT P. Rogers, MSC, USN	Naval Hospital, Groton, CT
LCDR Giannandrea, MC, USN	Naval Hospital, Groton, CT
Dr. Wallace	Naval Hospital, Groton, CT

United Kingdom

SURG CDR C.J. Kalman, RN	Institute of Naval Medicine (Project Off.)
SURG CAPT R.R. Pearson, RN	Institute of Naval Medicine
Dr. D.J. Smith	Institute of Naval Medicine
SURG CAPT D.J. McKay, RN	Flag Officer (Submarines)
CDR R.C. Whiteside, RN	Flag Officer (Submarines)
LT CDR D.B. Dougherty, RN	Flag Officer (Submarines)
Mr. C. Adams	Chief Naval Architect
Dr. W.R. Withey	Admiralty Research Est. (Physiol. Lab)
Mrs. P.R. Dibben	Admiralty Research Est. (Holton Heath)

France

MCA L. Giacomoni	CERTSM (Project Officer)
PCA C. Dumas	CERTSM
M. H. Bodilis	CERTSM
M. J. Hee	CERTSM
M. G. Masareil	CERTSM

Australia (Observer)  
SURG LIEUT CDR A. Robertson RAN

Canada (Observers)

Dr. K.N. Ackles	Defence and Civil Institute of Environmental Medicine
Dr. D.M. Kane	Defence and Civil Institute of Environmental Medicine
Mr. C.L. Allen	Canadian Defence Liaison, Washington

U.S. National Academy of Sciences (Observers)

Dr. F. Marzulli	National Research Council
Dr. K. Taylor	General Motors Research Lab
Dr. R.F. Henderson	Lovelace Research Institute
Dr. T.H. Risby	Johns Hopkins University
Dr. M. First	Harvard School of Public Health

## SUMMARY OF CONFERENCE

### SUBMARINE ESCAPE AND RESCUE

CDR Whiteside opened the session for the UK by defining Escape and Rescue:

Escape - in which survivors make their way to the surface without the direct help of any outside agency.

Rescue - in which survivors are collected by a vehicle which mates with the escape hatch and transfers them dry to the vessel.

Although there can be no assurance of 100% survival after a submarine accident, there can be sensible limits of insurance for many likely accident situations. All UK submarines are fitted with a mating ring compatible with the Deep Submergence Rescue Vehicle (DSRV). One third of all UK submarines operate in the relatively shallow depths of the continental shelf surrounding the British Isles. The most likely accident is a collision with the submarine at periscope depth. Escape is possible, but the degree of risk to the survivor is less when rescued. It is less likely that the submarine will be too deep for escape, but still above crush depth. Additionally there is the possibility that the internal pressure of the submarine will be greater than one bar. It is not safe to make escapes from even the shallowest depths if the pressure in the distressed submarine (DISSUB) is greater than only 1.8 bar.

The reasonable maximum submarine internal pressure on which to base Royal Navy (RN) escape and rescue policy and systems is somewhere between 1.8 and 4 bar absolute. RN submariners are trained to wait as long as possible before escaping and to remain in the DISSUB until recovery forces are on the scene; that is, unless internal conditions are such that remaining in the DISSUB is not possible. The RN does not regard salvage of the whole submarine as a means of saving life. The RN has been working on a simple, hand-held computer program to help the senior survivor make the critical decision on whether to escape or wait to be rescued.

As for the mother submarine (MOSUB) rescue scenario with the DSRV, no RN SSBNs have a compartment designed for use as a compression compartment, but investigation has revealed that the forward escape compartment could be pressurized to 2 bar. Since the USN CNO has issued a directive holding compression procedures in abeyance in USN MOSUBS, the only system in NATO that can carry out a pressurized rescue is the DSRV working from a UK MOSUB. It could be done today. The RN has taken the lead in the MOSUB scenario by including an airlock for new TRIDENT's in the compression compartment bulkhead thus enabling replenishment and personnel transfer during decompression cycles. This is a great advantage over USN 637 SSNs (the designated USN MOSUB) and RN RESOLUTION class SSBNs which do not have this capability.

The RN has established that the maximum DISSUB pressure that can be handled is 2.9 bar. This is the maximum pressure from which saturated survivors can safely be step decompressed to 2.0 bar (the maximum capability of the MOSUB

compression compartment). This compartment can accommodate approximately 72 people which is the maximum the DSRV could deliver between battery charges, making three rescue trips with 24 survivors on each. It is expected that the rescue and decompression for the maximum possible number of survivors (184 men) would take just over 8 days if all went smoothly. This added to the estimated 4-5 days to commence the operation from the first notification, results in a very long and demanding scenario for all concerned. In 1989, there is scheduled to be a joint US/UK DSRV flyaway exercise which will prove the whole concept.

Other discussion pointed out that the RN also is working on a system for decompressing the DISSUB by hoses from the surface. This could result in lowering the internal pressure to at least 2.9 bar, from which pressurized rescue could then be effected or, better yet, to carry out a normal unpressurized rescue.

Surgeon Commander C. J. Kalman, RN, discussed air quality issues in escape and rescue. Both such evolutions would be accomplished using air from the submarine high pressure air system (HPA). This air differs significantly from that used for normal diving and recompression chamber operations. During normal submarine operations the cyclic use of compressors returns air from the submarine atmosphere to the HPA bottle groups. Thus the submarine atmosphere and the HPA bottle groups reach equilibrium and gaseous contaminants present in the submarine will likewise be present in the HPA system. This system is a relatively closed system which is infrequently cleaned.

The requirement to compress the MOSUB compartment to 2 bar prior to the instigation of each decompression run produces a minimum figure of 50% HPA within the compartment at any one time. The longest exposure times within the compression compartment will be for those attendants locked in prior to compression (Resolution Class only) and for the first batch of rescues who must wait for two further transfers to arrive via the DSRV prior to decompression. The periods of exposure are estimated to be 16 hours between the initial compression of the compartment and the arrival of three DSRV loads. This is followed by a hold of 30 hours at 2 bar prior to decompression at 0.5 meters per hour (20 hours) resulting in a total time of some 66 hours. The 30-hour hold is the best estimate available for avoidance of decompression sickness during the final decompression for rescues saturated at the "worst case" DISSUB pressure.

In a detailed analysis, the greatest personal exposure involved in the RN MOSUB scenario has been identified and a worse case conservative estimate of effective toxic levels produced. Simple comparison between such levels and the published national industrial levels indicate, with the exception of halocarbons, no grossly unacceptable exposure. Therefore, the Biomedical Subcommittee of SCOSER endorses current RN MOSUB policy with the following modifications:

1. HPA system halocarbon samples taken prior to MOSUB deployment should indicate levels below 250 vpm (vapor parts for million) and that a MPC (maximum permissible concentration) of 250 vpm should be maintained in the MOSUB throughout the operation.

2. HPA system total organics samples taken prior to MOSUB deployment should indicate levels below the SGM0332 specified limit of 20 mg/m<sup>3</sup>.

3. The Biomedical Subcommittee accepts the on-going task of monitoring submarine atmosphere control limits to confirm continued endorsement of MOSUB policy.

4. If endorsed by the Biomedical Subcommittee, any trials would need to be subject to ethical considerations.

CDR Carson & CDR Adkisson presented the US prospective as seen by the medical support group with the DSRV. The DSRVs are capable of internal pressurization in the range of 0.8 to 5 ATA, and in a rescue can carry a maximum of 28 personnel (four crewmen and 24 rescuees) operating to a depth of 5000 feet. The rescue scenario begins with the notification that a submarine has been disabled. It is estimated that a response could be mounted in as little as 24 hours to 48 hours, with rescue operations underway, on site, in two to three days.

The general mission sequence is:

1. A submarine is bottomed at less than collapse depth.
2. SubOpAuth initiates submarine rescue program.
3. Rescue units assembled in area of distressed submarine.
4. Distressed submarine is located with DSRV. Assistance in determining the DISSUB location will normally be provided by ships at the site and from shore. Passive, distressed submarines can possibly be located by previously released buoys, oil slick, debris, or echo from search sonar.
5. First mating of DSRV with distressed submarine has been completed.
6. Rescue operation completed.

In a pressurized rescue scenario, if communications with the DISSUB are intact, the DSRV will be pressurized to the internal pressure of the DISSUB by mating with the MOSUB prior to transiting to the DISSUB. After returning to the forward compartment of the MOSUB which has been pressurized to the internal pressure of the DSRV, the rescuees will be transferred to the MOSUB forward compartment. This procedure can be repeated two or three times depending on the battery life of the DSRV. As the battery charge falls below 30%, the DSRV will return to the after escape trunk of the MOSUB for replenishment.

Following the transfer of all survivors, the MOSUB will begin controlled decompression of its forward compartment until the pressure reaches one bar. Replenishment of supplies can be accomplished by utilizing the DSRV as a shuttle between the after and forward hatches thereby providing food, water, medical, and other necessary supplies.

Theoretically, the MOSUB forward compartment can hold the entire DISSUB crew (assuming the maximum survivability of 120-180 men). Despite crowded conditions and reduced habitability aboard the MOSUB, survival is possible. Several SHIPALTS have been promulgated modifying the US SSN-637 class submarines so they could act as MOSUBs for the DSRV. These included modification of the bow compartment for use as a decompression chamber, providing facilities to accept the DSRV flyaway equipment and the ability to perform various hotel services for

the DSRV. Several of 637s were modified, at least partially, and documents indicate that pressurization may have been accomplished to 4 bar under test conditions.

The only practical means of forward compartment pressurization is using the MOSUB's air banks thus raising several issues:

1. Initial pressurization with normoxic air requires monitoring for pulmonary oxygen toxicity.
2. Normoxic air at increased pressure presents additional hazards and special fire precautions will be required until the oxygen level has been reduced, presumably by human respiration.
3. Potentially toxic materials stored in the forward compartment will have to be removed prior to pressurization.
4. Heads and potable water systems have pressure limitations of roughly 2.3 (cross connects) and 3.7 (system) bar respectively. Proper lineup of ship's sanitation to prevent inadvertent decompression of the forward compartment is necessary.

A mating ring enabling the mating of the DSRV with the deck decompression chamber (DDC) on an ASR (surface ship with chambers) is currently undergoing design. This would facilitate the pressurized transfer from the DSRV to the chambers. Studies at NSMRL examined safe surface intervals for personnel transfer which could be used until such time as the mating ring is available. Additionally, a DSRV venting/equalization valve installation has been planned for the upcoming modernization period. This will provide the capability for controlled venting of the DSRV.

Discussion following this presentation focused on DSRV type vehicles belonging to Japan and Sweden; and on the physical compatibilities (mating rings) among the different vehicles.

Dr. R. Withey presented results of UK experiments on decompression problems in submarine escape. Islander-2 was designed to investigate the maximum safe direct decompression step to 2 bar from oxygen/nitrogen saturation and from oxygen/nitrogen/carbon dioxide saturation; and the minimum duration of the hold at 2 bar before a subsequent decompression to 1 bar can safely be completed. A total of 79 submariner volunteers were exposed to the Islander-2 profile. The compression rate was 1.5 bar/minute. The atmosphere at saturation was either 0.4 bar oxygen/balance nitrogen, or 0.38 bar oxygen/0.02 bar carbon dioxide/balance nitrogen, depending on the phase of the experiment. The direct decompression to 2 bar was carried out at a rate of 0.5 bar/minute, and the atmosphere was changed to air. The decompression from 2 bar was carried out at a rate of 0.5 msw/hour in accordance with RN Table 72. Subjects were held at exactly 1 bar (irrespective of atmospheric pressure) for 24 hours before being released from the hyperbaric chamber.

Twenty subjects with no CO<sub>2</sub> were decompressed from 3.2 bar with 3 cases of decompression sickness (DCS). It was concluded that the maximum "safe" direct decompression step to 2 bar is 1.2 bar, i.e., from 3.2 bar to 2 bar. A holding time of 24 hours at 2 bar is insufficient to ensure a subsequent safe decompression to 1 bar, as indicated by later cases of DCS. With 0.02 bar CO<sub>2</sub> in

the saturation gas, 59 exposures were conducted at pressures of 2.9 to 3.2 bar with 8 cases of DCS. In light of these cases it was concluded that the maximum "safe" direct decompression step to 2 bar is 0.9 bar, i.e., 2.9 bar to 2 bar.

The final recommendations for the purposes of planning the rescue of survivors from a distressed submarine with a raised internal pressure and probably elevated CO<sub>2</sub> were:

1. A maximum safe direct decompression to 2 bar is from 2.9 bar.
2. A hold of at least 30 hours is required at 2 bar before commencing decompression to 1 bar.

In a further discussion, Dr. Withey posed some questions for future work by all countries. They included:

- confirm the required hold time at 2 bar
- clarify effects of CO<sub>2</sub>
- establish safe steps from higher saturation pressure
- consider effects of lower (e.g. 17%) O<sub>2</sub> concentrations
- consider oxygen toxicity
- create an appropriate mathematical model

US decompression experiments were described by Mr. J. W. Parker. The Naval Submarine Medical Research Laboratory initiated a series of chamber dives to establish the safe upward excursion limits from a worst case scenario where the DISSUB has an internal pressure of 5 ATA. This work was accomplished in two phases. The AIRSAT-5 series was designed to arrive at this limit in a nitrogen-oxygen (NITROX) atmosphere with a PO<sub>2</sub> of 0.4 ATA. This was done to eliminate the problems of pulmonary oxygen toxicity (POT). The nitrox equivalent of 5 ATA (132 fswg) is 4.36 ATA (111 fswg). The divers would be held at the excursion depth for 24 hours before commencing decompression to the surface.

The first two dives in the series involved an upward excursion to 3.12 ATA (70 fswg). With N=6, there were no symptoms of decompression sickness (DCS), so it was decided to alter the design to make the upward excursion to 2.82 ATA (60 fswg), where two dives were carried out without DCS. It was then decided to make the excursion five feet shallower to 2.67 ATA (55 fswg). The result was three out of four cases of DCS. The decision was then made to return to the 2.82 ATA upward limit and two additional dives were conducted. This time there were 3 cases of DCS at this excursion depth. The next series of three dives examined the upward excursion from 4.36 ATA to 2.97 ATA (65 fswg). With nine subjects there were no cases of DCS after the upward excursion. There was, however, one case of DCS (Type 1) at 1.42 ATA (14 fswg) which occurred during the subsequent decompression to the surface. It was felt, however, that this was not due to the upward excursion, but due to the later saturation decompression.

Now that the upward excursion limit on nitrox had been established, the next series of dives (AIRSAT-6) would study the upward excursion limit on compressed air from 5 ATA (132 fswg) to the air equivalent of the depth established previously in AIRSAT-5. This is 3.24 ATA (74 fswg). However, in order to reduce the effects of POT, the initial compression would be to 4.4 ATA (111 fswg).



After 60 hours at this depth, the atmosphere was changed to compressed air ( $PO_2=1.05$ ) and the depth increased to 5 ATA (132 fswg). This depth was maintained for 12 hours after which an immediate decompression to 3.24 ATA was accomplished. The subjects remained at this depth for 24 hours prior to commencing decompression to the surface. In the three dives with 13 subjects total, there were no cases of DCS during the 24-hour hold after the upward excursion, nor were there any cases of DCS during or after the subsequent decompression to the surface.

In the MOSUB scenario, then, it can be recommended that the forward compartment need be compressed only to 3.27 ATA (75 fswg) in order to receive survivors rescued by the DSRV from a DISSUB with an internal pressure of 5 ATA (132 fswg). As a caveat, this does take into account any toxic contaminants which may have been present in the DISSUB atmosphere prior to rescue.

G. Masarel described French experiments in pressurized rescue. This paper discussed a hypothesis for the rescue of personnel, who have been trapped in a pressurized submarine for some period of time. The discussion centered on the problem of rescuing personnel who have become saturation divers, by proxy, and how to most easily get them decompressed without running inordinate risks of decompression sickness. Where the UK proposed pressurizing the submarine's escape compartment to 2.0 ATA, the French propose pressurizing it to only 1.6 ATA. This pressure requires less air to maintain pressure and is less harmful to equipment within the compartment. To test the hypothesis, minipigs were subjected to pressures of 2.5, 3.0, 3.5, and 4.0 ATA for 24 hours and to 2.5, 2.7, and 3.0 ATA for 48 hours. In all cases, pressure was reached in 2 minutes. At the end of the pressurization period, the animals were depressurized to 1.6 ATA within 2 minutes, and held at that pressure for 24 hours. They were then returned to 1.0 ATA within 2 minutes. Doppler ultrasonic bubble detectors were implanted on the pulmonary arteries of the minipigs.

The experiments showed that the pigs could be safely 'rescued' from pressures up to 3.5 ATA after a 24 hour stay, put in the escape chamber at 1.6 ATA for 24 hours and then safely returned to 1.0 ATA, without symptoms of DCS. Additionally, the minipigs could be 'rescued' from a pressure of 2.75 ATA after a 48 hour stay, using the same protocol, without problems with DCS. Under the pressurized conditions, however, one must also consider Pulmonary Oxygen Toxicity (POT) as a danger. With pressurization in a Disabled Submarine (DISSUB) caused by HP or LP air leaks, there is an increased danger of POT because of the increased  $PO_2$ . However, this danger decreases as the number of survivors in the compartment increases, as the air is breathed down faster. In the event that flooding is the cause of the increased pressure within the DISSUB, hypothermia becomes the major problem for the survivors. Additional experimentation will be carried out to attempt to reach a good compromise between operational requirements aboard the MOSUB and realistic probabilities of pressurized rescue.

CDR P. Weathersby discussed the relevant statistical issues. Decompression is a variable event. Some people get decompression sickness (DCS) and others don't. A major question is; How does one predict who will get DCS or, in a group, how many will get DCS? It's impossible to predict the response of a single individual, but a prediction can be made on population response, using probabilistic models evaluated with the statistical concept of Maximum

Likelihood. Unfortunately, any analysis requires a very large number of experiments to get a very precise prediction. A series of mathematical models has been developed which can utilize different known dive profiles and outcomes to predict the probability of DCS, at some defined confidence limit. The models have been evaluated with about 2000 dives, most of which do not have profiles similar to submarine escape and rescue. Sometimes several variations of the model will work well with available data, and then give different predictions for new dives, for example in predicting the 1% DCS depth of a saturation exposure with return to 1 atmosphere. The statistical modeling approach will allow some predictions of hazard to be made under scenarios that are too unlikely or too dangerous to allow direct human testing.

CAPT C. Harvey outlined the selection of proper procedures in submarine rescue. The two major methods will utilize either a surface rescue ship (ASR) or a Mother Submarine (MOSUB) to transport the Deep Submersible Rescue Vessel (DSRV) to the site of the distressed submarine (DISSUB). If the ASR is used, the survivors must be brought to the surface and then physically exit the DSRV and cross the deck of the ASR to enter the decompression chamber. On the other hand, if a MOSUB is used, the survivors enter the DSRV from the escape hatch on the DISSUB and ride it to the MOSUB, where they enter the MOSUB via an escape hatch into a pressurized forward compartment, which doubles as a large decompression chamber. Two questions must be addressed if using a MOSUB, however: What pressure will be found in the rescue compartment of the DISSUB, and what is the minimum pressure you can use in the MOSUB? This presentation dealt with NSMRL's development of a Flow Chart which will cover every scenario for submarine rescue and be a sort of 'cookbook' for decompression of survivors. The Flow Chart will show all scenarios, decision points, known procedures, and will point out procedures that need additional work. An example of a scenario was presented and traced through the Flow Chart. Discussion focused on the need to get this Chart finished and distributed to the cognizant commands.

In a general discussion, two questions were thrown out for further study, in the area of decompression requirements- Can decompression be speeded up? And what % of oxygen should the DISSUB be brought to initially and during the decompression phase? Also asked was, what levels of carbon dioxide can be tolerated by the survivors? There was no consensus answer to these questions. Dr. Masurel was asked if the worst case scenario, all high pressure air banks ruptured, was used to set the pressure in the DISSUB in his presentation. He stated that 3 ATA was the maximum pressure considered, which is very close to that used by the US and the UK. He was also asked if any future human studies were planned for step-wise decompression. There are none currently being planned.

Some comments were made to clear up some perceived confusion, particularly by 'operators', of some of the basics of decompression. The oxygen level, both in the DISSUB and in the DSRV or the MOSUB compression chamber, is kept below 25% by volume because of fire considerations. In the DISSUB, anything over 0.7 ATA oxygen becomes a problem because of potential POT. The best oxygen level is partially based on the source of the oxygen. If the oxygen in the DISSUB is coming from the bleeding of air banks, you want to minimize the additional pressure and its increased DCS risk because the air is 80% nitrogen. However, if the oxygen is coming from chlorate candles or from an oxygen bank, there is no

reason to keep the oxygen level very low, as there isn't additional nitrogen coming into the atmosphere. Reiterating, during the decompression, about 0.7 ATA is the most desirable amount of oxygen to have in the atmosphere.

Some discussion occurred on the concept of a small microclimate (an enclosed area where oxygen can be breathed down, with attendant carbon dioxide scrubbing). The remainder of the large rescue compartment would have a higher  $PO_2$ , but the microclimate could be used for injured personnel or for personnel who are exhibiting symptoms of POT.

A question arose as to the effect of pulmonary oxygen toxicity on decompression. Rescue pressures used by the UK, and mentioned by the US, are such that if air is pressurizing the DISSUE, the oxygen levels are not high enough to have a toxic effect on the survivors. Oxygen should be minimized to levels compatible with life and health within the DISSUB, and maximized during decompression, since this will hasten the removal of nitrogen by replacing some of the inert gas in the atmosphere. A suggestion was also made to standardize the terminology used in describing the pressure within the submarine, using the tissue partial pressure of nitrogen, instead of total pressure and the partial pressure of oxygen, since everyone uses different terms, such as 'bar' or 'feet of seawater' or 'mm of Hg'. If everyone used the partial pressure of nitrogen that exists within the submarine and the absolute pressure you're going to, the graphs and tables relating to DCS problems would make more immediate sense.

Until there is a decision made as to whether any risk of pulmonary oxygen toxicity will be tolerated among survivors, the question concerning the effect of POT on decompression is moot. If no risk of POT or of DCS will be tolerated, very long decompression times, with low oxygen levels, must be used. In this case, nitrogen isn't a problem, since the decompression time is so long. If you're willing to tolerate some decompression risk, the time factor can be shortened.

Does oxygen have any direct effect on decompression or does only nitrogen? The results of a large human diving experiment at NMRI have shown no evidence that oxygen has any effect on decompression risk. If some of the survivors are showing symptoms of POT, how will the decompression affect them? No human studies have been attempted to answer this question, nor is it felt that any can be done, due to ethical reasons; but animal studies have shown that POT symptoms predispose one to decompression problems. That is, the decompression is not as innocuous for them as it would be for someone who has not shown POT symptoms.

After the discussion period, SURG CAPT Pearson turned to survival after escape. This presentation was a discussion of the UK's Submarine Escape and Immersion Suit and its latest modifications. The suit was initially developed in the 1950's, with fleet introduction in the 1960's. It has progressed and been modified since then, with the Mark VIII in fleet use now. Several significant inadequacies have been uncovered with the suit and improvements are currently underway. These improvements are in three major areas: thermal protection, splash protection, and seakeeping. In the area of thermal protection, the main thrust has been to relieve the problem of cold diuresis and the thermal effect of the urine collecting in the suit. Initially, a 'nappie' was going to be used, as a method of collecting the urine. Now in use is a penile sheath with a one-way

valve, that allows the urine to be vented from the suit into the water. The sheath is being used in lieu of two-sided penile tape, to attach the vent tube to the penis. Another improvement is the modification of the suit into a double compartmented configuration. This allows the back of the suit to maintain a layer of air between the skin and the suit, which is important since the person is in a supine position in the water. In addition, for those persons, particularly engineering personnel, who won't have time to don additional clothing prior to escape, an undersuit of thermal underwear (Flexalon or Thinsulate) is being made available, to be worn while on station. For splash protection, the splash screen from the UK's general immersion suit has been added to the Mark VIII. The screen also reduces the carbon dioxide build-up to tolerable levels. Not much design work has been done to improve the seakeeping capabilities of the suit, however. The improvements in this area are coming from pharmacological research.

Testing has been done, using skin temperature probes, rectal probes, ECG, etc., showing that an individual can survive for 24 hours under adverse condition while wearing the suit. The next improvement must come in the area of hand protection, as the neoprene gloves currently available as part of the suit are unsuitable. The Mark IX will contain these improvements as well as providing extra buoyancy behind the neck.

K. Ackles briefly described the Canadian experience with exposure. Canada is not doing much in the way of submarine escape research, as they already utilize the British escape system and the British escape suits. However, some work was done several years ago related to survival suits (quick-donning) for airplane passengers and crew. A variety of suit types were tested in 10°C water, for periods up to 3 hours. Some description of the methods of analysis and results was given.

SURG CDR Kalman discussed the use of drugs with escape. The British have looked for some time at the problem of survivors left in the water for long periods of time (up to 24 hours) prior to rescue. One of the major complaints is seasickness. The survivors leave a stable platform and suddenly find themselves in a medium of continuous motion. Seasickness sets in very rapidly, even in what must be called gentle seas. The standard prophylaxis has been oral administration of hyoscine. Two problems have been found with this, however. The first is that as soon as the seasickness sets in, the person vomits, usually throwing up the hyoscine tablet with the rest of the stomach contents. Second, the hyoscine doesn't last for the 24 hours that may be necessary to await rescue. For these reasons, a regimen of sublingual and transdermal hyoscine is being looked at. The sublingual application is very fast-acting, while the transdermal application is long-lasting. Another advantage of this regimen is that upon rescue, the transdermal patch can be removed, thereby stopping the therapy.

In addition to seasickness, the topic of thermal stress, particularly cold from diuresis is a problem. The initial thought was to give ADH to stop or at least control the diuresis, but this led to later problems with fluid balance. This problem is still being studied. Animal work is planned to look at the effects of pre-breathing oxygen, using anti-platelet drugs to reduce the reactivity of blood, and steroids to help reduce edema, caused by exposure.

Dr. Withey touched on the UK Depressurization Systems. This presentation is an update on work being done at the Admiralty Research Establishment's Experimental Diving Unit, on methods of reducing the pressure in a DISSUB, without harming the survivors. They are planning experiments on the use of hoses attached to the external salvage fittings of a DISSUB and run to the surface, where the pressure can be reduced through a valve system. Ventilation at constant pressure can also be provided. The system testing is scheduled to be done with the DISSUB at a depth of 200 m. using 300 m. of hose. The pressure can be controlled to a tolerance of 0.01 bar/hour. The hoses are available, and the studies are scheduled to begin during 1988.

A general discussion period followed. A comment was made that relative to the urine collection problem and the use of the penile sheath, persons in the construction industry, particularly persons who work up on tall buildings, have had the same problem for years. They have found a low cost solution, but it was not discussed in detail.

The UK and Norway are sponsoring a submarine escape exercise in July 1987, using the Mark VIII SEIS. The exercise will take place in a fjord in Norway and invitations are going out to other countries to send observers. The following countries are furnishing subjects for the exercise, which will be from up to 180 m. depth: UK, Norway, Australia, Holland, Sweden, West Germany, and Italy.

Some comments were made concerning the use of hoses to ventilate and decompress a DISSUB. The biggest worry was that the partial-pressure of oxygen would fall to unacceptably low levels during ventilation, while maintaining the necessary pressure within the DISSUB. The UK has a resupply capability, and they are certain that they can maintain the partial-pressure of the oxygen while ventilation takes place.

A comment was made about the use of the sublingual and transdermal hyoscine during escape. The transderm is rated for only 12 hours of use. However, the company that makes them is sure they will work for the required 24 hours. There was some discussion of the use of transderm scopolamine, as is used by the US. A potential problem is some data showing mild CNS symptoms in divers using scopolamine. The question was asked whether it is worth mild CNS symptoms, if the scopolamine protects the survivors from seasickness. The answer given was that the CNS involvement is probably preferred to the seasickness.

A final question was asked concerning whether or not there might be a DCS component to the rapid onset of seasickness among survivors, surfacing from a depth of 100 m. The answer given was that from that depth, the chances of DCS are minimal, so that probably isn't a concern.

#### SUBMARINE AIR QUALITY

The UK overall approach to submarine atmosphere monitoring was presented by Ms. Dibben and SURG CDR Kalman. Increased medico-legal requirements have led to the adoption of new monitors which are not yet installed in the fleet. A CAMS (mass spectrometer) will measure 12 selected gases continuously. A portable total organic monitor (photoionization detector) and a portable total aerosol

monitor (based on infrared scattering) will be used selectively but frequently. Organic analysis will also be provided on-shore. Each submarine will carry a supply of adsorbent tubes (Tenax) that will sample the ship's atmosphere, and then be sealed. Later, on-shore, the tubes will be subject to thermal desorption and quantitative identification by GC-MS (sensitive range  $C_0$  to  $C_{15}$ ). Spectra will be stored and statistical profiles generated on 20-30 compounds of most interest. The list of priority compounds could be readily changed.

Mr. Thill presented a status report on the pending major revision of the U.S. Submarine Atmosphere Control Manual. Equipment descriptions and especially the atmospheric contaminant limits were outdated. The new draft manual will incorporate several significant changes:

- More emphasis on the submarine CO's responsibility for materials control, painting limitation, and smoking
- Major revision of atmosphere contaminant limits based on US National Academy of Science recommendations
- Inclusion of new sections on gas free engineering and heat stress considerations
- Ready reference sections on response to atmosphere casualties and emergencies

The new manual is expected to be in final form in about 1 year.

Mr. Adams described the UK Atmosphere Control Manual, BR 1326. The document is not just a handbook but also serves to present design policy and technical specifications. Chapters are devoted to atmosphere control equipment, and several annexes describe atmosphere limits for contaminants, ventilation considerations, analysis stores lists, and reporting requirements. Responsibility for the document is vested in a single Submarine Air Purification Committee that represents operational, medical, engineering and marine architectural viewpoints. Material control procedures place new items into one of several categories based on toxicity and fire characteristics. About 8 new materials per month are added to the 750 already categorized. Operation of major atmosphere control equipment is described in the manual. Oxygen is provided by electrolysis units (nuclear subs) or chlorate candles (conventional subs). Carbon dioxide removal is by monoethanolamine (MEA) adsorption or molecular sieves (nuclear) or soda lime (conventional). Hydrogen and CO are catalytically burned. Filters, precipitators and charcoal beds are also used. For major analysis, two instruments are in use: a gas chromatograph (Rye) and a mass spectrometer (CAMS). Multiple portable/backup analyzers and shore based analysis is also specified. Formal test procedures are listed for both harbour and at-sea evaluation of atmosphere control for new and re-fitted submarines.

The French delegates presented information on a rarely studied contaminant in submarine atmospheres - phenol. Potential sources of phenol and its derivatives are cigarette smoke, sanitary disinfectants, and photographic

supplies. Studies were performed on extracts from main submarine charcoal beds. Caustic and acid-ether extraction treatments are followed by capillary gas chromatography. Positive assays were reported for phenol, m-and p-cresol, and two dimethylphenols. Further investigations are planned.

CDR Weathersby described a recently approved procedure to verify that submarine air banks are suitable for breathing by divers. The standard U.S. shore laboratory analysis for divers' air is not suitable because the submarine and its air bank - atmosphere is complicated and changes composition more rapidly than shore installations. The new procedure assumes a CO<sub>2</sub> scrubber in place and then requires routine monitoring of 8 substances using the ship's CAMS and detector tubes. A photoionization detector (PID) reading is also required. Depending on the PID reading, from 0 to 24 other detector tubes need to be used. The procedure has proved workable in several operations but several improvements are foreseen for procedures, instruments, and administration.

M. Bodilis and MCA Giacomoni presented the French Navy experience with (13x) molecular sieves for CO<sub>2</sub> removal. Tests began in 1964 and eventually led to sea trials on a SSBN in 1969. Laboratory experiments in regeneration by vacuum heating and RF heating led to their rejection as impractical, in favor of conductive heating regeneration. Water vapor had to be removed first by compression, condensation by cooling, and adsorption on activated alumina. Catalytic burners are also required. At sea trials used 2/3 of the air in the purification process with the other 1/3 used to regenerate the parallel molecular sieve unit. Cycle times were about 1.5 hours. Overall unit costs were 135 K-watt electrical, 7.5 metric ton, 15.1 cubic meter volume per unit (2 units per SSBN). The bulky size led to a second generation plant, despite 15 years satisfactory operation at-sea.

The newer unit combines the H<sub>2</sub>O-alumina and CO<sub>2</sub>-molecular sieve operations to save space and cooling water, and uses a low temperature (100°C) platinum catalytic burner. Its operation appears satisfactory also. Further work is in progress.

Mr. Adams described UK experience with molecular sieves for CO<sub>2</sub> removal. In the late 1970's a system using a temperature swing desorption on 4A/10A sieve, after 3A drying, was installed on TRAFALGAR class SSN's. The units controlled CO<sub>2</sub> satisfactorily but were large, complex, and not energy efficient. Pressure swing sieve systems were given extensive engineering evaluation but were discarded due to problems of large size and N<sub>2</sub> contamination of the CO<sub>2</sub> effluent stream to be pumped overboard. In fleet use, the temperature swing units worked satisfactorily but required additional units when the CO<sub>2</sub> rose continuously when only 1 unit was on-line. The sieve has been rejected for newer submarines in favor of monoethanolamine scrubbers similar to U.S. submarines.

M. Bodilis and MCA Giacomoni presented an overview of how atmosphere control equipment can paradoxically increase the hazards of a submarine atmosphere. Non-nuclear French submarines at various times used the CO<sub>2</sub> adsorbents: KO<sub>2</sub> based superoxide - which tended to explode; NaOH - which was very corrosive; then sodalime - which produced an offensive dust. Present sodalime is specially prepared to avoid at-sea bulk handling and now allows the elimination of particle filtration. Conventional oxygen delivery was by O<sub>2</sub> banks then chlorate candles.

Candle problems with  $\text{CO}_2$  and acids are now minimized by a pyrotechnic primer and a sodalime blanket.

Nuclear submarine problems are different due to higher availability of electric power and to longer mission duration (up to 90 days). Oxygen generation is similar in all 3 navies, and is kept safe by shut-down limits on  $\text{H}_2$  and  $\text{O}_2$  and strict training of personnel. Carbon dioxide and freon removal on hot 13X molecular sieve can produce acid gases (from freons) or CO (from hydrocarbons) so all effluent must be sent thru catalytic burners. Catalyst on these burners is platinum (vs the U.S. hopcalite) and operates near  $100^\circ\text{C}$ . Activated charcoal (260 kg in 3 kg canisters) and electrostatic precipitators - with attendant ozone problems - complement the system.

Dr. Carhart had a paper read by CAPT Knight on US laboratory experiments. Fire safety in submarines can be enhanced by operating at oxygen concentrations below 21%. There are three important consequences of using low oxygen concentrations for achieving passive fire protection:

- #1 FIRE PREVENTION. The term "oxygen index" may be defined as an oxygen concentration below which a given material, once ignited, will not propagate a fire. Although the reported index is test dependent, being particularly sensitive to the geometry of the test procedure, there are oxygen concentrations below which a test material will not burn. Gasoline does not burn in 12% oxygen, balance nitrogen.
- #2. REDUCTION IN EASE OF IGNITION AND GROWTH OF FIRES. Nineteen percent oxygen reduces the burning rates of paper and kerosene by 20%, yet an increase in the partial pressure of oxygen ( $\text{PO}_2$ ) at the same oxygen concentration in the gas mixture will generally have lesser effects on the burning rates. The total heat released by cellulose and hydrocarbons is 20% less in 19% oxygen than in 21% oxygen. Nineteen percent oxygen also increases the minimum ignition energy needed to ignite methane and ethane by 33% and 40% respectively.
- #3. ADDITIONAL TIME FOR REACTING TO AND EXTINGUISHING FIRES. There are few fires where corrective action is not taken soon enough to avoid disastrous results. Additional time to react (approximately 30% extra time) may permit the necessary steps taken to prevent a disaster. In closing, it is easy to reduce the oxygen concentration aboard a submarine. This need not be detrimental to the crew since it is the  $\text{PO}_2$ , not the oxygen concentration, that is essential for ensuring adequate life support. How far the oxygen concentration should be reduced should be answered by the medical community.

Captain Knight presented the US low  $\text{O}_2$  Proposal. In theory, submarine crews could live and work in 11% oxygen if the barometric pressure were adjusted to maintain the partial pressure of oxygen ( $\text{PO}_2$ ) above 122 torr. Studies at the Naval Submarine Medical Research Laboratory have shown that the oxygen saturation of arterial hemoglobin is not reduced by exposure to 17% oxygen ( $\text{PO}_2 = 130$  torr) despite significant reduction in the flammability of ignited candles. Nor are tests of human visual and mental function degraded by the exposure of seated subjects to 11.5% oxygen ( $\text{PO}_2 = 88$  torr). Further experimental work is needed to determine the safe, minimum  $\text{PO}_2$  for multiday exposures aboard submarines.



M. Bodilis presented the French use of HALON 1301. Halon 1301 is not used as a fire extinguishant on board French submarines, but approximately 1 kilogram of Halon 1301 is used as a propellant gas. Calculations showed that atmospheric dilution would be rapid. Tests showed that the compound was very stable in the atmosphere control equipment. Even at 300°C only small amounts of chlorine, bromine, CO, and CO<sub>2</sub> were produced in a laboratory regeneration system.

Initial discussion focused on the low oxygen work. Although the mean score for a group of test subjects may show no change of physiological function in an atmosphere of lowered PO<sub>2</sub>, one or more of the test subjects might have losses of function which are of practical significance. This raises the question, "What percentage of the crew suffers degradation of function in an hypoxic atmosphere?" It would be more appropriate to determine what the reduction of PO<sub>2</sub> does to the function of individuals rather than the group.

Canadian tests of standing steadiness and vestibular evoked responses have shown that vestibular function is degraded at an altitude of 8,000 ft (PO<sub>2</sub> = 120 torr), but not at 12,000 ft (PO<sub>2</sub> = 101 torr). This suggests that the central nervous system may be impaired by mild hypoxia.

Other potential problems are:

- Cigarettes that do not burn well in lowered concentrations of oxygen may release more toxic chemicals into the mainstream or sidestream smoke.
- The reductions of barometric pressure that occur in submarines may further reduce the PO<sub>2</sub> in an atmosphere of lowered oxygen concentrations.
- If lowered concentrations of oxygen retard the growth of fires, they might also delay the recognition of fires. A delay in recognition would offset the alleged advantage of lowered oxygen, which is to allow crews more time for extinguishment before a fire grows to an unmanageable size.
- A gradual reduction in oxygen concentration would allow the crew to physiologically adapt to their lowered ambient PO<sub>2</sub>. If done very gradually, more fire protection would exist at the end of the patrol than in the beginning.

The UK medical scientists do not intend to recommend lowering the PO<sub>2</sub> below the Royal Navy's current limit of 137 torr. The US would like to determine the limiting PO<sub>2</sub> for operational situations such as snorkeling. Neither Navy has apparently established the lower limit of PO<sub>2</sub> for physiological tolerance.

Discussion of other fire issues was limited. Halon 1301 is fitted in UK submarines for use in high risk areas such as ships' galleys. Regarding material flammability, it may be better to develop fire resistant materials for use in submarine construction than to predispose crewmembers to hypoxia by lowering the oxygen concentration.

## CLINICAL ISSUES

MCA Giacomoni addressed the question: Why is smoking not allowed on board French submarines? Cigarette smoke is potentially toxic due to the presence of alkaloids (eg nicotine), asphyxiants (eg CO), irritants, and carcinogens. Sidestream smoke is even richer in these pollutants than mainstream smoke. Studies were begun in the 1960's to prepare for the possible use of tobacco smoke on board French nuclear submarines. A survey of submarine crews showed that between 1963 and 1986 the number of smokers has decreased from 88% to 61% of the crew. The daily consumption of cigarettes has also declined from 15.6 to 13 per man. Since indoor air contains greater concentrations of particulates and gaseous pollutants when cigarettes are smoked in underventilated rooms, submarines were assessed for the capacity to remove 132 liters of CO and 83 grams of tars released daily into the sealed atmosphere. It was determined that the planned life-support system would be adequate for this purpose. Policy eventually dictated that smoking would be banned to avoid exposing non-smokers to the nuisance smoke.

Dr. Hee discussed the additivity of hydrocyanic acid and carbon monoxide. French scientists have been interested in estimating the acute toxicity of thermolysis products by completing three research objectives:

1. Determine the time-concentration relationships of hydrocyanic acid (HCN) and carbon monoxide (CO) on animal models.
2. Describe the laws governing the combined effects of HCN and CO.
3. Define the limit values for man. The time to incapacitation was studied by exposing mice and rats to mixtures of CO and HCN. Time-concentration curves were plotted from separate exposures to the gases. Rats were more sensitive to HCN than mice, but both species were equally sensitive to CO. Both species were exposed to 6 different mixtures of HCN (36-150 ppm) and CO (700-5100 ppm) and observed for time to incapacitation. The combined effects of CO and HCN were additive. Data from the rats were extrapolated to humans on the assumption that the ratio of minute ventilation to body weight was 6-fold higher in rats. After additional adjustments accounted for level of activity and more conservative times, the recommended concentrations for 15-minute exposures of humans were CO = 2000 ppm and HCN = 30 ppm.

Dr. Hee then presented work on particulate and gaseous pollution from tobacco smoking. Although crews do not smoke onboard the French submarines, an experiment was conducted to characterize the pollution of confined spaces with tobacco smoke. This paper, the first of two, reported the effects of various removal devices on the composition of the polluted atmosphere. A 50 m<sup>3</sup> room was contaminated by the smoking of 24 cigarettes at a rate of 2 every ten minutes. The following removal strategies were tested: diffusion through an open door; open-circuit, forced convection; and, three types of closed-circuit filtration systems. Without the removal strategies, there was a change in the distribution of particle sizes with the passage of time. The number of small particles (0.12-0.17 micrometers) dropped from 10<sup>6</sup> to approximately 10<sup>2</sup> particles per liter air during the first hour. At the same time, the number of larger particles (0.42-1.17 micrometers) increased. Other subpopulations of particles (0.17-0.42 and 1.17-6.12 micrometers) remained constant over the 3-hr period. The total population remained constant and in excess of 106 particles per liter air.

Technical problems prevented the reporting of nicotine levels. After 2 hrs, the main gaseous pollutants were methane-equivalent hydrocarbons (177 mg/m<sup>3</sup>), CO (26 ppm), NO (1 ppm), toluene (.7 ppm), NO<sub>2</sub>, formaldehyde, acetaldehyde, acrolein, and acetone. The concentrations of CO, NO, hydrocarbons and formaldehyde decreased with time, suggesting transfer between gas and particulate phases or the selective absorption onto biological or chamber surfaces. The strategy of diffusion nonselectively removed 50-75% of all pollutants. None of the filters removed CO and only absolute filters were capable of removing the particles. The electrostatic filters were not very effective due to the range of particle sizes.

In Dr. Hee's second paper the goal was to estimate the effect of tobacco smoke on nonsmokers. Six smokers and 4 nonsmokers sat in the 50 m<sup>3</sup> chamber while the smokers produced tobacco smoke at a rate of 0.24 cigarettes/ m<sup>3</sup>/hour. Several test sessions were used to evaluate the effects of filtering systems on the biological effects of tobacco smoke. Smoking was permitted between test sessions. The fully polluted atmosphere caused a maximal blinking frequency of the eyelids, a maximal nuisance index, and a minimal nasal resistance. The non-polluted atmosphere had the extreme opposite effect on these biological measurements. Treatment of the polluted air with filters was beneficial. The incremental change in the carboxyhemoglobin concentration was 1% and the increase in the urinary excretion of nicotine was 60-80 micrograms/day. Comparisons between data from the smokers and non smokers suggested that non smokers inhaled the equivalent of smoke from 1 cigarette during their confinement in the polluted chamber.

Dr. Smith presented UK research on CO and smoking. The advantages of curtailing smoking are the reductions in fire risk, atmosphere pollution, "passive" smoking, and carbon monoxide burden to the CO/H<sub>2</sub> burners. Multiday exposures to CO (75, 50, and 15 ppm) were studied at the Institute of Naval Medicine. There was no statistically significant deterioration of mental function in any environment, but the subjects' capacity for exercise decreased in relation to the blood level of carboxyhemoglobin (HbCO). Changes of the P-wave axis of electrocardiograms occurred in 7% of the subjects exposed to 50 ppm CO and 2% of those exposed to 15 ppm CO. One man, a heavy smoker, developed changes of the S-T segment on his electrocardiogram during exposure to 15 ppm CO. An extensive medical evaluation after the experiment failed to demonstrate an underlying cause for the temporary ST change. In another laboratory study, 24 subjects inhaled 500 ppm CO for one hour, resulting in an increase from a HbCO of 0-4.6% to a HbCO of 6.6-11.5%. Only one subject showed a reversible shift of the P wave axis from 70° to 0°. During a submarine patrol, 5 of 31 men experienced reversible changes of their P wave axis from 40-60° to 0-40°. In a second patrol study, 50 men were studied during a multiday exposure to 7 ppm CO. The P-R interval was slightly prolonged in 4 men. Nine men (6 non smokers and 3 smokers) experienced a reversible change in the P wave axis during the first half of the patrol. The true incidence of changes in P wave axis cannot be determined until a large number of subjects (n > 1000) can be studied.

CAPT Bumgarner presented US policy on smoking. Public and professional concerns for the health effects of smoking began in 1950 with the publication of a paper on the pathological consequences of tobacco smoking. In 1985, the Surgeon General of the US published his opinions about the detrimental effects of "active" and "passive" smoking. Recent attempts have been made in the US to

banish smoking from passenger aircraft. The Secretary of the Navy has established guidelines for creating a healthy working environment. One guideline is the restriction of smoking from work sites where smoke will risk impairing the health of non-smokers (SECNAVINST 5100.13A, 17 JUL 86). Today, approximately 10% of the submarine officers are smokers. The senior enlisted submariners have a higher percentage of smokers (50-75%) than the junior enlisted men (30%). Aboard submarines, tobacco smoke has adverse effects on both the people and the equipment. Several recommendations have been considered for reducing the smoke pollution aboard nuclear submarines. One strategy is to banish smoking throughout the ship, with the realization that some crewmembers would devolunteer from the Submarine Force. Nicotine chewing gum might be a suitable substitute for use by smokers during patrol. As an alternative, designated smoking areas might be established within the ship. Another strategy would be to remove smokers from submarines. This is unrealistic, since it would reduce the number of operating crews by 30%! Proposed U.S. policy guidance is attached as an Appendix.

LCDR Southerland presented US work on computer diagnosis. Medical evacuations are hazardous operations which endanger the participants and compromise the security of the submarine. Each medical evacuation costs approximately \$250,000. The US Navy has been developing the use of computer-assisted medical diagnosis for approximately 20 years. In the past 5 years, a computer program has been deployed aboard submarines to assist the hospital corpsman in diagnosing the cause of abdominal pain. At the present time, there is an insufficient number of cases of abdominal pain which have been managed by the computer program. One explanation for this is the lack of computer time available to the corpsmen. The planned deployment of IBM compatible computers will improve the capability for use by corpsmen. Programs for managing chest pain, psychiatric emergencies, and dental emergencies have been written for use at sea. Each program will contain a treatment module when it is ready for deployment. In the future, validity studies will be conducted using an alternate source of patients from military hospitals.

Smoking issues led to a lengthy discussion period. No speaker or member of the audience spoke in support of the practice of cigarette smoking aboard nuclear submarines. Rather, all discussion was oriented toward reducing or banning smoking from submarines. Some thought it would be useful to compare the atmospheres of a smoking and nonsmoking crew during submerged operations. Others thought the existing data are convincing with respect to the detrimental health effects of tobacco smoking. In order to implement changes in policy, a convincing summary of scientific data should be presented to the policy makers.

Regarding the French studies of tobacco pollution, the chamber study may not represent the reality of smoke pollution aboard submarines. The particle growth which occurred in the chamber might have resulted from high humidity or agglomeration. The lower humidity aboard US submarines is associated with smaller particles in lower concentrations (the submarine data are 20 years old and have not been revised by more current information). Caution must be taken in calculating the "equivalent cigarette" for sidestream smoke from measurements of HbCO and atmosphere pollution. With respect to the removal studies, the US Navy should consider using a high efficiency particulate filter --such as the F1 filter in the chamber study-- to reduce the smoke aerosols in the occupied

compartments of the ship. Unfortunately, the high efficiency filters require more space than the electrostatic precipitators (ESP's). The US Navy currently uses a dual-stage ESP with an efficiency of 60-70% towards the end of patrol. Tobacco smoke leaves a varnish-like collection of tars on the collecting plates. A single stage ESP has higher efficiency, but the higher voltage generates more ozone. Ozone is readily removed by charcoal filters. The charcoal filters in current use are characterized by an inefficient flow of air through the charcoal; nonetheless, the filters work well.

In other points of discussion, it was suggested that in the absence of other ECG defects, the reported UK changes of the P-wave axis do not seem to be clinically significant. Dr. Smith's work has established the basis for limiting long-term exposures to 15 ppm CO in submarine escape scenarios. In the emergency situation, the maximum permissible concentration is based on the time-concentration curve for HbCO = 30%. The ratio of nicotine to cotinine does not distinguish between particulate and gaseous sources of nicotine. Platelet adhesiveness might serve as an indicator of exposure to tobacco smoke.

#### PSYCHOLOGICAL ISSUES

Dr. Scott, the Commanding Officer of the Naval Hospital, Groton, provided introductory remarks as to the importance of considering the psychological health of the submarine service. Drawing on personal experience, Dr. Scott related several incidences where he reviewed every hospital case involving psychiatric problems. Although absolute incidence in the submarine population of severe psychiatric disorders is at or below average of other populations, this small percentage of individuals accounts for a significant number of service men. In particular, individuals with less obvious personality disorders should be identified and treated. The problems these individuals cause are in the areas of work performance and interaction with their fellow service men, officers, and medical personnel.

A more extensive screening program that goes beyond the identification of overt psychiatric disorders should be undertaken to identify individuals with maladaptive traits for performance in the submarine environment. Every effort should be made to screen individuals who come into the submarine force. A thorough screening procedure for severe psychiatric and personality disorders would avoid later administrative problems in separation of problem personnel. Primary savings would be in the area of training costs and staff time in evaluating and processing unfit individuals.

Dr. Giannandrea presented a brief description of the history and development of the submarine. He pointed out that the history of submarine service personnel has been marked by the risk of injury and death from the submarine environment. Many of the early attempts to develop submarines lead to fatalities. The character of the early submariner was shaped by recognition of the hazardousness of his sea duty. Individuals who adapted to submarine duty were attracted to these risks and the close fellowship with other submariners. It is in this context that submarine psychiatry must be understood. Dominant psychological mechanisms come into play in the denial of the risk of submarine duty. The

submarine is a crew serviced weapon that demands adaptation of the person to the environment. The submarine is formed along rigid specifications so that it is the individual who must adapt. In other occupations it is the environment that is changed to suit the individual.

The tendency to deny the dangers that are found in submarine duty as well as the long tedious, and physically demanding tasks make submariners vulnerable to psychiatric breakdown. The psychological mechanism of denial of danger and a high degree of affiliation with other men protect submariners from becoming psychiatric casualties. However, these traits also isolate these individuals from other non-submarine groups and denies them insight into their emotional lives. When severe situational problems arise in their personal lives they usually do not cope with these problems on a realistic basis. Rather, they employ the form of defense most successful in adapting to long arduous submarine missions, denial. Thus, many psychological problems are not dealt with openly.

The system of referral and record keeping in the military also views the need for psychological help as a blemish on the submariners record. They are expected to be more than human in dealing with day to day difficulties. When individuals are seen at the clinic, many problems have gone undetected for a long period of time and a change in the persons' situation, usually the failure to perform adequately, brings them for evaluation at the crisis point. Treatment at this point is usually difficult and results in the loss of trained personnel which would be avoidable had the problems been detected at an earlier time.

Dr. Wallace presented selected case histories of individuals referred for psychiatric treatment at the Naval Hospital Psychiatric Clinic. He illustrated both the need for more adequate screening procedures of incoming personnel and the need for earlier detection of psychological problems in personnel who have served with the submarine service for many years. Changes in individual's lives relating to divorce, financial difficulties, or mistreatment may lead to psychological casualties that could have been avoided.

Dr. Bryant presented recent research on the incidence of suicide referrals to the psychiatric clinic.

The social impact of completed suicide on the behavior of others was studied within the natural setting of four military groups within the submarine service. This study began after three completed suicides occurred over a short period of time (within one month) in Nuclear Power Training Unit, Naval Submarine Support Facility, and Basic Enlisted Submarine School. A 3-year baseline period was reviewed for the time period prior to the suicides. The review focused on referral information for those individuals evaluated for the presenting complaints of suicidal gestures, thinking, or preoccupation versus other symptoms or signs of psychopathology. The 3-year baseline data were then compared to a 6-month period after the single completed suicides for each study group. In addition, a fourth command, consisting of all individuals referred from submarine commands (Active Duty Submarine) in which there were no completed suicides during the study period, was compared to the three commands in which a suicide had occurred. Finally, a structural equations model was used to identify the effects of suicidal thinking on total pathology across commands.

Clear-cut, yet diverse, effects for exposure to the completed suicide were found for all groups. A significant increase in suicidal thinking after exposure to suicide was most prominent for basic enlisted submarine personnel. A linear increase in suicidal gestures was found over the total period for the Nuclear Power Training Unit, and a seasonal effect was obtained for the Naval Submarine Support Facility. In contrast to the commands exposed to suicide, Active Duty Submariners decreased referrals during the post-suicide period. When autoregressive functions were estimated within a structural equations model, increases in suicidal thinking within basic enlisted submarine school affected later pathology in other commands. Prior suicidal thinking (lagged by 1 month) in submarine school predicted increased total pathology in the Nuclear Power Training Unit and Basic Enlisted Submarine School as well as decreased referrals for Active Duty Submariners over the total study period. These results were discussed in terms of the effects of exposure to suicide and organizational responses to suicide risks.

Dr. Rodgers described the wide range of stresses that a submariner must undergo. She catalogued these into a general framework. Through an understanding of the unique sources of stress in a submariners life, such as deployment and returning home to reunite with one's family, effective interventions could be made at a community level.

A British and French discussion, following this session emphasized leadership over psychological assessment.

#### APPROPRIATE NATO STANAGS

M. Bodilis presented recent French work on life support stores. NATO STANAG (Standardization Agreement) 1295 concerns storage containers for these stores. The standard containers were developed by the UK but will not fit through the escape hatch in French submarines so the French have not ratified the STANAG. However, French work with the containers has shown the feasibility of efficiently packing the containers with chlorate candles for oxygen generation and textile wrapped sodalime for carbon dioxide absorption. Thus prepared, each container would provide several day life support for large numbers of crew without recourse to power or to any other materials.

SURG CDR Kalman forcefully presented the UK position on two related STANAGS: 1184 and 1206. For background, he stated that STANAGS are formulated by a NATO Navy Medical Working Party with no particular submarine experience. The submarine expertise is found at the Tripartite Meeting and in the Submarine Escape and Rescue Working Party (chaired by MCA Giacomoni), which has published useful standards such as S/MER,1301. The two STANAGS (1184 and 1206) concern atmospheric constituents in submersibles during routine (1206) and emergency (1184) operations. He pointed out that the definitions were vague, that the gases and levels already differ in importance and approach among different nations, that no monitoring methods were specified, and that the medical safety value of the documents was minimal.

In discussion, it was added that the naval architectural value of the documents was also low. No alternative medical justification for 1184 and 1206 was proposed. Country leaders met separately for further discussion. They then issued a joint statement (enclosed) recommending the withdrawal of STANAG 1184 MED(U) and 1206 MED(U) but supporting 1301 SMER.

#### CONCLUDING ACTIVITIES

There was an exchange of mementos among project officers and the host facility. Most prominent among them was a special carving with unusual pedigree presented by the UK (citation included with full papers).

A Joint Project Officers' Statement was issued regarding NATO STANAG's on submarine atmospheres.

The next Tripartite Meeting was scheduled for Oct-Nov 1988 in the United Kingdom. (The date was subsequently deferred to May 1989).



Joint IEP B52/AngloFrench DRG Area 8 (Submarine Medicine)  
Project Officers Statement

Date: 4 June 1987

Venue: Tripartite Meeting of 1 to 4 June 1987  
Naval Submarine Medical Research Laboratory, Groton,  
Connecticut, USA

Present: Captain R. L. Bumgarner, MC, USN, US Project Officer IEP-B52  
Medecin en Chef A. L. Giacomoni, French Coordinator A/F DRG Area 8  
Surgeon Commander C. J. Kalman, R.N., UK Project Officer IEP-B52 &  
joint coordinator, A/F DRG Area 8  
Dr. D. J. Smith, Joint UK Coordinator, A/F DRG Area 8

Subject. STANAG 1184 MED(N) and STANAG 1206 MED(N)

I Agreement It is the unanimous opinion of the undersigned that

1. The medical requirement for NATO standardization of design criteria for atmospheric contamination in submarines during normal operations could not be substantiated
2. No medical evidence exists to justify the provision of a NATO standardization agreement to Commanding Officers for submarine atmospheres in emergency situations
- 3 In the event that an emergency results in a disabled submarine coming to rest on the seabed, the NATO standardization as laid down in STANAG 1301 SMER is vital if satisfactory escape and rescue procedures are to be achieved

II. Recommendation. That the NATO Medical Working Party withdraws STANAG 1184 MED(N) and STANAG 1206 MED(N) from circulation

  
C. J. KALMAN  
Surgeon Commander, RN

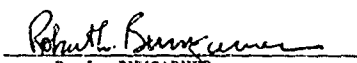
  
R. L. BUMGARNER  
Captain, MC, USN

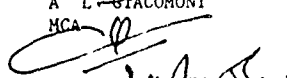
A. L. GIACOMONI  
MCA  

  
D. J. SMITH

(2) Presentation Remarks of CDR C. Kalman RN

In 1901 if there had been a meeting about anything to do with the Navy in the world, the dominant party would have been the United Kingdom. The Royal Navy was almost supreme. The only exception to that was the matters which we talk about today. The French already had a significant interest in submarines and had operated them successfully for years. The Americans also had picked up submarine experience. Prior to 1901 the Royal Navy, along the lines of the comments of our psychiatric representative, said that really the submarine was not a unit which the all powerful force would like to see introduced. However, by 1901 it became clear that our capital ships needed exercise with submarines and therefore we decided to get one for ourselves. We turned to a gentleman who in fact had designed submarines because he wished to destroy British power and British Naval power..... an American of Irish descent. It says a lot for his character that he was prepared to come and sell them to us for financial profit. So we built a submarine in 1901 and with the true modesty that comes from absolute power, we called it HOLLAND I despite the fact that you must have had four or five already.

1901 was an awful long time ago as shown in pictures of the launch of HOLLAND I in 1901. What sort of ships were flying about at the time? There is a fairly famous painting that actually shows HOLLAND II and the time that we are talking about.

The beginning of medical interest in submarines goes back to the Germans in fact, but was closely followed by the French. To correct some of the things said, the early submarines had very large medical interests. There was no propulsion requirement to change atmosphere in a man-powered submarine, you could sit on the bottom for ever. The requirement to change atmosphere was that the men required it. The later classes of submarines lost that requirement once we were committed to regular ventilation and we no longer had the major interest in submarine medicine that had existed before. The British, however, produced a significant change with their first submarines, the HOLLANDS, because, I suppose, their propulsion system was so uncertain. They increased the ship's company by three (mice). Now you might giggle at this, however, during our most recent hydrocarbon work there are a number of papers to say that you can train gerbils to react to almost individual organic contaminants and therefore, perhaps the mouse in a gasoline-driven submarine was not a bad monitor. It is also said that it was selected largely because the submariners don't like the taste of feathers. In fact, at that time seamen were paid the grand sum of a shilling a day and the mouse's wages were similar, a shilling a day, and they were listed on the ship's log as crewmembers so that the crew actually spent three shillings a day on mouse food and various other luxuries that they were allowed to take.

To finish the story of the HOLLAND then, in 1913 having spent a long and distinguished service career, it was decided that she was for the scrap yard. On towing around for final breakup, in a storm she broke her tow. No one was on board, no one decided to go back for her and she sank. Sixty-nine years later, in 1982, we brought her to the surface. The longest dive of any Royal Naval submarine. She flew the union jack put on her by Royal Naval divers while still underneath the sea, in a picture taken some hours after she broke the surface. Quickly she was chemically treated, and we now find her at the submarine museum close to HMS Dolphin in Gosport in Hampshire. A quite amazing dive and a quite amazing submarine. After sixty-nine years on the bottom, they took out her batteries, scraped the

terminals clean and they took charge. The battery tank of that submarine was made of the ancient British shipbuilding material teak. A small quantity of that has become available to us. What would you do with that teak? It may not be quite as rare as moon dust now sir, but there is more moon up there than there is of HOLLAND's wood.

Quite clearly what we would wish to do is produce for our submarine medicine colleagues a true representative of a submarine medicine task. To do that task is another submarine escape and rescue story I suppose because the first officer in command of the submarine escape training tank at HMS Dolphin, Matthew Todd an ex-craft captain, is also a skilled woodcarver and furniture restorer. So we gave him the wood and, sir, what we made is always going to be obvious. I rather believe that it should live here sir because that is where it belongs and I will present it to you as the project officer. Guard him well sir, he is your bi-thright.

DSRV-MOSUB PRESSURISED OPERATIONS - THE UK SCENARIO

BACKGROUND

*CDR R.C. Whiteside, RN*

1. For the benefit of some of the observers present, may I start by getting a couple of definitions clear to save any confusion later on? In NATO-speak there are two distinct methods of saving life after a submarine disaster. They are:-

Escape in which survivors make their way to the surface without the direct help of any outside agency and

Rescue in which survivors are collected by a vehicle which mates with the escape hatch and transfers them dry to the vehicle's mother vessel.

2. Obviously there can be no assurance of one hundred percent survival after a submarine accident, but there can be sensible limits of insurance. The guiding principle we use in the UK is to provide good insurance for the more likely accident situations and some, at least, for the less likely.

3. The UK's escape method utilises a one- or two-man tower (to allow very rapid pressurisation) combined with a hooded suit which allows the escaper to breathe normally throughout his ascent. The system has been proved at sea from 180 metres.

4. For rescue all UK submarines are fitted with a mating seat round each of their escape tower upper hatches. They can thus accept rescue by DSRV or any other submersible that is fitted with a mating skirt. They are not, however, fitted with the hatch bail necessary for rescue by the McCann Bell.

5. The UK is surrounded by a large expanse of continental shelf; over one third of our submarines' operating time is spent in these relatively shallow waters some of which are very crowded. We accordingly conclude that the most likely - or should I say the least unlikely accident - is a collision in which the submarine is either on the surface or at periscope depth and as a result of which it sinks in a depth of water from which escape is possible.

6. So why bother with Rescue then? For some very good reasons. Firstly, the degree of risk to the individual survivor is less if he can be rescued than if he has to make an escape. Secondly, it is not beyond the bounds of possibility that one of our submarines may be disabled on the bottom in a depth of water too deep for escape but above hull collapse depth. In this situation rescue is the only hope. And thirdly, even in depths of water shallow enough for escape - if there is an elevated pressure in the DISSUB's escape compartment escape may not be safe, and rescue may be the only way to provide the good insurance required by our guiding principle.

7. To elaborate on this third point for a moment. To make an escape from a hyperbaric atmosphere is to undergo a step decompression to 1.0 bar (the rate of ascent in the UK suit is some three metres per second). The correlation between the absolute pressure in the DISSUB and the depth from which escape is possible is shown on this slide (1). This is a predicted curve based on a very limited number of points established by observation. What it shows, though, is that it is not safe to make escapes from even the shallowest depth if the pressure in the DISSUB is more than only 1.8 bar. I am sure that there is almost bound to be some elevation of the pressure in the DISSUB's escape compartment due to ingress of water or air before the bulkhead could be shut down or due to high pressure air leaks or whatever?

8. In the UK we have been trying for the last year or more to make up our minds what a reasonable maximum pressure might be upon which to base our escape and rescue policy and systems. It is very difficult to arrive at an answer with any degree of confidence as accidents could vary so widely. While almost any pressure up to ambient at DISSUB depth is clearly possible, work to date does indicate that the answer may be somewhere between 1.8 and 3 to 4 bar absolute.

9. After an accident in depths from which escape is possible, UK submariners are trained to wait as long as possible before escaping. We hope to get recovery forces to the disaster scene before they escape and to be able to sustain them in the DISSUB until the DSRV can arrive to rescue them. However, if laid down limits of oxygen, carbon dioxide, carbon monoxide or absolute pressure are reached before recovery forces arrive, the survivors will make their escape and take their chances on the surface. Since this situation is a distinct possibility, we say that while rescue is the preferred method of saving life, escape is the most likely. In passing I can add that we do not regard salvage of the whole submarine as a means of saving life.

10. In order to help the Senior Survivor to make the critical decision on whether to escape or wait to be rescued, we have been working on a simple hand held computer program to complement or even replace the present instruction cards. The program will also help him to utilise his CO2 absorption units and cannisters to the best effect and tell him his endurance based on the number of survivors and life support stores remaining. It will be complemented by a more sophisticated program which can be taken to the scene in a ship of the recovery force and used by escape and rescue specialists to give the Senior Survivor even better advice. There is still some way to go with this scheme.

#### THE UK SCENARIO

11. When the American Deep Submergence Rescue System was introduced in the early seventies, we in the UK were quick to jump on the bandwagon. We decided that we would configure all our RESOLUTION Class SSBNs as mother submarines - on the grounds that, thanks to their operating cycle, one of them would always be available if a disaster occurred. We knew that the DSRV was capable of being pressurised to 5.0 bar and that the Shipalts for converting the 637 class SSNs as MOSUBS included making their forward compartment capable of pressurisation to 4.0 bar. No compartment in our SSBNs had been designed for use as a compression compartment but on investigation we determined that the forward escape compartment could be pressurised to 2.0 bar which is better than nothing. (The RESOLUTION Class suffers from one disadvantage in common with the 637s - there is no airlock in the bulkhead so that the only means of replenishment during a decompression would be by using the DSRV).

12. In the meantime, CNO had issued a directive to hold the decompression procedures in abeyance in US MOSUBS. This was for a number of reasons:-

- lack of adequate decompression tables for air saturation.
- worries about pulmonary oxygen toxicity among the survivors awaiting rescue and
- fire hazards in the forward compartment which contains a diesel engine and fuel amongst other things.

13. Although our American colleagues have done a good deal of work towards realising their aim to be able to carry out pressurised rescue, as far as I know their procedures are still in abeyance. Up to 1985 we Brits imagined that we had the capability, but I think we would have found it very difficult to carry out a successful decompression had we been called upon to do so. However during 1986, we produced the so called RESOLUTION MOSUB Scenario which is intended as an aid to the development of practical procedures for MOSUB operations and to the identification of material changes that may be necessary. Also last year I worked with COHSUB DEVGRU ONE and OP23 to produce pressurised rescue mating procedures for the DSRV working from a UK MOSUB.

14. As a result of this work the present situation is that the only system within NATO that can carry out pressurised rescue is the DSRV working from a UK MOSUB, and indeed if the requirement arose, we could and would do it today.

15. We have included the MOSUB task in the Staff Requirement<sup>1</sup> for our TRIDENT submarines now building. They will have the great advantage over the 637 SSNs and our RESOLUTION Class SSBNs, that they have an airlock in the compression compartment bulkhead which will allow replenishment and personnel transfer during decompression cycles.

16. The UK Scenario postulates a worst credible case of one of our SSBNs on contractors sea trials with a maximum of 184 men onboard all of whom survive the sinking which occurs on the edge of the continental shelf in an area up to 480nm from the MOSUB loading and departure port. By the time the rescue starts the survivors are saturated at a maximum pressure of 2.9 bar (I'll explain the reasoning for this figure in a moment). This pressure in the DISSUB is steady and cannot be reduced by internal or external means. All rescuees will therefore require decompression.

17. I don't want to bore you with the whole scenario, but only those parts of it that relate to the decompression. The maximum DISSUB pressure we can cope with is, as I said 2.9 bar. This is the maximum pressure from which saturated survivors can safely be step decompressed to 2.0 bar (the maximum capability of our MOSUB compression compartment) as shown by our Islander series of experiments. Following the latest set, Islander II, in the first half of 1986, we have arrived at the decompression profile shown on this slide (2) and it is round this that the whole scenario is built.

18. Our MOSUB compression compartment is in fact the submarine's forward escape compartment which only has a limited amount of space. Conveniently, it can accommodate a few more than 72 people which is the maximum the DSRV could ever deliver between battery charges, making three rescue trips with 24 survivors on each. So the whole time table looks something like what's on this slide (3). In the jargon we have developed, each DSRV rescue trip delivers a batch of 24 survivors (or less), the two or three trips between DSRV battery charges make up one rescue cycle, and all the survivors of one cycle constitute a wave. You may have noticed that these are only two rescue trips in the first cycle. This is to allow the DSRV more time and battery capacity to make his initial location and survey of the DISSUB.

19. As you can see, the decompression for the maximum possible number of survivors would take just over 8 days if all went smoothly. Add to this the length of time it might take for the MOSUB and DSRV to reach the DISSUB position from call out - about another 4½ days - and you have a very long and demanding operation for all concerned. What could we do to shorten the decompression phase? From a physiologists point of view, the hold and decompression must not be speeded up for fear of injuring the subjects while from an operators point of view, the quicker they can be accomplished the better. As an operator, I would welcome any safe reduction in the hold and decompression so I am glad that we will have an opportunity to discuss these after coffee.

20. We have done some trials this year to provide fine control of the bleed decompression in the MOSUB using a specially fitted valve in conjunction with a digital pressure sensor and count down clock. This worked really well, and will form part of the MOSUB equipment package which we are putting together.

21. One last point - 2.9 bar may not seem a very high maximum pressure from which we can safely carry out pressurised rescue, but in the context of the results of the studies I mentioned earlier on, it is not too bad. However, the UK is working on a system to decompress the DISSUB by hoses from the surface. No easy matter, but if we are successful, it will be possible either to bring the pressure to below 2.9 bar and then carry out pressurised rescue along the lines we have discussed or, better, to decompress all the survivors in the DISSUB right back to 1.0 bar and then carry out a normal unpressurised rescue.

22. So, to sum up - using the DSRV and a UK MOSUB, we have a pressurised rescue capability today but it is limited to a maximum DISSUB pressure of 2.9 bar. The safe decompression profile would make the operation very slow, anything that can safely be done to speed it up would be beneficial.

23. Finally, we have a bilateral US/UK DSRV flyaway exercise scheduled for 1989. I am due to leave the Navy in the autumn of that year and as my swansong its my ambition during that exercise to carry out a real-life pressurised rescue to prove the entire system. I hope I can count on the support of everyone here in achieving that ambition.

SLIDE 1

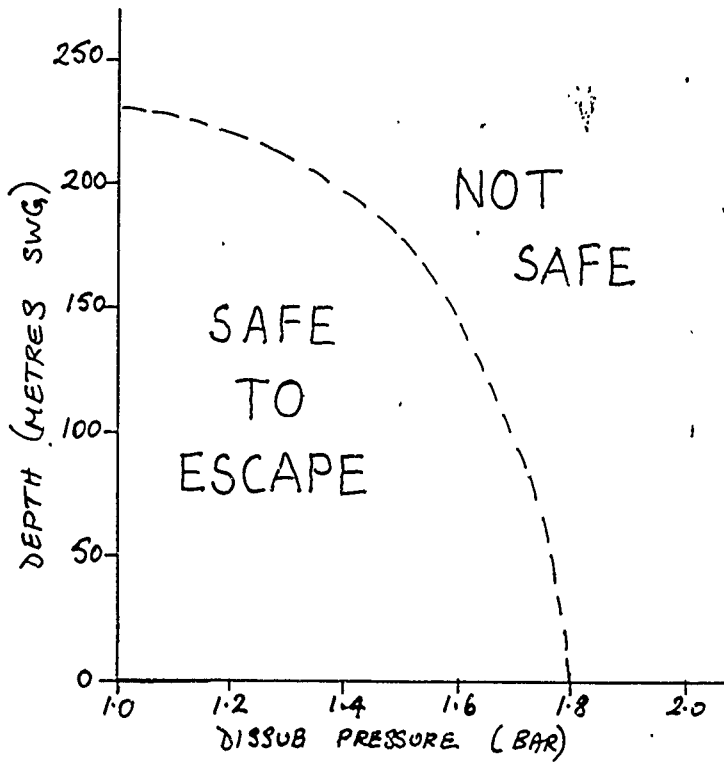



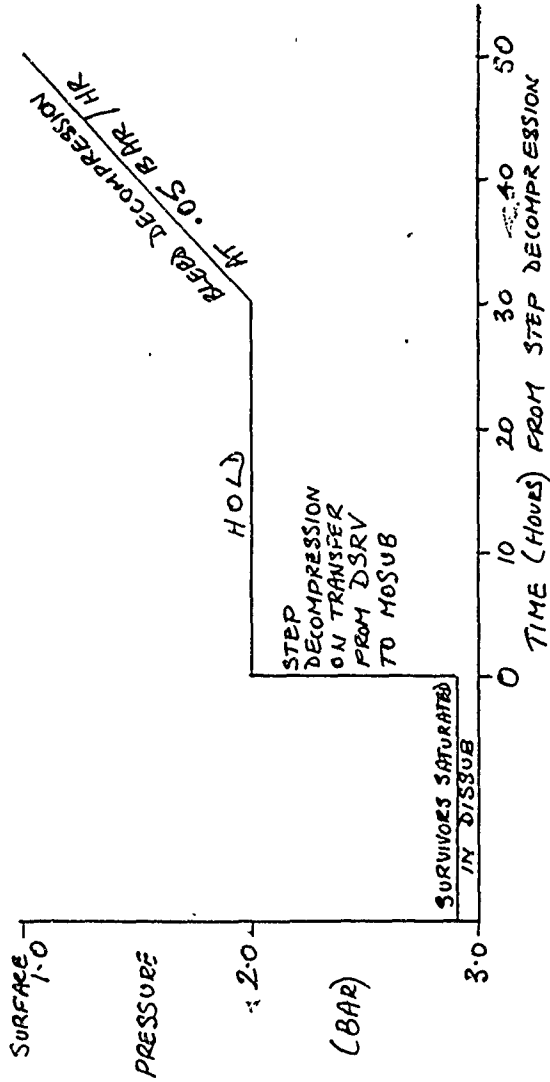

SLIDE 3

RESOLUTION MOSUB SCENARIO  
DECOMPRESSION OF 184 SURVIVORS

ELAPSED TIME (HOURS)	ACTIVITY
0	DISSUB LOCATED. DSRV DELIVERS FIRST BATCH OF 24 SURVIVORS TO MOSUB COMPRESSION COMPARTMENT
8	SECOND BATCH OF SURVIVORS DELIVERED
38	HELD FOR 30 HOURS DECOMPRESSED FOR 20 HOURS
58	FIRST BATCH OF SECOND WAVE DELIVERED
60	SECOND BATCH DELIVERED
68	THIRD BATCH DELIVERED
76	HELD AND DECOMPRESSED 50 HOURS
126	FIRST BATCH OF THIRD WAVE DELIVERED
128	SECOND BATCH
136	THIRD BATCH
144	THIRD WAVE HELD AND DECOMPRESSED 50 HOURS
194	DECOMPRESSION OF 184 SURVIVORS COMPLETED IN JUST OVER 8 DAYS.

INM REPORT NO. 3/87

INSTITUTE OF NAVAL MEDICINE  
ALVERSTOKE, GOSPORT, HANTS PO12 2DL

THE RN MOSUB SCENARIO, STANDARDS OF AIR PURITY

BY

SURGEON COMMANDER C J KALMAN, ROYAL NAVY

Approved by:



R R PEARSON  
Surgeon Captain Royal Navy  
Head of Undersea Medicine Div

Released by:



R W F PAUL  
Surgeon Captain Royal Navy  
Medical Officer in Charge

MARCH 1987

## THE RN MOSUB SCENARIO. STANDARDS OF AIR PURITY

### 1. INTRODUCTION

1.1 The submarine rescue system endorsed by the Standing Committee on Submarine Escape and Rescue (SCOSER) involves the transfer of rescues from the disabled submarine (DISSUB) to a mother submarine (MOSUB) via the US Navy Deep Submergence Rescue Vehicle (DSRV).

1.2 Within credible scenarios, it is acknowledged that the rescues may be saturated at increased pressure. In this event, they will be maintained at that pressure in the DSRV during transfer and then delivered to a pre-dedicated compartment within the MOSUB maintained at 2 bar pressure for subsequent decompression.

1.3 Despite the fact that rescue under pressure has long been included as an option in Royal Navy plans, currently no specialist panel exists within the MOSUB to facilitate the pressurisation of either DSRV or MOSUB compression compartment. It is envisaged, however, that both such evolutions would be accomplished using air from the MOSUB High Pressure Air (HPA) system.

1.4 Submarine HPA differs significantly from the standard laid down for normal diving and recompression chamber operations. The current intention to use such air within the RN MOSUB scenario therefore requires biomedical examination.

2. AIM

2.1 The aim of this paper is to:-

- a. Identify the levels of contaminants within submarine HPA.
- b. Examine the RN HOSUB scenario and identify the level and duration of exposure of personnel to submarine HPA at the various pressures.
- c. By the comparison of a. and b., derive the potential effective toxic exposure involved in the current PCSUB scenario and thus examine the acceptability of present policy for consideration by the Biomedical Sub-committee of SCOSER.

3. LEVELS OF CONTAMINANTS WITH THE HPA SYSTEM:

3.1 The HPA system supplies air to a number of submarine systems which, when used, results in some increase in ambient submarine pressure. During normal submarine operation, system contents are maintained by the cyclical use of compressors which return air from the submarine atmosphere to the HPA bottle groups. At sea, therefore, the submarine atmosphere and HPA bottle groups reach equilibrium and gaseous contaminants present in the submarine will likewise be present in the HPA system.

3.2 Maintenance of submarine atmosphere control standards is achieved by way of a three pronged policy of complete avoidance of certain agents, passive control by limitation of quantity for others and active control by removal for still more. The mechanism of control is laid down within BR1326 and 1326A. Where

applicable, a uniquely submarine ceiling level is laid down for certain agents as a basis for control measures. Such levels are listed as Maximum Permissible Concentrations for 90 days continuous exposure ( $MPC_{90}$ ) and are included in this paper as column 1 of Annex A. Real time and retrospective analyses of submarine atmospheres confirm that these limits can be maintained.

3.3 Despite gaseous exchange with the submarine atmosphere (para 3.1), the HPA system represents a relatively closed system which is infrequently cleaned. The requirement to use such air for the Submarine Emergency Breathing System (EBS) at 1 bar pressure determined the need to promulgate a standard of purity and to monitor bottle group air. SGM0332 lists this standard and details are included as column 1 of Annex B. Analysis of the results of HPA samples forwarded to the Submarine Environmental Chemical Unit (SECU) over the past year indicate the standard is currently maintained, maximum and mean results are included as columns 2 & 3 of Annex B.

3.4 In an effort to identify the maximum levels of contaminants which could be present within the HPA to be used for pressurisation in the MOSUB scenario, it is considered appropriate to assume  $MPC_{90}$  concentrations except where SGM 0332 levels indicate a lowering of this standard. It is apparent that such lowering only affects the level of carbon monoxide.

#### 4. LEVELS AND DURATION OF EXPOSURE

4.1 The MOSUB compression chamber in an ESBM has the ability to accommodate up to 77 men and can be compressed to 2 bar with ships HPA. The mid and aft spheres of the DSRV can accommodate up to 24 survivors on each trip and must be pressurised from MOSUB HPA through open hatches. The current "worst case" MOSUB scenario involves the rescue of a maximum of 164 survivors saturated at a pressure of up to 2.9 bar. The numbers involved require a total of eight transfers by DSRV from DISSUB to MOSUB decompression compartment, tired to provide rescues in three waves, decompression of each wave being completed prior to transfer of the next. The figure of 2.9 bar represents the current best estimate available for a maximum DISSUB pressure at which the transfer phase will not result in decompression sickness. In the absence of an identified maximum creditable accident pressure within the DISSUB it is acknowledged that attempts at rescue might have to be made at pressures greater than the stated figure and thus a higher level of 3.3 bar has been used to derive maximum potential toxic exposures in this paper.

#### 4.2 The Decompression Compartment

The requirement to compress the MOSUB compartment to 2 bar prior to the instigation of each decompression run, produces a minimum figure of 50% HPA within the compartment at any one time. The longest exposure times within the compression compartment will be for those attendants locked in prior to compression (Resolution Class only) and for the first batch of 24 rescues who must wait

for the remainder of their wave (2 further transfers) to arrive via the DSRV prior to decompression. The periods of exposure are estimated to be 16 hours between the initial compression of the compartment and the arrival of three DSRV loads, followed by a hold of 30 hr at 2 bar prior to decompression at 0.5m per hr (20 hr) resulting in a total time of some 66 hr. The 30 hr hold is the best estimate available for avoidance of decompression sickness during the final decompression for rescues saturated at the 'worst case' DISSUB pressure.

#### 4.3 The DSRV

The requirement for 3 transfer trips, involving charging to 3.3 bar followed by decompression to 2 bar prior to each decompression run produces a worst case figure of 86% MOSUB HPA within the mid and aft spheres during any trip. Having completed 3 transfers, it is intended that the DSRV will return to its cradle for depressurisation and battery charging prior to its provision with a fresh attendant re-pressurisation and deployment for subsequent decompression cycles if required. The longest exposure time within the DSRV will be for the attendant who must make three transfer trips with rescues before undergoing decompression with that batch. The attendants exposure period is estimated to be a maximum of 16 hr. within the DSRV.

4.4 In examining para 4.2 and 4.3 it is clear that a conservative assumption should be made that personnel exposed in this scenario will breath 100% MOSUB HPA. The maximum exposure for any individual is identified as being for the DSRV attendant who may experience some 16 hr at 3.3 bar within the DSRV before



a further 30 hr at 2 bar and subsequent decompression over 20 hours within the MOSUB. This exposure should therefore form the basis of any examination regarding the acceptability of the scenario and is shown graphically as Annex C.

## 5. EFFECTIVE TOXIC EXPOSURE

5.1 Alterations in absolute pressure and the concentrations of other agents may cause alteration in the possible toxic effects exerted by a number of contaminants. Within this paper, agents will be considered in three groups reflecting the type of change the scenario may produce in their toxic effect.

a. For gaseous agents with effects based either on reactivity or solubility, toxic exposure should be expressed in terms of partial pressure and hence the elevated pressures proposed in the scenario will cause increased effect. Since any examination of acceptability must compare such exposure with industrial limits normally expressed in terms of concentration by volume or mass per unit volume, it is considered more appropriate in this paper to consider such agents using the concept of "effective concentration", such a figure being produced by the multiplication of absolute concentration (by volume) by the absolute pressure in bars.

b. In considering carbon monoxide, toxic effect is not only dependant on its own partial pressure, but will also vary in inverse proportion to the partial pressure of oxygen. The MOSUB scenario involves both variations in total pressure

and oxygen concentration which must be considered therefore in the examination of the toxic effect of CO. Within this paper an effective concentration will be derived as described in para 5.1a. To take account of the effect of oxygen, a corrected 'effective concentration' will be produced by the division of the effective concentration in vpm by the partial pressure of oxygen in bars and then dividing the result by five.

i.e. 1.  $\frac{\text{actual CO(vpm)} \times \text{absolute pressure (bar)}}{\text{effective CO(vpm)}}$

2.  $\frac{\text{effective CO(vpm)}}{p_{O_2}(\text{bar})} \times 5 = \text{corrected effective CO(vpm)}$

c. For aerosols, toxic effect is determined in the main by aerodynamic diameter and is largely independent of pressure. No correction is therefore applied to levels of agents controlled on the basis of aerosol hazard, the specified MPC<sub>90</sub> (wt/vol) being considered a reasonable index of toxic effect.

5.2 In the UK, the Health and Safety Executive published Occupational Exposure Limits (OEL's) currently form the nationally promulgated levels for industrial toxicology and these limits will be used as the basis of comparison within this paper. It is noted, however, that OEL's are time weighted average (TWA) limits for 40 hr a week exposure for 50 weeks per year and are, therefore, not directly suited to compare with a single, once in a life-time exposure of 66 hr. Short term exposure limits (STEL) levels are also published if applicable. Lists of relevant TWA and STEL OEL's are included in Annex A as columns 3 and 4. The American Conference of Governmental Industrial Hygienists also

publish limits under the title of Threshold Limit Values (TLVs), such limits include the identification of Ceiling (C) levels which are not permitted to be exceeded for certain agents. In each case where a ceiling level is so specified for an agent considered within this paper, the actual level is equal to the 40 hr/week TWA OEL. The addition of \* in column 3 of Annex A indicates the dual definition of the level both as TLV(C) and TWA OEL.

5.3 As previously stated in paragraph 3.2, the majority of submarine atmosphere contaminants are controlled passively and therefore their slow accumulation over many days has already been considered with regard to the submarine's ability to maintain MPC<sub>90</sub> levels. With the exception of those agents listed within SGH0332, it is not considered that these contaminants would build up any more rapidly during the HOSUB scenario and their consideration in terms of an absolute MPC concentration of the MPC<sub>90</sub> level (Annex A column 1 or 2) throughout the exposure would appear appropriate. While the effective exposure for certain agents will, of course, vary with the pressure changes of the worst case profile (Annex C), in an effort to make more direct comparison with OELs, mean and maximum effective concentration figures have been derived over the entire worst case, 66 hour exposure, and are included in Annex A as columns 5 and 6.

5.4 With regard to those agents actively controlled within the submarine, such simple treatment as outlined in paragraph 5.3 may not be applicable. Control equipment may be located outside the decompression compartment and therefore MPC<sub>90</sub> levels may not be

guaranteed. Such agents can be considered in three groups:

a. Both DSRV and MOSUB compression facility have the ability to regulate and maintain oxygen and carbon dioxide levels between laid down parameters. Neither gas will therefore be considered further.

b. Halocarbons, used in the submarine as refrigerants and for fire fighting systems, are assumed to leak slowly. Thus, they are monitored routinely and kept within MPC levels by ship's husbandry. In the event of major leakage in excess of the MPC's, then action must be taken. Within the MOSUB scenario, no husbandry and monitoring could take place and therefore sources of these contaminants are removed from the compression compartment. Likewise, possible sources of hydrogen are not located within the facility. In the worst case, however, MOSUB HPA could contain these agents at MPC<sub>90</sub> levels and similar treatment as outlined for contaminants in para 5.3 is applicable to these agents also.

c. With regard to carbon monoxide, the situation is more complex, since no removal systems are fitted in either MOSUB compression compartment or DSRV. Throughout the rescue scenario, CO levels will continue to rise by endogenous production in both vessels and, in addition, from the burning of chlorate candles in the MOSUB facility as the means of oxygen production. Using the assumptions listed as Annex D, a corrected effective CO concentration profile has

been derived for the identified worst case exposure (para 4.4) and is given at Annex E. Likewise, mean and maximum corrected effective CO levels are included in columns 5 and 6 of Annex A. It should be pointed out that the few prolonged KN trials in submarine escape compartments have failed to demonstrate predicted rises in CO and it is presumed that this is due to the development of an equilibrium between atmosphere and exposed personnel. In a paper such as this, seeking endorsement for a policy, it was considered that theoretical levels should be included as the basis for consideration.

#### 6. COMPARISON WITH INDUSTRIAL LIMITS

6.1 Examination of Annex A indicates that on no occasions are ceiling or American Conference of Governmental Industrial Hygienists (ACGIH) promulgated Threshold Limit Values (TLV's) exceeded. In addition, in the vast majority of cases where MPC<sub>90</sub>'s have been specified for agents, the worst case mean exposure level estimation for the MOSUB scenario does not exceed the TWA OEL and the estimated maximum exposure does not exceed STEL OEL's. For a single group of agents the STEL levels are exceeded and these are considered below.

##### The Halocarbons

In current classes of submarine, R12 is the prime refrigerant gas and a MPC<sub>90</sub> (para 5.3b) is maintained at a level of 500vpm on the basis of thermal degradation and toxicity. In future classes of submarines, both R12 and R114 will be used and, in addition, a Halon 13B1 fire

fighting system will be installed. Although similar MPC<sub>90</sub>'s of 500vpm will be adopted for these agents, their similar toxicology and breakdown determine the need for a total Halocarbon MPC<sub>90</sub> of 500vpm made up of all three agents. The mean effective exposure estimation indicates a level close to OEL TWA level. However, the estimated maximum effective concentration of 1650vpm is some 400vpm above the STEL. There has been considerable recent interest in the toxicology of fluoro-carbons and, in particular, bronchospasm has been demonstrated experimentally for certain agents at levels as low as 1700vpm in humans. In the MOSUB scenario, it is considered that 66 hr exposure at 1650 vpm is unacceptable and HPA samples prior to MOSUB deployment should confirm total halocarbon levels below 250vpm and that a MPC of 250vpm should be maintained in the MOSUB for the duration of the operation.

#### 7. AGENTS WITHOUT SPECIFIED INDUSTRIAL LIMITS

7.1 Examination of Annex A demonstrates instances where no industrial limit is available for comparison with a specified MPC. Such agents are considered below:

a. Butanolanine (2amino-2methyl propanol)

In view of this agents specific application with UK submarines, it was considered applicable to specify a MPC, however with a melting point of 31°C and a boiling point of 165°C it is considered that even in the unlikely event that an airborne level did exist for a period, the agent would not remain in that form within the HPA system and thus

further examination within this paper is not warranted.

b. Hydrocarbons (Total organics and Total aromatics)

Within UK submarines a detailed organic finger print has been built up over the years and, on that basis, control of levels is based on individual MPC's for certain agents, with the majority of trace contaminants considered in terms of, easy to estimate, gross levels of total organics and aromatics. Such levels have no industrial equivalents. The figures listed in columns 5 and 6 of Annex A represent mean and maximum effective exposures based on the assumption that the specified MPC levels consist entirely of gaseous hydrocarbons. The estimates produced in this manner are considered to represent unacceptable exposure. In fact a significant proportion of the hydrocarbons measured by current monitoring techniques are in aerosol form and thus require no effect correction with regard to fluctuations in pressure. This situation is demonstrated clearly by the setting and maintenance of SGM0332 levels for submarine HPA at 50% of the total organic MPC. Consideration of the specified SGM0332 level of  $20\text{ng}/\text{m}^3$  produces mean and maximum effective exposures of  $43\text{ng}/\text{m}^3$  and  $66\text{ng}/\text{m}^3$  respectively for the RE MOSUB scenario. These levels are considered acceptable for a single emergency exposure of 66 hours and compare favourably with US Naval Submarine limits for total organics of  $70\text{ng}/\text{m}^3$ . It is recommended, therefore, that HPA samples taken prior to MOSUB deployment should confirm total hydrocarbon levels to be within the current standard as laid down in SGM0332.

8. DISCUSSION:

8.1 Direct comparison between TWA 40 hr per week exposure over a working lifetime and a level for a single, once in a life-time, lifesaving exposure of 66 hr, is difficult. It was suggested that if no ceiling industrial levels were exceeded and, in the worst case, estimated mean effective exposure was below or equal to TWA OEL, and the estimate maximum effective exposure was below or equal to STEL OEL, then such exposure would be considered acceptable for this emergency situation. The absence of some toxic effect could not be guaranteed by such a policy, particularly for those agents with threshold-less effects, however in comparison with the risks of not attempting rescue, a single emergency exposure would be justified.

8.2 This paper demonstrates that, for the most part, the suggestion (para 7.1) has been proved correct and that the exceptions represent no significant hazard or that they could be dealt with by modification to the scenario. On that basis the possibilities of installing further removal equipment either in the compartment itself or on line in the HPA system has not been examined though these possibilities exist and should be borne in mind if future re-examination demonstrates a significant toxic hazard.



9. CONCLUSION

9.1 The greatest personal exposure involved in the RN MOSUB scenario has been identified and a worse case conservative estimate of effective toxic levels produced. Simple comparison between such levels and the published national industrial levels indicate, with the exception of halocarbons, no grossly unacceptable exposure. Therefore, biomedical endorsement of current RN MOSUB policy with modification is possible.

10. RECOMMENDATIONS

10.1 The Biomedical Subcommittee of SCOSER endorses current RN MOSUB policy with the following modification.

a. HPA system halocarbon samples taken prior to MOSUB deployment should indicate levels below 250vpm and that a MPC of 250vpm should be maintained in the MOSUB throughout the operation.

b. HPA system total organics samples taken prior to MOSUB deployment should indicate levels below the SGM0332 specified limit of 20 mg/m<sup>3</sup>.

10.2 The Biomedical Sub-committee accepts the on-going task of monitoring submarine atmosphere control limits to confirm continued endorsement of MOSUB policy.

10.3 If endorsed by the Biomedical Subcommittee, any trials would need to be subject to ethical consideration.

5

CDR Carson  
CLR Adkisson

U.S. SCENARIO FOR DSRV ESCAPE UNDER PRESSURE

Submarine Development Group ONE, located in San Diego, California, is tasked by the Chief of Naval Operations to "possess and maintain a worldwide deep ocean search, location, recovery and rescue capability." One of its primary functions is maintenance of the U.S. Navy's submarine rescue systems.

Submarine rescue poses unique problems for the navies of the world. Recovering men from the depths of a hostile environment challenges current capabilities. The U.S. Navy maintains two systems for submarine escape, the McCann Submarine Rescue Chamber and the Deep Submergence Rescue Vehicles (DSRVs).

In 1939, fifty nine sailors were rescued from the USS SQUALUS (SS 192) utilizing the McCann Chamber. This system is capable of installation and deployment aboard a variety of military and commercial ships to effect a one atmosphere rescue from depths as great as 850 feet.

DEEP SUBMERGENCE RESCUE VEHICLES MYSTIC and AVALON were developed as an improved method of rescuing the crew of a submarine immobilized on the sea floor. DSRV 1 MYSTIC was brought on line in 1971 and DSRV 2 AVALON reported shortly afterwards. The DSRV's primary tasking is to rescue personnel from a U.S. Navy submarine should it become disabled during sea trials. Secondly, they are tasked with providing a worldwide rescue capability for U.S. or foreign submarines on a 24 hour notice. They are tasked, on an as available basis, to support advances in deep ocean research and exploration.

Should a submarine be bottomed at less than collapse depth, the DSRV system is activated. Two possibilities exist; either the submarine has maintained its structural integrity and its personnel are at normal atmospheric pressure of 1 bar or, the submarine hull has been damaged and some internal pressurization has occurred.

The possibility of a PRESSURIZED RESCUE presents the most formidable challenge for the submarine community. The DSRVs are capable of internal pressurization in the range of 0.8 to 5 ATA and in a rescue can carry a maximum of 28 personnel, 4 crewmen and 24 rescuees, operating to a depth of 5000 feet. A rescue scenario begins with notification that a submarine has been disabled. The following is an overview of a proposed operational scenario, utilizing a mother submarine to transport the DSRV, highlighting areas that require further evaluation and testing.

PRESSURIZED RESCUE SCENARIO:

General Mission Sequence Diagram

1	2	3	4	5	6
6 submarine is bottomed at less than collapse	SubOpArch includes submarine rescue	Rescue unit assembled in area of distressed	Distressed submarine located with DSRV	First mating of DSRV with distressed sub has been	Rescue Operation Completed

depth	program	submarine	completed	
ALARM PHASE	RESPONSE PHASE	LOCALIZATION PHASE	RENDEZVOUS/ MATING PHASE	RESCUE PHASE
From the time of notification, estimated times to complete loading and transport to the search area are:				
Mission preparation, crew alert and equipment readiness			1.0 hour	
Loading the DSRV on a C-5A aircraft			6.0 hours	
Loading remaining equipment on the C-141			2.0 hours	
Unloading the DSRV from the C-5A			2.0 hours	
Unloading remaining equipment from the C-141			2.0 hours	
Transferring DSRV to the support ship				
(a) ASR			5.0 hours	
(b) MOSUB			8.0 hours	

It is estimated that a response could be mounted in as little as 24 to 48 hours, with rescue operations underway, on site, in 2 to 3 days.

#### PREDOCKING PROCEDURES:

Pre-docking procedures include all crew assignments and instructions, preparations for unloading rescue mission equipment aboard the MOSUB, and a determination, if possible, of whether decompression of rescues will be required. If required, preparations will begin for pressurization of the MOSUB'S forward compartment. Procedures for pressurization listed in NAVSEA 0900-LP-102-6010 are not currently verified but could be utilized in an emergency.

#### DOCKSIDE PROCEDURES:

General submarine preparations will be made for underway as well as preparations for loading the DSRV. Once prepared, the DSRV will be loaded and undergo checkout and servicing as necessary.

While dockside procedures begin, arrangements will be made for special support, supplies and operational staff as required.

#### UNDERWAY PROCEDURES:

The MOSUB and DSRV leave port and transit to the accident site. The DSRV is manned during transit to conduct pre-dive checks. The MOSUB reduces its speed to 5 knots to dive and will later resume transit speed. Submerged transit is favored over a surface transit due to weight and speed considerations.

#### LOCATION PROCEDURES:

Assistance in determining the DISSUB location will normally be provided by ships at the site and from shore. Passive, distressed submarines can possibly be located by the following means:

- a. Previously released buoys
- b. Oil slick
- c. Debris
- d. Echo from search sonar

#### DSRV PRELAUNCH PROCEDURES:

Once localization has occurred, DSRV prelaunch procedures will begin. These consist of completing prelaunch checkout, transferring to internal DSRV power and disconnecting charging cables from the MOSUB

#### DSRV LAUNCH PROCEDURES:

Once all preparations are complete the DSRV and MOSUB will separate and the DSRV will head for the DISSUB.

#### DSRV MATING WITH DISSUB:

Based on the possible position of a disabled submarine it is necessary to be able to mate over a range of +/- 45 degrees. In order to create a firm seal the mating surfaces have to be compatible and a means of opening the submarine hatch from the outside is required. Prior to opening the hatch, there has to be a means of monitoring the internal atmosphere to identify hazardous gases or an increased pressure.

Mating will be accomplished using either the forward or after hatch depending upon which offers the most favorable approach and landing

#### DSRV/MOSUB COMMUNICATIONS:

The only voice communication channel available for use between the MOSUB and the DSRV on the submerged mission is the underwater telephone. This provides voice and continuous wave (CW) communication

Information flow from DSRV to MOSUB is required for departure, arrival, coordination, and emergency assistance. Other possible data which can be communicated are, instrumentation readings, condition of DISSUB including decompression requirements and condition of rescues

#### DSRV RECOVERY:

The DSRV will be recovered at the aft hatch of the MOSUB for replenishment and transfer of rescues if decompression is not indicated and for replenishment alone after offloading rescues at the forward hatch if decompression is required.

The three phases of recovery include, rendezvous, approach and mate

When mating is complete, the rescues will be transferred to the MOSUB and the DSRV will begin its replenishment procedures in preparation

for its next trip. This sequence will be repeated until all personnel have been rescued.

#### RESCUEE TRANSFER AND DSRV REPLENISHMENT (PRESSURIZED):

When pressurization has occurred and a decompression obligation incurred, the DSRV will mate with the forward hatch prior to replenishment at the aft hatch. Special procedures will be followed to prepare the forward compartment for pressurization, control the atmosphere, and during the mating procedure. If communications with the DISSUB are intact the following sequence is proposed:

The DSRV will mate to the after hatch of the MOSUB. She will open hatches to the sub below and pressurize internally through a lineup with the after escape trunk. The after escape trunk is isolated from the rest of the ship prior to pressurization. Once the DSRV has attained the same pressure as the DISSUB she will shut all hatches and prepare to make the first trip. The DSRV will transit and mate with the DISSUB hatch that offers the most favorable landing position. With pressure equalized the DSRV will open her midsphere hatch.

Depending upon injuries and the condition of survivors the DSRV will transfer a maximum of 24 people for transit back to the MOSUB. The DSRV will go to the forward hatch to offload survivors. The forward escape trunk will be pressurized to match the internal pressure of the DSRV. Once mated the DSRV will open hatches, transfer personnel and prepare to make her next trip to the DISSUB. She will repeat this procedure two or three times depending on battery life.

As the battery charge falls below 30%, the DSRV will return to the after escape trunk of the MOSUB for replenishment. The mid/aft sphere operators, having been under increased pressure for a number of hours will have to remain with the survivors in the forward compartment. The hatches will have to be controlled by people operating controls from inside the escape trunks. This is not of concern in the forward compartment but requires putting an additional person under pressure in the after escape trunk. The exposure, however, is of short duration, and does not impose a decompression obligation.

The DSRV will mate with the after hatch which has been pressurized. An inside operator will be required to open the submarine and DSRV hatches and stand by while a controlled depressurization back to 1 bar occurs. An alternative method of opening the midsphere hatch exists if the internal pressure is not excessive. The aft sphere can be isolated and the mid and forward sphere equalized at which point one of the DSRV operators will open the hatch. Normal replenishment may then proceed. When complete, a second midsphere operator will board the DSRV, pressurization will occur and the process repeated. This sequence of events will continue until all personnel have been taken from the DISSUB.

Following transfer of all survivors, the MOSUB will begin controlled decompression of its forward compartment until pressure reaches 1 bar. Replenishment of supplies can be accomplished by utilizing the DSRV as a shuttle between the after and forward hatches thereby providing

food, water, medical and other necessary supplies.

#### DECOMPRESSION:

Physiologically we can safely decompress a crew from a depth as great as 192 feet. The Naval Submarine Medical Research Laboratory in New London has studied decompression limits and surface excursions and, while requiring further testing and formal approval, the AirSat 4 decompression profile appears acceptable for emergency use.

Decompression will be carefully monitored for signs of decompression sickness with appropriate adjustments to decompression as necessary.

#### DECOMPRESSION FACILITIES:

The storage capacity of existing ASRs and MOSUB compartments for decompression purposes is limited. The dual decompression chambers aboard an ASR can hold an estimated sixty men. If one assumes maximum survivability of 120 to 180 men, two to three decompression cycles will be required. Theoretically, the MOSUB forward compartment can hold the entire DISSUB crew. Despite crowded conditions and reduced habitability aboard the MOSUB, survival is possible.

Several SHIPALTS were promulgated which modified the U.S. 697 Class submarines so they could act as MOSUBS for the DSRV. These included modification of the bow compartment for use as a decompression chamber, providing facilities to accept the DSRV flyaway equipment and the ability to perform various hotel services for the DSRV.

Several of the 697 class were modified, at least partially, and documents indicate that pressurization may have been accomplished to 4 bar under test conditions. This testing should be repeated but these ships could be called on to serve as MOSUBS for a pressurized rescue.

#### PRESSURIZATION:

The only practical means of forward compartment pressurization is by using the MOSUB's air banks. This presents additional issues.

Initial pressurization with normoxic air requires monitoring for pulmonary oxygen toxicity similar to the problem initially seen with DISSUB pressurization. Pure nitrogen banks might be used for pressurization if circumstances allowed.

Normoxic air at increased pressure presents additional hazards and special fire precautions will be required until the Oxygen level is reduced. Methods to control sources of ignition or rapidly reduce the O2 level should be investigated.

Potentially toxic materials stored in the forward compartment will be removed prior to pressurization and a listing of those materials should be prepared.

#### SUPPORT AND HOTEL SERVICES.

Providing adequate supplies, sanitary facilities and atmosphere control will require careful on site planning. In a situation where the forward compartment is completely isolated from the after compartment, supplies and equipment for an extended decompression are necessary and will be supplied in advance. Emergency replenishment can take place utilizing the DSRV itself, transferring supplies from aft to forward areas.

The heads and potable water systems have pressure limitations of roughly 2:3 (cross connects) and 3.7 (system) bar respectively. Water can be supplied during the early phases of deeper decompressions but consideration must be given to proper line up of the ship's sanitarries to prevent inadvertent decompression of the bow compartment.

#### MATING RING FABRICATION:

Transfer of personnel under pressure was an initial design feature of the ASR/DSRV platform. A mating ring to allow the DSRV and the Deck Decompression Chamber (DDC) aboard the ASR to be mated for transfer under pressure is currently undergoing design. Additional studies at New London examined safe surface intervals for personnel transfer between DSRV and the DDCs aboard the ASRs for use until the mating ring has been completed.

#### DSRV PRESSURE EQUALIZATION/VENTING:

A DSRV venting/equalization valve installation has been planned for the upcoming modernization period. This will provide the capability of controlled venting of the DSRV.

#### DISSUB ATMOSPHERE CONTROL

Casualty situations involving an internal pressurization will require monitoring of both oxygen and carbon dioxide. To decrease levels of CO<sub>2</sub>, LIQH scrubbers would be utilized. If electrical power is unavailable, current procedures call for spreading the CO<sub>2</sub> absorbant, along horizontal surfaces and allowing natural air convection and conduction to lower the CO<sub>2</sub> content. Manual CO<sub>2</sub> scrubbers are being studied and have had mixed reviews. Additional methods for lowering CO<sub>2</sub> partial pressure are being studied.

#### SUMMARY

The Deep Submergence Rescue Vehicles Mystic and Avalon continue to be the best method of escape from a disabled submarine at deep depths. Despite technical difficulties, the original concept of rescue under pressure is viable. The knowledge gained in the past several years, now makes it possible to plan for a fully pressurized rescue operation. The pressurized transfer conducted as part of Operation Sedgement in 1983 was an impressive first step. We are looking at the possibility of a fully pressurized scenario in the near future.

PRESSURIZED RESCUE

G. MASUREL

CERTSM - DCAN - TOULON NAVAL (FRANCE)

Rescue of submarine crew members entrapped in a distressed submarine under pressure by means of a DSRV can be sometimes limited.

In particular, the pressure within the submarine must not exceed 5 ATA, that is the upper DSRV pressurization limit.

More over, the DSRV is not fitted with any means of decompression. The survivors must therefore be rapidly decompressed in order to be transferred to an ASR chamber where they will be immediately recompressed before being decompressed according to applicable decompression schedules. They can also be transferred to the pressurized escape compartment of a MOSUB.

ECKENHOFF (1984) clearly indicated the conditions of such a rescue. He strongly recommended the transfer to a mother submarine as a much safer rescue means.



On this recommendation there may be two different approaches to the rescue problem as follows :

- 1) which is the escape compartment pressure required for the transfer of survivors having stayed at 5 ATA for long periods?
- 2) for a given escape compartment pressurization value as determined according to technical considerations, up to which pressure is it reasonable to consider rescuing survivors without running possible decompression risks?

For the first approach there soon appears a discrepancy between decompression requirements and submarine technical capabilities (such as air storage, crew isolation requirements, strength of some equipment within the escape compartment).

As regards the second approach, both the RN and the USN have chosen to study rescue limitations with an escape compartment pressurized at 2 ATA.

We have a different opinion as to the escape compartment pressurization :

On the one hand, we believe it is more realistic to pressurize an escape compartment at 1.6 ATA because this requires almost half as less air. It also raises no problem as regards the strength of built-in equipments in the escape compartment and makes it possible to exchange both crew members and equipments through the locks of our nuclear submarines.

On the other hand, there is no need for any further decompression procedure. Indeed, a simple pressure equilibration makes it possible to return to surface after a long enough period.

Therefore, we decided to verify our hypothesis in animals fitted with Doppler detectors implanted on their pulmonary arteries.

The experimental animals were minipigs of the Pitman-Moore strain, more than six years old, from our own breeding farm. As the latter was out of stock, we could not select our animals and we used the only available at the time of the experimentation.

There are two males and two females. They were not deprived of food since they were initially intended for breeding stock.

For instance, the males weights ranged between 110 and 120 kg (242 and 265 lbs). These animals had a very thick hide on their backs (between 40 and 50 mm in thickness). Such a hide weighed about 1/4 of the total animal weight.

The females weighed around 130 kg (287 lbs) with a rather heavy mass of fat estimated at 30 kg (66 lbs). Such an adiposity confronted us with great difficulties as regards nitrogen saturation problems because of fat affinity for nitrogen. This animal model may therefore be criticized since it may distort the results. But such a distortion contributes to a greater safety as the limits set with this model will certainly be nearer the mark for a population not well defined.

### Exposures

Our animals were subjected to 2 types of exposures.(Tabl.1)

On the one hand, they were exposed for 24 hours to pressures of 2.5, 3, 3.5 and 4 ATA reached within 2 minutes. At the end of 24 hour-periods the animals were decompressed to 1.6 ATA within 2 minutes for a maximum period of 24 hours. They were then returned to the atmospheric pressure within 2 minutes.

On the other hand, the animals were exposed for 48 hours to pressures of 2.5, 2.7 and 3 ATA according to the same compression and decompression procedures.

### Materials

The Doppler ultrasonic bubble detectors we used were specific ones. The detection system included a continuously-transmitting 5 MHz detector, a suitable filter, a calibration system and an integrator. Signals were processed by an HP 9825 computer delivering real-time plots of bubble flows estimated in arbitrary units. These units enable a comparison between different hyperbaric exposures.

The chamber was the CERTSM chamber especially adapted for animal saturation dives.

Results

Bubble detection results are presented in the form of bubble flow graphs which make it possible to decide that decompression is safe, as shown in Figure 1 or, on the contrary, that it is necessary to recompress when the bubble flow is approximating to 800 A.U. That is the maximum permitted bubble flow in this type of animal. Such a continuous detection enables us to come as close as possible to a serious decompression accident and to rapidly take action should if severe risks appear.(Fig.2)

On the whole, results are gathered in Figures:3.4.5.6. These figures are clear enough and speak for themselves. They show the profiles of the exposures carried out for each animal as well as the recompression performed as required by bubble profiles.

Results are summarized in the table 2. It can be seen that in the most favourable hypothesis of a very rapid rescue within a 24 hour period - which is unfortunately not likely to happen - this rescue remains possible up to 3.5 ATA.

In the least favourable and most likely hypothesis, the rescue of submarine crew members can be carried out up to 2.75 ATA

### Discussion

Taking into account the results obtained both by the RN (BELL, 1981) and by the USN (ECKENHOFF, 1984), and assuming with the latter that there ought to be a linearity between exposure and rescue pressures within the depth range being considered we can draw the curve shown in Fig.7

It can be seen that to a stop at 1.6 ATA corresponds a saturation pressure of 2.65 ATA. We can confirm this result within 0.1 ATA in the minipig.

Moreover, if we consider these results in the context of an actual accident we have to think that pressure within the escape compartment may be due to two main causes : either HP or LP air leaks, or a rapidly checked water leakage.

In the first case the important air volume will constitute sufficient air stores for the  $PiO_2$  to decrease slowly. Under these conditions symptoms of oxygen toxicity will probably occur within a time interval which will be all the shorter as the pressure is high. ECKENHOFF (1984) has reminded us that at 2.8 ATA in air atmosphere corresponding to 0.6 ATA of  $PO_2$  the first symptoms appear within 24 hours with a certain subsequent recovery. However, the oxygen toxicity threshold limit is then nearly reached and the severity of the symptoms increases rapidly above 2.8 ATA (Fig.8).

All this leads us to conclude that it is not possible to stay under pressure without risks and that survival under these conditions is not easy. However, the gathering of a great number of survivors within the submarine escape compartment shall be an advantage as regards oxygen toxicity risks. The  $PiO_2$  will decrease all the more rapidly - and so will the oxygen toxicity risk - as the ratio of the compartment volume to the survivors' number will be small.

In the second case the increase in pressure is due to a checked flooding of the escape compartment. It is to be reminded that above 3 ATA the compartment flooding will be such that escape locations emerging from water will be relatively reduced.

Then the cold will be a problem of prime importance. Survival under such conditions seems so precarious that one may wonder whether it is reasonable to imagine any survival at a pressure above 3 ATA.

Within these limits the carrying on of our experimentation will show whether a transfer to 700 mbar would be sufficient and a good compromise between operational requirements aboard the mother submarine and realistic probabilities of pressurized rescue.

T H E   E N D



	SITUATION 1	SITUATION 2
COMPRESSION	2 MINUTES	2 MINUTES
STAY AT DEPTH	24 HOURS	48 HOURS
DECOMPRESSION AT 6 msw	2 MINUTES	2 MINUTES
DECOMPRESSION STOP	24 HOURS AT 1.6 ATA	24 HOURS AT 1.6 ATA

EXPOSURE CONDITIONS

TABLE 1

PIG	SITUATION 1 STOP AT PRESSURE : 24 H			SITUATION 2 STOP AT PRESSURE : 48 H		
	FRA 130 KG (286 LB)	2.5 ATA	3 ATA	3.5 ATA	4 ATA RECOMP.	
CHA 120 KG (264 LB)		3 ATA	3.5 ATA	4 ATA RECOMP. A 1.6 ATA		
YVE 130 KG (286 LB)					2.5 ATA RAS	2.75 ATA RAS
MAR 105 KG (231 LB)					2.5 ATA RAS	2.75 ATA RAS
						3 ATA RECOMP.
						3 ATA RECOMP. AFTER SURFACING

DIFFERENT EXPOSURE RESULTS

TABLE 2

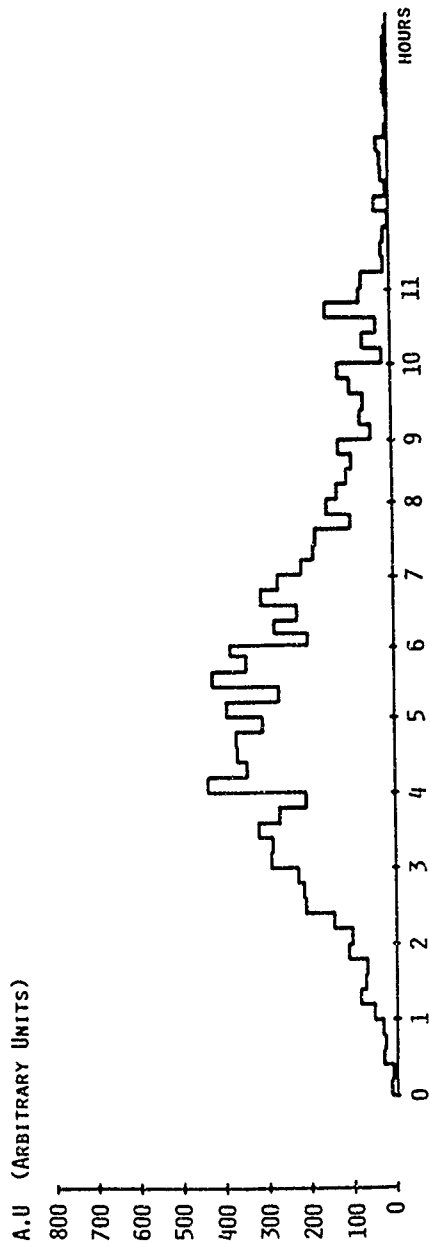

BUBBLE FLOW AFTER SURFACING  
MINIPIG CHA ♂

FIGURE 1

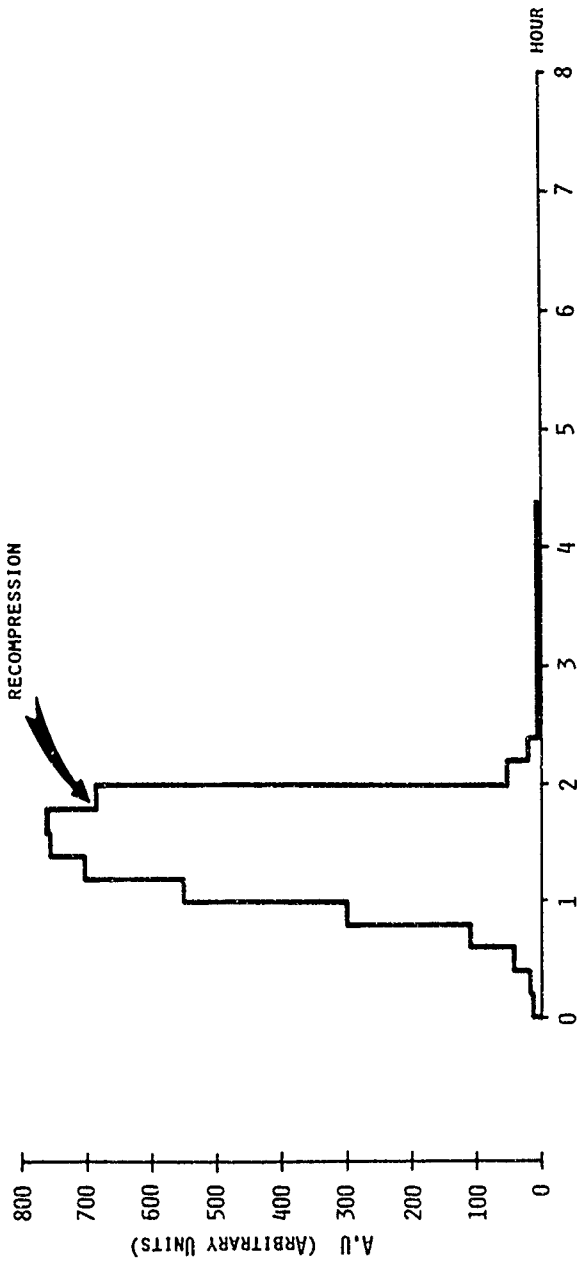

BUBBLE DETECTION RESULTS AFTER SURFACING  
(24 H AT 25 M) MINIPIG CHA ♂

FIGURE 2

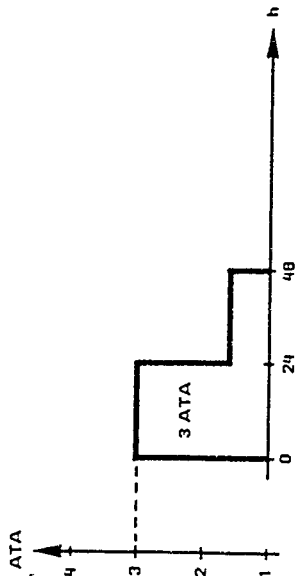
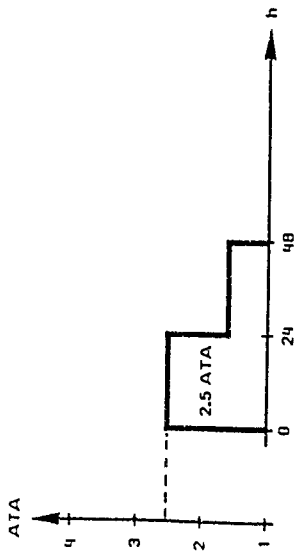

66

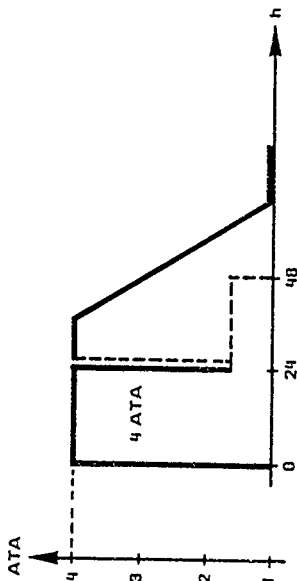
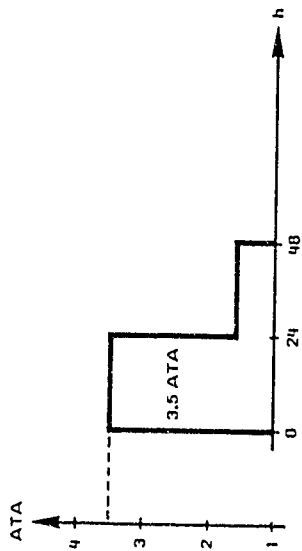

(MINIPIG FRA  $\varnothing$  286 Lb)

RESULTS OF A TRANSFER AT 1.6 ATA

FROM A 24 H - STAY AT PRESSURE

FIGURE 3

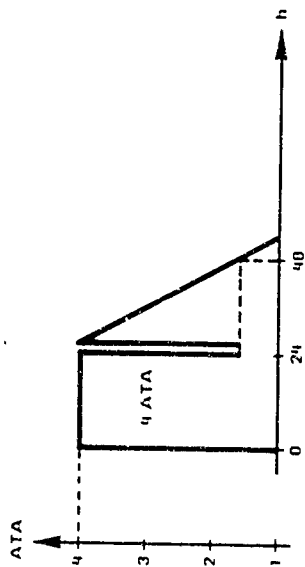
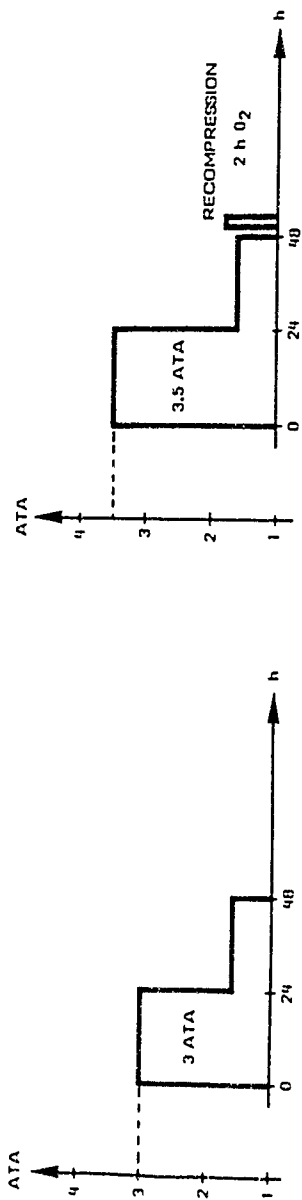

(MINIPIG CHA  $\odot$  264 Lb)

RESULTS OF A TRANSFER AT 1.6 ATA

FROM A 24 H - STAY AT PRESSURE

FIGURE 4

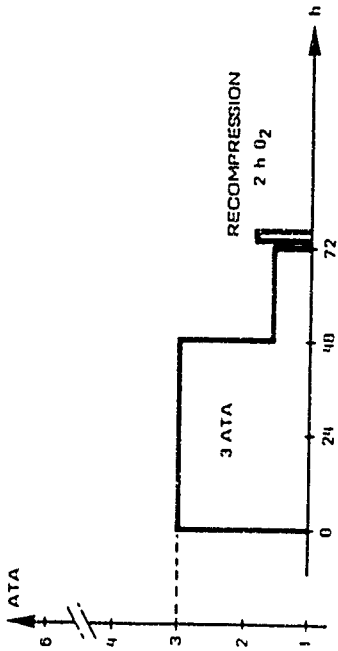
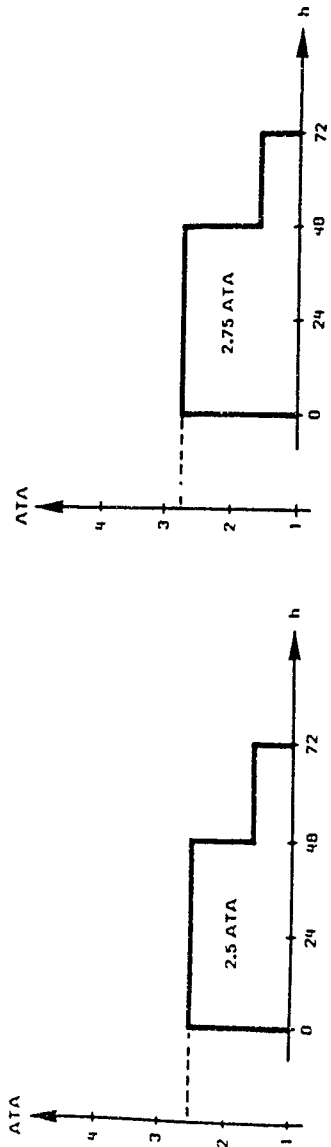

(MINIPIG MAG Q 286 LB)

RESULTS OF A TRANSFER AT 1.6 ATA  
FROM A 48 H - STAY AT PRESSURE

FIGURE 5

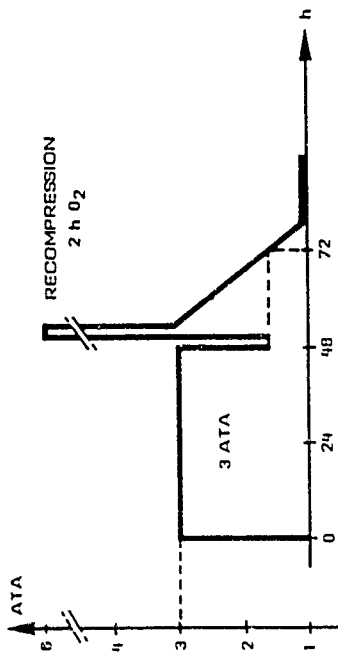
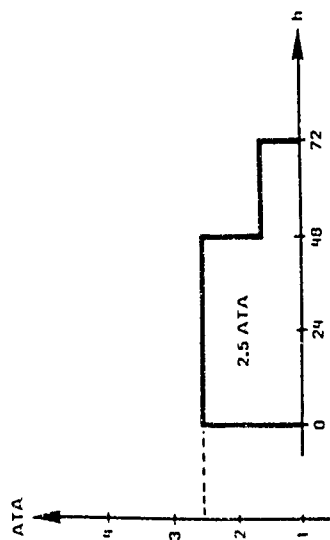
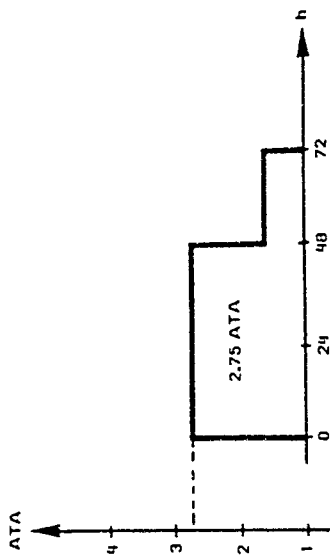

(MINIPIG YVE ♀ 286 Lb)

RESULTS OF A TRANSFER AT 1.6 ATA

FROM A 48 H - STAY AT PRESSURE

FIGURE 6



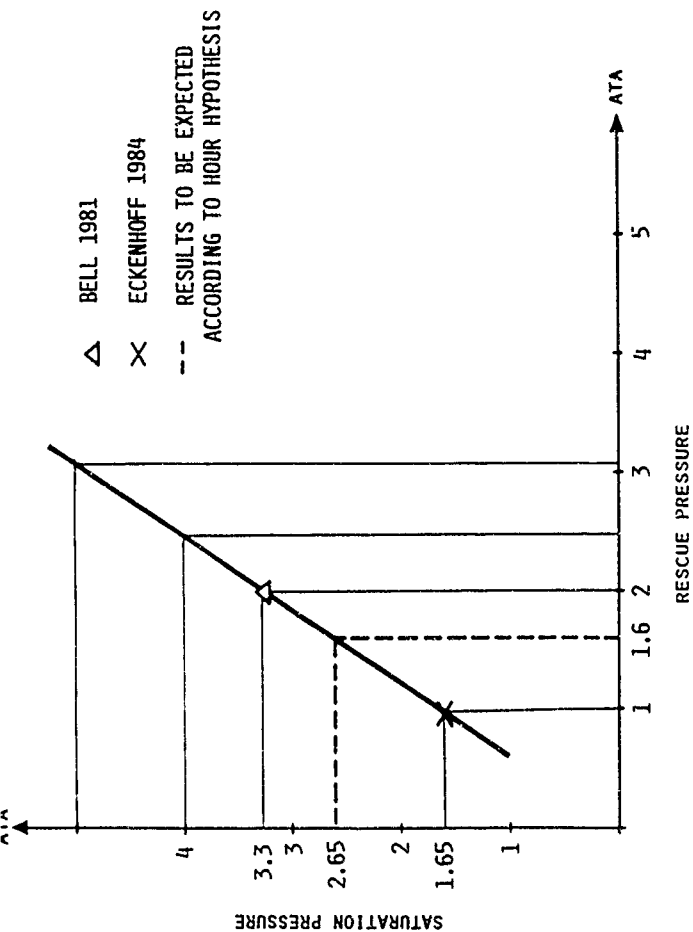

# LIMIT PRESSURE OF SATURATION AS A FUNCTION OF RESCUE PRESSURE

JUNE 7

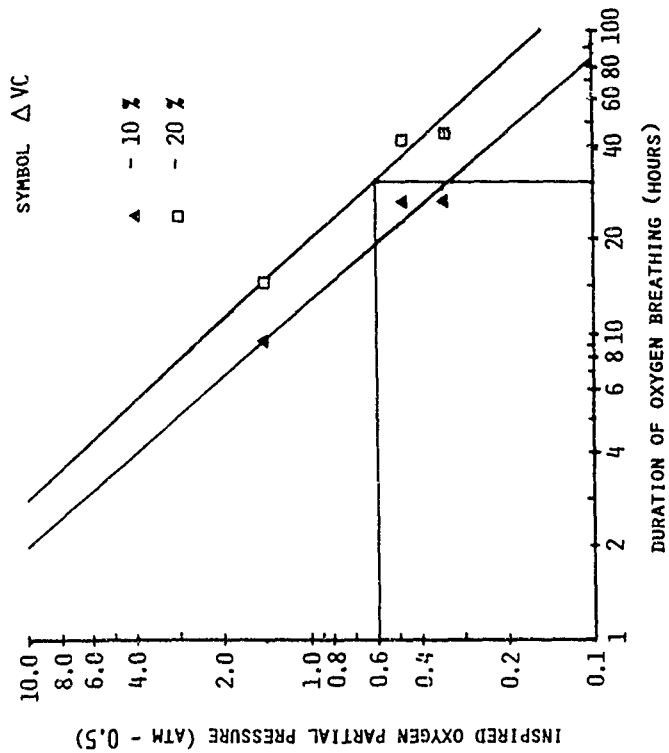

# PULMONARY OXYGEN TOLERANCE CURVES

PHYSIOLOGICAL LABORATORY, UNIVERSITY OF CALIFORNIA, BERKELEY, CALIF.

Presented at :  
Tripartite Meeting on Submarine Medicine, Groton CT, June 1987

### Submarine Air for Divers

P.K. Weathersby, E.T. Flynn, R.S. Lillo  
NSMRL and NMRI

Navy divers breathe compressed air for the bulk of their diving operations. Air purity is established by adherence to standard procedures and use of standardized equipment, both supported by years of field experience. The major expected source of contamination is from faulty compressor operation since "clean" outside air is available as a gas supply. A semiannual check of all Navy diving commands is mandated by the Diving Manual and checks whether compressor problems exist. Air samples are sent to a central contract laboratory and checked against the following standard:

Oxygen : 20-22 %  
Carbon dioxide : < 1000 ppm  
Carbon Monoxide : < 20 ppm  
Total hydrocarbons : < 25 ppm  
(less methane)  
Particulates/mist : < 5 mg/cu.m.  
Odor : Not objectionable

Thousands of samples are processed every year and the failure rate is low.

Normally, Navy diving is not allowed breathing air drawn from a submarine high pressure air bank. Why is the submarine air suspect? First, since the air banks are frequently bled into the ship and then recompressed, the air banks tend to approach an average of submarine interior air rather than outside "fresh" air. Thus the banks may contain levels of the thousands of compounds that were present in the submarine atmosphere at one time or another. A second concern is that the air banks vary over time in their concentration of

contaminants. The following data comes from the banks of a single submarine repeatedly sampled over an 8 month period:

Dry Deck Shelter Laboratory Analyses (1985-86)

Carbon dioxide: 0.01 to 0.59 %  
Carbon Monoxide: 1.2 to 3.9 ppm  
Methane: 2.0 to 11.8 ppm  
Freon-114: 0.1 to 14.2 ppm  
Freon-12: 0.1 to 12.0 ppm

It is clear that the concentrations change by more than a factor of 10, although in this case mostly within a safe range. The exception is carbon dioxide which if breathed by a diver at 99 fsw or 4 ATA would be 0.59% $\times$ 4 or about 2.4% surface equivalent (18 Torr); a definitely unhealthy level.

Use of compressed submarine air for divers presents hazards that pose more problems than breathing the same air by the submarine crew. First, as illustrated by the CO<sub>2</sub> example, toxicity of a gas sample increases with its partial pressure, and thus directly with depth for a given air sample. In addition, underwater tasks are normally done in small groups or even alone, so the ability to observe or communicate with a potentially toxic individual is very limited.

Recently a program was started that required compressed submarine air for divers use - the Dry Deck Shelter. A CO<sub>2</sub> scrubber with LiOH absorbent was placed in the divers air supply line in anticipation of the chronically elevated levels in operating submarines. However, a monitoring capability was desired to ascertain whether other substances might be present in unacceptable levels; and this capability was needed in a deployed submarine. For limits, the OSHA values for 40 hour workweek exposure was selected as more appropriate than the submarine atmosphere guidelines for 90 days. A pressure correction factor of 4 was chosen in the expectation that little if any diving would exceed 99 fsw or 4 ATA.

The major problem was specification of a monitoring procedure that would be feasible on board yet would allow reasonable assurance of safety. An attempt was made to conserve time if the air appeared either very dirty or very clean. If the purity was questionable, the procedure allowed some flexibility in deciding the identity, and thus the hazard of the single questionable substance rather than adopting an arbitrarily conservative rule.

The procedures required use of the ship's CAMS, a photoionization detector, and a number of detector tubes:

Interim DDS Air Purity Guidelines Procedures

1. Use CAMS-1 or Detector Tubes for:

Carbon monoxide	Freon 113
Carbon dioxide	Freon 114
Ammonia	Freon 12
Hydrazine	Vinyl chloride
2. Use photoionization detector for organic compounds:

if < 5 ppm	Gas O.K.
if > 50 ppm	Gas Unsatisfactory
if Between	Use detector tubes and individual limits for 24 compounds, as needed
3. Repeat as air bank changes (but carbon dioxide often)

The tubes, manufacturers, and limits were provided for the following:

Chlorobenzene	Cumene (Isopropyl benzene)
Cyclohexane	Ethyl benzene
Heptane	Hexane
Isopropyl alcohol	Methyl bromide
Methyl chloride (chloromethane)	Methyl chloroform (1,1,1-trichloroethane)
Methyl ethyl benzene	
Methyl ethyl ketone (2-butanone)	Methyl isobutyl ketone (4-methyl 2-pentanone)
Napthalene	Nonane
Octane	Phenol
Toluene	1,1,2-Trichloroethane
Trichloroethylene	1,2,4-Trimethyl benzene (pseudocumene)
Xylenes	

In operation, this monitoring required about 30 min to accomplish. Since the application is new, the ships were provided with stainless steel sample bombs for subsequent laboratory analysis of the air. Results of those analyses have been summarized above. As we learn more about the normal and abnormal components of submarine air, the recommended procedures will undoubtedly change.

A number of problems exist with these procedures now. First, the analysis looks at only a modest number of potential contaminants so other potentially important ones remain unexamined. This concern will decrease as more analytical information becomes available. Next, the array of different devices required makes adequate training for the procedures difficult. The monitoring is in batch mode rather than real-time. This aspect is not dangerous for most organics since the same compressed air bank will be in use. However, the CO2 scrubber has an unknown lifetime and unknown reliability so we would prefer a real time CO2 monitor. Also, there is a natural conflict between the diver who would like to determine that an air bank is clean and then "lock" it for his own use, and the submarine commander who wants his air banks available for maximum operational flexibility. Finally we have not yet determined the particulate load in the air, arising from the bank or related equipment and modified by passage through the scrubber.

PROPHYLACTIC DRUGS

KALMAN

INTRODUCTION

It has long been US policy to supply motion sickness prophylaxis for use prior to submarine escape. Recently the UK has decided to extend its interest in the possibilities for administration of drugs prior to escape and has identified a number of areas which it believes future research is indicated.

Initial Evaluation

At the initial stage it was suggested that a number of complications of submarine escape and subsequent survival on the surface might be susceptible to prophylactic drugs administered prior to leaving the submarine.

Conditions:

- 1) Decompression Related - Decompression Sickness  
                                  \ Cerebral Arterial Gas Embolism
- 2) Motion Sickness
- 3) Thermal Stress - hypothermia  
                                  \ hyperthermia
- 4) Dehydration

Motion Sickness

All those trials of the UK Submarine Escape Immersion Suit (SEIS) version which have included any examination of its surface capabilities have amply demonstrated the ability of this device to induce motion sickness of very rapid onset. In addition the process of updating the suit involved the formulation of an agreed statement of requirements which specified a surface survival period of 24 hours in Northern Atlantic winter conditions. Comparison of current policy of the oral administration of a single dose of hyoscine with the requirement of rapid onset of protection and sustained 24 hour protection clearly found current policy lacking. A number of agents were considered for future use.

Anti Motion Sickness Drugs

- 1. Anticholinergics
- 2. Antihistamines
- 3. Sympathomimetics
- 4. Combinations

In general it was agreed that mild sedation was the preferred side effect particularly within the compartment prior to escape and certainly stimulation was not desirable. Although the effects of any of the drugs on pressurization and ascent phase was largely unknown it was again agreed that mild sedation was probably the preferred option. Recent work at INM had again demonstrated the superiority of anti-cholinergics over antihistamines and it was considered that a single agent provide the simplicity required for submarine escape situations thus attention focused on Hyoscine. In order to cope with the new statement of

requirement the form of administration was considered. The required spread of onset could be obtained by an initial sublingual dose. However the 24 hour duration offered 2 separate possibilities. Firstly, a sustained release preparation is currently being developed in the UK, and secondly transdermal absorption could be used. It was considered that transdermal absorption had the significant advantage that treatment could be brought to an end as soon as the escaper had been picked up. Transdermal hyoscine was known to be effective if the patch was applied prior to the onset of symptoms. Thus the simultaneous administration of a sublingual dose and a 24-hour patch appeared to be the preferred option and will be further evaluated shortly.

#### Fluid Balance

The discussion about thermal stress prophylacs and fluid balance were combined by the suggestions that anti antidiuretic such as ADH could be administered to reduce urine loss. The Mark 8 SEIS is equipped with a "nappy" to absorb urine and this has long been shown to significantly reduce the thermal qualities of the suit. Preliminary examination indicates that fluid balance prior to, during and subsequent to escape is fairly complicated with a number of physiological response going on at the same time.

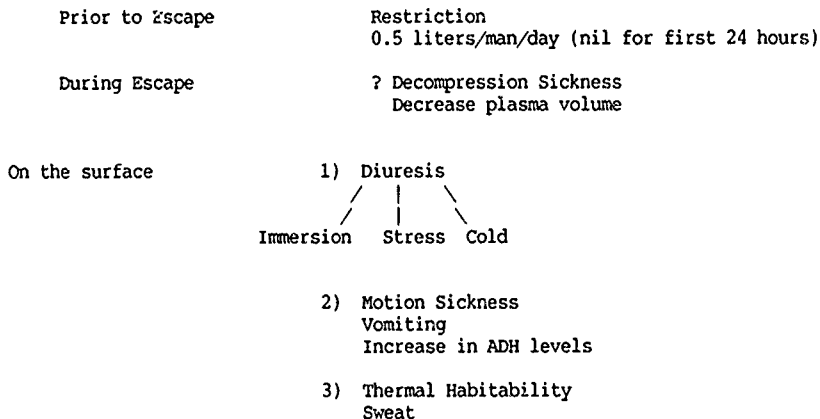

Without further work it was considered that the relative importance of the different responses was currently unknown, and certainly the effect of added administration of ADH would not be accurately predicted nor could it be considered beneficial. This decision led to the need to produce a significantly improved urine system for the Mark 9 SEIS and the trialing of the urine dump system.

#### Decompression Related Problems.

A bewildering number of agents continue to be suggested for the treatment of or prophylaxis against either decompression sickness, arterial gas embolism or

both; some of which may have some application in the submarine escape situation. The current UK position is to concentrate future research on 3 such agents namely:

Oxygen

Steroids

Antiplatelet drugs



## MOTION SICKNESS

REQUIREMENT      Rapid onset  
                      /      up to 24 hours duration

Current Policy    300 - 600 ugm HYOSCINE

### Future Possibilities

1. Anticholinergics    eg ----- hyoscine
2. Antihistamines    eg ----- cinnarizine. cyclizine
3. Sympathomimetics    eg ----- amphetamine, ephedrine
4. Combinations

### Conclusions

1. Mild sedation preferred
2. Hyoscine most effective agent

### PREFERRED OPTION FOR EVALUATION

HYOSCINE

SUBLINGUAL

+ simultaneous TRANSDERMAL PATCH

DRUG	CAGE	DC	REMARKS
OXYGEN	?	✓	possible benefit if included in MIS/BISS air. *
REDUCTION IN OEDEMA			
1) STEROIDS	✓	✓	could be administered prior to escape, worthy of investigation*
2) DIURETICS	?	✓	further problems with fluid balance
REACTIVITY OF BLOOD			
1) ANTICOAGULANTS	X	?	contraindicated in CAGE
2) ANTIPLATELET AGGREGATORS	✓	?	worthy of consideration*
CEREBRAL METABOLISM	?	?	Escapee's relatively fasted
ANTI ARRHYTHMICS	?	?	No plans for further work at present
LIGNOCAINE			
OTHERS			
VASODILATORS			
BRONCHODILATORS			No plans for further work at present
VALIUM			

## FLUID BALANCE

PRIOR TO ESCAPE - RESTRICTION  
0.5 LITERS/MAN/DAY (NIL FOR 24 HOURS)

DURING ESCAPE ? DECOMPRESSION SICKNESS  
↓ IN PLASMA VOLUME

ON THE SURFACE

1) DIURESIS  
/        |        \  
IMMERSION STRESS COLD

2) MOTION SICKNESS

VOMITING

↑ ADH LEVELS

3) THERMAL HABITABILITY

ATMOSPHERE PROFILING OF ORGANICS ON SUBMARINES: THE UK APPROACH

by

P R DIBBEN

Admiralty Research Establishment, Holton Heath, POOLE, Dorset, UK

The UK medical authorities have a requirement to identify and quantify the organic species in submarine atmospheres. This would provide a data base for medical studies, and would enable a watching brief to be kept on the levels of toxic and potentially hazardous species to which submarines are subjected. It would also aid in the setting of Maximum Permissible Concentrations (MPCs). In recent years the application of new technology in the development of the next generation of sampling and analysis methods has enabled to chemist to approach more closely to the medical objectives.

At present there are few organic compounds which can be monitored in real time, viz Freon 12, monoethanalamine (MEA), 1,1,1-trichloroethane, but in future it will be possible to monitor, in addition Freons 114 and 13B1, benzene, total aromatics, and total aliphatics using the Central Atmosphere Monitoring System (CAMS). Some portable equipment will also be available for monitoring species in real time not covered by CAMS, eg Otto Fuel. Two portable instruments will be introduced; a photoionisation detector (HNU PID) to monitor total organics and a nephelometer (GCA Miniram) to monitor total aerosols. The frequent use of these on each submarine will enable ships crews to be aware of any atmosphere contamination problems at an early stage, so that remedial action may be taken. The use of the CAMS, the total organics monitor (TOM) and the total aerosol monitor (TAM) will flag when to take organic or aerosol samples for retrospective analysis.

New methods have been developed for the sampling and retrospective analysis of organic vapours. The atmosphere is drawn, by means of a Draeger pump, through 0.12 g of the porous polymer, Tenax, contained in a glass tube. The tubes are then sealed and returned to the laboratory with all relevant details. The trapped organics are then thermally desorbed, using a Perkin Elmer ATD 50, and analysed by high resolution gas chromatography and mass spectrometry (Finnegan 5100 MS/DS). The method has been automated to enable a rapid and efficient service to be provided to the Navy and the medical authorities. During the development of these techniques, ARE performed sea trials to evaluate them, and it became clear that the number of organic species that could be identified was large (ie >200). Clearly, it would not be practical to monitor all these species for every atmosphere sample. In consultation with the medical authorities, a short list of 20-30 target compounds was suggested as those species currently of most interest, and therefore to be routinely monitored. This list may be amended as and when required. The data system will generate a quantitation report listing the target compounds and their concentrations along with details, such as where and when the sample was taken. These reports will be transferred from the GC/MS/DS to an IBM computer based data system for storage and processing. The details of data manipulation and statistical analysis required are still to be decided.

In conclusion, the advantages of this approach to atmosphere profiling of organics will be that:

1. There will be real time monitors (TOM and TAM) to allow submarines to achieve better atmosphere control, locate sources of contamination and take remedial action.
2. TOM, TAM and CAMS will be used to flag when to take atmosphere samples for retrospective analysis.
3. The automated retrospective analysis provides a quicker and more effective service to the Fleet.
4. The formation of a data base allows statistical analysis to be performed on 20-30 target species.
5. A retrospective search facility will be available for compounds of interest for medical reasons.

11111  
2 June  
Tripartite

- (1) CONVEY BACKGROUND OF ACM REVISION
- . WHY WAS IT UNDERTAKEN?
  - . WHO PUSHED TO GET IT DONE?
- (2) SUMMARIZE NEW CONTENT AND FEATURES
- . STRONGER WORDS ON PAINTING, SMOKING, USE OF PROHIBITED OR UNTESTED MATERIALS ... DIRECTED AT COs. (STRENGTHEN POSITION OF MDP)
  - . BUTTRESS TECHNICAL VALIDITY OF LIMITS BY OBTAINING NAS/NRC REVIEW OF SECTION 3.0.  
(UPDATE LIMITS TO PRESENT - NOT REVIEWED SINCE DEVELOPED IN 1950s)
  - . GAS FREE ENGINEERING AND HEAT STRESS SECTIONS  
(UNADDRESSED ELSEWHERE, NECESSARY)
  - . QUICK REFERENCES FOR ATMOSPHERE CASUALTIES (DESIRED BY MDPs)
  - . MORE DETAILED, COMPREHENSIVE SECTION ADDRESSING MATERIAL CERTIFICATION (HELP US WITH OBSERVED PROBLEMS - LACK OF FLEET UNDERSTANDING)
  - . UPDATE P/R/L LISTINGS
  - . UPDATE EQUIPMENT INFORMATION
  - . UPSHOT - WE'VE MADE THE ACM MORE RESTRICTIVE.
- (3) HAVING SAID ALL THAT - WE HAVE TO ACKNOWLEDGE SPECIAL OPERATIONAL CIRCUMSTANCES AND WORK TOGETHER TO MAKE SPECIAL OPS AS SAFE AS POSSIBLE.

Nuclear Submarine Atmosphere Control Manual (ACM)  
Revision:

Change Highlights

Background:

In 1985, the Naval Sea Systems Command began a revision of the ACM. The revision was intended to correct several shortcomings, including:

- o The absence of a critical review of atmosphere constituent limits since the ACM's original publication.
- o Incomplete or out of date equipment information and references.
- o Lack of references/procedures for heat stress or gas free engineering.
- o Lack of strongly-worded warnings regarding the management of materials that can contaminate ship atmospheres.
- o Lack of casualty-control reference material in an easy to access format.

The following outline describes the changes that have been made to the manual, now due for publication within the year

## 1.0 Introduction

Changes in this section will include:

- a. A summary of new material appearing in the manual, to include a description of the format changes and reasons for such changes, amplified guidance to Commanding Officers in the area of material control procedures, and a discussion of technical changes which have an impact on submarine operations.
- b. A discussion of the change in scope of the manual to place more emphasis on medical/toxicological considerations.

## 2.0 Fundamental Concepts and Definitions

No changes.

## 3.0 Characteristics of the Submarine Atmosphere

This section will not be substantially changed. However, the section contains tabular data on submarine atmosphere constituent/contaminant species and the limits applied to each which have been verified by technical reviews conducted by the National Academy of Sciences and the Navy submarine medical establishment.

## 4.0 Heat Stress and Gas Free Engineering

This new section addresses policies governing heat stress and gas free engineering.

## 5.0 Atmosphere Control and Analysis Systems

This section combines the former sections on atmosphere control equipment (Section 4.0), ventilation (Section 5.0), and atmosphere analysis (Section 6.0) into a single section dealing with systems and equipments used to maintain air quality within acceptable limits. No material has been deleted and new information has been added on the CAMS II, OGP, and Gas Management System.

## 6.0 Material Control Program

This section is to be updated to reflect recent changes to the program used to test and certify for use aboard submarines those materials which may pose a hazard as atmosphere contaminants.

## 7.0 Emergency Procedures and Casualty Considerations

This new section provides a quick reference for use by the submarine crew in combatting casualties involving atmosphere control equipment malfunction or damage, such as a carbon filter bed fire, spills of atmosphere contaminants, and acute exposure of personnel to atmosphere contaminants. This section will be tabbed for ease of reference. Although principally directed at the Medical Department Representative, this section will augment the body of casualty information available to the entire crew.

## 8.0 Records, Reports, and Logs

This section will not be substantially changed. Additions will include revised sheets for use with CAMS II, a Gas Management System log sheet, and modification of the Atmosphere Control Report necessary to reflect each ship's equipment configuration.



Adams Tue AM

*Secretary's Copy*

PRESENTATION TO IEP:B52 TRIPARTITE SUBMARINE MEDICAL CONFERENCE, NEW LONDON,  
1-5 JUNE 1987

BR1326 - AIR PURIFICATION IN SUBMARINES

VUGRAPH 1

INTRODUCTION

*The Atmospheric Control Manual*

1. Mr Chairman, Ladies and Gentlemen, BR1326 is to air purification in the Royal Navy what the Bible is to an evangelical preacher. It provides guidance and direction, and specifies standards of performance almost as demanding as those in Deuteronomy Chapter 5. Like the title of BR1326 suggests, the scope is extremely wide and in the limited time available it would be impossible to cover every subject in only the most superficial manner. Therefore, I propose to use BR1326 as a vehicle for describing how the Royal Navy controls submarine atmospheres, but I recognise that this is a medical conference and therefore I do not propose to deal in too great a detail on those aspects concerned with the technical make-up of air purification equipment.

VUGRAPH 1  
OFF

BR1326

2. In our hierarchy of documentation there are those documents concerned with procurement activities and those that are concerned with the in-service support task. Design policy standards represent the top level approach to achieving a requirement, with Naval , British International or Defence Standards specifying the technical requirement. Books of Reference, or BRs, deal with technical aspects of specific equipments or systems that are introduced into service. BR1326 is an unusual document in that it performs the three-fold role of being a Design Standard, a Technical Specification and a Technical Handbook.

VUGRAPH 2  
ON

VUGRAPH 2  
OFF

3. This apparent anomaly is quite supportable when it is appreciated that the air purification system, and I use the word system in its wider sense, is a complex system, and one which results from the interaction of numerous other systems. To be comprehensive, BR1326 must include details of everything that contributes to air purification, but must not duplicate information that is contained in other documents. From this next Vugraph you will see the subjects contained in BR1326.

VUGRAPH 3  
ON

4. At first sight you might well think that BR1326 does in fact cover all that is necessary to provide an air purification system. However, the BR is only a general manual where information is more properly covered in other handbooks, but it provides detailed information where the subject is not adequately covered elsewhere. This basically divides the chapters into two types. Firstly, those chapters dealing with equipment such as electrolyzers, scrubbers, and burners, etc, give a good general technical description of the hardware and provide details of the physical characteristics, together with different types of equipment fitted in the respective submarine classes. The reader is then referred to the Equipment Handbooks for more detailed information. This approach covers those subjects boxed in <sup>purple</sup> on the Vugraph. The second group of chapters shown boxed in green are those where either existing handbooks do not contain a satisfactory level of information, or are considered to be inappropriate as sources of information. In this way material in the green boxes represents the fundamental core of BR1326, whilst that material shown boxed in <sup>purple</sup> provides supplementary information.

VUGRAPH 3 OFF

5. In addition to the main subject chapters there are seven Annexes containing information on:

VUGRAPH 4 ON

(1) Maximum Permissible Concentrations and Explosive Limits.

(a) There are MPC's set for 90 day, 24 hour and 60 minute exposure levels. Not all substances have all three MPC's specified, and for those substances where three MPC's are specified for several of these the same limit is quoted for 90 day, 24 hour, and 60 minute exposures. Compounds measured on board in real time tend to have three MPC's. There are 23 compounds in this group.

(b) For compounds monitored retrospectively only the MPC 90 day is specified. This group of 15 substances includes the heavy metals.

(c) Lastly there are those compounds for which MPC's are set and contaminant levels are controlled by design, ie restricting the use of materials during building, refit, maintenance and whilst on patrol.

(d) Where the presence of explosive gas mixtures are suspected guidance is given on how to calculate a Lower Explosive Limit given the measured concentrations of each gas constituent of the mixture.

(e) Within this Annex information is also provided on the toxic physiological effects of contaminants and oxygen at varying exposure levels.

(2) Reduction of Contaminant Levels in Submarines - gives equations and graphs to assist ships staff in calculating the time taken to reduce contaminant levels given a certain LP blower or diesel throughput. The algorithms are particularly useful in the event of a fire, or contaminant excursion where contaminant levels reach or exceed emergency MPC exposure levels.

(3) Relevant Publications. This section lists some 65 related references to sources of information likely to be required. In this way BR1326 acts as a gazeteer and from the information provided, or the references listed, there is an exceedingly comprehensive coverage of all relevant publications.

(4) The Schedule of Atmosphere Analysis Equipment - details the official on-board allowances of fixed and portable equipment, including Draeger chemical detection tubes. When an item may be used for routine, post-fire or escape monitoring separate allowances are declared.

(5) The Tables of Test Gases - Currently there are 12 different types of test gas cylinder in use. These tables provide details of the gas specification, colour coding for bottles, stores identification details and quality assurance certification.

(6) The Annexes dealing with Control Logs and Air Purification Tests provide instruction on the completion and distribution of atmosphere log reports, and the programme of key events leading to the final Sea Acceptance Test. I shall say more about the reporting and sea test functions later.

VJGRAPH 4 OFF

ORGANISATIONAL

6. At this point it is appropriate to describe how the Ministry of Defence is organised to provide for good atmosphere control. In many respects we are fortunate in that despite the diversity of interests involved on the subject there is only one committee dealing with this particular subject. This must be something of a record!

7. The Submarine Air Purification Committee, or SAPC, is responsible for establishing and maintaining standards of performance. The Chief Naval Architects, Assistant Director of Submarines is the Chairman, and representatives from all Sea Systems Contollerate submarine projects, air purification equipment and instrumentation specialist sections attend. Medical advice is provided from the Institute of Naval Medicine. Scientific advice on new technologies and analytical techniques is provided from the Admiralty Research Establish at Holton Heath and <sup>FA</sup>Chemical Defence Establishment at Porton Down. The Submarine Environmental Chemistry Unit, currently based in Rosyth, report on the results of air purification tests. Whilst, lastly the Flag Officer Submarines represents the operator and provides a valuable direct line of communication between the SAPC and the submarine squadrons.

VUGRAPH 5 ON

8. BR1326 embodies the standards of the SAPC and defines the performance requirements of that Committee. As such, the BR is used by the Naval Staff in developing Staff Requirements for new submarines, and for submarine updates. Compliance with BR1326 is specified in contracts with shipbuilders and dockyards. Much care is taken to ensure the accuracy and relevance of the information contained in BR1326 and amendments are carefully vetted before being incorporated. Major revisions have to be agreed by the Submarine Air Purification Committee, whereas minor changes are dealt with out of committee.

9. Through its sponsorship of BR1326, and the feedback on achieved performance, the Submarine Air Purification Committee is involved in all phases of the submarine acquisition process.

VUGRAPH 5 OFF

## PHILOSOPHY OF AIR PURIFICATION

10. As you are all too well aware, the control and monitoring of contaminant substances is necessary to maintain the environment within safe limits. Control is achieved by two methods. Firstly, there is passive control exercised by avoiding or limiting toxic materials. Secondly, active control is by the production and removal of substances using dedicated plant. The initial starting point in the process is the declaration of the Maximum Permissible Concentration for those substances of interest, and as I have stated earlier there are some 57 substances for which MPC's are currently declared. These MPC's do not represent the totality of substances identified in the submarine atmosphere, which is nearer to 200 substances, but the MPC's are for substances which are likely to occur at concentrations approaching the limiting value.

11. Passive Control - is achieved by controlling the materials used in the build, day-to-day operation and maintenance of submarines.

Whenever a new material is proposed for use in a submarine it is submitted for formal assessment. This assessment examines the toxicological, occupational hygiene, and where appropriate the fire risk of the materials. The fire tests characterise the materials performance in terms of the flammability, oxygen, smoke and toxicity.

12. The occupational hygiene and toxicity assessment is undertaken by the Institute of Naval Medicine, and the fire testing is undertaken by commercial laboratories. The results of the tests are incorporated into two documents. These are:

- a. BR1326(A) - Materials Toxicity Guide.
- b. NES 705 Selection of Materials on the Basis of Their Fire Characteristics.

13. BR1326(A) classifies materials into 5 categories. These are:

VUGRAPH ON

Class 1 Prohibited items.

Class 2 May be used during construction and refit only. Not to be carried under closed boat conditions. The materials must be cured, diluted, or enclosed.

Class 3 May be used during maintenance periods and DEDs. Not to be carried during closed boat conditions. Again as for Class 2 the material must be cured, diluted or enclosed.

Class 4 Restricted item. May be carried at sea for use in specified circumstances.

Class 5 Permitted for use at sea in approved quantities.

VUGRAPH 6 OFF

14. The materials listed in BR1326(A) are presented in 14 Tables which are related to the application that the material is normally used for; ie adhesives, detergents, paints, jointing compounds and sealants etc. There are over 750 materials listed in BR1326(A) and currently new materials are being submitted at the rate of 8 per month. Wherever possible our policy is to put the onus on the user to demonstrate that an existing and proven material is not suited for his application. However, it must be recognised that materials is a constantly changing field and increasingly commercial forces will dictate the availability of suitable materials.

15. Active Control. Leaving Passive Control, I will now briefly discuss how active control is achieved.

Oxygen Generation - In nuclear submarines oxygen is provided by use of electrolyzers. Currently the majority of submarines are fitted with High Pressure Electrolyzers..

A new Low Pressure Electrolyser using solid polymer electrolyte developed by General Electric has now been developed and the first units are in service. The Low Pressure Electrolyser is a significant improvement on the High Pressure Electrolyser being lighter, smaller, cheaper and much less complex.

Chlorate candles are used to provide oxygen in conventional submarines and for escape purposes in all submarines.

Carbon Dioxide - For nuclear submarines regenerative scrubbers are used. Earlier submarines used mon-ethanolamine or MEA, whilst molecular sieve scrubbers were introduced into earlier Trafalgar-Class attack submarines. However, new type MEA scrubbers similar to the US Mk III VITOK units are to be fitted into new submarines and the Temperature Swing Molecular Sieve Plants are to be replaced.

As with oxygen, conventional submarines rely on consumable chemicals; namely soda lime for routine air purification, and all submarines use soda lime for escape purposes.

Carbon Monoxide - is removed together with hydrogen using catalytic burners operating at 235° Centigrade, although Temperature Swing Molecular Sieve Scrubbers have a low temperature burner integrated into the plant.

Aerosols are taken out using filters and precipitators and vapours are removed on the activated charcoal beds.

#### REQUIREMENTS FOR ATMOSPHERE ANALYSIS AND MONITORING

16. The recent major revision of BR1326 conducted in June 1986 lays down the Submarine Air Purification Committee's requirements for instrumentation and monitoring routines. There are three types of instrumentation used.

- Firstly - fixed atmosphere analysers
- Secondly - Portable and back-up instruments
- and Thirdly - supplementary instruments for occasional use.

17. Currently there are two fixed analysers in service. The Vugraph shows the characteristics. The Pye analyser is a gas chromatograph and measures hydrogen, oxygen, carbon dioxide, Refrigerant 12 and carbon monoxide levels. The CAMS is the latest instrument which is a mass spectrometer and in addition to measuring the same substances as the Pye, also measures Refrigerant R114, Halon, Benzene and the aliphatic and aromatic organic compounds.

VUGRAPH ~~7~~ ON

VUGRAPH ~~7~~ OFF

18. The Portable air monitoring and Standby back-up instruments provided are used to detect hydrogen, oxygen, Refrigerant R12 and R114, there is a refrigerant leak detector, an Otto fuel monitor. Draeger Gas Detector Tubes are used extensively and 10 different detection tubes are routinely carried, together with Bacharach MEA detector tubes.

19. The supplementary instruments used are basically for obtaining samples of organics, gaseous or aerosol contaminants for retrospective analysis at the Submarine Environmental Chemistry Unit. The supplementary instruments are also embarked if it is suspected that a particular contaminant is giving problems either generally throughout the submarine or localised in one particular area. In such instances the instruments are embarked and the crew are given specific instructions on the use and siting of these instruments. The samples thus obtained are returned to the Submarine Environmental Chemistry Unit for analysis and subsequent report.

20. A range of new portable instruments is currently being procured for routine on-board usage for the monitoring of aerosol and organic vapour levels. A new gas chromatograph mass spectrometer facility is being installed at the Submarine Environmental Chemistry Unit for the routine retrospective analysis of organic samples obtained in Tennax tubes.

21. As regards the on-board monitoring routines the Pye Analyser is not suitable for continuous on-line monitoring. 8 hourly checks are conducted in a designated compartment. At twice weekly intervals all compartments connected to the analyser are monitored. Portable instruments are used concurrently to provide a check on the Pye output. Weekly checks are conducted to monitor the efficiency of regenerative equipment. Every 3 months a comprehensive search is conducted for unsuspected contaminants using the full range of Draeger tubes carried.

22. The CAMS will provide 24 hour continuous coverage to the designated compartments and has an integrated alarm facility. It is also sufficiently flexible that it can be programmed to monitor a particular compartment continuously in the event of a problem arising.

23. The monitoring routines for organics and aerosols are conducted using retrospective analysis. Extensive post-build and refit samples are obtained from each major watertight compartment. These are



supplemented by the requirement for submarines to submit routine charcoal and aerosol samples at each patrol taken during a period of 7 days continuous dived state.

SATS/HATS

24. Before concluding this presentation I would briefly like to mention the initiatives that have been taken to formalise a system of Harbour and Sea Acceptance Tests for air purification. The June 1986 Revision of BR3126 defines the objectives as shown on this next Vugraph. These are:

VUGRAPH 8 ON

a. To demonstrate the ability of the air purification equipment to maintain the submarine atmosphere within the specified limits and below the 90 days M<sup>PC</sup> whilst maintaining normal submerged ventilation conditions for a minimum of 7 days.

b. To assess the performance of the atmosphere analyser and standby instrumentation to monitor the ships atmosphere.

VUGRAPH 8 OFF

25. Currently the tests apply to nuclear submarines, but will be extended to cover conventional submarines within the next 12 months. The tests consists of 3 phases:

Firstly, the Harbour Acceptance Test - is carried out towards the end of build, or refit whilst alongside. The HAT is really a quality assurance check to give confidence before proceeding to the SAT 1 and 2. All equipment must have been satisfactorily commissioned, the crew will have been trained in the operation and maintenance of regenerative equipment and analysis instrumentation, and the materials used in the build of the submarine or in the refit will have been checked against the toxicity index, BR1326(A).

Secondly Sea Acceptance Tests are undertaken once the submarine is in commission. SAT(1) is undertaken by Ships Staff during a 48 hour dived period with the normal ventilation line up. The first 24 hours is a stabilisation period, and test measurements are taken in the second 24 hour period. The performance efficiency of electrolyzers, scrubbers, catalytic burners, refrigerant removal units and precipitators is measured. Atmosphere measurements are

taken every two hours using the fixed analyser and portable instruments, and aerosol, organic vapour and MEA samples are taken for retrospective analysis ashore.

The SAT(2) is a 7 day continuous dived test comprising a 2 day stabilisation period, followed by a 5 day test period. A 2 or 3 man test team is embarked for the duration as the work involved is beyond Ships Staff resources. The measurements and samples taken are similar to those recorded during the SAT(1), with additional emphasis being placed on trace contaminant identification, and source location.

The final SAT(2) Test Report is sent to Flag Officer Submarines as the accepting authority. Deficiencies in performance will lead to the submarine being designated as operationally defective. This means that urgent support action is taken and remedial work is undertaken as a matter of priority. A situation could arise where the submarine may not be allowed to sail until the defect is corrected. The feedback loop for the requirement to conduct Sea Acceptance Tests which are specified in BR1326 is completed when the Submarine Air Purification Committee endorses the achieved results and agrees the recommendations for follow-up action.

#### CONCLUDING

26. I have used BR1326 as the central theme for this presentation, but have concentrated in some detail on those aspects where BR1326 has a unique position in the overall documentation structure. It provides physiological advice and technical description, it acts as a stores provisioning schedule, it lays down mandatory procedural requirements for monitoring and testing submarine atmospheres, and provides the basis for a contractual agreement. In short, BR1326 is the focal document for air purification in the Royal Navy.

27. I have a copy of BR1326 with me, together with copies of the HATs and SATs forms and these are available for examination after the session.

①

B.R. 1326

# AIR PURIFICATION IN SUBMARINES

# THE HIERARCHY OF DOCUMENTATION

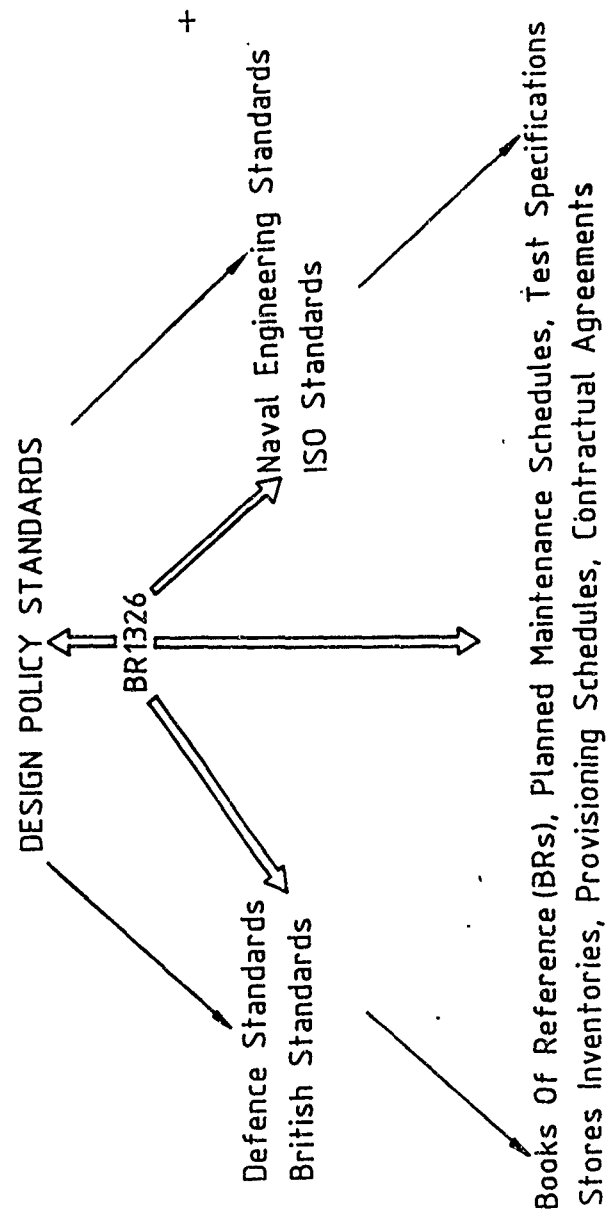

BR 1326 CONTENTS  
SCOPE OF MAIN CHAPTERS

1. DEFINITIONS AND UNITS
2. PHYSIOLOGY OF RESPIRATION
3. PHILOSOPHY OF AIR PURIFICATION
4. ATMOSPHERE ANALYSIS AND MONITORING
5. REMOVAL OF ORGANIC VAPOURS AND ODOURS
6. REMOVAL OF DUST AND AEROSOLS IN NUCLEAR SUBMARINES
7. REMOVAL OF HYDROGEN IN CONVENTIONAL SUBMARINES
8. PROVISION OF OXYGEN BY OXYGEN CANDLES
  
9. REMOVAL OF CARBON DIOXIDE BY CHEMICAL ABSORPTION
10. REMOVAL OF CARBON DIOXIDE IN NUCLEAR SUBMARINES
11. PROVISION OF OXYGEN BY ELECTROLYSIS
12. REMOVAL OF CARBON MONOXIDE, HYDROGEN AND REFRIGERANT GASES

BR1326 CONTENTS - ANNEXES

1. Maximum Permissible Concentrations and Explosive Limits
2. Reduction of Contaminant Levels by Ventilating
3. Relevant Publications - References/Bibliography
4. Schedules of Atmosphere Analysis Equipment
5. Tables of Test Gases
6. Control Log Reports and Air Purification Tests Schedules

HE243/CR

# THE SUBMARINE AIR PURIFICATION COMMITTEE

## CHAIRMAN

Chief Naval Architect (AD Submarines Safety/Standards)

## MEMBERS

Institute Of Naval Medicine

Medical Advice

Admiralty Research Establishment (Holtonheath)

Chemical Defence Establishment (Porton Down) } Scientific Advice

Flag Officer Submarines

Operational Advice

Director General Submarines

Director General Marine Engineering } Procurement Authorities

Submarine Environmental Chemistry Unit

Sea Trials/Sample Analysis

US Navy Technical Liaison Officer (Bath)

## IN ATTENDANCE

MEZ43/CR

6

# BR1326(A) MATERIALS TOXICITY GUIDE

## CLASSIFICATION

## USAGE

- |    |  |
|----|--|
| 1. | Prohibited Item  |
| 2. | Construction, Refit, Maintenance<br>under Open Boat Conditions |
| 3. | Maintenance Periods, Open Boat<br>Not to be Carried            |
| 4. | Restricted for use at<br>Sea to Specified Conditions           |
| 5. | Permitted at Sea in quantities<br>approved                     |



## FIXED ANALYSERS

<u>PYE</u>	(Gas Chromatograph)	<u>CAMS</u>	(Mass Spectrometer)
	Oxygen		Oxygen
	Carbon Dioxide		Carbon Dioxide
	Hydrogen		Hydrogen
	Carbon Monoxide		Carbon Monoxide
	Refrigerant 12		Refrigerant 12
			Refrigerant 114
			Halon
			Benzene
			Aliphatic Organics
			Aromatic Organics

ME243/CR

## AIR PURIFICATION ACCEPTANCE TESTS

- OBJECTIVE 1. To demonstrate the ability of the Air Purification Equipment to maintain the Submarine Atmosphere within the specified Limits and below MPC<sub>90</sub> whilst maintaining normal Submerged Ventilation Conditions for at least 7 days
- OBJECTIVE 2. To assess the performance of the Atmosphere Analyser and Standby Instrumentation to monitor the Ship's Atmosphere

REVEALING THE PRESENCE OF PHENOLS  
IN A SUBMARINE'S ATMOSPHERE

PCA CLAIR - M. ABRAN and PCCA DUMAS

Phenol, also called phenic acid is a whitish, water soluble solid obtained by the distillation of coal. It is used and its derivatives too (cresols, pyrocatechol, resorcinol, hydroquinol) in synthetic chemistry and especially in the making of plastics ; its derivatives are also used as disinfectant under the name of "GRESYL" and they exist in cigarette smoke. During a stay in a confined space, the intoxications due to these compounds can happen not only through the pulmonary tract but also through undamaged skin as some authors have shown (PIOTROWSKY J.K.), intoxication by ingestion is the result of different accidental circumstances.

In the system, phenol and its superior homologues, are combined in the form of sulphate, glucuronate and are excreted endily through the urinary system unchanged or combined or through the pulmonary. The manifestations of chronic intoxication, due to the free circulating phenol, are cutaneous, digestive, nervous, renal and hepatic. The recommended TLV in 1979 by ACGIH is for phenol 5 ppm (19 mg/m<sup>3</sup>) for 8 h/day and 40 h/week.

The presence on board submarines of plastics the disinfection of "toilets" with "gresyl", the use of hydroquinol-based photographic fixing solution, etc... and the potential hazards led us to look in the atmosphere for the presence of such or such phenolic compounds.

It is from the active charcoal used in the purifying of the atmosphere that we have conducted our investigation. A known amount of active charcoal, between 25 and 100 g, from the main filters is desorbed with Soxhlet and with methylisobutylcetone as solvent, then the organic phase obtained is treated by 1N Soda and stirred ; the phenolates thus formed change into an aqueous phase which is acidified with hydrochloric acid 1N, thus the phenolates change back into phenol and are extracted with ether which is analysed by gas chromatography. The chromatograph used is the 5880 A HEWLETT-PACKARD model, fitted with a flame ionization detector. The column, chosen for an optimization of the separation, is a capillary column CP SIL 43 CB, 25 cm long, 0.32 of inside diameter and the thickness of the film is 0.22  $\mu$ m. The vector gas is helium, its flow in the column is 4 ml/min for an entry pressure of 15 psi. The analysis is done in temperature programmation as follows : a first stage of 8 minutes at 115 °C, than an increase in temperature of 4 °C per minute up to a final stage at 190 °C.

That optimum chromatography on the capillary column CP Sil 43 enabled us to get the satisfactory separation of 15 phenolic compounds as shown in chromatogram N.1. We shall note the satisfactory separation of meta and paracresol (peaks N.4 and 5), which is practically impossible to achieve on a classical column or a non polar capillary. However, in spite of a thorough study of the chromatographic parameters (oven temperature and pressure of vector gas), it was impossible for us to separate the 2.3 and 2.5 of methylphenol gathered under peak N.7.

Applying that separation to the desorbed active charcoal previously purified by the described method, enables us to show the phenol (chromatogram N.2), as well as numerous other chromatographic peaks which are difficult to identify for sure without calling on mass spectrometry).

In that perspective, we set up a coupling GPC MS (Chromatograph Delsi 7000 - Finnigan Mat Ion Trap 700) which enabled us to show in the charcoal desorbed the following compounds :

- phenol
- meta and para cresol
- 2.3 and 2.5 dimethylphenol.

Chromatogram N.3 represented by the whole ion current of the mass detector gives a less satisfactory resolution than that obtained on plotting N.1 which comes from a simple flame ionization detection ; indeed meta and paracresol are not separated on chromatogram N.3. We are working now on the optimization of the separation of phenols with the system of coupling.

We cannot yet quantitatively estimate phenols in the atmosphere. However, it is possible to determine the quantity of phenol found in the active charcoal which varies between 0.06 and 0.1  $\mu\text{g/g}$  of charcoal. For the other identified phenols, the amount found is in the order of the  $\mu\text{g/g}$  of charcoal.

That method enabled us to show the presence of phenols, m + p Cresols, dimethylphenol in the active charcoal desorbed of one of our submarines. We are now going to study a sampling system adapted to a quantitative proportioning. According to the amounts found, we shall look for the eventual sources to determine after investigation whether it is possible to remove some.

ATTN = 215

Injection: 4Hl. Solution témoin de phénols.

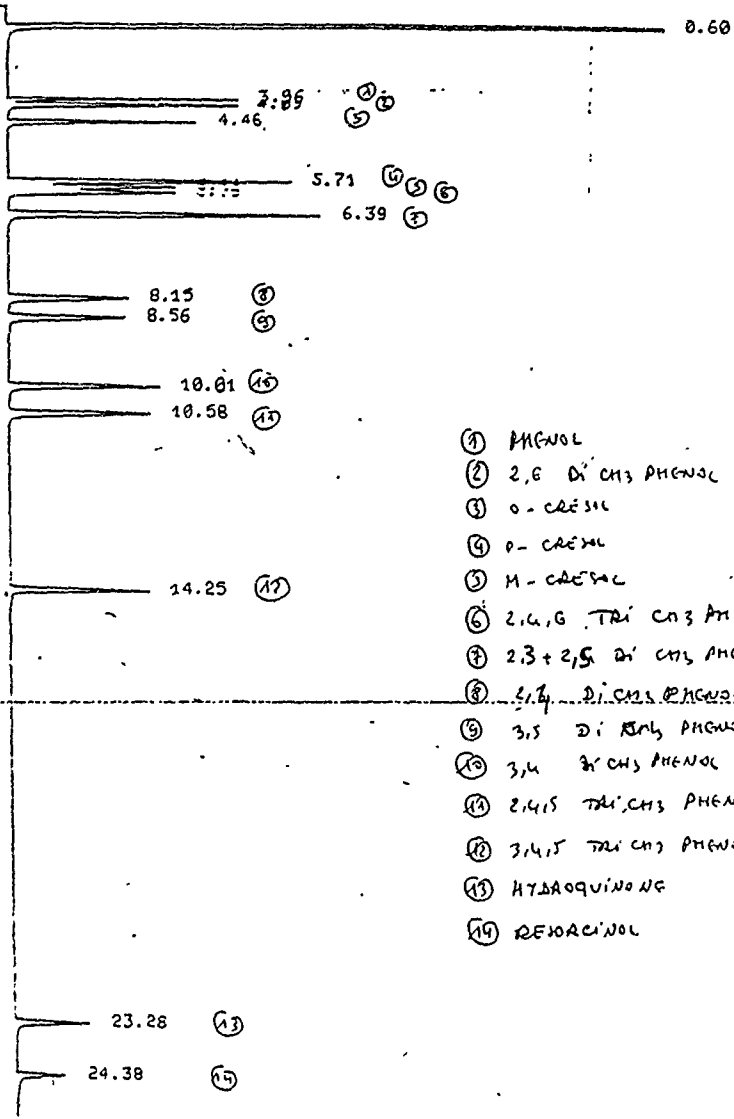

- ① PHENOL
- ② 2,6 Di CH<sub>3</sub> PHENOL
- ③ o - CRESOL
- ④ p - CRESOL
- ⑤ m - CRESOL
- ⑥ 2,4,6 TRI CH<sub>3</sub> PHENOL
- ⑦ 2,3 + 2,5 Di CH<sub>3</sub> PHENOL
- ⑧ 2,4 Di CH<sub>3</sub> PHENOL
- ⑨ 3,5 Di CH<sub>3</sub> PHENOL
- ⑩ 3,4 Di CH<sub>3</sub> PHENOL
- ⑪ 2,4,5 TRI CH<sub>3</sub> PHENOL
- ⑫ 3,4,5 TRI CH<sub>3</sub> PHENOL
- ⑬ HYDROQUINONE
- ⑭ RESORCINOL

2000 000000 INITIAL INJECTION @ 15:27 FEB 13 1957

10  
20  
30  
40  
50  
60  
70  
80  
90  
100  
110  
120  
130  
140  
150  
160  
170  
180  
190  
200  
210  
220  
230  
240  
250  
260  
270  
280  
290  
300  
310  
320  
330  
340  
350  
360  
370  
380  
390  
400  
410  
420  
430  
440  
450  
460  
470  
480  
490  
500  
510  
520  
530  
540  
550  
560  
570  
580  
590  
600  
610  
620  
630  
640  
650  
660  
670  
680  
690  
700  
710  
720  
730  
740  
750  
760  
770  
780  
790  
800  
810  
820  
830  
840  
850  
860  
870  
880  
890  
900  
910  
920  
930  
940  
950  
960  
970  
980  
990  
1000

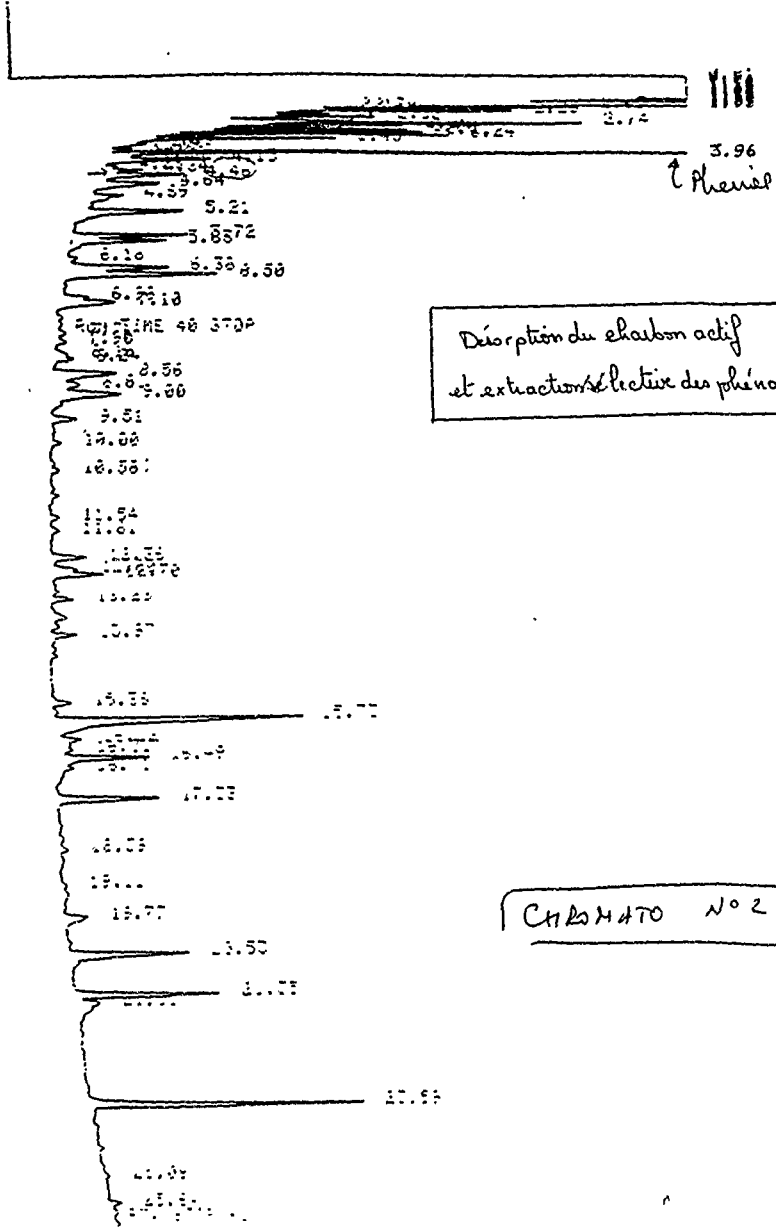

Désorption du charbon actif  
et extraction sélective des phénols

CHROMATO N° 2

Chromatogram C:FC359 Acquired: Mar-18-1987 11:40:16  
Comment: DESORBAT CHARBON ACTIV SNLE  
Scan Range: 370 - 1569 Scan: 1569 Int = 1624 Q 13.05 RIC: 100% =76452

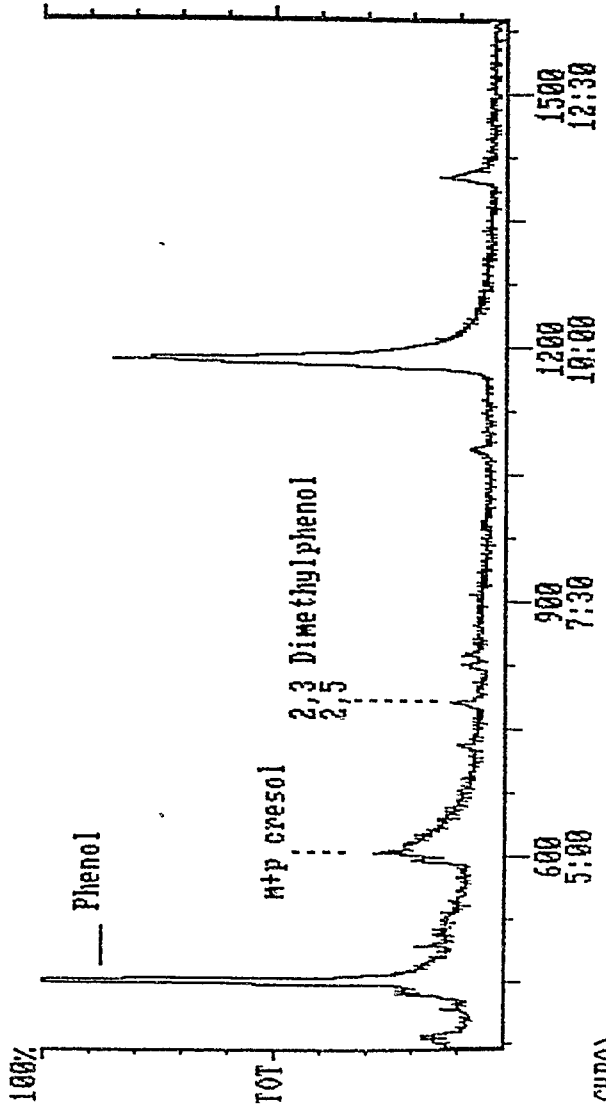

CHRO 11:40:16

Presented at :  
Tripartite Meeting on Submarine Medicine, Groton CT, June 1987

### Decompression Analysis for Submarine Rescue

P.K. Weathersby, J.R. Hays, B.L. Hart,  
S. Survanshi, L.D. Homer, E.T. Flynn  
NSMRL and NMRI

A general problem in recommending any decompression procedure is the inherent variability of decompression sickness (DCS) itself. An observation made in every decompression trial is that not all individuals within a group with exactly the same exposure will develop DCS, and that repeated exposures of the same individual on different days will not produce the same outcome every time. The physical and biological bases for this variability are simply unknown and are likely to remain so.

In abandoning the hope of making an absolute prediction for an individual, we can examine the behaviour of groups of men and consider the probability of suffering DCS, labelled  $p(\text{DCS})$ . With enough information, this probability can be established for conditions of interest; and procedures recommended with an acceptable degree of safety in terms of the procedure's  $p(\text{DCS})$ . The practical problem is with gathering enough information. Each known exposure has only a single bit of binary (yes/no) information, and many bits are required to have any confidence in our knowledge of the actual probability. Some examples are shown below.

Uncertainty in Single Repeated Trial			
DCS cases	Trials	% DCS	Confidence Limits, % DCS
0	5	0.0	0.0 - 52.2
0	20	0.0	0.0 - 16.8
0	180	0.0	0.0 - 2.0
1	50	2.0	0.1 - 10.7
5	250	2.0	0.6 - 4.6
20	1000	2.0	1.2 - 3.1

The column % DCS is the raw incidence observed. Because of the known variability of DCS, we cannot be sure that this raw incidence is precisely the underlying incidence, and in fact it seldom is. The confidence limit entries above are taken from tabulated 95% confidence limits on a binomial distribution (1). If we only need to be 90% or 80% certain of the actual range, then correspondingly narrower confidence limits are available.



The first set of entries shows the uncertainty expected for trials that do not result in any DCS. As the trial size increases, the uncertainty decreases. If the trial was only 5 safe dives, the incidence might be as high as 52% DCS; if it extended to 20 safe dives, we could be confident that the schedule would not produce over 17% incidence in the long run. About 180 dives free of DCS would be required to feel confident that the schedule in question is actually safer than 2% DCS, and nearly 400 repeated safe dives would be needed to convince us that the schedule is safer than 1%. Clearly, tables accepted after only 5 or 10 safe dives do not provide any real assurance of actual safety. The next set of entries show the results of several hypothetical trials that actually did result in DCS. In each case the raw results are 2% DCS, but the confidence range again shrinks with the effort of more dives. With a total trial size of 250 dives we would be confident that the actual incidence was under 5%; over 1000 dives would be needed to ascertain that our observed 2% was actually no higher than 3%.

Submarine escape/rescue questions are unlikely to ever command the resources to conduct 100 or more trials on each procedure we need to consider. However, with the appropriate analysis, many of the necessary dives can be obtained from other sources. The analysis needs to be able to accept non-replicated dives and combine them in estimating p(DCS) for similar procedures. Some of the sensitivity is lost compared to the hypothetical choice of each procedure tested dozens to hundreds of times. However the same "ballpark" is present: 20-50 dives can reassure us that the procedure is better than 10%; several hundred are required to assert confidently that the schedule is better than 2%.

What analysis can provide this ability? First is a mathematical model that relates important aspects of the procedure (depths and times at depth as a minimum) to a predicted p(DCS). We have explored a class of models called "risk models" expressed as:

$$p(\text{DCS}) = 1.0 - \exp(-r dt) \quad \langle 1 \rangle$$

In eqn. <1>, the term r is one of several possible definitions of instantaneous risk, of which eqn. <2> was found to be satisfactory:

$$r = a (P_{tN2} - P_{amb}) / P_{amb} \quad \langle 2 \rangle$$

Risk was thereby defined as proportional to a (calculated) supersaturation: tissue nitrogen pressure,  $P_{tN2}$ , minus the current ambient pressure,  $P_{amb}$ . Normalization by  $P_{amb}$  was found useful in early analysis of helium saturation data (4).  $P_{tN2}$  was calculated by assuming different versions of gas exchange kinetics; either a few traditional monoexponential "tissues" or some slightly more complex formulations that better described gas exchange in real animal tissues (2). Parameters such as 'a' in equation <2> and the necessary kinetic constants such as tissue half-times are estimated from all the data we have been able to assemble. The actual estimation used maximum likelihood in a manner described elsewhere (3,4).

This approach was developed at NMRI through the last several years. The first application demonstrated an ability to describe animal dose-response curves as well as human single-step decompression in helium-oxygen saturation diving (4). Next was an analysis of over 2000 air dives performed in American, British and Canadian naval laboratories (2). Data quality and comparability were serious issues in that study. The most successful model from that analysis was used in an optimization scheme to produce sets of standard air schedules with both 5% and 1% expected levels of p(DCS) (5), and was also used in straightforward prediction mode to compare relative safety of air decompression by present U.S. Navy, Royal Navy, and Canadian Forces decompression tables (6). Most recently, saturation decompression was examined.

The data involved in submarine rescue are of the form of saturation decompression from an oxy-nitrogen dive. About 250 well described exposures of this type were assembled from reports and additional information from NSMRL, NEDU, ARE(PL) and Duke (7). These were studied with several versions of equation <2> to find the most appropriate gas exchange model. As is common, several formulations worked well to describe the data. Next, another 1700 air dives, including the published UK submarine escape trials (8), were added so we now operated on nearly 2000 man-dives. Again several gas exchange versions worked well. After analysis, a number of new saturation decompression tables with a target DCS incidence of 1% were produced. Though they have not been tested on humans, they represent a careful prediction based on a large volume of human data.

What other uses can be made of this methodology? Figure 1 has 2 sets of predicted p(DCS) for air saturation and immediate return to 1 ATA. The dotted lines around each curve indicate the statistical uncertainty in the predictions that follow from limitations of the available data. The two sets of curves arise from 2 different gas exchange definitions, (one with an absolute threshold of pN<sub>2</sub>) which both fit the nearly 2000 dives equally well. For fitting the models, experiments were available in the 25-29 fsw range, but very few higher or lower. They agree well on predictions in the region where actual data were available, but diverge at both deeper and shallower depths. Thus the region below 23 fsw constitutes a real extrapolation into untested conditions. The important question of what is 1% p(DCS) depth for air saturation has uncertainty due to both statistical limitations in the original data and due to uncertainty over which model is better in this extrapolated region. The combined uncertainty places our 1% DCS answer in the range of 10 to 19 fsw.

We expect this analytical method to be used more extensively in examining other submarine rescue scenarios, especially those too unlikely or too hazardous to justify direct human testing. As more experimental data become available and are added to the analysis, our ability to make reliable predictions will achieve greater confidence.

## REFERENCES

1. Diem K, ed. Documenta geigy scientific tables. 6th ed. Ardsley NY: Geigy Chem Corp 1962:85-103.
2. Weathersby PK, Survanshi SS, Homer LD, Hart BL, Flynn ET, and Bradley ME. Statistically based decompression tables. I. Analysis of standard air dives: 1950-1970. Medical Research Progress Report of the Naval Medical Research Institute, Bethesda, Md.: NMRI 85-16, 62 pp. March 1985.
3. Kendall MG and A Stuart. The advanced theory of statistics. 4th ed. New York: Macmillan, 1979, vol 2, chap 18, 24, 30
4. Weathersby PK, Homer LD, and Flynn ET. On the likelihood of decompression sickness. J Appl Physiol 1984; 57:815-825.
5. Weathersby PK, Hays JR, Survanshi SS, Homer LD, Hart BL, Flynn ET, and Bradley ME. Statistically based decompression tables. II. Equal risk air diving decompression schedules. Medical Research Progress Report of the Naval Medical Research Institute, Bethesda, Md.: NMRI 85-17, 60 pp. March 1985.
6. Weathersby PK, Survanshi SS, Hays JR, and Maccallum ME. Statistically based decompression tables. III. Comparative risk using U.S. Navy, British, and Canadian standard air schedules. Medical Research Progress Report of the Naval Medical Research Institute, Bethesda, Md.: NMRI 86-50, 22 pp. July 1986.
7. Hays JR, Hart BL, Weathersby PK, Survanshi SS, Homer LD, and Flynn ET. Statistically based decompression tables. IV. Extension to air and N2-O2 decompression. Medical Research Progress Report of the Naval Medical Research Institute, Bethesda, Md.: NMRI 86-51, 51 pp. July 1986.
8. Donald KW. A review of submarine escape trials from 1945 to 1970 with a particular emphasis on decompression sickness. Medical Research Council, Underwater Physiology Report 290, 1970.

Fig 1

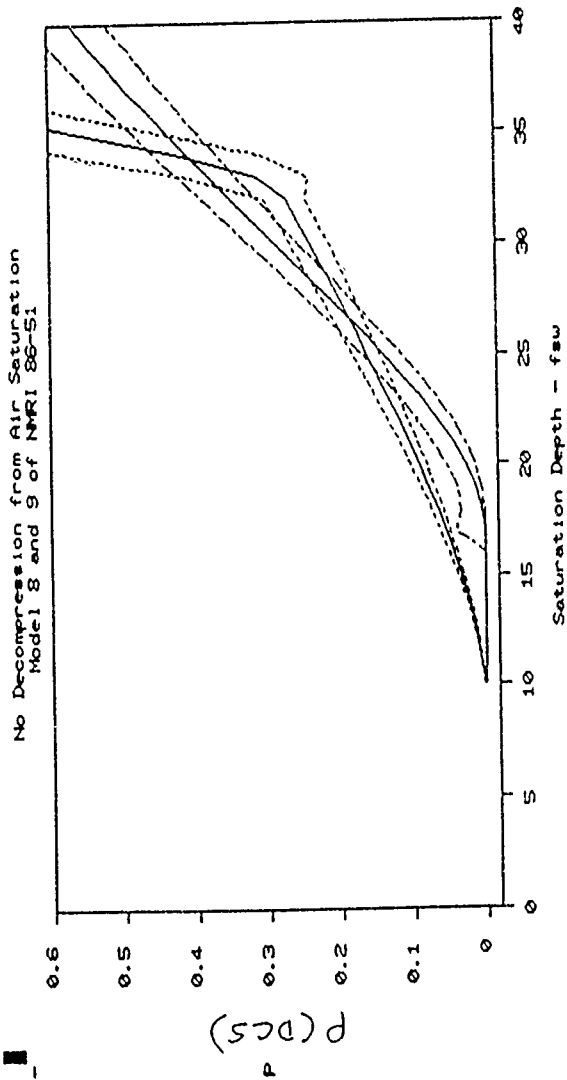

Mr. C. Adams

PRESENTATION TO THE US/UK/France TRIPARTITE MEETING ON SUBMARINE MEDICINE  
NEW LONDON, USA 1-5 JUNE 1987

ROYAL NAVY EXPERIENCE WITH MOLECULAR SIEVE CO<sub>2</sub> REMOVAL PLANT

VUGRAPH 1

INTRODUCTION

1. Mr Chairman, Ladies and Gentlemen, first generation nuclear submarines controlled carbon dioxide using MEA scrubbers. There is no doubt that this type of scrubber performed a useful job of work, although the shortcomings were apparent to operators on both sides of the Atlantic. The MEA plant required frequent attention to maintain the correct chemistry, the electric boiler heaters were prone to failure, MEA carry-over in the CO<sub>2</sub> discharge reduced compressor life, and the MEA contamination of the exhaust air created both medical and engineering problems.
2. Molecular sieve technology offered the potential for developing an efficient scrubber, amenable to continuous automated operation, and with the significant benefits of clean carbon dioxide and exhaust air discharges. In 1970 the Royal Navy initiated the development of the Temperature Swing Molecular Adsorber, or TSMA, as a replacement for the Foam Bed scrubber. Initial pilot scale process trials confirmed that it was possible to remove carbon dioxide from typical background levels of 1.5%, whilst restricting the quantity of nitrogen discharged overboard to acceptably low levels. Typically 0.2% of the discharge.
3. A navalised prototype plant was produced and after successful land-based proving trials it was installed in an SSN for sea trials in 1976. This plant, the Mk 1 TSMA was designed to remove 50 cubic feet per hour of carbon dioxide for a background concentration of 0.75%. At this time the Maximum Permissible Concentration was 1.0%.
4. In parallel with the fitting of the Mk 1 TSMA it was decided to build an improved TSMA with increased performance at reduced carbon dioxide concentrations and incorporating a low temperature carbon monoxide and hydrogen burner, as a means of overcoming severe corrosion problems that were being encountered at the time with the high temperature catalytic burners. This improved design TSMA could remove 50 cubic feet per hour of carbon dioxide against a 0.5 per cent background level.

5. The improved Mk 3 TSMA was designed to be installed in the TRAFALGAR - class SSNs. Two TSMA's along with two MK 5 High Pressure Electolysers were to be the planned equipment fit.

TSMA DESCRIPTION

VUGRAPH 2

6. This next vugraph shows the simplified process flow schematic, along with major process parameters. Air is compressed to 7 bar, and then cooled and dehumidified. The drying section consists of 3 beds each containing 3A sieve. Two dryer beds are on line at any one time and remove the moisture. The third bed is being regenerated. From the dryer beds the air, warm from adsorption is again cooled and flows through the two carbon dioxide adsorbing beds in use, where carbon dioxide and freon are removed on a mixture of 4A/10A sieve. The air then flows through the carbon monoxide burner and is then cooled. From here the air flow divides, some being passed through an air dryer heater to the regenerating dryer bed, and thence to exhaust back to the submarines atmosphere. The remainder of the air flow is routed to the adsorber bed that was regenerated during the previous cycle, and cools it. The outlet from the cooled adsorber is divided into two flows. One flow passes to the hydrogen burner, whilst the other by-passes the hydrogen burner.

7. The plant solely uses chilled water to cool the process flow and the carbon dioxide compressor. Control valves are pneumatically operated, and control cubicles are solid state electronics.

8. The next VUGRAPH shows a Mk 3 TSMA main unit, not shown are the control VUGRAPH 3 cubicles and carbon dioxide compressor assemblies.

MAIN COMPRESSOR  
VACUM PUMP  
ONE ADSORBER BED  
AIR DRYER BEDS ON OTHER PLANT  
48 PROCESS VALVES REQUIRING CYCLING

9. Despite achieving success in developing the Mk 3 TSMA Ministry of Defence engineers were only too well aware that the TSMA was a large, heavy, complex and costly plant that was not energy efficient. Therefore, at the same time as the Mk 3 TSMA was being produced a development programme was initiated to seek significant improvements in key areas of performance. The route followed was to investigate the pressure swing adsorption process.

#### PSMA DESCRIPTION

10. Pressure swing refers to the difference in carbon dioxide partial pressure in a molecular sieve bed between the adsorption and the desorption cycles. If carbon dioxide contaminated air is pressurised and the carbon dioxide removed in the adsorption phase, the carbon dioxide will then desorb from the sieve if the pressure in the bed is reduced to a value below that during which adsorption took place. If the right combination of adsorption and desorption pressures can be chosen then all the energy used to heat, cool and re-heat air in the TSMA process could be saved. In addition the overall process design would be considerably simplified.

11. Small scale pilot plant trials showed the concept to be feasible and in 1978 a breadboard plant designed to remove 70 cubic feet per hour of carbon dioxide at 0.5 per cent background was commissioned.

12. The VUGRAPH shows a process schematic for the PSMA system. Air is compressed to 1 bar and dehumidified, before being ducted to a hydrogen burner. The air then passes to a leading dryer bed containing 3A sieve before having the carbon dioxide removed in the leading carbon dioxide removal bed. The carbon monoxide is then removed at low temperature and the lean, dry air regenerates the saturated dryer bed and leaves the plant at a normal humidity, approximately 70 per cent relative.

13. The second stage saturated carbon dioxide bed is desorbed by a combination of vacuum assisted by a low level purge flow of lean air taken from the outlet of the leading carbon dioxide removal bed. The effluent from the second stage desorption bed is adsorbed onto the third stage leading carbon dioxide removal bed. To ensure full saturation of this bed, and reduce the nitrogen being discharged it is necessary to route the break through tail gas back to the plant inlet.

The saturated third stage bed is then desorbed by the third stage vacuum pump feeding to the carbon dioxide discharge compressor.

14. This next VUGRAPH shows the 70 cubic foot per hour breadboard plant. VUGRAPH 5  
The two large lower drums are the dryers, with the second stage carbon dioxide removal beds above them. The main blower is sited at the rear bottom right hand corner of the plant, with the third stage beds and vacuum pump sited above the blower.

15. The PSMA was a simpler plant than the TSMA, but despite 2 years intensive effort it was not possible to get the percentage purity of the carbon dioxide discharge up to a satisfactory level. The third stage was removed and a temperature swing stage substituted. This solved the problem of excessive nitrogen in the carbon dioxide discharge, but design studies for the required 100 cubic foot per hour plant showed the volume to be unacceptable. In addition we had little confidence that parametrically scaled design predictions could be achieved. Accordingly the PSMA programme was terminated.

#### THE REVIEW

16. The cancellation of PSMA was not seen as a disaster. After all the TSMA was fully developed and being ordered for the TRAFALGAR class submarines. This class of SSN was to be the first class required to achieve 0.5% carbon dioxide MPC. Two TSMAs each with a removal capability of 50 cubic feet per hour at 0.5% were to be fitted into each boat. The TSMAs were to be operated co-currently, as was the practice for MEA scrubbers. In the event of a TSMA being down the remaining plant would continue to run, but carbon dioxide background levels would rise. This was not an ideal situation, as originally the two TSMA fit was for a 1.0% background level with single plant running. However, there was some concern when in 1980 it was discovered that unlike the MEA plants which increased carbon dioxide removal capability as atmospheric background levels increase, the TSMA reaches a physical limit due to the thermal inertia of the plant. It could not be cycled faster than a fixed maximum rate. This meant that irrespective of whether the MPC was 0.5% or 1.0% three TSMAs were required. The particular characteristic of TSMA is shown on the next VUGRAPH compared to the characteristic of a MEA packed tower plant.

VUGRAPH 6

17. You can imagine the hiatus that this revelation created so late in a class build programme. However, the extra room and power was found and the



TRAFALGAR class went to sea on time.

18. Clearly there was need to review the way ahead for carbon dioxide removal. TSMA worked, but apart from removing the MEA associated problems it did not offer many advantages. PSMA had been cancelled, and offered no promise of improvements. Therefore, amine systems were re-examined and it was decided to build a packed tower MEA scrubber based on the US Mk 3A VITOK unit. This design offered known performance and low technical risk. The next VUGRAPH VUGRAPH 7 shows the comparative merits of TSMA, PSMA, the foam bed scrubber and the packed tower scrubber. It is quite obvious that even when the additional catalytic burners are taken into account the MEA option is by far the most attractive. You could afford to devote extra volume, chilled water and power to clean up the MEA in the discharges and still show overall benefits.

#### INSTALLATIONS

19. During the time that we were reviewing the options for scrubbers, the new low pressure solid polymer electrolyser completed development, and went into production. A comparison of installation options for oxygen production, carbon dioxide removal, and carbon monoxide and hydrogen removal showed a low pressure electrolyser and packed tower system to be superior in all respects to the high pressure electrolyser and TSMA options. The next VUGRAPH VUGRAPH 8 shows clearly the benefits. Note: that our experience now shows that the low temperature removal of carbon monoxide does not deal with organic vapours, hydrocarbon aerosols and other contaminants. A catalytic burner would therefore be a requirement in support of any TSMA option.

20. Because of the operational and technical advantages our new submarines will have packed tower MEA scrubbers, with low pressure electrolyses and catalytic burners. Submarines currently fitted with TSMA will have them removed at first refit and replaced with MEA packed tower plants.

#### PERFORMANCE AT SEA

21. The Royal Navy is now committed to a return to MEA for carbon dioxide removal. Often the wisdom of hindsight shows us that the basis for our past decisions was sometimes overly optimistic. In submarine designs such optimism commits us to an inferior technical solution that may have to be accepted throughout the life of the submarine.

I would like to be able to report that the TSMA was a victim of changed requirements, and that other things being equal was superior to the foam bed scrubbers that it was designed to replace. Unfortunately this is not the case. The final VUGRAPH shows a summary of the performance of foam bed and VUGRAPH 9 TSMA scrubbers. The figures in brackets relate to the early single Mk 1 TSMA plant that was put to sea for development experience and is still at sea.

22. Even allowing for the inferior reliability, and greater repair time of the foam bed compressors the overall availability of the Mk 3 TSMA is inferior to that of the foam bed scrubber. Sceptics might consider the comparison as unfair as the foam bed is a fully developed plant, with lots of operator experience to support it. Whilst the TSMA represents a new development, and the learning curve has to be climbed. I do not subscribe to such charitable comment. There is no justification in putting an under-developed plant to sea. The improvements between Mk 1 and Mk 3 TSMA show the gains that were made, and I have no confidence that even given sufficient time and resources, the TSMA could be made to have the same availability as the old foam bed scrubber.

23. No doubt the new packed tower MEA scrubber will have problems during its initial time in service. However, the technology is simple and the identification and rectification of defects is inherently less difficult than with a TSMA plant. I would expect that were I to be here in 7 years hence if a review of availability were to be conducted then I would predict that we would see a rising trend as the benefits of the new MEA packed tower plant became apparent.

24. Our experience with molecular sieve has been challenging, and not entirely wasted. The knowledge gained has provided a useful experience into the design and operation of this type of plant. There are applications on surface ships where sieve technology could be quite usefully applied, but unless there is a step change in adsorption technology, or new and severe medical controls on the use of MEA I do not see the Royal Navy reversing the decision to discard molecular sieves in favour of MEA scrubbers for the future control of carbon dioxide in our nuclear submarines.

POLLUTION OF THE ATMOSPHERE OF SUBMARINE  
HAZARDS DUE TO AIR REGENERATION SYSTEMS

---oOo---

H. BODILIS - L. GIACOMONI

---oOo---

1 - AIR REGENERATION OF SUBMARINES

The purpose of air regeneration in submarines is not only to allow life on board by doing away with noxious products, mainly carbon dioxide, and supplying oxygen. It is also to keep an atmosphere whose composition is as close as possible to that of normal air. That second purpose is difficult to attain and one cannot consider for instance to go down to the normal value of CO<sub>2</sub> in air (0.03 %), for to balance the hourly production of 100 men one would have to purify perfectly 8,000 m<sup>3</sup> of air during that time !

That is why compromise solutions between those two purposes have been sought and air regeneration systems have been studied and designed for submarines so that :

1) In a normal situation men can stay in a confined atmosphere for months without feeling the least physiological discomfort ;

2) In a degraded situation (case of accidental pollution) they can rapidly get rid of the resulting toxic products and bring their levels down to values inferior to those for long period C.M.A. (90 days).

However air regenerating systems in submarines can paradoxically cause, while working, various pollutions different from those they are supposed to get rid of.

We shall examine the various risks of producing toxic products by air regenerating systems in conventional and nuclear submarines and the solutions found or being experimented.

2 - CONVENTIONAL SUBMARINES

Conventional submarines have little energy, that is why air regenerating systems use non-regenerable products.

Despite the simplicity of the processes used, they can cause incidents and air pollutions. That is why they have sometimes been changed or improved.

a) CO<sub>2</sub> removal :

On board the first french submarines removing CO<sub>2</sub> was done with a mixture of superoxydes (oxyliths containing KO<sub>2</sub> mainly). The bad quality and impurities of the industrial product used were it to be at the origin of numerous incidents (violent explosions) which, in 1917, caused it to be forbidden.

It was replaced by soda (Na OH) but because of handling difficulties of this very corrosive product it was discarded and replaced in 1938 by sodalime. That product, mixture of Ca (OH)<sub>2</sub> (82 %) NaOH (3 %) and H<sub>2</sub>O (15 %) is little toxic, little caustic, of easy use and much cheaper than the other classical absorbents. Used dynamically in containers placed on fans it retains up to 200 litres of CO<sub>2</sub> per kilogram. Moreover in survival conditions it can be used statically and gives thus excellent results.

However, its friability which produced some dusts in the air on board, was a serious problem.

Two solutions were found :

1) The industrial manufacturing process was replaced by longer semi-industrial process in which the soda and water are added at the end of the manufacturing and not during the hydration phase of the quicklime ;

2) The product is no longer handled on board and the storage cells are directly used on the fans.

Those two solutions allowed the elimination of all dust filters whose progressive clogging led to a reduction of the air processed by the regeneration units.

b) Oxygen production :

On board french submarines, oxygen was supplied until 1956 by compressed oxygen in gas cylinders (250 bars) situated outside the pressure hull. That bulky and dangerous solution was replaced by a "candle" composed of four cubic blocks of a mixture whose main component is sodium chlorate. The combustion lasts 30 minutes and the released volume of oxygen is 2 m<sup>3</sup>.

The risks while using this candle is the production of CO, Cl<sub>2</sub>, HCl and dusts. For CO they have been limited through a maximum reduction of organic products in the pyrotechnic primer. For Cl<sub>2</sub> and HCl they were eliminated by putting sodalime round the blocks. Finally, a filter allows the retention of dusts formed during combustion.

These last few years two slight problems of operation have been noticed. The first being the emission of CO due to the deposit of oils and fats on the outside walls of the candle which reach temperatures higher than 300°C during combustion. So it was necessary to wrap the candles for them to remain clean while stored on board. The second type of incident is very rare and is caused by a too violent priming which punctures the wall and releases directly without filtering oxygen full of chlorine and dusts.

### 3 - NUCLEAR SUBMARINES

With nuclear submarines, patrols can last up to 90 days, therefore the problems of air regeneration are much more complicated than on board conventional submarines.

Their energy not being limited, for the scrubbing of CO<sub>2</sub> they are equipped with regenerable products reused in a cyclic way and with water electrolysis for the production of the necessary oxygen.

#### a) Oxygen production :

The problems raised by oxygen production plants are known, the plants or at least their operation principles having been used in our 3 navies. The risks they present are due to hydrogen or electrolyte aerosols leaks (potassium solutions) or to mishandling.

A very strict training of personnel, the setting up around these units of hydrogen and oxygen analysers which interfere directly on their operating (stop at 1 % H<sub>2</sub> and 23 % O<sub>2</sub>) have avoided all serious incident.

#### b) Removal of CO<sub>2</sub>

French nuclear submarines are fitted with air decarbonation plants which use molecular sieves. We shall examine their characteristics in another lecture. Here, we shall only see the advantages and eventual disadvantages of the system. Molecular sieves, especially the 13X type, allow an excellent removal of not only CO<sub>2</sub> but also of various other air pollutants particularly freons, some light hydrocarbons and the water-soluble products not energetically retained by active charcoal. The advantages of the molecular sieve were examined at the N.R.L. in the sixties and confirmed in CERTSM during tests in laboratory and on board submarines.

Air pollution from plants using molecular sieves can be due on board submarines to the simultaneous presence of water and freons on the sieve during the sequences of operation of the plant where it is to be heated. It can also be due to the passage, on the heated sieve, of air containing some freons or hydrocarbons.

In the first case, the acids produced (HF and HCl) are responsible for the degradation of the sieve and the production of dusts. In the second, acid formation is low, but the freons or hydrocarbons degrade into toxic products (this is particularly true with freon 11). The thermal decomposition of the organic products on the hot sieves may be incomplete and thus allow the formation of carbon monoxide. In the case of acetylene, the production of CO is particularly important. Therefore it is absolutely necessary to process all the air which comes out of the molecular sieve with the catalytic burner.

To avoid those problems, decarbonation plants must compulsorily be designed according to the following principles :

a) The air which reaches the molecular sieves columns in adsorption must be completely dehydrated (less than 5 ppm of water) ;

b) The gaseous halogenated compounds likely to be thermally degraded at the temperatures met inside the plant must be totally eliminated before reaching the columns containing hot molecular sieve or alumina, in regeneration ;

c) The whole amount of air processed by the decarbonation plants must pass on the catalytic burner.

c) CO and hydrogen removal

The removal of carbon monoxide and hydrogen is done by the catalytic burner whose active product is platinum oxide deposited on corundum (alumina). The weight of the platinum oxide represents 1 % of the weight of the catalyst. The CO and H<sub>2</sub> catalysis is complete at 50°C. For safety, the operating temperature is set at 100°C.

It is to be noted though that at such a temperature of operation, there may be a risk of incomplete combustion with formation of CO (particularly with acetylene). In that case one only needs to set operating temperature at 150°C the transformation of acetylene in CO<sub>2</sub> being then complete.

d) Activial charcoal :

Active charcoal is used in canisters made of 3 cm thick perforated sheet metal containing 3 kg of product each. They are distributed on board in filters containing a number of varying superimposed canisters which purify the air (1,500 m<sup>3</sup> per hour) at polluting sources (galley, toilets...). A filter, called main filter, is placed at the entrance of each decarbonation plant, it contains 15 canisters.

The amount of active charcoal use on board an SSBN, is 260 kg. The filter canisters are replaced every 30 days. The distribution of filters on board and of the stores of new and old products avoids all risks of fire which is the main problem with this product.

e) Electrostatic filters :

SSBN's are fitted with nine electrostatic filters (five in the propulsion room). The efficiency of the filtering with this system is remarkable and keeps the pollution in dusts and aerosols low.

However the operation of those filters may present a disadvantage. It is the production of ozone which may be reduced to its minimum by a judicious choice of the polarities of the filters. Coming out of the filters, the ozone concentration is generally two to eight times superior to the fixed 90 days CMA for that product (0.04 ppm).

The fast degradation of this product allows to keep the ozone content of inhabited rooms and watch station between 0.01 and 0.02 ppm.

Only the ozone concentration in the atmosphere of some watch stations of the propulsion is above the fixed 90 days CMA when the four filters of the room are operating. Stopping two of the filters, which is often possible (very low particulate pollution) allows going back to acceptable concentrations.

#### . 4 - CONCLUSION

As a conclusion, universally efficient air regeneration systems do not seem to exist. The systems must be chosen in relation to the particular environment in which they will be used. Especially on board a submarine where each component, be it for its design or modification, must be studied not only for its main operation but also for its interference with the whole of the components of the air regeneration system as soon as it may alter the quality of the atmosphere on board.

#### REFERENCES

- 1) Notice sur la régénération de l'air à bord des sous-marins en plongée.  
CEPSM - DM 7325 G N4 du 24 mars 1924.
- 2) R. BADRE et R. GUILLERM  
Aspects physiologiques et physico-chimiques du séjour prolongé dans des ambiances artificielles.  
Revue de Médecine Navale 1-2, 43-74 1958
- 3) H. BODILIS - G. MARBLE  
La chaux sodée . problèmes d'approvisionnement et d'utilisations dans la marine.  
Rapport 191/CERTSM - 1979
- 4) R. BADRE - R. GUILLERM  
La régénération de l'air à bord des sous-marins atomiques.  
Science, progrès, la nature  
N. 3394 2 41-47 1968
- 5) H. BODILIS  
Static absorption into sodalime  
4th Tripartite Submarine medicine conference  
INM Alverstoke may 1984
- 6) H. BODILIS  
Utilisation de la chaux sodée en condition de survie  
5e conférence sur la médecine appliquée aux sous-marins - Toulon -  
Juin 1985
- 7) H. BODILIS  
Carbon dioxide adsorption into molecular sieves  
4th tripartite submarine medicine conference  
INM Alverstoke may 1984

- 8) P. GUSTAFSON - SH SMITH  
Removal of organic contaminants from air by type 13x molecular sieve.  
NRL report 5560 december 6 1960
- 9) J.K. MUSICK - P. GUSTAFSON  
Molecular sieves for purification of submarine atmospheres  
NRL report 5465 march 21 1960
- 10) Carbon dioxide removal from air in submarines using molecular sieves  
materiais  
Report A/84 (W) Admiralty materials laboratory Holton Heath Poole Dorset  
February 1964
- 11) E.T. JOHNSON  
Compatibility of hot carbon dioxide gas and dichlorodifluoromethane with  
molecular sieves 5A and 13x  
NRL report 7037 june 2 1970
- 12) ET. JOHNSON - D.D. WILLIAMS - R.R. MILLER  
Stability of the molecular sieve structure in hostile environnements  
N.R.L. report 1970
- 13) T. MARTIN - C.J. LEPPARD - R.J.R. STICKLAND  
Submarine air purification equipement  
Paper N. 15 presented at the symposium on Naval submarines LONDON  
may 1983
- 14) H. BODILIS - M. ORILLON - G. MARELE  
La toxicologie des atmosphères confinées principes de la régénération de  
l'atmosphère  
SSA travaux scientifiques N. 2 pages 54-58 1981
- 15) B. FOULGER - C. DOWDING  
The interaction of halon 1301 with air purification equipment  
5e conférence tripartite TOULON juin 1985
- 16) P. PRATT  
The removal and generation of toxic compounds by CO<sub>2</sub> catalytic  
burners  
4th tripartite submarine medecine conference  
INM Alverstoke May 1984
- 17) H. BODILIS  
SNLE l'Indomptable - teneurs anormales en monoxyde de carbone dues à une  
fuite d'acétylène  
2016/CERTSM/85 du 15/05/1985
- 18) D. FEVRIER - G. FEVRIER - J.L. VERNET - P. MIGNON  
Decomposition of some halogenated hydrocarbons over fixed bed of platinum  
- alumina - alumina-molecular sieves  
ASME 76 ENAS 2 March 1976
- 19) J.P. MALASPINA - H. BODILIS  
Compte rendu d'essais à la mer du SNLE l'Inflexible - Essais FR2 -  
Contrôle de l'atmosphère  
2015/CERTSM/85/DR - 6 mai 1985



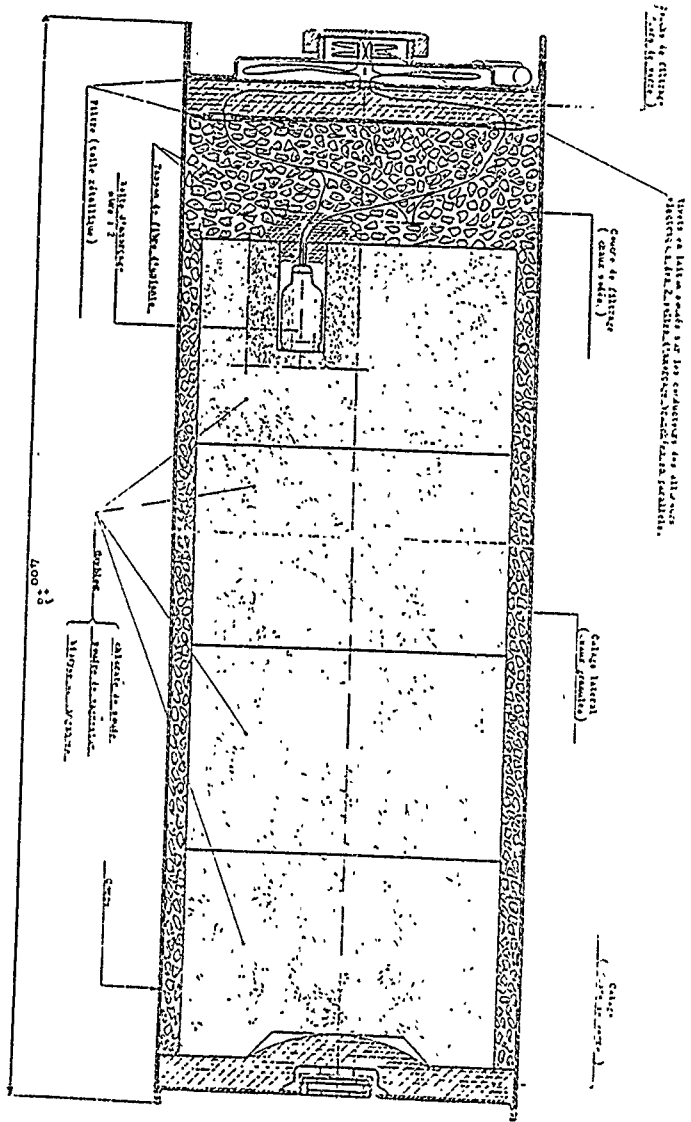

OXYGEN CANDLE

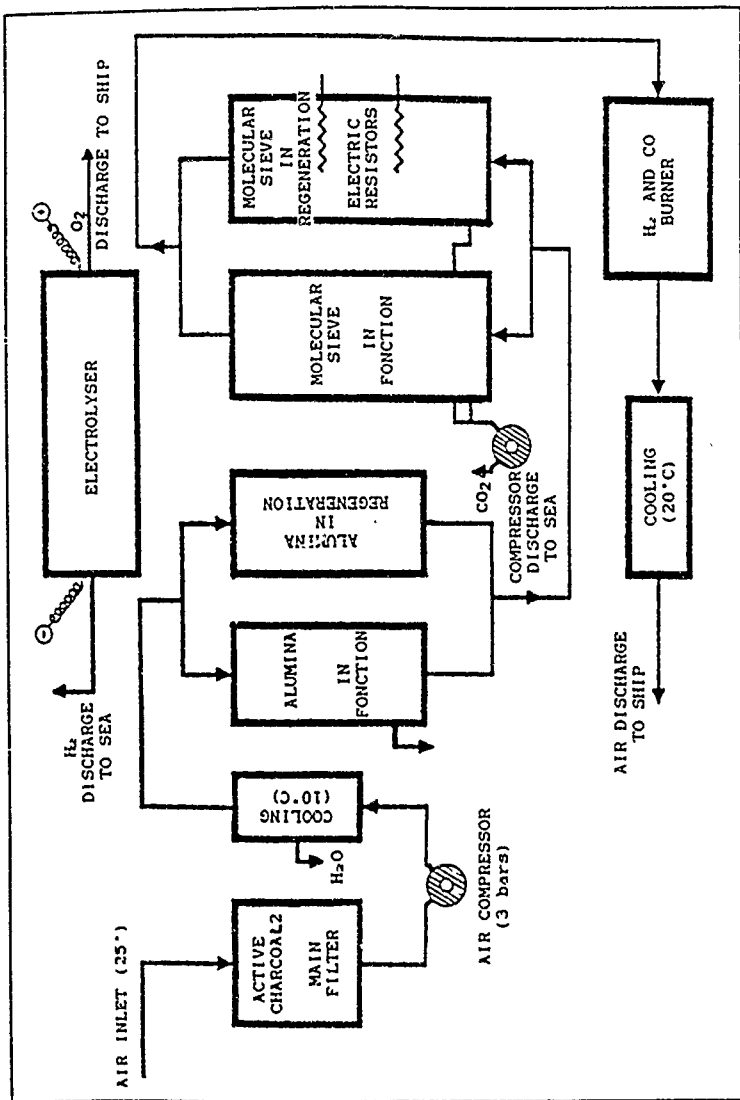

MOLECULAR SIEVE ADSORBER

IMPACT OF LOW O<sub>2</sub> ON FIRE SAFETY IN SUBMARINES

Homer W. Carhart, Head  
Navy Technology Center for Safety and Survivability  
Naval Research Laboratory  
Washington, D. C.

Introduction -

The thesis of this presentation is to show that fire safety in submarines can be enhanced by operating at oxygen concentrations below 21%. The "old wives tale" that a life-sustaining atmosphere is a fire-sustaining one (and vice versa) is not true. Fortunately, for us, we can take advantage of this fact.

Three consequences of low oxygen will be discussed: (1) some materials that burn in air (at 21% O<sub>2</sub>) might not burn at all in low oxygen; (2) even if a material does burn, ease of ignition and fire growth can be reduced markedly; and (3) we can buy additional time for reacting to and extinguishing the fire. We will not discuss the rapid extinguishment of a fire by nitrogen pressurization, which is a closely related topic but which falls under the category of active firefighting, not passive fire protection.

## Oxygen Index -

ASTM D-2836 is a procedure for measuring Oxygen Index. This is defined on the first vu-graph. Fundamentally, what this states is that under the conditions of the test, there is a concentration of oxygen below which a given material, once ignited, will not propagate a fire. The second vu-graph gives examples of oxygen indices for common materials. The fact that red oak, plywood, etc. have values above 21% (i.e., it might be implied they would not burn in air, when we all know they do) is because in the ASTM procedure, the sample is ignited at the top. This forces the fire to propagate downward - but, because of the buoyancy caused by gravity, most fires don't like to go in this direction. Therefore, they self-extinguish at an oxygen level higher than would occur for upward propagation.

However, even though the numbers are high, the concept is still valid, and there are oxygen concentrations below which a given material will not burn regardless of the geometry of the test procedure, or that in the real world. In the case of a hydrocarbon mixture - gasoline - the U.S. Bureau of Mines demonstrated decades ago that this lowest value was 12% O<sub>2</sub> when nitrogen was used as a diluent, and 14% O<sub>2</sub> for a CO<sub>2</sub> diluent.

If, as shown on the third vu-graph, one assumes a bottom oxygen value of 14%, a linear relationship would indicate that we might get as much as 30% enhancement in fire protection with as

little a drop in the ambient concentration of oxygen of only 2%. This would be fantastic, if numerically true. It is recognized that this calculation here is very unscientific, but it does indicate that enhanced protection could be considerable even with a small change in O<sub>2</sub> levels. The choice of 19% here is totally arbitrary on the part of the author, and was chosen because cigarettes will still burn, and submarines have often operated at this level with no untoward effects reported.

The bottom line is that where possible materials with high oxygen indices can be chosen and used, or if these already exist on submarines, they will not be part of the fuel load at low oxygen levels in case of a fire - whereas at 21% O<sub>2</sub> they would be.

#### Impact of Low O<sub>2</sub> on Fire Properties -

Examination of vu-graph No. 4 shows the effect on burning rate of paper as a function of oxygen concentration. These data are for horizontal burning. It is quite apparent from the steep slope that the burning rate is very sensitive to oxygen concentration, a drop of 2% (from 21 to 19) reduces the burning rate by about 20%. The critical factor here is concentration of oxygen, not total pressure or partial pressure of oxygen. This is shown in the fifth vu-graph in which one sees that even at 75 psia (5 atm.) total pressure, the burning rate of the paper increases \*

very little over that at atmospheric pressure - but, the graph also shows the marked effect in going from 21 to 31 to 41 percent oxygen.

Vu-graph No. 6 shows the effect of burning rate for kerosene, a Class B fuel, as a function of oxygen concentration. In this case, the effect of total pressure is more marked than for that of paper, a Class A material, but again the impact of small changes in concentration of oxygen have a large effect on burning rate. \*

It's interesting to note in this vu-graph that extrapolation of the data to zero burning rate gives values that are in the 12% ball park which matches the 12% lowest oxygen value found by the Bureau of Mines. Again, it is recognized this treatment is not highly scientific, the vagaries of fire behavior being what they are, but the graph does show once more that these trends can have a real impact.

Another fire property of consequence that is affected by low oxygen is total heat release. This is shown in vu-graph No. 7, where for cellulose and hydrocarbons, a drop to 19% oxygen decreases total heat release by close to 20% - again a significant amount. On the other hand, adiabatic flame temperatures are affected but little.

Concentration of oxygen also has a marked impact on the amount of energy needed to ignite a flammable mixture. Classical data from Lewis and von Elbe (also published from the Bureau of Mines) has been replotted in vu-graph No. 8 for methane and ethane. Note that the curves are not only exceedingly steep as shown, but are even plotted on a logarithmic basis for the energy component, showing the surprisingly high sensitivity of ease of ignition as a function of oxygen concentration. Extrapolation of these curves to 19% oxygen gives increases of 33 and 40% in the minimum energy needed to ignite methane and ethane respectively. It is recognized that in the real world of a submarine, most potential ignition sources would have energies orders of magnitude greater than the sub-millijoule values given here, but the trend is still eye-catching in its effect and does tell us that this phase of fire behavior is indeed very oxygen sensitive.

\*

Another fire property affected by oxygen levels is auto-ignition - sometimes called spontaneous ignition. Vu-graph No. 9 shows the effect on a number of hydraulic fluids. These data are taken from the NFPA Fire Handbook. Again it is seen that for six of the fluids the curves are very steep as we pass through 21% oxygen. Pseudo-quantification to 19% is not truly valid here because of the nature of autogeneous ignition. The process is much too complex to be described by the simplistic curves shown here (even though they are widely publicized) This is partly borne out by the data for MIL H-5606A, which show that its

\*

ignition is unaffected by oxygen concentration. But at least these overall data do show that potentially a marked effect can exist.

Vu-graph No. 10 shows data for the lower pressure limits for ignition of filter paper as a function of percent oxygen. If these data are plotted on semi-log paper, as shown in vu-graph No. 11, it indicates that by extrapolation to 19%, an increase of about 16% in total pressure is required (i.e., from 400 to 460 torr). Further reduction of O<sub>2</sub> level to 17% gives an additional increase of 18% (i.e., from 460 to 540 torr). It is interesting to note that extrapolation to 760 torr (i.e., sea-level pressure) gives a value of 14% oxygen as the limit. One has to wonder if this is a mere coincidence. The value 14% is too close to the other values we have seen earlier for other fire property limits.

In spite of the apparent complexities and vagaries of fire behavior, the author firmly believes that nature is not capricious and that she is really trying to tell us something here. The problem seems to be that we haven't become smart enough yet to ask her the right questions, and it's not her fault that we don't understand what's going on, but ours.



Response Time -

In a most practical real-world sense, the impact on fire protection in submarines by lowering the oxygen level will help us to "buy time" to react and take corrective action. If one plots almost any fire property with time, be it fire growth, total heat release, evolution of noxious products, temperature rise, etc., an exponential type curve is obtained, as illustrated by the heavy line in vu-graph No. 12. This is characteristic of a wide range of fires, from the fatal Apollo fire of two decades ago to that of dropping a cigarette on the sofa before going to bed. The main difference is only on the time scale. In the Apollo fire, in which the author was one of the principal investigators, the time from ignition to rupture of the capsule was only 15 seconds - the fire was almost explosive because the atmosphere was 100% oxygen at 16 psia. On the other hand, the cigarette might have been dropped on the sofa at 10 o'clock and it isn't until three in the morning that the house catches fire. \*

In most real world situations, a fire is spotted in its incipient stages and action is taken to quench it before it "bends the knee" on the curve. Thus, most fires don't make the news-papers. But there are the few where corrective action is not taken soon enough, or cannot be taken at all, and the fire bends the knee and a disaster results. If we could buy just a little more time to react, maybe then the necessary steps could be taken and the end result would be only an incident instead of a catas-

trophe. In the vu-graph, the dotted line shows a gain of 30%. Intuitively, as well as in reality, this would have to be a very significant factor in preventing a disaster. In discussing this with professional fire fighters, they would dearly love to have more time in which to react. It would surely make their efforts so much easier and so much more effective.

#### Impact on People -

This paper is aimed at a discussion of the effects of low O<sub>2</sub> on fire itself. The physiological effects of low O<sub>2</sub> belong in the realm of the medical community. However, the author wishes to emphasize that: (1) Fires are primarily dependent on oxygen concentration (i.e., mole fraction, or percent of oxygen) whereas life is dependent primarily on partial pressure of oxygen. The two are not synonymous and must not be confused with each other. (2) Fires are very sensitive to very small changes in oxygen concentration, whereas humans are very tolerant of wide changes in oxygen partial pressure. This latter point is illustrated in the last vu-graph, which shows a wide range of environments in which humans can exist and perform their duties.

These two points are the reasons why we can reap the very real benefits of being able to reduce fire hazards markedly in a closed environment, with precious little, if any, effect on human performance - merely by reducing the oxygen concentration. How

much it could be reduced should be answered by the medical community - to a value such that there is no decrement in performance. However, the more it can be reduced, the greater the fire protection. In a submarine, reducing the oxygen is easy - no special equipment or engineering changes need be made. On closing the hatch, one waits until the oxygen is "breathed down" to the desired value before adding fresh. Simplicity itself!

Anectdotally, the author remembers well being asked about smoking in the Sea Lab capsule years ago - an experiment in which we were involved in monitoring the atmosphere. The concentration of oxygen in the capsule was about 4%, the total pressure was about 7 atmospheres so the partial pressure of oxygen was about 0.3 atm. The author told CAPT Bond at the time that smoking would be impossible, but the aquanauts took tobacco with them anyway, and found, much to their disgust, that they could not even strike a match. Yet, they lived and functioned in this atmosphere for weeks. Percent oxygen does indeed make a difference!

OXYGEN INDEX

THE LOWEST CONCENTRATION OF OXYGEN WHICH WILL JUST  
BARELY SUPPORT PROPAGATION OF COMBUSTION FOR A  
GIVEN SUBSTANCE.

Fig 1

### OXYGEN INDICES

FILTER PAPER	18.2
COTTON	18.6
RAYON	18.9
SUGAR	22.0
RED OAK	22.7
WOOL	23.8
3/4 " PLYWOOD	24.3
3/8 " PLYWOOD	29.2

Fig 2

### REDUCED PROPAGATION RATE

- OXYGEN INDEX FOR HYDROCARBONS IS CA. 14% (I.E., BELOW 14% O<sub>2</sub> HYDROCARBONS WILL NOT BURN).
- SUBMARINES NORMALLY OPERATE AT CA. 21% O<sub>2</sub>, A DIFFERENCE OF 7%.
- IF SUBMARINE IS OPERATED AT 19% O<sub>2</sub>, THIS DROPS O<sub>2</sub> BY 2%, OR 2/7 OF THE 7%. (CA. 30%).
- WOULD THIS REDUCE PROPAGATION RATE BY 2/7 (30%)?

Fig 3

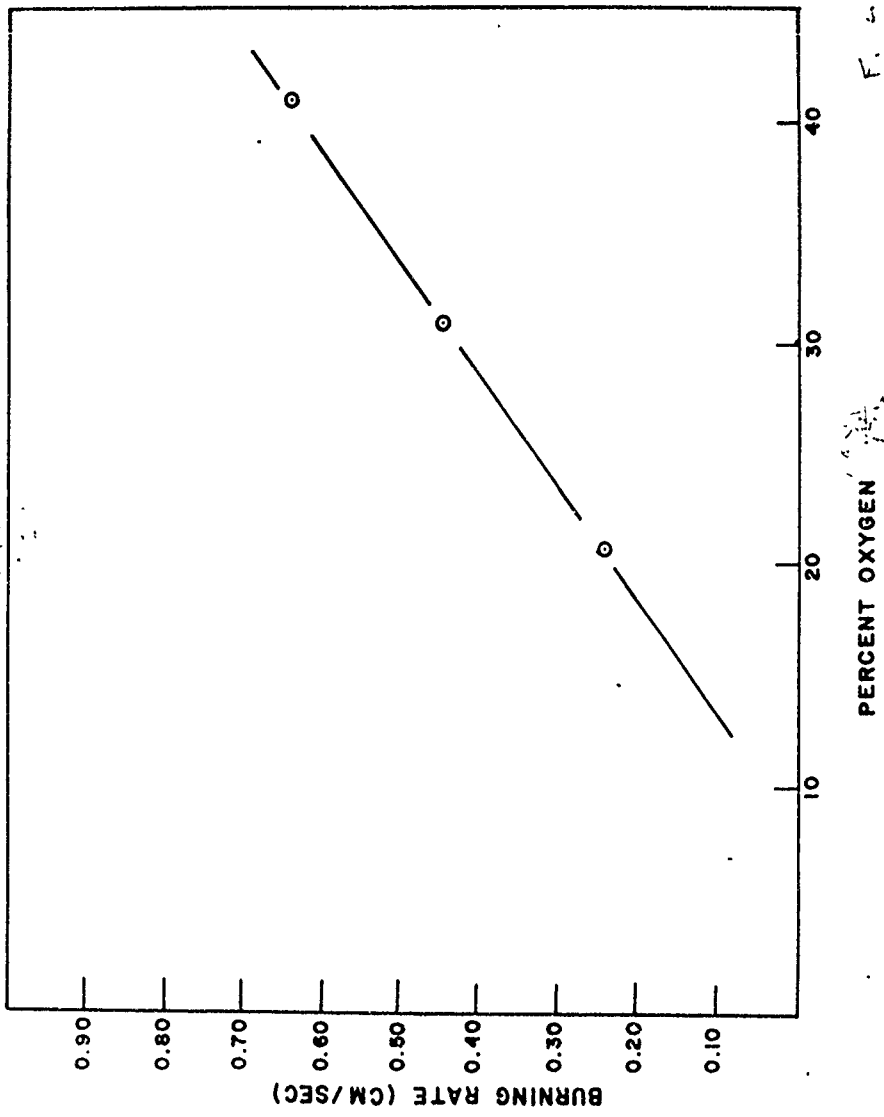

F. 2

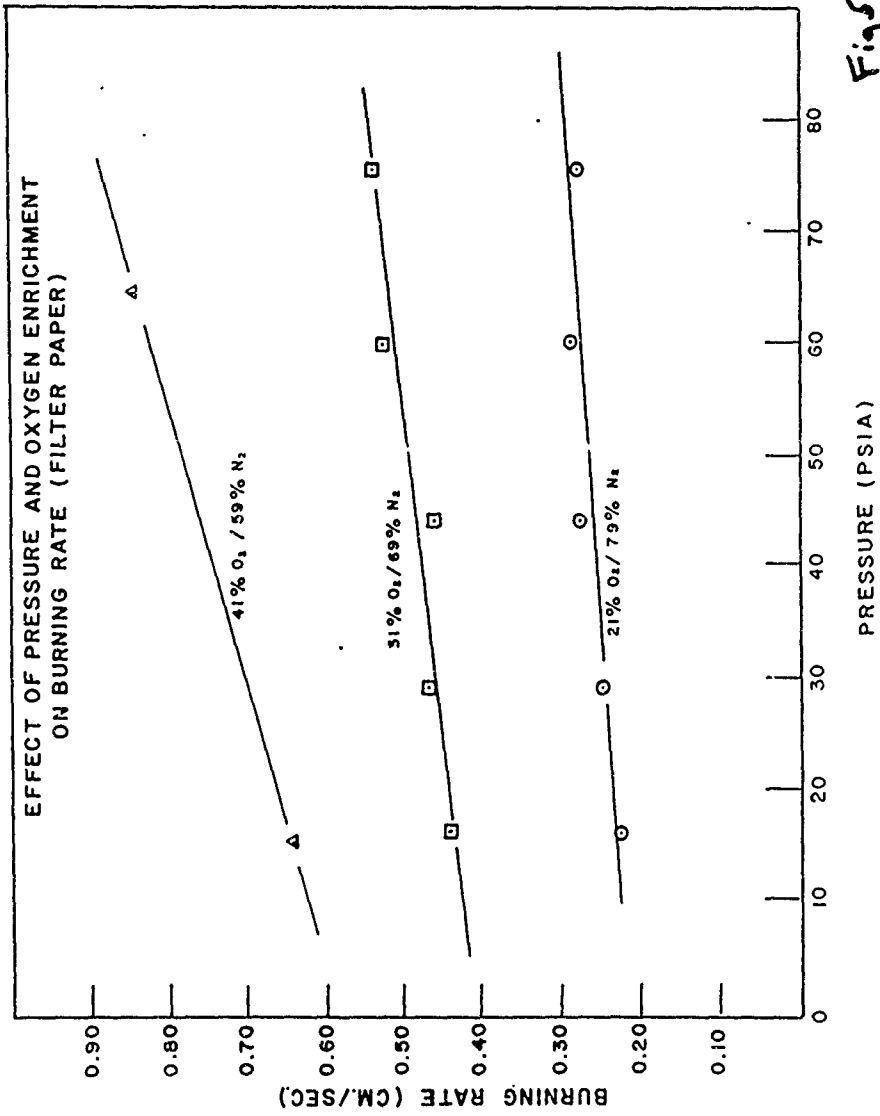

*Figs*



Pool Burning Rate vs Conc. O<sub>2</sub>

Kerosene

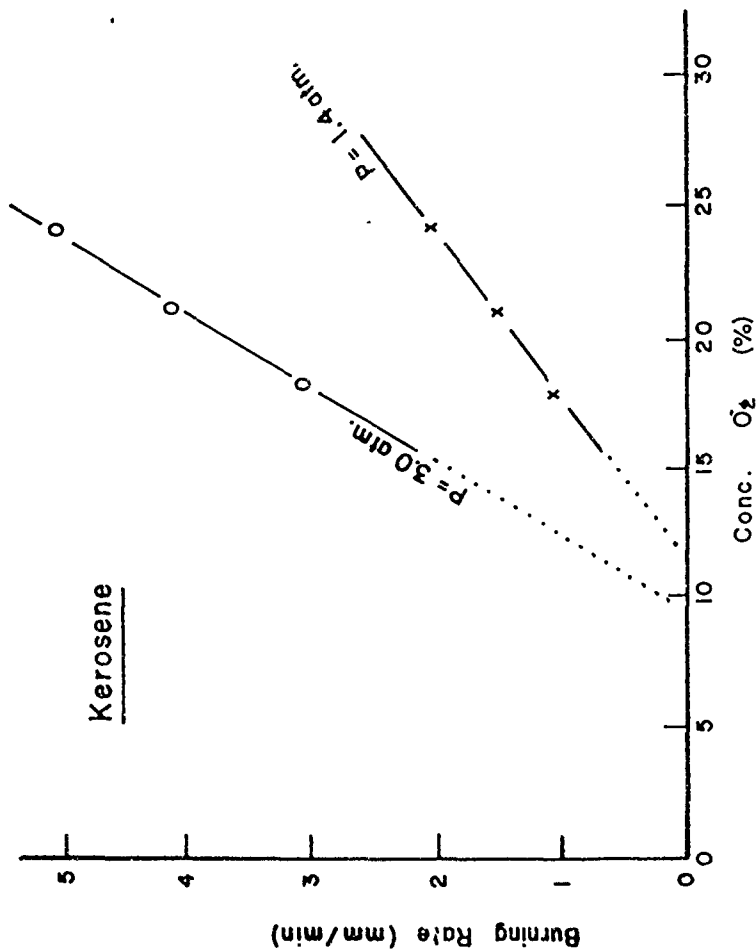

Fig 6

Table II  
TEMPERATURE AND HEAT RELEASE  
(10m<sup>3</sup> enclosure)

	Cellulose			Hydrocarbon		
	<u>19% O<sub>2</sub></u>	<u>21% (Air)</u>	<u>Diff.</u>	<u>19% O<sub>2</sub></u>	<u>21% (Air)</u>	<u>Diff.</u>
Max. Heat Release (KCal)	4029	4924	895	3463	4233	770
Max. Theor. Temp. (°C)	1713	1810	97	1279	1390	111

Extrapolated from 1986 NFPA Fire Code 53M.

Assume all but 10% avail. O<sub>2</sub> reacts.

Fig 7

46 5490

K-E SEMILOGARITHMIC CHARTS  
REPRODUCED FROM  
"K-E" RESEARCH CO. "K-E" CHARTS

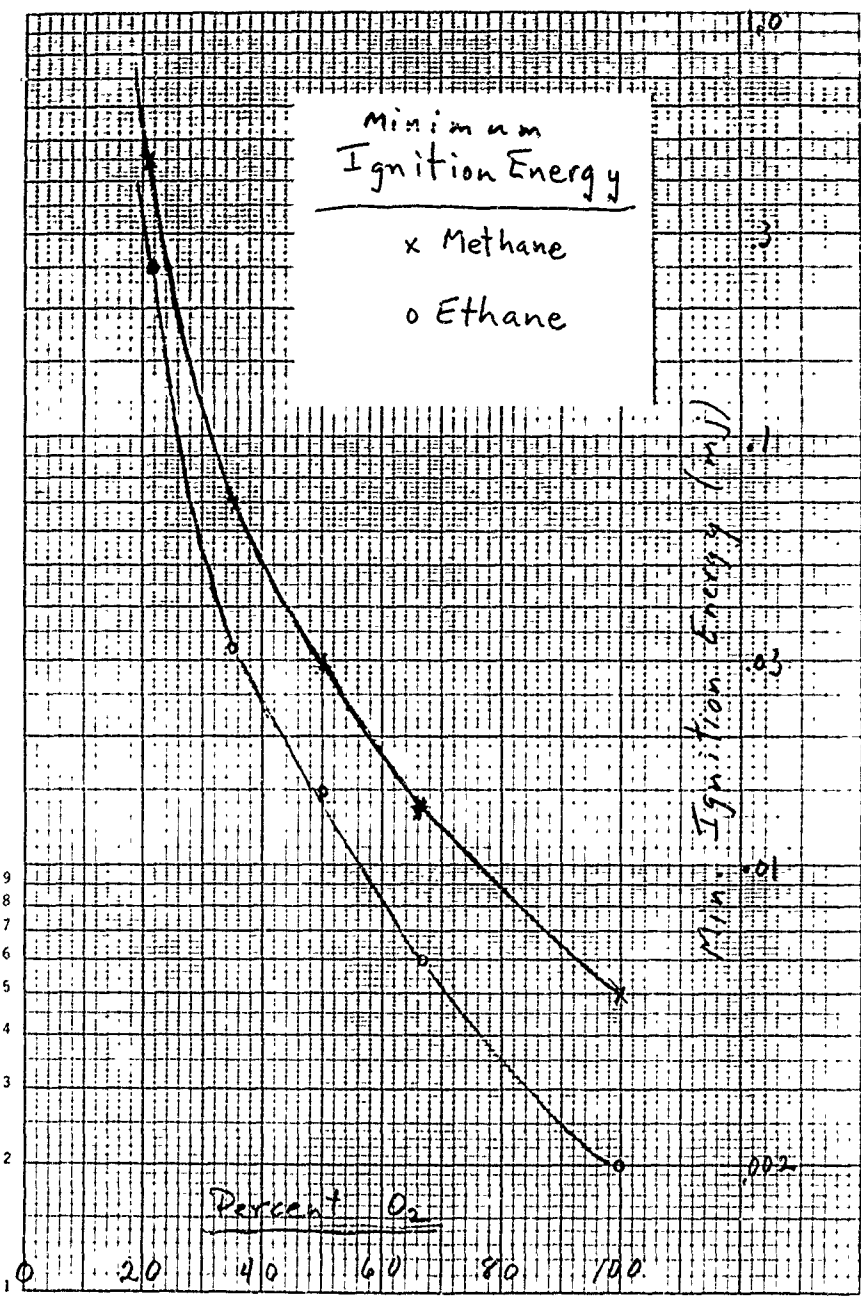

Fig 8

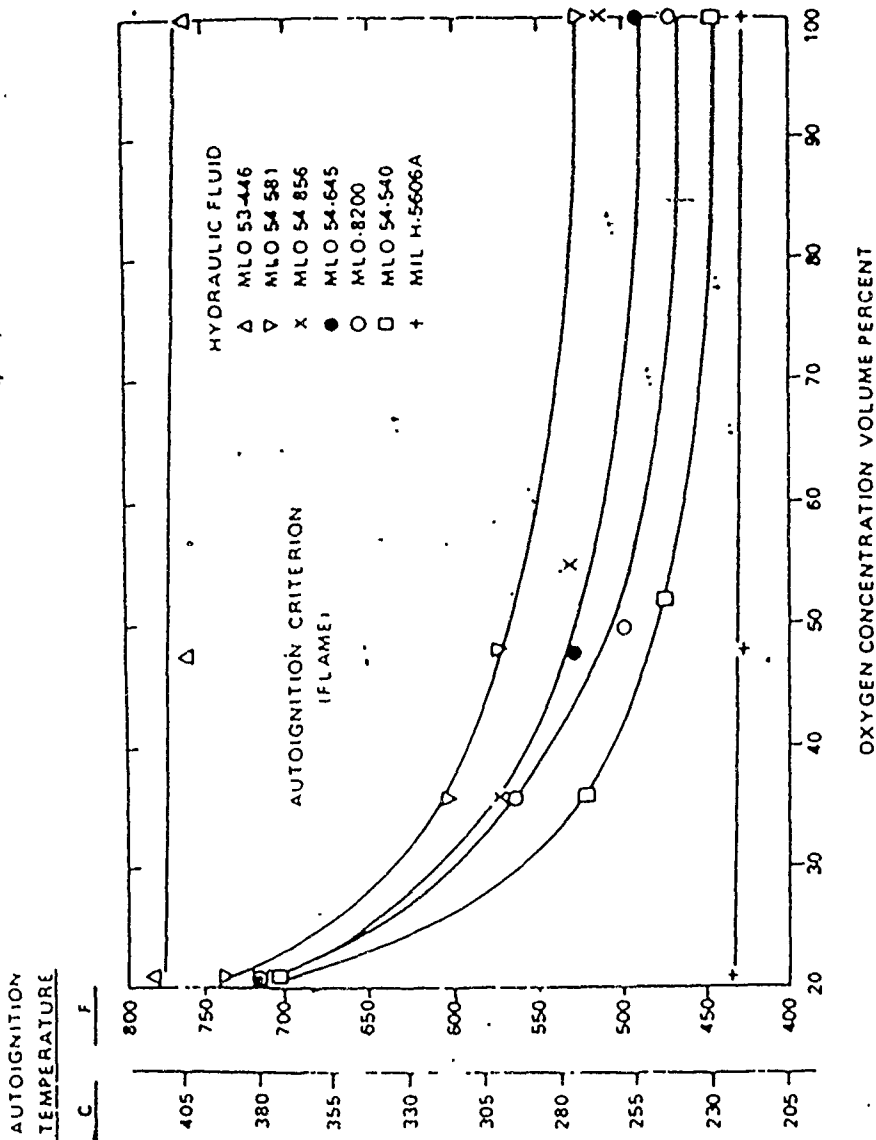
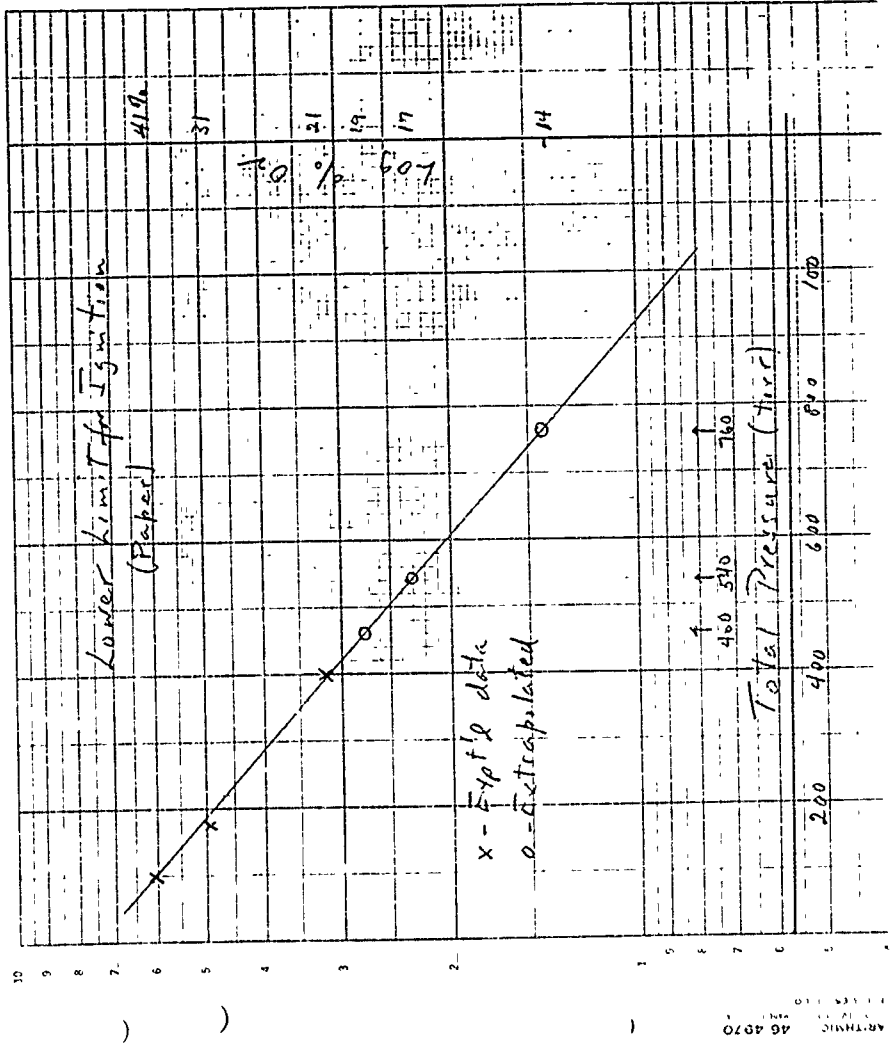

Figure 5-2 Minimum autoignition temperatures of seven hydraulic fluids at atmospheric pressure in various oxygen-nitrogen atmospheres (20-cc Pyrex vessel).<sup>30</sup>

Fig 9

LOWER LIMIT FOR IGNITIONS (FILTER PAPER)

<u>% O<sub>2</sub></u>	<u>TOTAL PRESS. (MM. HG)</u>	<u>PO<sub>2</sub> (MM HG)</u>
21	400	84
31	175	54
41	100	41



ARTRMIO 46 4970

FIRE INTENSITY - FLAME SPREAD  
TOTAL DAMAGE

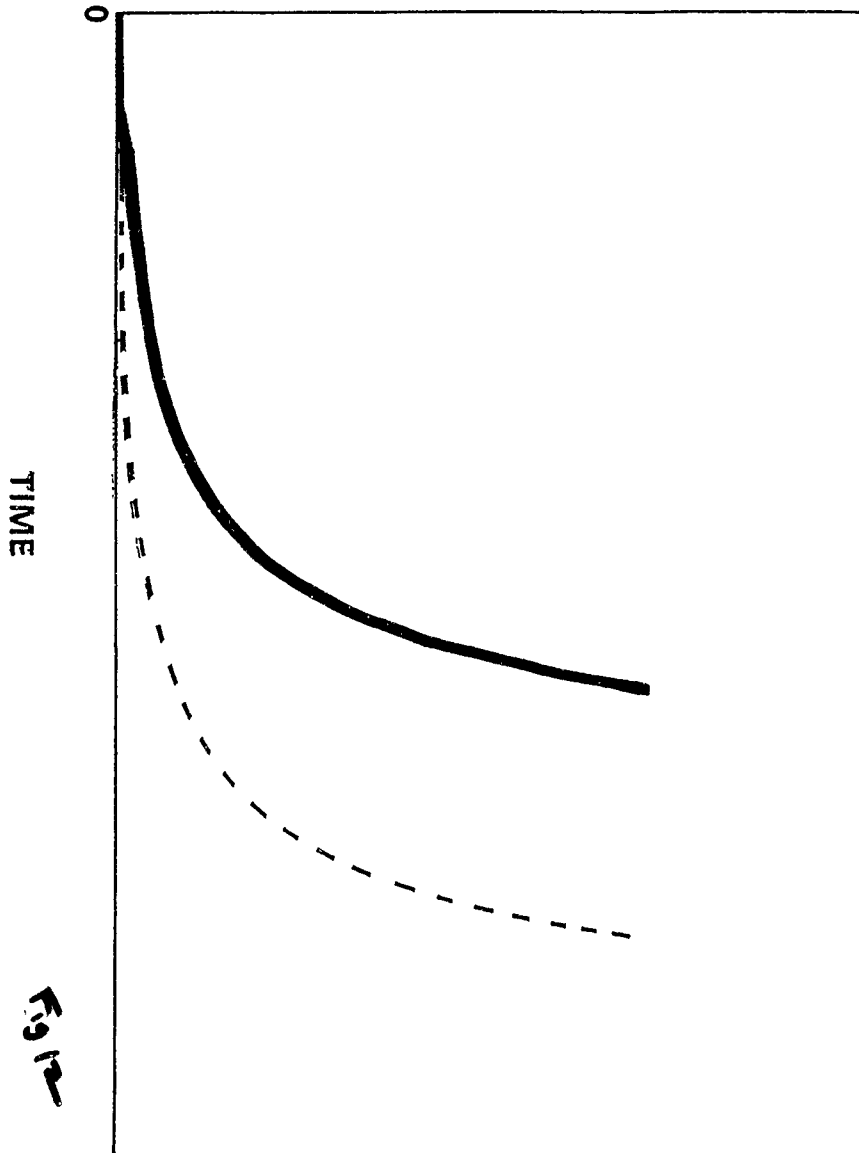

# Table IV

## OXYGEN PARTIAL PRESSURE IN INHABITED ATMOSPHERES

	<u>P O<sub>2</sub> (ATM.)</u>	<u>ELEV. (FT.)</u>
APOLLO, TAKE-OFF MODE	1.09	
APOLLO, FLIGHT MODE	0.3 - 0.37	
SEA - LEVEL	0.21	0
DENVER, COLORADO	0.175	5000
QUITO, ECUADOR	0.15	9300
LA PAZ, BOLIVIA	0.134	12,000
PIKES PEAK, COLORADO	0.123	14,100

Fig 13



The Naval Submarine Medical Research Laboratory's Studies  
of Human Responses to Fire-Retardant Atmospheres

CAPT Douglas R. Knight, MC, US Navy

Deployed submarine crews must quickly extinguish fires in order to prevent serious burns and smoke-inhalation. Otherwise, fire victims may require medical skills and supplies that exceed the capabilities and resources of the surviving crewmembers.

It's well known that efforts to combat or escape fires are usually futile when flames develop in oxygen-rich atmospheres, for the simple reason that lethal temperatures are produced within 60 seconds of combustion's onset (1-3). But even, in an atmosphere of 20% oxygen-80% nitrogen, dangerous temperatures can evolve in an astoundingly short period of time. Engineering studies (4) of submarine hull insulation fires have indicated that flames raise the air temperature to dangerous levels more quickly when the ship is submerged than when it is moored at the dock. This is illustrated in figure 1, which shows that high temperatures evolve more quickly when the hatches of the fire chamber are closed than when they remain opened. The difference between 30 seconds to skin injury (hatches closed) and 90 seconds (hatches open) could mean the difference between death and survival of fire fighters.

Submarine fire-safety may be improved by the use of a fire-retardant atmosphere in occupied spaces. Low concentrations of oxygen can protect humans from fire-damage by reducing the rate and spread of combustion, but care must be taken to avoid the hypoxic effects of oxygen-lean atmospheres. In theory, crews could live and work in 11% oxygen ( $FO_2$  .11) provided the barometric pressure is adjusted to maintain the partial pressure of oxygen

( $PO_2$ ) above 122 torr (figure 2). Eleven percent oxygen should prevent most types of fires, since 15% oxygen retards the combustion of paper and 13% oxygen extinguishes pentane flames (2, 4, 5).

Studies at the Naval Submarine Medical Research Laboratory (NSMRL) are defining the safe, minimum  $PO_2$  at normobaric pressure and the maximum barometric pressure for use without risk of nitrogen narcosis/decompression sickness.

The author had the unusual opportunity of observing flaming combustion in an inhabited environmental chamber, where the reduction of oxygen concentration from 21% to 19% diminished the melting rate of candles by one order of magnitude (figure 3). Seventeen percent oxygen diminished the burning rate by an additional order of magnitude without lowering oxygen's saturation of hemoglobin below that existing with 21% oxygen (figure 3).

Other studies at the NSMRL have evaluated man's visual function and mental performance during 1-4 hours of breathing 11.5-17% oxygen (8). These concentrations caused seated subjects to experience a physiological state of moderate hypoxia without adverse symptoms. Measurements of the hemoglobin saturation (figure 4) showed that 11.5% oxygen ( $PO_2$  88 torr) induced a state of hypoxia that would be expected to degrade scotopic vision (6, 7). It was therefore surprising to observe that the threshold intensity for scotopic vision was no different at 11.5% oxygen than at 21% oxygen (table 1). It is also interesting to note that human peripheral vision (figure 5) and timed computation (figure 6) were not reduced by 11.5% oxygen ( $PO_2$  88 torr).

Although studies at the NSMRL indicate that 17% oxygen (PO<sub>2</sub> 130 torr) is safe for use aboard submarines, further experimental work should be conducted to determine the safe, minimum PO<sub>2</sub> for multiday exposures aboard submarines.

#### REFERENCES

1. Galasyn, Valentine D. 1968. A Survey of Fire-Prevention Problems in Closed Oxygen Containing Environments. Report Number 526. U.S. Naval Submarine Medical Center, Groton.
2. Huggett, Clayton. 1969. Combustion processes in the aerospace environment. Aerospace Medicine 40: 1176-1180.
3. Harter, J. V. 1967. Fire at High Pressure. pages 55-80 in C. J. Lambertson, editor. Proceedings of the Third Symposium on Underwater Physiology. The Williams & Wilkins Company, Baltimore.
4. Alexander, J. I., et al. 1985. Submarine hull insulation fire test VII. 25 August 82. NRL Report 8872. Naval Research Laboratory, Washington.
5. Cook, Gerhard, A., Victor A. Dorr, and Bruce M. Shields. 1968. Region of noncombustion in nitrogen-oxygen and helium-oxygen diving atmospheres. I&EC Process Design and Development 7: 308-311.
6. McFarland, Ross A. 1970. The effects of exposure to small quantities of carbon monoxide on vision. Annals New York Academy of Sciences 174: 301-312.
7. McFarland, Ross A. and John N. Evans. 1939. Alterations in dark adaptation under reduced oxygen tensions. American Journal of Physiology 127: 37-50.
8. Knight, Douglas R., S. M. Luria, James F. Socks and William Rogers. 1987. The effect of nitrogen-based, fire-retardant atmospheres on visual and mental performance. The Ninth Symposium on Underwater Physiology (in press).
9. McFarland, Ross A. 1971. Human factors in relation to the development of pressurized cabins. Aerosp Med 42: 1303-1318.

#### LEGENDS

- Figure 1. THE ACCELERATION OF AIR TEMPERATURES IN CLOSED-SPACE FIRE.  
The data were adapted from reference 4.
- Figure 2. THEORETICAL LIFE-SUPPORT ZONE FOR CHRONIC EXPOSURE TO NITROGEN-OXYGEN GAS MIXTURES.  
The solid curves are isobars for  $PO_2$ ; the dashed line is an isobar for  $PN_2$ ; and the dotted curve is a borderline between  $FO_2$ 's which support the complete combustion of filter paper and those which only permit incomplete combustion (5).  $PN_2 < 1064$  torr should permit no-stop decompression without risk to decompression sickness.  $PO_2 > 122$  torr does not cause hypoxic impairment of performance by US Navy divers. The mole fraction of oxygen ( $FO_2$ ) at the intersection of these partial pressure curves, .11, theoretically suppresses flaming combustion without impairing human performance.
- Figure 3. The percentage saturation of arterial blood by oxygen (top graph) is compared with the melting rate of burning candles (bottom graph). The melting rate of a candle is the change of candle length divided by the burning time. Atmospheric properties: 0.9% carbon dioxide,  $72^{\circ}F$ , 50% rh, and 760 torr barometric pressure.
- Figure 4.
- Figure 5. PERIPHERAL VISION. A Goldman perimeter was used to collect the experimental conditions after approximately 7 sessions of training.
- Figure 6. TIMED COMPUTATION - The ordinate is the number of correct answers out of 30 arithmetic problems. There was a time-limit for each problem.

fig 21

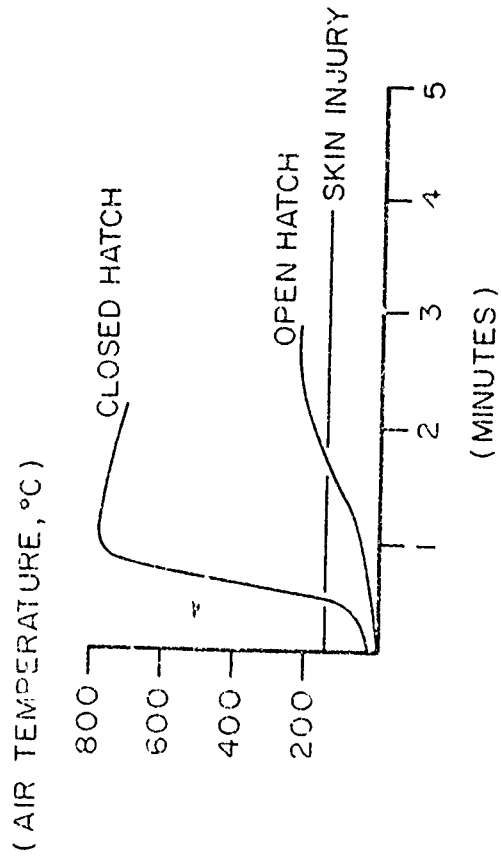

Fig 2

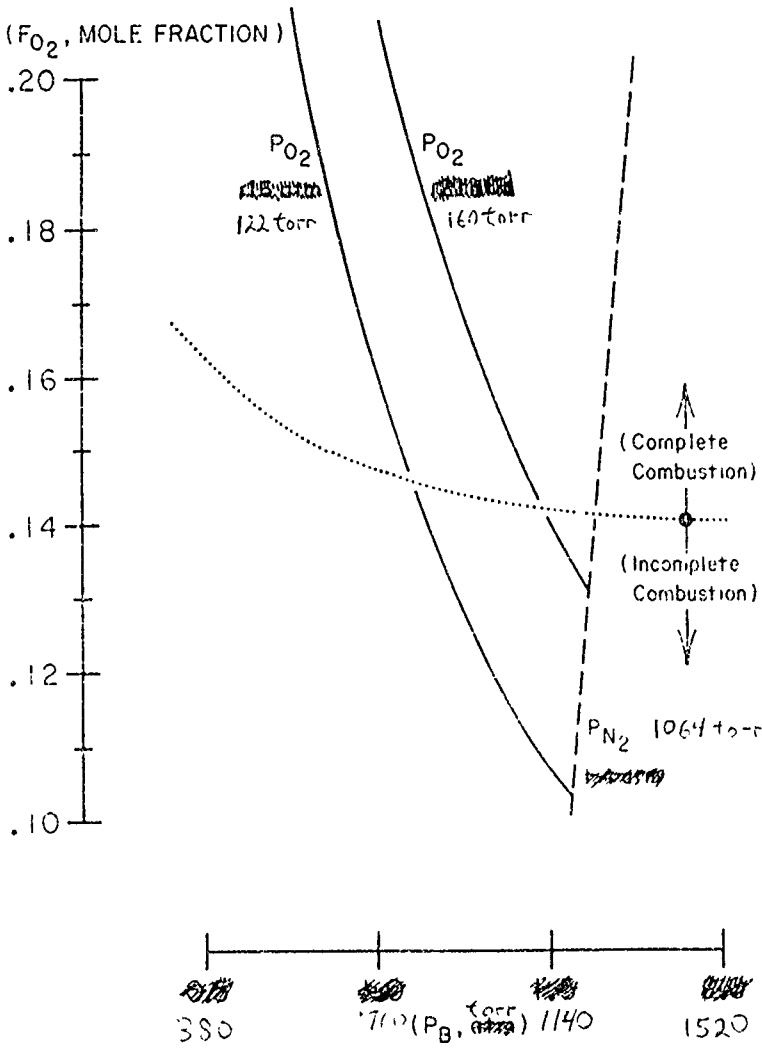

Fig 3

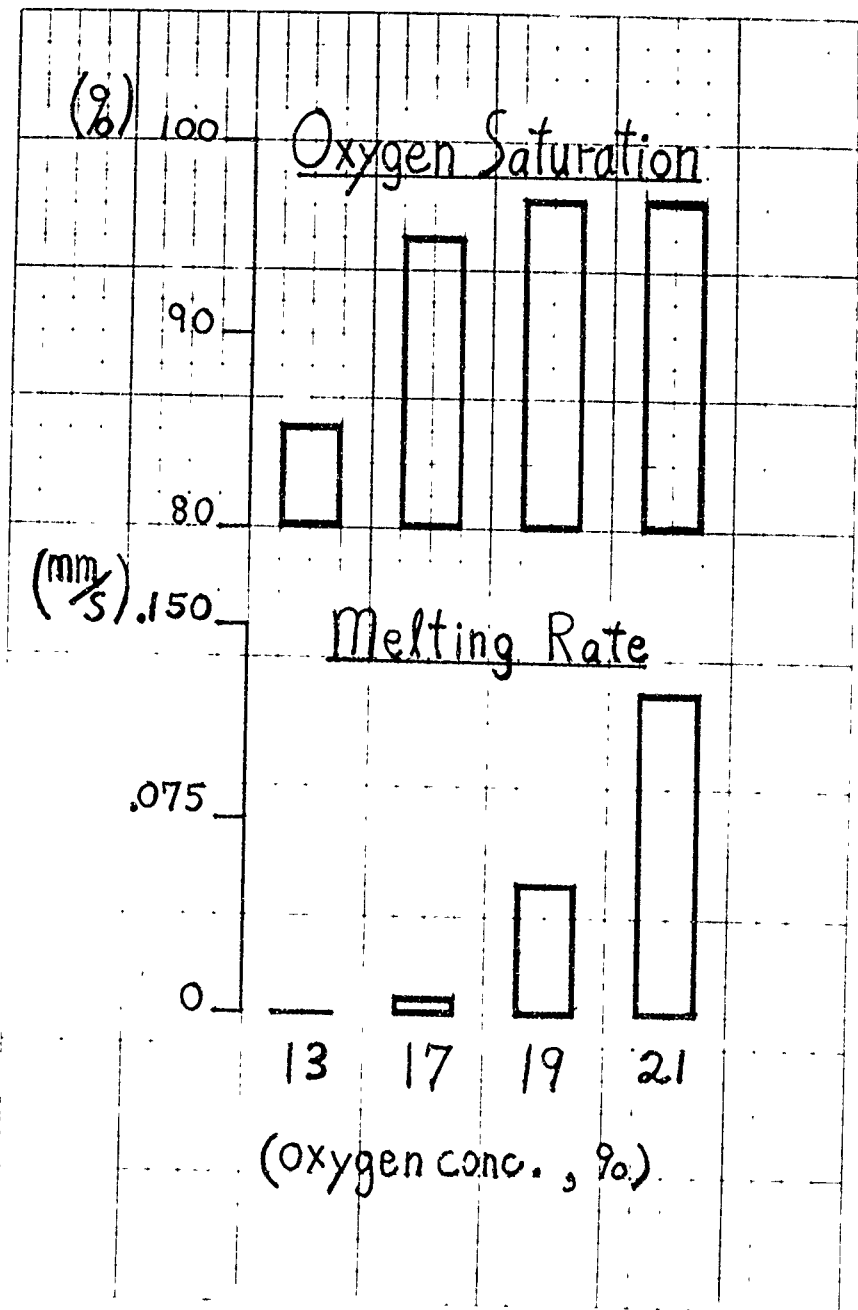
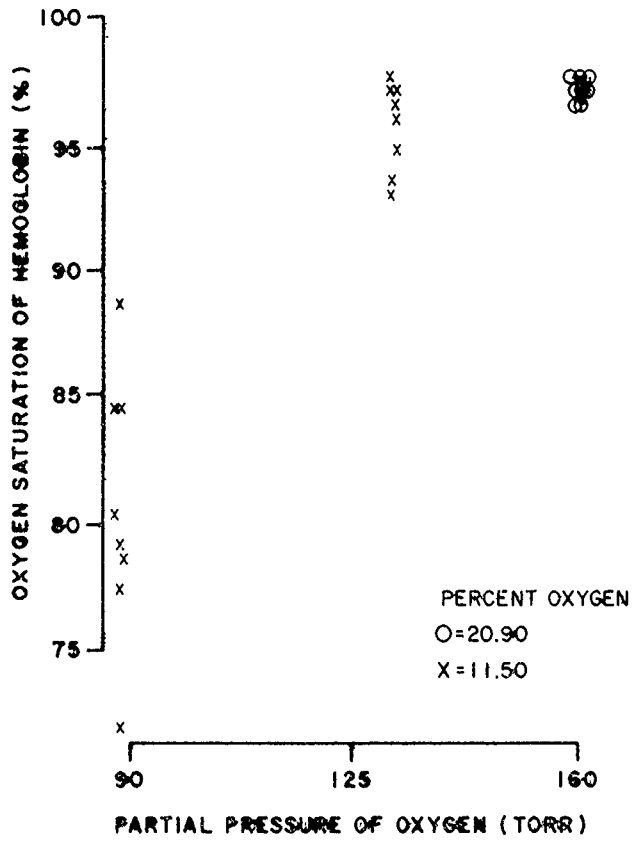

Fig 4

### ENVIRONMENTAL EFFECT ON Hb SATURATION



SUBJECT  
NO.

**3M** CATALOG NO 00 0  
27 CENTER ST PA  
MADE IN U S A



Fig 5

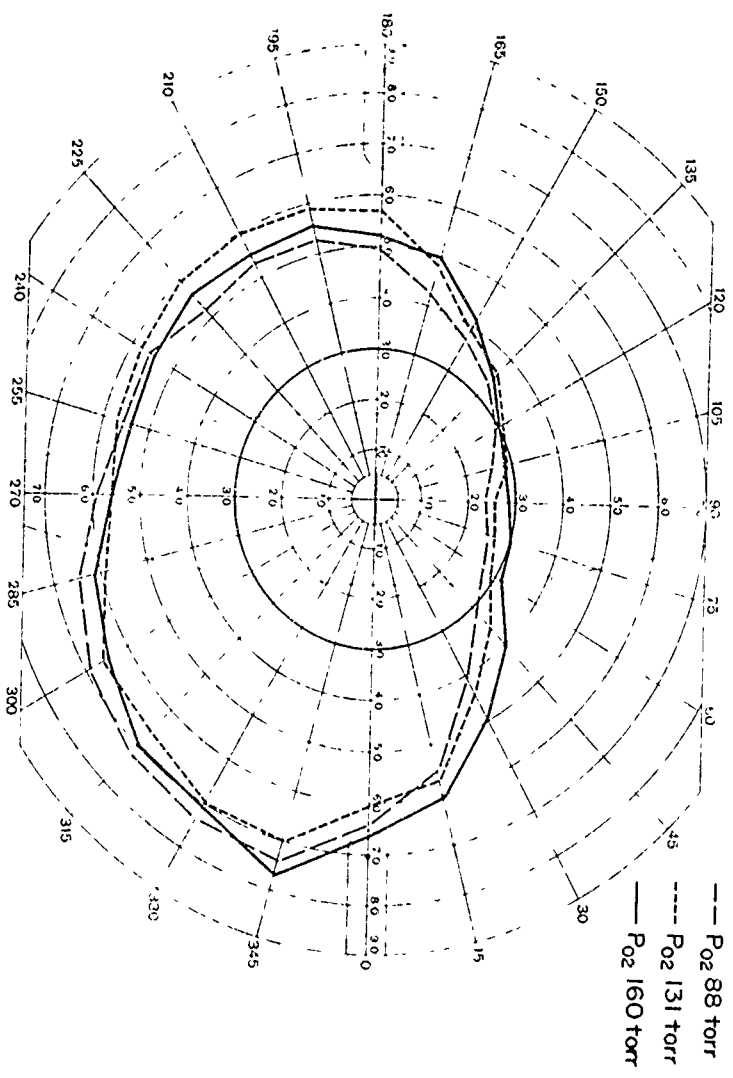

fig 46

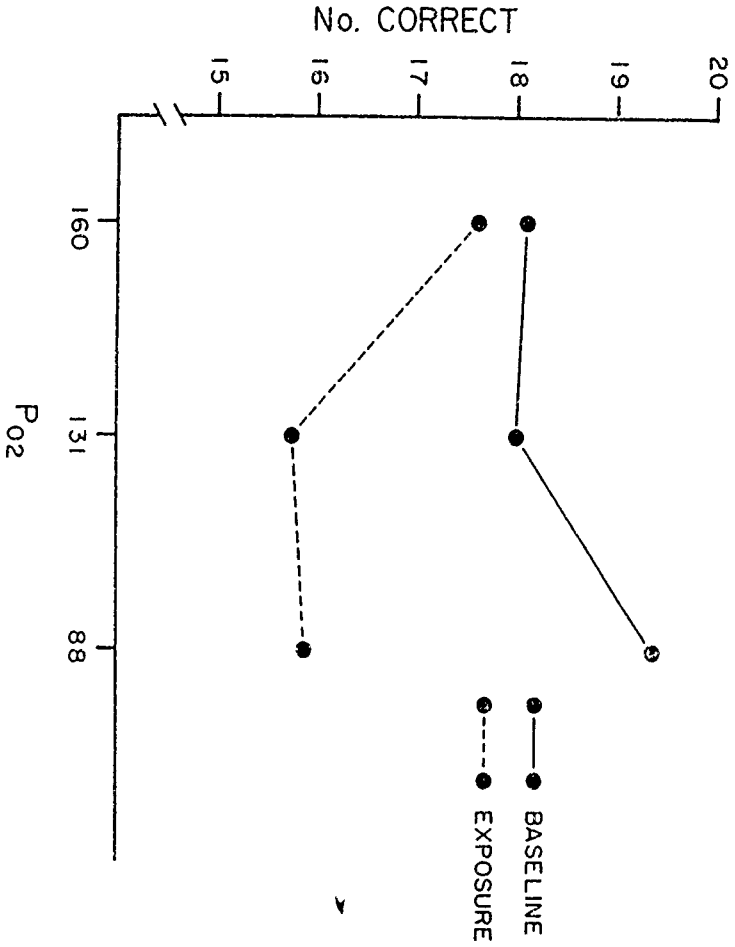

TABLE 1 Scotopic vision threshold, (Cd/m<sub>2</sub>)

<u>PO<sub>2</sub>, 160 torr</u>	<u>PO<sub>2</sub>, 131 torr</u>	<u>PO<sub>2</sub>, 88 torr</u>
4.16	4.05	4.28

USE OF HALON 1301 (FREON 13 B1)

ON BOARD FRENCH SUBMARINES

---o00---

H. BODILIS - L. GIACOMONI

---o0o---

1 - ORIGIN OF HALON 1301 IN A SUBMARINE'S ATMOSPHERE

The use of halon 1301 is very little on board french submarines. The amount on board is around one kilogram (1.8 kg) and is only used as a propellant gas (1).

Studies have however been made to determine what happens to halon in case of leakage on board then during passage through decarbonation plants and the catalytic burner used in the atmosphere regeneration system.

The circonstances of a possible leakage on board have been experimented. They imply a previous increase of the temperature of halon to 265°C. The test showed that in such a situation the whole of the released amount of halon was found diluted with other gases formed in the capacity where it has been vaporized, then emitted in the board atmosphere without having been thermally degraded while this heating at 265°C.

2 - HALON AND AIR PURIFICATION EQUIPMENT

The risks of thermal degradation halon 1301 may then undergo on the adsorbing beds of the regenerating system (alumina, molecular sieves and platinum catalyst) which purifies the air on board in wich it is diluted, have also been studied. The tests are not numerous for it was rapidly shown that amongst those used on board halon 1301 was the most reliable for thermal stability.

For those tests, a mixture of 4.000 ppm of halon in air goes at a a flow of 100 liters per hour though a 18 mm diameter Pyrex tube containing successively 50 grammes of various products (alumina, 13X or 5A molecular sieve, platinum catalyst). The measurements were made at 150°C and 300°C (2).

At 150°C, there is no decomposition of halon 1301. At 300°C, it is very low, for example after a 60-minutes passage on the 13X molecular sieve, 7 % of the injected freon did not come out, after 400 minutes only 2 % were missing. The capacity of the sieve for CO<sub>2</sub> was measured before and after the test in the same conditions using the CERTSM automatic test set up (3), it decreases from 7 % to 4.6 %. Besides, its analysis shows the presence of 0.006 % bromide and 0.08 % fluorine (percentage in proportion to 100 grammes of molecular sieve). Those products were not detectable in the new molecular sieve analysed before the test. Finally, the

trace gaseous products detected during the test when coming out of the tubes were in decreasing order CO<sub>2</sub>, CO, HF and BR<sub>2</sub>.

### 3 - CONCLUSION

On the problems caused by halon 1301 in the submarine atmosphere, the CERTSM experience is limited. It only allows to state that this product is very stable, and the conditions which might lead to its thermal degradation are very rarely met in the on board equipment it can go through. On the other hand, its thermal degradation at higher temperatures during fires is better known particularly by our colleagues of the Air Force who have studied it.

### REFERENCES

- 1) J. BLIN - H. BODILIS - M. BOURDIN  
Risques de dégagements toxiques liés à l'amorçage d'une pile de torpilles (PB.8) composée d'éléments argent-zinc.  
ET/053/80/272 CERTSM du 14.05.1980
- 2) D. FEVRIER - J.L. VERNET  
Etude de décomposition catalytique de quelques halogénométhanés.  
Parfums, cosmétiques et arômes N. 28  
Juillet - Août 1979 pages 89-98.
- 3) H. BODILIS  
Carbone dioxide adsorption onto molecular sieves  
4rt tripartite submarine médecine conference  
INN ALVERSTOKE MAY 1984
- 4) F. FOULGER - G. DOWDING  
The interaction of halon 1301 with air purification equipment  
5e conférence tripartite sur la médecine appliquée aux sous-marins  
Toulon Juin 1985

ORIGIN OF HALON 1301 IN A SUBMARINE'S ATMOSPHERE

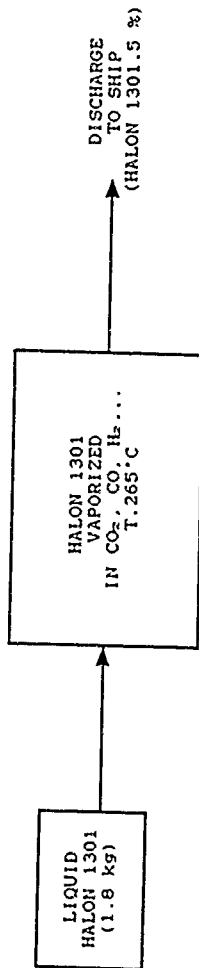

HALON 1301 - THERMAL DEGRADATION

TEST INSTALLATION

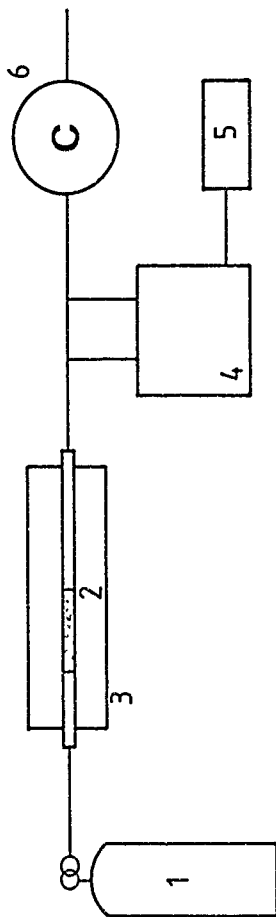

1 GAS CYLINDER (4000 ppm of Halon in air).

2 PYREX TUBE (MOLECULAR SIEVE, ALUMINA OR PLATINUM CATALYST).

3 OVEN (TEMPERATURE REGULATION).

4 and 5 : GAS ANALYSERS

6 : FLOW METER

ADDITIVITY OF HYDROCYANIC ACID AND CARBON MONOXIDE  
INCAPACITATING EFFECTS ON ANIMAL MODELS.

J. HEE

\*\*\*\*\*

As part of our studies to estimate the acute toxicity of thermolysis products we were induced to determine the acute toxicity peculiar to major constituents of these products, including hydrocyanic acid and carbon monoxide. The purpose of this study was to determine time/concentration relationships for a given effect on animal models, to find out laws governing the combination of the effects of both gases and to put forward limit values applicable to man. This paper only deals with the results concerning gas incapacitating effects.

## 1. MATERIALS AND METHODS.

Our study was carried out simultaneously in two animal species, namely rats and mice.

The experimental exposure device, as shown in figure 1, mainly included a 550 L airtight chamber equipped with two homogenizing fans, a pollutant gas inlet and a closed-circuit analyzing system comprising two specific infrared absorption analyzers

Four rats were put in separate squirrel wheels connected to a computerized data acquisition system which made it possible to measure, for each animal, the duration and quantity of work done either as a spontaneous activity (in the absence of any stimulation) or as a conditioned activity (conditioning sound stimulation) or even as a stimulated activity ("absolute" stimulation in the form of electric shocks in the animal legs).

Besides, six mice were installed in small separate plethysmographs in such a way that only their head were exposed to the chamber atmosphere. The recording of pressure variations within the plethysmographs made it possible



not only to measure the animal respiratory frequency but also to detect the mice agitation phases and therefore to find out the moment when the spontaneous motor activity disappears.

Each test included three periods :

- a 5-min control period in pure air
- a 15-min intoxication period, and
- a 10-min recovery period after pollution removal.

As far as pure gases are concerned the concentration ranges studied were as follows : from 30 to 172 ppm for hydrocyanic acid and from 700 to 6400 ppm for carbon monoxide. Moreover, six different mixtures of both gases were tested at the concentrations listed in table 1.

## 2. RESULTS.

This paper will give only the results relating to mean times-to-incapacitation for mice (T<sub>ia</sub>) and rats (T<sub>im</sub>). For the rats we also took into account the time within which 50 per cent of the animals grew incapacitated (T<sub>150</sub>).

2.1. The results for hydrocyanic acid are diagrammatically shown in figure 2. From the mean times-to-incapacitation it can be deduced that mice appear to be less sensitive to hydrocyanic acid than rats. As a matter of fact, the times-to-incapacitation of 900 seconds, that is 15 minutes, is reached with 102 ppm in mice and with 22 ppm in rats.

2.2. With carbon monoxide, the differences between both species are less marked as can be seen in figure 3. The concentrations corresponding to a mean times-to-incapacitation of 900 sec amount to 719 ppm in rats and 890 ppm in mice.

2.3. The mean times-to-incapacitation observed with the different gas mixtures are gathered in Table 2.

### 3. DISCUSSION.

These results enable us to try to answer the first purpose of our study, namely the determination of the concentration likely to incapacitate a man within 15 minutes. As far as the quantity of inhaled toxic pollutant is directly related to the respiratory flow and, assuming an identical extraction coefficient, the dose can be calculated per kg of body weight, taking into account the respiration per unit of weight, that is 0.53 L/kg in rats and 0.09 L/kg in man. Therefore, it can be deduced that this dose varies 6 times less rapidly in man than in rats. This allow us to think that the dose reached within 15 minutes in man corresponds to that obtained in rats within 2 minutes and 30 seconds.

If, for safety's sake, we do not consider the time-to-incapacitation but the deconditioning time, as the first symptom or behaviour degradation, we can calculate a critical concentration of 4,388 ppm of CO or 60 ppm of hydrocyanic acid. When a moderate activity results in doubling the respiratory flow, these values must be divided by 2 to set limits applicable to man, namely 2,000 ppm for CO and 30 ppm for hydrocyanic acid.

Several authors have proposed different ways to determine the laws governing the combination of effects produced by mixtures of both poison gases. The proposed solutions have given different results as regard the additivity of such effects. With the time/concentration relationship for each compound it is possible to calculate "iso-effect equivalences" between the different gases, according to the model put forward by LYNCH (1975).

Thus, in a CO+HCN mixture it is possible to express the HCN concentration in "CO equivalent concentration", to add this value to the existing CO concentration and, to calculate the expected effect of the gas mixture. If the

observed value is systematically lower than the calculated value, the mixture effect can then be considered as a synergetic effect. In the contrary case, the mixture has antagonistic effect. Finally, if values are equivalent, the prevailing hypothesis is that of a simple additivity of the gas effects.

Figure 4 is diagram showing the correlation between observed and calculated values for the 6 mixtures studied. It shows that, despite a very slight tendency toward synergy, the closeness of the points to the identity line corroborates the hypothesis of additivity of carbon monoxide and hydrocyanic acid effects.

#### 4. CONCLUSION.

Thus, our animal model makes it possible to determine incapacitating concentrations in man of major pollutants such as carbon monoxide and hydrocyanic acid during acute exposures. It also permits to confirm that both poison gases in mixture have an additive effect on the motor behaviour as well as on lethality, although they have different mechanisms of action.

#### 5. BIBLIOGRAPHY.

LYNCH R.D.

On the non existence of synergism between inhaled hydrogen cyanid and carbon monoxide.

Fire Research Note n°1035 (1975) 5 p.

(Fire Research Station, Borehamwood, U/K.)

\*\*\*\*\*

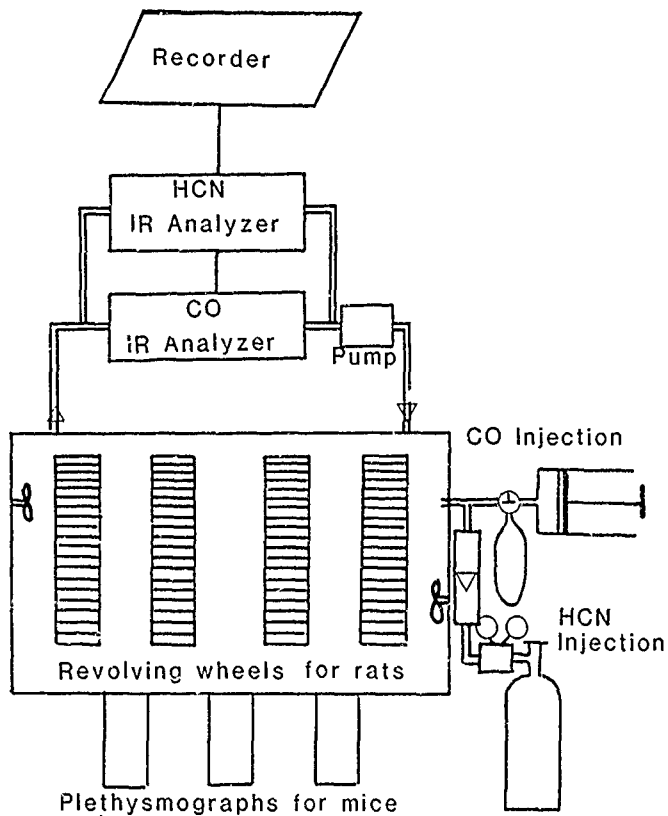

Figure 1 Device for exposing animals to carbon monoxide and hydrocyanic acid.

Table 1

Composition of the six gas mixtures.

Mixtures	[CO] ppm	[HCN] ppm
A	700	142
B	1250	140
C	1350	73
D	3700	60
E	3800	150
F	5100	26

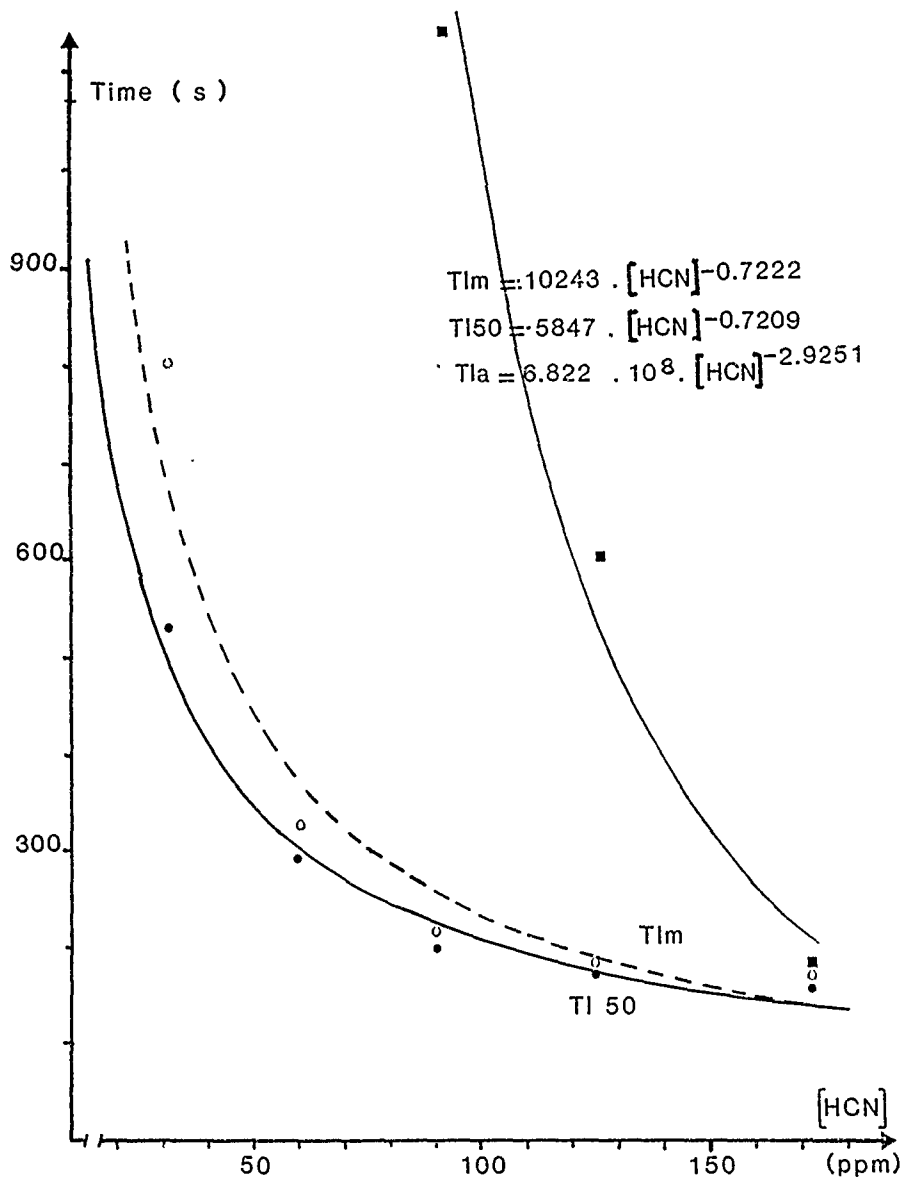

Figure 2 Time-to-incapacitation in rats ( TIm $\circ$ , TI50  $\bullet$  ) and mice ( TIa  $\blacksquare$  ) versus hydrocyanic acid concentration.

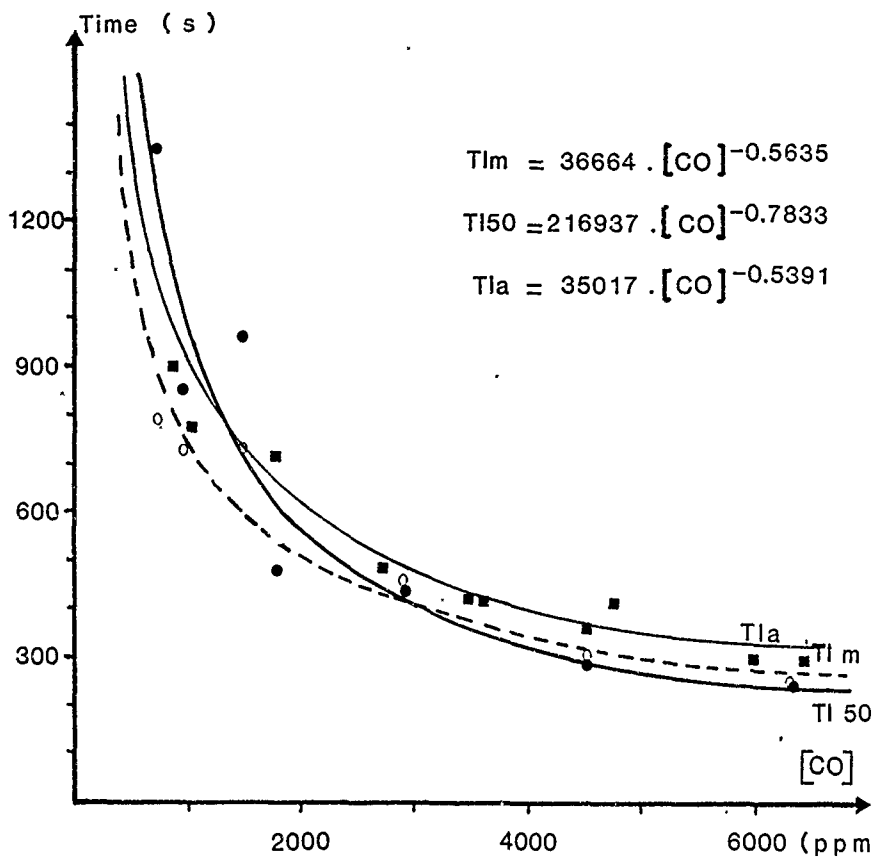

Figure 3 Time-to-incapacitation in rats ( TIm, TI50 ● ) and mice ( Tla ■ ) versus carbon monoxide concentration.

Table 2 - Average time-to-incapacitation observed  
with mixtures of hydrocyanic acid and carbon monoxide.

Mixture	[ CO ] ppm	[ HCN ] ppm	Time-to-incap. (s)	
			Rats (n)	Mice (n)
A	700	142	190 (3)	240 (5)
B	1250	140	153 (6)	240 (5)
C	1350	73	315 (5)	900 (10)
D	3700	60	195 (6)	360 (5)
E	3800	150	161 (6)	420 (10)
F	5100	26	197 (4)	300 (6)



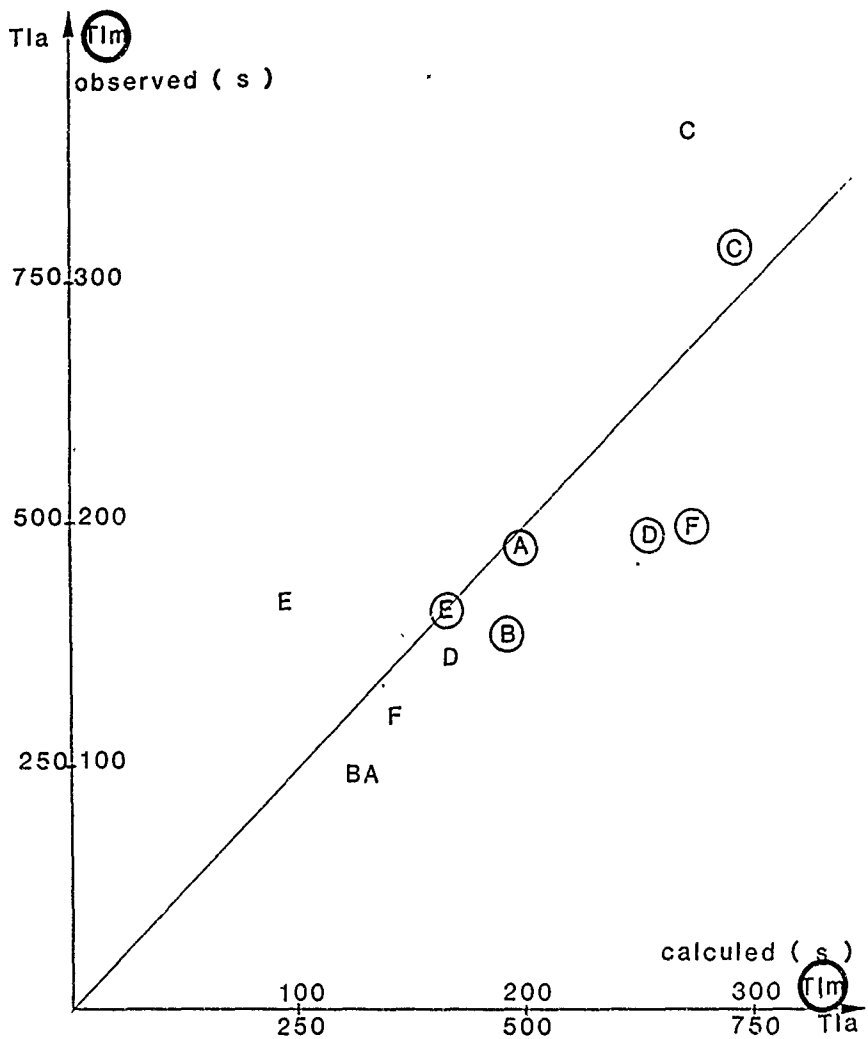

Figure 4 Correlation between observed and calculated times-to-incapacitation in rats ( TIm ) and mice ( Tla ) exposed to 6 mixtures ( A-F ) of CO and HCN.

PASSIVE AND ACTIVE EXPOSURE TO CIGARETTE SMOKE  
UNDER CONTROLLED CONDITIONS.

J. HEE

\*\*\*\*\*

As part of an experimental study of atmosphere pollution by tobacco smoke we have tried to show the acute effects of a smoky atmosphere and to correlate the observed effects with controlled environmental parameters.

The other purpose of the study was to estimate the non smokers' exposure to tobacco smoke and to compare it with the smokers' exposure.

1. MATERIAL AND METHODS.

1.1. As a reminder, this study was carried out within a 50-m<sup>3</sup> climatic chamber in which 6 smokers and 4 non smokers were alternately seated at a table. During the first two hours of each 3-hour test period, the smokers took turns at smoking 1 cigarette every 30 minutes, for a total of 24 cigarettes (full flavour tipped cigarettes). This test protocol thus ensured a continuous smoke production corresponding to 0.24 cigarette/m<sup>3</sup>/hour during the first two hours. After this smoking period the subjects remained one more hour in the chamber, in the absence of any new smoke production.

It is to be noted that smokers were allowed to smoke their usual cigarettes when not under test, except for one subject (S 10) who smoked only the 4 cigarettes allocated during each test.

Five test situations were thus examined as follows :

- total confinement without smoke production (TC),
- total confinement with smoking (test C/S),
- diffusion ventilation by permanent opening of a door (test D/S),
- confinement and centrifugal filtration with active charcoal (test F3ac/S),

- confinement and absolute filter (F1/S).

1.2. The subjects were exposed to the following measurements :

- nasal resistance measured by means of a rhinomanometer in 8 subjects (5 S + 3 NS),
- estimation of the irritant effect of a smoky atmosphere
  - . according to the eyelid blinking frequency as automatically recorded in 8 subjects (5 S + 3 NS),
  - . according to answers given to a questionnaire (10 subjects),
- measurement of the carboxyhemoglobin amount in all the subjects before and after each test, as a function of carbon monoxide concentration in end tidal air after a 20-second apnea.
- measurement of urinary excretion of nicotine per 24 hours.

## 2. RESULTS.

2.1. Nasal resistance variations against a control value measured before each test are given in Figure 1. There is a gradual nasal resistance increase in total confinement without tobacco smoke pollution (T/C test). This increase is higher in smokers than in non-smokers and it completely disappears in the presence of smoke (tests C/S and F1/S). Intermediate variations are observed when keeping the chamber door open (D/S test) and using active charcoal filter F3. Such variations must however be interpreted very carefully. As a matter of fact, the resistance measured at time t0 and used as control value was, on average, lower in control test TC. Therefore, at the end of the test, it was not significantly different from resistance measured at the end of test F1/S.

2.2. Average variations of the eyelid blinking frequency as observed in 8 subjects are given in Figure 2 which is a schematic representation showing that maximum increase is reached after 1 h 45 min of exposure. Compared with the effect of smoke in total confinement (C/S), the use of

filter F1 paradoxically tends to aggravate signs of ocular irritation. But the use of the active charcoal centrifugal filter (F3ac/S) and the opening of the chamber door (D/S situation) both tend to reduce eye irritation signs. However, such differences are not statistically significant.

Subjective feelings such as they appear from answers to questionnaires (see Fig. 3) corroborate the objective measurements and show that nuisance is essentially caused by eye irritation.

A comparison between these results and pollutant analyses show that the particulate phase is not, or only lightly, involved in the irritating effect. The latter is more closely correlated with the formaldehyde concentration than with all other analysed gas components.

2.3. Fig. 4 is a graphical representation of average variations in carboxyhemoglobin concentration. It enables us to make a comparison between smokers and non-smokers as well as between different test conditions.

As expected the increase in COHb is higher in smokers than in non smokers : 5.2 times higher in the D/F test and 2.5 times higher in the other tests. In actual fact, these relationships are an underestimate of the relationship between smoke quantities respectively inhaled by both groups of subjects. All things being equal, the absorption of carbon monoxide actually decreases as the initial COHb increases. Now, the carboxyhemoglobin level before the tests was ranging between 3.8 and 6.0 %, on an average, in smokers, and only between 0.7 and 1.2 %, on an average, in non-smokers. This a well-known phenomenon which is corroborated by the fact that the carboxyhemoglobin increase in subject 10 (smoker), who had an initial carboxyhemoglobin level of 1 % or so, was always higher than the average increase in other smokers.

Consequently, from the carbon monoxide intake it can be deduced that in three hours of total confinement non smoking subjects inhaled the equivalent of 1 to 1.2 actively smoked cigarette. As a reminder, the atmosphere pollution levels in our tests were 3 to 4 times higher than

pollutant concentrations usually observed in the smokiest public places. The variations of carboxyhemoglobin levels observed in non smokers as a function of test specifications are closely related to carbon monoxide concentrations in air. It can be seen that the atmosphere pollution has a noticeable effect even on smokers despite their high initial intoxication level.

2.4. The urinary excretion of nicotine is a specific criterion of tobacco smoke absorption. Therefore, a comparison was essential between smokers and non smokers to form another estimate of passive smoke intoxication.

Average results expressed in micrograms per 24 hours are graphically shown in Fig. 5. Because of differences in values the results are given on a logarithmic scale. Subject 10 who smoked only the 4 test cigarettes per day was deliberately set apart from the other smokers. Considering the urinary nicotine excretion of this smoker after the total confinement test (that is, 340  $\mu\text{g}$ ) and, assuming that the excreted quantity is proportional to the absorbed amount, it can be calculated that non smokers would have inhaled the equivalent of 0.75 to 0.90 cigarette, depending on whether passive absorption by the smokers is disregarded or not.

From both the average daily consumption of cigarettes (all brands being considered) and the average urinary excretion of our smokers it is possible to calculate a urinary nicotine excretion of 86  $\mu\text{g}$  per cigarette smoked. On the basis of this value the non-smokers would have inhaled the equivalent of 0.73 cigarette in total confinement. Such a value is close to the value given by the first calculation. The absolute filter F1 reduces this value to 0.2 cigarette while the active charcoal filter (F3ac) and diffusion ventilation (D) reduce it to 0.1 and 0.06 cigarette, respectively.

As we already told you in our previous paper, our nicotine concentration measurements in air are unfortunately not reliable enough for us to correlate non smokers' urinary excretion with the nicotine concentration in the atmosphere. However, in order to clarify the

question it should be noted that after three hours of total confinement the average nicotine concentration in air was 359  $\mu\text{g}/\text{m}^3$ . If we estimate that each subject inhaled approximately 1  $\text{m}^3$  of air during the test and we assume that a total nicotine amount was absorbed, we will then underestimate the passive inhalation by a factor of 2, taking into account previous calculations and nicotine concentration in the smoke main stream of our cigarettes (0.95 mg). Thus, subject to validation of nicotine concentrations in air, the values measured in the atmosphere do not seem to permit a correct estimation of smoke quantities passively inhaled by non smokers.

Finally, we would like to specify that nicotine was the best tobacco smoke impregnation tracer under our experimental conditions, because of its short half-life. However, many authors have already shown that for chronic exposures it is better to determine the quantity of cotinine, a major metabolite of nicotine, whose half-life is longer. Such quantitative analyses are to be carried out either in plasma or in urines rather than in saliva.

### 3. CONCLUSION.

Our experimental study has led us to come to the following conclusions :

- The tobacco smoke pollution of the atmosphere results in a nuisance that mainly affects the eyes.
- The particulate phase filtration tends to aggravate the ocular irritation whose intensity appears to be correlated with formaldehyde concentration in air.
- A three-hour stay in a smoky atmosphere whose average pollution level is 3 to 4 times higher than in the smokiest public places is equivalent to a smoke inhalation of 0.75 to 1 cigarette.
- In the absence of additional carbon monoxide pollution the carboxyhemoglobin measurement is a good criterion for estimating

exposures tobacco smoke. In the presence of carbon monoxide extrapolation, it will be better to determine either the nicotine concentration for acute exposures, or the amount of cotinine for chronic exposures. Such a determination will be made either in urines or in plasma

- The quantity of passively inhaled smoke can be estimated in "cigarette equivalent" if we consider that a cigarette corresponds to a 1 % or so increase in COHb and to a 60 to 80 µg increase in the urinary nicotine excreted per 24 hours.

\*\*\*\*\*

#### Acknowledgements.

This study was carried out in collaboration with the Research Department of S.E.I.T.A. Paris (Dr P. SCHILTZ).

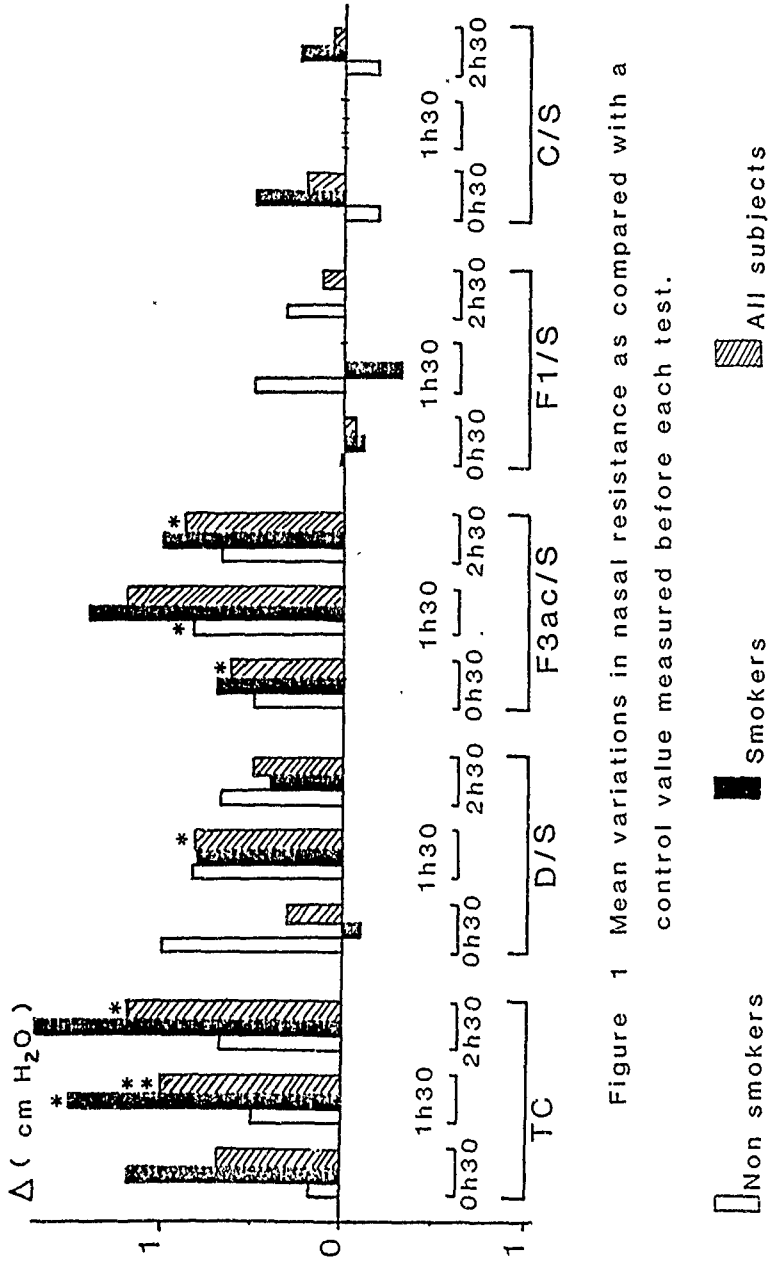

Figure 1 Mean variations in nasal resistance as compared with a control value measured before each test.

Non smokers     
  Smokers     
  All subjects

Statistical significance      \* 0,05      \*\* 0,02



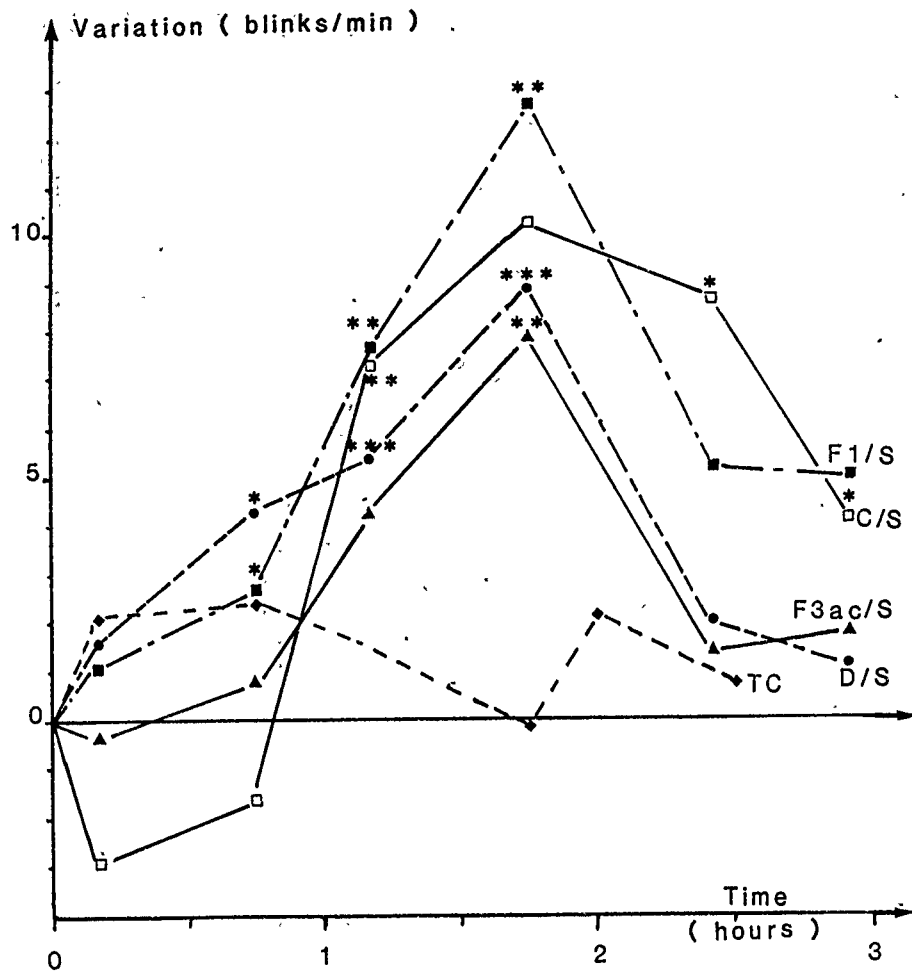

Figure 2 Mean variation of eyelid blinking frequency ( b/min ) with respect to the value measured before each test.

Significance      \* 0,05      \*\* 0,01      \*\*\* 0,001

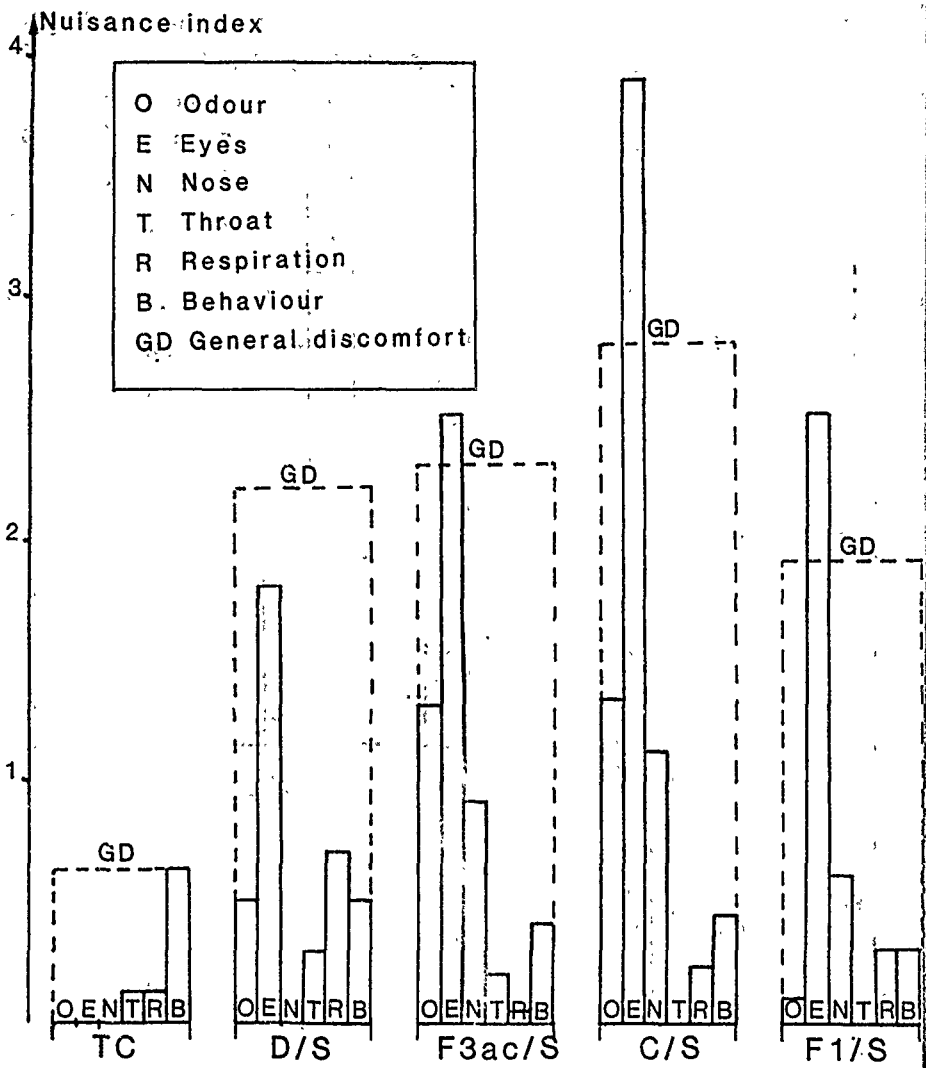

Figure 3 Mean nuisance index in different conditions of exposure to environmental tobacco smoke.

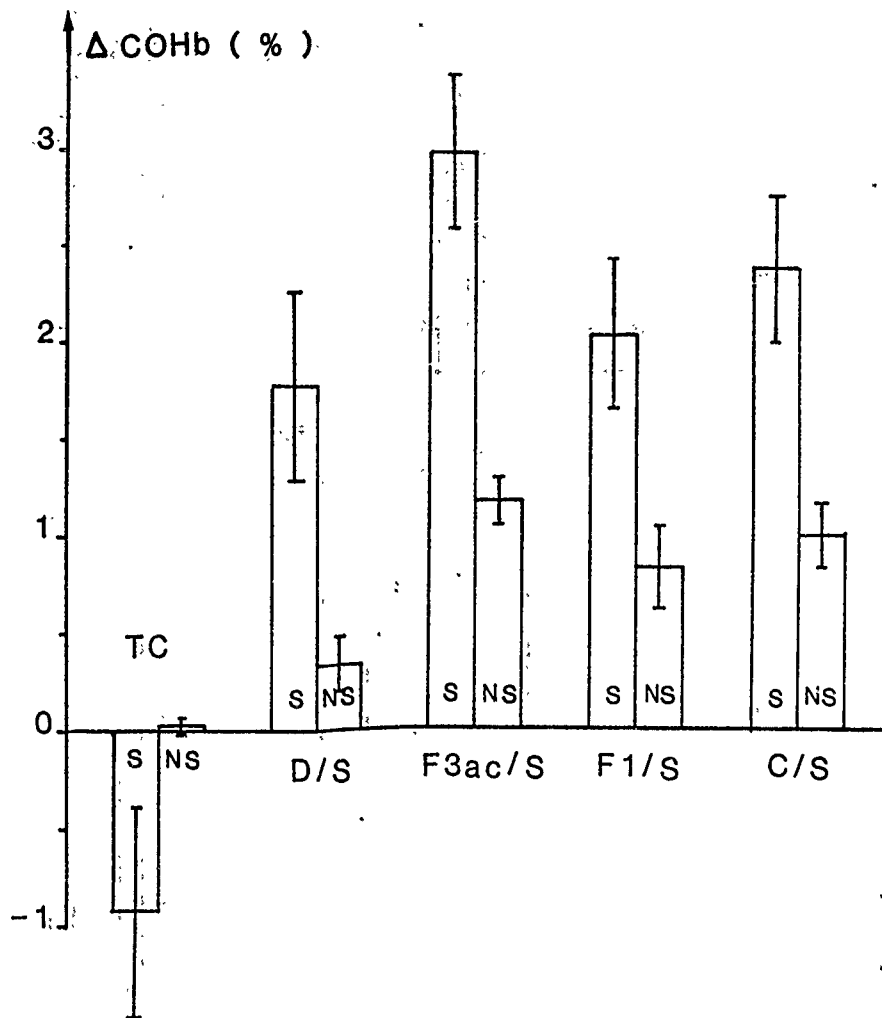

Figure 4 Mean variation ( $\pm$  E.S. ) of carboxyhemoglobin percentage after different exposures.

( S : Smokers, NS : Non Smokers )

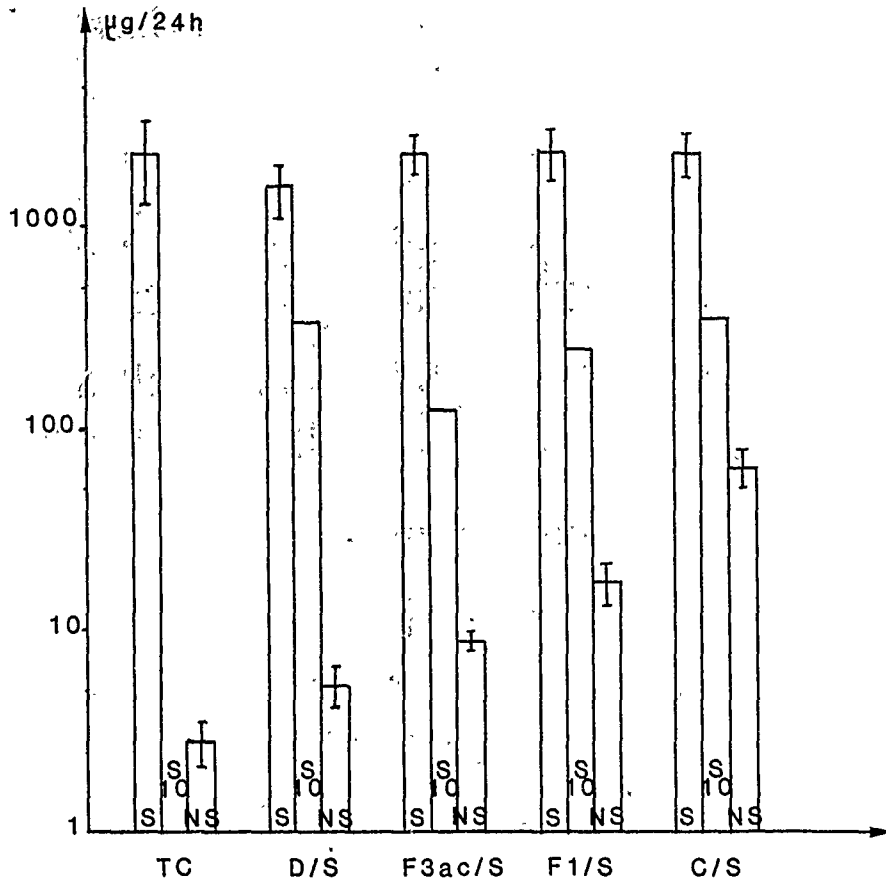

Figure 5 Urinary excretion of nicotine by smokers ( S ),  
subject 10, and non-smokers ( NS )

211

PARTICULATE AND GASEOUS POLLUTION FROM TOBACCO SMOKING  
INFLUENCE OF VARIOUS REMOVING DEVICES

J. HEE

The problem of the environmental pollution from tobacco smoking and its effects on non smokers is now a question of current interest. What may be worrying under usual life environmental conditions is obviously all the more worrying in confined or semi-confined spaces as is more and more often the case with battleships.

Therefore, although smoking is forbidden on board French submarines we decided to characterize the tobacco smoke pollution from both qualitative and quantitative points of view. We also decided to estimate the effects of various removing devices on different types of smoke constituent parts, as well as the influence of such a pollution on non-smokers. The latter point will be dealt with in another paper.

1 - MATERIALS AND METHODS :

To avoid any interference with another source of pollution our study was carried out in a 50 m<sup>3</sup> tight climatic chamber. This chamber could be either ventilated, with open or closed-circuit ventilation, or not ventilated.

Cigarette smoke was given off continuously over a 2-hour period, either naturally by six smoking volunteers or by means of a BORGWALDT smoking machine of the Hamburg 'II' type, at the rate of 2 cigarettes every 10 minutes (a total of 24 cigarettes). For the first case, 10 subjects were present in the chamber. For the second case, there were only two subjects.

Each smoking test was prolonged by 1 hour after the smoking end, i.e. a total test period of 3 hours.

Three control tests were performed in total confinement. One control test was carried out with smokers (C/S) and the two other tests with the smoking machine, either with (Cb/M) or without air stirring (C/M).

Three ventilation removal tests were carried out. In test D/S ventilation was ensured by simple diffusion (by permanently keeping the confined chamber door open). During the other two tests, we used open-circuit forced ventilation with two different flow rates : 170 m<sup>3</sup>/hr (test V2/M) and 250 m<sup>3</sup>/hr (test V1/M), respectively.

Finally, three types of closed-circuit filtration systems were tested as follows : a 99.999% DOP absolute filter (F1) either with (test F1 ac/M) or without an additional active charcoal filter (test F1/S with smokers ; test F1/M with the smoking machine) ; an electrostatic filter F2 and a centrifugal filter F3 connected, or not, to an additional activated charcoal filter.

Ventilation - or filtration - was applied continuously from the very start of the experiment.

Pollution analysis related more particularly to :

- aerosols, measured by weight using a piezobalance and in particle number using a laser corpuscle counter ;
- nicotine, whose concentration is determined by gas chromatography after gas scrubber trapping ;
- carbon monoxide, determined by means of an infrared analyzer ;
- nitrogen oxides analyzed by chemiluminescence ;
- formaldehyde determined by colorimetry ;
- total hydrocarbonic products analyzed by flame ionization ;
- some organic compounds (acetaldehyde, acrolein, acetone, toluene, etc.) determined by gas chromatography after trapping in a solide sorbent.

## 2 - RESULTS

As we don't have time to enter into all the details of the results, this paper will summarize the main points to be noted.

As far as particulate pollution is concerned, we can see that smoke production is accompanied by a significant change in the particle size spectrum which does not correspond to what is generally observed with cigarette smoke. It is indeed usually considered that the size of nascent smoke micelles ranges from 0.1 to 0.3  $\mu\text{m}$ . However, in total confinement (see fig. 1) a maximum increase in particles between 0.42 and 0.62  $\mu\text{m}$  can be observed. This increase concerns particles which grow all the bigger as time elapses. Simultaneously, there is a drop in very fine particles (less than 0.17  $\mu\text{m}$  in size). All such results may be accounted for by micelle coalescence phenomena. They show that time must be taken into account to characterize tobacco smoke pollution. From a quantitative point of view (see fig. 2), there are some discrepancies according as pollution is expressed in particle number, by total volume or by weight. This can modify the hierarchical order between different situations. On the whole, it should be remembered that the absolute filter F1 achieves a smoke removal at least equivalent to that performed by open-circuit ventilation. As for the electrostatic filter F2, it is markedly less efficient and particle size analysis shows that this filter is only effective for particles bigger than 0.62  $\mu\text{m}$  in diameter. Last of all, the centrifugal filter is even less effective.

This paper will not give the results of the analysis of nicotine concentrations in the atmosphere, because of significant discrepancies resulting not from the analysis proper but more likely from our sampling method. As a matter of fact, the effectiveness of our trapping process in acidified ethanol is not the same according as nicotine is found in the particulate or vapour phase of the smoke. Moreover, the proportion of nicotine in the particulate or vapour form may also vary widely as a function of smoking or removal conditions. However, to let you from a correct estimate of the importance of nicotine pollution, it should be mentioned that the average nicotine concentration in the atmosphere amounted to 360 µg/m<sup>3</sup> during the total confinement test carried out with smokers.

As regards gaseous pollution all the results obtained at the end of the smoking test period in total confinement are given in table 1. This test can be regarded as a control test. In fact, the concentration variations with time are different from one compound to the other. There is a gradual increase in the concentrations of all constituents during the smoking period. But in the following period, there occurs either a stabilization (NO<sub>2</sub>, acrolein, acetone, toluene) or a more or less important decrease (in CO, NO, hydrocarbon compounds, formaldehyde). Such different variations are connected with transfers between gaseous and particulate phases of the smoke as well as with selective absorptions by the smokers and the chamber walls. The variations with time of the relationships between the various constituents confirm how difficult it is to select good tobacco smoke pollution tracers. Besides, we found out that relationships between the various constituents vary according as smoke is produced by smokers or by a smoking machine. It was, however, not possible to determine whether this was related to the smoke source or to the different number of subjects within the chamber.

Lastly, we could show that the putting into service of removing devices had various effects on gaseous components. Such effects are graphically represented in fig. 3 and 4 which correspond to tests carried out with smokers and with a smoking machine, respectively. The first figure shows that a significant proportion (50 to 75 %) of gaseous pollutants can be removed merely by keeping the chamber door open (D/F test). Such a smoke removal method as well as air purification by open-circuit ventilation are obviously not selective. The active charcoal centrifugal filter (F3 ac) removes a significant proportion of toluene and, to a lesser extent, of other organic compounds, except formaldehyde which is not retained on this filter. The absolute filter F1 is a remarkably efficient aerosol filter but its effectiveness is only moderate for acrolein and toluene. Besides, formaldehyde tends to increase. However, it may be asked whether at least part of the pollutant removal ascribed to filter F1 is not actually carried out by absorption by the many subjects (10) present in the chamber. Indeed, in tests performed by only two subjects with the smoking machine (see fig. 4) the filter F1 does not reduce acrolein and, a noticeable increase in toluene can be observed. A tendency toward an increase in formaldehyde is observed again and even intensified. The addition of activated charcoal to this filter brings about a complete change in the situation. It induce a significant decrease in measured organic compounds, except in acetaldehyde (ethanal). The effects of the electrostatic filter (F2) and of the centrifugal filter (F3) are mainly characterized by a quite important increase in formaldehyde and toluene. As expected, the various filters have practically no influence on carbon monoxidé.

### 3 - CONCLUSION:-

From this experimentation, we can come to the following conclusions.

3.1 - Even in the absence of any undesired pollution it is difficult to characterize tobacco smoke pollution because of transfers between particulate and gaseous phases. Owing to such transfers, the measurements are dependent upon time.

3.2 - In the particulate phase, the smoke pollution can be characterized both by an increase in the number of particles ranging between 0.40 and 0.60  $\mu\text{m}$  in size and by a drop in the number of micelles finer than 0.17  $\mu\text{m}$ .

3.3 - The determination of the nicotine concentration in the atmosphere, which is obviously the most specific tracer of tobacco smoke pollution, still gives rise to methodological problems.

3.4 - Carbon monoxide remains the most stable tracer. Unfortunately, it is not specific of tobacco smoke.

3.5 - Because of smoke particle size range, the electrostatic filters have not proved very effective. Only absolute filters are capable of removing aerosols produced within this particle size range.

3.6 - Particulate filtration may paradoxically induce an increase in the concentration of some compounds in the gaseous or vapour phase. This is particularly true for formaldehyde and toluene.

3.7 - The use of activated charcoal, whose adsorption is selective, cannot completely solve the problem of organic pollution caused by tobacco smoke.

-----

#### - Acknowledgements

This study was carried out in collaboration with Research Department of S.E.I.T.A. Paris (Dr P. SCHILTZ).



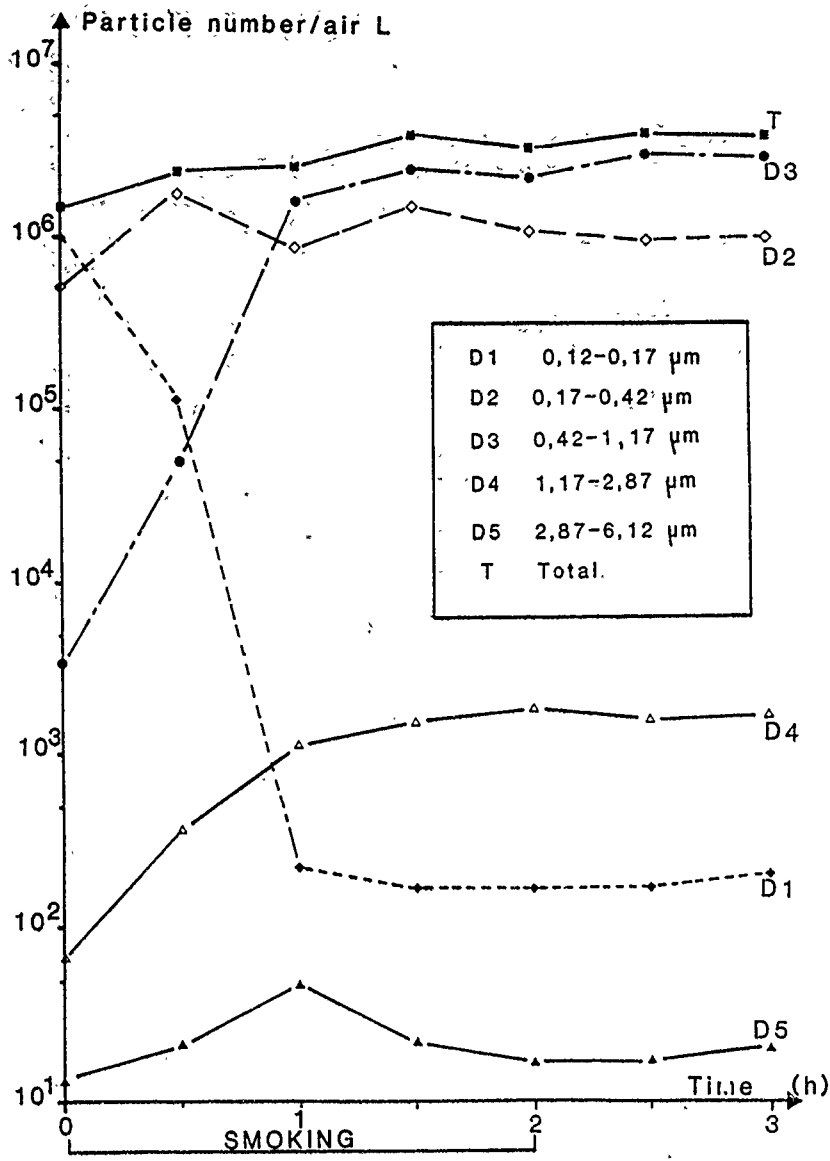

Figure 1 Particle number variations with time in confinement according to particle size classification ( smoke from smokers )

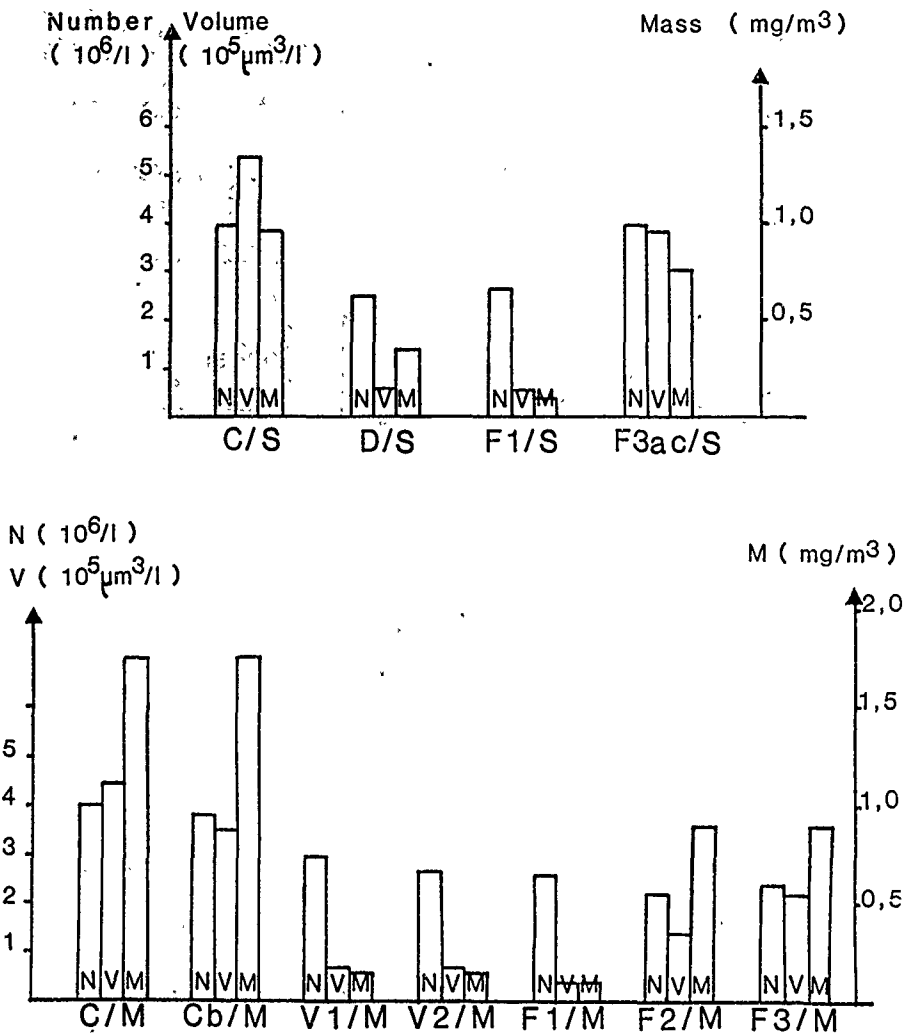

Figure 2 Different expressions of particulate concentration at the end of smoking period under various conditions.

Table 1

Main gaseous pollutants after two hours smoking  
in confined atmosphere — 24 cigarettes in 50 m<sup>3</sup>

Compound	Concentration ( ppm )
Carbon monoxide	25.7
Gaseous hydrocarbons	177*
Nitrogen monoxide	1.05
Nitrogen dioxide	0.22
Formaldehyde	0.29
Acetaldehyde	0.33
Acroleine	0.11
Acetone	0.45
Toluene	0.74

\* mg/m<sup>3</sup> of methane

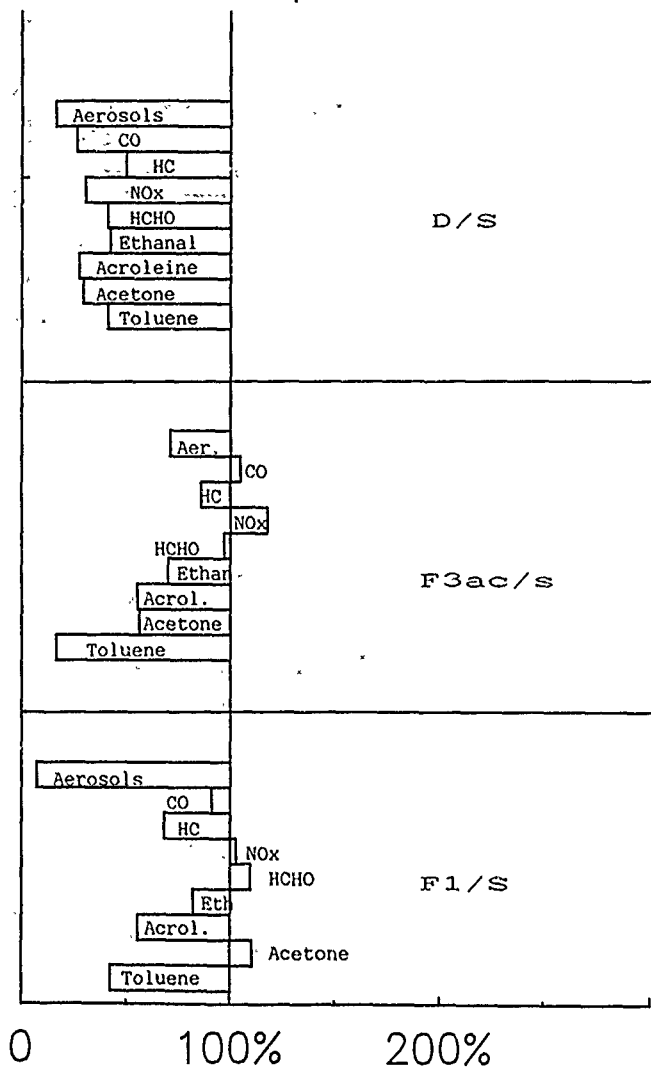

Figure 3 - Effects of different removal processes on the concentration of tobacco smoke pollutants ( tests with smokers )

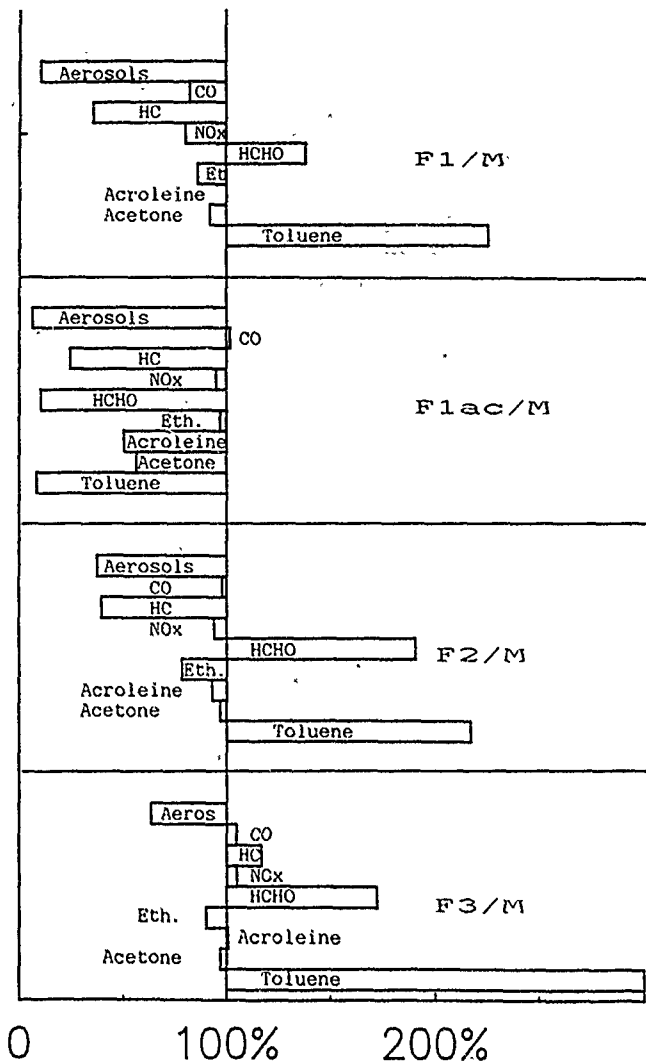

Figure 4 - Effects of different filtration systems on the concentration of tobacco smoke pollutants ( tests with a smoking machine )

## WHY IS SMOKING NOT ALLOWED ON BOARD FRENCH SUBMARINES ?

MCA GIACOMONI

The question of the eventual use of tobacco on board French nuclear submarines was raised at the beginning of the 1960's. The importance of the smoking habits in the french population being taken into account and since recruiting submariners was on a voluntary basis, the importance of the question seemed obvious.

At the time, doctors and biologists of CERTSM got in touch with SEITA, firm with the monopoly in France for tobacco production and distribution, to carry out studies to know the toxicological impact of tobacco better and if possible to reduce it.

There were different successive works :

- to assess the importance of the problem by estimating the smoking habits of future submarine crews ;
- to get an estimation of the atmospheric pollution due to smoking and the hazards or harmful effects on non-smokers ;
- to study the means to reduce eventually that pollution.

It is to be noted that in that latter field works were taken as far as developing an hypotoxic cigarette which led to the French production of low-tar cigarettes.

### 1 - TOBACCO CONSUMPTION BY THE SUBMARINE CREWS :

For the habits of our submariners we gathered in table 1 the result of two surveys conducted at an interval of 23 years.

In 1963, the crews of our submarines had 88 % smokers who smoked an average of 15.6 cigarettes a day.

In 1986, only 61 % were smokers and smoked on average less than 13 cigarettes a day.

The evolution of the smoking habits on board our submarines has followed that of the French population who tends to reduce its consumption and generally to give up the brown-tobacco untipped cigarette for the blond-tobacco tipped full flavor cigarette and even, lately, for the low-tar or ultra low-tar cigarette.

## 2 - COMPOSITION OF TOBACCO SMOKE :

Tobacco smoke is composed essentially of the association of a particulate phase making a dense aerosol (about  $10^6$  micelles per ml) with a diameter between 0.1 and 0.8  $\mu$  and a gas phase.

The toxic harmful chemicals to be considered in the smoke are divided in 4 groups ;

- the alkaloids group, mainly composed of nicotine, is present in both phases ;
- Carbon monoxide, present in the gas phase ;
- a group of irritating substances containing aldehyde, ketonic and acid compounds, all water soluble and present in both phases ;
- a group of polycyclic carbohydrates and various substances with a reputation for being carcinogenic.

When a cigarette is smoked those various substances are distributed in several fractions which must be taken into account as soon as one is interested in environmental pollution by tobacco :

- The mainstream makes up the fraction directly inhaled by the smoker ;
- The sidestream produced by the spontaneous combustion of the cigarette other than the puffs, spreads directly in the atmosphere ;
- Part of the mainstream which is exhaled by the smoker and which, according to a recent study, could be as much as 50 % of the inhaled smoke cleared of the greater part of its water soluble components.

Obviously, the sidestream and the exhaled smoke are at the origin of the atmospheric pollution and the eventual exposure of non smokers.

Table 2, borrowed from M. W. FIRST shows that the sidestream is on average two to four times richer in pollutants than the mainstream. Fortunately for non smokers it is diluted into the air and eventually purified by air regeneration systems.

## 3 - ASSESSMENT OF ENVIRONMENTAL POLLUTION BY TOBACCO SMOKE :

To assess the importance of environmental pollution by tobacco smoke, CERTSM conducted numerous measurement campaigns on site in places where people smoke. The results of those measurements show that with an appropriate ventilation pollution by smoke remains usually moderate and is for the non-smoker just a "nuisance" rather than an obvious toxic hazard.

As an example, some data have been taken from a more recent study carried out in a high-rise building in the region of Paris, inside rooms in which the smoking habits of the people were different.

For the particulate pollution of these rooms, we see that (figure 3) the presence of smokers, objectified by the measurement of the amount of nicotine in air, goes with a higher particulate pollution distributed as far as its particle size is concerned, along a particular profile (figure 4).

The very low pollution of the "open space" room is explained in spite of the presence of smokers by the dimensions and the good ventilation of the room.

For the gaseous pollution, we can see (figure 5) that, for example, the amounts of carbon monoxide, aldehydes and formic acid are generally higher in rooms with smokers.

However, in all cases, whether it be for vapors or particles we can see that the measurements done in that building where the air is conditioned and recycled are far lower than the exposure limit values usually accepted by work hygienists.

#### 4 - TOBACCO POLLUTION AND SUBMARINES :

The 1963 survey showed for an SSBN a likely daily consumption of 15.43 cigarettes. The evaluation done then, of the resulting atmospheric pollution, supports (taking into account the type of cigarette smoked then) the evaluation which can be done from our table 1 and the indications we have for the smoke exhaled by smokers. That is to say the daily release in the atmosphere of the sub of 132 liters of carbon monoxide and 83 g of tars (i.e. several kilograms for an SSBN patrol).

To purify those pollutants the planned air processing systems on board submarines should be adequate. The organic products either in gas or particulates phase could be removed by active charcoal filters, electrostatic precipitators and molecular sieves of the decarbonation plants, the catalytic burner being able to remove easily the carbon monoxide. As for the capacity and therefore the volume of that equipment, the planned supplementary demand because of tobacco pollution was one of the arguments which helped justify the attitude finally adopted to forbid smoking. However, if it is true that French SSBN's make do now with an amount of active charcoal (about 200 kg) lower than that on board British and US subs the amount of pollutants generated by tobacco does not seem to be enough to justify really that difference.

A more serious argument was that related to the problem raised by the purifying of tobacco smoke at the source, during an eventual intensive smoking in exiguous compartments (crew station of officer's room for instance). The necessary air renewing intensity for that purifying calling then for an important increase of the ventilation flows.

#### 5 - CONCLUSION

In fact, the attitude finally adopted by French specialists to advise against smoking on board nuclear submarines does not come from technical or mathematical arguments, but rather, thanks to numerous studies and the acquired knowledge, from an early awareness, at a time when social groups were not yet aware of it, of the hazard to smokers, the discomfort or real danger imposed on non smokers and the eventual creation of local nuisances difficult to remove thus leading inevitably to that discomfort.



CERTSM has nevertheless gone on being interested in the problem raised by the use of tobacco in a confined atmosphere and the future lectures of D. J. HEE will precise the particulars.

Today the opinion of doctors and hygienists lead to an ever growing popular consensus to admit smoking as being one of our worst habits.

The temptation would be great to praise ourselves with a decisions which is justified today by the evolution of mentalities and habits if we did not remember those two arguments which are very important and may be the reason for the decision : on one hand, the long established habit not to smoke for safety reasons on bord our diesel electric submarines and on the other hand, the last arguments but by far not the least, the fact that our first C.O. on an SSBN was himself a convinced non smoker.

# CIGARETTES CONSUMPTION ( FRENCH SUBMARINE CREWS )

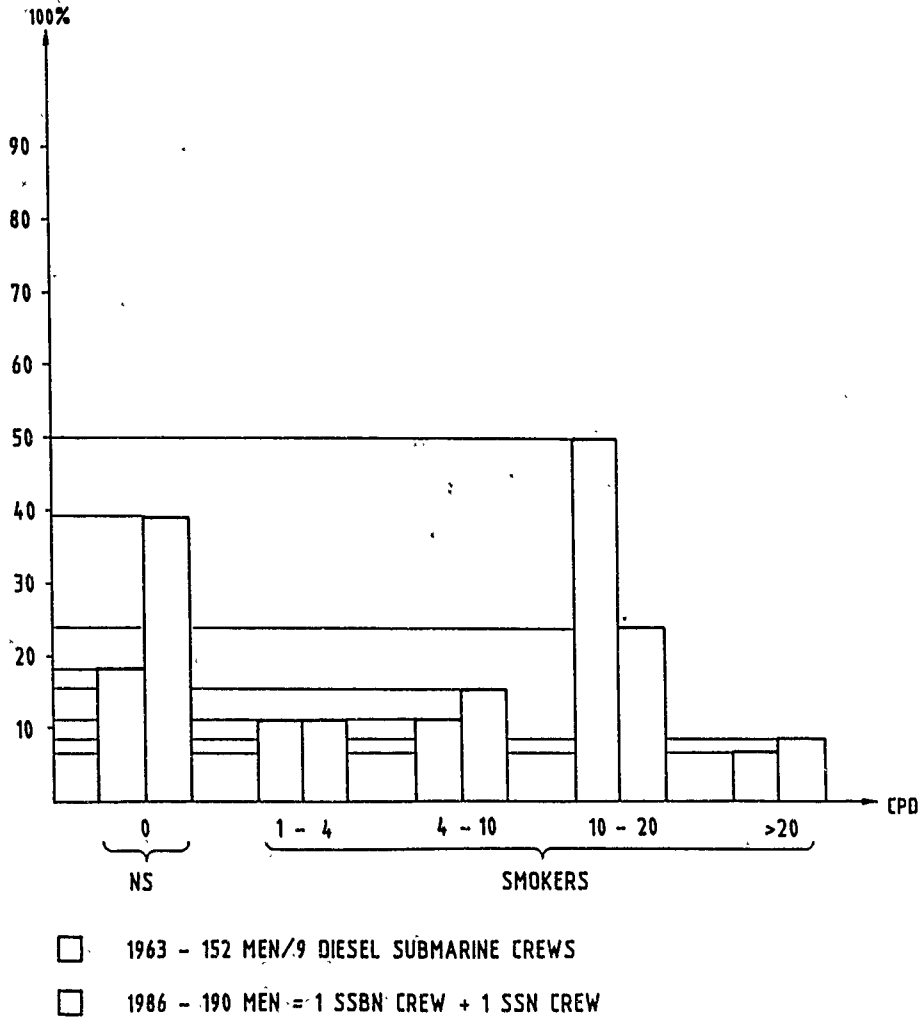

FIG : 1

# COMPARISON OF MAINSTREAM AND SIDESTREAM SMOKE CONSTITUENTS

( mg/cig )

Compound	Mainstream	Sidestream	Ratio Sidestream/ Mainstream
Tobacco burnt	347 ( 20 sec. )	411 ( 550sec. )	1.2 ( .27 )
No. particles produced	$10^{12}$	$3.5 \times 10^{12}$	3.5
Tar	20.8	44.1	2.1
	10.2 *	34.5 *	3.4 *
Nicotine	0.92	1.69	1.8
	0.46 *	1.27 *	2.8 *
Benzo ( a ) pyrène	$3.5 \times 10^{-5}$	$13.5 \times 10^{-5}$	3.7
Pyrene	$13 \times 10^{-5}$	$39 \times 10^{-5}$	3.0
Phenols	0.228	0.603	2.6
Ammonia	0.16	7.4	4.6
Nitrogen Oxides	0.014	0.051	3.6
Carbon Monoxide	19	88	4.7

\* Filter cigarette.

- FROM MW FIRST 1983.

FIG. 3

# INDOOR POLLUTION - MIDDLE AFTERNOON ( 3 to 4 PM. ) PARTICLES WEIGHT/NICOTINE

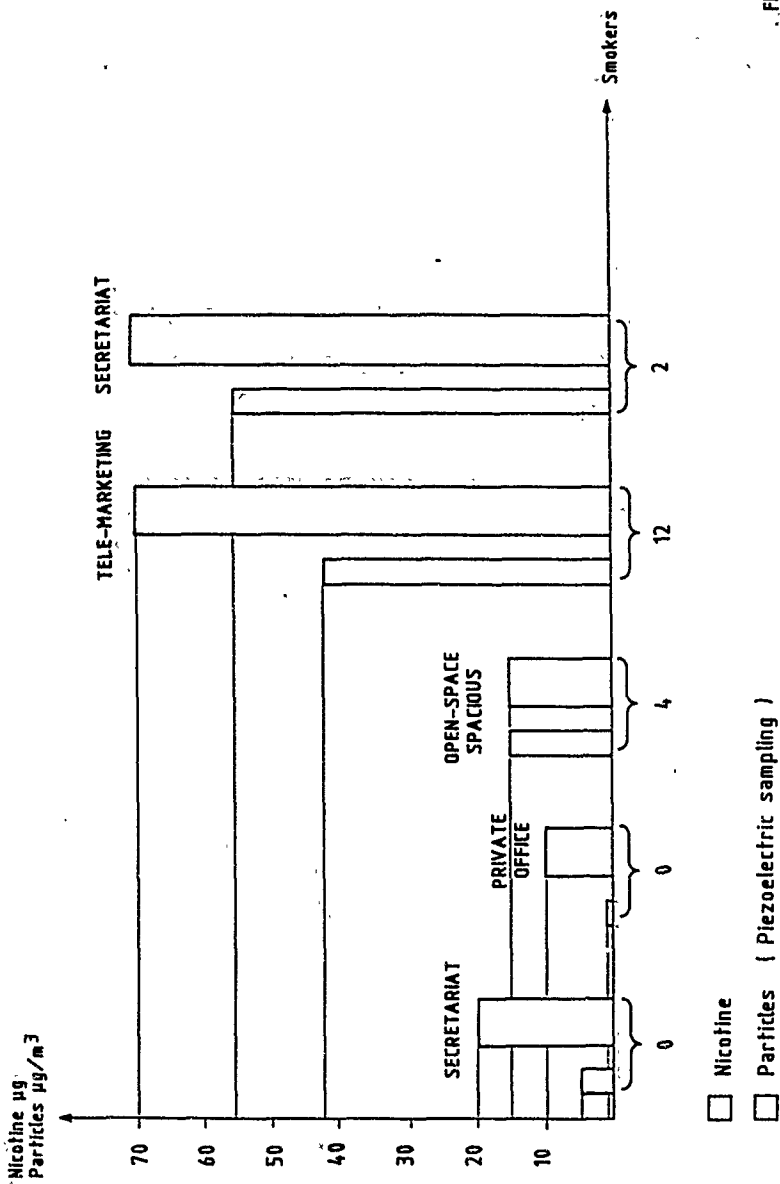
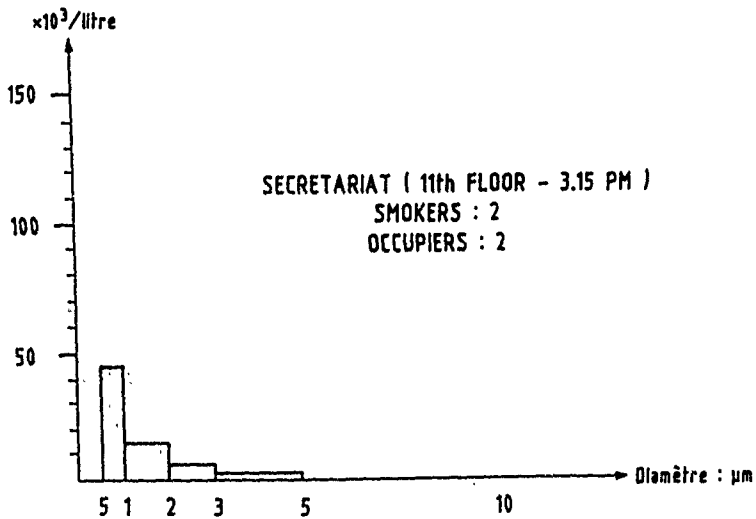
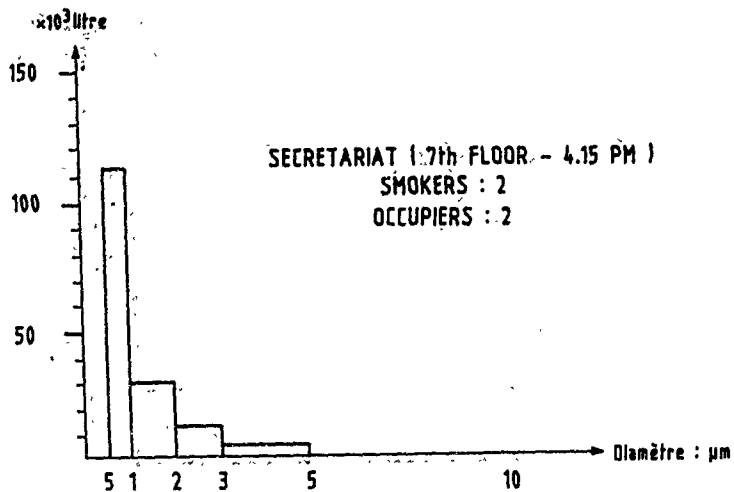

FIG : 3

# SIZE SPECTRUM OF PARTICLES



# GAZEUS INDOOR POLLUTION

LOCAUX							
	Télé Marketing	Secrétariat 7è	Secrétariat 11è	Bureau 11è	Open Space 11è	Salle de conférences	TLV (ACGIH)
Nbre. de fumeurs	12	2	0	0	5	4	
O <sub>2</sub> ( % )	20,77	20,60	20,65	20,80	20,85	20,60	>17*
CO <sub>2</sub> ( % )	0,055	0,080	0,070	0,050	0,045	0,050	0,5
CO ( mg/m <sup>3</sup> )	7,7	3,2	0,85	0,5	2	1,5	55
NO ( µg/m <sup>3</sup> )	209	312,15	251,5	245	270	209	30.000
NO <sub>2</sub> ( µg/m <sup>3</sup> )	169	272,5	357	226	150	226	6.000
SO <sub>2</sub> ( µg/m <sup>3</sup> )	<250	<250	<250	<250	<250	<250	5.000
O <sub>3</sub> ( µg/m <sup>3</sup> )	<50	<50	<50	<50	<50	<50	200
HCHO ( mg/m <sup>3</sup> )	<0,2	0,25	<0,1	<0,1	<0,1	<0,1	3
HCOOH ( mg/m <sup>3</sup> )	8,1	5,75	5,75	2	5,65	2	9
Nicotine ( µg/m <sup>3</sup> )	41,5	55	4	-	15	-	500

\* CERTSM TLV IN CONFINED ATMOSPHERE

FIG : 5

#### 4.5. POLICY GUIDANCE CONCERNING TOBACCO SMOKING ON SUBMARINES.

The rather sobering facts of tobacco smoking effects must be considered with regard to the submarine artificial atmosphere. The benchmark 1950 report, by E. L. Wynder and E. A. Graham, one of the 100 most significant medical articles ever published, has left little open, honest scientific or medical doubt about the deleterious health effects of tobacco smoking. Since 1964 the Surgeon Generals of the U.S. have reported annually to the nation the mounting and overwhelming evidence of tobacco's ill effects. This year, 1988, cerebrovascular accidents, strokes, have been confirmed to be a result of tobacco use, and have been added to the familiar list of tobacco associated diseases.

Over 300,000 deaths a year in the U.S., 15% of all U.S. deaths, are caused by tobacco, not including deaths due to fires caused by cigarette smoking (1500) or deaths due to involuntary or passive inhalation of tobacco smoke (uncalculated).

The following Bibliography, paragraph 4.5.1, provides basic information on tobacco effects for commanders, commanding officer and their medical officers - the cited sources are pertinent and factual, and it is the specific responsibility of each squadron, group and force medical officer to assist commands with the Navy Tobacco Prevention Program, as stated in the basic instruction, SECNAV Instruction 5100.13A, and amplified specifically for the Medical Department in CNO msg 061957Z NOV 87. It is particularly poignant that there is no other more preventable set of morbid, although often latent, diseases than those caused by tobacco and its chemical and metabolic products. It is the purpose of the Navy program to enhance the safety and well-being of the crews and ships by taking advantage of the opportunity that our medical and scientific knowledge affords us.

What can be done regarding tobacco use on submarine? A review of some facts is apropos. Sound studies sponsored by DOD and the Navy demonstrate that about 28 percent of our Navy recruits smoke on entrance to the Navy, and the percentage grows to 49 percent upon the sailors' integration into Navy crews. The smoking problem must be, has been, attacked as each recruit enters the Navy. It must be continued after the member joins his or her ship. The Medical Department should be actively involved in that educational effort, by command direction.

Fundamental to all of the anti-smoking efforts is an

Enclosure (1)

acknowledgement by each person that tobacco contains the addicting drug nicotine. Nicotine is legal, although it and the other chemical congeners of tobacco kill more people than any other cause in society, except unrelated cardiovascular disease and, perhaps, cancer. Thus, the Secretary of the Navy, in SECNAV Instruction 5100.13A issued the imperative: "Smoking shall be permitted only to the extent that it does not endanger life or property, or risk impairing non-smokers' health."

The last part of the SECNAV statement reflects an integral matter that has been contested, but is now accepted scientifically, is the effect of passive tobacco smoke inhalation. Again, the U.S. Surgeon General has issued a rather profound statement on the matter: "...involuntary smoking is a cause of disease, including lung cancer, in healthy non-smokers. A simple separation of smokers and non-smokers within the same air space may reduce, but does not eliminate, the exposure of non-smokers to ETS (environmental tobacco smoke)." When the facts are coupled with the guidance noted above, the issues on smoking aboard submarines come into better focus.

Given the two facts that: (1) passive inhalation is dangerous, and that (2) 40 to 50 percent of the atmospheric contaminants on our best atmospherically controlled submarines, the Tridents, are derived from tobacco, it becomes rather clear that the issue is more serious than apparent, because the injury is paid for many years later, as a rule. Tobacco smoking also impedes wound healing and it also degrades performance. How can tobacco smoking be permitted on a submarine? The pragmatic answer is: it is virtually impossible to operate our submarines without tobacco smokers since they comprise 15 to 40 percent of each crew. This, in turn, makes great the need for education on tobacco effects and the encouragement of abstinence from its use, as has been supported by the CNO msg 211052Z-OCT 87. As a digression, with regard to electrical and electronic equipment, it has been estimated that 35 to 50 percent of the superficial corrosion on conductor contacts is due to the residue of tobacco aerosols. The residue is a dull, pale yellow-brown film visible on "white" surfaces inside a submarine. The residue plates out and corrodes materials, and cause adaptive changes of physiological mechanisms in our bodies, as well. About the only "good statement" concerning tobacco smoking is that the addicted user must have nicotine for relaxation, especially while under stress.

There is no easy solution to the tobacco problem, aboard submarines as elsewhere, despite the facts, regulations and

Enclosure (1)



guidance. The eventual solution can only be the abstinence from tobacco use, but the attainment of that goal, as part of the submarine atmosphere control program, depends on individual attitudes and positive command leadership. Some commands have been quite successful. Appendix D provides a realistic practical sample instruction regarding the use of tobacco aboard submarines.

4.5.1. SELECTED BIBLIOGRAPHY ON TOBACCO SMOKING FOR COMMANDERS, COMMANDING OFFICERS, AND MEDICAL OFFICERS.

1. Bahrke, M.S. et al: "Tobacco Use and Performance on the US Army Physical Fitness Test." in Military Medicine 153: 229-235, 1988
2. CNO 061957Z NOV 87, "Supporting the Navy Smokeout"
3. CNO 211052Z OCT 87, NAVOP 097/87
4. Cronan, T.A. and Conway, T.L.: "Is the Navy Attracting or Creating Smokers?" in Military Medicine 153: 175-178, 1988
5. Department of Defense Directive, Health Promotion, Number 1010.10, March 11, 1986
6. Felding, J.E.: "Smoking: Health Effects and Control" in The New England Journal of Medicine 313: 491-498, 555-561, 1985
7. Hammond, E.C. and Horn, D.: "Smoking and Death Rates: Reports on 44 months of follow up on 187,783 men." in The Journal of the American Medical Association 166: 1294 -1308, 1958
8. National Research Council, Committee on Toxicology: Monitoring of Air in Submarines, National Academy Press, Washington, DC, 1988
9. National Research Council, Committee on Toxicology: Health Effects in Divers of Breathing Submarine Air Under Hyperbaric Conditions, National Academy Press, Washington, DC, 1988
10. National Research Council, Committee on Toxicology: Environmental Tobacco Smoke, National Academy Press, Washington, DC, 1986

Enclosure (1)

11. National Research Council, Committee on Toxicology: The Airline Cabin Environment, National Academy Press, Washington, DC, 1986
12. NERO, A.V.: "Controlling Indoor Air Pollution" in Scientific American 258(5): 42-46, May 1988.
13. Office on Smoking and Health, Center for Health Promotion and Education, CDC: "Smoking - Attributable Mortality and Years of Potential Life Lost - United States, 1984" in The Journal of the American Medical Association 258: 2648-2657, 1987
14. Office on Smoking and Health, CDC: The Health Consequences of Smoking: Cancer - a Report of the Surgeon General, US Department of Health and Human Services, Public Health Service, 1982: xi. (DHHS Publication No. (PHS)82-50179, 1982, Rockville, Maryland
15. Office on Smoking and Health, CDC: The Health Consequences of Involuntary Smoking: a Report of the Surgeon General, US Department of Health and Human Services, Public Health Service, 1986. (DHHS Publication No. (CDC) 87-8398:259-322, Rockville, Maryland
16. Rossier, R.N.: Trident Atmosphere Control Sea Trial Final Report, Contract No. N00024-73-C-0232, General Dynamics, Electric Boat Division, Groton, Connecticut, 1984
17. Sandler, D.P., et al: "Passive Smoking in Adulthood and Cancer Risk" in American Journal of Epidemiology 121: 37-48, 1985
18. SECNAV INSTRUCTION 5100.13A, of 13 Jul 86: Tobacco Prevention Program in the Navy and Marine Corps
19. Spengler, J.D. and Sexton, K: "Indoor Air Pollution: A Public Health Perspective" in Science 221: 9-17, 1983
20. White, G.L., et al: "Cigarette Smoking and Combat Injuries" in Military Medicine 153: 381-382, 1988
21. Wolf, P.A., et al: "Cigarette Smoking as a Risk Factor for Stroke" in The Journal of The American Medical Association 259: 1025-1029, 1988

Enclosure (1)

14

USE OF CONTAINERS TO PROVIDE LIFE SUPPORT

STORES TO DISTRESSED SUBMARINES

---oOo---

H: BODILIS; L. GIACOMONI

---oOo---

1 - REMINDER AND DEFINITION OF NEEDS

The possible uses of sodalime under static conditions to fix the carbon dioxide of escape compartments of submarines in survival situation were treated during the fourth and fifth tripartite meetings in 1984 and 1985 (2 and 3).

It was then shown that :

- a) CO<sub>2</sub> is very efficiently fixed by sodalime used in static (about 200 litres per kg). Besides the capacity of the product is not altered if the compartment is overpressured.
- b) The minimum contact surface between the sodalime bed and the air of the compartment was defined with tests as 0.85 m<sup>2</sup> under a 5.6 cm thick bed (that is approximately 20 kg of sodalime) to ensure the absorption of the CO<sub>2</sub> produced by one man during 192 hours (8 days) (cf. Curve 1).
- c) For safety reasons, the recommended exchange surface to be used on board submarines was set at 1.70 m<sup>2</sup> per man which gives, for the necessary 20 kg, a bed thickness of 2.8 cm.

In this survival situation, oxygen is supplied partly by the reserve of air on board whose concentration can be lowered without any risk, from 21 % to 15 %, then by the chemical generators (chlorate candles).

With their stocks, French submarines can ensure the survival of 70 men in each escape compartment for 8 days. When the compartment is not overpressured, the limiting factor of survival is the decrease of oxygen partial pressure. In case of overpressure, the increase of carbon dioxide partial pressure would then be limiting factor.

That is why, it was considered, in case of having to lengthen survival duration, to supply the submarine with complementary regeneration products with the help of containers sent on board through the escape trunks. The STANAG 1295 (1) project gives the characteristics of the container defined by the Royal Navy. We have studied here the capacity it offers for the transfer of regeneration products under a form which can be directly used inside the escape compartment. We shall consider, as a calculation unit, a 48-hour complementary survival in an escape compartment of 70 men.

CONTACT SURFACE : 4.32 m<sup>2</sup>  
SODA LIME WEIGHT : 96 kg  
TEMPERATURE : 10°C  
AIR HUMIDITY : 70 %  
CO<sub>2</sub> INFLOW : 100 l/hr

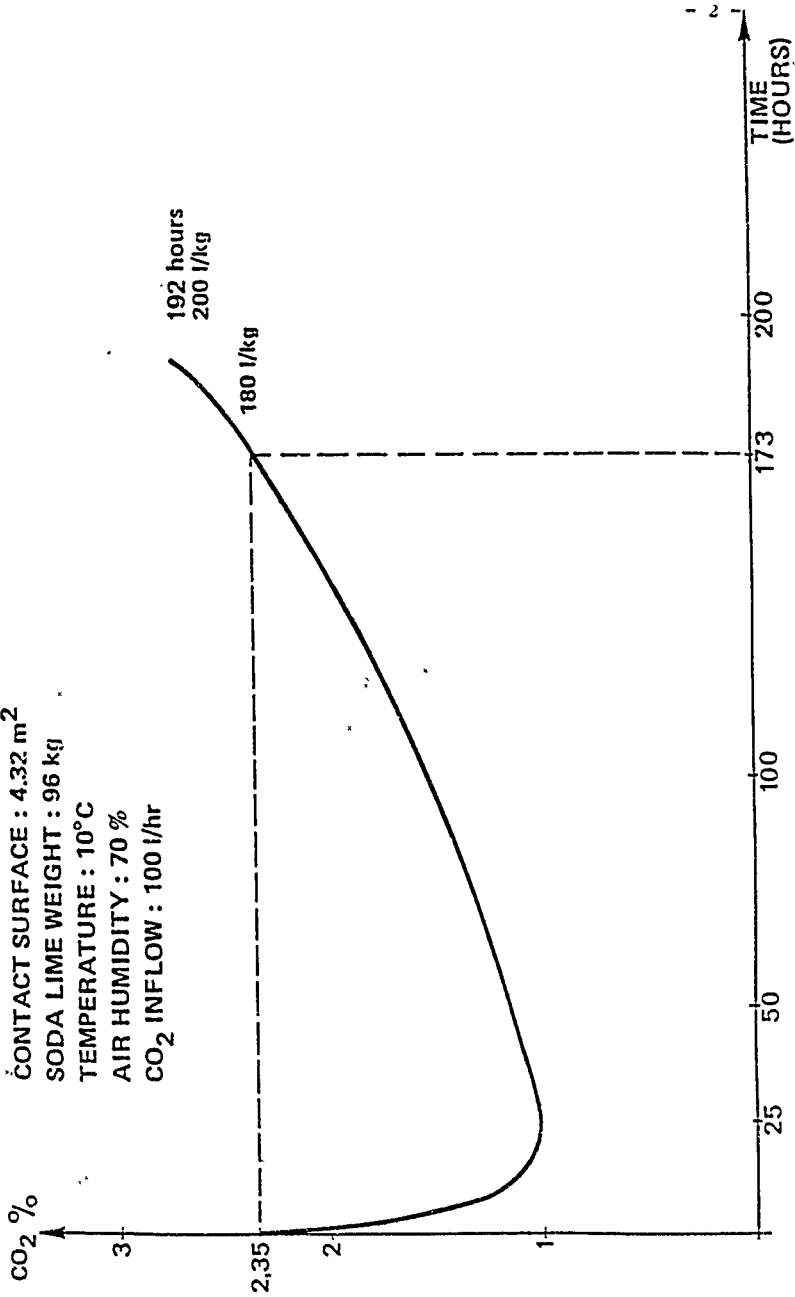

## 2 - NEEDS FOR REGENERATION PRODUCTS

### 2.1 - Oxygen supply

Various tests on board submarines in climatic chamber and in antinuclear shelters have set the mean consumption of oxygen per man and per hour at 20.4 litres. To ensure that need, we have in France a candle wich produces 2 m<sup>3</sup> of oxygen; the consumption of 98 men/hour.

The French candles are presented in a metal casing and have an electric ignition, thus their use does not call on a specific combustion device. One only needs to set them on a metallic surface and ignite them with a portable igniter. Finally, the mass of the candles is 11 kg and its volume 8.2 litres.

### 2.2 - Fixing CO<sub>2</sub>, needs in sodalime

The tests carried out at CERTSM show that in survival conditions, with a minimum activity in cold atmosphere (about 1500 kilocalories) and men wearing warm clothing, the CO<sub>2</sub> production is 16.3 litres per man per hour. To fix that CO<sub>2</sub>, sodalime can be used in two ways :

The first (cf. Curve 2) is to set out, as soon as the survival period begins, the whole of the available stock of product. Then the value of CO<sub>2</sub> changes in the way shown by Curve 2. It falls very rapidly as soon as the product is set out, stabilizes then rises progressively back to the initial CO<sub>2</sub> concentration. Plastic gauze bags, divided into 2.8 cm thick rolls allow the yield of the sodalime shown in chapter one which corresponds to a low consumption (103 grammes per man per hour).

The second is to distribute progressively the bags containing the sodalime so that to keep a constant CO<sub>2</sub> concentration close to the initial one. Curve 3 gives an example of this use. It shows that after 48 hours the sodalime fixes 159 litres of CO<sub>2</sub> per kilogram. We were able to check that both conditions of use lead to similar yields and an identical need in sodalime (102.6 g per man per hour).

#### Remark

During the 8 days survival period allowed by the use of the stocks on board, the first solution which brings about a very progressive increase of CO<sub>2</sub>, seems to be more favourable for physiological adaptation (3).

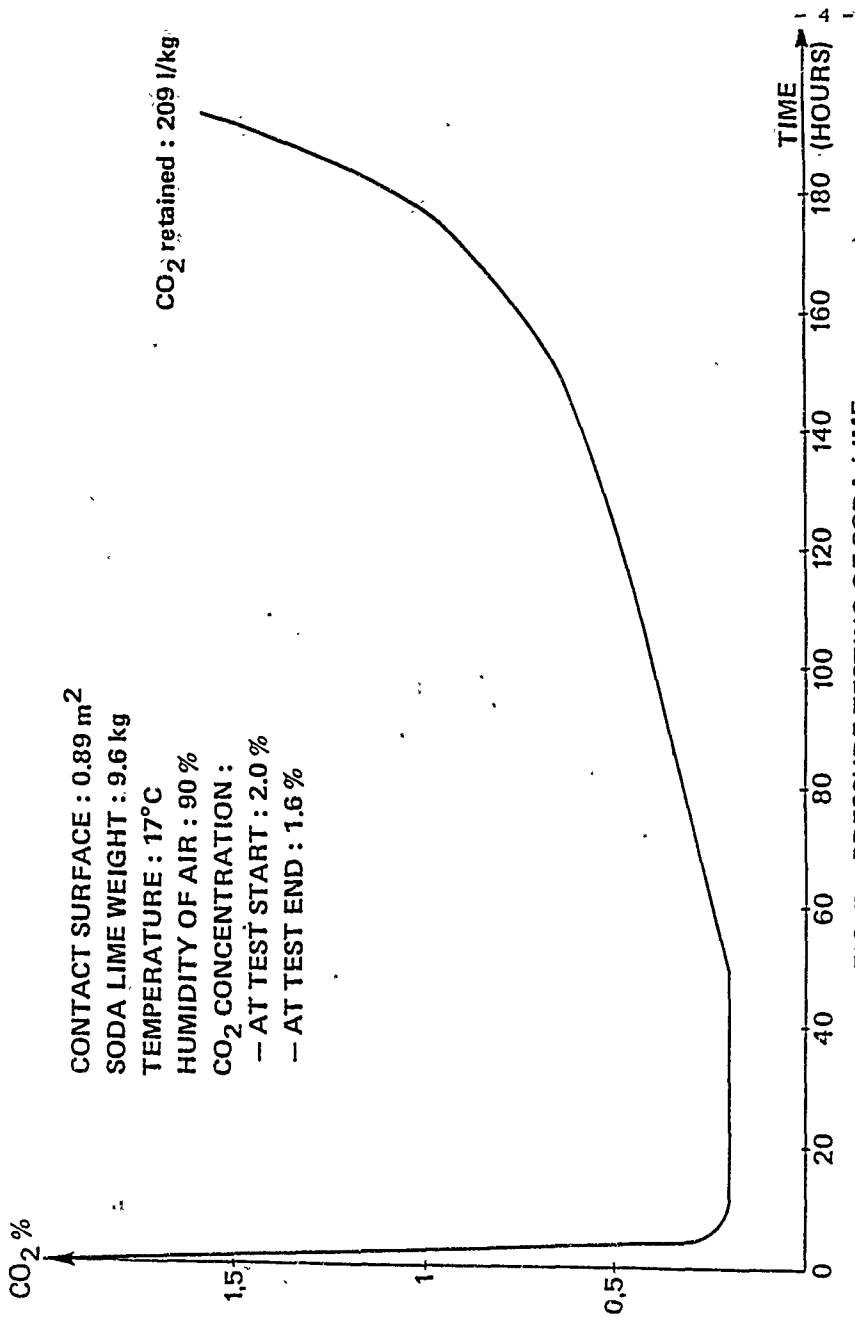
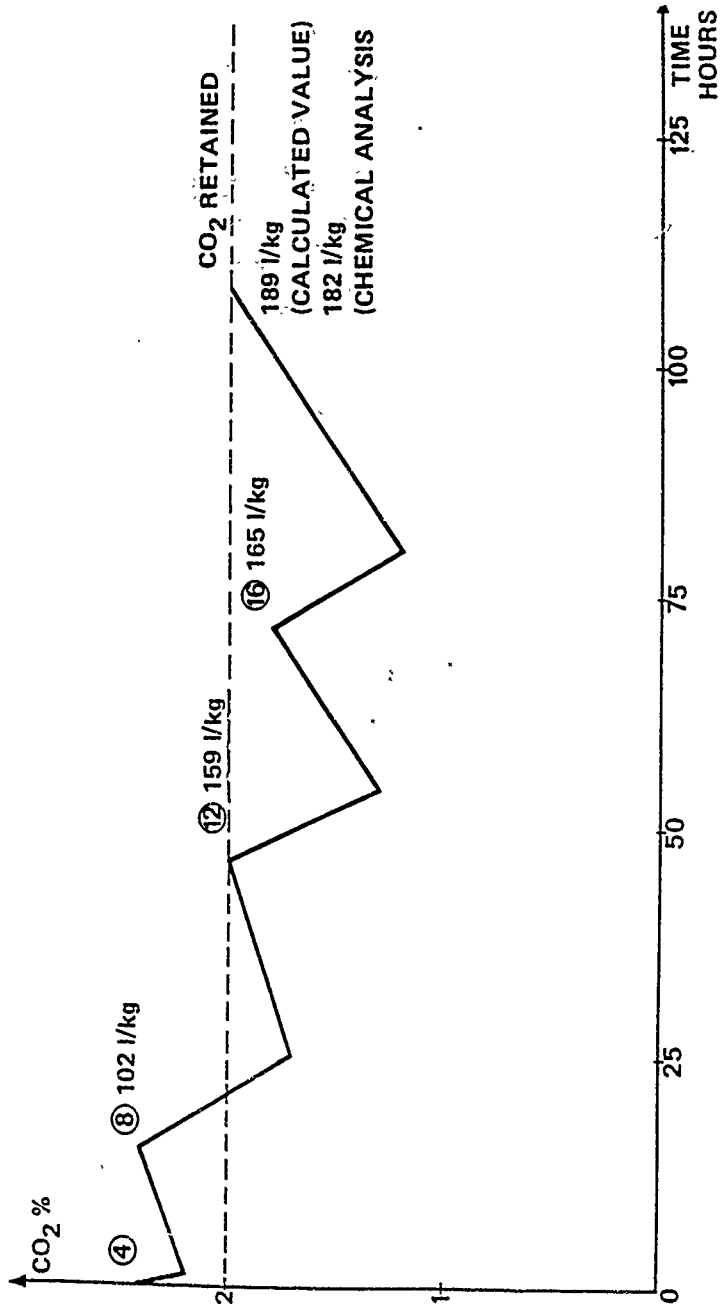

FIG. 5 -- PRESSURE TESTING OF SODA LIME



TESTING 3 cm THICK CANISTERS (TEST RESULTS)

### 3 - CONTAINERS FOR THE TRANSFER OF LIFE SUPPORT PRODUCTS

#### 3.1 - Inside dimensions

The STANAG 1295 project defines the following dimensions for the containers :

Minimum inside diameter : 300 mm  
Disposable inside height : 1200 mm  
That is to say an available volume of 85 litres.

#### 3.2 - Filling the container

In the available volume, we can put a maximum of 3 candles which have to be stacked, their dimensions not allowing a side by side disposition. With those three candles each producing 2 m<sup>3</sup> of oxygen, the container can therefore meet the need in oxygen of 294 men/hour. The volume occupied by those candles is 25 litres. The corresponding amount of sodalime, about a little under 31 kg, put in the bags, will occupy 52 litres. That is to say a total occupied volume of about 77 litres out of the available 85 litres.

#### NOTES :

- a) French submarines will soon have a candle with the same dimensions as that of 2 m<sup>3</sup> now being used, but it will produce 3 m<sup>3</sup>, its weight will be 13 kg. If those candles are used, the amount of sodalime for three candles (about 72 litres) will not fit in the container. It would then be more practicle to make do with two candles (294 men/hour) and the corresponding 52 litres of sodalime. A vacant volume of about 16 litres would then be left in the container, it could be used to transfer other indispensable products (medecine or food for instance).
- b) The use of sodalime in plastic gauze bags is well suited to the filling of the container. The gauze bags, whose height must be a little under that of the container (1.2 m), are squeezed against the candles which are stacked against the wall of the container (that disposition is better than which would place the candles in the axis of the container).

### 4 - HYPOTHESES OF APPLICATION TO FRENCH SUBMARINES

As an example we calculated the number of containers to be transferred to keep in survival for 48 hours the 70 men theoretically inside an escape compartment. The number is 12 containers, that is at least 1 container every 4 hours. It is only a school hypothesis since the bottom hatch of the escape trunks chambers on French submarines is too narrow for the container defined by the Royal Navy.



Table 1 shows the necessary number of containers and the volume and weight of products it must contain to ensure the survival of 70 men for 48 hours. A comparison between candles 2 m<sup>2</sup> and 3 m<sup>2</sup> is also presented (columns 2 and 3).

The use of 3 m<sup>2</sup> candles does not lower the number of containers to be used, however it gives a much greater available vacant volume than the 2 m<sup>2</sup> candle solution. That volume can be used to embark products other than those needed for air regeneration (food, medicine).

#### 5 - CONCLUSION

France did not ratify STANAG 1295. Determining the necessary amounts of regeneration products to ensure complementary survival duration allows however a better understanding of the problem and the proposal of solutions for the submarines of the Navies which can use the container defined by the ROYAL NAVY.

#### NOTE :

A recent draft STANAG (Ref 4) gives the basis of data to determine sodalime and candles to be stored in a submarine escape compartment for air regeneration purposes under survival conditions.

They are as follows :

Oxygen consumption 18.7 litres/hour/men

Carbon dioxide production 17 litres/hour/men

The retained values to determine the life support stores in French submarines and in containers are not very different (respectively 20.4 litres for oxygen, and 16.3 litres for carbon dioxide). It is obvious that the candles can supply this lower consumption of oxygen defined by the STANAG. On the other hand the series of test (Ref 2 and 3) has shown that the carbon dioxide absorption efficiency of sodalime used in plastic gauze bags is excellent, and there is no problem to retain a carbon dioxide production increasing up to 20 litres per hour and per men.

TABLE 1

Number of containers, volume and weight of products  
to ensure life support in each escape compartment  
of a French submarine.

1	Container	3 x candle 2 m <sup>2</sup>	2 x candle 3 m <sup>2</sup>
2	Number	12	12
3	Available volume	85 litres	85 litres
4	Candles (Volume)	25 litres	17 litres
5	Sodalime (Volume)	52 litres	52 litres
6	Occupied volume	77 litres	69 litres
7	Vacant volume	8 litres	16 litres
8	Maximal weight container + stores	130 kg	130 kg
9	Empty container (Weight)	40 kg	40 kg
10	Candles (Weight)	33 kg	26 kg
11	Sodalime (Weight)	31 kg	31 kg
12	Stores (Weight)	64 kg	57 kg
13	Container + stores (Weight)	104 kg	97 kg
14	Vacant weight	26 kg	33 kg

STANAG 1295  
CONTAINERS TO PROVIDE LIFE SUPPORT STORES  
TO DISTRESSED SUBMARINES.

CONTAINER

1) INSIDE DIMENSIONS : Diametre : 300 mm  
Height : 1200 mm  
Volume : 85 l

2) FILLING

	Volume (litres)	Weight (kg)	Vacant volume (litres)
3 candles (2 m <sup>3</sup> )	25	33	
Sodalime	52	31	
	77	64	
2 candles (3 m <sup>3</sup> )	17	26	
Sodalime	52	31	
	69	57	

APPLICATION TO FRENCH SUBMARINES

Containers to ensure the survival of 70 men for 48 hours : 12  
(one every 4 hours).

## REFERENCES

- 1) STANAG 1295  
Minimum requirements for pressure tight containers for the supply of Life Support Stores to distressed submarines.
- 2) H. BODILIS  
Static absorption into Sodalime  
4<sup>e</sup> Tripartite Submarine Medicine Conference  
INM ALVERSTOKE, May 1984
- 3) H. BODILIS  
Utilisation de la chaux sodée en condition de survie  
5<sup>e</sup> Conférence sur la Médecine Appliquée aux Sous-Marins.  
CERTSM - TOULON - Juin 1985
- 4) STANAG 1301 (EDITION 1)  
MAS (NAVY) 042 S/MER/1301 - 23 March 1987  
Submarine escape and rescue. Minimum conditions for survival in a distressed submarine prior to escape or rescue.

10  
P.F. Giannandrea, M.D.  
LCDR MC USN  
Tripartite Meeting  
1-4 June 1987

AN INTRODUCTION TO SUBMARINE PSYCHIATRY

I. Introduction and Brief History

A. Two Important Principles

B. Leonardo da Vinci Workbooks

C. First Prototype

1. Cornelius von Drebbel - 1620
2. Demonstration on the Thames

D. First Tested Prototype in Combat

1. The Turtle - American Revolutionary War
2. David Bushnell
3. Ezra Lee and the HMS Eagle

E. The Chronology of Robert Fulton's Nautilus

1. France 1801 - Napoleon
2. Britain - Admiral St. Vincent
3. United States - Steam Engine

F. First Successful Use in Combat

1. H.L. Hunley
2. The Confederate cause in the American Civil War
3. Charleston Harbor - Sinking of the U.S.S. Housatonic 17 Feb 1864

G. U.S.S. Holland

1. First submarine in the U.S. Fleet

H. Diesel Submarines

1. W.W.I
2. W.W.II

I. The Nuclear Submarine

1. The U.S.S. Nautilus
2. The U.S.S. George Washington-first ballistic submarine

II. The Working Environment and the Mission

A. General Environmental Conditions

B. No Escape

1. Diving tower as symbol

C. Inactivity

D. Boredom

E. The family-gram

III. The Submarine Crew

A. General Issues

1. Winston Churchill quote
2. "crew served weapon"
3. a large special forces unit

B. Secrecy

1. "loose lips still sink ships"
2. Secrecy equals safety
3. PRP certification
4. Influence on medical care delivery

C. Group Cohesiveness

1. Example of team work
2. Rituals underway
  - a. Dolphin ceremony
  - b. Scapegoating
  - c. Sub-group competition

D. Tolerance of Space Restriction and Personal Living Conditions

1. Living Conditions
2. Privacy
3. Sleep
4. Transitional object restriction
  - a. Family-grams
  - b. Kohut research
    - (1) Self objects
    - (2) Self esteem

E. Time and Time Management

1. Critical decision-making
2. Drills
3. "idle" time
4. Meal time
  - a. Ritualization
  - b. Social function
  - c. Weight problems

F. Perceptual Changes

1. Visual
2. Olfactory and gustatory

G. Physical fitness

H. Humor, sexual behavior and physical contact

1. Anecdotal experience
2. Sexual humor
3. "Half-way" ritual
4. The pin-up
5. Pranks
  - a. Trimming party

I. The Independent Duty Corpsman

IV. The Submarine Psychiatry Literature

A. General comments and introduction

B. Categories of studies.

1. Psychological
2. Syndromal
3. Individual-adaptational.
4. Psychological Screening.

C. Selected Subjects

1. Submariner's wives syndrome
2. Separation experience
3. Phobia-counterphobia
4. Family coping strategies
5. Screening process.
6. Sexuality and adaptation
7. Adaptation to exotic environment studies
8. Medical officer anecdotal reports

V. Conclusions

A. Summary

B. Questions and answers





REFERENCES

- EARLS, Jim - "Human Adjustment to an Exotic Environment: The Nuclear Submarine", Archives of General Psychiatry, 20:117, 1969.
- GILES, J.T. et al - "Characteristics of the Submarine Line Officer"; Naval Submarine Medical Research Laboratory Report #666, 1971.
- HEYDER, D.W. et al - "Sexuality and Affect in Frogmen", Archives of General Psychiatry, 11:286, 1964.
- ISAY, Richard - "The Submariners Wives Syndrome", Psychiatry Quarterly, 42:647, 1968.
- KING, B. - "Some Correlates of Disqualification in the Submarine Service", Naval Submarine Medical Research Laboratory Report #291, 1957.
- MARSELLA, Anthony et al - "The Effects of Father Presence and Absence Upon Maternal Attitudes", Journal of Genetic Psychology, 125:257, 1974.
- MC CUBBIN, Hamilton et al - "Coping Repertoires of Families Adapting to Prolonged War-Induced Separations", Journal of Marriage and Family, August 1976, Page 461.
- NODDIN, E. - "Studies in Enlisted Submariners Motivation-I", Naval Submarine Medical Research Laboratory Report #703, 1972.
- O'BRIEN, M. - "Phobia and Counterphobia to Submarines", Submarine Medical Officers Training Thesis, 197?.
- PEARLMAN, Chester - "Separation Reactions of Married Women", American Journal of Psychiatry, 126:946, 1970.
- SERXNER, Jonathan - "An Experience in Submarine Psychiatry", American Journal of Psychiatry, 125:63, 1968.
- SNYDER, Alice - "Periodic Marital Separation and Physical Illness", American Journal of Orthopsychiatry, 48:637, 1978.
- WEYBREW, Benjamin et al - "The Mental Health of Nuclear Submariners in the United States Navy", Military Medicine, March 1979, Page 188.
- WEYBREW, Benjamin et al - "Psychiatric Aspects of Adaptation to Long Submarine Missions", Aviation, Space and Environmental Medicine, June 1979, Page 575.
- WEYBREW, Benjamin - "Submarine Crew Effectiveness During Submerged Missions of 60 Days or More Days Duration", Naval Submarine Medical Research Laboratory Report #686, 1971.



- WEYBREW, Benjamin et al - "Attitude Changes During and Following Prolonged Periods of Marine Submergence", Naval Submarine Medical Research Laboratory Report #369, 1961.
- WEYBREW, Benjamin et al - "Factors Related to the Failure of Enlisted Submarine School Graduates to Qualify", Naval Submarine Medical Research Laboratory Report #586, 1969.
- WILKEN, D. - "Significant Medical Experiences Aboard Polaris Submarines: A Review of 360 Patrols during the Period 1963 - 1967", Naval Submarine Medical Research Laboratory Report #560, 1969.
- YOUNISS, R. - "An Investigation of Motivation for Submarine Duty and Its Relation to Submarine School Success", Naval Submarine Medical Research Laboratory Report #278, 1956.



1987 Tripartite

COMPREHENSIVE CONTEXTUAL ANALYSIS OF CONFLICT  
WITHIN THE SUBMARINE COMMUNITY

PAULETTE A ROGERS  
Lieutenant, Medical Service Corp  
United States Navy

and

Head, Psychology Branch  
Department of Psychiatry  
Naval Hospital Groton, CT

... "MORE AND MORE, THE MOST USEFUL CRITERION OF MENTAL ILLNESS APPEARS NOT ONLY TO BE RELATED TO THE INCIDENCE AND SEVERITY OF PSYCHOPATHOLOGICAL SYMPTOMS BUT ALSO, AND PERHAPS MORE IMPORTANTLY, TO THE DEGREE TO WHICH THIS SYMPTOMATOLOGY RESULTS IN SOCIAL DYSFUNCTIONING OR, IN EXTREME CASES, SOCIAL INCAPACITATION. THIS 'SOCIAL-DYSFUNCTIONAL' CRITERION OF MENTAL HEALTH IS PARTICULARLY APROPOS THE PROBLEM OF ADJUSTMENT OF THE 100 TO 140 NUCLEAR SUBMINE CREWMEMBERS CONFINED IN CLOSE PROXIMITY TO EACH OTHER FOR EXTENDED SUBMERGED MISSIONS OF 60 DAYS OR MORE."

Weybrew, B. & Noddin, B. (1979) Military Medicine

OPERATIONAL SUBMARINES AND NUMBER OF BILLETS  
BY TYPE OF SUBMARINE

	SSBN	SSB	SS
NUMBER OF OPERATIONAL SUBMARINES	42	104	6*
NUMBER OF SUBMARINES UNDER CONSTRUCTION	3	8	0
<u>BILLETS</u>			
OFFICERS	12**	12	10
ENLISTED	138**	113	115
ESTIMATED TOTAL IN SUBMARINE SERVICE	12,600	12,980	750
12 SUBMARINE TENDER CREWS	11,600		
FINAL TOTAL	37,930		

\* This includes 5 SS and 1 NR

\*\*Multiply this twice since each SSBN has a blue and gold crew assigned.

CONTEXTS UNDER CONSIDERATION

---

- I THE INDIVIDUAL
- II FAMILY/ SIGNIFICANT OTHER(S)
- III IMMEDIATE ENVIRONMENT
- IV GREATER SYSTEM
- V GREATER COMMUNITY

**DISTRIBUTION OF RATING OR SKILLS CATEGORIES  
WHICH MAKE - UP THE SUBMARINE CREW**

SPECIALTY	SSBN (N=150)*	SSN (N=125)*	SS (N=125)*
ADMINISTRATIVE/EXECUTIVE DEPARTMENT		4%	
ENGINEERING DEPARTMENT		65%	
WEAPONS DEPARTMENT		8%	
SUPPLY DEPARTMENT		8%	
OPERATIONS/NAVIGATION DEPARTMENT		13%	
MEDICAL/DENTAL DEPARTMENT		1%	

\* These are gross estimates since billet allowance and the on-board count vary  
Percentage distributions are often mission dependant and fluctuate accordingly.

A DEFINITION OF PERSONALITY

... "THE PROGRESSIVE FINAL INTEGRATION OF ALL SYSTEMS OF RESPONSE THAT REPRESENT AN INDIVIDUAL'S ADJUSTMENT TO HIS [HER] VARIOUS ENVIRONMENTMENTS."

Gordon W. Allport



1      THE INDIVIDUAL

1. Psychological
2. Psychophysiological
3. Medical/Psychiatric

II FAMILY/SIGNIFICANT OTHER(S)

Consider strengths and weaknesses within this context

**III IMMEDIATE ENVIRONMENT**

1. **Morale**
  - a. **Leadership Capability**
2. **Stressors**
  - a. **Confinement**
  - b. **Restriction**
  - c. **Stimulus Invariance**
  - d. **Revitalized Ambient Atmosphere**
  - e. **Threat of Hyperbaric Exposure**
  - f. **Threat of Radiation Exposure**
  - g. **Interruption of Diurnal Periodicity -  
Circadian Rhythm Disturbance**
  - h. **Sustained Effort**
  - i. **Sleep Deprivation**
  - j. **Fatigue**
3. **Demographic Data**
  - a. **Sex**
  - b. **Race**
  - c. **Age**

IV

GREATER SYSTEMS

1. Immediate Command Structure
  - a. Training
  - b. Operational
  - c. Internal Organizational Dynamics
  - d. Goals
  - e. Efficacy
  
2. Greater Military/Service Structure
  - a. Rank Structure
  - b. Inherent and explicit expectations

V

GREATER COMMUNITY

1. City
2. State
3. County
4. World

INTRACONTEXTUAL

VS.

INTERCONTEXTUAL

INTRA

INDIVIDUAL

INTRA

FAMILY

INTRA

IMMEDIATE ENVIRONMENT

INTRA

GREATER SYSTEM

INTRA

GREATER COMMUNITY

POSSIBLE OCCASSIONS OF CONFLICT  
Contextual Interphases

---

1. INDIVIDUAL	VS.	FAMILY
2. INDIVIDUAL	VS.	IMMEDIATE WORK ENVIRONMENT
3. INDIVIDUAL	VS.	GREATER SYSTEM
4. INDIVIDUAL	VS.	GREATER COMMUNITY
5. FAMILY	VS.	IMMEDIATE ENVIRONMENT
6. FAMILY	VS.	GREATER SYSTEM
7. FAMILY	VS.	GREATER COMMUNITY
8. IMMEDIATE ENVIRONMENT	VS.	GREATER SYSTEM
9. IMMEDIATE ENVIRONMENT	VS.	GREATER COMMUNITY
10. GREATER SYSTEM	VS.	GREATER COMMUNITY







**BIOLOGICAL ADAPTATION IS A COMPLEX FUNCTION OF**

**(1) THE NATURE AND SEVERITY OF THE IMPOSED ENVIRONMENTAL  
STRESSES**

**AND**

**(2) THE ADAPTIVE CAPACITY OF THE PERSONS INVOLVED**

Weybrew, B. (1971) NSMRL Report No. 686

CASE A

A 20 Y.O. MARRIED WHITE MALE ATTACHED TO AN SSBN REPORTED THAT HE HATED THE NAVY SINCE HE FIRST ENLISTED. HE STATED THAT HE HAD COPED WITH THE SERVICE WITHOUT SIGNIFICANT INCIDENT UNTIL HIS FIRST MAJOR DEPLOYMENT. HE REPORTS THAT HE HAS "HELD BACK FOR TOO LONG" AND NOW FEELS DEPRESSED. HE FELT THAT HE WAS "ABOUT TO EXPLODE," BUT DID NOT WISH TO CAUSE TROUBLE FOR EITHER HIMSELF OR THE NAVY. HE INDICATED THAT HE HAD A PARTICULARLY DISTRESSING 85 DAY DEPLOYMENT. HE DID NOT LIKE THE ATMOSPHERE AND DOES NOT WISH TO DEPLOY AGAIN.

SIGNIFICANT HISTORY

FAMILY HX OF ALCOHOLISM AND PATIENT ALCOHOL ABUSE SINCE AGE 18.

DIAGNOSIS

SUBSTANCE USE DISORDER, ALCOHOL ABUSE

CASE B

A 21 Y.O. SINGLE WHITE MALE ET3 IN A NUCLEAR POWER TRAINING PROGRAM WAS DISENROLLED AFTER A SUICIDE ATTEMPT WITH OVER THE COUNTER MEDICATION. HE STATED THAT HIS PERFORMANCE STARTED TO DECREASE AFTER HE BEGAN TO RUMINATE ABOUT HIS "MISERABLE CHILDHOOD". HE STATED THAT HIS ROOMMATES PARENTS SEEMED TO HAVE GOOD RAPPORT WITH THEIR SON AND THE PATIENT REALIZED THAT HE HAD NOT HAD GOOD PARENTS BECAUSE OF FREQUENT EPISODES OF VERBAL AND PHYSICAL ABUSE UNTIL HIS SOPHOMORE YEAR OF HIGH SCHOOL. HE STATED THAT HE HAD BEEN 7% BEHIND IN THE PROGRESS CURVE SINCE THANKSGIVING (HE WAS INTERVIEWED 3 MONTHS AFTER THANKSGIVING), AND OFTEN THOUGHT OF SUICIDE. HE FINALLY DECIDED TO OVERDOSE AFTER HE FAILED TO GET 29 POINTS FOR HIS DAY OF TRAINING. THOUGH HE IMPROVED SLIGHTLY AFTER DISENROLLMENT, HE OCCASSIONALLY HAD SUICIDAL RUMINATION.

OTHER HISTORY: FELT BERATED AND BELITTLED BY SOME OF HIS SUPERIORS.

DIAGNOSES :

1. Major Affective Disorder, Depression, single episode
2. Neurotic Depression, chronic, intermittent
3. Mixed Personality Disorder w/ obsessional and passive-dependant features
4. Benign high frequency tremor/ Benign systolic murmur

ENVIRONMENT - INDIVIDUAL INTERPHASE

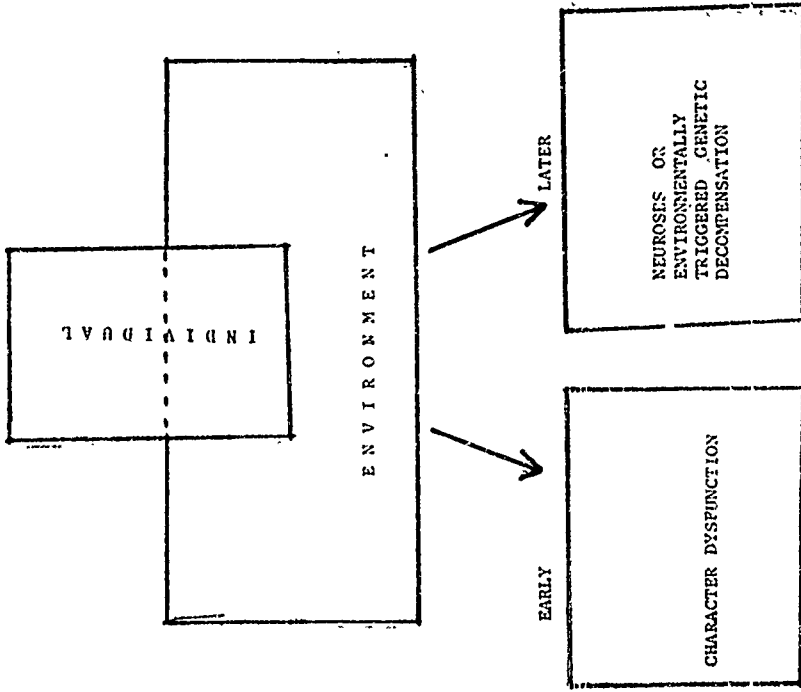

CHARISMATIC QUALITIES OF SUBMARINE OFFICERS AND PETTY OFFICERS

"...FOLLOWING THE FIRST SUCCESSFUL PASSAGE BENEATH THE POLAR ICE CAP BY THE SUBMARINE NAUTILUS IN 1958, THE MEDICAL OFFICER STATED 'THAT THE EFFECTIVENESS OF THE CREW DURING THE TREACHEROUS CROSSING WAS IN LARGE MEASURE THE RESULT OF THE MANNER IN WHICH THE OFFICERS AND PETTY OFFICERS CHANNELLED AND INTEGRATED INDIVIDUAL CREW MEMBER EFFORT INTO TEAM EFFORT SO THAT THE MISSION CAME TO A TRIUMPHANT CONCLUSION.'

CHARISMA...

ALTHOUGH DIFFICULT TO ASSESS, LEADERSHIP POTENTIAL OF THE KIND TYPICALLY FOUND IN SUBMARINE CREWS QUITE LIKELY HAS COMPONENTS ORIGINATING BOTH FROM NATURE AND NURTURE.

WHATEVER THEIR SOURCE, THESE PERSONAL QUALITIES APPEAR TO BE ESSENTIAL FOR THE MAINTENANCE OF SUBMARINE CREW EFFECTIVENESS DURING LONG SUBMERGED MISSIONS. ""

Weybrew, B. (1971) NSMRL Report No. 686



**F O C A L   I N T E R V E N T I O N   P O I N T S**

- I    P R E - S E L E C T I O N   /   P O S T - S E L E C T I O N**
- A.   F O R M A L   P S Y C H O L O G I C A L   T E S T I N G   A N D  
     E V A L U A T I O N**
- B.   E V A L U A T I O N   B Y   I N V I T R O   S I M U L A T I O N**
- C.   F O R M A L   P E E R   E V A L U A T I O N**

**I D E A L L Y   F A M I L Y   A N D   S I G N I F I C A N T   O T H E R S   S H O U L D  
B E   I N C L U D E D   I N   P R E - S E L E C T I O N   E V A L U A T I O N .**

III FOCUS ON SUBMARINE ENVIRONMENT

OR

MAN-MACHINE SYSTEM

1. REEXAMINE AND CHANGE AS INDICATED

A. DEPLOYMENT SCHEDULES

AND/OR

2. IMPROVE METHODS OF COPING WITH DEPLOYMENT  
AND/OR ENVIRONMENT VIA SPECIFIC TRAINING

A. BIOFEEDBACK

B. HYPNOTHERAPY

C. ASSERTIVENESS TRAINING

D. LEADERSHIP AND MANAGEMENT TRAINING

E. STRESS MANAGEMENT

3. IMPROVE LEADERSHIP

A. INCREASE SENSITIVITY TO "MAN" SIDE  
OF MAN-MACHINE SYSTEM

II INCREASE FAMILY SUPPORT

1. FORMAL ORIENTATION TO DUTIES OF  
SERVICE MEMBER
2. DEVELOPMENT OF INCREASED SUPPORT FOR FAMILY  
I.E. RESETTLEMENT OF COMMAND UNITS
3. DEVELOPMENT OF MECHANISMS FOR UNIFYING,  
EDUCATING, AND SUPPORTING FAMILIES.  
I.E. MULTIPLE FAMILY GROUPS  
GOALS: EDUCATION  
VENTILATION OF FEARS AND  
WORRIES  
SUPPORT

"...THE FIRST ESSENTIAL OF A SUCCESSFUL MILITARY  
LEADER IS TO BE ABLE TO UNDERSTAND AND COMPREHEND  
THE EMOTIONS AND THE SPIRIT WHICH LIVE IN THE  
HEARTS AND SOULS OF THE MEN HE COMMANDS."

Major General John A. LeJeune, USMC

MATRIX OF FUTURE CHANGE

probability

state of nature		
	gradual change	rapidly discontinuous change
course of action		
linear and sequential	succeed	fail
holistic and intuitive	succeed	succeed



PROMETHEUS AND SYSSYPHUS VS. ORPHEUS AND NARCISSUS