

1

FTD-ID(RS)T-0327-91

AD-A238 929



# FOREIGN TECHNOLOGY DIVISION



LAUNCH PREPARATION AND ROCKET LAUNCHING

by

B.P. Voronin, N.A. Stolyarov

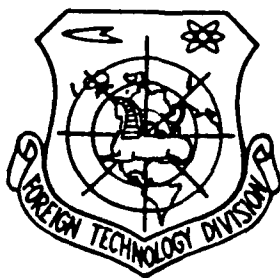

Approved for public release;  
Distribution unlimited.

91-06361



91 7 29 053

# PARTIALLY EDITED MACHINE TRANSLATION

FTD-ID(RS)T-0327-91

23 May 1991

MICROFICHE NR: FTD-91-C-000370

LAUNCH PREPARATION AND ROCKET LAUNCHING

By: B.P. Voronin, N.A. Stolyarov

English pages: 181

Source: Podgotovka K Pusku i Pusk Raket, Voyennoye, Moscow, 1972, pp. 1-107

Country of origin: USSR

This document is a machine translation.

Input by: Jennifer M. Langford, Laura M. Matthews, Amy B. Pennington, Young H. Perry

Merged by: Nancy L. Burns

Requester: DIA/RTS2A2 ILL Gwen Estep

Approved for public release; Distribution unlimited.



SEARCHED

SERIALIZED

INDEXED

FILED

MAY 23 1991

FBI - WASHINGTON

A-1

<p>THIS TRANSLATION IS A RENDITION OF THE ORIGINAL FOREIGN TEXT WITHOUT ANY ANALYTICAL OR EDITORIAL COMMENT STATEMENTS OR THEORIES ADVOCATED OR IMPLIED ARE THOSE OF THE SOURCE AND DO NOT NECESSARILY REFLECT THE POSITION OR OPINION OF THE FOREIGN TECHNOLOGY DIVISION</p>	<p>PREPARED BY</p> <p>TRANSLATION DIVISION FOREIGN TECHNOLOGY DIVISION WPAFB OHIO</p>
---	---

TABLE OF CONTENTS

U.S. Board on Geographic Names Transliteration System .....	ii
Introduction .....	3
Chapter 1. Preparation of Missiles for Launching on a Technical Site .....	5
Chapter 2. Missile Preparation for Launching at Launch Site .....	37
Chapter 3. Vertical Rocket Launching .....	94
Chapter 4. Inclined Rocket Launching .....	131
References .....	181

## U. S. BOARD ON GEOGRAPHIC NAMES TRANSLITERATION SYSTEM

Block	Italic	Transliteration	Block	Italic	Transliteration
А а	<i>А а</i>	A, a	Р р	<i>Р р</i>	R, r
Б б	<i>Б б</i>	B, b	С с	<i>С с</i>	S, s
В в	<i>В в</i>	V, v	Т т	<i>Т т</i>	T, t
Г г	<i>Г г</i>	G, g	У у	<i>У у</i>	U, u
Д д	<i>Д д</i>	D, d	Ф ф	<i>Ф ф</i>	F, f
Е е	<i>Е е</i>	Ye, ye; E, e*	Х х	<i>Х х</i>	Kh, kh
Ж ж	<i>Ж ж</i>	Zh, zh	Ц ц	<i>Ц ц</i>	Ts, ts
З э	<i>З э</i>	Z, z	Ч ч	<i>Ч ч</i>	Ch, ch
И и	<i>И и</i>	I, i	Ш ш	<i>Ш ш</i>	Sh, sh
Й й	<i>Й й</i>	Y, y	Щ щ	<i>Щ щ</i>	Shch, shch
К к	<i>К к</i>	K, k	Ъ ъ	<i>Ъ ъ</i>	"
Л л	<i>Л л</i>	L, l	Ы ы	<i>Ы ы</i>	Y, y
М м	<i>М м</i>	M, m	Ь ь	<i>Ь ь</i>	'
Н н	<i>Н н</i>	N, n	Э э	<i>Э э</i>	E, e
О о	<i>О о</i>	O, o	Ю ю	<i>Ю ю</i>	Yu, yu
П п	<i>П п</i>	P, p	Я я	<i>Я я</i>	Ya, ya

\*ye initially, after vowels, and after ъ, ь; e elsewhere.  
When written as ѣ in Russian, transliterate as yě or ě.

### RUSSIAN AND ENGLISH TRIGONOMETRIC FUNCTIONS

Russian	English	Russian	English	Russian	English
sin	sin	sh	sinh	arc sh	$\sinh^{-1}$
cos	cos	ch	cosh	arc ch	$\cosh^{-1}$
tg	tan	th	tanh	arc th	$\tanh^{-1}$
ctg	cot	cth	coth	arc cth	$\coth^{-1}$
sec	sec	sch	sech	arc sch	$\operatorname{sech}^{-1}$
cosec	csc	csch	csch	arc csch	$\operatorname{csch}^{-1}$

Russian      English

rot          curl  
lg            log

### GRAPHICS DISCLAIMER

All figures, graphics, tables, equations, etc.  
merged into this translation were extracted  
from the best quality copy available.

Page 1.

LAUNCH PREPARATION AND ROCKET LAUNCHING.

B. P. Voronin, N. A. Stolyarov.

Page 2.

Military publishing house continues to publish a series of pamphlets "Rocket Engineering", which is designed for soldiers and sergeants, the cadets of military schools, and also a wide circle of readers who are interested in rocket technology.

In the pamphlet in popular form are presented questions on missile preparation for launching (transportation to place of launch, checking of the rocket, installation to position for launching, servicing) and launching. The systems and units which participate in launch preparation and rocket launching are examined.

The pamphlet with the use of materials of open Soviet and foreign press is written.

Page 3.

#### INTRODUCTION.

Armed forces of the Soviet Union, ready in any minute to give destructive resistance to imperialistic aggressors, are a powerful stronghold of peace and security of the people.

Strategic rocket forces, troops of the air defense of country, Air Force, Navy and ground forces are equipped with the most ideal technology, contemporary weaponry, including nuclear rocket.

Rocket forces by their powerful nuclear strikes are capable of inflicting decisive damage to enemy and creating a basic turning point in course of combat operations.

Soviet people are deservedly proud of its combat rocket engineering, created by genius of our scientists and engineers and serving as a reliable stronghold to the cause of peace and safety on earth.

Scientific-technical progress of our country contributes to continuous development of rocket weaponry.

Contemporary rocket is an elaborate set of technical equipment, which includes a system of control, safeguards, electrical equipment,

means of communication, etc.

Correct functioning of systems is possible only in such a case when all devices, incorporated in them, work smoothly. Therefore, missile preparation for the launching is a complex problem, on the quality of execution of which the success of rocket launching depends.

Degree of perfection of operation of missile preparation for launching in many respects determines combat readiness of missile complexes. The application of means of automation and mechanization in operations of missile preparation and their further improvement made it possible to reduce the readiness time of rockets for launching and the number of service personnel.

Page 4.

CPSU [Communist Party of the Soviet Union], Soviet government take all measures for the further increase in combat readiness of troops. This is a reliable guarantee of the independence and the safety of our native land and countries of socialist camp.

In the proposed pamphlet, utilizing foreign sources and open domestic publications, in popular form questions of launch preparation and rocket launching of different purpose are examined.



Page 5.

CHAPTER 1.

PREPARATION OF MISSILES FOR LAUNCHING ON A TECHNICAL SITE.

Preparation of missiles for launching, which are located in conditions of storage or which enter from manufacturing plants, is accomplished with the aid of ground equipment located on technical and launching sites, and includes in itself different operations on assembly, checking, transportation, equipment, installation, servicing, aiming and conducting prelaunch missile preparation.

This equipment depending on purpose can be classified as lifting-transporting, overload, adjusting, servicing, control-experimental, electric power and launching.

For guaranteeing fire-prevention safety, the conducting of neutralizing and washing operations, the ground equipment includes auxiliary equipment, which is composed of mobile and fixed systems of fire extinguishing, neutralizing washing vehicles, air preheaters and other equipment.

Equipment, with the aid of which there are provided the reception, storage, assembly, technical maintenance, examination, and in certain cases also the servicing of rockets, is called technical, but territory with equipment located on it is the maintenance area.

On the maintenance area are located the storage of rockets and completing elements, building of assembly, compressor station, electric power substation, point of checking rockets and other auxiliary official locations.

Page 6.

Constructions and sites of maintenance area are located in specific sequence, which ensures accomplishing technological operations during missile preparation.

Maintenance area can be fulfilled in stationary or mobile version and be intended for servicing several launching sites.

Rockets and their parts which have arrived from supply bases can be contained in maintenance area in conditions of prolonged storage or in conditions of intermediate readiness.

In conditions of prolonged storage the rocket and completing parts are contained in factory containers.

In conditions of intermediate readiness rocket is assembled and can be located in buildings on mechanized shelves or in open area under covers.

Combat work on missile preparation for launching begins from its

assembly and it is carried out in several areas with enlistment of necessary technological equipment.

After checking of onboard equipment, assembled rocket leaves for launching site.

#### 1. ASSEMBLY OF ROCKETS.

From storage facilities or from manufacturing plants the rocket usually acts as individual parts, in a special hermetically sealed container. Tactical missiles, as a rule, arrive in the assembled form. As far as overall large and heavy strategic missiles are concerned, they are supplied to the place of start in the form of separate stages or even sections.

Combat work on missile preparation for launching begins with extraction of its parts from container and their loading to movable technological stands for assembly. Rockets are collected in special areas or buildings which have the necessary equipment. The assembly of the rockets, which start from the shaft, is produced with the load of rocket into the shaft.

Before assembly of rocket its separate stages are checked.

Depending on design of rocket assembly can be accomplished in a horizontal or vertical position.

Page 7.

Horizontal assembly received the greatest propagation, but horizontal assembly is not always acceptable for powerful rockets, since there appear definite difficulties during the installation of such rockets to the vertical position. Furthermore, the rocket installed to the vertical position must be tested, since ascent of rocket can be the reason for the appearance of malfunction.

Horizontal assembly of stages of powerful rockets is conducted on assembly-mating carriages or erecting fixture with the aid of cranes and longitudinal traverses.

An example of horizontal assembly can be the assembly of the rocket "Minuteman". Each stage of rocket is placed on the carriages, which facilitate the overload, servicing and mating of the stages. With the aid of these carriages the stages of rocket are rolled onto a special five-axle platform, on which occurs the assembly of rocket with the aid of assembly-mating equipment (Fig. 1.1).

Mechanism of equipment provides movement of stages of rocket both in longitudinal and in transverse direction during simultaneous rotation around longitudinal axis. A precise coincidence of mating points of rocket is reached thus.

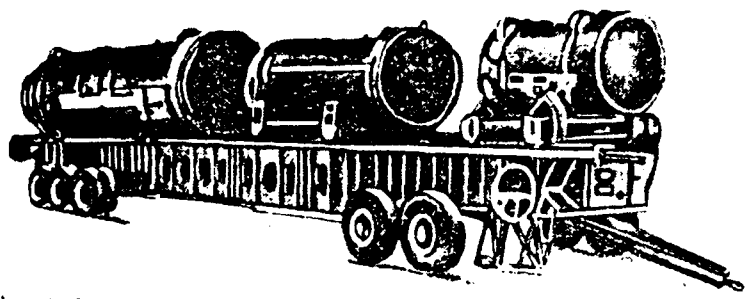

Fig. 1.1. Five-axle platform for assembly of intercontinental ballistic missile "Minuteman".

Page 8.

Mating of warhead of powerful rockets at the maintenance area, as a rule, does not occur. This is caused by the specific special features of transportation, storage and preparation of warhead. Warhead will be joined with the rocket on the launching site.

They conduct vertical assembly with application of bridge cranes. Access to the hatches of the stages of rockets in this case is provided by the servicing units, which have extensible sites and also create a number of tiers of circular servicing.

Fig. 1.2 shows vertical assembly of rocket "Saturn-5" in assembly-testing housing. The stages of rocket enter the low part of the building of the vertical assembly, where they are checked and tested.

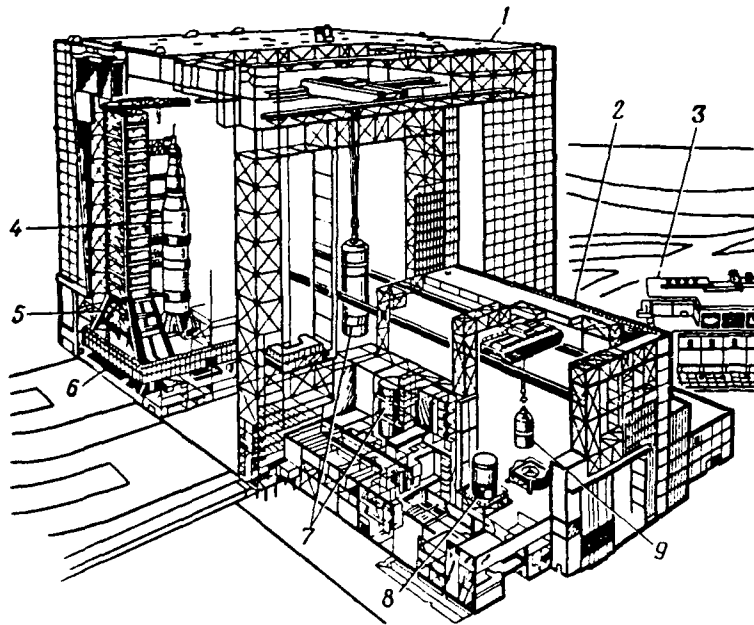

Fig. 1.2. Assignment of vertical assembly of rockets: 1 - high-altitude part; 2 - low span; 3 - building of control center; 4 - assembled carrier rocket; 5 - cable-servicing tower; 6 - crawler transporter; 7 - second stages of rocket (one is located in process of checking, another is transferred by crane); 9 - nose section.

Page 9.

After checking the stages of rocket with the aid of bridge cranes and lifting and handling devices are transferred into the high-altitude part of the building, which has several boxes for vertical assembly.

Assembly is accomplished by consecutive mating of stages or missile bays with the aid of docking-assembly equipment. It should be noted that rockets with solid fuel engines are collected completely in the maintenance area. In this case in the maintenance area several assembly lines are created.

## 2. CHECKING ROCKETS.

Checking rocket is accomplished with the aid of monitoring-measuring equipment (KIA). Composition of the KIA and volume of tests at the technical and launching sites can sharply differ. The more complete checkings of units and systems of rocket are conducted in the maintenance area. At the launching position during the determination of rocket in readiness for launching is produced in essence the qualitative checking of rocket according to the principle "operably - defectively" ("yes - no").

All conducted with rocket tests are made autonomous and complex.

Autonomous tests - checking separate systems, assemblies, and units of rocket according to expanded program out of connection of



these devices with each other.

Complex tests - totality of operations, conducted for purpose of checking correctness of functioning of all systems of rocket in interconnection (complex).

If during autonomous tests is checked proper working order only of separate systems and assemblies, then during complex tests are checked all elements, which ensure functional connections between systems, i.e., are checked elements of onboard electrical equipment: switchgear, power sources, onboard cable system. The imitation of prelaunch servicing procedure, launching and rocket flight is carried out during the complex checkings with the aid of the imitation equipment. The target of checkings is the determination of the conformity of the technical characteristics and parameters of systems to desired values.

Page 10.

In this case is produced both qualitative and quantitative evaluation of parameters.

Quantitative estimation of parameters makes it possible to produce control and replacement of blocks and units. The volume of tests, periodicity and composition of monitoring-measuring equipment depend on the conditions of the content of rocket and degree of its combat readiness in the conditions of storage.

Checking can be automatic, semiautomatic and manual (visual).

Automatic check is conducted without operator interference according to program placed into equipment it also provides large gain in time, eliminates subjective nature of evaluation of parameters, decreases quantity of operators, gives possibility of recording results of checking with automatic detection of place of malfunction.

Equipment of manual check is carried out in the form of separate panels with control panels, instruments, indicators and switches of ultimate purpose.

Each of these panels is intended for checking of specific block or system of onboard equipment. Via sending in specific routine and supplying test signals onboard the rocket by readings of measuring instruments and light signal panel is determined working order of the checked block or assembly. The application of systems of manual check requires high expenditures of time, labor of highly skilled specialists and does not provide objective check and rapid search for malfunctions.

Complexity of onboard systems, continuously increasing enumeration of controlled parameters, tendency to reduce time of check to minimum and to decrease expenditures for operation lead to need of using universal automated experimental complex (AIK).

Block diagram of one of possible versions of this universal AIK, which makes it possible to test several types of rockets, is given in Fig. 1.3.

AIK unites in itself devices of perception of information, a device for accomplishing operations of measurement, processing and storing information.

Page 11.

Requirements for AIK by the best form are achieved during its construction on base of control computer (UVM), which has multipurpose purpose.

Basic coupling elements of control system with test equipment are sensors. By sensor usually is understood device, which provides perception and conversion of the inspected parameters into the form of electrical signals, and also the parameters, which have nonelectric nature, into electrical signals of the corresponding form, convenient for measurement.

Practical application finds large quantity of diverse sensors the work of which is based on use of most varied physical phenomena. Depending on form of input value are distinguished the sensors of linear and angular transfer, speed and acceleration, the temperature-sensing devices, pressure, humidity, etc.

Into system of check can be introduced both common sensors and sensors of tolerance check, which provide a check of limits of change in inspected parameter and which put out signal while leaving it beyond permissible limits.

All switchings, necessary during checking and connected with transmission of control signals onboard and interrogation of sensors, are produced with the aid of relay and semiconductor switchboards, which work on signals of program control unit according to specific program or cyclically.

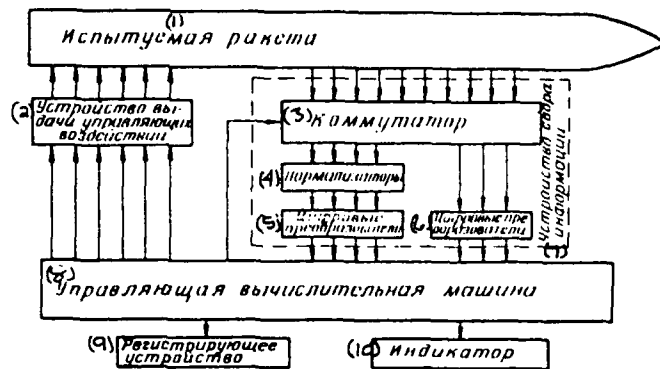

Fig. 1.3. Block diagram of automatic system of check on base TsVM [ЦВМ - digital computer].

Key: (1). Test rocket. (2). Device for transmission of controllers of effects. (3). Switch. (4). Normalizers. (5). Digitizer. (6) Digitizer. (7). Equipment of collection of information. (8). Control computer. (9). Recording equipment. (10). Indicator.

Page 12.

Central unit of UVM is program control unit, intended for transmitting program of check, written with program carrier (punched tape, punched card, magnetic tape), and its distributions between separate devices of UVM. The presence of an interchangeable program of check makes it possible to utilize one and the same installation for checking different rockets. The control panel and control, operated by operator, include the controls of the manual control, which ensure switching on and disconnection of AIK, its bringing into the initial state, the selection of operating mode. If the parameter is within the limits of the field of tolerance, then the result of comparison is registered in storage cell for this parameter and simultaneously is recorded with paper tape. Simultaneously is issued the command for authorization of the continuation of checking into the program unit. In the case of deviating the parameter beyond the limits of allowance the signals are supplied to operator and further checking stops. The inclusion of the program of the search for malfunctions occurs. After checking of a specific group of parameters accurately is established the reason for malfunction and on the indicator is indicated the place of damage. AIK makes it possible to carry out testings of rockets in several minutes.

Abroad to development and creation of automatic equipment for checking state of rockets is given important value. According to data of foreign press, for checking such rockets as "Minuteman", "Polaris", "Titan" and, etc. wide application find automatic installations on the

base of digital computer technology. With their aid accomplishing entire complex of pre-start tests occupies less than one minute, after conducting all checking and obtaining the positive results the rocket leaves for the launching position.

### 3. TRANSPORTION OF ROCKETS.

Transportion of rockets and special loads of rocket armament is accomplished by their delivery from manufacturing plants to arsenals, warehouses, and stations for the supply of position areas with parts.

Page 13.

Furthermore, transportation of rockets is produced in limits of arrangement of missile complex with shipment of rocket from engineering to launching site, during completion of maneuver, redislocation of areas of arrangement of complex.

Transportation of rockets is connected with definite difficulties, caused by comparatively large overall size and weight of rocket, by stringent requirements for permissible shock, bending and vibration loads of onboard equipment, by requirement, in a number of cases, of thermostatic control of both nose section and entire rocket as a whole.

All these special features of rocket as a transport load must be considered during selection of means of transportation. In the

general case the application of one or the other transportation means is determined by the type of missile complex, by the distance of transportation, by the presence and the state of roads, airfields, helicopter sites.

Foreign experience of operating rocket weapon shows that, as a rule, transportation means for rockets are developed in rare cases specially and only uses means of transportation from number of those produced for needs of industry with their subsequent conversion.

Tendency of non-application of commercial transport samples in favor of special is caused by requirement of their high mobility, maneuverability, trafficability, high operational reliability with minimum dimensions and weight. For transportation of rockets are employed highway, railroad, air and water forms of transport.

For purpose of lessening time and force during work of loading-unloading, protection of rocket from external effects of environment, vibrations and impacts during transportation in army of USA widely are used containers. As an example can serve the transportation of rockets "Polaris", "Minuteman", "Saturn", etc.



Impact loads during transportation in containers do not exceed 3 g.

For transportation of warheads and blocks of guidance system highly sensitive to vibration, impact loads and temperature changes use special containers. Thus, for the transportation of the inertial guidance system of rocket "Polaris" is utilized the container, equipped with a system of thermostatic control.

Constructed containers can be utilized during transportation by all forms of transport, and also used as adapters during loading discharging operations and installation to launching system.

For transportation of rockets and their elements along highways wide application find most diverse transport means: towed carriages, wheel and crawler transporters, self-propelled launchers, transport-transfer and transport-docking assemblies.

Means of highway transport are divided into those towed and self-propelled. The towed carriages can be fulfilled in the form of trailers or semitrailers. Semitrailer is linked with the tow car with the aid of a supporting-coupling device and transfers the part of its weight and rocket to the undercarriage of the tow car. During the use of semitrailer transport means the length of train obtained is smaller than for trailer tractor-trailer units, which raises its maneuverability. Furthermore, they have large lateral stability from the tilting.

Fig. 1.4 shows transportation of rocket "Atlas" on semitrailer. With the aid of this semitrailer is provided the loading and unloading of rocket during transportation by its aircraft.

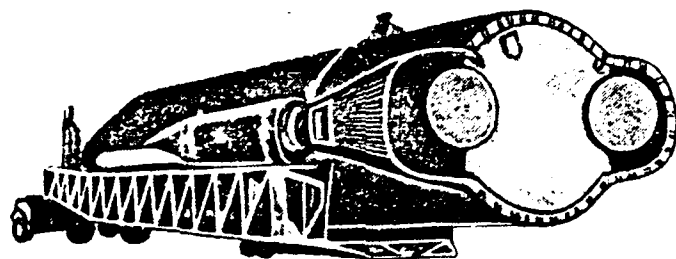

Fig. 1.4. Transportation of rocket "Atlas" on semitrailer.

Page 15.

For transportation of antimissile missile "Sprint" is utilized special transporter (Fig. 1.5.), which has cylindrical container with conditioning system. The vertical position of container with the rocket is the special feature of this transportation. The same transporter is utilized also during the installation of rocket into the silo launch system.

As the tractor for transportation of rockets on trailers and semitrailers are utilized, as a rule, existing army vehicles, respectively finished.

Large dimensions of transport carriages depress maneuvering possibilities of tractor-trailer unit. Therefore carriages are made with rotary rear tread.

According to purpose carriages are divided into transport, transport-lifting, transport-docking and transport-transfer.

Self-propelled means of transportation are more compact in comparison with those towed, since rocket is fastened immediately on chassis of vehicle, which contributes to increase in maneuverability and trafficability.

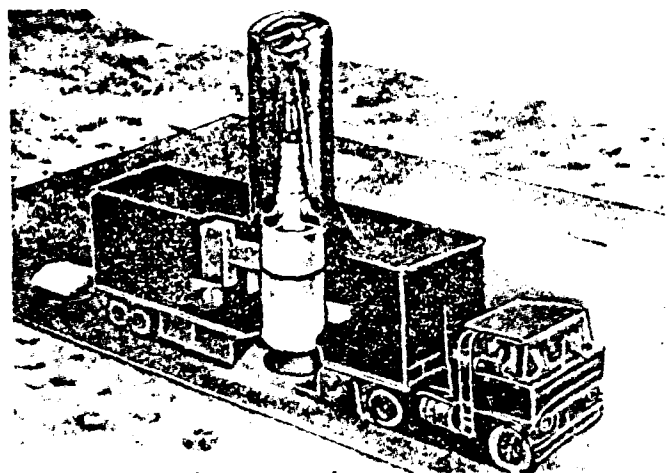

Fig. 1.5. Transportation of rocket "Sprint".

Page 16.

According to type of running part self-propelled means of transportation are subdivided into wheel and crawler. Crawler have large trafficability, but they are inferior to wheel in speed of movement and reliability.

However, self-propelled transportation means have limited load capacity, determined for wheel assemblies by permissible axle weight. A good state of roads and the reliable construction of the highway means of transport make it possible to transport rockets with a speed of up to 80 km/h.

For obtaining of larger load capacity and high trafficability in powerful tow cars and heavy duty transporters each wheel is supplied with direct-motor drive, which contributes to more effective use of power of engine. As the example to this construction can serve the tractor-trailer unit, which consists of their 13 trailer assemblies by general load capacity 150 t and having length 175 m. Each of 54 wheels of tractor-trailer unit with diameter on 3 m has direct-motor drive. Tractor-trailer unit possesses high trafficability.

Transportation along highways up to large distances has size and weight limitations. Especially difficulties appear during the transportation of solid-fuel engines for the heavy rockets. All these facts, and also limited capabilities of transport equipment are one of the reasons for the low propagation in the USA of the transportation

of heavy rockets along the highways. Therefore highway transportation means are used during transportation up to comparatively small distances, which do not exceed several hundred kilometers. In the USA MBR and heavy rocket carriers to distant distances are transported predominantly on air or water. The basic means of the transportation of rockets and their elements by air are aircraft, helicopters. In the foreign press it is reported that the projects of use for the same targets of dirigibles, balloons. However, transportation by air places specific limitations to the dimensions and the weight of the transported rockets.

Aircraft of USAF [ BBC CIAA - United States Air force] are capable of transporting rocket or its stages with weight not of more than 45 t and with diameter not of more than 3 m (Fig. 1.6).

Page 17.

For transportation of large in dimension and cargo weight it is necessary to considerably reconstruct aircraft or to fasten rockets to outside of cargo hold.

At present rockets "Minuteman" in assembled form are transported by aircraft "C-133b" and "C-141". Rockets in the special container load into the aircraft by the method of rolling. For accomplishing this operation special loading-unloading equipment is used.

To USA are conducted works on conversion of some transport

aircraft for purpose of their adaptation for delivery of separate stages of heavy carrier rockets. Thus, was investigated the possibility of the transportation of the heavy stages of rockets, attached above the wing of aircraft.

For guaranteeing possibility of loading stage S-4 of rocket "Saturn" into aircraft "Boeing-377" it underwent considerable conversion. In this aircraft was increased the diameter of fuselage more than twice, and the volume of cargo hold approximately three times.

During loading of rocket into aircraft "Boeing-377" it is divided into the leading and tail sections, which after loading are bolted together.

Some firms in USA investigate possibility of applying dirigibles for transportation of heavy rockets from assembly plants to launching site (Fig. 1.7).

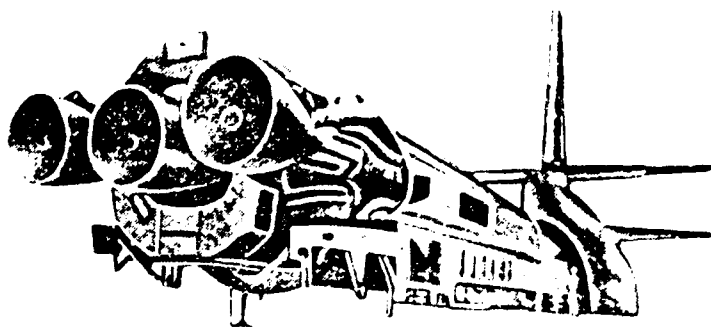

Fig. 1.6. Loading rocket into aircraft (USA).

Page 18.

In this case is indicated a yard of advantages of their application in comparison with aircraft: the possibility of freight handling of considerably larger dimensions and weight, the necessity of a not large and simply equipped landing field. Important advantage is the possibility of transportation virtually to unlimited distances with g-forces, which do not exceed 0.5 g.

Dirigibles existing in USA make it possible to transport loads with diameter to 7.6 m, length 24.3 m and with weight to 15 t. One of the firms proposed the plan of building jet all-weather dirigible with load capacity 113.4 t with the flight speed 160 km/h (length of dirigible 173 m with diameter 54 m).

Is planned building also lighter dirigibles with housings, covered with gastight fabric.

In press of USA is reported about project of giant towed glider/airframe for transportation of heavy rockets up to distance of 2200 km (without refueling of tug). It is proposed to utilize transport airplane "C-133" for towing.

For transportation of heavy rockets, and also their launching American specialists propose project of application of balloon of toroidal form (Fig. 1.8).



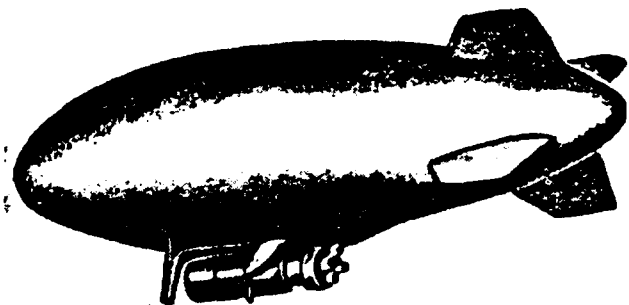

Fig. 1.7. Transportation of stage S-4 of carrier rocket "Saturn-1" on a dirigible.

Page 19.

Aerostatic lift will be created by gaseous envelope, and movement in the necessary direction - with the aid of three engines, hung from the cardan devices in the lower part the balloon. Engines can be turned along the azimuth and along the angle of elevation  $\pm 40^\circ$ , thanks to which control of the motion of balloon is achieved.

In the opinion of specialists of USA, balloon will be able to transport rocket "Minuteman" with average speed of 121.5 km/h at altitude upto 6000 m. From below to balloon envelope with the aid of aluminum tubes fastens the container for the rocket, which makes it possible to transport loads with weight to 45 t. Container with the rocket installed in it is closed hermetically. For the installation of rocket the balloon scaffolds at height 30-60 m, after which the rocket is winched and they draw in container.

For delivery of rockets by railroad transport are used wagons and platforms both specially fulfilled and common after appropriate conversion.

In special railroad wagons rocket is shielded from atmospheric effects, and shock absorption system eliminates g-forces than higher permitted.

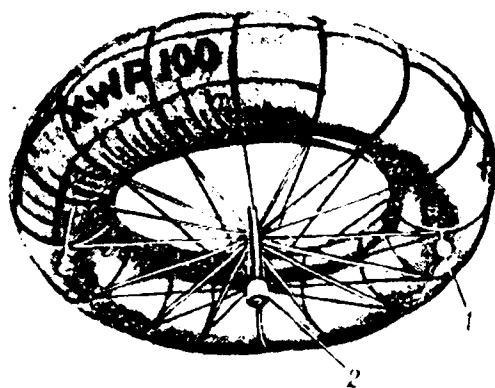

Fig. 1.8. Balloon for transportation of MBR "Minuteman" (drawing): 1 - balloon; 2 - rocket.

Page 20.

Thus, for the protection from the axial g-forces the mechanisms of the auto-link of cars have special shock-absorbing attachments; inflatable air cushions are utilized as shock absorbers for the rockets.

After loading of rocket into railroad car onto rubber pads, attached at fixed points of missile body, air is injected. With the transportation of rocket in this suspended state it experiences only insignificant contact pressure, which is distributed over the surface. The application of this shock-absorbing system makes it possible to transport rockets up to considerable distances without the fear of its coming out of the structure due to the effect of vibration and impact loads.

Size limitations, placed on transported rockets or its stages, are shortcoming in transportation along railroads. Thus, the railroads of the USA make it possible to transport rockets to a diameter, which does not exceed 4.2 m. For eliminating this shortcoming the design of the building of a transcontinental road with a wider gauge and not having a limitation on the height was proposed.

Transportation of rockets on iron roads for great distances did not receive in USA wide acceptance. The basic reasons for this are the developed network of highways and the wide application of transportation of rockets by air and water.

Transportation of rockets by water received in USA wide distribution, to what to no small degree contributed presence of waterways and their successful arrangement. Weight and size limitations to the transported load virtually are absent during transportation by water. In this case the rocket experiences low g-forces. Especially advisable is the application of this method, if the diameter of the transported stages of rockets exceeds 4 m, and weight 360 t. However, the duration of the transportation of rocket on the water is calculated by days and even weeks.

In USA for transportation of stages of heavy carrier rockets are used most frequently self-propelled and towed barges. As an example of this can serve the transportation of the stages of rocket "Saturn" (stage is rolled to the barge together with a ground carriage or it is loaded with the aid of cranes).

Page 21.

In the USA is conducted extensive research work on use of water surface for transportation. Thus, project "Hydra" provides for the transportation of rocket into the area of launching, its installation to the vertical position on water and launching. Is noted comparative simplicity and reliability of conducting given operations and their perspective.

Tendency of continuous increase in weight and dimensions of newly constructed rockets, increased sensitivity of their instruments to

vibration and to impact loads create complex problem of transportation of rockets. Therefore further improvement of means and methods of transportation is considered a task of paramount importance.

Page 22.

CHAPTER 2.

MISSILE PREPARATION FOR LAUNCHING AT LAUNCH SITE.

Launch site includes complex of technological equipment and constructions, which ensure installation of rocket to launching system, testing, servicing, guidance and launching. In certain cases at the launch site the vertical assembly of rocket on the launching system is performed.

Equipment, located at launch site, can be movable or stationary, by which is determined number of constructed buildings on it.

At launch site are placed launchers, control center, buildings with facilities for storage and servicing of rockets with propellant components and compressed gases, neutralization equipment, transformer substation and diesel electric power plant, means of fire extinguishing, siding tracks.

Division of operations of missile preparation for launching, conducted at technical and launch sites, is somewhat conditional. In practice these questions are solved differently, depending on purpose and design of rockets.

Preparation of rockets of different types has its characteristic

features. Therefore it is expedient to examine general questions of preparation of rockets.

Page 23.

## 1. INSTALLATION OF ROCKETS.

Installation of rockets to launchers is produced with the aid of adjusting equipment, in which are included different special machines, called depending on their purpose by fitters, transporter-erector assemblies (transporter-erectors) and transport-loading machines. Transporter-erector assemblies and transport-loading machines accomplish not only the installation of rockets to the firing position, but also their delivery to the launch site.

Installation of rockets to launcher is accomplished in essence by two methods: "hanging out" and by "tilting".

Installation of rockets by method of "hanging out" can be produced with use of gun carriage fitter with lifting boom (Fig. 2.1) or fitter with lifting-rotating boom.

Rocket is placed by crane on boom of fitter and is fastened to it. In the forward section the hinged opened grips, which eliminate shift of rocket in the transverse direction, hold rocket. Fastening of rocket in the rear end is made rigid and does not allow possibility of shifting of rocket in either the transverse or axial direction.



After attachment of rocket to the fitter it is brought to the launcher and will be joined with it.

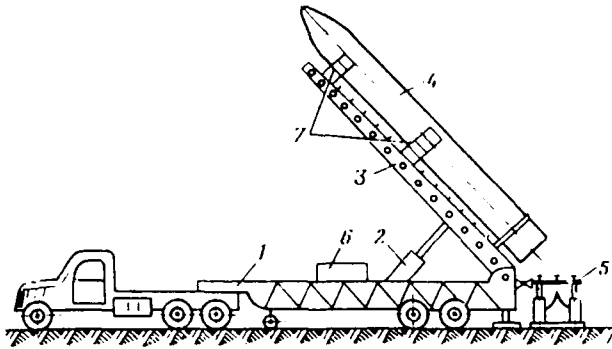

Fig. 2.1. Installation of rocket to launching platform with the aid of lifting boom of fitter; 1 - frame; 2 - hydraulic jack of lifting mechanism of boom; 3 - boom; 4 - rocket; 5 - launching platform; 6 - control panel; 7 - maintenance platform.

Page 24.

Boom of fitter, hinged connected with frame, rises by hydraulic jack to vertical position, and rocket is weighed above launching system.

Approach of supports of rocket with supports of launcher is produced with the help of jacks of the launch platform or movable carriages of the boom of fitter.

After the transfer of the weight of rocket to the launch installation and its attachment the rocket is released from fastening to boom of fitter, and boom is removed from rocket to small angle.

For servicing of rocket during its preparation for launching are

utilized maintenance platforms, mounted on boom. After the carrying out of all works the boom is shifted into the horizontal position, and fitter drives off from the launching platform.

For installation of rockets, having relatively low weight and dimensions, are used self-propelled units with lifting boom. One of similar design is American transporter-erector for the tactical missile "Persian".

Special feature of transporter-erector - launching platform, which is hinge fastened to its frame, and rotary part of platform - to base of first stage. The conversion of platform from mobile into the firing position is accomplished by its rotation around the axis of hinge by an angle, close to  $90^\circ$ . Platform rests on the soil by three stabilizing jacks, which ensure its automatic levelling.

Lift of boom with rocket to vertical position is accomplished by two hydraulic jacks. If during the ascent of rocket is disrupted the levelling launching platform by more than  $6^\circ$ , ascent of rocket automatically ceases and siren is switched on. The ascent of rocket is renewed after repeated levelling. After missile erection and its attachment to the launching platform the boom of rocket returns to the initial horizontal position. Entire process of missile erection and lowerings of boom occupies only 1 min.

Method of "hanging out" is basic mounting method of rockets onto shaft. For this purpose are used also fitters with the lift-guide boom. Boom in this fitter serves not only for missile erection, but also is guide during lowering or ascent of rocket from the shaft. As an example to this design can serve the transporter-erector of rocket "Minuteman" (Fig. 2.), which is universal movable assembly. It provides transportation of rocket, lifting it to the vertical position and lowering into launch shaft.

Fitter is tractor-trailer unit, which consists of four-axis wheel tow car of high trafficability, three-axis semitrailer, container and equipment for lifting container with rocket to vertical position and loading it into shaft.

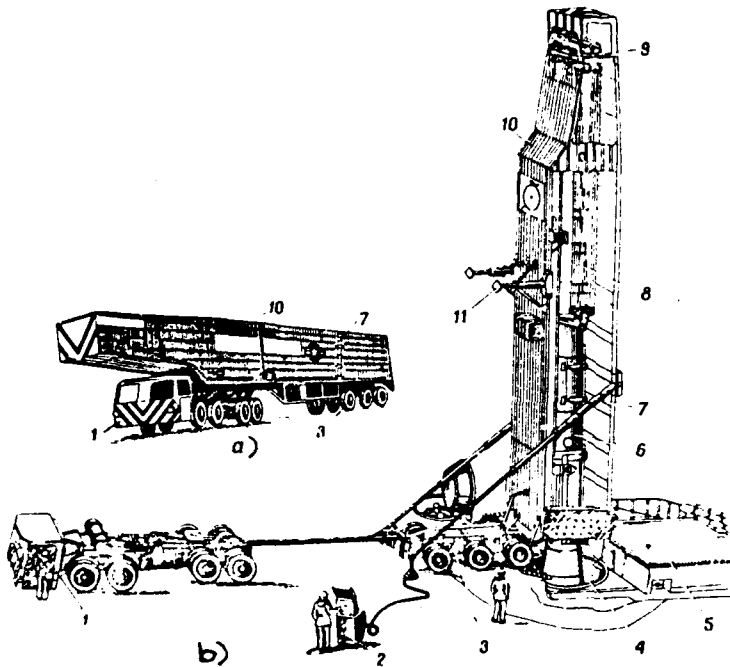

Fig. 2.2. Transporter-erector of rocket "Minuteman": a) general view of fitter in mobile position; b) installation of rocket [ILLEGIBLE] "Minuteman" into silo launch system; 1 - tow car; 2 - control panel; 3 - three-axis semitrailer; 4 - shaft; 5 - shielding roof; 6 - rocket; 7 - hydraulic jack mechanism for lifting of container; 8 - block-and-tackle system; 9 - hoist; 10 - container; 11 - support of container.

Page 26.

Installation of rocket occurs as follows. Fitter is fastened to the edge of shaft, and container is hinged connected with the special brackets of area in shaft. For conversion of rocket into the vertical position are used two telescopic hydraulic jacks, located on both sides of container. The pumps of hydraulic system work from the box

of the power take-off of the power transfer of tow car.

For lift and lowering of rocket serves hoist, built in forward section of container and which consists of winch and block-and-tackle system; four cables of block-and-tackle system with one end fastened to ring of rocket, and other end - to four winch drums. Rocket descends into the silo on a carrier ring and together with it is installed on the rotary ring of launching platform. Fitter provides the submersion depth of rocket of up to 22 m.

Control of lifting mechanisms of container and of lifting mechanisms and lowering of rocket is accomplished from control panel.

If in course of installation of rocket into silo automatic system for control malfunctions, switching on of manual system for control occurs. The total time of installation of rocket into the silo is 55 min.

Advantage of method of "hanging out" considers possibility of applying fitter lifting boom, which has comparatively small dimensions and weight. This is explained by the fact that during the ascent of rocket there is no need for producing compensation for torque, created by the weight of rocket and boom, with torque from the weight of fitter. As other advantages of this type of fitter is considered comparative simplicity of operations on missile erection, high rates of climb in the case of applying the hydraulic drive and high

smoothness of change in rate of climb.

To a number of shortcomings in fitter with lifting boom is carried need for transfer of rocket from transport carriage to boom of fitter, that increases time of missile preparation for launching and creates need for having in content of adjusting equipment a crane.

For installation of rocket by method of "hanging out" can be used mobile wheel cranes with rotating platform and variable boom (Fig. 2.3). A crane of such type is utilized during the installation of rockets "Redstone".

Page 27.

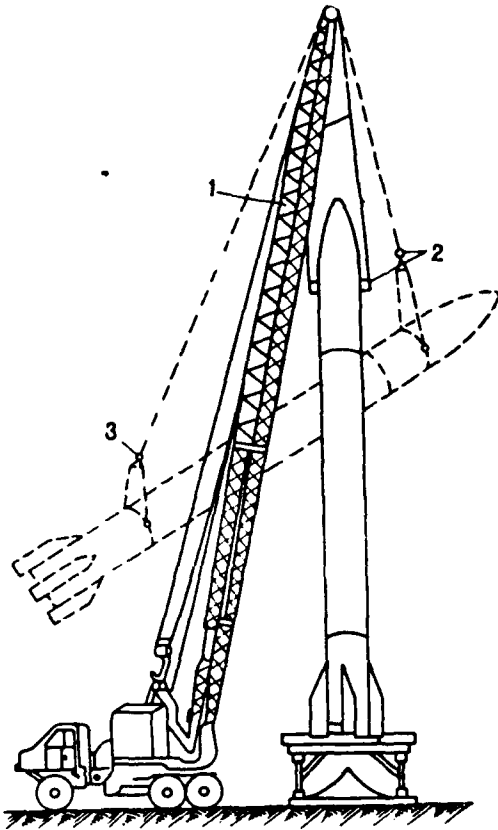

Fig. 2.3. Installation of rocket to launching platform with the aid of crane: 1 - boom; 2 - load-gripping equipment; 3 - supplementary load-gripping equipment.

Page 28.

Rocket on transport carriage arrives at starting position and is installed next to starter and crane. They release the rocket from the fastening to the carriage and with the aid of load-gripping equipment fasten the cables of boom to the nose and tail sections of the rocket.

With start of lifting mechanism of crane they move carriage to starter so that tail section would prove to be above starter. Then,



removing the cable of block-and-tackle system, rocket under its own weight in the vertical position is shifted and installed on the starter.

Method of "hanging out" with application of two-hook cranes is used also during installation of rockets into silo launch devices. Thus, during the installation of rocket "Titan" first stage of rocket with the help of crane is installed vertically on the platform of the hoisting machine of the shaft and descends into it until the upper part of first stage is at ground level. Then to first stage the second (Fig. 2.4) is joined and the assembled stages of rocket descend into the shaft to the level of the upper part of the second stage. Further to the second stage with the aid of the crane is aligned nose cone with the warhead. After connecting of cone the rocket descends into the shaft and is closed by a folding ferro-concrete roof.

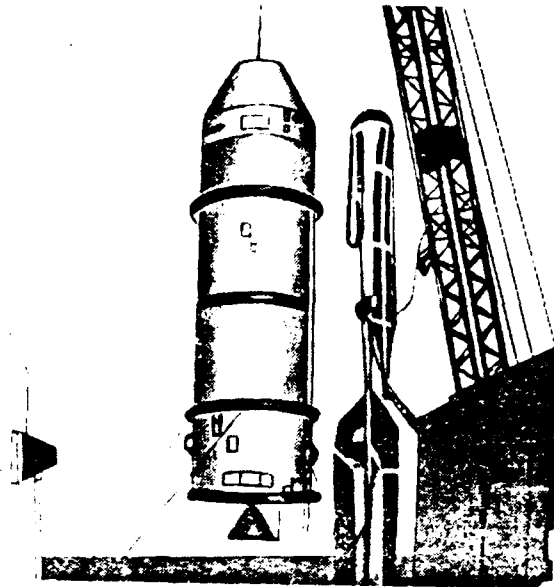

Fig. 2.4. Installation of second stage of rocket "Titan" into shaft.

Page 29.

Control of crane with assembly is accomplished by operator from cabin of crane or remotely. In the latter case the operator can be located in any place near the shaft.

Advantage of method of "hanging out" is possibility of application instead of crane fitter. Furthermore, with this method there is no need for accomplishing a transfer of rocket from transportation means in the process of installation.

Should be related a number of shortcomings: swaying of rocket during installation, large duration and labor expense of working operations, considerable weight of crane, caused by need for having

large load capacity.

Installation of rocket by method of "tilting" requires presence of supporting mast, whose upper part by cables is connected with nose section of rocket. On the other side of the upper part of the frame are connected the cables of the winch, by rotating which occurs the rotation of the rocket, hinge attached on the launching platform. The installation of rocket to the launching platform with the use of a portal fitter is an example of the application of this method (Fig. 2.5).

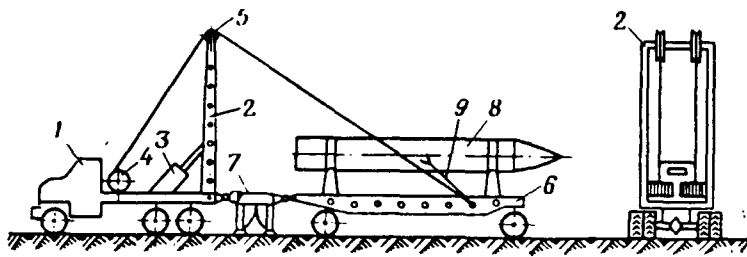

Fig. 2.5. Installation of rocket to launching platform by method of "titlting" with the aid of portal fitter: 1 - tow car; 2 - portal; 3 - hydraulic jack; 4 - lifting mechanism; 5 - block-and-tackle system; 6 - transport carriage; 7 - launching platform; 8 - rocket; 9 - rod.

Page 30.

Portal fitter is fed to launching platform and is joined with it. The portal, which is the supporting frame of cable-block-and-tackle system, is shifted by hydraulic jack to the vertical position.

On the other side of launching platform is attached transport carriage with rocket packed on it.

Removable modules of block-and-tackle system, whose cables are moved across upper blocks of portal, are fastened hinged to trunnion of carriage frame.

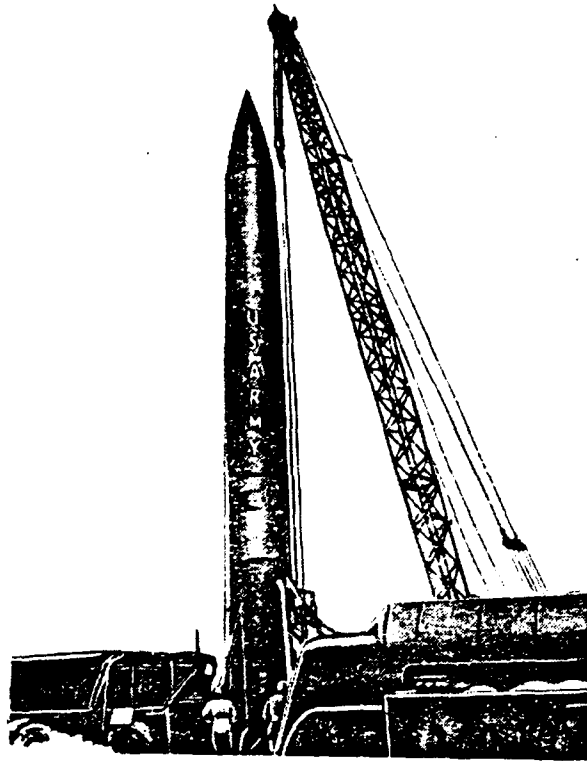

Fig. 2.6. Installation of rocket "Redstone" to vertical position.

Page 31.

Upon start of lifting mechanism cables of block-and-tackle system are wound around drums, and rocket together with carriage frame rises to vertical position. From the tilting of rocket to the portal the system "rocket-carriage" is held by the rod, which goes into the grooves of portal.

After entry of rod into grooves of portal it begins to differ from vertical line by angle, at which rocket with carriage emerges to vertical position.

After attachment of rocket on launching platform it is released from fastening to carriage. Upon switching on of hydraulic jack the portal is shifted in vertical position and rod presses on the carriage and tips it back.

Under its own weight on cables of block-and-tackle system carriage frame descends to horizontal position and connects to tread.

Method of "tilting" finds application also during installation of rocket "Redstone" (Fig. 2.6). Advantage of this installation diagram is the possibility of lifting the large in dimension and weight rockets by the launching platform with comparatively low efforts of hoist. This is achieved due to the high altitude of portal.

To shortcomings in this mounting method should be related large required weight of fitter, necessary for stabilization of ascent of rocket, and considerable time of output of rocket to vertical position.

Diagrams of installation of rockets with use different fitters are very many. The application of one or the other mounting method of rocket to the launching system is determined by the type of missile complex, by the conditions for combat employment.

Thus, for mobile rocket complexes determining is considered time of bringing rocket into vertical position, i.e., initial position for

launching.

For stationary missile complexes with shaft type launchers time of installation of rocket to firing position is not determining. Here paramount role plays the evenness of ascent of rocket to the vertical position and its lowerings into the shaft.

Page 32.

## 2. FUELING BY PROPELLANT COMPONENTS.

Fueling of rockets can take place both on technical and launch sites with use of stationary or mobile fueling equipment. Fueling includes operations for filling of missile tanks with propellant components.

In fuelling equipment are included: refueling assemblies, pump and compressor stations, a reserve, cisterns, equipment of interconnection of separate assemblies of fueling equipment and rocket, system of thermostatic control of fuel and system of remote and automatic control and direction of process of fueling.

Arrangement of assemblies of systems and the very systems of fueling are determined by type of launch site and depend on number of launchers.

Stationary fueling equipment is placed in place of storage of

propellant components or on combat positions. In this case the equipment is located at such a distance from the starters, which provides safety during their emergency starting.

Stationary fueling equipment, as a rule, is located underground and has connection with rocket through fueling connections. Control of operation of fixed systems is accomplished by an automatic or remote system for control.

Depending on form of refueling propellant components the equipment for refueling of oxidizer and fuel is distinguished.

Are distinguished feed systems: pump, by method of extrusion, by gravity and combined.

In pump feed system (Fig. 2.7a) propellant components from storage into missile tanks on manifolds are transferred by pump.

Reservoir-storage is a cistern, intended for method and storing propellant components. On the refueling reservoir are established different sensors, which ensure the control/check of pressure, temperatures, and also liquid level in the cistern.

Page 33.

For initial filling of pump and guarantee of its normal work into the closed space of reservoir on component is produced pressurization



of gas, which creates to mirror of component excessive pressure 0.5-1.5 kg/cm<sup>2</sup>. Then pump is switched on. Propellant components on the partition manifold through the shut-off valve flow to the pump and further through the filling valves of system, the filter and filler equipment into the missile tank. Refueling missile tank occurs through the filling valves of high and low consumption before reaching in the missile tank of a specific level, after which the valve of high consumption is closed and final refueling occurs through the valve of low consumption. The drain of component from all main lines in reservoir-storage of system is produced at the termination of servicing.

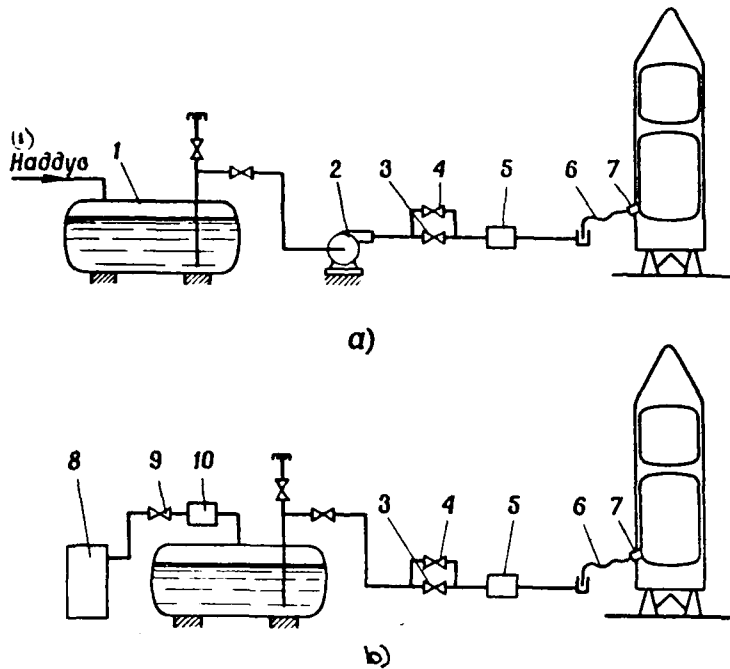

Fig. 2.7. Schematic of refueling rockets: a) by pump feed; b) by supply by extrusion; 1 - reservoir; 2 - pumping station 3 and 4 - valves; 5 - filter; 6 - flexible hose; 7 - filler connection; 8 - source of compressed gas; 9 - reducer; 10 - controlling equipment. Key: (1). Pressurization.

Page 34.

Pump feed system was used for fueling of rockets "Redstone". Fueling was produced with the aid of refueling assemblies, assembled on semitrailers. For guaranteeing prolonged storage with minimum loss of liquid oxygen, oxygen cistern had vacuum thermal insulation.

Another example of application of pump feed system is refueling rocket "Titan-2". Into the assembly of fuelling equipment of this rocket enter fueling reservoirs, equipment for the support of a

specific temperature of fuel, a system of pumps, flow meters. During refueling the supply of liquid oxidizer is provided at a rate of 9400-13600 l/min.

Necessary accuracy of fueling is provided with the aid of a flow-dozer meter, on digit counters of which before refueling is established predetermined volume of fuel. Counters are connected with cutoff valves and control them during the transmittal of dose. Signal to cutoff is supplied taking into account time to the operation of valves.

Temperature sensors of flow-dozer meter make it possible to introduce corrections into digit counter for change of assigned volume of refueled fuel depending on temperature.

In pump feed system in essence are employed centrifugal pumps, since with relatively small sizes they can supply large quantity of fuel at high pressures. The frequency of the rotation of pumps reaches 2000 r/min. For operation of pump a sufficiently powerful energy source is required.

System of refueling with pump feed received wide acceptance. This is explained by the fact that such systems widely are used in the national economy for pumpover of fluid. Pump feed provides pumpover with the required consumption and the necessary pressure.

System of servicing with supply of propellant components by extrusion (Fig. 2.7b) does not contain pumping stations. The necessary pressure for overcoming the line resistance, and also differences of altitude of arrangement of reservoir-storage and missile tanks is reached due to the creation of required excess pressure in the reservoir above the surface of propellant component. For this serves receiver with a reserve of the necessary quantity of compressed gas (air, nitrogen, helium and other gases). The value of excess pressure determines the fuel consumption during the refueling.

Page 35.

Refueling missile tanks is conducted as follows. Compressed gas from the receiver through the reducer, with the aid of which is supported the operating pressure in reservoir-storage assigned, enters into reservoir-storage. Excess pressure is created above the surface of liquid. Under the effect of excess pressure the liquid begins to be displaced from the reservoir and through the filling valves, filler equipment enters missile tank.

Pressure feed system of propellant components makes it possible to obtain considerable speed of refueling. However, this requires an increase in the boost pressure in the system, which in turn raises requirements for the strength of cistern.

Pressurization method is used during refueling of tanks of ballistic missile of average radius of action "Top". The cisterns for

the propellant components are located on both sides from the launching platform on the ground and fueling equipment is assembled. For the creation of the necessary pressure into both cisterns is supplied compressed gaseous nitrogen or helium from the cylinder battery, assembled on the semitrailer. Manifold for supplying of propellant components to the rocket is hung from brackets and is connected with the cistern through the valve box. Connection to the fuel system of rocket is accomplished through the quick-release filler connection. Sections of manifold are connected in such a way that the fueling can be produced, also, during the ascent of rocket. The speed of fueling can exceed 1000 l/min.

After termination of fueling of tanks with propellant components is carried out only additional feeding by liquid oxygen for compensation for losses of oxygen from evaporation. Additional feeding ceases for 2 min until the launching.

System of refueling with supply of propellant by extrusion is inherent number of shortcomings. Thus, for refueling by extrusion the reservoir-storage must have thicker walls in comparison with the same reservoirs of pump systems, since work occurs at higher pressures.

Page 36.

Furthermore, for pressure transfer of propellant components is required a reserve of comparatively large quantity of compressed gas, which requires special equipment for its yield, storage and

transportation. For pressure transfer of 1 m<sup>3</sup> of fuel at a pressure of 35-40 atm(gage) are required about 50 kg of gas.

To number of deficiencies should be related complexity of safe operation of system during servicing with toxic propellant components. After termination of refueling the reservoirs prove to be filled with high-pressure gas, mixed with propellant vapors.

Simplest is refueling by gravity. The displacement of propellant component is accomplished because of hydrostatic pressure, formed due to a difference in levels in reservoir-storage and the missile tanks, which must be located lower during this method of refueling. This method of refueling wide application did not obtain, since comparatively much time is required for the refueling.

Systems of refueling are called combined systems, which use pump and pressurized-propellant feed simultaneously.

Speaking about systems of refueling, one should speak also about high requirements, presented to precision of transmission of components of propellant. The dose put out can be prescribed by weight or volume. Contemporary systems of refueling have an error, which does not exceed 0.1-0.5% of the refueling dose. This precision is provided for by the selection of the corresponding method of dosing and mode of refueling. Thus, the application of a two-stage mode of the supply of propellant components during high-speed refueling allows

to considerably decrease the error of the transmission of dose.

Sense of mode consists of following: at first occurs refueling with maximally possible expenditure, and upon achievement in missile tank by component of propellant of specific level according to signal of sensor of check system level productivity of refueling is reduced from high expenditure to low. When level reaches the given value, occurs the closing of valve of low expenditure and refueling ceases.

Dosing of refueling propellant component can be external, when dose put out is measured off by measuring device of fueling equipment, or internal, when servicing ceases on signal of sensors or equipment, available in missile tank.

Page 37.

During application of external dosing in composition of fueling equipment are located weight or measured systems, flow meters. During external weight dosing the measuring off of dose is accomplished with the aid of stationary weights or by the weighing of the parts of the dose in the cistern of dosing device.

External volumetric dosing takes place with the aid of liter gauge or with use of measured reservoirs taking into account temperature of fueling component.

Drain of propellant components is achieved with the aid of

fueling equipment during emergency starting, leak of propellant components from missile tanks, or expiration of warranty period of maintenance of rockets in a state of readiness.

As can be seen from given examples, systems for refueling rockets with liquid propellant components are complex and bulky equipment. Therefore in the USA is paid considerable attention to creation of rockets on solid fuel and, for the purpose of their weight reduction during transport, to accomplishment of fueling rockets with solid fuel directly at the launch site.

Is developed project, by which fuel is delivered to launch site in special containers. Before the fueling, the propellant is mixed in the chamber of mixer with a special additive, which causes its solidification. For the purpose of shortening time of fueling is proposed the manufacture of a two-chambered mixer: in one chamber the mixing of propellant with the additive is taking place, and from the other is occurring the fueling of engine chamber of rocket.

For solidification of fuel to engine block a special cover, which ensures necessary temperature conditions, is put on. Hermetic sealing of filler neck is produced at the termination of fueling.

Duration of fueling is determined by dimensions of rocket and can take several days. Fueling rockets with solid fuel at the launch site directly simplifies the process of missile preparation for launching



considerably and eliminates the need for complex fueling equipment. This contributes to a considerable increase in combat readiness of missile complex.

Page 38.

### 3. FUELING WITH COMPRESSED GASES.

In rocket engineering wide application obtained compressed gases, which include compressed air, nitrogen and helium. They are utilized for:

- fueling and refueling of onboard spherical tanks of rockets;
- conducting pneumatic testings;
- operational provisions of pneumatic automatics of the systems of refueling and launchers during preparation and rocket launching;
- extrusion of propellant components from the cisterns during refueling of missile tanks by method of extrusion, and also from the dump tanks of the systems of refueling;
- pressurization of cisterns and creation of inert gas cushion in them during the storage of propellant components;
- guarantee of conducting routine maintenance work with rockets and ground equipment;
- pressing of the joints of manifolds during the check of their pressure integrity;
- guarantee by a working medium of refrigeration gas machines.

For fueling of rockets and supplying technological equipment with compressed gases serve systems of gas supplies, in which are included stationary or movable compressors and nitrogen extracting stations, receiver, dispensers by compressed gases and gasifiers of liquefied

gases.

Mobile include stations and dispensers, assembled on chassis of vehicles or other mobile bases.

Fixed systems are installed in special constructions.

Mixed are called such systems, in which storage facility of compressed gases is assembled stationarily, and refueling and its additional feeding are produced by mobile compressor and nitrogen extracting stations.

Let us examine principle of work of compressor system, utilized for obtaining compressed air. It consists of compressor plant and equipment for the cooling, drying and cleaning of the compressed air (Fig. 2.8) put out.

Page 39.

Widest use in rocket engineering received piston compound compressors, which ensure obtaining high-pressure gas. The diesels or three-phase induction motors are used as the drive motor of compressor.

Utilized compressed gas must not contain mechanical impurities and must not have increased humidity, since this can be reason for failure of elements of pneumatic automatics of onboard systems or ground equipment. Therefore the compressed air, given by compressor plant, is cleaned of mechanical impurities and oil, undergoes drying. For removal of the mechanical impurities are used most frequently ceramic filters.

67  
4

Fig. 2.8. Diagram of mobile station with driving compressor: 1 - water-oil separator; 2 - high-pressure filter; 3 - valve, which supports pressure; 4 - telethermometer; 5 - adsorber; 6 - tube of suction of stage II; 7 - tube of forcing of stage I; 8 - safety valve; 9 - ceramic filter; 10 - adsorber; 11 - safety valve of stage IV; 12 - valve, which supports pressure; 13 - distributing column; 14 - shutoff valve (Distribution); 15 - shutoff valve (grid); 16 - shutoff valve (Tanks); 17 - power governor of engine; 18 - receiver; 19 - manometer of stage I; 20 - manometer of stage II; 21 - manometer of stage III; 22 - manometer of stage IV; 23 - manometer (Pressure in the grid); 24 - manometer (Check of pressure); 25 - blowoff valve; 26 - valve of the blasting of cooler of stage II; 27 - valve of the blasting of cooler of the stage I; 28 - valve of the blasting of high-pressure filter; 29 - valve of the blasting of the tanks of receiver.

Key: (1). Cooler ... of stage. (2). ... st. (3). Compressor. (4). Engine. (5). Hose.

Page 40.

Removal of moisture is produced with chemical or physical methods. With chemical methods air is dried by absorption of moisture by such substances as solid sodium hydroxide (NaOH), potassium hydroxide (KOH), and by others.

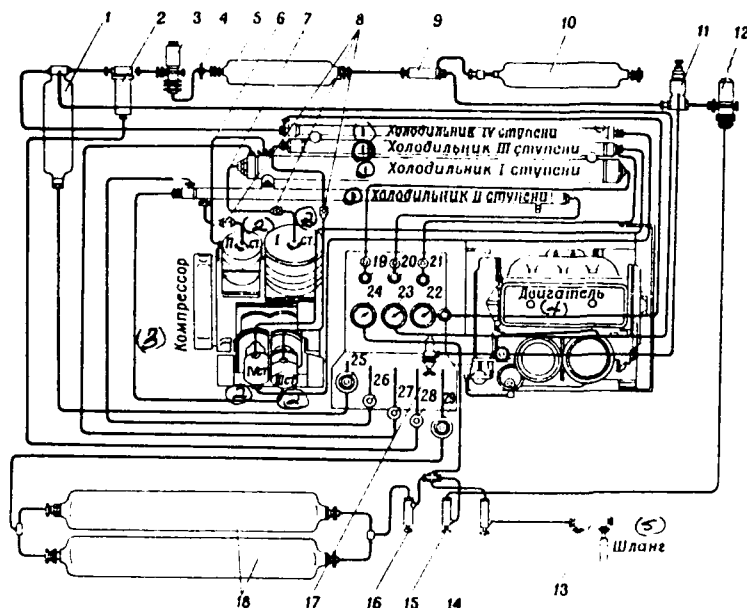
With physical methods of drying removal of moisture can be produced by inertia method, absorption by adsorbents, freezing in alternately effective heat exchangers.

For preliminary removal of drop moisture and particles of oil are used moisture-oil separators, installed in places for intense condensation of moisture and oil.

Principle of moisture-oil separator is based on separation of drops of oil and water from compressed air under action of inertial forces with abrupt change in direction of motion of air.

For final drying of air is produced absorption of moisture by adsorbents, as which most frequently are used silica gel and alumogel.

From adsorber dried air passes through ceramic filter, it is cleaned of dust of adsorbent and through control panel is supplied to users.

Precooling in air or oxygen-water coolers of air before adsorber

considerably depresses content in it of moisture and are created favorable conditions for work of adsorber.

For obtaining nitrogen from air are used nitrogen extracting stations. In this case compressed air, used for obtaining nitrogen during a deep cooling, undergoes removal of carbon dioxide and acetylene. Carbon dioxide with a low temperature and with an increase in pressure is converted into a solid, which can lead to disruption of operations of the nitrogen extracting station. The removal of carbon dioxide can be produced by chemical method via the transmission of air through a solution of alkali.

As a result of air reaction is cleaned of carbon dioxide, and soda formed in this case remains in solution of alkali.

Page 41.

Physical method of removal of carbon dioxide from air consists in its adsorption by silica gel at temperature of 150°C and pressure 200 kg/cm<sup>2</sup>. Simultaneously in this case silica gel removes acetylene and other hydrocarbons, which are contained in air.

For storing of compressed gases are utilized tanks, placed in special storage - receiver and on mobile dispensers.

Receivers are placed, as a rule, at launch site, in shielded constructions, near from starter, next to systems of refueling with propellant components.

After refueling of rocket with propellant components and with compressed gases begins final stage of prelaunch missile preparation for launch - aiming.

#### 4. GUIDANCE (AIMING) OF BALLISTIC MISSILES.

So that calculated trajectory of ballistic missile would pass through target, it is necessary before rocket launching to fulfill precise orientation of its housing and sensors of autonomous system for control on vertical line and along azimuth. The totality of operations on spacial orientation of the missile body and sensors of control system is called aiming rocket.



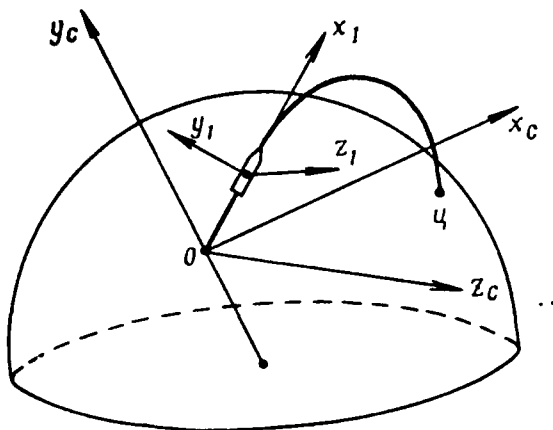

Fig. 2.9. Starting coordinate system.

Page 42.

Orientation of missile body and sensors of control system during aiming is accomplished relative to starting system of coordinates  $Ox_c Y_c Z_c$  (Fig. 2.9). Its beginning coincides with the center of mass of rocket, established on the launching platform; axis  $OY_c$  is directed vertically upward, and axes  $Ox_c$  and  $OZ_c$  lie at the horizontal plane (axis  $Ox_c$  lies at the plane, passing through the target).

Vertical plane  $Y_c OX_c$ , passing through programmed trajectory of motion of rocket, they call plane of firing.

Angular stabilization and control of rocket in flight can be accomplished with use of instruments, made on base of free gyroscopes.

As example of this system can serve inertial system for control, whose sensors are located on a gyrostabilized platform, strictly fixed relative to fixed coordinate system. The position of the axis of platform forms the inertial system they call reference plane of the stabilization of rocket. The axes of inertial coordinate system coincide with the axes of the suspension of platform, and reference plane of stabilization coincides with the plane of the internal framework of platform. The orientation of gyroscope-stabilized platform relative to missile body (adjustment) is produced with the aid of a three-channel system of azimuthal and horizontal setting, which ensures the retention of platform in position after its uncaging until rocket launching.

Coordinate system, rigidly connected with missile body, forms body coordinate system ( $OX_1, Y_1, Z_1$ ). Its beginning is placed in the center of mass of rocket; axis  $OX_1$  coincides with the axis of rocket, the direction of remaining axes is determined by the arrangement of steering controls. The plane, passing through the axis of rocket and the steering controls I-III, is called reference plane of symmetry.

In process of aiming axes of connected and inertial coordinate systems must be in a specific manner oriented relative to axes of starting coordinate system.

Page 43.

In this case reference planes of stabilization and symmetry of rocket must be combined with range plane, and axis of rocket and axis  $OY$  of inertial coordinate system - are vertical. This orientation of the axes of the coordinate systems is accomplished in this way:

- vertical adjustments of rocket;
- leveling gyroscope-stabilized platform;
- adjustment of gyroscope-stabilized platform;
- azimuthal aiming of rocket.

Operations of aiming are performed with the aid of devices and instruments, whose action is based on different physical principles. Thus, during the aiming are utilized optical, photoelectric, gyroscopic, electronic and electromechanical instruments. All these

instruments and devices are united into a single semiautomatic or automatic system of aiming.

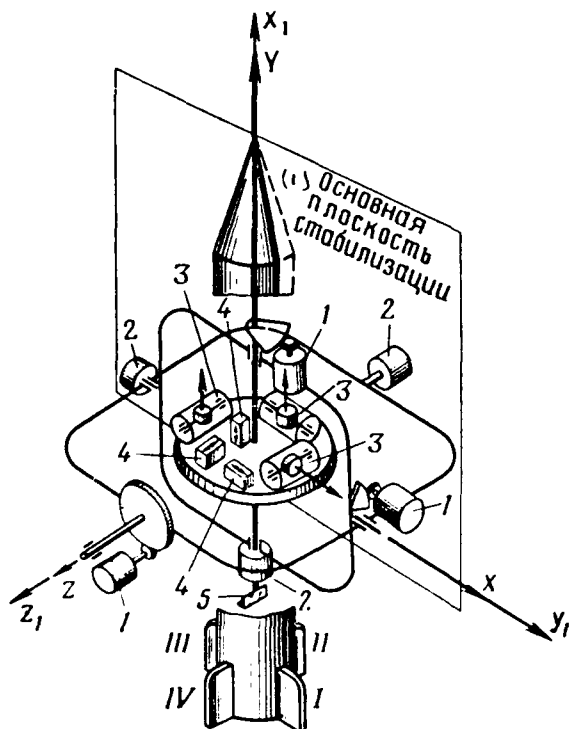

Fig. 2.10. Inertial and connected coordinate system: 1 - engine of stabilization; 2 - sensor of angle; 3 - gyroscope; 4 - accelerometer; 5 - control prism.

Key: (1). Reference plane of stabilization.

Page 44.

Vertical adjustment of rocket consists in installation of it strictly to vertical position on launching platform and is accomplished with the aid of jacks of launching platform. The check of the vertical position of axis of rocket relative to vertical line is accomplished by two theodolites, installed at angle of  $90^\circ$  to each other at a certain distance from the rocket. Before work both theodolites thoroughly are leveled with the aid of levels.

For vertical adjustment of rocket in its lower and upper parts of housing are plotted reference points, line between which is parallel to axis of rocket. Via successive sighting by theodolite of reference points is determined the precision of the vertical adjustment of rocket.

Position of upper and lower points on vertical filament of cross lines of grid of theodolite does not coincide with slope of rocket. In this case, lowering or jacking of launching platform, they slope missile body to the appropriate side.

Analogous operation is performed with the aid of another theodolite. Vertical adjustment will be completed with the agreement of reference points in the field of view of both theodolites with the vertical filaments of cross lines of their grids.

Errors of vertical adjustment are determined in essence by

inaccuracy in installation of reference points relative to axis of rocket and by errors, caused by inaccuracy in levelling and sighting of theodolite. The errors of vertical adjustment affect the accuracy of azimuthal aiming and usually comprise several angular minutes.

Levelling gyroscope-stabilized platform consists of coincidence of axis OY of inertial coordinate system with vertical axis  $OY_c$  of launch coordinate system.

Levelling of the gyroscope-stabilized platform is accomplished automatically by servo systems of its bringing relative to horizontal axes.

Accelerometers, installed on stabilized base of gyroscope-stabilized platform and producing electrical signals, which depend on position of gyroscope-stabilized platform relative to direction of acceleration of gravity, serve as sensors, which fix deviation.

Page 45.

Adjustment of gyroscope-stabilized platform consists in coincidence of reference plane of stabilization with reference plane of symmetry of rocket. Adjustment is produced by the rotation of the base of platform relative to missile body.

During preparation of basic firing data it is necessary to have coordinates of point of standing of launching platform and target coordinate. The adjustment of the system of control of rocket and its azimuthal aiming is produced on the basis of these data.

Azimuthal aiming of rocket includes following basic tasks:

- determination of reference directions and their fixing in terrain;
- fixing reference plane of stabilization of rocket;
- coincidence of reference plane of stabilization with range plane.

Reference geodetic directions characterize position of range plane. The orientation of directions consists in the determination of geodetic azimuth of direction and can be produced from the geodetic grid, by astronomical methods, also, with the aid of gyroscopes.

Astronomical orientation has high accuracy and is used in the absence in area of launching sites of developed geodetic grid.



Orientation with the aid of gyroscopes can be carried out with the use of external gyro instruments, placed at a specific distance from launching platform, or onboard gyroscopes of inertial system of control of rocket, which work in conditions of azimuth determination of reference direction.

Two methods are used for fixation of reference directions.

The first consists in use of reference points, fixed in terrain by signs.

With second method reference directions are fixed with the aid of collimator (optical instrument, utilized during aiming of rocket). For the reference direction in this case the line, passing through center of the objective of collimator and cross lines of its grid, is accepted.

Page 46.

For the orientation on the collimator of theodolite it is installed in the parallel beam better than, those which proceed from the collimator. Their sighting axes will be parallel with the coincidence of cross lines of the grids of theodolite and collimator.

Coincidence of stabilization plane of rocket with range plane is final stage of operation of azimuthal aiming. This operation can be accomplished by rotation of rocket on the launch platform or by

separate coincidence with range plane: first reference plane of symmetry, and then of the base plane of the stabilization of rocket.

Fixation of base plane of stabilization is produced with the aid of mirror and mirror prisms, which are fastened to gyrostabilized platform and with great precision are oriented relative to reference plane of stabilization of rocket. The special feature of a rectangular mirror prism is the fact that the plane of the incident light ray to the hypotenuse face of the prism and the plane of the reflected beam are parallel. Therefore prism it is not necessary to accurately verticalize. Incident and reflected beams do not coincide in the presence of the angular error between the sighting axis and the perpendicular to the edge of the right angle of prism.

With error, equal to zero, incident and reflected beams are parallel to each other.

Determination of azimuthal position of control prism, attached on gyroscope-stabilized platform, is produced with the aid of autocollimator - instrument, installed in the plane of firing. In this case the light rays, which come out from the instrument by parallel beam, are reflected from the surface of prism and pass through the instrument in opposite direction.

If surface of control prism is not perpendicular to sighting axis of autocollimator, straight and reflected images of its grid do not

coincide. Via turn of rockets (or gyroscope-stabilized platform) to the coincidence of straight and reflected images the grids of instrument produce the azimuthal aiming (Fig. 2.11). This operation can be accomplished by hand or automatically.

Page 47.

As intake effect of system serves angular error in position of reference plane of stabilization. The error signal, isolated with azimuth scale protractor, after intensification is supplied to the engine, which by the rotation of launching platform reduces the sighting error to zero.

Precision of adjustment of intake with comparatively low speed is important requirement for system.

For improvement of transition processes into servo system are introduced correcting circuits. Reducer makes it possible to turn launching platform with the rocket at the high and low speeds depending on the value of the error signal. By this is reached the high precision of the installation of rocket aiming.

Design of systems of aiming and diagrams of their arrangement at launch site significantly change depending on design of rockets, type of systems of control and type of launchers.

Let us examine principle of operation of a number of aiming

systems based on specific examples.

Fig. 2.12 shows schematic of single-channel system of aiming rocket "Saturn". Before the aiming geodetic joining is produced.

Autocollimating azimuth scale protractor of aiming system is installed on fixed base at distance 300 m from launcher. The inspection of the accuracy of the installation of the protractor is accomplished on the special prism, which fixes reference geodetic direction.

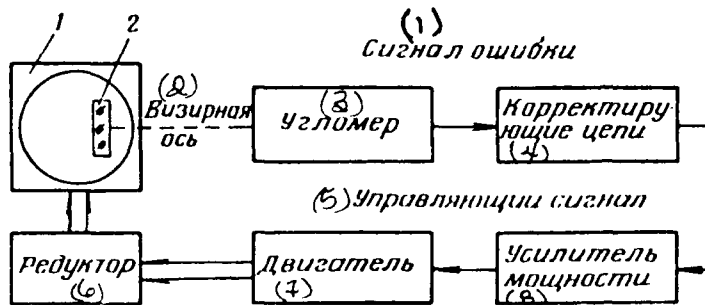

Fig. 2.11. Block diagram of servo system of turn of rocket: 1 - launching platform; 2 - control prism.

Key: (1). Error signal. (2). Sighting axis. (3). Azimuth scale protractor. (4). Equalizers. (5). Control signal. (6). Reducer. (7). Engine. (8). Power amplifier.

Page 48.

The light rays, which come out from the objective of azimuth scale protractor, with the aid of the servo reflector are turned exactly on  $90^\circ$  and at angle of  $25^\circ$  to the horizon head for onboard control prism, reflected from the prism - to the azimuth scale protractor.

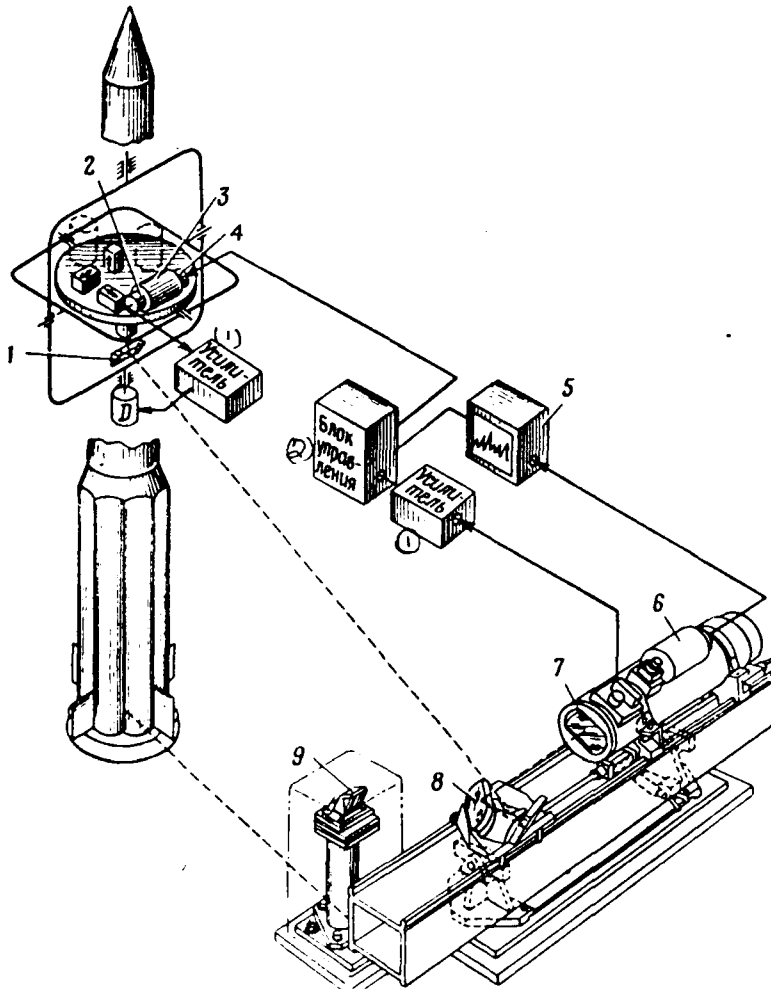

Fig. 2.12. Diagram aiming rocket "Saturn": 1 - control prism; 2 - sensor of precession angle; 3 - gyroscope; 4 - sensor of torque; 5 - television receiver; 6 - picture transmitter; 7 - objective; 8 - reflector; 9 - prism.

Key: (1). Amplifier. (2). Control unit.

Page 49.

With sighting error is produced controlling electrical error signal, which through amplifier, control unit makes for torque sensor

of roll gyroscope. Under the effect of torque the gyroscope precesses together with the platform around the vertical axis.

With the coincidence of perpendicular to control prism with sighting axis of azimuth scale protractor mismatch error becomes equal to zero and precession ceases.

Onboard control prism is attached on the basis of gyroscope-stabilized platform in special suspension, which can rotate up to  $360^\circ$ . This gives possibility, of changing the position of prism, to change the direction of launching in the fixed position of the sighting axis of azimuth scale protractor.

For inspection of work of aiming system serves television equipment, whose transmitting camera is placed on azimuth scale protractor. Furthermore, in the azimuth scale protractor is a sighting device, which makes it possible to produce visual monitoring of the accuracy of aiming.

Fig. 2.13 shows two-channel system of aiming, which accomplishes separate coincidence of plane of symmetry and stabilization plane of rocket with range plane. The azimuth scale protractor of the servo system of the rotation of rocket is installed near the launching platform. Sighting by this azimuth scale protractor is accomplished on the control prism, attached on the rotary part of launching platform. The error signal of azimuth scale protractor is supplied to

the drive of the rotation of launching platform. With the aid of a near azimuth scale protractor is accomplished rough aiming, which is necessary for the work of distant azimuth scale protractor.

For retargetting of rocket along another target on launching platform a supplementary prism, which corresponds to azimuth of new target, is fastened.

Distant azimuth scale protractor is utilized for rotation of gyroscope-stabilized platform along azimuth to coincidence of base plane of stabilization of rocket with range plane.

Dependence of point of standing of azimuth scale protractor on launch azimuth of rocket is shortcoming in this system, since direction of sighting axis of azimuth scale protractor, coinciding with range plane, must coincide simultaneously with direction to control prism.

With change in line of fire position of azimuth scale protractor must be moved along a circular arc.



Page 50.

This shortcoming does not have system of aiming of the rocket "Saturn", since in it for changing azimuth of firing it suffices to turn control prism relative to gyroscope-stabilized platform.

Fig. 2.14 shows schematic of aiming rocket "Minuteman" during launching from silo. Aiming is accomplished with the aid of onboard digital computer (TsVM).

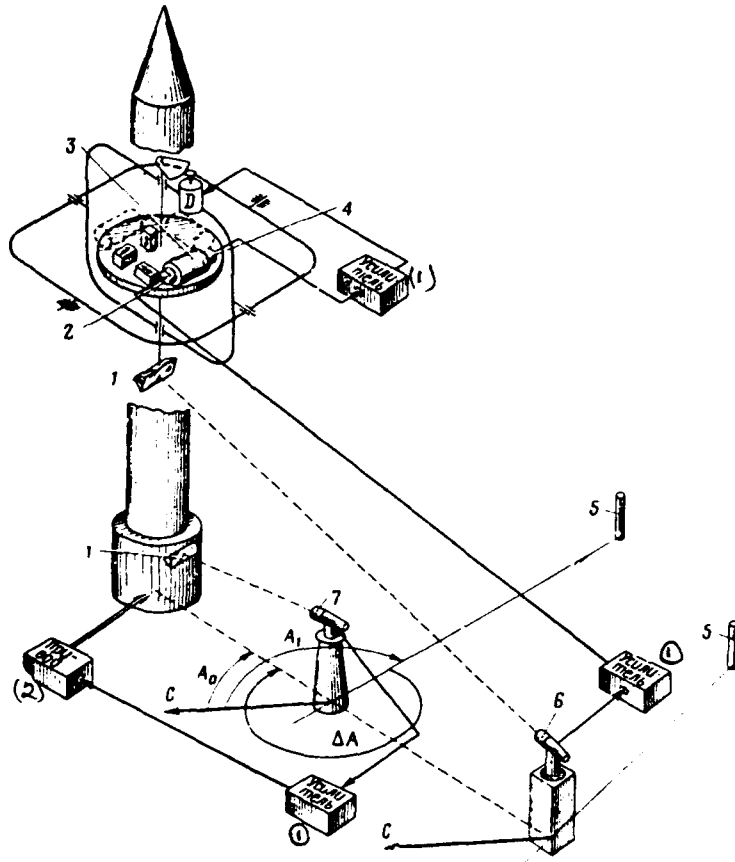

Fig. 2.13. Two-channel system of aiming: 1 - control prism; 2 - sensor of torque; 3 - gyroscope; 4 - sensor of precession angle; 5 - reference point; 6 - distant azimuth scale protractor; 7 - near azimuth scale protractor.

Key: (1). Amplifier. (2). Drive.

Page 51.

The position of the autocollimating azimuth scale protractor, installed in the end of silo, on a special live ring, depends on the azimuth of firing. The rough aiming of rocket is produced by the turn

of rocket with the aid of the rotary equipment of launching platform, precise - by rotation of the gyrostabilized platform along the azimuth with accuracy 0.1".

Operation on aiming of rocket occupies about 24 h.

For short time of missile preparation for launching gyrostabilized platform is found constantly in running order. Therefore due to the friction in the axles of the suspension of platform, residual unbalancing and other factors the platform will have a shift, which eliminates aiming system.

Light ray of protractor passes through hatches to silo tube and container of rocket and, after being reflected from control mirror, it falls again into azimuth scale protractor. As a result of the analysis of the reflected beam and by the shift of platform is produced the control signal, which through the amplifier, the converter is supplied for on-board digital computer, accomplishing continuous correction of the position of the gyrostabilized platform along the azimuth.

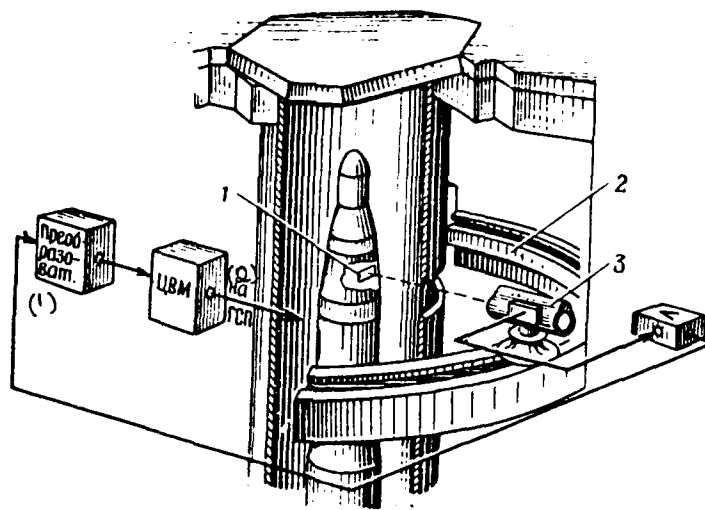

Fig. 2.14. Schematic of aiming rocket "Minuteman" during launch from silo: 1 - control mirror; 2 - live ring; 3 - azimuth scale protractor.

Key: (1). Converter. (2). on.

Page 52.

For retargetting of rocket into "memory" of TsVM besides basic goal will be brought in data of other 8 targets. In this case upon command from the control post, which is found on the distance of several kilometers, proceeds the turn of gyroscope-stabilized platform to the specific angle from the reference direction.

Maximum angles of turn of gyroscope-stabilized platforms, in limits of which is possible the remote retargetting of rocket, compose  $\pm 70^\circ$ . During the retargetting to greater angles is required the supplementary turn of rocket in the silo.

According to report to foreign press, is conducted work on equipment of rocket "Minuteman-3" by a device, which makes it possible to produce its retargetting in flight.

Aiming rockets during launch from mobile launchers (submarines, flatcars) is most complex problem, since under these conditions continuous correction of onboard systems for control is required and it is necessary to take special measures for elimination of effect of vibration and tossing on accuracy of aiming. The determination of launcher positions in this case is produced with the use of gyroscopic devices of navigation aids. As an example of this can serve the system of aiming rocket "Polaris".

During motion of submarine data about its place, course and speeds, which come from ship inertial navigational system, continuously are supplied into control system of firing rocket and are introduced into onboard rocket guidance systems. As a result the corrections into the flight program of rocket up to the start are produced. However, due to the drift of the gyroscopes and other errors the determination of the coordinates of the submarine and parameters of its motion by onboard navigation aid occurs with the errors, which have tendency in the course of time to increase due to their storage.

Page 53.

For determining of these errors and input of corrections into

navigation aid application of astronavigational systems, radio-sextant or systems, which use signals of artificial Earth satellites is provided for (ISZ [ MC3 - artificial earth satellite]).

At present all submarines, armed with rockets "Polaris", are equipped with navigational complex AN/BRN-3, designed for use of artificial Earth satellites "Transit". The accuracy of the determination of moving coordinates in this case is approximately 50 m.

Principle of operation of navigational complex consists of following.

Measuring points of ground-based equipment pick up signals of onboard radio transmitters with ISZ and transfer them to data processing center by radio communication link. On the basis of these data in the data processing center is designed the orbit ISZ and through the ground transmitting stations of the data input for the satellites it is recorded in its onboard memory unit. Through the two minute intervals each ISZ transfers to the earth the data about its position in orbit, which are received by submarine. These data are worked in TsVM, and by the parameters of motion of ISZ are determined the coordinates of submarine.

After comparison in TsVM of coordinates of submarine, obtained from navigational complex AN/BRN-3, with data, produced by inertial

navigation system, into latter are introduced corresponding corrections.

For realization of possibility of retargetting rockets in TsVM of submarine are introduced programs, which foresee destruction of specific targets.

Introduction of new programs into memory of TsVM is feasible only at base.

Retargeting occurs in 30 s by input of program into onboard rocket guidance systems.

The operation of aiming is the final procedure of prelaunch missile preparation.

Page 54.

### CHAPTER 3.

#### VERTICAL ROCKET LAUNCHING.

Vertical launching in essence is used during launching of intercontinental ballistic missiles. Preference to this form of launching is given for several reasons.

First, with vertical launch missile rapidly passes dense layers of atmosphere and accomplishes programmed turn in permitted layers of air virtually in the absence of aerodynamic influence. Low air resistance gives the possibility with the low expenditure of energy to develop high speeds.

In the second place, for this missile launch is sufficient small excess of engine thrust above weight of rocket.

Thirdly, vertical launch is accompanied in essence by axial g-forces of design. This makes it possible to decrease the lateral stiffness, after facilitating thus rocket.

Fourthly, for this form of launching ground-based launch gear of missile is more compact and more convenient, than, for example, with inclined launch.



Vertical launching is suitable for rockets, launched from surface of the earth (water), or from silo (submarine in submerged state). The selection of launching depends on the special features of the missile complexes, which can be stationary and mobile. Stationary complexes in turn are divided into those opened and underground.

Page 55.

Mobility of complex is reached by fact that all launching equipment of ballistic missile is installed on transporters; auxiliary equipment is installed on trailers, and can easily be moved from place to place, rapidly installed at launch site in operating position, with the aid of it to load rocket with fuel, to produce verification test of all systems of rocket and accomplish launching.

In launching of rockets from fixed bases and mobile means are their special features.

#### 1. ROCKET LAUNCHING FROM STATIONARY LAUNCHERS.

Launchers (PU) of first missile complexes were located on earth's surface. Recently wide acceptance received silo missile complexes, since rocket in the silo was shielded not only from radioactive radiation, vibrations and the thermal effect of nuclear weapons of the enemy, but also from bad weather. In the silo there is a possibility to support stable temperature, a specific microclimate. Launching from a silo launch installation has a number of special features.

Based on example of examination of MBR of three generations of USA "Atlas", "Titan", "Minuteman" and their launching systems it is possible to trace trends in development of methods of vertical missile launch from silos. Thus, for instance, initially rockets "Atlas" and "Titan" prior to launch rose on hoists from the silos and engine start was produced on the earth's surface. Flame deflectors directed gases in parallel to launch pad. However, this launching method was very expensive in view of unwieldiness and complexity of the equipment for suspension and ascent of rocket from the silo.

Launching of MBR directly from silo without lift to surface reduced cost of launching one rocket by 20-30%. In this case due to the absence of cage and hoist the depth of silo decreases. Rocket "Titan-2" and latter modifications of rocket "Atlas" are adapted for launching from a silo.

Third generation MBR - solid-propellant three-stage rockets "Minuteman" are launched from silos. The building of complex "Minuteman" preceded vast scientific research works. A question of a selection of the most rational type of launching silo with the use of different methods for the removal from it of the exhaust gases first of all was studied.

Page 56.

Three basic types of silos were examined:

- simple silo, in which the exhaust gases were removed to the surface through the space between the missile body and the walls of silo;

- concentric silo - with the gas bleed through the channels, which are located in the gap between the internal walls of silo and the external walls of silo liner; this type of silo is utilized, in particular, for MBR "Titan-2";

- U-shaped type of silo, with which in one elbow of silo the rocket is placed, and the exhaust gases are removed through another.

As a result of investigations it was explained that first type of silo by construction is simpler than two others. However, the use of such silo requires resolution of more complex technical problems, since the effect of temperature, pressure and vibration loads, which appear during the launching of rocket, grows with the decrease of the diameter of silo. From an economic point of view, this silo proved to be advantageous and was therefore accepted as basic for the missile complex "Minuteman".

Besides direct launching of rocket from launching silo in USA much attention was given to development of "cold" launching method.

With this method rocket is ejected from the silo with the aid of pneumatic system, after which are started the first stage engines. This starting system eliminates the need for the protection of the launching configuration and equipment from the gas jet. Furthermore,

the application of a similar method will make it possible to increase the payload of rocket without an increase in the quantity of propellant.

This method of launching found use during launching of rockets from nuclear powered submarines and during launching of antimissile missile "Sprint".

Combat version of launching silo of antimissile missile "Sprint" is container, placed into concreted silo.

Antimissile missile, whose diameter is lower than diameter of container, is installed on piston. Piston is forged ring with a convex upper lid, which envelopes under the tail skirt of antimissile missile.

Page 57.

For preventing the gas escape under the piston is installed flexible packing in the form of a number of aluminum plates and teflon. Under the effect of hot gases the teflon expands and tightly forces plates against the walls of container.

For retention of rocket accurately in center of container between it and rocket are installed four bushings from foam plastic. These bushings hold rocket in the center of container and damp its lateral vibrations. The same purposes serve four gaskets in the form of

(valve) seats, installed at forward end of first stage of antimissile missile.

Gas generator of solid fuel is located directly under piston. Upon the inflammation of fuel charge the gases enter space under the piston. Under the effect of pressure of gas from the quick burning charge of the fuel in several milliseconds begin to be moved piston together with the rocket upward. In proportion to its lift and increase in the volume under it progresses the burning of fuel charge, which provides the maintenance of constant pressure under the piston. Maximum acceleration is obtained at the upper point of the position of piston.

Circular framework construction with openings in the walls is located at end of container. When piston passes this construction, gases emerge through its openings and acceleration of piston ceases. The upper part of the framework construction consists of a steel ring with four lead wedges, with those sharp ends turned down. When piston reaches these wedges and strikes against them, occurs its separation from antimissile missile. Besides the fact that the method of launching makes it possible to impart to rocket supplementary momentum, it prevents negative effect on the rocket of excessively high temperatures, which appear during operation of power plant in the silo, since RDTT [ PTTT - solid-propellant rocket engine] of first stage of antimissile missile is started after the exit of bottom part from the silo.

Described method of "cold" launching provides approximately 5% of maximum speed of antimissile missile.

"Cold" launching is considered not only for surface-to-air missiles, but also rockets of other designations can be accomplished, utilizing potential energy of environment, for example hydraulic power or air (Fig. 3.1).

Page 58.

For this purpose were investigated the launchers of three forms: water-air, water, and air-vacuum.

Water-air launcher consists of placed into water launching tube and two chambers, divided by diaphragm.

Water level in it is somewhat depressed by forcing of air into lower chamber, and increased pressure destroys diaphragm. As a result in both chambers the air pressure is sharply depressed, which causes the lift of the water column, under effect of which the rocket begins to move upward along the tube.

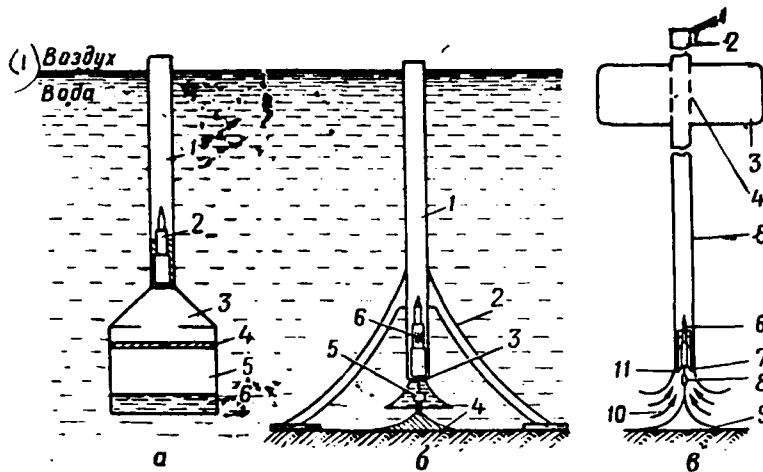

Fig. 3.1. Schematics of possible promising launchers of ballistic missiles: a) water-air launcher: 1 - launching tube; 2 - rocket; 3 - upper chamber; 4 - diaphragm; 5 - lower chamber; 6 - initial water level in lower chamber; b) water launcher: 1 - launching tube; 2 - supporting element; 3 - launching platform and pallet; 4 - supporting platform; 5 - mechanism of release of rocket; 6 - rocket; c) air-vacuum installation: 1 - destroyed seal; 2 - shock-absorbing chamber; 3 - expansion chamber; 4 - static opening; 5 - evacuated tube; 6 - rocket; 7 - pallet of rocket; 8 - mechanism of release; 9 - base; 10 - atmospheric pressure; 11 - vacuum seal.

Key: (1). air / water.

Page 59.

Water launcher consists of launching tube, supporting element, base and launching platform, on which rocket is installed in special pallet. Before the launch the water is evacuated from the launching tube.

Due to difference of hydrostatic pressures rocket at moment of its release from launching platform starts to move upward along launching tube, in this case momentum of large force, depending on hydrostatic pressure, which acts on pallet, and ambient pressures, can be obtained. Acceleration of rocket rapidly decreases in proportion to the filling of launching tube with water. Therefore it is considered, that the application of water launcher is inexpedient at speeds higher than 30.5 m/s even with a very large length of tube.

Air-vacuum installation - is partially evacuated tube, in which to rocket is imparted speed due to pressure difference in tube and atmospheric pressure on pallet of rocket. Pallet is equipped with vacuum seal and mechanism for releasing the rocket during launch.

It is considered that air-vacuum installation makes it possible to obtain considerable fuel economy and it can be used for rocket launching of different weight categories and sizes due to change of degree of vacuum in launching tube and weight of pallet, so that maximum g-forces would be in permissible limits. On the upper part of the launching tube the expansion chamber, which reduces to the minimum a decrease in the velocity of rocket due to the compression of residual air in the evacuated tube, is established.

It is assumed that volume of expansion chamber must be more than volume of half of launching tube, and total area of openings, which



connect launching tube with expansion chamber, is more than than cross-sectional area of the tube.

After breach of vacuum seal in upper section of launching tube atmospheric air, which enters launching tube, strikes rocket. For decreasing the shock they lengthen launching tube beyond the limits of expansion chamber, forming the shock-absorbing chamber. The length of this chamber depends on the value of vacuum and volumes of expansion chamber and launching tube.

Page 60.

They consider that rocket launching with the aid of air-vacuum installation in comparison with routine launching makes it possible to increase weight of fuel by 50%, and payload weight - by 30%. In this case it is considered that an air-vacuum installation makes the rocket less than sensitive to wind gusts at low altitudes; rocket becomes aerodynamically more stable; furthermore, rises the effectiveness of the controls of aerodynamic guidance. The determination of rocket in the launching tube makes it possible to support the temperature of onboard missile gear in period of its preparation for launch in a specific range.

Similar installations were recommended for rocket launching of small and average (of type "Sergeant", "Pershing"). For the rockets heavier "Minuteman" is considered advisable to nevertheless use launching, utilizing a compressed gas.

Table 1. Fundamental characteristics of the rockets of family, "Minuteman".

(a) Наименование данных	(b) „Минитмен-1“	(в) „Минитмен-2“	(г) „Минитмен-3“
(1) Стартовый вес, т . . . . .	29,5	31,7	34,5
(2) Общая длина, м . . . . .	17	18,2	18,2
(3) Диаметр корпуса первой ступени, м . . . . .	1,8	1,8	1,8
(4) Дальность действия, км . . . . .	~10130	>11200	>12700
(5) Скорость в конце активного участка, м/сек . . . . .	7550	7550	7550
(6) Тип боевой части и мощность ядерного заряда	(7) Ядерная ~1,0 Мг	(8) Ядерная >2 Мг	(9) Ядерная с тремя боеголовками по 0,2 Мг
(10) Период развертывания ракет в подземных пусковых шахтах . . . . .	1961— 1965 гг.	1964— 1967 гг.	1970— 1975 гг.
(11) Срок снятия ракет с вооружения . . . . .	1973 г.	1975 г.	—

Key: (a). Designation of data. (b). Minuteman. (1). Launching weight, t. (2). General length, m. (3). Diameter of housing of first stage, m. (4). Range, km. (5). Speed at the end of active section, m/s. (6). Type of warhead and power of nuclear charge. (7). Nuclear. (8). Nuclear with three warheads, each 0.2 Mt. (9). Period of development of rockets in underground launching silos. (10). Period for removal of rockets from armament.

Page 61.

However, the simplest and most propagated launching is at present direct launching from the silo with the removal of the exhaust gases through the space between the missile body and the wall of silo into the atmosphere. As already noted precisely, this launching method has rocket "Minuteman" (see Table 1), which is the basis of the strategic forces of the MBR of the USA.

Rockets are placed in silos, having a depth of approximately 27 m and diameter 3.6 m. In the base of the silo tube on a concrete cushion with a thickness of 1.2 m is placed steel plate - flame bucket. Rocket is installed on a special rotary ring (Fig. 3.2).

From above underground rocket silos are covered by massive steel roofs weighing several tons, designed for the effect of shock wave in the case of nuclear explosion near silo.

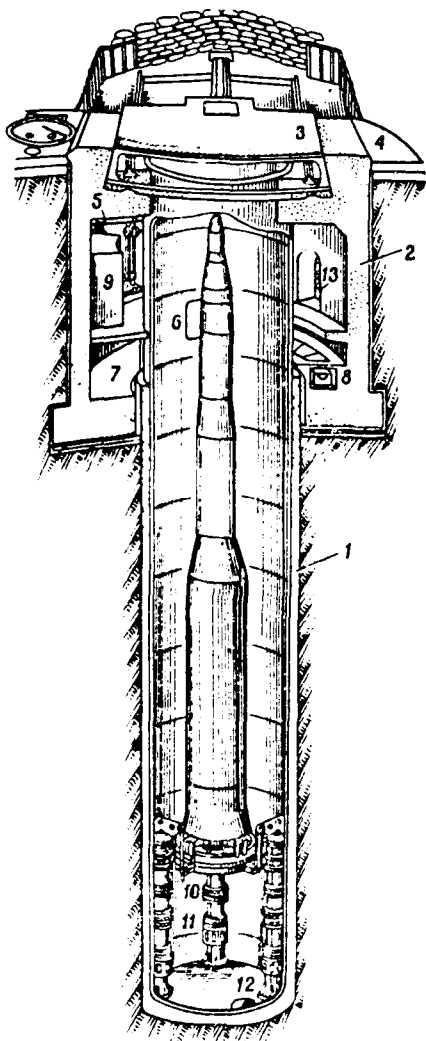

Fig. 3.2. Silo launch installation of rocket "Minuteman": 1 - silo tube; 2 - end of silo; 3 - shielding shelter; 4 - concrete area; 5 - electric hoist; 6 - hatch; 7 - floor with shock absorbers of impact loads; 8 - storage batteries and installation of air conditioning; 9 - equipment for control and power sources; 10 - carrier ring; 11 - elastic elements of system of shock absorption of rocket; 12 - sump; 13 - compressor.

Page 62.

Before the launching the roofs are shifted according to the guide rails. Control of their shift is accomplished remotely from the control center. At a temperature of  $-40^{\circ}\text{C}$  roof is opened in 3 s. For the creation of the proper climatic conditions underground locations of positions are equipped with the installations of conditioners of air and with filters.

Of stages of rocket "Minuteman", the section of control and nose section, which contains warhead, they deliver to launching site separately in special containers.

Into silos they are consecutively loaded with the aid of a special transporter-erector and there assembled.

In silo rocket is installed on special ring, fastened to three spring shock absorbers of identical device. Shock absorbers are spread along the circumference of silo tube. This system of the retention of rocket in the vertical position raises its resistance to dynamic loads, which appear under the mechanical influence of nuclear explosion.

System of shock absorption of rocket is designed with repeated reserve to possible g-forces under effect on silo of excess pressure. Rocket in the silo can for a long time be in a state of constant alert. The combat readiness of rockets is very high and composes only

30 s. Since the silo is unmanned, then inspection of the state of launching site and rocket is accomplished remotely from the control center (Fig. 3.3).

Command point, which is simultaneously control center for rocket launching, is placed in an underground construction.

Equipment of control center consists of several panels, of them basic:

- control panel of communication;
- block of data processing;
- control panel for launching.

Control panel of communication is utilized for obtaining command for launch and for arming for war of equipment of launching silos, and also for obtaining information about state of equipment placed there.

Page 63.

With the aid of block of data processing information about state of rocket and launching gear of silo gives possibility to operators to correctly evaluate situation.

All checkings, both periodic and prelaunch, are fully automated, which considerably shortens their periods and raises reliability of technology. These checkings are produced according to the previously comprised program.

In case of any malfunction in rocket or starting equipment of silo into control center enters a reporting signal. In obtaining of this signal the operator, who is located in the center, sends a command the silo and obtains more detailed information about the failure. For eliminating the malfunction the operator calls maintenance crew.

Control panel of launching provides indication of technical state of rockets and starting equipment. However, here there is the equipment, which allows after several seconds prior to launch to select one of eight targets.

On control center continuously are on duty two officer-operators, which upon obtaining of corresponding command can carry out rocket launching. Each of these operators has their key of the launching, by which closing the electrical circuits of control panel of launching is accomplished.

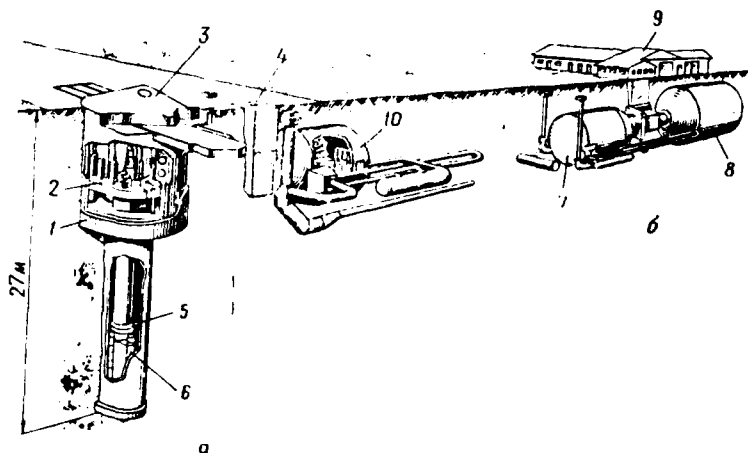

Fig. 3.3. Launching site of rocket "Minuteman-2": a) silo; b) control center; 1 - place for storage batteries; 2 - location for equipment (end); 3 - roof of silo; 4 - hatch for entry and exit; 5 - launching platform; 6 - system of shock-absorbing suspension; 7 - underground building for equipment; 8 - control post to launching; 9 - ground-based auxiliary building; 10 - underground bunker.

Page 64.

The key to launching is inserted into a socket of panel only upon obtaining of the corresponding command. In order to exclude the unsanctioned actuating of the systems of panel, besides the simultaneous insertion of keys it is necessary to complete a number of strictly consecutive and matched operations, which one person make cannot. Only after this can "launch" signal reach the rocket and produce its launching.

After pushing of knob "launch" signal enters silo launch



installation, where begins missile preparation for launch. In this case the roof of silo at first with the aid of a solid-fuel gas generator is shifted along rails to the side.

System of control of rocket is switched on during opening of roof, and first-stage engine is switched on after 15-20 s. For the exit of rocket from the silo are required about 2 s. Upto the moment of switching on of engines the operator can at any moment stop prelaunch missile preparation.

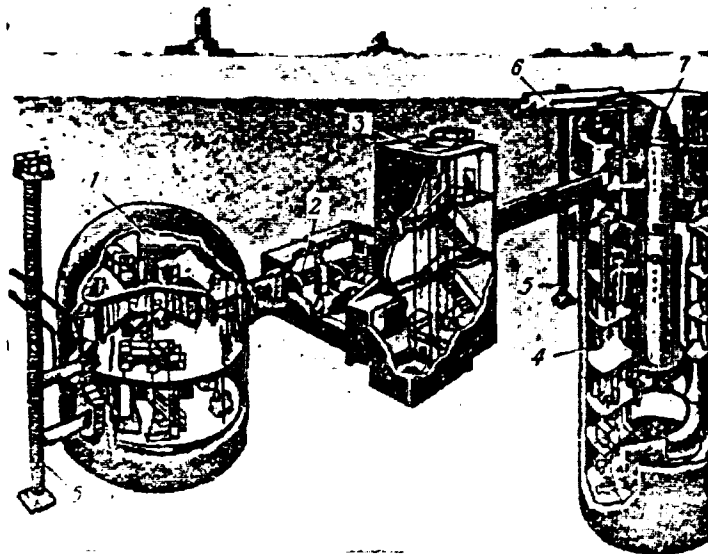

Fig. 3.4. General view of starting ballistic missile site "Titan-2":  
1 - control center of launching; 2 - coupling tunnel; 3 - duct; 4 -  
launching silo of rocket; 5 - air conduit; 6 - roof in moved position;  
7 - rocket.

Page 65.

From silo is launched rocket "Titan-2", which also consists in arsenal of USA. Launch site of "Titan-2" occupies area approximately 200×200 m. On it are placed a silo type underground launcher, underground control center for rocket launching and servicing constructions, which include the shaft for emergency exit, coupling tunnel and entry by an air-lock chamber (Fig. 3.4).

Launching silo with a depth about 45 m and inner diameter of 12.2 m is made according to concentric diagram with removal of exhaust

gases along channels, placed between walls of silo liner and walls of silo tube. This gas bleed is feasible due to the application of a W-shaped blast deflector. In the free space between the silo liner and the tube of silo are placed nine platforms for auxiliary launching equipment. The walls of silo are equipped with sound absorbers. On top silo is closed by shielding reinforced concrete slab.

If we examine rocket launching in a "historical" sequence, then it will seem that initially rockets started from open launching sites, i.e. from launching platforms, located on earth's surface. Then rockets were hidden in the silos and only before launching them were they raised to the surface (Fig. 3.5).

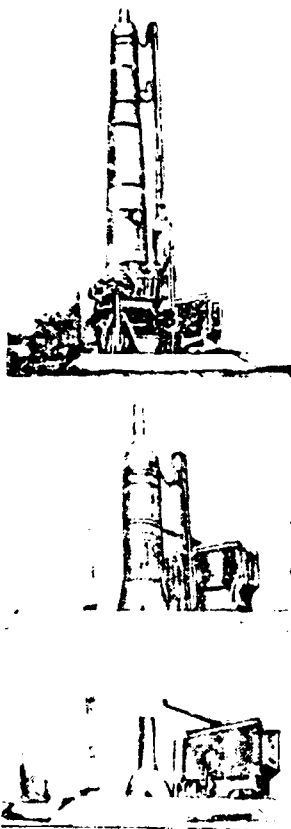

Fig. 3.5. Ascent of rocket from silo.

Page 66.

Following stage was launching of rockets directly from silos. At present together with the improvement of silo launch installations are introduced the methods of "cold" launching from underground (underwater) constructions and devices. One of the forms of "cold" launching is missile launch from submarines.

## 2. LAUNCHING BALLISTIC MISSILES FROM SUBMARINES.

According to the affirmation of foreign specialists, under conditions of missile and nuclear weapons warfare will increase role of nuclear powered submarines, armed with ballistic missiles (see Table 2). For this very reason in the USA is given considerable attention to improvement of both rockets themselves and their operation.

Each ship-rocket carrier, armed with rockets "Polaris", has 16 launching silos, located in the middle part of the ship hull. The launching silo is a double-walled steel construction of cylindrical form, consisting of several sections.

Table 2. Fundamental characteristics of strategic ballistic missiles VMS of the USA.

(a) Наименование данных	(b) „Поларис А-1“	(b) „Поларис А-2“	(c) „Поларис А-3“	(c) „Посейдон“
(1) Стартовый вес, т . . . . .	—	—	~14	~30
(2) Общая длина, м . . . . .	8,35	9,4	9,6	10,4
(3) Диаметр корпуса, м . . . . .	1,37	1,37	1,37	1,8
(4) Дальность действия, км . . . . .	2140	2700	~4600	~4600
(5) Скорость в конце актив- ного участка, м/сек . . . . .	6800	6800	6800	6800
(6) Тип боевой части и мощ- ность ядерного заряда	(7) Ядерная 0,8 Мт	(7) Ядерная ~0,5 Мт	(7) Ядерная ~1 Мт	(8) Ядерная 10—14 босголо- вок по 50 кг
(9) Период развертывания ра- кет на атомных подвод- ных лодках . . . . .	1959— 1961 гг.	1961— 1964 гг.	1964— 1967 гг.	1971 г.

Key: (a). Designation of data. (b). Polaris. (c). Poseidon.  
 (1). Launching weight, t. (2). Overall length, m. (3). Diameter of housing, m. (4). Range, km. (5). Speed at the end of active part, m/s. (6). Type of warhead and power of nuclear charge. (7). Nuclear. (8). Nuclear ... of warheads at ... kg. (9). Period of scanning of rockets on nuclear powered submarines.

Page 67.

Height and inner diameter of silo correspond to the dimensions of the rocket installed in it. The launching silos are located by eight in two rows. Each of them is a separate launcher (Fig. 3.6).

For allowance to operating systems of rockets in walls of silos are three inspection holes, that are closed by covers. Allowance to the instrument missile bay is provided through the roof hatch.

Through two of the others - to the link up point of the engines of the first and second stages. Jacket of the launchin silo is rigidly connected with the hull of ship. Internal is installed on 20-30 shoes, which rest on hydraulic shock absorbers. Rocket is installed in the silo on a special pendulum bearing and is fastened to it with the aid of a binding ring. Since the inner diameter of the launching silos is more than the diameter of rockets, are used ferrules, which operate during the launching as "piston rings". From above the silo is closed with a thin plastic diaphragm, situated under the durable cover of silo. Within the launching silos with the aid of airconditioning systems the temperature and humidity are maintained as assigned.

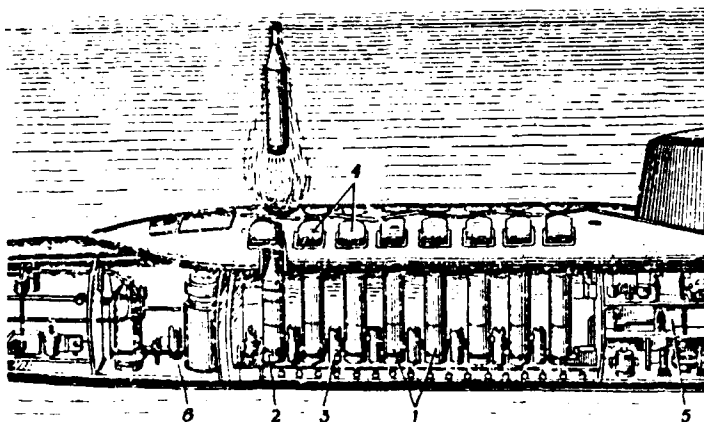

Fig. 3.6. Diagram of location of silos in rocket section of nuclear powered submarine; 1 - silo; 2 - rocket "Polaris"; 3 - tank with compressed air; 4 - cover; 5 - control station of rocket firing; 6 - reactor compartment.

Page 68.

Prior to missile launch pressure in launching silo is aligned with outboard, after which durable cover of silo is opened. But thin plastic diaphragm obstructs the access of water into the silo. The launching silos are equipped with the special safety blocking system, which eliminates the possibility of firing engine in the silo or its spontaneous combustions, and also the passage of command "launch", if launch preparation of rockets did not yet end.

Feeding voltage is supplied to onboard equipment of rocket through separation joint. Orientation and acceleration of gyroscopes occurs. Then from the ship system for control of rocket firing into the memory unit of onboard computer of equipment for control begin



continuously to enter the data, which assign the coordinates of trajectory and velocity of rocket flight at the end of the active section. For this a special calculator automatically determines the position of ship relative to the intended target. These data and the course data of ship, speed of its running, pitch angles, meteorological conditions enter the computer, which gives to system of missile guidance trajectory elements, passing through the target. Information about the course of prelaunch servicing procedure is transferred to the control panel for rocket launching system, where the corresponding signal panels and indicator lights are ignited.

Its launching is accomplished after final readiness of rocket for launching. The process of the launching of rocket occurs as follows.

During transmittal of command "launch" is started by small RDTT, installed outside of launching tube. The exhaust of this engine is directed through a chamber, filled with water. Hot gases pass through water and convert it into vapor. The mixture of vapor with the cooled gases (steam gas) is supplied into the lower part of the launching silo under the base of rocket and ejects it upward. RDTT is made so that rate of combustion of its fuel charge increases with an increase in the volume under the rocket rising upward. This makes it possible to ensure the prescribed state of motion of rocket in the silo.

Page 69.

The starting acceleration of rocket is approximately 10 g and its exit

velocity from the silo obtains more than 50 m/s.

For ejection of rockets of type A-1 and A-2 instead of steam gas was utilized compressed air. This greatly complicated launching system. With the application of steam gas the need for a complex system of valves and conduits/manifolds was eliminated. It did not become a necessity for storage on the submarine of heavy steel reservoirs with compressed air and supplementary compressors.

With upward motion rocket breaks thin plastic diaphragm and outboard water freely enters silo.

For compensation for excess in weight of ship, which appears with filling of silo with water, is provided blasting of water ballast with the aid of a special automatic machine of substitution system. After the exit of rocket from the silo it is again closed automatically by durable cover, and the outboard water located in it pours into a special cistern, placed within the boat.

After unguided and wobbly travel through the thickness of water the rocket emerges to surface. During the lift to the level 20-30 m above the surface of sea automatically fire the first-stage engines (Fig. 3.7). Engines are switched on by an electromechanical device and a powerful fuse. The tail plugs of nozzles, which protect engines from the entry of water during the underwater course of rocket, are ejected at the moment of the start-up of engine.

Diagram of change in speed of motion of rocket "Polaris" is depicted in Fig. 3.8.

Controlled rocket flight begins from moment of switching on of first-stage engines.



Fig. 3.7. Rocket "Poseidon", being fired from a nuclear powered submarine.

Page 70.

According to a report to the foreign press, by assignment of command VMS of USA naval specialists began study of possibilities of designing of a new, atomic guided-missile submarine highly immune to antisubmarine forces of the enemy. This system is the further development of a rocket-sea system "Polaris" - "Poseidon". To the new rockets it is proposed to give the name of "Perseus". Their designed range of firing is 11-12 thousand km. Each nuclear powered submarine must bear 20-24 rockets, placed vertically into silos. The development of this new boat is planned to begin in 1973, and in 1977-1978 first ship to transmit to fleet. Entire program of building of new underwater nuclear rocket system, as the specialists of VMS of the USA assume, can be carried out to 1985 so that new guided-missile vessels would be introduced into the fighting strength of VMS from

DOC = 91032704

PAGE

~~30~~  
123

1980 to the replacement of now active ships, in which by that time will elapse the 20-year service life of reactor.

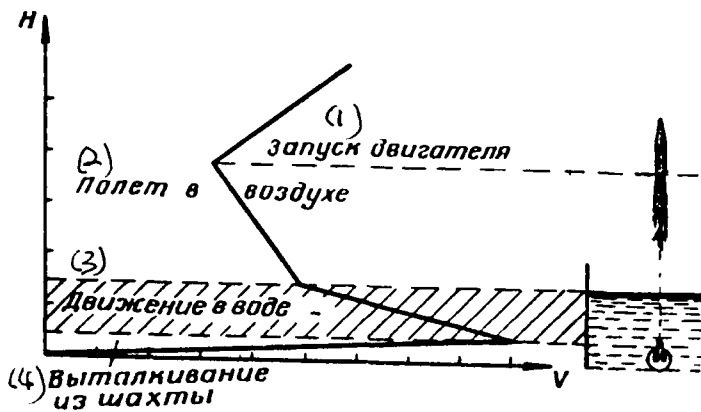

Fig. 3.8. Diagram of change in speed of rocket "Polaris" during launch from underwater.

Key: (1). Engine starting. (2). Flight in air. (3). Motion in water. (4). Ejection from silo.

Page 71.

### 3. VERTICAL ROCKET LAUNCHING FROM MOBILE LAUNCHERS.

For destruction of targets in tactical depth of the battle formation of enemy, not accessible for any reasons for aviation, are utilized ballistic missiles with mobile launchers. These rocket installations can maneuver in the terrain, retaining constant alert, the possibility to be rapidly set up from the march for rocket launching.

Mobility of missile complex gives to it advantage over stationary complexes of survivability.

Mobility of complex assumes complete independence of launcher. This means that on the launcher are all means, necessary for missile preparation for launching and its launching. Exactly therefore PU have a system, which ensures aiming of rockets. Such complexes must have reliable and simple in operation auxiliary equipment.

Let us examine process of preparation and rocket launching from mobile launcher based on example of rocket "Pershing".

Solid-propellant rocket "Pershing" relates to ballistic missiles of operational designation. It replaced rocket "Redstone" with an engine, which works on liquid propellant. Rocket "Pershing" is in service of American ground forces and West German VVS, it can strike targets, which are found on the distance from 185 km to 740 km. Launching weight of rocket 4.5 t, length 10.5 m, the diameter of housing 1 m. Rocket can bear nuclear charge. Launches rocket from a self-propelled crawler (Fig. 3.9) or mobile wheel installation.

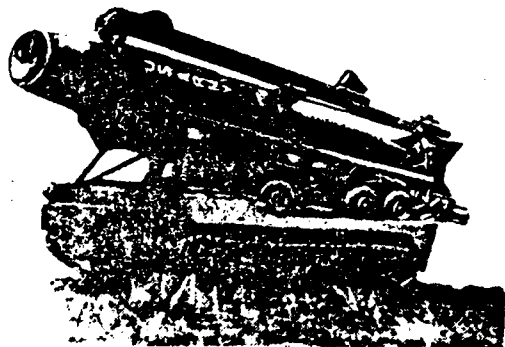

Fig. 3.9. Launching assembly with first stage of rocket "Pershing".

Page 72.

Since 1969 system "Pershing" began to be replaced by the improved version "Pershing-1A", in which the rocket remained almost without a change, and new ground equipment made it possible to increase the rate of fire of complex due to the decrease of readiness time for the launching. Time of preparation for launching for the system "Pershing" 30 min. The time of preparation is considerably less for the improved system. Ground equipment from crawler transporters is converted to wheeled machines, which considerably raised the mobility of complex. The use of wheeled machines instead of crawler, in the opinion of foreign specialists, with cross-country movement decreases the vibration of equipment and thus raises the reliability of complex. Furthermore, the wheeled machines cheaper than crawler in production require smaller attendance.

Let us examine sequence of launch preparation and rocket launching.



Initially rocket is delivered to maintenance area in four containers, shipped by 5-ton trucks. Containers are designed in such a way that they make it possible to carry out complete testing of missile bays and its nose section directly in the containers. This gives the possibility rapidly to detect and to withdraw defective section of rocket. In the containers the engines of the first and second stages are located, instrument section and the nose section of the rocket. In the instrument compartment the blocks of the inertial system for control of rocket are placed, including electronic computers, gyroscopes, accelerometers, the gyrostabilized platform, and also equipment for supplying the corresponding signals for arming.

Calculation according to servicing of rocket after checking of missile bays in containers reveals them and with the aid of crane truck with a load capacity of 5 t are established missile bays on launching assembly. Their mating and fastening to the hoist here occurs. The nose section of the rocket is removed from the container and is placed on the platform, assembled on the wheel or crawler transporter. After these operations the rocket from the area of assembly (the maintenance area) is delivered to the firing position, which in advance is selected and scorched and is prepared in accordance with assigned mission.

Page 73.

Launching assembly with attached on it rocket "Pershing" will

drive up to previously prepared site. The transporter, on which was transported nose section, is stopped in front of starting assembly in such a way that with the aid of the hoist it would be possible to butt nose section with the rocket. The station of checking is located not far from the starting assembly. Calculation according to servicing of rocket connects the cables of the station of checking with the rocket. After this, the rocket is set in position for launch (Fig. 3.10).

Sequence of its installation to this position following. The launching platform, which during the transportation was connected with the rocket, descends on three jacks and automatically is leveled with the aid of a computer. Then launcher beam together with the rocket rises to the vertical position. Rocket is installed on the rotary ring of the launching platform, with the aid of which it is turned along the azimuth in the assigned direction. The cable mast with electric wires and manifolds of the compressed air is fastened to the ring. After the attachment of rocket on its launching platform it is detached from the launcher beam and boom descends.

Operator of station of checking begins checking readiness of rocket for launching. Equipment of rocket and its nose section are checked automatically.

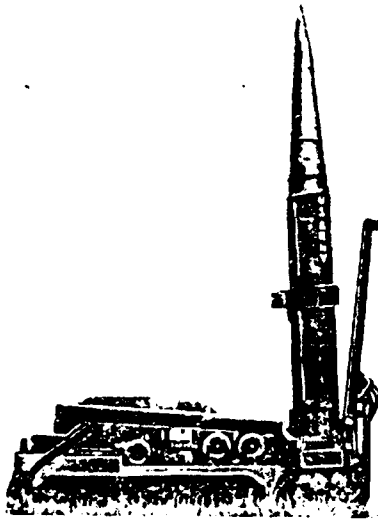

Fig. 3.10. Rocket "Pershing" on launching platform before launch.

Page 74.

Operator with the aid of electronic computer determines basic firing data and introduces these data into onboard system administrations.

Work of entire onboard and ground-based equipment for control is continuously checked by station of checking for purpose of detection of possible malfunctions in rocket system before launching.

Launching of rocket is produced from external command (fire) panel, located in shelter, distant on 150 m from launch unit. With the pressure of starting button electronic component starts countdown. The onboard power sources are started, the gyrostabilized platform is uncaged, which is the main component of onboard system of control of

DOC = 91032704

PAGE

130  
~~37~~

rocket, cable mast is thrown to the side, then is started an engine of the first stage.

Rocket rapidly lifts off the pad, rises vertically upward, and then is turned in direction of target.

Page 75.

#### CHAPTER 4.

#### INCLINED ROCKET LAUNCHING.

Inclined launch, as a rule, is used for controlled and unguided tactical missiles and ZUR.

Special feature of inclined launch - in ratio of thrust and launching weight of rocket. If during a vertical launch for takeoff it is completely sufficient that the thrust would be 1.35 times more than the launching weight, then this reserve thrust is insufficient for the inclined launch. With this ratio of thrust and weight of rocket in the case of launching at angle of  $40^\circ$  to the vertical line the vertical component of thrust would be equal to the weight of rocket and rocket could not rise. It only would slip in the direction of inclination until part of the fuel was burned-out and its weight becomes less than the vertical component of the engine thrust. Therefore considerable engine thrust is necessary for the assignment to rocket of the required inclined trajectory.

#### 1. INCLINED ROCKET LAUNCHERS.

Depending on type of missile complex, as in the case of vertical launching, launchers can be stationary and mobile.

Stationary, for example, are made launchers of antiaircraft missile systems (ZRK) of air defense of country (Fig. 4.1) and ZRK PVO [ IIB- - Air Defense] of ships (Fig. 4.2), since their re-basing in course of combat operations is not provided for. The winged missiles are launched from stationary PU.

Page 76.

Mobile PU can be self-propelled and not self-propelled (towed and carried). Besides mobility PU can be classed depending on the angle of increase and azimuth. These angles during the launching are both variable and constant. On the launcher are placed usually one or several rockets (which increases rate of fire).

Using method of loading rockets PU are by automated, mechanized and manual loading. The automated loading is used in stationary PU. Manual - when the weight of rocket is small, order 60-80 kg. In the remaining cases is used the mechanized loading, i.e., with the participation of man.

Majority of PU has base, on which are placed different devices and mechanisms, that guides, to which are fastened rocket and mechanisms of guidance of guide. PU differ from each other in terms of the great variety of designs of guides. For the small unguided rockets the guides are tubular, chute, grooved, honeycomb, in the form of containers. For the large unguided and guided missiles the guide, as a rule, has girder design.

Most complex are PU for surface-to-air missiles. ZRK must repel the attack of air enemy from any direction. Therefore PU must have circular horizontal (azimuthal) focusing, also, over wide limits vertical (elevation) focusing.

Let us examine equipment of launcher of rockets of inclined launch based on example of PU of antiaircraft missile system (Fig. 4.3).

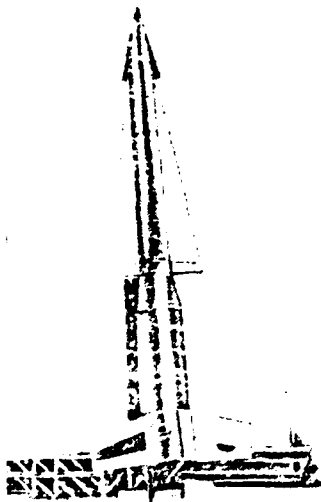

Fig. 4.1. ZUR "Nike-Hercules" on stationary launcher.

Page 77.

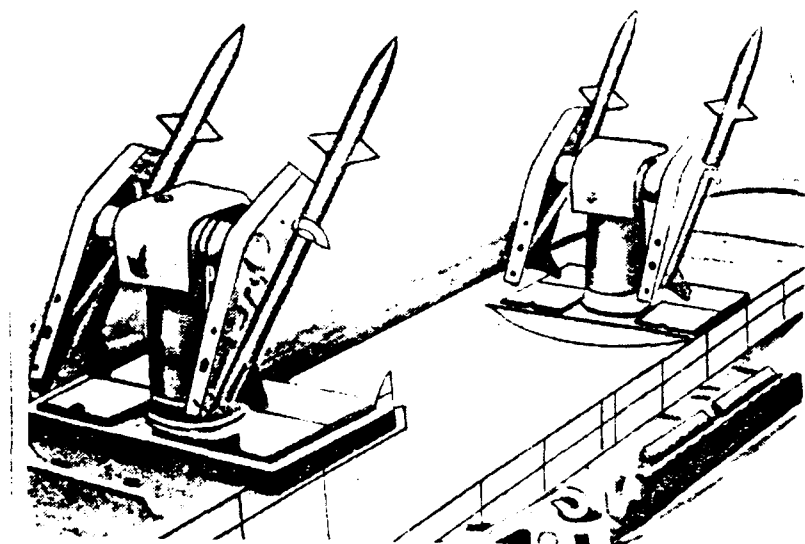

Fig. 4.2. ZUR "Terrier" aboard ship.



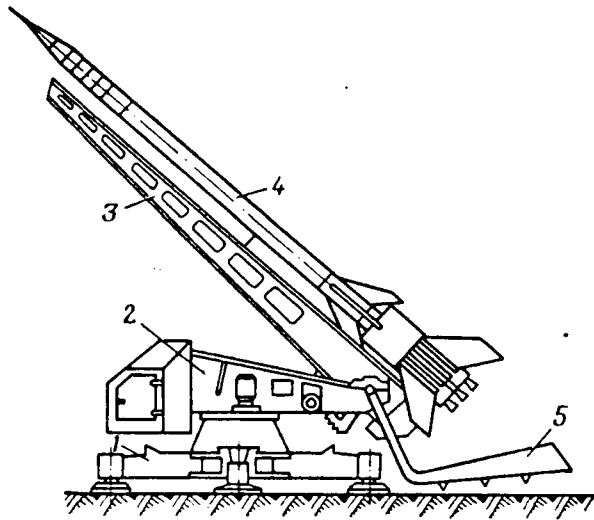

Fig. 4.3. Mobile launcher ZUR: 1- platform; 2 - machine tool; 3 - boom (guide); 4 - rocket; 5 - blast deflector.

Page 78.

Schematic diagram of PU depends on type of actuators, which synchronously work with radars and which set rotary and hoists, to motion.

Actuators can be electrical, hydraulic and pneumatic.

Base PU can be located on specially prepared positions (concreted area, earth, deck of ship) or on transfer platforms (crawler or wheel).

Guide is intended for attachment of rocket prior to launch and for preliminary guidance of rocket to target. The rocket, packed on the guide, is connected with the launching ground equipment by

electrical cable with the separation joints.

In design concept guides are usually rail type cantilever beam, designed for packing one or several rockets. In this case the rocket by its leading elements is located in the longitudinal slots of guide. The basic purpose of guides consists of the guarantee of stable position and required direction of the motion of rocket in the boost period. With the aid of breaking-locking mechanisms the rocket is held on the guide prior to the launch during the guidance and transportation, the rocket can be located from above or from below guide depending on design of PU.

Length of guide is selected from condition of guaranteeing given speed of descent of rocket. It should be noted that during the upper arrangement of rocket due to the tilting moment appears the danger of its impact against the guide (Fig. 4.4a).

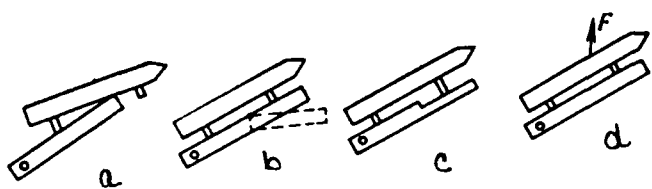

Fig. 4.4. Possible versions of prevention of impacts of rocket against launching rack.

Page 79.

This danger will be greater, the lower the speed of the descent of rocket with guiding PU. In order not to allow the impact of rocket against guide, is used a "breaking" guide (Fig. 4.4b); they make of different length the leading elements of rocket, located on stepped guide (Fig. 4.4c); they compensate the tilting moment by lift formation and by action of the thrust force of rocket at angle toward the guide (Fig. 4.4d).

Blast deflector considerably weakens destructive action of gas jet on launch pad; it is located behind rocket and during rotation guiding of PU along azimuth is moved together with rocket. At zero time by the action of gas jet the reflector is forced against the ground and protects PU from possible tilting.

To supplementary devices is related the undercarriage, with the aid of which is accomplished movement of PU, different devices for disconnection of undercarriage and for installation of PU at the launch site.

## 2. INCLINED ZUR LAUNCH.

Smallest combat unit of anti-aircraft guided missile weapon is the anti-aircraft missile complex (ZRK). Into its composition besides the missiles enter the systems, which ensure detection, identification and selection of target, control of launch and missile flight, launching equipment and different auxiliary equipment, which ensures storage, checking, transportation and the loading of missiles.

In present time in the arsenal of the USA and NATO alliance countries are several forms of ZRK; however, process of firing in them is in principle identical. Here it is possible to isolate the following stages: detection, identification and selection of target for bombardment, determination of the moment of launching, launching ZUR, guidance of ZUR to the selected target.

Different methods of guidance can be used for guidance of ZUR to target. The widest use received remote control and homing.

Remote control (remote guidance) is characterized by fact that control signals are produced by ground-based equipment and are transferred onboard rocket. Remote control can be command or by beam.

Page 80.

In command guidance system the radar of missile guidance station

determines coordinates of target (distance, azimuth, angle of elevation). When target enters into the zone of rocket launch, operator produces rocket launch with pushing of knob. The coordinates of rocket are usually determined by the same radar, as target. The data about the coordinates of rocket and target enter the computer, which determines the errors of the trajectory deviation of rocket and issues steering commands. These commands by the special command radio communication link are transferred onboard the rocket. Onboard a receiving device accepts the radio signals of steering commands, produces their intensification and conversion. Then the voltages of steering commands enter the autopilot, which "turns" the controls of rocket and it is concluded to the kinematic (calculated) trajectory.

Calculated trajectory depends on guidance method. It is selected by such that its curvature, especially in the rendezvous area with the target, would be smallest. In this case to the rocket smaller requirements relative to its maneuverable properties are presented and vectoring error will be minimum.

However, with production by target of active noise interference/jamming to determine distance becomes difficult. Only the angular coordinates of target are determined. In this case missile is guided to the target according to the method of "three-point". With this method of guidance the rocket continuously is held on the line: radar of guidance station - target. Three-point guidance method has very simple instrument realization and, although

it is inferior to other methods in accuracy of guidance, provides the required probability of kill of target in conditions with it active jamming.

For reliable accompaniment of rocket by radar on rocket is installed repeater, which emits response signals, many times exceeding power reflected.

Page 81.

Beam riding missile guidance of radar, continuously directed toward target, makes it possible to considerably simplify equipment of guidance system. Furthermore, this system makes it possible to guide to the target simultaneously several rockets. They all are guided to the target according to the method of "three-point". With the deviation of rocket from SI of the beam of radar in onboard equipment are produced the control signals, which are supplied to the autopilot.

Greater accuracy in comparison with method of "three-point" gives double-beam system. Such systems have two radars, one of which tracks a target and determines its coordinates, another - follows the rocket, determines its coordinates and guides its flight. Just as with the command remote control, the data about the coordinates of target and rocket enter a computer, which compares the true position of rocket in the trajectory with the calculated and produces the error signal. The steering command of the beam of target-tracking radar is produced on the basis of the obtained error signal. Beam begins to change its

position in space. Since onboard system for control of rocket provides its determination on the axis of beam, then rocket will be moved in space together with it to encounter with target.

Overall shortcoming in all remote-control systems is decrease of accuracy of guidance of rocket to target with increase in distance, which is connected with errors in determination of coordinates of rocket and target. This shortcoming homing systems do not have, in which by measure of the closing in of rocket with the target the errors decrease.

Homing is characterized by fact that control signals are produced on board rocket. Homing is provided by special equipment - self-homing head (GSN). GSN makes it possible to accurately determine direction to the target - the line of the sighting: rocket - target. Furthermore, instruments of GSN make it possible to determine the value of the angular velocity of movement in the space of the line of sighting. According to these data onboard computer issues steering commands of rocket, which enter autopilot, are produced the deflection of controls and change in the trajectory of the motion of rocket.

Are distinguished three methods of homing: active, semi-active and passive.

Page 82.

With active homing target is irradiated by electromagnetic energy

from source, which stands on board rocket. The signal reflected from the target is received by receiving antenna of GSN, which usually is utilized also as that transmitting. For an increase in the range of system the directional pattern of antenna is taken as far as possible as narrow as possible. This makes it possible to concentrate more of energy during irradiation of target and to accept the weak signal reflected. The system of angular target tracking GSN provides the continuous coincidence of the axis of antenna with the target. Therefore the axis of antenna determines the position of the line of sighting in space. The data about the angular velocity of the rotation of antenna enter computer and are utilized for the generation of steering commands for rocket.

During semi-active homing irradiator is established on the ground or on any flight vehicle (during guidance of air-to-air missiles). The installation of irradiator on the ground makes it possible to obtain large emitted high-frequency powers, and large dimensions of the transmitting antenna - to concentrate this energy into a very narrow beam. However, equipment of rocket is considerably simplified, facilitated, and respectively it becomes considerably cheaper than with active homing.

With passive homing guidance electromagnetic, thermal, light or any other target emission can be utilized.

Thermal infrared heads increasingly more frequently find use as



sensing elements of GSN.

Use of electromagnetic target emission usually occurs during construction by it of active jamming.

In active and semi-active GSN also is provided for possibility to accept not only reflected signals, but also signals of jamming, since high-frequency field of jamming considerably exceeds field of signal.

Let us examine sequence of launch preparation, launching and guidance of ZUR to target based on example of rocket "Hawk".

Ground-based complex "Hawk", accepted for armament in 1959, is capable of striking individual and group supersonic targets at low and medium altitudes (Fig. 4.5). The combat unit of complex is a battery, in which are included two guidance radar for rockets, six mobile launchers with eighteen rockets, control center and other different auxiliary equipment.

Page 83.

ZUR "Hawk" - single-stage, with single-chamber RDTT, which has two modes of thrust: launching and cruise. These modes are provided due to the grains of charge, which have various forms and composition. Immediately afterward launching and in the acceleration phase engine develops full thrust, which after a certain time decreases, retaining then the constant reduced level to the complete burnup of fuel or the

encounter with target.

Rocket has length of approximately 5 m, diameter of housing 0.35 m and launching weight of 590 kg. On it there are two pairs each of moving and fixed aerodynamic surfaces. Guidance system of rocket - radar, with a semi-active self-homing head. In the sharpened head part, formed by radio-transparent fairing, is located the guidance equipment. The warhead is located further. Common type of warhead, blasts at the target by radio-detonator.

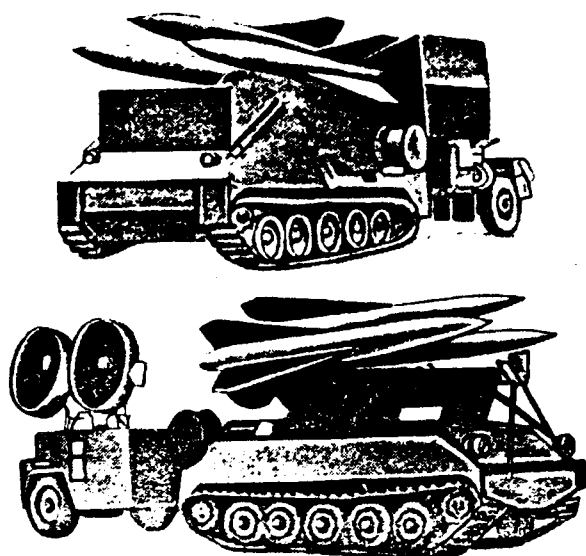

Fig. 4.5. Combat devices of anti-aircraft missile system "Hawk":  
above - self-propelled launcher with search radar for low-altitude  
targets; below - the same, with radar of illumination of target.

Page 84.

From initial position battery can be in a few minutes set up in firing position, from which is provided direct visibility between radars and launchers. The process of setting up the battery consists in the arrangement of all means in the terrain, the alignment of horizontal position of PU, the packing of coupling cables, starting up of electric generators and start of radars.

Two acquisition and target detection radars at high and low altitudes work synchronously, accomplishing circular scan of space. The first works in the pulse, and the second in the continuous mode of radio-wave emission. Information about air situation enters the

control center. In it there are indicators and control panels of fire control. Information processing about discovered targets here occurs, are distinguished their and foreign aircraft and threatening targets, which are subject to bombardment first of all, are selected.

At selected for destruction target is aimed RLS of irradiation. Due to the antenna system all high-frequency energy of transmitter is focused and illuminates the target with a very narrow beam. The reflected energy is accepted by the antenna of the self-homing head. Occurs the "capture" of target by self-homing head (GSN). From this point on, and to destruction of target GSN continuously tracks the target. GSN of rocket possessing increased selectivity can distinguish reflected signals from local fixed objects and from a moving target. This is especially important when firing at low-altitude targets.

Guidance radar continues to continuously track the target and to irradiate it. Launching racks together with the rockets installed on them are turned in the direction of target (with little warning). Antenna of GSN is directed accurately toward the target. At the control center the operator follows the "capture" of target by self-homing head on a specially lit signal panel.

Page 85.

Rocket launching is accomplished upon entry of target into destruct range. Igniters ignite fuel of RDTT, engine begins to work,

providing in the initial moment very great thrust, due to which the rocket leaves from the short guides. After achievement of calculated, supersonic speed the engine thrust decreases to such value so as to maintain speed of the rocket as constant. With the deviation of rocket from the kinematic trajectory of the GSN to the autopilot are given out control signals. The controls of rocket are turned, and it again emerges to the required trajectory. During the approach to the target the radio-detonator operates and sets off the warhead. Radio-detonator must fuze warhead (BCh) at absolutely the specific moment of time, otherwise fragments of BCh can fly before the target, if blasting was premature, or after the target, if the blasting occurred late.

Probability of destruction of target by one rocket is approximately 85%. Therefore for an increase in the probability of destruction of target launching two or even three rockets with a certain small interval between each launching is accomplished.

Each RLS of irradiation provides simultaneous bombardment of one target, a battery - two.

According to reports to the foreign press, in USA is developed a system SAM-D for defense of forces from aircraft and guided missiles. System SAM-D has self-propelled PU with several rockets, system of fire control, control center and group of communications, which are placed on the crawler transporters.

Rocket single-stage, solid-propellant, has range approximately three times greater than rocket "Hawk" (for "Hawk" D=35- 40 km).

Rockets of system SAM-D are stored, transported, and launched from special containers (Fig. 4.6).

Systems of control of rockets of different complexes have much in common. However, if we compare ground-based and ship ZRK, having approximately identical characteristics, then their first and basic difference will be launchers.

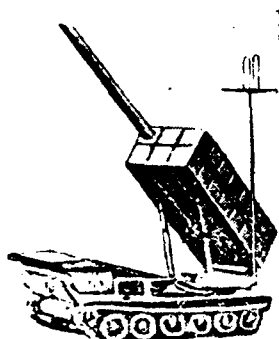

Fig. 4.6. Rocket launching from container (rocket SAM-D).

Page 86.

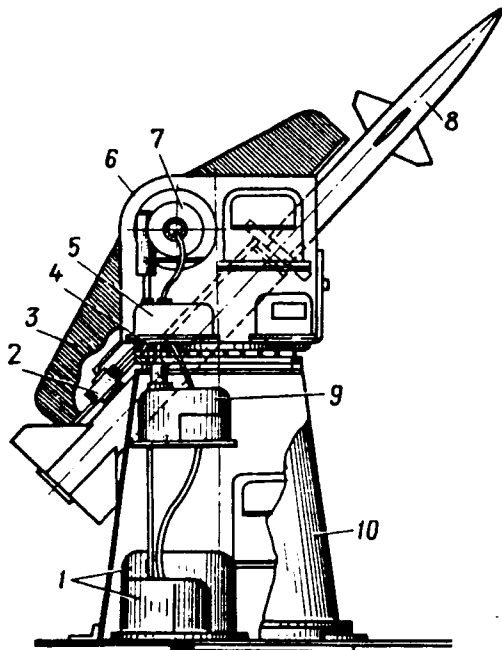

Fig. 4.7. Schematic of sea-going launcher for ZUR of type "Terrier":  
1 - mechanisms of replenishment of hydraulic drives with hydraulic mixture; 2 - lock for holding of rocket on guides; 3 - guide; 4 - gear train of mechanism for horizontal training; 5 - hydraulic motor of mechanism for elevation of guides; 6 - head (rotating part of launcher); 7 - pin with mechanism of elevation; 8 - ZUR; 9 - hydraulic motor of mechanism for horizontal training; 10 - fixed base (pedestal).

Page 87.

Sea-going launchers relate to stationary. They must provide firing during tossing, have maximum angles of traverse; they must be equipped with a system of automatic loading.

Let us examine equipment and operation of sea-going launcher based on example PU ZUR "Terrier" (Fig. 4.7).

Rocket "Terrier" two-stage, solid-propellant.

Launcher for launching of rocket "Terrier" is low hollow cylindrical pedestal, fastened to a plate of foundation. On top on the pedestal is established the step bearing, on which is located the head with the pins protruding from two sides. The guides for the launching of rockets are attached on each pin.

In pedestal drives and rotating mechanisms of head and guides are placed. Head can be turned  $360^\circ$  and produce the required horizontal training for direction of guides. The elevation of guides is accomplished by rotation of pins. Maximum angle of elevation of guides about  $90^\circ$ .

On cruisers in magazines in the vertical position are stored up to 144 rockets (Fig. 4.8a). Supply of rockets to the launchers is automated. For loading the guide of the PU is placed in the vertical position, the cover of the hatch of magazine is shifted also the rocket rises upward with the aid of lifts. During the lift the stirrups of rocket are inserted into the grooves of the guides of PU and move on them to the attachment of rocket to the firing position. For the loading of PU are required approximately 30 s.



Control of all operations, connected with loading, prelaunch servicing procedure and inspection of rockets on PU, and also with launch itself, is produced with the aid of remote systems.

After loading of rocket and connection of its onboard equipment through umbilicals to system of control guiding PU automatically turns in necessary direction, accepts necessary angle of elevation and follows motion of radio beam of radar SNR (Missile Guidance Station).

After missile takeoff guiding launcher frame automatically is placed in vertical position, and head is turned in horizontal plane to necessary value. The process of loading automatically is repeated.

Is possible horizontal arrangement of rockets in magazines and storage (see Fig. 4.8b). This placement of rockets, as can be seen from reports to the foreign press, is forced and caused mainly by insufficient height of the hull of ship and more frequently it is utilized aboard the ships, re-equipped for rocket carriers.

Page 88.

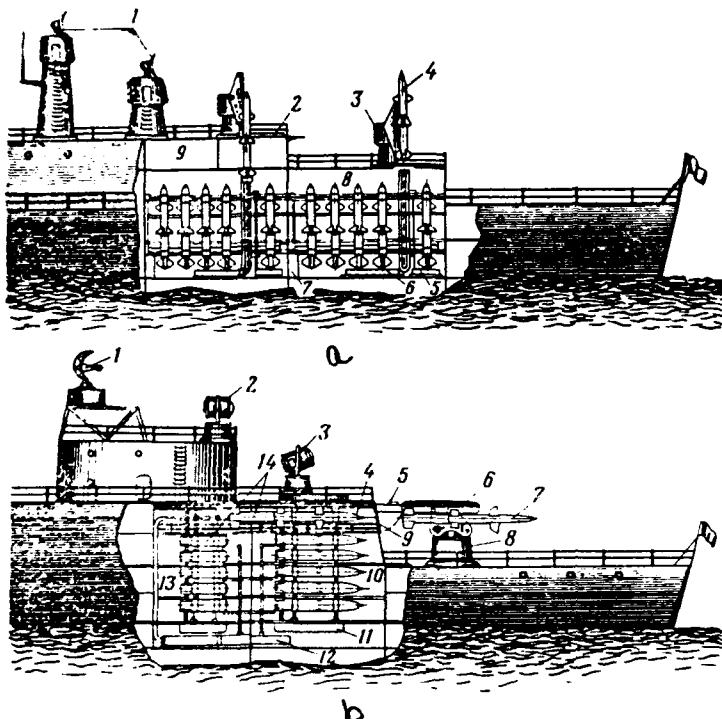

Fig. 4.8. Approximate diagram of arrangement of ZUR aboard ships:  
 a) vertical: 1 - guidance station of ZUR; 2 - hoist system hatch-door; 3 - launcher; 4 - ZUR; 5 - mechanism of system of cross feed; 6 - mechanism of system of vertical supply; 7 - mechanism of system of longitudinal feed; 8 - magazine for storage of ZUR; 9 - post of prelaunch inspection; b) horizontal: 1 - station of target detection; 2 - tracking station of target; 3 - guidance station of ZUR; 4 - post of prelaunch servicing procedure; 5 - operational position of reversing beam; 6 - guiding; 7 - AA guided missile; 8 - launcher; 9 - cover of post of prelaunch servicing procedure; 10 and 13 - magazine; 11 - mechanism of vertical feed; 12 - mechanism of longitudinal feed; 14 - booster engines.

Page 89.

Inclined launch has most miniature surface-to-air missile - ZUR of carried complex "Red AY".

Carried complex "Red AY" relates to troop air defense weapons. It is accepted for the armament of ground and airborne troops, and also marines of the USA. Complex consists of two combat elements: ZUR and launching gun, which fulfills the function of a peculiar launcher (Fig. 4.9). Total weight of complex is 12.7 kg. It is carried by one soldier on a belt behind the back.

Of functions of acquisition system and target designator as means of control of launch of ZUR, it is possible in complex the man, which visually detects target, follows it through optical sight, aiming in this case launcher with ZUR, and launching ZUR is produced.

For rocket launching it is necessary that its infrared self-homing head would take target, about which the one shooting notifies himself by buzzer signal, and also by special index in field of view of sight. After this, the launcher is set in action by pressure on trigger. It includes an onboard power source and causes the inflammation of prelaunch fuel RDTT.

Rocket "Red Eye" - supersonic, that homes; has two-chamber RDTT with two modes of thrust - prelaunch and cruise. Prelaunch mode is necessary in order to expel rocket from the launching tube to a safe distance for firing. After this is switched on the cruising mode.

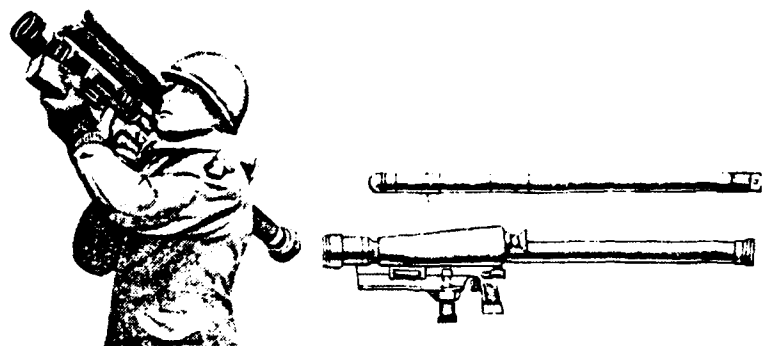

Fig. 4.9. ZRK "Red Eye".

Page 90.

ZUR has two pairs of moving and fixed aerodynamic surfaces. Fixed surfaces are opened immediately after flight of ZUR from the guns, the moving (surfaces) control rocket flight.

Firing distance of 3.6 km, altitude of target to 1.5 km. Warhead is common.

Launching gun weighs about 4 kg and consist of a glass-plastic tube, an optical sight, and the stock. In the stock are assembled the power source, buzzer interrupter and lever with the starter.

### 3. INCLINED TACTICAL MISSILE LAUNCH.

In this class of rockets besides those controlled are used unguided combat missiles. Being inferior to the guided missiles in the accuracy of firing, the unguided rockets have a number of essential advantages, such, as simplicity of the equipment, relatively small weight and dimensions, high combat readiness and rate of fire, low cost of production.

Transportation and launching of these rockets do not present great difficulties. The launchers of these rockets have several guides, assembled into separate blocks. For mobility they are installed on wheeled vehicles and crawler transporters. The fire control is produced from a special panel, located in a compartment of

the vehicle. Driver can establish any order of firing: single, double, triple shots and salvo fire. Typical for this type of weapon are our guard mortars, which were being used during the Great Patriotic War and called among the people "Katyusha" rocket launchers. They effectively strike targets at distances of several kilometers. At larger distances the effectiveness of their application sharply is reduced due to large scattering.

For effect on troops and objects of the enemy, located in tactical depth and in the rear of the enemy, in arsenal consist rockets and winged missiles, which have firing distances from 100 to 800 km and more. Thus, for instance, in the arsenal of the USA are the rockets "Honest John", "Sergeant", and "Lance" (see Table 3).

Page 91.

Launchings of these rockets are produced from inclined launchers with different slope angles to the horizon, besides the rocket "Sergeant", whose angle of slope of guide is determined also composes  $75^\circ$  (Fig. 4.10).

Let us examine process of launch preparation and rocket launching of "Sergeant".

In missile complex besides launcher with control panel of launching are included station of pre-firing check even two transporters of containers with missile bays. Entire missile complex

"Sergeant" is placed in four biaxial semitrailers, towed by 5th wheel truck tractors of increased trafficability (Fig. 4.11). Time of missile preparation for launching is approximately 50 min.

Table 3. Basic tactical and technical data of tactical missiles.

4) Наименование данных	2) "Онест Джон"	3) "Сержант"	4) "Ланс"
5) Стартовый вес, кг	2140	4500	1400
6) Размеры, м:			
длина	10,5	7,5	6,1
диаметр	0,76	0,8	0,56
7) Дальность действия, км	7,5—37	40—140	5—140
8) Система наведения	9) Неуправляемая	10) Программируемая, инерциальная	10) Программируемая, инерциальная
12) Двигательная установка	РДТТ	РДТТ	11) Пятикамерный ЖРД
14) Дополнительные сведения	15) Стабилизируется вращением, создаваемым специальными двигателями и скошенными стабилизаторами. Серийное производство прекращено	16) Аэродинамическая система корректировки скорости	17) Система транспортабельна по воздуху на самолетах и вертолетах

Key: (1). Designation of data. (2). "Honest John". (3). "Sergeant". (4). "Lance". (5). Starting weight kg. (6). Dimensions, m: length diameter. (7). Range, km. (8). Guidance system. (9). Not guided. (10). Programmed, inertial. (11). Programmed, inertial. (12). Engine installation. (13). Five-chamber ZhRD [ ЖРД - liquid propellant rocket engine]. (14). Supplementary information. (15). It is stabilized by rotation, created by special engines and chamfered stabilizers. Series production is ended. (16). Aerodynamic system of correction of speed. (17). System is transportable by air on aircraft and helicopters.

Page 92.

With an announcement for combat readiness begins checking all assemblies and systems of rocket, which is located at the maintenance



area. Sections are checked directly in the containers, which have external joints. After checkings the battery is advanced to the indicated launch position.

First the launcher starts being turned. The power gas-turbine power station, attached to the launcher, is started for this, rod for the assembly of rocket is separated and is set in action the device of azimuthal training. Launcher with the aid of three hydraulic jacks rises to height on the order of 0.45 m and is aligned in the horizontal plane (Fig. 4.12). The precomputations for guidance of PU according to azimuth are made after this. The orientation of PU along the azimuth is produced with the aid of the theodolites.

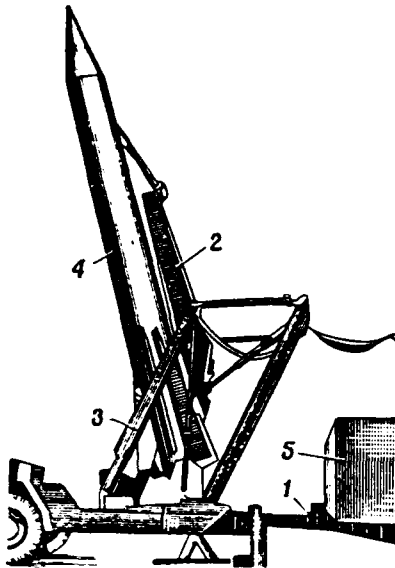

Fig. 4.10. Launcher with inclined launch for a guided missile: 1 - semitrailer; 2 - guide; 3 - lifting mechanism of boom; 4 - rocket; 5 - compartment of control.

Page 93.

Calculation of six people performs all these operations in 5-7 min.

Containers with missile bays are brought to launcher. Structurally rocket "Sergeant" consists of three sections: head, central and tail. In the nose section the warhead is placed, in the central - control system, in the tail - power plant. Head and central sections are made from aluminum alloy, and tail - made of thin steel in the form of three welded between themselves cylinders. Four controls are located on the external surface of tail section.

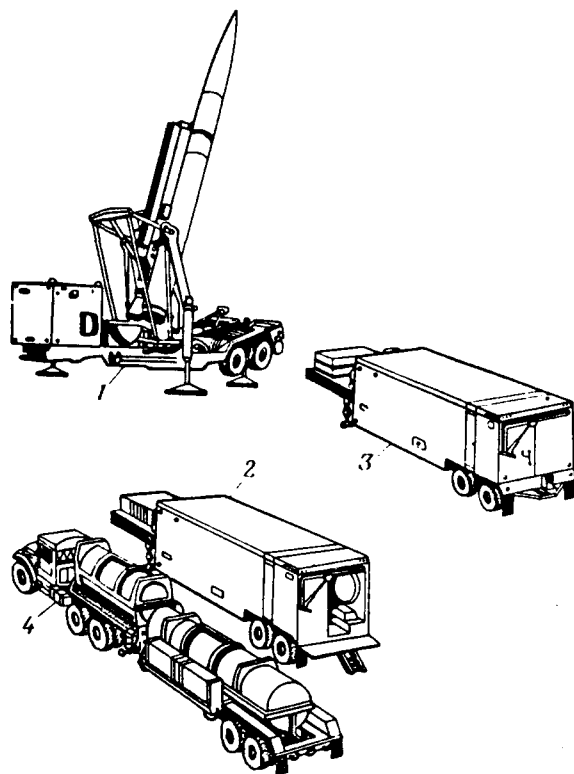

Fig. 4.11. Composition of missile complex "Sergeant": 1 - launcher with rocket; 2 - machine for autonomous tests; 3 - divisional field repair-control station; 4 - tractor truck with semitrailer for transportation of containers with elements of rocket.

For an increase in the effectiveness in the action of control surface are four jet nozzles.

Sections extracted from containers are collected on the PU. The guide PU, equipped with an electrohydraulic lifting mechanism, is utilized as the lift. The process of assembly continues for 10 min. Simultaneously with the assembly into onboard computer the necessary data for the guidance of rockets to the target are introduced

manually.

All necessary calculations for rocket launching are produced directly at launch site on basis of indications, coming from higher headquarters.

After assembly through control station an automatic complex pre-firing check of rocket is produced by launch. The flight program is automatically introduced into onboard system of control of rocket, and the designed bearing angle is transferred to the control elements of the mechanism of rotation of PU.

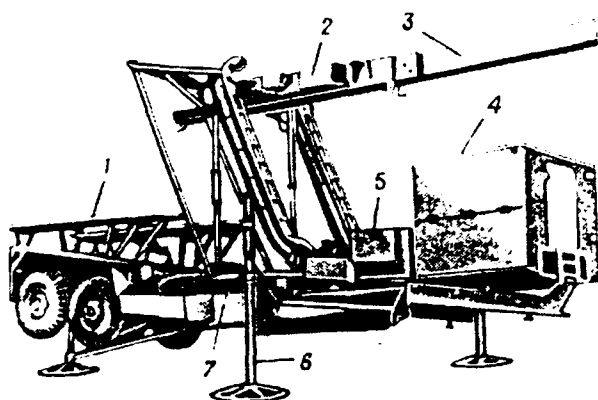

Fig. 4.12. Launcher for rocket "Sergeant": 1 - chassis; 2 - beam; 3 - boom; 4 - control station for launch; 5 - gas-turbine power station; 6 - hydraulic jack; 7 - rotatable loop.

Page 95.

When all preparatory operations are completed, operator, who controls the launch, replaces safety two-pin plug with combat and switches on automatic mechanism for reading of prelaunch time, designed for 20 min.

At 6 min prior to launch all personnel, except operator of launch, leaves launch site, and signal panels on panel for fire control post are switched on at 3 min prior and operator of launch transfers to a previously prepared shelter, situated approximately 75 m from launcher. Hence with the aid of a movable panel he oversees the launching of rocket and if necessary at any moment can stop launch preparation.

At 80 s prior to launch is accomplished final control along

azimuth and to rocket is given angle of elevation of  $5^\circ$ , and in 30 s -  $75^\circ$ . At this angle of elevation all launches occur independent of nature and distance of target.

After rocket launching control of its flight is accomplished by inertial system for control. For regulating the flight speed of rocket at the end of powered flight trajectory lobe speed brakes are utilized. Engine cutoff in flight does not occur. Control system issues the commands, under effect of which the controls of rocket are turned and speed brakes are produced or are removed.

Rocket "Sergeant" relates to second generation of tactical missiles. Third generation rocket is rocket "Lance" (Fig. 4.13).

Series production of missile "Lance" is intended to begin in 1972 for replacing unguided rockets "Honest John" and tactical ballistic missiles "Sergeant", long ago cut from production.

Rocket "Lance" - single-stage, with liquid fuel engine. Rocket is loaded with fuel at the plant and can for a long time be located in the filled state. It is launched from a self-propelled crawler or wheel unit.

As the launching equipment they intend to utilize modified launcher of ship-to-air missile "Terrier".

In USA is developed new version of troop system "Lance" with increased flying range.

In examination of inclined launch of tactical missiles one cannot fail to mention cruise missiles, frequently called "winged missiles".

In appearance cruise missiles resemble contemporary aircraft, but is considerably simpler on its equipment, since they are intended for one-time combat use. From them is required simplicity of design of the separate assemblies, simplicity of technology of manufacture and cheapness of production.

Trajectory of flight of winged missile differs from the trajectory of guided missiles of all forms. Its basic part passes to a specific altitude with a virtually constant velocity, that is one of the shortcomings. The small trajectory height of winged missile makes it vulnerable by means of PVO virtually in the entire flight trajectory. True, this shortcoming can be to some degree compensated by their mass application.

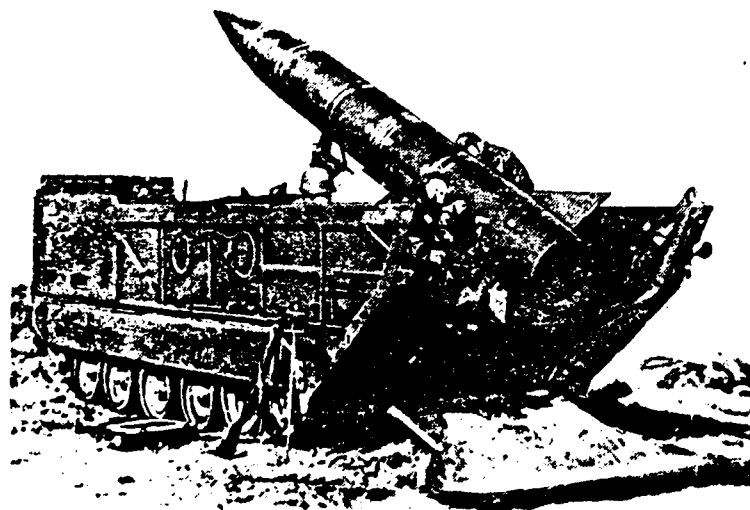

Fig. 4.13. Tactical ballistic missile "Lance" on a self-propelled unit.

Page 97.

Basic advantage of winged missile is the fact that they can throw charge of necessary power to an assigned distance with comparatively low fuel consumption. Their launching is accomplished from inclined launchers - guides at a specific angle to the horizon. The necessary speed for takeoff from the launch site for winged missiles is composed with the aid of accelerators.

During Second World War instead of accelerators for winged missiles "Fau rockets (v-1,v-2)-y" Germans used the bulky catapult, in engine device of which was utilized the energy of the decomposition of hydrogen peroxide. On the guides of this catapult the winged missile collected the necessary speed and moved further due to the cruise



thrust.

Launch preparation and launch of winged missiles is the most convenient of all to examine based on an example of the last model of the winged missile "Mace" (Fig. 4.14), which is a pilotless tactical bomber with a highly placed sweptback wing. Projectile has one turbojet engine (TRD [ TPД - turbojet engine]). As the fuel is utilized kerosene.

Quantity of auxiliary equipment considerably decreases due to absence of ground equipment for control of projectile.

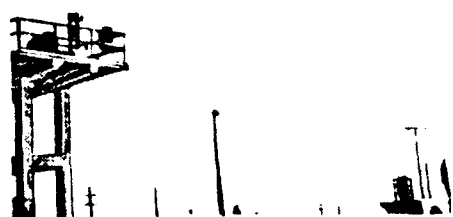
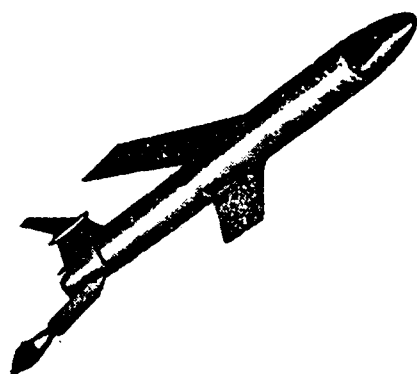

Fig. 4.14. Launching of cruise missile "Mace".

This substantially facilitates use of the system. Projectiles "Mace" are located on small launch sites. They are supplied to the launch sites in the assembled form. Preparation time of projectile for launch at the launch sites 1 h.

Before launching crew services winged missile with fuel and compressed air, are installed a booster engine, the warhead, fuse, program unit of control system and then final testing is carried out.

Upon command "launch" is started first turbojet engine from special starter, which is located on launcher (approximately 3 min prior to start). When the engine thrust reaches the specific value, onboard equipment converts to the supply from onboard sources. Upon

achievement of the nominal revolutions of turbojet engine the charge of the booster is ignited. By the force of thrust is broken the clamp bolt to the launcher, and winged missile takes off into air.

Stability of winged missile at moment of launching is provided due to work of the accelerator. Time of its operation is approximately 2 s. Developed thrust of approximately 55 t. After jettisoning of accelerator the thrust is provided by turbojet engine.

With deviation of winged missile from predetermined course control system corrects error signal, which enters into autopilot in the form control voltages and returns projectile to predetermined trajectory.

Control system makes it possible to produce flight of winged missile at very low altitudes, less than 300 m, which considerably facilitates overcoming air defense systems. Possible to also program flight altitude along an assigned route.

System of control mounted in the form of separate blocks is possible to place in winged missile one or another system depending on situation and decided task.

Control system can be two types. The first version of a system of control - inertial, and the second - is the method utilized of the comparison of two images of the terrain: the photographed layout of

terrain prior to the flight and received (photographed) in flight.

Page 99.

Winged missile during approach to target enters into dive and in immediate proximity of target fuse sets off the warhead. Is feasible contact blasting of warhead.

Ship cruise missiles are very similar to ground-based. A latter modification of an American cruise missile is rocket "Regulus-2" (Fig. 4.15). Its launching weight is 10.4 t the length of fuselage 17.4 m with a diameter of approximately 1.8 m and the span of wings 6.1 m. The outer planes of wing are made folding for facilitating arrangement on ship or submarine. From storage cruise missile rises on elevators and with the aid of a rotary crane is installed on PU.

PU is sufficiently simple girder design. Usually two short guides of PU before launching of cruise missile are established on the preset angle of increase with the aid of a special electro- or pneumohydraulic drive.

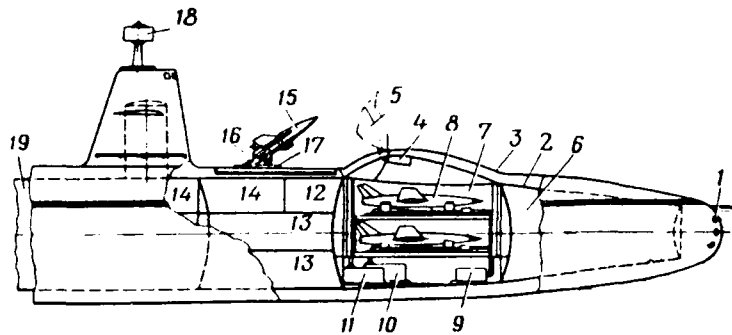

Fig. 4.15. Approximate schematic of arrangement of cruise missiles on nuclear powered submarine: 1 - bow torpedo tube; 2 - durable housing; 3 - light housing; 4 - mechanism of opening of cover of hatch of hangar; 5 - hatch cover at moment of supplying cruise missile to launching device or into hangar; 6 - compartment of torpedo tubes; 7 - hangar; 8 - cruise missile; 9 - mechanism of system of longitudinal supply; 10 - mechanism of system of cross feed; 11 - mechanism of system of vertical supply; 12 - control station of feed system; 13 - living quarters; 14 - posts of prelaunch inspection and launch; 15 - cruise missile in position for launch; 16 - guides of launching device; 17 - mechanism for rotation and lift of guides; 18 - antenna post RLS; 19 - reactor compartment.

Page 100.

System of control of "Regulus-2" is combined: during the first stage - command, on beam, is further - homing.

Before launching is started TRD with thrust with afterburning up to 7 t. During the launching of two boosters (RDTT) cruise missile descends with PU and in 4 s their operation composes supersonic flight

speed. The maximum speed, which it can develop, is 560 m/s at altitude 16 km. Flying range up to 1000 km. With the use of external fuel tanks the flying range of "Regulus-2" increases to 1600 km.

#### 4. LAUNCH OF AIRCRAFT MISSILES.

Launchers of aircraft missiles and their launching almost in no way differ from launchers, installed on different transportation means. Aircraft missiles depending on purpose are divided into two large classes: "air - ground" and "air - air". By air-to-surface missiles are surprised ground-based or underwater targets, and air-to-air missiles are utilized for destruction of aerial targets.

Just as tactical missiles with inclined start, aircraft missiles are controlled and not guided. The guided missiles have larger effective casualty radius and, consequently, also large sizes. To their number are referred air-launched cruise missiles and ballistic air-to-surface missiles and some air-to-air missiles. Let us examine the special features of launching these rockets.

#### Launching Air-Launched Cruise Missiles.

In American Air Force for armament of bombers of type B-52 is used rocket "Hound Dog". With this rocket it is possible to strike targets at the large distance from objectives shielded by means of PVO. The range of rocket is more than 1000 km.

Page 101.

In England for these purposes is utilized rocket "Blue Steel". The distance of it much less composes 320 km. As the carrier are utilized "Volcano" bombers.

Both rockets have inertial system for control with use of data of navigation equipment of aircraft. To rocket can be predetermined program of any flight profile at any altitudes, beginning from the ceiling of combat employment to low altitudes, and is also provided for maneuvering with the target approach. All this complicates defence problem of objective. Both rockets are carriers of a nuclear charge.

Aircraft B-52 can bear two - four rockets "Hound Dog". They are hung on pylons between the internal engine nacelles and the fuselage. The equipment for the adjustment of guidance system is located within the pylon. For the control of rockets on board the bomber two panels are established. From one panel is accomplished launching and the inspection of the work of the engines of rockets, from another - the adjustment of the guidance system and dropping of rockets. The precomputation of course and flight altitude of "Hound Dog" is produced with the aid of aircraft calculating equipment; obtained data are introduced into the memory unit of onboard system for control.

During launching separation of rocket and launching TRD occurs. Engine is suspended in the nacelle, in the tail part of the missile

body (Fig. 4.16). It works on the same propellant, as the aircraft -  
carrier.





Fig. 4.16. Rocket "Hound Dog" under fuselage of aircraft.

Page 102.

After separation the inertial system for control accomplishes the stabilization of rocket, and then programmed control. But in target area depending on the introduced program cruise missile accomplishes the nose dive from large height or even, on the contrary, it approaches the target at low altitudes.

Launching aviation air-to-air missiles.

Air-to-air missiles can be controlled and not guided. In essence they arm fighter-interceptors, which are equipped with instruments for searching out air enemy and conducting combat with it under any meteorological conditions outside of target visibility. The rockets, at first not guided, and then controlled, strongly made room for small arms and aircraft cannons, since they have more powerful warheads and possess good accuracy of guidance, which considerably raised the probability of the destruction of aerial targets.

Unguided rockets are very simple in their design. In spite of simple device the unguided rockets possess sufficiently high effectiveness, which is achieved by the application of salvo fire. For example, the American unguided rocket "Mighty Mouse" of the bore of 70 mm, with a weight of 8.5 kg and by a length of 1.2 m is launched on the target from a distance up to 2 km and more.

On fighter these rockets are established in special container - cassette, from which they are launched. In all in the container of aircraft are established 24 rockets. With salvo fire is feasible launching 12 or all 24 rockets.

For increase in firepower unguided rockets can be equipped with atomic warheads of low power.

However, unguided air-to-air missiles have essential shortcoming - it is not possible to correct their position in period of approach with target. This fact caused appearance of guided missiles, which possess greater accuracy of firing. These rockets in contrast to the unguided rockets have a control system.

Page 103.

Control of rocket can be accomplished both with the aid of aircraft onboard equipment and also autonomously (by homing). Self-homing heads can be thermal or radar. The application of a combined guidance system is possible. In this case at the first moment of flight the

flight control of rocket is accomplished with the aid of aircraft equipment, further approach is produced with the aid of a self-homing head.

Launching of rockets from aircraft is produced from specially equipped starters, from securely fastened guides of different construction. The external mechanisms of launchers for decreasing the drag are closed by fairings. Rocket is located prior to start on the guides and with the aid of fastening locks is rigidly attached.

When mark from target occupies specific position on screen of indicator of radio sight, pilot presses trigger button. The engines of rockets are started, the locks of fastening rocket release it, and it according to the guides begins motion. The missile preliminarily prepared for takeoff is guided to the target by radio beam or upon commands of a self-homing head.

Launching airborne ballistic rockets.

In foreign press it is reported that technical progress in field of creation of guidance systems and engine installations by the 80's will make it possible to create strategic ballistic air-to-surface missiles with a range of 8800 km. The carrier of such rockets, probably, will be an aircraft of the C-5a type "Galaxy", on which it will be possible to place 10-12 similar rockets.

Aircraft, armed with ballistic missiles, is a peculiar flying launcher, which possesses such important advantages as mobility, invulnerability and possibility of rapid retargetting. For the development of ballistic missiles of this class in the USA were spent many efforts, as a result of which was created rocket "Skybolt". However, it did not justify itself, and its further development was ended. It is of definite interest to become acquainted with the rocket "Skybolt", since it is possible to consider it typical ballistic aviation missile.

Page 104.

Rocket "Skybolt" was a two-stage with engines on solid fuel with a calculated distance of 1600-2400 km (Fig. 4.17). Launching was designed from aircraft, which fly at an altitude of 10-14 km with a subsonic speed of 960 km/h. The firing of first-stage engine had to occur at a safe distance from the aircraft. The flight of the launched rocket had to pass at a rate of 2 km/s along the ballistic trajectory at an altitude of 320-480 km after launching above the previously selected calculated points with the agreed to coordinates.

For airborne ballistic rockets of the 80's with an ideal guidance system launching can pass above any arbitrary point, since onboard navigation aid of carrier aircraft will continuously determine its coordinates and necessary data for destruction of specific target will be introduced during missile preparation for launching into its onboard calculator.

History of development of different types of weapons shows that for replacement of an old weapon comes a new, that more advanced and effective one.

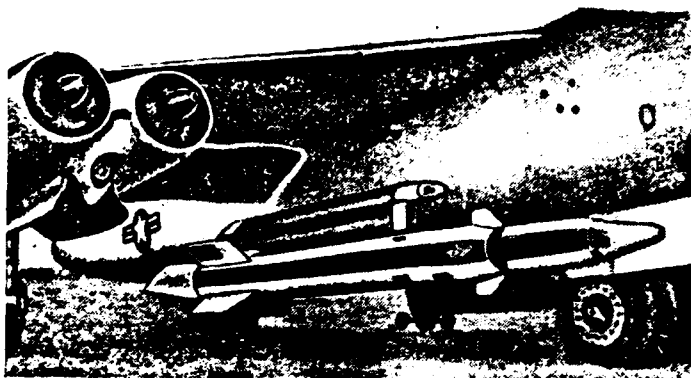

Fig. 4.17. Exterior view of airborne ballistic rocket "Skybolt".

Page 105.

Under contemporary conditions as this, weapons are considered rockets, especially controlled, whose combat characteristics differ significantly from combat characteristics of artillery, torpedo and aviation weaponry.

Operations of preparation and rocket launching are improved and will be improved. The trend of development of rocket weapon is such, which on these operations is expended increasingly less time, these operations are automated.

Over long term necessity for many preparatory operations to launching will fall, which will even more increase combat readiness of rocket weapon.

Page 106.

## REFERENCES.

- Алешков М. Н., Жуков И. И. и др. Физические основы ракетного оружия. Воениздат, 1965.
- Белавин Н. И., Куплянский В. М. Главное оружие флота. Воениздат, 1965.
- Бургесс Э. Баллистические ракеты дальнего действия. Воениздат, 1963.
- Ефимов М. В. Прицеливание баллистических ракет. Воениздат, 1968.
- Латухин А. Н. Боевые управляемые ракеты. Воениздат, 1968.
- Маленькая энциклопедия «Космонавтика». Изд-во «Советская энциклопедия», 1968.
- Патрикеев М. В. Пуск управляемых ракет. Воениздат, 1967.
- Пересада С. А. Зенитное управляемое ракетное оружие. Воениздат, 1968.
- Пронин Л. Н. Баллистические ракеты. Воениздат, 1969.
- Пульманов Н. В. Дизель-компрессоры со свободподвижущимися поршнями. Машгиз, 1959.
- Руденко Р. В. Грузоподъемные машины. Машгиз, 1957.
- Сомик В. В., Коньков Н. Г. Автомат проверяет самолет и ракету. Воениздат, 1967.
- Феодосьев В. И., Сняреву Г. Б. Введение в ракетную технику. Оборонгиз, 1960.
- Журналы: «Вопросы ракетной техники», «Техника и вооружение» за 1965—1971 гг.
- Иностранные журналы по вопросам ракетной техники за 1965—1971 гг.

Page 107.

No Typing.