

AD-A236 431



STUDY
PROJECT

The views expressed in this paper are those of the author and do not necessarily reflect the views of the Department of Defense or any of its agencies. This document may not be released for open publication until it has been cleared by the appropriate military service or government agency.

UNITED STATES ARMY SPECIAL FORCES:
FROM A DECADE OF DEVELOPMENT TO A SUSTAINED FUTURE

BY

LIEUTENANT COLONEL CORSON L. HILTON
United States Army

DTIC
ELECTE
MAY 20 1991

S C D

DISTRIBUTION STATEMENT A: Approved for public
release; distribution is unlimited.

USANC CLASS OF 1991



U.S. ARMY WAR COLLEGE, CARLISLE BARRACKS, PA 17013-5050

91-00114



91 5 20 041

REPORT DOCUMENTATION PAGE

Form Approved
OMB No. 0704-0188

1a. REPORT SECURITY CLASSIFICATION Unclassified		1b. RESTRICTIVE MARKINGS	
2a. SECURITY CLASSIFICATION AUTHORITY		3. DISTRIBUTION/AVAILABILITY OF REPORT Approved for public release. Distribution is unlimited.	
2b. DECLASSIFICATION/DOWNGRADING SCHEDULE		4. PERFORMING ORGANIZATION REPORT NUMBER(S)	
4. PERFORMING ORGANIZATION REPORT NUMBER(S)		5. MONITORING ORGANIZATION REPORT NUMBER(S)	
6a. NAME OF PERFORMING ORGANIZATION U.S. Army War College	6b. OFFICE SYMBOL (if applicable)	7a. NAME OF MONITORING ORGANIZATION	
6c. ADDRESS (City, State, and ZIP Code) Carlisle Barracks, PA 17013-5050		7b. ADDRESS (City, State, and ZIP Code)	
8a. NAME OF FUNDING/SPONSORING ORGANIZATION	8b. OFFICE SYMBOL (if applicable)	9. PROCUREMENT INSTRUMENT IDENTIFICATION NUMBER	
8c. ADDRESS (City, State, and ZIP Code)		10. SOURCE OF FUNDING NUMBERS	
		PROGRAM ELEMENT NO.	PROJECT NO.
		TASK NO.	WORK UNIT ACCESSION NO.
11. TITLE (Include Security Classification) United States Army Special Forces: From a Decade of Development to a Sustained Future			
12. PERSONAL AUTHOR(S) Hilton, Corson L., LTC, USA			
13a. TYPE OF REPORT Final	13b. TIME COVERED FROM _____ TO _____	14. DATE OF REPORT (Year, Month, Day) 1991 April 02	15. PAGE COUNT 51
16. SUPPLEMENTARY NOTATION			
17. COSATI CODES		18. SUBJECT TERMS (Continue on reverse if necessary and identify by block number)	
FIELD	GROUP	SUB-GROUP	
19. ABSTRACT (Continue on reverse if necessary and identify by block number) The decision in 1978 to retain the 7th Special Forces Group (Airborne) marked the end of almost two decades of decline of Special Forces' structure. Revised national strategy and robust revitalization programs have thrust Special Forces into a new era. This study will provide a review of the reasons for Special Forces' resurgence, the programs that improved Special Forces, and a summary of Special Forces' current status. The paper will then analyze Special Forces with a view toward improvement and Special Forces' utility in the future. The primary purpose of this study is to provide a compendium of the actions that have improved Special Forces, and to provoke dialogue and action to continue that improvement. It is recommended that the Army Special Operations Command, under the authority of the United States Special Operations Command, initiate actions to develop a plan for Special Forces as part of the Army of the future.			
20. DISTRIBUTION/AVAILABILITY OF ABSTRACT <input checked="" type="checkbox"/> UNCLASSIFIED/UNLIMITED <input type="checkbox"/> SAME AS RPT. <input type="checkbox"/> DTIC USERS		21. ABSTRACT SECURITY CLASSIFICATION Unclassified	
22a. NAME OF RESPONSIBLE INDIVIDUAL Mr. D. H. Dearth		22b. TELEPHONE (Include Area Code) (717) 245-3991	22c. OFFICE SYMBOL AWCD

USAWC MILITARY STUDIES PROGRAM PAPER

The views expressed in this paper are those of the author and do not necessarily reflect the views of the Department of Defense or any of its agencies. This document may not be released for open publication until it has been cleared by the appropriate military service or government agency.

UNITED STATES ARMY SPECIAL FORCES:
FROM A DECADE OF DEVELOPMENT TO A SUSTAINED FUTURE

AN INDIVIDUAL STUDY PROJECT

by

Lieutenant Colonel Corson L. Hilton
United States Army

Mr. Douglas H. Dearth
Project Advisor

U.S. Army War College
Carlisle Barracks, Pennsylvania 17013

Accession For	
ERIC GRA&I	<input checked="" type="checkbox"/>
DTIC TAB	<input type="checkbox"/>
Unannounced	<input type="checkbox"/>
Justification	
by _____	
Distribution/	
Availability Codes	
Dist	Avail and/or Special
A-1	

DISTRIBUTION STATEMENT A: Approved for public release; distribution is unlimited.



ABSTRACT

AUTHOR: Corson L. Hilton, Lt. Col., USA

TITLE: United States Army Special Forces:
From a Decade of Development to a Sustained Future

FORMAT: Individual Study Project

Date: 2 April 1991 **PAGES:** 51 **CLASSIFICATION:** Unclassified

The decision in 1978 to retain the 7th Special Forces Group (Airborne) marked the end of almost two decades of decline of Special Forces' structure. Revised national strategy and robust revitalization programs have thrust Special Forces into a new era. This study will provide a review of the reasons for Special Forces' resurgence, the programs that improved Special Forces, and a summary of Special Forces' current status. The paper will then analyze Special Forces with a view toward improvement and Special Forces' utility in the future. The primary purpose of this study is to provide a compendium of the actions that have improved Special Forces, and to provoke dialogue and action to continue that improvement. It is recommended that the Army Special Operations Command, under the authority of the United States Special Operations Command, initiate actions to develop a plan for Special Forces as part of the Army of the future.

INTRODUCTION

This study has two purposes: to review the activities of the past decade that have led to the current organization and structure of the United States Army Special Forces; and to determine if Special Forces is best postured to satisfy current and future requirements. The author's intent is to provoke dialogue and action to ensure continued enhancement and sustainment of Army Special Forces' hard earned vitality and viability.

The Army's Special Forces has improved dynamically and dramatically since 1980. After consideration in 1978 of reducing the Army Special Forces' structure to two active component groups, the Army today is completing the activation of its fifth active component group. The future portends reductions in Army forces and a concurrent elimination of many programs, and probably a revision of national strategy. The military forces to implement that strategy are sure to be reviewed. In this context, it is now prudent to review the present organization of Special Forces and its future requirements. This will be accomplished by first chronicling the major activities and programs that have improved Special Forces organization and structure since 1980. It is important to understand why Special Forces has been enhanced so dramatically as a tool to understanding its future utility. After a review of the past and a "snapshot of the present," the author will analyze the future

requirements for Army Special Forces. Based on this determination, the study will provide recommendations for actions to improve the organization and maintain the vitality of Army Special Forces through the 1990s.

Improvement of Special Forces has been a high priority for the U.S. Army over the past ten years. As this study will show, the Army has invested an extraordinary amount of initiative, development, and effort in the resurgence of Special Forces. It is important that these efforts continue, and that the imperatives of national strategy for the employment of special operations forces (and Special Forces) continue to be effectively and efficiently supported.

This study is necessarily vague in certain areas to avoid classified matters. Discussion of classified material is not essential to accomplish the purpose of this paper. An unclassified paper, further, is more easily circulated among all those who should be involved in the dialogue for the sustainment of Special Forces. This study will comment on Special Forces doctrine, organization and structure. It will not, however, comment on joint command and control, other than to acknowledge the prominence that system has in the Special Forces environment. The scope of this study will be restricted to those activities the Army may undertake to improve and sustain the robust Special Forces it has today.

THE PAST

Special Forces was comprised in 1966 of seven active component groups: the 1st, 3rd, 5th, 6th, 7th, 8th, and 10th Special Forces Groups (Airborne).¹ Four of these groups, the 1st, 3rd, 6th, and 8th, were further augmented and designated Special Action Forces (SAF).² By 1980, Special Forces had been reduced to three active component groups and an authorized strength of about 3600 personnel in the Special Forces organizations.³ These three groups were commanded by the U.S. Army Forces Command (FORSCOM) through the United States Army John F. Kennedy Center for Military Assistance (USAJFKCMA). Special Forces training and doctrine were provided and developed by the Institute for Military Assistance, which was subordinate to the commander of the USAJFKCMA, but also was subordinate to the U.S. Army Training and Doctrine Command (TRADOC).⁴

The Army reduced Special Forces' structure in the 1970s because of the perceived need to confront the Soviet-Warsaw Pact Forces, and a withdrawal from extensive foreign internal defense and development operations. This was an era of constrained resources, exacerbated by the loss of a relatively inexpensive manpower pool with the repeal of Selective Service under President Nixon in 1972. The doctrinal thrust of the Army was toward a structure dominated by heavy (armor/mechanized) forces and projected forward-deployed combat power in Central Europe. The resulting Special Forces structure of three groups appeared

adequate to meet the unconventional warfare requirements of the 1970s.

Special Forces reflected the lower priority that had been placed on it. Single units were tasked to conduct operations in multiple theaters, with obsolescent equipment, and at marginal manning levels. Command and control was cumbersome and not well understood by the Army. Special Forces' doctrine was developed in the 1950s for unconventional warfare, and did not address the new and emerging Air-Land Battle concepts. Special Forces wasn't broken, but it sure looked like it!

Today, Special Forces has five active component groups: the 1st, oriented to the Pacific; the 3rd, toward sub-Saharan Africa; the 5th, toward the Middle-East; the 7th, with responsibility for Central and South America and the Caribbean, and the 10th, oriented toward Europe. These Special Forces groups are commanded by the Army Special Operations Command (ASOC), activated on 1 December 1989. The Army Special Operations Command exercises command of Special Forces through the Special Forces Command, a major subordinate unit of the ASOC activated in the Fall of 1990. Special Forces doctrine and training is provided by the United States Army John F. Kennedy Special Warfare Center and School (USAJFKSWCS).

Command responsibility for this structure is vested with the United States Special Operations Command, formed by legislative mandate in November 1986, which became operational on 16 April 1987.⁵ At the highest levels of government, Special Forces is

monitored, with all other Special Operations Forces, by the Assistant Secretary of Defense for Special Operations and Low Intensity Conflict (ASD SO/LIC).

How did the Army achieve such a Special Forces structure? What led to the enhancement of Special Forces, and indeed of special operations forces? An understanding of the history of this enhancement and improvement enables one to discern the direction for Special Forces in the next ten years, and the arguments for sustaining that force. Logically, one may also determine the sufficiency of current and programmed structure and organization of Special Forces to fulfill current and future requirements. The following portion of the study chronicles the major actions which contributed to the present status of Special Forces.

RESURGENCE

With the increased concern over widespread insurgency, a trend toward detente with the Soviet Union, and the increased concern with transnational terrorism, a new U.S. strategic approach to challenges to U.S. interests in 1980 was required. That new approach was first stated by the then Army Chief of Staff's paper in the 1981-82 Army Green Book, entitled The Challenge of Change. It could be argued that this also began Special Forces' resurgence. This was the first time the Army was exposed to the "spectrum of conflict" concept. General Meyer wrote:

"Today, the cumulative effect we seek for the U.S. Army is the speedy creation of the following: Forces with

the flexibility to respond globally, in NATO or in other more distant locations; Forces capable of sustained operations under the most severe conditions of the integrated battlefield; Forces equally comfortable with all the lesser shades of conflict. Table 1 explains my view of why this element is so critical. (Low-risk, high-leverage ventures such as . . . activities on the lower end of the spectrum are simply the most likely military challenges to occur.); Forces that are created wisely so as to make best use of the nation's resources".⁶

Fig. 1 Spectrum of Conflict

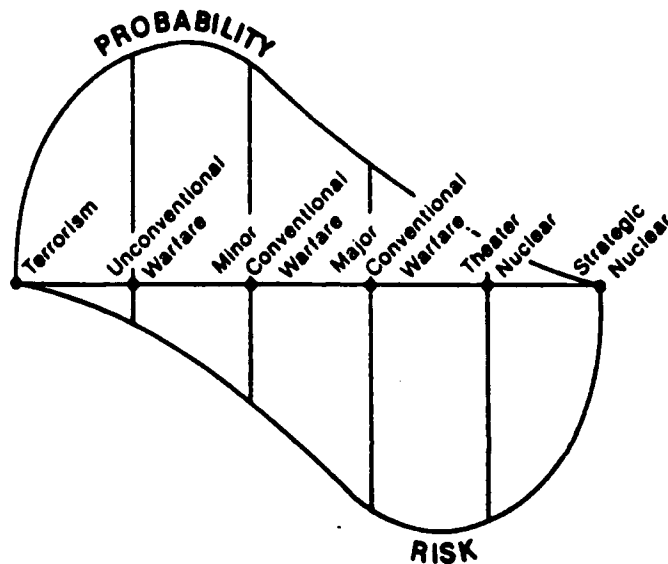

General Meyer's concept of the spectrum of conflict has evolved into the doctrinal use of the term "operational continuum." The operational continuum is defined by JCS Pub 3-0 (Test Pub) as:

"The strategic environment within each theater consisting of a variety of conditions - political, economic, military - and a range of threats that result in a wide range of operations that can correspondingly occur in response to those conditions and threats. These operations are conducted within a continuum consisting of three general states: peacetime competition, conflict, and war."

Further, the Army has adopted the operational continuum as a means to define the environment in which it will operate in the future. As applied to Low Intensity Conflict and Special Forces' applicability, the Army must acknowledge the role Special Forces has to play. The operational continuum as graphically defined by the Army concurs with the JCS definition.³

Fig. 2 Operational Continuum

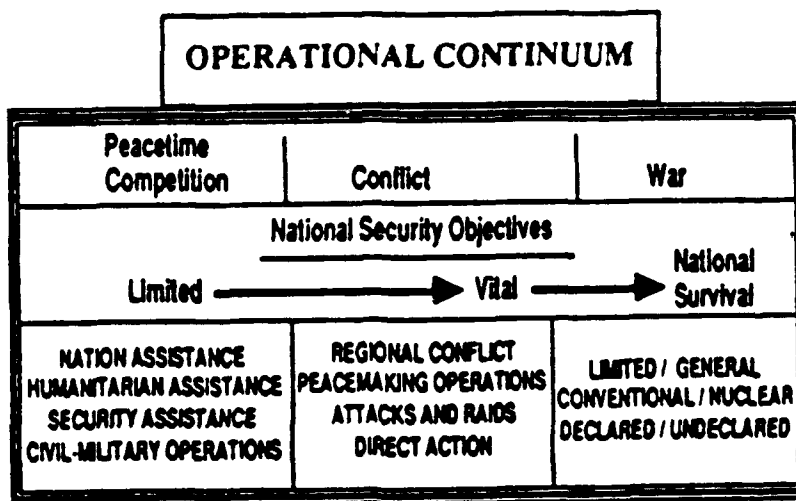

General Meyer's vision caused the Army to rethink its priorities and strategy. With a perceived increase in the threat from transnational terrorism, burgeoning insurgencies throughout the world, and a changing U.S. policy to aggressively provide more security assistance to developing nations, our nation at the start of the 1980s required a force to address these challenges. It also needed a force to continue to support its alliances, particularly those with developing nations. Special Forces was assigned the roles and missions, and possessed the capability, to

operate throughout the spectrum of conflict, particularly at the lower end of General Meyer's graphic. It was decided, therefore, that Special Forces should be improved and expanded to meet these newly acknowledged requirements.

In February 1982, the Department of the Army directed the USAJFKCMA, through FORSCOM, to develop an organization to command all Army special operations forces (SOF), which were to include all Special Forces, ranger, psychological operations, civil affairs, and special operations aviation units. The directive ordered the activation of a new Special Forces group (the 1st SFG(A)) to be oriented to the Pacific, enhancements to psychological operations and civil affairs units, and up-grade of current special forces units to authorized level of organization (ALO) 1. In June 1982, at a briefing on Army SOF, General Meyer directed that the Army improve its SOF organization, force structure, and doctrine.⁹

After the June 1982 brief to General Meyer, a series of programs and plans to improve Special Forces were implemented. The first of these, in concert with the Army's combat developments system, was the Special Operations Forces Mission Area Analysis (SOFMAA). The SOFMAA was completed in May 1983. It identified 55 deficiencies in doctrine, training, organization, and material, as well as 160 actions to correct these deficiencies.¹⁰

Since 1982, Army special operations forces, including Special Forces, have received support and sustainment from a

series of actions, plans, and programs, all of which have been established within the developmental schemes of the Army. Today, there are three documents specifically oriented to Special Operations Forces (SOF) which continue to develop and sustain Special Forces. These documents are: The Special Operations Forces Modernization Action Program (S), 2 NOV 89; The United States Army Special Operations Forces (SOF) Master Plan (S), 24 OCT 86; and the Special Operations Forces Functional Area Assessment (FAA), 1989-1992. The SOF Master Plan provides "conceptual guidance for our efforts to enhance the Army capability to execute and support special operations; . . . it identifies requirements, current and programmed forces, and continues the momentum . . . toward the revitalization of Army SOF."¹¹ The Special Operations Forces Modernization Action Program(S) is the primary tool used to prepare SOF input to the Program Objective Memorandum (POM) of the Planning, Programming, Budget, and Execution System. The SOF FAA serves the same development objectives as do the FAA's for all other functional areas in the Army.

The revitalization of Special Forces also included a progression of command-and-control decisions and Congressional directives. The Army, on its own initiative, designated the USAJFKCMA as the 1st Special Operations Command at Fort Bragg, North Carolina, in October 1982. It was responsible for bringing "active and reserve component special operations forces to authorized levels of operational capabilities in training,

equipment, and personnel readiness, and in sustaining this readiness."¹²

1st SOCOM commanded all active component Special Forces Groups until it was replaced in 1989 when the Army Special Operations Command (ASOC) was formed. In July 1983, the Institute for Military Assistance became the United States Army John F. Kennedy Special Warfare Center and School, immediately subordinate to the U.S. Army Training and Doctrine Command (TRADOC). It remained under command of TRADOC until it was placed under command of the ASOC. The ASOC was formed to provide the Army Special Operations Forces Component to the new United States Special Operations Command (USSOCOM). USSOCOM and its subordinates were established as a result of the Nunn-Cohen Amendment to the Fiscal Year 1987 National Defense Authorization Bill which "included legislation that directed a significant reorganization of the Defense Department's special operations forces (SOF). Specifically, the legislation directed the formation of a unified combatant command for special operations, the creation of an Assistant Secretary of Defense for Special Operations and Low Intensity Conflict . . ."¹³, and other provisions. With the ASOC and the Special Warfare Center subordinate to USSOCOM, it was decided to clarify the command lines further by designating a Special Forces Command to be a major subordinate command of the ASOC. The Special Forces Command is comprised of all Special Forces groups, less the two

National Guard groups. The National Guard Special Forces elements are commanded by their state Adjutants General.¹⁴

Special Forces' resurgence also required the Army's personnel management system to adapt to Special Forces' new priority and growth. A series of actions since 1952 designated soldiers as Special Forces qualified, while maintaining them in a parent Branch. General Order #35 was signed on 19 June 1987, establishing the Special Forces Branch, which had been approved by the Secretary of the Army on 9 April 1987.¹⁵ This resulted in the establishment of Special Forces as a separate branch. Subsequent to General order #35, the Special Forces Branch has included all enlisted soldiers in CMF18, warrant officers with MOS180A, and commissioned officers qualifying for Special Forces.¹⁶ The goals of the Branch are: to enhance the Army's war fighting capability; to provide a systemic process for the accession, qualification, and professional development of future Special Forces leaders; to resolve long standing readiness problems; to develop functional area expertise within the Special Forces; and to cross-fertilize the Special Forces officer through functional area assignments across the breadth of the Army.¹⁷ The promotion and school selection rates in the Branch, for almost all ranks, are above the Army average. The success of the Branch is evident.

Special Forces has developed in the past ten years from a three-group structure with diffused command representation to five groups commanded by a specialized structure formed for that

purpose. Special Forces units are all ALO 1 units, and are supported by specific personnel and logistics organizations. Represented by an Army Major Command (MACOM), a CINC, and an assistant secretary of defense, Special Forces is well positioned to continue to support national objectives across the operational continuum. The past decade has been one of growth and success for Special Forces. Let us now view how Special Forces is currently organized and structured.

SPECIAL FORCES TODAY

The U.S. Army organizes, trains, equips, and provides Special Forces to perform five primary missions:¹⁸

- unconventional warfare (UW)
- foreign internal defense (FID)
- direct action (DA)
- strategic reconnaissance (SR)
- counter-terrorism (CT)

The primary organizations used to execute these missions are the twelve-man Special Forces Operations Detachment - Alpha, or "A" teams, and the Special Forces Operational Detachment - Bravo, otherwise known as Special Forces companies (formerly known as "B" teams). A Special Forces battalion is comprised of a support company and three Special Forces companies of six "A" teams each. A Special Forces group consists of three Special Forces battalions, a headquarters and headquarters company, and a support company. The five active component Special Forces groups

are commanded by the Special Forces Command, a major subordinate unit of the Army Special Operations Command.

Special Forces Operational Detachment - A

The Special Forces Operational Detachment - A (SFOD-A) (See Appendix A, page 34) has been reviewed periodically since its establishment in 1953. The SFOD-A was originally configured with 15 personnel. Its current organization was implemented in 1987. The SFOD-A organization was formally reviewed in 1986 by a board headed by then BG Wayne Downing. The conclusions of the board were that the organization and missions for the SFOD-A are ". . . excellent and should remain. It [the SFOD-A] was initially based on UW and FID. To perform other missions task organization tailored to the mission is required; however, the required skills are available."¹⁹ "The SFOD-A is specifically designed to organize, equip, train, advise or direct, and support indigenous military or paramilitary forces in UW and FID operations . . . The Detachment can serve as a manpower pool from which Special Forces commanders organize tailored teams to perform Direct Action, Strategic Reconnaissance, or other missions."¹⁷

Special Forces Operational Detachment - B

The SFOD-B, or ODB as it is sometimes called, (See Appendix A, page 35) is a Special Forces company headquarters configured for multi-purpose command-and-control. It is structured by TOE to command six SFOD-A's.²⁰ In a recent review of the organization, the Special Warfare Center and School concluded

that "The ODB structure as it is currently configured will essentially provide a sufficient base from which to task organize/tailor the force necessary to meet mission requirements"2:

Special Forces Operational Detachment - C

The SFOD-C (See Appendix A, page 36) is the Special forces battalion headquarters which provides command-and-control and staff actions in support of the battalion's operations. The Special Forces battalion, in addition to the headquarters detachment, also has assigned a support company which has the mission to provide the battalion intelligence, electronic warfare, combat service support and signal support (See Appendix A, page 37). This battalion organization differs markedly from the previous organization, in that Special Forces battalions can now operate independently of the Special Forces Group without augmentation. Before this 1986 reorganization, the Special Forces battalion depended on the Special Forces group to provide major logistical, intelligence, and service support.

United States Army Special Forces Group (Airborne)

The Special Forces Group (Airborne) (See Appendix A, pages 38 through 40) provides command-and-control and staff planning and support to its three Special Forces Battalions. The Group exercises its responsibilities through a Headquarters and Headquarters Company and a Group Support Company.

Special Forces Command

Special Forces groups are commanded by the Special Forces Command (SFC), a major subordinate unit of the Army Special Operations Command (ASOC). The SFC provides command-and-control, staff planning, and support to its assigned Special Forces Groups. Command-and-control is exercised through the Headquarters, and signal and logistical support are provided by the 112th Signal Battalion and 528th Support Battalion. Both units are assigned to the SFC (See appendix B). The missions of the SFC include:

- command assigned and attached CONUS-based active component Army Special Operations Forces
- exercise operational control of U.S. Army Reserve Special Forces Groups
- organize, train, equip, and validate [for mission readiness - author] subordinate units and prepare them for worldwide deployment and employment
- conduct validation of Army National Guard Special Forces units
- provide support and staff augmentation for contingency operations
- conduct mobilization organization, training, equipping, and validating activities for reserve component units

John F. Kennedy Special Warfare Center and School

Special Forces' unique capabilities are developed by the doctrinal and training programs of the John F. Kennedy Special Warfare Center and School (SWCS), which is the proponent for the Army's special operations forces (except for rangers and aviation). The mission of SWCS is to provide the doctrine, training, material, organization, and leader development for special operations forces.²³ SWCS conducts selection, assessment, and training for both Special Forces officers and Special Forces non-commissioned officers with medical, communications, engineer, weapons, and operations/intelligence specialties. SWCS also conducts Special Forces Warrant Officer, military free-fall, and underwater operations courses, as well as many other courses and activities which are not related to Special Forces.

The JFKSWCS does not function autonomously, but in concert with the U.S. Army Training and Doctrine Command and USCINCSOC to produce coordinated doctrine in support of Air-Land Battle.

United States Army Special Operations Command

The United States Army Special Operations Command (USASOC) was formed as a result of the Nunn-Cohen Amendment to the 1987 Defense Authorization Bill. It, with similar commands in the Navy and Air Force, is a component of the United States Special Operations Command (USSOCOM) (See Appendix B, page 42).

The USASOC's missions include the responsibility to:²⁴

- recruit, train, equip, organize, and validate Army Special Operations Forces (SOF) for employment by unified combatant commands
- command all CONUS-based special operations forces and the John F. Kennedy Special Warfare Center and School
- execute operational control of Army Reserve SOF (assume command in 1991)
- coordinate training guidance to ARNG SOF through the Army National Guard Bureau
- provide training guidance and standards to overseas-based active Army SOF through the theater Army commanders

DOCTRINE AND TRAINING

Special Forces doctrine is fully modernized and functional. Thirteen field manuals (FM's), nine Army Training and Evaluation Programs (ARTEPS), and eight technical circulars (TC's) have been developed and have either been published since 1988 or are scheduled for publication by 1995.²⁵ USAJFKSWCS is an active participant in developing doctrine in concert with other Army and Joint Services, as reflected by the coordination of recent Army and Joint service publications dealing with special operations forces. USAJFKSWCS also conducts over 30 Special Forces specific training programs, resulting in uniquely qualified, mission-capable Special Forces soldiers.²⁶

As in other Branches, Special Forces assigns the soldier from individual training (USAJFKSWCS) to a unit. There the Special Forces unit, under command of the Special Forces Command, conducts unit training to include ARTEP's. The units must also validate each SFOD-A's capabilities to conduct Special Forces operations in an annual validation exercise.

The initial basic qualification training program for a Special Forces soldier requires seven months. Additional training, including language training, can require an additional year. Other advanced training, such as underwater operations or survival, evasion, resistance and escape (SERE) training can require six months. The Special Forces doctrine requires a uniquely capable soldier, and Special Forces training provides him.

LOGISTICS

Although Special Forces uses a lot of equipment and material common in the Army, it also possesses a considerable amount of low-density, Special Forces unique items. The maintenance of these items requires a logistical system familiar with Special Forces requirements. Each theater army has been allocated a Theater Army Special Operations Support Command (TASOSC) to ". . . plan and coordinate the support and sustainment of Army Special Operations Forces (ARSOF) conducting special operations." By providing the vital link between the theater Army and theater ARSOF units, the TASOSC ensures that the theater Army meets its

administrative, support, and sustainment responsibilities for ARSOF.²⁷ The TASOSC's have not been operational long enough to fully determine their effectiveness. They appear to be a logical answer to the logistical and administrative requirements of deployed Special Forces.

In addition to unit organic support and the TASOSC, the Special Forces unit may be supported by the 628th Support Battalion and the 112th Signal Battalion. These units are subordinate to the Special Forces Command, and primarily provide support during contingency or augmentation operations. The combination of the units organic support elements, the Special Forces command, and the TASOSC should prove sufficient to satisfy Special Forces' support requirements. The evaluation of mechanisms supporting Special Forces during Operations JUST CAUSE and DESERT STORM will provide the information necessary to confirm the effectiveness of Special Forces' support structure and organization.

CURRENT AND PROJECTED SPECIAL FORCES

REQUIREMENTS

The requirements for and employment of Special Forces have increased through the 1980s, commensurate with Special Forces' growth. From 1987 to 1990, Special Forces conducted more than 500 deployments to 59 countries.²⁸ A recent Department of Defense study concluded that the requirements for Special Forces can be satisfied only by the current and projected Special Forces

structure. As evidence of the future, "NSR27, signed by the President in June 1990, directed an examination of the structure and procedures used by the USG to address the problems of Low-Intensity Conflict."²³ According to the March 1990 National Security Strategy of the United States, Special Forces, as part of SCF, will have a continuing and increasing role to play in the security affairs of the United States. The Strategy states:

"American forces must therefore be capable of dealing effectively with the full range of threats, including insurgency and terrorism. Special operations forces will have particular utility in this environment, but we will also pursue new and imaginative ways to apply flexible general purpose forces to these problems. We will improve the foreign language skills and cultural orientation of our armed forces, and adjust our intelligence capabilities to better serve our needs. Units with unique capabilities [like Special Forces] will receive increased emphasis. Training and research and development will be better attuned to the needs of low intensity conflict."²⁴

There has been a steady increase over the past ten years in the use of Special Forces, in a variety of environments and across the operational continuum in which U.S. forces were involved. Recent examples include Operation JUST CAUSE in Panama and DESERT SHIELD/DESERT STORM in the Middle-East. The obvious conclusion is that the Special Forces, as a major part of Army SOF, will continue to be tasked similarly in the future.

CRITIQUE OF CURRENT ORGANIZATION, STRUCTURE, AND CAPABILITIES

The current organization and structure of Special Forces reflects the successful efforts of the Army during the past

decade to improve and enhance Special forces capabilities. These efforts are the result of General Meyer's strategic vision in 1982 to enhance Special forces as part of an over-arching improvement to the Army. Specific Congressional legislation has also contributed to the Special Forces we have now. Strategic concepts have driven the doctrine, which in turn has driven the organization and structure. The result is an Army Special Forces capability exceeding that of any previous era.

As organization and structure requirements are always dynamic, there appear to be areas for improvement. The SFOD-A, in most situations short of conflict, may be required to assume more of a role in civil affairs and psychological operations activities. It is not currently structured, equipped, or trained to do that. In its own study, the USASWCS noted that the SFOD-A "may require CA/PSYOP personnel in Foreign Internal Defense"3. The SFOD-A may require the attachment of civil affairs/psychological operations (CA/PSYOP) personnel for specific missions, such as FID. The SFOD-A structure may also be changed to add Special Forces personnel specifically schooled in CA/PSYOP, or personnel within the current structure may be so schooled. Currently, the Warrant Officer on some SFOD-A's receives some CA/PSYOP training. The requirement should be addressed more formally.

The Special Forces Company, or SFOD-B, having had its headquarters augmented with additional senior personnel resulting from MTOE changes since 1988, is capable again of functioning in

most scenarios without augmentation. This paper concurs with the USAJFKCMA study that concluded: "The ODB structure as it is currently configured will essentially provide a sufficient base from which to task organize/tailor the force necessary to meet mission requirements"³²

The Special Forces Battalion, or SFOD-C, possesses an improved capability to operate independently from the Special Forces group. The battalion's structure replaces the requirement for a battalion to receive a "slice" from the group in order to operate as a Forward Operational Base (FOB). The group augmentation provided signal, intelligence, and service support assets to the battalion, which now has them assigned. This is an excellent improvement to the structure over that of ten years ago. It has not, however, eliminated the requirement for augmentation by the group or from other organizations as the mission requires. For example, in a large foreign internal defense mission, the battalion would probably require civil affairs, psychological operations, engineer, and law enforcement augmentation. The Special Forces battalion was reviewed by the SOFFAA, and was confirmed to be a viable organization.

The Special Forces Group (Airborne) has not been reviewed since the SOFMAA was completed in 1983, except for revisions to its organization reflecting the transfer of signal, intelligence, and service support assets to the Special Forces battalions. The group configuration has proved to be adequate to accomplish its missions, although it requires combat support and combat service

support augmentation from the Special Forces Command and/or the theater Army when deployed. There is, however, a tested and proven organizational concept that would enhance the Group's capabilities to execute its primary mission of foreign internal defense. That concept is the Security Assistance Force. This study does not quarrel with the current structure and organization of the Special Forces group. In the next section, however, a partial reorganization of Special Forces groups missioned primarily for foreign internal defense will be proposed.

Special Forces, as a result of ten years of study, legislation, funding, and improvement is more capable than ever before. It can now provide the capabilities envisioned when the enhancements were begun. There does not appear to be reasonable argument for radical change to the structure or the organization of Special Forces. Special Forces as currently organized, structured, and apportioned by the Joint Strategic Capabilities Plan (JSCP), however, reflects pre-1989 programs. Further, the alignment of reserve component Special Forces groups, both National Guard and Reserve, reflects a strategy that has not changed much in twenty years. As part of the continuing dynamism of Special Forces, this paper proposes the following actions to project Special Forces requirements into the future, while maintaining the improvements of the past decade.

a) Configure Special Forces groups as Security Action Forces where required.

b) Apportion the reserve component Special Forces Groups in alignment with a strategy reflecting the changed U.S. strategic national interests, world situation, and readiness requirements.

c) Continue to develop programs to achieve the language qualifications required for Special Forces' operations.

d) Develop personnel sustainment programs which will permit Special Forces to maintain its strength in the context of a significantly reduced Army.

SECURITY ASSISTANCE FORCES (SAF)

Selected Special Forces groups should be augmented and redesignated as SAF's in order to contend with the future threat to U.S. strategic interests in theaters requiring primarily counterinsurgency and security assistance operations.

The threat of low-intensity conflict in many regions is evident and will not soon diminish. As stated in the Secretary of Defense report to Congress, "Low-intensity conflict (LIC) poses a major threat to our security and our interests around the world."³³ He went on to state that "we must address not only the problems posed by our enemies but also the many problems plaguing the developing world."³⁴ A better way for Special Forces to meet the requirements noted by Mr. Carlucci may be the SAF.

The SAF is a thirty year old concept intended to add versatility to a Special Forces group's capabilities. As originally conceived, a 1500-man Special Forces group was augmented by a civil affairs group, a psychological operations

battalion, an engineer detachment, a military police detachment, and an ASA (Army Security Agency - electronic intelligence) unit. The SAF was capable of undertaking wide-ranging military assistance missions. Four SAF's had been formed by the mid-1960s: one each for missions in the Far East, Latin America, Africa and the Middle East.³⁵ It should be noted that although the SAF's primary mission was security assistance, it was fully capable, perhaps even more so than a "pure" Special Forces group, of conducting the other Special Forces missions.

The mission of a SAF was to deploy in support of unified commands in the execution of FID missions. When the SAF's were employed by unified commanders in their internal defense and development role, it was to assist a military advisory group's foreign internal defense plan. The SAF provided training, operational advice, and assistance to host country forces.³⁶

Special Forces groups, as now configured, can satisfy their foreign internal defense missions. Special Forces' major command, the ASOC, has all active component psychological and civil affairs units assigned to it. The ASOC has the capability of providing the structure and organization for SAF's, to include psychological operations and civil affairs capabilities. Other capabilities, such as engineers and military police, if not assigned to the ASOC, could easily be attached. It would appear to be a logical extension of ASOC's mission to organize SAF's for those theaters which can justify such a requirement. This paper

suggests Central and South America and sub-Saharan Africa as initial priorities.

RESERVE COMPONENT SPECIAL FORCES GROUPS

Special Forces reserve components consist of two Army National Guard units, the 19th and 20th Special Forces Groups, and two Army Reserve units, the 11th and 12th Special Forces Groups. The utility of the reserve component units is demonstrated by the mobilization and activation of the 20th SFG(A) for DESERT STORM. Although the unit was oriented to Europe, and minor problems were encountered during mobilization, the unit's mobilization demonstrates the flexibility and utility of the Special Forces reserve components.

The reserve component Special Forces require several improvements: more cogent and responsive command-and-control; a better integration with the active component; and a probable realignment from their current regional orientations. The reserve component provides 42.4% of the Special Forces capability. That is a significant resource that requires more attention and modernization effort.

Reserve components have been the beneficiaries of much study and development in the past decade. They are a part of all the active component developmental and sustainment systems. With a rapidly changing world and a decreasing budget, it is essential to develop an active and reserve component relationship featuring

enhanced reserve component capability and a closer association with the active component.

SPECIAL FORCES LANGUAGE CAPABILITIES

Special Forces' language capabilities are not at the desired levels of proficiency. This is a concern to everyone in the SOF community. On 17 November 1988, the Assistant Secretary of Defense for Special Operations and Low Intensity Conflict stated that "The difficulty of achieving adequate levels of proficiency in various languages continues to impact adversely upon the readiness of our special operations forces" ³⁷ The problem has not gone unnoticed by the Special Warfare Center and School. In the 1989-92 Functional Area Assessment, SWCS identified four future actions to resolve the shortfall. ³⁸ Additionally, the Army Special Operations Command received authority on 30 August 1990 to conduct language training in ten languages. ³⁹ The Special Forces community is doing a great deal to meet its language requirements.

Special Forces requirements for language capable personnel are unique. To partially resolve the shortage of language/area-familiar personnel, there is a need for legislation similar to the Lodge Bill, Public Law 957, enacted by the 81st Congress. This bill, sponsored by Henry Cabot Lodge, permitted foreign nationals to enlist in the U.S. Armed forces after World War II. ⁴⁰ With the exception of some security constraints, this approach may be easily accomplished and provide a pool of native

language speakers from which to draw in the future. With demographic predictions of a reduction in the pool of 19-25 year old males in the U.S. starting in 1990, this intensified recruiting effort may help resolve manpower shortfalls as well.

SUSTAINMENT OF SPECIAL FORCES

The greatest threat to the sustainment of current and programmed Special Forces structure is the imminent reduction of personnel strength in the Army. As this is being written, the projected end strength for the Army in FY97 is 535,000 personnel. Of that number, 90,000 have been Congressionally-mandated to be medical personnel.⁴¹ In gross numbers, therefore, if Special Forces remains a non-accession branch (one doesn't enter Special Forces directly, but only after service in another branch) it will draw from a pool of 445,000 personnel to man five active component groups.

Although there are no planned decrements to Special Forces at this time, and funding is generally sufficient, the programs to sustain Special Forces through the 1990s appear to require improvement.

There is work underway to address this issue. For Special Forces officers, branch detailing is being discussed. Personnel would serve in a basic branch and then apply for assignment to Special Forces. If the officer qualified, he would then serve a three year tour before exercising an option to either branch

transfer to Special Forces or return to his parent branch. This plan is still being considered.

Regardless of the solution, the reduction of Army strength is the potentially greatest threat to a Special Forces structure that has been ten years in development. The Army must develop a plan augmenting normal force programming systems to ensure Special Forces structure is sustained.

CONCLUSIONS

Special Forces has achieved its current status and reputation because of (1) its capabilities across the operational continuum and (2) a change in U.S. strategy recognizing the requirement to counter low intensity conflicts as a primary national interest. The Army view of Special Forces, and of special operations forces is "Special Operations Forces are an essential part of the . . . 'Total Army'. They perform critical functions complementing heavy and light forces in the middle and upper reaches of the conflict spectrum. They are generally the force of first choice for dealing with threats at the lower end of the conflict spectrum due to their regional expertise, language qualifications, austere support requirements, and lower visibility."⁴² Special Forces enjoys a position almost unique in the Armed Forces. The fact that it, along with other special operations forces, has been the subject of legislation designed specifically to enhance and sustain it indicates the Congress's conviction about its utility and future. The plans and programs

conducted by the Army beginning in 1981 have resulted in a fully functioning organizational mechanism supporting Special Forces. Special Forces doctrine, personnel management, intelligence capabilities, operational abilities and commitments, and logistical support are all modern and continuing. As evidenced by the Army's accomplishments of the past ten years, one must conclude Special Forces is alive and well, totally established in the Service and Joint communities, and viable, given the in-place systems. One must further conclude, however, that the dynamism of the global situation, an impending defense budget cut and a concomitant build-down of the Army pose potential problems for the future of Special Forces. Those problems could be manifested as reductions in Special Forces structure.

The future of Special Forces and its current structure seems assured if it can argue successfully the following: that it is a vital part of both the Army and Joint capabilities across the operational continuum; that it provides unique and essential capabilities in a rapidly changing environment; and that it is affordable and must be retained in the active structure. This study believes Special Forces has done, and can continue to do, this.

RECOMMENDATION

With the conclusion of USSOCOM's three year Joint Mission Analysis in the summer of 1991, it is imperative that the Army continue to lead the development of its Special Forces. The

activities identified and many programs developed to revitalize Special Forces are being successfully completed. It is time to "recycle" to insure that what we have now is that which we need and want in the future. This study, therefore, recommends the initiation of an Army study and analysis to develop a plan for Special Forces as part of the Army of the future. This endeavor should be undertaken by the Army Special Operations Command, which has operational, training, and doctrinal responsibilities for Army Special Forces. USSOCOM should monitor and be the approving authority for the findings of this study. It is further recommended that this effort be coordinated across the Army by the proponent of the Special Operations Forces Modernization Action Program.

APPENDICES

APPENDIX A - Special Forces Organizations

- A-1 Special Forces Operational Detachment-A
- A-2 Special Forces Company
- A-3 Special Forces Battalion Headquarters Detachment
- A-4 Special Forces Battalion Support Company
- A-5 Special Forces Group
- A-6 Headquarters and Headquarters Company, Special Forces Group
- A-7 Special Forces Group Support Company

Source: Army Special Operations Forces Reference Data, U.S. Army John F. Kennedy Special Warfare Center and School, Ft. Bragg, 8 February 1991.

APPENDIX B - Special Forces Command Organization

Source: U.S. Army Special Operations Command Briefing, September, 1990.

APPENDIX C - Acronyms/Abbreviations

APPENDIX A

SPECIAL FORCES ORGANIZATIONS

**SPECIAL FORCES OPERATIONAL DETACHMENT (A DET),
SPECIAL FORCES COMPANY**

TOE 31847L000, 1 April 1990.

CAPABILITIES

- A. Plan and conduct SF operations separately or as part of a larger force.
- B. Infiltrate and exfiltrate specified operational areas by air, land, or sea.
- C. Conduct operations in remote areas and hostile environments for extended periods of time with a minimum of external direction and support.
- D. Develop, organize, equip, train, and advise or direct indigenous forces up to battalion size in special operations.
- E. Train, advise, and assist other U.S. and allied forces and agencies.
- F. Plan and conduct unilateral SF operations.
- G. Perform other special operations as directed by higher authority.

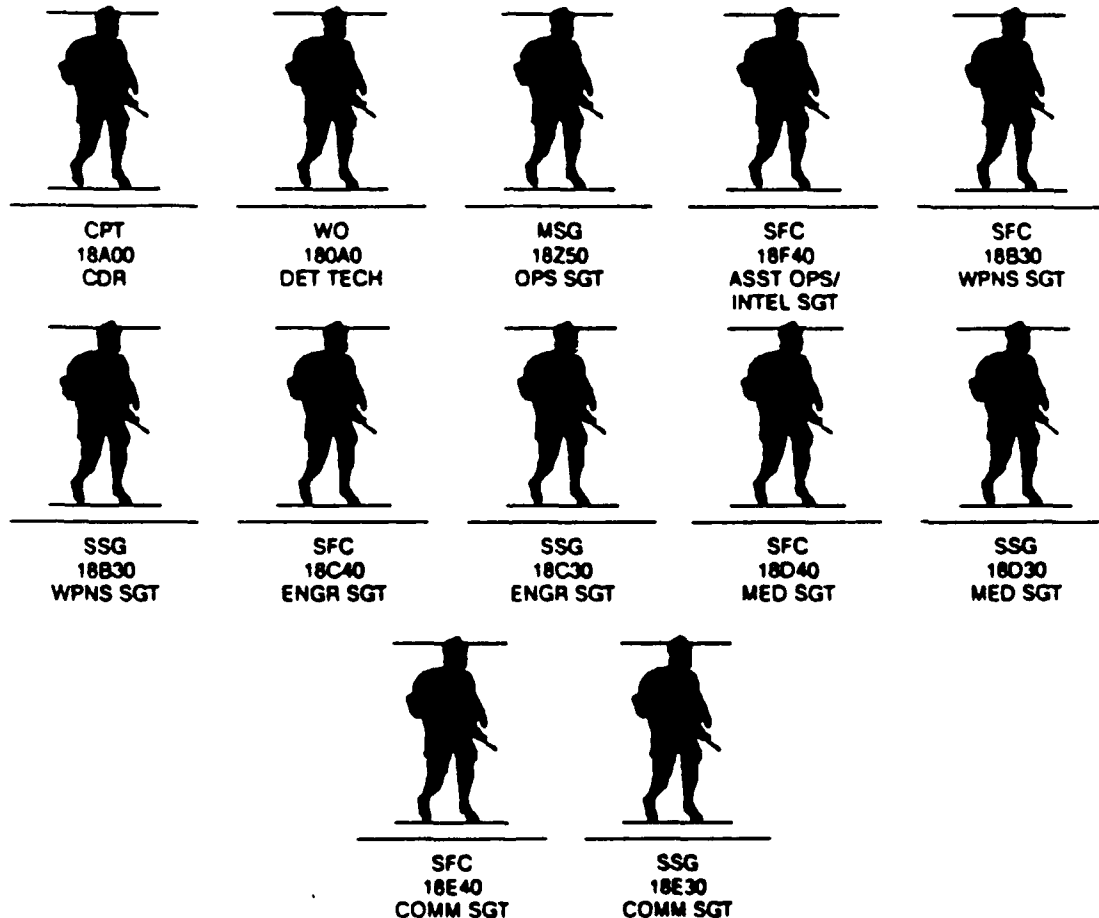

NOTE: There are six A Detachments per SF company. By TOE, each SF company has one SFOD A trained in combat diving and one SFOD A trained in military free-fall (MFF) parachuting. The A Detachment has two enlisted specialists in each of the five SF functional areas: weapons, engineer, medical, communications, and operations and intelligence. The detachment can serve as a manpower pool from which SF commanders organize tailored SF teams to perform direct action, special reconnaissance, or other missions.

OFF	WO	ENL
24	21	201

SPECIAL FORCES COMPANY, SPECIAL FORCES BATTALION

TOE 31807L0, 1 April 1990.

MISSION

To plan and conduct unconventional warfare, foreign internal defense, direct action, special reconnaissance, and counterterrorism in peace, conflict, and war.

CAPABILITIES

- Plan and conduct Special Forces operations separately or as part of a larger force.
- Train and prepare Special Forces teams for deployment.
- Infiltrate and exfiltrate specified operational areas by air, land, or sea.
- Conduct operations in remote areas and hostile environments for extended periods with minimal external direction and support.
- Develop, organize, equip, train, and advise or direct indigenous forces of up to regimental size in special operations.
- Train, advise, and assist other U.S. and allied forces and agencies.
- When augmented, establish and operate an advanced operational base (AOB) to expand the C2 capabilities of an SFOB or FOB.

COMPANY HEADQUARTERS (B DETACHMENT)

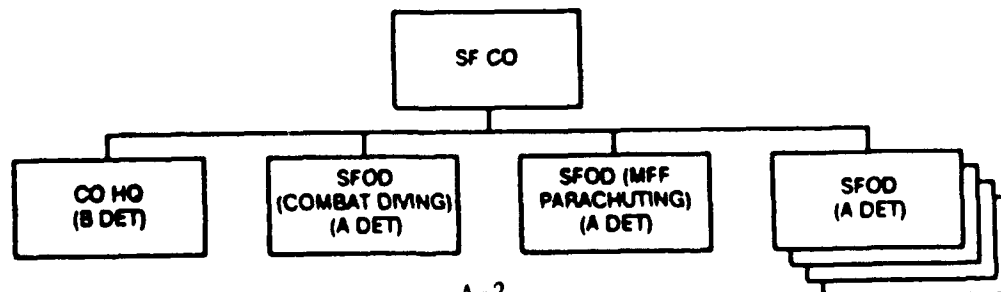
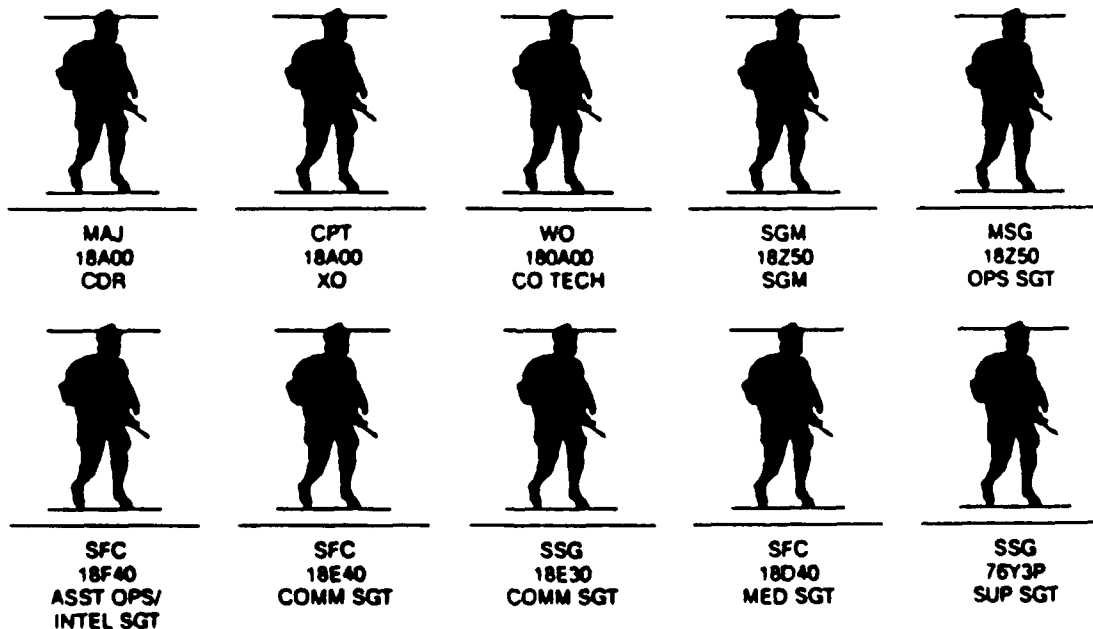

A-2

35

OFF	WO	ENL
11	2	25

BATTALION HEADQUARTERS DETACHMENT (C DETACHMENT)

TOE 31806L000, 1 April 1990.

MISSION

To provide command and control of elements of the Special Forces battalion.

CAPABILITIES

The SFOD C, also known as C detachment, provides C2, staff planning, and staff supervision of battalion operations and administration. The SFOD C detachment —

- Plans, coordinates, and directs SF operations separately or as part of a larger force.
- Provides command and staff personnel to establish and operate an FOB.
- Provides advice, coordination, and staff assistance on the employment of SF elements to a joint SOC, JSOTF, SAO, or other major headquarters.

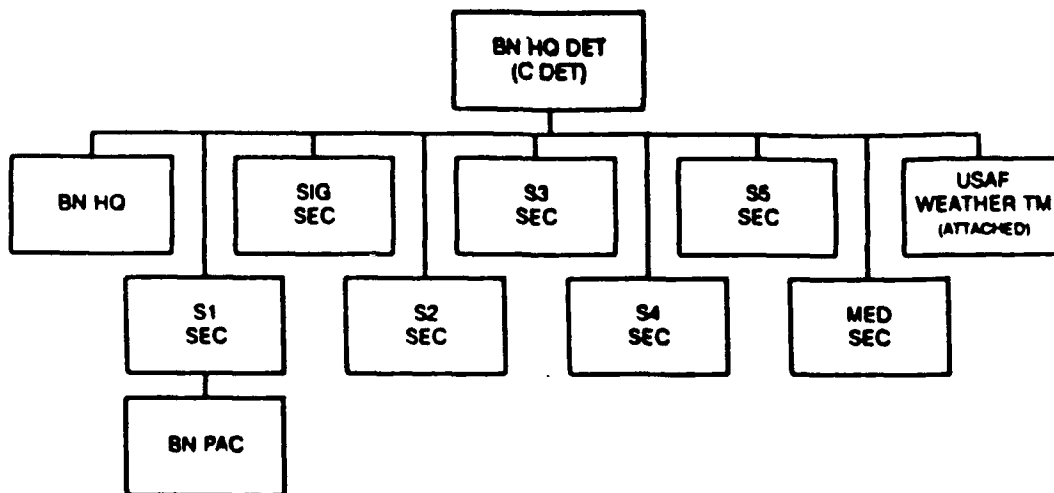

OFF	WO	ENL
4	1	94

**BATTALION SUPPORT COMPANY,
SPECIAL FORCES GROUP (AIRBORNE)**

TOE 31808L000, 1 April 1990.

MISSION

To provide administrative, logistical, intelligence, and communication support for the Special Forces battalion.

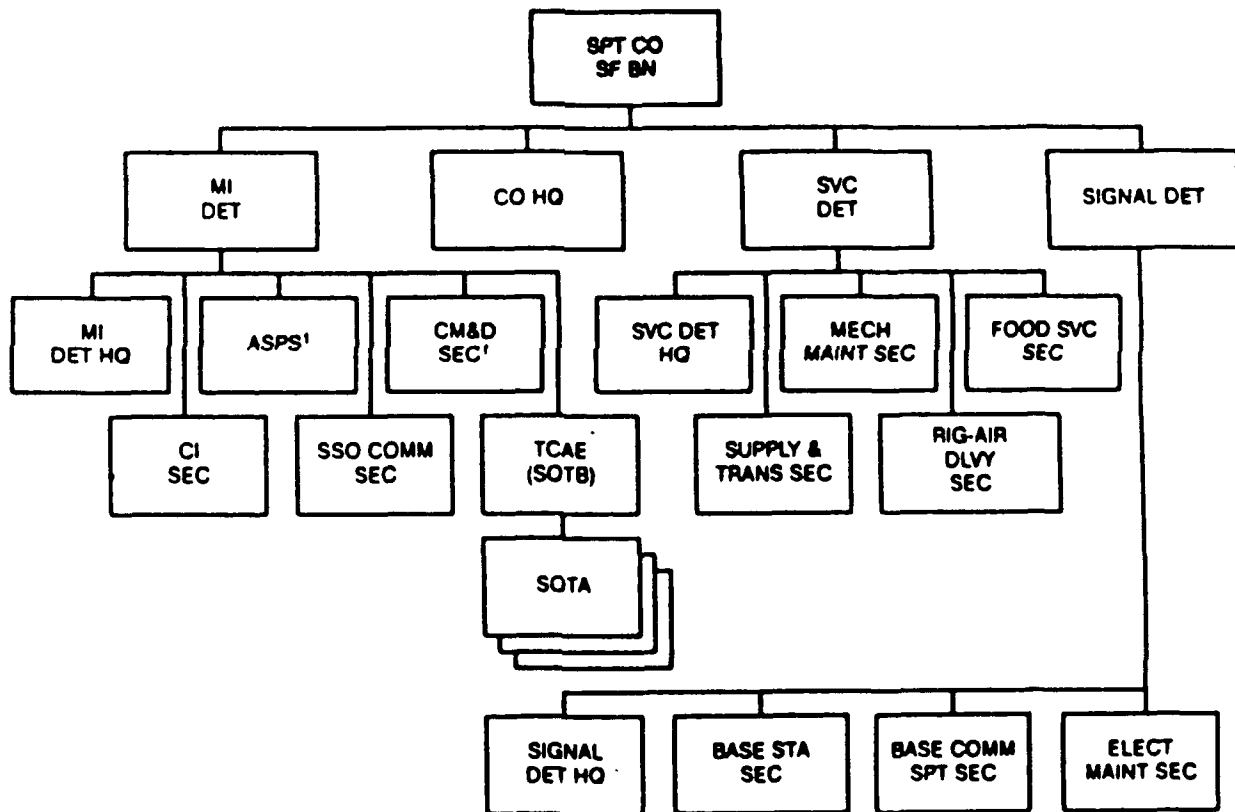

MHC		
OFF	WO	ENL
28	3	58

SPT CO		
OFF	WO	ENL
13	12	151

SF BN		
OFF	WO	ENL
39	24	320

SPECIAL FORCES GROUP (AIRBORNE)

TOE 31800L100, 1 April 1990.

SUMMARY

The Special Forces group (airborne) [SFG(A)] is a multipurpose and extremely flexible organization. Its mission is to plan, conduct, and support special operations (SO) in any operational environment in peace, conflict, and war.

The group's C2 and support elements can function as the headquarters for an Army special operations task force (ARSOTF) or for a joint special operations task force (JSOTF) when augmented by resources from other services. The group's C2 and support elements can—

- Establish, operate, and support a Special Forces operational base (SFOB) and three forward operational bases (FOBs).
- Provide three special operations command and control elements (SOCCEs) to conventional headquarters at corps level or higher.
- Train and prepare SF teams for deployment.
- Direct, support, and sustain deployed SF teams.

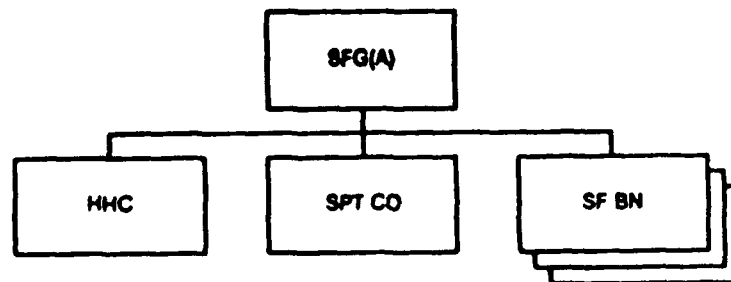

OFF	WO	ENL
28	3	58

**HEADQUARTERS AND HEADQUARTERS COMPANY,
SPECIAL FORCES GROUP (AIRBORNE)**

TOE 31802L000, 1 April 1990.

MISSION

To provide command and control and staff planning for the Special Forces group and attached elements.

CAPABILITIES

The group headquarters and headquarters company (HHC) provides C2, staff planning, and staff supervision of group operations and administration.

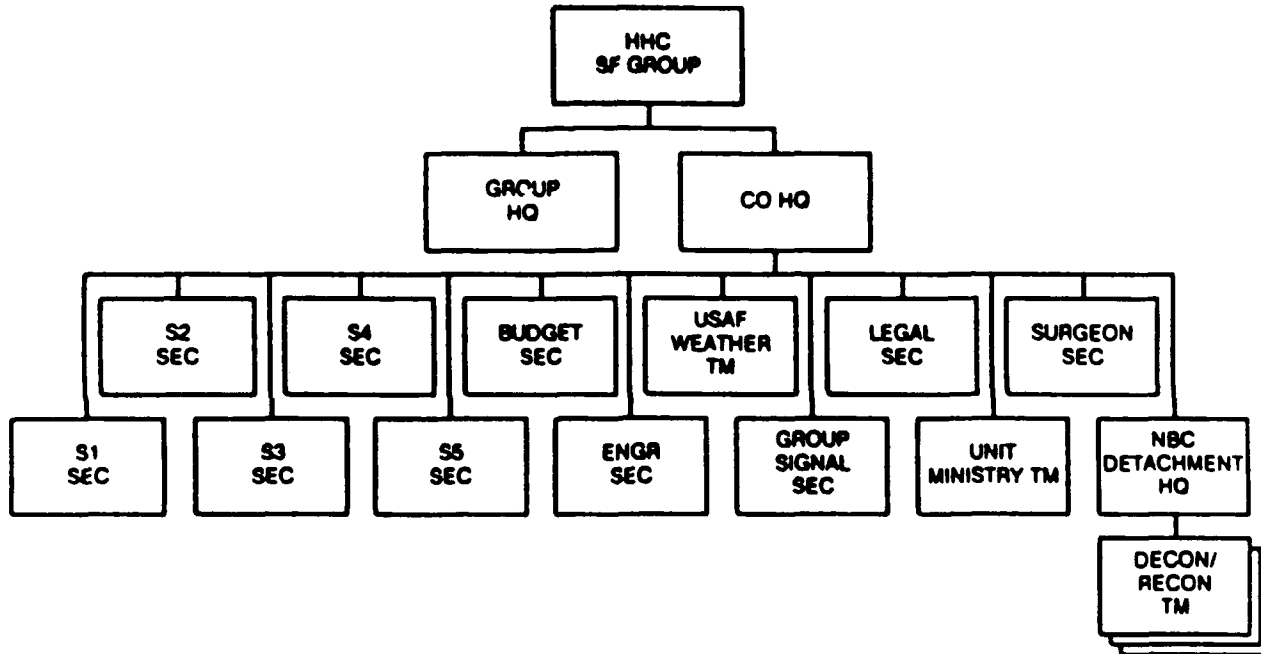

OFF	WO	ENL
13	12	151

SUPPORT COMPANY, SPECIAL FORCES GROUP (AIRBORNE)

TOE 31803L000, 1 April 1990.

MISSION

To provide logistical, intelligence, communications, and limited administrative and aviation support for the Special Forces group and its deployed elements.

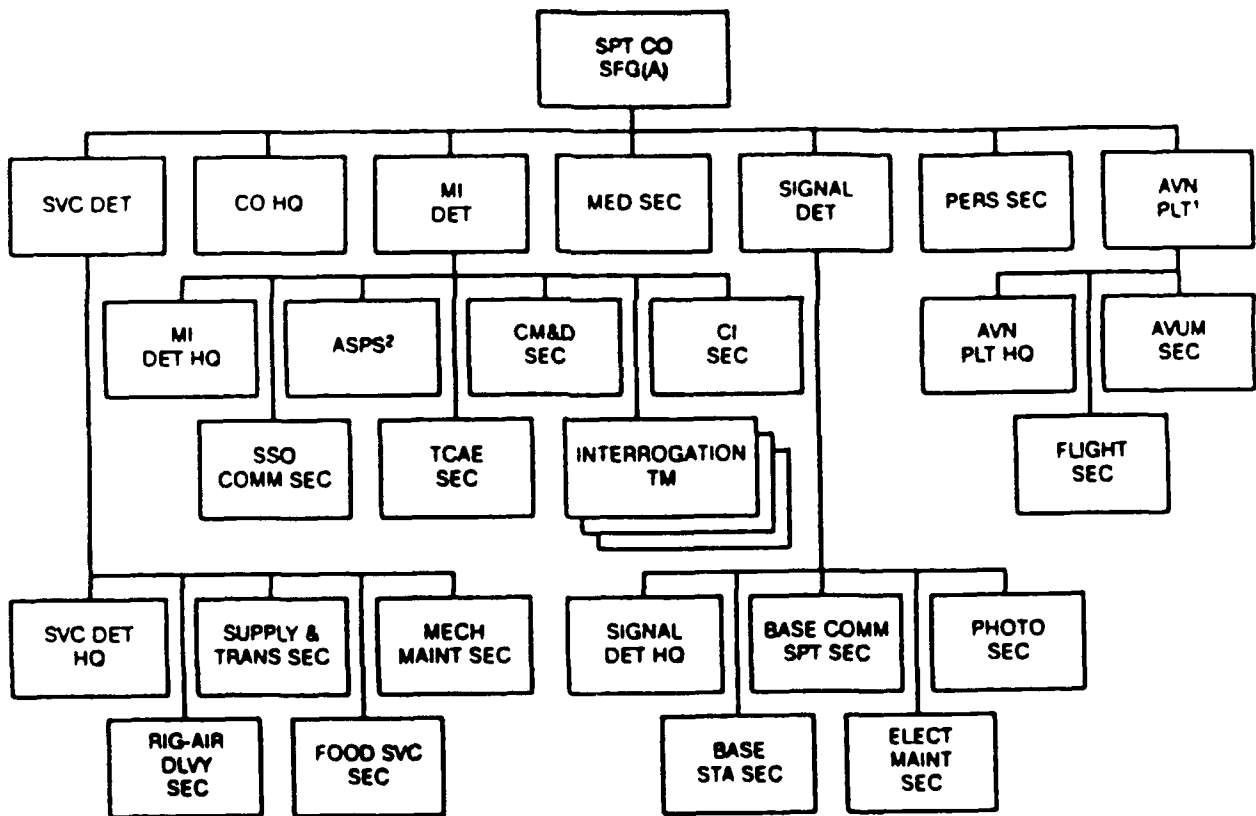

APPENDIX B

SPECIAL FORCES COMMAND ORGANIZATION

COMMAND ORGANIZATION

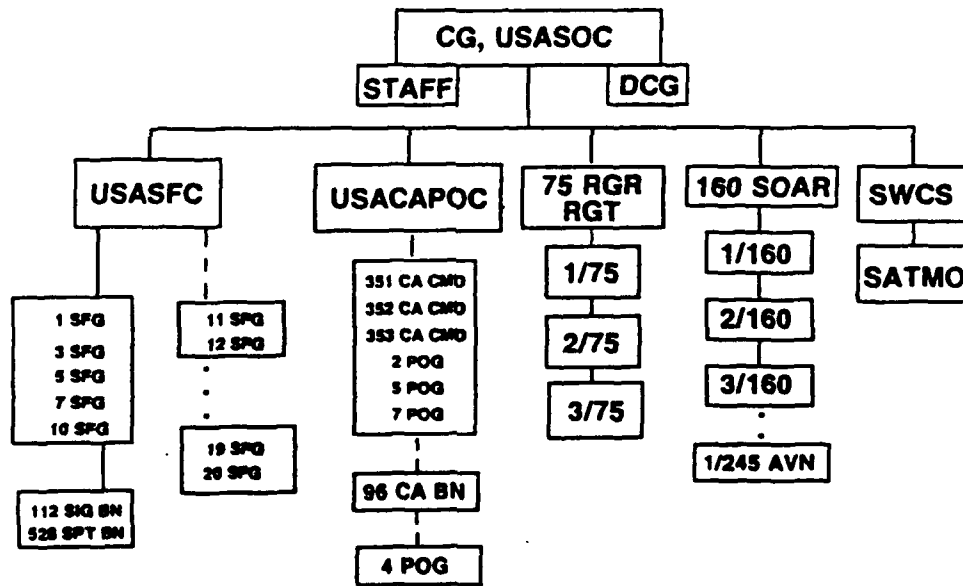
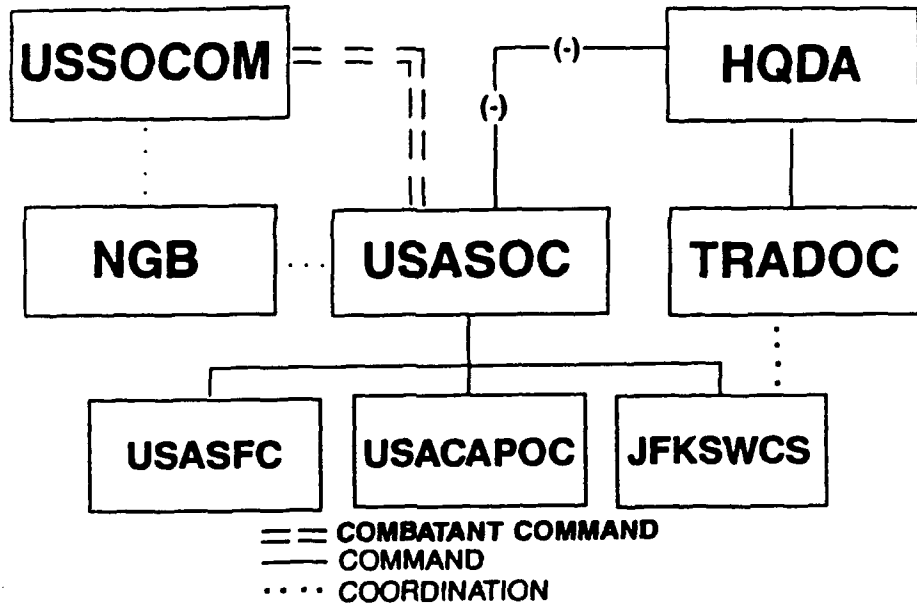

- HQDA - Headquarters, Department of the Army
- JFKSWCS - John F. Kennedy Special Warfare Center and School
- NGB - National Guard Bureau
- SOAR - Special Operations Aviation Regiment
- TRADOC - Training and Doctrine Command
- USACAPOC - U.S. Army Civil Affairs and Psychological Operations Command
- USASFC - U.S. Special Forces Command
- USASOC - U.S. Army Special Operations Command
- USSOCOM - U.S. Special Operations Command

APPENDIX C

ACRONYMS/ABBREVIATIONS

Acronyms/Abbreviations

ARSOF Army special operations forces

ARTEP Army training and evaluation program

ASD SO/LIC Assistant Secretary of Defense for Special Operations and Low Intensity Conflict

CA civil affairs

CT counter-terrorism

DA direct action

FID foreign internal defense

FOB forward operational base

JSCP Joint Strategic Capabilities Plan

LIC low intensity conflict

MTOE modified table of organization and equipment

PCM program objective memorandum

PSYOP psychological operations

SAF Special Action Force

SFG(A) Special Forces Group (Airborne)

SFOD-A Special Forces Operational Detachment-A

SFOD-B Special Forces Operational Detachment-B

SFOD-C Special Forces Operational Detachment-C

SO special operations

SOF special operations forces

SOFFAA Special Operations Forces Functional Area Assessment

SOFMAA **Special Operations Forces Mission Area Analysis**
SOFMAP **Special Operations Forces Modernization Action Program**
SOFMAP **Special Operations Forces Master Plan**
SR **strategic reconnaissance**
TASOSC **Theater Army Special Operations Support Command**
TOE **table of organization and equipment**
USAFORSCOM **United States Army Forces Command**
(FORSCOM)
USAJFKOMA **United States Army John F. Kennedy Special Warfare Center for**
Military Assistance
USAJFKSWCS **United States Army John F. Kennedy Special Warfare Center and School**
(SWCS)
USASFC **United States Army Special Forces Command**
(SFC)
USASOC **United States Army Special Operations Command**
(ASOC)
USATRADOC **United States Army Training and Doctrine Command**
(TRADOC)
USSOCOM **United States Special Operations Command**

ENDNOTES

1. Gordon L. Rottman, U.S. Army Special Forces 1952-84, p. 9.
2. Charles M. Simpson III, Inside the Green Berets, The First Thirty Years, p. 70.
3. Ibid., p. 223.
4. Rottman, p. 18.
5. General Carl W. Stiner, "Prime-Time Players in the Third World Network of Conflict," Army 1990-91 Green Book, October 1990, p. 191.
6. General E. C. Meyer, "The Challenge of Change," Army 1981-82 Green Book, October 1981, p. 14.
7. JCS Pub. 3-0 (Test Pub.), Doctrine for Unified and Joint Operations, January 1990, pp. 1-6.
8. U.S. Army Training and Doctrine Command, Trends and Implications for the U.S. Army's Future Airland Battle, 7 February 1991, p. 4 (Draft - not an approved Department of Army position).
9. (U)Special Operations Forces Modernization Action Program(SOFMAP)(S), HQDA, DCSOPS, August 1989, sec. 1, p.6.
10. Ibid.
11. John O. Marsh, Memorandum for the Secretary of Defense, SUBJ: United States Army Special Operations Forces (SOF) Master Plan, 24 October 1986.
12. SOFMAP, sec. 1, p. 6.
13. Henry L. T. Koren Jr., "Congress Wades into Special Operations," Parameters, December 1988, p. 62.
14. United States Army Special Operations Command, Command Brief, September 1990.
15. DA MSG 171909Z Jun 87, DA Washington D.C. //DAPE-MPO// SUBJ: Special Forces Branch Accessions.
16. Career Management Field "18" designates all Special Forces enlisted, non-commissioned, and commissioned officers as being members of the Special Forces Branch. The designation "180A" does the same for all warrant officers.
17. Special Forces Branch Implementation Plan, Memo, 17 June 1987, HQDA MILPERCEN.

18. HQDA, Doctrine for Special Forces Operations, FM 31-20, April, 1990, p. 3-1.
19. HQDA, USAJFKSWCS, Memorandum for Record, SUBJECT: Review/Validation of Army Special Forces Operational Detachment "A" Organization, 25 November 1986, p. 1.
20. FM 31-20, p. 4-13.
21. USAJFKSWCS ODB Organizational Study, June 1990.
22. United States Army Special Operations Command, Command Brief, September 1990.
23. Ibid.
24. Ibid.
25. HQDA, Special Operations Forces Functional Area Assessment, 1989-1992, pp. I-C-1, I-C-2.
26. Ibid., p. I-C-7.
27. FM 31-20, p. 5-5.
28. General J. J. Lindsay, "Low-Intensity Conflict: Risks Increase," Defense, May June 1989, p. 32.
29. Memorandum for Staffing Committee for NSR 27, Office of the Assistant Secretary of Defense for Special Operations and Low Intensity Conflict, 2 November 1990.
30. George C. Bush, National Security Strategy of the United States, March 1990, p. 28.
31. USAJFKSWCS, Review/Validation of Army Special Forces Operational Detachment "A" Organization.
32. USAJFKSWCS, ODB Organizational Study.
33. Frank C. Carlucci, Annual Report to the Congress, Fiscal Year 1989, p. 58.
34. Ibid., p. 59.
35. Leroy Thompson, The Illustrated History of the U.S. Army Special Forces, p. 42.
36. Major Phillip T. Klapakis, Security Assistance Forces (SAF): A US Military Option for Counterinsurgency, Marine Corps Command and Staff College, 29 March 1990, p. 4.

37. Charles S. Whitehouse, Memorandum for Director, Joint Staff, SUBJECT: Master Plan to Remedy Shortfalls in Language Capabilities, 17 November 1988.

38. SOFFAA, p. I-C-11. 1-Establish a data base to monitor language qualification. 2-USAJFKSWCS will teach 16 languages at the Functional level in FY90. 3-1st SOCOM [ASOC] will code authorization documents by the TAADS-R system, showing LIC and proficiency by line number. 4-USAJFKSWCS will use coded authorizations from 1st SOCOM [ASOC] to develop methodology for inventory tracking of functional language trained personnel.

39. Memorandum for Commander, United States Army Special Operations Command, Subject: U.S. Army Special Operations Command Language Program, from Office of the Deputy Chief of Staff for Intelligence, Washington, 30 August 1990. Languages are: Arabic-Egyptian, French, German, Korean, Persian-Farsi, Polish, Portuguese, Spanish-LA, Tagalog, and Thai.

40. Thompson, p. 43.

41. Address at the Army War College, Carlisle, PA, 11-15 February 1991.

42. SOFMAP, p. 1.

BIBLIOGRAPHY

BOOKS

1. Rottman, Gordon L. U.S. Army Special Forces 1952-84. London: Osprey Pub., 1985.
2. Simpson, Charles M., III. Inside the Green Berets: The First Thirty Years. Novato: Presidio Press, 1983.
3. Thompson, Leroy. The Illustrated History of the U.S. Army Special Forces. Secaucus: Citadel, 1988.
4. Keegan, John and Wheatcraft, Andrew. Zones of Conflict: An Atlas of Future Wars. New York: Simon and Schuster, 1986.

PERIODICALS

1. Koren, Henry L. T., Jr. "Congress Wades into Special Operations." Parameters, Vol. XVIII No. 4, December 1988, pp. 62-74.
2. Lindsay, J.J., GEN. "Low-Intensity Conflict: Risks Increase." Defense, May-June 1989.
3. Meyer, E.C. GEN. "The Challenge of Change." Army 1981-82 Green Book. Association the United States Army, Arlington: October 1981.
4. Stiner, Carl W., GEN. "Prime Time Players in the Third World Network of Conflict." Army 1990-91 Green Book. Association of the United States Army, Arlington: October 1990.

PUBLIC DOCUMENTS

1. Bush, George C. National Security Strategy of The United States. Washington: The White House, 1990.
2. Carlucci, Frank C. Annual Report to the Congress: Fiscal Year 1989. Washington: U.S. Department of Defense, 18 February 1988.
3. Marsh, John O., Secretary of the Army. Memorandum for the Secretary of Defense, United States Army Special Operations Forces (SOF) Master Plan. 24 October 1986.
4. Office of the Assistant Secretary of Defense for Special Operations and Low Intensity Conflict. Memorandum for Staffing Committee for NSR 27. 2 November 1990.

5. Whitehouse, Charles S., Assistant Secretary of Defense for Special Operations/Low-Intensity Conflict. Memorandum for Director, Joint Staff, Master Plan to Remedy Shortfalls in Language Capabilities. 17 November 1988.

INTERVIEWS

1. Barratto, David J., BG. Commander, United States Army John F. Kennedy Special Warfare Center and School. Personal Interview. Fort Bragg: 11 December 1990.
2. Garrison, William F., BG. Deputy Commanding General, United States Army Special Operations Command. Personal Interview. Fort Bragg: 12 December 1990.
3. Guest, James A., MG. Commander, United States Army Special Forces Command. Personal Interview. Fort Bragg: 13 December 1990.

STUDENT RESEARCH PAPERS

1. Klapakis, Phillip T., MAJ. Security Assistance Forces (SAF): A US Military Option for Counterinsurgency. Thesis. Quantico: Marine Corps Command and Staff College, 29 March 1990.

DEPARTMENT OF DEFENSE MANUALS/MEMORANDUMS/MESSAGES

1. The Joint Chiefs of Staff. JCS Pub. 3-0 (Test Pub.), Doctrine for Unified and Joint Operations. Washington: January 1990.
2. U.S. Department of the Army. Message. Special Forces Branch Accessions. DAPE-MPO, 171909Z, June 1987.
3. U.S. Department of the Army. Memorandum. Special Forces Branch Implementation Plan. HODA MILPERCEN, 17 June 1987.
4. U.S. Department of the Army. Deputy Chief of Staff for Operations and Plans. Special Operations Forces Functional Area Assessment. 1989-1992.
5. U.S. Department of the Army. Deputy Chief of Staff for Operations and Plans. U.S. Army Special Operations Forces Master Plan. 24 October 1989.
6. U.S. Department of the Army. Deputy Chief of Staff for Operations and Plans. U.S. Army Special Operations Forces Modernization Action Plan. (S/NF), August 1989.

7. U.S. Department of the Army. Field Manual 31-20: Doctrine for Special Forces Operations. Washington: April 1990.
8. U.S. Department of the Army. United States Army John F. Kennedy Special Warfare Center and School. Army Special Operations Forces Reference Data. Fort Bragg: 8 February 1991.
9. U.S. Department of the Army. United States Army John F. Kennedy Special Warfare Center and School. ODB Organizational Study. June 1990.
10. U.S. Department of the Army. Memorandum. Review/Validation of Army Special Forces Operational Detachment "A" Organization. United States Army John F. Kennedy Special Warfare Center and School, 25 November 1986.
11. U.S. Department of the Army. United States Army Special Operations Command. Command Briefing. September 1990.
12. U.S. Department of the Army. U.S. Army Training and Doctrine Command. Trends and Implications for the U.S. Army's Future Airland Battle. (Draft - for review purposes only; not an approved Department of Army position). 7 February 1991.