

AD-A231 571

2

MTL TR 90-61

DTIC AD

THE BSU-86/B BOMB FIN ASSEMBLY FIRST ARTICLE CONFORMANCE TESTING

MARC S. PEPI, VICTOR K. CHAMPAGNE, Jr., and
CATHERINE M. ZOLLER
MATERIALS TESTING AND EVALUATION BRANCH

December 1990

Approved for public release; distribution unlimited.

DTIC
ELECTE
FEB 05 1991
S E D

Sponsored by
Pacific Missile Test Center (NAVAIR)
Point Mugu, CA 93042



US ARMY
LABORATORY COMMAND
MATERIALS TECHNOLOGY LABORATORY

U.S. ARMY MATERIALS TECHNOLOGY LABORATORY
Watertown, Massachusetts 02172-0001

91 2 04 142

The findings in this report are not to be construed as an official Department of the Army position, unless so designated by other authorized documents.

Mention of any trade names or manufacturers in this report shall not be construed as advertising nor as an official indorsement or approval of such products or companies by the United States Government.

DISPOSITION INSTRUCTIONS

Destroy this report when it is no longer needed.
Do not return it to the originator.

Block No. 20

ABSTRACT

The Navy Pacific Missile Test Center (PMTTC) requested that the U. S. Army Materials Technology Laboratory (MTL) perform a series of metallurgical tests on 16 components of the BSU-86/B bomb fin assembly. The parts were characterized in accordance with applicable standards and contractual requirements as part of a First Article Inspection to confirm and verify specific fabrication operations performed by the manufacturer. The intent of the First Article Inspection is to certify the ability of the manufacturer to produce a component which satisfies the standards of quality and workmanship agreed upon by the U. S. Government and contractor.

All components tested conformed to the established criteria for hardness and chemical composition. The bomb fins satisfied the minimum ultimate tensile strength (UTS) of 73,000 psi, as well as the intergranular corrosion test. Metallographic examination verified that the microstructure of all the components reflected their corresponding heat treatment and/or prior fabrication. The thickness of the surface coatings examined conformed to required specifications with the exception of the zinc plating located on the link pin which did not meet minimal thickness requirements. The components satisfied the acceptance standards for salt spray testing except for the link pin. Recommendations were provided to strip and replat the link pins already produced with inferior coatings at the request of PMTTC.

Accession For	
NTIS GRA&I	<input checked="" type="checkbox"/>
DTIC TAB	<input type="checkbox"/>
Unannounced	<input type="checkbox"/>
Justification	
By _____	
Distribution/	
Availability Codes	
Dist	Avail and/or Special
A-1	



CONTENTS

	Page
INTRODUCTION	1
PROCEDURE	7
TEST RESULTS	
Hardness Testing	15
CHEMICAL ANALYSIS	23
SALT SPRAY TEST	
Procedure	26
Results	26
Procedure	27
Results	27
Procedure	27
Results	27
Procedure	27
Results	28
METALLOGRAPHIC EXAMINATION	
Clevis	31
Clevis Bolt	31
Collar	31
Fin Spring	31
Fin Support	31
Latch	31
Lever	31
Link	36
Link Pin	36
Self-Locking Nut	36
Setscrew	36
Shock Absorber	36
Spring Arming Wire Housing Assembly	36
Tension Spring	36
Tube, Guide Wire	36
COATING THICKNESS MEASUREMENTS	41
INTERGRANULAR CORROSION TEST	
Procedure	45
Results	45
TENSILE TEST	49
RECOMMENDATIONS	
Link Pin Replate Procedure	50
CONCLUSIONS	51

INTRODUCTION

Sixteen components of the BSU-86/B bomb fin assembly obtained from a First Article Inspection of Defense Research, Inc. (DRI) were submitted by the Pacific Missile Test Center (PMTTC) to the U.S. Army Materials Technology Laboratory (MTL) to verify their conformance to applicable drawing specifications. Macrographs of each component in the as-received condition are shown in Figures 1 through 16. A listing of the components under evaluation and their corresponding engineering drawing numbers are listed in Table 1.

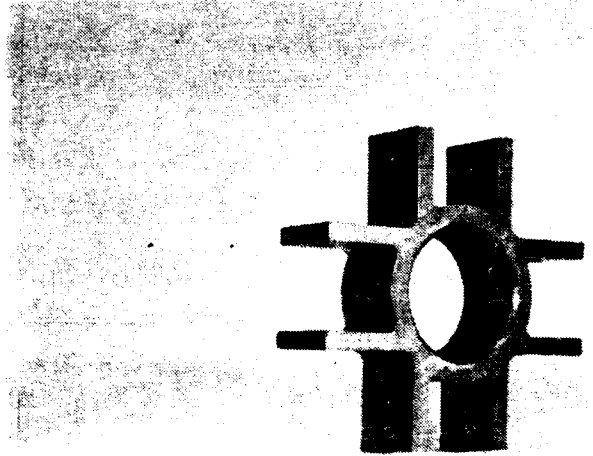

Figure 1. Macrograph of the clevis in as-received condition. MAG 0.25X



Figure 2. Macrograph of the clevis bolt in as-received condition. MAG 1X

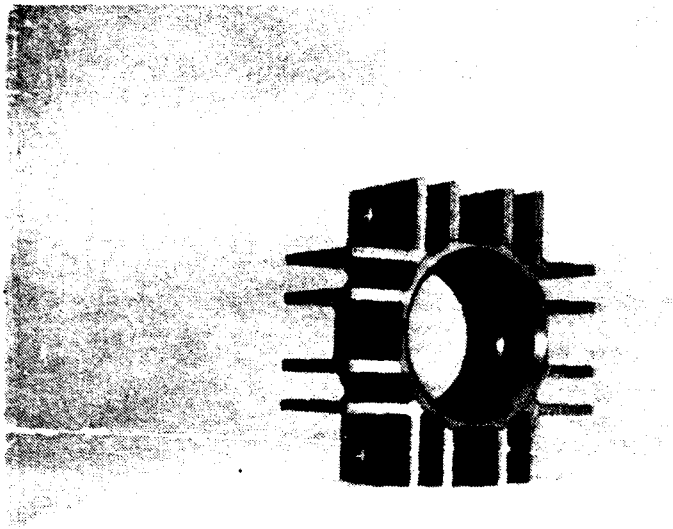

Figure 3. Macrograph of the collar in as-received condition. MAG 0.3X

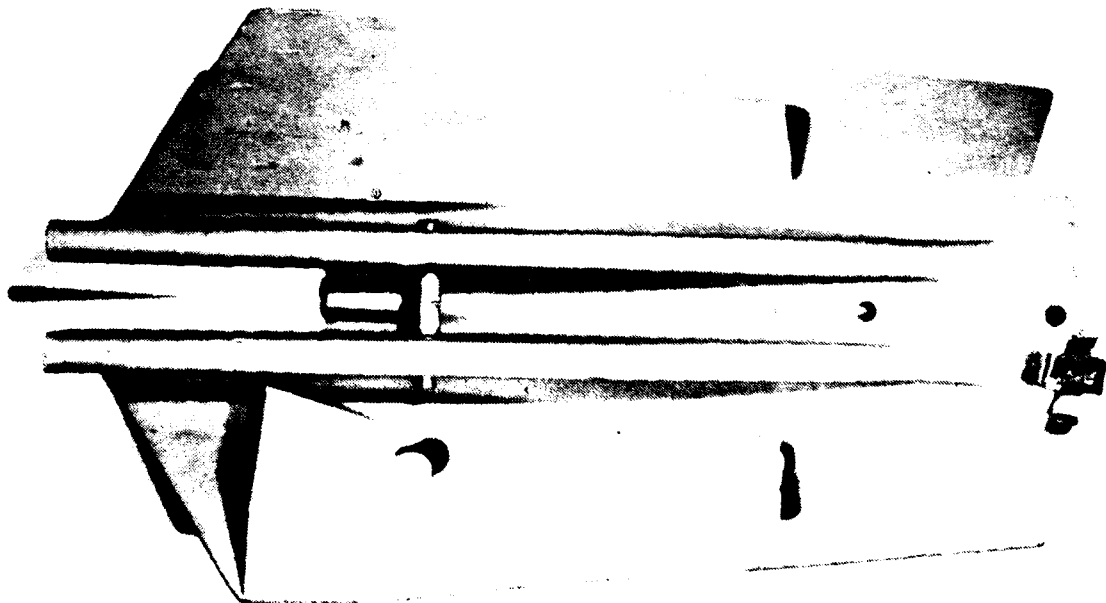

Figure 4. Macrograph of the bomb fin in as-received condition. MAG 0.2X

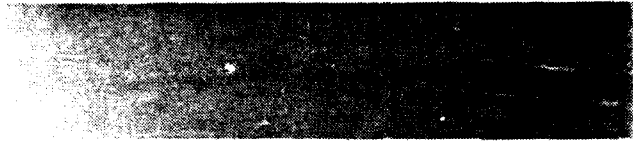

Figure 5. Macrograph of the fin spring in as-received condition. MAG 0.7X



Figure 6. Macrograph of the fin support in as-received condition. MAG 0.15X

Figure 7. Macrograph of the guide tube in as-received condition. MAG 0.25X

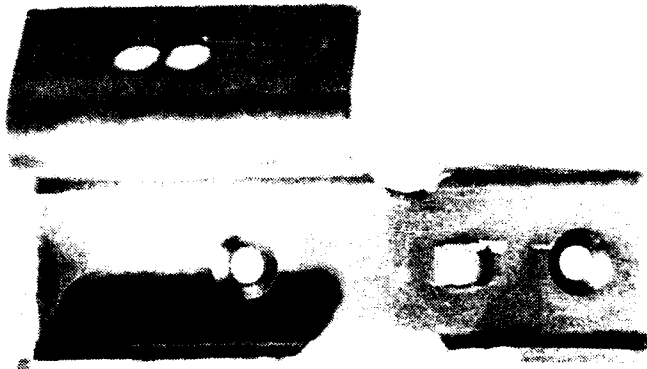

Figure 8. Macrograph of the latch in as-received condition. MAG 1.5X

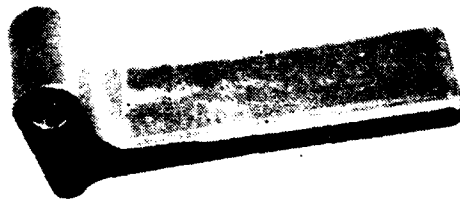

Figure 9. Macrograph of the lever in as-received condition. MAG 1.5X



Figure 10. Macrograph of the link in as-received condition. MAG 0.15X



Figure 11. Macrograph of the self-locking nut in as-received condition. MAG 2X

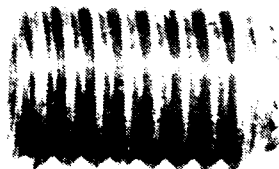

Figure 12. Macrograph of the setscrew in as-received condition. MAG 2X



Figure 13. Macrograph of the link pin in as-received condition. MAG 1X

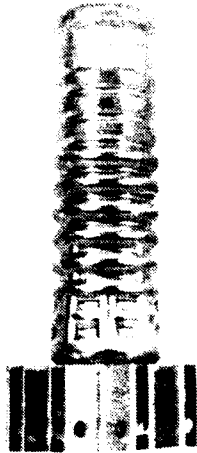

Figure 14. Macrograph of the shock absorber in as-received condition. MAG 0.15X



Figure 15. Macrograph of spring arming wire housing assembly in as-received condition. MAG 0.15X



Figure 16. Macrograph of tension spring in as-received condition. MAG 1X

Table 1. COMPONENTS UNDER EVALUATION

Number	Component	NAVAIRSYSCOM Drawing No.
1	Clevis	2605248
2	Clevis Bolt	AN28-604 (vendor part no.)
3	Collar	Z605199
4	Fin	923AS160
5	Fin Spring	1561419
6	Fin Support	2605094
7	Guide Tube	1298307
8	Latch	923AS254
9	Lever	923AS253
10	Link	2877672
11	Link Pin	1562347
12	Self-Locking Nut	NAS10ZZN8 (vendor part no.)
13	Setscrew	2877751
14	Shock Absorber	2605175
15	Spring Arming Wire Housing Assembly	923AS5225-2
16	Tension Spring	923AS227

PROCEDURE

The BSU-86/B component drawings were reviewed to establish a test schedule based on the applicable drawing requirements. The testing consisted of chemical analysis, hardness testing, metallographic examination, salt fog testing, tensile testing, and intergranular corrosion tests. The required testing for each component along with the governing specification is listed in Table 2.

Table 2. COMPONENT TESTING REQUIREMENTS AND GOVERNING SPECIFICATIONS

Key

C = Chemical Analysis

H = Hardness Testing

S = Salt Spray Fog Testing

T = Tensile Testing

I = Intergranular Corrosion Testing

NOTE: All components were examined metallographically.

Number	Component	Test	Governing Specification
1	Clevis	C	AMS-4153
		H	AMS-4153
		S	MIL-A-8625
2	Clevis Bolt	C	AMS-6300
		H	MIL-B-6812
		S	QQ-P-416
3	Collar	C	AMS-4154
		H	AMS-4154
		S	MIL-A-8625
4	Fin	T	E.D. 923AS160
		I	MIL-H-6088F
5	Fin Spring	C	MIL-S-5059
		H	MIL-S-5059
		S	QQ-P-35
6	Fin Support	C	MIL-A-12545
		H	MIL-A-12545
		S	MIL-A-8625
7	Guide Tube	C	QQ-A-200/5
8	Latch	C	MIL-S-5059
		H	MIL-S-5059
		S	QQ-P-35
9	Lever	C	AMS-5342
		H	AMS-5342
		S	QQ-P-35
10	Link	C	QQ-A-225/9
		S	MIL-A-8625
11	Link Pin	C	ASTM A 108
		H	E.D. 1562347
		S	QQ-P-416
12	Self-Locking Nut	H	MIL-N-25027
		S	QQ-P-416
13	Setscrew	H	MIL-G-18240
		S	QQ-P-416
14	Shock Absorber	C	ASTM A 513
		H	E.D. 2605175
		S	QQ-P-416
15	Spring Arming Wire Housing Assembly	C	QQ-A-250/11
16	Tension Spring	C	ASTM A 313
		H	ASTM A 313
		S	QQ-P-35

In order to expedite the First Article Inspection review and meet established deadlines for the collection of test data, the components were sectioned immediately upon arrival at MTL. Two cross-sectional specimens were taken from the parts. One specimen was cut into small chips for chemical analysis utilizing a diamond blade on a cutoff machine. The remaining sample was mounted and prepared for metallographic examination and subsequent hardness testing. The cut surfaces of the components were then cleaned and, as required by applicable specifications, coated to prevent false corrosion indications during salt spray testing. After the components were subjected to salt spray testing, they were examined visually. Diagrams displaying how each specimen was sectioned are shown in Figure 17. Tensile tests, as well as intergranular corrosion tests, were then performed on samples fabricated from the bomb fin assembly.

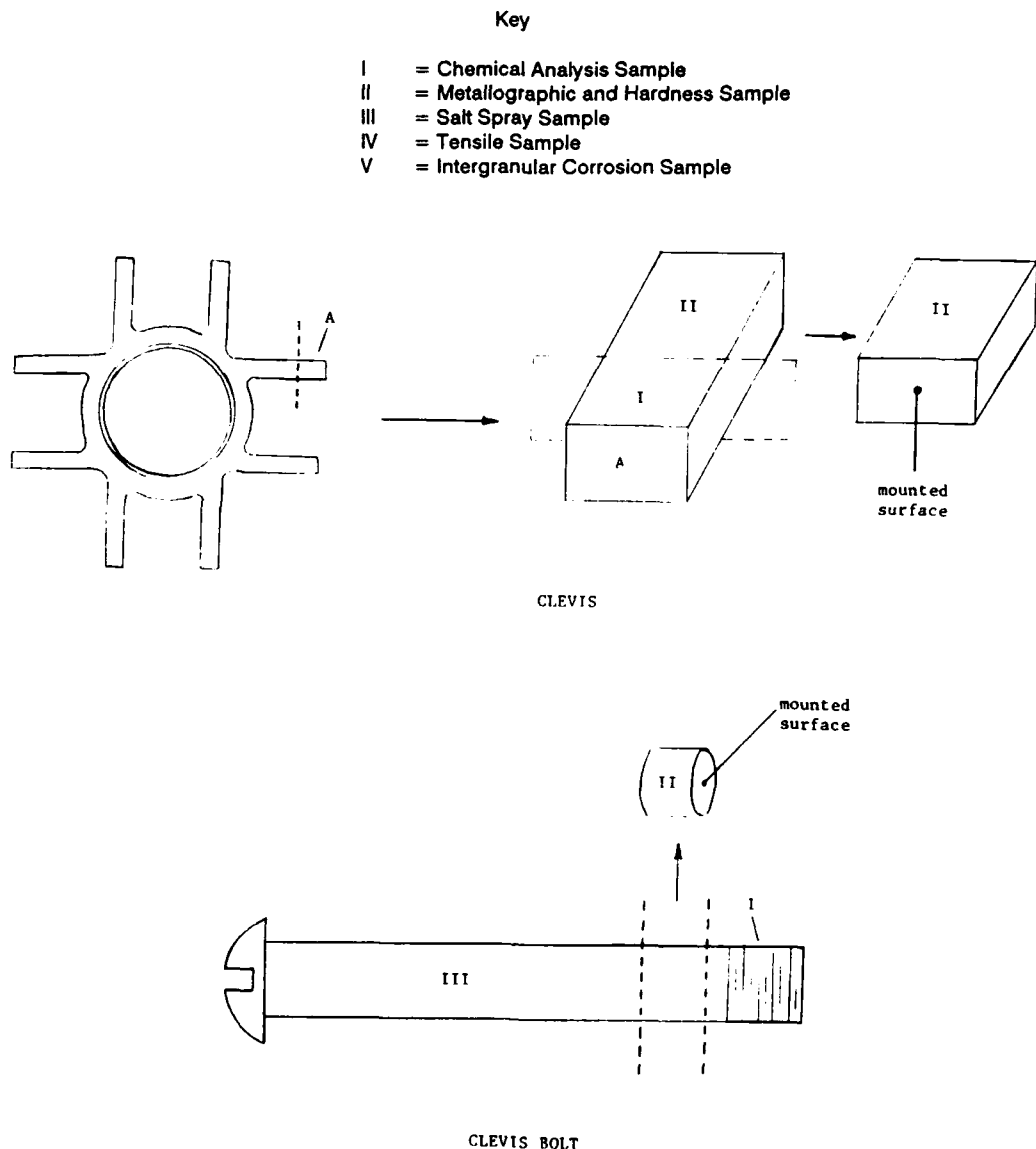

Figure 17. Component sectioning diagrams showing test sample preparation (drawings not to scale).

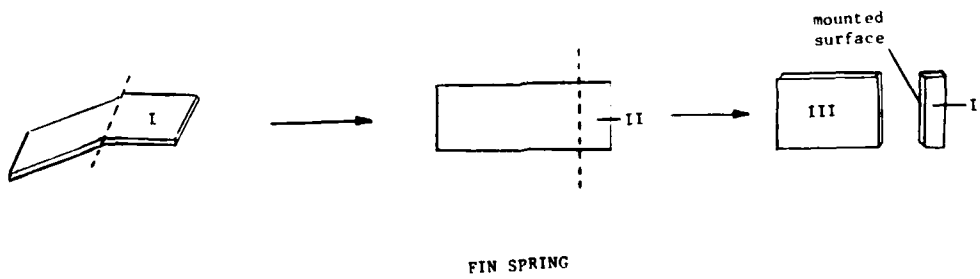
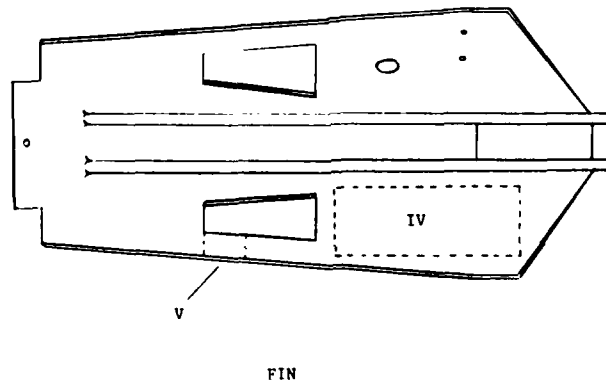
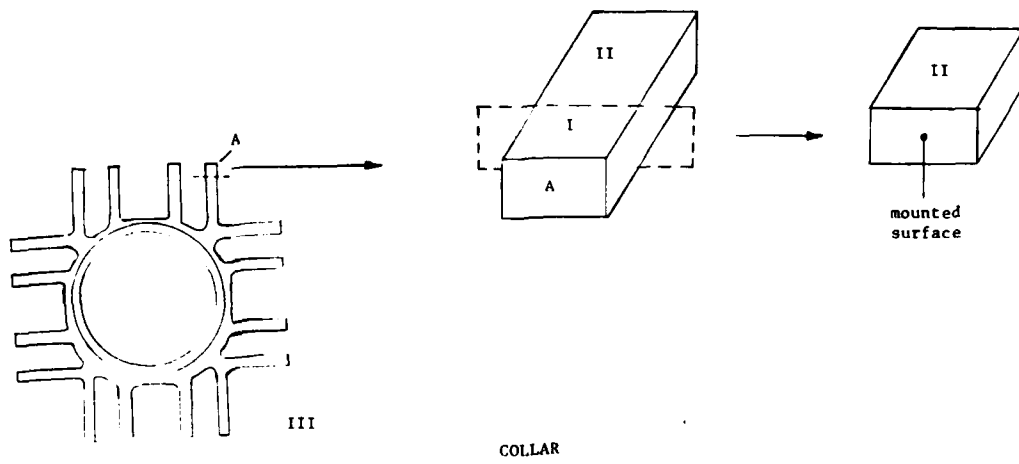

Figure 17 (cont'd). Component sectioning diagrams showing test sample preparation (drawings not to scale).

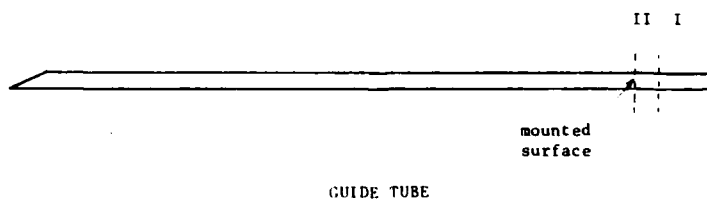
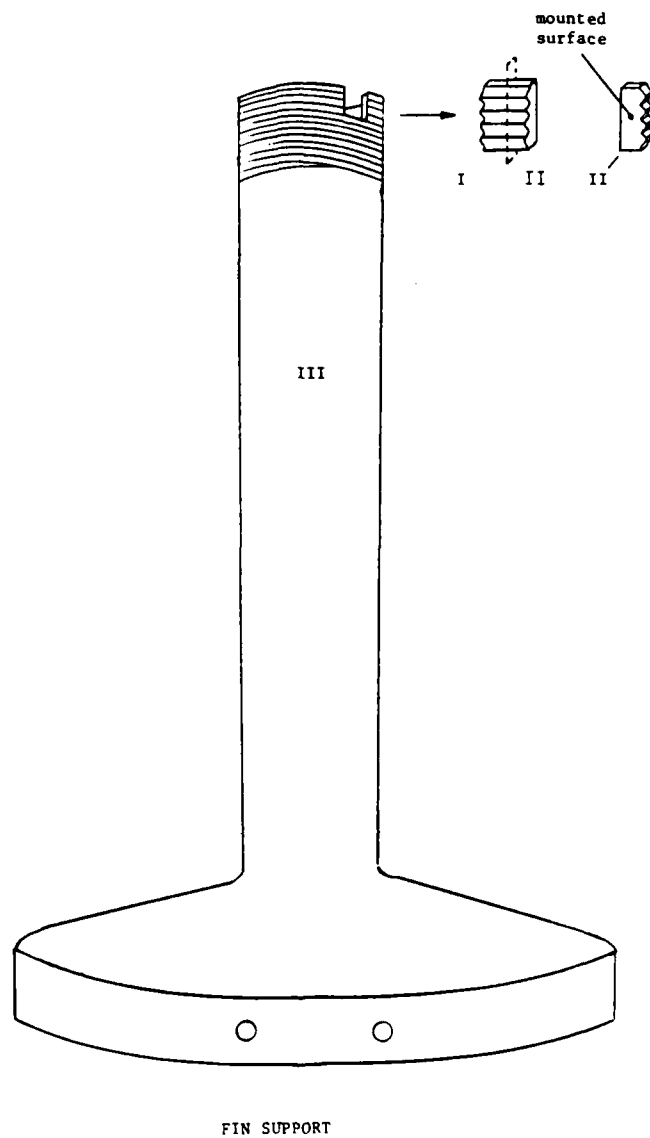

Figure 17 (cont'd). Component sectioning diagrams showing test sample preparation (drawings not to scale).

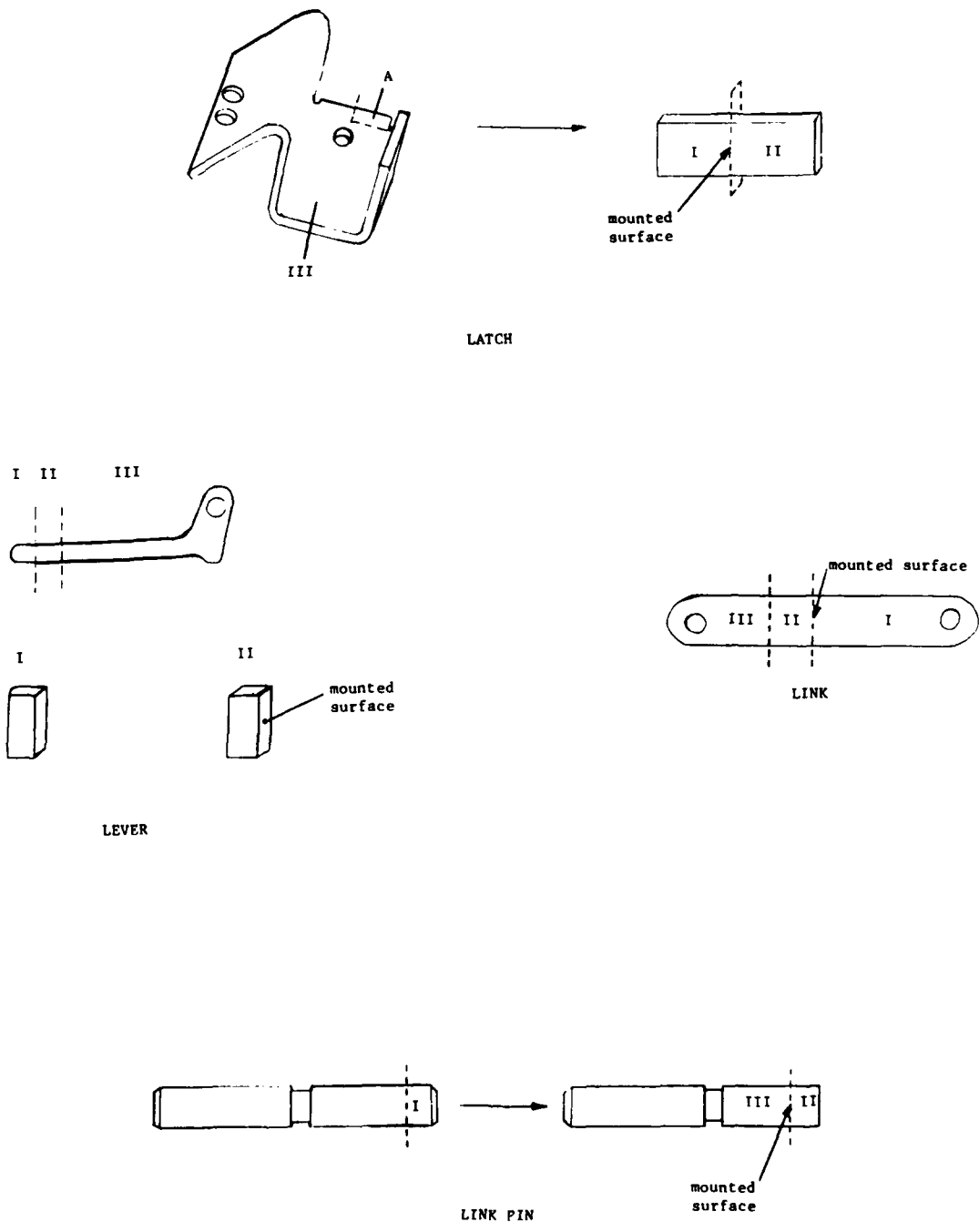

Figure 17 (cont'd). Component sectioning diagrams showing test sample preparation (drawings not to scale).

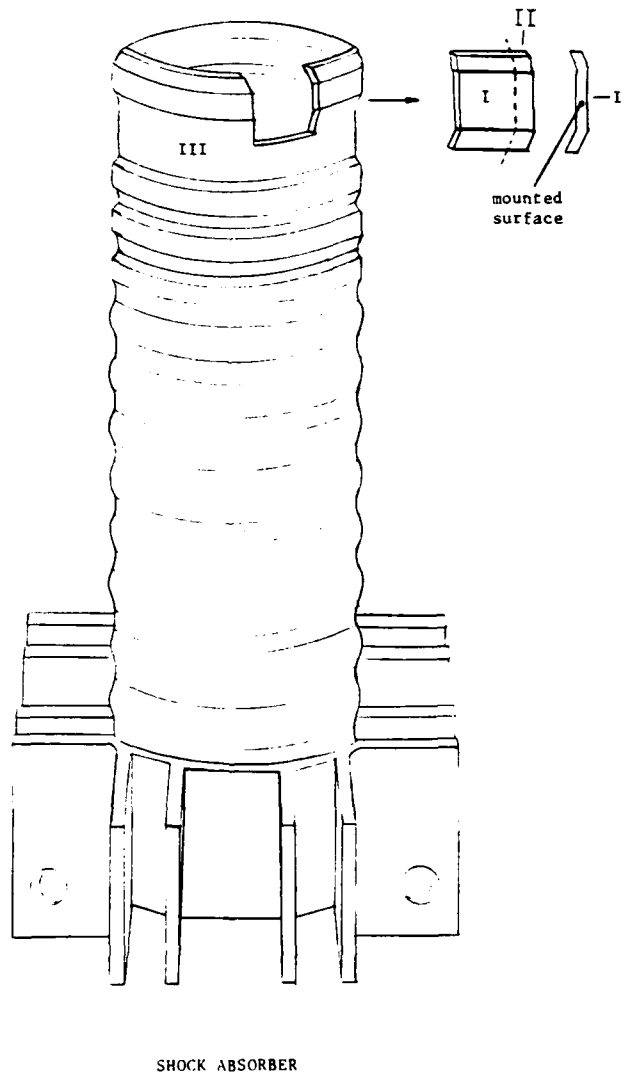
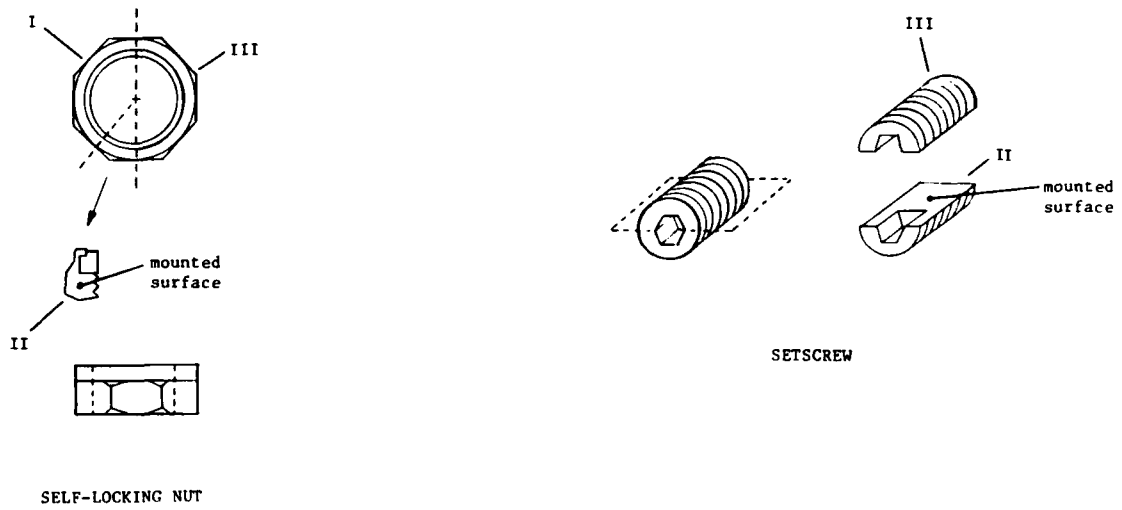
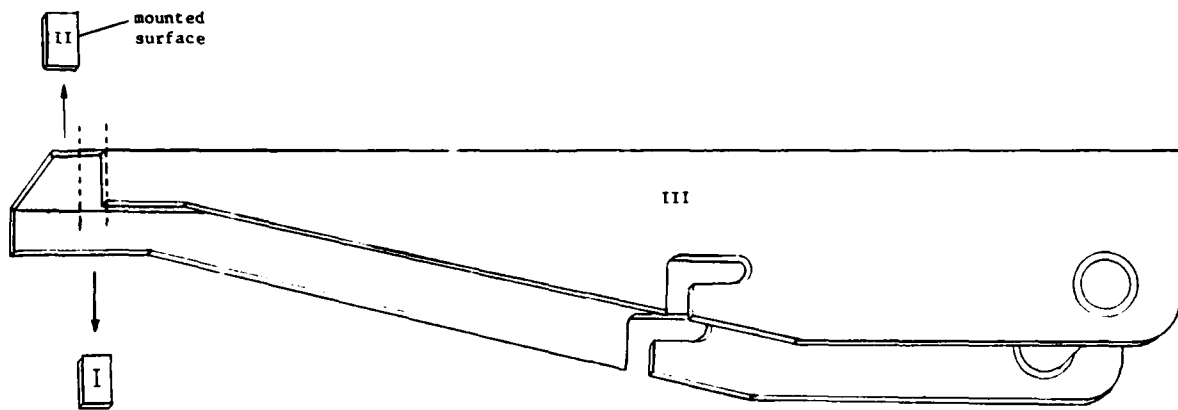
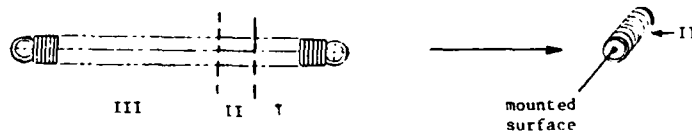

Figure 17 (cont'd). Component sectioning diagrams showing test sample preparation (drawings not to scale).



HOUSING ASSEMBLY



TENSION SPRING

Figure 17 (cont'd). Component sectioning diagrams showing test sample preparation (drawings not to scale).

TEST RESULTS

Hardness Testing

Ten hardness measurements were taken of each mounted metallographic specimen. The hardness test chosen, either Rockwell B (macro), Rockwell C (macro), or Knoop (micro), depended upon the anticipated material hardness and the available cross-sectional area. Approximate values for Brinell hardness and tensile strength were obtained from a Wilson Conversion Chart.

In each of the following hardness tables (see Tables 3 through 13), the component is identified and the hardness test performed is indicated. The required hardness has been listed and can be compared to the measured values. The hardness of each component satisfied the requirements specified on the engineering drawing.

Table 3. MACROHARDNESS MEASUREMENTS

Reading	HRC
1	44.0
2	46.7
3	48.0
4	45.5
5	46.6
6	48.0
7	48.7
8	48.8
9	48.4
10	47.9
Avg.	47.3
S.D.	1.55
Required	45-53

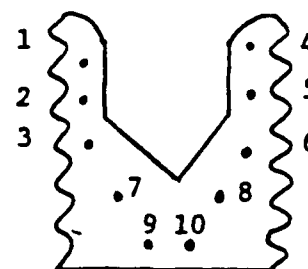

Cross-sectional sample that was hardness tested.

Table 4. MACROHARDNESS MEASUREMENTS

Rockwell "C" Scale 150 kgf Load Diamond Penetrator Link Pin	
Reading	HRC
1	30.9
2	33.0
3	33.0
4	32.2
5	33.2
6	33.6
7	33.7
8	33.7
9	33.8
10	31.8
Avg.	33.0
S.D.	0.94
Required	27-33

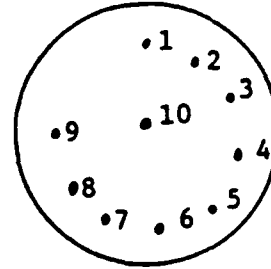

Cross-sectional sample that was hardness tested.

Table 5. MACROHARDNESS MEASUREMENTS

Rockwell "C" Scale 150 kgf Load Diamond Penetrator Clevis Bolt	
Reading	HRC
1	29.7
2	30.2
3	30.0
4	29.7
5	30.3
6	31.4
7	31.8
8	31.9
9	32.3
10	31.2
Avg.	30.9
S.D.	0.98
Required	26-32

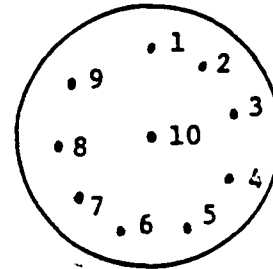

Cross-sectional sample that was hardness tested.

Table 6. MACROHARDNESS MEASUREMENTS

Knoop Hardness 20X to 500 gf Load Pyramidal Diamond Indenter Tension Spring		
Reading	Knoop	Tensile Strength (ksi) Conversion
1	574	273
2	540	255
3	519	246
4	567	270
5	580	277
6	558	264
7	579	275
8	571	270
9	614	292
10	524	246
Avg.		267
S.D.		14.44
Minimum Requirement		248

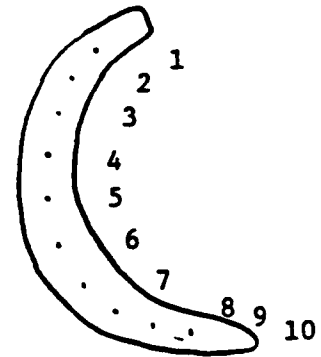

Cross-sectional sample that was hardness tested.

Table 7. MACROHARDNESS MEASUREMENTS

Rockwell "C" Scale 150 kgf Load Diamond Penetrator Lever	
Reading	HRC
1	37
2	38
3	37
4	38
5	38
6	37
7	38
8	38
9	38
10	37
Avg.	37.6
S.D.	0.52
Minimum Requirement	30

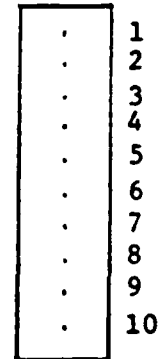

Cross-sectional sample that was hardness tested.

Table 8. MICROHARDNESS MEASUREMENTS

Knoop Hardness 20X to 500 gf Load Pyramidal Diamond Indenter Latch		
Reading	Knoop	HRC Conversion
1	389	39
2	372	37
3	356	36
4	399	40
5	383	38
6	414	41
7	412	41
8	379	38
9	374	37
10	400	40
Avg.		38.7
S.D.		1.77
Required		37-41

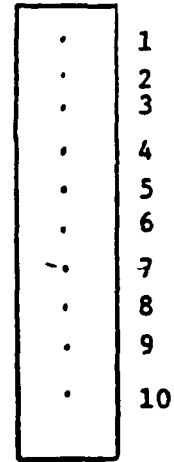

Cross-sectional sample that was hardness tested.

Table 9. MICROHARDNESS MEASUREMENTS

Knoop Hardness 20X to 500 gf Load Pyramidal Diamond Indenter Fin Spring		
Reading	Knoop	HRC Conversion
1	389	39
2	537	37
3	356	36
4	399	40
5	383	38
6	414	41
7	412	41
8	379	38
9	374	37
10	400	40
Avg.		38.7
S.D.		1.77
Required		37-41

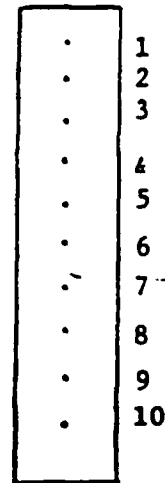

Cross-sectional sample that was hardness tested.

Table 10a. MACROHARDNESS MEASUREMENTS

Rockwell "B" Scale 100 kgf Load 1/16 Inch Diamond Penetrator Shock Absorber - Convoluted Section	
Reading	HRB
1	78.3
2	77.0
3	79.0
4	79.5
5	78.0
6	77.3
7	79.4
8	79.0
9	77.8
10	76.3
Avg.	78.2
S.D.	1.08
Required	54-60

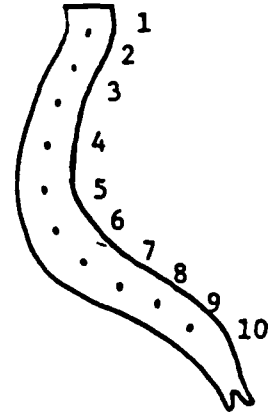

Cross-sectional sample that was hardness tested.

Table 10b. MACROHARDNESS MEASUREMENTS

Rockwell "B" Scale 100 kgf Load 1/16 Inch Diamond Penetrator Shock Absorber - Convoluted Section	
Reading	HRB
1	74.8
2	74.7
3	76.5
4	74.4
5	74.3
6	73.6
7	75.1
8	74.5
9	74.1
10	75.2
Avg.	74.7
S.D.	0.78
Required	54-60

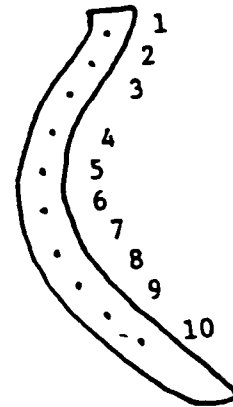

Cross-sectional sample that was hardness tested.

Table 10c. MACROHARDNESS MEASUREMENTS

Rockwell "B" Scale 100 kgf Load 1/16 Inch Diamond Penetrator Shock Absorber - Convoluted Section	
Reading	HRB
1	73.1
2	74.5
3	73.2
4	74.1
5	74.6
6	73.8
7	73.7
8	74.2
9	73.9
10	74.3
Avg.	73.9
S.D.	0.51
Required	54-60

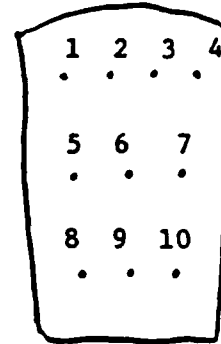

Cross-sectional sample that was hardness tested.

Table 10d. MACROHARDNESS MEASUREMENTS

Rockwell "B" Scale 100 kgf Load 1/16 Inch Diamond Penetrator Shock Absorber - Convoluted Section	
Reading	HRB
1	69.6
2	70.8
3	69.9
4	69.3
5	69.5
6	69.1
7	70.5
8	71.4
9	69.1
10	69.4
Avg.	69.9
S.D.	0.78
Required	54-60

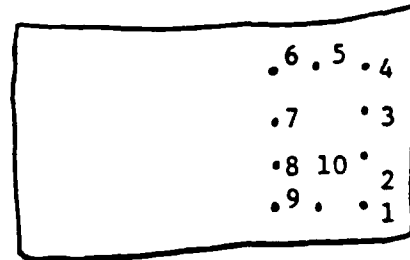

Cross-sectional sample that was hardness tested.

Table 10e. MACROHARDNESS MEASUREMENTS

Rockwell "B" Scale 100 kgf Load 1/16 Inch Diamond Penetrator Shock Absorber - Flat Section	
Reading	HRB
1	60.3
2	60.6
3	59.6
4	59.2
5	59.8
6	58.3
7	59.0
8	59.1
9	60.5
10	61.8
Avg.	59.8
S.D.	1.01
Required	54-60

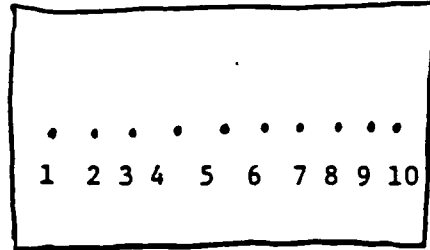

Cross-sectional sample that was hardness tested.

Table 10f. MACROHARDNESS MEASUREMENTS

Rockwell "B" Scale 100 kgf Load 1/16 Inch Diamond Penetrator Shock Absorber - Flat Section	
Reading	HRB
1	62.0
2	61.2
3	62.2
4	60.5
5	60.4
6	60.1
7	59.4
8	59.6
9	60.2
10	60.8
Avg.	60.6
S.D.	0.93
Required	54-60

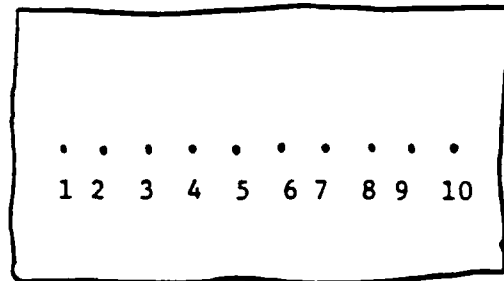

Cross-sectional sample that was hardness tested.

Table 11. MICROHARDNESS MEASUREMENTS

Knoop Microhardness 20X to 500 gf Load Pyramidal Diamond Indenter Collar		
Reading	Knoop	Brinell Conversion
1	189	172
2	190	174
3	188	172
4	184	169
5	184	169
6	181	166
7	181	166
8	184	169
9	186	170
10	186	170
Avg.		169.7
S.D.		2.54
Required		135-140

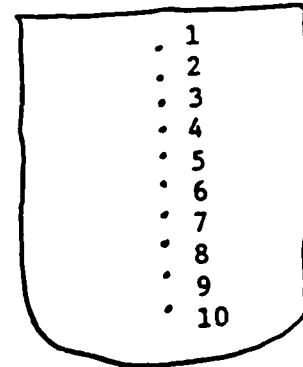

Cross-sectional sample that was hardness tested.

Table 12. MICROHARDNESS MEASUREMENTS

Knoop Microhardness 20X to 500 gf Load Pyramidal Diamond Indenter Support Fin		
Reading	Knoop	Brinell Conversion
1	162	147
2	163	150
3	164	150
4	164	150
5	169	156
6	168	153
7	181	165
8	186	170
9	174	159
10	160	147
Avg.		154.7
S.D.		7.8
Minimum Requirement		135

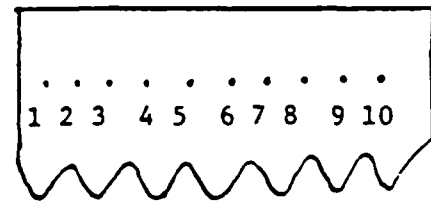

Cross-sectional sample that was hardness tested.

Table 13. MACROHARDNESS MEASUREMENTS

Rockwell "B" Scale 100 kgf Load 1/16 Inch Diamond Penetrator Clevis		
Reading	HRB	Brinell Conversion
1	78.3	144
2	82.3	156
3	82.5	157
4	83.2	159
5	83.0	159
6	83.5	160
7	83.0	159
8	82.9	159
9	83.0	159
10	82.9	159
Avg.		157.1
S.D.		4.74
Minimum Requirement		130

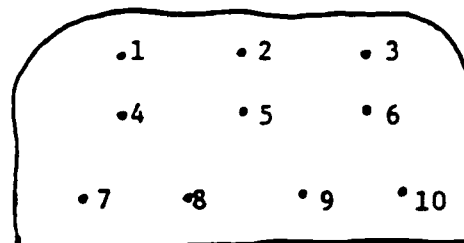

Cross-sectional sample that was hardness tested.

The shock absorber showed readings well above the required hardness values; these readings, however, were taken on the convoluted section of the shock absorber (see Tables 10a through 10d). Since this portion of the shock absorber was worked during fabrication, its tensile strength and subsequent hardness are increased. The shock absorber was fabricated of 1010 steel, which exhibits a marked increase in tensile strength due to cold working and strain hardening. Note that the readings fall within the required range when the measurements were taken on an area of the shock absorber that was not convoluted (see Tables 10e and 10f).

CHEMICAL ANALYSIS

The chemical compositions of the BSU-86/B bomb fin assembly components were determined by atomic absorption and inductively-coupled argon plasma emission spectrometry. This procedure quantifies the elemental composition of each specimen as a percentage of total weight. The carbon and sulfur contents were determined by the LECO combustion method. All of the analyzed components satisfied their specified chemical compositions.

Results of the chemical analysis, as well as nominal chemical compositions (where applicable), are shown in the following table.

Table 14. CHEMICAL COMPOSITIONS OF BSU-86/B BOMB FIN ASSEMBLY COMPONENTS

Clevis

Element	Cu	Mg	Mn	Fe	Si	Zn	Ti	C	Al
Percent	4.41	0.38	0.68	0.18	0.72	0.054	0.024	0.009	Rem.
Nominal	3.9-5.0	0.2-0.8	0.4-1.2	<0.7	0.5-1.2	<0.25	<0.15	<0.1	Rem.

The clevis conforms to AMS 4153 for 2014-T6 extruded aluminum alloy.

Clevis Bolt

Element	C	S	Cu	Mn	Mo	Ni	P	Si	Cr
Percent	0.377	0.017	0.076	0.86	0.21	0.089	0.017	0.26	0.14
Nominal	0.35-0.40	<0.04	<0.35	0.7-0.9	0.2-0.3	<0.25	<0.04	0.15-0.35	<0.20

The clevis bolt conforms to AMS 6300 for low alloy forged steel.

Collar

Element	Zn	Mg	Cu	Cr	Fe	Si	Mn	Ti	Al
Percent	5.39	2.25	1.36	0.20	0.13	0.069	0.015	0.029	Rem.
Nominal	5.1-6.1	2.1-2.9	1.2-2.0	0.18-0.28	<0.5	<0.4	<0.3	<0.2	Rem.

The collar conforms to AMS 4154 for 7075-T6 aluminum alloy.

Fin Spring

Element	C	Mn	P	S	Cr	Ni	Si	Cu	Mo
Percent	0.079	1.39	0.027	0.008	16.9	7.33	0.46	0.43	0.35
Nominal	≤0.15	≤2.0	≤0.045	≤0.03	16.0-18.0	6.0-8.0	≤1.0	≤0.75	≤0.75

The fin spring conforms to MIL-S-5059 for stainless steel.

Fin Support

Element	Si	Fe	Cu	Mn	Mg	Cr	Zn	Ti	Al
Percent	0.072	0.19	1.31	0.014	2.16	0.24	5.35	0.029	Rem.
Nominal	≤0.40	≤0.50	1.2-2.0	≤0.3	2.1-2.9	0.18-0.28	5.1-6.1	≤0.2	Rem.

The fin support conforms to MIL-A-12545 for 7075-T6 aluminum alloy.

Latch

Element	C	Mn	P	S	Cr	Ni	Si	Cu	Mo
Percent	0.099	1.39	0.022	0.011	17.3	7.61	0.33	0.16	0.16
Nominal	≤0.15	≤2.0	≤0.045	≤0.03	16.0-18.0	6.0-8.0	≤1.0	≤0.75	≤0.75

The latch conforms to MIL-S-5059 for 301 chromium-nickel stainless steel.

Table 14 (cont'd). CHEMICAL COMPOSITIONS OF BSU-86/B BOMB FIN ASSEMBLY COMPONENTS

Lever												
Element	C	Mn	Si	P	S	Cr	Ni	Nb + Ta	Cu	Al	Sn	
Percent	0.007	0.44	0.59	0.023	0.011	16.2	4.15	0.21	0.020	3.23	0.027	0.011
AMS-5342	≤0.06	≤0.7	0.5-1	≤0.025	≤0.025	15.5-16.7	3.6-4.6	0.15-0.40	2.8-3.5	≤0.05	≤0.02	

The lever conforms to AMS 5342 for 17-4 PH stainless steel.

Link										
Element	Mg	Si	Cu	Cr	Fe	Ti	Mn	Zn	Bi	Al
Percent	2.21	0.055	1.46	0.19	0.13	0.028	0.017	5.31-5.57	.008	Rem
QQ-A-225/9	2.1-2.9	≤0.4	1.2-2.0	0.18-0.28	≤0.5	≤0.2	≤0.3	5.1-6.1	≤0.05	Rem

The link conforms to QQ-A-225/9 for 7075-T6 aluminum alloy.

Link Pin				
Element	C	Mn	P	S
Percent	0.331	1.44	0.01	0.12
ASTM A 108	0.32-0.39	1.35-1.65	≤0.04	0.08-0.13

The link pin conforms to ASTM A 108 for 1100 series steel.

Self-Locking Nut										
Element	C	S	Al	Co	Cu	Mn	Mo	Ni	P	Si
Percent	0.051	0.017	0.023	0.017	0.017	0.44	0.034	0.049	0.015	0.07

No chemical specification for the self-locking nut was cited on the engineering drawing.

Setscrew										
Element	C	S	Al	Co	Cu	Mn	Mo	Ni	P	Si
Percent	0.368	0.031	0.024	0.017	0.15	0.79	0.21	0.17	0.007	0.23

No chemical specification for the setscrew was cited on the engineering drawing.

Shock Absorber				
Element	C	Mn	P	S
Percent	0.089	0.40	≤0.004	0.011
ASTM A513	0.08-0.13	0.3-0.6	≤0.04	≤0.05

The shock absorber conforms to ASTM A513 for grade 1010 steel.

Table 14 (cont'd). CHEMICAL COMPOSITIONS OF BSU-86/B BOMB FIN ASSEMBLY COMPONENTS

Spring Arming Wire Housing Assembly

Element	Mg	Si	Cu	Fe	Cr	Zn	Ti	Mn	Al
Percent	1.13	0.49	0.23	0.49	0.19	0.049	0.017	0.055	Rem.
QQ-A-250/11	0.8-1.2	0.4-0.8	0.15-0.4	≤0.7	0.04-0.35	≤0.25	≤0.15	≤0.15	Rem.

The spring arming wire housing assembly conforms to QQ-A-250/11 for 6061-T6 aluminum.

Tension Spring

Element	C	Mn	P	S	Si	Ni	Cr
Percent	0.059	1.36	0.023	0.009	0.31	8.72	18.1
ASTM A313-302	≤0.15	≤2.0	≤0.045	≤0.03	≤1.0	8.0-10.5	17-19
ASTM A313-304	≤0.08	≤2.0	≤0.045	≤0.03	≤1.0	8.0-10.0	18-20

The tension spring conforms to ASTM A 313 for 302 or 304 stainless steel.

Tube, Guide Wire

Element	Si	Fe	Cu	Mn	Zn	Al
Percent	0.25	0.53	0.13	1.17	0.02	Rem.
QQ-A-200/5	≤0.6	≤0.7	0.05-0.2	1-1.5	≤0.1	Rem.

The guide wire tube conforms to QQ-A-200/5 for 3003 aluminum.

SALT SPRAY TEST

A salt spray test was performed on components of the BSU-86/B bomb fin assembly in accordance with ASTM B 117 to test the integrity of the component coatings in a corrosive environment. The procedure and test criteria for each part is listed below along with the results.

Procedure

Lever

The Lever was cleaned in a 20% HNO₃ solution in accordance with ASTM A 380. The lever tension spring, latch, and fin spring were subjected to salt spray testing for a minimum of two hours. The parts were then evaluated for corrosion using the criterion from Section 3.7.2 of QQ-P-35C which states, "...the passivated surface shall be capable of withstanding salt spray exposure without evidence of rust or staining."

Results

The samples did not show any evidence of corrosion during the testing period and upon final inspection.

Procedure

Self-Locking Nut, Setscrew, and Clevis Bolt

The self-locking nut, setscrew, and clevis bolt were subjected to salt spray testing for 96 hours in accordance with QQ-P-416. These components all have Type II, Class B cadmium plating in accordance with their appropriate specification. The corrosion criterion given by QQ-P-416 for cadmium coating reads:

"(E-2a). The appearance of white corrosion products, visible to the unaided eye at normal reading distance, at scratches through the chromate film to the cadmium plate or at unscratched areas of the chromate film, shall be cause for rejection except that white corrosion products at sharp edges shall not constitute failure.

(E-2b). The appearance of more than six corroded areas per square foot of surface that are visible to the unaided eye, or of any corroded areas larger than 1/16 inch in diameter, shall be cause for rejection. For purposes of this requirement, a corroded area is defined as exposure of corrosion of the basis metal."

Results

The self-locking nut, setscrew, and clevis bolt displayed no evidence of corrosion after testing.

Procedure

Collar, Fin Support, Clevis, and Link

The collar, fin support, clevis, and link were exposed to salt spray (5% NaCl in solution) for 336 hours in accordance with MIL-A-8625E. These samples were evaluated using the criterion set forth in MIL-A-8625E which states:

"When visually examining for corrosion resistance, test specimens shall show no more than a total of 15 isolated spots or pits, none larger than 0.031 inch in diameter, in a total of 150 square inches of test area grouped from five or more test pieces; nor more than five isolated spots or pits, none larger than 0.031 inch in diameter, in a total of 30 square inches from one or more test pieces; except those areas within 0.062 inch from identification markings, edges, and electrode contact marks remaining after processing."

Results

The clevis, collar, fin support, and link displayed no evidence of corrosion upon final inspection.

Procedure

Link Pin and Shock Absorber

The link pin (NAVAIR Engineering Drawing No. 1562347) and shock absorber (NAVAIR Engineering Drawing No. 2605175) may be coated with either zinc or cadmium. It was determined through energy dispersing spectroscopy (EDS) that the link pins and shock absorber had been zinc plated. These components were subjected to salt spray testing for

96 hours as specified in ASTM B633 for SC4 zinc plating. The evaluation criterion set forth in ASTM B633, Section 7.4 reads:

"Zinc coatings with Type II and Type III treatments shall show neither corrosion products of the zinc nor basis metal corrosion products at the end of the test period. The appearance of corrosion products visible to the unaided eye at normal reading distance shall be cause for rejection except that white corrosion products at the edges of specimens shall not constitute failure."

Results:

The shock absorber showed no evidence of corrosion products, neither of the zinc plate nor the basis metal.

Link pin (1) showed substantial evidence of white corrosion products and corrosion products of the basis metal, as shown in Figures 18 through 20, are macrographs revealing the corrosion of base metal on link pin (2) upon final inspection. Link pin (2) also showed evidence of corrosion products, as illustrated in Figure 21. Corrosion of the base metal was observed upon further magnification of link pin (2), as shown in Figures 22 and 23. Failure could be due to either a lack of surface preparation before coating or an insufficient plating thickness. A discussion of the surface coating is presented in the "Coating Thickness Measurements" section of this report.



Figure 18. Macrograph of link pin (1) following salt spray test period. White powder corrosion is evident. MAG 1X



Figure 19. Macrograph of link pin (1) revealing corrosion of base metal following salt spray test period. MAG 7.5X

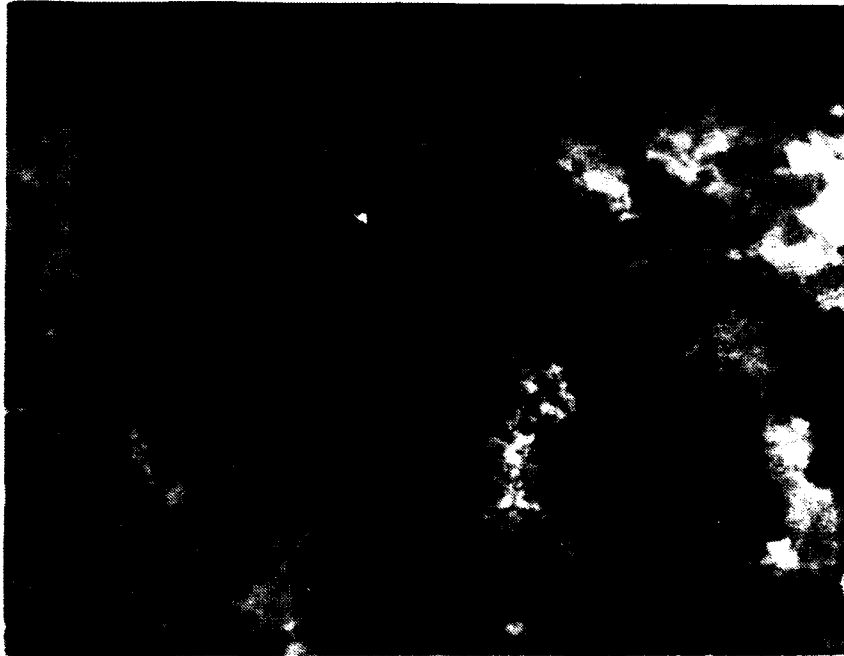

Figure 20. Base metal corrosion of link pin (1) at higher magnification (see Figure 19). MAG 40X

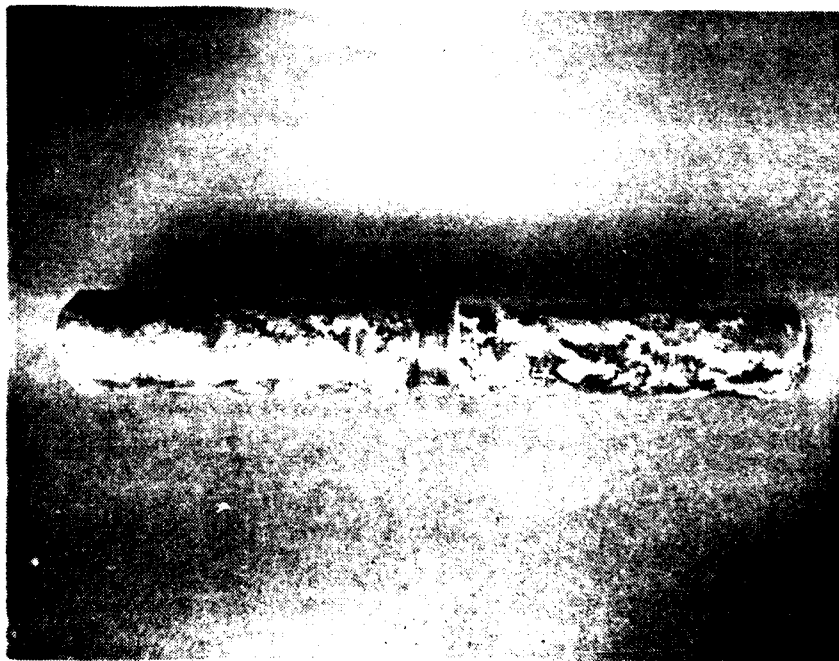

Figure 21. Macrograph of link pin (2) following salt spray test period. White powder corrosion is evident. MAG 1X

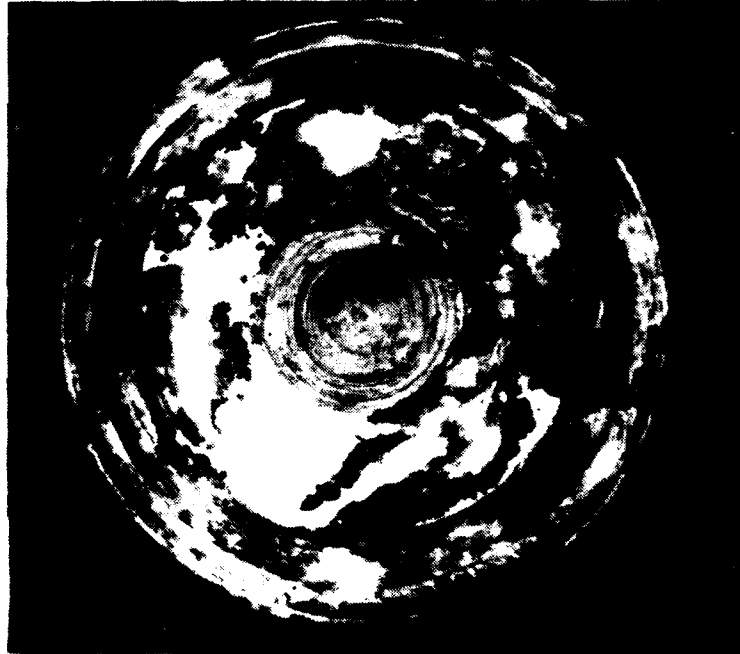

Figure 22. Macrograph of link pin (2) showing corrosion of base metal following salt spray test period. MAG 7.5X



Figure 23. Base metal corrosion of link pin (2) at higher magnification (see Figure 22). MAG 40X

METALLOGRAPHIC EXAMINATION

Micrographs were taken of BSU-86/B bomb fin assembly specimens to determine whether the microstructures conformed to corresponding material specifications. The specimens were examined with the metallograph and no excessive abnormalities were observed. A summary of the microstructures follows:

Clevis

Evidence of recrystallization at grain boundaries and an even dispersion of precipitates are representative of the heat treatment and age hardening processes conforming to 2014-T6 aluminum alloy (see Figure 24a). A possibility of slight overaging exists at the outside surface of the component (see Figure 24b).

Clevis Bolt

The microstructure indicates a fine tempered martensitic steel, conforming to MIL-B-6812 (see Figure 25). The slight decarburization evident at the surface is well within the permissible range specified in AMS 6300 (refer to Figure 40).

Collar

The microstructure is representative of solution-treated, quenched, and artificially-aged 7075 aluminum alloy in the T6 condition. Grain elongation is evidence of the extrusion process. The material conforms to AMS 4154 (see Figure 26).

Fin Spring

The nickel-stabilized austenitic structure depicted in the micrograph is representative of 301 stainless steel, as specified in MIL-S-5059. The flow lines indicate prior forming (see Figure 27).

Fin Support

The microstructure is representative of the solution heat-treatment and age-hardening process utilized for the 7075 aluminum alloy specified in MIL-A-12545, as evidenced by the observed precipitates. Grain elongation is generated by the fabrication process (see Figure 28).

Latch

The 301 stainless steel had been annealed and contained an equiaxed grain structure. Flow lines reveal evidence of prior processing. Evidence of a carbide network could not be discerned in accordance with MIL-S-5059D (see Figure 29).

Lever

The microstructure of the 17-4 PH stainless steel consisted of pools of ferrite and ferrite stringers in a tempered martensitic matrix. The material conforms to AMS 5342 (see Figure 30).

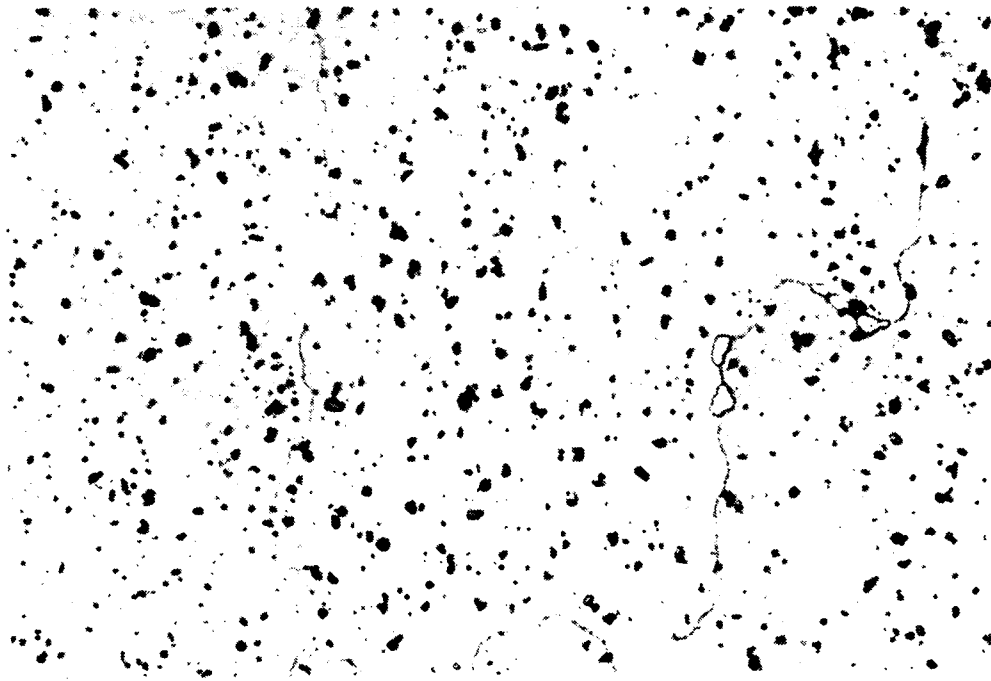

Figure 24a. Optical micrograph of the clevis showing typical microstructure of 2014-T6 aluminum alloy. MAG 200X

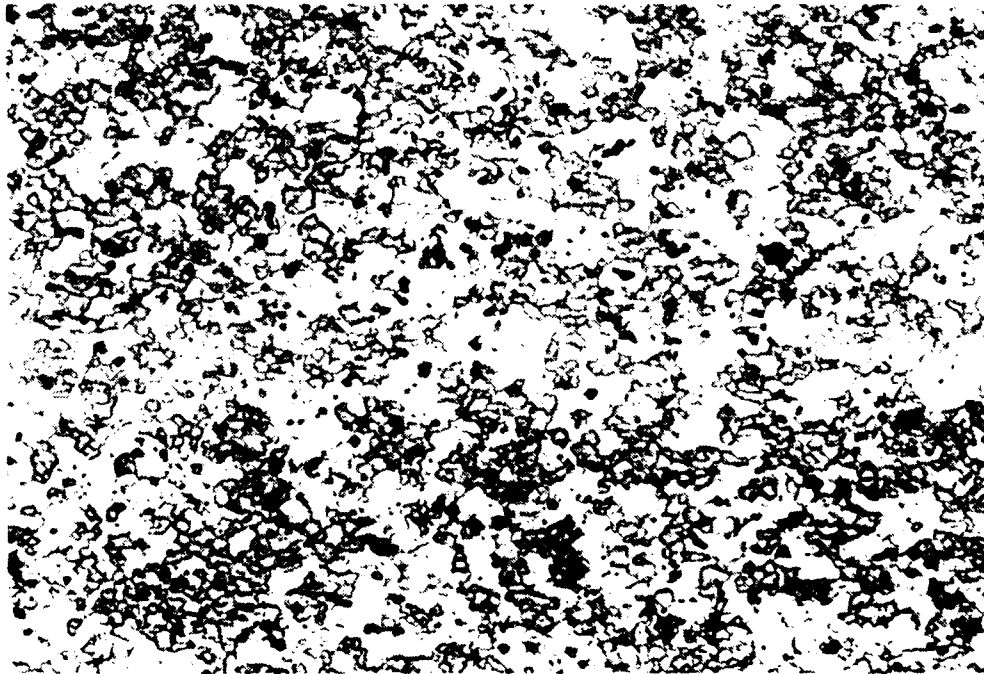

Figure 24b. Optical micrograph showing slight overaging at the outside surface of the clevis specimen. MAG 200X



Figure 25. Optical micrograph of the clevis bolt showing typical fine tempered martensite. MAG 1000X



Figure 26. Optical micrograph of the collar revealing a microstructure representative of a tempered 7xxx series aluminum alloy. MAG 200X



Figure 27. Optical micrograph of the fin spring revealing the microstructure of 301 stainless steel and evidence of flow lines indicative of prior forming. MAG 200X



Figure 28. Optical micrograph of the fin support microstructure revealing evidence of the age-hardening process used with the 7075 aluminum alloy. MAG 200X

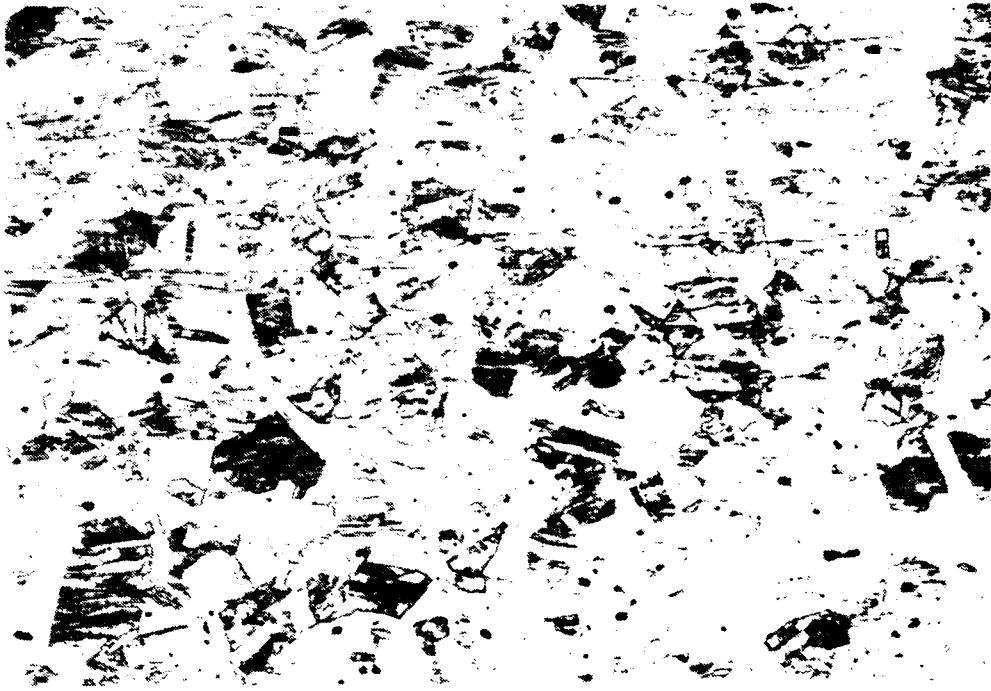

Figure 29. Optical micrograph of the latch showing equiaxed grains and evidence of flow lines. MAG 200X

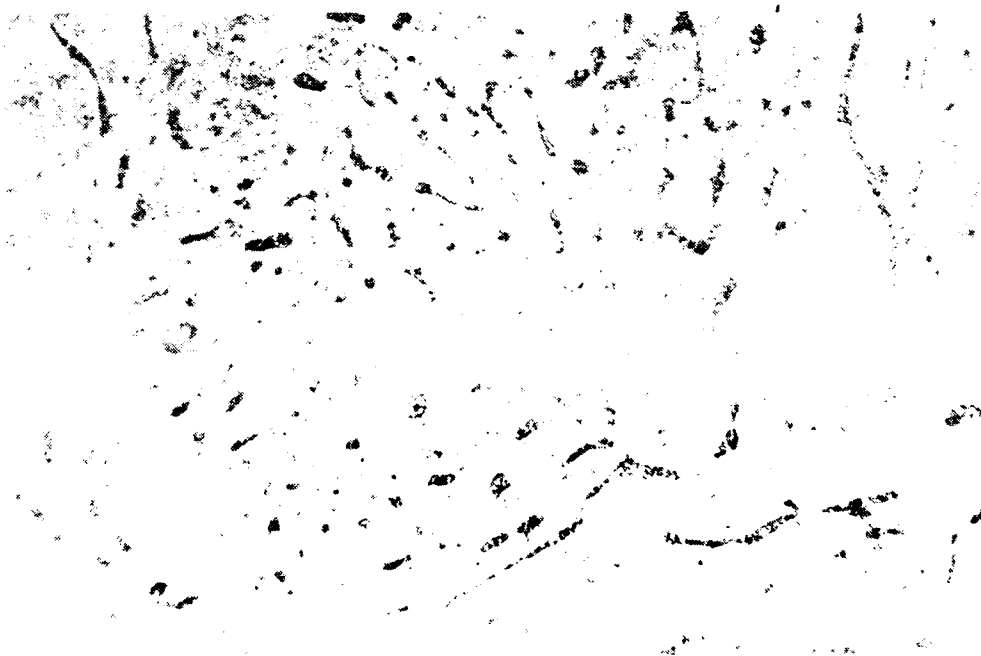

Figure 30. Optical micrograph of the lever showing ferrite within a martensitic matrix. MAG 500X

Link

The specimen displayed recrystallization at grain boundaries and an equiaxed grain structure. The microstructure was indicative of a 7075-T6 aluminum alloy conforming to QQ-A-225/9 (see Figure 31).

Link Pin

The lath martensite microstructure is typical of carbon steel which has been solution heat-treated and rapidly quenched conforming to ASTM 108 (see Figure 32).

Self-Locking Nut

Pools of pearlite within a ferritic matrix are representative of the heat treatment utilized for this low carbon steel. Grain elongation reveals prior processing (see Figure 33).

Setscrew

The microstructure is representative of a typical quenched and tempered low alloy steel (see Figure 34).

Shock Absorber

The microstructure consists of a ferritic core containing pools of pearlite. A self-annealing process has occurred at the inner and outer edges of the part (micrograph shows outer edge only) as a result of greater strain hardening at the surface, as evidenced by the grain refinement along with an absence of pearlite (see Figure 35).

Spring Arming Wire Housing Assembly

The micrograph reveals a fine banded dispersion of small particles of a chromium intermetallic phase typical of a 6061 aluminum alloy in the T6 condition. The material conforms to QQ-A-250/11 (see Figure 36).

Tension Spring

Transformation of some austenite to martensite in 302 stainless steel during forming can be observed in the micrograph. Flow lines are additional indications of processing, as specified in ASTM A313 (see Figure 37).

Tube, Guide Wire

The micrograph reveals evenly dispersed precipitates, and is representative of drawn 3003 aluminum alloy, as specified in QQ-A-200/1 and WW-T-700/2 (see Figure 38).

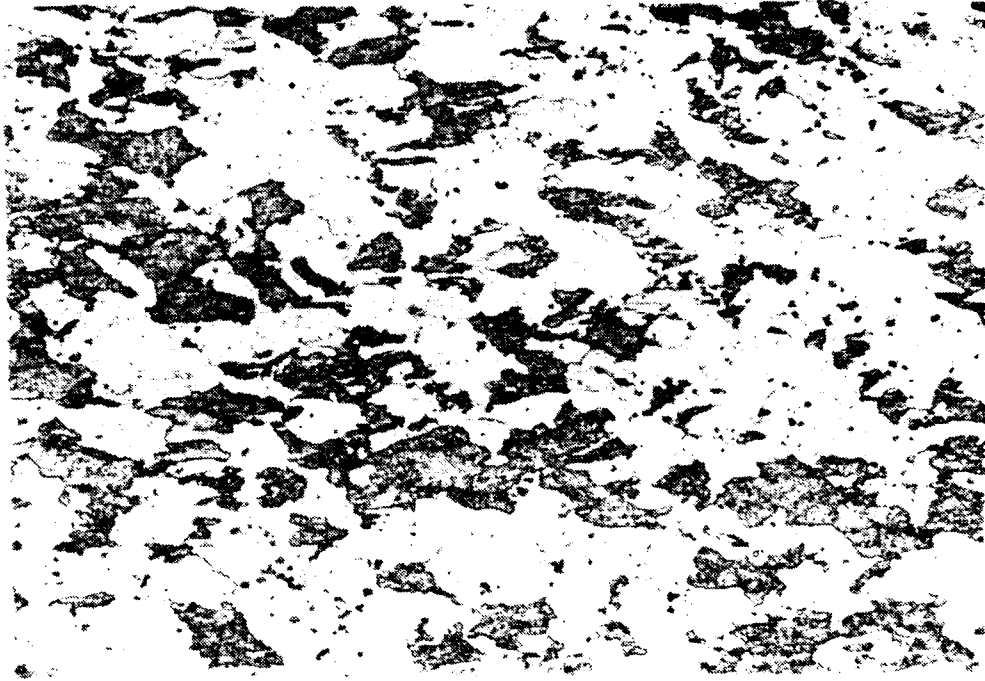

Figure 31. Optical micrograph of the link showing a microstructure representative of 7075 aluminum alloy in the T6 condition. MAG 200X

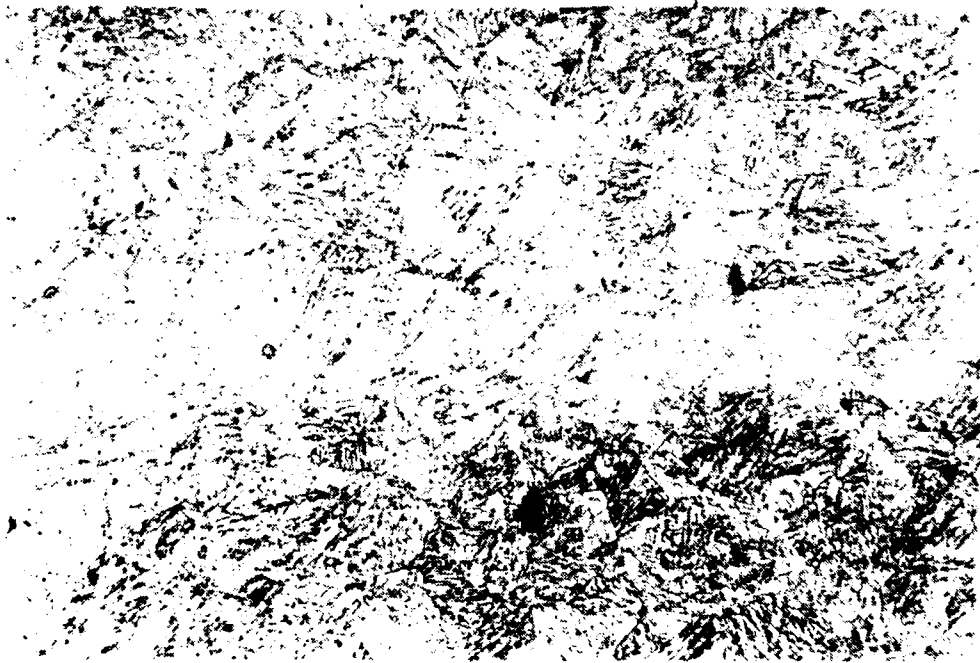

Figure 32. Optical micrograph of the link pin showing a typical lath martensitic microstructure. MAG 500X

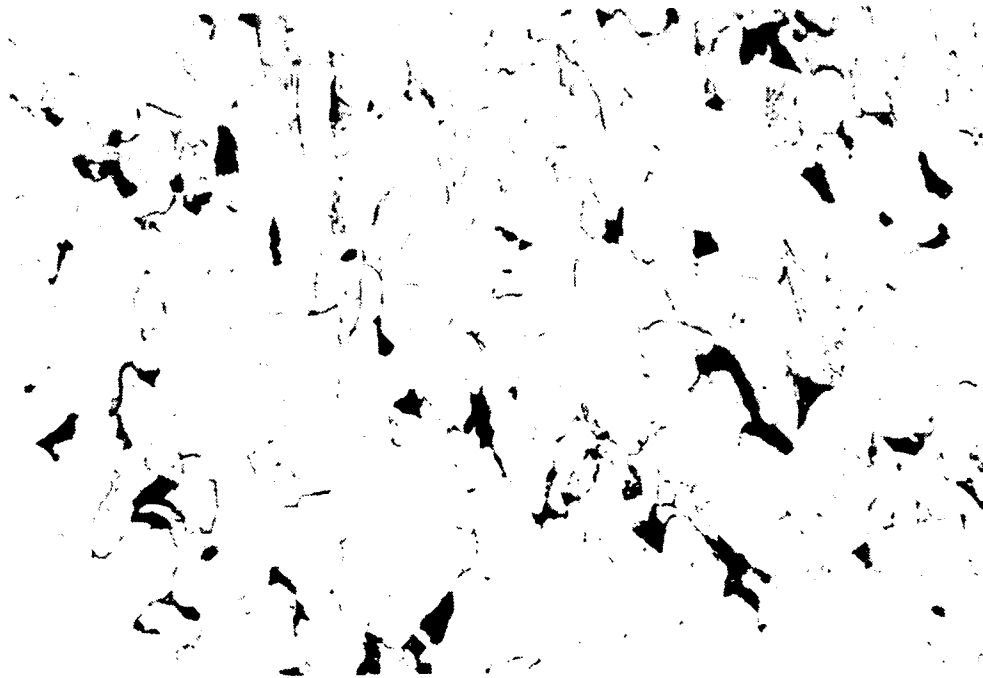

Figure 33. Optical micrograph of the self-locking nut microstructure revealing pools of pearlite within a ferritic matrix. MAG 500X

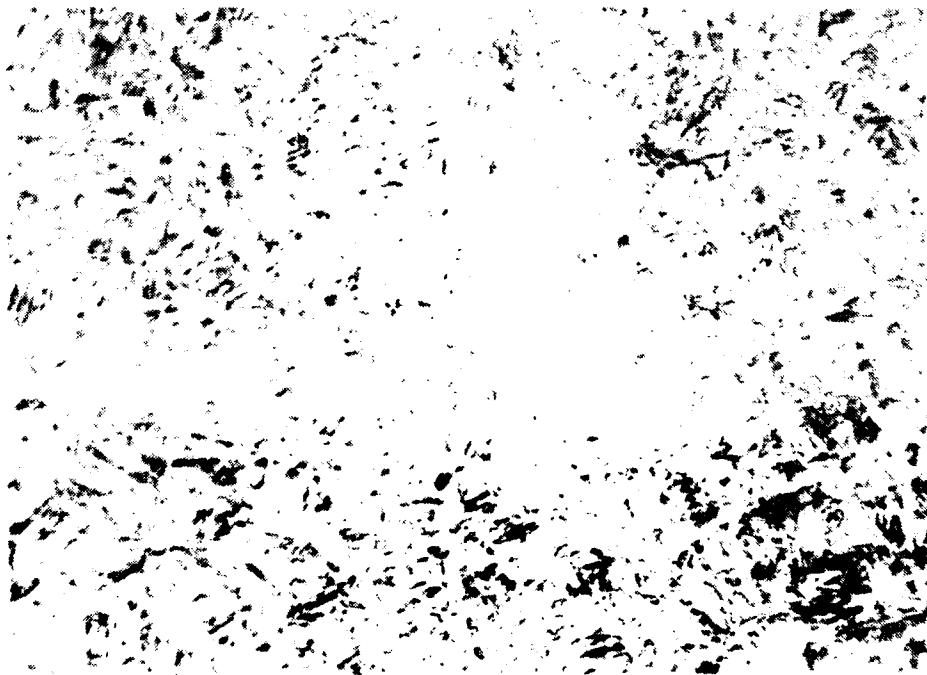

Figure 34. Optical micrograph of the setscrew showing a typical tempered martensitic microstructure. MAG 800X

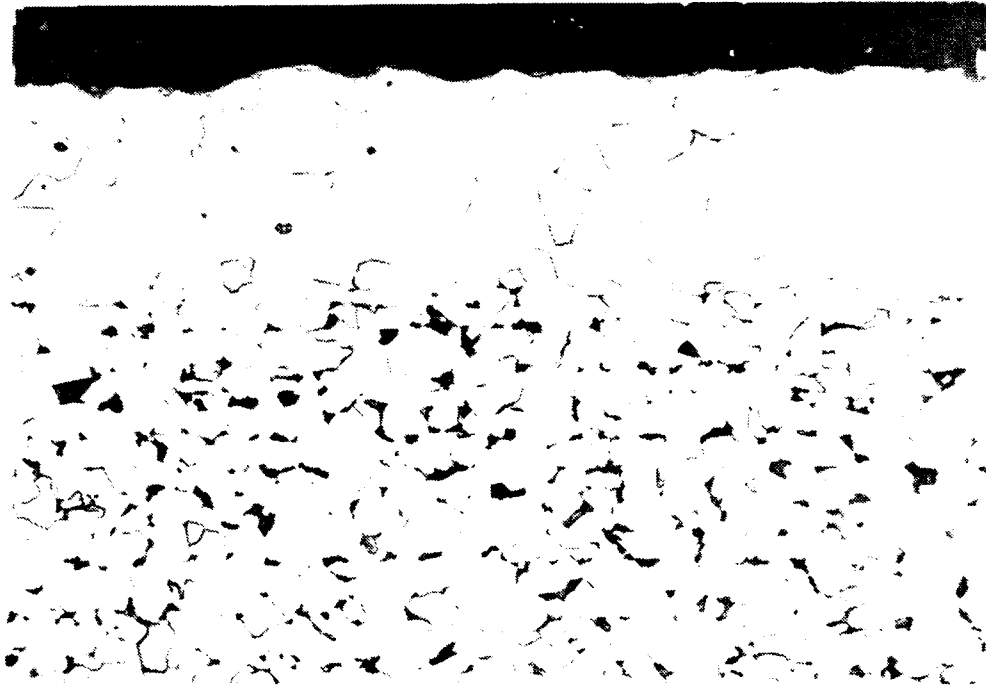

Figure 35. Optical micrograph of the shock absorber microstructure showing pools of pearlite within a ferritic matrix. MAG 200X

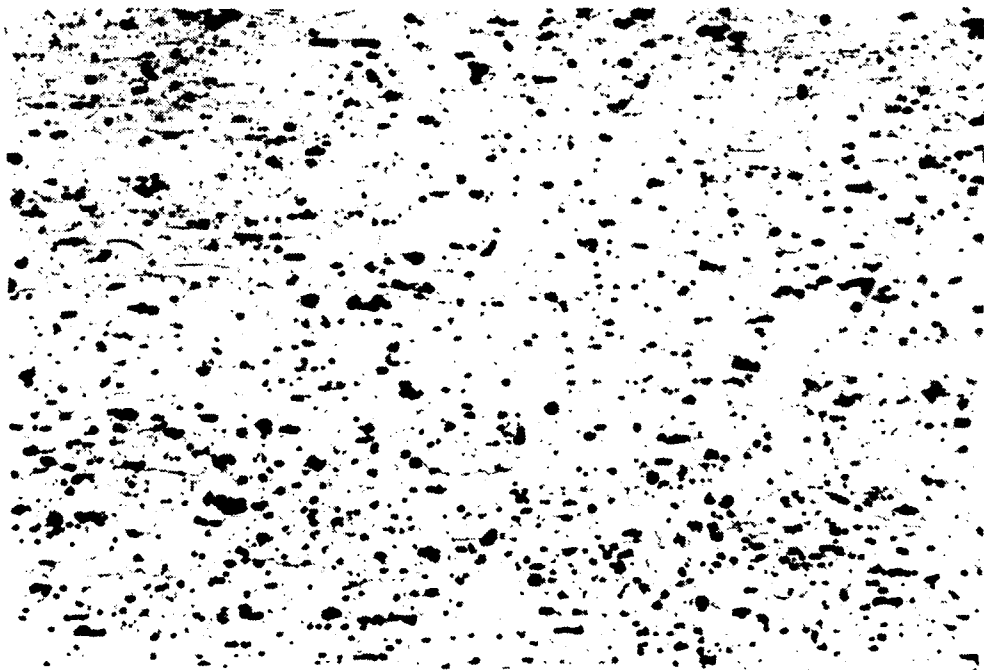

Figure 36. Optical micrograph of the spring arming wire housing assembly showing a fine dispersion precipitation representative of a 6xxx series aluminum alloy in the T6 condition. MAG 200X

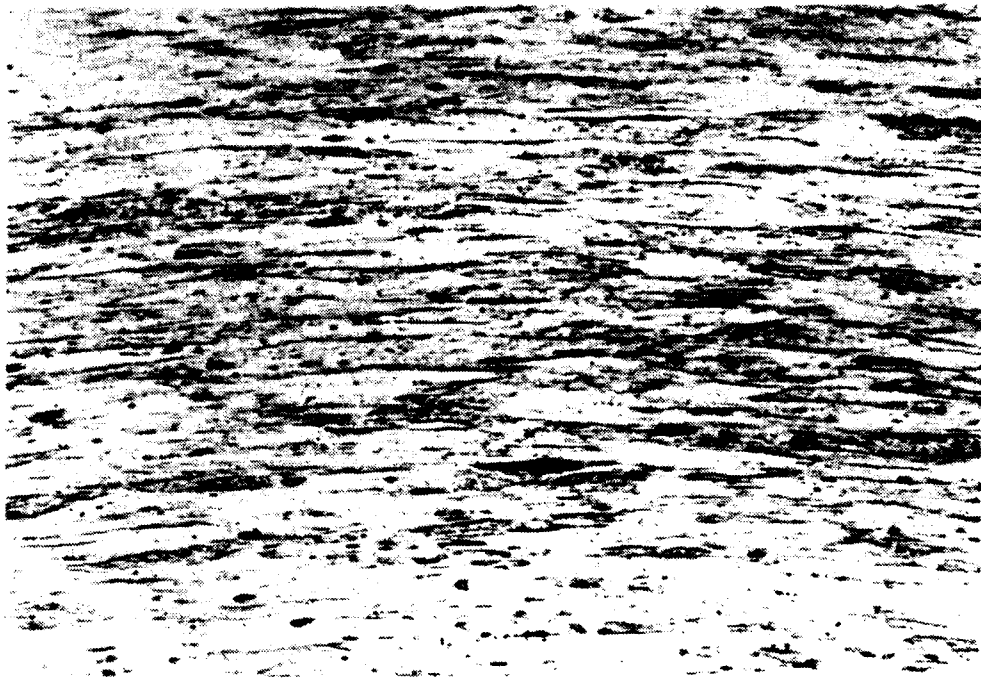

Figure 37. Optical micrograph of the tension spring microstructure reveals some martensite in an austenite matrix of the 302 stainless steel. MAG 200X

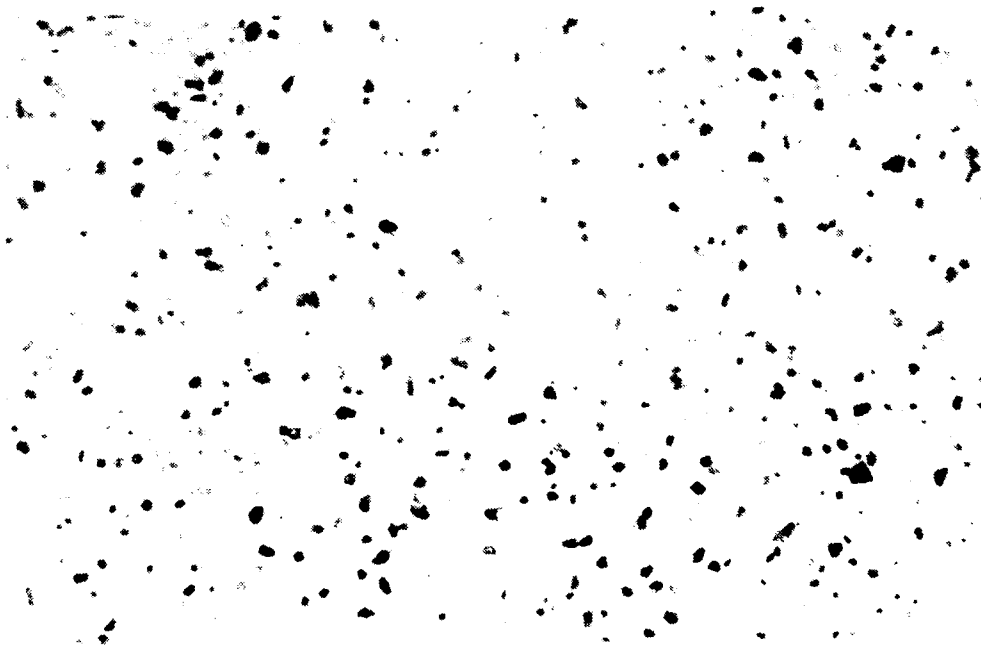

Figure 38. Optical micrograph of the guide tube showing no abnormalities within the microstructure of the 3003 drawn aluminum alloy. MAG 500X

COATING THICKNESS MEASUREMENTS

The coating thickness of cadmium-plated or zinc-plated specimens were measured utilizing cross-sectional specimens examined within the metallograph.

The plating on the shock absorber achieved a thickness of 0.001 inch (see Figure 39). The plating thickness conforms to NAVAIR Engineering Drawing No. 2605175.

The cadmium plating on the clevis bolt was 0.0006 inch (see Figure 40) conforming to QQ-P-416 for Class B coating, as specified in MIL-B-6812D.

The cadmium plating on the self-locking nut was 0.001 inch (see Figure 41) conforming to QQ-P-416 for Class B coatings, as specified in MIL-N-25027E.

The cadmium plating on the setscrew was 0.0005 inch (see Figure 42), conforming to MIL-F-18240D.

Energy dispersing spectroscopy (EDS) was performed on a transverse cross section of the link pin to determine the composition of the coating. An analysis of the coating elements confirmed a zinc plating, as well as a chromate treatment (see Figure 43). The zinc plating on the link pin was 0.0002 inch (see Figure 44) which does not conform to NAVAIR Engineering Drawing No. 1562347 (see the Recommendations section). The thickness specified in ASTM B633 for Type II, SC4 is a minimum of 0.001 inch. It is highly probable that an insufficient plating thickness contributed to the link pin failures when subjected to the salt spray test.

A zinc chromate primer and paint were applied to the surface of the spring arming wire housing assembly (see Figure 45). The zinc chromate primer and paint coatings were both 0.002 inch conforming to NAVAIR Engineering Drawing No. 923AS225.

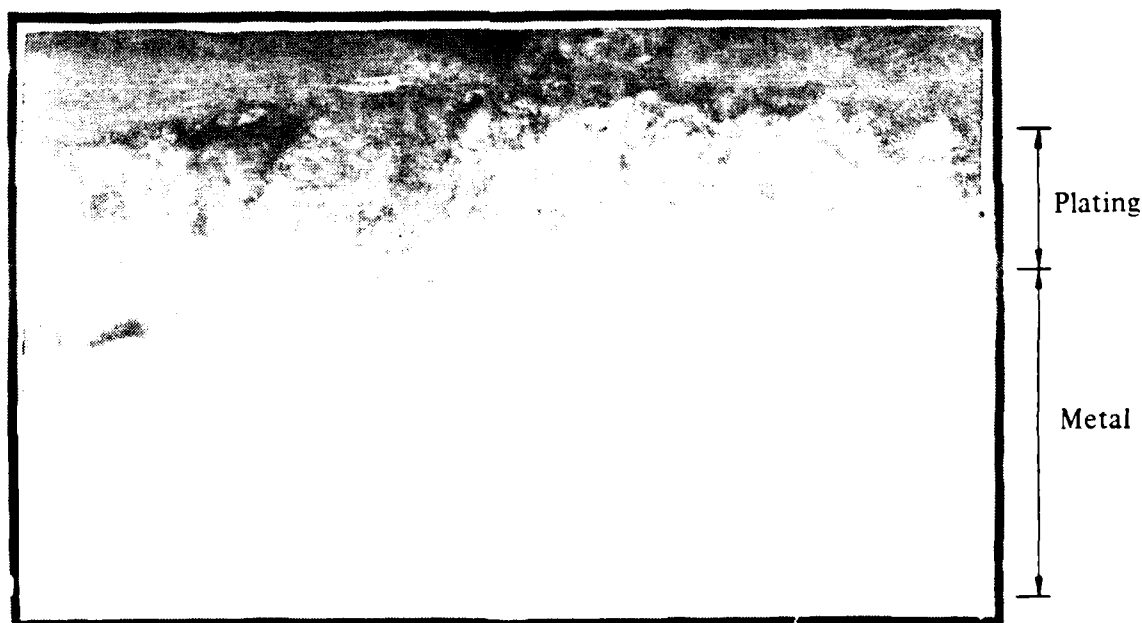

Figure 39. Optical micrograph of the shock absorber revealing a plating thickness of 0.001 inch MAG 1000X

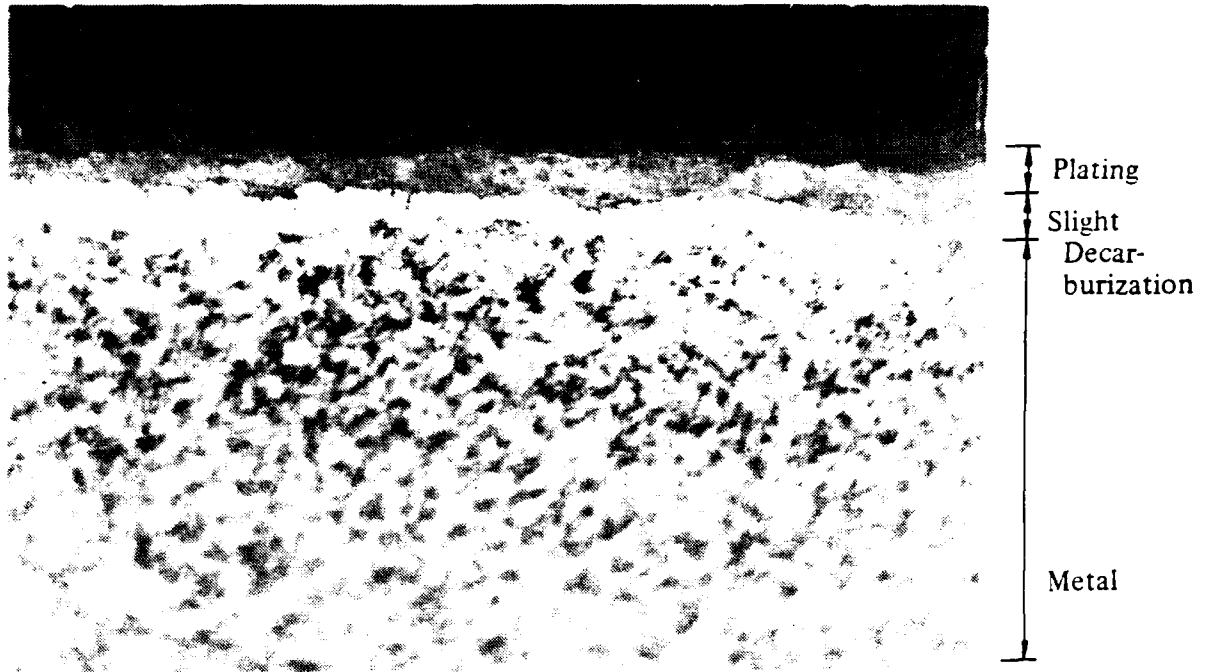

Figure 40. Optical micrograph of the clevis bolt revealing a plating thickness of 0.0006 inch. Slight decarburization is evident at the surface. MAG 1000X



Figure 41. Optical micrograph of the self-locking nut revealing a plating thickness of 0.001 inch. MAG 500X



Figure 42. Optical micrograph of the setscrew revealing a plating thickness of 0.0005 inch. MAG 800X

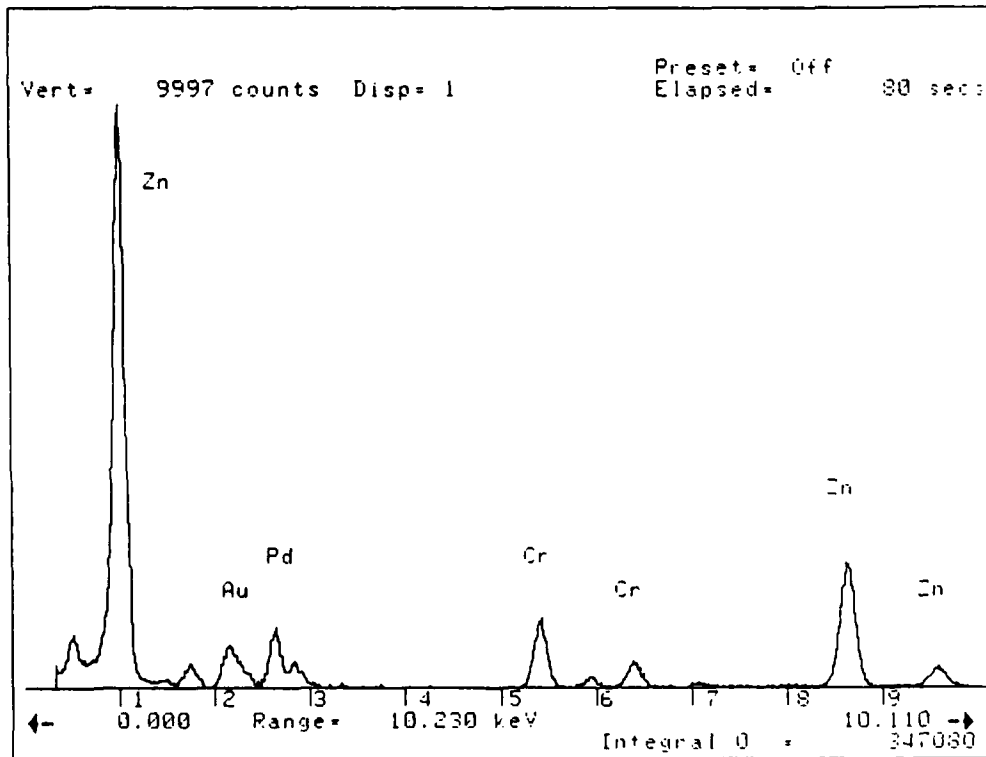

Figure 43. EDS results confirming zinc plating and chromate treatment of the link pin
 (Note: The sample was coated with gold paladium prior to SEM examination accounting for their presence on the graph.)

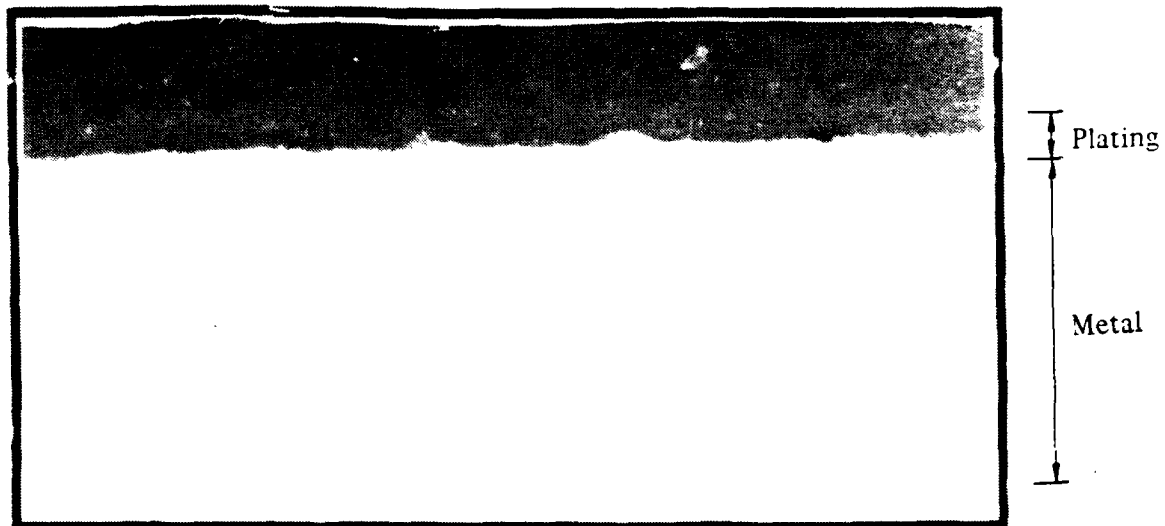

Figure 44. Optical micrograph of the link pin revealing a plating thickness of 0.0002 inch. MAG 1000X

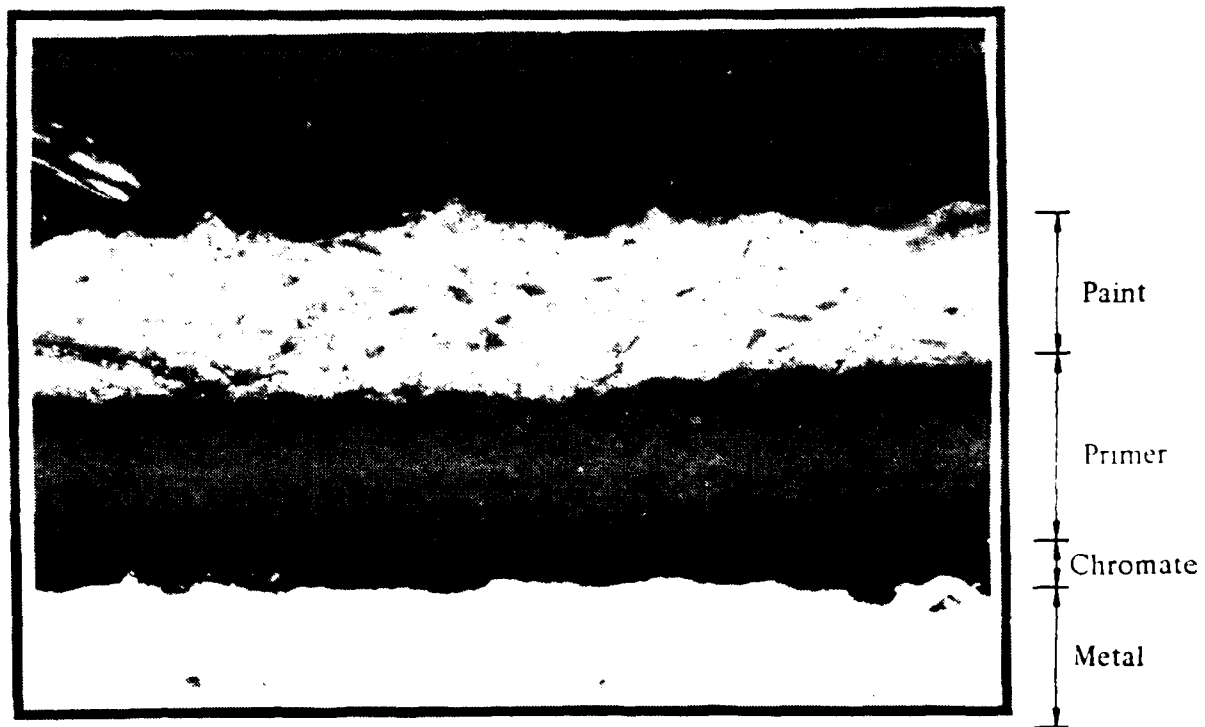

Figure 45. Optical micrograph of spring arming wire housing assembly showing a chemical conversion coating, primer, and paint. MAG 500X

INTERGRANULAR CORROSION TEST

Procedure

An intergranular corrosion test was performed on three bomb fins in accordance with MIL-H-6088F. The bomb fins were fabricated from 7075 aluminum alloy which was later heat treated to the T6 condition. Specimens were cut directly from the bomb fins, as shown in Figure 15 (see "Fin"). The dimensions of the specimens were 3/4 inch in width, 1-3/6 inch in length, and 5/32 inch in depth. The surface of each specimen was sanded with a 600-grit emery paper to produce an even finish and no other finishing techniques were used, as required by the specification.

The specimens were subjected to a one minute etching solution containing nitric acid at 70% concentration, hydrofluoric acid at 48% concentration, and distilled water. The specimens were then rinsed in distilled water before immersion for one minute in a 70% nitric acid solution at room temperature. Finally, the specimens were placed in a solution prepared in the following manner: a volume of a solution containing 57 g sodium chloride and 10 ml hydrogen peroxide (30% conc.) totalling 30 ml for each square inch of specimen surface area was diluted to one liter with distilled water. The immersion period in this solution was six hours at $86^{\circ}\text{F} \pm 9^{\circ}\text{F}$, as specified.

The specimens were sectioned and prepared for metallographic analysis after the six hour test period.

Results

Overall, the specimens displayed no severe intergranular corrosion. Referring to Figure 46, the observed corrosion was between a severity of "a" or of "b," as shown in Figure 47. Figure 47 displays slight corrosion along the grain boundaries of as-polished specimen. Figure 48 shows the same region in the etched condition. Figure 49 reflects the same region at 500X magnification. However, a few localized regions with severities of "e" were observed on each specimen. Figure 50 is a representative micrograph displaying this type of severity.

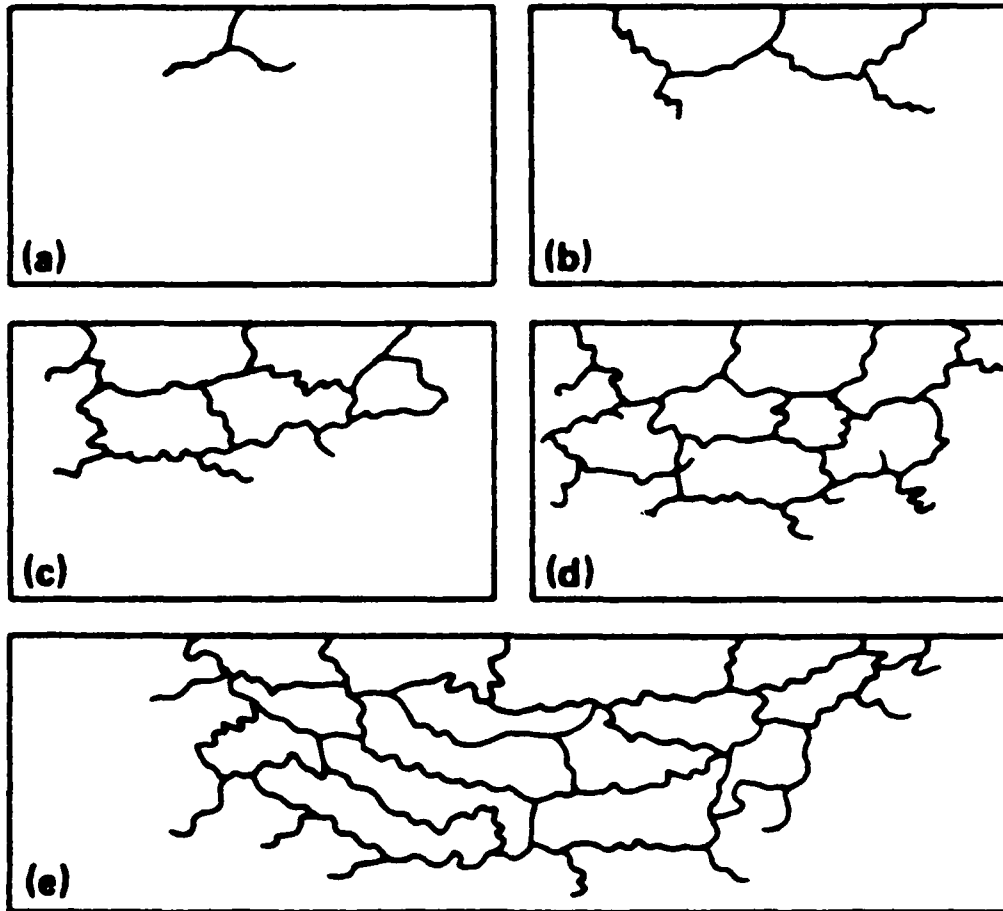

Figure 46. Five degrees of severity of intergranular attack.

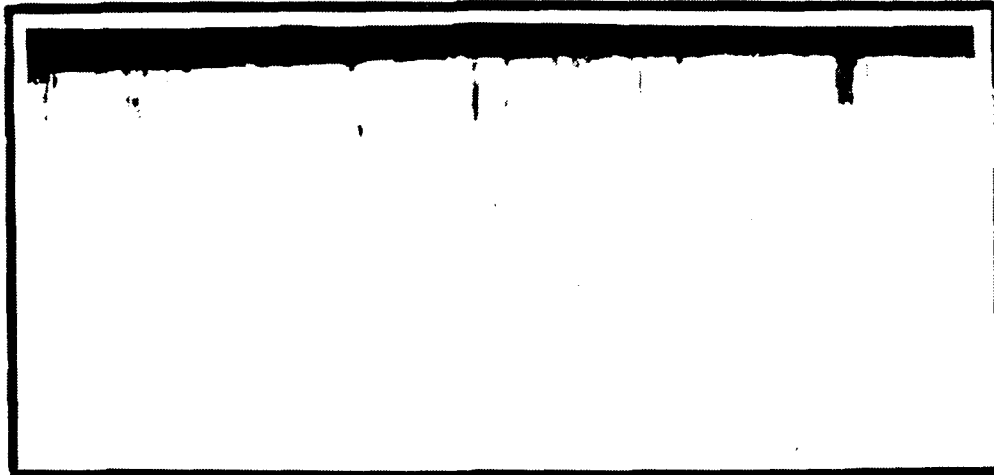

Figure 47. Type "a" or "b" severity of corrosion along the grain boundaries of an as-polished specimen. MAG 100X

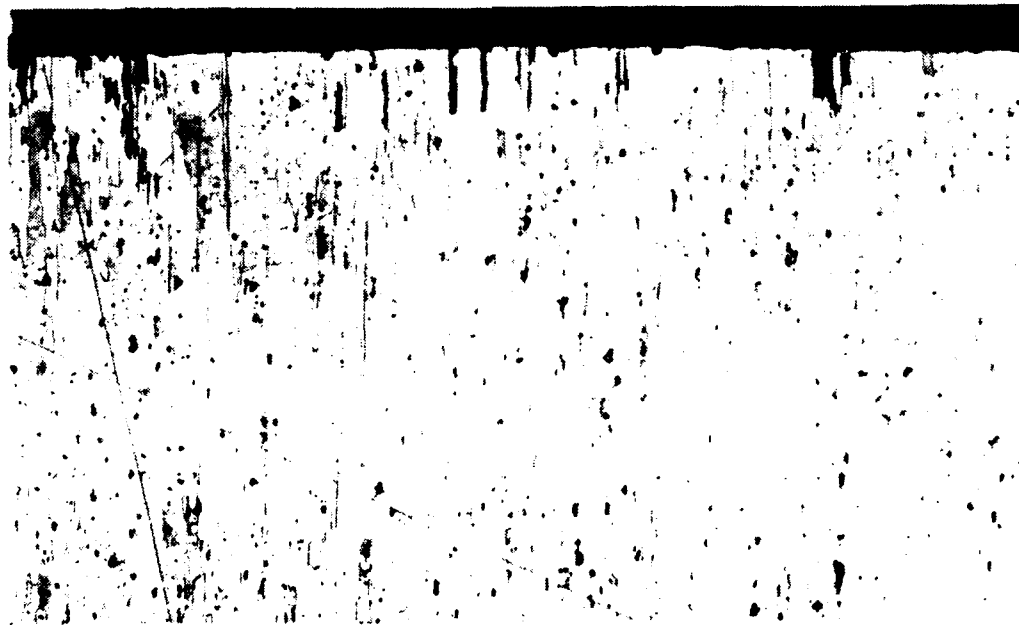

Figure 48. Type "a" or "b" severity of corrosion along the grain boundaries of an as-polished specimen. MAG 100X

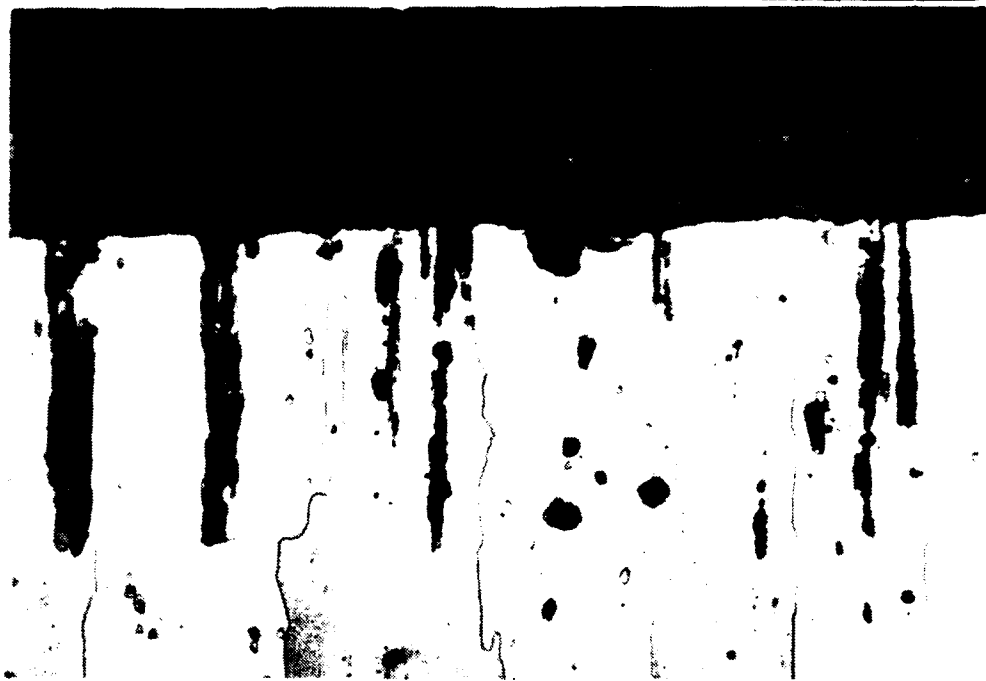

Figure 49. Type "a" or "b" severity of corrosion along the grain boundaries of the same region in the as-etched condition. MAG 500X



Figure 50. Type "e" severity of corrosion along the grain boundaries of a specimen in the as-polished condition. MAG 500X

TENSILE TEST

Twelve tensile specimens were sectioned from three different BSU-86/B bomb fins and machined per ASTM E 8, "Rectangular Tension Test Specimens" (see Figure 51). These specimens were cut perpendicular to the rolling direction of the bomb fin material. The fins are required to have an ultimate tensile strength of 73,000 psi, as specified on NAVAIR Engineering Drawing No. 923AS160. As shown in Table 15, these specimens exceed this requirement. Tensile tests were performed on an Instron Electromechanical Test Machine at room temperature (70°F) and 50% relative humidity.

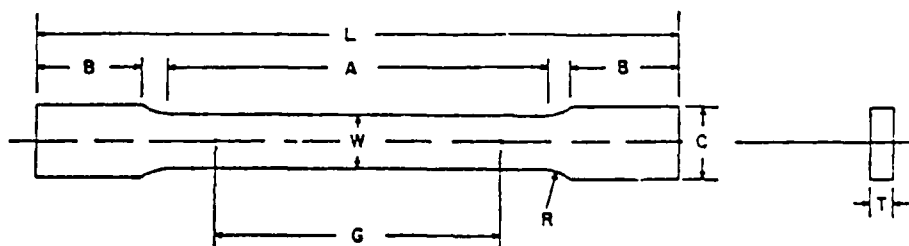

- G - Gage Length
- W - Width
- T - Thickness
- R - Radius of fillet, min
- L - Over-all length, min
- A - Length of reduced section, min
- B - Length of grip section, min
- C - Width of grip section, approximate

Dimensions = inches

Sheet-Type, 1/2-in. Wide

2.000 ± 0.005

0.500 ± 0.010

thickness of material

1/2

8

2 1/4

2

3/4

Figure 51. Rectangular tension test specimens.

Table 15. TENSILE TEST RESULTS HEADSPEED = 0.05 IN./MIN. 2 INCH - 10% EXTENSOMETER

Specification Identification	Original Area (sq. in.)	Original Gage Length (in.)	RA (%)	Elon. (%)	Modulus (x 10 ⁶) (psi)	UTS (psi)
DRI 1A	0.0778	2.000	14.1	15.4	9.8	83,290
1B	0.0779	2.000	21.2	12.5	9.6	83,180
1C	0.0772	2.000	22.7	14.9	9.8	83,420
2A	0.0787	2.000	14.4	8.0	8.4	83,230
2B	0.0780	2.000	16.9	12.3	9.9	83,970
2C	0.0773	2.000	22.5	12.2	10.3	83,310
3A	0.0782	2.000	24.7	15.3	9.4	83,760
3B	0.0782	2.000	24.7	14.7	9.6	84,020
3C	0.0772	2.000	19.3	11.8	10.1	83,290
4A	0.0777	2.000	21.9	16.8	9.1	82,880
4B	0.0775	2.000	14.2	10.0	9.7	83,230
4C	0.0770	2.000	17.4	15.0	9.7	83,770
VHTC						
I	0.0198	1.010	21.2	12.5	8.4	82,830
II	0.0197	1.010	25.4	11.6	10.2	83,250

RECOMMENDATIONS

Link Pin Replate Procedure

The zinc plating of a link pin (NAVAIRSYSCOM Drawing No. 1562347) was measured as part of a First Article Inspection of DRI. The thickness requirement for a SC4 service condition (very severe, as described on the engineering drawing) is 0.001 inch, as specified by ASTM B 633-85. The actual thickness measured no greater than 0.0003 inch.

As a result of this, a study was performed to determine whether to replate over the chromate coating to the required thickness or to remove the original chromate coating before replating.

It was found that it is not feasible to replate zinc over a chromate coating because it does not provide a suitable adhesion base for the zinc plating.

Therefore, the chromate coating must be stripped and a zinc plating applied to the existing zinc. Metallic coatings are often stripped and replated because of insufficient thickness. Acid formulations used as strippers must be strong enough to remove the coating being stripped yet should not attack the base metal. The process recommended for this particular problem is chromic acid immersion. This is a chemical method for selectively stripping metallic coatings. This immersion process removes deposits by dissolution. Immersion strippers are preferred over electrolytic strippers (which plate out metal ions on cathodes) because the stripping is more uniform and less equipment is needed. In addition, since racking is not required there is an increased ease of operation. This method is also preferred from an economic standpoint as no electricity is required.

The procedure calls for a 30 second to one minute dip of the part into chromic acid at a concentration of 210.0 g/L (28.0 oz/gal) at a temperature of 190°F to 212°F.¹ The part should then be washed thoroughly. This process does not attack the base metal, yet to prevent possible problems due to hydrogen embrittlement, the part should be baked at 375°F for 23 hours before another zinc plating is applied.

CONCLUSIONS

All components tested conformed to the established criteria for hardness and chemical composition.

The components satisfied the acceptance standards for salt spray testing except for the link pin.

Metallographic examination verified that the microstructure of all components reflected their corresponding heat treatment and/or prior fabrication.

The thickness of the surface coatings conformed to required specifications, with the exception of the zinc plating located on the link pin which did not meet minimal thickness requirements.

The bomb fins satisfied the minimum ultimate tensile strength (UTS) of 73,000 psi and the requirements of the intergranular corrosion test.

1. Stripping Metal Coatings, Charles Rosenstein, Metal Finishing Guidebook and Directory, 1990.

DISTRIBUTION LIST

No. of Copies	To
1	Office of the Under Secretary of Defense for Research and Engineering, The Pentagon, Washington, DC 20301
1	Metals and Ceramics Information Center, Battelle Columbus Laboratories, 505 King Avenue, Columbus, OH 43201
1	ATTN: Sharad Pednekar
2	Commander, Defense Technical Information Center, Cameron Station, Bldg. 5, 5010 Duke Street, Alexandria VA 22304-6145
2	ATTN: DTIC-FDAC
1	Commander, U.S. Army Materiel Command, 5001 Eisenhower Avenue, Alexandria, VA 22333
1	ATTN: AMCQA-P, S. J. Lorber
1	Commander, Pacific Missile Test Center, Point Mugu, CA 93042
1	ATTN: Sam Keller, Code 2043
1	Bill Mcauley (Code 2043)
1	John Durda, Code 2041
1	Carl Louck, Code 2041
1	John Piercy, Code 2041
1	Commander, U.S. Army Laboratory Command, 2800 Powder Mill Road, Adelphi, MD 20783-1145
1	ATTN: AMSLC-IM-TL
1	AMSLC-CT
1	Commander, Rock Island Arsenal, Headquarters AMCCOM, Rock Island, IL 61299-6000
1	ATTN: AMSMC-PCA-WM, Joe Wells
1	AMSMC-QAM-I, Gary Smith
1	AMSMC-ASR-M, Brian Kunkel
1	John Housseman
1	Commander, U.S. Army Test and Evaluation Command, Aberdeen Proving Ground, MD 21005
1	ATTN: Library
1	Commander, U.S. Army Engineer School, Fort Belvoir, VA 22060
1	ATTN: Library
1	Naval Air Systems Command, Department of the Navy, Washington, DC 20360
1	ATTN: AIR-03PAF
1	Naval Research Laboratory, Washington, DC 20375
1	ATTN: Code 5830
1	Naval Air Development Center, Warminster, PA 18974
1	ATTN: Library

No. of
Copies

To

Commander, U.S. Army Aviation Systems Command (AVSCOM) St. Louis,
MO 63120-1798

1 ATTN: AMSAV-ECC, Emanuel Buelter
1 AMSAV-ECC, Robert Lawyer
1 AMSAV-EFM, Frank Barhorst
1 AMSAV-EFM, Kirit Bhansali
1 AMSAV-E, Carl Smith
1 AMCPM-AAH, Dave Roby
1 AMCPM-AAH, Bob Kennedy

Commander, Corpus Christi Army Depot, Corpus Christi, TX 78419-6195

1 ATTN: AMSAV-MRPD, Nicholas Hurta, Mail Stop 55
1 AMSAV-MRPD, Lou Neri, Mail Stop 55
1 SDSCC-QLM, David Garcia, Mail Stop 27
1 SDSCC-QLM, Charlie Wilson, Mail Stop 27

Commander, Armament Research, Development and Engineering Center,
Picatinny Arsenal, NJ 07806-5000

1 ATTN: SMCAR-CCS-C, Anthony Sebasto, Bldg. #1

Program Manager, Government-Industry Data Exchange, GIDEP Operations Center,
Corona, CA 91720-2000

1 ATTN: J. C. Richards, Program Director

Director, U.S. Army Materials Technology Laboratory, Watertown, MA 02172-0001

2 ATTN: SLCMT-TML
3 Authors

U.S. Army Materials Technology Laboratory
Watertown, Massachusetts 02172-0001
THE BSU-86/B BOMB FIN ASSEMBLY FIRST
ARTICLE CONFORMANCE TESTING -

Marc S. Pepi, Victor K. Champagne, Jr., and
Catherine M. Zoller

Technical Report MTL TR 90-61, December 1990, 54 pp-
illus-tables,

The Navy Pacific Missile Test Center (PMTc) requested that the U. S. Army Materials Technology Laboratory (MTL) perform a series of metallurgical tests on 16 components of the BSU-86/B bomb fin assembly. The parts were characterized in accordance with applicable standards and contractual requirements as part of a First Article Inspection to confirm and verify specific fabrication operations performed by the manufacturer. The intent of the First Article Inspection is to certify the ability of the manufacturer to produce a component which satisfies the standards of quality and workmanship agreed upon by the U. S. Government and contractor. All components tested conformed to the established criteria for hardness and chemical composition. The bomb fins satisfied the minimum ultimate tensile strength (UTS) of 73,000 psi, as well as the intergranular corrosion test. Metallographic examination verified that the microstructure of all the components reflected their corresponding heat treatment and/or prior fabrication. The thickness of the surface coatings examined conformed to required specifications with the exception of the zinc plating located on the link pin which did not meet minimal thickness requirements. The components satisfied the acceptance standards for salt spray testing except for the link pin. Recommendations were provided to strip and replating the Link Pins already produced with inferior coatings at the request of PMTC.

AD UNCLASSIFIED
UNLIMITED DISTRIBUTION

Key Words

Bomb fin assembly
First Article Inspection
Mechanical properties

U.S. Army Materials Technology Laboratory
Watertown, Massachusetts 02172-0001
THE BSU-86/B BOMB FIN ASSEMBLY FIRST
ARTICLE CONFORMANCE TESTING -

Marc S. Pepi, Victor K. Champagne, Jr., and
Catherine M. Zoller

Technical Report MTL TR 90-61, December 1990, 54 pp-
illus-tables,

The Navy Pacific Missile Test Center (PMTc) requested that the U. S. Army Materials Technology Laboratory (MTL) perform a series of metallurgical tests on 16 components of the BSU-86/B bomb fin assembly. The parts were characterized in accordance with applicable standards and contractual requirements as part of a First Article Inspection to confirm and verify specific fabrication operations performed by the manufacturer. The intent of the First Article Inspection is to certify the ability of the manufacturer to produce a component which satisfies the standards of quality and workmanship agreed upon by the U. S. Government and contractor. All components tested conformed to the established criteria for hardness and chemical composition. The bomb fins satisfied the minimum ultimate tensile strength (UTS) of 73,000 psi, as well as the intergranular corrosion test. Metallographic examination verified that the microstructure of all the components reflected their corresponding heat treatment and/or prior fabrication. The thickness of the surface coatings examined conformed to required specifications with the exception of the zinc plating located on the link pin which did not meet minimal thickness requirements. The components satisfied the acceptance standards for salt spray testing except for the link pin. Recommendations were provided to strip and replating the Link Pins already produced with inferior coatings at the request of PMTC.

AD UNCLASSIFIED
UNLIMITED DISTRIBUTION

Key Words

Bomb fin assembly
First Article Inspection
Mechanical properties

U.S. Army Materials Technology Laboratory
Watertown, Massachusetts 02172-0001
THE BSU-86/B BOMB FIN ASSEMBLY FIRST
ARTICLE CONFORMANCE TESTING -

Marc S. Pepi, Victor K. Champagne, Jr., and
Catherine M. Zoller

Technical Report MTL TR 90-61, December 1990, 54 pp-
illus-tables,

The Navy Pacific Missile Test Center (PMTc) requested that the U. S. Army Materials Technology Laboratory (MTL) perform a series of metallurgical tests on 16 components of the BSU-86/B bomb fin assembly. The parts were characterized in accordance with applicable standards and contractual requirements as part of a First Article Inspection to confirm and verify specific fabrication operations performed by the manufacturer. The intent of the First Article Inspection is to certify the ability of the manufacturer to produce a component which satisfies the standards of quality and workmanship agreed upon by the U. S. Government and contractor. All components tested conformed to the established criteria for hardness and chemical composition. The bomb fins satisfied the minimum ultimate tensile strength (UTS) of 73,000 psi, as well as the intergranular corrosion test. Metallographic examination verified that the microstructure of all the components reflected their corresponding heat treatment and/or prior fabrication. The thickness of the surface coatings examined conformed to required specifications with the exception of the zinc plating located on the link pin which did not meet minimal thickness requirements. The components satisfied the acceptance standards for salt spray testing except for the link pin. Recommendations were provided to strip and replating the Link Pins already produced with inferior coatings at the request of PMTC.

AD UNCLASSIFIED
UNLIMITED DISTRIBUTION

Key Words

Bomb fin assembly
First Article Inspection
Mechanical properties

U.S. Army Materials Technology Laboratory
Watertown, Massachusetts 02172-0001
THE BSU-86/B BOMB FIN ASSEMBLY FIRST
ARTICLE CONFORMANCE TESTING -

Marc S. Pepi, Victor K. Champagne, Jr., and
Catherine M. Zoller

Technical Report MTL TR 90-61, December 1990, 54 pp-
illus-tables,

The Navy Pacific Missile Test Center (PMTc) requested that the U. S. Army Materials Technology Laboratory (MTL) perform a series of metallurgical tests on 16 components of the BSU-86/B bomb fin assembly. The parts were characterized in accordance with applicable standards and contractual requirements as part of a First Article Inspection to confirm and verify specific fabrication operations performed by the manufacturer. The intent of the First Article Inspection is to certify the ability of the manufacturer to produce a component which satisfies the standards of quality and workmanship agreed upon by the U. S. Government and contractor. All components tested conformed to the established criteria for hardness and chemical composition. The bomb fins satisfied the minimum ultimate tensile strength (UTS) of 73,000 psi, as well as the intergranular corrosion test. Metallographic examination verified that the microstructure of all the components reflected their corresponding heat treatment and/or prior fabrication. The thickness of the surface coatings examined conformed to required specifications with the exception of the zinc plating located on the link pin which did not meet minimal thickness requirements. The components satisfied the acceptance standards for salt spray testing except for the link pin. Recommendations were provided to strip and replating the Link Pins already produced with inferior coatings at the request of PMTC.

AD UNCLASSIFIED
UNLIMITED DISTRIBUTION

Key Words

Bomb fin assembly
First Article Inspection
Mechanical properties