

DTIC FILE COPY

2

AD-A228 057

# NAVAL POSTGRADUATE SCHOOL Monterey, California



DTIC  
ELECTE  
OCT 24 1990  
S B D

## THESIS

TACTICAL HF FIELD EXPEDIENT ANTENNA  
PERFORMANCE  
VOLUME I

by

Gurkan Turkes

March 1990

Thesis Advisor:

Richard W. Adler

Approved for public release; distribution is unlimited

90 10 23 153

Unclassified

security classification of this page

REPORT DOCUMENTATION PAGE

1a Report Security Classification <b>Unclassified</b>		1b Restrictive Markings	
2a Security Classification Authority		3 Distribution/Availability of Report <b>Approved for public release; distribution is unlimited</b>	
2b Declassification Downgrading Schedule		4 Performing Organization Report Number(s)	
4 Performing Organization Report Number(s)		5 Monitoring Organization Report Number(s)	
6a Name of Performing Organization Naval Postgraduate School	6b Office Symbol (if applicable) EC	7a Name of Monitoring Organization Naval Postgraduate School	
6c Address (city, state, and ZIP code) Monterey, CA 93943-5000		7b Address (city, state, and ZIP code) Monterey, CA 93943-5000	
8a Name of Funding, Sponsoring Organization USAISEIC	8b Office Symbol (if applicable) ASB-SET-P	9 Procurement Instrument Identification Number	
8c Address (city, state, and ZIP code) Ft. Huachuca, AZ 85613		10 Source of Funding Numbers SED 13-89	
		Program Element No	Project No
		Task No	Work Unit Accession No
11 Title (Include security classification) <b>APPROVED FOR PUBLIC RELEASE; DISTRIBUTION IS UNLIMITED</b> <b>TACTICAL HF FIELD EXPEDIENT ANTENNA PERFORMANCE VOLUME I</b>			
12 Personal Author(s) Gurkan Turkes			
13a Type of Report Master's Thesis	13b Time Covered From To	14 Date of Report (year, month, day) March 1990	15 Page Count 79
16 Supplementary Notation The views expressed in this thesis are those of the author and do not reflect the official policy or position of the Department of Defense or the U.S. Government.			
17 Cosati Codes		18 Subject Terms (continue on reverse if necessary and identify by block number)	
Field	Group	Computer Simulation, Numerical Electromagnetics Code (NEC), Tactical HF Field Antennas	
19 Abstract (continue on reverse if necessary and identify by block number) This thesis investigates the performance of various configurations of tactical High Frequency (HF) field deployable antennas in the presence of lossy earth. Antennas investigated include horizontal dipoles, short sloping wires, inverted vees, and monopoles with buried and elevated radials. Numerical models of the antennas are exercised via the Numerical Electromagnetics Code (NEC) for radiation pattern performance. Antennas are analyzed for applicability to (1) short-range Near Vertical Incident Skywave (NVIS), where high elevation radiation angles are required, (2) medium- and long-range low radiation angle use, and (3) vertically polarized low-angle radiation for ground wave communication. Good NVIS and ground wave performance occurs for horizontal dipoles. Sloping wires and sloping dipoles are similar to horizontal dipoles but exhibit a moderate amount of azimuth plane directivity. Vertical monopoles with at least 15 buried radials produce medium- and long-range skywave coverage and good ground wave performance. Four elevated radials for quarter-wavelength monopoles are shown to out-perform 15 buried radials and are much easier to erect. The larger and more difficult-to-erect inverted vee dipole slightly outperforms a monopole by virtue of modest azimuth plane directivity. The results of this study can be included in an antenna engineering handbook and can be used to interface with existing ionospheric propagation codes in order to obtain optimum communication effectiveness. (RH) ↑			
20 Distribution Availability of Abstract <input checked="" type="checkbox"/> unclassified-unlimited <input type="checkbox"/> same as report <input type="checkbox"/> DTIC users		21 Abstract Security Classification Unclassified	
22a Name of Responsible Individual Richard W. Adler		22b Telephone (include Area code) (408) 646-2352	22c Office Symbol Code EC Ab

Approved for public release; distribution is unlimited

Tactical HF Field Expedient Antenna Performance Volume I

by

Gurkan Turkes  
Lieutenant Junior Grade, Turkish Navy  
B.S., Turkish Naval Academy, 1982

Submitted in partial fulfillment of the  
requirements for the degree of

MASTER OF SCIENCE IN ELECTRICAL ENGINEERING

from the

NAVAL POSTGRADUATE SCHOOL  
March 1990

Author:

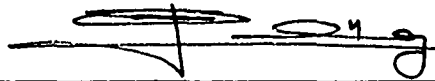

Gurkan Turkes

Approved by:



Richard W. Adler, Thesis Advisor

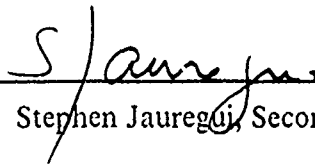

Stephen Jauregui, Second Reader

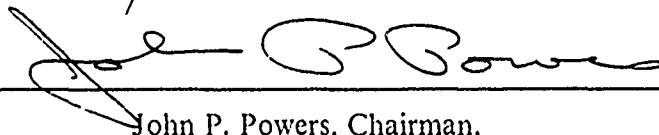

John P. Powers, Chairman,  
Department of Electrical and Computer Engineering

## ABSTRACT

This thesis investigates the performance of various configurations of tactical High Frequency (HF) field deployable antennas in the presence of lossy earth. Antennas investigated include horizontal dipoles, short sloping wires, inverted vees, and monopoles with buried and elevated radials. Numerical models of the antennas are exercised via the Numerical Electromagnetics Code (NEC) for radiation pattern performance. Antennas are analyzed for applicability to (1) short-range Near Vertical Incident Skywave (NVIS), where high elevation radiation angles are required, (2) medium- and long-range low radiation angle use, and (3) vertically polarized low-angle radiation for ground wave communication. Good NVIS and ground wave performance occurs for horizontal dipoles. Sloping wires and sloping dipoles are similar to horizontal dipoles but exhibit a moderate amount of azimuth plane directivity. Vertical monopoles with at least 15 buried radials produce medium- and long-range skywave coverage and good ground wave performance. Four elevated radials for quarter-wavelength monopoles are shown to out-perform 15 buried radials and are much easier to erect. The larger and more difficult-to-erect inverted vee dipole slightly outperforms a monopole by virtue of modest azimuth plane directivity.

The results of this study can be included in an antenna engineering handbook and can be used to interface with existing ionospheric propagation codes in order to obtain optimum communication effectiveness.

<b>Accession For</b>	
NTIS GRA&I	<input checked="" type="checkbox"/>
DTIC TAB	<input type="checkbox"/>
Unannounced	<input type="checkbox"/>
Justification	
By _____	
Distribution/	
<b>Availability Codes</b>	
Dist	Avail and/or Special
A-1	



## TABLE OF CONTENTS

I. INTRODUCTION .....	1
A. BACKGROUND .....	1
B. IMPORTANT ANTENNA PARAMETERS .....	2
C. BASIC THEORY OF THE ANTENNAS .....	3
1. Half-Wavelength Dipole .....	3
2. Vee Dipole .....	3
3. Monopole .....	4
D. INFORMATION ABOUT GROUND .....	5
II. NUMERICAL METHODS AND TECHNIQUES FOR ANTENNA ANALYSIS .....	9
A. ANTENNA MODELING AT THE NAVAL POSTGRADUATE SCHOOL .....	9
B. THE NUMERICAL ELECTROMAGNETIC ENGINEERING DESIGN SYSTEM (NEEDS) .....	9
C. THE NUMERICAL ELECTROMAGNETICS CODE (NEC-3 MAINFRAME) .....	10
D. WIRE MODELING GUIDELINES .....	12
III. DESCRIPTION OF ANTENNA NUMERICAL MODELS .....	14
A. HALF-WAVELENGTH HORIZONTAL DIPOLE .....	14
B. QUARTER-WAVELENGTH SLOPING WIRE .....	14
C. HALF-WAVELENGTH SLOPING DIPOLE .....	21
D. HALF-WAVELENGTH INVERTED VEE DIPOLE .....	21
E. QUARTER-WAVELENGTH MONOPOLE WITH A 4 FOOT GROUND ROD .....	31
F. QUARTER-WAVELENGTH MONOPOLE WITH RADIAL WIRES .....	31
1. Wires buried 2 inches deep (4, 15, and 30 wires) .....	31
2. Wires elevated $0.08 \lambda$ high (4, 15, and 30 wires) .....	31
IV. CONCLUSIONS AND RECOMMENDATIONS .....	43
A. CONCLUSIONS .....	43

B. RECOMMENDATIONS .....	43
APPENDIX A. NPGNEC MAINFRAME (NEC-3) LIBRARY .....	45
APPENDIX B. SAMPLE SESSION OF NEC .....	47
LIST OF REFERENCES .....	49
INITIAL DISTRIBUTION LIST .....	50

**LIST OF TABLES**

Table 1. GROUND TYPES ..... 8

## LIST OF FIGURES

Figure 1. The half-wavelength dipole . . . . .	4
Figure 2. The vee dipole antenna . . . . .	5
Figure 3. The elevation pattern of the half-wavelength inverted vee dipole . . . . .	6
Figure 4. The monopole antenna fed from a coaxial cable . . . . .	7
Figure 5. The half-wavelength horizontal dipole . . . . .	15
Figure 6. The elevation patterns of the half-wavelength horizontal dipole . . . . .	16
Figure 7. The azimuth pattern of the half-wavelength horizontal dipole . . . . .	17
Figure 8. The azimuth pattern of the half-wavelength horizontal dipole . . . . .	18
Figure 9. The azimuth pattern of the half-wavelength horizontal dipole . . . . .	19
Figure 10. The quarter-wavelength sloping wire . . . . .	20
Figure 11. The elevation patterns of the sloping wire for 28.5 MHz . . . . .	22
Figure 12. The elevation patterns of the sloping wire for 21.3 MHz . . . . .	23
Figure 13. The elevation patterns of the sloping wire for 7.2 MHz . . . . .	24
Figure 14. The azimuth pattern of the quarter-wavelength sloping wire . . . . .	25
Figure 15. The half-wavelength sloping dipole . . . . .	26
Figure 16. The elevation patterns of the half-wavelength sloping dipole . . . . .	27
Figure 17. The azimuth pattern of the half-wavelength sloping dipole . . . . .	28
Figure 18. The half-wavelength inverted vee dipole. . . . .	29
Figure 19. The elevation patterns of the 120 ft high inv. vee dipole . . . . .	30
Figure 20. The elevation patterns of the 35 ft high inv. vee dipole . . . . .	32
Figure 21. The azimuth pattern of the half-wavelength inverted vee dipole . . . . .	33
Figure 22. The quarter-wavelength monopole with a 4 ft ground rod . . . . .	34
Figure 23. The elevation pattern of the quarter-wavelength monopole . . . . .	35
Figure 24. The azimuth pattern of the quarter-wavelength monopole . . . . .	36
Figure 25. The quarter-wavelength monopole with buried radial wires . . . . .	37
Figure 26. The radiation patterns of the monopole with buried radials . . . . .	38
Figure 27. The performance curves of the buried radial wire system . . . . .	39
Figure 28. The quarter-wavelength monopole with elevated radial wires . . . . .	40
Figure 29. The radiation patterns of the monopole with elevated radials . . . . .	41
Figure 30. The performance curves of the elevated radial wire system . . . . .	42



## I. INTRODUCTION

### A. BACKGROUND

The military forces of today have the capability to be highly mobile, strike quickly over long distances, and integrate complex intelligence resources and weapon systems to effectively deliver combat power at critical points. The control and coordination of these capabilities rely on dependable communications. To support the complex nature of the modern battlefield, the military employs numerous and varied communication systems.

Before the advent of satellites, long range communications were routed over high frequency ( HF ) skywave paths. HF technology has been relatively neglected as satellite communications are more reliable and the data rate is much higher than HF links. But in a worst-case operational scenario, the assumption would have to be made that satellite communications would be impossible. In this situation all essential external communications would have to be made with HF communication systems. HF communication systems provide the military short-, medium-, and long-range communication for voice, digitally coded burst messages, radio teletype traffic, and radio telegraph. Users of military HF communications vary from special operation teams which are operating in isolated areas to major military command headquarters which control joint service operations.

The high frequency (HF) band covers frequencies between the 3 and 30 MHz as defined by the International Radio Consultative Committee (CCIR). For the HF band, there are two possible propagation modes, skywave and ground wave, where the skywave is the dominant mode of propagation.

The changing conditions of the ionosphere effect the useful extent of the HF band. For example, the ionosphere varies in density over :

1. 24 hour cycle
2. 4 season cycle
3. 11 year cycle

as well as randomly due to solar disturbances.

In this thesis, the following set of HF tactical antenna model configurations were analyzed at 3.8, 7.2, 14.2, 21.3, and 28.5 MHz frequencies that cover the HF band :

- Half-wavelength horizontal dipole

- Half-wavelength inverted vee dipole
- Half-wavelength sloping dipole
- Quarter-wavelength sloping wire
- Quarter-wavelength monopole with 4 ft ground rod
- Quarter-wavelength monopole with 4, 15, and 30 radial wires, one quarter-wavelength long, buried 2 inches deep or elevated 0.08 wavelengths high.

The results of this study can be used to interface with existing ionospheric propagation codes in order to obtain optimum communication effectiveness.

## B. IMPORTANT ANTENNA PARAMETERS

Antenna parameters such as input impedance, average power gain, length, height above ground, number of radials and the position of them with respect to the ground, ground rods, sloping angles for dipoles, and the feed points were varied. The effect of the input impedance on the radiation pattern is one of the most important observable and controllable factors. The input impedance of an antenna is the impedance presented by the antenna at its terminals and is composed of real and imaginary parts [Ref. 1],

$$Z_{in} = R_m + jX_m , \quad (1)$$

where  $Z_{in}$  is the antenna impedance,  $R_m$  is the antenna resistance, and  $X_m$  is the antenna reactance. The resistive part consists of two components,

$$R_m = R_L + R_r , \quad (2)$$

where  $R_L$  is the loss resistance and  $R_r$  is the radiation resistance of the antenna:

The loss resistance  $R_L$  represents both power dissipated on the antenna structure and associated hardware as heating losses and power dissipated in the ground because of the ground-system losses. The radiation resistance  $R_r$  is a form of dissipation and represents power that leaves the antenna as radiation and never returns. On many antennas, the loss resistance is small compared to the radiation loss [Ref. 1].

The antenna impedance is important for transfer of power from a transmitter to an antenna or from an antenna to a receiver. For example, to maximize the power transferred from a receiving antenna, the antenna impedance should be a conjugate match which means a load of equal resistances and equal magnitude and opposite sign reactances. Finally, it should be noted that the antenna impedance for receiving and transmitting is the same as a consequence of reciprocity [Ref. 1].

## C. BASIC THEORY OF THE ANTENNAS

### 1. Half-Wavelength Dipole

This is a very widely used antenna. It has a linear current distribution whose amplitude varies as one-half of a sine wave with a maximum at the center [Ref. 1].

The advantage of a half-wavelength dipole is that it can be made to resonate and present a zero input reactance. The real part of the input impedance (the input resistance) represents far field losses (i.e., dissipation). The current distribution of the half-wavelength dipole is

$$I(z) = I_m \sin[\beta(\frac{\lambda}{4} - |z|)] , \quad (3)$$

where  $|z| \leq \frac{\lambda}{4}$  and  $\beta = \frac{2\pi}{\lambda}$ .

This current goes to zero at the ends ( $z = \pm \frac{\lambda}{4}$ ) and its maximum value  $I_m$  occurs at the center ( $z = 0$ ) as seen in Fig. 1a [Ref. 1].

Starting from this current formula the complete (i.e., normalized) far-field pattern can be obtained as [Ref. 1]

$$F(\theta) = g(\theta)f(\theta) = \frac{\cos[(\frac{\pi}{2}) \cos \theta]}{\sin \theta} , \quad (4)$$

where  $g(\theta)$  is called the element factor and  $f(\theta)$  is called the normalized pattern factor. The  $\theta$  variation of the function  $F(\theta)$  determines the far-field pattern as seen in Fig. 1b [Ref. 1].

### 2. Vee Dipole

"This antenna can be visualized as an open circuit transmission line that has been bent so that ends of length ( $h$ ) have an included angle  $\gamma$  as seen in Fig. 2 [Ref. 1]."

The input impedance of a vee dipole is generally less than a straight dipole of the same length. The directivity of a vee dipole can be greater than that of a straight dipole. The corresponding directivity of the vee dipole is [Ref. 1]

$$D = 2.94(\frac{h}{\lambda}) + 1.15 \quad (5)$$

$$D_{dB} = 10 \log(D) \quad (6)$$

Figure 3 is a typical radiation pattern (elevation) of the inverted vee dipole.

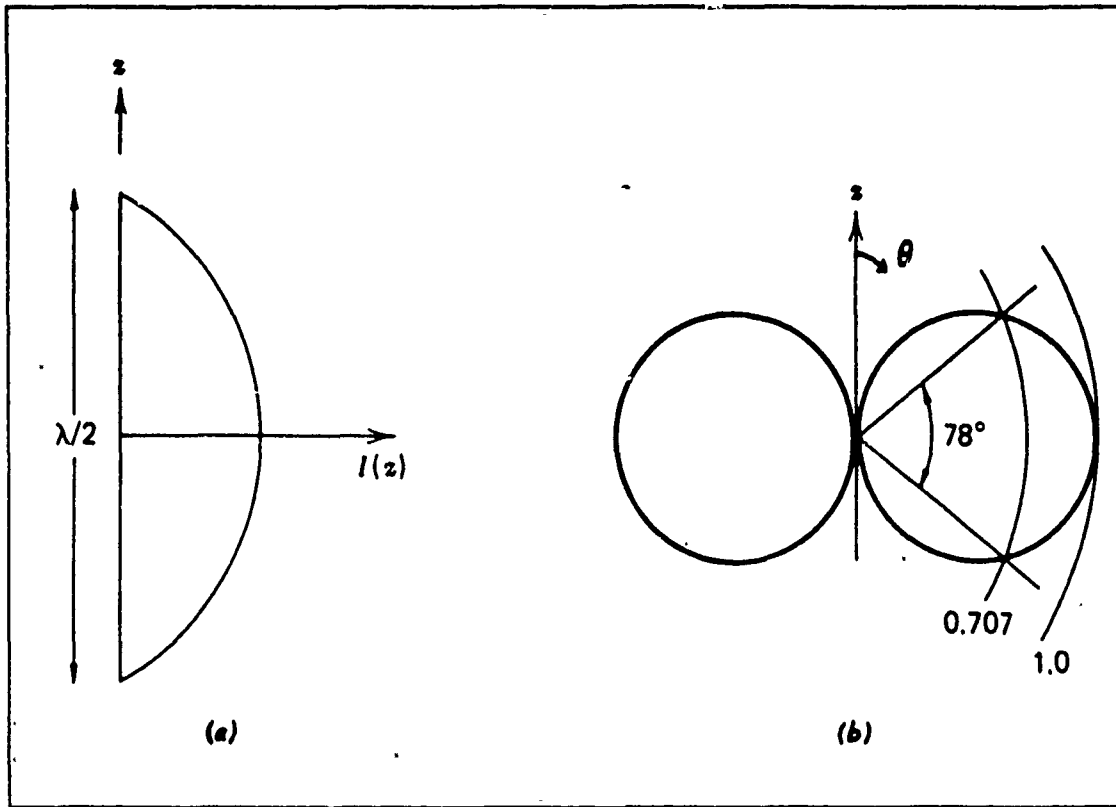

Figure 1. The half-wavelength dipole: (a) Current distribution  $I(z)$  (b) Radiation pattern  $F(\theta)$  (From Ref. 1)

### 3. Monopole

"A monopole is a dipole divided in half at its center feed point and fed against a ground plane. High frequency monopoles are often fed from coaxial cables behind the ground plane as seen in Fig. 4." [Ref. 1]

The currents and charges on a monopole are the same as on the upper half of its dipole counterpart. The principles of image theory are applicable and the terminal voltage is half that of the dipole because the gap width of the input terminals is half that of the dipole and the same electric field over half the distance gives half the voltage. The input impedance for a monopole is therefore half of its dipole counterpart as is the radiation resistance and input power.

$$Z_{IN,MONO} = \frac{1}{2} Z_{IN,DIPOLE} \quad (7)$$

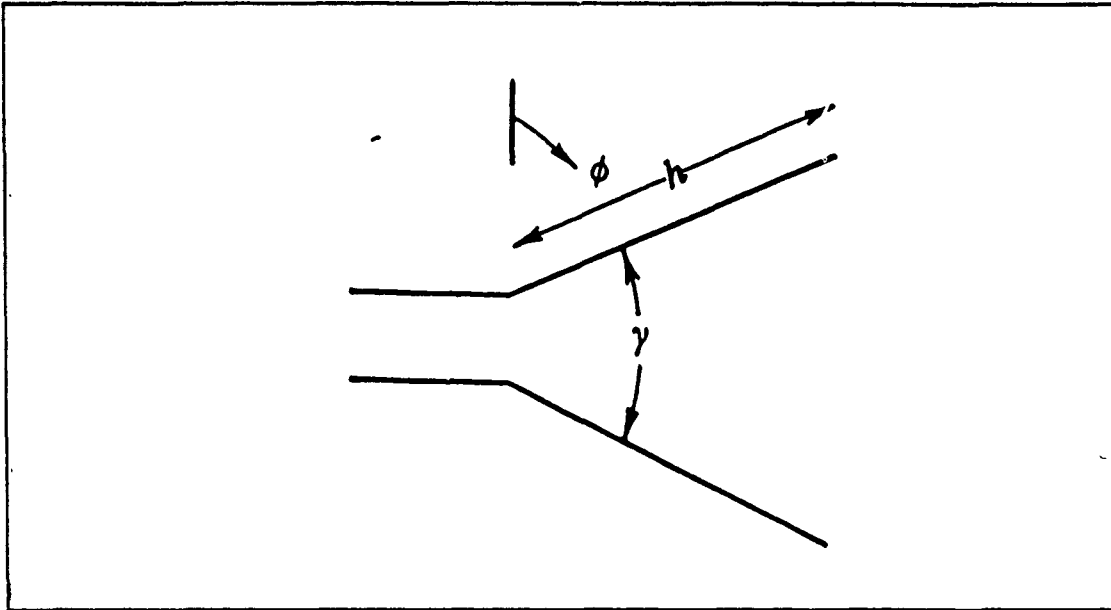

Figure 2. The vee dipole antenna: (From Ref. 1)

$$R_{r,MONO} = \frac{1}{2} R_{r,DIPOLE} \quad (8)$$

The radiation pattern of a monopole above a perfect ground plane is the same as that of a dipole similarly positioned in free space, since the fields above the image plane are the same.

#### D. INFORMATION ABOUT GROUND

The operation of HF antennas which usually are wire antennas is affected significantly by the presence of typical environmental surroundings such as the earth, buildings, etc. A ground plane can take many forms, such as radial wires around a monopole, the roof of a car, or the real earth (i.e., ground). In many situations the earth is well approximated as being infinite and planar, but it is a poor conductor. In the Antenna Engineering Handbook, practical ground types are considered under six different categories as seen in Table 1 [Ref. 2].

In this thesis, the various configurations of the antennas were investigated over fair (average) ground. The reason fair ground was chosen is because there are many configurations of the antennas and five different frequencies. Fair ground also has average values of permittivity and conductivity, compared to other ground types.

INV. VEE DIP. H=7.62M=25' FR=14.2MHZ L=LAMBDA/2  
ELEVATION PAT. EPS=10,SIG=.003

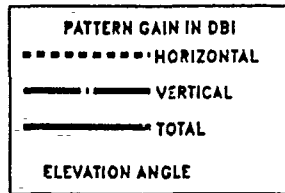
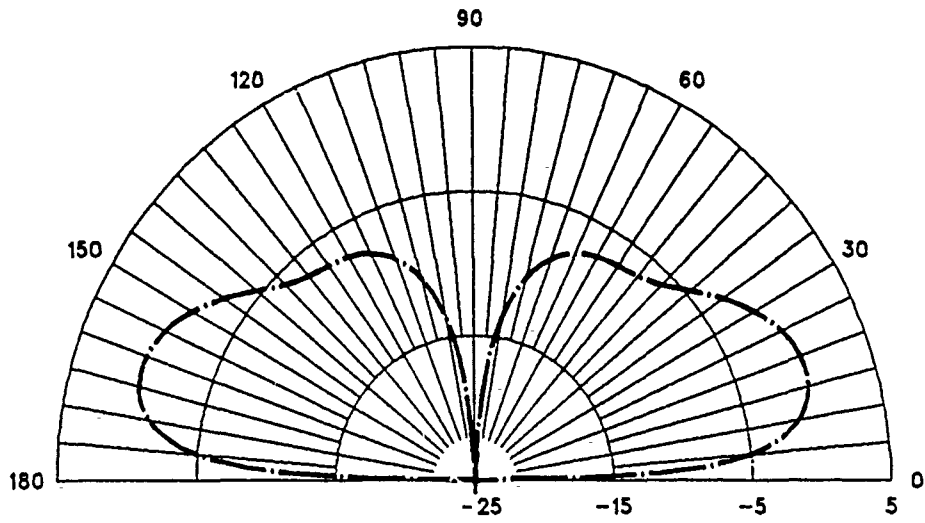

Figure 3. The elevation pattern of the half-wavelength inverted vee dipole

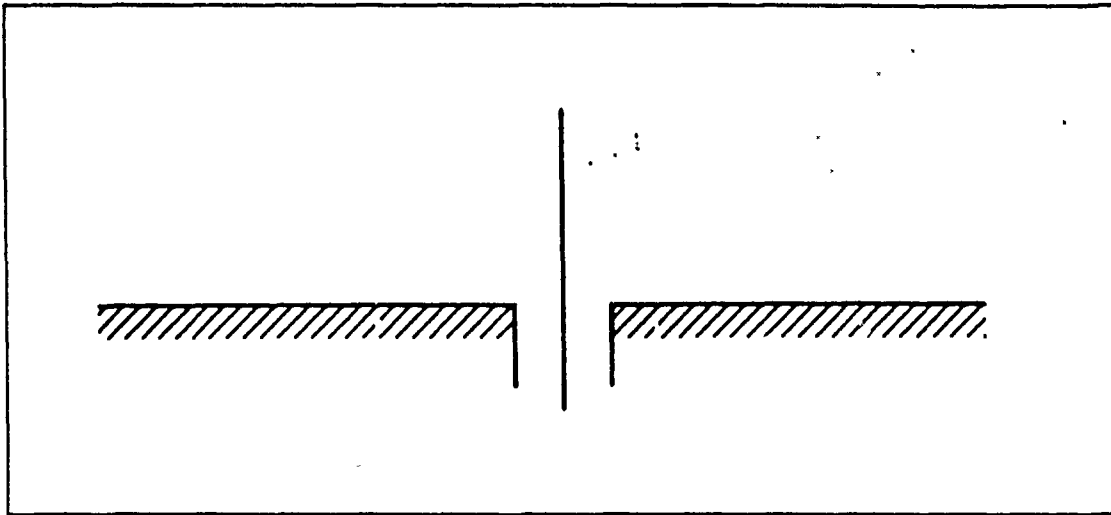

Figure 4. The monopole antenna fed from a coaxial cable: (From Ref. 1)

The effect of imperfect ground, which has low conductivity compared to perfect ground, is more ohmic losses. The electric fields penetrate into the earth and excite currents. These currents give rise to ohmic losses which appear as an increase in the input ohmic resistance. Therefore the radiation efficiency of the antenna decreases [Ref. 1] as

$$e = \frac{R_{rl}}{R_{rl} + R_{OHMIC}} = \frac{R_{rl}}{R_{IN}}, \quad (10)$$

where  $e$  is the radiation efficiency,  $R_{rl}$  is the radiation resistance,  $R_{OHMIC}$  is ohmic resistance, and  $R_{IN}$  is the input resistance.

The pattern of an antenna over finite ground is different from the pattern when the antenna is operated over a perfect ground plane. By using image theory, approximate patterns can be obtained. The Numerical Electromagnetics Code (NEC) includes the Fresnel plane wave reflection coefficient method for modeling structures over ground. This method is fast but of limited accuracy and should not be used for structures very close to the ground.

**Table 1. GROUND TYPES (FROM REF. 2).**

Conductivity (mhos/m)	Relative permittivity	Land type
0.00022	2.5	flat desert, cities
0.0012	7.0	mountains;steep rocky hills
0.003	10.0	average ground
0.011	13.0	pastoral land, medium hills
0.065	22.5	rich farm land
0.15	34.0	rice paddy

There is another method which is called Sommerfeld/Norton for wire antennas only. This method was used in this research since it is more accurate for structures which are close to ground although it is slower and requires more memory space. The Sommerfeld/Norton method requires a separate computer program (SOMNTX) to be run prior to NEC in order to generate and store a " Ground Interaction Matrix " which is then called by NEC.

The losses in an earth ground can be reduced by providing a highly conductive return path. This is usually achieved with a Radial Wire Ground System which produces a pattern more nearly like that for a perfect ground, increasing low elevation angle radiation which is very useful for long distance communications. The radial wires can be laid on top of the ground or buried slightly beneath it. In fact, they need not be buried, but it is usually convenient to do so; however, they should not be buried too deep. For high-power transmitting antennas it is important to have a well designed radial system to achieve high efficiency.



## II. NUMERICAL METHODS AND TECHNIQUES FOR ANTENNA ANALYSIS

### A. ANTENNA MODELING AT THE NAVAL POSTGRADUATE SCHOOL

At present, there are two widely used antenna modeling programs which are available at NPS. They are the Mini-Numerical Electromagnetics Code (MININEC) which runs on a personal computer (PC) and the Numerical Electromagnetics Code (NEC) which runs on a mainframe computer and on a PC.

### B. THE NUMERICAL ELECTROMAGNETIC ENGINEERING DESIGN SYSTEM (NEEDS)

As a system, NEEDS consists of a package of programs and operates on a PC/XT or PC/AT computer. The programs are MININEC and NEC2 for antenna modeling; IGUANA, a graphics utility system; GRAPS for plotting; and several auxiliary programs.

#### 1. MININEC

MININEC is an interactive program which is useful for many applications in wire antennas, especially for small problems.

##### a. Capabilities

Although it has limited capabilities, MININEC is a good tool for antenna analysis and design. The capabilities of MININEC are [Ref. 3]:

- Up to 10 wires and 75 unknowns (segments) may be used in constructing a MININEC model.
- Antennas can be modeled either in free space or over perfectly conducting ground.
- Electric and magnetic fields (near and far) can be calculated.
- Solutions can be obtained for impedances and currents on wires.
- Far fields can be calculated in either volts per meter or in terms of power radiation pattern.
- Lumped parameters (such as loading coils and traps) can be included in a MININEC model.
- Fresnel reflection coefficient correction of radiation patterns may be included in MININEC models via up to five changes in ground surface impedance. The ground model may resemble either a circular or cliff model.

##### b. Limitations

Limitations of MININEC are [Ref. 3] :

- The number of wires and segments can be used in modeling are limited. Only simple structures or a simplification of larger structures can be modeled.
- MININEC can not perform surface modelings via a surface current patch.
- MININEC can not be used for antennas closely coupled to finite ground.

## 2. GRAPS

GRAPS is a program designed for plotting output data from MININEC, NEC, or general data. It is menu-driven and written in BASIC. The various types of GRAPS plots are linear, bilinear, log-linear, polar, Smith, and log-log [Ref. 4].

## 3. NEC2

NEC2 is a version of NEC limited to structures which are in free space or above the earth [Ref. 5].

## 4. INTERACTIVE GRAPHICS UTILITY FOR AUTOMATED NEC ANALYSIS (IGUANA)

This system was developed to reduce the time required for NEC antenna model evaluation by providing partial automation to both the data entry and the data display processes. In particular, IGUANA simplifies modeling of structures by allowing use of a digitizer or mouse to input views of a structure. This data can then be edited and combined with other views of the object to produce a three-dimensional model. Facilities are included for user input of required control and documentation cards, data transmission to a mainframe host computer, and display of NEC output data [Ref. 6].

## C. THE NUMERICAL ELECTROMAGNETICS CODE (NEC-3/MAINFRAME)

### 1. INTRODUCTION

All antennas from this thesis have been modeled using the Numerical Electromagnetics Code, Version 3 (NEC-3) with double-precision accuracy on the IBM 3033 computer, while NEEDS was used as an auxiliary tool. It is a user-oriented computer code written in FORTRAN and the most capable and flexible tool available at NPS for electromagnetic modeling of wire antennas. Because it is a powerful and complex tool, a considerable learning process is required to master its capabilities. Technically, NEC is used to analyze antennas or other metal structures based on the use of numerical solutions of integral equations for currents induced on the structure by an incident plane wave or a voltage source. NEC-3 has the following capabilities [Ref. 7] :

- Up to 300, 1000, or 2000 wire segments, depending on the version of NEC being used.

- Up to 150, 500, or 1000 surface patches.
- More rapid computations than obtained using NEC2 on a PC.
- Convenient storage of NEC datasets and results, and ready accessibility to data.
- A library of useful PROGRAMS, EXECs, and data handling utilities (see Appendix A)

The NEC codes use both an electric field integral equation (EFIE) and a magnetic field integral equation (MFIE) to solve general electromagnetic radiation problems. The solution is obtained by using the method of moments.

## 2. ELECTRIC FIELD INTEGRAL EQUATION (EFIE)

In solving for the current, two approximation options are available in NEC, the thin-wire kernel and the extended thin-wire kernel. For thin-wire the current on the surface of segment is reduced to a filament of current on the segment axis. Using the extended thin-wire kernel, a current is uniformly distributed around the segment surface. The EFIE used in NEC is given in [Ref. 7]:

$$-\hat{s} \cdot \bar{E}'(\bar{r}) = \frac{-j}{4\pi\omega\epsilon} \int_{c(\bar{r})} I(s') (\hat{s} \cdot \hat{s}' k^2 - \frac{\partial^2}{\partial_s \partial_{s'}}) g(\bar{r}, \bar{r}') ds' \quad (11)$$

where:

- $\hat{s}$  = unit vector along the wire axis.
- $s'$  = distance along the wire axis.
- $\bar{E}'(\bar{r})$  = incident electric field at  $r$ .
- $\omega$  =  $2\pi f$ , where  $f$  is the frequency.
- $I(s')$  = axial current.
- $\epsilon$  = permittivity.
- $k$  =  $\omega\sqrt{\mu\epsilon}$  = phase constant.
- $\bar{r}$  = observation point.
- $\bar{r}'$  = source point.
- $g(\bar{r}, \bar{r}')$  =  $\exp\left[\frac{-jkr}{R}\right]$  = free space Green's function.
- $R$  =  $(\bar{r} - \bar{r}')$

## 3. MAGNETIC FIELD INTEGRAL EQUATION (MFIE)

NEC includes a patch option for modeling surfaces using the MFIE. This formulation is restricted to closed surfaces with nonvanishing enclosed volume. The MFIE used in NEC is given in [Ref. 7]:

$$\bar{J}_s(\bar{r}) = 2\hat{n} \times \bar{H}^{inc}(\bar{r}) + \frac{1}{2\pi} \hat{n} \times \int_s \bar{J}_s(\bar{r}') \times \nabla' g ds' \bar{r} \epsilon s' \quad (12)$$

where:

- $\bar{J}_s(\bar{r})$  = surface current density.  
 $\bar{H}^{inc}(\bar{r})$  = incident magnetic field at the observation point.  
 $\hat{n}$  = unit vector normal to the surface.

#### D. WIRE MODELING GUIDELINES

Short straight segments for wires and the flat patches for surfaces are the basic devices for modeling structures with NEC. Since only wire antennas were investigated in this thesis, guidelines are given for modeling wire antennas.

An antenna and any other conducting object in its vicinity that affect performance must be modeled with strings of segments following the paths of the wires. Proper choice of segments is the most critical step in obtaining accurate results. For accuracy and efficient run-time, the number of segments should be the minimum required.

A wire segment is defined by the coordinates of its two end points and by its radius. Geometrical and electrical guidelines for segments are given below [Ref. 7] :

1. Geometrically, segments should follow the paths of conductors as closely as possible.
2. Each wire must be broken into segments of length  $\Delta$  , where

$$0.1\lambda < \Delta < 0.001\lambda$$

and  $\lambda$  is the wavelength of the desired frequency.

3. The segment length  $\Delta$  should be  $0.05\lambda$  or less when modeling critical regions of an antenna.
4. Using extremely short segments, less than about  $10E-3 \lambda$ , should be avoided since it may lead to numerical inaccuracy.
5. The wire radius must be small compared to the segment length  $\Delta$  . For the thin-wire kernel approximation,  $\frac{\Delta}{a}$  must be greater than about 8 for errors of less than 1%.
6. But, for the extended thin-wire kernel approximation, the radius of the wire can be increased for modeling large-diameter conductors, up to  $\frac{\Delta}{a} = 2$  for the same accuracy as the thin-wire kernel approximation.

7. If the distance between the ends of two segments is greater than about  $1E-3$  times the length of the shortest segment, NEC will not allow the current to flow from one segment to other.
8. Identical coordinates should be used for connected segment ends.
9. The end of one wire must be connected to the junction of two segments on another wire, and not to the mid-point of a single segment.
10. Large changes in radius between the two adjacent connected wires should be avoided. The change in radius between adjacent segments should generally be limited to a factor of two or less. It is also important that the largest radius not violate guidelines (5) and (6), in regard to the radius versus segment length.
11. A segment is required at each point where a network connection or a voltage source is located.
12. Any changes in segment length between two adjacent connected wires should be limited to a factor of 2:1 or less. Very long and straight wires may be modeled using tapered segment lengths (with the "GC" card), as long as the lengths of two adjacent segments are held to a ratio of 2:1 or less.

### III. DESCRIPTION OF ANTENNA NUMERICAL MODELS

#### A. HALF-WAVELENGTH HORIZONTAL DIPOLE

Figure 5 shows the configuration of the antenna. The results of this configuration for different frequencies and different types of ground can be used as a reference for comparison to other configurations. Generally speaking, the radiation patterns (elevation) show that this configuration is good for Near Vertical Incident Skywave (NVIS - high elevation angle radiation) communications, but it may also provide some ground wave (low elevation angle radiation) vertically polarized communications.

In Figure 6a the height of the antenna is close to one half-wavelength. For fair ground, since the image is not exactly of equal amplitude and opposite phase, there is not a perfect null at  $\theta = 0$ . The azimuth pattern at  $\theta = 45$  degrees is shown in Figure 7. This antenna provides medium and long range communications. In Figure 6b the height of the antenna is now close to two wavelengths with a near out of phase condition giving a maximum at  $\theta = 0$  and more lobes at this higher frequency (14.2 MHz). It favors NVIS, medium, and relatively poor long range communications compared to same antenna at 3.8 MHz. Figure 8 shows the azimuth pattern of this antenna at  $\theta = 43$  degrees. The four-wavelength high dipole provides good medium and long range communications as seen in Figure 6c. The azimuth pattern of the same antenna is given in Figure 9.

The horizontally polarized gain is dominant over the vertically polarized gain in the broadside direction as seen in Figures 7, 8, and 9. These figures also show that this antenna is very good for skywave omnidirectional use because total gains of the antenna for different frequencies have a circular shape in the azimuth plane, especially for high frequencies (see Figures 8 and 9).

#### B. QUARTER-WAVELENGTH SLOPING WIRE

The configuration of the quarter-wavelength sloping wire is in Figure 10. The results show that radiation patterns of a quarter-wavelength sloping wire are more directive than those of a half-wavelength horizontal dipole. But in some cases, the main lobe direction may not be in the sloping (desired) direction due to the antenna height, frequency, and top angles.

# HALF-WAVELENGTH HORIZONTALLY POLARIZED DIPOLE

HEIGHTS ( ft. )

- 25
- 35
- 50
- 90
- 120

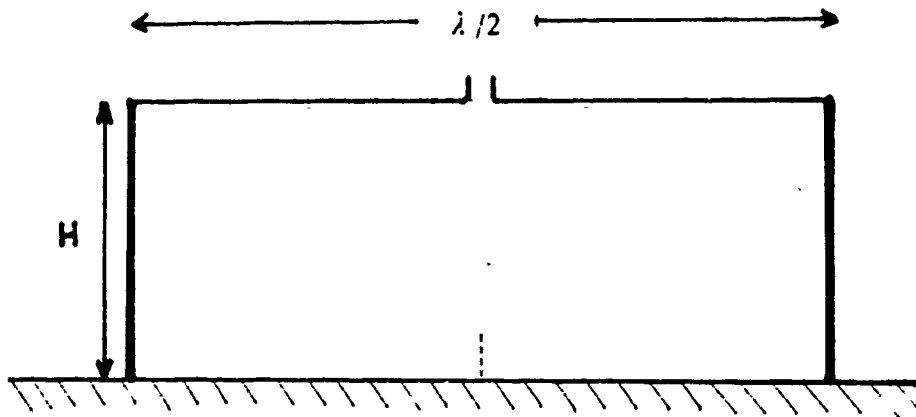

THETA = 90.00 PHI = 60.00 ETA = 90.00

Figure 5. The half-wavelength horizontal dipole

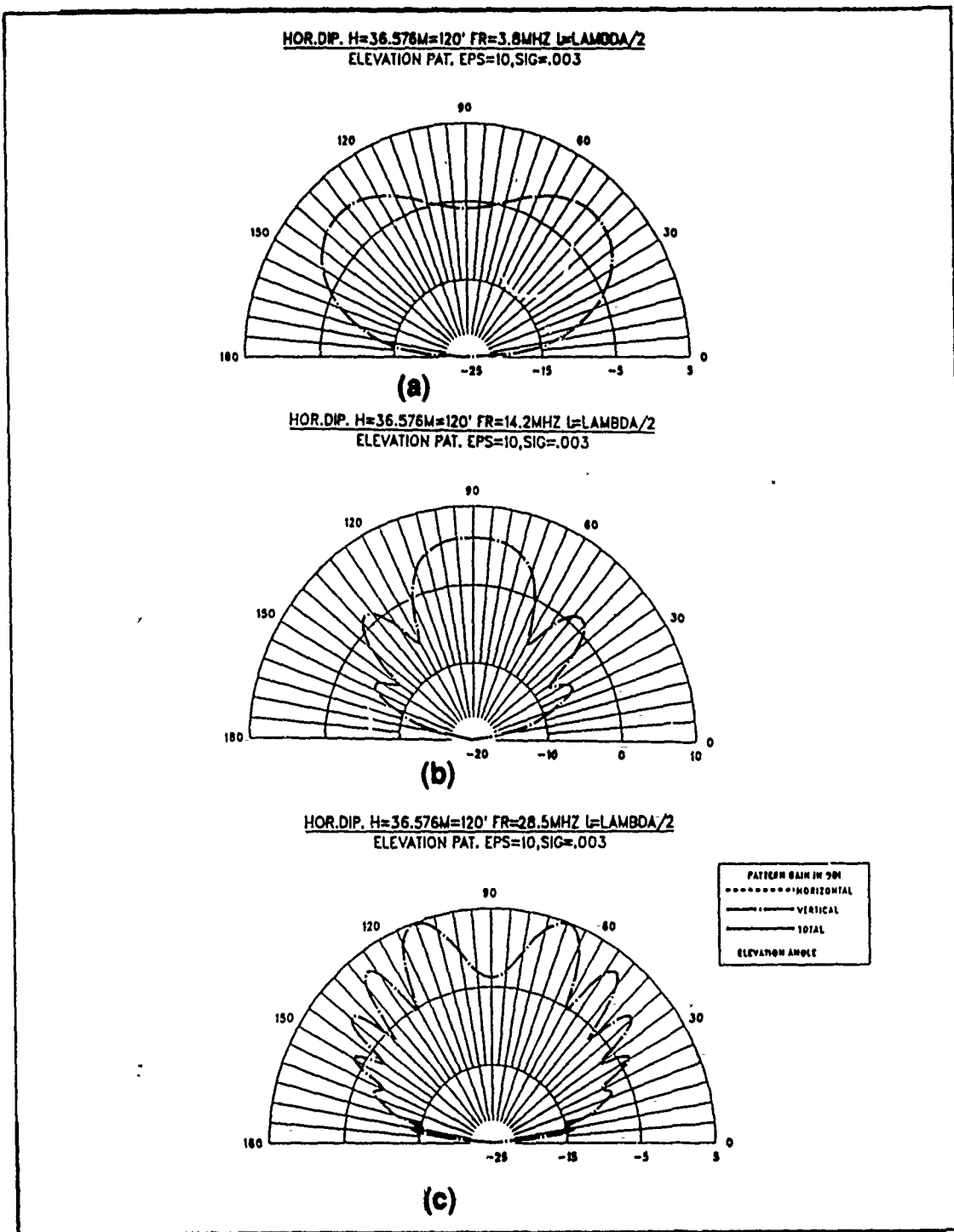

Figure 6. The elevation patterns of the half-wavelength horizontal dipole: (a)  $F_r = 3.8$  MHz (b)  $F_r = 14.2$  MHz (c)  $F_r = 28.5$  MHz



HOR.DIP. H=36.576M=120' FR=3.8MHZ L=LAMBDA/2  
 AZIMUTH PAT. EPS=10,SIG=.003 THETA=45

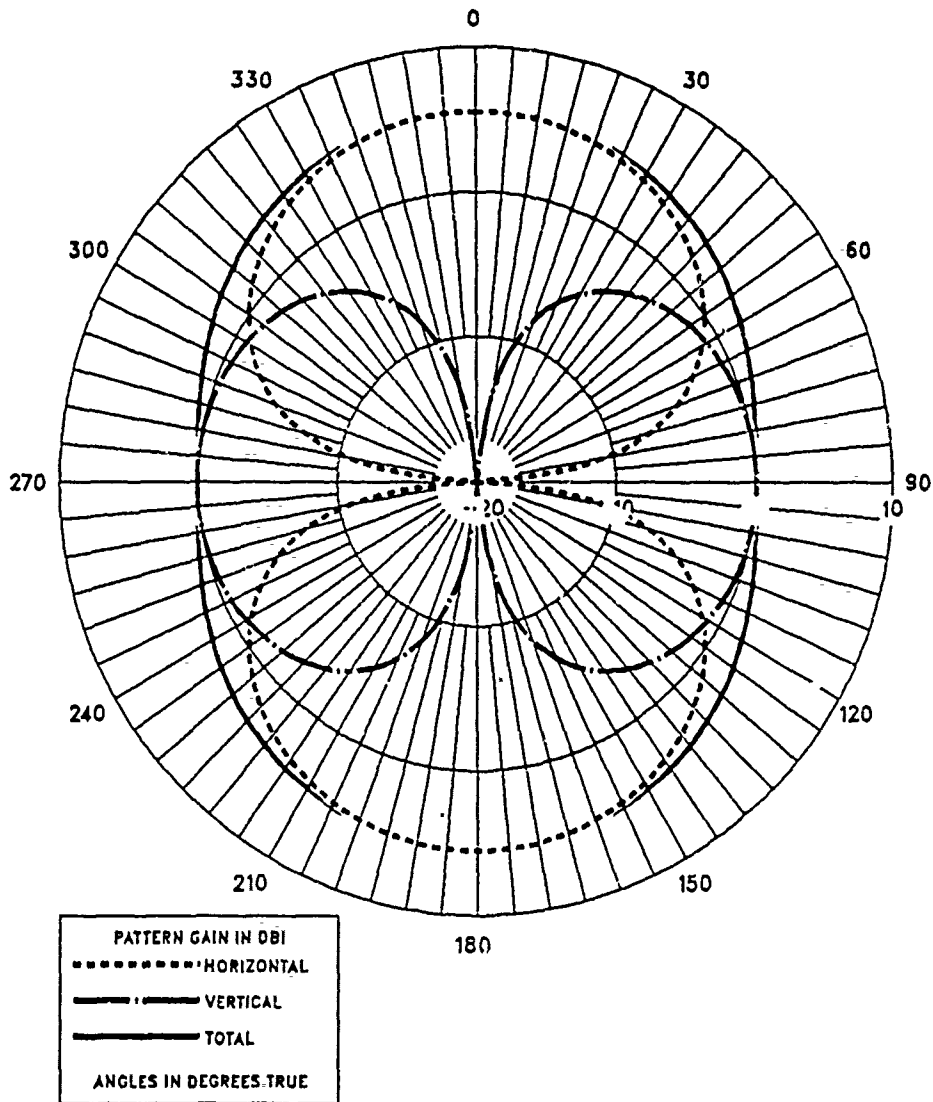

Figure 7. The azimuth pattern of the half-wavelength horizontal dipole: Antenna is 120 ft. high and frequency is 3.8 MHz

HOR.DIP. H=36.576M=120' FR=14.2MHZ L=LAMBDA/2  
 AZIMUTH PAT. EPS=10,SIG=.003 THETA=43

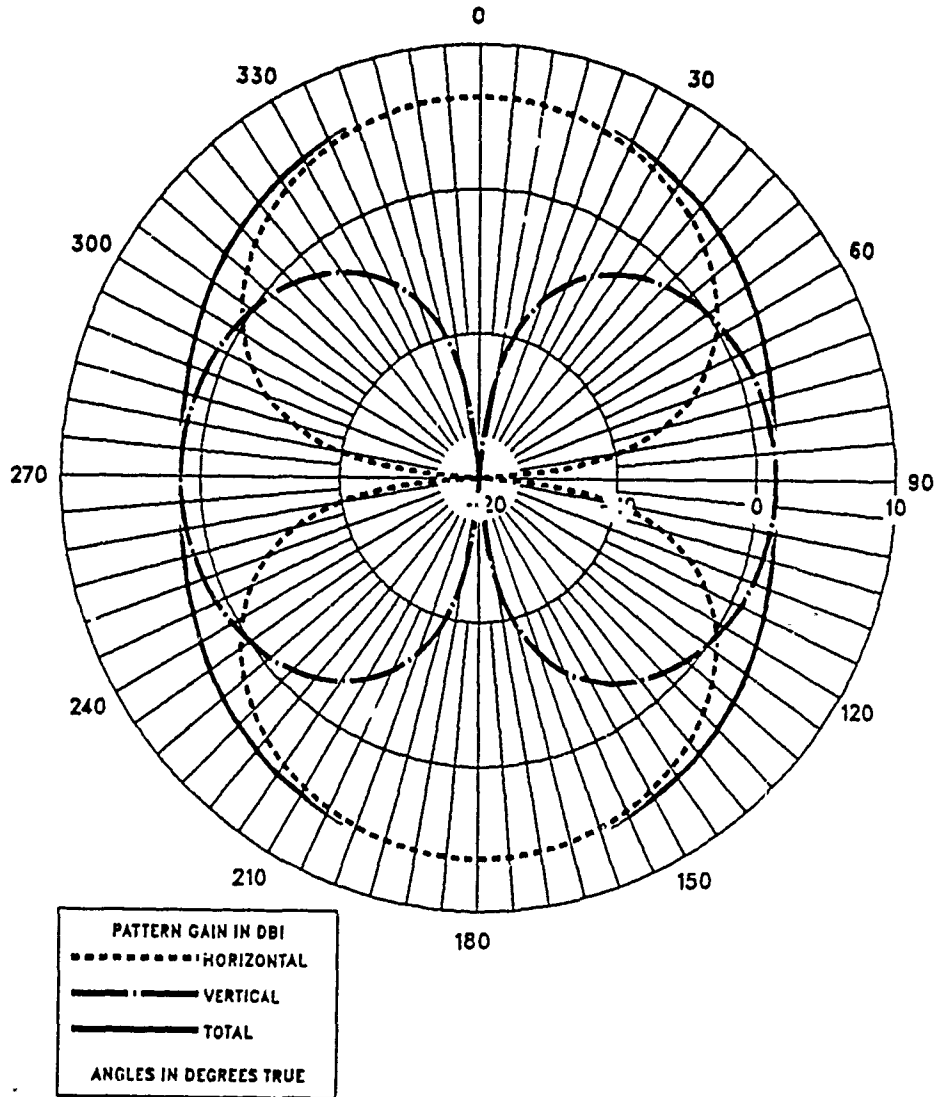

Figure 8. The azimuth pattern of the half-wavelength horizontal dipole: Antenna is 120 ft. high and frequency is 14.2 MHz

HOR.DIP. H=36.576M=120' FR=28.5MHZ L=LAMBDA/2  
 AZIMUTH PAT. EPS=10,SIG=.003 THETA=20

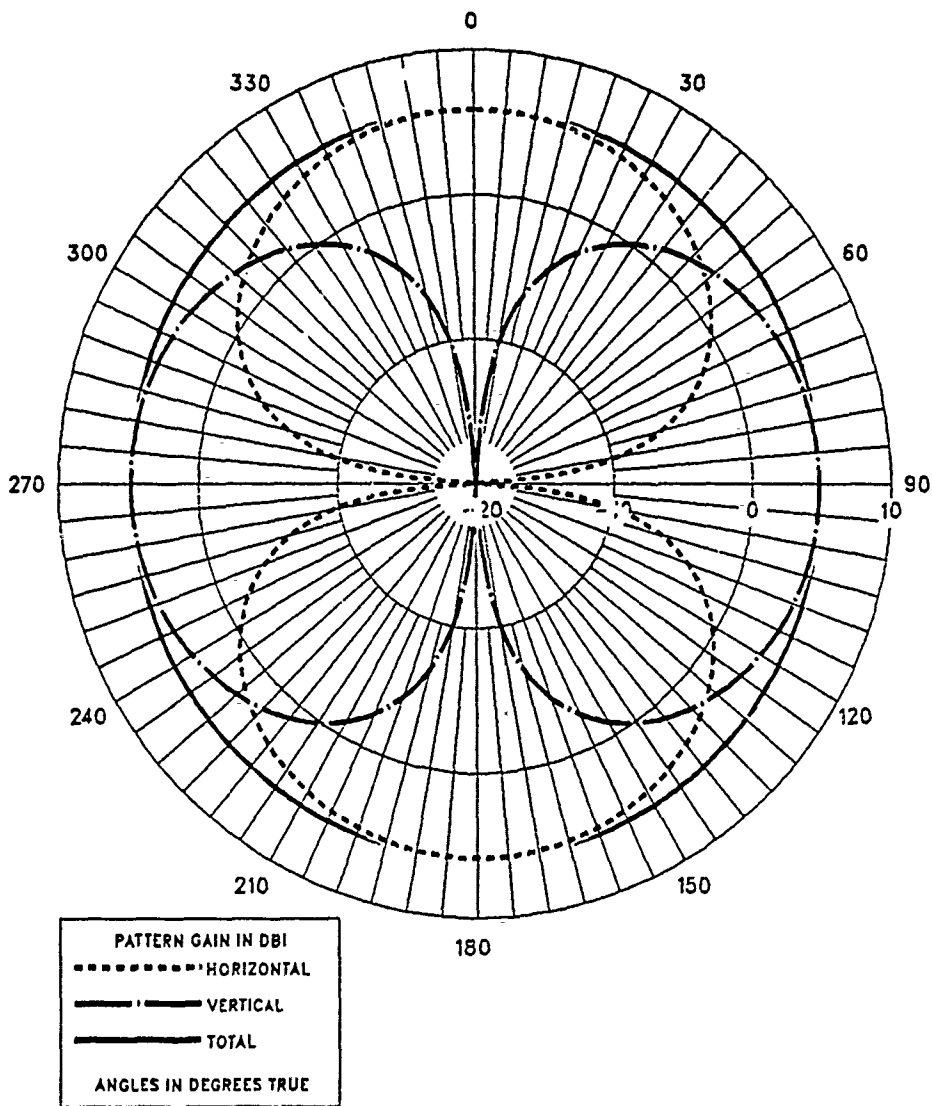

Figure 9. The azimuth pattern of the half-wavelength horizontal dipole: Antenna is 120 ft. high and frequency is 28.5 MHz

## QUARTER-WAVELENGTH SLOPING WIRE

- 30 AND 45 DEGREES TOP ANGLES ( TA ).
- 50' AND 90' HIGH ( H ).
- 4' GROUND ROD.
- CONNECTED TOWER.
- FEED AT TOP.

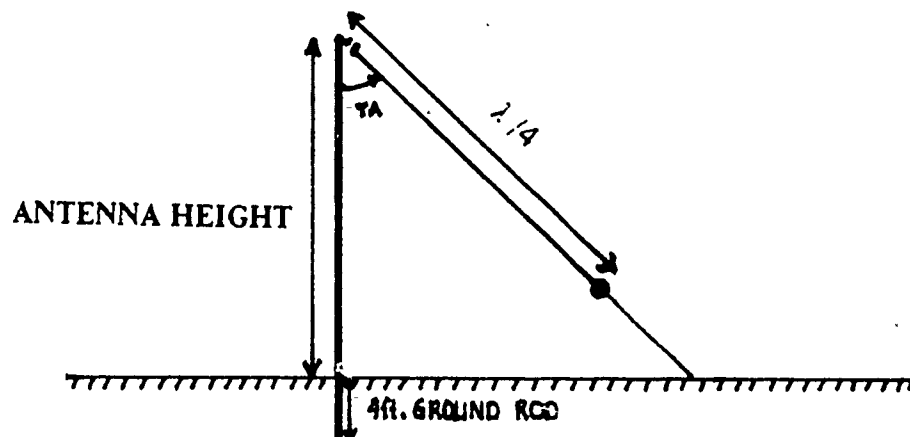

Figure 10. The quarter-wavelength sloping wire

Figures 11c and d, 12a and b, and 13c and d show elevation patterns which have main lobes in the opposite direction of sloping (undesired) for frequencies of 28.5, 21.3, and 7.2 MHz respectively. From these figures, it can be seen that medium- and long-range communications can be provided and higher frequencies of HF band give multilobe radiation patterns. The height of the antenna, frequency, and top angle affect the side lobe levels.

In addition, radiation patterns of this configuration are more directive than those of a horizontal dipole in the direction the antenna slopes as seen in Figure 14.

### **C. HALF-WAVELENGTH SLOPING DIPOLE**

Figure 15 shows the configuration of the antenna. This configuration has a more directive pattern than the quarter-wavelength sloping wire. In general, the effects of height, frequency, and top angle are similar to those observed for the quarter-wavelength sloping wire.

Radiation patterns in Figure 16 show that large top angles produce small side lobes in the direction opposite of the slope. The vertically polarized gain is maximum in the sloping direction as seen in the azimuth pattern (Figure 17).

### **D. HALF-WAVELENGTH INVERTED VEE DIPOLE**

The configuration of the antenna is shown in Figure 18. Construction limitations restrict this antenna to a tower that is not electrically connected to the antenna and the angle between each leg and tower to be a maximum of 45 degrees. In addition, the distance between the end of each leg and the ground should not exceed 10 ft.

Figure 19 shows three elevation patterns of this configuration for frequencies of 3.8, 14.2, and 28.5 MHz and a 120 ft antenna. By comparing Figures 19a and 23, it can be seen that the inverted vee dipole provides radiation that is more directive than for a monopole antenna. This antenna also provides medium range as well as long range communication.

Increasing the frequency results in more gain for a 120 ft high antenna as seen in Figure 19. The elevation patterns for frequencies of 3.8, 14.2, and 28.5 MHz with a 35 ft high antenna are in Figure 20. A comparison of Figures 19 and 20 shows that more gain is obtained by increasing frequency rather than by increasing the height of the antenna.

The azimuth pattern of the 35 ft high inverted vee dipole at a frequency of 3.8 MHz is in Figure 21. This pattern is vertically polarized in the direction of the antenna.

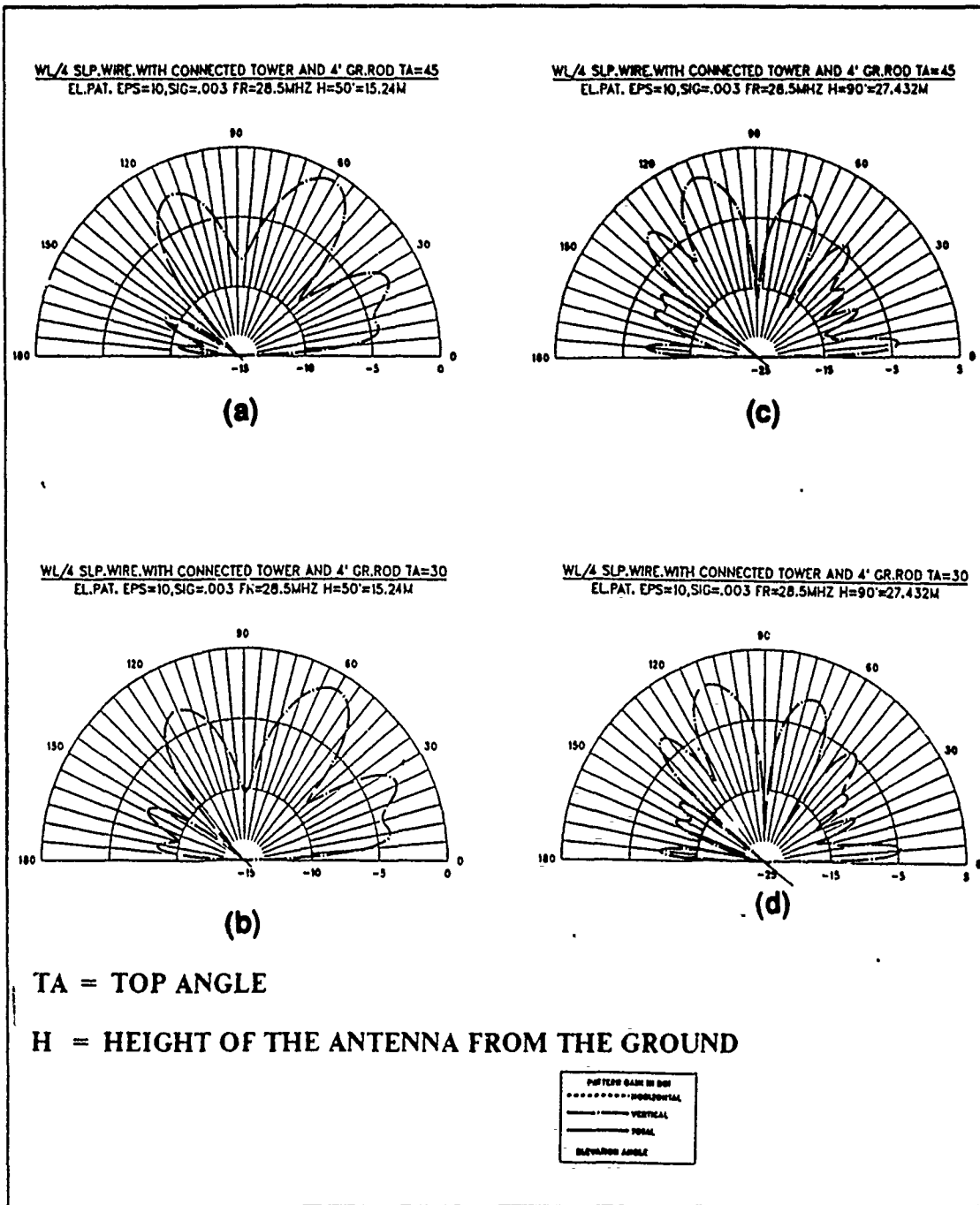

**Figure 11.** The elevation patterns of the sloping wire for 28.5 MHz: (a) TA = 45 degrees, H = 50 ft. (b) TA = 30 degrees, H = 50 ft. (c) TA = 45 degrees, H = 90ft. (d) TA = 30 degrees, H = 90 ft.

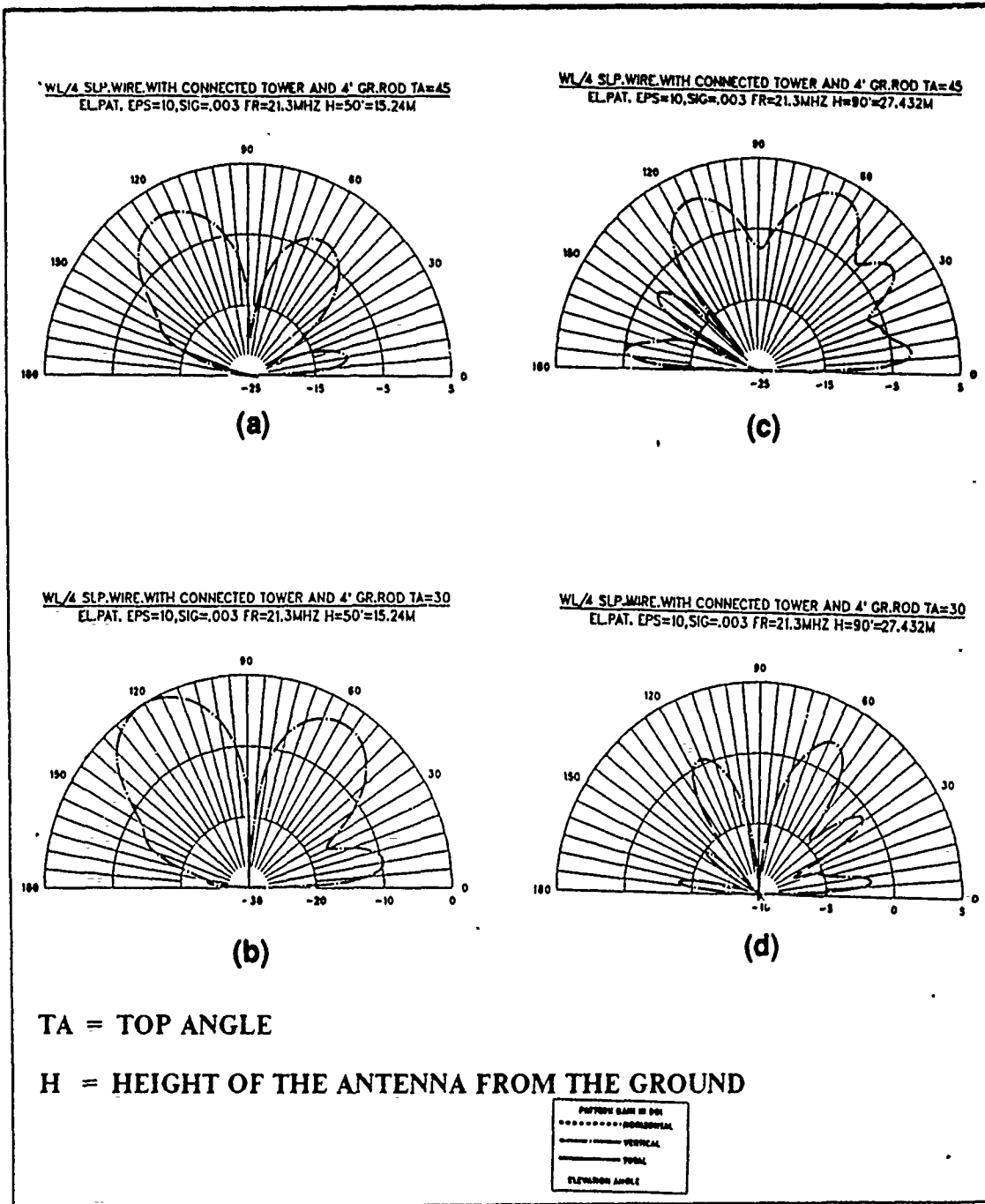

Figure 12. The elevation patterns of the sloping wire for 21.3 MHz: (a) TA = 45 degrees, H = 50 ft. (b) TA = 30 degrees, H = 50 ft. (c) TA = 45 degrees, H = 90ft. (d) TA = 30 degrees, H = 90 ft.

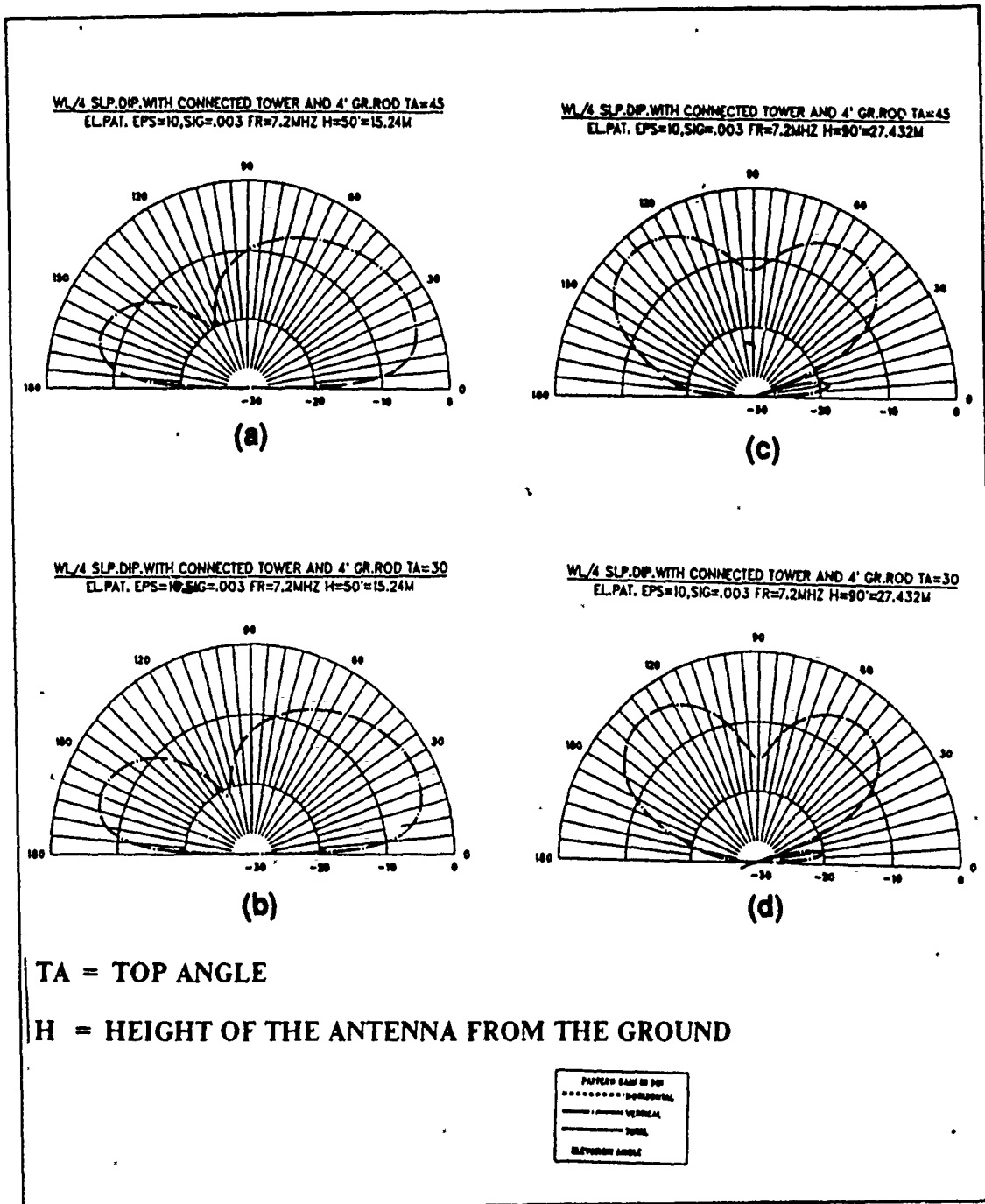

Figure 13. The elevation patterns of the sloping wire for 7.2 MHz: (a) TA = 45 degrees, H = 50-ft. (b) TA = 30 degrees, H = 50 ft. (c) TA = 45 degrees, H = 90ft. (d) TA = 30 degrees, H = 90 ft.



WL/4 SLP.WIRE.WITH CONNECTED TOWER AND 4' GR.ROD TA=45  
 AZ.PAT. EPS=10,SIG=.003 FR=28.5MHZ H=50'=15.24M TH=30

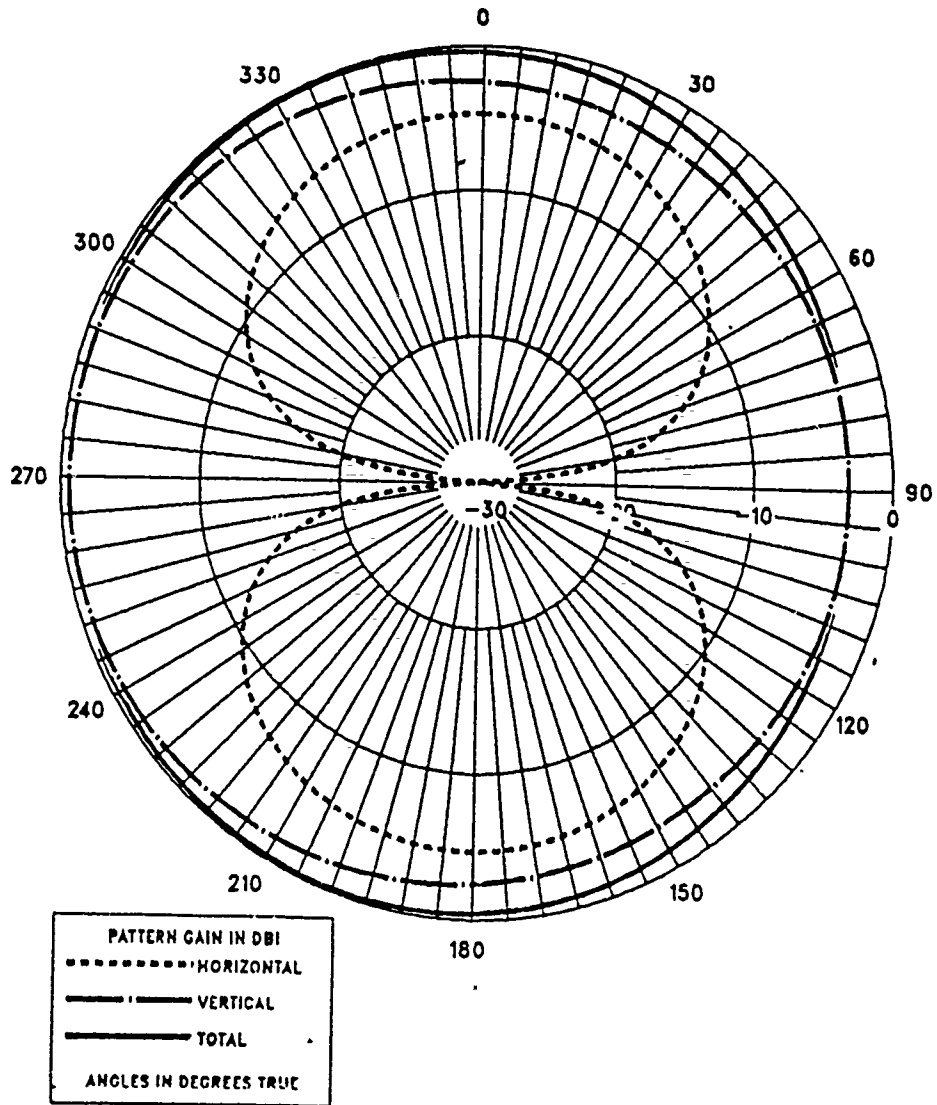

Figure 14. The azimuth pattern of the quarter-wavelength sloping wire

### HALF-WAVELENGTH SLOPING DIPOLE

- 30 AND 45 DEGREES TOP ANGLES ( TA )
- 50' AND 90' HIGH
- DETACHED TOWER
- CENTER FEED
- 4' GROUND ROD

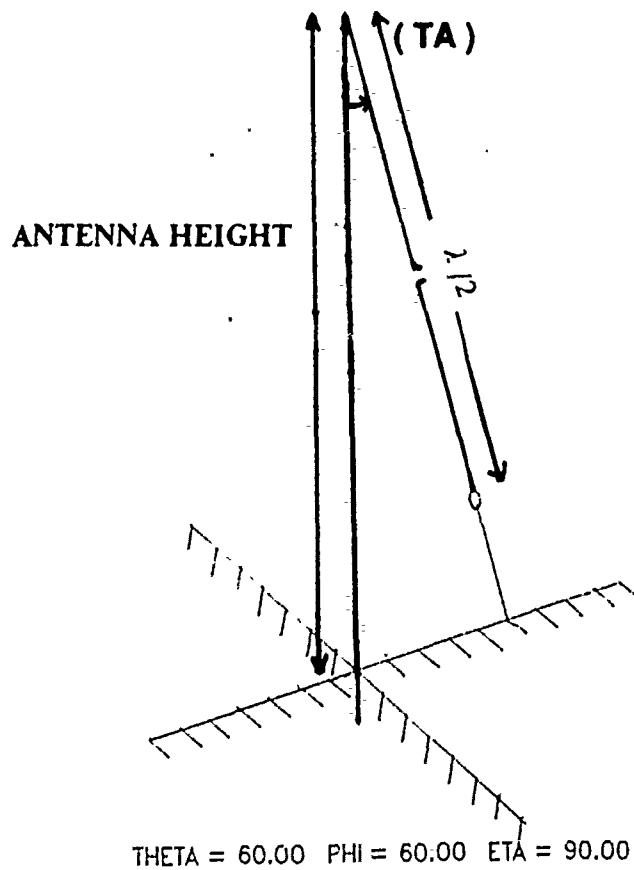

Figure 15. The half-wavelength sloping dipole

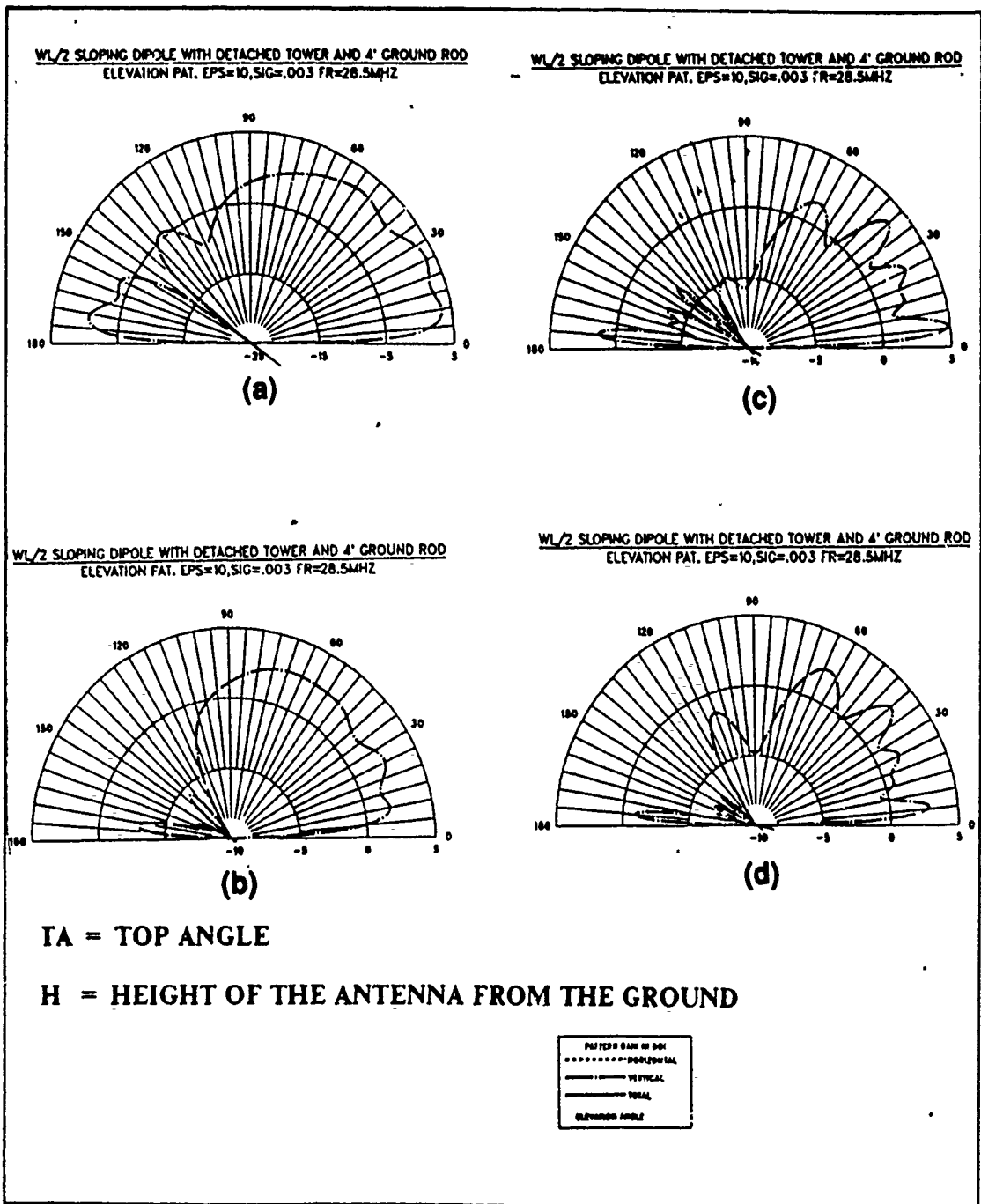

Figure 16. The elevation patterns of the half-wavelength sloping dipole: (a) TA = 30 degrees, H = 50 ft. (b) TA = 45 degrees, H = 50 ft. (c) TA = 30 degrees, H = 90 ft. (d) TA = 45 degrees, H = 90 ft. and the frequency is 28.5 MHz for all patterns.

WL/2 SLOPING DIPOLE WITH DETACHED TOWER AND 4' GROUND ROD  
 AZIMUTH PAT. EPS=10, SIG=.003 FR=28.5MHZ THETA=23

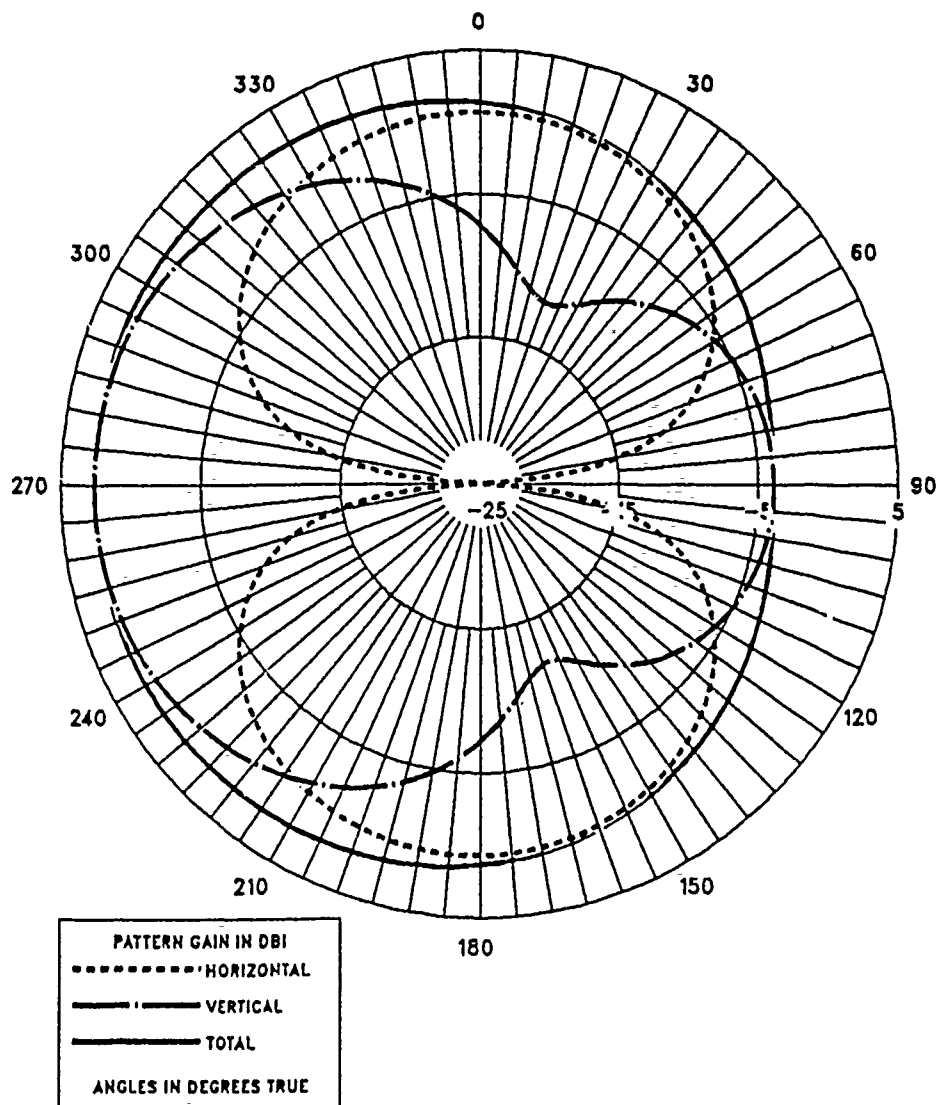
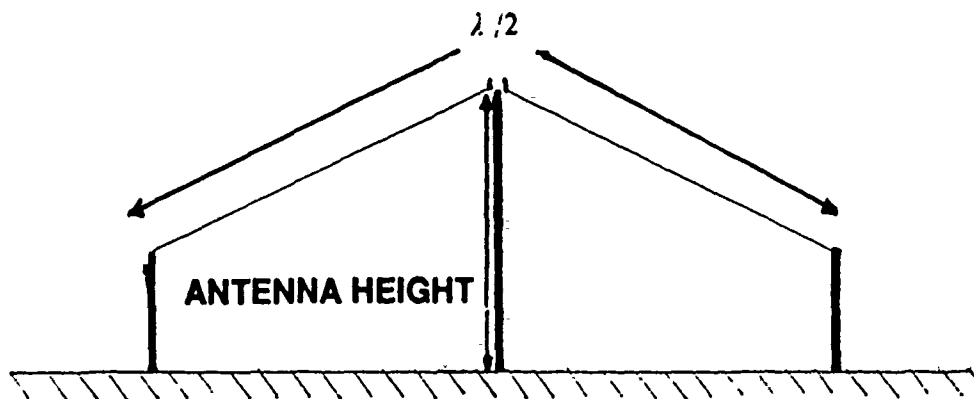

Figure 17. The azimuth pattern of the half-wavelength sloping dipole: TA = 45 degrees, H = 50 ft.

# HALF-WAVELENGTH INVERTED VEE DIPOLE WITH A DETACHED TOWER

HEIGHTS ( ft. )

- 25
- 35
- 50
- 90
- 120



THETA = 90.00 PHI = 60.00 ETA = 90.00

Figure 18. The half-wavelength inverted vee dipole.

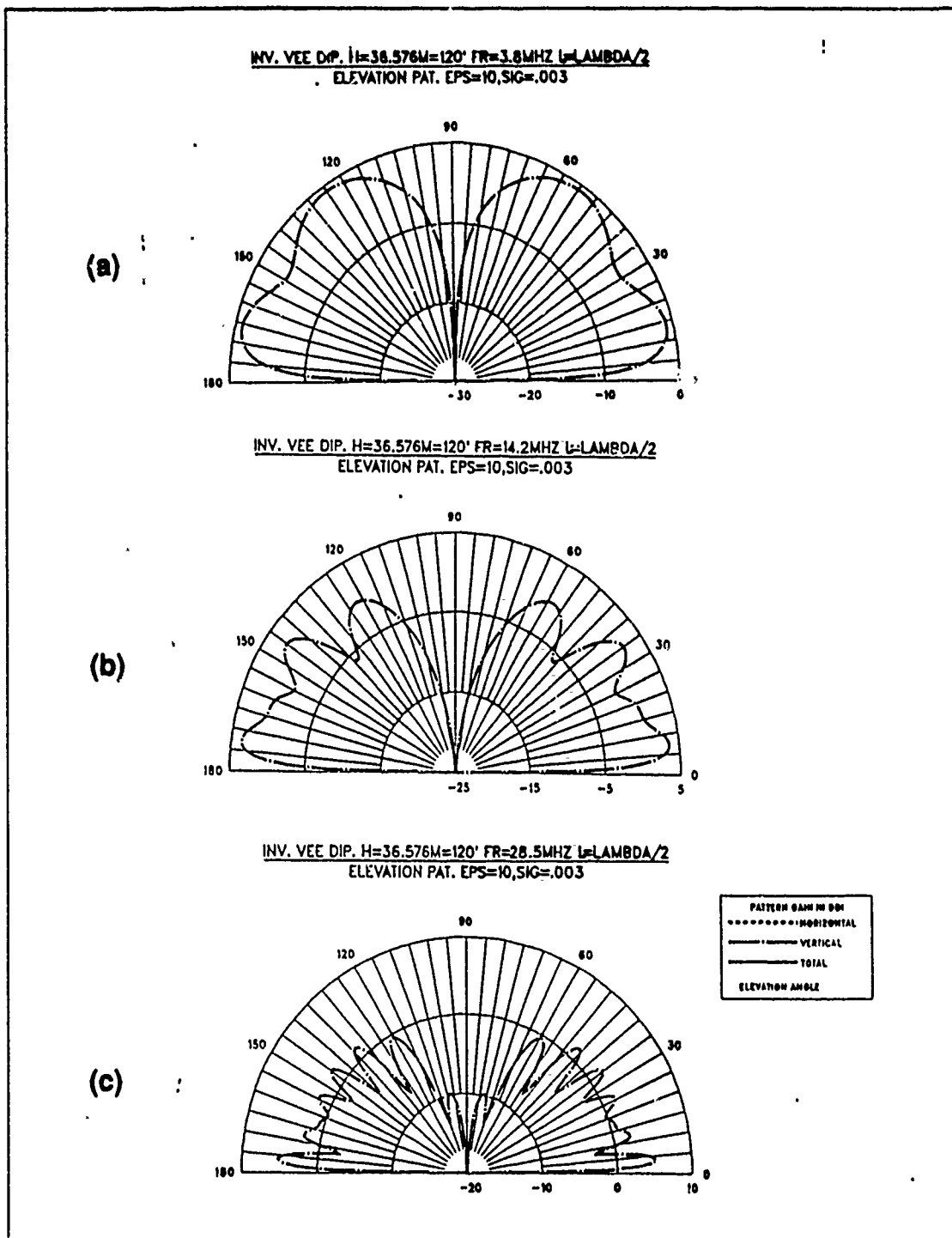

Figure 19. The elevation patterns of the 120 ft. high inv. vee dipole: (a) Fr= 3.8 MHz (b) Fr= 14.2 MHz (c) Fr= 28.5 MHz

## **E. QUARTER-WAVELENGTH MONOPOLE WITH A 4 FOOT GROUND ROD**

Figure 22 shows the configuration of the antenna with insulated supporting wires and a 4 ft ground rod. The elevation and azimuth patterns of this configuration are the same typical monopole radiation pattern shape as seen in Figures 23 and 24 respectively.

Its low take-off angle provides long distance skywave communications, but it has poor NVIS performance due to lower gain at the high elevation angles.

## **F. QUARTER-WAVELENGTH MONOPOLE WITH RADIAL WIRES**

### **1. Wires buried 2 inches deep (4, 15, and 30 wires)**

The configurations of the antenna with 4 and 15 radial wires buried 2 inches deep are in Figure 25. Figure 26 shows elevation and azimuth patterns of the 15 radial wire configuration. The shape of the radiation patterns were not effected by changing the frequency or any other antenna parameter such as the number of radials and type of ground system. The effects of these parameters are related to gain of the antenna.

The relative radiated power versus frequency (HF band) for different numbers of radial wires can be seen in Figure 27. It should be noted that higher frequencies produce more power as the number of radial wires increases.

### **2. Wires elevated $0.08 \lambda$ high (4, 15, and 30 wires)**

Figure 28 shows the configurations of the antenna with 4 and 15 radial wires elevated  $0.08 \lambda$  high. Elevation and azimuth patterns of this antenna for 15 radial wires can be seen in Figure 29.

The relative power versus frequency (HF band) for different number of elevated radial wires was plotted in Figure 30. This configuration with 4 radial wires produces more power than the same configuration with 15 and 30 radial wires. In addition, higher frequencies produce more power as the number of radial wires decreases.

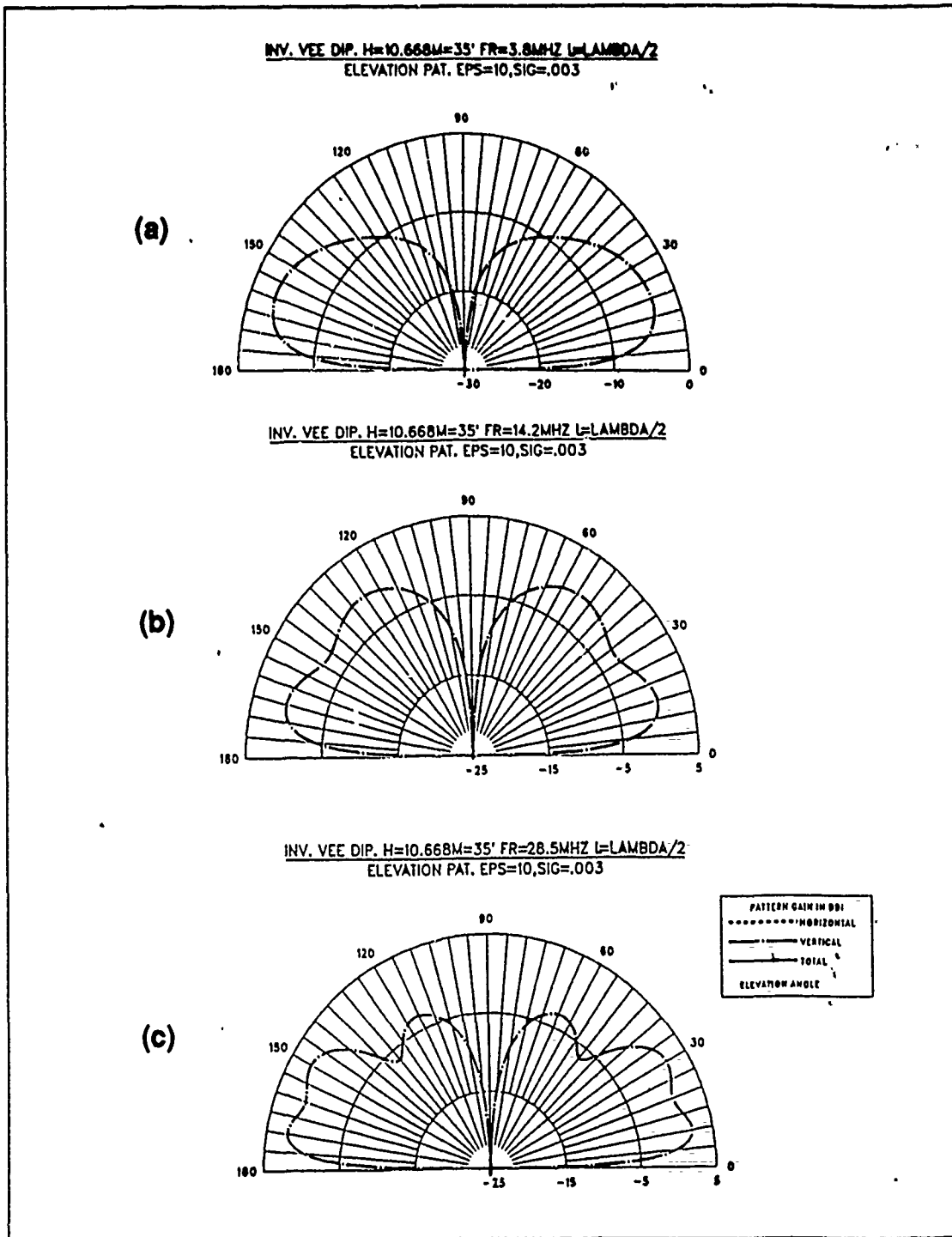

Figure 20. The elevation patterns of the 35 ft. high inv. vee dipole: (a) Fr= 3.8 MHz (b) Fr= 14.2 MHz (c) Fr= 28.5 MHz



INV. VEE DIP. H=10.668M=35' FR=3.8MHZ L=LAMBDA/2  
 AZIMUTH PAT. EPS=10, SIG=.003 THETA=45

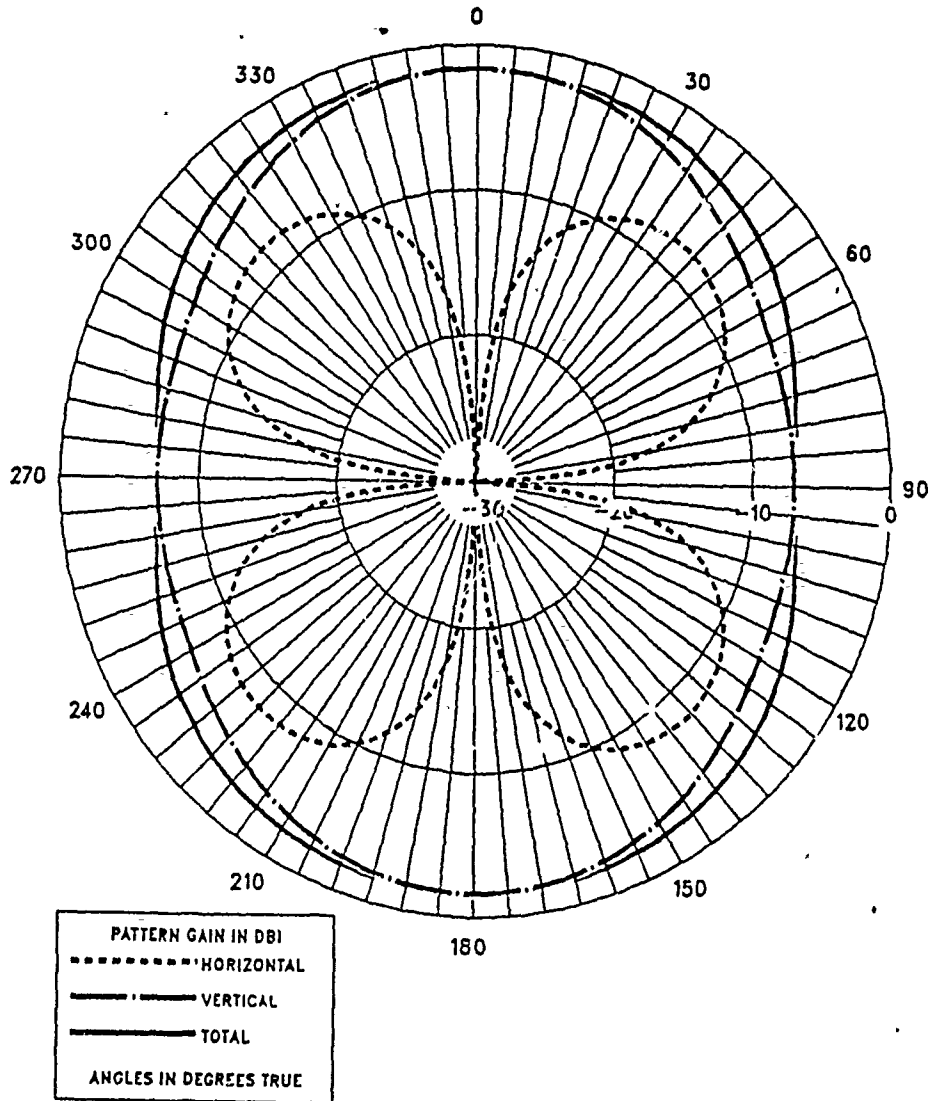

Figure 21. The azimuth pattern of the half-wavelength inverted vee dipole: Frequency is 3.8 MHz and the antenna is 35 ft high.

**QUARTER-WAVELENGTH MONOPOLE WITH A 4 FOOT GROUND ROD**

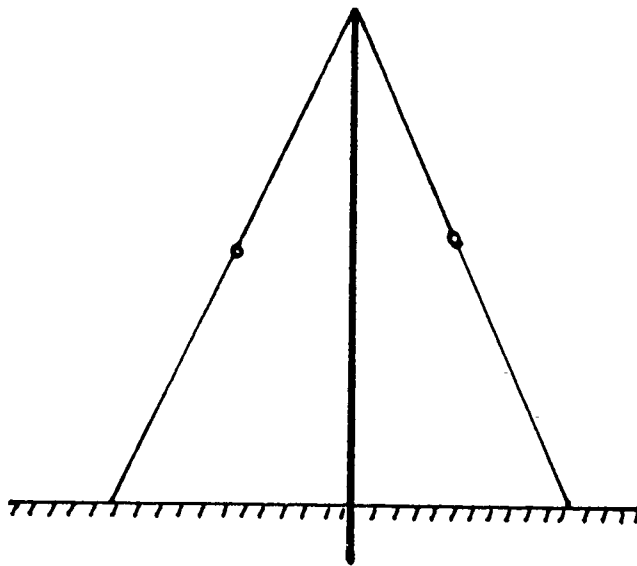

Figure 22. The quarter-wavelength monopole with a 4 ft ground rod.

QUARTER WAVELENGTH MONOPOLE WITH 4' GROUND ROD  
 ELEVATION PAT. FR=3.8MHZ

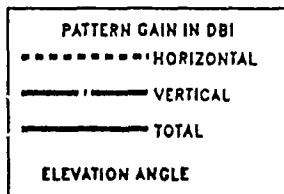
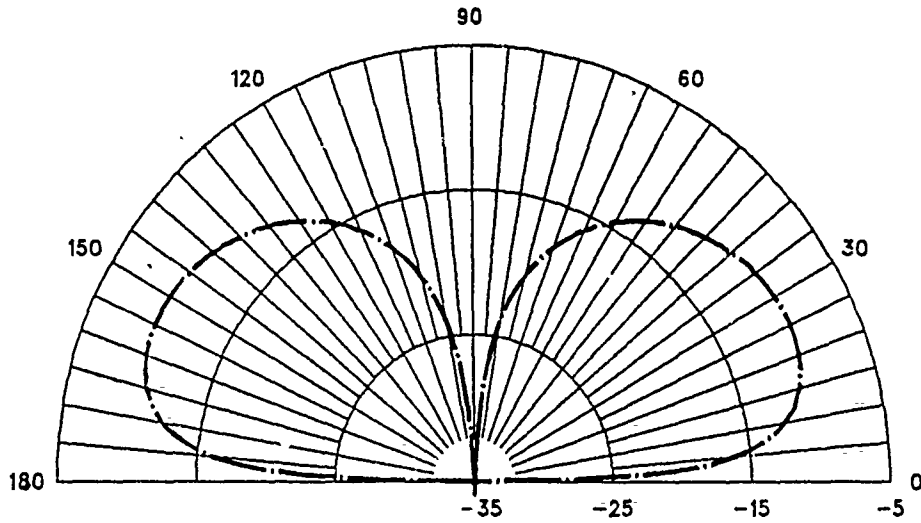

Figure 23. The elevation pattern of the quarter-wavelength monopole with a 4 ft ground rod.

QUARTER WAVELENGTH MONOPOLE WITH 4' GROUND ROD  
 AZIMUTH PAT. FR=3.8MHZ THETA=60

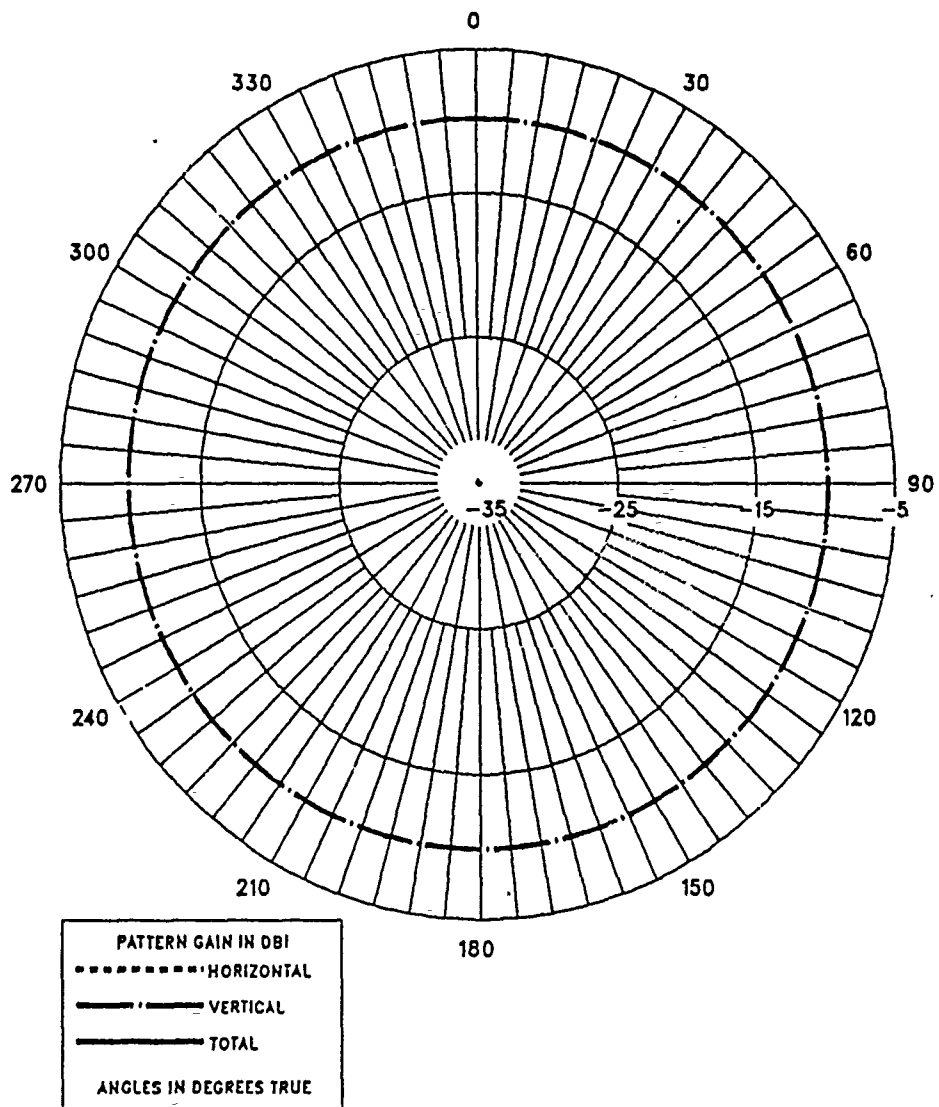
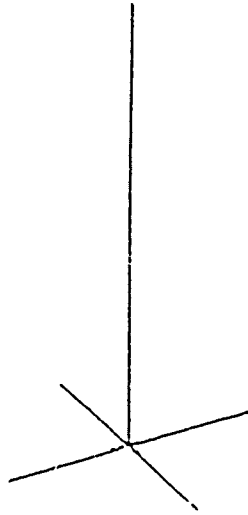

Figure 24. The azimuth pattern of the quarter-wavelength monopole with a 4 ft ground rod.

MONOPOLE WITH 4 RADIAL WIRES ( 2" BURIED )

MONOPOLE WITH 15 RADIAL WIRES ( 2" BURIED )



THETA = 60.00 PHI = 60.00 ETA = 90.00

**(a)**

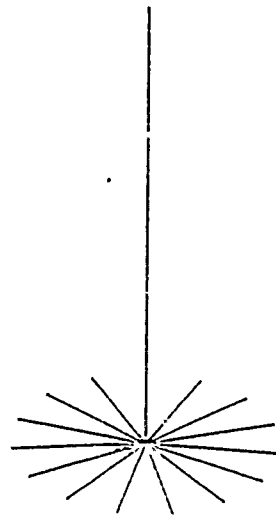

THETA = 60.00 PHI = 60.00 ETA = 90.00

**(b)**

Figure 25. The quarter-wavelength monopole with buried radial wires: (a) 4 wires  
(b) 15 wires

WL/4 MONOPOLE WITH 15 WL/4 RADIALS ( 2" BURIED ) FR=3.8MHZ  
 ELEVATION PAT. EPS=10,SIG=.003

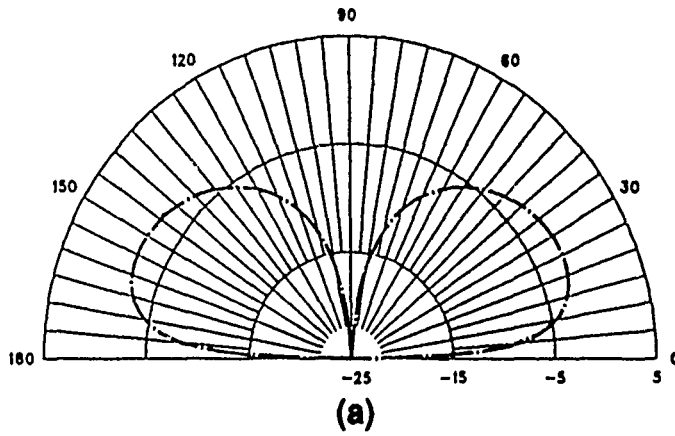

WL/4 MONOPOLE WITH 15 WL/4 RADIALS ( 2" BURIED ) FR=3.8MHZ  
 AZIMUTH PAT. EPS=10,SIG=.003 THETA=63

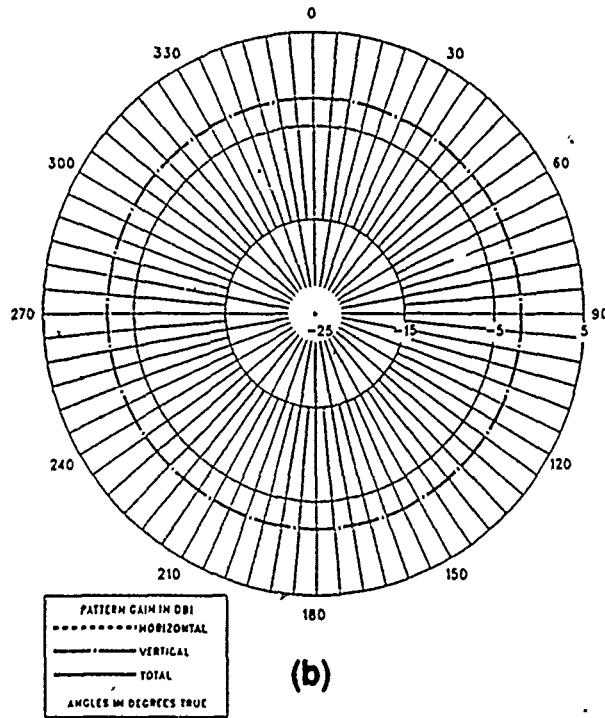

Figure 26. The radiation patterns of the monopole with buried radials: (a) Elevation pattern (b) Azimuth pattern

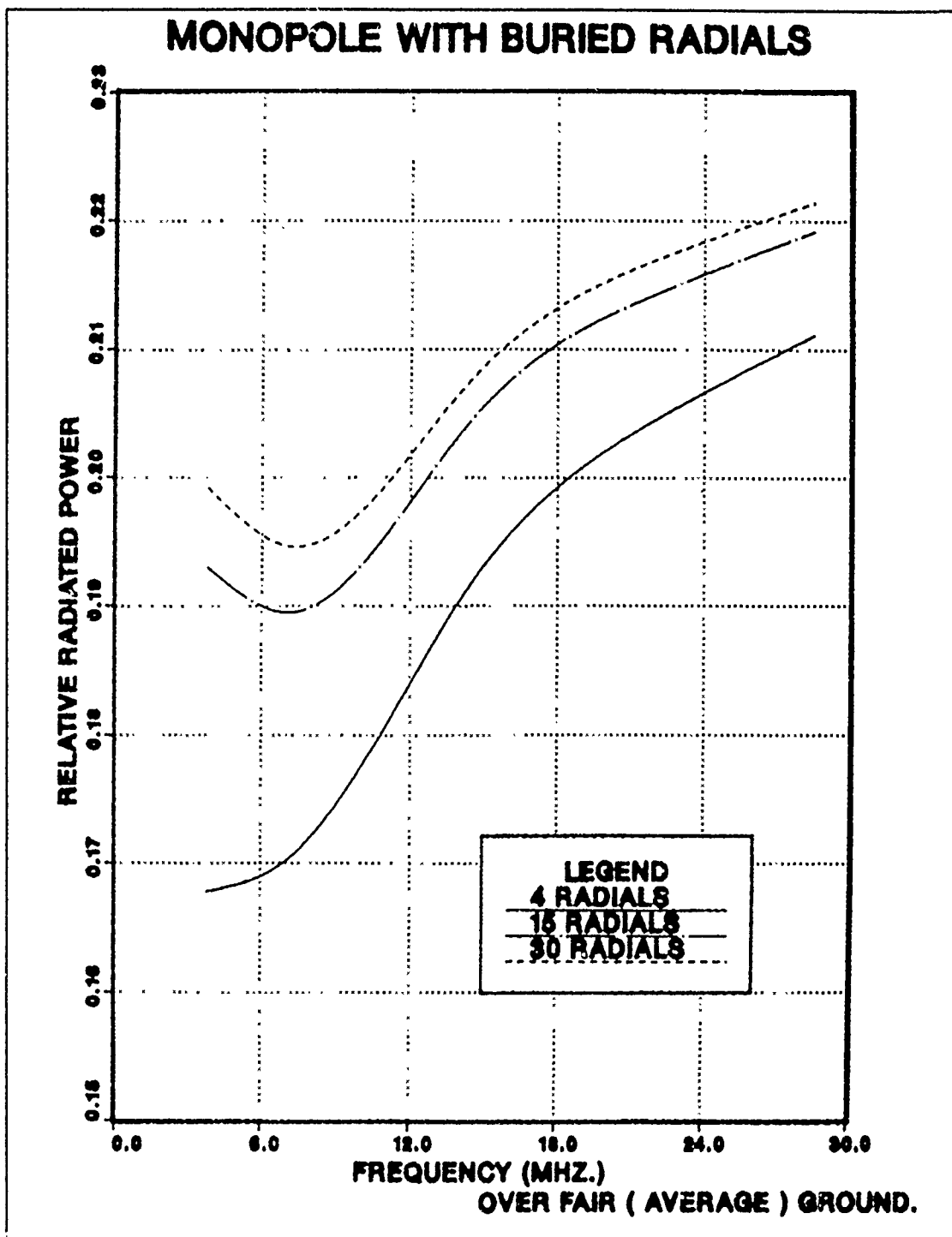
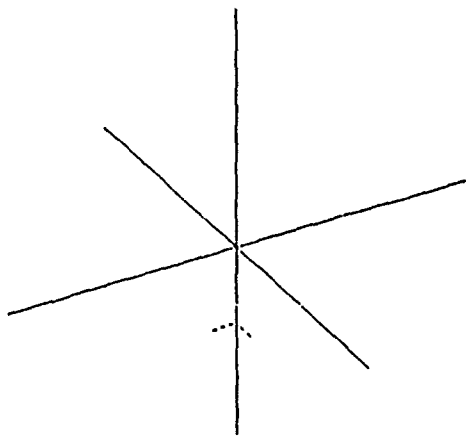

Figure 27. The performance curves of the buried radial wire system: Quarter-wavelength monopole with radial wires buried 2 inches

MONOPOLE WITH 4 RADIAL WIRES ( .08 LAMBDA ELEVATED )



MONOPOLE WITH 15 RADIALS ( .08 LAMBDA ELEVATED )

THETA = 60.00 PHI = 60.00 ETA = 90.00

(a)

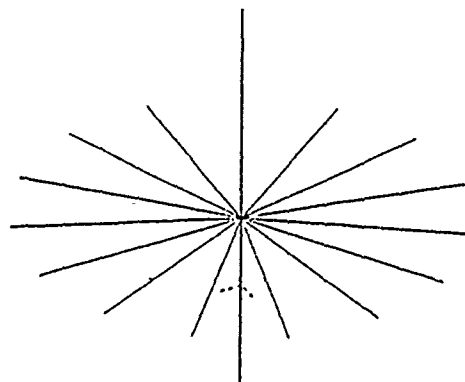

THETA = 60.00 PHI = 60.00 ETA = 90.00

(b)

Figure 28. The quarter-wavelength monopole with elevated radial wires: (a) 4 wires (b) 15 wires



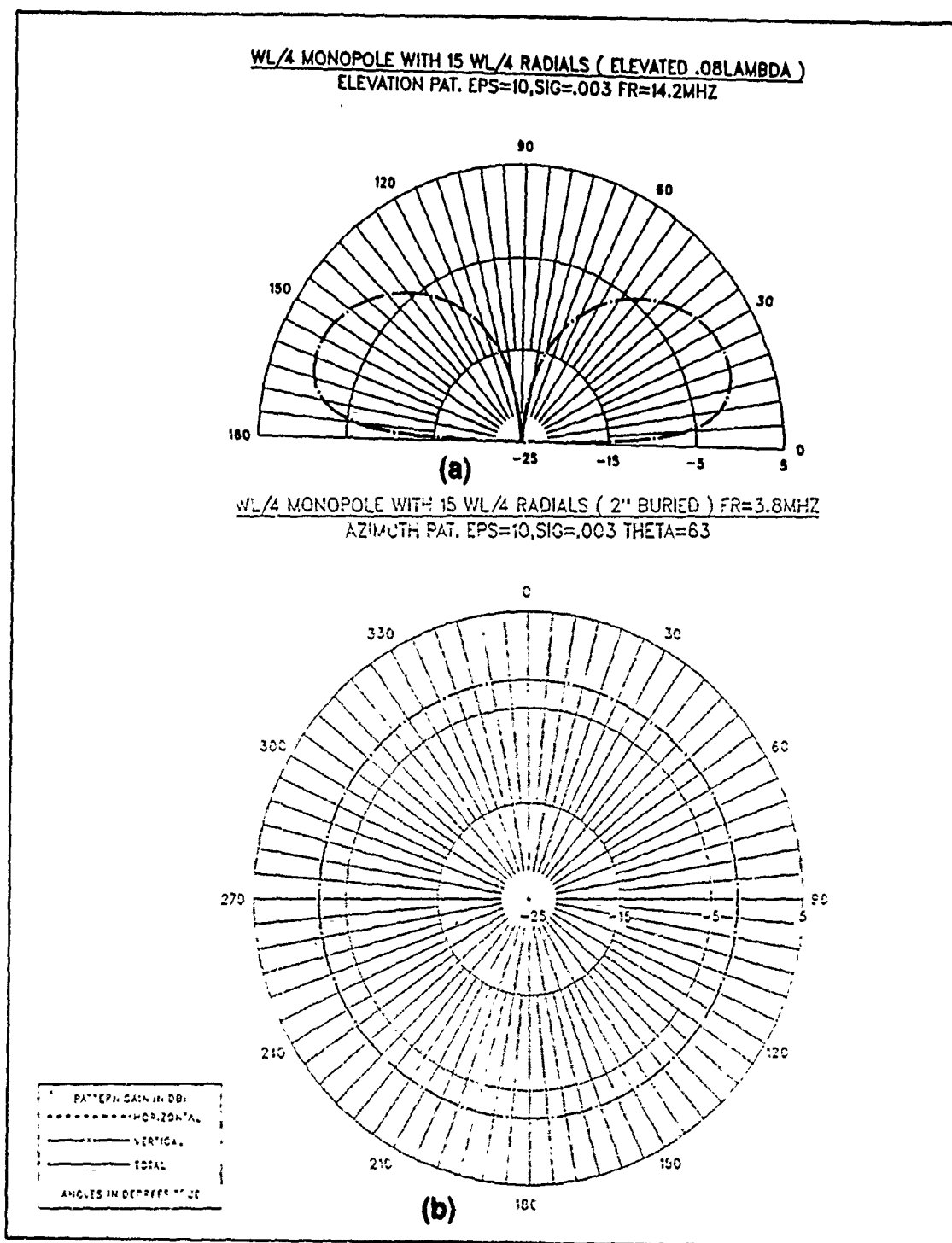

Figure 29. The radiation patterns of the monopole with elevated radials: (a) Elevation pattern (b) Azimuth pattern

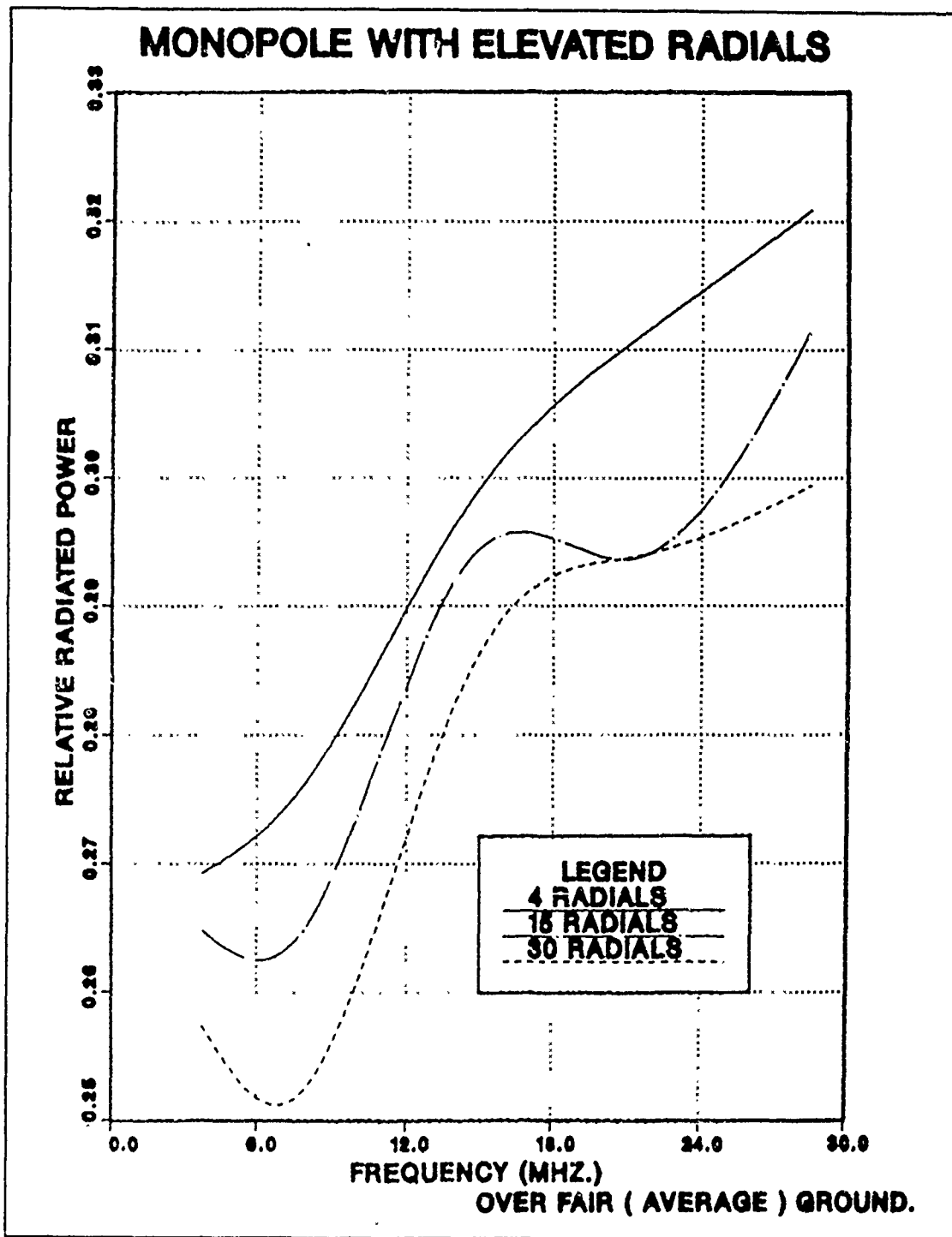

Figure 30. The performance curves of the elevated radial wire system: Quarter-wavelength monopole with radial wires elevated  $0.08 \lambda$  high

## IV. CONCLUSIONS AND RECOMMENDATIONS

### A. CONCLUSIONS

Various configurations of monopole and dipole antennas have been studied at frequencies of 3.8, 7.2, 14.2, 21.3, and 28.5 MHz over fair (average) ground. All antennas were modeled using the Numerical Electromagnetics Code (NEC) with double precision accuracy. Specific observations are :

1. Radiation patterns of a half wavelength horizontal dipole may be used as a reference for other works. This antenna is good for NVIS communications; in addition, it may provide ground wave communications.
2. The quarter wavelength sloping wire and half wavelength sloping dipole provide more directional radiation than the half wavelength horizontal dipole. Antenna parameters, such as the frequency, height of the antenna, and top angle should be chosen to produce a main lobe in the desired direction.
3. A half-wavelength inverted vee dipole produces radiation that is more directive than that of a monopole antenna and provides medium- and long-range communications. More gain can be obtained by increasing frequency rather than by increasing the height of the antenna.
4. The quarter wavelength monopole provides good ground wave communications. The skywave does not depend on ground constants as much as the ground wave does, but it has poor NVIS performance.
5. The monopole with a ground rod is less effective than with a radial wire ground system in reducing the effect of finite ground on low-angle radiation.
6. A radial wire ground system is a good ground plane for a monopole. The followings are observations of radial wire ground systems :
  - With fewer radial wires, the elevated radial wire ground system gives better results than the buried ground system (compare Figures 27 and 30).
  - The increase in radiated power for a monopole with buried radial wires when the number of wires are between 4 and 15 is more than the increase between 15 and 30 wires (Figure 27).
  - Higher frequencies show more radiated power for both buried and elevated radial wire ground systems (Figures 27 and 30).
7. The effect of imperfect ground on the radiation pattern is less severe for horizontal antennas than for vertical antennas.

### B. RECOMMENDATIONS

Additional studies are needed :

1. In this thesis, the antennas have been studied at frequencies of 3.8, 7.2, 14.2, 21.3,

and 28.5 MHz over fair ground. The work can be extended by doing more analysis at different frequencies in the HF band and over different types of ground.

2. Antenna types investigated were various configurations of monopoles and dipoles in this thesis. Other types of conventional antenna configurations shou'd also be studied.
3. New geometrical structures of wire antennas can be created and modelled based on the performance of antennas in this study.

## APPENDIX A. NPGNEC MAINFRAME (NEC-3) LIBRARY

A brief description of the programs which can be found in the NEC FORTRAN library are described below:

1. NECARY  
A version of NEC designed for use with large arrays.
2. NECGS  
A version of NEC which makes use of geometrical symmetry in order to simplify generation of monopole structures. It is quite useful for analysis of monopoles with radial wires and with top loading.
3. NPGNEC (NEC3)  
The most current and capable version of NEC available at NPS. It is suitable for wires above and beneath the interface.
4. NPSNEC (NEC2)  
A mainframe implementation of NEC2 (which is normally used on a PC).
5. PLOTDG  
A plotting program that plots the geometry created by NEC geometry data cards. It is useful for checking these cards before submitting a job for processing.
6. PLOTNF  
A program used to plot near fields in log or linear format.
7. PLOTDGLP  
A program designed for plotting the data geometry on the laser printer for thesis use.
8. PLOTDGTX  
A program used for plotting the data geometry on a TEK618 display unit.
9. PLOTDG79  
A program for plotting the data geometry on a 3279 terminal.
10. PLOTH3SD  
A program designed for plotting radiation patterns of the sky and surface waves. The input must contain horizontal, vertical, and radial components. The output is a plot of all three components plus the total in dB/V/M.
11. PLOTH3SW  
A program similar to PLOTH3SD except the output is in V/M.
12. PLOTHNAB  
This program plots surface wave data for azimuth patterns in mV/M.
13. PLOTVNAB  
This program plots sky and surface wave elevation patterns in mV/M.
14. PLOTTRPHM  
A program for plotting the horizontal, vertical, and total gain components of azimuth radiation patterns.

13. PLOTTPVM

A program like PLOTTPHM for plotting radiation patterns in the vertical plane for free space.

16. PLOTTPVE

A program like PLOTTPHM for plotting radiation patterns in the vertical plane for half space.

17. RP1MAKER

A program generating the NEC RP1 cards needed to get vertical plane surface wave data for plotting.

18. SOMNEC

A program generating the interpolation table when using the Sommerfeld/Norton method for finite ground environments. It must be run prior to NEC2 when the Sommerfeld/Norton ground option appears on a ground (GN) card; it requires epsilon, sigma, and frequency in MHz.

19. SOMNTX

A program similar to SOMNEC, but for use with NEC3.

The NEC Module library includes modules compiled from the above FORTRAN programs. RECON < filename > must be typed to get the module from the MVS library into a form that can be run on VM/CMS.

## APPENDIX B. SAMPLE SESSION OF NEC

The following steps explain the NEC session process. It would vary depending on the particular circumstances and the type of problems.

### A. LOG ON

### B. GET NECPROF RUNNING

Type NECPROF and enter.

Type ICMS and enter.

Type NECPROF and enter.

The first entry of NECPROF is to start to NEC session ; the second one is to format the disk which will be used.

### C. CREATE DATA FILE

This should be done on the B disk, but it is not necessary. To get into the B disk use PF9:PF21 key, then use XEDIT to create a data file, for example, MWRW1 DATA B1 (see Volume II). It can then be run by using the PF2 or PF14 keys, or by typing the name of the program which will be run next to the data file in the B disk file list. After the program run, the B disk file list includes the following files :

```
MWRW1 DATA      B1
FILE FT08F001    B1
MWRW1 LISTING    B1
MWRW1 PLOTDATA   B1
```

It should be noted that to get to the above display, it is necessary to exit from the old B disk file list display by using the PF3,PF15 key and then get back into it by using the PF9 PF21 key.

### D. EXECUTE THE CHOSEN PLOTTING PROGRAM

The plotting program to be used is determined by which display is needed. For example, if a horizontal azimuthal plot of the data is needed, PLOTTRPHM is used by first typing RECON PLOTTRPHM. Then, to display a horizontal azimuthal radiation pattern, PLOTTRPHM is typed next to MWRW1 PLOTDATA in the B disk file list. The result will appear either on the TEK618 display unit (if TEK618 was selected in the PLOT CMD file) or as a DISSPLA METAFILE (if COMPRS option was selected in the PLOT CMD file). If the second option was selected, the PF3 PF9 key should be used to see DISSPLA METAFILE which was just created. To send METAFILE through the

DISSPLA plotting program, DISSPOP or THESPOP should be typed next to METAFILE in the B disk file list. This will produce a plot on the IBM 3800 laser printer.

#### E. LISTING FILES

During the running of the program, a LISTING file is created. The listing shows the results of the calculations. It can be printed by typing PRINT next to the file name in the B disk file list. Normally this printout and a plot represent the output to be saved.

#### F. LOGGING OFF

Before logging off, since the B disk is temporary, the files needed or necessary should be saved by sending them to the A disk. This is done by typing the CA next to a filename in the B disk file list. To work with this file again, it can be sent to the B disk by typing CB next to the filename in the A disk file list. After the necessary files have been saved, the session will be terminated by typing LOG. It is possible to get back to the ICMS without logging off.



## LIST OF REFERENCES

1. Stutzman, W. L., Thiele, G. A., *Antenna Theory and Design*, by John Wiley & Sons, Inc., 1981.
2. Oney, C. *Tactical HF Field Expedient Antenna Performance*, MSEE Thesis, Naval Postgraduate School, Monterey, CA, December 1989.
3. Logan, J.C., Rockway, J.W., Naval Ocean Systems Document 938, *The New MININEC (Version 3): A Mini-Numerical Electromagnetics Code*, September 1986.
4. Logan, J.C., Strauch, J., Naval Ocean Systems Document 1326, *GRAPS User's Guide*, October 1988.
5. Burke, G.J., Poggio, A.J., *Numerical Electromagnetics Code (NEC) - Method of Moments*, NEC Ver.2, Part III: User's Guide, Lawrence Livermore National Laboratory, January 1981.
6. Unisys Corporation, *User's Guide For The IGUANA For Version 5.4*, Prepared for the Naval Ocean Systems Center, 30 September 1988.
7. Naval Ocean Systems Center Technical Document 116, Volume 2, *Numerical Electromagnetics Code ( NEC ) Method of Moments*, January 1981.

## INITIAL DISTRIBUTION LIST

	No. Copies
1. Library, Code 0142 Naval Postgraduate School Monterey, CA 93943-5002	2
2. Chairman, Code EC Department of Electrical and Computer Engineering Naval Postgraduate School Monterey, CA 93943-5000	1
3. Director, Research Administration, Code 012 Naval Postgraduate School Monterey, CA 93943-5000	1
4. Naval Postgraduate School Dr. Richard W. Adler, Code EC/Ab Monterey, CA 93943-5000	5
5. Naval Postgraduate School Prof. S. Jauregui, Code EC/Ja Monterey, CA 93943-5000	1
6. Penn State University ATTN: J. K. Breakall, CSSL 211 EE East University Park, PA 16802	5
7. U.S. Army Information Systems Engineering and Integration Center ATTN: Commander (Janet McDonald, ASB-SET-P) Ft. Huachuca, AZ 85613-5300	5
8. Gnkur. Bsk. ligi Muhabere Bilgi Destek Daire Bsk. ligi Bakanliklar - ANKARA - TURKEY	1
9. Kara Kuvvetleri Komutanligi Muhabere Bsk. ligi Bakanliklar - ANKARA - TURKEY	1
10. Deniz Kuvvetleri Komutanligi Muhabere Bsk. ligi Bakanliklar - ANKARA - TURKEY	1
11. Hava Kuvvetleri Komutanligi Muhabere Bsk. ligi Bakanliklar - ANKARA - TURKEY	1

12. Golcuk Tersane Komutanligi 1  
AR-GE  
Golcuk - KOCAELI - TURKEY
13. Kara Harp Okulu Komutanligi 1  
Okul Kutuphanesi  
Bakanliklar - ANKARA - TURKEY
14. Deniz Harp Okulu Komutanligi 1  
Okul Kutuphanesi  
Tuzla - ISTANBUL - TURKEY
15. Hava Harp Okulu Komutanligi 1  
Okul Kutuphanesi  
Yesilyurt - ISTANBUL - TURKEY
16. Mu.Ok. ve Egt. Mrk. K. ligi 1  
Muhabere Okulu  
Mamak - ANKARA - TURKEY
17. Orta Dogu Teknik Universitesi 1  
Okul Kutuphanesi  
ANKARA - TURKEY
18. Bogazici Universitesi 1  
Okul Kutuphanesi  
ISTANBUL - TURKEY
19. Nedim KATAL 1  
Kuyubasi sok. Cimen Apt. No:13  
Kiziltoprak - ISTANBUL - TURKEY
20. Gurkan TURKES 1  
Dz. Kd. Utgm.  
Denizalti Filosu K.ligi - Golcuk - KOCAELI - TURKEY
21. Defense Technical Information Center 2  
Cameron Station  
Alexandria, Virginia 22304-6145

RPO,1,121,1500,20,0.0,0,3,0  
RPO,1,121,1500,10,0.0,0,3,0  
RPO,1,121,1500,0,0.0,0,3,0  
EN

CM GEOMETRY : QUARTER WAVELENGTH MONOPOLE  
CM WITH QUARTER WAVELENGTH 30 RADIAL WIRES  
CM BURIED 2" = .0508M DEEP  
CM FREQUENCY : 3.8MHZ  
CM WAVELENGTH (FOR SKY WAVES) = 78.9473M  
CM WAVELENGTH (FOR GROUND WAVES) = 18.939M  
CM WIRE : #12 ( RADIUS R=.010265M )  
CM GROUND(0) : EPSILON = 10 SIGMA=.003  
CE  
GW 2,1, 0,0,0, 1.5773,0,-.0508, .010265  
GW 3,2, 1.5773,0,-.0508, 4.7337,0,-.0508, .010265  
GR 0,30  
GW 1,10, 0,0,0, 0,0,19.7368, .010265  
GE 0  
FR 0,0,0,0,3.8  
GN 2,0,0,0,10,.003  
EX 0,1,1,01,1,0  
PL3,2,1,0  
RP1,1,121,0,7.62,0.0,0,3,1609.3  
PL3,2,2,0  
RP1,1,121,0,7.62,0.0,0,3,1609.3  
PLO,0,0,0  
RPO,1,121,1500,80,0.0,0,3,0  
RPO,1,121,1500,70,0.0,0,3,0  
RPO,1,121,1500,60,0.0,0,3,0  
RPO,1,121,1500,50,0.0,0,3,0  
RPO,1,121,1500,40,0.0,0,3,0  
RPO,1,121,1500,30,0.0,0,3,0  
RPO,1,121,1500,20,0.0,0,3,0  
RPO,1,121,1500,10,0.0,0,3,0  
RPO,1,121,1500,0,0.0,0,3,0  
EN

CM GEOMETRY : QUARTER WAVELENGTH MONOPOLE  
CM WITH QUARTER WAVELENGTH 4 RADIAL WIRES  
CM BURIED 2" = .0508M DEEP  
CM FREQUENCY : 7.2MHZ  
CM WAVELENGTH (FOR SKY WAVES) = 41.66M  
CM WAVELENGTH (FOR GROUND WAVES) = 11.785M  
CM WIRE : #12 ( RADIUS R=.010265M )  
CM GROUND(0) : EPSILON = 10 SIGMA=.003  
CE  
GW 2,1, 0,0,0, .2902,0,-.0508, .010265  
GW 3,9, .2902,0,-.0508, 2.94178,0,-.0508, .010265  
GR 0,4  
GW 1,10, 0,0,0, 0,0,10.4166, .010265  
GE 0  
FR 0,0,0,0,7.2  
GN 2,0,0,0,10,.003  
EX 0,1,1,01,1,0

PL3,2,1,0  
 RP1,1,121,0,7.62,0.0,0,3,1609.3  
 PL3,2,2,0  
 RP1,1,121,0,7.62,0.0,0,3,1609.3  
 PLO,0,0,0  
 RPO,1,121,1500,80,0.0,0,3,0  
 RPO,1,121,1500,70,0.0,0,3,0  
 RPO,1,121,1500,60,0.0,0,3,0  
 RPO,1,121,1500,50,0.0,0,3,0  
 RPO,1,121,1500,40,0.0,0,3,0  
 RPO,1,121,1500,30,0.0,0,3,0  
 RPO,1,121,1500,20,0.0,0,3,0  
 RPO,1,121,1500,10,0.0,0,3,0  
 RPO,1,121,1500,0,0.0,0,3,0  
 EN

CM GEOMETRY : QUARTER WAVELENGTH MONOPOLE  
 CM WITH QUARTER WAVELENGTH 15 RADIAL WIRES  
 CM BURIED 2" = .0508M DEEP  
 CM FREQUENCY : 7.2MHZ  
 CM WAVELENGTH (FOR SKY WAVES) = 41.66M  
 CM WAVELENGTH (FOR GROUND WAVES) = 11.785M  
 CM WIRE : #12 ( RADIUS R=.010265M )  
 CM GROUND(0) : EPSILON = 10 SIGMA=.003  
 CE  
 GW 2,1, 0,0,0, .2902,0,-.0508, .010265  
 GW 3,3, .2902,0,-.0508, 2.94178,0,-.0508, .010265  
 GR 0,15  
 GW 1,10, 0,0,0, 0,0,10.4166, .010265  
 GE 0  
 FR 0,0,0,0,7.2  
 GN 2,0,0,0,10,.003  
 EX 0,1,1,01,1,0

PL3,2,1,0  
 RP1,1,121,0,7.62,0.0,0,3,1609.3  
 PL3,2,2,0  
 RP1,1,121,0,7.62,0.0,0,3,1609.3  
 PLO,0,0,0  
 RPO,1,121,1500,80,0.0,0,3,0  
 RPO,1,121,1500,70,0.0,0,3,0  
 RPO,1,121,1500,60,0.0,0,3,0  
 RPO,1,121,1500,50,0.0,0,3,0  
 RPO,1,121,1500,40,0.0,0,3,0  
 RPO,1,121,1500,30,0.0,0,3,0  
 RPO,1,121,1500,20,0.0,0,3,0  
 RPO,1,121,1500,10,0.0,0,3,0  
 RPO,1,121,1500,0,0.0,0,3,0  
 EN

CM GEOMETRY : QUARTER WAVELENGTH MONOPOLE  
 CM WITH QUARTER WAVELENGTH 30 RADIAL WIRES  
 CM BURIED 2" = .0508M DEEP  
 CM FREQUENCY : 7.2MHZ  
 CM WAVELENGTH (FOR SKY WAVES) = 41.66M  
 CM WAVELENGTH (FOR GROUND WAVES) = 11.785M

CM WIRE : #12 ( RADIUS R=.010265M )  
 CM GROUND(0) : EPSILON = 10 SIGMA=.003  
 CE  
 GW 2,1, 0,0,0, .2902,0,-.0508, .010265  
 GW 3,3, .2902,0,-.0508, 2.94178,0,-.0508, .010265  
 GR 0,30  
 GW 1,10, 0,0,0, 0,0,10.4166, .010265  
 GE 0  
 FR 0,0,0,0,7.2  
 GN 2,0,0,0,10,.003  
 EX 0,1,1,01,1,0  
 PL3,2,1,0  
 RP1,1,121,0,7.62,0.0,0,3,1609.3  
 PL3,2,2,0  
 RP1,1,121,0,7.62,0.0,0,3,1609.3  
 PLO,0,0,0  
 RPO,1,121,1500,80,0.0,0,3,0  
 RPO,1,121,1500,70,0.0,0,3,0  
 RPO,1,121,1500,60,0.0,0,3,0  
 RPO,1,121,1500,50,0.0,0,3,0  
 RPO,1,121,1500,40,0.0,0,3,0  
 RPO,1,121,1500,30,0.0,0,3,0  
 RPO,1,121,1500,20,0.0,0,3,0  
 RPO,1,121,1500,10,0.0,0,3,0  
 RPO,1,121,1500,0,0.0,0,3,0  
 EN

CM GEOMETRY : QUARTER WAVELENGTH MONOPOLE  
 CM WITH QUARTER WAVELENGTH 4 RADIAL WIRES  
 CM BURIED 2" =.0508M DEEP  
 CM FREQUENCY : 14.2MHZ  
 CM WAVELENGTH (FOR SKY WAVES) = 21.167M  
 CM WAVELENGTH (FOR GROUND WAVES) = 6.459M  
 CM WIRE : #12 ( RADIUS R=.010265M )  
 CM GROUND(0) : EPSILON = 10 SIGMA=.003  
 CE  
 GW 2,1, 0,0,0, .1533,0,-.0508, .010265  
 GW 3,9, .1533,0,-.0508, 1.60653,0,-.0508, .010265  
 GR 0,4  
 GW 1,10, 0,0,0, 0,0,5.2816, .010265  
 GE 0  
 FR 0,0,0,0,14.2  
 GN 2,0,0,0,10,.003  
 EX 0,1,1,01,1,0  
 PL3,2,1,0  
 RP1,1,121,0,7.62,0.0,0,3,1609.3  
 PL3,2,2,0  
 RP1,1,121,0,7.62,0.0,0,3,1609.3  
 PLO,0,0,0  
 RPO,1,121,1500,80,0.0,0,3,0  
 RPO,1,121,1500,70,0.0,0,3,0  
 RPO,1,121,1500,60,0.0,0,3,0  
 RPO,1,121,1500,50,0.0,0,3,0  
 RPO,1,121,1500,40,0.0,0,3,0  
 RPO,1,121,1500,30,0.0,0,3,0  
 RPO,1,121,1500,20,0.0,0,3,0

RP0,1,121,1500,10,0.0,0,3,0  
RP0,1,121,1500,0,0.0,0,3,0  
EN

CM GEOMETRY : QUARTER WAVELENGTH MONOPOLE  
CM WITH QUARTER WAVELENGTH 15 RADIAL WIRES  
CM BURIED 2" = .0508M DEEP  
CM FREQUENCY : 14.2MHZ  
CM WAVELENGTH (FOR SKY WAVES) = 21.1267M  
CM WAVELENGTH (FOR GROUND WAVES) = 6.459M  
CM WIRE : #12 ( RADIUS R=.010265M )  
CM GROUND(0) : EPSILON = 10 SIGMA=.003  
CE  
GW 2,1, 0,0,0, .3183,0,-.0508, .010265  
GW 3,4, .3183,0,-.0508, 1.6107,0,-.0508, .010265  
GR 0,15  
GW 1,5, 0,0,0, 0,0,5.2816, .010265  
GE 0  
FR 0,0,0,0,14.2  
GN 2,0,0,0,10,.003  
EX 0,1,1,01,1,0  
PL3,2,1,0  
RP1,1,121,0,7.62,0.0,0,3,1609.3  
PL3,2,2,0  
RP1,1,121,0,7.62,0.0,0,3,1609.3  
PL0,0,0,0  
RP0,1,121,1500,80,0.0,0,3,0  
RP0,1,121,1500,70,0.0,0,3,0  
RP0,1,121,1500,60,0.0,0,3,0  
RP0,1,121,1500,50,0.0,0,3,0  
RP0,1,121,1500,40,0.0,0,3,0  
RP0,1,121,1500,30,0.0,0,3,0  
RP0,1,121,1500,20,0.0,0,3,0  
RP0,1,121,1500,10,0.0,0,3,0  
RP0,1,121,1500,0,0.0,0,3,0  
EN

CM GEOMETRY : QUARTER WAVELENGTH MONOPOLE  
CM WITH QUARTER WAVELENGTH 30 RADIAL WIRES  
CM BURIED 2" = .0508M DEEP  
CM FREQUENCY : 14.2MHZ  
CM WAVELENGTH (FOR SKY WAVES) = 21.1267M  
CM WAVELENGTH (FOR GROUND WAVES) = 6.459M  
CM WIRE : #12 ( RADIUS R=.010265M )  
CM GROUND(0) : EPSILON = 10 SIGMA=.003  
CE  
GW 2,1, 0,0,0, .3183,0,-.0508, .010265  
GW 3,4, .3183,0,-.0508, 1.6107,0,-.0508, .010265  
GR 0,30  
GW 1,5, 0,0,0, 0,0,5.2816, .010265  
GE 0  
FR 0,0,0,0,14.2  
GN 2,0,0,0,10,.003  
EX 0,1,1,01,1,0  
PL3,2,1,0

RP1,1,121,0,7.62,0.0,0,3,1609.3  
 PL3,2,2,0  
 RP1,1,121,0,7.62,0.0,0,3,1609.3  
 PLO,0,0,0  
 RPO,1,121,1500,80,0.0,0,3,0  
 RPO,1,121,1500,70,0.0,0,3,0  
 RPO,1,121,1500,60,0.0,0,3,0  
 RPO,1,121,1500,50,0.0,0,3,0  
 RPO,1,121,1500,40,0.0,0,3,0  
 RPO,1,121,1500,30,0.0,0,3,0  
 RPO,1,121,1500,20,0.0,0,3,0  
 RPO,1,121,1500,10,0.0,0,3,0  
 RPO,1,121,1500,0,0.0,0,3,0  
 EN

CM GEOMETRY : QUARTER WAVELENGTH MONOPOLE  
 CM WITH QUARTER WAVELENGTH 4 RADIAL WIRES  
 CM BURIED 2" = .0508M DEEP  
 CM FREQUENCY : 21.3MHZ  
 CM WAVELENGTH (FOR SKY WAVES) = 14.0845M  
 CM WAVELENGTH (FOR GROUND WAVES) = 4.385M  
 CM WIRE : #12 ( RADIUS R=.010265M )  
 CM GROUND(0) : EPSILON = 10 SIGMA=.003  
 CE  
 GW 2,1, 0,0,0, .097138,0,-.0508, .010265  
 GW 3,9, .097138,0,-.0508, 1.083718,0,-.0508, .010265  
 GR 0,4  
 GW 1,10, 0,0,0, 0,0,3.5211, .010265  
 GE 0  
 FR 0,0,0,0,21.3  
 GN 2,0,0,0,10,.003  
 EX 0,1,1,01,1,0  
 PL3,2,1,0  
 RP1,1,121,0,7.62,0.0,0,3,1609.3  
 PL3,2,2,0  
 RP1,1,121,0,7.62,0.0,0,3,1609.3  
 PLO,0,0,0  
 RPO,1,121,1500,80,0.0,0,3,0  
 RPO,1,121,1500,70,0.0,0,3,0  
 RPO,1,121,1500,60,0.0,0,3,0  
 RPO,1,121,1500,50,0.0,0,3,0  
 RPO,1,121,1500,40,0.0,0,3,0  
 RPO,1,121,1500,30,0.0,0,3,0  
 RPO,1,121,1500,20,0.0,0,3,0  
 RPO,1,121,1500,10,0.0,0,3,0  
 RPO,1,121,1500,0,0.0,0,3,0  
 EN

CM GEOMETRY : QUARTER WAVELENGTH MONOPOLE  
 CM WITH QUARTER WAVELENGTH 15 RADIAL WIRES  
 CM BURIED 2" = .0508M DEEP  
 CM FREQUENCY : 21.3MHZ  
 CM WAVELENGTH (FOR SKY WAVES) = 14.0845M  
 CM WAVELENGTH (FOR GROUND WAVES) = 4.385M  
 CM WIRE : #12 ( RADIUS R=.010265M )



CM GROUND(0) : EPSILON = 10      SIGMA=.003  
 CE  
 GW 2,1, 0,0,0, .2694,0,-.0508, .010265  
 GW 3,3, .2694,0,-.0508, 1.0915,0,-.0508, .010265  
 GR 0,15  
 GW 1,10, 0,0,0, 0,0,3.5211, .010265  
 GE 0  
 FR 0,0,0,0,21.3  
 GN 2,0,0,0,10,.003  
 EX 0,1,1,01,1,0  
 PL3,2,1,0  
 RP1,1,121,0,7.62,0.0,0,3,1609.3  
 PL3,2,2,0  
 RP1,1,121,0,7.62,0.0,0,3,1609.3  
 PLO,0,0,0  
 RPO,1,121,1500,80,0.0,0,3,0  
 RPO,1,121,1500,70,0.0,0,3,0  
 RPO,1,121,1500,60,0.0,0,3,0  
 RPO,1,121,1500,50,0.0,0,3,0  
 RPO,1,121,1500,40,0.0,0,3,0  
 RPO,1,121,1500,30,0.0,0,3,0  
 RPO,1,121,1500,20,0.0,0,3,0  
 RPO,1,121,1500,10,0.0,0,3,0  
 RPO,1,121,1500,0,0.0,0,3,0  
 EN

CM GEOMETRY : QUARTER WAVELENGTH MONOPOLE  
 CM            WITH QUARTER WAVELENGTH 30 RADIAL WIRES  
 CM            BURIED 2" =.0508M DEEP  
 CM FREQUENCY : 21.3MHZ  
 CM            WAVELENGTH (FOR SKY WAVES)      = 14.0845M  
 CM            WAVELENGTH (FOR GROUND WAVES) = 4.385M  
 CM WIRE       : #12 ( RADIUS R=.010265M )  
 CM GROUND(0) : EPSILON = 10      SIGMA=.003  
 CE  
 GW 2,1, 0,0,0, .2694,0,-.0508, .010265  
 GW 3,3, .2694,0,-.0508, 1.0915,0,-.0508, .010265  
 GR 0,30  
 GW 1,10, 0,0,0, 0,0,3.5211, .010265  
 GE 0  
 FR 0,0,0,0,21.3  
 GN 2,0,0,0,10,.003  
 EX 0,1,1,01,1,0  
 PL3,2,1,0  
 RP1,1,121,0,7.62,0.0,0,3,1609.3  
 PL3,2,2,0  
 RP1,1,121,0,7.62,0.0,0,3,1609.3  
 PLO,0,0,0  
 RPO,1,121,1500,80,0.0,0,3,0  
 RPO,1,121,1500,70,0.0,0,3,0  
 RPO,1,121,1500,60,0.0,0,3,0  
 RPO,1,121,1500,50,0.0,0,3,0  
 RPO,1,121,1500,40,0.0,0,3,0  
 RPO,1,121,1500,30,0.0,0,3,0  
 RPO,1,121,1500,20,0.0,0,3,0  
 RPO,1,121,1500,10,0.0,0,3,0

RPO,1,121,1500,0,0,0,3,0  
EN

CM GEOMETRY : QUARTER WAVELENGTH MONOPOLE  
CM WITH QUARTER WAVELENGTH 4 RADIAL WIRES  
CM BURIED 2" =.0508M DEEP  
CM FREQUENCY : 28.5MHZ  
CM WAVELENGTH (FOR SKY WAVES) = 10.5263M  
CM WAVELENGTH (FOR GROUND WAVES) = 3.299M  
CM WIRE : #12 ( RADIUS R=.010265M )  
CM GROUND(0) : EPSILON = 10 SIGMA=.003  
CE  
GW 2,1, 0,0,0, .06496,0,-.0508, .010265  
GW 3,9, .06496,0,-.0508, .80719,0,-.0508, .010265  
GR 0,4  
GW 1,10, 0,0,0, 0,0,2.6315, .010265  
GE 0  
FR 0,0,0,0,28.5  
GN 2,0,0,0,10,.003  
EX 0,1,1,01,1,0  
PL3,2,1,0  
RP1,1,121,0,7.62,0.0,0,3,1609.3  
PL3,2,2,0  
RP1,1,121,0,7.62,0.0,0,3,1609.3  
PLO,0,0,0  
RPO,1,121,1500,80,0.0,0,3,0  
RPO,1,121,1500,70,0.0,0,3,0  
RPO,1,121,1500,60,0.0,0,3,0  
RPO,1,121,1500,50,0.0,0,3,0  
RPO,1,121,1500,40,0.0,0,3,0  
RPO,1,121,1500,30,0.0,0,3,0  
RPO,1,121,1500,20,0.0,0,3,0  
RPO,1,121,1500,10,0.0,0,3,0  
RPO,1,121,1500,0,0.0,0,3,0  
EN

CM GEOMETRY : QUARTER WAVELENGTH MONOPOLE  
CM WITH QUARTER WAVELENGTH 15 RADIAL WIRES  
CM BURIED 2" =.0508M DEEP  
CM FREQUENCY : 28.5MHZ  
CM WAVELENGTH (FOR SKY WAVES) = 10.5263M  
CM WAVELENGTH (FOR GROUND WAVES) = 3.299M  
CM WIRE : #12 ( RADIUS R=.010265M )  
CM GROUND(0) : EPSILON = 10 SIGMA=.003  
CE  
GW 2,1, 0,0,0, .1998,0,-.0508, .010265  
GW 3,3, .1998,0,-.0508, .8183,0,-.0508, .010265  
GR 0,15  
GW 1,10, 0,0,0, 0,0,2.6315, .010265  
GE 0  
FR 0,0,0,0,28.5  
GN 2,0,0,0,10,.003  
EX 0,1,1,01,1,0  
PL3,2,1,0  
RP1,1,121,0,7.62,0.0,0,3,1609.3

PL3,2,2,0  
 RP1,1,121,0,7.62,0.0,0,3,1609.3  
 PL0,0,0,0  
 RPO,1,121,1500,80,0.0,0,3,0  
 RPO,1,121,1500,70,0.0,0,3,0  
 RPO,1,121,1500,60,0.0,0,3,0  
 RPO,1,121,1500,50,0.0,0,3,0  
 RPO,1,121,1500,40,0.0,0,3,0  
 RPO,1,121,1500,30,0.0,0,3,0  
 RPO,1,121,1500,20,0.0,0,3,0  
 RPO,1,121,1500,10,0.0,0,3,0  
 RPO,1,121,1500,0,0.0,0,3,0  
 EN

CM GEOMETRY : QUARTER WAVELENGTH MONOPOLE  
 CM WITH QUARTER WAVELENGTH 30 RADIAL WIRES  
 CM BURIED 2" =.0508M DEEP  
 CM FREQUENCY : 28.5MHZ  
 CM WAVELENGTH (FOR SKY WAVES) = 10.5263M  
 CM WAVELENGTH (FOR GROUND WAVES) = 3.299M  
 CM WIRE : #12 ( RADIUS R=.010265M )  
 CM GROUND(0) : EPSILON = 10 SIGMA=.003  
 CE

GW 2,1, 0,0,0, .1998,0,-.0508, .010265  
 GW 3,3, .1998,0,-.0508, .8183,0,-.0508, .010265  
 GR 0,30  
 GW 1,10, 0,0,0, 0,0,2.6315, .010265  
 GE 0  
 FR 0,0,0,0,28.5  
 GN 2,0,0,0,10,.003  
 EX 0,1,1,01,1,0  
 PL3,2,1,0  
 RP1,1,121,0,7.62,0.0,0,3,1609.3  
 PL3,2,2,0  
 RP1,1,121,0,7.62,0.0,0,3,1609.3  
 PL0,0,0,0  
 RPO,1,121,1500,80,0.0,0,3,0  
 RPO,1,121,1500,70,0.0,0,3,0  
 RPO,1,121,1500,60,0.0,0,3,0  
 RPO,1,121,1500,50,0.0,0,3,0  
 RPO,1,121,1500,40,0.0,0,3,0  
 RPO,1,121,1500,30,0.0,0,3,0  
 RPO,1,121,1500,20,0.0,0,3,0  
 RPO,1,121,1500,10,0.0,0,3,0  
 RPO,1,121,1500,0,0.0,0,3,0  
 EN

CM GEOMETRY : QUARTER WAVELENGTH MONOPOLE  
 CM WITH QUARTER WAVELENGTH 4 RADIAL WIRES  
 CM ELEVATED .08LAMBDA=6.3158M  
 CM FREQUENCY : 3.8MHZ  
 CM WAVELENGTH (FOR SKY WAVES) = 78.9473M  
 CM WAVELENGTH (FOR GROUND WAVES) = 18.939M  
 CM WIRE : #12 ( RADIUS R=.010265M )  
 CM GROUND(0) : EPSILON = 10 SIGMA=.003

CE  
 GW 1,10, 0,0,6.3158, 19.7368,0,6.3158, .010265  
 GR 0,4  
 GW 2,10, 0,0,6.3158, 0,0,26.0526, .010265  
 GW 3,1, 0,0,6.3058, 0,0,0, .010265  
 GW 4,1, 0,0,0, 0,0,-1.2192, .010265  
 GE 0  
 FR 0,0,0,0,3.8  
 GN 2,0,0,0,10,.003  
 EX 0,2,1,01,1,0  
 PL3,2,1,0  
 RP1,1,121,0,7.62,0.0,0,3,1609.3  
 PL3,2,2,0  
 RP1,1,121,0,7.62,0.0,0,3,1609.3  
 PL0,0,0,0  
 RP0,1,121,1500,80,0.0,0,3,0  
 RP0,1,121,1500,70,0.0,0,3,0  
 RP0,1,121,1500,60,0.0,0,3,0  
 RP0,1,121,1500,50,0.0,0,3,0  
 RP0,1,121,1500,40,0.0,0,3,0  
 RP0,1,121,1500,30,0.0,0,3,0  
 RP0,1,121,1500,20,0.0,0,3,0  
 RP0,1,121,1500,10,0.0,0,3,0  
 RP0,1,121,1500,0,0.0,0,3,0  
 EN

CM GEOMETRY : QUARTER WAVELENGTH MONOPOLE  
 CM WITH QUARTER WAVELENGTH 15 RADIAL WIRES  
 CM ELEVATED .08LAMBDA=6.3158M  
 CM FREQUENCY : 3.8MHZ  
 CM WAVELENGTH (FOR SKY WAVES) = 78.9473M  
 CM WAVELENGTH (FOR GROUND WAVES) = 18.939M  
 CM WIRE : #12 ( RADIUS R=.010265M )  
 CM GROUND(0) : EPSILON = 10 SIGMA=.003

CE  
 GW 1,10, 0,0,6.3158, 19.7368,0,6.3158, .010265  
 GR 0,15  
 GW 2,10, 0,0,6.3158, 0,0,26.0526, .010265  
 GW 3,1, 0,0,6.3058, 0,0,0, .010265  
 GW 4,1, 0,0,0, 0,0,-1.2192, .010265  
 GE 0  
 FR 0,0,0,0,3.8  
 GN 2,0,0,0,10,.003  
 EX 0,2,1,01,1,0  
 PL3,2,1,0  
 RP1,1,121,0,7.62,0.0,0,3,1609.3  
 PL3,2,2,0  
 RP1,1,121,0,7.62,0.0,0,3,1609.3  
 PL0,0,0,0  
 RP0,1,121,1500,80,0.0,0,3,0  
 RP0,1,121,1500,70,0.0,0,3,0  
 RP0,1,121,1500,60,0.0,0,3,0  
 RP0,1,121,1500,50,0.0,0,3,0  
 RP0,1,121,1500,40,0.0,0,3,0  
 RP0,1,121,1500,30,0.0,0,3,0  
 RP0,1,121,1500,20,0.0,0,3,0  
 RP0,1,121,1500,0,0.0,0,3,0

RPO,1,121,1500,10,0.0,0,3,0  
RPO,1,121,1500,0,0.0,0,3,0  
EN

CM GEOMETRY : QUARTER WAVELENGTH MONOPOLE  
CM WITH QUARTER WAVELENGTH 30 RADIAL WIRES  
CM ELEVATED .08LAMBDA=6.3158M  
CM FREQUENCY : 3.8MHZ  
CM WAVELENGTH (FOR SKY WAVES) = 78.9473M  
CM WAVELENGTH (FOR GROUND WAVES) = 18.939M  
CM WIRE : #12 ( RADIUS R=.010265M )  
CM GROUND(0) : EPSILON = 10 SIGMA=.003  
CE  
GW 1,5, 0,0,6.3158, 19.7368,0,6.3158, .010265  
GR 0,30  
GW 2,10, 0,0,6.3158, 0,0,26.0526, .010265  
GW 3,1, 0,0,6.3058, 0,0,0, .010265  
GW 4,1, 0,0,0, 0,0,-1.2192, .010265  
GE 0  
FR 0,0,0,0,3.8  
GN 2,0,0,0,10,.003  
EX 0,2,1,01,1,0  
PL3,2,1,0  
RP1,1,121,0,7.62,0.0,0,3,1609.3  
PL3,2,2,0  
RP1,1,121,0,7.62,0.0,0,3,1609.3  
PLO,0,0,0  
RPO,1,121,1500,80,0.0,0,3,0  
RPO,1,121,1500,70,0.0,0,3,0  
RPO,1,121,1500,60,0.0,0,3,0  
RPO,1,121,1500,50,0.0,0,3,0  
RPO,1,121,1500,40,0.0,0,3,0  
RPO,1,121,1500,30,0.0,0,3,0  
RPO,1,121,1500,20,0.0,0,3,0  
RPO,1,121,1500,10,0.0,0,3,0  
RPO,1,121,1500,0,0.0,0,3,0  
EN

CM GEOMETRY : QUARTER WAVELENGTH MONOPOLE  
CM WITH QUARTER WAVELENGTH 4 RADIAL WIRES  
CM ELEVATED .08LAMBDA=3.3328M  
CM FREQUENCY : 7.2MHZ  
CM WAVELENGTH (FOR SKY WAVES) = 41.66M  
CM WAVELENGTH (FOR GROUND WAVES) = 11.785M  
CM WIRE : #12 ( RADIUS R=.010265M )  
CM GROUND(0) : EPSILON = 10 SIGMA=.003  
CE  
GW 1,10, 0,0,3.3328, 10.415,0,3.3328, .010265  
GR 0,4  
GW 2,10, 0,0,3.3328, 0,0,13.7478, .010265  
GW 3,1, 0,0,3.3228, 0,0,0, .010265  
GW 4,2, 0,0,0, 0,0,-1.2192, .010265  
GE 0  
FR 0,0,0,0,7.2  
GN 2,0,0,0,10,.003

EX 0,2,1,01,1,0  
 PL3,2,1,0  
 RP1,1,121,0,7.62,0.0,0,3,1609.3  
 PL3,2,2,0  
 RP1,1,121,0,7.62,0.0,0,3,1609.3  
 PLO,0,0,0  
 RPO,1,121,1500,80,0.0,0,3,0  
 RPO,1,121,1500,70,0.0,0,3,0  
 RPO,1,121,1500,60,0.0,0,3,0  
 RPO,1,121,1500,50,0.0,0,3,0  
 RPO,1,121,1500,40,0.0,0,3,0  
 RPO,1,121,1500,30,0.0,0,3,0  
 RPO,1,121,1500,20,0.0,0,3,0  
 RPO,1,121,1500,10,0.0,0,3,0  
 RPO,1,121,1500,0,0.0,0,3,0  
 EN

CM GEOMETRY : QUARTER WAVELENGTH MONOPOLE  
 CM WITH QUARTER WAVELENGTH 15 RADIAL WIRES  
 CM ELEVATED .08LAMBDA=3.3328M  
 CM FREQUENCY : 7.2MHZ  
 CM WAVELENGTH (FOR SKY WAVES) = 41.66M  
 CM WAVELENGTH (FOR GROUND WAVES) = 11.785M  
 CM WIRE : #12 ( RADIUS R=.010265M )  
 CM GROUND(0) : EPSILON = 10. SIGMA=.003

CE  
 GW 1,5, 0,0,3:3328, 10.415,0,3.3328, .010265  
 GR 0,15  
 GW 2,10, 0,0,3.3328, 0,0,13.7478, .010265  
 GW 3,1, 0,0,3.3228, 0,0,0, .010265  
 GW 4,2, 0,0,0, 0,0,-1.2192, .010265  
 GE 0  
 FR 0,0,0,0,7.2  
 GN 2,0,0,0,10,.003  
 EX 0,2,1,01,1,0

PL3,2,1,0  
 RP1,1,121,0,7.62,0.0,0,3,1609.3  
 PL3,2,2,0  
 RP1,1,121,0,7.62,0.0,0,3,1609.3  
 PLO,0,0,0  
 RPO,1,121,1500,80,0.0,0,3,0  
 RPO,1,121,1500,70,0.0,0,3,0  
 RPO,1,121,1500,60,0.0,0,3,0  
 RPO,1,121,1500,50,0.0,0,3,0  
 RPO,1,121,1500,40,0.0,0,3,0  
 RPO,1,121,1500,30,0.0,0,3,0  
 RPO,1,121,1500,20,0.0,0,3,0  
 RPO,1,121,1500,10,0.0,0,3,0  
 RPO,1,121,1500,0,0.0,0,3,0  
 EN

CM GEOMETRY : QUARTER WAVELENGTH MONOPOLE  
 CM WITH QUARTER WAVELENGTH 30 RADIAL WIRES  
 CM ELEVATED .08LAMBDA=3.3328M  
 CM FREQUENCY : 7.2MHZ

CM WAVELENGTH (FOR SKY WAVES) = 41.66M  
 CM WAVELENGTH (FOR GROUND WAVES) = 11.785M  
 CM WIRE : #12 ( RADIUS R=.010265M )  
 CM GROUND(0) : EPSILON = 10 SIGMA=.003  
 CE  
 GW 1,5, 0,0,3.3328, 10.415,0,3.3328, .010265  
 GR 0,30  
 GW 2,10, 0,0,3.3328, 0,0,13.7478, .010265  
 GW 3,1, 0,0,6.3058, 0,0,0, .010265  
 GW 4,2, 0,0,0, 0,0,-1.2192, .010265  
 GE 0  
 FR 0,0,0,0,7.2  
 GN 2,0,0,0,10,.003  
 EX 0,2,1,01,1,0  
 PL3,2,1,0  
 RP1,1,121,0,7.62,0.0,0,3,1609.3  
 PL3,2,2,0  
 RP1,1,121,0,7.62,0.0,0,3,1609.3  
 PLO,0,0,0  
 RPO,1,121,1500,80,0.0,0,3,0  
 RPO,1,121,1500,70,0.0,0,3,0  
 RPO,1,121,1500,60,0.0,0,3,0  
 RPO,1,121,1500,50,0.0,0,3,0  
 RPO,1,121,1500,40,0.0,0,3,0  
 RPO,1,121,1500,30,0.0,0,3,0  
 RPO,1,121,1500,20,0.0,0,3,0  
 RPO,1,121,1500,10,0.0,0,3,0  
 RPO,1,121,1500,0,0.0,0,3,0  
 EN

CM GEOMETRY : QUARTER WAVELENGTH MONOPOLE  
 CM WITH QUARTER WAVELENGTH 4 RADIAL WIRES  
 CM ELEVATED .08LAMBDA=1.6901M  
 CM FREQUENCY : 14.2MHZ  
 CM WAVELENGTH (FOR SKY WAVES) = 21.1268M  
 CM WAVELENGTH (FOR GROUND WAVES) = 6.459M  
 CM WIRE : #12 ( RADIUS R=.010265M )  
 CM GROUND(0) : EPSILON = 10 SIGMA=.003  
 CE  
 GW 1,10, 0,0,1.6901, 5.2817,0,1.6901, .010265  
 GR 0,4  
 GW 2,10, 0,0,1.6901, 0,0,6.9718, .010265  
 GW 3,1, 0,0,1.6801, 0,0,0, .010265  
 GW 4,3, 0,0,0, 0,0,-1.2192, .010265  
 GE 0  
 FR 0,0,0,0,14.2  
 GN 2,0,0,0,10,.003  
 EX 0,2,1,01,1,0  
 PL3,2,1,0  
 RP1,1,121,0,7.62,0.0,0,3,1609.3  
 PL3,2,2,0  
 RP1,1,121,0,7.62,0.0,0,3,1609.3  
 PLO,0,0,0  
 RPO,1,121,1500,80,0.0,0,3,0  
 RPO,1,121,1500,70,0.0,0,3,0  
 RPO,1,121,1500,60,0.0,0,3,0

RPO,1,121,1500,50,0.0,0,3,0  
RPO,1,121,1500,40,0.0,0,3,0  
RPO,1,121,1500,30,0.0,0,3,0  
RPO,1,121,1500,20,0.0,0,3,0  
RPO,1,121,1500,10,0.0,0,3,0  
RPO,1,121,1500,0,0.0,0,3,0  
EN

CM GEOMETRY : QUARTER WAVELENGTH MONOPOLE  
CM WITH QUARTER WAVELENGTH 15 RADIAL WIRES  
CM ELEVATED .08LAMBDA=1.6901M  
CM FREQUENCY : 14.2MHZ  
CM WAVELENGTH (FOR SKY WAVES) = 21.1268M  
CM WAVELENGTH (FOR GROUND WAVES) = 6.459M  
CM WIRE : #12 ( RADIUS R=.010265M )  
CM GROUND(0) : EPSILON = 10 SIGMA=.003  
CE  
GW 1,10, 0,0,1.6901, 5.2817,0,1.6901, .010265  
GR 0,15  
GW 2,10, 0,0,1.6901, 0,0,6.9718, .010265  
GW 3,1, 0,0,1.6801, 0,0,0, .010265  
GW 4,3, 0,0,0, 0,0,-1.2192, .010265  
GE 0  
FR 0,0,0,0,14.2  
GN 2,0,0,0,10,.003  
EX 0,2,1,01,1,0  
PL3,2,1,0  
RP1,1,121,0,7.62,0.0,0,3,1609.3  
PL3,2,2,0  
RP1,1,121,0,7.62,0.0,0,3,1609.3  
PLO,0,0,0  
RPO,1,121,1500,80,0.0,0,3,0  
RPO,1,121,1500,70,0.0,0,3,0  
RPO,1,121,1500,60,0.0,0,3,0  
RPO,1,121,1500,50,0.0,0,3,0  
RPO,1,121,1500,40,0.0,0,3,0  
RPO,1,121,1500,30,0.0,0,3,0  
RPO,1,121,1500,20,0.0,0,3,0  
RPO,1,121,1500,10,0.0,0,3,0  
RPO,1,121,1500,0,0.0,0,3,0  
EN

CM GEOMETRY : QUARTER WAVELENGTH MONOPOLE  
CM WITH QUARTER WAVELENGTH 30 RADIAL WIRES  
CM ELEVATED .08LAMBDA=1.6901M  
CM FREQUENCY : 14.2MHZ  
CM WAVELENGTH (FOR SKY WAVES) = 21.1268M  
CM WAVELENGTH (FOR GROUND WAVES) = 6.459M  
CM WIRE : #12 ( RADIUS R=.010265M )  
CM GROUND(0) : EPSILON = 10 SIGMA=.003  
CE  
GW 1,5, 0,0,1.6901, 5.2817,0,1.6901, .010265  
GR 0,30  
GW 2,10, 0,0,1.6901, 0,0,6.9718, .010265  
GW 3,1, 0,0,1.6801, 0,0,0, .010265



GW 4,3, 0,0,0, 0,0,-1.2192, .010265  
 GE 0  
 FR 0,0,0,0,14.2  
 GN 2,0,0,0,10,.003  
 EX 0,2,1,01,1,0  
 PL3,2,1,0  
 RP1,1,121,0,7.62,0.0,0,3,1609.3  
 PL3,2,2,0  
 RP1,1,121,0,7.62,0.0,0,3,1609.3  
 PLO,0,0,0  
 RPO,1,121,1500,80,0.0,0,3,0  
 RPO,1,121,1500,70,0.0,0,3,0  
 RPO,1,121,1500,60,0.0,0,3,0  
 RPO,1,121,1500,50,0.0,0,3,0  
 RPO,1,121,1500,40,0.0,0,3,0  
 RPO,1,121,1500,30,0.0,0,3,0  
 RPO,1,121,1500,20,0.0,0,3,0  
 RPO,1,121,1500,10,0.0,0,3,0  
 RPO,1,121,1500,0,0.0,0,3,0  
 EN

CM GEOMETRY : QUARTER WAVELENGTH MONOPOLE  
 CM WITH QUARTER WAVELENGTH 4 RADIAL WIRES  
 CM ELEVATED .08LAMBDA=1.1268M  
 CM FREQUENCY : 21.3MHZ  
 CM WAVELENGTH (FOR SKY WAVES) = 14.0845M  
 CM WAVELENGTH (FOR GROUND WAVES) = 4.385M  
 CM WIRE : #12 ( RADIUS R=.010265M )  
 CM GROUND(0) : EPSILON = 10 SIGMA=.003  
 CE  
 GW 1,10, 0,0,1.1268, 3.5211,0,1.1268, .010265  
 GR 0,4  
 GW 2,10, 0,0,1.1268, 0,0,4.6479, .010265  
 GW 3,1, 0,0,1.1168, 0,0,0, .010265  
 GW 4,4, 0,0,0, 0,0,-1.2192, .010265  
 GE 0  
 FR 0,0,0,0,21.3  
 GN 2,0,0,0,10,.003  
 EX 0,2,1,01,1,0  
 PL3,2,1,0  
 RP1,1,121,0,7.62,0.0,0,3,1609.3  
 PL3,2,2,0  
 RP1,1,121,0,7.62,0.0,0,3,1609.3  
 PLO,0,0,0  
 RPO,1,121,1500,80,0.0,0,3,0  
 RPO,1,121,1500,70,0.0,0,3,0  
 RPO,1,121,1500,60,0.0,0,3,0  
 RPO,1,121,1500,50,0.0,0,3,0  
 RPO,1,121,1500,40,0.0,0,3,0  
 RPO,1,121,1500,30,0.0,0,3,0  
 RPO,1,121,1500,20,0.0,0,3,0  
 RPO,1,121,1500,10,0.0,0,3,0  
 RPO,1,121,1500,0,0.0,0,3,0  
 EN

CM GEOMETRY : QUARTER WAVELENGTH MONOPOLE  
 CM WITH QUARTER WAVELENGTH 15 RADIAL WIRES  
 CM ELEVATED .08LAMBDA=1.1268M  
 CM FREQUENCY : 21.3MHZ  
 CM WAVELENGTH (FOR SKY WAVES) = 14.0845M  
 CM WAVELENGTH (FOR GROUND WAVES) = 4.385M  
 CM WIRE : #12 ( RADIUS R=.010265M )  
 CM GROUND(0) : EPSILON = 10 SIGMA=.003  
 CE  
 GW 1,5, 0,0,1.1268, 3.5211,0,1.1268, .010265  
 GR 0,15  
 GW 2,10, 0,0,1.1268, 0,0,4.6479, .010265  
 GW 3,1, 0,0,1.1168, 0,0,0, .010265  
 GW 4,4, 0,0,0, 0,0,-1.2192, .010265  
 GE 0  
 FR 0,0,0,0,21.3  
 GN 2,0,0,0,10,.003  
 EX 0,2,1,01,1,0  
 PL3,2,1,0  
 RP1,1,121,0,7.62,0.0,0,3,1609.3  
 PL3,2,2,0  
 RP1,1,121,0,7.62,0.0,0,3,1609.3  
 PL0,0,0,0  
 RP0,1,121,1500,80,0.0,0,3,0  
 RP0,1,121,1500,70,0.0,0,3,0  
 RP0,1,121,1500,60,0.0,0,3,0  
 RP0,1,121,1500,50,0.0,0,3,0  
 RP0,1,121,1500,40,0.0,0,3,0  
 RP0,1,121,1500,30,0.0,0,3,0  
 RP0,1,121,1500,20,0.0,0,3,0  
 RP0,1,121,1500,10,0.0,0,3,0  
 RP0,1,121,1500,0,0.0,0,3,0  
 EN

CM GEOMETRY : QUARTER WAVELENGTH MONOPOLE  
 CM WITH QUARTER WAVELENGTH 30 RADIAL WIRES  
 CM ELEVATED .08LAMBDA=1.1268M  
 CM FREQUENCY : 21.3MHZ  
 CM WAVELENGTH (FOR SKY WAVES) = 14.0845M  
 CM WAVELENGTH (FOR GROUND WAVES) = 4.385M  
 CM WIRE : #12 ( RADIUS R=.010265M )  
 CM GROUND(0) : EPSILON = 10 SIGMA=.003  
 CE  
 GW 1,5, 0,0,1.1268, 3.5211,0,1.1268, .010265  
 GR 0,30  
 GW 2,10, 0,0,1.1268, 0,0,4.6479, .010265  
 GW 3,1, 0,0,1.1168, 0,0,0, .010265  
 GW 4,4, 0,0,0, 0,0,-1.2192, .010265  
 GE 0  
 FR 0,0,0,0,21.3  
 GN 2,0,0,0,10,.003  
 EX 0,2,1,01,1,0  
 PL3,2,1,0  
 RP1,1,121,0,7.62,0.0,0,3,1609.3  
 PL3,2,2,0  
 RP1,1,121,0,7.62,0.0,0,3,1609.3

PLO,0,0,0  
RPO,1,121,1500,80,0.0,0,3,0  
RPO,1,121,1500,70,0.0,0,3,0  
RPO,1,121,1500,60,0.0,0,3,0  
RPO,1,121,1500,50,0.0,0,3,0  
RPO,1,121,1500,40,0.0,0,3,0  
RPO,1,121,1500,30,0.0,0,3,0  
RPO,1,121,1500,20,0.0,0,3,0  
RPO,1,121,1500,10,0.0,0,3,0  
RPO,1,121,1500,0,0.0,0,3,0  
EN

CM GEOMETRY : QUARTER WAVELENGTH MONOPOLE  
CM WITH QUARTER WAVELENGTH 4 RADIAL WIRES  
CM ELEVATED .08LAMBDA=.8421M  
CM FREQUENCY : 28.5MHZ  
CM WAVELENGTH (FOR SKY WAVES) = 10.5263M  
CM WAVELENGTH (FOR GROUND WAVES) = 3.299M  
CM WIRE : #12 ( RADIUS R=.010265M )  
CM GROUND(0) : EPSILON = 10 SIGMA=.003  
CE  
GW 1,10, 0,0,.8421, 2.6316,0,.8421, .010265  
GR 0,4  
GW 2,10, 0,0,.8421, 0,0,3.4737, .010265  
GW 3,1, 0,0,.8321, 0,0,0, .010265  
GW 4,5, 0,0,0, 0,0,-1.2192, .010265  
GE 0  
FR 0,0,0,0,28.5  
GN 2,0,0,0,10,.003  
EX 0,2,1,01,1,0  
PL3,2,1,0  
RP1,1,121,0,7.62,0.0,0,3,1609.3  
PL3,2,2,0  
RP1,1,121,0,7.62,0.0,0,3,1609.3  
PLO,0,0,0  
RPO,1,121,1500,80,0.0,0,3,0  
RPO,1,121,1500,70,0.0,0,3,0  
RPO,1,121,1500,60,0.0,0,3,0  
RPO,1,121,1500,50,0.0,0,3,0  
RPO,1,121,1500,40,0.0,0,3,0  
RPO,1,121,1500,30,0.0,0,3,0  
RPO,1,121,1500,20,0.0,0,3,0  
RPO,1,121,1500,10,0.0,0,3,0  
RPO,1,121,1500,0,0.0,0,3,0  
EN

CM GEOMETRY : QUARTER WAVELENGTH MONOPOLE  
CM WITH QUARTER WAVELENGTH 15 RADIAL WIRES  
CM ELEVATED .08LAMBDA=.8421M  
CM FREQUENCY : 28.5MHZ  
CM WAVELENGTH (FOR SKY WAVES) = 10.5263M  
CM WAVELENGTH (FOR GROUND WAVES) = 3.299M  
CM WIRE : #12 ( RADIUS R=.010265M )  
CM GROUND(0) : EPSILON = 10 SIGMA=.003  
CE

GW 1,10, 0,0,.8421, 2.6316,0,.8421, .010265  
 GR 0,15  
 GW 2,10, 0,0,.8421, 0,0,3.4737, .010265  
 GW 3,1, 0,0,.8321, 0,0,0, .010265  
 GW 4,5, 0,0,0, 0,0,-1.2192, .010265  
 GE 0  
 FR 0,0,0,0,28.5  
 GN 2,0,0,0,10,.003  
 EX 0,2,1,01,1,0  
 PL3,2,1,0  
 RP1,1,121,0,7.62,0.0,0,3,1609.3  
 PL3,2,2,0  
 RP1,1,121,0,7.62,0.0,0,3,1609.3  
 PLO,0,0,0  
 RPO,1,121,1500,80,0.0,0,3,0  
 RPO,1,121,1500,70,0.0,0,3,0  
 RPO,1,121,1500,60,0.0,0,3,0  
 RPO,1,121,1500,50,0.0,0,3,0  
 RPO,1,121,1500,40,0.0,0,3,0  
 RPO,1,121,1500,30,0.0,0,3,0  
 RPO,1,121,1500,20,0.0,0,3,0  
 RPO,1,121,1500,10,0.0,0,3,0  
 RPO,1,121,1500,0,0.0,0,3,0  
 EN

CM GEOMETRY : QUARTER WAVELENGTH MONOPOLE  
 CM WITH QUARTER WAVELENGTH 30 RADIAL WIRES  
 CM ELEVATED .08LAMBDA=.8421M  
 CM FREQUENCY : 28.5MHZ  
 CM WAVELENGTH (FOR SKY WAVES) = 10.5263M  
 CM WAVELENGTH (FOR GROUND WAVES) = 3.299M  
 CM WIRE : #12 ( RADIUS R=.010265M )  
 CM GROUND(0) : EPSILON = 10 SIGMA=.003  
 CE

GW 1,5, 0,0,.8421, 2.6316,0,.8421, .010265  
 GR 0,30  
 GW 2,10, 0,0,.8421, 0,0,3.4737, .010265  
 GW 3,1, 0,0,.8321, 0,0,0, .010265  
 GW 4,5, 0,0,0, 0,0,-1.2192, .010265  
 GE 0  
 FR 0,0,0,0,28.5  
 GN 2,0,0,0,10,.003  
 EX 0,2,1,01,1,0  
 PL3,2,1,0  
 RP1,1,121,0,7.62,0.0,0,3,1609.3  
 PL3,2,2,0  
 RP1,1,121,0,7.62,0.0,0,3,1609.3  
 PLO,0,0,0  
 RPO,1,121,1500,80,0.0,0,3,0  
 RPO,1,121,1500,70,0.0,0,3,0  
 RPO,1,121,1500,60,0.0,0,3,0  
 RPO,1,121,1500,50,0.0,0,3,0  
 RPO,1,121,1500,40,0.0,0,3,0  
 RPO,1,121,1500,30,0.0,0,3,0  
 RPO,1,121,1500,20,0.0,0,3,0  
 RPO,1,121,1500,10,0.0,0,3,0

RPO,1,121,1500,0,0.0,0,3,0  
EN

## INITIAL DISTRIBUTION LIST

	No. Copies
1. Library, Code 0142 Naval Postgraduate School Monterey, CA 93943-5002	2
2. Chairman, Code EC Department of Electrical and Computer Engineering Naval Postgraduate School Monterey, CA 93943-5000	1
3. Director, Research Administration, Code 012 Naval Postgraduate School Monterey, CA 93943-5000	1
4. Naval Postgraduate School Dr. Richard W. Adler, Code EC/Ab Monterey, CA 93943-5000	3
5. Naval Postgraduate School Prof. S. Jauregui, Code EC/Ja Monterey, CA 93943-5000	1
6. Penn State University ATTN: J. K. Breakall, CSSL 211 EE East University Park, PA 16802	1
7. U.S. Army Information Systems Engineering and Integration Center ATTN: Commander (Janet McDonald, ASB-SET-P) Ft. Huachuca, AZ 85613-5300	3
8. Nedim KATAL Kuyubasi sok. Cimen Apt. No:13 Kiziltoprak - ISTANBUL - TURKEY	1
9. Gurkan TURKES Dz. Kd. Utgm. Denizalti Filosu K.ligi - Golcuk - KOCAELI - TURKEY	1
10. Defense Technical Information Center Cameron Station Alexandria, Virginia 22304-6145	2