

DTIC FILE COPY

2

# HISTORY OF THE SHAPED CHARGE EFFECT

The First 100 Years

by  
Donald R. Kennedy

AD-A220 095

DTIC  
LECTE  
AR 30 1990

D

D

DISTRIBUTION STATEMENT A  
Approved for public release  
Distribution Unlimited

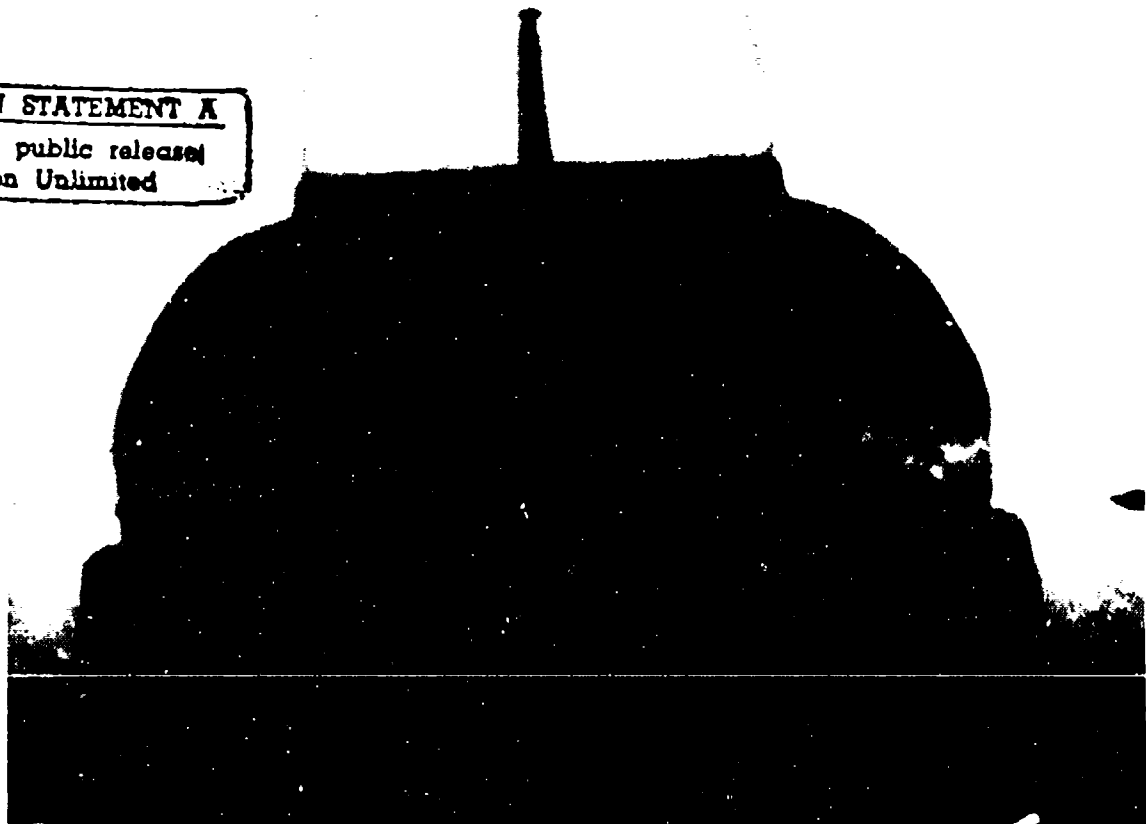

90 03 28 036

Front Cover: Flash Radiograph showing detonation of 66-mm LAW shaped charge with liner collapse and jet formation at  $T=25$  microseconds. Note case's expansion and breakup and shockwave about emerging jet's tip. Radiograph made at Battelle Columbus, courtesy Mr. J. E. Backofen.

PAGES \_\_\_\_\_  
ARE  
MISSING  
IN  
ORIGINAL  
DOCUMENT

- called 3/28/90 - GPO printed but no record of

3/28/90 called author & left message to call back on 29/Mar. selling



D. R. KENNEDY & ASSOCIATES, INC.  
Defense Technology Support Services

Offices in Los Altos  
745 Distel Drive, Suite 21  
Los Altos, CA 94022  
(415) 968-7727  
Mail Address:  
P.O. Box 4003  
Mountain View,  
CA 94040-0003

Defense Technical Information Center  
ATTN: DTIC-FDA Room 5A473  
(Acquisition and Selection Branch)  
Building #5, Cameron Station,  
Alexandria, Virginia 22304-6145

(SAFE envelope to  
Los Alamos)

FREE - NO  
CHARGE

Gentlemen:

*Price - GPO* (DOES NOT SELL, THEY JUST PRINTED IT) March 22, 1990

The publication "Contributors Handbook to the Defense Technical Information Center", February 1990 arrived yesterday. The reason for my letter is that I have a 130-page document that should probably be in DTIC, however I could not find any mechanism in your booklet for its submittal. Mr. Garrett in the DTIC R&E Programs Branch (ext. 44408) suggested that I write this to your attention.

In 1983, I researched and wrote a paper entitled "The History of the Shaped Charge Effect-the First 100 Years". It was written in response to the request of Dr. Manfred Held of MBB Schrobenhausen, West Germany, for a paper to be presented in Germany commemorating the 100th anniversary of the shaped charge. I personally sponsored the paper as my contribution to the anti-armor community, of which I have been one of the leading technologists since 1950. The paper was reviewed by OSD's Office of Freedom of Information and Security Review and was determined to be both unclassified and cleared for unlimited dissemination. Unfortunately, the OSD clearance was came one day too late for me to attend the meeting in Germany.

Since 1983, several one-at-a-time-Xerox copies were sent to people in the US and Europe who were aware of the paper and requested a copy. Many urged me to have the paper published but I had neither the time nor the financial resources. I mentioned my situation to my friend Tom Hafer at DARPA and he requested DOE's Los Alamos National Laboratory to consider publishing the paper, inasmuch as they were now involved in the armor/anti-armor research. LANL agreed, but only as a non-priority project. It remained unpublished for over three years. I traveled to Los Alamos several times, again on my own resources, to review and re-edit the text with a succession of editors, none of whom carried it through. At last this year Mr. Gordon Foreman at ATAC, Los Alamos National Laboratory carried the task to fruition and published 1000 copies of the document. He did a beautiful job! Some 300 copies were issued at DARPA/DOE's Armor/Anti-Armor Information exchange meeting at Los Alamos earlier this month (6 to 8 March). Los Alamos has a list of additional suggested recipients, and I plan to send 100 personally inscribed copies to key personnel in the U.S. and European anti-armor community.

My question, is DTIC interested in introducing this into the DTIC system? If not, please return the 2 enclosed copies to the undersigned. If any questions, please call (415) 968-7727 (in California, 3 hours earlier than your time).

Enc: 2 Copies Ref. Paper.  
(Please Note on Pg 130;  
U.S. Govt Printing Office:  
1990-0-773-034/20013)

Sincerely,

*Donald R. Kennedy*  
Donald R. Kennedy

# HISTORY OF THE SHAPED CHARGE EFFECT

The First 100 Years  
a paper in four parts

by

Donald R. Kennedy  
Consultant in Defense Technology

Originally prepared for  
presentation at the  
100th Anniversary of the Discovery of the Shaped Charge Effect  
By Max Von Foerster  
observed at  
MRB Schrobenhausen, West Germany, 20-22 September 1983

FREE OF CHARGE FROM LOS ALAMOS NATIONAL  
LABORATORY, P.O. BOX 1663, LOS ALAMOS,  
New Mexico 87545 per Donald Kennedy  
TELECON 3/30/90 VG

|                    |                                     |
|--------------------|-------------------------------------|
| Accession For      |                                     |
| NTIS CRA&I         | <input checked="" type="checkbox"/> |
| DTIC TAB           | <input type="checkbox"/>            |
| Unannounced        | <input type="checkbox"/>            |
| Justification      |                                     |
| By                 |                                     |
| Distribution /     |                                     |
| Availability Codes |                                     |
| Dist               |                                     |
| A-1                |                                     |

D. R. Kennedy & Associates, Inc  
P. O. Box No. 4003, Mountain View, California 94040-0003  
Telephone (415) 968-7727



## ACKNOWLEDGMENTS

This paper was originally written (and rewritten) for presentation at the September 1983 symposium at Schrobhausen. For various reasons, the writer was at the last moment unable to attend the meeting. However, a copy of this paper was reviewed by the Office of the Assistant Secretary of Defense, Directorate of Freedom of Information and Security Review, and released for open publication on 19 September 1983. The author wishes to thank Mr. T. M. Colkitt and his associates for a rapid review and clearance in time to send a copy to Schrobhausen for inclusion, in whole or part, in the published colloquium.

Special acknowledgments are made to the following individuals who provided written and verbal information:

Joseph Backofen, formerly with Battelle Columbus Laboratories, now Federal Government

Nicholas E. Berkholz, Honeywell Ordnance, Elk River, MN

Edward Elkins, Pres., Armoflex Inc., Santa Maria, CA

Conrad Frank, US Army ARRADCOM, Aberdeen, MD

Dr. Henry Mohaupt, Montecito, California

Dr. Franz Thomanek, MBB, Retired Vice President, Vancouver, B. C.

Guy C. Throner, formerly with Battelle Columbus Laboratories

...and to those who provided information to Mr. Backofen and Mr. Berkholz:

Dr. Heinz Freiwald, Bonn, Germany

Dr. Manfred Held, MBB, Schrobhausen

Dr. Walter Trinks, West Germany MOD

With special thanks to the late Dr. Hubert Schardin for his history of the shaped charge and to my late colleague at Aerojet, Mr. Heinz Gehlhaar, who so kindly translated it from German at my request.

Thanks to DARPA who sponsored the September 1983 armor/anti-armor workshop held at Battelle where a partial presentation of the paper was given as the banquet speech.

And thanks to my associate, Ms. Donna Dorset, and to Ms. Virginia Lujan and Mr. Gordon Foreman of Los Alamos National Laboratory, who readied this text for publication.

In appreciation,  
Donald R. Kennedy  
Los Altos, California

“HISTORY IS ALWAYS WRITTEN WRONG,  
AND SO ALWAYS NEEDS TO BE REWRITTEN”

George Santayana

“THOSE WHO CANNOT REMEMBER THE PAST,  
ARE CONDEMMED TO REPEAT IT”

George Santayana

“THIS HISTORY WILL NEVER BE COMPLETED,  
THERE WILL ALWAYS BE SOMETHING NEW TO INSERT OR COR-  
RECT”

Donald Kennedy

## FIGURES LIST

| Figure | Subject, Date                                             |
|--------|-----------------------------------------------------------|
| 1      | Von Baader, Journal Account, March 1792                   |
| 2      | Von Foerster's experiments as reported in 1883            |
| 3      | Gustav Bloem's U.S. patent issued in 1886                 |
| 4      | Munroe's guncotton experiments, Scribners Mag. 1888       |
| 5      | Munroe's safe defeat by dynamite shaped charge, 1900      |
| 6      | Figure from WASAG Patent, 1911                            |
| 7      | Figures from KAST, 1911                                   |
| 8      | Figures from Egon Von Neumann article, 1914               |
| 9      | Figures from Bomborn, Kast, Haid, 1921-1924               |
| 10     | Charles Watson's percussion fuze U.S. patent filed 1921   |
| 11a    | Figures from Sucharewsky, 1926                            |
| 11b    | Sucharewsky, cont.                                        |
| 11c    | Sucharewsky, cont.                                        |
| 12     | Figures from Lodati, 1932                                 |
| 13     | Payman, 1935                                              |
| 14     | R. W. Wood's paper on explosively formed projectile, 1936 |
| 15     | Thomanek, F., describing early work in 1960               |
| 16     | Mohaupt, et al., first patent illustrations, 1939/1941    |
| 17     | Schematic of Eban Emael charge, first used May 1940       |
| 18     | German engineer charge, ca. 1942                          |
| 19     | German detonation wave shaped (concrete) hemisphere 1943  |
| 20     | German wave shaped vs point initiated hemisphere, 1943    |
| 21     | German grenade with tapered, acute angle liner, 1942/43   |
| 22     | German bottle liner, Puppchen and Panzershreck, 1942      |
| 23     | German Panzerfaust                                        |
| 24     | German advanced shaped charge technology examples WWII    |
| 25     | German MISTEL missile with 7700 lb shaped charge, 1943    |



## FIGURES LIST (continued)

| Figure | Subject, Date                                                                       |
|--------|-------------------------------------------------------------------------------------|
| 26     | German MISTEL, warhead sketch                                                       |
| 27     | German and technology-transferred Japanese AT mines, 1944                           |
| 28     | Japanese anti-tank lunge mine (suicide mine) ca. 1944                               |
| 29     | Précoul patent 1946                                                                 |
| 30     | Mohaupt patent filed October 1941 for HEAT Projectile                               |
| 31     | Mohaupt patented liners and projectile filed October 1942                           |
| 32     | Blackington patent filed August 1942, HEAT rifle grenade                            |
| 33     | U.S. 2.36-in. Bazooka Rocket Launcher, ca. 1942                                     |
| 34     | 3.5-in. Super Bazooka                                                               |
| 35     | Shaped charge torpedo warhead, U.S.N., WWII, ca. 1944/45                            |
| 36     | Antisubmarine HEAT Scatterbomb, U.S. Navy, WWII, ca. 1945                           |
| 37     | Antisubmarine shaped charge/HE follow-through, U.S.N. 1945                          |
| 38     | Moses patent, wave shapers, follow-through, U.S. 1949                               |
| 39     | 6.5-in. ATAR HEAT rocket, U.S. NOTS, 1950 (schematic)                               |
| 40     | Test of 15-in. long standoff shaped charge device, at 300 ft. Standoff (NOTS, 1952) |
| 41     | 8-in. Aluminum Shaped Charge vs. Aircraft at 150 Ft. Standoff (NOTS 1954)           |
| 42     | Single Row, 9-liner Multiple Jet Shaped Charge (NOTS 1952)                          |
| 43     | Five Row, 45 Liner Multiple Jet Shaped Charge (NOTS 1952)                           |
| 44     | Test of 96-Jet Hypervelocity Fragment Projector Concept (NOTS 1952)                 |
| 45     | Diagram of Behind Armor Effects                                                     |
| 46     | Underwater HEAT device, Sketch of Setup, U.S. NOTS 1952/53                          |
| 47     | USMC Self-buried HEAT land mine, Sketch, U.S. NOTS/Aerojet 1952-1958                |
| 48     | Potential Shaped Charge Liner Materials                                             |
| 49     | DART ATGM warhead, Aerojet General, 1954-1958                                       |
| 50     | Pouter wave-shaped oil well charge, U.S. Patent 1961                                |
| 51     | AGX-3100 Dual-Purpose, 250-lb warhead, Aerojet, 1959                                |

## FIGURES LIST (continued)

| Figure | Subject, Date                                                             |
|--------|---------------------------------------------------------------------------|
| 52     | Liner array provided for AGX-3100 tests (Aerojet-1959)                    |
| 53     | Test of AGX-3100, Eglin AFB, 1959 (led to MAVERICK)                       |
| 54     | 12 inch Aluminum Shaped Charge Damage to Bunker, Eglin AFB (Aerojet-1959) |
| 55     | AGX-3000 series warheads, Aerojet 1959-63 (led to HSM)                    |
| 56     | Concept of HAMMER Shaped Charge Bomblet                                   |
| 57     | HAMMER Shaped Charge Bomblet Tandem Nesting Concept (Aerojet 1962)        |
| 58     | M42/M46 HEDP Grenade, originated at Aerojet, 1962                         |
| 59     | Aerojet "Oil Tool" Shaped Charge — Inspiration for M42 HEDP Grenade       |
| 60     | 7-inch DART ATGM Warhead and "X-Charge" Derivative (Aerojet Ordnance)     |
| 61     | First MAVERICK Shaped Charge Test vs Reinforced Concrete (FMC-1969)       |
| 62     | Basic MAVERICK warhead and FISC variant                                   |
| 63     | Published Illustrations of MAVERICK Shaped Charge Warhead                 |
| 64     | Professor Schardin Visits Aerojet Ordnance, (Aerojet-1963)                |
| 65     | Shaped Charge Pioneers Thamanek, Throner, Kennedy (Battelle-1982)         |



## INTRODUCTION (And Opening Remarks)

It is a privilege to share with you some of the history of a phenomenon we call by so many names: in my country, the shaped charge; in Germany, the Hohlladung; in England the hollow charge; and in the Soviet Union; the cumulative charge. I'm sure there are other names in other languages.

When Dr. Held called early this year (1983) with an invitation to present a paper on the 100-year history of the shaped charge, I accepted the challenge because this technology has been one of my principal areas of interest since 1950, or about a third of the time period we will discuss. Fortunately, I have many good friends who, over the past twenty years, have provided various bits of information on shaped charge history. I am particularly indebted to my good friend Joseph Backofen, formerly of Battelle in Columbus, who provided copies of materials given to him by others, including our host Dr. Held, by Dr. Trinks, and by Dr. Thomanek. I am particularly grateful to Dr. Thomanek for his help in translating some of the German language papers and in imparting his own vast and direct experience as the father of the modern shaped charge. I also wish to thank my long time associate and good friend, Guy C. Throner, who introduced me to the shaped charge in 1950 at China Lake, and with whom I was associated at the Naval Ordnance Test Station in the early 1950s, at Aerojet General Ordnance Division (of which he was founder) from 1953 through 1964, and at the FMC Defense Technology Laboratories (which he also organized and headed) from 1965 to 1974. Mr. Throner not only instilled in me the curiosity to pursue the shaped charge effect, but also provided some of the historical documents to which I refer in this paper.

The writer has been most fortunate, in the 33 years of association with the shaped charge, to have been acquainted professionally with such excellent men as Dr. Louis Zernow, the late Dr. Hubert Schardin (who visited with us in California on several occasions in the 1950-1960 period), the late Dr. Theodore Von Karman and Dr. Fritz Zwicky with whom we were so closely associated at Aerojet in the 1950s, Dr. Emerson Pugh and Dr. Robert Eichelberger at Carnegie Institute of Technology, the late Dr. Thomas Poulter of Stanford Research Institute, Dr. Melvin Cook of the University of Utah, Dr. John Rinehart at China Lake in the early 1950s, and many others involved in the various phases of shaped charge research and its related technologies in the United States and Europe.

As one of the 1950s era "shaped charge empiricists" responsible for several successful products in the NATO inventories, I will attempt to relate the history of this most interesting effect as I have been able to perceive it from the study of many documents over the past few years. One's perception is of course limited by one's own experience, by the documents one has read, and by the various persons with whom one is able to discuss the history. Fortunately, the latter has included some of the world's true experts, such as Dr. Thomanek.

Telephone conversations were also held with the Swiss inventor of the shaped charge, Dr. Henry Mohaupt (who resides in Santa Barbara, California). Dr. Mohaupt noted that he is in the process of preparing his own history of the shaped charge. Even though it was not possible to meet with him for direct discussion, he did provide a considerable insight into his activities in the 1935-41 period. He also suggested a reference as further source material.

When Dr. Held first extended the invitation to attend the present observance and present a paper on shaped charge history, I asked, somewhat facetiously, "which version do you wish, the German, English, or American version, or all three?" This was a more profound comment than expected, because these versions are, in some key respects, quite different. This is attributed to the fact that the histories were prepared by people with their own national pride, limitations on sources because of security classification, and perhaps, their own prejudices.

Part 1 of this paper reviews the world activity in the shaped charge from its beginning in 1883. The paper also reviews an earlier cavity charge effort that is mentioned in so many references. The earlier work, which dates to 1792, is now determined to be a different phenomenon from the cavity charge as we now know it. However, it is included here because it is so often mentioned in the literature.

The request for the paper was later redefined by Dr. Held to concern only the United States activity in the shaped charge from WWII to date, and that is the second of the two parts presented here. However, the U.S. has never had a complete history of its own, and because the research material was already accumulated and begins with the American, Dr. Charles Munroe, in 1888, it was decided to continue with the history of U.S. shaped charge from that date. This was a fortuitous decision because I was able to locate some new information on a mid-1920s shaped charge design in the patent records.

The U.S. history from 1950 to date is primarily that of the writer and his associates. Other U.S. investigators attending the Schrobenhausen observance are to present the U.S. history from the standpoint of their own work and points of view.

It is of interest to note that many of those engaged in shaped charge research and development in the United States are well acquainted and through their careers often work for or with one another in various affiliations, both within the Government and in industry. Therefore, the history of one group, as described here, may actually represent the history of many persons in the United States working in this exciting field.

**HISTORY OF THE SHAPED CHARGE  
PART I**

**HISTORY OF THE  
SHAPED CHARGE THROUGH WORLD WAR II**

by  
Donald R. Kennedy



## PART 1

---

### The "Gas Jet" Period: 1883-1938

The audience assembled at MBB Schrobenuhausen to honor the centennial of the 1883 discovery of the true cavity charge effect by Max Von Foerster. He is considered the discoverer of the hollow charge effect, having first reported his discoveries in 1883, some five years prior to the reports by Dr. Charles E. Munroe in the United States. Indeed, the German-origin histories of the hollow charge effect, which are the most comprehensive yet seen by this writer, amply cite Von Foerster's early work as the original discoverer of the effect.

The bibliography prepared for the present history paper begins with the reference to Von Foerster's paper published more than a hundred years ago. Note that the bibliography is arranged chronologically, inasmuch as this is date-oriented history.

Prior to discussion of the 100-year history, it is necessary to go back to 1792 and review what some have taken to be the real origin of the cavity effect.

### The Cavity Effect That Was Not A Shaped Charge

#### *F. X. Von Baader — 1792*

Although we are celebrating the 100th anniversary of Max Von Foerster's discovery, it is noted that several bibliographic references (39, 46, 49, 61, 66) cite prior work by Von Baader, an 18th century philosopher. To quote from one source (Ref. 39): "Von Baader...who was also interested in the more practical subject of mining, is credited by Serle with advocating a conical or mushroom shaped space at the forward end of the blasting charge used in mining to increase the explosive effect and save powder...Von Baader's suggestion in a mining journal was apparently read and put into practice in Norway, as it was later described by a German, Hausmann (1806) in his account of travels through Norway...Hausmann's description apparently led to its adoption in the Harz Mines for a short time only to be discontinued." Although the source of these statements was not specifically identified in the referenced paper, the bibliography lists a September 1941 British-origin report (Ref. 34) concerned with the history of the shaped charge.

A 1947 U.S.-origin paper (Ref. 46) states, "The essential features of this (the cavity) effect had been observed about 1800 in both Germany and Norway and although no great use was made of it, it (the hollow charge effect) was temporarily abandoned."

A 1948 paper by Birkoff, Duncan P. MacDougall, Pugh, and Taylor (Ref. 49) notes that the "earliest known reference to this (cavity effect) is 1792; a popular account appeared in Van Nostrand's Magazine in 1884." Although no reference appears in the bibliography attached to the 1948 paper, a reference document was included in Nick Berkholtz' 1985 history, and with his permission, is included here as Fig. 1.



A 1950 British-origin paper (Ref. 52) by W. M. Evans and A. R. Ubbelohde contains three key references which tend to tie much of the above together. These are listed in that paper as follows:

- Baader, J. (See Serle, A.) "Leitfaden zur Bergbaukunde," p 306, Leipzig 1884 (which translates roughly as a "Manual on Mountain Mining Knowledge"). (The initial "J" with Baader is disturbing...all other reference is to a man named "Franz Xavier Von Baader".)
- Hausmann, L., "Reise durch Skandinavien in den Jahren 1806 und 1807" Gottingen, 1811 (which translates to "Tour through Scandinavia in the years 1806 and 1807").
- Gurlt, K., "Uber den Abbau Grubengas fuhrender Steinkohlen platz," Dresden, 1883 (roughly translates to reducing fire damp gas in a coal mine).

Another mention of Baader is in an excellent but unfortunately, unidentified draft report, clearly of British-origin (Ref. 61). The British report notes: "the first known reference to this curious phenomenon dates as far back as the 1790's, when a *Norwegian*, Baader, recommended use of a dome-shaped air space in mining charges." The author perhaps incorrectly assumed that Von Baader was a Norwegian because his techniques were first used there.

In a search for information on the "Norwegian" philosopher Von Baader, the *Encyclopedia Britannica* is noted to devote a full half page to a *German* philosopher by that name, but discussed only his theological views. An analyst at the DARPA sponsored Tactical Technology Center at Battelle, Columbus, found an encyclopedia (Ref. 94) that notes that the German theologian and philosopher, Franz Xavier Von Baader had at one time *worked as a mining engineer!* Von Baader was born in Munich in 1765 and died in Munich in 1841. He would have been 26 years of age in 1792. The encyclopedia stated that Von Baader had received a medical degree in 1784, but "In 1792 he decided to give up medicine and went to London to study mineralogy...the four years he remained there...on his return to Munich he was appointed consulting engineer for the Bavarian mines...he taught archeology there (i.e., at the University of Munich) until his death in Munich on May 23, 1841." It is possible that he was the "philosopher Von Baader" cited in the British-origin histories. It is noteworthy that he was living in England at the time of the reputed discovery. If Von Baader was in fact the first to advocate the hollow charge principle, it *is still* a German discovery, but 91 years earlier than Von Foerster, and by a man who came from a city only a few tens of kilometers from this assemblage at Schrobenhausen!

One reference (39) discussed another German in the same time frame as Von Foerster. Quoting that reference, "Gurlt of Germany recommended in 1883 the use of hollow charges for fire damp work in order to allow expansion of the explosive gases and thereby secure their cooling...this cooling, however, lessens the explosive action and should only be used where a rupturing and not a shattering action is required...the experiments carried out in the Saar mines did not show that blasting by hollow charges was better than with full charges

and the practice gradually fell into disuse." Gurlt seems to be stating an opposing view to Von Baader before him and to his contemporary, Von Foerster. However, it must be noted that the explosives used were different, being low explosives on the one hand, and high explosives on the other.

Von Baader may have indeed been the first to suggest the use of a hollow charge *principle*, however as Dr. Thomanek correctly pointed out (Ref. 93), mining explosives (e.g., black powder) used in Von Baader's time were not capable of detonation and thus could not create a shock wave. The first practical *high* explosives were guncotton, first demonstrated by the Swiss chemist Frederick Schoenbein in 1845, and nitroglycerin, derived by Ascanio Sobrero, professor of Chemistry at the University of Turin, Italy, in 1846 (Refs. 95, 96). The "phenomenon of detonation" was first recognized by Berthelot and Vielle (1881, 1882) and by Mallard and Le Chatelier (1881) in studies of flame propagation (Ref. 96). Thus, it was not until after the middle of the 19th century that detonable explosives were available. Compressed gunpowder (nitrocellulose) was first patented by Simon Davey and James Watson in 1874 (letters patent No. 2641, July 29, 1874 at London).

## Beginning Of Shaped Charge Research — The Unlined Cavity Period

### *Max Von Foerster — 1883*

In 1883, Max Von Foerster, then Chief of the Nitrocellulose factory of Wolff & Co., in Walsrode, Germany, reported on his experiments with compressed nitrocellulose. Von Foerster's report (Refs. 1, 2) is described in a history of the shaped charge prepared in September 1941 as a Doctoral dissertation by Heinz Friewald of the German Academy of Aviation Research (Ref. 33). It is clear from Dr. Friewald's description of Von Foerster's investigations, that Von Foerster is the true discoverer of the modern hollow charge effect and is, therefore, due the honors to be conferred by those assembled at Schrobenhausen. The dissertation includes quotes from Von Foerster's original work (Fig. 2).

There is also some small confusion concerning Max Von Foerster. One Anglo-American source (Ref. 39) identifies him as a "Captain in the German Army," yet another, possibly more reliable German source (Ref. 33), identifies Von Foerster as an "Ingenieur und Premierleutnant." (Question, is the latter the same as a captain?)

### *Gustav Bloem — 1885*

A U.S. Patent (Ref. 3) issued in May 1886 to Gustav Bloem of Dusseldorf, Kingdom of Prussia, German Empire, was for his invention "Shell for Detonating Caps." His invention comprised a hemispherical cavity in the base of a metal detonator so that "by these constructions the concentration of the effect of the explosion in an axial direction...is increased." An illustration accompanying the Bloem patent (Fig. 3a, 3b) clearly shows the lined cavity charge.

### *Charles E. Munroe — 1888-1900*

The name most commonly associated with the hollow charge effect is that of Professor Charles E. Munroe, a civilian employed as a chemist by the United States Navy's Naval

Torpedo Station, Newport, Rhode Island (Ref. 50). Munroe's discoveries date from 1888 (Refs. 4, 5, 6, 7, 8) and are well recorded in the open literature (Fig. 4). Dr. Munroe was possibly not aware of the Von Foerster publication of five years earlier. Although Munroe may not be the first to discover the hollow charge effect, he was perhaps the first to successfully demonstrate the *lined cavity* principle by defeating a massive steel target. In an article published (Ref. 8) in 1900 (Fig. 5), Munroe tells of defeat of "a safe twenty-nine inches cube with walls four inches and three-quarters thick, made up of plates of iron and steel,...when a hollow charge of dynamite nine pounds and a half in weight and untamped was detonated on it, a hole three inches in diameter was blown clear through the wall, though a solid charge of the same weight and of the same material produced no material effect. The hollow cartridge was made by tying the *sticks of dynamite around a tin can, the open mouth of the latter being placed downward...*"

According to the 1941 German history of the shaped charge (Ref. 33), the above described experiments by Munroe took place in 1894. Although this was probably the first recorded successful demonstration of the metal-lined-cavity effect, Munroe was apparently unaware of the effect of the tin can, and the importance of the liner was not to be recognized for another forty-four years.

The publicity accorded Munroe's findings in such publications as *Popular Science Monthly* probably accounts for the association of his name with the effect in both England and the United States. As a side note, the literature spells "Munroe" at least three other, incorrect ways: "Monroe," "Munro," and "Monro."

Appendix A reproduces an early article about work and an apparent obituary of Dr. Munroe, both provided through the courtesy of Mr. Robert B. Hopley of IRECO, Salt Lake City, Utah.

### **WASAG and Neumann —1911**

Apparently, the prior works of both Von Foerster and Munroe were unknown to the examiners who allowed the patents to Westfälische Anhaltische Sprengstoff A. G. (WASAG) in Germany in 1910, and in England in 1911 (Refs. 9, 10). There is no evidence that Von Foerster or Munroe sought to patent their early discoveries, and patents are the principal sources researched by patent attorneys. The WASAG patent claim cites (1) "an explosive charge or body having on the side intended to face the object to be destroyed a cavity, of conical or other suitable shape, for the purpose of enhancing the explosive effect..." and (2) "a cavity filled with an inert material or lined with sheet metal or other suitable material..." The patent further notes that "explosive charges which are to be fixed to the objects to be destroyed, for instance in dealing with blasting charges for mines, a lining for the cavity need only be provided in order to afford protection from moisture, for which purpose a coating of paraffined paper, linen, or similar material is sufficient. Linings made of sheet zinc and adapted to the shape of the explosive charge may also be employed." For gun-fired projectiles, a stronger material was suggested to resist deformation at impact and for torpedoes, a "lining of thin steel or brass would be sufficient...but for explosive projectiles the lining would be made of stronger sheet steel..." (See Fig. 6). Once again, a workable metal-lined conical cavity was described without a realization of the liner's potential contribution.

***British Trials — 1913***

The British explored the development (Ref. 39) of a hollow charge warhead for a torpedo in 1913. Trials carried out by H. M. S. Vernon "confirmed the claims made by the (WASAG) patent in that hollowing out of the charge appeared to concentrate the force of the explosion and gave apparently directive effect." It is not stated whether the torpedo warhead was lined. However, if the recommendations of the WASAG patent were followed, it probably was lined with thin sheet metal. The reference continues: "The Research Department of Woolwich Arsenal in 1913 criticized the suggestion made by WASAG that hollow charges might be used in projectiles, as being impracticable in that it would be impossible to prevent the forward set of the charge in impact. They also pointed out difficulties in placing of the fuze, which from the nature of the charge needed to be a base fuze, and base fuzes were not accepted at that time. Woolwich concluded that their experiments proved that the claim of the patent was not of great value and no further action was proposed." Thus, the shaped charge failed to be introduced into World War I even though the necessary technology had been introduced and demonstrated to have a good potential (for examples, the 1894 Munroe experiment with the dynamite and tin can liner, and the figure shown in the 1911 WASAG patent, a practical and modern design).

***Germany: Neumann, Neumann, Von Kast, Bomborn, Lupus, Escales, and Stettbacher — 1911–1935***

From 1911 through 1935, a series of papers were issued which were mainly concerned with the hollow charge effect (Refs. 9-31 incl.) and its applications in mining and in detonator devices. Many of the papers were by German authors including M. Neumann, E. Neumann (see Figs. 7, 8, 9), Von Kast, A. Stettbacher, R. Escales, B. Bomborn, and M. Lupus.

***United Kingdom: A. Marshall — 1915–1920***

An Englishman, Arthur Marshall, authored a book (Ref. 15) in 1915 and a paper (Ref. 19) in 1920 concerned with the hollow charge effect. The 1920 paper was perhaps the first history of the cavity effect, although Marshall failed to note the earlier work by Von Foerster. Thus, both English and American students of the hollow charge continued to be unaware of Von Foerster's work and instead attributed the discoveries to Munroe.

***United States: Charles Watson — 1921–1925***

In 1925, two U.S. Patents (Ref. 24) were issued to an American, Charles P. Watson for "Percussion Fuzes" (Fig. 10) that incorporated a parabolic shaped booster charge with a hemispherical metal lined cavity at the output end of the booster explosive. In the language of the patent: "thus very much intensifying the effect of the booster charge." Watson attributed the enhanced output to the parabolic shape of the booster chamber side walls which in his own words "direct the detonation waves of force in a forward direction toward the cavity of the shell." The inventor also noted "I close the open enlarged end of the booster cavity by means of an arched plug or shield to hold the booster charge in place under all conditions of accident or service to which the fuze may be subjected until the moment when it is to be fired upon contact with the target." Watson also noted that only one fifth to one

sixth as much explosive was required with the directed energy booster and that it would function "across a considerable air gap." Again the enhanced effect of a lined cavity had been observed and its contribution and importance gone unrecognized. The Watson patent applications were filed in 1921. This significant invention was apparently overlooked by many historians of the shaped charge effect.

### *Russia and Sucharewski — 1925-1926*

In 1925 and 1926, M. Sucharewski issued the first treatises of Russian origin on the shaped charge (Ref. 25). He described extensive experiments with unlined cavities in a wide variety of shapes (Fig. 11). Sucharewski noted that the "conical cavity generates the smallest penetration effect" (for an unlined charge) but did observe "the tremendous practical importance of shaped charge shells is...the possibility of reducing the shell weight to one-half and increasing the explosive effect by a factor of 3 to 5." Professor Schardin notes (Ref. 60) "that in spite of Sucharewski's explicit statement in 1925, there did not follow any development of shaped charge shells in Russia" and commented that "this is astounding because Sucharewski, who knew the work of Foerster, Munroe, and WASAG, writes as follows: 'Munroe's tests did not give any answers to the question about the extensive application of shaped charges and most conceivably, the principle of the shaped charge has not been introduced either for military blast technique or for other practical applications'." (Note: It is equally inconceivable to this writer that those familiar with Dr. Munroe's published works would fail to note experiments where a thick steel safe was penetrated by the dynamite and tin can device!)

### *Italy: D. Lodati — 1932*

In 1932 D. Lodati in Milan published the first Italian-origin-paper (Ref. 26) in which he discussed "an explanation of the explosive behavior of hollow blocks of compressed TNT" (Fig. 12). Professor Schardin subsequently noted (Ref. 60) that "the Italian, Lodati, reported about extensive shaped charge tests of his own which did not contribute anything basically new."

### *U.K.: Payman and Woodhead — 1935-1937*

The British investigators Payman and Woodhead submitted a paper (Ref. 31) to the Royal Society in 1937 in which they described observations of jetting from the ends of detonators (Fig. 13). Although they correctly referred to the Munroe effect, and measured significant velocity gains from cavities in the end of explosive charges, the significance of their observations was apparently not recognized.

### *U.S. (UK): R. W. Wood — 1936*

The first published description of an explosive-formed hypervelocity mass was a 1936 paper (Ref. 29) by Professor R. W. Wood of John Hopkins University. His paper, "Optical and Physical Effects of High Explosives" was published in the Proceedings of the Royal Society of which Wood was a member. His scholarly works included descriptions of the plastic flow of metals, the secondary flash of detonation, and the spectra of deflagration and detonation. In the course of his paper, Wood described the shaped-charge related end effect

we now refer to variously as P-charge, Self-Forged-Fragment (SFF), or Explosive-Formed-Penetrator (EFP) (Fig. 14). Although Wood both recognized and accurately described the unique effect produced by the metal cavity lining, again the importance of the finding to potential military applications was unrecognized.

(Note: The discovery of the importance of the metal lining occurred in the late 1930s, thus ending the nearly 54 year period since Von Foerster's first discovery in which the hollow charge was regarded as an interesting, but not too practical, laboratory effect.)

## THE LINED CAVITY PERIOD: MID-1930s TO DATE

### *The Discovery Period — 1935–1938*

It is rather difficult to discern just which individual first discovered the value of the cavity liner and reduced it to practice. The secrecy surrounding any significant invention having a potential military application makes it rather difficult to put an exact date on the discovery. Dr. Henry Mohaupt claims (Refs. 67, 74, 92) his initial observation of the lined cavity effect "in late 1935" at his laboratory in Zurich, Switzerland. Dr. Franz Rudolf Thomanek, an associate of the Aeronautical Research Institute, Braunschweig, and later of the Ballistic Institute Berlin, Gatow, cites 4 February 1938 as the date of his discovery of the lining effect (Ref. 75). It is important to note that both discoveries were apparently accidental, as is the case of so many important discoveries, and that the existence of the jetting effect was not established until such diagnostic tools as the flash radiograph and Kerr Cell became available.

### *German Discoveries*

#### *C. Cranz, H. Schardin, and Thomanek — 1937*

German interest in the effects of hollow charge phenomena had always been high. In the period 1926–1929, Carl Cranz and Hubert Schardin worked on the Mach effects (Ref. 60), and by 1937, Schardin had the idea that this possibly could be an explanation of the shaped charge effect. In experiments designed to test the hypothesis, Thomanek made the discovery of the importance of the cavity liner, the first material being the glass used in the experiment to evacuate the cavity. Tests were immediately conducted with other materials and mild steel and copper were found superior. The penetration factor was two calibers in the initial tests (Fig. 15). The experiments also revealed the critical importance of liner thickness and the need for thickness control (i.e., precision in manufacture). Liner shapes were also studied, with the hemispherical liner being one of the effective shapes adopted by the engineers. The effect of standoff was also determined (Ref. 60).

Thomanek also describes (Ref. 75) work on detonation wave shapers in 1939, experiments with progressive and degressive (i.e., tapered thickness) liners in 1940, investigation of bottle and trumpet shaped liners in 1941, and first development of spin-compensated liners in 1943. The latter were fluted liners made of cast zinc. According to Thomanek, the later U.S.-developed spin-compensated liners have a nearly identical appearance.

Thomanek and Brandmeyer's first German patent bears a priority date of 9 December 1939. An international patent (Ref. 37) was assigned in Hungary in 1943. Thomanek established and operated a company to develop and manufacture shaped charge weapons for the Reich. His company developed and manufactured more than five million munitions items, including artillery shells, rifle grenades, land mines, shaped charge bomblets (for air delivery), and 21-cm shaped charge/KE follow-through munitions for the defeat of concrete targets.

Appendix B reproduces a resume of Dr. Thomanek's prepared for the 1983 meeting and edited (and annotated) by this writer.

### *Allied Discoveries*

#### *Mohaupt of Switzerland and France — 1935 (?)*

Meanwhile, in England, quoting (Ref. 39):

"...at the end of 1937, Professor D. E. Matthias wrote to the British Air Ministry claiming invention of a projectile 'combining the advantages of the enormous pressure of H.E. shell with the perforating capability of the A.P. shell'...It was claimed that a...rifle grenade fired at a range of 100 meters was...capable of penetrating 40 mm of steel. Trials were staged in Zurich before representatives of the Research Department of Woolwich Arsenal, who came to the conclusion that the inventor, Dr. Mohaupt, a Swiss engineer, was making use of hollowed charges and a series of experiments was carried out to test this supposition. The effects obtained by the Research Department were such as to confirm their views and cause the Air Ministry to refuse the exorbitant price asked for an option on the invention."

Perhaps what the British civil servants had failed to note was that Henry Mohaupt was working alone, without support of a Government or large industrial firm, and needed to recover the considerable expenses he had incurred in the developments to that point (Ref. 92). It is also possible that the British observers merely *thought* they knew about the technique that Mohaupt was using, but were not aware that he was demonstrating a lined cavity charge which was, in fact, a new technology.

Reference 39 continues: "In 1939 Matthias, Mohaupt, and Kauders applied for a French patent for an 'improved explosive projectile' which embodied a metal lining in a cavity charge. The inventors believed that the liner served to form a secondary projectile, which was credited for the penetrating effect of cavity charges rather than as a source of a penetrating jet...The demonstration conducted by Dr. Mohaupt at Zurich aroused new interest in the cavity phenomena in England, where in 1938 the possible application of the cavity effect to service munitions was reconsidered with particular reference to... demolition work...The effects of both lined and unlined charges were investigated" showing the "...lined cavity charges to be far superior to unlined cavity charges "

Thus, the modern history of the shaped charge with the lined cavity evidently starts between late 1935 and early 1938. It is conceivable that the inventions were developed simultaneously and independently in both the German and the Swiss laboratories. The secrecy typically surrounds any experimental work that involves a potential military application. However, it is also conceivable that some of the technology was, in effect, transferred, inasmuch as

both originators of the effect were in proximity — southern Germany and Switzerland border each other.

Dr. Mohaupt's French patent claims as a date of patent 9 November 1939 (recall that the Thomanek/Brandmeyer German patent was dated 9 *December* 1939). In August 1941, an Australian patent (Ref. 32) was issued to Berthold Mohaupt, Henry Mohaupt, and Erick Kauders, of France, and cited Patent No. 113,685 dated 27 November 1940, Sager Societe Anonyme de Gestion et D'Exploitation de Brevets, of Fribourg, Switzerland. The Australian patent in the writers reference file is stamped "Received by the Library, U.S. Patent Office, 18 November 1941."

A study of the claims and illustrations in the Australian patent reveals the presence of certain design features that we now know would preclude the function of the patent-described designs as shaped charges, i.e., as jet-producing devices. First, each of the three patent illustrations (Fig. 16) includes either a tubular or solid axial "needle" (presumed to be made of a metal) extending from the nose fuze *through* the lined cavity and extending to the base of the explosive charge. Both the tube and needle would interfere with and preclude a jet formation as a result of their location along the charge axis. Second, devices, identified as detonators, are distributed in the aftermost portion of the explosive charge and at some distance off the axis. (Dr. Thomanek explained [Ref. 93] the use of groups of three or four detonators was a common practice at the time of the invention, the purpose being to take advantage of intensification at the central axis that results from the so-called "Dautriche" effect.) Third, several small conical liners are shown to be disposed radially about the interior of the projectile body and just behind the forward oriented (axial) liner. Not only would the laterally aimed cones be unable to form jets but their presence would also interfere with the sweep of the detonation wave over the main liner. Thus, the patent designs as shown are not considered practical, whereas the WASAG patent, issued some thirty years earlier, shows more practical designs that are considered capable of producing an effective jet.

#### ***Beginning of United States Involvement — Late 1940***

Henry Mohaupt is credited (Ref. 74) with bringing the lined shaped charge technology to the United States on 18 October 1940 and demonstrations were made to the U.S. Army Ordnance Department shortly after. The demonstrations were well received and quickly led to the development of a 2.36-inch rifle grenade. Through an evolutionary process, the grenade was soon provided with a rocket propulsion device which soon became known in the U.S. Army as the "Bazooka." The name derived from a unique apparatus used by the then-popular comic, Bob Burns, who used a homemade musical instrument that he called "Bazooka," consisting of pieces of gas pipe and a metal funnel which, in certain respects, did resemble the rocket-launching device.

The Swiss inventor, Henry Mohaupt, is acknowledged in the West (Ref. 74) as: "the inventor of the cone liner concept...The program of adapting the Mohaupt devices suddenly appeared at Picatinny (Arsenal, New Jersey) in early 1941 as a completely novel munition. Up to that time, no work had been done at Picatinny or elsewhere in the United States in any attempt to apply shaped charges...On June 4, 1941, a secret classification was given to the program. Because Mohaupt was an alien at the time, the designation meant he could no



longer sit in on technical conferences." The technology transfer had already occurred so the loss of Mohaupt to the program was not as serious as it might have been.

The above noted description of the cavity charge performance observed by Dr. Mohaupt as "forming a secondary projectile," and the obvious flaw in the patent sketch (Fig. 16) suggest that Mohaupt may not have achieved a true jet producing device prior to his patent applications. However, the fact that the first U.S.-developed device, the 2.36-inch Bazooka, used a base fuze, and that a true jetting action was achieved, suggests that the flaw was discovered and corrected at an early date. In a telephone discussion with the writer (Ref. 92), Dr. Mohaupt noted that the patent applications and accompanying drawings were in the hands of patent attorneys in Portugal and that he had no opportunity to review them before his hurried departure from the Continent in late 1940. He indicated that he was well aware of the obvious design errors.

The significance of Dr. Mohaupt's contributions to the United States, in introduction and design of the first munitions to incorporate the cavity liner, is as important as of the contributions made by Dr. Thomanek to the German Government at the beginning of World War II. It is in fact not necessary to know who was "first," but rather that each had made a major contribution to the nature of combat. At last, the infantryman had a tool that he could use with good effect against his worst adversary, the tank.

The hollow-charge principle was introduced into combat in the middle of the night of May 10/11, 1940, when German glider troops landed on Fort Eben Emael (Ref. 68), key-stone of the Allied defense system along the German-Dutch- Belgian border. The German troops emplaced crude hemispherical hollow charges (Fig. 17) on the massive, 400-mm (16-in.) thick, steel cupolas that protected the fort's guns. The fort was reduced and captured within a few hours by a small force of elite troops equipped with two new war machines, the glider and the shaped charge, simultaneously introduced into combat for the first time. The hemispherical steel-lined charges were crudely designed considering the already advanced German state of the art at that time. The development of the charges used at Fort Eben Emael, is attributed to Dr. Wulfken of the Pioneer Division of the Army Weapons Office (Refs. 68, 79). The engineer charges were large and heavy (50 kg), and were employed at zero standoff. Although the hemispherical cavity was lined with a thin metal lining, it was for protection of the explosive and neither designed nor intended for jet effect. The fact that a thick annular explosive charge was in direct contact with the target possibly resulted in more target damage from the shock spalling than from the hollow-charge effect. However, as crude as they were, the charges accomplished the purpose for which they were designed, surprising the attacking troops as much as the defenders, none of whom had ever seen such an instrument of war in action. (Ironically, the only member of the troop that was familiar with the action of the charge was in a glider that crashed short of the target.)

German technology resulted in several developments that are regarded by some in the U.S. to have been U.S.-originated developments of a more recent time. These included advanced design charges with hemispherical liners (Fig. 18), detonation wave-shaped hemispherically-lined charges with concrete (i.e., "Beton") wave shapers (Figs. 19, 20), designs with acutely angled and tapered wall liners typical of those used in Soviet munitions to this date (Fig. 21), compound shaped liners incorporating both conical and hemispherical elements (fig. 22), and many others. Perhaps the German shaped charge that was best known to U.S.

Forces in the European theatre was the Panzerfaust (Armor Fist) (Fig. 23). It was used on occasion by U.S. troops in preference to the less capable Bazooka. German scientists were also involved with more sophisticated shaped charges as exemplified by the compound explosive charge for the torpedo warhead and the tandem arrays shown in Fig. 24.

### *The German MISTEL, the World's Largest Shaped Charge Weapon — 1944*

- The German efforts to exploit the shaped charge principle led to several unique applications, including research and development of torpedo warheads incorporating the shaped charge effect, tandem shaped charge/follow-through munitions, and various other advanced concepts. However, none of the German inventions was quite as dramatic and epic in scale as the system known variously as the Beethoven Apparatus or Mistel project (Ref. 73), which involved the mounting of a fighter aircraft (e.g., a Bf-109 or FW-190) "pickaback" on top of a larger bomber aircraft (e.g., JU88) that carried an enormous shaped charge in its nose (Fig. 25). The concept called for the pilot of the top mounted fighter to fly the combination aircraft apparatus to the target area, aim the bomber at the target, lock its controls, release it, and return to his base. The name Mistel (Mistletoe) referred to the parasitic mounting of the top aircraft on the host aircraft. In the tactical version, the bomber's nose was replaced by a very large warhead consisting of a 2-meter (6-ft+) diameter shaped charge with a wide-angled liner. The warhead weighed 3500 kg (7700 lb), of which the explosive alone weighed 1720 kg (3800 lb)! The liner appears in sketches to have an included angle of about 120-degrees (Fig. 26). It is reported to have been about 30 mm thick and "made of a soft metal such as copper or aluminum." Because of the copper shortage in Germany during the war (most of it was used to make brass for the Navy), it is possible that the Mistel liners may have been fabricated of aluminum, if the above noted source is correct. However, both the liner's thickness and the targets (armored naval vessels, massive concrete works, etc.) suggest to the author that the liner material could also have been mild steel, the same as used in all of the other German shaped charges at the time. One source (Ref. 99) describes a 1000 kg steel cone with a theoretical armor penetration of 7.5 meters (about 3.7 calibers), a measured concrete penetration of 18.5 meters (9+ calibers) and a first test against a captured French battleship in 1943. The Mistel systems were planned for such uses as attack against the British Fleet at Scapa Flow. However, the tides of war had changed before many of them could be used. A few were used apparently with little effect against bridge targets in Berlin in the last few days of the war. Many were captured intact by the Soviet forces. These are the largest known shaped charges made to date.

The technology of the shaped charge was transferred by the German Government to her Axis partners, Italy and Japan, early in the war. However, the results were mixed, as attested by such developments as the Japanese "Lunge" mine (Figs. 27, 28), where the operator's chances of survival were virtually nil as a result of the rather direct delivery method that had to be employed.

At the beginning of the War, the early model Italian shaped charge grenades were *unlined* and used a slow acting base fuze. The explosive would often squash against the target and cause a scabbing effect. Dr. Walter Trinks, a German observer, applied for a Reichs patent on what we now call "HEP" or "squash-head" ammunition (Ref. 69) as a result of his becoming aware of the effect produced by the malperforming Italian ammunition.

Although this discussion of worldwide technology of the shaped charge terminates at the end of World War II, one additional entry from 1946 must be included here for completeness. This is a French patent by Michel Précoul filed in early 1946, for "perfections" of shaped charges (Fig. 29) in which he introduces some very interesting concepts in wave shaping and tandem arrangements up to three lines in sequence. It is not clear how timing was to be effected to enable the jet sequence to function.

### **In Conclusion**

This brings the world history of the shaped charge up to the mid-World War II period and concludes Part I.

Part II starts over at 1888, but concentrates only on United States shaped charge research and development activity to 1950. For completeness, some of the following repeats material presented in Part I. However, much of the writing is different, having been written from a different standpoint and at another time. Some of the figures in Part I are also referred to in Part II. Therefore, all figures are consolidated at the back of the report and are numbered consecutively. They are identified with that part of the report where they are first referenced.

Part III covers the period from 1950 to date and summarizes the shaped charge history of only the writer and his colleagues.

**HISTORY OF THE SHAPED CHARGE  
PART II**

**HISTORY OF THE  
SHAPED CHARGE DEVELOPMENT IN THE UNITED STATES  
FROM 1888 TO 1950**

by  
Donald R. Kennedy

## PART II

---

### History Of The Shaped Charge Development In The United States — 1888-1950

Part I was concerned with the history of the effect from the late 18th century into the mid-1950s period. Part II, is concerned only with the history of the shaped charge in the United States from 1888 to 1950. For completeness, portions of Part II are necessarily redundant to Part I. A subsequent section, Part III, covers the period since 1950 but is restricted to shaped charge research and development activities performed by or under direction of the writer and his colleagues.

It is the writer's contention that any modern history is best written by those who actually performed the work. Therefore, the Army's history should properly come from the Ballistic Research Laboratory, Picatinny Arsenal, and Redstone Arsenal; Navy history should come from the Naval Surface Weapons Center and Naval Weapons Center; and the Air Force history should be prepared by the Air Force Armament Laboratory at Eglin AFB. Contributions from the industrial and institutional sector should be provided by the following (listed alphabetically, not necessarily in order of contribution): Aerojet Ordnance, Avco, Battelle Memorial, California Research and Technology, Carnegie Institute of Technology, Denver Research Institute, Drexel University, Firestone, Honeywell Ordnance, Jet Research Co., Martin Orlando, MB Associates, Physics International Co., Shock Hydrodynamics (Zernow Technical Services), S-Cubed, Sparta Research, Stanford Research Institute, Unidynamics, Southwest Research Institute, and all others who have made significant contributions to the technology of the shaped charge.

Part II may never be complete until contributions are made by the above organizations. The following is therefore restricted to the period of 1888 through approximately 1950. The period 1941-1950 will be incomplete until supplemented by appropriate inputs from the Government and industrial organizations listed above.

#### The U.S. Beginning — The Munroe Period: 1888-19

The history of the shaped charge effect in the United States is 95 years old as of 1983, dating from the discoveries by Professor Charles E. Munroe in 1888 (Refs. 4, 5, 6, 7, 8). Dr. Munroe was at that time a civil employee, a chemist, for the United States Navy's Naval Torpedo Station at Newport, Rhode Island where he was engaged in experiments with pressed blocks of nitrocellulose explosive, also known as guncotton. Many are familiar with Munroe's well known explosively imprinted initials and leaves, hallmarks of his first discovery (Fig. 4 and Appendix A).

Guncotton was not a new explosive in 1888. Following its discovery in 1846, it had been used as early as the mid-1850s by Emmanuel Nobel in exploding mines protecting the mouth of the Neva River in the Crimean War (Ref. 15). A European patent for machines to make compressed cartridges of nitrocellulose was granted in 1874. Von Foerster's experiments with compressed nitrocellulose took place in Germany in 1883.

It can not be determined from the available papers whether Munroe was aware of Foerster's experiments with nitrocellulose five years earlier. No references are listed in the magazine article reprints. Max Von Foerster first reported his discovery of the cavity effect in 1883 in Germany, and in 1884 in *Van Nostrand's Engineering Magazine*, which Munroe, a chemist, may not have seen. However, Munroe himself reported his findings on projectile fillers in Vol. XXXII of the 1885 issue of the same magazine (Ref. 8). It is difficult to understand how Munroe could have missed the Von Foerster paper published in the same magazine only a few months earlier, particularly when it concerned the same explosive material he was working with. Perhaps Von Foerster's early discovery was not widely recognized because he failed to receive good media coverage. Professor Munroe, on the other hand, published his findings several times in both scientific and popular journals and magazines in the period 1888 to 1900 (Refs. 4, 5, 6, 7, 8). One of the Munroe papers was also published in 1894 in the U.S. Congressional record (Ref. 7). As a result of his extensive publishing of results, Munroe's work is well known, particularly in the United States.

What Munroe himself apparently failed to recognize, as have many of those who studied the history of the shaped charge, was that he was apparently the first to have *demonstrated* the *lined* cavity effect in an experiment that he reported in 1894 (Ref. 8). In this experiment, (Figs. 5, 6) Munroe's charges comprised several sticks of dynamite tied in an annulus about a tin can (note: a genuine tin can, in the 1890s). A second bundle of dynamite sticks placed immediately behind the flat base of the can served as the back of the cavity charge. The latter bundle also surrounded the detonator employed to initiate the combination charge. In Munroe's own words in an article published in 1900, he tells of use of such a charge to defeat the wall of a safe that was:

“...twenty-nine inch cube with walls four inches and three quarters thick, made up of plates of iron and steel...when a hollow charge of dynamite nine pounds and a half in weight and untamped was detonated on it, a hole three inches in diameter was blown clear through the wall, though a solid charge of the same weight and of the same material produced no material effect. The hollow cartridge was made by tying the *sticks of dynamite around a tin can, the open mouth of the latter being placed downward...*”

The effects described would possibly not have occurred if the cavity had not had a liner made of the highly ductile metal, tin. (Today's steel “tin” cans may not work as well.)

### The U.S. Inactive Period — 1900–1940

For the nearly 40 years following Munroe's first discoveries, little of significance appeared in the literature concerning interest or activity in the United States in shaped charge technology. The only exceptions found thus far were two patents filed in 1921 and 1923 by Charles P. Watson (Ref. 24), and a paper by Professor R. W. Wood, submitted to the Royal Society in 1936. Prof. Wood, an Englishman, was at the time on the faculty of the Johns-Hopkins University in Baltimore, Maryland (Ref. 29).

### *The Watson Patents — 1921–1925*

The two Watson patents were issued in 1925 for “percussion fuzes” (Fig. 10) which incorporated a parabolic booster charge with a hemispherical metal-lined cavity at the output end of the fuze body. In the language of the patent “*thus very much intensifying the effect of the booster charge.*” Watson ascribed the observed intensified output to the parabolic shape of the booster chamber’s sidewalls which, again in his words: “*direct the detonating waves of force in a forward direction toward the cavity of the shell.*” Watson noted “I close the open enlarged end of the booster cavity by means of an *arched plug or shield* to hold the booster charge in place under all conditions of accident or service to which the fuse may be subjected until the moment when it is to be fired upon impact with the target.” He further notes in reference to the quantity of explosive required in the booster that only one fifth to one sixth as much explosive was required with his directed energy booster, and that the fuze would function “across a considerable air gap.” Thus, again the enhanced effect of a metal lined cavity, in this case the “arched plug or shield,” had been observed, but its importance remained unrecognized.

### *Professor Wood — 1936*

Professor Wood’s 1936 paper included a scientific description (Fig. 14) of what is now referred to as a “self-forging fragment,” “explosively-forged projectile,” or in Germany, a “P-charge.” All have a common basis in the well-known Misznay-Schardin effect. It is conceivable that Professor Wood’s paper may have given the Hungarian Army officer, Misznay, the idea for end-effects devices in World War II. Incidentally, the legend, (at least as this writer has heard it) is that the name “Misznay-Schardin effect” resulted from a visit to Hungary by Professor Hubert Schardin to interview Misznay. On his return to Germany, Dr. Schardin wrote a technical paper describing Misznay’s effect. Dr. Schardin’s name has been identified with the effect ever since.

It may be argued that the paper by Professor Wood should more properly be attributed to the United Kingdom even though Wood was on the Johns-Hopkins University facility at the time he submitted it. Since it is recognized that most of the people in the United States have roots in another land, the question is whether Wood eventually became an American citizen. The cavity end-effect so accurately described by Professor Wood was his analysis of an event in England involving the unfortunate demise of a young woman as a result of being struck by a hypervelocity pellet from a detonator accidentally embedded in a piece of coal in her heating stove. She opened the stove door at the wrong moment and became the first victim of what later came to be known as the Misznay-Schardin effect, and now the Explosively Formed Projectile (EFP).

### **British Influence**

The evidence suggests that if it were not for the research of the cavity effect in Great Britain from 1911 through the late 1930s, and Britain’s awareness of the work of the Swiss, Dr. Henry Mohaupt, the United States’ awareness and effective utilization of the shaped charge as a weapon effect might not have been achieved until much later in the war. Indeed, virtually all United States shaped charge literature from 1940 through 1942 appears to have

been of British origin, even though the lined shaped charge technology had been transferred by Dr. Mohaupt to the U.S. Army in late 1940.

### **Mohaupt vs. Thomanek — Who was First?**

As an aside, it is of interest to note that both accredited discoverers of the lined cavity effect, specifically Dr. Franz Rudolf Thomanek on behalf of Germany and Dr. Henry Hans Mohaupt on the behalf of the Allied powers, were (at the time of the 1983 writing of this paper) both residing along the West Coast of North America. Dr. Thomanek resided in North Vancouver, British Columbia, and Dr. Mohaupt near Santa Barbara, California.

It is difficult to determine which man was first to recognize the lined cavity effect. Dr. Thomanek's discoveries are well documented and dated (Refs. 33, 37, 60, 75, 78, 93) and include a history of the work that motivated him. However, Dr. Mohaupt claims a somewhat earlier discovery (Refs. 32, 47, 65, 67, 92). The writer has been unable to locate any contemporary documents substantiating Mohaupt's claims, as valid as they may be. As a result, the dates and specific events are difficult to resolve. Also, the background and motivation that led to Dr. Mohaupt's discoveries remain unclear to this writer even after two telephone interviews with Dr. Mohaupt (Ref. 92) and reading the only source he recommended. The latter was an account written by Dr. Mohaupt as part of a book published in 1966 (Ref. 67). Articles written 25 years after the fact are inherently less accurate than contemporary documents. Dr. Mohaupt refused the writer's requested visit for a direct interview, noting he was "presently involved in writing his own history of the shaped charge," which could account for his reluctance to discuss the subject.

Henry Mohaupt is properly accorded the honor of being the "father" of the lined cavity effect in the United States (Ref. 74). Because he did not attend the Schrobenhausen meeting, this paper discusses some of Dr. Mohaupt's work prior to his coming to the United States in October of 1940. Most of the following is quoted from his own writings in the mid-1960s (Ref. 67).

#### ***Mohaupt's Discovery***

Dr. Mohaupt claims discovery of the shaped charge lined cavity effect as early as 1935, which, of course, precedes Dr. Thomanek's discovery in February of 1938. Mohaupt writes:

"in the course of an investigation into the behavior of condensed high explosives and metal fragmentation conducted by (Mohaupt) in 1935 in his laboratory in Zurich, it was observed that metal fragments originating from the charge face opposite the point of initiation exhibited much higher velocities than fragments in the lateral...spray." Noting the divergent spray, Mohaupt reasoned that a "...parallel or convergent fragment spray could be produced by variations in the angle of attack of the the detonation front with respect to the projectile contour" and "...tests with hollow steel cones in the range of 22 to 45 degrees semiangle, launched base foremost from cast high explosive charges were then conducted...A tapered penetration canal of tremendous depth was produced" in thick steel targets.



It is probable that Mohaupt had only indirect evidence because of a lack of suitable instrumentation (e.g., flash radiograph) which made it difficult to interpret the effect observed on the plate targets and infer the mechanism. Mohaupt's 1966 article continues:

"...in the period of 1935 to 1939, projectiles ranging from an antitank rifle grenade...to artillery projectiles up to a caliber of 100 mm were tested in static and dynamic firings at the Swiss Army Proving Ground at Thun, the French Naval Artillery Proving Ground at Gavre, as well as at (Mohaupt's) laboratory...Following a conference at Woolwich Arsenal, the effects of this new principle were demonstrated...in early 1939 at Zurich to a British Military Mission."

Dr. Mohaupt further states:

"The spectacular penetration and target-explosion results achieved aroused the immediate interest of the British military in this new principle and led to development programs of their own."

Again it must be observed that these words by Dr. Mohaupt were published nearly a quarter of a century *after* those events occurred. More contemporary reports suggest that the British had perceived things differently than described by Dr. Mohaupt. According to a 1945 source (Ref. 39) the British Government thought Mohaupt was just demonstrating the already "well known cavity charge effect" and refused to meet what they considered to be his "exorbitant" price. The British observers were possibly unaware of the *lined* cavity effect Mohaupt was attempting to demonstrate. However, it is equally conceivable that Dr. Mohaupt did not always achieve a true jet effect because of his possible use of a tube or solid bar extending along the central axis from the nose to the base fuze element. Such devices are clearly shown (Fig. 16) in the patents (Ref. 32) issued in France in 1940 and in Australia in 1941, wherein the inventors (Mohaupt and his two associates) had claimed the formation of "*a secondary projectile*" rather than a jet! It is clear in both the figure and description in the patent that interference of the central tube would effectively prevent a jet formation, but would allow the formation of a secondary projectile as noted by the inventors. It is this writer's contention that contemporary reports (e.g., late 1930s) are needed to resolve the many questions concerning the dates, designs, and descriptions of the effects produced. The writer's attempts to obtain such documents from the Woolwich Arsenal were unsuccessful.

Mohaupt continues in the 1966 published article:

"...by request of the French Government after the outbreak of World War II, demonstration firings with antitank projectiles and 100 mm beehive demolition charges were then conducted at Bourges Proving Ground. The penetration of these charges had been further improved by the use of very precise cones and by the use of cast main charges composed of mixtures of...(Pentolite)...and similar cast charges containing Hexogen (RDX) and TNT...the French Government authorized immediate quantity production of these antitank projectiles by the Establishments E. E. Brandt...However the rapid deterioration of the military situation put an end to the program and the French Government authorized release of the secret information to the United States Government...In 1940, a French representative, Col. P. Delalande, and (Mohaupt) were requested to proceed to the United States for this purpose..."

In another source (Ref. 74) it is noted that Col. Delalande (also referred to as "Major Lelande") possessed a diplomatic visa and was thus able to leave immediately, while Dr. Mohaupt was forced to wait in Portugal until his papers were in order.

Henry Mohaupt arrived in the U.S. on 18 October 1940. Shortly after Mohaupt's arrival, the first demonstration of the lined cavity effect was conducted at Aberdeen Proving Ground in Maryland. It is fortunate that the demonstrations were observed by the right people because prompt action was taken. The Aberdeen demonstrations were arranged by the French Army representative, Col. Paul Delalande, who had arrived a few weeks earlier. He had also made arrangements for the test devices for the demonstrations to be made prior to Dr. Mohaupt's arrival. The charges were fabricated by the E. I. DuPont Company, which subsequently became the principal industrial organization in the United States involved in shaped charge research in support of the Army's development efforts during World War II.

The demonstrations were successful in convincing Army observers to act on what they had seen, cognizance for development was assigned to Picatinny Arsenal. The project was classified "Secret." Although Mohaupt was an alien and did not have a security clearance that would allow his direct participation, he continued as an effective consultant to the Army. His independent efforts led to significant design patents for artillery projectiles utilizing the shaped charge (Fig. 30) and new liner configurations (Fig. 31). The liner patent filed in 1942 shows a grenade that the writer considers a very modern design. The patent also illustrated bi-metallic liners, tapered liners, and tapered cone-hemispherical configurations. Mohaupt was truly years ahead of his time. The liner patent was retained under secrecy orders and was not issued until 1961.

### **Introduction of the Bazooka**

The first product based on Mohaupt's transfer of technology was the M9A1 2.36-inch rifle grenade (Fig. 32) (Refs. 46, 47). The interfering tube on the axis was no longer employed and a true jet-producing device was achieved. However, the inadequate range and accuracy of the rifle grenade was a problem. The marriage of a rocket motor to the M9A1 grenade warhead eventually resulted in the 2.36-inch M2A3 HEAT rocket (Fig. 33), better known as the "Bazooka" (Ref. 74). It was soon to become the most widely employed antiarmor weapon used by the United States armed forces in World War II.

It is noted that the German "Panzerschreck" and "Panzerfaust" [Fig. 23] designs were allegedly based on a Bazooka captured either in the Tunisian campaign or in the Soviet Union in late 1942 [Ref. 72]. However these contentions are vigorously denied by Dr. Thomanek, who was responsible for the design and manufacture of 50% of the total German WWII shaped charge weapons inventory.

The first production lot of 600 Bazooka rounds was delivered to the North African theater in September 1942 to the British Forces. Although the British Commander was convinced of the capability of the new weapon to defeat the 50-mm armor of the German Pzkw-III, he reluctantly refused to commit the new weapon to battle because the terrain offered no protection for the users who were required to be at close range to be effective. The Bazooka was reportedly not committed to combat until the Tunisian campaign in the spring of 1943. The Bazooka was one of the most important of the new U.S. munitions to be introduced in

World War II. It was generally believed by the American public to be an invincible weapon and powerful killer of armor, a theme portrayed in many of the the WWII movies. However, as much of a morale booster as it may have been, the Bazooka also had its shortcomings.

### ***Problems of the Bazooka***

In the Sicilian campaign, the U.S. Army's Lt. General James Gavin was to later observe (Ref. 77) that the Bazooka lacked penetration capability and that his troops were literally being crushed into the earth by German tanks they were unable to defeat. General Gavin lamented that the weapon "could have been tested against the German tanks captured in North Africa, but evidently it was not." But according to other sources, the weapons *had* been tested against German tanks in North Africa. In retrospect, it is possible that the problem was not in the lack of penetration of the shaped charge, but the failure of the fuzes to initiate the warhead quickly enough. In 1951, this writer was invited to observe infantry training at Camp Roberts, California, where it was obvious that the 2.36-inch Bazookas were, for the most part, failing to detonate high order and form a jet as designed. Instead, most of the rounds were apparently functioned low order from crush-up on the target, as evidenced by the presence of many undeformed conical liners laying about on the test field. Further, the damage to the armor targets usually resembled that produced by a HEP or squash head mechanism. Even the Army instructors seemed to be unaware that their Bazookas were malfunctioning. They described the Bazooka's terminal effect as "discharging a baseball sized chunk of metal from the far side of the armor." There was no mention of a penetration hole.

Gen. Gavin's complaints about the Bazooka may have been instrumental in the Army's development, later in World War II, of the larger and more powerful version, the 3.5-inch "Super-Bazooka" (Fig. 34). However, the latter was not introduced into WWII but was kept "on the shelf" until 1950. It was hurriedly introduced into the Korean War after early actions using the older 2.36-inch Bazooka showed it to be inadequate for defeat of the Russian armor employed by the North Korean Army. U.S. Army combat teams were reporting being overrun by the Soviet T34-85 tanks (Refs. 72, 74, 77). Similar problems were reported by Navy and Air Force pilots who complained that 5-inch HVAR rockets were "bouncing off" of the North Korean tanks. The U.S. Navy response to the latter problem is discussed in Part III of this paper.

### **Other U.S. Army Developments in WWII**

Army-developed shaped charge munitions in World War II included the above described Bazooka and rifle grenade, plus HEAT rounds for the 57-mm recoilless rifle, 75-mm and 105-mm howitzers, and such engineer demolition charges as the 15-lb M2A3 and 40-lb M3 charge. Other munitions in development at the end of the war included a 4.2-inch round for the chemical mortar, a 4.2-inch rocket, a 7.2-inch rocket, and, as was noted, the 3.5-inch Superbazooka. Development of many of the above listed munitions was completed too late for use in WWII. According to a report issued by the Ballistic Research Laboratory in June 1943, the Army was also interested in development of HEAT shell for 10-inch and 16-inch mortars. There is no evidence that such large mortar HEAT rounds were ever developed.

### **Navy Developed Shaped Charges, WWII**

The United States Navy's interest in the shaped charge covered a broader scope than the Army's. Navy research and development (Ref. 43) included torpedo warheads with 18-inch diameter liners (Fig. 35), a 6-inch shaped charge anti-submarine "scatter" bomb for vertical attack on submarines (Fig. 36), and a 3.5-inch shaped charge/projectile-follow-through bomb for anti-submarine use (Fig. 37). The shaped charge torpedo warhead was to be used on a torpedo with a 21-inch diameter. The warhead contained 520-lb of Torpex explosive behind a 60-degree steel conical liner. This was the largest shaped charge developed by the United States services in WWII. (Compare with the German MISTEL's 2-meter diameter!)

The U.S. Navy also made extensive use of the shaped charge for explosive ordnance disposal (EOD) operations (Ref. 39). Both conical and linear lined charges were employed, with most of the liners made of steel. In late 1945, Navy EOD Lieutenant G. C. Throner developed lead-lined shaped charges to permit opening of explosive munitions without detonating the HE payload high order.

Private firms, such as DuPont, and institutions of learning, such as the Carnegie Institute of Technology, supported the military in the research on the shaped charge in WWII. A group at Carnegie Institute of Technology (CIT) led by Dr. Emerson Pugh engaged in fundamental research on the shaped charge, the Misznay-Schardin effect, armor to defeat the shaped charge, and spin-compensation principles. The group included Robert Eichelberger who later headed the Army's BRL. CIT made many of the major contributions to the shaped charge technology.

### **Post-War Shaped Charge Research**

With the end of World War II in the late summer of 1945, most of the U.S. weapons research ceased with the exception of rockets, missiles, atomic weapons, and the shaped charge, each of which had captured the imagination of the U.S. Government. During the late 1940s, commercial investigators, including those who formerly worked on military applications, continued to pursue and apply the technology of the shaped charge in such non-military areas as mining, oil well completion, steel furnace tapping, and scientific research such as the creation of artificial meteors, etc. Others, including Throner and his associates at the Naval Ordnance Test Station, assisted the developers of rockets, missiles, and atomic weapons with innovative development of shaped charge devices for safety destruct, stage separation, and similar missile and test range functions. The postwar period saw the beginnings of innovation and new concepts exploration and application. The theory was being developed by such investigators as R. J. Eichelberger at CIT, and experimentalists explored techniques such as detonation wave shapers (Fig. 38), multi-staged (i.e. tandem) shaped charges, shaped charge follow-through, and other performance-enhancement mechanisms.

## HISTORY OF THE SHAPED CHARGE PART III

### AN ANECDOTAL HISTORY OF THE SHAPED CHARGE DEVELOPMENT IN THE UNITED STATES FROM 1950-1986

*LIMITED TO THE WORK OF D. R. KENNEDY AND HIS COLLEAGUES AT THE FOLLOWING:*

*The U.S. Naval Ordnance Test Station (1950-1953)*

*Aerojet General Ordnance (1953-1965)*

*FMC Defense Technology Laboratories (1965-1975)*

*Shock Hydrodynamics (1975-1976)*

*Stetter Associates (1976-1978)*

*D. R. Kennedy And Associates (1970-1983)*

Part III of the shaped charge history covers the period since 1950, but is restricted only to the experience of the writer and his associates. Others are expected to present the history of the shaped charge developments from the standpoint of the Army and the Air Force. However, the present discussion includes developments by the writer and his colleagues for the various armed services. This is a commentary on the kinds of devices developed, the organizations and persons involved, and when and where a particular development was performed. The technology is discussed only in broad terms, particularly when it may involve topics related to current work, some of which may still be considered classified by the respective Government agencies. Part III also attempts to fill in some of the voids and cover certain programs and work not well known to the other U.S. students of the shaped charge.

## PART III

---

### **Activity In Shaped Charge Technology By D. R. Kennedy And Colleagues: 1950 – Present**

#### **Introduction**

The following narrative of United States shaped charge history is limited to the activity of the writer\* and his colleagues from 1950–1986. The first period was effectively from 1950 through mid-1953 at the U.S. Naval Ordnance Test Station (NOTS, now Naval Weapons Center) at China Lake, California. The second period extends from mid-1953 to the end of 1964 with Aerojet General Ordnance Division in Azusa, Downey, and Glendale, California, where the writer was the first employee of the Ordnance Division and Head of Advanced Design. The third period begins in January 1965 through January 1975 at the FMC Corporation's Defense Technology Laboratories, Santa Clara and San Jose, California, where the writer was a co-founder and again responsible for advanced design munitions technology. The period from early 1975 through late 1976 was with the Shock Hydrodynamics Division of Whittaker Corporation, North Hollywood, California, as a staff scientist with a responsibility for kill mechanisms enhancement research. Activities since late 1976 have been with a consulting munitions manufacturing technology firm and since May 1978 as a consultant, subcontractor, and prime contractor as D. R. Kennedy and Associates, Inc.

During a period of some 36 years, the writer was fortunate to have participated in, and in some cases pioneered, many diverse aspects of shaped charge research, development, and production for munitions and special devices for virtually all environments of land, sea, air, and space. It is possible that few investigators have had such an opportunity to work so continuously across such a wide spectrum of activity in the field of the shaped charge and related munitions technologies. The writer considers himself fortunate to continue to be involved at the cutting edge of the technology. However, the real fortune is the association with so many of the excellent people in the U.S. and allied nations.

Although the following discussion by no means depicts all aspects of the United States activity in shaped charge technology, it is representative of general trends during the period

---

\* Prior to associating with the U.S. NOTS in April 1949, the writer's experience included (1) academic training in the chemical engineering; (2) a year with Convair's missile flight test organization at San Diego, flight testing large rocket vehicles including the MX-774 (precursor to the ATLAS), Bumblebee, Lark, etc., at White Sands and Point Mugu; and (3) war service from 1940 through 1943 with a U.S. Army antiaircraft group in the Pacific Theatre of Operations. The author was present during the Japanese attack on Pearl Harbor, where one could gain an appreciation of the awesome capability of so-called conventional munitions. It was the latter experience that encouraged the writer to work in the field of non-nuclear technology.

beginning 1950. It also includes certain aspects of shaped charge applications and research unique to the writer and his associates.

### **Shaped Charge Research at the Naval Ordnance Test Station — 1950 – 1953**

The writer's introduction to the shaped charge began in the early summer of 1950 at the U.S. NOTS, in the Mojave desert, 175 miles north and east of Los Angeles. The writer was at that time a Navy civilian employee as a scientific staff assistant on the Rockets and Explosives Department staff. The Department Head was Commander Levering Smith, later Admiral Smith, who was for many years the guiding light behind the Navy's Special Projects Office; i.e., Polaris, Poseidon, and Trident projects.

For reference, most WWII rocket warheads were explosive filled, blast and natural fragmentation types, many having been adapted directly from bombs and artillery projectiles. In the late 1940s, NOTS was engaged in development of the 2.75-inch AAFRR (air-to-air-folding-fin rocket); the 5.0-inch HPAG (high performance air-to-ground), also HPAA (air-to-air), and HPAW (air-to-underwater), and the 12.75-inch Weapon A (later Weapon Alfa) anti-submarine weapon. Special warheads and fuzes were being developed by the Navy at China Lake with support in special areas from the Naval Ordnance Laboratory, the Naval Proving Ground at Dahlgren (warheads), the National Bureau of Standards (proximity fuzes), the Johns-Hopkins University Applied Physics Laboratory, and the New Mexico School of Mines. To 1950, the primary warheads for the 2.75-inch and 5.0-inch rockets were blast-fragmentation types especially designed for the delivery environment and expected target spectrum. For example, the 2.75-inch warheads were designed to penetrate and detonate within aircraft, and the HPAW warheads were designed to enter water at both high speed and high obliquity without changing their trajectory. The research and development of special warheads as the discrete rod, controlled fragmentation, and shaped charge warheads, did not begin until the late 1940s.

The event that created an intense interest in the shaped charge at NOTS was a problem reportedly encountered by the U.S. Navy and Air Force pilots when attacking tanks employed by the North Koreans during the initial phase of the Korean campaign. The pilots complained that the 5.0-inch aircraft HVAR rockets were "bouncing" off of the Soviet-built T-34 tanks. (The HVAR used a 50-lb, blast-fragmentation warhead, which was essentially a modified 5-inch Naval gun projectile). To make the matter even worse, it was reported that the formidable Joseph Stalin III heavy tanks had been seen on the Trans-Siberian Railway, apparently enroute to Korea.

An urgent wire from the Chief of Naval Operations to the Naval Ordnance Test Station to "do something about the problem" resulted in the virtually unheard of feat of development "from scratch" of a totally new warhead and fuze system and delivery of the first 1000 rounds to Korea in less than *20 days!*

### **The 6.5-Inch ATAR (Code Name "RAM")**

The 6.5-inch Anti-Tank Aircraft Rocket (ATAR) employed a shaped charge warhead designed by G. C. Throner, a former EOD officer, based on the in-house studies he had

performed at China Lake. He was then head of the NOTS Explosive Ordnance Branch, an organization concerned primarily with the range support of the several missile development programs at China Lake.

The new warhead and fuze for the appropriately code-named "RAM" were, by necessity, designed around materials and technologies immediately available to the remotely located Ordnance Station. The warhead's case was a 6.625-inch diameter steel tube of the type used in oil wells. The liner was a 60-degree included-angle, steel cone, sand-cast by the NOTS foundry. The liner was used in an as-cast condition with very little machining required about the base. The Composition-B explosive filler was cast at an on-base AEC-operated explosive pilot plant facility. The newly designed fuze was an electric, point initiated, base detonated system. Some of the fuze parts came directly from the shelves of the Navy commissary. Hearing aid batteries (it was claimed NOTS took most the batteries off the stores in the Western half of the United States) were used to charge a capacitor power supply. The acceleration actuated arming-delay mechanism used a spring taken from commercial clothespins and BB shot in a piece of copper tubing. The setback operated delay was literally designed overnight, and its production was completed just prior to delivery of the first 1000 rounds to the battle area. Figure 39 is a sketch of the 6.5 ATAR.

The first prototype warhead was being dynamically projected and detonated at the end of the 1500-ft. ballistic test track by the third evening of the 24-hours-per-day all-out crash effort. Full weight dummy rockets were ballistically tested from both Navy and Air Force aircraft by the first weekend, and dynamic tests against an M3 Grant tank placed at the end of the ballistic track were performed the second week. (*LIFE Magazine* photographers arrived to record that event.) The first 1000 rounds were shipped from NOTS on the 19th day. A formal NAVORD report containing a technical description of the new weapon, firing instructions, and firing tables was included in each box containing a round. The entire RAM effort, which eventually utilized most adults residing at the NOTS (including the housewives who assembled fuzes on tables lining the corridors of the Michelson laboratory), cost the Navy only \$167,000, or \$167 per weapon, exclusive of the cost of the on-the-shelf 5.0-inch HVAR rocket motor!

As a result of this highly exciting "crash program," there developed within China Lake's technical community, a great curiosity concerning shaped charge technology. A small in-house fund of \$14,000 was made available to explore the effects produced beyond armor by the shaped charge. The writer, now designated an "ordnance engineer," was assigned to a three-month duty with the Explosive Ordnance Branch organization to perform the study. Soon thereafter, the Bureau of Ordnance increased the scope of the project, added more funding and two new assignments: one to "investigate things shaped charge," and the other, to explore a newly identified phenomenon observed in research by John Rinehart at the New Mexico School of Mines, an effect he called "vaporifics" (Ref. 69). The assignment to "investigate things shaped charge" (the entire description) was taken quite literally. The mechanism was explored in all possible combat environments from underwater and underground to extreme altitude.

Mr. Throner was already experimenting with shaped charges in a variety of novel arrangements starting in the late 1940s. He performed experiments with multistage liners as early as 1949, including some with three or more liners in a pagoda-like, tandem arrangement



with a common explosive charge. Although some tandem charges occasionally performed as hoped, the ability to solve the jet traffic problem by the then-available diagnostic means was well beyond the capability of the investigators. Taking a clue from the nuclear weapons explosive lens work he had participated in at NOTS, Throner also explored the benefits of detonation wave shapers and shock operated jetting mechanisms starting in the late 1940s. The choice wave shaper materials were aluminum or uniformly grained woods such as maple. (Note: The Army favored the use of oak at that time, see Fig. 38.)

The NOTS work in the period 1950-53 was characterized by multiple study efforts. The group had the benefits of excellent facilities, virtually no limit on explosives quantities, a large EOD group attached (15 officers and men all experienced in explosive ordnance disposal), and a pool of "free" help in the form of newly hired engineers who could be assigned to short term tasks while awaiting their security clearances to work on more sensitive projects. The Explosive Ordnance Branch facility included all necessary shops such as armor preparation, carpentry, machine shop, and photo lab, plus magazines and facilities to proof fuzes (e.g., drop tower, transportation vibration, jolt and jumble). It was an experimentalist's paradise.

Much of the work was literally performed day and night (because of the extreme heat of the desert summer days and also to improve photographic capabilities such as open-shutter observations).

Some of the many investigations that were conducted during the three year period included the following:

### *Long Standoff Shaped Charge Experiments*

Experiments in which both shaped charges and Misznay-Schardin projectors were fired at standoffs as great as 100 meters (240 liner diameters), were designed to explore the aluminum metal explosive response to hypervelocity impact that was then known as the vaporific effect (Ref. 55). The experimental test devices ranged from single explosively forged pellets fired in various gas media, to shaped charges of 4-inch to 15-inch diameter, fired at standoffs of 100 to 300 feet against both airframe and explosive; e.g., live bomb targets. Figure 40 illustrates the 15-inch shaped charge test device that employed a spun-aluminum parabolic-shaped case containing 125 lb of Composition-B. The liner was a 1.5-inch-thick, 120-degree, conical aluminum casting (356-alloy) used in its as-cast condition. The latter device was to be the first nonnuclear explosive device known by the writer to have been loaded with Octol explosives (1952). Charge aiming was always a problem over such great standoffs. To accurately aim the 300-ft standoff devices, it was necessary to use a flashlight at the desired aimed point reflected from a first-surface mirror affixed to the face of the liner (essentially a 600-ft optical lever). Figure 41 shows the before and after view of an 8-inch, 45-degree, aluminum conical lined charge fired from a standoff of 150 ft. against the after half of a B-29 fuselage. Point of aim is the "X" mark on the fuselage.

### ***Multiple Shaped Charge Tests***

As extensions of the long standoff studies, multiple-liner devices were designed and tested which simultaneously projected multiple jets, ranging from as few as four, to as many as 180; the latter being achieved by placing the liners on the surface of a large hemisphere.

Note: The European-developed ROLAND missile warhead may have been influenced by Dr. Thomanek seeing photographs of the tests of such devices during his 1961 visit to the United States (Ref. 70). Figure 42 illustrates a single row 9-lined experimental device. Figure 43 shows a 45-liner device with 5 rows of 9 liners on a common case and with 5 points of initiation along the axis. Figure 44 shows the firing of a large hemispherical dome device with 96 aluminum shallow-dish liners embedded in its surface.

### ***Shaped Charges at Extreme Altitude Conditions***

Studies were made of small shaped charges at long standoffs in a 40-ft-long vacuum chamber to determine the effects on aluminum airframe materials impacted by hypervelocity fragments at very high altitudes; i.e., greater than 50,000 meters. Other studies examined the effects of impacts in atmospheres such as argon, nitrogen, helium, oxygen, and engine exhaust gas (Ref. 58).

### ***Behind-Armor Effects (BAE) Studies***

Studies were made of the effects produced by shaped charges behind armor. This pioneering effort (apparently the first significant study in the world), explored the behind-armor effects (BAE) of both large and small shaped charges with liners of copper, steel, and aluminum. The effects measured included the mass, characteristics, and angular distribution of the behind armor spall and the overpressure and temperature in confined volumes, as a function of liner geometry (Ref. 56). Figure 45 illustrates the effects identified in the early NOTS studies. Much of this work was also performed against actual tank vehicles at Aberdeen Proving Ground, Maryland, as a cooperative venture between the Army and the Navy. In one Aberdeen experiment, the beyond-armor light emission of an aluminum jet was measured by a bolometer device provided by the Army. A 5-inch aluminum lined charge was buried cone-up in the ground, and a 10-inch-thick armor plate was placed above it. The jet remaining after passing through the 10-inch plate was assessed as having a luminosity equivalent to 240 #2 flashbulbs, the second largest photoflash bulbs then in existence.

### ***Shaped Charges Under Water***

Shaped charge performance underwater was studied in simulated attacks on spaced submarine targets as a function of liner material and geometry at underwater standoffs up to 5 feet (Ref. 59). Figure 46 illustrates a typical test setup.

### ***Shaped Charges Under Ground***

Studies of both shaped charge and Misznay-Schardin mechanisms in a deeply buried land mine environment (e.g., 7-ft earth overburden), including multi-staged (tandem) follow-through mechanisms, were performed in a 140-mm caliber. Figure 47 illustrates a mine

device developed by the Navy and Douglas Aircraft. Many of the early experiments were performed at NOTS. Work was resumed in 1954 at Aerojet (discussion follows).

### ***Liner Materials Studies***

Performance of previously untried shaped charge liner material candidates, both metals and ceramics, was evaluated. Included were the first tests with titanium- and zirconium-lined shaped charge devices. A related study involved the fabrication of liners cast from copper/aluminum mixtures ranging from all-copper to all-aluminum. The purpose was to seek an alloy possessing the better characteristics of each material. Figure 48 illustrates potential liner material candidates. Several of these materials were first examined at NOTS.

### ***Shaped Charges vs. Live Ordnance***

The effects of aluminum-lined shaped charges against 500-lb, explosive-filled bombs at extreme standoffs were performed to determine the ability of such devices to detonate the explosives by hypervelocity fragment impact.

### ***Shaped Charges vs. Fuels in Tanks***

An important part of the work with anti-armor shaped charge mechanisms concerned the behavior of charges with various liner materials against tanks. A Soviet T34-85 hull, turret, and gun assembly was provided for such studies. Other work was performed in cooperation with the Aberdeen Proving Grounds (APG) personnel using both U.S. and German tanks at the APG facilities. An important part of the studies was evaluating the effects of various liner materials in raising fires in diesel fuels behind armor. The aluminum-lined charges consistently produced a major fire event.

The studies described and many others at NOTS contributed new knowledge of the potential of the shaped charge mechanism in weapons applications in all Navy operating environments. Many of today's U.S. weapons can be traced to the early NOTS studies, including (1) the use of aluminum in large charges in both surface and underwater applications, (2) the potential in space warfare, and (3) the appreciation of the need for enhanced effects behind armor. In 1973, this writer prepared a special Air Force report (Ref. 69) reviewing the early NOTS vaporific effects studies. Included were reprints of certain key reports that were prepared in the early 1950-1953 period. The report is recommended to those interested in the historical aspects of the phenomenon of the vaporific effect (a solid-state fuel/air explosive phenomenon).

### **Formation of the Aerojet General Ordnance Organization — 1953**

Three 1953 events resulted in a breakup of the original NOTS explosive ordnance team and relocation of three key members to an industrial organization, Aerojet General in Azusa, California. Both the Army and the Air Force had become interested in the aluminum shaped charge work at NOTS, the Army for a new anti-tank missile called "DART," and the Air Force for the anti-aircraft missile known as BOMARC. The Navy was not enthusiastic about supporting the other services and their contractors, and was at the time down-playing weapons research activities. The latter was accompanied by a reshuffling of civil service

personnel from other facilities which resulted in some unacceptable personnel problems within the Explosive Ordnance Branch at NOTS.

At the invitation of Aerojet General (its President was then Dan Kimball who had just left the post of Secretary of the Navy under President Truman), and with the concurrence of both the NOTS Station Commander and the Chief of the Bureau of Ordnance, Throner and two engineers joined Aerojet in mid-1953 to establish what eventually became the Aerojet Ordnance Division. This was an opportunity to put the fruits of the NOTS research into practice. Among the contracts received were those for development of the DART anti-tank missile's warhead (Fig. 49) and blast controlled-fragmentation warheads for both the Air Force BIRDOG and Army NIKE HERCULES antiaircraft missiles. Proposals were also submitted in response to the solicitation for a multiple shaped charge warhead for the BOMARC antiaircraft missile. Awards were made to Rheem Defense Products and the University of Utah. Aerojet participated in later phases of BOMARC warhead definition.

### **DART T42E1 Anti-Tank Guided Missile (ATGM) Warhead — 1954 – 1958**

The DART (Ref. 83) ATGM warhead employed an aluminum shaped charge liner. The DART warhead (Fig. 49), an axial shaped charge, had a diameter of 7 inches and gross weight of 20 lb, of which 17 lb was the assigned Composition B explosive filler. To meet the weight assigned to the warhead section by the missile systems contractor (the Aerophysics Development Corporation), it became necessary to introduce several innovations applied for the first time to an item of nonnuclear ordnance. These included the use of a lightweight, air-filled (i.e., syntactic foam) detonation wave shaper (similar to that in today's Rheinmetall 120-mm DP round), an outer case of high-strength filament wound fiber glass in an epoxy resin matrix, and a molded fiberglass base closure and fuze mount structure. Lead wires from the nose fuze switches to the base mounted fuze were flat strips cut from copper sheet and laid up *within* the fiber glass case. The latter technique possibly led to the technology for flat wire conductors common today. Octol explosives were also introduced as an alternate, higher performance filler (believed the first ATGM application). The DART missile program was terminated in 1958, primarily because the missile itself was becoming seriously overweight.

The T42E1 DART warhead was extensively tested against tanks at Aberdeen Proving Grounds, and proved to be one of the more potent shaped charge warheads ever fired against medium and heavy tank targets in terms of the behind armor effects. The DART was the first nonnuclear warhead to use a detonation wave shaper, although wave shapers were being commonly used in commercial oil well completion charges (as in Fig. 50).

### **BOMARC IM-99A Missile Warhead — 1954 – 1958**

The BOMARC warheads developed by Rheem and the University of Utah incorporated a series of wide angled aluminum liners about the periphery of an annular ring explosive body, similar to the NOTS experimental device shown in Fig. 42, and the later German ROLAND antiair missile and KORMORAN antiship missile warheads. The BOMARC warhead work was terminated in the late 1950s in favor of a continuous rod warhead which became the

vogue in the early 1960s period. Aerojet performed the design study recommending the rod warhead for BOMARC and a large fragment alternate as a backup because of concerns with the ability to properly fuze the rod warhead.

### **Aerojet Satellite Projector — 1954 – 1956**

The aluminum shaped charge technology was also used in an early attempt to put a satellite (i.e., jet particles) into an earth orbit. A conical 35-degree included-angle aluminum-lined shaped charge with a fiber glass body was installed on a multistage rocket assembly made up of bundles of LOKI rockets. The vehicle was fired into near space and the warhead detonated to project its hypervelocity fragments (10.7 Km/sec) with the hope of putting some identifiable man-made materials into orbit. These experiments were performed in 1955 and 1956 with test vehicles fired from Holloman Air Force Base, New Mexico. Although both the rockets and warhead fired, it was never established whether any aluminum particles were detected in orbit. This was not the first such attempt. On 16 December 1946, a V2 rocket fired from White Sands Proving Ground, New Mexico, carried six, steel-lined, shaped charge grenades for the purpose of generating artificial meteorites. The firing was made at night to facilitate observation. The firing mechanism evidently failed at the crucial moment (Ref. 97).

### **AGX-Series Shaped Charge Warheads — 1958 – 1964**

In 1953, the Navy began development of the BULLPUP air-to-surface guided missile. The Navy proposed that the warhead be a standard Mk81 low-drag, 250-lb bomb. Because published data indicated that the bomb would collapse at an impact velocity much in excess of 1100 ft/sec, Aerojet Ordnance proposed an alternate approach using a large, aluminum-lined, shaped charge in a controlled fragmentation body. The Aerojet unsolicited proposal was alternately accepted and rejected, depending on the occupant of the Navy "desk" at any given time. In 1958, Aerojet Ordnance, using \$2700 of its own funds, fabricated, loaded, and donated six 250-lb warhead test devices to the Navy. They were built with varying features to allow the Navy to qualitatively evaluate the various mechanisms against real targets in their own facilities. The Naval Proving Ground at Dahlgren could not obtain the \$80,000 funding required for the rather elaborate tests they planned to perform. The Air Force, when advised of this by Aerojet, arranged for transfer of the warheads to Eglin Air Force Base, where they were tested in May 1959 against a variety of existing targets. Figures 51, 52, 53, and 54 show the warhead's cross section, the various liners offered for tests, and a typical test setup and result.

The Air Force was impressed with the tests against the tank, bunker, aircraft, and heavy truck targets. As a result, the AGX-3200 warhead development was started in 1960. This was to be a shaped charge/controlled fragmentation warhead 10 inches in diameter and 250 lb in gross weight, to be slipped into the BULLPUP in the place of the Mk81 Bomb (Fig. 55, center design). However, a change in the missile guidance and control system design resulted in major components being placed immediately in the shaped charge's jet formation zone, with the result of a significant loss of penetration capability. Development was terminated as a result.

The AGX-3300 concept was proposed at the same time, as a shaped charge with projectile follow-through, again in BULLPUP size (Fig. 55, bottom design). The ideas illustrated by the AGX-3100 and AGX-3300 warheads intrigued the U.S. Air Force sufficiently that two missiles were subsequently developed to employ such mechanisms, (1) the Hard Structure Munition (HSM) which used the shaped charge with projectile follow-through, (e.g., the AGX-3300 method), and (2) the Maverick missile which uses a large aluminum-lined shaped charge based on the AGX-3100/3200 concepts demonstrated at Eglin Air Force Base in 1959. The Air Force HSM development was begun by Goodyear Aerospace with a Chamberlain warhead in 1964, but for various reasons, including warhead problems, has not yet entered the USAF inventory. HSM is a very large air-to-surface weapon and includes both an 18-inch aluminum-cone shaped charge and a 1000-lb semi-armor-piercing (SAP) follow-through unit with pilot-selective-delayed fuzing.

Aerojet General Corporation acquired Rheem's Defense Products Division in 1959. The two ordnance organizations combined and became one of the largest industrial research, development, and production organizations in the United States devoted to explosive munitions. The research department was organized and headed by Dr. Louis Zernow, who joined Aerojet in 1955. With Dr. Zernow's shaped charge research background at the Army Ballistics Research Laboratory, and with Mr. Throner's and the writer's applied research work for the Navy, Aerojet was one of the leading shaped charge technology centers in the U.S. until the departure of three key individuals in 1963 and 1964.

The Aerojet Ordnance Division was active in the development of more than a hundred munition products in addition to the above noted large shaped charges. The M-48 Claymore Misznay-Schardin APERS mine was developed at Aerojet in the late 1950s. The Air Force BLU-7 B/B vertical (top) attack shaped charge bomblet was developed in 1959. The concept for the tube artillery and artillery rocket ICM shaped charge submissile was originated by the writer in 1962, and was originally designed for a 30-km range rocket barrage system known as HAMMER, a joint U.S./F.R.G. program in the early 1960 period (the grandparent of the current MLRS now in the U.S. and NATO inventory). The HAMMER project was eventually terminated for political reasons.

The HAMMER Grenade (Figs. 56, 57) was a 40-mm-diameter, tandem-nesting unit, with a stacking height of only 25 mm. It weighed only 60 g but was designed to defeat 75 mm of top armor at a minimum standoff. With the termination of the barrage rocket program, a heavier, longer, and stronger version of the bomblet was designed (also as an in-house project by Aerojet Ordnance) to be carried and dispersed from large-caliber artillery (cargo) projectiles. The design concept was offered to the U.S. Army in 1962. It was accepted and eventually became today's M42 HEDP grenade. The grenade is in high quantity production in three variations, the M42, the M46 for gun-fired artillery, and the XM77 for the MLRS rocket system. Figure 58 illustrates the M42 grenade.

Both the BLU-7 and M42 vertical attack anti-armor grenades employ copper conical liners. The original versions of the M42 and HAMMER bomblet shaped charges were based on Aerojet-funded and developed oil-well-completion shaped charge devices that incorporated cone-hemisphere liners (Fig. 59). The latter were later noted to be very similar to one of the designs patented by Henry Mohaupt in 1961 (Ref. 65), based on his original filing in October 1942 (Fig. 31). However, the Aerojet designs were based on mid-1950s company-sponsored

research, at a time when the Mohaupt patent application was still under secrecy orders. The Aerojet designs were clearly independently conceived.

Many shaped charge research and advanced technology programs were performed by the Aerojet Ordnance Division in the period 1953-1965. Dr. Zernow's research group added significantly to the fundamental knowledge. Although the empiricists were gradually being augmented by the scientists and the computers with hydrocodes, significant new techniques continued to be discovered, often by accident. One was a shaped charge designated the X-charge, (Fig. 60) essentially a foreshortened version of the DART warhead. DART warheads were briefly employed as safety destructor charges for a nuclear rocket engine (NERVA), but proved to penetrate too well. In an attempt to increase the average jet velocity and also reduce the jet length to achieve a greater energy deposition in the NERVA target for improved lateral dispersion of its nuclear fuel, a fully waveshaped version in the configuration of the letter X was evolved. It was configured in an 8-inch diameter, employed a 90-degree aluminum conical liner and a mirror image 90-degree syntactic foam wave shaper, extending from the liner apex. To the delight of the investigators, an extremely high average velocity jet was produced. It was capable of defeating massive concrete targets at very long standoff distances. The jet tip was recorded by high speed cameras to have an average velocity over a 60-ft standoff in excess of 42,000 ft/sec (12 km/sec). (It is possible that the Lagrangian-Eulerian transform 2-D shaped charge code developed in 1973 by Lawrence Livermore National Laboratory [LLNL] resulted from an attempt to rationalize the X charge performance. The LLNL study confirmed the earlier observed velocity.)

The Aerojet Ordnance Research Department also succeeded in accelerating Misznay-Schardin folding plate projectiles (today's EFP) to velocities in excess of 20,000 ft/sec (6.1 km/sec) by the application of air-lensing techniques. Researchers also used the shaped charge to simulate the attack of rod-like penetrators on complex target arrays in simulated high velocity encounters in the range of 20,000 to 40,000 ft/sec.

Perhaps the most novel multi-stage, tandem shaped-charge/Misznay-Schardin devices were the 140-mm, aerially delivered, antitank mines designed to impact the earth at moderately high velocities and bury themselves deeply. The mine (Fig. 47) known as "Douglas Model 31" was designed to function when the magnetic fuze sensed a tank above the mine. Because it was possible for the self-buried mine to have from 4 to 7 feet of earth between the shaped charge and the belly armor (18 inches above the earth surface), a multi-stage tandem shaped charge with follow-through system was developed and successfully demonstrated in 1958. The explosive system consisted of a small shaped charge that was fired first to penetrate the earth over the mine to cause it to react laterally. This jet was followed by a jet from a 5.5-in copper hemisphere liner, and in turn by a chemical-follow-through material (e.g., a teflon-coated magnesium powder) which was aspirated by the vacuum of the jet's tail. The mine worked as designed. However, the mine project was terminated when it was decided that a simpler mine might be even more effective and not have its effectiveness restricted to only a portion of the target's belly area.

### **The FMC Defense Technology Laboratories — 1965 – 1974**

Europeans are often amazed that American engineers move from positions with industry to government and vice versa, and from one industrial firm to another. This is a legacy of the

kind of business practice in such industries as aircraft and aerospace, where engineers and production workers follow the contract awards. There is no official "state" industry in the U.S. munitions business as in some European and Asian nations.

Certain changes in Aerojet management in the early 1960s encouraged some personnel (of the "old guard") to seek other employment. The Ordnance Division suffered several significant losses. In 1963, Dr. Zernow, and others from the research department, resigned from Aerojet to form Shock Hydrodynamics, which later was to become a division of Whittaker Corporation. In the early 1970s, Mr. K. Kreyenhagen and others left Shock Hydrodynamics and former California Research and Technology. Likewise, Mr. Throner, the writer, and a few others left Aerojet in the winter of 1964/65 to form the FMC Corporation's Defense Technology Laboratories (DTL), at Santa Clara, California. Other key Aerojet personnel eventually joined the FMC group.

In the period 1965 to 1974, the DTL became an important part of the U.S. munitions industry, producing millions of 4.2-inch mortar shell metal parts assemblies and several hundred thousand rounds of Beehive flechette ammunition, in five configurations, in support of the Southeast Asia war.

### **MAVERICK Shaped Charge Warhead**

The 10-inch, 125-lb MAVERICK missile shaped charge warhead was designed and developed by the DTL group in the years 1967-1970, as a direct outgrowth of the studies at NOTS in the early 1950s and demonstrations of the AGX-3100 at Eglin Air Force Base in 1959. MAVERICK was designed to defeat an array of some 44 medium to hard surface targets. The tank was but one of eleven primary targets. Unfortunately, many people think of MAVERICK as an antitank missile (which puts it in the category of using an elephant to stomp on ants). MAVERICK does an excellent job against many hard targets including bunkers and naval craft.

The MAVERICK warhead was originally configured as a shaped charge and controlled fragmentation device that effectiveness studies had shown to be optimum for the missile application and its target spectrum. However, an Air Force official requested that the fragment case be removed because he was convinced that the pilot of a launch aircraft could fly into the fragment spray. An unconfined, light-weight design was the result. The initial version employed a two-stage tandem liner designed to produce a precursor jet to clear the nose mounted guidance and control equipment from the path of the main jet. Fig. 61 shows the set up and result of the first test of MAVERICK against a reinforced concrete target. The tandem liner arrangement is shown to have penetrated the entire 80 inches of 4800-psi concrete and approximately 80 inches of wood and earth below the concrete. Fuze interface and alignment problems eventually made it necessary to blend the hemispherical copper precursor liner, its cylindrical standoff tube, and the main 50-degree conical aluminum liner, into a single component. The result was the trumpet configuration in use today. The latter design is very inexpensive and made it possible to significantly improve the penetration and achieve a very small standard deviation in penetration. The MAVERICK liner was the first developed U.S. trumpet design to enter the U.S. inventory. Figure 62 shows the general configuration of a MAVERICK shaped charge warhead (shown in the lower half of the figure) compared with a variant, known as "FISC" in the upper half of the figure. The FISC



variant is described in a following paragraph. Figure 63 is unusual in that open publications rather accurately describe the warheads in operational missiles, in this case the ATGM-65 MAVERICK. Both the above described shaped charge and a subsequently developed, 300-lb. semi-armor-piercing (SAP) alternate warhead are shown in the Figure.

### ***Fragment-Incendiary-Shaped Charge (FISC) Version of MAVERICK Warhead***

A variation of MAVERICK incorporating both controlled fragmentation and incendiary capability was undertaken as a special task for the Air Force. The warhead, designated FISC was subjected to many tests of its capability. FISC devices were fired in arenas containing drums of diesel fuel at ranges in excess of 100 ft, the shaped charge jets were fired through multiples of 1-in. steel plates at intervals of 10 ft over a distance of 60 ft to determine ship penetration capabilities. Jets were fired into massive concrete and hard earth targets and were found capable of creating clear, cylindrical holes in the earth with diameters of 30 to 36 inches and depths of 11 to 13 feet, depending on the soil consistency. Although FISC warheads were intended only to demonstrate capabilities, the lessons learned have been applied to subsequent devices with considerable success.

### **Underwater Shaped Charges (For Torpedo Applications)**

The underwater anti-submarine mine and torpedo warhead was another area of considerable interest for possible application of the shaped charge. The writer was the proposal and preliminary design engineer for the Mk46 lightweight torpedo's warhead and its exploder while at Aerojet in 1959. In 1965, shortly after formation of the FMC Defense Technology Laboratories, an unsolicited proposal was submitted to the Navy to incorporate a shaped charge mechanism in the lightweight torpedo warhead, based on probability of encounter of increasingly hard-to-defeat future submarine targets. The FMC proposal was rejected in 1965. By 1973, Navy personnel were increasingly aware of the problem but weren't interested in improved capability warheads for the lightweight torpedoes. The writer and his associates were active with proposals, presentations, and technical discussions with the Navy and its cognizant organizations, trying to convince them of the role of the shaped charge, and in particular the reactive liner shaped charge, in the undersea environment.

### **Other DTL Shaped Charge and EFP Activities**

Other DTL shaped charge research and development included improvements of the 40-mm M433 HEDP grenade, research of the X-charge mechanism in sizes from 3- to 15-inch diameter (including tests against armor at standoffs to 50 calibers), and a major research of Misznay-Schardin antitank belly mines with reactive liners and fuze-controllable peripheral initiation. The latter effort included studies of the effects of the MS mines behind armors simulating both tank belly and top surfaces. A cylindrical, 240-cubic-foot volume, tank-simulation chamber was instrumented at many positions to record the pressure and temperature time sequence of the metal-oxidation combustion event produced by belly mines fired under the chamber.

A much larger confined target, representing a scale model of a hardened aircraft hangerette, was also constructed and used to measure the performance of X-charges fired through a

---

complex array of earth, concrete, and steel prior to entering the large volume target. Pressure and thermal events were recorded at each meter of length of the 6-meter-long target.

### **End of DTL — 1974**

The FMC Defense Technology Laboratories were disbanded in 1974. This action was prompted by many factors, including an increasing pressure by peace demonstrators protesting the war in Vietnam, a growing concern by FMC attorneys that the company could be held liable for harm to persons from DTL-produced explosive munitions, and a feeling by some of officials that a munitions development organization might harm the company's then lucrative international trade. (Combat vehicles were not considered to be in the same category as explosive munitions.)

### **Shock Hydrodynamics — 1975 - 1976**

The writer joined Dr. Zernow at Shock Hydrodynamics in January 1975 and operated remotely as the "Los Altos office" for the next two years. The principal shaped charge activity included research of mechanisms in the underwater environment (in support of the Navy's torpedo program) and design studies for the ILAW (later VIPER) proposal and the Rockwell International proposal for the HELLFIRE warhead. The writer was introduced to Mr. Joseph Backofen of Battelle while collaborating on the proposal for the HELLFIRE missile warhead at Rockwell International's Columbus, Ohio, facility. (Rockwell won the contract.)

The change of the Government's fiscal year in 1977 resulted in a 3-month period with insufficient funds available to support many of its contractors. Although Shock Hydrodynamics payrolls were met, there were no funds for necessary travel or proposal studies. At the suggestion of both sponsors and associates, the writer elected to work as a consultant, first in association with other former DTL associates then at Stetter Associates, and since May 1978, as an independent contractor and consultant.

### **Stetter Associates, Inc. — 1976 - 1978**

At Stetter Associates, one of the principal tasks was providing engineering support to the Government agencies and prime contractors engaged in the production of the 155-mm M483 cargo round and its M42 and M46 HEDP grenade payload. These are probably the single highest production-rate explosive munition items in the current U.S. and NATO inventory. As the original designer of the M42, the writer was retained by Stetter Associates to assist in trouble shooting both the metal parts manufacture and the load, assemble, pack (LAP) operations of the M42 grenade and its carrier projectile. Because it was also necessary to seek other contracts as a staff consultant, certain of the latter sponsors (mostly in the ballistic missile defense activities) urged the writer to go "on his own" and the advice was followed.

### **D. R. Kennedy and Associates, Inc. — 1978 - Present**

Since May 1978, the writer has continued to work at the leading edge of the shaped charge technology, participating with, or for, various clients, including the U.S. Department of

Defense and its agencies, Physics International Company, Battelle Columbus Laboratories, Aerojet General, Ford-Aerospace, ISC-Technologies, Fairchild Weston, MB-Associates, S-Cubed, California Research and Technologies, Southwest Research Institute, Quantic Industries, and many other contractors. Shaped charge activities have involved such warheads as IMAAWS (Rattler, AAWS-M), the 105-mm XM-815, the 105-mm M456 redesign, Tank Breaker, LAW-750, the M42 HEDP grenade, the improved Rockeye, advanced TOW, the advanced lightweight torpedo program, and many others, which because of currency are not discussed here.

The writer has been fortunate in working with others in the development of shaped charge computational models, and in various fundamental and applied researches and design studies. Several of the latter were in collaboration with Joseph Backofen while at Battelle Columbus, Dr. Ronald Brown of Physics International, Dr. Robert Sedgwick of S-Cubed, Bruce Morris of Southwest Research, and other innovative individuals.

In 95 years, the United States participation in the technology of the shaped charge has included original discovery and demonstration of the *lined* cavity effect by Munroe, a 40-year period of virtual inactivity, the introduction of the weapons technology by transfer from the Swiss inventor Henry Mohaupt in 1940, and as a result, more than 45 years of continuous research, development, and effective utilization of the cavity effect in both commercial and military applications.

The writer has been privileged to have participated in more than 36 of these years of research and development of the shaped charge. In this time we have seen the exciting period of exploration by the empiricists, who provided weapons for the armed forces, new products for the commercial world, and at times, new questions to be resolved by the theoretical physicists. We have seen the exploitation of the shaped charge for weapons and non-weapons applications in all tactical operating environments from under the sea to the far reaches of space. We have seen commercial applications in the oil patch, in the steel mill, in the mine, and in construction and demolition work. Shaped charges are components of systems for separation, safety destruct, and similar operations on space craft. We have seen development of the understanding of physics and the computer as tools to assist in the design of advanced shaped charges. We now have a better understanding of the phenomena and the vital role of materials in creating effects in the target, and further, how we may suppress the effects behind armor and protect man and machine from HEAT weapons. We have seen penetration capability nearly treble as we better understand the behavior of materials, their manufacture, and their interface with the chemical explosive driver.

Yet we still have much to learn and a need to further understand the intricacies of the shaped charge and the closely related explosively formed projectiles. We are still at the threshold of these exciting technologies. We have much to do and learn. I wish the members of the "shaped charge community" the best of success for the next 100 years.

It is indeed a fascinating field of endeavor!

Don Kennedy

**HISTORY OF THE SHAPED CHARGE  
PART IV**

**SHAPED CHARGE RELATED MISCELLANEA**

by  
Donald R. Kennedy



## PART IV

---

Part IV of the "History of the Shaped Charge" contains a broad assortment of shaped charge-related miscellanea, including some seldom seen, one-of-a-kind photographs and written materials that describe or in some way pertain to the individuals, topics, and events discussed in the preceding parts of this Paper.

Some of these items are literally "off the wall," others are from the author's long buried files dating from 1950, and others are bits of shaped charge related materials provided by friends and associates, both past and present, all over the Western world.

These are included here to add a little "spice" and to remind the readers that we are talking about real people doing real and, for the most part, very interesting things.

Photographs of Dr. Hubert Schardin (sorry, I've never seen one of the Hungarian, Misznay), Franz Rudolf Thomanek, and some of the characters still in this business from pictures taken in the early 1960's appear in Figs. 64 and 65.

Other pictures are of the early shaped charge work at Aerojet, including the precedents of the M42 HEDP grenade, the DART ATGM warhead and its antecedent, the X-Charge, and the damage done to a massive bunker by a large shaped charge, one of six donated to the Navy, turned over to the AirForce, that became the model for the MAVERICK missile.

Following the references, a life history of Dr. Monroe appears in Appendix A. Amazingly enough, he lived until 1938, so some of us, like Lou Zernow, Bob Eichelberger, Herb Weintraub, me, and others, are in a true sense contemporaries of the "Grand Old Man of U.S. shaped charges." An early article describing some of Monroe's early works is also included in Appendix A through the courtesy of its author, Bob Hople, now at IRECO. A personal history by Dr. Thomanek is presented in Appendix B, with a little editing to "Americanize" his original version. Appendix C reproduces some of the first flash radiographs of the shaped charge made in Germany in 1938. These were provided through the courtesy of Institute Saint Louis.

It is hoped that these will add a little more to the fun of working in this exciting field, and preserve in one place, some things we shouldn't lose track of.

Don Kennedy  
July 1988



## REFERENCES

### Annotated and Arranged Chronologically

1. 1883, "Versuche mit Komprimierter Schiessbaumwolle" (Experiments with Compressed Nitro Cotton) by Max Von Foerster, Chief of the nitrocellulose factory, Wolff & Co., Walsrode, Germany, Mittler and Son, Publisher, Berlin.
2. 1884, "Experiments With Compressed Gun Cotton;" Max Von Foerster, *Van Nostrand's Engineering Magazine*; Vol. 31, July-December 1884, pp. 113-119, Plates I and II.
3. 1886, United States Patent 342,423 filed 20 January 1886, issued 25 May 1886, to Gustav Bloem of Dusseldorf, Kingdom of Prussia, German Empire, for "Shell for Detonating Caps." Introduces hemispherical cavity metal detonators so that "by these constructions the concentration of the effect of the explosion is an axial direction...is increased."
4. 1888, "On Certain Phenomena Produced by the Detonation of Gun Cotton" Charles E. Munroe, *Newport Natural History Society, Proceedings 1883-1888*, Report No. 6.
5. 1888, "Wave-like Effects Produced by the Detonation of Gun Cotton," by Charles E. Munroe, *American Journal of Science (Silliman)* 36, 1888, pp. 48-50.
6. 1888, "Modern Explosives" by Charles E. Munroe, *Scribner's Magazine*, Vol. III, January-June 1888 pp. 563-576, New York.
7. 1894, C. E. Munroe, Executive Document No. 20, 53rd Congress, 1st Session, Washington D.C. (describes dynamite cartridges about an empty tin can, the first demonstration of a lined cavity?).
8. 1900, "The Applications of Explosives" by Charles E. Munroe, *Popular Science Monthly*, a two-part article pp. 300 and concluding on pp. 455 of *PSM* Vol. 56. Munroe is identified as a "Professor of Chemistry, Columbian University."
9. 1910/1911, "Verfahren zur Herstellung von Sprengkorpem" (Procedures for the Manufacture of Explosive Charges) Westfalisch-Anhaltische Sprengstoffe A.G., Patent DRP-Anmeldung W36269 14 December 1910 in "*Zeitschrift fur das gesamte Schiess-und Sprengstoffwesen*" 6, 1911, pp. 358.
10. 1911, "Improvement in Explosive Charges or Bodies," Patent No. 28,030 (UK) to Westfalisch-Anhaltische Sprengstoff-Actien-Gesellschaft (WASAG) of Berlin, Germany, 12 December 1911.
11. 1911, "Einiges uber brisante Sprengstoff," (Some highly brisant explosives), paper by Dr. M. Neumann, Wittenburg, Germany, *Zeitschrift fur Angewandte Chemie*, 24 November 1911. Pages 2233-2240.



## References

---

12. 1911, Mitgeteilt im Rahmen eines Aufsatzes von Kast u. Haid über Sprengkapsel-Prüfmethoden, Schrifttumsverzeichnis Nr20.
13. 1912, "Method for Construction of Explosive Blocks," Patent No. 249630, issued to WASAG, Berlin, Germany, 22 July 1912.
14. 1914, "New Hollow Bodies of High Explosive Substances" by Engineer Egon Neumann, Darmstadt, Germany, *Zeitschrift für Das Gesamte Schiess-Und Sprengstoffwesen*, No. 10, pp. 183-7. 15 May 1914.
15. 1915, "Explosives-Their Manufacture, Properties, Tests, and History" Arthur Marshall, Chemical Inspector, Indian Ordnance Department, Pub. J&A Churchill, London, pp. 321.
16. 1915, "Verfahren und Vorschläge zum Detonieren von Sprengladungen" (Proposed Method to Detonate Explosive Charges) A. Stettbacher, *Zeitschrift f.d. ges. Schiess-und Sprengstoffwesen*, 10, 1915, pp. 16.
17. 1915, "Die Explosivstoffe," R. Escales, VI. Heft, R. Escales "Nitrosprengstoffe," 1915, Leipzig, pp. 321.
18. 1917, "Initialexplosivstoff" by Dr. Richard Escales and Dr. Alfred Stettbacher, Leipzig, Germany. (Cites WASAG and Neumann and their own work with TNT.)
19. 1920, "The Detonation of Hollow Charges" by A. Marshall, in *Journal of Society Chem. Ind.* Vol XXCXIX No. 3, pp. 35T. (Cites information "learned from Professor Charles E. Munroe of Washington" who gave him early reference. Marshall was evidently unaware of Foerster's prior work, judging from lack of citation in this, possibly the *first history of the shaped charge*).
20. 1921, "Spreng-und Zundstoffe" by Prof. Dr. H. Kast, Braunschweig, published by Vieweg & Son. Cites earlier patents and references, including v. Foerster's 1883 paper.
21. 1921, "Die neue deutsche Sprengkapsel von Schulze," (The new German detonator by Schulze) Bernh. Bomborn, *Zeitschrift f.d. ges. Schiess. und Sprengstoffwesen*, 16, 1921, pp. 177.
22. 1924, "Untersuchung über die Brauchbarkeit der Methoden zur praktischen Prüfung von Sprengkapseln," (Research into Feasible Methods for the Practical Test of Detonators), H. Kast u. Haid., *Zeitschrift f.d. ges. Schiess. und Sprengstoffwesen*, 19, 1924, pp. 146, 183.
23. 1925, "Sprengkapseln und Initiatoren" (Detonators and Initiators), M. Lupus, pp. 83, *Zeitschr.f.d.gesamte Schiess.u.Sprengstoffwesen*, 20, 1925.

24. 1925, United States Patents 1,534,011 and 1,534,012 filed 22 September 1921, and 27 August 1923, both issued on 14 April 1925 to Charles P. Watson for "Percussion Fuzes." Incorporates hemispherical metal-lined cavity at output end of fuze body, "thus very much intensifying the effect of the booster charge." Inventor ascribes effect to parabolic shape of the booster chamber sidewalls, which "direct the detonating waves of force in a forward direction toward the cavity of the shell."
25. 1925/1926, M. Sucharewski, first Russian treatises on shaped charge citing their experiments and noting "the conical cavity generates the smallest penetration effect" (i.e., unlined), and "the tremendous practical importance of the application of shaped charge shells is...the possibility of reducing the shell weight to one-half and increasing the explosive effect by a factor of 3 to 5." Published in *Technica i Snabschenie krasnoi Armii*, 1925, No. 170, pp. 13-18, and no. 177, pp. 13-18, and *Voina i Technica*, 1926, No. 253, pp. 18-24.
26. 1932, "An Explanation of the Explosive Behavior of Hollow Blocks of Compressed TNT" by C. Lodati, Milan, Italy, (cites Neumann and Escales) in *Giornale di chim. ind. ed. appl.*, Vol. 14, 1932, pp. 130.
27. 1933, "Schiess-und Sprengstoffe," (Blasting and High Explosives) S. Stettbacher, publ. by J. A. Barth, Leipzig, 2nd Ed. 1933, pp. 51.
28. 1935, "Explosion Waves and Shock Waves, II, The Shock Waves and Explosion Products sent out by Blasting Detonators" by W. Payman, D. W. Woodhead, and H. Titman, *Proceedings of Royal Society of London*, No. A 865, Vol. 148, pp. 604.
29. 1936, "Optical and Physical Effects of High Explosives," Prof. R. W. Wood, Johns Hopkins University, *Proceedings of The Royal Society of London*, Vol. 157A, 1936, pp. 249-261. Discusses (1) Plastic Flow of Metals, (2) The Secondary Flash of Detonation, and (3) Spectra of Deflagration and Detonation." This is the first scientific description of the modern "self-forged-fragment" or "P-charge" principle.
30. 1936/37, "Fortschrittliche Sprengtechnik IV, Zuender und Brizanzwirkung insbesondere bei Minenladungen." (Progress in Explosive Techniques, 4, Ignition and Explosive Effects, Particularly in Mining Explosives), Erweiterter Sonderdruck aus der Zeitschrift "Nitrozellulose" 29, Published by Pansegrau, Berlin, Wilmersdorf, 1936/37.
31. 1937, "Explosion Waves and Shock Waves, V.-The Shock Wave and Explosion Products from Detonating High Explosives" by W. Payman, D.Sc., Ph.D., and D. W. Woodhead, Ph.D., F.I.C, the *Proceedings of Royal Society of London*, A., Vol. 163. Observed jetting from end of metal detonators, refers to Munroe effect, measured velocity gains from cavity in end of explosives.
32. 1941, August, "An Improved Explosive Projectile," Patent, Commonwealth of Australia, assigned to Berthold Mohaupt, Henry Mohaupt, and Erick Kauders of

## References

---

- France. Cities Patent No. 113,685 dated 27 November 1940, Sager Societe Anonyme de Gestion et D'Exploitation de Brevets, Fribourg, Switzerland, Sec. 121, date claimed for patent: 9 November 1939. (Marked as "received by the Library, U.S. Patent Office 18 November 1941.)
33. 1941, "The History of Hollow Charge Effect of High Explosive Charges" by Heinz Feiwald, Gatow, with foreword by Hubert Schardin, for German Academy of Aviation Research, 15 September 1941. A comprehensive and complete history of the shaped charge with the original work frequently reproduced. Includes 29 literature citations beginning with v Foerster.
34. 1941, "Cavity Effect of Explosives, Summary of History and Service Uses," Research Department, Woolwich Arsenal, U.K. September 1941. Note, the same date as German history cited above. Reference is made in (43) below, to British Report A.C. 1312 "Survey of the History and Uses of the Hollow Charge Effect up to 1941," which *may* be the same report.
35. 1943, "Preliminary Report on Enhancement of the Hollow Charge Through Lens Directed Initiation" by Prof. Dr. Erich Schumann and Dr. Gerd Hinrichs, Physics Institute of Berlin University. (Discusses wave shaped initiation of hemisphere shaped charges, reporting 25% increase in penetration when lenses are employed. Dated 30 March 1943.)
36. 1943, "The Influence of Gun-Tube-Induced Spin on the Penetration Performance of Shaped Charge Projectiles," by Prof. Dr. Hubert Schardin, Chief, Ballistics Institute, Air Force Technical Academy, Berlin-Gatow, November 1943.
37. 1943, December 9, Hungarian Patent 134378 "High Explosive Charge" assigned to Engineers Carl Brandmayer and Franz Rudolf Thomanek, Berlin.
38. 1944, "The Hollow Charge: a Deadly Explosives Principle Which Uses Blast to Bore a Hole Through Solid Armour," *The Illustrated London News*, 25 November 1944.
39. 1945, "The Cavity Charge, Its Theory and Applications to the Opening of Explosive Filled Ordnance, etc.," Lt. H. W. Kline, U.S.N.R., Ordnance Investigation Laboratory, Naval Powder Factory, Indian Head, Maryland, 15 August 1945.
40. 1945, "Development of Hollow-Charge Work by Rheinmetall, Borsig, Berlin," interrogation of Dr. Oscar Herrmann by the British Intelligence Objectives Sub-Committee, 16 November 1945.
41. 1945, "Shaped Charge, Munroe Effect," V. Torrey, *Explosives Engineering* 23, 1945, pp. 160.
42. 1945, "Bazooka's Grandfather," V. Torrey, *Popular Science Monthly*, 146, 1945, pp. 65.

43. 1946, "The Preparation and Testing of Explosives," Summary Technical Report of Division 8, National Defense Research Committee, Chapter 3, Applications of High Explosives, pp. 50-58 (shaped charges) prepared by D. P. MacDougall, and Chapter 4, pp. 67-82, Shaped Charges, by M. A. Paul. Includes Bibliography with 22 references for applications of shaped charges and 59 references for shaped charge technology. DTIC AD 221 595, issued Washington, D.C. 1946.
44. 1946, "The Shaped Charge for Cheaper Mine Blasting," J. b. Huttle, *Engineering and Mining Journal* No. 5, 147, 1946, pp. 58.
45. 1946, "Applications of Shaped Explosive Charges to Mining Operations: Tests on Steel and Rock," R. S. Lewis and G. B. Clark, *Bulletin, University of Utah* No. 5, 1946, pp. 37.
46. 1947, "The Shaped Charge," lecture by L. H. Eriksen, Technical Division, Picatinny Arsenal, 4 April 1947.
47. 1947, U.S. Patent No. 2,419,414 for "Projectile" to Henry H. Mohaupt, 22 April 1947, originally filed 3 October 1941.
48. 1948, U.S. Patent No. 2,441,388 to G. W. Blackinton and J. J. Calhoun, for "Projectile," filed 19 August 1942, issued 11 May 1948, the design patent for the first U.S. rifle grenade.
49. 1948, "Explosives with Lined Cavities" Garrett Birkoff of Harvard University, Duncan MacDougall of Naval Ordnance Laboratory, Emerson M. Pugh of Carnegie Institute of Technology, and Sir Geoffrey Taylor, Trinity College, Cambridge England; *Journal of Applied Physics*, Vol. 19, pp. 563, June 1948. (Notes "earliest known reference to this is 1792; a popular account appeared in Van Nostrand's Magazine in 1884," also see Reference 2).
50. 1948, "Secrets of the Shaped Charge" by George B. Clark, in *Ordnance Magazine*, July-August 1948, pp. 49-51.
51. 1949, "A Study of the Mechanism of Munroe Charges, Part I-Charges With Conical Liners" by H. Kolsky, C. I. Snow, A. C. Shearman, and "Part II-Charges with Hemispherical Liners" by H. Kolsky, all authors from Butterwick Research Laboratories, Imperial Chemical Industries, Ltd., England, published in *Research Supplement*, 2-2, 1949, pp. 89-98.
52. 1950, "Formation of Munroe Jets and their Action on Massive Targets" by W. M. Evans, Ph.D., and A. R. Ubbelohde, D.Sc., *Research Supplement* 3-7, received May 1950.
53. 1950, "Some Kinematic Properties of Munroe Jets," W. M. Evans and A. R. Ubbelohde, *Research Supplement* 3-8, May 1950.

## References

---

54. 1951, "Kerr Cell Photography of High Speed Phenomena" E. M. Pugh, R.v. Heine-Geldern, S. Foner, and E. C. Mutschler, of Carnegie Institute of Technology, Pittsburgh, Pennsylvania, *Journal of Applied Physics*, Vol 22 No. 4, April 1951, pp. 487-493.
55. 1951, "Studies of Damage to Aircraft by Shaped Charges at Long Standoff," NOTS, China Lake, D. R. Kennedy, G. C. Throner, et al, NAVORD Rept. 2018, based on NOTS Technical Memorandum No. 443, 20 August 1951.
56. 1952, "Effects of Shaped Charges Beyond Defeated Armor," U.S. Naval Ordnance Test Station (NOTS) China Lake, California, D. R. Kennedy, G. C. Throner, NOTS Technical Memorandum No. 462, 27 June 1952. (Also issued as NAVORD Report No. 3448, 27 November 1956, ATI 204 389).
57. 1952, "Fast Jets From Collapsing Cylinders," W. S. Koski, F. A. Lucy, R. G. Schrefler, and F. J. Willig, Los Alamos Scientific Laboratory, New Mexico, *Journal of Applied Physics*, Vol. 23, No. 12, December 1952, pp. 1300.
58. 1953, "Some Effects of Reduced Atmospheric Pressure on Hypervelocity Fragment Beams," NOTS China Lake, G. Dehority, D. Kennedy, et al, U.S. NOTS Technical Memorandum No. 1465, 29 Mzy 1953.
59. 1953, "Preliminary Tests of Underwater Shaped Charges," U.S. NOTS Technical Memorandum 1062, 11 June 1953, D. R. Kennedy, et al, NOTS, China Lake, California.
60. 1954, "Development of the Shaped Charge" Prof. Dr. Hubert Schardin, published in *Wehrtechnische Hefte*, 1954, Heft 4., a history of shaped charge with emphasis on the German developments and research in World War II. U.S. Translation by Heinz Gehlaar (then at Aerojet General).
61. Circa 1957, (undated) "The H.E.A.T.," "Hollow Charge Effect: Historical and General, Theories of Hollow Charge Collapse, Theory of Penetration into Resisting Media," attributed to W. M. Evans, U.K., a 33 page, typed draft believed prepared in the later half of the 1950's. Author notes "the first known reference to this curious phenomenon dates as far back as the 1790's, when a Norwegian (sic), Baader, recommended the use of a dome-shaped air space in mining charges."
62. 1958, "Science of High Explosives," "Principles of Shaped Charges," pp. 226, Dr. Melvin A. Cook, University of Utah, ACS Monograph Series, Reinhold Publishing Corp., New York.
63. 1959, "Die Erste Hohlladungswaffe--The First Hollow Charge Weapon" by Dipl. Ing., Franz Rudolf Thomanek, publ. in *Explosivstoffe* Nr. 1, 1959, pp. 9-11.

64. 1960, "Die Entwicklung der Ausgekleiden Hohlladung"- "The Development of the Lined Hollow Charge," Franz Rudolf Thomanek, *Explosivstoffe* No. 8, 1960, pp. 177-179.
65. 1961, U.S. Patent No. 2,974,595 for "Projectile" to Henry Hans Mohaupt, filed 11 September 1947, a continuation of a 1942 application.
66. 1966, "Selected Topics on the State-of-The-Shaped Charge Art," Mr. D. R. Kennedy, paper given at the AOA Bomb and Warhead Section Annual meeting at Naval Weapons Center, China Lake, 19 April 1966. (First presentation of history to U.S. citing v. Foerster as original discoverer of effect.)
67. 1966, *Aerospace Ordnance Handbook* edited by Frank B. Pollard and Jack H. Arnold, Jr., Chap. 11 "Shaped Charges and Warheads" by Henry Mohaupt, publ. Prentice-Hall, Inc., Englewood Cliffs, New Jersey, Library of Congress No. 66-19781.
68. 1970, "The Fall of Eben Emael," by Col. James E. Mrazek, (describes the first use of the shaped charge effect in combat).
69. 1973, "Hohlladung und Panzerschutz." (Shaped Charges and Armor Protection: Their Alternate Continuous Development) by Ministerialrat Dr. W. Trinks, *Jahrbuch der Wehrtechnik*, Folge 8, Wehr und Wissen Verlagsgesellschaft mbH Koblenz/Bonn, pp. 154-163, 1973.
70. 1973, "Review of the Early History of the Vaporific Effect" Report No. AFATL-TR-73-198, D. R. Kennedy, FMC/Defense Technology Laboratories, September 1973 for U.S. Air Force, Eglin AFB, Florida, A.D. No. 527 876.
71. 1973, "Fragmentation/Incendiary Shaped Charge Warhead Device," Report No. AFATL-TR-73-56, D. R. Kennedy, et al, FMC Defense Technology Laboratories for U.S. Air Force, March 1973, A.D. No. 526 857L.
72. 1975, "Men Against Tanks-History of Anti-Tank Warfare" by Col. John Weeks, British Army (Infantry), Mason/Charter Publishers, Inc.
73. 1977, "Mistletoe-The Deadly Parasite" by R. Coles and P. L. Rickson, *Air Classics Quarterly Review*, Vol. 4, No. 3, Fall 1977 pp. 38/47, 86/99. (History of Luftwaffe development of Mistel series Pick-a-Pack air-to-surface aircraft/missiles with 2-meter diameter shaped charges).
74. 1978, "Shaped Charge-Armor Nemesis" by Donald R. Beeman, formerly the director of engineering, Picatinny Arsenal, *National Defense*, May-June 1978, pp. 561.
75. 1978, "Meine Hohlladungs-Aktivitäten" by Franz Rudolf Thomanek, for periods 1932-1935, 1938-1945, 1957-1969, and 1975-date, 10 March 1978.

## References

---

76. 1978, "The Weaponization of Shaped Charge Technology" by J. E. Backofen, Jr., Battelle Columbus Laboratories, paper in Poster Session of the 4th International Symposium on Ballistics 17-19 October 1978.
77. 1978, "On to Berlin" by Lt. Gen. James M. Gavin, USA, Viking Press, 1978 pp. 43, 51 (problems in combat with inadequate performance of Bazooka).
78. 1980, 21 March, Letter from F. R. Thomanek to J. E. Backofen with information on production quantities of German WWII shaped charges and other information from German research.
79. 1980, March, Letter W. Trinks to J. E. Backofen with information on German pre-war and WWII research in shaped charge.
80. 1980, "Shaped Charges Versus Armor," Joseph E. Backofen, of Battelle, Columbus Lab., *ARMOR Magazine*, July-August 1980, pp. 60.
81. 1980, "Shaped Charges Vs. Armor-Part II," J. E. Backofen, *ARMOR* September-October 1980, pp. 16.
82. 1980, "Shaped Charges vs. Armor-Part III," J. E. Backofen, *ARMOR* November-December 1980, pp. 24.
83. 1981, "DART," D. R. Kennedy, *ARMOR* September-October 1981, pp. 22 (U.S. shaped charge state-of-art warhead technology from 1954-58.)
84. 1981, "Antitank Mines" J. E. Backofen, and L. W. Williams, *ARMOR* July-August 1981, pp. 26 (includes shaped charge and Misznay-Schardin effect mines).
85. 1981, "Antitank Mines-Part II" J. E. Backofen, L. Williams, Battelle, *ARMOR* September-October 1981 pp. 35.
86. 1981, "Antitank Mines-Part III," J. E. Backofen, L. Williams, Battelle, *ARMOR* November-December 1981, pp. 34.
87. 1982, "Armor Technology," J. E. Backofen, *ARMOR* May-June 1982 pp. 39 (discusses influence of shaped charges on armor design).
88. 1982, "Armor Technology-Part II," J. E. Backofen, *ARMOR*, September-October 1982, pp. 35, (continuation of above).
89. 1983, "Armor Technology-Part III," J. E. Backofen, *ARMOR*, March-April 1983 (continuation of four part series).

90. 1983, "Armor Technology-Part IV," J. E. Backofen, *ARMOR Magazine*, May-June 1983 (conclusion of above series).
91. 1982, March, unpublished paper, D. R. Kennedy, summarizes post WWII research into effects behind armor of shaped charge with emphasis on activities at U.S. NOTS, China Lake, 1950-1953 with brief review of subsequent work at BRL, MVEE and other facilities. Prepared for presentation at ADPA Bomb and Warhead Annual Meeting, May 1982.
92. 1983, January 20 and June 6, Telephone discussions between Dr. Henry Mohaupt in Santa Barbara, California and D. R. Kennedy in Los Altos, California with reference to Mohaupt's early activities in Switzerland.
93. 1983, June 11, Discussions in Vancouver, B.C. and July 14, discussions in Munich, Germany, between Dr. F. R. Thomanek and D. R. Kennedy, including translation of German references and informal communications re: Dr. Thomanek's early work.
94. *The Encyclopedia Americana*, Vol. 3, International Edition Americana Corp., Danbury, Connecticut 06816.
95. 1983, printing of 1966 book *Explosives in History* by N. B. Wilkerson, The Hagley Museum, copyright 1966 Eleutherian-Hagley Foundation.

**Note:** References 76, 80-82, and 84-90 include comprehensive bibliographies of shaped charge, armor, and related subjects.



## Appendix A

### Dr. Charles Edward Munroe

Dr. Charles Edward Munroe, chemist, who invented smokeless powder, died December 7, 1938, at his home in Forest Glen, Maryland. He was 89 years old.

Dr. Munroe invented smokeless gun powder and the principle of detonation known in the Navy as the "Munroe Effect" while engaged in chemical activities at the Naval Torpedo Station and the Naval War College at Newport, Rhode Island, from 1886 to 1892.

There, it was said, he "toyed with death and made a companion of TNT for six years," in the period in which he invented indurite, the first smokeless powder adopted by the United States Navy for use in the large guns.

Dr. Munroe, of Revolutionary ancestry, was born at Cambridge Massachusetts. At Harvard, he studied under Professor Wolcott Gibbs, regarded as the foremost American chemist of his time, and was graduated in 1871. After graduation, Dr. Munroe became an assistant in chemistry at Harvard and in 1872 established for the first time a course in chemical technology.

In 1873 and 1874 he conducted at Harvard the first established summer school in chemistry in the United States, giving instruction in general chemistry with illustrated lectures, along with qualitative and quantitative analysis. The late Harvey M. Wiley, pure food expert, said he believed that Dr. Munroe was the "first Harvard teacher who ever fraternized with his pupils."

Dr. Munroe was Professor of Chemistry at the United States Naval Academy at Annapolis, Maryland, from 1874 to 1886, when he went to the torpedo station. In 1889 he started his experiments with smokeless powder manufacture at a time when the larger nations of the world were seeking to produce such a powder. The announcement of the achievement of remarkable results in France had spurred this activity.

The work at the torpedo station is recounted in the Navy's archives. In his 1892 report, Benjamin F. Treacy, Secretary of the Navy, said, "It is gratifying to be able to show that what we could not obtain through the assistance of others, we succeeded in accomplishing ourselves, and that the results are considerably in advance of those hitherto attained in foreign countries."

President Benjamin Harrison, in his annual message to Congress on December 6, 1892, described the development as one of the achievements of his administration.

In an address before the Congress of Arts and Sciences at St. Louis in 1904, Dr. Marcus Benjamin called Dr. Munroe the first in the world to prepare a "smokeless powder that consisted of a single substance in a state of chemical purity."

The "Munroe Effect" has been described by J. N. Taylor, of the Chemical Division of the United States Bureau of Foreign and Domestic Commerce, who related that Dr. Munroe

## Appendix A

---

discovered that if letters such as "U.S.N. 1884," were sunk in the face of a gun-cotton cube which was detonated in contact with a steel plate, the letters would be indented on the plate.

Writing in *General Science Quarterly* in 1926, Mr. Taylor said, "If the letters were raised above the surface of the gun-cotton cube, placed in contact with the steel plate and the cube detonated, the letters would be faithfully reproduced on the plate as before, but raised above the surface thereof."

"In other words, it was discovered that the further molecules of explosives belonging to the group in proximity to the plate gathered energy as they traveled. By placing the ends of sticks of dynamite forming a bomb in an echelon formation, those at the center of the groups of sticks being, perhaps a few inches further from the end of the bomb than those on the outer edges, and increased penetration effect could be obtained on detonation of the bomb." The "effect," according to Mr. Taylor, "throws a light on the nature of the detonation wave and may well be the key to airplane bombing." The results of some of Mr. Munroe's experiments with the "effect" took the form of handsome impressions of leaves, laces, and other objects on squares of armor plate, fashioned into a fire screen which he presented to the Cosmos Club in Washington.

From 1892 to 1917 Dr. Munroe was head professor of chemistry at George Washington University, and after 1917 was Dean Emeritus of the School of Graduate Studies and Professor Emeritus of Chemistry. George Washington University conferred on him the degree of Doctor of Philosophy and Doctor of Laws.

From 1919 to 1933 he was chief explosives chemist of the Bureau of Mines in Washington. He was formerly chairman of the National Research Council's committee on explosives investigations.

For 50 years he was engaged in compiling a vast bibliography of explosives, starting with Page 1, Volume 1 of the *Philosophical Transactions of the Royal Society*, dated 1665.

He was the last surviving charter member of the American Chemical Society, organized in New York in 1876. His high rank in chemistry was recognized throughout the world and in 1900 the Swedish Academy of Science appointed him to nominate the candidate for the Nobel prize in chemistry.

Above article supplied through the courtesy of Mr. Robert B. Hopler, *IRECO, Incorporated*, contributing editor of *The Journal of Explosives Engineering*.

## Appendix B

### SHAPED CHARGES AGAINST ARMOR

by

Prof. Dr. Ing Franz Rudolf Thomanek,  
Vancouver, Canada (1983)

(Note: The following is a lecture presented by Dr. Thomanek at a 1983 meeting at MBB Schrobenhausen, West Germany, honoring the centennial of the discovery of the cavity effect by Max Foerster. This is retyped in his own words, with minor changes in format for clarity, and a few editorial remarks, of a draft given to your editor as thanks for helping to "Americanize" the original draft.)  
ye editor-- Donald R. Kennedy)

"The subject of my paper is the story of the shaped charge as a means to defeat armored targets.

A century ago, Foerster first showed the effect of a cavity in a high explosive charge. I am talking about the events half a century later or from today, half a century back.

Before entering into my subject, I would like to ask a question: "What is the purpose of such a lecture?"

There are two well known opinions about history:

1. History never repeats
2. History always repeats

If the first statement is true, there would be almost no reason for my presentation. So, I prefer the second one. I think a little improvement of the future would be possible by teaching, as an involved eyewitness, what happened and the mistakes I made in the past. Thank you, Dr. Held, for giving me the opportunity to do so.

In the first part, I'll talk about the first anti-tank gun using a shaped charge, the second part will discuss the discovery of the liner, the third part deals with common shaped charges, the last part covers precision charges.

#### TG 70/M34

To understand what triggered me, we must go back to the years around 1930 in Vienna. The environment was a society with faith in a better future coming from technical and scientific contributions, and in Austria, technicians and scientists were highly respected. Problems like space and rockets for space travel attracted some interest, especially for me. I was trying to get all of the literature about rockets and contacted the small number of experts in this field. I became one of the enthusiasts hampered by the shortage of money for experimental work. What could I do to get money? My solution was to invent something by myself.

With an open mind I studied military periodicals and books on ballistics, explosives, and related areas. Coincidentally, I received two pieces of information at the same time, one about the shaped charge effect, and the other about a French tank. The heavy armor of the new NC 27 tank was impossible to kill with the existing anti-tank cannons. This fact led me to the idea of replacing the kinetic energy of an armor piercing projectile by the energy of the explosive. Only a limited velocity was necessary to transport the projectile to the target.

In 1932, I designed an anti-tank gun as an infantry weapon and suggested it to an office of the Austrian Army. The reaction was obvious. No one listens to a university freshman. For me, it was quite clear, the Austrian officials were halfwits. A better address must be the famous German Army. So I sent my proposal to the military attache of the German embassy in Vienna. Once more, nothing happened. They must have been crazy too.

Meanwhile, the Third Reich began. Why not go directly to Hitler? Naturally, a chain of connections was necessary, leading me through a large number of important persons to the top. Maybe this could be done, but another requirement, building a prototype, was more difficult. A friend of mine had a contact with a small German explosive company. Sharing my rights with my friend and the company, we started the development of the ammunition and the weapon. The cost, 6000 RM, was financed by the company. The shell penetrated 35 mm of homogeneous armor in a static test. In a flight test against an old oil tank, (we could not afford a large armor plate) it worked well too. Putting both tests together, we were convinced we were able to defeat a tank.

In June 1935, my friend and I had a road accident in which he was killed.

In the meantime, after two failures in reaching the top, I found a way to put the little perforated armor plate on the night table in Hitler's bedroom in his private flat in Munich. A little label on the table told that the penetration in the plate was made by the new TG 70/M34. After several weeks, I received a phone call ordering me to come to Berlin on the 28th of November 1935. In the huge conference room of the Reichsregierung I presented my ideas to Hitler, Goering, Hess, Himmler, the Commanding Generals of the Army and the Airforce, with their general staffs. Hitler instantly said;

"I am in a hurry and so I will express my opinion immediately. This proposal could be the solution I have always wanted to give the individual soldier a weapon to defeat tanks. Maybe the same principle could be used in bombs and torpedoes."

He left and the others stayed for two hours of discussion with me.

In December (1935) officers of the Army Weapons Bureau came to our plant with a large armor plate to see how the gun worked. The shell detonated but no shaped charge effect appeared. We thought our simple arming device was the reason for the failure. Years later, I got more details from insiders, telling me what really happened. Hitler, after finding the plate on his night table, asked the Weapons Bureau what they were doing about shaped charges. The Bureau then started at once on the development of a shell with a cavity in the charge using a modified smoke shell. By the time of my presentation in the Reichskansler, the Bureau had had the same trouble with the fuze. With such a poor result in our own shooting, I was naturally depressed and couldn't understand why the officials were not.

They asked me to join the Bureau, and talked about a good salary, so the outlook was not so bad. At Christmas, I received an offer to enter the bureau as a technician with half the pay they had mentioned earlier. Nevertheless, I agreed on the condition that I would do my work only in the field of shaped charges and get the permission to graduate from the university. Both were rejected, so I was out. The company backed out of our agreement in order to end their financial commitment.

(Ed. note: The above tests took place at a time when the cavity in the explosive was still unlined. The 1911 WASAG patent had recommended lining the cavity of a projectile with a metal, cork, etc., to maintain the cavity's integrity upon dynamic impact with its target. It is quite possible that the problems noted above were not fuzing problems, but instead a mechanical failure of the cavity at impact with the steel target.)

The first attempt to achieve success was ended. I was alone, but free. I resumed my studies in Berlin, specializing in ballistics and explosive sciences.

In the search for new opportunities to continue the shaped charge development, I got in touch with a manufacturer of howitzers. The manufacturer asked the Weapons Bureau for a contract and got a sharp rejection. To stop me, the Weapons Bureau ordered an investigation against me by the Gestapo (*Geheim Stadts Polizei*). The accusation was betrayal of top secret matters and theft. After several hours of interrogation, I was released.

This was the end of my second attempt.

## DISCOVERY OF THE LINER EFFECT

The lesson learned by now was that going to the top is not a guarantee of success. The resistance of the people below would be too strong. I realized this and looked for another way. There was the brand new organization of the Ministry of the Airforce. In the technical office I found my mentor, Dr. Thome. Parallel to his position in the Ministry, he also was the Director of the Weapons Institute at Braunschweig. He gave me all I needed, the support of the Institute and permission to finish my work for the Masters degree in Berlin.

From the very beginning of our experimental work, we had cast the explosive charges with a mixture of TNT and Hexogen (RDX), so I built a little facility for melting and casting of explosives. To test their penetration, I used blocks of aluminum alloy because these blocks were easier to handle than targets of steel or lead. Now I was ready to realize all of my plans accumulated in the preceding years.

I had in mind two directions, first to increase the mass and/or density of the gases, and second, to improve the velocity of the gas flow by expansion into a vacuum.

(Ed. note: at this time, the cavity effect was still considered to be only a gas dynamics effect.)

For the first point, I had divided the charge into an inner and outer concentric part. The explosive on the inner part was mixed with oxides of heavy metals or metal powders. As anyone here (at the Schróbenhausen meeting) knows, there are only minor effects on the penetration capability with all of the changes in geometrical shapes and additives to the explosive.

For the second part of the development, the charge could either be put into an evacuated casing, or the cavity could be evacuated. Because the casing would be confinement, it

## Appendix B

---

appeared better to make an evacuated glass cone and cast the explosive over it. On the 4th of February 1938, the test was fired. The crater in the aluminum block looked entirely different. Instead of the usual hemisphere shape, it was a carrot-like crater with an equal volume but with 128 mm instead of 52 mm of depth.

First we thought of a shrink hole in the aluminum block, but a repeated test confirmed the result. We were excited. This was the breakthrough I had sought for such a long time.

Next we tested the influence of the vacuum but there was none. Now it was clear that the glass was responsible for the effect.

(Note: Colonel Frank of the BRL relates the following story concerning this particular event...one that Dr. Thomanek has never discussed...Frank said that one of the evacuated liners broke and Thomanek told his assistant to fire it anyway just to get rid of it. The assistant had some difficulty in convincing Thomanek to come see the result of the test which gave the same penetration as with the vacuum. This apparently was the event in which the glass liner's contribution first became evident.)

Dr. Thome reported the result. A decision was made sending me to the Ballistic Institute of the Airforce Academy at Berlin-Gatow, which was directed by Schardin, because there was much better equipment for high speed photography. I joined the Schardin group in May 1938. I built a new small casting facility, a test range, and a test chamber for underwater detonation. I used the 24-spark camera developed by Cranz and Schardin, and started development of a 24-mm projectile. This was the caliber of the so-called battle pistol used by the airborne troops. Instead of copper, the liner was made of brass to spare some copper.

Shortly after beginning my work at Gatow, Dr. Thome was found dead, hanging naked on a window cross at his private flat in Berlin. To this day, as far as I know, nobody knows whether it was a suicide or a murder. Voss, Thome's assistant, took over Thome's position at the ministry and now Schardin had to report to him.

Maybe under some pressure for the DWM which was involved in the development of the battle pistol, Voss ordered Schardin to have me stop my development efforts and do only research. Today, I better understand the discrepancy between the need of manpower for an effective development and my one man show I was playing. But in 1939, I felt it unfair to me and more reasonable to concentrate all efforts to develop weapons using the liner effect, instead of searching for a scientific explanation. I protested in a report to the office of the Fuehrer, quoting 13 similar appearing cases. In all such cases, the officials took the development away from the inventors. A court martial rehabilitated Voss, naming me as a trouble maker and possibly a crook. Therefore, I was disqualified and prohibited from working in any private or government position with military purposes.

So my third attempt became a disaster.

(Ed. Note: The parallel here is remarkable, Henry Mohaupt, a Swiss, brought his shaped charge invention to the United States in October 1940, and after a successful demonstration, the U.S. Army took over the development and excluded Mohaupt from further participation for "security" reasons.)

## COMMON SHAPED CHARGES

In the next years, it turned out that these disastrous events were the necessary steps for later success. Working in a management consulting bureau, I got the experience in managing administration and accounting I would need so badly in the future. For my next attempt, the fourth one, it was clear that the only way for me was to found my own company. With my partner, Brandmayer and his contacts, we were able to show the new head of the Weapons Bureau our charges that could penetrate homogeneous armor 1.5 calibers thick.

Surprisingly, in the meantime, neither the Airforce nor the Army (who had been informed by Schardin in May 1939 about the liner effect) had done very much.

We received our first contract to develop a 57-mm grenade. One after the other, we improved, developed, and produced artillery shells, mines, rifle grenades, Panzerfaust prototype and Panzerschreck. Our production plant, started in 1942 in Bavaria, grew to a capacity of 17,000 Kg of explosive per day. About half of the German shaped charge ammunition was made in our plant. I received royalties for my patents totalling 1.85 million RM. Maybe the royalties from Japan came to Germany, but they never came to me. I had made a fortune, but the end of the war destroyed nearly all of it.

## PRECISION CHARGES\*

Twelve years after the war, the rearmament of Germany began. Boelkow contacted me and I became a mini-partner of MBB with mutual ownership of my patents. In trying to find the best location for a new plant, I found a dismantled plant. In 1958, I established the plant (here) at Schrobenhausen. In the next ten years we grew to a very effective group of experts for development and production. One of the most understanding supervisors in our Government, always relying upon our ability to handle our tasks, was Dr. Trinks. He helped us very much. Another important factor for our success was a joint venture with France promoted by Dr. Boelkow. Working together with M. Precoul was especially fruitful. Naturally there were problems and quarrels, but over all it was the most effective, and personally, my happiest time.

Regarding my time, I haven't mentioned the many men who worked with me and all would have deserved it. Instead I would like to say thank you very much for all of your hard work, brilliant ideas, and working together as a family. This was the source of our success.

For the future, I wish all members of Schrobenhausen the very best. May the plant and MBB prosper forever."

S/ F. R. Thomanek.

\* It is assumed that Dr. Thomanek had more to say in this section. It was possibly added after the draft received by your editor, and possibly was not prepared until he went to Schrobenhausen for the meeting later in 1983. Thomanek was quite well aware of the need for, and the application of, precision in the manufacture and high explosive loading of the shaped charge mechanism.

(Note: Dr. Schardin visited Aerojet Ordnance on several occasions in the late 1950's and early 1960's. At his recommendation, Dr. Thomanek visited Aerojet Ordnance at the Downey, California plant in 1961.

This was his first time ever out of Germany and Austria, and his command of English was as limited as our German. We conversed mostly by sketching things and pronouncing the English or German language. The ideas for the Milan wave shaper and both the Roland and Kormoran multi-jet warheads were possibly influenced by his 1961 visit..Ed.)



## Appendix C

## Some of the First Flash Radiographs of the Shaped Charge

In April 1988, Dr. Claude Fauguignon, Adjoint Scientific Director, Institute Saint Louis (ISL) graciously forwarded to the writer, the following set of three remarkable flash radiographs of a hemisphere shaped charge, made in 1938 by Dr. Thomer while at Dr. Schardin's "Luftwaffe Akademie" at Berlin-Gatow. Dr. Thomer gave Dr. Fauguignon the photos in 1975 upon his (Thomer's) retirement from ISL.

Dr. Thomer is not to be confused with Dr. Thome, the mentor of Dr. Thomanek, in as much as Dr. Thome died under mysterious circumstances in the late 1930's.

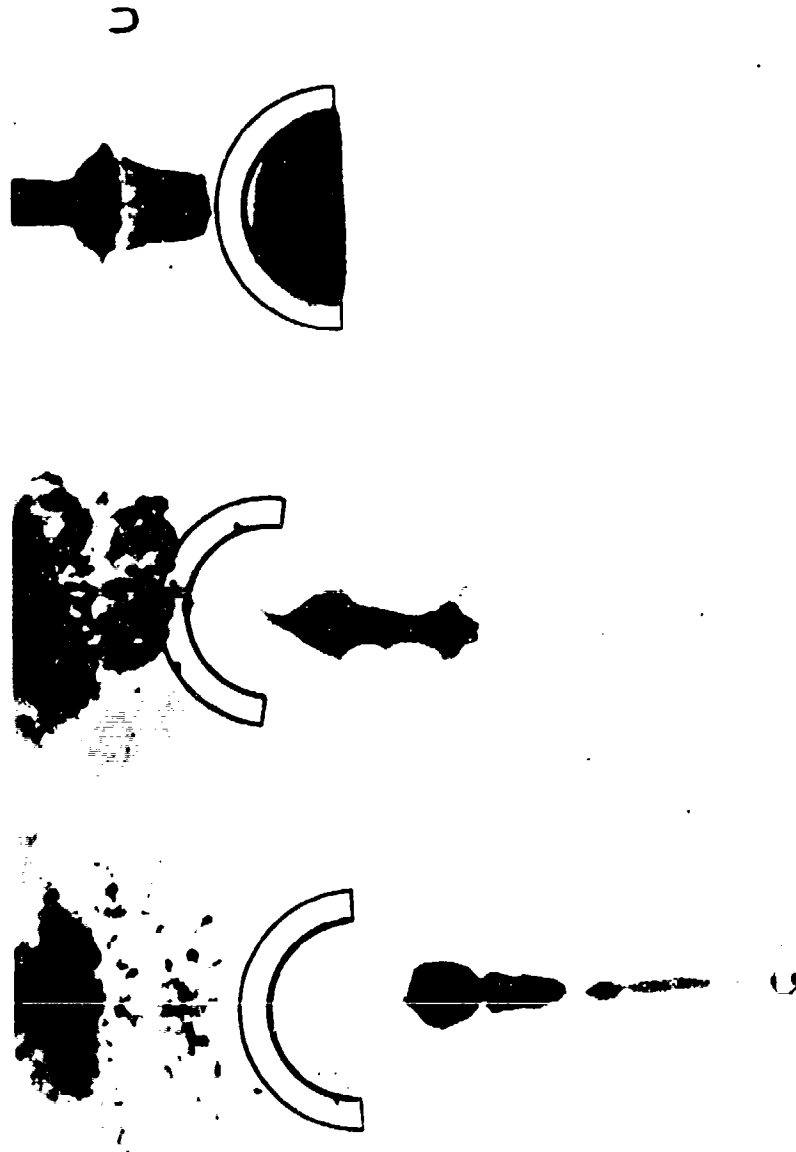



# Bergmännisches Journal.

Drittes Stück. März, 1792.

L244

Baader, F.

## INVESTIGATION OF A THEORY OF BLASTING

(Versuch einer Theorie Der Sprengarbeit). Bergmännisches Journal Von Kohler und Hoffman, v. 1, Mar. 1792: 193-212.

This is the earliest known reference to the the "hollow charge principle". For a discussion of this reference see item no. L416 appendix A.

I.

## V e r s u c h einer Theorie der Sprengarbeit,

von

Franz Baader, Doctor.

I.

Die Wirkungssphäre jeder Masse Pulver, deren Form ein Würfel oder eine Kugel ist, oder diesen nahe kommt, muß man sich gleichfalls als eine vollkommene Kugel denken, vorausgesetzt, daß diese ganze Pulvermenge sich mit einemmale entzündet, und die umgebende Masse von allen Seiten gleichen Widerstand leistet. — Die Größe des Radius dieser Wirkungssphäre ist sodann in geradem Verhältnisse der gleichzeitig entbundenen Kraft, d. i. der Güte und Menge des Pulvers, und dem verkehrten des Widerstandes, den ihr die Festigkeit der umgebenden Masse, oder was hier besonders wichtig ist, der

*Bergm. Jouru. B. 1. St. 3. M. Mangel*



Abb. 2

M. v. Förster, Wirkung von vollen und hohlen Patronen auf Eisenplatten. 1883

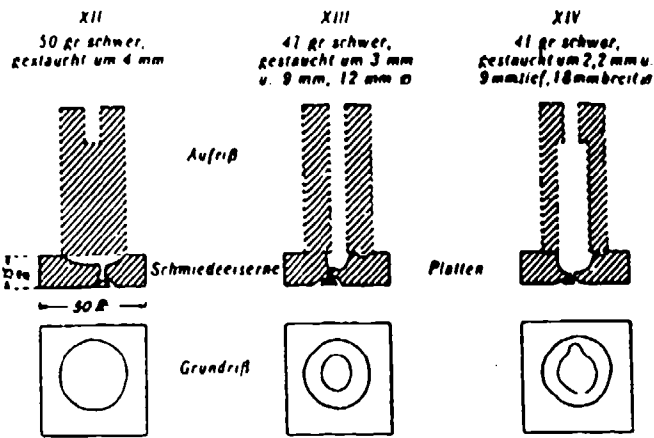

Abb. 1

M. v. Förster, Stauchversuche mit ausgehöhlten Patronen. 1883

# UNITED STATES PATENT OFFICE.

G. Bloem  
Shell for Detonating Caps  
Patented May 25, 1886

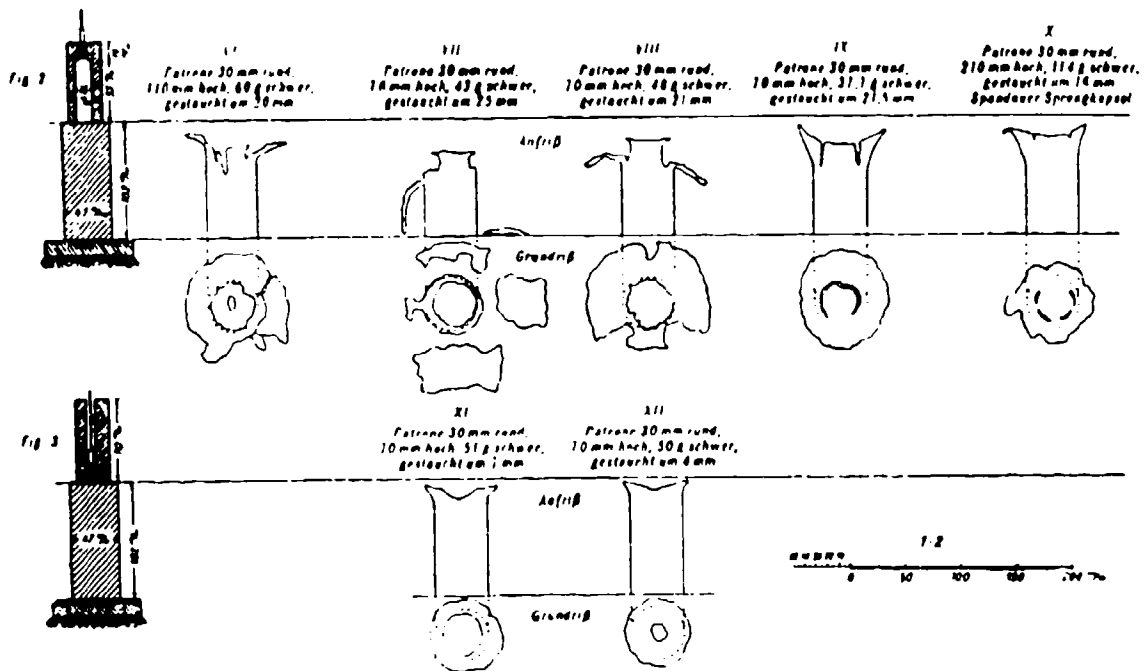
342,423.

GUSTAV BLOEM, OF DUESSELDORF, PRUSSIA, GERMANY.

## SHELL FOR DETONATING CAPS.

Specification forming part of Letters Patent No. 342,423, dated May 25, 1886.  
Application filed January 29, 1885. Serial No. 100,178. (No model.)

To all whom it may concern,

I, Gustav Bloem, of Dues-  
seldorf, in the Kingdom of Prussia, German  
Empire, have invented certain improvements  
in shells for fulminate and dynamite ex-  
ploders and Cotton-Powder or Gun-Cotton  
detonators, of which the following is a full and  
clear specification, reference being had to the  
accompanying drawings, forming part of the  
specification, in which the same letters of ref-  
erence indicate corresponding parts in all fig-  
ures.

In the drawings, Figures 1, 2, and 3 are sec-  
tional views showing the invention. Figs. 4,  
5, and 6 show different forms of shell bottoms.  
The invention relates to an improved con-  
struction of the shell of exploders or blasting  
caps or detonators filled with a fulminating  
compound, and used as primers to explosive  
bombs or charges of gunpowder, dynamite,  
gun-cotton or cotton powder and similar ex-  
plosive substances.

The invention consists in combining such a  
shell having a weak bottom with an outer cy-  
lindrical strong sleeve.

The bottom *b* of the shell *a* is pierced, (see  
Figs. 4 and 5,) without disengaging therefrom  
any portions of the bottom or otherwise made  
quite thin and weak. The shell is surround-

ed as far as the remaining compound ex-  
tends by a sleeve, *c*, (or more than one,) grasp-  
ing by a narrow inward rim, *d*, under the edge  
of the bottom *b*. The sleeve *c* or the sleeves  
may project from the outside of the shell *a*,  
as in Figs. 1 and 3, or be flush with it, as in  
Fig. 2, in which latter case the inside diam-  
eter of the shell *a* becomes at this place smaller  
in proportion. By these constructions the  
concentration of the effect of the explosion in  
an axial direction of the exploder is increased.  
It must be remarked that the bottom *b* of such  
exploder with sleeve *c*, or sleeves, may be  
pressed inward hemispherically, as in Fig. 6.

The improved shell is used in blasting-caps,  
exploders, or detonators for gunpowder, dy-  
namite, gun-cotton or cotton-powder, and other  
explosive substances.

The shell *a*, having weak bottom *b*, combined  
with the surrounding sleeve or sleeves *c*, hav-  
ing inward rim, *d*, substantially as herein above  
and described.

This specification signed by me this 18th day  
of December, 1885.

Witness:  
P. F. BLOEM,  
JEROME ERNST.

GUSTAV BLOEM. [L. s.]

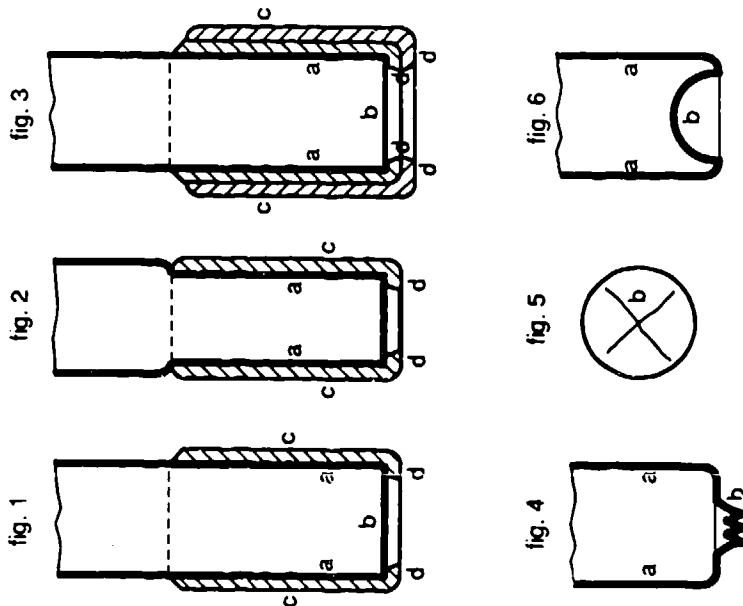

Fig. 3 Gustav Bloem's U.S. patent issued in 1886

# SCRIBNER'S MAGAZINE

PUBLISHED MONTHLY  
WITH ILLUSTRATIONS

VOLUME III    JANUARY - JUNE



CHARLES SCRIBNER'S SONS NEW YORK  
F. WARNE & CO. LONDON



Disk of Guncotton and like Photo upon which a Disk has been Oriented.  
(The letters and figures stamped in the disk are reproduced in picture; the same resulted as the one above.)



Fig. 4    Munroe's guncotton experiments. Scribners Mag. 1888

which is often fifteen hundred feet or more in depth. A perforated weight is then strung on the wire, and when the tempo is in place the weight is allowed to fall, strike the cap, and explode the charge.

Dynamite has been used to knock out the blocking from the ways when launching ships. Fired on an iron plate placed on the top of a pile and covered with a tamping of earth or clay, it has successfully and economically replaced the pile-driver. It has been found efficient in excavating holes in which to plant telegraph and telephone poles; in driving water out of quicksands in which foundations are to be laid or shafts to be driven; in slaughtering cattle; in breaking down ice dams to prevent inundations; in blowing up buildings to prevent the spread of conflagrations; in razing unsafe walls of burned buildings; in destroying wrecks which endanger navigation, and even in freeing vessels which are hard aground on shoals.

An especially notable instance was in the blasting out of the *dams* in the river at Johnston after the frightful flood that occurred there, which formed an enormous dam above the bridge and threatened its existence, and which was successfully and expeditiously removed by blasting after all other means had been tried in vain.

In fact, the amount of explosives consumed in the industries is so great that the quantity employed for military purposes sinks into insignificance. Yet we have failed to refer to those industries—quarrying and mining, and the engineering operations—in which they are most extensively and commonly used, being employed so largely in mining alone that it is an almost daily occurrence for blasts containing twenty, thirty, and even fifty thousand pounds of explosives to be used in a single charge; and



BLASTING DYNAMITE CHARGE. MOUNT. EXHIBITION.



BLASTING DYNAMITE CHARGE. NEW ZEALAND.



Abb. 11  
Munroe, Anwendung einerleer Sprengtreue um eine Bierbierke um offhroom-  
Ladung. 1894



Abb. 12 und 13  
Munroe, Ergebnis der Sprengung mit der Ladung gemäß Abbildung 11

Fig. 5 Munroe's safe defeat by dynamite shaped charge, 1900

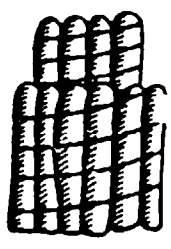
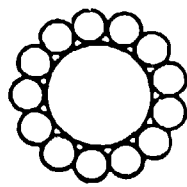
Abb. 14

Vollkörper  
(Längsschnitt)  
310 g Trinitrotoluol

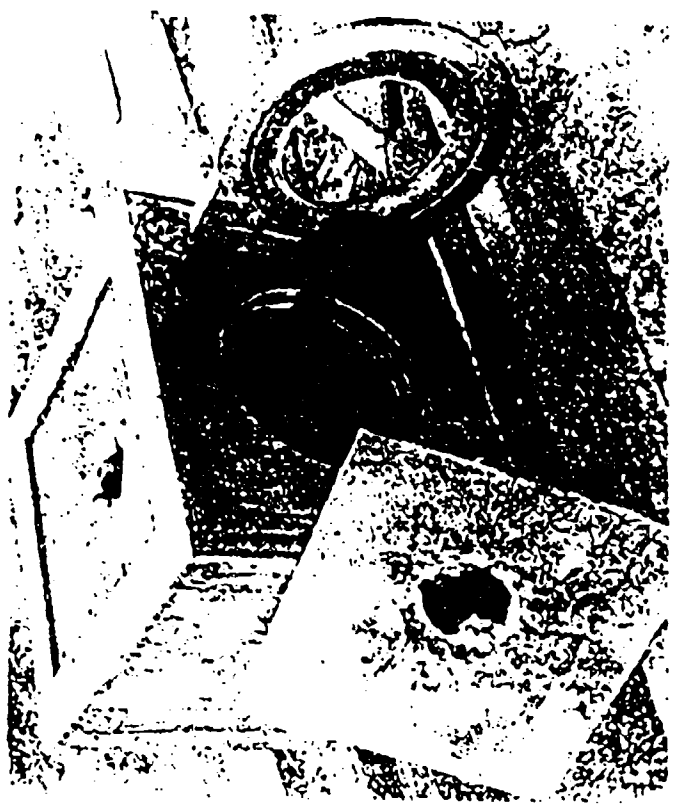
Körper mit Hohlraum  
(Längsschnitt)  
247 g Trinitrotoluol

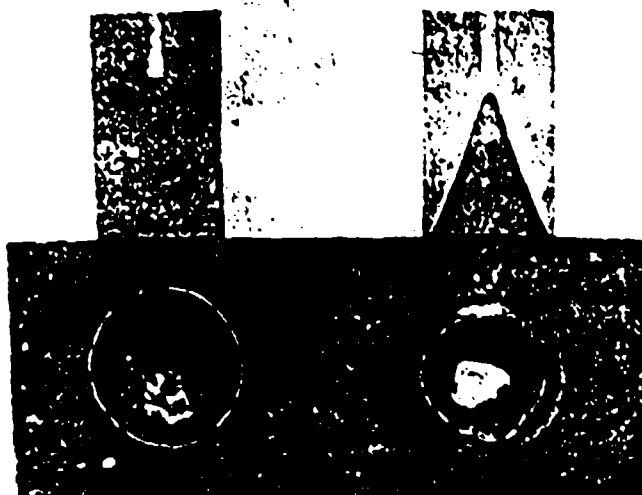

M. Neumann,  
Vergleich der  
Sprengwirkung  
eines Hohl- und  
eines Vollkörpers  
auf eine 25 mm  
starke Eisen-  
platte. 1911

<sup>1)</sup> Gemeint ist die Westfälisch-Anhaltische Sprengstoff AG. in Reinsdorf b. Wittenberg.

Abb. 15

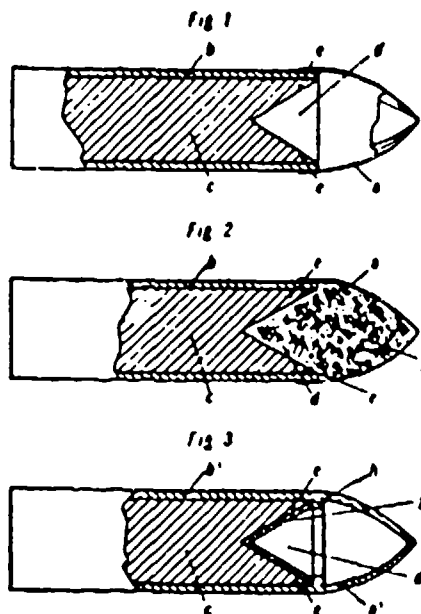

WASAG. Geschosse  
mit Hohlraum. (Man  
beachte die Ausklei-  
dung des Hohlraums  
in Fig. 3.) 1911

Fig. 6 Figure from WASAG Patent, 1911



Oberfläche der Stahlplatte



Unterseite der Stahlplatte.



Abb. 16  
Kast, Vergleich der Sprengwirkung eines Hohl- und  
eines Vollkörpers auf eine Eisenplatte. 1911

### Neuartige Bohrkörper aus Brillanzstoffen.

Von Ingenieur Egon Neumann Darmstadt.

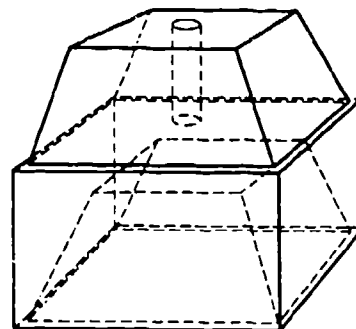
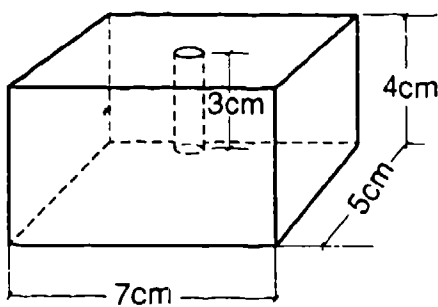

Abb. 17



Abb. 20

Bomben. Verschiedenartige Sprengkapseln: Figur 4 und 5 sind Kapseln mit Hohlraum nach Schuler. 1921

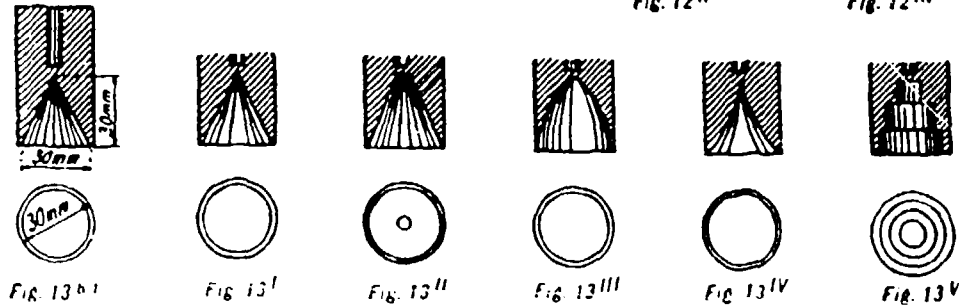
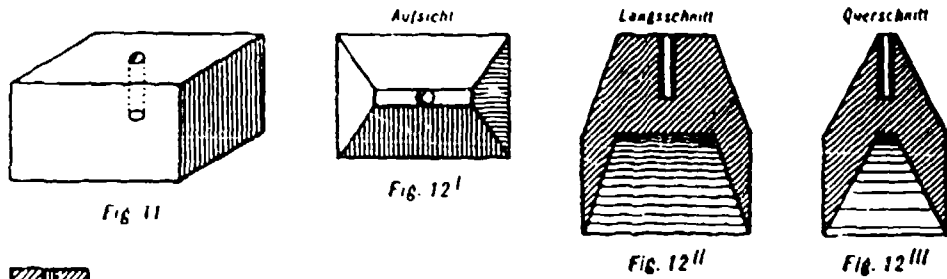
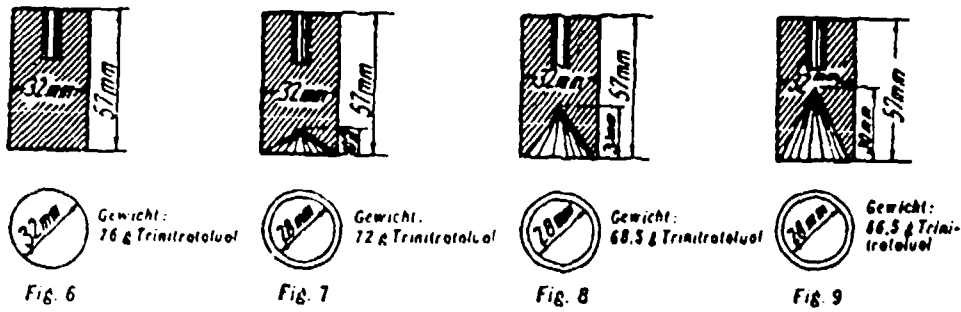
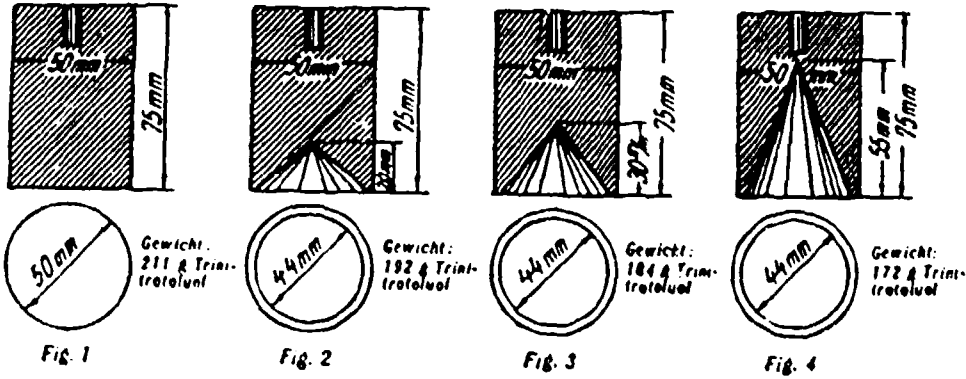

Abb. 21

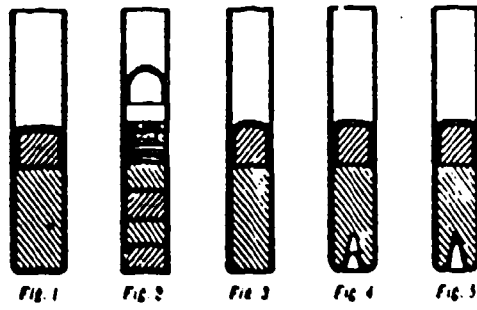
Bomben. Wirkung einer normalen Sprengkapsel Nr. 8 (links) und einer schwächeren Schuler-Hohlraumsprengkapsel (rechts) auf Bleiplatten von 7 mm; A = Vorderseite, B = Rückseite. 1921

Weiss Freiwald: Zur Geschichte der Hohlraumablenkung bei Sprengladungen



Abb. 22

Kast u. Haid, Sprengkapseln ohne und mit Hohlraum, mit und ohne Einleges. 1924

April 14, 1925.

1,534,011

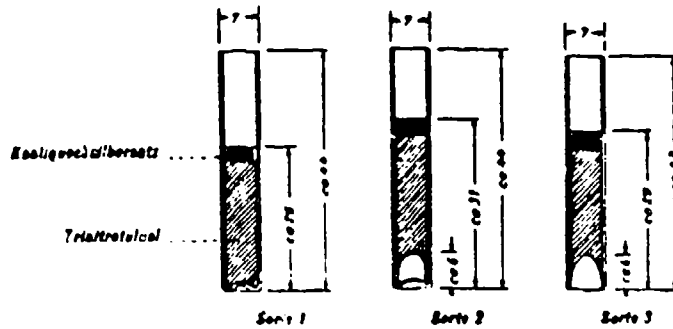
C. P. WATSON

PERCUSSION FUSE

Filed Sept. 22, 1921

2 Sheets-Sheet 1

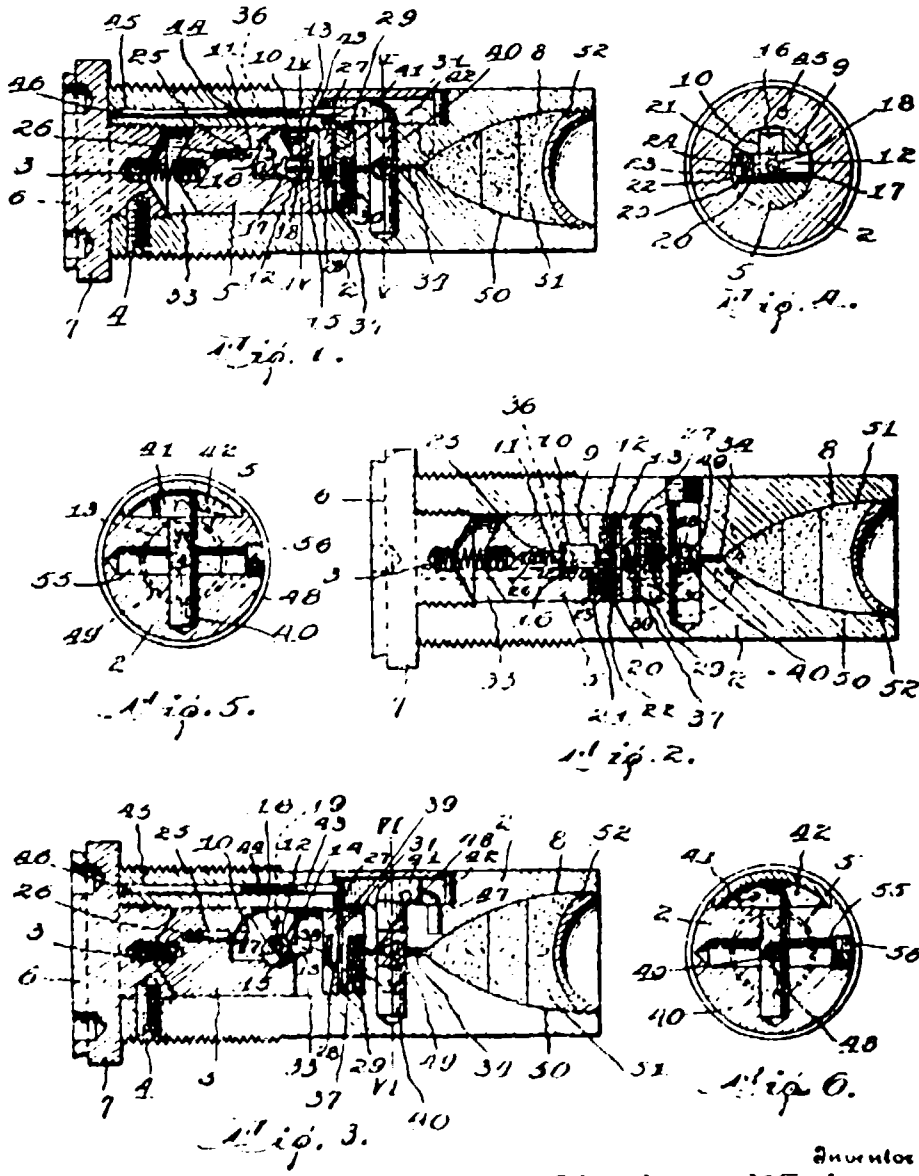

Inventor  
Charles P. Watson.

by John S. Bunker

Attorney

Fig. 10 Charles Watson's percussion fuze U.S. patent filed 1921



Heinz Freiwald: Zur Geschichte der Hohlraumwirkung bei Sprengladungen



Abb.25

Sucharewsky, Figur 9 zeigt eine Sprengkapsel mit Hohlraum, Figur 11 die zweidimensionale Demonstration der Hohlraumwirkung (Holzbrett mit aufgenagelter Zundschnur aa, b), Figur 13. Hohlraumpatrone mit Kumulationszundug. 1925



Abb. 34  
 Lodati, Wirkung von Sprengkörpern mit verschiedenen Hohlräumen auf Eisenplatten.  
 1932

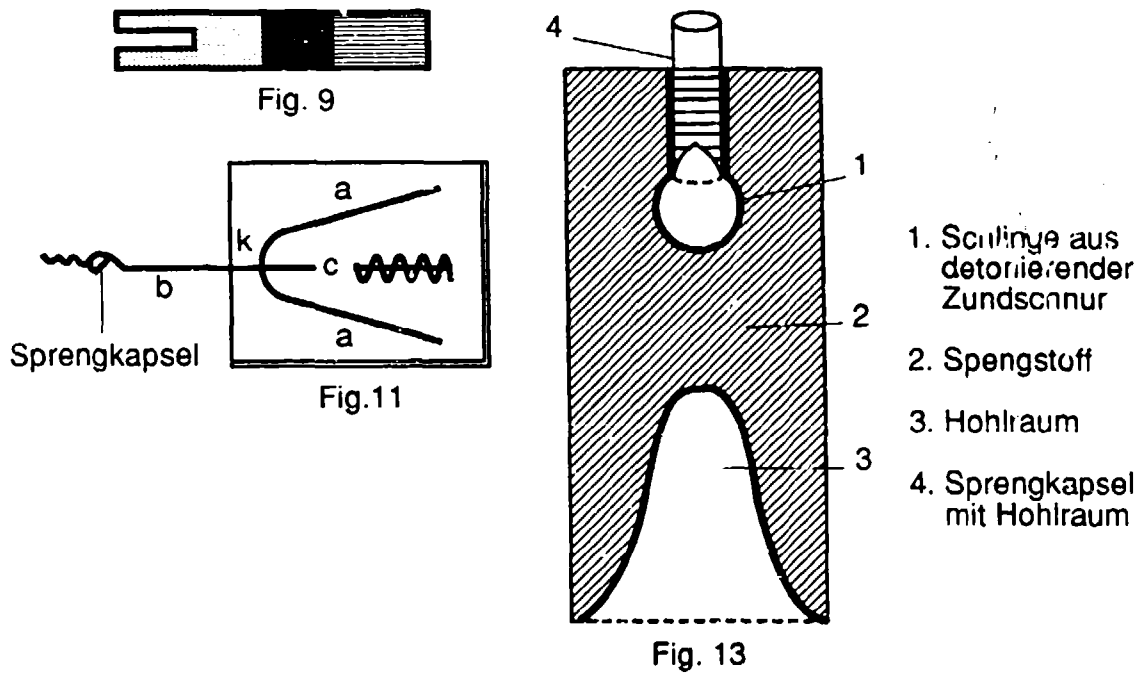

Abb. 35

Payman, Vergleich von Sprengkapseln mit flachem (A und B) und konisch eingedrücktem Boden (C) mittels der »Übertragungs-Prüfung«. 1935

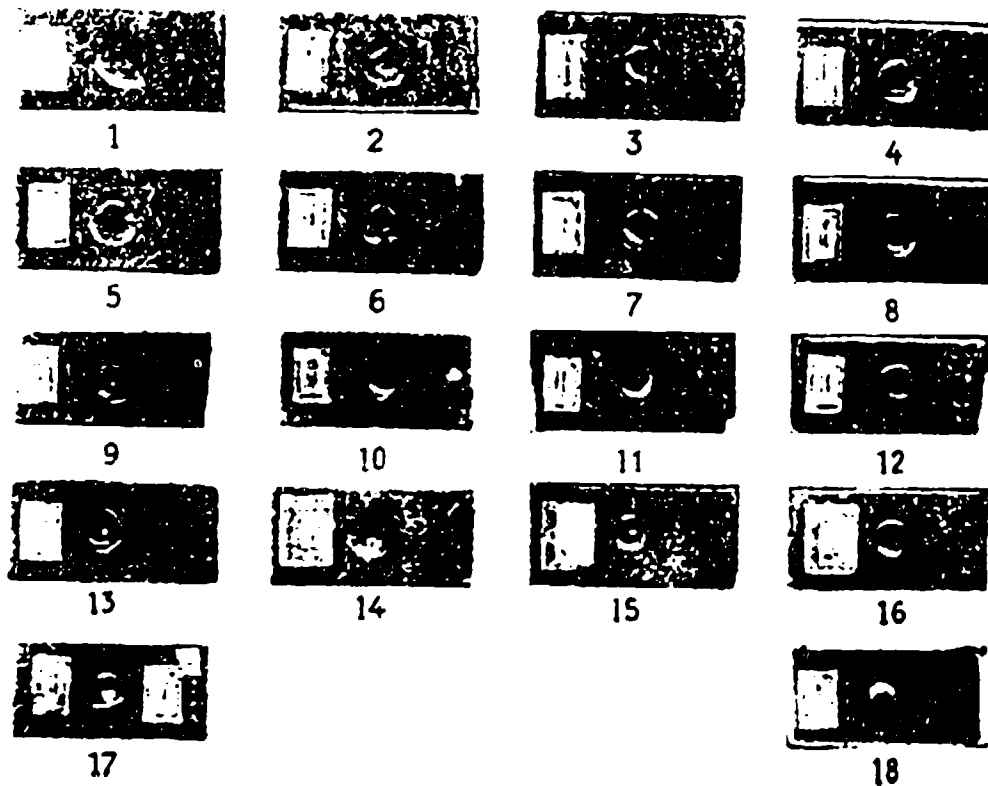
Fig. 13a Payman, 1935

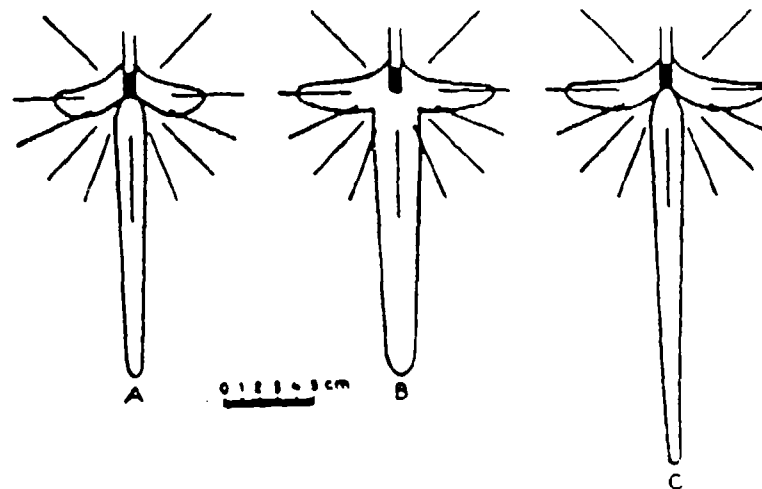

Abb. 37

Payman, Funkenaufnahmen einer detonierenden Aluminium-Sprengkapsel mit konisch eingedrücktem Boden. 1935

Fig. 13a Payman, Cont.



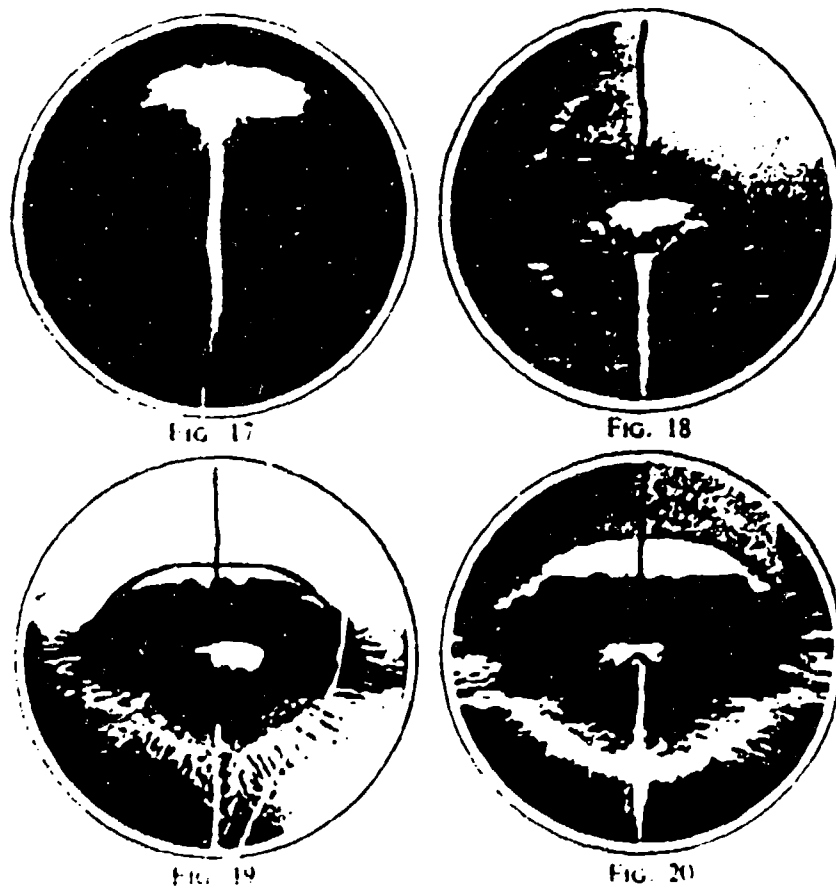
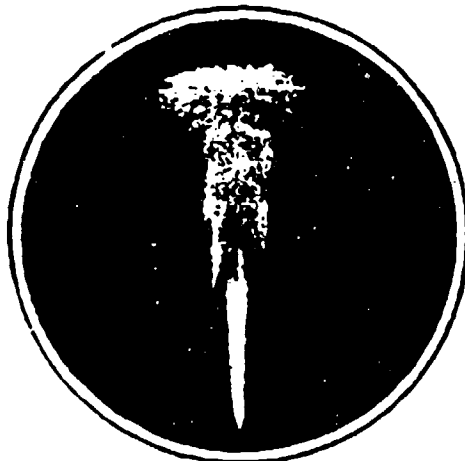

FIG. 11

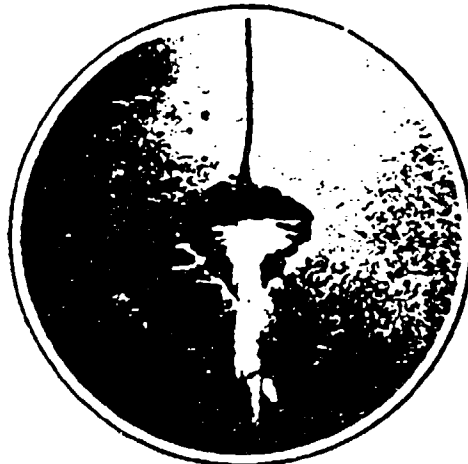

FIG. 13



FIG. 14



FIG. 15



FIG. 16

Abb. 36

Payman, Funkenaufnahmen einer detonierenden Aluminium-Sprengkapsel mit flachem Boden. 1935

Fig. 13b Payman, Cont.

## Optical and Physical Effects of High Explosives

By R. W. WOOD, For. Mem. R.S., Professor of Experimental Physics,  
Johns Hopkins University

(Received 25 June, 1936)

(PLATES 7 AND 8)

### I—PLASTIC FLOW OF METALS

My interest in the study of the effects produced by high explosives originated in the investigation of "evidence" in a number of murders by bomb, and more especially in connexion with a most unfortunate and unusual accident which resulted in the almost instant death of a young woman who, on opening the door of the house furnace to see if the fire was burning properly, was struck by a small particle of metal which flew out of the fire and penetrated the breast bone, slitting a large artery and causing death in 2 or 3 minutes from internal haemorrhage. The particle, which was not much larger than a pin-head, was submitted to me for identification, and though its form resembled nothing with which I was familiar, I surmised that it was probably a part of a dynamite-cap or "detonator" used for exploding the dynamite charges in the mines, which, by some carelessness on the part of a miner, had been delivered intact with the coal.

These detonators are spun from very thin sheet copper and consist of a tube about 5 mm. in diameter and 40 mm. in length. The head is formed into a shallow cup, as shown in cross-section in fig. 1, and the tube is charged with mercury fulminate and fired by an electrically heated wire. It seemed probable that the solid pellet of copper, recovered during the autopsy, had been formed in some way from the concave head of the detonator by the enormous instantaneous pressure developed by the detonation of the fulminate.

I accordingly suspended one about 2 feet above a large earthenware jar holding about five gallons of water, pointing the head downwards. On firing the detonator the jar was shattered into a dozen or more pieces by the pressure wave exerted in the water by the passage of the small copper fragment (the head of the detonator) entering the water with three times the velocity of a rifle bullet, just as a milk can filled with water is burst open when the bullet of a high powered rifle is fired through it. The minute fragment of copper which was found in the ruins of the jar matched perfectly the fragment found during the autopsy but bore

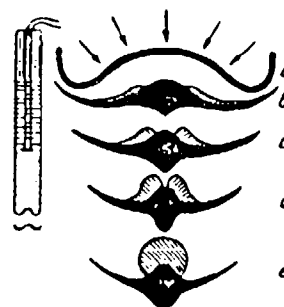

FIG. 1.

VOL. CLVII.—A.

3

Proceedings, Royal Society, (London) 1936

## Die Entwicklung der ausgekleideten Hohlladung

The Development of the Lined Hollow Charge  
Le Développement de la charge creuse revêtue  
El desarrollo de la carga hueca revestida



Abb.3



Abb.4  
Sprengstoffgewicht  
Auskleidungsgewicht

Invention date claimed: France 9 Nov 1939

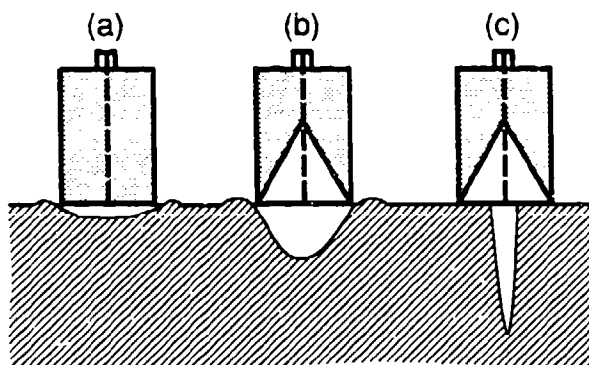
Australia 14 Aug 1941 "An Improved Explosive Projectile"

Applicant: Sager, Societe Anonyme de Gestion et d'Exploitation de Brevets

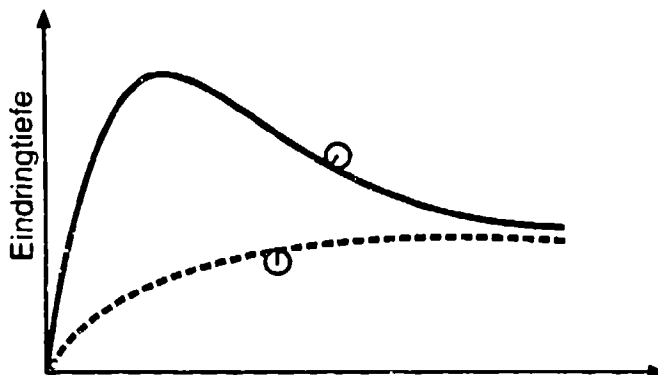
Assignors: Berthold Mohaupt, Henry Mohaupt, Erich Lauders, of France.

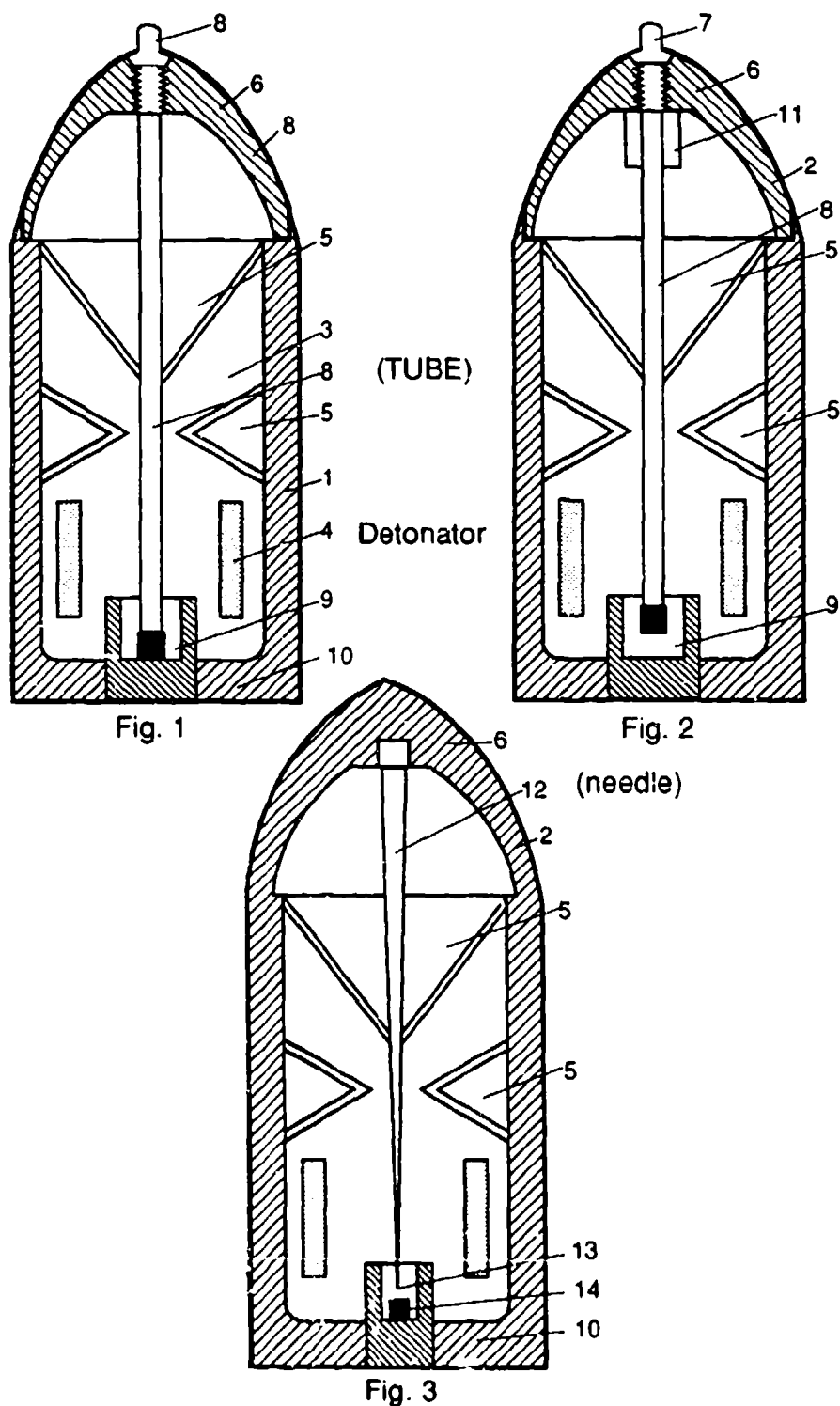
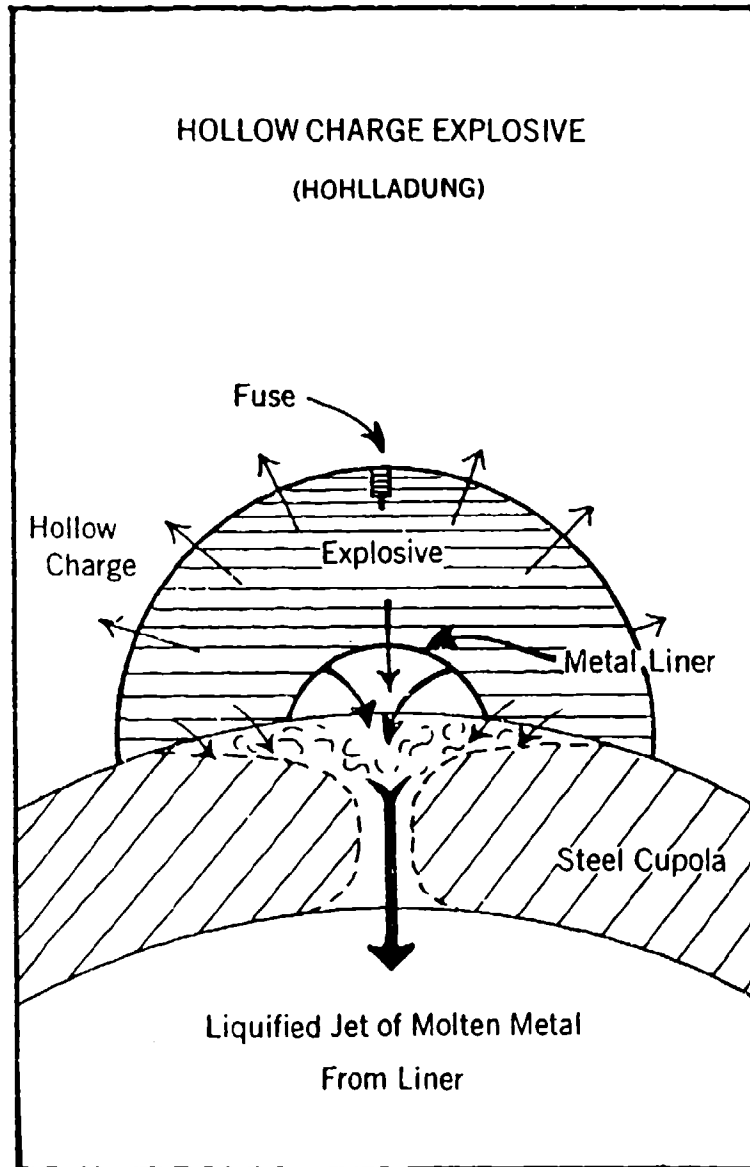
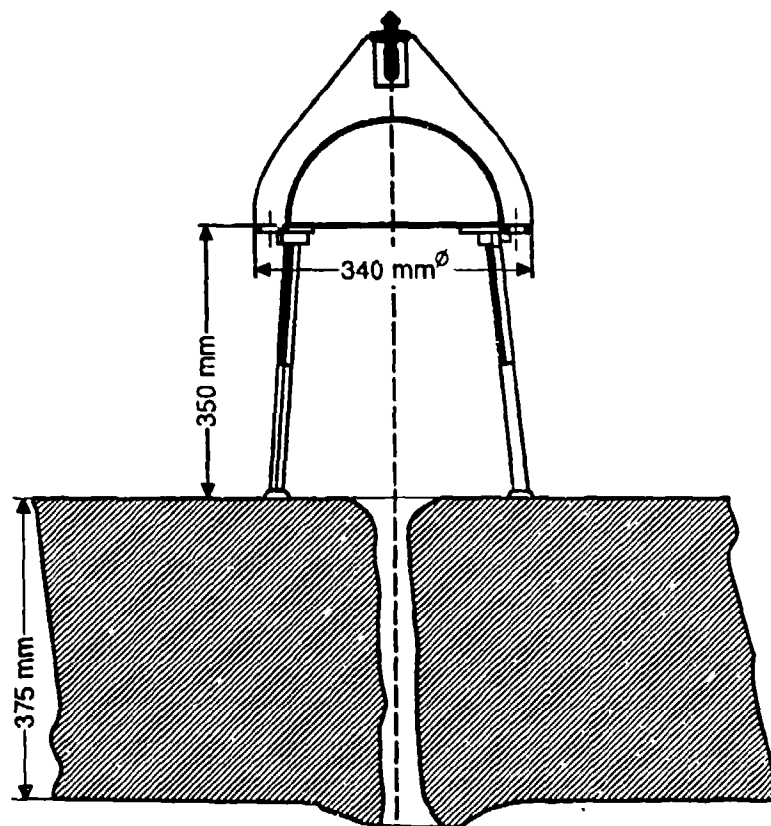

Fig. 16 Mohaupt, et al., first patent illustrations, 1939/1941



From Book The Fall of Eben Emael  
Prelude to Dunkerque  
 by Col. J.E.Mrazek

*Fig. 17 Schematic of Eben Emael charge, first used May 1940*



Blasting Charge for the Engineer Corps -  
HI 5 (15 KG Shaped Charge)

1943 German paper "Preliminary Information report about the enhanced performance of hollowcharge bodies by directed initiation (lenses)"  
von Prof. Dr. Erich Schumann u. Dr. Gerd Hinrichs

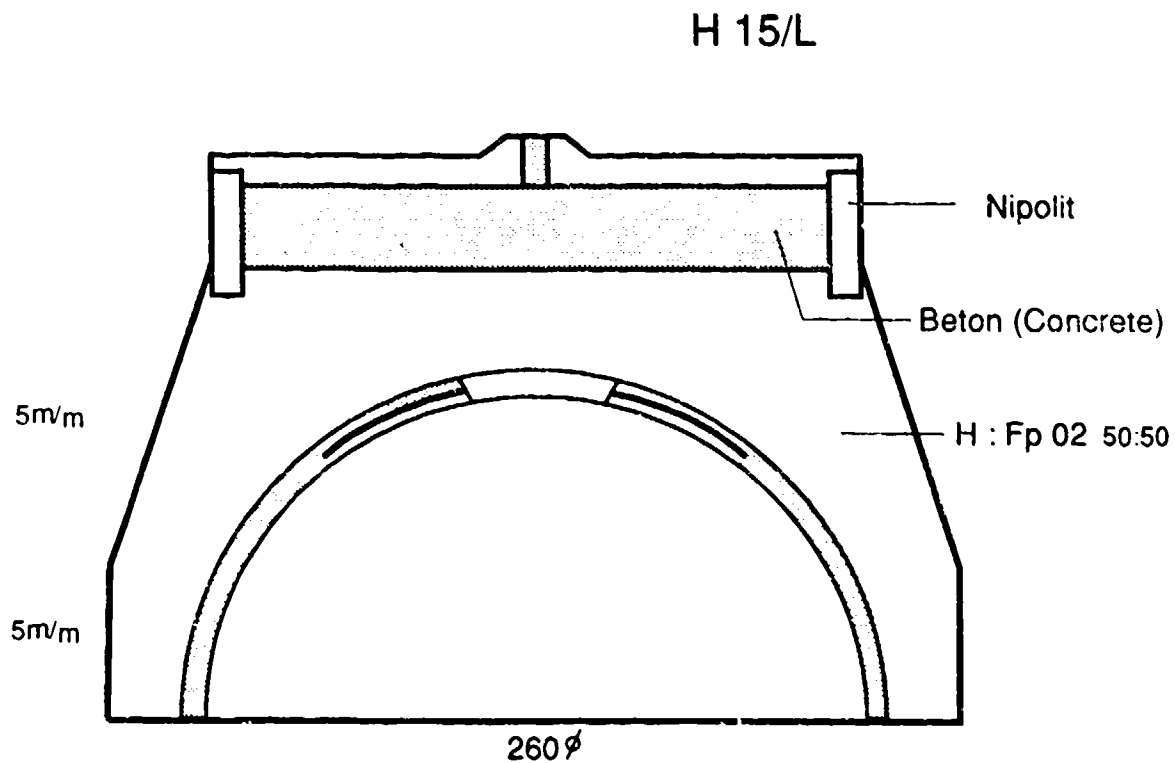

Fig. 19 German Detonation wave shaped (concrete) hemisphere 1943

Sprenglöcher der Hohlsprengkörper  
 H 15 ohne Linse  
 H 15/L mit Linse

Hochstellung 50 cm

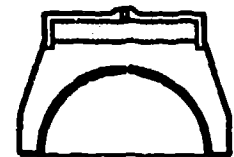
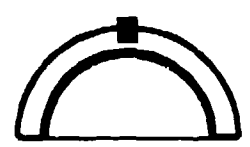
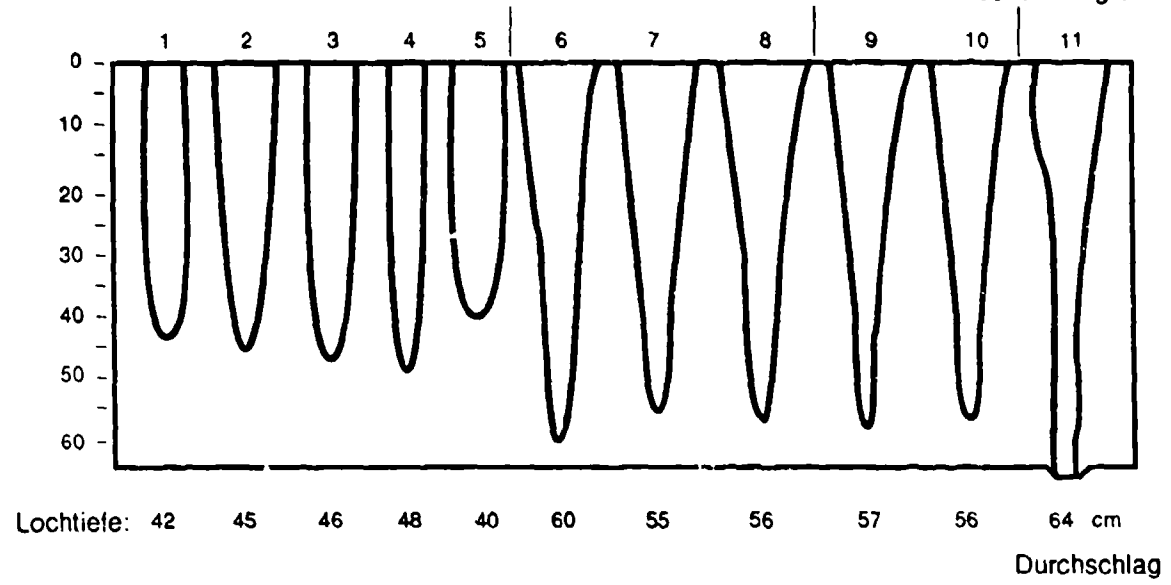
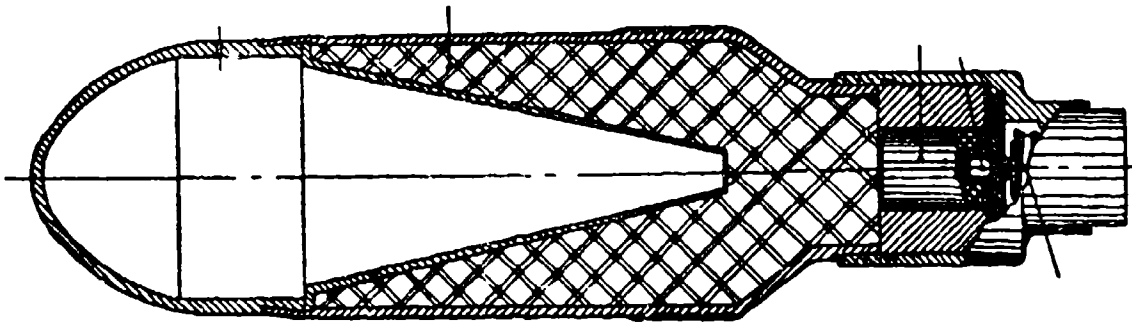
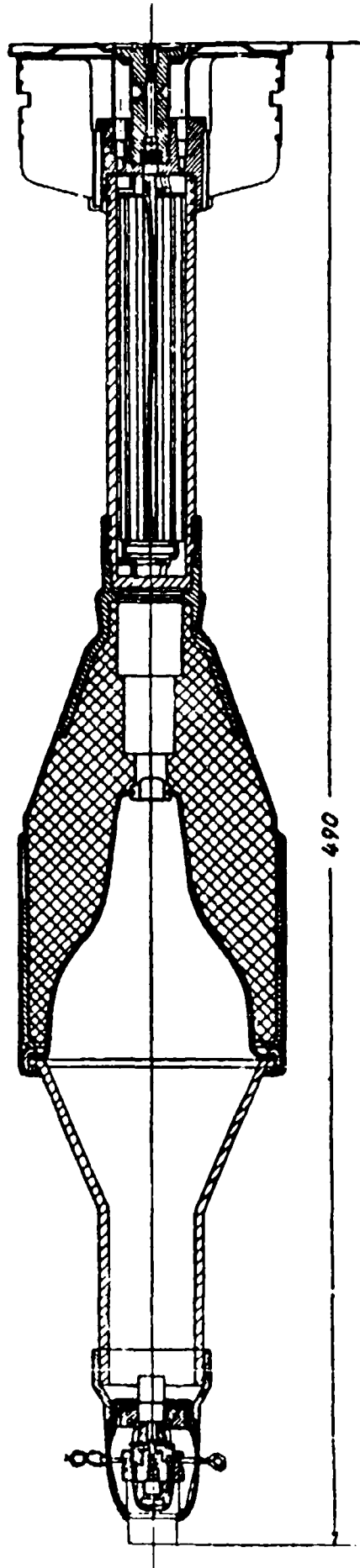

Fig. 20 German wave shaped vs point initiated hemisphere, 1943





6.6 CM SCHIESSBECHER ANTI-ARMOR GRENADE  
(ADAPTATION OF THE LARGE RIFLE GRENADE FOR  
THE 2 CM CALIBER).



PROJECTILE FOR THE WEAPON "PUPPCHEIN".  
SPINLESS, PD-FUZE, BOTTLE-SHAPED LINER,  
ACCELERATION BY BARREL PRESSURE AND OWN  
PROPULSION, DESIGN ADAPTED FOR "PANZERSCHRECK".

*Fig. 22 German bottle liner, Puppchen and Panzerschreck, 1942*

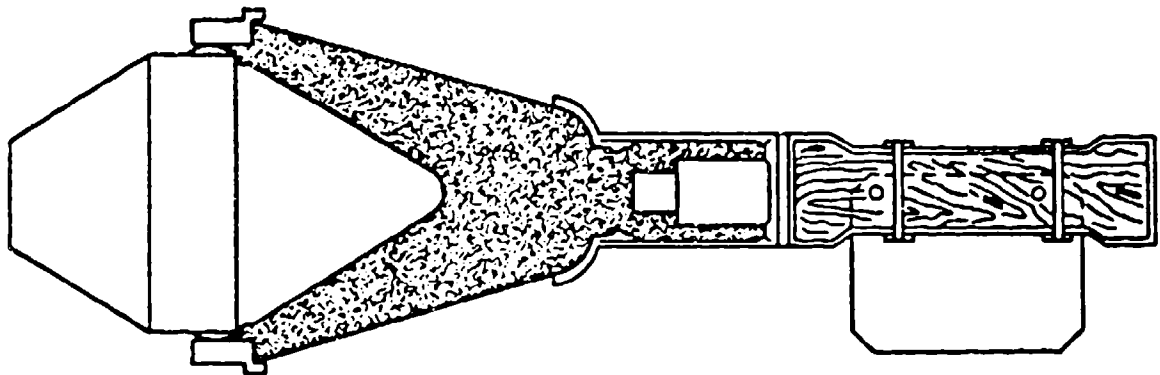

(A) "PANZERFAUST" H.E.A.T. ROCKET (GERMAN & SOVIET)

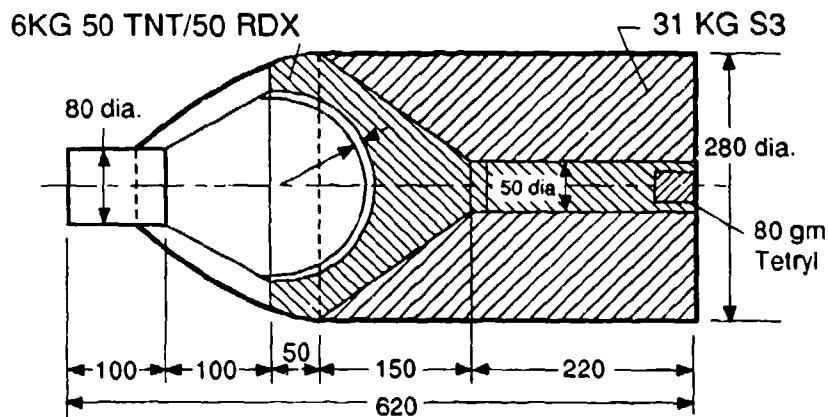

Model Torpedo Warhead Equipped with Hollow Charge

Source: "Introduction to the Theory of Underwater Explosions"  
 By Chemical-Physical Research Institute of German Navy, Kiel, 1945  
 Translated by David Taylor Model Basin, 1948, AD 125 636

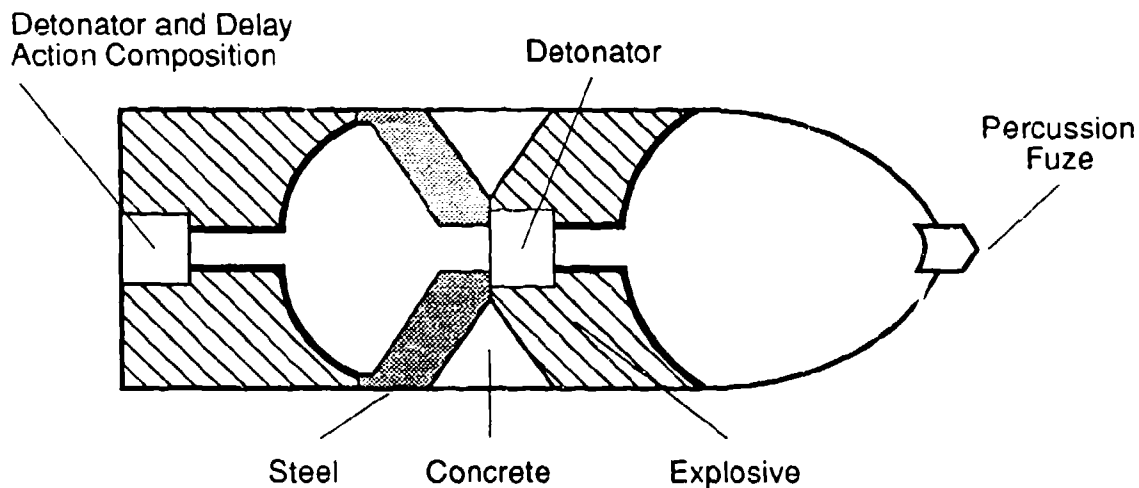

Source: Ordnance Department U.S. Army Picatinny Arsenal  
 Lecture by L.H. Eriksen Technical Division, 4 Apr 1947  
 "The Shaped Charge"

Fig. 24 German advanced shaped charge technology examples WWII

OFFICIAL DESIGNATION: BEETHOVEN-GERAT      UNOFFICIAL NAME: VATER UND SOHN  
 ALSO MISTEL-1 (L WER UNIT A PARASITE, HENCE "MISTLETOE")

FW-190 FIGHTER

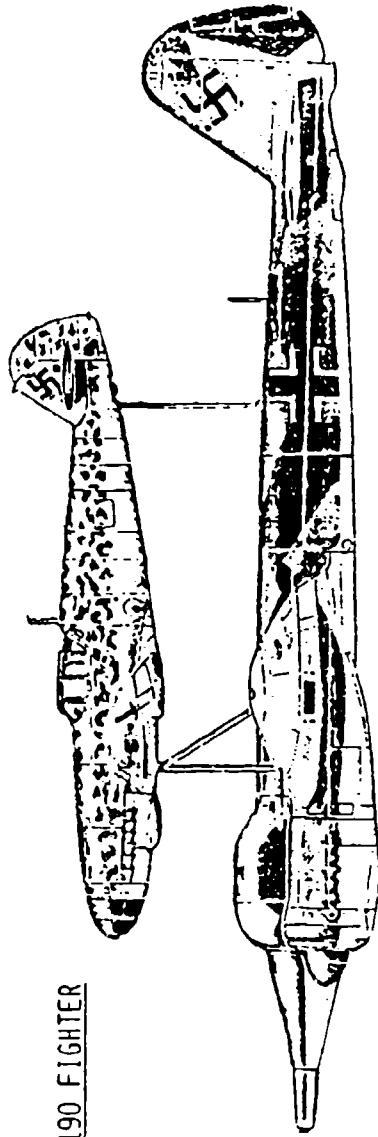

Ju-88 BOMBER

WARHEAD: HOLLOW CHARGE

GROSS WT. 7700-LB

DIA. 6-F.

H.E. WT. 3800-LB

STANDOFF 5-F.T.

THEORETICAL PENETRATION

24-F.T. STEEL (4-C.D.)

60-F.T. CONCRETE

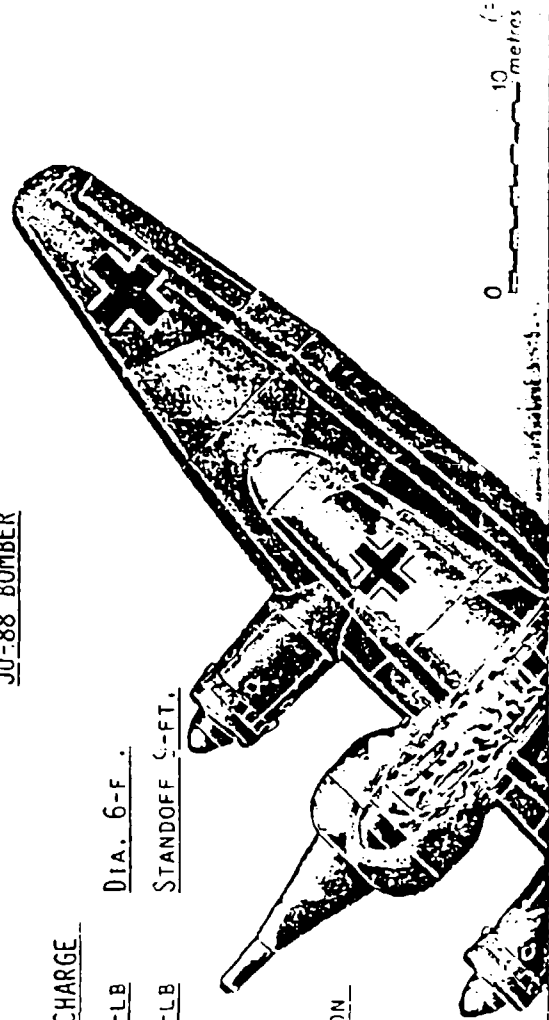

Fig. 25 German MISTEL missile with 7700-lb shaped charge, 1943

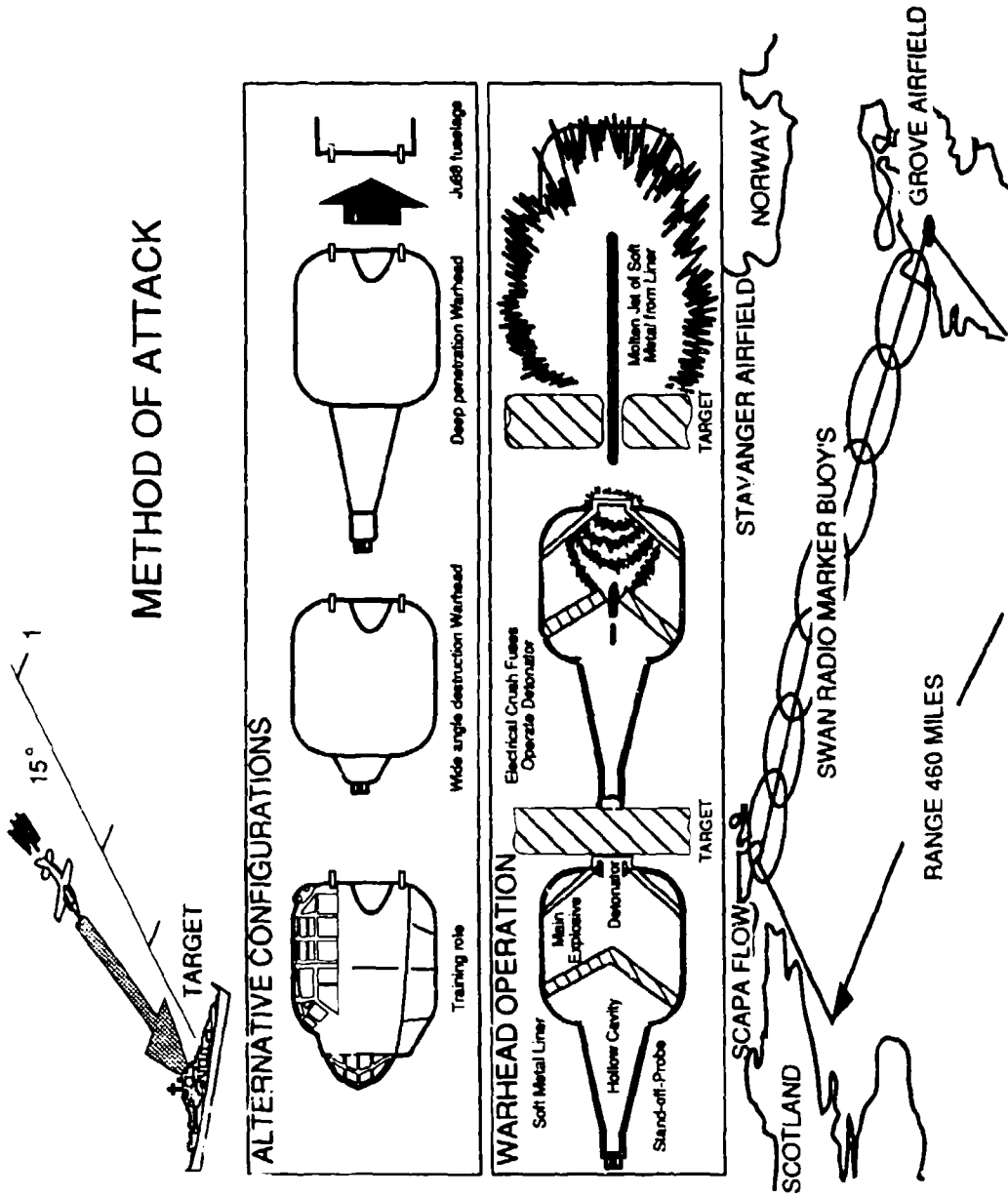

Fig. 26 German MISTEL, warhead sketch

### Haft-Hohlladung 3 kg

The idea of this hollow charge headed anti-tank mine was that it was to be placed on to the side of a tank where it would be held in position at the optimum distance for the hollow-charge to ignite by three strong magnets. As such it was very much a weapon for 'close-in' tank-killer squads in built-up areas and was not often on general issue to infantry units. It was usually issued to special-purpose engineer units who also used it for demolition purposes. When placed on a tank a friction igniter was pulled which had a 4½ or 7½ second delay before firing the charge.

#### DATA

WEIGHT 3.49 kg 7 lb 12½ oz  
WEIGHT OF CHARGE (TNT) 0.89 kg  
1 lb 15½ oz  
DIAMETER OF CHARGE 108 mm 4¼ in  
HEIGHT OF CHARGE CONTAINER  
197 mm 7¾ in  
HEIGHT OF MAGNETS 70 mm 2¾ in



1



3



2

1, 2. Haft-Hohlladung 3 kg 3. Pulling the friction igniter of a Haft-Hohlladung which has been placed against a T-34 tank. The charge would then detonate after a preset 4½- or 7½-second delay.

Fig. 27 German and technology-transferred Japanese AT mines, 1944

## ANTITANK "LUNGE" MINE

This suicide mine, an antitank device used by Japanese Close quarter Combat Units, consists of a conical-shaped hollow charge encased in a steel container, and a wooden handle. Three legs equally spaced around the base of the charge provide proper stand-off distance. A well in the apex of the charge contains the detonator.

The firing mechanism, quite simple in construction, consisting of a needle type striker, a shear pin, and a safety pin, is housed in a metal sleeve. This sleeve, which holds the mine and the handle 2.4 inches apart, slips over the end of the handle and is held in place by the shear pin and safety pin. It is attached to the body of the mine by a threaded connecting ring.

To operate the mine, the soldier must first remove the safety pin, and then, using bayonet tactics, lunge forward striking the mine squarely against the tank. When the legs of the mine strike the target, the handle is driven forward breaking the shear pin, and the striker is driven into the detonator, initiating explosion of the mine.

The mine will penetrate 6 inches of steel plate; with contact at a 60° angle, steel plates of approximately 4 inches can be penetrated.

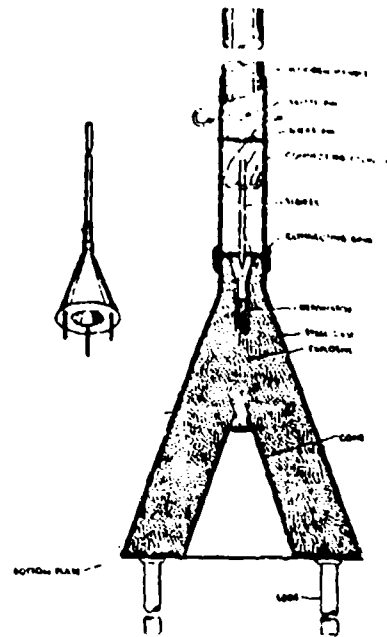

### SPECIFICATIONS

|                                    |            |
|------------------------------------|------------|
| Length of mine body (approx.)      | 12 in.     |
| Diameter of base of body (approx.) | 9 in.      |
| Length of handle                   | 55 in.     |
| Diameter of handle                 | 1 1/2 in.  |
| Weight of explosive charge         | 6 1/2 lbs. |
| Length of legs                     | 3 1/2 in.  |
| Weight of mine (total)             | 16.2 lbs.  |



(Was this, perchance, an American invention?)



Societ  d'In-  
 genieria e  
 Industrie S.p.A.  
 Via S. Pietro  
 12, 10121  
 Torino, Italia

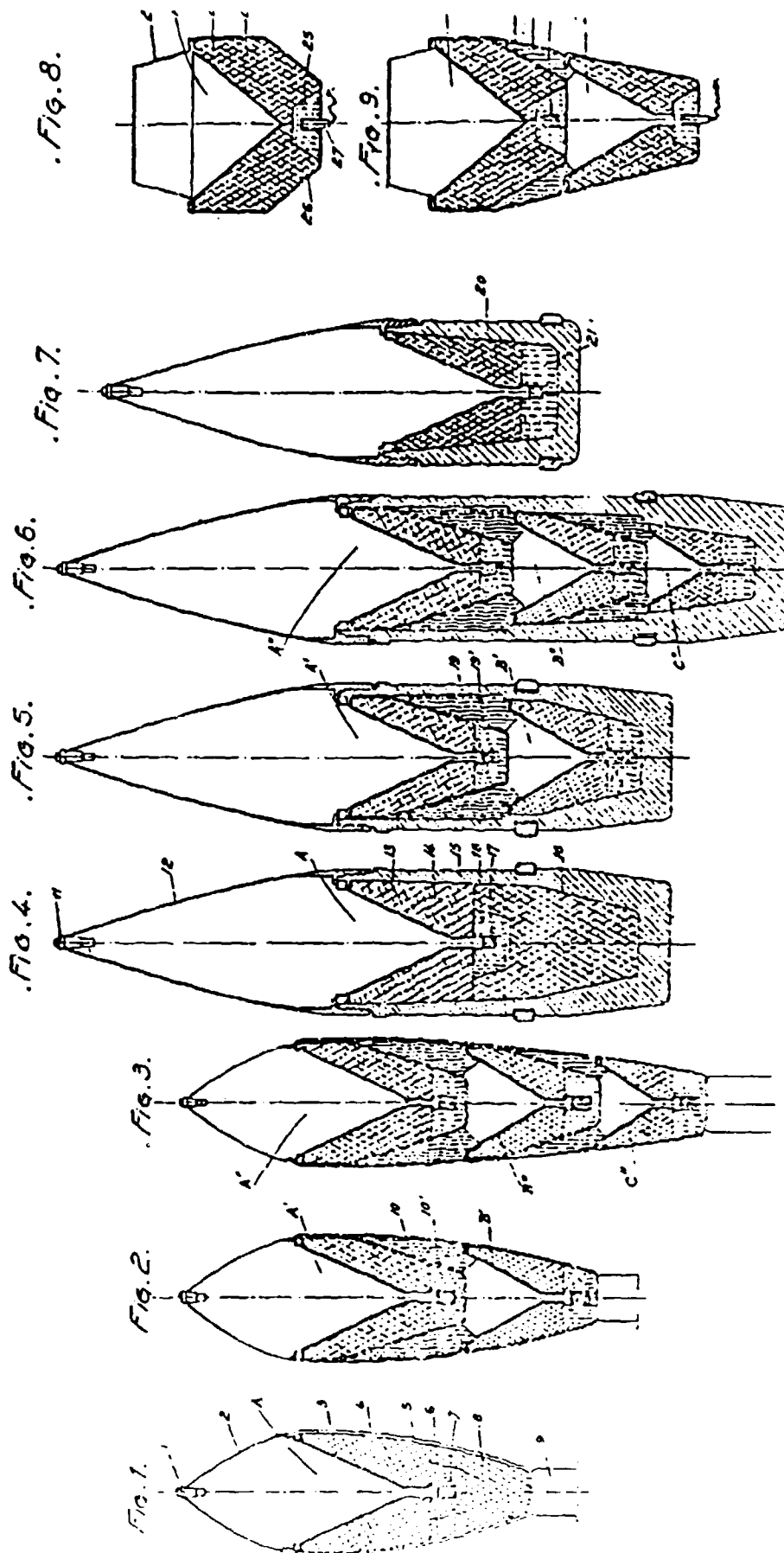

Fig. 29 Pr coul patent 1946

April 22, 1947.

H. H. MOHAUPT  
PROJECTILE

2,419,414

Filed Oct. 3, 1941

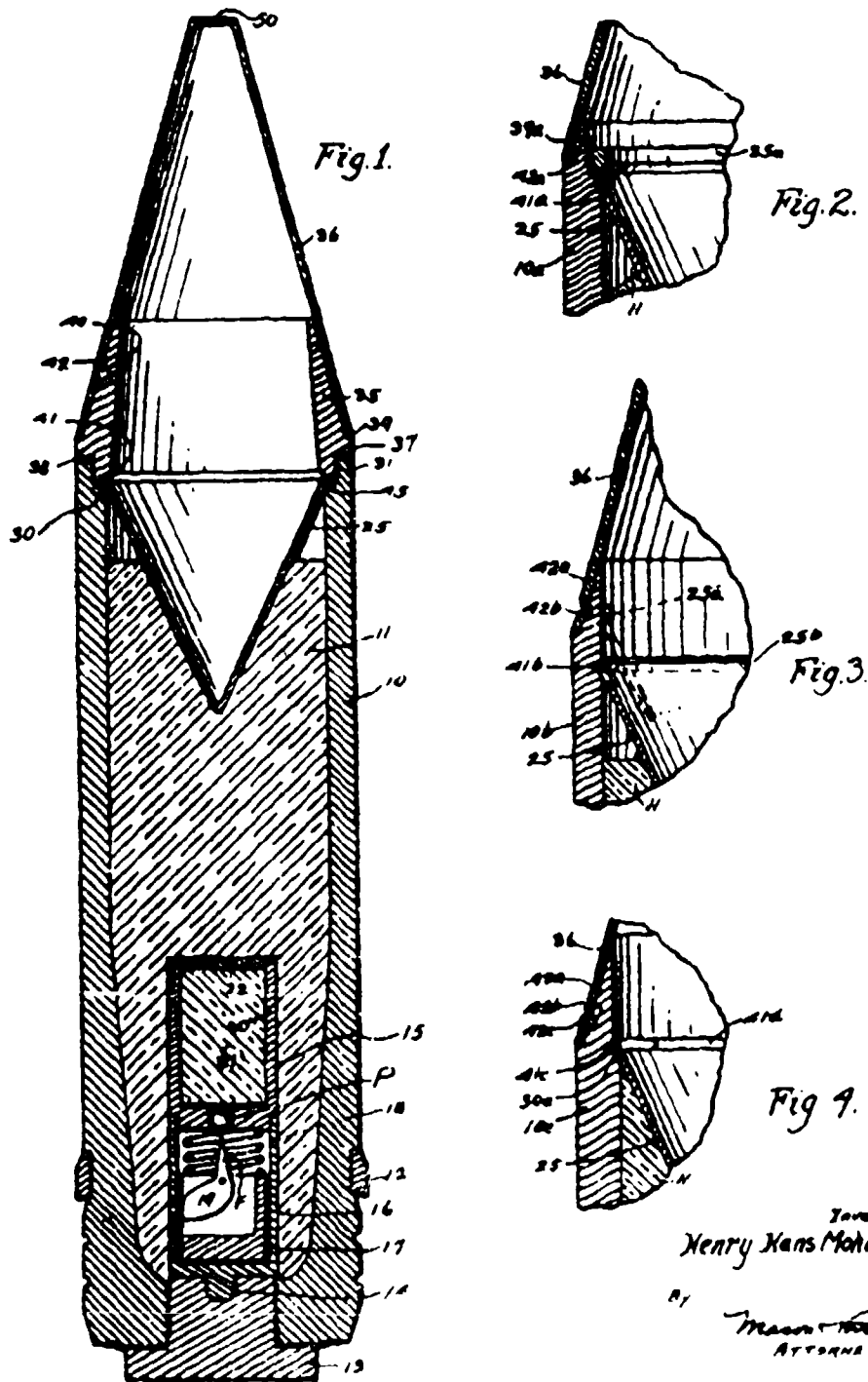

Inventor:  
Henry Hans Mohaupt.

By  
Maas & Maas  
ATTORNEYS.

March 14, 1961

H. H. MOHAUPT  
PROJECTILE

2,974,595

Original Filed Oct. 29, 1942

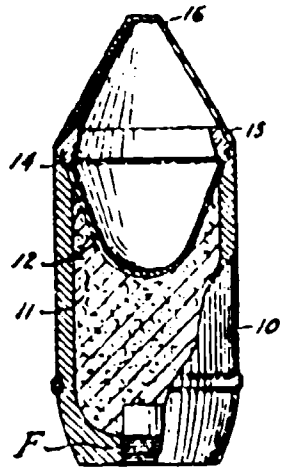

Fig. 1.

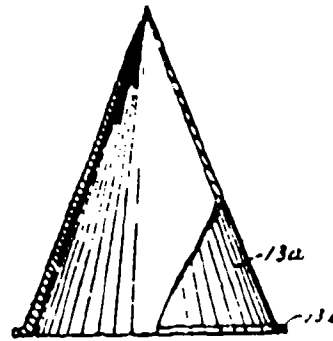

Fig. 3.

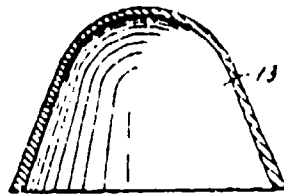

Fig. 2.

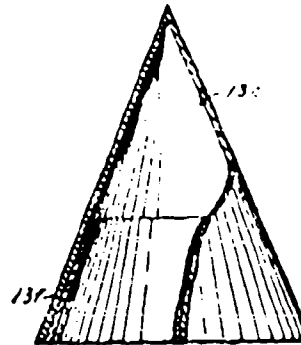

Fig. 5.

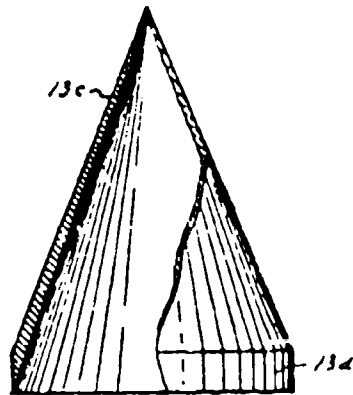

Fig. 4.

HENRY HANS MOHAUPT

INVENTOR

BY *Herbert J. Brown*

ATTORNEY

May 11, 1948.

G. W. BLACKINTON ET AL

2,441,388

PROJECTILE

Filed Aug. 10, 1942

2 Sheets-Sheet 1

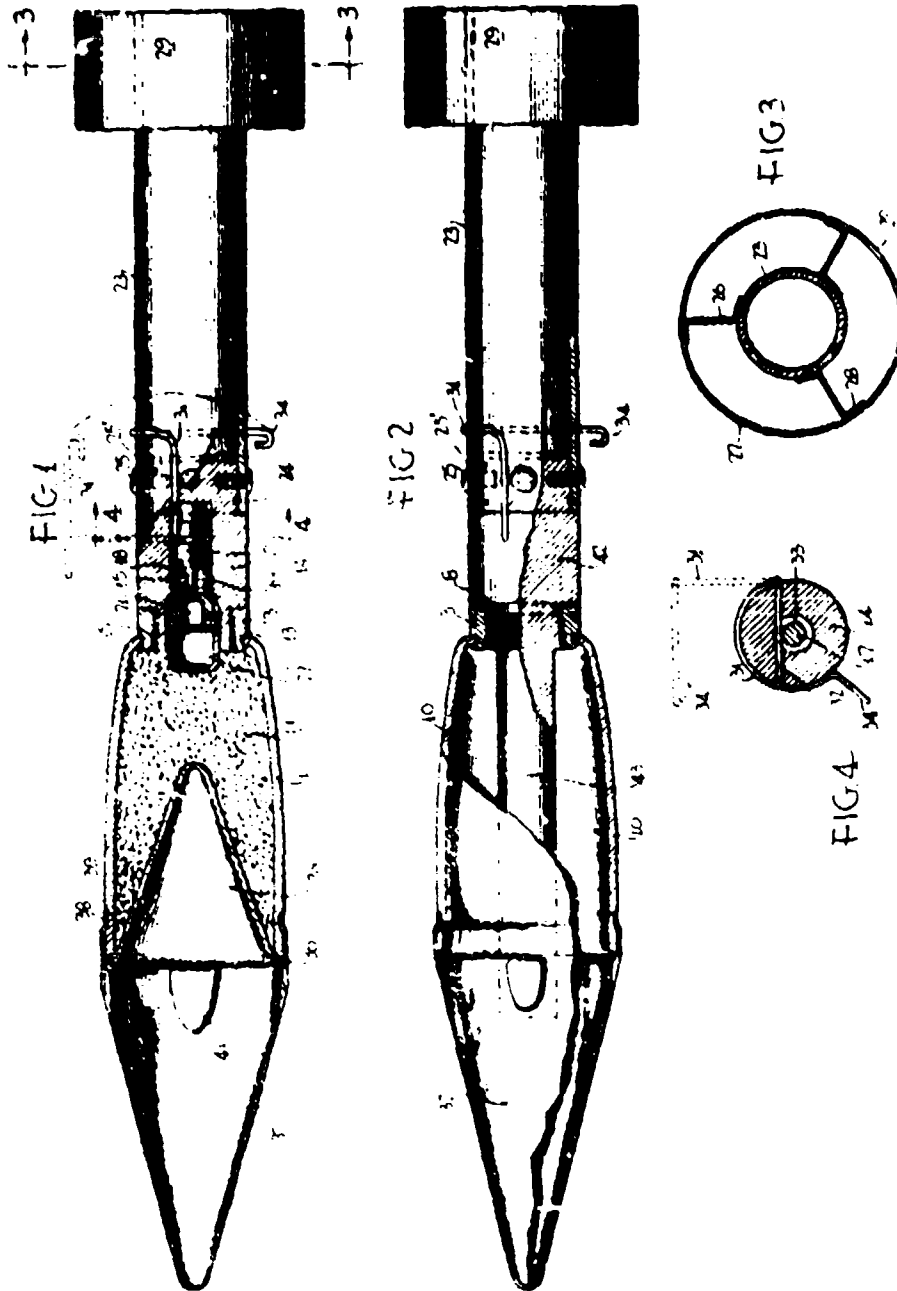

INVENTORS  
George W. Blackinton  
John J. Calhoun  
BY *John P. Taylor*  
ATTORNEY

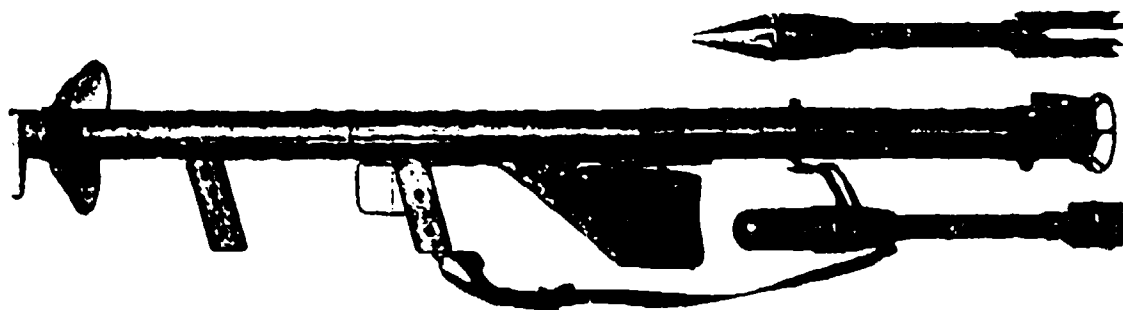

B

- B. An early production model of the US Bazooka. The round-nosed bomb is a late model, posed to show the difference between it and the pointed-nose first versions;

*Fig. 33 U.S. 2.36-in. Bazooka Rocket Launcher, ca. 1942*

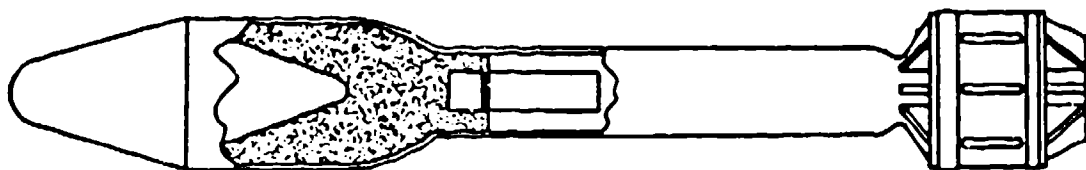

(B) 3.5 in. H.E.A.T. ROCKET (U. S.)

*Fig. 34 3.5-in. Super Bazooka*

SHAPED-CHARGE FOLLOW-THROUGH ROCKET

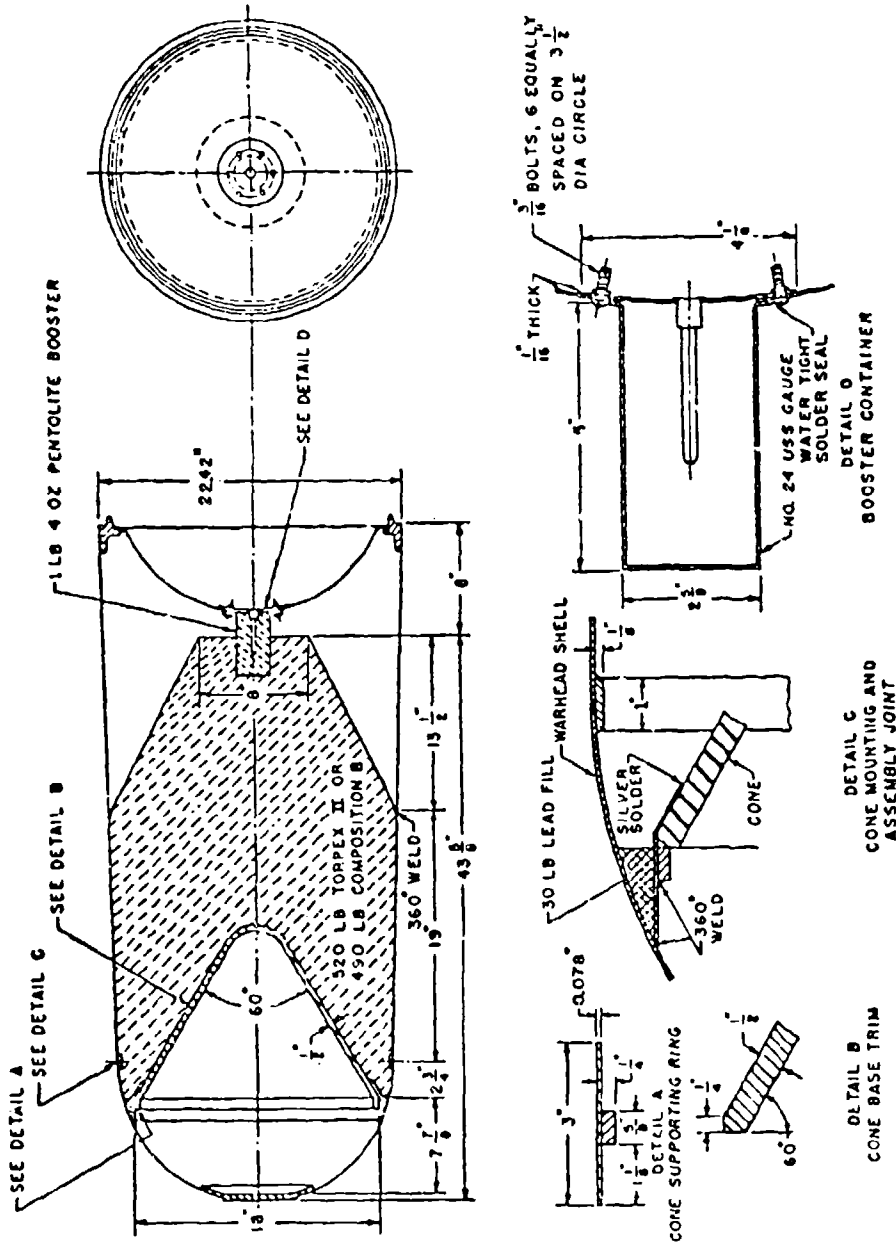

FIGURE 3. Shaped-charge torpedo warhead.

Fig. 35 Shaped charge torpedo warhead, U.S.N., WWII, ca. 1944/45

## ANTISUBMARINE SHAPED-CHARGE BOMB\*

|                         |                                   |
|-------------------------|-----------------------------------|
| Bomb case diameter      | 6.00 in.                          |
| Cone base diameter      | 5.85 in.                          |
| Cone angle              | 15°                               |
| Cone wall thickness     | 0.185 ± 0.020 in.                 |
| Cone material           | Mild steel<br>(Armed to SAE 1020) |
| Cone manufacture        | Cold stamping                     |
| Explosive               | 60/40 Cyclotol                    |
| Explosive charge length | 12 in.                            |
| Explosive charge weight | 12.5 in.                          |
| Bomb length             | 22 in.                            |
| Bomb weight             | 38 lb                             |

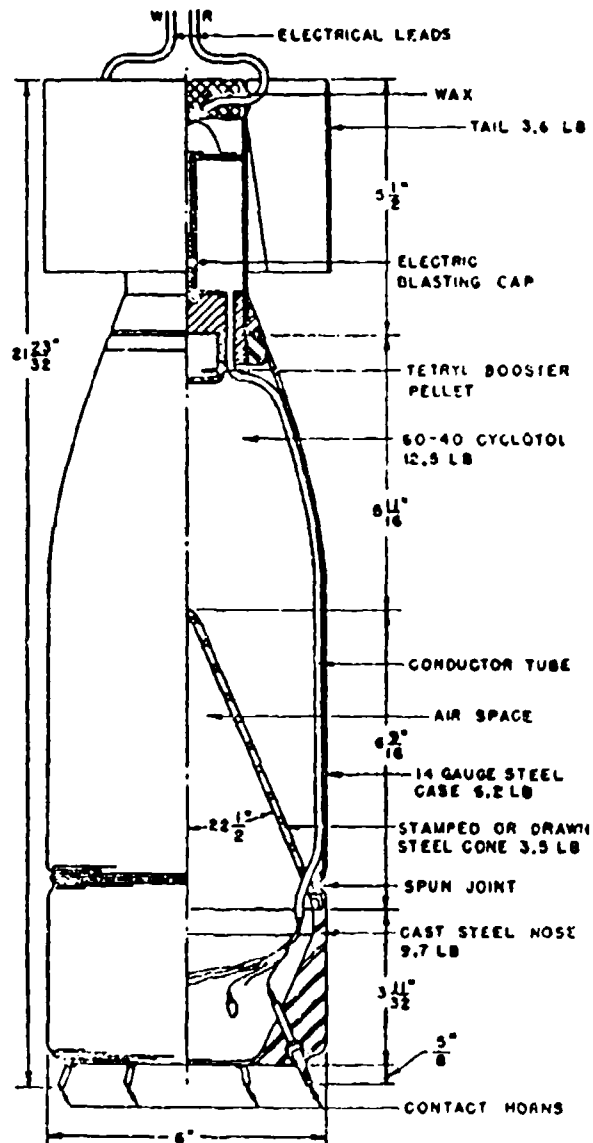

FIGURE 1. Antisubmarine shaped-charge bomb.

ANTISUBMARINE SHAPED-CHARGE  
FOLLOW-THROUGH BOMB

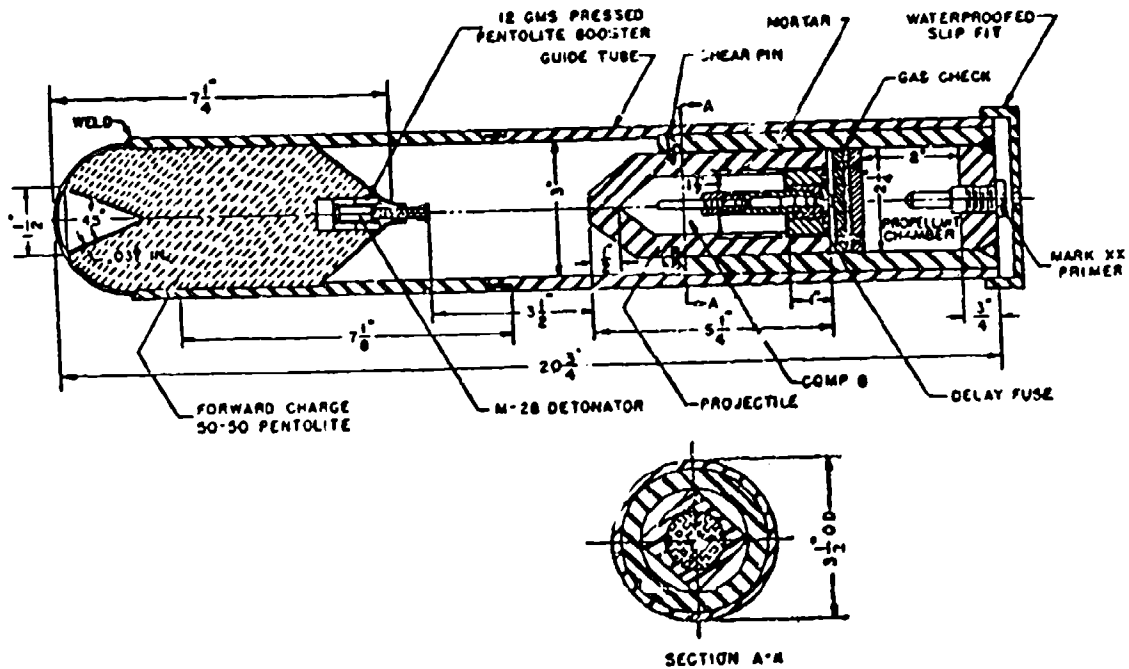

FIGURE 2. Antisubmarine shaped-charge follow-through bomb.

AD 221 595  
 The Preparation and Testing of Explosives  
 Summary Technical Report of Division 8, NDRC, Vol 1  
 Washington D.C. 1946  
 Page 53



PROJECTILE FOR SHAPED CHARGES

Filed Nov. 16, 1949

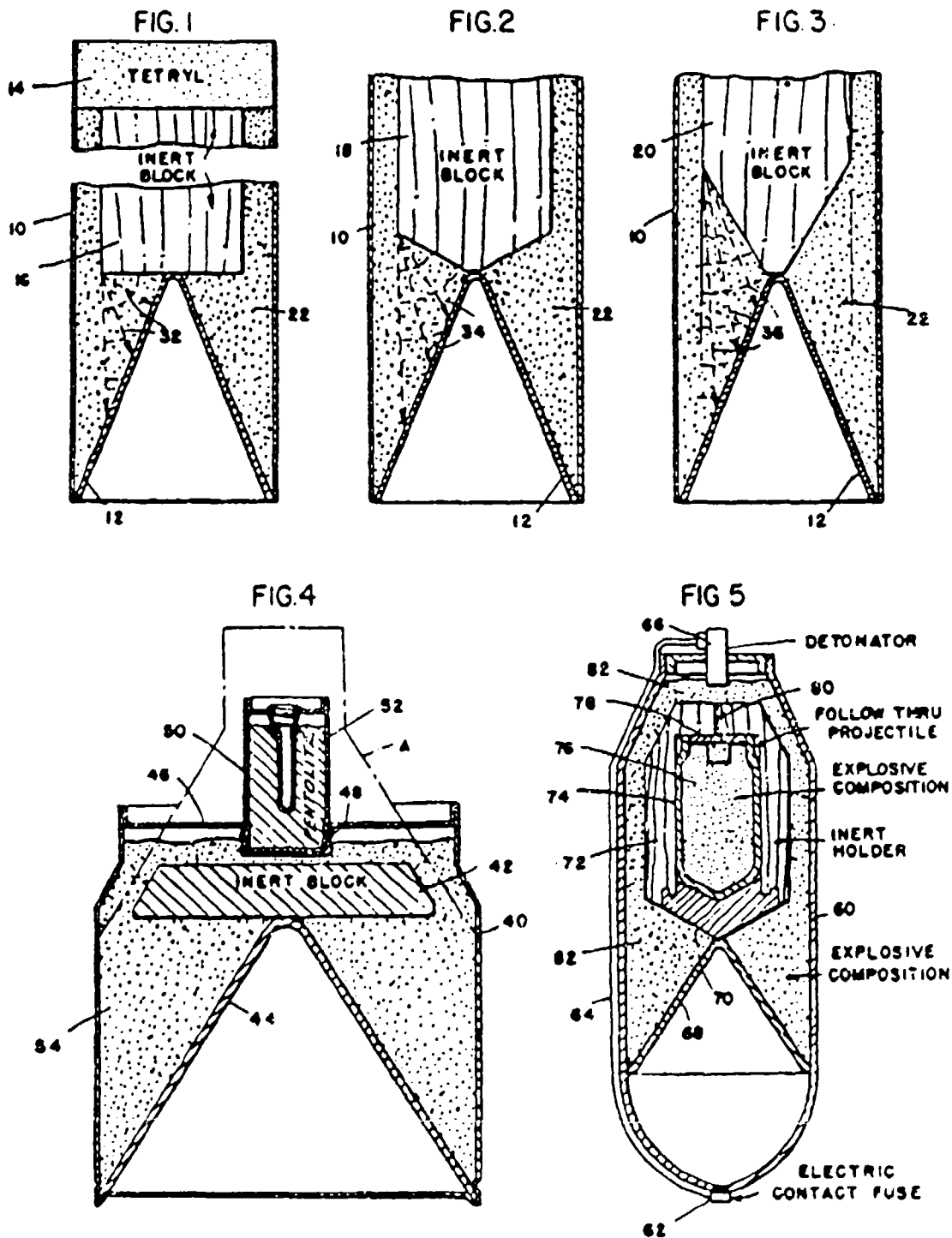

Fig. 38 Moses patent wave shapers, follow-through, U.S. 1949

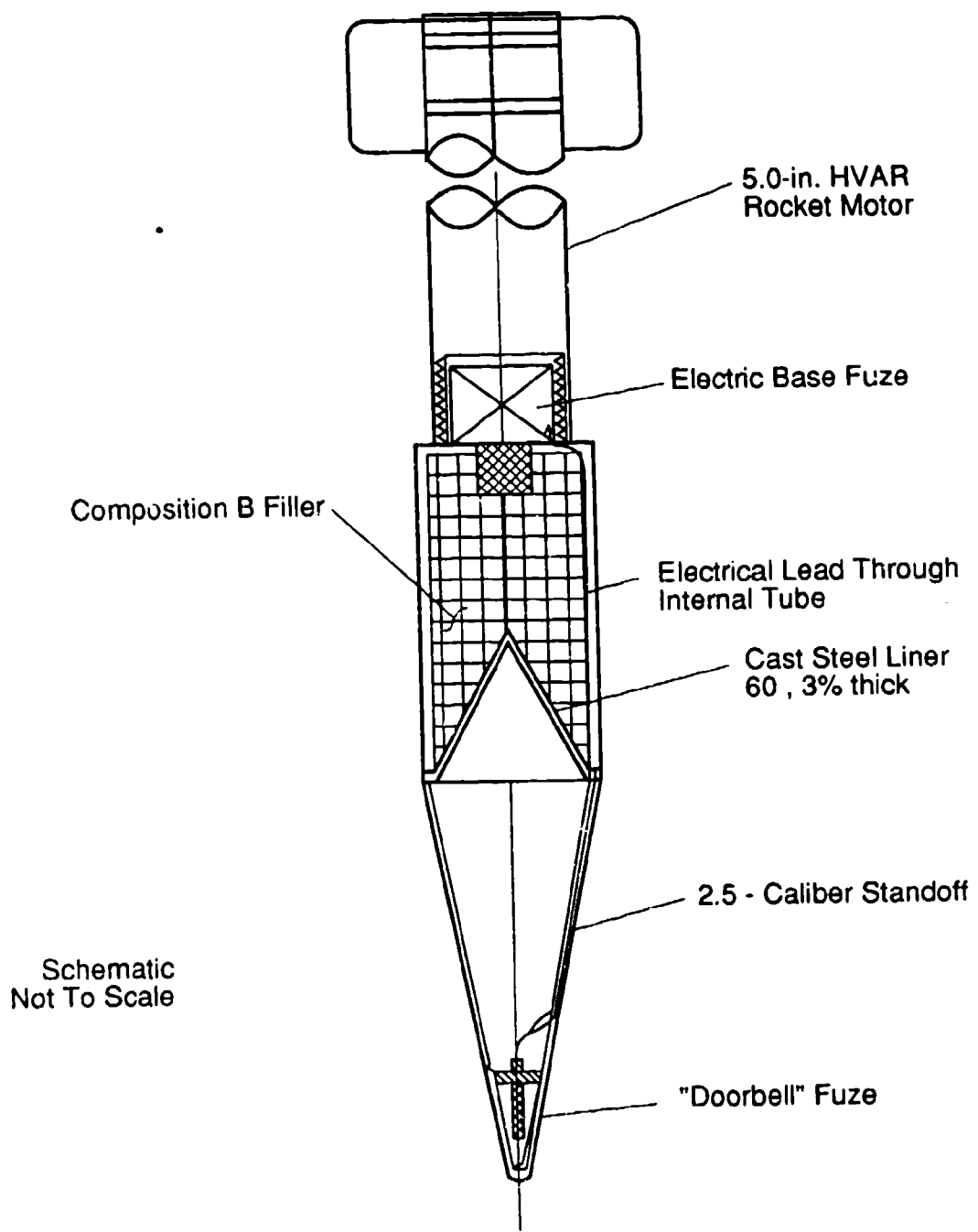
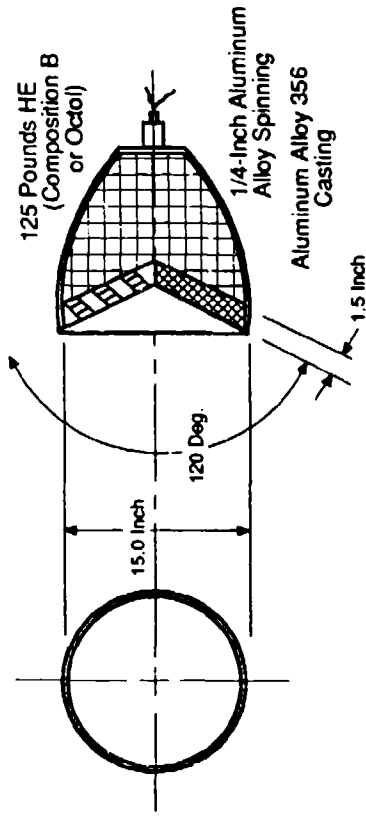
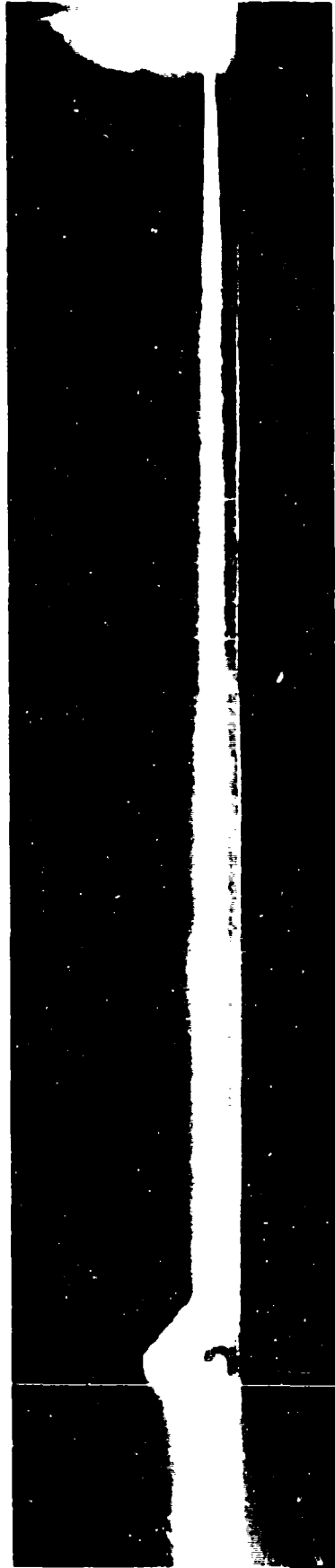

Fig. 39 6.5 -in. ATAR HEAT rocket, U.S. NOTS, 1950 (schematic)



Approximate Configuration, NOTS 15-Inch Shaped Charge



First test of 15-inch diam. 120-degree, 10% thick aluminum lined shaped charge at standoff of 300 feet against fuselage of B-29 Aircraft. Open shutter, night time photo taken at Area R, NOTS China Lake, 1952. Note that jet nearly missed target necessitating development of "600-ft. optical lever" aiming method using mirror on face of charge and flashlight at desired aiming point.

*Fig. 40 15-in. long-standoff shaped charge device, U.S. NOTS, 1952*

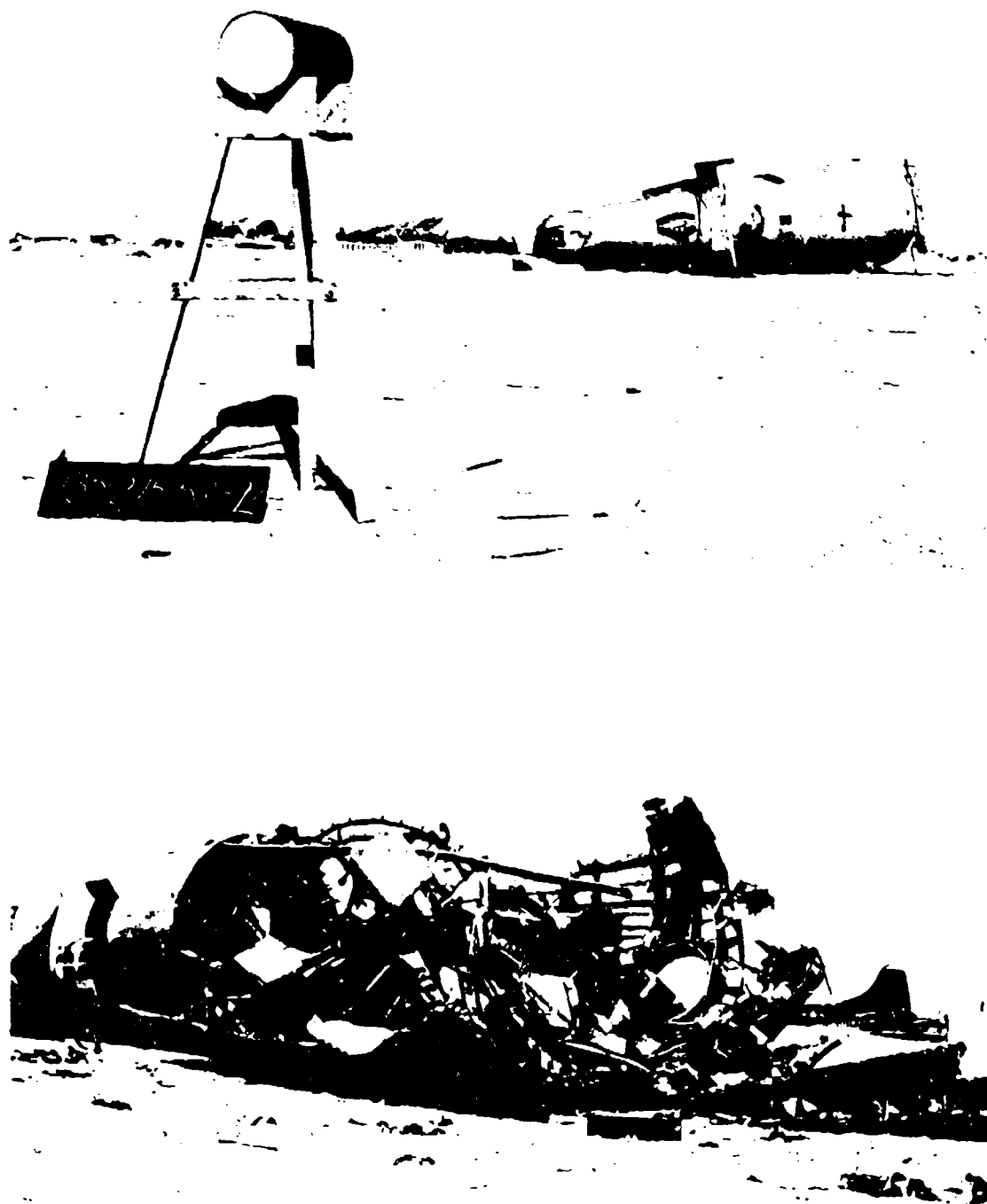

Effect on B-29 aircraft forward fuselage section of jet produced by 8-inch Dia. 45-deg., aluminum, conical-liner shaped charge at standoff of 150 feet with aiming point the "+" on the right hand side of target. Post-test view is excellent example of "vaporific effect", a combination momentum and aluminum oxidation reaction event. Photos taken at NOTS China Lake, CA 1954.

*Fig.41 8-in. Aluminum Shaped Chage vs. Aircraft at 150-ft. Standoff (NOTS 1954)*

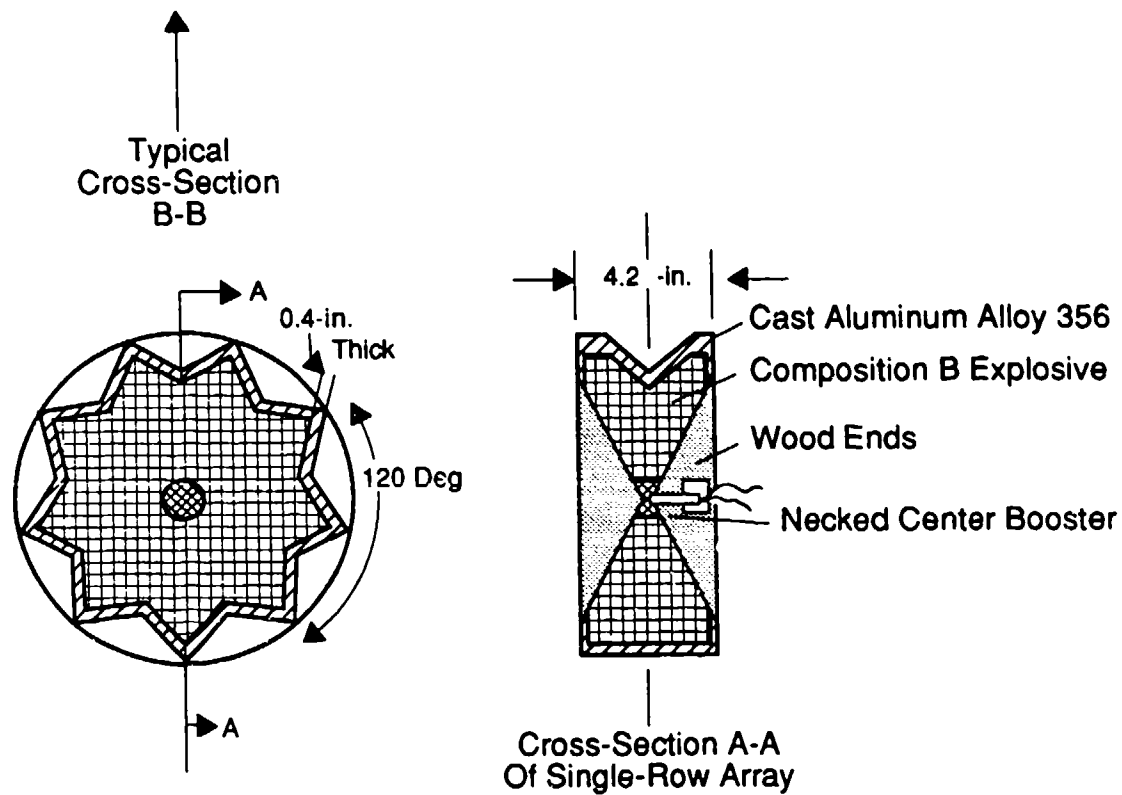

Multiple jet shaped charge, 9 each, 90-deg. aluminum cone liners in ring, targets B-29 aircraft aft fuselage, inner wing panel, and rudder. US NOTS 1952.

Fig. 42 Multiple liner anti-airtarget HEAT device, U.S. NOTS, 1952

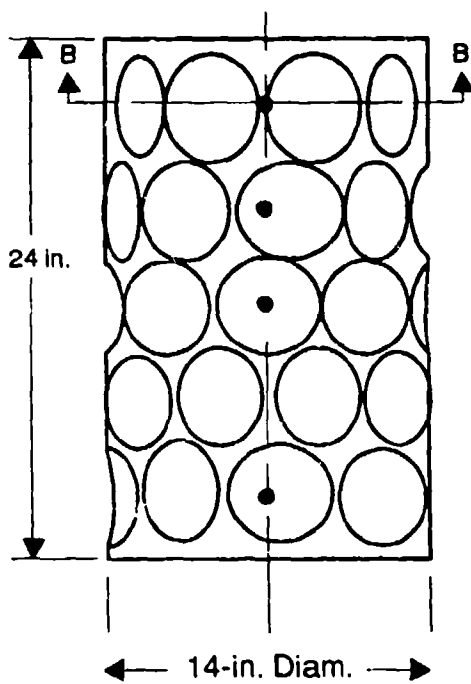

45-Cone Multiple-Row Array. Five rows of nine, with common cylindrical case and explosive charge. Note five points of initiation on centerline.

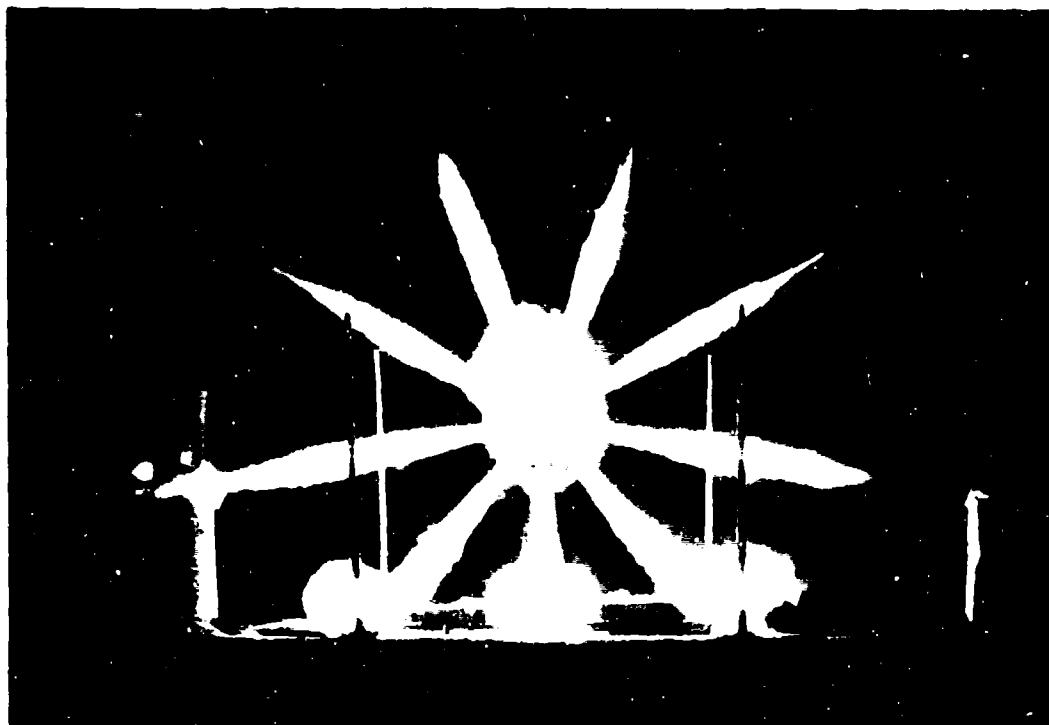

Multiple jet shaped charge with 5 rings of 9 aluminum cones about common charge of 125-lb Comp B with 5-point initiation (failed to function simultaneously in this shot). Photo used as advertising by Aerojet in 1965 issue of Ordnance Magazine. US NOTS 1952.

Fig. 43 45 line, 5-row multi-liner device U.S. Notes, 1953

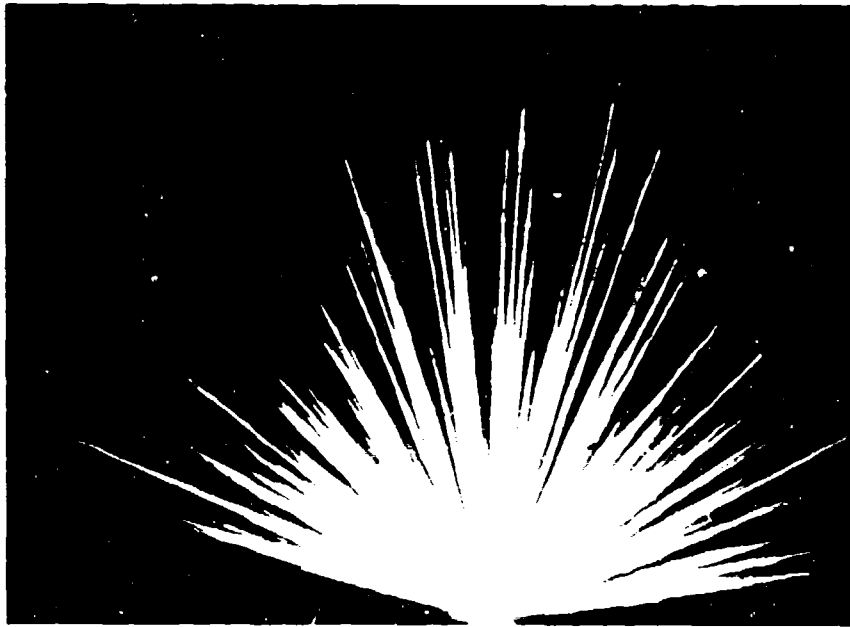

Hypervelocity multiple jetting warhead concept, NOTS, China Lake 1952. An array of 96 1.5-in. diam., 0.125-in. thick, aluminum dish (EFP) liners embedded in surface of an 18-in.-diam., 26-lb. Comp C-3 HE-loaded, hemisphere dome with single-point initiation. Visible jets measure about 100 ft. long, with velocity at 98 ft. recorded at 12,000 ft/sec.

*Fig.44 Test of 96-Jet Hypervelocity Fragment Projector Concept (NOTS 1952)*

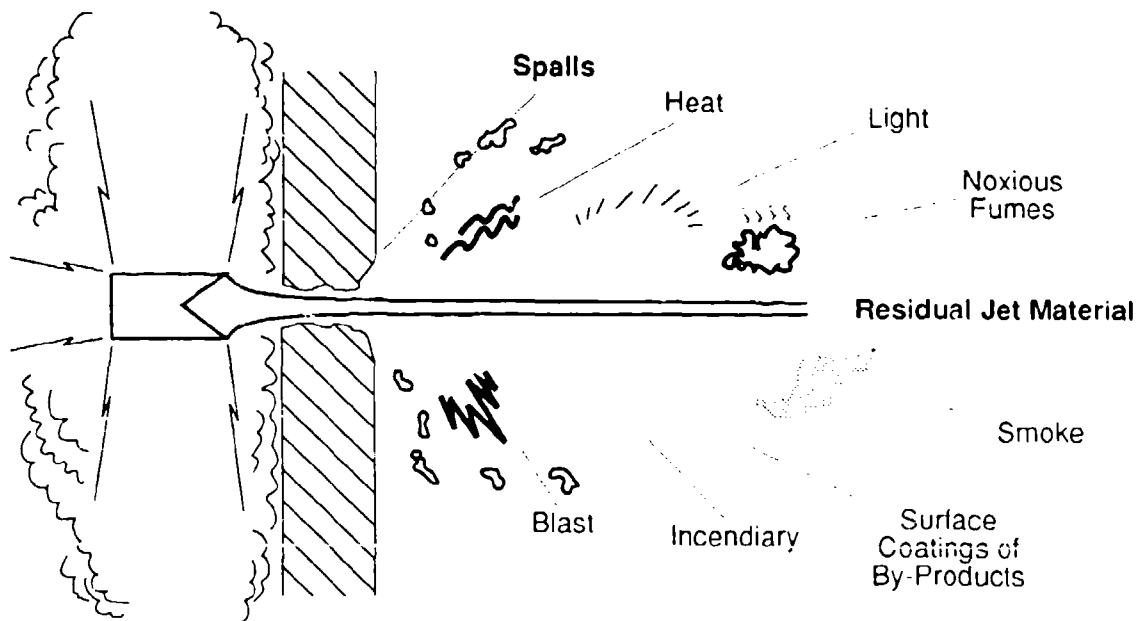

*Fig. 45 Diagram of Behind Armor Effects*

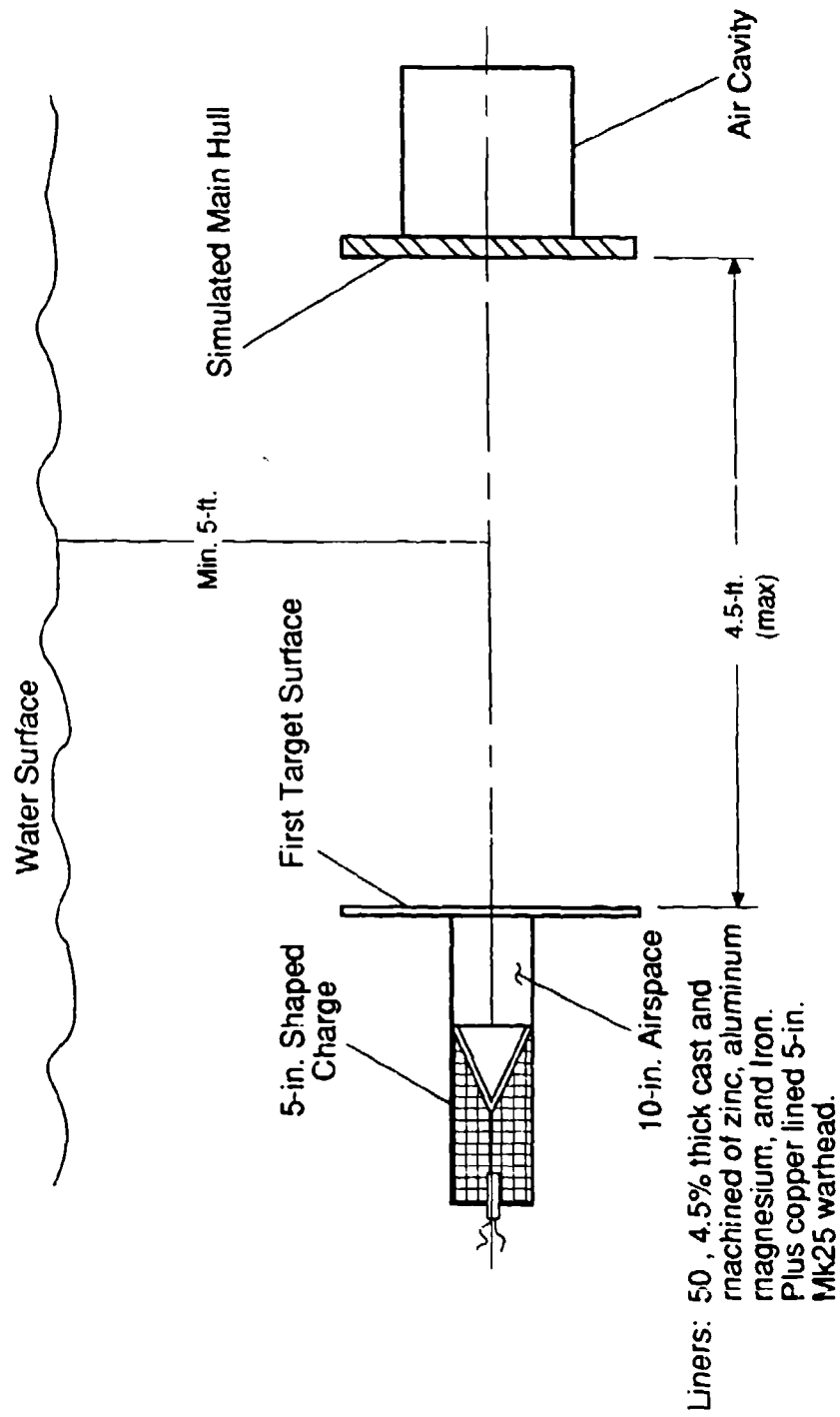
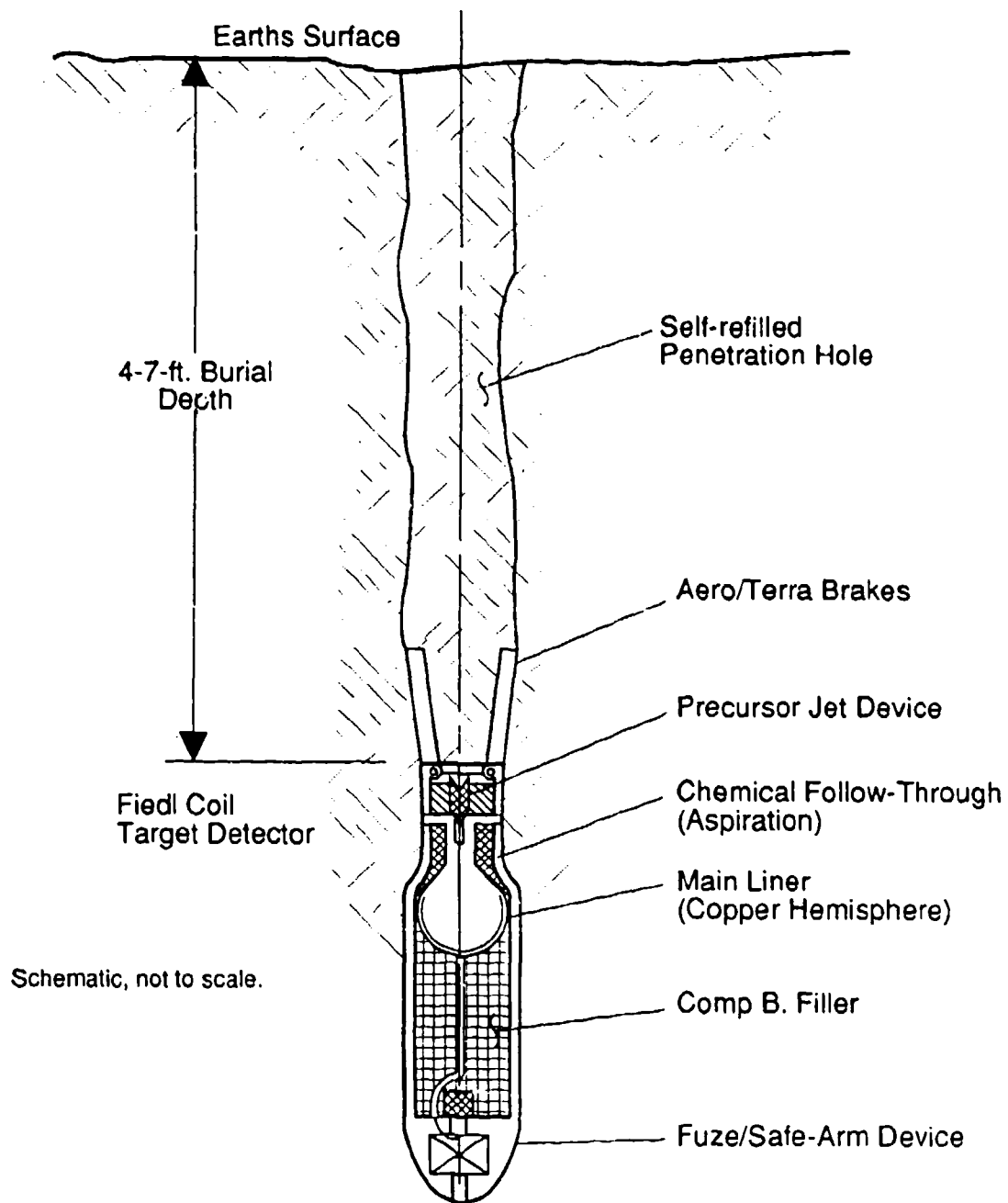

Fig. 46 Underwater HEAT device, Sketch of Setup, U.S. NOTS 1952/53





Underground Tests Series - U.S. NOTS 1952  
 Aerojet General Development 1954 -1958

Fig. 47 USMC self-buried HEAT land mine, Sketch, U.S. NOTS/Aerojet 1952

| Face Centered Cubic Crystal<br>(High ductility-good jets) |                  |                   | Body Centered Cubic Crystals<br>(low ductility-chunky jets) |                  |                   | Hexagonal Crystals<br>(Powder Jets) |                  |                   |
|-----------------------------------------------------------|------------------|-------------------|-------------------------------------------------------------|------------------|-------------------|-------------------------------------|------------------|-------------------|
| Element                                                   | Density<br>gm/cc | Melting<br>Pt. °C | Element                                                     | Density<br>gm/cc | Melting<br>Pt. °C | Element                             | Density<br>Gm/cc | Melting<br>Pt. °C |
| *Aluminum                                                 | 2.69             | 660               | Chromium                                                    | 7.22             | 1890              | *Beryllium                          | 3.5              | 1278              |
| *Copper                                                   | 8.93             | 1083              | *Iron                                                       | 7.86             | 1535              | Boron                               | 2.34             | 2300              |
| *Gold                                                     | 18.98            | 1063              | Lithium                                                     | 0.53             | 186               | *Cadmium                            | 8.65             | 321               |
| *Lead                                                     | 11.34            | 327               | Molybdenum                                                  | 9.01             | 2620              | *Carbon                             | 3.52             | 3550              |
| *Nickel                                                   | 8.8              | 1455              | Tantalum                                                    | 16.6             | 2996              | *Cobalt                             | 8.71             | 1495              |
| *Platinum                                                 | 21.37            | 1773              | Vanadium                                                    | 5.96             | 1710              | *Magnesium                          | 1.74             | 657               |
| *Silver                                                   | 10.42            | 960               |                                                             |                  |                   | Osmium                              | 22.5             | 2700              |
| Tungsten<br>(Beta)                                        | 19.3             | 3770              |                                                             |                  |                   | *Titanium                           | 4.5              | 1800              |
|                                                           |                  |                   |                                                             |                  |                   | *Zinc                               | 6.92             | 419               |
|                                                           |                  |                   |                                                             |                  |                   | *Zirconium                          | 6.44             | 1857              |
| <u>Mixtures</u>                                           |                  |                   |                                                             |                  |                   |                                     |                  |                   |
| Antimony-lead                                             |                  |                   |                                                             |                  |                   |                                     |                  |                   |
| Glass                                                     |                  |                   |                                                             |                  |                   |                                     |                  |                   |
| Aluminum-zinc                                             |                  |                   |                                                             |                  |                   |                                     |                  |                   |
| Aluminum-copper                                           |                  |                   |                                                             |                  |                   |                                     |                  |                   |
| Zirconium-tin                                             |                  |                   |                                                             |                  |                   |                                     |                  |                   |
| *known to have been<br>experimentally investigated        |                  |                   |                                                             |                  |                   |                                     |                  |                   |

Fig. 48 Potential Shaped Charge Liner Materials

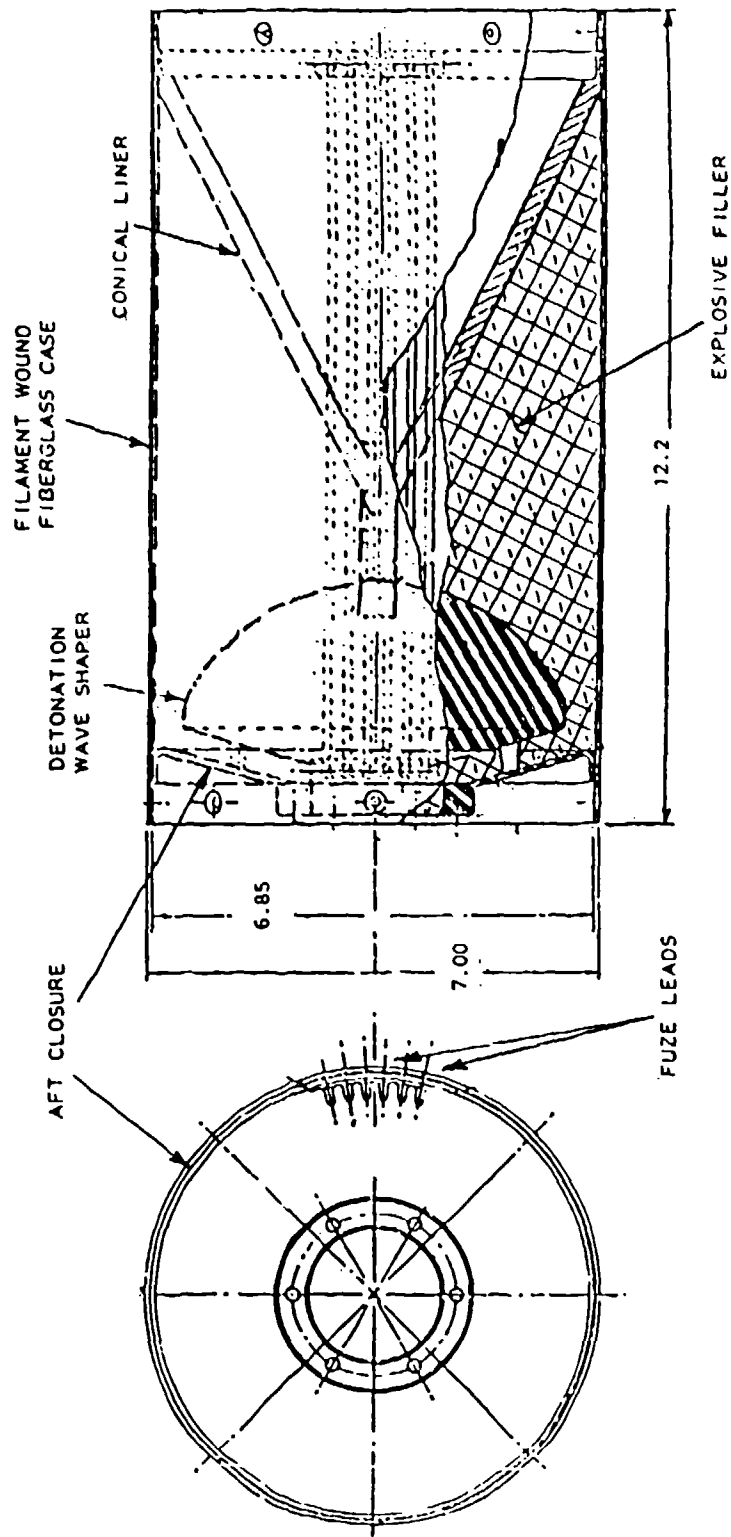

Fig. 49 DART ATGM warhead, Aerojet General, 1954-1958

June 9, 1964

T. C. POULTER

3,136,249

SHAPED CHARGE EXPLOSIVE UNIT AND LINER THEREFOR

Filed June 12, 1961

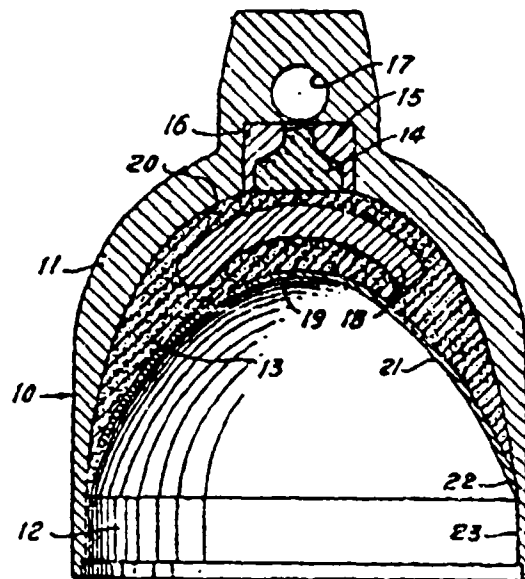

Fig. 1

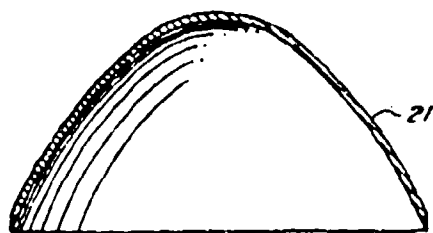
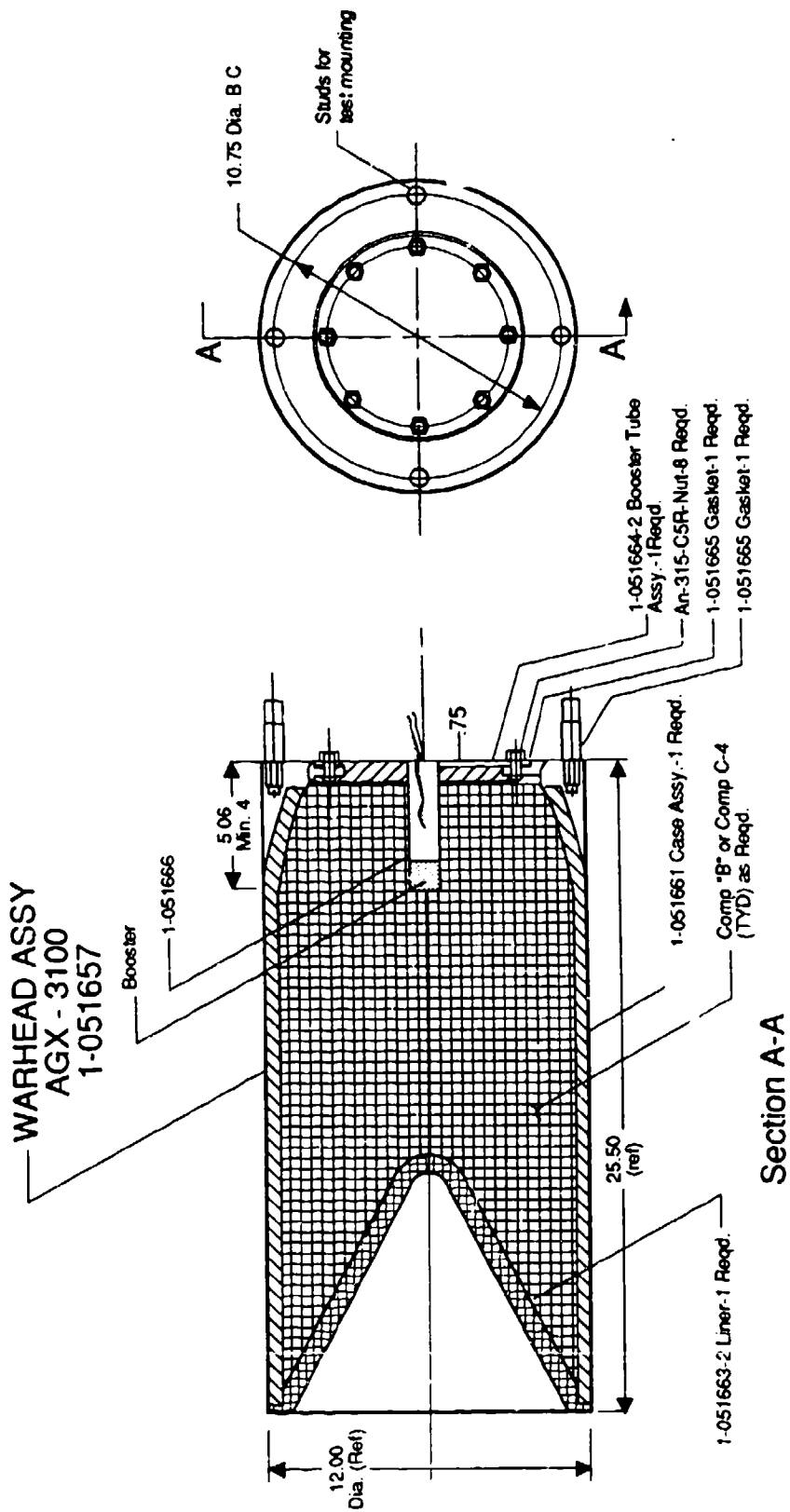

Fig. 2

INVENTOR  
Thomas C. Poulter

BY *John C. Evans, Jr.*  
ATTORNEY



Details from Original Sketch

Fig. 51 AGX-3100 Dual-Purpose, 250-lb. warhead, Aerojet, 1959

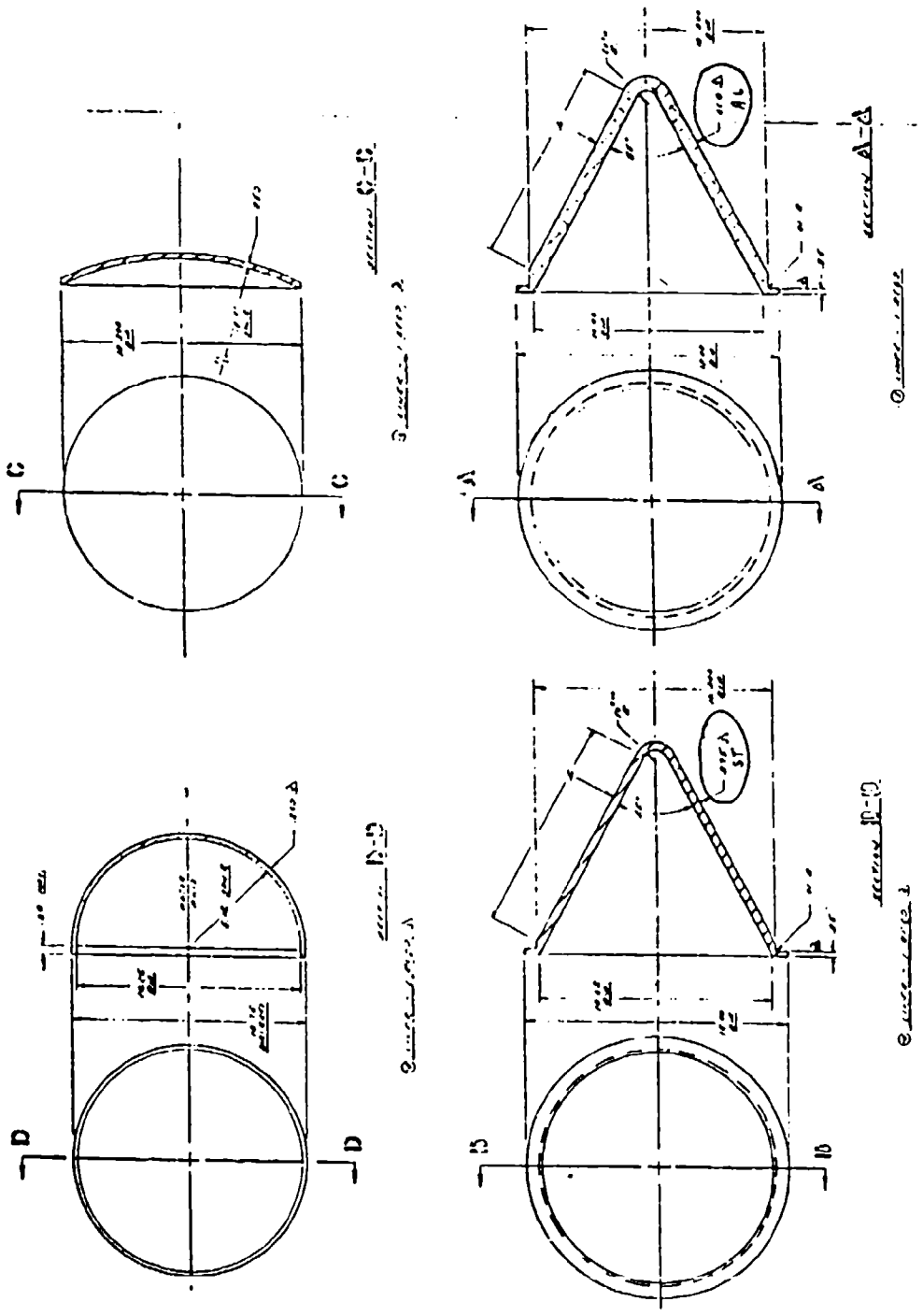
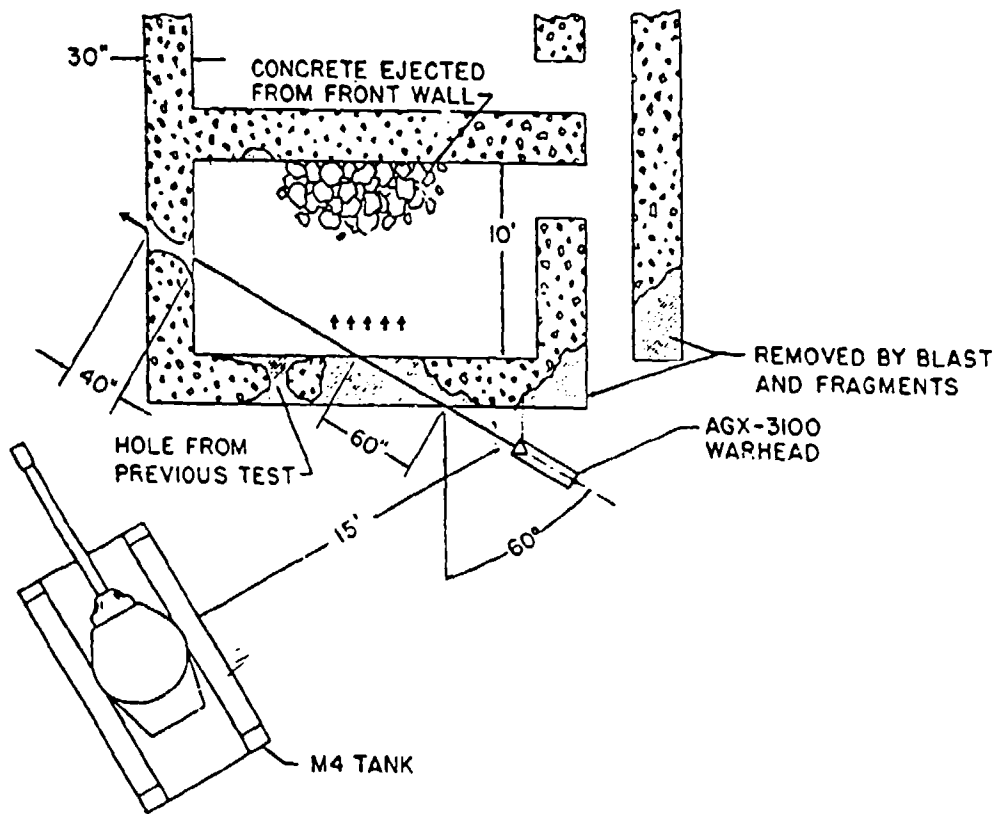

Fig. 52 Liner array provided for AGX-3100 tests, Aerojet, 1959



Test setup for AGX-3100 warhead Test No. 2.  
 Jet penetrated more than 100 in. of concrete.

Fig. 53 Test of AGX-3100, Eglin AFB, 1959 (led to MAVERICK)



Damage to Concrete Bunker at Eglin Air Force Base "Little Tokyo" area, April 1959, by Aerojet's 250-lb., 12-inch O.D., AGX-3100 Proposal Warhead with Aluminum Conical Liner and Controlled Fragmentation Case. Warhead was statically fired from position where two men stand. Fired at an angle of 60 deg. off normal (30 deg. off surface). The approximately 1-inch-diameter aluminum jet created the large penetration hole through equivalent path of 100 inches of concrete. Fragments removed corner of bunker. Entire roof structure was blown upward by the energy deposited inside bunker by combustion of the jet (vaporific effect). This test encouraged future development of the MAVERICK missile to incorporate same features.

*Fig. 54 12-in. Alumun SIC Damage to Bunker*



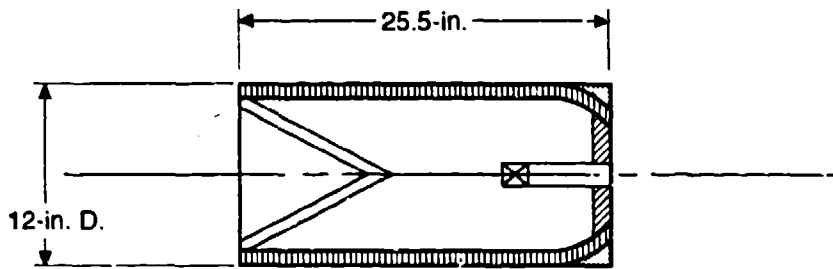

AGX-3100 Warhead

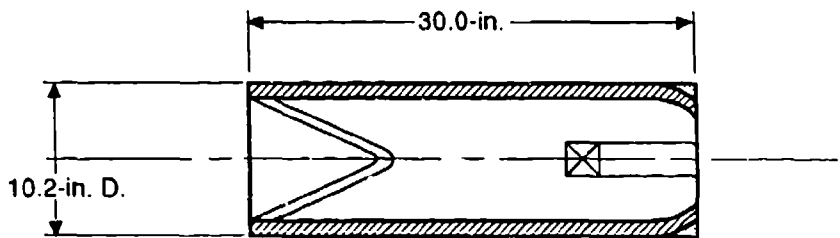

AGX-3200 (for BULLPUP)

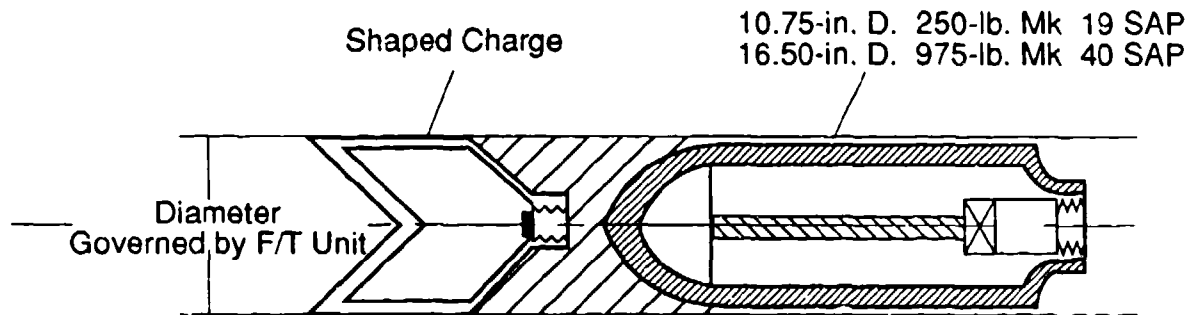

Concept: ACX-3300 Shaped Charge? SAP Follow-Through (F/T)

Fig. 55 AGX-3000 series warheads, Aerojet 1959-63 (led to HSM)



Aerojet 1962 proposed concept for HAMMER barrage rocket system, a dual-purpose shaped charge, fragmentation submunition. Cutaway show fuze assembly embedded in wave shaper with tape stabilizer and stab-detonator holder extended aft. The spring steel standoff legs snap together to form a skeleton ogive. Note cone/hemisphere liner's apex. At impact, aft stab detonator assembly moves forward to strike firing pin in rotor to initiate HE aft of wave shaper. 1.5-in. body diameter, 1.0-in., stacking height, 0.12-lb. weight. Antecedent of today's M42/M48 HEDP ICM grenade.

*Fig. 56 Hammer Grenade*



Aerojet Ordnance 1962 HAMMER bomblet concept in tandem nested packing arrangement. Tape stabilizer on aft unit is extended and standoff of forward unit has formed skeleton ogive.

*Fig. 57 Hammer Grenade Nesting*

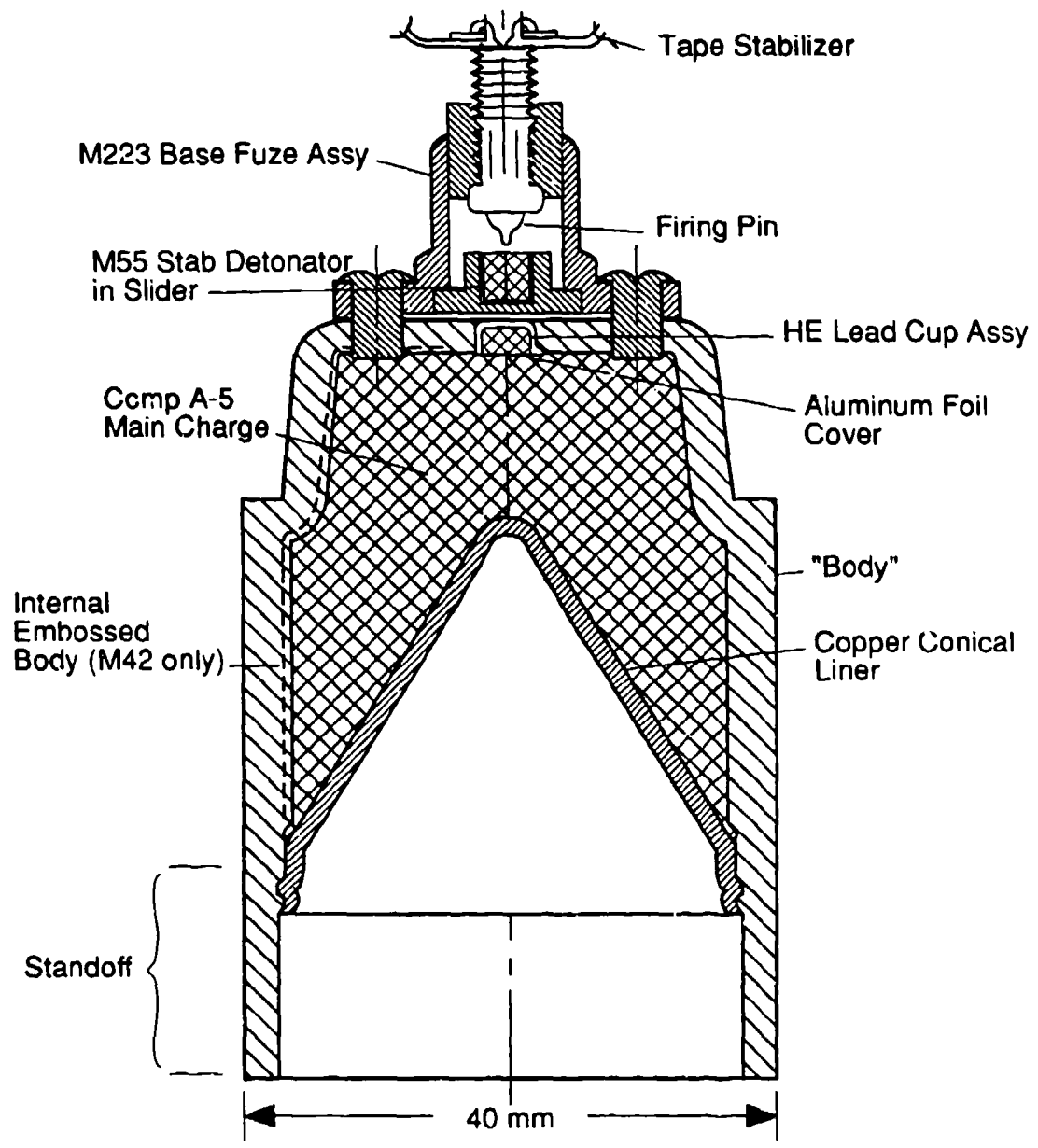
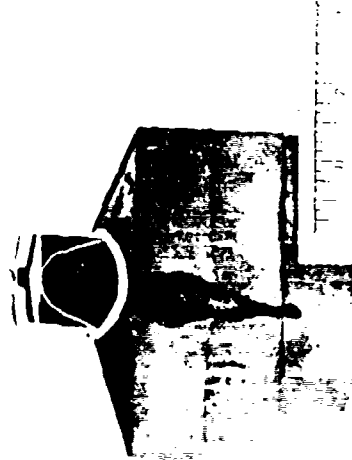
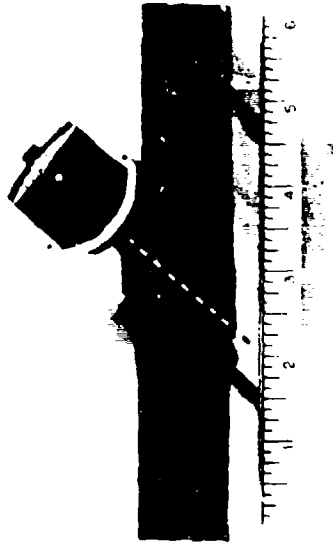
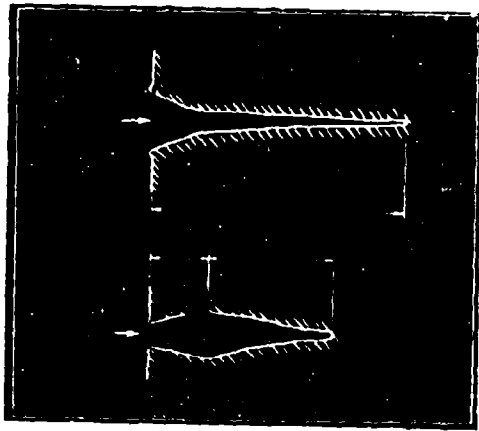
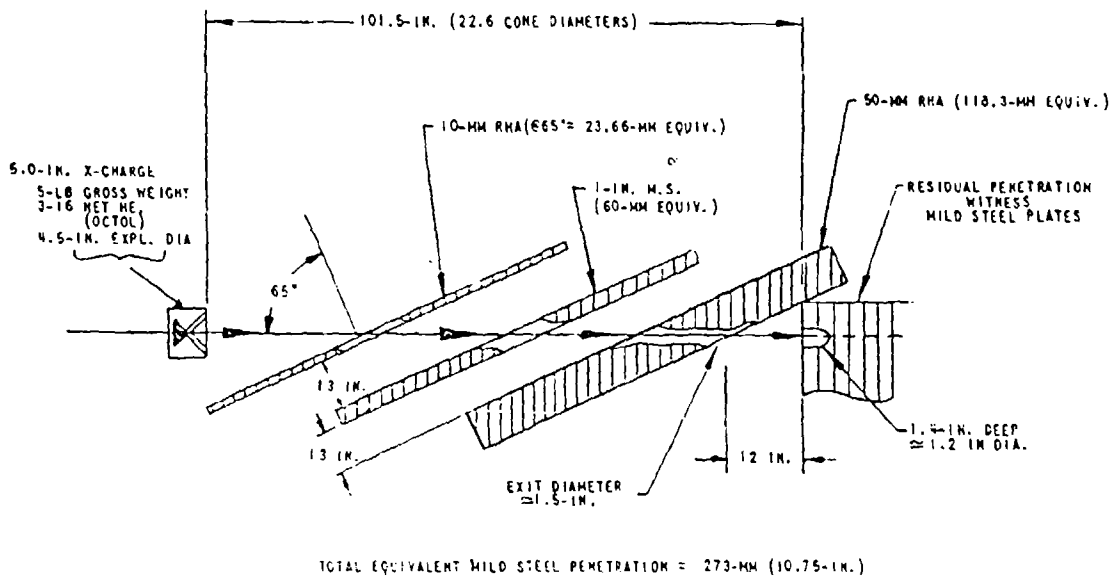
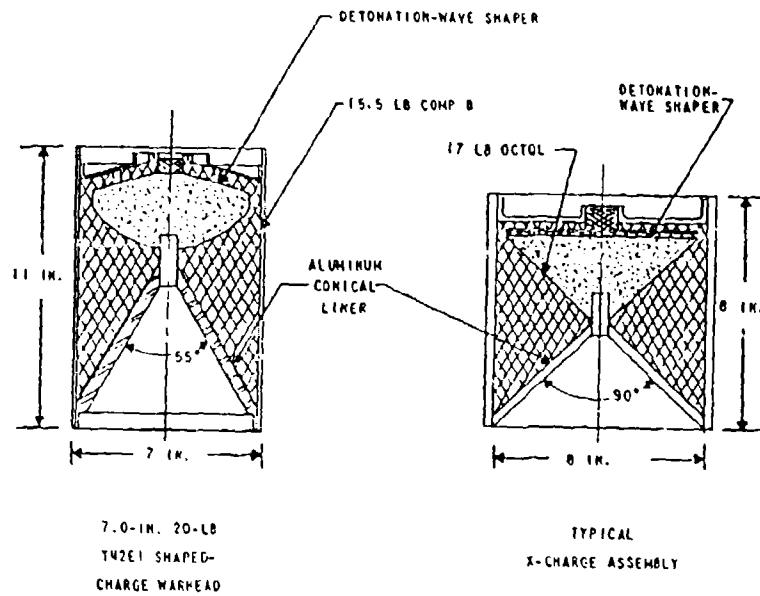

Fig. 58 M42/M46 HEDP Grenade, originated at Aerojet, 1962



Sequence of illustrations and photographs of effects of 1.12-inch-diameter shaped charge designed by Aerojet Ordnance for use in the "Oil Patch", ca.1956. These tests, conducted by D.R.Kennedy in 1961 were inspiration for HAMMER, bomblet and later M42 HEDP ICM grenade family.

*Fig. 59 Aerojet "Oil Tool" Shaped Charge - Inspiration for M42 HEDP Grenade*



Sketch comparing 7-inch T42 DART ATGM Warhead, and the "X-Charge" derivative, and performance of a 4.5-inch aluminum conical-lined, "X-Charge" against a NATO Triple Medium target array. Aerojet Ordnance, ca. 1962. Required a 4-caliber standoff to defeat array.

Fig. 60 7-in. DART ATGM Warhead, and the "X-Charge" Derivative (Aerojet Ordnance)

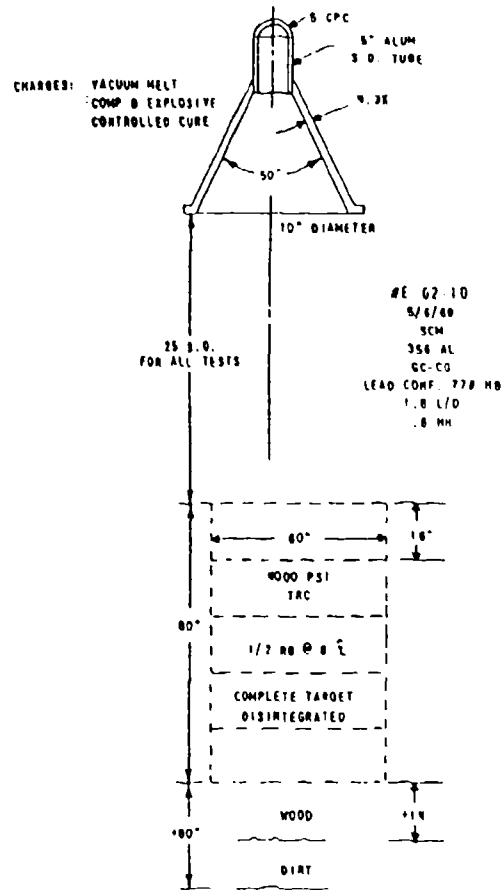
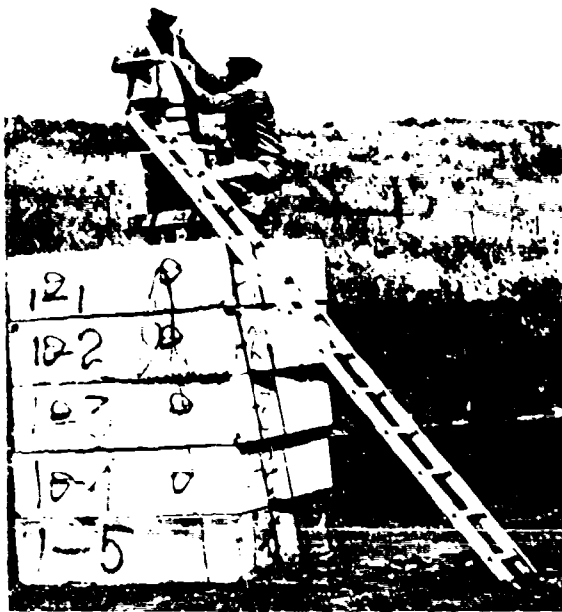

TRIPLE REINFORCED CONCRETE



First test of initial version of MAVERICK warhead against reinforced concrete pile 80 inches high by 60 inches square. Objective was to defeat 75 inches and measure cavity made by jet, but, as can be seen, such measurement was rendered impossible. Note earlier configuration of liner with apex tube and precursor hemisphere copper liner. (FMC Defense Technology Laboratories Hollister, Ca., Facility, May 6, 1969).

Fig. 61 First Maverick Shaped Charge Test vs. Reinforced Concrete (FMC-1969)

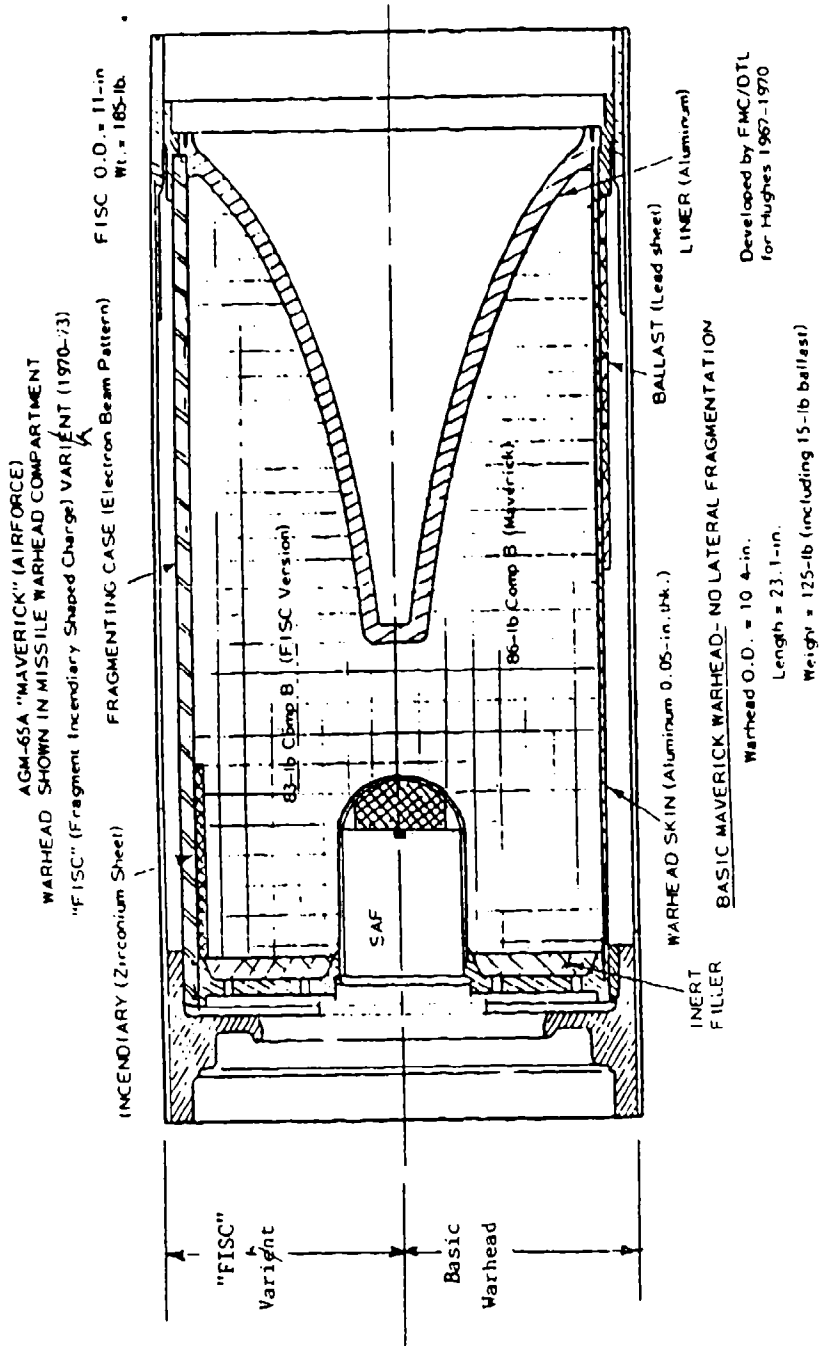

AGM-65 MAVERICK shaped charge warhead (lower half) of figure, compared with the FISC (Fragment-Incendiary-Shaped Charge) variant (upper half).

Fig. 62 Basic MAVERICK warhead and FISC variant



HUGHES AGM-65 MAVERICK

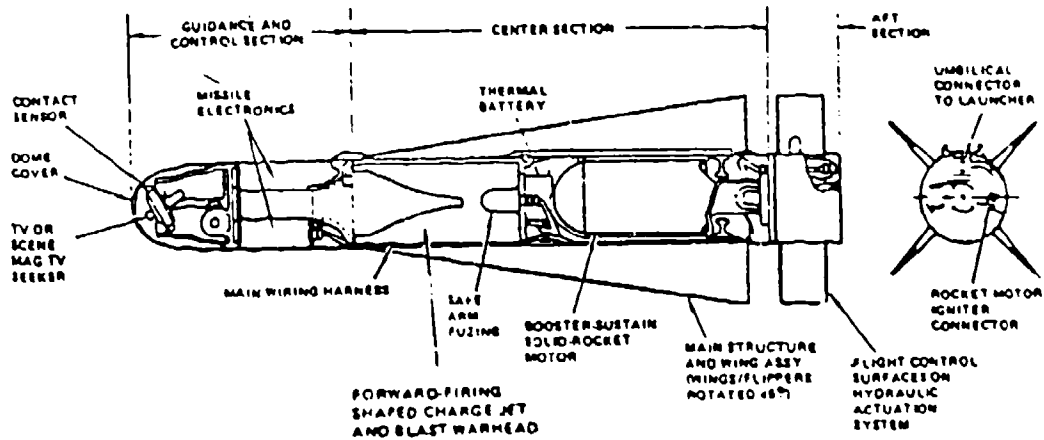

MAVERICK GUIDANCE/WARHEAD FAMILY

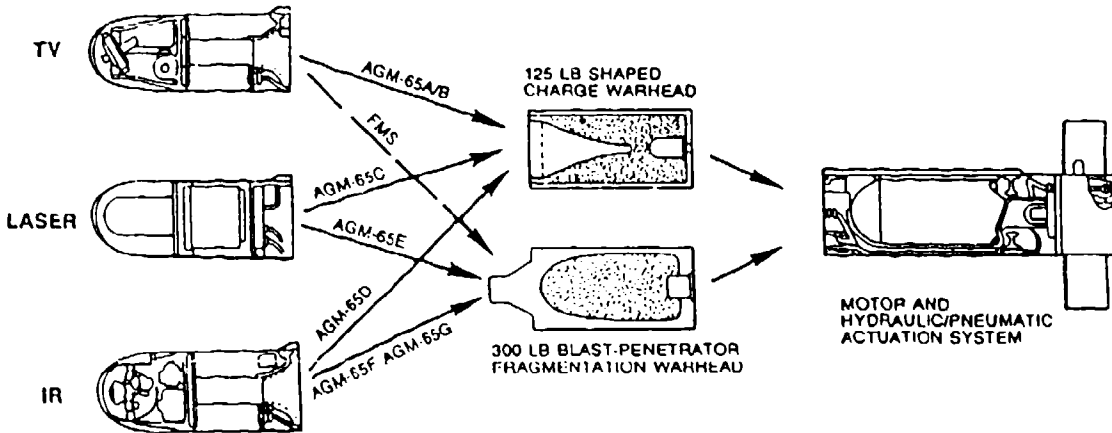

Published illustrations of MAVERICK and its warhead and seeker options. (Top) As published in 10 March 1984 issue of Flight International Magazine (It is rare for a warhead to be illustrated in a magazine, in particular for missiles that are still operational). (Bottom) From a Hughes Aircraft brochure.

Fig. 63 Published Illustrations of MAVERICK Shaped Charge Warhead



FIFTEEN MEN—A noted European scientist, Prof. Hubert Schardin, was being honored when his birthday cake was cut. It was celebrated at lunch (with birthday cake, of course) by the group above. From left, Dr. H. H. Brown, J. P. Carson, Prof. Schardin, D. R. Kennedy, K. N. Kreyenhagen, Dr. H. J. Fisher, G. C. Throner.

Professor Hubert Schardin visiting Aerojet General Corporation (AGC) Ordnance Division on his 61st Birthday, August 1963. (L to R): Dr. Richard Braun (former Director of Research, Rheinmetall and school mate of Dr. Schardin), J.P. Carson, Chief Engineer AGC Ordnance, D.R. Kennedy (Hd. Advanced Design), Dr. Schardin (then Director, Institute Saint Louis), Mr. Kenneth Kreyenhagen, (AGC Ordnance Research Dept.), Dr. H.J. Fisher (AGC Ordnance Research Dept.), Mr. Guy C. Throner, (Manager, AGC Ordnance Division). At Downey California.

Fig. 64 Professor Schardin Visits Aerojet Ordnance, (Aerojet-1963)



Three old-time "Shaped Charge" types meet at Battelle Columbus Laboratories. April 1964. Left: D.R. Kennedy (ye author and clean living ex-smoker), Center: Dr. Franz Rudolph Thomanek, (holding cigarette) discovered importance of lining shaped charge in 1938, post-WWII founder of MBB Schrobenhausen, Right: Guy C. Throner (with pipe) ordnance career extended from 1941 included forming US NOTS Explosive Ordnance Branch in 1944, Aerojet Ordnance in 1953, and FMC Defense Technology Laboratories in 1964.

*Fig. 65 Shaped Charge Pioneers Thomanek, Throner, and Kennedy (Battelle-1982)*

**SPECIAL RESUME -- ARMOR/ANTI-ARMOR CREDENTIALS OF  
DONALD R. KENNEDY**

Mr. Donald R. Kennedy, President and Principal Investigator of the technical services firm of D.R. Kennedy & Associates, Inc., Los Altos, California, is internationally recognized in the field of non-nuclear ordnance of all types and applications, and in particular for his work in the field of armor/anti-armor technology.

He has worked at the leading edge of anti-armor technology since 1950, and is responsible for such diverse products as the M42/M46 HEDP ICM grenades and the Maverick ATGM-65A missile shaped charge warhead. In 1951 he pioneered the study of shaped charge behind armor effects (BAE) and remains involved in BAE technology. In 1962 he conceptually designed a total light-weight combat vehicle system based on maximum combat survivability for both crew and machine.

He is a life member of the ADPA, of which he has been a member since 1951, and serves on their Bomb and Warhead Section Steering Committee. In 1984 he received the ADPA's Bronze Medal for "exceptional munitions research," while in 1983 he became a member of the U.S. Army's Order of Santa Barbara for his contributions to field artillery.