



US ARMY CORPS OF ENGINEERS
Hydrologic Engineering Center

AD-A219 222

PROCEEDINGS OF A

Hydrology
&
Hydraulics

DTIC
ELECTE
MAR 16 1990
S E D

Conference

on
Functional & Safety Aspects
of Corps Projects

TABLE OF CONTENTS

	Page No.
FOREWORD	vi
ACKNOWLEDGEMENTS	vii
SUMMARY	viii
SUMMARY OF SESSION 1: PROJECT PERFORMANCE AND DAM SAFETY . . .	1
INCREASED SPILLWAY CAPACITY THROUGH USE OF A FUSE PLUG SPILLWAY - CENTER HILL DAM (Paper 1) John Hunter U.S. Army Engr. Dist., Nashville	3
THE EFFECT OF PRIVATELY OWNED DAMS IN THE GILLS CREEK BASIN (Panel 1) Robert Occhipinti U.S. Army Engr. Dist., Charleston	19
WYNOOCHEE LAKE, WASHINGTON, TRANSFER OF OMR&R RESPONSIBILITIES TO THE CITY OF ABERDEEN, WASHINGTON (Panel 1) Christopher J. Lynch U.S. Army Engr. Dist., Seattle	27
NON-FEDERAL DAM SAFETY ISSUES IN MRD (Panel 1) Warren J. Mellema & Albert R. Swoboda (Presented by Warren J. Mellema) U.S. Army Engr. Div., Missouri River	29
CALIFORNIA STATE DAM SAFETY PROGRAM (Panel 1) Surya Bhamidipaty U.S. Army Engr. Div., South Pacific	35

TABLE OF CONTENTS (continued)

	Page No.
SUMMARY OF SESSION 2: LOW LEVEL-OF-PROTECTION LEVEE PROJECTS	41
CATASTROPHE AVERSION ANALYSES NECESSARY FOR TOTAL RIVER DIVERSION BY TUNNELS - HARLAN, KY (Paper 2) Don B. Getty U.S. Army Engr. Dist., Nashville	43
LOWER SANTA ANA RIVER CHANNEL DESIGN (Paper 3) Joseph B. Evelyn U.S. Army Engr. Dist., Los Angeles	59
COLDWATER CREEK LEVEES - WHAT FREEBOARD? (Panel 2) Ronald J. Dieckmann U.S. Army Engr. Dist., St. Louis	75
LEVEE FREEBOARD FOR WYOMING VALLEY, PA (Panel 2) Dennis Seibel U.S. Army Engr. Dist., Baltimore	81
LEVEL OF PROTECTION FOR URBAN LEVEES (Panel 2) Ronald L. Turner U.S. Army Engr. Dist., Fort Worth	85
LEVEE FREEBOARD (Panel 2) Tim Temeyer U.S. Army Engr. Dist., Omaha	87
EVENING SPEAKER	
REQUIREMENTS FOR SELECTING A PLAN OTHER THAN NED PLAN Harry E. Kitch Headquarters, U.S. Army Corps of Engineers	89

TABLE OF CONTENTS (continued)

	Page No.
SUMMARY OF SESSION 3: CHANNEL PROJECTS	93
SEDIMENTATION AND STABILITY ANALYSIS OF NONCONNAH CREEK MEMPHIS, TN (Paper 4)	
William A. Thomas, Jerry W. Webb, & David P. Berretta (Presented by Jerry W. Webb) U.S. Army Engr. Dist., Memphis	95
OPPORTUNITIES FOR ENVIRONMENTAL ENHANCEMENT FOR BRUSH CREEK (Paper 5)	
Walter M. Linder U.S. Army Engr. Dist., Kansas City	111
ECORSE CREEK FLOOD CONTROL STUDY (Paper 6)	
Guri S. Jaisinghani U.S. Army Engr. Dist., Detroit	125
SOWASHEE CREEK FLOOD CONTROL PROJECT FUNCTIONAL AND SAFETY ASPECTS (Panel 3)	
Jack G. Ward U.S. Army Engr. Dist., Mobile	141
TRY SIMPLE SOLUTIONS FOR HI-TECH PROBLEMS (Panel 3)	
David R. Gregory U.S. Army Engr. Dist., Albuquerque	145
ISSUES RELATED TO CHANNEL PROJECTS (Panel 3)	
Ronald A. Yates U.S. Army Engr. Div., Ohio River	149

TABLE OF CONTENTS (continued)

	Page No.	
SUMMARY OF SESSION 4: INTERIOR PROJECTS	155	
POND CREEK PUMPING PLANT LOUISVILLE, KY, FLOOD PROTECTION		
(Paper 7)		
Laurence Curry, Jr. U.S. Army Engr. Dist., Louisville	157	
SLIDELL, LOUISIANA INTERIOR STUDY		
(Paper 8)		
Robert H. Fitzgerald U.S. Army Engr. Dist., Vicksburg	173	
FORMED SUCTION INTAKE (FSI) APPURTENANCE GEOMETRY		
(Panel 4)		
Bobby P. Fletcher U.S. Army Engr., Waterways Experiment Station	183	
LITTLE CALUMET RIVER, INDIANA INTERIOR DESIGN CONSIDERATIONS		
(Panel 4)		
John G. Morgan U.S. Army Engr. Dist., Chicago	187	
INTERIOR FLOOD HYDROLOGY (IFH) COMPUTER PROGRAM		
(Panel 4)		
Michael W. Burnham U.S. Army Engr., Water Resources Support Center, Hydrologic Engineering Center	191	
SUMMARY OF SESSION 5: DESCRIPTION, EVALUATION, AND DATA		
REQUIREMENTS FOR PROJECT ANALYSIS		195
HYDROLOGIC ENGINEERING PERSPECTIVE ON FLOOD HAZARD AND PROJECT FORMULATION		
(Paper 10)		
Darryl W. Davis and Michael W. Burnham (Presented by Michael W. Burnham) U.S. Army Engr., Water Resources Support Center, Hydrologic Engineering Center	197	

TABLE OF CONTENTS (continued)

	Page No.
HYDROLOGIC ENGINEERING DATA NEEDS FOR PROJECT FORMULATION (Panel 5) Robert G. Engelstad U.S. Army Engr. Dist., St. Paul	205
HYDROLOGIC ENGINEERING DATA NEEDS FOR MT. ST. HELENS FLOOD CONTROL STUDY (Panel 5) Ronald C. Mason U.S. Army Engr. Dist., Portland	207
HYDROLOGIC ENGINEERING DATA NEEDS FOR PROJECT FORMULATION (Panel 5) George A. Sauls U.S. Army Engr. Dist., Philadelphia	211
HYDROLOGIC ENGINEERING DATA NEEDS FOR PROJECT FORMULATION (Panel 5) Paul R. Hein U.S. Army Engr. Dist., Pittsburgh	213
PARTICIPANTS	217
AGENDA	225

Accession For	
NTIS GRA&I	<input checked="" type="checkbox"/>
DTIC TAB	<input type="checkbox"/>
Unannounced	<input type="checkbox"/>
Justification	
By _____	
Distribution/ _____	
Availability Codes	
Dist	Avail and/or Special
A-1	



FOREWORD

The papers and panel discussions in these proceedings were presented at the U. S. Army Corps of Engineers (USACE) Hydrology and Hydraulics Conference on Functional and Safety Aspects of Corps Projects, 17-19 October 1989. The conference was hosted by the Nashville District and sponsored by HQUSACE Hydraulics and Hydrology Branch. The technical program was coordinated by the Hydrologic Engineering Center (HEC). The 35 conference participants represented Corps HQUSACE, division, district, and laboratory offices.

The seminar objectives were to: 1) present and discuss specific issues related to the functional and safety aspects of Corps projects, and 2) document the key issues and findings of the conference.

The conference consisted of five half-day sessions. Included were a dam safety session, separate sessions on low-level-of-protection considerations for levee, channel, and interior areas, and a session on data requirements for project analysis. Each session included presentations, most with accompanying papers followed by a question and answer period, and concluded with a panel discussion of a session related topic. Each attendee made a presentation or participated on the panel. A synopsis of each session precedes that session's papers and panel discussions.

These proceedings are organized in the same sequence as the agenda. Each paper and panel is numbered as shown in the agenda, and at the bottom of each page.

ACKNOWLEDGEMENTS

The Nashville District served as an excellent host throughout the conference. Opening remarks by Colonel James P. King, Nashville District Commander, and Richard J. Conner, Chief, Engineering Division, and their participation during the first day of the conference were appreciated by all of the participants. Jesse Perry, Chief, Hydrology and Hydraulics Branch, attended and participated in the entire conference. Special acknowledgement is due to Dennis Williams, Chief, Hydrologic Engineering Section, who coordinated with numerous people for the conference location, accommodations, and arrangements that made it an exceptional experience.

Michael W. Burnham, Chief, Planning Division, Hydrologic Engineering Center was responsible for coordinating the technical program and publishing the conference proceedings. Lew Smith, Hydraulic Engineer, HQUSACE, provided many valuable suggestions on participants. Darryl Davis, Director, Hydrologic Engineering Center, contributed significantly to the format of the conference program. Finally, a special thanks to Arlen Feldman, Chief, Research Division, Hydrologic Engineering Center, who as moderator of the conference kept it on schedule, and whose wit kept it interesting.

SUMMARY

The Hydrology and Hydraulics Conference on Functional and Safety Aspects of Corps Projects provided an excellent forum for hydrologic engineers to present case examples and share ideas relating to functional and safety considerations of flood damage reduction projects. Hydrologic engineers play an important role in the planning, design, and operation of USACE flood damage reduction projects. Hydrologic engineers by training and experience, understand the variable nature of flooding, the limitations of technical methods used to quantify flooding and risk, and the different characteristics of flood damage reduction measures. They tend to be the technical professionals concerned with the physical performance of projects. In the mind of a hydrologic engineer, the primary purposes of flood damage reduction projects are to reduce the flood hazard to persons and damage to property.

Proceedings, Flood Damage Reduction Safety
Discussions following each presentation often represented several perspectives. Although numerous issues were discussed, four were identified as needing immediate attention.

1. How can hydrologic engineers appropriately express the need, and then implement proper consideration of project performance and safety in the formulation and evaluation of flood damage reduction alternatives?
2. How can compliance with local agreements that affect the performance and design criteria of the implemented project be assured? Examples are: ponding area storage for pumping facilities, and regulatory actions of floodplain development and activities that affect storage and conveyance.
3. How can the USACE consider, during the conduct of a study, criteria by others for existing projects that don't meet their safety requirements?
4. How can the USACE fund and implement a data collection program to document, for future study needs, available flood-related data immediately after the event?

SUMMARY OF SESSION 1: PROJECT PERFORMANCE AND DAM SAFETY

Overview

This session included an overview of the major issues regarding project performance and safety to be covered during the conference and concentrated on issues related to dam safety.

Papers and Presentations

Roy G. Huffman, HQUSACE, overviewed key technical issues from the hydrologic engineering perspective regarding functional and safety aspects of USACE projects. Mr. Huffman stated the need for greater focus during feasibility studies on how projects perform. He stressed that new guidance directs that safety and performance be considered but lacks detail on how to integrate these considerations into the economic (NED) analysis. He emphasized that there is no single design flood, and that the hydrologic engineer must consider the project performance for the full range of events from all sources.

Mr. Huffman also stressed that hydrologic engineers must take into account the institutional and legal provisions associated with operation/maintenance/replacement. This begins with project formulation and design, and continues through the local cost-shared agreements and operation and maintenance manuals. Finally, he emphasized the need for the hydrologic engineer to coordinate and understand the data requirements, assumptions, study objectives and procedural requirements from an interdisciplinary perspective. No paper was provided.

Earl E. Eiker, Chief, Hydraulics and Hydrology Branch, HQUSACE, reiterated the need for hydrologic engineers to properly consider project performance and safety in the planning and design of flood damage reduction projects. He briefly overviewed the status of the dam safety program and stressed the importance of coordination with other disciplines in formulating viable projects. No paper was provided.

Paper 1. A presentation and paper entitled "Increased Spillway Capacity Through Use of a Fuse Plug Spillway, Center Hill Dam, Tennessee," was given by John W. Hunter, Nashville District. The paper presents a summary of the analysis and recommendations determined by the Nashville District to correct the design and deficiencies at Center Hill Dam. The recommended action consists of remedial work on the main dam and increased spillway capacity added to an existing saddle dam to provide PMF protection. A unique sand-filled fuse plug is utilized to provide additional weir capacity during extreme flood events. For floods exceeding the maximum flood elevation, the fuse plug will be overtopped washing out the sand fill and leaving a weir capable of protecting the dam to the PMF level.

Panel 1 Discussions

Bob Occhipinti, Charleston District, described the Gills Creek watershed in Richland County, South Carolina. The 73 square mile watershed has about 100 privately owned dams developed for lake-front properties, and five federal dams. The state safety criteria for the dams is that they must pass the one-percent chance exceedance event with one foot of freeboard. Mr. Occhipinti described previous USACE investigations and the hydrologic engineering complexities of analyzing the Gill Creek system of lakes for an ongoing feasibility study.

Christopher Lynch presented the Seattle District's Wynoochee Lake study involving the potential transfer of its operation, maintenance, repair and rehabilitation from the Corps to the city of Aberdeen, Washington. The operation of the Wynoochee project has several unique features which require experienced and well-trained hydrologic engineers and meteorologists. Mr. Lynch described the district's plan to assure the continued safe and effective operation of the Wynoochee project after its transfer to the City of Aberdeen.

Warren Mellema discussed non-federal dam safety issues within the Missouri River Division. The Missouri River Basin encompasses all or parts of 10 states each with different dam safety criteria. The criteria are also varied among responsible federal agencies. Dams residing on military installations often present yet different issues and problems since they don't necessarily fit state or federal guidelines. Mr. Mellema concurs with recent USACE guidelines of the dam rehabilitation program that integrate dam safety concerns with downstream risks. This approach could also be applied to new dams.

Surya Bhamidipaty, South Pacific Division, discussed the dam safety program of the State of California. The state, which has about 1200 dams, requires that all dams within its jurisdiction be capable of adequately passing a design flood. The design flood is selected based on the downstream damage potential. Mr. Bhamidipaty defines the criteria required to perform the dam safety analysis.

Increased Spillway Capacity Through Use of a Fuse Plug Spillway Center Hill Dam

by

John Hunter¹

Introduction

The Institute for Water Resources and the Office of the Chief of Engineers have developed guidelines to assist in evaluating hydrologic deficiencies for existing Corps dams. These guidelines, "Guidelines for Evaluating Modifications of Existing Dams Related to Hydrologic Deficiencies", are expected to be reviewed and updated as experience, application, and further research is made. The guidelines are presented as a screening process which separates dams that require full Probable Maximum Flood (PMF) protection from dams that may be considered hydrologically safe without full PMF protection. They also serve as an evaluation process for selection of a cost effective alternative to correct any hydrologic deficiencies. In application, the process establishes a method of ranking Corps dams as to which dams should first be funded for remedial repairs and which dams should be funded at all.

The "Center Hill Dam Study for Correction of Spillway Deficiency" was completed in April 1989 and is waiting approval. This paper will briefly discuss the hazard assessment used in that study with emphasis on the issues not supported in the guidelines. Also, a controversial fuse plug alternative recommended by the Nashville District will be discussed.

Project Description

Center Hill Dam is located in the rural eastern portion of middle Tennessee in a fairly steep mountainous terrain. The dam controls a drainage area of 2,174 square miles. The dam is located at Mile 26.6 of the Caney Fork of the Cumberland River. Caney Fork enters the Cumberland River at Mile 309.2 in the immediate vicinity of Carthage, Tennessee. Control of the Cumberland River is a primary mission of the Nashville District. This is achieved through a system of mainstem and tributary dams. Center Hill is one of the five dams in the system utilized for flood control. Other dams in the system are primarily for navigation, hydropower, and recreation.

¹Hydraulic Engineer, Nashville District, U.S. Army Corps of Engineers

Center Hill Dam is a concrete and earthen structure 226 feet in height with a length of 2160 feet. A 1382-foot concrete gravity section in the dam contains eight spillway gates and hydropower facilities. The remaining 778 feet of the dam is a homogenous rolled-fill embankment. A saddle, as shown in **Figure 1**, is located just upstream of the main dam on the right rim of the reservoir. The saddle is filled with a 775-foot long by 125 high rolled fill earthen embankment similar to that of the main dam.

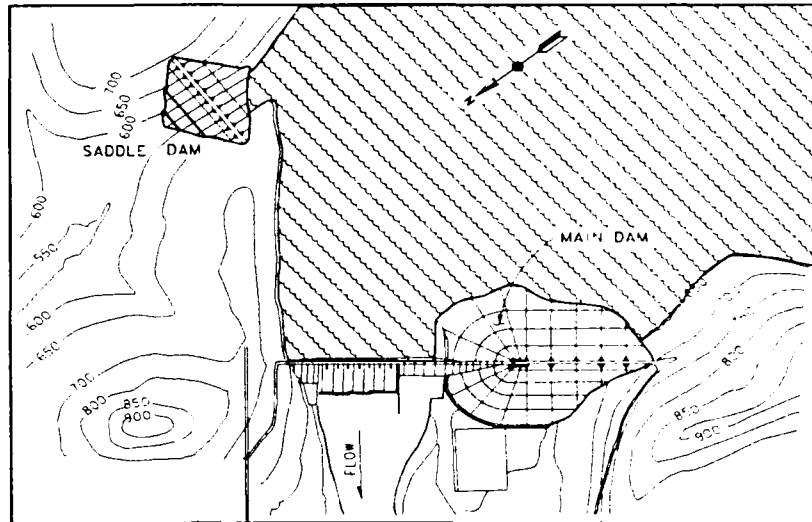

Figure 1
CENTER HILL DAM AND SADDLE DAM

Base Storm

The base precipitation used to generate the design inflows for Center Hill was the Probable Maximum Precipitation (PMP). Rainfall was determined according to procedures outlined in Hydrometeorological Report (HMR) numbers 51 and 52. This rainfall was then increased by 4.5 percent in accordance with HMR 47 and 56 to account for orographic effects in stippled regions of the basin. The total average basin rainfall for the PMP was determined to be 23.3 inches.

Initial Reservoir Elevation

The IWR guidelines states the initial reservoir water surface be determined by routing an antecedent flood event through the reservoir. The antecedent event recommended is to begin 5 days prior to the onset of the design event and is assumed to be 50 percent of the design storm. For the Cumberland River Basin, the National Weather Service (NWS) recommended to the Nashville District that the greater of 30 percent of the PMP rainfall followed by a 3 day dry period between the antecedent storm and the PMP or 39 percent of the PMP followed by a 5 day dry period be used. This is consistent with their findings discussed in HMR No. 56. The NWS recommended scenarios were analyzed and the worst case, 30 percent of the PMP, followed by a 3 day dry period, was used for the Center Hill Study.

The IWR guidelines does not recommend a method of determining the starting reservoir elevation at the onset of the antecedent storm. For the Center Hill study, the reservoir's highest monthly median elevation was selected. Since that study, the Nashville District has adopted use of the median reservoir elevation for mid-July. This decision was based on NWS studies contained in HMR No. 53 and 56 which determined mid-July to be the month of greatest potential PMP type rainfall for the study region which includes the Cumberland River Basin.

Threshold Flood

The threshold flood is described in the IWR guidelines as "that flood that results in a peak reservoir water surface elevation equal to the dam crest elevation less the appropriate freeboard." The intent of this definition is to determine the inflow event into the reservoir, in terms of percentage of the PMF, that will exceed the design criteria of the dam. In the case of Center Hill Dam, as is the case for many existing dams, the level of hydrologic safety and structural safety are not equal. This is primarily due to updated design standards. The earthen portion of Center Hill Dam is hydrologically safe to elevation 692.4 (696.0 top of dam minus 3.6 feet of freeboard). However, the concrete portion of the dam meets specified structural design criteria only to elevation 691.0. The threshold flood was determined to be 75 percent of a PMF under hydrologic criteria and 72 percent for structural criteria.

Hazard Analysis

The hazard analysis used in the Center Hill Study was developed with several objectives in mind. The first was to establish the magnitude of the existing hazards at the dam. Another was to provide a measure of the differences between alternatives designed to reduce these potential hazards. The last objective was to provide the data necessary to establish a base safety condition. The items selected to measure hazard were threatened population (TP), population at risk (PAR), and direct flood damages. The failure of a multipurpose dam such as Center Hill is characterized by many losses other than direct flood damages that are both economically and socially devastating. A short list for Center Hill would include loss of water supply to tens of thousands of people, loss of hydropower, loss of flood control, loss of recreation and related businesses, and loss of the dam itself, as well as the mental anguish and disruption throughout the recovery period. These losses were assumed constants since they are prevalent for most any failure scenario.

Economic Losses. A multi-project data base was developed which included approximate first floor elevations, structure types and river miles for all structures expected to be flooded by a worst case Center Hill Dam failure scenario. The data base extended from Center Hill Dam downstream approximately 300 miles to Barkley Dam. The Nashville District's Direct Inundation Reduction Benefits (DIRB) program was used to determine dollar damages and structures involved in various flooding scenarios. The

DIRB program calculates depth of inundation and damages for each structure within a data base utilizing flood profiles such as those developed by HEC-2. The depth damage curves used in DIRB are based on expected damages at various steps or heights of flooding.

Population at Risk. A structure's inhabitants were said to be at risk if the structure's first floor elevation was reached by the flood profile. Population at risk was determined for both a day and night flood failure scenario. Each structure type was given a weighted value of inhabitants for the day and night scenario. These weighting were based on sample interviews.

Threatened Population. Members of Nashville District's Safe Dam Committee and the Center Hill study team met in an effort to develop a real-life scenario of the events that would most likely occur should a PMS, and impending dam failure, center in the basin above the dam. They were equipped with rainfall data, hydrograph information at damage centers, flood profiles calculated at specific hours before and after failure, flooded area maps, and potential action and response times obtained from local emergency service personnel. The area to be considered for possible threatened population was limited to the first thirty miles below the dam. It was determined that areas further than thirty miles would have sufficient warning time and evacuation routes to vacate. The area to be considered for TP was then divided into two reaches. The first reach included all structures in the Caney Fork basin affected by a failure condition. Most of these structures were in small rural communities located up tributaries branching off the Caney Fork. The second reach consisted of the town of Carthage which is located at the confluence of the Caney Fork and the Cumberland River. The following is a brief excerpt from the scenario developed.

"At Hour 204, communications in Reach 1 essentially becomes ineffective. There is no evacuation plan for this area, road accesses to the flood plain areas are increasing becoming cutoff either by local flows or Caney Fork backwater, electric lines and phone cables are destroyed, and the substation and local radio station at Carthage is flooded. Hour 204 is the appropriate time at which warning and evacuation ends. Therefore, in Reach 1, all persons above the profile corresponding to the Hour 204 and up to the peak failure profile are considered TP."

"Hour 210, for Reach 2, is a critical time. Effective communication in the Carthage area ends at this time. Carthage has been isolated by road for about 6 hours at this time, the rate of rise of the Cumberland River is rapid (2 feet per hour) with the river 8 feet above the flood of record, electricity and phone services are out, the local radio station has been flooded, street crossings may be washed out by local flows, evacuation of people is chaotic (no evacuation plan exists for Carthage), and health problems are becoming a factor. The TP count therefore begins with the Hour 210 profile and extends to the peak failure profile."

Existing Hazards

The previous paragraphs have discussed the methods used to estimate economic losses, probable PAR, and TP for the Center Hill study. The existing hazards prevalent downstream of the dam were determined using these methods for the threshold flood, the threshold flood with a hypothetical failure of the dam, and a PMF with a failure of the dam.

The incremental difference between the threshold flood with and without failure was used to determine if the existing hazards were significant enough to warrant a study of alternatives. An additional 3,556 structures were flooded by a failure of the dam during a threshold flood in comparison to the threshold flood without failure. Approximately 2,500 of these structures are homes.

To measure the full extent of the existing hazards, an evaluation was made using the full PMF. Since the PMF was determined to result in a failure of the existing dam, this condition was used. A comparison of the PMF (failure conditions) with the threshold flood (failure conditions) shows an additional 700 structures flooded, of which nearly 500 are homes.

The significance of hazard is very subjective when using it to compare severe circumstances. The numbers presented tend to only help define the magnitude of people directly impacted by a failure of Center Hill Dam. The severity of these impacts are best defined by comparing differential flood heights. The increase in flood heights between the threshold flood with and without failure range from 40 feet at the dam to 15 feet at a distance of over 150 miles below the dam. For the full PMF, the depth of flooding is increased an additional 10 to 15 feet.

Alternative Investigation

Several alternatives were considered to correct the inadequate spillway capacity at Center Hill Dam. These alternatives can be characterized by their physical location. The following is a brief description of the alternatives based on their location. **Table 1** contains a listing of the major components of these alternatives and their respective costs.

Dam Modifications. These alternatives involve modifying the existing dam. They include raising both the concrete and earthen portion of the dam and structurally strengthening portions of the dam. They are designed to provide for the maximum allowable water surface elevation of the reservoir to be increased. This classification also includes alternatives that modify the existing structure to increase spillway capacity.

Saddle Dam Modifications. These alternatives involve modifying the existing saddle dam. The saddle dam (**Figure 1**) is an earthen dam located just upstream of the

Table 1

DESCRIPTION OF ALTERNATIVE	COST
1 raise dam 10 feet to contain PMF a. 2000 ft concrete wall b. anchor dam to bedrock	\$17,200,000
2 fuse plug in saddle dam a. 650 ft by 32 ft fuse plug structure b. rock excavation c. 850 ft floating breakwater	\$13,200,000
3 gated spillway in saddle dam a. 13 gates at 50 ft by 32 ft b. rock excavation c. piles and cutoff wall	\$51,315,000
4 fuse plug or spillway gates located in the left rim a. rock excavation b. highway bridge (2 lanes at 1000 ft) c. fuse plug or gates in left rim	\$39,100,000 for fuse plug option
5 fuse plug in saddle dam combined with raising the allowable pool elevation from 691 to 692.4 by anchoring 6 monoliths a. 600 ft by 34 ft fuse plug structure b. 800 ft floating breakwater c. anchor 6 monoliths d. lands downstream of saddle dam	\$12,750,000
6 raise dam 3 ft combined with fuse plug a. raise 1600 ft of dam to elev 699 b. 400 ft by 34 ft fuse plug structure c. 600 ft floating breakwater d. anchor dam to bedrock	\$28,800,000
7 raise dam 6 ft combined with fuse plug a. raise 1800 ft of dam to elev 702 b. 200 ft by 34 ft fuse plug structure c. 400 ft floating breakwater d. anchor dam to bedrock	\$19,200,000
8 raise dam 3 ft combined with spillway gate a. raise 1600 ft of dam to elev 699 b. 8 gates at 50 ft by 34 ft c. piles and cutoff wall d. anchor dam to bedrock	\$42,200,000
9 raise dam 6 ft combined with fuse plug a. raise 1300 ft of dam to elev 702 b. 700 ft by 14 ft fuse plug structure c. 900 ft floating breakwater d. anchor dam to bedrock	\$23,300,000

main dam in the right rim of the reservoir. The dam closes a natural topographical saddle located in this right rim. The alternatives considered for this location are designed to increase the spillway capacity. These alternatives include a gated spillway structure and an erodible fuse plug cut into the existing saddle dam embankment. The discharges from these structures would travel approximately 7400 feet down a valley roughly paralleling the Caney Fork and re-enter the Caney Fork approximately 4600 feet downstream from Center Hill Dam.

Left Rim Alternatives. These alternatives would be located in a natural topographic saddle located just upstream of Center Hill Dam in the left reservoir rim. The invert of this saddle is above the existing Center Hill top of dam elevation. These alternatives are similar to the saddle dam alternatives in that they include gated spillways and erodible fuse plugs. These alternatives were investigated in an attempt to reduce project costs. The valley downstream from the left rim site is much shorter than the valley below the existing saddle dam. Also, the left rim valley, unlike that below the existing saddle dam, is unpopulated. It was hoped that the rock excavation required in the left rim would be more than offset by the reduced downstream real estate costs.

Combined Center Hill Dam and Saddle Dam Alternatives. These alternatives include a combination of modifications to the existing Center Hill Dam and the saddle dam as mentioned above.

Hazard Assessment of Alternatives

All alternatives, for Center Hill, were designed to safely pass the PMF event. Although not addressed in the guidelines, a key consideration in evaluating the hazards, or reduction in hazards associated with these alternatives, is a comparison of the impacts of the proposed modifications to the conditions existing at the project. **Table 2** contains a summary of the hazard assessment for Center Hill. There are several comparative analyses that can be made using this summary. For example, the population at risk during the day is shown to be greater than the population at risk during the night. This is due to the large number of businesses affected by the flood wave in the Nashville area. In the case of threatened population, the greatest number of people are affected at night. This is due to Nashville being downstream from the area within the threatened population reach.

The most meaningful assessment of the alternatives is made by comparing the hazards existing at the dam under PMF conditions, the hazards for a threshold flood (72 percent of the PMF), and the hazards for each alternative. To make this comparison there are a few conditions that must be understood. The threshold flood is unchanged from existing conditions for all alternatives except Alternative 2. Alternative 2 involves a fuse plug which is designed to overtop and erode at an elevation less than the present level of protection of the project. Since the threshold flood represents the maximum flood that can safely pass through the dam, it can be used as the base from which to compare the

**TABLE 2
DOWNSTREAM IMPACTS OF ALTERNATIVES**

CONDITION	PAR DAY	PAR NIGHT	TP DAY	TP NIGHT	DAMAGES (Billions)
100 PERCENT PMF					
ALT 1	28590	22748	2555	3011	1.132
ALT 1 (WITH FAILURE)	34350	28523	3631	4574	1.440
ALT 2, 3	29738	24075	2902	3408	1.188
ALT 2, 3 (WITH FAILURE)	34648	29025	3644	4604	1.470
ALT 5	29762	24130	2912	3428	1.200
ALT 5 (WITH FAILURE)	34649	29028	3644	4604	1.481
ALT 6, 8	29329	23678	2799	3261	1.170
ALT 6, 8 (WITH FAILURE)	34635	28995	3639	4594	1.458
ALT 7, 9	29065	23235	2662	3056	1.153
ALT 7, 9 (WITH FAILURE)	34529	28828	3638	4589	1.456
72 PERCENT PMF					
ALT 2	23622	19328	2624	3053	.976
ALT 1, 3, 5, 6, 7, 9	SAME AS FOR BASE CONDITION THRESHOLD FLOOD				
BASE CONDITIONS					
EXISTING DAM (WITH FAILURE)	34256	28320	3640	4593	1.461
THRESHOLD FLOOD	23027	17850	1748	1891	.902
THRESHOLD FLOOD (WITH FAILURE)	31897	26793	3564	4456	1.318

alternatives. An example comparison would be to take the threatened population during the night for Alternative 1 of 3,011 and subtract the threshold flood base of 1,891. The resulting 1,120 people can be compared to the 2,702 people (4,593 minus 1,891) threatened by an existing failure of the dam. Using this type comparison, it is found that all the alternatives evaluated reduce the existing hazard by 40 to 60 percent. This 40 to 60 percent reduction can be translated into an average of 55 feet reduction in water surface immediately downstream of the dam to 25 feet of reduction at a distance of over 150 miles downstream.

Another assessment of the alternatives can be made by using the description of alternatives contained in **Table 1** to distinguish alternatives involving raising the dam. By comparing the alternative's design components with the amount of improvements, shown in **Table 2**, it can be seen that raising the dam (increased storage) results in more improvements than fuse plugs (increased spillway capacity). However, a comparison of the costs associated with these alternatives shows them to be more costly.

Any modification to a dam may inadvertently increase risks to the people downstream. One source of these risks is an unexpected failure of the dam. A classical example of this would be the failure of a dam which had been significantly raised to safely pass a PMF. If such a dam were to fail during a high headwater event, the flood profile downstream could be greatly increased. To evaluate these hazards at Center Hill, a hypothetical piping failure was assumed to occur with each of the alternatives in place. The failure occurred when the PMF reached its maximum headwater elevation. By comparing the resulting hazards displayed in **Table 2** of the failure condition with the existing dam failure condition, it can be seen that there are essentially no increased risks associated with the alternatives selected for Center Hill.

One of the reasons for the development of hazard data was to determine if a base safety condition exists at a dam. The purpose of the base safety condition is to establish the design event for the alternatives being considered. This condition is defined in the IWR guidelines as "the smallest inflow flood where there is no significant increase in adverse consequences from dam failure compared to non-failure adverse consequences". If failure conditions always results in significant increases, then the design event for modifications to the dam is the PMF. By comparing the with and without failure conditions for each of the alternatives in **Table 2**, it is seen that a significant hazard exists at Center Hill for all alternatives for both the threshold and PMF floods. Therefore, the design event for all alternatives was the PMF.

Summary of Alternative Investigations

The hazard analysis for Center Hill demonstrated that no alternative stood out as being far better or far worse than another; therefore, overall project costs were used as the determining factor for selecting the recommended alternative for Center Hill. The structural methods considered for the various alternatives included raising the dam and

adding spillway gates or a fuse plug. The following is a cost-related assessment of these structural measures.

Left Rim Versus Right Rim. As discussed previously, both gates and fuse plugs were considered for the left and right rim of the reservoir. It can easily be seen by comparing the costs of right rim fuse plug Alternative 2 (\$13 million) with left rim fuse plug Alternative 4 (\$39 million) that the rock excavation costs in the left rim remove it as an acceptable site.

Gate Versus Fuse Plug. With the hydraulic effects of the gates and the fuse plug in the saddle dam area being essentially the same, the only tangible difference between these alternatives is the cost of the construction. The gated and fuse plug alternatives have similar costs for both excavation and protection from flooding during construction. The fuse plug requires a floating breakwater device to protect the erodible crest. The gated structure requires special foundation work (piles) to provide the rigid stability needed for its mechanical operation. The addition of the piles requires a cutoff wall to be placed in the existing saddle dam fill material below the spillway structure. The cutoff wall is to prevent uncontrolled seepage due to settlement between the spillway (which is supported by the piles) and the compacted earth underneath. A direct comparison of the fuse plug costs versus the costs of the gates, machinery to open the gates, and the supporting structure for the gates is conclusive that the fuse plug option is less costly. The additional foundation work required for the gated structure only adds to this alternative's high cost. As can be seen from **Table 1**, by comparing the \$13 million dollar cost of Alternative 2 with the \$51 million dollar cost for Alternative 3, a gated spillway option would be hard to justify.

Fuse Plug Versus Raising Dam. The major advantage of using a fuse plug option at Center Hill is cost savings. However, these cost savings are not directly attributable to the cost of the fuse plug itself. In fact, the cost of a fuse plug is generally greater than the cost of raising the dam. The cost savings at Center Hill are realized because the fuse plug option does not require costly structural stabilization measures that are required for the dam raising alternatives. A detailed stability analysis of the dam concluded that the maximum pool level could be raised from elevation 691.0 to elevation 692.4 by anchoring six monoliths to the monolith underlying each. For any pool levels greater than elevation 692.4, the entire concrete portion of the dam would have to be anchored with steel tendons to bedrock. Three alternatives in the Center Hill study involved raising the dam three, six and ten feet above the 692.4 elevation. The anchoring costs for these ranged from six to nine million dollars. These additional costs were not necessary for the fuse plug option since it can be designed to keep the reservoir level below the 692.4 elevation.

Recommended Plan for Improvement at Center Hill Dam

The purpose of the Center Hill study was to evaluate the present condition of the dam

with respect to hydrologic safety and to present a plan to bring it to safe standards, if required. It has been determined that the dam is not safe for floods exceeding 72 percent of the PMF. All alternatives developed would accomplish the task of safely passing a full PMF. However, cost was used as the deciding factor on the selection of the recommended alternative by the Nashville District. Therefore, Alternative 5 is the recommended plan for improvement at Center Hill Dam.

Description of Recommended Plan

Alternative 5 consists of two main structural components. The first involves anchoring six monoliths in the concrete portion of Center Hill Dam to the monolith immediately underlying each. A stability analysis indicated the maximum allowable reservoir elevation of 691.0 could be raised to 692.4 if the six leaking monoliths were anchored. The second component entails excavating and replacing a portion of the existing saddle dam with an erodible fuse plug as shown in **Figure 2**.

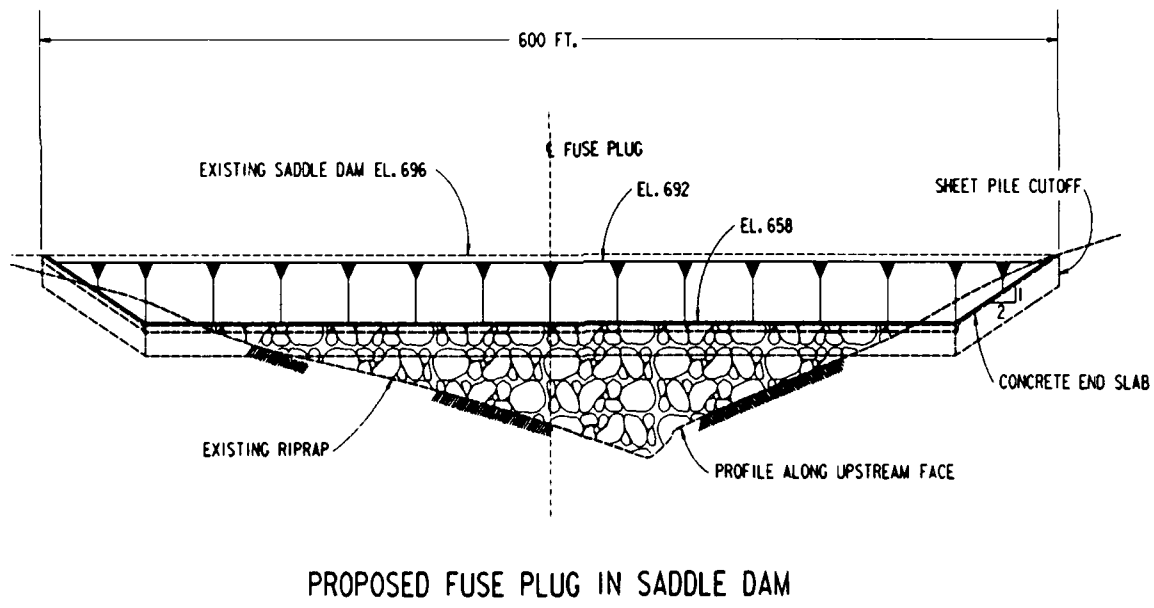
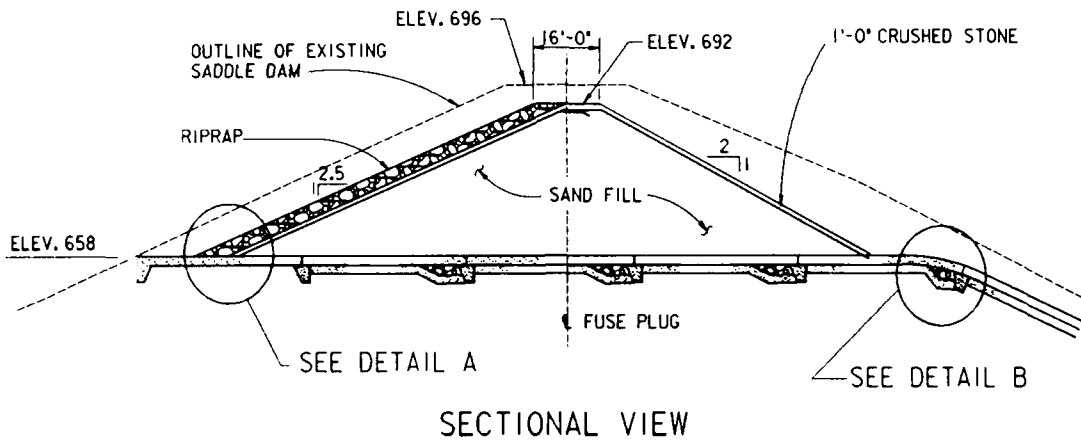
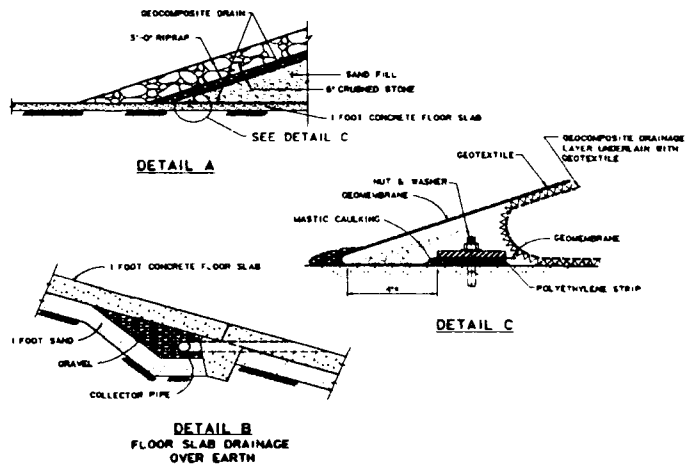

Figure 2

Figure 3



The fuse plug (see Figure 3) is primarily made of a homogeneous sand grain material. The reservoir water is prevented from going through the sand by use of an impervious geomembrane. The geomembrane is located parallel to the reservoir face of the fuse plug. The reservoir face of the fuse plug consists of a layer of riprap underlain by a blanket of crushed stone. A geocomposite drainage layer is provided beneath the geomembrane and along the floor slab to prevent excessive hydrostatic forces from acting upon the membrane. A layer of geotextile is provided beneath the geocomposite to prevent uncontrolled migration of sand into the drainage layer. The plug will be separated from the existing saddle dam by a reinforced concrete floor slab. The floor slab is equipped with floor drains. The crest and downstream face of the sand plug will be protected with a crushed stone blanket.



The fuse plug is designed such that once the reservoir elevation exceeds the elevation of the top of the plug (692.0) the overtopping water will wash out the sand fill. This process will collapse and tear-off the geomembrane as the supporting sand is washed out. Once the plug is washed out, a trapezoidal concrete weir will remain. The weir is sized to supply enough additional spillway capacity to prevent the reservoir from exceeding its maximum allowable elevation. The bottom elevation of the fuse plug was set at the 2 year frequency reservoir elevation of 658.0. This was selected as the minimum elevation to facilitate construction, maintenance and rebuilding (should the fuse plug be used).

The width of the fuse plug was determined by routing the PMF through the reservoir and varying the width until the maximum allowable pool elevation of 692.4 was obtained. The top of the fuse plug was set a elevation 692.0. This is one foot above the existing maximum safe pool level of the dam. For the routing, the fuse plug was modeled as a breach section in a dam with a time to failure of 30 minutes. This resulted in a fuse plug width of 600 feet.

A breakwater device is required in combination with the fuse plug alternative to protect its crest from wind and wave runup. For this, a commercially available floating breakwater structure was selected. This structure will extend approximately 800 feet across the reservoir face of the fuse plug. This length allows for an additional 100 feet past each end of the fuse plug to protect from waves circling around the end of the breakwater device.

Controversial Aspects Concerning the Center Hill Fuse Plug Alternative

For the Center Hill project, there were several opinions as to whether it would be better to raise the dam, use a fuse plug or find an "ideal" combination of the two. For most, the idea of raising the dam or combining this with a fuse plug, was to eliminate the fuse plug option or at least reduce its height significantly. Most of the controversy surrounding the acceptance of a fuse plug stems from the uncertainties surrounding a proposal that is non-standard or unproven by time. The following paragraphs will examine some of the more frequent items that have been questioned concerning the Center Hill fuse plug design.

- 1) What happens if the fuse plug does not erode within the designed 30 minutes? A physical model study is scheduled that will include testing for erosion rates of the fuse plug. Other items to be tested in the model study are the design of the geomembrane, protection of the plug, design of the exit channel, and an outlet rating curve. The 30 minutes used in the present study is our best approximation of a reasonable erosion time. An analysis was made to determine if the selection of Alternative 5 is sensitive to this parameter. The results indicated that if it took 4 times as long for

the plug to erode than estimated, the pool would rise an additional 1.5 feet. This would translate to an increased fuse plug width of approximately 50 feet, which would not impact the project cost enough to change the alternative selection.

- 2) If the fuse plug is washed out at the 75 percent PMF level, are we not inducing damages downstream for floods between it and the 100 percent PMF? The existing dam has been calculated to be stable for reservoir levels up to elevation 691.0. This elevation is equivalent to a 72 percent PMF. For levels exceeding this elevation, the stability of the dam degrades rapidly and failure by overturning becomes probable. The fuse plug alternative does increase discharges from the dam for floods greater than a 75 percent PMF, when compared to spillway only discharges. However, when compared to the more probable failure discharges, the fuse plug alternative reduces downstream hazards significantly.
- 3) Many reviewers of the proposed Center Hill fuse plug have stated that they would feel much better about such an alternative if the invert were higher than the 2-year frequency headwater elevation. That is, they feel the risks associated with a premature failure of the fuse plug could be lessened by raising the invert to a much less frequent headwater event. However, Nashville District feels it is much wiser to have the invert at the lower level for several reasons. First, the plug can be monitored with water on it much more often. This would allow for a better opportunity to correct any unforeseen problems. Another is that downstream damages can be reasonably controlled, as is discussed in the following paragraphs, by the spillway gates for most high head situations. Lastly, it would be very expensive to raise the invert. Raising the invert would require either a much wider cut or raising the dam. Any increased width would result in expensive rock cuts into the valley walls of the saddle area. Raising the dam would require the expensive anchoring costs mentioned previously.
- 4) What happens if the fuse plug leaks and fails prematurely? The fuse plug is designed with a drainage system that can safely carry away a sizable amount of leakage. However, should for some unknown reason the plug fail, a reasonable level of protection could be expected to be maintained downstream under most circumstances. Since the fuse plug is designed to prevent a catastrophe due to dam failure, it is only reasonable to evaluate a failure of the fuse plug for non-dam-threatening events. For this, a flood of similar magnitude to the flood of record for the reservoir was selected. The highest reservoir elevation at Center Hill occurred in May of 1984 when the reservoir reached an elevation of 681.5. This is approximately one foot above the previous flood of record which occurred in February of 1950. A 30 percent PMF, which results in a peak reservoir elevation of

681.1, was used to analyze the consequences of a premature fuse plug failure. For the failure, the entire plug was assumed to erode in 30 minutes due to a piping failure. The resulting flood wave from the breach was approximately 10 feet high immediately downstream from the main dam and dissipates to 5 feet at Carthage, which is the first major damage center downstream.

In general, during flood conditions, Center Hill Dam is used first to control flooding at Carthage. Outflows from the dam generally range from 9,000 cfs to 12,000 cfs prior to heavy rains. During heavy rains, and prior to the peak at Carthage (from flows other than out of Center Hill), the outflow is cut back to zero if Carthage is above flood stage and storage is available in the reservoir. After the flood wave has passed Carthage, outflow is re-initiated with typical discharges ranging from 9,000 cfs to 30,000 cfs. This operation procedure produces the situation where the peak pool elevation at Center Hill occurs several days after the flood at Carthage.

For historical floods, if the fuse plug were in place and a piping failure occurred, two situations define the range of resulting consequences. The first would be a situation where the fuse plug fails while no outflow is being made from the dam and a flood is cresting at Carthage. For this situation, the pool elevation has been historically low and a failure would result in a maximum increases at Carthage of less than 3 feet. The second situation would be a failure during the peak reservoir level at the dam. This situation is similar to the 30 percent PMF failure mentioned previously with its maximum increases at Carthage of less than 5 feet. For historical floods, this 5 feet increase would arrive several days after the occurrence of a much higher peak flood level from Cumberland River flows.

From the above discussion, it would appear that a "sunny day" failure of the fuse plug during a record high pool elevation at the dam with no flood conditions at Carthage would result in the worst case hazard downstream. However, during such a situation, the outflow from the dam would be equal to or greater than 30,000 cfs (based on the spillway gates being open downstream of the dam). It was determined, for the 30 percent PMF failure, that if the spillway gates and turbines were shut down during a failure of the fuse plug, the increases in depth of flooding at Carthage could be reduced from 5 feet to 1 foot.

Conclusions

The intent of this paper is to demonstrate that a fuse plug type alternative is a viable option for the correction of spillway adequacy problems. It was found that this is

especially true when a dam cannot be raised without requiring expensive stability treatment. To raise Center Hill Dam the ten feet required to safely pass the PMF, the concrete portion of the dam would have to be anchored to bedrock to prevent overturning. It is the 9 million dollar cost attributable to this treatment that justifies the fuse plug option. The Nashville District expects a final design for the fuse plug to be adopted for Center Hill following the physical model study.

References

1. Hansen, E.M., Schreiner, L.C. and Miller, J.F., 1982: Application of Probable Maximum Precipitation Estimates - United States East of the 105th Meridian. **Hydrometeorological Report** No. 52, National Weather Service, National Oceanic and Atmospheric Administration, U.S. Department of Commerce, Washington, DC.
2. Ho, F.P. and Riedel, J.T., 1980: Seasonal Variation of 10-Square Mile Probable Maximum Precipitation Estimates, United States East of the 105th Meridian. **Hydrometeorological Report** No. 53, National Weather Service, National Oceanic and Atmospheric Administration, U.S. Department of Commerce, Silver Springs, Md.
3. Schreiner, L.C. and Riedel, J.T., 1978: Probable Maximum Precipitation Estimates, United States East of the 105th Meridian. **Hydrometeorological Report** No. 51, National Weather Service, National Oceanic and Atmospheric Administration, U.S. Department of Commerce, Washington, DC.
4. Schwarz, Francis K., 1973: Meteorological Criteria For Four Basins in the Tennessee and Cumberland River Watersheds. **Hydrometeorological Report** No. 47, National Weather Service, National Oceanic and Atmospheric Administration, U.S. Department of Commerce, Silver Springs, Md.
5. Zurndorfer, E.A., Schwarz, F.K., Hansen, E.M., Fenn, D.D. and Miller, J.F., 1986: Probable Maximum and TVA Precipitation Estimates With Areal Distribution for Tennessee River Drainages Less Than 3,000 Square Miles in Area. **Hydrometeorological Report** No. 56, National Weather Service, National Oceanic and Atmospheric Administration, U.S. Department of Commerce, Silver Springs, Md.
6. Stakhiv, E.Z. and D. Moser, **Guidelines for Evaluating Modifications of Existing Dams Related to Hydrologic Deficiencies**. U.S. Army Engineer Institute for Water Resources. IWR Report 86-R-7.
7. U.S. Army Corps of Engineers, **Center Hill Dam, Cumberland River Basin, Tennessee, Study for Correction of Spillway Deficiency, Dam Safety Assurance Program**, Prepared by the Nashville District, U.S. Army Corps of Engineers, Nashville, Tennessee, 1988.

THE EFFECT OF PRIVATELY OWNED DAMS IN THE GILLS CREEK BASIN

by Robert Occhipinti¹

STUDY AREA DESCRIPTION

General. The Gills Creek basin (figure 1) is located entirely in Richland County, South Carolina. It encompasses the eastern portion of the city, a large portion of Fort Jackson and the entire corporate limits of two small towns. The Gills Creek drainage basin is a 73 square mile tributary of the Congaree River.

Land Use. The lower third of the basin (overlay for figure 1) is characterized by a wide, moderately developed flood plain with flat topography marshy soils. The eastern third of the basin is predominately sand hills with mostly undeveloped Fort Jackson land. The western third is almost completely developed urban areas with rolling hills and sandy soils.

LOCAL DAMS

The most striking hydrologic characteristic of the Gills Creek basin is the number of dams (figure 2). The rolling topography of the upper two-thirds of the basin is ideal for the construction of small dams and lake front property. Approximately 100 privately owned, uncontrolled dams lie in the upper two thirds of this basin. In addition, about five other dams are owned or were built by the Federal Government. Since most of the dams were built by developers to create lake front property from twenty-five to ninety years ago; very little consideration was given to safety, maintenance or hydraulic capacity. The location of the major dams are shown on figure 2. With so many poorly designed, aging dams around, you can imagine that there have been a number of serious problems. The most graphic occurred in the 1940's when a storm caused the two largest dams at the very bottom of the chain to fail domino fashion. The lowest of these dams, Lake Katherine, after a second sudden complete failure of the left embankment in fifteen years, was repaired by filling the breached embankment with large rocks and soil. This helped result in the third failure (piping failure) of the embankment years later.

¹Chief of Hydrology and Hydraulics Section, Charleston District, U.S. Army Corps of Engineers

PREVIOUS STUDY EFFORTS

Survey Report. A draft Survey Report for Gills Creek was submitted to South Atlantic Division in 1969. It recommended construction of a flood control dam and a channel enlargement in two reaches.

Flood Insurance Studies. Among the more significant previous study efforts of the Gills Creek basin were the flood insurance studies. They recognized that the precarious condition of the dams would have a great effect on the hydrology of the basin. For this analysis it was decided that once a dam was theoretically overtopped by two feet of water it would fail and release a slug of water to the next dam. Then it was checked for the total depth of overtopping to determine if it failed.

National Dam Safety Reports. Another major effort to address the hazards of the Gills Creek basin came from the National Dam Safety Program. Of the twenty dams in the basin determined to be high hazard, ten were declared to be unsafe. One of the major dams in the basin (our old friend at the bottom of the basin, Lake Katherine) was not declared unsafe only because a severe constriction downstream caused very high tailwaters totally submerging the dam. It was determined that a failure of this dam during a storm would not raise the ultimate downstream hazard. All hydraulic studies of this area were really hampered by the fact that there is only one stream gage in the basin. The gage has a relatively short, dry period of record in Columbia's history. Rapid urbanization has also neutralized most of the information that could be provided by the dam safety program for South Carolina in less than ten years.

State of South Carolina Efforts. As a result of the national dam safety effort, the state of South Carolina passed its own dam safety law. Basically the law adopted the standards of the National Dam Safety Program recommendations. In attempting to enforce this law the state learned that most of these dams were owned by the developer as a corporation with no assets. The State has settled for pressuring the owners of unsafe dams to bring them up to safely passing or storing the one hundred-year flood. The way they got around the invisible owners was by getting a court order and draining the lake behind the unsafe dam. This got the surrounding land owners to organize to buy and repair the dam. This has worked slowly, but well. Of the ten high hazard dams declared unsafe, two under state control and one under federal control remain to be upgraded at this time.

LATEST STUDY EFFORT

The latest effort was a feasibility study that was to address dam safety and resolve flood control problems (overlay to figure 2). One of the major problems with the basin was how to define an existing condition in a basin that has continuous dam failures and upgrades. In a normal basin study, a variable such as increasing urbanization has a significant but predictable impact on discharge. For this basin we assumed fully developed conditions, no further urbanization would occur. The impact of upgrading uncontrolled dams has a similar effect, except it cannot be predicted from the beginning of the study. You must know how each dam is going to store or pass a storm. This has resulted in potentially never completing the existing conditions. When a dam was upgraded all the discharges from that point downstream changed. For future conditions we assumed that the land use was unchanged but that the major dams were upgraded to pass the one hundred-year storm with one foot of freeboard, thus meeting the state's requirements. This is not as clean as it sounds; since, as we improved the dam to pass more flow, downstream flooding increased.

In a future with a federal project condition (a dry reservoir on Fort Jackson) the cost of upgrading the private dams would be smaller than in a future without a federal project condition, due to the additional storage of the federal reservoir. The difference is a benefit from the project.

When you have multiple dams in a chain and you start playing with their outflow characteristics, some unusual things start happening. Since the dams are privately owned and the only constraint is that they pass the one-hundred year flood with 1 foot of freeboard, the number of possible outflow relationships at a point downstream of any of the dams becomes infinite. If we assume the dam owners would only pass and not store the water; which is what usually happens, since the owners live upstream on the lake, then the possibilities, though infinite, become somewhat manageable. Of course, you have to start from upstream-down, or an upgraded dam will be undersized when its upstream neighbors are finished.

The final thing I would like to point out is that as you upgrade a chain of uncontrolled dams to pass more water and you look at the predicted response well downstream (say at a gage), the discharge for a given frequency will only go up, and very significantly (figure 3).

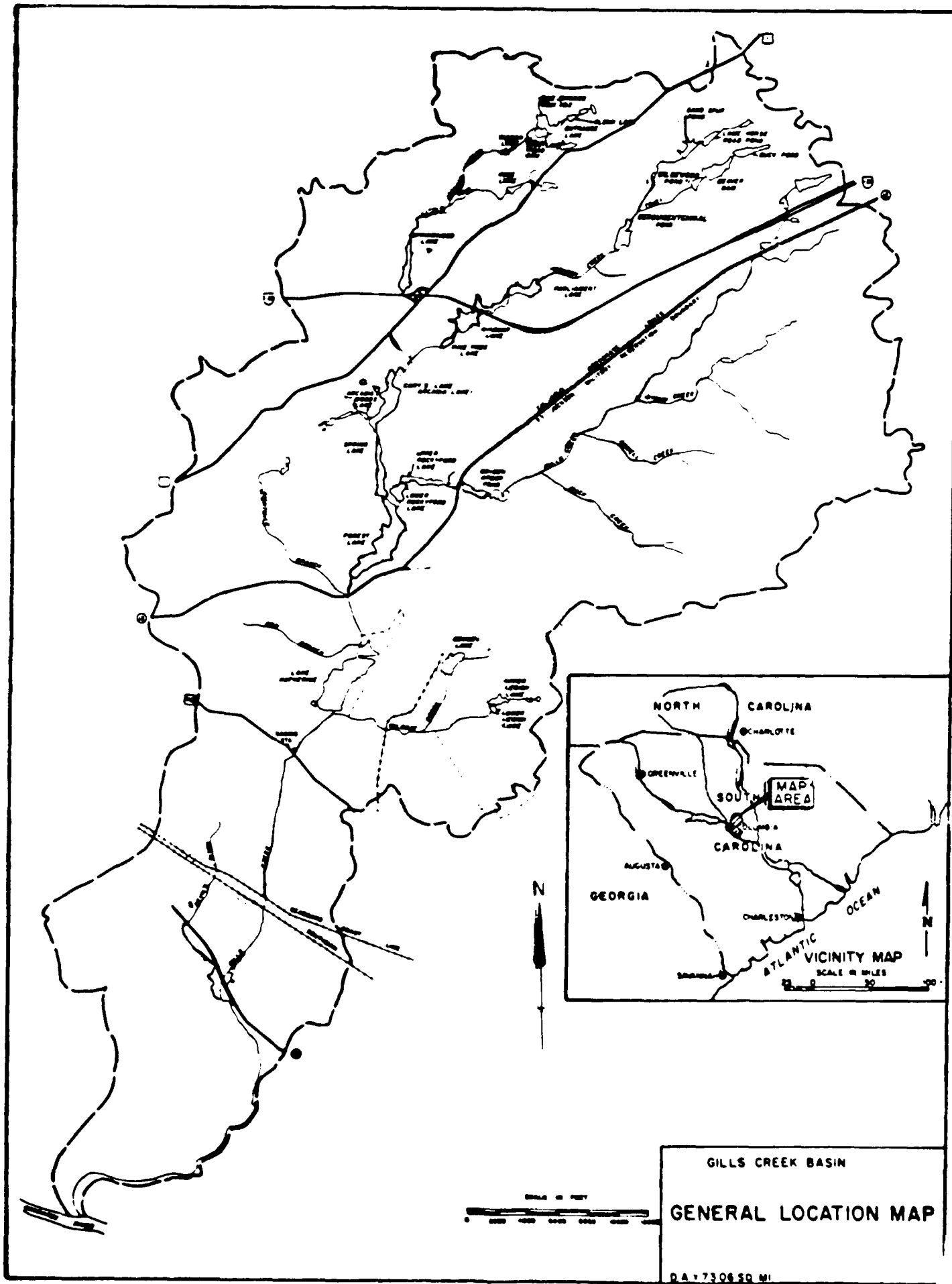

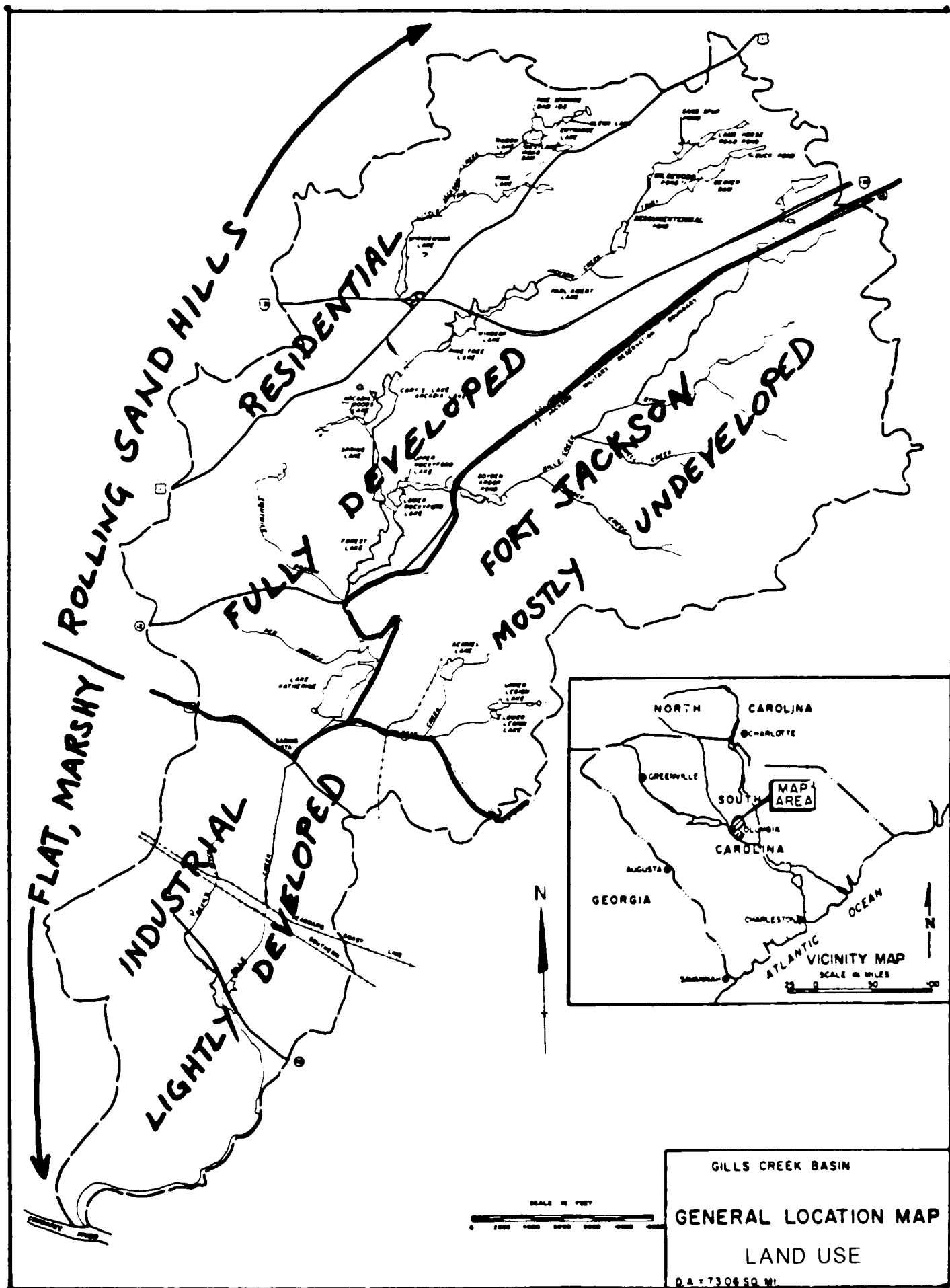

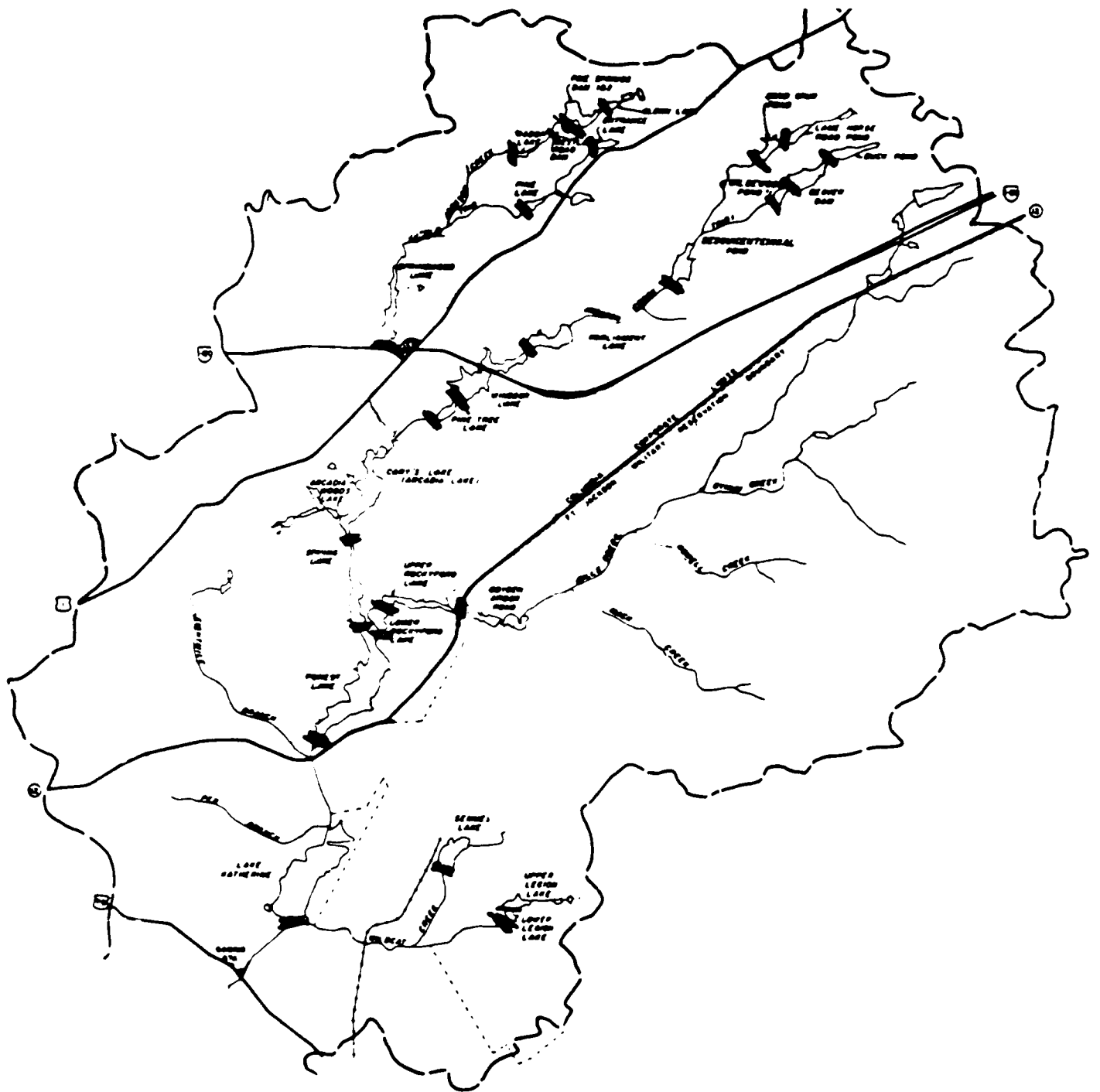

LOCATION OF DAMS
IN BASIN MODEL

FIGURE 2

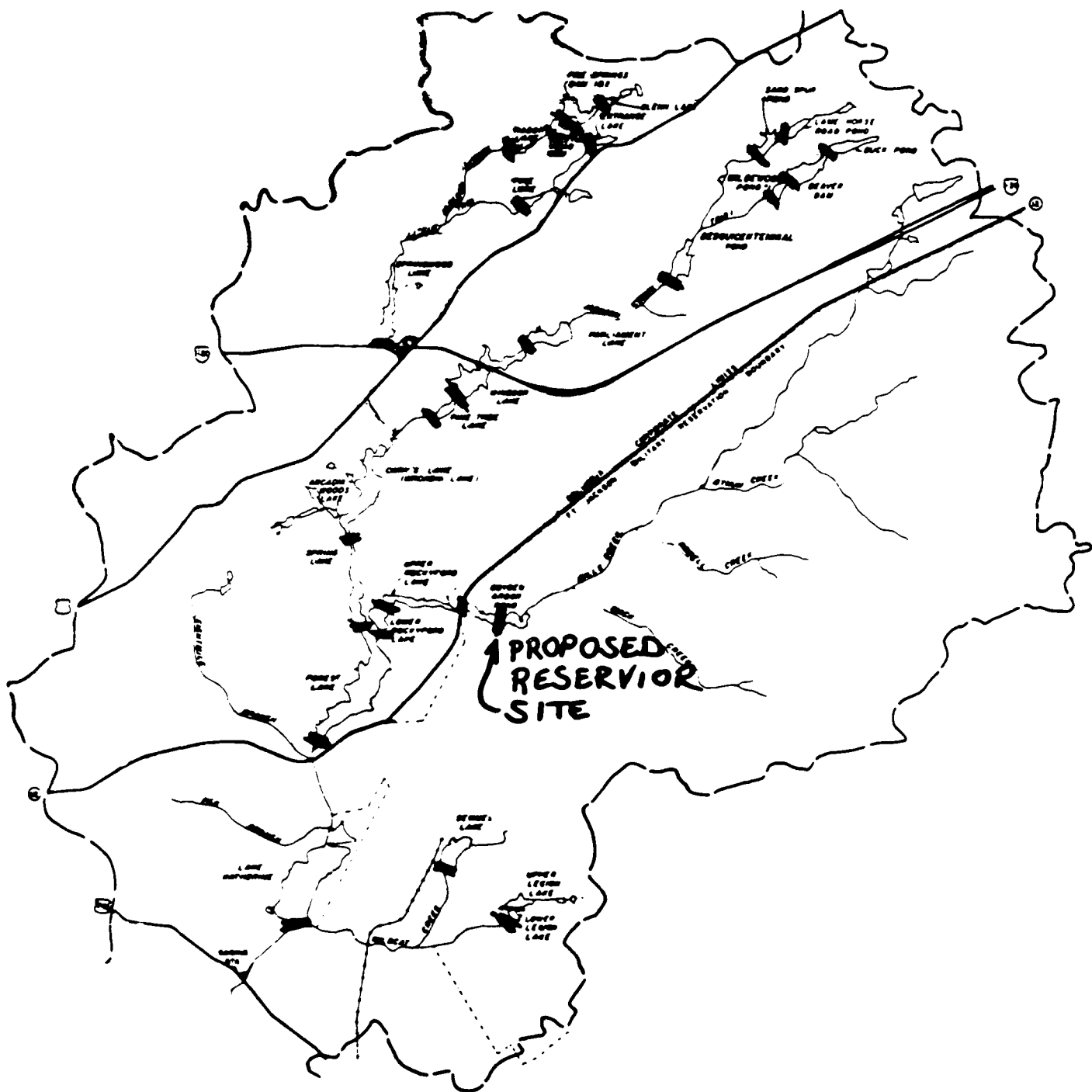

LOCATION OF DAMS
IN BASIN MODEL

OVERLAY

FIGURE 2

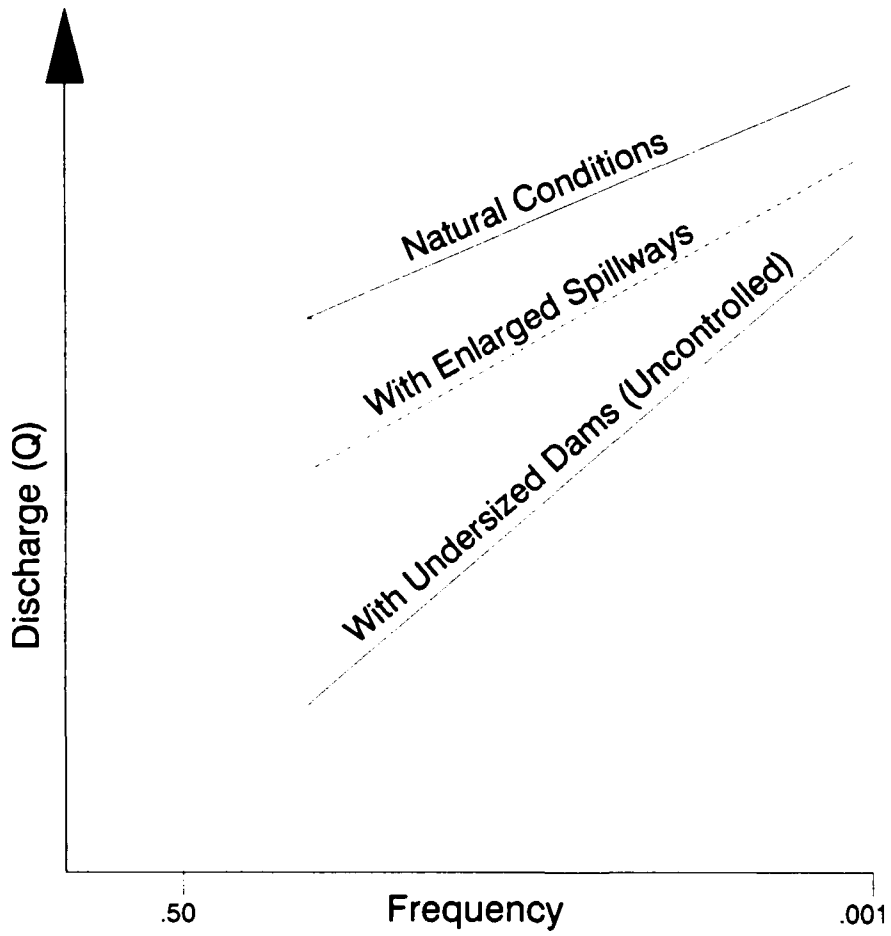

Figure 3

WYNOOCHEE LAKE, WASHINGTON
Transfer of OMR&R Responsibilities to the
City of Aberdeen, Washington

by

Christopher J. Lynch¹

Section 4 of the Water Resource Development Act of 1988 authorizes the U.S. Army Corps of Engineers (USACE) to transfer the responsibilities for operation, maintenance, repair, and rehabilitation (OMR&R) of the Wynoochee Lake Project, Wynoochee River, Washington, to the city of Aberdeen, Washington. The authorization also makes allowance for the possibility of eventual transfer in fee title of the entire project to the city if their operation is found to be successful.

The project was initially authorized by section 203 of the Flood Control Act of 1962. It was built and in operation by October 1972 as a multi-purpose project primarily for flood control and water supply, although irrigation, fish and wildlife, and recreation were included benefits. Wynoochee Lake's 35,000 acre-feet of flood control storage provides the maximum possible effective reduction of floods up to and including the 100-year flood. It protects six miles of farmland and light density residential areas in the lower Wynoochee valley.

Prior to construction, the city of Aberdeen entered into an agreement obligating them to pay a share of the construction and OMR&R costs proportionate to the estimated water supply benefits. Less than anticipated economic growth and greater than anticipated increases in OMR&R costs have forced Aberdeen into a fiscal crisis. To avert bankruptcy, Aberdeen sought congressional intervention which resulted in the authorized transfer. Aberdeen believes it can accomplish the necessary OMR&R for less total expenditure than the portion of the total cost they had been paying USACE to accomplish the same OMR&R. They hope this arrangement will minimize or even reduce their debt.

Wynoochee project has several unique features which call for experienced and well-trained hydrologic engineers and meteorologists. Its location on the southern side of the Olympic Mountains exposes it to 150 inches of frontal, orographic and convergence precipitation each year. Because of the basin's geographic location and elevation, the freezing level is extremely important in determining the portion of the basin where rain is falling and the portion where snow is melting or accumulating.

¹ Hydraulic Engineer, Seattle District, U.S. Army Corps of Engineers

The lake is situated in a narrow, rapidly-rising valley with a very short and fast response time, which calls for knowledgeable and experienced weather forecasters and regulators in flood situations. Floods requiring regulation occur on the average about every two years. Flood alerts occur several times each year to monitor storms with flood-producing potential. Monitoring and regulating such flood events requires enough qualified staff to work from two to five days around the clock.

The Wynoochee River Above Black Creek streamgage station, located 46 miles downstream of the project, serves as the river's control point. Seventy-four percent of the total drainage area above the control point station is downstream of the dam and represents 114 square miles of uncontrolled drainage area. Only 26 percent, or 41 square miles, of the total drainage area above the control point station is controlled by the project. The large percentage of uncontrolled drainage area can generate enough local runoff to cause flooding at the control point, even when releases from the project are minimal. The concentration time of local inflow is shorter than the travel time of project releases. Successful regulation, therefore, requires quantitative precipitation forecasts and necessitates the understanding and use of a good basin forecasting and flood routing model.

Adding to these hydrologic challenges are constraints imposed by the dam itself. Unlike most USACE projects, Wynoochee Dam does not have surcharge storage. To avoid overtopping the dam, much more care must be exercised by knowledgeable regulators than would be necessary if surcharge storage were available. For extremely large events, the spillway gate regulation schedule must be applied every 15 minutes to prevent overtopping.

Experience and model tests have also shown that the spillway and sluices must be operated in accordance with specific criteria. The sluiceways experience excessive vibration and could potentially be damaged or destroyed if operated between 70 and 100 percent open. Therefore, this range is avoided. The spillway was initially designed to pass 52,500 cfs, but is now restrained to 43,500 cfs to avoid overtopping the left spillway wall, except when larger discharges would be required to save the dam. Additionally, criteria governing the proportional amount of flow out of each spillway gate has been determined to minimize erosive impact on the downstream canyon walls.

The combination of all these contributing factors makes Wynoochee the most volatile and challenging project for the Seattle District to regulate and substantiates the need for well qualified and experienced hydraulic engineers overseeing its operation. Seattle District is in the final stages of development of a plan which will expeditiously transfer operation, maintenance, repair, and rehabilitation of Wynoochee Project to the city of Aberdeen and assure its continued safe and effective operation.

NON-FEDERAL DAM SAFETY ISSUES IN MRD

by

Warren J. Mellema¹ & Albert R. Swoboda¹

INTRODUCTION

Hydrologic criteria governing the design of both federal and non-federal dams often vary significantly between states in the same hydrologic region, between states and the separate federal agencies, and between federal agencies themselves. This multiplicity of jurisdictions and guidelines complicates the entire subject of hydrologic adequacy of dams, and often makes it difficult to fully implement our own (Corps) requirements in situations where overlapping jurisdiction occurs. The situation can even become further clouded in situations where non-Corps projects are incorporated into or become part of an overall Corps flood control plan.

STATE GUIDELINES

The regional boundaries of the Missouri River Basin encompass all or part of ten Midwestern states, the boundaries of which crisscross the basin. These artificial lines in space, however, are major dividing lines in how dam safety is viewed, and how the hydrologic adequacy of a given project is perceived. In one state, a dam may be considered "safe" only if it can safely store or pass the PMF, whereas immediately downstream across a state boundary, a dam on the same stream with similar size and hazard classifications must only pass 0.4 PMF. These apparent differences are not only difficult to rationalize from an engineering standpoint, but are even more difficult to explain to local interests, as it appears that dam safety becomes more a function of its location in the basin rather than sound engineering standards. Table 1 summarizes the dam safety guidelines in use today in nine Midwestern states, and illustrates the variability that exists between states.

An argument can be made that state criteria, although interesting, does not and should not really impact how the federal agencies assess projects, as the federal agencies establish and are responsible for and set their own standards. In reality, however, state engineers are usually involved in any major construction within their jurisdictions, and their general viewpoint and assessment serves as an important indicator as to what is accomplished in a given state. This is particularly true when it comes to rehabilitation of existing projects that no longer meet either state or federal criteria, and where federal criteria may be more demanding than state criteria. Local interests may look to and point to the state criteria as the standard, and thus put pressure on the federal agency to relax their criteria in the interest of reducing costs.

FEDERAL GUIDELINES

Federal agencies most concerned with dams (the Corps, Bureau of Reclamation, SCS, Forest Service, TVA, etc.) are not exempt from variations in criteria when evaluating the ability of dams to withstand extreme floods. Although basic criteria for most federal agencies state that high hazard dams must contain or pass

¹Hydraulic Engineers, Missouri River Division, Corps of Engineers, Omaha, NE

the PMF, the system often breaks down when it comes to determining what constitutes high hazard, significant hazard or low hazard. Additional ambiguity exists when one is faced with further breaking down the dams into large, intermediate, and small size classifications. Regardless of the criteria in use by the various agencies, it is apparent that the "hydrologic adequacy" of projects constructed by various federal agencies does in fact vary between federal agencies, and similar projects may be viewed and perceived differently depending upon who owns the project. This ambiguity carries over into the rehabilitation arena, and impacts how various agencies view existing projects, and whether they should or should not be upgraded or rehabilitated.

The "Committee on Safety Criteria for Dams" of the National Research Council completed an inventory of existing hydrologic criteria for federal, state, and consulting firms throughout the United States.(1). They concluded the following:

1) Use of PMP estimates for evaluating spillway capacity requirements for large, high-hazard dams predominates, although a number of state agencies have indicated that their standards do not require that such dams pass the full estimated PMF based on the PMP.

2) The influence of the practices of the principal federal dam-building agencies is evident in the majority of the standards for large, high-hazard dams, but the practices of those agencies have had less effect on current state standards for small dams in less hazardous situations.

3) Apparently as a result of the National Dam Inspection Program for non-federal dams carried out by the Corps of Engineers in the 1977-1981 period, several state dam safety agencies have adopted the spillway capacity criteria used in those inspections.

4) Several states have adapted the standards used by the Soil Conservation Service for the design of the tens of thousands of smaller dams constructed under the agency's programs.

5) Current practices include use of arbitrary criteria (such as 150 percent of the 100-year flood, fractions of the PMF, and combinations of the PMF with probability based floods) for which there is no apparent scientific rationale.

6) Practices of the major federal dam-building agencies for large, high-hazard dams have been adopted by most U.S. companies owning dams and by U.S. engineering firms designing dams for domestic and foreign clients. (The regulations of the Federal Energy Regulatory Commission have required such standards for licensed hydroelectric projects.)

7) It appears that only three agencies (the Federal Energy Regulatory Commission, the Mississippi Department of Natural Resources, and the New York State Department of Environmental Conservation) have issued explicit standards for existing dams that differ from the requirements for new dams. (however, other responses did not specifically state whether different standards were applicable to existing dams.)

FEDERAL - MILITARY RELATIONSHIP

Dams residing on military installations present an entirely different set of issues and concerns, as they do not seem to fit either state or federal guidelines. Recent experiences in MRD seem to indicate that they are primarily concerned with meeting the criteria for the particular state in which they reside, and have no real interest or intent in meeting federal guidelines. The entire question of basic responsibility and hydrologic criteria for dams on military installations is in need of direction and resolution.

POTPOURRI

The question of criteria/responsibility for the hydrologic adequacy of dams seems to be in transition in many states and some federal agencies, tending toward less variability in basic criteria. Relaxation of this criteria, however, frequently persists, and decisions made more on how much the owner can afford, rather than on what really needs to be accomplished to reduce that risk to tolerable limits. Recent guidelines issued by the Corps in relation to the dam rehabilitation program seem to be leading toward an approach which integrates dam safety concerns with downstream risk. This is a step in the right direction, and would direct limited resources toward those projects in greatest need of repair. This same kind of an approach could be developed for new dams, and would seem to be where we should be directing our efforts.

(1) "Safety of Dams - Flood and Earthquake Criteria", National Academy Press, 2101 Constitution Ave., NW, Washington, DC 20418, 1985

**TABLE 1
STATE SPILLWAY CRITERIA¹**

SIZE OF DAM	HIGH HAZARD			SIGNIFICANT HAZARD			LOW HAZARD		
	LARGE	INTER	SMALL	LARGE	INTER	SMALL	LARGE	INTER	SMALL
STATE²									
KANSAS³	0.4 PMP	0.3 PMP	0.25 PMP	0.4 PMP	0.3 PMP	P ₁₀₀	0.4 PMP	0.25 PMP	P ₁₀₀
NEBRASKA	FOLLOW GUIDELINES ESTABLISHED BY THE SOIL CONSERVATION SERVICE								
	PMP	PMP	PMP	P ₁₀₀ + 0.4 (PMP-P ₁₀₀)			P ₁₀₀ + 0.4 (PMP-P ₁₀₀)		
S. DAKOTA	PMF	0.5 PMF	0.5 PMF	PMF	0.5 PMF	100 YR.	0.5 PMF	100 YR.	50 YR.
COLORADO⁴	PMP	PMP	PMP	0.75 PMP	0.5 PMP	0.5 PMP	100 YR.	100 YR.	100 YR.
WYOMING⁵	P ₁₀₀ (PRACTICE PMF)	P ₁₀₀	P ₁₀₀	P ₁₀₀ (REGULATIONS BEING REVISED)	P ₁₀₀	P ₁₀₀	P ₁₀₀	P ₁₀₀	P ₁₀₀
MONTANA	PMF	0.75-0.5 PMF	0.3-0.2 PMF	N/A	N/A	N/A	N/A	N/A	N/A
N. DAKOTA	PMP	PMP	0.5 PMP	0.5 PMP	0.5 PMP	0.3 PMP	0.3 PMP	0.3 PMP	0.3 PMP TO P ₅₀
MISSOURI	0.75 PMP	0.75 PMP	0.75 PMP	0.5 PMP	0.5 PMP	0.5 PMP	0.4 PMP	0.4-0.25 PMP	0.25 PMP
IOWA	PMF	PMF	PMF	0.5 PMF	0.5 PMF	0.5 PMF	0.5 PMF	P ₁₀₀ + 0.12 (PMP-P ₁₀₀)	P ₅₀

1 NOTE: DETERMINATION OF HAZARD AND SIZE CLASSIFICATION DIFFER BETWEEN STATES. TABLE REFLECTS A BROAD INTERPRETATION OF STATE GUIDELINES, ATTEMPTING TO GROUP PROJECTS OF SIMILAR SIZE AND HAZARD INTO COMPARABLE GROUPS.

2 NOTE: SEE TABLE 2 FOR LIST OF STATE REFERENCES.

3 NOTE: KANSAS REQUIRES 2 TO 3 FT. FREEBOARD ABOVE SPILLWAY DESIGN FLOOD.

4 NOTE: COLORADO REQUIRES 1 FT. FREEBOARD ABOVE SPILLWAY DESIGN FLOOD.

5 NOTE: WYOMING REQUIRES 1½ FT. FREEBOARD ABOVE SPILLWAY DESIGN FLOOD.

TABLE 2

<u>KANSAS</u>	Table 2, Engineering Guide 1, ED-1, Kansas State Board of Agriculture, Division of Water Resources, May 1, 1986, as referenced in letter dated 31 July 1989.
<u>NEBRASKA</u>	USDA Soil Conservation Service, Technical Release No. 60, June 76, Revised Aug 81, as referenced in letter dated 28 July 1989.
<u>SOUTH DAKOTA</u>	Safety of Dams Rules, Chapter 74.02.08, revised thru April 23, 1989, as referenced in letter dated 31 July 1989.
<u>COLORADO</u>	Rules & Regulations for Dam Safety and Dam Construction, Office of the State Engineer, Colorado, 26 Aug 1988.
<u>WYOMING</u>	State of Wyoming, Safety of Dams Program, (Wyoming Statutes 41-3-307, thru 41-3-318), and per letter from State Engineers Office, Cheyenne, Wyoming, dated 12 July 1989.
<u>MONTANA</u>	Department of Natural Resources & Conservation, Chapter 14, Dam Safety, Rule 36.14.502, per letter dated 11 July 1989.
<u>NORTH DAKOTA</u>	North Dakota Dam Design Handbook, North Dakota State Engineer, June 1985, Project No. 1579-1, per letter dated 6 July 1989.
<u>MISSOURI</u>	Rules & Regulations of the Missouri Dam & Safety Council, Revised 1989, TABLE 5, 10 CSR 22-3.020, per letter dated 6 July 1989.
<u>IOWA</u>	Iowa Department of Water, Air and Waste Management, Technical Bulletin No. 16, Criteria and Guidelines for Iowa Dams, per letter dated 6 July 1989.

CALIFORNIA STATE DAM SAFETY PROGRAM

SURYA BHAMIDIPATY
HYDRAULIC ENGINEER, SOUTH PACIFIC DIVISION

ABSTRACT

The history of the development of dam safety program in the State of California is discussed. The criteria used in assessing the safety of dams are outlined. A procedure to develop the design flood is explained.

HISTORY OF THE PROGRAM: The first of the modern state programs for regulation of dams in the interest of public safety was authorized by California State Legislature following the failure of St. Francis Dam in Southern California in 1929. The program has been strengthened at least twice following other major dam failures or near failures in the state. It has become an often cited model of effective state regulation of dams. The California program was the pattern for development of the Model Law for State Supervision of Safety of Dams and Reservoirs, promulgated in 1970 by the United States Committee on Large Dams. A number of Western States followed California's example and legislated programs to regulate dams in the interest of safety.

NUMBER AND TYPE OF DAMS: There are about 1200 dams in the state (earthfill dams-74%, concrete dams-15% and rockfill dams-9%).

EVOLUTION OF PROGRAM: The 1929 law applied to all onstream dams, over six feet high and storing 50 acre feet or 25 feet high and storing 15 acre feet except federal dams (Fig.1). After the failure of the Baldwin Hills Dam in 1963, the law was amended to establish state jurisdiction over all offstream dams. In 1972, following the near failure of San Fernando Dam in Southern California, the State Legislature passed a law which required dam owners to prepare inundation maps under a postulated failure.

DESIGN FLOOD: The state requires that all dams within its jurisdiction be capable of adequately passing a selected design flood. The design flood is selected based on damage potential downstream.

HAZARD ASSESSMENT: The hazard classification is selected from a rating system that considers reservoir capacity, dam height, estimated number of people that would be placed in peril and need to be evacuated in anticipation of dam failure, and potential downstream property damage. The method as indicated in Table 1 produces a composite numerical rating termed the Total Class Weight (TCW).

PRECIPITATION: The minimum allowable design event required is a 1000 year storm which corresponds with a TCW of four. The maximum event is a storm derived from the Probable Maximum Precipitation and is equated with a TCW of 30. The design event is interpolated between these limits at the computed TCW. If the TCW is greater than 30 the design storm is PMP. If the TCW is less than 30, a statistical frequency estimate of the rainfall is chosen. It is assumed that extreme precipitation follows a Pearson Type III probability distribution with a general skew of 1.3 for northern California and 1.5 for southern California. The equation for precipitation is:

$$P = M + k * CV * M$$

where:

- P = extreme precipitation value
- M = average of extreme values
- k = frequency factor
- CV = coefficient of variation

The appropriate coefficient of variation for the drainage basin is obtained from California State Department of Water Resources Bulletin 195. This publication is a statistical compilation of observed rainfall data for both long-term and short-term durations from measuring stations in California. The mean rainfall values for various time durations are found from above publication or from other available rainfall records for stations in the vicinity of the given basin. These means combined with the proper number of standard deviations give the precipitation estimates. The number of standard deviations required for 1000 year storm is 4.96 for northern California and 5.23 for southern California. The equivalent number of standard deviations for the PMP is obtained from a generalized contour plot relating this upper limit to geographical location. Using a nonlinear proration between these two points ($k_{1000 \text{ TCW}}$ and k_{PMP} , TCW_{PMP}), the k for the given TCW is obtained.

The rainfall depth-duration values are estimated either by the PMP procedures or the above described statistical method. After adjustment for watershed area, the results are plotted on log-log scales and smoothed if necessary to obtain the depth-duration curve.

UNIT HYDROGRAPH: Where no known reliable hydrographs exist, recourse is made to the computation of a synthetic unit hydrograph by Clark's method. Clark's unitgraph parameters are obtained from a generalized study of observed rainfall and runoff events and are related with drainage basin characteristics by regression analysis. This study is applicable to the entire state except for the area south of the Tehachapi Mountains and the area east of the Sierra Nevada Mountains. The study was limited to drainage basins approximately 30 square miles or less in area. It should be noted that approximately 80 percent of the dams under the jurisdiction of the Division of Safety of Dams have drainage areas of less than this size.

FLOOD HYDROGRAPH AND FLOOD ROUTING: Standard methods are used to develop flood hydrographs and to rout floods through reservoirs.

EVALUATING SPILLWAY CAPACITY: New embankment dams must pass the spillway design flood with a minimum of 1.5 feet of freeboard above the maximum reservoir flood stage. Additional freeboard is required for wave conditions from wind effects. Existing earth dams must pass the spillway design flood without overtopping.

REFERENCES:

1. California Department of Water Resources (1976), Rainfall Analysis for Drainage Design, Bulletin No. 195, 3 volumes.
2. Division of Safety of Dams (1981), Hydrology Manual - Flood Estimates for Dams.
3. Emil R. Calzascio and Jaime A Fitzpatrick, Hydrologic Analysis within California's Dam Safety Program.

JURISDICTIONAL DAM SIZE IN THE STATE OF CALIFORNIA

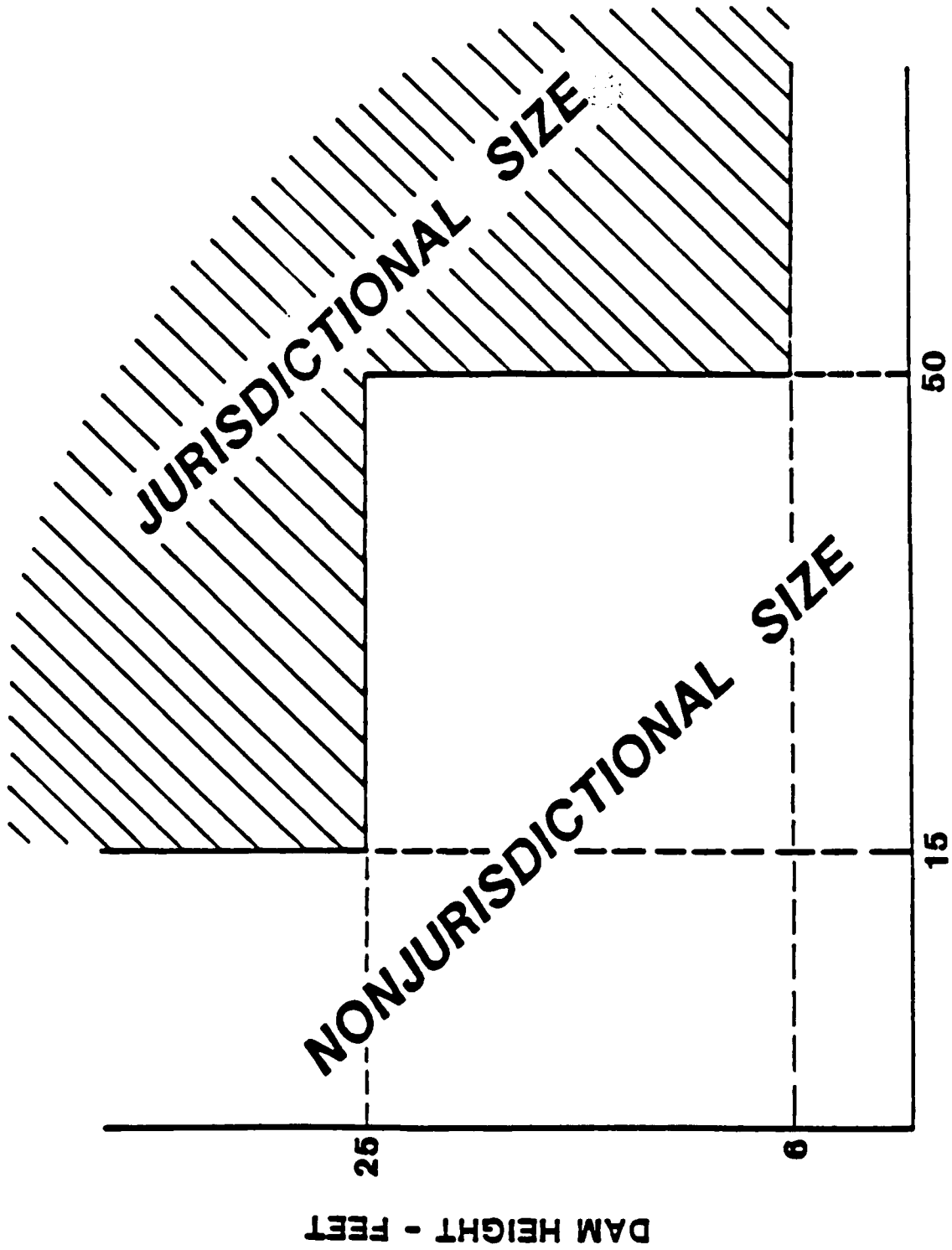

STORAGE CAPACITY - ACRE - FEET
FIGURE 1

TABLE 1

DAMAGE POTENTIAL CLASSIFICATION FOR
FLOOD ESTIMATE AND SPILLWAY ANALYSIS

Name of Dam _____ Type of Dam _____ Dam No. _____
 County _____ Located on _____

Damage Potential Rating

	Extreme	High	Moderate	Low
Capacity _____ A.F. _____ (circle weight) 6	100,000 & Over 6	1,000-99,999 4	100-999 2	15-99 0
Height _____ Ft. _____ (circle weight) 6	150 & Over 6	100-149 4	50-99 2	6-49 0
Estimated Evacuation _____ (circle weight) 12	1,000 & Over 12	100-999 8	1-99 4	None 0
Potential D/S Damage _____ (circle weight) 12	High 12	Moderate 8	Low 4	None 0

Total Class Weight _____

SUMMARY OF SESSION 2: LOW LEVEL-OF-PROTECTION LEVEE PROJECTS

Overview

This session examined the issue of level-of-protection considerations in Corps projects. Three presentations were made and a panel discussion held.

Paper Presentations

Paper 2. Don Getty, Nashville District, presented a paper entitled "Catastrophe Aversion Analyses Necessary for Total River Diversion by Tunnels - Harlan, Kentucky." This flood control project is the only USACE project in which a large stream (103 square miles) is totally and permanently diverted by a system of tunnels. The key issue addressed, was the potential of the tunnels to become clogged by debris during a large event. This could result in catastrophic loss of life and/or significant flood damage to downstream Harlan, Kentucky. The paper describes how the tunnels could be designed to prevent a catastrophic loss under the worst possible conditions.

Michael Burnham, HEC, overviewed the level-of-protection issues on the lower American River in the vicinity of Sacramento. The city is protected from flooding by the upstream Folsom Dam and levees along the American River. The system was completed in the mid 1950's and was thought to provide greater than 100-year exceedance interval (1-percent chance) event protection based on about 35 years of streamflow data used in its design.

A reevaluation of the hydrologic data after the 1986 flood, using 25 more years of streamflow data, determined that the present protection level of the American River system is a 60-year exceedance interval event. The result is, most of Sacramento is now within the regulatory flood insurance program. Conflicts and debates have subsequently arisen concerning appropriate levels and locations of development and the associated flood risks. The Corps is presently studying alternatives that will provide greater protection to the city of Sacramento. No paper was provided.

Paper 3. Joseph Evelyn, Los Angeles District, presented a paper entitled "Lower Santa Ana Channel Design." The lower Santa Ana River conveys flood flows through one of the most highly urbanized floodplains in the country. The lower Santa Ana River flood control improvements include channels, levees and upstream flood control elements. Mr. Evelyn discussed the three design objectives. First, the improved channel must safely handle the design flood with respect to water and sediment. Second, the initial overtopping of the channels or levees should occur at the least hazardous locations. Third, the improved system must continue to function without structural failure during flood events larger than the design flood.

Panel 2 Discussions

Ron Dieckmann, St. Louis District, presented "Coldwater Creek Levees - What Freeboard?". He discussed the functional and safety related aspects of freeboard for levees with a maximum height of five feet on Coldwater Creek, in north St. Louis County, Missouri. The district recommended a freeboard of .5 feet for the levees, however, HQUSACE review comments state that a minimum of one foot freeboard should be used.

Dennis Seibel, Baltimore District, discussed levee freeboard for Wyoming Valley, Pennsylvania. The Wyoming Valley project involves the raising of existing levees that protect several communities along the Susquehanna River in northeastern Pennsylvania. The existing levee system was overtopped in the 1972 flood as a result of tropical storm Agnes. The project is presently being designed to overtop in the least damaging manner, which is the downstream end first.

Ronald L. Turner, Fort Worth District, described the Trinity River levee system in the vicinity of Dallas and Ft. Worth, Texas in his panel presentation, "Level of Protection for Urban Levees." The system was designed to provide SPF protection with four feet of freeboard. Revised estimates of the SPF indicate that the present freeboard is less than one foot. Failure of the levee system from a SPF event would likely cause heavy loss of life and over \$9 billion damage. If the levees were considered dams in the dam safety program the area would be classified as high hazard.

Timothy Temeyer, Omaha District, discussed the freeboard used on existing Omaha District levee projects. Mr. Temeyer summarized the adequacy of the Missouri River Levee System, and described how the degree of protection provided by most levee units had decreased either by reduction in channel capacity or by changes in hydrology. He stressed the need to design the levee freeboard to function over the entire life of the project.

**Catastrophe Aversion Analyses
Necessary for
Total River Diversion by Tunnels
- Harlan, Kentucky**

by

Don B. Getty¹

Introduction

Study Purpose. A total river diversion proposal using a system of tunnels in the plan of flood protection for the city of Harlan, Kentucky necessitated an unusual hydrologic and hydraulic analysis to determine its feasibility. The purpose of the feasibility assessment was to determine if a tunnel system could be adequately designed to prevent a catastrophe from occurring if the design flood was exceeded.

Key Issues. The major issue surrounding the use of tunnels versus a traditional open cut diversion was the susceptibility of tunnels to become blocked by debris during a flood event. It was feared that if the tunnels became sufficiently blocked during a large flood, then the diversion structure protecting the town of Harlan would be overtopped, thus creating the potential for a catastrophe.

Summary of Findings. A hydrologic and hydraulic analysis of the selected configuration of tunnels was performed under a wide range of conditions to determine the response of the entire flood control project in the Harlan study area. The rationale used in this analysis and its results are presented in this paper. After analyzing the impacts of many large historical and hypothetical storms occurring in the basins above Harlan on the tunnel system experiencing debris blockage levels of 30% and 50%, it was concluded that tunnels could be safely used in the proposed flood control project.

Physical Setting

Project Area and Watershed Description. The city of Harlan is located in southeastern Kentucky near the confluence of three streams that form the Cumberland River. **Figure 1** is a basin map of the region. **Figure 2** shows the project area which includes the city and several small communities in its immediate environs. The population of the project area is approximately 5500.

Harlan lies in the Appalachian Mountains where much of the topography of the region could be characterized as steep, irregular mountains. Elevations in the basin above Harlan range from 1160 feet to 5500 feet above sea level. Most of the development in the area, including transportation facilities, is concentrated in the floodplains. The total drainage area of the three streams converging in the Harlan area is approximately 374 square

¹ Hydraulic Engineer, Nashville District, U.S. Army Corps of Engineers

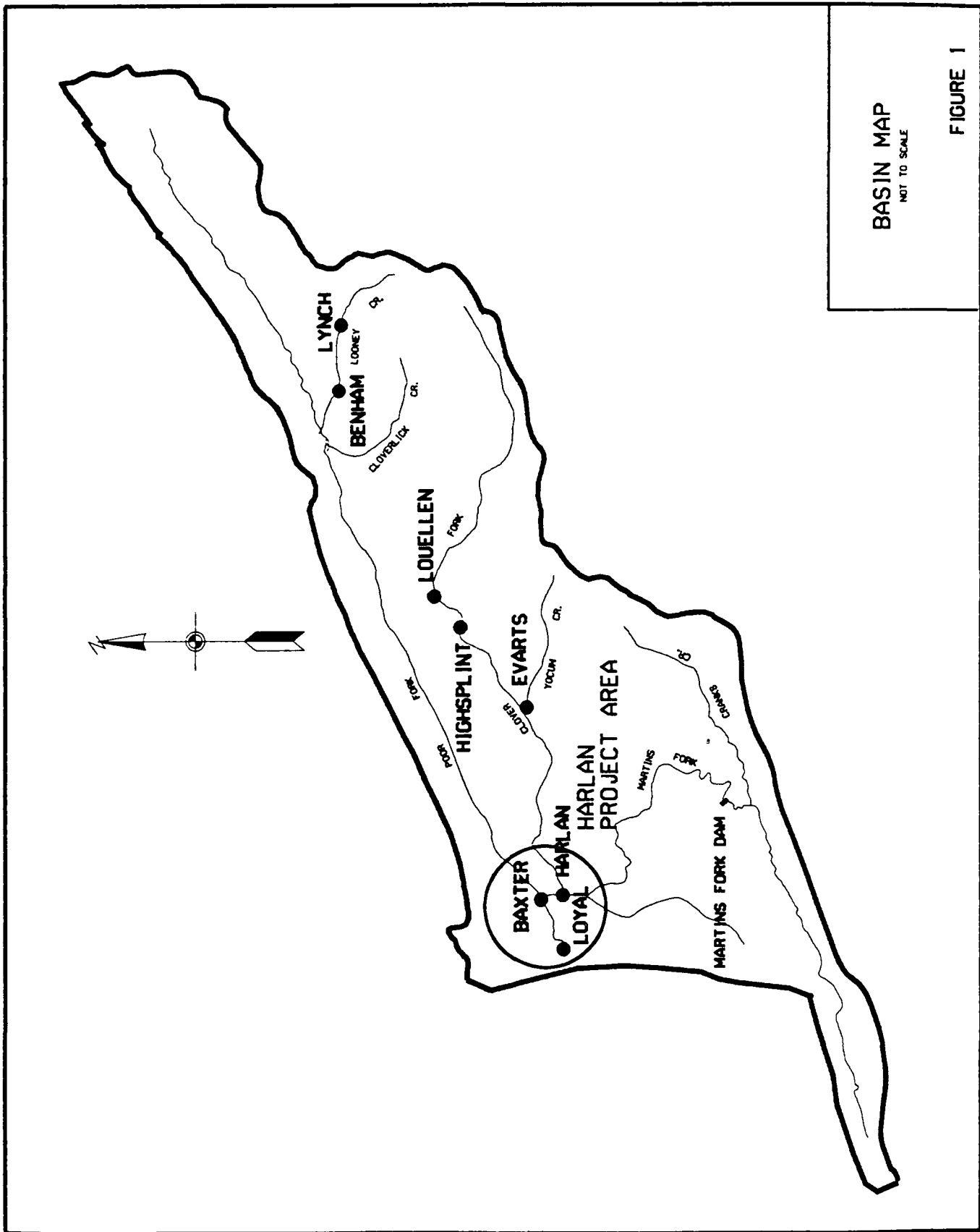

BASIN MAP
NOT TO SCALE

FIGURE 1

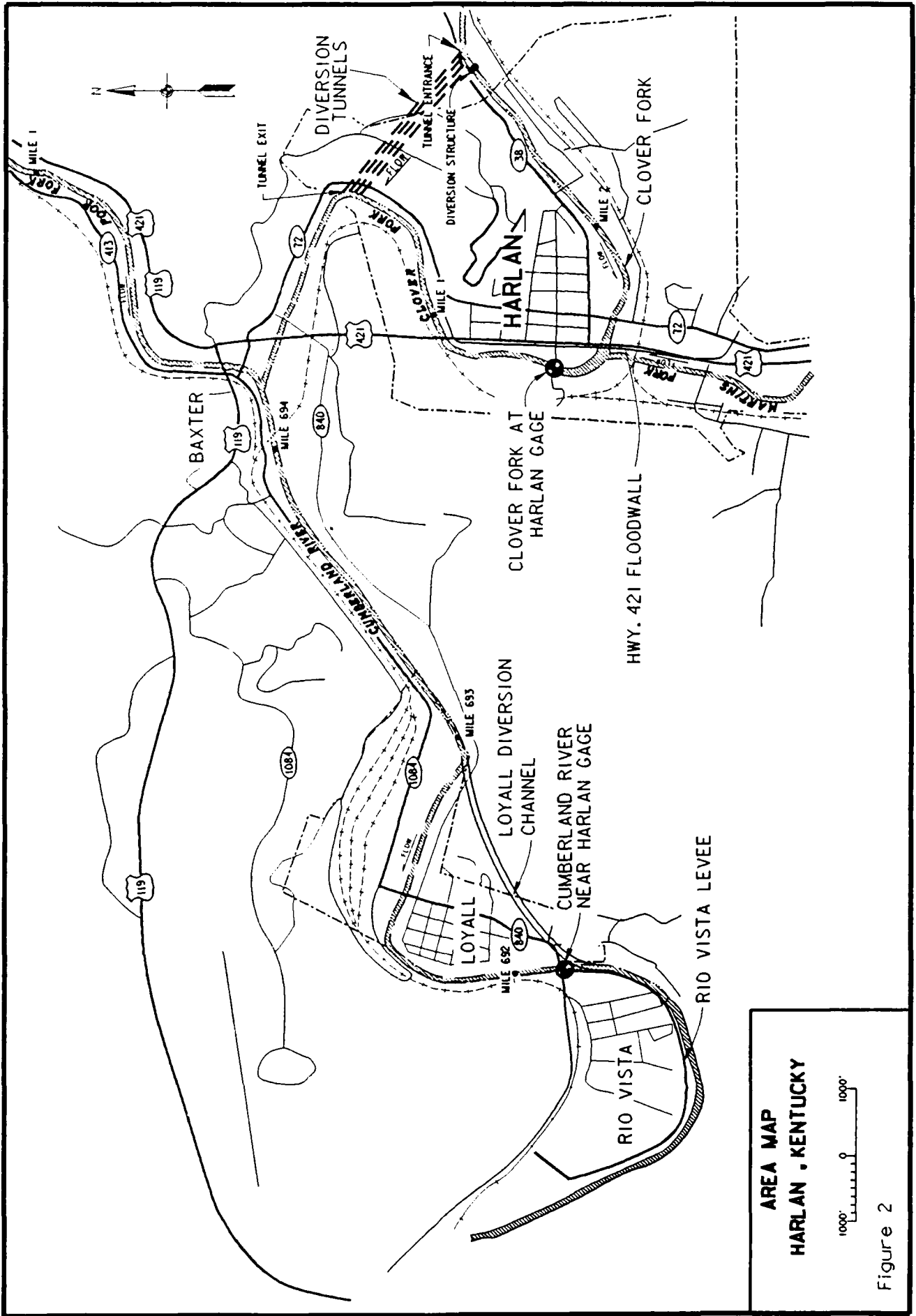

**AREA MAP
HARLAN, KENTUCKY**

1000' 0 1000'

Figure 2

miles. The only flood control reservoir above Harlan is Martins Fork Dam which controls the upper 56 square miles of the 117 square mile Martins Fork basin. Flood height reductions in the order of two to three feet to the city of Harlan are realized with the Dam.

Precipitation for the project area averages 49 inches per year, with greatest amounts occurring during late winter or early spring. The average temperatures in the region range from 75 degrees Fahrenheit in July to 33 degrees Fahrenheit in January. The U.S. Geological Survey maintains two Corps of Engineers' gaging stations within the project area: Cumberland River near Harlan (mile 691.8) and Clover Fork at Harlan (mile 1.5). Their locations are shown on **Figure 2**. Continuous records have existed for the "near Harlan" gage since November 1941 and for the Clover Fork gage since October 1977. Average daily discharges for the two gages are 686 cfs and 407 cfs, respectively.

Storms and Floods. Harlan has experienced many major floods since records have been available beginning in 1918. Most floods occur after large, rapidly-moving frontal systems cross the area. Rainfall records from the large historical storms show that they can be centered over any of the three basins above Harlan.

The flood of record for the area was the April 1977 flood. Average basin rainfall above Harlan for the storm that caused this flood was determined to be 7.5 inches over the period of 1800 hours on April 3 to 2400 hours on April 4. At the near Harlan gage, the Cumberland River crested at 1170.4 feet, 5.4 feet higher than the previous floods of record at Harlan - the March 1963 and December 1969 floods.

Project Description

Authority for Flood Protection. As a result of the devastation caused by the April 1977 flood, Congress provided in Section 202 of the Energy and Water Development Act of 1981 (Public Law 96-367), authority for the Chief of Engineers to:

"Design and construct, at full Federal expense, flood control measures in the portions of the Big Sandy (Levisa and Tug Forks) and Cumberland River Basins damaged by the April 1977 flood."

This initial legislation only provided for flood protection measures that would protect the area from a recurrence of the 1977 flood. Subsequent legislation allowed for the construction of protection measures to prevent damages from a Standard Project Flood (SPF) if the consequences from overtopping caused by large floods would be catastrophic.

Plan Development. A feasibility study completed in 1984 - the General Design Memorandum (GDM) - resulted in a recommended plan of flood protection to provide SPF level of protection for the city of Harlan and its environs. The structural features of this plan are depicted in **Figure 2**. These features will be constructed in four separate contracts:

- 1) The Harlan diversion,
- 2) The Harlan floodwall and levee,
- 3) The Loyall diversion, and
- 4) The Loyall and Rio Vista levee.

The structural component of interest to this paper is the Harlan diversion which was planned as an open cut diversion in the GDM. Subsequent cost estimates based on new construction methods showed a substantial cost savings using tunnels instead of an open cut. The tunnel system is comprised of four horseshoe shaped tunnels and a diversion structure to divert all water from Clover Fork into the tunnels (see **Figure 3**). The diversion will remove flow from a one mile reach of Clover Fork that presently flows through the city before its confluence with Martins Fork. Clover Fork has a drainage area of approximately 103 square miles at the entrance to the tunnels making this total tunnel diversion the largest of its type within the Corps' network of flood control projects. Before a tunnel system of this size could be approved as an acceptable structural feature, all safety issues related to its design and operation had to be resolved.

Study Approach

Procedures. It was agreed at a conference of technical experts from the Corps of Engineers that the appropriate method to determine the hydrologic and hydraulic safety of a tunnel system was to ensure that a catastrophe would not result from the occurrence of any of a wide range of very severe meteorological events. These events were to include the most intense historical storms to have occurred in the midwestern and eastern U.S. and several magnitudes of Probable Maximum Storms (PMS). The response of any tunnel system to the flood caused by these storms would be simulated through the use of computer models. Results of the computer simulations would be compared to a set of criteria to test whether each tunnel system design would cause a catastrophe for each storm applied.

Probable Maximum Storms. A total of 11 different PMS's were generated and analyzed through the course of this analysis. These 11 storms represented a total range of critical centerings, orientations, and storm sizes for the three basins in the Harlan area. The 11 storms and their descriptions are given in **Table 1**. Rainfall amounts were determined according to the procedures outlined in Hydrometeorological Report numbers 51 and 52 (Schreiner, et al, 1978 and Hansen, et al, 1982). Nine of the storms were ultimately selected to be used for detailed analysis. All of the selected storms were first centered over the Clover Fork Basin to create the greatest discharge scenarios through the tunnels. Some of these storms were then centered over the Martins Fork or Poor Fork basins to analyze an initial overtopping of the Highway 421 floodwall at Harlan. It was found that because of its downstream location and its height, an initial overtopping of the floodwall at Harlan was considered to be less critical than an initial overtopping of the diversion structure.

Historical Storms. The National Weather Service identified a total of 14 historical storms that it considered appropriate to use in this analysis. However, sufficient data and sufficient rainfall intensities were only available on eight of these storms for use in this study. They are listed in **Table 2**.

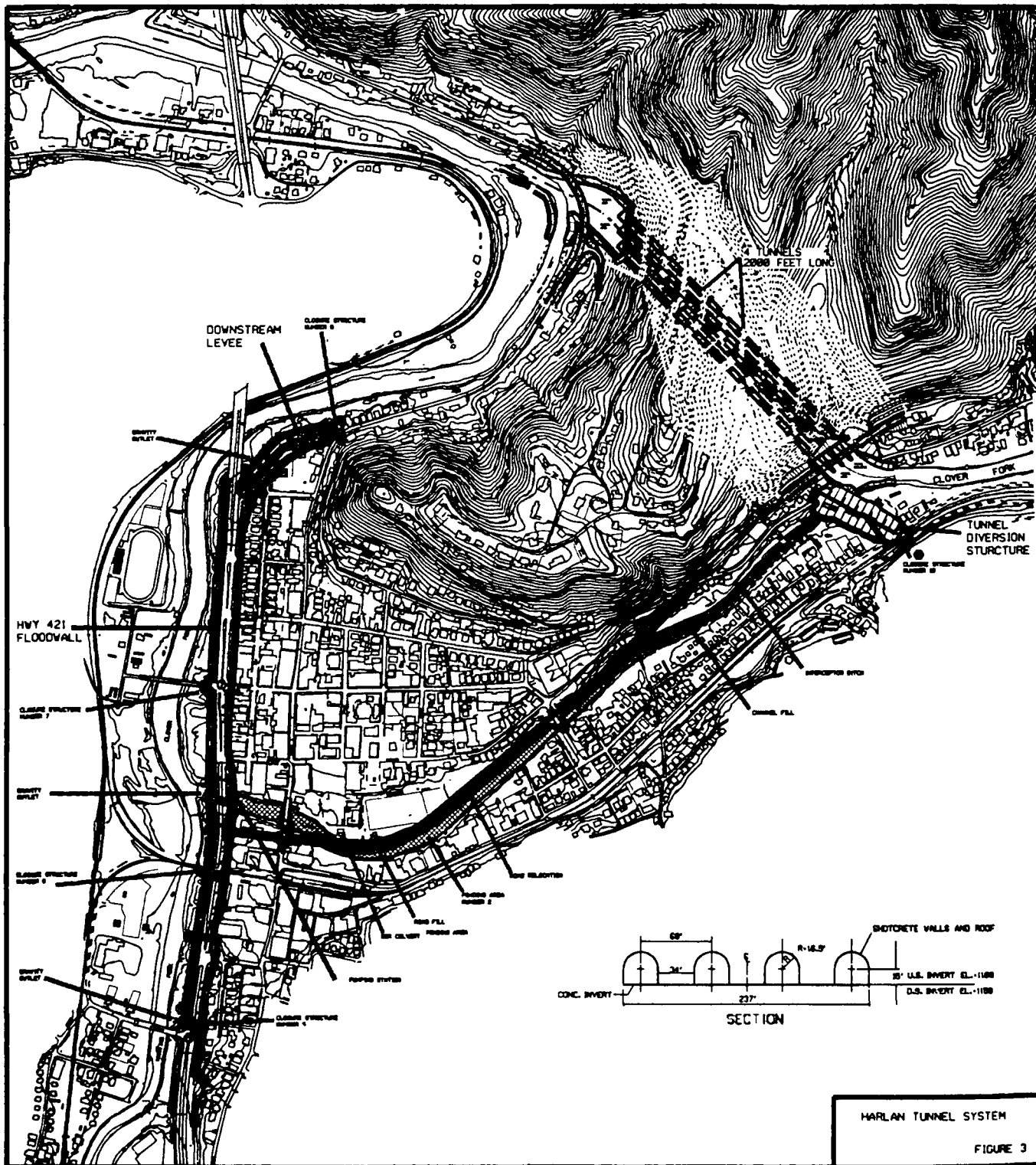

HARLAN TUNNEL SYSTEM
FIGURE 3

Table 1 - List of All Probable Maximum Storms Analyzed

Probable Maximum Storms		
Storm Area (mi ²)	Center*	Orientation** (Degrees)
10	CF	235
10	Lower CF	245
25	CF	235
40	CF	235
50	CF	235
50	CF	180
50	CF	130
100	CF	225
450	CF	237
1000	PF	233
1000	MF	234

*The centering of the storm will be over the centroid of the basin unless otherwise noted (CF abbreviates Clover Fork).

**The preferred orientation of the PMS for the Harlan area is 225 degrees (from HMR 52).

Catastrophe Criteria. The number and size of tunnels were originally designed to provide for the same SPF headwater elevation as the open cut diversion assuming that the tunnels were 30% blocked by debris. They were also sized at the maximum diameter allowable based on geologic constraints. Because of the design complexities involved in the changing of the tunnel sizes, it was decided to keep the number and size of tunnels constant for the catastrophe analysis. The only remaining variable in the hydraulic design of the tunnel system for this analysis was therefore the height of the diversion structure. The diversion structure was to be sized and designed to prevent a catastrophe from occurring as a result of the storms that were chosen to be analyzed. A catastrophe is defined for a flood protection project as a significant chance for loss of life or a great economic loss for the protected area if a flood greater than the design flood occurs.

It was recognized at the beginning of this analysis that most of the floods being analyzed would overtop the downstream floodwall of the proposed project in some manner no matter the height of the diversion structure and no matter whether an open cut or tunnels would be selected. Therefore, the catastrophe analysis had to include two basic constraints: 1) the selected diversion height would allow sufficient warning times for evacuation from the protected areas, and 2) a diversion failure would not create unduly high velocities and depths of flooding both in Harlan and in communities downstream.

Table 2 - Pertinent Data on Historical Storms used in this Study

Storm	Occurrence Date	Peak Tunnel HW Elevation* (ft.)	Total Rain-fall over CF Basin (in.)	Max. RF in 3 Hour Period (in.)
Simpson P.O., KY	7/4-5/1939	1201.4	9.1	8.7
Lebanon, TN	8/2-3/1939	1191.8	7.5	3.3
Lewisburg, TN	6/18/1939	1195.9	7.4	6.8
Middlesboro, KY	4/4/1977	1187.4	8.0	1.3
Glennville, WV	8/4-5/1943	1199.9	8.8	8.2
Signal Mt., TN	3/11-12/1963	1191.9	8.3	3.7
Kelso, MO	8/11-12/1952	1211.4**	13.8	9.4
Holt, MO	6/22/1947	1204.9	10.4	9.8
Hypothetical Storms				
Maximized PMS (450 mi ²)	NA	1211.9**	32.4	14.3
SPF	NA	1208.9	16.0	6.2

*These elevations are based on 50% tunnel blockage.

**This elevation reflects the 1209 diversion structure overtopping and breaching.

The GDM set a minimum evacuation warning time of three hours for the structurally protected areas. This value was used in this analysis and was considered to be a design constraint for all the storms and diversion structure heights analyzed. Considering this warning time constraint and the other constraints on the diversion structure to prevent a catastrophe, a set of criteria was developed to ensure a proper diversion height could be established to satisfy all possible scenarios. The catastrophe criteria and the rationale for it is given below.

- 1) Recurrence frequency of trigger elevation for evacuation - The trigger river elevation to initiate evacuation of the structurally protected area must be set high enough to prevent an unduly high number of false evacuations.
- 2) Upstream or downstream trigger elevation - An assessment must be made to determine if both an upstream and downstream trigger elevation must be set in order to assure three hours of warning time under all flood conditions. If both are needed, they must meet the criteria in 1). An upstream trigger would be at the headwater of the tunnels. A downstream trigger elevation would be at the Clover Fork gage which is just below the existing confluence of Clover Fork and Martins Fork.

3) Tunnel blockage of 30% and/or 50% - A sensitivity assessment must be made to evaluate the effects of 30% and/or 50% blockage of the tunnels on all flood scenarios.

4) Overtopping of the diversion structure into a dry or wet Harlan - An assessment must be made to determine if the diversion structure can overtop before the downstream Highway 421 floodwall in Harlan overtops. If the diversion structure overtops first, it must be assured that a great economic loss will not result due to significant velocity damage or higher flood heights. If this cannot be proved, the diversion structure must be sized to ensure the downstream floodwall overtops first; thus, providing a "cushioning layer" of water in Harlan to minimize flow-through velocities.

5) Downstream impacts of diversion structure overtopping - An assessment must be made to determine the impacts of an overtopping failure of the diversion structure on the downstream communities of Loyall and Rio Vista. It should be shown that a failure of the diversion structure would not significantly increase discharges or stages in these communities.

To satisfy the catastrophe criteria, the diversion structure was to be designed to meet the above criteria for the entire range of storms that were tested. However, after comparing the rainfall of the historical storms to the PMS's, it was evident that only one historical storm, the Kelso, MO storm, had sufficient rainfall to be utilized in the actual design of the diversion structure.

Assumptions. The major assumption in this study was that the maximum debris blockage expected by the tunnels would be 50%. This decision was made in the aforementioned technical conference. It was based on a field assessment of the debris expected from the Clover Fork basin and the spacing, size, and number of the tunnels (4 tunnels at 33 feet in width and 32 feet in height with a spacing of 34 feet). The 50% figure was considered a conservative upper limit; therefore, calculations using a 30% blockage factor were also utilized to represent a more reasonable design level. It was also not possible to predict the rate or time at which the tunnels would become blocked; therefore, a conservative approach was selected which maintained constant blockage levels throughout the flood hydrographs for all simulations.

In all of the diversion structure overtopping scenarios, a total failure was assumed to occur two hours after initial overtopping. This assumption was based on the geotechnical aspects of the diversion structure's design.

Computational Methods. The approach used to select a height for the diversion structure was to develop a range of heights that would encompass all possible heights that could possibly meet the design criteria (SPF protection) and the catastrophe criteria. Two diversion heights were selected to represent the minimum and maximum heights based on the most liberal and conservative design considerations, respectively. The minimum height was based on a SPF headwater elevation at the tunnels plus a 30% blockage factor and three feet of freeboard. This minimum diversion structure height corresponded to a top elevation of 1209 feet or a maximum height above streambed of approximately 39 feet. The maximum diversion height was designed to ensure initial overtopping of the Harlan floodwall for the ten storms (9 PMS's and the Kelso storm) in conjunction with a 50% blockage factor applied to the tunnels. The top elevation of this maximum structure was determined to be 1240 feet or a maximum height of approximately 70 feet above

streambed. The 50 square mile PMS with a 130 degree orientation was the storm that dictated this elevation. The flood resulting from this PMS would not overtop the 1240 structure but it would minimally overtop the Highway 421 floodwall. All other storms would either overtop the floodwall initially or would not overtop the 1240 diversion structure.

The Hydrologic Engineering Center computer program "Flood Hydrograph Package" (HEC-1) was used to determine flow discharges and stages for the various diversion structure heights and storms analyzed. In its standard form, HEC-1 could not satisfactorily separate the outflows of the tunnels from the overtopping and breach flows of the diversion structure into Harlan. Therefore, the program was modified to provide this capability. Rainfall loss rates for all floods modeled in this study were the same as those used in the original SPF calculations. Three hour unit hydrographs for all the major sub-basins above Harlan and calibrated routing methods were utilized in HEC-1 to determine the discharges in the project area.

Study Results

1209 Diversion Structure. Pertinent results of the response of the Harlan flood protection scheme to the nine PMS's and the Kelso storm with the 1209 diversion structure in-place are given in Tables 3 and 4. Table 3 is the results for 30% tunnel blockage while Table 4 represents a tunnel blockage of 50%. The tables have been formulated to present the results so they can be compared to the catastrophe criteria described previously. As can be seen from Table 4 (the more conservative analysis), the 1209 structure met the evacuation constraint. A three hour evacuation time was guaranteed with all trigger elevations set above the 180 year frequency elevation. If a headwater trigger is utilized, the initiation of evacuation could be raised to at least a 300 year frequency. The 1209 structure also met the downstream impact criteria as the increase in peak discharge at Loyall was not significant for all the storms. The maximum stage increase at Loyall would only range from approximately 0.4 to 0.9 feet. The only catastrophe constraint the 1209 structure could not meet was the requirement of initial overtopping of the Harlan floodwall. Most of the storms overtopped this diversion structure first or close to the same time of the Harlan floodwall. However, the discharge through the breach when the interior water surface elevation in Harlan reached 1180 is not significant. The 1180 elevation is the point in which the toe of the diversion structure is inundated; thus, it represents the point when the velocities from the breach begin to be minimized by the ponded water. The only historical storm to overtop this structure was the Kelso storm. The peak tunnel headwater stages (elevations at the diversion structure) achieved by all the historical storms are given in Table 2.

1240 Diversion Structure. Only three of the ten storms used in this study overtopped the 1240 diversion structure. Since an overtopping of the diversion structure is the probable means for a downstream catastrophe to occur with the tunnel configuration, the 1240 structure was only analyzed for the three overtopping storms. These storms overtopped with tunnel blockages of both 30% and 50%; therefore, there were actually six conditions of overtopping in this analysis. Tables 5 and 6 give the results of overtopping for these three storms for 30% and 50% tunnel blockage, respectively. An analysis of the 1209 structure is included for comparison. As can be seen, the 1240 structure did not meet most of the catastrophe criteria. Flooding impacts at downstream communities would be significantly worse from a flood overtopping a 1240 structure as compared to existing conditions or conditions if a 1209 structure were in-place. The impacts to the protected area if

Table 3 - Analysis of Diversion Structure, Top Elevation = 1209¹, Tunnel Blockage = 30%

PMS			Tunnel HW Trigger ⁴		Tunnel TW Trigger ⁴		Peak Q (cfs)				Peak Harlan CBD	
Area (mi ²)	Center ²	Ori-entation ³ (Deg.)	Elev. (ft.)	Freq ⁵ (30%)	Elev. (ft.)	Freq ⁶	At Loyall	At Loyall - Existing Cond.	Thru Breach	Breach - Harlan at EL 1180 ⁷	Vel. ⁸ (fps)	Elev. (ft.)
10	CF	235	1196.6	>500	1185.9	>500	131,900	128,600	31,700	6,400	2.8	1201.2
10	Lower CF	245	1200.5	>500	1187.3	>500	111,500	108,800	26,100	6,000	2.4	1200.8
25	CF	235	1193.2	>500	1184.6	350	166,000	161,500	45,500	8,000	3.8	1202.0
40	CF	235	1193.5	>500	1185.3	400	184,600	180,200	51,400	8,500	4.3	1202.3
50	CF	235	1193.5	>500	1185.6	450	193,000	189,400	53,700	9,000	4.4	1202.4
50	CF	180	1193.9	>500	1184.4	300	145,100	141,400	38,600	7,000	3.3	1201.6
50	CF	130	1193.2	>500	1183.4	220	148,100	144,100	42,700	8,000	3.6	1201.9
100	CF	225	1193.5	>500	1186.6	>500	208,500	205,100	53,000	8,500	4.0	1204.1
450	CF	237	1194.0	>500	1188.5	>500	246,300	239,100	56,500	10,000	3.4	1208.2
Historical Storm												
Kelso, MO			1200.8	>500	1188.7	>500	115,100	115,900	22,800	5,000	2.1	1200.5

¹The 1209 top elevation for the diversion structure was calculated by adding 3 feet of freeboard and a 30% blockage factor to the SPF headwater elevation of the tunnels.

²The centering of the storm will be over the centroid of the basin unless otherwise noted (CF abbreviates Clover Fork).

³The preferred orientation of the PMS for the Harlan area is 225 degrees (from HMR 52).

⁴The trigger elevation initiates evacuation of the protected area. It has been set to ensure a minimum of three hours before overtopping begins.

⁵For 30% blockage, the headwater elevation of the tunnels for a 100 year discharge = 1188.1 and elevation 1193.0 for the 500 year discharge.

⁶The elevation for the 100 year flood = 1180.8 and the elevation for the 500 year flood = 1185.8 at the tailwater of the tunnels.

⁷1180 represents the elevation in the protected area when the toe of the diversion structure is inundated.

⁸This velocity corresponds with the maximum breach discharge flowing through Harlan.

Table 4 - Analysis of Diversion Structure, Top Elevation = 1209¹, Tunnel Blockage = 50%

PMS			Tunnel HW Trigger ⁴		Tunnel TW Trigger ⁴		Peak Q (cfs)				Peak Harlan CBD	
Area (mi ²)	Center ²	Orien- tation ³ (Deg.)	Elev. (ft.)	Freq ⁵ (50%)	Elev. (ft.)	Freq ⁶	At Loyall	At Loyall - Existing Cond.	Thru Breach	Breach - Harlan at EL 1180 ⁷	Vel. ⁸ (fps)	Elev. (ft.)
10	CF	235	1197.8	>500	1184.7	350	132,000	128,600	35,200	7,100	3.1	1201.4
10	Lower CF	245	1201.1	>500	1186.2	>500	112,800	108,800	28,600	8,700	2.6	1201.1
25	CF	235	1195.7	300	1183.8	270	166,000	161,500	48,600	8,300	4.1	1202.2
40	CF	235	1196.0	350	1184.5	330	184,600	180,200	54,300	8,500	4.5	1202.4
50	CF	235	1196.1	350	1184.8	350	193,000	189,400	56,500	9,500	4.6	1202.5
50	CF	180	1195.7	300	1183.3	210	145,100	141,400	41,900	7,400	3.6	1201.8
50	CF	130	1195.9	350	1182.7	180	148,100	144,100	45,900	7,900	3.9	1202.1
100	CF	225	1196.1	350	1185.7	480	208,400	205,100	55,800	9,000	4.0	1204.1
450	CF	237	1196.4	400	1187.5	>500	244,500	239,100	59,100	9,000	3.4	1208.2
Historical Storm												
Kelso, MO			1201.2	>500	1187.1	>500	120,400	115,900	30,100	5,500	2.7	1201.1

¹The 1209 top elevation for the diversion structure was calculated by adding 3 feet of freeboard and a 30% blockage factor to the SPF headwater elevation of the tunnels.

²The centering of the storm will be over the centroid of the basin unless otherwise noted (CF abbreviates Clover Fork).

³The preferred orientation of the PMS for the Harlan area is 225 degrees (from HMR 52).

⁴The trigger elevation initiates evacuation of the protected area. It has been set to ensure a minimum of three hours before overtopping begins.

⁵For 50% blockage, the headwater elevation of the tunnels for a 100 year discharge = 1192.8 and elevation 1197.4 for the 500 year discharge.

⁶The elevation for the 100 year flood = 1180.8 and the elevation for the 500 year flood = 1185.8 at the tailwater of the tunnels.

⁷1180 represents the elevation in the protected area when the toe of the diversion structure is inundated.

⁸This velocity corresponds to the maximum breach discharge flowing through Harlan.

Table 5 - Overtopping Flood Comparison of Minimum and Maximum Diversion Structure Heights - Tunnel Blockage = 30%

Feature	50 sq. mi. PMS		100 sq. mi. PMS		450 sq. mi. PMS	
	1209 Diversion Structure	1240 Diversion Structure	1209 Diversion Structure	1240 Diversion Structure	1209 Diversion Structure	1240 Diversion Structure
Peak Harlan Elev. (ft.)	1202.4	1207.3	1204.1	1209.1	1208.2	1211.2
Peak Breach Q (cfs)	53,700	105,600	53,000	103,800	56,500	112,900
Max. Harlan Velocity (fps)	4.4	6.7	4.0	6.0	3.4	6.0
Natural Q at Loyall (cfs)	189,400	189,400	205,100	205,100	239,100	239,100
Increase in Q at Loyall (cfs)	3,600	88,500	3,500	87,900	7,200	86,800
Increase in Stage at Loyall (ft.)	0.5	10.6	0.4	10.5	0.9	9.8

Table 6 - Overtopping Flood Comparison of Minimum and Maximum Diversion Structure Heights - Tunnel Blockage = 50%

Feature	50 sq. mi. PMS		100 sq. mi. PMS		450 sq. mi. PMS	
	1209 Diversion Structure	1240 Diversion Structure	1209 Diversion Structure	1240 Diversion Structure	1209 Diversion Structure	1240 Diversion Structure
Peak Harlan Elev. (ft.)	1202.5	1206.6	1203.8	1208.0	1207.6	1210.7
Peak Breach Q (cfs)	56,500	120,700	55,800	118,900	59,100	122,300
Max. Harlan Velocity (fps)	4.6	7.9	4.2	7.3	3.7	6.6
Natural Q at Loyall (cfs)	189,400	189,400	205,100	205,100	239,100	239,100
Increase in Q at Loyall (cfs)	3,600	93,800	3,400	90,400	5,400	82,400
Increase in Stage at Loyall (ft.)	0.5	11.2	0.4	10.8	0.7	9.3

an overtopping occurred would also be much worse with the 1240 structure. Breach discharges from the 1240 structure would be significantly greater than those from a 1209 structure. Corresponding flow velocities and peak elevations in Harlan would also be much higher. From this comparison, it is apparent that the possibility of a catastrophe would be much greater with a 1240 structure than with a 1209 structure.

Harlan Interior Flow-through Velocities. Even though the 1209 diversion structure is preferable to the 1240 structure based on the catastrophe criteria, it has not been shown that flow velocities through the interior of Harlan would not create great economic damage in the event of an overtopping of the 1209 structure. Therefore, an analysis was performed to assess the velocity damage potential due to an overtopping. Interior flow velocities were determined in a time-sequence for two types of overtopping scenarios: an initial overtopping of the Highway 421 floodwall and an initial overtopping of the diversion structure. The analysis determined interior flow depths and velocities at various locations for both scenarios at several time increments during the overtopping. It is beyond the scope of this paper to present the detailed results of this analysis but it should be noted that the analysis was very conservative in nature. Calculated interior flood depths were underestimated and the corresponding flow velocities were overestimated. This is because it was assumed that there was no ponded water in the interior when the overtopping was initiated. During an actual overtopping, it is expected that the interior drainage system will become overloaded² and a large amount of interior ponding would result before overtopping begins. This situation would result in higher interior flood depths during initial filling, and thus, lower flow velocities than actually calculated. The results of the analysis showed there is little difference in the amount of damage that can be expected from the two types of overtopping. The flow velocities and depths for both types are similar. Their similarity is reflective of the view that it is unimportant from a velocity-damage viewpoint where the initial overtopping occurs. Also, the relative low values for even the conservative flow velocities reflect that a great economic loss would not be caused by flow velocities during an overtopping.

Conclusions

Discussion. Based on this study, it has been shown that the Harlan tunnel system can be designed to prevent a catastrophe from occurring due to a flood that exceeds the design flood. Diversion structures heights above elevation 1209 will increasingly create more adverse conditions downstream for overtopping floods. Higher structures will also increase flood heights upstream of the tunnels for large overtopping floods. The appropriate design for the diversion structure is therefore the minimum height that will provide SPF protection. The 1209 structure is at the minimum height that will provide SPF protection and has met all the catastrophe criteria except that the Highway 421 floodwall does not overtop first for most of the storms used in this study. However, the exemption of this requirement is justified since the initial overtopping of the diversion structure would not create a catastrophe. This conclusion is based on two factors:

- 1) The protected area will be evacuated by the time overtopping starts; therefore, there will not be the chance of loss of life.
- 2) The physical characteristics of the proposed project and the topography of the protected area are such that flow-through velocities experienced for an overtopping at any location would not create great economic damage. That is not to say that velocities in the immediate area of overtopping would not create damage, as that will happen no matter where the initial overtopping occurred.

² An assessment could not be made as to the capacity of the interior drainage system because its design is partially dependent on an economic analysis. This analysis was beyond the scope of this paper.

However, flow-through velocities in the interior of Harlan would be minimized by the ponded water that would be present by the time that the significant overtopping discharges occurred that created high velocities. Therefore, a catastrophe would be averted for an overtopping at either location.

Progressions Since Completion of this Study. Since the completion of this catastrophe analysis, a physical model study has been completed that determined the most effective tunnel entrance configuration to pass debris expected during a flood (Martin, 1989). An additional design study also determined the need for additional freeboard to provide SPF protection which increased the final design crest elevation of the diversion structure to 1211.5 feet (Nashville District, Corps of Engineers, 1988). Also, the diversion structure was designed to be failure resistant; thus, reducing breach discharges and flow velocities in the interior in the event of an overtopping. Construction of the tunnels will commence in the fall of 1989.

References

1. Schreiner, L.C. and Riedel, J.T., 1978: Probable Maximum Precipitation Estimates, United States East of the 105th Meridian. Hydrometeorological Report No. 51, National Weather Service, National Oceanic and Atmospheric Administration, U.S. Department of Commerce, Washington, D.C.
2. Hansen, E.M., Schreiner, L.C., and Miller, J.F., 1982: Application of Probable Maximum Precipitation Estimates - United States East of the 105th Meridian. Hydrometeorological Report No. 52, National Weather Service, National Oceanic and Atmospheric Administration, U.S. Department of Commerce, Washington, D.C.
3. Martin, S., 1989: Model Study of Clover Fork Diversion, Harlan, Kentucky - Draft Report. Waterways Experiment Station, U.S. Army Corps of Engineers, Vicksburg, MS.
4. Nashville District, Corps of Engineers, 1988: Project Design Flood and Hydrologic Impacts, Harlan, Kentucky. Feature Design Memorandum No. 2, Nashville District, U.S. Army Corps of Engineers, Nashville, TN.

LOWER SANTA ANA RIVER CHANNEL DESIGN

by

Joseph B. Evelyn¹

Introduction

Study purpose. This paper presents the hydrologic and hydraulic design aspects of the Corps' recommended improvements to the lower Santa Ana River channel in Orange County, California with emphasis on the functional performance and safety aspects of the project design. The lower Santa Ana River channel improvements are a major element of the total Santa Ana River Project which also includes upstream flood control storage elements.

Design objectives. The lower Santa Ana River conveys flood flows through one of the most highly urbanized floodplains in southern California. The high flood damage potential of the densely populated floodplain led to establishing three channel design objectives at the outset of the study. First, the improved channel must safely handle the design flood with respect to both water and sediment transport. Second, initial overtopping of the channel resulting from floods larger than the design flood should occur at the least hazardous locations from a public safety standpoint. Third, the improved channel, which in certain reaches consists of levees, must continue to function without failure during flood events larger than the design flood.

Project design. A cost effective hydraulic design which achieved the three principal design objectives was developed during Phase II General Design Memorandum studies (Los Angeles District, Corps of Engineers, 1988). With respect to the first objective, the hydraulic design of the channel for the design flood was accomplished using standard Corps hydraulic design guidance in Engineer Manual 1110-2-1601 (Corps of Engineers, 1970). Channel design was based on providing the required conveyance capacity considering such factors as right-of-way availability, gradient of existing channel and flood plain, sediment transport aspects, minimizing operation and maintenance costs, minimizing overall channel costs, incorporating existing channel improvements (such as drop structures), and minimizing bridge replacement and utility relocations. The second principal design objective was achieved by following the guidance provided in Engineer Technical Letter 1110-2-299 (Corps of Engineers, 1986), which addresses the overtopping design of levees and floodwalls. Levee heights were designed to cause initial overtopping at the least hazardous locations along the river: groundwater recharge basins, parking lots, recreational parks, and freeway buffer zones. In addition, the recommended channel design calls for

¹Chief, Hydrology and Hydraulics Branch, Los Angeles District, U.S. Army Corps of Engineers

hardening of the back side of the levees in the overtopping reaches to prevent failure of the structure from erosion during flood events larger than the design flood, thereby achieving the third design objective.

Physical Setting

Description of watershed. The Santa Ana River Basin (Figure 1) can be divided into an upper basin of 2,250 square miles upstream of Prado Dam, the major existing flood control structure on the river, and a lower basin of 200 square miles located in Orange County downstream of Prado Dam. The Santa Ana River has its head-waters in the San Bernardino Mountains, and flows through a steep canyon until it reaches the flat upper basin floodplain southeast of San Bernardino. Approximately 37 percent of the basin lies within the rugged San Gabriel, San Bernardino, San Jacinto, and Santa Ana Mountains. Most of the remaining area consists of flatter-sloped valleys formed by a series of broad alluvial fan surfaces which abut the base of the mountain front. The Santa Ana River has an average gradient of about 240 feet/mile in the mountains and about 20 feet/mile near Prado Dam.

From the foothills of the San Bernardino Mountains to Prado Reservoir, the river is alternately natural and improved as it passes through various undeveloped and developed areas; a number of major tributaries flow into the river in this reach, contributing significantly to flows reaching Prado Reservoir. Below Prado Dam, the river runs for about 8 miles through the Santa Ana Canyon before entering the coastal floodplain. From this point, the channel runs through highly developed areas, with residential and commercial development adjacent to the channel right-of-way, until it reaches the Pacific Ocean.

The climate of the Santa Ana River Basin is mild with warm, dry summers and cool, wet winters. Both temperature and precipitation vary considerably with distance from the ocean, elevation, and topography. The 97-year mean seasonal precipitation for the basin, which averages about 20 inches, varies from 10 inches south of the city of Riverside to about 45 inches in the higher mountain areas. Nearly all precipitation occurs during the months of December through March. Rainless periods of several months during the summer are common.

Streamflow, which is perennial in the canyons of the Santa Ana River and in the headwaters of most of its tributaries, is generally ephemeral in most valley segments. Streamflow increases rapidly in response to effective precipitation. High intensity precipitation, in combination with the effects of steep gradients and periodic denudation by wildfire can result in intense sediment-laden floods. Deposition of sediment occurs in the stream channels as they flow from the canyon mouths onto the flatter-sloped valley floor surface. The urbanization taking place in the valley areas of the Santa Ana River Basin makes the basin more responsive to rainfall.

The flood problem. The lower Santa Ana River Basin is currently protected by Prado Dam and Reservoir, which were constructed by the Corps in 1941 to control a design flood having a peak discharge of 190,000 cubic feet per second (ft^3/s) and a 4-day volume of 275,000 acre-feet. At the time, it was thought that the dam and reservoir would be capable of controlling a 200-year flood. But changes have occurred in the existing project, in the tributary drainage area,

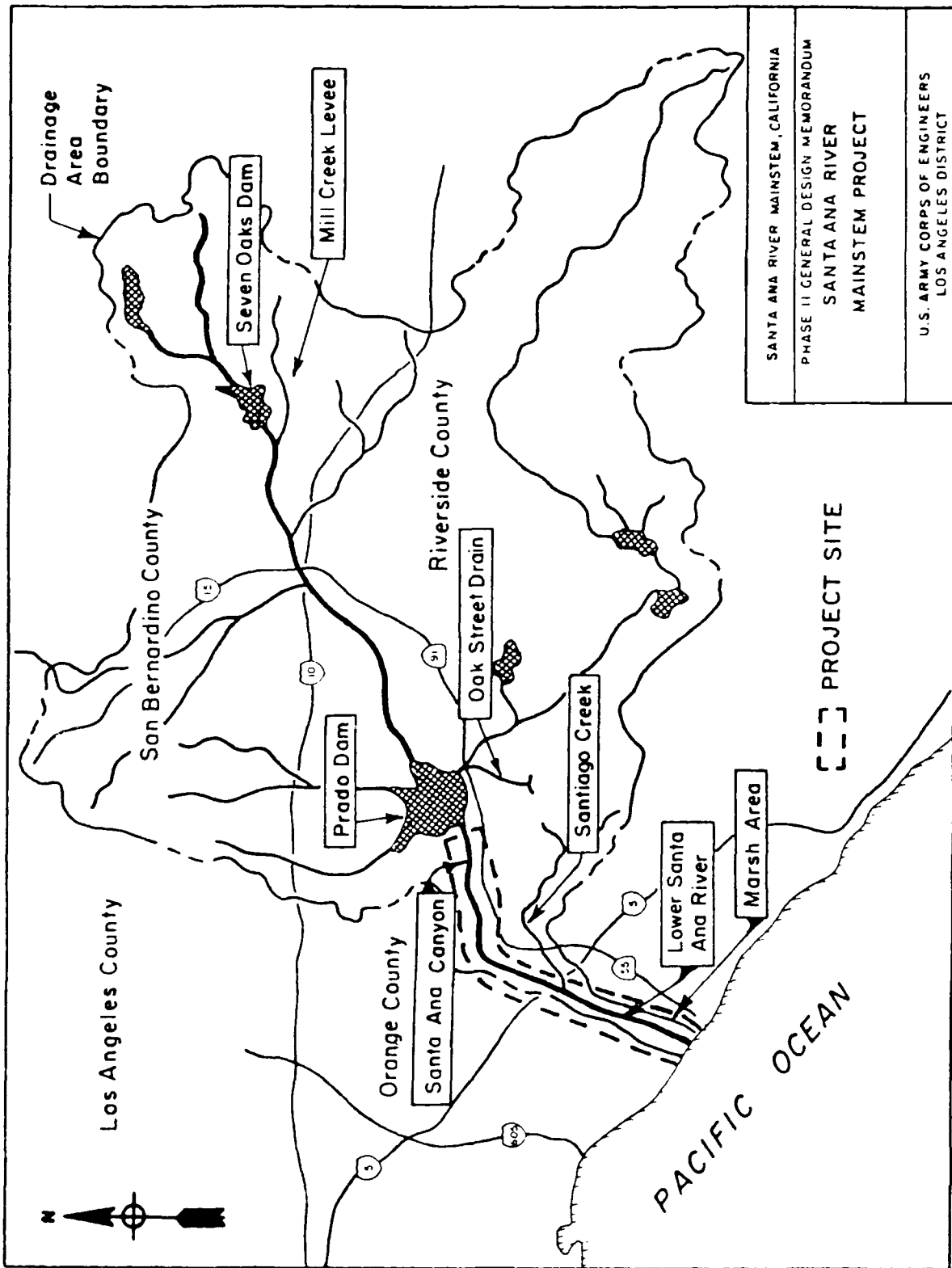

FIGURE 1

and in the data available on precipitation and runoff in the nearly 50 years since Prado Dam was built. Sedimentation has decreased the capacity of the reservoir about 12 percent, or 26,000 acre-feet. Upstream development has increased since 1940 thereby increasing runoff. Future projections indicate that urbanization will continue at a rapid rate during the next 50 to 100 years, with or without future flood control improvements.

Controlled releases from Prado Reservoir had to be reduced from the originally scheduled 9,300 cubic feet per second to about 5,000 cubic feet per second because it became apparent during the floods of 1969, 1978, 1980, and 1983 that sustained reservoir releases cause severe erosion and damage to existing channels and levees downstream.

As a result, the population living and working in the highly urbanized areas below Prado Dam have less than 70-year protection. Major floods exceeding the capacity of the existing Prado reservoir would cause catastrophic damages in an area inhabited by more than 2 million people. A 200-year flood would inundate over 110,000 acres, and directly affect hundreds of thousands of homes, thousands of business and factories, and hundreds of schools; the direct damages from such a flood are estimated at about 15 billion dollars.

Existing water control facilities. In addition to Prado Dam, the main flood control facility on the mainstem Santa Ana River, several other facilities control or divert runoff in the lower Santa Ana River watershed downstream of Prado Dam (Figure 2). Carbon Canyon Dam, a Corps reservoir on Carbon Canyon Creek, controls runoff reaching the Santa Ana River via the Carbon Canyon Creek Diversion channel, which has a design capacity of 2800 ft³/s at its confluence with the Santa Ana River.

On Santiago Creek, Villa Park Dam, an Orange County Environmental Management Agency (OCEMA) flood control dam, is the primary flood control facility. This dam controls runoff from 84 square miles of drainage area. Santiago Creek confluences with the Santa Ana River about 10 miles upstream of the Pacific Ocean.

OCEMA has constructed and maintained an extensive system of channel improvements along the lower Santa Ana River that have generally proved capable of handling runoff of short duration from the drainage area downstream of Prado Dam. However, this channel has performed poorly in handling long duration releases from Prado Dam even though reservoir releases of about 5000 ft³/s are a fraction of the channel's short duration hydraulic conveyance capacity. Sediment transport problems consisting mainly of severe scour and invert degradation have resulted in major structural failures of the channel during the floods which required sustained reservoir releases from Prado Dam.

Santa Ana River Project

Recommended plan. The recommended Santa Ana River project plan (Figure 1) provides a high level of flood protection along the entire river with appropriate mitigation measures for environmental impacts and consideration for social disruption. The recommended plan on the mainstem river consists of the following elements: Seven Oaks Dam located in the upper Santa Ana Canyon; delineation of

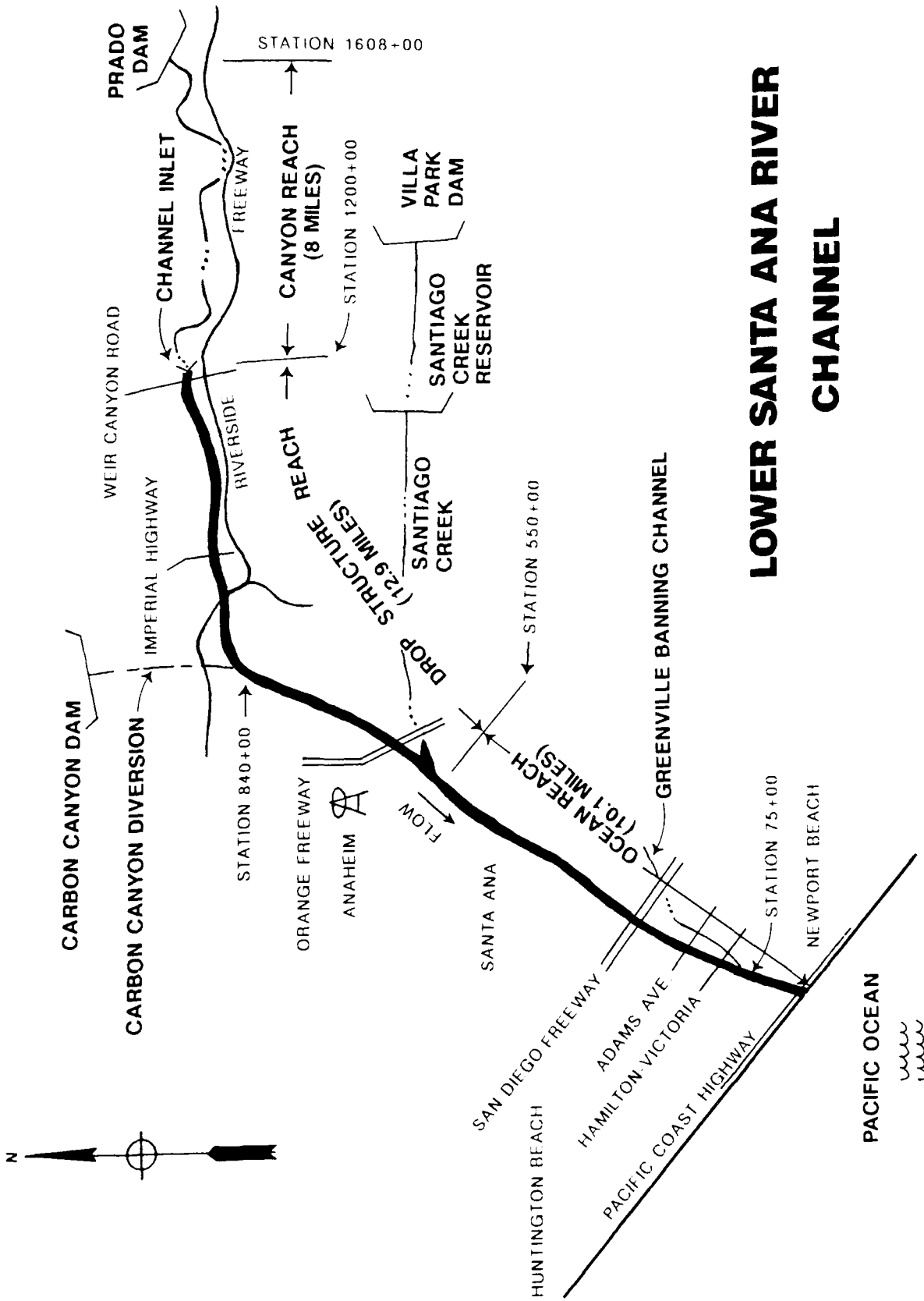

LOWER SANTA ANA RIVER CHANNEL

FIGURE 2

the 100 year floodway for the 35 mile reach between Seven Oaks Dam and Prado Dam; raising the existing Prado Dam; acquisition of the lower Santa Ana River Canyon floodplain immediately downstream from Prado Dam; and improvements to the lower 23 miles of the river which passes through highly urbanized Orange County. Subsequent paragraphs describe the recommended project elements along the lower Santa Ana River in more detail.

Prado Dam and Reservoir. Prado Dam will be raised approximately 29 feet, thereby increasing its reservoir flood control storage from 196,000 acre-feet to 362,000 acre-feet. The modified dam will have a peak controlled outflow of 30,000 ft³/s. The existing spillway crest will be raised by 20 feet from elevation 543 to 563 feet NGVD.

Santiago Creek. The Santiago Creek flood control improvements will include storage of floodflows in existing gravel pits downstream of Villa Park Dam, installation of outlet works for the upper portion of the gravel pits, and downstream channel improvements to pass the 100-year design discharge. The channel improvements will consist of a trapezoidal channel with riprap protection in the invert and side slopes, constructed within the existing right-of-way. The project will provide a 100-year level of protection. The 100-year design discharge on Santiago Creek at the confluence with the Santa Ana River is 5,000 ft³/s.

Lower Santa Ana River. Improvements in the lower Santa Ana River involve increasing channel capacities predominantly within the existing right-of-way. The 31 mile channel from Prado Dam to the Pacific Ocean (Figure 2) will be improved to provide 190-year flood protection. Channel capacity will range from 30,000 ft³/s at the outlet of Prado Dam to 47,000 ft³/s at the Pacific Ocean. In the 8 mile "Canyon Reach", extending from Prado Dam downstream to Weir Canyon Road, approximately 1,123 acres of canyon lands will be acquired to ensure that no changes will take place in the floodplain that might affect safe releases from Prado Dam during a flood event or jeopardize the open space habitat in the area. Bank protection will be provided for existing developments in the canyon reach. At the downstream end of the canyon, an inlet just upstream of Weir Canyon Road is provided for the next 12.9 mile reach of channel called the "Drop Structure Reach". This reach consists of a trapezoidal earth-bottom channel with riprap side slopes and contains 14 drop structures (Figure 3). Channel base widths range from 260 to 330 ft. with invert design slopes varying from 0.00168 to 0.00222. The remaining downstream 10.1 mile reach, referred to as the "Ocean Reach", from the Santiago Creek confluence to the Pacific Ocean is a concrete-lined channel for 7 miles through a highly urbanized area. Channel base widths range from 160 to 450 feet and design invert slopes range from 0.0005 to 0.0025. The downstream three miles of this reach is an earth-bottom trapezoidal channel with revetted side slopes. Channel improvements are constrained by existing channel widths, drop structures, bridge deck levels, utilities along the river, right-of-way, and urban development adjacent to the channel.

The remainder of this paper discusses hydrologic and hydraulic design aspects of the "Drop Structure Reach" and "Ocean Reach" of the lower Santa Ana River.

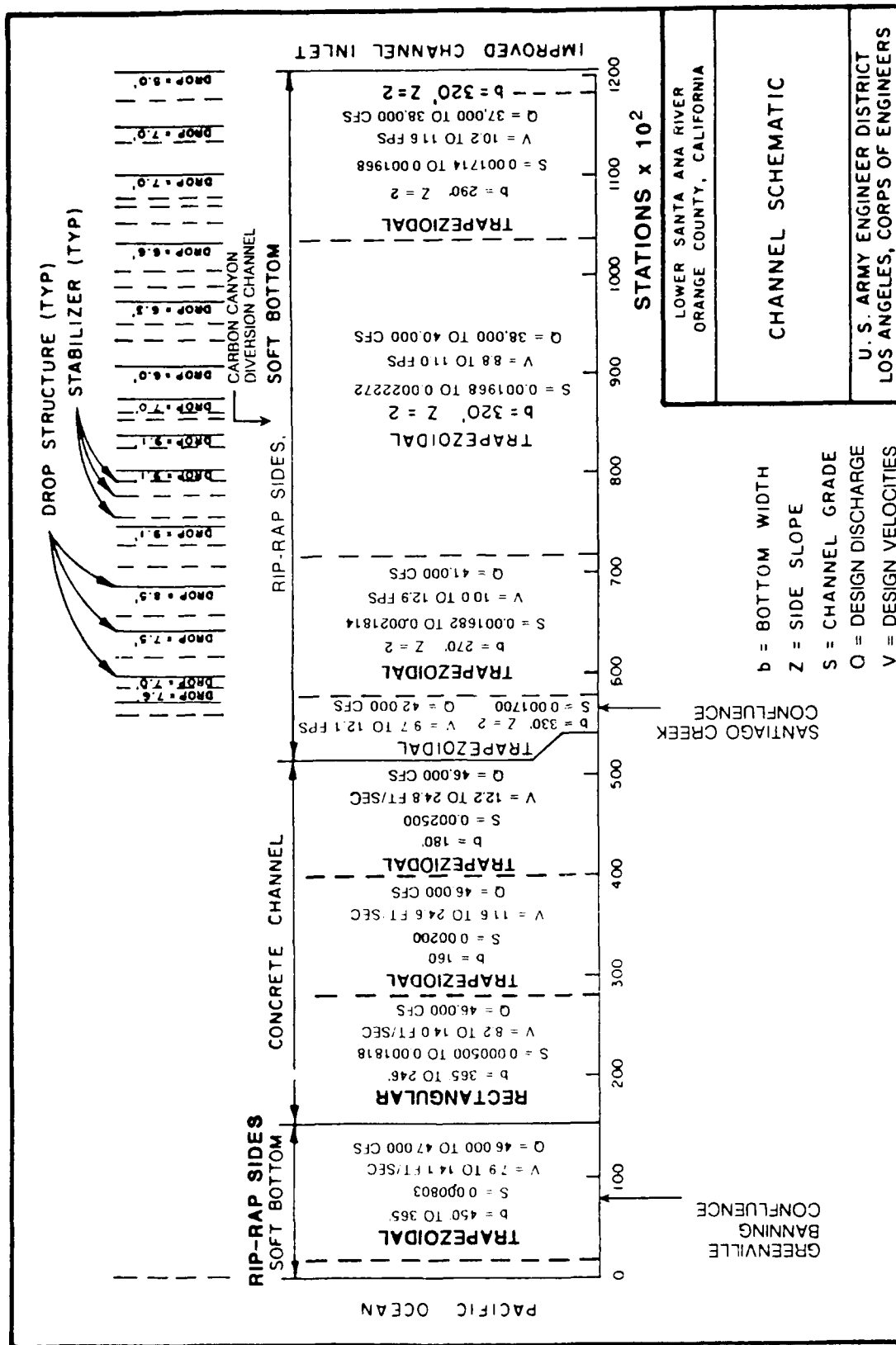

FIGURE 3

Hydrology

During the plan formulation studies for the Santa Ana River project, the design release from Prado Dam was determined to be 30,000 ft³/s. Contemporaneous runoff from the 200 mile drainage area downstream of Prado Dam increases the design discharge to 37,000 ft³/s at Weir Canyon Road, to 40,000 ft³/s downstream of Carbon Canyon Creek Diversion Channel, to 46,000 ft³/s downstream of the confluence with Santiago Creek, and to 47,000 ft³/s downstream of the confluence with Greenville-Banning Channel to the Pacific Ocean (Figure 2). The design flood from Prado Dam to the Pacific Ocean is a 190-year event under future conditions with the recommended plan in place.

Several fortuitous hydrologic and/or geographic facts with respect to the lower Santa Ana river drainage area enable the hydraulic design of the recommended channel to be capable of handling not only the design flood discharges, but also to maintain channel structural integrity for much larger flood events. First, due to the fact that the Santa Ana River floodplain is an alluvial fan, flood waters that overtop the entrenched channel banks in the drop structure reach flow westward away from the channel. These overflows do not reenter the lower river because the gradient of floodplain leads directly to the coast rather than confining and redirecting these overflows back to the lower river channel. Second, the uncontrolled drainage area tributary to the lower river channel downstream of Prado Dam is relatively small (about 200 square miles) with the side inflows distributed along the 31 mile length of the river to the ocean. In addition, the Santiago Creek drainage area, which is about 103 of the total 200 square miles, has two existing storage facilities plus one proposed additional storage facility (Santiago Creek Reservoir) that reduce the magnitude of floodflows. These hydrologic facts limit the magnitude of tributary inflows and made it feasible to design the lower Santa Ana River channel to retain its structural integrity for flood events larger than the design flood.

For flood events when the mainstem Santa Ana River is carrying more than the design flood discharge, channel freeboard was provided in a manner that causes tributary side inflows to weir over the levees at desired locations, or be conveyed to the ocean without structural failure of the channel or levees. Thus, the hydrologic characteristics of the drainage area tributary to the lower river, along with the alluvial fan physiography of the floodplain were major factors in the development of the channel design, including freeboard and overtopping design.

Hydraulic Design

General. The hydraulic design was accomplished in a manner to achieve the design objectives of (1) safely conveying the design flood, (2) insuring initial overtopping at the least hazardous locations, and (3) preventing failure of the channel (including levees) for flood events substantially larger than the design flood. Initial design efforts centered on identifying the most effective channel configurations to convey the design flood within each reach. Channel design considered existing channel widths and alignments, existing grade control structures, bridge deck levels, utilities adjacent the river, available rights-of-way, and urban development adjacent the channel. The channel design specifically addressed alignment, sediment transport, grade control structure

design, transitions, bridges, freeboard, roughness coefficients, confluence structures, and riprap requirements. Water surface profiles in the improved channel reach were calculated using the Los Angeles District's computer program "WASURO". This program uses either the direct step or standard step method to solve the one-dimensional energy equations with energy losses due to friction evaluated with the Manning formula. The channel was designed using straight-line transitions for the concrete channel with appropriate wall flare as per EM 1110-2-1601 (Corps of Engineers, 1970). Aspects of the channel design important to safety and overflow performance are addressed in additional detail in subsequent paragraphs.

Sediment transport. The hydraulic design of the channel included detailed analysis of the transport of sediment loads along the Santa Ana River from Prado Dam to the Pacific Ocean using the HEC-6 computer program (Hydrologic Engineering Center, 1977). In the case of high sediment loads, the analysis clearly indicates sediment deposition will occur in one earth-bottomed channel reach just downstream of the drop structure reach inlet and in the 5 mile reach upstream from the ocean outlet (Figure 2). The break in grade from steep to mild slope in the ocean reach, 5 miles from the outlet, changes the flow condition from rapid to tranquil state resulting in substantial sediment deposition. Water surface profiles were computed using sediment deposition in the channel at the peak of the design flood to establish channel wall heights. In the case of low sediment loads, the channel and levee toe protection was designed to be below the estimated general and local scour depths.

Grade control structures. For the earth-bottom drop structure channel reach, the recommended channel design calls for modification of the existing 11 drop structures, plus the addition of 3 new drop structures and 21 stabilizers, to maintain stable invert grades and to control channel scour (Figure 3).

- 1) Drop structure design. Hydraulic model studies were performed at the Waterways Experiment Station to ensure the required hydraulic performance of the drop structures in the earth-bottom channel reach. The design objectives of the model testing program were to insure that the drop structures would provide good energy dissipation within the basin, minimize downstream scour, maximize the utilization of the existing drop structure configurations, minimize the cost of modifications, and provide for good performance for a range of discharges and tailwaters. It is necessary that the drop structures adequately dissipate energy not only for the channel design discharge (unit discharges of 125 to 165 ft³/s per foot width) but also for the maximum freeboard design discharge (unit discharges of 165 to 215 ft³/s per foot width). As a result of the model tests, it was determined that the existing 11 drop structures could be retained by modifying them to include a parabolic curved chute downstream from the crest, additional basin length, two rows of baffle blocks, and a sloping end sill. Model tests of the recommended drop structures resulted in a stable hydraulic jump throughout the range of discharges and a reduction in velocities at the end sill.
- 2) Stabilizers. The sediment transport analysis included a sensitivity analysis indicating that if the sediment inflow into the improved reach

was significantly reduced, the bed slope upstream from drop structures would flatten to nearly a horizontal slope and hence general degradation of the channel would occur. To limit channel degradation, a minimum of one stabilizer is to be incorporated upstream from each drop structure, except for one short 2,200 foot long subreach.

Water surface profile computations. Water surface profiles were calculated using the Los Angeles District's computer program "WASURO". Friction losses in the program are accounted for by use of the Manning's roughness coefficient "n". In the earth-bottomed reaches, the "n" value was evaluated using several methods that account for the roughness due to the bed grain size and bed form. A range of bed "n" ranging from 0.015 to 0.022 was derived using Corps EM 1110-2-1601, U.S. Geological Survey, Alam and Kennedy, and Simons & Li methods. In addition to the bed "n" value, a composite "n" value for the channel was computed using the Corps' Hydraulic Design Criteria (Waterways Experiment Station, 1988) to account for the different bed and side-slope roughness. Composite "n" values computed using these 4 methods varied from 0.018 to 0.025. Because of this variation in the composite "n" value and because the flow is in the upper regime of the plane bed/antidunes, two "n" values were used to design the channel. A high "n" of 0.03 was applied for water surface profiles used to set top of channel. This "n" value is at the upper limit for bed forms in the plane bed/antidune range and so represents a conservative approach to determining top of channel. A low "n" value of 0.02 was used for determining channel velocities and depths in the design of channel revetment such as riprap. This "n" value represents a reasonable low value in the plane bed regime. Water surface profiles computed through bridges generally assumed 2 feet of debris on each side of each pier.

Riprap Design. Riprap revetment was designed using average velocity and average depth computed by the "WASURO" computer program using Manning's "n" value of 0.02. Guidance provided in Engineer Manual 1110-2-1601 (Corps of Engineers, 1970) and Engineer Technical Letter 1110-2-120 (Corp of Engineers, 1971) was followed in the computation of local boundary shear, riprap design shear, and riprap layer thickness. The analysis resulted in riprap layer thickness varying from a minimum of 12 to a maximum of 54 inches. In the channel reaches that require riprap 36 inches or thicker, it was determined to be more economical torevet the levee with a 15-inch layer of grouted riprap. Revetment toe protection is in general accordance with Method A, on plate 37 of EM 1110-2-1601 (Corps of Engineers, 1970). The levee toe depth will extend a minimum of 5 feet below the design invert just upstream from a hardpoint such as a drop structure or stabilizer. Upstream from these hardpoints, the levee toe grade line was extended at one-half the design invert slope until it merges with the toe design of the next upstream hardpoint. The toe depth design was verified with the results of the sediment transport analysis. Based on that analysis, the toe depth was increased to a constant 10 feet below the design invert in only the first drop structure subreach downstream from Weir Canyon Road. Finally, the riprap design was checked for adequacy under bankfull flow conditions.

Freeboard. The objective of freeboard design of flood control channels is to reduce damages to property and minimize risk of loss of life by floodwaters overtopping channel floodwalls or levees. Freeboard design uses a concept called "superiority" whereby floodwaters with water surfaces higher than the design

level can be forced to overtop the channel in least hazardous locations. The freeboard design on the lower Santa Ana River was a two-step process. First, the minimum freeboard was determined. Then, the locations for initial overtopping of the channel at least hazardous overbank areas for floods exceeding the channel capacity were determined. In addition, freeboard design features were incorporated in order to prevent levee destruction from floods causing overtopping, thereby enabling continued release capability from Prado Dam upstream.

Minimum freeboard. The minimum recommended freeboard is based on Corps guidance in EM 1110-2-1601 for riprap channels and earth levees. The riprap trapezoidal channel in the drop structure reach is entrenched below ground except for some reaches where channel levees extend above ground a few feet. The minimum freeboard allowance for this type of channel is 2.5 feet. The only major factor that would affect this freeboard value was the changed conveyance due to bed forms and sedimentation. However, since the "n" value was set conservatively high due to bed forms and the effect of sedimentation in the channel was taken into account, the 2.5 foot value for minimum freeboard was judged adequate. In the ocean reach, the channel is leveed. Corps criteria calls for minimum levee freeboard to be 3.0 feet. Again, other factors that would influence the selection of a minimum freeboard greater than 3.0 feet were assessed directly in water surface profile determination. Therefore, 3.0 feet minimum freeboard was set for the entire ocean reach.

Overflow design. The selection and design of the locations for flow overtopping the channel was based on a systematic approach starting at the upstream end of the improved channel and working in the downstream direction.

- 1) Channel overflow sections in the drop structure reach were designed using the following steps:
 - a. An incremental series of water surface profiles were computed for discharges above the design water surface to determine the location of initial overtopping. In the drop structure reach the relationship between channel conveyance and stage is fairly linear, which translates into overtopping of the channel at numerous locations simultaneously.
 - b. The channel in the drop structure reach is essentially entrenched with the exception of relatively short lengths of levee a few feet high immediately upstream of drop structures. Therefore, the top of levee height was set as 3.0 feet above the design water surface, except for the locations selected as the least hazardous overbank areas. At these locations the minimum freeboard of 2.5 feet was retained to insure initial overtopping would occur there.
 - c. The "WASURO" program was rerun using a side overflow weir option to determine the split flow quantities. The length of the overflow weir was determined by a trial and error procedure taking into account the quantity of flow needed to exit the channel, and the capacity upstream and downstream from each side weir. Local side drain inflow was also accounted for in the analysis. The overflow

weir coefficient was taken as 2.65, which represents the coefficient for a broad-crested weir.

- d. The results of the application of the above steps are summarized in Table 1 and presented graphically in Figure 4. Flows leaving the channel at these locations will enter into overbank areas consisting of parks, freeway buffer zones, groundwater basins, and parking lots. The backside of levees with overflow will be protected by 12-inch thick grouted riprap to prevent erosion through the levee. It should be noted again that the channel in the drop structure reach is essentially entrenched with only a few low leveed reaches. For large Santa Ana River floodflows, say emanating from Prado Dam spillway and arriving at the canyon mouth, only 56,000 ft³/s will be able to remain in the improved channel. The remainder of the flow will spill out onto both sides of the floodplain without significant damage to the improved channel or overtaxing the conveyance of the improved channel at a point downstream.

Table 1. Drop Structure Reach Overflow Sections

Overflow Section Stations		Overflow Levee	Channel Discharge Upstream (ft ³ /s)	Discharge Over Sideweir (ft ³ /s)	Channel Discharge Downstream (ft ³ /s)
Upstream	Downstream				
1202+50	1031+70	both	1/	2/	56,000
1000+00	986+00	right	57,700	700	57,000
941+00	928+00	right	57,700	1,700	56,000
844+00	822+00	both	63,000	3,000	60,000
733+00	710+00	both	60,000	3,800	56,200
682+00	670+00	right	60,000	1,500	58,500

1/ Santa Ana River Canyon conveys all floodflows emanating from upstream watershed.

2/ Initial overtopping reach downstream from Prado Dam for all flows exceeding 56,000 ft³/s.

Note: Downstream of the last overflow section, between stations 682+00 and 670+00 (roughly Santiago Creek confluence to the ocean), all tributary inflow that can enter the lower Santa Ana River is conveyed to the ocean without channel overflow.

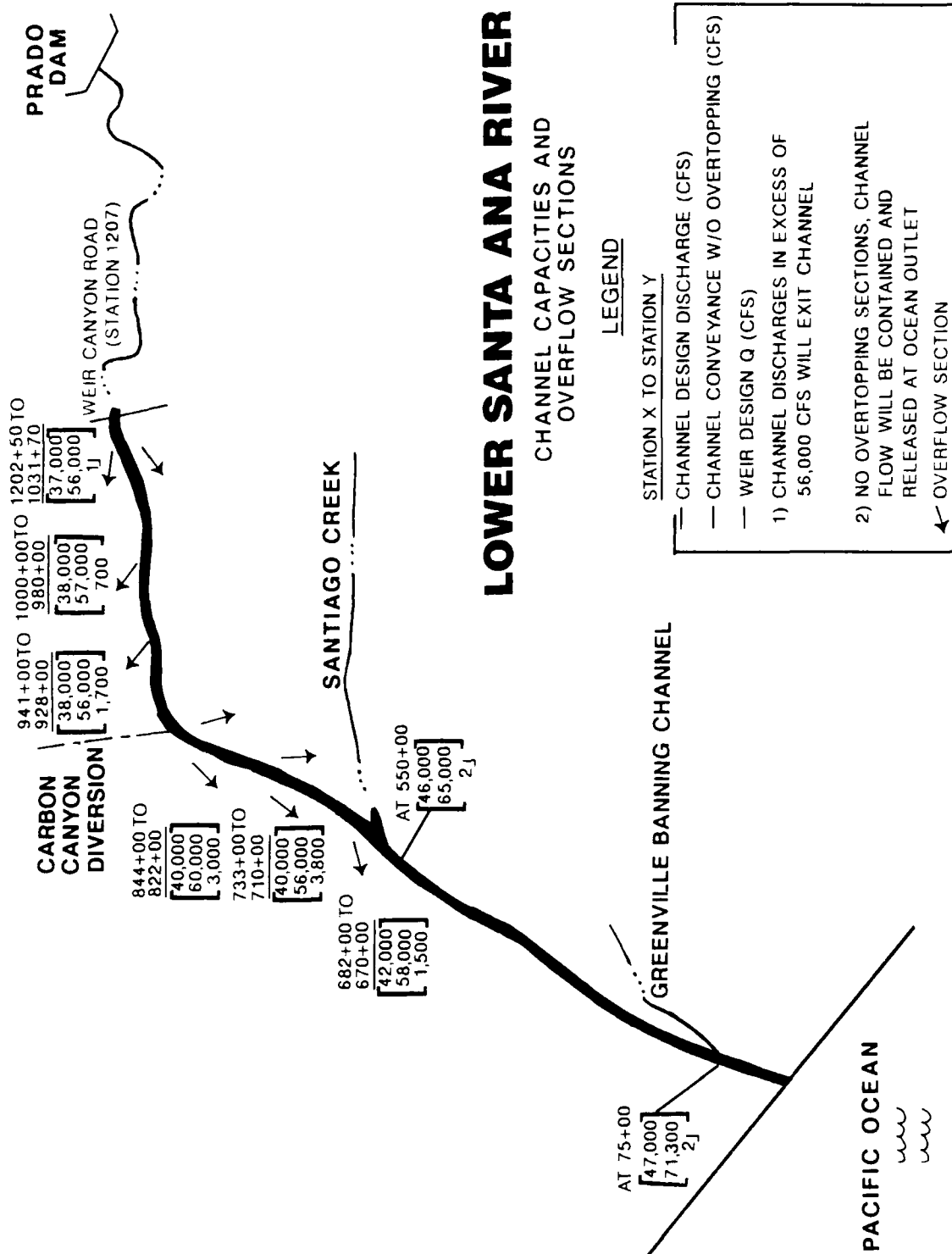

FIGURE 4

- 2) For the ocean reach between the Santiago Creek and Greenville-Banning Channel confluences, the freeboard design discharge varied from 65,000 ft³/s to 65,500 ft³/s. The 65,000 ft³/s discharge was determined by combining the maximum discharge from the drop structure reach of 58,500 ft³/s plus a runoff contribution from Santiago Creek of 6,500 ft³/s, which corresponds to a bankfull channel condition. Local inflow from storm drains and pumping plants contributes an additional 500 ft³/s in this reach. No least hazardous overtopping location was identified between the inlet of the ocean reach (station 550+00) and the ocean outlet. Consequently, sufficient freeboard was provided to convey the freeboard design discharge from the Santiago Creek confluence down to the Greenville-Banning channel confluence. The freeboard analysis indicates that the channel with 3 feet of freeboard could convey the 65,000 ft³/s from station 550 + 00 to about station 290 + 00. Downstream from station 290 + 00, freeboard was increased to as much as 5 feet to convey 65,500 ft³/s in a bankfull mode to the Greenville-Banning Channel confluence. The Adams Avenue and Hamilton-Victoria Avenue bridges (stations 171+80 and 90+40 respectively), which remain in place, have 1.0 and 1.5 feet of freeboard, respectively, for the design discharge of 47,000 ft³/s. Additional freeboard was provided upstream of these bridges to enable them to pass 65,500 ft³/s in a pressure flow mode.
- 3) The Greenville-Banning Channel confluence occurs in the recommended plan at about station 75 + 00. The Greenville-Banning Channel enters parallel to the Santa Ana River as a 60-foot wide concrete rectangular channel. The bankfull capacity of Greenville-Banning Channel at the confluence is 5,800 ft³/s. Sufficient freeboard was provided along the Santa Ana River from the Greenville-Banning Channel confluence to the ocean outlet to enable the channel to convey 71,300 ft³/s which is the combination of the 65,500 ft³/s from the mainstem along with the Greenville-Banning Channel potential inflow.

Study Results and Conclusions

The lower Santa Ana River channel design presented herein provides a high degree of flood protection in combination with safety features that minimize adverse impacts from floods exceeding the design flood magnitude. Channel design with respect to overtopping was performed in accordance with Corps guidance. In addition, the performance requirements of the channel for the freeboard design flood were considered in the hydraulic design of drop structures, sediment transport, riprap, and toe protection. An overall consistent hydraulic design was achieved to insure channel performance in accordance with design requirements and objectives. The recommended channel design for the lower Santa Ana River also took advantage of the hydrologic peculiarity of the lower watershed that limited the size of local inflows and made it possible to design a channel with a high level of resistance to failure from floods exceeding design magnitude.

REFERENCES

Design Memorandum No. 1, Phase II GDM on the San Ana River Mainstem including Santiago Creek, Volume 3 and Appendixes, Lower Santa Ana River (Prado Dam to Pacific Ocean), Corps of Engineers, Los Angeles District, August 1988.

Engineer Technical Letter No. 1110-2-120, Additional Guidance for Riprap Channel Protection, Corps of Engineers, 14 May 1971.

Engineer Technical Letter No. 1110-2-299, Overtopping of Flood Control Levees and Floodwalls, Corps of Engineers, 22 August 1986.

Engineer Manual 110-2-1601, Hydraulic Design of Flood Control Channels, Corps of Engineers, 1 July 1970.

HEC-6 Generalized Computer Program, "Scour and Deposition in Rivers and Reservoirs" Users Manual, Corps of Engineers, Hydrologic Engineering Center, March 1977.

Hydraulic Design Criteria, Waterways Experiment Station, Corps of Engineers, 24 June 1988.

COLDWATER CREEK LEVEES-WHAT FREEBOARD ?

by

1

Ronald J. Dieckmann

Introduction

The purpose of this paper is to discuss the functional and safety related aspects of freeboard for low height levees on Coldwater Creek, in north St. Louis County, Missouri. Two low levees with a maximum height of five feet were authorized as part of an overall feasibility study plan composed of channel enlargement and bridge modifications to the main stem of Coldwater Creek, and a flood forecasting and warning system. The key issue with regard to these levees is whether or not freeboard is necessary. The St. Louis District originally recommended no freeboard be used for these two specific levee situations. After discussions with LMVD prior to publishing the draft feasibility report, the District assigned 0.5 feet of freeboard to each levee. HQDA review of the final feasibility report states that the District should use a minimum of one foot of freeboard.

Physical Setting

The Coldwater Creek basin lies in the northern part of St. Louis County, Missouri. The 45 square mile watershed has an elongated shape, with a 19.5 mile long main channel and relatively short tributary streams. The average stream slope for Coldwater Creek is about 16 feet per mile. The creek generally flows north from its headwaters and then turns east for the last few miles before entering the Missouri River. The mouth of Coldwater Creek is at mile 6.9 on the Missouri River. Figure 1 is a map of the Coldwater basin. Most of the basin is composed of highly developed residential, commercial, and industrial areas as well as the entire Lambert-St. Louis Airport complex. The creek flows underground in a double 10 foot by 15 foot box culvert for 1.2 miles through the airport. Many of the main tributaries of Coldwater are concrete-lined channels and numerous small tributaries have been enclosed in pipes or flow in concrete-lined open channels. Downstream from the airport, most of the main channel of Coldwater has been realigned and deepened as urban development occurred over the years. Upstream of the airport, most of the main channel has been realigned and the extreme upper reach of the creek is a concrete-lined open channel. Except for this uppermost part, the channel banks are lined with natural vegetation.

Available Data

Basic information utilized in this project included mapping developed by the Corps. The maps consist of photographic coverage of the entire watershed and two foot contours in the floodplain area. All the buildings in the floodplain were inventoried and nearly all the first floor elevations were determined by instrument survey. Extensive use of HEC-1 and HEC-2 computer models was made to define existing and future basin hydrology and water surface profiles. The National Weather Service maintains an hourly, recording precipitation station at the St. Louis airport, which is within the basin.

1

Hydraulic Engineer, St. Louis District, U. S. Army Corps of Engineers

Highwater marks were gathered for two significant events that occurred in July 1978 and April 1979. Both the HEC-1 and HEC-2 models were calibrated to these two events. Other recent damaging floods occurred in 1957, 1970, 1980, 1981, 1982, and 1986. Potential flood damages were defined for the main channel of Coldwater and its larger tributaries. The number of damaged structural units include 563 units for the 10% flood event and 1390 units for the 1% event.

Project Plan

The overall project plan is composed of 5.9 miles of improved and widened channel and an enlarged railroad opening on Coldwater downstream of the airport, 2.2 miles of improved and widened channel upstream of the airport, a flood forecasting and warning system, various recreational and environmental measures, and the two low levee measures known as L-7 and L-8. Figure 1 indicates the location of each levee in the basin and Figure 2 shows a detailed plan view of the proposed levees and protected buildings. Levee location L-7 would provide increased protection for five clustered buildings at the Old St. Ferdinand's Shrine. The Shrine is located inside the wedge formed at the junction of Coldwater and Fountain Creek, a major tributary. The buildings include a church built in 1820, a convent, a rectory, an old school building, and a newer school building that is now owned by the Knights of Columbus. The church, convent, and rectory are on the National Register of Historical Places. These buildings are only used periodically for meetings of the Knights of Columbus or for tours by the historical association which owns the Shrine. The levee would have a maximum height of five feet, including 0.5 feet of freeboard. Levee location L-8 would provide increased protection for the basements of seven homes with walk-out basements along a residential street adjacent to Coldwater. The major flood control improvement for this project plan is the channel widening work. Under future conditions these channel improvements would provide protection for floods up to the 10% event. Behind the low levees flood protection would be increased to the 1% flood event for levee L-7 (Shrine) and to the 4% flood event for levee L-8 (homes).

Freeboard Issue

Although these two low levees are a rather minor part of the overall project plan, the appropriate freeboard provides an interesting issue to consider. The basis for believing that very little or no freeboard in these two situations is acceptable is the very low risk of loss of life at either location. Generally in the Coldwater Creek area, the biggest risk to life is not to building occupants, but to people in automobiles who drive across flooded roads, especially at bridges. The depth and duration of a large flood event in the Coldwater basin would not generally cause concern for loss of life to people in their homes. Since the rate of rise is very short (approximately one to two hours from bank full to the 1% flood elevation), it would be unlikely that anyone would even be outside at either levee location during an intense storm event. Even though the flood waters may fill the protected areas quickly once overtopped, people would be able to move to safety on upper floors in either the houses or the Shrine buildings. In addition, high ground is within 225 feet of the furthest protected building.

At both locations, the District believes in limiting the total height of the levees to a maximum of five feet. By using this approach, as the

freeboard increases the level of claimed protection decreases. Admittedly, the District has no special data which makes five feet magical, but from a safety viewpoint, it appears that increasing the total height from five feet upward to as much as seven or eight feet actually increases the risk to life rather than decreasing it. Rather than building them higher than five feet, it would be better to abandon the levees as part of the overall plan.

Additional reasons why minimum to no freeboard is believed appropriate include:

a. the flood warning and preparedness features of the plan. A well executed flood warning plan would minimize loss of life situations by providing a mechanism to give special warning to the seven homeowners and the Shrine.

b. little danger of having a temporary adverse shift in the rating curve. Both levee locations are in reaches of improved channel. These improved channel reaches have riprapped toe protection, and stable grass-lined side slopes. The local sponsor, Metropolitan Sewer District (MSD), has a good record of maintaining their facilities. Both MSD and the local communities also prevent large debris build-ups from occurring at bridges. For these reasons it would seem unlikely that there would be any significant upward shift in the rating curve.

c. no need to control the location of overtopping to non-critical areas. Both low levees proposed for Coldwater protect such short reaches with little difference in interior ground elevation, the location of overtopping does not seem to be a critical item.

d. no need to protect against wave action on a levee. The Coldwater Creek floodplain is rather narrow providing limited fetch plus the duration of high stages being just a few hours, discounts the need for freeboard.

These levees would be built with as flat a side slope as practically possible, giving them the appearance of being part of the property landscaping. The top of the levee would not need a driving surface on it, but would be vegetated with a good grass cover and any other plants which would help hold the soil during overtopping. With this design plus the short duration of high stages, it would be very unlikely that a sudden failure situation would develop.

Current Status and Conclusions

Currently the project is being reviewed by the Office of the Assistant Secretary of the Army (Civil Works). It has not been authorized at this time. Funding to begin PED studies is expected in FY90.

The appropriate freeboard could range from zero to possibly three feet, based largely on the judgment of the hydraulic engineer. This freeboard issue for Coldwater Creek low levees should be resolved during the PED studies.

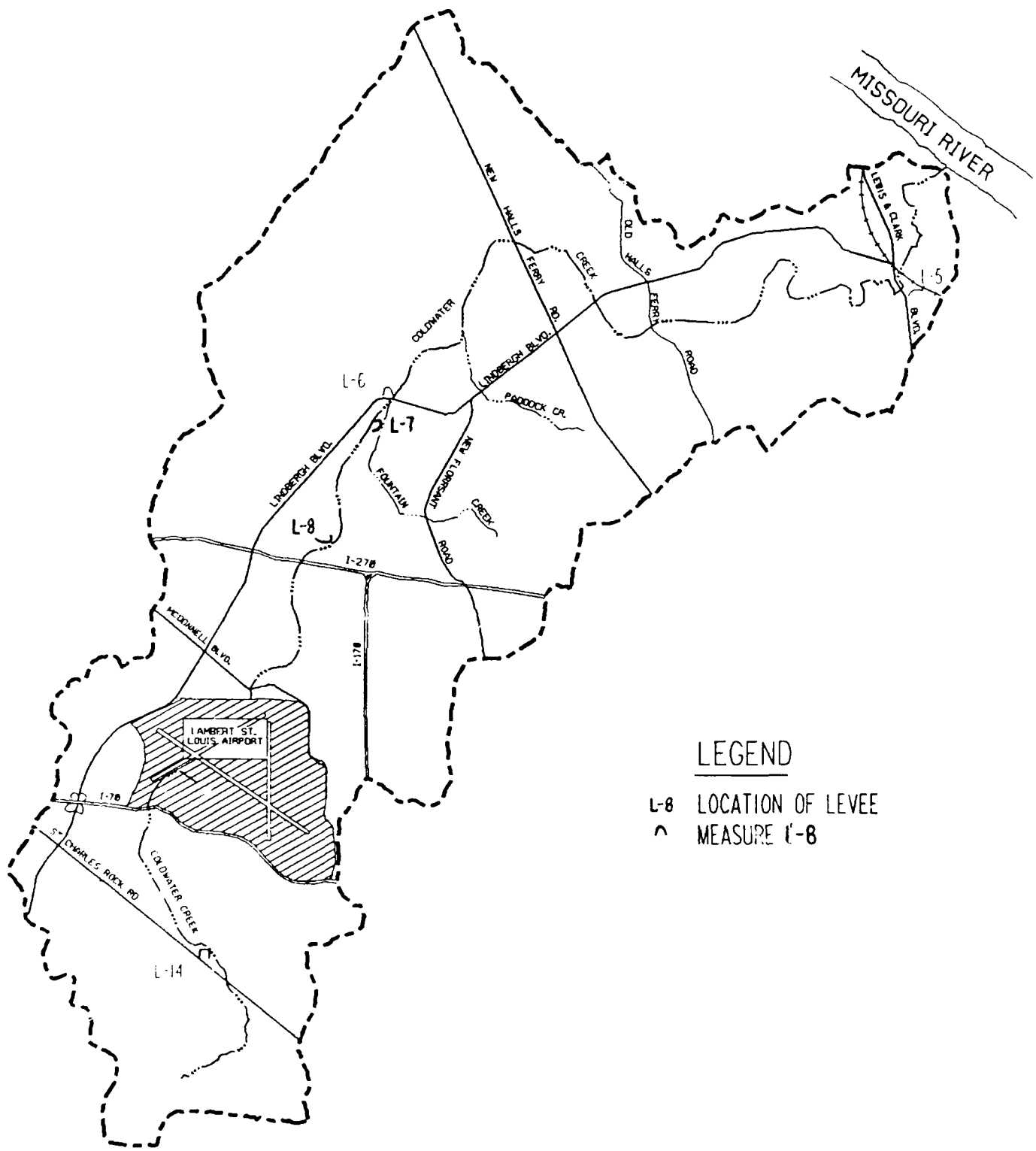

LEGEND

- L-8 LOCATION OF LEVEE
- △ MEASURE L-8

COLDWATER CREEK, MISSOURI
SMALL LEVEE MEASURES

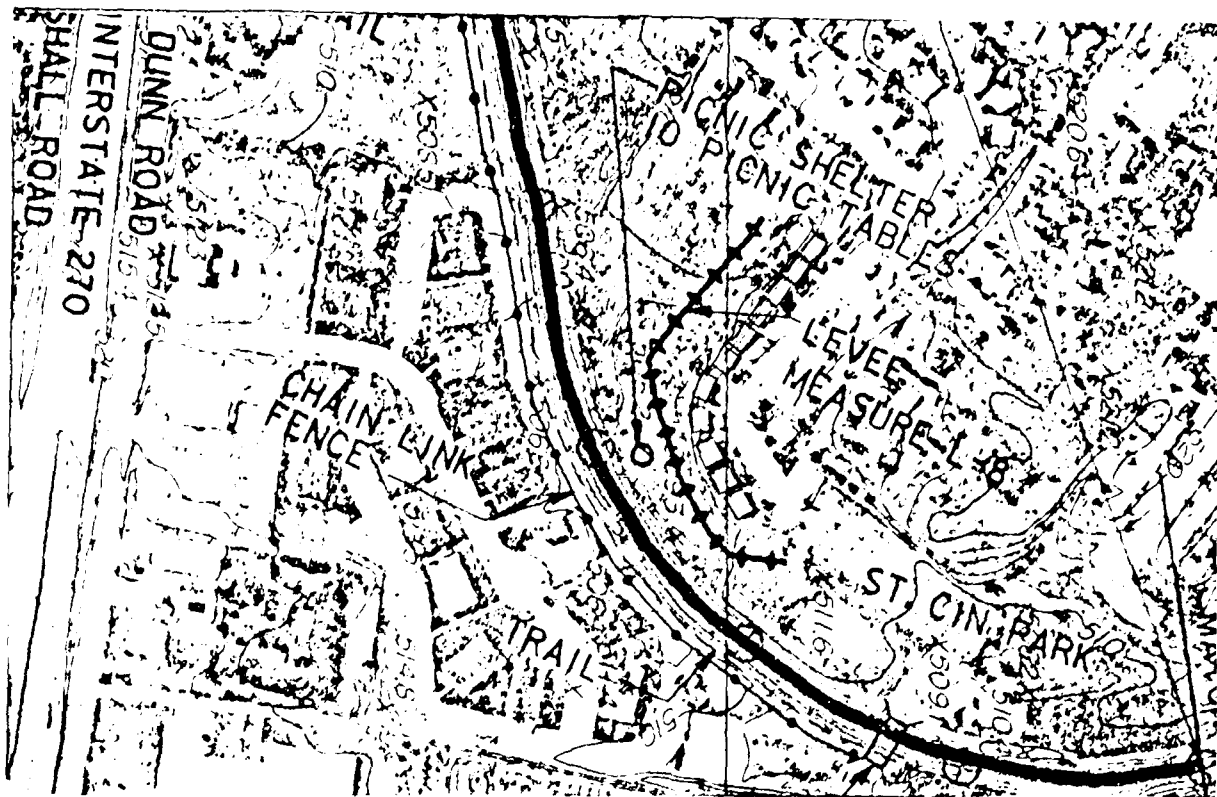

LEVEE L-8

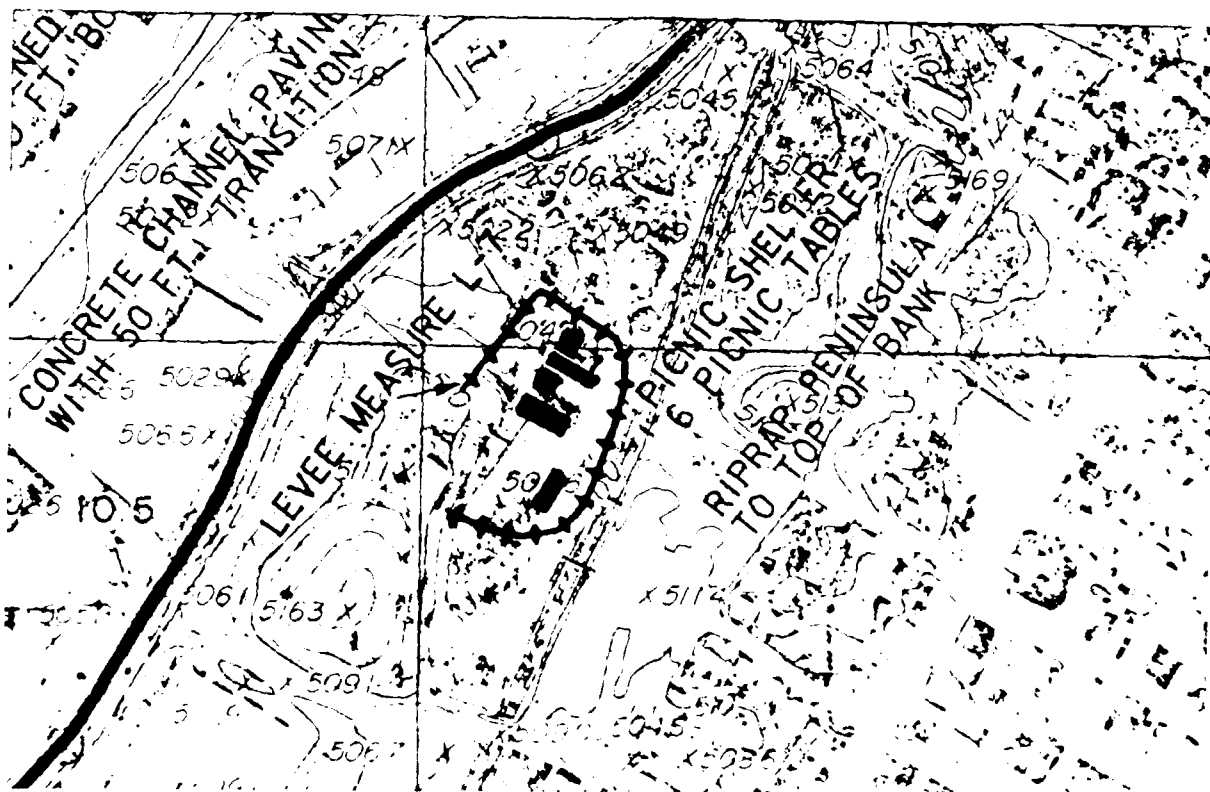

LEVEE L-7

LEEVE FREEBOARD FOR WYOMING VALLEY, PA.

by

DENNIS SEIBEL ¹

Background. The issue of levee freeboard is of critical importance for the Wyoming Valley, PA. Local Flood Protection (LFP) Project. The Wyoming Valley project involves the raising of existing levees that protect the communities of Plymouth, Kingston-Edwardsville, Swoyerville-Forty Fort and Wilkes-Barre/Hanover Township in northeastern Pennsylvania, along the banks of the Susquehanna River.

The existing protection was constructed in the late 1930's, early 1940's and early 1950's. The project was designed to pass the March 1936 flood (Q=232,000cfs), with the provision of a uniform increment of 3 feet of freeboard throughout the entire length of the project (approximately 14 miles). The protection was overtopped during the June 1972 flood, which occurred as a result of Tropical Storm Agnes, with an estimated maximum flow of 345,000 cfs.

Levee Overtopping. When the existing protection was overtopped in June 1972, the levees (and sheetpile walls) were not necessarily overtopped at the downstream end first. The protection was overtopped in several locations, causing failure of at least one reach of levee and one section of sheetpile wall. The failure of the levee and sheetpile wall sections caused a very high velocity jet of flow (similar to a dam failure) to enter the "protected area" and caused a considerable amount of structural damage to buildings.

The proposed levee raising project is intended to provide protection equivalent to a recurrence of the June 1972 flood, which as now estimated, would have a peak discharge of 318,500 cfs. The flood control effects of two dams in Northern Pennsylvania (Cowanessque Lake and Tioga-Hammond Lakes), which have been constructed since 1972, have been included in the determination of the design discharge.

To avoid a catastrophic overtopping of the proposed levee raising project, as occurred in 1972, additional freeboard is being included along the length of the project in the determination of the top of protection profile. A minimum of 3 feet of freeboard was utilized at the downstream end of the project. In accordance with ETL 1110-2-299², the top of protection profile was designed to overtop in the least damaging manner. Because of the highly urbanized nature of the "protected area" along the Susquehanna River, no area exists along the protection that would be suitable for flood relief. The only reasonable location to allow overtopping to occur first is at the most downstream limit of the project. The overtopping of the downstream end of the protection first would allow the "protected area" to slowly fill with water and cushion the effects of overtopping longer reaches of the protection, if the discharge continues to increase.

¹ Chief, Hydrology-Hydraulics Section, Baltimore District, U.S. Army Corps of Engineers

In accordance with the ETL, the discharge that would first overtop the protection at the downstream end was determined to be 362,000 cfs. A water surface profile for the overtopping discharge was determined, assuming the flow to be contained by the levees. To assure that the protection would be overtopped at the downstream end first, an amount of incremental freeboard, up to a maximum of 0.75 feet, was added to the water surface profile for the overtopping discharge. The resultant top of protection profile indicates the freeboard above the design discharge (318,500 cfs) water surface profile should vary from a minimum of 3.0 feet of freeboard at the downstream end to a maximum of 4.6 feet at the upstream end of the project (see Figure 1).

Summary

Based on the previous overtopping of the existing Wyoming Valley project, levees should be designed to overtop in the least damaging manner. For highly urbanized flood plains, the least damaging form of overtopping will involve overtopping of the downstream end of the protection first.

The use of the ETL to establish the top of protection profile will assure that any potential overtopping of a levee project will occur in the least damaging manner.

2 U.S. Army Corps of Engineers, Engineering Technical Letter (ETL) 1110-2-299, "Overtopping of Flood Control Levees and Floodwalls", 22 August 1986.

CONCEPT OF INCREMENTAL FREEBOARD

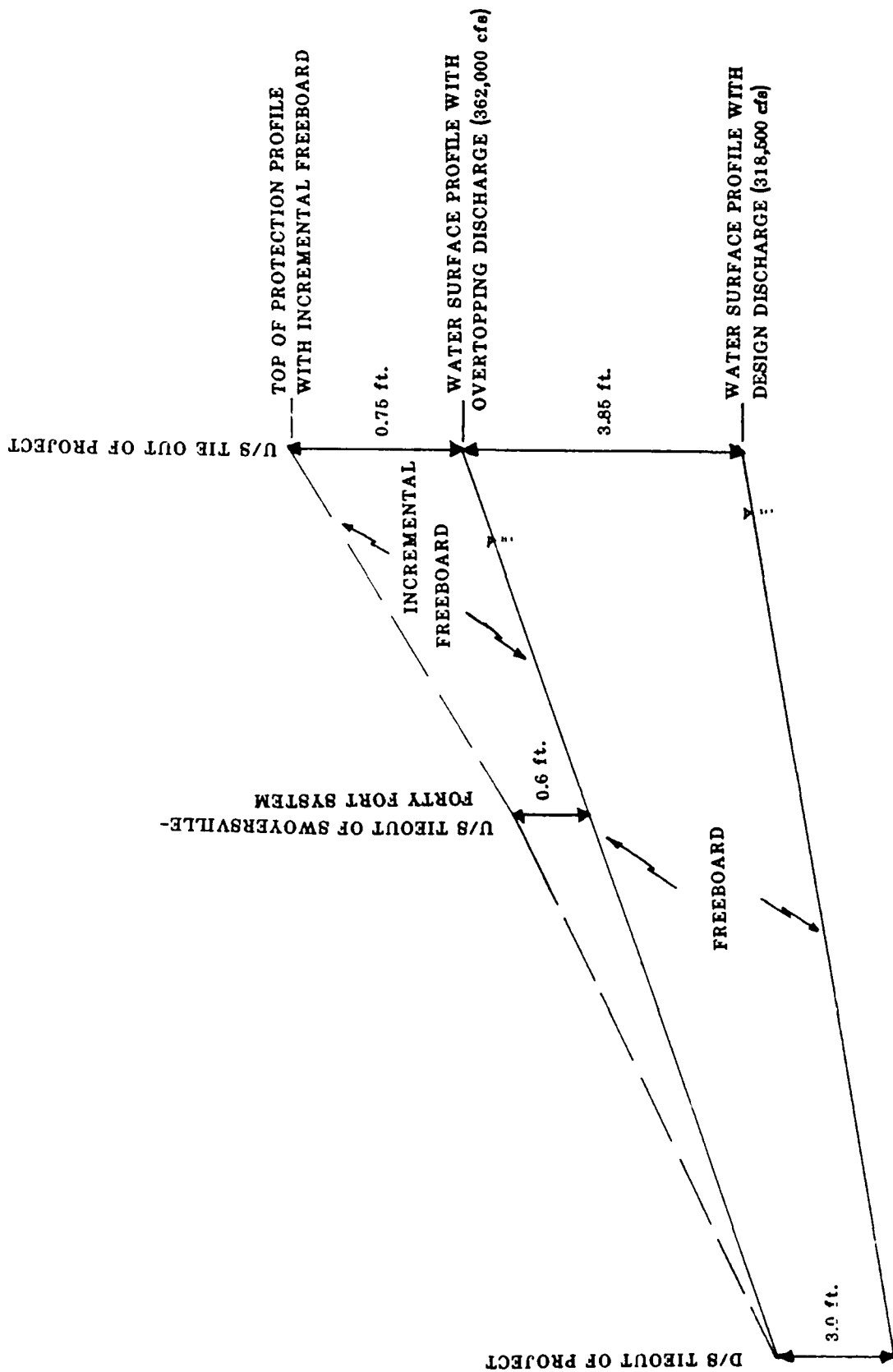

FIGURE 1

LEVEL OF PROTECTION FOR URBAN LEVEES

by

RONALD L. TURNER ¹

A Philosophy of Design for Urban Levees

The Trinity River levees in Fort Worth, Texas were overtopped in 1949, resulting in devastating flooding of both commercial and residential development in the city. The Fort Worth District was formed in 1950 out of the Galveston District's Fort Worth sub-office. The philosophy of design for both level of protection and amount of freeboard for a levee system which protected urban development was influenced by those earlier levee failures. The level of protection adopted for levee projects constructed by the District was the standard project flood, and the freeboard requirements were set at four feet above the SPF design water surface. This four feet was established as an additional safety factor over the more traditional 3 feet because of the flashy nature of floods within the Fort Worth Districts boundaries. Time periods of 12 to 24 hours between heavy rainfall and peak rise discharges are common. High intensity rainfalls are also not uncommon for this area, so that local officials rarely would have an opportunity to provide emergency construction to prevent overtopping. Even though four feet of freeboard was provided in the original design, current calculations of discharge produced by an SPF on the watershed would reduce freeboard to less than one-half foot at the most critical location.

The Dallas Floodway System as an Example.

The Dallas Floodway system was originally constructed by local interests in the 1930's. In the 1950's, it became a federal project and was reconstructed with some channel improvement and strengthening of the levees. The general layout of the system, which was not changed by the federal project, consists of a floodway which varies in width from 2000 to 3000 feet, a river channel having about 6000 to 8000 cfs capacity, and levees along each side of the floodway with typical levee heights of about 30 feet above the floodplain. The system has a total length of about 11 miles. The level of protection provided in design was for a standard project flood. The design discharge of the system was 225,100 cfs, and the levees were designed with 4 feet of freeboard. One foot of freeboard provides about 10,000 cfs additional capacity. A survey of the levee grade in the early 1980's indicated the levees had settled in excess of one foot in places. A current estimate of the discharge from an SPF is about 240,500 cfs, with a hydrograph volume of 900,000 acre-feet. It was estimated in a 1988 reconnaissance study of the floodway that failure of both levees with a single event SPF would cause economic damages in the 9 billion dollar range. No estimate has been made of potential for loss of life, but it would be heavy.

¹ Chief, Hydraulics Design Section, U.S. Army Corps of Engineers, Fort Worth District

The National Dam Safety Program Criteria, ER1110-2-106

Using criteria developed by the national dam safety program, embankments which impound flood volumes above 50,000 acre-feet, would be classified in the large dam category. The hazard potential classification would place embankments in the high hazard category if projected loss of life from a failure would be "more than a few" or if economic loss would be "excessive". From Table 3, paragraph 3.4 of the Engineer Regulation, the recommended design flood for an embankment with high hazard and large size classifications would be the PMF.

While a levee is not a dam, there are many parallels for levee embankments which protect large tracts of urban development. This is particularly true where the streams involved have the capability of developing large flood volumes, and the development includes residential dwellings where significant loss of life would occur with a sudden failure. We should recognize that we are dealing with an area affecting life and safety for which the general population has no capability of assessing risks. Although the writer would not propose that levees as a general rule be provided with the levels of protection and freeboard comparable to the National Dam Safety Program criteria, projects with failure impacts which would be in the same order of magnitude as those projects analyzed in the National Dam Safety Program should be examined with similar criteria. Further, no basic disagreement is found with the safety-valve concept presented by Smith and Munsey in their 1984 paper.² Because of the high value of urban land, however, it is difficult to find locations which are suitable to use for flood relief and which would provide enough volume of storage to be significant. This paper is addressed to those locations for which a safety-valve design is not a viable option.

Summary

For those urban levee projects protecting residential development for which no relief method can readily be designed into the project, a level of protection provided by an SPF design should be used for project design, with a minimum of three feet of freeboard. Where failure impacts could be severe, evaluation should be made to quantify them. Where identified losses would be unacceptable, a more conservative design, similar to that required for dam embankments, would be in order.

2 Smith, Lewis A. and Thomas E. Munsey, "Overtopping of Flood Control Levees and Floodwalls" in Water for Resource Development, proceedings of ASCE conference 14-17 Aug 1984, edited by David L. Schrieber.

Panel Summary - Levee Freeboard
Workshop on Functional Aspects of Corps Projects
Nashville District
17-19 October 1989

by

Tim Temeyer¹

The freeboard used on existing Omaha District levee projects has normally been 2 or 3 feet depending on the type of area protected, the confidence in the hydrology and hydraulics analysis, and other factors. On most of the levee projects, the freeboard has been 2 or 3 feet, with the top of levee profile determined by adding the freeboard amount to the design water surface profile. On some newer levee designs, instead of using a consistent increment of freeboard along a levee alignment, the top of levee profile has been determined by using a backwater model to compute a levee top profile that will contain a discharge higher than the design discharge. Additional adjustments to the levee top profile are sometimes made to control overtopping. Following is a partial summary of the freeboard used for existing levee projects.

2 foot of freeboard - 22 projects (agricultural and urban)
3 foot of freeboard - 18 projects (agricultural and urban)
5 foot of freeboard - 2 projects (urban)

In a study done on the adequacy of the Missouri River Levee System, the degree of protection provided by most of the levee units had decreased either by reduction in channel capacity or by changes in hydrology. The original freeboard provided as part of these levees has prevented the failure of these levees on numerous occasions. Following is a summary of how channel capacity and hydrology changed on the Missouri River Levee System:

Missouri River Mainstem Levees

Channel capacity decreased - 13 levee units
Channel capacity stayed constant - 3 levee units
Channel capacity increased - 0 levee units

New hydrology increased discharges - 0 levee units
New hydrology kept discharges constant - 16 levee units
New hydrology decreased discharges - 0 levee units

Missouri River Tributary Tieback Levees

Channel capacity decreased - 13 levee units
Channel capacity stayed constant - 2 levee units
Channel capacity increased - 1 levee unit

New hydrology increased discharges - 11 levee units
New hydrology kept discharges constant - 2 levee units
New hydrology decreased discharges - 3 levee units

The changes in channel capacity were due to sedimentation, changes in land use, private levee construction riverward of federal levees, closure of old river chutes, and tree and brush growth on the berms and channel bank areas. The combination of changes in channel capacity and changes in hydrology resulted in large changes in the degree of protection provided by the projects. On Missouri River mainstem levee units, the original degree of protection has been reduced from greater than 100-year to as low as 20- to 30-year protection. On tributary tieback levee units, the degree of protection has been reduced from 50-year to as low as 5- to 10-year. However, even with the reduced degree of protection, the original freeboard provided on these levee units has prevented their failure from discharges less than the design discharge.

Two conclusions can be drawn from the results of the Missouri River Study. One is that the original freeboard has served a valuable function in maintaining the capability of the levee systems to contain flood flows, and that providing adequate freeboard should continue to be an important part of the design of a levee system. The other is that in the design of freeboard for levee projects, the probability of changes in channel capacity over the entire life of the project should be taken into account. In some cases where changes in channel capacity might be expected, features such as controlled overtopping and a levee top profile based upon backwater studies may not function adequately during the entire life of the project. In these cases, a top of levee profile based upon adding a consistent freeboard amount to the design water surface profile should also be considered.

Summary - In designing levee freeboard, the capability of the freeboard to function over the entire life of the project should be considered. In some cases, a top of levee profile based upon adding a consistent freeboard amount to the design water surface profile may be the most desirable.

¹Chief, Hydraulics Section, Omaha District, U.S. Army Corps of Engineers

Requirements for Selecting A Plan
Other Than NED Plan

Presentation Given to Hydrology and Hydraulics Workshop
on Functional and Safety Aspects of Corps of Engineers Projects
by

Harry E. Kitch, P.E.

Acting Deputy for Planning
Policy and Planning Division

The 1983 Economic and Environmental Principles and Guidelines for Water and Related Land Resources Implementation Studies (P&G) require that the plan that maximizes net economic benefits, consistent with protecting the Nation's environment, be selected unless the ASA(CW) grants an exception when there is some overriding reason based on other Federal, state, local or international concerns . The ASA(CW) will determine the reasons for selecting a plan other than the NED plan. The basis for the selection should be fully reported, including the considerations used in the selection process.

Our plan formulation process is based on the development of a range of significantly different plans, one of which is designated as the NED plan, as described above. The selection is based on a comparison of the evaluated effects (primarily NED) and how well each alternative meets the tests of completeness, effectiveness, efficiency and acceptability but other perceivable effects may also have weight. In each alternative, the planning team should suggest

adjustments in design to reflect various assessments of risk and uncertainty and should use these assessments in the decision making process. This information must be displayed in the reporting documents.

While these requirements of P&G apply to any kind of Corps project and a clear and complete rationale for deviations from selecting the NED plan must be presented for every case, our regulations provide the most guidance for flood control projects. This, happily, is also the primary focus of this workshop.

Our guidance on this topic is in our, soon to be published, ER 1105-2-100 and before that was in an EC. Our guidance requires additional justification for larger than NED scale plans. Projects of smaller than the NED plan (less costly) are most likely to be approved. In those case where the NED plan provides less than 100 year protection and you have convinced yourselves that 100 year protection is appropriate, then you have a reasonable expectation that an exception will be approved if you adequately document the following conditions:

(a) show that implementation of the NED plan would leave significant portions of an urban area within the post-project 100 year floodplain;

(b) show that incremental costs are not unreasonable;

(c) show that 100 year protection will reduce flood insurance requirements for the non-Federal interests;

(d) show that 100 year protection has potential to reduce future not subsidized reimbursements for flood losses (e.g. disaster relief); and

(e) show that 100 year protection significantly changes local planning environment.

Now, if you want to provide even greater protection (over 100 year) and can do all of the above, then you also have to analyze strategies to reduce the residual risk associated with the NED plan and you must document the special considerations which remain critical even after the analysis of residual risk.

The risk reducing analysis must document the nature and characteristics of a potential failure (at levels above NED) and look for ways of reducing the risk associated with the NED plan. These ways may include project designed failure modes or nonstructural flood warning. These must be measures that are over and above those which are incrementally justified and included in the NED plan.

When you have done all this and still have conditions which you believe are still critical, then you have to document these special conditions. This documentation must include discussions that describe the flood characteristics that require a high degree of protection, and the characteristics of the area which remains at risk after the risk-reducing measures described earlier. And finally you must document the plans of the non-Federal interests for development in the floodplain that can't be located out of the floodplain. These plans must have a high likelihood of implementation in the with- project condition but would not be implemented in the without- project condition.

All these arguments for higher levels of protection must be substantially documented and based on analyses. You must do these

analyses in an incremental manner and not presume a specific level of protection at the outset.

Based on this incremental analysis of the levels of protection, the costs of the protection, degree of residual damage reduction and degree of risk reduction must be displayed and a rationale presented for the recommended degree of protection.

Now after telling you all the requirements necessary to have a "reasonable expectation" of having an exception to NED granted, you'd like me to give you some examples or case studies of projects where an exception has been granted. Unfortunately, there haven't been any and very few have even been submitted. Perhaps one of you will be involved in the first successful project granted an exception to NED and will become a guru for the rest of the Corps.

In addressing this subject with the OASA(CW) staff, they said the main thing to consider when asking for an exception is to do the analyses and then honestly answer the question - "Does this all make sense?"

Remember that project development is a team and partnership proposition now. Project scale, level of protection, scope and all other aspects are determined by many factors that require teamwork and most of all - communication, understanding and trust among members of the team!

THANK YOU.

SUMMARY OF SESSION 3: CHANNEL PROJECTS

Overview

The topics covered in the presentations included sediment and environmental considerations in channel design and a low level of protection channel project. The session included three paper presentations and three panel discussions.

Paper Presentations

Paper 4. Jerry W. Webb, Memphis District, presented a paper entitled "Sedimentation and Stability Analysis of Nonconnah Creek, Memphis, Tennessee." Mr. Webb's paper describes the study which utilized a staged sedimentation analysis approach similar to that described in draft EM 1110-2-4000. The main channel had been modified historically due to mining operations and floodplain fills. The initial study was performed with limited information on the geometry, sediment, and hydrologic data. The detailed sediment study, which included similar geometric data, and detailed sediment samples and hydrologic information was conducted as part of the Phase II GDM investigation.

Paper 5. Walter M. Linder, Kansas City District, presented a paper entitled, "Opportunities for Environmental Enhancement for Brush Creek." Flood control studies of Brush Creek, located in metropolitan Kansas City, showed modifying a 7400 foot long reach of the channel to be economically feasible and acceptable to local interests. Mr. Linder described the project setting, the coordination required between the numerous interest groups, and the use of a physical model to first develop the design for the federal flood control only project and then evaluate the city's proposed enhancements to the USACE recommended project.

Paper 6. Guri S. Jaisinghani, Detroit District, presented a paper entitled, "Ecorse Creek Flood Control Study." The Ecorse Creek study investigated the need for flood protection for the urban Ecorse Creek drainage basin in southeastern Michigan. Mr. Jaisinghani described the study setting, data availability, and the approach used for the study. Several structural and nonstructural alternatives were evaluated. The ultimate results of the study showed one retention basin to be economically justified. The NED plan would provide only two to five year flood protection for most areas and would have a reduction in the existing annual flood damage of eleven percent. As a result, the BERH has requested its staff to make recommendations on the future utility of similar investigations.

Panel 3 Discussions

Jack G. Ward, discussed Mobile District's Sowashee Creek flood control project functional and safety issues. The Sowashee Creek Project is designed to reduce flood damage in the urban and industrial areas of Meridian, Mississippi. Seven alternatives

were investigated including the recommended plan as proposed by the public and local sponsor. The plan involves channel enlargements of selected reaches and clearing and snagging of other reaches along the stream. The recommended plan was that which maximized the B/C ratio and provided varying levels-of-protection throughout the study area as opposed to a specific design frequency. Certain features of the project were designed to preclude failure during a severe event.

David Gregory's panel presentation, "Try Simple Solutions for Hi-Tech Problems," stressed that as *newer and more sophisticated technologies* are developed and applied to a wider array of hydraulic engineering design problems, we need to be careful that these tools do not override engineering judgement and common sense. Mr. Gregory, from the Albuquerque District illustrated his point as he described a flood control study on the Puerco River at Gallup, New Mexico, which ultimately involved a simple analysis approach to a sediment-channel capacity issue. Initial proposals were to apply detailed models and/or physical models to address the sediment issue.

Ronald A. Yates, Ohio River Division, presented issues related to channel projects. Mr Yates stated the need for channel and other projects to be engineered to function properly and for the project to be maintained throughout its economic life. Mr. Yates presented several examples of inadequate maintenance causing design failure in the Ohio River Division. He stressed the desirability to fund the documentation of these problems so that this knowledge may be transferred to others.

SEDIMENTATION AND STABILITY ANALYSIS OF NONCONNAH CREEK
MEMPHIS, TN

William A. Thomas ¹ Jerry W. Webb ² , David P. Berretta ²

INTRODUCTION

Study Purpose.

Generally, an alluvial stream is continually changing position and configuration as a consequence of hydraulic forces acting on its bed and banks. These changes usually result from natural environmental changes or from changes caused by man's activities. When a stream is modified locally, changes in channel characteristics frequently occur both up and downstream. The response time for adjustments is variable and is dependent on the degree of stability of the original channel, extent of the improvement, type of soil in which channel is bedded, and intensity and frequency of flows which the channel must carry. The objective of this sedimentation study is to provide a theoretical treatment of the aggradation/degradation processes in an attempt to calculate the probable aggradation and degradation of the stream bed profile as the creek responds to future hydrology and future sediment discharges.

Key Issues.

The design procedure and rationale for the design of this project are typical of most flood control projects with the exception of the high degree of protection that the existing channel provides in some reaches. The channel capacity has resulted from localized mining and borrow operations or from uncontrolled dynamic responses of the channel to man's activities. Therefore, many desirable characteristics of a stable, mature drainage system are not exhibited under existing channel conditions. The proposed channel improvements have been designed using the guidance provided in ER 1110-2-1405 (USACE, 1982) which states:

"The hydraulic design of a local flood protection project must result in a safe, efficient, reliable, and cost effective project with appropriate consideration of environmental and social aspects."

The regulation elaborates on each component of the above statement explaining the intent of each component but not defining the appropriate degree that each must be studied. Components taken from the regulation include:

1. Safety - potential hazards to humans and property, creation of a false sense of security, consequences of flows exceeding the improved channel capacity.
2. Efficiency - channel cross section, plan, and bottom profile configuration to optimize conveyance and operation and maintenance.

¹ Research Engineer, Waterways Experiment Station, U.S. Army Corps of Engineers

² Hydraulic Engineer, Memphis District, U.S. Army Corps of Engineers

3. Reliability - ability to achieve project purposes throughout project economic life.
4. Cost Effectiveness - initial, operational, maintenance, and replacement costs optimized on an annual cost basis.
5. Environmental and social aspects - fish and wildlife, beautification, recreational opportunities, handicap access, and mitigation of adverse impacts.

The regulation also states requirements of the hydraulic design presentation. Special key issues that were of interest in this project include protective measures, water surface profile stability, and approach and exit channels. The regulation states the requirement that all channel elements must "perform satisfactorily for flows up to and including the annual flood frequency which has a 50 percent probability of being exceeded during the project economic life. The suggestion is also made in the regulation that a sedimentation study is a necessary part of the profile stability presentation. Elements of a satisfactory sedimentation study are provided, but specific guidance as to how to determine the severity of the sedimentation aspects and substantiate the design measures taken to maintain profile stability is not provided. The study of Nonconnah Creek utilized supplementary guidance provided in draft EM 1110-2-4000 (USACE, 1987), Sedimentation Investigations of Rivers and Reservoirs. Engineering judgment is still required to assess the appropriate level of study. In certain situations, a sediment impact assessment is the highest level of study that is necessary. Initially, it was thought that this was the case with the Nonconnah Creek study and a detailed sedimentation model would not be required. During the review of the Phase II General Design Memorandum (GDM), Memphis District was directed to perform an analytical study even though sufficient data was not available for calibration.

PHYSICAL SETTING

Proposed Project Features.

The recommended plan of improvement to be separately implemented by the Corps of Engineers includes features for flood control, fish and wildlife enhancement, and recreation. Flood control is the primary project purpose, and its implementation is separate from the two supplemental features. Flood control measures include improving the lower 18.2 miles of Nonconnah Creek, of which 10.5 miles will be channel clearing and snagging only, and the remaining 7.7 miles will be channel enlargement. This improvement will provide a 100-year frequency level of flood protection. The fish and wildlife enhancement measure includes the preservation of a 33-acre tract of cypress and other bottomland hardwoods which contains an unusual diversity of wildlife for an area surrounded by urban development. Recreational measures include the development of the fish and wildlife enhancement area to facilitate nature study and observation. Recreational measures also include the construction of 8.8 miles of a combined bike and hike trail within the channel construction right-of-way area along three separate segments of Nonconnah Creek.

Existing Channel.

The existing channel is rather narrow and deep and is bedded in sand or gravel throughout the study reaches. The banks are predominantly clay or silt, occasionally intermixed with a strata of sand.

Historic Channel Stability.

The upper reaches of Nonconnah Creek were modified by local interests over 50 years ago. Little is known as to the stability of the channel immediately following the channel improvements. The earliest aerial photographs of the entire study reach were flown in 1958. These photographs show a rather artificial looking channel up to Winchester Road (Mile 17.34). Long straight reaches of channel were cut through historical meander traces. The channel meander lengths measured approximately 1000 to 1200 feet in the lower 4 miles, approximately 600 to 800 feet in the middle 8 miles, and approximately 400 to 600 feet in the upper 6 miles. With the exception of the airport and a few scattered subdivisions, the area south of Nonconnah Creek was undeveloped. There were 15 bridges between the mouth and Winchester Road; consequently, the channel alignment was virtually locked in by 1958.

Aerial photographs from the 1970's and 1980's prove that the basin was urbanizing at a rapid rate. All traces of historical meander patterns were gone. Two areas, one located downstream of Perkins Road (Mile 11.53) and the other located downstream of Mt. Moriah Road (Mile 12.59), were extensively excavated for commercial development in the floodplain. Other locations have served to support mining operations. Although the stream was, and continues to be, highly disturbed by commercial activities, the low flow channel has formed alternate bars indicating a tendency to reestablish a meander pattern. Current topographic information indicates that the bottom width of the creek varies from 300 to 500 feet with the exception of a one-half mile reach of the creek (Mile 11.53 to Mile 11.94) which has an average bottom width of about 100 feet. (In August, 1987, this reach was altered by a local developer.)

In the early 1980's, the local governments began an extensive bridge monitoring and rehabilitation program after the catastrophic failure of a bridge. Local improvements consisted of riprap and gabion protection of the channel and banks at some bridges. These improvements not only are protecting the bridges, but are also serving as grade control structures.

Reconnaissance of Nonconnah Creek.

From field observations of the prototype made during this study, the following information was surmised:

1. Throughout the study limits, commercial activities have made it very difficult to assess the degree of instability of the existing channel. The stream bed profile is lowering as evidenced by the addition of stone protection at several bridges. These improvements not only are protecting the facilities but are also serving as grade control. Generally, the banks appear remarkably stable to be so tall and steep.
2. There is evidence that the stream has transported substantial quantities of silt, sand and gravel in the recent past. Buried logs are visible 12 to 15 feet below the present topbank. Reaches formally used as borrow sites are slowly being refilled by Nonconnah Creek.

3. There is visible evidence of bank instability downstream of Getwell Road where banks are wet from groundwater seepage.

4. The larger tributaries that enter Nonconnah Creek have been either concrete lined or stabilized with riprap or gabions. These man-induced alterations have also contributed to the physical changes to the main creek.

STUDY APPROACH

This study utilizes a staged sedimentation study approach similar to the descriptions in draft EM 1110-2-4000. During the early stages of project formulation, there was little or no sediment data. The main channel had been modified historically, and mining operations and usage of the floodplain for fill to accommodate the increasing urbanization indicated that calibration of a numerical model was not possible. In light of the dynamic state of the channel geometry, an initial sediment impact assessment was performed. Based on the results of that analysis and information determined during the hydraulic studies protective measures were designed for all structural components of the project. Subsequent to submission of the Phase II GDM (USACE, 1987), reviewing authorities required a detailed sedimentation study. The following paragraphs discuss available data, methodology, and results of both levels of the analysis.

Initial Assessment

Available Data during Initial Assessment.

Data necessary for conducting the sedimentation study were of three types: geometric, sediment, and hydrologic. Visual inspections of the Nonconnah Creek basin also aided in the sediment study.

1. Geometric Data. Channel cross sections, bed profiles, and alignments were obtained from field surveys. Analysis of aerial photographs, quadrangle maps, and proposed channel improvements were also used.

2. Sediment Data. Sediment data consisted of the channel bed composition, the strata underlying the bed material, and the inflowing sediment load. Due to past and current dredging activities throughout the basin, no bed samples were taken. Visual inspections were used in determining the bed composition. The existing bed consists of sands and gravels throughout the study reaches which are constantly being disturbed. Twenty-nine channel borings and associated grain size distribution curves were used to define the underlying strata. These gradation curves were also used to estimate grain size distribution curves for the bed material. These generalized gradation curves were used in the sediment calculations.

3. Hydrologic Data. Land use studies indicate that the total basin is currently 43 percent urbanized with a projected increase to 66 percent by the year 2043. The basin area below John's Creek (Mile 11.94) is approximately 78 percent urbanized with a projected increase to 97 percent by

the year 2043. The study area was modeled using the HEC-1 (HEC, 1985) Flood Hydrograph computer package as part of the hydrologic and hydraulic analyses. The hydrologic studies estimate that these future projected increases in urbanization will increase the 100-year discharge by approximately 20 percent. For this level of study the hypothetical discharges for a 2-year frequency event were multiplied by a range of ratios (25, 50, and 75 percent) to better evaluate in-bank flows under normal, daily conditions. These discharges were input into the hydraulic model to determine variables needed in this evaluation. Observed 24 hour rainfall from 1977 to 1986, was used in estimating the number of events per year that could be expected for a estimated discharge.

General Procedures Adopted in Initial Assessment

The following discussion addresses the initial assessment of channel stability with respect to the existing conditions and the recommended improvements. The stability analysis performed includes a qualitative and relative quantitative evaluation of potential problems and betterments resulting from proposed channel improvements.

Computational Methods.

Representative channel reaches with respect to hydraulic characteristics were designated along Nonconnah Creek. Hydraulic, hydrologic, and geometric data were extracted from the HEC-1 and HEC-2 (HEC, 1982) computer models for the 2-year frequency event and several lesser flows including ratios of 25, 50, and 75 percent. Average reach parameters were determined from actual parameters of the cross sections through that reach. The total bed-material load for each reach for the different events was estimated using Toffaleti's Method as included in the Waterways Experiment Station (WES) program H0926, Corps Library for Hydraulic Design. A comparison between maximum and minimum values of various geometric and hydraulic parameters for existing and improved conditions was performed. Table 1 presents the results of the 2-year frequency event. Similar analysis was performed using the 25, 50, and 75 percent ratios of the 2-year event with similar results.

TABLE 1
COMPARISON OF GEOMETRIC AND HYDRAULIC PARAMETERS
 (2-YR FREQUENCY EVENT)

	<u>Existing Conditions</u>		<u>Improved Conditions</u>	
	Min.*	Max.*	Min.*	Max.*
V (fps)	1.4	5.6	1.8	6.6
D (ft)	15.2	15.2	13.9	13.9
W (ft)	644.0	207.0	642.0	194.0
Se (ft/ft)	.000083	.001142	.000141	.001799
G	8.04	8.13	8.04	8.13

*These values represent the minimum and maximum average reach values from the most sensitive reaches. Minimum variable values are for reach 11, Mile 12.02-12.46 and the maximum variable values are for reach 10, Mile 11.50-11.94.

Results of Initial Assessment

The degree and location of channel aggradation and/or degradation and overall channel stability were evaluated by comparing the sediment transport for existing conditions with that under the proposed plan of improvement. These results were used to estimate rates of scour and deposition which are presented in Table 2.

Table 2
RATE OF SCOUR AND DEPOSITION**

Stream From (mi.)	Mile To (mi.)	Reach*	Existing Conditions		Improved Conditions	
			Scour (ft/yr)	Deposition (ft/yr)	Scour (ft/yr)	Deposition (ft/yr)
0.29	2.35	1	0.3-0.6		0.0-1.9	0.0-0.4
2.65	3.14	2	1.9-4.5		0.0-2.1	0.0-2.1
3.23	4.32	3	0.0-0.6	0.0-1.8	0.0-0.2	0.0-0.1
4.35	5.54	4	1.8-2.9		0.0-1.2	0.0-1.3
5.62	6.86	5		0.3-0.5	0.1-0.6	
6.90	7.63	6	2.5-5.0		0.0-1.2	0.0-1.2
7.78	8.09	7		1.2-3.2	0.0-1.2	0.0-0.2
8.18	10.35	8	0.4-1.0		0.2-0.5	
10.46	11.44	9		0.7-1.5		1.2-1.8
11.50	11.94	10	4.7-9.3		7.9-12.7	
12.02	12.46	11		0.3-0.9		0.7-1.3
12.63	14.37	12	0.0-0.2	0.0-0.1	0.0-0.1	0.0-0.2
14.46	15.53	13	0.3-0.6		0.3-0.9	
15.62	17.25	14	0.2-0.4		0.3-0.7	
17.37	21.01	15	----	----	-----	-----

* This reach breakdown was used in the sedimentation study only and should not be confused with the economic reaches.

** This table presents a snapshot of deposition and erosion rates and is not to be used to calculate long term volumes.

Based on historic information and field observations, the results in Table 2 give a good indication of existing conditions. Reaches 13 through 15 have not experienced significant modifications over the past several years. Reach 12 has oscillatory tendencies; aggrading under certain flow conditions, and degrading under other flow conditions. Reach 11 is a depositional reach and has been an active borrow area. Reach 10 is a very dynamic reach with active bank caving and erosion. This reach is critical in that commercial development has been allowed to encroach to topbank and Johns Creek, the major tributary, enters Nonconah Creek in this reach and aggravates the problem. In August, 1987, Reach 10 was extensively modified by a local developer. The channel bottom width was approximately doubled and the side slopes improved. The developer has implemented some bank stabilization measures. Reach 9 is also a depositional reach and has been an active borrow area. Reach 8 shows signs of instability through channel widening and bank caving. Reach 7 exhibits depositional tendencies which is substantiated by current dredging operations that have gone on for several years. Reaches 3 through 6 show the same

scouring and/or depositional tendencies as previously explained. Reaches 1 and 2 are located in the Mississippi River backwater areas. Results indicate headwater scouring; however, these reaches have been relatively stable over the past few years.

The proposed improvements give a relative indication of conditions after the project is in place and identified problem areas. Most reaches develop oscillatory tendencies seeking a state of quasi-equilibrium. Historic depositional reaches 9 and 11 will continue to follow this trend. Reach 10 shows an increase in scouring tendency which will require channel and bank stabilization. Otherwise, the responses to natural morphological changes would be propagated to reaches above and below and cause changes to their respective channel characteristics. Due to current activities in Reach 10, the type of stabilization required will be determined for plans and specifications.

The proposed improvements also recognize the need for increased channel stability around bridge structures and in certain bendways. Protection will be provided at all facilities as required by accepted criteria. This protection will also function as grade control of the channel. Bendways located between Mile 0.76 and Mile 0.94, Mile 4.77 and Mile 4.90, and the outlet channel for Nonconnah Pump Station will also be protected.

Interpretation of Results of Initial Assessment

In alluvial streams it is expected that banks will erode, sediment will be deposited, and floodplains and tributaries will undergo modification with time. The Nonconnah Creek basin in recent years has experienced rapid growth which has altered channel characteristics. Channel velocities are high, and man's activities have caused extensive instability. The proposed improvement will be constructed along the existing channel alignment. The improvement will essentially provide a consistent level of protection for the drainage system to convey future flows through the basin. The impacts to the existing river morphology will consist of accentuating the oscillatory tendencies along various reaches of the channel. Operation and maintenance costs have been included for removal of material at appropriate intervals throughout the project life. Anticipated stability problems under improved conditions will consist of sloughing banks on outside bends and dynamic conditions throughout Reach 10. The analysis indicates that stabilization will be necessary at these areas.

Detailed Analytical Study

Available Data during Detailed Studies.

Data necessary for conducting the sedimentation study were similar to the initial assessment and consisted of three general types: geometric, sediment, and hydrologic.

1. Geometric Data. Same as initial assessment.
2. Sediment Data. In April 1988, 54 sediment samples were taken from the channel bed at 27 locations spaced along the 20 mile study area. Two samples were taken in the dry at each location, one from near the water's edge and the other from the point bar deposits midway of the channel. Grain size distribution curves were developed for the samples. In addi-

tion, channel borings and associated grain size distribution curves were used to define the underlying strata.

3. Hydrologic Data. Rainfall - runoff simulations using historical rainfall (1964-1987) observed at the National Weather Service Office at Memphis International Airport were used to estimate the relative impacts of existing and improved conditions. Composite unit hydrographs were computed from the 10-year and 100-year flood hydrographs from the HEC-1 models. Daily discharges were computed using the observed rainfall applied to the composite unit hydrograph. The computation of daily discharge uses the antecedent precipitation index method to compute losses. This data was reduced to blocked histograms using the Sediment Weighted Histogram Generator (SWHG) developed by the Hydrologic Engineering Center, Davis, California. The program processes daily discharges into representative discharges and time periods. Histograms were computed at four locations for existing and improved conditions using Total Water Volume as a basis for proportioning tributary inflows.

General Procedures Adopted for Detailed Study

The following discussion addresses the analytical approach taken during the detailed studies of channel stability with respect to existing conditions and the recommended improvements. Following the initial assessment, a sedimentation study was performed by Mr. William A. Thomas, Hydraulics Laboratory, Waterways Experiment Station (WES) and personnel from Memphis District. The results of the study are published in a miscellaneous paper entitled "Nonconnah Creek Sedimentation Study Analysis Using A Numerical Modeling Approach". These results are summarized in this section and serve as a basis for establishing operation and maintenance requirements of the project sponsors.

Computational Methods

The WES computer program, "Sedimentation in Stream Networks," TABS-1 (TABS, undated) was used to investigate the adequacy of proposed channel invert controls by forecasting channel aggradation and degradation over the next 10 to 25 years. Nonconnah Creek has been disturbed too severely to permit the normal model confirmation. Therefore, the investigation used a long term runoff record developed from rainfall, and single event runoff hydrographs developed using HEC-1. The objective was to calculate the probable aggradation and degradation of the stream bed profile as the creek responded to the modeling approach. The model is unconfirmed, and consequently, the results do not meet standards associated with a numerical model. Therefore, the approach provided a theoretical treatment of the degradation/aggradation processes along Nonconnah Creek. It also provides a numerical model which could be confirmed if adequate field data were available. Finally, the approach utilized the fullest extent of present technology to study a project which involves mobile bed hydraulics and all the channel bed dynamics associated with fluvial processes.

Evaluation of Existing Hydraulic Parameters

Typically velocity, width, depth, slope, and meander wave length are expected to be related to a dominant water discharge. The sediment concentration in the flow, sediment particle size in transport and on the stream bed, and cohesive characteristics of the stream banks are parameters in these relation-

ships. The 2-year frequency discharge is often quoted in the literature as approximating the dominant discharge. Regime relationships for width, depth, and slope are presented in the report "Hydraulic Design of Stable Flood Control Channels, II-Draft Guidelines for Preliminary Design" prepared by Northwest Hydraulic Consultants, LTD (Northwest, 1984). These regime relationships for width, depth, and slope were applied to Nonconnah Creek using the 2-year discharge (17,692 cfs at the mouth) so that this channel could be compared with those known to be in regime.

1. Calculated Water Surface Top Width. Water surface top widths were calculated with the HEC-2 models. The average value in the lower 4 miles of the existing channel is about 260 feet. This compares favorably with data presented in the above report. This reach is considered the most likely to have been formed by alluvial processes because of the lack of recent man-induced modifications. Throughout the other reaches, the channel has been disturbed, and the top width does not represent a regime value.

2. Channel Depth. The lower reach of Nonconnah Creek does not give a good comparison of channel depth to the regime values presented in above report. Mississippi River backwater directly influences the hydraulic-hydrologic-sediment transport characteristics. The best locations for comparing channel depth to regime values seem to be one of the upstream borrow areas which are being replenished by Nonconnah Creek.

3. Energy Slope. The energy slope tends to increase slightly in the upstream direction. The mean value between Mile 8 and Mile 12 is about .0007 ft/ft. The regime relationship is dependent on the bed particle size as well as the water discharge. Using a mean value of D50 of 8 mm and a 2-year discharge of about 9000 cfs, the resulting slope is about .00035 ft/ft. Since the slope responds more quickly to changes in the inflowing sediment load than either the channel width or the channel depth, it is the least dependable regime parameter. The bed slope depends more strongly on particle size in the stream bed and concentration-particle size in the inflowing bed material sediment load than either the depth or width. For equilibrium systems the regime value might be significant; however, when the system is as far from equilibrium as Nonconnah Creek, one should be interested in but not confined to a regime slope.

4. Mean Channel Velocity. The channel velocities for the 2-year discharge tend to increase slightly from Mile 13 to the mouth. The calculated values fluctuate from cross section to cross section, but a regression line through these values goes from 3 feet per second near Mile 13 to 6 feet per second at the mouth.

Evaluation of Inflowing Sediment Load

No suspended sediment measurements are available, but sands and gravels are the predominant sediment sizes on the bed of the existing channel. Therefore, sediment transport theory was used to calculate the bed material sediment discharge for existing conditions. These calculations require hydraulic parameters plus the gradation of the bed surface. The portion of Nonconnah

Creek upstream from Winchester Road (Mile 18.10 to Mile 20.98) was selected for the transport capacity calculations. The existing conditions geometry and n-values formed the geometric model. Four flood discharges were selected, and the starting elevations for the water surface profiles were taken from the HEC-2 model. TABS-1 was used for the calculations.

1. Transport Capacity Calculations Since the bed samples from "mid-bar locations" were the most likely to have been deposited during floods, they were used to describe the bed material for sediment transport calculations for the four selected flood discharges. Starting with the 2-year flood peak discharge, a zero sediment inflow was prescribed for the TABS-1 code. The Laursen Transport function as modified by Madden in 1985 was used to calculate the total sand and gravel load moving in the model and the concentration by size class. The average transport capacity was calculated by averaging the 11-cross sectional values from Mile 18.10 to Mile 20.98. Those values were then coded as the inflow to the upstream end of the model and the calculation repeated for that same water discharge. After three iterations, the inflow was in balance with the average transport in that reach as shown by a zero trapping efficiency and negligible bed change at each cross section. That value was selected; the next water discharge was prescribed and the procedure started over. The resulting inflowing bed material sediment discharge at the starting point for the analysis (Winchester Road) is shown in Table 3.

Table 3
The Inflowing Sediment Load by Size Class, Tons/Day (*)

Q	1.000000	8,000.00	16,000.00	100,000.00
VFS	0.002614	100.00	190.00	1,775.00
FS	0.026138	1,000.00	1,900.00	17,750.00
MS	0.018386	703.40	1,336.46	12,485.00
CS	0.0036593	140.00	266.00	2,485.00
VCS	0.0006795	26.00	49.40	461.50
VFG	0.0003136	12.00	22.80	213.00
FG	0.0002404	9.20	17.48	163.30
MG	0.0001934	7.40	14.06	131.35
CG	0.0000522	2.00	3.80	35.50
SUM	0.0522761	2,000.00	3,800.00	35,500.00

(*) The first value in each column is the water discharge in cfs. The remaining values are the sediment discharges for each size class, listed in column 1, in tons/day.

2. Sediment Inflow from Tributaries The sediment inflow from tributaries was assumed to be zero. This was based on the fact that no bars were found at the mouths of tributaries, and there was noticeable degradation downstream from existing drop structures on Johns Creek and Ten Mile Creek. There were no significant deposits within the concrete lined tributaries. This supported the assumption that no significant sediment

load was being introduced by the tributaries. Also this assumption resulted in more erosion occurring in the model than would occur in the prototype.

Results of Detailed Analytical Study

With respect to predicted bed surface profiles, the existing profile was compared to the predicted profile calculated for the end of the 24 year period of analysis. A degradational trend is indicated through the study limits. It should be noted that the lower two miles are not representative of long term trends because of the influence of Mississippi River backwater.

For improved conditions, the calculated bed surface profile at the end of the 24 year forecast period indicates that from approximately Mile 3 to Mile 12, the future bed profile is substantially lower with the project than without. This reflects the design of the project channel and not degradation due to stream action. From the analysis it can be shown that the recommended improvements will make the Nonconnah Creek channel invert more stable than it would be without the project. This improvement is attributed to the localized grade control provided by the protective measures included as project features at bridges and pipelines.

As the bed degrades, the water surface profile in Nonconnah Creek will drop causing steeper gradients on some tributaries. This is reflected in Table 4 which shows the water surface profile for initial conditions, the predicted water surface profile at 24 years into the future for the without project condition and the predicted water surface profile at 24 years into the future for the proposed project condition.

Most of the major tributaries that enter Nonconnah Creek have been either concrete lined or stabilized with some type of stone protection. A reconnaissance of the major tributaries was made with a representative of the City of Memphis to assess the existing condition of each confluence, to discuss the proposed improvements along the main stem of Nonconnah Creek, and to agree on protection requirements. It was determined that the confluence with Days Creek, Mile 6.16, and Ten Mile Creek, Mile 9.46, will be protected as a part of the improvement to Nonconnah Creek, but no additional protection will be placed at other confluences.

Table 4
Base Level Lowering With and Without the Project

Section Id No	Initial WS Elev	Predicted WS		Base Level Change		Section Id No	Initial WS Elev	Predicted WS		Base Level Change	
		Future w/o	Future w/proj	w/o	w/proj			Future w/o	Future w/proj	w/o	w/proj
21.005	289.18	289.54	289.51	0.36	0.33	17.346	270.82	269.47	270.42	-1.35	-0.40
20.980	289.05	289.11	289.06	0.06	0.01	17.340	270.69	269.44	270.31	-1.25	-0.38
20.791	287.60	287.66	287.42	0.06	-0.18	17.246	270.13	268.64	268.18	-1.49	-1.95
19.870	282.20	284.12	283.90	1.92	1.70	17.113	269.36	268.03	267.81	-1.33	-1.55
19.690	281.44	283.42	283.24	1.98	1.80	16.670	266.79	267.48	267.59	0.69	0.80
19.520	280.75	282.42	282.25	1.67	1.50	16.400	264.83	267.35	267.53	2.52	2.70
19.066	279.04	279.11	278.84	0.07	-0.20	16.347	264.84	267.15	267.33	2.31	2.49
18.971	278.75	278.51	278.34	-0.24	-0.41	16.252	264.80	264.68	264.01	-0.12	-0.79
18.895	278.35	277.73	277.66	-0.62	-0.69	16.195	264.62	264.42	263.85	-0.20	-0.77
18.850	278.11	277.10	276.81	-1.01	-1.30	15.840	263.84	262.84	262.41	-1.00	-1.43
18.600	276.87	275.39	274.65	-1.48	-2.22	15.624	263.63	261.31	261.84	-2.32	-1.79
18.100	274.45	273.42	272.35	-1.03	-2.10	15.605	263.50	261.21	260.73	-2.29	-2.77
17.365	270.95	269.68	270.72	-1.27	-0.23	15.600	263.50	261.22	259.88	-2.28	-3.62

Table 4 (continued)
Base Level Lowering With and Without Project

Section Id No	Initial WS Elev	Predicted WS		Base Level Change		Section Id No	Initial WS Elev	Predicted WS		Base Level Change	
		Future w/o	Future w/proj	w/o	w/proj			Future w/o	Future w/proj	w/o	w/proj
15.525	263.33	261.16	259.77	-2.17	-3.56	8.180	221.74	221.05	219.72	-0.69	-2.02
15.431	262.50	260.93	259.70	-1.57	-2.80	8.092	221.66	220.39	218.75	-1.27	-2.91
15.336	261.40	260.26	259.63	-1.14	-1.77	7.960	221.58	219.60	217.30	-1.98	-4.28
15.260	260.39	259.23	259.37	-1.16	-1.02	7.903	221.56	219.33	216.65	-2.23	-4.91
15.190	259.76	259.01	258.96	-0.75	-0.80	7.780	221.35	219.08	216.32	-2.27	-5.03
15.095	259.36	258.82	258.49	-0.54	-0.87	7.625	220.79	218.89	216.07	-1.90	-4.72
15.000	258.99	258.44	258.08	-0.55	-0.91	7.220	219.73	218.69	215.82	-1.04	-3.91
14.860	258.69	258.23	257.96	-0.46	-0.73	6.899	218.90	218.50	215.67	-0.40	-3.23
14.457	258.03	258.01	257.84	-0.02	-0.19	6.862	218.78	218.44	215.64	-0.34	-3.14
14.419	257.83	257.87	257.71	0.04	-0.12	6.850	218.74	218.44	215.49	-0.30	-3.25
14.400	256.80	256.82	256.83	0.02	0.03	6.740	218.39	218.33	212.64	-0.06	-5.75
14.370	254.47	253.76	252.32	-0.71	-2.15	6.560	217.60	217.88	211.89	0.28	-5.71
14.211	254.10	253.52	252.14	-0.58	-1.96	6.490	216.88	216.24	211.38	-0.64	-5.50
14.040	253.56	252.75	251.53	-0.81	-2.03	6.301	214.41	214.09	209.59	-0.32	-4.82
13.600	250.74	248.28	248.27	-2.46	-2.47	5.920	213.32	213.04	207.70	-0.28	-5.62
13.380	248.53	247.69	247.81	-0.84	-0.72	5.621	212.93	211.80	205.96	-1.13	-6.97
13.010	247.11	246.50	246.88	-0.61	-0.23	5.540	212.79	210.76	204.71	-2.03	-8.08
12.632	245.97	245.41	245.61	-0.56	-0.36	5.250	211.98	210.03	203.91	-1.95	-8.07
12.613	245.85	245.20	245.39	-0.65	-0.46	4.960	210.91	209.83	203.55	-1.08	-7.36
12.590	245.78	243.96	243.89	-1.82	-1.89	4.491	209.61	209.65	203.43	0.04	-6.18
12.461	244.35	242.73	242.97	-1.62	-1.38	4.472	209.60	209.65	203.22	0.05	-6.38
12.308	241.11	242.07	242.35	0.96	1.24	4.460	209.59	209.65	203.12	0.06	-6.47
12.210	240.99	241.14	241.08	-3.85	0.09	4.349	209.44	209.62	203.02	0.18	-6.42
12.144	240.90	240.42	240.26	-0.48	-0.64	4.320	209.40	209.59	202.84	0.19	-6.56
12.018	240.56	239.42	239.23	-1.14	-1.33	4.311	209.36	209.56	202.80	0.20	-6.56
11.942	240.41	238.96	238.74	-1.45	-1.67	4.170	208.94	209.23	202.36	0.29	-6.58
11.896	240.12	238.89	238.69	-1.23	-1.43	4.161	208.94	209.14	202.10	0.20	-6.84
11.840	239.55	238.84	238.66	-0.71	-0.89	4.140	208.91	208.74	201.66	-0.17	-7.25
11.783	239.22	238.82	238.63	-0.40	-0.59	4.131	208.89	208.61	201.67	-0.28	-7.22
11.726	239.17	238.77	238.61	-0.40	-0.56	3.639	207.65	204.26	199.28	-3.39	-8.37
11.669	239.08	238.72	238.57	-0.36	-0.51	3.450	205.90	202.19	198.46	-3.71	-7.44
11.612	238.95	238.69	238.55	-0.26	-0.40	3.380	204.34	201.48	198.13	-2.86	-6.21
11.555	238.75	238.68	238.55	-0.07	-0.20	3.225	203.88	199.85	197.60	-4.03	-6.28
11.530	237.75	238.30	237.77	0.55	0.02	3.135	203.26	199.25	197.42	-4.01	-5.84
11.498	236.99	238.24	237.19	1.25	0.20	3.048	200.31	198.91	197.29	-1.40	-3.02
11.435	236.97	238.07	236.99	1.10	0.02	2.650	198.45	195.22	197.06	-3.23	-1.39
11.230	236.85	237.18	235.92	0.33	-0.93	2.590	198.33	194.79	196.92	-3.54	-1.41
11.006	236.42	236.59	235.34	0.17	-1.08	2.350	197.94	194.42	196.80	-3.52	-1.14
10.869	236.24	236.29	235.04	0.05	-1.20	2.184	197.53	194.23	196.77	-3.30	-0.76
10.727	236.13	235.96	234.51	-0.17	-1.62	2.140	197.27	194.20	196.49	-3.07	-0.78
10.695	236.12	235.92	234.28	-0.20	-1.84	2.088	197.21	194.16	196.37	-3.05	-0.84
10.637	236.10	235.88	233.95	-0.22	-2.15	2.079	197.20	194.15	196.35	-3.05	-0.85
10.527	236.05	235.78	233.32	-0.27	-2.73	2.070	197.18	194.13	196.33	-3.05	-0.85
10.461	236.00	235.73	233.02	-0.27	-2.98	2.060	196.94	194.10	195.02	-2.84	-1.92
10.351	235.88	235.68	232.73	-0.20	-3.15	2.051	196.92	194.07	191.91	-2.85	-5.01
10.256	235.80	235.66	232.67	-0.14	-3.13	1.833	196.37	192.83	191.59	-3.54	-4.78
10.167	235.70	235.65	232.66	-0.05	-3.04	1.786	196.25	192.42	191.42	-3.83	-4.83
10.129	235.35	235.38	232.01	0.03	-3.34	1.760	196.13	192.26	191.30	-3.87	-4.83
10.110	234.97	234.19	230.34	-0.78	-4.63	1.751	196.08	192.22	191.28	-3.86	-4.80
9.880	231.91	230.43	226.76	-1.48	-5.15	1.690	195.82	191.97	191.14	-3.85	-4.68
9.830	231.56	230.33	226.68	-1.23	-4.88	1.661	195.69	191.84	191.07	-3.85	-4.62
9.450	230.21	229.42	226.20	-0.79	-4.01	1.481	194.83	190.75	190.10	-4.08	-4.73
9.100	229.03	227.55	225.65	-1.48	-3.38	1.230	191.80	189.51	188.43	-2.29	-3.37
8.926	228.27	226.76	225.44	-1.51	-2.83	0.797	189.73	186.20	185.35	-3.53	-4.38
8.888	228.02	226.33	225.24	-1.69	-2.78	0.760	189.68	185.60	184.92	-4.08	-4.76
8.870	227.84	226.07	225.12	-1.77	-2.72	0.750	189.59	185.36	184.70	-4.23	-4.89
8.610	225.14	224.69	224.05	-0.45	-1.09	0.617	189.06	184.22	183.76	-4.84	-5.30
8.497	223.27	224.16	223.44	0.89	0.17	0.290	182.93	182.06	182.06	-0.87	-0.87
8.490	223.02	224.09	223.30	1.07	0.28						

Interpretation of Results of Analytical Study

Although this study predicts a degradational trend with the project in place, this study supports the fact that the project will provide a more stable channel than will exist without the project.

The calculated bed change in the approach channel is less than 1 foot. This is attributed to the stone protection proposed at the bridge crossings for Winchester Road, Hacks Cross Road, and Forest Hill-Irene Road. The calculated water surface profiles show no appreciable base level lowering in the 3 miles of approach channel to the project.

Nonconnah Creek empties into McKellar Lake which flows into the Mississippi River. Maintenance dredging is required at the mouth of Nonconnah Creek. From this study it can be inferred that the proposed project should decrease sediment outflow by 28 percent. This is a direct reduction of a major sediment source to the lake which should reduce maintenance dredging quantities for that portion of the navigation project.

Within the limits of study, the calculated maximum amount of degradation is about the same with the project as without it. However, the average amount of degradation over the 18.2 mile project length is 1.5 feet with the project and 2.0 feet without the project for the 24 year period of analysis. These values show that the project will reduce the rate of bed degradation by 25 percent. The average amount of aggradation is 0.25 feet without the project and 0.20 feet with the project for a reduction of 20 percent.

There is every indication that degradational and aggradational trends will continue past the 24 year projection at no decrease in rates. In other words, in 50 years the average depth of degradation is expected to be 3 feet with the project and 4 feet without the project. Continued downcutting of the stream bed, either with or without the project, will eventually increase bank heights to produce instabilities. The project sponsor has been made aware that the project will not cause such a condition; however, the proposed design does not stabilize Nonconnah Creek to the point of preventing such a condition from occurring.

CONCLUSIONS

The sedimentation studies define the damage potential and potential hazard to life, and provide essential information for local sponsors to assess the functionality of the project. The requirements of ER 1110-2-1405 have been met and guidance provided in the draft EM 1110-2-4000 have been utilized in developing the study methodology and procedure.

The initial assessment was accurate with respect to relative trends, but was not detailed enough to fully define long term performance and reliability. The more detailed analytical analysis was considered necessary for use in establishing recommendations and/or requirements of project sponsors.

Even though adequate field data could not be obtained to confirm the numerical model to normal standards, the study combined engineering judgment with a theoretical treatment of the degradation/aggradation processes along Nonconnah Creek. It utilized the fullest extent of present mobile boundary technology to study a project in which mobile bed hydraulics, and the channel bed dynamics associated with the fluvial processes, are expected to be highly significant during the life of the project.

Deposition in the Project Reach.

The existing channel and adjacent floodplain have historically been used as a borrow pit for fill material, but there are no indications that such excavation was needed to offset deposition in the channel. Two areas, one located downstream of Perkins Road (Mile 11.53) and the other located downstream of Mt. Moriah Road (Mile 12.59), were extensively excavated during the 1970's. Available topographic information indicates that the bottom width of the creek varies from 300 to 500 feet. Both are depositional areas. Studies have also indicated that the reach of channel at approximately stream mile 8.00 exhibits depositional tendencies. This condition is supported by sand and gravel operations which have removed and stockpiled fill material. The analysis indicates depositional tendencies in these reaches will continue even with the implementation of proposed improvements. It is anticipated that controlled removal of material may enhance the stability of the project. Based on the sensitivity of the system to these operations, the local sponsor or his representative should place a moratorium on mining and excavation for fill material until the monitoring program can establish a baseline condition from which future activities can be regulated.

Existing and Future Channel Stability.

The stream bed profile is generally degrading as evidenced by gabions, and other types of grade stabilization at several bridges. However, the banks appear remarkably stable to be so high and steep. There is evidence of bank failure downstream of Getwell Road where banks are wet from seepage. Elsewhere, point bars have developed indicating the reestablishment of meander patterns in the straight channel alignment. The sedimentation study has shown that the project will make the Nonconnah Creek channel invert more stable than it would be without the project under both existing and future hydrologic conditions described above. The calculated maximum amount of degradation is about the same with the project as without the project. However, the average amount of degradation over the 18.2 mile project length is 1.5 feet with the project and 2.0 feet without the project for the 24-year period used in the analysis. Continued downcutting of the stream bed, either with or without the project, will eventually increase bank heights to the point of failure.

Present Condition of Hydraulic Structures in the Approach Channel.

The bridge crossings at Hacks Cross Road and Forest Hill-Irene Road were included in the study limits. Currently, these bridges have some channel protection consisting mostly of broken concrete rubble placed over time. This upper reach has not experienced significant modifications over the past several years. Stone protection is included for these sites to minimize project impacts. The calculated bed change (with or without the project) will be less than 1 foot. This is attributed to the hard points at the bridge crossings. Monitoring of facilities outside the project limits will be necessary to insure continued functioning throughout the project's life.

OPERATION AND MAINTENANCE GUIDELINES

The sedimentation studies show that future channel stability will improve with the project in place. However, continued downcutting of the stream bed, with or without the project, will eventually increase bank heights. The

project is not causing such a condition; however, the proposed design does not stabilize the creek to the point of preventing downcutting from occurring. Therefore, the project should be monitored to detect bank failures, loss of protection at bridges, loss of channel capacity, and other changes to allow for timely maintenance and repair. The model results provided the basis for establishing guidelines for operation and maintenance of the project which were furnished to the project sponsor. Provisions of the proposed operation and maintenance agreements are described in the following paragraphs.

Maintenance.

Periodic inspections of the channel and appurtenant works shall be made by the local sponsor or his representative prior to the beginning of the flood season and immediately following each major highwater period. The representative shall make certain that:

1. The channel is clear of debris and growth which would restrict or block flow;
2. The capacity of the channel is restored when the channel has lost 10 to 20 percent of the cross section below the designed flowline;
3. The channel is not being restricted by the depositing of waste materials, building of unauthorized structures, or other encroachments;
4. Channel dredging and land-filling within the 100-year floodplain is restricted so as not to endanger project purposes and appurtenances and meet Federal, state, and local regulations;
5. Riprap sections and retaining walls are in good condition;
6. Approach and egress channels adjacent to the improved channel are sufficiently clear of obstructions, debris, and in good repair to properly function.

Reports.

The local sponsor or his representative is responsible for the preparation and submission of reports regarding the condition of the flood control project. These reports shall include:

1. Number of inspections and dates thereof
2. Changes in channel conditions at the monitor ranges
3. Channel conditions in the vicinity of bridges
4. Condition of bridge protection
5. Any other conditions which are suspect
6. Any filling or mining operations in the 100-year flood plain

Monitoring.

The local sponsor or his representative should establish an effective monitoring program. This program should include the establishment of permanent ranges along Nonconnah Creek at approximately ten key locations for making periodic surveys of channel cross-sections. This should allow comparisons of cross-sections over time to monitor scour and deposition, thalweg fluctua-

tions, and changes in rating curves. From the sediment model study, the following locations should be established as initial permanent monitoring ranges:

1. Mile 1.90, downstream of Nonconnah Creek Pumping Station
2. Mile 2.50, downstream of ICG Railroad
3. Mile 5.00
4. Mile 7.60, downstream of Hurricane Creek
5. Mile 9.60, upstream of Ten Mile Creek
6. Mile 11.80, upstream of Perkins Road
7. Mile 13.50
8. Mile 15.30, upstream of Howard Road Outfall
9. Mile 16.70, downstream of Winchester Road
10. Mile 18.20, end of project

Should dynamic changes occur at any of these ranges, additional sites should be established to define the problem areas. Channel conditions in the vicinity of all bridges should be closely monitored to determine if there is a need for maintenance. Aerial photographs should be used to monitor changes in channel alignment, bend migration, bank caving, and developments in the floodplain that could impact on channel stability.

REFERENCES

1. HEC-2. Generalized Computer Program. 1982. "Water Surface Profiles," Users Manual, The Hydrologic Engineering Center, U.S. Army Corps of Engineers, Davis CA.
2. HEC-1. Generalized Computer Program. 1985. "Flood Hydrograph Package," Users Manual, The Hydrologic Engineering Center, U.S. Army Corps of Engineers, Davis CA.
3. Northwest Consultants, LTD. 1984. "Hydraulic Design of Stable Flood Control Channels, II - Draft Guidelines for Preliminary Design," Prepared for: U.S. Army Corps of Engineers, Seattle, WA.
4. TABS-1. WES Computer Program. (undated). "Sedimentation in Stream Networks," Waterways Experiment Station, U.S. Army Corps of Engineers, Vicksburg, MS.
5. U.S. Army Corps of Engineers. 1987. "Nonconnah Creek, Tennessee and Mississippi, Phase II General Design Memorandum No. 101," U.S. Army Corps of Engineers, Memphis TN.
6. U.S. Army Corps of Engineers. 1982. "Hydraulic Design for Local Flood Protections Projects," ER 1110-2-1405, U.S. Army Corps of Engineers, Washington, DC.
7. U.S. Army Corps of Engineers. 1987. "Sedimentation Investigations of Rivers and Reservoirs," EM 1110-2-4000, U.S. Army Corps of Engineers, Washington, DC.

OPPORTUNITIES FOR ENVIRONMENTAL ENHANCEMENT FOR BRUSH CREEK

by

Walter M. Linder¹

Introduction

Brush Creek, which drains a highly urbanized area in the heart of metropolitan Kansas City, experienced a flash flood in September 1977 that took 12 lives and caused \$66.4 million in damages. Flood control studies showed modifying a 7,400 foot long reach of the channel would be economically feasible and acceptable to local interests. Conventional mathematical computations did not provide accurate water surface profiles because of the steep slope and numerous bridge and conduit restrictions. A physical model was used to develop a channel modification design for flood control. The Parks and Recreation Department of Kansas City, Missouri, proposed additional modifications for environmental enhancement at City cost. Model studies of the proposed environmental design were funded by the City to assure that flood control features were not compromised. This paper describes the project setting, the coordination required between the numerous interests, and the use of the physical model to first develop the design for a Federal flood control only project and then evaluate the City's proposed environmental enhancement.

Physical Setting

Brush Creek drains 29.4 square miles of totally urbanized area in the heart of metropolitan Kansas City. Approximately 43 percent of the basin lies in the state of Kansas and the remaining 57 percent is located in Missouri. Government jurisdiction in the basin is divided between 2 states, 3 counties, and 12 incorporated communities. From its headwaters in northeastern Johnson County, Kansas, Brush Creek flows in a northeasterly direction. A short distance upstream of State Line Road it is joined by Rock Creek, a major left bank tributary. After crossing into Jackson County, Missouri, it continues in an easterly direction about 5 miles (mi) and joins the Blue River which is a right bank tributary of the Missouri River. Throughout most of its length, both in Kansas and Missouri, the stream has been straightened and modified to suit development. This has created the potential for severe flash flooding. Starting about 2,000 feet (ft) downstream of State Line Road, the channel bottom was paved in the mid 1930's for a distance of about 3.8 mi. Adjacent to the paved reach is an area known as the Country Club Plaza, which is considered a predecessor of the modern shopping center. It is an area of popular restaurants, luxury hotels and apartments, exclusive stores, and speciality shops.

1. Chief, Hydrologic Engineering Branch, Kansas City District, U.S. Army Corps of Engineers

The width of the paved bottom varies from 60 to about 80 ft. A small channel, which carries the normal flow of a few cubic feet per second (cfs), is centered on the paved bottom. On each side of the paving are low, near vertical masonry walls that are generally 3 to 4 ft high, but extend to a height of nearly 20 ft along the right bank in the vicinity of Troost Avenue. The adjacent banks in the vicinity of the Plaza have slopes on the order of 1V on 8H to 1V on 12H. These slopes are maintained in a park-like setting with well mown grass and scattered large individual shade trees. This area receives extensive recreational use during much of the year. Downstream of the Plaza the right bank is steeper and covered with trees and brush. City streets parallel both sides of the channel for most of its length. The depth of the channel varies from 10 to about 20 ft. The slope of the stream is very steep, and varies between 17 and 23 ft/mi. High flow velocities are common and exceed 30 feet per second (ft/sec) during high flows. Below State Line the channel is crossed by numerous bridges which present varying degrees of flow restriction. These include two railroad bridges, 16 street bridges, two pedestrian bridges, and two large conduits. The upstream conduit, located a short distance downstream of the Plaza, passes under what is known as Volker Park. It is a triple box conduit 840 ft long, with each box 10 ft high and 20 ft wide. Its capacity is somewhat less than a 10-year flood event. The second conduit is located about 4,000 ft farther downstream and makes a 90-degree bend while passing under the intersection of two major traffic arteries. It consists of two triple box conduits added upstream and downstream of an old concrete arch bridge. Each box is 14 ft high and 22 ft wide. The total enclosed length is 418 ft. Its capacity is somewhat greater than a 50-year flood event. Discharges greater than about a 20 to 25-year event will initiate flooding in the Plaza area.

The September 1977 Flood

Beginning early the morning of September 12, 1977, the Kansas City metropolitan area experienced the greatest storm-total rainfall ever recorded, with 12 to 14 inches (in) falling on the Brush Creek basin. The storm actually was two record breaking events of 6 to 8 hours duration, separated by a 12-hour interval. Each storm in itself was equivalent to about a 100-year or greater event. The first storm produced about 5.5 in of rain in about 6 hours, but did not cause serious flooding. Its effect was to saturate the pervious area in the basin. That evening the second storm produced an additional 8 to 10 inches of rainfall. Figure 1 presents a map of the Brush Creek basin showing storm total rainfall amounts. Water levels in Brush Creek went from near zero to maximum stage within 2 hours. Figure 2 shows the stage-discharge hydrograph at Main Street. The peak discharge at Main Street was estimated to be between 17,000 and 18,000 cfs. The Plaza area was devastated with 5 to 6 ft of water in shops and restaurants adjacent to the stream. Twelve lives were lost in the Brush Creek basin and damages were estimated at \$66.4 million. The frequency of flooding below State Line was estimated to be a 200 to 500-year event. Except for three high level bridges, every bridge and conduit below State Line Road was overtopped by a significant amount.

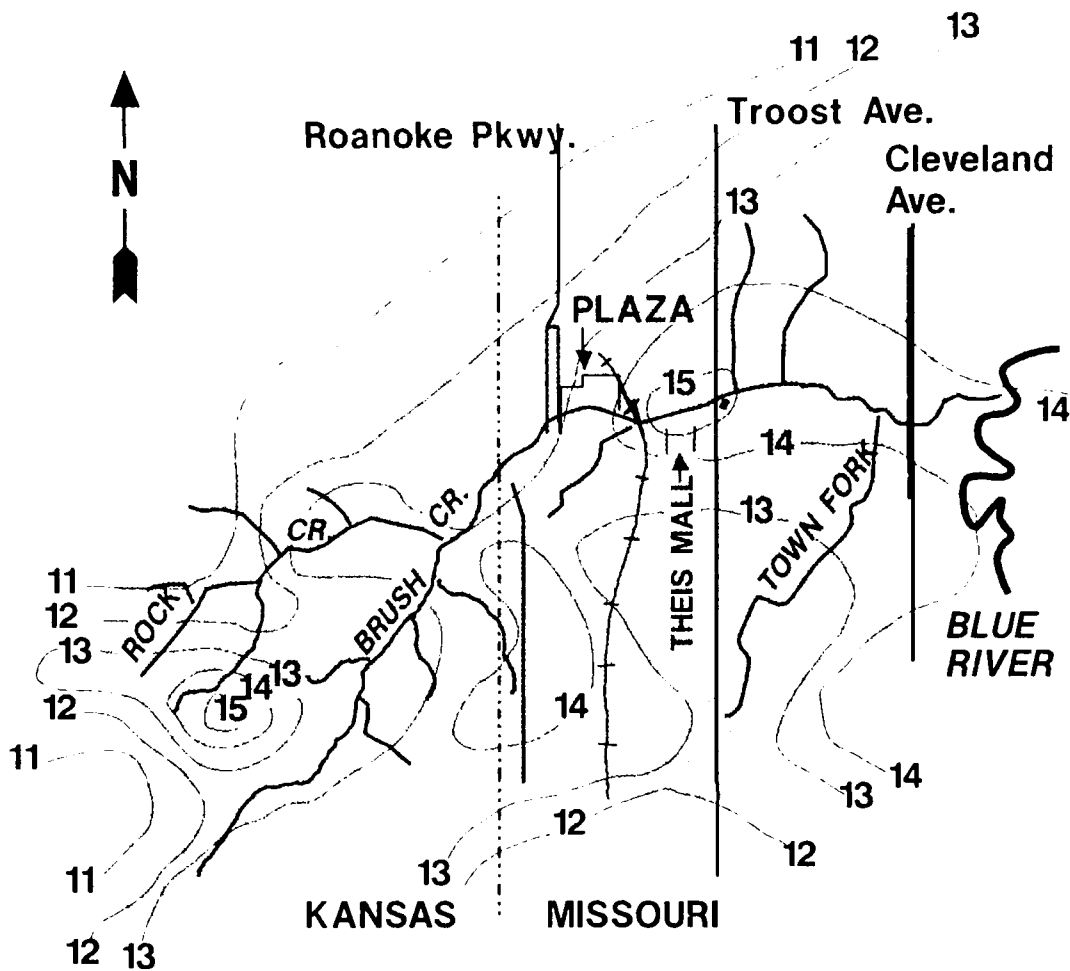

Figure 1 - 1977 Flood Rainfall on Brush Creek Basin

Flood Control Studies

The City of Kansas City, Missouri requested the Kansas City District to investigate the feasibility of flood control for Brush Creek. A number of channel modification plans were investigated, but the only plan which maximized net economic benefits and was acceptable to local interests was a 7,400 ft length of channel deepening in the vicinity and downstream of the Plaza. This plan was recommended in a 1981 Feasibility Report and was subsequently authorized by the Water Resources Development Act of 1986. This was the first project in the Kansas District to fall under the new cost sharing requirements. It also made the sponsor, the City of Kansas City, Missouri, a full partner in the project. In addition to sponsoring the Federal project, the City intends to extend channel modification upstream and downstream of the Federal project to provide flood protection for a larger area.

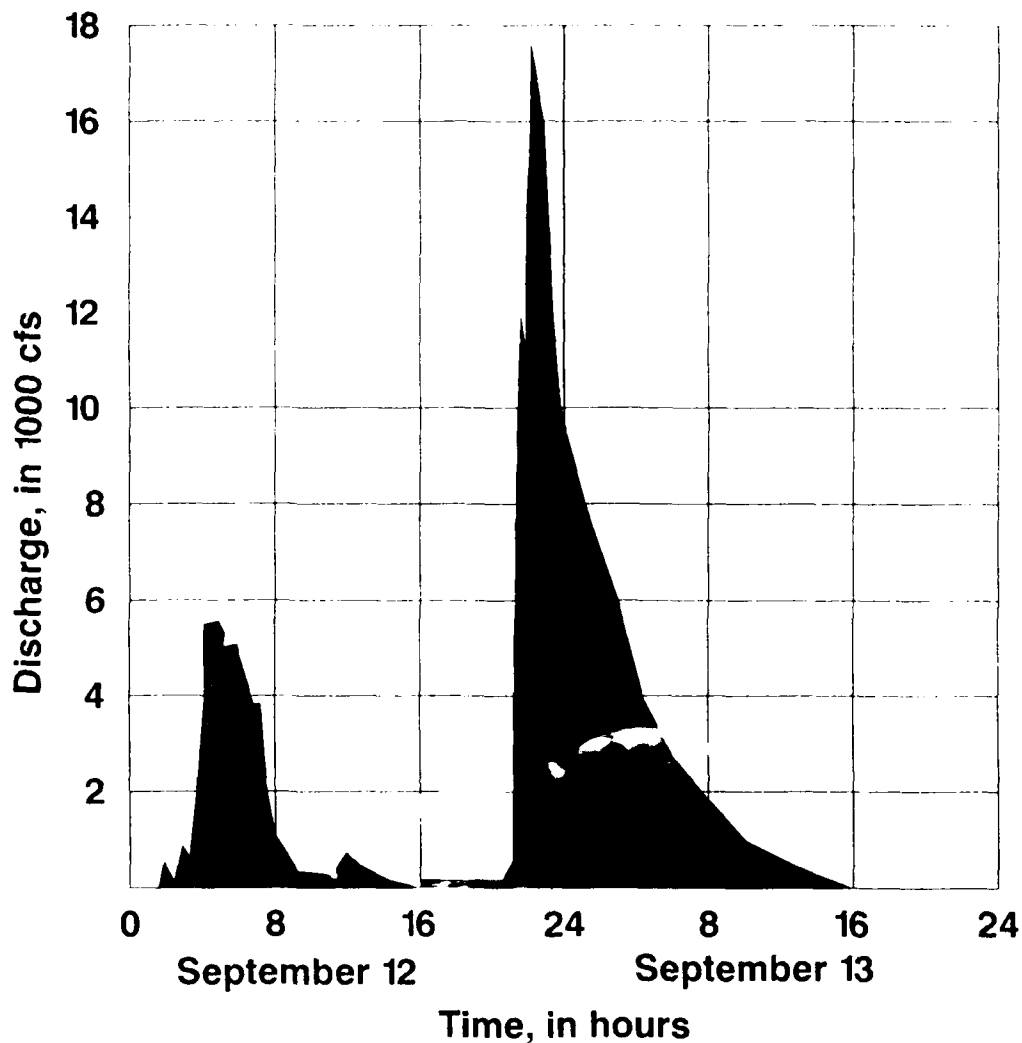

Figure 2 - Brush Creek 1977 Flood Hydrograph at Main Street

Flood Probability

There were no long term gauging stations in the Brush Creek basin, as the gauge at Main Street had been in operation only a few years and was discontinued shortly after the 1977 flood. Therefore, discharge-frequency relationships for flood control studies were based on a watershed run-off model calibrated to the 1977 flood. The model used was a Missouri River Division adaptation of the E.P.A. Storm Water Management Model (SWMM). Discharge values determined for the 500-year flood, which was selected as a design goal, varied from 19,500 cfs at State Line to 28,300 cfs at the downstream end of the study reach. Table 1 presents the September 1977 flood and 500-year design flood discharges as determined by the runoff model.

TABLE 1

BRUSH CREEK
DISCHARGE - FREQUENCY DATA

<u>Location</u>	<u>Drainage Area sq. mi.</u>	<u>Sept 1977 Flood (Discharge in cfs)</u>	<u>500-Year Flood</u>
State Line Rd. to Ward Parkway	12.7	17,500	19,500
Ward Parkway to Wornall Road	15.2	18,600	20,700
Wornall Road to Oak Street	16.3	19,960	22,100
Oak Street to Troost Ave.	19.4	22,830	24,500
Troost Ave. to Woodland Ave.	21.1	27,590	28,300
Woodland Ave. to Benton Blvd.	22.9	30,470	30,400
Benton Blvd. to Mouth	29.4	39,470	38,500

Water Surface Profile Computations

Water surface profiles for feasibility studies were computed with the HEC-2 program, using the channel modification option for simulating a deepened channel. During detailed design studies, the cross sections were recoded using the actual coordinate points for the deepened section. The computations indicated the flow was near or below critical depth at a number of locations within the study reach due to the steep slope and paved channel bottom. The closed conduits and restrictive bridges presented additional computational difficulties. Further analysis led to the conclusion that the HEC-2 program could not provide the required degree of accuracy. An attempt was made to use a generalized program based on both the energy and momentum equations. However, this produced inconsistent results that were no more reliable than the HEC-2 computations.

Physical Model Studies

Need For Model Studies. When it became apparent that computations would not provide the desired accuracy for a design water surface profile, a decision was made to proceed with a physical model study. The benefits to be gained from a model study included:

- o A more accurate definition of existing and modified water surface elevations.

- o Assurance that the proposed design would achieve the desired degree of flood protection.

- o Definition of flow velocities for determining the need to protect exposed rock surfaces and hydraulic forces acting on bottom paving and retaining walls.

- o definition of energy dissipation and erosion protection requirements at the upstream end of channel deepening.

- o A visual concept of the project through visits to the model by local and Corps officials and through video tape presentations to other interested parties.

Kansas City, Missouri funded their share of the costs of modeling the Federal Project reach and all additional costs related to their proposed upstream extension.

Model Description. The model was built to represent the channel, the adjacent overbank and the parallel streets for a 15,000 ft reach extending downstream from State Line Road to Woodland Avenue. This provided sufficient length to include the Federal project as well as the proposed City extensions. The 1:35 scale model was approximately 430 ft long and 12 to 15 ft wide. Bridges were made removable in order to be able to determine the impact of individual or groups of bridges. The model was initially constructed to represent the proposed deepened channel. A bond breaker (paper) was placed over the bottom of the deepened channel which then was backfilled with concrete mortar to represent existing conditions. This was done to minimize the cost in converting the model from existing to the proposed modified conditions. The channel bottom was then smoothed to represent the roughness of concrete paving. Overbank and channel side slopes were left with the normal concrete mortar finish. This was considered to be representative of prototype "n" values of 0.011 to 0.013 for the concrete paving and 0.020 to 0.025 for the well maintained overbanks.

Table 1 shows a significant increase in discharge in the downstream direction. For example, at the 500-year discharge the flow increases from 19,500 cfs at State Line Road to 28,300 cfs between Troost avenue and Woodland Avenue. This 8,800 cfs increment represents approximately a 45 percent increase in flow through the study reach. This increase results from several large storm sewers that discharge into the channel and overbank flow from the adjacent streets and low areas that carry surface run-off in excess of the storm sewer's capacities. The increase in discharge in the downstream direction was introduced into the model through plastic pipes buried in the overbank at the locations of large existing storm sewers. The appropriate increment of additional flow at each location was determined with the use of the run-off model.

Model Verification. The ability of the model to properly simulate prototype conditions was verified by reproducing the September 1977 flood using discharges determined by the run-off model. Figure 3 shows the 1977 flood high water marks and the channel center line water surface profile from the model. Comparison of water surface elevations in the model with observed high water marks shows the model gave a good reproduction of prototype conditions.

Existing Conditions Tests. Tests proceeded with identification of existing conditions. The model clearly indicated areas of supercritical flow as well as the substantial head losses created by the conduits and various bridges. The only bridges that did not significantly impede the flow were the new Wornall Road bridge and the relatively high J.C. Nichols Parkway bridge. Bridges shown to be major flow obstructions were Rockhill Road, the abandoned railroad bridge, Main Street, and Troost Avenue. The two latter bridges are high level bridges with narrow openings through which all the flow must pass. Flow was supercritical from the Troost Avenue bridge downstream to about midway between Troost and the Paseo. At that point backwater caused by the restriction of the Paseo conduit created a hydraulic jump. Water surface profiles were obtained for the 10, 25, 50, 100 and 500-year flood events. Flow velocity measurements were obtained for the 50, 100 and 500-year discharges. Velocities were measured near the bottom, mid-depth and near the surface at the channel center line and the left and right edges of the channel. The existing conditions profiles from the model were compared with computed profiles developed and used to determine flood damages for the 1981 Feasibility Report. Although there were some deviations from the computed profiles, the model verified flood damages and project benefits.

Modified Channel Tests. Next a series of tests were conducted to determine the incremental effect of the various bridges and the Volker Park conduit. The conduit and all bridges between Roanoke and the Paseo were sequentially removed and water surface profiles obtained for the full range of flood discharges. These tests showed that even with the conduit and the bridge structures removed, the narrow openings at Main Street and Troost Avenue still acted as controls. Further lowering of the water surface required enlargement of the bridge openings in addition to channel deepening.

The backfill in the bottom of the channel was then removed and the combination of channel deepening, removal of the Volker Park conduit, enlargement of the opening through the Main Street bridge, removal of the railroad bridge and replacement of the Rockhill Road bridge was evaluated. Additional tests used expanded metal on the channel bottom to simulate the rough bottom that might result from not paving the exposed rock bottom of the deepened channel. Figure 4 shows 500-year water surface profiles for existing conditions and the proposed channel modifications. The existing bed and the deepened channel bottom are also shown as well as the upstream deepening proposed by the City to extend flood protection upstream of the Federal Project.

The authorized Federal project for flood control only developed by model testing would consist of channel deepening generally inside the existing

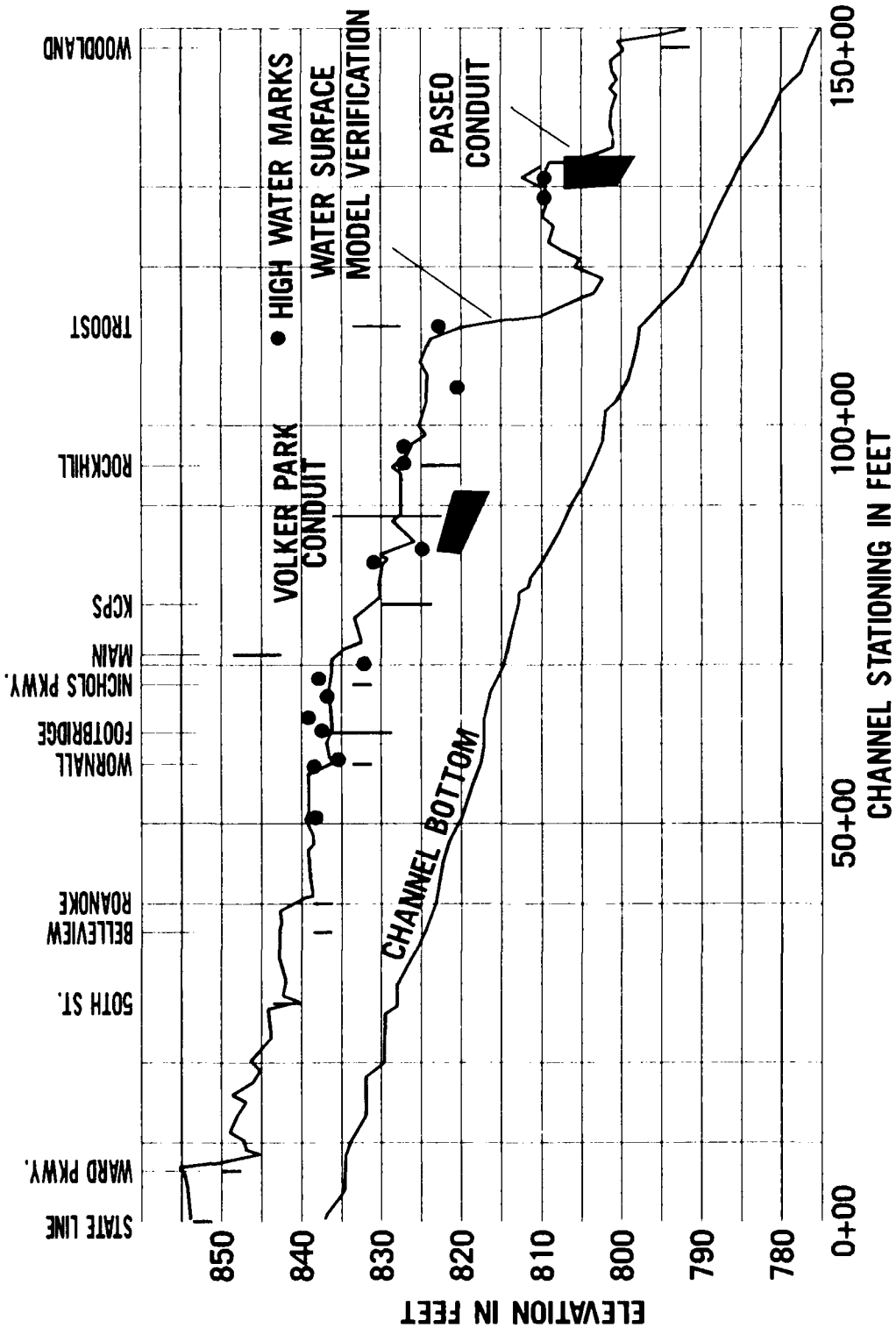

Figure 3 - Brush Creek Model Verification 1977 Flood

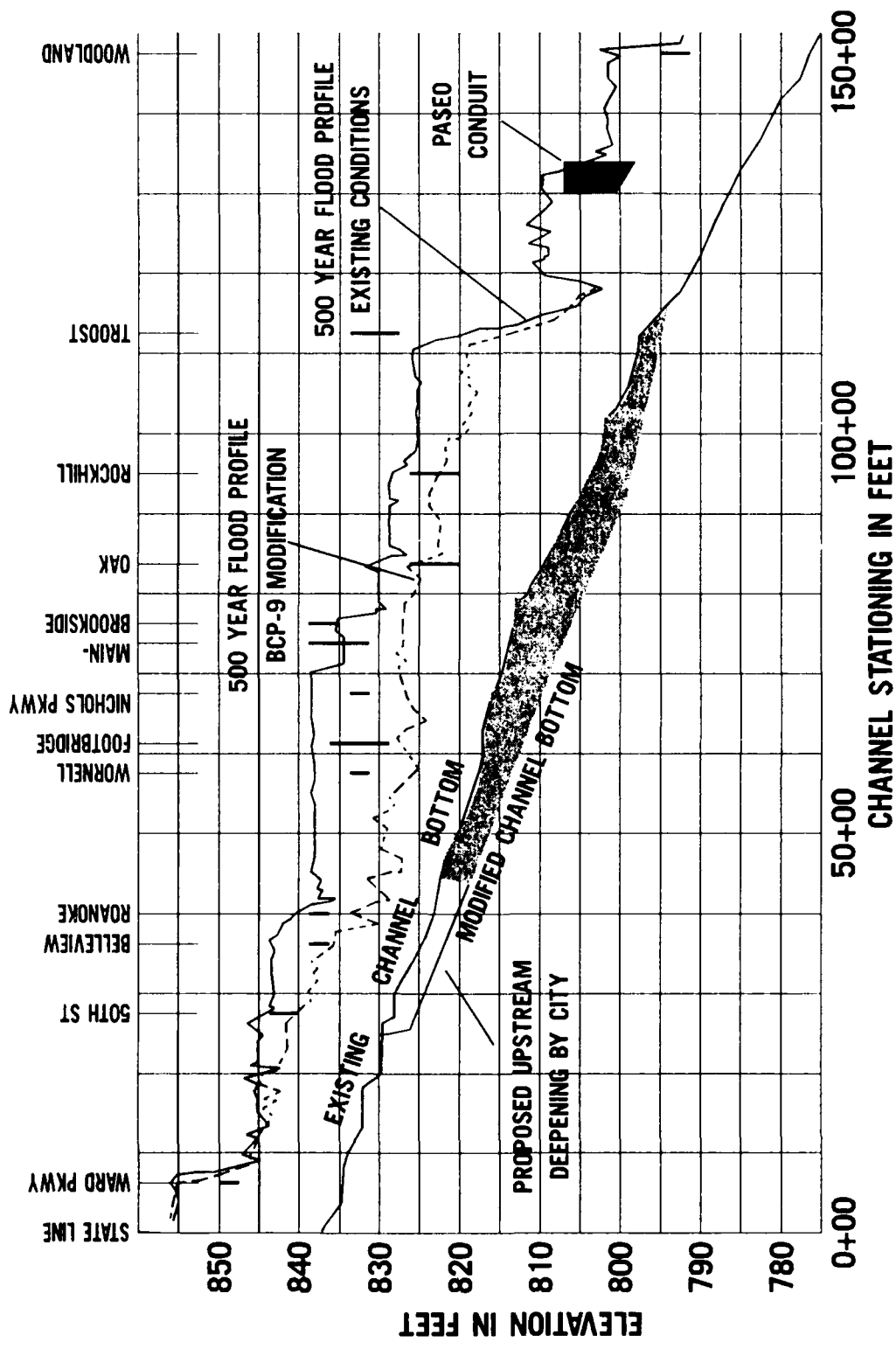

Figure 4 - Brush Creek 500-Year Design Flood Profiles

bottom paving. The amount of deepening would vary from zero at the downstream end just below Troost to a maximum of about 8 ft just downstream of the Plaza. The exposed sides of the vertical cut would be protected by anchored concrete walls in areas of rock excavation and by concrete retaining walls in areas of overburden. The tests with a roughened bottom showed that bottom paving would be required to protect the rock in the channel bottom from weathering and erosion that would cause an unacceptable increase in surface roughness and in turn an increase in water surface elevations. The conduit within the Federal project reach would be replaced with an open channel and a new bridge at Oak Street which presently passes over the conduit. The existing Rockhill Road bridge would be removed and replaced. The abandoned railroad bridge just downstream of Main Street would be removed. The existing bridge at Main Street as well as the left abutment fill would be removed. Main Street bridge will be replaced by two new bridges a short distance downstream at a location previously planned for linking major north-south traffic arteries. Although the Troost Avenue bridge raises upstream water surface elevations for a considerable distance, the high cost of replacing this bridge could not be justified. Flood protection for the proposed University of Missouri at Kansas City Research Park, which is to be located on the left bank just upstream of Troost Avenue, will be provided by area fill and a roadway fill along the left bank of Brush Creek. The City's proposed upstream extension of channel deepening will require replacement of an additional bridge at 50th Street. The model showed these modifications would lower the 500-year flood profile as much as 8 to 10 ft in the high damage Plaza area.

Impact of Channel Modification on Downstream Discharges. During feasibility studies local interests expressed the concern that channel modifications would result in increased flooding downstream of the project. A V-notch weir was installed at the downstream end of the model and a time history of weir headwater was recorded for flood discharge hydrographs routed through the model. This was done for the 500 and 100-year floods for both existing and modified conditions. The recorded headwater stages were then converted to discharge. Comparison of existing and modified conditions indicated the project could increase the 500-year flood discharge about two percent, with a stage increase of about 0.02 ft at Woodland Avenue. There was little or no change in the 100-year flood discharge. The conclusion was that the project would cause little or no increase in downstream flooding.

ENVIRONMENTAL ENHANCEMENT

Concept. The Brush Creek project is located in an area that is aesthetically very sensitive. Much of the adjacent area consists of an exclusive shopping district and luxury hotels and apartments. The existing channel and overbank receives very heavy use as an urban park. Several new office complexes adjacent to the channel are either under construction or in advanced stages of planning. Any change that would degrade the present visual environment would be unacceptable to numerous public and private interests. During early design studies for Brush Creek, the Kansas City Parks and Recreation Department expressed a desire for environmental enhancement of the project. This enhancement was to be patterned after the well known "River Walk" area in San Antonio, Texas. To further develop this plan, the Parks and

Recreation Department engaged the San Antonio architect/engineer firm of Groves and Associates to develop a concept that would provide the desired enhancement. This concept, which has come to be known as the "Park Plan", was developed for the entire reach of Brush Creek from State Line Road to its junction with the Blue River.

The Kansas City District worked very closely with the City's Public Works Department, the Parks and Recreation Department, and their consultant to develop a basic environmental plan that would be acceptable to the many interests in the Brush Creek corridor. This plan consists of additional widening and deepening of the channel, with several low dams creating a series of pools and natural appearing waterfalls. Channel walls would be irregular in alignment to create the appearance of a natural stream. Walkways would be located adjacent to the pools with ramps or steps between the various levels and to the adjacent street level. Two stepped drop structures with stilling basins would be included to dissipate energy at abrupt changes in channel bottom elevation. Additional features would include terraced plantings of the upper slopes and fountains and water walls to provide further visual enhancement and improve water quality in the pools by aeration.

Small Model Tests. There was considerable initial concern that the Park Plan would compromise the flood control function, particularly the possible adverse effect of placing dams in the modified channel. Concurrent with testing of existing conditions in the large model, a small model of a portion of the Park Plan was constructed to evaluate the concept at minimum cost. A 1,700 ft reach from just upstream of Wornall Road to just downstream of Main Street was constructed at a scale of 1:60 in a tilting flume. A proposed dam between J.C. Nichols Parkway and Main Street was included in the model. The tilting flume was used in order to be able to adjust for the inability to correctly scale "n" values in such a small model. Water surface profiles were recorded for the 100 and 500-year flood discharges with dam heights of 2.5, 7.5, 10, and 12.5 ft at two different tailwater elevations. These tests indicated a dam up to 10 ft high would be acceptable for that location. A higher dam would cause unacceptably high water surface elevations in the vicinity of the Plaza. The small model also showed the restricted bridge opening at Main Street caused a significant increase in upstream water surface elevations. Based on the results of the small model tests, the the concept of the Park Plan was considered to be acceptable. However, since the model was so small and examined only only a short reach of the project, the large model was used to develop a basic Park Plan design for the entire study reach from the upstream end of the Federal project downstream to Woodland Avenue.

Large Model Tests. The large model was remolded, entirely at City cost, to represent the proposed Park Plan. After reconstruction, tests were conducted to obtain water surface profiles, flow velocities, develop an acceptable design for the drop structures located just below Roanoke Parkway and Troost Avenue, and determine the best location and height of the dams forming the pools. The drop structures were patterned after a design the Waterways Experiment Station developed for modifying grade control structures in the Santa Anna River in the Los Angeles area. However, instead of using a parabolic shaped crest, a series of horizontal steps between 2 and 3 ft high

were used for public safety and visual appearance. Should someone attempt to walk across the crest of a parabolic drop, it would be very easy to slip and fall into the downstream stilling basin pool. It would then be very difficult, if not impossible, to get out of the stilling basin. The stepped drop would be much safer in both respects. The steps will also appear as low waterfalls during low to moderate flows. Normal low flows will be passed through the structure leaving the exposed steps dry. A stilling basin with two rows of baffle blocks and a sloping end sill provide for energy dissipation.

Dams would be constructed with an irregular crest alignment, with the crest and downstream side faced with rock to make them appear as natural waterfalls. Initially five dams were proposed at the following locations: between J.C. Nichols Parkway and Main Street, upstream and downstream of Rockhill Road, in the vicinity of the Paseo, and a short distance upstream of Woodland Avenue. It was later determined that the large sanitary trunk sewer crossing under the channel a short distance upstream of Oak Street would be very costly to relocate, as the City's Pollution Control Department would not accept an inverted siphon replacement for any of the sewers presently crossing under the channel. The dam between J.C. Nichols Parkway and Main Street was moved downstream to the location of the sewer crossing so that the sewer might cross the channel through the dam with little or no relocation required. The next downstream dam was eliminated, since it was located such a short distance downstream. The crest of the dam below Rockhill Road was raised several feet to provide sufficient depth of pool downstream of the relocated dam. A short reach of dry channel will be located between the second dam and the drop below Troost Avenue.

The City's downstream extension will replace the Paseo conduit with a channel cutoff. Two new bridges will carry the multi-laned Paseo across the channel cutoff. The third dam will be located at the downstream end of the cutoff, and the fourth and last dam will be located a short distance upstream of Woodland Avenue.

Additional tests indicated it would be possible to reduce excavation quantities by raising the bed upstream of the first dam approximately 5 ft and carrying the bed profile horizontally upstream to an intersection with the former sloped bed. Further tests with a roughened bed indicated the crest of the first dam should be lowered a foot to maintain the desired water surface elevation in the vicinity of the Plaza during a design flood. The roughened bottom test and velocity measurements also indicated paving of the entire bottom would not be necessary for the purpose of lowering the water surface profile. This will result in significant cost savings.

Figure 5 compares typical cross sections for the existing channel, the flood control only project, and the Park Plan. It should be noted that the Park Plan requires a significantly deeper and wider channel to provide the desired visual effect and retain the flood control function.

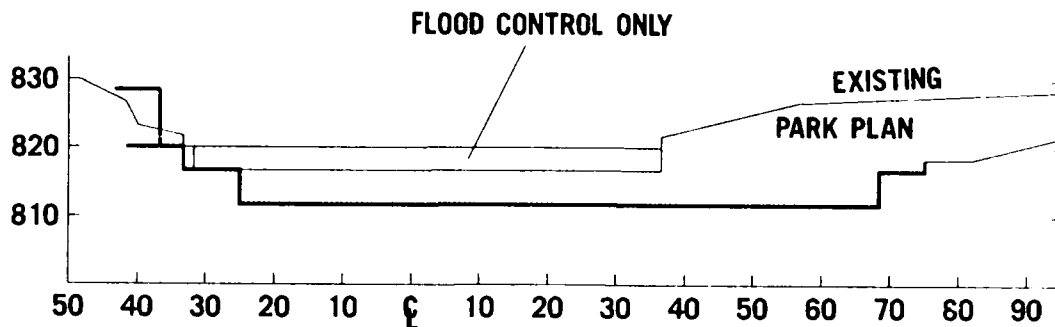

Figure 5 - Brush Creek Comparison of Typical Channel Cross Sections

Figure 6 shows 500-year flood profiles for existing conditions, the flood control only project, and the Park Plan. The existing channel bottom and the bed profile with dams and pools are also shown. The water surface profile for the Park Plan is essentially the same as for the flood control only plan, and in some areas is slightly lower.

Conclusion. Model tests of the Park Plan showed that with only minor modifications the objective of flood control could be retained and at the same time provide a major visual enhancement to the Brush Creek corridor. Water surface profiles for the 500-year flood were found to be essentially the same as for the flood control only project.

The final cost of the project will be shared by the Federal Government contributing its share of a flood control only project. The City will pay the local sponsors share of the flood control project and all of the additional costs for the Park Plan and including the upstream extension of channel deepening.

Development of an acceptable plan for both flood control and the Park Plan required intense coordination efforts between various departments of the City Government, the Corps of Engineers and a number of private interests in the area. Plans for proposed changes in the street system in the area were carefully reviewed to avoid conflicts with the project. Relocation of numerous utilities located under or adjacent to the channel will require additional coordination. The physical model was extremely useful in providing a visual concept of the project through the medium of video tape and on-site visits by representatives of the Corps, City and private interests. Without full partnership in financing, planning and design between the City and the Kansas City District, the development of an environmentally acceptable project would not have been possible.

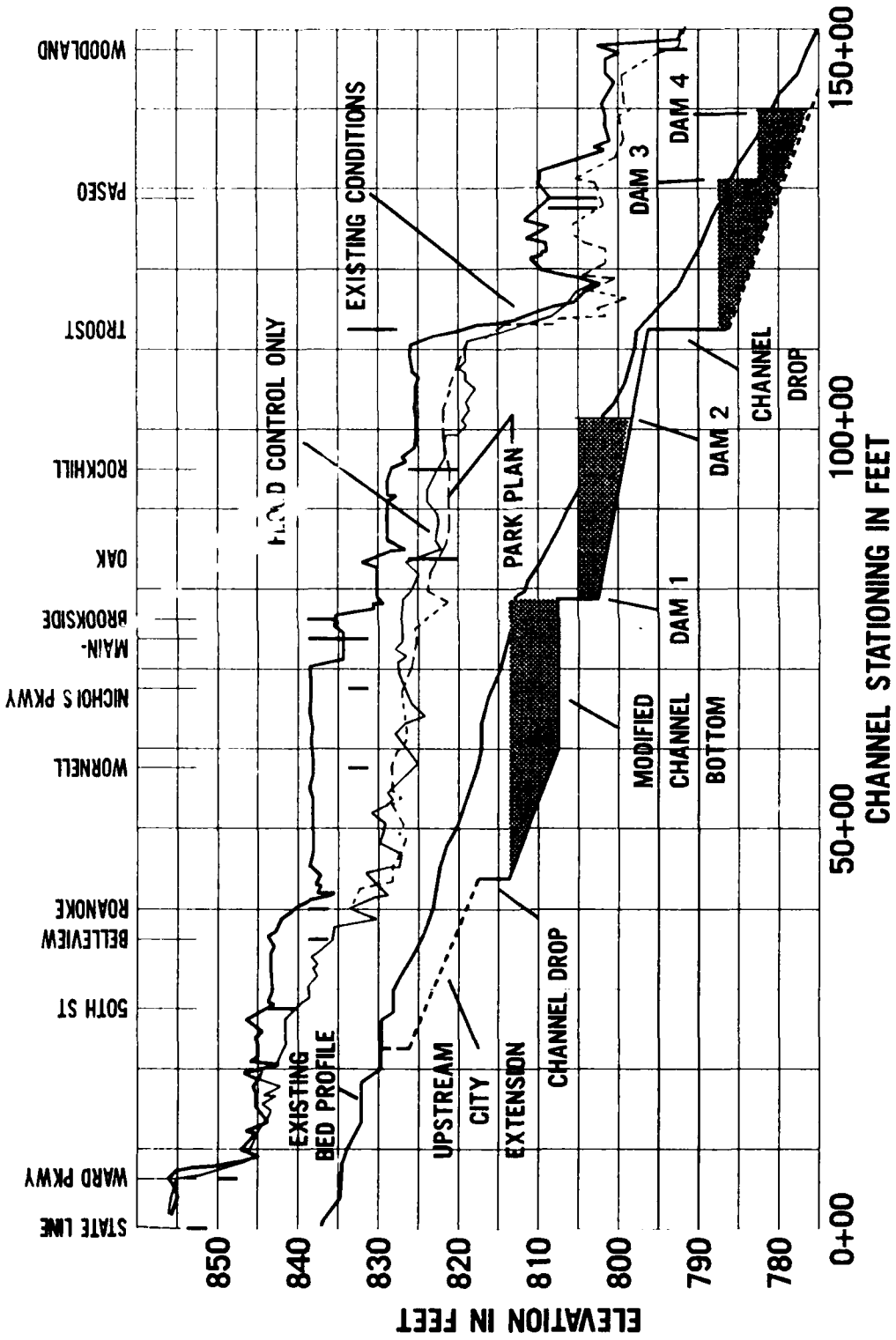

Figure 6 - Brush Creek Comparison of 500-Year Flood Profiles

ECORSE CREEK FLOOD CONTROL STUDY

by

Guri S. Jaisinghani¹

INTRODUCTION

The Ecorse Creek Flood Control Study investigated the need for flood protection for the Ecorse Creek Drainage Basin in southeastern Michigan (Figure 1). The study was initiated as a result of keen interest expressed by the Michigan Senators and Representatives of the United States Congress following extensive damages caused by widespread basin flooding in 1979. This basin is essentially an urbanized area which includes portions of twelve communities. Several structural and nonstructural alternatives for flood protection were considered during the feasibility phase of this study, including retention basins, earth channels, paved channels, various combinations of channels and retention basins and diversions and relocation. After evaluating all alternatives, the retention basin was determined to be the most economically attractive alternative, and was therefore further studied in detail. During the Board of Engineers for Rivers and Harbors (BERH) and the Office of the Chief of Engineers (OCE) review of the feasibility report, it was determined that the hydrologic and hydraulic modeling had not adequately accounted for the overbank storage. The models were subsequently rerun to incorporate revised storage/discharge relationships. This resulted in reduced peak flows and stages in a critical area, and thus impacted plan formulation. Previously, the number and sizes of the retention basins had been optimized for volume and bypass rates utilizing the original storage/discharge relationships. Due to the revision of these relationships, only one basin of the seven originally considered was determined to be economically justified. The results of the "with- project" analysis indicated that the National Economic Development (NED) plan would provide for a range of two to twenty year flood protection in most areas and would reduce annual flood damages in a range of eleven to thirty percent. The BERH was concerned about the limited level of protection provided by this project and requested its staff to make recommendations on the future utility of similar investigations.

PHYSICAL SETTING AND AVAILABLE DATA

The Ecorse Creek Drainage Basin is located in the south central portion of Wayne County, Michigan (Figure 2). The Ecorse Creek watershed encompasses an area of approximately 44.6 square miles, extending east from the Detroit Metropolitan Wayne County Airport to the Detroit River. The drainage basin is essentially rectangular with a length of 12 miles in the east-west direction and a width of four miles in the north-south direction. Three main open water courses and one primarily enclosed drain are located within the basin. The open water courses are the North Branch Ecorse Creek, the Sexton-Kilfoil Drain, also known as South Branch Ecorse Creek, and the Ecorse River. The

¹Hydraulic Engineer, Detroit District, U.S. Army Corps of Engineer.

Le Blanc Drain is the enclosed system. Additionally, several minor drains empty into the North Branch Ecorse Creek and Sexton-Kilfoil Drain. All water courses within the drainage basin are unged.

The North Branch Ecorse Creek is nearly 13 miles in length. The longitudinal slope of channel bottom is relatively flat resulting in the deposition of sediments during low flow periods, which reduces the capacity of the channel. The Sexton-Kilfoil Drain is approximately 10 miles in length and is also characterized by sluggish flow during low discharge periods. The Le Blanc drain, approximately 5 miles in length, conveys stormwater runoff from the central portion of the basin. From the confluence of the North Branch, the Sexton-Kilfoil Drain and the Le Blanc Drain, the Ecorse River runs for approximately 0.5 mile into the Detroit River. The flow characteristics of the Ecorse Creek system are influenced by the levels of the Detroit River for about 2000 feet upstream. Due to the accumulation of debris, there has been some recent channel clean out along the North Branch Ecorse Creek in Dearborn Heights and in Allen Park. In the early 1960's, the Sexton-Kilfoil drain was improved between Allen Road and the Detroit River by the Wayne County Drain Commission. One environmental problem in the basin is the extensive contamination of sediments in the lower reaches of the north and the south drains of Ecorse Creek.

The entire drainage basin is very flat, especially along the lower reaches of North Branch Ecorse Creek in the cities of Dearborn Heights, Taylor and Allen Park. The basin has undergone substantial urbanization and will continue to urbanize in the future. The flood plain along the North Branch is predominantly occupied by residential development with occasional open areas and mobile home parks along the banks. The area along the Sexton-Kilfoil Drain is primarily residential with some open areas. The current population density in the project area is approximately 3,400 persons per square mile.

STUDY APPROACH

The discharge-frequency relationships for all streams in the study area were developed for the existing and future (year 2000) conditions. Since the Ecorse Creek Basin is unged, no historical records were available to compare results of the computed discharge-frequency. The methods of hydrologic analyses used for this study included the Kinematic Wave Model, the U.S. Department of Agriculture SCS TR-20, the Regional Discharge-Frequency Analysis and Brater's Method. The Kinematic Wave Model was used as the primary hydrologic model and other models were used for comparison purposes. For the Kinematic Wave Model, the effects of increasing urbanization were accounted for by changing the parameters which describe the basin. For each sub-area, a determination was made of the contributing drainage area, the pervious and impervious overland flow strips and the collector and main channels. Physical channel parameters such as length, slope, roughness, channel shape, size and side slope and area served by the collector channels were also determined. In addition, loss rates based on Soil Conservation Service (SCS) maps were also determined for present and future land development.

The rainfall distribution used in the HEC-1 model was taken from winter and summer hyetographs for Southeastern Michigan published by Brater and Sherill; the winter months' data were corrected to include snowmelt. Annual rainfall amounts based on the combined probability of summer and winter rainfall were obtained for various frequency events.

Initially, the Kinematic Wave Model was used to route the overland and stream flows. The peak discharges obtained by this method were found to be significantly higher than those obtained by the other methods. The normal depth method of routing was used for routing of floods along the main channel. Peak discharges for 2-, 5-, 10-, 50-, 100- and 500-year events were developed. Since the hydrologic analysis completed for the Sexton-Kilfoil Drain indicated a 10-year frequency flood discharge for the major part of the drain of less than 800 cfs, the lower limit set by the Corps of Engineers' criteria (ER-1165-2-21), the Sexton-Kilfoil Drain did not qualify for inclusion in the final plan.

The cross-sections used in the hydraulic computations, for the most part, were obtained from the Michigan Department of Natural Resources (MDNR). Additional bridge cross-sections were field surveyed. The water surface profiles for this study were computed for the existing and proposed conditions by using the HEC-2 computer program. The backwater model was calibrated to the Flood Insurance Study (FIS) profiles which have been adopted by various communities in the Ecorse Creek Basin.

STUDY RESULTS

Both structural and nonstructural measures to reduce flood damages were evaluated during this study. Nonstructural measures included flood plain regulation, basin management, and flood insurance. All nonstructural alternatives were found to be economically or institutionally unfeasible. Various structural alternatives were developed based upon expected future conditions. These structural alternatives consisted of the retention basins, retention basins with earth channel improvements, retention basins with paved channel improvements, earth channel improvements and paved channel improvements. Earlier preliminary studies excluded any plans that required the diversion of flood water south to the Huron River and north to the Rouge River.

Hydrologic/hydraulic analyses, evaluating both economic and environmental consequences of the five structural alternatives, determined that the retention basin alternative was the most desirable.

Two design factors considered in the design of the retention basins were the capacity (based on future conditions) of the reservoir and the bypass rate of the diversion structure. The multiplan-multiflood analysis capability of the HEC-1 computer program was used to investigate various reservoir size scenarios for the watershed. Reservoir sizes ranging from a minimum of zero acre-feet to a maximum of 500 acre-feet and bypass rates of 100-300 cfs were

considered. Each reservoir scenario was analyzed on last-added basis. In this analysis, a single reservoir was deleted from the system to measure the incremental impact of each reservoir.

The BERH/OCE review of the hydrologic analyses for the North Branch Ecorse Creek indicated that the overbank storage of flood water in the reaches between I-94 and I-75 and the city of Dearborn Heights was not fully accounted for. After several meetings between the BERH, OCE and District personnel, it was decided that the Detroit District would request the Hydrologic Engineering Center (HEC) to review the hydrology and hydraulics portion of the feasibility report and examine the HEC-1 and HEC-2 models used for the study.

HEC concluded that in spite of the unengaged nature of Ecorse Creek, the District had done a good job in collecting regional data and in demonstrating that the HEC-1 model generated runoff values were reasonable. However, the HEC-1 model proved to be deficient in the routing of runoff to the basin outlet. The deficiency was believed to be due to the fact that the stages computed by the routing exceeded the bounds of the specified rating curves used for most of the reaches.

To improve the routing methodology, the following procedure was used:

In the feasibility report, it was determined that the representation of cross-section geometry used in the hydrologic analysis did not extend far enough into the overbank areas to account for the storage. To more accurately account for the overbank capacity, the geometry of every cross-section (approximately 200) was reviewed to assure that each, represented actual field conditions. This was accomplished by utilizing available topographic mapping, FIS flood plain information and recent field survey data. Consequently, the cross-sections were extended from several hundred feet up to 5,000 feet, with an average change from the original cross-sections of approximately 2,000 feet. These changes were then input into the HEC-2 model. From this model, cumulative volumes and stages for the 2-, 5-, 10-, 50-, 100- and 500-year frequency events were determined and storages were computed between the 13 nodes.

The storage-discharge relationships derived from the HEC-2 model were input into separate hydrologic models (HEC-1) for each frequency event, to obtain new flows. These flows were then input into the HEC-2 model to develop a revised set of cumulative volumes, stages and storages thus producing a second storage-discharge relationship for each node.

During this analysis, the HEC-1 and HEC-2 runs were provided to the HEC for technical review. Based on their comments, modifications to the input parameters of the models were made. These changes included: (1) use of a 48 hour storm pattern (revised from a 24-hour storm used previously) to incorporate the timing of the peak flows within the storm duration (HEC-1); (2) adjustment of the location of the bank stations at each cross-section to represent the geometry of the main channel (HEC-2); (3) modification of the Manning's "n" values at each cross-section for non-flow overbank areas and new

main channel geometry (HEC-2); and (4) removal of unnecessary encroachments. Comparisons between the HEC-1 storage-discharge relationships and those from the revised HEC-2 model showed enough of a difference to require a second iteration to bring these relationships into closer agreement with each other. The revised HEC-2 storage-discharge relationships were input into the HEC-1 models to obtain new flows for all frequency events. These flows were then input in the HEC-2 model to obtain new cumulative volumes and stages and a third set of storage-discharge relationships. The results from this iteration compared very favorably with HEC-1 and HEC-2 data and were then considered final (Figures 3-8).

Comments received from the BERH/OCE required further refinements in the hydrologic and hydraulic analyses and to the feasibility report:

1) Adjustments for Effects of Debris Pile-up on Bridges and Culverts. Since the North Branch Ecorse Creek is restricted with heavy vegetation, the channel and floodplain characteristics may change during a storm due to the accumulation of debris. To analyze the debris pile-up on bridge piers and culvert entrances on this creek, the backwater models for the future "without-project", and selected plan conditions, were adjusted for a 20% reduction in the effective bridge opening and low steel elevation of selected bridges and culverts. The results indicated that no appreciable change in the water surface profiles occurred due to this adjustment.

2) Re-analysis of Earth Channel Alternatives. The city of Allen Park and its congressional representative expressed a concern that the earth channel alternatives had not been adequately examined during the study. Therefore, at the Board's request, the hydraulic and economic analyses of these alternatives for the North Branch Ecorse Creek at 10-, 50-, 100- and 500-year frequency levels of protection were re-analyzed. It was subsequently determined that none of the earth channel alternatives investigated were economically justified. A primary reason for the overall increase (compared to other alternatives) in the cost was the necessity to rebuild or relocate a large number of bridges. Environmental concerns would also make this alternative questionable since much of the material to be excavated is highly contaminated; furthermore, the disposal of this contaminated material would be a major concern. An earth channel providing a 10-year level of protection was determined to have a first cost of \$ 74.3 million and a benefit-cost ratio of 0.97. Thus, this re-analysis indicated that the earth channel alternative is economically and environmentally unacceptable.

3) Waiver of the 800 cfs Rule for Sexton-Kilfoil Drain. The local sponsor and congressional representatives requested the Board for a waiver of the 800 cfs minimum flow criterion for the 10-percent flood as it applies to the Sexton-Kilfoil Drain. The Board concluded that the investigated improvements would result in the Sexton-Kilfoil Drain not meeting the minimum flow criteria requirements for Federal participation under existing flood control authorities. In addition, it was concluded that the investigated retention basins were not economically justified with or without application of the 800 cfs criterion. The benefit-cost ratio without applying the minimum

flow criterion was 0.89 based on hydrologic conditions expected to prevail during the period of analysis. Application of the minimum flow criterion reduced the benefit-cost ratio to 0.33.

4) Level of Flood Protection. (The feasibility report was revised to include the following discussion.) The recommended plan provides for relatively low levels of flood protection, particularly in the city of Dearborn Heights. The levels of flood protection that would be provided generally range from 2-year to 20-year frequency for the areas downstream of I-94 and from 2-year to 7-year frequency upstream of I-94. Under this plan, annual flood damages would be reduced by 18 percent for the entire North Branch Ecorse Creek.

Although the proposed project for the North Branch Ecorse Creek would reduce flood damages resulting from overland flooding due to a frequent flooding event, it would not provide significant relief from major flooding events. Therefore, it is important that the local sponsor fully understand the limitation of the protection afforded by the project, if implemented, and at least annually inform affected interests of these limitations.

5) Flood Warning and Response Plans. (The feasibility report was revised to include the following discussion.) Flood warning and preparedness systems improve the community's capability for receiving accurate and timely forecasts of potential damaging floods. These systems provide the communication channels, information and resources necessary for individuals to safely evacuate, and for floodplain occupants to take effective damage reduction actions.

In respect to the improvement of a community's capability to respond to a damaging situation, the State of Michigan has passed the Emergency Preparedness Act, Act 390, P.A. 1976. The intent of this act is to provide, to the community, protection and recovery from natural and man-made disasters within the State. Implementation of this act requires the establishment of County and/or local coordinators to administer disaster preparedness and assistance programs. Also required is the creation of local disaster emergency plans which are developed for local conditions, and are consistent with other local, County and State emergency preparedness plans.

Wayne County has a local disaster emergency plan and coordinator to administer emergency preparedness planning throughout the county. Additionally, all communities within the Ecorse Creek Basin, except for the Cities of Wyandotte and Ecorse, have plans and coordinators. Emergency preparedness for these two communities are handled by the County's Emergency Manager (EM). Alerts pertaining to pending disasters, such as floods, are normally transmitted to the coordinators via facsimile from the National Weather Service and/or the State Police as monitoring agencies for this area. Once an alert is received, the local coordinator disseminates the warning to the various support functions, as identified in the local plan. If necessary, affected areas of the population center can also be contacted by the local police or through television and radio media so that damage reduction measures

can be initiated. Representatives from Wayne County have stated that the existing system is considered adequate to respond to flood emergencies within the Ecorse Creek Basin. As such, no separate flood-warning system is warranted for the Federal Project.

CONCLUSIONS

Based on experience gained from the Ecorse Creek Flood Protection Study, the District Hydraulics and Hydrology Branch has become more cognizant of the following elements which may be applicable in all future studies.

1) Storage in overbank areas. This may require additional field survey work which may result in an increase of the project cost.

2) Debris pile-up on bridge piers & culvert entrances. An up-to-date survey may be required of all bridges and culverts and channel areas where restrictions occur.

3) Installation of temporary river gages in the project areas. Depending upon the size of the project, consideration may be given to the installation of temporary gages in ungaged areas. A good correlation of observed and computed flows is essential for any reliable hydrologic results.

4) Effect of flat floodway in Flood Insurance Studies. Federal Emergency Management Agency (FEMA) has been made aware of the overbank storage and its impact on encroachments. FEMA may look into restudying flood insurance studies completed for the city of Dearborn Heights and other areas of this project. A possible impact of this action would be to greatly expand the floodway, with severe repercussions on the urbanized area. Local cooperation in controlling encroachments is needed in the project area.

5) Proper maintenance of the project area. The District should assure that the channel is adequately maintained so that the improvements result in the project functioning as intended throughout its life.

6) The 800 cfs rule. Any stream, or a part of a stream that has a 10-year frequency flood discharge of less than 800 cfs, is eliminated from consideration for further study unless written notification is provided by the Division or Headquarters Offices.

7) Low level of protection. Perhaps the most important lesson learned from the Ecorse Creek Study is the need for new guidelines to assure that the low level of protection being provided is sufficient and will not be quickly lost because of basin changes during the project life. The current policy does not limit our involvement based on the level of protection, but is solely dependent upon the benefit/cost ratio.

REFERENCE

(1) Brater, E.F. and Sherrill, J.D, Rainfall-Runoff Relations on Urban and Rural Areas, Report No. EPA-670/2-75-046, U.S. Environmental Protection Agency, Office of Research and Development, Cincinnati, Ohio, May 1975.

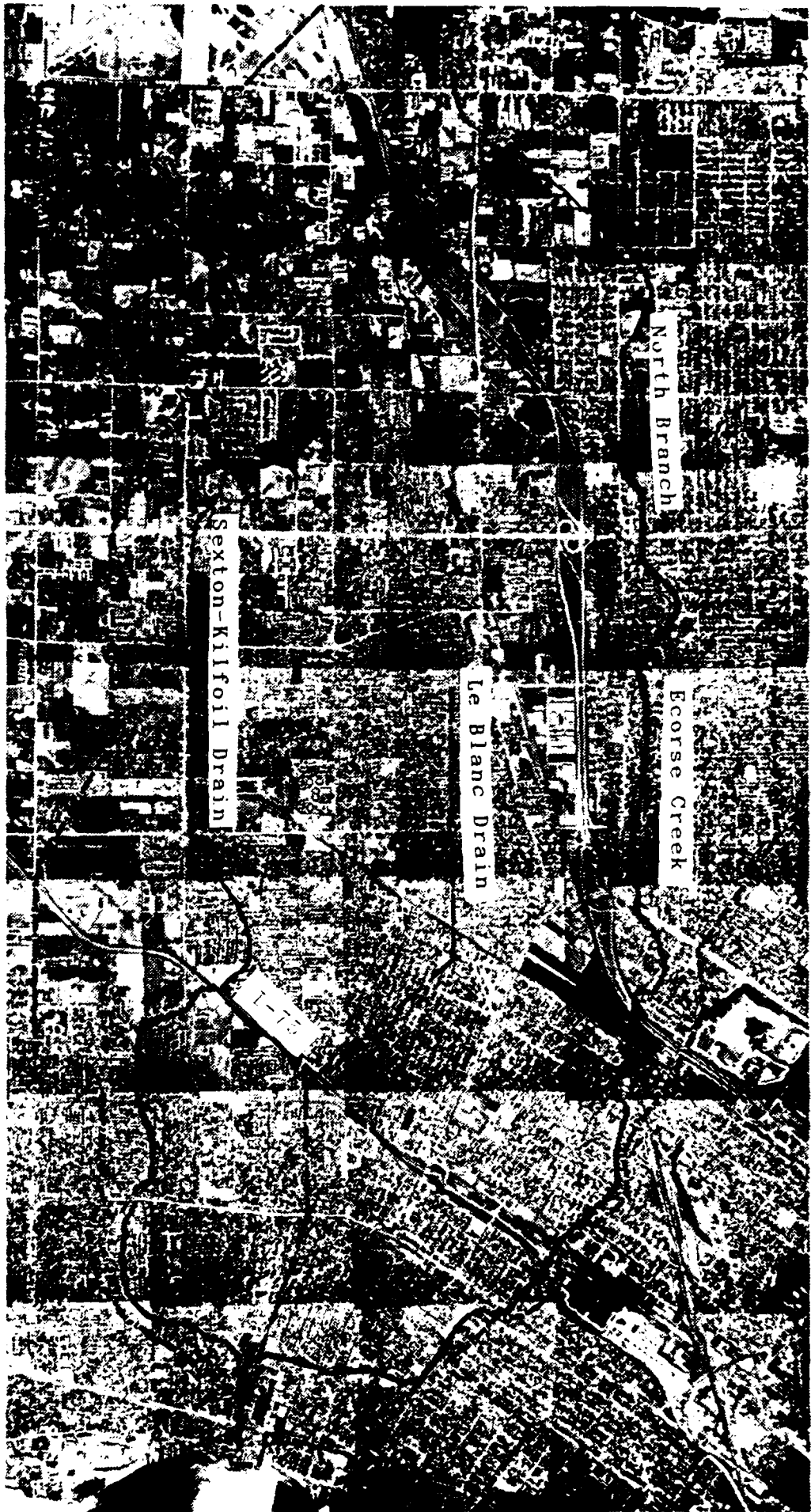

ECORSE CREEK DRAINAGE BASIN

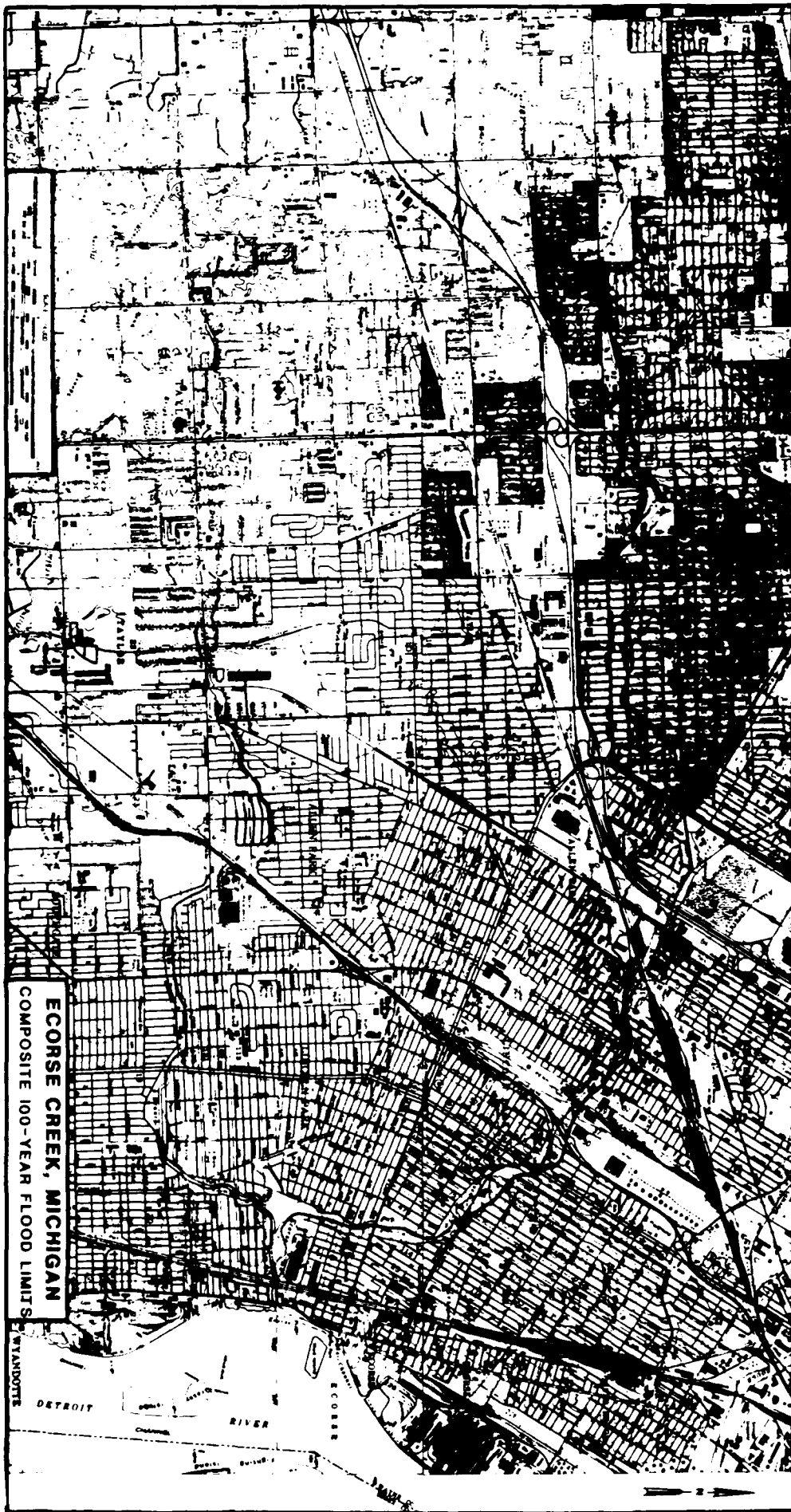

FIGURE 2

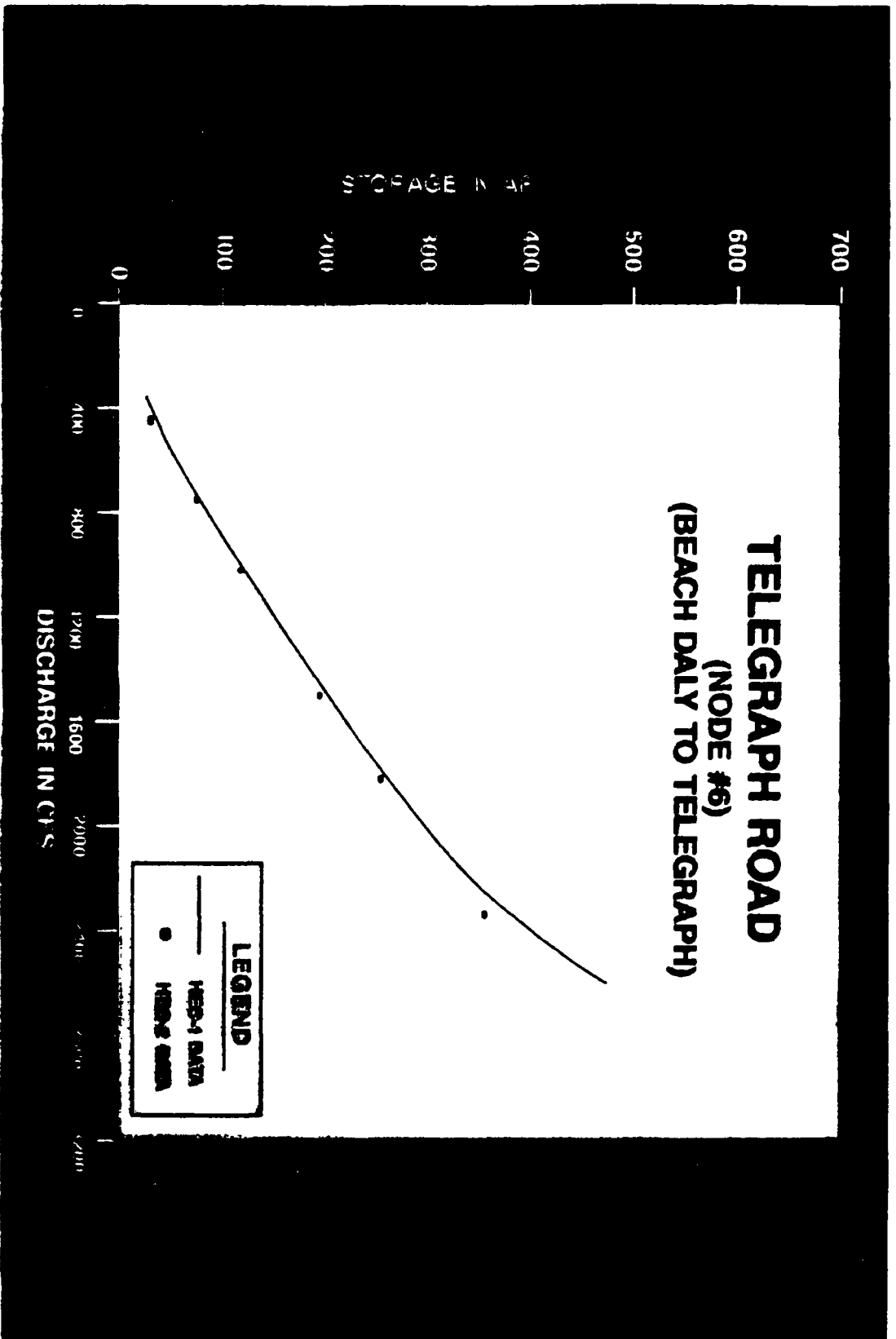

Figure 3

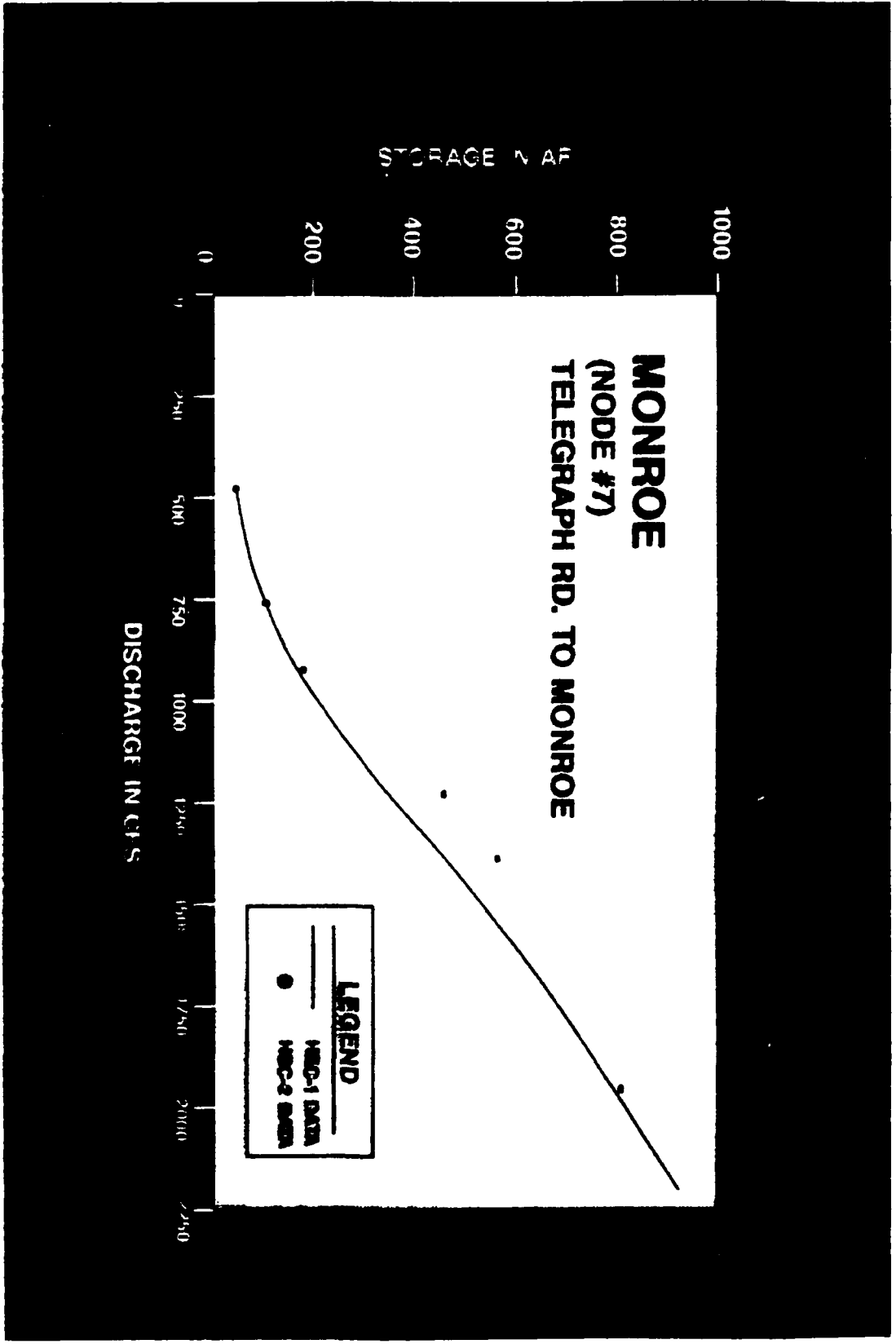

Figure 1

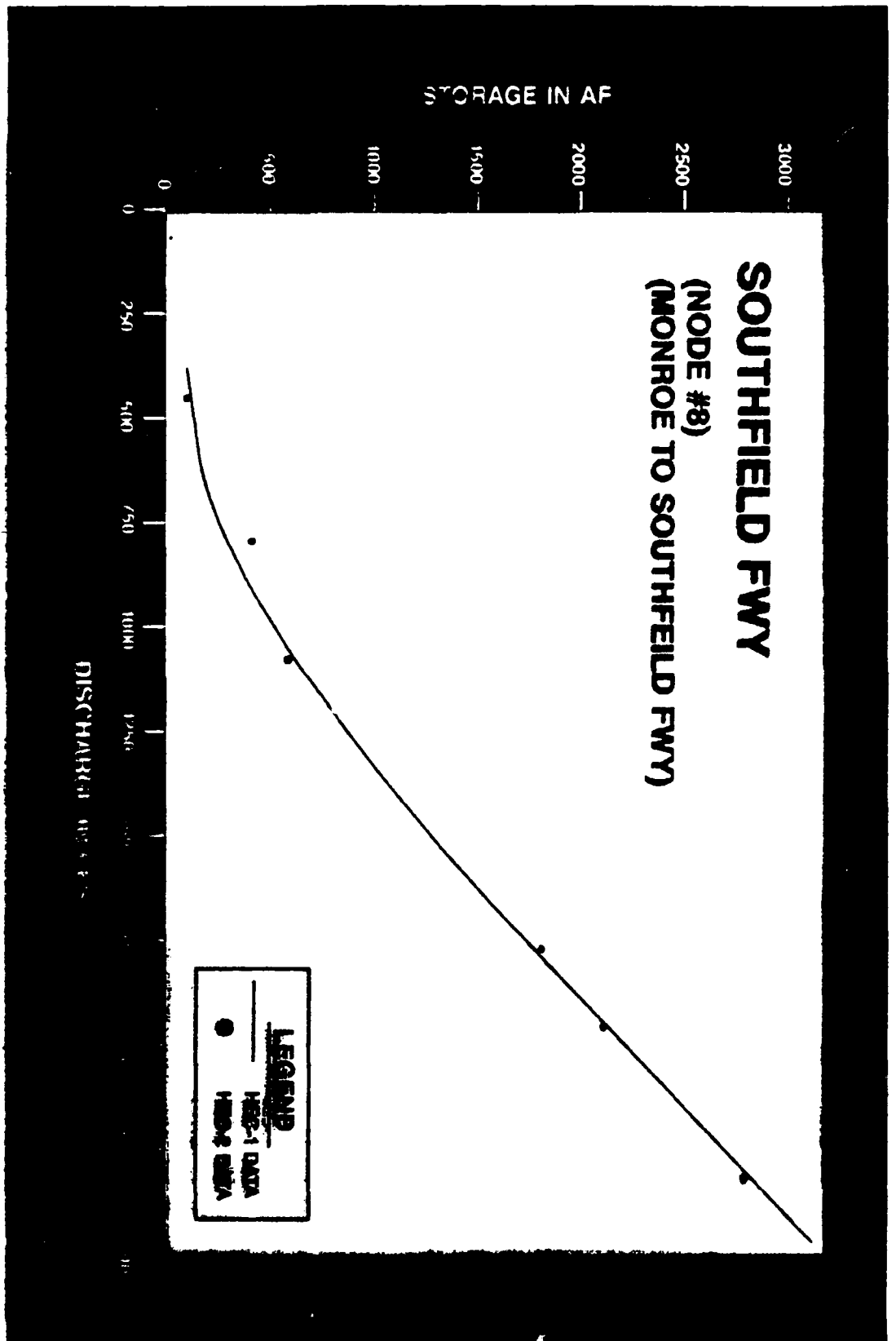

Figure 5

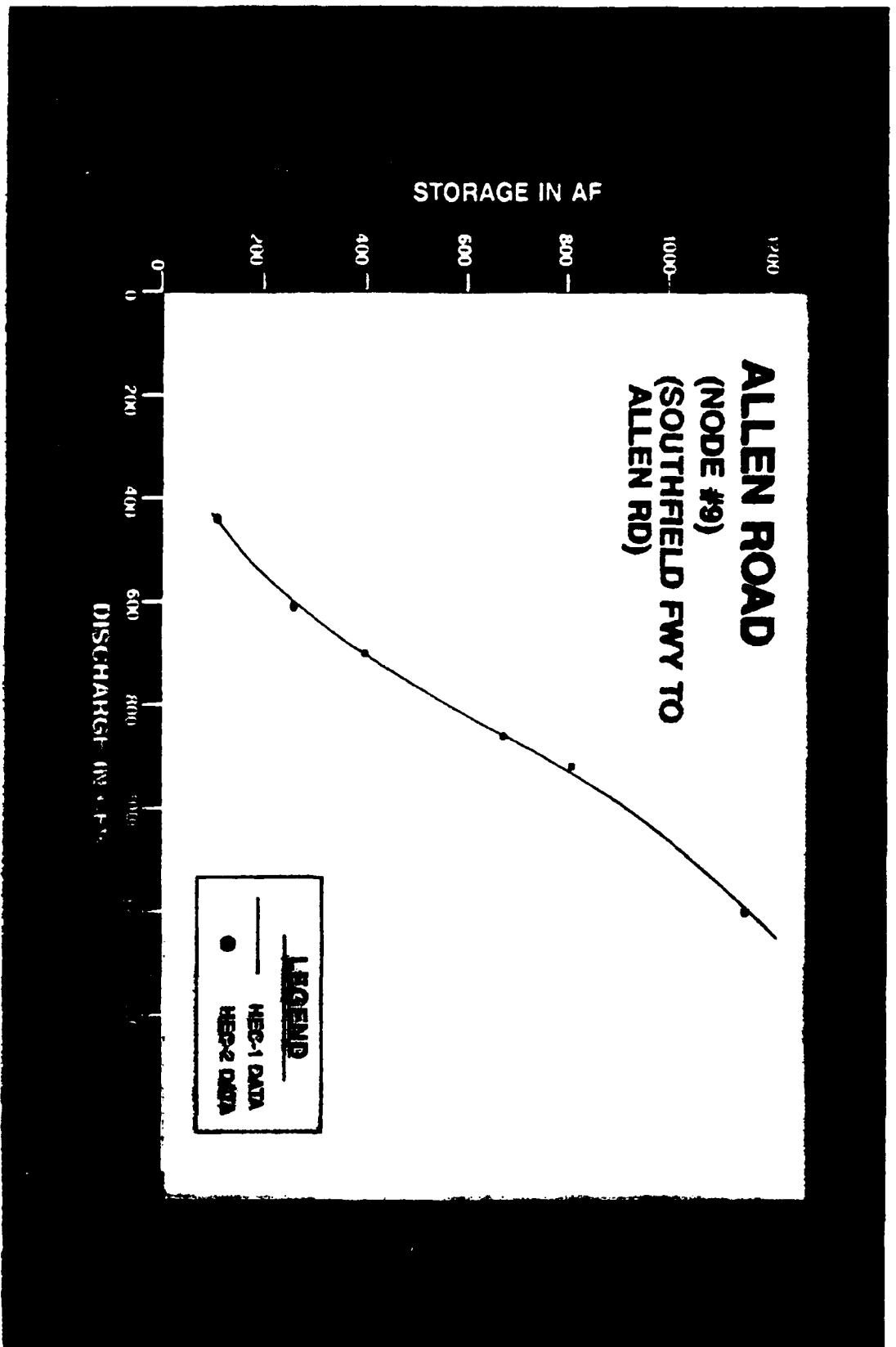

Figure 6

I-75
(NODE #10)
(ALLEN ROAD TO I 75)

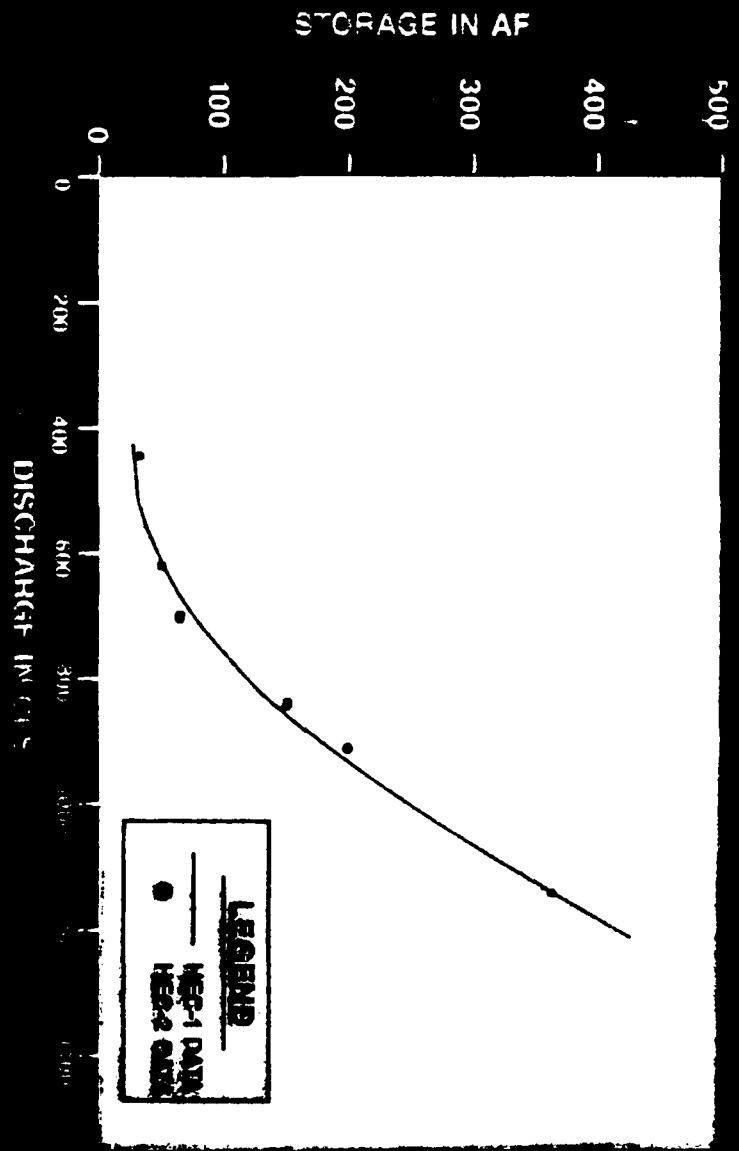

Figure 7

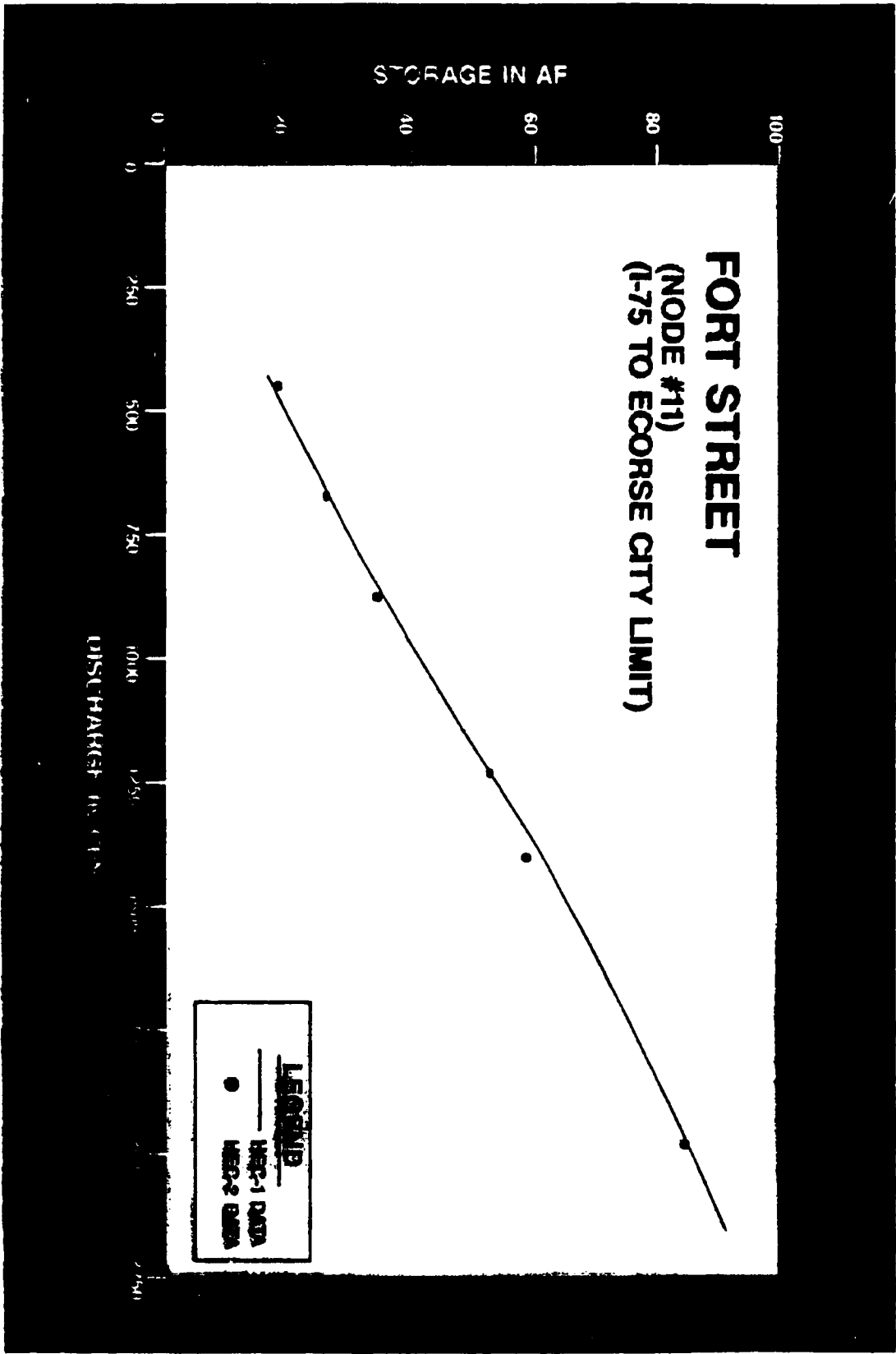

Figure 8

SOWASHEE CREEK FLOOD CONTROL PROJECT
FUNCTIONAL AND SAFETY ASPECTS

by

JACK G. WARD¹

INTRODUCTION

The initial reason for the Sowashee Creek Flood Control Project study was recurring flood damage in the urban and industrial areas of Meridian, Mississippi. Of course, the objective of the study was to provide a project with the largest B/C Ratio that had the least adverse impact on the environment. Whether this be the no action alternative, an extensive system of impoundment structures and downstream channelization, or some compromise in between these two extremes, was the purpose of the study.

As shown on Figure 1, the final design for the Sowashee Creek Flood Control Project was a compromise between the two extremes and involved only channel improvements. The improvements involved a lower clearing and snagging reach, a lower channel enlargement reach, a middle reach of clearing and snagging, an upper channel enlargement reach, and an upper clearing and snagging reach. There was not a specific flood frequency used for design of the channel in whole or in part; but rather, the design compromise was one which produced the best B/C Ratio for the range of floods considered. Certain features of the project were designed to preclude failure during a severe flood event because of the severe consequences of the failure of that feature.

PHYSICAL SETTING AND AVAILABLE DATA

Sowashee Creek drains an area of approximately 81 square miles in Lauderdale County, MS. Meridian is near the center of the county and the creek has its origin just to the east-northeast of the city. From its source, Sowashee Creek flows southwesterly through Meridian to its mouth where it joins Okatibbee Creek in the Pascagoula River Basin. The average fall of Sowashee Creek is 10 feet per mile. The drainage basin is approximately 15 miles long and 8 miles wide near the center. The climate of Meridian is mild in nature, with the average temperature for the summer months of June, July, and August being 79.8 degrees F and the average temperature during December, January and February being 48.4 degrees F. The wettest month is March with an average of 5.97 inches of rainfall. October is the driest month with an average of 2.36 inches of rainfall. The average annual precipitation is 53.8 inches.

¹Hydraulic Engineer, Mobile District, U.S. Army Corps of Engineers

The USGS has operated one stream gaging station on Sowashee Creek since 1950. The 6 April 1964 flood is the highest recorded since the gage was installed and had a peak discharge of 9,530 cfs. Another large flood occurred on 28 March 1951 with a peak discharge of 8,030 cfs. Two historic peaks which occurred in February 1936 and April 1938 were estimated to be 24,000 cfs and 15,000 cfs, respectively. The average discharge for the 50-year period of record is 64.7 cfs. The minimum flow of 0.2 cfs occurred on 1 October 1954 and several times again during the summer of 1957. Data from observed high water profiles for the 1964, 1974, and 1979 floods were available. Geometric data used in the modeling of Sowashee Creek were taken from cross-sections surveyed in 1975. These sections were supplemented with tape surveys made from aerial photography taken in 1978. Sediment data were collected at various locations along the creek. Several field trips were made to observe geomorphological characteristics, manmade structures, and channel & basin stability appearances. Historical aerial photographs of the area were also analyzed.

STUDY APPROACH

The Sowashee Creek Project is a simple flood control project to reduce flood damages in the urban and industrial areas of Meridian Ms. The study involved compiling hydraulic data and stream geomorphic data for the project area. Discharge frequency estimates for the evaluation and design of the project were based on regional frequency relationships developed in the Mobile District. Frequency curves were computed for selected locations within the study reach and were adjusted for urbanization. HEC-1 and HEC-2 models were developed for existing conditions. Observed high water profiles for the 1964, 1974, and 1979 floods were available for use in calibrating the models. From this baseline data, project conditions models were developed and economics were evaluated for each plan along with environmental considerations. Based on the existing conditions survey of the stream, equilibrium slopes were established. Equilibrium slopes were then computed for the alternatives with grade control structures being incorporated in each plan of improvement.

RESULTS & CONCLUSIONS

The initial study evaluated a total of six alternative schemes or plans. With input from the public and local sponsor, a seventh compromise plan was developed which was adopted as the recommended plan of action. This plan called for the channel enlargement of selected reaches and the clearing & snagging of selected reaches of the Creek and was adopted after further discussion and compromise with environmental agencies. There was not a specific flood frequency used for design of the channel in whole or in part; but rather, the design compromise was one which produced the best B/C Ratio for the range of floods considered. Certain features of the project were designed to preclude failure during a severe flood event because of the severe consequences of the failure of that feature. For instance, riprap

placement limits and size were selected based on preventing project failure up through the 100-year flood. This does not mean that the project will not sustain damage for the 100-year flood or some much less severe flood, but rather it does mean the functionality of the project will not be impaired. The decision as to placing or not placing riprap at any specific location was based on a number of factors, keeping project functionality and safety in mind:

1. The functional importance of the area being protected (e.g., what is the consequence of a bank failure in terms of economic loss and possible loss of life) has a direct bearing on the frequency of flood selected for consideration in providing bank protection.
2. The mean channel velocity as computed in HEC-2 backwater runs for the respective frequency of protection chosen at a particular site was considered.
3. The channel geometry in the vicinity of a particular site will affect the way in which channel flow will attack the channel boundary.

It can readily be seen that a great deal of engineering judgement is needed in this type of analysis because it is not a purely objective one.

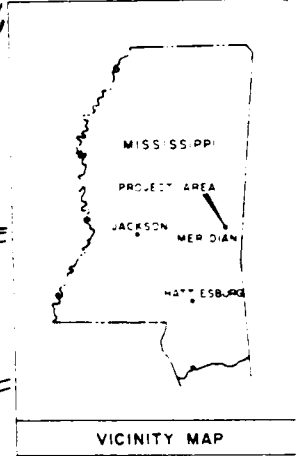
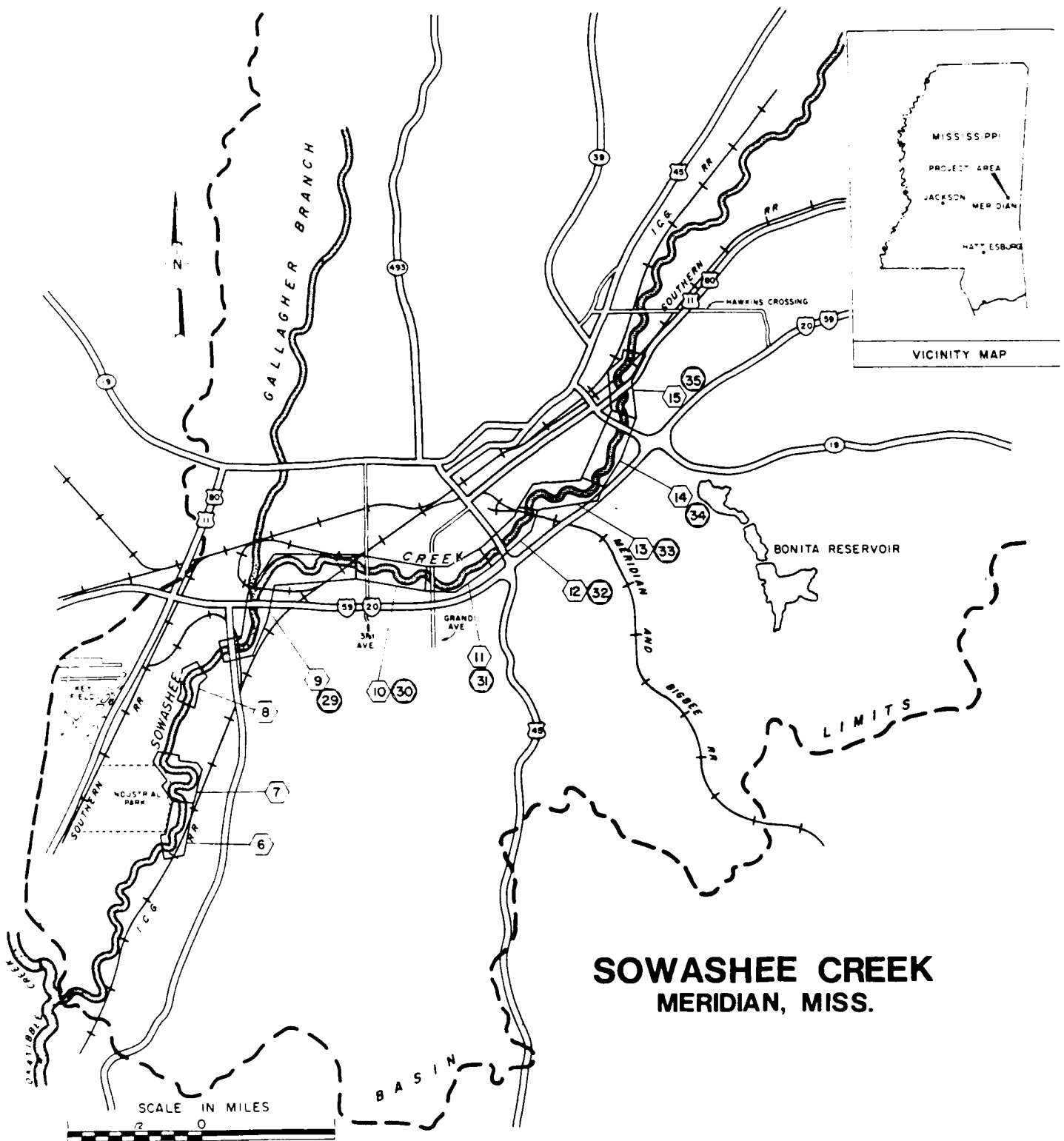

RECEIVED

NOV - 8 1989

TRY SIMPLE SOLUTIONS FOR HI-TECH PROBLEMS

HEC

by

David R. Gregory ¹

Introduction

As newer and more sophisticated technologies are developed and applied to a wider array of hydraulic engineering design problems we need to take care that these tools do not override engineering judgement and common sense. Often so much emphasis is placed on canned hydraulics programs that some very simple yet logical solutions are overlooked. Our approach to problem solving needs to be balanced between knowledge and sound judgement.

Problem Definition

During a reapportionment of jurisdiction in 1986, Albuquerque District's boundaries were extended west to the state line. Along with this added area the District also inherited from Los Angeles District a General Design Memorandum for a flood control project on the Puerco River at Gallup New Mexico. However, this DM was termed suspect by reviewers at both the Division and Headquarters level. Necessary approval seemed unlikely. At the center of questions to be resolved were uncertainties regarding sediment build-up and its effect on the performance of the designed channel.

Gallup is west of the continental divide approximately 140 miles west of Albuquerque and 130 miles south of Farmington at an elevation of 6500 feet. Average annual precipitation is less than 12 inches. The Puerco river is an ephemeral stream with a drainage area of 560 square miles. The 2-year storm event is 2500 cfs.

The gist of the design task was to provide flood protection in the form of a leveed channel to contain the 1 percent chance flow of 20,000 cfs. A large part of this plan was to increase channel capacity by excavating the Puerco through the project reach to the excavation and grade built by the New Mexico State Highway Department in 1979. As mentioned above, this plan was met with skepticism by some who felt the channel was in a transitional stage. A comparison of channel profiles, figure 1, for 1984 and 1988 and the 1979 as built profile of the New Mexico State Highway Department completed channel work showed that there has been a trend toward aggradation in the Puerco River through the project reach. Consequently, the channel capacity at the time of the later two profiles was much less than the channel capacity after the New Mexico State Highway Department completed channel work during 1979. Much attention was focused on the reduced flow capacity at the Gamarco Spur Railroad Bridge and the consequences of the design discharge at the bridge when capacity was insufficient. Backwater computations from an HEC-2 model indicated that the design discharge would breach the project levees when the capacity at the bridge was at the aggraded 1984 condition. The original remedy to this problem was annual sediment excavation from the channel invert. Many felt this solution was short-sighted. Although the sponsor had tentatively agreed on maintenance stipulations requiring annual sediment removal there was no way to insure that this requirement would be fulfilled throughout the life of the project.

¹ Hydraulic Engineer, Albuquerque District, U.S. Army Corps of Engineers

One theory regarding this seeming trend toward aggradation suggested that sediment buildup during the 1980's is the result of a temporary sediment plug caused by realigning the river upstream of the project during the NMSHD channelization. Once this plug migrates through, the river will return to a lower channel invert and greater channel capacity.

Results & Conclusions

In an attempt to resolve this issue a numerical sediment transport model, HEC-6, was initiated. As the task became more involved personnel from the WES were contacted for advice and guidance and two engineers from AD worked under supervision at the WES to expedite results. Although reliable mapping data and invert profiles were available for a substantial period stream gage data needed for model calibration was grossly insufficient and model results were inconclusive.

Attendants at the Issue Resolution Conference were concerned because of the lack of definitive sediment results. Other alternatives were discussed including an option to raise the seldom used railroad spur bridge thereby increasing the flow capacity. The bridge could be lowered with short notice if needed. A physical model study was also discussed. In an attempt to establish a foundation base, some of the initial assumptions made by the design engineers were reexamined. This routine change in thought direction helped instill confidence that AD design was appropriate.

An analysis was made of the hydraulic capacity of the Puerco River through the Gamarco Spur Railroad Bridge. This analysis considered the potential of a moveable bed beneath the bridge. A rating curve was plotted for the channel immediately upstream from the bridge. From this rating, a velocity vs. discharge curve was plotted and superimposed on the flood hydrograph. The hydrograph of the design flow, figure 2, shows a flow duration of approximately 30 hours. This rating indicates that water will contact the low steel at a discharge of 6,500 cfs, 4 hours into the hydrograph. Flows greater than 7,000 cfs will pass through the bridge opening as pressure flow. Flows will increase from 7,000 cfs on the rising limb of the flood hydrograph, to a peak discharge of 20,000 cfs about 4 hours later. During this period channel velocities could exceed 14 fps if the area beneath the bridge remained unchanged. However, the channel bed through this reach is composed of 3 to 4 feet of fine homogeneous sand above a thick layer of clay. Under pressure flow the fine sand in the channel will continually scour until equilibrium between continuity and sediment transport is reached resulting in greater channel capacity and lower water surface elevation.

Although this analysis to the sediment-channel capacity question is very simplistic, it was sufficient to satisfy those with approving authority that the design for the Puerco River Levee and Channelization Project was sound and will provide the intended degree of flood protection. Toward the final phase of construction the USGS will install sediment ranges to monitor sediment changes in the Puerco River. In the future data from these sediment ranges will enable engineers to build numerical sediment transport models that produce sound quantitative results.



US Army Corps
of Engineers
Albuquerque District

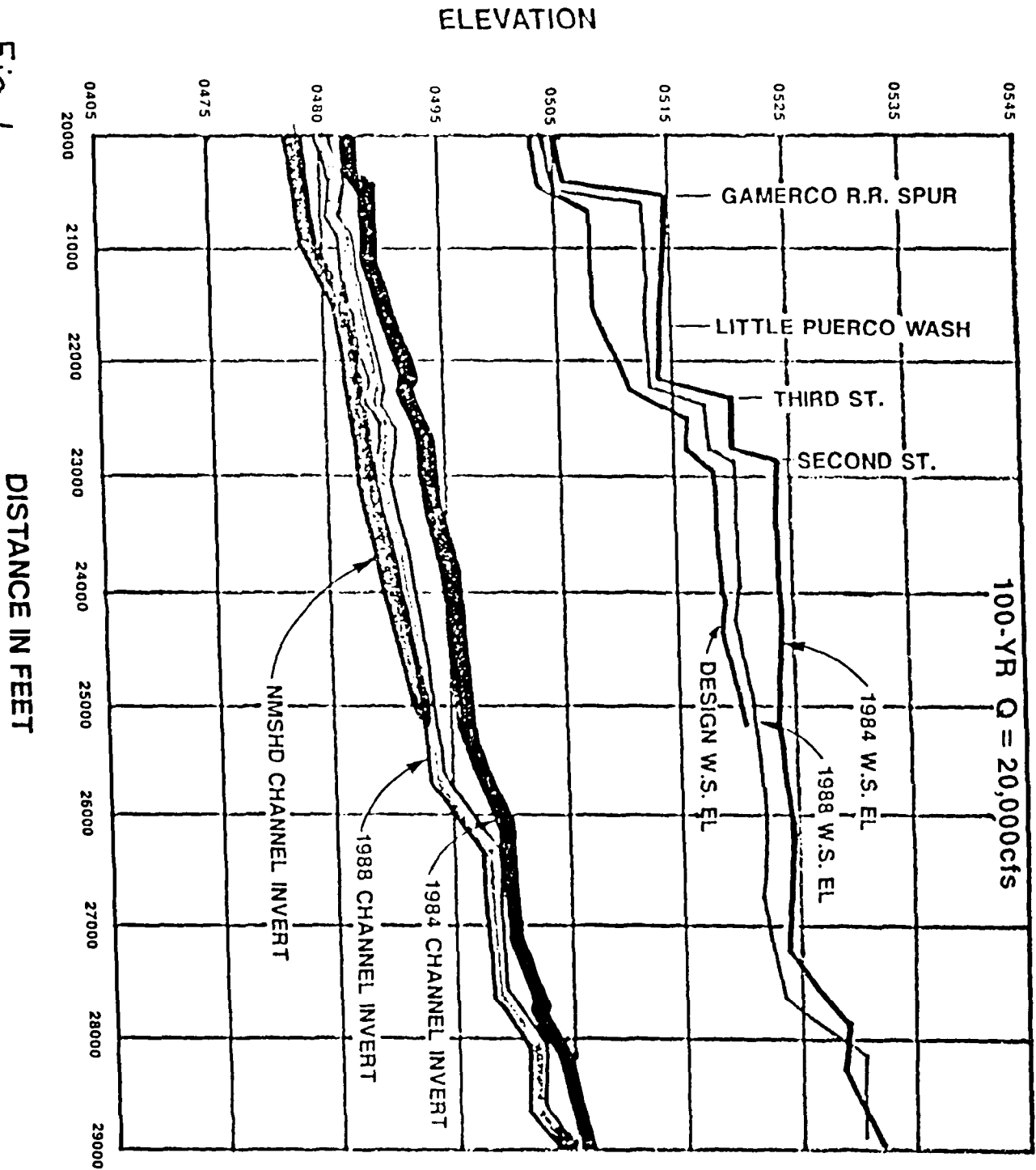

Fig. 1

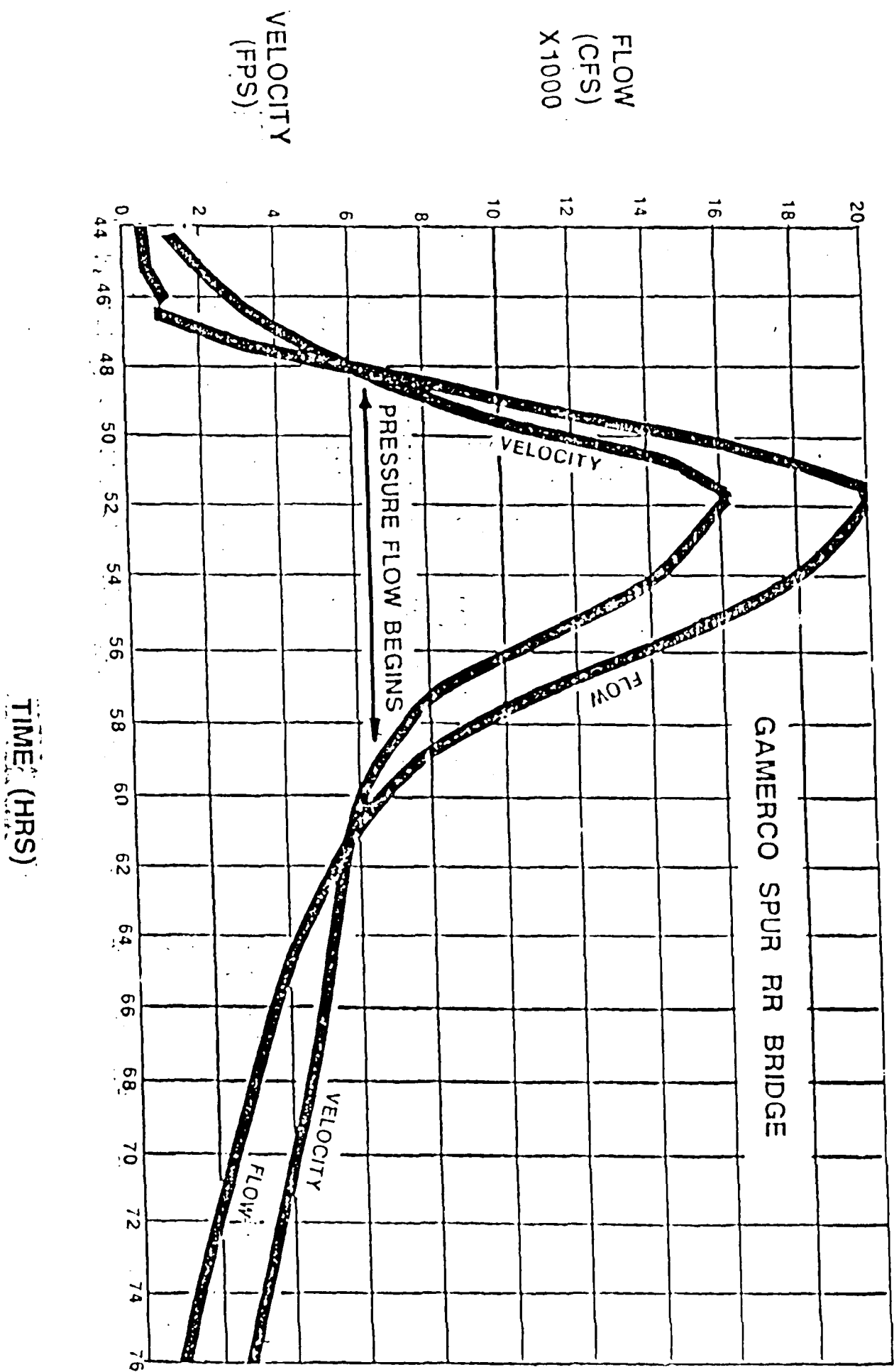

Fig. 2

Issues Related to Channel Projects

by

Ronald A. Yates¹

Although I am very interested in flood control channel design, I am not here to discuss ER's, EC's, EM's, technical notes, design parameters, etc. I'll leave that to you in the audience who are more qualified. Instead I would like to discuss some CEORD problems, get some feedback on problems in other divisions and use this opportunity for meaningful discussion.

In CEORD, the design of small flood control projects comprise a significant portion of our flood control planning and design effort. Currently, we are studying only a few flood control problems that could possibly identify a multipurpose reservoir as a feasible alternative. When Yatesville reservoir construction is completed in FY 92, CEORD will have a "mature" reservoir system. Presently, no new reservoir is in the design or construction phase. As shown on Plate 1, the trend in CEORD is towards the design of more of these flood control projects, which includes channel improvements. Consequently, there will now be more visibility of these projects to upper management. Whereas a decade ago, there was no Project Review Board, no Life-Cycle Project Manager, no quarterly review meetings to discuss the progress of Corps projects. Now these management mechanisms are in place and, in my opinion, small flood control projects will soon be given more scrutiny than previously. We need to be able to reduce design costs of these projects while maintaining design function and safety. Because if we, the design professionals, don't accomplish this, the review board, etc., might be arbitrary and capricious in assigning reductions in design costs. Designing to cost is our slogan. We need to determine the design methods that will reduce costs and not have cost reductions allocated to design! One method to accomplish this is to determine the most frequent design problems, analyze projects that seem to function as designed, analyze projects that don't function as designed, and write short reports on design problems for our colleagues to use as references. Another method is to use conferences, such as this, to transfer innovative solutions to engineering problems.

Most of the flood problems in which a channel improvement develops as a solution was caused by a locally inadequate channel size. If we, the hydraulic design engineers, value personal and agency integrity, the designed project should adequately function during its economic life and probably long thereafter. This will be possible only if we have engineered a project to function properly and if the project is properly maintained. This problem of inadequate maintenance is cited by each of the CEORD districts as cause for design failure.

As an example, in 1985, the Pittsburgh District investigated the effects of siltation and vegetation on the James C. Fulton Local Flood Protection Project; Chartiers Creek, Brideville, PA. Estimates of Mannings "n" that considered both the vegetation on the channel banks and the sediment deposition in the channel were made. Backwater computations were then run to determine the expected increase in the design water surface elevation. At the downstream gaging station, the 90+ year design stage would be reached about once every 60 years on the average. The district reported the findings to the locals, with the recommendation that the brush and trees be removed from the bank and the sediment removed from the channel, although the latter was of secondary concern.

¹Chief, Water Management Branch, Ohio River Division, U.S. Army Corps of Engineers

Two and one-half years later nothing had been done. A reevaluation of channel hydraulics indicated that the design stage would now be reached about once every 45 years on the average. Again, the district's recommendation was to maintain the channel.

As another example of inadequate maintenance, the Louisville District cited a project on the Little Blue River at English, Indiana. Constructed in 1964, district personnel stated that it was completely ineffective during the flood of 1979. The original project was designed for protection of agricultural lands in English and Crawford counties. Federal project cost was \$372,000 in November 1964. Although that now seems insignificant, using ENR escalation, current year cost would be \$1,823,000. No hydraulic evaluation of the project failure was initiated.

In the document "Flood Control Channel Nationwide Inventory," published in April 1988, the lack of local maintenance of the project was cited by many districts as a problem. However, several districts felt they had a good handle on the O&M issue. To initiate discussion, I would like to hear from other districts. Does the Corps need additional authorities to handle this problem? As part of the LCA, should the Corps demand that an escrow account be established for maintenance? How do we better estimate future maintenance cost? Is it worth the extra design cost to have a good handle on O&M costs and O&M procedures to give to the local sponsors, if we cannot insist on proper maintenance? How do we protect the local people, if the project is allowed to fail by lack of maintenance? How do we protect the federal investment?

Sometimes a project fails because of exceedance of design conditions, or occurrence of unanticipated conditions, or a combination of both. For example, on 19-20 July 1977, severe thunderstorms lingered in the area above Johnstown, PA. This isohyetal map (Plate 2) gives you an appreciation for the intensity of this storm. Most of the precipitation occurred in the eight-hour period from 8 p.m. on 19 July to 4 a.m. on 20 July.

The project was designed to accommodate a discharge equivalent to the maximum natural flow of record, 83,000 cfs in the Conemaugh River at the "Point" (17 March 1936), with a minimum of bank overflow, and to practically eliminate damage from a recurring flow of this magnitude. The peak discharge of the 20 July flood reached approximately 120,000 cfs at the "Point." An approximately 11-ft. reduction was attributed to the Johnstown LPP with associated benefits of \$322,000,000 (1977). Actual damage at Johnstown was estimated at \$117M.

The Pittsburgh District prepared a post flood report published in April 1979. The district concluded that severe flooding at Johnstown would have occurred even if the channel had been designed for the occurrence of the 1977 event. The hills surrounding Johnstown are steep resulting in rapid runoff with little infiltration loss. Overland flow as deep as three feet in spots swept cars, houses, buildings and debris down the hillsides into the main streets of Johnstown, flooding that area. In designing this project in the late 1930's, we looked at the accumulation of runoff and the resultant inflow hydrograph to the project. Then we determined the design characteristics of the project that were needed to economically pass this flood. We spent considerable time, in fact most of our time, designing and reviewing this aspect of the project. We didn't look very hard at the overland flow required to get the runoff to the channel. As I mentioned, in this case the project design was exceeded and the downtown area (the area to be protected) was flooded both by the overland flow and the river flow. My concern, lessons learned, etc., has been what if the project's design flood had not been exceeded and the protected area was

flooded by the overland flow which we virtually ignored. A point for discussion and audience interchange is: What are our responsibilities as an agency and as professional engineers in bringing this potential problem to the customers? It certainly will be a large incremental study cost to develop and calibrate an overland flow model to be able to explain to people what might happen.

After the occurrence of the 1977 flood, the district did a quick analysis of the area interior to the project. None of the small streams in the Johnstown area have flood protection projects. Developing projects for them would be costly and difficult to construct. Many bridges cross these streams, with many houses and buildings built near the streambanks. This leaves little room for walls, dikes, or widening the streams. Even if all the streams contained flood control projects, considerable overland flow would still have occurred. There is no way all or even most of the overland runoff from a storm such as occurred in July 1977 could be controlled. So, even if we had carefully considered overland flow, we couldn't have controlled it. Needless to say, we in CEORD, are more aware of the effects from overland flow.

To put the magnitude of this flood in perspective, downstream from Johnstown is the Conemaugh reservoir. Though the pool crest was the fifth highest since the dam was placed in operation, the peak inflow was far greater than any other previous flood. In fact, the calculated peak inflow of 193,800 cfs was slightly greater than the peak inflow of the computed standard project flood, but because of the relatively short duration of the storm, the equivalent storage volume was not attained.

In summary, lack of maintenance and exceedance of design criteria are some causes of failure in flood control channels in CEORD. Due to lack of funding, documentation of problems is not always possible. I would like to propose that a funding mechanism should be available for the purpose of transferring this knowledge to our successors. Presently, we seem to be at the mercy of others to determine if money is available for such a report.

CHANNEL PROJECTS' IN CEORD

<u>DISTRICT</u>	<u>1988</u>	<u>1989</u>	<u>1990</u>	<u>1991</u>
PITTSBURGH	32	33	33	33
HUNTINGTON	36	36	37	40
LOUISVILLE	21	21	25	27
NASHVILLE	<u>7</u>	<u>8</u>	<u>8</u>	<u>8</u>
	96	98	103	108

***Includes clearing and snagging projects under Section 208, channel projects under Section 205, and separately authorized channel projects.**

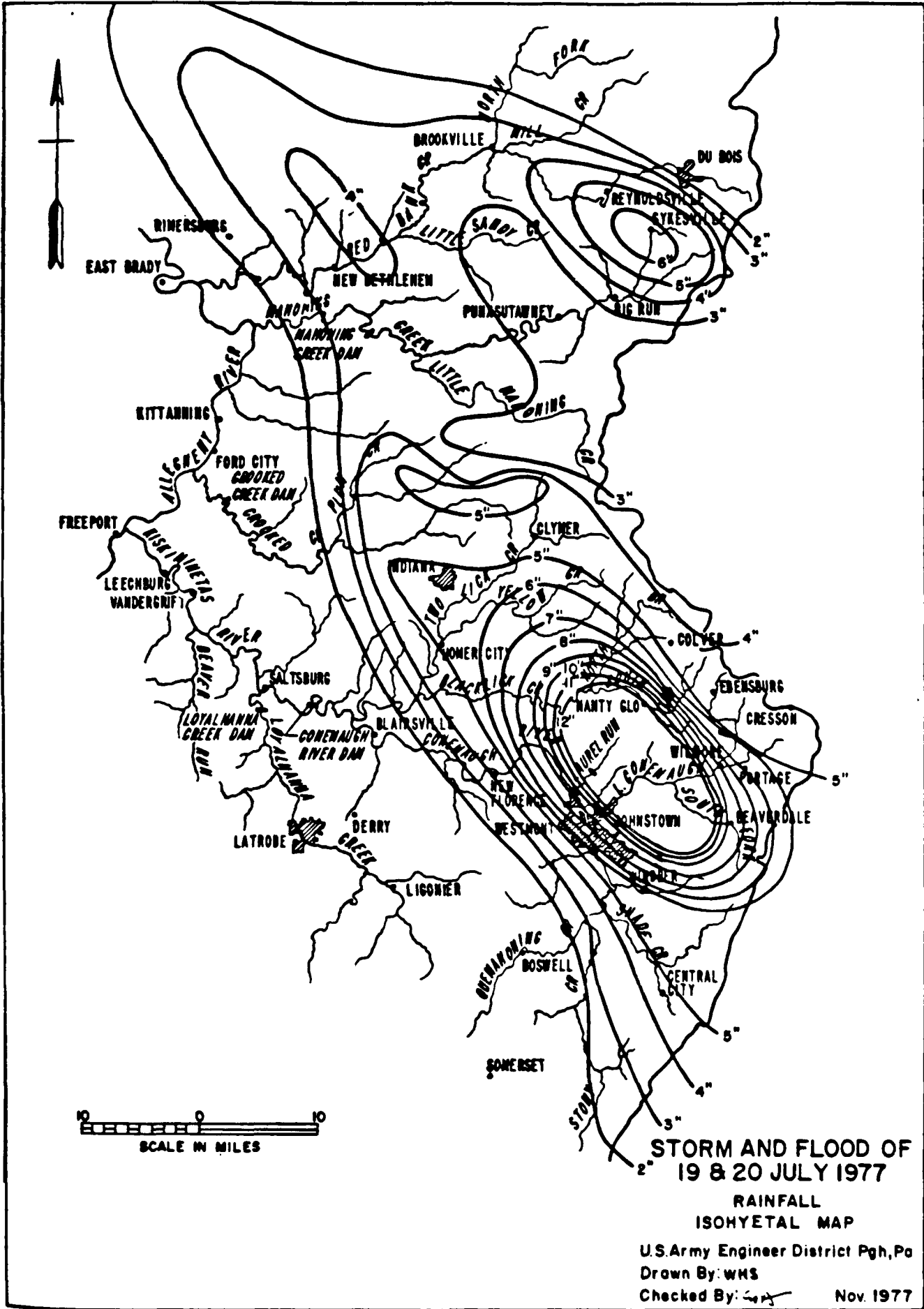

**STORM AND FLOOD OF
19 & 20 JULY 1977**

**RAINFALL
ISOHYETAL MAP**

U.S. Army Engineer District Pgh, Pa
 Drawn By: WMS
 Checked By: [Signature]
 Nov. 1977

ISSUES RELATED TO CHANNEL PROJECTS:

- A. Determine methods to reduce design and planning costs, especially on small projects.
- B. Local sponsor neglect of O&M is a significant problem. The agency doesn't seem to be able to force the sponsor to maintain the project. Possible solutions: Additional authorities for the Corps; Set-up an O&M escrow account as part of the LCA. Is it worth the extra cost in design to refine O&M costs and O&M procedures for the local sponsor, if the agency cannot insist on proper maintenance. How does the agency protect the local people if the project is allowed to fail through neglect of maintenance? How does the agency protect the federal investment?
- C. Funding should be provided to H&H for development of reports describing project performance during flood events. Would be useful for future planning and design as well as describing to local sponsors the effect of maintenance or lack of maintenance on project performance.
- D. Funds should be provided to H&H for development of flood reports whenever significant flooding occurs on a district watershed.

SUMMARY OF SESSION 4: INTERIOR PROJECTS

Overview

Interior projects are defined as areas protected from flooding by main rivers, lakes, and other water bodies by a levee or wall. However, the levee or wall, termed the line-of-protection, may result in flood waters from the interior area being aggravated. Two papers were presented and the topic of interior facilities design and operation was addressed by three panelists.

Paper Presentations

Paper 7. Laurence Curry, Louisville District, presented a paper entitled, "Pond Creek Pumping Plant Louisville, Kentucky, Flood Protection." The Pond Creek Pumping Plant is a major feature of the Louisville levee system designed to protect residential, industrial, and farm lands from flooding from the Ohio River. The interior system, which includes a gravity outlet at the pumping plant, provides 20-year exceedance interval protection. Mr. Curry described the study approach and key issues regarding safety considerations during the planning and design of the pumping plant.

Paper 8. Robert H. Fitzgerald, Vicksburg District, gave a paper entitled "Slidell, Louisiana Interior Study." Slidell is located on the Pearl river northeast of New Orleans. Mr. Fitzgerald presented the key issues associated with analysis of the interior area study portion of the feasibility investigation. Several of these issues concerned limited ponding areas, environmental concerns of adjacent wetlands areas, and the potential for heavy coastal rainfall that would result in significant residual damage associated with a recommended plan.

Panel 4 Presentations

Bobby P. Fletcher from the Waterways Experiment Station, presented, "Form Suction Intake (FSI) Appurtenance Geometry." Vertical pumps with suction bell intakes used in flood control pumping stations have experienced problems of subsurface and surface vortices and uneven flow patterns due to adverse flow conditions in the sump. This may lead to frequent maintenance, rehabilitations of the facility, and limited operation performance. Mr. Fletcher described the investigation and testing of a formed intake which indicates that the design would provide satisfactory hydraulic performance for all anticipated flow conditions regardless of the adverse approach flow.

John G. Morgan, with the Chicago District, discussed "Little Calumet River, Indiana, Interior Design Considerations." The Little Calumet River is located in northwestern Indiana and northeastern Illinois, in the greater metropolitan Chicago area. The project under design consists of construction of new levees, replacement of existing levees,

construction of a major flood control structure, channel improvements, bridge modifications, and modification of 12 existing and construction of one new pump station. Mr. Morgan described the study status and approach used in the invest and design of the complex system.

Michael W. Burnham, HEC, discussed the topic, "Interior Flood Hydrology (IF Computer Program)." The HEC, with assistance of a private contractor, is develc computer program to assist USACE personnel in performing hydrologic analysis interior areas. The program will operate on personal computers. It enables use: perform interior analysis of two interior subbasins and the exterior area using continuous simulation analysis, coincident frequency analysis, and single-event analysis approaches. The program is scheduled for initial release in the summer 1990.

POND CREEK PUMPING PLANT
LOUISVILLE, KY FLOOD PROTECTION
BY
Laurence Curry, Jr. 1/

Design Objective.

Pond Creek Pumping Plant was designed as a major feature of a 14 mile extension of the Louisville levee system to protect over 38 square miles of residential, industrial and farm lands from Ohio River flooding. A secondary purpose was to design the gravity outlet to impound an 810 acre recreational lake within the protected area. Several important considerations which impacted the 20-year design process included guidance from the Board of Rivers and Harbors which caused design capacity to be linked to actual events. Value Engineering resulted in up to four million dollars in savings and greater reliance on electronic gate controls. Flood insurance guide lines influenced selection of the 100 year design ponding frequency.

Degree of Protection.

At the time of survey scope studies in 1964, a draft of EM 1110-2-1410, Interior Drainage for Urban Areas was issued. This permitted use of a stage duration curve to determine a hypothetical design storm coincident with flood stages. Example: a 100-year storm coincident with a 2% stage duration was equivalent to a 2-year all-season TP 40 storm. This EM also set degrees of protection based on land use and an array of design ponding level objectives as shown below:

<u>Class</u>	<u>Description</u>	<u>Degrees of Protection Desired (Year)</u>
Class I	Concentrated Commercial and Industrial Section	100-Year
Class II	Highly Developed Residential Commercial Section	50-Year
Class III	Relatively Low-Valued Urban Section	25-Year

<u>Pond Level (Class I)</u>	<u>Design Objective</u>	<u>Design Frequency</u>
A	In Banks	2
B	Open Areas Flooded	10
C	Significant Property Damage	100
D	Life Threatening Damage	SPF

1/ Hydraulic Engineer, Louisville District, U.S. Army Corps of Engineers

Land Use Designation. The first built-in safety factor was designation of the protected area as "Class I" based on projected growth rather than existing growth. This designation was also influenced by the development of the flood insurance program which emphasized strict regulation of the 100-year flood plain. The 125-square mile watershed (Figure 1) was subdivided, a compound unit hydrograph was developed (Figure 1A) and a 100-year design storm computed and routed through storage. The survey scope 100-year ponding level was based on the lowest existing structure. The resulting design pumping capacity was 2,400 cfs.

Rainfall Criteria. When the survey report was reviewed by Board of Rivers and Harbors in 1967, there were objections to the hypothetical storm and a strong suggestion that actual events be considered over the 70-year period rainfall records. Rainfall depths for hypothetical storms and the three most severe flood period storms are tabulated below. There was obviously more correlation between rainfall and river flooding at this site than indicated by the duration vs all-season frequency relationship.

Storm	Rainfall Depths (Inches)			
	6 hr	24 hr	96 hr	240
100 year all season	3.95	6.45	8.08	10.60
100 year flood period	1.55	3.00	4.15	5.50
March 1945	2.57	3.63	6.39	8.10
January 1937	1.53	4.01	10.28	14.87
March 1964	3.80	6.97	8.53	12.73
Standard Project Flood	9.40	13.40	16.40	21.40

Design Storms. During the GDM phase, the 1937 storm was selected as the 100-year design storm and the 1964 storm as a more severe test storm since it had an all-season frequency greater than 100 years. (Figures 2 & 3). Cost curves for real estate, operation maintenance and first cost were developed in order to optimize total pumping cost. A design capacity of 4,100 cfs (5 units) was selected utilizing 13,200 acre-feet (AF) of storage between elevations 421 and 432. This represents 2.0 inches of runoff over the 125 square mile drainage area. (Top of Levee is elevation 457 and gravity invert is at 390). The various components of the optimized pumping cost (1972 prices) are tabulated below. Final cost of the plant in 1985 dollars was about \$15,000,000. The selected design ponding elevation required purchase of several buildings.

Item	First Cost*	Annual Cost**
Plant	4,500,000	149,600
Easements	1,000,000	33,200
Major Replacements	---	10,800
Maintenance	---	5,400
Operation	---	13,500
Power Cost	---	36,500
Total	5,500,000	249,000

* 1972 Prices

** Interest rate 3.25%

Reliability and Cost.

The barrier dam which was to be 67 feet high had to combine three features, the pumping plant, gravity outlet and recreation lake outlet works. In the early design stages, electrically operated gravity gates were not considered reliable enough or accurate enough for hourly lake regulation. A weir was considered necessary for low and moderate flows with gates used during major runoff events. The normal pool of the lake was set at elevation 421, the same as pump starting elevation, to simplify pumping operations. Early designs called for the weir and gravity conduit to be combined, but separate from the pumping plant to ensure that flow lines into the pumps would not be disturbed by the gravity structure. However, model studies ^{2/} showing vortexing problems with the separate gravity structure. Also, the wing walls required for a separate gravity structure were very costly because of the size of the barrier dam and the gravity passages (2 at 15 by 15 feet). It was decided to combine pumping and gravity, with gravity in the center bay for symmetry and reasonable flow lines to the pumps. The weir would be replaced by a self-regulating automatic gate, which maintained a stable recreation pool on the landside by hydrostatic pressure and balances. This design was model tested and found satisfactory. However, a VE study team pointed out that debris created by forested areas and icing problems during extremely cold winters would make the auto gate reliability questionable. At this time (1982), electronic operation of large hydraulic equipment at locks and dams was considered reliable. A decision was made to rely on large roller gates with opening and closing speeds carefully programmed for electronic regulation. Figures 4, 5, and 6 are elevation, plan and cross-section of final design. Figure 7 is the 100-year all-season hydrograph as regulated with the recreation lake in place.

^{2/} WES TR HL-88-7, Fletcher, 1988

Number of Pumping Units. The number of units evolved from 5 to 6 when model studies showed that a pumping unit over the center (gravity bay) would have less than desirable inflow conditions. However, the VE team reduced the number from 6 to 4 when research showed that since the 700 cfs units required for a 6-unit plant would be custom made, there was little cost advantage in the smaller pumps and a great cost savings in reducing the pumping bays from 6 to 4. Each unit has a design head capacity of 1025 cfs.

Flood Plain Management.

The levee extension and barrier dam would lower the 100-year flood a maximum of 11 feet (from elevation 443 to 432). After approval of the DM2 (Major Ponding Area Determination), the local sponsor obtained property surveys of all lands required for ponding easements. Purchase of easements soon followed. Early in this process, it became obvious that the recreation lake should be delayed. There was industrial development and high quality clay deposits being mined in the immediate vicinity of the proposed recreation lake which would greatly increase the cost of ponding easements. Although sanitary sewer construction was improving the water quality of Pond Creek, the impacts of surface runoff from industrial sites will make water quality in the recreation lake difficult to predict. While the gravity bay has been designed to accommodate the recreation pool, the purchase of permanent flooding rights and the actual impoundment have been postponed indefinitely. The ponding easements being taken restrict filling between elevation 421 and 432 unless it is balanced with excavation within the same elevation range.

New Development Safety Factor. To provide a safety factor, the Corps suggested to the local sponsor that residential development be restricted to at least 3 feet above the 100-year ponding elevation 432, based on the fact that a standard project flood (SPF) elevation 437 would not be a life threat to development beginning only 2 feet lower at elevation 435. The local sponsor, not wanting to legalize the concept of the SPF, suggested that development be restricted to the ponding level that would occur with one pumping unit disabled during the entire design storm. This level, computed to be elevation 435.4, was adopted as a special flood plain management tool.

Flood Insurance Restudy. A final measure was the inclusion of the Pond Creek ponding area in the flood insurance restudy maps for the protected area within two years of the September 1989 dedication of the project. This study was assigned by the Federal Emergency Management Agency to the Corps. The local sponsor is Jefferson County, which includes the City of Louisville. However, storm water management, flood plain management and flood insurance administration is the responsibility of the Metropolitan Sewer District, which also will operate and maintain the Flood Protection system, including the Pond Creek Pumping Plant. The project has the effect of lowering the 100-year flood plain eleven feet, from elevation 443 to 432.

Additional Safety Factors:

The first safety consideration incorporated into the pumping plant design after the GDM, was to design the gravity outlet to limit SPF headwater ponding to elevation 437, five feet above the flood period 100-year ponding elevation. The resulting twin 15-foot by 15-foot passages limit the 100-year gravity ponding to elevation 428. This was recommended in DM2, Major Ponding Area Determination, in 1973.

Test Storm. The March 1964 storm had a 24-hour rainfall depth exceeding the 100-year frequency all-season storm and yet it occurred coincident with a major flood on the Ohio River. The selected pumping capacity of 4,100 cfs was tested against this event and limited ponding to elevation 434.5, only 2.5 feet above design ponding and within the 3.4-foot buffer zone established for development. This is considered to be a flood period event exceeding the design frequency which would cause moderate damage as limited by operation of the project.

Actual Capacity During Major Floods. The design head corresponding to the 4,100 cfs design capacity of the pumps was selected as 28 feet (Modified 1937 crest elevation 449 minus pump starting elevation 421). However, during critical periods during the 1937 and 1964 storms, pumping heads were on the order of 18 feet corresponding to a total pumping capacity of 4,700 cfs. Based on the varying capacity of the selected pumps during the 1937 design storm, the peak ponding would actually be 430.0. This is considered to provide a cushion against down time, leakage or other mechanical problems during a critical event.

Service and Emergency Gates. Because of the critical need for gravity closure at this plant, two sets of two gravity roller gates are provided in tandem. In the future, the upstream gates will be geared for very slow operation at the time of impoundment of the recreation lake in order to regulate lake levels on an hourly basis. This would also prevent sudden increases in downstream flows because of local runoff.

Operability.

To guard against operational errors, all float gages (one per unit) are calibrated to mean sea level. Also wire weight gages are provided at the upstream and downstream face of the plant to accurately determine differential head through the gravity bays. If the tailwater level is above pump starting elevation 421 and there is a positive hydrostatic head across the plant of over one foot, the gravity gates can be opened to take advantage of the greater capacity of the gravity structure while the pumps are still operating. This operation during a recurrence of the March 1964 flood would increase outflows from 4,100 to 8,100 cfs compared to peak inflow of 16,200 cfs.

Trash Racks and Baffle Blocks. In order to provide maximum flexibility in removal of trash from the trash racks (2 inch spacing), a mobile crane has been provided to remove trash as it accumulates. The final item of this report is a negative one. A stilling basin was designed based on standard Corps formulas and model testing. Because D_2 was much greater than normally encountered (Design $Q = 15,000$, $D_2 =$

28.5), baffle blocks were quite tall (10 feet). Since there was not sufficient room on the basin floor for traditional baffle block shapes, rectangular columns were provided. After recent diversion of all flows through the pumping plant, these have proved to be debris catchers during low to moderate flows. Consideration will be given to shortening these columns in the future, if it can be determined that the retreat channel can withstand some additional turbulence. The stream profile of Pond Creek showing major floods before and after construction is Figure 8.

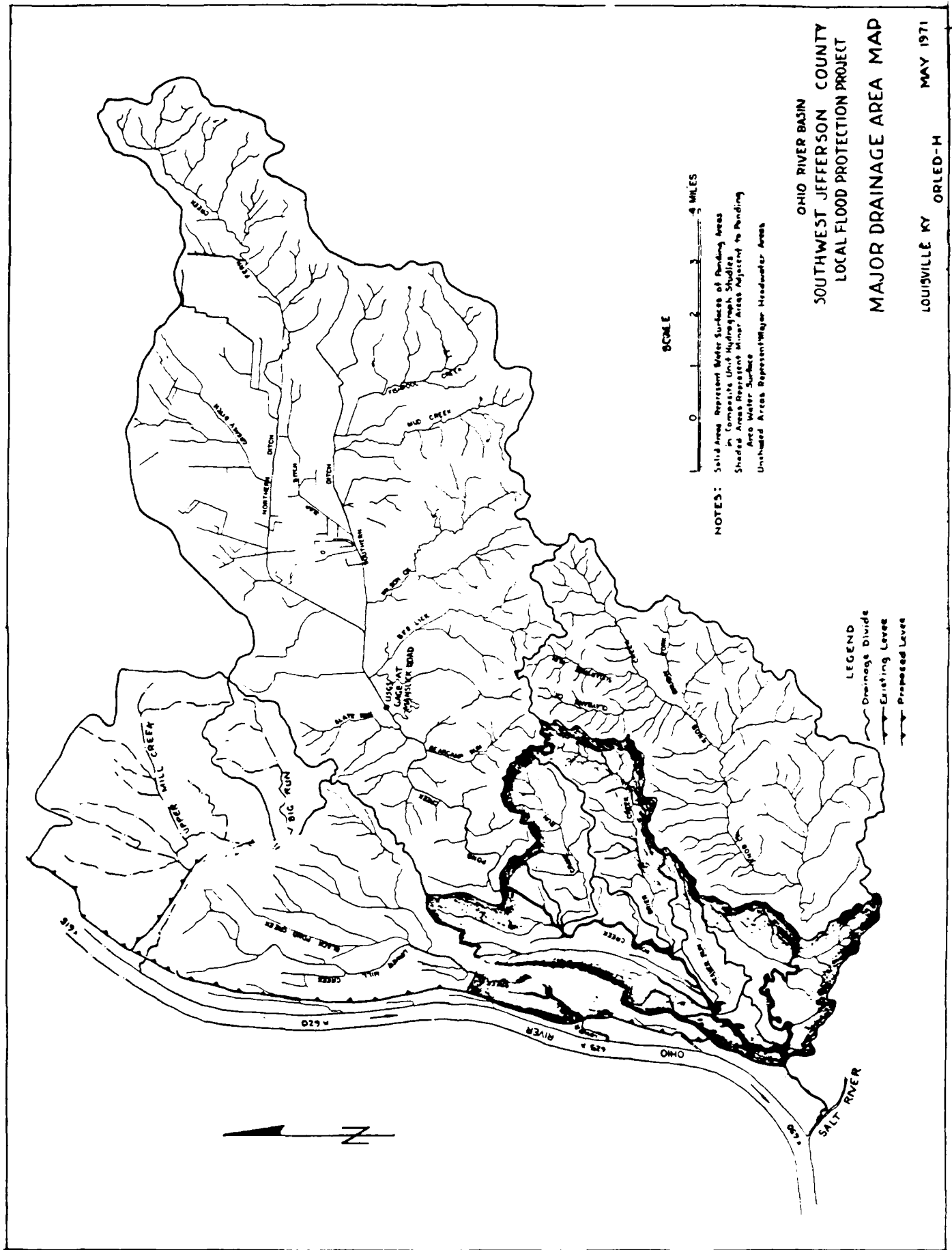

OHIO RIVER BASIN
 SOUTHWEST JEFFERSON COUNTY
 LOCAL FLOOD PROTECTION PROJECT
 MAJOR DRAINAGE AREA MAP
 LOUISVILLE KY ORLED-H MAY 1971



NOTES: Solid Areas Represent Meter Surfaces of Flooding Areas
 in Composite Unit Hydrograph Studies
 Shaded Areas Represent Minor Areas Awaiting to Pending
 Area Water Surface
 Unshaded Areas Represent Major Headwater Areas

LEGEND
 --- Drainage Divide
 --- Existing Levee
 --- Proposed Levee

Figure 1



11 inch Rainfall Excess

Notes: Unit Graph for 75.1 Sq. Mi. Area
Based on Snyder's Method and Flow
Records for Upstream Gaging Station
(D. A. - 64 Sq. Mi.). Smaller Area Unit
Graphs were Based on Koelzer Unit Graph
Curves for 4 Basic Topographic Classi-
fications.

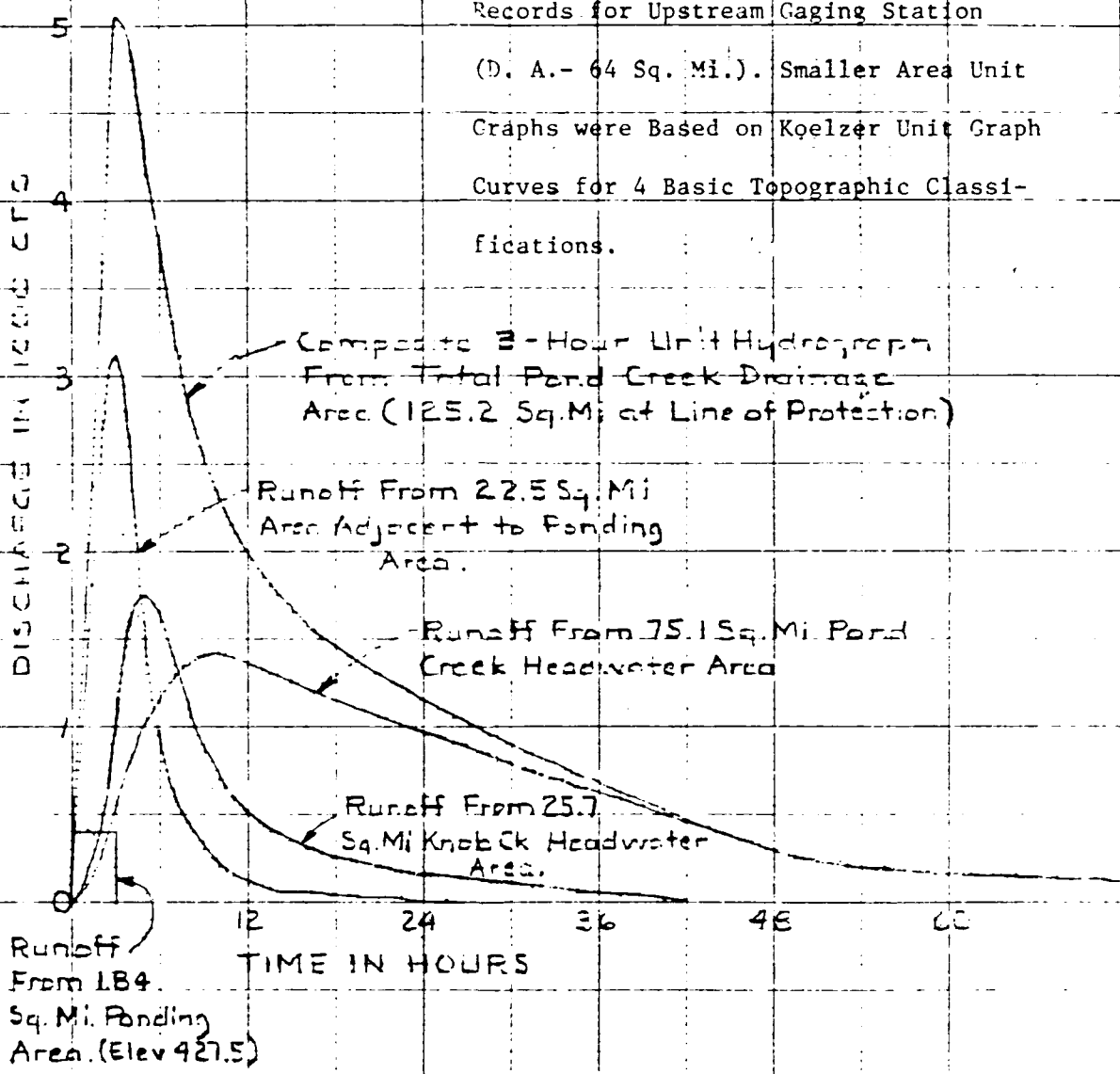

OHIO RIVER BASIN
 SOUTHWEST JEFFERSON COUNTY
 LOCAL FLOOD PROTECTION PROJECT
 POND CREEK PUMPING PLANT
 THREE-HOUR UNIT HYDROGRAPH
 LOUISVILLE KY. ORLED-H MAY 1971

DM NO 1

Figure 1-A

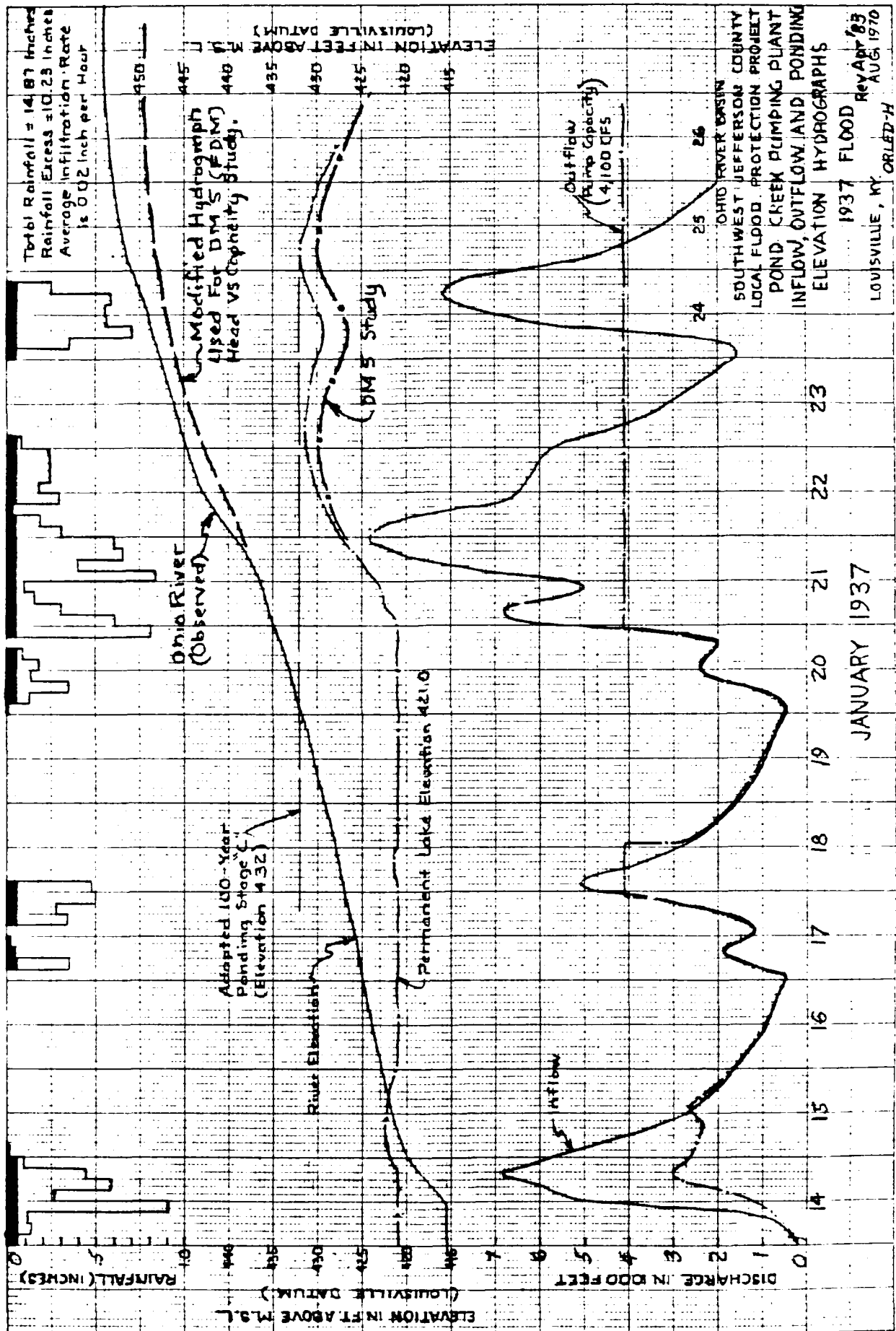

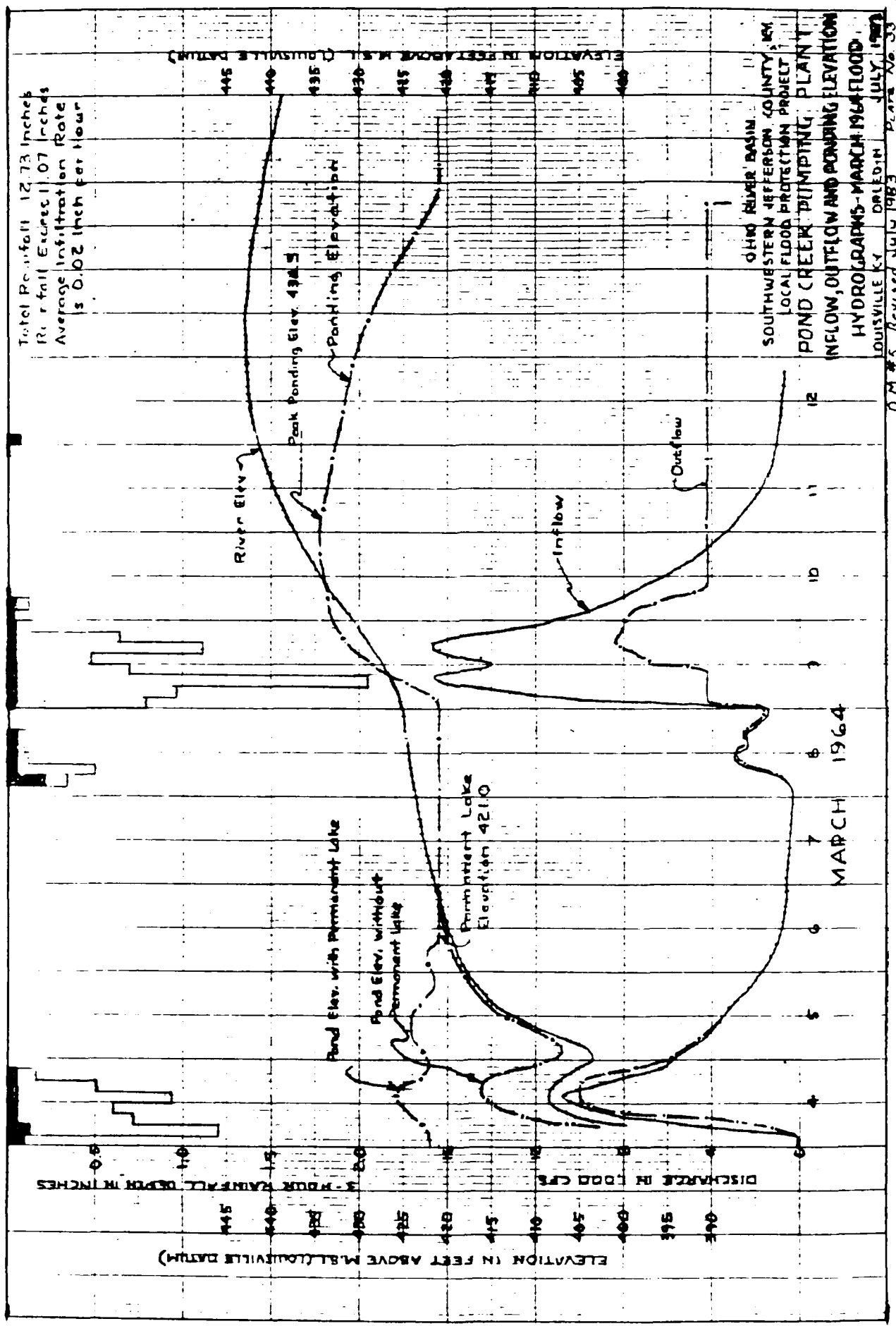

MARCH 1964 FLOOD

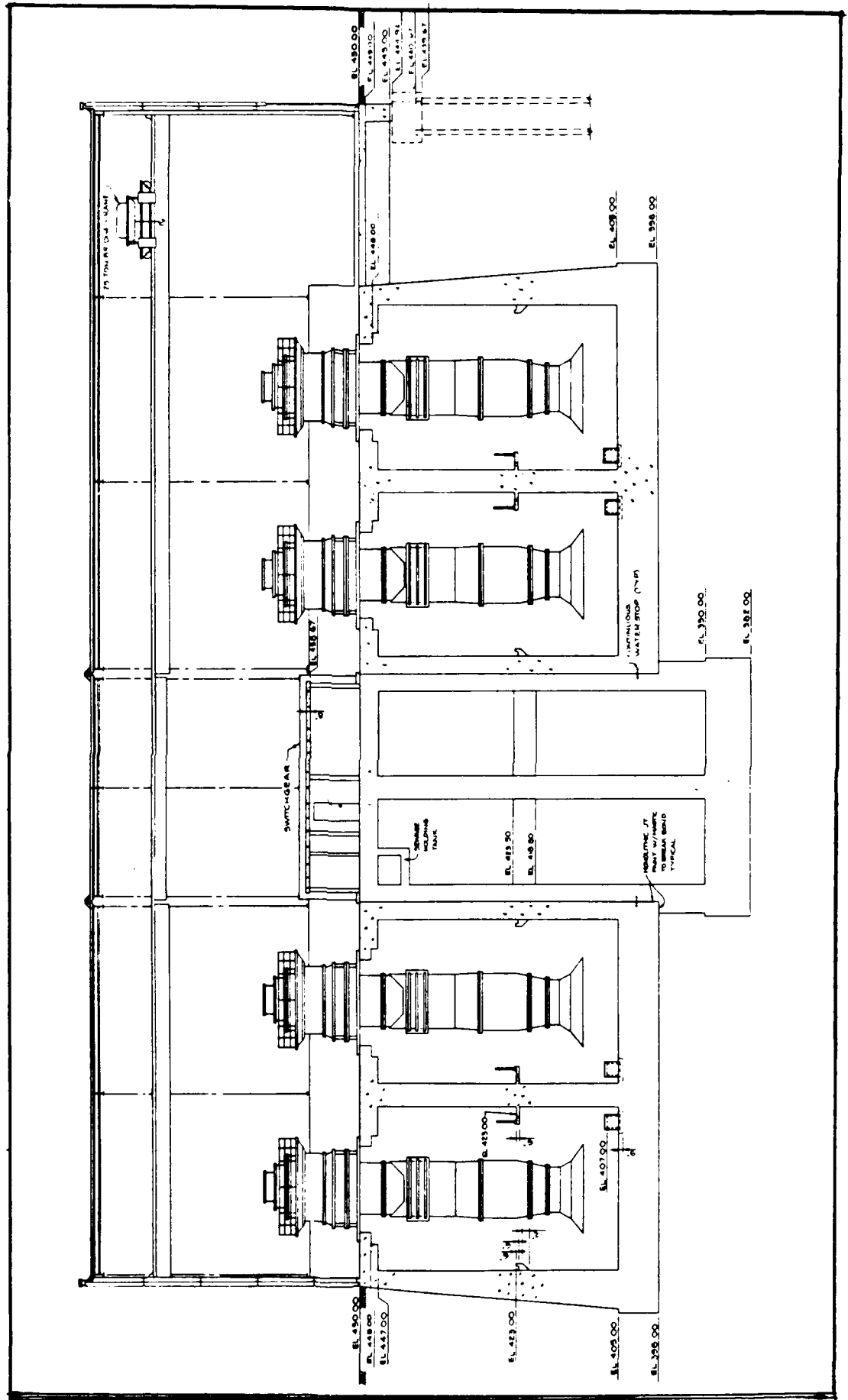

POND CREEK PUMPING STATION

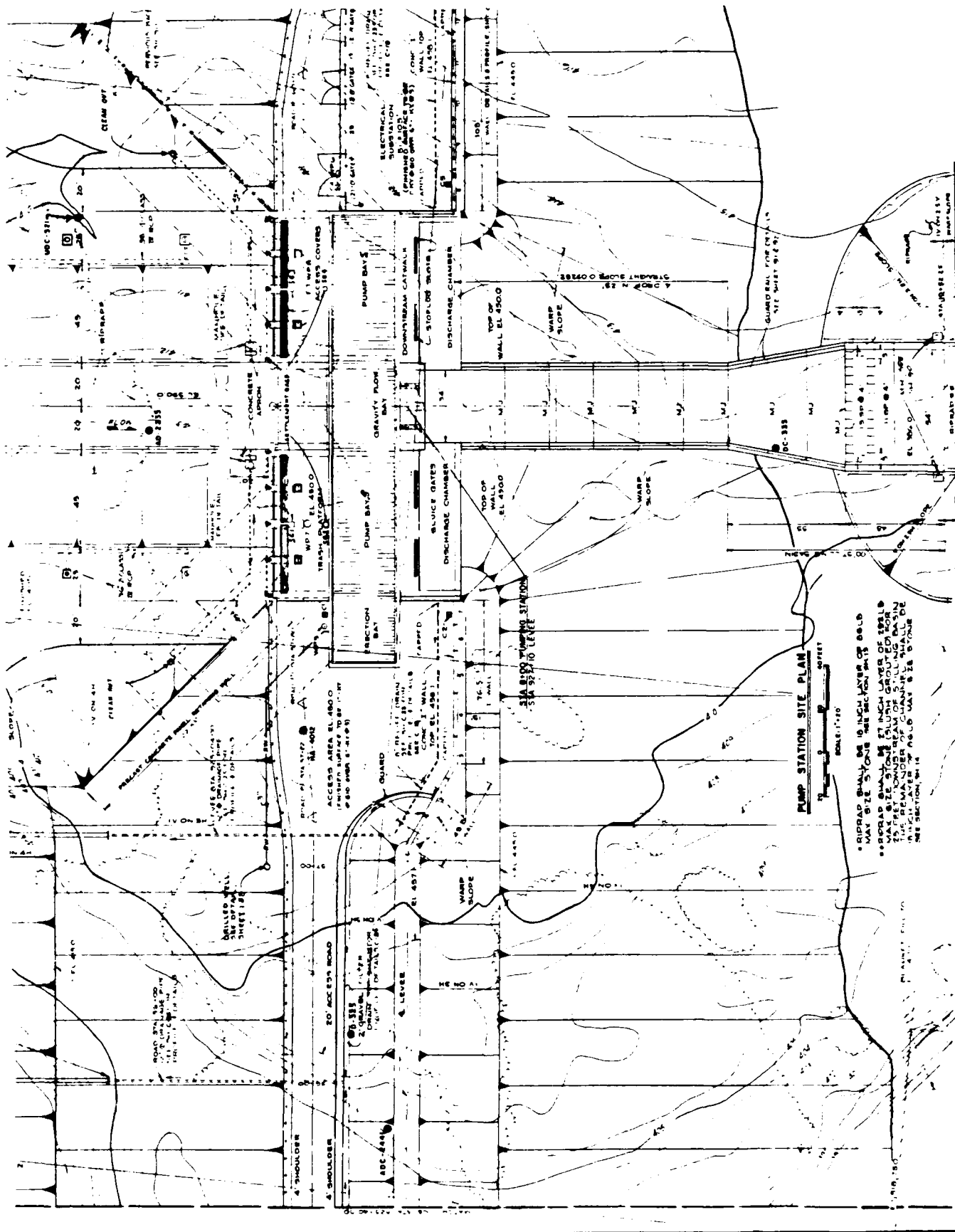

POND CREEK PUMPING STATION

Figure 5

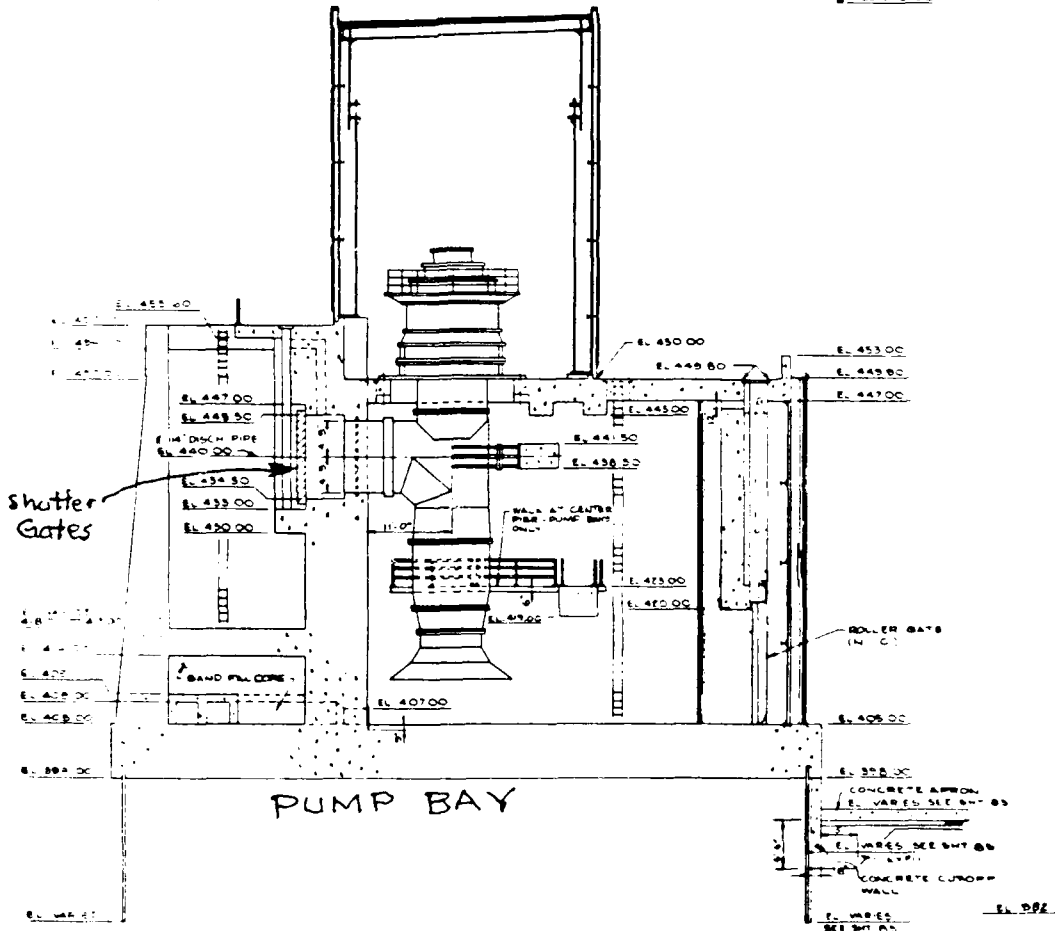
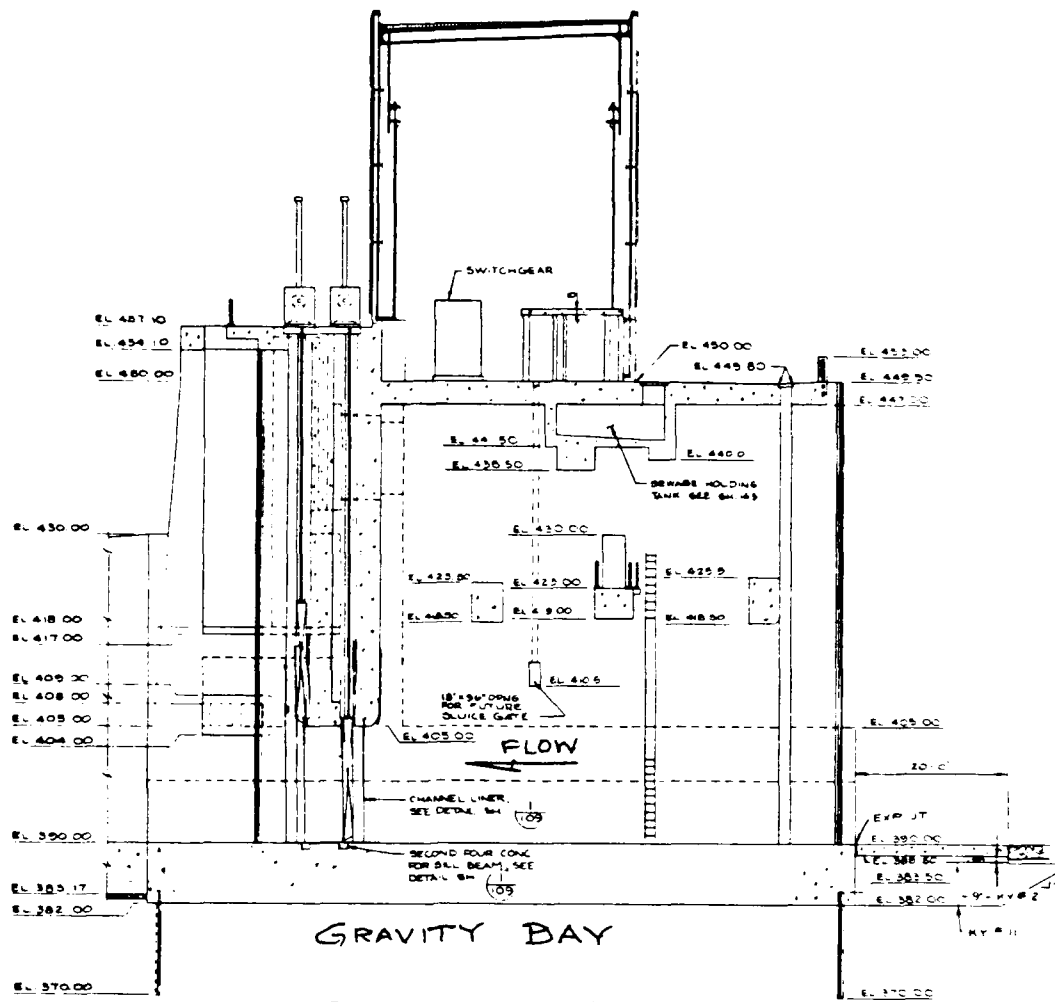
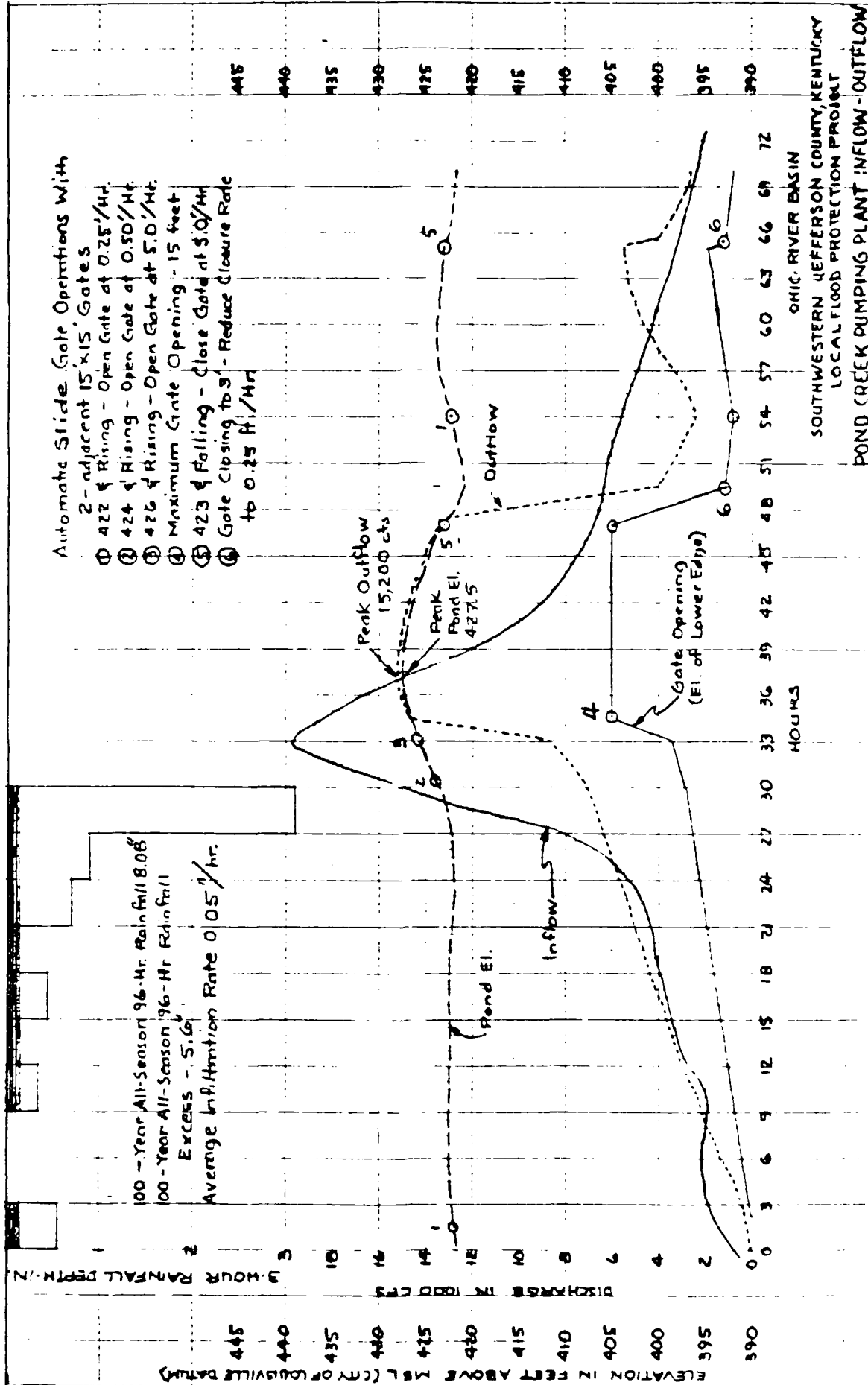
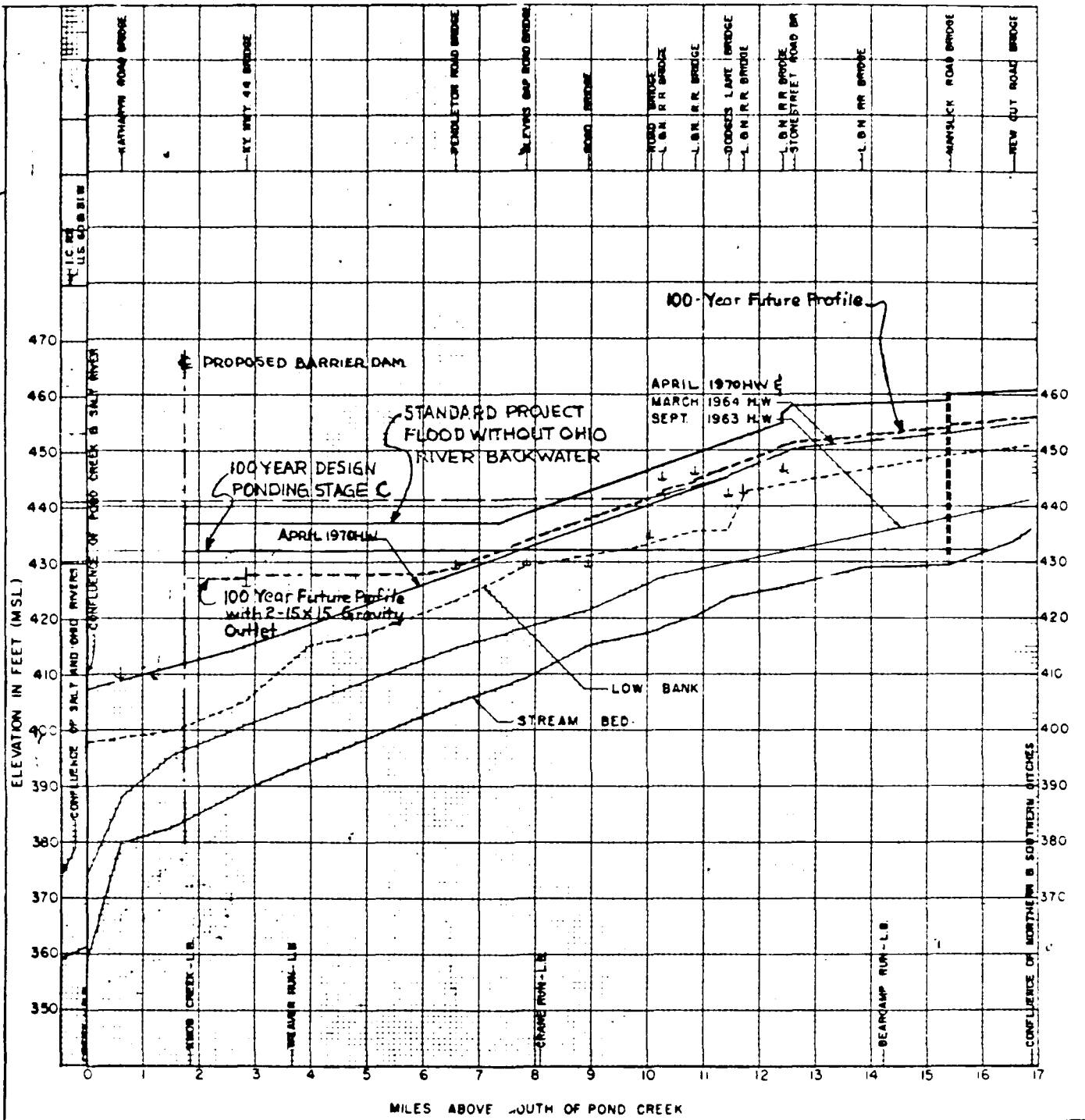

Figure 6



100-YEAR ALL-SEASON FLOOD

Figure 7



SALT RIVER BASIN

POND CREEK
(NORTHERN DITCH & FERN CREEK)

PROFILES

SHEET 1 OF 1
LOUISVILLE DISTRICT ORLED-H JAN 1965
REV APR 1974

SLIDELL, LOUISIANA INTERIOR STUDY

by

Robert H. Fitzgerald¹

Introduction

Background. Slidell, Louisiana is located on the Pearl River northeast of New Orleans, Louisiana. The area has experienced much growth during the past 10-15 years. Much of the new development has been within the floodplain of the Pearl River and began during a period of relatively low river conditions prior to 1979. Major flooding was then experienced on the Pearl in 1979, 1980 and 1983 with the 1983 event being the flood of record for the area. Damages caused by the 1983 event were estimated to be \$5.5 million with approximately 700 to 800 homes and businesses flooded. As a result of these damaging floods, feasibility studies were initiated by the U.S. Army Corps of Engineers, Vicksburg District (LMK) in 1983. These studies identified potential flood reduction measures for the area. The results are reported in the "Slidell, Louisiana and Pearlinton, Mississippi Interim Report on Flood Control" (U.S. Corps of Engineers, 1986).

Purpose of Study. The purpose of the feasibility study was to identify and analyze flood reduction measures for the Slidell, Louisiana and Pearlinton, Mississippi area. Additionally, the study was to identify and recommend for further action the best plan for providing flood protection. The purpose of this paper is to briefly describe the interior analysis portion of the feasibility study and to report some of the findings from the study.

Key Issues. Much of the area to be protected is developed at the present time. As a result, available storage within the ponding areas is somewhat limited. Damage to the environment is also of great concern as the wetlands extend very close to the development in many locations. Definition of the line of protection and minimum interior facility (minimum facilities required to prevent induced flooding during low river conditions) became difficult as tradeoffs between protecting the environment and protecting the developed property were considered. Residual flooding was also a major concern due to the large number of structures within the area. The proximity of the area to the coast and the associated potential for heavy rainfall further emphasized the residual flooding issue.

¹Hydraulic Engineer, Vicksburg District, U.S. Corps of Engineers

Summary of Findings. The lack of abundant storage volume in some of the ponding areas was accounted for in sizing the gravity outlets associated with the minimum facility. Pumps were found to be incrementally justified in most areas. The line of protection was drawn such that no major damage to the environment will result upon construction, while providing protection to most of the highly developed areas. Residual flooding was addressed from both excessive interior rainfall and greater than design stages on the river. In both cases, it was found that flooding was severe but not significantly worse than without the levee in place.

Physical Setting and Available Data

Pearl River Basin. The Pearl River originates in east central Mississippi and flows some 415 miles in a southerly direction to Lake Borgne and the Gulf of Mexico. A large portion of Mississippi and part of southeastern Louisiana drain into the Pearl River. The total drainage area is about 8760 square miles.

Slidell, Louisiana is located in the extreme lower end of the Pearl River Basin. The entire study area extends from the vicinity of U.S. Highway 90 on the south to near Interstate Highway 59 (I-59) on the north. The area is located about 25 miles northeast of New Orleans, Louisiana.

Interior Drainage Basins. The area within the proposed levee system is divided roughly in half by Interstate Highway 10 (I-10). The portion to the north of I-10 has a drainage area of about 3770 acres. About 6500 acres drain into the area to the south of the divide. Another smaller ponding area to the south has a drainage area of approximately 360 acres. Stream slopes within each of the interior basins are very flat and the runoff rates are quite sluggish. Portions of the basins are highly developed. However, a large number of trees and forested areas remain, particularly in the residential areas.

The potential for damage due to flooding is quite high. Most of the recent development has been built above the 100-year floodplain. However, structural damage begins at about the 10-year flood event in several areas. Street flooding begins at or below the 10-year event in many areas, limiting access in some locations.

While the potential for structural damage due to flooding within the area is quite high, the potential for loss of life is relatively low. The rate of rise in the Pearl River is such that adequate time for evacuation is available prior to a major flood event.

Available Data. Daily stage and discharge data are available at several locations along the Pearl River. Gages within the study area include the Pearl River at Pearl River, Louisiana and East Pearl River at U.S. Highway 90 stations. The Pearl River at Pearl River, Louisiana gage is located near the upstream boundary of the study area and has stage and discharge records extending in time from 1900 to present with limited data as early as 1874. Flow frequency relationships were developed from this data. The East Pearl at U.S. Highway 90 gage is primarily a tide gage and only stage data are available. Gage records at this location extend from 1962 to present. Limited stage and discharge data were obtained at various locations throughout the study area during the 1979, 1980 and 1983 flood events.

Daily rainfall data are available at Slidell, Louisiana and numerous other locations within the Pearl River Basin. Data from the Slidell station extending from 1956 to present were used for the interior analysis portion of this study.

Pearl River channel cross section profiles were obtained during the mid 1980's. Flood profiles for the recent major flood events were obtained from observed high water marks. Topographic data and first floor structure elevations were obtained as part of the feasibility study.

Study Approach

Procedures Adopted. Interior analysis procedures adopted for this study were taken from EM 1110-2-1413 (U.S. Corps of Engineers, 1987) which was in draft when the feasibility study was initiated. Specifically, the historic period-of-record procedure was adopted. This procedure is a continuous simulation method which utilizes period by period river stage and rainfall data. Hypothetical hydrograph computation procedures were used to develop the Standard Project Flood (SPF) hydrographs. Gravity outlets were designed using hypothetical frequency inflow hydrographs and the modified Puls routing procedure.

Assumptions and issues regarding project performance and safety. Evacuation of interior runoff was very important to the success of the project. Many local residents expressed concern that flooding would occur within the protected area due to lack of adequate outlet capacity. As hydrologic engineers, our concern was not our ability to provide adequate outlet capacity but rather the local sponsor's ability to maintain the ponding area volume upon which that capacity was dependent. The assumption was made that the ponding areas would be protected from development which would adversely impact the available storage volume. Residual flooding was also an issue regarding the safety of the project. While no assumptions were made regarding residual flooding, a thorough analysis was made to identify the threat and minimize the impacts should the design flood be exceeded.

Computational Methods. The computational methods used in the hydrologic and hydraulic analysis of the study are discussed below:

- 1) Pearl River frequency profiles were developed using the computer program HEC-2 (HEC, 1982). Flows were obtained from available flow frequency relationships for the Pearl River at the Pearl River, Louisiana gage. Observed flood profiles from the recent major flood events were used for calibration.
- 2) Unit hydrographs were computed for each interior basin using an empirical method developed by the U.S. Geological Survey (USGS, 1967) specifically for the southeastern portion of Louisiana. Basin parameters, size, mean length and lag time for a given basin are applied to a dimensionless unit hydrograph to obtain the unit hydrograph for the given basin. The dimensionless unit hydrograph was developed by the USGS using regionalized data from gaged streams within southeastern Louisiana.
- 3) A rainfall-runoff computer model developed in LMK was used to compute continuous period runoff hydrographs for each ponding area. The model requires monthly runoff coefficients, a user defined unit hydrograph and daily rainfall and river stage data. Within the model, rainfall excess was computed by multiplying rainfall times the appropriate monthly runoff coefficient. The runoff hydrographs were then computed by applying the rainfall excess to the unit hydrograph. Periods less than 24 hours in length were obtained by interpolation of the rainfall and river stage data. A river stage transfer option within the model was invoked to transfer observed river stages from the gage location to the appropriate outlet structure location. Seepage inflow was computed as a function of river stage and added to the runoff hydrograph to obtain the total pond inflow hydrograph.
- 4) The LMK pump and gravity routing model was used to compute continuous period pond volume and stage data. The model used the modified Puls procedure to route pond inflow hydrographs through storage under either pump or gravity outlet conditions as appropriate. The continuous period pond inflow and river stage hydrographs were obtained directly from the rainfall-runoff model output. Gravity outlet discharge ratings, pump capacities, pump operation criteria, and pond elevation versus volume relationships were input into the model. Changing river conditions were accounted for by use of a tailwater rating for the gravity outlet and head versus capacity relationships for the pumps as appropriate.

- 5) The HEC-1 Flood Hydrograph Package (HEC, 1981) was used for the hypothetical frequency event analysis. Synthetic rainfall was obtained from Technical Paper No. 40 (NWS, 1961). Standard Project Flood hydrographs for the interior areas and for the Pearl River were computed using procedures outlined in EM 1110-2-1411 (U.S. Corps of Engineers, 1965). Standard Project Storm (SPS) rainfall was computed and input into HEC-1 (HEC, 1981) for computation of the runoff hydrographs and storage routing procedures.
- 6) Ponding area volume versus frequency relationships were developed using both graphical and analytical techniques. Pond elevation versus frequency relationships were then computed using appropriate elevation versus volume relationships. Extrapolation of the curves beyond the 100-year frequency was checked by comparison with results obtained by routing the hypothetical 100-year and SPF events through pond storage under various river conditions.

Study Results

Summary of study results. The primary results of the study were the project design flowline, the with and without project stage frequency relationships, gravity outlet capacities, pump capacities and pump operation data. Period by period ponding area and river stage hydrographs were also produced. A comparison of the data from these hydrographs was very helpful in determining stage reductions for specific flood events. The project design flowlines for 3 alternatives studied are shown on Figure 1. Figure 2 shows pond elevation versus frequency relationships for existing conditions and various improved conditions for one area. A plot showing the pond and river stage hydrographs for the 1983 flood event in one area is at Figure 3. Gravity outlets ranged in size from a double 7-foot by 8-foot concrete box culvert to a single 24 inch diameter pipe. Recommended pump capacities ranged from 15 cfs to 250 cfs depending upon the area. Average annual days of pump operation range from 13 days to 54 days for the recommended plan. Average static pump head was less than 3 feet for all areas.

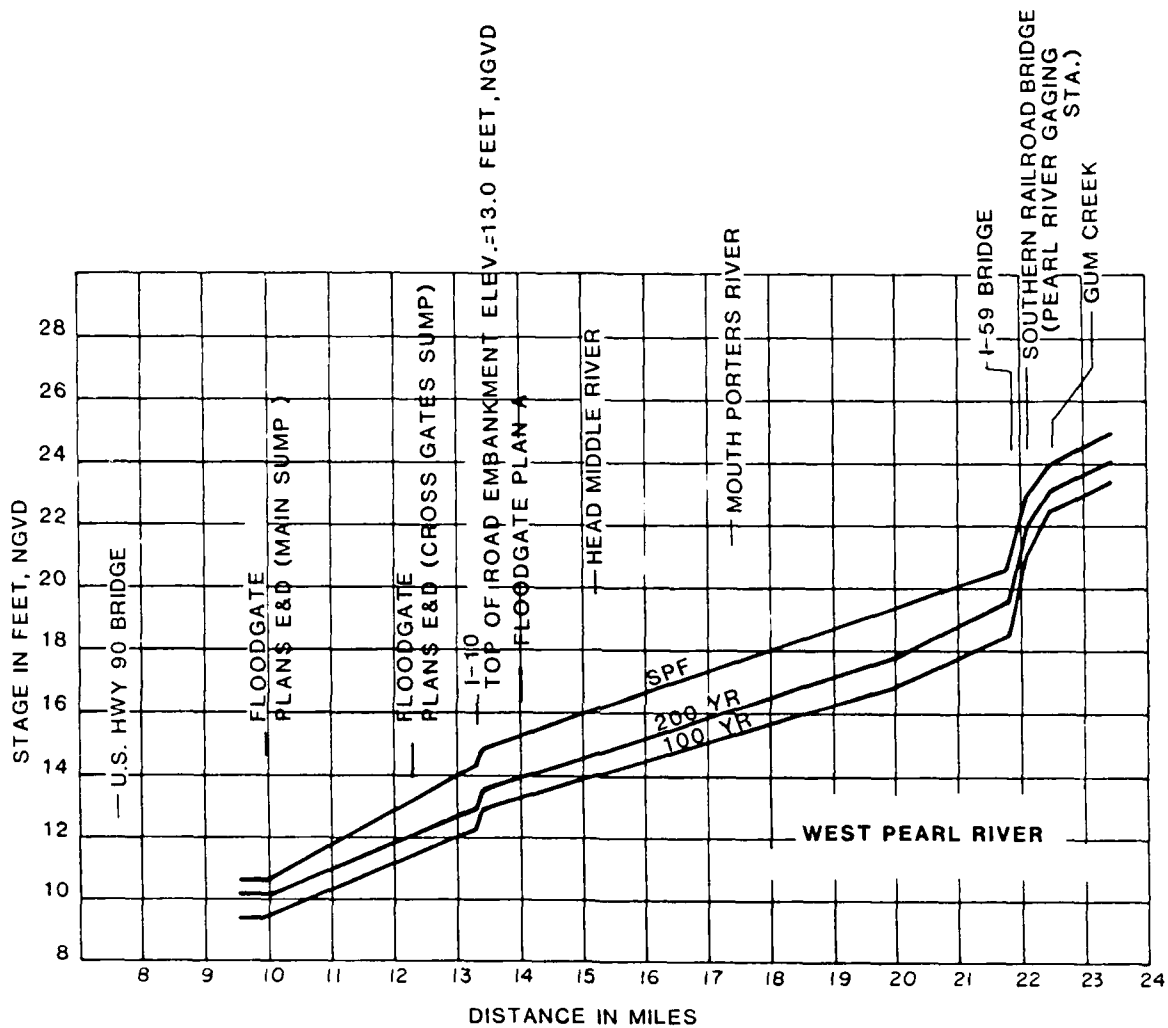

Figure 1. Project design flowlines for the 100-year, 200-year and SPF flood events on the West Pearl River.

Hydrologic engineering results related to performance and safety. A provision was included in the recommended plan which would require that the local sponsor zone or otherwise restrict development within the designated ponding areas. The results of the interior analysis were used to define these areas and to justify the need for the provision. The flowline computations were used in the residual flooding analysis. For example, the

SPF flowline is only about 1.0 to 1.5 feet higher than the recommended design flowline. Likewise, the interior SPF computations were used to simulate an intense rainfall such as might result from a hurricane or tropical storm. In both these cases, flooding would be severe but not significantly worse than without the project in place.

The results of the interior routings were used to establish recommended pump operation criteria and will be used in writing the operation and maintenance manuals for the project upon construction. No unusual problems were indicated with operation of the project as recommended.

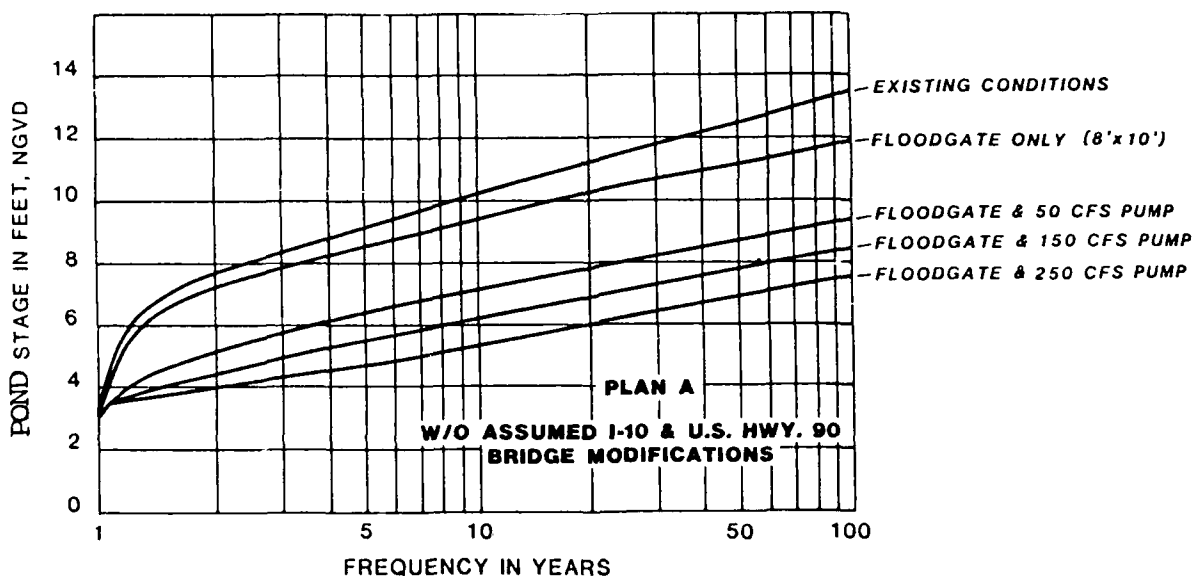

Figure 2. Pond stage versus frequency relationships for existing conditions and various alternative plans.

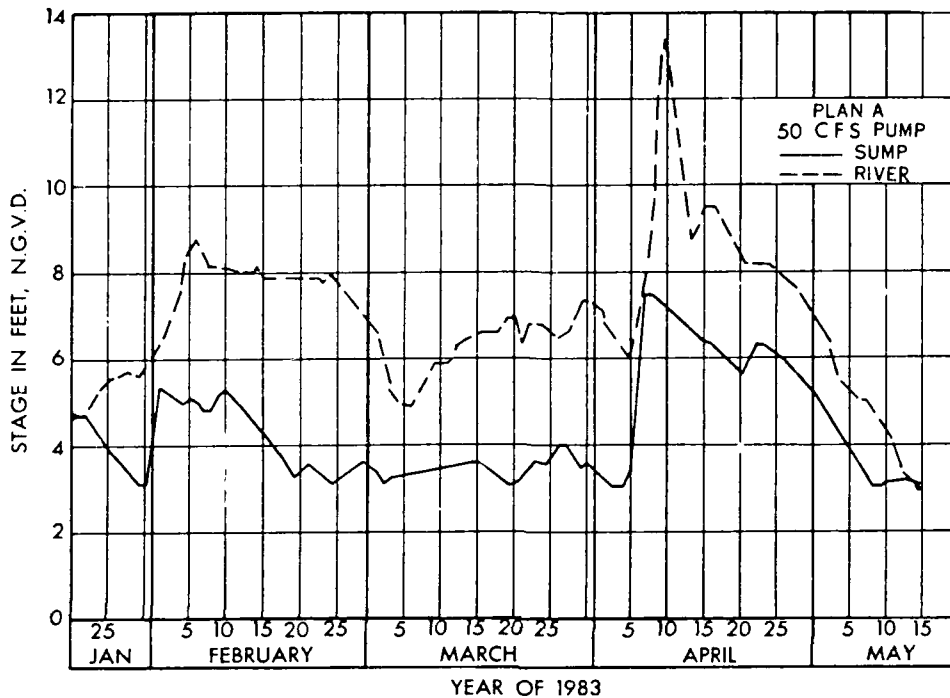

Figure 3. Pond and river hydrographs of the 1983 flood event

Conclusions

The feasibility report (U.S. Corps of Engineers, 1986) identified the recommended plan as a combination of levee alignments both north and south of I-10 providing protection from the 200-year flood on the Pearl River. The recommended levee alignment caused minimum damage to the environment while protecting most of the developed areas. Residual flooding, while always a threat on any project, should not create a life threatening situation within the area. The project as designed should be easily operable by the local sponsor.

This plan is the National Economic Development plan which maximized net project benefits.

REFERENCES

- U.S. Corps of Engineers 1986. "Pearl River Basin, Slidell, LA and Pearlinton, MS, Interim Report on Flood Control", U.S. Army Corps of Engineers, Vicksburg District
-
- _____ 1987. Engineer Manual, EM 1110-2-1413, "Engineering and Design, Hydrologic Analysis of Interior Areas", U.S. Army Corps of Engineers, Office of Chief of Engineers, Washington, D.C.
-
- _____ 1965. Engineer Manual, EM 1110-2-1411, "Standard Project Flood Determinations", U.S. Corps of Engineers, Office of Chief of Engineers, Washington, D.C.
- Geological Survey 1967. Unit Hydrographs for Southeastern Louisiana and Southwest Mississippi, Technical Report 2b, U.S. Department of Interior, Washington, D.C., in cooperation with Louisiana Department of Public Works, Baton Rouge, LA.
- National Weather Service 1961. Rainfall Frequency Atlas of the United States, Technical Paper Nos. 40 and 49, U.S. Department of Commerce, Washington, D.C.
- Hydrologic Engineering Center 1981. HEC-1 Flood Hydrograph Package, Program Users Manual, U.S. Army Corps of Engineers, Davis, CA.
-
- _____ 1982. HEC-2 Water Surface Profiles, Program Users Manual, U.S. Army Corps of Engineers, Davis, CA.

FORMED SUCTION INTAKE (FSI)
APPURTENANCE GEOMETRY

by

Bobby P. Fletcher¹

Introduction

Vertical pumps with suction bell intakes used in flood-control pumping stations have experienced problems in the form of subsurface and surface vortices and uneven flow distribution due to adverse flow conditions in the sump. These adverse flow conditions usually result in frequent maintenance and post-construction modifications, and in some severe cases, prevent operation of the pumps.

A formed suction intake (FSI) was investigated in a physical model at the US Army Engineer Waterways Experiment Station (WES). Test results indicated that this FSI design would provide satisfactory hydraulic performance for all anticipated flow conditions regardless of the adverse approach flow. The FSI used in the tests is shown in Figure 1.

Research was initiated following numerous requests for guidance on how the appurtenance geometry (pump bay width and/or length) to the FSI could be varied relative to the direction of flow approaching a sump and discharge and submergence of the FSI.

Test Facilities

The investigation was conducted in a flume 45 ft long, 35 ft wide, and 4 ft deep. A sketch of the test facility with flow approaching the FSI at an angle of 90 degrees is shown in Figure 2. The dimensions of the FSI, discharge, submergence, pump bay width, and pump bay length are presented in terms of the throat diameter d (Figure 1). Flow through the FSI was provided by centrifugal pumps. The flume was designed to facilitate simulation of various approach flow geometries. The sump sidewalls, FSI, and pump column were constructed of transparent plastic to permit observation of subsurface currents.

Evaluation Techniques

Hydraulic performance of the FSI was evaluated using the following criteria:

- 1) Visual observations were made to detect surface vortices.
- 2) Swirl angle was measured by a vortimeter (Figure 1) to indicate the strength of swirl entering the pump intake.

¹ Research Hydraulic Engineer, Hydraulics Laboratory, US Army Engineer Waterways Experiment Station, 3909 Halls Ferry Road, Vicksburg, MS 39181-6199

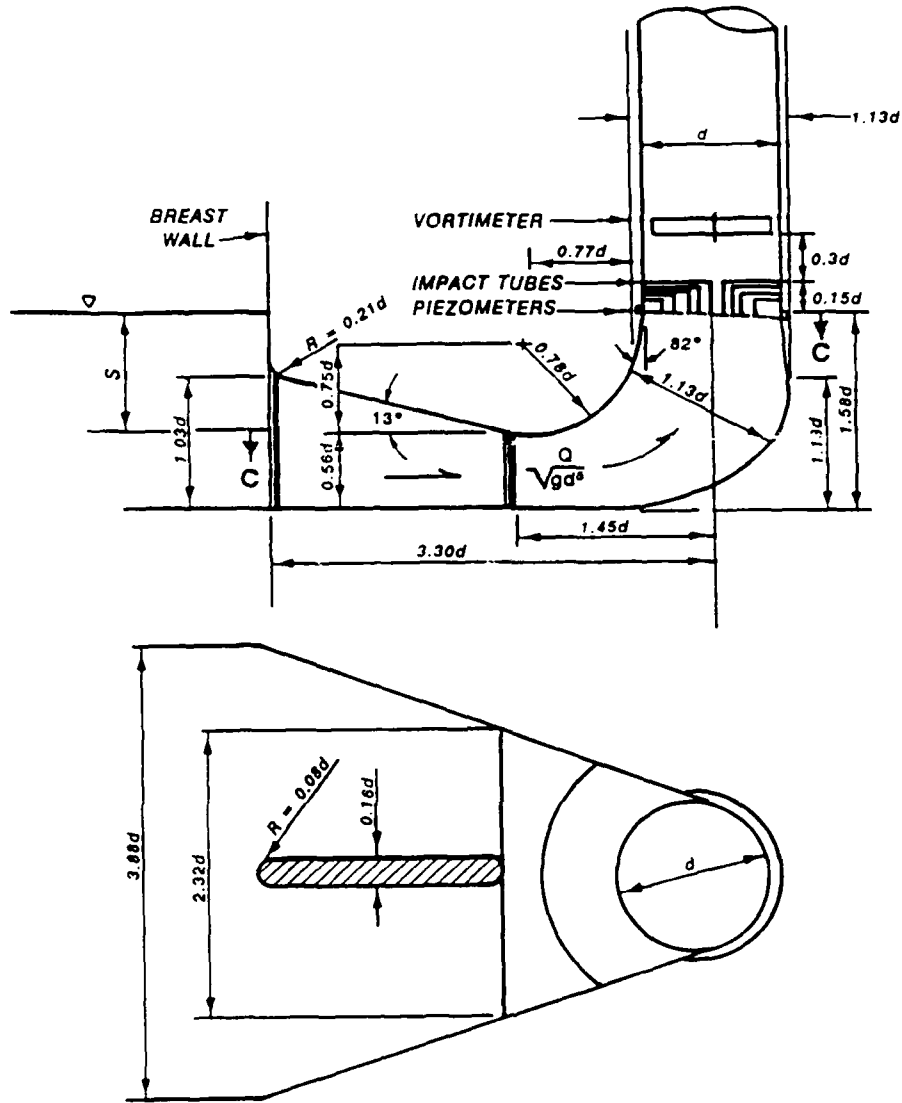

SECTION C-C

Figure 1. Formed suction intake

- 3) Velocity distribution and flow stability in the pump column were measured by 25 impact tubes located at the approximate location of the propeller (Figure 1).

Tests and Results

Model tests were conducted to develop criteria needed for the design of the pump bay width and length relative to direction of approach flow, discharge, and submergence. This was accomplished by holding four variables constant while varying one until adverse hydraulic performance occurred. Test results indicated that the FSI design presented in Figure 1 will provide satisfactory hydraulic performance for discharges Q equal to or less than a

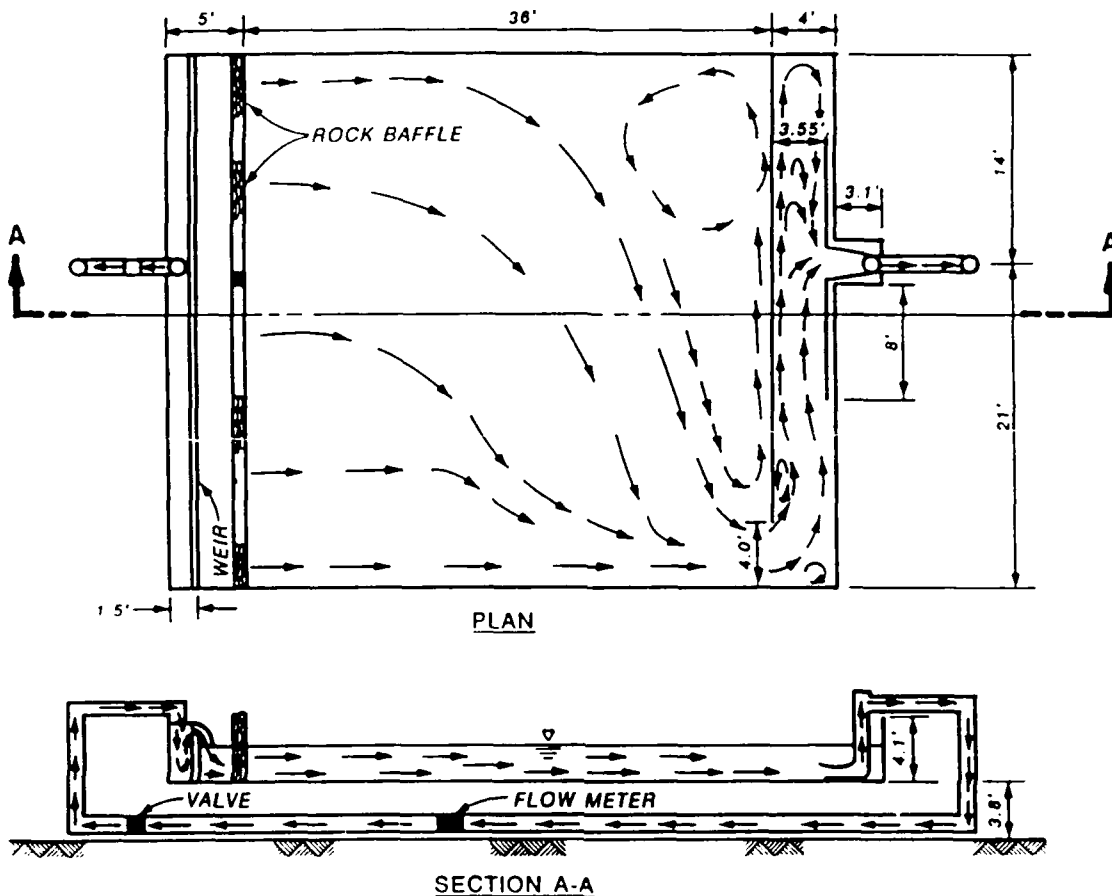

Figure 2. Formed suction intake, 90-degree approach to pump intake

value of $1.99\sqrt{gd^5}$ (where g is the acceleration due to gravity), depth of water over the intake roof S equal to or greater than a value of $0.94d$, bay width W equal to or wider than a value of $2.28d$, pump bay length equal to or longer than a value of od , and approach flow angle to the pump bay of 90 degrees or less.

Conclusions

The test results described are applicable only to the FSI design shown in Figure 1. Model tests have demonstrated that changing one or more of the internal dimensions may adversely affect the performance of the FSI. Due to inquiries from US Army Corps of Engineer Districts about varying the internal geometry of the FSI, research at WES is in progress to investigate the hydraulic limits of its internal geometry. Variables to be evaluated include side-wall and roof flare, roof curve, invert curve, and cone angle.

Little Calumet River, Indiana Interior Design Considerations

by

John G. Morgan¹

Project Description

The Little Calumet River, Indiana project is located in northwestern Indiana. The communities of Gary, Griffith, Hammond, Highland, and Munster will be protected. A map of the watershed is shown in figure 1. The Little Calumet River project consists of the construction of approximately 12 miles of new levee, the replacement of approximately 10 miles of existing levee, the construction of the Hart Ditch Control Structure, 7 miles of channel improvement, the modification of 4 bridges, the construction of one new pump station, the modification of 12 existing pump stations, the construction of 35 closure structures, and the floodproofing of approximately 35 homes.

Little Calumet River Watershed

The Little Calumet River is located in northwestern Indiana and northeastern Illinois and has a total drainage area of 622 square miles. The Little Calumet River is tributary to both Lake Michigan and the Des Plaines River through the Calumet-Sag Channel and the Sanitary and Ship Canal. The drainage area of the Little Calumet River in the project area is approximately 95 square miles. Hart Ditch, the major tributary in the project area has a drainage area of 70 square miles. During low flow periods all of the discharge from Hart Ditch flows west into Illinois. During flood events the flow from Hart Ditch will split and flow both east to Lake Michigan and west to Illinois. The amount of flow in either direction is governed by the amount of flow entering the Little Calumet River from the other major tributaries, Thorn Creek and Deep River.

Project Status

The project was authorized for construction by Congress in the Water Resources Development Act of 1986. The Little Calumet River, Indiana Phase 2 General Design Memorandum is currently under review at North Central Division. Six Feature Design Memoranda are planned to complete the design of different segments of the project. Feature Design Memoranda for the interior drainage and levees in the eastern reach are scheduled to begin in FY90. Floodproofing of homes and construction of ring levees protecting utilities is also scheduled to begin in FY90.

¹ Hydraulic Engineer, Chicago District,
U. S. Army Corps of Engineers

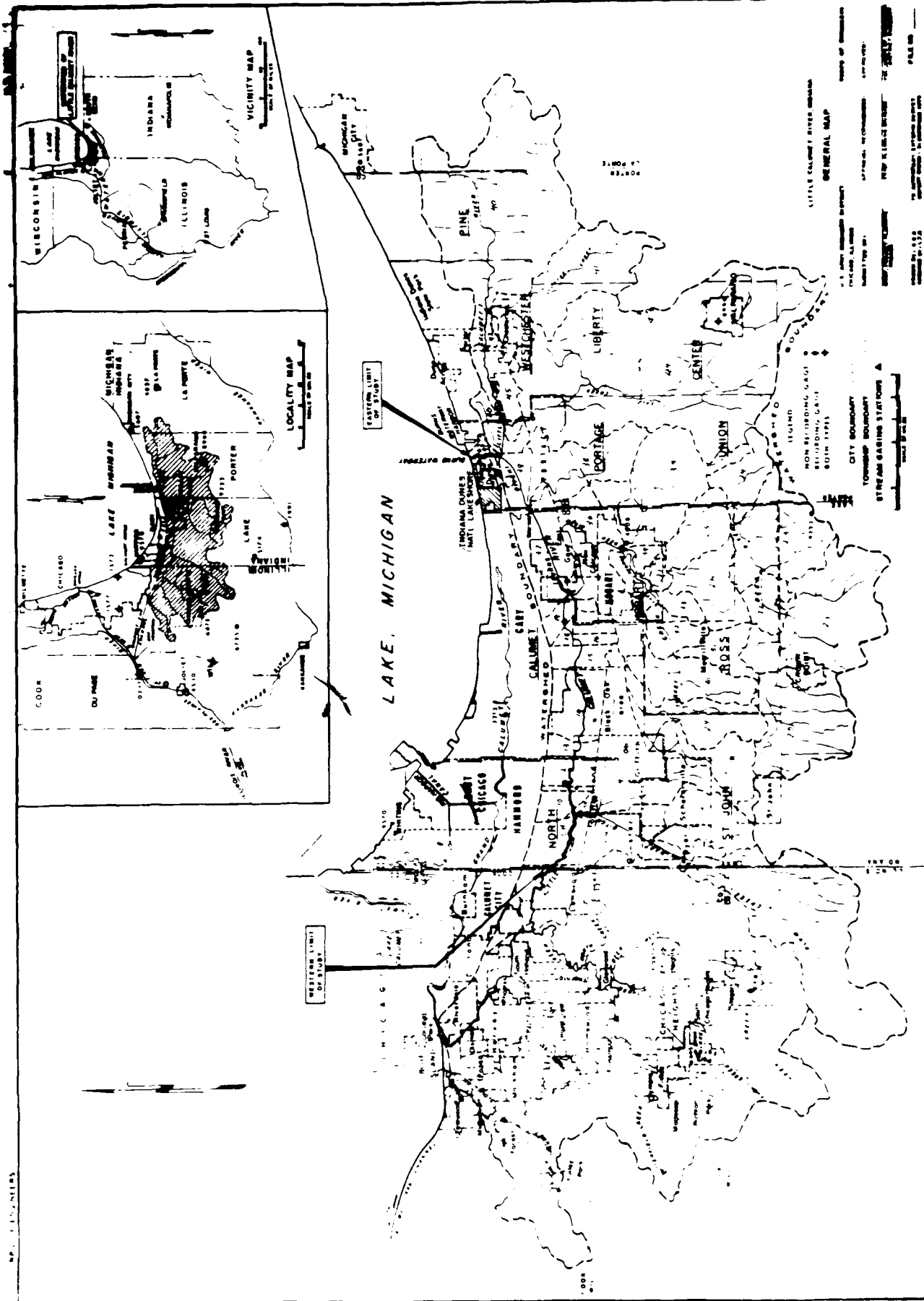

Figure 1
 Little Calumet River Location Map

Previous Interior Drainage Analyses

Phase 2 GDM Analysis. The interior drainage design for this project consisted of incorporating and upgrading existing interior pump stations in areas where levees are being replaced and determining the interior drainage design requirements in the area where new levees will be constructed. The analysis of planned and existing interior facilities was complicated by the lack of up-to-date sewer atlases and as-built drawings for both pump stations and drainage systems from the local communities.

Existing Pump Stations. There are 15 existing pump stations located within the project area. One pump station will be replaced completely as part of the project. Twelve of the remaining fourteen pump stations will be modified to bring them up to Corps standards. The other two pump stations were replaced by the local communities in the 1985 and 1986. The capacities of the existing pump stations range from 617 cfs to 11 cfs. The tributary drainage areas range from 0.25 to 1.30 square miles. Several of the pump stations have capacities in excess of the computed SPF peak discharge for their tributary area.

An operating constraint on three of the pump stations limits pumping when stages in the Little Calumet River exceed 592.0 NGVD. The total pumpage must be reduced so that flooding is not aggravated in Illinois. This restriction is part of the permit issued by the Corps of Engineers to the Hammond Sanitary District. The total capacity of the three pump stations is 1,321 cfs. This discharge corresponds to approximately the Little Calumet River 10-yr discharge in this reach. The reduced pump station capacity allowed is approximately 1,050 cfs depending on which pumps are locked out. This discharge corresponds to the pumping capacity prior to the rebuilding of one pump station in 1985.

The modifications planned for the existing pump stations include installation of gravity outlets, sluice gates, gravity inlets for surface water and upgrading of electrical and control equipment.

Interior Areas Behind New Levees. The Phase 2 GDM recommended only gravity drains for the new interior areas. This was due to a large amount of open space available along the levee alignment for ponding areas. The Little Calumet River does not peak in the eastern reaches until several days after a storm event due to large amounts of overbank storage in wetland areas along the river. This allows the interior areas to drain prior to the river's rise. The large amount of existing publicly owned land behind the levee alignment allows for sufficient interior storage for rainfall that occurs while the river is at flood stage.

Planned FDM Analyses.

During the Interior Drainage Feature Design Memoranda for the eastern and western reaches, the District will be designing ponding areas, gravity drains, pump station modifications, one new pump station, levee toe drainage and drainage collection facilities. In the Phase 2 GDM, the capacities of most of these facilities were determined on an economic basis. The level of detail was not sufficient to proceed directly to preparation of plans and specifications.

As part of the design effort the District will be testing the new interior drainage program being developed by HEC. This is being done primarily to confirm the Phase 2 GDM design. The District's current program is capable of only running discrete events. Since the interior design in the eastern reaches is dependent on gravity drainage prior to river stage increases or storage during high river stages, the District wishes to confirm its design in these areas using the new program.

**PANEL DISCUSSION
INTERIOR FLOOD HYDROLOGY (IFH) COMPUTER PROGRAM**

by
Michael W. Burnham¹

Background

The Hydrologic Engineering Center (HEC), with the assistance of a private contractor, is developing a computer program to assist Corps district personnel in performing hydrologic engineering analysis of interior areas. The program will operate on personal computers. It is scheduled for initial release in the spring of 1990. The application of the program will be initially presented in the Interior Flooding training course at the HEC on June 4-8, 1990.

The Interior Flood Hydrology (IFH) computer program is designed to analyze flooding conditions within interior areas in accordance with the principles set forth in EM 1110-2-1413 (Corps of Engineers 1987). An interior area is defined as the area protected from direct riverine, lake, or tidal flooding by levees, seawalls, and low depressions or natural sinks. Figure 1 is a sketch illustrating important concepts of interior area flooding.

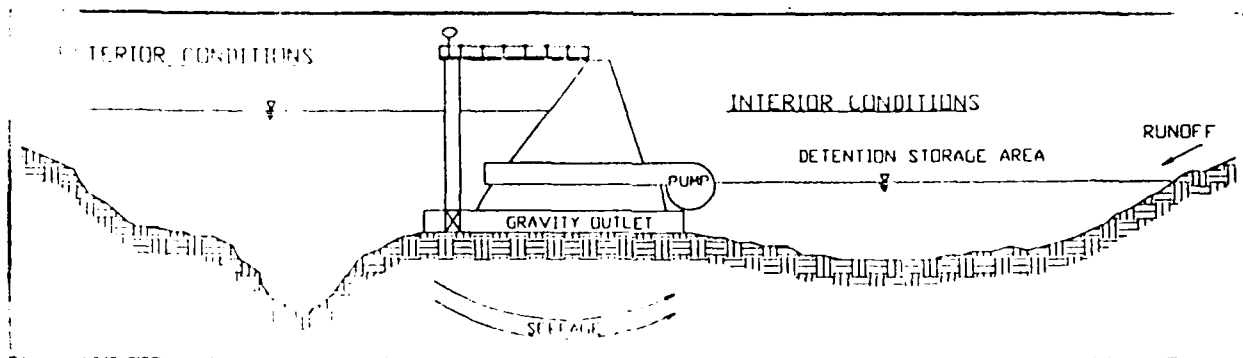

Figure 1

The levee or wall, termed the line-of-protection, excludes flood waters originating from the exterior. However, interior runoff flooding is usually not reduced and may be aggravated. Gravity outlets, pumping stations, interior detention storage basins (ponding areas), and diversions are measures commonly implemented within interior areas to reduce flooding and safely pass interior runoff through the line-of-protection.

¹ Chief, Planning Division, Hydrologic Engineering Center, Davis, California

Analysis Approaches

The IFH program enables the user to perform interior flooding analyses of two interior subbasins and the exterior using the following approaches:

1) **Continuous Simulation Analysis.** This method uses historic or stochastically generated continuous precipitation and streamflow records for the interior and exterior conditions.

2) **Coincident Frequency Analyses.** The coincident frequency approach assumes total independence of the interior and exterior flood events and uses the total probability theorem to determine the frequency of interior flooding given a period-of-record for the exterior flooding conditions.

3) **Single-Event Analysis.** This method assumes the interior and exterior flood events are dependent and are evaluated by assuming that the single event storm occurs over both the interior and exterior areas.

The IFH program performs several major operations for each method of analysis. They include: 1) definition of interior analysis data, 2) performance of the interior area analysis, 3) development of hydrologic analysis summary tables, and 4) development of plan comparisons of the hydrologic analyses. The program uses the HECDSS to store and process time series data and self-documenting ASCII flat files for all other data.

Data Definition Modules

The data entered for the hydrologic analyses are stored in seven input data modules used for analysis by the IFH program. These modules are described in subsequent paragraphs.

PRECIP Module. The data in the PRECIP module describes the rainfall for the upper, lower, and exterior subbasins. Rainfall records may be input by the user or imported from an external DSS file.

RUNOFF Module. The RUNOFF module data set describes the hydrologic response characteristics of each of the three subbasins for the interior analysis. The data sets include parameters and coefficients for infiltration/loss, unit hydrograph, base flow and recession, and channel routing. The methods vary with the analysis approach used. Table 1 summarizes the available methods by approach.

POND Module. A storage volume versus elevation relationship is required for the interior ponding area for the analysis. The module provides this information.

GRAVITY Module. The GRAVITY module accepts data that describes the gravity outlet characteristics and computes the gravity outlet rating tables for up to 25 different outlets.

TABLE 1

Computational Method or Option	Continuous Simulation	Coincident Frequency	Single Event
Rainfall Losses			
Generalized Runoff Coefficients	0		
Initial & Uniform With Recovery	0		
Initial & Uniform, No Recovery		0	0
SCS Curve Number		0	0
Green-Ampt		0	0
Holtan		0	0
No Losses	0	0	0
Unit Hydrographs			
Clark	0	0	0
Snyder	0	0	0
SCS Unitgraph	0	0	0
User-Defined	0	0	0
Base Flow and Recession			
Base Flow	0	0	0
Recession		0	0
Streamflow Routing (Upper Sub-Basin Only)			
Modified Puls	0	0	0
Muskingum	0	0	0
Muskingum-Cunge	0	0	0
Lag Only	0	0	0
No Routing	0	0	0

PUMP Module. The PUMP module accepts data that describes up to 10 pump outlets for the interior system. The operating parameters for each pump include: maximum pump capacity, pump start and stop elevations by month, a pump capacity versus operating head table, a pump efficiency, and the maximum static head against which the pump can operate.

EXSTAGE Module. The EXSTAGE module accents data that describes the exterior tailwater stages which affect seepage, gravity outlet and pump discharge values. The module accepts stage hydrographs, converts discharge hydrographs to stage hydrographs, and transfers hydrographs for analyses to desired locations on the main stem.

AUXFLOW Module. This module describes the inflow to the interior area other than subbasin runoff and outflow which may occur other than gravity outlets or pumping. The auxiliary flows include seepage, overflows, and diversions.

Interior Area Analyses and Result Summaries

After the data definition modules have been assembled the computations may be performed. The user specifies the analysis parameters. They include: whether or not the gravity and pump outlets are operated simultaneously, the starting pond elevation, the minimum head for the gravity outlet operation, computation interval, the beginning and ending date of the analysis, and whether the analysis is for a partial or annual series frequency. The program computations are then performed including generation of basin average precipitation, runoff hydrographs, and routings of the interior flood waters through the line-of-protection.

The user may specify a series of output reports after the analysis is conducted. For the continuous simulation approach these reports are categorized as: analysis input summaries, calculation period summaries, water year annual summaries, and analysis record summaries. Figure 2 depicts the output screen that the user may use to select the reports desired for viewing. Graphic representations and hard copy outputs may be selected in addition to the screen displays. The output summaries vary with the other two analytical approaches.

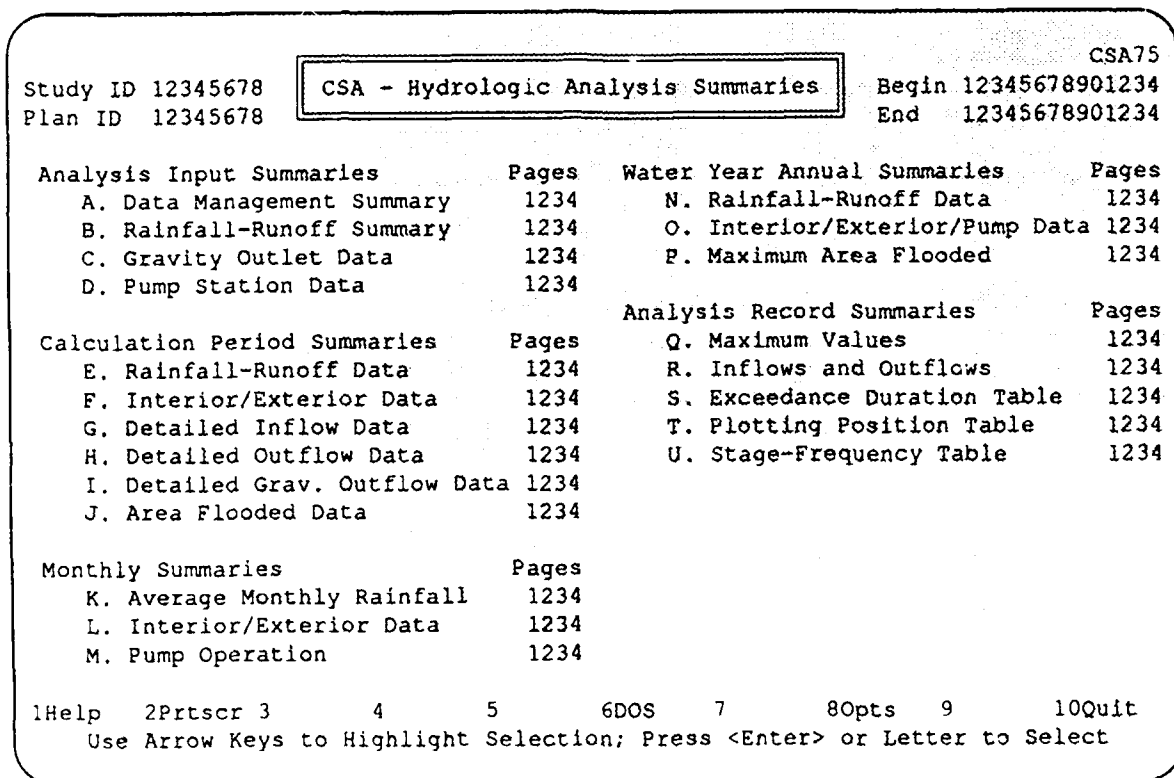

Figure 2

SUMMARY OF SESSION 5: DESCRIPTION, EVALUATION, AND DATA REQUIREMENTS FOR PROJECT ANALYSIS

Overview

Two presentations were made and the topic of hydrologic engineering data needs for project formulation was addressed by four panelists.

Lewis Smith, HQUSACE, gave a presentation entitled "Project Description." Mr. Smith stressed that hydrologic and hydraulic engineers should adequately describe the study conditions and scope in the feasibility and design study documents. No paper was provided.

Paper 9. Michael W. Burnham, HEC, presented a paper entitled "Hydrologic Engineering Perspective on Flood Hazard and Project Formulation." Hydrologic engineers by training and experience understand the variable nature of flooding, the limitations of the technical methods used to quantify flooding and associated risk, and the characteristics of flood damage reduction measures. The USACE policy for project feature selection and sizing is the concept of economic efficiency, or maximization of the net economic development (NED) benefit. The issues of project performance and safety are not directly addressed in this formulation and are in fact dealt with externally to the NED decision process.

Panel 5 Discussions

Robert G. Engelstad, St. Paul District, emphasized the need for good stream gaging information to perform the required hydrologic engineering analysis for feasibility investigations. Mr. Engelstad stated that an improved study product can be obtained from a streamgaging program that is started in the reconnaissance-phase or earlier if possible. The USACE also needs to find a way to fund the documentation of flood information including stream measurements and high water marks during and immediately after the event. Development of guidelines for testing and documenting stream gaging validity at locations where basin characteristics and hydrologic responses change is also needed.

Ronald C. Mason, with the Portland District, discussed the hydrologic engineering data needs for the Mt. St. Helens flood control Study. Mr. Mason stated the importance of valid hydrologic engineering data to facilitate the formulation of quick and reliable solutions to danger of flooding and sediment accumulation for 20 miles of the lower Cowlitz River. The eruption of Mt. St. Helens had transformed the river from a cobbled streambed to a sandbed stream with a new slope and energy gradient. He detailed the data collection process and its integration into the flooding and sediment analyses.

George A. Sauls, Philadelphia District discussed hydrologic engineering data needs for project evaluation. Mr. Sauls stressed that hydrologic, hydraulic and economic evaluations are interrelated and that the study success depends on proper coordination among the participating disciplines. The coordination process must consider the specific problem area, data availability, potential solutions and study techniques that will be employed to ensure smooth study execution and confidence in results.

Paul Hein, Pittsburgh District, presented a discussion on hydrologic engineering data needs for project formulation. Mr. Hein defined the primary hydrologic engineering data needs to be: stream flow, precipitation and other climatologic, flood, and water quality for any study area large all small. He then described the availability of each type of data within the Pittsburgh District and concluded by saying he feels the district would probably have sufficient hydrologic data to plan, construct, and operate any flood control project within its boundaries.

HYDROLOGIC ENGINEERING PERSPECTIVE ON FLOOD HAZARD AND PROJECT FORMULATION

by

Darryl W. Davis and Michael W. Burnham¹

Overview and Summary

Hydrologic engineers by training and experience understand the variable nature of flooding, the limitations of technical methods used to quantify flooding and associated risk, and the unique and different characteristics of flood damage reduction measures. Hydrologic engineers, while not alone in this regard, tend to be the technical professionals most concerned with the physical, technical performance of projects. In their minds, the purpose of flood damage reduction projects is to reduce the flood hazard to persons and property. Emphasis is on the physical performance of the project in reducing flooding with concern for the reliability and safety of the project in accomplishing its goal.

Flood damage reduction projects are designed to reduce the flood hazard to persons and property located in flood prone areas. With rare exception, decisions must be made that accept solutions that result in less than complete elimination of the flood risk. Hydrologic engineers play a critical role in developing information needed in the decision process and provide expert advice on flood characteristics, risk issues, project performance, and project formulation and evaluation.

This paper discusses flood hazard and formulation/evaluation of projects from the perspective of the hydrologic engineer. Comments are included regarding strengths and weaknesses in our present planning and evaluation procedures.

Project Development Process

The development of a flood damage reduction project includes many steps and involves participation by many parties. The process and participating parties are well defined in policy documents. See for example the Policy Digest 89 (Corps of Engineers, 1989). The basic steps include:

1. Authorization of investigation by Congress,
2. Performance of project planning studies by field offices,

¹Director, and Chief, Planning Division, respectively, Hydrologic Engineering Center, Davis Calif.

3. Review and validation of project features, justification, and implementation agreements by Corps chain-of-command and other agencies and parties,
4. Authorization by Congress for construction, and
5. Design and construction by the Corps.

Steps 2. and 3. are the stages in which the specific project features are developed and refined. Each of these steps includes many sub-steps in which technical studies are performed, coordination within and outside the Corps accomplished, and decisions made regarding project formulation and evaluation. These are therefore the critical stages of project development from the hydrologic engineer's viewpoint. Most often the critical decisions regarding project features, performance, and safety are made at the planning stage (step 2.) although changes can and do result from the review and validation process. Occasionally changes are required as a result of design but this should be considered undesirable and the exception rather than the rule.

Planning Process

The planning step includes two phases: the reconnaissance-phase and the feasibility-phase. The reconnaissance-phase is an abbreviated full-scoped planning investigation that addresses the relevant technical, financial, and institutional issues. The reconnaissance-phase must determine if a feasible solution to the identified problem can be developed and whether there is a federal interest. The feasibility-phase is a continuation of the planning process for studies in which the reconnaissance-phase findings are positive and there exists an interested local sponsor.

The planning process within which the hydrologic engineer functions consists of the six major tasks - Specification of Problems and Opportunities, Inventory and Forecast, Alternative Plans, Evaluation of Effects, Comparison of Alternative Plans, and Plan Selection. The planning process is iterative, progressing in specificity and detail as the investigation proceeds. It is an open, public process with intermediate decisions occurring at several levels and by several parties. The tasks are discussed in more detail below, emphasizing the hydrologic engineering perspective and to a lesser degree, flood damage.

Specification of Problems and Opportunities. This first step establishes the base conditions for the planning endeavor, establishes the range of possible solutions, and provides essential insight needed to perform the remaining steps. The major tasks are:

- 1) Define the flood hazard - determine the present flood hydrology and generally identify threatened properties. This information provides the basis for project development.

- a) Hydrologic and hydraulic investigations develop the specific characteristics of flooding potential in the basin (flood flows and frequency, flood elevations, flood plain boundaries), character and variability of flooding (shallow or deep, swift, debris laden etc.). The information, while not final in early planning stages, is developed by conventional H&H analysis and presented in tables, charts, and maps.
 - b) Threatened properties are those that are subject to flood hazard. A later step will develop a detailed inventory but the focus here is to establish the relative nature and magnitude of flood hazard. Data from historic floods - news accounts, past reports, interviews with residents . . are the information sources. It is important to note the general property types, eg. low/high density residential, commercial, industrial, vital public facilities etc.
- 2) Specify opportunities - ascertain the general nature of solutions that might be appropriate.
- a) The general geography of the watershed, location and density of development, nature of flood hazard - all interact to reveal possible solutions. Solutions involving reservoirs, levees, and bypasses must be physically possible and make sense and not in obvious conflict with critical community values and environmental resources. The local community is also a valuable source of ideas early in the investigation. Potential nonstructural measures should be commensurate with the flood hazard, nature of development, and address a significant aspect of the flooding problem.
 - b) The range of possible solutions will have a significant impact on the subsequent investigations. Therefore it is important at this stage to be comprehensive in the exploration of possible solutions yet equally important to be practical so as to conserve scarce investigation time and resources. The hydrologic engineer's practical experience on what works and what does not can be most helpful to this step.

Inventory and Forecast. This step develops detailed information about the present and future likely conditions within the watershed and study area. The inventory is meant to be comprehensive in terms of documenting all resources of importance to the study, including environmental resources, but relates mostly to development within the floodplain and watershed that affect plans. The major tasks are:

- 1) Inventory flood plain development (usually the job of the project economist) - determine the present properties and other important resources subject to present and future flooding. The usual

practice is to perform an exhaustive inventory of all structures within the flood plain (500 yr. or occasionally SPF), and create a structure inventory data base. Structure values are determined by indirect methods such as sampling, referral to similar real estate sales, and use of tax records. Damage functions to associate with the inventory are often adopted from previous studies but at times are determined by detailed study of the damage potential of a representative set of existing structures.

- 2) Inventory watershed development - determine the present status of development throughout the watershed, the detail depending on the relevance to the investigation. If the watershed contributing to flooding in the study area is small to modest in size (in the tens to hundreds square miles), and urban development is anticipated to occur, an accurate spatial distribution of the existing development is needed for performing hydrologic analysis for existing and future conditions. The status and condition of the stream drainage network may likewise be critical.
- 3) Forecast future conditions, H&H - hydrologic and hydraulic conditions within the study are needed for determining the flood damage reduction requirements and performance of measures proposed as solutions. Forecasting future watershed development is necessary to that task, as are studies of the geomorphology of the stream system. The degree of importance of this task is study specific. In many cases, future conditions will not materially change. In small urban watersheds, it is almost always needed.
- 4) Forecast future conditions, economics - the likely future development throughout the watershed, and within the floodplain may likewise be important. Corps policies governing benefit computations have significant influence on assumptions about the specific location and elevation of future development with the floodplain.

Alternative Plans. Alternative plans are formulated to address the flooding problems and accomplish other planning objectives. The alternatives are formulated to achieve the national goal of economic development consistent with preservation and enhancement of cultural and environmental values. One or more measures assembled into one or more plans should be formulated to enable the full range of reasonable solutions to emerge from the investigations. The major tasks are:

- 1) Identify/correlate problem areas with damage reduction measures. This is somewhat stating the obvious that the identified problems are the major source of insight into practical solutions. It should go without saying that simply listing all possible measures as a check list is not necessarily useful. The hydrologic engineer's experience is invaluable to this task and critical to the ultimate formulation of meaningful projects.

- 2) Formulate measures and plans that emphasize comprehensive solutions, and also measures and plans that address specific clearly identified localized problems.
- 3) Array the candidate plans for further investigation.

Evaluation of Effects. This step develops the information needed to determine and display the accomplishments, as well as negative effects, of measures and plans as compared to the without condition. The evaluation of effects is accomplished across the full spectrum of concerns - hydraulic and hydrologic, economic, environmental, and other. Evaluations include:

- 1) Hydrologic & Hydraulic - with proposed measures and plans flood frequencies and flood elevations are developed by conventional hydrologic simulation analysis. The information is developed at all important locations within the basin and for the full range of possible flood events, including those that exceed project design. Other more specialized data such as erosion and sediment deposition, velocities, storage usage, etc. are developed as appropriate.
- 2) Flood Damage - with measures and plans flood damage reduction benefits are computed. Consideration is given to any future changes in development and value of properties. Particular attention must be given to residual flooding and flood damage to ensure complete understanding of the performance of the measures.
- 3) Other - a number of other evaluations are needed to prepare complete descriptions of the accomplishments, impacts and costs of proposed measures. Cost is an increasingly important issue in cost-shared studies.

Comparison of Alternative Plans. This is identified as a separate step to ensure that the planning process pauses sufficiently to array the measures and plans under consideration, and compares them on a consistent basis.

- 1) Comparisons should be for the full range of relevant issues - performance in reducing flood damage, safe and predictable operation for the full range of possible flood events, cost of placing (and continuing) in service, induced losses, environmental impacts and enhancements, local acceptance, cost share burdens, etc. The relevant issues are reasonably well documented in Corps regulations.
- 2) The comparison of plans should provide valuable information that may enable formulating additional plans that better accomplish overall planning goals. An iteration back to the Alternative Plans task would occur.

Plan Selection. Plan selection takes place in a diffused decision process. The participants in the planning activities within the Corps (eg. H&H staff, economists, environmental specialists, engineering design and cost specialists, planning study manager) and local sponsor representative have strong influence on the plan selected and processed in reporting documents. The selecting official at the field level is the District Engineer. The feasibility report will identify his selection as the "Plan". The Division performs independent review and may recommend to higher authority a different plan but for practical purposes, this rarely occurs. The Board of Engineers for Rivers and Harbors, may, based on their review, recommend an alternative to the Chief of Engineers. The transmittal to Congress, over the Chief's signature, contains all the cumulative reviews and documentation, including views provided by other federal, state, and private concerns. Congress is the ultimate decision maker in that it acts to pass a law authorizing implementation of the plan it deems to be suitable. It generally conforms to one in the documentation and with few exceptions, is the District Engineer's plan.

- 1) Plan selection at the Corps field office level must consider existing laws and regulations, both its own and that of other agencies. The recommended plan must be the plan that meets all the statutory tests and maximizes the economic contribution to the nation. It is at this stage that the hydrologic engineer has what may be the last and most promising opportunity to present his perspective. The project the District puts forward must, regardless of its other attributes, perform its intended flood damage reduction function safely and reliably over the full range of possible flood events. Often lost in the local agreements, environmental statements, and benefit/cost analysis is this critical aspect of the proposed project.
- 2) Since Congress may pass any act it wishes, it has more freedom in specifying the plan in the authorizing legislation.

Project Formulation Criteria

The policy governing project feature selection and sizing is well defined in some areas but less so in others. There is well defined policy regarding economic criteria, reasonably well defined policy governing engineering design aspects of project features, but less well defined policy regarding the physical, technical performance of projects in feature selection and sizing.

The Corps policy for project feature selection and sizing is the concept of economic efficiency. The concept is that project features must be selected and sized to maximize the net economic development (NED) benefit. Technical studies are performed to develop information that support application of this concept. The issues of physical performance and safety are not directly addressed when applying this formulation concept. They are presumed to be dealt with external to the NED decision process by considering only project

features and sizes that are considered acceptable by the Corps. While this may apply in principle, once the project feature selection and sizing studies are underway, the issues of flood reduction performance, safety, and level-of-protection tend to be obscured. The advocates (hydrologic engineers) for stronger inclusion of performance and other issues in project feature selection and sizing must then argue for deviations from the economic optimum. This is unfortunate since these issues should be considered integral to the formulation process.

We know that different projects perform differently for the range of flood events that might be experienced, particularly those that exceed design. Reservoirs and levees, for example, simply do not perform the same way when their design capacity is exceeded. We also know that flooding is a highly variable, site specific and random process. Further, using average (or "expected") values as is the common case in most economic optimization studies further obscures the true flood reduction performance. Hydrologic engineers are skeptical of such theoretical calculations as regards the important issue of selecting project features and sizing them. We would prefer to use such economic optimization studies to assist in determining the nature and approximate sizes of features. The final critical decision on feature selection and sizing would be determined by careful consideration of specific flood reduction, residual flooding, and physical site characteristics.

While level-of-protection is often used as the single index of risk performance of projects, it is an overly simplified measure of project performance. It measures only the threshold of incipient flooding. It does not measure risk regarding hazard to life, severity of damage, or consequence of design being exceeded. Hydrologic engineers prefer more comprehensive characterizations of project performance to include such items as: reliability, design exceedance consequences, flexibility, safety, and the like. We wish to participate in the project formulation process so that we might directly include these concerns at the critical times in the decision process.

Epilogue

It is useful to view the project development/planning process as comprised of several participants each with a special role to play. The professionals engaged in planning are charged with the technical task of defining the problem, proposing solutions, and arraying the full range of consequences of the solution to other decision makers. The role of the hydrologic engineer in this process must be meaningful and substantive. He is the expert on issues of flooding, project performance, risk of design exceedance, and reliability.

Decision making is an open, public process. Not all relevant factors are quantifiable and thus other views, judgments, and even value systems are relevant and deserving of a role. The political process is the mechanism for making decisions in the light of varying views, alternative beneficiaries, and constituencies. We as professionals ensure that the deliberations and discussions are based on as sound and factual basis as is possible.

Conclusions

1. Flooding is a highly variable, complex, and site specific phenomena. Developing safe, practical, reliable performance solutions to flooding problems is likewise a complex task. We must deal with this complexity in an open, practical fashion. We must avoid use of overly simple project formulation and evaluation concepts.
2. It is important that the project development process be sensitive to and take advantage of the natural relationship between site specific flooding characteristics, floodplain occupancy, and different and unique characteristics of flood reduction measures.
3. We should be practical in the degree to which maximizing net economic benefits dictates project feature selection and size. The goal from the hydrologic engineers perspective is safe, reliable, and economical reduction of the flood threat to floodplain occupants.
4. There is no simple formula for success. All participating professionals engaged in project development have important roles to play. The role of the hydrologic engineer role is a critical one.

References Cited

Corps of Engineers, U.S. Army, 1989. EP 1165-2-1 Digest of Water Resources Policies and Authorities.

PANEL 5

HYDROLOGIC ENGINEERING DATA NEEDS FOR PROJECT FORMULATION

by

Robert G. Engelstad¹

Although it would be quite straightforward to consider hydrologic engineering data needs with a specific project in mind, the concerns regarding the adequacy of data still gets back to basics. Briefly, the intent of this presentation is to concentrate on stream gaging needs for Hydrologic Engineering studies at the project formulation stage. The following six areas address these basics:

1. An improved study product can be the result of a streamgaging program that may have been started at the recon stage, or earlier by the local sponsor. There have been several occurrences of projects that sit for a number of years before going to the next phase of study. If a gaging program would have continued during this period, a higher quality product is possible. It seems then, that this becomes a case of cost vs. hydrologic result.
2. A streamgaging program is needed at the Feasibility Stage, because:
 - a. USGS-we are seeing a gradual curtailment of operations and staffing at field offices.
 - b. DCP installation-either by the Corps or under contract, recognizing the potential of problems due to a lack of a rating curve, perhaps only for the short term however.
 - c. Synthetic techniques- these may be needed in any event depending on how many years of record is collected. Better calibration of a model is possible if at least some data is available, thereby greatly reducing any "shots in the dark".
3. The funding of stream gages early in the formulation process can best be accomplished by investing time early with the Study Manager. There needs to be a better understanding as to the requirements for a proper representation of the basin runoff aspects at the beginning of the study. Cost sharing with the local sponsor could be pursued early in the study for gage installation, and continued local sponsorship of the gage for continuity purposes through later phases of the study, either by the Corps or by the watershed engineer for other basin study benefits.
4. The Corps needs to find a way to get ER500 (PL99) funding or its equivalent and H&H staff in the field to document events that relate to a study in the near future, or potentially a more long-range future study. This comment is geared primarily for small drainage areas, those type of basins for which we can get off to a faster start with any storm data on file. A large drainage area flooding situation usually has 50+ Corps construction types assigned to work, so merging in a half dozen H&H types is relatively easy. The main problem we have is a severe event occurring over a small area with a short-term flood duration where sending out engineers for fast levee construction is not feasible; therefore, by extension there is no need for H&H staffing either with their attendant funding requirements. An obvious conflict then exists because there is no study funding in this area currently, but should there be a study in the future the Corps should be in a position to get H&H study efforts underway quickly.

1. Chief, Hydrology Section, ED-GH Branch, St. Paul District

5. The Corps needs to develop guidelines for determining a means for continuing streamgaging viability at a location. This would record basin changes, and may pay off in reduced likelihood of restudy due to changing watershed conditions (i.e. a changed local city council representation that dramatically changes the rate of basin urbanization, or changes in the base streamflow discharge rates, or basin loss rates).

6. Even though there may be a better result from development of Geographic Information System databases in support of studies, to what extent does the Corps balance direct participation at the input level, versus utilization of existing databases? It would seem that, depending on how the Corps sees the current level of development of GIS for future studies, we could be "waiting for someone else to develop a database while they are waiting for the Corps"?

HYDROLOGIC ENGINEERING DATA NEEDS FOR MT. ST. HELENS FLOOD CONTROL STUDY

BY

Ronald C. Mason, P.E.¹

BACKGROUND

During the 18 May 1980 eruption of Mount St. Helens, a debris avalanche deposited some 3 billion cubic yards of material in the upper 17 miles of the North Fork of the Toutle River Valley. Mudflows incorporating melted snow, glacial ice, rock and other debris coursed down the Toutle and Cowlitz Rivers damaging structures and causing flooding in the lower Cowlitz River. Some 50 million cubic yards of sediments were deposited in the Cowlitz River and overbank areas. Bankfull capacity in the Cowlitz River was reduced from 70,000 CFS to less than 13,000 CFS. Another 50 million cubic yards of material was deposited upstream and downstream from the mouth of the Cowlitz River in the Columbia River. The navigation channel in the Columbia River, normally maintained at a minus 40 feet below the Columbia River Datum, filled to a minus 14 feet in some places, closing the river to deep-draft vessels. Emergency actions were undertaken to restore the navigation channel in the Columbia River and increase the channel capacity in the Cowlitz River to 50,000 CFS by the Fall of 1980. In May 1982, President Ronald Reagan directed the Corps of Engineers to prepare alternative strategies to deal with the long term movements of sediments that were deposited by the May 1980 eruption of Mt. St. Helens. By November 1983, the Federal Government had expended in excess of one-third of a billion dollars to minimize damage and property losses in those areas adversely affected by the extraordinary conditions created as a result of the May 1980 eruption.

SCOPE OF STUDY

For purposes of the study (see figures 1 & 2), the affected area was divided into three zone : (1) Toutle River basin, (2) the lower 20 miles of the Cowlitz River, and (3) the Columbia River downstream from the mouth of the Cowlitz River.

In the Toutle Basin, investigations focused on (1) determining a safe water level for the newly formed Spirit Lake and locating a site for a tunnel outlet, and (2) estimating the amount and rate of sediment erosion that would take place over the next 50 years. The data requirements for these efforts will be the focus of this discussion.

Study of the lower 20 miles of the Cowlitz River concentrated on the danger of flooding from continued sediment accumulation. Primary focus was on assessing water elevations and economic loss from flooding and the impacts of proposed alternative measures to reduce those losses.

The analysis on the Columbia River was directed toward the effects of alternative

1. Chief, Hydrologic and River Engineering Section, COE, Portland District Office

management strategies on the navigation channel maintenance and on impacts to fish and wildlife.

HYDROLOGIC DATA NEEDS

As studies proceeded, it became readily apparent that due to the unique conditions at Mt. St. Helens, valid data was necessary to facilitate the formulation of quick, reliable solutions. Development of a sediment budget for a 50 year project life for the Toutle watershed and water surface profiles for the Cowlitz River were exceptionally difficult tasks to complete. The requirement for good hydrologic and hydraulic data was critical.

The Cowlitz River had been transformed from a cobble streambed into a sandbed stream with a new slope and energy gradient. Sediment studies conducted during 1981-1982 showed that the annual yield to the Cowlitz River from the Toutle River would be in the range of about 25 million cubic yards. This value was determined by gathering streamflow data and preparing a flow duration curve for the Toutle River. This curve was then integrated with a sediment load curve which had been prepared by collecting sediment data during the previous two years. This annual sediment yield based on a flow duration curve was then adjusted to account for flood events. The adjustment was computed based on observed flood hydrograph data and sediment data obtained during the flood events since the May 1980 eruption.

With a yield of 25 million cubic yards to the Cowlitz River, water surface profiles would become very important in populated areas. New Manning "N" values needed to be determined. Predicting the type of bedforms became necessary because of their impact on roughness coefficients. What would be the nature of the material that would be transported to the Cowlitz River? Data concerning grain sizes and their distribution along the river became an important part of the data collection process. Bed samples were taken at 1/2 mile intervals and sediment discharge stations were established at river miles 4.5 and 16.9. Cross section data also had to be obtained due to the new mudflow deposits within the channel and overbank areas. With this new hydrologic data, water surface profiles were developed for the leveed areas along the Cowlitz River. Then levels of protection were determined when coupled with safe levee heights. This process was repeated about every three to four months as sediment deposition occurred. The information was also used to locate areas and amounts of deposition that were occurring in the Cowlitz River. Ultimately, this cross section data would allow engineers to make predictions for the amount of future dredging. After years of effort, no sediment routing computer model was capable of modeling the Cowlitz River with reliable and consistent results. For the "no action alternative", the simple use of cross section data was used to predict that a flow of 30,000 CFS by 1990 would inundate populated areas along the Cowlitz River.

The analysis in the Toutle watershed presented problems that dealt with hydrologic and sedimentation conditions that were unique for the Portland District. The primary goal was to develop a sediment budget for a 50 year project life. Dredging studies in the Cowlitz River had already shown that the predicted annual yields from the Toutle River would in the very near future exceed available disposal sites. A large sediment retention structure (SRS) to capture sediments was formulated as

one of the alternatives, and in 1986 became part of the selected alternative. Within the watershed, there were no precipitation stations with hourly data. Weather stations outside the basin were used to calibrate HEC-1 models but, due to the mountainous terrain, and spatial and temporal conditions, some results as to pre-eruption and post eruption unit hydrographs could not be classified as 100% satisfactory. Because of this, four weather stations were established within the watershed to continue to operate. In 1982, the upper part of the Toutle drainage was still in the initial stages of development. The stream network was still forming and small ponds were not contributing to the basin runoff. Photogrammetric data obtained every 3-4 months allowed engineers to follow the developing drainage network. In this manner, sub-basin drainage areas and other water yield parameters could be computed. Then with the use of a rainfall runoff model(HEC-1), flood hydrographs could be developed. This hydrologic data is now used to predict streamflows into the SRS which will be completed by 1 January 1990.

The SRS dam is 185 feet high with 258 mcy of sediment storage. The size of the structure was dictated by the sediment budget for the project life(50 years). The total yield from the debris avalanche is expected to be 640 mcy, with the SRS retaining 258 mcy. The 640 mcy is made up of two components (1) mudflows, and (2) sediments due to hydrologic conditions. All of the hydrologic data obtained in the Toutle watershed has been incorporated into the various studies used to prepare the sediment budget for the SRS.

CONCLUSION

In summary, since a majority of the sediment budget is caused by hydrologic events, good hydrologic data to produce a reasonable sediment budget was and is today of paramount importance. As with most Corps of Engineers studies, the need for good hydrologic data can not be stressed enough. But, while stressing the need for more data, we can not forget about the need for high quality professional engineers that have the experience and knowledge to use the hydrologic data collected.

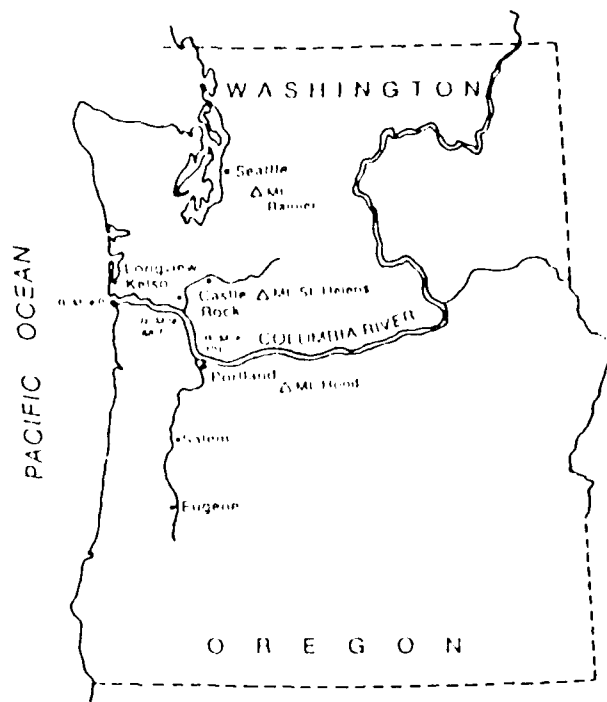

Figure 1-1. Vicinity Map

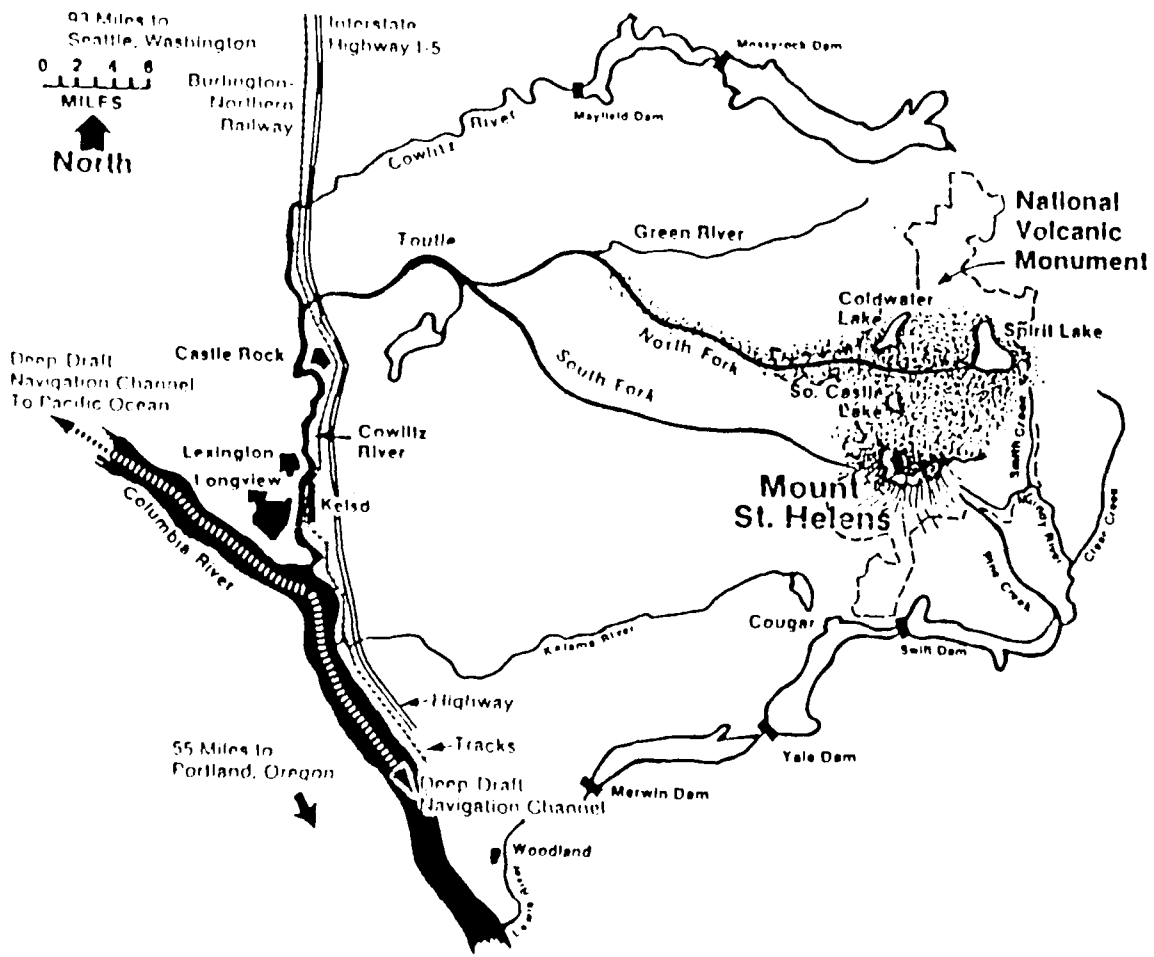

Figure 1-2. Study Area For the Comprehensive Plan

HYDROLOGIC ENGINEERING DATA NEEDS FOR PROJECT FORMULATION

GEORGE A. SAULS, PE¹

The task of project formulation typically requires evaluation of a wide range of potential solutions to a specific problem. While the number and type of possible solutions is dependent on the specific problem, certain basic hydrologic engineering data needs exist for virtually all studies.

Since the project formulation process includes economic evaluation of alternatives through comparison of BCR estimates, hydrologic frequency estimates are required as input. Depending on the problem, these frequency estimates could be for variables such as discharge, stage, volume, or duration for the existing condition and all alternatives to be evaluated. These frequency estimates are crucial for development of the economic models used for evaluation of the existing problem as well as for assessing the economic viability of various potential plans of improvement.

Data required to make these estimates could include detailed streamflow records and precipitation data for all gage locations within the study area for a number of historic flood events. Historic flood elevations may also be required. Topographic data is necessary as basic input for development of hydraulic models used to make frequency estimates. Other data needs could include basin topography and soil type for estimation of runoff characteristics and infiltration rates to use in hydrologic model development. Sedimentation data may be required to assess reservoir infill rates or stability of certain channel configurations. Data detailing historic changes in basin conditions could be vital in the analysis if significant changes due to urbanization or regulation have occurred. Removal or reconstruction of dams, bridges, or levees could also be important for model development. Channel realignments can change hydraulic characteristics and must be considered in model development. These and other factors should be considered when determining specific hydrologic data needs for a particular study.

Hydrologic data needs should consider the requirements for model development, calibration, and verification. Verification being based on independent events not used for model development or calibration. All too often analyses are conducted without

¹ Chief, Hydrology-Hydraulics Branch, Engineering Division
U.S. Army Corps of Engineers, Philadelphia District.

sufficient effort directed toward calibration and verification. This not only applies to the hydrologic and hydraulic models but also to the economic models that are so dependent on the hydrologic and hydraulic inputs. Additional efforts in calibration and verification of these models is a basic requirement for enhanced confidence in study results and conclusions.

Two other specific areas requiring significantly more detailed data and improved coordination between the hydraulics and economics technical elements are where partial duration frequency analysis techniques are employed or where coincident conditions analyses are envisioned. These two types of analyses can significantly increase the basic data requirements and involve more detailed analysis, both from a hydraulics as well as an economics viewpoint. For the partial duration analysis historic flood and damage data are necessary to assess both hydrologic independence and economic recovery time. Coincidental conditions analysis require detailed data evaluations to establish independence and make appropriate frequency estimates. Various plans of improvement can significantly impact these relationships, thus requiring coordination early in the study process to insure proper evaluation of specific solutions.

Close coordination among the various technical study elements is essential to insure proper selection and use of index locations, reach lengths, and reference flood profiles used for the economic evaluation of the existing conditions damages as well as the computation of benefits provided by the various plans of improvement. Improper selection of these parameters can impact validity of results to varying degrees depending on the plan of improvement, thus making fair and equitable comparisons of alternatives impossible. Increased understanding of the interaction and interdependence of the hydrologic and economic analytical techniques is essential to insure proper project formulation.

Hydrologic, hydraulic and economic evaluations are closely interrelated and study success depends on proper coordination in development, calibration, and verification of models along with proper utilization in evaluating potential solutions. This coordinated process must consider the specific problem area, data availability, potential solutions and study techniques that will be employed to ensure smooth study execution and confidence in results.

PANEL 5
HYDROLOGIC ENGINEERING DATA NEEDS FOR PROJECT FORMULATION

by

PAUL R. HEIN¹

Basic Data Needed

When planning either a flood reduction or a navigation project there is no substitute for actual hydrologic engineering data. The basic information required for any project is essentially the same, whether it is large or small, urban or rural. The big difference for a project with a large drainage area versus a small drainage area is the quantity and quality of data that is available. In the Pittsburgh District, we would consider a large basin drainage area to be 500 or more square miles. Some data usually is available for any basin of 100 or more square miles, with diminishing availability as the drainage area (DA) decreases. The following hydrologic data would be considered necessary in the formulation of any project: stream flow, precipitation, and other climatologic, flood, and water quality. Sedimentation and ice gorging information can be helpful and may be essential depending on the stream, but, with a few exceptions, they are not major problems in our District.

Stream Flow Data. Almost every stream in our District, with a drainage area of over 100 square miles, contains a stream gaging station. It may not be a recording gage but some stream flow data would be available. A recording gage containing a data collection platform (DCP) would be desirable. The gaging station may be operated cooperatively by the U.S. Geological Survey (USGS) and the Corps of Engineers (COE), the National Weather Service (NWS), or our District. The cooperative USGS - Corps stations have a stage flow relationship and are reduced to obtain flood peaks and mean daily flows. Our Corps District gage records are not analyzed unless a project is to be studied, although flood peaks may be available. Fifty years of record probably is adequate to develop a flow frequency for a particular gaging station. A record of 25 years usually is considered a minimum period of record. Little data are available for streams less than 10 square miles in drainage area due to the difficulty in rating the flow. The difficulty is due primarily to the short lag time between the end of rainfall and peak flow not allowing enough time to make a stream flow measurement. A recording stream gage is very helpful in determining flow frequency and a unit hydrograph, but it is not absolutely necessary. If nothing else is available, a regional flow frequency can be used or a theoretical flow frequency can be developed using multiple regression formulas.

Precipitation Data. The District now operates 88 rain gages equipped with DCP's for use in operating the flood control dams. In addition, we maintain 110 more rain gages where we receive at least daily precipitation readings. The

¹ Chief, Hydrologic Engineering and Water Quality Section, Hydrology and Hydraulics Branch, Pittsburgh District, U.S. Army Corps of Engineers.

NWS operates at least 150 more rain gages throughout the District. Both the District and the NWS plan to install more gages in the future. At least daily readings are received by the NWS for their gages while some give hourly readings. Hourly readings are helpful in developing unit hydrographs and in using computer models such as the HEC-1. Thus, in total, we have over 350 rain gages that are operated by Federal Agencies in our District. This does not include the many rain gages that are operated by private companies or individuals. Other weather information that may be necessary would be daily and monthly snowfall; minimum, maximum, and average temperatures; minimum, maximum and average rainfall; and prevailing wind direction. This information is useful for not only planning the operation of the project but also helpful in determining the water quality requirements. Snow surveys are made each year in which a significant snowpack develops and all major ice gorges are studied. These are helpful in determining if ice gorging or snow runoff will be a problem in a specific area. For example, the ice gorging information was helpful in designing the unique local flood reduction project at Oil City, Pennsylvania which employs ice-control structures. This project, designed by the District in cooperation with Cold Regions Research and Engineering Laboratory (CRREL), prevents flooding that resulted solely from ice gorging.

Flood Data. Since March 1963, the Hydrology and Hydraulics Branch has obtained field data for all major floods on all streams in the District. The data we gather includes bucket surveys of rainfall, high-water marks, and extent of flooding. The high-water marks are referenced to National Geodetic Vertical Datum (NGVD) as is the information for the bridges and other features in and over the stream. Bridge information includes deck, clearance, streambed, and low water. Benchmarks and reference points on the bridges also are established. Data comprised of a list of the high-water marks, bridge benchmarks and reference marks, USGS 7.5 minute quad topography sheets showing the location of the numbered high-water marks and bridges, and a stream profile are assembled in a folder. Should another flood occur, particularly on a stream being studied for a project, we quickly can get another flood profile. This is particularly helpful if the latest flood is higher than the first. It also helps to answer requests from federal, state, and local offices and private citizens concerning a recent or historic flood. The high-water profiles are extremely important in planning a project and responding to technical requests. During these flood investigations, we also have found people who maintain rain gages, or record the level of floods. All of this information is gathered, analyzed, and recapped for a post-flood report for major floods. During a study for a local project, we may investigate previous floods by not only talking to local residents but by reviewing local newspapers on microfilm for flood information. This sometimes results in conflicting information but is nevertheless valuable in studying a local project.

Water Quality. Water quality information, including sedimentation, is becoming increasingly important in planning for the design and operation of most projects. This is especially true with the addition of the hydro-power stations at our flood control dams and navigation projects. Data collected prior to construction of the project is compared to data collected after the project is built to analyze the project impacts. We now have eight water quality monitoring stations in operation, seven in Pennsylvania and one in West Virginia. We intend to establish a second station

in West Virginia in the near future. We now are negotiating with the USGS to maintain these stations. Three of the stations are maintained year round while five are maintained June through September. The parameters we collect are dissolved oxygen (DO), pH, specific conductance, and water and air temperature. We would like to install more of the water quality stations but they are extremely expensive to maintain. Some water quality data is available from past records kept by the Corps, USGS, or other federal agencies.

Additional Data Needed

After obtaining and reviewing the available hydrological engineering data mentioned, we then determine if additional data is needed. If time and funds are available, we may install a recording stream gaging station with DCP at a site. We also would try to establish sufficient rain gages in the basin to not only help in the planning stage but also to use in the operation of the finished project. Sedimentation data is required now at all projects so we would establish the means to gather this data. We currently are proposing to rehabilitate a project having multiple debris basins (Turtle Creek) which filled almost immediately after construction and were not maintained by the local sponsor. Subsequent to the rehab, we will set up a monitoring program to obtain design information applicable to this region which will aid in predicting volumes of sedimentation and in economic sizing of trap facilities. If the project involves a small drainage area and funds and time are not available, we would utilize existing data. If no data is available, we would borrow data from a contiguous stream or develop frequencies by means of multiple regression formulas or regional analysis.

Closing Statement

Whether we have a large or small drainage area, we probably have sufficient hydrologic engineering data to plan, construct, and operate any flood reduction project in the Pittsburgh District.

PARTICIPANTS

Functional and Safety Aspects of Corps Projects

Conference Participants

17-19 October 1989

Surya Bhamidipaty
Hydraulic Engineer
Coastal Engineering & Water Div.
US Army Engr. Div., South Pacific
630 Sansome St., Room 720
San Francisco, CA 94111-2206
(415) 556-5709

Michael W. Burnham
Chief, Planning Div.
Hydrologic Engineering Center
609 2nd St.
Davis, CA 95616
(916) 746-1104

Larry Curry, Chief
Evaluation and Design Section
US Army Engr. Dist., Louisville
P.O. Box 59
Louisville, TN 40201-0059
(502) 582-5648

Ron Dieckmann
Hydraulic Engineer
Hydrologic and Hydraulics Branch
US Army Engr. Dist., St. Louis
210 Tucker Blvd.
St. Louis, MO 63101-1986
(314) 263-5358

Earl Eiker, Chief
Hydraulics and Hydrology Branch
Headquarters, US Army Corps of Engineers
Washington, DC 20314-1000
(202) 272-8500

Bob Engelstad, Chief
Hydrology Section
US Army Engr. Dist., St. Paul
1135 USPO & Custom House
St. Paul, MN 55101-1479
(612) 220-0610

Joseph B. Evelyn, Chief
Hydrology and Hydraulics Branch
US Army Engr. Dist., Los Angeles
P.O. Box 2711
Los Angeles, CA 90053-2325
(213) 894-5520

Arlen Feldman, Chief
Research Division
Hydrologic Engineering Center
609 2nd St.
Davis, CA 95616
(916) 756-1104

Bob Fitzgerald
Hydraulic Engineer
Hydraulics Branch
US Army Engr. Dist., Vicksburg
P.O. Box 60
Vicksburg, MS 39180-0060
(601) 634-7108

Bobby Fletcher
Research Hydraulic Engineer
Hydraulics Laboratory
US Army Engr. Waterways Experiment Station
P.O. Box 631
Vicksburg, MS 39180-0631
(601) 636-3111 ext., 4147

Don Getty
Hydraulic Engineer
Hydrology and Hydraulics Branch
US Army Engr. Dist, Nashville
P.O. Box 1070
Nashville, TN 37202-1070
(615) 736-2021

Dave Gregory
Hydraulic Engineer
Hydraulic Engineering Branch
US Army Engr. Dist., Albuquerque
P.O. Box 1580
Albuquerque, NM 87103-1580
(505) 766-3225

Paul Hein, Chief
Hydrologic Engineering & Water Quality Section
US Army Engr. Dist., Pittsburgh
1000 Liberty Ave.
Pittsburgh, PA 15222-4186
(412) 644-6951

Roy G. Huffman, Chief
Hydrologic Engineering Section
Headquarters, US Army Corps of Engineers
Department of the Army
Washington, DC 20314-1000
(202) 272-8505

John Hunter
Civil Engineer
Hydrology and Hydraulics Branch
US Army Engr. Dist., Nashville
P.O. Box 1070
Nashville, TN 37202-1070
(615) 736-5631

Guri Jaisinghani
Hydraulic Engineer
Hydrology and Hydraulics Branch
US Army Engr. Dist., Detroit
P.O. Box 1027
Detroit, MI 48231-1027
(313) 226-4761

Harry Kitch, Acting Deputy for Planning
Policy and Planning Division
Headquarters, US Army Corps of Engineers
Washington, DC 20314-1000
(202) 272-0146

Walt Linder, Chief
Hydrologic Engineering Branch
US Army Engr. Dist., Kansas City
700 Federal Building
Kansas City, MO 64108-2896
(816) 426-3854

Chris Lynch
Hydraulic Engineer
Hydrology and Hydraulics Branch
US Army Engr. Dist., Seattle
P.O. Box C-3755
Seattle, WA 98123-2255
(206) 764-3590

Ron Mason, Chief
Hydrologic and River Engineering Section
US Army Engr. Dist., Portland
P.O. Box 2946
Portland, OR 97208-2946
(503) 326-6470

Warren Mellema, Chief
Hydraulics and Hydrology Section
US Army Engr. Div., Missouri River
P.O. Box 103
Downtown Station
Omaha, NE 68101-0103
(402) 221-7323

John Morgan, Chief
Flood Control Section
US Army Engr. Dist., Chicago
219 S. Dearborn St.
Chicago, IL 60603-1797
(312) 353-8884

Bob Occhipinti, Chief
Hydraulic and Hydrology Section
US Army Engr. Dist., Charleston
P.O. Box 919
Charleston, SC 29402-0919
(803) 724-4678

George Sauls, Chief
Hydrology-Hydraulics Branch
US Army Engr. Dist., Philadelphia
2nd & Chestnut Streets
Philadelphia, PA 19106-2991
(215) 597-6829

Dennis Seibel, Chief
Hydrology and Hydraulics Section
US Army Engr. Dist., Baltimore
P.O. Box 1715
Baltimore, MD 21203-1715
(301) 962-4840

Lew Smith
Hydraulic Engineer
Hydraulics and Hydrology Section
Headquarters, US Army Corps of Engineers
Washington, DC 20314-1000
(202) 272-8506

Tim Temeyer, Chief
Hydraulics Section
US Army Engr. Dist., Omaha
215 North 17th St.
Omaha, NE 68102-4978
(402) 221-4417

Ron Turner, Chief
Hydraulics Design Section
US Army Engr. Dist., Fort Worth
P.O. Box 17300
Ft. Worth, TX 76102-0300
(817) 334-2054

Jack Ward
Hydraulic Engineer
Water Management Section
US Army Engr. Dist., Mobile
P.O. Box 2288
Mobile, AL 2628-0001
(205) 690-2737

Jerry Webb
Hydraulic Engineer
Hydraulics and Hydrology Branch
US Army Engr. Dist., Memphis
B-202, 167 N. Main
Memphis, TN 38103-1894
(901) 521-3391

Ron Yates, Chief
Water Management Branch
US Army Engr. Div., Ohio River
P.O. Box 1159
Cincinnati, OH 45201-1159
(513) 684-3071

AGENDA

**HYDROLOGY AND HYDRAULICS CONFERENCE
ON
FUNCTIONAL AND SAFETY ASPECTS OF CORPS PROJECTS**

17-19 October 1989

Tuesday, 17 October

<u>Time</u>	<u>Description</u>
8:00 - 8:10 a.m.	Introductions (Richard J. Connor, Chief Engineering Division, CEORN) Welcome by Nashville District (Colonel James P. King, District Commander)
8:10 - 8:15	Comments/Introductions (Earl Eiker, Chief, H&H Branch, HQUSACE)
8:15 - 8:30	Introduction of Technical Program (Michael Burnham, Arlen Feldman, HEC)

Session 1: Project Performance Overview and Dam Safety

8:30 - 9:05 a.m.	Remarks Project Performance (Roy Huffman, HQUSACE)
9:05 - 9:45	Remarks Status of National Dam Safety Program (Earl Eiker, HQUSACE)
9:45 - 10:00	Break
10:00 - 10:45	Paper 1 Increased Spillway Capacity Through Use of a Fuse-Plug Spillway, Center Hill Dam, Tennessee (John W. Hunter, Nashville District)
10:45 - 11:45	Panel 1 Non-Federal Dam Safety Issues 1. Bob Occhipinti, Charleston District 2. Chris Lynch, Seattle District 3. Warren Mellema, Missouri River Division 4. Surya Bhamidipaty, South Pacific Division
11:45 - 1:00 p.m.	Lunch

**HYDROLOGY AND HYDRAULICS CONFERENCE
ON
FUNCTIONAL AND SAFETY ASPECTS OF CORPS PROJECTS**

17-19 October 1989

Tuesday, 17 October 1989 (Continued)

Session 2: Low Level-of-Protection Levee Projects

<u>Time</u>	<u>Description</u>
1:00 - 1:45 p.m.	Paper 2 Catastrophe Aversion Analyses Necessary for Total River Diversion by Tunnels - Harlan, Kentucky (Don Getty, Nashville District)
1:45 - 2:30	Level-of-Protection Issues on Lower American River (Mike Burnham, HEC)
2:30 - 3:00	Break
3:00 - 3:45	Paper 3 Santa Ana River Study (Joe Evelyn, Los Angeles District)
3:45 - 4:45	Panel 2 Levee Freeboard 1. Ron Dieckmann, St. Louis District 2. Dennis Seibel, Baltimore District 3. Ron Turner, Ft. Worth District 4. Timothy Temeyer, Omaha District
6:00 - 7:00	Dinner
7:00 - 8:00	Evening Speaker Project Planning Requirements For Selecting Other Than NED Plan (Harry Kitch, Deputy Chief for Planning, HQUSACE)

**HYDROLOGY AND HYDRAULICS CONFERENCE
ON
FUNCTIONAL AND SAFETY ASPECTS OF CORPS PROJECTS**

17-19 October 1989

Wednesday, 18 October 1989

Session 3: Channel Projects

<u>Time</u>	<u>Description</u>
8:00 - 8:45 a.m.	Paper 4 Noconnah Creek Study (Jerry Webb, Memphis District)
8:45 - 9:30	Paper 5 Opportunities for Environmental Enhancements for Brush Creek (Walt Linder, Kansas City District)
9:30 - 10:00	Break
10:00 - 10:45	Paper 6 Ecorse Creek Flood Control Study (Guri Jaisinghani, Detroit District)
10:45 - 11:45	Panel 3 Issues Related to Channel Projects 2. Jack Ward, Mobile District 3. Dave Gregory, Albuquerque District 4. Ron Yates, Ohio River Division
11:45 - 1:00 p.m.	Lunch
1:00 - 6:00	Free Time Big South Fork Field Trip and Resort Activities are available during this time.
6:00 - 7:00	Dinner

**HYDROLOGY AND HYDRAULICS CONFERENCE
ON
FUNCTIONAL AND SAFETY ASPECTS OF CORPS PROJECTS**

17-19 October 1989

Wednesday, 18 October 1989 (Continued)

Session 4: Interior Projects

- | | |
|-------------|--|
| 7:00 - 7:45 | Paper 7 Pond Creek Pumping Plant, Louisville, KY Flood Protection, Larry Curry, Louisville, District) |
| 7:45 - 8:30 | Paper 8 Slidel, Louisiana Interior Study (Bob Fitzgerald, Vicksburg District) |
| 8:30 - 8:45 | Break |
| 8:45 - 9:30 | Panel 4 Interior Facilities Design and Operation Issues |
| | 1. Bobby Fletcher, WES |
| | 2. John Morgan, Chicago District |
| | 3. Mike Burnham, HEC |

**HYDROLOGY AND HYDRAULICS CONFERENCE
ON
FUNCTIONAL AND SAFETY ASPECTS OF CORPS PROJECTS**

17-19 October 1989

Thursday, 19 October 1989

Session 5: Description, Evaluation, and Data Requirements for Project Analysis

<u>Time</u>	<u>Description</u>
8:00 - 8:45 a.m.	Paper 9 Project Description (Lewis Smith, HQUSACE)
8:45 - 9:30	Paper 10 Hydrologic Engineering Perspective on Flood Hazard and Project Formulation (Darryl Davis, HEC)
9:30 - 10:00	Break
10:00 - 10:45	Panel 5 Hydrologic Engineering Data Needs for Project Formulation <ol style="list-style-type: none">1. Bob Englestad, St. Paul District2. Ron Mason, Portland District3. George Sauls, Philadelphia District4. Paul Hein, Pittsburgh District
10:45 - 11:15	Summary and Conclusions

REPORT DOCUMENTATION PAGE				Form Approved OMB No. 0704-0188	
1a. REPORT SECURITY CLASSIFICATION Unclassified		1b. RESTRICTIVE MARKINGS			
2a. SECURITY CLASSIFICATION AUTHORITY		3. DISTRIBUTION / AVAILABILITY OF REPORT			
2b. DECLASSIFICATION / DOWNGRADING SCHEDULE					
4. PERFORMING ORGANIZATION REPORT NUMBER(S) Seminar Proceedings No. 21		5. MONITORING ORGANIZATION REPORT NUMBER(S)			
6a. NAME OF PERFORMING ORGANIZATION Hydrologic Engineering Center		6b. OFFICE SYMBOL (If applicable) CEWRC-HEC	7a. NAME OF MONITORING ORGANIZATION		
6c. ADDRESS (City, State, and ZIP Code) 609 2nd St. Davis, CA 95616		7b. ADDRESS (City, State, and ZIP Code)			
8a. NAME OF FUNDING / SPONSORING ORGANIZATION Headquarters, USACE		8b. OFFICE SYMBOL (If applicable)	9. PROCUREMENT INSTRUMENT IDENTIFICATION NUMBER		
8c. ADDRESS (City, State, and ZIP Code) Washington, DC 20314-1000		10. SOURCE OF FUNDING NUMBERS			
		PROGRAM ELEMENT NO	PROJECT NO.	TASK NO.	WORK UNIT ACCESSION NO.
11. TITLE (Include Security Classification) Proceedings of a Hydrology & Hydraulics Conference on Functional and Safety Aspects of Corps Projects					
12. PERSONAL AUTHOR(S) Michael W. Burnham, Editor					
13a. TYPE OF REPORT Conference Proceedings		13b. TIME COVERED FROM 16 Oct to 19 Oct	14. DATE OF REPORT (Year, Month, Day) 1990, February, 5		15. PAGE COUNT 226
16. SUPPLEMENTARY NOTATION Collection of papers presented at a conference held at Crab Orchard, Tennessee, 16-19 October, 1989					
17. COSATI CODES			18. SUBJECT TERMS (Continue on reverse if necessary and identify by block number) Hydrologic Analysis, Safety, Risk, Project Performance, Plan Formulation, Low Levee of Protection		
FIELD	GROUP	SUB-GROUP			
19. ABSTRACT (Continue on reverse if necessary and identify by block number) A collection of papers, panel discussions and topic session summaries. Topic sessions include: Project Performance and Dam Safety; Low Level-of-Protection Levee Projects; Channel Projects; Interior Projects; and Description, Evaluation, and Data Requirements for Project Analysis. A list of the participants and conference agenda are included.					
20. DISTRIBUTION / AVAILABILITY OF ABSTRACT <input checked="" type="checkbox"/> UNCLASSIFIED/UNLIMITED <input type="checkbox"/> SAME AS RPT. <input type="checkbox"/> DTIC USERS			21. ABSTRACT SECURITY CLASSIFICATION Unclassified		
22a. NAME OF RESPONSIBLE INDIVIDUAL Michael W. Burnham (Darryl Davis, Director)			22b. TELEPHONE (Include Area Code) (916) 756-1104		22c. OFFICE SYMBOL CEWRC-HEC