

DTIC FILE COPY

4

A TRIDENT SCHOLAR PROJECT REPORT

NO. 157

AD-A216 268

"The Behavior and Capabilities of Lithium Hydroxide
Carbon Dioxide Scrubbers in a Deep Sea Environment"



UNITED STATES NAVAL ACADEMY
ANNAPOLIS, MARYLAND

This document has been approved for public
release and sale; its distribution is unlimited.

DTIC
ELECTE
JAN 02 1990
S B D

90 01 02 062

REPORT DOCUMENTATION PAGE		READ INSTRUCTIONS BEFORE COMPLETING FORM
1. REPORT NUMBER U.S.N.A. - TSPR; 157 (1989)	2. GOVT ACCESSION NO.	3. RECIPIENT'S CATALOG NUMBER
4. TITLE (and Subtitle) THE BEHAVIOR AND CAPABILITIES OF LITHIUM HYDROXIDE CARBON DIOXIDE SCRUBBERS IN A DEEP SEA ENVIRONMENT.	5. TYPE OF REPORT & PERIOD COVERED Final 1988/89	
	6. PERFORMING ORG. REPORT NUMBER	
7. AUTHOR(s) Jennifer R. Jaunsen	8. CONTRACT OR GRANT NUMBER(s)	
9. PERFORMING ORGANIZATION NAME AND ADDRESS United States Naval Academy, Annapolis.	10. PROGRAM ELEMENT, PROJECT, TASK AREA & WORK UNIT NUMBERS	
11. CONTROLLING OFFICE NAME AND ADDRESS United States Naval Academy, Annapolis.	12. REPORT DATE 7 July 1989	
	13. NUMBER OF PAGES 132	
14. MONITORING AGENCY NAME & ADDRESS (if different from Controlling Office)	15. SECURITY CLASS. (of this report)	
	15a. DECLASSIFICATION/DOWNGRADING SCHEDULE	
16. DISTRIBUTION STATEMENT (of this Report) This document has been approved for public release; its distribution is UNLIMITED.		
17. DISTRIBUTION STATEMENT (of the abstract entered in Block 20, if different from Report)		
18. SUPPLEMENTARY NOTES Accepted by the U.S. Trident Scholar Committee.		
19. KEY WORDS (Continue on reverse side if necessary and identify by block number) Diving, Submarine Scrubbers (Chemical technology) Hydroxides		
20. ABSTRACT (Continue on reverse side if necessary and identify by block number) Lithium Hydroxide (LiOH) is the principal chemical absorbent used as a carbon dioxide scrubber material by NASA in the shuttle spacecraft. LiOH scrubbers are now being proposed for the Navy's newest and most advanced mixed-gas, closed circuit diving rig, the EX 19, designed for long-term, covert diving operations. Although extensive investigations have been conducted in the past dealing with carbon dioxide absorption by LiOH scrubbers in outerspace conditions, (OVER)		

relatively little is known about the process in the underwater environment. The objective of this project was to investigate the absorption of metabolically-produced carbon dioxide by lithium hydroxide scrubbers under constraints unique to the deep sea diver. An experimental mock-up of a closed circuit diving rig was constructed in the Coastal Engineering Laboratory and used to conduct this study. Several parameters, including initial moisture content, flow rate through the the canister, canister length-to-diameter ratio, carbon dioxide injection level, and ambient temperature, were varied. The time of breakthrough was recorded for each test and compared to theory, yielding plots that show several relationships in CO₂ absorption, the greater part of which may be corrected with past studies. Furthermore, both the initial and final weights, as well as the temperature profile, of the LiOH bed were recorded and used to evaluate both weight and temperature as predictors of breakthrough, with temperature following a consistent pattern and appearing extremely promising. The potential of prebreathing and rejuvenation to increase canister utilization was also explored, rejuvenation improving utilization by an additional twenty percent of the original duration. The objective of this study was successfully accomplished and further study of the potentials of temperature as a breakthrough predictor and rejuvenation is strongly recommended.



Accession For	
NTIS GRA&I	<input checked="" type="checkbox"/>
DTIC TAB	<input type="checkbox"/>
Unannounced	<input type="checkbox"/>
Justification	
By	
Distribution/	
Availability Codes	
Dist	Avail and/or Special
A-1	

U.S.N.A. - Trident Scholar project report; no. 157 (1989)


"The Behavior and Capabilities of Lithium Hydroxide
Carbon Dioxide Scrubbers in a Deep Sea Environment"

A Trident Scholar Project Report

by

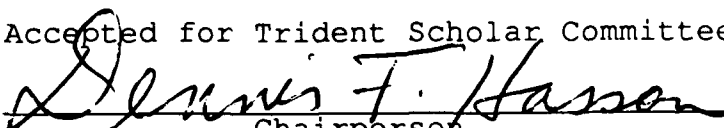
Midshipman Jennifer R. Jaunsen, Class of 1989

U.S. Naval Academy
Annapolis, Maryland

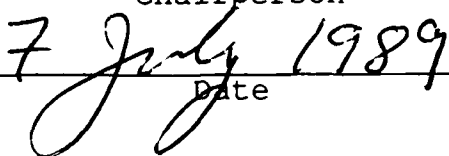


Professor M.L. Nuckols
Naval Systems Engineering

Accepted for Trident Scholar Committee



Chairperson



Date

ABSTRACT

Lithium Hydroxide (LiOH) is the principal chemical absorbent used as a carbon dioxide scrubber material by NASA in the shuttle spacecraft. LiOH scrubbers are now being proposed for the Navy's newest and most advanced mixed-gas, closed circuit diving rig, the EX 19, designed for long-term, covert diving operations. Although extensive investigations have been conducted in the past dealing with carbon dioxide absorption by LiOH scrubbers in outerspace conditions, relatively little is known about the process in the underwater environment. The objective of this project was to investigate the absorption of metabolically-produced carbon dioxide by lithium hydroxide scrubbers under constraints unique to the deep sea diver. An experimental mock-up of a closed circuit diving rig was constructed in the Coastal Engineering Laboratory and used to conduct this study. Several parameters, including initial moisture content, flow rate through the canister, canister length-to-diameter ratio, carbon dioxide injection level, and ambient temperature, were varied. The time of breakthrough was recorded for each test and compared to theory, yielding plots that show several relationships in CO₂ absorption, the greater part of which may be

correlated with past studies. Furthermore, both the initial and final weights, as well as the temperature profile, of the LiOH bed were recorded and used to evaluate both weight and temperature as predictors of breakthrough, with temperature following a consistent pattern and appearing extremely promising. The potential of prebreathing and rejuvenation to increase canister utilization was also explored, rejuvenation improving utilization by an additional twenty percent of the original duration. The objective of this study was successfully accomplished and further study of the potentials of temperature as a breakthrough predictor and rejuvenation is strongly recommended.

TABLE OF CONTENTS

	<u>Page</u>
Title Page	
Abstract	1
Table of Contents	3
List of Tables	4
List of Figures	5
Introduction	7
Discussion of Theory	10
Description of Apparatus	17
Experimental Procedure	23
Parameters Studied	28
Parameters Measured	32
Results	33
Discussion	34
Conclusions	42
Tables	44
Figures	47
References	74
Appendices	
A: LiOH Supply Specifications	76
B: Test Data	77

LIST OF TABLES

	<u>Page</u>
Table 1: Strip Chart - CO ₂ Percentage Conversion	44
Table 2: Flow Rate Variation	45
Table 3: L/D Ratio Variation	45
Table 4: Summary of Testing	46

LIST OF FIGURES

	<u>Page</u>
Figure 1: EX 19 MOD 1 System Schematic	47
Figure 2: Schematic of Experimental Set-up	48
Figure 3: Breathing Machine	49
Figure 4: Humidifier	50
Figure 5: LiOH Canister Thermocouple Locations	51
Figure 6: LiOH Canister, 89.5 gm (Dry)	52
Figure 7: Strip Chart Calibration System	53
Figure 8: Equilibrium Phases of LiOH with H ₂ O	54
Figure 9: Initial Moisture Content of LiOH	55
Figure 10: LiOH Canister Testing, Bed Temperature versus Time	56
Figure 11: Wet Bed Temperature Compared with Effluent CO ₂ Level	57
Figure 12: Dry Bed Temperature Compared with Effluent CO ₂ Level	58
Figure 13: Effect of Flow Rate on Absorption Efficiency	59
Figure 14: Effect of Flow Rate on Canister Weight Gain	60
Figure 15: Temperature Profiles, RMV Variation	61
Figure 16: Effect of L/D Ratio on Canister Efficiency	62

Figure 17:	Effect of L/D Ratio on Canister Weight Gain	63
Figure 18:	L/D Ratio #2, Dry Bed Temperature Profile	64
Figure 19:	L/D Ratio #2, Wet Bed Temperature Profile	65
Figure 20:	L/D Ratio #2, Bed Dimensions and Thermocouple Placement	66
Figure 21:	Effect of CO ₂ Loading on Canister Weight Gain	67
Figure 22:	Temperature Profile, CO ₂ Loading Variation	68
Figure 23:	Effect of CO ₂ Loading on Absorption Efficiency	69
Figure 24:	Injection Level versus Temperature	70
Figure 25:	Effect of Gas Temperature on Absorption Efficiency	71
Figure 26:	Effect of Rejuvenation on LiOH Utilization	72
Figure 27:	Comparison of LiOH Utilization	73

INTRODUCTION

In closed circuit diving applications, no gas escapes from the closed loop of the diving rig, meaning there are no bubbles to give the diver away. Closed circuit capability makes covert diving operations possible: therefore, improvement upon the existing technology would be a great boon to the U. S. Navy. In a typical closed circuit rig, the breathing gas circulates from the diver to a compliant volume, through an oxygen sensor/injection system and a carbon dioxide scrubber, then into a second compliant volume before returning to the diver. The carbon dioxide scrubber is the crucial element in the cycle, because it removes the metabolically-produced carbon dioxide from the circulating gas, thereby preventing carbon dioxide poisoning. The amount of carbon dioxide that the scrubber is capable of absorbing determines the maximum dive duration: the more carbon dioxide absorption capability the better.

Many studies of carbon dioxide absorption have been conducted, the various options for carbon dioxide removal including hydroxides, amines, molecular sieves, cryogenics, and membranes(1). Currently the Navy uses Sodasorb, a registered tradename of the W. R. Grace Co.,

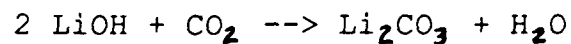
which consists primarily of calcium hydroxide, a dry chemical packed in a bed. Carbon dioxide passing through the canister reacts with the chemical to produce calcium carbonate and water. Another dry chemical, Baralyme, is currently used by the British in similar diving rigs. The most recently considered option for carbon dioxide absorption is lithium hydroxide (LiOH), a dry chemical in the same convenient form as Sodasorb and Baralyme, but more reactive. LiOH canisters react more violently with injected carbon dioxide, lasting for longer periods of time and having increased efficiencies(2). The most attractive feature of LiOH is that it absorbs the most carbon dioxide per unit weight, allowing smaller, lighter, and less bulky canisters to be carried on the diver's back. Furthermore, the performance of LiOH remains constant despite the lower temperatures and increased pressures of the ocean's depths(4), while Sodasorb's efficiency decreases rapidly with decreasing ambient temperature. The disadvantage of LiOH lies in the toxic dust inherent with this chemical, which requires the wearing of a face mask and goggles when handling the dry chemical and mandates some sort of special filter, such as micro-porous membranes, in a closed circuit rig to guard against diver inhalation of any caustic slurry. While there is much experimentation

currently being performed using LiOH as a scrubber material, including the Navy's own experimental closed circuit rig, the EX 19 (see figure 1), relatively little has been done to characterize the substance, i.e., how the carbon dioxide absorption is affected by parameters such as respiratory rate, carbon dioxide loading, initial moisture content, and canister length-to-diameter ratio. Other important questions to consider include: (1), the effect of prebreathing the canister; (2), the potential for LiOH rejuvenation after breakthrough; (3), the effect of the shelf-life of LiOH on its performance; and (4), the temperature profile of the LiOH bed during the absorption process, especially at breakthrough.

For this study, a mock-up of a closed circuit diving rig was constructed in the Coastal Laboratory at the United States Naval Academy, and efficiency studies under various parametric conditions were conducted.

DISCUSSION OF THEORY

Lithium hydroxide belongs to a group of materials classified as alkali metal hydroxides. These materials react with carbon dioxide to form carbonate, bicarbonate, or hydrates of the same alkali metal. In the case of LiOH, the net reaction is:



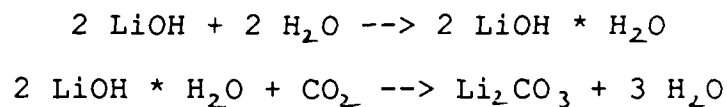
Thus, LiOH reacts with carbon dioxide in a two-to-one ratio. Knowing the molecular weights of LiOH and CO₂, 23.94 and 44.0 grams per mole, respectively, the theoretical absorption capacity of LiOH can be calculated as follows:

$$\frac{1 \text{ mole CO}_2}{2 \text{ mole LiOH}} * \frac{44.0 \text{ lb CO}_2 / \text{mole CO}_2}{23.94 \text{ lb LiOH/mole}} = 0.92 \frac{\text{lb CO}_2}{\text{lb LiOH}}$$

Therefore, one pound of LiOH can theoretically absorb 0.92 pound of CO₂. By comparison, one pound of calcium hydroxide absorbs only 0.59 pound of CO₂. Clearly, the capacity of LiOH is much higher on a weight basis. In

addition, the higher reactivity of LiOH, particularly in cold environments, makes it the superior scrubber material.

Note that the reaction between LiOH and CO₂ can only take place in the presence of water vapor. The net reaction is actually the combination of the following two reactions:



If there is insufficient water present, the hydrate, LiOH·H₂O, cannot be formed, resulting in incomplete carbon dioxide reaction. However, an excess of water vapor can also be a problem, causing a water film to form around the LiOH granules which acts as a barrier, again resulting in incomplete reaction between LiOH and CO₂. Insufficient water vapor is not a concern in scrubber design due to the saturated moisture content of the exhaled human breath; however, excess water is a different case. From the reactions, it can be seen that one mole of water is produced for every mole of CO₂ absorbed. Using molecular weights, the following calculation is performed:

$$\frac{1 \text{ mole H}_2\text{O}}{1 \text{ mole CO}_2} * \frac{18 \text{ lb H}_2\text{O/mole}}{44 \text{ lb CO}_2/\text{mole}} = 0.41 \frac{\text{lb H}_2\text{O}}{\text{lb CO}_2}$$

It is apparent that as the reaction occurs and water is produced, a film barrier can build up to the point where reaction can no longer continue in a complete manner. The water film could cause breakthrough to occur prematurely and reduce canister efficiency.

Theoretical bed life (TBL) is defined as the length of time the scrubbing agent in the canister will be able to absorb carbon dioxide and may be computed by dividing the theoretical absorption capability of the canister (in pounds of CO₂) by the rate of metabolic CO₂ production (in pounds of CO₂ per minute). The LiOH used for this testing is NASA-grade (3), having a bulk density of 0.0148 lb per cubic inch, or 0.41 gram per ml (see Appendix A). The volume of LiOH used is approximately 11 cubic inches, meaning that the theoretical weight of LiOH in the canister per test run is:

$$208 \text{ ml} * 0.41 \text{ g LiOH/ml} = 85.28 \text{ g LiOH (0.188 lb LiOH)}$$

However, due to the age of the LiOH material used in this study (storage: approximately two years) and absorption

of water from the atmosphere, the initial "wet" weight of scrubber material used in testing this volume ranged from 120 grams to 95 grams, decreasing as testing progressed. When baked in an oven for approximately four hours, this same amount of LiOH weighed an average of 89.5 grams, confirming excessive water absorption and partial LiOH degradation due to the harsh environmental conditions of its storage. Temperatures in the Coastal Laboratory varied from 60 to 80 degrees Fahrenheit, and relative humidity levels, at times, approached 100%.

Theoretically, the canister can absorb:

$$0.188 \text{ lb LiOH} * 0.92 \text{ lb CO}_2/\text{lb LiOH} = 0.173 \text{ lb CO}_2$$

In all closed-circuit apparatus, CO₂ is injected at a level of 4%, the rate of metabolic CO₂ production. CO₂ injection level is a function of the experimental respiratory minute volume (RMV). Defined as the volume of air inhaled and exhaled in one minute's time, RMV values range from 6 to 90 standard liters per minute (SLPM), depending on lung capacity and activity level. For initial experimental runs, efforts were made to simulate the flow conditions in the EX 19 canister. An RMV of 62.5 SLPM was chosen, representing a conservative value for a hard-working diver. In order to obtain a

realistic CO₂ absorption profile, this RMV must be scaled to accommodate the reduction in size of the experimental canister. The area of the actual EX 19 LiOH bed is 121 square inches; therefore, the flow velocity through the bed is:

$$V(\text{gas}) = \text{RMV} / A$$

where "A" is the cross sectional area of the canister,
or,

$$\begin{aligned} 62.5 \text{ SLPM} * 144 \text{ sq in/sq ft} / 121 \text{ sq in} * 28.3 \text{ lit/cu ft} \\ = 2.63 \text{ ft/min} \end{aligned}$$

Dwell time, the time during which the circulating gas is in contact with the LiOH bed, for this canister can be found by dividing the bed length by this flow velocity. Since the area of the baseline canister used in this experiment is 11 square inches, the resulting scaled RMV is:

$$\begin{aligned} 2.63 \text{ ft/min} * 11 \text{ sq in} * 28.3 \text{ lit/cu ft} / 144 \text{ sq in/sq ft} \\ = 5.71 \text{ SLPM (approximately 6 SLPM)} \end{aligned}$$

Tidal volume (TV) is defined as the volume of one breath; respiratory rate (RR), as the number of breaths in one minute. From standard tables, typical TV and RR values for an RMV of 6 SLPM are 0.5 liters per breath and 12 breaths per minute, respectively. It is these settings that were used for the breathing machine in the experimental set-up during initial testing. Since RMV is the product of TV and RR:

$$\text{RMV} = .5 \text{ lit/breath} * 12 \text{ breath/min} = 6.0 \text{ SLPM}$$

Because a CO₂ injection level of 4% is desired, the flow rate of CO₂ into the system is:

$$\dot{V}(\text{CO}_2) = .04 * 6.0 \text{ SLPM} = 0.24 \text{ SLPM}$$

Converting this value to the metabolic CO₂ production rate is accomplished by multiplying by the density of CO₂ at 0 degrees F and 1 atmosphere:

$$\begin{aligned} .24 \text{ SLPM} * .123 \text{ lb/cu ft} / 28.3 \text{ lit/cu ft} \\ = 0.00104 \text{ lb/min} \end{aligned}$$

Now, TBL can be calculated:

$$\text{TBL} = 0.173 \text{ lb CO}_2 / 0.00104 \text{ lb CO}_2 / \text{min}$$

TBL = 166 min (2.77 hr)

The canister efficiency is a measure of the performance of the chemical as a carbon dioxide absorbing agent and can be defined as the quotient of canister breakthrough time and theoretical bed life. Canister breakthrough time is the time required for the outlet CO₂ level to reach 0.5%, the level at which physiological changes in the body due to excess CO₂, such as nausea, headaches, etc., first occur. Efficiency is affected by numerous factors, such as temperature, flow rate through the canister, humidity level of the gas, and the canister length-to-diameter (L/D) ratio. Typical efficiencies for a LiOH canister range from 0.5 to 0.8 (1). For these studies, the time to breakthrough will be experimentally determined, allowing efficiencies of the bed under varying parameters to be evaluated and compared.

DESCRIPTION OF APPARATUS

The experimental set-up used in this study is a mock-up of a closed circuit diving rig (see figure 2) located in the Coastal Engineering Laboratory of the U.S. Naval Academy. A breathing machine provides a sinusoidal flow pattern through the system. Air from the breathing machine goes through a manikin head and into a humidifier that is temperature controlled by a hot plate. In the humidifier, water and heat are added to the circulating air, and, at the outlet of the humidifier, carbon dioxide is injected into the system, simulating exhaled breath. Next, the gas enters the bottom plenum of the CO₂ scrubber, flowing up through the LiOH bed, and exiting the canister to a compliant volume. From the compliant volume the air travels back to the manikin head, through a directional check valve, and begins the cycle again.

BREATHING MACHINE

It is the breathing machine that actually drives air around the closed loop in the form of pulse flow (see figure 3). This machine consists of a motor which drives a crankshaft. The crankshaft in turn pushes a piston with a rolling seal to and fro, creating a sinusoidal displacement of air. The volume of air displaced per

stroke simulates the tidal volume and is varied by adjusting the crankshaft length. The rate of crankshaft rotation determines the breathing rate and is adjusted via a rheostat on the control box. A vacuum pump, drawing approximately 5 psi vacuum, guards against inversion of the rolling seal. The vacuum can be adjusted by a bleed valve located between the pump and the cylinder.

SPIROMETER

A water seal spirometer is employed to measure the tidal volume created by the breathing machine, allowing breathing machine calibration. Air from the breathing machine flows into the base of the spirometer, displacing a floating cylinder with a pen attached at the top. The pen rises and falls as the cylinder is displaced, recording the tidal volume on a revolving circular barrel.

HUMIDIFIER

The humidifier consists of a cylindrical container, two-thirds full of water, that sits on a hot plate (see figure 4). Air entering the humidifier is routed through a hose to the bottom of the cylinder where it passes through a diffusing screen before bubbling up to the

outlet at the water's surface. The hot plate heats the humidifier water to about 98.6 degrees F, regulated by a Digi-sense temperature controller. The actual air temperature leaving the humidifier is measured by a type K Chromel/Alumel thermocouple and displayed on the Digicator LCD. Thus, air exiting the humidifier is approximately body temperature and 100% moisture content, simulating exhaled breath.

CO₂ INJECTION SYSTEM

In order to simulate the carbon dioxide exhaled in breath, CO₂ is injected at an optimum rate of 4% into the outlet hose of the humidifier. The flow of CO₂ out of the carbon dioxide bottle is controlled by a regulator, a valve at the beginning of the feed line, and a micrometer valve. Both the bottle and the first valve are opened fully when injecting CO₂, while the micrometer valve is used to regulate the actual injection level and remains untouched after the CO₂ injection calibration procedure has been completed. The injection level can be monitored on the strip chart recorder by positioning the sampling valve on top of the LiOH canister to draw a sample stream from the inlet plenum.

LiOH CANISTER

The canister used in this study is an experimental design and was obtained from Duke University (4). Made of 1/4" transparent acrylic, the canister is placed upright on its end to reduce the possibility of gas channeling. Gas enters the bottom plenum of the canister, flows upward through the center section in which the LiOH is packed, and exits the top plenum to a compliant volume. A removable spacer reduces the volume of the center section to approximately 11 cubic inches. In addition, two removable sleeves with spacers were constructed so that the L/D ratio may be varied by reducing the diameter and increasing bed length while the volume of LiOH in the canister remains constant. Thermocouples are located at the inlet and outlet of the canister, as well as within the LiOH bed itself, to monitor gas temperature (see figures 5 & 6). The corresponding temperature readings are displayed on the Digicator LCD. Air samples are drawn from either the inlet or outlet side of the LiOH bed, depending on the position of the sampling valve at the top of the canister. The air sample is pulled through a Beckman Industrial Model 864 Non-dispersive Infrared Analyzer by a sampling pump, then fed back into the outlet plenum of the canister.

COMPLIANT VOLUME

Air flows from the LiOH canister outlet into a compliant volume before returning to the manikin head. The compliant volume used in this mock-up is a Mk 6 UBA breathing bag which hangs over the edge of the table in a vertical position, allowing any condensate to fall to the bottom where it can be drained through a small outlet valve following each test run. The breathing bag is included in the system to add compliancy, meaning the diver breathes air out of the bag vice sucking it through the circuit. In other words, compliancy allows the diver to expend less of his energies breathing.

INFRARED ANALYZER

A Beckman Industrial Model 864 Non-dispersive Infrared Analyzer (IR) detects the amount of CO₂ present in the air flowing through the canister and sends this information to a strip chart recorder. A gas sample is continually pulled from either the inlet or outlet side of the LiOH bed at a rate of 0.5 liter/minute by a sampling pump and fed through a condensate collector and a flowmeter prior to being injected into the IR. Gas exiting the IR is routed back into the outlet of the canister. The pump used in the sampling system is a small battery-powered aquarium pump, needed because the

IR lacks an internal circulating capability. A Dwyer "visi-float" flowmeter with a range of 0 to 4.0 SLPM measures the flow rate into the IR.

STRIP CHART CALIBRATION SYSTEM

The strip chart is calibrated by pumping helium gas and a 6.0% CO₂-in-air mixture through the IR (see Figure 7). Helium is used as the zero deflection on the strip chart while 6.0% CO₂ is used for full scale. A 4.0% CO₂ mixture is used as a reference point and is recorded only after the IR has been calibrated with no drift evident. Values of strip chart deflection are correlated to CO₂ percentage using the IR's nonlinear calibration curves. Note that in order to agree with the 4.0% CO₂ reference datum, the nonlinear curve was shifted and an extrapolated table of strip chart values and their corresponding percentages derived (see Table 1).

EXPERIMENTAL PROCEDURE

The procedure used for all canister tests performed in this study was as follows:

1. Measure approximately 208 ml LiOH in a graduated cylinder; record initial weight.
2. Bake LiOH for at least four hours in a 180-degree F oven; record dry weight.
3. Turn on IR; set on "TUNE." IR must warmup for at least one hour, preferably eight hours, prior to testing.
4. Turn on breathing machine and vacuum pump; allow at least 30 minutes warm-up time. Adjust pump bleed valve to obtain 5 psi vacuum.
5. Calibrate the CO₂ detection system. Turn on the strip chart recorder. Close the two valves on the canister sample lines, isolating the IR and its calibration system from the rest of the circuit. Open the valve to atmosphere, as well as the bottles of helium, 4% CO₂, and 6% CO₂. Open the helium injection valve to obtain a flowmeter reading between 0.5 and 1.0 SLPM. Set this flow as the zero displacement position on the strip chart, using the "zero" control knob. Close

the helium valve. Open the 6% CO₂ injection valve, again using a flow of 0.5 - 1.0 SLPM. Set this CO₂ level as the full deflection on the strip chart. Close 6% valve. Alternate injecting helium and 6% CO₂ until there is no drift evident. The system is now calibrated. Mark needle deflection for both 0 and 6% on the strip chart paper. Open the 4% CO₂ injection valve, establish 0.5 - 1.0 SLPM flow, and mark deflection. Close all bottles of gas, close the valve to atmosphere, and open the canister sample lines.

6. Calibrate the "lungs" of the system. Close the appropriate valve to isolate the breathing machine from the rest of the circuit. Open the valve to the spirometer. The spirometer needle will rise and fall as the crankshaft on the breathing machine moves the piston back and forth. The tidal volume (TV) is read from the needle's vertical displacement on the spirometer barrel and may be adjusted via the control on the breathing machine crankshaft. The respiratory rate (RR) is controlled by the rheostat on the breathing machine control box and is checked using a stopwatch.

7. Set CO₂ injection level. Desired CO₂ injection is 3.5 - 4.0 %, the amount of CO₂ found in exhaled breath. Flip sampling valve at the top of LiOH canister to the CO₂ inlet sample line. Check RR on breathing

machine and adjust as necessary before placing machine on line with the circuit. Close the spirometer valve. Disconnect the line between the compliant volume and the manikin head, allowing the circuit to run without LiOH loaded in the canister by drawing room air into the circuit (CO_2 level at sea level is about 0.035%, effectively zero deflection on the strip chart) and dumping injected CO_2 to the atmosphere. Inject CO_2 into system by opening both the bottle and the valve adjacent to the regulator fully. Turn the sampling pump on. Adjust the micrometer valve for a CO_2 injection level of 4%, checking against the reference 4.0% level already recorded on the strip chart. When the level stabilizes at 4%, close the CO_2 bottle and the first valve. DO NOT TOUCH THE MICROMETER VALVE. Allow the breathing machine to run for a few extra minutes to flush excess CO_2 from the system, then isolate the breathing machine using the appropriate valve, and reconnect the line between the compliant volume and the manikin head. Turn the sampling pump off.

8. Turn on the hot plate and the Digisense temperature controller. Set hot plate on "FULL" to heat water in humidifier as quickly as possible to 98.6 degrees F. Set the Digisense to maintain the desired temperature. Monitor the humidifier thermocouple reading

on the Digicator LCD, reducing the hot plate setting to "5" as soon as the temperature exceeds 90 degrees F (this practice helps to prevent an overshoot in temperature).

9. Open the LiOH canister and pour new LiOH in slowly, allowing time to settle. If the LiOH is loosely packed, channeling will occur and breakthrough will be reached prematurely. Pack LiOH down evenly, using vibration and a spring-loaded retaining screen, and reassemble the canister, ensuring that all screws and clamps are secured snugly.

10. At this point, the actual test may be performed. Record ambient temperature and pressure, as well as the initial temperatures of the circuit thermocouples from the Digicator LCD. Turn on the strip chart speed, using a setting of 10 cm per hr. Open the valve to connect the breathing machine to the closed circuit, closing the spirometer valve. Turn on the sampling pump. Open the CO₂ bottle and first regulating valve fully, marking the time of CO₂ injection as time zero on the strip chart and starting the stopwatch. Record thermocouple readings every 5 minutes. Switch the sampling source valve at the top of the canister to check the CO₂ injection level. If the level is not within the range of 3.5 - 4.0 %, the run may be salvaged by adjusting the micrometer valve on the CO₂ injection line

by tiny increments. After checking the injection level, switch the valve back to sample the CO₂ at the outlet of the bed and continue recording temperatures at five-minute intervals. Make special note of the time and temperature at canister breakthrough, continuing the test until CO₂ reaches an effluent level of 1.0 %. Recheck the CO₂ injection level by disconnecting the line between the compliant volume and the manikin head and flipping the sampling valve to inlet CO₂. Record this level on the strip chart. At this time the test run is complete. Close the CO₂ bottle and regulating valve. Turn everything off EXCEPT the IR and the strip chart power switch. Recheck and mark the calibration of the strip chart deflection using the three bottled gases (see step 5 above). Turn off the IR and strip chart power.

11. Open the canister, removing and weighing the old scrubber material. Record this final weight.

PARAMETERS STUDIED

1. INITIAL MOISTURE CONTENT

Recent testing by NASA shows a reduction in LiOH activity level after a three-year shelf-life (7), raising questions about the importance of storage methods and how the age of the chemical affects its performance. This degradation in chemical performance is generally attributed to moisture absorption from atmospheric air. For this study, wet versus dry LiOH performance was compared. "Wet" LiOH has been stored for two years in the harsh environment of the Coastal Laboratory (temperatures range between 60 to 80 degrees F; humidity approaches 100%) in its original packing; however, the plastic bag containing the LiOH was simply folded, not bound, thus allowing the chemical to absorb large amounts of excess water from the atmosphere and exist in its monohydrate equilibrium phase (see Figure 8). "Dry" signifies LiOH that has been baked in the laboratory oven for at least four hours at 180 degrees F, the baseline for all testing.

2. FLOW RATE

Because the diver's breathing rate and tidal volume vary with his activity level, testing of three different

flow rates, or respiratory minute volumes (RMV), was conducted: RMV = 6, 12, and 18 SLPM (see Table 2). RMV = 6 SLPM was scaled to the EX 19 flow velocity for a hard-working diver; RMV = 12 was used as the baseline for all other phases.

3. L/D RATIO

The optimal geometry for the chemical bed in CO₂ scrubbers has long been in question: is it better to have a short, wide bed (large diameter) or a long, narrow one (long length) for maximum absorption? The volume of LiOH in the test bed remained constant for all tests: approximately 208 ml. Using two insertable sleeves with spacers, the diameter of the bed was reduced while the length was simultaneously increased. Note that the original canister diameter of 3.75 inches was considered the baseline (see Table 3).

4. CO₂ INJECTION LEVEL

Different diving rigs have different CO₂ levels present in the circulating gas. In a closed circuit rig, no air is added or allowed to escape from the circuit; thus, the gas entering the scrubber has the CO₂ content found in exhaled human breath. In contrast, the circulating gas of a semi-closed diving rig is

continually supplemented by a fresh gas supply, reducing the CO₂ level at scrubber entry to 1%. The carbon dioxide injection levels used were 4, 2, and 1%.

4% represents the CO₂ level in exhaled human breath, 1%, the level in semi-closed rigs, such as the U.S. Navy's Mk 12 Surface Supplied Diving System, and 2 % was chosen as a midpoint between the two.

5. AMBIENT TEMPERATURE

In practice, LiOH scrubbers have shown no decline in performance due to low ambient temperatures. To simulate a change in ambient temperature due to the colder water at depth, the hot plate temperature was varied. Baseline tests used the hot plate to heat the humidifier to about 100 deg. F, representative of body temperature. Other runs did not employ the hot plate; therefore, the humidifier temperature and the canister inlet temperature were simply equal to room temperature, 65 deg. F.

6. REJUVENATION

The phenomenon of rejuvenation is the ability of a previously expended canister (meaning the effluent CO₂ level in the canister has reached 0.5%) to absorb an additional amount of CO₂ after sitting unused for a particular period of time. The rejuvenation capabilities of calcium hydroxide, Ca(OH)₂, were studied at the Naval Coastal Systems Center in Panama City, Florida. For this

study, the potential of rejuvenation to increase LiOH canister utilization was explored. The canister was run to breakthrough, 0.5 % effluent CO₂ level, stored in a sealed plastic tub, allowed to sit for about 18 hours overnight, then run to breakthrough again the next day.

7. PREBREATHING

NASA found that the initial respiration of a canister at a low RMV increased its useful life (6). This phenomenon was tested by running the canister at RMV = 6 SLPM for one hour, then increasing the flow rate to RMV = 12 SLPM for the remainder of the experimental run. A comparison of these results was made with experimental runs using a constant flow rate of 12 liter/minute to assess the benefits of this procedure.

PARAMETERS MEASURED

For each experimental run of the closed circuit mock-up, the following measurements were recorded either by hand or by strip chart (see Appendix B):

1. Ambient temperature and pressure at commencement of each test
2. Initial and final CO₂ injection levels
3. Initial (wet), baked (dry), and final weights of LiOH bed
4. Time of canister breakthrough (0.5% CO₂ effluent), as well as the time at which 1% CO₂ effluent is reached
5. Temperature of the humidifier (T1), central outlet temperature of the LiOH bed (T2), inlet plenum temperature of the canister (T3), outlet plenum temperature (T4), and, for L/D ratios #2 and #3 only, edge outlet temperature of the LiOH bed (T5) at five-minute intervals, until reaching 1.0% CO₂ effluent

RESULTS

The testing was conducted in six phases for a total of 27 successfully completed runs. Temperature data were taken by hand as carbon dioxide level was recorded on the strip chart (see Appendix B) for each test point. After the completion of two tests per set of conditions, the TBL and efficiency were calculated. When deviations in excess of 10% were recorded between runs having identical conditions, a third test run was performed, and the three were averaged. For flow rate, L/D ratio, and CO₂ injection level, the parameter in question was plotted versus canister efficiency and percent weight increase of the LiOH bed. As expected, there was no significant variation due to reduction in ambient temperature. Rejuvenation and prebreathing tests will be discussed in terms of their potential for canister utilization increase.

DISCUSSION

Phase 1: In phase 1 testing, the RMV was varied for both wet and dry LiOH, exploring the effects of initial moisture content, as well as gas flow rate, on chemical absorption efficiency. The bar chart shown in Figure 9 illustrates the level of excess moisture present in the LiOH canisters prior to baking due to the harsh storage environment. During initial testing (RMV = 6 SLPM), the levels of moisture were extremely high, approaching 30% of the unbaked LiOH weight. Because testing was conducted in order of increasing flow rate, moisture had a greater detrimental effect on the lower RMV rates. For RMV = 6 SLPM, corresponding to a gas dwell time of 1.8 seconds, the wet runs show a marked decrease in peak temperature of reaction from the dry runs, but these temperatures do attain a consistent level corresponding to initial moisture content (see Figure 10). Breakthrough temperatures were consistent for both wet and dry runs, about 110 degrees F and 175 degrees F, respectively. This consistency in temperature level suggests that there is a relationship between initial moisture content and reduction in reaction temperature. Before using the LiOH, weigh and determine amount of moisture present by taking the weight difference of

actual and expected weight based on LiOH density. If the relationship between moisture and peak temperature is indeed related, the reduction in temperature based on initial moisture content can be predicted.

For RMV = 12 SLPM, corresponding to a dwell time of 0.9 seconds, the initial moisture was reduced to about 10 - 15 grams of water and the testing was found to be repeatable. While for RMV = 6 SLPM the overall efficiency of the wet canister was reduced, RMV = 12 SLPM showed an increased canister duration with efficiencies of the wet LiOH of 57.3% as compared to efficiencies of dry LiOH of 40.7%. Despite an initial effluent CO₂ level over 0%, the wet LiOH canister duration was improved over the dry LiOH and even lasted longer than the dry LiOH from 0.5% to 1.0% effluent CO₂ (5 minutes for dry; 15 minutes for wet). The reasons for this increase in performance may be because the wet LiOH falls into the optimum equilibrium monohydrate range according to Boryta's testing (2) (see Figure 8). Since the formation of lithium carbonate is actually the net of two reactions, the first step is the hydration of LiOH. Pre-hydrating to a lesser degree may aide in moderating, slowing, and drawing out the violent reaction between CO₂ and LiOH, actually allowing it to occur more completely. Note that the peak temperature is again reduced for the

wet chemical (see Figures 11 and 12) and that peak has not yet been reached when breakthrough occurs.

For RMV = 18 SLPM, corresponding to a dwell time of 0.6 seconds, both efficiency and weight gain are approximately the same for wet and dry LiOH. Note that neither dry nor wet LiOH reactions start on 0% CO₂ effluent; however, the wet again lasts longer from 0.5% to 1.0% CO₂, wet having a duration of 15 minutes versus a 3-minute duration for dry. Again the wet bed temperature is still climbing as breakthrough occurs.

In general, the efficiency and percent weight increase of the canister increases with the increase of canister dwell time, also called residence time (see Figures 13 and 14), and the bed temperature profiles for dry LiOH tests follow a consistent pattern (see Figure 15), experiencing a drop in bed temperature just prior to breakthrough. This temperature drop represents the diminishing of the reaction in the bed, and was found to be an excellent, dependable predictor of breakthrough.

Phase 2: For the testing in phase 2, the geometry of the canister was varied to keep a constant volume of 208 milliliters. Results of the changing geometry did not follow a trend; in fact, the efficiency rose slightly, then appeared to drop off again as dwell time and bed

length increased (see Figure 16). As for the percent weight gain experienced by the different L/D runs, L/D #1 and #3 gained practically the same amount on average, while L/D #2 gained 3% less than the other two (see Figure 17). From this series it can be concluded that neither of the extremes in geometry, either large diameter or long length, are beneficial to CO₂ absorption and that a midpoint between the two configurations, such as L/D #2, is preferable for increasing efficiency.

Additionally, L/D #2 testing was attempted for both wet and dry LiOH at RMV = 6 SLPM; however, the time of breakthrough exceeded TBL making the results theoretically unsound and completely inconclusive with regards to efficiency. One interesting result of these experiments was the generation of reaction front profiles for both wet and dry runs (see Figures 18 and 19). Four thermocouples were positioned one each at the edge and center of both the inlet and outlet of the LiOH bed (see Figure 20). From figure 18, the wave of chemical reaction taking place in the bed can be seen. For dry LiOH, the reaction progresses from the inlet of the bed towards the outlet, with edge temperatures peaking at the same time as the central temperatures but to a lesser degree due in part to the heat loss through the canister wall. For the wet LiOH (see Figure 19), the central

outlet temperature is still climbing when breakthrough occurs (time = 248 minutes), while for the dry runs, the drop in central outlet temperature signals imminent breakthrough.

Phase 3: For the phase 3 testing of different carbon dioxide injection levels, the results did follow some expected trends: (1), the weight gain increased linearly with decreasing percent CO₂ injection (see Figure 21); and (2), the peak outlet temperature profile once again confirms the onset of breakthrough (see Figure 22). However, as the CO₂ percentage in the gas flow decreases, the time lapse between peak temperature and breakthrough increases in duration. Canister efficiencies were seen to increase as CO₂ level decreased, but the gain was seen to stop and may even have been slightly reversed between 1% and 2% injection (see Figure 23). However, this trend is not considered statistically significant since the efficiency levels of 1% and 2% differ by only 3%. Thus, it may be assumed that the optimum CO₂ injection level was reached at about 2% and was not improved any farther in this testing. Furthermore, a proven trend can be shown between CO₂ injection level and peak reaction temperature, with temperature increasing as % CO₂ loading increases (see Figure 24).

Phase 4: As for the phase 4 testing of ambient temperature, no significant deviation from the baseline runs developed, echoing LiOH performance in practical applications and lending validity to this study (see Figure 25). Weight gains and efficiencies were consistent across the range of temperatures tested, while the only difference in temperature profile was a peak of approximately 200 degrees F for 65 deg. F ambient vice the typical 214 degrees F for 100 deg. F ambient. The peak temperature continued to occur immediately preceding the breakthrough.

Phase 5: The rejuvenation potential of LiOH was studied in phase 5. On day #1, 50% of the LiOH bed was utilized, and, after an overnight rejuvenation period of 18 hours, an additional 10% of the LiOH's theoretical potential was realized (see Figure 26). These positive results mean that expended LiOH canisters could be re-used for a brief period in emergency situations, adding a margin of safety to diving operations. However, the Day 2 temperature profiles do not show a temperature drop prior to breakthrough (see Appendix B, pp. 124-129). Like wet LiOH, the temperature continues to increase. Note also the increased efficiency of day 1 testing as compared to

baseline RMV = 12 SLPM tests and 65 degrees F ambient tests (efficiencies in both cases were around 40%). The improvement in efficiency is due to reduced CO₂ injection levels for rejuvenation testing of 3.4%, permitting a slower and more complete reaction. It is important to consider that the flow rate used in rejuvenation series was RMV = 12 SLPM, double the RMV = 6 SLPM that was scaled to the EX 19 flow for a hard-working diver. To further explore the potentials of rejuvenation, more realistic flow rates should be employed, the slower speeds allowing a more complete reaction to occur during the first run and probably decreasing the rejuvenation potential of the chemical. Fortunately, there will always be some potential for rejuvenation because the excess water film that builds up and inhibits the reaction will have dissipated.

Phase 6: NASA's study of canister prebreathing showed an increase in the attainable LiOH canister efficiency (6). In this study, the canister was prebreathed for an hour prior to testing and showed an improved utilization over both wet and dry runs for RMV = 12 SLPM, but less than rejuvenation's total utilization (see Figure 27). However, it must be understood that the prebreathing rate used, RMV = 6 SLPM, was scaled to an EX 19 endurance flow

rate, not the resting rate that NASA used in its study. Furthermore, the percent chemical utilized during the prebreathing stage was added to the utilization calculated for the remainder of the test run at RMV = 12 SLPM. Logically, prebreathing is a low resting RMV that should improve the canister efficiency by pre-hydrating the LiOH bed and moderating the violent chemical reaction similar to the effect of the excess initial moisture content seen in wet RMV = 12 SLPM testing.

CONCLUSIONS

In conclusion, the objective of this study, a look at the effects of parameter variation for the express purpose of better lithium hydroxide characterization and improved understanding of the absorption process, was successfully accomplished, discussed, and documented in detail. The only remaining result of importance is the emergence of temperature as an excellent predictor of breakthrough, as long as the LiOH has been stored properly and carefully to guard against excess moisture absorption. As seen in all phases of dry LiOH testing, the peak temperature of reaction occurred just prior to LiOH bed breakthrough, illustrating repeatedly that this temperature drop could be used as a dependable means to anticipate and prevent CO₂ poisoning of the diver. However, if the LiOH is initially moist, this temperature-drop principle can no longer be applied, because the temperature continues to increase after breakthrough has occurred. Excess moisture level can easily be detected by comparing a known volume's weight with the LiOH density. Partially used canisters, like those studied during day 2 of rejuvenation testing, fall into the excess initial moisture content category and defy the rule. Therefore, for anything other than dry

LiOH, this method of prediction may not work and could result in poor canister performance.

TABLE 1

STRIP CHART VALUE----->	CO ₂ PERCENTAGE
100 ----->	6
86 ----->	5
83 ----->	4.75
79 ----->	4.5
75 ----->	4.25
71 ----->	4
68 ----->	3.75
65 ----->	3.5
62 ----->	3.25
58 ----->	3
44 ----->	2
40 ----->	1.75
36 ----->	1.5
32 ----->	1.25
28 ----->	1
15 ----->	.5

TABLE 2

----FLOW RATE VARIATION----

RMV (SLPM)	TV (l/br)	RR (br/min)
6	.5	12
12	.75	16
18	1	18

TABLE 3

----L/D RATIO VARIATION----

L (in)	D (in)	A (sq in)
1	3.75	11.04
1.675	3	7.07
3.75	2	3.14

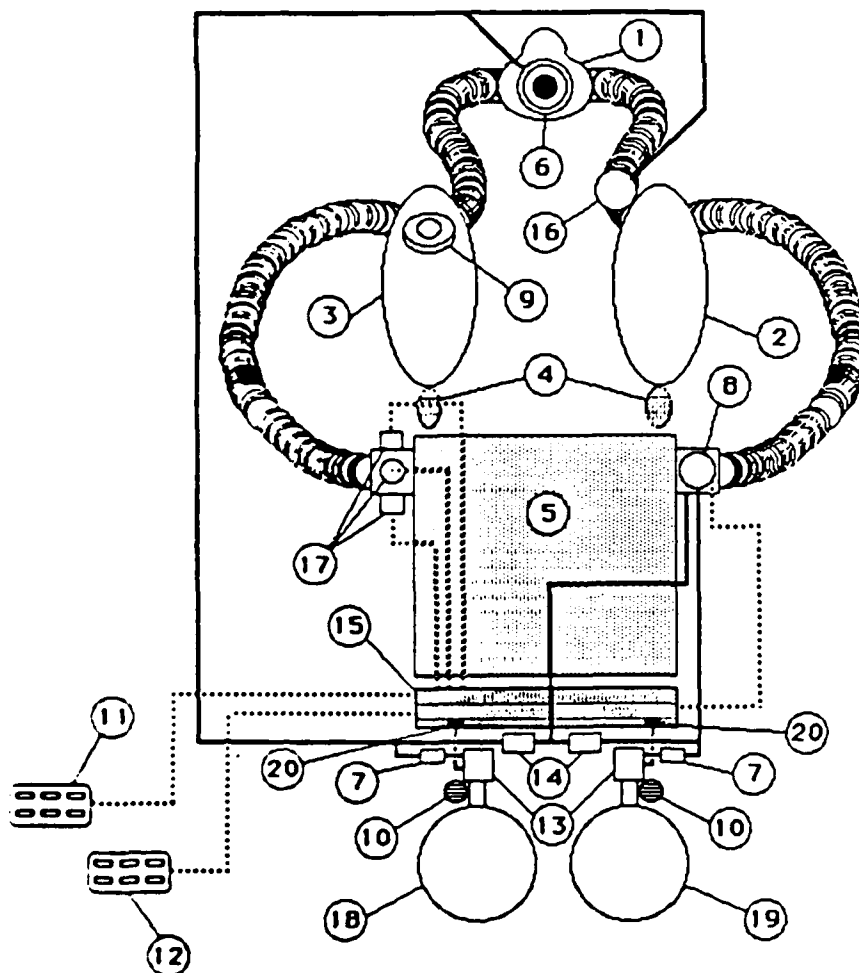
TABLE 4: SUMMARY OF TESTING

TEST DESIGN	INSTRUMENT SLIP	L/D RATIO	F (GPa) MPa	F/F _{0.2}	F/F _{0.05}	T (hrs)	T (hrs)	EFF	ft	ft	ft	ft
1	1	5	.2667	.0358	100	3.13	1.55	43.52	.0461	1.808	11.65	
		6	.2667	.0325	100	3.45	3.3	95.55	.0461	1.808	24.11	
		5	.2667	.035	100	3.2	2.58	60.63	.0461	1.808	17.62	
		4	.2667	.04	100	1.46	.893	57.05	.0922	.904	23.34	
		5	.2667	.0405	100	1.44	.825	57.29	.0922	.904	26.46	
		6	.2667	.04	100	.97	.283	29.18	.1383	.6026	14.1	
		13	.2667	.04	100	.97	.317	32.58	.1383	.6026	14.71	
		6	.2667	.0375	100	2.93	2.8	93.55	.0461	1.808	39.53	
		6	.2667	.0365	100	3.07	2.65	92.85	.0461	1.808	42.15	
		10	.2667	.0425	100	1.37	.567	41.39	.0922	.904	28.01	
		12	.2667	.0425	100	1.38	.55	39.86	.0922	.904	21.73	
		13	.2667	.04	100	.97	.283	29.18	.1383	.6026	19.93	
		13	.2667	.0419	100	.927	.275	29.67	.1383	.6026	20.23	
2	1	13	.5417	.0435	100	1.34	.612	45.67	.144	.9401	31.51	
		13	.5417	.0435	100	1.34	.606	45.37	.144	.9401	31.94	
		3	1.875	.04	100	1.45	.625	43.10	.324	.9642	26.18	
		4	1.875	.0403	100	1.45	.657	46	.324	.9642	24.23	
		12	.2667	.02	100	2.9	1.68	57.93	.0922	.904	40.65	
		12	.2667	.0105	100	3.14	1.92	61.19	.0922	.904	41.13	
		3	.2667	.011	100	5.29	3.08	58.22	.0922	.904	43.14	
		4	.2667	.0103	100	5.67	3.21	56.61	.0922	.904	47.75	
4	1	12	.2667	.0403	65	1.445	.608	42.08	.0922	.904	23.14	
		12	.2667	.0398	65	1.463	.558	38.14	.0922	.904	22.18	

FIGURE 1:

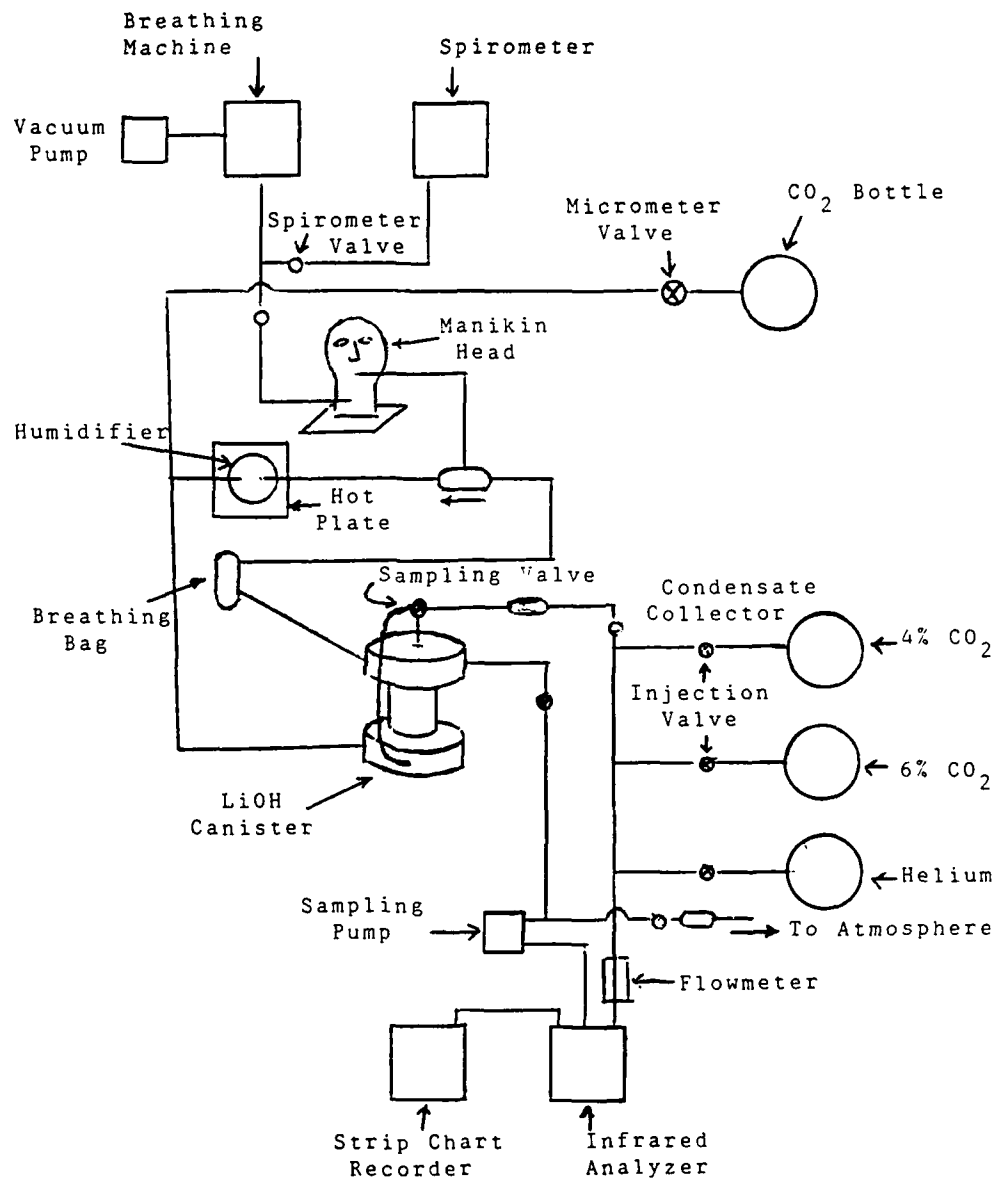
EX 19 MOD 1
SYSTEM SCHEMATIC

47



- | | | |
|-----------------------------|------------------------|--------------------|
| 1 ORAL NASAL | 8. O2 ADD VALVE | 15. IES |
| 2 BREATHING BAG, INHALATION | 9. RELIEF VALVE | 16. DILUENT ADD |
| 3 BREATHING BAG, EXHALATION | 10. SHUTOFF VALVE | 17. O2 SENSORS |
| 4 WATER REMOVAL SYSTEM | 11. PRIMARY DISPLAY | 18. DILUENT BOTTLE |
| 5 CO2 SCRUBBER | 12. SECONDARY DISPLAY | 19. O2 BOTTLE |
| 6 BAIL-OUT REGULATOR | 13. PRESSURE REGULATOR | 20. PRES TRANS |
| 7 FILTER | 14. MANUAL ADD VALVE | |

Figure 2: Schematic of Experimental Set-up



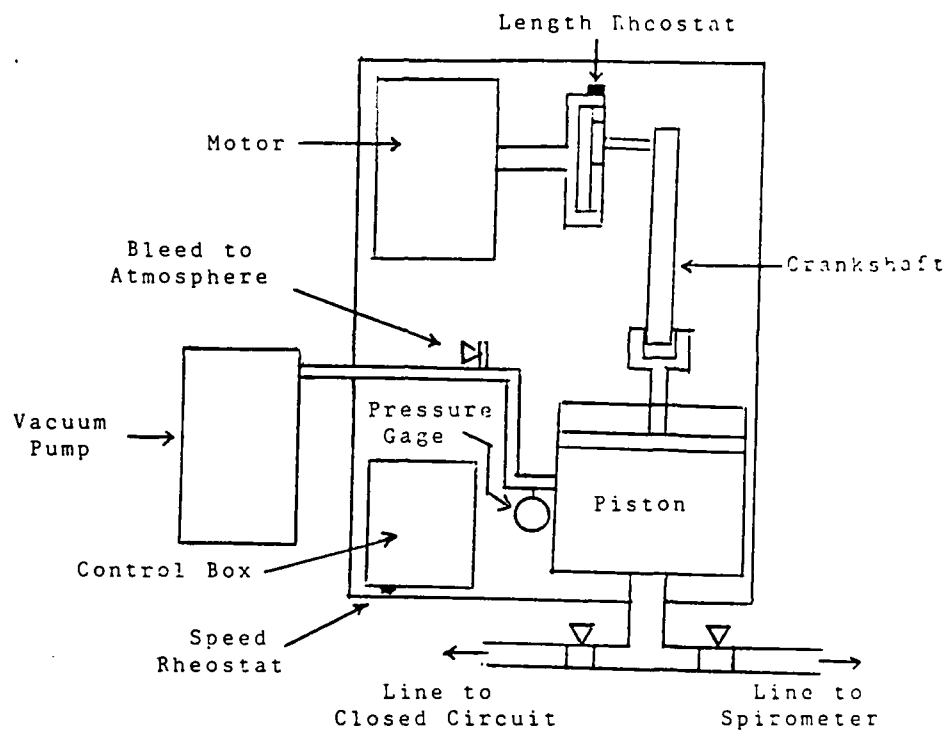


Figure 3: Breathing Machine

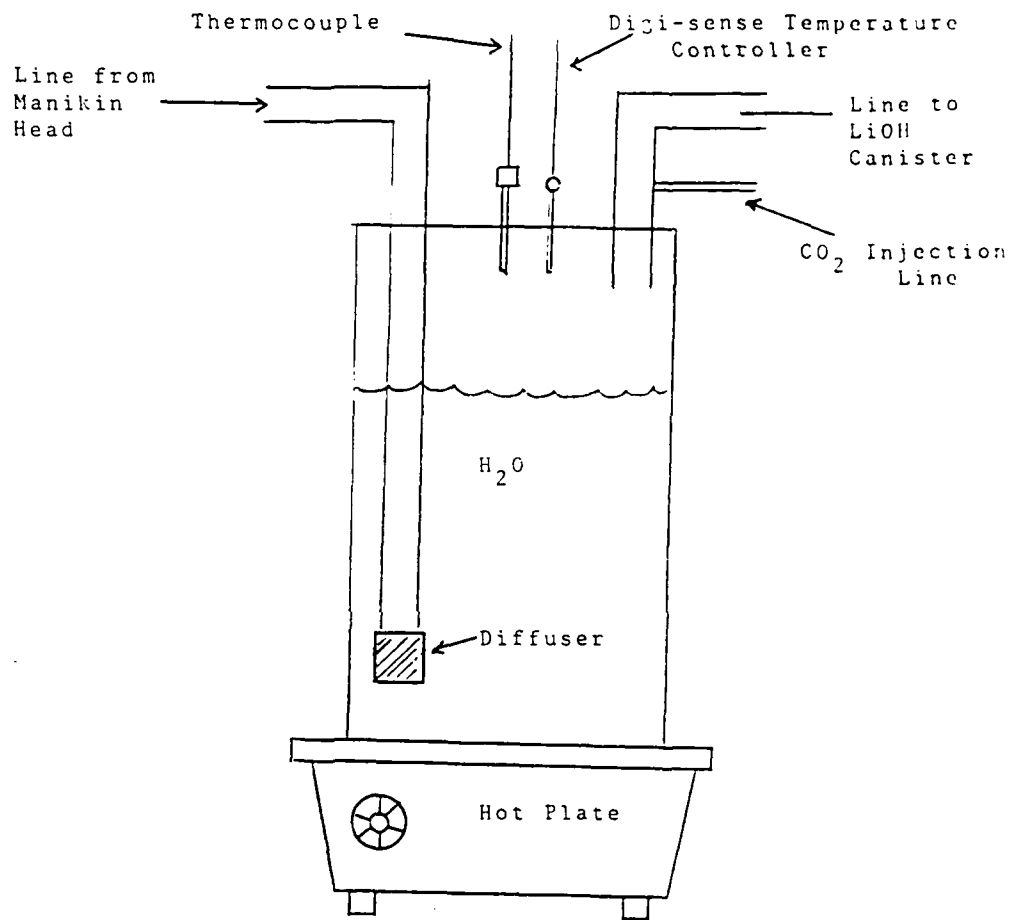


Figure 4: Humidifier

**FIGURE 5: LIOH CANISTER
THERMOCOUPLE LOCATIONS**

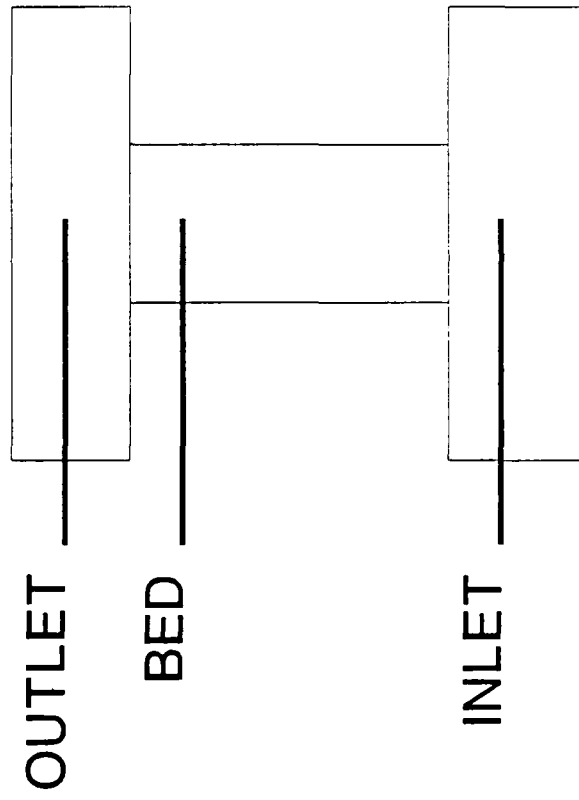
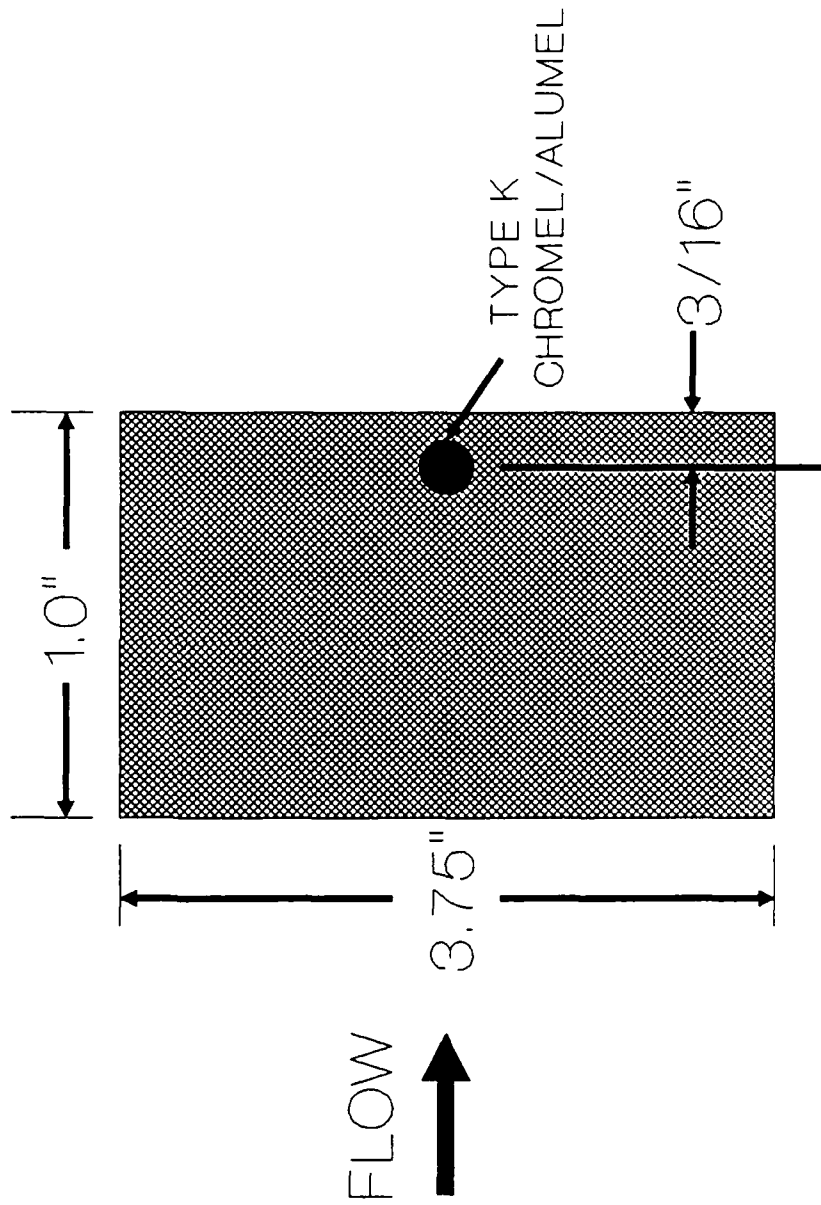


FIGURE 6: LiOH CANISTER
89.5 GM (DRY)



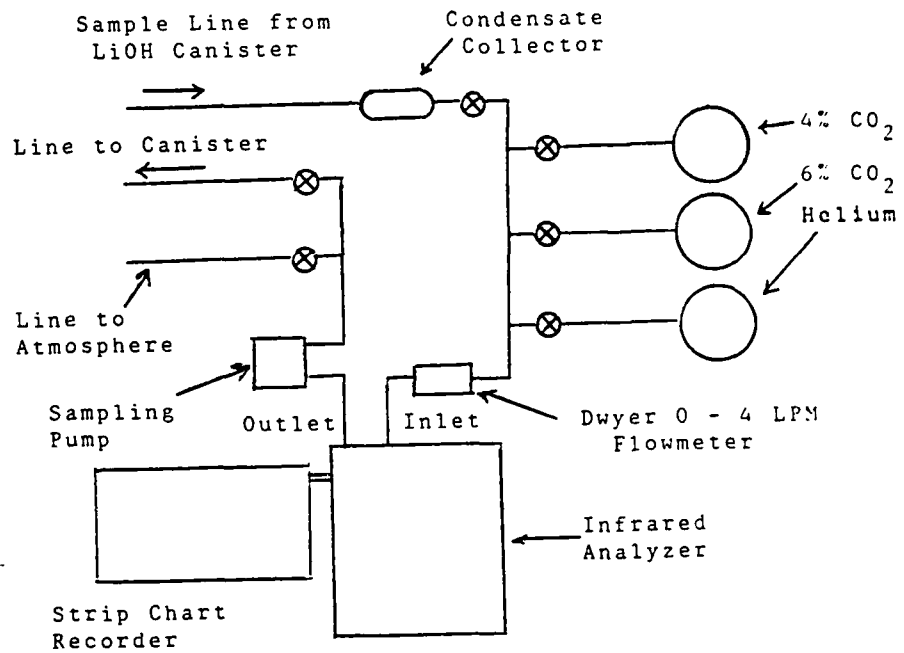


Figure 7: Strip Chart Calibration System

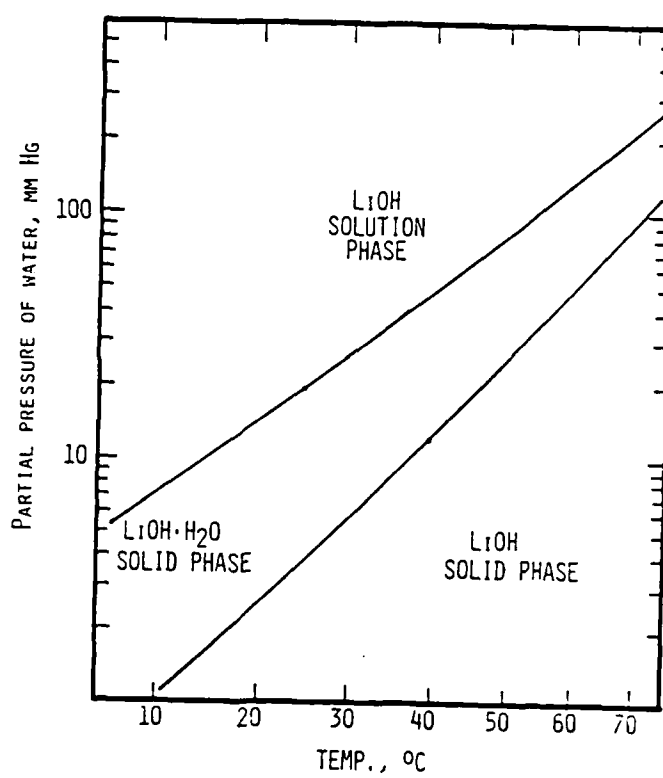
Figure 8: Equilibrium Phases of LiOH With H₂O (2)

FIGURE 9
INITIAL MOISTURE CONTENT OF LiOH

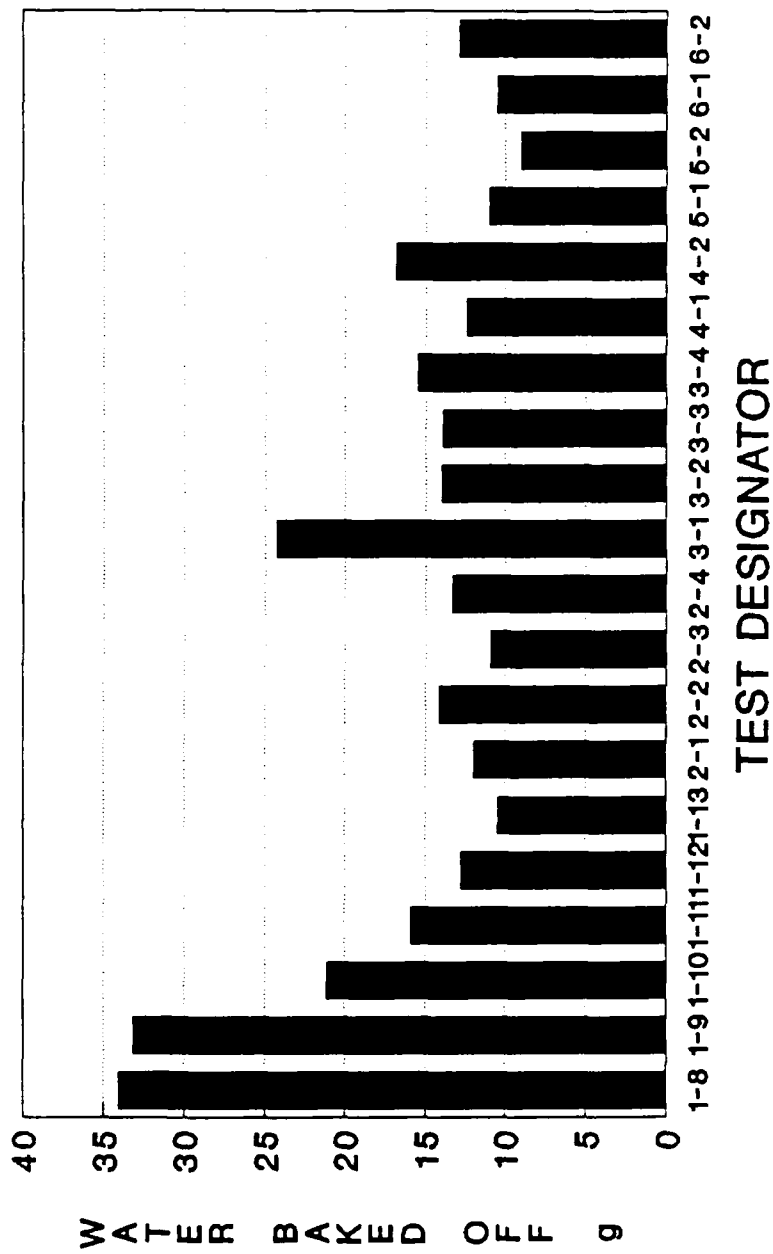
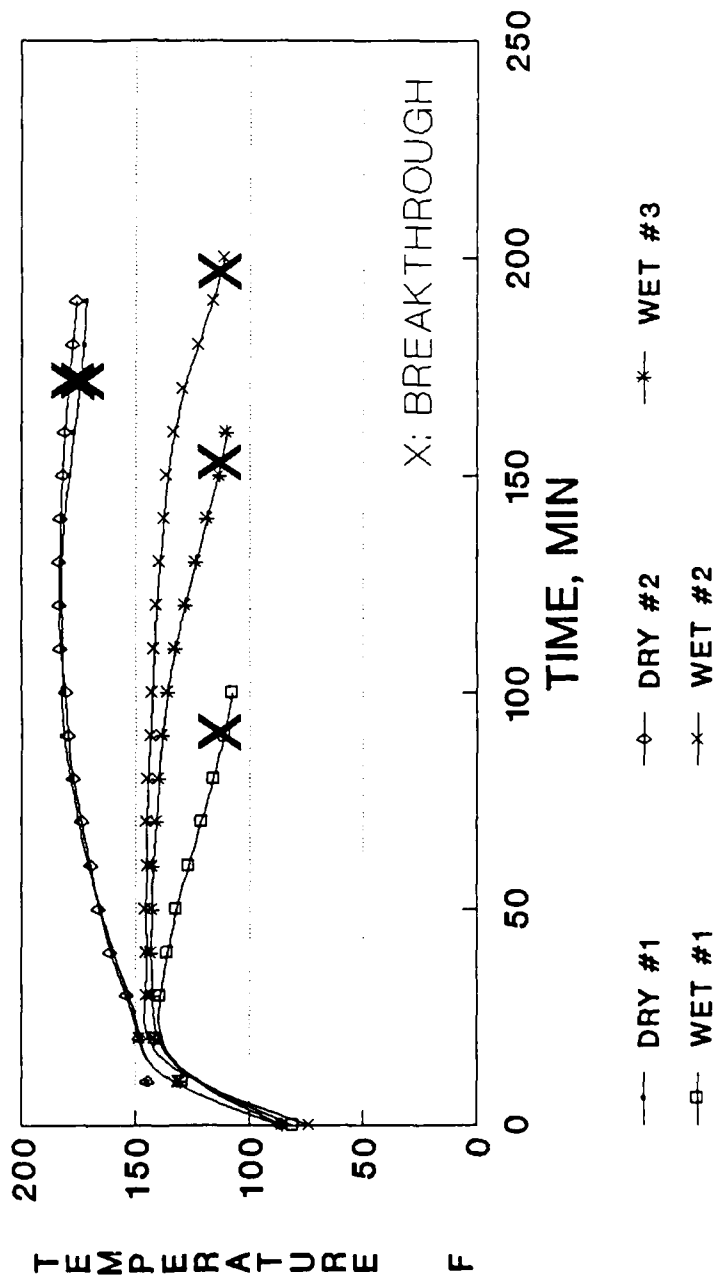
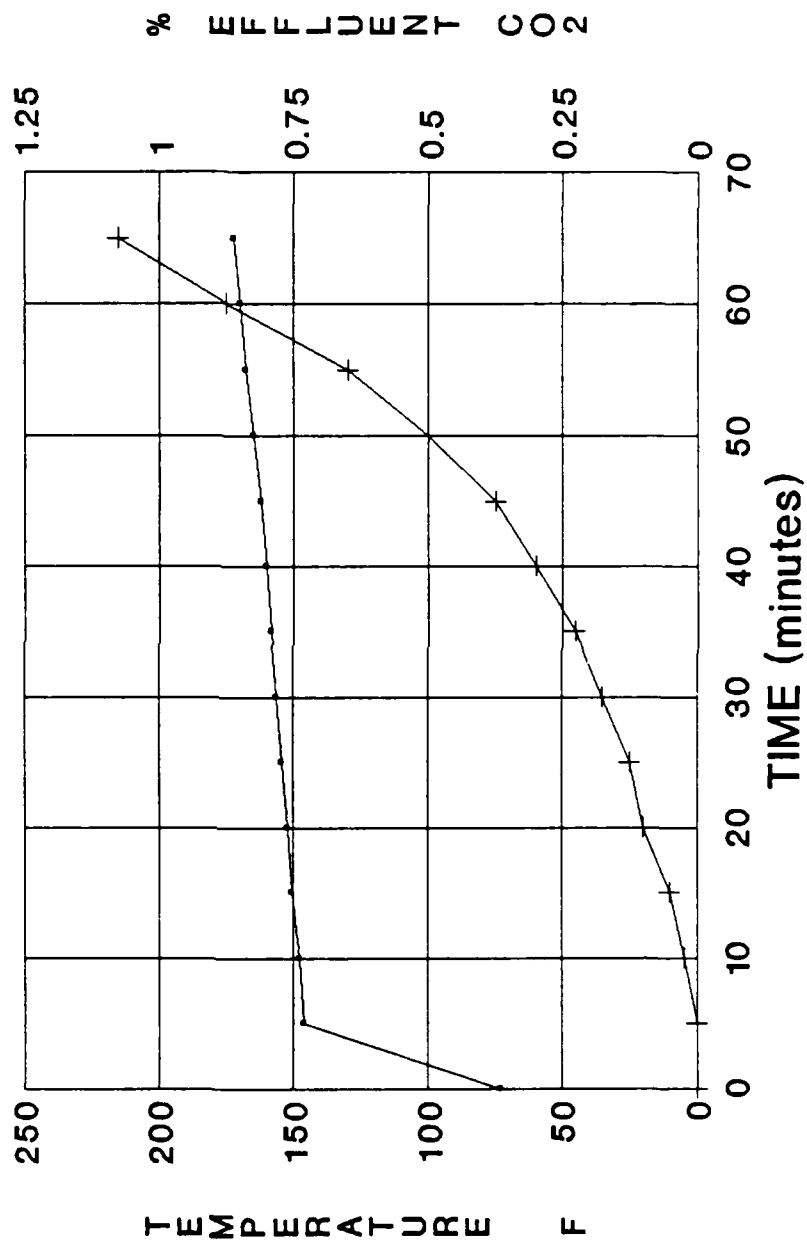


FIGURE 10: LIOH CANISTER TESTING
 BED TEMPERATURE VS TIME



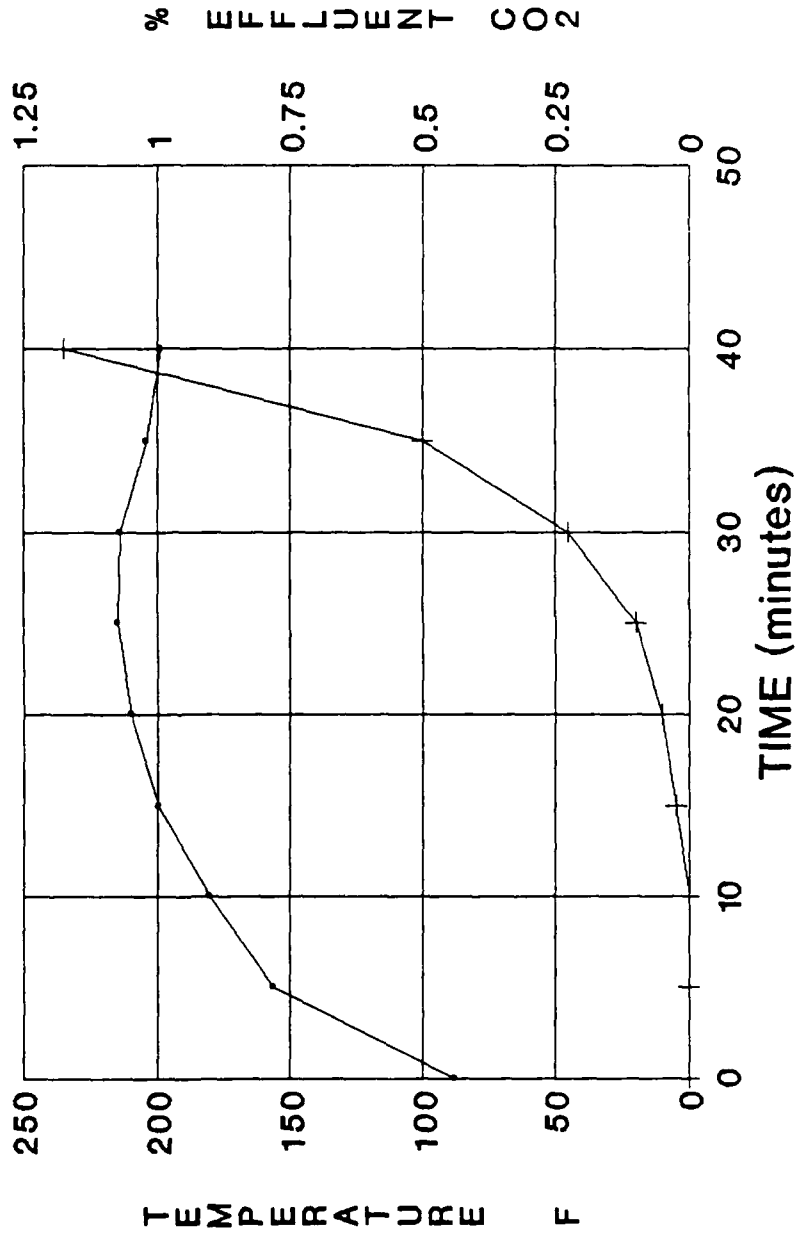
RMV-6 LPM; 3.5% CO2 INJECTION RATE

FIGURE 11: WET BED TEMPERATURE
COMPARED WITH EFFLUENT CO₂ LEVEL



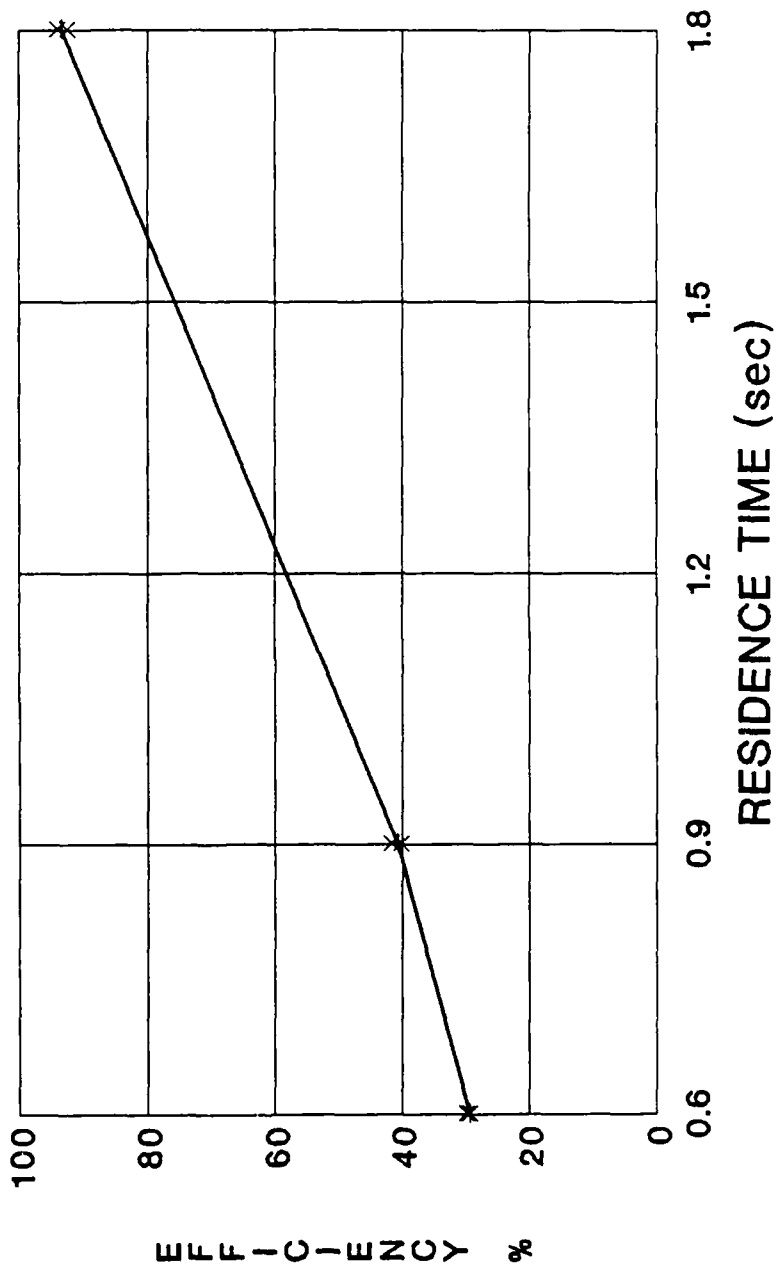
RMV-12; 4.0% CO₂ INJECTION; WET LIOH

FIGURE 12: DRY BED TEMPERATURE COMPARED WITH EFFLUENT CO2 LEVEL



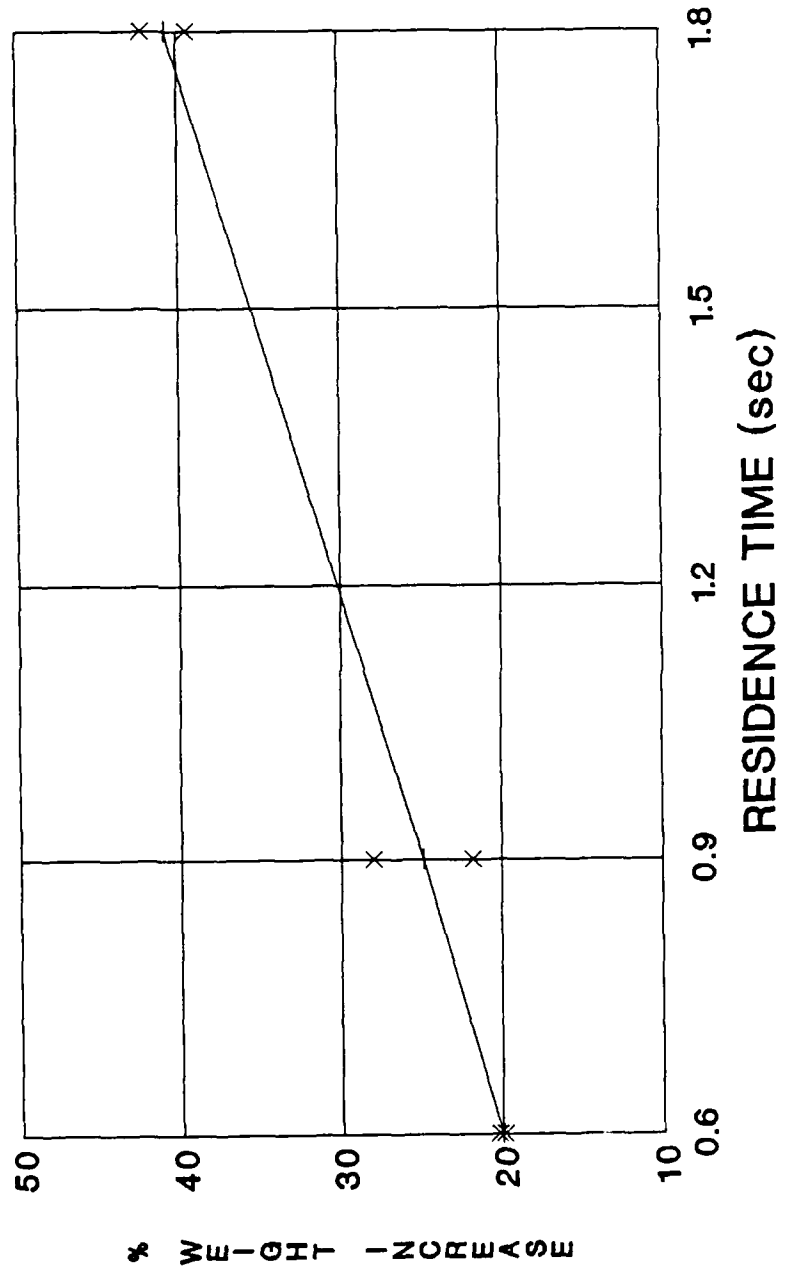
RMV-12; 4.25% CO2 INJECTION; DRY LIOH

**FIGURE 13: EFFECT OF FLOW RATE
ON ABSORPTION EFFICIENCY**



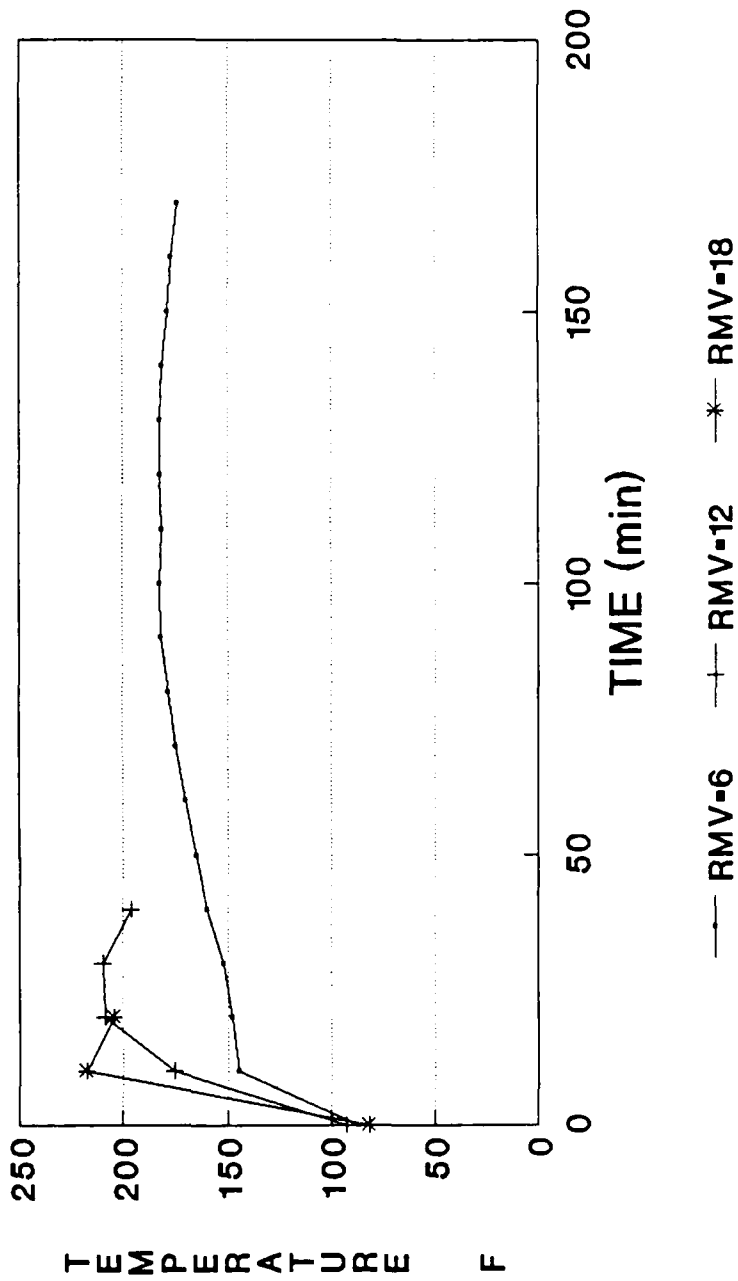
4.0% CO₂ INJECTION; DRY LI₂O

**FIGURE 14: EFFECT OF FLOW RATE
ON CANISTER WEIGHT GAIN**



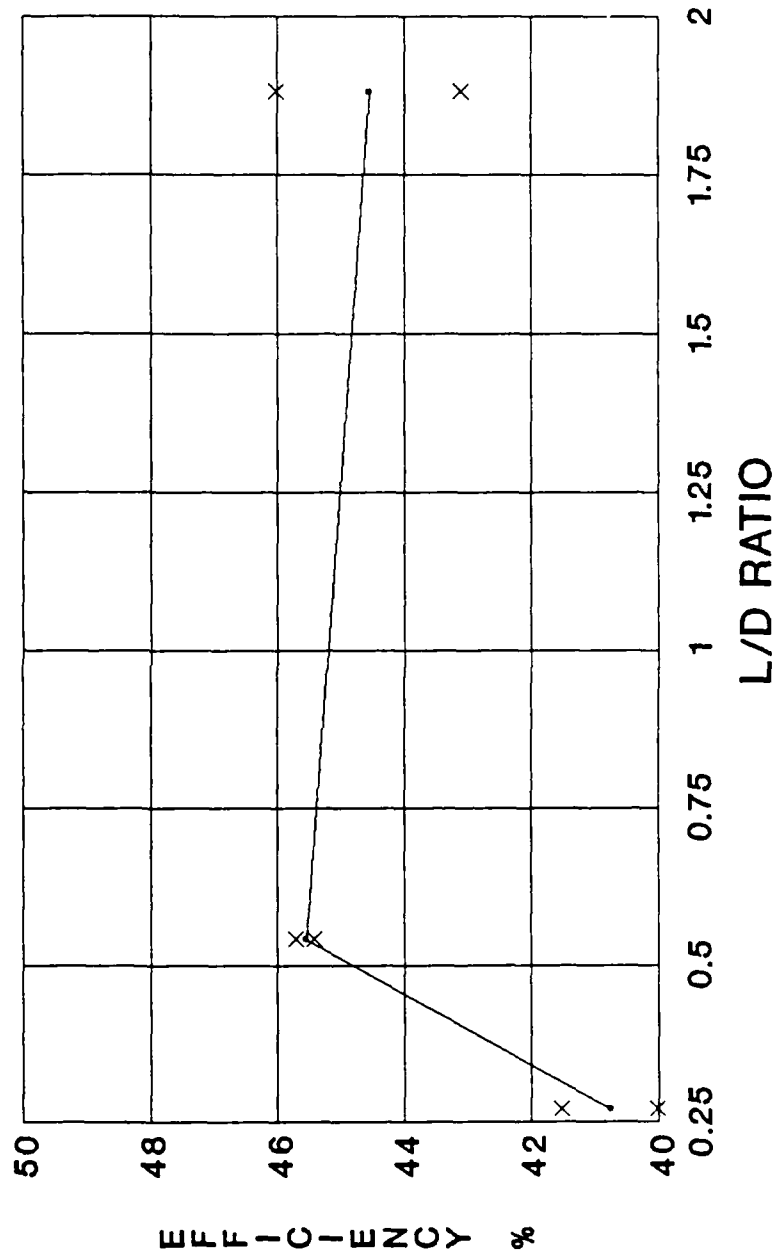
4.0% CO₂ INJECTION; 90 grams DRY LIOH

FIGURE 15: TEMPERATURE PROFILES
RMV VARIATION



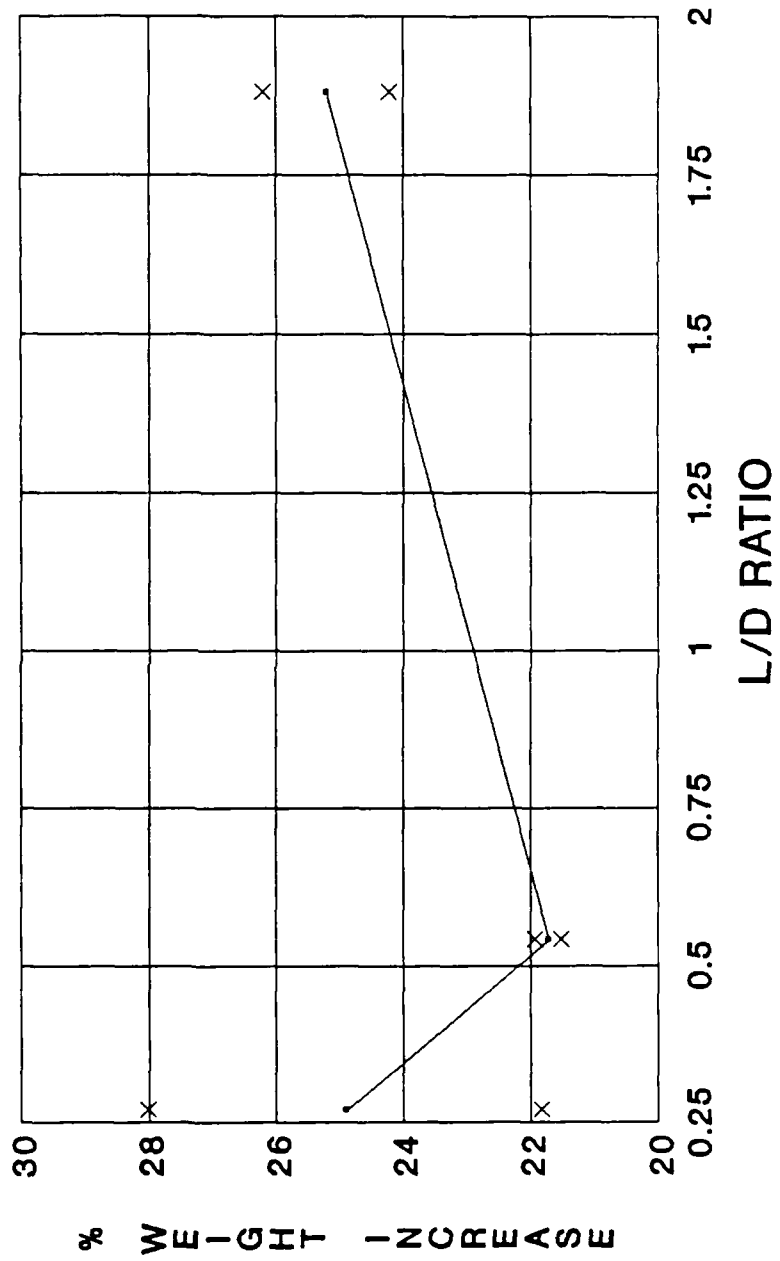
4.0% CO2 INJECTION; DRY LIOH

**FIGURE 16: EFFECT OF L/D RATIO
ON CANISTER EFFICIENCY**



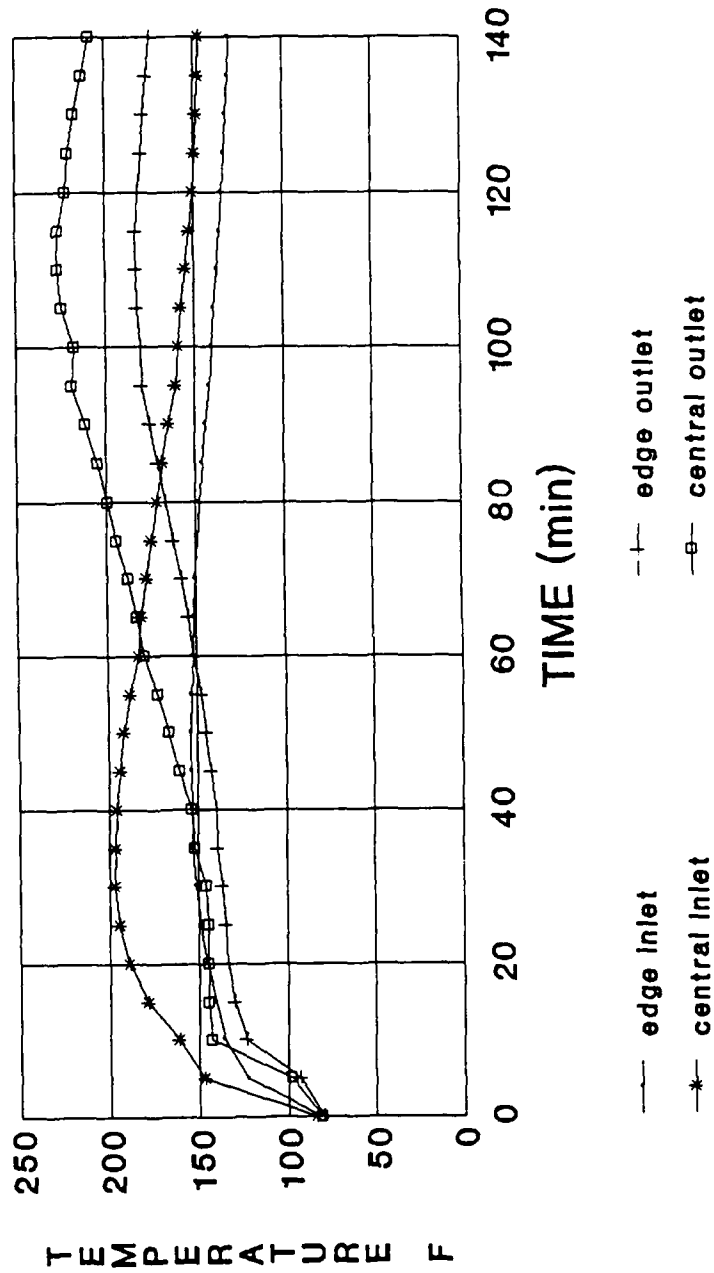
RMV - 12; DRY LIOH

FIGURE 17: EFFECT OF L/D RATIO
ON CANISTER WEIGHT GAIN



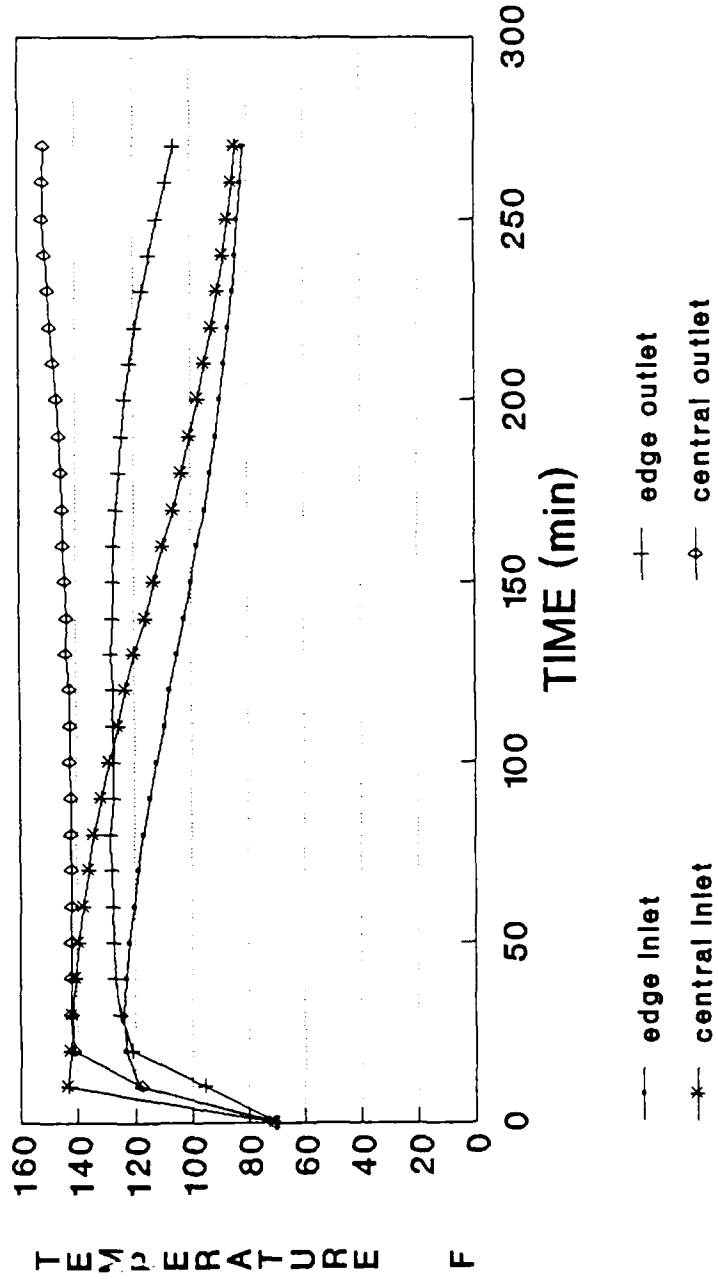
RMV-12; DRY LIOH

FIGURE 18: L/D RATIO #2
 DRY BED TEMPERATURE PROFILE



RMV-6; DRY LIOH; 4.55% CO₂ INJECTION

FIGURE 19: L/D RATIO #2
WET BED TEMPERATURE PROFILE



RMV-6; WET LIOH; 4.0% CO2 INJECTION.

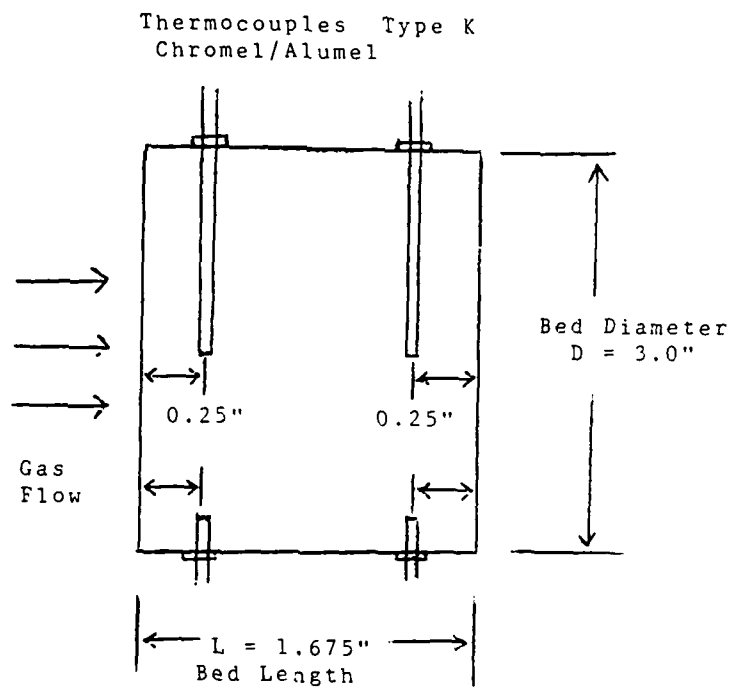
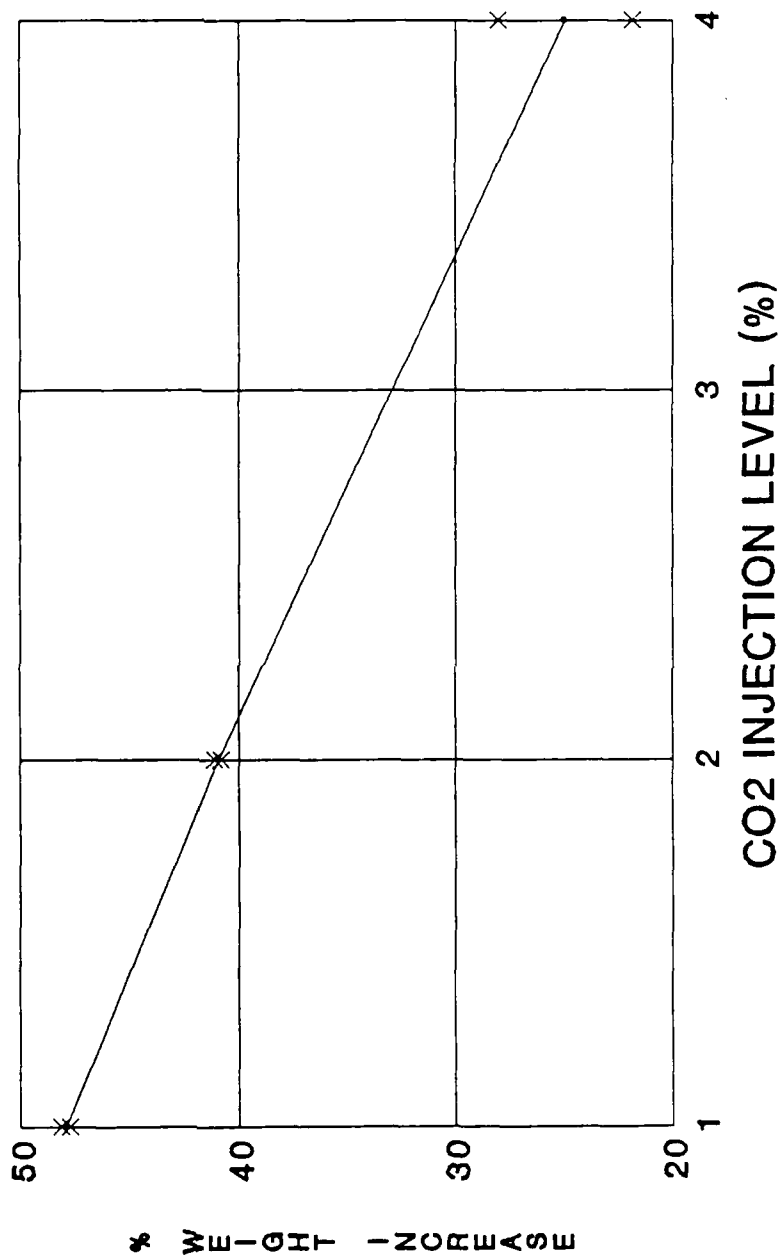


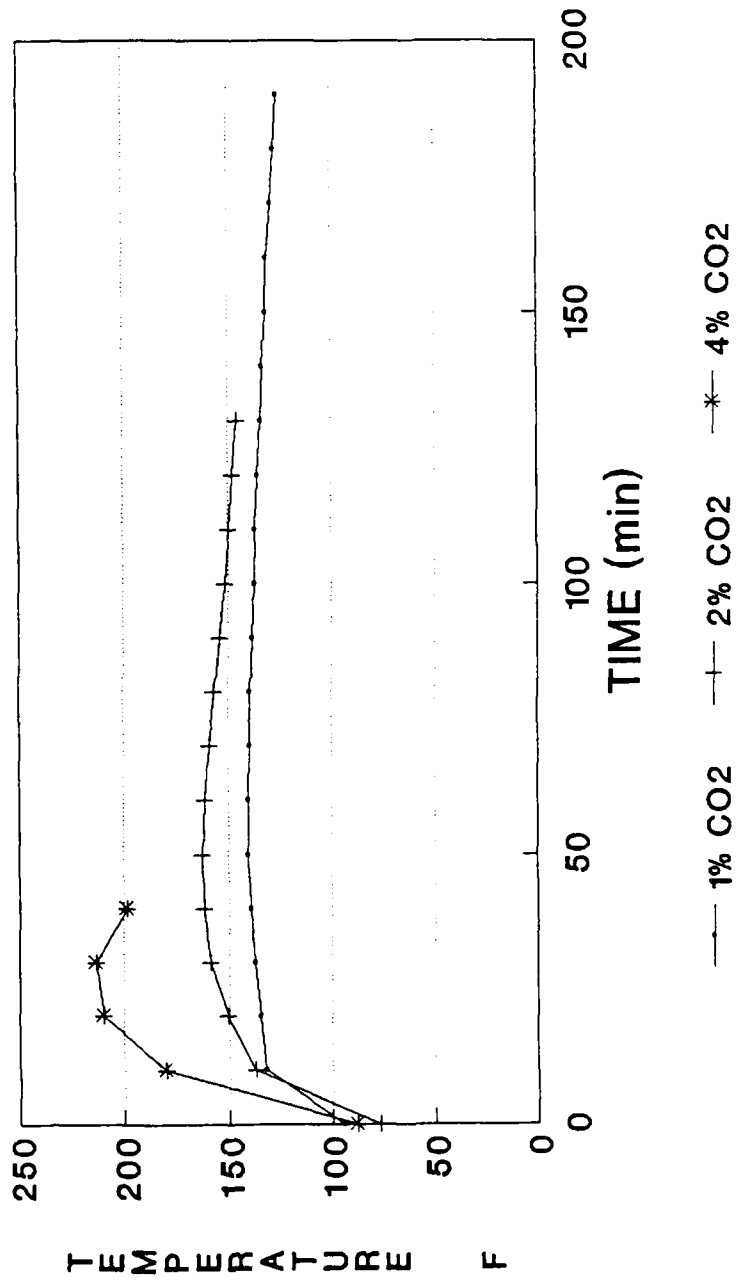
Figure 20: L/D Ratio #2
Bed Dimensions and
Thermocouple Placement

**FIGURE 21: EFFECT OF CO2 LOADING
ON CANISTER WEIGHT GAIN**



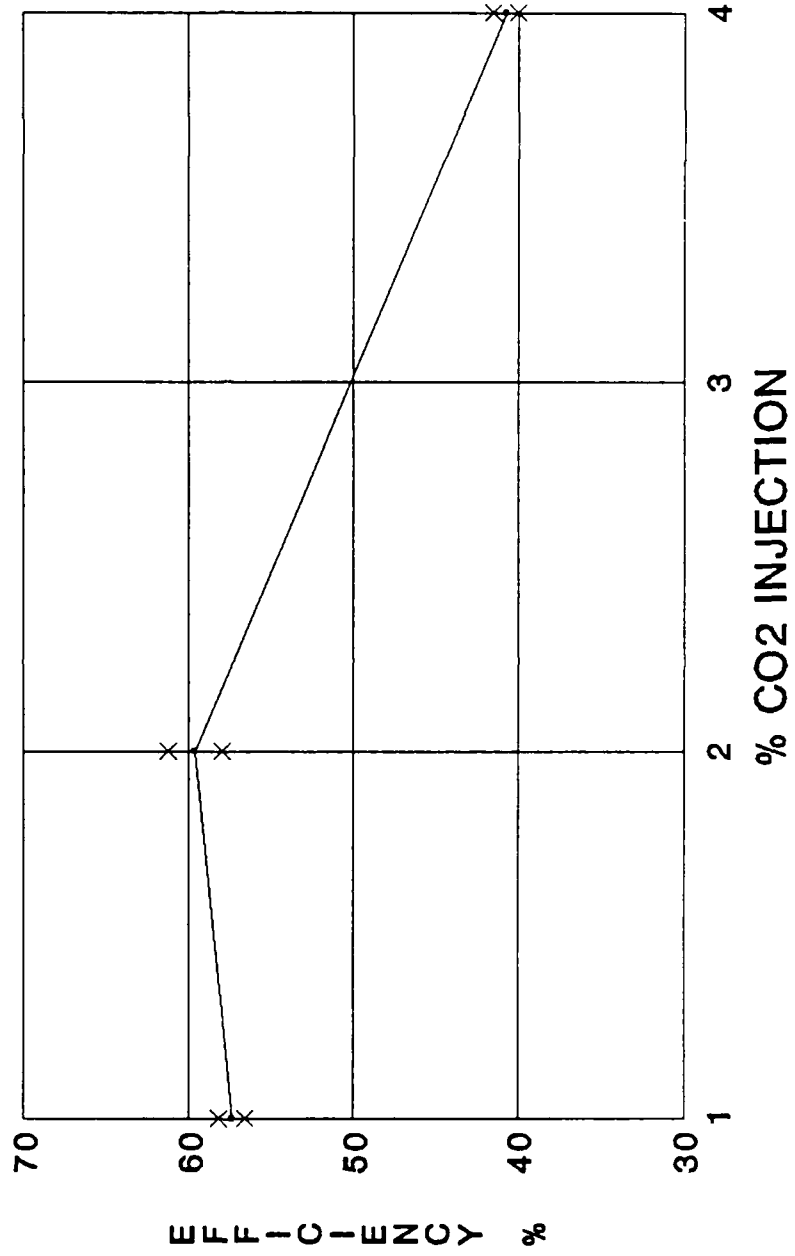
RMV-12; 90 grams DRY LIOH

FIGURE 22: TEMPERATURE PROFILE
CO2 LOADING VARIATION



RMV-12; DRY LIOH

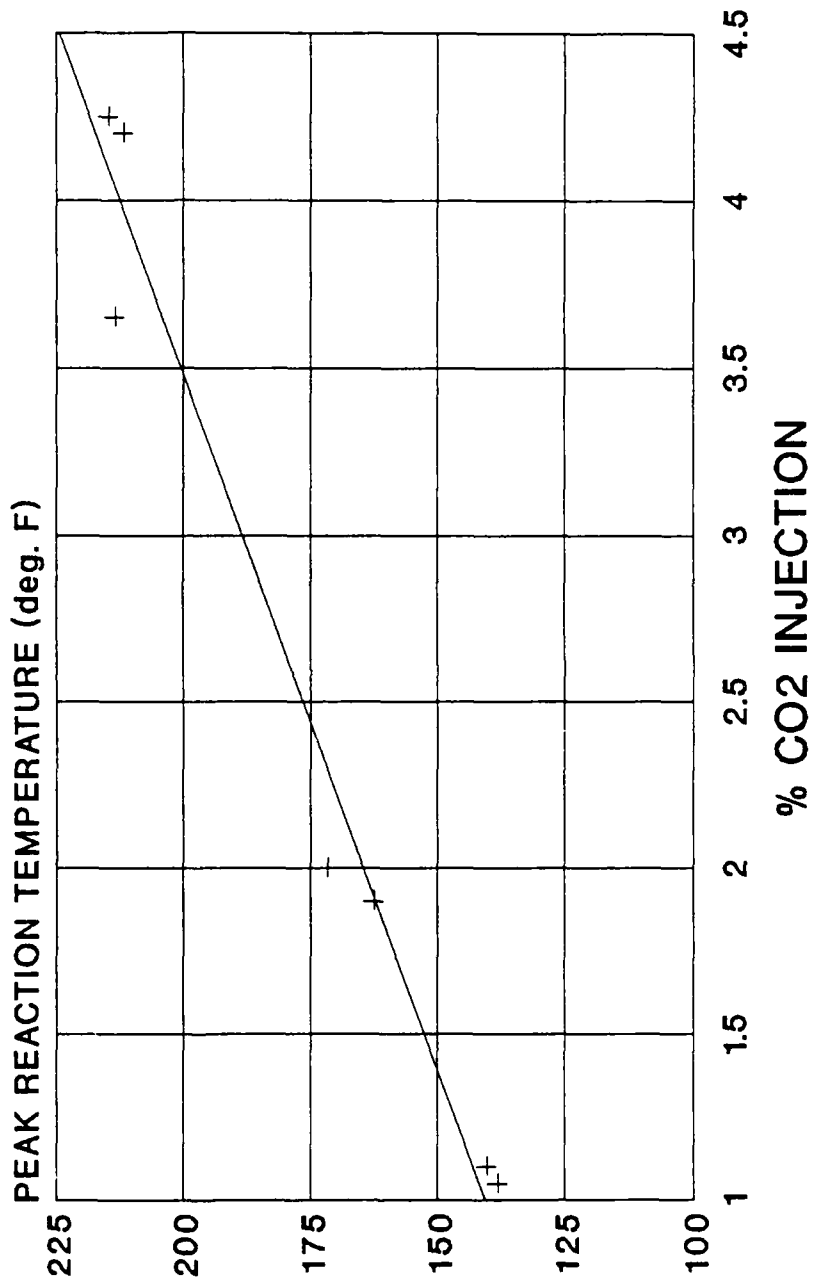
FIGURE 23: EFFECT OF CO2 LOADING
ON ABSORPTION EFFICIENCY



RMV-12; DRY LIOH

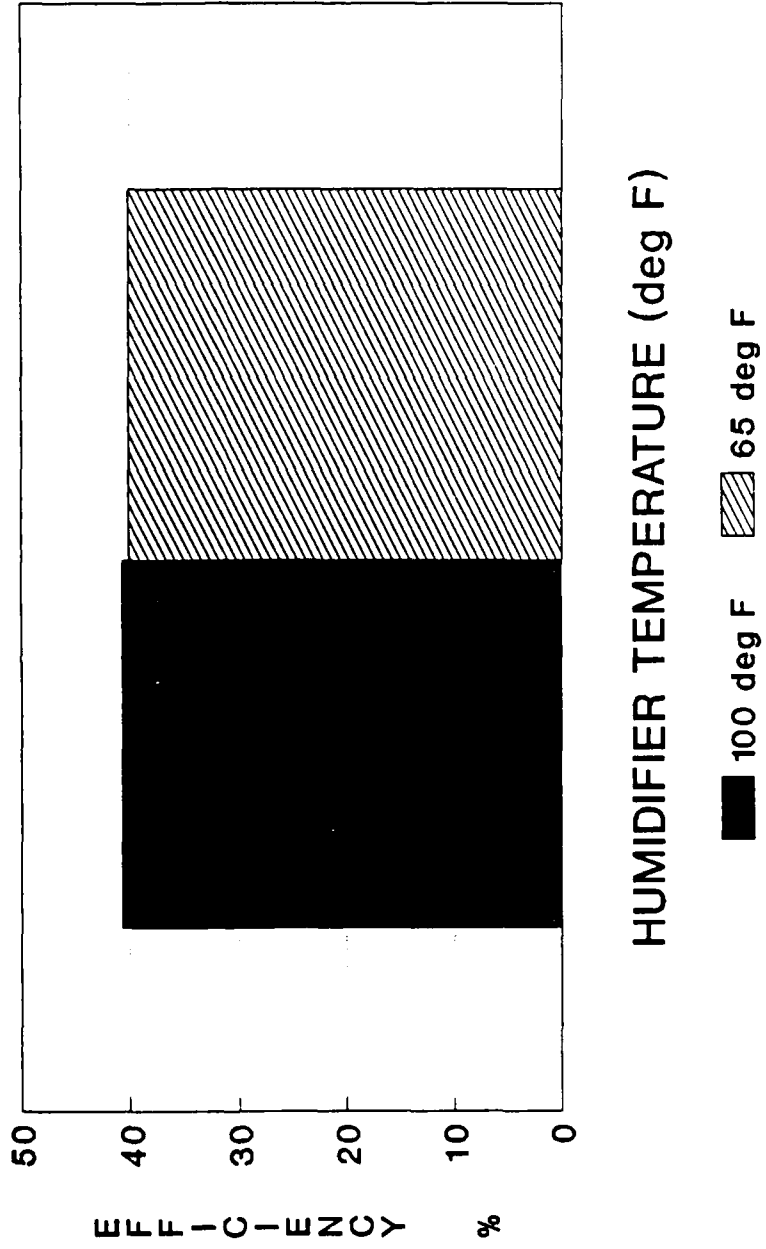
FIGURE 24

INJECTION LEVEL VERSUS TEMPERATURE



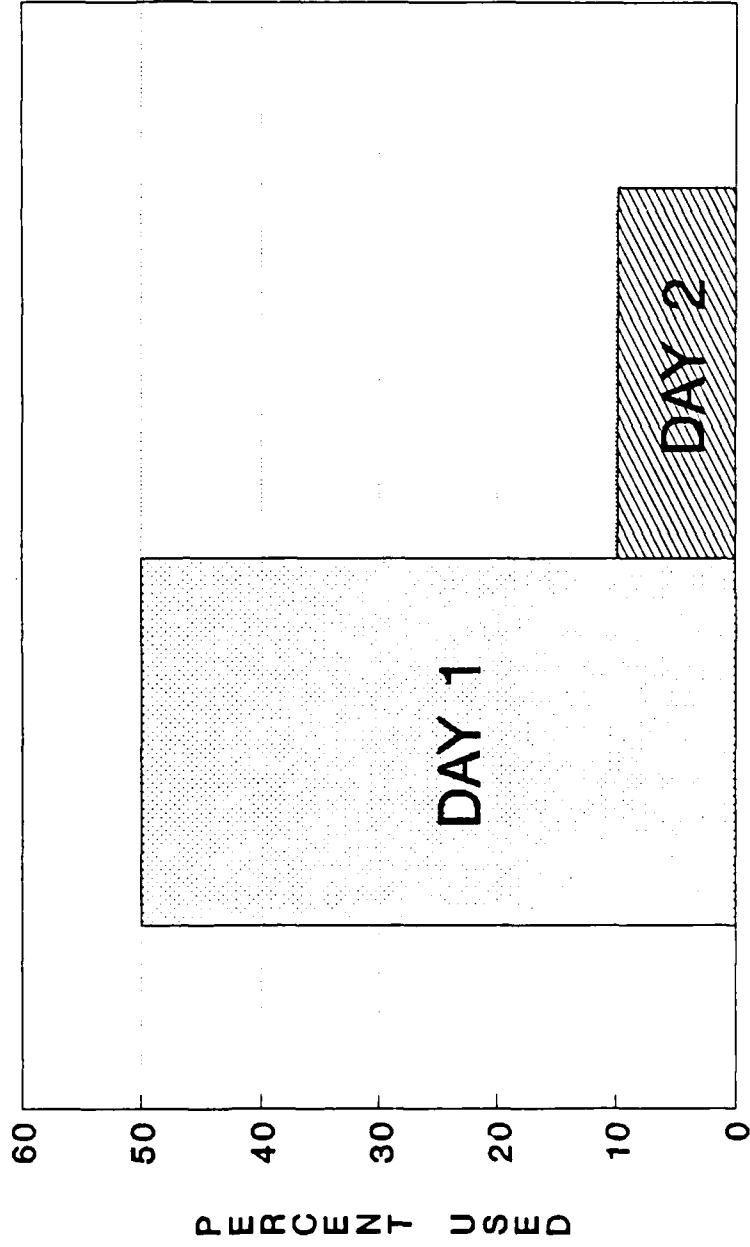
DRY LIQH; RMV = 12

FIGURE 25: EFFECT OF GAS TEMPERATURE
ON ABSORPTION EFFICIENCY



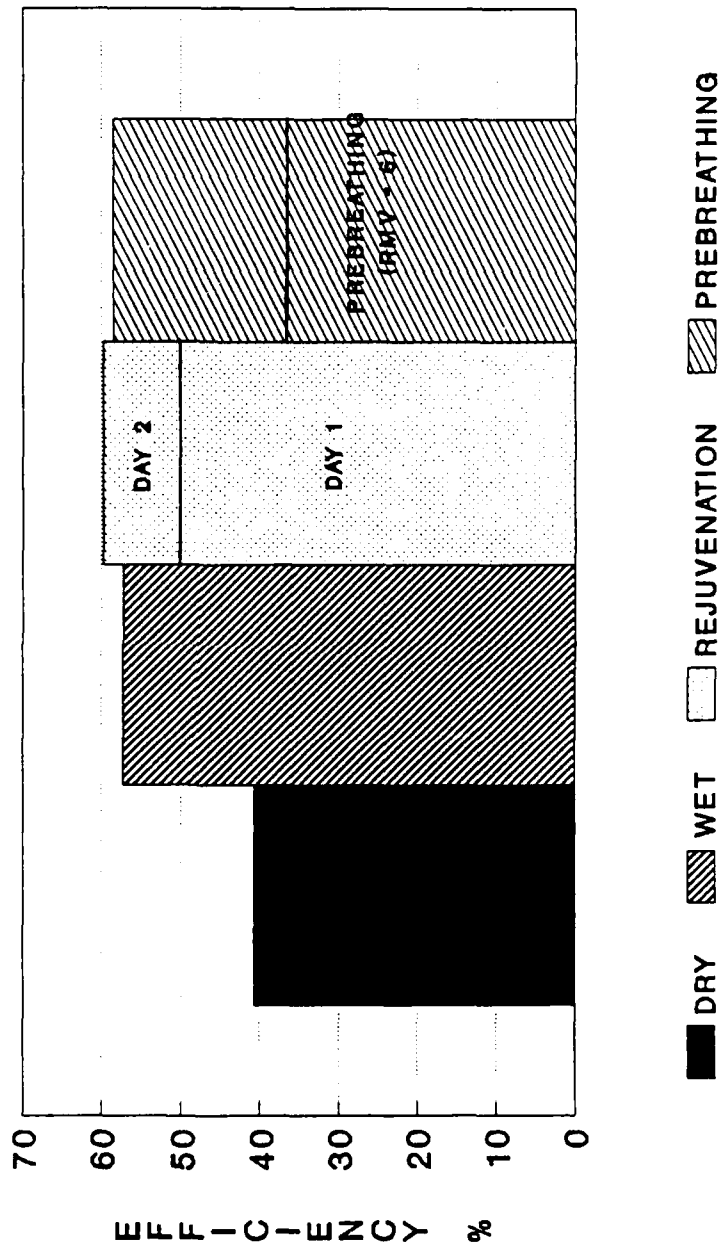
RMV-12; DRY LIOH

**FIGURE 26: EFFECT OF REJUVENATION
ON LIOH UTILIZATION**



RMV-12; DRY LIOH; 3.5% INJECTION

FIGURE 27 COMPARISON OF LiOH UTILIZATION



4.0% CO₂ INJECTION; RMV=12

REFERENCES

1. Wang, T. C., "Carbon Dioxide Scrubbing Materials in Life Support Equipment," The Characterization of Carbon Dioxide Absorbing Agents for Life Support Equipment, OED-Volume 10, Nov. 1982, ASME, New York, pp. 1-21.
2. Boryta, D. A., and A. J. Maas, "Carbon Dioxide Absorption Dynamics of Lithium Hydroxide," The Characterization of Carbon Dioxide Absorbing Agents for Life Support Equipment, OED-Vol. 10, Nov. 1982, ASME, New York, pp. 83-101.
3. Memorandum from Nuckols to Lippitt dtd 14 July 1986, "Procurement Specifications for LiOH," Analysis Efforts for the Conventional Dive System, Volume 2: 15 May - 15 Aug 1986, USNA-Research Report EW-23-86, Annapolis, Maryland.
4. Natoli, Michael J., Unmanned Development Testing of the U.S.Navy Conventional Diving System (CDS), Phase III, Duke University, Durham, North Carolina, July 9, 1987.
5. Wang, T., M. Lion and C. Hendry, "Computer Program for Lithium Hydroxide - Carbon Dioxide Absorption in Underwater Life Support Systems," Harbor Branch Oceanographic Institution, Fort Pierce, Florida, 1988.

6. Young, Robin A., "Absorption Capability of CO₂ Scrubbers under Variable Metabolic Loadings," USNA-Research Report EW-6-87, Annapolis, Maryland, May 1987.

7. Memorandum from Nuckols to Lippitt dtd 4 Aug 1988, "Long Term Storage of LiOH," Analysis Efforts for the Conventional Dive System, Volume 3, USNA Research Report EW-88, Annapolis, Maryland.

APPENDIX A

LiOH SUPPLY SPECIFICATIONS
=====

DESIGNATOR: NASA-grade (tested by NASA, prior to Navy acceptance)
BULK DENSITY: 0.0148 lb / cub. in (0.41 g / ml)
PACKED BY: Foote Mineral
DATE OF PACKING: 7 JAN 87
RECEIVED BY: U.S. Naval Academy
DATE RECEIVED: 22 JAN 87

STORAGE DATA

Length: @ 2 years
Location: Coastal Laboratory, USNA
Dates: JAN 87 - APR 89

DATES OF TESTING: DEC 88 - APR 89

APPENDIX B: TEST DATA

PHASE 1: WET RMV VARIATION

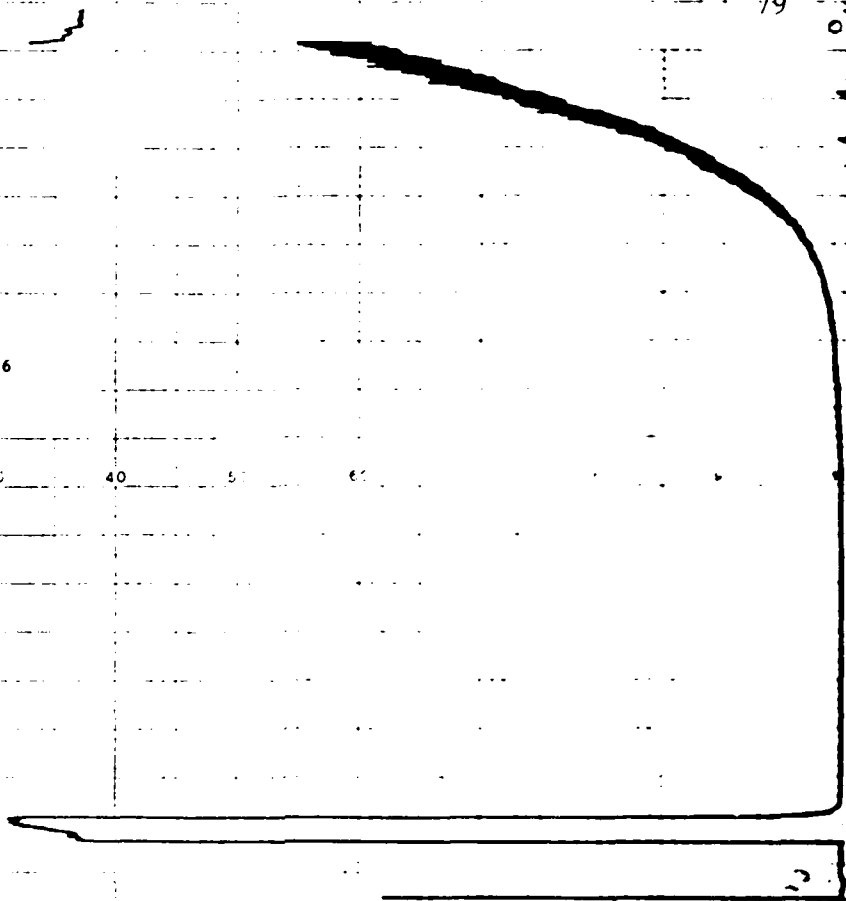
Test Designator: 1-1

RMV =	6	SLPM	TIME	T1	T2	T3	T4
TV =	.5	lit/br	(min)	(hum)	(bed)	(in)	(out)
RR =	12	br/min					
			0	98	81	77.1	76.2
T(amb) =	77	deg F	5	98.4	111	77.9	77.8
P(amb) =	30.44	in Hg	10	98.4	129.4	78	80.6
			15	98.2	138.2	78.1	83.5
V(sc) =	10	cm/hr	20	97.9	140.8	78.4	87.8
			25	97.7	140.3	78.5	90.2
W(wet) =	120.03	g	30	97.6	139.4	78.6	92
W(dry) =	N/A	g	35	97.4	138	78.8	94.2
W(fin) =	133.91	g	40	97.4	135.8	78.8	95.4
			45	97.4	133.8	78.8	96.6
CO2 INJECTION			50	97.5	132.2	78.8	98.3
Init =	3.75	%	55	97.6	130.2	78.9	97.8
Final =	3.4	%	60	97.6	126.9	78.9	97.8
Ave =	3.575	%					
			5	97.7	124.1	79.1	98.2
			10	97.8	121.2	79.2	98.2
T(break) =	93	min	15	97.8	118.4	79.2	98.4
			20	97.8	115.9	79.3	98.7
			25	97.8	113.5	79.4	98.7
			30	97.8	111.1	79.4	98.6
			35	97.8	108.9	79.4	98.3
			40	97.8	107.6	79.4	97.8
			45	97.8	106.7	79.4	97.4

TEST 1-1 RMV(WET) = 6

0 10 20 30 40 50 60

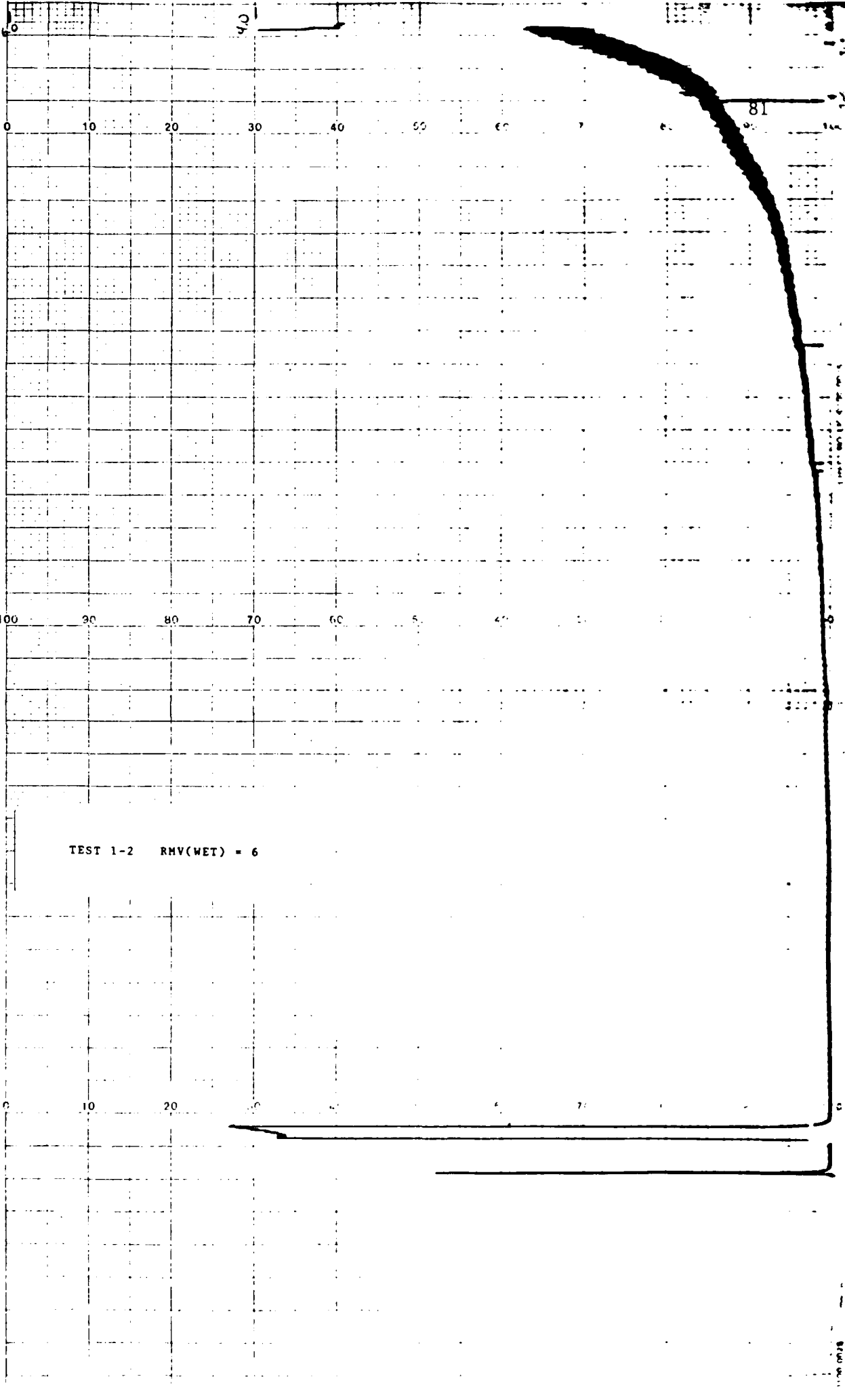
60 70 80 90 100



PHASE 1: WET RMV VARIATION

Test Designator: 1-2

RMV =	6	SLPM	TIME	T1	T2	T3	T4
TV =	.5	lit/br	(min)	(hum)	(bed)	(in)	(out)
RR =	12	br/min					
T(amb) =	70	deg F	0	92.4	73.7	71.5	71
P(amb) =	30.47	in Hg	5	95.3	107.6	72.3	72.2
V(sc) =	10	cm/hr	10	98	131.3	73.1	75.8
W(wet) =	120.01	g	15	99.4	140.3	74.1	79.6
W(dry) =	N/A	g	20	99.8	142.9	74.8	83.6
W(fin) =	148.94	g	25	100	145.3	75.6	86.5
CO2 INJECTION			30	99.9	145.2	76.3	89.8
Init =	3.5	%	35	99.5	145.1	77.2	92.7
Final =	3	%	40	99.4	145	77.6	93.3
Ave =	3.25	%	45	98.9	145.5	78	94
			50	98.6	145.5	78.4	95.6
			55	98.3	145.2	78.9	96.7
			60	97.9	144.7	79.3	98.8
			5	97.7	144.8	79.6	99.7
T(break) =	197.5	min	10	97.5	145	80	99.9
			15	97.4	145	80.2	101.1
			20	97.3	144.4	80.5	101.7
			25	97.3	143.8	80.7	101.8
			30	97.2	143.2	81.1	102.5
			35	97.1	142.8	81.2	102.5
			40	97.1	142.6	81.3	102.7
			45	97	142.1	81.4	103.1
			50	97.1	141.5	81.6	103
			55	96.9	141.2	81.7	103.8
			60	97	140.7	81.7	104
			5	97	140.1	81.9	104.6
			10	97	139.2	82	105
			15	97	138	82	104.4
			20	97.1	137.4	82.1	104.5
			25	97.4	137.6	82.4	103.9
			30	97	136.2	82.1	104.6
			35	96.9	134.7	82	104.8
			40	96.8	132.8	81.9	104.8
			45	96.9	131.2	82	104.4
			50	96.9	129.2	82.1	104.8
			55	97	127.1	82.1	104.7
			60	97	122.6	82.2	104.8
			5	97	120.2	82.3	104.5
			10	96.9	116	82.3	104
			15	96.9	113	82.4	103.4
			20	96.9	110.9	82.4	103.4
			25	96.9	108.3	82.4	103
			30	96.9	106.2	82.5	102



TEST 1-2 RNV(WET) = 6

PHASE 1: WET RMV VARIATION

Test Designator: 1-3

RMV =	6	SLPM	TIME	T1	T2	T3	T4
TV =	.5	lit/br	(min)	(hum)	(bed)	(in)	(out)
RR =	12	br/min					
T(amb) =	79	deg F	0	92.6	85.4	81.2	79.4
P(amb) =	30.16	in Hg	5	94.3	106.8	80.6	80.8
			10	95.8	130.1	80.5	82.7
			15	97.1	139.6	80.2	86.1
V(sc) =	10	cm/hr	20	97.9	141.8	80	88.8
			25	98.4	142.5	79.9	90.4
W(wet) =	120.01	g	30	98.6	142.6	79.7	93
W(dry) =	N/A	g	35	98.6	142.9	79.6	94.4
W(fin) =	141.39	g	40	98.6	142.9	79.6	95.1
			45	98.4	142.9	79.6	96.2
CO2 INJECTION			50	98.4	142.8	79.5	96.8
Init =	3.5	%	55	98.4	142.6	79.4	97.2
Final =	3.5	%	60	98.3	142.4	79.3	98.5
Ave =	3.5	%					
			5	98.2	142.1	79.1	98.7
			10	98.2	140.6	79	98.9
T(break) =	155	min	15	98.2	140	79	99.3
			20	98.2	139.7	78.8	99.6
			25	98.2	139.2	78.8	99.8
			30	98.1	138.1	78.7	100.2
			35	98.2	137.1	78.6	100.2
			40	98.2	135.9	78.4	100.3
			45	98.2	134.3	78.4	99.8
			50	98.2	132.7	78.3	100.2
			55	98.2	130.3	78.3	100.2
			60	98.2	128.1	78.2	100.1
			5	98.2	125.7	78.1	100.9
			10	98.2	123.5	78	100.9
			15	98.2	121.4	77.9	101.5
			20	98.2	118.6	77.8	101.2
			25	98.2	116.5	77.8	101.1
			30	98.2	113.5	77.8	100.2
			35	98.2	112.2	77.7	99.6
			40	98.2	110.2	77.6	99.4
			45	98.2	108.1	77.5	98.9

100 90 80 70 60

83

TEST 1-3 RMV(WET) = 6

100 90 80 70 60

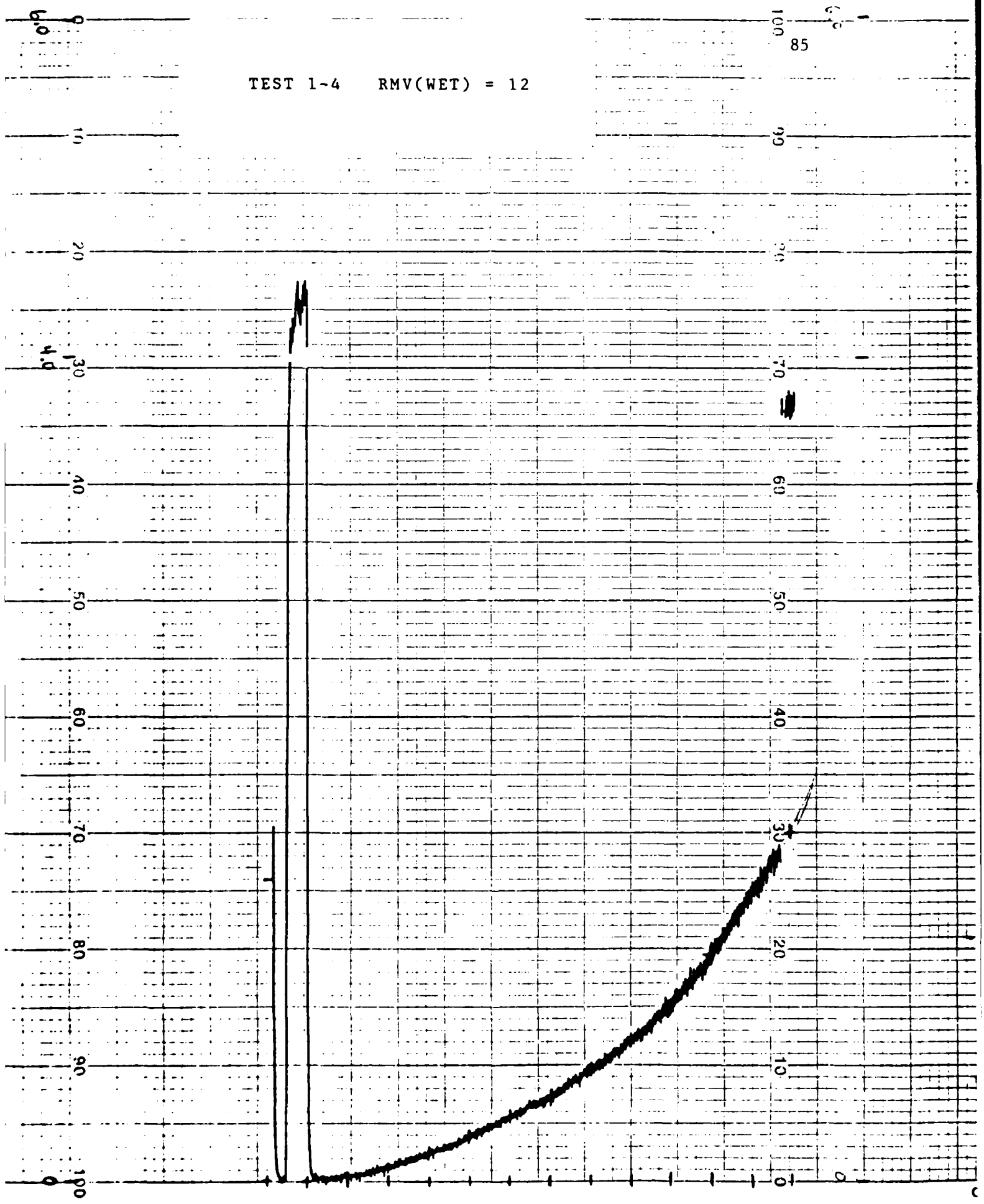
PHASE 1: WET RMV VARIATION

Test Designator: 1-4

			TIME (min)	T1 (hum)	T2 (bed)	T3 (in)	T4 (out)
RMV =	12	SLPM	0	101.3	73	70.2	79.9
TV =	.75	lit/br	5	101.4	146.3	71.8	88.2
RR =	16	br/min	10	101.3	147.7	72.6	94.8
T(amb) =	65.6	deg F	15	101	150.7	73.4	98.6
P(amb) =	30.2	in Hg	20	100.8	152.2	73.7	101
V(sc) =	10	cm/hr	25	100.7	154.2	73.9	103.2
W(wet) =	100.43	g	30	100.4	156.4	74.4	105.6
W(dry) =	N/A	g	35	10.3	158.2	74.5	107.6
W(fin) =	123.87	g	40	100.2	159.9	74.6	107.7
CO2 INJECTION			45	100.2	162.2	74.6	109.1
Init =	4.3	%	50	100.2	164.7	74.7	109.9
Final =	3.7	%	55	100.2	167.5	74.7	109.7
Ave =	4	%	60	100.3	169.8	74.8	109.9
			5	100.4	172	74.8	111.2

T(break) = 50 min

TEST 1-4 RMV(WET) = 12



PHASE 1: WET RMV VARIATION

Test Designator: 1-5

RMV =	12	SLPM	TIME	T1	T2	T3	T4
TV =	.75	lit/br	(min)	(hum)	(bed)	(in)	(out)
RR =	16	br/min					
T(amb) =	64.9	deg F	0	100.4	72.2	70.2	81.6
P(amb) =	30.15	in Hg	5	100.7	144.3	71.6	87.4
V(sc) =	10	cm/hr	10	100.8	148.6	72.4	96.7
W(wet) =	94.5	g	15	101	151.8	73	99.8
W(dry) =	N/A	g	20	101	156.5	73.4	103.2
W(fin) =	119.48	g	25	100.9	164.8	73.6	105.2
CO2 INJECTION			30	100.8	173.6	73.8	107.3
Init =	4.2	%	35	100.8	180.8	73.9	107.9
Final =	3.9	%	40	100.7	187.1	73.9	109.9
Ave =	4.05	%	45	100.6	190.9	74	111
			50	100.7	192.6	74	114.1
			55	100.7	193.3	74	116.4
			60	100.7	192.5	74.1	117.8

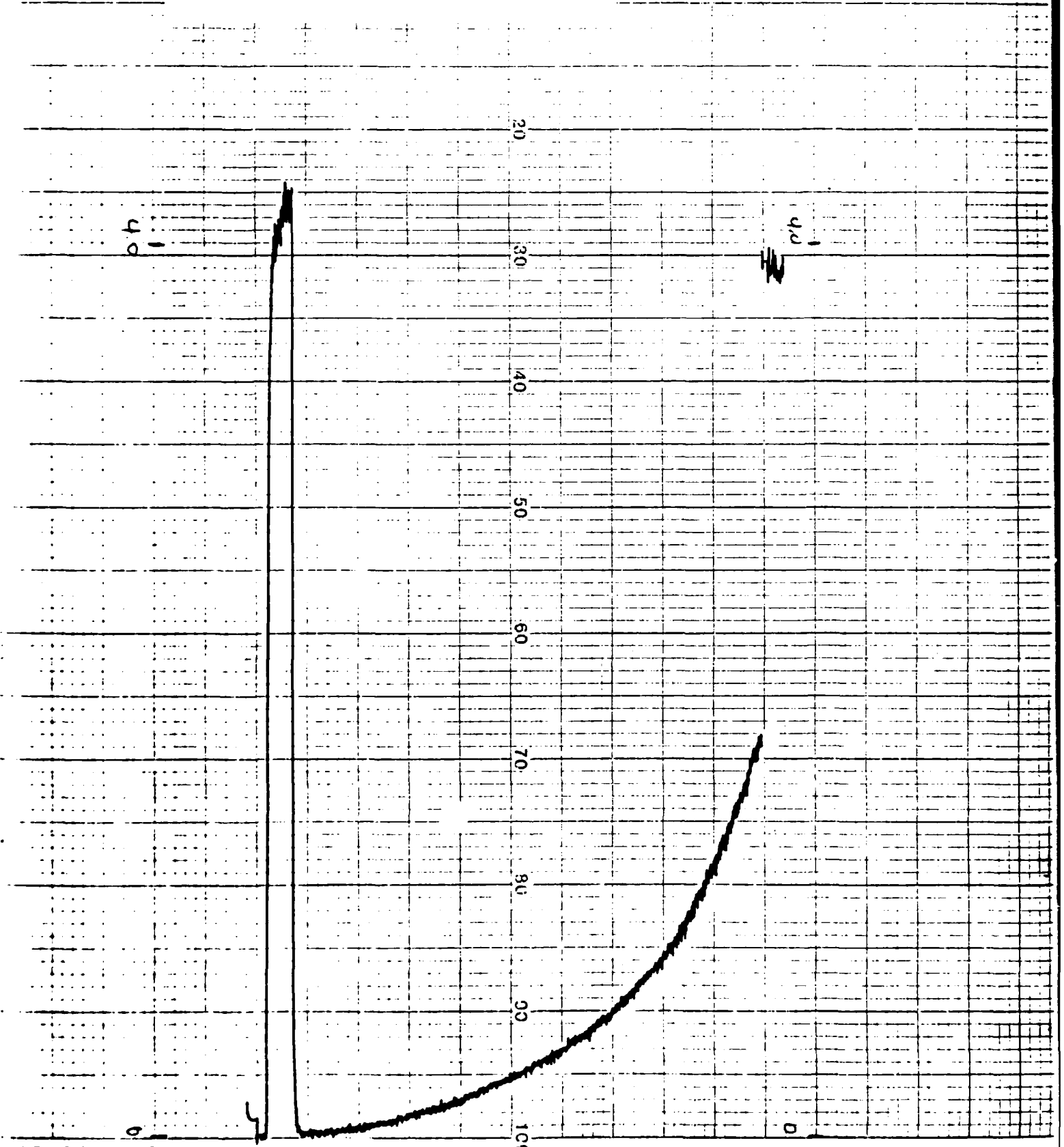
T(break) = 49.5 min

TEST 1-5 RMV(WET) = 12

4.0

4.0

20
30
40
50
60
70
80
90
100



PHASE 1: WET RMV VARIATION

Test Designator: 1-6

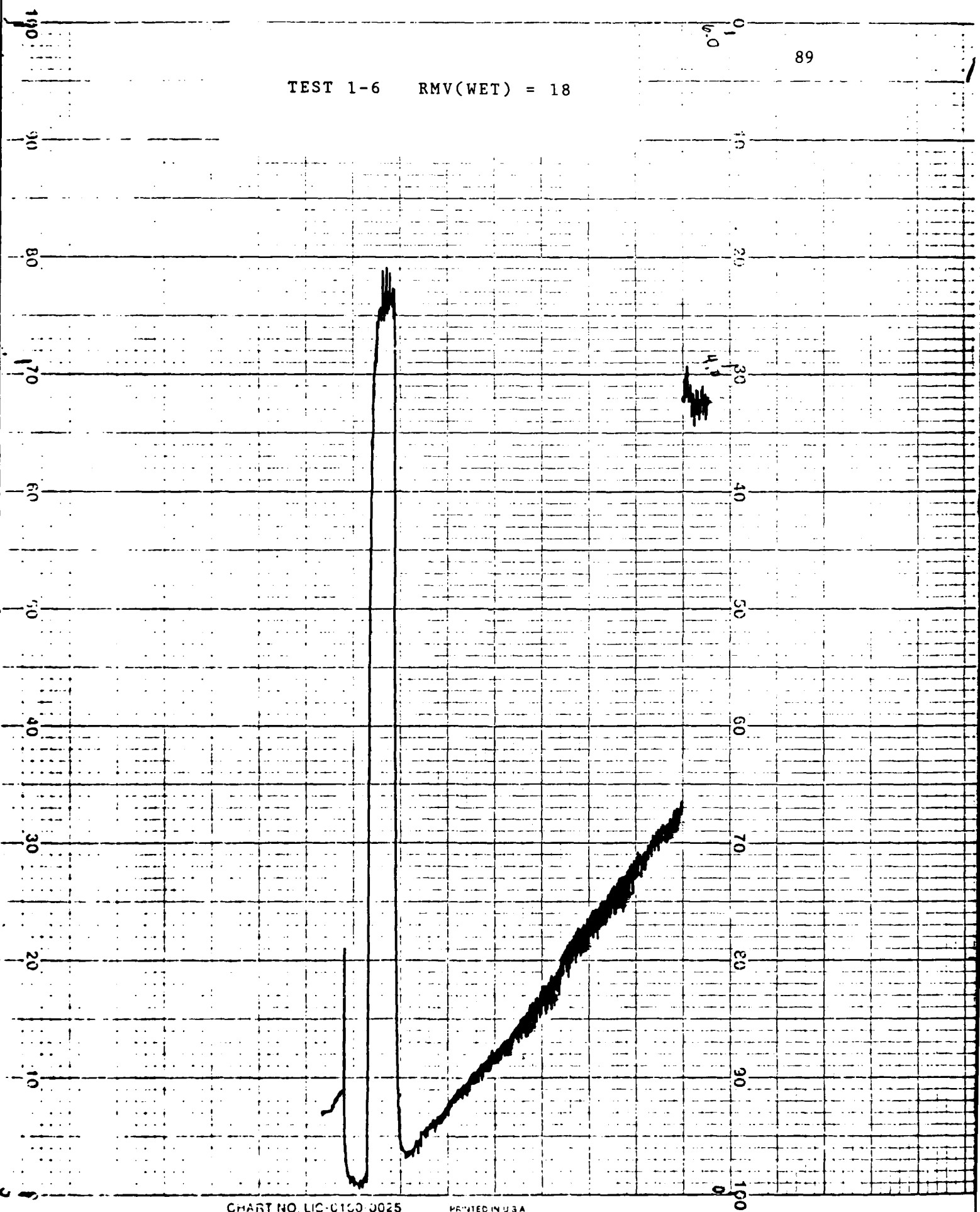
RMV =	18	SLPM	TIME	T1	T2	T3	T4
TV =	1	lit/br	(min)	(hum)	(bed)	(in)	(out)
RR =	18	br/min					
			0	90.2	79.6	75.4	72.9
T(amb) =	74.5	deg F	5	93.6	149.5	77.5	99.1
P(amb) =	30.4	in Hg	10	96.1	150.9	79.5	105.9
			15	97.7	152.6	81.1	111.9
V(sc) =	15	cm/hr	20	98.4	154	82.4	115
			25	98.8	154.4	83.2	116.3
W(wet) =	109.91	g	30	98.8	154.9	84	120.8
W(dry) =	N/A	g					
W(fin) =	125.41	g					

CO2 INJECTION

Init =	4.3	%
Final =	3.7	%
Ave =	4	%

T(break) = 17 min

TEST 1-6 RMV(WET) = 18



PHASE 1: WET RMV VARIATION

Test Designator: 1-7

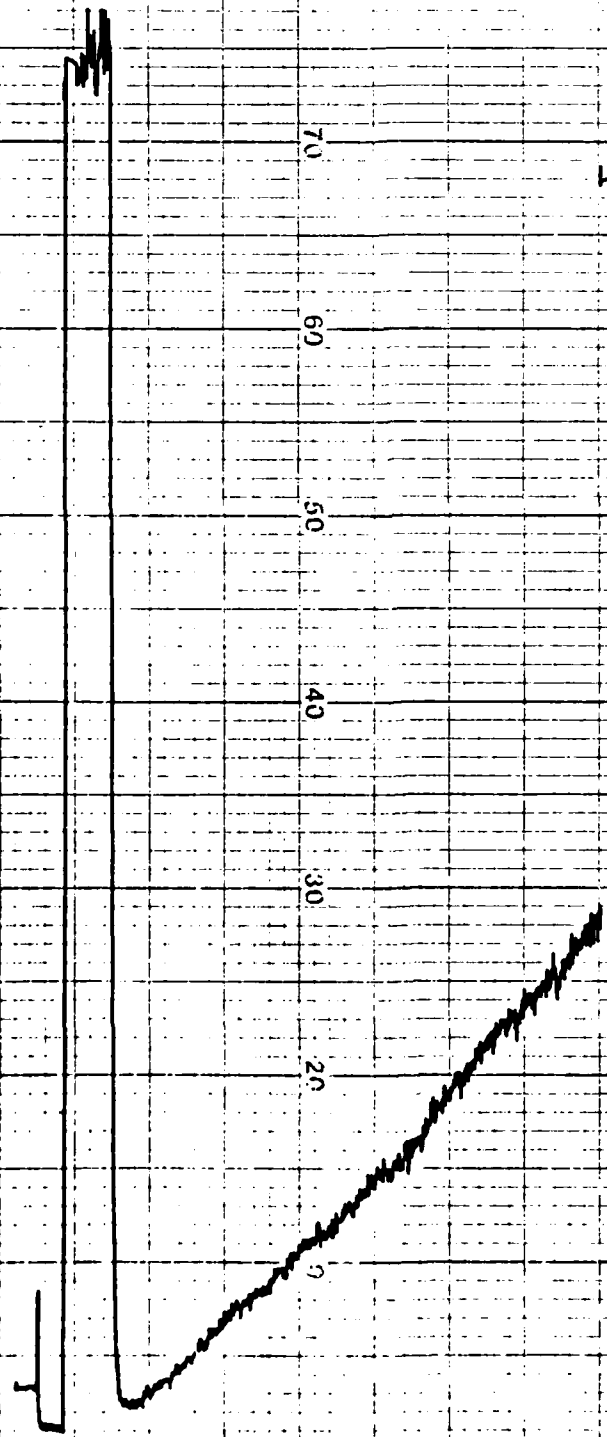
RMV =	18	SLPM	TIME	T1	T2	T3	T4
TV =	1	lit/br	(min)	(hum)	(bed)	(in)	(out)
RR =	18	br/min					
			0	96.6	82.6	79.3	81.6
T(amb) =	74.5	deg F	5	96.8	151	80.8	102.2
P(amb) =	30.4	in Hg	10	97.2	152.9	82	109.3
			15	97.6	155.1	82.7	112.3
V(sc) =	15	cm/hr	20	98	156.5	83.4	114.8
			25	98.2	158.2	84	118.3
W(wet) =	104.85	g	30	98.2	160.8	84.2	119.4
W(dry) =	N/A	g					
W(fin) =	120.27	g					

CO2 INJECTION

Init = 4.25 %
 Final = 3.75 %
 Ave = 4 %

T(break) = 19 min

TEST 1-7 RMV(WET) = 18



PHASE 1: DRY RMV VARIATION

Test Designator: 1-8

RMV =	6	SLPM	TIME	T1	T2	T3	T4
TV =	.5	lit/br	(min)	(hum)	(bed)	(in)	(out)
RR =	12	br/min					
T(amb) =	82	deg F	0	90	86.5	82.1	82.8
P(amb) =	30.06	in Hg	5	94.1	119.6	83.2	80.6
V(sc) =	10	cm/hr	10	96.1	144.5	83.6	85.5
W(wet) =	120	g	15	97.3	146.5	83.8	89.9
W(dry) =	86.87	g	20	97.9	147.4	84	92.4
W(fin) =	121.08	g	25	98.2	148.9	84.2	94.5
CO2 INJECTION			30	98.1	152.1	84.4	95
Init =	4	%	35	97.9	155.7	84.6	96.2
Final =	3.5	%	40	97.7	159.6	84.8	97.4
Ave =	3.75	%	45	97.5	163	84.9	97.9
T(break) =	168	min	50	97.3	165.2	85	98.9
			55	97.1	167.8	85.1	100
			60	96.9	170.4	85.2	100.4
			5	96.8	172.9	85.3	101
			10	96.8	175	85.3	103
			15	96.6	176.7	85.4	103.2
			20	96.6	178.1	85.5	103.9
			25	96.6	180	85.6	104.5
			30	96.6	181.7	85.6	104.7
			35	96.6	181.8	85.6	105.3
			40	96.6	182.5	85.7	105.6
			45	96.6	181.5	85.6	106.6
			50	96.6	181.4	85.7	106.6
			55	96.6	182	85.7	106.9
			60	96.6	182.5	85.7	108.6
			5	96.6	182.6	85.7	109.2
			10	96.6	182.4	85.7	108
			15	96.5	181.9	85.8	108.8
			20	96.5	181.3	85.8	109
			25	96.5	180.5	85.8	109.5
			30	96.5	178.8	85.8	109.5
			35	96.5	177.8	85.9	109.9
			40	96.5	177	85.8	110.2
			45	96.5	176.1	85.8	110.6
			50	96.4	174.2	85.9	110.7
			55	96.4	173.1	85.9	111
			60	96.4	172.5	85.8	111.3
			5	96.4	172	85.8	111
			10	96.4	171.3	85.8	110.7

TEST 1-8 RHV(DRY) = 6

100 90 80 70 60 50 40 30

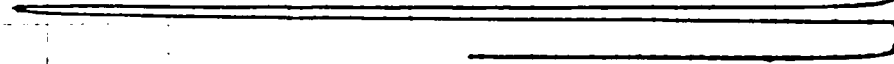
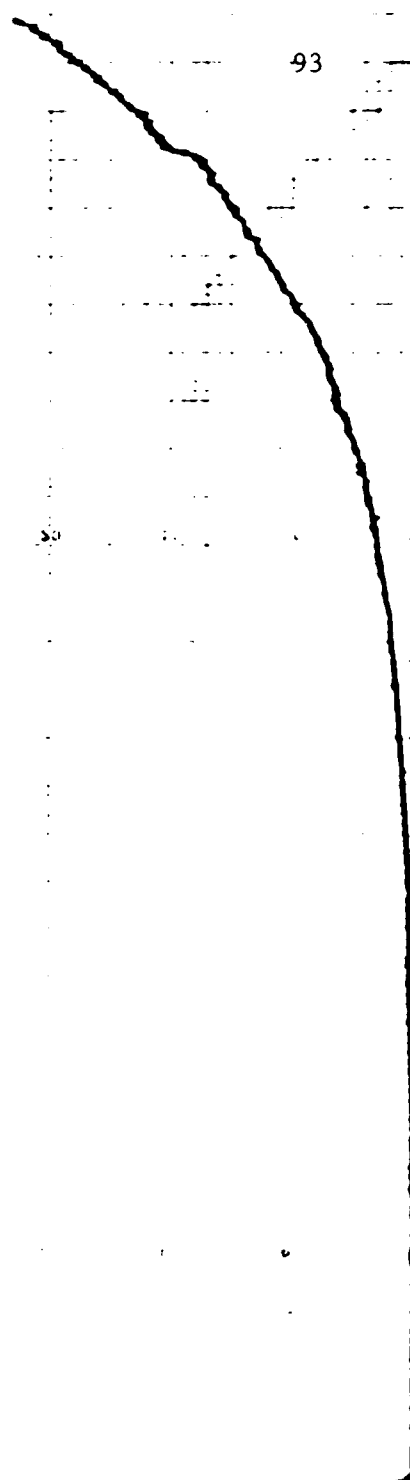
0 10 20 30 40 50

6.0

4.0

6.5

4.5



PHASE 1: DRY RMV VARIATION

Test Designator: 1-9

RMV =	6	SLPM	TIME	T1	T2	T3	T4
TV =	.5	lit/br	(min)	(hum)	(bed)	(in)	(out)
RR =	12	br/min					
			0	90	86.5	80.6	82.2
T(amb) =	82	deg F	5	94.5	125.6	81.9	79.6
P(amb) =	30.47	in Hg	10	96.5	144.6	82.3	87.1
			15	97.8	146.4	82.7	91.5
V(sc) =	10	cm/hr	20	98.4	147.8	83	93.7
			25	98.7	150.4	83.2	95.5
W(wet) =	120.01	g	30	98.6	153.8	83.5	97.8
W(dry) =	86	g	35	98.4	158	83.8	98.7
W(fin) =	122.25	g	40	98.3	160.7	83.9	99.2
			45	98	163.4	84.2	100
CO2 INJECTION			50	97.8	166	84.3	100.9
Init =	4	%	55	97.6	168.2	84.4	101
Final =	3.3	%	60	97.4	169.5	84.5	101.5
Ave =	3.65	%					
			5	97.3	171.9	84.5	102.6
			10	97.2	173.3	84.6	103.3
T(break) =	171	min	15	97.1	175	84.7	104.5
			20	97.1	177.3	84.8	105.2
			25	97	178.7	84.8	106.2
			30	97	179.6	84.9	106.6
			35	97	179.1	85	106.8
			40	97	180.4	85	106.9
			45	97	182.5	85	107.6
			50	97	183	85	108
			55	97	183.2	85.1	108.4
			60	97	183.4	85.2	105.8
			5	97	183.2	85.3	105.8
			10	97	183.1	85.3	106
			15	96.9	183	85.3	106.5
			20	97	182.8	85.3	106
			25	96.9	182.6	85.3	106.1
			30	96.9	182	85.3	105.8
			35	96.9	181.6	85.3	106.5
			40	96.9	181	85.4	107.3
			45	96.9	180.3	85.4	108.2
			50	96.9	179.6	85.4	107.8
			55	96.9	178.5	85.4	107.6
			60	96.9	177.5	85.4	107.7
			5	96.9	176.6	85.3	107.6
			10	96.9	175.8	85.3	107.5
			15	96.9	174.6	85.3	107.6

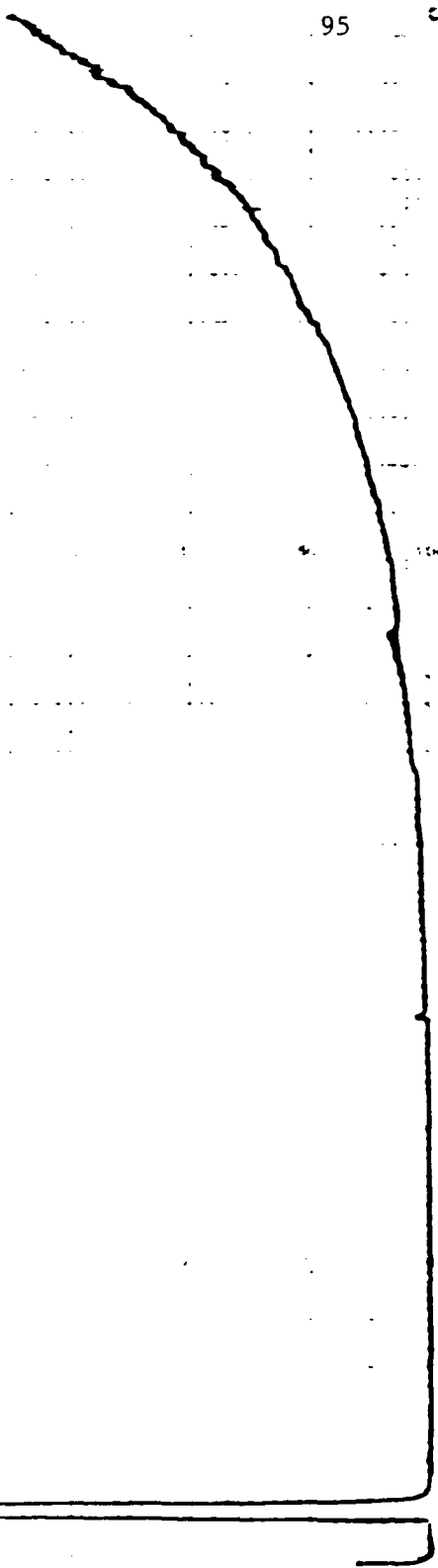
95

TEST 1-9 RMV(DRY) = 6

0 10 20 30 40 50 60 70 80 90 100

100 90 80 70 60 50 40 30 20 10 0

6.0 4.0 2.0 1.0 0.5 0.2 0.1 0.05 0.02 0.01 0.005 0.002 0.001



PHASE 1: DRY RMV VARIATION

Test Designator: 1-10

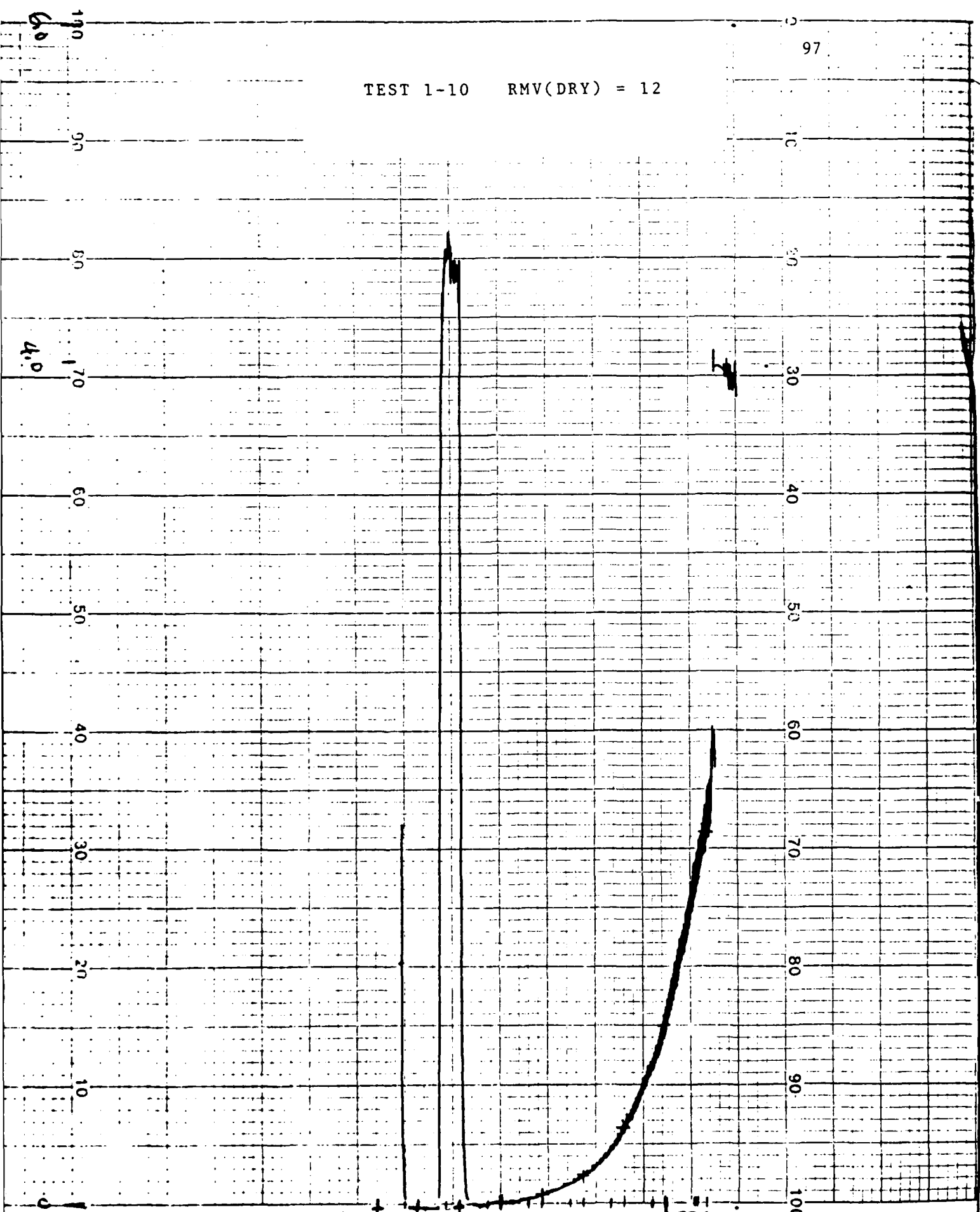
RMV =	12	SLPM	TIME	T1	T2	T3	T4
TV =	.75	lit/br	(min)	(hum)	(bed)	(in)	(out)
RR =	16	br/min					
			0	94.7	88	76.6	76
T(amb) =	75.4	deg F	5	98.4	156.4	78.1	93.7
P(amb) =	3.7	in Hg	10	99.6	180.4	79	97.2
			15	100.5	199.6	79.8	101.4
V(sc) =	10	cm/hr	20	100.7	209.5	80.6	105.7
			25	100.4	214.6	81	110.9
W(wet) =	108.39	g	30	100	213.6	81.6	115.6
W(dry) =	87.72	g	35	99.4	203.8	81.8	119.7
W(fin) =	111.6	g	40	99	198.5	81.9	122.4

CO2 INJECTION

Init = 4.5 %
 Final = 4 %
 Ave = 4.25 %

T(break) = 34 min

TEST 1-10 RMV(DRY) = 12



PHASE 1: DRY RMV VARIATION

Test Designator: 1-11

			TIME (min)	T1 (hum)	T2 (bed)	T3 (in)	T4 (out)
RMV =	12	SLPM	0	90.3	92.3	75	75.5
TV =	.75	lit/br	5	93.7	146.8	76	89.3
RR =	16	br/min	10	96.2	175.5	77	95
T(amb) =	74	deg F	15	97.6	197.2	77.9	99.9
P(amb) =	30.15	in Hg	20	98.4	208.6	78.6	105.9
V(sc) =	10	cm/hr	25	98.9	211.5	79.4	112.2
W(wet) =	109.5	g	30	98.9	209.6	79.8	115.5
W(dry) =	93.66	g	35	98.8	201.3	80.2	120.1
W(fin) =	114.07	g	40	98.6	196	80.3	122

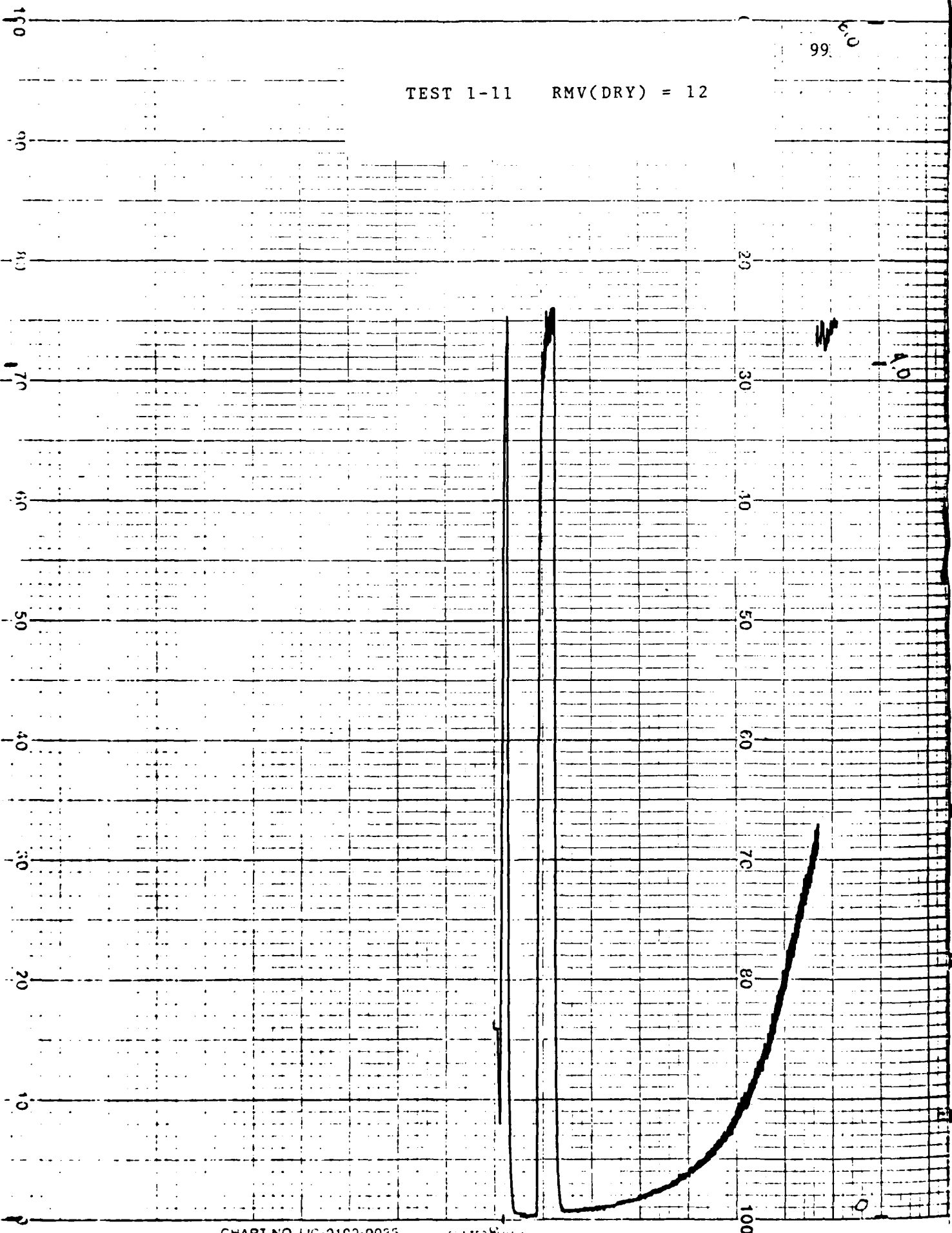
CO2 INJECTION

Init = 4.25 %
 Final = 4.2 %
 Ave = 4.225 %

T(break) = 33 min

99.6°C

TEST 1-11 RMV(DRY) = 12



PHASE 1: DRY RMV VARIATION

Test Designator: 1-12

RMV =	18	SLPM	TIME	T1	T2	T3	T4
TV =	1	lit/br	(min)	(hum)	(bed)	(in)	(out)
RR =	18	br/min	-----				
			0	91	81.7	75.9	73.8
T(amb) =	74.2	deg F	5	94	170.3	77.8	96.5
P(amb) =	30.15	in Hg	10	96.3	217.3	79.8	105.8
			15	97.6	216.9	81.2	118.8

V(sc) =	15	cm/hr	20	98.2	204.3	82.2	130.9
---------	----	-------	----	------	-------	------	-------

W(wet) =	103.75	g
W(dry) =	91.01	g
W(fin) =	109.15	g

CO2 INJECTION

Init =	4.25	%
Final =	3.75	%
Ave =	4	%

T(break) = 17 min

6.0

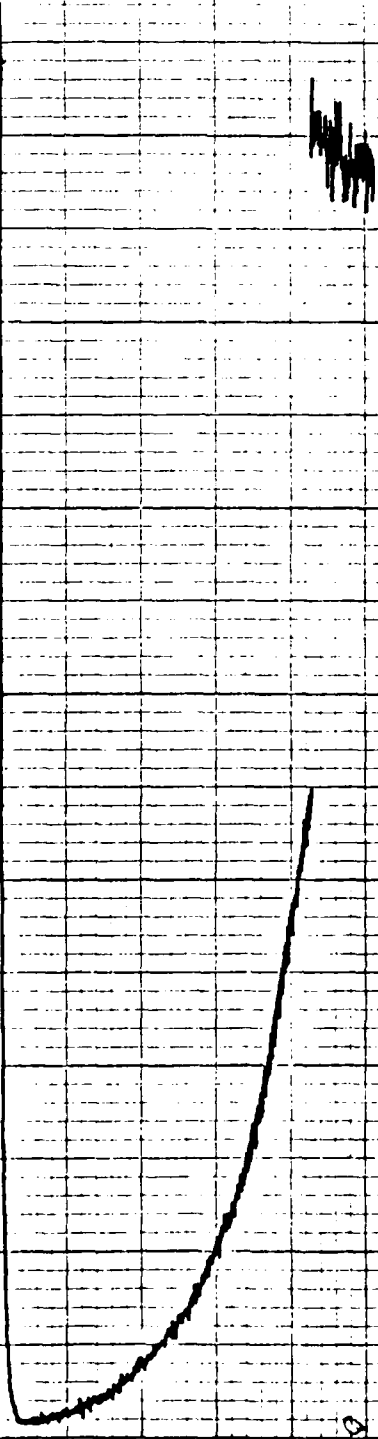
101

TEST 1-12 RMV(DRY) = 18

20
30
40
50
60
70
80
90
100

4.0

4.0



PHASE 1: DRY RMV VARIATION

Test Designator: 1-13

			TIME (min)	T1 (hum)	T2 (bed)	T3 (in)	T4 (out)
RMV =	18	SLPM					
TV =	1	lit/br					
RR =	18	br/min					
T(amb) =	74.4	deg F	0	95.9	80.7	78.9	80.1
P(amb) =	30.15	in Hg	5	96.2	163.6	80.6	99.8
			10	96.7	219.4	81.8	108.5
			15	97.2	229.5	82.6	123.9
V(sc) =	15	cm/hr	20	97.6	216.4	83.1	134.8

W(wet) = 100.5 g
W(dry) = 90.08 g
W(fin) = 108.3 g

CO2 INJECTION

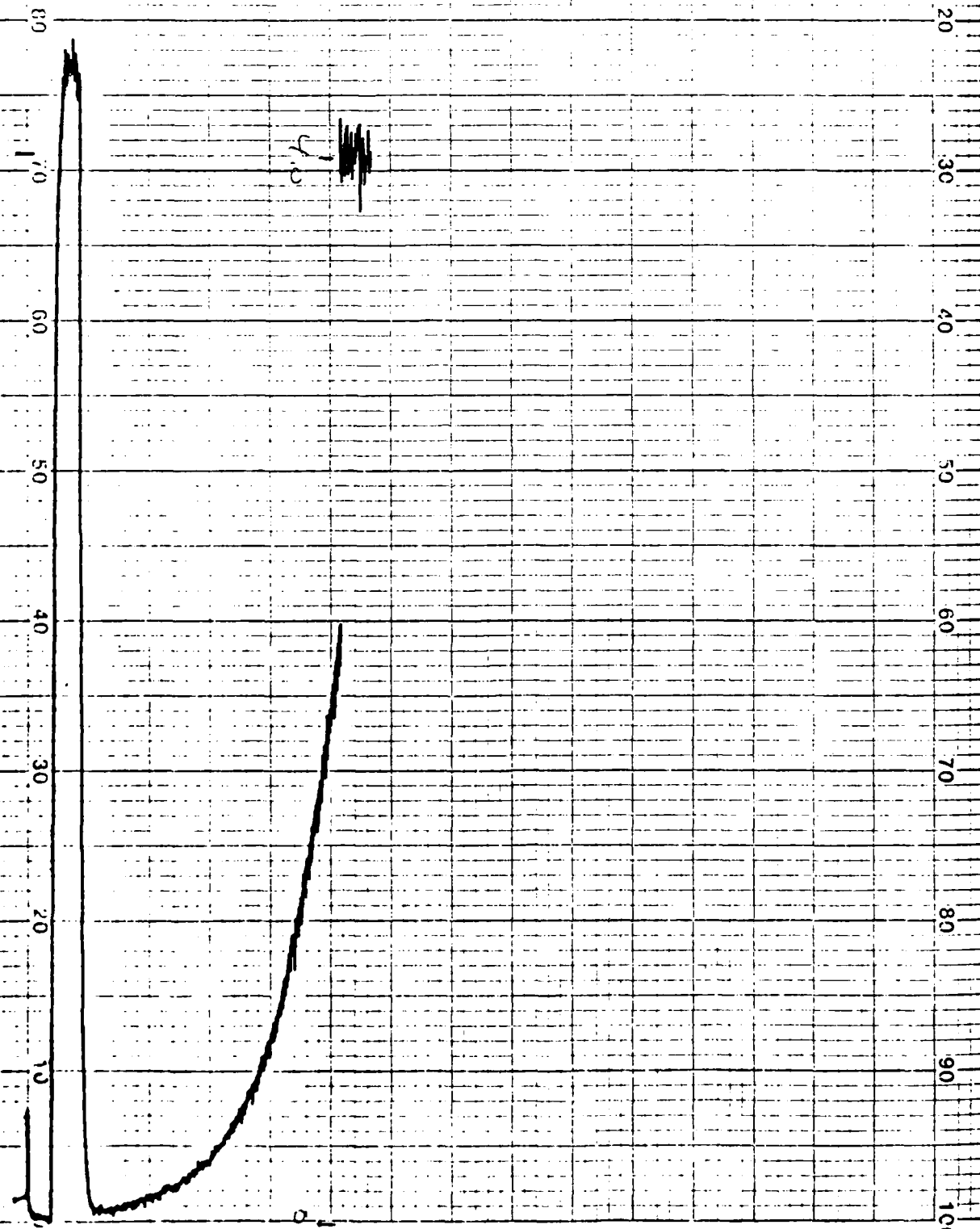
Init = 4.375 %
Final = 4 %
Ave = 4.1875 %

T(break) = 16.5 min

TEST 1-13 RMV(DRY) = 18

4.0

4.0



PHASE 2: L/D RATIO VARIATION

Test Designator: 2-1

			TIME (min)	T1 (hum)	T2 (bed)	T3 (in)	T4 (out)	T5 (edge)
RMV =	12	SLPM	0	102.2	76.6	75	70.1	75.1
TV =	.75	lit/br	5	101.4	132.9	75.9	79.3	112.8
RR =	16	br/min	10	100.7	141.8	77	89.2	126.6
T(amb) =	73.2	deg F	15	100	148.7	77.6	94.5	131.5
P(amb) =	29.98	in Hg						

V(sc) =	10	cm/hr	20	99.3	193.2	78	98.1	144
W(wet) =	101.2	g	25	98.9	228.5	78	101.4	160.8
W(dry) =	89.25	g	30	98.6	229	78.2	106.7	174.7
W(fin) =	108.45	g	35	98.4	215.2	78.2	112.5	176.5
			40	98.3	202.6	78.6	115.1	171.6

CO2 INJECTION

Init =	3.9	%
Final =	4.8	%
Ave =	4.35	%

T(break) = 36.75 min

L/D #2

L =	1.675	in
D =	3	in

6.0

10

6.0

105

TEST 2-1 L/D #2

4.0

80

4.0

70

60

50

40

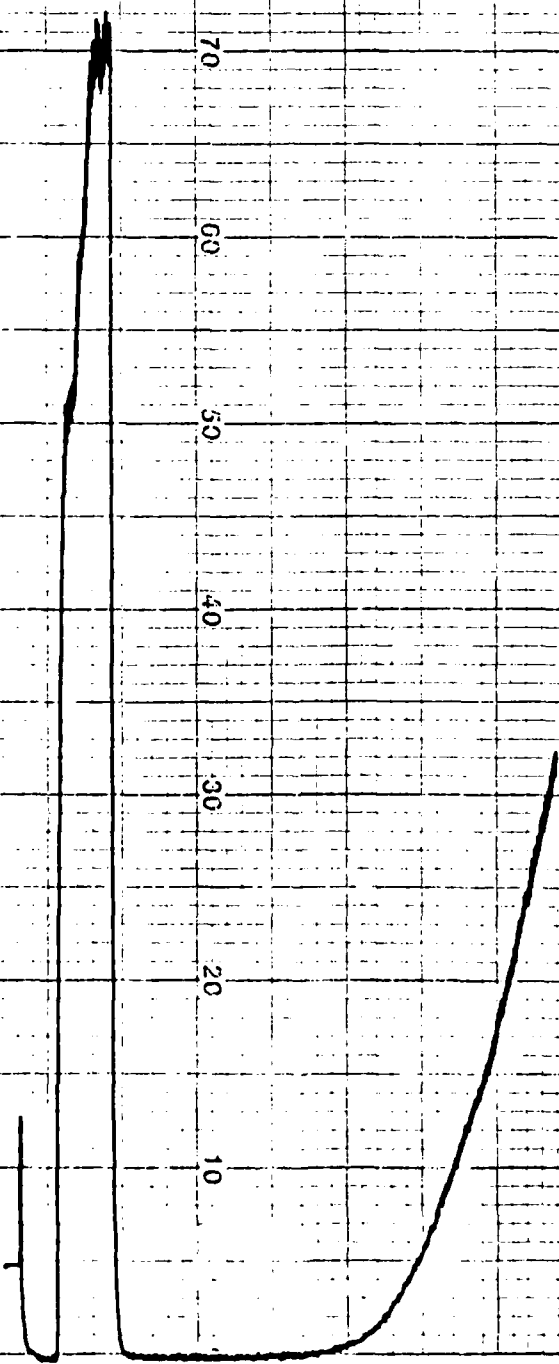
30

20

10

0

0



PHASE 2: L/D RATIO VARIATION

Test Designator: 2-2

			TIME (min)	T1 (hum)	T2 (bed)	T3 (in)	T4 (out)	T5 (edge)
RMV =	12	SLPM	0	100	83.3	76.3	81.9	85.3
TV =	.75	lit/br	5	99.8	136.6	76.6	86.1	118.8
RR =	16	br/min	10	99.5	141.8	77.3	93	127.7
T(amb) =	72.4	deg F	15	99.2	160.7	77.8	96.2	139.2
P(amb) =	30.16	in Hg	20	98.8	205.5	78.1	98.2	159.4
V(sc) =	10	cm/hr	25	98.6	240.1	78.4	105	178.8
W(wet) =	104.25	g	30	98.5	236.4	78.3	109.1	178
W(dry) =	90.02	g	35	98.4	217	78.6	114.5	169.2
W(fin) =	109.99	g	40	98.4	202.5	78.6	117.3	161.7

CO2 INJECTION

Init = 3.9 %
 Final = 4.8 %
 Ave = 4.35 %

T(break) = 36.5 min

L/D #2

L = 1.675 in
 D = 3 in

TEST 2-2 L/D #2

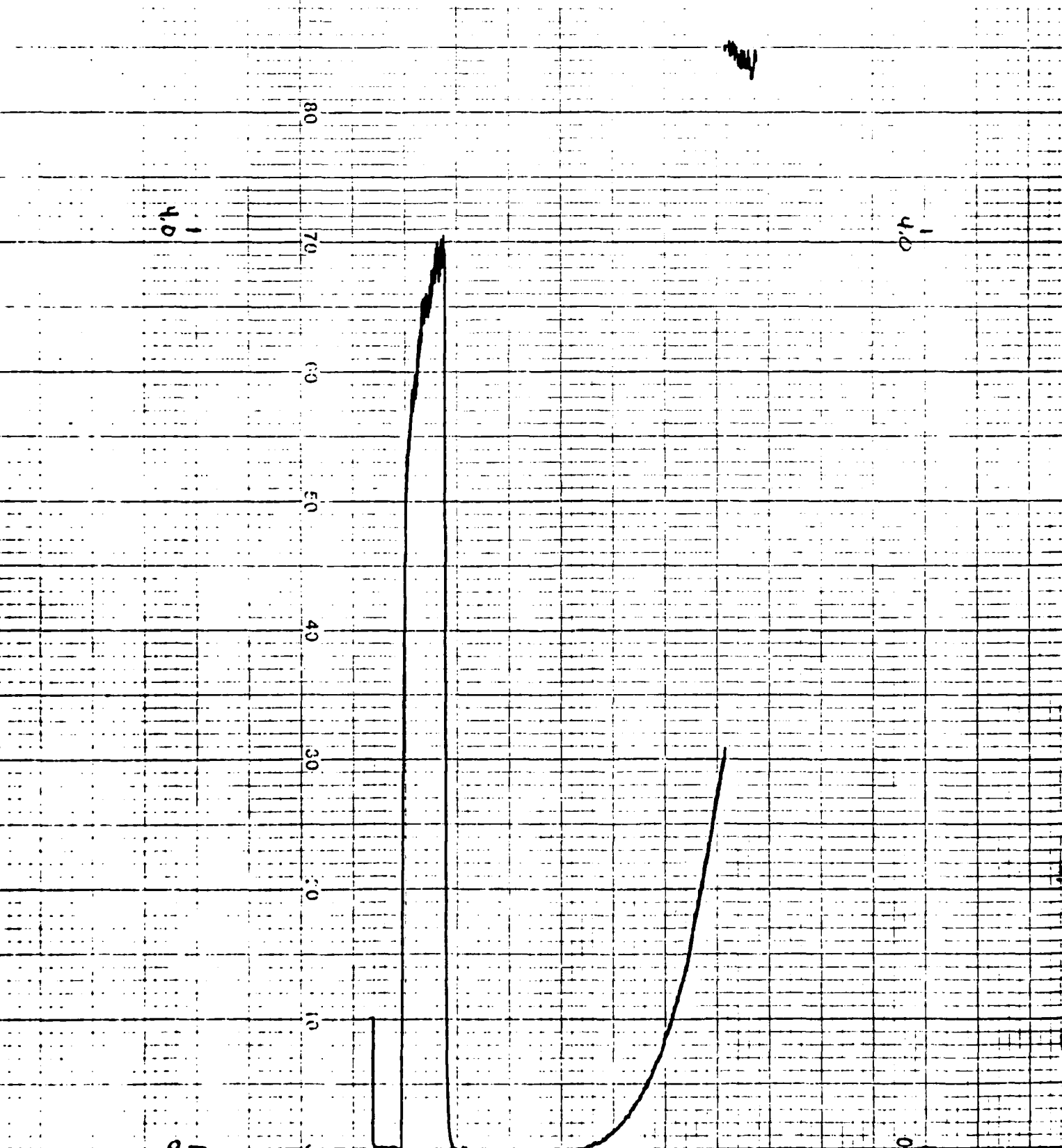
9.0
107

6.0

4.0

4.0

100
90
80
70
60
50
40
30
20
10
0



PHASE 2: L/D RATIO VARIATION

Test Designator: 2-3

			TIME (min)	T1 (hum)	T2 (bed)	T3 (in)	T4 (out)	T5 (edge)
RMV =	12	SLPM	0	103.4	68.8	68.3	61.8	68.3
TV =	.75	lit/br	5	102.4	139.8	71	71.8	117.8
RR =	16	br/min	10	101.7	141	73	80.3	125.3
T(amb) =	63.9	deg F	15	101	185	74.5	85.1	136.7
P(amb) =	30.06	in Hg	20	100.4	249.1	75.6	88.8	171.9
V(sc) =	10	cm/hr	25	100	230.5	76.7	91.4	185.2
W(wet) =	101.58	g	30	99.7	207	77.2	98.3	182
W(dry) =	90.68	g	35	99.4	192.6	78	102.8	176.5
W(fin) =	114.41	g	40	99.2	183.4	78.6	106.2	171
			45	99	176.8	79.1	107.8	165.8
CO2 INJECTION			50	98.9	171.6	79.4	108.2	161
Init =	4.3	%	55	98.8	167.8	79.6	108.4	156.8
Final =	3.7	%						
Ave =	4	%						

T(break) = 37.5 min

L/D #3

L = 3.75 in

D = 2 in

6.0

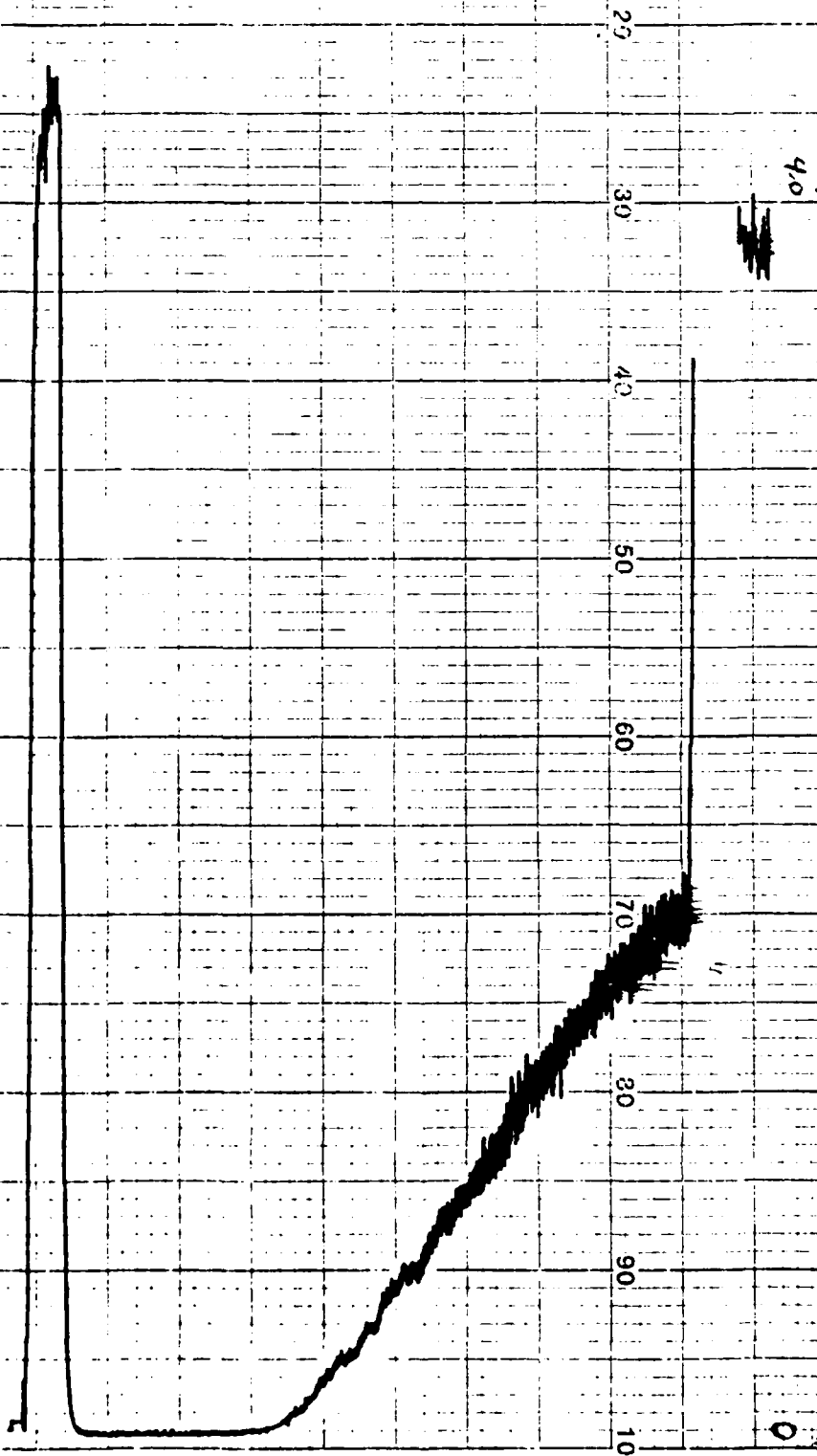
6.0

109

TEST 2-3 L/D #3

4.0

4.0



PHASE 2: L/D RATIO VARIATION

Test Designator: 2-4

			TIME (min)	T1 (hum)	T2 (bed)	T3 (in)	T4 (out)	T5 (edge)
RMV =	12	SLPM	0	99.5	84.4	77.4	84.2	91.4
TV =	.75	lit/br	5	99.3	141.8	78.6	88.8	125.1
RR =	16	br/min	10	99.1	142.6	79.4	92.3	129.8
			15	98.9	155.5	79.8	94.8	133.5
T(amb) =	73.4	deg F	20	98.6	256.5	80.3	96.5	163.7
P(amb) =	30.36	in Hg	25	98.6	251.6	80.5	98.9	193
V(sc) =	10	cm/hr	30	98.3	223.2	80.7	104.8	196.3
W(wet) =	104.1	g	35	98.2	202.3	80.8	110.2	190.2
W(dry) =	90.8	g	40	98.2	189.2	81	113.1	182
W(fin) =	112.8	g	45	98.2	180.8	81.1	115	174.7
CO2 INJECTION			50	98.2	175.3	81.2	114.8	168.5
Init =	4.15	%						
Final =	3.9	%						
Ave =	4.025	%						

T(break) = 40 min

L/D #3

L = 3.75 in

D = 2 in

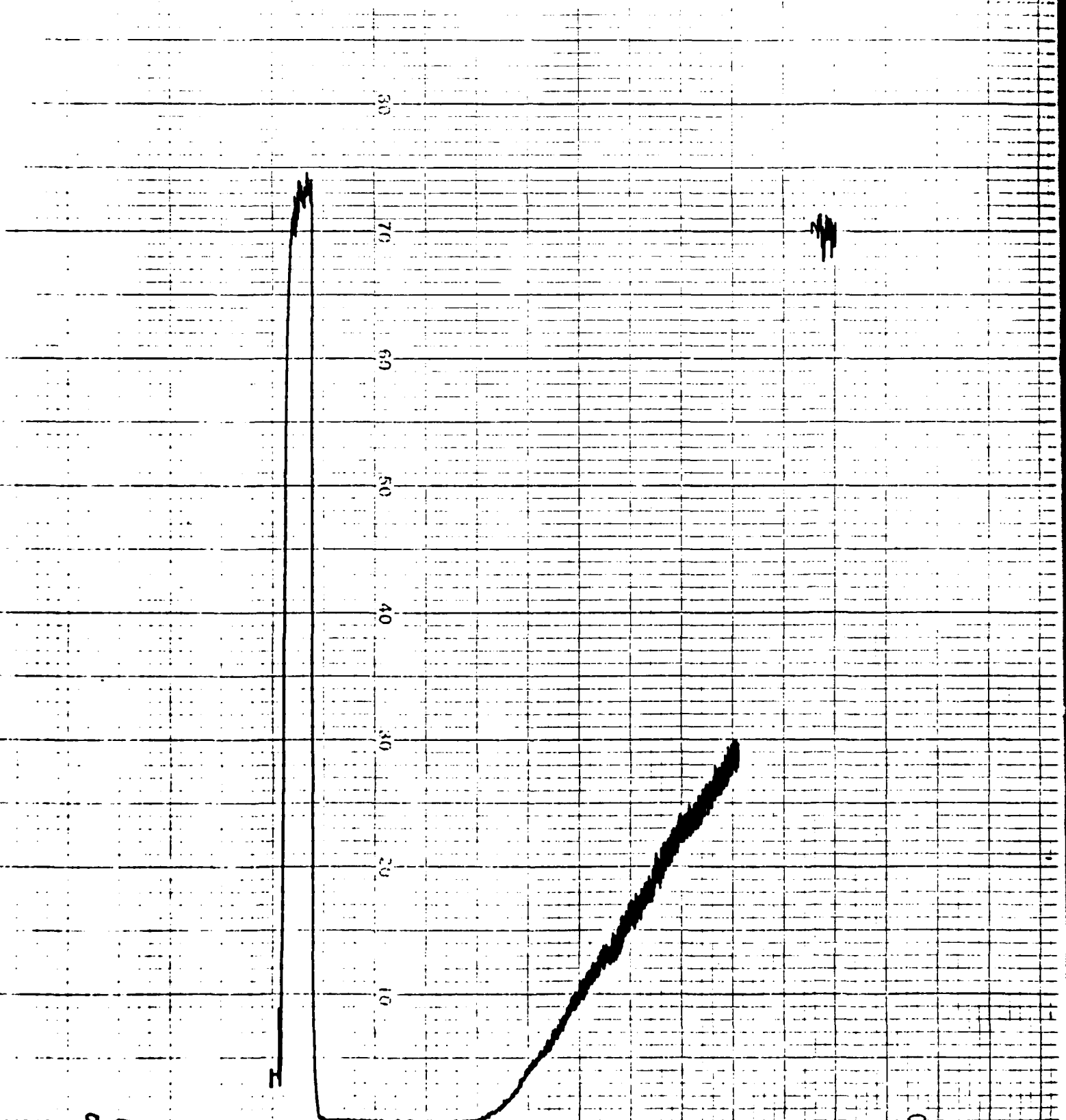
50

100

100

111

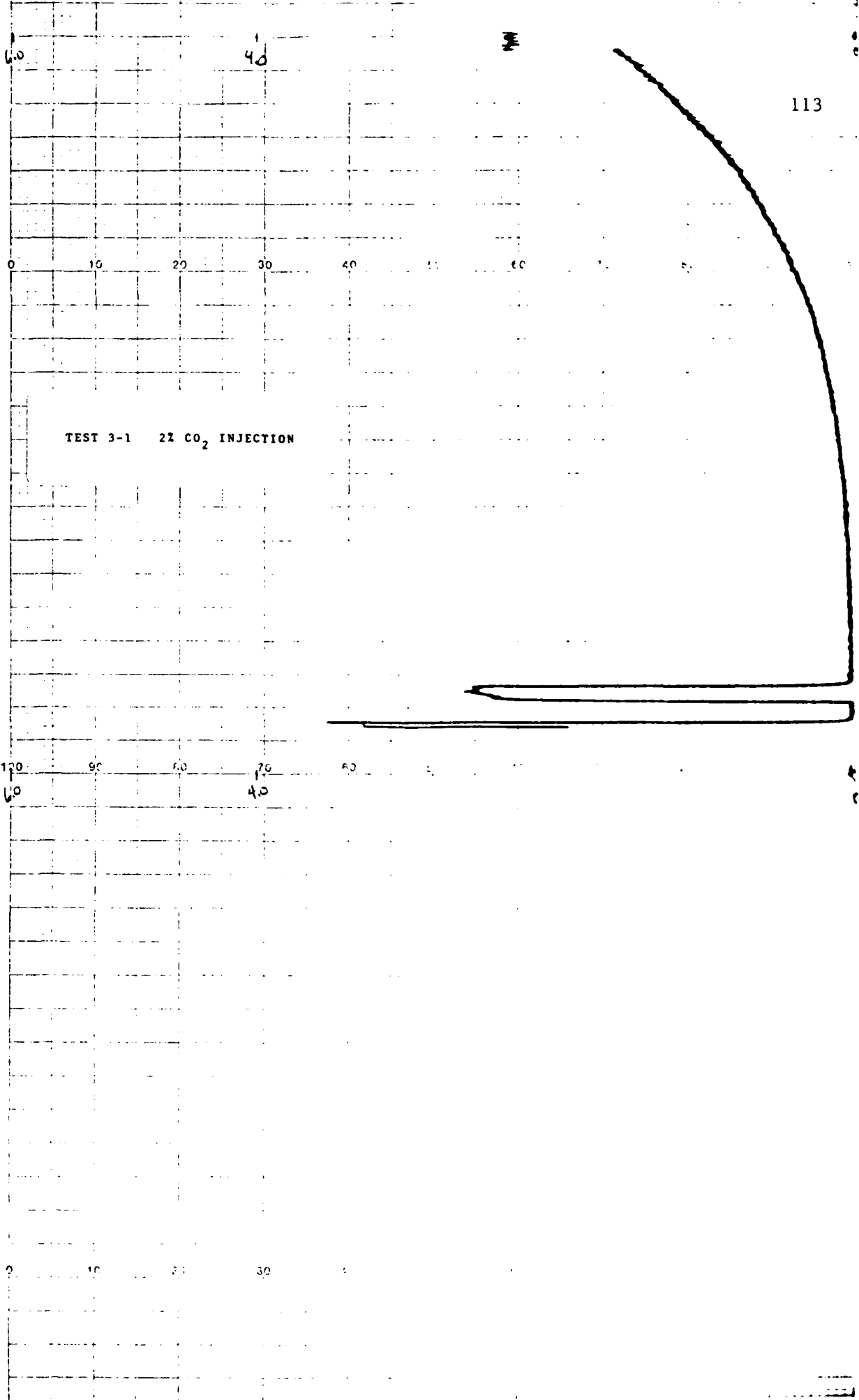
TEST 2-4 L/D #3



PHASE 3: CO2 LOADING VARIATION

Test Designator: 3-1

RMV =	12	SLPM	TIME	T1	T2	T3	T4
TV =	.75	lit/br	(min)	(hum)	(bed)	(in)	(out)
RR =	16	br/min					
T(amb) =	75.4	deg F	0	90.1	119.2	76.6	77.2
			5	95.5	133.8	77.2	83.6
P(amb) =	30.21	in Hg	10	97.8	140.3	78.4	90.7
			20	99.7	159.3	80.2	98.3
V(sc) =	10	cm/hr	30	99.8	168.3	81.6	103.8
			40	99.2	171.7	82.3	106.7
W(wet) =	114.06	g	50	98.7	171.5	82.6	110
W(dry) =	89.84	g	60	98.5	169.8	82.8	112.8
W(fin) =	126.54	g					
CO2 INJECTION			10	98.4	166.9	82.8	114.9
Init =	2	%	20	98.4	163.6	83	115.1
Final =	2	%	30	98.4	160.5	83	116.1
Ave =	2	%	40	98.4	157.8	83.2	117.2
			50	98.4	155.2	83.2	117
			60	98.4	152.8	83.2	118.5
T(break) =	101	min					

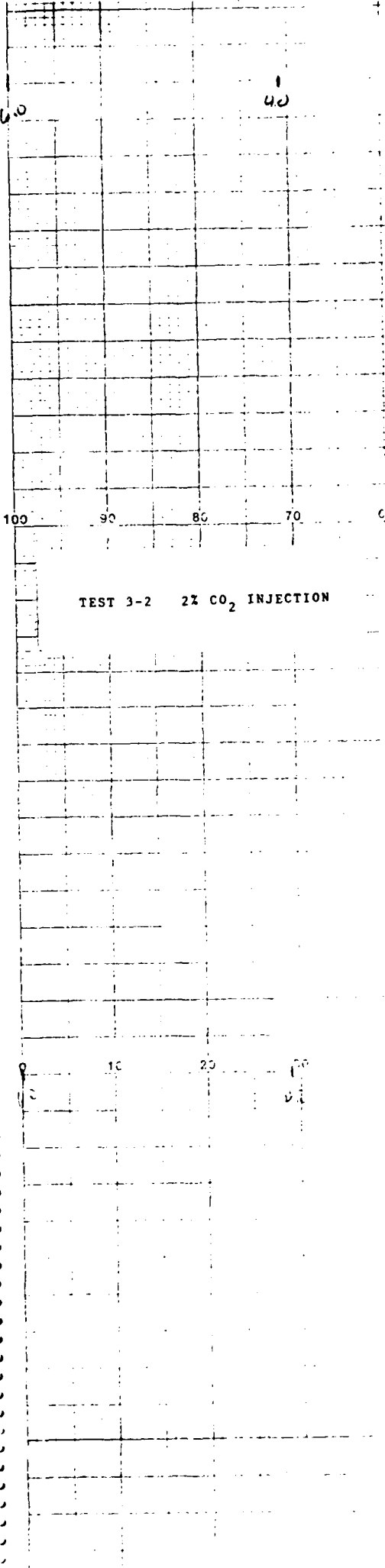


PHASE 3: CO2 LOADING VARIATION

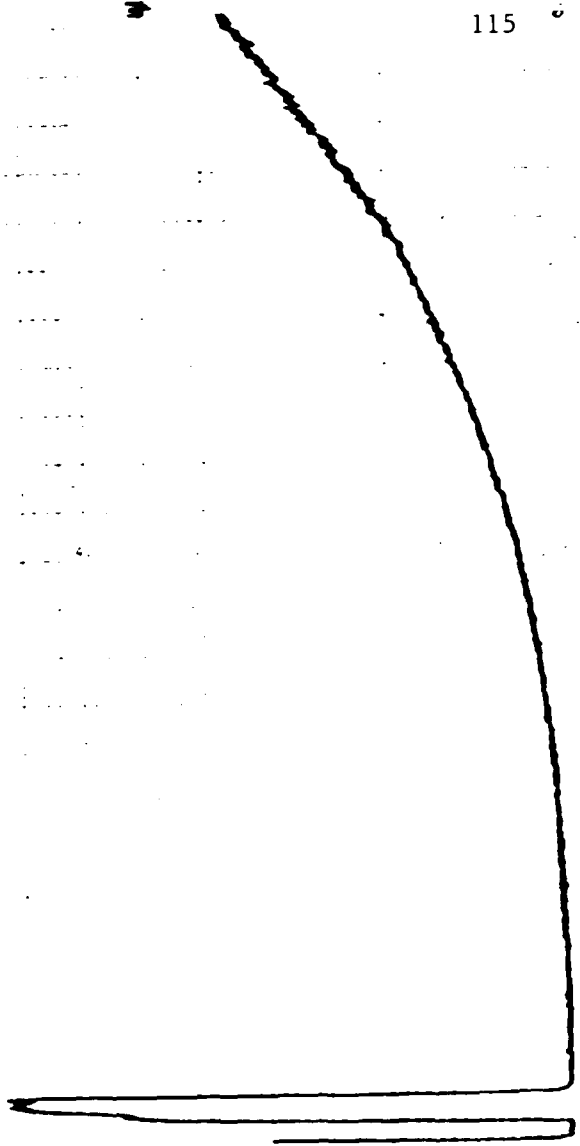
Test Designator: 3-2

RMV =	12	SLPM	TIME	T1	T2	T3	T4
TV =	.75	lit/br	(min)	(hum)	(bed)	(in)	(out)
RR =	16	br/min					
T(amb) =	73.4	deg F	0	90.9	76.6	74.2	72.9
P(amb) =	30.04	in Hg	5	94.7	127.8	75.2	79.4
			10	97.2	136.9	76.3	87.6
			20	99.7	150.1	78.4	94.8
V(sc) =	10	cm/hr	30	100	158.9	79.7	99.8
			40	99.7	161.6	80.5	102.2
W(wet) =	103.25	g	50	99.2	162.5	81.2	106.1
W(dry) =	89.3	g	60	98.9	161.4	81.4	108.3
W(fin) =	126.03	g	-----				
			10	98.7	159	81.6	109.6
CO2 INJECTION			20	98.6	156.4	81.7	110.1
Init =	2.2	%	30	98.6	154	81.7	112.1
Final =	1.5	%	40	98.6	151.4	81.7	112.5
Ave =	1.85	%	50	98.5	149.3	81.8	112.8
			60	98.4	147.4	81.7	112.2

T(break) =	115	min	10	98.4	145.5	81.6	111.6
			20	98.4	143.9	81.6	111.5



TEST 3-2 2% CO₂ INJECTION



PHASE 3: CO2 LOADING VARIATION

Test Designator: 3-3

RMV =	12	SLPM	TIME	T1	T2	T3	T4
TV =	.75	lit/br	(min)	(hum)	(bed)	(in)	(out)
RR =	16	br/min					
			0	99.8	94.1	77.4	81.4
T(amb) =	72.8	deg F	5	99.6	126.8	78.4	85.7
P(amb) =	30.45	in Hg	10	99.4	132	78.8	90.3
			20	99.1	134.4	79.9	93.8
V(sc) =	10	cm/hr	30	99	137.1	80.2	95.8
			40	99	139.1	80.5	97
W(wet) =	103.75	g	50	99	140.3	80.5	98.8
W(dry) =	89.84	g	60	99	140.2	80.7	99.4
W(fin) =	133.09	g					
			10	98.9	139.9	80.8	100
CO2 INJECTION			20	98.9	139	80.8	100.5
Init =	1.2	%	30	98.9	138	81	101.4
Final =	1	%	40	98.9	137.2	81.1	102.4
Ave =	1.1	%	50	98.9	136.6	81.1	103.5
			60	98.9	135.5	81.3	103.5
T(break) =	185	min	10	98.9	134.2	81.4	103.9
			20	98.9	132.8	81.5	103.7
			30	98.8	131.5	81.7	103.4
			40	98.8	130.6	81.7	103.8
			50	98.8	128.6	82	104.2
			60	98.8	127.2	82	103.8
			10	98.8	125.8	82.1	103.4
			20	98.8	124.3	82.1	103.5
			30	98.8	122.9	82	103.2
			40				
			50	97	183.2	85.3	105.8

TEST 3-3 12 CO₂ INJECTION

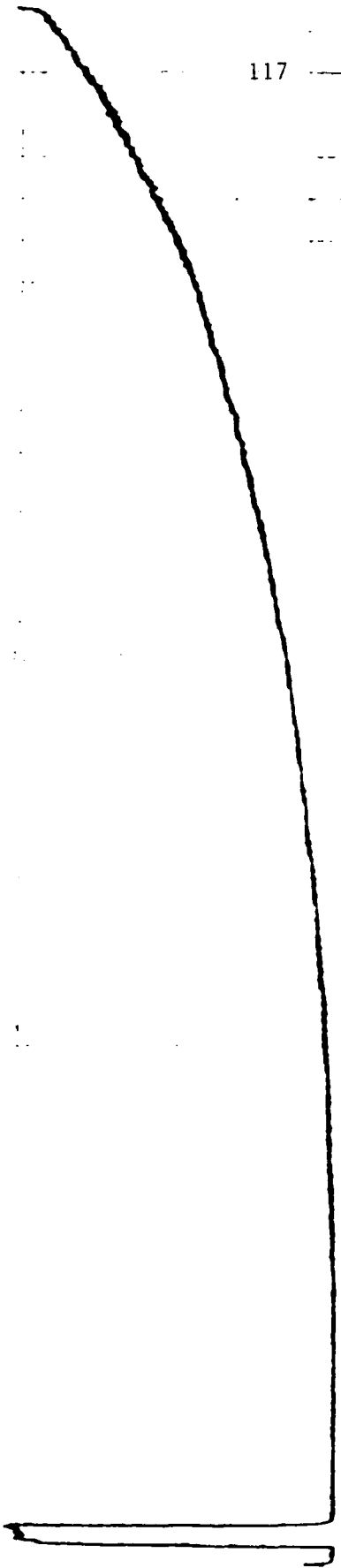
100 90 80 70 60

0 10 20 30 40 50 60 70 80 90 100

100 90 80 70 60

60

42



PHASE 3: CO2 LOADING VARIATION

Test Designator: 3-4

RMV =	12	SLPM	TIME	T1	T2	T3	T4
TV =	.75	lit/br	(min)	(hum)	(bed)	(in)	(out)
RR =	16	br/min					
T(amb) =	65.1	deg F	0	100.5	77.2	68.6	67.3
P(amb) =	30.04	in Hg	5	101.9	117.5	71.4	72.6
			10	102	126.3	72.9	78.8
			20	101.2	131.2	74.6	86
V(sc) =	10	cm/hr	30	100.2	135.4	75.5	90.3
			40	99.7	137.6	75.9	92.8
W(wet) =	105.26	g	50	99.4	138	76.1	94.2
W(dry) =	89.81	g	60	99.3	137.6	76.3	95.6
W(fin) =	132.69	g					
CO2 INJECTION			10	99.3	136.6	76.3	96.4
Init =	1.15	%	20	99.3	136	76.3	97
Final =	.9	%	30	99.3	135.2	76.3	97.4
Ave =	1.025	%	40	99.3	133.7	76.4	98
			50	99.3	131.1	76.5	98.6
			60	99.2	129.9	76.5	98.2
T(break) =	192.5	min					
			10	99.3	129.3	76.4	98.4
			20	99.3	127.9	76.4	98.8
			30	99.3	126.7	76.5	98
			40	99.3	125.2	76.5	98.7
			50	99.3	123.8	76.7	98.8
			60	99.3	122.4	76.7	98.9
			10	99.2	121	76.6	98.4
			20	99.3	119.4	76.7	98.1
			30	99.3	118.1	76.8	98.1
			40	99.2	116.4	76.8	97.8
			50	99.3	114.4	77	97.7

TEST 3-4 1% CO₂ INJECTION

0 10 20 30 40 50 60 70 80 90 100

100 90 80 70 60 50 40 30 20 10 0

0 10 20 30 40 50 60 70 80 90 100



PHASE 4: AMBIENT TEMPERATURE VARIATION

Test Designator: 4-1

RMV =	12	SLPM	TIME	T1	T2	T3	T4
TV =	.75	lit/br	(min)	(hum)	(bed)	(in)	(out)
RR =	16	br/min					
			0	65.1	68.7	65.6	63.7
T(amb) =	65.4	deg F	5	65	139.9	65.8	75.8
P(amb) =	30.04	in Hg	10	65	160.2	65.8	87.3
			15	65	180.8	65.8	91.4
V(sc) =	10	cm/hr	20	65	194.7	65.7	95.8
			25	65	200.8	65.8	100.5
W(wet) =	99.19	g	30	65	200.8	65.8	106
W(dry) =	86.81	g	35	65	193.8	65.8	110.3
W(fin) =	106.9	g	40	65	183.5	65.8	113.4

CO2 INJECTION

Init = 4.15 %
 Final = 3.9 %
 Ave = 4.025 %

T(break) = 36.5 min

TEST 4-1 65 deg. F AMBIENT

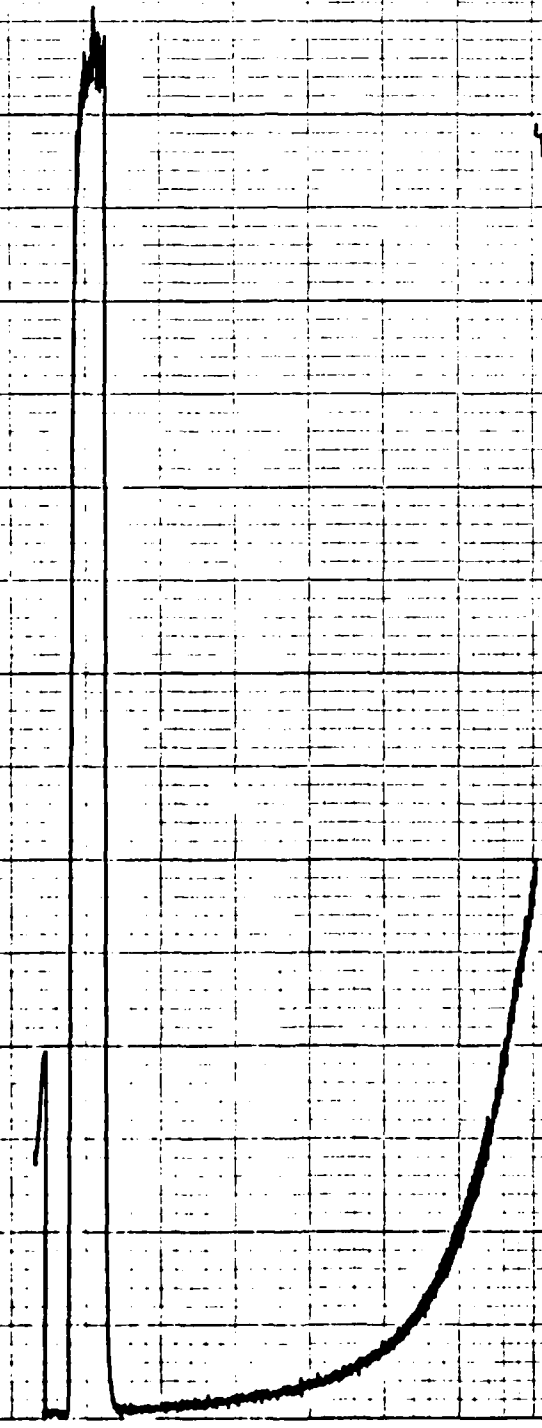
60

60

4.0

4.0

20
30
40
50
60
70
80
90
100



PHASE 4: AMBIENT TEMPERATURE VARIATION

Test Designator: 4-2

			TIME (min)	T1 (hum)	T2 (bed)	T3 (in)	T4 (out)
RMV =	12	SLPM	0	65.1	69.4	66.3	74.2
TV =	.75	lit/br	5	65.1	141	66.2	82.8
RR =	16	br/min	10	65.1	160.6	66.2	90.2
T(amb) =	65.5	deg F	15	65.1	187.6	66.2	95
P(amb) =	30.04	in Hg	20	65.1	200.6	66.2	98.8
V(sc) =	10	cm/hr	25	65.1	202.1	66.2	103.6
W(wet) =	106.85	g	30	65.2	197.4	66.2	108.7
W(dry) =	90.02	g	35	65.2	187.6	66.2	110.8
W(fin) =	109.99	g	40	65.2	178	66.2	113.1

CO2 INJECTION

Init =	4.2	%
Final =	3.75	%
Ave =	3.975	%

T(break) = 33.5 min

TEST 4-2 65 deg. F AMBIENT

6.0

6.0

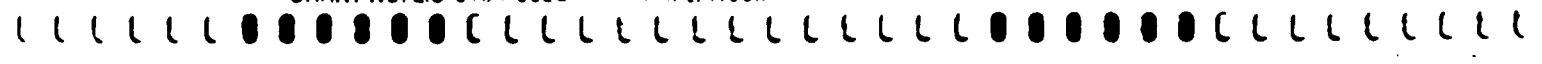
4.0

4.0

0

0

10
20
30
40
50
60
70
80
90
100



PHASE 5: REJUVENATION

Test Designator: 5-1

DAY 1

RMV = 12 SLPM
 TV = .75 lit/br
 RR = 16 br/min

T(amb) = 69.3 deg F
 P(amb) = 30.21 in Hg

V(sc) = 10 cm/hr

W(wet) = 101.63 g
 W(dry) = 90.66 g
 W(fin) = 114.7 g

CO2 INJECTION

Init = 3.8 %
 Final = 3 %
 Ave = 3.4 %

T(break) = 54.5 min

TIME (min)	T1 (hum)	T2 (bed)	T3 (in)	T4 (out)
0	104.2	73.8	71.8	70.8
5	103.2	142	74.6	82.6
10	102.3	156.4	75.9	92.6
15	101.4	175.8	76.6	96.9
20	100.6	187.6	77.3	99.9
25	100	193.8	77.5	103.6
30	99.6	198	77.8	108
35	99.3	199.2	78	111
40	99.2	197.8	78.1	113.7
45	99.1	194.8	78.2	116.8
50	99.1	190.6	78.3	118.9
55	99	185.7	79.1	119.1

DAY 2

T(amb) = 68.4 deg F
 P(amb) = 30.04 in Hg

W(init) = 114.7 g
 W(fin) = 122.99 g

CO2 INJECTION

Init = 4.09 %
 Final = 3.6 %
 Ave = 3.845 %

T(break) = 9.5 min

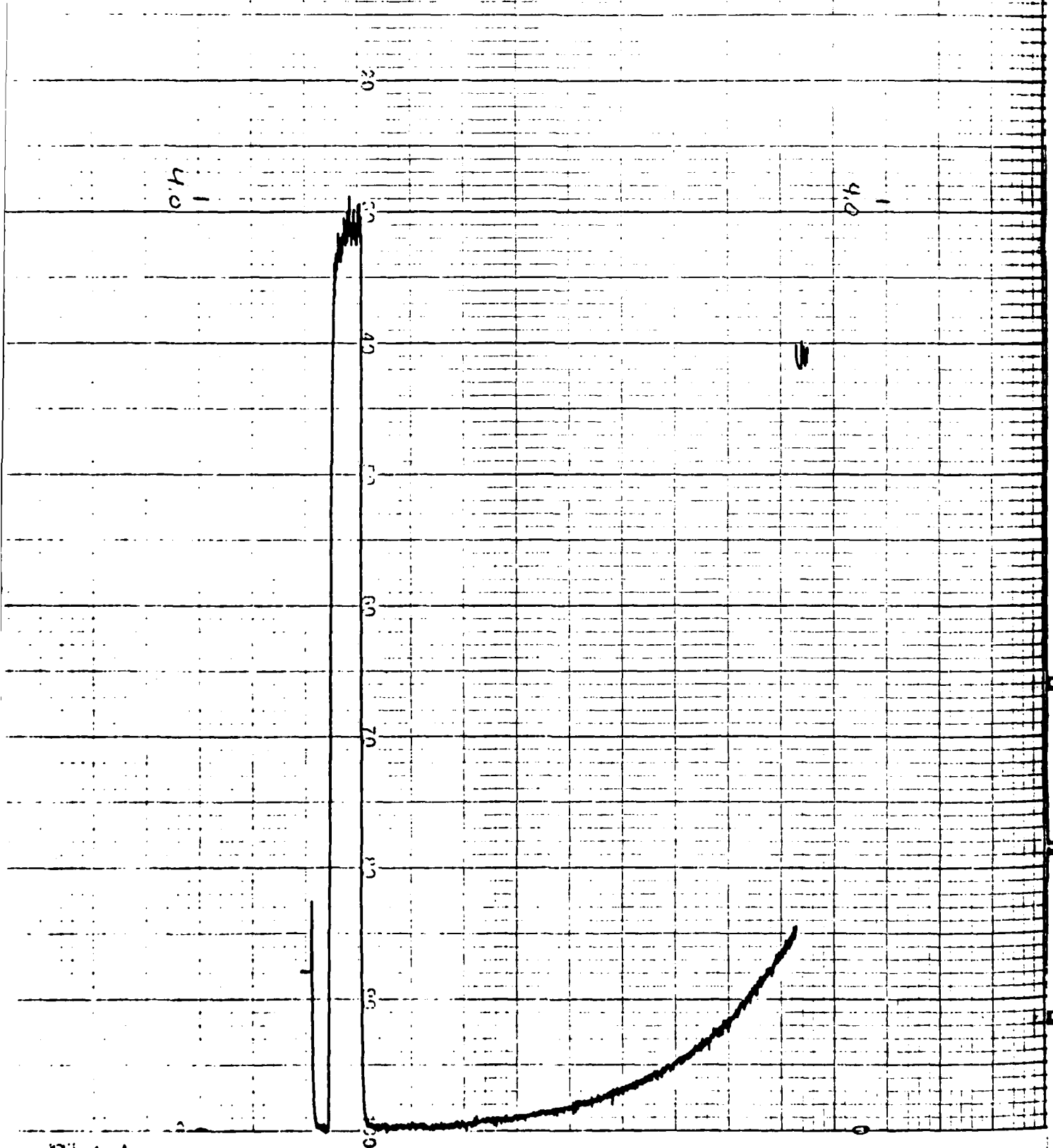
TIME (min)	T1 (hum)	T2 (bed)	T3 (in)	T4 (out)
0	100.8	71.6	70.5	69.7
5	103.1	141.2	72.6	82.6
10	103.2	157.6	74.2	92.9
15	102.8	171.8	75.4	97.1

60

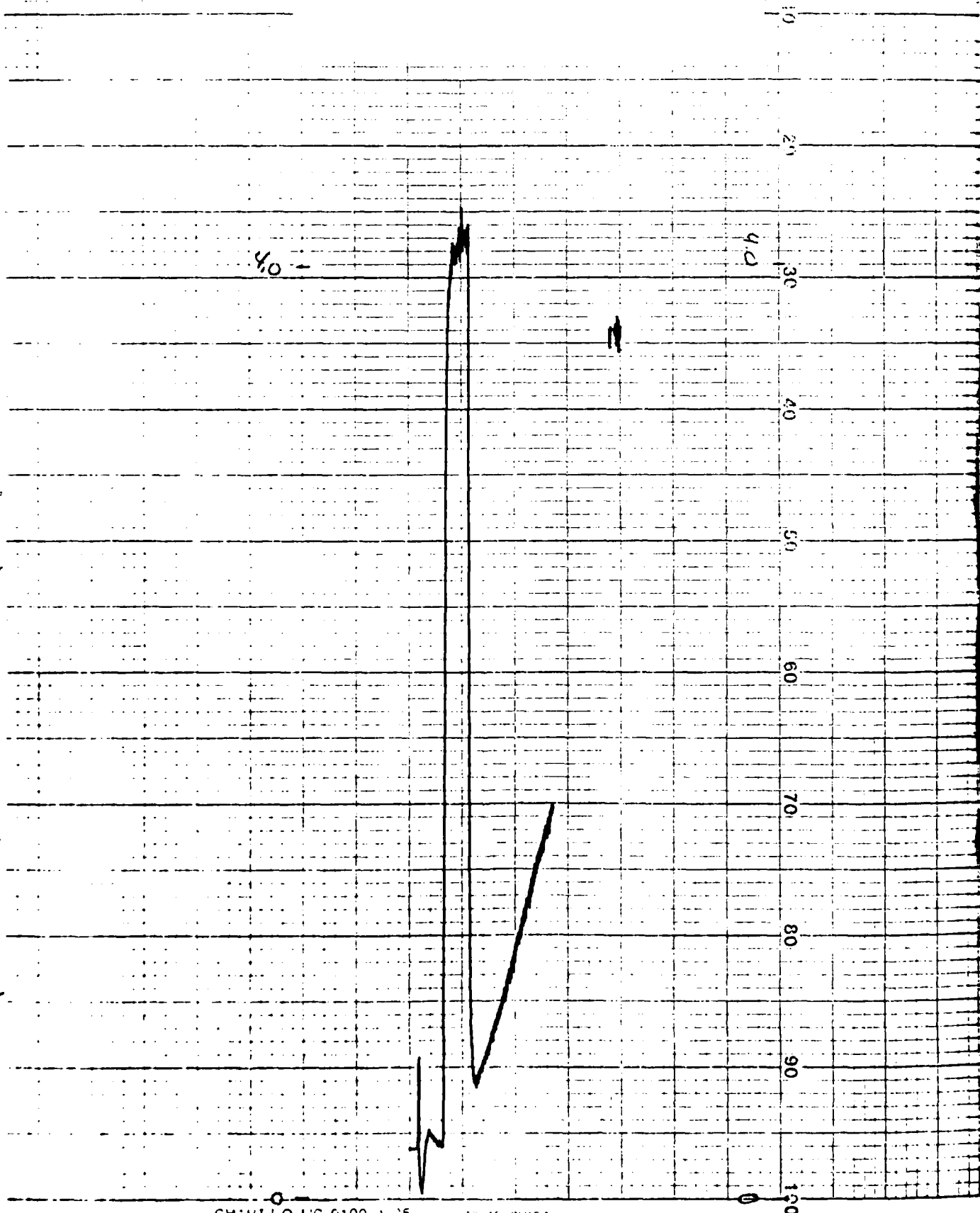
60

125

TEST 5-1 REJUVENATION (DAY 1)



TEST 5-1 REJUVENATION (DAY 2)



PHASE 5: REJUVENATION

Test Designator: 5-2

DAY 1

			TIME (min)	T1 (hum)	T2 (bed)	T3 (in)	T4 (out)
RMV =	12	SLPM					
TV =	.75	lit/br					
RR =	16	br/min					
T(amb) =	69.3	deg F	0	100.4	73	75.1	87.2
P(amb) =	30.21	in Hg	5	100.2	143.8	76.6	91.8
			10	99.9	163.3	77.5	99.5
			15	99.6	185.6	78.1	102.9
V(sc) =	10	cm/hr	20	99.4	197	78.4	107
			25	99.2	203.3	78.8	111
W(wet) =	98.85	g	30	99	202.4	79	117.4
W(dry) =	89.95	g	35	98.9	203.6	79.1	120.4
W(fin) =	112.32	g	40	98.8	200.3	79.2	123.4
			45	98.8	194.8	79.4	125.8
			50	98.8	191.8	79.5	126.7
CO2 INJECTION							
Init =	3.8	%					
Final =	3	%					
Ave =	3.4	%					
T(break) =	48	min					

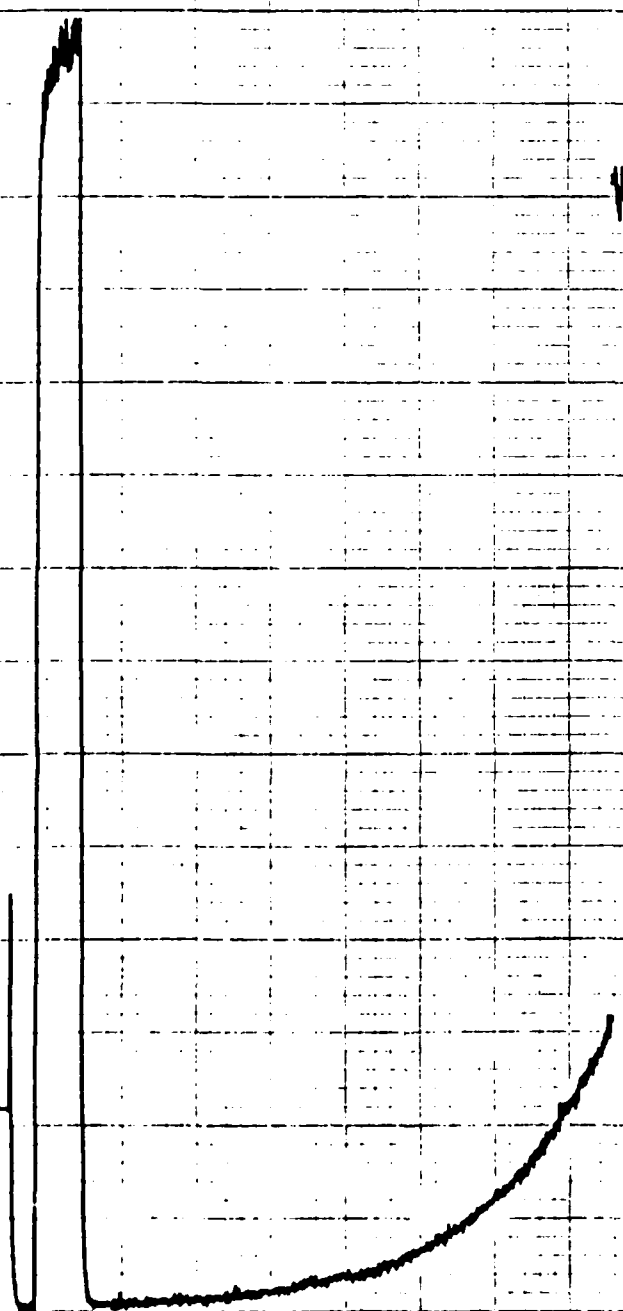
DAY 2

			TIME (min)	T1 (hum)	T2 (bed)	T3 (in)	T4 (out)
T(amb) =	68.8	deg F					
P(amb) =	30.04	in Hg					
W(init) =	112.32	g	0	100.4	77.6	74.1	77.6
W(fin) =	120.22	g	5	100.2	146.3	75.1	146.3
			10	99.8	166.2	76	166.2
CO2 INJECTION							
Init =	4.43	%					
Final =	4	%					
Ave =	4.215	%					
T(break) =	7.5	min					

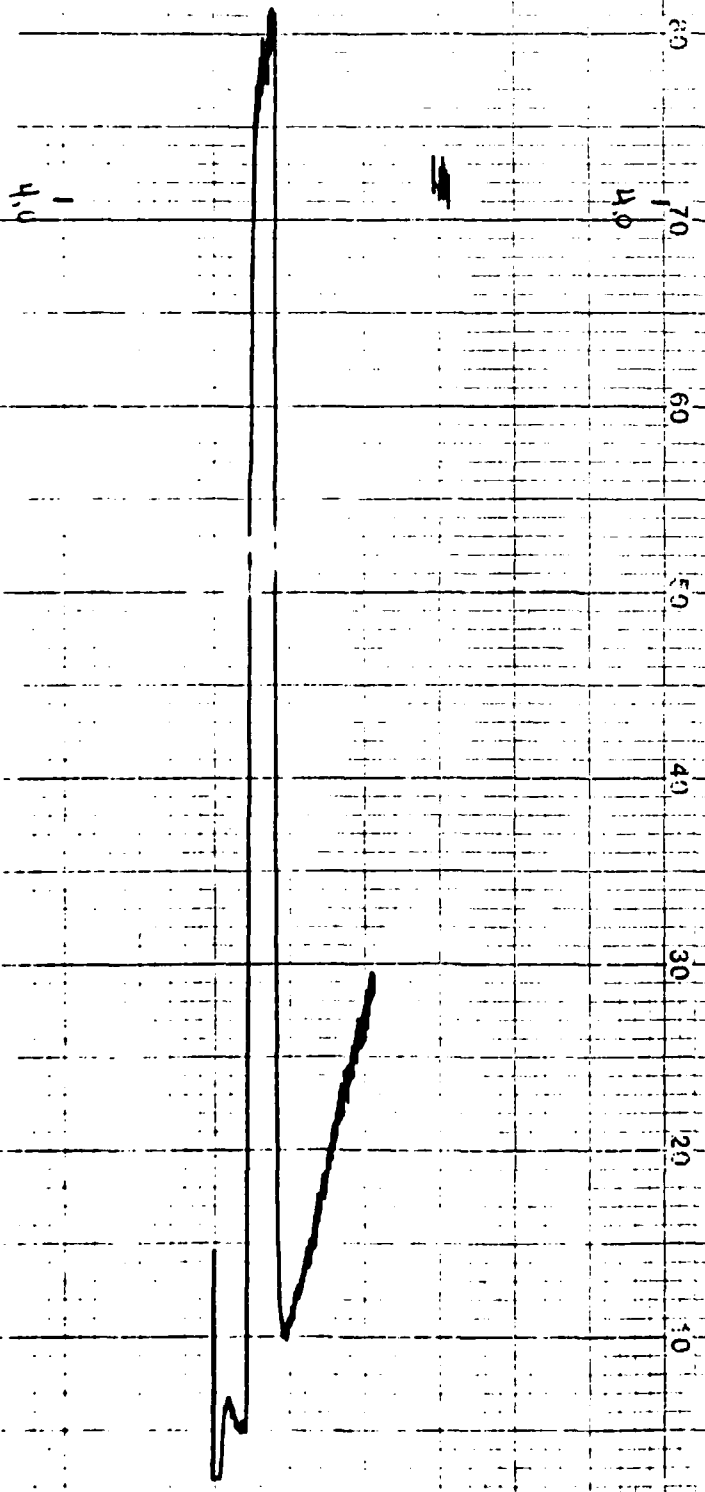
TEST 5-2 REJUVENATION (DAY 1)

100
90
80
70
60
50
40
30
20
10
0

0
128
10
20
30
40
50
60
70
80
90
100



TEST 5-2 REJUVENATION (DAY 2)



PHASE 6: PREBREATHING

Test Designator: 6-1

			TIME (min)	T1 (hum)	T2 (bed)	T3 (in)	T4 (out)
RMV =	12	SLPM					
TV =	.75	lit/br					
RR =	16	br/min					
			0	101.4	71.4	70.5	67.3
T(amb) =	68.7	deg F	10	101.1	141.5	71	75.9
P(amb) =	30.06	in Hg	20	100.7	148.2	71.6	85.3
			30	100.3	159.6	72	89.9
V(sc) =	10	cm/hr	40	100.2	168.8	72	93.5
			50	100.1	175.4	72.1	95.8
W(wet) =	100.68	g	60	100	179.8	72.4	96.6
W(dry) =	90.2	g					
W(fin) =	118.19	g	5	100.2	192.7	73.7	105
			10	100	198.1	74.9	110.8
CO2 INJECTION			15	99.8	194	75.8	116.9
Init =	4.05	%	20	99.6	188.2	76.2	118.9
Final =	3.75	%	25	99.5	182.7	76.7	121.5
Ave =	3.9	%					

T(break) = 18.5 min

PREBREATHING DATA

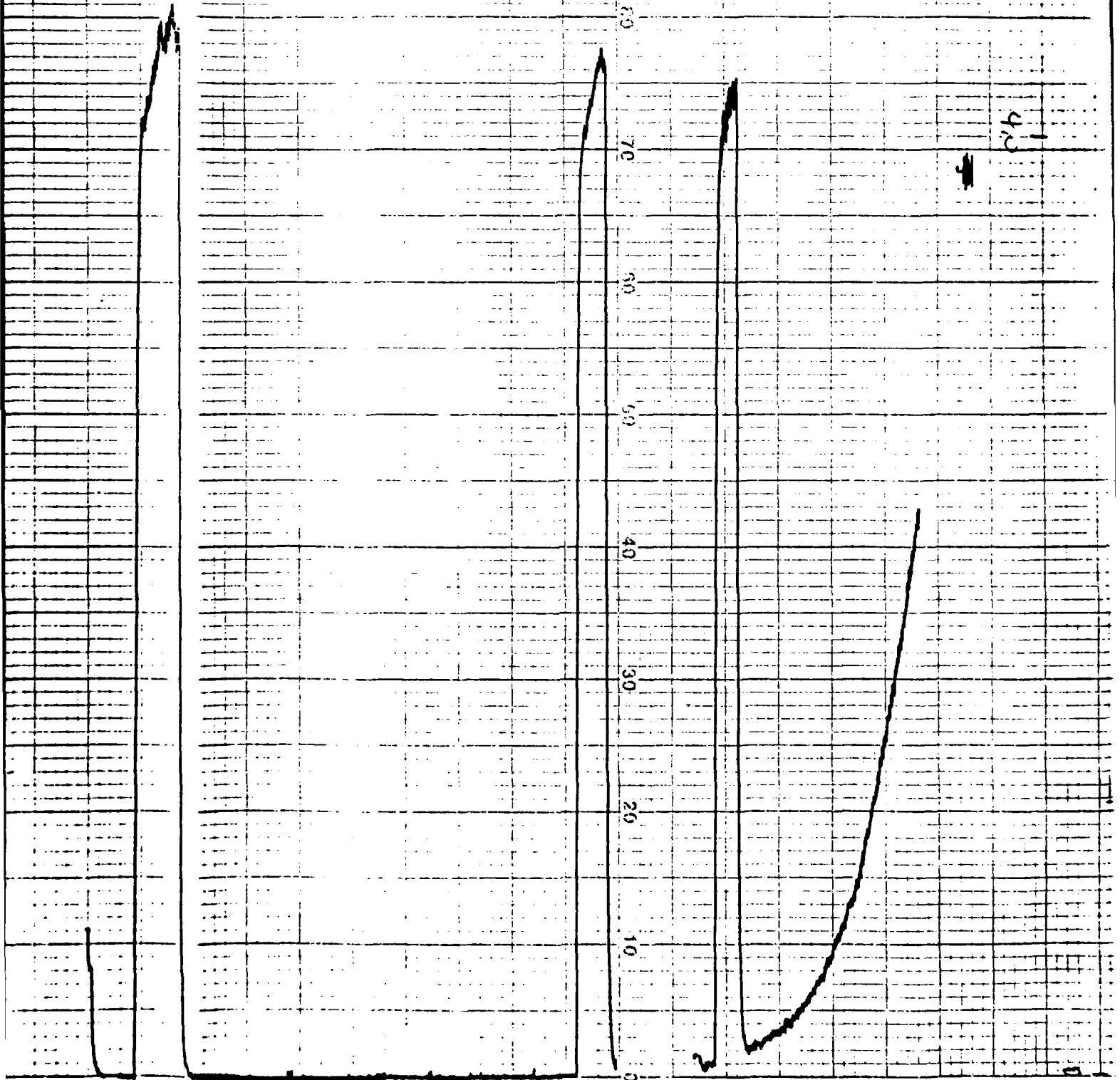
DURATION = 60 min

RMV =	6	SLPM
TV =	.5	lit/br
RR =	12	br/min

CO2 INJECTION

Init =	4.45	%
Final =	4.3	%
Ave =	4.375	%

TEST 6-1 PREBREATHING



PHASE 6: PREBREATHING

Test Designator: 6-2

			TIME (min)	T1 (hum)	T2 (bed)	T3 (in)	T4 (out)
RMV =	12	SLPM	0	101	72.2	72.6	81.2
TV =	.75	lit/br	10	100.9	144.6	72.6	84
RR =	16	br/min	20	100.4	150	72.5	89.6
T(amb) =	68.7	deg F	30	100.2	162.7	72.6	92.6
P(amb) =	30.06	in Hg	40	100.1	172.4	72.6	94
V(sc) =	10	cm/hr	50	100.1	177.8	72.6	96.2
W(wet) =	103	g	60	100.1	182.5	72.6	98.1
W(dry) =	90.14	g					
W(fin) =	115.65	g	5	100.1	199.9	73.8	106
CO2 INJECTION			10	100	203.2	74.6	11.5
Init =	4.3	%	15	99.8	196.7	75.2	116.5
Final =	4	%	20	99.7	189.3	75.8	120.2
Ave =	4.15	%					
T(break) =	16.5	min					

PREBREATHING DATA

DURATION= 60 min

RMV =	6	SLPM
TV =	.5	lit/br

RR =	12	br/min
------	----	--------

CO2 INJECTION

Init =	4.6	%
Final =	4.5	%
Ave =	4.55	%

TEST 6-2 PREBREATHING

133

