

NAS
NAE
IOM

Hypersonic Technology for Military Application

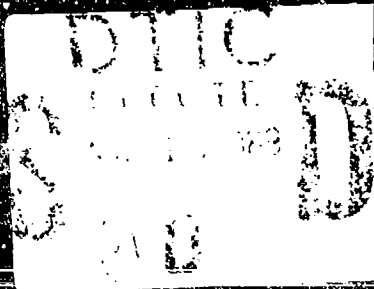

RESTRICTION STATEMENT A
Approved for Public Release
Distribution Unlimited

Committee on Hypersonic Technology
for Military Application
Air Force Studies Board
Commission on Engineering and Technical Systems
National Research Council

REPORT DOCUMENTATION PAGE

Form Approved
OMB No. 0704-0188

1a. REPORT SECURITY CLASSIFICATION unclassified		1b. RESTRICTIVE MARKINGS n/a	
2a. SECURITY CLASSIFICATION AUTHORITY USAF AFSC/CA		3. DISTRIBUTION/AVAILABILITY OF REPORT unclassified/unlimited	
2b. DECLASSIFICATION/DOWNGRADING SCHEDULE			
4. PERFORMING ORGANIZATION REPORT NUMBER(S) n/a		5. MONITORING ORGANIZATION REPORT NUMBER(S) n/a	
6a. NAME OF PERFORMING ORGANIZATION AIR FORCE STUDIES BOARD NATIONAL RESEARCH COUNCIL	5b. OFFICE SYMBOL (if applicable) n/a	7a. NAME OF MONITORING ORGANIZATION HQ AFSC/CA	
6c. ADDRESS (City, State, and ZIP Code) 2101 Constitution Avenue, N.W. Washington, D.C. 20418		7b. ADDRESS (City, State, and ZIP Code) Andrews Air Force Base, MD 20330	
8a. NAME OF FUNDING/SPONSORING ORGANIZATION HQ AFSC	8b. OFFICE SYMBOL (if applicable) n/a	9. PROCUREMENT INSTRUMENT IDENTIFICATION NUMBER	
8c. ADDRESS (City, State, and ZIP Code) Andrews AFB, MD 20330		10. SOURCE OF FUNDING NUMBERS	
		PROGRAM ELEMENT NO. n/a	PROJECT NO. n/a
		TASK NO. n/a	WORK UNIT ACCESSION NO. n/a
11. TITLE (Include Security Classification) Hypersonic Technology for Military Application (U)			
12. PERSONAL AUTHOR(S) Committee on Hypersonic Technology for Military Application			
13a. TYPE OF REPORT final	13b. TIME COVERED FROM 1/87 TO 7/88	14. DATE OF REPORT (Year, Month, Day) 14 April 1989	15. PAGE COUNT 88
16. SUPPLEMENTARY NOTATION			
17. COSATI CODES		18. SUBJECT TERMS (Continue on reverse if necessary and identify by block number)	
FIELD	GROUP	SUB-GROUP	
01	03		hypersonic aircraft,
21	05		National Aerospace Plane. (JRS)
19. ABSTRACT (Continue on reverse if necessary and identify by block number)			
<p>With the current interest in and potential for hypersonic flight, there is a need to determine for the Air Force and for the nation the R&D approaches required to realize the opportunities offered by flight in this regime.</p> <p>The committee: (1) determined possible military uses of hypersonic flight, (2) drew on the developing hypersonic technology base, including the evolving results of NASP Phase II, to assess the technical feasibility of meeting the potential applications, (3) identified the technological needs for hypersonic flight, (4) assessed the R&D support requirements including availability of expertise, data bases, and test facilities, (5) provided technical advice to the command level on the R&D strategy of the NASP.</p>			
20. DISTRIBUTION/AVAILABILITY OF ABSTRACT <input checked="" type="checkbox"/> UNCLASSIFIED/UNLIMITED <input type="checkbox"/> SAME AS RPT <input type="checkbox"/> DTIC USERS		21. ABSTRACT SECURITY CLASSIFICATION unclassified	
22a. NAME OF RESPONSIBLE INDIVIDUAL Mr. Vernon H. Miles, Sr. Director AFSSB		22b. TELEPHONE (Include Area Code) 202/334-3531	22c. OFFICE SYMBOL n/a

Hypersonic Technology for Military Application

Committee on Hypersonic Technology
for Military Application
Air Force Studies Board
Commission on Engineering and Technical Systems
National Research Council



Accession For	
NTIS CRA&I	<input checked="" type="checkbox"/>
DTIC TAB	<input type="checkbox"/>
Unannounced	<input type="checkbox"/>
Justification	
By	
Distribution/	
Availability Codes	
Dist	Avail and/or Special
A-1	

NOTICE: The project that is the subject of this report was approved by the Governing Board of the National Research Council, whose members are drawn from the councils of the National Academy of Sciences, the National Academy of Engineering, and the Institute of Medicine. The members of the committee responsible for the report were chosen for their special competences and with regard for appropriate balance.

This report has been reviewed by a group other than the authors according to procedures approved by a Report Review Committee consisting of members of the National Academy of Sciences, the National Academy of Engineering, and the Institute of Medicine.

The National Academy of Sciences is a private, nonprofit, self-perpetuating society of distinguished scholars engaged in scientific and engineering research, dedicated to the furtherance of science and technology and to their use for the general welfare. Upon the authority of the charter granted to it by the Congress in 1863, the Academy has a mandate that requires it to advise the federal government on scientific and technical matters. Dr. Frank Press is president of the National Academy of Sciences.

The National Academy of Engineering was established in 1964, under the charter of the National Academy of Sciences, as a parallel organization of outstanding engineers. It is autonomous in its administration and in the selection of its members, sharing with the National Academy of Sciences the responsibility for advising the federal government. The National Academy of Engineering also sponsors engineering programs aimed at meeting national needs, encourages education and research, and recognizes the superior achievements of engineers. Dr. Robert M. White is president of the National Academy of Engineering.

The Institute of Medicine was established in 1970 by the National Academy of Sciences to secure the services of eminent members of appropriate professions in the examination of policy matters pertaining to the health of the public. The Institute acts under the responsibility given to the National Academy of Sciences by its congressional charter to be an adviser to the federal government and, upon its own initiative, to identify issues of medical care, research, and education. Dr. Samuel O. Thier is president of the Institute of Medicine.

The National Research Council was organized by the National Academy of Sciences in 1916 to associate the broad community of science and technology with the Academy's purposes of furthering knowledge and advising the federal government. Functioning in accordance with general policies determined by the Academy, the Council has become the principal operating agency of both the National Academy of Sciences and the National Academy of Engineering in providing services to the government, the public, and the scientific and engineering communities. The Council is administered jointly by both Academies and the Institute of Medicine. Dr. Frank Press and Dr. Robert M. White are chairman and vice chairman, respectively, of the National Research Council.

This report represents work under Contract No. F49620-87-C-0122 between the United States Air Force and the National Academy of Sciences.

Copies of this report are available from:

~~Air Force Studies Board
National Research Council
2101 Constitution Avenue, N.W.
Washington, D.C. 20814~~

and from the Defense Technical Information Center, Alexandria, Virginia.

AIR FORCE STUDIES BOARD

John I. McLucas, *Chairman*
QuesTech Inc.

John J. Martin, *Vice Chairman*
NASA (retired)

Julian Davidson, *Chairman Emeritus*, Booz Allen and Hamilton, Inc.

Josephine D. Davis, Albany State College

Paul R. Drouilhet, MIT Lincoln Laboratory

Craig L. Fischer, M.D., Diametrix Inc.

Grant L. Hansen, Unisys Corporation

James E. Hubbard, Jr., Charles Stark Draper Laboratory

Benjamin Huberman, The Consultants International Group

Erich P. Ippen, Massachusetts Institute of Technology

Lorenz A. Kull, Science Applications International Corporation

John K. Lauber, National Transportation Safety Board

James W. Mar, Massachusetts Institute of Technology

Gary D. Mather, Booz Allen and Hamilton, Inc.

Robert C. Mathis, General, U.S. Air Force (retired)

Brockway McMillan, *Chairman Emeritus*, Bell Telephone Labs, Inc.
(retired)

Hyla S. Napadensky, Napadensky Engineers, Inc.

Brian O'Brien, *Chairman Emeritus*, Private Consultant

Oswald G. Villard, Jr., *Member Emeritus*, Stanford University

Robert A. White, University of Illinois, Urbana-Champaign

COMMITTEE ON HYPERSONIC TECHNOLOGY FOR MILITARY APPLICATION

Jack L. Kerrebrock, *Chairman*
Massachusetts Institute of Technology

Robert F. Bestgen, Battelle Columbus Laboratory

Seymour M. Bogdonoff, Princeton University

Dean R. Chapman, Stanford University

Donald C. Fraser, Charles Stark Draper Laboratory

Nicholas J. Grant, Massachusetts Institute of Technology

Richard C. Henry, Lt General, USAF (retired)

Robert H. Korkegi, National Research Council

Artur Mager, Consultant

James W. Mar, Massachusetts Institute of Technology

Frank E. Marble, California Institute of Technology

Duane T. McRuer, Systems Technology Incorporated

Ronald Smelt, Lockheed (retired)

Morris A. Steinberg, Lockheed (retired)

Robert A. White, University of Illinois at Urbana-Champaign

LIAISON REPRESENTATIVES

Lt. Col. Vincent L. Rausch, AFSC/NAI, Wright-Patterson AFB, Ohio
Lawrence M. Weeks, NASA, Washington, D.C.

AIR FORCE STUDIES BOARD STAFF

Vernon H. Miles, Sr., Director
Donald L. Whittaker, Research Associate/Editor
Terrie Noble, Administrative Associate
Katherine H. Atkins, Secretary

CONTENTS

Executive Summary ■ 1

Introduction ■ 8

1.0 Potential Military Hypersonic Applications ■ 11

2.0 Technologies Relevant to Hypersonic Vehicles and Their Status ■ 13

- 2.1 Aerodynamic - Propulsive Integration
- 2.2 Propulsion Systems
- 2.3 Aerodynamics
- 2.4 Controls, Guidance, Instrumentation and Information Systems
- 2.5 Materials for Hypersonic Vehicles
- 2.6 The Structural Challenge
- 2.7 The Role of Computational Fluid Dynamics
- 2.8 Experimental Capabilities

3.0 Findings and Recommendations ■ 56

- 3.1 Potential Military Hypersonic Applications
- 3.2 Propulsion - Airframe Integration
- 3.3 Propulsion Systems
- 3.4 Aerodynamics
- 3.5 Controls, Guidance, Instrumentation and Information Processing
- 3.6 High Temperature Materials, Cryogenics and Cooling
- 3.7 Structural Concepts
- 3.8 The Role of CFD
- 3.9 Test Requirements

Appendixes

- A. Statement of Task ■ 67
- B. Acronyms ■ 68
- C. Glossary ■ 69
- D. Dimensionless Groups in Fluid Mechanics ■ 73
- E. Request for Information from NASP Contractors ■ 75
- F. Briefing and Meeting Schedule ■ 83

EXECUTIVE SUMMARY

The Committee on Hypersonic Technology for Military Application of the Air Force Studies Board was formed to:

- Evaluate the potential military applications of hypersonic aircraft.
- Assess the status of technologies critical to the feasibility of such vehicles.

MILITARY APPLICATIONS

Early in our proceedings, we found that firm military operational concepts do not exist for applications of hypersonic aircraft. Determination of operational requirements must await a better understanding of critical technologies. Thus, the focus of this report is an evaluation of the status of these technologies. From this evaluation we concluded that:

- Hypersonic aircraft technology and ramjet/scramjet propulsion offer potentially large increases in speed, altitude, and range of military aircraft, and may enable or extend important Air Force missions.
- The simplest (and probably most feasible) hypersonic vehicle would cruise in the range below Mach number 8.
- The most attractive missions involve flight to orbital or near-orbital speed above the sensible atmosphere. These missions offer flexible recall, en route redirection, and return to base.
- Any potential military advantage in the speed range between Mach number 8 and orbital velocity would be negated by technical difficulties in the areas of surface heating and thrust, and weapons carriage, aiming, and release.
- The global or near-global range

coupled with the cryogenic fuels of hypersonic aircraft will require unusual base support requirements that must be considered in any judgment of their operational utility.

NATIONAL AEROSPACE PLANE PROGRAM

Part of our task is to advise the Commander of AFSC on the:

- Research and development strategy of the National Aerospace Plane (NASP) research vehicle designed for single-stage-to-orbit (SSTO) capability.
- Research vehicle approach for the aerospace plane that will maximize the acquisition of knowledge in the technical areas most critical for hypersonic vehicles.

The aerospace plane program is in the technology development phase, and decisions to build an SSTO vehicle will not be made before 1990. Due to the technical uncertainties, we agree with this approach. In particular, substantial technology demonstrations are needed, especially in high temperature materials and structural concepts appropriate to them, before a commitment to build an SSTO research vehicle can be technically justified.

We recommend that the NASP program office retain the ultimate goal of demonstrating the technical feasibility of SSTO capability, but maintain an option of selecting less than SSTO as part of a prudent risk management strategy. Consideration should be given to incorporating design features into this research vehicle that allow such modifications as may be found necessary from flight experience.

The research vehicle should also have auxiliary rocket propulsion to enable controlled flight with some independence from the air-breathing propulsion system. The auxiliary propulsion will enable greater exploration of the vehicle's flight characteristics and will help ensure flight safety. The drawback is that this auxiliary propulsion system will make the research vehicle heavier, thus making it more difficult to achieve the structural weight fraction required for SSTO capability. Further, the program office might design a series of flight research vehicles, each one able to access an increment of the total flight corridor up to orbital conditions.

TECHNOLOGY ASSESSMENT

The following is a summary of the status of the major technical areas critical to hypersonic aircraft. Technical reviews such as this one tend to focus on deficiencies and problems. Because our purpose is to help the Air Force support solid approaches and correct deficiencies in its program, this report will follow that pattern. The committee wishes to be on record, however, as strongly favoring a vigorous, vehicle-focused hypersonic technology program, carried on at least at the level of the planned aerospace plane program.

Propulsion-Airframe Integration

The success of any hypersonic vehicle will depend as much, or perhaps more, on the integration of the various contributing technologies into a complete system, as on the individual technologies. Such integration is quite mission-specific. Integration of the propulsion system and airframe is basic to determining the aerodynamic shape of a hypersonic vehicle. How such integration is achieved becomes increasingly important as the maximum air-breathing Mach number rises toward orbital values.

Efficient operation at very high Mach number requires configurations that pose serious integration problems at other Mach numbers. Consequently, the low speed propulsion system must be integrated with the hypersonic propulsion system and overall aerodynamics in a way that does not degrade performance prohibitively over the entire vehicle speed range.

Finally, the amount of hydrogen required for engine cooling exerts an unusually high leverage on the airplane size. Under the most severe conditions, the molar flow rate of hydrogen coolant within the airframe and engine structure is more than double the molar flow rate of air through the engine. Consequently, the cooling system must be effectively integrated with airframe and engine system, and coolant plumbing and pumping losses must be minimized.

To help solve these problems in the NASP research vehicle program, we recommend that engine-airframe integration receive emphasis in the design definition by teams drawn from both engine and airframe contractors.

Propulsion Systems

The key technology for hypersonic air-breathing propulsion at higher flight Mach numbers is the supersonic combustion ramjet (scramjet). In this device, injection of hydrogen fuel and its mixing with air is the most influential factor affecting engine performance. Current techniques for modeling related phenomena are inadequate. Conventional one-dimensional or quasi one-dimensional computation of the reacting flow in the combustor is insufficient and often misleading. Further, the stability of the scramjet flow with hydrogen reaction is not understood. Flow instability poses the possibility of developing strong shock waves and catastrophic loss of the engine.

For the scramjet to operate at peak performance throughout its Mach number range, extensive geometric changes must be made while maintaining minimum internal aerodynamic losses. These changes place additional demands on the design of coolant passages and on coolant management. Also, transitions between the various operating modes of the propulsion system present severe design and control problems if extreme loads on the engine and airframe are to be avoided. Since experimental verification of most transitional modes cannot be accomplished in ground-based facilities, the complete engine will undergo much of its high Mach number development during the flight program. Thus, it will be necessary to incorporate auxiliary rocket propulsion in the research vehicle with fuel supply and controls separate from the scramjet, to be able to vary the engine operating point at fixed flight conditions. Additionally, some rocket propulsion must be incorporated in the propulsion system of vehicles with orbital capability, for final insertion into orbit and for the de-orbit maneuver.

Aerodynamics

The aerodynamic problems of hypersonic flight can be considered in two categories. Below Mach number 10, the problems are primarily of a fluid mechanical nature, where one must accurately determine the pressure distribution, skin friction, heat transfer, flow field details, and mixing. Above Mach number 10, the same fluid mechanics problems remain, with the additional complication of the rate kinetics of real gases, the special low density phenomena of high altitude flight, and the effect of small bluntness on slender bodies. It is not yet possible to simulate or compute with any degree of certainty, these phenomena over the entire flight range.

There is a critical need for aerodynamic data, both for input to computational fluid dynamics (CFD) studies, for CFD validation and for engineering design. At low hypersonic speeds no current facility has a high enough Mach number (8 to 10) with an adequate Reynolds number and size for the necessary aerodynamic and configuration studies. At high hypersonic speeds - above Mach number 10 - it will be necessary to simulate the aerodynamics (viscous effects and flow field), while including real gas effects at conditions ranging from the continuum low altitude regime to the free molecular regime at high altitude. No current facility or facilities can simulate the full range of flow parameters with the needed flow quality.

Since complete simulation in ground-based facilities cannot be carried out, it will be necessary to check individual elements of CFD codes. Thus, there will be a need for flight tests for full validation of CFD codes particularly at high Mach numbers.

To provide essential data for hypersonic vehicle designs, we recommend:

- The immediate consideration of a quiet tunnel in the Mach number 10 range and of a size and Reynolds number capability to permit testing of hypersonic configurations at close to full-scale conditions. The Gas Dynamics Facility at the Arnold Engineering Development Center, for example, might be so modified.
- A combined CFD/experimental program focused on key hypersonic aerodynamic elements.
- That a high priority be given to a national integrated program to determine reaction rates at high temperatures as a needed input into CFD computations.
- That special attention be paid to the problems of low density flows because of the special phenomena associated with high altitude, high Mach number flight. We also sug-

gest that the personnel of the NASA Ames Research Center could provide a key nucleus for such an effort.

Control, Guidance, and Information Systems

Hypersonic vehicles present significant challenges in control of the vehicle trajectory and also in the control of vehicle configuration, aerodynamics, dynamics, propulsion, and cooling with particular emphasis on the need for their complete integration. These demands in turn present difficult challenges in the associated fields of instrumentation and information systems. The net result is that information and control technology joins materials, propulsion, and aerodynamics as an enabling technology.

Since the lower surfaces of the projected hypersonic aircraft are part of the engines, angle of attack and sideslip will significantly affect engine performance. Precise control of the entire integrated vehicle, perhaps as accurately as to within 0.1 degree, is therefore necessary. Further, exacting speed control may be needed for engine transition and aerodynamic heating that, in conjunction with the other demands on the control system, may prove difficult to achieve. In the presence of maneuvers and thrust asymmetries, speed control presents a challenge in controls technology far beyond that posed by any aircraft yet designed. Offsetting this very severe challenge is the potential offered by advanced control technology. But to realize these potentially significant returns, it will be important to systematically identify those areas where such benefits are possible and incorporate them into the designs.

Both the performance and safety of the vehicle will depend fully on onboard processing. Projections for throughput requirements for the onboard information

system range up to 25-50 million instructions per second. This high level of throughput will cause reliability requirements to be in the range of 10 million to one billion hours between failures. This level of reliability and throughput has not yet been achieved in a flight qualified installation. Other agencies such as NASA and DARPA have sponsored high reliability, high throughput laboratory level programs that may help assure the availability of an adequate onboard processing system.

The thermal environment, even inside a hypersonic vehicle, is likely to be quite hostile to electronic, sensor, and hydraulic systems. Active cooling undoubtedly will be necessary. Advances in high temperature electronics, cabling, and hydraulics also will be highly desirable to offer more design flexibility and reduce the weight requirements for active cooling. In addition, the combination of speed, low density, and high temperature impose conditions for sensors beyond anything required to date. The problem becomes even more complex when the need for redundancy is added. A program to identify and develop the necessary sensors is imperative.

A control system designed to accommodate all the uncertainties that can be anticipated at this stage of the design would have to be very robust and complex. Considerable savings in controls expenditures are likely if a phased flight development approach is adopted to reduce uncertainty as the flight envelope is expanded from subsonic to hypersonic speeds. To make this possible the information processing system installed in the prototype aircraft must be exceptionally reliable and be able to expand gracefully to the necessary size and throughput required for the final configuration, without need for redesign or reconfiguration.

Materials, Structures, and Cooling

The system challenge posed by a hypersonic vehicle to the materials and structural community is reflected in the structural weight fraction, which is the weight of all the structure divided by the take-off gross weight (TOGW). With presently envisioned air-breathing propulsion systems using cryogenic fuels, a fuel fraction of approximately 0.75 is required for SSTO performance. Design studies show that the consequent structural weight fraction of an SSTO vehicle must be approximately 0.15. Present military aircraft that operate mainly in the slightly supersonic regime have structural weight fractions of approximately 0.30. An increase in either the fuel fraction or the structural weight fraction means either a multi-fold increase in TOGW (if the payload is not to decrease) or a vanishingly small payload (if TOGW is not to increase). Thus, from the viewpoint of structural weight fraction, we consider the SSTO objective very demanding. It can be met only with new materials and new structural concepts.

The structures will face severe design conditions arising from aerodynamic heating. The aircraft will require new materials with elevated temperature properties comparable to those of the high strength aluminum alloys at room temperature. A necessary consort to the "strength" materials will be coatings to prevent oxidation at the elevated temperatures at which they will have to operate. The aircraft will also require materials for insulation and for both passive and active cooling.

Experimental material cannot be readily used in a flight test vehicle. The scale-up of a material system that has been proven in the laboratory to the production quantities demanded by even a research vehicle requires the development of a materials fabrication technology. Also, the properties of these new

materials are very process-dependent, so that extensive processing experience must be accumulated before they can be reliably employed. Even after the materials are available with nominally adequate properties, the structural designer must confront the effects of the high temperatures, including: stresses induced by the differential expansion of the structure (the so-called thermal stresses), degradation of the material properties, and distortion of the shape of the structure, which will lead to interactions with the flight loads. Designing for thermal stresses requires temperatures to be predicted with great precision. Also required are an accurate knowledge of the thermal conductivity, thermal coefficient of expansion, heat capacity as a function of temperature, and the thermal impedances of joints and connections. Design considerations are further complicated by the additional stresses caused by loads due to maneuvers, gust, and landing.

In sum, vehicles with orbital or near-orbital capability in a single stage will require new materials and novel structural concepts to meet the structural integrity requirements of strength, rigidity, longevity, damage tolerance, and efficiency; all of these at a cost commensurate with the importance of the mission. An aggressive and sustained materials and structures program will be required to develop these technologies to meet the presently envisioned objectives of the aerospace plane. Considerable progress toward such a program has been made in the last year, but we still regard materials and structures as a probable limiting factor in meeting the objective of SSTO performance.

The Role of Computational Fluid Dynamics

Computational fluid dynamics ! become a principal tool for aerodynamic and propulsive-flow design of hypersonic

vehicles. Computers can simulate simultaneously the hypersonic flight parameters of velocity, free stream density, physical scales, and free stream thermochemical state, while the present ground-based test facilities cannot. The role of CFD is especially significant for high altitude hypersonic flight conditions involving reaction-rate dependent air chemistry.

Current supercomputers and numerical methods are able to simulate three dimensional flows using the Reynolds-averaged (time-averaged) Navier-Stokes equations. However, the lack of capability for modeling of turbulent stresses, heat flux, and transition locations, form the principal current limitations of CFD techniques. Although the validation of three-dimensional hypersonic CFD codes is now relatively limited, we expect this situation to improve considerably in the near future as various results from such codes and hypersonic experiments become available.

The most intense local heating rates on vehicles such as the projected NASP research vehicle are expected to be on cowl lips, caused by shock-on-shock heating. Present CFD simulations of this phenomenon agree well with experiments for the lower portion of the hypersonic flight corridor where shock wave thickness is negligible. However, neither computations nor experiments have yet been made for these high altitude hypersonic flight conditions.

The limitations of current CFD simulations are not inherent to CFD itself, but are due largely to the present state of supercomputer development. Advanced CFD technology will require more powerful supercomputers than those expected to be available in the near future.

Our recommendations are that:

- an effort be made to significantly improve the modeling of turbulent

mixing flows relevant to hypersonic flight and of turbulent boundary layer flows in the presence of heat transfer and pressure gradient.

- high-altitude shock-on-shock cowl lip heating be investigated by direct simulation Monte Carlo methods, appropriate new experiments, and continuum equations more advanced than Navier-Stokes.
- the direct numerical simulation of turbulence in compressible flows should be an integral part of the long range technology development program of the Air Force.

Test Requirements

Most U.S. hypersonic facilities were built when the major national effort was on ballistic missiles and space vehicles. A careful examination is required of their utility for the design and testing of the new generation of hypersonic vehicles. The nation must consider not only current, but also long term needs for hypersonic testing.

Since ten years or more are required to design, build, and commission new facilities, it must be accepted that only currently available facilities will contribute to the testing needs of the NASP program during the technology development and design phases. It is very important, therefore, to ensure that all existing facilities are used as effectively as possible. We should note that many of these are 20 to 40 years old and flow conditions in them are not sufficiently well known. Research must be done in such facilities, to identify their flow characteristics.

Components of hypersonic vehicles will have to be tested at unprecedentedly high temperatures, for which existing but inactive facilities such as those at Plum Brook, Ohio, and the NASA Dryden Test Facility should be reactivated. Serious consideration should

also be given to the construction of facilities for component testing at temperatures above the 1200° C limit of these existing facilities.

We do not know the local composition, temperature, and turbulence of the upper atmosphere well enough to infer high altitude hypersonic flight conditions from ground test data. Measurements and analyses should be made of these characteristics of the atmosphere to provide a firmer base for use of test data in vehicle design and in flight test planning.

It will not be possible to test hypersonic vehicles with orbital or near-orbital capability over the full range of

their flight conditions prior to flight. Thus, hypersonic aircraft research above Mach number 8 will require a philosophy of flight research somewhat more akin to that practiced for missiles and launch vehicles. A clear recognition of this will be essential to success of the program.

The NASP flight research program will collect more basic information on aerodynamics, propulsion, control, and structural behavior than any previous flight research program. We recommend that very careful consideration be given to the flight test scenario during the design of the research vehicle, not afterward.

INTRODUCTION¹

The Committee on Hypersonic Technology for Military Applications was formed in early 1987 by the Air Force Studies Board of the National Research Council in response to a request from the Air Force Systems Command. We were asked to evaluate potential applications of hypersonic air-breathing vehicles to military missions, and to assess the status of those technologies critical to the feasibility of such vehicles. Further, we were asked to examine the full range of issues relevant to potential military hypersonic applications, including the classes of missions and the types of vehicles that would be appropriate to them, at least to the extent that understanding of such issues is necessary to an evaluation of hypersonic technologies. We determined very early in our proceedings that a firm conceptual basis for military air-breathing hypersonic operations, that is, a set of mission scenarios, does not yet exist. Therefore, our discussion of potential missions will be relatively brief; the principal emphasis of our discussion will be the status of the critical technologies.

In the time frame of the committee's activities, the National Aerospace Plane program has dominated hypersonic research in the USA. With its focus on technology development for, and preliminary design of, a research vehicle capable of air-breathing operation to orbital speeds without staging, the NASP

program has highlighted hypersonic technology requirements and provided the bulk of the support for hypersonic research for the last three years. The program has led to a review and to some extent rediscovery of the rather extensive work done on hypersonic propulsion and configurations in the 1960s and early 1970s. It has, therefore, also been the source of much of the committee's information on the status of hypersonic technologies. Our assessment of hypersonic capabilities is thus to some extent in the context of the tentative requirements set for the NASP research vehicle. However, other requirement statements, perhaps somewhat less demanding of the critical hypersonic technologies, may ultimately be of considerable interest to the Air Force. We have attempted to maintain this perspective in our deliberations.

The committee was briefed by all major government and industrial participants in hypersonic research and technology development, including the relevant units of the Air Force Wright Aeronautical Laboratories, the NASP Joint Program Office, and NASA Langley Research Center. Individual members of the committee had additional contacts during this period. Two members of the committee were members of the NASP Review Panel of the Defense Science Board, providing the committee as a whole with an insight into that group's findings. After the selection of con-

¹To assure the widest dissemination, a special effort has been made to publish this report without security restrictions. The committee believes that it has adequately examined and reported the state of the technology to provide the reader with an accurate assessment of hypersonic technology development without divulging classified information.

tractors for Phase II, the preliminary design phase of the NASP Program, we were briefed by the two propulsion contractors selected for phase 2B, and met informally with the other prospective propulsion contractor who participated in Phase 2A. The committee was then briefed by the three airframe contractors selected for phase 2, part 2.

To ensure that we and the several contractors engaged the issues that the committee believed were important, we prepared a questionnaire and sent it to the contractors through the director of the NASP Joint Program Office (see Appendix B). In general, the contractors responded quite adequately to our queries, and added their own special points.

Inevitably, many judgmental issues arise in any assessment such as this. We have tried to ensure that we understand the views of the hypersonic research and technology community, and to the extent that we agree, we have incorporated these judgments in this report. But the final responsibility for the findings and recommendations of this report rests with us, and where our views differ from others, our experience and judgment have prevailed.

In addressing our charge, we have placed the major emphasis on evaluation of the technologies most critical for hypersonic flight. We judge these to be, in order of importance:

- the supersonic combustion ramjet (scramjet) engine
- the technology of integrating such engines with the airframe, including the aerodynamics and control of the resulting "flying engines"
- the structural concepts and high-temperature low-density materials required to achieve the desired weight fractions
- guidance and control of such large, flexible, complex vehicles as result from the requirement to operate

throughout the flight corridor from takeoff to orbital or near-orbital velocity.

We have evaluated these technologies against our perception of the needs for military hypersonic flight in the broadest sense.

Also in keeping with its charge, the committee has examined the technology needs for the experimental hypersonic vehicle, the X-30, which is the focal point for the NASP program. We believe the design of the X-30 requires sufficient understanding of the critical technologies to enable the design of a reusable vehicle (or vehicles) with reasonable assurance that they will be able to fully explore the flight conditions of interest for hypersonic flight vehicles. Tentatively, this envelope includes the Mach number range from 0 to 25, at associated altitudes such that the dynamic pressure is in the range from 500 to 2000 psf. It includes steady state flight as well as acceleration and deceleration in the hypersonic regime. Since the X-30 will be a research vehicle, we believe that it may reasonably incorporate technologies that are not fully mature; however, given the high visibility and cost of the program, they will have to be sufficiently reliable in an experimental context to assure that the program can be completed and realize its experimental objectives. These requirements are considerably less demanding than those for an operational vehicle with the same envelope, in terms of the required reliability, durability, and safety of the vehicle. On the other hand, they are more demanding of operational flexibility if the vehicle is to be capable of accessing all parts of the altitude-Mach number space that may be of interest for various possible operational vehicles, any one of which may have to operate in a more limited envelope. As will be elaborated in the ensuing discussion, the research vehicle may require special features, particularly in

propulsion and control, that will not be required in an operational vehicle.

Facilities for testing can be considered a critical issue for hypersonics. Indeed, if the NASP program were to proceed in the classical way, with full verification of all major components and systems before flight, a major national commitment would be required, far exceeding that presently planned. We have not addressed this possibility. We have taken the view that the NASP program must depart from the classical approach by making much more extensive use of numerical modeling (made possible by recent advances in computational fluid dynamics), and by depending more on flight research. There is no other option, if the NASP program is to proceed on the planned schedule.

It is not clear that full validation testing is possible at the high Mach number limits of the envelope, but even if feasibility could be established, 10 or more years would be required to design, build, and activate such major facilities. In connection with the NASP program, we have therefore asked how existing facilities can best be used, and what component testing is feasible on the time scale of the NASP program.

In the context of long term operational uses of hypersonic vehicles, the issue of test facilities must be reexamined. If we are to build such vehicles, extensive testing capabilities probably will be needed to ensure their economical development. This committee has not addressed this issue in depth.

1.0 POTENTIAL MILITARY HYPERSONIC APPLICATIONS

The Air Force and the NASP Joint Program Office each briefed the committee on the military aspects of a hypersonic vehicle. Clearly a hypersonic vehicle has several advantages. Flight time to the target could be less than one hour at near-orbital speeds. While this is comparable to the flight time of a ballistic missile, a hypersonic vehicle could have the advantage of flexible recall and en route re-direction. Considering the range to potential areas of interest and targets from the interior of the United States, the military potential is readily apparent.

As shown in Figure 1-1, a hypersonic vehicle can reach a point on the opposite side of the earth from Omaha, Nebraska in about one hour. The dynamic pressure on the vehicle could be considerably less than 1000 psf at this flight condition.

A hypersonic vehicle can also range from Omaha to Moscow, USSR to run either a strike mission or a high altitude reconnaissance mission in about 30 minutes. An ICBM can also accomplish a strike mission in about 30 minutes, with its warheads either reentering ballistically or as hypersonic glide vehicles, which can maneuver. Once launched, however, the ICBM cannot be recalled; the hypersonic aircraft can. The reconnaissance mission can also be done by other means, such as by an SR-71 at 80,000 ft. in over three hours or by a satellite pass over Moscow at a predictable time. Again, the response time of the hypersonic vehicle is measured in minutes against many hours for the two alternate means mentioned.

From the viewpoint of degree of technical difficulty, the full range of

operational missions at hypersonic speed can be divided into three areas. All sustained (steady) flights at such speeds will be confined to a restricted "corridor" of altitudes at each speed (Mach number). Above this corridor the aircraft cannot provide enough lift or thrust; below it, vehicle heating or structural loads are excessive. These design factors are discussed in more detail later. The approximate form of the flight corridor is shown in Figure 1-2, where the three operational areas are defined in terms of the Mach number and altitude range of each.

Area 1, including operations at up to about Mach number 8, requires the least complex hypersonic vehicles from a technical point of view. Nevertheless, it offers significant reductions in mission time. Vehicles for operation in this region appear reasonably achievable, and the stress of the flight environment appears to be tolerable for sensor operation and weapon delivery. The pattern of manned military operations in this area will be similar to those of the SR-71.

Area 2 involves mission accomplishment from space, outside the sensible atmosphere, between Mach numbers 20 and 25. In our view, this area encompasses the most attractive hypersonic aircraft missions because of launch flexibility, short flight time, and the ability to take advantage of the relatively benign environment of space for mission accomplishment. Maneuvering is another attractive feature.

The major technical challenges for Area 2 are presented by the accelerating climb through the atmosphere and the subsequent re-entry. Although many of the technical advances of the space

program are directly applicable, the requirement to fly with a completely recoverable air-breathing vehicle adds formidable new problems. These are addressed later in this report.

Area 3, between the two areas discussed above, involves sustained cruising flight in the atmosphere roughly between Mach numbers 8 and 20. This is a very stressful flight environment with high skin temperatures, control and maneuvering difficulties, ionized boundaries through which sensors must operate, and high infrared signatures that would make the vehicle vulnerable to detection. For these reasons, we have great reservations about the military utility of sustained hypersonic flight in the atmosphere above Mach number 8.

In examining potential applications in any of these three areas, one must take account of some basic limitations and restrictions on the operations of hypersonic aircraft. Their minimum turning radius is measured in hundreds or even thousands of miles - proportional to the square of the speed; they can maneuver in flight with modest energy expenditures, in contrast to the ballistic missile, but flight path curvatures must be small compared to those of current aircraft. One important consequence is that global or near-global range is necessary, and the plane will often have to circle the planet to return to base after the mission.

Another restriction is inherent in the base support requirements associated with cryogenic fuels. They will require a complete departure from conventional airport storage and distribution facilities. For economic reasons alone, we are unable to envision a network of airfields giving the flexibility that today's aircraft enjoy. However, some mitigating

factors should be considered in addressing these logistic issues.

For the last 15 years or more, hydrogen-fueled aircraft have been the subject of serious study by NASA and U.S. commercial aircraft companies, primarily to enable fast, economical, long-range flight such as supersonic trans-Pacific flights. The airport facilities required for liquid hydrogen handling have received quite detailed study, and the problems appear tractable.

The military hypersonic aircraft, in common with these commercial concepts, will fly farther and higher than today's aircraft, which suggests that a much smaller number of cryogenically-equipped airports will be needed for satisfactory operation. Finally, all classes of hypersonic aircraft will require the same type of base facilities, and it may be of interest to examine the concept of a new type of Air Force base, capable of supporting all classes of mission, and fully-equipped for cryogenic fuels.

It follows from these arguments that any forecast of missions for hypersonic aircraft must include a careful examination of the unusual support requirements. We suggest that as hypersonic technology advances, periodic studies of the logistical support requirements should be made to give confidence in the vehicle's military utility.

In sum, we believe that there are clear potential advantages to the Air Force in hypersonic air-breathing capability. These potential advantages are sufficient to justify an intensive technology development program, including flight vehicle research sufficient to determine the military utility of hypersonic flight at orbital or near-orbital speeds.

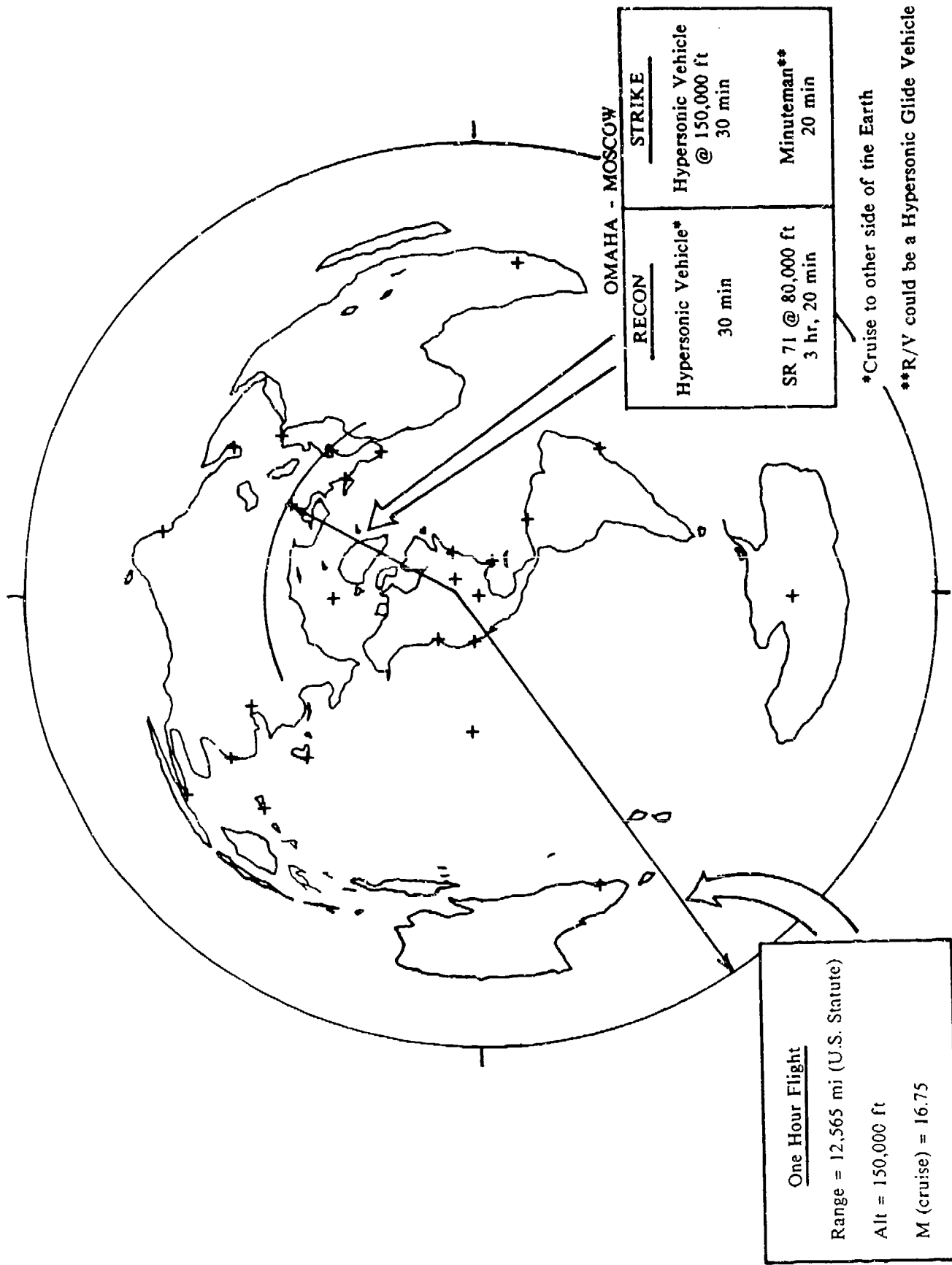

FIGURE 1-1

Hypersonic Vehicle Reconnaissance and Strike Range

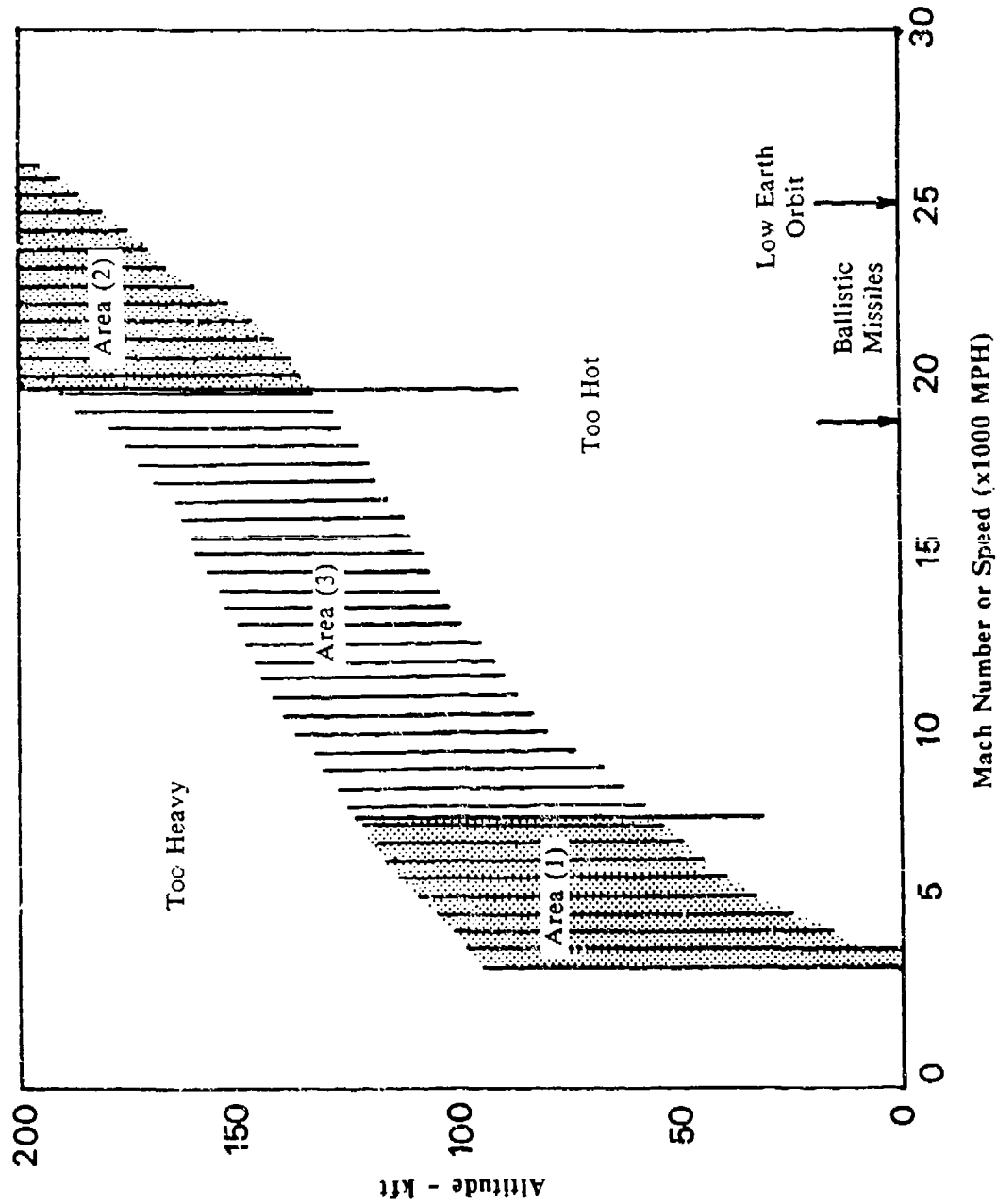

FIGURE 1-2
Approximate Corridor of Steady (Cruising) Flight

2.0 TECHNOLOGIES RELEVANT TO HYPERSONIC VEHICLES AND THEIR STATUS

2.1 Aerodynamic - Propulsive Integration

As usually conceived, the hypersonic air-breathing propulsion system uses a low speed system for operation from standstill to about Mach number 2.5, a ramjet for operation to about Mach number 6.5, and a scramjet for Mach numbers above 6.5. *If these three systems are to be combined, this must be done in a way that does not degrade their individual performances when they are active, and with acceptable weight and complexity.* This is a major challenge for the designer of hypersonic aircraft, and must be recognized as such. We will not deal with it comprehensively in this discussion, however. Our focus here is primarily on hypersonic propulsion.

Integration of the airframe and propulsion system is a central feature of all conceptual designs for hypersonic flight vehicles mainly because the engine capture area must be a large fraction of the vehicle frontal area. Among the contributing factors are:

- 1) a low thrust per unit of engine air-flow at hypersonic speeds, which results from the small fractional change in energy of the engine air-flow that can be achieved through combustion;
- 2) the need to fly as high as possible to minimize the heat load on the structure, which results in a proportionately low engine mass flow for any given capture area; and
- 3) the desire to make efficient use of the compression by the bow shock of the vehicle, which leads to the need to capture, in the engine, most of the flow through this shock.

The need to maintain a weak bow shock to minimize losses and for a large capture area require slender configurations in which the entire forebody, or at least its lower surface, comprises the engine inlet. (See Figure 2-1.) The same factors dictate that the aft end of the fuselage serve as the expansion surface for the propulsive streamtube.

While the resulting configurations are conceptually appealing, especially to the propulsion-oriented, they pose problems that, though not entirely new, are certainly more serious than for more conventional designs, in which the propulsive streamtube and fuselage and wing airflows are farther apart. Thus, in most if not all conceptual designs for hypersonic vehicles, the propulsion system is assumed to ingest the boundary layer flow that develops on the forebody. Most successful propulsion installations in the past have avoided this. If the propulsion system ingests the boundary layer: 1) the ramjet, whether operating in the subsonic or supersonic combustion mode, must pass two parallel streams of very different velocities and temperatures, or 2) the boundary layer flow must mix with the free-stream. The former will lead to constraints on the supersonic combustion process, because the pressure must be equalized between the supersonic and subsonic streams, imposing serious performance penalties. The latter may result in losses, or in heating of the supersonic stream, which is counter to the principal rationale for the supersonic combustion ramjet, namely to lower the combustion temperature.

These issues are discussed further in the propulsion sections. However, it is

proper here to ask whether the engine should ingest the boundary layer from the forebody. One can imagine configurations in which the boundary layer flow bypasses the combustor, the inlet ingesting flow primarily from outside the boundary layer, but we have seen little evidence of serious consideration of this possibility.

The high degree of integration also poses serious control problems if, as seems probable, the inlet compression and nozzle expansion occur only on the lower surface of the vehicle. Both the inlet and nozzle then contribute strongly to the vehicle's lift, particularly at high flight Mach numbers. A balance between the lift forces on the inlet and nozzle will determine the pitching moment produced by the propulsive streamtube. While the lift and thrust can conceivably be oriented through the center of mass and the pitching moment can be nulled at the design point, it is not yet clear how these balances can be maintained at off-design conditions, without large forces from control surfaces. Furthermore, even if a design can be evolved to meet these requirements in normal operation, what pitching moment will follow from a sudden loss of heat addition in the combustor, and the resulting modification of the nozzle expansion? Although an inlet unstart probably will be unacceptable in a scramjet operating at very high Mach numbers, how will control deal with such an unstart?

A further control difficulty may arise from the ingestion of the ramp boundary layer by the engine. To see this, suppose the airplane pitches upward so as to increase the angle of attack. The ramp boundary layer and shock layer now accumulate more losses, higher static pressure, hotter and lower stagnation pressure air, and these are ingested into the engine. With no change in fuel flow, the engine thrust and the pressure on the nozzle face

change and a strong pitching moment is developed. Although quasi-steady operation of the engine is involved, the coupling with the airframe dynamics is strong and must be dealt with by the control system. This is not only an issue of sensors and control response, it is a question of engine and airframe design. For example, should steps be taken to design or position the engine to be less sensitive to such disturbances? In the extreme, should the engine avoid ingesting the boundary layer entirely? The presently proposed configurations for the NASP are subject to such airframe interactions that may pose significant control problems.

Most of the current airplane configurations use a modular propulsion system with several engines side by side under the airframe. The individual modules probably will operate under nearly identical conditions and usually not interact or interfere with each other. However, when changing propulsion mode from low speed engine to ramjet and from ramjet to scramjet, each of the modules will sometimes experience a start-up transition that might induce airflow disturbances that propagate upstream of the inlet. It is unlikely that this phase of operation will occur simultaneously for each of the modules and, indeed, it may not occur symmetrically with respect to the desired thrust axis. Furthermore, if for some reason the starting transients are severe, the inlet disturbances or inlet malfunction can propagate from one module to the other, perhaps leading to a catastrophic malfunction of the propulsion system. Such difficulties can be closely coupled with yawing disturbances of the airplane which may, in turn, be induced by unsymmetric mode changes of the engine modules.

The large nozzle expansion required for efficient hypersonic operation leads to a serious base drag problem at transonic speeds, where the nozzle

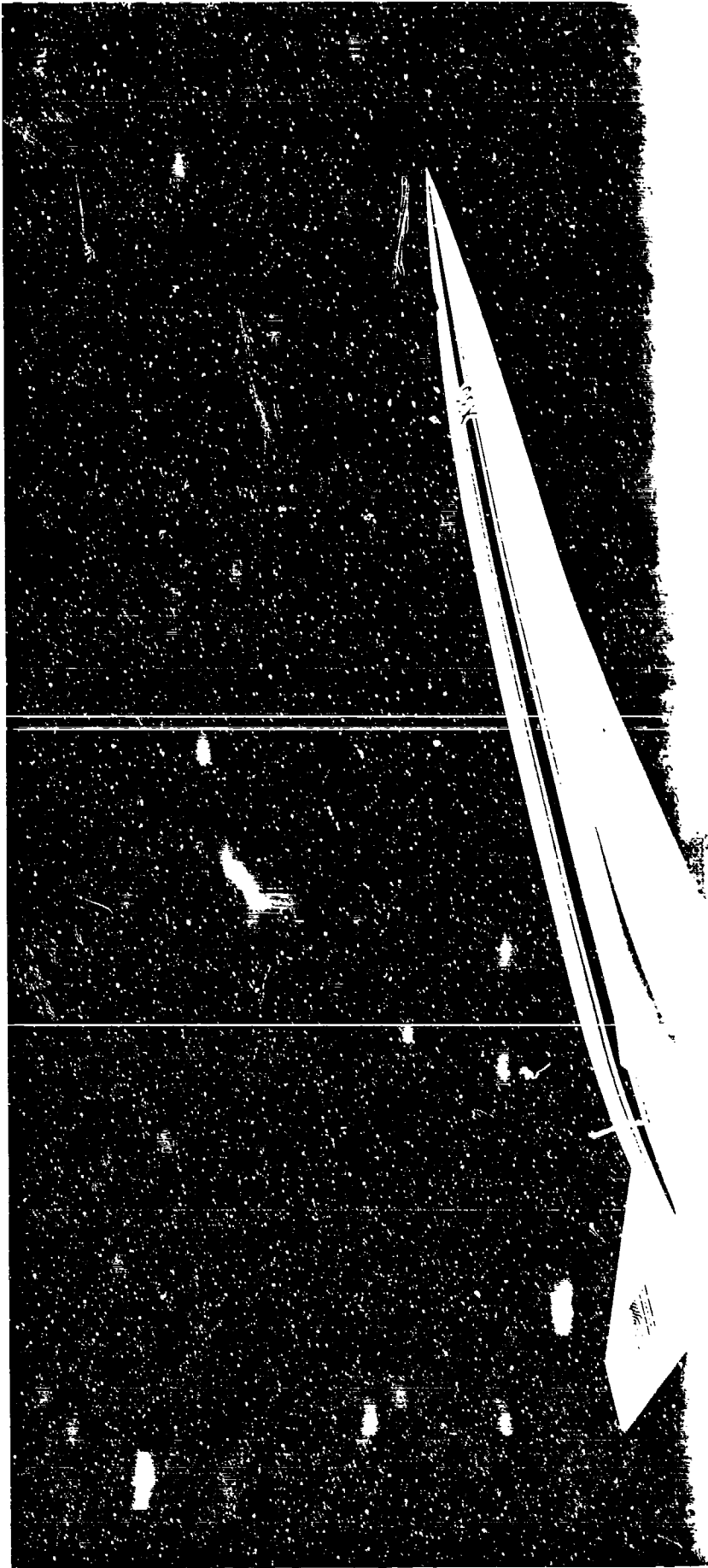

FIGURE 2-1
NASP Concept

pressure ratio is far too low to fill the entire base area. This problem has appeared in non-afterburning operation of aircraft where the nozzle area required for afterburning operation has dictated a large base area. Ejector nozzles, which fill this base area with a secondary or tertiary air stream, have provided partial solutions, but this avenue will be much harder to follow for hypersonic aircraft. Base burning is a possible alternative, but one whose heating and fuel consumption implications have not been fully explored.

Another class of problems arises from the need to integrate the low speed propulsion system with the high speed ramjets, with acceptable weight and complexity, and without serious interference with the function of the scramjet at high Mach numbers. There should be no extraneous projections into the airflow that would cause strong shocks or excessive heating. All surfaces of the engine flow path must be actively cooled, and this further argues for a minimum of complexity. *While we certainly do not argue that innovative solutions to these design problems are improbable, there is no base of successful designs on which to draw to solve them.*

The importance of aerodynamic-propulsive integration for hypersonic vehicles has been recognized for many years, and has been highlighted over the last two by active participants in the NASP program and by advisory groups. But today there is more enthusiasm than integration. This problem is not being adequately addressed and will remain so as long as responsibility for the propulsion system and vehicle are divided.

We urge that an organizational structure be created where responsibility for the conceptual design of both engine and vehicle reside in one organization. This must be done soon, so that these issues are faced in the conceptual design

phase, not after a configuration has been selected.

2.2 Propulsion Systems

In addition to the several technological areas that are either unique to the scramjet or are emphasized to an unusual degree, there are important issues of (1) transition (2) the limitations to development and testing above Mach number 8, and (3) the extraordinarily sensitive interaction between the engines and the airframe. These issues will be discussed separately after we have examined the basic technologies pertinent to the high-speed engine.

2.2.1 Basic Scramjet Engine

If the requirements underlying the principles fundamental to the scramjet engine are not satisfactorily met, the engine may perform no better, or perhaps worse, than a high performance rocket. The main issue is to maintain the static temperature of the air in the combustor at a reasonable value while the aircraft is flying in the Mach number range 10-24. At a very high air temperature the eventual reaction of hydrogen and oxygen to water vapor is very slow or incomplete or both, and the specific impulse of the engine falls from a value in excess of 1000 seconds to well below 500 seconds. This concept breeds two conflicting technological problems. First, due to the high air velocity in the combustor, the combustor would have to be very long to achieve a reasonable residence time. Second, extreme heat transfer rates and wall shear losses require the combustor to be as short as possible. How to balance these issues and whether or not there is an acceptable balance underlie the factors discussed below.

The processes of injecting the hydrogen fuel and mixing it with air in

the scramjet appear to be the most difficult obstacles to the realization of a successful engine; and they are processes in which our present fundamental and technological base is weakest. Hydrogen fuel must be injected into the engine with very low losses, at local Mach numbers as high as 8, where losses have the greatest effect because of the small fractional heat addition due to combustion. It is generally agreed that shear layer mixing rates drop under some conditions of supersonic relative motion between streams. The technological basis for this is not extensive and design experience is lacking. Possible alternatives, such as mixing augmenters, wall injection, and shock enhanced mixing are in an even more primitive technological state.

It must be made clear here that satisfactory mixing for a chemical reaction process contrasts sharply with one in which, for example, momentum is being exchanged. The mixing must be complete on the molecular level to allow combustion. Not only is this a more time-consuming process but the experimental difficulties of assessing the completeness of molecular mixing are considerable, and therefore the technological basis will be slow to develop.

Considerable effort is now being expended in appropriate investigations and the results will be of unusual value not only to the present development but also to future efforts of scramjet development. It is not now clear just how extensive the data will have to be to impact the NASP Program.

During the most important periods of scramjet operation the combustor Mach number is in the range of 2.5 to 8. This flow field is quite complex due to the heat release, which is controlled by the molecular mixing process, and by the ramp boundary layer and bow shock layer that may be ingested by the engine. The heat release has a pro-

nounced effect on the structure of the flow field which, in turn, strongly influences the mixing processes. This coupling introduces complexities that we find very difficult to cope with either experimentally or computationally. Today it is impossible to describe with certainty the best geometry of the combustion chamber, for any Mach number or altitude.

A serious concern among workers experienced in the field is the stability of the hypersonic flow in the combustion chamber during combustion. Would a small disturbance imposed on a design flow field decay, diverge, or lead to a pulsating combustion process? A central obstacle to understanding the result of such a time-dependent disturbance to the combustion chamber flow is our current incapability to either experimentally measure or to compute this chemically-reacting flow.

The ingestion of the ramp boundary layer and shock layer may lead to large variations in the air density and stagnation pressure over the cross-section of the inlet. The air density from top to bottom of the engine inlet may sometimes vary by a factor of four. Experience has shown that such conditions facilitate communication of disturbances through the boundary layer ahead of the engine, which may result in unfavorable inlet conditions and even inlet instability. Such a disturbance may couple with the combustion process in the chamber with possibly unfortunate results. Our experience with this problem is restricted to a much lower Mach number regime than that appropriate to the NASP and requires serious experimental attention and perhaps design compromises.

Almost exclusively, our ability to calculate chemically-reacting unsteady flow fields is restricted to one dimension. Such steady one-dimensional calculations are being used in engine performance calculations, yet quasi one-

dimensional analysis can cope neither with the mixing-controlled combustion issue nor with the stability problem. But difficulties arise even at the more elementary level of performance calculation. When the engine ingests the ramp boundary layer and bow shock layer, the gas entering the combustor has a very non-uniform temperature distribution over its cross-section. As a consequence, the chemistry, which has a strong and non-linear temperature dependence, may vary even more violently over the cross-section. In trying to adapt one-dimensional analysis to this problem one is faced with the issue of choosing appropriate average values for each cross-section, which introduces large and unacceptable errors in the results. Also, the output of a one-dimensional analysis can provide only a uniform input to the nozzle calculation that follows. Even an approximate calculation of the nozzle expansion process makes it clear that the pressure distribution over the nozzle surface and, consequently, the calculated performance of the engine, is very sensitive to the details of the gas state distribution at the start of expansion. It is most important to make at least an approximate accounting for the two- and three-dimensional nature of the combustor and nozzle gas dynamics.

As a result of the relatively high temperature and short residence time in the combustion chamber, the hydrogen-oxygen reaction will not reach an equilibrium water vapor concentration before reaching the nozzle. So it is important that the reaction between OH and H be completed to the maximum degree during expansion in the nozzle. Because it is most unlikely that crucial experiments can be done, a high degree of reliance must be placed upon computations. These must, at the least, be for two-dimensional reactive flow and preferably three-dimensional. Moreover, we must account for the non-uniform state of the gas at the nozzle entrance. At

present this magnitude of numerical calculation is impossible and the situation is unlikely to change very soon. The nozzle may be one aspect of the NASP that undergoes significant development during flight test.

As we have noted above, the ingestion of the ramp boundary layer and shock layer exacerbates the problems of the intake, combustor, and nozzle. Although it is difficult to study without better computational capabilities, we must nevertheless consider whether or not the boundary layer should be swallowed. Even at the cost of some possible reduction of the airplane performance, the additional design certainty that would accrue from capturing clean air might result in an overall benefit.

2.2.2 Cooling Problems

Although active cooling with hydrogen will be employed over several sections of the airplane, the larger part of the cooling load is connected with the engine. Even the most optimistic estimates show that the hydrogen flow rate required for cooling exceeds the stoichiometric fuel flow requirement above Mach number 15. Less optimistic analyses suggest that *above Mach number 20 the hydrogen cooling requirement may exceed four times that for combustion*. This means that the molar flow rate of hydrogen in the cooling passages of the airframe is more than twice the total flow rate of air into the engines. And because it is the molar flow rate of gas that determines the pumping power requirement, details of the cooling passages and the active management of the coolant flow to different regions of the airframe and engine are as important as the external gas dynamics. In fact, because the airframe is largely sized by the hydrogen tankage, the cooling requirement exerts an unusually high leverage on the airplane size and

weight. The actual cooling requirement is now one of the least certain elements in the entire vehicle, so the airframe probably will be over-sized to accommodate this uncertainty.

The design of cooling passages in the engine and assurance of their effectiveness are made much more difficult, and may perhaps be compromised, by the extensive geometric changes required of the engine over its Mach number range. It is in the regions of the hinged joints, and the scramjet may require several of them, that meticulous design and careful coolant management must be exercised.

The emergence of coolant effectiveness, active coolant management, and a high degree of integration of the coolant system with the structural design as a significant and novel aspect of the NASP is just beginning to be taken seriously. Furthermore, this issue will command attention for any hypersonic airplane, and the technology base that is acquired here will be of permanent value.

2.2.3 Propulsion System Transition

The acceleration of the NASP from take-off to orbital velocities requires not only widely different operating conditions for each engine but the transition between the two or three different engines, each of which is designed to operate in a specific Mach number range. In the "conventional" arrangement, one engine will operate from zero to low supersonic Mach numbers, a ramjet with subsonic combustion up to the lower limit of the scramjet range and, finally, the scramjet to near orbital velocities. It may be anticipated that these changes of propulsion mode will be sensitive processes, requiring careful control to assure that each newly fired engine starts properly and that the transition induces no extreme and unusual loads. Though we have

some experience with this sort of problem, two important factors make the present situation unique. First, the transition to the scramjet mode lies in a Mach number range far outside our experience and where an error may be costly. Second, in contrast with our experience, experimental verification and development will not be possible. The chance for serious trouble here is so likely and the potential damage so great that the issue is significant. The development problems of the individual propulsion systems are so severe in themselves that considerations of this problem might be postponed too far into the program.

2.2.4 Auxiliary Rocket Propulsion

Because the ground-based test facilities for the NASP will be unable to accommodate the Mach number and enthalpy range appropriate to the high speed engine, much of the engine testing and development must be planned as part of the flight program. Engine development and testing will occur as the flight envelope of the airplane is expanded into the higher Mach number range. During this process, the airplane will require a separate propulsion system to allow a range of conditions under which to test the engine. This probably would take the form of several hydrogen-oxygen rockets distributed appropriately over the airframe but physically separate and with an independent control system. These rockets should be capable of taking over the propulsion and trim of the airplane during testing of the high-speed engine. This will allow much greater flexibility in exploring the operating envelope of the engine at nearly constant inlet conditions. This requirement will hold not only for the NASP but for any hypersonic research vehicle using scramjet propulsion.

It appears that there is a quite separate requirement for some degree of

rocket propulsion as a component of the final NASP propulsion system itself. Rocket propulsion will be needed to insert and stabilize the vehicle in orbit, and possibly to maneuver in orbit and de-orbit. It is very likely that the rockets will prove invaluable in maintaining thrust and trim during change of propulsion mode.

Part of the long-term growth process for a conventional aircraft and propulsion system is the gradual improvement of the thrust level and efficiency of the engine, and a corresponding improvement of the overall aircraft performance. The NASP will be no exception to this pattern and will, in fact, undergo even more striking changes than the conventional aircraft. In its initial form, the scramjet probably will become ineffective at velocities considerably below orbital velocity and will require a component of rocket propulsion during some final portion of its acceleration. But the long-term growth of the engine will reduce, though probably not eliminate, this requirement, and the propulsion system must accommodate this growth without severe design changes to the entire airplane. Rocket thrust should be an *integral* part of the final operational NASP propulsion, not just a temporary feature of the flight test program.

2.3 Aerodynamics

The aerodynamics of a hypersonic vehicle must be closely integrated with the power plant. Presentations to this committee arbitrarily focused on the aerodynamics of the entire vehicle including the inlet, but excluded the propulsion system element, consisting of the fuel injectors, combustion chambers, and expansion nozzle, despite the fact that many items included in the aerodynamic discussion are important in the propulsion system itself. The aerodynamic discussions must address flight

conditions from take-off to orbit, conditions of high dynamic pressure (2000 psf seems to be an approximate, practical, upper limit), low Reynolds number conditions at high altitude, and conditions in the non-continuum region approaching free molecular flow. The aerodynamic considerations require the treatment of real gases with full viscous effects applied to configurations that consist of blunt noses and leading edges on slim bodies with complex configurations that generate three-dimensional gradients and shock waves. The requirement is to predict, with reasonable accuracy, the following parameters, assuming similar inputs will be provided by the propulsion system:

- Local pressures, heat transfer, and skin friction, on the surface of the entire vehicle, including the flow through the inlet.
 - a) To provide the forces (lift, drag, moment, etc.) over the full flight envelope
 - b) To provide the detailed thermal loads for cooling and structural design, and
 - c) To provide dynamic inputs to the aerodynamic and thermal control systems.
- The three-dimensional flowfield with detailed information on the local conditions and the state of the gas, for configuration and control design, for inlet positioning conditions, and optimum inlet design for flow to the combustion chamber.

The statuses of the various aerodynamic technology elements have been evaluated on the basis of the experimental data base from wind tunnels and flight, and from the examination of computations that have been validated or calibrated under the appropriate conditions. Current computational capability enables us to calculate complex flows, but is limited in dealing with the details of viscous and real gas effects. Current technology provides the capability to

compute real gas effects if the significant reaction rates are known. In general, aerodynamic characteristics for three-dimensional configurations up to about Mach number 10 are reasonably known or can be predicted, if transition location and the extent of transition can be provided. Beyond that, where real gas effects become important and viscous effects more complex, very little three-dimensional aerodynamic information is available beyond the blunt body configuration for realistic design procedures. The following comments address the inclusion of detailed viscous effects, real gas effects, and real gas complex flow conditions.

2.3.1 Viscous Effects

The primary viscous effects are experienced in the boundary layer where the hypersonic conditions require a considerable extension of low speed experience and computations to high Mach numbers and "cold wall" conditions. The main problem is to define the condition of the boundary layer at any point on the vehicle during any condition of flight. This definition is required to calculate heat transfer and skin friction (critical elements in the design of the structure and cooling system), to predict and avoid unacceptable separations, and to compute performance.

2.3.1.1 Transition Point Determination

Determination of the transition point is a critical element in the design and performance of a hypersonic vehicle. Unfortunately, there is no well-founded theory for this determination. Conventional low Mach number use of the parameter Re_x/M at values as low as 150 to about 300 has not been validated under the conditions of hypersonic flight or for complex flows. New attempts to use the parameter e^{η} are being studied by

NASA/Langley. The problem is that wind tunnel data are biased by wind tunnel disturbances and free flight results are primarily for simple bodies, axisymmetric, with zero gradients. Considerable work is being done in this field, including extensions of laminar, linear stability theory, and attempts to evaluate cold wall effects in the lower hypersonic region. Still missing are *high* Mach number data with 3-D gradients and shock waves. Proposals are being considered for extended wind tunnel tests under the appropriate conditions and for flight tests of bodies that might include more complex geometries. The problem is made even more difficult by the lack of knowledge of the disturbance field in the stratosphere, which could be a factor in triggering transition.

2.3.1.2 Extent of the Transition Region

Although it is critical to determine the transition point, the condition of the boundary layer downstream of that point is also important. There is some indication that the transition region between fully laminar and fully turbulent flow gets longer as Mach number increases. It is possible, therefore, that a considerable region of transitional flow will occur over a hypersonic vehicle or in a hypersonic inlet. The characteristics in this region are unknown. It is believed to be partially laminar and partially turbulent, in a temporal sense, but detailed information in this region must await solution of the transition point problem of sub-section 2.3.1.1.

2.3.1.3 Turbulent Boundary Layer

Somewhere downstream of the transition point, the flow will be fully turbulent. At higher Reynolds number conditions, low altitude flight, a considerable part of the hypersonic vehicle may be turbulent. Depending on the trajectory chosen, this turbulent

flow could occur under Mach number conditions that have not been extensively studied. The effects of high external Mach number and cold wall, with gradients have not been well-validated for the higher Mach number regimes.

2.3.1.4 Test Conditions

It is possible to do considerable work on items 2.3.1.1 through 2.3.1.3 in ground facilities below Mach number 10, although the results to date are only preliminary and effects of wind tunnel conditions on such phenomena as the transition point have not been fully explored. The effects of cold walls in 3-D complex flows, with the gradients and shock waves that are required for optimized configurations in this lower Mach number range, along with inlet studies, can be studied, but have not.

These same problems at high Mach numbers are critical issues because facilities are limited, and all of the parameters for boundary layer validation must be applied, including wind tunnel disturbance effects (now including entropy and constituent effects), wall cooling and catalysis, and wall roughness.

2.3.2 Real Gas Effects

Blunt body flows have been calculated and validated to some considerable detail. There is some question of the results for very high altitudes where the constituents of the atmosphere and the local conditions are not well known. Accurate measurement of the conditions ahead of the vehicle in flight would provide an important input into the analysis of the results, and considerable effort is being expended in this area, although solutions to the problem are not yet in hand.

Slim, complex, three-dimensional bodies with blunt noses and leading edges provide a special problem in real gas effects. Although the blunt nose solutions are well known, the streamlines downstream of the blunt nose carry different histories; mixing and recombination rates depend on local conditions. A similar problem is experienced in the expansion of the combustion chamber flows through the nozzle. Although the chemical kinetics for the blunt nose are well known, not all of the data needed for recombination rates for the downstream flows are in hand. These data should be obtainable, however.

The effects of real gas kinetics on boundary layer characteristics are only beginning to be explored. The effects are probably not important below Mach number 10. Above 10, surface catalysis and chemical reactions in the boundary layer flow, with cold walls, could affect boundary layer characteristics and the transition point and transition region. Studies are only in their elementary phase and some reasonable solutions for the boundary layer characteristics will be required before the addition of real gas effects can be attempted in detail.

2.3.3 Real Gas Effects in Complex Flows

Inlets, bodies, fins, and wings, and their interactions, cause a combination of viscous effects, shock waves, and strong gradients with real gas effects. These must be understood to give detailed flowfields, such as for the combustor, where the local conditions and the constituents (state of the gas) must be known at each point. Local, configuration-specific hot spots must be identified. Inlets have been tested at low Mach number. At high Mach numbers, the inlet tests must be closely associated with a well-defined initial flow determined by the details of the forebody. The lack of adequate testing facilities and the complexity of the flow

makes this an important problem that will require considerable further work, both for computational validation and for inlet optimization at high Mach numbers.

2.4 Control, Guidance, Instrumentation, and Information Systems

As with propulsion, aerodynamics, and materials, further developments in controls are required for hypersonic flight. Challenges in controls-related areas include vehicle trajectory, configuration, and effective dynamics, and the related fields of instrumentation and information systems. The Wright Brothers, in 1901, realized that approaches to problems in propulsion, structures, and aerodynamics were more or less understood, but that an "inability to balance and steer still confronts students of the flying problem...[and] when this one feature has been worked out, the age of flying machines will have arrived...." Today for hypersonic flight, we recognize a host of aerodynamic, materials, propulsion, etc., problems clearly enough that we can, to some degree, define and even assess them. But the means to achieve directed and governed propelled hypersonic flight can be seen, at best, only dimly. The problem is how to exert simultaneous control over aircraft flight path, aerodynamic attitude (local flows at critical locations), and propulsion. All guidance and control system aspects are somewhat critical, but the most important "missing means" are probably the fundamental system architecture and control structure, special sensors, effectors, and the information processors that implement the control structure.

In this section, we discuss various issues central to controlled hypersonic flight: physical factors, vehicle dynamics, vehicle-flight control systems, sensors, and information systems. Although some of the key problems in these areas can be alleviated by adopting

the system design and test philosophy of gradual and punctuated buildup described below, an aggressive technology development program in controls, sensors, and information systems is still necessary.

The uniqueness of vehicle dynamics and flight control disciplines to hypersonics is sometimes a matter of degree rather than of kind. Control of sideslip, for example, is a ubiquitous general problem in aircraft, but the control precision needed for some hypersonic aircraft configurations can be an order of magnitude greater than for other craft. Further, the ways to achieve this control on a multiply-redundant system basis are, at best, obscure and possibly beyond the present state of the art. This ancient problem could become a design driver at best and a potential show stopper at worst.

2.4.1 Physical Factors

Hypersonic vehicles will demand sophisticated control for the engines, inlet, and guidance and control of the aircraft. Subsystems probably will be more complex than even an entire aircraft automatic flight control system of today. The demands on the information processing equipment will be very significant. This will lead to hierarchical distributed fault-tolerant information systems. Embedded in these systems will be many sensors and effectors at diverse locations around the aircraft. This, in turn, will place unique requirements on the subsystems and sensors. All the aircraft designs will have a large cryogenic tank at the center of the fuselage. The many sensors, wires, fiber cables, and hydraulic lines will have to pass through these tanks or be routed around them. Either way, there is a technology issue. At a minimum, the components will have to operate in the environment peculiar to their location. Some sensors and effectors together with their connectors and cabling will be near the

skin, in the engine, and in the cryogenic fuel. They must accommodate large temperature gradients while guaranteeing electrical, optical, and hydraulic integrity. If routed near the aircraft subskin, they must withstand the very high temperatures expected in that area, yet exposure to cryogenic temperature will be a challenge to hydraulics, if used.

Typical maximum operating temperature for today's fiber cables is 75-85° C. New fiber for aircraft applications to 200° C is being tested. Beyond 200° C, current organic jacket material becomes inappropriate. Questions concerning the optical properties of specific fiber types exist for very high temperatures. The waveguide itself is made of fused silica, the material used in space shuttle windows. However, without a protective jacket, this fiber is subject to serious mechanical and chemical damage, particularly in the vibratory environment likely in a hypersonic vehicle. Two program paths are needed to minimize risks. One is a technology program focused on the thermal capabilities of sensors, cables, and connectors and the other is careful attention to the details of the thermal environment to which this type of equipment will be subjected.

Hypersonic vehicles with their very high temperature will present an unusual requirement on control system sensors. Even in conventional vehicles, it is a challenge to be able to locate the sensors involved in stabilization of flexible body modes at useful locations. Nodes and antinodes are sometimes preferred by the flight control system designer, but such locations may be counter-indicated by other demands. This problem will be compounded by the likely significant variation in mass distribution as fuel is consumed. Because these vehicles will usually exhibit both lateral and longitudinal instabilities (requiring a high-bandwidth controller to correct) and also are projected to have low

frequency body bending modes, active control of body bending will be needed. This will require a set of sensors distributed around the body at particular locations selected to expedite control. Just as the cables may be exposed to very high temperatures, so will these sensors.

Most accelerometers and rate gyros available for such applications are limited to approximately 85° C maximum temperature. Piezo-electric accelerometers are available that can operate up to around 250° C. Clearly, either cooling must be provided or a new family of high temperature body motion sensors will be needed. The problem is even more complex because the body bending parameters could be a function of temperature. In a normal situation, when a sensor cannot be properly placed, a model of the structure can be used to estimate the signal that would be obtained from properly located sensors. This is not a preferred solution. Where bending parameters are temperature-dependent, it is even less desirable since the model required here will be even more complex. This will place considerable robustness demands on the control system.

Almost all modern aircraft use hydraulics to provide the necessary forces for control. Hypersonic aircraft likewise will need high bandwidth, high strength controls. Either hydraulics or newer technology high strength electrical actuators will be required. Either way, high pressure hydraulics (or electrical power cables) must be either routed under the skin where they will suffer a totally new environment due to the high temperatures that could be encountered or passed through or near the cryogenic tanks. A key factor will be the chemical stability of the hydraulic fluid which limits its lubrication properties. Carburization and viscosity losses usually limit petroleum-based fluids to applications around 200° C.

Synthetic emulsions may work up to approximately 400° C. Fluids would need fire retarding capability in the event of a leak. Servo valves present additional problems due to magnetic degradation. Their performance in most cases begins to be affected at about 200° C. Again, this important technology development issue must not be overlooked and the design must consider protection of this type of equipment also.

2.4.2 Vehicle Dynamics and Controls

2.4.2.1 "Aerodynamic-Attitude" (Angle of Attack and Sideslip) Control

Projected hypersonic "aircraft" are basically engines with attachments. The local flow directions at key locations near the engines are central to engine operation. The basic airplane performance is extremely sensitive to the angle of attack and sideslip. On large vehicles, the lower frequency structural and slosh modes may be significant contributors to the local effective angle of attack and sideslip as seen by the engine.

It follows from this litany that the establishment and maintenance of the local angle of attack and sideslip within very narrow bounds by the inner loops of the attitude control/structural mode control system(s) are an enabling, limiting, and driving technical requirement. This amounts to precision control of the vehicle as an engine mount! The precise requirements are a bit obscure, but angle of attack established and held to 0.1 degree even while maneuvering is supportable for some proposed configurations. Just how this is to be done as part of the flight control system (which simultaneously controls the flight path vector) is a question of the first order.

The maintenance of near-zero aerodynamic sideslip in the presence of

thrust asymmetries, during maneuvers, etc., in the supersonic and hypersonic regimes is a critical problem in almost all its aspects - control power and effectiveness, sensing, and actuation. Precise sideslip control is needed in essentially all hypersonic designs.

2.4.2.2 Integrated Propulsion/Flight Control and Guidance

Speed control is sometimes essential to the trajectory adjustment control for hypersonic vehicles. Ramjet and scramjet engines have some unknown dynamic features that can seriously affect a tightly integrated propulsion/flight control system. Thus, the very feasibility of speed control may be questionable. Even without speed control, ways to cope with unstart, minimizing thrust asymmetries (e.g., through center of gravity control, offsetting effectors, etc.) are not certain.

2.4.2.3 Aerothermoelastic and Slosh Mode Characteristics and Control

The nature of the structural dynamic and slosh mode characteristics, how these are affected by temperature, and the implications for structural and slosh mode control are a first magnitude problem, especially for manned vehicles.

Because flight control systems have been required to cope with structural and slosh modes for many years there is a tendency to treat this as a problem that will yield to available flight control technology. Things will be different with hypersonic aircraft. In the past, most flight control systems have relied on proper sensor placements and suppression of the lower frequency structural and slosh modes picked up by the sensors using notch or low-pass filters. For large flexible vehicles that are flown statically unstable to maximize performance, and for which active con-

control of the lower frequency structural modes is needed for structural system optimization, the traditional approaches will no longer apply. Active control of the instability and of lower frequency structural/slosh modes will demand very large controller bandwidth. Lags appropriate for traditional "gain-stabilized" structural mode filters are inconsistent with the controller bandwidth needs and cannot be tolerated by the control system. Even if they were, such lags would also lead to piloting difficulties and poor flying qualities. (For example, relatively large effective time delays, partially due to structural mode filters, played a major role in the ALT 5 Shuttle PIO.) The net result for structural/slosh mode control is that the system may have to be "phase stabilized" in such a way that the net effective vehicle dynamics are appropriate for piloted control. This has never been done for manually controlled aircraft-existing specifications don't even permit it to be tried! Thus, the problem is completely different in both kind and degree from what one would casually expect as an extrapolation of existing technology.

2.4.2.4 Engine/Inlets/Diffuser, etc., Control

The vehicle-flight and propulsion system controls have been mentioned above as a major overall integration problem. And even in cases where the engine can be looked at as an entity that is somewhat separate from the vehicle, the maintenance of reasonable operating conditions by the engine control system will not yield to a simple extrapolation of existing technology, and perhaps not even of existing control concepts.

For example, while the control of thermal states throughout the vehicle is difficult, within the engine it is awe-inspiring! Close coordination of thermal

cooling and engine flows is essential, with even closer integration of other engine and thermal variables being a likely requirement.

Since these vehicles will be so critically dependent on controls, it is important to consider some issues relating to control system integrity. While highly reliable fly-by-wire control systems are now standard, the level of integration of flight, aerothermoelastic, thermal, and propulsion controls required here poses a significant new dimension to the problem. Control system architectures for these vehicles will be driven by the simultaneous requirements for tight local control of high frequency phenomena and coordinated action across the entire system to assure appropriate control integration. Hence the need for distributed hierarchical systems with life critical integrity. The basic principles for such systems are not established, proven architectures are not available, and only rudimentary design, evaluation, and validation tools are in place.

As one would expect in the interdisciplinary arena of controls/aerodynamics/propulsion/thermal/structural dynamics interactions, the quantitative dimensions of many facets of these problems will be configuration specific. The problems themselves, however, are general, and the fundamental control system architectures available to solve them are relatively limited. For example, one can list perhaps a dozen specific overall vehicle dynamic phenomena stemming from interacting aerodynamic, structural, and propulsion sources that must be offset or corrected by the controls in some flight regimes. These phenomena then define the fundamental control system architectural possibilities as well as the key sensing and effecting means. Yet, as we have noted, the definition, feasibility, and detailed consideration of technology needs pertinent to these architectural possibilities, associated sensing and effecting means, etc., appear

to have received insufficient attention.

2.4.3 Sensors

Hypersonic vehicles place new requirements on sensors required for feedback control. In addition to the thermal requirements outlined above, entirely new classes of sensors are needed. The aircraft is, in effect, a flying inlet and outlet for the engine. Control of the flow is essential. This will require air data, pressure, and local flow sensing on a scale never before required. Unfortunately, such sensors do not exist. Probably the finest aerodynamic data sensing system yet tested was the "Q Ball", a servo-driven spherical nose installation on the X-15. It delivered angle of attack, side-slip, dynamic pressure, etc., over a very wide range of conditions - up to a maximum q of 2,200 psf (at about Mach number 5) and worked well up to a maximum achieved Mach number of 6.7 (at a q of about 780 psf). The Shuttle Entry Air Data System (SEADS) has been operated on one flight up to Mach number 27 but at very low density. When used as basic sensors for high bandwidth flight control, these sensors normally will have to be multi-redundant. Even worse, heat transfer rates will increase as leading edge radius decreases. Considering the shapes of projected hypersonic vehicles, a compound problem of very high temperature and no room for equipment such as the "Q ball" will further complicate the sensor problem even before redundancy is considered.

Measurements of mass flow, density, and three-dimensional velocity are needed at very high data rates. Species (H_2O , O, OH, etc) measurements using various experimental techniques may be fruitful in these areas, but are yet to be proven in ground tests, much less on board. Even temperature sensing is a problem. Thermocouples are useful up to perhaps 1700° C, but installation on

the skin with wiring is a severe challenge. We have a long way to go in the sensor area and an ambitious R&D program will be needed in this area also.

2.4.4 Information System Requirements

For one hypersonic vehicle concept, three airframe and engine contractors have made preliminary projections of throughput for the onboard information system that range up to 25-50 million instructions per second (MIPS). A reliability requirement in the 10^{-7} to 10^{-9} failures per hour range is likely to be necessary. Whereas the reliability requirement can be met with today's technology, obtaining the necessary throughput at that reliability in an aircraft-qualified installation is a considerable technical challenge. Figure 2-2 indicates how well some current systems can do. While some programs are aimed at very high throughputs, such as DARPA's strategic computing initiative, very little work has been done to provide that level of computing capability at the reliabilities necessary for this application. A system of this capability that can also grow by accretion of functions and equipment will have to be designed in parallel with the aircraft to assure that necessary system architecture can be built into the aircraft. Obviously, it will be necessary to develop the technology in time to do this. If a phased test program is employed, full availability of this system can be deferred. Its basic design, however, and laboratory proof of its viability must be established in time to make a commitment for defined hypersonic vehicle programs.

2.4.5 System Design Philosophy

The uncertainties in the vehicle and propulsion system dynamics constitute a significant, perhaps even a governing, challenge for the development of hyper-

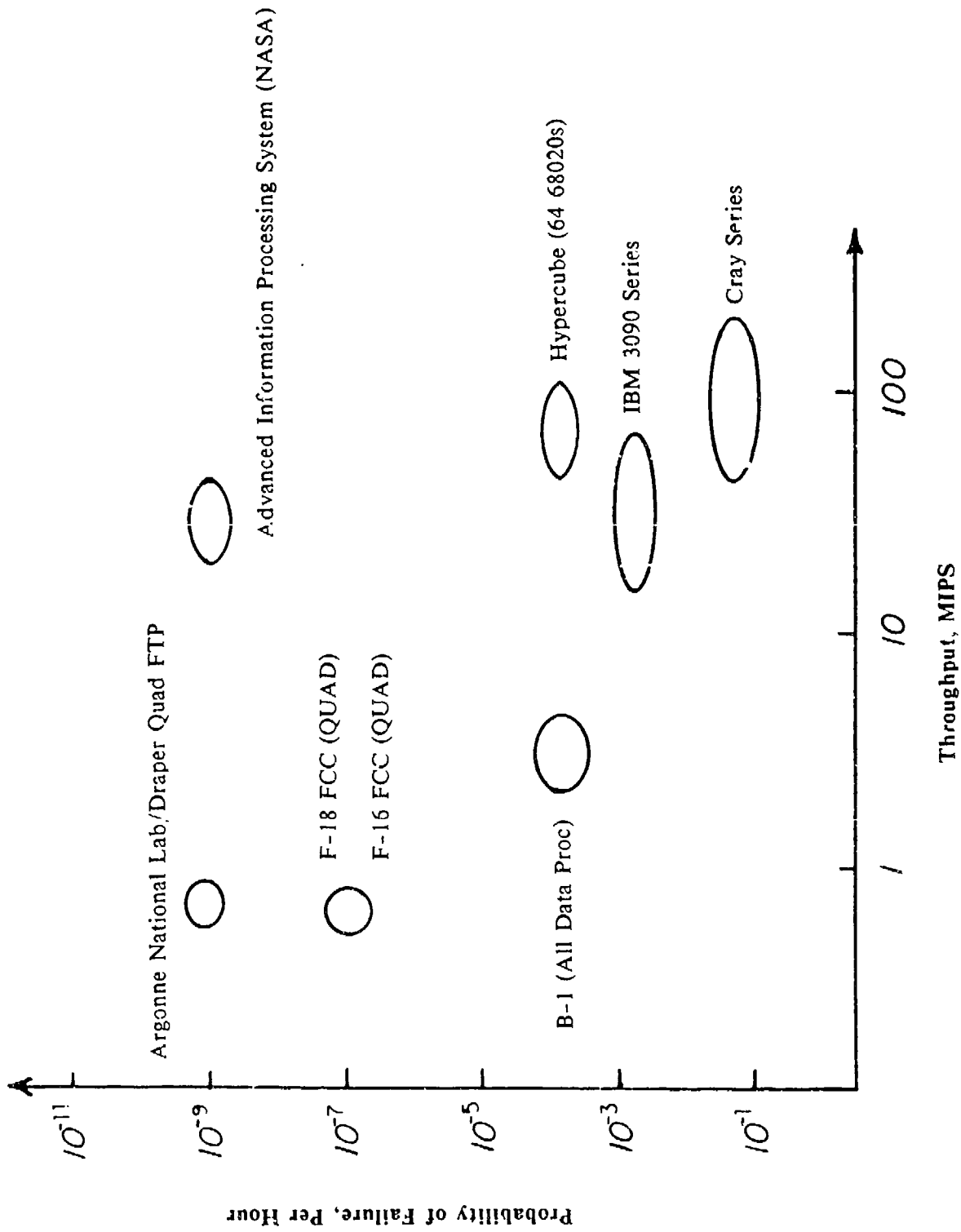

FIGURE 2-2
Performability of Existing Computers

sonic vehicle control systems. These lead to a requirement for a very robust control system and perhaps sophisticated outer loop guidance capability. Through careful planning, including early decisions in the areas of systems architecture and on some of the subsystem physical factors, we believe some of the demands in these areas can be ameliorated by the exploitation of a carefully phased flight test program. The full-up controls capability will not be necessary during early flight test in a program that slowly evolves toward hypersonic speeds, the full-up controls capability could evolve slowly during the flight test program.

Most important among the attributes required for this approach is a control configuration which is at first as simple as possible but that can grow by accretion as the incremental test program proceeds. The most significant implication of this is for the digital information systems architecture. From the very beginning, it must provide the necessary levels of safety, fault tolerance, and reliability. But it must also be able to evolve into a much larger system without rewiring the aircraft, making any significant physical changes, or reworking the software. This means the system architecture must from the start be designed to be expandable while simultaneously providing the necessary levels of reliability. When such a system is in place, it can be used for fundamental flight control purposes at the beginning and then evolve toward a fully integrated engine, airflow, structure control system. In the early stages of the flight program, for example, nominal trajectories and minimally compensated inner loop control functions would be used. More elaborate compensation and optimal control and guidance laws would follow when needed. As the program begins to reach the middle velocities where auxiliary constraints such as temperatures become important, additional control loops will be added as

needed. They would be added with good knowledge of the vehicle parameters and dynamics from previous flight tests. This would reduce the need for overly robust control systems that will be a challenging technical problem and should simplify the controls requirements for the vehicle. If during any flight, a parameter, such as a temperature limit, was reached, the flight speed would be reduced and perhaps that particular test terminated until a full understanding of why the limit was exceeded was obtained and the control law modified. This punctuated buildup and elaboration of controls consonant with an orderly phased flight test program leads to a full capability that probably will not be as elaborate as would have to be planned for if, the full capability was to be installed in the vehicle from the beginning of the flight test program. This advantage will have to be carefully balanced against the implications of cost and schedules to the test program should a problem arise that requires significant redesign and validation of the control system.

2.5 Materials for Hypersonic Vehicles

2.5.1 Introduction

Structures for hypersonic vehicles must be lightweight, high-temperature resistant, inspectable, durable, and reliable. These requirements demand materials and concepts for structural design of hypersonic vehicles that are still in the emerging technology phase of development. Since different portions of the vehicle will encounter different pressures and atmospheric and temperature regimes, depending on the vehicle configuration and on the trajectory flown, we must consider a wide variation of potential structural concepts. These will be influenced by mission requirements, desired performance, and the required payload.

Many considerations affect materials choices for hypersonic vehicles. Some of the more obvious: load-temperature-time cycle, vehicle reusability requirements, interior environment requirements, and the type of fuel and propulsion system chosen. Materials-related factors that affect the lifetime of the structural elements are:

- resistance to chemical attack
- oxidation and corrosion resistance
- chemical stability as affected by alloy depletion at the surface and by diffusion at elevated temperatures
- interphase stability at high temperatures between fibers and matrix, between coatings and contacted phases, etc.
- metallurgical stability, i.e., grain growth, over-aging, or precipitation during use and in thermal cycling
- creep
- high fatigue resistance
- low crack propagation rates, and
- designs that are inspectable, refurbishable, and damage tolerant.

Temperature regimes range from cryogenic temperatures (-268°C) for fuel containment up to $1100\text{-}2200^{\circ}\text{C}$ for leading edges, control surfaces, and stagnation points. Also, dynamic pressures up to 2000 psf may be experienced, posing very stringent requirements on both structural concepts and materials choices. For example, the wing leading edge is one of the most critical design areas because of the severity of the aerothermal environment. We must overcome such problems as localized heating, thermal gradients, connection to the airframe structure, aerodynamic loads, thermal stresses and distortions, and interface heating. A number of leading edge concepts exist such as radiatively-cooled, heat-pipe cooled, and actively cooled designs. Similar considerations apply to nose caps and control surfaces as well as to the fuselage.

At high altitude, atmospheric oxygen begins to dissociate above Mach number 7, with both oxygen and nitrogen almost fully dissociated above about Mach number 15, and ionization above about Mach number 20. These real gas effects at the stagnation regions will require coatings to protect against oxidation, to form high emittance surfaces to lower surface temperatures, and to protect against erosion.

Many factors will determine which materials are best for the various structural elements of a hypersonic vehicle. In briefings to this committee on vehicle concepts and configurations, large portions of the vehicle structure were described as stiffness critical, other areas were judged to be buckling or crippling critical, other areas strength critical. Some areas were designed by fracture toughness considerations, thermal fatigue, creep, etc. In examining these requirements, it becomes evident that a great deal of materials testing will be required to create an adequate materials properties data base. Many materials of interest are anisotropic and process dependent; these factors complicate and expand the amount of testing needed to develop a reliable data base. Finally, many of these properties must be obtained for temperatures from -268°C to 2200°C .

The committee was briefed by the Air Force, NASA Langley personnel, and the airframe and propulsion contractor teams on the NASP program concerning material choices and the status of their developments. Centralization of the Materials Technology Maturation Program according to the type of materials under consideration is an important correct step to obtain the required data in a cost-effective and expeditious manner. It is important to realize that getting property data meaningful for design requires material specimens in the proper size, thickness, and finish that have been processed with a well-defined ped-

agree. Most of the available data consist of tensile strength properties at room temperature and higher obtained on small coupon-type specimens and by three-point bend tests. Much of the data are not yet of sufficient quantity to be statistically significant for design purposes and emanate only from a single source. In some vehicle configurations described to us, the structural weight fraction necessary to achieve the performance goals set for the NASP research vehicle dictates that the vehicle be made largely of metal-matrix composites, carbon-carbon composites, thermoplastics, titanium, and titanium aluminides.

A materials development program must include several related vehicle design inputs, such as stiffness vs. strength, minimum gauge requirements, acceptable creep elongation and fatigue life, and behavior in oxidizing and other chemical environments. Compared to the materials data required for subsonic aircraft, hypersonic aircraft materials data base requirements are much more extensive because of the need for thermal, chemical, oxidation and other data at elevated temperatures over specified time periods.

2.5.2 High Temperature Materials

Potential system requirements dictate that the structural weight fraction of proposed hypersonic vehicles be much smaller than that of conventional subsonic aircraft. To satisfy the need for minimal structural weight fraction, one is forced to consider material concepts on the edge of emerging technology. High temperature materials are needed that maintain useful properties at the necessarily elevated working temperatures; they must be high in stiffness, high in strength, low in density, oxidation resistant, have high fracture toughness, and creep resistance. In addition they must have several other

desirable properties, including fabricability, joinability, ease of assembly, reasonable cost, reproducibility, and they must be available in sizes and shapes suitable for fabrication into final product sections.

High temperature, lightweight structural materials of interest include the new RST high temperature aluminum alloys, high temperature RST and oxide dispersion strengthened titanium alloys, the titanium aluminide and nickel aluminide intermetallic alloys ($TiAl$, Ti_3Al , $NiAl$, and Ni_3Al), and metal matrix component alloys with reinforcing particulates, or fibers, of SiC and other refractory materials. The high temperature materials that are available in quantity and well characterized are the successfully applied nickel and cobalt base superalloys dispersion-strengthened with fine refractory carbides and oxides.

The requirements for cryogenic fuel containment pose material needs that include light-weight super-insulation, organic-based graphite composite materials for propellant tanks and internal structural applications and a variety of non-structural materials. Temperatures of interest go down to $-240^{\circ}C$.

The conventionally processed titanium alloy, Ti-6Al-4V, has strength to $300^{\circ}C$, and the RST-processed Ti (dispersion-strengthened) alloys may sustain temperatures of at least $800^{\circ}C$. However, titanium and its alloys oxidize above $550^{\circ}C$ in long time applications, and are also susceptible to hydrogen embrittlement. This reactivity poses significant applications problems because hydrogen will be the primary fuel and will be used for regenerative cooling of parts of the structure. There is a need for the development of high thermal conductivity, low density materials (that are not embrittled by hydrogen and maintain adequate high temperature strength) for piping for regenerative cooling of the structure and parts of the

propulsion system. A portion of the Materials Maturation program is devoted to this task. Materials under consideration include the titanium aluminides and copper based metal matrix composites.

2.5.2.1 The Aluminides

For service above about 700-1000° C for relatively long times, there is much interest in the intermetallic compounds: Ni_3Al , $NiAl$, Ti_3Al , and $TiAl$. These basic materials offer significantly lower density (the lightest being the $TiAl$ phase), improved stiffness, high strength-to-weight, and improved oxidation resistance due to the high aluminum content, to operating temperature levels significantly higher than those of their metallic base alloy counterparts.

However, these are intermetallic compounds and have poor ductility at room temperature and below, except for the modified Ni_3Al phase-alloyed with boron. They have relatively low strength at temperatures above about 800° C in the unalloyed state and have relatively low melting temperatures compared to those of the refractory metals, and the ceramic and carbon-based composite materials.

For structural application at 700-1000° C, the titanium aluminides show much potential. They are up to 50% lighter and have higher specific stiffness than the superalloys (see Table 2-A). Titanium aluminides have been proposed as matrix materials for SiC and other fiber-reinforced metal matrix composites, where the high temperature strength of the fibers offsets the rapid fall-off in strength of the titanium aluminide above 800° C.

All of these materials are products of newly emerging technologies with a limited data base for design, development and testing to ascertain the resultant

properties. Although the high specific strength and low density evoke great interest for structural applications in the 700-1000° C range, the materials are inherently brittle at low temperature and efforts are underway to increase their ductility. Such improvements in low temperature ductility are mandatory if these materials are to be useful. Titanium aluminide honeycomb panels have been successfully produced by brazing. The key to titanium aluminide metal matrix composites is the fabrication of foil, which can be diffusion bonded around fibers such as SiC. Foil 0.003" thick has recently been produced with sufficient tolerance for this application. However, reproducibility of results requires considerable additional work, and higher temperature oxidation testing is urgently needed.

Little is known about the interactions of the matrix and fibers and particulate reinforcements at elevated temperatures. It is likely that a barrier coating will be needed on the fibers to prevent degradation. Since these materials are desired in minimum gauge structures and in honeycomb panels, the problem of internal oxidation at elevated temperatures must also be addressed.

Titanium aluminides and carbon-carbon composites are often suggested for higher temperature applications. RST titanium is specified but no information about properties, availability of shapes and structures, etc. seems available. Finally, composite metallic materials, again largely based on titanium alloys, are specified as major components of the vehicle structure; mainly in SiC fiber-reinforced titanium and titanium aluminides. Data are extremely limited; manufacturing methods are not well known; size and shape potential are in question. Vehicle designers appear to be relying on material producers to supply these materials and data. RSR titanium aluminide (RSR powder metalurgy) is of

	Superalloys	Ti Alloy	Ti ₃ Al	TiAl
Density (lbs/in ³)	0.3	0.16	0.15	0.14
Modulus (x10 ⁶ psi)	28	16	18	25
Max Temp: (°C)				
Creep	1000*	540	815	1000
Oxidation	1000	600	650	1040

*1095 °C for ODS (or MA) alloys

TABLE 2-A
Titanium Aluminides Property Comparison

unknown merit, especially for large structures. Few details are available on the powder metallurgy processes being used especially regarding oxygen contamination, powder characteristics, and the subsequent consolidation methods and conversion to structural shapes. Titanium aluminide foil material and honeycomb structures are specified but supporting data on product yield, sizes, methods of joining, shapes, and properties are not available other than those quoted above. Two specialty alloys, MA 956 and MA6000E, mechanically alloyed, nickel base, oxide dispersion-strengthened alloys are in production and used in aircraft. They have a fair data base, but we have limited data on fabrication, performance, oxidation, resistance, etc.

A general criticism of the status of most composite materials, and particularly of the aluminides is that mechanical test data are extremely limited, and, in many specific cases, unavailable. Most of the data are short-time tensile data; few data are available for lives of 100 to 1000 hours at high temperatures in appropriate atmospheres. Crack growth data are generally unavailable. Longtime tests at maximum temperature are unavailable. Choices of materials are based largely on inadequate data and optimistic projections. Although titanium aluminide appears to be the choice of some airframe designers, others depend heavily on carbon-carbon composites. Most test work has been with carbon-carbon (including small panels). There has been very little work with the titanium aluminides and there has been very little material to work with. In this respect the use of carbon-carbon may be somewhat more realistic, particularly at the higher temperatures. The joining methods with carbon-carbon composites and metal matrix composites are a serious concern and as yet not much work has been done.

The NASP technology maturation program is aimed at improving materials

through conventional alloying, by applying RST principles, through oxide dispersion strengthening and by application of the aluminides as the matrix for composite structures. Since the basic aluminides are relatively new structural materials, their properties and those of the alloys that may be developed from them are largely unknown. The aim is to produce alloys capable of operation up to about 1000-1100° C while maintaining fabricability, formability, and while retaining oxidation resistance for thousands of hours, and exhibiting suitable strength, toughness, etc.

Some properties of titanium aluminide materials are compared to conventional nickel base superalloys and titanium alloys in Table 2-A. Improvements in high temperature strength using metal matrix composites are shown in Figure 2-3.

2.5.2.2 Superalloys

The superalloy compositions and structures are based on extensive and excellent performance records for numerous applications where the maximum operating temperatures are about 950° C and life is in the tens of thousands of hours.

Current nickel base superalloys have been developed for high strength and long time service in turbine combustion atmospheres with performance far in excess of any anticipated demands. Melting at temperatures at about 1300° C, the nickel base superalloys have operated at temperatures up to 1000° C, uncooled, and higher with cooling, or in excess of 80% of the absolute melting temperature. For increased high temperature performance, these alloys have also been prepared as directionally solidified (DS), coarse grained, precision cast blades, and as single crystal (SC) alloys with preferred crystalline orientations. The literature and prior

experience are abundant for temperature-stress-life time applications of these materials for a broad range of operating conditions. Further, a number of coatings have also been developed of the MCrAlY type where M is generally Ni, Co, Fe, or combinations of these elements and the Cr, Al, and Y are as indicated. These coatings have excellent life performance and are routinely applied as needed.

The major negatives of the superalloys are low melting temperatures and a relatively high specific gravity.

2.5.2.3 Dispersion Strengthened (Stabilized) Alloys

Where oxides are used as the dispersoids, the resultant alloys are ODS (oxide dispersion stabilized) alloys; where carbides are the dispersoids, the alloys are carbide dispersion strengthened (CDS). Only refractory oxides are inert in most metallic matrixes, and the oxide does not contribute to the strength through interaction with the matrix; carbides and other intermetallics are generally wetted by the metallic matrix and therefore can contribute directly to strengthening through resultant bonding forces.

The ODS alloys have reached a state of development where significant increases in applications are being achieved. (See Figure 2-4.)

Oxide volume contents from as little as 0.5% to as much as 10% have been used in both pure metal bases and complex alloys such as the commercial nickel base alloy IN-100 (Ni-Co-Cr-Mo-Al-Ti-V-B-Zr-C). Strength generally increases with increasing oxide volume content, as do the elastic modulus and hardness, whereas formability, ductility, and toughness decrease. The critical structural parameter is the interparticle spacing among dispersoids, making it

desirable to use exceedingly fine dispersoids (0.01 to 0.2 microns) to achieve high strength levels, long time stability at very high fractional melting temperatures, combined with demonstrated practical formability, useful ductility, and toughness. With these very fine dispersoids one needs only 1 to 2 volume percent of oxide to achieve the desired high temperature stability and strengthening. For still greater stiffness, higher volume contents of oxides can be added (10-30%), with further benefits in strength but loss of ductibility.

Dispersion strengthened (as well as composite alloys) are strengthened through the stored energy of cold work in processing. The very fine interparticle spacing pins high levels of dislocations (cold work); and the avoidance of significant alloy recovery or recrystallization preserves the strengthening benefits effectively almost to the melting temperature of the alloy.

Recent studies have now established preferred alloy processing methods to incorporate the fine oxide particulates reproducibility; in fact, several processing technologies are being used successfully.

Highly successful ODS materials have been reported based on Mg, Al, Ag, Cu, Fe, Ni, Co, Pt, stainless and heat resistant alloys, the superalloys, titanium, and others. Alloyed matrixes are used to achieve selected properties, such as corrosion or oxidation resistance, and high strength, but pure metals are also used effectively for high strength and high conductivity as with Cu, Ag and Al.

Refractory carbides are also of interest for selected CDS alloys. Because the carbides are rarely inert in most metallic systems, strengthening is often enhanced by bonding reactions between the very fine carbide dispersoids and the metallic matrix. For maximum alloy stability at the highest

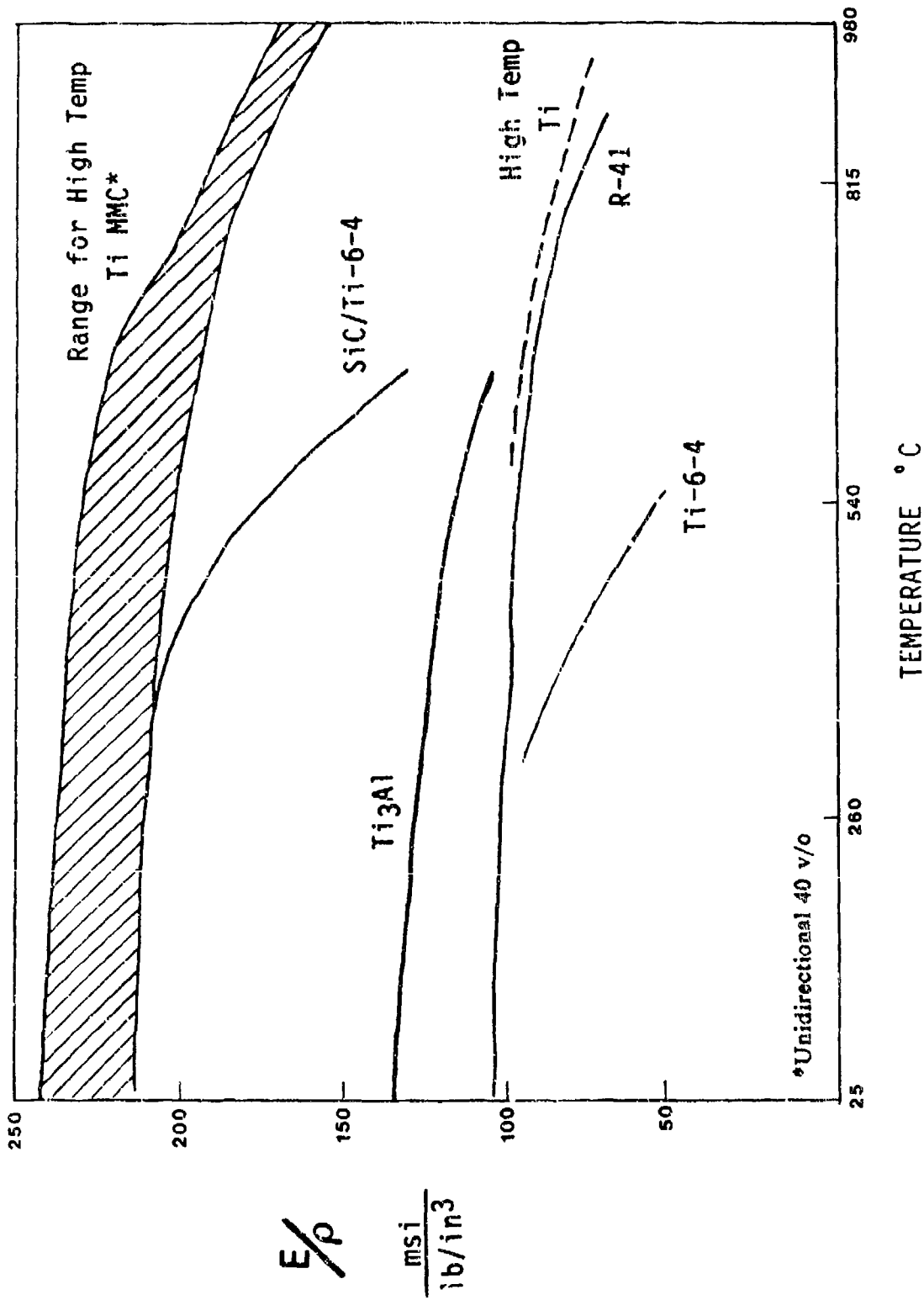
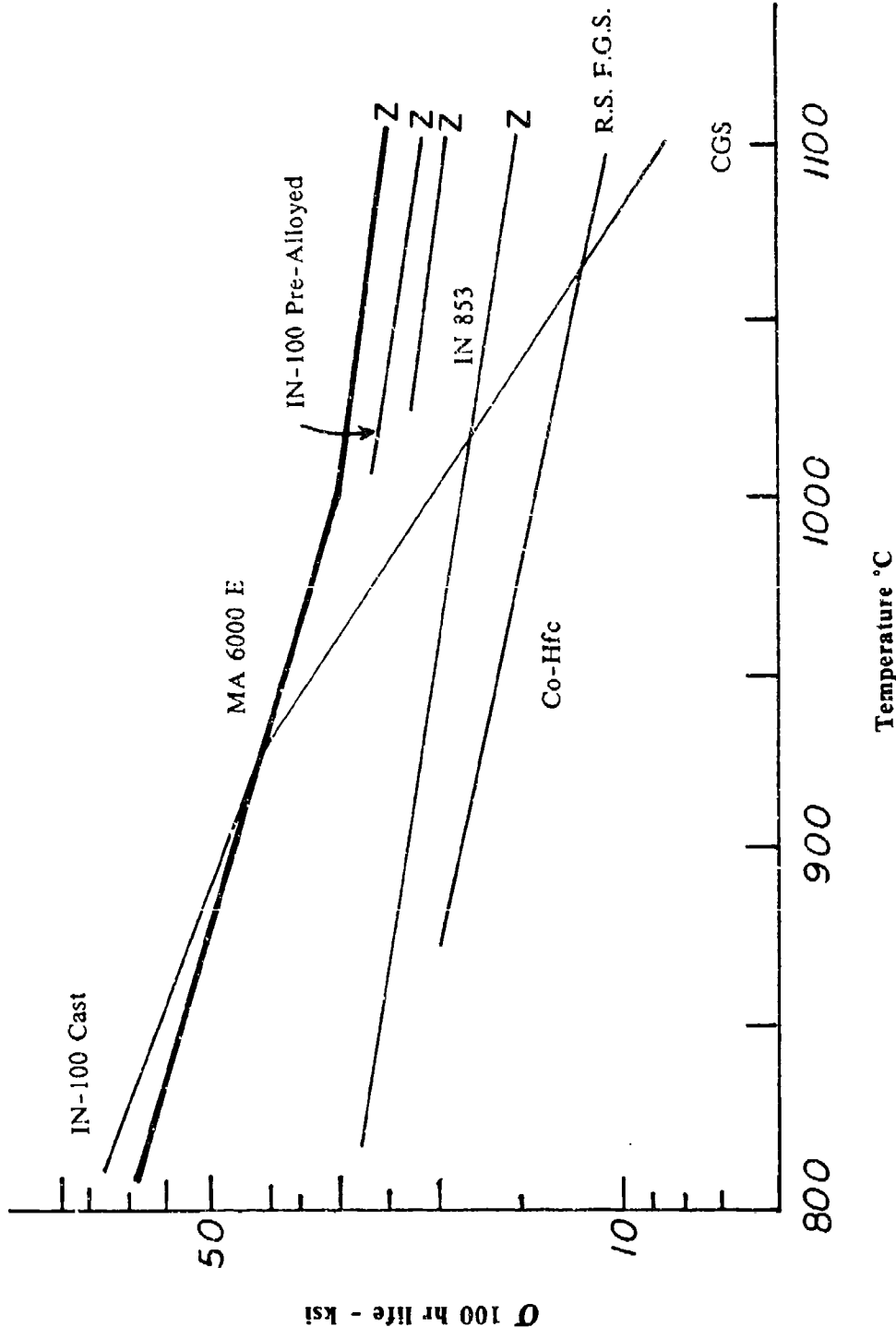

FIGURE 2-3
Reinforcement Improves Stiffness/Temperature
Capability



1-2% Oxide

Useful to 0.85 Tm

Long term stability

Oxidation Resistant - with Coatings

FIGURE 2-4

Oxide Dispersion Stabilized Alloys

possible temperatures, only the refractory carbides such as HfC, ZrC, and SiC are of interest. As a result of such bonding, strengthening is achieved and retained at low or high temperatures even after recrystallization, unlike the case for the ODS alloys. At very high temperature, say, above about 0.6 of the absolute melting temperature, strength properties fall off more rapidly than for the ODS alloys.

Refractory carbides, with much lower values of heat of formation than refractory oxides, tend to be coarser than the oxides. Further, the ultrafine carbides, if prepared separately for subsequent blending interactions, may form oxide films that will modify the expected interactions. Thus, carbides tend to be coarser than oxides, and are always used in larger quantities, for example, from 10-25 volume percent for maximum strengthening.

Combinations of fine oxides at low volume content with fine carbides at high volume content recently have been shown to provide interesting and useful combinations of properties, each according to its interactions with the matrix. For specific applications intermetallics other than the carbides can be used effectively to achieve other combinations of properties; these include the refractory borides, nitrides, silicides, etc.

Relatively little developmental work has been done with higher melting alloys than those of Fe, Ni, and Co. Platinum has been dispersion stabilized with ThO₂ and showed very large increases in strength in long time tests at 1300° C. Rupture strength values for lives of 100 to 1000 hours were 10 to 20 times greater than for pure platinum and four times greater than for the best known alloy, namely Pt-40% Rh. The upper temperature limit for ODS alloys has not yet been determined. In terms of oxidation and certain corrosion phenomena, these precious metal ODS alloys

offer some interesting properties.

Minor efforts have been undertaken with Nb, Mo, Ta, and W as high temperature ODS alloys. Molybdenum has been dramatically strengthened to 1600° C by fine dispersions of HfC, produced by conventional melting technology. Powder metallurgy blending should result in higher temperature performance with ODS alloys, with carbide dispersion strengthening of combinations of both.

2.5.2.4 Carbon-Carbon Composites and Ceramic Composite Materials

For temperatures to 2200° C, carbon-carbon composite materials have shown excellent properties and performance on the shuttle leading edges and nose. New, improved manufacturing methods continue to be developed. Section sizes of interest for airframes are being fabricated. Carbon-carbon composites show excellent combinations of properties: very low specific gravity, high modulus, low thermal conductivity, improving strength at high specific levels with increasing temperature, excellent thermal and mechanical shock resistance and toughness. Oxidation is a problem but rates are not catastrophic, as with some of the refractory metals in an oxidizing atmosphere; however, coating will undoubtedly be required for long life performance.

At somewhat lower temperatures, from about 1400° to 1900° C, ceramic composite materials show promise. Manufacturing technologies are being developed, and reinforcement with refractory and carbon fibers look promising. Oxidation resistance is excellent; strength levels are attractive; but thermal stresses and thermal and mechanical shock are more severe than with the carbon-carbon composites. Specific gravity, specific strength, and specific modulus values are all excellent.

Because of their high temperature capability, favorable properties, and low density, carbon-carbon composites represent enabling technology for advanced propulsion systems and hypersonic vehicle structures. These systems have a spectrum of temperature requirements in uncooled nose sections, leading edges of inlets and wings in hypersonic aircraft design, from 1650° to 2200° C. The current generation of superalloys is limited to approximately 1000° C. With improvements now being developed, such as directional solidification, oxide dispersion strengthening and RST, use temperatures as high as 1100° C are probable. However, to operate at 1400° C and higher, carbon-carbon and ceramic composites, ceramics, and coated refractory-based alloys are the remaining viable materials.

To date much of the mechanical property data for design of carbon-carbon has been obtained on test coupons at elevated temperatures, although other properties of the material may be more critical because of the specific structural concept. The properties of carbon-carbon composites depend strongly on the processing history of the material. The thermal expansion, tensile strength, bimodularity, shear deformation, and notch sensitivity are all interrelated and depend strongly on the processing of the composite. During manufacture, crease cracks and waviness sometimes appear. These are caused by thermal stresses arising from the heating of the preformed structure to the graphitization temperature and occur because of the anisotropy of both the thermal expansion and the elastic modulus. Small changes in the constituents, geometry, or processing might lead to a rash of failures unless the mechanisms of failures are understood and processing variables are very carefully controlled. Defects in the composites can affect the performance of the end product; the causes and the significance of voids and delaminations,

in particular, must be identified. Such defects can originate during one or more of the processing steps, e.g. during pre-impregnation lay up, impregnation, and high temperature pyrolysis and graphitization steps. The most fundamental cause of defects in the high temperature processing phases is the thermal expansion anisotropy of crystalline graphite parallel and perpendicular to the basal plane, with variation of thermal expansion in different directions in the composite, producing high stresses at elevated temperatures, subsequently giving rise to structural flaws. Another aspect of the thermomechanical behavior at high temperatures that should be examined is the potential for stress relaxation by creep, particularly above 1650° C.

All carbon-carbon composites in hypersonic vehicles will encounter oxidizing environments, and the single most critical factor that could limit the use of such materials for structural applications is reliable oxidation protection. They will need coatings to protect them from oxidation. Long term oxidation protection of carbon-carbon composites at temperatures over 1650° C will require coatings and material combinations different from those used successfully on the space shuttle. Outer coatings of SiC and Si₃N₄ cannot be used at temperatures over 1900° C because reaction products disrupt the SiO₂ layer necessary for oxidation protection. Oxide coatings may have to be used. Criteria for selection of oxide coatings include melting point, vapor pressure, thermal expansion, and reactivity. Fundamental issues of thermodynamics and kinetics limit the material choices to a small number of oxides.

Joining of carbon-carbon composite panels presents major problems. Fastener openings must be protected from oxidation. Fastener materials must have the same coefficients of expansion as

the composite, since any protrusion above the surface could produce a shockwave causing very high heating at the shock interface. Gap fillers will be needed (as do the shuttle tiles). Tolerances on thin carbon-carbon skins will be very close since the fasteners cannot be used to form the skins to the substructure as is done with metals, and shims cannot be used. The carbon-carbon material may be limited to a relatively low operating strain. Carbon-carbon composites are weak in shear, exacerbating the problem of load transfer through the fastener assembly. Also, if the processing of the material is not rigorously controlled and the graphite fibers are not uniformly bonded to the graphitized matrix, hysteresis in thermal expansion and contraction can occur, varying from panel to panel thus complicating the thermal-structural analysis.

Major use of carbon-carbon composites can be specified with confidence, only after several technical issues are resolved and understood, including the best fibers to use and the relation of the matrix-fiber interface to properties, the best precursors, the processing steps that will minimize cracks and defects, and a detailed data base on the properties and behavior of carbon-carbon composites in the intended applications.

2.5.2.5 Processing Developments for Advanced Metallic Materials

Since about 1950 a significant number of processing technologies have been developed for incorporating fine refractory particulates into metallic matrixes. Recently, Benjamin and co-workers at the International Nickel Company, developed a mechanical alloying process for blending ultrafine Y_2O_3 into nickel base superalloys. Following hot extrusion of the metallic master alloy powder mix with the Y_2O_3 , the alloys are zone anneal-processed (ZAP),

undergoing directional recrystallization and extreme grain growth of the highly cold worked extruded product just below the melting temperature. This process produces an oriented, elongated very coarse grain structure that has extended the operating temperature of the nickel base alloy from about 900 to 1100° C without loss of creep resistance, a phenomenal improvement in high temperature operating performance. A simpler technique by Smith and co-workers at MIT simplified the overall processing developed by Benjamin and achieved similar properties at 1100° C. At 1100° C, at high engineering stresses and long life, the resultant ODS nickel-base superalloy recrystallized to an oriented, very coarse grained structure and showed operating capability at almost 90 percent of the melting temperature (absolute) of the basic nickel base alloy. The Pt-ThO₂ alloy discussed above showed outstanding 1300° C properties at greater than 80 percent of the (absolute) melting point of pure Pt. The upper temperature limit for high strength applications has not been reached as of now.

The processing technologies required for the production of ODS and CDS alloys are important. The results recounted above demonstrate the tremendous strides made in increasing the temperature potential for alloys embodying such structures.

In particular, the processing technologies currently available make it imperative to apply the same processes to the refractory metals and their alloys: Nb, Mo, Ta, and W, with emphasis on Nb and Mo and their selected alloys. Because of their relatively low specific gravities, very high useful temperatures, and outstanding elastic modulus in the case of molybdenum, the potential exists for high strength operation at 1400° to 1750° C. This would mean transcrystalline deformation and fracture modes (relatively much more ductile than in the

intercrystalline failure mode) which would result in increased ductility. The more simple niobium (molybdenum) ODS alloys might indeed also be ductile near room temperature (low ductile to brittle transition temperature compared to molybdenum.)

2.5.2.6 Other Developments

The development of the Osprey and Liquid Dynamic Compaction (LDC) "spray atomization and collection" processes has opened new potential for producing bulk, complex, reactive metal products and shapes. By combining rapid solidification processing (1000°C/s) to minimize segregation during solidification, and minimizing exposure to the atmosphere, the aluminides, in particular, should benefit on both counts. This also would be true for the refractory metals and alloys; however, the problem of extremely high melting temperatures vis-a-vis atomization has not yet been adequately addressed and deserves attention.

The still more recent development of fine solid particle (oxides, carbides, etc.) injection into an atomized liquid metallic spray offers unusual potential for injecting fine particulates with uniform distribution during production of sheet, strip, plate or preform bodies while achieving high as-deposited densities, typically 96+ percent, in conventional metallic alloy deposition. Very fine structures, relatively free of segregation, and at low contamination levels are indicated to be quite practical. Supplementing the usual Osprey and LDC processes, a linear atomizer has been patented and used to sharply increase rates of deposition and to make possible the production of large, flat, uniform cross-sectional sheets, strip, and plate. The LDC production of dispersion strengthened alloys with very fine dispersoids, oxides, carbides, borides, etc., at low volume content (1 to 3 volume percent) to produce ductile,

tough strong alloys, or metal matrix composites (oxides, carbides, borides, etc.) using coarser dispersoids and high volume content (10 to 30 volume percent) appears feasible and should be studied, in particular because bulk shapes can be produced at high density, convertible to full density by hot working or hot isostatic pressing (HIP).

2.5.3 Coatings

Coatings will play a large role in insuring stability of the major structural materials at the high temperatures that hypersonic vehicles will be subjected to in flight at the high Mach numbers. In the case of compressor and turbine blades of modern jet engines, coatings are mandatory to insure adequate life. In previous applications of nickel base alloys to thin gauge honeycomb face sheets of high temperature structures, thermal cycling for short periods of time to 1100° C causes internal oxidation to occur. Data on several nickel base alloys thermally cycled 10 times for one hour each time to temperatures of 1200° C indicate that internal oxidation will occur from both sides of a minimum gauge sheet using up a good portion of the load carrying capability of the material. (See Figure 2-5.) In the case of the aluminides an external coating may be needed as well as a barrier coating in the fibers for the metal matrix composites to prevent interdiffusion. Simple binary diffusion couples can be used to determine optimum coating materials for these applications.

Extended use of carbon-carbon composites at elevated temperature is limited by the extent to which they can be protected from oxidation. Oxidation protection has concentrated on the use of exterior coatings such as silicon nitride and silicon carbide. However, their use alone is not sufficient to protect the carbon-carbon substructure against

oxidation at some of the temperatures to be encountered. One reason for this is the thermal expansion mismatch between the substrate and the coating. Carbon-carbon 2-D composites have low in-plane and high through-thickness thermal expansion. During cooling from the processing temperature, thermal stresses are generated that craze the coating. Defects in the coating, such as pinholes and thin spots, lead to premature degradation of the substrate, and the steady state and dynamic fatigue loads of flight can cause additional cracking. To overcome this problem the use of glass-forming sealants based on silicon dioxide that will flow at the temperatures encountered to seal cracks and pinholes has proven very advantageous. This sealant remains intact both chemically and physically over a wide range of environments. It has proven very effective on the nose cap and leading edges of the shuttle. However, for the times at the contemplated highest temperatures of hypersonic flight most coatings will either melt, evaporate, or decompose. For example, some of the carbon-carbon composite structure will encounter temperatures of at least 1900° C, at pressures of 0.1 atmosphere or less. Under these conditions, a silicon dioxide sealant could react with the silicon carbide coating, forming silicon monoxide, which at this pressure and temperature can boil off as a gas. Hence, barrier coatings or different sealants are needed.

2.6 The Structural Challenge

The challenge confronting the structural designer of a hypersonic vehicle is reflected in the structural weight fraction, which is the weight of the whole structure divided by the take-off gross weight (TOGW). System requirements and propulsion systems presently envisioned require fuel fractions in the neighborhood of .75 for single stage to orbit. Some design studies are predicat-

ing structural weight fractions in the vicinity of .15. This leaves .10 of the TOGW for the payload and all the subsystems which make the airplane a useful system. As will be demonstrated with historical data, a structural weight fraction of .15 requires a giant step function increase in the capabilities of materials and structural concepts.

If we assume the payload fraction is .05, then a 10,000 pound payload requires an airplane with a TOGW of 200,000 pounds. If the structural weight fraction increases by .01 at the expense of the payload fraction, i.e., the payload fraction decreases to .04, then the TOGW increases to 250,000 pounds to carry the same 10,000 pound payload. Thus a 7 percent increase in the structural weight fraction (.01/.15) in the preliminary design stage with fixed payload results in a 25 percent increase in TOGW. Contrarily, a 7 percent increase in the structural weight fraction for an airplane with a fixed TOGW of 200,000 pounds means a 20 percent decrease in payload.

To return to the question of feasible structural fractions, summary weight statements are shown in Table 2-B for the shuttle orbiter and for the C-141 military logistics transport. Both use mostly aluminum alloys for their structures. The orbiter can use aluminum alloys because a passive thermal protection system maintains the temperature of the aluminum structure at acceptable levels.

The first four items, wing, tail, body and alighting gear, comprise the structure of the vehicle. Note that these add up to a structural weight fraction of .297 for the orbiter and of .273 for the C-141. However, the thermal protection system of the orbiter should be considered as a part of the structural weight fraction; when this is added to the first four items, the structural weight fraction becomes .409. The fuel

fraction for the C-141 is less than one-half of that required for a single stage to orbit hypersonic vehicle. It should also be observed that airplanes must have important sub-systems such as propulsion, electronic, air conditioning, etc.: the designers of these sub-systems will demand their fair share (in their view) of the total weight fraction.

Structural weight fractions of other transport category aircraft such as the L-1011 and the 747 are approximately .30. Transport category aircraft are designed to maneuver limit load factors of 2.5; gusts in the atmosphere may induce slightly larger load factors. Structural weight fractions of fighter type aircraft such as the F-15 and F-18 are approximately .32; these aircraft are designed to maneuver limit factors in excess of 7.

The smallest structural weight fraction of a vehicle is .11 for a supertanker (to this committee's knowledge) and that is of approximately 1200 million pounds!

2.6.1 Determination of Structural Mass Fraction for High Performance Vehicles

Several different criteria are used to evaluate the optimum design concepts for various portions of the vehicle based on its configuration, the trajectory flown, the aerothermal environment encountered, and a number of other factors. Portions of the vehicle may be stiffness critical, others buckling or crippling critical; some areas may be designed by fracture toughness, strength, thermal fatigue, creep, compression, oxidation, etc. To determine the structural mass of the component to be evaluated we must note the probable failure modes that the component could encounter. The mass of the component is distributed according to the primary failure modes that size the structure for

the vehicle under consideration. In this procedure, the structural mass of the component is distributed to prevent failure in the critical (primary) failure mode. These primary failure modes determine the local thickness and stiffness of the structure, and thus "size" the structure for that particular type of vehicle. The durability and damage tolerance allowable is determined by analysis of fatigue, crack growth, fracture toughness, and stress corrosion or oxidation for each material. When these factors are taken into account together with gauge tolerance and other considerations of fastening and joining, a more realistic structural weight fraction is then obtained than that which is predominantly a function of strength and stiffness.

2.6.2 Structural Concepts

Hypersonic vehicle performance depends intimately on such structural concepts as material choice, active/passive cooling, insulation, thermal protection, thermal/structural behavior, configuration, fabrication, and manufacturability. Vehicle structural concepts depend on the mission profile, e.g., a high-Mach cruiser with frequent use and short turn-around times will have different requirements than an orbital vehicle used frequently or a hypersonic reentry vehicle used only once.

The technology base for structures running for sustained periods at elevated temperatures needs to be developed. The mechanics of hot structures is not well understood in such areas as vehicle leading edges, vehicle nose or lip regions, airframe surfaces including control surfaces, internal load-carrying structures, or local regions of severe aerothermal loads. Leading edges, for instance, are a critical design area because of extremely high localized heating, high thermal gradients and stresses, coupled with aerodynamic loads,

AVERAGE DEPTH OF PENETRATION (Inch x 10⁻³)

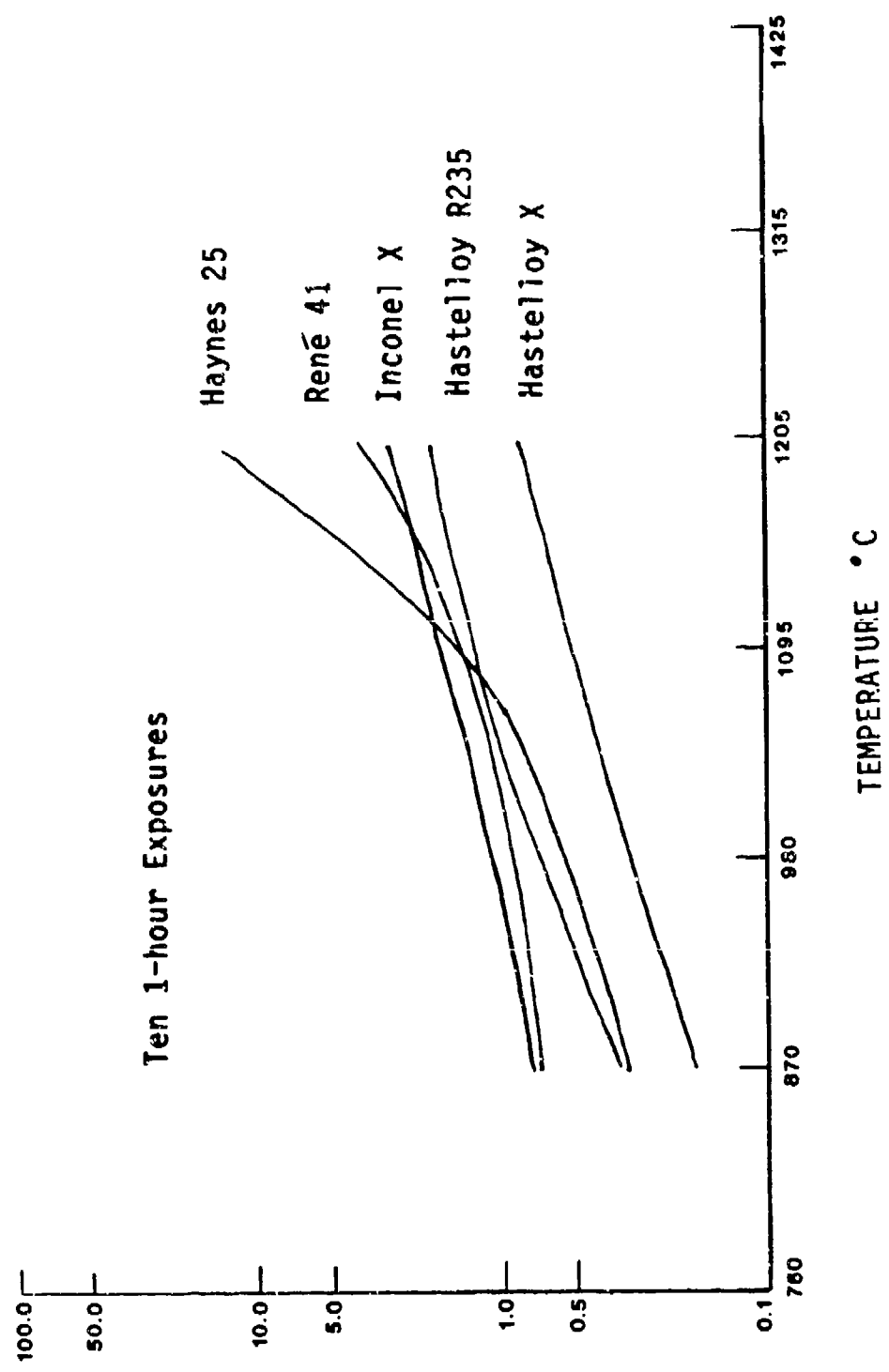

FIGURE 2-5
Depth of Attack of Various Alloys
Cycled 10 Times to the Indicated Temperatures

	ORBITER	ORBITER	C-141	C-141
COMPONENT	WEIGHT Pounds	FRACTION %of TOGW	WEIGHT Pounds	FRACTION %of TOGW
Wing	14,718	0.061	34,350	0.109
Tail	2,891	0.012	5,907	0.019
Body	41,540	0.172	34,523	0.110
Alighting Gear	12,569	0.052	10,935	0.035
Surface Control	2,255	0.009	3,652	0.012
Propulsion	34,027	0.141	25,212	0.080
Aux. Power Plant	3,941	0.016	523	0.002
Hydraulics	2,293	0.009	2,689	0.009
Electrical	4,041	0.017	2,683	0.009
Electronics	5,063	0.021	2,871	0.009
Furnishings	2,130	0.009	5,017	0.016
Air Conditioning	3,649	0.015	2,537	0.008
Thermal Protection	27,154	0.112		0.000
Crew	1,252	0.005	2,756	0.009
Fuel	23,856	0.099	111,480	0.354
Payload	60,000	0.249	70,000	0.222
TOGW	241,379	1.000	315,135	1.000

TABLE 2-B
Summary Weight Statements for Shuttle Orbiter
and C-141

which together prevent a safe, reusable, reliable, light leading edge. Active cooling is also required, with attendant technology development required for hypersonic vehicles.

An indication of the thermal environment that must be sustained in hypersonic flight is shown in Figure 2-6. Multiple materials are necessary for local conditions on the vehicle. Active cooling is essential at the higher thermal fluxes that are characteristic of the hypersonic regime.

Specific structural technology base requirements for hypersonic flight are:

- 1) **Vehicle leading edge** - Analysis tools are needed for active cooled edges (convective, transpiration), heat-pipe cooled edges, radiatively cooled edges, or for other alternate means of leading-edge cooling. Verification of these analytical procedures is necessary through testing at sufficient scale before the technology is ready for design or development.
- 2) **Nose or lip regions** - Again, analytical tools are necessary for active, passive, or reactive cooled noses or lips. A durable light structure is desired. Verification through testing beyond proof-of-concept experiments is important before the technology is ready for development purposes.
- 3) **Airframe surfaces and control surfaces** - Hypersonic vehicles will run hot. Local temperatures will often exceed 1650° C. Active cooling everywhere is not practical. Structural element (spar, rib, stiffener, panel, etc.) technology at elevated temperatures needs development. Testing is necessary to validate structural concepts with and without thermal protection and for various cooling concepts and joining concepts.

- 4) **Internal structure** - Practical means need to be developed to design internal structures which can carry significant loads while running hot, or for cold internal structures that attach to hot structures. There is a technology requirement to develop procedures to conduct simultaneous thermal, structural, and dynamic analysis. Again, verification through component testing where aerodynamic and thermal loads are imposed is necessary before the technology is ready for design or development purposes.

- 5) **Local aerothermal loads** - Intense local loads often drive structural concepts. A comprehensive data base and analytical tools need to be developed to allow durable and safe structural concepts at minimum weight.

2.6.3 Development Process

Figure 2-7 illustrates the development process for producing structural concepts for a hypersonic vehicle with specified mission/performance goals given an adequate technology base. Testing of structural concepts at the component level and assembled level in a realistic thermal/structural environment would be a large part of the development process. The result of this development procedure would be critical structural hardware experience. Presumably the structural concepts developed are designed to realistic criteria, ultralight, temperature resistant, and durable.

The next logical step to advance a technology toward use as structural hardware is often discounted. This step is fabrication or demonstration of manufacturability. Very often, high technology endeavors (such as the development of hypersonic vehicles) stretch-out or fail because of lack of attention to the industry which must

produce the parts. Successful structural concepts for hypersonic vehicles will require careful development of component fabrication processes, manufacturing process methods and procedures, fastening technology, joining methods, assembly techniques, inspection methods, sealing technology, methods of repair or rework, and maintainability considerations. A lack of technological maturity in any of these areas leads to incomplete structural hardware experience. Successful activity in these areas would in principle lead to structural concepts that are not only ultralight, temperature resistant, and durable but also producible, maintainable, and repairable.

The final step of the development process is flight testing to assess safety-of-flight, operations, supportability, and vehicle performance. How rugged, how reliable, how accurate, and how operationally useful the hypersonic vehicle is would follow from this flight test program.

2.6.4 Status of Structural Concepts for Hypersonic Vehicles

The NASP program has an aggressive Technology Maturation Plan to develop the technology base to design an experimental hypersonic X-plane. Prior to this NASP program, hypersonic technology base development had been spotty at best for 20 years with the exception of technology for reentry vehicles and the shuttle orbiter.

After careful study of those elements of the Technology Maturation Plan directed at structural concepts, we conclude that the projected technology base has generic as well as design specific validity for hypersonic vehicles. The Technology Maturation Plan should result in a structural data base valid for hot structures a few feet by a few feet. There probably are adequate test facilities to provide a credible thermal-

structural loading of such test articles applicable to some NASP components.

We are, however, concerned about the lack of large scale test facilities required to validate components at full-scale. Of concern is the ability to adequately test a wing-fuselage carry through section, a tank-fuselage section, or an actively-cooled full airframe section. It might be impossible to adequately ground test a full-size representative section in a combined aerothermal environment. Such testing can be done only in flight. The attendant technical risk in proceeding to flight with only moderate confidence in the flight vehicle design is accordingly high.

We are also concerned about the eventual feasibility of producing hypersonic vehicle structures that are durable and easy to maintain, and economical in small or large quantities. The design and fabrication of actively-cooled structures must consider factors such as regenerative cooling channels, piping, valves, etc. Such plumbing must be considered as part of the structural weight fraction. The high-temperature materials for hypersonic aircraft may require great care to process, fashion or maintain. It is worth considering multiple production sources of key vehicle sections. A good deal more emphasis must be placed on production issues before judgments of the operational utility of hypersonic vehicles are approached.

2.6.5 Structural Design Considerations

The attainment of routine hypersonic flight places before the structural designer a host of new design conditions which accompany the large amounts of thermal energy generated in the boundary layer. An air-breathing aircraft passes through flight regimes from subsonic through supersonic to reach hypersonic, all in two to three minutes.

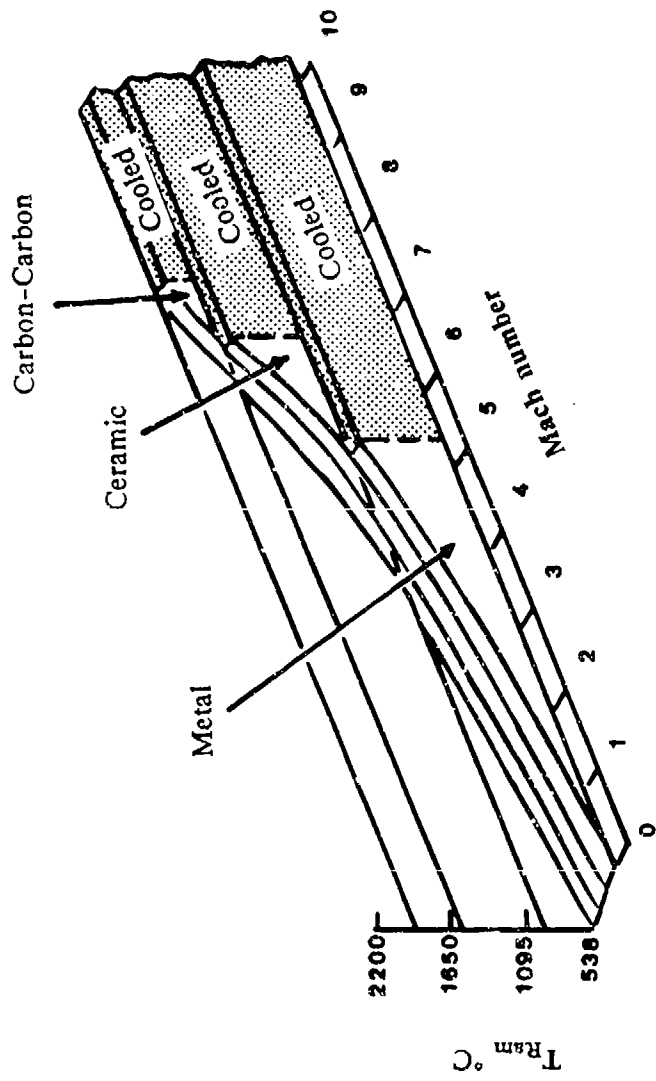

FIGURE 2-6

Thermal Environment of Materials at Hypersonic Speeds

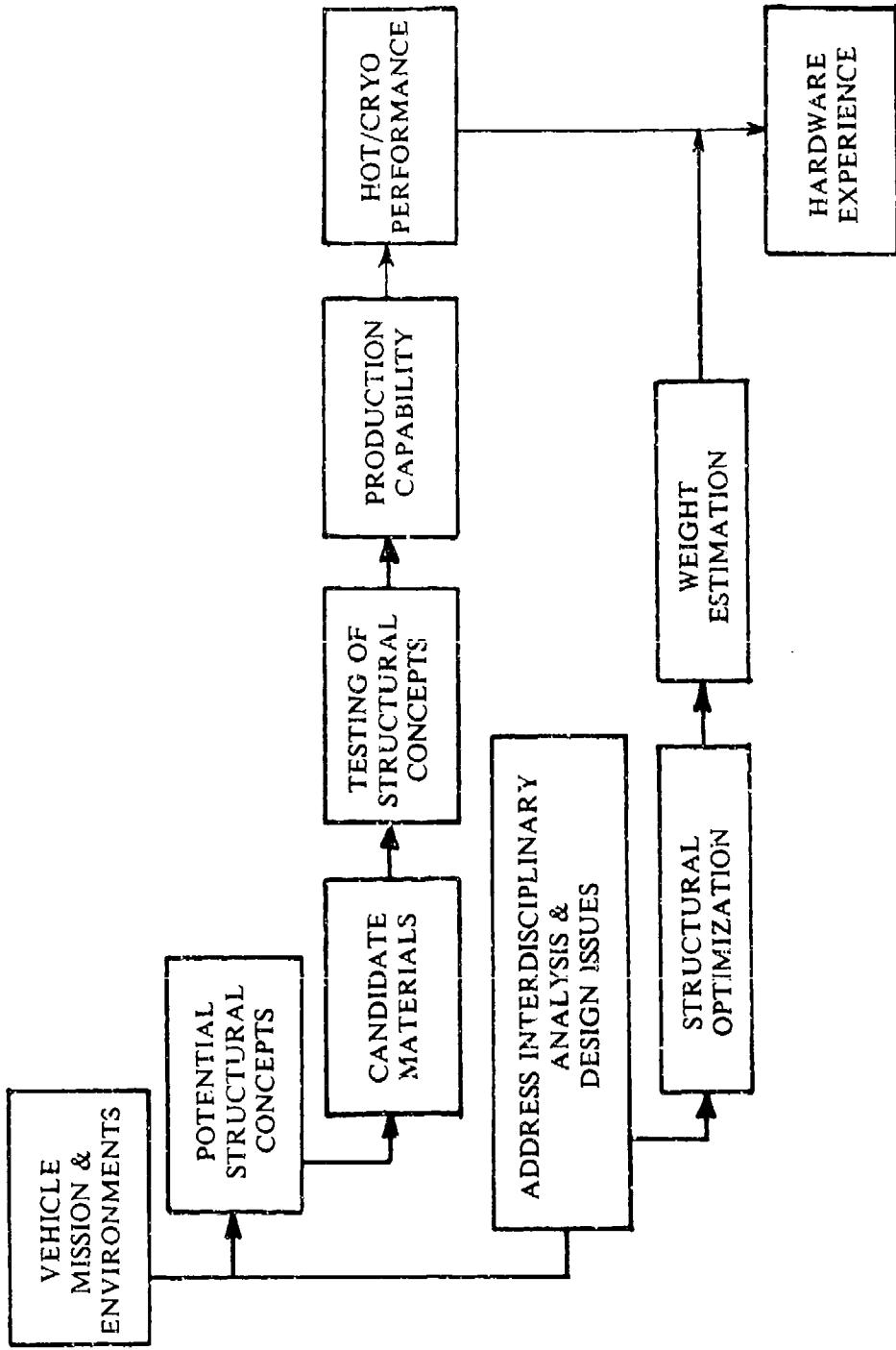

FIGURE 2-7
 Development of Structures That Meet
 Mission/Performance Goals

Stagnation temperatures quickly reach 500°+ C at low altitudes and 2200° C at high altitudes. The common aircraft aluminum alloys, which melt at about 600° C, become worthless as structural materials at about 400° C. Thermal stresses are induced by the transient nature of the flight profile. For example, a steel alloy wing structure may undergo thermal stresses of 75,000 to 150,000 psi during the transient temperature gradients induced as the aircraft attains hypersonics cruise if specific design details cannot minimize the adverse effects of thermal gradients. If all the structural parts reach 550° C, a ten-foot-span wing of stainless steel would expand over an inch in length. Internal push-pull rods and hydraulic lines might differ in temperature by several hundred degrees, and, in length, by intolerable amounts. These are some of the simpler thermal phenomena that confront the structural designer.

2.6.5.1 The Structural Designer's Approach, Circa 1988

It is informative and instructive to consider courses of action that the structural designer can take. Several courses of action are apparent.

The designer would naturally explore first the possibilities of using new materials. Obviously, if a material were available that had a coefficient of thermal expansion comparable to pyrex glass, and had elevated temperature strength properties comparable to those of 7075-T6 at normal temperatures, then the thermal problem would be trivial. Strength properties are important but such factors as corrosion resistance, susceptibility to thermal stresses, maturity of the manufacturing infrastructure to translate materials into structural forms and availability are of equal significance. Historically, the record shows that many years are required to gather a data base sufficient

for design and to bring the manufacturing and material producing infrastructure to an acceptable level of maturity.

Good properties at high temperatures necessarily require high melting temperatures. Melting point data may, however, be misleading. For example, the available titanium alloys do not fulfill the promise that the high melting temperature of pure titanium would indicate. Thus, at 200° C, which is approximately one-third of its melting point, 2024-T4 aluminum still retains about 80 percent of its normal temperature tensile yield strength. At a comparable percentage of its melting temperature, i.e., at about 550° C, titanium has only about 25 percent of its normal temperature strength.

The high temperatures have other effects that must be anticipated. Thin-skin monocoque or semi-monocoque construction which is not free to expand can fail by thermal buckling. Thick skin construction leads to larger thermal stresses because of the larger temperature gradients.

The structural designer can also devise preventive measures. For example, the load-carrying structural members can be covered with a passive thermal protection system (TPS) such as that used in the orbiter. A passive thermal protection system can a) reduce the rate of heat flow into the structure and, hence, b) increase the time necessary for the load carrying structure to reach a given temperature. Since the insulation material has a certain heat capacity, it can also serve as a sink for a portion of the thermal energy.

Problems accompany the use of a passive thermal protection system. If the coating is bonded tightly to the structure, then the strains of the coating will be transferred to the structure, but, more seriously, the coating will be unable to expand freely

and may crack. This suggests the possibility of applying the insulation in a "fish-scale" or "roof-shingle" pattern. In this manner, the insulation is free to expand. Another possibility is to "float" the structure in an insulated shell. The transfer of air loads from the shell to the main load carrying members could be effected by a network of posts, and if these posts could be arranged so that the loads are predominantly compression, then glass or ceramics can be used.

The structural designer can also devise ways to cool the structure and in this manner use the best properties of the materials. Cooling the structure involves many more complications. The cooling of the structure requires free access of the cooling agent; at this moment, invention is required. Transpiration cooling offers another possibility if a suitable porous material can be created.

2.6.5.2 The Aerodynamic Heating Phenomena

A proper assessment of the effects of aerodynamic heating requires an understanding of the source of the thermal energy. During flight a thin boundary layer, in which the air velocity drops from flight speed to zero, envelops the aircraft. We understand the consequences of the boundary layer phenomena for low speed flight, but at higher speeds the dissipation of energy within the boundary layer represents an important additional factor. In fact, the degradation of mechanical energy into heat is approximately proportional to the square of the velocity gradient. As heat is so produced near the surfaces, some conduction into or out of the surfaces is to be expected. Thus, there is also a thermal as well as a momentum boundary layer within which convection, conduction, and dissipation are balanced.

Two parameters of chief interest to the structural designer are the recovery factor and the heat transfer coefficient. The recovery factor relates stagnation temperature and free-stream temperature to the adiabatic wall temperature. Once this number is known, the adiabatic wall temperature can be found. This is the temperature at the surface of the object if the object is insulated against heat transfer. Having found the adiabatic wall temperature, the problem is one of convective heat transfer from the boundary layer to the structure. Here we find the biggest hiatus in present knowledge. Some information exists on the heat-transfer coefficient for steady heat flow but much remains to be done before the transient problem can be solved.

The magnitude of the recovery factor ranges between 0.80 and 0.95. It depends chiefly upon the nature of the flow, i.e., laminar or turbulent, on the Prandtl number (a dimensionless combination of specific heat at constant pressure, viscosity, and thermal conductivity) and upon the shape of the solid boundary to the flow.

The heat-transfer coefficient is the constant of proportionality which relates the heat flow into the structure and the temperature difference between the structure and its recovery temperature. It is conveniently combined with a characteristic length and thermal conductivity into a dimensionless number called the Nusselt number. The Nusselt number varies with Reynolds number, Prandtl number, shape of the solid boundary and the nature of the flow, i.e., laminar or turbulent. All of these dimensionless parameters depend on the properties of the fluid, and these, in turn, are all functions of the temperature.

The exterior surface of the structure is a boundary of the flow across which there will be interaction between conditions in the structure and conditions in

the boundary layer. Heat transfer in the boundary layer depends on the temperature at the surface of the structure. As the surface temperature rises, the gradient will change, and the rate of heat flow into the structure will change. If the flow conditions are not changing with time, the necessary trial procedure in determining the correct balance between heat transfer in the boundary layer and heat flow into the structure may not be too difficult. If the flow conditions are transient, then the trial procedure becomes quite cumbersome. A necessary objective of research would be to define the degree of interdependence, but it is likely that there will be important flight configurations in which the interaction cannot be neglected. Again, the structural designer here needs certain detailed information about the flow, though this is perhaps of minor interest to the aerodynamicist. In the past, it was the structural designer who demanded knowledge of the spanwise and chordwise pressure distributions and who felt the greatest need for detailed information on transient aerodynamic forces. So in this new field, it is again the structural designer who needs intimate knowledge of the origin and transfer of thermal energy in the boundary layer.

2.6.5.3 The Temperature Distribution in the Structure

All three basic heat-transfer processes: convection, conduction, and radiation, are present in the aircraft temperature distribution problem. Heat enters the structure from the boundary layer, is conducted to distant portions of the structure, and escapes at the surface by radiation. Heat transfer out of the structure by convection and by radiation can be considered as additional boundary conditions to the main process of heat conduction into remote portions of the structure. Determination of the temperature distribution in the structure,

therefore, depends chiefly on the solution of the heat-conduction equation in solids. This equation discloses that the mass density, specific heat, and thermal conductivity of the structure are the material properties present. All three are functions of the local temperature. Unfortunately, data about the variation of these material properties with temperature are meager. But even if such data existed, the solution of the heat conduction equation can be obtained only by numerical methods.

The flight history of the vehicle will determine the type of boundary conditions that the temperature distribution must satisfy. Two types are possible: those that depend on time, and those that do not.

If the vehicle is accelerating, diving, or climbing, then transient conditions exist on the surface of the structure, and time becomes a very important factor in the formulation of the boundary conditions. On the other hand, if the vehicle is in level, constant speed flight, then the boundary conditions do not depend on time. In both cases, the temperature distribution in the structure varies continuously with time. It should also be noted that the entire flight history must be specified. Thus it is insufficient to specify a flight at constant velocity because the temperature distribution at the initiation of constant velocity will determine the character of the subsequent heat flow, and this initial temperature distribution depends on how the vehicle attained this velocity.

Experimental data on temperature distributions are also quite meager because of an absence of a suitable laboratory source of thermal energy, an absence of experimental techniques, and inadequate knowledge of what is important.

2.6.5.4 Structural Effects of High Temperatures

The objectives of the structural designer are to design a structure that fulfills the following requirements.

- a. **Strength**, i.e., the structure must be strong enough to withstand all conditions imposed on it which are within the established limitations of that particular model without permanent deformations or failures of any member.
- b. **Rigidity**, i.e., the structure must possess sufficient rigidity to prevent such aeroelastic phenomena as flutter or static divergence.
- c. **Longevity**, i.e., the structure must meet all requirements for a specified number of missions.
- d. **Damage tolerance**, i.e., the structure must be able to resist failure due to the presence of flaws, cracks or other damage for a specified period of unrepaired usage.
- e. **Efficiency**, i.e., the vehicle must be able to meet its performance specifications as to speed, climb, etc. which means obtaining the required strength and rigidity for the least possible weight.
- f. **Economy**, i.e., the above objectives must be obtainable at a cost established by the importance of the mission or by the expense of alternative methods of accomplishing the same mission.

A gross measure of the efficiency of the structure is given by the structural weight fraction. Measures of the structural integrity of the structure are given by the margins of safety. These result from extensive calculations under a number of critical conditions to which all other conditions are compared.

These critical conditions are either obviously worse than others or have been shown from experience to be the most severe. In the case of the added complication of high temperatures, the relative severity of different conditions is far from obvious, and there is insufficient accrued experience to delineate the most severe temperature distributions. Consequently, much analytical and experimental work must be done before design criteria can be formulated.

High temperatures in the structure have three primary adverse effects:

- Stresses are induced by the differential expansion of different portions of the structure.
- The properties of the material are adversely affected.
- The shape of the structure is distorted, which may lead to nonlinear interactions with the flight loads.

If it can be assumed that the structure behaves elastically and if the temperature distribution is known, then in theory the stresses can be calculated. But, if the materials behave inelastically, as they will at the high temperatures, then there are no proven methods available. Certain strength properties of current materials at high temperatures are known, but there are wide gaps in this picture. Time is again a very important parameter because failure at elevated temperatures is not instantaneous but may take time to develop. Also, after exposure to high temperatures for a certain amount of time, the elastic properties of the material at normal temperatures can also be affected. It is envisioned that the structural designer may be able or may be forced to specify the amount of time which the vehicle can sustain a certain flight path or flight maneuver. The factor of time also introduces new modes of structural behavior. Thus creep and creep-buckling under constant load can

occur.

Superimposed upon the stresses caused by thermal expansion are the ordinary flight loads caused by gusts, pullouts, etc. In some cases, these can be added linearly, but in other cases there will be interactions. Here again the interactions which bring the structure closer to failure must be considered in the design.

2.6.5.5 Summary

It is apparent from this brief examination that the invention of new materials is the panacea for hypersonic flight. The structural designer must rely on the material scientist to invent the material and can only offer words of encouragement and point out what properties should be optimized.

It is perhaps less apparent what other structural research goals should be set. Unfortunately, personal opinions cannot be entirely divorced from evaluations that must precede the establishment of research goals. The following steps should be taken at this time.

1. Create experimental facilities that can enable the structural designer to arrive at an optimum structure by cut-and-try methods.
2. Study flow patterns to evaluate the effect of shape in reducing the boundary layer temperature.
3. Study the possibility of minimizing thermal gradients and, therefore, stresses by design alterations; vis., with the same flight program comparison of stress distributions in structures with systematic differences in the following characteristics.
4. Study the feasibility of controlling the heat flow by the following

means:

- a. lightweight passive thermal protection systems
- b. internal impedances such as joints
- c. active cooling
- d. other ingenious means

In part, the above items assume certain data that are not yet available. Some of these deficiencies concern data of a very basic nature, including:

- a. High-temperature properties of aircraft materials
- b. Effects of heating rate on material properties
- c. Heat-transfer coefficients for the entire flight regime, from supersonic to hypersonic
- d. Recovery factors

These data can be obtained only experimentally. Some of the other deficiencies concern techniques, i.e., the state of the art needs to be advanced. The following are included in this category:

- a. Efficient methods of calculating temperature distribution
- b. Efficient methods of calculating temperature stresses and strains

The ramifications of the aerodynamic heating problem are so wide that, undoubtedly, there are good arguments for drastically altering or adding to the above.

2.7 Role of Computational Fluid Dynamics

Computational fluid dynamics (CFD) has become the principal tool for aerodynamic and propulsion-flow design of hypersonic vehicles. Three circumstances have contributed to this. First, existing ground-based experimental facilities are unable to realistically

simulate the combined thermal, dynamic, and chemical flow conditions of hypersonic flight. Second, the power of current supercomputers now enables 3-D-flow simulations of realistic flight conditions using the full Reynolds-averaged Navier-Stokes equations. Third, the extent of flow detail obtained in computer simulations is inherently much greater than experiments can provide. The inadequacy of simulation in ground-based experimental facilities is especially acute for the high-velocity, high altitude portions of hypersonic trajectories involving non-equilibrium air chemistry. Under these conditions, chemical reaction rates are important, and realistic air flow simulation requires that the flight parameters of velocity, free stream density, free stream thermochemical state, and physical scale all be simulated together.

Though realistic air flow simulations are impossible in present experimental facilities, they are, at least in principle, possible in CFD simulations. Ballistic ranges can simulate velocity, free stream density, and free stream chemical state, but not the physical scale of flight vehicles. Even if money were no object, and a full-scale experimental hypersonic flow facility were envisioned, known technology does not provide a guide to produce a clean air flow around a stationary test object with the requisite velocity, density, temperature, and chemical state.

Computers, however, can simulate the proper free-stream and physical scale conditions, while providing detailed information on temperature, density, pressure, and chemical species concentration at every point in the flow field provided the physical behavior can be adequately modeled, within present limits of computational power. Such detail, of course, also yields information, on surface skin friction, heating, lift, drag, thrust, and pitching moments. In consequence, the potential overall ability

of computers to simulate the proper thermodynamic and chemical aspects of hypersonic flight, while providing extraordinarily detailed information, has made it apparent that CFD continues to be essential for the design of hypersonic vehicles. We must note, however, that some level of physical approximation will be required to bring the numerical problem within practical computational capabilities. The modeling of turbulence is one example. It follows that experimental verification of the physical validity of the numerical models is crucial to the central role of CFD in hypersonics.

The anticipated near-future feasibility of scramjet propulsion has added to the role of CFD some major elements missing from the design of past hypersonic vehicles.

Hypersonic flow problems associated with ballistic missiles, Apollo, and shuttle, for example, were those of unpowered atmosphere entry and descent. But hypersonic vehicles that must ascend through the atmosphere with air-breathing engines and descend during unpowered reentry involve much more complex hypersonic flows, as noted earlier. Air-breathing ramjet and scramjet flows can interact strongly with the external flow over the vehicle body, as discussed more fully in section 2.2. Experimental simulations of the integration of external aerodynamic flows with hypersonic propulsive flows are not feasible for flight conditions, but computer simulations are. Thus CFD is an especially critical technology in the design of hypersonic vehicles that involve major problems of airframe/-engine integration.

2.7.1 Status of Hypersonic CFD

The current state of CFD codes for hypersonic flow depends on the type of computation being made, whether for

external aerodynamics, inlet, combustion, or nozzle flow. Some hypersonic vehicles, such as boost-glide, involve only external aerodynamic flows, whereas NASP involves all types.

2.7.1.1 External Aerodynamics

Computational fluid dynamics codes for this type of flow are the most advanced. With present supercomputers and codes, we can make 3-D computations of aerodynamic and heating parameters using the Reynolds-averaged Navier-Stokes equations for hypersonic flow over fuselage-wing-rail configurations, provided we know the location of boundary layer transition. The aerospace industry already has such codes for perfect gas and equilibrium-air chemistry. Three-dimensional codes for nonequilibrium (reaction rate dependent) chemistry are available now in a few laboratories, while others, currently being developed by aerospace companies, are expected soon. The main limitation to the realization of these codes is that the location of, or some criterion for, transition must be known. A second limitation is that present semi-empirical models for the turbulence stresses and heat flux while acceptable, are not as accurate as would be desirable for hypersonic wall-bounded flows having strong transverse or streamwise pressure gradients. With continued calibration of hypersonic codes, and exploration of new or modified turbulence models, the degree of CFD realism should improve with time.

2.7.1.2 Inlet Flows

In hypersonic inlets, pronounced 3-D aspects of flow can be produced by interaction of shock waves with a boundary layer, and by the presence of internal corners. The relatively simple parabolized form of the Reynolds-averaged Navier-Stokes equations (PNS)

is useful for such flows if the inlet passage is slender and there is no streamwise flow separation. PNS codes have been used for some time throughout the aerospace industry. Hypersonic codes for 3-D flow with equilibrium air-chemistry using the full Reynolds-averaged Navier-Stokes equations also exist widely. Analogous inlet codes, however, do not yet exist widely, although some with reaction rate rather than equilibrium air chemistry are under development in various places and should be available for application in the near future. As in the case of external aerodynamic flows, the main limitations to the physical reality of inlet codes are in the uncertain empirical criterion used for transition from laminar to turbulent flow when it occurs on portions of inlet surfaces, and the uncertain semi-empirical models used for hypersonic turbulence stresses and heat transfer.

There is an additional special limitation of present inlet codes. They are unable to treat realistically the high altitude flight conditions of flow over cowl lips with small radii of curvature. Maximum cowl-lip heating on a vehicle like NASP occurs at high altitudes and high Mach numbers. The physical flow conditions in flight are of a type not yet investigated realistically by either CFD or experiment. In high altitude flight, the shock wave thickness on a cowl-lip is not negligible compared to shock detachment distance. Instead, the flow can be of the "merged" type wherein the lip bow wave is merged together with the lip boundary layer. The interaction of a relatively thick fuselage bow shock impinging on a merged lip shock layer has not yet been explored. Present CFD simulations and experimental investigations have corresponded to low-altitude flow conditions wherein the shock wave thickness is negligible compared to the detachment distance. Under these conditions, unlike high altitude conditions, it is unnecessary to compute through the shock wave struc-

ture. Unfortunately, the Navier-Stokes equations have long been known to be very inaccurate for computing the flow structure within shock waves, so these equations cannot be used to get reliable CFD results for the particular conditions existing on cowl lips in high altitude flight. Since the shock on cowl lip heating may be very high, it must be investigated more realistically than it has been, by either direct simulation Monte Carlo methods, or by appropriate new experiments, or by continuum equations more appropriate than Navier-Stokes.

2.7.1.3 Combustion Flows

Computational fluid dynamics codes for scramjet combustors in hypersonic flight are in a relatively primitive state because of two circumstances. First, models for turbulent mixing in reacting compressible flows have been far less successful to date than have models for boundary layer flows. Second, experimental data on hydrogen-air mixing in scramjet combustors for flight faster than Mach number 8 have not been available to provide any code calibration in this important Mach number range. The degree of incomplete fuel-air mixing, and the nonuniform distribution of both species concentration and of thermodynamic state are issues of potentially vital importance. It is unfortunate that the turbulent-mixing and chemically reacting type of flow in combustors, which is yet to be investigated experimentally for flight above Mach number 8, is also the same type of flow for which present CFD computations are the most uncertain.

2.7.1.4 Nozzle Flows

In the expansion of combustion products through a nozzle, or a partly wall-bounded nozzle, reaction-rate chemistry is essential to the flow

computation. Currently 2-D reaction-rate codes are used to compute nozzle exhaust expanding into ambient air, but 3-D reaction-rate codes for an expansion partly over the surface of a vehicle, and partly into a vehicle-dependent external aerodynamic flow, do not yet exist, although they are under development.

Vital to a nozzle flow computation is knowledge of the distribution of species, thermodynamic state, and dynamic quantities exhausting from the combustor. One must also know what chemical reactions are important, and what their rates are, since non-equilibrium chemistry is essential in nozzle expansion. In the nozzle flow computation, a new element arises because the exhaust-fuselage boundary layer might relaminarize. Like transition, relaminarization is poorly understood for the conditions of hypersonic flight.

2.7.2 Validation of Hypersonic CFD Codes

An experimental validation of non-equilibrium hypersonic CFD codes is more difficult than for conventional aircraft codes because of the absence of ground-based test facilities that can stimulate together the total variety of physics represented in hypersonic codes. Different experimental facilities, however, can test different components of the overall hypersonic physics simulated in the codes. Hypersonic wind tunnels, for example, can test a code's ability to simulate perfect-gas flows over complex 3-D geometries, although not always at the desired flight Mach and Reynolds numbers. Shock-tube type facilities, on the other hand, can test a code's ability to simulate high temperature thermochemical aspects of a flow, although usually for simplified geometries and not always at the desired Reynolds number. Even though ground facilities cannot test together all interacting components of the physics

represented in a hypersonic CFD code, it is nevertheless essential to test by comparison with experiment as many of a code's physics components as is feasible. Even when this is done, some aspects of a hypersonic code (e.g. transition location, and nonequilibrium radiative heating) cannot be adequately tested by comparison with available ground test experiments. Flight tests may be the only way to thoroughly test the ability of a code to accurately compute such flow field parameters.

2.7.3 Future Role of CFD

Overall, hypersonic CFD today appears acceptable for external aerodynamics and inlet flows provided that the location of transition is known, and for nozzle flows, provided the initial entrance conditions are known. CFD, however, is weak for combustor flows, and is unable to reliably predict the location of transition. We must recognize that these current limitations are not inherent to CFD, but are mainly a consequence of the present state of supercomputer development which forces the use of a Reynolds-averaged form of the Navier-Stokes equations. While this time-averaging process produces equations that are solvable on current computers in a practical amount of time, it requires that the turbulent stresses and heat flux be modeled, thereby introducing the primary inaccuracies in present day codes. If the full time-dependent Navier-Stokes equations were employed instead, the turbulent eddies would be directly computed rather than modeled, and the degree of CFD realism would be expected to greatly increase. Such calculations for a complex three-dimensional vehicle are outside the reach of today's supercomputers. However, they may be feasible for computing the onset and extent of boundary layer transition on a fuselage using current or next generation supercomputers. This advanced type of computation would

require the development of methods for computing through transition in a hypersonic boundary layer on a vehicle flying through a prescribed disturbance field. Knowledge of the disturbance field in the stratosphere would, of course, also be needed. These obstacles to the direct numerical simulation of transition and turbulence (DNST) probably will be overcome in the long range future. This will open up an entirely new level of CFD capability having much greater realism than present capabilities provide.

The potential future importance of DNST to the Air Force is great, since it would largely overcome most of the present limitations of CFD. Such a capability would provide a large increase in the effectiveness of CFD applications to the design of aircraft and turbine engines as well as hypersonic vehicles. In view of such a major future potential, the technology of DNST computation is clearly important to the long range interests of the Air Force. Since this potential would serve industry and other agencies as well as the Air Force, it may by itself justify the development of future supercomputers with power sufficient to realize this next-generation level of advanced CFD technology.

2.8 Experimental Capabilities

Ground test requirements for hypersonic flight vehicles, even for cases of simulation rather than duplication of flight conditions, impose extreme demands on the equipment in terms of pressure and temperature (see Figure 2-8). Further, such facilities are expensive, ranging from \$1-2 million to in excess of \$500 million and take several years to construct or bring on-line. During the 1960's extensive hypersonic test facilities were constructed in the U.S., and overseas, so that by 1971, 52 major operational aerodynamic test units existed, as shown in Figure 2-9. How-

ever, during the 1970's and 1980's the number of operational facilities was reduced dramatically so that by 1986 only 23 were still in useful condition (see Figure 2-10). Engine test facilities are similarly restricted (see Figure 2-11). Indeed, while recent interest has led to some moth-balled facilities being refurbished some are still being considered for destruction.

Further, many of these facilities are 20 to 40 years old and do not produce appropriate flow conditions to address the problems presented by hypersonic air-breathing vehicles and their development. Indeed, recent studies of the upper atmosphere indicate that the common concept of a quiescent and relatively uniform regime (a goal of some facility developments such as the NASA Quiet Tunnel) may not represent reality. Also, research is needed on facilities and their effect in particular on such phenomena as boundary layer transition and chemical kinetics.

Even where ground testing has been used extensively, such as the space shuttle with 35,000 occupancy hours and other vehicles (see Table 2-C), flight performance is not always well predicted. For the hypersonic regime, extrapolation to portions of the flight envelope will further increase the probability of error. CFD codes will help in some cases; however, code validation in many areas remains to be done and requires the same ground test facilities discussed above and in the following sections.

Thus, for the foreseeable future, it appears that it will not be possible to verify advances in many of the hypersonic technologies through ground testing. Consequently, flight test programs are needed for components of hypersonic air-breathing vehicles that cannot be adequately tested in ground facilities, for validation of concepts, and proof of CFD codes. Such testing

represents an extension of the ground test concept and is complementary to, not a substitute for complete systems ground testing. Experimental aircraft such as the projected NASP research vehicle will be essential in expanding the data base for large portions of the flight envelope. In the following sections general facility requirements, and then specific requirements for aerodynamics, propulsion, and materials and structures, will be discussed separately.

2.8.1 Test Requirements

Test requirements for a hypersonic vehicle capable of flying over a speed range up to orbital (Mach number 25) are extremely severe. Data for aerodynamic, propulsion, and structural materials are required up to the very high pressures and temperatures at which air becomes a hot plasma composed of molecular and atomic particles, ions, and free electrons. In stagnation regions of a hypersonic vehicle at high altitudes, atmospheric oxygen begins to dissociate above about Mach number 7. Both oxygen and nitrogen are almost fully dissociated at Mach number 15, and ionization becomes important at Mach numbers approaching 20.

Data are required for pressure distributions, surface friction, temperature distributions, heat transfer rates from cooled surfaces, chemical reaction rates at high temperatures, and in locally disturbed flow, fuel/air mixing rates, material properties at high temperatures, and structural response.

The key test parameters for aerodynamic testing are Mach number, Reynolds number, Knudsen's number, and facility total enthalpy as well as transients in these variables. For the combustion processes associated with the type of air-breathing cycles being considered, this list is substantially

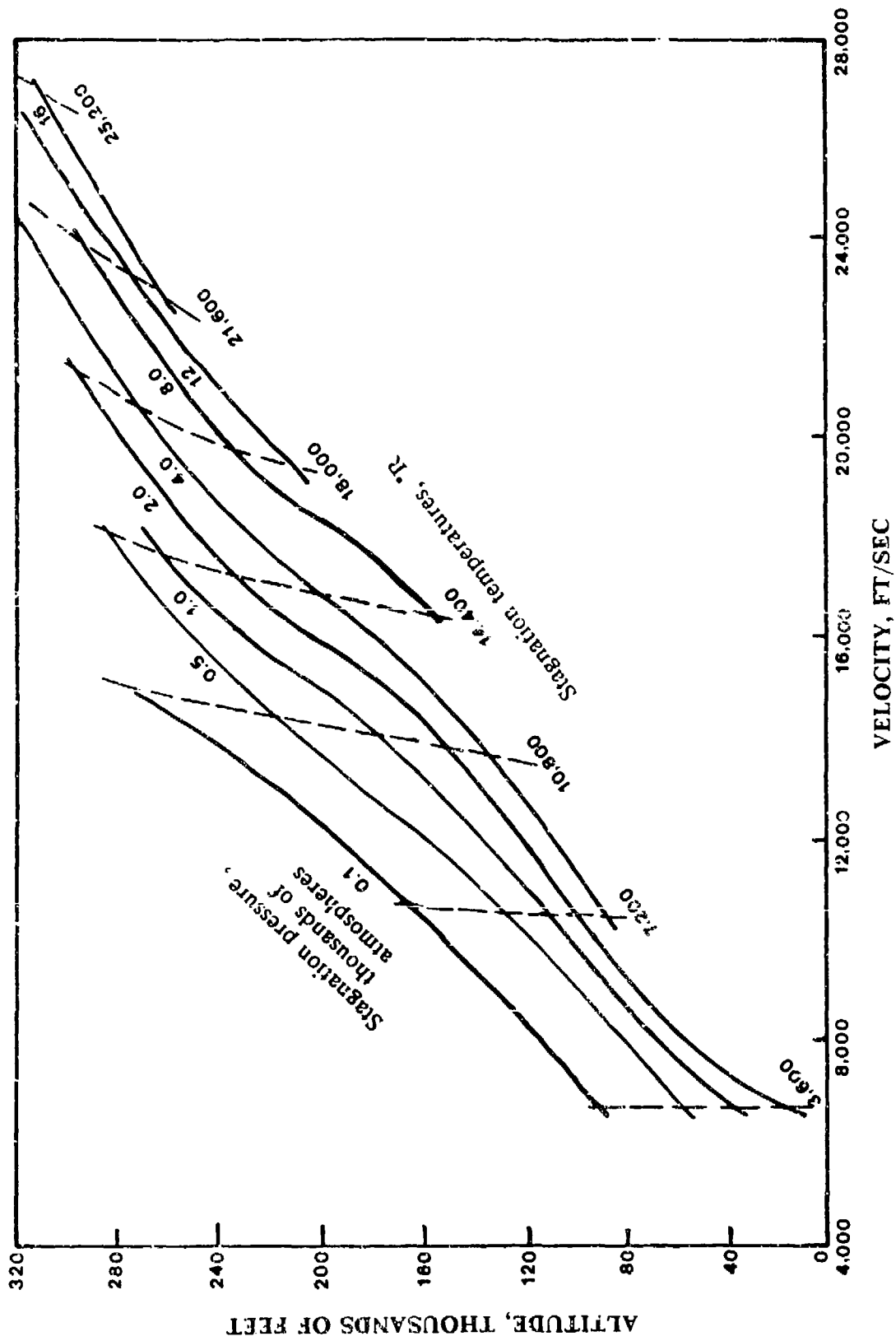

FIGURE 2-8
 Stagnation Pressures and Temperatures Required to
 Duplicate Flight Conditions Over a Wide Range of
 Speeds and Altitudes

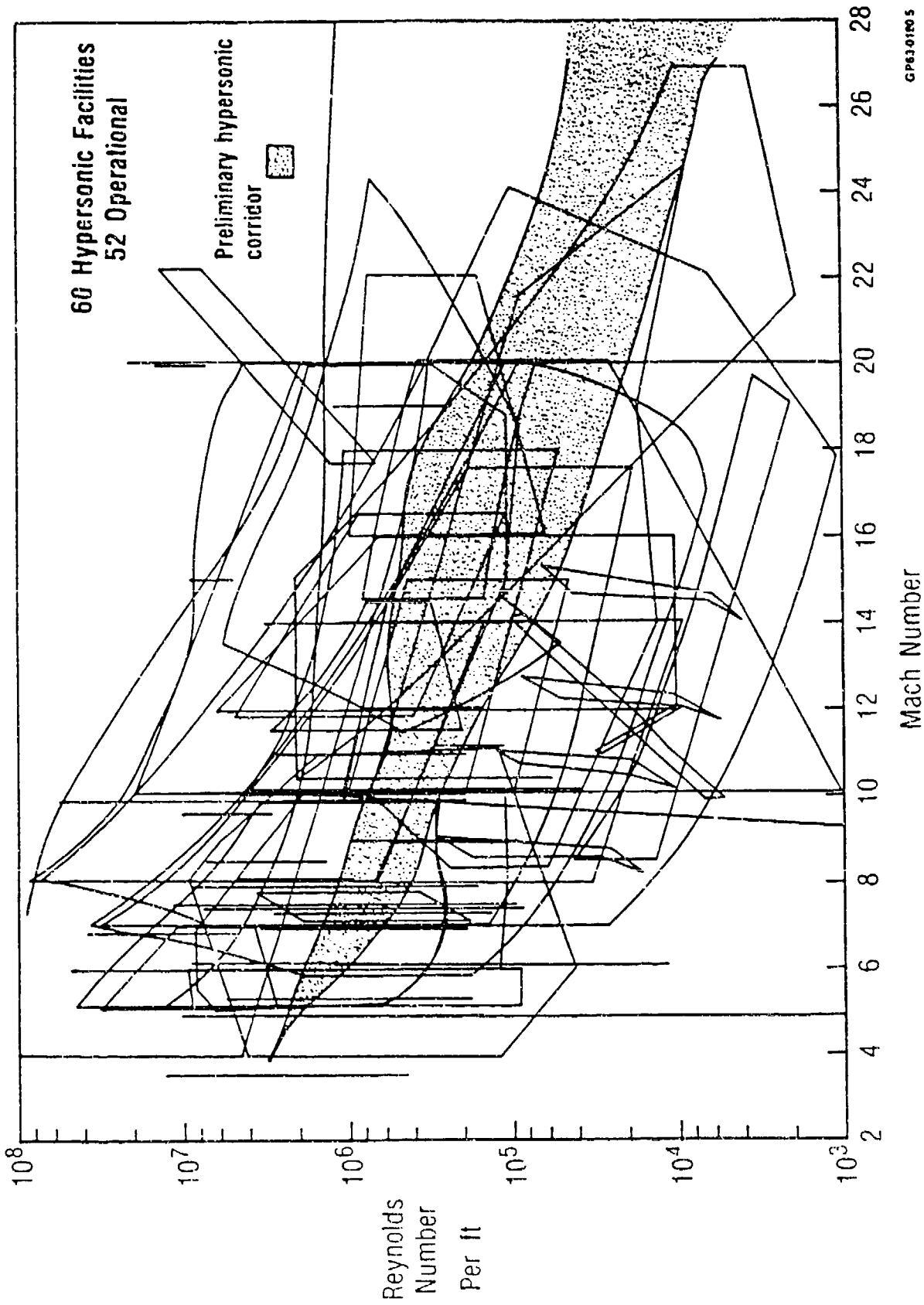

FIGURE 2--9

1971 Hypersonic Testing Capabilities
Wind Tunnels, Shock Tunnels, and Plasma Tunnels

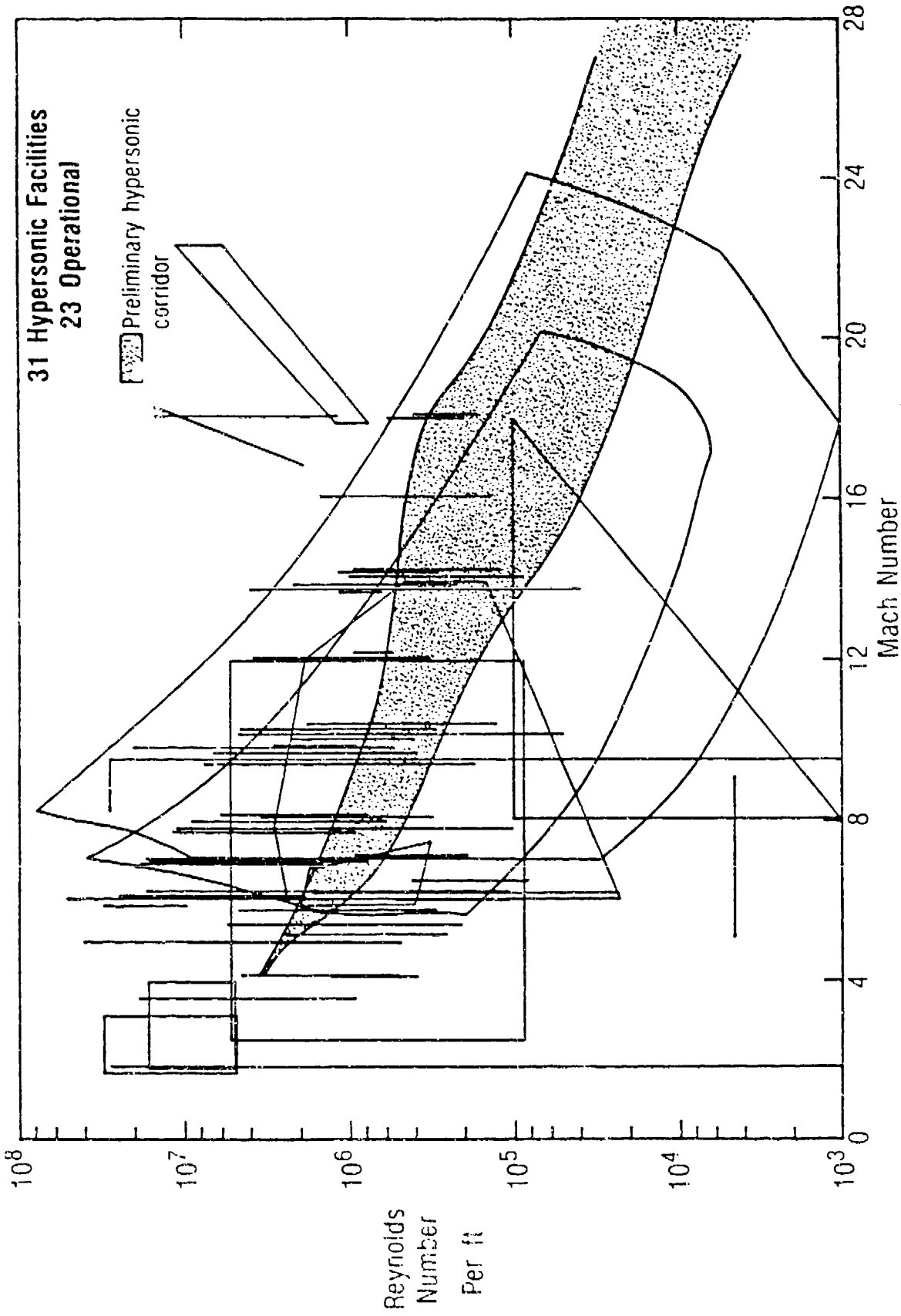

FIGURE 2-10

1986 Hypersonic Testing Capabilities

Wind Tunnels, Shock Tunnels, and Plasma Tunnels

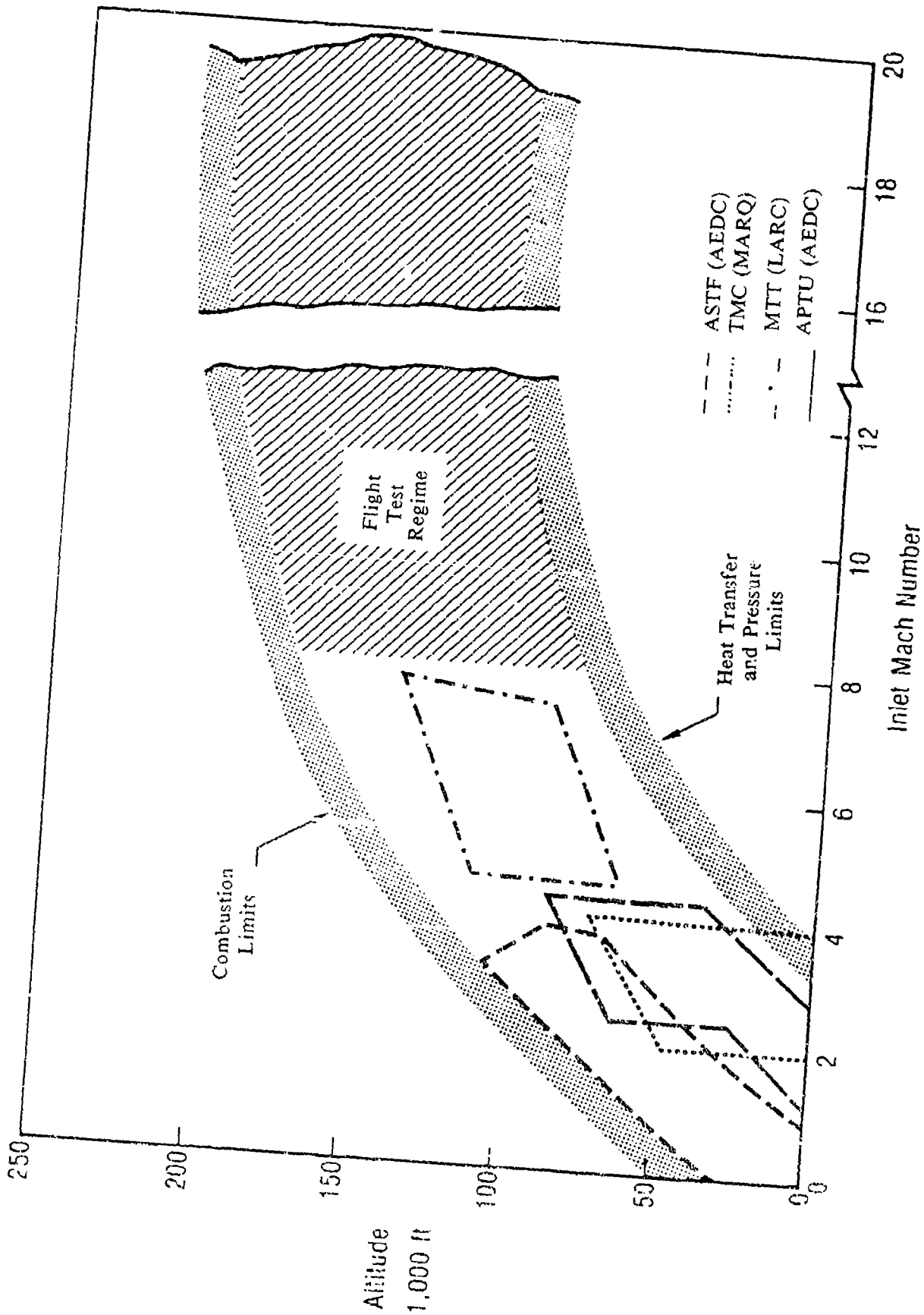

FIGURE 2-11
1985 Propulsion Test Capabilities

Representative Testing for Some Systems

	Subsonic	Transonic	Supersonic	Hypersonic	Hypervelocity	Total # Tunnel
Mercury	14.91	38.37	38.00	3.42	5.17	33
Apollo	14.23	32.26	33.71	10.16	9.64	28
X-20	3.81	24.68	24.54	21.30	25.67	29
C-5A	61.69	38.31	0	0	0	14
F-111	15.14	52.35	32.53	0	0	23

TABLE 2-C

Percent of Total Hours for Various Types of Tunnels

longer and allows for less flexibility in terms of simulation through dimensionless variables. Thus, it is necessary to consider Prandtl number, Stanton number, Eckert number, Lewis number, and species chemical reaction rates non-dimensionalized by residence time. For some cases scaling or non-dimensionalization is ineffective and full-scale hardware testing is needed, such as with structural panels and joint sections. (See Appendix C: Glossary and Appendix D: Dimensionless Groups in Fluid Mechanics for explanations of these dimensionless variables.)

From an aerodynamic and propulsion standpoint it is necessary to locate the region of boundary layer transition on a slender vehicle forebody to determine flow conditions in the inlet of air-breathing engines and the subsequent combustion process, particularly above Mach number 6 for which scramjet propulsion is envisaged. Thus, full Reynolds number and Mach number should be reproduced in a ground test facility, if full simulation were to be achieved.

In contrast to a rocket-powered vehicle such as the space shuttle, which can have a steep ascent trajectory, a hypersonic vehicle using air-breathing propulsion for boost to orbital velocity would require a trajectory over an extended Mach number range in the lower atmosphere to meet the air mass flow requirements of its engine. This implies a high dynamic pressure of about 1500 psf corresponding to which the Reynolds number on a full-scale vehicle would exceed 100 million up to Mach 10 or higher. Although a steeper rate of ascent probably would have to be followed above Mach number 12 because of temperature limitations on materials, Reynolds numbers of the order of 10 to 20 million can be expected up to above Mach number 20.

For free stream Mach numbers above about 10, test requirements become even

more severe for slender vehicles because Mach number, free flight Reynolds number, and full enthalpy must be reproduced in a single test facility as real gas effects become important. In contrast, a blunt vehicle such as the Apollo capsule or even the space shuttle (which reenters and stays at a high angle of attack - 40 deg - down to about Mach number 10) requires full enthalpy simulation, but not the full Mach number and Reynolds number.

Since viscous and high temperature effects are important for virtually all hypersonic testing, facilities using air as a medium are required because other gas media (freon, helium, pure nitrogen) do not provide the right quantitative simulation and there are no satisfactory means of converting all the required data to air.

The above requirements hold for both aerodynamic/aerothermodynamic and propulsion testing. For the latter, it is not sufficient to test at free stream conditions corresponding to the lower Mach number at the immediate engine inlet (direct connect testing) because of flow distortion in the actual flight inlet due to ingestion of the thick forebody boundary layer, the impingement of shocks generated upstream and shock wave-boundary layer interactions. Thus full Mach number and forebody geometry are required to test the propulsion system.

Another important use of hypersonic ground test facilities will be validation of CFD codes as the dependence on numerical techniques as a design tool is expected to be extensive in the hypersonic regime because of physical limitations of wind tunnels at the higher Mach numbers.

This will require wind tunnels with capabilities not only at the desired test conditions, for example Mach number and Reynolds number for aerodynamic

tests, but with well-documented flow quality due to their effect on important phenomena such as boundary layer transition. Most of the existing tunnels were built primarily for lift and drag type measurements or leading edge heat transfer and do not have good enough flow qualities for code validation.

Thus, in general, facilities using air as the test medium and operating Reynolds numbers of 100 million would be required for full testing of a hypersonic cruise vehicle intended for operation up to Mach numbers 10 or 12, while Reynolds number up to 10 to 20 million and Mach numbers up to 25 would be required for an air-breathing orbital vehicle. Furthermore, full temperature simulation and high Re would be required for a hypersonic lifting vehicle operating above about Mach number 10.

2.8.2 Aerodynamic Test Capabilities

Facilities for aerodynamic and propulsion testing in the subsonic, transonic, and supersonic regimes (below Mach number 5) are adequate to meet most future requirements if some facilities in need of repair are rehabilitated.

Above Mach number 5 there are some 30 major facilities¹ in the United States and eight in Western Europe, the United Kingdom, and Japan. All but one half dozen were built in the 1950s and 1960s. All of the newer facilities were built in the early to mid-1970s. None are known to have been built after 1976.²

Of these 30 facilities, seven (virtually all in U.S. industry) are on standby status, i.e., they are not presently operational. Only seven hypersonic facilities using air are capable of yielding Reynolds numbers based on chord length³ in excess of 20×10^6 . (See Table 2-D.)

Of these high Re facilities only the Calspan shock tunnels are able to produce free flight total temperatures above Mach 10, and only the 96-in. shock tunnel approaches total temperatures for a Mach number well in the teens. Test durations for these facilities are a few milliseconds.

From a propulsion standpoint, scramjet research has been undertaken in the 4 ft. diameter Scramjet Test Facility at the NASA Langley Research Center at Mach number 6 and temperatures up to 4000° R on small models under one sq. ft. in cross-section. Scramjet tests up to Mach number 7 were run in the HRE hypersonic test facility at Plum Brook, Ohio, over a decade ago, but this facility has not been in use since.

Aside from limited parameter simulation, a drawback in most existing facilities is that the flow quality is not good enough for boundary layer transition simulation. Boundary layer transition on wind tunnel models has generally been found to occur at much lower Reynolds numbers than in free flight. This is due mainly to disturbances in the flow emanating from wind tunnel settling chambers and acoustic radiation from nozzle wall boundary layers. A supersonic facility designed to minimize such disturbances has been under study at the NASA Langley Research Center - the "quiet supersonic tunnel". Present plans are for a Mach number 3.5 capability with possible addition of a Mach number 6 nozzle later.

Thus, capabilities for aerodynamic and propulsion testing to meet requirements in the hypersonic regime are extremely limited below Mach number 10 and virtually non-existent above Mach number 10.

Because wind tunnels (even shock tunnels despite their very short running times) are temperature-limited for

Facility	Location	M	T°R Max	Re x 10 ⁻⁶
96-in. Shock Tunnel	Calspan	6.5-24	11,500	139
48-in. Shock Tunnel	Calspan	5.5-20	5,800	92
Hypervelocity Tunnel #9	NSWC	10-14.5	3,660	92
Hypervelocity Tunnel #8	NSWC	5-8	1,460	85
Mach 6 High Re	NASA LaRC	6	1,060	45
Mach 6 High Re	AFWAL	6	1,100	28
3.5-ft Wind Tunnel	NASA ARC	5, 7, 10	3,460	24 (standby)

TABLE 2-D
High Speed Aerodynamic Facilities

structural reasons, such schemes as MHD acceleration of a hypersonic stream generated by a wind tunnel, are being investigated as a way to achieve high Mach numbers. The committee has reviewed one such proposal for steady state crossed-field acceleration of air to 25,000 feet per second, and we find the proposal does not reflect understanding of the large body of knowledge developed by the MHD community over the last 20 years. The analysis on which the proposal is based is limited to "one-dimensional" or channel flow, without consideration of wall effects. These effects limit the feasibility of such devices and have received a great deal of study. The overall conclusion of these detailed studies is that the steady crossed-field accelerator is an ineffective device for producing large gas velocities, because too large a fraction of the input energy goes into heating the walls, as well as the gas to be accelerated.

2.8.3 Materials and Structures Test Facilities

The Air Force recently conducted a study of the high temperature test technology needed for hypersonic vehicle applications. They found that heating capability above 1400° C. will be difficult to achieve and that instrumentation is not available for use above 800° C. Also, high temperature strain gauges are not available for temperatures over 800° C. When testing must combine flowing air, and mechanical and thermal cycling to obtain the necessary data for structural design, one must conclude that additional testing capabilities are needed to get the data in an expeditious manner.

2.8.3.1 Structures Testing

Hypersonic vehicles will require structures that are ultra-light, temper-

ature resistant, inspectable, durable, and safe. The structural design concepts depend on vehicle configurations chosen for the flight profiles that will be flown, and from the material choices available. Structural optimization can be done once all the loads are known, the stresses determined, heat transfer known, the aeroelastic behavior of the vehicle determined, and once the strength, stiffness, and fracture toughness of the materials selected are known in considerable detail for all conditions of vehicle operation.

The design criteria for a hypersonic vehicle will determine the amount and type of structural development testing required. This should include the specification of time, temperature, load synthesis, cumulative creep criteria, oxidations criteria which can then influence coating criteria, fracture mechanics and fatigue, sonic fatigue and panel flutter. A typical structural component is shown in Figure 2-12.

2.8.3.2 Facilities

The Air Force study mentioned above indicated that there are existing facilities adaptable for major component testing. However, a major structural component test facility was estimated to cost \$90 million dollars. A full-scale test facility that would be required for structural certification was estimated to cost \$462 million dollars. In the National Space Transportation and Support Study 1995-2010, prepared by the Joint DOD/NASA Transportation Technology Team, total structures/-materials funding included facilities. The facilities funding totaled \$554 million dollars that included a structural certification facility. In fact, these figures add up to about the same amount as estimated by the Air Force for hypersonic vehicle structural testing and certification.

There has been some discussion of activating the NASA Plumbrook high temperature test facility in Sandusky, Ohio, and the NASA Dryden facility at Edwards Air Force Base, but to date there seems to be no funding to activate these facilities. In 1985, the Aerospace Industries Association's Aerospace Technical Council established a High Temperature Test Facility (HTTF) Collaborative R&D Ad Hoc Group to determine whether the Members of A.I.A. should form a partnership to develop such an HTTF. In February of 1987, the Ad Hoc Group, after visiting the NASP program office, reported that DOD and NASA were doing a "good job assessing and developing the necessary test facilities" that would cover most of the needs identified by the HTTF ad hoc group and that the group should be disbanded with no further action. As of March 1988, there seems to be no positive action with funding to proceed to define these facility needs. The major test facility, now being refurbished to carry out testing in aerothermal loads and high temperature structures, is the Langley 8-Foot high temperature tunnel, a Mach number 7 blowdown type of facility in which methane is burned in air under pressure and the resulting combustion products are used as the test medium with a maximum stagnation temperature near 3800° R to reach the required energy level of flight simulation. This facility will, however, not be ready for testing until the late fall of 1988. There is an urgent requirement for the development of major high temperature materials and structural component test facilities. The development of such facilities is mandatory to insure that an adequate data base of material properties is developed and that structural design concepts can be evaluated to support hypersonic vehicle design.

In the end, flight experiments may be necessary as an adjunct to evaluate the structural concepts being considered

because of the inability to adequately simulate the combined environments of temperature and flow. Experimental data can be obtained in several ways.

Rocket or free-flight tests lack adequate communication between the flying vehicle and the test engineer. Only a small amount of data are obtained from each flight, and each flight represents a very large expenditure of money and engineering time. To get a maximum return from flight tests, simulated flight tests first should be performed in the laboratory.

2.8.3.3 High-Speed Wind Tunnel Tests

To obtain high temperatures in a wind tunnel the air must be heated to the desired temperatures, and this poses new problems in wind tunnel design. Such a venture entails its own host of difficulties and results undoubtedly will not be forthcoming for some time.

2.8.3.4 Laboratory Tests with Heating Devices

Laboratory heating devices that produce thermal energy can be developed. Such devices should be investigated, and the possibilities are many. Radiant devices, such as those in ordinary household cooking ranges or in refractory ovens, can be arranged in a dense pattern over a broad area to obtain a distributed source of high radiant energy. The transient heating phase could be controlled by changing the distance between model and heater. It could also be done by a system of shutters on the heater. Chordwise and spanwise variation of temperatures could be obtained by painting or otherwise preparing the exposed surface of the model to achieve different absorptions. The design of the heater could also be arranged so that its thermal output varies across its face. But the scarcity

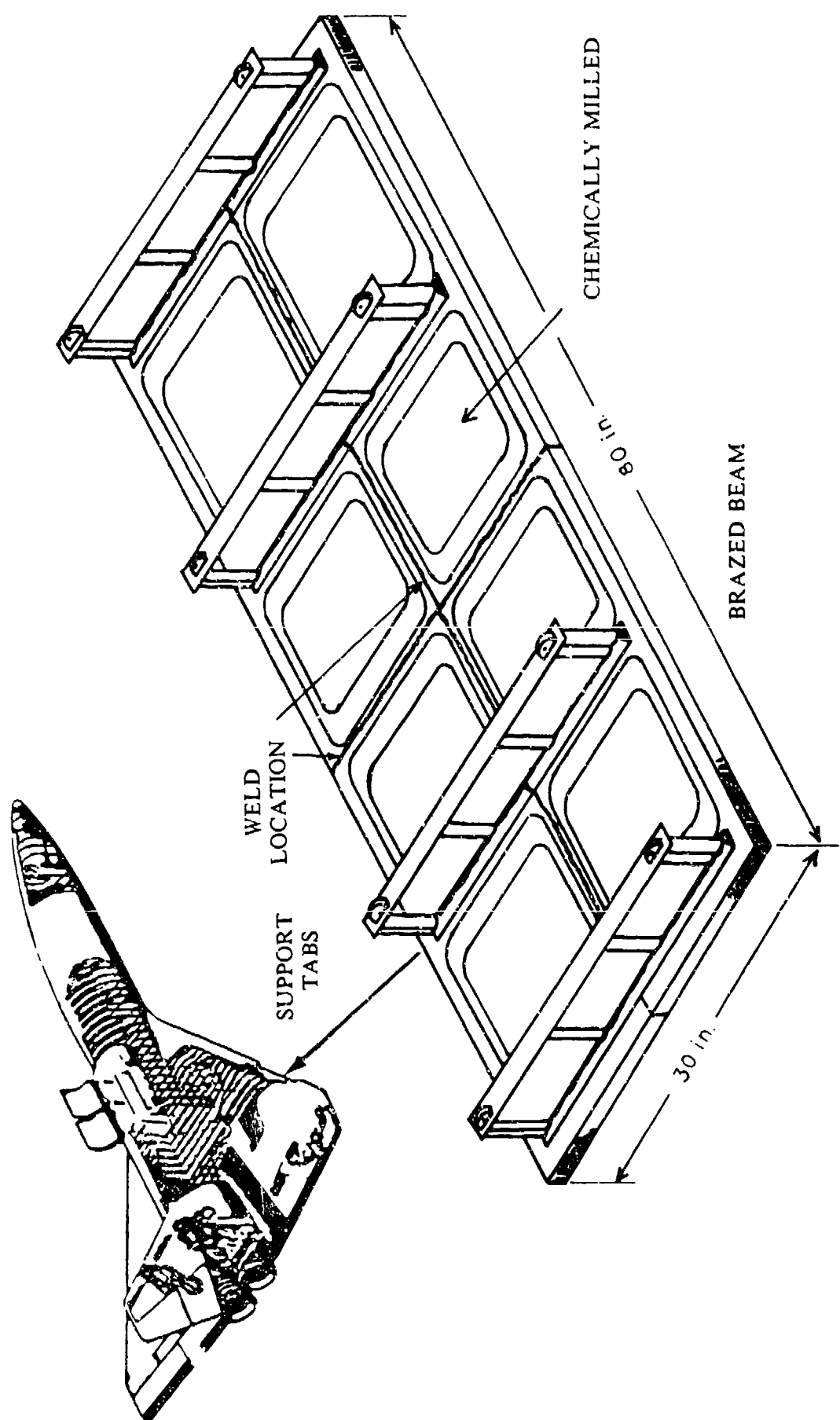

FIGURE 2-12
Flat Panel Test Component

of experimental data and the complexity of the problem would indicate that much can be learned and perhaps should be first learned from experiments on simple models using simple experimental apparatus.

-
1. Test section 1 ft. in diameter or more.
 2. In contrast, there is evidence that the Soviet Union continued to build hypersonic facilities through the 1970s and 1980s.
 3. Chord length defined as the square root of the test section area.

3.0 FINDINGS AND RECOMMENDATIONS

Below are the principal findings we have adduced from our review of hypersonic technology for military application, and the recommendations we offer to further these technologies and their applications.

3.1 Potential Military Hypersonic Applications

- (1) Hypersonic aircraft technology, in association with air-breathing propulsion, offers potentially large increases in speed, height, and range of military aircraft, and may enable or extend important Air Force missions.
- (2) Operational hypersonic aircraft will necessarily have very large turning radii, and useful missions therefore require global or near-global range.
- (3) Cryogenic fuels are necessary, and any studies of hypersonic aircraft missions should therefore include a careful examination of the base support requirements which they imply.
- (4) The simplest class of hypersonic cruise vehicle would fly up to Mach number 8. This class can significantly advance the reconnaissance and strike missions now done by the SR-71.
- (5) The most attractive potential Air Force missions involve flight to orbital or near-orbital speeds above the sensible atmosphere. In contrast to ballistic missiles and satellites, these offer flexible recall, en route redirection, and return to base.
- (6) Sustained hypersonic flight in the atmosphere between the two extremes of (4) and (5) above presents major technical difficulties. Problems of surface heating, thrust, vehicle stability and control, infrared signature, aiming, and weapon release could make any potential military advantage in this speed range unlikely.

3.2 Propulsion-Airframe Integration

- 1) Engine-airframe integration is a key aspect of configuration definition for hypersonic vehicles-increasingly so as the maximum air-breathing Mach number increases.
- 2) The combination of long forebody and low Reynolds number produce a thick entropy layer that must be ingested by the engine or diverted. Its thickness is sensitive to Mach number and Reynolds number, and will vary significantly over the flight corridor.
- 3) The Low Reynolds number is dictated at high Mach number by the need to reduce heat transfer rates and pressure loadings, to transition to rocket propulsion for orbital insertion, or both.
- 4) A very large ratio of capture area to frontal area results from low Reynolds number (high altitude) and small fractional energy addition due to combustion.
- 5) Efficient operation at very high Mach numbers require configurations that pose serious integration problems at off-design Mach num-

ber. The large nozzle expansion leads to very large base drag at transonic speeds. The interaction of the nozzle expansion plume with the slipstream, and with the reaction control system, will influence both the net thrust and moments at near orbital speeds.

- 6) Integration of the low speed propulsion system with the hypersonic propulsion system, in a way that does not degrade the performance at hypersonic speeds, is a major concern.
- 7) The variation of engine-inlet boundary layer conditions with flight conditions (Mach number, Reynolds number, and altitude) must be quantitatively predictable, or an engine concept must be devised that is insensitive to the boundary layer thickness.
- 8) Items 5, 6 and 7 above are unsolved problems. Engine-airframe integration should receive more emphasis, by teams drawn from both engine and airframe contractors.

3.3 Propulsion Systems

- (1) Injection of hydrogen fuel and rapid mixing with air with minimum loss is the most influential factor affecting the engine length and heat load.
- (2) The heat release pattern in the engine is determined by the rate of molecular mixing, and the supersonic flow in the engine is extremely sensitive to the heat release pattern.
- (3) The ingestion of ramp boundary layer and bow shock layer by the engine poses difficult problems of engine design and penalizes engine performance.
- (4) The stability of the scramjet flow with hydrogen reaction is not understood; instability poses the possibility of developing strong shock waves and catastrophic loss of engine.
- (5) Short term design studies and long term research studies of hydrogen injection and mixing should be increased as soon as possible to assure that this issue does not become an obstacle to high-speed engine development. Measurement of molecular mixing should be emphasized and the exploration of novel techniques of mixing augmentation must be encouraged. Because the combustor heat release pattern is mixing controlled and, further, because the state of the air entering the combustor may be extremely non-uniform, the mixing process must be understood to the extent that it can be *controlled* as well as accelerated.
- (6) One-dimensional or quasi one-dimensional computation of reacting flow in the combustor is inadequate and often misleading.
- (7) The H-OH reaction must be completed for the scramjet to perform well. Much of this reaction will happen during expansion in the nozzle and this reaction may "freeze out" early in the expansion process.
- (8) Under the most severe conditions of operation the molar flow rate of hydrogen in the cooling passages is more than double the total molar flow rate of air through the engines. Effective use of coolant and minimization of pumping losses is imperative and an unusual degree of integration with structural design is required.

- (9) The hydrogen requirement to cool the engine exerts an unusually high leverage on the airplane size and weight. It is essential to refine the accuracy of and confidence in estimates of cooling requirements before final selection of airplane size.
- (10) High priority and additional emphasis must be given to the research and design studies concerned with the utilization and management of hydrogen coolant flow. This is of particular importance in the portions of the engine that experience geometric changes during the acceleration.
- (11) Film cooling and sweat cooling with hydrogen have very attractive features and both technological and research efforts must be augmented. The gas dynamic peculiarities of using hydrogen as the coolant should be emphasized in these studies. This work must be accelerated because coolant requirements have such a powerful impact upon the airframe design.
- (12) The scramjet must operate at peak performance throughout its entire Mach number range during acceleration. The configuration and geometric changes required over this range are very extensive and must be done with the minimum introduction of shocks and other losses.
- (13) The geometric changes required of the scramjet over its Mach number range place demands upon design of cooling passages, coolant flow management and tails that are of unprecedented difficulty.
- (14) Transition between the three operating modes of the propulsion system, subsonic to ramjet, ramjet to scramjet, and the re-start and reverse transitions upon re-entry, present extremely sensitive and difficult problems. These must be solved to avoid placing unacceptable structural and thermal loads on the airframe and engine, which may lead to failure.
- (15) The transition from one engine mode to another, especially from the ramjet to scramjet, might produce large unsteady loads and unsatisfactory starting. To insure against these problems, sufficient rocket propulsion should be incorporated into the powerplant complex to suppress any severe problems during transition.
- (16) Some rocket propulsion must be incorporated into the final propulsion system a) to reach orbit from the scramjet Mach number limit, b) to facilitate the gradual introduction of advanced scramjet technology over the life of the airplane, and c) for de-orbit maneuver.
- (17) The high-speed engine development should be predicated on the probability that most of the development will be done in flight test. To develop an engine in flight, an auxiliary rocket propulsion system, separate from the NASP engine package, will be needed to augment thrust and assure airplane trim during high-speed engine tests.
- (18) Complete scramjet engines will undergo development and testing during the flight program, not in ground-based facilities. Consequently, it is necessary to incorporate some rocket propulsion - separate from any that may be integrated with the scramjet - for setting desired engine test conditions and extending the flight envelope of the airplane.

- (19) With boundary layer ingestion, the scramjet engine is quite sensitive to angle of attack. This variation in engine operation will be reflected in changes of pressure distribution over the discharge nozzle, resulting in a large pitching moment. These difficulties may be avoided only through unusually careful integration during airframe and control system design and development.
- (20) The modular design of the scramjet engine allows interaction between the inlets of adjacent modules during ramjet start-up and transition from ramjet to scramjet operation. This interaction can propagate inlet malfunctions from one module to adjacent modules. This behavior appears likely to be particularly sensitive to yawing motions of the airplane.
- (21) The strong interaction between the high speed engine, the forebody ramp, and the external nozzle, and the very powerful dependence of this interaction upon pitch and yaw of the entire airplane has important implications upon the control system and the coupling of engine and airplane. Consideration should be given to design compromises that would reduce this potential problem, even at the expense of reduced performance of the earliest NASP configurations.

3.4 Aerodynamics

This committee has identified two main aerodynamic problem areas. At low hypersonic Mach numbers (below about 10), the problem is mainly one of fluid mechanics. The prediction of the boundary layer and flow field characteristics are required to permit the detailed determination of the pressure distribution, skin friction, heat transfer, and

the flow field condition around the body and through the inlet to the combustion chamber. Above Mach number 10, the aerodynamic problems involve the factors identified in the lower Mach range, with the additional complication of the rate kinetics of real gas effects and the special problems of low density flows and small bluntness dimensions. Neither the low nor high Mach number areas are currently amenable to detailed wind tunnel exploration or validated computation to provide a well-grounded base for design, although some results are available from facilities that partially simulate the real flows. Therefore, progress must rely on a fragmented approach, where limited experiments and computation will in time provide an adequate base for design. Validation of this base will require flight tests that include many elements simultaneously, a situation not amenable to full simulation on the ground or by validated computation.

3.4.1 Low Hypersonic Speeds (Mach Numbers 6 to 10)

- 1) The prime requirements are to identify the location and details of transition initiation, the transition region, the mixed flowfield and boundary layer characteristics around and through complex geometries with cold walls, and the mixing phenomena in the combustion chamber. These problems are recognized and are within reach of current technology *but have not been solved.*
- 2) A unique Mach number 3.5 "quiet" research facility at NASA Langley is beginning to provide results indicating the necessity for such flow characteristics. A Mach number 6 research facility has been approved, but not built. These research facilities are inadequate for the requirements of Mach

number, Reynolds number, and size for the aerodynamic configuration, and mixing studies needed up to Mach number 10.

- 3) A facility is needed to generate detailed experiments for computational validation and engineering design data for complex configurations, under conditions where the effects of cold walls, roughness, and flow field disturbance characteristics can be evaluated. Such a facility could provide the connection between the stratospheric disturbance field (yet to be measured and modeled) with the wind tunnel data shown to be sensitive to this parameter.
- 4) We recommend that the highest priority be placed on the design, construction, and operation of a "quiet" wind tunnel in the Mach number range of 10, with a scale and Reynolds number capability to permit flight simulation. An expeditious approach may be the conversion of an available facility with the required operating conditions, such as the AEDC Gas Dynamics Facility.

3.4.2 High Hypersonic Speeds ($M > 10$)

- 5) For these conditions, the requirement is a simulation of BOTH the aerodynamics (viscous and flow field described at low M) and the real gas effects including chemical non-equilibrium effects. High Reynolds number continuum flow to the high free molecular region must be understood and predicted.
- 6) No current facility or facilities can cover the complete range of flow parameters with the flow quality (mean distribution, constituent and density determination, and flow field disturbance field) needed, and this lack will be an important detriment to the generation of engineering design data.
- 7) Existing and proposed facilities, such as arc tunnels, MHD accelerators, shock tunnels, and flight ranges, each have *some* potential to generate the required data, but all have significant limitations.
- 8) CFD needs validation data, but it appears that it must be done in elements since no *full* simulation of high hypersonic speeds is available or within sight in ground test facilities. For this reason, flight tests will be necessary for full validation of CFD codes.
- 9) The full characteristics of the flow fields generated by present facilities are incomplete and not yet matched to the requirements of CFD for specific validation experiments, although the technology is, in many cases, within reach.
- 10) We recommend a combined CFD experimental program focused on key hypersonics aerodynamic elements to provide validated units for combination into realistic configurations at flight conditions that can be reached by ground facilities.
- 11) We recommend that the field of low density flows be given special attention with regard to direct simulation of particulate flows and experimental validation. This would provide much needed information on high altitude, high Mach number flight conditions where continuum Navier-Stokes computations are of uncertain accuracy. The application of the aerodynamic studies, both computational and ground-based, will require detailed knowledge of the characteristics of the stratosphere to translate the

research results into engineering data.

- 12) Real gas reaction and recombination rates for all constituents and flight conditions are required. Many of these rates are known at low temperatures and extrapolation to higher temperatures appear to be within reach of computational chemistry.
- 13) We recommend a national integrated program of high priority to provide these rates for inclusion into CFD computations. The NASA Ames Group provides a key nucleus for such an effort.

3.5 Controls, Guidance, Instrumentation and Information Processing

- 1) No successful hypersonic engine or airframe will be possible without multi-redundant, multi-effector active control of aircraft rigid, structural, and slosh modes; aircraft and propulsion system; and thermal effects.
- 2) Information and controls must join aerodynamics, structures, materials, and propulsion as a central and enabling technology
- 3) Control challenges for hypersonic aircraft are well beyond any previous accomplishments, in terms of overall aircraft and propulsion system integration, in the required precision, and at subsystem levels (e.g., engine, thermal)
- 4) Very high throughput, fault-tolerant control is essential to meet the unprecedented combined requirements for throughput and reliability.
- 5) Essential hypersonic flow sensors for airplane and engine controls do not exist.
- 6) Control actions have the potential to reduce the sensitivity of engine characteristics to uncertainties and fluctuations, however just what to control, either directly or as a surrogate, to achieve these benefits is not well known, and appropriate sensors may not be available now.
- 7) The hypersonic thermal environment challenges the capability of existing electronic and hydraulic technology.
- 8) A phased flight program, with associated phased flight control system configurations that gradually work up the speed envelope, is necessary to reduce controls risks.
- 9) Three parallel actions are recommended to reduce the risks involved with this technology area:
 - a. Aggressive technology maturation efforts in control system architecture (feedback system structure) and associated analysis/synthesis activities to cope with the novel flight, engine, and thermal control needs.
 - b. System studies into hardware and software as needed to assure the availability of adequate controls and associated equipment.
 - c. Efforts to define earlier (than X-30 flight) experiments that can be done to at least partially validate the equipment and techniques prior to commitment to hypersonic flight. Flight tests at lower speeds on other aircraft should be considered as well as laboratory and simulation-based testing.

These actions should focus on all aspects of control: subsystem control, integration of systems, reduction of sensitivities, control/information system archi-

ecture, environmental issues, sensors, etc.

10) We recommend several more specific actions in this broad framework. In all cases, the above parallel approach applies.

a) An effort should be launched to explore and identify areas where control activities give some promise of reducing the effects of uncertain behavior in the engine. Effective quantities to be sensed or otherwise estimated and possible control system architectures are central issues. Studies of alternative mechanizations of sensors or their surrogates will be needed as part of this effort. In carrying this out, the need for sensors in ground testing should be examined as well, including applications to high-speed wind tunnels.

b) In some areas, such as in fault tolerant and high throughput information systems architectures, there already exist government-supported technology programs. The hypersonic program offices should establish liaisons with these activities to promote their applications to hypersonic vehicles.

11) The tremendous heat loads that will be a natural part of hypersonic flight, together with the uncertainty of the heat transfer properties of new materials when combined in a specific design configuration, lead to the possibility of broad uncertainties in the thermal environment for key information/control equipment, including cables and hydraulics. Detailed attention should be placed on highly robust thermal control to accommodate the wide uncertainties in thermal environment.

12) Another issue that will have to be examined early enough to enable pursuit of alternatives, if needed, is that of communications. Above approximately Mach 10 there is likely to be a layer of ionized particles over some sections of the aircraft. This phenomenon will be configuration specific. An investigation is needed to ensure that reliable communication pathways will be available. If a definitive answer to this is not available early, a technology program may be needed to assure additional options for the first flight test vehicles. As part of this communications assessment, an examination should be made of the relevance of previous accomplishments in this area.

13) The flight program and control design philosophy should be configured to recognize the levels of knowledge about uncertainties in the flight control system equipment associated with each phase. Gradual work up through the speed envelope, is essential to reduce the risks in control systems for all their primary functions.

3.6 High temperature Materials, Cryogenics, and Cooling

1) The structural weight fraction required for single-stage near-orbital hypersonic flight will require stiff, ultra-light, high temperature materials to insure vehicle performance and usable payload over the intended range for desired missions.

2) The vehicle configuration and the trajectory flown will determine structural concepts and material requirements. Various portions of the vehicle will require different materials because of varying structural loads and temperature

- isotherms that will be experienced in hypersonic flight.
- 3) Material requirements will cover the range from -268°C (cryogenic fuel tanks) to 2200°C for nose and wing leading edges.
 - 4) The major new requirements for ultra-lightweight, high temperature, high stiffness, oxidation resistant materials will dictate the use of materials and material concepts now in the realm of emerging technologies.
 - 5) Those high performance materials that *have* been identified as having significant structural properties at the high temperatures of interest, and their ranks thin as temperatures rise, do not have an adequate data base, nor are their failure mechanisms adequately understood, nor do we know their ability to maintain adequate properties for the necessary times at elevated temperature to insure a design with the necessary structural integrity for the intended missions.
 - 6) We do not have enough data to develop design criteria to use these emerging materials.
 - 7) We do not know if these materials can be produced in the proper quantity, quality, and forms with consistent properties to insure a manufacturable design and to insure structural integrity of the proposed hypersonic vehicle.
 - 8) Specific requirements for materials for hypersonic vehicles include.
 - a) Reliable test data on such diverse variables as strength, modulus, structural stability, ductility, oxidation resistance, interphase reactions, high temperature creep, and joining.
 - b) Creep and stress rupture tests for time periods of at least 100 hours, preferably for 1000 hours, in appropriate atmospheres.
 - c) Fracture properties such as fatigue crack growth rates and fracture toughness values at appropriate temperature.
 - d) Oxidation resistance up to about 100 hours over a range of temperature.
 - e) Structural and property changes under the above conditions.
 - f) Reproducibility of structures and properties from repeated fabrication or processing studies.
 - g) Development of higher temperature test facilities (tension, compression, fatigue, thermal stress, etc.) than are now available.
 - h) Availability of at least two material producers for each of the classes of materials selected is desired.
 - i) Encouragement of alternate manufacturing or processing sources.
- ### 3.7 Structural Concepts
- 1) The expected performance of the propulsion sub-system of a hypersonic air-breathing vehicle dictates a fuel fraction in the neighborhood of .75 for orbital or near orbital single stage performance. For a useful payload function and a reasonable take-off gross weight, the structural weight fraction must be about .18.
 - 2) Design philosophy and specifications play a dominant role in the structural design, so the structural weight fraction is sensitive to the specifications imposed on the vehicle.

- 3) Present vehicle specifications that insure structural integrity are the result of years of service experience on subsonic and slightly supersonic aircraft. Their impact, if imposed on hypersonic aircraft, must be studied and evaluated with a fresh (i.e., zero-base) outlook because the weight increases that result from these historical specifications may keep the hypersonic aircraft on the ground.
- 4) Structural failure modes depend on the local details of the design, in addition to material properties and applied stress levels. These, in turn, are driven by the configuration of the aircraft and the internal layout.
- 5) Tensile strength is only one discriminant of material goodness for aircraft, and it is misleading to rank materials using tensile strength.
- 6) An extensive plumbing system for active cooling will form a large part of the structural weight fraction of the vehicle.
- 7) The large fuel fraction and the use of low density fuel (i.e., hydrogen) means a large portion of the airframe will be tankage.
- 8) Thermal stresses are driven by temperature gradients. Heat flow in the structure will be affected by the conductance of structural joints, viewing angles of colder regions to hotter regions, and the thermal characteristics of the materials.
- 9) New structural design concepts are required to meet the unique environments encountered by hypersonic aircraft. Active cooling, insulation, thermal protection, etc., are added to meet the traditional requirements of strength, aeroelasticity, and longevity. Structural design concepts must be proven by the fabrication of hardware which are then tested to the simulated environment.
- 10) The structural integrity of aircraft are verified by full-scale testing statically and under cyclic loads to determine the longevity and durability. It does not seem practical to simulate the temperature environment of hypersonic aircraft.
- 11) Hypersonic aircraft will be hot on the outside and very cold in some parts of the inside, which presents an unusual and severe environment for sensors, fiber optics, cables, etc.

3.8 The Role of CFD

- 1) CFD has become a principal tool for aerodynamic and propulsive-flow design of hypersonic vehicles because computers can simulate simultaneously the hypersonic flight parameters of velocity, free stream density, physical scale, and free stream thermochemical state. Present ground-based experimental facilities cannot simulate together all of these parameters, especially for high altitude hypersonic flight conditions involving non-equilibrium air chemistry.
- 2) Current supercomputers and numerical methods can simulate 3-D flows using the Reynolds-averaged Navier-Stokes equations, but these equations require that the turbulence viscous stresses and heat flux be modeled, and that the location and extent of transition from laminar to turbulent flow be known *a priori*.

- 3) Present modeling of turbulence stresses and heat flux, and modeling of transition location, are the principal current limitation of C₁D. Present validations of CFD code are relatively limited for hypersonic flows. Turbulence models for attached wall-bounded flows appear more acceptable than for compressible-flow mixing processes such as are involved in combustors.
 - 4) Present CFD results appear acceptable for nozzle flows provided the initial entrance conditions and all relevant reaction rates are known, but CFD is incapable of determining whether or not relaminarization takes place on a nozzle wall.
 - 5) Current CFD simulations of the intense aerodynamic heating for shock on cowl lip shock conditions agree well with experimental results, but both results correspond to the lower altitude portion of the hypersonic flight corridor where shock thickness is negligible. For the high altitude flight conditions wherein the thickness of a shock wave can become sizable compared to the lip shock detachment distance, neither computations nor experiments have yet been made.
 - 6) The present limitations of CFD technology are not inherent to CFD itself, but are a consequence of the state of supercomputer development, which forces the use of a time-averaged ("Reynolds-averaged") form of the Navier-Stokes equations.
 - 7) The long range future of CFD has the potential of using the time-dependent Navier-Stokes equations wherein turbulent eddies are directly computed rather than modeled. This could greatly reduce the limitations and inaccuracies of CFD, but will require more powerful supercomputers than those now available.
 - 8) The future realization of advanced CFD involving the direct numerical simulation of transition and turbulence would have important long-range consequences to the Air Force in the design of future hypersonic vehicles (and also aircraft and turbine engines.)
 - 9) Greater emphasis should be placed on the modeling of compressible turbulent-mixing flows. Increased effort should also be given to modeling of hypersonic turbulent boundary layers in the presence of heat transfer and pressure gradients.
 - 10) High altitude shock-on-shock heating on a cowl lip, the most intense local heating expected on vehicles such as NASP, must be investigated by direct simulation Monte Carlo methods, appropriate new experiments, and continuum equations more advanced than Navier-Stokes.
 - 11) The direct numerical simulation of turbulence in compressible flows should be an important part of the long-range technology development program of the Air Force.
- ### 3.9 Test requirements
- 1) Research on facilities is needed to identify their effect on the simulated gas flow and its interaction with real gas kinetics.
 - 2) Direct connect testing of scramjet combustors cannot be done with conventional nozzle concepts and high enthalpy sources.
 - 3) While it appears that facility capability is sufficient in some

- areas, it should be noted that many of the facilities are 20 to 40 years old and do not have flow conditions of sufficiently good quality for aerodynamic and chemical kinetic testing and code validation.
- 4) Facility development and construction require a five to 10 year period and new facilities are not therefore likely to contribute substantially to design definition of the NASP research vehicle.
 - 5) Facilities for structural testing at 1200° C and above do not exist.
 - 6) Details of the upper atmosphere, including its local composition and flow turbulence are not sufficiently well-known to adequately establish the relation of flight conditions to results from ground test facilities.
 - 7) Hypersonics requires a substantial and continuing investment in the development of new facilities and instrumentation.
 - 8) In the Mach number range of 5 to 10, the knowledge and technology for facility construction exist; however, we have not developed the facilities to generate the required data base.
 - 9) At Mach number 10 and above, no one facility today can fully simulate all hypersonic flight parameters.
 - 10) Continued research is needed to explore the possibilities of developing such a facility for aerodynamic and propulsion testing and CFD validation.
 - 11) In the absence of full simulation, limited simulation testing should be done where possible for CFD validation.

APPENDIX A: Statement of Task

With the current interest in and potential for hypersonic flight, there is a need to determine for the Air Force and for the nation the research and development approaches required to realize the opportunities offered by flight in this regime.

In its report, *National Aeronautical R&D Goals*, March 1985, the Aeronautical Policy Review committee of the OSTP enunciated a transatmospheric goal as, "exploiting the growing convergence of aeronautics and space technology." It states that "the capability to routinely cruise and maneuver into and out of the atmosphere, to gain rapid responsiveness for low earth orbit missions (manned or unmanned), or to attain very rapid transport services between earth destinations from conventional runways, must be viewed as aerospace options with global importance for the future."

The National Aerospace Plane program has been established to build a single stage research vehicle that can take off from a runway, achieve orbit, and return. A joint program among DARPA, Air Force, SDIO, Navy, and NASA, with planned total funding of \$3.1B, NASP is in an accelerated technology development phase (II), which leads to a phase III technical readiness assessment in late 1989. If the assessment is positive, the program will proceed to design, fabrication, and test of a flight research vehicle in the 1990-1995 period.

Against this background, the task of the AFSB committee on hypersonic technology is to:

- determine possible military uses of hypersonic flight
- draw on the developing hypersonic technology base, including the evolving results of NASP Phase II, to assess the technical feasibility of meeting the potential applications.
- identify the technological needs for hypersonic flight.
- assess the research and development support requirements including availability of expertise, data bases, and test facilities.
- provide technical advice to the command level on the research and development strategy of the NASP, including:
 - the level of technical risk in a single-stage to orbit research vehicle, and strategies for risk reduction
 - the research vehicle program approach to maximize the acquisition of knowledge in the most critical technical areas.

APPENDIX B: Acronyms

CDS	carbide dispersion stabilized (alloys)
CFD	computational fluid dynamics
DARPA	Defense Advanced Research Projects Agency
DOD	Department of Defense
HGV	hypersonic glide vehicle
HIP	hot isostatic pressing
HTTF	high temperature test facility
LDC	liquid dynamic compaction
MIPS	millions of instructions per second
NASA	National Aeronautics and Space Administration
NASP	National Aerospace Plane
ODS	oxide dispersion stabilized (alloys)
PIO	pilot induced oscillations
PNS	parabolized Reynolds-averaged Navier-Stokes equations
psf	pounds per square foot
RST	rapidly solidified titanium
TOGW	take-off gross weight
TPS	thermal protection system
ZAP	zone anneal-processed

APPENDIX C: Glossary

- adiabatic** Thermodynamic change in system without heat transfer across system boundary. In context of Gas Laws, possible to admit of exact adiabatic processes and visualize them happening; shockwave, though not isentropic, is not adiabatic in classical sense because thermodynamic changes are not reversible.
- air-breathing** Aspiring air, specifically aircraft propulsion system that sustains combustion of fuel with atmospheric oxygen. Imposes constraints on vehicle speed and height, but invariably offers longer range than rocket system for same vehicle size or mass.
- anisotropic** Having properties, as conductivity, speed of transmission of light, etc., that vary according to the direction in which they are measured.
- bluntbody flows** A blunt trailing edge or rear face of body cause turbulence immediately downstream, but main airflow cannot detect that body or airfoil has come to an end and thus continues to behave as if in passage over surface of greater length or chord.
- boundary layer** Layer of fluid in vicinity of a bounding surface: e.g., layer of air surrounding a body moving through the atmosphere. Within the boundary layer fluid motion is determined mainly by viscous forces, and molecular layer in contact with surface is assumed to be at rest with respect to that surface. Thickness of boundary layer is determined mainly by viscous forces, and molecular layer in contact with surface is assumed to be at rest with respect to that surface. Thickness of boundary layer is normally least to distance from surface to fluid layer having 99% of free-stream velocity. Boundary layer can be laminar or, downstream of transition point, turbulent.
- cold wall** The condition of low model surface temperatures to allow more accurate aerodynamic testing in a hypersonic wind tunnel.
- creep** Slow plastic deformation under prolonged constant load, greatly accelerated by high temperatures.
- cryogenic** Operating at extremely low temperatures.
- diabatic process** Process in thermodynamic system with transfer of heat across boundaries.
- drag** Retarding force acting upon body in relative motion through field, parallel to direction of motion. Sum of all retarding forces acting on body, such as induced drag, profile drag.
- dynamic pressure** Pressure of a fluid resulting from its motion when brought to rest on a surface, given by $q = \frac{1}{2}\rho V^2$; in incompressible flow, difference between total pressure and static pressure.

- e^n** A parameter used to correlate boundary layer transition; the faster by which disturbances grow before transition occurs.
- enthalpy** Total energy (heat content) of system or substance undergoing change from one stage to another under constant pressure, expressed as $H = E + PV$, where E is energy, P pressure, and V volume.
- flight envelope** Curves of speed plotted against altitude or other variable defining performance limits and conditions within which equipment must work.
- flow fields** Small regions within the physical flow plane, in each of which all flow properties, including velocity, direction, pressure, etc. are considered constant.
- free stream** Fluid outside region affected by aircraft or other body.
- hypersonic** faster than Mach number 5.
- Knudsen number, Kn** Mean free path divided by characteristic length of body.
- laminar boundary layer** Comprise successive laminar layers, that adjacent to surface having zero relative velocity and successive layers adding velocity out to the free stream.
- laminar flow** Fluid flow in which streamlines are invariant and maintain uniform separation with perfect non-turbulent sliding between layers.
- Lewis number** $Le = Pr (Prandtl)/Sc (Schmidt)$, used in hypersonics.
- lift** 1. Total lifting force from a wing (component of resultant force along lift axis), aerostat envelope or other source excluding engine thrust. Normally, force supporting aircraft. 2. Any element of such lift, acting through particular point.
- Mach number, M** Ratio of true airspeed to speed of sound in surrounding fluid (which varies as square root of absolute temperature).
- moment** Turning effect about an axis; force multiplied by perpendicular distance from axis to force.
- monocoque** Three-dimensional form, such as fuselage, having all strength in skin and immediate underlying frames and stringers, with no interior structure or bracing.
- Monte Carlo methods** Use of random numbers to generate statistics on the behavior of estimators of an assumed set of structural equations.
- Navier-Stokes equations** Basic set of equations for motion of body or flow parcel in viscous fluid.
- Nusselt number** Non-dimensional parameter $Nu = -qD/\lambda\delta T$ where q is quantity of heat, D is typical length, λ is thermal conductivity and δT is temperature difference.
- pitch** Angular displacement (rotation) about lateral (OY) axis.

pitching moment One causing pitch, measured as positive when nose-up or tail-heavy.

Prandtl number Ratio of momentum diffusivity to thermal diffusivity, $Pr = \mu C_p / \lambda = \nu \alpha$, where μ is viscosity, C_p is specific heat at constant p, λ is thermal conductivity, ν is kinematic viscosity, and α is angle of attack.

pyrolysis Chemical decomposition by heating.

q dynamic pressure

ram Increase in pressure in forward-facing tube, duct, inlet, etc., as result of vehicle speed through atmosphere; if fluid flow were brought to rest in duct, pressure would be q, dynamic pressure. Hence ram inlet, ram pressure, ramjet, ram air, ram effect.

ramjet Air-breathing jet engine similar to turbojet but without mechanical compressor or turbine; compression is accomplished entirely by ram and is thus sensitive to vehicle forward speed and non-existent at rest (hence ram cannot start from rest). Inefficient below Mach number 3 but extremely important for unmanned vehicles, especially in conjunction with rocket (e.g., ramrocket). Also called athodyd, Lorin duct; not to be confused with pulsejet or resonant ducts.

ramp Sharp-edged wedge with sloping wall forming inner wall of supersonic inlet duct to create oblique shock(s) and improve pressure recovery, especially at supersonic speeds; usually has variable geometry.

regenerative cooling Use of cool incoming liquid, e.g., rocket engine propellant, to remove heat from hot hardware, e.g., rocket nozzle skirt and exit cone. Essential feature is that heat transfer is beneficial to both cooled item and coolant.

Re_x Reynolds number based on position along surface measured from start of boundary layer growth.

Reynolds number Most important dimensionless coefficient used as indication of scale of fluid flow, and fundamental to all viscous fluids; $R = \rho V l / \mu$ where ρ is density, V velocity, l a characteristic length (e.g., chord of wing) and μ viscosity = $V l / \nu$ where ν is kinematic viscosity. Expression is ratio of inertia to viscous forces. It shows, e.g., that for dimensionless similarity, model tests in tunnels should be run at pressures greater than atmospheric.

Schmidt number $Sc = \mu / \rho D_{12}$ where μ is viscosity, ρ is density, and D_{12} diffusion coefficient; ratio of viscous and mass diffusivity, or kinematic viscosity divided by mass diffusivity.

scramjet Supersonic combustion ramjet; one in which flow through combustor itself is still supersonic.

shock front The initial part of a shock wave in which the pressure rises from zero up to its peak value. The shock front is generally assumed to be infinitely thin and a mathematical discontinuity, but is actually of finite thickness. This front is not in equilibrium; it is a transition region between equilibrium conditions in the air ahead of the shock and the changed gas mixture behind it.

shock layer In supersonic aerodynamics, the region between the shock front and the boundary layer; assumed to be an inviscid flow. Radiation from the shock layer to the nose cone of high speed missiles is one of the causes of skin heating.

shock wave A surface or sheet of discontinuity set up in a supersonic field of flow through which the fluid undergoes a finite decrease in velocity accompanied by a marked increase in pressure, density, temperature, and entropy, as occurs, e.g., in a supersonic flow about a body.

sideslip Flight maneuver in which controls are deliberately crossed, e.g., to sideslip to left airplane is banked to left while right rudder is applied; result is not much change in track but flight path inclined downward, i.e. steady loss of height without significant change in airspeed and with longitudinal axis markedly displaced from flightpath. Angle of sideslip is angle between plane of symmetry and direction of motion (flightpath, or relative wind). Rate of sideslip is component of velocity along lateral axis.

sloshing Gross oscillatory motion of liquid in tank sufficient to impose severe structural stress or affect vehicle trajectory.

stagnation point Point on surface of body in viscous fluid flow (one facing upstream and one down) where fluid is at rest with respect to body, flow in boundary layer on each side of stagnation point being in opposite directions.

stagnation temperature That at stagnation point, when all relative kinetic energy has been converted isentropically to heat.

Stanton number Non-dimensional number defining heat transfer through a surface; $St = -q/\rho V C_p dT$ where q is total quantity of heat, ρ is density of fluid (e.g., air), V is relative velocity, C_p is specific heat at constant pressure and dT is recovery temperature minus wall temperature.

static divergence The efflux per unit volume from a point.

thermal fatigue Mechanical fatigue caused by stresses repeatedly imposed by thermal cycling (oscillation between low and high temperatures).

thrust Force, especially that imparting propulsion.

transitional flow A flow of fluid that is changing from laminar flow to turbulent flow.

trim Angle between longitudinal axis (OX) and local horizontal, especially of airship, marine aircraft or seaplane float on water.

turbulent flow Flow having turbulence superimposed on main movement, measured as velocity increments about all three axes expressed as fraction or percent of mean flow velocity.

viscosity Internal friction in fluid; property that enables fluid to generate tangential force and offer dissipative resistance to flow, defined as ratio of shear stress to strain; in air almost unaffected by pressure but increases with temperature.

APPENDIX D: Dimensionless Groups in Fluid Mechanics

Parameter	Definition	Qualitative ratio of effects	Importance
Reynolds number	$Re = \rho UL/\mu$	Inertia/Viscosity	Always
Mach number	$Ma = U/a$	Flow speed/Sound speed	Compressible flow
Froude number	$Fr = U^2/gL$	Inertia/Gravity	Free-surface flow
Weber number	$We = \rho U^2 L/\gamma$	Inertia/Surface tension	Free-surface flow
Cavitation number (Euler number)	$Ca = p - p_w/\rho U^2$	Pressure/Inertia	Cavitation
Prandtl number	$Pr = \mu c_p/k$	Dissipation/Conduction	Heat convection
Eckert number	$Ec = U^2/c_p T_o$	Kinetic energy/Enthalpy	Dissipation
Specific-heat ratio	$\gamma = c_p/c_v$	Enthalpy/Internal energy	Compressible flow
Strouhal number	$St = \omega L/U$	Oscillation/Mean speed	Oscillating flow
Roughness ratio	ϵ/L	Wall roughness/ Body length	Turbulent, rough walls
Grashof number	$Gr = \beta \Delta T g L^3 \rho^2/\mu^2$	Buoyancy/Viscosity	Natural convection
Temperature ratio	T_w/T_o	Wall temperature/ Stream temperature	Heat transfer
Pressure coefficient	$C_p = p - p_\infty/\frac{1}{2}\rho U^2$	Static pressure/ Dynamic pressure	Aerodynamics, hydrodynamics

Parameter	Definition	Qualitative ratio of effects	Importance
Lift coefficient	$C_L = L/\frac{1}{2}\rho U^2 A$	Lift force/ Dynamic force	Aerodynamics, hydrodynamics
Drag coefficient	$C_D = D/\frac{1}{2}\rho U^2 A$	Drag force/ Dynamic force	Aerodynamics, hydrodynamics
Lewis number	$\rho c_p D/\mu$	Mass diffusion/ Energy diffusion	
Knudsen's number	Molecular mean free path/ length	Measure of continuum or Free molecular flow	
Stanton number	$\dot{h}/c_p \rho v = (c_f/2)(1/PR)^{2/3}$	Reynolds analogy between friction and heat transfer	
Schmidt number	$\mu/\rho D$	Viscous to Diffusion ratio	

The only unusual parameter here is D , which is a diffusion coefficient.

APPENDIX E: Letter to National Aerospace Plane Contractors

Date: July 14, 1987
To: NASP Contractors
From: AFSB Committee on Hypersonic Technology for Military Operations
Subject: Approach Being Taken to Critical Technologies for NASP

INTRODUCTION

The National Research Council Air Force Studies Board has been requested by the Commander, Air Force Systems Command, to conduct a broad review of the status of technologies critical to hypersonic flight, and to assess the possible applications of hypersonic flight by the Air Force. More specifically, the task of the committee is to:

- 1) develop an understanding of possible military applications of hypersonic flight.
- 2) draw on the developing hypersonic technology base, including the evolving results of NASP Phase II, to assess the technical feasibility of realizing the potential applications.
- 3) identify the technological needs for hypersonic flight.
- 4) assess the research and development support requirements including availability of expertise, data bases, and tests facilities.
- 5) provide technical advice to the command level on the research and development strategy of the NASP, including:
 - a) the level of technical risk in a single-stage to orbit research vehicle, and strategies for risk reduction.
 - b) the research vehicle program approach to maximize the acquisition of knowledge in the most critical technical areas.

In addressing this charge, the committee has received briefings from cognizant staff of the Air Force and NASA, and has formulated a preliminary view of technical issues, the resolution of which it deems most crucial to realization of practical hypersonic flight.

The engineers and scientists of your organization have much to contribute to this review. We would welcome the opportunity to meet with them and examine the major technical problems and possible solutions to them. We have discussed these issues among ourselves and have compiled a list of questions that would serve to identify most of the crucial problems as we see them at the present time. We share this list with you below in the hope that you will orient your briefings toward and be prepared to discuss these issues. We will be able to spend one day with your firm and would like to spend our time in technical discussions with your best research and engineering talent. We are interested in the technical substance of your program and wish to assure you that the results of our discussions will not in any way affect the competitive character of your company's efforts. We have presented a rather lengthy list of questions and must leave to your judgment the specifics of the agenda and the prioritization of our concerns. Feel free to add to the list other matters that you judge to be of comparable importance.

We recognize that some of the questions posed here may be unanswerable at present. In these cases, we solicit your view as to whether the NASP program is structured to enable their resolution in the future.

BROAD ISSUES

The NASP program plays a central role in the nation's hypersonic research program. Although there are other programs of basic and applied research that are contributing to the technology base and to understanding of the behavior of hypersonic vehicles in flight, the X-30 is intended to be a key research vehicle, enabling exploration of the technologies critical to hypersonic flight. Similarly, in addressing technical risks and risk reduction for hypersonic applications, the NASP technology maturation program, though a subset of the overall hypersonic flight technology program, is of key importance.

To achieve its research objectives, the NASP program must provide access, for experimentation, to the high Mach number regions of flight that are not accessible in ground test, and must enable validation of those systems concepts and verification of solutions to those technical problems, that are unique to hypersonic flight.

Thus, the committee judges the requirement for design of NASP to be sufficient understanding of the critical technologies to enable the design of a reusable vehicle (or vehicles) with reasonable assurance that they will be able to explore the flight corridor of interest for hypersonic flight vehicles. Tentatively, this corridor includes the Mach number range from 0 to 25, at associated altitudes such that the dynamic pressure is in the range from 500 to 200 psf. It includes steady state flight, as well as acceleration and deceleration, in the hypersonic regime. Since the X-30 is to be a research

vehicle, it may reasonably incorporate technologies that are not fully mature; however, given the high visibility and cost of the program, these will have to be sufficiently reliable in an experimental context to give reasonable assurance that the program can be completed, and realize its experimental objectives. We seek your assistance in identifying the key technology demonstrations that must be in place before design of the X-30 research vehicle, as well as those that will stem from its operation.

TECHNOLOGICAL ISSUES

The committee has identified a set of technical issues that it believes to be critical, and for which it seeks clarification of the present level of understanding. The set is not claimed to be complete, and the committee solicits identification and understanding of issues or problems additional to those listed below.

For each technical area, a brief statement of the issue will be followed by a set of questions to which we request your response, specifically for those that fall in your area of responsibility. We will also appreciate your views on issues outside your direct areas of responsibility, should you care to offer them.

HYPERSOUND PROPULSION

The committee considers the viability of the supersonic combustion ramjet to be a key issue for hypersonic applications, since it is the SCRAMJET that promises the high values of specific impulse at Mach numbers above 7, which are essential to global hypersonic flight or single-stage transportation to orbit. Yet from the information available thus far to the committee, serious questions of feasibility exist in a number of areas. The principal areas of concern are:

- a) Non-uniform flow in the engine inlet and hence into the combustion chamber
- b) Hydrogen injection and mixing
- c) Hydrogen-air reaction in the combustor
- d) The effect of combustor-exit non-uniformities on nozzle performance
- e) Gas flow and chemical recombination in the nozzle area
- f) Transient and unsteady behavior of the propulsion system

The questions to which we request your response are:

- 1) What candidate injection systems have you identified, and to what extent have you evaluated their performance with regard to fluid mixing, molecular mixing, and pressure loss? What do you consider adequate mixing, and how have you assessed the penalties of incomplete mixing?

- 2) How are you addressing the reactive flow in the nozzle; in particular, to what extent are reaction kinetics included in nozzle performance calculations?
- 3) What calculation techniques are you using to determine the effects on the nozzle performance of nozzle-inlet thermal and composition stratifications resulting from non-uniform combustion or mixing?
- 4) How are you assessing the stability of the inlet-combustor-nozzle flow system and its response to small perturbations introduced for example by atmospheric disturbances, vehicle attitude changes, or vehicle deflections?
- 5) How are you addressing the issue of three-dimensional flow non-uniformities in the engine inlet due to such phenomena as shock wave-boundary layer interaction?
- 6) How are you addressing the operational transition between RAMJET and SCRAMJET operation?
- 7) How do you propose to adjust the engine configuration to varying flight conditions and to maintain regenerative cooling of critical areas during these adjustments?
- 8) How are you assessing the engine off-design performance and its effect on vehicle drag and cooling?
- 9) How are you approaching the engine-airframe integration process, including the plume-slipstream interaction?

LOW SPEED PROPULSION

The principal area of concern here is the design of a low-speed propulsion that will provide adequate take-off and transonic thrust, sufficiently high specific impulse, high enough thrust to weight ratio, and be integrable into the SCRAMJET envelope without detriment to the RAMJET and SCRAMJET performance.

The questions to which we are seeking answers are:

- 1) What candidate systems are you considering and to what extent have you identified their performance characteristics including possible losses due to integration into the RAMJET and SCRAMJET?
- 2) What analyses or experiments have you made that will permit you to assess the transition process from low speed to RAMJET operation?
- 3) What techniques are you using to assess the stability and control of this transitional operation?

BOUNDARY LAYER TRANSITION

The problem of predicting boundary layer transition for the external flow, for the internal flow on the inlet, and in the nozzle at flight Mach numbers above 10 may lead to unacceptable uncertainties in the skin friction drag, heat transfer, and boundary layer thickness. It would appear that the location and extent of transition must be reasonably well predicted under conditions of real, reacting gases, three-dimensional flows in pressure gradients, and with non-uniformities, unless large margins in drag and heat transfer are acceptable for the experimental vehicle, which seems unlikely. The questions we hope you will address are:

- 1) What techniques are you using to predict the locations of transition in each of the critical areas of the vehicle?
- 2) To what extent have these techniques been verified experimentally, including the effects enumerated above?
- 3) If we must accept large uncertainties in transition locations, what are the resulting penalties to the vehicle performance?
- 4) To what extent can laminar flow be realized over large portions of the vehicle in the presence of practical roughness, by shape changes for favorable pressure profiles, by control of surface smoothness and temperature, by selection of low Reynolds number flight paths, etc.? Are you exploring such possibilities?

VEHICLE HEATING

Our experience thus far with hypersonic vehicles suggests that locally high heating will result from complex three-dimensional flows in corners, from shock-on-shock interactions, and from other phenomena that result in very thin shear layers. At the very high Mach numbers these phenomena will be complicated by the effects of nonequilibrium chemistry and perhaps radiation. Since we do not have and do not expect to have the capability to fully explore these complex phenomena experimentally, it would seem necessary to rely heavily on extrapolation by computational fluid dynamics techniques from the available data base. Our questions are:

- 1) What data base have you for addressing these issues?
- 2) What areas on the vehicle have you identified as especially critical from the viewpoint of heat transfer, and how are you predicting the heat transfer at these points? Are you counting on non-catalytic coatings to reduce surface temperatures in certain areas?
- 3) What computational techniques are you using for dealing with the three-dimensional, reacting flows at critical points? How have these techniques been verified?

- 4) Are there critical reaction rates that, you believe, are not yet known to sufficient accuracy?
- 5) Have you considered the effects of shock-on-shock interactions such as may arise from a bow shock crossing a wing or inlet leading edge shock, if this occurs within the pitch, yaw and Mach number envelope of your vehicle design?

STRUCTURES AND MATERIALS

The X-30 research vehicle and NASP technology maturation program are to explore structural concepts that will cope with the rigors of flight at hypersonic velocities and with the attendant structural integrity issues. Structural concepts must address, for examples, the choice of materials, thermal protection, active cooling, insulation, configuration, and fabrication. Structural integrity requires an assessment of the ability of the concept to meet the critical flight conditions with positive margins of safety. This requires knowledge of failure modes, which means the gathering of a data base from experiments.

Much emphasis is being placed in the technology maturation program on developing new materials that will have better high temperature properties than are presently available. In comparison with the materials data required for subsonic airplanes, the hypersonic airplane data requirement is much more extensive because, e.g., thermal, chemical, oxidation, and other data at elevated temperatures are required. We wish to ascertain whether these materials will be ready for the X-30 vehicle.

A relatively small fraction of an airplane is critically loaded in tension, yet the materials community appears to be using specific tensile strength as a principal figure of merit for new materials. The more prevalent modes of failure are those due to buckling, fatigue, and fracture caused by small flaws. It is the committee's perception that these modes of failure are not well understood for many of the materials projected for use in the NASP. Additional areas of concern are the fracture toughness at room temperature of the high temperature materials, and the effect of fastener holes on the strength and toughness of the advanced filamentary composite materials. Our questions are:

- 1) On what data base do you draw for design, considering the issues discussed above? How has it been validated?
- 2) What major structural tests do you envision for validation of the structure of the NASP during design and prior to flight test?
- 3) Do the verification tests require thermal simulation? If so, what facilities are available or must be provided?
- 4) Are the available computational techniques adequate for prediction of the structural deformations due to aerodynamic loads and heating?

- 5) What are the critical flight conditions for the various structural components?
- 6) What are the critical modes of failure, i.e., what structural behavior determines the sizes of the various structural components?
- 7) What are the projected methods of fabrication?
- 8) Will your concept meet the letter and/or spirit of specifications such as MIL-STD 1536A and MIL-A 83444?
- 9) What minimum or representative sizes of test materials are contemplated for materials evaluation? What minimum or representative sections are contemplated for systems?
- 10) Of the several concepts for reusable thermal protection systems, such as radiatively-cooled structures with internal insulation, external insulation, or convectively cooled structure, which do you consider most feasible for each of the critical heating areas of the NASP?

CONTROL

The control system for the X-30 will have to integrate control of the vehicle attitude, engine geometry and fuel supply, center of gravity, and the trajectory to high degrees of precision because of the sensitivity of the hypersonic vehicle to all of these.

It may also have to actively control lower frequency structural and shock modes, maintain shock positions in the inlet so as to maximize performance and avoid unstart, counter any thrust malalignments, etc. Precision requirements for sideslip and angle of attack control are at least unusual and perhaps unprecedented.

Because the degree of interaction of controls and guidance with the aerodynamics, propulsion, and structural aspects of the vehicle are to some extent configuration-specific, we are interested in insights you have gained from your studies. Some questions are:

- 1) How have you addressed the problem of simultaneous control of flight path, aerodynamics, propulsion, and damping of structural and slosh modes?
- 2) What vehicle configuration (aerodynamic, structural, propulsion, etc.) and control system features have been governing factors in your design?
- 3) How have the requirements for control been explicitly considered in your design studies?

- 4) What are the most highly leveraged performance, weight, etc., improvements in the engine, aerodynamics, structure, etc., that can be expected to be achieved through active control?
- 5) What component (e.g., sensor and effectors) and system elements will require significant development and testing for research vehicle applications? What facilities will be needed for testing of critical system elements and the integrated systems to assure stability of the research vehicle?
- 6) What modeling or analytical techniques have you used to deal with interactions involving control?
- 7) What are the most stressing computational, data management and "avionics" issues associated with the experimental vehicle? What is the total computational load you envision?

SYSTEMS INTEGRATION

The X-30 as a research vehicle will be among the most highly integrated assemblages of technologies ever attempted. The propulsion system must be intimate with the airframe system, the airframe must be controlled in flight as well as thermally balanced. In general, the X-30 will function effectively only if its parts function cooperatively to a degree that is unusual, perhaps unique.

Our questions are:

- 1) What specific integrating methods and techniques are you using to treat the airframe, engine inlet, engine, and nozzle as an integrated system?
- 2) What methods are appropriate for integrating the flight controls of the vehicle, vehicle trajectory, fuel controls, and the thermal system required to actively cool the X-30?

SYSTEM CONCEPT

To help us understand your responses to these questions about critical technologies, we would very much appreciate a brief description of the vehicle concept that you consider most promising for the X-30 hypersonic research aircraft, along with the following:

- 1) Flight trajectory profiles
- 2) Isotemperatures at critical points of the trajectories
- 3) Performance characteristics, such as take-off and landing distances, acceleration rates, maximum velocity range, etc.
- 4) A weight statement summary
- 5) A table of materials, amount used, and location, and
- 6) Margins of safety for the most critical locations.

APPENDIX F: Schedule of Committee Meetings**First Meeting**

National Research Council
2100 Pennsylvania Avenue, NW
Room 3H 455
Washington, D.C.
30 April - 1 May, 1987

Agenda**Thursday, 30 April 1987**

0800	Introductory Comments	Jack Kerrebrock, Chairman
0805	Overview of Hypersonic R&D at NASA	Duncan McIver, NASA HQ
0835	Configuration and Performance Studies	James L. Hunt, NASA/Langley Research Center
0920	High Mach Propulsion	Griffin Y. Anderson, NASA/Langley Research Center
1005	Break	
1020	Low Mach & Special Systems Propulsion	Robert Coltrin, NASA/Langley Research Center
1105	High Temperature Materials	Darrel Tenney, NASA/Langley Research Center
1150	Working Lunch	
1230	Computational Fluid Dynamics	Paul Kutler, NASA/Ames Research Center Douglas Dwoyer, NASA/Langley Research Center
1315	Stabilization & Control	Steve Sliwa, NASA/Langley Research Center
1400	Structures	Donald Rummeler, NASA/Langley Research Center
1445	Break	

1500	Thermal/Structural Test Facilities	Sidney Dixon, NASA/Langley Research Center
1545	Boundary Layer Transition	Dennis Bushnell, NASA/Langley Research Center
1630	Executive Session	Chairman Kerrebrock
1800	Social Period	Committee Room 2, 2nd Floor Joseph Henry Building
1845	Dinner	Committee Room 2, 2nd Floor Joseph Henry Building

Friday, 1 May 1987

0800	Executive Session	Chairman Kerrebrock
0930	Break	
0945	Executive Session (continued)	
1100	Electromagnetic Propagation in Plasma	Leon Poirier, RADC/EE, Hanscom AFB
1200	Working Lunch	
1230	USAF and Soviet Hypersonic Test Capability	Jim Mitchell, AEDC
1400	Meeting Wrap-up and Discussion	Chairman Kerrebrock
1500	Adjourn	

Second Meeting

Naval Postgraduate School
101A Spanagel Hall
Monterey, California
2-3 June 1987

Agenda**Tuesday, 2 June 1987**

0800	Welcome/Introduction Administrative Remarks	Jack Kerrebrock, Chairman Vernon Miles, Director
0825	HOTOL	Tom Curran/John Leingang, AFWAL/CA-P
1000	Break	
1025	SWERVE	Walton E. Williamson, Sandia National Laboratory
1150	Chairman's comments on morning briefings	Chairman Kerrebrock
1215	Lunch	Officers Club
1320	Hypervelocity Integrated Control Technology Challenges/ Flight Control Air Data Sensors	David K. Bowser, AFWAL/FIGC
1400	Future Threats to an Operational Hypersonic Vehicle	Frank Jankowski, FTD/TQI
1500	Break	
1510	Hypersonic Road Map	Keith Richey, AFWAL/CAF
1645	Executive Session	Chairman Kerrebrock
1830	Cocktails	La Novia Room, NPS
1915	Dinner	La Novia Room, NPS

Wednesday, 3 June 1987

0830	High Temperature Materials	Nicholas Grant
0930	NA&P Technology Maturation	Lt. Col. Vince Rausch, AFSC/NAI

1000 Executive Session Chairman Kerrebrock
1420 Meeting adjourned

Third Meeting

National Research Council
2001 Wisconsin Avenue
Green Building, Room 120
Washington, D.C.
22-23 October 1987

Agenda**Thursday, 22 October 1987**

0800 Introductory Remarks Chairman Kerrebrock
0805 Administrative Announcements Vernon Miles
0810 Update on NASP Robert Barthelemy, AFSC/NA
0900 Engine Contractor No. 1
1200 Working Lunch/Discussion Chairman Kerrebrock
1330 Engine Contractor No. 2
1630 Discussion
1730 Return to Quarters
1830 Dinner

Friday, 23 October 1987

0800 Engine Contractor No. 3
1100 Discussion
1200 Working Lunch/Discussion continued
1500 Adjourn

Fourth Meeting

The Aerospace Corporation
2350 El Segundo Blvd
Building A, Room 1052
Los Angeles CA
23-24 November 1987

Agenda**Monday, 23 November 1987**

0800	Introductory Remarks	Chairman Kerrebrock
0805	Administrative Announcements	Vernon Miles
0810	Update on NASP	Lt. Col. Vincent Rausch, AFWAL/NAI
0900	Airframe Contractor No. 1	
1200	Working Lunch/Discussion	Chairman Kerrebrock
1330	Airframe Contractor No. 2	
1630	Discussion	
1730	Return to Quarters	

Tuesday, 24 November 1987

0800	Airframe Contractor No. 3	
1100	Discussion	
1200	Working Lunch/Discussion continued	
1500	Adjourn	

Fifth Meeting
National Research Council
2001 Wisconsin Avenue
Green Building, Room 134
Washington, D.C.
21-22 January 1988

Agenda

Thursday, 21 January 1988

0830 Work Session
1700 Adjourn
1800 Dinner

Friday, 22 January 1988

0830 Work Session
1500 Adjourn

Sixth Meeting
Naval Postgraduate School
Monterey, California
10-11 March 1988

Agenda

Thursday, 10 March 1988

0830 Work Session
1700 Adjourn
1800 Dinner

Friday, 11 March 1988

0830 Work Session
1500 Adjourn