

2

DTIC FILE COPY

AD-A190 840

Light and Heavy Forces In a Desert Environment:  
Considerations for Employment in Defensive Operations

by

Major Benjamin R. Nixon  
Infantry

DTIC  
SELECTED  
APR 01 1988  
S D

School of Advanced Military Studies  
U.S. Army Command and General Staff College  
Fort Leavenworth, Kansas

12 January 1988

Approved for public release; distribution is unlimited.

UNCLASSIFIED

SECURITY CLASSIFICATION OF THIS PAGE

REPORT DOCUMENTATION PAGE				Form Approved OMB No. 0704-0188	
1a. REPORT SECURITY CLASSIFICATION UNCLASSIFIED		1b. RESTRICTIVE MARKINGS			
2a. SECURITY CLASSIFICATION AUTHORITY		3. DISTRIBUTION/AVAILABILITY OF REPORT Approved for public release; distribution unlimited			
2b. DECLASSIFICATION/DOWNGRADING SCHEDULE					
4. PERFORMING ORGANIZATION REPORT NUMBER(S)		5. MONITORING ORGANIZATION REPORT NUMBER(S)			
6a. NAME OF PERFORMING ORGANIZATION School of Advanced Military Studies, USACGS		6b. OFFICE SYMBOL (If applicable) ATZL-SWV	7a. NAME OF MONITORING ORGANIZATION		
6c. ADDRESS (City, State, and ZIP Code) Fort Leavenworth, Kansas 66027-6900		7b. ADDRESS (City, State, and ZIP Code)			
8a. NAME OF FUNDING/SPONSORING ORGANIZATION SAMS, USACGS		8b. OFFICE SYMBOL (If applicable) ATZL-SWV	9. PROCUREMENT INSTRUMENT IDENTIFICATION NUMBER		
8c. ADDRESS (City, State, and ZIP Code) Fort Leavenworth, KS 66027		10. SOURCE OF FUNDING NUMBERS			
		PROGRAM ELEMENT NO.	PROJECT NO.	TASK NO.	WORK UNIT ACCESSION NO.
11. TITLE (Include Security Classification) Light and Heavy Forces In a Desert Environment: Considerations for Employment in Defensive Operations.					
12. PERSONAL AUTHOR(S) Benjamin R. Mixon, MAJOR, US Army					
13a. TYPE OF REPORT Monograph		13b. TIME COVERED FROM _____ TO _____	14. DATE OF REPORT (Year, Month, Day) 12 January 1988		15. PAGE COUNT 64
16. SUPPLEMENTARY NOTATION					
17. COSATI CODES			18. SUBJECT TERMS (Continue on reverse if necessary and identify by block number) Desert Warfare, Defensive Operations, World War II, Arab-Israeli Wars, Tobruk, Sidi bou Zid, El Alemein, Light Infantry.		
FIELD	GROUP	SUB-GROUP			
19. ABSTRACT (Continue on reverse if necessary and identify by block number) Light and Heavy Forces In a Desert Environment: Considerations for Employment in Defensive Operations  by Major Benjamin R. Mixon, US Army, 64 Pages  This monograph discusses the considerations for employment of light and heavy forces in a desert defense. Employment of these types of forces hinges on basic tactical fundamentals but must consider the unique nature of the environment. The capabilities of each force must be maximized to fight and win. This monograph examines the desert enviroment and light forces to focus attention on the considerations for employment of light and heavy forces in the defense.					
20. DISTRIBUTION/AVAILABILITY OF ABSTRACT <input type="checkbox"/> UNCLASSIFIED/UNLIMITED <input checked="" type="checkbox"/> SAME AS RPT. <input type="checkbox"/> DTIC USERS			21. ABSTRACT SECURITY CLASSIFICATION Unclassified		
22a. NAME OF RESPONSIBLE INDIVIDUAL Mixon, Benjamin R.		22b. TELEPHONE (Include Area Code) (913) 682-3437		22c. OFFICE SYMBOL ATZL-SWV	

DD Form 1473, JUN 86

Previous editions are obsolete.

SECURITY CLASSIFICATION OF THIS PAGE

UNCLASSIFIED

Continuation of Block 19

The monograph first examines the nature of the desert and its impact on military operations. Next, historical examples from World War II and the 1967 and 1973 Arab-Israeli Wars are discussed to determine how infantry forces were employed with heavy forces in desert defenses. Specifically, the battles of Tobruk, El Alamein and Sidi Bou Zid during World War II and initial battles of the Arab-Israeli wars provide the historical setting. Lessons learned from recent exercises are discussed to focus on the employment today's light forces with heavy forces.

Finally, a discussion of current light infantry defensive tactical doctrine sets the stage for an analysis of the major considerations for the employment of light forces with heavy forces in the desert. The issues of defensive missions, task organization and augmentation are addressed. This discussion highlights the role of light forces in the desert and emphasizes the considerations for employment in a desert defense.

**Light and Heavy Forces In a Desert Environment:  
Considerations for Employment in Defensive Operations**

by

**Major Benjamin R. Mixon  
Infantry**

**School of Advanced Military Studies  
U.S. Army Command and General Staff College  
Fort Leavenworth, Kansas**

**12 January 1988**

Accession For	
NTIS GRA&I	<input checked="" type="checkbox"/>
DTIC TAB	<input type="checkbox"/>
Unannounced	<input type="checkbox"/>
Justification	
By	
Date	
Special Instructions	
Call	
A-1	

**Approved for public release; distribution is unlimited.**



School of Advanced Military Studies  
Monograph Approval

Name of Student: Major Benjamin R. Nixon

Title of Monograph: Light and Heavy Forces In a Desert Environment:  
Considerations for Employment in Defensive  
Operations.

Approved by:

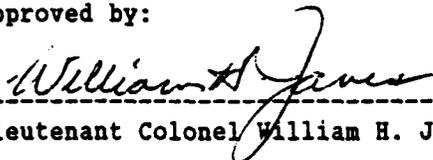
  
----- Monograph Director  
Lieutenant Colonel William H. Janes

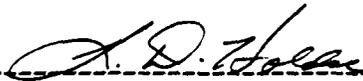
  
----- Director, School of  
Colonel L. D. Holder Advanced Military Studies

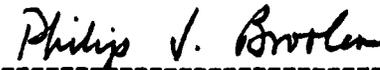
  
----- Director, Graduate Degree  
Philip J. Brookes, Ph.D. Programs

Accepted this 4th day of March 1987

### ABSTRACT

Light and Heavy Forces In a Desert Environment: Considerations for Employment in Defensive Operations by MAJ Benjamin R. Nixon, USA, 60 pages.

This monograph discusses the considerations for employment of light and heavy forces in a desert defense. Employment of these types of forces hinges on basic tactical fundamentals but must consider the unique nature of the environment. The capabilities of each force must be maximized to fight and win. This monograph examines the desert environment and light forces to focus attention on the considerations for employment of light and heavy forces in the defense.

The monograph first examines the nature of the desert and its impact on military operations. Next, historical examples from World War II and the 1967 and 1973 Arab-Israeli Wars are discussed to determine how infantry forces were employed with heavy forces in desert defenses. Specifically, the battles of Tobruk, El Alamein and Sidi Bou Zid during World War II and initial battles of the Arab-Israeli wars provide the historical setting. Lessons learned from recent exercises are discussed to focus on the employment of today's light forces with heavy forces.

Finally, a discussion of current light infantry defensive tactical doctrine sets the stage for an analysis of the major considerations for the employment of light forces with heavy forces in the desert. The issues of defensive missions, task organization and augmentation are addressed. This discussion highlights the role of light forces in the desert and emphasizes the considerations for employment in a desert defense.

## Table Of Contents

	Page
I. Introduction.....	1
II. Desert Environment and Its Significance on Military Operations.....	3
III. Light Forces in the Desert During World War II.....	9
IV. Arab-Israeli Wars of 1967 and 1973.....	20
V. Recent Experience and Lessons Learned.....	24
VI. Defensive Operations With Light and Heavy Forces.....	27
VII. Light and Heavy Forces Defending in the Desert.....	31
VIII. Conclusion.....	36
 Maps:	
A. Desert Areas of the World.....	39
B. Africa Corps Offensive-1941.....	40
C. Tobruk Defensive Perimeter.....	41
D. Africa Corps Attacks to Alamein.....	42
E. El Alamein Line.....	43
F. First Battle of El Alamein-July 1942.....	44
G. Battle of Alam Halfa Ridge-August 1942.....	45
H. The Dorsal Positions in Central Tunisia.....	46
I. Battle of Sidi Bou Zid-February 1943.....	47
J. Sinai 1967.....	48
 Figure:	
1. Russian-Style "Sword and Shield Defense".....	49
2. Light Infantry Division Organization.....	50
Endnotes.....	51
Bibliography.....	56

## I. INTRODUCTION

Two of the critical words which military planners draw from the acronym METT-T (mission, enemy, terrain, troops available and time) to analyze a military plan are terrain and troops available. The significance of terrain was emphasized by the Prussian military thinker Carl von Clausewitz. He recognized that "the principle effect was in the realm of tactics, but the outcome was a matter of strategy."<sup>1</sup> He further emphasized "that the influence which terrain brings to bear upon the general, and particularly the political composition of the fighting forces, is closely followed in importance by its influence on the ratio between the arms of the services."<sup>2</sup> Terrain has certain characteristics which are considered in military operations and the use of a particular type of force is often driven by the type of terrain.

Historically, armies have deployed to theaters of operation outside their own territory unprepared for the particular challenges placed on force structure and tactics by the terrain. The problem is complicated further by the different requirements for conducting offensive and defensive operations. The United States Army has a wide variety of theaters of operation to fight in and a certain force structure to meet the requirements of these theaters. This paper will examine a type of terrain found in many of those theaters to determine how to use one of the types of forces available for employment. The purpose of this paper is to answer the question: How can light infantry conduct defensive

operations in the desert with heavy forces in a mid to high intensity conflict?

This question is important considering the vast amount of the world's geography which is desert and the strategic interests of the U.S. in some desert regions. The emphasis which the U.S. Army has placed on formation of light infantry divisions (LID) demands an examination of how to use these strategically deployable assets in a desert environment. Recent and past warfare and the importance of desert regions indicates that the chances of conflict in the desert are probable and warrant research.

Significant military operations were conducted in desert terrain during World War II. Many of the lessons learned from these battles have been forgotten or require modification to meet modern conditions. The most violent and destructive warfare involving modern mechanized forces and new technology took place during the Arab-Israeli wars of 1967 and 1973. These past conflicts and recent training experiences are examined in this paper in search of lessons learned which are applicable to today's forces.

Additionally, this paper will address the research question by discussing the nature of the desert and some of the aspects which affect forces employed in this type of terrain. Even though the desert may contain mountains, mountain operations require separate consideration therefore they are not addressed. An analysis of the current organization and tactical doctrine of light infantry employed with heavy forces in the defense sets the stage for the main discussion.

The types of forces referenced in this study are light and heavy forces. These terms are used to represent specific types of units. The light infantry described in this study is organized under L-series table of organization and equipment. It requires the smallest amount of lift for deployment from CONUS and has a high tooth to tail ratio . Conceivably, many of the solutions applied to the use of this type of force with heavy forces are applicable to Airborne and Air Assault Divisions. However, it is not the intent of this paper to address these forces specifically. The heavy forces used in this study are those organized under J-series table of organization and equipment. These include both armored and mechanized divisions. The capabilities of these light and heavy forces must complement each other when employed in any type of terrain, especially in the desert.<sup>3</sup>

J.F.C. Fuller recognized the significance of the roles of different forces in warfare due to mechanization as early as 1925. He suggested that we should think in terms of tactical functions of forces.<sup>4</sup> He stressed that forces could perform certain functions but that the ground was the deciding factor.<sup>5</sup> Application of this simple idea may allow for possible answers to the question of employment of light and heavy forces in a desert defense.

## II. DESERT ENVIRONMENT AND ITS SIGNIFICANCE ON MILITARY OPERATIONS

Most dictionaries define a desert as "a region rendered barren or partially barren by environmental extremes, especially by low rainfall."<sup>1</sup> This definition suggests an area of continuous sand dunes where nothing could survive. In fact, there are distinctly different types of deserts and survival is possible. It is important to understand the basic nature of the desert and its significance in the world and on military operations. This knowledge allows for proper use of military forces conducting a defense in the desert.

There are three types of deserts: mountain, rocky plateau, and sandy or dune deserts.<sup>2</sup> Deserts may cover great land distances and be bordered by arid land or oceans but in many cases the different types of deserts may border each other covering great expanses of land. The vegetation in deserts is sparse, often consisting of scrub bushes or various types of grasses. Roads and trails are scarce and travel over them is difficult. In many cases single roads will connect inhabited areas. The three types of deserts have these common characteristics but each has features which require separate consideration.

Mountain deserts contain scattered ranges of mountains, barren hills and basins.<sup>3</sup> The mountains are rocky and vary in height. As they slope down into the basin area, large erosion areas develop called wadis. The rapid water run off during infrequent rains can make these basin areas and wadis impassable. Frequently, shallow lakes are formed which quickly dry up. In some areas salt marshes have formed which will hinder or block movement. The largest mountain deserts exist in Turkey and Iran. The Saudi Arabian peninsula contains mountain deserts and

ranges which parallel the Mediterranean Sea, the Red Sea, the Gulf of Aden and Arabian Sea.<sup>4</sup>

Rocky plateau deserts have relatively slight relief interspersed by extensive flat areas with quantities of solid or broken rock at or near the surface.<sup>5</sup> This type of desert has both wadis and significantly eroded areas. Often, these areas are so steep that they can not be crossed. The Golan heights is an example of a rocky plateau desert.<sup>6</sup>

Sandy or dune deserts are extensive flat areas covered with sand or gravel, the product of ancient deposits or modern wind erosion.<sup>7</sup> These sand areas are flat or consist of large sand dunes. These deserts can be completely impassable in some areas. However, history has proven that no area should be considered completely impassable to mobile forces. The Sahara Desert of Africa and the Empty Quarter of the Arabian desert are examples of this type of desert.<sup>8</sup>

These brief descriptions of deserts may develop an opinion that deserts are relatively unimportant areas and that there would be no reason for armed conflict to occur in the desert areas of the world. This is far from the truth. A large portion of the earth's surface is classified as desert. Considering this fact, history and the current world situation provide substantial evidence that conflict in desert regions is possible.

Currently, the most important deserts-politically and militarily-are the Sahara (which includes the Libyan and Nubian Deserts) in North Africa, the Arabian and Seistan Deserts in the Middle East.<sup>9</sup> "These deserts are important because they separate two or more spheres of

political and religious influence, they contain valuable resources, and they have strategic implications because of their locations (Map A)."<sup>10</sup> This was the United States Army's description of the significance of these deserts in 1964. It was based on the experiences of World War II and the the world situation in 1964. These areas remain significant today.

The Arab-Israeli conflict of 1967 and 1973 and the continued tensions which exist in South West Asia and North Africa reinforce the importance of these desert areas and the possibility of armed conflict. A large quantity of the world's oil resources comes from this area. The tensions caused by the Iran-Iraq War and the aggressive actions of various religious movements and radical political leaders focus world attention on these desert areas. These facts, combined with the alliances the United States maintains, make South West Asia and the surrounding areas strategically important.

The United States position as a world power with the capability to project military force world wide underscores the possibility that U.S. forces may fight in a desert environment. The National Training Center, located in the Mojave Desert, is an important proving ground for the U.S. Army's tactics and capability to fight in the desert. The desert is an environment in which the the U.S. Army must possess the capability to fight in and win.

Important military characteristics that influence desert operations are terrain, lack of man-made combat service support assets, lack of concealment and excellent observation and fields of fire.<sup>11</sup> In combat,

opposing forces must contend with the affects of the area in which the fighting takes place. Tactical fundamentals which are appropriate in other types of terrain are generally suitable for operations in the desert. However, the ground commander must consider the employment of forces in the desert as a unique situation requiring different techniques.

Terrain affects all military operations. The German general, Alfred Toppe, in interviews conducted after World War II described the influence of terrain in the desert as follows:

"The influence of terrain on tactical operations is just as decisive in the desert as in other theaters of war. It is only more difficult to take advantage of the peculiarity of the terrain for one's own intentions, since due to the lack of forests, cultivated areas, villages, etc. it is seldom possible for troops to approach and assemble under cover. However, even in the desert there are the most widely different opportunities to take advantage of the terrain and, for example, to conceal troop assemblies in ravines and valleys from ground observation and - to a limited extent - even from air observation. In both the attack and defense the important thing was always to have reconnoitered the terrain carefully in advance.<sup>12</sup>

The barren nature of the desert limits the amount of key terrain. However, in certain situations, key terrain will be present and important to military operations. Normally, key logistics installations, sources of water, and terrain features such as mountain passes, or dominating high ground are key terrain. The focus of military operations in the desert is generally the destruction of the enemy force. However, when key terrain is present, its impact on military operations is often more significant than in other types of terrain.

Tactical mobility is the key to successful desert operations.<sup>13</sup>  
"Maintaining a mobility superiority over the enemy is fundamental to the attainment of decisive combat power."<sup>14</sup> The vast nature of the desert enhances mobile operations of armored and mechanized forces. The mobility of forces in the desert is often compared to that of a naval task force at sea.<sup>15</sup> Natural obstacles do exist but generally they can be outflanked. Often it is the cross country capability of support vehicles and the long lines of communications that influence operations rather than restrictive terrain. Mobility plays a significant role in the desert and has the greatest impact on light forces because they have limited tactical mobility.

Observation and fields of fire are such that the advantage offered by long range weapons is decisive during engagements. Today's long range weapons and precision guided missiles maximize the effect of observation and fields of fire in desert operations. Additionally, this aspect of desert warfare makes it difficult to conceal large units whether they are moving or stationary. Light forces have an advantage in that they are easier to conceal than heavy forces but they have limited numbers of long range weapons.

Cover and concealment are difficult to achieve in the desert. The openness of the ground requires forces to make maximum use of the terrain. In many cases, defensive positions cannot be dug due to the hardness of the ground. Other steps must be taken such as piling up rocks for individual positions, placing vehicles in washed out areas or providing additional engineer support. Concealment is achieved by

reducing outline, shadow, and shine. The reverse slope defense will assist forces in achieving cover and concealment. Light forces can make maximum use of this technique to gain protection from enemy fires and observation, and to offset their lack of long range weapons systems.

These general considerations have an impact on the use of heavy and light forces in the desert. The capabilities of the light force to occupy and hold rugged terrain can prove advantageous in support of the mobility of the heavy force. History provides some examples of the effect the desert has on operations involving light and heavy forces. It is appropriate to turn to historical examples in search of lessons for the future while considering the aspects of the desert mentioned previously.

### III. LIGHT FORCES IN THE DESERT DURING WORLD WAR II

World War II was the first major conflict where mechanization became a dominant influence. The German maneuver tactics, often referred to as Blitzkrieg, quickly overran Europe. Early in 1941 North Africa became the sight of battles involving the Axis powers and the British forces. This theater of operations became the major allied concern. The decision was made to defeat the axis forces in Africa as the first step to restore world peace.

This period of World War II provides many examples of infantry forces conducting defensive operations with heavy forces. The World War II forces considered in this paper were motorized infantry. They were

generally transported by wheeled vehicles or in half tracks. The vehicles offered no advantage in firepower for defensive operations. There is great similarity between World War II infantry and modern day light infantry forces when employed in the defense.

Specific defensive battles which are discussed include the battles for Tobruk and El Alamein involving British infantry and the Battle of Sidi Bou Zid involving American infantry forces. General examples of employment of light forces in the desert provide the lessons from this period of history. These specific battles were chosen because they involve defense in the desert under three different circumstances. These are defense of a logistics base, a prepared defense and an unprepared defense. The use of light infantry in each of these cases highlights a function light infantry may perform in the desert.

British forces were effective in defeating the Italian forces in North Africa. By 1941, just prior to the landing of General Erwin Rommel's Africa Corps, it appeared that the British would dominate this theater. However, British priorities shifted to the German threat in Greece. Rommel seized the initiative to launch offensive operations. Rommel achieved success in his drive which was oriented toward taking Egypt and the Suez Canal (Map B). However, his supply lines became overextended. The port of Tobruk could provide Rommel an excellent logistics base and it blocked the high speed avenue of approach to Egypt.<sup>1</sup> Rommel decided to take it to support his operations.

"Tobruk is important due to the fact that it is the only good harbor on the North African Coast between Alexandria and Sfax."<sup>2</sup> "The Italians had built a series of defenses around Tobruk consisting of a double ring of concreted emplacements eight or nine miles from the town and harbor covering a frontage of thirty-five miles."<sup>3</sup> "The eastern and western extremities of this perimeter were protected by steep wadis, impassable to tanks and mechanized vehicles."<sup>4</sup> A partially completed and concealed anti-tank ditch, barbed wire and a line of anti-tank/personnel mines protected the large plain around the perimeter (Map C). "The 150 individual strongpoints along the perimeter were placed in a zigzag pattern, with the posts one forward and one in the rear, with intervals of about 750 yards between forward posts."<sup>5</sup> The British forces captured Tobruk and established a defense using the Italian emplacements as a starting point.

The main defending force was the 9th Australian Division. This division consisted of three infantry brigades, an anti-tank regiment, three field artillery regiments, an engineer battalion, and a signal battalion. It was reinforced with an additional infantry brigade, an armored brigade, two anti-aircraft brigades, and numerous service support units. The division was truly capable of conducting combined arms operations and had the capability to defeat enemy armor.<sup>6</sup>

The defense was organized on three defensive lines which were called red, blue and green line (Map C). The division's infantry brigades occupied red line and the strongpoints along it. The blue line was held by three reserve battalions. The armored brigade protected key

roadways leading into the perimeter and was the mobile reserve. This organization provided a defense in depth and took full advantage of the capabilities of the combined arms elements within the perimeter.<sup>7</sup>

The principle enemy force opposing the 9th Australian Division was the 5th German Light division. This was a light armored division which was operating below its authorized allocation of personnel and equipment. It contained about 150 tanks, a machine gun regiment, an artillery regiment and an antitank regiment. It was a formidable opponent due to the capabilities of the organic tanks.<sup>8</sup>

The Italian forces which were operating with the Germans had elements from an infantry division, a motorized division, and an armored division. These forces added only about six infantry battalions and 80 M-13 tanks to the fighting power of the enemy force.<sup>9</sup>

The battle for Tobruk which began on 11 April, often referred to as the Easter Battle, commenced with numerous probes by the enemy infantry and armor to break through the red line and find a weak spot in the defenses. The Australian infantry protected the obstacles surrounding the perimeter and stripped away the enemy infantry from the tanks. The infantry remained hidden until the vehicles would pass, then sprang from their concealed holes and killed the enemy infantry. Vehicles were taken under fire by antitank weapons and direct fire artillery. The enemy was not able to penetrate the defensive line.<sup>10</sup>

The Germans and Italians conducted more attacks during the following weeks. They were able to penetrate the perimeter with infantry and armored forces. The enemy elements that penetrated were

isolated and attacked with the mobile reserve. The gap that was created by any penetration was immediately closed by infantry and antitank assets. The Australian infantry patrolled aggressively to deny the enemy observation of the defense and to determine the enemy intentions. The Australians held their ground during these periods and continued the defense for 242 days until Rommel's forces moved to other operations. It was not until the summer of 1942 that Tobruk was captured.<sup>11</sup>

The defense of Tobruk provides a good example of defense of a logistics base with light infantry against an armored force. The infantry was supported with additional antitank resources and armored elements for tank killing capability. Artillery support was increased and the division was well supported logistically.

The Australians took maximum advantage of a defense in depth by positioning the infantry and antitank assets well forward and dispersed while the mobile elements were deep to maneuver against armored breakthroughs. The defense was aggressive and made maximum use of offensive action. Combined arms principles were an integral part of the defense. Finally, the Australian infantry possessed the skill, toughness and aggressive nature that makes properly supported infantry in the defense a formidable opponent.

Following the fall of Tobruk, Rommel was able to undertake offensive operations in an attempt to capture Egypt. British forces fought the Germans while falling back to a defensive area known as the El Alamein line (Map D). It is along this line that the defense of North Africa held and the British were able to return to the offense.

The organization of this defense and the battles which occurred along the El Alamein line provide a good example of how light infantry was integrated into a defense in the desert against armored forces.

"The Alamein line butted the sea in the north and in the south spread out into the Quattrra depression—a flat plain of loose sand studded with numerous salt marshes and hence completely impassable for motor vehicles (Map E)."<sup>12</sup> "The line could not be turned and as a result the war took on a form of which both sides possessed great experience and theoretical knowledge and in which neither could produce any revolutionary technique which would come as an innovation to the other."<sup>13</sup> Alamein was a unique position in the desert. It was one of the few positions considered defensible in North Africa.

Several major battles occurred in the vicinity of El Alamein involving the British Eighth Army and Rommel's Africa Corps. These battles involving armored and infantry forces of the Eighth Army and the armored thrusts of the Africa Corps incorporated some of the same fundamentals witnessed at Tobruk with some important differences. These differences were the amount of artillery and air support used by the Eighth Army and the mobility of forward deployed infantry.

The battle of Alamein also provides a particularly vivid example of how a German tank attack was stopped by infantry and anti-tank guns once guns of sufficient power had been deployed by the British.<sup>14</sup> The British forces had recently received the new 6-pounder antitank gun which proved an effective tank killer. This underscores the importance

of antitank weapons to light infantry. These assets often form the linchpin of the light infantry's defense.

"The plan was to create three defended localities, about fifteen miles apart, at El Alamein, Bab el Qattarra (also known as Quaret el Abd), and Naqb Abu Dweis (Map F)."<sup>15</sup> These points were partially prepared in advance and integrated infantry and antitank assets into a well protected area. Mobile forces were positioned in depth to block and counterattack penetrations of the defensive line.

It was clear to General Auchinleck, the British commander of troops, that the immobile infantry in the Alamein defenses was helpless against a breakthrough, therefore, only those that were transportable stayed on the line.<sup>16</sup> Keeping the infantry mobile in the defense gave him some flexibility which he used several times. However, it was the combination of the fixing of the enemy at the strongpoints by infantry and attacking with the mobile elements that stopped Rommel.

"Such a mobile enemy could not be stopped from passing between and then isolating these "boxes", as the defensive positions were sometimes called....An essential part of the defense was therefore the existence of at least two armored divisions to operate in the gaps between the defensive positions and to deal with any enemy which might penetrate between them or concentrate against one of them."<sup>17</sup> Such was the case in the defensive battles at El Alamein. The defensive plan incorporated strong artillery support and intensive air support in depth. The mobility of Rommel was checked by the reinforced infantry and defeated with the armored forces.

The first battle of El Alamein ended in late July 1941. The opposing forces shifted into a defensive mode to resupply and refit. The Eighth Army's new commander, General Bernard Montgomery, planned a defense similar to Auchinleck's: "to hold the Alam Halfa Ridge with strong infantry and antitank forces, block penetrations in the north with infantry and counter a German threat in the South with the 7th Armored Division (Map G)."<sup>18</sup>

Rommel's attack was stopped by armored and the antitank forces. The strong infantry positions to the north of the main effort (Map G) withstood the secondary and diversionary attacks while the heavy forces engaged and defeated the enemy armored forces. This ended the battle of Alam Halfa and forced Rommel's Africa Corps into the defense.

The next several months saw a major offensive opened by Eighth Army which ultimately lead to a retreat of Axis forces in early November.<sup>19</sup> Within days of Rommel's retreat, American forces entered North Africa with landings in Morocco and Algeria. The war entered into a new phase. The British forces had demonstrated that infantry supported with a good antitank system could perform a function in the defense in the desert. Light infantry must receive support from heavy forces, artillery, air support and, when the situation warrants, mobility to reposition. This application of combined arms using the infantry to force enemy armored elements into an area where armored forces could defeat them, assisted in achieving victory in these battles and others. The American army would learn these lessons the hard way.

The American army entered into the desert untried in combat and this type of environment. They learned many lessons about fighting in the desert. We will focus on a battle which took place during the American action in the vicinity of Kasserine Pass. This battle, Sidi Bou Zid, is an example of a defense conducted on basically unprepared ground which failed to maximize the strengths of infantry and heavy forces. It attests to the vulnerability of light infantry in the desert when improperly employed.

The military course of events leading up to the battle of Sidi Bou Zid found the Allied forces on the offensive. Following the landings, the objective was to capture the Tunisian ports of Bizerte and Tunis.<sup>20</sup> The British First Army of the Allied forces, under command of General Sir Kenneth Anderson, was on the defensive in central Tunisia by early February due to enemy attacks and the extended lines of communication. No one doubted that the enemy would attack again in central Tunisia; the only question was where. The Axis plan included attacks on Sidi Bou Zid and Gafsa (MAP H). Thus, the stage was set for the battle.<sup>21</sup>

The 1st Armored Division had responsibility for defending the area which included Sidi Bou Zid. The division was not deployed at full strength due to six of its battalions being committed to other missions for II Corps and 1st Army. The defense of its area was dictated by the Corps commander. It called for two reinforced infantry battalions to defend from two hill masses covering the approaches into Sidi Bou Zid. A reinforced armor battalion was held in reserve by Combat Command A, the organization in charge of this sector. The division held one light

tank battalion and one armored infantry battalion in reserve to support this sector and one other (MAP I).<sup>22</sup>

The German forces attacked this area with two Panzer divisions moving on two avenues of approach into the defensive area (MAP I). The forward deployed American infantry battalions were unable to stop the early morning attack of the Panzer divisions. The hilltops upon which they were positioned were not mutually supporting and the gap between them was not covered by obstacles to slow the enemy. The plan was to cover this gap with the armor battalion. It was not in position when the attack occurred. It met the enemy head on while moving into position and was defeated.<sup>23</sup>

The momentum of the German attack was not stopped. Employment of the division and subsequently, the corps reserve only slowed the enemy temporarily. The infantry strong points were not able to bring the full power of both their positions to bear on the enemy to assist in these counterattacks. These positions were surrounded, attacked separately, and defeated. During the retreats, the dismounted infantry were pursued by enemy motorized infantry, captured and in many cases killed.<sup>24</sup>

Sidi Bou Zid was lost and the Allied forces, particularly the Americans, would suffer more defeats in subsequent engagements before the advance was halted. The battle of Sidi Bou Zid highlighted the mobile nature of warfare in the desert.

Defense in the desert cannot rely on isolated strongpoints because they are vulnerable to encirclement and defeat. The defeat mechanism is the armored force. The infantry is used to engage the enemy with

antitank and artillery at longer ranges and strip away his infantry. The positions at Sidi Bou Zid had neither a strong armored force nor infantry positioned to defend an area which would force the enemy into a kill zone thus setting up a counterattack by armor forces.

The British and American experience in the desert suggests that today's light forces have a role in the defense with heavy forces. The combat capability of World War II forces was similar to our present day light infantry. They required augmentation by antitank assets, artillery and air but had a greater transportation capability. The use of augmented infantry to hold ground allowed for the use of heavy forces to position in depth for attack. The British achieved success following these general guidelines. The Americans forces learned these lessons and applied them in future battles.

Many changes have occurred since World War II in weaponry capabilities. Heavy forces move faster and have much more firepower. Air support is more lethal and can cover wide expanses of the battlefield. Given these general improvements, it is appropriate to examine the most recent combat experiences involving heavy forces in the desert to determine the function performed by infantry forces. It is with this in mind that the next section focuses on the Arab-Israeli Wars of 1967 and 1973.

#### IV. ARAB-ISRAELI WARS OF 1967 AND 1973

The Arab-Israeli Wars of 1967 and 1973 were the first wars since World War II to involve large armored forces in the desert. A great deal of technological improvement had occurred in weapons systems and command and control equipment. However, the battles and engagements were decided by the proper employment of forces equipped with these improved weapons. This section examines the use of infantry with heavy forces on the defense during two major battles which occurred.

The Egyptian defenses in the Sinai and the Israeli breakthrough during the 1967 war provide the first case for examination. "The Egyptians followed a Russian-style "sword and shield" strategy in which the "shield" forces, entrenched in fortified perimeters, were to stop the Israeli advance while the "sword" forces moved up to counter-attack."<sup>1</sup> The fortified positions were located at the Rafah/El Arish axis, the Abu Ageilia/Umm Katef crossroads and Kuntilla/Nakhl axis (MAP J).<sup>2</sup> An infantry division supported with tanks and artillery occupied each position and was protected on the flanks by additional divisions or impassable terrain. The sword force consisting of an armored division and a composite force of one commando brigade, a tank brigade and artillery brigade was positioned in depth (MAP J).<sup>3</sup>

The Israeli plan consisted of three phases; the breakthrough followed by a penetration into the Sinai and capture of mountain passes leading to the Suez to cut off Egyptian forces.<sup>4</sup> The breakthrough plan called for two Israeli armored divisions to assault the fortified areas

at Rafah/El-Arish and Katef/Abu Ageila. "A third division would negotiate the sandy, apparently impassable area between two strong points which would isolate the positions, preventing lateral support and blocking any counterattack."<sup>5</sup>

The Russian style defense appeared impenetrable; however, the Egyptians placed too much reliance on so called impassable terrain (Figure 1). In the northern and southern strongpoints, the Israelis maneuvered to gain an advantage on the strongpoints by avoiding minefields and moving through unguarded terrain. The battles for the independent strong points were fierce but the positions were isolated. The Egyptians held on for the counterattack force to strike but the forces failed to attack in time to catch the Israelis. The counterattack elements were bogged down attacking Israeli forces or were ambushed by Israeli forces which maneuvered around the positions. Another factor which lead to the defeat was the reduction of the supporting artillery by ground and heliborne forces.

The Israelis continued their push through the defensive belt to capture the Sinai and defeat the Egyptian Army. The initial breakthrough demonstrated the vulnerability of reinforced infantry in the desert. The defense failed because the mobility of the Israeli forces was not checked in time for the attack force to mass and attack. "Additionally, it appears that minefields were not effective in the northern position and the defenses did not adhere to the principle of all-around defense."<sup>6</sup>

The primary lesson in this battle is that infantry which is augmented in the defense does not always win. The entire defensive organization must control the movement of the enemy, while destroying his forces and setting him up for the killing blow. "Had the Egyptians held more doggedly to key positions, like the Russians at Kursk, the outcome may have been different."<sup>7</sup> It is this holding capability of the infantry when augmented that is so important in the desert. They must be positioned to allow this to happen.

The 1967 War set the stage for the 1973 Yom Kippur War. The Israelis occupied a defensive line in the Sinai adjacent to the Suez Canal. It was the Egyptian intent to break across the Suez, penetrate this defensive line and regain the lost territory of the 1967 War. This initial breakthrough by Egyptian forces to establish a defense to support offensive action provides the second example of infantry employed in the desert.

The Egyptian plan called for multiple crossings by the infantry forces of five infantry divisions. Although each of the three brigades had an organic armor battalion, the initial crossing and the subsequent defense were a dismounted infantry show. The soldiers crossed in boats with their weapons and loads on their backs.<sup>8</sup> "It would be a historic encounter: the first combat between the essentially World War II concept of armor and the infantry weapons of the next generation."<sup>9</sup>

"Realizing the necessity of stopping Israeli armor before it reached the water's edge, Egypt had immediately deployed infantry armor killer teams along the main east-west roads leading to the Canal."<sup>10</sup> "These

were armed with man-portable RPG7 and PUR64 Snagger Antitank Guided Missiles."<sup>11</sup> These initial waves stopped the hastily thrown together armor attacks. As the forces across the canal grew, the bridgehead extended beyond the Israeli defensive line. A defense was established by the Egyptian infantry to protect the crossing site. The bulk of this defense was dismounted infantry supported by armor units.<sup>12</sup>

This defensive line held during the next two days under Israeli counterattack. "It is interesting to note, that in the battle of the canal many Israeli tank casualties resulted from massed RPG7 fire from entrenched Egyptian infantry."<sup>13</sup> Infantry forces can only hold against armor for so long in the desert or in any other terrain. As previously discussed, the mobile armor reserve is the defeat mechanism. The Egyptian forces failed to maintain a strong mobile reserve to deal with Israeli attacks and penetrations. The Israelis rapidly replaced initial losses and achieved superiority in tanks. Thus, the defensive capability of the infantry was exhausted and the armor was not able to defeat the enemy.<sup>14</sup>

The war entered into a new phase with the Israeli forces eventually defeating the Egyptian forces and the other Arab countries facing them. The emergence and use of improved antitank weapons had added to the infantry's capability to defend against armor in the desert. Increased ranges and accuracy made the infantryman a lethal weapon against armor. However, the war reinforced the principles from the past. In the desert, mobility is the key to victory. The infantry, which is properly equipped with antitank weapons, can defeat armor and in most

cases hold them for a period of time. The mobile force consisting of armor and heavy infantry must be brought to bear on an armor threat. The later stages of the Yom Kippur War reinforced this fact most of all.

The United States Army studied the results of the Arab-Israeli Wars. Equipment development, tactics and doctrine were affected by the lessons from these wars. The United States recognized the importance of this area of the world and the Army's capability to fight in the desert. The establishment of the desert training center was the one of results of this renewed emphasis on mobile warfare and desert operations. It is the lessons which are learned from the National Training Center and other operations involving heavy and light forces in the desert that this paper will now focus on.

#### V. RECENT EXPERIENCE AND LESSONS LEARNED

Lessons learned during recent exercises conducted by the Army's two Light Infantry Divisions (10th and 7th) have reinforced some of the lessons from the past and presented some fresh ideas. Additionally, exercises conducted by the 101st Air Assault Division and the 82d Airborne Division have provided some lessons that are applicable to the employment of a light infantry force. Viewed together, these experiences offer excellent tactical considerations for employing light and heavy forces in the desert.

The 2d Brigade, 10th Infantry Division participated in Exercise Celtic Cross IV in 1986. This exercise reinforced the importance of barrier planning and the integration of this plan into the total defensive plan. The defensive plan cannot rely on the barrier plan to succeed. The barrier plan must complement the forces on the ground and the plan of defense. A detailed intelligence estimate is required to identify all possible enemy avenues of approach. Mobile reserves are necessary at battalion and brigade level to provide flexibility to the defense. Due to the need to mass fires, specific control measures to concentrate fires are required. This is the case in any defense but particularly so in a defense with light infantry due to their reliance on massed fires.<sup>1</sup>

An interesting observation from this exercise was that the greatest force multiplier occurred when the light and heavy forces were task organized at battalion level. This observation merely underscores the problem which exists in the heavy force structure of the J-series heavy division organization. That problem is the lack of infantry in M2 Bradley equipped battalions. However, if this observation is considered in the employment of these forces in the desert then another lesson learned is of equal importance. The forces observed that task organization done by adding light forces to heavy was sound but adding heavy forces to light created significant logistics problems.<sup>2</sup>

Command, control and communications is an area requiring special attention when heavy and light forces fight together. When the forces are task organized it is necessary to position headquarters in close

proximity of each other. This is due to the limited communications capability of the light forces. At a minimum, liaison is required between each unit. The light and heavy force operate using different terminology and graphics. This problem is minimized by establishing commanders intent and using a common military terminology.<sup>3</sup>

Light infantry forces defending in other than small hunter-killer teams require significant engineer support.<sup>4</sup> This observation is valid when construction of obstacles is required as a part of the defense. Desert defensive operations almost always require obstacles to reinforce the chances for success. These obstacles are more effective when covered by fire and when positioned in depth and staggered.<sup>5</sup> Staggering affords the infantry force a better chance for flank shots.

These recent experiences indicate that the fundamentals from combat experience of the past remain valid in today's training environment. Light infantry employed with heavy forces in the desert on the defense can perform specific functions. They can provide the fixing force for the mobile attack. There are several ways to employ this concept with various task organizations. The lessons from the past and the present indicate that you must understand the nature of the desert terrain, augment light forces with antitank assets, artillery and air support, and provide mobility to the light force. These elements impact on the employment of light infantry in the desert and enhance the chances for success. Keeping these factors in mind, this examination turns to the organization and defensive doctrine of the current light forces. This

discussion will focus on the employment of light forces with heavy forces.

## VI. DEFENSIVE OPERATIONS WITH LIGHT AND HEAVY FORCES

Current doctrinal manuals address the use of light forces with heavy forces. This section will first describe the organization, capabilities, and defensive doctrine of the light divisions. This will provide a base for a more detailed focus on light forces used in the defense with heavy forces. This background discussion and the subjects addressed in the previous sections allow for a specific examination of the use of light forces with heavy forces in the defense in the desert.

Light Infantry Divisions are organized, equipped, and trained to respond to a broad spectrum of contingencies and to reinforce forward deployed forces.<sup>1</sup> The division is lightly equipped to enhance strategic mobility. It consists of three maneuver brigades consisting of nine infantry battalions, a combat aviation brigade consisting of an attack helicopter battalion, two combat aviation companies and a reconnaissance company, divisional artillery which has three field artillery battalions and one field artillery company and a division support command (Figure 2). The division also has an engineer battalion and an air defense battalion. The division organization has a high ratio of combat to combat support units.

The fighting force of the three maneuver brigades is the infantry battalion. This element has three rifle companies and headquarters company for a total of 559 men. The headquarters company contains the combat and combat service support assets of the battalion. These consist of the support platoon, the medical platoon, scout platoon, signal platoon, 81mm mortar platoon, and antitank platoon. The mortar platoon is equipped with four 81mm mortars and the antitank platoon is equipped with four TOW antitank missiles systems. These platoons are equipped with HMMWV vehicles to move their weapons systems and personnel. The rifle companies are foot mobile and are equipped with two 60mm mortars and three medium antitank weapons (Dragon).<sup>2</sup>

The combat aviation brigade and field artillery brigade are the principle combat support organizations in the division. The three battalions of the divisional field artillery provide fire support to the maneuver brigades with their organic 105mm howitzers. One 155mm artillery company provides general support to the division's units. The combat aviation brigade's two combat aviation companies can lift a single infantry battalion in one lift with its helicopters. The attack battalions add a significant antitank and fire support capability to the division. The recon battalion, which includes both ground and air reconnaissance capabilities, is an important intelligence gathering element of the division.<sup>3</sup>

The combat engineer battalion and the air defense battalion are the other combat support organizations within the division. The engineer battalion provides support to the maneuver brigades for mobility,

countermobility, and survivability on the battlefield. "The air defense battalion provides low altitude air defense coverage to the division with a mix of lightweight gun and manportable air defense systems."<sup>4</sup> These organizations provided the minimum support necessary in these two vital combat support areas.

The light infantry division of today is designed primarily to fight in a low intensity conflict but is capable of fighting in a mid to high intensity conflict with heavy forces. The division or its subordinate elements is limited in its employment with heavy forces by its lack of mobility and logistics capability. The mobility difference and the fact that the light force is a man powered force logically places the light infantry as best suited for operations in restrictive terrain. The defense of restrictive terrain by light forces can benefit the heavy force and make good use of the capabilities of both forces.

Light infantry forces can conduct defend in a variety of ways. They can defend in sector, defend from a battle position or strongpoint, or defend along a perimeter. Selection of the type of defense is based on METT-T. The defense can employ a variety of techniques such as reverse slope, elastic defense or seamless web.<sup>5</sup> These techniques provide the light force with numerous ways in which to maximize their strengths and overcome their weaknesses. The light infantry force must use these techniques when fighting a heavy force to establish depth in the defense and to gain protection from long range fires.

The conduct of defensive operations with heavy and light forces requires maximizing the strengths of both forces. The heavy force keeps its freedom to maneuver units while the light unit places its force to best use restrictive terrain to gain a mobility advantage over the mounted force.<sup>6</sup> This is done in a variety of ways which include positioning the heavy forces in depth to attack enemy forces after the light force shapes the battlefield; positioning the light force within the heavy forces sector to deny the enemy passage through restrictive terrain; or given proper terrain, the heavy force can defend in the covering force area while the light forces occupies the main battle area.<sup>7</sup>

The risk involved in defensive operations is that the enemy may isolate the light force from the heavy force. Plans are required to counter this to ensure survival of the light force. This aspect of light and heavy operations may restrict the mobility of the heavy force, require support for breakout and linkup operations or, at a minimum, place a burden on the force for transportation of the light forces. These factors impact on the use of light forces with heavy forces and will dictate the task organization.<sup>8</sup>

Current doctrine addresses the other issues involving the light and heavy force mix. Field Manuals 7-72, 71-3, Field Circular 71-101 and a number of other documents provide guidelines for employment of light and heavy forces. They stress that the corps commander is the task organizer for light and heavy forces. Cross attachment of the forces is not recommended below brigade level. The combat support requirements

along with the capability of each force to support the other are key factors in the planning process. The doctrine provides clear, concise guidance concerning the light and heavy mix. It is the adaptation of this to the desert that adds to the difficulty of the light and heavy mix.

#### VII. LIGHT AND HEAVY FORCES DEFENDING IN THE DESERT

Doctrinal sources have addressed the specifics of using light and heavy forces together for defensive operations. As mentioned earlier, the basic considerations are maximizing the mobility and destructive power of the heavy force with the restrictive terrain holding capability of the light force. There are two factors which place the light force at a disadvantage in a mid to high intensity conflict. They are the lack of mobility and the minimal number of long range anti-tank weapons. The desert has traditionally been an environment of high mobility with a significant advantage going to the force with the longest and most effective tank killing weapon. These factors above all others must be balanced with doctrinal guidance when employing these forces together in the desert.

It is not likely that a US force will be fully deployed in a desert country before an enemy attacks.<sup>1</sup> In this event, it is critical that a secure lodgement area is available for arriving forces. These forces will move by air and sea while forces in country conduct defensive operations to gain time. Light forces with their rapid deployability

can get to the lodgement area quickly and thicken the defense while awaiting the arrival of heavy forces. Light forces used in this manner enable more mobile forces already in the country to move forward and fight an aggressive defense.

This type of defense involving light forces is more static than defenses conducted in other parts of the desert. However, as demonstrated at Tobruk, the light force requires augmentation of anti-tank weapons, artillery and a highly mobile reserve to address penetrations of the defensive line. The light force can strip away supporting infantry and destroy thin skin vehicles at close range in the same manner as the battle of Tobruk. They can add depth to the defense and act as an intelligence and early warning device capable of identifying the enemy main effort and directing fires.<sup>2</sup>

The defense of the lodgement area or other key logistics support areas can incorporate light forces up to division size. In the selection of this defensive mission and the task organization of the force, the fundamentals of mobility and antitank capability come to the forefront. In most circumstances, the force can be flanked therefore a mobile reserve is necessary. This force may consist of heavy ground forces or the attack helicopters organic to the light division. The enemy situation and the degree of risk the commander is willing to accept will impact significantly on this defensive option.

The light force requires significant logistical augmentation. Defense of a lodgement area has reduced lines of communication because of its proximity to the support base. Additionally, the requirement for

transportation of the light force is greatly reduced. This aspect will benefit the corps commander as he searches for means to support forward deployed forces. These reduced lines of communication make it easier to place heavy forces under the control of light forces. The defense of this type of area with light and heavy forces incorporates the strengths of each force while minimizing the weakness of the light force.

"Generally speaking, fronts to be defended in the desert are too extended to permit the creation of a continuous line of defense."<sup>3</sup> There are few Alameins in the desert. Light forces defending with heavy forces can hold restrictive terrain to protect armor forces and release those forces to conduct counterattacks. As demonstrated in the Arab-Israeli wars, no terrain in the desert should be considered impassable.

Light forces properly augmented with antitank and combat support can defend from battle positions in depth to attrit the enemy and to hold him for counterattack by the heavy force. This was Rommel's belief of the proper role of infantry in the desert.<sup>4</sup> However, he also believed that "light forces without transportation cause terrible difficulty in a retreat thus causing motorized forces to be committed to buy time for the light force."<sup>5</sup> This concern caused Auchinleck during the defense of Alamein to use only forces that were transportable. This factor above all others is key to the use of light forces with heavy forces in the desert.

The technique of defending from battle positions as mentioned above bears a strong resemblance to the British technique of establishing "boxes" such as at Alamein and the American positions at Sidi Bou Zid.

The outcome of these battles indicates that the positions must be mutually supporting, capable of stopping or holding an armor threat for the counterattack and have organic mobility or accept the risk of the enemy force bypassing it. In the desert, more so than in other terrain, a force can be isolated and defeated piecemeal. This occurred not only in the Sidi Bou Zid battle but also in the Arab-Israeli Wars. Light forces in the desert are particularly vulnerable to this; therefore, tactical employment must attempt to avoid this situation.

The Egyptian breakthrough across the Suez Canal in the Yom Kippur War is an interesting example of the use of light infantry in an offensive/defensive situation. Light infantry is capable of moving across difficult terrain which may canalize or restrict the heavy force. This infiltration capability of the light force coupled with the ability to hold restrictive terrain can provide time and support for an offensive operation. This is a high risk use of infantry.

This operation is limited by two factors. The light force can not be left too long in the defensive area without armor and logistical support. However, there is a more acute problem. The light infantry forces of the American army are very lightly manned with man portable antitank weapons. The individual antitank weapon (LAW) has limited range and armor stopping capability. The light infantry must have better individual antitank killing capability to provide the numbers of anti-tank killing weapons necessary for this type of defense to have a chance of success. The defense area must be thick with tank killing weapons. Each man should have the capability to stop a tank. Current

doctrine stresses the importance of properly task organizing light and heavy forces. It recommends that task organization not take place lower than brigade level.<sup>6</sup> A separate brigade is the preferred unit to place OPCON to a light division because it has integral combat and combat service support assets and normally receives its combat service support from corps.<sup>7</sup> A heavy division can accept a light brigade with little difficulty. However, it is the questions surrounding combat service support which pose an even greater problem in the desert.

During desert operations, lines of communication and supply may become extended and difficult to traverse. Light forces have very limited capability for self sustainment. They require augmentation from corps when employed independently. The problem is compounded in the desert and with light and heavy forces fighting together the logistic considerations are magnified even more. Simply moving the light forces will consume a great deal of the lift assets of the corps not to mention resupply. Heavy forces can meet many of the requirements of the light force. Heavy forces can resupply the light force and use organic transportation to move them. In a situation where the logistics base is a great distance from the battle area it appears that the suitable task organization is to place light forces attached to heavy forces.

This brings forth the major question of the optimal size, and composition of heavy and light forces in the desert. The requirement for antitank, artillery, and lift augmentation was discussed along with the logistical considerations. There is no question as to the utility

of light forces in the desert. Considering the factors mentioned above and the historical examples it appears that light infantry forces of brigade size attached to heavy divisions have the greatest utility. The only exception to this is the defense of a lodgement area. However, in this case, as discussed, the light force must have a heavy force attached as a mobile attack force.

Attaching light brigades to heavy forces for defensive operations in the desert during the defense provides the much needed light infantry to the force. The light brigade should have its slice of combat support and combat service support units from divisional elements including attack helicopter assets. The heavy forces can provide a great deal of the lift and logistic requirements of the light brigade with little degradation to its other forces. The light brigade can provide the command and control of augmentation forces needed to have an integrated defense. No solution is fixed and certainly this does not provide a set solution for all situations. It does provide a practical recommendation to the employment of light and heavy forces in the desert during defensive operations.

#### VIII. CONCLUSION

Light forces have fought successfully in the desert in the past and can in the future. They provide the heavy forces a much needed ground holding capability especially in restrictive terrain. As evidenced by the historical examples, mobility in the desert is a significant factor

for consideration in the use of light forces. Additionally, light forces as organized in the current light infantry division organization require antitank and artillery augmentation.

Light forces can not fight independently for extended periods even when augmented with antitank assets, artillery and heavy forces. It is the swift sword of destruction offered by the heavy force that is decisive in the desert. The light force can provide the shield. In the desert this shield is particularly vulnerable to defeat.

Consideration of logistical problems, combat power and mobility is essential in the employment of light forces in the desert. These factors may limit light forces employment options. The peculiar nature of the desert with its variety of terrain ranging from wide open maneuver areas to almost complete restriction will dictate the use of the light force with heavy forces. The considerations remain the same but they must be adapted to the requirements of the desert.

Current organization of light forces limits the defensive employment options with heavy forces in the desert. The light divisions are principally designed for low intensity conflict but can be employed in a mid to high intensity conflict. Appropriate emphasis was placed on the need for augmentation of light forces in preceding paragraphs. As long as light forces retain the principal focus of low intensity conflict then they will require augmentation in mid to high intensity conflict in any environment; especially the desert.

Looking to the future the question arises as to changes to the light divisions for fighting in the desert. This is almost a moot point given their current mission focus. The question of fighting in the desert is important for all forces which potentially might deploy to the desert and fight. U.S. Army forces must prepare to fight in many different environments. Each requires different techniques and tactics to reap success. Current doctrine addresses the use of light and heavy forces and the general principles that apply. The desert requires examination of these principles and adaptation to the situation for light and heavy forces to win. Each has a function in achieving victory. The light force can play an important part in the equation.

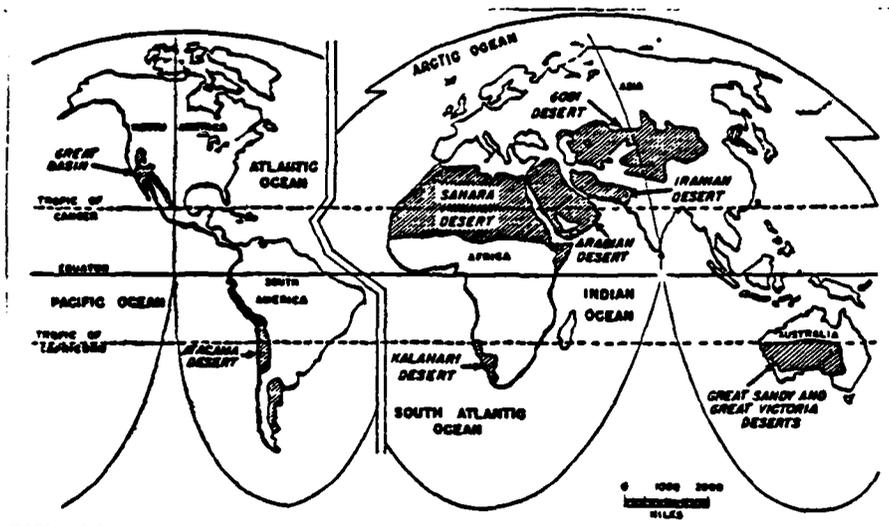

MAP A (Reproduced from Field Manual 31-25 dated January 1964, pp. 5.)

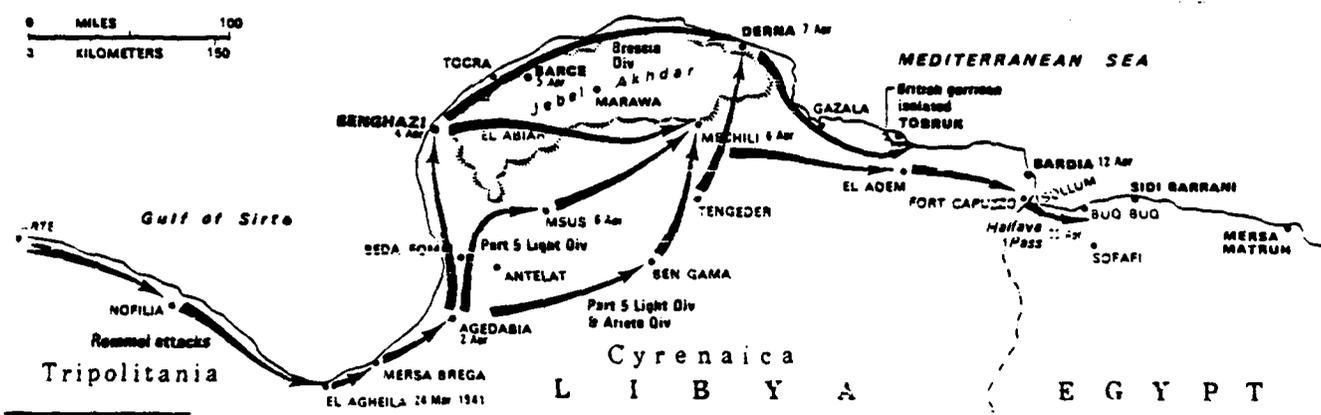

MAP B (Reproduced from Atlas of World War II by Richard Natkiel, pp. 45.)

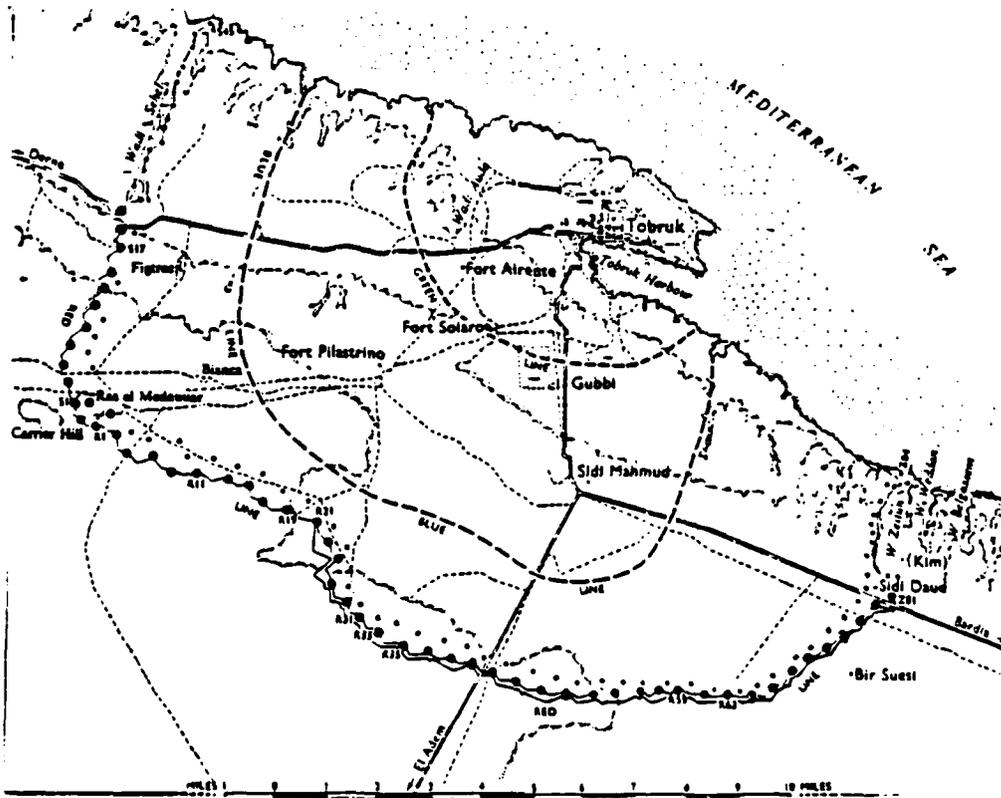

MAP C (Reproduced from The 9th Australian Division Versus the Africa Corps by Colonel Ward A. Miller, pp. 11.)

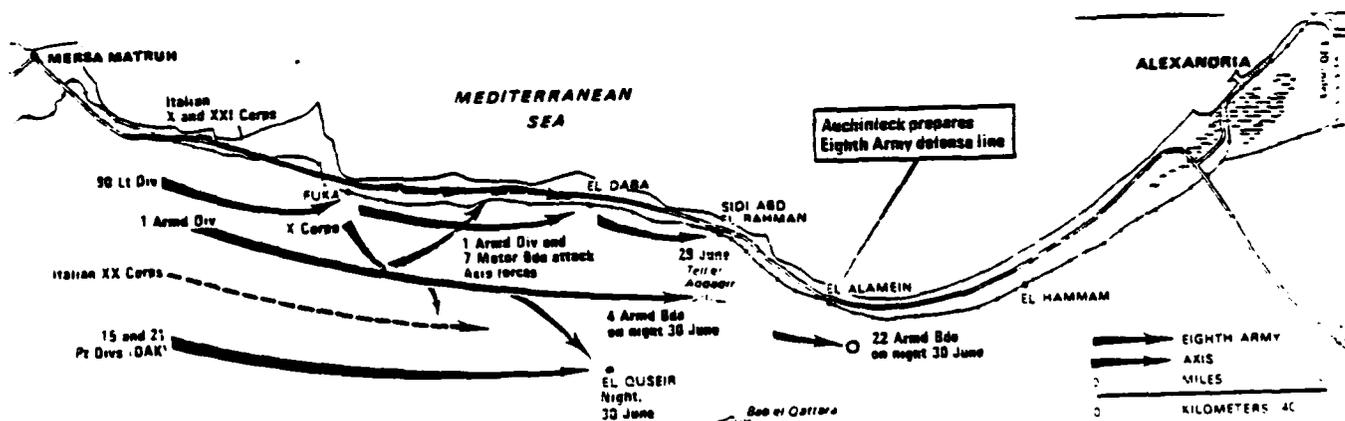

MAP D (Reproduced from Atlas of World War II by Richard Natkiel, pp. 54.)

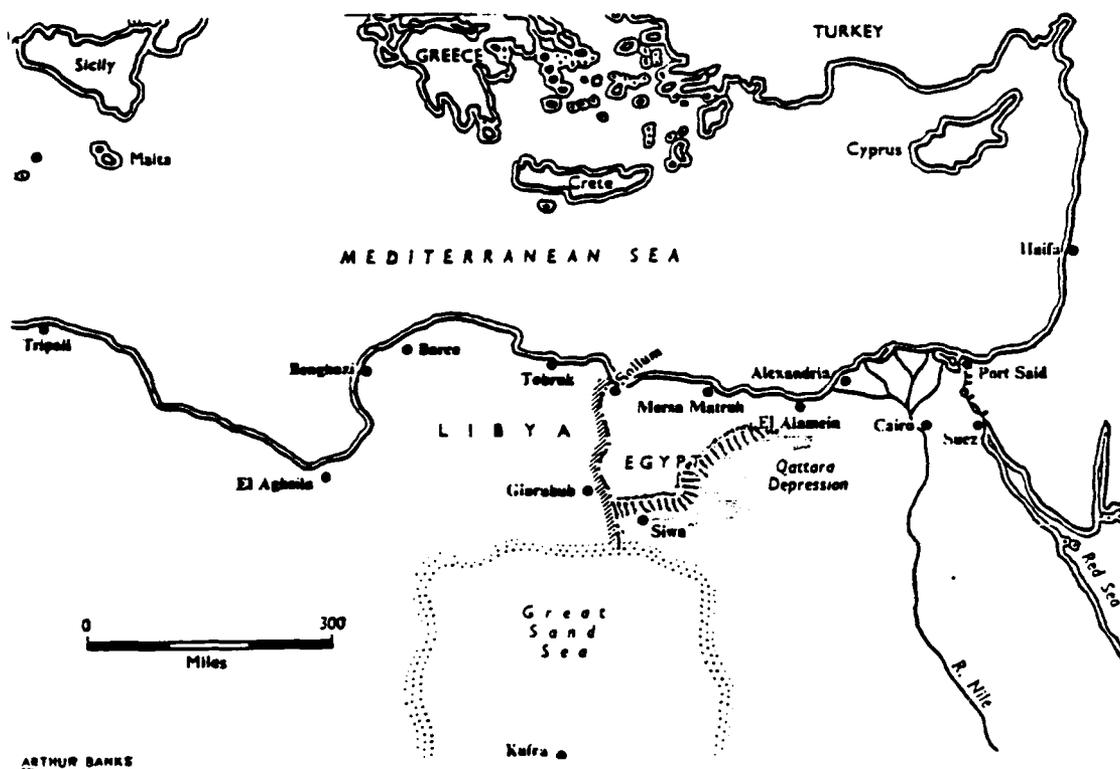

MAP E (Reproduced from El Alamein by Michael Carver, pp. 12.)





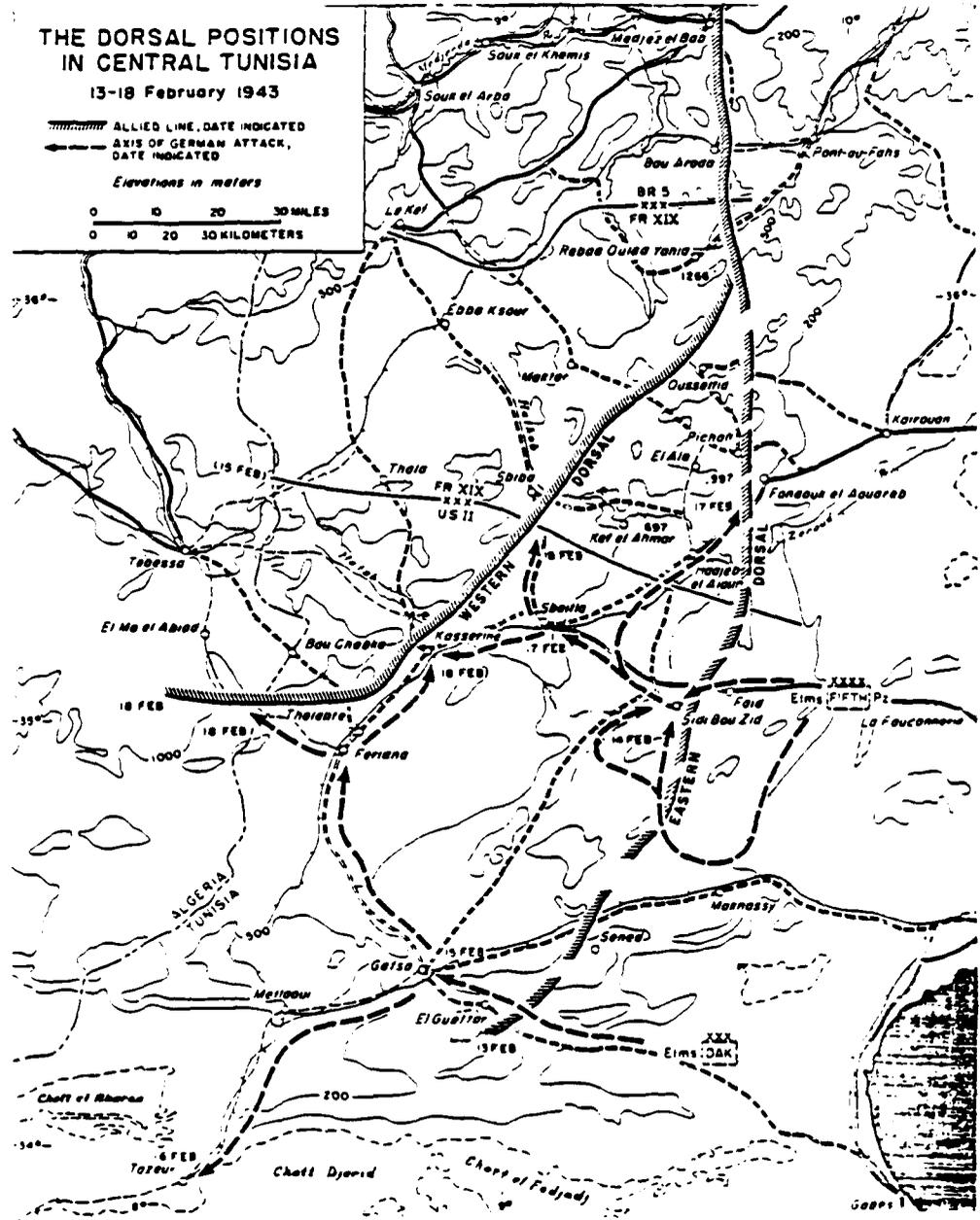

MAP H (Reproduced from Northwest Africa: Seizing the Initiative in the West by George F. Howe, pp. 404.)

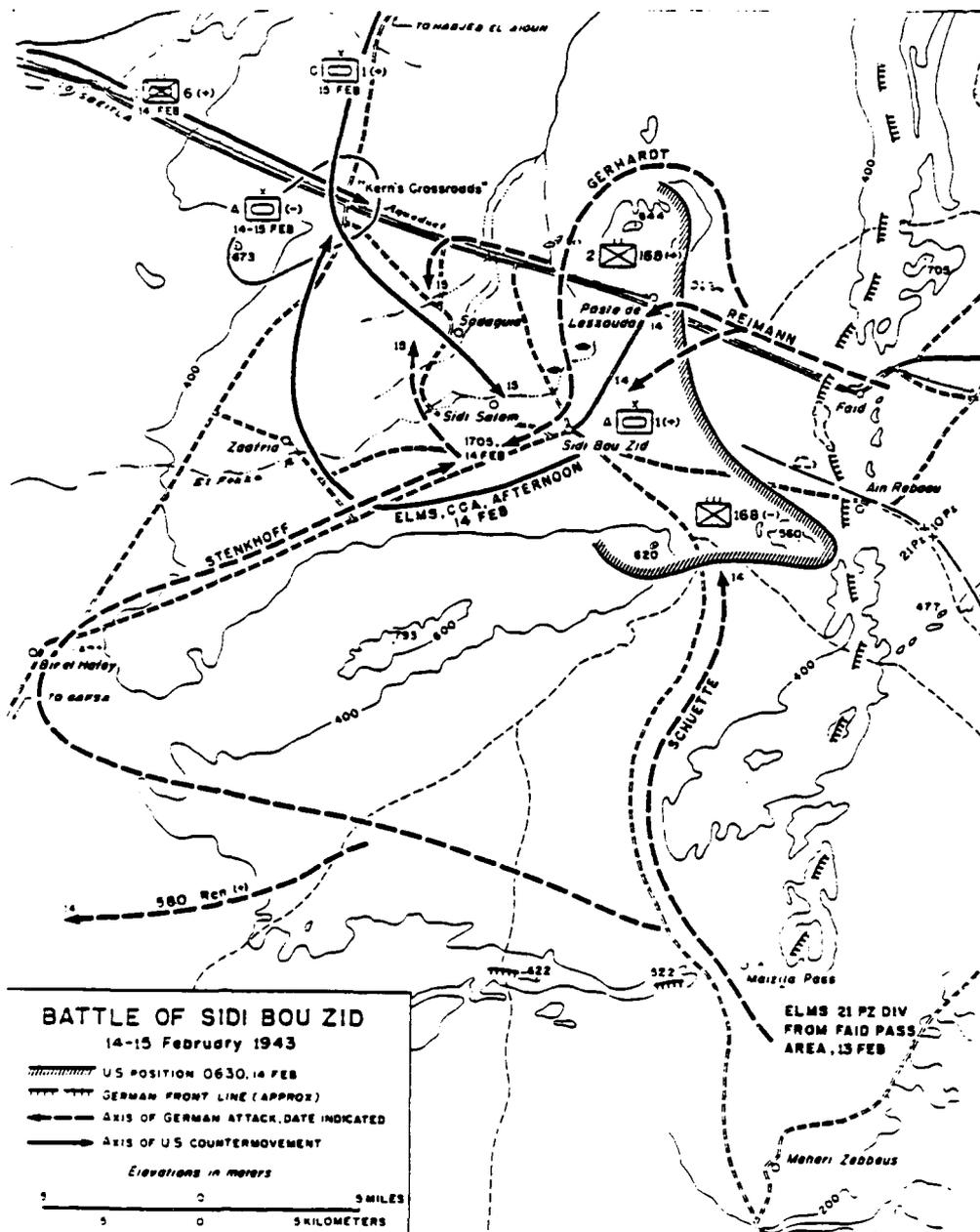

MAP I (Reproduced from Northwest Africa: Seizing the Initiative in the West by George F. Howe, pp. 408.)

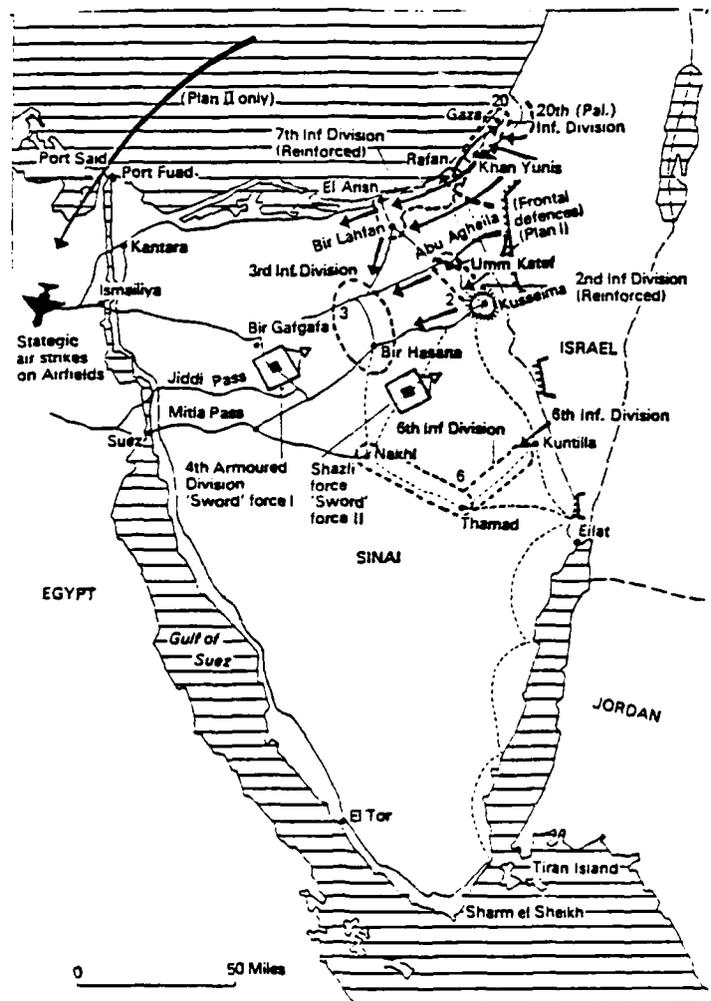

**Sinai 1967: Egyptian troop deployments (Major units only) 5 June**

(Plan II only) 20th (Pal.) Inf. Division  
 7th Inf. Division (Reinforced)  
 (Frontal defence) (Plan II)  
 2nd Inf. Division (Reinforced)  
 3rd Inf. Division  
 6th Inf. Division  
 6th Inf. Division  
 4th Armoured Division 'Sword' force I  
 Shazli force 'Sword' force II

Strategic air strikes on Airfields  
 (Plan II only)  
 (Frontal defence) (Plan II)

0 50 Miles

Sinai 1967: Egyptian troop deployments (Major units only) 5 June  
 Plan prepared by C.O.S. Gen. Y. Rabin at request of cabinet when L. Eshkol was Min. of Defence (Outline reconstruction)  
 Plan presented by Gen Y. Gavish G.O.C. Southern command to Min. of Defence M. Davan and approval on eve of war  
 Infantry Division  
 Armoured Division

MAP J (Reproduced from The Israeli Army 1948-1973 by Edward Luttwak and Daniel Horowitz, pp. 232.)



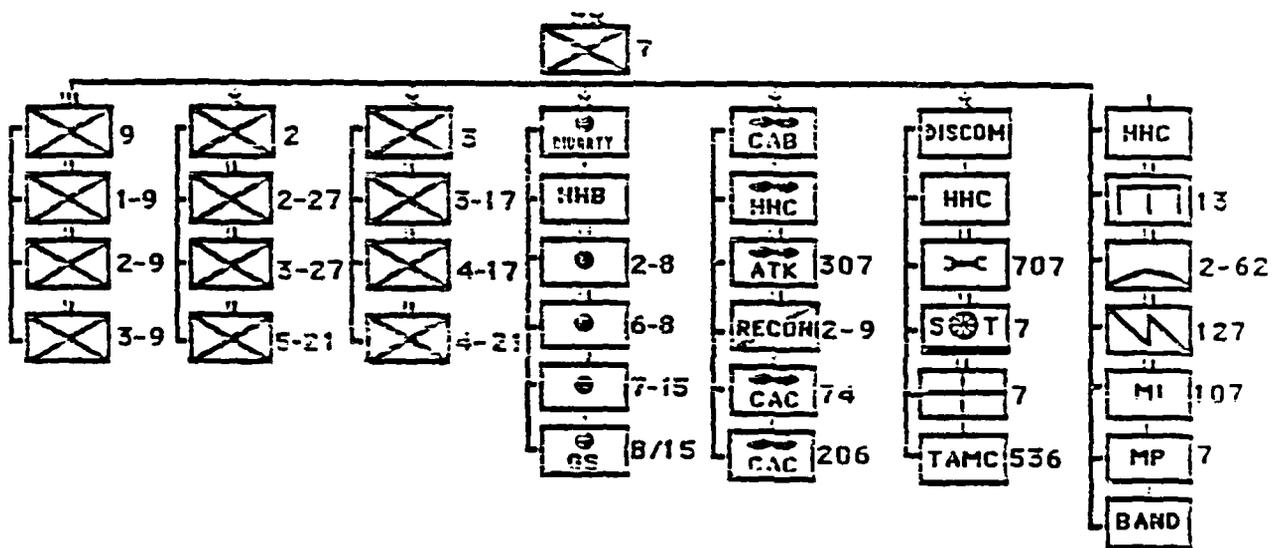

Figure 2 (Reproduced from 7th Infantry Division Capabilities Book dated 1987, pp. 4.)

## ENDNOTES

### SECTION I.

1. Carl Von Clausewitz, On War, (Princeton, New Jersey, 1976), p. 348.
2. Ibid., p. 350.
3. U.S. Command and General Staff College, Student Text 101-1, Organizational and Tactical Reference Data for the Army in the Field, (Fort Leavenworth, KS, June 1987), p. 5-1 thru 5-24. Provides easy reference for the table of organization, equipment and capabilities of U.S. Army units. Additionally, it refers user to current doctrinal sources which describe tactical doctrine for the units listed.
4. J.F.C. Fuller, "Tactics and Mechanization", Infantry Journal (May 1925), p. 459.

### SECTION II.

1. William Morris, The American Heritage Dictionary of the English Language, (New York, 1970), p. 357.
2. U.S. Army, Field Manual 90-3, Desert Operations, (Washington, D.C., August 1977), p. 2-3.
3. Ibid., p. 2-3.
4. George M. Howe, "Classification of World Deserts", (Natick, Massachusetts, December 1968), p. 43.
5. U.S. Army, Field Manual 90-3, Desert Operations, p. 2-4.
6. Ibid., p. 2-4.
7. Ibid., p. 2-5.
8. Ibid., p. 2-5.
9. U.S. Army, Field Manual 31-25, Desert Operations, (Washington, D.C., January 1968), p. 4-5.
10. Ibid., p. 4-5.
11. U.S. Army, Field Manual 90-3, Desert Operations, p. 4-2.
12. Alfred, Toppe, Desert Warfare: German Experience in World War II, (Germany, 1947), p. 61.
13. U.S. Army, Field Manual 90-3, Desert Operations, p. 4-3.

14. U.S. Army, Field Manual 31-25, Desert Operations, (Washington, D.C., February 1972), p. 2-5.

15. U.S. Army, Field Manual 90-3, Desert Operations, p. 4-3.

SECTION III.

1. Colonel Ward A. Miller, "The 9th Australian Division Versus the Africa Corps: An Infantry Division Against Tanks-Tobruk, Libya 1941", Combat Studies Institute, (Fort Leavenworth, Kansas, 1986), p. 4-6. Richard Natkiel, Atlas of World War II, (New York, 1985), p. 44-45.

2. Anthony Smith, Tobruk, (New York, 1959), p. 22.

3. Ibid., p. 23.

4. Ibid., p. 23.

5. Miller, "The 9th Australian Division Versus the Africa Corps", p. 10.

6. Ibid., p. 51-54.

7. Ibid., p. 8-10.

8. Ibid., p. 16.

9. Ibid., p. 15-16.

10. Ibid., p. 19-21 and Smith, Tobruk, p. 51-56.

11. Smith, Tobruk, p. 19-33.

12. Liddel Hart, Rommel Papers, (New York, 1953), p. 254.

13. Ibid., p. 254.

14. Paddy Griffith, Forward into Battle, (Great Britain, 1981), p. 93.

15. Major General I. S. O. Playfair, History of the Second World War: The Mediterranean and Middle East Vol. III, (School of Advanced Military Studies reprint, Fort Leavenworth, Kansas, AY 87/88), p. 332.

16. Correlli Barnett, The Desert Generals, (Indiana, 1960), p. 197.

17. Michael Carver, El Alamein, (New York, 1962), p. 18.

18. Natkiel, Atlas of World War II, p. 56.

19. Ibid., p. 58.
20. Captain William R. Betson, "Sidi Bou Zid-A Case History of Failure", Armor, (November-December 1982), p. 38.
21. George F. Howe, Northwest Africa: Seizing the Initiative in the West, (Washington, D.C., 1957), p. 39-40.
22. Ibid., p. 411-422.
23. Ibid., p. 422-423.
24. Martin Blumenson, Kasserine Pass, (New York, 1966), p. 122.

#### SECTION IV.

1. Edward Luttwak and Daniel Horowitz, The Israeli Army-1948-1973, (Massachusetts, 1983), p. 233-234.
2. Ibid., p. 234, Provides good description of employment of 7th Division.
3. Ibid., p. 234 and Chaim Herzog, The Arab-Israeli Wars, (New York, 1984), p. 154-155.
4. Herzog, The Arab-Israeli War, p. 157.
5. Ibid., p. 157.
6. A. Harding Ganz, "Abu Ageila, Two Battles-Part II: 1967" Armor (July-August 1974), p. 16.
7. John A. English, On Infantry, (New York, 1981), p. 187.
8. Jac Weller, "Foot Soldiers in the Desert", Army (August 1974), p. 21.
9. Lt. General Saad el Shazly, The Crossing of the Suez, (San Francisco, 1980), p. 224-226.
10. Kenneth S. Brower, "Armor in the October War", Armor (May-June 1974), p. 13.
11. Ibid., p. 13.
12. Herzog, The Arab-Israeli Wars, p. 239-242 and Shazly, The Crossing of the Suez, p. 228-232.
13. English, On Infantry, p. 188.

14. Shazly, The Crossing of the Suez, p. 242-243.

SECTION V.

1. U.S. Army, Headquarters, 2d Brigade 10th Mountain Division, "Celtic Cross IV After Action Report", (2 October 1986), p. 1-10.

2. U.S. Army, "Celtic Cross After Action Report", p. 1-10.

3. Colonel William W. Hartzog and John D. Howard, "Heavy/Light Operations", Military Review (April 1987), p. 24-33 and Center For Army Lessons Learned, "Close Combat Observations-Light" (16 September 1987), p. 92 and 119.

4. Center For Army Lessons Learned, "Close Combat Observations-Light", p. 67.

5. Ibid., p. 64.

SECTION VI.

1. U.S. Army, Field Circular 71-101, Light Infantry Division Operations, (Fort Leavenworth, KS, July 1984), p. 1-2.

2. U.S. Army, Field Manual 7-72, Light Infantry Battalion, (Washington, D.C., March 1987), p. 1-5 thru 1-18.

3. U.S. Army, Field Circular 71-101, Light Infantry Division Operations, p. 4-21 thru 4-44.

4. Ibid., 4-33 and 4-50.

5. Ibid., 4-27 thru 4-40.

6. U.S. Army, Field Manual 71-3, The Armor and Mechanized Brigade, Final Draft, (Washington, D.C., April 1987), p. A-5.

7. Ibid., p. A-5.

8. Ibid., p. A-5.

SECTION VII.

1. U.S. Army, Field Manual 90-3, Desert Operations, (1977), p. 4-64.

2. General William E. Depuy, "Light Infantry: Indispensable Element of a Balanced Force", Army, (June 1985), p. 62.

3. Andre Gimond, "Desert Warfare" Military Review, (August 1948), p. 78.

4. Hart, Rommel Papers, p. 200.
5. Ibid., p. 198.
6. U.S. Army, Field Manual 71-3, The Armor and Mechanized Infantry Brigade, p. A-1.
7. Ibid., A-1.

## BIBLIOGRAPHY

### Books

- Adan, Avraham (Bren), On The Banks of the Suez. Presidio, CA: Presidio Press, 1980.
- Barnett, Corelli, The Deserts Generals. Bloomington, Indiana: Indiana University Press, 1960.
- Blumenson, Martin, Kasserine Pass. New York, NY: Berkley Publishing Group, 1983.
- Carver, Michael, El Alamein. London, England: William Clowes and Sons, 1962.
- Clausewitz, Carl Von, On War. Princeton, New Jersey: Princeton University Press, 1976. Edited and Translated by Michael Howard and Peter Paret.
- English, John A., On Infantry. New York, NY: Praeger Publishing Co., 1984.
- Greenfield, Kent R., Palmer, Robert R. and Wiley, Bell I., The Organization of Ground Combat Troops. Washington, D.C.: Office of the Chief of Military History, Department of the Army, 1947.
- Griffith, Paddy, Forward Into Battle: Fighting Tactics from Waterloo to Vietnam. Strettington, Great Britain: Anthony Bird Publications, 1981.
- Hart, Lidell, The Rommel Papers. New York, NY: Da Capo Press, 1953.
- Herzog, Chaim, The Arab-Israeli Wars. New York, NY: Vintage Books, 1984.
- Howe, George F., Northwest Africa: Seizing the Initiative in the West. Washington D.C.: Office of the Chief of Military History, Department of the Army, 1957.
- Luttwak, Edward and Horowitz, Daniel, The Israeli Army: 1948-1973. Cambridge, MA: Abt Books, 1983.
- Marshall, S. L. A., Brigadier General, Swift Sword. New York, NY: American Heritage Publishing Co. Inc., 1967.
- Natkiel, Richard, Atlas of World War II. New York, NY: The Military Press, 1985.

Playfair, I. S. O., Major General, History of the Second World War, The Mediterranean and Middle East, Volume II. London, England: Her Britannic Majesty's Stationary Office, 1954.

Shazly, Saad el, Lt. General, The Crossing of the Suez. San Francisco, CA: American Mideast Research, 1980.

Smith, Anthony Heck-Stall, Tobruk. New York, NY: W.W. Norton and Co. Inc., 1959.

Stokesbury, James L., A Short History of World War II. New York, NY: William Morrow and Co., 1980

Strawson, John, The Battle for North Africa. New York, NY: Charles Scriber Sons, 1969.

Weeks, John, Men Against Tanks. New York, NY: Mason and Charter Publishing Co., 1973.

Whiting, Charles, Kasserine: First Blood. New York, NY: Stein and Day Publishers, 1984.

#### MANUALS

Field Circular 71-101, Light Infantry Division Operations. Fort Leavenworth, KS: United States Army Command and General Staff College.

Field Manual 31-25, Desert Operations. Washington DC: War Department, 1942.

Field Manual 31-25, Desert Operations. Washington DC: HQ Department of the Army, 1955.

Field Manual 31-25, Desert Operations. Washington DC: HQ Department of the Army, 1964.

Field Manual 31-25, Desert Operations. Washington DC: HQ Department of the Army, 1972.

Field Manual 71-3, The Armor and Mechanized Infantry Brigade (Final Draft). Washington, DC: HQ Department of the Army, 1987.

Field Manual 7-72, Light Infantry Battalion. Washington, DC: HQ Department of the Army, 1987.

Field Manual 90-3, Desert Operations. Washington, DC: HQ Department of the Army, 1977.

Field Manual 100-5, Operations. Washington, DC: HQ Department of the Army, 1986.

Student Text 101-1, Organization And Tactical Reference Data For The Army IN The Field. Fort Leavenworth, KS: United States Army Command and General Staff College, 1987.

#### ARTICLES AND PERIODICALS

Adams, John A. "Heavy Versus Light Forces: A Middle Ground." Military Review. October 1986, pp. 65-73.

Barclay, Brigadier C.N. "Learning the Hard Way: Lessons From the October War." Army. March 1974, pp. 25-30.

Beston, Captain William R. "Sidi Bou Zid-A Case History of Failure." Armor. November-December 1982, pp. 38-44.

Blanchard, Allan E. "The 6 Day War." Army. August 1967, pp. 24-33.

Brower, Kenneth S. "Armor in the October War." Armor. May-June 1974, pp. 10-15.

Clarkson, Colonel J.M.E. "Spark at Yom Kippur: Many Surprises in an 18 Day War." Canadian Defense Quarterly. Spring 1974, pp. 9-22.

Crowell, Major General Howard G. Jr. and Bates, Lieutenant Colonel Jared. "Heavy-Light Connection: Division." Infantry. July-August 1984, pp. 15-18.

DePuy, General William E. "Light Infantry: Indispensable Element of a Balanced Force." Army. June 1985, pp. 26-41.

Downing, Brigadier General Wayne A. "Light Infantry Integration in Central Europe." Military Review. September 1986, pp. 18-30.

Dunn, Major James A. "Heavy Force, Light Force." Armor. September-October 1987, pp. 10-15.

Fuller, Colonel J.F.C. "Tactics and Mechanization." Infantry Journal. May 1925, pp. 457-465.

Galvin, Major General Jack. "The Heavy/Light Concept." Armed Forces Journal International. July 1982, pp. 67-80.

Ganz, Harding A. "Abu Ageila, Two Battles-Part Two: 1967." Armor. July-August 1974, pp. 15-21.

Gimond, Andre. "Desert Warfare." Military Review. August 1948, pp. 73-83.

Hartzog, Colonel William W. and Howard, Colonel John D. "Heavy/Light Operations." Military Review. April 1987, pp. 24-33.

Heiman, Leo. "Infantry in the Middle East, Part One." Infantry. January-February 1968, 16-24.

Heiman, Leo. "Infantry in the Middle East, Part Two." Infantry. March-February 1968, pp. 4-14.

Newell, Lieutenant Colonel Clayton R. "Heavy-Light Forces: Divisions of Brigades." Infantry. January-February 1985, pp. 12-13.

Ozolek, Major David J. "Infantry in Desert Armor Operations." Armor. September-October 1983, pp. 26-29.

Robinett, Brigadier Paul M. "The Axis Offensive in Central Tunisia-February 1943." Armor. May-June, pp. 7-17.

Weller, Jac. "Foot Soldiers in the Desert." Army. August 1974, pp. 21-26.

#### DOCUMENTS

British War Office, "Notes From Theaters of War." 1943. CGSC reference file, CARL.

Canby, Stephen and Luttwak, Edward. "Designing a Balanced Rapid Deployment Force--Test Case: Defense of Persian Gulf." C and L Associates. Potomac, Maryland. 1981.

Campbell, Major Charles C. "Light Infantry and the Heavy Force: A Marriage of Convenience or Necessity." School of Advanced Military Studies Monograph. December 1985. CARL reference #ADA167710-2.

Center For Army Lessons Learned. "Close Combat Observations (Light)." File name PRG00015P13D, Date and Time September 16 1987, 1603 hours. Computer Printout.

Combat Studies Institute Fort Leavenworth, KS., "The Battle of Sidi Bou Zid." CARL reference #AD151626-3.

Eighth Army and British War Department, "Notes and Lessons of Recent Operations in the Western Desert." 1942. CGSC reference file, CARL.

Headquarters European Theater of Operations Historical Division, "Desert Warfare: German Experience in World War II." Translated from interviews with General Alfred Toppe, German Army. CGSC reference file, CARL.

House, Captain Jonathan M. "Toward Combined Arms Warfare: A Survey of 20th Century Tactics, Doctrine and Organization." U.S. Army Command and General Staff College Combat Studies Institute. Fort Leavenworth, KS., August 1984.

Howe, George M. "Classification of World Deserts." United States Army Natick Laboratories and The Travelers Research Center. December 1968. CARL reference #AD683603.

Hill, Lieutenant Colonel Robert W. "The Arab-Israeli Six Day War, 1967." U.S. Army War College. Carlisle Barracks, PA. 1968. CARL reference #19103.243-2.

Miller, Colonel Ward A. "The 9th Australian Division versus the Africa Corps: An Infantry Division Against Tanks-Tobruk, Libya 1941." U.S. Army Command and General Staff College Combat Studies Institute. Fort Leavenworth, KS. August 1986.

United States Army Training and Doctrine Command. "1st Increment Lessons Learned from the Middle East Crisis." January 1974. CARL reference #N5734.51.

United States Army Training and Doctrine Command Combined Arms Test Activity. "Light Infantry Division Field Certification Report." Fort Hood, TX. January 1987.

United States Army War Department. "The Libyan Campaign November 1941-January 1942." Campaign Study No. 1. August 1942.

United States Army, 2d Brigade 10th Mountain Division. "Celtic Cross IV After Action Report." Fort Benning, GA. October 1986.

United States Army, 7th Infantry Division. "7th Infantry Division Capabilities Book." 7th Infantry Division. Fort Ord, CA. 1987.