

AD-A185 351

SINGLE AND TANDEM ANCHOR PERFORMANCE OF THE NEW NAUY
MOORING ANCHOR: THE NAUMOOR ANCHOR(U) NAVAL CIVIL
ENGINEERING LAB PORT HUENEME CA R J TAYLOR JUL 87
NCEL TN-1774 F/G 13/2

1/2

UNCLASSIFIED

NL



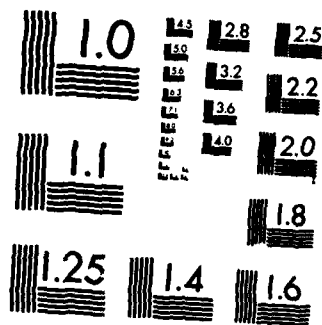

MICROCOPY RESOLUTION TEST CHART
NATIONAL BUREAU OF STANDARDS-1963-A

AD-A185 351

NCEL
Technical Note

DTIC FILE COPY

N-1774

July 1987

By Robert J. Taylor
Sponsored By Naval Facilities
Engineering Command
and Naval Sea Systems Command

12

Single and Tandem Anchor Performance of the New Navy Mooring Anchor: The NAVMOOR Anchor

ABSTRACT A new Navy mooring anchor (NAVMOOR), has been designed to satisfy a variety of Navy anchor applications. Various sizes of anchors have been designed, fabricated, and structurally and operationally proof-tested. This report describes the NAVMOOR Anchor, presents the results of prototype single and tandem anchor tests in sand and mud seafloors, provides anchor performance specifications, and presents Navy fleet mooring anchoring guidelines. The NAVMOOR Anchor was shown to be structurally and operationally superior to the Navy's STATO Anchor which in the past was the most effective general purpose anchor for Navy applications. The NAVMOOR Anchor was effective in dense sand and soft mud seafloors when used in single and tandem anchor leg configurations. Tandem anchor system holding capacity was shown to be at least twice the capacity of a single NAVMOOR Anchor. The Navy's fleet mooring requirements from class C (100-kip capacity) to class AAA (500-kip capacity) can be satisfied with only two sizes of NAVMOOR Anchor, the 10,000-pound and 15,000-pound NAVMOOR, used in various single and tandem anchor leg configurations.

DTIC
ELECTRONIC
OCT 07 1987
S
D
STP

NAVAL CIVIL ENGINEERING LABORATORY PORT HUENEME, CALIFORNIA 93043

METRIC CONVERSION FACTORS

Approximate Conversions to Metric Measures

Symbol	When You Know	Multiply by	To Find	Symbol
in	inches	2.5	centimeters	cm
ft	feet	30	centimeters	cm
yd	yards	0.9	meters	m
mi	miles	1.6	kilometers	km
in ²	square inches	6.5	square centimeters	cm ²
ft ²	square feet	0.09	square meters	m ²
yd ²	square yards	0.8	square meters	m ²
mi ²	square miles	2.6	square kilometers	km ²
	acres	0.4	hectares	ha
oz	ounces	28	grams	g
lb	pounds	0.45	kilograms	kg
	short tons (2,000 lb)	0.9	tonnes	t
tblsp	tablespoons	5	milliliters	ml
fl oz	fluid ounces	15	milliliters	ml
c	cups	30	milliliters	ml
pt	pints	0.24	liters	l
qt	quarts	0.47	liters	l
gal	gallons	0.95	liters	l
ft ³	cubic feet	3.8	liters	l
yd ³	cubic yards	0.03	cubic meters	m ³
		0.76	cubic meters	m ³
°F	Fahrenheit temperature	5/9 (after subtracting 32)	Celsius temperature	°C

Approximate Conversions from Metric Measures

Symbol	When You Know	Multiply by	To Find	Symbol
mm	millimeters	0.04	inches	in
cm	centimeters	0.4	inches	in
m	meters	3.3	feet	ft
m	meters	1.1	yards	yd
km	kilometers	0.6	miles	mi
cm ²	square centimeters	0.16	square inches	in ²
m ²	square meters	1.2	square yards	yd ²
km ²	square kilometers	0.4	square miles	mi ²
ha	hectares (10,000 m ²)	2.5	acres	
g	grams	0.035	ounces	oz
kg	kilograms	2.2	pounds	lb
t	tonnes (1,000 kg)	1.1	short tons	
ml	milliliters	0.03	fluid ounces	fl oz
l	liters	2.1	pints	pt
l	liters	1.06	quarts	qt
l	liters	0.26	gallons	gal
m ³	cubic meters	36	cubic feet	ft ³
m ³	cubic meters	1.3	cubic yards	yd ³
°C	Celsius temperature	9/5 (then add 32)	Fahrenheit temperature	°F

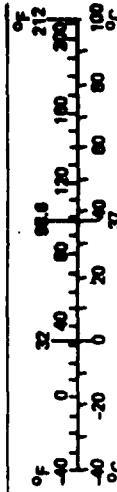
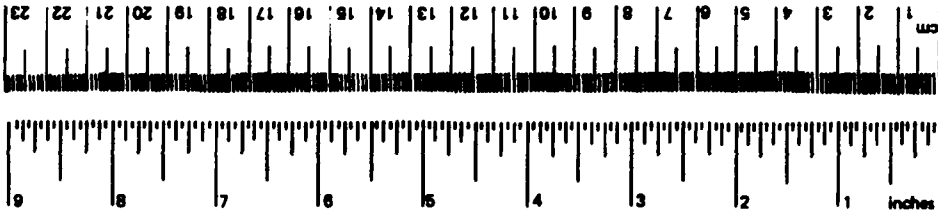

*1 in = 2.54 (exactly). For other exact conversions and more detailed tables, see NBS Misc. Publ. 286, Units of Weights and Measures, Price \$2.25, SD Catalog No. C13.10.286.

Unclassified

A185 351

SECURITY CLASSIFICATION OF THIS PAGE (When Data Entered)

accl

REPORT DOCUMENTATION PAGE		READ INSTRUCTIONS BEFORE COMPLETING FORM
1. REPORT NUMBER TN-1774	2. GOVT ACCESSION NO. DN665003	3. RECIPIENT'S CATALOG NUMBER
4. TITLE (and Subtitle) SINGLE AND TANDEM ANCHOR PERFORMANCE OF THE NEW NAVY MOORING ANCHOR: THE NAVMOOR ANCHOR		5. TYPE OF REPORT & PERIOD COVERED Final; Oct 1984 - Dec 1986
		6. PERFORMING ORG. REPORT NUMBER
7. AUTHOR(s) Robert J. Taylor		8. CONTRACT OR GRANT NUMBER(s)
9. PERFORMING ORGANIZATION NAME AND ADDRESS NAVAL CIVIL ENGINEERING LABORATORY Port Hueneme, California 93043-5003		10. PROGRAM ELEMENT, PROJECT, TASK AREA & WORK UNIT NUMBERS 63721N; 42-060
11. CONTROLLING OFFICE NAME AND ADDRESS Naval Facilities Engineering Command Alexandria, Virginia 22332		12. REPORT DATE July 1987
		13. NUMBER OF PAGES 87
14. MONITORING AGENCY NAME & ADDRESS (if different from Controlling Office) Naval Sea Systems Command Washington, DC 20362-5101		15. SECURITY CLASS (of this report) Unclassified
		15a. DECLASSIFICATION DOWNGRADING SCHEDULE
16. DISTRIBUTION STATEMENT (of this Report) Approved for public release; distribution unlimited.		
17. DISTRIBUTION STATEMENT (of the abstract entered in Block 20, if different from Report)		
18. SUPPLEMENTARY NOTES		
19. KEY WORDS (Continue on reverse side if necessary and identify by block number) Anchors, seafloor, anchor holding capacity, moorings		
20. ABSTRACT (Continue on reverse side if necessary and identify by block number) A new Navy mooring anchor (NAVMOOR), has been designed to satisfy a variety of Navy anchor applications. Various sizes of anchors have been designed, fabricated, and structurally and operationally proof-tested. This report describes the NAVMOOR Anchor, presents the results of prototype single and tandem anchor tests in sand and mud seafloors, provides anchor performance specifications, and presents Navy fleet mooring anchoring guidelines. The NAVMOOR Anchor was shown to be structurally and operationally superior		

Unclassified

SECURITY CLASSIFICATION OF THIS PAGE (When Data Entered)

20. Continued

to the Navy's STATO Anchor which in the past was the most effective general purpose anchor for Navy applications. The NAVMOOR Anchor was effective in dense sand and soft mud seafloors when used in single and tandem anchor leg configurations. Tandem anchor system holding capacity was shown to be at least twice the capacity of a single NAVMOOR Anchor. The Navy's fleet mooring requirements from class C (100-kip capacity) to class AAA (500-kip capacity) can be satisfied with only two sizes of NAVMOOR Anchor, the 10,000-pound and 15,000-pound NAVMOOR, used in various single and tandem anchor leg configurations.

Library Card

Naval Civil Engineering Laboratory
SINGLE AND TANDEM ANCHOR PERFORMANCE OF THE NEW
NAVY MOORING ANCHOR: THE NAVMOOR ANCHOR (Final), by
Robert J. Taylor

TN-1774 87 pp illus July 1987 Unclassified

1. Anchors 2. Anchor holding capacity I. 42-060

A new Navy mooring anchor (NAVMOOR), has been designed to satisfy a variety of Navy anchor applications. Various sizes of anchors have been designed, fabricated, and structurally and operationally proof-tested. This report describes the NAVMOOR Anchor, presents the results of prototype single and tandem anchor tests in sand and mud seafloors, provides anchor performance specifications, and presents Navy fleet mooring anchoring guidelines. The NAVMOOR Anchor was shown to be structurally and operationally superior to the Navy's STATO Anchor which in the past was the most effective general purpose anchor for Navy applications. The NAVMOOR Anchor was effective in dense sand and soft mud seafloors when used in single and tandem anchor leg configurations. Tandem anchor system holding capacity was shown to be at least twice the capacity of a single NAVMOOR Anchor. The Navy's fleet mooring requirements from class C (100-kip capacity) to class AAA (500-kip capacity) can be satisfied with only two sizes of NAVMOOR Anchor, the 10,000-pound and 15,000-pound NAVMOOR, used in various single and tandem anchor leg configurations.

Unclassified

SECURITY CLASSIFICATION OF THIS PAGE (When Data Entered)

CONTENTS

	Page
INTRODUCTION	1
BACKGROUND	1
ANCHOR DESCRIPTION AND OPERATIONAL FEATURES	1
General	1
Anchor Design	2
ANCHOR APPLICATIONS	5
Navy Fleet Moorings	5
Navy Salvage	5
Amphibious Operations	6
ANCHOR TESTING PROGRAM	6
Test Locations	6
Test Procedures and Equipment	7
SINGLE ANCHOR TEST RESULTS AND ANALYSIS	8
Port Hueneme Beach Tests	8
Port Hueneme Sand Single Anchor Tests	9
San Francisco Bay Mud Single Anchor Tests	11
Summary of Single Anchor Tests	13
TANDEM ANCHOR TEST RESULTS AND ANALYSIS	13
Port Hueneme Sand Tandem Anchor Tests	13
San Francisco Bay Mud Tandem Anchor Tests	15
Summary of Tandem Anchor Tests	16
NAVMOOR ANCHOR SIZE GUIDELINES FOR NAVY FLEET MOORINGS	16
SUMMARY AND CONCLUSIONS	17
REFERENCES	18
Appendix - Design Drawings for NAVMOOR Anchors	A-1

	For
	CRA&I <input checked="" type="checkbox"/>
	SAB <input type="checkbox"/>
	Sed <input type="checkbox"/>
	Di <input type="checkbox"/>
By _____	
Dist (date) / _____	
Availability Codes	
Dist	Avail and/or Special
A-1	23



INTRODUCTION

The Naval Civil Engineering Laboratory (NCEL) has developed a new anchor suitable for a wide range of mooring applications. The new anchor is called the NAVMOOR Anchor. This development was initiated by the Naval Facilities Engineering Command in response to expanded Navy fleet mooring requirements from 300,000 pounds (class AA) to 500,000 pounds (class AAA). Support for this development was also provided by the Supervisor of Salvage, Naval Sea Systems Command.

This report describes the NAVMOOR Anchor design and operational features and presents the results of small-scale anchor tests on the beach and tests of full-size single and tandem NAVMOOR Anchors in sand and mud. Performance specifications of the NAVMOOR Anchor for sand and mud seafloors are also provided.

BACKGROUND

A program was established at NCEL in 1979 to improve the Navy's fleet mooring capability. Detailed anchor testing programs were conducted at several sites to determine the performance of Navy and commercial anchors (Ref 1 through 5). These tests provided data to support development of improved methods for predicting the performance of drag embedment anchors and methods for improving the performance of anchors (Ref 6 through 11).

Refined mooring load determinations and a reassessment of the Navy's mooring needs resulted in an upgrade in the Navy's mooring requirements to 500,000 pounds maximum. An analysis of high efficiency (high holding capacity to weight ratio) anchor options was performed (Ref 12). The analysis concluded that the Navy's expanded mooring requirements could be satisfied with a structurally and operationally improved version of the Navy's STATO Anchor used in single and tandem anchor leg configurations.

Before proceeding with the new anchor development, a program of model and small-scale tests of anchors was conducted (Ref 13) to evaluate the practicality and effectiveness of using anchors in tandem and to evaluate STATO Anchor configuration changes to enhance performance. Results were positive and justified prototype anchor development and testing to quantify single and tandem anchor performance in sand and mud seafloors.

ANCHOR DESCRIPTION AND OPERATIONAL FEATURES

General

The NAVMOOR Anchor (Figure 1) was designed for single and tandem anchor leg applications. A tandem anchor leg configuration is illustrated in Figure 2 with the NAVMOOR Anchor. In this example, chain is

used to connect the anchors but wire is also acceptable. The NAVMOOR Anchors are designed to structurally tolerate a tandem system capacity of up to 2-1/2 times the capacity of a single anchor. Model and small-scale tests (Ref 13) showed that two anchors of the STATO type (when rigged in tandem) could develop a total system holding capacity of 2-1/2 times the capacity of a single anchor. This design and application approach contrasts with normal commercial practice in the use of tandem anchors.

Normally, when a tandem anchor (also called a piggyback) is used in commercial practice, the primary anchor has failed to hold to its design load. The tandem anchor is added to bring the total capacity of the system up to the capacity originally required of the primary anchor. In contrast, the NAVMOOR Anchor system is structurally designed and operationally capable of being used to satisfy loads associated with much larger single anchors. The fact that anchor efficiency decreases as anchor size increases and that the efficiency of two anchors rigged in tandem is equal to or greater than that of the individually pulled anchors, results in less total weight for a tandem anchor system compared to a single anchor. Also, smaller anchors in a tandem system are easier to handle and recover, particularly in mud seafloors.

Anchor Design

Two views of a NAVMOOR Anchor, 1,000-pound nominal size, are shown in Figure 1. The general configuration of the STATO Anchor was used as the basis for the NAVMOOR Anchor design. For comparison, a STATO Anchor is shown in Figure 3. Plan dimensions of these two anchor types are similar for anchors of comparable nominal weight to ensure at least the same single anchor performance. For reference, design drawings for two versions of the NAVMOOR Anchor are provided in Appendix A. They include the 2,000-pound NAVMOOR Anchor with standard stabilizers designed for causeway mooring applications and the 6,000-pound NAVMOOR Anchor for salvage with folding stabilizers.

There were three principal problems with the STATO Anchor that needed to be corrected to provide an anchor type that would satisfy the Navy's anchoring requirements. The STATO Anchor is not structurally suited to tandem anchor use, has experienced performance problems in hard soil, and has had general structural problems. The NAVMOOR Anchor was designed to eliminate these problems. Other changes were made to simplify construction, improve handling, and expand fabrication options.

The design process began with the design of a 10,000-pound NAVMOOR Anchor for fleet moorings. Finite element analysis techniques were used to optimize the structural integrity of the anchor within a given weight specification. After the design was completed, an exact scale model (about 200 pounds) was designed, constructed, and tested in sand. Some design changes were found to be necessary to simplify construction; otherwise, the design and anchor performance were acceptable. For example, when tested with the 200-pound STATO Anchor (actual weight was 280 pounds), the NAVMOOR Anchor held 25 percent more than the 30 percent heavier STATO Anchor. Next, the 10,000-pound NAVMOOR Anchor was fabricated, instrumented with strain gages, and structurally tested to its design load. The strain gage layout is shown by Figure 4. Twenty single

and rosette gages were used principally in the vicinity of the anchor crown. The anchor was loaded several times at the third point of the fluke (measured from the fluke tip) to its design proof load of 210 kips. The anchor's proof load was established as 70 percent of the total expected anchor holding capacity, which for the 10K NAVMOOR Anchor was 300 kips. Some changes were needed in the anchor stopper design to reduce stress concentrations; otherwise the design was sound. This calibrated design could then be used as a basis for larger or smaller NAVMOOR Anchor designs.

The NAVMOOR Anchor, like most other anchors, is described by a nominal weight which often differs from actual anchor weight. Anchor weight can exceed nominal weight by as much as 10 to 15 percent depending upon fabrication means, anchor application, and the designers choice of plate thickness. External anchor dimensions are controlled to ensure consistent and predictable performance. The nominal weights of the NAVMOOR Anchor were based on the STATO design. The 6,000-pound STATO design was used as the basis for extrapolation of all NAVMOOR Anchor sizes. The STATO Anchor weights were based on anchor weight without mud palms. Mud palms add about 10 percent to the anchor weight; in addition, normal weight variations to accommodate available plate sizes could be as much as 10 percent. As an example, the 6,000-pound NAVMOOR Anchor has two configurations; one for fleet mooring applications and one for salvage applications. The weights of these anchors are 5,940 pounds and 7,200 pounds respectively, even though external dimensions and actual performance are comparable. The higher weight of the salvage anchor results from a strengthened anchor palm to support the stabilizer hinge mechanism and the heavier folding stabilizers.

The principal features of the NAVMOOR Anchor are described in the following paragraphs. Use Figures 1 and 2 as reference for the following discussions.

Anchor Flukes. The plan size of the NAVMOOR and STATO Anchor flukes are similar. The NAVMOOR flukes are of box-like construction to reduce fluke stress and to lighten and streamline the flukes. The STATO flukes are comprised of a central plate with external rib stiffeners. The stiffeners trap sand during penetration in sand resulting in higher penetration resistance and poor hard soil performance. The primary penetration resistance on the anchor during the initial embedment phase is on the flukes; this resistance is a function of fluke roughness. The smooth NAVMOOR flukes cause significantly less penetration resistance than the rough STATO flukes. Model and small-scale tests showed at least a 30 percent improvement in anchor capacity for a smooth-fluked anchor in sand.

The initial design of the NAVMOOR Anchor flukes used internal rib stiffeners located at the folds in the fluke cover plates; this complicated fluke construction. Subsequently, a more refined finite element analysis was performed to see if the ribs could be eliminated without creating an unacceptable weight increase. The ribs could be eliminated with a minor increase in cover plate thickness. All current NAVMOOR Anchor designs employ hollow flukes with no internal rib stiffness.

Stopper Assembly. The stopper assembly consists of a fixed stopper to restrict the fluke angle to 50 degrees for mud use and a welded-on sand wedge to reduce the fluke angle to 32 degrees for sand use. Another restriction to the design is that the anchor penetration angle be 65 degrees to ensure penetration in hard soil. The penetration angle described in Reference 5 is the external angle between the fluke and seafloor when the fluke is open and the fluke tip and shank end are on the seafloor.

The STATO Anchor experienced structural problems, principally because of high stresses occurring at the stopper and trunnion area. The trunnion is the pin located in the anchor crown that connects the shank to the fluke assembly. A finite element analysis that concentrated on this highly stressed area identified specific problem areas and enabled confident design. The analysis was supplemented and calibrated by full-scale instrumented testing of a NAVMOOR Anchor prototype.

Anchor Mud Palms. The NAVMOOR Anchor mud palms are an integral part of the anchor and are used in sand and mud seafloors. The STATO Anchor mud palms are welded add-ons when the anchor is to be used in mud. There is a small performance reduction in sand due to the permanent NAVMOOR Anchor mud palms but this is compensated for by the enhanced performance caused by the smooth flukes.

Anchor Stabilizers. Simple pipes are used for the standard NAVMOOR Anchor stabilizers compared to the welded, tapered construction for the STATO Anchor stabilizers. Model tests showed that the pipe was equal or more effective in controlling anchor roll than the tapered units. The NAVMOOR Anchor stabilizers are bolted or tac-welded in place. They are easily removed for shipping and storage ease.

Shank Assembly. The NAVMOOR Anchor shank is significantly different than the STATO Anchor shank. The STATO shank terminates at the trunnion pin within an enclosed anchor crown as do most anchors. For these anchors, padeyes are connected directly to the anchor crown. The flukes must be fixed open to prevent fluke closure when load is applied by a tandem anchor. The NAVMOOR shank extends through the anchor crown. This enables connection of the tandem anchor directly through the anchor shank. The pinned tandem link (shown in Figure 1 in the lower view) provides the means for the tandem connection and moves independent of anchor fluke movement. Loading by the tandem anchor does not cause fluke closure with resulting loss of primary anchor capacity.

As mentioned earlier, model and small-scale tests demonstrated that two anchors in tandem could develop a capacity 2-1/2 times the capacity of a single anchor. These tests showed that the tandem or piggyback anchor could hold 50 percent more than a single, individually pulled anchor. The anchor shank and connecting hardware are structurally designed to safely hold 2-1/2 times the capacity of a single anchor. The tandem link is sized for a load 1-1/2 times single anchor load.

ANCHOR APPLICATIONS

A variety of NAVMOOR Anchor sizes have been designed to satisfy many anchoring applications. Several of the prototypes are shown in Figure 5.

Navy Fleet Moorings

The Navy maintains about 300 permanent fleet moorings at harbors worldwide. These moorings currently range up to 300,000 pounds in capacity. However, the Navy has designs for and is procuring hardware for storm moorings to 500,000 pound capacity. NAVMOOR Anchor designs were developed to satisfy requirements typically above 300,000 pounds but can be used effectively for lesser capacity moorings. Twelve 10,000 pound (nominal weight) NAVMOOR Anchors (shown to the right in Figure 5) have been fabricated for the Navy's inventory for preproduction evaluation. A design for a 15,000-pound NAVMOOR Anchor was also completed for the fleet mooring program.

To reduce production costs, the 10,000-pound NAVMOOR Anchors were partially cast. The anchor shank and palm were cast and the flukes were fabricated and then welded to the cast palm. The "cast" NAVMOOR Anchor weight was equal to the fully fabricated anchor weight. In addition, anchor stresses, as measured during structural proof testing were also comparable to those of the fabricated anchor.

Navy Salvage

The Navy Supervisor of Salvage identified the need for an improved drag anchor for salvage operations. It had to be compatible with the ARS 50 class ships, hold 100,000 pounds in a broad range of seafloor conditions, and be suitable for free-fall deployment. A 6,000-pound NAVMOOR Anchor satisfied holding requirements but the anchor had to be modified to adapt to stowage in existing anchor pockets on the ARS 50 class ships. A prototype 6,000-pound NAVMOOR Anchor is shown in Figure 5 with one stabilizer in the open position. The stabilizers remain closed while on deck but can open during free fall to the seafloor. The stabilizers fully open on the seafloor from drag force on the plates on the end of the stabilizers when the anchor is proof set.

Tests conducted in soft mud in San Francisco Bay and user tests off the ARS 50, USS SAFEGUARD in sand and coral off Hawaii confirmed the ruggedness of the design and the operation of the folding stabilizers. The 6,000-pound NAVMOOR Anchor is shown in Figure 6 on the SAFEGUARD being released from the forward and after pockets.

As a result of the tests, some design changes were made to ease handling, reduce maintenance, and reduce cost. Based upon the positive results achieved with the cast version of the 10,000-pound NAVMOOR Anchor, the preferred construction method for the NAVMOOR Salvage Anchor is also a combination of cast and fabricated elements.

Amphibious Operations

Three sizes of anchors were designed for anchoring applications associated with amphibious logistics:

1. A 100-pound NAVMOOR Anchor was designed to provide side-stays for a floating fuel line. The anchor replaces a 200-pound STATO Anchor (280 pounds actual weight) which was too heavy for manhandling and a 150-pound LWT which was ineffective in mud. Several hundred 100-pound anchors have been procured.

2. A 1,000-pound NAVMOOR Anchor was designed as a replacement for the 2,500-pound LWT for the Navy's new Powered Causeway Section (PCS) because of space limitations on the PCS. Although lighter, the NAVMOOR Anchor will hold several times more than the LWT in mud and roughly two-thirds as much in sand. To date, 25 PCS's have been outfitted. Some design changes have occurred as a result of inservice use. The anchor shank has been strengthened to better tolerate off-line loading. The sand wedges used to reduce the fluke angle to 32 degrees are now lightly welded in place rather than bolted in place. This last change has been made for all the NAVMOOR Anchors.

3. A 2,000-pound NAVMOOR Anchor was designed as the new mooring anchor for the Army Corps of Engineers causeway system. This anchor replaces the LWT because of the general ineffectiveness of the LWT in mud seafloors. Also, the tandem anchoring capability of the NAVMOOR Anchor allows procurement of a single anchor size to satisfy varying loads along the causeway by using single and tandem anchor leg configurations.

ANCHOR TESTING PROGRAM

Anchor testing progressed through various stages including laboratory model testing, small-scale testing on the beach at Port Hueneme, California, and prototype testing in sand off Port Hueneme and in mud off Hunters Point, San Francisco Bay. The model test program (Ref 14 and 15) will not be discussed in this report. These tests were simply used to guide preliminary design to ensure at least comparable performance of the NAVMOOR Anchor to the proven STATO Anchor design and to evaluate minor configuration changes to enhance anchor performance.

Test Locations

Port Hueneme. The seafloor material at this ocean test site consisted of a dense well-graded gravelly fine sand. A typical grain size curve for a sample is provided in Figure 7. This site has changed considerably since 1981 when prior anchor tests were conducted (Ref 5). At that time, the site consisted of a poorly-graded fine sand. For reference, the 1981 distribution is also plotted on Figure 7. The seafloor material at this site provided a good test of the penetrating capability of the NAVMOOR Anchor in hard seafloor conditions.

San Francisco Bay, Hunters Point. The Hunters Point site was selected because there was a significant amount of historical data on the STATO Anchor (Ref 16) and the site was previously classified as a normally consolidated silty clay (mud). The grain size distribution for the Hunters Point mud is shown in Figure 8. The soil classified as an organic clayey silt. Undrained soil shear strength data taken from three cores are plotted in Figure 9. Historical data from previous NCEL tests (Ref 14) are also plotted for comparison. The historical data was generated from unconfined compression tests whereas the current data came from vane shear testing. Vane shear testing causes less sample disturbance, thus higher average values; nonetheless, results are similar. A reasonable approximation for the strength profile can be stated as the soil strength increases at the rate of 10 psf/ft of depth.

Test Procedures and Equipment

Small Scale Testing. Tests were performed on the beach at Port Hueneme for comparative evaluations of anchor performance prior to prototype testing. The beach material consisted of a poorly graded, medium dense, fine sand. The testing procedure was unsophisticated but very effective. Anchors were pulled with a bulldozer as shown in Figure 10. Total load was recorded using a dynamometer at the bulldozer. Drag distance was visually recorded by observing the travel of a marked line attached to the anchor relative to a fixed point. Other measurements taken at the completion of the test were anchor roll angle, anchor shank pitch angle, anchor chain angle, and anchor depth.

Prototype Testing. The ocean test setups used at Port Hueneme and San Francisco Bay are shown schematically in Figures 11 and 12. The test setups were different but both produced the data needed to establish anchor performance. The test setups and equipment capabilities were suitable for testing either single or tandem anchors.

Each anchor was instrumented to determine anchor depth, anchor shank pitch, anchor roll, and anchor load. A load cell was located between the chain and anchor shackle. An instrument package was strapped to the anchor shank (Figure 13). It contained inclinometers to measure pitch and roll, a pressure transducer to measure anchor depth, all signal conditioning equipment, and load cell amplifiers. A hose attached to the pressure transducer was buoyed off to ensure that it remained in the water column to avoid false readings. The measurement system(s) was connected to the instrumentation onboard the test barge via a 1,000-foot-long electrical well-logging cable. Mooring line load and line angle at the barge and barge displacement relative to a fixed spar buoy were measured. These data were needed to calculate true anchor drag distance as well as to determine the contribution of the bottom resting chain to total anchoring capacity.

At Port Hueneme, anchor loading was accomplished by a 250-ton capacity chain jack that pulled the test barge at about 2 feet per minute toward the restraint mooring that was located on the beach. At San Francisco, a 150-ton capacity winch was leased to speed the testing process. Because of winch capacity limits, the wire was two-parted through a sheave located on another YC barge (Figure 12). The barge system used at Hunters Point

is shown in Figure 14 at the completion of a test series when the barges were near touching. There was sufficient wire to allow barge separation of almost 600 feet which enabled about five tests to be conducted before the wire had to be overhauled.

SINGLE ANCHOR TEST RESULTS AND ANALYSIS

Port Hueneme Beach Tests

General. Before fabricating the prototype 10,000-pound NAVMOOR Anchor, a scale model was constructed to evaluate comparative performance against the STATO Anchor as well as to devise efficient fabrication methods. An anchor of approximately 200-pounds (actual weight was 211 pounds) was desired for comparison to the 200-pound STATO Anchor. It was later discovered that the actual weight of the 200-pound STATO Anchor was 280 pounds; nevertheless, a relative comparison was still possible. The model NAVMOOR Anchor was an exact scaled replica of the prototype. The stress levels in the model at design load are very low compared to the prototype. If the NAVMOOR model had been designed as a working prototype, much smaller steel sections could have been used which would have resulted in a lighter, more streamlined anchor. However, the dual purpose of evaluating anchor constructability would not have been served.

Test Results for 200-Pound Anchors. Five tests each were conducted with the NAVMOOR and STATO Anchors and the results are shown in Figure 15 and 16. To minimize beach variability effects on test results, the anchors were alternately pull tested. The average estimated performance curve for each anchor was plotted on Figure 17. Drag distances were nondimensionalized by reference to anchor fluke length to allow performance comparison to larger or smaller anchors. It is clear from Figure 17 that the NAVMOOR Anchor was more effective than the STATO Anchor in beach sand. The average holding performance advantage of the NAVMOOR anchor was 25 percent. From an anchor efficiency standpoint, the advantage was significantly greater because of the actual weight difference. Anchor efficiency is defined as the ratio of anchor holding capacity to nominal anchor weight.

Figure 18 illustrates one reason why the STATO Anchor is less efficient than the NAVMOOR Anchor in sand even though their general configurations are similar. The external ribs on the STATO Anchor confine and trap sand during the embedment process. This results in higher penetrating resistance that is a function of the friction between the anchor fluke and the penetrated medium. The coefficient of friction between the rough-fluked STATO Anchor and the beach sand is related to the sands intergranular friction, which for a medium density sand equals about 0.7. The coefficient of friction between a smooth steel surface, like the NAVMOOR Anchor fluke, and the beach sand is 0.3 to 0.4. From these preliminary test results it appeared that the goal to improve hard soil performance had been achieved.

Test Results for 100-Pound Anchor. A 100-pound NAVMOOR Anchor was designed for the specific application of side-stay anchor for a floating

fuel line. The 100-pound weight was selected to enable manhandling. Beach tests were conducted to evaluate anchor stability, performance consistency, relative holding capacity, and penetrability. The results of the five tests conducted are shown in Figure 19. Two of the five tests were run in wet dense sand near the water's edge. The remaining three tests were performed in dry sand. Results were indistinguishable. The 100-pound NAVMOOR Anchor had no difficulty penetrating the dense near-shore sand. The average performance was plotted in Figure 17. Interestingly, the 100-pound NAVMOOR Anchor held about 75 percent as much as the nearly 3 times heavier 200-pound STATO Anchor.

Later, in preparation for the final design of a 6,000-pound NAVMOOR Anchor for salvage operations, the 100-pound NAVMOOR Anchor was modified to accept folding stabilizers scaled from the prototype NAVMOOR Salvage Anchor. The test model is shown in Figure 5. Comparative beach tests were performed with the standard 100-pound anchor and the 100-pound anchor with folding stabilizers. Results are not presented, but the performance of these two anchors was indistinguishable and can be represented by the curve of Figure 17. This was a surprise because the larger folding stabilizers were expected to offer greater penetrating resistance which should have caused lower capacity.

Port Hueneme Sand Single Anchor Tests

General. Various sizes of NAVMOOR Anchors (1,000, 6,000 and 10,000 pounds nominal weight) were tested as single anchors. The 1,000-pound size is shown ready for tests as a single anchor in Figure 13. Typical load-drag distance data describing the performance of a single anchor is shown in Figure 20. The cyclic character of the data does not reflect actual anchor performance; rather, it reflects the effect of the test method on the results. The chain jack used to apply the test load hauled in about 3-1/2 feet of chain before it had to be reset to pull again. During the resetting process, up to 1 foot of chain was let out. This caused the large drop in anchor load which was a function of mooring geometry rather than anchor slippage. To simplify evaluation of anchor performance, the data were replotted to show peak values that correctly represent anchor capacity.

NAVMOOR 1,000-Pound Anchor Test Results. The performance of the single 1,000-pound NAVMOOR Anchor is shown in Figures 21 and 22. The test mooring leg from barge to anchor consisted of 36 feet of 2-1/2-inch chain and 45 feet of 1-1/2-inch chain. Total horizontal tension at the deck and tension at the anchor were measured directly. The anchoring tension was determined by subtracting the load caused by the surface resting chain from total tension. The anchoring tension defines the true anchor holding capacity which includes load carried by the anchor and buried chain. In both anchor tests, load was still increasing at a gradual rate when testing was stopped (Figures 21 and 22) so neither anchor reached maximum capacity. The point at which maximum capacity is reached can often be difficult to detect during the test. Also, use of the chain jack was so tedious that tests were often stopped when performance appeared to be peaking. In both tests, the anchoring tension was approximately 30 kips at 40 feet of drag distance.

The anchor was extremely stable during both tests; maximum anchor rotation varied from 2 to 5 degrees. The rotation angle remained near constant during drag suggesting that it was seafloor slope dominated. Anchor shank angle at maximum load was 8 to 9 degrees with the shank tip below the shank crown. This was comparable to past STATO Anchor test results and to NAVMOOR Anchor beach test results.

NAVMOOR 10,000-Pound Anchor Test Results. The results of two tests run with the NAVMOOR 10,000-pound Anchor are shown in Figures 23 and 24. The test mooring consisted of 360 feet of 2-1/2-inch chain. Results were consistent in the dense, gravelly sand. In both tests, all chain was lifted off the seafloor before peak load was achieved. This had little or no effect on performance because the anchor was nearing peak capacity at the time and the chain angle at the seafloor was less than one degree.

When the anchor was recovered after the first test, it was noted that the stabilizers were bent backwards (Figure 25). To solve the problem, the stabilizer pipes were strengthened and shortened by about 15 percent. Shortening of the stabilizers was acceptable because the anchor had demonstrated excellent stability in all laboratory, beach, and prototype testing. Also, note on the anchor in Figure 25 that the paint has been removed from fluke and stabilizer surfaces. This illustrates difficulty of maintaining a painted anchor used in granular seafloors. Maximum roll of the 10,000-pound NAVMOOR Anchor was 5 to 6 degrees, which was consistent during drag again suggesting that it was seafloor slope dominated. Maximum shank angle was 8 to 9 degrees with the shank tip below the anchor crown, which was comparable to the 1,000-pound NAVMOOR Anchor.

An interesting comparison was made between the results of the prototype tests of the 10,000-pound NAVMOOR Anchor and the beach tests of the 200-pound scale model of the 10,000-pound NAVMOOR Anchor. Results were plotted in nondimensional form in Figure 26 as anchor efficiency (holding capacity to weight ratio) versus drag distance/fluke length. Although the beach tests were in dry sand, the average beach test performance curve was remarkably similar to the prototype performance curves. This suggests that more than relative performance evaluations of anchors in sand can be accomplished very inexpensively by conducting tests of moderately sized scale model anchors in beach sand.

NAVMOOR 6,000-Pound Anchor Test Results. The 6,000-pound NAVMOOR Anchor was tested twice and the data are plotted in Figures 27 and 28. The load cell at the anchor did not work reliably in either test; however, anchoring load could still be determined by subtracting the bottom chain effect from horizontal deck load. At the point that all chain is off the seafloor, anchoring load and deck load are equal.

For comparison, a 6,000-pound STATO Anchor was tested and results are presented in Figure 29. Comparative performance of the STATO and NAVMOOR Anchors is shown in Figure 30. All anchors remained very stable during the test, but the STATO Anchor in particular had difficulty penetrating the dense sand. The second NAVMOOR test, 12-85 PH, also showed the effects of the dense seafloor; anchor load built rapidly then

leveled off at about 150 kips. The first NAVMOOR Anchor test showed a more gradual load building during the 80 feet of drag. Load was still increasing when the test was stopped at 174 kips. The more gradual buildup of load and the higher peak capacity for the first test suggested a lower soil density at this test location. When this anchor was recovered, there were no gravel remnants on the anchor as there had been on the other anchors.

Historical STATO Anchor test data (Ref 14) at this site showed constant load buildup to 180 kips and testing was stopped to avoid anchor damage. Reported soil properties showed a uniform sand of medium density. The character of this site has changed and its effect on STATO Anchor performance has been significant. The performance of the smooth-fluked NAVMOOR Anchor was better than the STATO Anchor in dense sand. The difference in performance in a lower density sand should be less pronounced.

Single Anchor Performance Analysis in Sand. Performance curves for all prototype single NAVMOOR Anchor tests conducted in the dense gravelly sand are provided in Figure 31. There is a common general degradation in anchor performance with increasing anchor size. Nominal rather than actual anchor weight is used to develop the curves. These results should reflect conservative performance of the NAVMOOR Anchor in sand because the data were gathered in dense gravelly sand which is a difficult material to penetrate. These results demonstrate that the NAVMOOR Anchor does improve the Navy's hard soil anchoring capability. The sharp, smooth flukes of the NAVMOOR Anchor enhance penetration in hard soils.

The actual performance curves for the NAVMOOR Anchor, plotted in Figure 31, were used to define an average curve for each anchor size tested. These average performance curves are presented in Figure 32. Even though the trends in Figure 32 showed that maximum capacity was not generally achieved, it was assumed that it was achieved for purposes of defining anchor capacity. The maximum holding capacity for each anchor, from Figure 32, were plotted versus anchor weight in Figure 33. The performance of geometrically similar anchors can normally be represented as a straight line on a log-log plot of holding capacity versus nominal anchor air weight and these data followed that trend. The straight line through the test results is represented by the equation,

$$H_m = 31W_A^{0.94} \quad (1)$$

where H_m = anchor holding capacity - kips

W_A = anchor air weight (nominal) - kips

San Francisco Bay Mud Single Anchor Tests

General. The 6,000-pound and 10,000-pound NAVMOOR Anchors were used to evaluate single anchor performance in mud. The 6,000-pound STATO Anchor was also tested to provide a baseline for comparison to NAVMOOR Anchor performance and to historical STATO Anchor test data. Model tests

in soft clay with 1/20 scale models of 6,000-pound anchors showed that performance was comparable. Thus, it was expected that prototype behavior would also be similar in mud.

Single Anchor Test Results. An actual data plot for a 10,000-pound NAVMOOR Anchor test in mud is shown in Figure 34. Horizontal deck load, anchoring load or true anchor holding capacity, and surface chain load are plotted versus anchor drag distance. Anchoring load was determined by subtracting the load caused by the surface resting chain from the deck load. In all of the mud tests, testing was stopped before maximum load was achieved. At about 90 feet of drag the anchor crown buoy was pulled underwater and the instrument cable was near breaking so, the tests were stopped. Actually, achievement of maximum load can take 200 to 300 feet of drag. At about 90 feet of drag, the anchor achieves 70 to 80 percent maximum capacity and ultimate capacity can be projected with reasonable accuracy.

Figure 34 shows that the anchor was very stable throughout drag. Its roll angle oscillated between 5 to 8 degrees from horizontal. Maximum anchor shank pitch was 8.1 degrees (shank shackle above the anchor crown). Based upon an analysis of STATO data from Ref 5, the maximum shank angle for the 6,000-pound STATO Anchor at maximum load and embedment depth is about 24 degrees (shank shackle up). It's obvious from this and all subsequent tests in mud that the NAVMOOR Anchor, whose performance will be shown to be similar to the STATO Anchor, was not at peak capacity.

Results of all 10,000-pound and 6,000-pound NAVMOOR Anchor tests are provided in Figures 35 and 36. Note that all the tests for each size anchor are quite similar. The NAVMOOR Anchor flukes tripped open reliably and the anchor remained stable during the penetration process. Maximum shank angles were far below projected maximum so the anchors would continue to embed.

Single Anchor Performance Analysis. Results of a 6,000-pound STATO Anchor test are superimposed on the NAVMOOR test data in Figure 36 and the results are comparable. With the similarity of the NAVMOOR and STATO data, historical STATO data for the site could be used to estimate maximum NAVMOOR Anchor capacity. This, of course, assumed that the current STATO data agreed with historical data; this comparison is excellent (Figure 37). Historical data for the 6,000-pound and 9,000-pound STATO Anchors were used to define an average performance curve that could be used to project NAVMOOR Anchor test results for the 6,000-pound and 10,000-pound NAVMOOR Anchors, respectively. For example, the estimated average performance of the 9,000-pound STATO Anchor in mud is shown on Figure 38. The selected performance curves for this and the 6,000-pound STATO Anchor conservatively represent anchor performance in mud. Normalized holding capacity-drag distance relationships for the two STATO Anchors were developed (Figure 39) from the average performance curves and were then used to project NAVMOOR Anchor data to determine estimated maximum capacities. Average performance curves for the NAVMOOR Anchors were developed from the test data (Figures 35 and 36) and extrapolated (Figure 40).

The maximum estimated capacities for the 6,000-pound and 10,000-pound NAVMOOR Anchors are 131 kips and 215 kips, respectively. These maximum

values were plotted with historical STATO Anchor data to determine a performance specification in mud (Figure 41). A curve, which reasonably represents the data, is

$$H_m = 25W_A^{0.94} \quad (2)$$

where H_m = anchor holding capacity - kips

W_A = anchor air weight (nominal) - kips

Summary of Single Anchor Tests

The performance of the NAVMOOR Anchor in sand was defined through a series of small-scale and prototype anchor tests. The NAVMOOR Anchor demonstrated excellent stability throughout the tests and an ability to penetrate and hold consistently in a dense gravelly sand. NAVMOOR Anchor performance exceeded that of the STATO Anchor in dense sand. A goal to improve the Navy's hard soil anchoring capability has been achieved.

Anchor holding capacity in sand can be defined by the equation,

$$H_m = 31W_A^{0.94} \quad (3)$$

where H_m = anchor holding capacity - kips

W_A = anchor air weight (nominal) - kips

NAVMOOR Anchor performance in mud was consistent and comparable to the Navy's STATO Anchor. Excellent anchor stability throughout anchor drag was demonstrated. Anchor holding capacity in mud can be defined by the equation,

$$H_m = 25W_A^{0.94} \quad (4)$$

TANDEM ANCHOR RESULTS AND ANALYSIS

Port Hueneme Sand Tandem Anchor Tests

General. The 1,000-pound and 6,000-pound NAVMOOR Anchors were used to evaluate tandem anchor performance in sand. NAVMOOR 1,000-pound Anchors are shown ready for tandem anchor testing in Figure 42 (the suspended anchor is the tandem anchor). The chain from it is connected to the tandem link at the rear of the primary anchor. This link is pin-connected to the shank, not to the anchor crown.

Tandem Anchor Tests and Analysis. Two tests were performed with 1,000-pound NAVMOOR Anchors and one with 6,000-pound NAVMOOR Anchors. The test with the 6,000-pound NAVMOOR Anchors was stopped because of a

hydraulic power unit failure which also ended the test effort. The second test with the 1,000-pound anchors was also stopped before maximum load because of equipment problems. Nevertheless, the data that was gathered agreed with model and small-scale test results and was suitable for definition of tandem anchor performance in sand.

Results of the 1,000-pound NAVMOOR Anchor tests are shown in Figures 43 and 44. In the first test (test 3-85PH) deck load and load at the tandem anchor were measured. The load cell in front of the primary anchor functioned intermittently. Those data were questionable and are not presented. In the second test, deck load and load at the primary anchor were recorded. The load cell at the tandem anchor did not operate.

The characteristic performance of these anchors in tandem was interesting. Note the dips in the anchor load and deck load curves in Figure 43. At about 20 to 25 feet of drag, the tandem anchor feels the soil disturbed by the forward anchor. Eventually, the tandem anchor begins to embed deeper through the disturbed soil and the load begins to increase at a more rapid rate. This behavior was previously noted in model and small-scale anchor tests. Figure 45 shows the dips, although more pronounced, for 200-pound STATO Anchors tested in tandem. Since soil failure in sand occurs through a zone extending many feet forward of an anchor, the effect of the soil disturbance by the forward anchor would be noticed before the tandem anchor reached the disturbed soil.

The first tandem 1,000-pound NAVMOOR Anchor tests showed that two anchors used in tandem will develop at least twice the capacity of a single anchor. The second test was less conclusive because the test was stopped due to equipment problems. However, the anchoring and deck load curves for both tests were quite similar to the point where the second test was stopped.

Results of the tandem 6,000-pound NAVMOOR Anchor tests are shown in Figure 46. Load increased rapidly until the rear anchor approached the zone disturbed by the forward anchor. Then, the characteristic dip in the load displacement curve occurred similar to all previous tandem anchor tests. (Note the anchor roll plotted above the load displacement curve in Figure 46.) The inboard anchor started to roll slightly when the rear anchor neared the disturbed soil. However, the 6 to 7 degree roll stabilized and then began to decrease. This shows that the NAVMOOR Anchor has good stability and will recover after being perturbed. Anchor load continued to increase at a lesser rate until the test and overall test effort had to be stopped because of a major test equipment failure. The rate of load increase after about 40 feet of drag was about twice that for a single anchor suggesting that both anchors were functioning properly.

The anchor shank angle of the primary anchor started at 7 to 8 degrees (shank shackle down) and gradually decreased to 2 to 3 degrees when the test was stopped. This contrasts to a 10- to 11-degree shank angle (shank shackle down) for the single NAVMOOR Anchor throughout the test. A difference was that a very large load cell requiring 3-inch shackles was needed in the tandem test to handle the expected high load, compared to a load cell 60 percent as wide using 2-1/4-inch shackles for single anchor tests. This added bearing resistance at the shank shackle end will affect anchor performance. Also, at about 145 kips load, all the chain was lifted off the seafloor. Maximum chain angle at the seafloor was 3 to 4 degrees which will slightly affect the primary anchor

performance. The tandem anchor will not be affected. The good stability of the anchors and the uniform load buildup comparable to the sum of two independent anchors shows that the two anchors in tandem will develop a system capacity at least equal to the sum of two individually pulled anchors in sand.

San Francisco Bay Mud Tandem Anchor Tests

General. Tandem anchor tests were conducted with 6,000-pound NAVMOOR Anchors. In these tests, the anchors were separated by a 90-foot length of wire rope. This length of wire rope conveniently allowed each anchor to be handled and placed on the seafloor without disturbing the other anchor and it exceeded the minimum allowable anchor separation of 3 to 4 fluke lengths (Ref 13) to achieve stable performance. Chain could have been used to connect the anchors but wire provides less penetrating resistance and its use should enhance system performance.

Tandem Anchor Tests and Analysis. Performance curves for two tandem anchor tests with 6,000-pound NAVMOOR Anchors are provided in Figures 47 and 48. Similar to the single anchor tests, the maximum drag distance that could be accommodated was about 90 feet. At 90 feet, the total system holding capacity was 210 kips, which is roughly twice the capacity of a single anchor at that drag distance. This suggests that the tandem system was functioning effectively.

At the completion of the first test, the tandem anchor was pulled out of the seafloor and replaced on the seafloor; the primary anchor was left embedded. Figure 48 shows the continuation of the test as if it started at zero drag distance. Anchoring load started at 95 kips, which reflects the capacity of the primary anchor at 90 feet of drag and then increased to 210 kips in 40 feet of additional drag. The tandem anchor was then pulled out of the seafloor and the primary anchor was tested to determine its capacity at test completion. The primary anchor had a capacity of 148 kips.

Figure 49 shows the two NAVMOOR Anchor tests in combination as a single test series. For reference, the average performance curve for a single 6,000-pound NAVMOOR Anchor is plotted for the same total drag distance. At the completion of the first test segment, the primary anchor was holding slightly less than an average single anchor. At the completion of the second test segment, the primary anchor was holding considerably more than an average single anchor. Initially, this was surprising because the embedment of the first anchor was supposed to have been slowed by the drag of the surface resting tandem anchor; rather, it seems that the upward pull on the tandem link caused the anchor shank to pitch forward. This decreases anchor shank angle which effectively increases fluke angle relative to its trajectory and causes more rapid penetration and an accelerated increase in capacity. In fact, the primary anchor's capacity exceeded the predicted ultimate capacity of a single anchor and it was still continuing to increase at a rapid rate. The tandem anchor was also behaving as a normal single anchor. With continued drag, its capacity would exceed single anchor capacity because the anchor is stable and it was being pulled from a point beneath the surface; thus, it did not have to embed a large length of chain during

the process. The capacity of the tandem anchor system in mud will certainly exceed the capacity of the sum of two single anchors. Model tests (Ref 13) showed that a tandem anchor system would hold 20 to 30 percent more than the sum of single anchors. Test results in San Francisco Bay mud indicate that this may be a conservative estimate for prototype anchors.

The key to the effective use of tandem anchors, particularly in mud seafloors, is good anchor stability. Previous tests (Ref 13 and 17) showed that tandem anchor performance depended primarily upon the stability of the primary anchor. Most anchor types become immediately unstable when used in a tandem anchor system and could not develop the full capacities of the individual anchors. As the primary anchor rolls, it can come to the surface and restrict embedment of the rear or tandem anchor. The STATO Anchor type demonstrated good stability during model and small-scale tests in a tandem anchor system. Because of the configuration similarities, the NAVMOOR Anchor was expected to behave similarly. Prototype results have verified that the NAVMOOR Anchor is stable as a single anchor and as the primary anchor in a tandem anchor system. Therefore, each anchor can develop at least its full capacity in a tandem anchor system.

Summary of Tandem Anchor Tests

The NAVMOOR Anchors demonstrated excellent stability when used in tandem. As noted earlier good anchor stability is a key element in the proper functioning of anchors in tandem. Test results in sand and mud seafloors showed that two NAVMOOR Anchors connected in tandem will develop at least twice the capacity of a single anchor. While the test data suggest that this is a conservative estimate, particularly in mud seafloors, the recommended ultimate capacity of a tandem anchor system in sand and mud seafloors is twice the capacity of a single anchor.

Since the performance relationships provided for the NAVMOOR Anchors in sand and mud seafloors show that anchor efficiency decreases as anchor size increases, there are advantages to using two anchors in tandem compared to the use of a single large anchor. The anchors are lighter and easier to handle and recover, and the tandem system is more efficient resulting in a lighter system.

NAVMOOR ANCHOR SIZE GUIDELINES FOR NAVY FLEET MOORINGS

Using the NAVMOOR Anchor performance relationships presented in this report, anchor size requirements for various mooring classes could be determined. Actual calculated anchor sizes based on a safety factor of two are provided in Table 1. Recommended sizes established by rounding up or down while remaining within an allowable factor of safety range of 1.75 to 2.25 are provided in Table 2. Acceptance of a factor of safety of less than 2 is reasonable because anchor performance criteria and methods used to establish mooring loads are conservative.

Mooring classes below class C in mud and class B in sand were not considered because standard stockless anchors available in Navy inventory can be used to readily satisfy these needs. The approximate maximum anchor size considered was 15,000 pounds, which is based upon a

recovery limitation in mud seafloors. The Navy's ability to recover an anchor is generally limited to about 200,000 pounds which approximates the pullout load for a 15,000 pound NAVMOOR Anchor set to its safe working load in mud.

Four ground leg options with the NAVMOOR Anchor are provided. These options are standard within the Navy. The four ground leg options listed in decreasing order of desirability are:

(1) Single chain, single anchor. This is the simplest ground leg option consisting of a single anchor on a single mooring chain.

(2) Single chain, tandem anchor. This consists of two anchors connected in tandem on a single mooring leg. Minimum recommended anchor separation referenced to the length of the anchors fluke is 3 fluke lengths. Larger lengths would commonly be used to simplify handling.

(3) Twin chain, single anchor. This consists of two single anchor legs connected to a common point e.g., ground ring, buoy, etc. To avoid anchor interference when the anchors are dragged, the anchors are staggered by a minimum of 3 fluke lengths.

(4) Twin chain, tandem anchor. This consists of two tandem anchor legs connected to a common point. The anchors are staggered by a minimum of 3 fluke lengths to avoid interference.

Table 2 shows that the Navy's fleet mooring requirements from class C (100 kips) to AAA (500 kips) can be satisfied with only two sizes of anchors, the 10,000-pound and 15,000-pound NAVMOOR Anchors. Actually, with the 15,000-pound anchor in the twin chain tandem anchor leg configuration, moorings to 650-kip capacity in mud and 800-kip capacity in sand could be established.

SUMMARY AND CONCLUSIONS

A new Navy mooring anchor (NAVMOOR) has been developed to satisfy a variety of Navy anchor applications. Various sizes of anchors have been designed, fabricated, and structurally and operationally proof-tested. Prototype testing of single anchors and of anchors in tandem were completed in sand and mud seafloors. Results have shown that the NAVMOOR Anchor is structurally and operationally superior to the Navy's STATO Anchor which in the past was the most effective general purpose anchor for Navy applications. The NAVMOOR Anchor demonstrated its effectiveness in dense sand and soft mud seafloors when used in single or tandem anchor leg configurations. The NAVMOOR Anchor has enhanced the Navy's capability to anchor in harder seafloors and has provided a means to satisfy its expanded fleet mooring requirements to a 500-kip capacity.

The holding capacity of a single NAVMOOR Anchor can be defined by the equations:

$$H_m = 25W_A^{0.94} - \text{mud}$$

and

$$H_m = 31W_A^{0.94} - \text{sand}$$

where H_m = anchor holding capacity - kips

W_A = anchor air weight (nominal) - kips

In a tandem anchor system each anchor will develop at least its full rated holding capacity. Tandem anchor system capacity is defined as twice the capacity of a single anchor.

The ability of the NAVMOOR Anchor to be used in single and tandem anchor configurations and to function effectively in a broad range of seafloor conditions minimizes the Navy's anchor inventory needs while satisfying high capacity mooring requirements.

The Navy's fleet mooring requirements from class C (100 kip capacity) to class AAA (500 kips) can be satisfied with only two sizes of NAVMOOR Anchor, the 10,000-pound and 15,000-pound NAVMOOR, used in various single and tandem anchor leg configurations.

Because the tandem anchor system employs smaller anchors to satisfy new mooring requirements, the Navy's existing equipment assets are adequate for installation and recovery of the new moorings.

Various size NAVMOOR Anchors have been designed, fabricated, and employed for Navy mooring applications. These include anchors for amphibious logistics applications, salvage, and fleet moorings. The NAVMOOR Anchor design is flexible and can be adapted as needed for other applications as well.

REFERENCES

1. Civil Engineering Laboratory. Test data summary for commercially available drag embedment anchors, by R. J. Taylor. Port Hueneme, CA, Jun 1980.
2. _____. Technical Note N-1592: Conventional anchor test results at San Diego and Indian Island, by R. J. Taylor. Port Hueneme, CA, Jul 1980.
3. _____. Technical Note N-1592: Conventional anchor test results at Guam, by R. J. Taylor. Port Hueneme, CA, Oct 1980.
4. _____. Technical Memorandum M-42-82-02: Performance of conventional anchors, by R. J. Taylor. Port Hueneme, CA, Mar 1981.
5. Naval Civil Engineering Laboratory. Technical Note N-1635: Drag embedment anchor tests in sand and mud, by R. J. Taylor. Port Hueneme, CA, Jun 1982.

6. _____. Techdata Sheet 83-08: Drag embedment anchors for Navy moorings, by R. J. Taylor. Port Hueneme, CA, Mar 1983.
7. _____. Techdata Sheet 83-09: STOCKLESS and STATO Anchors for Navy fleet moorings, by R. J. Taylor. Port Hueneme, CA, Mar 1983.
8. _____. DOT Handbook, Chapter 7: Drag anchors, selection and design. Port Hueneme, CA, Mar 1985.
9. _____. Contract Report 83.036: A method for predicting drag anchor capacity. Houston, TX, Brian Watt Inc. Aug 1983.
10. _____. Technical Report N-1688: Design guide for drag embedment anchors, by R. J. Taylor and P. Valent. Port Hueneme, CA, Jan 1984.
11. _____. Techdata Sheet 83-05: Multiple STOCKLESS Anchors for Navy fleet moorings, by R. J. Taylor. Port Hueneme, CA, Feb 1983.
12. _____. Technical Memorandum M-42-82-04: Anchoring options for high capacity Navy fleet moorings, by R. J. Taylor and G. R. Walker. Port Hueneme, CA, Sep 1982.
13. _____. Technical Note N-1707: Model and small-scale tests to evaluate the performance of drag anchors in combination, by R. J. Taylor and G. R. Walker. Port Hueneme, CA, Oct 1984.
14. _____. Technical Memorandum M-42-83-01: STATO model anchor tests in sand, by G. R. Walker. Port Hueneme, CA, Feb 1983.
15. _____. Model anchor test records by R. J. Taylor, unpublished. Port Hueneme, CA, 1983.
16. _____. Technical Report R-044: New and modified anchors for moorings, R. C. Towne and J. V. Stalcup. Port Hueneme, CA, Mar 1960.
17. P.J. Klaren. Anchors in tandem on the use of backup anchors (piggy-backs), Holland Shipbuilding, Anchor Advise Bureau, 1973.

Table 1. Calculated NAVMOOR Anchor Size^a for Navy Fleet Moorings

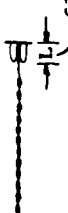
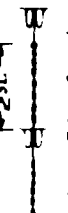
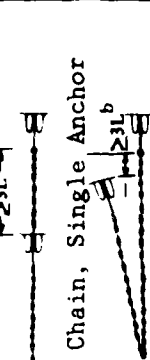
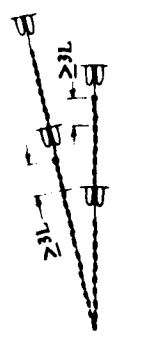
Mooring Class	Mooring Capacity (kips)	Anchor Weight (Nominal) for Ground Leg Options (lb)				
		1. Single Chain, Single Anchor 	2. Single Chain, Tandem Anchor 	3. Twin Chain, Single Anchor 	4. Twin Chain, Tandem Anchor 	
		Mud ^c	Sand ^d	Mud	Sand	
AAA	500					
BBB	400					
AA	300					
BB	250					
CC	200					
DD	175	16,560	13,180	14,060	11,340	11,580
A	150	14,060	11,340	11,580	9,340	9,130
B	125	11,580	9,340			
C	100	9,130				

^aCalculated anchor size based upon system factor of safety of 2.

^bMinimum anchor separations related to fluke length (L).

^cIncludes very soft to soft silt and clay seafloors.

^dIncludes sands and medium to stiff clay seafloors.

Table 2. Recommended NAVMOOR Anchor Size^a for Navy Fleet Moorings

		Anchor Weight (Nominal) for Ground Leg Options (lb)							
Mooring Class	Mooring Capacity (kips)	1. Single Chain, Single Anchor		2. Single Chain, Tandem Anchor		3. Twin Chain, Single Anchor		4. Twin Chain, Tandem Anchor	
		Mud ^c	Sand ^d	Mud	Sand	Mud	Sand	Mud	Sand
AAA	500								
BBB	400								
AA	300								
BB	250								
CC	200								
DD	175	15,000	15,000	15,000	15,000	15,000	15,000	10,000	10,000
A	150	15,000	10,000	15,000	10,000	10,000	10,000	10,000	10,000
B	125	10,000	10,000	10,000	10,000	10,000	10,000	10,000	10,000
C	100	10,000	10,000	10,000	10,000	10,000	10,000	10,000	10,000

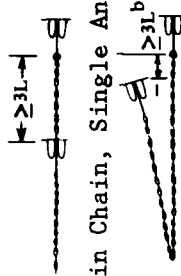
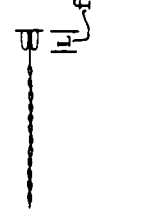

^aRecommended anchor sizes provide system factor of safety of 1.75 to 2.25.

^bMinimum anchor separations related to fluke length (L).

^cIncludes very soft to soft silt and clay seafloors.

^dIncludes sands and medium to stiff clay seafloors.

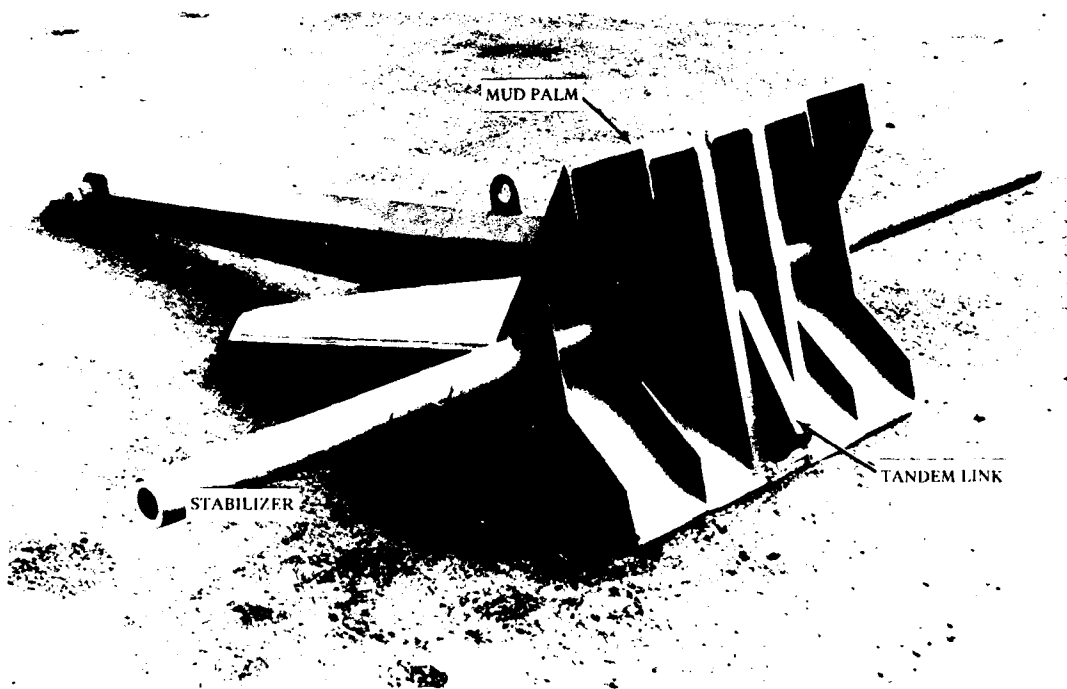
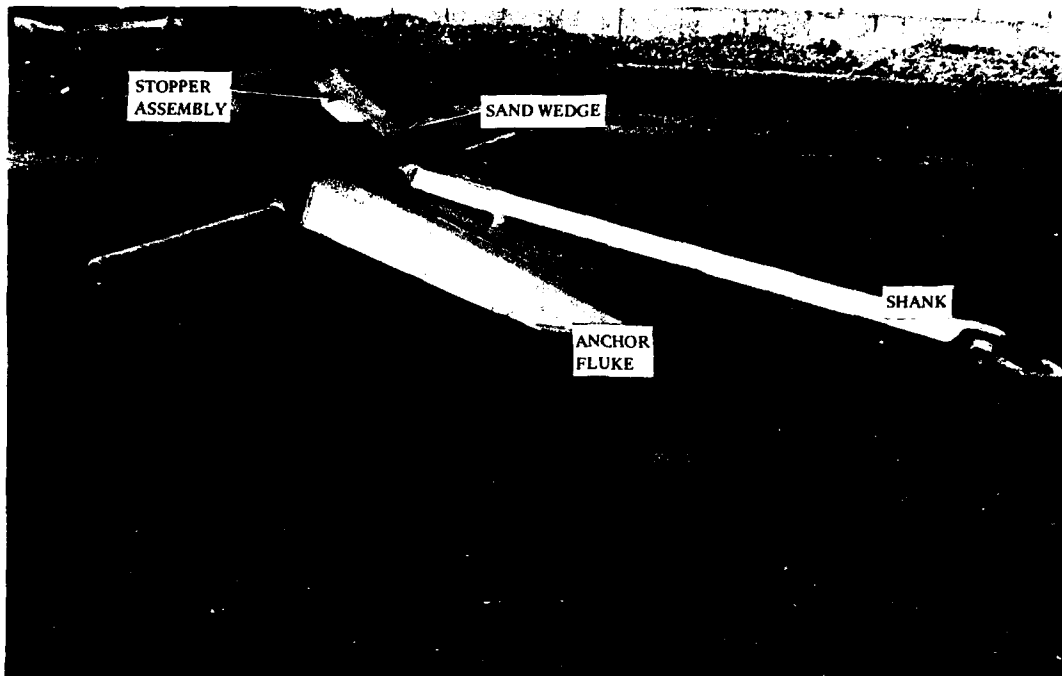

Figure 1. 1,000-pound NAVMOOR Anchor.

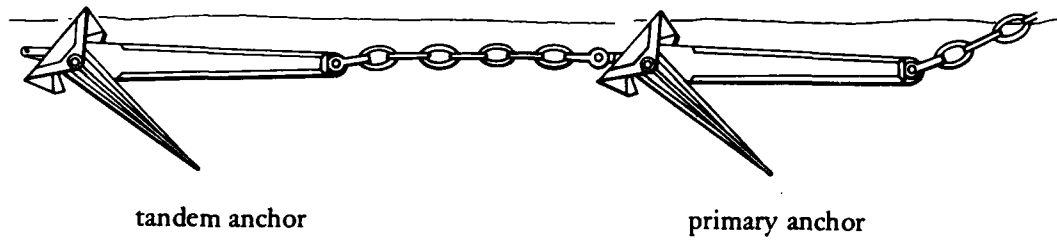

Figure 2. NAVMOOR Anchors shown rigged in tandem.

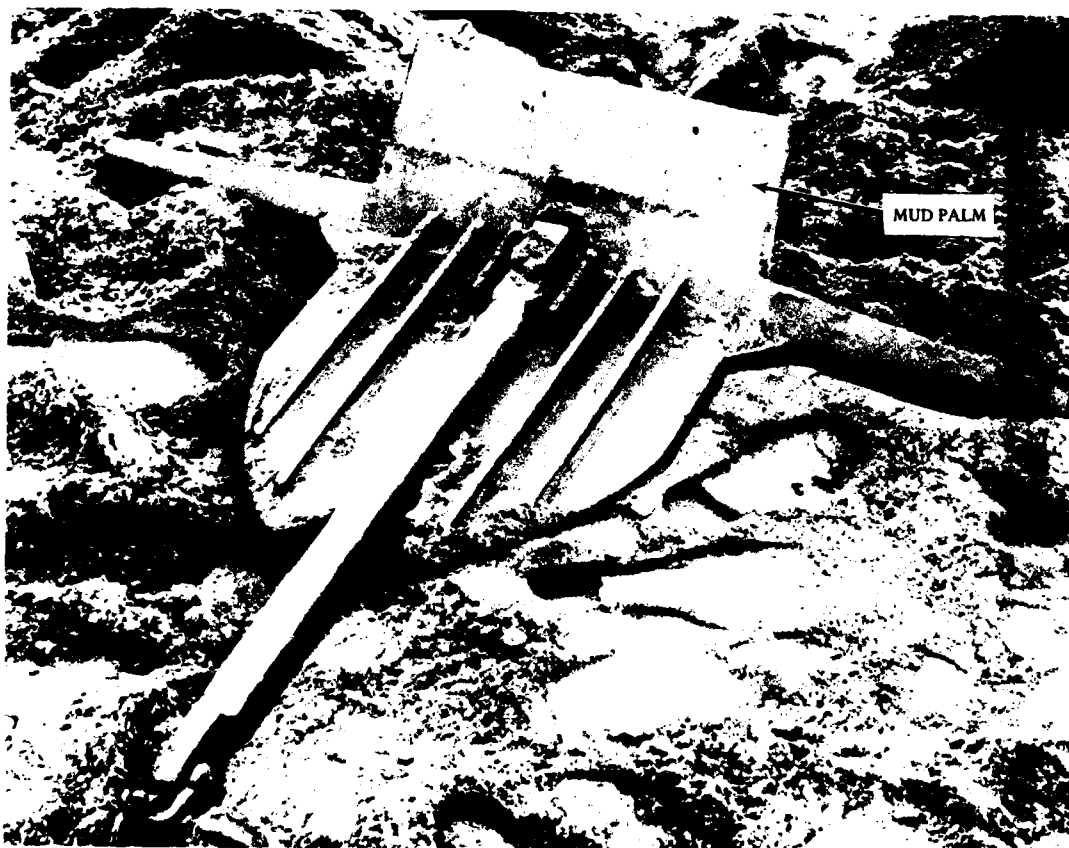

Figure 3. 200-pound STATO Anchor.

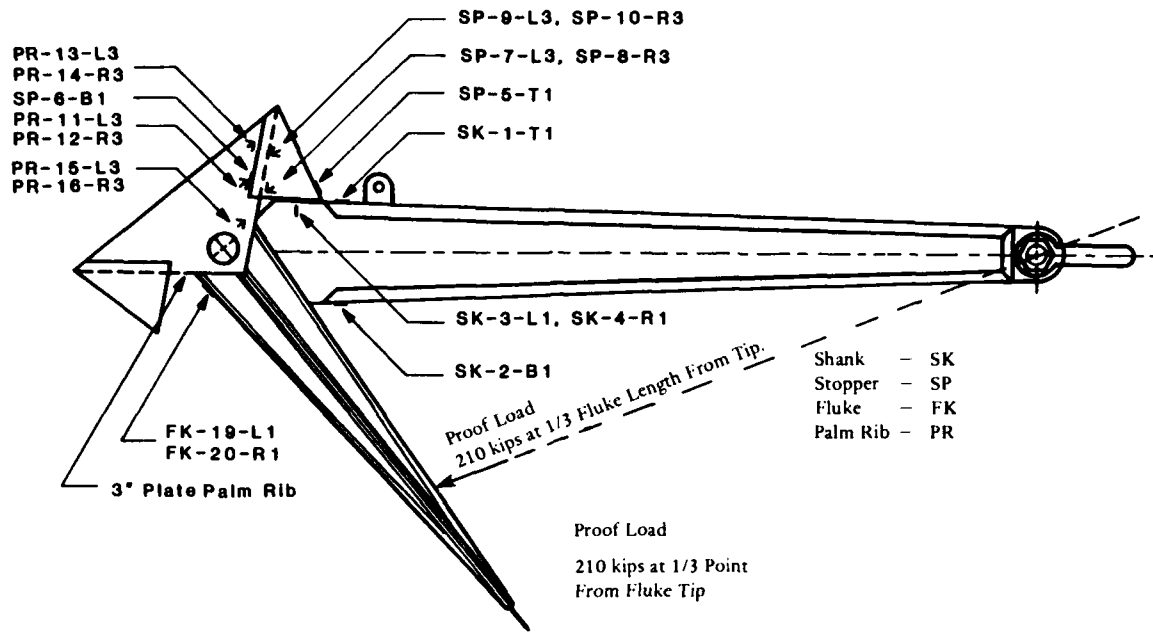
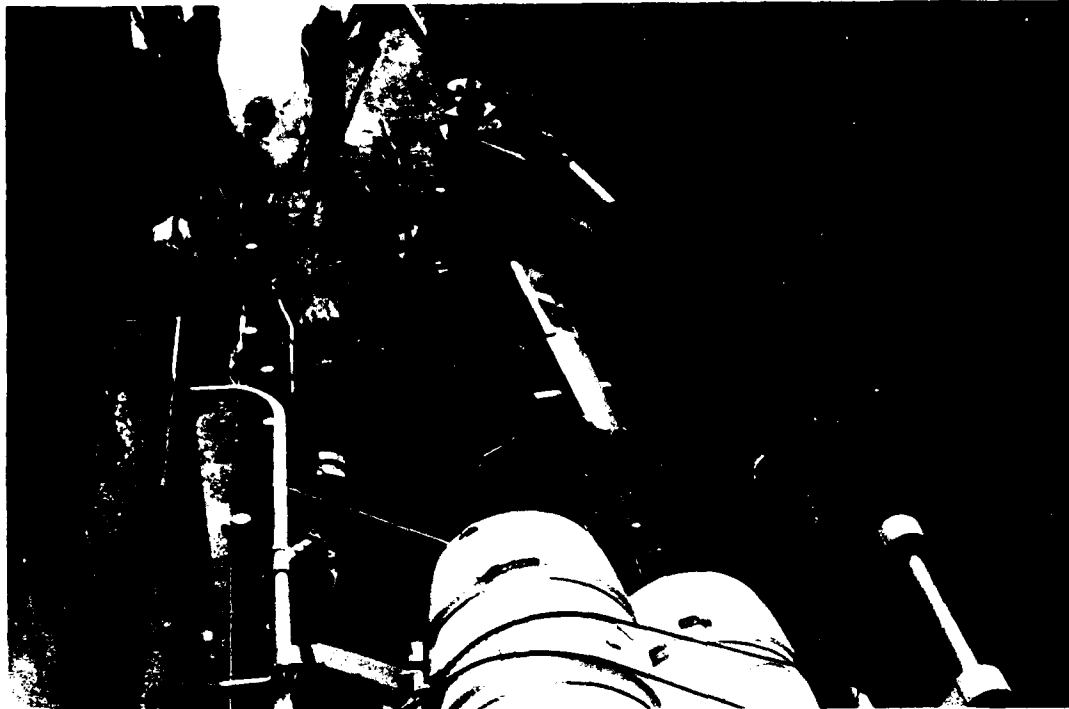

Figure 4. Plan view - strain gage locations for 10K NAVMOOR Anchor proof tests.



Figure 5. NAVMOOR Anchors. Left to right: (1) 1,000-pound, (2) 200-pound, (3) 6,000-pound with folding stabilizers, (4) 100-pound model with folding stabilizers, (5) 100-pound, and (6) 10,000 pound.



a. Anchor mounted horizontally in forward pocket.

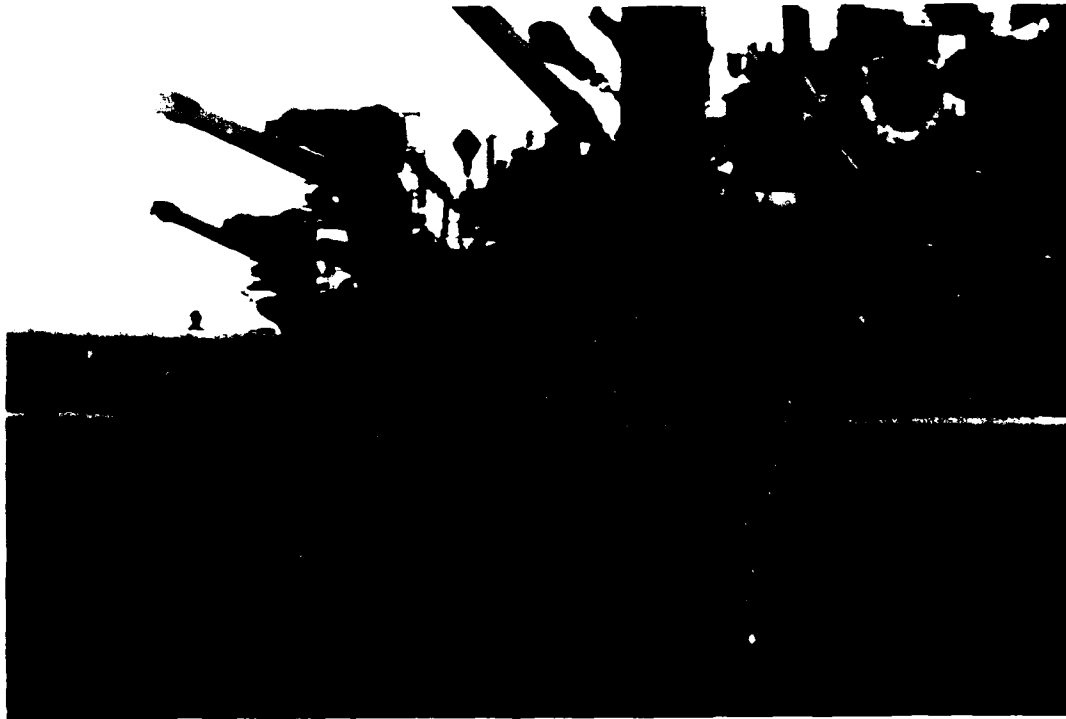

b. Anchor mounted vertically in after pocket.

Figure 6. NAVMOOR Anchors for salvage being deployed from the USS SAFEGUARD, ARS 50.

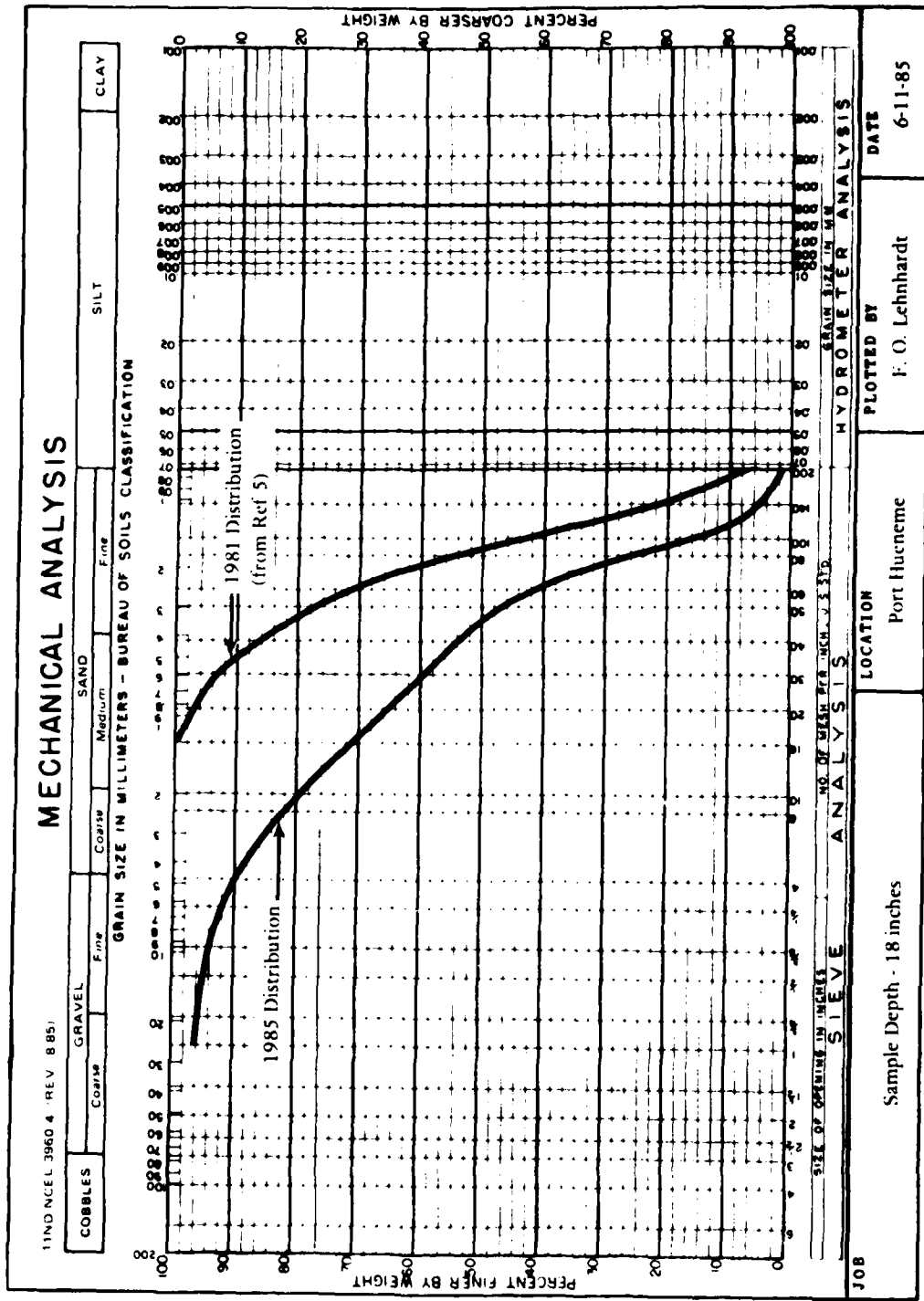

Figure 7. Grain size distribution for Port Huene sand, west jetty.

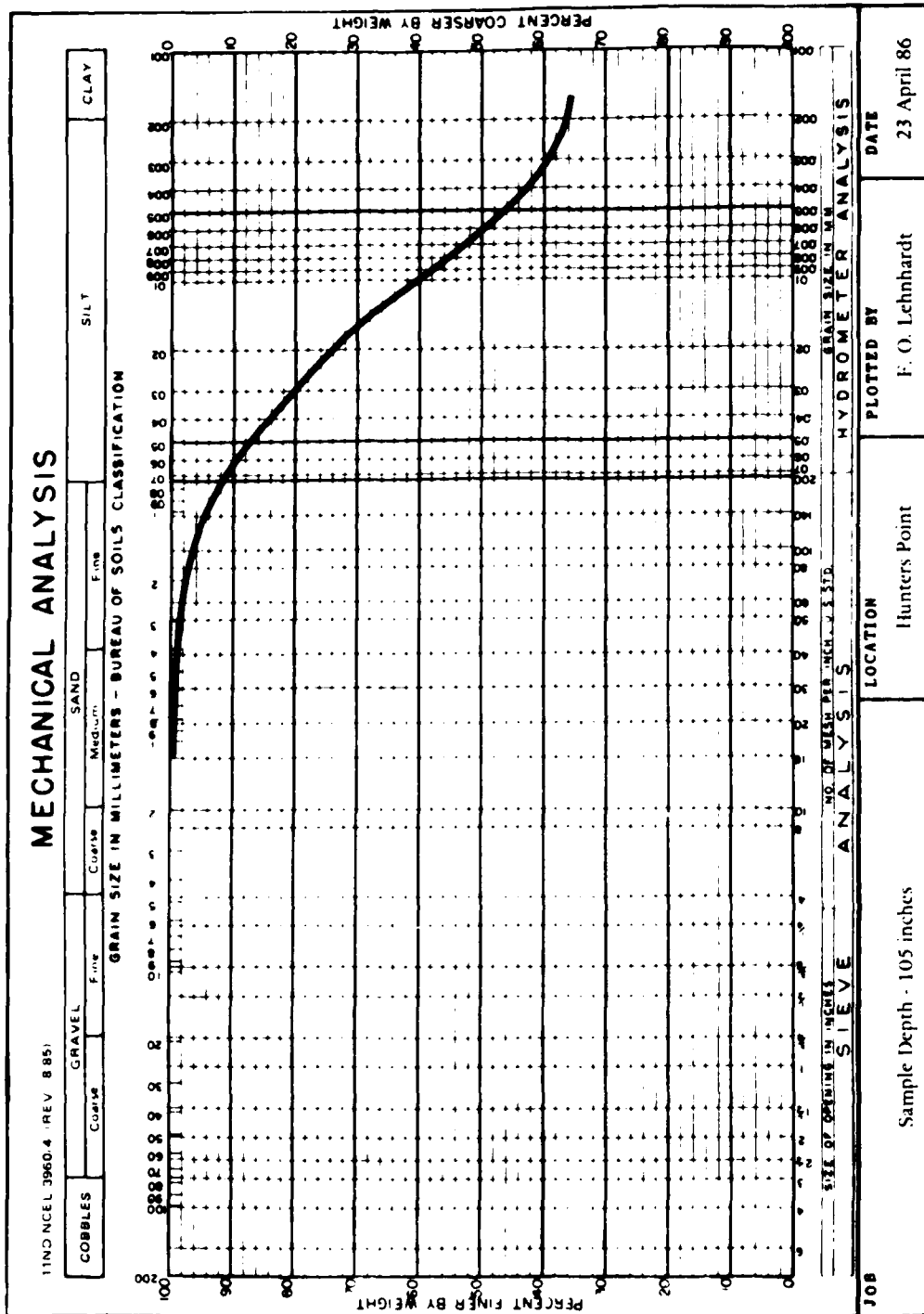

Figure 8. Grain size distribution for San Francisco Bay mud at Hunters Point.

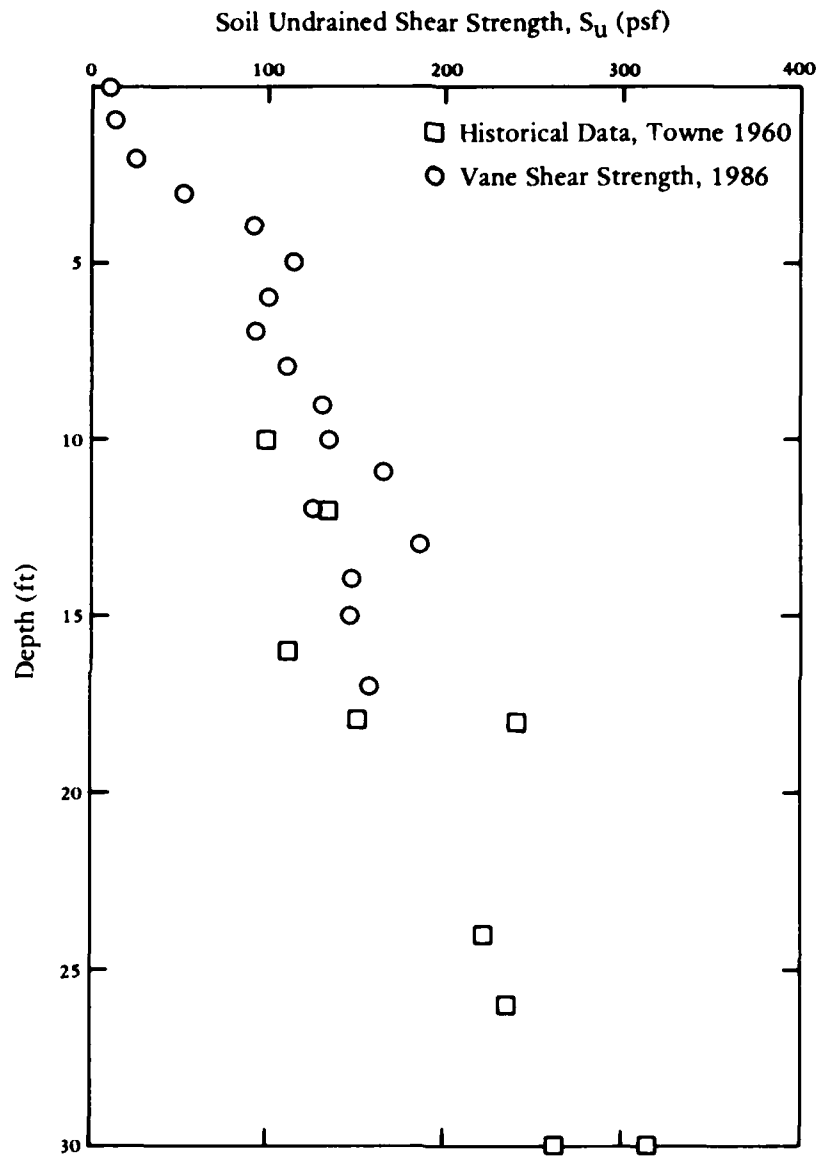
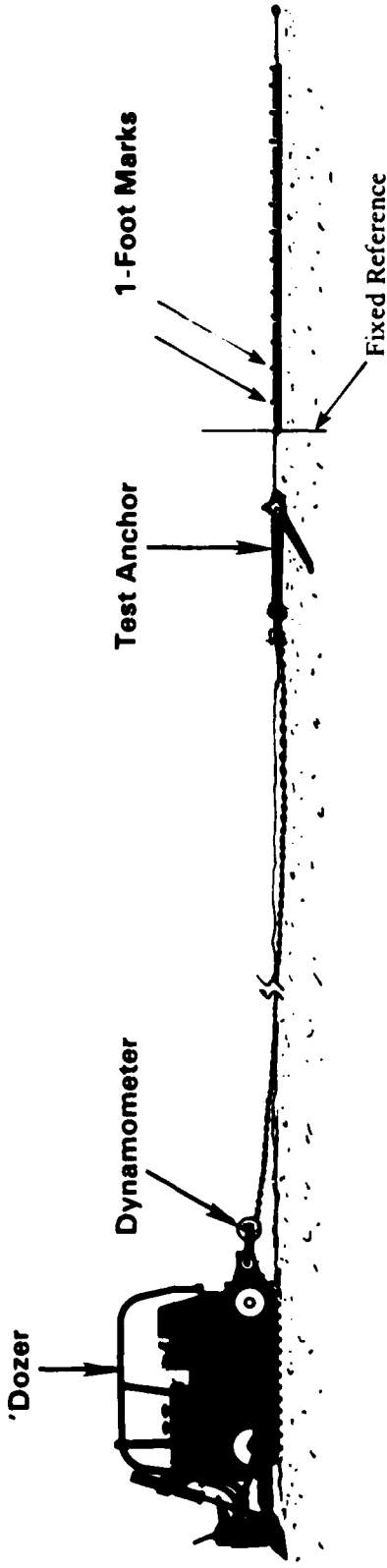

Figure 9. Soil undrained shear strength profile for San Francisco Bay mud, Hunters Point.



Test Measurements

- Total anchor tension
- Anchor drag distance
- Anchor roll angle (final)
- Anchor shank pitch angle (final)
- Anchor chain angle (final)
- Anchor depth (final)

Figure 10. Small-scale test arrangement used for NAVMOOR Anchor beach tests.

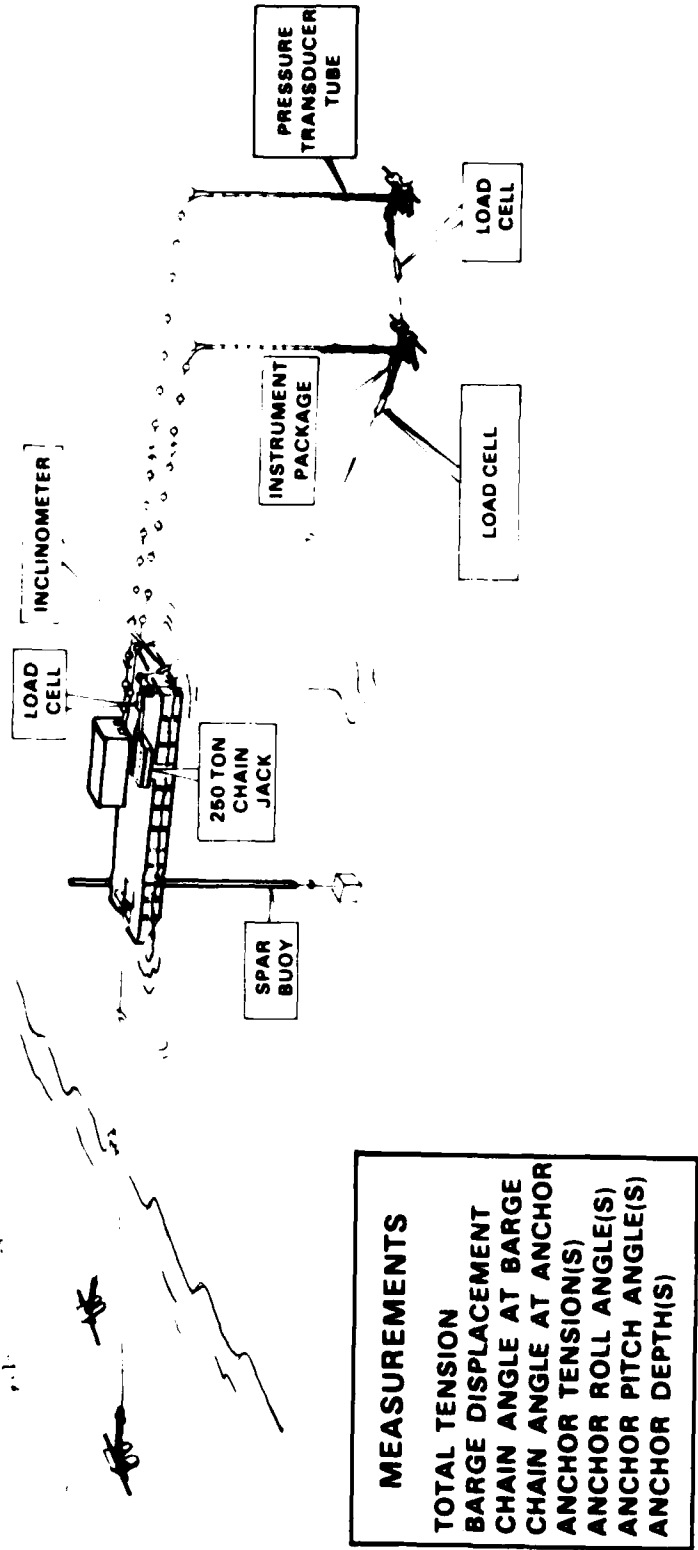

Figure 11. Test configuration for NAVMOOR Anchor tests in sand at Port Hueneme.

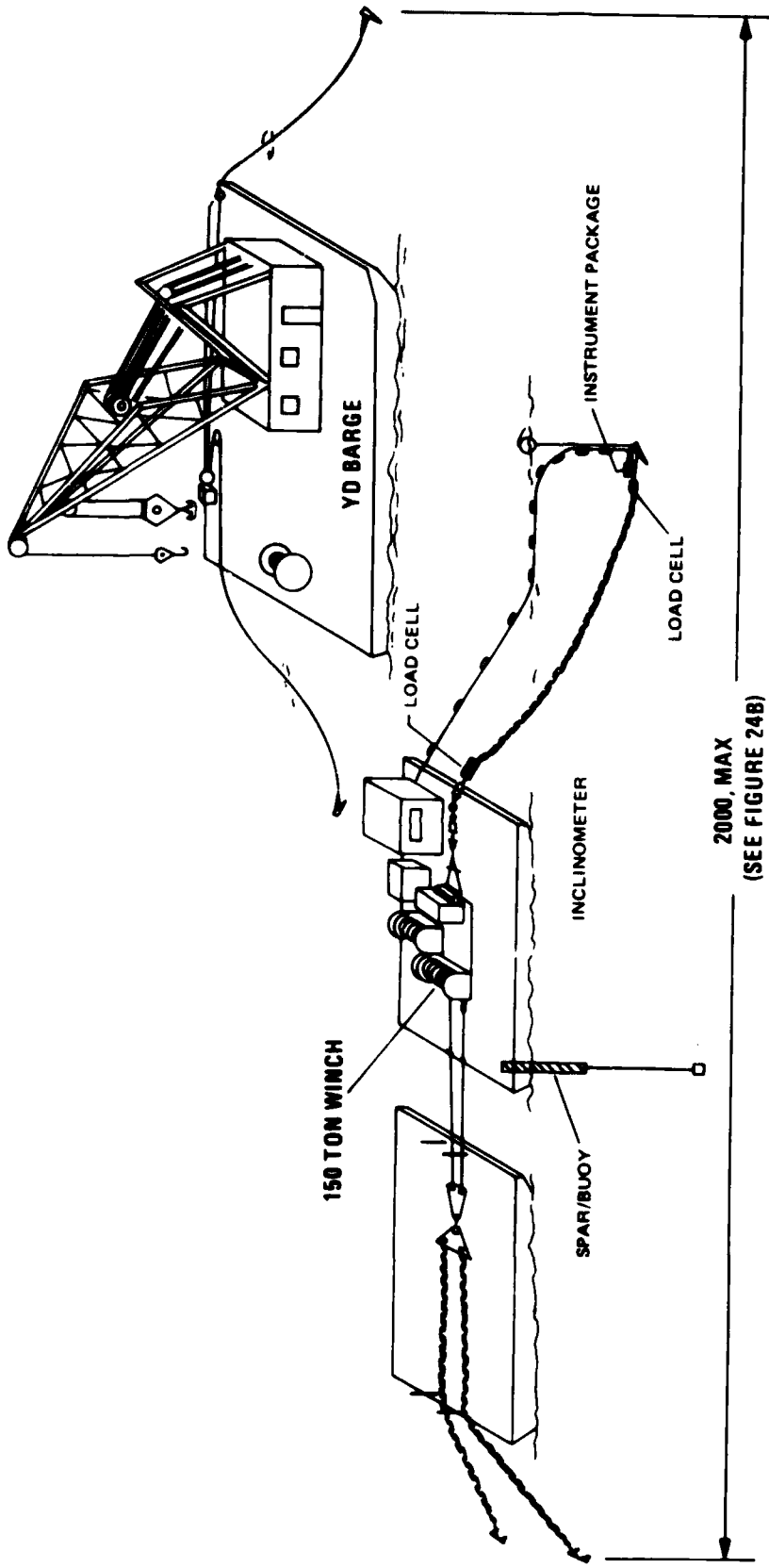

Figure 12. Test configuration for NAVMOOR Anchor tests in mud at Hunters Point, San Francisco Bay.



Figure 13. 1,000-pound NAVMOOR Anchor with instrumentation system.

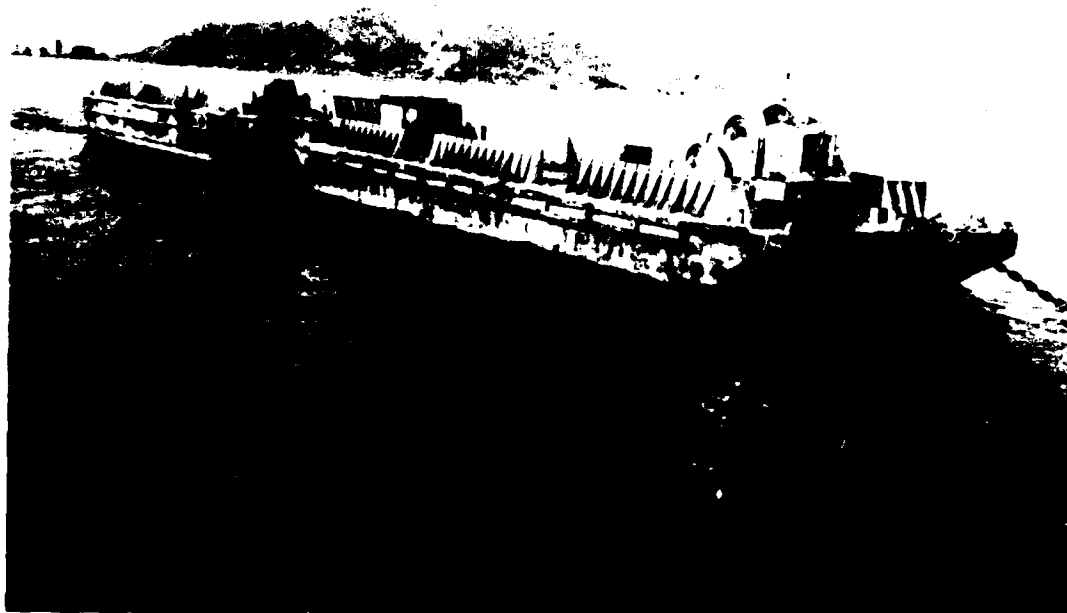
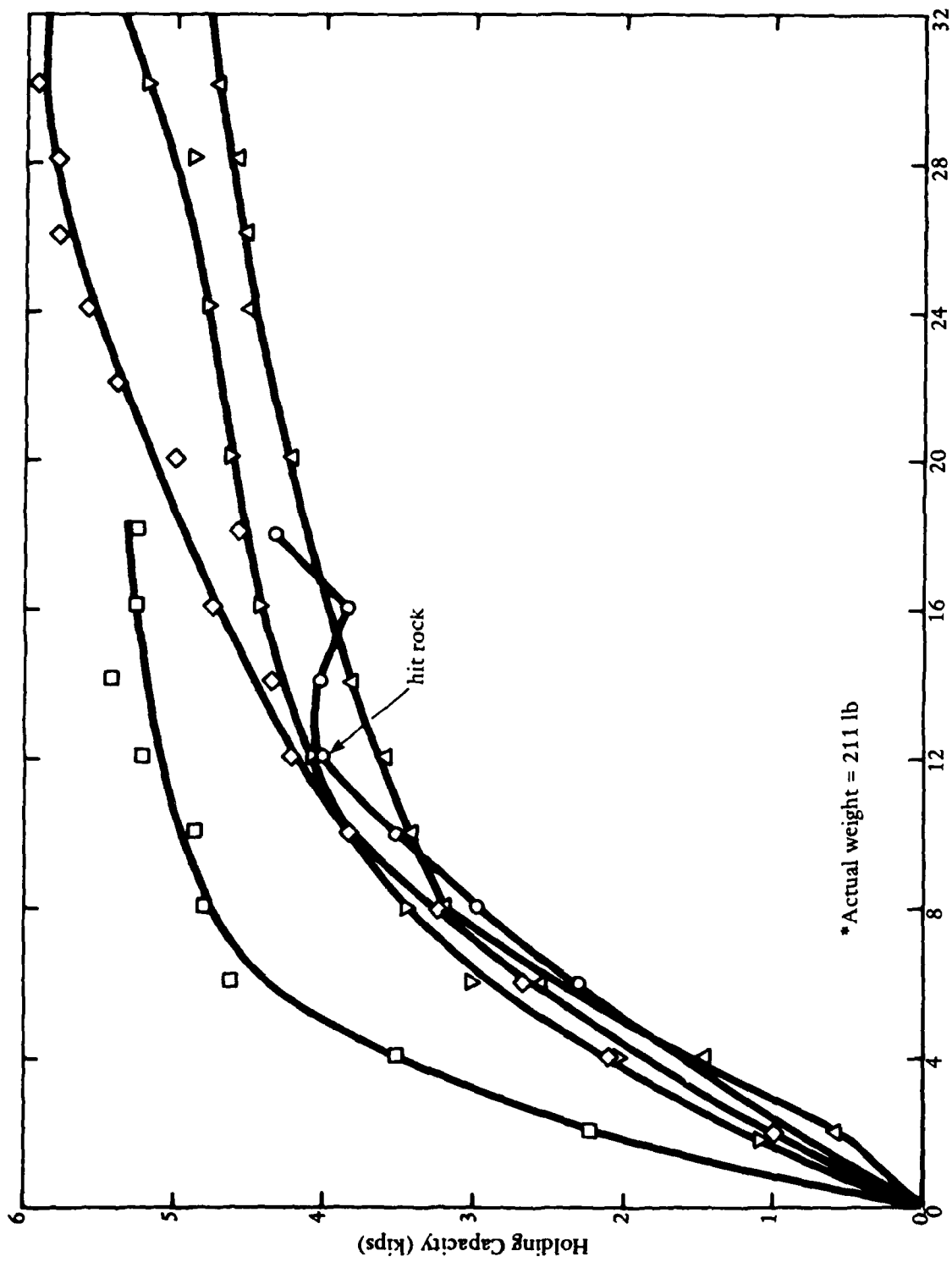

Figure 14. Test barge setup used for NAVMOOR Anchor testing in San Francisco Bay mud, Hunters Point.



* Actual weight = 211 lb

Figure 15. 200-pound NAVMOOR Model Anchor performance in dry Port Hueneme beach sand.

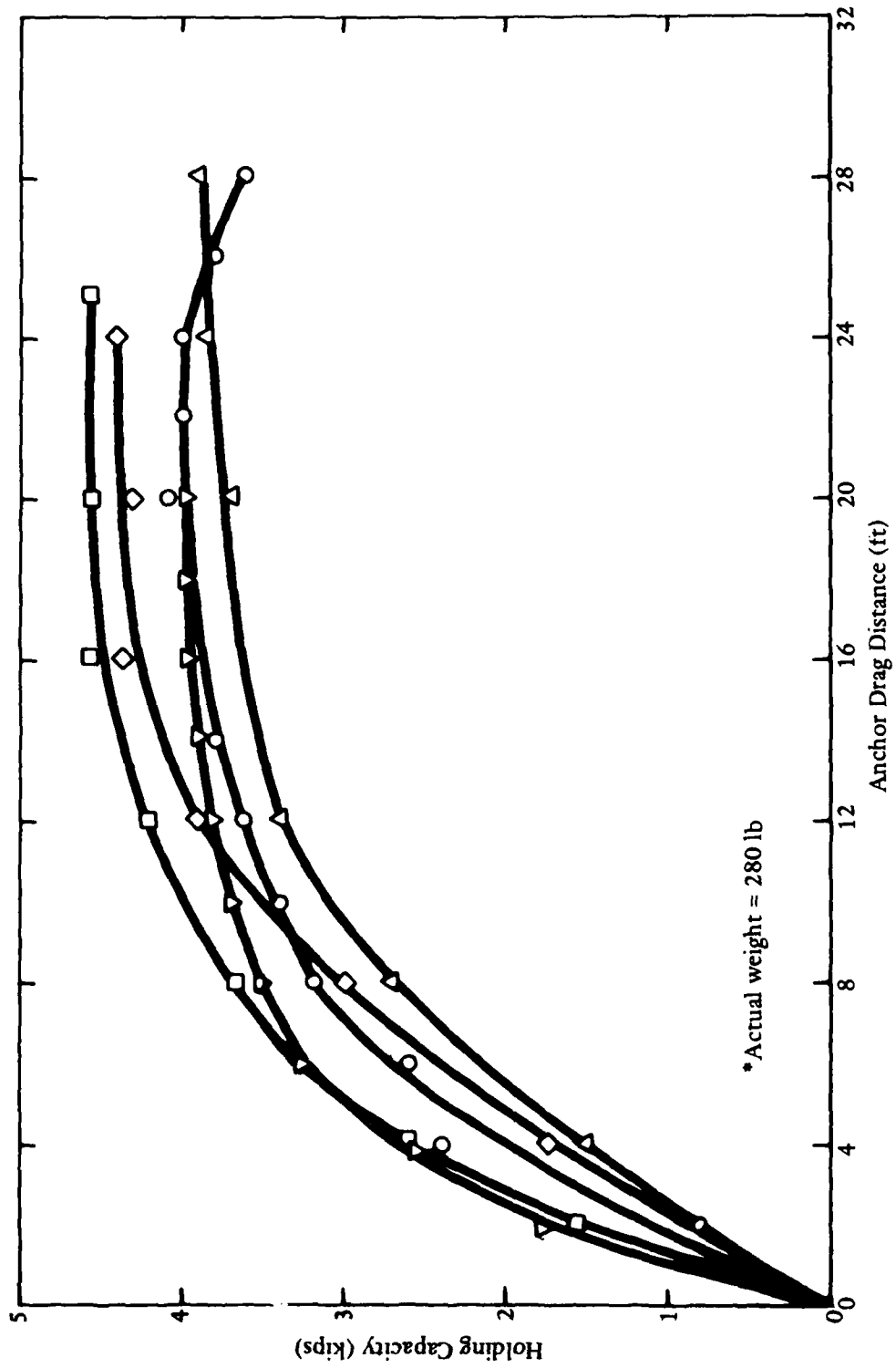

Figure 16. 200-pound STATO Anchor performance in dry Port Hueneme beach sand.

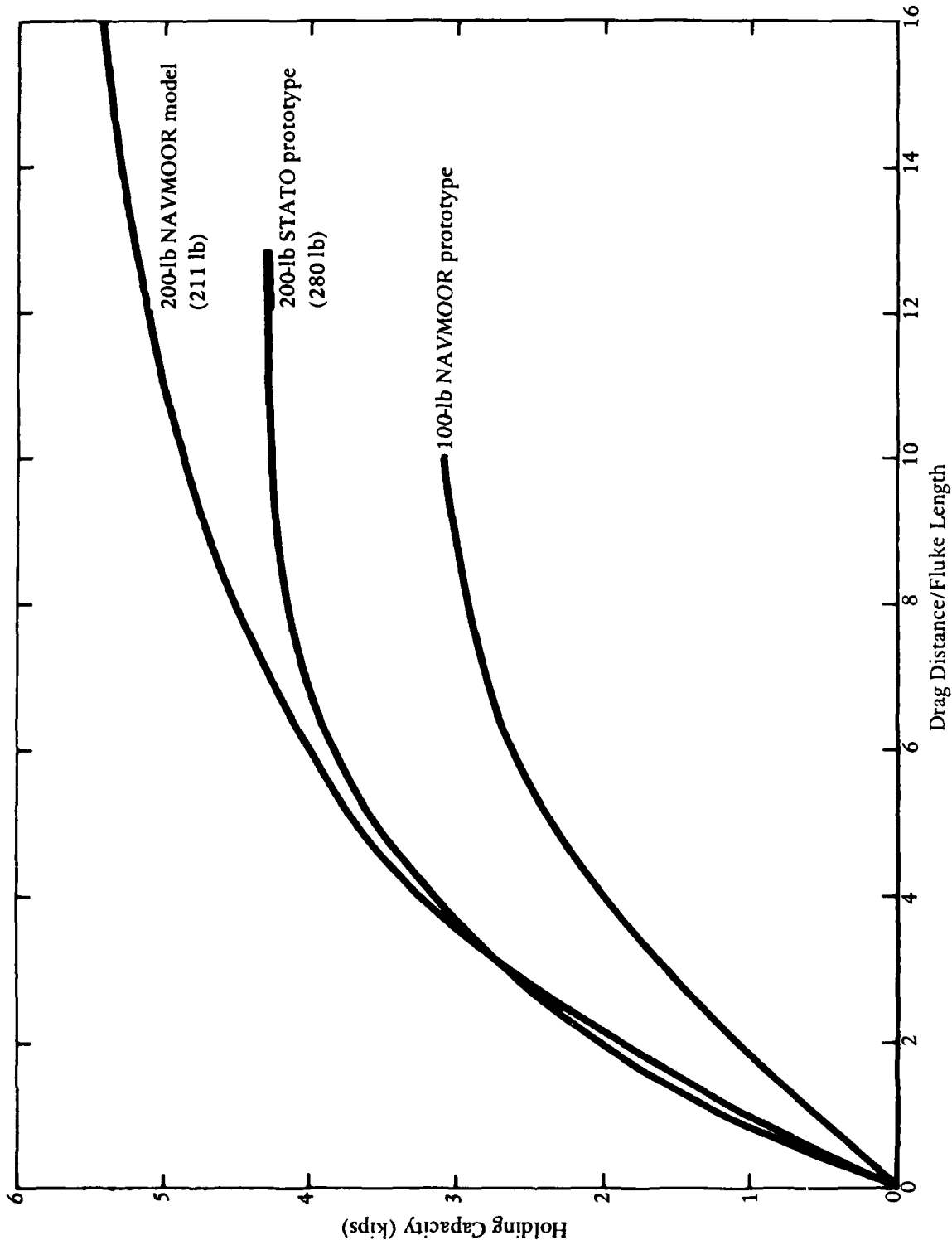

Figure 17. Average performance curves for small NAVMOOR Anchors in dry beach sand.



Figure 18. STATO Anchor flukes showing sand trapped between flukes ribs.

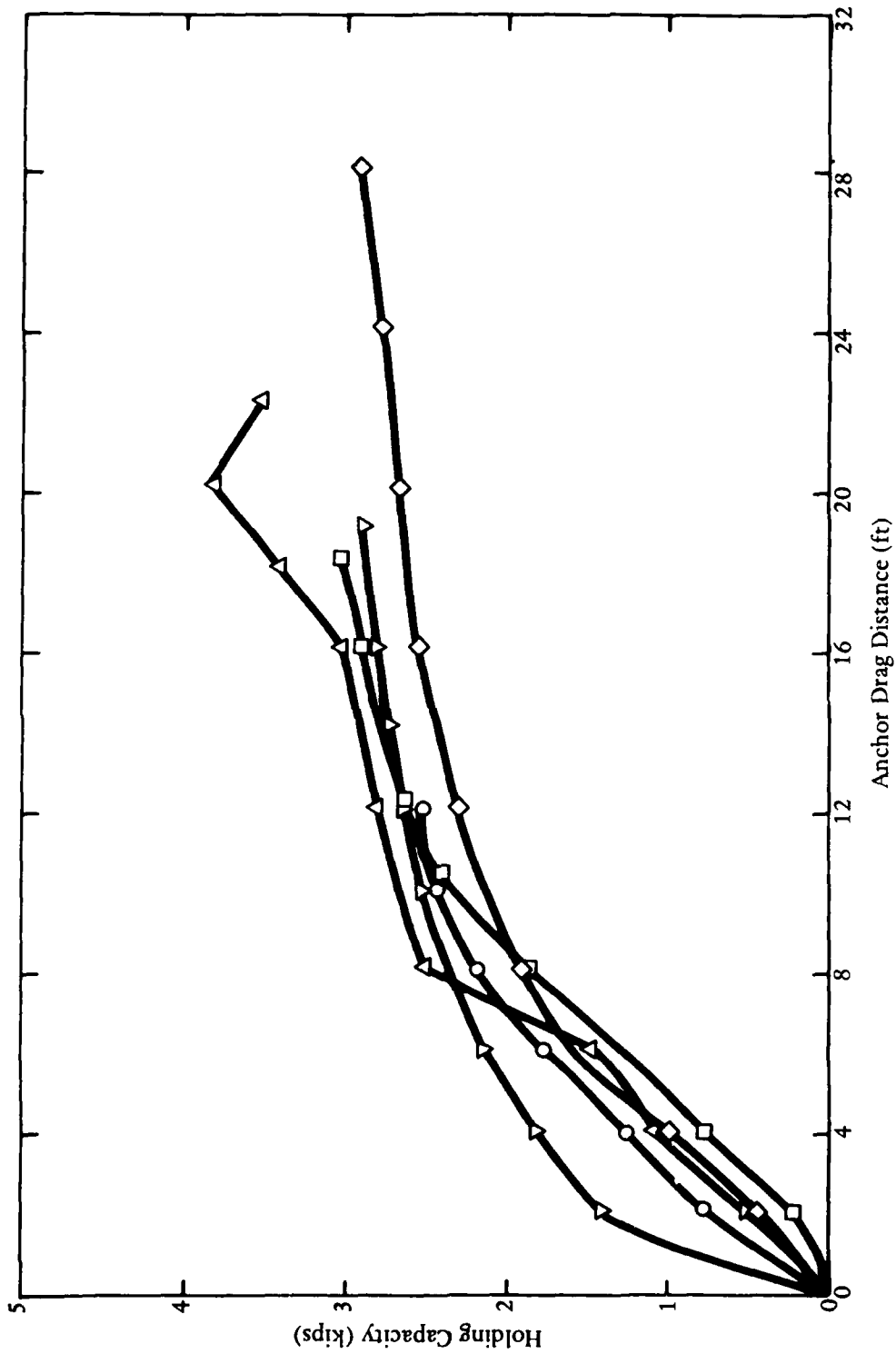

Figure 19. 100-pound NAVMOOR Anchor performance in dry Port Hueneme beach sand.

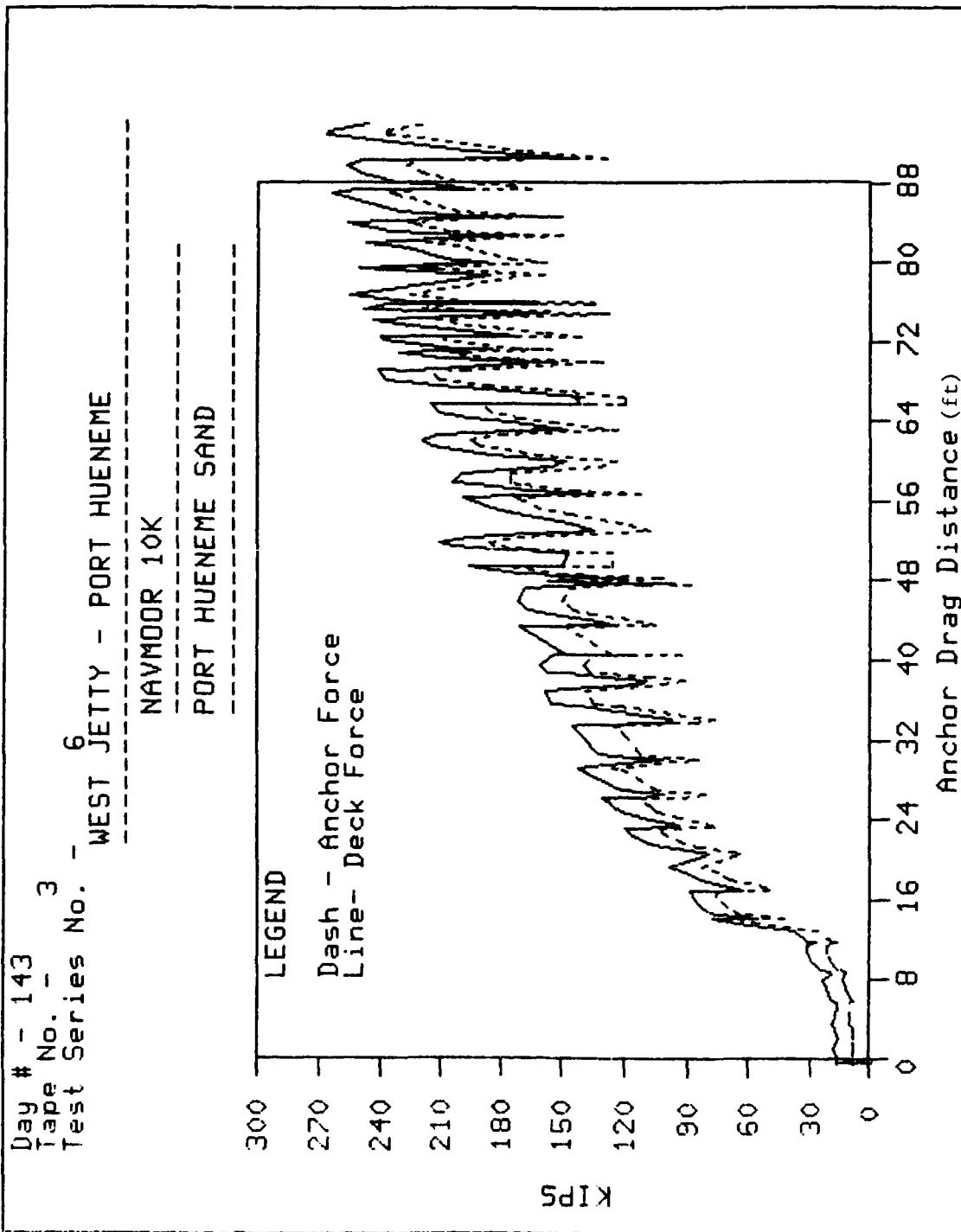

Figure 20. Typical load-drag distance test data for the NAVMOOR Anchor in Port Hueneme sand.

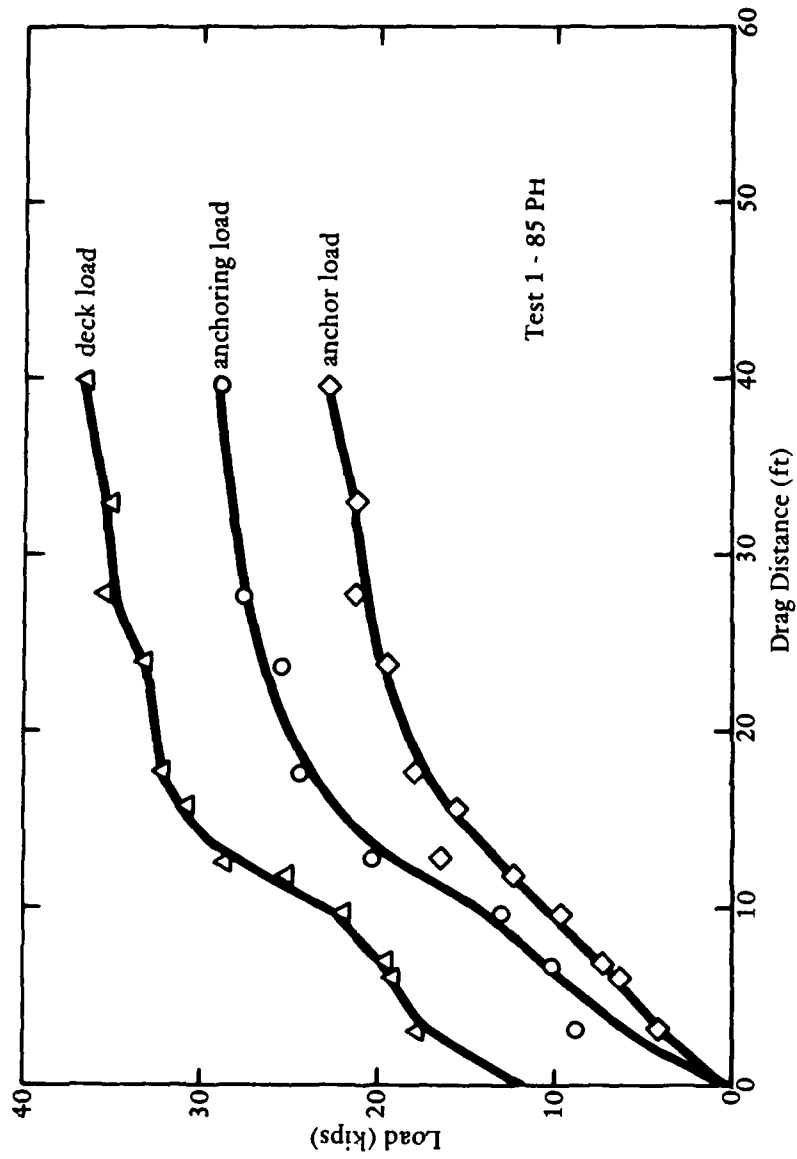

Figure 21. 1,000-pound NAVMOOR Anchor performance in Port Hueneme sand.

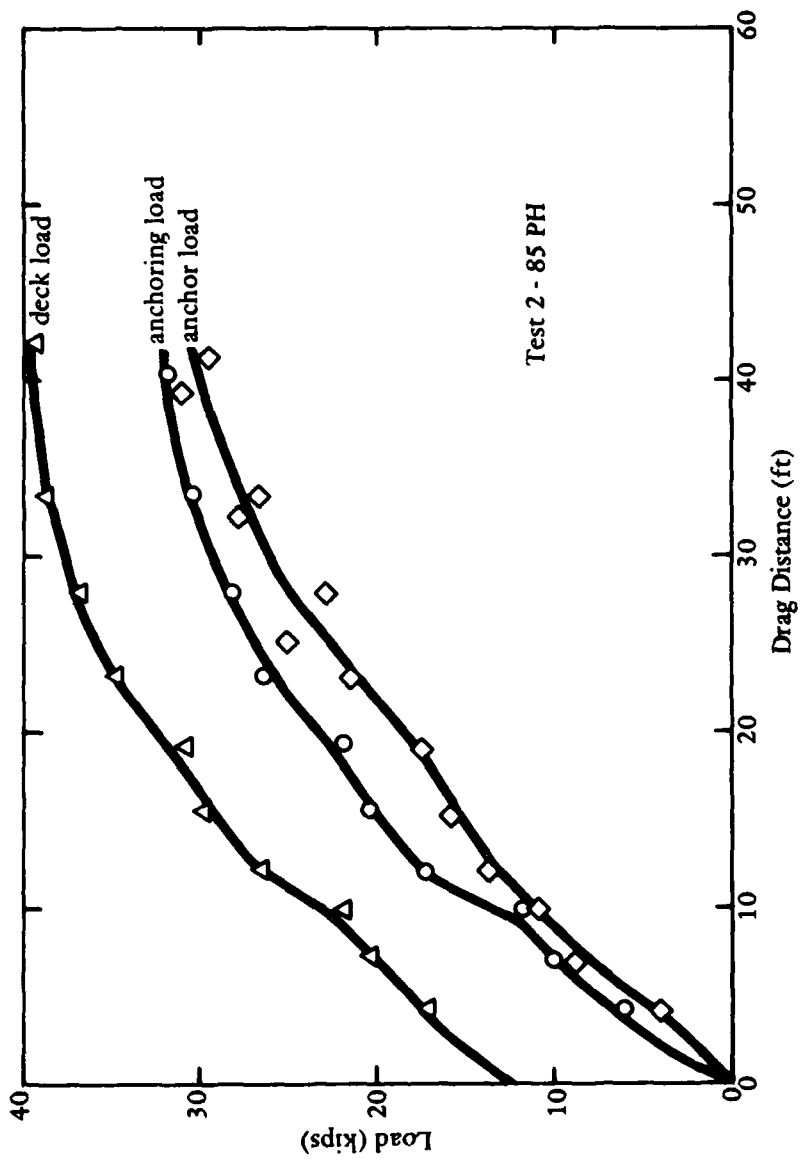

Figure 22. 1,000-pound NAVMOOR Anchor performance in Port Hueneme sand.

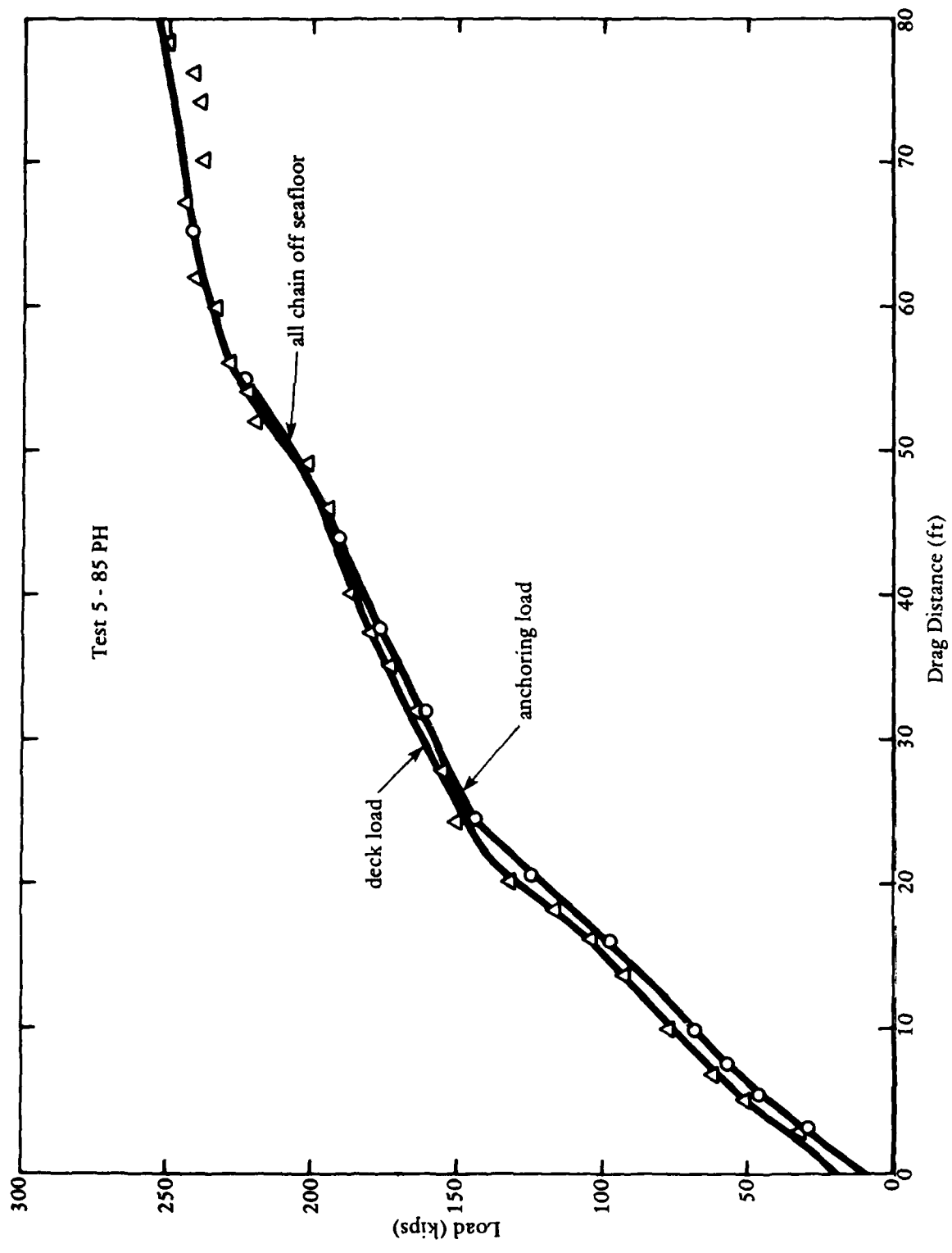

Figure 23. 10,000-pound NAVMOOR Anchor performance in Port Hueneme sand.

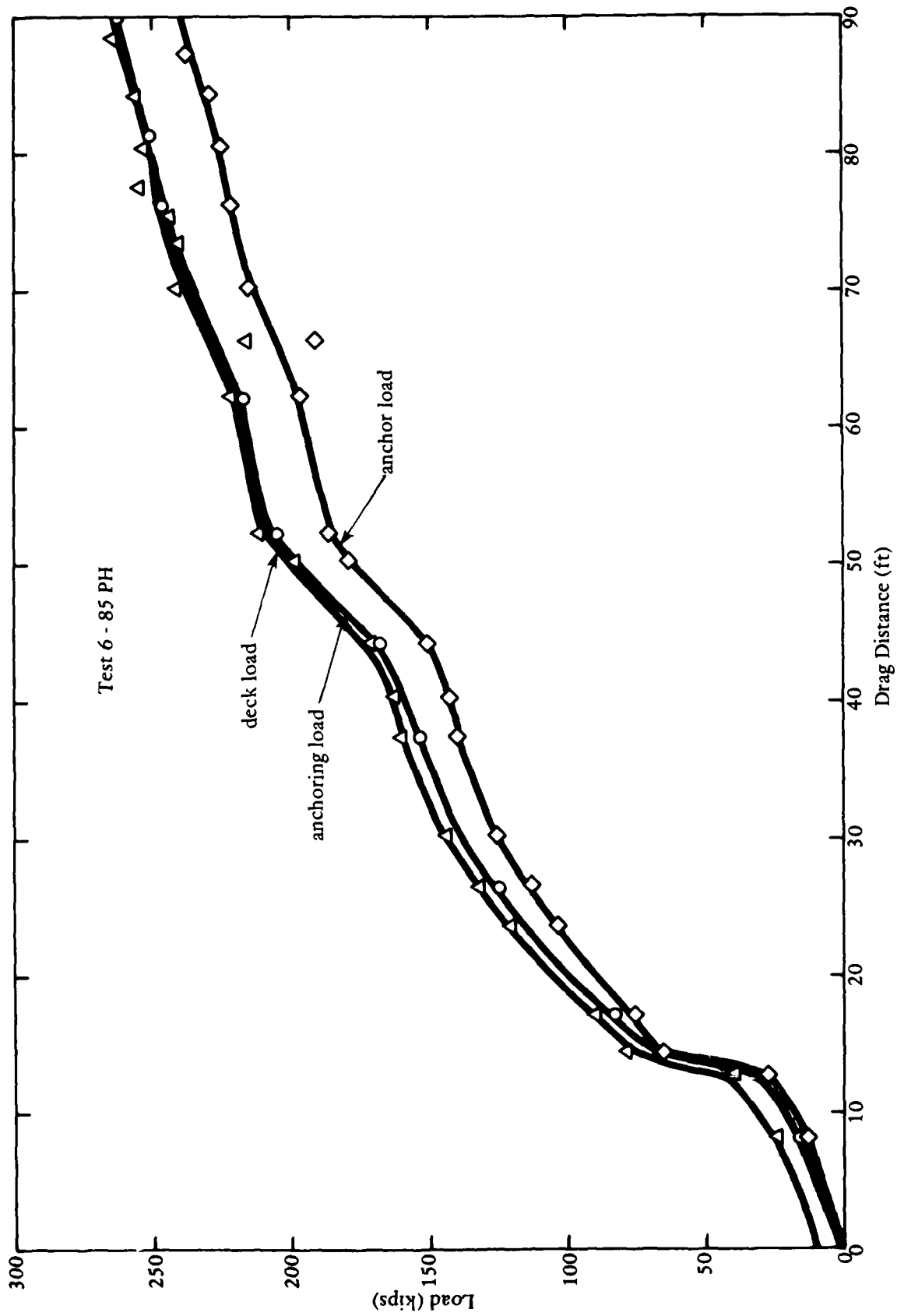

Figure 24. 10,000-pound NAVMOOR Anchor performance in Port Hueneme sand.

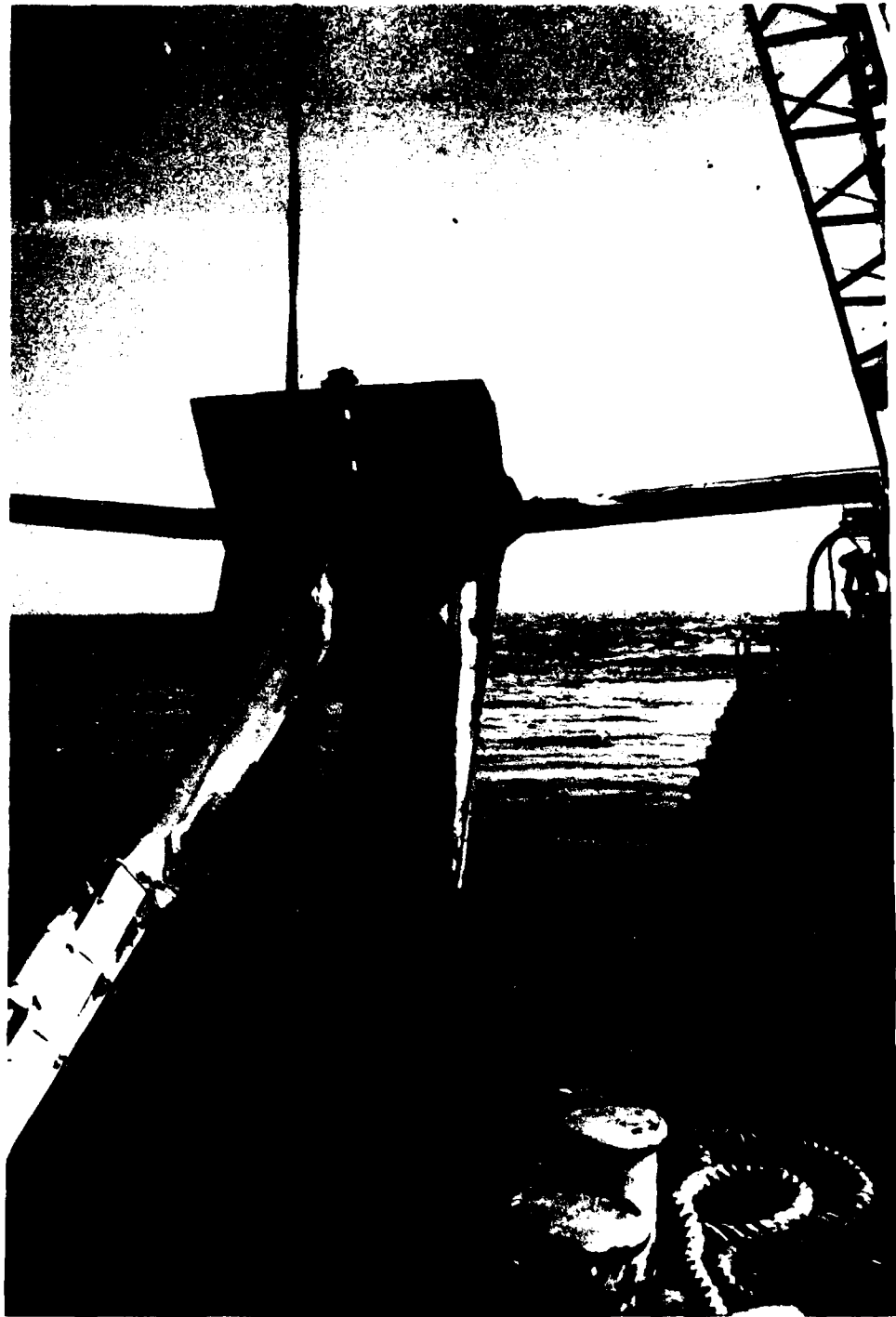

Figure 25. 10,000-pound NAVMOOR Anchor after testing showing bent stabilizers.

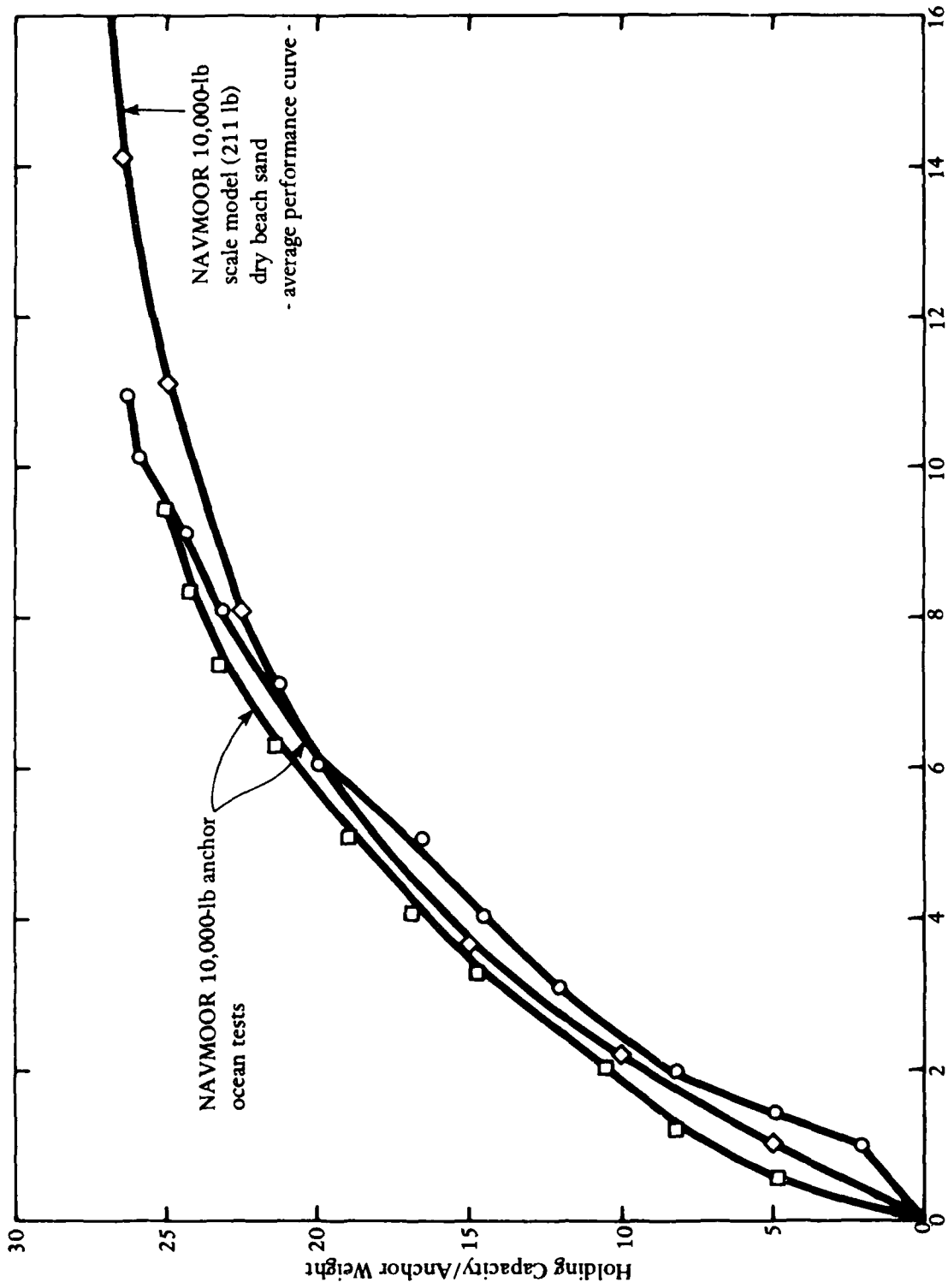

Figure 26. Performance curves of prototype and scale model NAVMOOR Anchors.

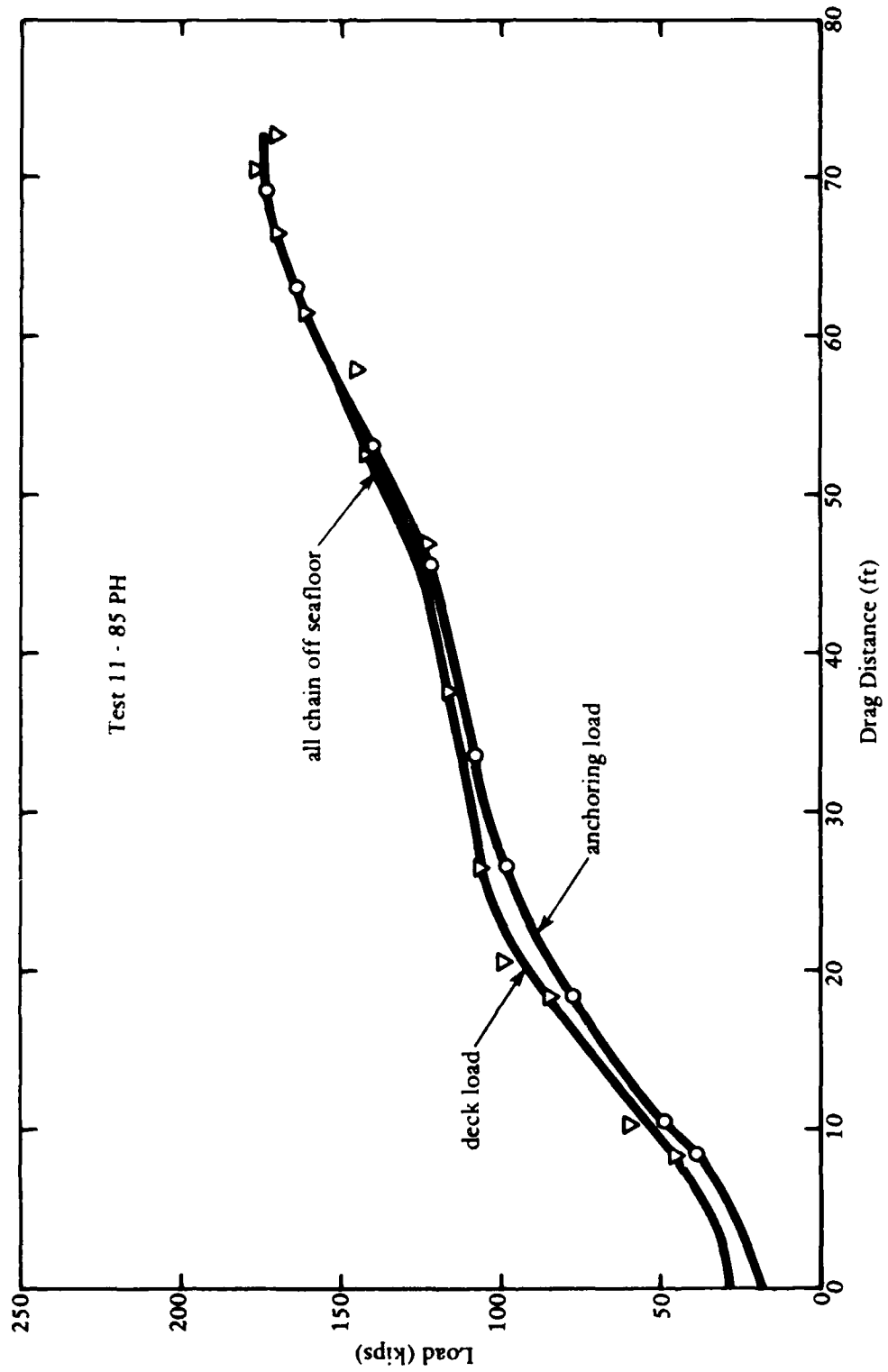

Figure 27. 6,000-pound NAVMOOR Anchor performance in Port Hueneme sand.

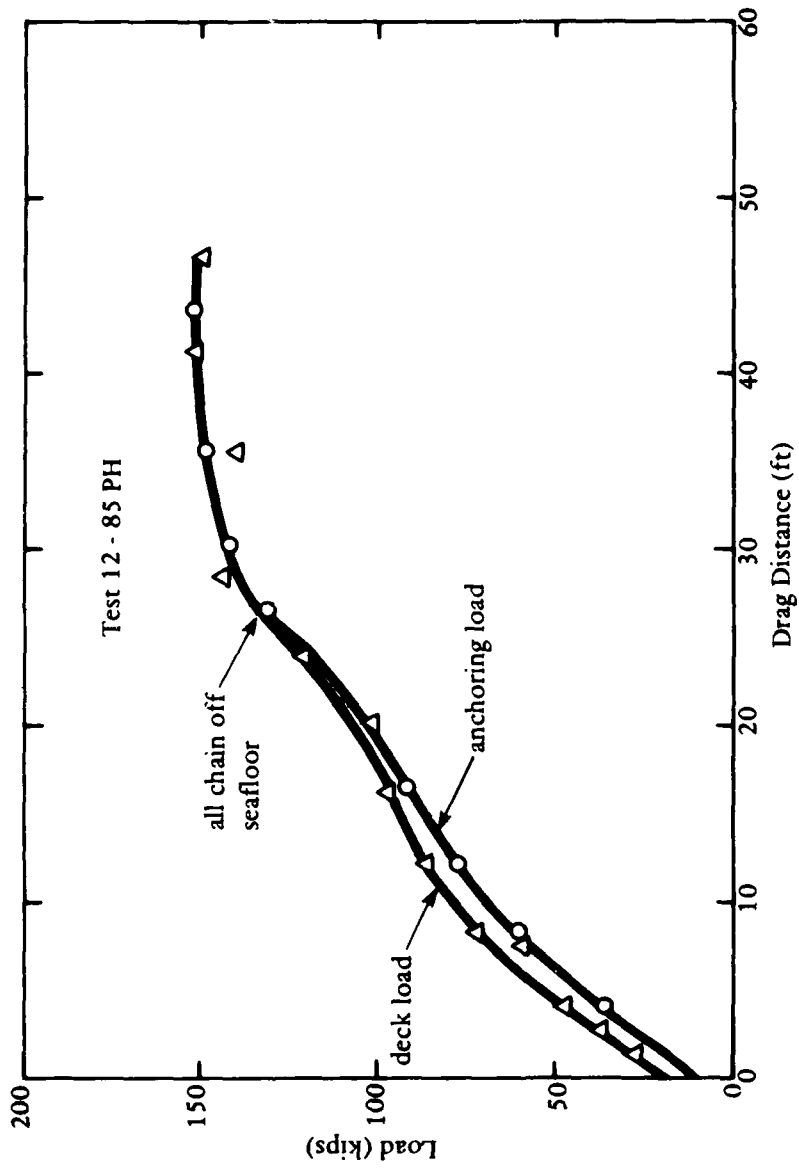

Figure 28. 6,000-pound NAVMOOR Anchor performance in Port Hueneme sand.

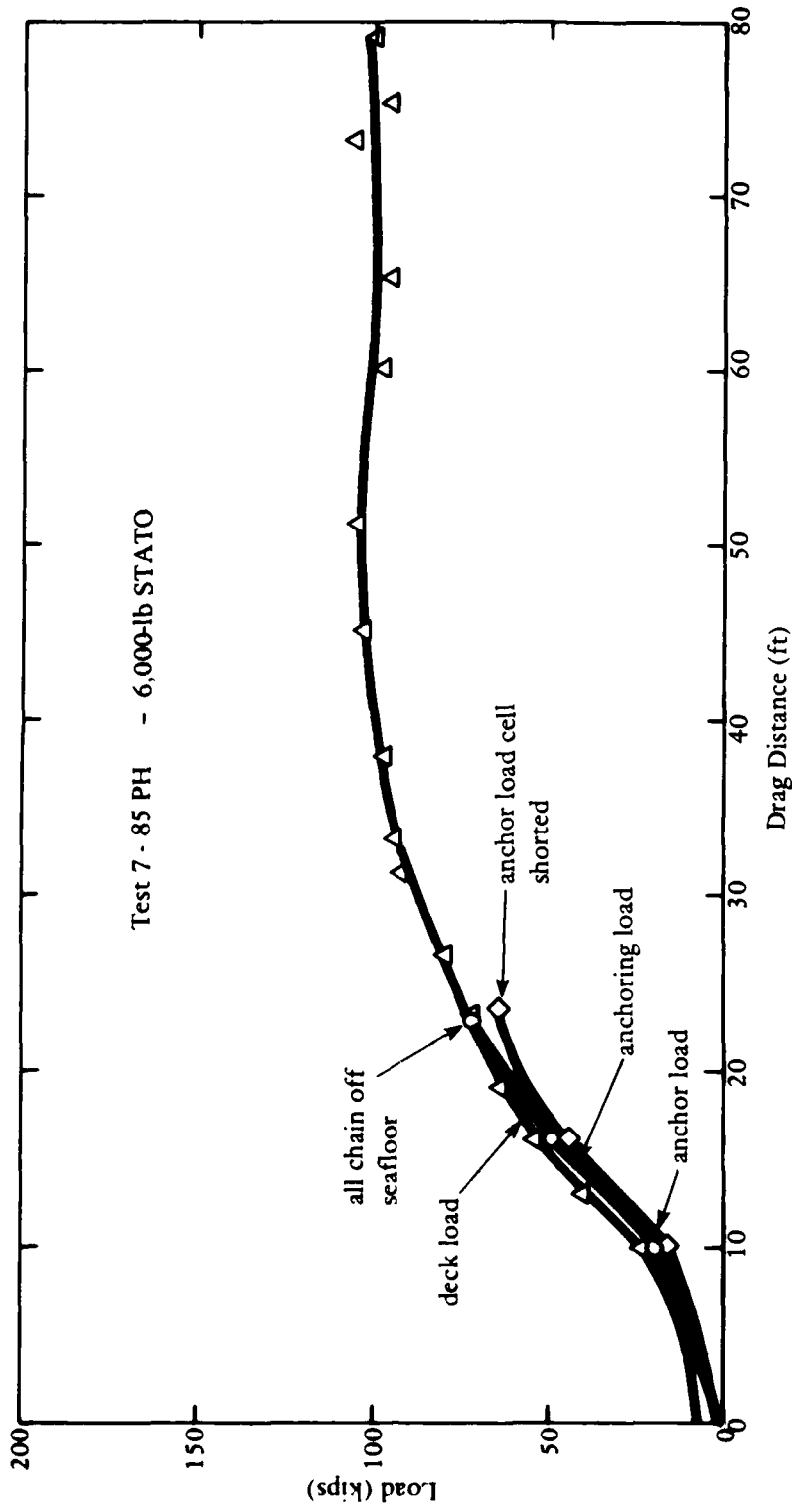

Figure 29. 6,000-pound STATO Anchor performance in Port Hueneme sand.

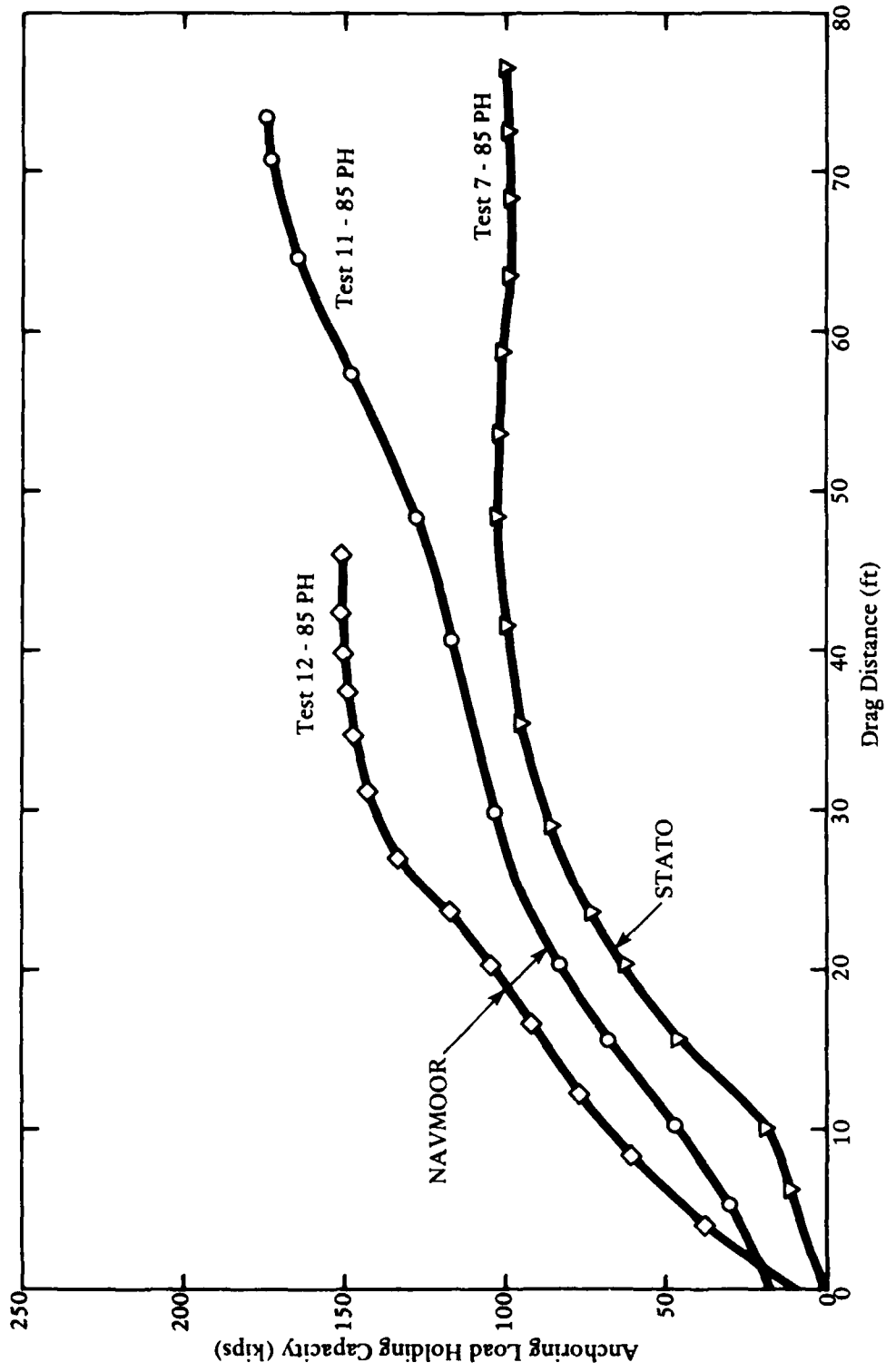

Figure 30. Comparative performance of 6,000-pound NAVMOOR and STATO Anchors in dense gravelly Port Hueneme sand.

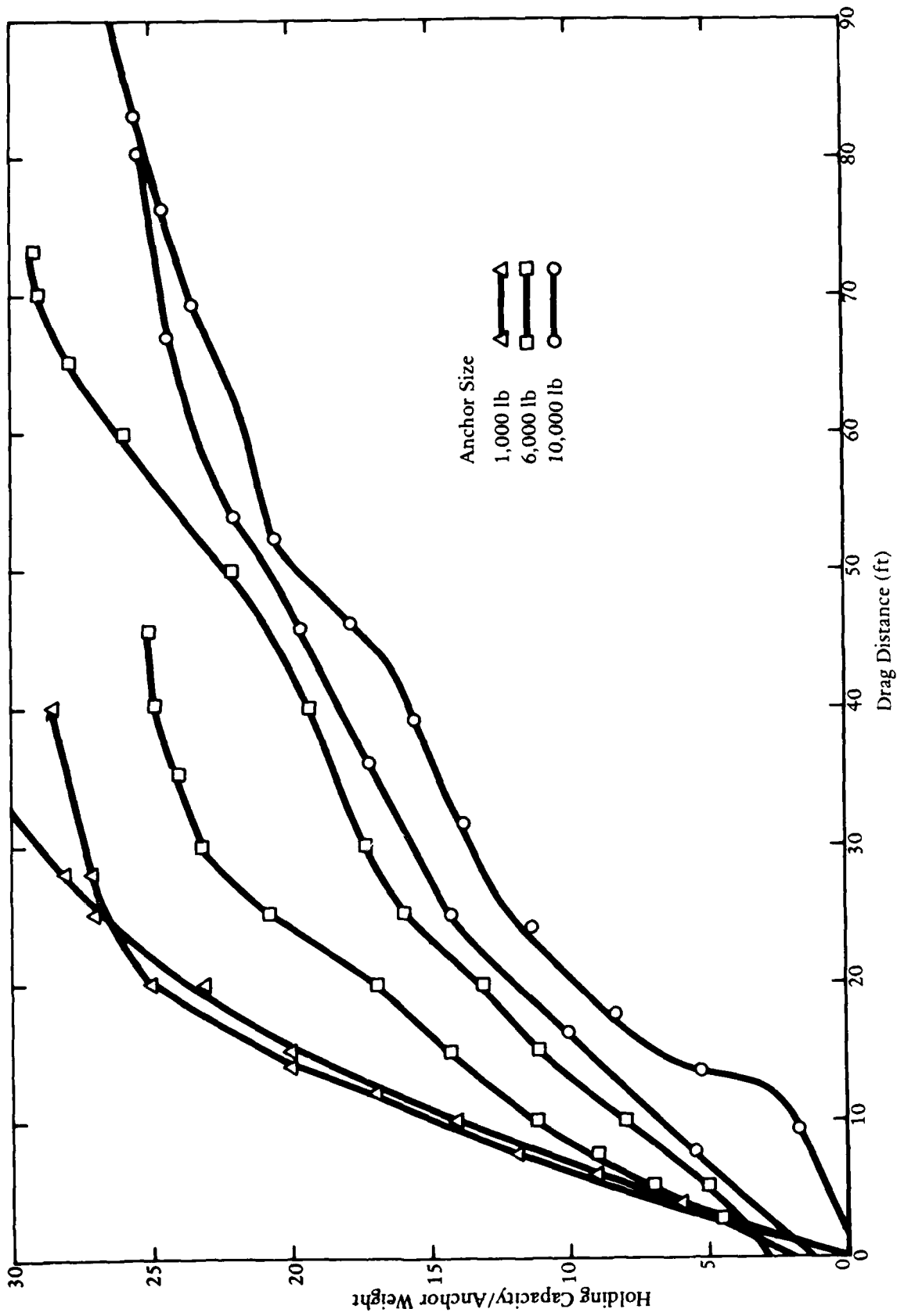

Figure 31. Performance curves for NAVMOOR Anchors in dense gravelly sand at Port Hueneme.

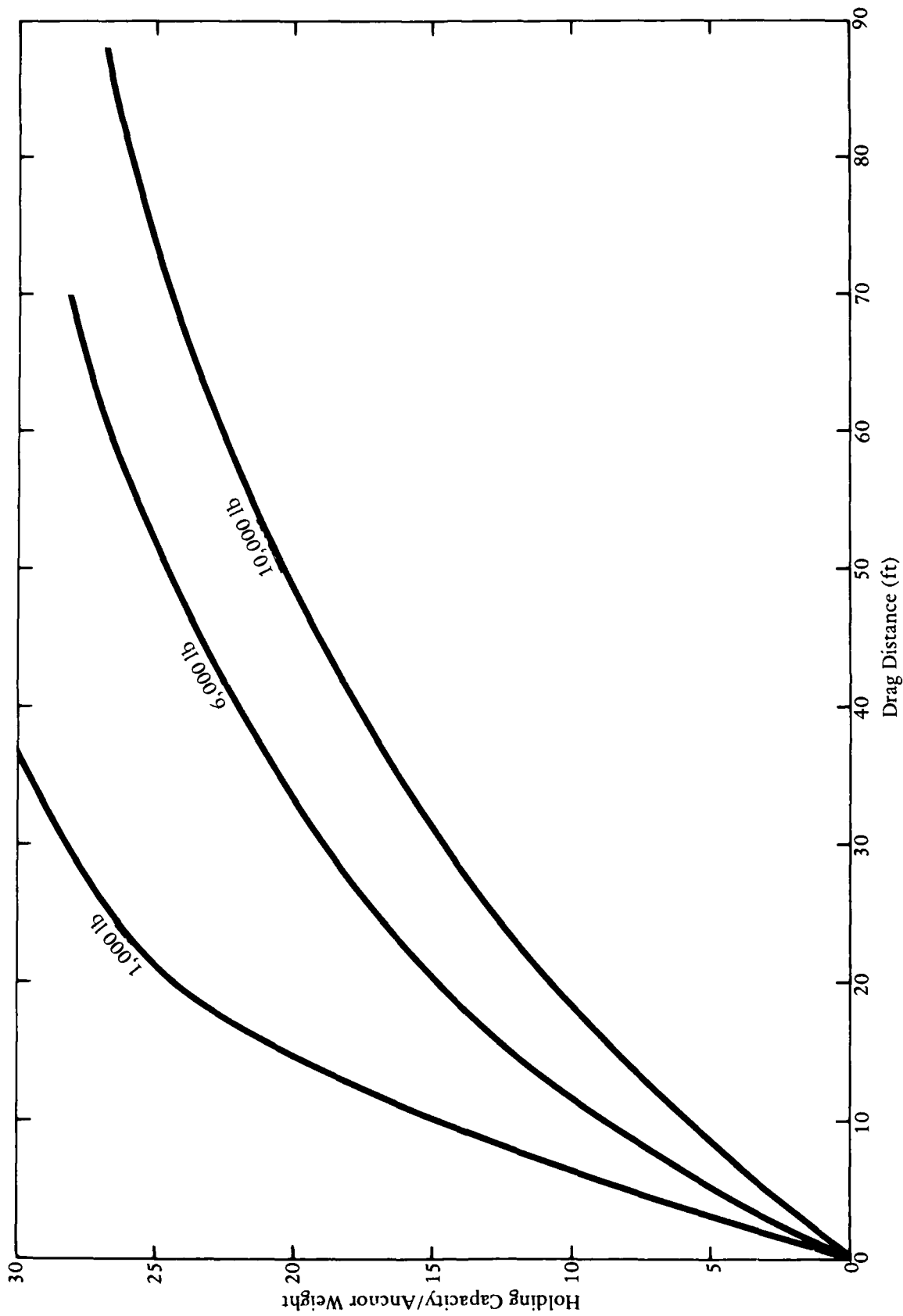

Figure 32. Average performance curves for NAVMOOR Anchors in dense gravelly sand at Port Huene.

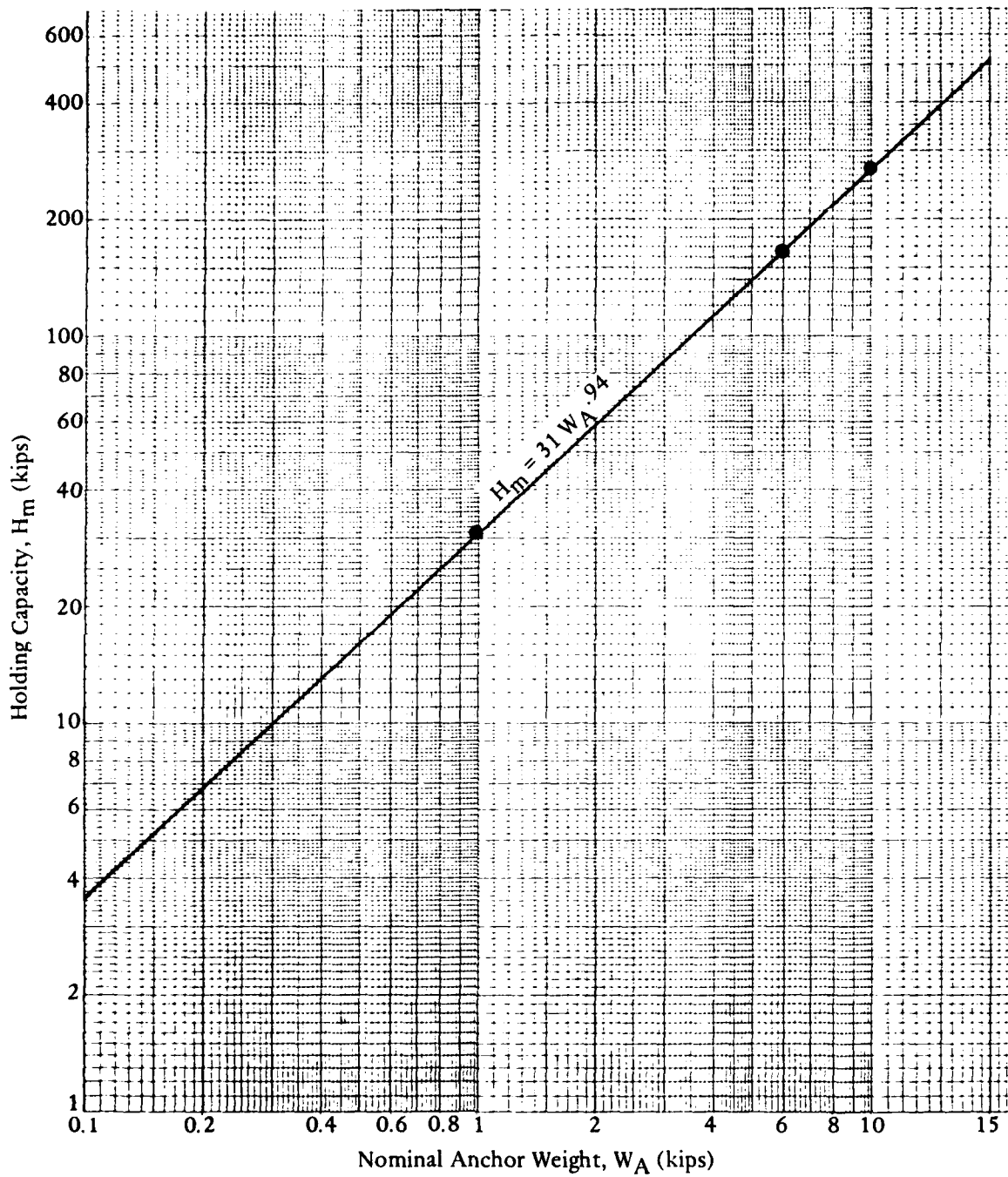

Figure 33. NAVMOOR Anchor performance specification in sand.

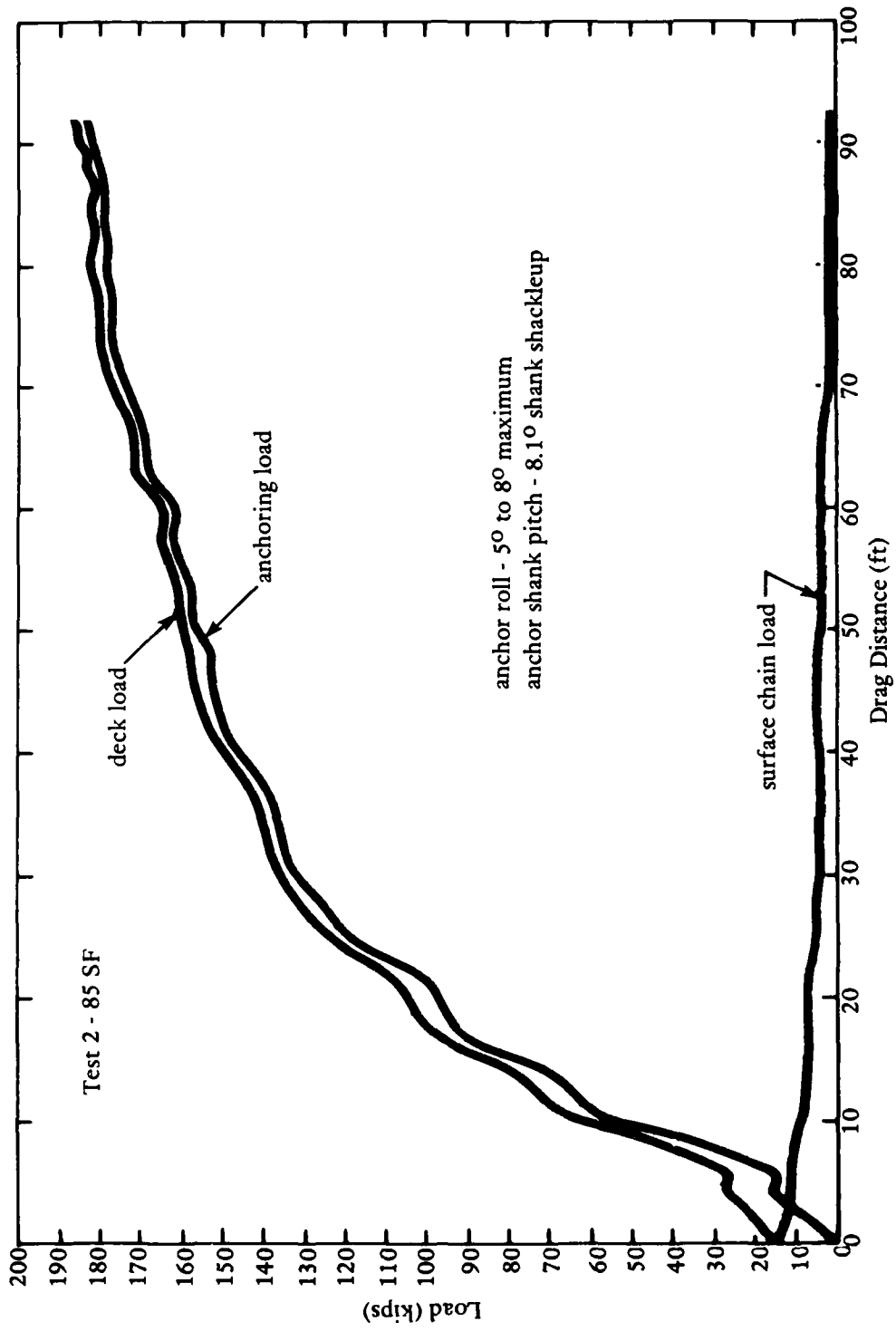

Figure 34. 10,000-pound NAVMOOR Anchor performance in San Francisco Bay mud.

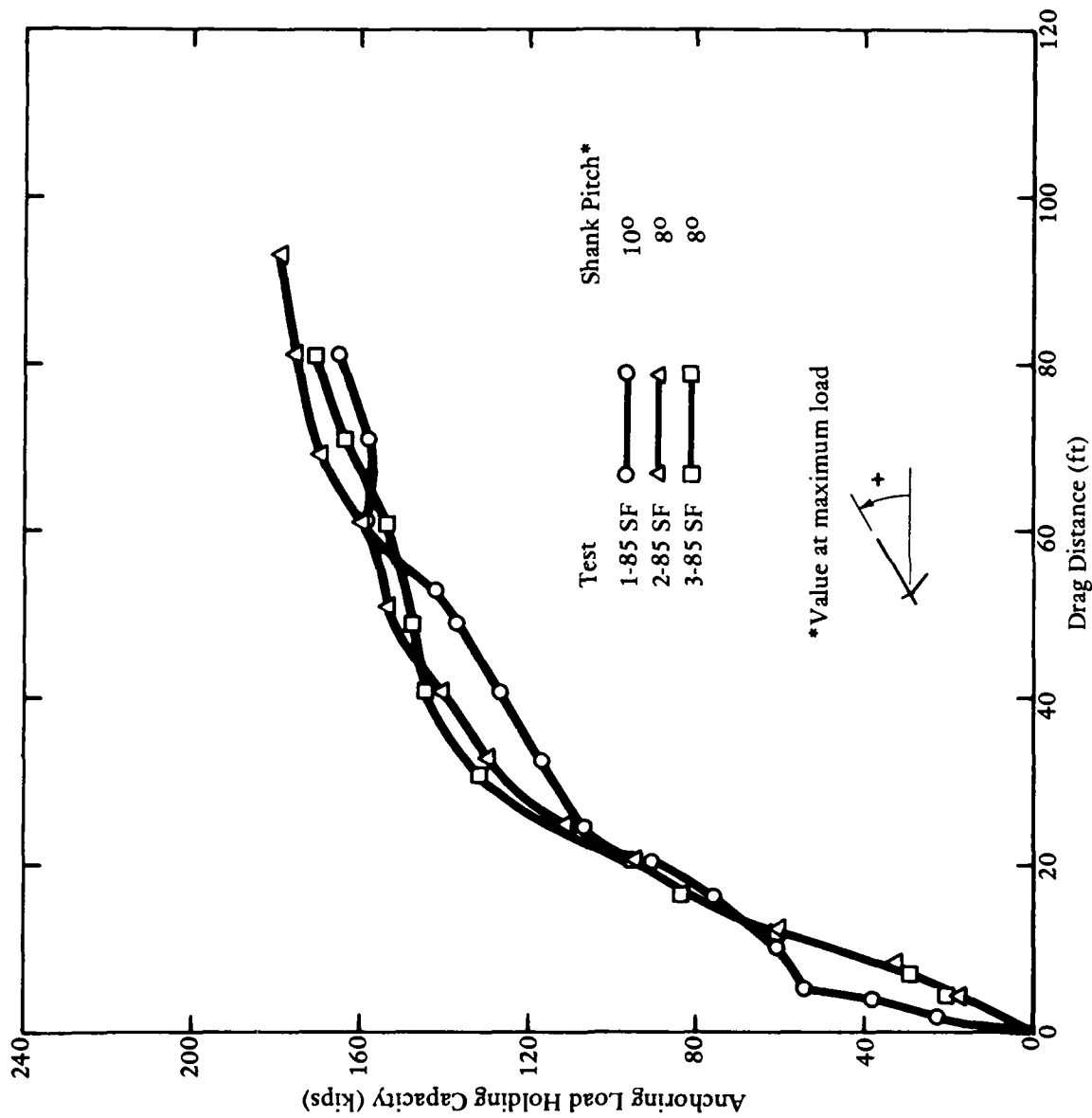

Figure 35. 10,000-pound NAVMOOR Anchor performance curves in San Francisco Bay mud.

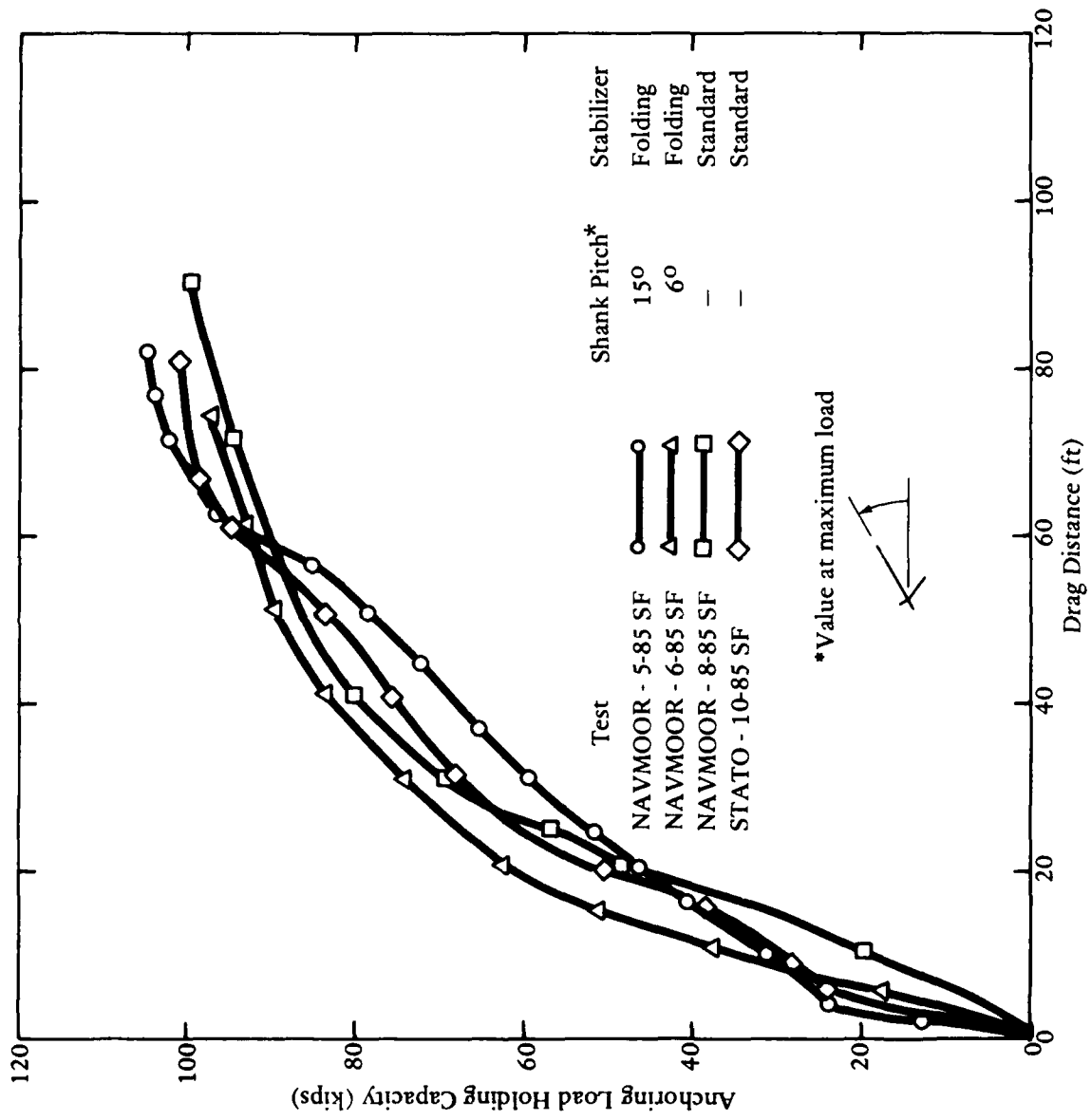

Figure 36. 6,000-pound NAVMOOR and STATO Anchor performance curves in San Francisco Bay mud.

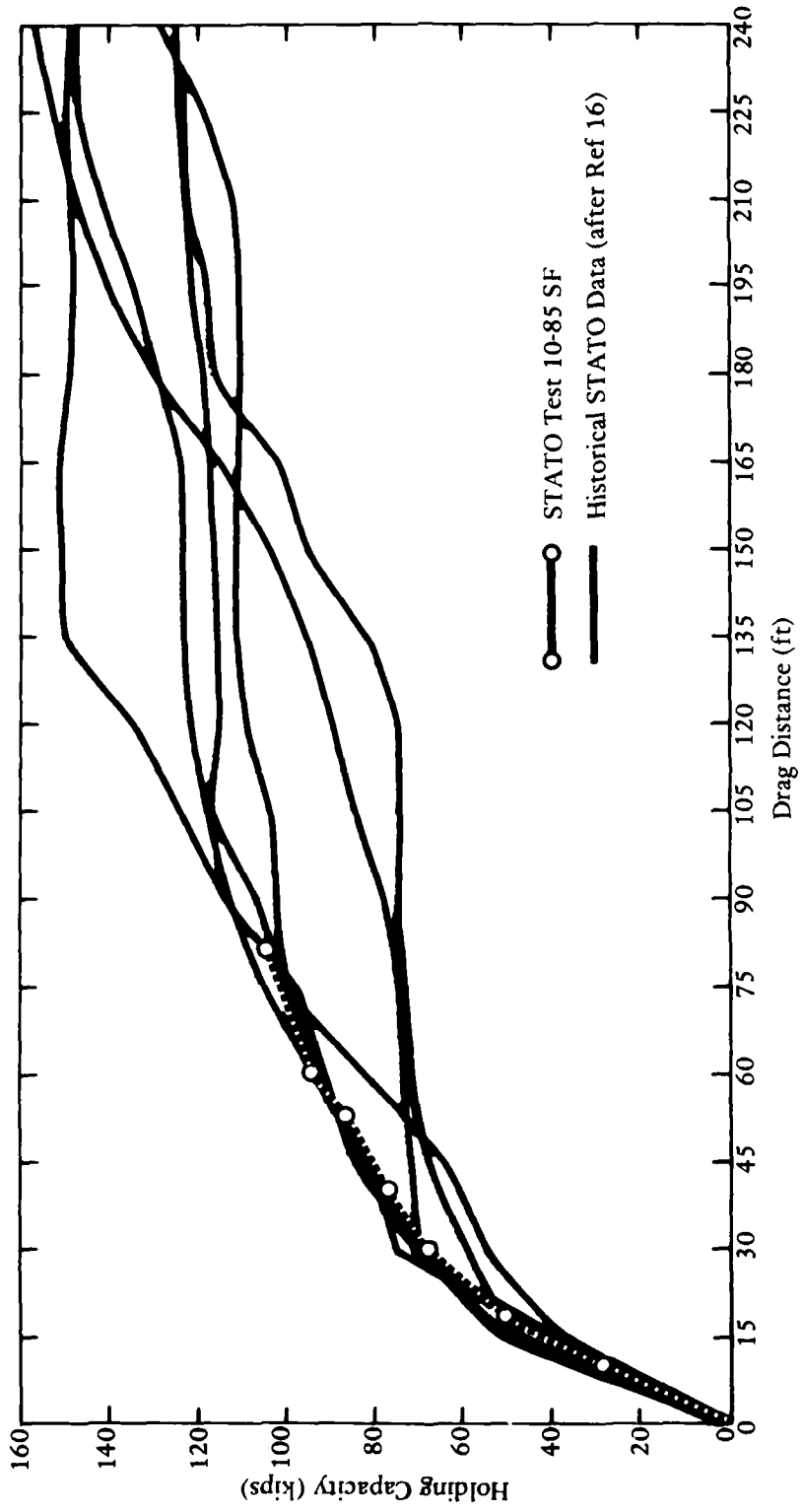
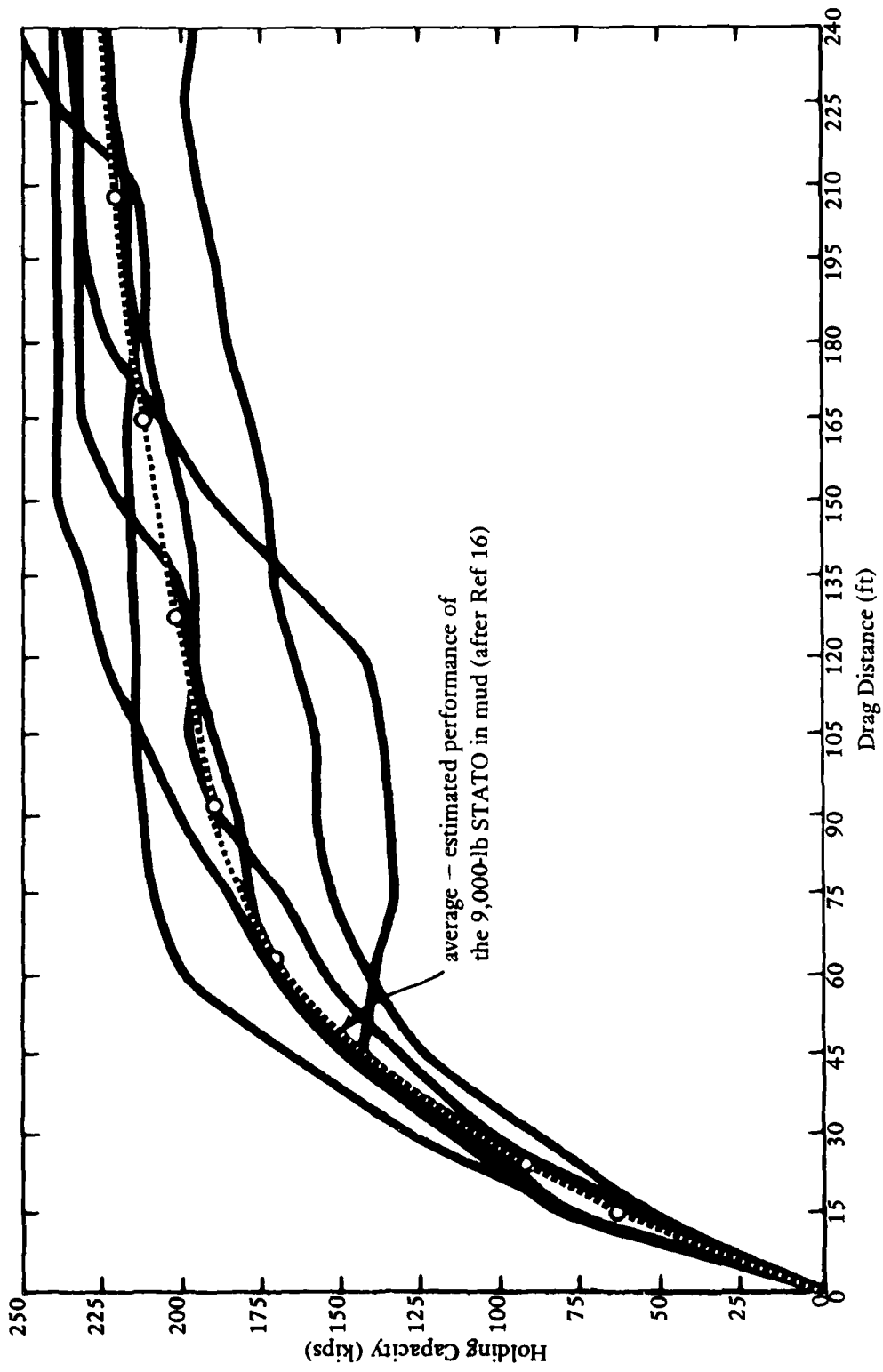

Figure 37. Comparison of recent and historical 6,000-pound STATO Anchor test data.



average - estimated performance of
the 9,000-lb STATO in mud (after Ref 16)

Figure 38. Historical 9,000-pound STATO Anchor data for San Francisco Bay mud.

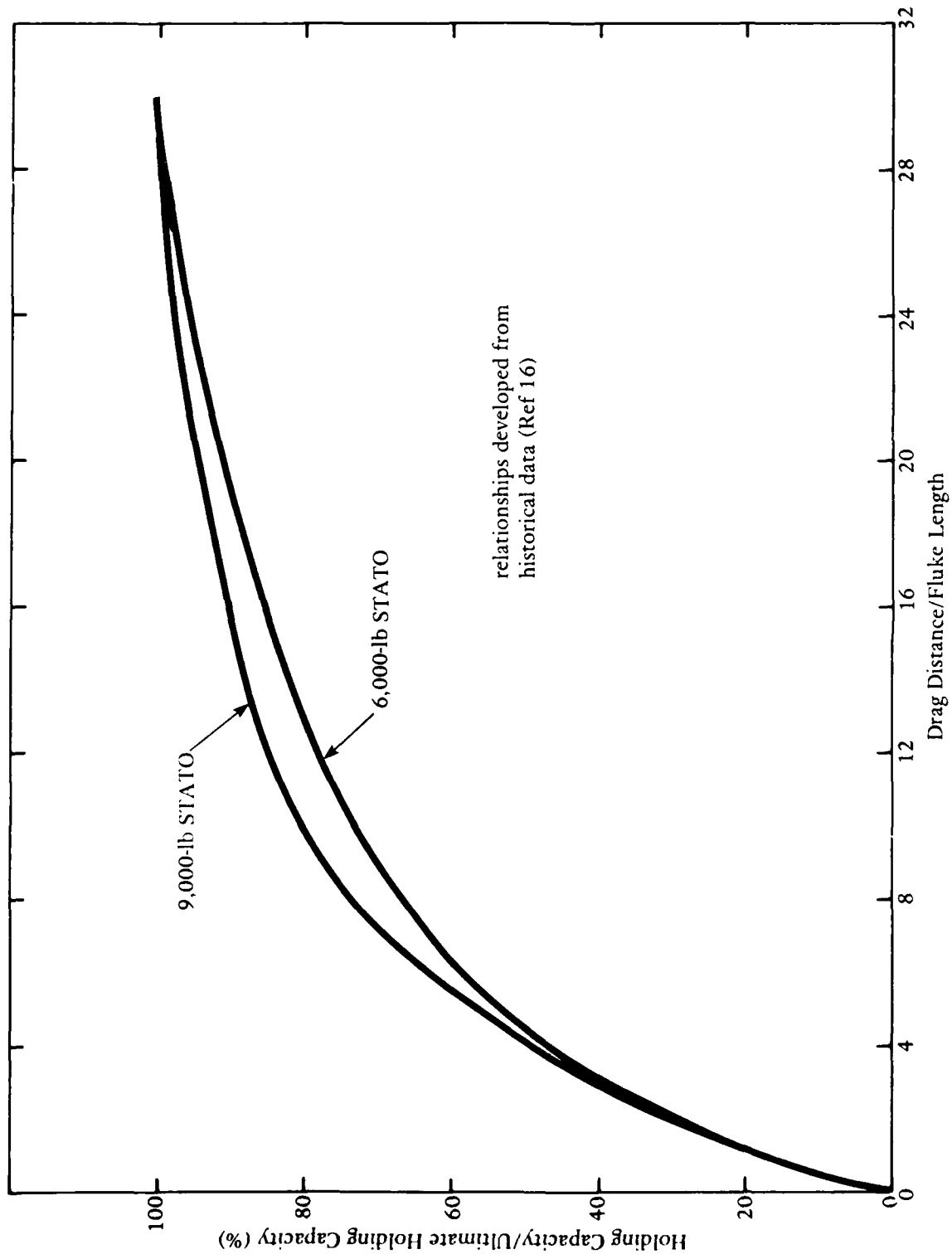

Figure 39. Normalized holding capacity-drag relationships for STATO (NAVMOOR) Anchors in San Francisco Bay mud.

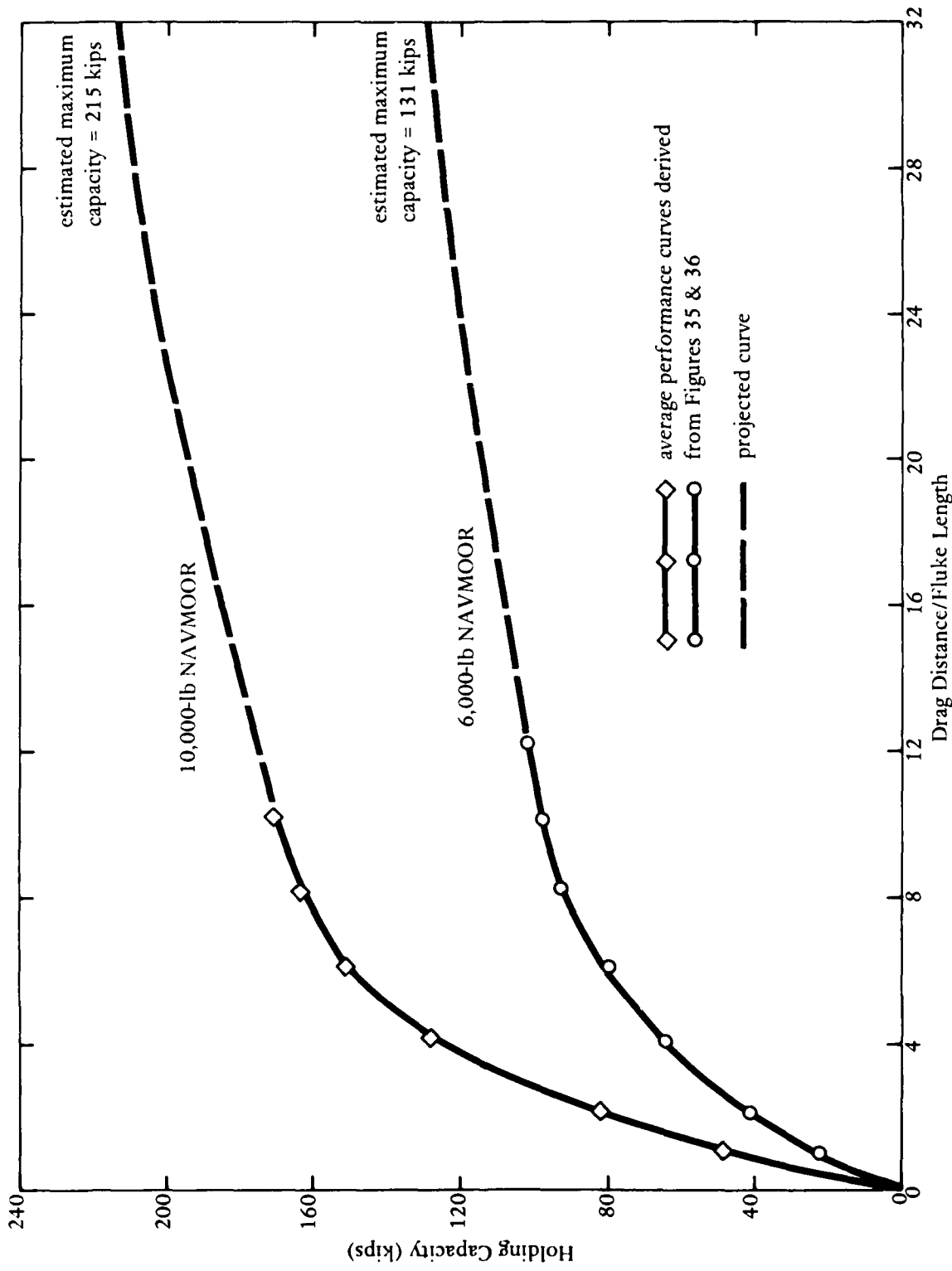

Figure 40. Average performance curves for NAVMOOR Anchors in San Francisco Bay mud.

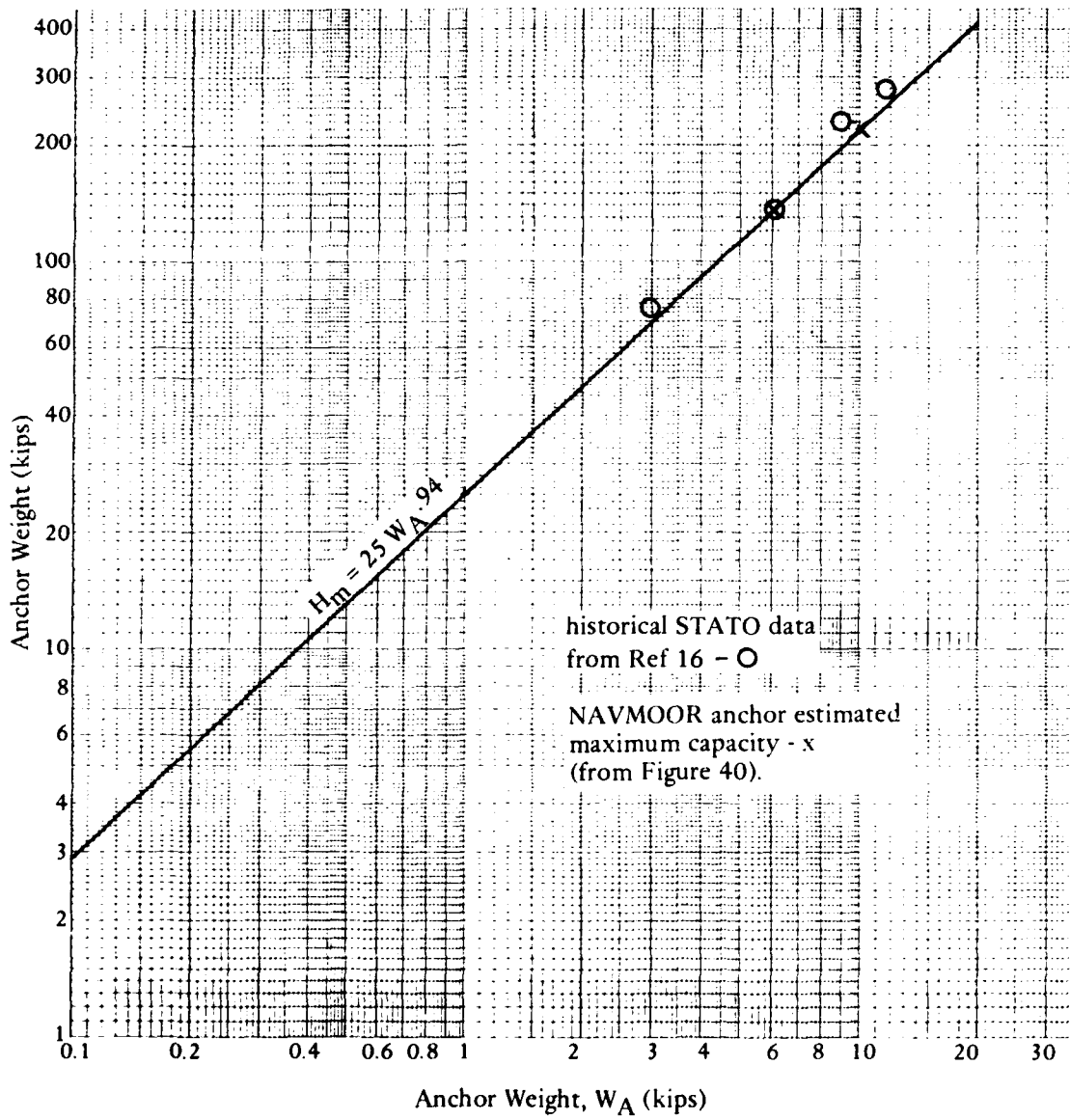

Figure 41. NAVMOOR Anchor performance specification in mud.

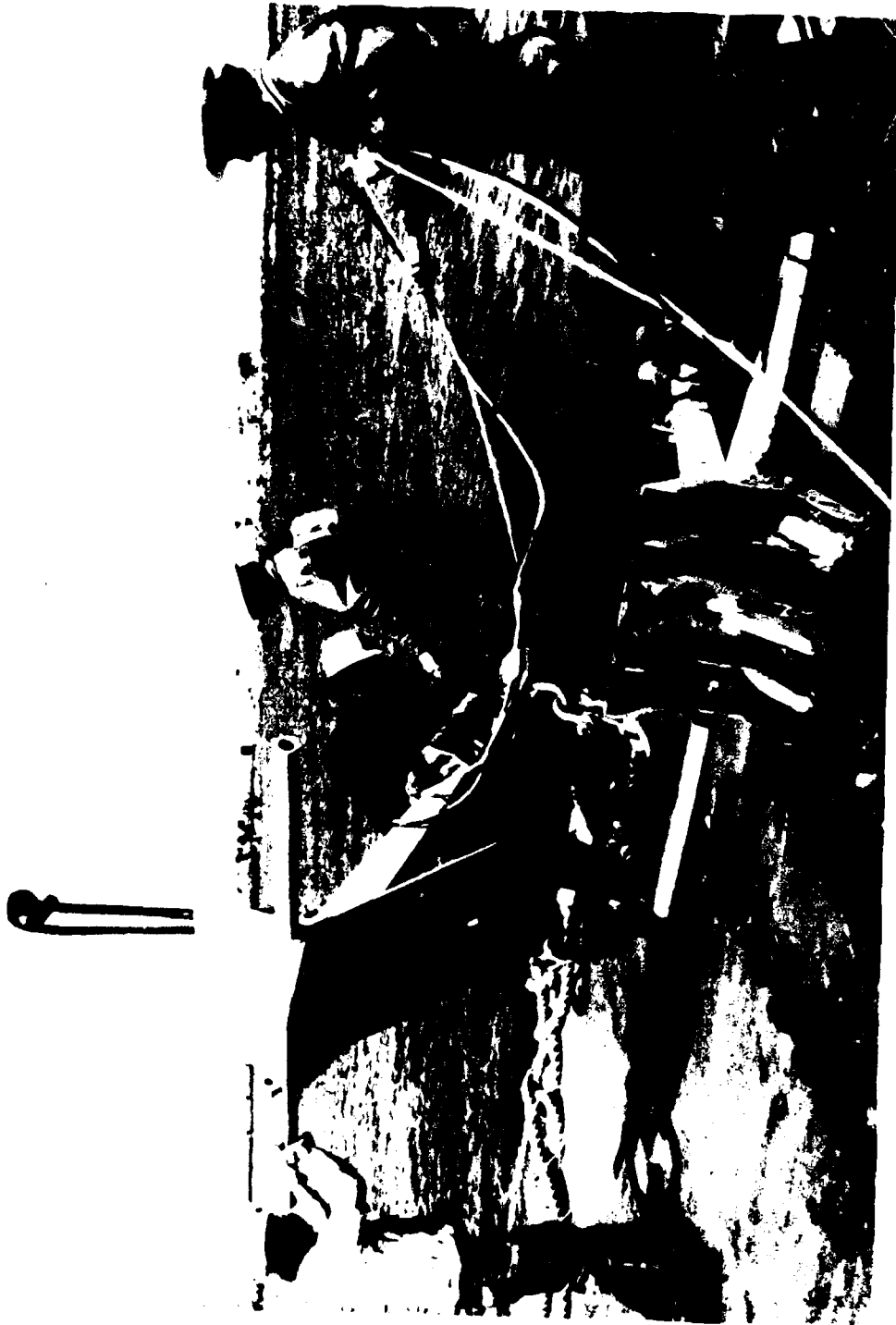

Figure 42. 1,000-pound NAVMOOR Anchors being deployed for tandem anchor testing in Port Hueneme sand.

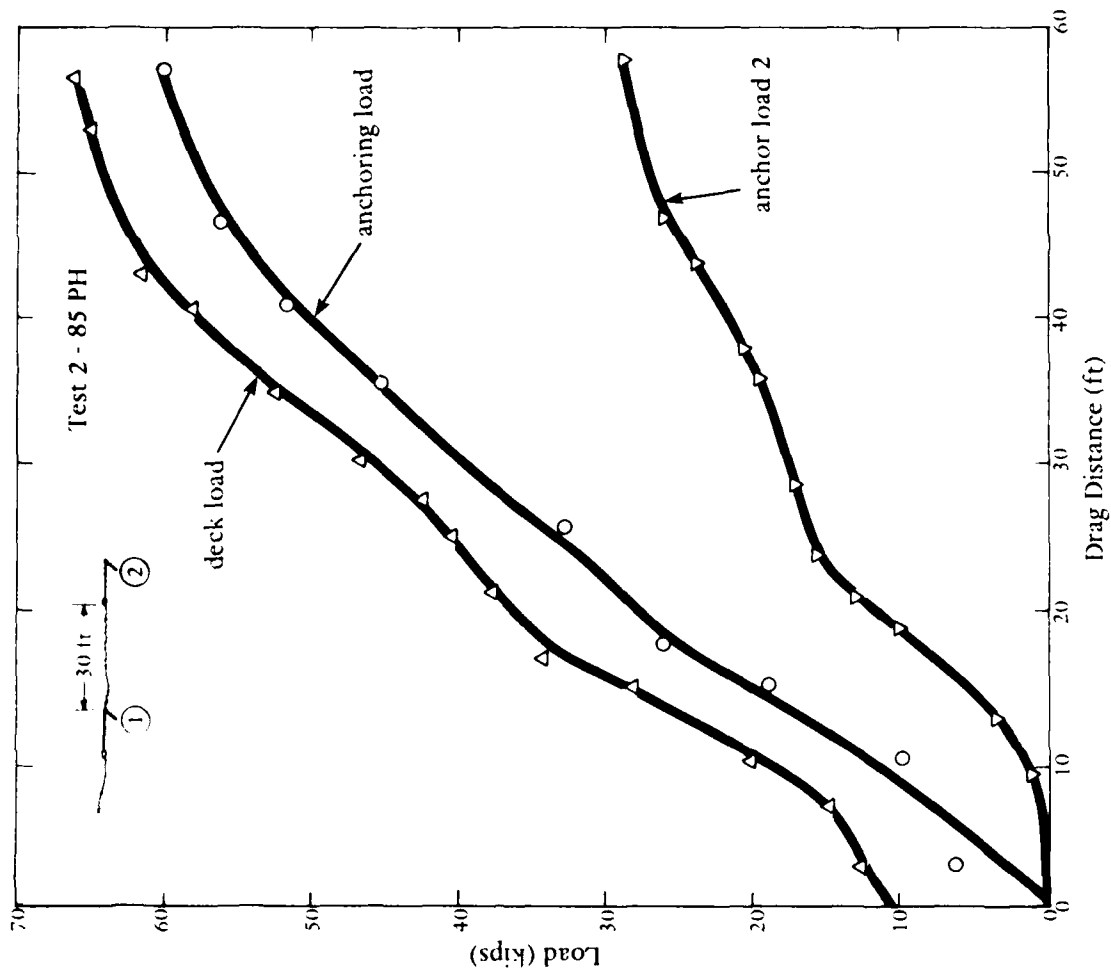

Figure 43. 1,000-pound tandem NAVMOOR Anchor performance in dense gravelly sand at Port Hueneeme.

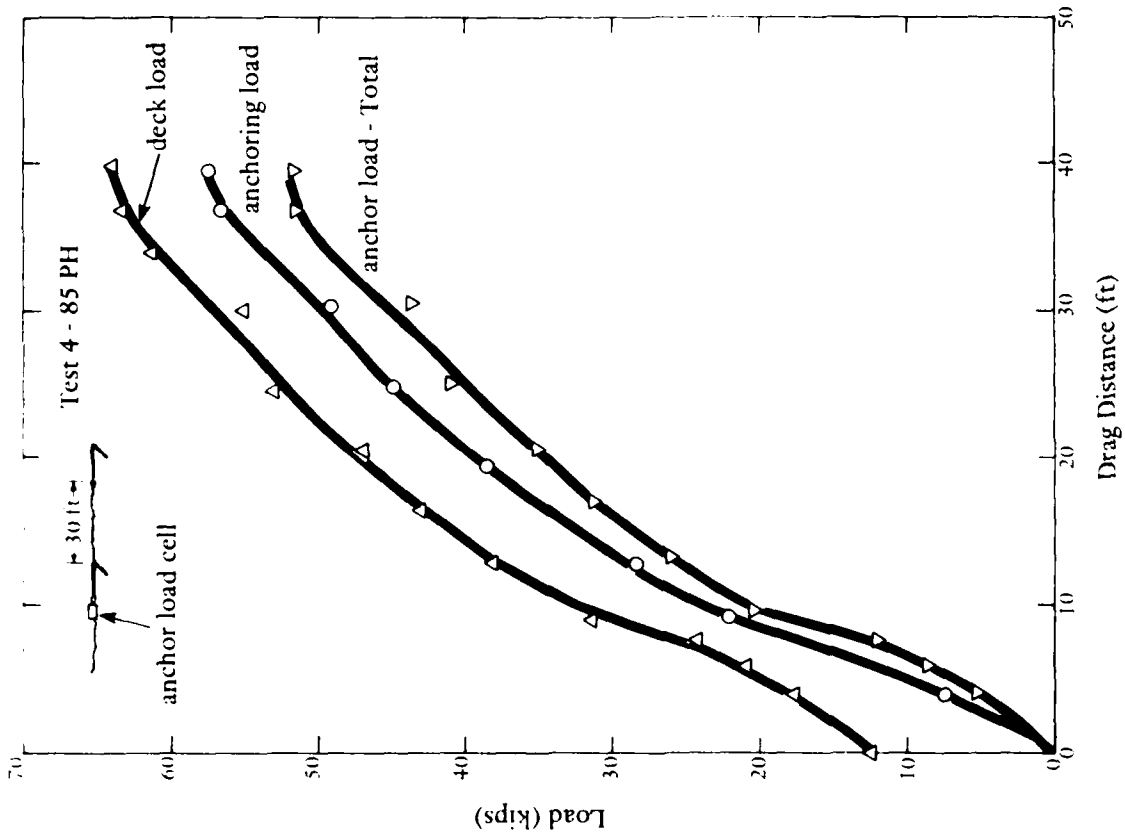

Figure 44. 1,000-pound tandem NAVMOOR Anchor performance in dense gravelly sand at Port Hueneeme.

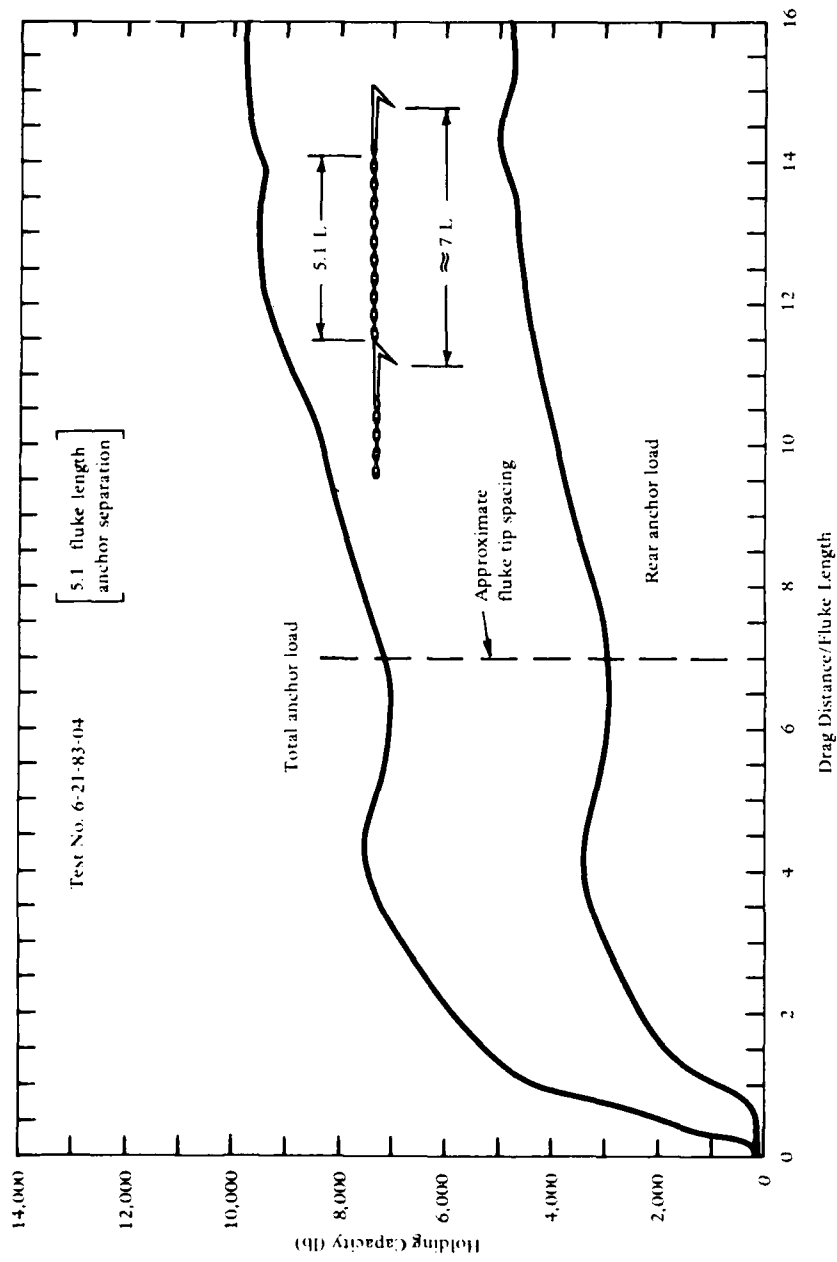

Figure 45. Holding capacity versus drag distance for 200-pound STATO Anchors in tandem, in sand (from Ref 13).

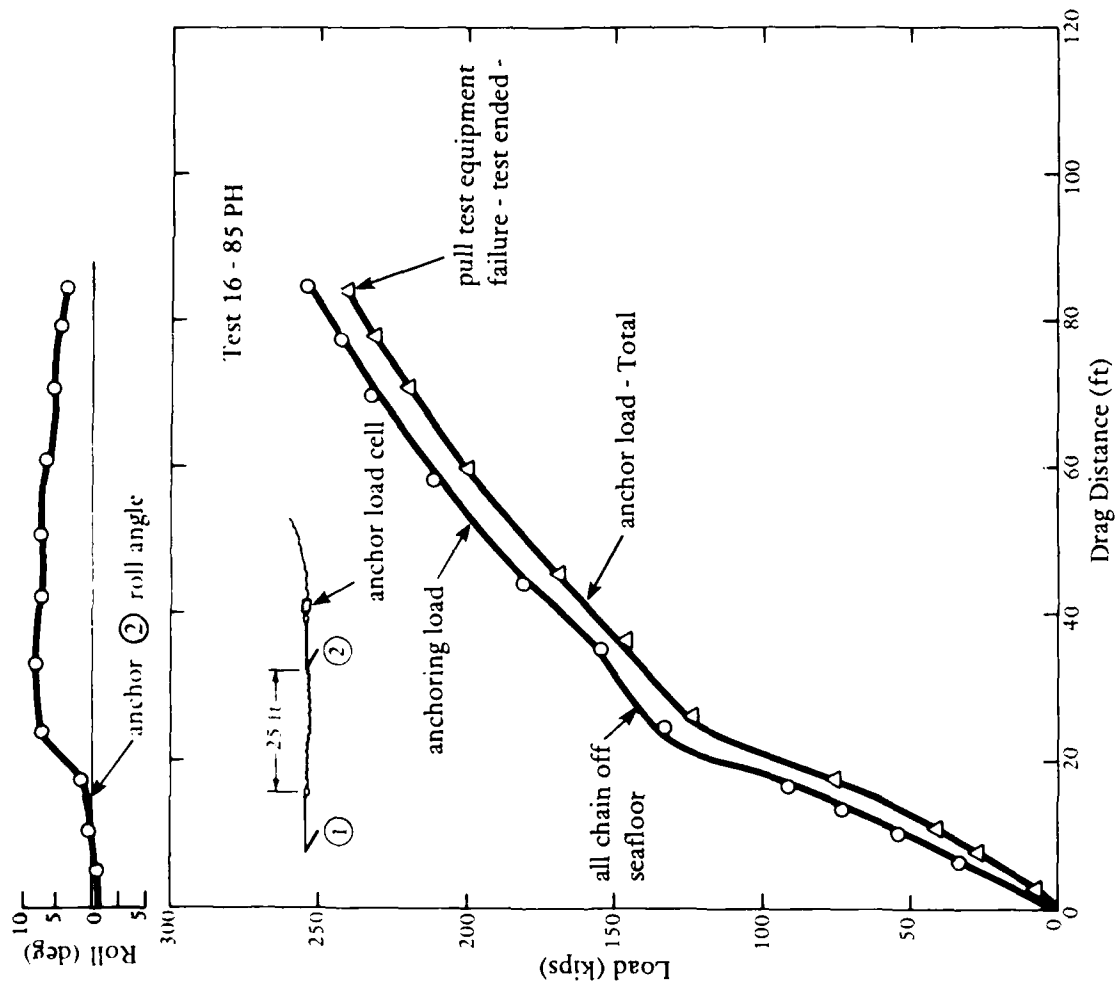

Figure 46. 6,000-pound tandem NAVMOOR Anchor performance in dense gravelly sand at Port Hueneme.

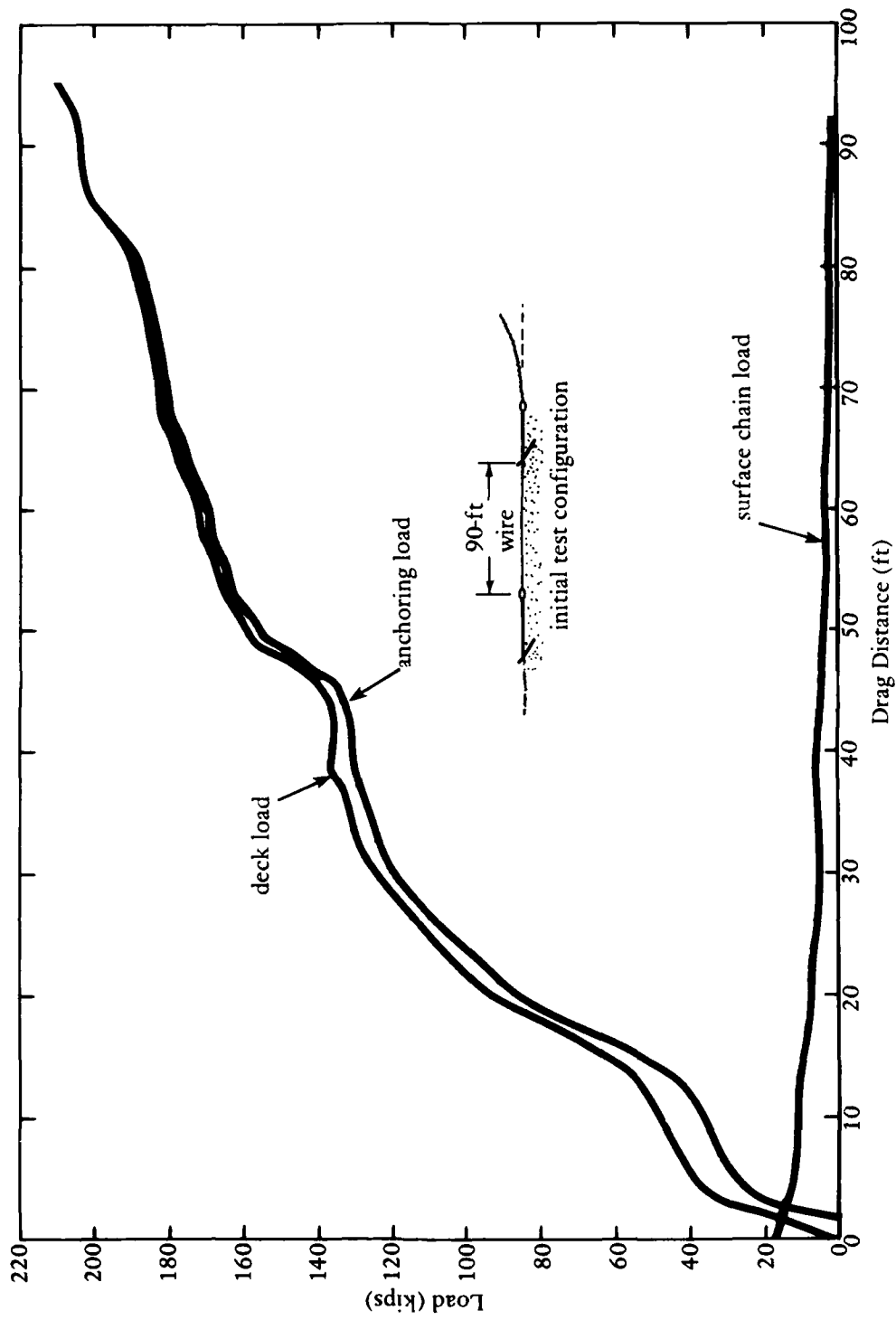

Figure 47. 6,000-pound tandem NAVMOOR Anchor performance in San Francisco Bay mud.

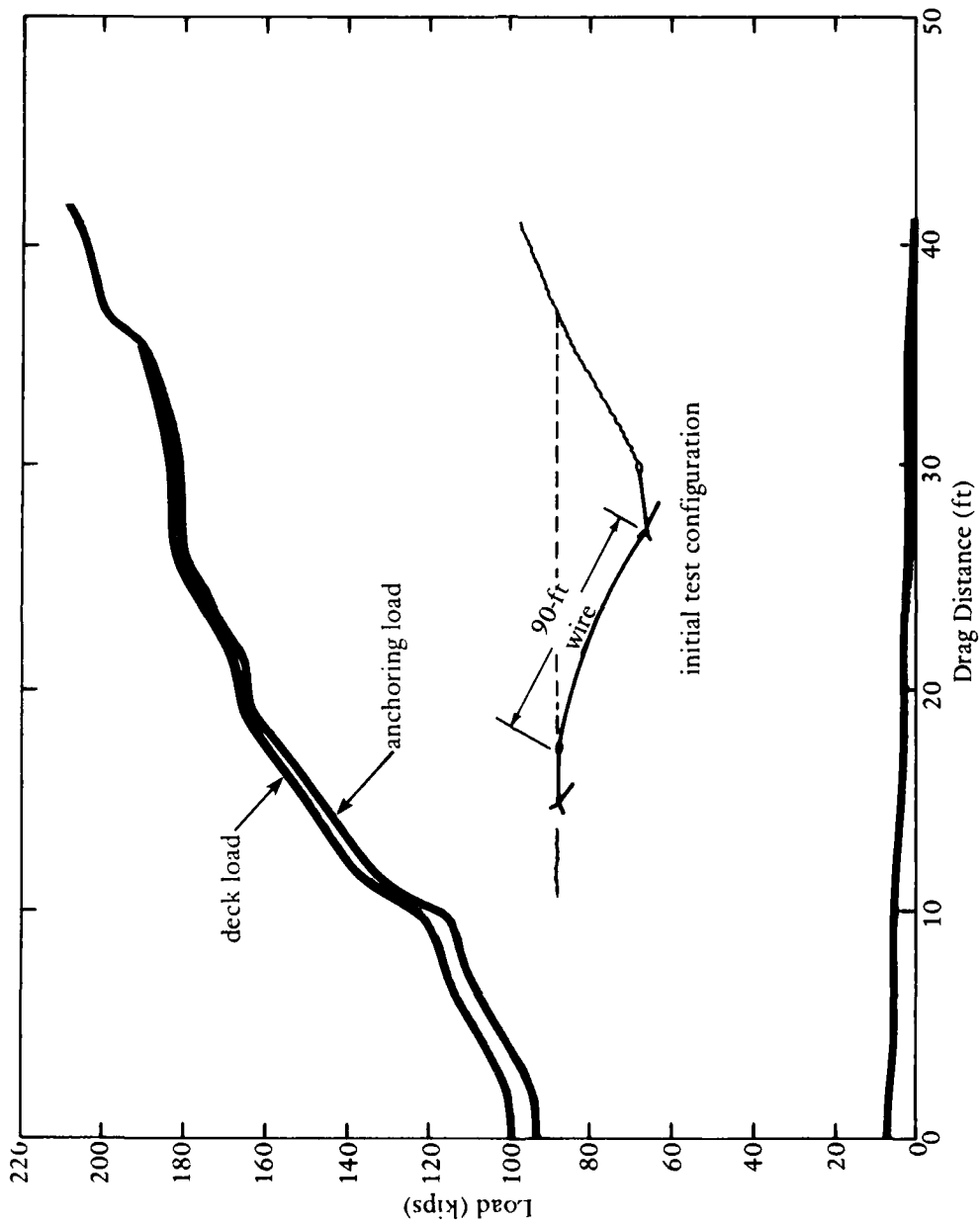

Figure 48. 6,000-pound tandem NAVMOOR Anchor performance in San Francisco Bay mud.

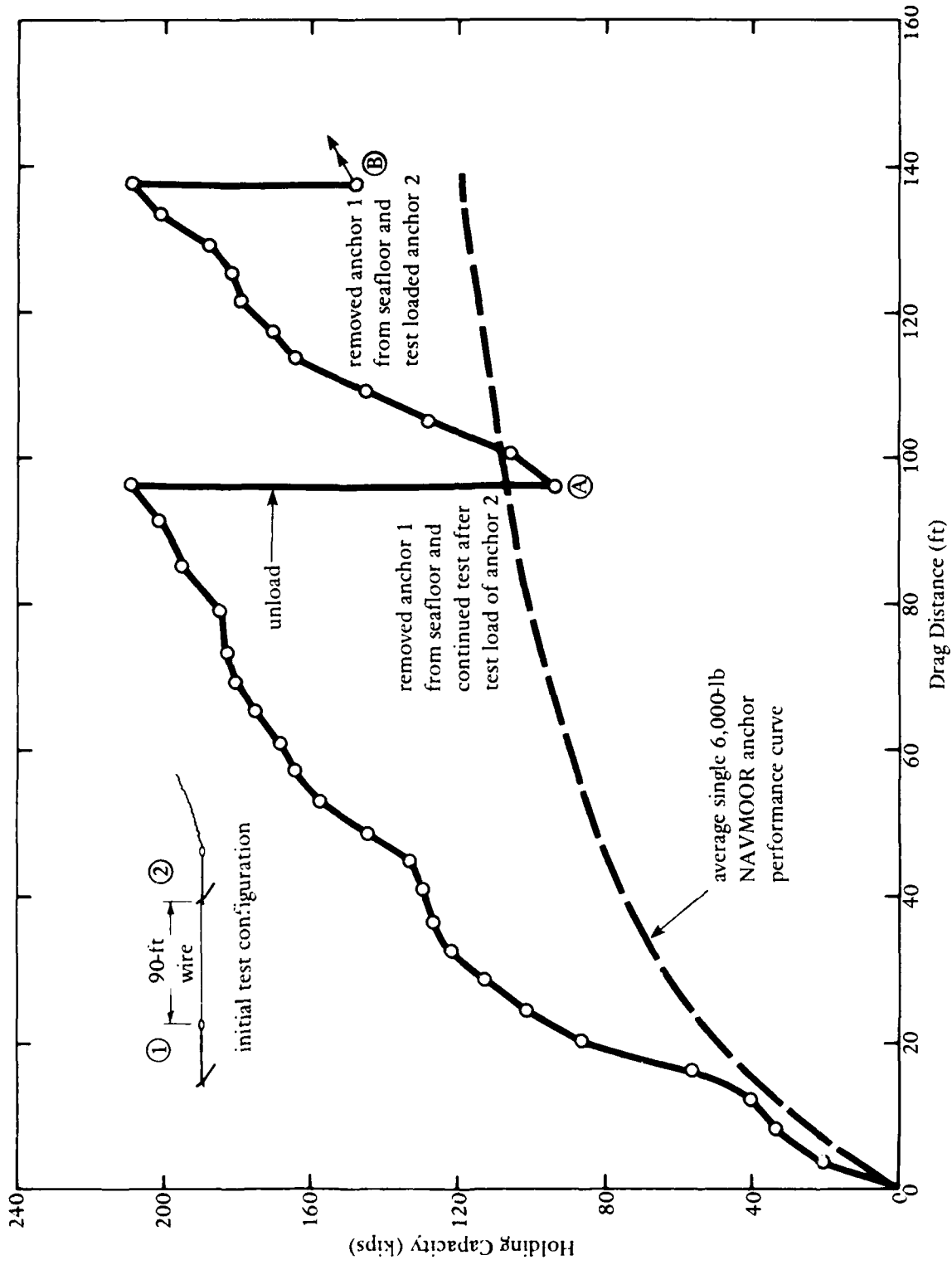

Figure 49. 6,000-pound tandem NAVMOOR Anchor performance in San Francisco Bay mud, showing results of sequential testing.

APPENDIX

DESIGN DRAWINGS FOR NAVMOOR ANCHORS

The design drawings for two general types of NAVMOOR Anchors are provided.

The 2,000-pound NAVMOOR Anchor design drawings represent anchors designed for amphibious logistics use. The principal difference between this anchor and anchors designed specifically for fleet mooring applications is the shank design. Shank taper is nearly nonexistent at the crown end to increase shank bending resistance to lateral loading. The shank of fleet mooring anchors can be more tapered to improve anchor penetrability because these anchors are rarely subjected to significant off-line loading.

The 6,000-pound NAVMOOR Anchor for salvage employs folding stabilizers to enable anchor stowage in existing pockets on Navy ARS ships. The anchor crown has been strengthened to accommodate the folding stabilizers. The anchor shank is also less tapered than fleet mooring anchors to simplify anchor recovery through ARS ship stern chutes. Other minor differences exist for this anchor to ease handling on board ship and to reduce anchor maintainability.

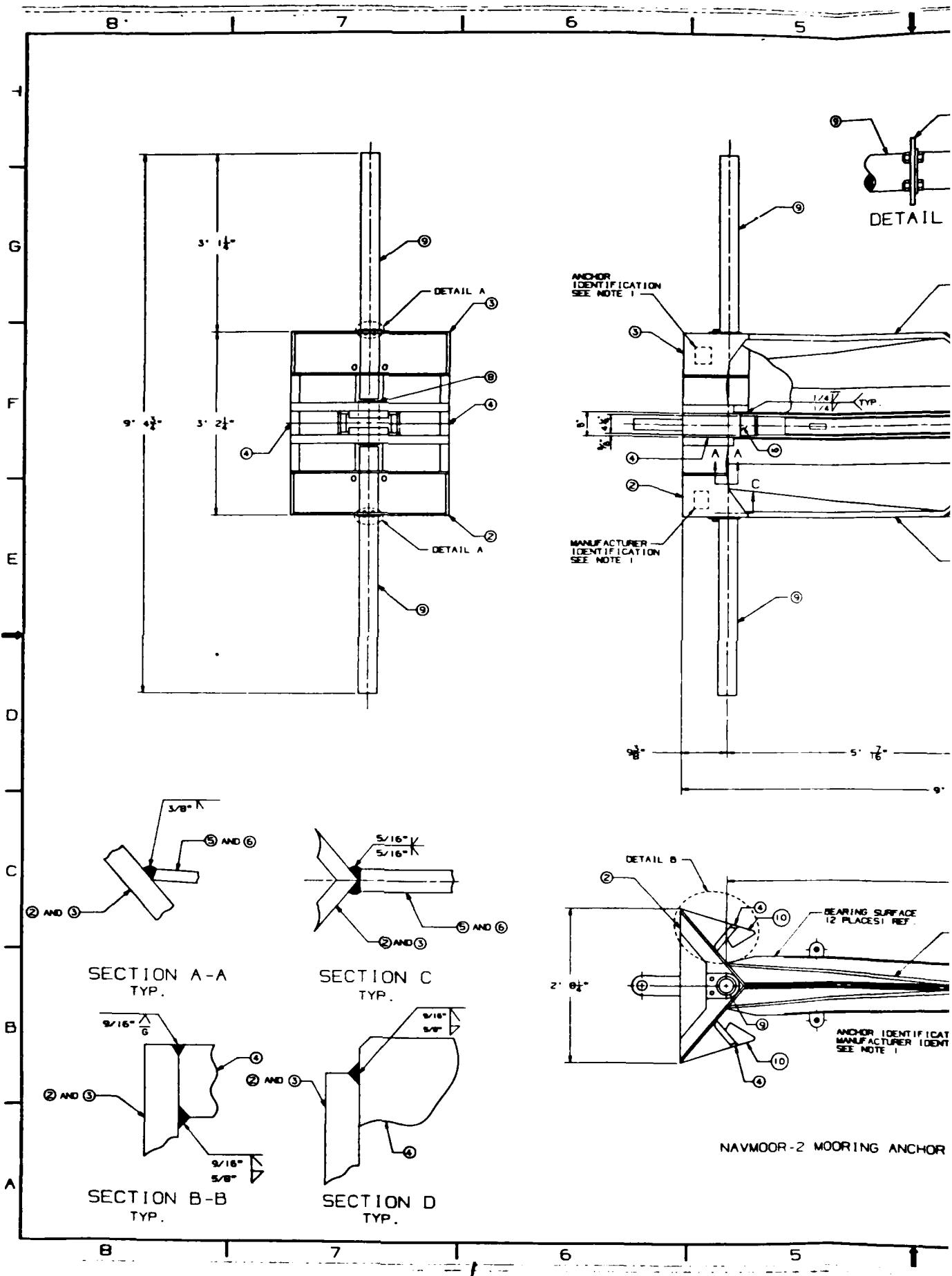

4 3 2 1

REVISIONS		
NO.	DESCRIPTION	DATE

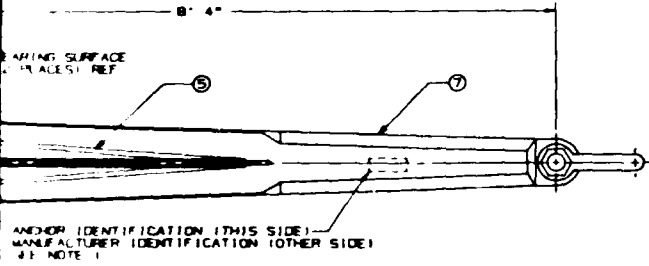
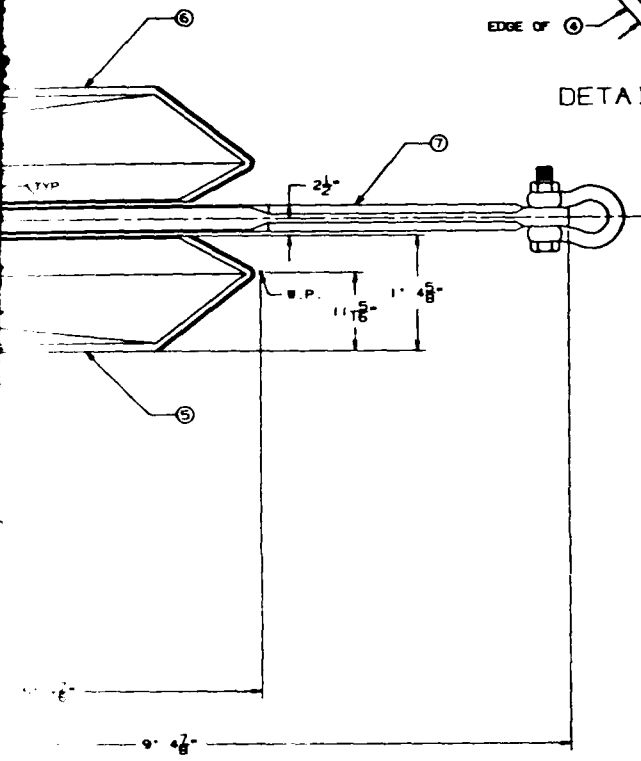
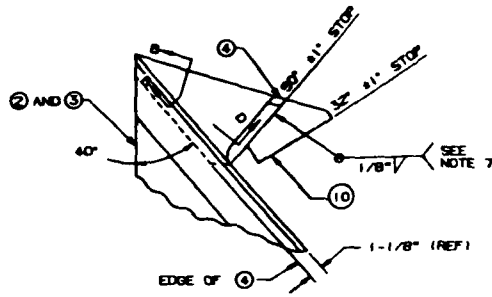
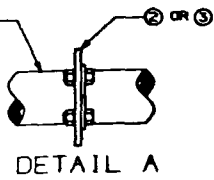

GENERAL NOTES :

- SEE SPECIFICATION (MOST RECENT ISSUE, ENTITLED: "PURCHASE DESCRIPTION, PROTOTYPE NAVMOOR-2 MOORING ANCHOR") FOR ADDITIONAL REQUIREMENTS.
- ALL STRUCTURAL STEEL SHALL CONFORM TO ASTM SPECIFICATION A36, OR FORGED STEEL CONFORMING TO A666 CLASS D, OR CAST STEEL CONFORMING TO A27, GRADE 70-36 OF THE MOST RECENT ISSUE UNLESS OTHERWISE NOTED.
- SHANK AND DOUBLER SHALL BE EITHER CUT FROM STRUCTURAL STEEL CONFORMING TO COR-TEN B (ASTM A558) FY : 50 KSI, OR FORGED STEEL CONFORMING TO ASTM A666 CLASS F, OR CAST STEEL CONFORMING TO ASTM A148, GRADE 80-50.
- FLUKE ASSEMBLY SHALL BE FABRICATED. ALL WELDING SHALL CONFORM TO THE STRUCTURAL WELDING CODE OF THE AMERICAN WELDING SOCIETY AWS D1.1 OF THE MOST RECENT ISSUE.
- FILLER MATERIAL FOR WELDING SHALL CONFORM TO AWS AS.1 OR AS.5 E70XX.
- DIMENSIONS SHOWN ON THIS SHEET ARE FOR REFERENCE ONLY.
- RECOMMENDED WELDING PROCEDURES (MAY BE USED WHEN PALM IS A WELDMENT) :
 - (i) COMPLETE ITEMS (2) AND (3) SEPARATELY.
 - (ii) WELD ITEMS (4) AND (5) OF (5) AND (6) TO (2) AND (3).
 - (iii) WELD ITEMS (6) OF (5) AND (6).
 - (iv) WELD ITEMS (4) TO (2) AND (3). BOTH BEARING SURFACES OF (7) SHALL BE FLUSHED TO (4) AND (3) AT SPECIFIED OPENING ANGLES.
 - (v) WELD ITEM (10) TO (4).
- SPECIFIED WELD SIZES SHALL BE REPLACED BY SECTION WITH EQUIVALENT RADIUS IN THE EVENT OF CASTING THE COMPONENT.

QTY	ITEM NO	PART NO	DESCRIPTION	MATERIAL
2	10	6195315-252	32° STOPPER	
2	9	6195317-452	STABILIZER ASSEMBLY	
1	8	6195317-4T1	TRANSITION ASSEMBLY	
1	7	6195317-4S1	SHANK ASSEMBLY	
1	6	6195316-3P1 L	FLUKE ASSEMBLY (OPPOSITE HAND)	
1	5	6195316-3P R	FLUKE ASSEMBLY (AS SHOWN)	
2	4	6195315-251	90° STOPPER	
1	3	6195315-3P1 L	PALM ASSEMBLY (OPPOSITE HAND)	
1	2	6195315-3P1 R	PALM ASSEMBLY (AS SHOWN)	
1	1	6195314-1	NAVMOOR-2 MOORING ANCHOR GENERAL ASSEMBLY	

MOORING ANCHOR GENERAL ASSEMBLY ①

TOLERANCES : X DECIMAL TOLERANCES : X DECIMALS TO DECIMALS FRACTIONS ANGLES	QUANTITY FOR EACH ASSEMBLY	PARTS LIST	APPROVED BY: [Signature] DATE: [Date] CHECKED BY: [Signature] DATE: [Date]	NAVMOOR-2 MOORING ANCHOR 2,400 LBS. (WT.) GENERAL ASSEMBLY
	MCA ENGINEERING, INC. 2225 S. GARDEN ST. ANAHEIM, CALIF. 92805	NAVMOOR-2 MOORING ANCHOR 2,400 LBS. (WT.) GENERAL ASSEMBLY	NAVMOOR-2 MOORING ANCHOR 2,400 LBS. (WT.) GENERAL ASSEMBLY	NAVMOOR-2 MOORING ANCHOR 2,400 LBS. (WT.) GENERAL ASSEMBLY

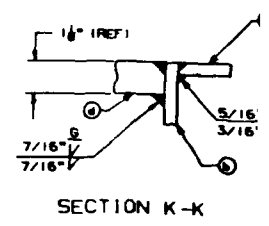
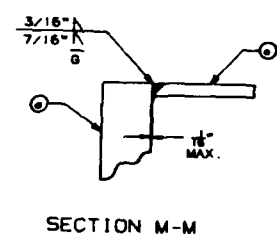
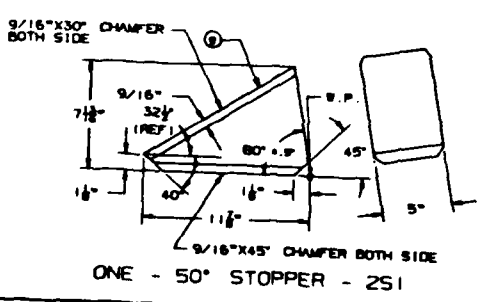
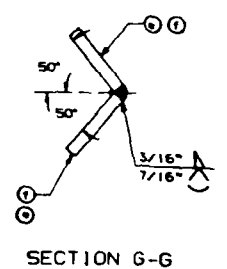
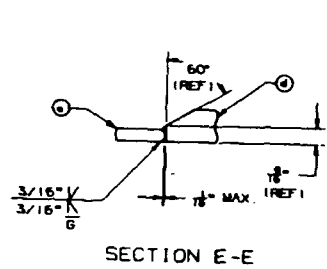
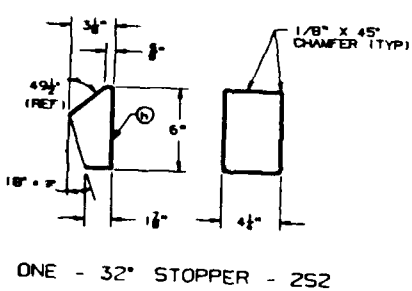
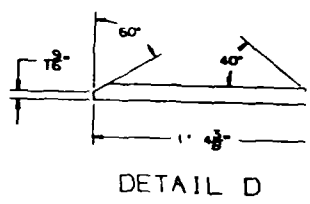
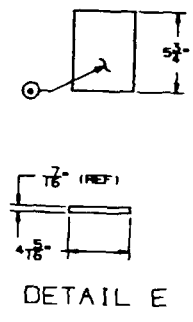
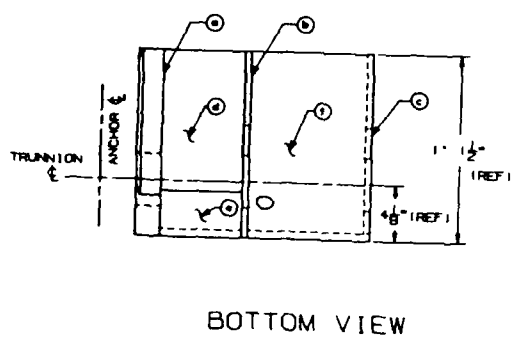
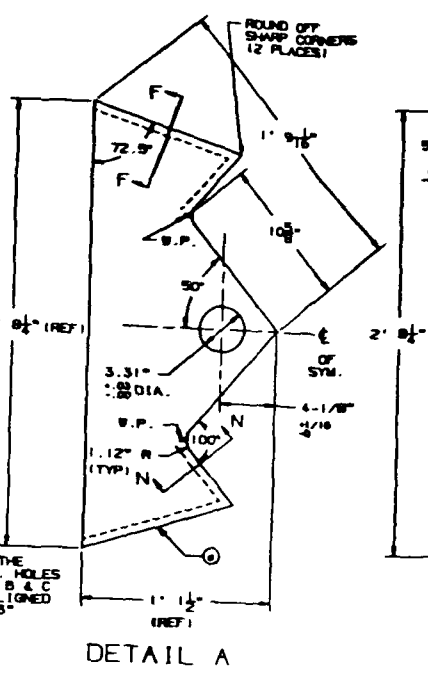
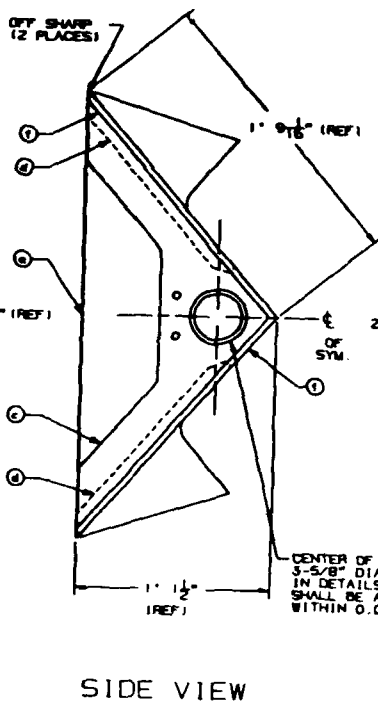
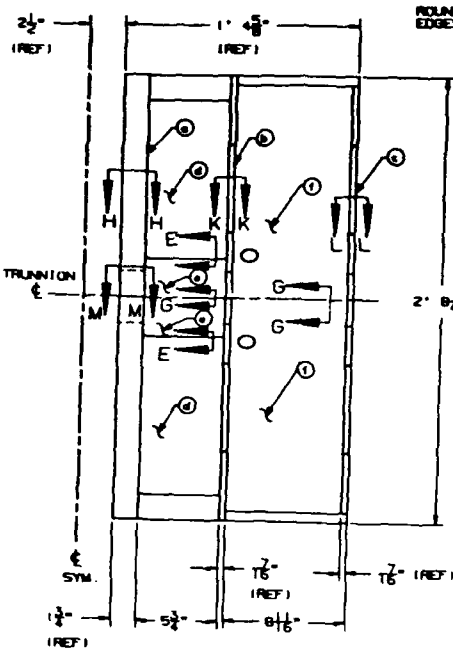
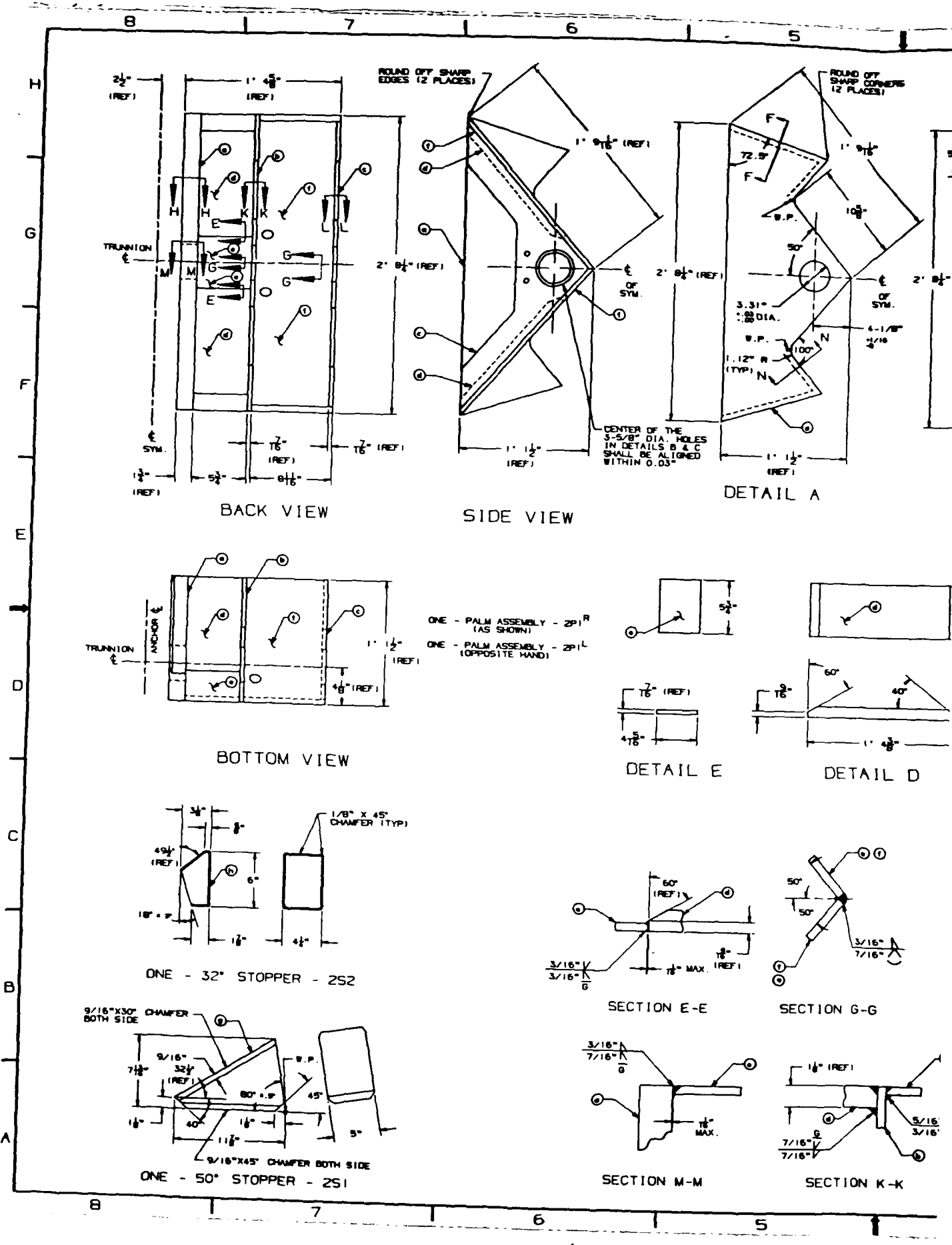

ROUND OFF SHARP CORNERS (2 PLACES)

REVISIONS	
NO.	DESCRIPTION

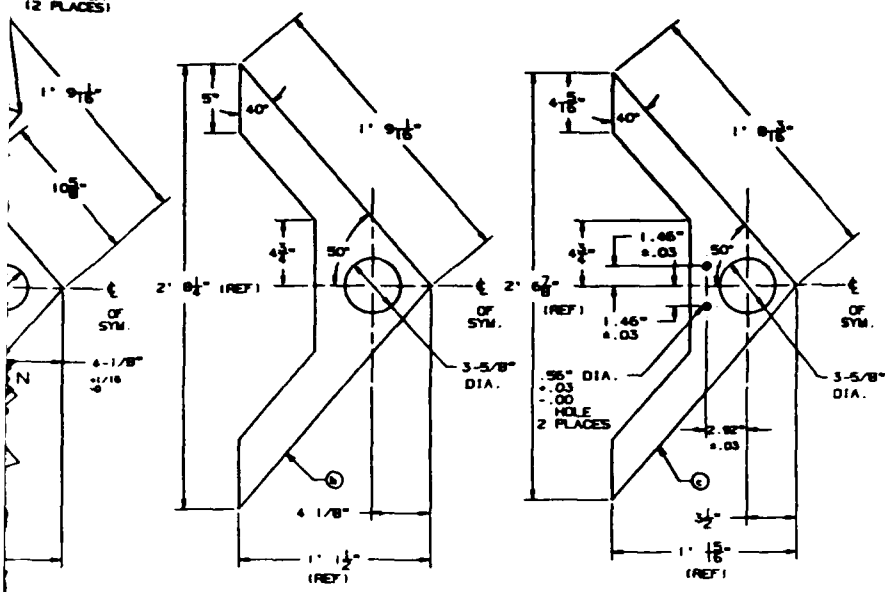

DETAIL B

DETAIL C

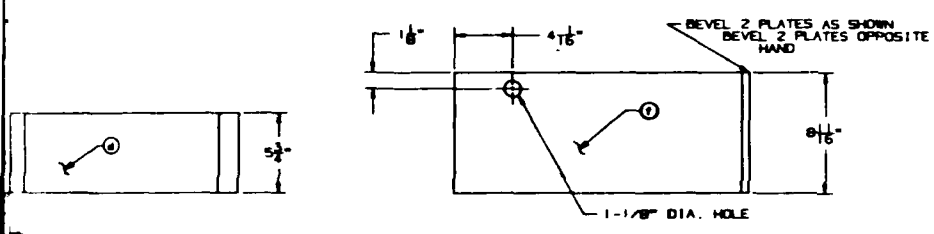

DETAIL D

DETAIL F

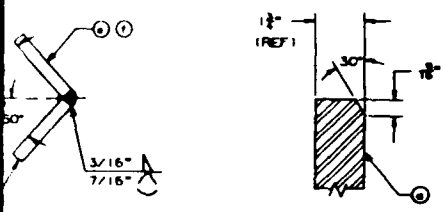

SECTION G-G

SECTION F-F

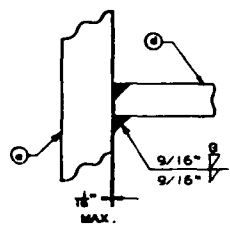

SECTION H-H

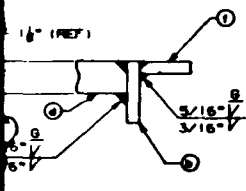

SECTION K-K

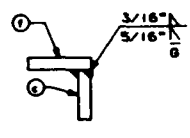

SECTION L-L

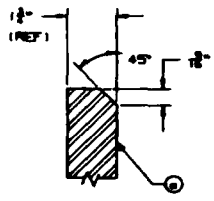

SECTION N-N

QTY	DESCRIPTION	UNIT	REMARKS
1	PL 3-1/2\" X 4-1/4\"	0	0
ONE - 3\" STOPPER - 252			
1	PL 7-1/2\" X 8-1/2\"	0	11-7/8
ONE - 8\" STOPPER - 251			
1	PL 7/16\" X 8-11/16\"	1	8-11/16 PALM COVER #3 DETAIL F
1	PL 7/16\" X 4-8/16\"	0	8-5/8 PALM COVER #2 DETAIL E
1	PL 1-1/8\" X 8-3/4\"	1	4-5/8 PALM COVER #1 DETAIL D
2	PL 7/16\" X 1-15/16\"	2	8-7/8 PALM SPAR #3 DETAIL C
2	PL 7/16\" X 1-1-1/2\"	2	8-1/4 PALM SPAR #2 DETAIL B
2	PL 1-3/4\" X 1-1-1/2\"	2	8-1/4 PALM SPAR #1 DETAIL A

QTY	DESCRIPTION	UNIT	REMARKS
ONE - PALM ASSEMBLY (AS SHOWN)			
ONE - PALM ASSEMBLY (OPPOSITE HAND)			

MCA ENGINEERS, INC. DEPARTMENT OF THE NAVY NAVAL FACILITIES ENGINEERING CENTER
 NAVAL CIVIL ENGINEERING LABORATORY
 PORT HUEBNER, CALIFORNIA 93043
 NAVMOOR-2 MOORING ANCHOR
 2,400 LBS. (WT.)
 PALM ASSEMBLY, STOPPER ASSEMBLY
 F 80091
 SCALE NONE
 SHEET 2 OF 4

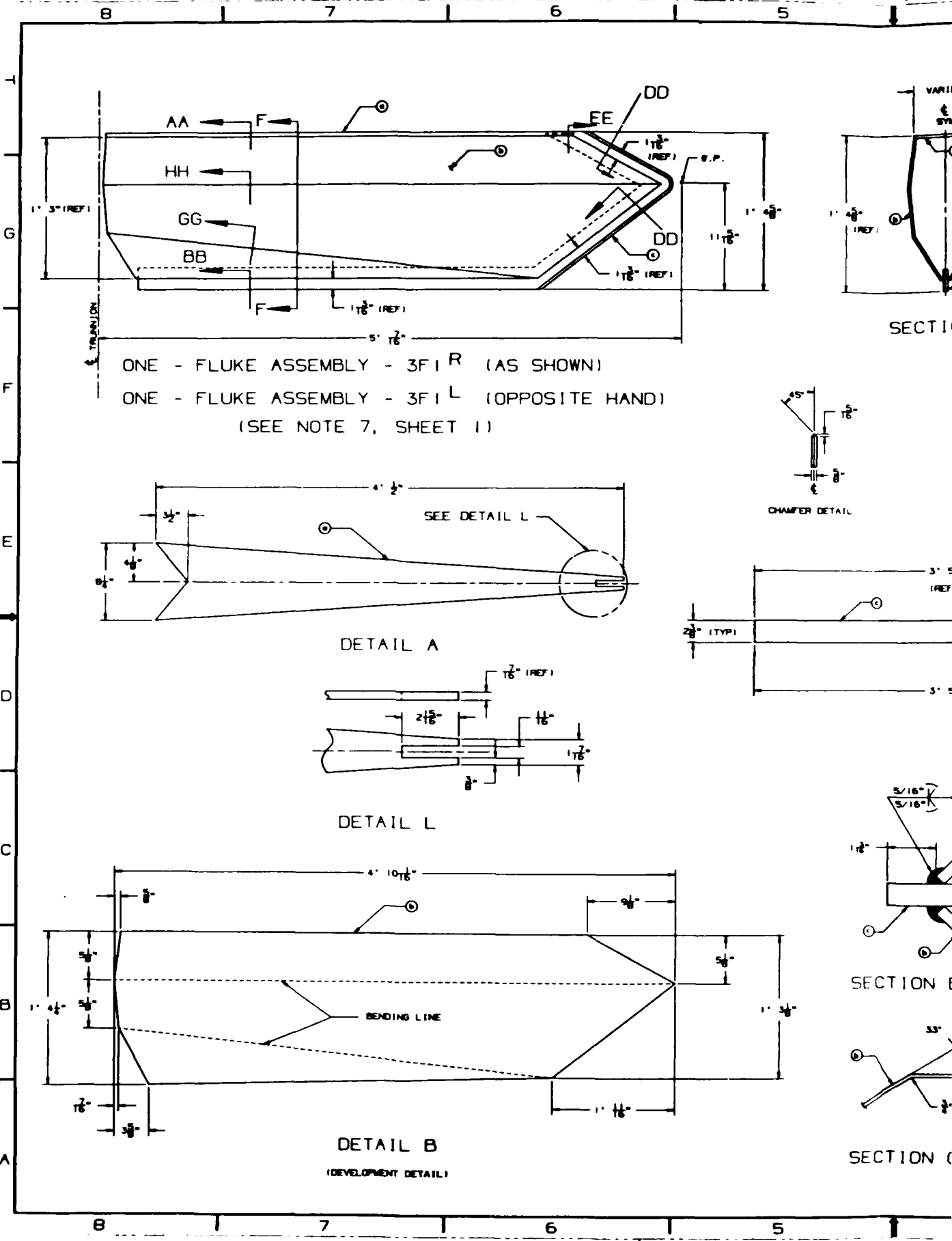

ONE - FLUKE ASSEMBLY - 3F1 R (AS SHOWN)
 ONE - FLUKE ASSEMBLY - 3F1 L (OPPOSITE HAND)
 (SEE NOTE 7, SHEET 1)

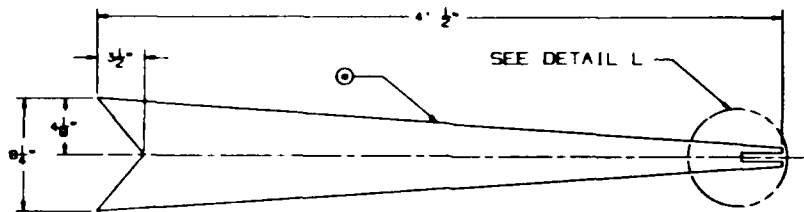

DETAIL A

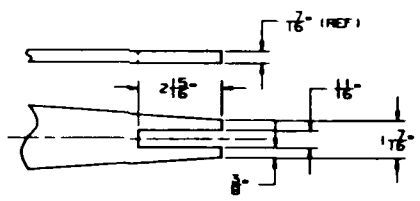

DETAIL L

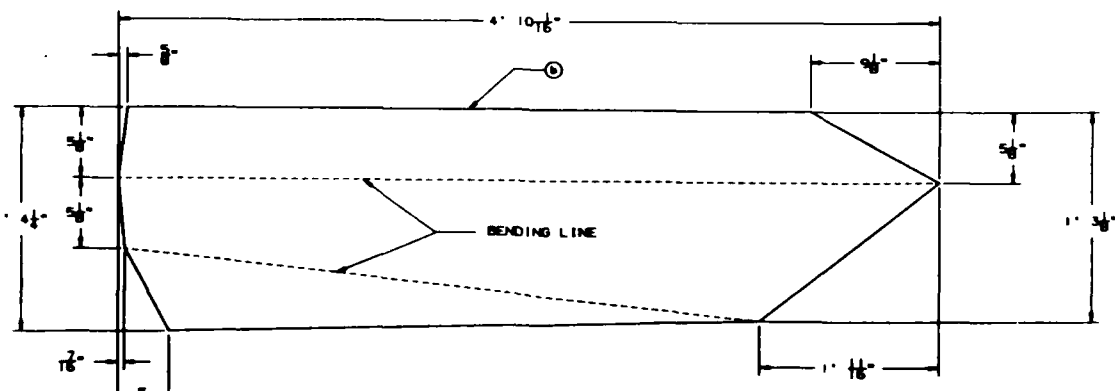

DETAIL B
 (DEVELOPMENT DETAIL)

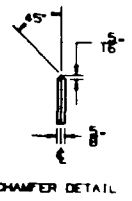

CHAMFER DETAIL

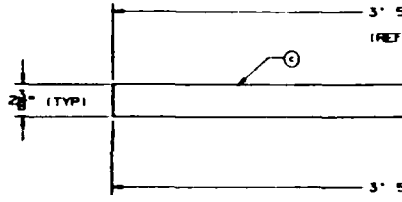

SECTION E

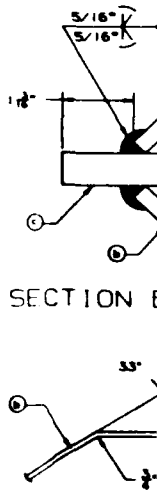

SECTION C

REVISIONS		
NO.	DESCRIPTION	DATE

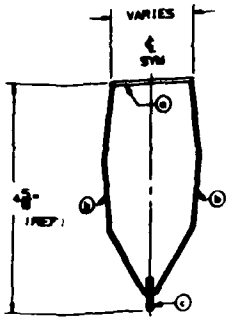

SECTION F-F

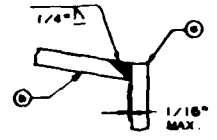

SECTION A-A

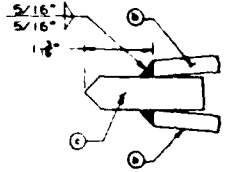

SECTION D-D
(TYPICAL)

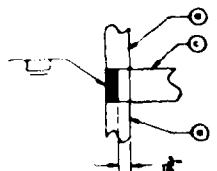

SECTION E-E

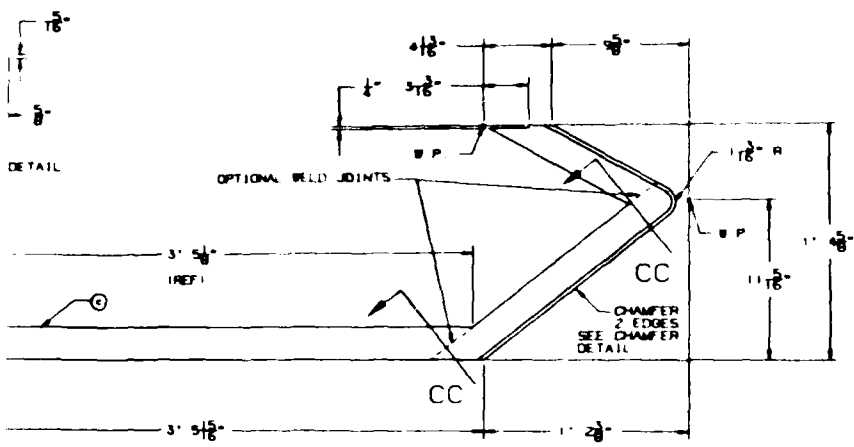

DETAIL C

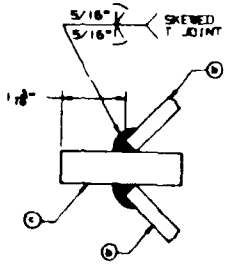

SECTION B-B

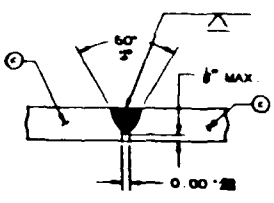

SECTION C-C
(OPTIONAL)

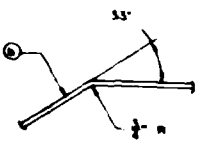

SECTION G-G



SECTION H-H

QTY	SIZE	MATERIAL	DETAIL
2	PL 3/8"	A36	DETAIL C
2	PL 1/2"	A36	DETAIL B
2	PL 3/4"	A36	DETAIL A

ONE - FLAKE ASSEMBLY - 20" R (AS SHOWN)
ONE - FLAKE ASSEMBLY - 20" R (OPPOSITE HAND)

NO.	SIZE	LEN	REMARKS

BILL OF MATERIAL

SEA ENGINEERING, INC. 1000 17th St, San Francisco, CA 94133	DIVISION OF THE CORP. WALSH & COMPANY ENGINEERS NAVAL CIVIL ENGINEERING LABORATORY PORT MERRITT, CALIFORNIA 94043
DRAWN BY J. D. B. (JDB) CHECKED BY J. D. B. (JDB) DATE 7/25/59	NAVYMOOR-2 MOORING ANCHOR 2,400 LBS. (ET. 1) FLAKE ASSEMBLY
PART NO. F 80091 SCALE NONE	DRAWING NO. 6195316 SHEET 3 OF 4

86-17-3F

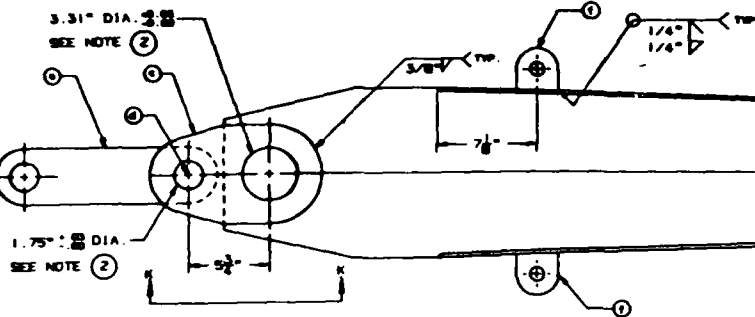
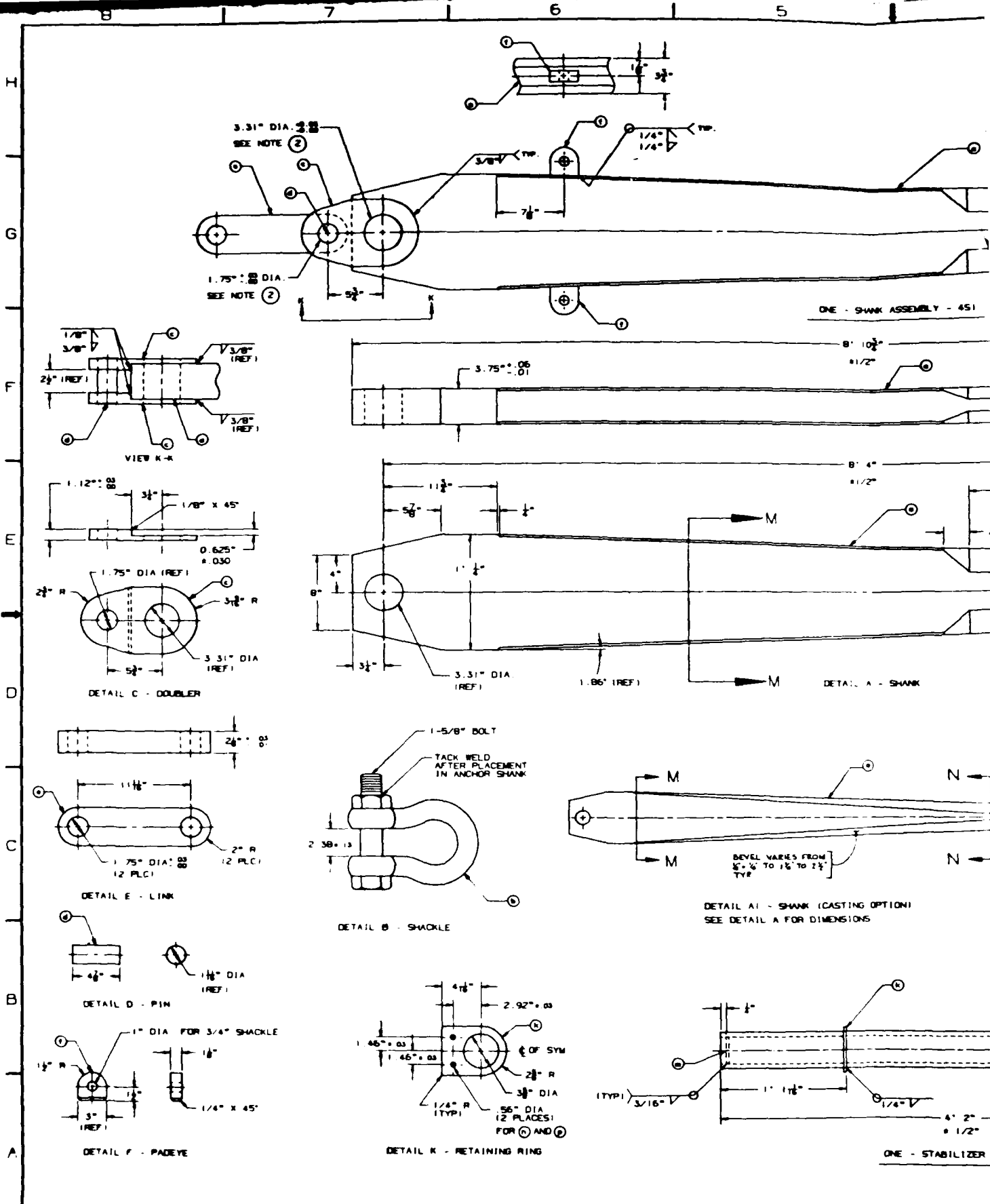

ONE - SHANK ASSEMBLY - 451

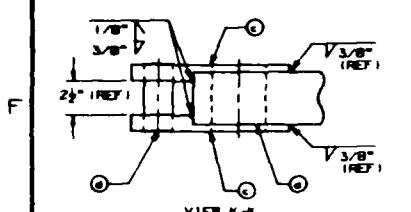

VIEW K-K

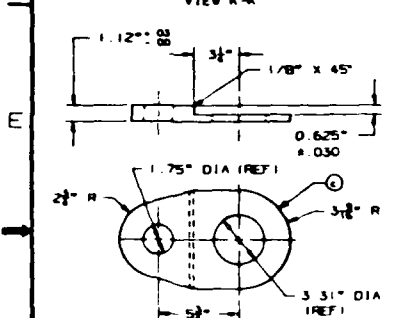
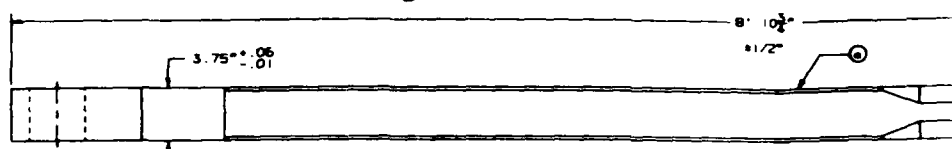

DETAIL C - DOUBLER

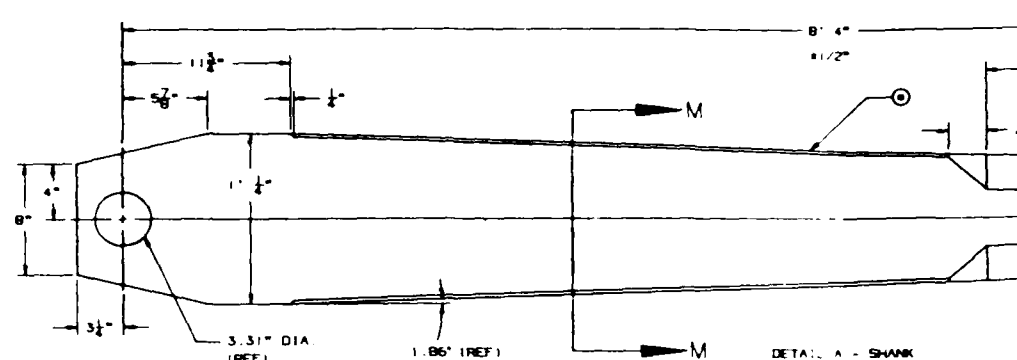

DETAIL A - SHANK

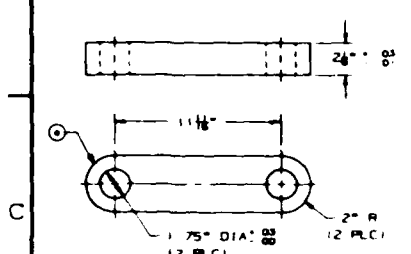

DETAIL E - LINK

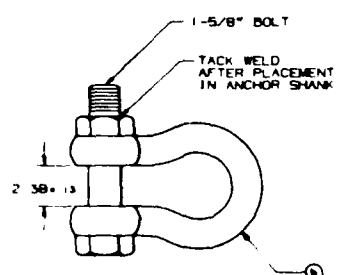

DETAIL B - SHACKLE

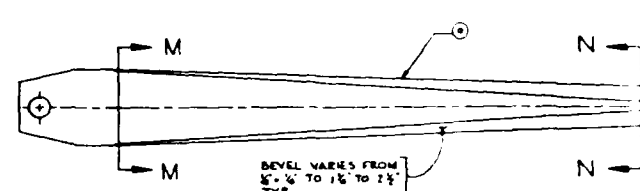

DETAIL A1 - SHANK (CASTING OPTION)
SEE DETAIL A FOR DIMENSIONS

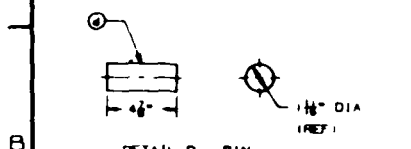

DETAIL D - PIN

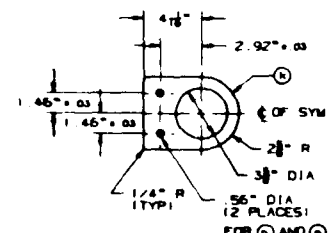

DETAIL K - RETAINING RING

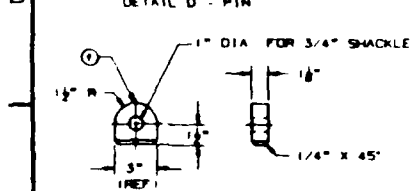

DETAIL F - PADEYE

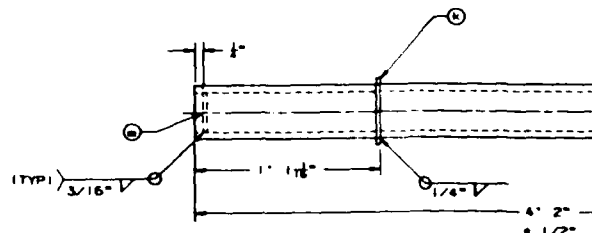

ONE - STABILIZER A

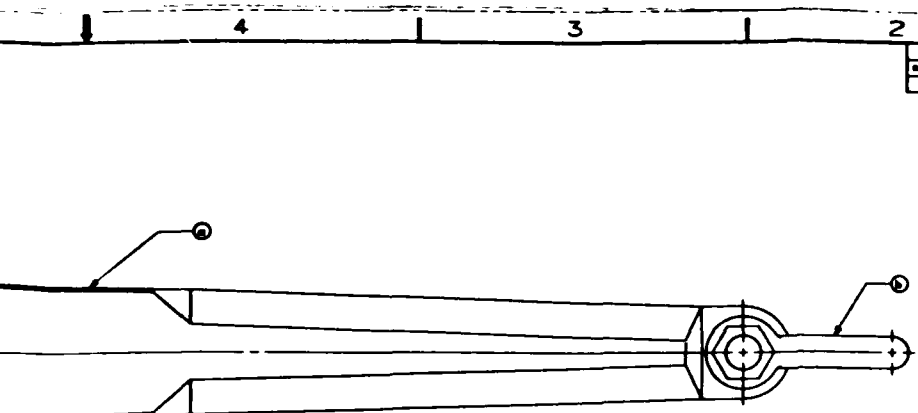

ONE - SHANK ASSEMBLY - 451

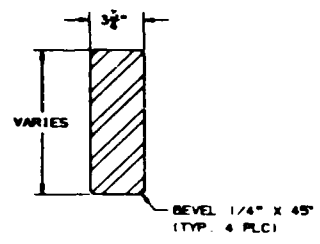
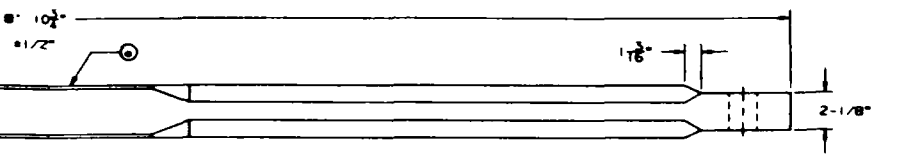

SECTION M-M

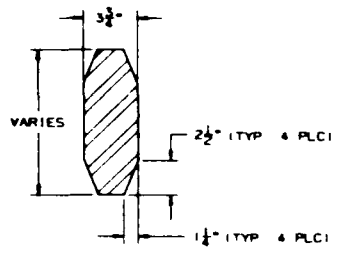
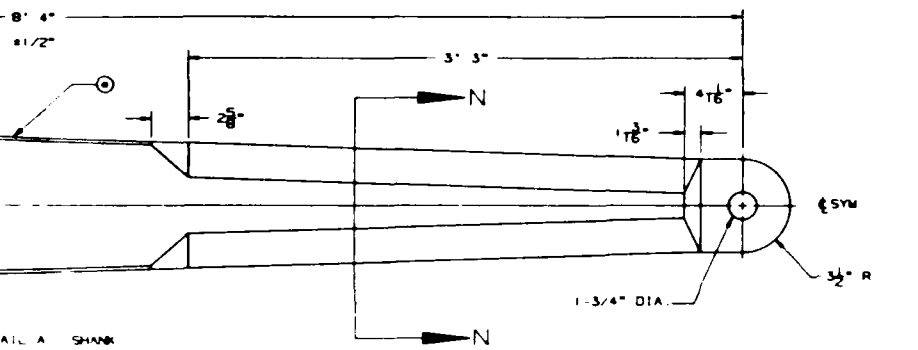

SECTION N-N

(SEE NOTE 1)

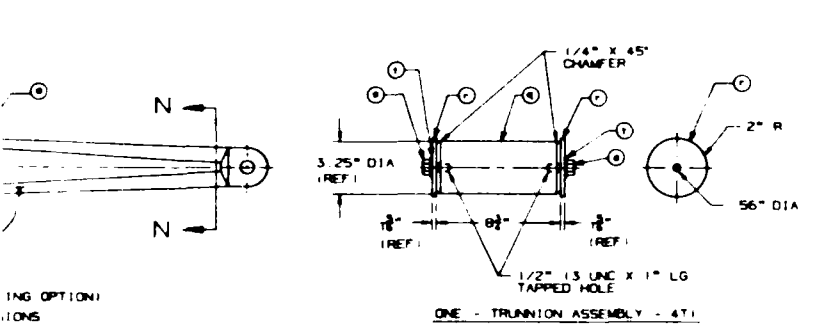

ONE - TRUNION ASSEMBLY - 471

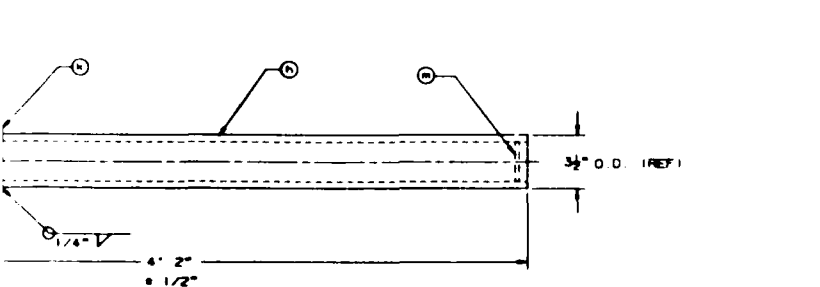

ONE - STABILIZER ASSEMBLY - 452

- NOTE ① THE TOLERANCE OF THE CROSS SECTION DIMENSIONS SHALL BE $\pm 1/16"$
 ② PART ① WELDED TO ② BEFORE HOLES ARE DRILLED

1	2	1-1/2" DIA			HEAVY DUTY HELICAL SPRING LOCK WASHER, CORROSION RESISTANT
2	2	1/2" - 13 UNC	0	1-1/4"	HEX HEAD BOLT, ASTM A325 CORROSION RESISTANT TYPE 3
3	2	5/16" PL 5/16" OD 5/16" ID			KEEPER PLATE
4	1	3-1/4" DIA	0	8-3/4"	TRUNION PIN, COLD DRAWN AISI 1018, Fy = 54 KSI
ONE - TRUNION ASSEMBLY - 471					
5	2	1/2" DIA			HEAVY DUTY HELICAL SPRING LOCK WASHER, CORROSION RESISTANT
6	2	1/2" - 13 UNC	0	1-1/4"	HEX HEAD BOLT WITH NUT, ASTM A325 CORROSION RESISTANT TYPE 3
7	2	5/16" PL 2-1/4" OD			END PLATE
8	1	5/16" PL 3-1/2" OD	0	8-11/16"	RETAINING RING DETAIL R
9	1	3" PIPE (HOB)	4	2	ASTM A53 GRADE B
ONE - STABILIZER ASSEMBLY - 452					
10	2	1-1/4" X 3" PL	0	3	PAGEYE DETAIL P
11	1	2-1/4" X 4" PL	1	3-11/16"	LIMB, ASTM A536 MOD Fy = 60 KSI DETAIL E
12	1	1-11/16" DIA BAR	0	4-7/8"	PIN, COLD DRAWN AISI 4340, Fy = 90 KSI DETAIL D
13	2	1-1/8" PL X 7-1/8"	1	1/16"	DOUBLER SEE NOTE 3 SHT DETAIL C
14	1	1-1/2" DIA HOB			BOLT TYPE ANCHOR SHACKLE 300,000 LBS BREAKING STRENGTH DETAIL B
15	1	3-3/4" PL X 12-1/2"	0	10-3/4"	SHANK SEE NOTE 3 SHT DETAIL A

MARK	SIZE	FT	IN	REMARKS
NO.			LENGTH	

BILL OF MATERIAL

MCA ENGINEERS, INC. DEPARTMENT OF THE SHIP, NAVAL FACILITIES ENGINEERING DIVISION
 NAVAL CIVIL ENGINEERING LABORATORY, PORT HUENEME, CALIFORNIA 93043
 NAVYMOOR-2 MOORING ANCHOR 2,400 LBS. (WT. 1)
 SHANK ASSEMBLY, TRUNION ASSEMBLY, STABILIZER ASSEMBLY
 SIZE: 80091
 DATE: 6/15/64
 SHEET 4 OF 4

ALL DIMENSIONS UNLESS SPECIFIED OTHERWISE ARE IN INCHES UNLESS NOTED OTHERWISE
TOLERANCES:
FRACTIONS $\pm 1/16"$
DECIMALS $\pm 0.005"$
ANGLES $\pm 1"$

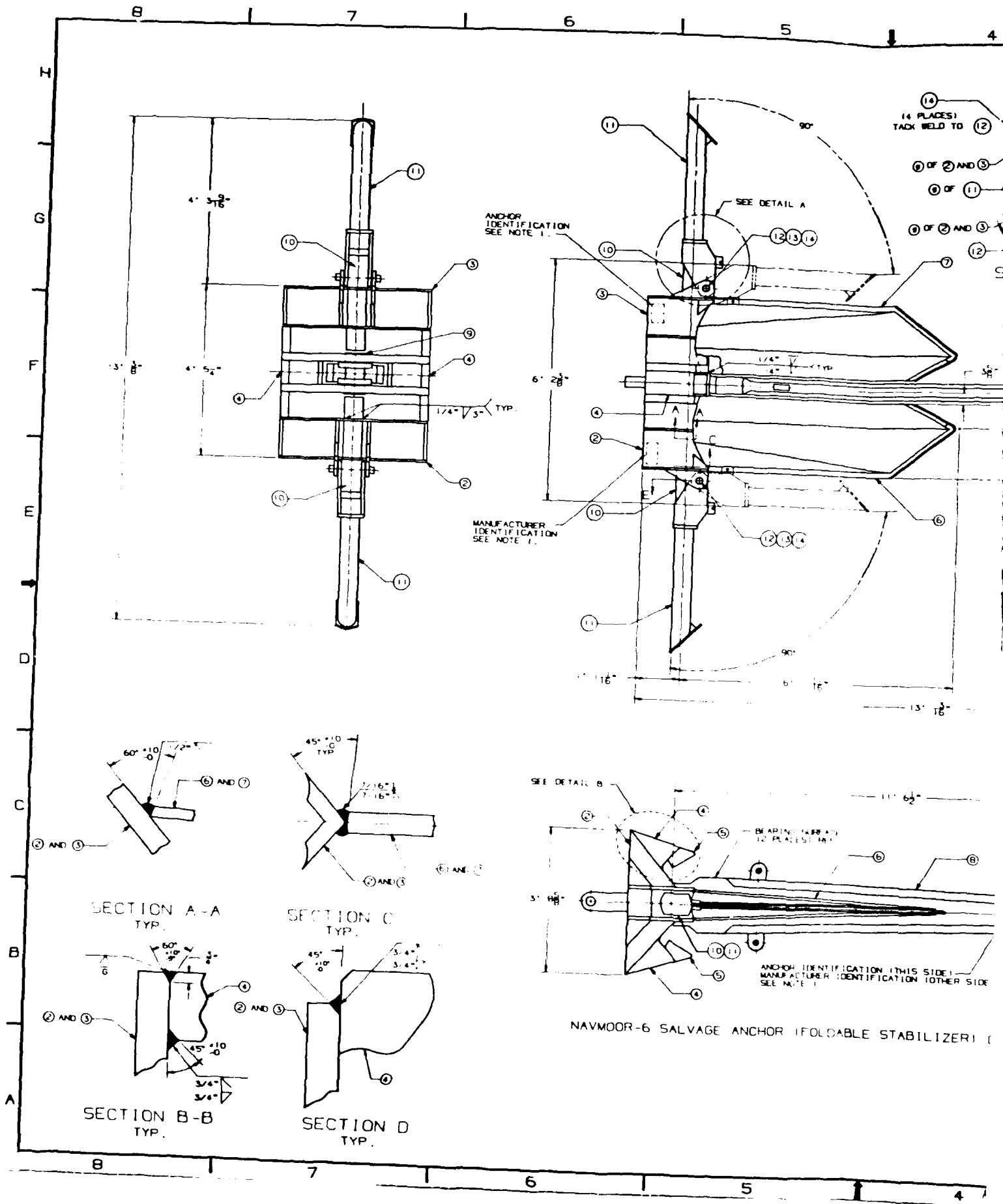

REVISIONS			
NO.	DESCRIPTION	DATE	BY

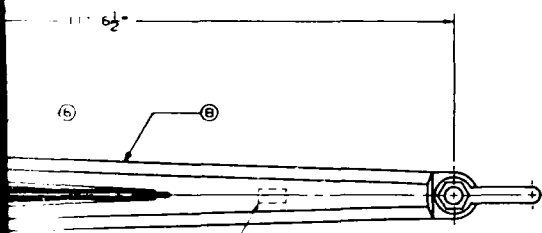
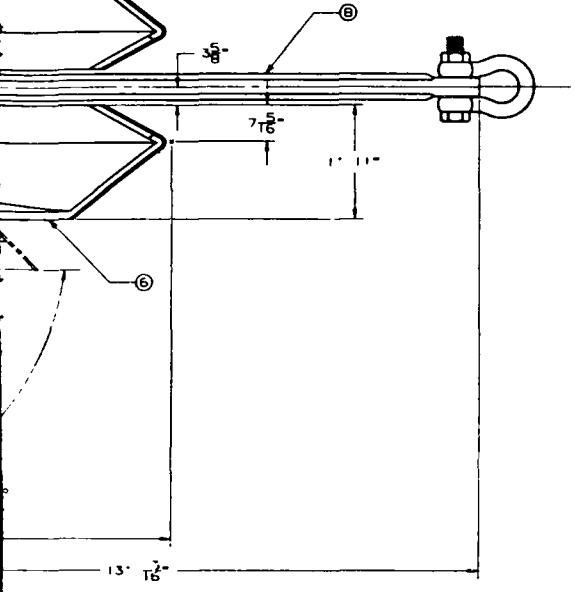
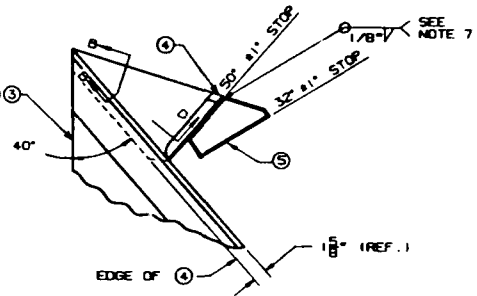
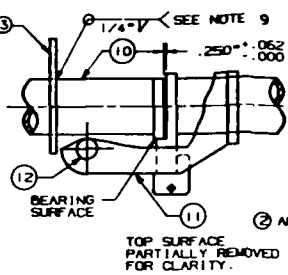
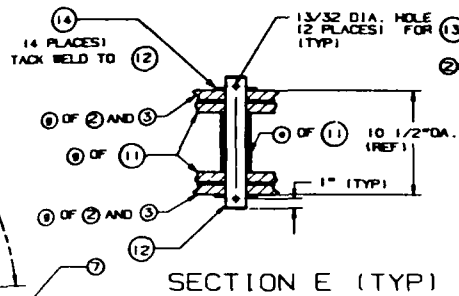

GENERAL NOTES :

- SEE SPECIFICATION (MOST RECENT ISSUE, ENTITLED: "PURCHASE DESCRIPTION, PROTOTYPE NAVMOOR-6 SALVAGE ANCHOR") FOR ADDITIONAL REQUIREMENTS.
- ALL STRUCTURAL STEEL SHALL CONFORM TO ASTM SPECIFICATION A 36 OF MOST RECENT ISSUE UNLESS OTHERWISE NOTED.
- SHANK, STOPPERS AND DOUBLER SHALL BE EITHER CUT FROM STRUCTURAL STEEL CONFORMING TO ASTM A 36, FORGED STEEL CONFORMING TO ASTM A 668 CLASS D, OR CAST STEEL CONFORMING TO ASTM A 27, GRADE 70-36.
- WELDING SHALL CONFORM TO THE STRUCTURAL WELDING CODE OF THE AMERICAN WELDING SOCIETY AWS D1.1 OF THE MOST RECENT ISSUE.
- FILLER MATERIAL FOR WELDING SHALL CONFORM TO AWS A5.1 OR A5.5 E70XX.
- UNLESS OTHERWISE NOTED, DIMENSIONS SHOWN ON THIS SHEET ARE FOR REFERENCE ONLY.
- RECOMMENDED WELDING PROCEDURES (MAY BE USED WHEN PALM IS A WELDMENT) :
 - (i) COMPLETE ITEMS (12) AND (13) SEPARATELY.
 - (ii) WELD ITEMS (a) AND (4) OF (16) AND (7) TO (12) AND (13).
 - (iii) WELD ITEMS (b) OF (16) AND (7).
 - (iv) WELD ITEMS (4) TO (12) AND (13), BOTH BEARING SURFACES OF (18) SHALL BE FLUSH TO (4) AND (5) AT SPECIFIED OPENING ANGLES.
 - (v) WELD ITEM (15) TO (14).
- SPECIFIED WELD SIZES SHALL BE REPLACED BY SECTION WITH EQUIVALENT RADII IN THE EVENT OF CASTING THE COMPONENT.
- PROPERLY INSTALL SHANK (18) AND TRUNNION PIN (19). WELD (10) TO (12) OR (13) WHILE MAINTAINING THE SPECIFIED SPACING AND ALIGNMENT OF THE BEARING SURFACES. INJECT GREASE THROUGH ITEM (m) OF (iii) UNTIL GREASE SHOWS UP BETWEEN (iii) AND (12). THEN REPLACE ITEM (m) OF (iii) BY ITEM (n) OF (iii).

QTY	ITEM NO.	PART NO.	DESCRIPTION	MATERIAL
4	14	6195301-14	WASHER 4" O. D. X 2-1/16" X 1/4" THK. (INCL.) MACHINE THICKNESS TO HOLD OVER ALL DIMENSIONS AS REQ'D.	316 S.S.
2	13	6195301-13	3/8" X 3" COTTER PIN	316 S.S.
2	12	6195301-12	HINGE PIN 2" DIA. X 13-7/16" LB. FY = 90 KSI A151 6140	
2	11	6195305-562	MOVABLE STABILIZER ASSEMBLY	
2	10	6195305-951	FIXED-STABILIZER ASSEMBLY	
1	9	6195304-471	TRUNNION PIN	
1	8	6195304-451	SHANK ASSEMBLY	
1	7	6195303-3F1 L	FLUKE ASSEMBLY (OPPOSITE HAND)	
1	6	6195303-3F1 R	FLUKE ASSEMBLY (AS SHOWN)	
2	5	6195305-954	32° STOPPER	
2	4	6195305-953	50° STOPPER	
1	3	6195302-2P1 L	PALM ASSEMBLY (OPPOSITE HAND)	
1	2	6195302-2P1 R	PALM ASSEMBLY (AS SHOWN)	
1	1	6195301-1	NAVMOOR-6 SALVAGE ANCHOR (FOLDABLE STABILIZER) GENERAL ASSEMBLY	

TOLERANCES : X DECIMALS X DECIMALS X DECIMALS X DECIMALS FRACTIONS ANGLES	MCA ENGINEERS, INC. 1000 S. GARDEN ST. SUITE 100 ANAHEIM, CALIF. 92805		DEPARTMENT OF THE NAVY NAVAL FACILITIES ENGINEERING DIVISION NAVAL CIVIL ENGINEERING LABORATORY PORT HUENEME, CALIFORNIA 93043	
	DES. BY: [Signature] CHECKED BY: [Signature] DATE: 7/25/85		NAVM 1R-6 SALVAGE ANCHOR 7,200 LBS. (WT.) GENERAL ASSEMBLY	
	QUANTITY FOR EACH ASSEMBLY: 1		PARTS LIST ITEM NO. 1 PART NO. 6195301 DESCRIPTION: NAVM 1R-6 SALVAGE ANCHOR (FOLDABLE STABILIZER) GENERAL ASSEMBLY MATERIAL:	
	SUBMITTED BY: [Signature] DATE: 7/25/85		F 80091 SHEET 1 OF 5	

2

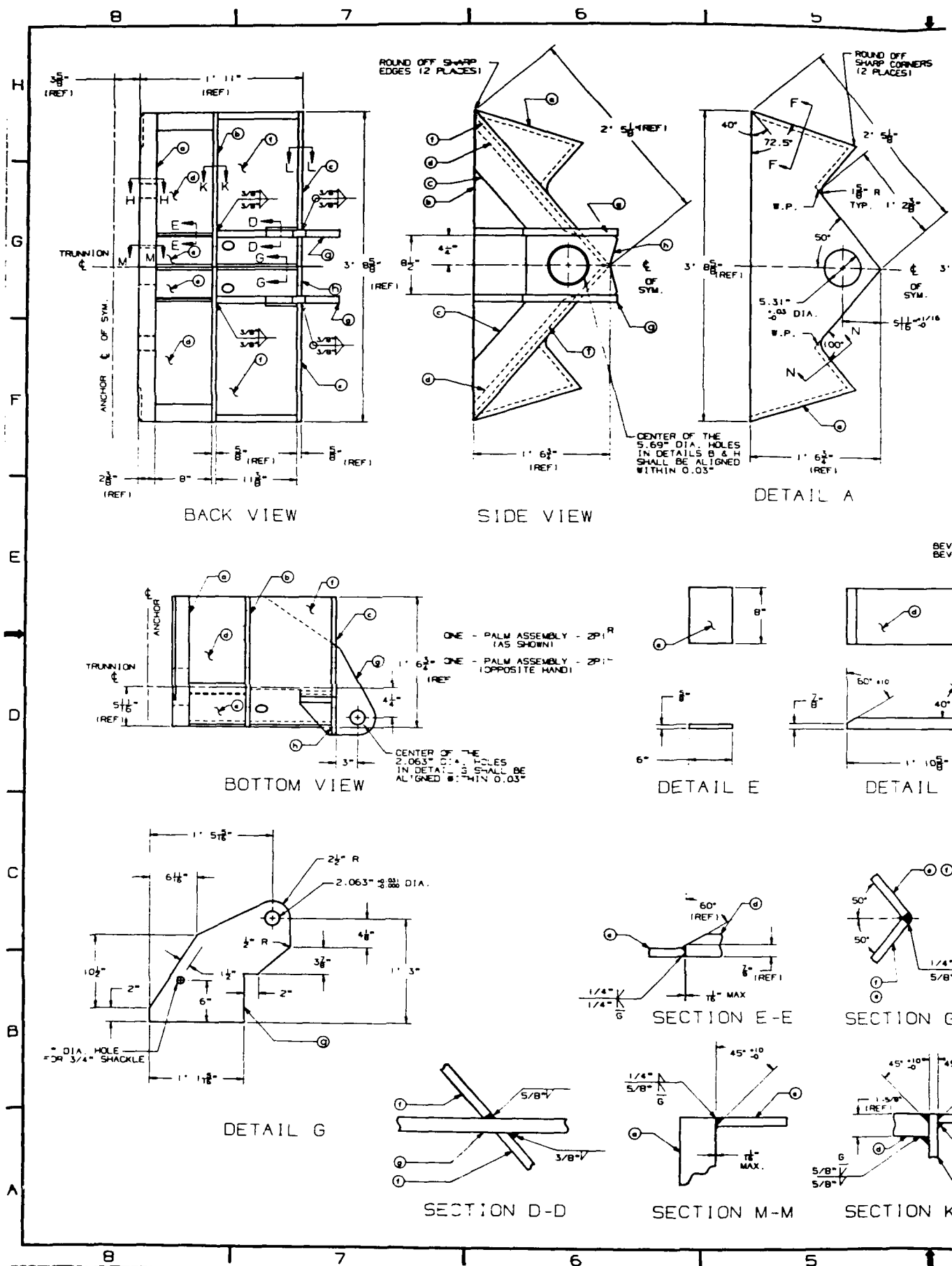

BEV
BEV

REVISIONS		
NO.	DESCRIPTION	DATE

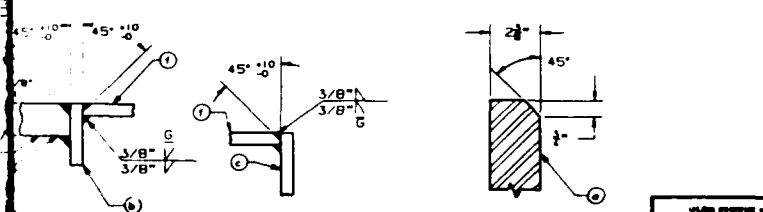
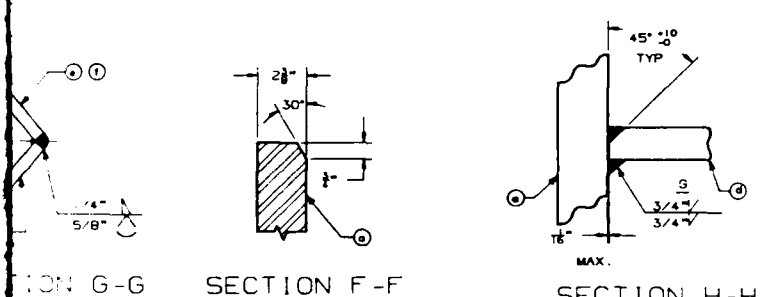
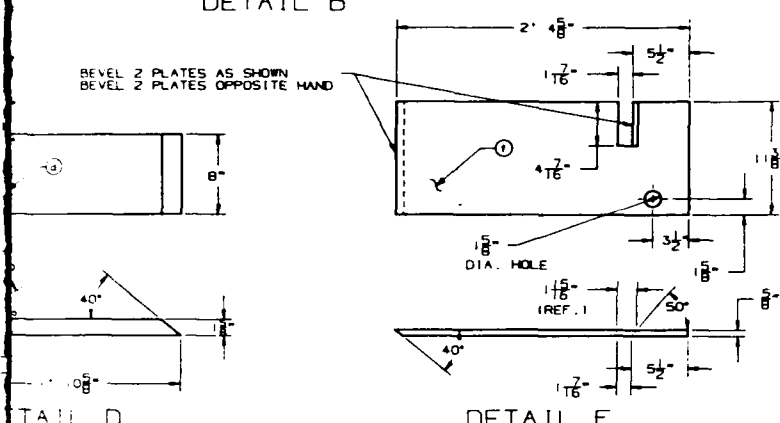
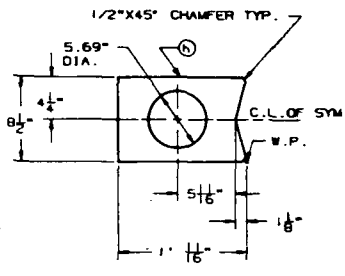
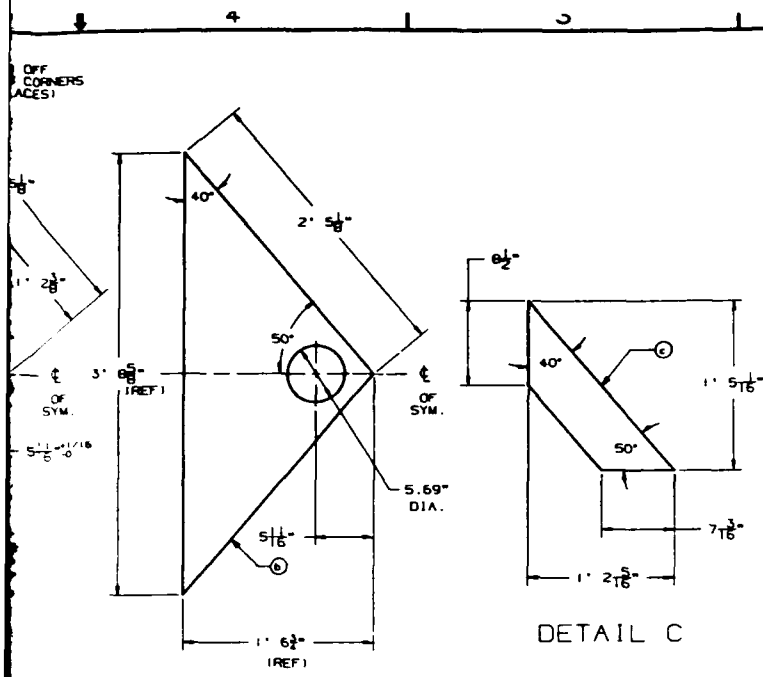

NOTE:
 RECOMMENDED WELDING PROCEDURES (MAY BE USED WHEN PALM IS A WELDMENT):
 (1) WELD ITEMS (1), (2), (3), AND (4) FIRST
 (11) THEN WELD ITEMS (5) AND (6)
 (111) WELD COVER PLATES (7)
 (1111) WELD ITEMS (8) LAST.

NO.	QTY	PL. SIZE X THICK.	DESCRIPTION	DETAIL
1	2	PL. 5/8" X 8-1/2"	11/16 PALM SPAR #4	DETAIL H
2	4	PL. 1" X 11-5-1/2"	7-13/16 PALM CLEVIS	DETAIL G
3	4	PL. 5/8" X 11-5/8"	4-5/8 PALM COVER #3	DETAIL F
4	4	PL. 5/8" X 8"	PALM COVER #2	DETAIL E
5	4	PL. 1-5/8" X 8"	10-5/8 PALM COVER #1	DETAIL D
6	4	PL. 5/8" X 5-5/16"	10-5/16 PALM SPAR #3	DETAIL C
7	2	PL. 5/8" X 1'-6-3/4"	8-5/8 PALM SPAR #2	DETAIL B
8	2	PL. 2-3/8" X 1'-6-3/4"	8-5/8 PALM SPAR #1	DETAIL A

ONE - PALM ASSEMBLY - SPAR (AS SHOWN)
 ONE - PALM ASSEMBLY - SPAR (OPPOSITE HAND)

MARKING: SIZE, LENGTH, REMARKS

QTY. OF MATERIAL

DESIGNED BY: J.C. OR H.M.D. OR D.C.
 DRAWN BY: J.C. OR H.M.D. OR D.C.
 CHECKED BY: J.C. OR H.M.D. OR D.C.
 AUTHORITY: 22-15-173/18/19

6155302

6155302

6155302

6155302

UNLESS OTHERWISE SPECIFIED
 DIMENSIONS ARE IN INCHES UNLESS
 TOLERANCES:
 FRACTIONS = 1/16"
 DECIMALS = 0.005"
 ANGLES = °

2

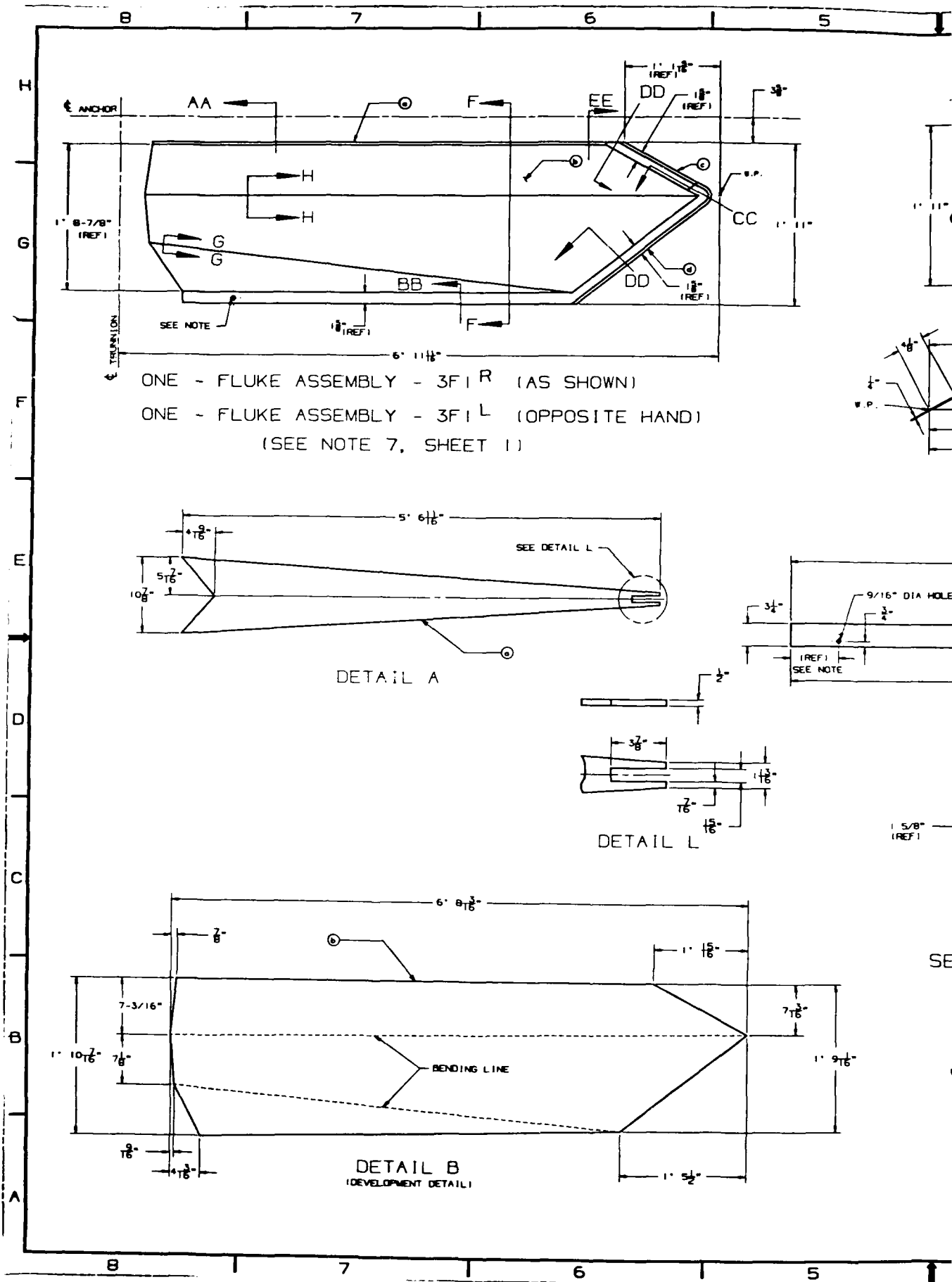

ONE - FLUKE ASSEMBLY - 3F1 R (AS SHOWN)
 ONE - FLUKE ASSEMBLY - 3F1 L (OPPOSITE HAND)
 (SEE NOTE 7, SHEET 1)

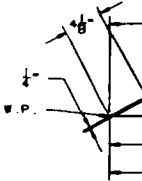

$1/8"$
 (REF)

SE

REVISIONS		DATE	APP'D.

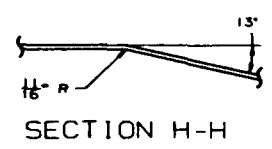
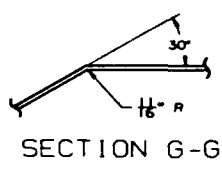
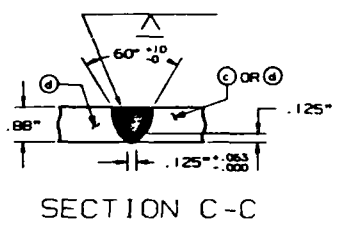
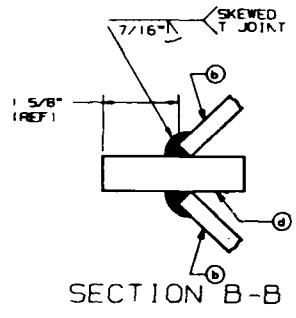
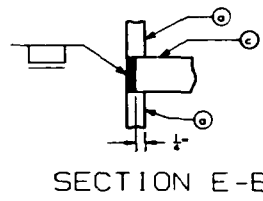
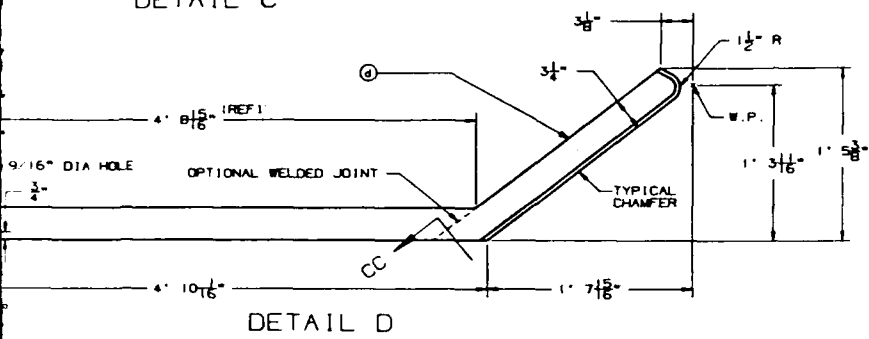
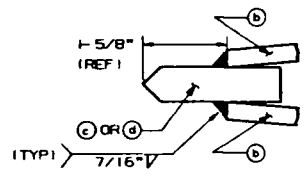
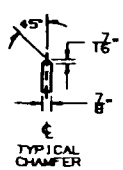
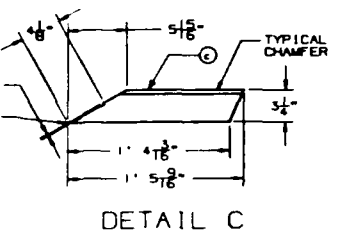
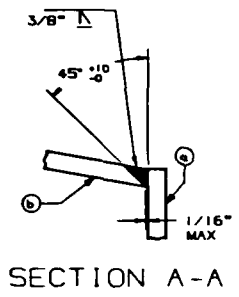
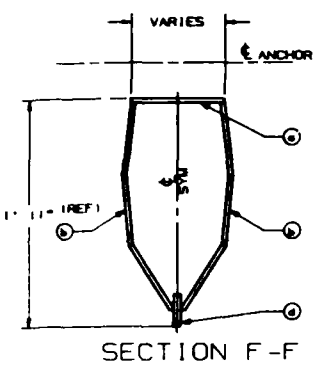

NOTE: LOCATE HOLE TO MATCH SIMILAR HOLE OF ITEM (C) SHEET 5 AFTER STABILIZER ASSEMBLY IS PIN-CONNECTED TO THE PALM ASSEMBLY AS SHOWN ON SHEET 1.

QTY	DESCRIPTION	SIZE	UNIT	REMARKS
2	PL 7/8" X 1" 5-3/8"	6	6	EDGE PLATE #2 DETAIL D
2	PL 7/8" X 3-1/4"	1	5-5/16	EDGE PLATE #1 DETAIL C
4	PL 1/2" X 1" 10-7/16"	6	8-3/16	FLUKE PLATE DETAIL B
2	PL 1/2" X 10-7/8"	5	6-11/16	FLUKE SPAR DETAIL A

ONE - FLUKE ASSEMBLY - SP1 R (AS SHOWN)
ONE - FLUKE ASSEMBLY - SP1 L (OPPOSITE HAND)

QTY	SIZE	UNIT	REMARKS

BILL OF MATERIAL

MCA ENGINEERS, INC. DEPARTMENT OF THE NAVY NAVAL FACILITIES ENGINEERING DIVISION
NAVAL CIVIL ENGINEERING LABORATORY
PORT HUENEME, CALIFORNIA 93043

NAVMOR-5 SALVAGE ANCHOR
7,200 LBS. (WT.)
FLUKE ASSEMBLY

REV. JC OR DJB DR. JLG
DATE: 10/25/54
SUBMITTED BY: JLS/TG/SH/WH

DESIGNER: JLS
DRAWN: SH/WH
CHECKED: JLS
APPROVED: JLS

SIZE: F 80091
SCALE: NONE
SHEET 3 OF 5

UNLESS OTHERWISE SPECIFIED
DIMENSIONS ARE IN INCHES UNLESS NOTED
TOLERANCES:
FRACTIONS ± 1/16"
DECIMALS ± 0.005"
ANGLES ± 1°

2

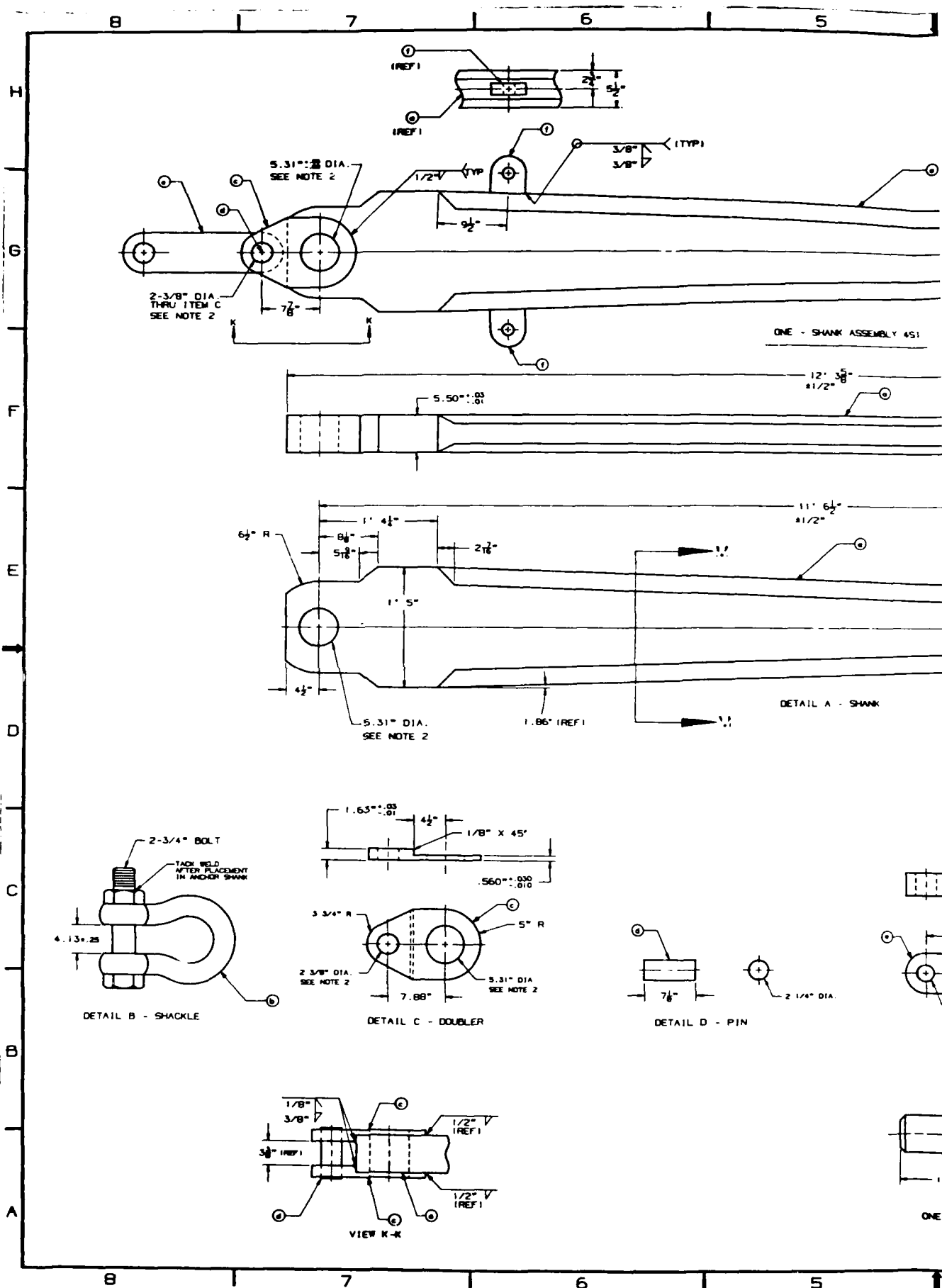

REVISIONS		
NO.	DESCRIPTION	DATE

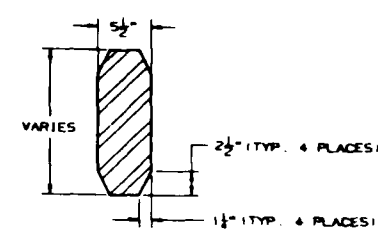
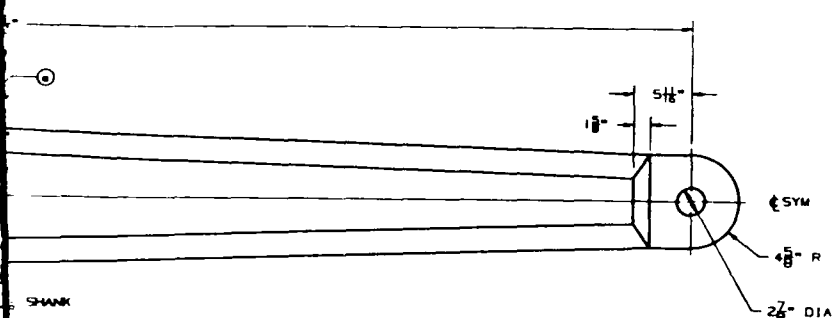
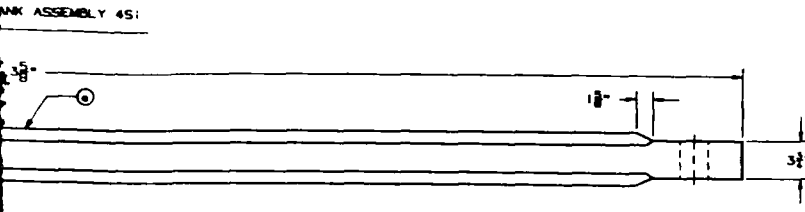

SECTION M-M
(SEE NOTE 1)

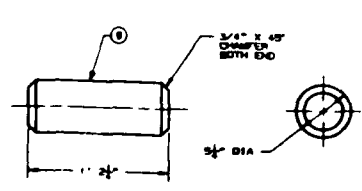
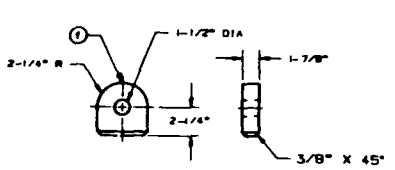
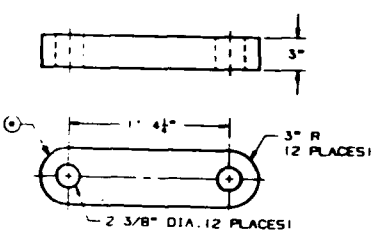

NOTE: ① THE TOLERANCE OF THE SHANK'S CROSS SECTION DIMENSIONS AT THE CHAMFERED PORTION SHALL BE $\pm 1/16$ "
 ② PART ① WELDED TO ② BEFORE HOLES ARE DRILLED

QTY	DESCRIPTION	SIZE	LENGTH	REMARKS
1	TRUNNION PIN - 4T1	5-1/4" DIA	2-1/4"	TRUNNION PIN (COLD DRAWN) AISI 1018 PY = 54 KSI
1	TRUNNION PIN - 4T1	1-7/8" X 4-1/2" PL	4-1/2"	PADEYE
1	LINK	3" X 6" PL	10-1/4"	LINK ASTM A 588 400 PY = 60 KSI
1	2-1/4" DIA BAR	2-1/4" DIA BAR	7-1/8"	PIN (COLD DRAWN) AISI 4340 PY = 98 KSI
2	1-5/8" 10" PL	1-5/8" 10" PL	4-5/8"	DOUBLER SEE NOTE 3 SHY. 1 DETAIL C
1	2-1/2" NOM DIA	2-1/2" NOM DIA	-	BOLT TYPE ANCHOR SHACKLE DETAIL B 950,000 LBS BREAKING STRENGTH
1	5-1/2" X 17" PL	5-1/2" X 17" PL	3-5/8"	SHANK SEE NOTE 3 SHY. 1 DETAIL A

MARK NO	SIZE	IN. LENGTH	REMARKS

MCA ENGINEERS, INC. DEPARTMENT OF THE NAVY NAVAL CIVIL ENGINEERING LABORATORY
 7,200 LBS. (WT. 1)
 SHANK ASSEMBLY, TRUNNION PIN

TOLERANCES:	VALUES:
FRACTIONS	1/16"
DECIMALS	0.005"
ANGLES	1°

APPROVED	DATE	SIZE	CHK	DRWT	BY	FILE NUMBER
		F	80091			6155304

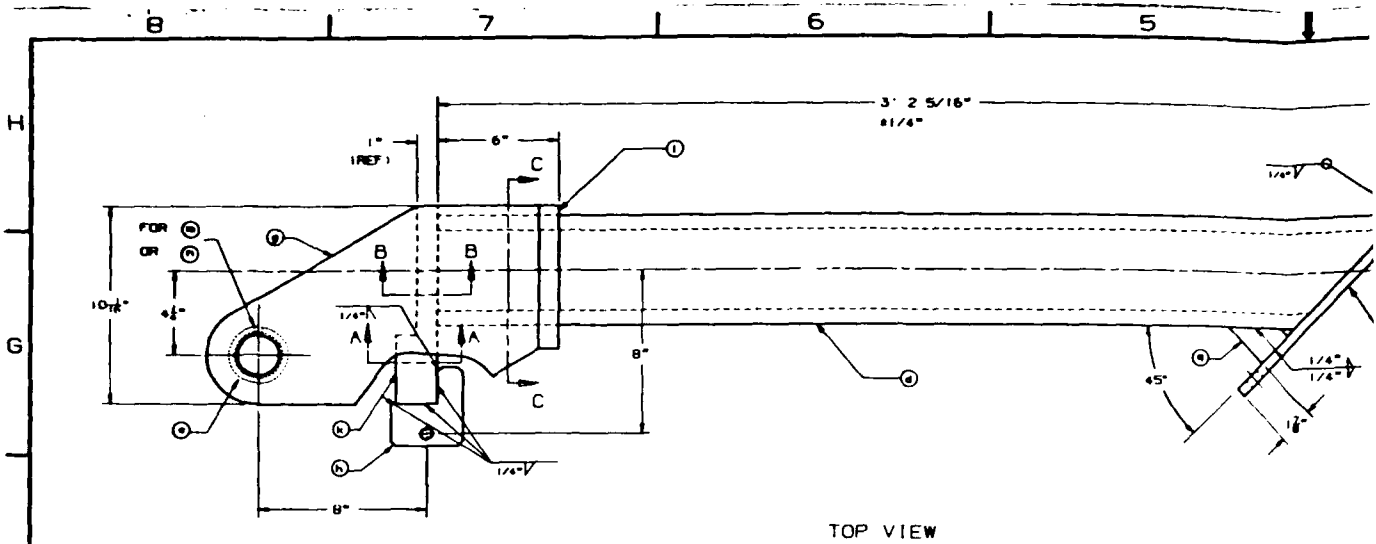

TOP VIEW

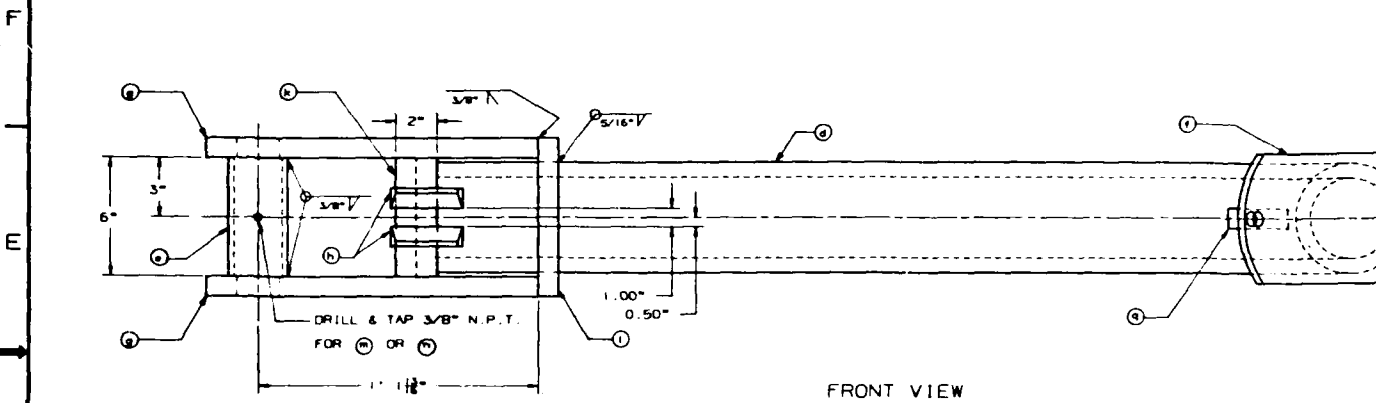

FRONT VIEW

ONE - FOLDABLE STABILIZER ASSEMBLY - 552

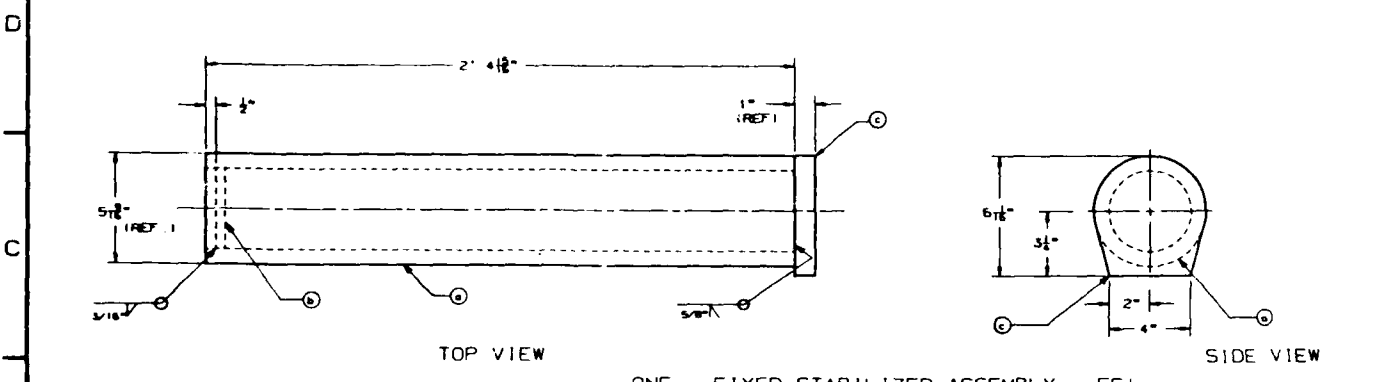

TOP VIEW

SIDE VIEW

ONE - FIXED STABILIZER ASSEMBLY - 551

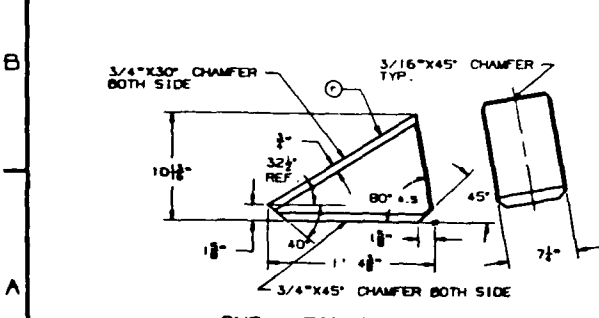

ONE - 50° STOPPER - 553

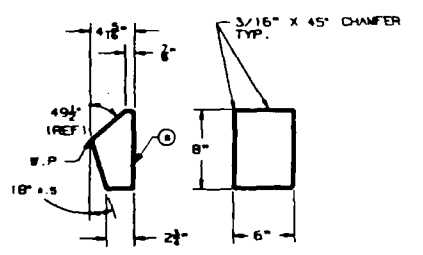

ONE - 32° STOPPER - 554

REVISIONS		
NO.	DESCRIPTION	DATE

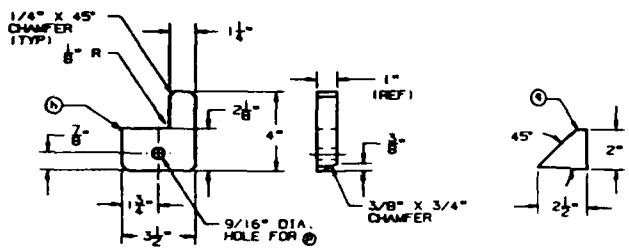

DETAIL H

DETAIL O

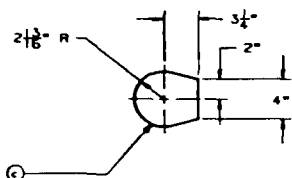

DETAIL C

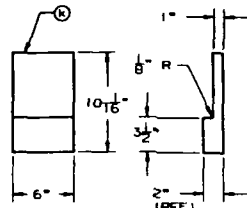

DETAIL K

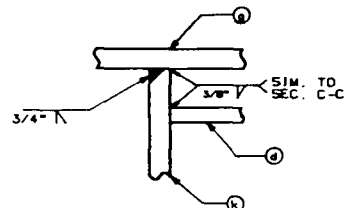

SECTION B-B (TYP)

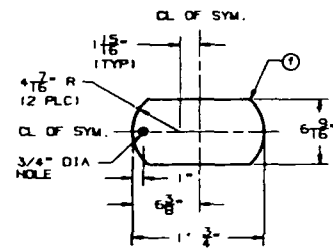

DETAIL F

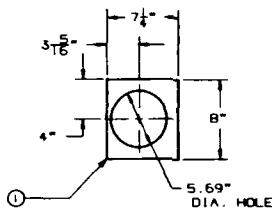

DETAIL L

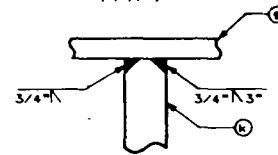

SECTION A-A (TYP)

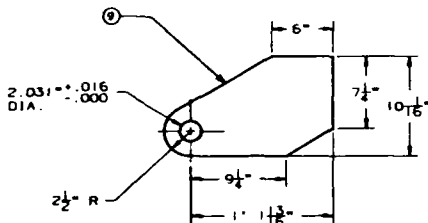

DETAIL G

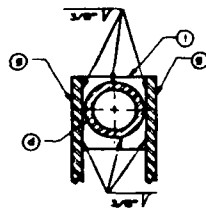

SECTION C-C

1	PL 4-5/16\"/>		
ONE 3/2\"/>			
1	PL 7-1/4\"/>		
ONE 5/2\"/>			
1	PL 1/2\"/>		
1	1/2\"/>		
1	3/8\"/>		
1	3/8\"/>		
1	PL 1\"/>		
1	PL 2\"/>		
2	PL 1\"/>		
2	PL 1\"/>		
1	PL 1/2\"/>		
1	2-1/2\"/>		
1	3\"/>		
ONE - FOLDABLE STABILIZER ASSEMBLY - 352			
1	PL 1\"/>		
1	PL 1/2\"/>		
1	3\"/>		
ONE - FIXED STABILIZER ASSEMBLY - 351			
MARKING	SIZE	IN LENGTH	REMARKS
BILL OF MATERIAL			
MCA ENGINEERS, INC.		DEPT. OF THE NAVY	
NAVAL CIVIL ENGINEERING LABORATORY		PORT HUENEME, CALIFORNIA 93043	
NAVMOR-6 SALVAGE ANCHOR			
7,200 LBS. (WT.)			
STABILIZER ASSEMBLY, STOPPERS			
APPROVED	DATE	SIZE	CAGE IDENT NO.
DESIGNER OFFICE	DATE	F	80091
PREPARED	DATE	SCALE NONE	PRO. DRAWING NO.
FOR CONTRACTOR, SPEC.	DATE		6155305
TOLERANCES		FRACTIONS = 1/16\"/>	
DECIMALS = 0.00\"/>			
ANGLES = 1\"/>			
DRAWN BY		SHEET 5 OF 5	

UNLESS OTHERWISE SPECIFIED
DIMENSIONS ARE TO FRACTIONAL DIMENSIONS

TOLERANCES
FRACTIONS = 1/16\"/>

2

DISTRIBUTION LIST

AF 6550 CES/DEEE, Patrick AFB, FL; AFIT/DET (Hudson), Wright-Patterson AFB, OH; AFIT/DET, Wright-Patterson AFB, OH; HQ ESD/DEE; SM-ALC/MAWFE (R Anderson), McClellan AFB, CA
AF HQ PREEES Washington DC : Traffic Mgmt Cargo Br, Washington, DC
AFB AFSC/DEEQ (P Montoya), Peterson AFB, CO; AUL LSE 63-465, Maxwell AFB, AL; HQ MAC/DEEE, Scott AFB, IL; SAMSO/MNND, Norton AFB CA
AFESC DEB, Tyndall AFB, FL; HQ AFESC/TST, Tyndall AFB, FL; HQ, RDC, Tyndall AFB, FL; HQ TST, Tyndall AFB, FL
ARMY 416th ENCOM, Akron Survey Tm, Akron, OH; 501st Spt Gp, Ch Bldgs & Grnds Div, Yongsan, Korea; AMCSM-WS, Alexandria, VA; BMDSC-RE (H McClellan), Huntsville, AL; Comm Cmd, Tech Ref Div, Huachuca, AZ; Diving Det, Ft Eustis, VA; ERADCOM Tech Supp Dir (DELS-D), Ft Monmouth, NJ; Engr Div New England, NEDED-D, Waltham, MA; HQDA (DAEN-ZCM); POJED-O, Okinawa, Japan; R&D Cmd, STRNC-US (J Siegel), Natick, MA
ARMY CERL CERL-ZN, Champaign, IL; Library, Champaign IL
ARMY CORPS OF ENGRS ED-SY (Loyd), Huntsville, AL; HNDED-SY, Huntsville, AL; Library, Seattle, WA
ARMY CRREL CRREL-EA, Hanover, NH; Library, Hanover, NH
ARMY DEPOT SDSNC-TP-M (Lorman), New Cumberland, PA
ARMY ENGR DIST LMVCO-A Bentley, Vicksburg, MS; Library, Portland OR; Phila. Lib, Philadelphia, PA
ARMY ENVIRON, HYGIENE AGCY HSHB-EW, Aberdeen Proving Grnd, MD
ARMY EWES Library, Vicksburg MS; WESCD (TW Richardson), Vicksburg, MS; WESCP-D (Vallianos), Vicksburg, MS; WESCV-Z (Whalin), Vicksburg, MS; WESCW-D, Vicksburg, MS; WESGP-E (Green), Vicksburg, MS
ARMY LOGISTICS COMMAND ALC/ATCI-MS (Morrissett), Fort Lee, VA
ARMY MAT & MECH RSCH CEN DRXMR-SM (Lenoe), Watertown, MA
ARMY MAT SYS ANALYSIS ACT DRXSY-CM (M Ogorzalek), Aberdeen Proving Grnd, MD
ARMY MTMC MTT-CE, Newport News, VA
ARMY TRANS SCH ASTP-CDM, Fort Eustis, VA; ATSP-CDM (Civilla), Fort Eustis, VA; ATSP-CD-TE, Fort Eustis, VA
ARMY ARADCOM STINFO Div, Dover, NJ
ARMY BELVOIR R&D CEN STRBE-AALO, Ft Belvoir, VA; STRBE-BLORE, Ft Belvoir, VA; STRBE-CFLO, Ft Belvoir, VA
ARMY CERL Ross, Champaign, IL
ADMINSUPU PWO, Bahrain
BUREAU OF RECLAMATION D-1512 (GW DePuy), Denver, CO; J Graham, Denver, CO
CBC Code 10, Davisville, RI; Code 155, Port Hueneme, CA; Code 156, Port Hueneme, CA; Code 156F, Port Hueneme, CA; Code 430, Gulfport, MS; Code 15, Port Hueneme, CA; Library, Davisville, RI; PWO (Code 80), Port Hueneme, CA; PWO, Gulfport, MS; Tech Library, Gulfport, MS
CBU 401, OIC, Great Lakes, IL; 411, OIC, Norfolk, VA
CNO Code NOP-964, Washington, DC; Code OP 23, Washington, DC; Code OP 323, Washington DC; Code OP 414, Washington DC; Code OP 424, Washington DC; Code OP 97, Washington, DC; Code OP 987, Washington, DC; Code OP-987J, Washington, DC; Code OPNAV 09B24 (H), Washington, DC
COGARD R AND DC Library, Groton, CT
COMCBLANT Code S3T, Norfolk, VA
COMCBPAC Diego Garcia Proj Offr, Pearl Harbor, HI
COMDT COGARD Library, Washington, DC
COMFAIRMED SCE, Naples, Italy
COMFEWSG DET Security Off, Washington, DC
COMFLEACT PWO, Kadena, Okinawa; SCE, Yokosuka Japan
COMNAVACT PWO, London, England
COMNAVAIRSYSCOM Code 41712, Washington, DC
COMNAVBEACHGRU ONE, CO, San Diego, CA; TWO, CO, Norfolk, VA
COMNAVFORKOREA ENJ-P&O, Yongsan, Korea
COMNAVLOGPAC Code 4318, Pearl Harbor, HI
COMNAVMARIANAS Code N4, Guam
COMNAVSUPFORANTARCTICA DET, PWO, Christchurch, NZ
COMNAVSURFLANT CO, Norfolk, VA; Code N42A Norfolk, VA
COMNAVSURFPAC Code N-4, San Diego, CA
COMOCEANSYSLANT Fac Mgmt Offr, PWD, Norfolk, VA
COMOCEANSYSPAC SCE, Pearl Harbor, HI
COMSC Washington DC
COMSUBDEVGRUONE CO, San Diego, CA; Ops Offr, San Diego, CA
COMSURFWARDEVGRU CO, Norfolk, VA
COMTRALANT SCE, Norfolk, VA
COMUSNAVCENT Code N42, Pearl Harbor, HI

NAVRESCEN PE-PLS, Tampa, FL
COMOPTEVFOR CO, Norfolk, VA
DEPCOMOPTEVFORPAC Code 701A, San Diego CA; Code 705, San Diego, CA
DIA DB-6E1, Washington, DC; DB-6E2, Washington, DC; VP-TPO, Washington, DC
DIRSSP Tech Lib, Washington, DC
DLSIE Army Logistics Mgt Center, Fort Lee, VA
DNA STTI/TL, Washington, DC
DOD DFR NE, O'Donovan, PE, McGuire AFB, NJ
DOE Wind/Ocean Tech Div, Tobacco, MD
DTIC Alexandria, VA
DTNSRDC Code 1541 (Rispin), Bethesda, MD; Code 1561, Bethesda, MD; Code 172, Bethesda, MD; Code
4111, Bethesda, MD; DET, Code 119, Annapolis, MD; DET, Code 1250, Annapolis, MD; DET, Code 1568,
Annapolis, MD; DET, Code 2724, Annapolis, MD; DET, Code 284, Annapolis, MD; DET, Code 4120,
Annapolis, MD; DET, Code 522 (Library), Annapolis, MD
EPA ANR-458, Washington, DC
EODGRU ONE DET, CO, Point Mugu, CA
FAA Code APM-740 (Tomita), Washington, DC
FCTC LANT, PWO, Virginia Bch, VA
FMFLANT CEC Offr, Norfolk VA
FMFPAC FEO, Camp HM Smith, HI; G5 (SCIAD), Camp HM Smith, HI
GSA Chief Engrg Br, Code PQB, Washington, DC
LIBRARY OF CONGRESS Sci & Tech Div, Washington, DC
MARCORPS FIRST FSSG, Engr Supp Offr, Camp Pendleton, CA
MARINE CORPS BASE PAC FWD, ACOS Fac Engr, Camp Butler, JA; PAC FWD, Dir, Maint Control,
Camp Butler, JA; PWO, Camp Lejeune, NC; PWO, Camp Pendleton, CA
MARITIME ADMIN MAR-770 (Corkrey), Washington, DC; R&D, Washington, DC
MCAS Dir, Ops Div, Fac Maint Dept, Cherry Point, NC; PWO, Kaneohe Bay, HI; PWO, Yuma, AZ
MCDEC M & I, Div Quantico, VA; NSAP REP, Quantico VA
MCLB PWO (Code B520), Barstow, CA
MCRD SCE, San Diego CA
NAVSCSCOL PWO, Athens, GA
NAF AROIC, Midway Island; PWO, Atsugi, Japan
NALF OIC, San Diego, CA
NAS Chase Fld, Code 18300, Beeville, TX; Code 0L, Alameda, CA; Code 163, Keflavik, Iceland; PWO (Code
182) Bermuda; Code 187, Jacksonville, FL; Code 22, Patuxent River, MD; Code 70, Marietta, GA; Code
72E, Willow Grove, PA; Code 83, Patuxent River, MD; Dir, Engrg Div, Millington, TN; Engrg Dir, PWD,
Adak, AK; Code 1833, Corpus Christi, TX; Fac Plan Br Mgr (Code 183), NI, San Diego, CA; Lead CPO,
PWD, Self Help Div, Beeville, TX; Code 1821A, Miramar, San Diego, CA; PWD Maint Div, New Orleans,
LA; PWO, Beeville, TX; PWO, Dallas TX; PWO, Glenview IL; PWO, Keflavik, Iceland; PWO, Key West,
FL; PWO, New Orleans, LA; PWO, Sigonella, Sicily; PWO, South Weymouth, MA; PWO, Willow Grove,
PA; SCE, Barbers Point, HI; SCE, Cubi Point, RP; SCE, Norfolk, VA; Security Offr (Code 15), Alameda,
CA; Security Offr, Kingsville, TX
NATL BUREAU OF STANDARDS Bldg Mat Div (Mathey), Gaithersburg, MD; Bldg Mat Div (Rossiter),
Gaithersburg, MD; R Chung, Gaithersburg, MD
NATL RESEARCH COUNCIL Naval Studies Bd, Washington, DC; Naval Studies Board, Washington, DC
NAVAIRDEVCEN Code 832, Warminster, PA
NAVAVNDEPOT Code 61000, Cherry Point, NC; Code 640.1, San Diego, CA
NAVAIRTESTCEN PWO, Patuxent River, MD
NAVAUDSVCHQ Director, Falls Church VA
NAVCAMS SCE (Code N-7), Naples, Italy
NAVCHAPGRU CO Williamsburg VA; Code 30, Williamsburg, VA; Code 60, Williamsburg, VA
NAVCOASTSYSCEN CO, Panama City, FL; Code 2360, Panama City, FL; Code 423, Panama City, FL; Code
630, Panama City, FL; Code 715 (J. Mittleman) Panama City, FL; Code 719, Panama City, FL; Code 772
(C.B. Koesy), Panama City, FL; Tech Library, Panama City, FL
NAVCOMMSTA Code 401, Nea Makri, Greece; Dir, Maint Control, PWD, Diego Garcia; PWO, Exmouth,
Australia
NAVCONSTRACEN Code 00U15, Port Hueneme CA; Code B-1, Port Hueneme, CA; Code D2A, Port
Hueneme, CA; Curriculum & Instr Stds Offr, Gulfport, MS
NAVEDTRAPRODEVCEN Tech Lib, Pensacola, FL
NAVELEXCEN DET, OIC, Winter Harbor, ME
NAVEODTEHCEN Tech Library, Indian Head, MD
NAVFAC PWO (Code 50), Brawdy Wales, UK; PWO, Centerville Bch, Ferndale CA
NAVFACENGCOM CO (Code 00), Alexandria, VA; Code 03, Alexandria, VA; Code 03T (Essoglou),
Alexandria, VA; Code 04, Alexandria, VA; Code 04B2 (M. Yachnis), Alexandria, VA; Code 04A,
Alexandria, VA; Code 06, Alexandria VA; Code 07A (Herrmann), Alexandria, VA; Code 07M (Gross),
Alexandria, VA; Code 09M124 (Lib), Alexandria, VA; Code 100, Alexandria, VA; Code 1002B,

Alexandria, VA; Code 1113, Alexandria, VA; Code 04A4E (Bloom), Alexandria, VA; Code 04A3, Alexandria, VA

NAVFACENGCOM - CHES DIV. Code 101, Washington, DC; Code 405, Washington, DC; Code 407 (D Scheele), Washington, DC; Code FPO-1C, Washington, DC; Code FPO-1E, Washington, DC; Code FPO-1PL, Washington, DC; FPO-1P 1P3, Washington, DC

NAVFACENGCOM - LANT DIV. Br Ofc. Dir, Naples, Italy; Code 405, Norfolk, VA; Library, Norfolk, VA

NAVFACENGCOM - NORTH DIV. CO, Philadelphia, PA; Code 04, Philadelphia, PA; Code 04AL, Philadelphia, PA; Code 202.2, Philadelphia, PA; Code 408 AF, Philadelphia, PA

NAVFACENGCOM - PAC DIV. Code 09P, Pearl Harbor, HI; Code 101 (Kyi), Pearl Harbor, HI; Code 2011, Pearl Harbor, HI; Code 402, RDT&E LnO, Pearl Harbor, HI; Library, Pearl Harbor, HI

NAVFACENGCOM - SOUTH DIV. Code 1112, Charleston, SC; Code 405, Charleston, SC; Code 406, Charleston, SC; Geotech Section (Code 4022), Charleston, SC; Library, Charleston, SC

NAVFACENGCOM - WEST DIV. 09P 20, San Bruno, CA; Code 04B, San Bruno, CA; Library (Code 04A2.2), San Bruno, CA; RDT&E LnO, San Bruno, CA

NAVFACENGCOM CONTRACTS Code 460, Portsmouth, VA; DOICC, Diego Garcia; DROICC, Lemoore, CA; OICC, Guam; OICC, Rota, Spain; OICC, Virginia Beach, VA; OICC/ROICC, Norfolk, VA; ROICC (Code 495), Portsmouth, VA; ROICC, Corpus Christi, TX; ROICC, Crane, IN; ROICC, Keflavik, Iceland; ROICC, Key West, FL; ROICC, Point Mugu, CA; Earle, ROICC, Colts Neck, NJ; SW Pac, OICC, Manila, RP; Trident, OICC, St Marys, GA

NAVFUEL DET OIC, Yokohama, Japan

NAVHOSP CO, Long Beach, CA; Dir, Engrg Div, Camp Lejeune, NC; PWO, Guam, Mariana Islands; SCE (Knapowski), Great Lakes, IL; SCE, Camp Pendleton CA; SCE, Pensacola FL

NAVMAG Engr Dir, PWD, Guam, Mariana Islands; SCE, Guam, Mariana Islands; SCE, Subic Bay, RP

NAVMARCORESCEN LTJG Davis, Raleigh, NC

NAVMECOM SE REG, Hd, Fac Mgmt Dept, Jacksonville, FL; SWREG, Code 29, San Diego, CA; SWREG, Head, Fac Mgmt Dept, San Diego, CA

NAVOCEANO Code 6200 (M Paige), Bay St. Louis, MS; Library, Bay St Louis, MS

NAVOCEANSYSCEN Code 5204 (J. Stachiw), San Diego, CA; Code 541 (Bachman), San Diego, CA; Code 94 (Talkington), San Diego, CA; Code 944 (H.C. Wheeler), San Diego, CA; Code 964 (Tech Library), San Diego, CA; Code 9642B (Bayside Library), San Diego, CA; DET, R Yumori, Kailua, HI; DET, Tech Lib, Kailua, HI

NAVORDMISTESTSTA Dir, Engrg, PWD, White Sands, NM

NAVINSERVRA Annapolis, MD

NAVPGSCOL Code 1424, Library, Monterey, CA; Code 61WL (O. Wilson), Monterey, CA; Code 68 (C.S. Wu), Monterey, CA; E. Thornton, Monterey, CA; Haderlie, Monterey, CA; PWO, Monterey, CA

NAVPHIBASE Harbor Clearance Unit Two, Norfolk, VA; PWO, Norfolk, VA; SCE, San Diego, CA

NAVRESREDCOM Commander (Code 072), San Francisco, CA

NAVSCOLCECOFF Code C35, Port Hueneme, CA; Code C44A, Port Hueneme, CA

NAVSEASYSYSCOM Code 00C, Washington, DC; Code 035, Washington DC; Code 05M, Washington, DC; Code 06H4, Washington, DC; Code 56W23 (J Coon), Washington, DC; Code 644, Washington, DC; Code CEL-ID23, Washington, DC; Code OOC-D, Washington, DC; Code PMS 395 A2, Washington, DC; Code PMS-396.3211 (J. Rekas) Washington, DC; Code SEA-99611, Washington, DC; PMS-395 A1, Washington, DC; SEA-05R4 (J. Freund), Washington, DC; SEA-5433, Washington, DC

NAVSEC Code 6156D, Washington, DC; Code 6157D, Washington, DC

NAVSECGRUACT PWO, Adak, AK

NAVSECGRUCOM Code G43, Washington, DC

NAVSHIPREPFAC Library, Guam; SCE, Subic Bay, RP

NAVSHIPYD Carr Inlet Acoustic Range, Bremerton, WA; Code 202.4, Long Beach, CA; Code 202.5 (Library), Bremerton, WA; Mare Island, Code 280, Vallejo, CA; Mare Island, Code 280.28, Vallejo, CA; Code 420, Long Beach, CA; Code 440, Bremerton, WA; Code 440, Portsmouth, NH; Library, Portsmouth, NH; Norfolk, Code 440, Portsmouth, VA; Code 440.4, Bremerton, WA; Mare Island, Code 457, Vallejo, CA; Norfolk, Code 420, Portsmouth, VA; PWO, Bremerton, WA; PWO, Charleston, SC; Mare Island, PWO, Vallejo, CA

NAVSTA A, Sugihara, Pearl Harbor, HI; CO, Long Beach, CA; CO, Roosevelt Roads, PR; Dir, Engr Div, PWD (Code 18200), Mayport, FL; Engrg Dir, Rota, Spain; WC 93, Guantanamo Bay, Cuba; PWO, Mayport, FL; SCE, Guam, Marianas Islands; SCE, San Diego CA; SCE, Subic Bay, RP; Security Offr, San Francisco, CA; Util Engrg Offr, Rota, Spain

NAVSUPPFAC Dir, Maint Control Div, PWD, Thurmont, MD

NAVSUPPO Sec Offr, La Maddalena, Italy

NAVSWC Code E211 (C. Rouse), Dahlgren, VA; DET, PWO, White Oak, Silver Spring, MD; DET, White Oak Lab, Code WSO, Silver Spring, MD; PWO, Dahlgren, VA

NAVTECHTRACEN SCE, Pensacola FL

NAVTRASTA PWO, San Diego, CA

NAVWARCOL Code 24, Newport, RI; Lib Serials, Newport, RI

NAVWPNCEN CO, China Lake, CA; Code 2636, China Lake, CA; DROICC (Code 702), China Lake, CA; PWO (Code 266), China Lake, CA

NAVWPNSTA Earle, Code 092, Colts Neck, NJ; Dir, Maint Control, PWD, Concord, CA; Engrg Div, PWD, Yorktown, VA; PWO, Charleston, SC; Earle, PWO, Colts Neck, NJ; PWO, Seal Beach, CA
NAVWPNSTA PWO, Yorktown, VA
NAVWPNSTA Supr Gen Engr, PWD, Seal Beach, CA
NAVWPNSUPPCEN Code 09, Crane, IN
NETC Code 42, Newport, RI; PWO, Newport, RI
NCR 20, CO, Gulfport, MS
NMCB 3, Operations Offr; 40, CO; 5, Operations Dept; 74, CO
NOAA Joseph Vadius, Rockville, MD; Library, Rockville, MD; M Ringenbach, Rockville, MD
NOAA DATA BUOY OFFICE Ch, Engrg Div, Bay St. Louis, MS
NORDA CO, Bay St. Louis, MS; Code 1121SP, Bay St. Louis, MS; Code 350, Bay St. Louis, MS; Code 352, Bay St. Louis, MS; Code 410, Bay St. Louis, MS; Head, Geotech Br (Code 363), Bay St. Louis, MS; Ocean Prog Off (Code 500), Bay St. Louis, MS; Ocean Rsch Off (Code 440), Bay St. Louis, MS
NRI Code 5800, Washington, DC; Ocean Tech Div (O. Griffith), Washington, DC
NSC Cheatham Annex, PWO, Williamsburg, VA; Code 54.1, Norfolk, VA; SCE, Charleston, SC
NSD SCE, Subic Bay, RP
NUSC DET Code 3322 (Brown), New London, CT; Code 3232 (Varley) New London, CT; Code 44 (RS Munn), New London, CT; Code TA131 (De la Cruz), New London, CT
OCNR Code 1114SE, Arlington, VA; Code 1121 (EA Silva), Arlington, VA; Code 33, Arlington, VA
CNR DET, Dir, Boston, MA; DET, Dir, Pasadena, CA
OCNR DET, Code 481, Bay St. Louis, MS
PACMISRANFAC PWO, Kauai, HI
PHIBCB 1, CO, San Diego, CA; 1, ELCAS Offer, San Diego, Ca; 1, P&E, San Diego, CA; 2, CO, Norfolk, VA
PMTC Code 1018, Point Mugu, CA; Code 3144 (G Nussear), Point Mugu, CA; Code 5021 (S Opatowsky), Point Mugu, CA; Code 5041, Point Mugu, CA
PWC ACE Office, Norfolk, VA; Code 10, Great Lakes, IL; Code 10, Oakland, CA; Code 101 (Library), Oakland, CA; Code 123-C, San Diego, CA; Code 30, Norfolk, VA; Code 400, Pearl Harbor, HI; Code 400, San Diego, CA; Code 420, Great Lakes, IL; Code 420, Oakland, CA; Code 424, Norfolk, VA; Code 425 (L.N. Kaya, P.E.), Pearl Harbor, HI; Code 500, Norfolk, VA; Code 500, Oakland, CA; Code 590, San Diego, CA; Code 700, San Diego, CA; Code 500, Great Lakes, IL; Code 400, Great Lakes, IL; Library (Code 134), Pearl Harbor, HI; Library, Guam, Mariana Islands; Library, Norfolk, VA; Library, Pensacola, FL; Library, Yokosuka JA; Tech Library, Subic Bay, RP
SEAL TEAM 6, Norfolk, VA
SPCC PWO (Code 08X), Mechanicsburg, PA
SUBASE Bangor, PWO (Code 8323), Bremerton, WA; Code 04.5, Sann Diego, CA
SUBRESUNIT Sea Cliff DSV4, OIC, San Diego, CA; Turtle DSV-3, OIC, San Diego, CA
SUPSHIP Tech Library, Newport News, VA
UCT ONE CO, Norfolk, VA
UCT TWO CO, Port Hueneme, CA
US DEPT OF INTERIOR BLM, Engrg Div (730), Washington, DC; Nat'l Park Svc, RMR PC, Denver, CO
US GEOLOGICAL SURVEY F Dyhrkopp, Metairie, LA; Gregory, Reston, VA; J Bales, Raleigh, NC; Marine Geology Offc (Piteleki), Reston, VA; Marine Oil & Gas Ops (R Krahl), Reston, VA
USAF SCOL OF AEROSPACE MED Hyperbaric Med Div, Brooks AFB, TX
USCINCPAC Code J44, Camp HM Smith, HI
USDA Ext Serv (T Maher), Washington, DC; For Serv, Equip Dev Cen, San Dimas, CA; Forest Serv, Reg 8, Atlanta, GA
USNA Chairman, Mech Engrg Dept, Annapolis, MD; Mgr, Engrg, Civil Specs Br, Annapolis, MD; Stop 11d, Annapolis, MD
USS USS FULTON, Code W-3, New York, NY

PLEASE HELP US PUT THE ZIP IN YOUR
MAIL! ADD YOUR FOUR NEW ZIP DIGITS
TO YOUR LABEL (OR FACSIMILE),
STAPLE INSIDE THIS SELF-MAILER, AND
RETURN TO US.

(fold here)

DEPARTMENT OF THE NAVY

NAVAL CIVIL ENGINEERING LABORATORY
PORT HUENEME, CALIFORNIA 93043-5003

OFFICIAL BUSINESS

PENALTY FOR PRIVATE USE, \$300
1 IND-NCEL-2700/4 (REV. 12-73)
0830-LL-L70-0044

POSTAGE AND FEES PAID
DEPARTMENT OF THE NAVY
DOD-318



Commanding Officer
Code L088
Naval Civil Engineering Laboratory
Port Hueneme, California 93043-5003

AD-A185 351

SINGLE AND TANDEM ANCHOR PERFORMANCE OF THE NEW NAVY
MOORING ANCHOR: THE NAUMMOOR ANCHOR(U) NAVAL CIVIL
ENGINEERING LAB PORT HUENENE CA R J TAYLOR JUL 37
NCEL TN-1774 F/G 13/2

2/2

UNCLASSIFIED

ML

END

DATE

FORM

11/87

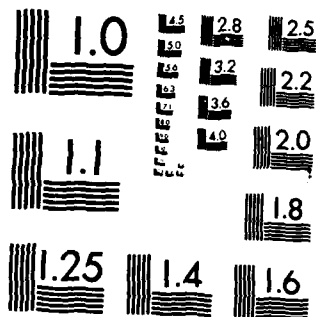

MICROCOPY RESOLUTION TEST CHART
NATIONAL BUREAU OF STANDARDS-1963-A

INSTRUCTIONS

The Naval Civil Engineering Laboratory has revised its primary distribution lists. The bottom of the label on the reverse side has several numbers listed. These numbers correspond to numbers assigned to the list of Subject Categories. Numbers on the label corresponding to those on the list indicate the subject category and type of documents you are presently receiving. If you are satisfied, throw this card away (or file it for later reference).

If you want to change what you are presently receiving:

- Delete – mark off number on bottom of label.
- Add – circle number on list.
- Remove my name from all your lists – check box on list.
- Change my address – line out incorrect line and write in correction (PLEASE ATTACH LABEL).
- Number of copies should be entered after the title of the subject categories you select.

Fold on line below and drop in the mail.

Note: Numbers on label but not listed on questionnaire are for NCEL use only, please ignore them.

Fold on line and staple.

DEPARTMENT OF THE NAVY

NAVAL CIVIL ENGINEERING LABORATORY
PORT HUENEME, CALIFORNIA 93043-5003

OFFICIAL BUSINESS
PENALTY FOR PRIVATE USE, \$300
1 NCB-NCEL-2700/4 (REV. 12-78)
0000-LL-L70-0044

POSTAGE AND FEES PAID
DEPARTMENT OF THE NAVY
DOD-316



Commanding Officer
Code L08B
Naval Civil Engineering Laboratory
Port Huene, California 93043-5003

DISTRIBUTION QUESTIONNAIRE

The Naval Civil Engineering Laboratory is revising its primary distribution lists.

SUBJECT CATEGORIES

- 1 **SHORE FACILITIES**
- 2 Construction methods and materials (including corrosion control, coatings)
- 3 Waterfront structures (maintenance/deterioration control)
- 4 Utilities (including power conditioning)
- 5 Explosives safety
- 6 Aviation Engineering Test Facilities
- 7 Fire prevention and control
- 8 Antenna technology
- 9 Structural analysis and design (including numerical and computer techniques)
- 10 Protective construction (including hardened shelters, shock and vibration studies)
- 11 Soil/rock mechanics
- 13 BEQ
- 14 Airfields and pavements
- 15 **ADVANCED BASE AND AMPHIBIOUS FACILITIES**
- 16 Base facilities (including shelters, power generation, water supplies)
- 17 Expedient roads/airfields/bridges
- 18 Amphibious operations (including breakwaters, wave forces)
- 19 Over-the-Beach operations (including containerization, materiel transfer, lightering and cranes)
- 20 POL storage, transfer and distribution

- 28 **ENERGY/POWER GENERATION**
- 29 Thermal conservation (thermal engineering of buildings, HVAC systems, energy loss measurement, power generation)
- 30 Controls and electrical conservation (electrical systems, energy monitoring and control systems)
- 31 Fuel flexibility (liquid fuels, coal utilization, energy from solid waste)
- 32 Alternate energy source (geothermal power, photovoltaic power systems, solar systems, wind systems, energy storage systems)
- 33 Site data and systems integration (energy resource data, energy consumption data, integrating energy systems)
- 34 **ENVIRONMENTAL PROTECTION**
- 35 Solid waste management
- 36 Hazardous/toxic materials management
- 37 Wastewater management and sanitary engineering
- 38 Oil pollution removal and recovery
- 39 Air pollution
- 44 **OCEAN ENGINEERING**
- 45 Seafloor soils and foundations
- 46 Seafloor construction systems and operations (including diver and manipulator tools)
- 47 Undersea structures and materials
- 48 Anchors and moorings
- 49 Undersea power systems, electromechanical cables, and connectors
- 50 Pressure vessel facilities
- 51 Physical environment (including site surveying)
- 52 Ocean-based concrete structures
- 53 Hyperbaric chambers
- 54 Undersea cable dynamics

TYPES OF DOCUMENTS

- | | | | |
|-------------------------------------|--|-------------------------|--|
| 85 Techdata Sheets | 86 Technical Reports and Technical Notes | 82 NCEL Guide & Updates | <input type="checkbox"/> None—
remove my name |
| 83 Table of Contents & Index to TDS | | 91 Physical Security | |

DATE
LMED
88