

MICROCOPY RESOLUTION TEST CHART
NATIONAL BUREAU OF STANDARDS-1963-A

SRA RESOURCE MANAGEMENT

FINAL REPORT ON TASK 1: MEASURES OF EFFECTIVENESS

AD-A173 705

Authors: Leonard Greenberg
Terry A. Bresnick
Jacob W. Ulvila
F. Freeman Marvin
Guy P. Clark
John G. Stanley

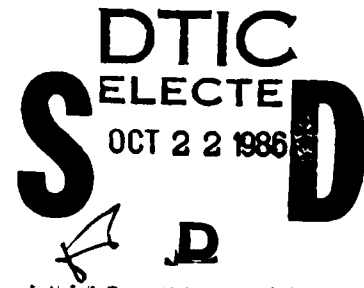

September 1986

FINAL REPORT

This document is available to the U.S. public through the National Technical Information Service, Springfield, Virginia 22161

DTIC FILE COPY

Prepared for:

DISTRIBUTION STATEMENT A
Approved for public release;
Distribution Unlimited

U.S. Department of Transportation
United States Coast Guard
Office of Research and Development
Washington, D.C. 20593

Report No. CG-D-20-86

SRA RESOURCE MANAGEMENT
FINAL REPORT ON TASK 1: MEASURES OF EFFECTIVENESS

Authors: Leonard Greenberg
Terry A. Bresnick
Jacob W. Ulvila
F. Freeman Marvin
Guy P. Clark
John G. Stanley



September 1986

FINAL REPORT

This document is available to the U.S. public through the National
Technical Information Service, Springfield, Virginia 22161

Prepared for:

U.S. Department of Transportation
United States Coast Guard

Office of Research and Development
Washington, D.C. 20593

NOTICE

This document is disseminated under the sponsorship of the Department of Transportation in the interest of information exchange. The United States Government assumes no liability for its contents or use thereof.

The contents of this report do not necessarily reflect the official view or policy of the Coast Guard; and they do not constitute a standard, specification, or regulation.

This report, or portions thereof may not be used for advertising or sales promotion purposes. Citation of trade names and manufacturers does not constitute endorsement or approval of such products.

1. Report No. GC-D-20-86		2. Government Accession No. AD-A173 705		3. Recipient's Catalog No.	
4. Title and Subtitle SRA RESOURCE MANAGEMENT FINAL REPORT ON TASK 1: MEASURES OF EFFECTIVENESS				5. Report Date Septemer 1986	
				6. Performing Organization Code	
7. Author(s) L. Greenberg, T. A. Bresnick, J. W. Ulvila, F. F. Marvin, G. P. Clark, J. G. Stanley				8. Performing Organization Report No.	
9. Performing Organization Name and Address Mandex, Inc. 8003 Forbes Place Springfield, Virginia 22151				10. Work Unit No. (TRAIS)	
				11. Contract or Grant No. DTCF23-85-C-20078	
12. Sponsoring Agency Name and Address Department of Transportation U.S. Coast Guard Office of Research and Development Washington, D. C. 20593				13. Type of Report and Period Covered Final 30 Sep 85 to 30 Sep 86	
				14. Sponsoring Agency Code G-DST-1	
15. Supplementary Notes Other major contributors: Decision Science Consortium, Inc. PharoLogic, Ltd.					
16. Abstract This document describes the first phase of a five-year study designed to develop a decision model (or set of models) capable of supporting the resource management activities of the Coast Guard's Short Range Aids to Navigation Program. The first phase, which included visits to virtually all Coast Guard District Offices and meetings with pilots associations and selected user groups, resulted in the development of standardized, realistic measures by which the predicted outcome of proposed management decisions can be expressed. The spectrum of decisions addressed includes the full range of program activities relating to short range aids to navigation: acquisition and deployment mix, scheduled and unscheduled maintenance policy, staffing and training of personnel, as well as decisions to invest in R&D and technological innovation. Measures of effectiveness developed under the first task deal primarily with safety (avoidance of accidents) and timeliness (avoidance of delays). A framework is established for expressing the components of these dimensions in a highly disaggregated fashion suitable to the context at hand. Other measures of effectiveness dealing with less tangible issues are also defined. Several appendixes dealing with specialized technical issues are included. Topics covered include: multiattribute utility analysis, use of probability distributions to characterize mariner behavior, and the use of cost-effectiveness and judgmental assessment techniques. A hypothetical example illustrating the application of these techniques to a typical decision scenario, and a detailed workplan for the remaining phases of the project, are also included.					
17. Key Words Decision Model Cost-Benefit Analysis Aids to Navigation Resource Management Measure of Effectiveness			18. Distribution Statement Document is available to the public through the National Technical Information Service, Springfield, Virginia 22161		
19. Security Classif. (of this report) UNCLASSIFIED		20. Security Classif. (of this page) UNCLASSIFIED		21. No. of Pages 299	22. Price

METRIC CONVERSION FACTORS

Approximate Conversions to Metric Measures

Symbol	When You Know	Multiply by	To Find	Symbol
LENGTH				
in	inches	2.5	centimeters	cm
ft	feet	30	centimeters	cm
yd	yards	0.9	meters	m
mi	miles	1.6	kilometers	km
AREA				
sq in	square inches	6.5	square centimeters	cm ²
sq ft	square feet	0.09	square meters	m ²
sq yd	square yards	0.8	square meters	m ²
sq mi	square miles	2.6	square kilometers	km ²
ac	acres	0.4	hectares	ha
MASS (weight)				
oz	ounces	28	grams	g
lb	pounds	0.45	kilograms	kg
	short tons (2000 lb)	0.9	tonnes	t
VOLUME				
tsp	teaspoons	5	milliliters	ml
Tbsp	tablespoons	15	milliliters	ml
fl oz	fluid ounces	30	milliliters	ml
c	Cups	0.24	liters	l
pt	pints	0.47	liters	l
qt	quarts	0.96	liters	l
gal	gallons	3.8	liters	l
cu ft	Cubic feet	0.03	Cubic meters	m ³
cu yd	Cubic yards	0.76	Cubic meters	m ³
TEMPERATURE (exact)				
°F	Fahrenheit temperature	5/9 (after subtracting 32)	Celsius temperature	°C

Approximate Conversions from Metric Measures

Symbol	When You Know	Multiply by	To Find	Symbol
LENGTH				
mm	millimeters	0.04	inches	in
cm	Centimeters	0.4	inches	in
m	meters	3.3	feet	ft
km	kilometers	1.1	yards	yd
		0.6	miles	mi
AREA				
cm ²	square centimeters	0.16	square inches	in ²
m ²	square meters	1.2	square yards	yd ²
km ²	square kilometers	0.4	square miles	mi ²
ha	hectares (10,000 m ²)	2.5	acres	ac
MASS (weight)				
g	grams	0.036	ounces	oz
kg	kilograms	2.2	pounds	lb
t	tonnes (1000 kg)	1.1	short tons	st
VOLUME				
ml	milliliters	0.03	fluid ounces	fl oz
l	liters	2.1	pints	pt
l	liters	1.06	quarts	qt
l	liters	0.26	gallons	gal
m ³	Cubic meters	35	Cubic feet	ft ³
m ³	Cubic meters	1.3	Cubic yards	yd ³
TEMPERATURE (exact)				
°C	Celsius temperature	9/5 (then add 32)	Fahrenheit temperature	°F

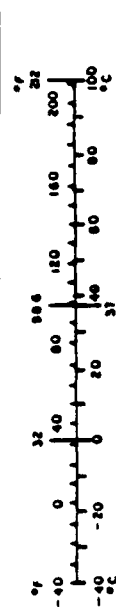
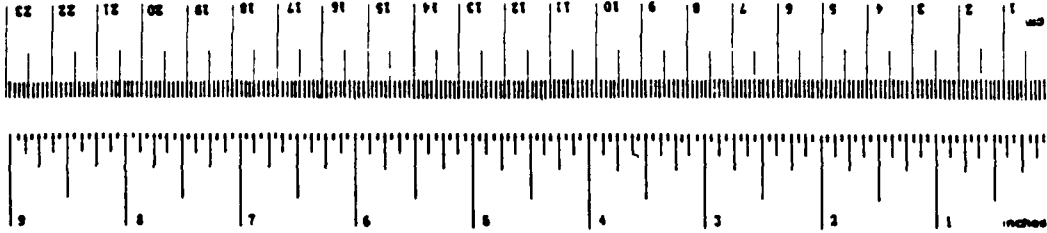

* 1 in. = 2.54 exactly. For other exact conversions and more detailed tables, see NBS Misc. Publ. 226, Units of Weight and Measures, Price \$7.25. SI Catalog No. C1310 Z66.

PREFACE

This report documents the first task of a multiphase project designed to develop a comprehensive resource management tool to support Coast Guard decisions relating to the Short Range Aids to Navigation (SRA) Program.

Implemented for the purpose of improving the safety and expediting the passage of marine traffic, the SRA program is characterized by a wide variety of resources and a comprehensive set of policies governing the use of those resources. The resources in question include:

- o Nearly 50,000 short range aids to navigation (buoys, beacons, light houses, sound signals, etc.)¹
- o The personnel responsible for servicing these devices, both on a routine and "discrepancy" basis
- o The platforms (vessels, vehicles, and aircraft) required to transport the servicing personnel to and from their duty stations and to conduct the necessary maintenance

Decisions concerning the efficient use of these resources, based on quantitative analysis, supported wherever possible by empirical data, are basic to effective program management. Program modifications that can be made without impairing the safety and timeliness of vessel traffic must be evaluated; program improvements, where needed, must be assessed both from the standpoint of their likely benefits and their likely cost.

The resource management tool contemplated by this study is to be developed through a series of tasks, each an independent entity unto itself yet all highly interrelated. The first task, the subject of this report, is to develop one or more measures of effectiveness (MOEs) by which the performance of alternative system configurations and their associated policies can be evaluated and compared.

¹ Plus another 42,000 aids maintained by private interests. The Coast Guard does not maintain private aids but is responsible for regulating them.



A-1

es

Following completion of this task, the next seven tasks address selected aspects of the SRA resource management decision process, making use of the measures of effectiveness previously developed. The decision aspects selected for detailed investigation are as follows:

- o Routine servicing
- o Platform capabilities
- o Discrepancy response criteria
- o Alternative modes of accomplishing the servicing function
- o Staffing levels
- o Multimission effects (i.e., the use of SRA platforms and personnel to accomplish search and rescue, law enforcement, etc.)
- o Possible tradeoffs between short range aids and radio-navigational devices

The final task of this project is to synthesize the preceding efforts into a definitive analytical model -- or set of models -- capable of serving as a resource management tool for future programmatic decisions.

The format of this report is as follows:

- o Chapter 1 provides a broad project overview. The purpose of the project, its relationship to other recent and ongoing studies, and its basic structure and timing are discussed.
- o Chapter 2 describes several concepts that underlie the development of a suitable analytical model. Those concepts involve four basic linkages:
 - (a) The linkage between SRA resource management decisions and day-by-day program operations (i.e., the time and resources available to conduct routine servicing, the time and resources available to conduct discrepancy response, and so on)
 - (b) The linkage between day-to-day program operations and long-term system availability and/or accuracy

- (c) The linkage between system availability/accuracy and the "probable" decisions reached by individual mariners
 - (d) The linkage between mariner decisions and their consequences in terms of impaired (or improved) safety and/or timeliness.
- o Chapter 3 describes the methods used in pursuing this first task, the development of measures of effectiveness. Four basic methods -- review of related documents, field visits and interviews, data search, and the development of the measures themselves -- are discussed.
 - o Chapter 4 describes the specific measures of effectiveness developed to date. Program benefits fall into three broad categories: safety, timeliness, and other. Program costs fall into two categories: those applicable to the Coast Guard and those applicable to other government agencies.
 - o Chapter 5 presents an illustrative example of how the MOEs and analytic methods, used in concert, can be applied to a typical resource management scenario, involving the acquisition of a buoy tender for the 13th District. Strictly hypothetical, this example is intended solely to illustrate the methodology and not to suggest definitive answers.
 - o Chapter 6 is a detailed work plan for the remaining project tasks.

Seven appendixes are included. Appendix A consists of trip reports covering visits to eleven Coast Guard districts, including local and regional pilot associations and other user groups, and to the American Pilots Association. Appendixes B through E are methodological in nature, dealing with several relevant technical issues involved in decision analysis. Appendix F contains numerical details bearing on the illustrative example presented in Chapter 5.

A project of this nature and complexity could not be carried out without the assistance and support of others. A special note of appreciation is in order for several individuals who gave unstintingly of their time and themselves

in helping the project attain its goals. Foremost is Mr. Karl R. Schroeder, Short Range Aids to Navigation Section Chief in the USCG Office of Research and Development, whose guidance, patience, and understanding were a consistent source of support throughout. LCDR H. H. Sharpe of the Office of Navigation and CDR William K. May, formerly Navigation Systems Technology Branch Chief in the Office of R&D, provided important technical insights and other essential support.

Others at Coast Guard Headquarters to whom the project team is indebted include LCDR Theo Moniz who provided useful information on the Marine Casualty Reporting System, CDR Joseph A. Telep who provided an overview of other reporting systems, Mr. Harley R. Cleveland who reported on international efforts to assess the reliability and availability of aids to navigation systems, and Mr. James K. Augustine who provided useful input on marine litigation costs and experience. Mr. Allen van Emmerik of the Department of Justice was also helpful in the latter regard.

Other individuals who provided useful information included Capt. Pat Neeley of the American Pilots Association and Mr. William Murdin of the Army Corps of Engineers.

This acknowledgement would be incomplete without a strong statement of gratitude to the many Coast Guard officers and civilians at the district office level whom we visited, and to the various pilot associations, industry groups, and other user organizations with whom discussions were held, for their forthright incisive commentary on the technical problems presented by this project and, in many instances, their useful hints at solutions. The list of organizations and individuals involved is too long to mention, but to all we are deeply indebted.¹

A final note of appreciation to those responsible for the production of this report: Ms. Frances Inman of Mandex, Inc., and Ms. Diane Laaksonen of Decision Science Consortium.

¹ The names and affiliations of all persons visited are documented in the trip reports contained in Appendix A.

TABLE OF CONTENTS

	Page
1. INTRODUCTION	1-1
1.1 Purpose of this Project	1-1
1.2 Relationship to Other Studies	1-5
1.3 Project Structure and Timing	1-7
2. CONCEPTUAL MODEL OF SHORT RANGE AIDS TO NAVIGATION	2-1
3. TECHNICAL APPROACH TO TASK 1	3-1
3.1 Review of Related Documents	3-1
3.2 Field Visits and Interviews	3-12
3.3 Data Search	3-14
3.4 MOE Development	3-14
4. MEASURES OF EFFECTIVENESS	4-1
4.1 Overview	4-1
4.2 Key Issues	4-1
4.2.1 Illustrative resource management decisions	4-1
4.2.2 Criteria for selecting measures of effectiveness	4-3
4.3 Descriptions of Measures	4-4
4.3.1 Structure of the model	4-4
4.3.2 Detailed descriptions	4-6
4.4 Review of Data Sources	4-33
5. ILLUSTRATIVE RESOURCE MANAGEMENT DECISION: A BUOY TENDER FOR PUGET SOUND	5-1
5.1 The Decision Setting	5-1
5.1.1 Background	5-2
5.1.2 Capabilities desired for a Puget Sound buoy tender	5-3
5.2 Analysis Using the RMT Approach	5-4
5.2.1 Problem definition	5-5
5.2.2 Identification of alternatives	5-5
5.2.3 Review of comparison MOEs	5-6
5.2.4 Evaluation of each alternative on the MOEs	5-8
5.2.5 Prioritization of the comparison MOEs	5-17
5.2.6 Comparison of alternatives	5-20
5.2.7 Sensitivity analysis	5-25
6. WORKPLAN FOR TASKS 2 THROUGH 9	

TABLE OF CONTENTS (continued)

	Page
APPENDIX A: TRIP REPORTS	A-2
Ninth Coast Guard District, Cleveland, OH	A-2
First Coast Guard District, Boston, MA	A-6
American Pilots Association Headquarters, Washington, DC	A-16
Seventh Coast Guard District, Miami, FL	A-18
Eighth Coast Guard District, New Orleans, LA	A-24
Third Coast Guard District, New York, NY	A-40
Second Coast Guard District, St. Louis, MO	A-43
Twelfth Coast Guard District, San Francisco, CA	A-59
Fourteenth Coast Guard District, Honolulu, HA	A-62
Fifth Coast Guard District, Portsmouth, VA	A-66
Thirteenth Coast Guard District, Seattle, WA	A-70
Seventeenth Coast Guard District, Juneau, AK	A-70
APPENDIX B: MULTIATTRIBUTE UTILITY ANALYSIS	B-1
B.1 Identification of Alternatives	B-2
B.2 Identification of Attributes	B-3
B.3 Evaluation of Alternatives on Attributes	B-8
B.4 Prioritization of Attributes (Weighting)	B-13
B.5 Comparison of Alternatives	B-21
B.6 Sensitivity Analysis	B-24
B.7 Complicating Factors and Extensions	B-28
APPENDIX C: MODELS WITH PROBABILITY DISTRIBUTIONS	C-1
APPENDIX D: COST-EFFECTIVENESS TECHNIQUES FOR RESOURCE MANAGEMENT	D-1
D.1 Introduction	D-1
D.2 Example Problem	D-5
D.3 Use of the Results	D-11
APPENDIX E: USE OF JUDGMENTAL ASSESSMENT TECHNIQUES	E-1
E.1 Probability Elicitation	E-1
E.2 Group Elicitation	E-2
APPENDIX F: A BUOY TENDER FOR PUGET SOUND	F-1
REFERENCES	R-1

LIST OF FIGURES

	Page
1.1 SRA Program Elements.....	1-3
1.2 Project Overview.....	1-8
2.1 Representation of AtoN Performance as a Series of Probabilistic Events.....	2-4
3.1 U.S. Coast Guard Districts.....	3-13
4.1 Structure of the MOE Model.....	4-5
4.2 Illustrative Cost Per Accident.....	4-10
4.3 Conditional Probability Tree.....	4-12
4.4 Conditional Probability Tree for Delay.....	4-19
5.1 Organizational Impact on the Coast Guard.....	5-16
5.2 Value Graph for Organizational Impact on the Coast Guard	5-17
5.3 Costs vs. Benefits	5-23
5.4 Value Curve for Commercial Economic Safety Benefits	5-24
5.5 Costs vs. Benefits with "Risk Averse" Economic MOEs	5-25

LIST OF TABLES

	Page
4.1	Outline Structure of MOEs.....4-7
4.2	Excerpt from <u>Port Series Reports</u>4-35
4.3	Excerpt from <u>Waterborne Commerce of the United States</u> (Vessel Traffic by Commodity).....4-36
4.4	Excerpt from <u>Waterborne Commerce of the United States</u> (Number of Transits by Vessel Draft).....4-37
4.5	Excerpt from <u>Fisheries of the United States</u>4-39
4.6	Excerpt from <u>Corps of Engineers Database</u>4-41
4.7	Excerpt from <u>Commodity Movement Annual</u>4-42
4.8	Excerpt from <u>United States Oceanborne Foreign Trade Routes</u>4-44
5.1	13th District AtoN Servicing Forces.....5-2
5.2	Outline Structure of MOEs Relevant to Illustrative Example.....5-9
5.3	Example of Economic Analysis.....5-10
5.4	Commercial Economic Safety Benefits.....5-12
5.5	Commercial Personal Safety Benefits.....5-13
5.6	Ship-Related Timeliness.....5-14
5.7	Coast Guard Organizational Impacts.....5-15
5.8	List of MOE Scores.....5-18
5.9	Range of Scales for Economic Considerations.....5-19
5.10	List of MOE Weights.....5-21
5.11	Combined Value of Economic Safety Benefits.....5-22
5.12	Combined Value of All Safety Benefits.....5-22
5.13	Combined Value of All Benefits and Costs.....5-23
5.14	Combined Value of All Benefits and Costs (revised).....5-25
5.15	Sensitivity of Weight on OTHER BENEFITS.....5-26
5.16	Sensitivity of Weight on BENEFITS.....5-27

1. INTRODUCTION

1.1 Purpose of this Project

The Coast Guard's Short Range Aids to Navigation (SRA) program is the product of an evolutionary process conducted over the past two hundred years. Since 1790, the Coast Guard and its predecessors have established and maintained aids to navigation, designed to facilitate the safe and expeditious passage of marine traffic. Over the years, these devices ("AtoN"s) have benefited untold mariners, saving lives, sparing property damage, and generally enhancing the flow of commercial, recreational, and military marine traffic.

In its present form, the SRA program consists of nearly 50,000 lights, ranges, beacons, buoys, sound signals, and other audible/visible devices.¹ Dotting the nation's waterways, these devices are the outwardly visible signs of the program but by no means its total substance. The SRA program, viewed in its broadest context, also includes:

- The personnel that service these devices and maintain them in a high state of operational availability,
- The platforms (vessels, vehicles, and aircraft) that carry the service personnel to and from their duty stations and on which the service functions (generally) are performed, and
- The policies that govern the interaction of these disparate program elements, i.e., the frequency with which AtoNs are routinely serviced, the rapidity with which AtoNs reported to be discrepant are restored, the mix and level of capability of both the AtoNs and their servicing platforms, and so on.

¹ Another 42,000 or so short range aids to navigation are maintained by private interests. Not all short range aids, incidentally, are of an audible or visible nature. Racons (radar beacons) are devices that produce a coded response when triggered by a radar signal, generally in the X- or S-band marine radar frequency range. Racons, generally collocated with other signals, provide radar enhancement and improve aid identification. They are of particular help during the transition from ocean to inland navigation.

The SRA program, in brief, consists of the four major elements shown in Figure 1.1. The heart of the program, as stated, are the basic aids to navigation. These are in turn influenced by the three P's: people, platforms, and policies. Together, these elements combine to save lives, reduce property damage, and minimize traffic delays. They also constitute the third most costly Coast Guard program, an obvious attention-getter in these days of meticulous (and sometimes not so meticulous) cost cutting.

Conventional wisdom has long maintained that the benefits of the SRA program far outweigh its cost. That proposition, however, remains to be conclusively demonstrated. No one knows for sure how many lives the program has saved, how much property damage it has spared, how many closed ports or other traffic delays it has avoided, and what cost savings the avoidance of those delays has produced. Nor is anyone able, at the present time, to predict:

- a. The additional savings (in lives, property damage, and delays) that would result if the program's existing resources were to be upgraded (in either number or capability).
- b. The reduced savings if the program's existing resources were to be downgraded.
- c. The revised savings if the program's resources were to be managed differently.

The purpose of this study is to develop a resource management tool -- a computerized program (or set of programs perhaps) -- capable of asking these questions, of making these predictions. The goal is to provide a rational, quantitative basis for judging the "value" of the SRA program and for reaching future management decisions -- decisions to upgrade, downgrade, and/or manage differently. The management tool, if it is to be useful at all, must be capable of answering "what if" questions of the following nature:

- (1) To what extent will mariners benefit (i.e., lives be saved, damage be avoided, or delays reduced) if routine servicing of AtoNs were to be performed more often? What will this take in the way of additional resources?

FIGURE 1.1 SRA PROGRAM ELEMENTS

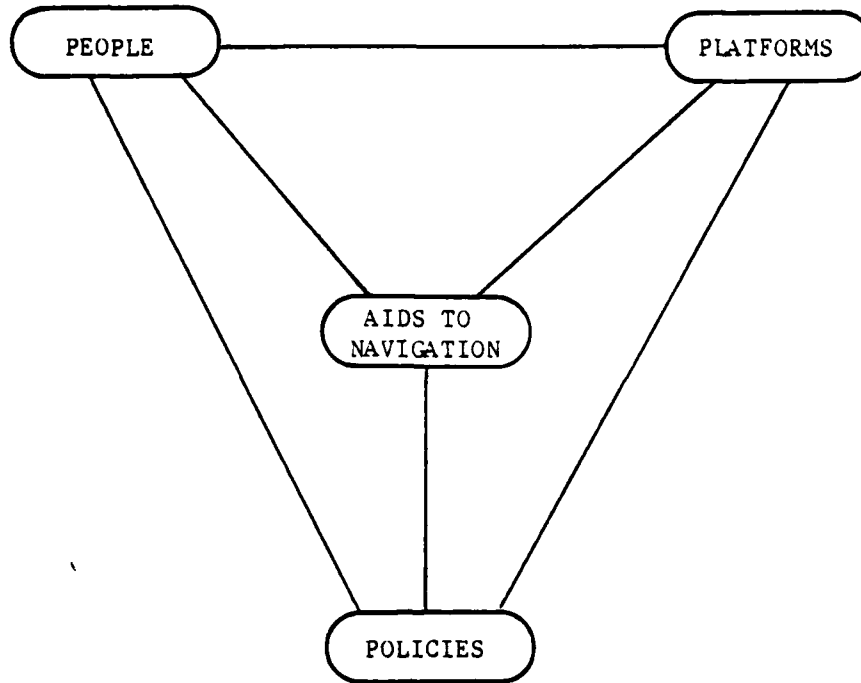

AIDS TO NAVIGATION

- o BEACONS
 - LIGHTS
 - DAYBEACONS
- o BUOYS
 - LIGHTED
 - UNLIGHTED
- o RANGES
- o LIGHTHOUSES
- o SOUND SIGNALS
- o FOG SIGNALS
- o RACONS

PEOPLE

- o TENDERS
- o ANTs
- o LIGHT STATIONS
- o BASES/DEPOTS
- o GROUPS
- o DISTRICT OFFICES
- o HEADQUARTERS

PLATFORMS

- o WLB
- o WLM
- o WLI
- o WLIC
- o WLR
- o ANB
- o BU
- o BUSL
- o TANB
- o T/B
- o FUTURE
- o VEHICLES
- o AIRCRAFT

POLICIES

- o ROUTINE SERVICING
- o DISCREPANCY RESPONSE CRITERIA
- o MULTIMISSION EFFECTS
- o STAFFING LEVELS
- o USE OF RADIO AIDS

(2) To what extent will mariners benefit (lives be saved, damage avoided, delays reduced) if the operational characteristics of existing AtoNs -- their reliability, light intensity, source of power, etc. -- were to be upgraded?

(3) To what extent will mariners suffer if, as a result of budget reductions, the servicing and/or operational characteristics of AtoNs were to be compromised?

These questions are intended merely to be illustrative; they constitute only a portion of the spectrum of possible resource management decisions. Similarly, the benefits suggested -- saved lives, reduced property damage, reduced delays -- are by no means the full set of possible program outcomes; other outcomes, involving both the national and local economies, the Coast Guard and other interested parties, are also possible. The methodology developed through this project must be capable of addressing both sides of the coin: (a) the full set of SRA resource management decisions available to the Coast Guard and (b) the full set of benefits, positive or negative, flowing from those decisions.

The remaining sections of this chapter address the relationship of this project to other recent and ongoing Coast Guard studies (Section 1.2) and the basic structure and timing of this multiphase research and development effort (Section 1.3). Chapter 2 presents the conceptual basis on which the model development is expected, at least initially, to proceed. Chapter 3 describes the technical approach adopted to date and Chapter 4, the outcome of that approach. Chapter 5 is a hypothetical illustration of the manner in which the model is expected, ultimately, to operate. Finally, Chapter 6 presents a detailed workplan for the ensuing phases of the project.

Six appendixes are included. Appendix A is a series of trip reports documenting visits made by the study team to eleven of the Coast Guard District Offices. Appendix B describes a mathematical technique, termed multiattribute utility analysis, on which a substantial portion of the model development is

likely to be based. Appendices C through E deal with a variety of methodological issues: Appendix C describes the use of probability distributions in decision analysis; Appendix D deals with cost-effectiveness techniques and Appendix E with the use of group assessment techniques in contexts involving the application of subjective judgment. Appendix F provides numerical details relating to the hypothetical illustration discussed in Chapter 5.

1.2 Relationship to Other Studies

This project bears a direct relationship to the Coast Guard's Waterway Analysis and Management System (WAMS). WAMS is a national, decentralized initiative undertaken by the individual district offices under the mandate provided by Commandant Instruction 16500.11, dated 4 September 1984. As stated in COMDTINST 16500.11, District Commanders are to:

- (1) Geographically identify all waterways for which they are responsible, identifying the particular Light List Numbers (AtoNs) applicable to each waterway.
- (2) Classify each waterway as "critical" or "non-critical" based on certain military, environmental, and navigational criteria.
- (3) Analyze each waterway in terms of the work required to put it into proper condition. "Proper condition," although not explicitly defined, entails (among other things):
 - (a) Meeting the needs of the users
 - (b) Achieving efficiencies, wherever possible, without degrading system performance.

WAMS encourages a broad systems outlook, taking into account (for example) the availability of radio-navigational aids and the possibility of interdistrict cooperation to achieve greater efficiency. No specific analytic format is specified; the individual districts are free to use whatever methods suit their local needs.

The relationship between the present Resource Management Study and WAMS is bilateral in nature. This study is perceived as a vehicle for producing an analytic tool (or set of tools) for use in WAMS. The WAMS analyses, on the other hand, will predictably generate volumes of data useful in illuminating the relationships needed to carry out this study. A clearly symbiotic relationship -- each study benefiting from the existence of the other -- is envisioned.

A second relevant initiative is the Systems Design Manual for Restricted Waterways, developed by the Eclectech Associates Division of Ship Analytics, Inc. Completed in March 1985, the Design Manual provides procedures for designing and evaluating systems of AtoNs in restricted waterways navigated by deep draft vessels. Employing a structured approach to system design and evaluation, the manual presents, among other things, a useful measure of quality -- the so-called Relative Risk Factor (RRF) -- for use in evaluating alternative AtoN configurations. The usefulness of this measure is restricted, however, in at least two respects:

- a. It deals with only one portion of the outcome spectrum -- safety -- and even then in only a relative rather than an absolute sense.
- b. Its applicability is restricted to deep dredged channels. Most aids to navigation do not mark such waterways.¹

Like WAMS, the Design Manual for Restricted Waterways has applicability and value to this Resource Management Study. Its major value lies in the transferability of its analytic approach and in the fact that many of the numbers produced can be used productively in selected portions of the analytic model resulting from this study.

¹ To illustrate this limitation, the 17th District's resources include six of the Coast Guard's 28 offshore buoy tenders and more than 10% of the field personnel identifiable in the SRA program, yet this District has no waterways for which the Design Manual is suitable. (There are restricted waters in Alaska, but not of the straight dredged channels upon which the manual is based.)

A third initiative relevant to the present study is the Transportation Systems Center (TSC) work in developing A Logical Model Representing SRA-Mission Command and Control, 23 September 1983. This R&D project, intended to improve existing command and control systems, has the following objectives:

- a. Increase the availability and timeliness of information for Coast Guard decision-makers at a reasonable cost.
- b. Reduce the amount of manual manipulation of both operational and administrative information.
- c. Reduce the information processing workload at lower command echelons.
- d. Upgrade Coast Guard communications capabilities to support increasing information demands.

The thrust of the study is to improve the flow of existing information in terms of economy (by reducing the time and cost of generating and relaying information) and efficiency (more and better output for less input effort).

The data flow diagrams developed in the TSC study are of value to this project in illuminating the mission relationships with which this project is concerned. Additionally, the study has the potential of identifying and/or improving existing data bases within the Coast Guard upon which this project might wish to draw.

1.3 Project Structure and Timing

The project consists of nine distinct tasks, shown in Figure 1.2. Although highly interrelated, each of the tasks is a discrete study unto itself. Summary descriptions of the tasks are provided below.

Task 1 (Measures of Effectiveness)

This first task has as its goal the development of a measure, or set of measures, by which the performance of the SRA program can be expressed. Two

FIGURE 1.2 PROJECT OVERVIEW

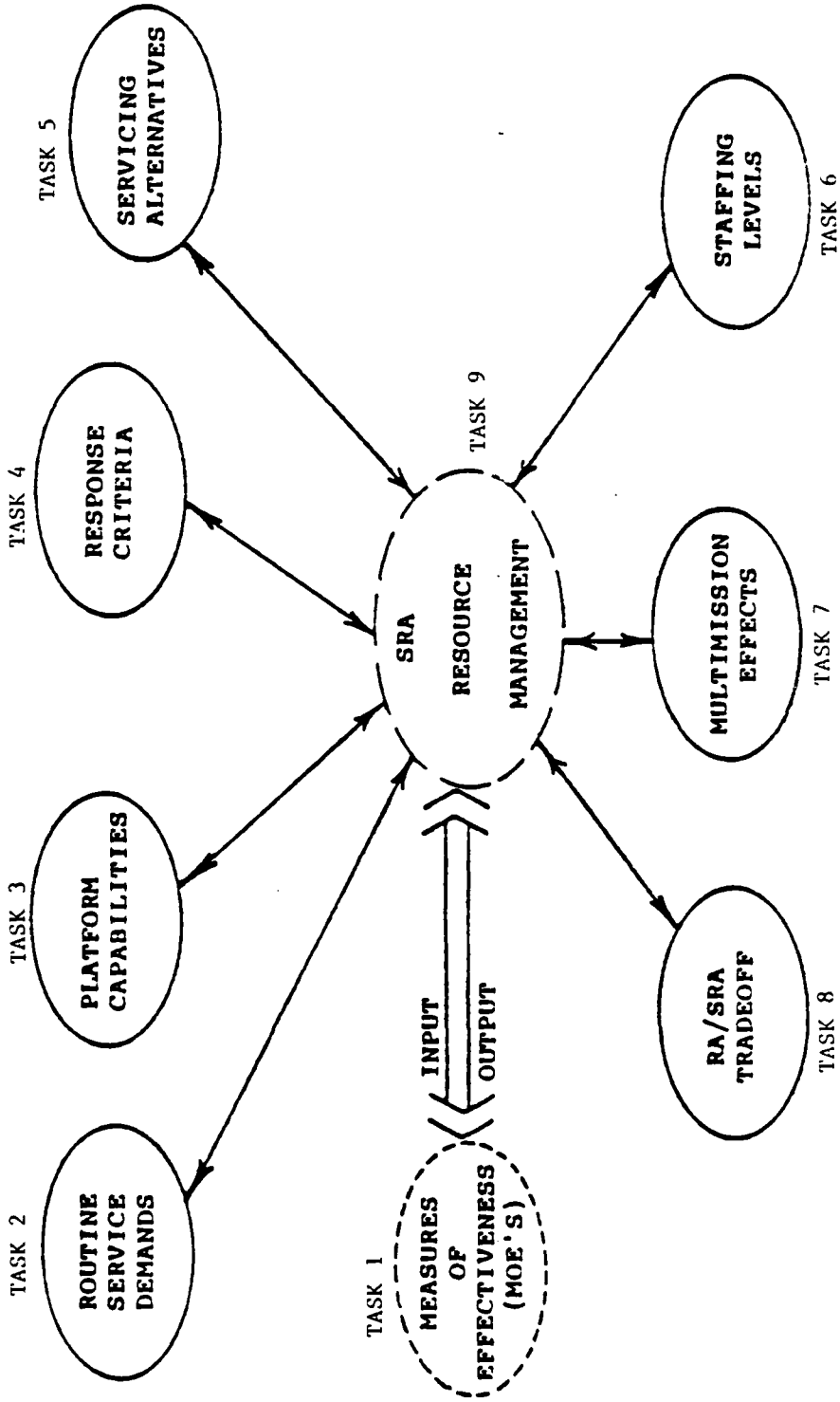

- - - - MOE'S
 ——— CONSTRAINTS
 - - - - ANALYTICAL MODEL

SOURCE: Contract Statement of Work

classes of measures, corresponding to the classic definitions of "outcome" and "process" measures, are envisioned:

a. Those that pertain to system output ("outcome" measures)

Measures of this nature might typically include:

- o Accident rate (or reduction in accident rate)
- o User satisfaction
- o Cost (to the user and others) of transit delays
- o Value of goods transported

b. Those that pertain to system input ("process" measures)

Typical of these are:

- o Program costs
- o Resource levels (people and platforms)
- o AtoN system configuration

The intent in developing these measures is to provide a common basis for expressing the consequences of alternative SRA resource management decisions. The goal, in brief, is to develop measures of effectiveness ("MOE"s) that are:

- (a) Sensitive to resource management decisions
- (b) Quantifiable
- (c) Realistically measurable

The measures developed will be used in conducting each of the remaining tasks. They will be revised and augmented as necessary and eventually incorporated into the final analytic model.

Task 1 began 1 October 1985. This report documents the methods employed (Chapter 3) and results achieved (Chapter 4). Also included is a conceptual discussion of how MOEs relate to SRA resource management decisions (Chapter 2) and a hypothetical illustration of how these measures might be used (Chapter 5).

Tasks 2 (Routine Service Demands) through 6 (Staffing Levels)

Each of these tasks addresses a different set of SRA resource management issues. Within each task, the interplay of alternative policies and practices is to be explored, with the goal of establishing in which direction optimality lies. Specifically:

- Task 2 (Routine Service Demands) deals with alternative policies for the routine (scheduled) servicing of AtoNs. Given existing and postulated equipment failure rates, optimum servicing cycles are to be evolved.¹
- Task 3 (Platform Capabilities) deals with the alternative policies and capabilities involved in the acquisition, upgrading, and management of AtoN servicing platforms. Speed, endurance, draft, lift capability, staffing, and life cycle cost are among the attributes to be considered.
- Task 4 (Response Criteria) deals with possible modifications to existing Coast Guard criteria for responding to AtoN discrepancies. The interaction of discrepancy response criteria with routine servicing policy (see footnote this page) will be taken into account.
- Task 5 (Servicing Alternatives) deals with alternative methods for accomplishing AtoN servicing. Innovative methods of expediting both routine and discrepancy work (e.g., the use of multidistrict platforms to conduct discrepancy response) are to be identified and evaluated.
- Task 6 (Staffing Levels) deals with alternative personnel configurations. Criteria for determining optimum staffing levels at various program echelons are to be developed.

¹ Every routine servicing cycle involves two sets of costs. The first is the cost of conducting scheduled maintenance; the second is the cost of responding to discrepancies when they occur. As the length of the servicing cycle varies, these costs move in opposite directions. The "optimum" servicing cycle is the one that minimizes the sum of these costs. (Unfortunately, the optimum cycle, because of resource limitations, may not always be attainable.)

Tasks 7 (Multimission Effects) and 8 (RA/SRA Tradeoff)

These tasks differ from Tasks 2 through 6 in that the issues involved go beyond the strict boundaries of the SRA program. In each case, however, the intent is the same: to explore alternative approaches designed to expand program capability.

- Task 7 considers the effect of varying levels of multimission involvement on SRA mission performance. Since SRA platforms have multimission capabilities (law enforcement, search and rescue, etc.), their use in these modes provides obvious benefits to the taxpayer. There is a point, however, at which multimission involvement begins to compromise the basic SRA function. That point needs to be identified.

- Task 8 examines the tradeoffs involved in using different combinations of radio (RA) and short range (SRA) aids. Again, the effect of varying levels of RA/SRA reliance on the measures of effectiveness developed in Task 1 will be considered.

Task 9 (Analytical Model)

This final task represents the culmination of the project. Its goal is to integrate all of the efforts previously conducted into a single tool, or set of tools, capable of assessing any given set of SRA resource management options and reaching decisions concerning their suitability and optimality. Sensitivity analyses, examining the consequences of alternative assumptions concerning selected key variables, will be an important feature of this task and of the model itself.

The precise form of the model is expected to evolve as the study progresses. At this point, however, certain aspects of the model seem, at least in concept, fairly evident. Chapter 2 is devoted to a brief conceptual discussion of these issues.

2. CONCEPTUAL MODEL OF SHORT RANGE AIDS TO NAVIGATION

Any system of aids to navigation can usefully be regarded as a monumental information system. The "system" conveys information to a variety of individuals, in a variety of settings, engaged in the process of making decisions. The recipients of the information are mariners of various types; the decisions with which they are concerned are of a distinctly unique form:

- a. When to start a turn
- b. When to end a turn
- c. When to reduce speed in anticipation of a hazard

and so on.

The information conveyed may not in all cases be needed. Some mariners, in some settings, may be perfectly capable of reaching appropriate decisions without AtoN assistance; others, in other settings, may need every bit of help they can get.

Every information system, of course, has its pitfalls. There are endless opportunities for error:

- The information conveyed may not be accurate (a buoy may have drifted off-station)
- The mechanism for conveying the information may not be operative (a light may be out)
- The information may be accurate and properly conveyed but improperly interpreted or acted upon (inept mariner)

Given a breakdown in either the transmittal of information or its reception and interpretation, an improper steering decision may result. The mariner may, for example, start his turn at the wrong point, may fail to start it at all, or may turn in the wrong direction. Whether or not an improper decision is reached depends on many factors: (a) the mariner's level of sophistication and

degree of local knowledge, (b) the extent to which the mariner tends to rely, unduly, on precise buoy locations, (c) the degree of redundancy in the AtoN system, and (d) the existence or non-existence of natural or man-made landmarks and other guides.

Whether or not an improper decision, if reached, results in negative consequences again depends on a number of factors: (a) how close the vessel was to the channel edge or other hazard, (b) the vessel speed, (c) the prevailing current, (d) the presence or absence of other traffic, (e) the existence or non-existence of other landmarks that might have alerted the mariner in time, (f) the prevailing weather and visibility, and so on.

The accident rate associated with a given AtoN configuration may, in other words, be expressed as a function of:

- a. The rate at which messages that are flawed or incomplete tend to occur
- b. The probability, given a flawed or incomplete message, that mariners will reach improper steering decisions
- c. The probability, given an improper steering decision, that an accident will result.

Not all mariner actions, however, involve steering decisions. If a mariner is aware that the system is flawed -- whether through personal observation, local notice, broadcast notice, or word of mouth -- he is presented with a whole new set of options. Depending on the criticality of the aid or aids in question and the urgency of his mission, the mariner might choose to:

- Proceed as usual, relying on local knowledge or other resources
- Proceed at reduced speed, exercising due caution
- Go to anchor, awaiting daybreak or improved visibility
- Select an alternate route

Whichever of these options he selects, the mariner may be obliged to pay a price. Option 1 ("proceed as usual") may increase his risk of grounding or collision. Option 2 ("proceed at reduced speed") limits the safety risk but introduces a potential time delay. Option 3 ("wait it out") eliminates the safety risk at an even greater cost in timeliness. Option 4 ("find another route") may not be an available -- or acceptable -- option but if it is, entails a new set of safety risks and delay factors.

Conceptually, then, if an AtoN system is flawed or incomplete, there are two possible chains of events that might ensue. These chains, both involving events of a probabilistic nature, are shown in Figure 2.1. One chain has the mariner, with some probability, making an improper steering decision; that decision is then followed, with some probability, by an accident (collision or grounding); any such accident is in turn followed, with some probability, by negative consequences of one form or another (death, injury, property damage, lost cargo, port closure, etc.).

The second chain, operative only if the mariner is aware of the system flaw or discrepancy, has the mariner reaching one of four possible decisions. Each of those decisions, as discussed earlier, has an associated set of possible safety risks and/or delay factors.

The uppermost box in Figure 2.1 requires some elaboration. It says, in effect, that a message conveyed to the mariner (or at least certain classes of mariners) was in some way flawed or incomplete. This situation can arise in either or both of two ways:

- (1) System discrepancies. -- One cause of flawed or incomplete messages is that the system is "discrepant" (one or more buoys missing or off-station, one or more lights extinguished or reduced in intensity, etc.). The likelihood of such an occurrence is largely a function of SRA resource management decisions. In particular, it is a function of the resources available, and applied, to prevent such occurrences or to correct them when they take place. Specifically, it is a function of:

FIGURE 2.1 REPRESENTATION OF AtoN PERFORMANCE AS A SERIES OF PROBABILISTIC EVENTS

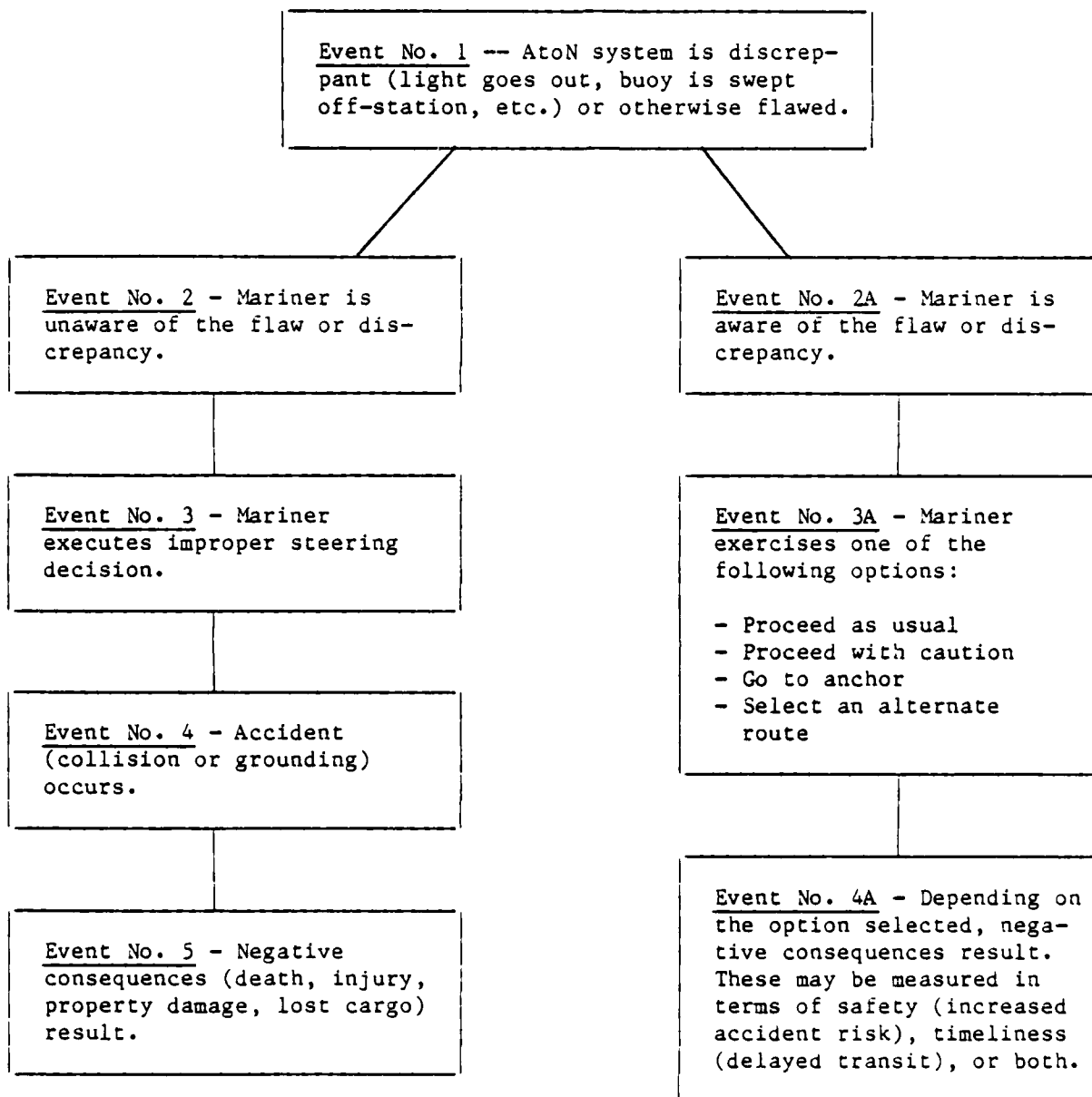

NOTE: The probabilities implied by this chart depend heavily on mariner type, vessel class, and environmental setting, among other factors. Some of these probabilities may, for all practical purposes, be zero.

- a. The number and quality of resources available to perform routine servicing
- b. The number and quality of resources available to respond to reported discrepancies
- c. The servicing policies that govern both of the above
- d. The hardware characteristics (and particularly the reliability) of the system equipment
- e. Other aspects of Coast Guard policy -- e.g., multimission decisions -- that impinge on SRA performance

(2) System design. -- A second cause of flawed or incomplete AtoN messages is the existence of a basic system design weakness or deficiency. Typical of such deficiencies are:

- o Lights of inadequate intensity for the range that needs to be covered
- o Excessive distance between successive buoys marking a channel
- o Poorly visible paint on daymarks

These inadequacies are typically not correctable through maintenance. Unlike discrepancies, they are not probabilistic in nature; they either exist or they do not.

The events outlined in Figure 2.1, and their associated probabilities, are by no means easily defined. Actions taken by commercial pilots in no way resemble those taken by pleasure boaters; actions taken in the daytime are different from those taken at night; actions taken on the Mississippi differ from those taken in the Intracoastal Waterway; and so on. Any model, however, that seeks to relate resource management decisions to their consequences in terms of impaired (or improved) safety and/or timeliness would do well to incorporate, within its basic structure, the dynamics by which such impairment (or improvement) takes place. This is the premise on which we have proceeded.

The model currently envisioned consists of four basic modules, each capable of being studied on its own or in concert with the others. The four modules are described below.

- a. Module No. 1 examines the link between SKA resource management decisions and their impact on Coast Guard day-to-day operations.

Example: Every management decision relating to the servicing function has a predictable impact on day-to-day operations. Decommissioning a tender, for example, will mean x fewer days of underway operations in a given district. This will in turn mean y fewer days available for the routine inspection of moorings and replacement of batteries, z fewer days available for discrepancy response, and so on. The model should permit the user to identify these linkages as a basic first step toward examining the interplay that follows. Certain fixed constraints, such as a minimum percentage of time devoted to Charlie (maintenance) status will be built into the module. District geography -- i.e., the travel time between home ports and AtoN locations -- will need to be taken into account.

- b. Module No. 2 examines the link between Coast Guard day-to-day operations and long-term system availability and accuracy.

Example: Any reduction in the number of days of routine inspection activity in a given district will again have predictable consequences. Depending on the specific discrepancy rates involved, a greater number of buoys may be expected to drift off-station, a greater number of lights may be expected to fail than in the past. These differences will in turn affect the accuracy and completeness of messages conveyed to mariners transitting the waterway in question; that is to say, system availability and accuracy will both be affected. Given knowledge of past equipment discrepancy rates and the time required to restore AtoNs to operability (taking into account travel time), the system availability, by AtoN class and location, can be mathematically determined. The model should be capable of establishing these values, as a step toward examining their further consequences.

- c. Module No. 3 examines the link between system availability/accuracy and the consequent decisions reached by mariners, including the results of those decisions.

Example: Any impairment (or improvement) in system availability or accuracy will in turn, with some likelihood, have an impact on the decisions mariners reach (see Figure 2.1). These effects may in turn have an impact on safety ("accident risk") or timeliness ("transit delays"). The purpose of this module is to model these effects, making use of experiential data where they exist and special analyses where they do not. The relative risk factor, developed in the Design Manual for Restricted Waterways, is expected to play a role in the safety determinations.

This module will typically produce output of the following form:

- (a) Safety impact. - The expected increase (or decrease) in frequency of accidents, by accident type.
- (b) Timeliness impact. - The expected increase (or decrease) in transit delays, by type of delay and entity affected.
- d. Module No. 4 translates the preceding impacts into their expected economic consequences.

Example: Every accident of a given type has an expected cost, based on actuarial experience, in terms of injuries, deaths, property damage, lost cargo, and other tangible factors. Every time delay can be similarly translated into an expected cost, by making use (if appropriate) of demurrage costs, the cost of idle stevedore crews, and so on. Module No. 4, making use of a combination of existing data and data yet to be established, will provide the necessary translation.

This module in effect bridges the gap between Coast Guard resource management decisions and their economic consequences, to the extent that those consequences can be expressed economically.

Translating these concepts into actuality will not be easy. Although the eventual analytic model is, at this stage, little more than a design concept, several basic principles can reliably be stated:

- a. Each module should be capable of expressing, in quantitative terms, the specific relationships it is designed to explore. Since not all individuals behave alike, each of those relationships will need to be described in the form of a probability distribution descriptive of how mariners behave statistically. Also, since not all marine settings are alike, different probability distributions will be needed to characterize varying conditions of visibility, weather, time of day, etc.
- b. Sensitivity analyses should be encouraged. The user should be free to explore the consequences of alternative assumptions concerning key variables whose precise values may not be known or universally accepted.
- c. The model should be capable of being operated at either the micro or macro level. At the micro level, the model will focus on individual AtoNs; at the macro level, it will focus on "clusters" of AtoNs with similar characteristics. Although the macro approach is generally more efficient, the model should, in theory at least, be capable of being applied microcosmically as well.
- d. The modular construction will permit each module to be exercised independently, at a great savings in overall running time. Among other advantages, this approach will permit interim solutions to be derived for each stage of the model without the necessity for running the model as a whole.

The "benefits" generated by the model will, as stated, generally be expressed in economic terms. However, as subsequent sections of this report will disclose, not all benefits associated with the SRA program are of a pecuniary nature -- or can be expressed unambiguously in pecuniary terms. Where this is the case, other methods -- notably the use of multiattribute utility analysis -- are called for. Other sections of this report will deal with these issues in greater detail.

3. TECHNICAL APPROACH TO TASK 1

The purpose of Task 1 is to develop a measure or measures of effectiveness (MOEs) by which the operation of the SRA program can be evaluated. This task provides a logical framework for detailed analysis of the components of the SRA program. Decisions must ultimately be made on platform capabilities and configurations, response criteria, servicing demand policies, staffing, and so forth, and each time a change is made at any of these decision points, the overall effectiveness of the SRA system can be affected. While the specific decisions may differ for each component, the ultimate impact on the entire system should be evaluated in terms of common MOEs. The Coast Guard often makes complex tradeoffs among these components since the objectives of individual components may be in conflict (e.g., reductions in discrepancies may require increased staffing at higher costs). The goal of Task 1 is to develop a structure of MOEs that provides linkages among independent components, and displays them either individually or at an aggregated level.

In executing this task, we included the following major steps: (1) review of related documents; (2) field visits and interviews; (3) data search; and (4) MOE development.

3.1 Review of Related Documents

As an initial step, we reviewed pertinent documents provided by the USCG Office of Research and Development. As we proceeded with our district visits and interviews, other appropriate references were made available such as Coast Guard file documents, budget request documents, district reports and data files, Corps of Engineers reports, etc. This section of the report presents a short overview of the key documents reviewed and discusses their relevance to the Resource Management Tool (RMT). Other documents that were reviewed but not summarized due to non-relevance are also listed. While the document review was conducted as part of Task 1, its applicability is far more general in that many documents cover all tasks, and some will not be directly applicable until Tasks 2 through 9. Reports that are data oriented are described in more detail in Section 4.4.

Aids to Navigation Manual - Administration
Commandant Instruction M16500.7
16 November 1981

This manual provides the policy for administering the Short Range Aids to Navigation Program. It includes a review of types of aids, general administrative principles, guidelines for marking systems, operating instructions, training guidelines, etc.

Relevance to RMT: Very High

In addition to defining components of the SRA system, this manual describes in general terms MOEs that can be incorporated into our model. Benefit categories include economic (delays), safety (groundings/collisions), and convenience. The report provides factors that should be considered in quantifying benefits, as well as factors that cannot readily be quantified in the conventional sense (such as prevention of pollution, recreational benefits, etc.). It also provides guidance on AtoN operational policy such as discrepancy response.

Benefits of Short Range Aids to Navigation (SRA) System
Memorandum from G-CPE to G-CCS
8 June 1981

This memo contains a paper that attempts to develop an approximate measure of benefit of the SRA system. It used expert judgment as a major data source. Two benefit measures were investigated--benefits from delay avoidance, and benefits from preventing groundings/collisions. The analysis was probabilistic and used dollars as a single measure of benefit.

Relevance to RMT: Very High

The MOEs used in this paper, delays and accident costs, will be used in our MOE model; however, they will be complemented by others. The probabilistic analysis used in the paper will be expanded, and a utility theory approach to benefit measure will be added. The paper identifies key data sources as Coast Guard Captains of the Port, the Council of American Flag Operators, and the Corps of Engineers. While we disagree with some of the assumptions and algorithms used, the paper provides insights into good sources of data. The analysis was simplistic and could provide a stepping stone for the more detailed probabilistic analysis of the RMT.

Classification of Aids to Navigation According to their Reliability
The Technical Committee on Reliability of Aids to Navigation
IALA Bulletin 1986/1

This paper describes methods suggested to objectively define the importance of aids to navigation. One method involves listing relevant factors and assigning importance coefficients as the basis for resource allocation. A second method used multi-criteria analysis to allocate

resources. Availability of aids was calculated as a function of Mean Time Between Failure (MTBF) and Mean Time to Repair (MTTR).

Relevance to RMT: High

Some of the modules of the RMT deal with Routine Service Demands, Servicing Alternatives, and Response Criteria. Formal reliability/availability analysis will be integral parts of these modules. The ideas cited in the above paper are directly applicable.

Cost Analysis of Contractor Serviced Aids to Navigation
Temple, Barker, and Sloane, Inc.
August 1982

This report describes a study of the feasibility of contractor vs. government servicing of offshore aids. The AtoN assets considered are limited to those serviced by 180' buoy tenders. The analysis focuses on relative costs of operations.

Relevance to RMT: High

The report describes detailed costing procedures for personnel operations, and other related costs which should prove useful as inputs to the RMT.

Discount Rates to be Used in Evaluating Time Distributed Costs and Benefits
OMB Circular A-94
27 March 1972

This circular describes standard discounting procedures to be used in evaluating measurable costs and benefits of projects or programs when they are distributed over time.

Relevance to RMT: High

Several of the MOEs in the RMT deal with dollars distributed over time; therefore, time value of money analysis is appropriate. In doing such analysis, OMB guidelines for discounting will be used.

Dod Should Defer Buying New TACAN Equipment
GAO report
12 November 1981

This report describes a review of an analysis by the Navy and Air Force to determine if a new Tactical Air Navigation (TACAN) System should be purchased. It was reviewed to determine if a reasonable method existed to measure impacts of changes in a navigation system on potential users.

Relevance to RMT: Low

While a detailed cost analysis was performed, the Navy and Air Force did not specifically identify or measure the impact of alternatives to TACAN

and thus could not complete a proper cost-effectiveness analysis.

Economic Analysis of Investment and Regulatory Decisions

FAA-APO-82-1

Federal Aviation Administration, Department of Transportation

January 1982

This handbook describes economic analysis techniques used by the FAA to analyze policy decisions. It focuses on benefit estimation, cost estimation, time value of money, and inflation effects.

Relevance to RMT: Very High

The handbook is particularly relevant to the measures of effectiveness module. The benefit analysis described for FAA includes discussion of the primary benefit areas--safety, delay reductions, and cost savings. These have clear parallels in USCG application. General discussions include judgmental models, quantification of intangibles, and life-cycle costing, all of which are applicable to the SRA system. Furthermore, time value of money analysis will be essential in assessing costs of SRA alternatives.

Economic Benefits of Improved Watertight Subdivision for Great Lakes Bulk Carriers

Department of Commerce

Maritime Administration Report #1628-2-R1

December 1978

This report describes a very detailed approach towards evaluating economic benefits/losses associated with bulk carriers. Stochastic models are used to analyze probability of accidents and utility theory is used to evaluate benefits of improved safety systems. Benefits are considered in terms of shipowners, the fleet, the government, and the public. Time value of money analysis is used to calculate Net Present Utility as an overall cost measure.

Relevance to RMT: Very High

This report offers some excellent ideas on how to model accidents and other incidents. The multi-constituency approach to benefits, along with the use of utility theory, are all planned for the RMT. The report suggests useful sources of data and provides some information on costs that can be used directly.

Economic Values for Evaluation of Federal Aviation Administration Investment and Regulatory Programs

APO Bulletin 84-3

June 1984

This paper updates economic values used by the FAA in evaluating investment and regulatory programs. It describes "critical values" denoted in

monetary terms that can be used in cost/benefit or cost-effectiveness analyses.

Relevance to RMT: Moderate

One component of RMT is value of lives lost as a result of accidents. This document provides FAA guidelines for determining the Value of a Statistical Life. Since both USCG and FAA are Department of Transportation organizations, it may be appropriate to use these value of life estimates in the RMT.

Economics of Shipping Practice and Management
(Extract of Chapter 5, "Economics of Ship Operation")

This report provides estimates based on 1980 costs for operating costs of various classes of ships. Included are fuel costs, maintenance costs, new costs, general administration costs, insurance costs, and capital costs.

Relevance to RMT: Moderate

In determining costs of delay for the MOE model, the estimates contained in this report may be reasonable approximations for the specified classes of vessels.

Feasibility Study for Remote Monitoring of Lighthouses
14th District
18 December 1985

The purpose of this study is to determine if Remote Control and Monitor Systems (RCMS) is a feasible alternative for lighthouse control. The study includes a review of capabilities of RCMS impacts on discrepancy response, impacts on costs, and impacts on billets.

Relevance to RMT: Low

This study was reviewed to determine if an adequate methodology was used to evaluate impacts on the AtoN system that could be transferred to the Resource Management Tool. Reliability levels of the lighthouses were so high already that it is unlikely that significant impact on the SRA system can be detected. The issue basically becomes a cost issue only.

Good Intentions about Long Range Planning for Short Range Aids to Navigation
LCDR Robert Armacost
February 1977

This report provides a good review of the planning and budgetary processes that have evolved within the USCG. It discusses problems in planning, benefits assessment, and program implementation, and provides an action plan for modifying the planning and budgetary process.

Relevance to RMT: Moderate

The report provides an overview of previous resource management approaches and presents insights into why some failed. It also provides a good reference list of documents that should be reviewed for the RMT project. It does not, however, offer solutions to the problems of quantifying the benefits that have been difficult to deal with in the past.

Mission Need Statement (MNS) for the WLB/WLM Capability Replacement
Memorandum
27 March 1985

This memo provides an excellent statement of needs for a replacement to the WLB/WLMs. It describes tasks, missions, and characteristics of the capability that is needed. In particular, it gives estimates of usage in multi-mission roles.

Relevance to RMT: High

In particular, the decision to replace a specific cutter is a candidate decision for analysis using the RMT. The memo provides good descriptions of multi-mission roles, and provides estimates of average hours and sorties spent in various roles as well as monetary implications of these actions. These data can be used as surrogates for measures of effectiveness. Unfortunately, in discussing the value of meeting the need, the effects on the SRA system are described in vague generalities and are not specific enough for use in the RMT.

Mobile Ship Channel - Waterways Analysis and Management
Eighth Coast Guard District
4 February 1985

This document describes a WAMS analysis for the 8th CGD. It includes a description of waterway users, critical areas, and the aids to navigation system. The major emphasis is on the adequacy of the waterway aid system and on the projects recommended to improve it.

Relevance to RMT: Low

While this report provides a good description of the Mobile Ship Channel, there is very little in it that is generic enough to be of value in the MOE module. There is no discussion of benefits associated with the proposed projects, and not enough data to develop detailed accident models.

Prototype Waterways Analysis of Green Bay, WI
9th District
19 March 1985

This report documents a first attempt at a WAMS analysis for one of the critical waterways in the 9th District. This particular waterway was deemed to have the least adequate AtoN system.

Relevance to RMT: High

The WAMS analysis for critical waterways can provide valuable input into the RMT. Part of the 9th District's WAMS included a Corps of Engineers Environmental Impact Statement, and several memoranda that provided insight into characteristics, problems, and proposed solutions associated with the waterway. While general data appear to be readily available, there is nothing to indicate the specific impact of actions taken on users of the waterway.

Quantification of A/N Benefits

Memorandum

17 December 1980

In this memo from USCG Chief of Staff to Chief, Office of Navigation, several references are presented that describe approaches to quantifying dollar benefits of the AtoN program.

Relevance to RMT: High

Of particular interest are the following reports which will be obtained for further review:

- *Harbor Development*, Corps of Engineers, May 1966;
- *Postulated Benefits Resulting from Long Distance Maritime Aids to Navigation*, National Navigation Planning Staff, July 1968;
- *Study of Maritime Aids to Navigation in the Short Distance Maritime Environment*, Geonautics, Inc., February 1969.

These references may prove valuable in modeling economic impacts of AtoN decisions.

RCP Data Workbook

U.S. Coast Guard

October 1984

This workbook provides guidelines for preparing resource change proposals (RCPs) by USCG planners. It contains descriptions of the RCP scoring system, tables of codes used in filling out forms, and examples of the scoring process.

Relevance to RMT: High

Many candidate decisions that are applicable for the RMT are those that would require an RCP. This handbook provides insights into the analytical processes that planners currently use, to include MOEs, methods of stating benefits, and approaches to costing. Much of this is directly applicable to the RMT. It addresses only benefits and costs from the USCG perspective and makes few inroads into measuring impacts on the rest of the system.

Short Range Aids to Navigation Study
June 1983

This document provides a detailed and comprehensive description of each geographical segment of the AtoN system. For each area, there is a description of aids; a description of the servicing units, requirements and costs; a discussion of system planning factors; and a detailed analysis of system alternatives and their corresponding costs.

Relevance to RMT: Extremely High

This document, when coupled with trip reports for visits to the districts, provides a complete discussion of district-by-district (or at least segment-by-segment) differences. These differences will be the basis for tailored versions of the Measures of Effectiveness Model in the Resource Management Tool. The factual information contained in this report will be exceptionally useful in developing subcomponent models.

Short Range Aids to Navigation Systems: Design Manual for Restricted Waterways
June 1985

This manual provides procedures for designing or evaluating systems of aids in restricted waterways navigated by deep draft vessels. It can be a useful tool in preparing a WAMS analysis, and can be used to evaluate directly specific configurations of aids. The primary output of the design is a Relative Risk Factor (RRF) that provides a subjective (but quantified) assessment of risk.

Relevance to RMT: Very High

The relative risk factor is a good approach towards probabilistically evaluating specific configurations of aids in a given waterway. In developing a Resource Management Tool, we will attempt to use the RRF either directly or as an indirect input to several component modules. These include the discrepancy response module, the servicing policy module, and perhaps the platform module. At a minimum, the RRF analysis will provide insight into the probabilistic models needed for each component module.

Short Range Aids to Navigation
Program Plan FY 83-92

The document describes the complete SRA program as proposed for years 83-92. It develops objectives and sub-objectives, goals and milestones for all aspects of the SRA system. Additionally, it provides standards against which progress towards milestones can be evaluated. It also identifies areas in which R&D expenditures might be most fruitful.

Relevance to RMT: Very High

This report describes many of the programmed decisions that are viable candidates for analysis using the RMT. It provides excellent insights

into the rationale behind proposed programs, and begins to address the components of benefit associated with each.

Sponsor's Requirements Document: Buoy Boat (Draft)
Undated

This report describes requirements for a replacement buoy boat. It identifies operational needs as well as tradeoffs required in providing transportation and servicing capabilities for Aids to Navigation Teams (ANTS).

Relevance to RMT: Low

This report was reviewed in an attempt to gain insight into the tradeoff process currently used by the USCG. The Buoy Boat decision could be a candidate type of decision for which the Resource Management Tool could be useful. Unfortunately, the report merely states detailed specifications and has no discussion of tradeoffs or impacts on the AtoN system if the requirements are not met.

SRA - A Logical Model Representing SRA-Mission Command and Control
Technical Memorandum 4.8
23 September 1983

This report documents a research project that used structured analysis as a tool for requirements definition and systems specifications. The focus was on C² functions, and the project attempted to depict C² operations in terms of data flows into the system, data files, data processing of external source data, and data out of the system. Information requirements for various missions were examined to include SAR, ELT, PES, MER, SRA, IO, and WMM.

Relevance to RMT: Moderate

The logical model is too low a level of detail to be directly applicable to the RMT. However, there will be detailed models for discrepancy response, servicing policy, etc. in the RMT. These models will include detailed probabilistic models of impacts on the SRA system. The logical model may be somewhat useful in developing these probabilistic models by identifying the key uncertainties.

Transportation Lines of the United States
Corps of Engineers
Report WRSC-TL-83 & 84
July 1985

This volume contains information on all American flag vessels operating or available on 1 May 1983. It contains data on vessel characteristics, transportation lines, cargo capacities, etc.

Relevance to RMT: High

In the MOE model, we will be evaluating economic consequences of accidents and delays. This manual will be extremely useful in approximating the vessel characteristics needed to prepare a detailed probabilistic cost model.

Waterborne Commerce of the United States
Dept. of the Army, Corps of Engineers
WRSC-WCUS-83-1,2,3,4,5
1983

These volumes provide detailed information on commercial vessel traffic by geographical region of the US. It provides passenger, tonnage, and commodity data for major harbors and waterways, and also provides traffic breakout by type of vessel.

Relevance to RMT: Very High

These data will be used to calculate expected values of delays in transits as well as expected values associated with collisions/groundings. This could be done on a waterway-by-waterway base, or by aggregating across waterways and using nominal or average values in our MOE model.

Waterways Analysis and Management System (WAMS)
Commandant Instruction 16500.11
4 September 1984

The WAMS instruction defines a standard approach to be used in analyzing aids to navigation systems. The focus is on the individual waterway and its aids to navigation system rather than on individual aids. WAMS defines requirements, deficiencies, and resources required. It provides for a decentralized analysis of the system by field unit commanders.

Relevance to RMT: Very High

WAMS analyses will be used to identify unique features of waterways and districts. The proposed MOE model will be tailored to reflect differences in districts, and the WAMS reports will be a primary reference. Of particular interest are multi-mission assignments, mission effectiveness of each class of servicing platform, performance standards, and criticality of waterways.

Other Studies/Reports Reviewed

Additional Billet in 14th District Aids to Navigation Branch, February 1983

Aids to Navigation in the Deep Draft Waterway Complex Leading from the Gulf of Mexico to Baton Rouge, 8th CGD, January 1981.

A/N Positioning, Briefing to Admiral Stewart by D. Nelson, 11 August 1977.

Audit of Maintenance of Navigational Aids, USCG, Boston, MA, Office of Inspector General Report RI-CG-4-053.

Coast Guard Action Needed to Promote Safer Marine Transportation (Comptroller General Report CED-79-37), May 21, 1979.

The Coast Guard IRM Architecture (Draft), 18 April 1986.

The Coast Guard's Programs of Aids to Navigation Along Louisiana's Coast could be more Effective (Comptroller General Report CED-80-58), 11 April 1980.

The Economics of Deepwater Terminals, Department of Commerce, 1972.

Fisheries of the US, 1984, US Department of Commerce, April 1985.

Great II - Upper Mississippi River: Main Report and Executive Summary, Great River Environmental Action Team, December 1980.

Information on the USCG Decision to Purchase the M/V Cowslip Vessel (CED-81-128), General Accounting Office, June 25, 1981.

Information Requirements Analysis of Coast Guard Operating Systems, Advanced Technology, 10 September 1985.

The Lighthouse in Economics, R.H. Coase, *The Journal of Law and Economics*, Volume 17, 1974.

Management Information in the Coast Guard (Thesis), Stephen Masse, August 1971.

MSIS Data Dictionary on the Automated Office System, USCG Manual, April 1986.

Port Series Reports, Corps of Engineers Water Resources Support Center.

Report on the Activities of the Technical Committee on the Reliability and Availability of Aids to Navigation, XIth Conference of the International Association of Lighthouse Authorities, 1985; and *IALA Technical Committee Update*, Harley Cleveland, 1986.

Safety at Sea - Its Risk Management, I.C. Clingan, Paper presented at 1985 IALA Conference.

Ship Handling in Narrow Channels, Carlyle Plummer, 1978.

Study of Great Lakes Vessel Casualties and the Impact of Proposed US Coast Guard Stability Requirements, Marine Consultants and Designers, Inc., September 29, 1983.

Transportation Statistical Reference File (DOT) - Users Manual, June 1983.

US Oceanborne Foreign Trade Routes, DOT Maritime Administration, June 1985.

Use of Basswood and Articulated Beacons in 14th CGD, 14 September 1985.

3.2 Field Visits and Interviews

During Task 1, the Mandex/DSC/PharoLogic team visited all USCG districts shown in Figure 3.1 except the 11th. (This district was not visited due to its limited AtoN role and its similarity to other districts.) The purpose of these visits included the following:

- to determine what was unique about each district;
- to determine how potential MOEs might differ among districts;
- to determine availability and sources of data;
- to meet with USCG and other personnel to include pilots' associations, port authorities, shippers, maritime groups, other industry groups, Corps of Engineers personnel, etc. that have specific interests in the AtoN systems;
- to gain familiarity about Coast Guard operations in general and short range aids to navigation in particular;
- to ensure that specific concerns of each district were considered in the overall resource management tool.

Additionally, several visits were made to various offices at Headquarters, USCG, as well as to other groups in the Washington, D.C. area (e.g., Corps of Engineers, pilots' associations, Department of Justice).

The field visits and interviews are documented in trip reports found in Appendix A. Results of these visits helped to tailor the MOEs described in Section 4, and will serve as a basis for modules that will be developed in later tasks.

U.S. Coast Guard Districts

Pacific Area
COMPACAREA

Atlantic Area
COMLANTAREA

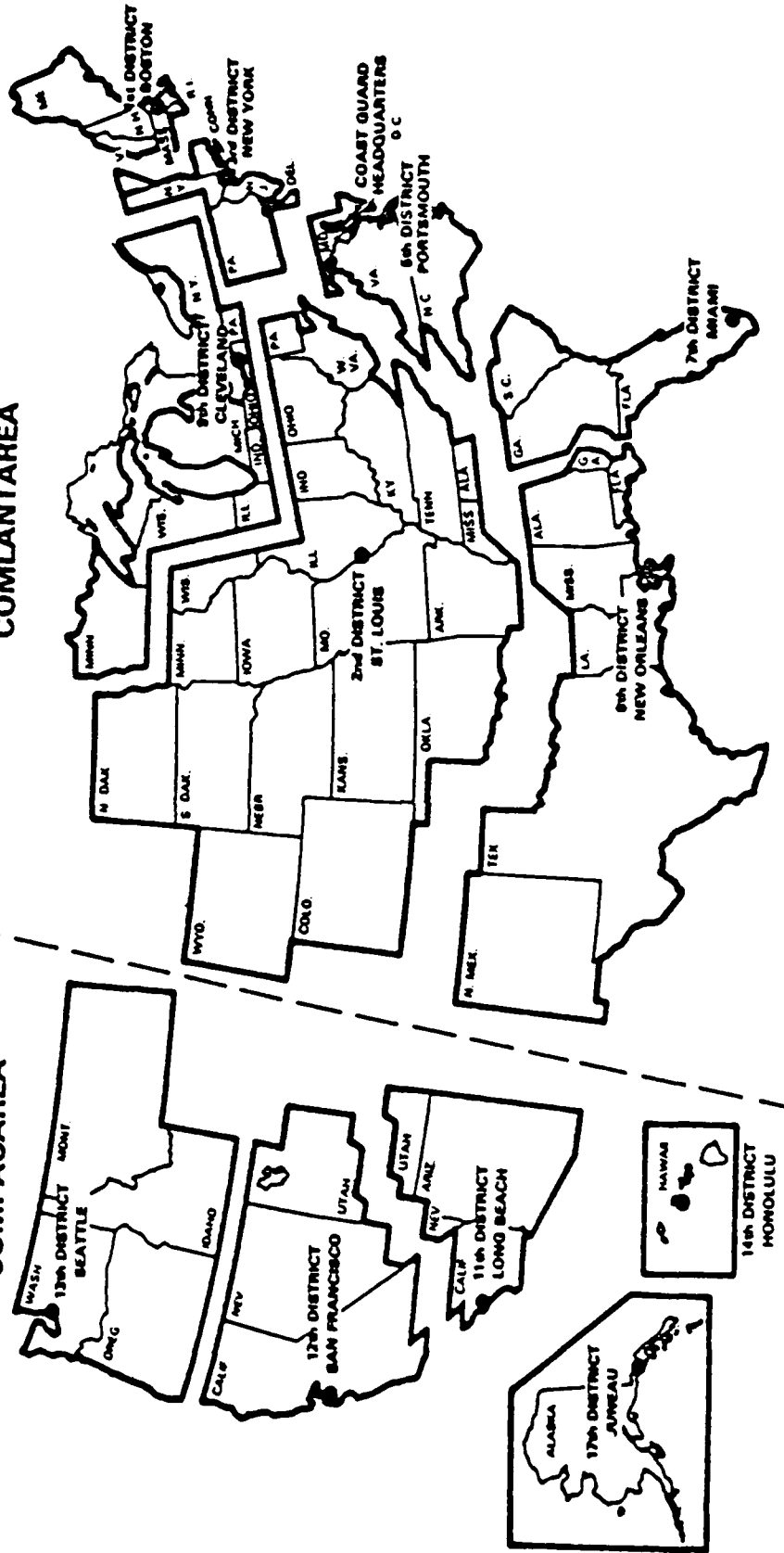

Figure 3.1

3.3 Data Search

As part of the literature review, district, and Headquarters visits, we continually probed for availability of databases, both internal and external to the Coast Guard. In general, we found that there were only limited sources of safety data, and those that were available will require significant analysis and transformation to be usable by the Resource Management Tool. There was a much richer foundation for sources of economic data, particularly in documents prepared by the Corps of Engineers and by port authorities. More detailed descriptions of these data sources are given in Section 4.4.

3.4 MOE Development

In preparing the MOE structure described in Section 4, we used an iterative process that began with a broad context for MOEs and ended with a concise set of discriminating measures. Initially, we developed a long list of potential MOEs that was unconstrained by data availability, criteria independence considerations, or even specific bases for measurement. With each district visit or document reviewed, new insights were gained that allowed us to consolidate, refine, and extend the structure to be more representative of what was needed to address the candidate decisions. This "pruning" and consolidation process is described in Section 4.2.3, and the current set of MOEs represents a set of factors that is comprehensive yet compact, measurable, obtainable, independent, and sensitive to differences among decision options. While the MOEs are presented here as a "final" model, we anticipate that as Tasks 2 through 9 are completed, the MOE model will continue to be iterative and will be modified as appropriate.

4. MEASURES OF EFFECTIVENESS

4.1 Overview

Task 1 involved identifying measures of effectiveness (MOEs) appropriate for characterizing SRA resource decisions. To quote from the Statement of Work:

The purpose of this task is to develop a measure or measures by which the operation of the SRA program can be valued. These measures should belong to one of two general classes; those judging the product, output, or usefulness of our program, and those measuring the costs or inputs needed to achieve them. The MOEs dealing with our program product must include some quantitative assessment of the SRA system's effectiveness in facilitating safe, expeditious marine transportation. Some findings from the ongoing Waterways Performance Study, dealing with risk assessment in waterways, should contribute to this effort.

At this point, we are not so much interested in a measurement of system effectiveness as in a means to measure. This means is to be used in the succeeding tasks to evaluate alternatives, and select those deemed the best.

This section describes the results of the process to identify MOEs. Section 4.2 describes key issues in the development of MOEs. Section 4.2.1 illustrates some of the types of resource management decisions that will be able to be evaluated using the MOEs. Section 4.2.2 describes the criteria used in the final selection of MOEs. Section 4.3 gives the description of all MOEs. An overview of the measures is provided in Section 4.3.1, and detailed descriptions are provided in Section 4.3.2. This latter section also describes some of the ways that the measures might be modeled in the Resource Management Tool (RMT) to be developed in Tasks 2-9. Data sources that could be used to estimate MOEs are reviewed in Section 4.4.

4.2 Key Issues

4.2.1 Illustrative resource management decisions. The tool to be developed in this project will assist Coast Guard managers in making a variety of resource management decisions. These decisions will be in the general

areas of: routine service demands, platform capabilities, response criteria, servicing alternatives, staffing levels, multi-mission effects, and radio aid/short range aid tradeoffs. While these areas will be explored in depth in Tasks 2-8, several of the types of decisions for which the Resource Management Tool is useful have been identified. Illustrative of these decisions are the following:

- distributing a funding reduction (e.g., a Gramm-Rudman 5% cut);
- decommissioning or transferring a buoy tender (e.g., WALNUT or HOLLYHOCK);
- changing the number of aids in a waterway (e.g., a 20% cut in New York harbor, adding ranges to the Mississippi River-Gulf Outlet (MRGO), adding racons to 10 identified aids);
- switching to a new technology (e.g., the previous decision to use solar energy, the expanded use of articulated beacons, or the introduction of a new minor light or new buoy equipment);
- adopting new electronic and positioning systems (e.g., Loran-C for Harbor and Harbor Entrance (HHE) Navigation or Automated Aid Positioning System (AAPS));
- changing force levels (e.g., reducing personnel on WLBs by 10% or reducing the size of ANTS by 10%, reducing Headquarters staff by 15%);
- changing major maintenance programs (e.g., slipping the Service Life Extension Program (SLEP), doubling the number of lighthouses reconditioned each year);
- changing the discrepancy response policy (e.g., changing the HIGH PRIORITY response time from 18 hours to 24 hours);
- changing equipment specifications (e.g., reducing the intensity of lights, increasing the reliability of flashers);
- eliminating a class of aids or signals (e.g., eliminating the fog system);
- changing tender areas or missions (e.g., soft district boundaries, multi-district discrepancy platforms);
- eliminating an item from the supply system (e.g., eliminating type C photocells and replacing type Cs by type Rs);
- changing training and professionalism levels.

4.2.2 Criteria for selecting measures of effectiveness. During the initial phase of this task, little effort was made to eliminate potential MOEs from the evaluation structure. Rather, the approach was initially to include a wide set of MOEs with little regard for whether or not data were available, the MOEs could be measured, etc. This approach provided a rich menu of potential MOEs that could later be pruned after visiting all districts and gathering as much information as possible. This ensured that no MOEs were eliminated prematurely.

Midway through Task 1, it was clear that the set of MOEs as they were then framed was too large, had too much double counting and overlap, and had many factors that had no apparent metric. The next step in the process, therefore, was to develop a set of criteria that could be used to eliminate MOEs that were not useful and to retain those that would serve to evaluate the range of decisions for which the Resource Management Tool is being developed. These criteria are as follows:

- *Measurable:* Can a suitable metric be found that will allow measurement on a quantitative basis? Ideally, all MOEs would be expressed in terms of dollars (e.g., dollar value of accidents, costs of delays in shipping). However, it is recognized that many MOEs may not have a logical dollar measurement and need to be treated differently (e.g., pressure brought to bear by historical preservation societies). For such factors, often referred to as intangibles, relative "utility" measures will be used that allow comparison of alternatives.
- *Obtainable:* Can necessary data and judgments be found or estimated in a logical fashion? While an MOE may be measurable, such as cost of accidents, there may be insufficient data available to make reasonable judgments. For an MOE to be included, it must be clear that such information is obtainable either in the form of hard data or subjective estimates from experts.
- *Sensitive:* Is the MOE capable of distinguishing among alternatives? There is no advantage in including an MOE that is completely insensitive across a range of decision alternatives. On the contrary, the purpose of the Resource Management Tool is to discriminate among potential decisions in staffing, platform configuration, servicing policies, etc.
- *Independent:* Does the MOE measure a unique aspect of the evaluation that is not included elsewhere? Often, it is difficult to avoid double counting and overlap among the MOEs. Lack of independence among MOEs can be treated by eliminating some MOEs or by combining the dependent MOEs into new composite MOEs that are independent.

- *Comprehensive yet compact:* When all MOEs are put together in an evaluation hierarchy, do they account for most of what is important? Is the evaluation structure too complex, cluttered, and unwieldy? Often, for the sake of completeness, the set of MOEs includes far too many factors that do not add to the ability to discriminate among alternatives. Just as often, many critical factors are inadvertently not concluded that are of great importance in differentiation. In selecting appropriate MOEs, these conflicting goals (comprehensive vs. complete) must be balanced carefully.

4.3 Descriptions of Measures

4.3.1 Structure of the model. The model of measures of effectiveness is structured around the categories of benefits and costs that are important to the Coast Guard. The basic structure of the model is shown in Figure 4.1. A net assessment of any SRA resource decision balances the benefits of the decision against its costs. In order to estimate the impacts of decisions, the main categories are subdivided as shown. Benefits are divided into the general categories of benefits due to improved safety, benefits due to enhanced timeliness, and other benefits. These, in turn, are subdivided as follows:

- Safety benefits are subdivided into economic benefits of increased safety and benefits of increased personal safety;
- Timeliness benefits subdivided into those related to the operation of the ship and consignor or consignee benefits due to savings in shore-based costs;
- Other benefits are subdivided by the party that benefits: mariners, the Coast Guard, other government agencies, or the general public.

Costs are similarly divided into costs to the Coast Guard and other costs to the federal government, which are subdivided as:

- Coast Guard costs are subdivided into operating expense (OE), capital costs (AC&I), and research and development costs (R&D);
- Other costs to the federal government are subdivided into costs of litigation and other costs.

In the full model, categories are further subdivided. For example, economic safety benefits are subdivided by the affected party into: commer-

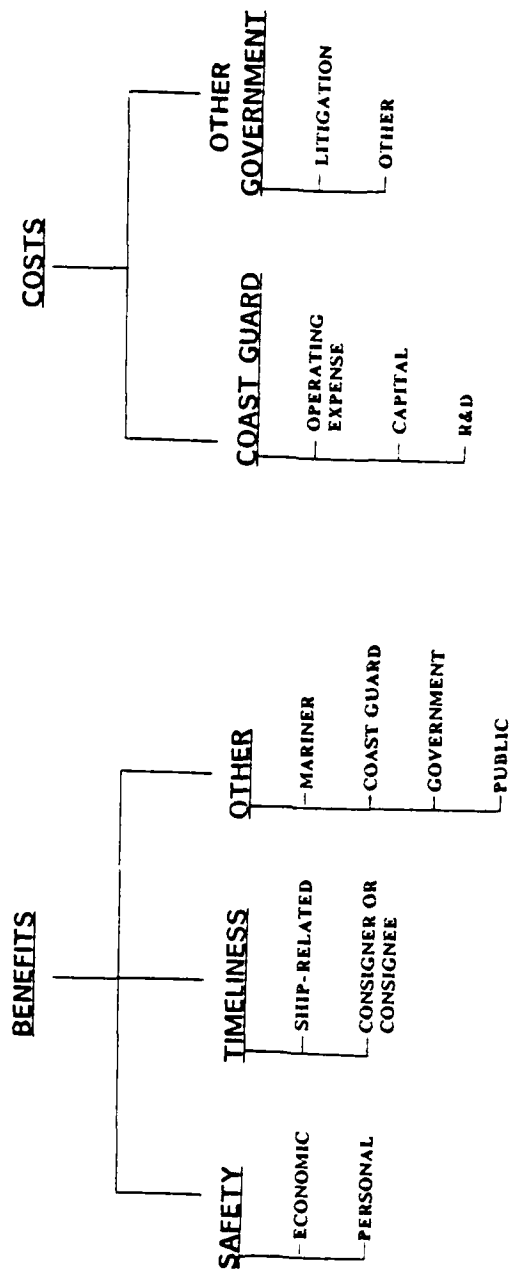

Figure 4.1: Structure of the MOE Model

cial mariners, recreational boaters, governmental users, and the general public. This subdivision allows for better estimation and modeling of the impacts of various decision alternatives, but it creates a complexity that makes the display of the model difficult. For this reason, an outline structure was created to represent the entire MOE model. By following the numerical code associated with each node in the structure, the "path" to each MOE can be traced. This structure is displayed in Table 4.1. The detailed discussion of the measures in Section 4.3.2 is organized around this outline structure.

4.3.2 Detailed descriptions. The following paragraphs provide detailed descriptions of the measures of effectiveness. Each measure is described and possible methods of modeling or otherwise assessing performance of decision options against the measure are discussed. Data sources relevant to the measure are also discussed. In some cases, the discussion of data sources is somewhat speculative, but it is always based on at least fragmentary information or opinions collected during interviews. In addition, measures in the "Other" category generally are less tangible factors with fewer sources of data. A fuller discussion of major data sources is given in Section 4.4. The primary goal of Task 1 was to identify and define measures of effectiveness so as to provide a means to measure the effects of SRA resource decisions. Identification of data to actually do the measurement was clearly secondary. For this reason, the review and identification of data sources is considered preliminary. More extensive data source development work will be accomplished as models are actually built to address SRA resource areas during Tasks 2-8.

Not all of the measures identified in this model will be important or even applicable to all decisions. This has two important impacts on the use of the MOEs. First, measures that are not applicable to a decision, either because they are not impacted or because they are affected equally by all decision alternatives, need not be assessed. They are addressed in the model by assigning tradeoff weights of zero (see discussion below). Second, the appropriate level of detail for modeling will vary. In general, less detailed models will be required for less important measures, since errors of modeling or approximation for these measures will have less impact on the evaluations of alternatives.

Table 4.1: Outline Structure of MOEs

- 1 Benefits
 - 1 1 Safety
 - 1 1 1 Economic Considerations
 - 1 1 1 1 Commercial Users
 - 1 1 1 2 Recreational Boaters
 - 1 1 1 3 Government Users
 - 1 1 1 4 General Public
 - 1 1 2 Personal Safety
 - 1 1 2 1 Commercial Users
 - 1 1 2 2 Recreational Boaters
 - 1 1 2 3 Government Users
 - 1 1 2 4 General Public
 - 1 2 Timeliness
 - 1 2 1 Ship-Related Costs
 - 1 2 2 Consignor or Consignee Costs
 - 1 3 Other Benefits
 - 1 3 1 Mariner Interests
 - 1 3 1 1 Non-Accident Costs
 - 1 3 1 2 User Satisfaction
 - 1 3 2 Coast Guard Interests
 - 1 3 2 1 Multimission Capability
 - 1 3 2 2 Organizational Impact
 - 1 3 2 3 Standard Measures of Performance
 - 1 3 3 Other Government Interests
 - 1 3 3 1 International
 - 1 3 3 2 Federal Government
 - 1 3 3 3 State/Local Governments
 - 1 3 4 Public Interests
 - 1 3 4 1 Economy
 - 1 3 4 2 Environmental
 - 1 3 4 3 Historic Preservation
- 2 Costs
 - 2 1 Coast Guard Costs
 - 2 1 1 Operating Expense (OE)
 - 2 1 2 Capital Costs (AC&I)
 - 2 1 3 Research and Development Costs (R&D)
 - 2 2 Other Federal Government
 - 2 2 1 Litigation
 - 2 2 2 Other

For the most part, the following paragraphs discuss individual measures and how they might be estimated in an application of the tool. Another important feature of the tool is the ability to combine estimates on different measures into summary measures on overall or intermediate measures. For example, "Ship-Related Costs" and "Consignor or Consignee Costs" can be combined into the intermediate measure "Timeliness." Similarly, "Safety," "Timeliness," and "Other Benefits" can be combined into the overall measure of "Benefit." The method of combination is through the use of "swing weights" to compare the importance of variation on one measure of effectiveness with the importance of variation on another measure of effectiveness (see Appendix B for a more complete discussion of swing weights). Swing weights allow the model to be refined and customized for any given application, for example to accommodate changes in priorities. Some of the tradeoffs can be built into the tool or developed on a parametric basis. For example, in the comparison of annual operating expense (Measure 2.1.1) and capital costs (Measure 2.1.2), it is appropriate to use the technique of discounted cash flow (or, equivalently, annualization). This is accommodated in the model by having the weight reflect the discount rate (e.g., 10%) and the time horizon. Swing weights also allow for the differential treatment of different factors that are measured in the same units. For example, a dollar of economic safety loss to a commercial mariner could be valued at more, or less, or the same as a dollar to government users. This method also allows a comparison of factors that are measured in different units (e.g., dollars, injuries) and a comparison of intangible factors that lack convenient units of measurement (e.g., organizational impact, historic preservation). More specific tradeoff weights will be developed in the application of the MOEs to SRA resource decision areas in Tasks 2-8. These developments will be incorporated into the final development of the tool in Task 9.

The following discussions are generally more detailed for the measures of benefits, since most of the costs are currently estimated in the Coast Guard budgeting process. For these costs, the tool will utilize the present methods of assessment.

Measure 1.1.1.1 Economic benefits of safety for commercial users. This attribute measures the direct and indirect economic benefits that accrue to

commercial users with a change in safety. These benefits typically will include the dollar value of lost or damaged cargo, damage to the vessel, increased insurance costs, clean-up costs, and the cost of temporarily replacing lost cargo capacity. (If insurance costs are included, then only the uninsured portion of the actual losses is considered.) They also include, where applicable, the costs of delays due to an accident, such as delays caused by a blocked or closed channel. Safety benefits (or disbenefits) are the costs avoided (or incurred) as a result of the reduction (or increase) in accident frequency resulting from an SRA resource deployment. Effects of all types of accidents (e.g., groundings, collisions, rammings) are included. Effects on all types of commercial vessels (e.g., cargo carriers, fishermen, charter and cruise boat operators) are included.

Possible Models. This attribute may be modeled in a number of different ways, depending on the level of detail required to evaluate the alternatives. Conceptually, though, this attribute is modeled by:

$$\Sigma \text{ Number of accidents} \times \text{Cost per accident.}$$

That is, a summation of the number of accidents times the cost per accident. The summation is over any and all conditions that are appropriate for the evaluation and that are distinctive. For example, if an alternative being evaluated could be expected to affect uniformly the number of accidents (e.g., to reduce the number by 10%) but leave the cost per accident unchanged, then an aggregate description of each factor (possibly in the form of overall probability distributions) would be sufficient. Such an aggregated model might also be necessary if more detailed information is unavailable and cannot be estimated.

For some evaluations, disaggregations will be appropriate. In these cases, the summation might be over such features as:

- the type and severity of accident;
- the type and value of cargo;
- the type of vessel;
- environmental conditions.

These features could be identified for several reasons. First, each factor could exhibit a markedly different number and cost of accident. Second, it could be possible to estimate these different numbers and costs. Third, the proposed action being evaluated could affect different conditions differently. For example, it might only affect very severe groundings or only affect containerized cargo vessels, or only vessels over 20,000 dead weight tons, or only in foggy conditions. In this case, it will be much easier to assess the effects of the action if those assessments are made conditional on the right set of factors. Completeness is then ensured by the summation. (Note that summation is used in the general sense and includes integration over continuous variables.)

Examples of possible conditional inputs are shown in Figure 4.2. Cost per accident in dollars is shown as a conditional probability distribution where the conditioning is on type of vessel. These inputs would be made based on accident data (possibly modified by judgment). (A given analysis may use measures of central tendencies of the distributions, such as means or medians, or it may include measures of dispersion as well, such as standard deviations, or the whole distribution might be used. See Appendix C for additional discussions of the possible ways in which probability distributions may be used in the analysis.)

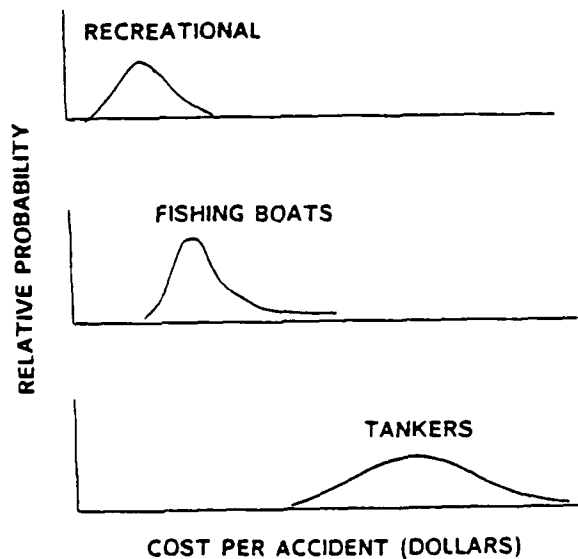

Figure 4.2: Illustrative Cost Per Accident

Since accident cost data are sketchy in the CASMAIN database, this estimate will require adjustment. Adjustments may be sought from U.S. Coast Guard personnel or may be obtainable from insurance companies or shippers. Additionally, distributions may be more readily estimated if conditioned on other factors as well. Data on cargo movements are contained in *Waterborne Commerce of the U.S.*, *Commodity Movement Annual*, and *U.S. Oceanborne Foreign Trade Routes*.

The number of accidents may also be modeled at a number of different levels depending on the level of detail required by decisions being evaluated. One promising possibility is to tie this estimate to transits as follows:

$$\text{Number of accidents/year} = \Sigma P(\text{accident per transit}) \times \text{Number of transits/year}$$

where $P(\text{accident per transit})$ is the probability of an accident per transit. This formulation may be especially good if evaluations are made on the basis of a waterway. In this case, $P(\text{accident per transit})$ could be estimated using both historical information to provide a base rate and the Relative Risk Factor (RRF) (see the *Design Manual for Restricted Waterways*, 1985) to adjust the base rate for the resource management decision. Number of transits per year can also be estimated from data, possibly adjusted by estimates of general economic activity or anticipated port-specific changes. Summation is again over all conditioning factors, such as waterways.

In cases where a resource management decision will have a major effect on aid discrepancies (including, but not limited to, the frequency of discrepancies or the length or type of discrepancy), it may be appropriate to model at the level of aid discrepancies. This could be accomplished by the conditional probability tree shown in Figure 4.3. With this model, the probability of accident per transit is calculated as:

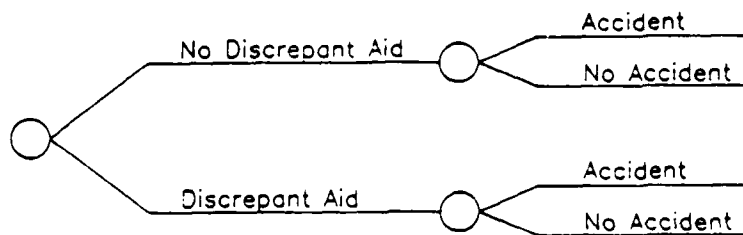

Figure 4.3: Conditional Probability Tree

$$P(\text{accident per transit}) = P(\text{no discrepant aid}) \times P(\text{accident given no discrepant aid}) + P(\text{discrepant aid}) \times P(\text{accident given discrepant aid}).$$

This is a form that also lends itself to estimation using historical data on accident frequencies and the relative risk factor. For example, $P(\text{accident given no discrepant aid})$ could be based on base rate data (possibly with adjustments). The Relative Risk Factor (RRF) could be used to estimate the change to $P(\text{accident given discrepant aid})$. At a first pass, the RRF could be used directly to update for discrepancies by treating them as a different aid configuration (e.g., a light out in a 3-buoy turn might be treated as a two-buoy turn). This might then be adjusted for features that increase or decrease the hazard (e.g., adjusting for the fact that the third buoy is still there). This form of representing $P(\text{accident per year})$ also relates naturally to such information as reliability and aid restoration time, which will be available from ATONIS. For example, $P(\text{discrepant aid})$ could be estimated from reliability data for a given type of discrepancy and the fraction of total available transit time in a year that it takes to restore the aid. This formulation might also distinguish between aids to navigation in critical and non-critical waterways and provide detailed modeling only for aids in critical waterways.

Measure 1.1.1.2 Economic benefits of safety for recreational boaters.

Recreational boaters may also be affected economically by a change in safety. This criterion considers only the economic effects associated with the vessel and equipment. This factor does not reflect safety effects associated with injuries or death, which are covered by Measure 1.1.2.2.

We expect that for most SRA resource decisions the economic safety benefits for recreational boaters will be small compared with other economic effects. Although there are many more recreational than commercial boaters, recreational vessels generally have shallower drafts and are less valuable (especially considering cargo value). This indicates that the factor could be treated in a much more aggregated way than economic benefits for commercial users. For example, for most decisions, we expect that a single distribution on recreational boat cost given an accident could be combined with an overall assessment of how the probability of accident would change. Data from the Boating Accident Reporting System is probably adequate. Additionally, since most SRA assets are for the primary benefit of commercial users and since recreational boaters make little use of many of the important commercial channels and waterways, in some evaluations, results may be insensitive to this criterion.

Measure 1.1.1.3 Economic benefits of safety for government users. Many government-owned and government-operated vessels operate in waters that are marked by the AtoN systems. These include vessels of the U.S. Navy, the Military Sealift Command, the National Oceanic and Atmospheric Administration (NOAA), the U.S. Army Corps of Engineers, state and local governments, and others. Economic benefits of safety for these users could include the cost of vessels, equipment, and the cost of temporarily replacing the resource. Many of the aids to navigation that the Coast Guard maintains were established at the request of U.S. government bodies, and government vessels make extensive use of the system, especially in selected locations such as the vicinity of major Navy bases.

In cases where government vessels are significant users of the aids to navigation affected by a decision, this measure might be modeled in much the same way as commercial mariners (Measure 1.1.1.1). That is, the model may need to be fairly disaggregated. In cases where government vessels are not as important, a highly aggregated model would be appropriate.

CASMAIN, a Component of the Marine Casualty Information Reporting System, is an important source of data on accident frequency (for accidents that are investigated by the Coast Guard). Other information, such as number of tran-

sits and the value of vessels, is likely to be dispersed, possibly by user, difficult to obtain, and at least partially classified. We have not identified the sources for these data. USCG data, adjusted by judgment to reflect the portions of missing data, are probably the best that are readily available. For more important decisions, it may be worth seeking better data directly from the affected government user. If the effect of a decision could be adverse, the user may volunteer data that show why the decision should not be taken (such data, of course, will need to be reviewed closely for reasonableness).

Measure 1.1.1.4 Economic benefits of safety for the general public. The general public may be affected economically by maritime safety. Such costs include, for example, costs to damaged bridges, piers, and other structures due to rammings, costs of damaged buildings due to explosions or fires (for instance in an LNG accident), and costs of environmental clean-up beyond those borne by the shippers.

It is likely that this measure will be best modeled at two levels. A highly aggregated model, for example using composite distributions for the overall system, will be appropriate for most evaluations, especially ones that apply system-wide. A detailed model will be appropriate for evaluations of resource decisions that are of limited scope but could have catastrophic consequences, for example decisions that could affect LNG safety.

Data needed for this measure are of two types, "normal" accident data and catastrophic data. CASMAIN contains a limited amount of data from which the distribution of "normal" accident costs might be estimated. However, these data are incomplete. They might be supplemented with information from local governments, port authorities, or insurance companies, but we have not confirmed the availability of this supplementary information. If data are incomplete or otherwise not fully representative (which appears to be the case), then either supplementary information or judgment should be used to correct this shortcoming.

Data on catastrophic accidents are much more limited or nonexistent (e.g., there has been no major LNG accident). For the most catastrophic pos-

sibilities (e.g., LNG tankers), estimates have been made of possible consequences and have been reported in official documents such as Environmental Impact Statements. In addition, the most catastrophic possibilities have been the subject of independent estimation reported in the general literature. These sources might be used to provide estimates [e.g., McMullen, 1979 for information on the Point Conception LNG Site].

Measure 1.1.2.1 Personal safety benefits to commercial users. This attribute measures the costs in human terms resulting from changes in safety of crew and passengers of all classes of commercial vessels. Key among these effects are injuries and deaths, but other factors such as lost workdays and increased medical or insurance costs are reflected as well.

The basic modeling approach is similar to that used for economic benefits of safety, namely, the model considers the chances and consequences of an accident. As with all other MOEs, the level of detail in the modeling will depend on the decision being evaluated. For many decisions, the level of detail and modeling approach will be similar to that used for measuring economic benefits. For example, a model may sum the products of the probability of an accident times the number of deaths and injuries for each condition used in the economic analysis, as explained above for Measure 1.1.1.1. On occasion, it may be necessary to redefine some condition to better address personal safety. For example, if certain kinds of accidents produce severe economic consequences but minor personal safety consequences, then these accidents would not be included among "severe accidents" for purposes of a conditional probability estimate of personal safety benefits.

Deaths and injuries are the primary measures of this criterion and they will be used to characterize effects of decisions. However, to determine the overall evaluation of decisions, statistical reductions in deaths and injuries must be weighed against all other MOEs. This inevitably requires consideration of the difficult moral, ethical, philosophical, and political issues of the value of a life. Alternative ways of assessing this value have led to a variety of different values in use in regulatory decision making. For example, recent FAA guidance (APO-84-3) indicates standardized values of \$650,000 for a statistical life and \$48,000 for a serious injury (in 1983

dollars). These values are standardized values for use in evaluating FAA investments in regulatory actions and represent minimum estimates of the dollar amounts which society as a whole would be willing to sacrifice for the given benefit. These are updated values of those used in FAA-APO-81-3, which based valuation on the "value to self and others" approach incorporating an "indirect willingness-to-pay" or "revealed preference" approach to arrive at a value of \$530,000 in 1980 dollars. The Nuclear Regulatory Commission, on the other hand, uses values of \$1 million for a statistical life and \$100,000 for a serious injury for some regulatory analysis purposes (see e.g., NUREG/CR-3976). Alternatively, NRC's proposed safety goals (NUREG 0880) propose the use of a value of \$1,000 per man-rem averted for regulations that would provide "incremental reduction of risk below the numerical guidelines for societal mortality risks." Wood (1983) traces this figure to a value of a statistical life of \$1 million, which he claims was inferred from hazardous duty pay of an Air Force pilot in 1963 (which would establish a value of \$980,000 in 1963 dollars). Others involved in nuclear regulation contend that \$1,000/man-rem is consistent with a value of \$10 million for a statistical life.

We have not identified any U.S. Coast Guard guidance on this matter; we will continue to investigate it. The model will allow a range on possible values.

CASMAIN contains data on injuries and deaths including: crewmember, passenger, and other deaths; crewmember, passenger, and other injuries; and the nature and cause of injury. The completeness of this database has not been confirmed. If there are problems of completeness or representativeness, then the data should be augmented by other sources (e.g., insurance company data, if available) or judgment. We have not identified a database with information on lost workdays or increased medical or insurance costs. This information might be available from insurance companies.

CASMAIN data are organized in a manner that facilitates the estimate of probabilities and numbers of deaths and injuries conditional on the type or cause of accident, the type of vessel, or environmental conditions. This is

compatible with the type of modeling that might be used, for example as described in Measure 1.1.1.1.

Measure 1.1.2.2 Personal safety benefits to recreational boaters. Personal safety of recreational boaters may also be affected by SRA resource decisions. To the extent that serious recreational boating accidents are related to the aids to navigation, this criterion is likely to be more important than the economic benefits of safety (Measure 1.1.1.2), especially when compared with the commercial mariner. This is due to the low economic value of recreational vessels when compared with the value of the vessel and cargo of a commercial mariner. The value of a life of a recreational boater, however, is as high as that of a commercial mariner (some may argue that the value is higher, based on notions of control of assumed risk), so the life to economic ratio is higher for recreational boaters.

The Boating Accident Reporting System (BARS) and Recreational Boating List of Fatalities (FATALS) provide information on injuries and deaths in recreational boating accidents. If a large number of these could be affected by SRA resource decisions, then a detailed model, similar to that described for commercial mariners (but with different parameters and critical aids), could be used to represent this measure. If, however, there are few recreational boating accidents involving deaths and injuries that are affected by AtoN, then a judgmental adjustment of historical data will be sufficient for the analysis. Judgments would most likely come from appropriate Coast Guard personnel.

Measure 1.1.2.3 Personal safety benefits to government users. This measure accounts for personal safety aspects of SRA resource decisions that affect government-owned and government-operated vessels. It likely will be modeled in a manner similar to that used for commercial mariners or recreational boaters. CASMAIN has appropriate data for accidents that were investigated by the Coast Guard. Additional information may be maintained by users (e.g., Department of Defense, Corps of Engineers, states) and may be appropriate in some cases, but we have not confirmed this.

Measure 1.1.2.4 Personal safety benefits to the general public. This measure accounts for deaths and injuries to the general public that are affected by maritime safety. It is likely that only catastrophic accidents (e.g., major explosions and fires) will have the potential for much impact here. The model for this measure will be similar to the model for the catastrophic accident part of Measure 1.1.1.4. The primary units of measurement are deaths and injuries, but these will probably be converted to dollars in the model, using similar techniques (but not necessarily the same values) as for other personal safety benefits.

Measure 1.2.1 Ship-related costs of timeliness. Timeliness benefits are the costs avoided (or incurred) as a result of reductions (or increases) in transit time resulting from SRA resource decisions. These benefits apply primarily to commercial and Governmental users, not recreational boaters. As with other criteria, the detail of modeling to estimate timeliness benefits will depend on the decision being evaluated. Conceptually, delay could be modeled as:

$$\sum \text{Number of delays} \times \text{Cost per delay.}$$

Likely conditions to be summed over include the type and extent of delay, the type of vessel and cargo, environmental conditions, and the mariner's awareness of a situation that might warrant delaying.

In some cases, it may be appropriate to develop a model at the level of the waterway. In this case, the length of delay could be determined using a conditional probability tree such as the one shown in Figure 4.4. This tree starts with an assessment of the probability that a transiting mariner would encounter a discrepant aid or group of aids (a more detailed model would also define the type of discrepancy). This probability is influenced by factors such as: equipment reliability; routine servicing policy; the staffing, training, and competence of crews; discrepancy monitoring and reporting; and discrepancy response. If a discrepant aid is encountered, then an assessment is made of the mariner's prior awareness of the discrepancy. The probability that he is aware is influenced by marine information policy and practice (including both the USCG's Broadcast and Local Notices to Mariners and bridge-

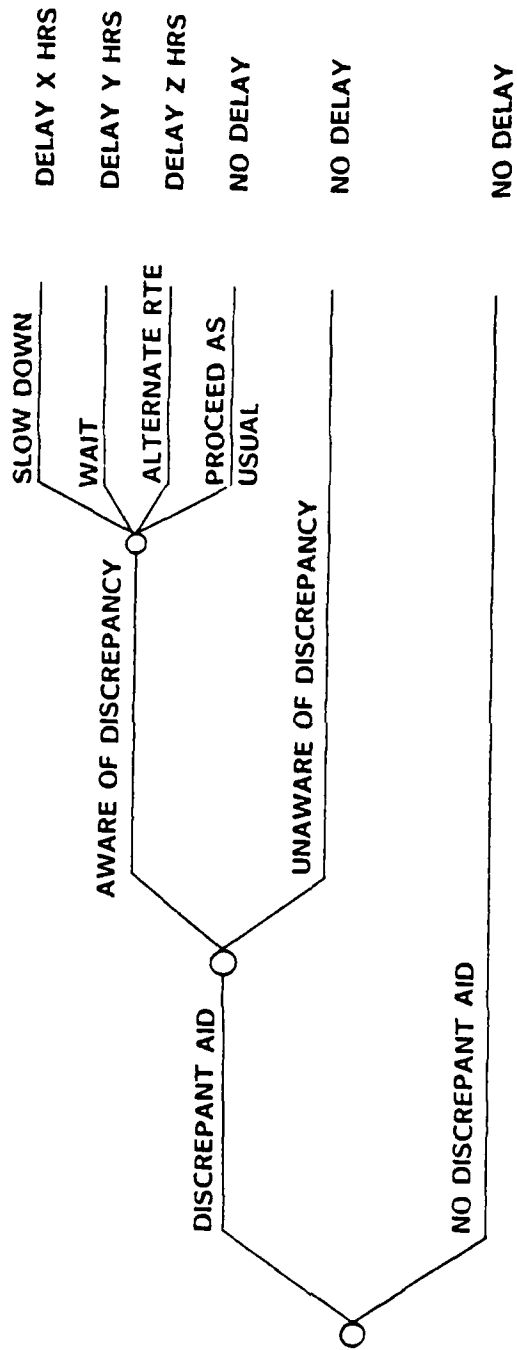

Figure 4.4: Conditional Probability Tree for Delay

to-bridge communications). If the mariner is aware of the discrepancy, then an assessment is made of his actions. This is done by assessing the probability that he would: slow down and transit the waterway; wait for conditions to change (e.g., the discrepancy to be fixed or, if it is a light out, for daylight); take an alternate route; or proceed as usual. Any endpoint that results in proceeding as usual, whether or not there is a discrepancy or awareness, results in no cost of delay (it may, however, have an increased risk of accident, which is accounted for with criteria under safety). Each of the other endpoints involves some delay, which may be represented as a point estimate or a probability distribution. In the diagram, if X, Y, and Z are expected delays for their corresponding endpoints, then the expected delay is calculated as:

$$\text{Expected delay} = P(\text{discrepant aid}) \cdot P(\text{aware of discrepancy}) \cdot [P(\text{slow down}) \cdot X \text{ hours} + P(\text{wait}) \cdot Y \text{ hours} + P(\text{alternate route}) \cdot Z \text{ hours}].$$

This combines with the cost per hour of delay to give the cost per transit which is combined with transits per year to give cost per year.

Aid outage, including the probability of a discrepancy, the type of discrepancy, and the time to restore, could be estimated based on actual performance as reported in the AtoN Information System (ATONIS). Shipping companies have data on the cost of operating a ship, and we have heard figures in the range of \$1500-\$2000 per hour for cargo vessels from several sources. Transits per year will vary by waterway and information is available from port authorities (e.g., the Port of New Orleans reports 4089 vessel arrivals in 1984), *Waterborne Commerce of the U.S.* (for domestic traffic), and *U.S. Oceanborne Foreign Trade Routes* (for international traffic). (Older information from Coast Guard *Port Access Route Studies* may also be useful.) Mariner behavior would be more difficult to estimate but could be done judgmentally or possibly by a survey.

Measure 1.2.2 Consignor or consignee costs of timeliness. Delays also involve costs that are not related to the cost of operating a ship. These costs include the costs of paying idle stevedore gangs that were ordered, demurrage, and other costs of delay that are not accounted for in Measure

1.2.1. These costs may accrue to shipper or receiver, consignor or consignee. These costs could be considerable. For example, we were told that stevedore costs run about \$50 to \$75 an hour per person. A typical cargo ship may require two gangs of sixteen men each, which comes to \$1600 to \$2400 an hour, which is on a par with the cost of running a ship.

Conceptually, this measure can be modeled in a manner similar to the ship-related costs. Namely, these costs could be estimated from the number of delays and costs per delay. Further, delays due to aids to navigation could be modeled based on aid discrepancies, awareness, and the mariner's action (e.g., slow down, wait, alternate route, proceed as usual) in response to discrepancies. For this much of the analysis, the same technique could be used as with ship-related costs of delay (Measure 1.2.1) to estimate a probability distribution on delay time.

An additional assessment is then needed of the action to be taken given the delay. For example, stevedore gangs are scheduled in advance and typically require a guaranteed minimum (e.g., two gangs of sixteen for four hours) that must be paid whether work is done or not. The shipper has some discretion over this cost in that the gangs could be ordered in advance or not and could be sent home or not after they are ordered (and paid the minimum). Shipping lines have policies regarding these matters, and this information could be solicited from the lines. If this is not possible or permissible, then estimates will be made based on information received from pilots, pilot groups, or labor unions. A limited amount of this information has already been received, for example from pilots in Seattle (see trip report in Appendix A).

Measure 1.3 Other benefits. Other benefits include factors other than safety and timeliness that are important to the commercial mariner or other vessel operator, the Coast Guard, other governmental agencies, and the general public. These benefits may be measured in dollars (e.g., normal operating costs of commercial mariners) or they may require other units of measurement. This category includes all benefits (as contrasted with reduced U.S. government costs) that are not accounted for under either safety (category 1.1) or timeliness (category 1.2).

Measure 1.3.1 Other benefits to mariner interests. Other benefits to mariner interests include both reductions in costs due to other than accidents and all factors of user satisfaction other than cost-related.

Measure 1.3.1.1 Non-accident costs to the mariner. The benefit category of non-accident costs to the mariner includes any reduction (or increase) in cost due to an SRA resource decision. Such costs include, but are not limited to: normal operating expense, maintenance expense, capital costs, and training expense.

As an example of how these costs may occur, the Coast Guard could make an SRA decision that required a certain piece of equipment on some types or classes of commercial vessels. This decision might be in the form of a stated requirement, or it might result from the elimination of an aid to navigation. (Conversely, some SRA decisions could result in reduction of some routine costs of mariners.) The disbenefits of the decision would be estimated from the number of new equipments that would need to be purchased, the price per unit, and the added maintenance and training expense. Data for these estimates are not of uniformly high quality. If existing equipment would be required, a fairly accurate assessment of its initial cost could be estimated from manufacturers' price lists. The number of purchases would be more difficult to estimate. The Marine Safety Information System (MSIS) contains data on commercial vessels that were certified or inspected by the U.S. Coast Guard and should provide a good count of such vessels. In addition, *Transportation Lines of the United States* lists all U.S. flag freight and passenger vessels (ferries, fishing vessels, and recreational craft are not included). A count of other vessels may be difficult to obtain. Estimates of the number of these vessels that do not have the equipment and would need, therefore, to add it, would be more difficult to obtain. A judgmental estimate could be made by the Coast Guard and this could be supplemented with information from equipment manufacturers (e.g., past sales data), vessel operators, or their trade associations. Specific sources may differ by the type of equipment involved. Training and maintenance costs could be estimated from manufacturers' recommendations, possibly augmented judgmentally by the experience of several users. As with all aspects of the measures of effectiveness, the appropriate level of detail will vary with the decision.

Measure 1.3.1.2 User satisfaction of commercial mariners. User satisfaction of commercial mariners accounts for benefits other than those relating to safety, timeliness, or cost. A number of aspects of user satisfaction were mentioned during interviews with mariners. These included: confidence in the AtoN system, appearance of the AtoN system, rapport with the Coast Guard, accuracy of information, and quality and timeliness of communication with the Coast Guard.

There are several ways that the impact of AtoN decisions on user satisfaction might be estimated. At one extreme, the direct judgment of the Coast Guard might be used to assess the impact on overall user satisfaction or on its components. These judgments might be reflected in relative value scales that are either defined by the alternatives themselves or by scales with benchmark references (see Appendix B for a further discussion of relative value scales.) These judgments might then be augmented by those of selected users or user groups. At the other extreme, user satisfaction might be estimated from an extensive detailed survey of users (coded by category of commercial mariner) and a statistical analysis of solicited and unsolicited correspondence received by the Coast Guard (including complaints). Combinations of judgmental and statistical methods will likely produce the best estimates. The level of detail and extent that effort will be devoted to the assessment of this measure will depend on its importance to the decision, the extent that improved estimates could change the decision, and the degree of defensibility needed in the estimate (e.g., for purposes of communication).

Measure 1.3.2 Coast Guard interests. SRA resource decisions could impact the interests that are specific to the Coast Guard such as multi-mission capability, organization impact, and standard measures of performance. These interests are included under the following subcategories.

Measure 1.3.2.1 U.S. Coast Guard multi-mission capability. Multi-mission capability measures the impact that SRA resource decisions would have on the performance of other missions by resources that are primarily assigned to AtoN duties. These include: military training and preparedness; search and rescue (SAR); support of Federal and local law enforcement agencies (e.g., immigration, drug traffic, fishing); ice breaking; and other missions (e.g.,

marine science activities (MSA), cooperation with other agencies (COOP), marine environmental response (MER), port environmental safety (PES), public information affairs (PIA)). The exact missions that might be impacted would depend on factors such as the resources affected and their geographic location. In some analyses, it may be important to subdivide this measure into its components or into those components that would be affected.

There are several ways that the effect on multi-mission capability might be modeled. Some SRA resource decisions could increase or decrease the amount of time available for multi-mission activities. For example, increasing the routine servicing interval without changing the number of tenders could allow the tenders to devote more hours each year to multi-mission activities. The primary measure could then be something like hours per year. This measure might be used directly in the analysis, for example by trading off hours devoted to multi-mission activities against the other measures. This assessment might be made by direct judgment, by "pricing out," or by estimating a "replacement" cost. A more meaningful measure might be obtained by estimating the effect of the additional time on the missions. For example, the increased time might be expected to increase the number of drug arrests by X, or allow the participation in another military exercise, or allow for the servicing of Y more National Data Buoy System (NDBS) weather buoys, or to perform Z more rescues, or some other effect. It may turn out, however, that the additional time produces no effect on the mission. This might be because the mission is "saturated" (e.g., all rescue possibilities can be handled without the additional resource) or because the time increment is too small or spread too thinly (e.g., an extra two hours per week will not permit participation in a 5-day military exercise). Such estimates will require judgmental assessments of both what is needed and what could be done.

In many cases, the assessment of the effect on multi-mission capability will require an estimate of a sequence of decisions that the Coast Guard would make. The process of making these estimates may uncover additional alternatives. For example, in analyzing a hypothetical decision to remove a WLB from the 7th Coast Guard District (for example by decommissioning), one possibility would be to severely reduce drug interdiction activity by the remaining WLBs. An alternative would be to retain the same level of drug interdiction ac-

tivity, but reduce the time spent on AtoN. Other decisions that could impact on multi-mission would require similar identifications of a range of Coast Guard decision possibilities.

The *Abstract of Operations* has annual reports on vessel utilization, including utilization in multi-mission roles. This will provide a base for estimating whether a decision is likely to have an effect on multi-mission and for estimating the magnitude of potential impact. The Coast Guard Service-Wide Search and Rescue Statistics (Ref. No. 450 in the Transportation Statistics Reference File maintained by DoT's Transportation System Center) may contain useful information on SAR. We have not come across data on multi-mission performance such as number of drug or fisheries arrests or number of military exercises, but such data may be tabulated locally.

Measure 1.3.2.2 Organizational impact on the Coast Guard. SRA resource decisions could have impacts on the Coast Guard organization. Such impacts include personnel job satisfaction and morale, professional development and training (AtoN and general), and self-image. To the extent that changes in these factors have other impacts (e.g., reduced morale may reduce safety), those impacts are accounted for in the other measures. This measure reflects the value of organizational impacts in and of themselves.

Data for this measure are sparse, which will make assessments difficult. Impacts of decisions on training should be straightforward and similar to the way that impacts on multi-missions are estimated. For example, decisions that affect the amount of crew time spent on activities other than training affect the time available for training. Impacts on other organizational factors such as job satisfaction, morale, and self-image will be more difficult. It is likely that this will first be estimated by direct judgment of the Coast Guard analyst. If this measure is important enough to the decision, the estimate could be refined with survey or interview data collected specifically for this purpose.

Measure 1.3.2.3 Standard measures of performance. Several measures of performance have been used in the past to characterize the performance of the Coast Guard in its AtoN mission. These include: discrepancy rate, opera-

tional readiness, discrepancy response time, etc. Most of the value from improving these measures comes derivatively from the impact that the improvement would have on other factors (e.g., safety and timeliness). To the extent that value is derivative, it will be reflected in those other measures, not here. However, some residual value may attach to these factors, if for no other reason than that they have been used historically and, therefore, may continue to be demanded as measures by important organizations outside of the Coast Guard (e.g., Congress). This measure accounts for only this residual value. (Its importance--great or small--will be reflected, of course, in the weight assigned in the complete model structure.) Data for these measures have been developed routinely by the Coast Guard for years, and we expect few problems in obtaining assessments.

Measure 1.3.3 Other government interests. Coast Guard SRA resource decisions could have a number of effects on other governmental bodies or on agreements between governments. These include international effects, effects on other units of the Federal government, and effects on state and local governments.

Measure 1.3.3.1 International. The U.S. is party to a number of agreements with the International Association of Lighthouse Authorities (IALA) and the International Maritime Organization (IMO) that could be affected by SRA resource decisions. In addition, the U.S. maintains agreements with other countries individually and the Coast Guard otherwise cooperates with other governments (e.g., Canada) on matters such as territorial waters and fishing accords. A number of possible SRA decisions could have significant effects on these international relations. For example, many mariners have expressed dissatisfaction with the decision to change the color of some aids to navigation from black to the shade of "IALA green" chosen by the Coast Guard to bring the U.S. into compliance with an IALA convention. The Coast Guard could consider returning to black buoys either completely or partially (e.g., in inland waterways). Such a change would have positive benefits on User Satisfaction (Measure 1.3.1.2) and possibly on safety (since green buoys are difficult to distinguish from the background or water in some locations and under some conditions) and cost. Such a move could, however, put the U.S. in violation of an agreement, which has a negative impact.

Data on these effects are fragmentary at best. If the U.S. has deviated from past agreements, there may be some record of the consequences. More likely, the effects will need to be estimated judgmentally. Likely sources of the judgments include Coast Guard legal officers, admiralty lawyers in the Department of Justice, and U.S. representatives to the organizations (from the Coast Guard or elsewhere in the Federal government, such as the Department of State). As for actions that might change the degree or amount of cooperation with other governments, historical analog may be used to estimate effects, if similar periods of increased or decreased cooperation existed in the past. Here, data may come from recorded documents or from "institutional memory" as represented by people involved in previous incidents.

Measure 1.3.3.2 Federal government. This measure accounts for other benefits or disbenefits that SRA decisions would have on other U.S. government departments or agencies. For example, a Coast Guard decision that would affect the availability or use of AtoN resources for responding to pollution incidents could affect the Environmental Protection Agency (EPA). This measure also accounts for impacts, if any, on national security.

Some data for this measure are likely to exist in budgetary documents prepared by other agencies, but we have not sought this information yet. For any particular decision, it is likely that at least some judgment will be needed to estimate the effect on this measure. These judgments could come from Coast Guard personnel who interact with the other agency or they could come from personnel at these agencies.

Measure 1.3.3.3 State and local governments. Some Coast Guard SRA resource decisions could have implications for state and local governments, especially those that are involved in waterborne commerce. Such impacts could relate to costs or to government functions such as regulation and registration. Data on the effects on state and local governments are scarce. It may be possible, in some cases, to obtain data from the state or locality involved in a decision, but such data requests will likely need to be in the narrow context of a particular decision and the data received will likely be of only limited general value. Thus, impacts on this measure will probably need to be made judgmentally.

Measure 1.3.4 Public interest. A variety of public interests could be affected by Coast Guard AtoN resource decisions. While the impact on some of these effects may be small compared with other impacts, they may have political consequences that make them very important, or at least important enough to include in a sensitivity analysis. This category of measures is also difficult to measure. Major public interests are economic, environmental, and historic preservational.

Measure 1.3.4.1 Economy. SRA resource decisions could have a variety of economic impacts other than on commercial mariners, and these effects are accounted for in this measure. Decisions could impact such boating-related industries as ship and boat builders, marinas, yards, and repair facilities. Local economies could also be affected. These effects could include, for instance:

- the economic effect on a port city of a change in cargo passing through as a result of an SRA resource decision;
- the economic impact on a town of the addition or subtraction of a Coast Guard vessel or other resource stationed nearby;
- the effect on the local economy of a change in recreational or charter boating due to a change in aids to navigation.

The basic unit of measurement for this factor is dollars, but the factors may have a political dimension as well, which should be included. For example, in an evaluation of a possible decision to decommission a cutter, the economic effect on the town where the cutter is based should be reflected. In addition, the political impact (e.g., as eventually expressed in Congressional pressure not to decommission the cutter, which could have far-reaching budgetary implications) should also be reflected.

Data for parts of this measure are readily accessible. For example, *Waterborne Commerce of the U.S.* provides data on cargo movements. Local chambers of commerce have some relevant economic data (e.g., we heard estimates that a large cruise ship would inject about \$500,000 into St. Petersburg's economy on a typical Saturday--see trip report in Appendix A.) WAMS analyses, when completed, will collect in a single source much relevant local economic data. Shipbuilders, boat manufacturers, and their trade associations may have

estimates of the size, scope, and geographical distributions of these industries (we have not confirmed this). Some ports (e.g., the Port of New Orleans) also keep relevant economic data.

The effects of alternatives on the measure will be more difficult to estimate. In clearcut cases (e.g., the decommissioning of a vessel), an estimate of the economic effect will be relatively straightforward; whatever the contribution (which may be available from the local Chamber of Commerce) it is lost. Other impacts will likely need to be estimated judgmentally (e.g., as an estimated percentage reduction of the present amount).

Political impact can be the most difficult component to estimate. It is fairly easy to determine at any given time who the affected Congressman is, what his announced opinions are (if any), and how influential he is (e.g., through his committees or his relationship with the executive branch or party leaders). However, it may be difficult to predict the exact response in a given case because it may be influenced by many factors. It is possible that congressional aides would be very helpful in predicting the political reactions. Judgment of Coast Guard personnel, particularly if they have had dealings with the congressman (e.g., the USCG Congressional Affairs Office) involved (or other politicians at the local level) will probably be the best source of information. If the impact is important and uncertain enough, this source could be supplemented with the judgments of political observers outside the Coast Guard.

Measure 1.3.4.2 Environmental. SRA resource decisions could have effects on the environment. This might relate, for example, to pollution from oil, chemicals, or hazardous cargo spills as a result of an accident. The model for this measure could be similar to that used for safety benefits. That is, the probability of an accident and consequences of the accident could be modeled. In this case, consequences of an accident might be the discharge of pollutants. For each type of pollutant, an estimate would be made of the discharge (e.g., in tons) given an accident, taking account of mitigating actions. A scale would then be devised that related discharge to value, accounting for the environmental effects of the discharge.

Some data exist for making this estimate. *Waterborne Commerce of the U.S.* has data on cargo amounts. The Pollution Incident Reporting System (PIRS) and CASMAIN have information on accidents that resulted in pollution. These may be sufficient to estimate a probability distribution of pollution given an accident. If not, data may need to be sought from other sources such as the EPA. Accident probabilities would be estimated in the same manner as described under Measure 1.1.1.1.

Measure 1.3.4.3 Historic preservation. The Coast Guard restores and maintains many historic lighthouses. SRA resource decisions that affect this maintenance (e.g., increasing or decreasing the number of restorations per year, changing maintenance schedules, structurally changing the aid to navigation, or seeking to decommission a lighthouse as an aid to navigation) could affect the public interested in preserving the historic nature of lighthouses.

Since the Coast Guard has made or suggested changes in lighthouse maintenance, rehabilitation, and operation in the past, data should be available on the public and political implications of the suggestions (e.g., in letters to the Coast Guard from the public and historical societies and in congressional inquiries), but we have not verified this. These base data can provide a first-cut estimate of the impact of a contemplated decision. The seriousness of this impact, of course, must still be estimated judgmentally, and judgment may also be needed to estimate differences between a decision under consideration and one that happened in the past.

Measure 2.1.1 Coast Guard operating expense (OE). This measure includes the costs to operate, maintain, administer, and support AtoN activities. Included are all short- and long-term recurring costs, e.g., pay and allowances, supplies, and maintenance.

Operating expenses are estimated now for both budget and resource change proposal analyses. Estimated costs are based on staffing standards, OMB estimates, manuals, instructions, COMDTNOTES (e.g., COMDTNOTE 7100), and specially-generated estimates. Use of this tool should not change the manner in which OE is estimated for any given Coast Guard decision or proposal. The typical unit of measurement of OE is dollars per year. With such units, an

estimate is also required of the number of years that the expense will persist. These two estimates permit the use of discounted cash flow techniques to compare OE costs with capital costs.

Measure 2.1.2 Coast Guard capital costs (AC&I). This measure includes capital costs of a non-recurring nature. For example, it could include the cost of a major overhaul of a vessel (e.g., a SLEP) or other major equipment costs associated with an AtoN resource decision.

AC&I costs are also estimated regularly in a number of Coast Guard analyses, and the use of this tool will not change the manner of this estimate or the data used.

Measure 2.1.3 Coast Guard research and development (R&D) costs. Some AtoN resource decisions, especially ones that involve new technologies, may involve research costs to explore new technologies or development costs to adapt new or existing technologies for AtoN applications. These costs, which may be recurring or non-recurring, are included in this measure. R&D costs are currently estimated from a variety of sources for present Coast Guard analyses, and the use of this tool will not change the manner of this estimate or the data used.

Measure 2.2.1 Litigation costs. The Federal government sustains costs in litigating suits brought by mariners alleging improper action by the Coast Guard relative to AtoN. These include both costs of defending the Coast Guard and the costs of settlements (either negotiated or adjudicated). Costs of defense include the costs of Coast Guard legal personnel in the Districts (the District has authority to settle cases under \$25,000), Coast Guard legal personnel at Headquarters (USCG Headquarters has authority to settle cases between \$25,000 and \$50,000), the cost of U.S. Department of Justice legal personnel (for cases over \$50,000), and other Federal government costs associated with the case (e.g., the costs of travel and expert witnesses).

A variety of arguments are used in legal cases that could be affected by AtoN resource decisions. These include, for example:

- an aid off station;
- an aid missing;
- an aid temporarily relocated;
- an aid watching improperly;
- insufficient notice of a problem or discrepancy;
- failure to meet USCG standards for responding to discrepancies;
- abuse of discretionary authority.

AtoN resource decisions could affect litigation costs by affecting the number of accidents, the number of law suits brought given an accident, the probability of settling the suit without a payment, or the size of a payment at settlement.

This measure could be modeled as a detailed probabilistic model. For example, the accident probability model described for Measure 1.1.1.1 could be extended to include nodes for the probability of a suit, its outcome, and the size of settlement. However, this level of detail is probably not warranted due to the size of settlements. For example, Mr. James K. Augustine, Assistant Division Chief of Coast Guard Headquarter's Claims and Litigation Division, reported to us that of the 37 cases closed in 1985, 25 involved no payment and, of the over \$70 million claimed, only about \$290,000 was paid. (This is consistent with similar data generated ten or twelve years ago.) Clearly, most suits are minor, even of a nuisance variety, despite the few well-publicized exceptions (e.g., Northern Gulf and Tamano). A preferred alternative model would address how a proposed SRA resource decision could change the probability of a "disastrous" law suit.

The Coast Guard maintains incomplete data on the size and disposition of law suits, which could establish a limited base rate for estimates. Judgment will be needed to assess how an action might change this base rate, especially the unlikely event of a very large settlement cost.

Litigation costs also include the costs of recovery by the Federal Government of damages to AtoN by mariners and/or vandals.

4.4 Review of Data Sources

A secondary objective of Task 1 was to identify sources of data that are available to estimate measures of effectiveness. Part of this identification process was conducted during trips where local sources of data were identified (e.g., port authorities, shipping companies, and associations). Generally, the time available during trips was too short to follow-up on these leads (with some notable exceptions such as the Port of New Orleans, the American Waterways Operators, several shippers, and numerous pilots' associations). These local sources will be investigated further, as appropriate, during the conduct of Tasks 2-8. In addition, a number of centralized data sources were identified. These are mainly statistical documents and computerized databases compiled and maintained by the U.S. Army Corps of Engineers, the U.S. Department of Commerce, the U.S. Coast Guard, and other elements of the U.S. Department of Transportation.

The section above provides some references to sources that could be used to provide inputs to estimate measures of effectiveness. This section provides brief descriptions of the major relevant documents and databases. Each data source is described briefly and a number of sample pages are provided. In addition, specific access information is given, when available. For the most part, these data are readily available in the Washington D.C. area.

Port Series Reports. The reports in the Port Series describe the principal United States coastal, Great Lakes, and inland ports, and are compiled and published under authority of law to meet the needs of Federal, state, municipal, and port agencies, and others interested in the development of harbors and the use of port and terminal facilities. Port series reports consist of complete descriptions of a port area's waterfront facilities, including information on berthing accommodations, petroleum and bulk handling terminals, grain elevators, warehouses, cranes, transit sheds, marine repair plants, fleeting areas, and floating equipment. The locations of the described facilities are depicted on aerial photographic maps of waterfront areas. This series may be useful in determining the indirect costs of delayed traffic as well as benefits to the local economies. Sections on weather conditions at

each port may be used to correlate accidents and delays with adverse weather patterns (sample in Table 4.2). (Prepared and for sale by the Water Resources Support Center, Casey Building, Fort Belvoir, VA 22060.)

Waterborne Commerce of The United States. This series contains statistics on the movements of commodities and vessels at the ports and harbors and on the waterways and canals of the United States in five parts: Atlantic Coast, Gulf Coast and Mississippi River System, Great Lakes, Pacific Coast and Alaska and Hawaii, and the National Summary. Both the foreign and domestic commerce moved on U.S. waters are included. Data are presented in two sections by commodities moved given in short tons and by vessel trips for the harbors and waterways. The data are grouped by U.S. Army Engineer Districts. This annual report would be very useful for estimating the economic value of commercial freight traffic and the volume of commercial transits through the ports and waterways. Although economic data are only provided by tonnage of each commodity, other sources could help fix a dollar value per ton of each commodity (sample in Table 4.3). Number of transits, combined with accident and delay data, would allow calculation of accident rates and delay rates (sample in Table 4.4). Compiled under the supervision of the Water Resources Support Center, Data Collection Management Division, U.S. Army Corps of Engineers, Casey Building, Fort Belvoir, VA 22060. Phone: (703) 355-2252. For sale by District Engineer, U.S. Army Engineer District, New Orleans, P.O. Box 60267, New Orleans, LA 70160.

Transportation Lines of the United States. This annually revised publication contains information on the vessel operators and their American flag vessels operating or available for operation in the transportation of freight and passengers. General ferries, floating equipment used in construction work (such as dredges, piledrivers, and flats), fishing vessels, and recreational craft are not included. Table 1 lists the name, address, and Engineer District where registered of each vessel operator. Table 2 lists the operators in alphabetical sequence and describes each vessel operated by indicating its Coast Guard number, net register tonnage, VTCC (vessel type, construction and characteristics), register and overall breadths, draft (both loaded and light), horsepower, carrying capacity in short tons or units of cargo and number of passengers, heights of fixed superstructures, cargo handling equipment,

Table 4.2: Port and Harbor Facilities

OIL HANDLING AND BUNKERING

Four of the waterfront facilities on Coos Bay described in this report are equipped to receive petroleum products by barge or by small tanker. Hillstrom Marine Service (P.W.D. Ref. No. 1) fuels vessels but receives only by tank truck. The facility has metered pumps which are used primarily for fueling fishing vessels.

Bassett-Hyland Energy Co. (P.W.D. Ref. No. 25) has metered pumps used for fueling fishing vessels, towboats, and tugs.

Unocal Corp. (P.W.D. Ref. No. 26) provides bunkering service to deep-draft vessels in addition to fueling small vessels.

P.W.D. REF. NO.	OPERATOR AND/OR USER	STORAGE TANKS	
		NUMBER	CAPACITY (BARRELS)
25	Bassett-Hyland Energy Co.....	12	61,000
13	Oregon Coast Towing Co.....	7	72,000
22	do.....	13	70,600
26	Unocal Corp.....	11	133,000
Totals.....		43	337,100

None of the facilities on Yaquina Bay described in this report are equipped to receive petroleum products by vessel. Depoe Bay Fish Co., Newport Shrimp Co., and Port of Newport (P.W.D. Ref. Nos. 50, 54, and 55, respectively) have metered pumps for fueling fishing vessels and tugs.

WAREHOUSES AND OPEN STORAGE

General cargo is handled at four facilities located on Coos Bay. Storage space necessary for the commodities handled is provided by the companies as listed in the table below. Yaquina Terminals (P.W.D. Ref. Nos. 56 and 57) has the only storage for cargo at Newport; one 11,500-square foot transit shed and 26 acres of open storage area, all used for lumber.

Table 4.3: New England Division

RUCKSPURT HARBOR, MAINE (INCLUDED IN PENNASCOT RIVER, MAINE)

SECTION INCLUDED: HARBOUR PROPER, INCLUDING WESTERN END OF THE EASTERN CHANNEL, OPPOSITE THE NORTHERN END OF VERONA ISLAND, CONTROLLING DEPTH: 5.2 FEET, PROJECT DEPTH: 16.0 FEET IN MIDDLE CHANNEL AT MEAN LOW WATER.

COMPARATIVE STATEMENT OF TRAFFIC

YEAR	TONS	YEAR	TONS
1974	1,153,520	1979	1,201,658
1975	1,145,250	1980	1,193,304
1976	1,145,142	1981	1,195,294
1977	1,191,026	1982	1,201,897
1978	1,174,778	1983	1,202,254

FREIGHT TRAFFIC, 1983

(SHORT TONS)

COMMODITY	TOTAL	FOREIGN		DOMESTIC		
		IMPORTS	EXPORTS	COASTWISE		INTERNAL
				RECEIPTS	SHIPMENTS	
TOTAL	1,202,254	1,188,025	245,650	5,140	24,519	
2011 GASOLINE	137,540		137,540			
2012 JET FUEL	14,304		14,304			
2013 KEROSENE	17,057		17,057		3,311	
2014 DISTILLATE FUEL OIL	98,058		73,414	3,140	21,504	
2015 RESIDUAL FUEL OIL	1,188,025	1,188,025				
2001 PETROLEUM AND COAL PROD, NEC	497		497			

PENNASCOT RIVER, MAINE

SECTION INCLUDED: WHARF TO HARBOR, CONTROLLING DEPTH: 18 FEET IN CHANNEL OPPOSITE LAWRENCE COVE AND 21.4 FEET IN CHANNEL OPPOSITE FRANKFORT FLATS, PROJECT DEPTH: 22 FEET BETWEEN RUCKSPURT AND RINTFRONT, 15 FEET NEAR STEARNS HILL AND CONSBY HARBORS, 13 FEET AT HARBOR AT HARBOR, ALL AT MEAN LOW WATER, NAVIGATION SEASON: ABOUT 9 MONTHS.

COMPARATIVE STATEMENT OF TRAFFIC

YEAR	TONS	YEAR	TONS
1974	1,670,185	1979	1,601,000
1975	1,667,833	1980	1,459,214
1976	1,421,835	1981	1,430,172
1977	1,412,439	1982	1,106,329
1978	1,766,167	1983	1,469,444

FREIGHT TRAFFIC, 1983

(SHORT TONS)

COMMODITY	TOTAL	FOREIGN		DOMESTIC		
		IMPORTS	EXPORTS	COASTWISE		INTERNAL
				RECEIPTS	SHIPMENTS	
TOTAL	1,197,781	1,188,025	16,028	576,350	12,762	24,519
0101 ANIMALS AND PRODUCTS, NEC	4,040		4,040			
2011 FRESH FISH, EXCEPT SHELLFISH	333		333			
2012 SHELLFISH, EXCEPT PREPARED	753		753			
2011 MEAT, FRESH, CHILLED, FROZEN	9,444		9,444			
2031 FISH AND SHELLFISH, PREPARED	65		65			
2030 VEGETABLES AND PREP, NEC	201		201			
2042 ANIMAL FEEDS	43		43			
2011 GASOLINE	264,261			264,261	1,367	
2012 JET FUEL	23,720			23,720		
2013 KEROSENE	18,457			11,440		3,311
2014 DISTILLATE FUEL OIL	200,000			144,000	11,195	21,504
2015 RESIDUAL FUEL OIL	1,188,025	1,188,025				
2014 ASPHALT, TAR, AND BITUMEN	15,576			15,576		
2001 PETROLEUM AND COAL PROD, NEC	457			457		
3731 SHIPS AND BOATS	1		1			
TOTAL NON-FISHES	11,997,781					

SEARSPURT HARBOR, MAINE

SECTION INCLUDED: CHANNEL FROM DEEP WATER TO PIERS AND TURNING BASIN AT ROCK POINT, CONTROLLING DEPTH: 35 FEET IN 35 FOOT ACCESS CHANNEL; 30 FEET IN 35 FOOT TURNING BASIN, PROJECT DEPTH: 35 FEET, ALL AT MEAN LOW WATER.

COMPARATIVE STATEMENT OF TRAFFIC

YEAR	TONS	YEAR	TONS
1974	1,214,294	1979	1,240,216
1975	1,305,660	1980	1,197,694
1976	1,313,413	1981	1,079,013
1977	1,497,140	1982	767,711
1978	1,339,443	1983	820,444

vessel operating base, and year built or rebuilt. Table 3 lists the type of service, principal commodities carried, and waterways upon which and the location between which the services are conducted. For sale by District Engineer, U.S. Army Engineer District, New Orleans, P.O. Box 60267, New Orleans, LA 70160.

Fisheries of the United States. (April 1985) This publication is a report of the U.S. and foreign catches in the U.S. Fishery Conservation Zone (FCZ). A section briefly describes the background and results of Marine Recreational Fishery Statistics Surveys. Data are presented on recreational catch in number by species, and fishing trips by area on the Atlantic, Gulf, and Pacific coasts, and estimates of the number of commercial fishing vessels by type. The rest of the report provides data on U.S. commercial landings, foreign catches, employment, prices, and production of processed products. The section on landings may be useful for estimating economic worth of commercial and recreational fishing activity. Landings are shown in tables listed by major U.S. ports, by fish species, by regions, by states, by product end use, by month of the year, by fishing craft, and by distance caught offshore. The number of fishing vessels, when combined with accident data, can help provide accident rates (sample in Table 4.5). Prepared by the National Fishery Statistics Program, National Marine Fisheries Service, National Oceanic and Atmospheric Administration, U.S. Department of Commerce. Phone: (202) 634-7281.

Lloyd's Weekly Casualty Reports. These data are only on passenger, oil tanker, and chemical ships worldwide. They do not include bulk cargo or mobile oil drilling units (MODUs). Consolidated into annual statistical reports. Published by the Corporation of Lloyd's, London House, 6 London Street, London E.C., 3R7AB, England. New York claims agent, Phone: (212) 425-8050.

Boating Accident Reporting (BAR) System. This USCG database holds records on all reported recreational boating accidents in the country. The data include the state and county of the accident site, date, fatalities, boat information, operator information, environmental conditions, and type of waterway. This database contains boating accident records from 1969 to 1985.

Table 4.5: U.S. Commercial Landings

COMMERCIAL FISHERY LANDINGS AND VALUE AT MAJOR U.S. PORTS, 1981-84

Port	Quantity				Port	Value			
	1981	1982	1983	1984		1981	1982	1983	1984
 Million pounds.....				 Million dollars.....			
Cameron, La.	447.8	714.7	743.9	879.2	New Bedford, Mass.	77.9	83.3	109.2	107.7
Pascagoula-Moss Point, Miss.	220.5	331.8	380.2	425.3	Los Angeles Area, Calif. (1)	110.5	92.9	85.1	84.8
Empire-Venice, La.	221.5	267.3	281.9	383.5	Kodiak, Alaska	132.9	90.1	60.4	69.9
Dulac-Chauvin, La.	203.9	265.8	269.2	327.2	Dulac-Chauvin, La.	51.5	51.7	47.7	59.7
Los Angeles Area, Calif. (1)	373.8	334.8	262.3	237.0	Aranas Pass-Rockport, Tex.	41.0	41.0	50.0	51.1
Beaufort-Morehead City, N.C.	177.0	116.4	187.2	185.3	Brownsville-Port Isabel, Tex.	48.4	52.2	56.0	51.0
Gloucester, Mass.	168.9	148.8	150.9	179.1	Empire-Venice, La.	30.5	38.4	31.8	41.6
Kodiak, Alaska	193.2	106.3	89.0	113.8	Cameron, La.	29.9	40.4	39.5	38.2
New Bedford, Mass.	76.2	94.9	111.8	99.5	Gloucester, Mass.	46.1	43.8	38.0	37.1
Point Judith, R.I.	41.7	64.2	81.8	69.9	Bayou La Batre, Ala.	31.4	33.8	28.5	31.5
Seattle, Wash.	25.0	44.4	42.2	60.3	Hampton Roads Area, Va. (3)	22.8	17.5	20.8	29.5
Petersburg, Alaska	39.9	38.8	50.3	54.1	Point Judith, R.I.	13.2	20.5	25.5	27.3
Dutch Harbor-Unalaska, Alaska	73.0	47.0	48.9	46.9	Sitka, Alaska	(2)	(2)	(2)	26.8
Cape Canaveral, Fla.	17.0	12.5	15.4	45.1	Cape Canaveral, Fla.	15.9	12.8	16.0	28.2
San Diego, Calif.	149.7	106.8	84.6	43.6	Pascagoula-Moss Point, Miss.	18.8	18.5	23.2	25.0
Rockland, Maine	44.7	50.1	54.8	42.9	Petersburg, Alaska	22.0	19.8	19.3	24.9
Sitka, Alaska	(2)	(2)	(2)	39.8	Lafitte-Barataria, La.	20.8	21.9	16.5	24.1
Portland, Maine	39.9	67.5	53.9	37.0	Golden Meadow-Leeville, La.	19.9	21.5	15.2	23.6
Cape May-Wildwood, N.J.	42.7	44.9	43.8	34.1	Key West, Fla.	27.0	19.0	18.6	21.8
Bellingham, Wash.	27.0	26.6	23.9	34.0	Cape May-Wildwood, N.J.	20.5	18.1	24.8	21.4
Hampton Roads Area, Va. (3)	29.1	33.2	32.1	33.3	Beaufort-Morehead City, N.C.	17.2	20.0	21.6	21.3
Monterey, Calif.	49.8	44.5	17.8	30.3	Dutch Harbor-Unalaska, Alaska	57.8	47.8	36.4	20.3
Atlantic City, N.J.	18.1	19.9	18.1	28.8	San Diego, Calif.	83.0	59.7	37.5	20.1
Wanchese-Stumpy Point, N.C.	39.0	32.5	27.0	28.1	Galveston, Tex.	13.3	15.0	16.0	20.1
Newport, Oreg.	46.7	46.7	28.8	25.7	Freeport, Tex.	26.8	26.0	17.0	19.1
Aranas Pass-Rockport, Tex.	24.4	18.0	21.0	25.2	Seattle, Wash.	15.0	15.6	8.5	16.5
Ocean City, Md.	23.4	23.4	20.6	24.4	Dalcomb, La.	18.8	17.6	6.2	14.9
Astoria, Oreg.	44.8	45.0	28.5	23.1	Bellingham, Wash.	12.0	16.9	8.6	14.9
Brownsville-Port Isabel, Tex.	28.9	19.0	21.0	23.0	Portland, Maine	17.0	15.1	16.0	14.5
Eureka, Calif.	36.0	36.0	21.9	22.5	Atlantic City, N.J.	7.9	8.8	7.5	14.4
San Francisco Area, Calif.	35.7	43.5	42.0	22.4	Fort Myers, Fla.	18.0	11.9	8.6	13.9
Boston, Mass.	28.4	27.6	24.2	20.2	Apalachicola, Fla.	12.3	10.2	14.1	13.2
Coo's Bay-Charleston, Oreg.	36.5	37.0	26.2	20.1	Bon Secour-Gulf Shores, Ala.	11.8	12.4	11.8	11.5
Cordova, Alaska	(2)	(2)	(2)	18.3	Port Moller, Alaska	(2)	(2)	(2)	11.5
Port Moller, Alaska	(2)	(2)	(2)	18.3	Boston, Mass.	12.4	13.3	11.3	11.2
Bayou La Batre, Ala.	25.1	17.8	13.8	18.2	Grand Isle, La.	7.8	5.7	7.7	11.0
Key West, Fla.	18.0	10.0	11.7	17.7	Ocean City, Md.	10.5	9.9	9.3	11.0
Oriental-Vandemere, N.C.	17.1	14.0	14.0	17.2	Wanchese-Stumpy Point, N.C.	12.7	13.0	9.4	10.8
Golden Meadow-Leeville, La.	18.5	14.2	9.3	18.2	Delacroix-Yadloskey, La.	(2)	9.8	9.0	10.8
Crescent City, Calif.	16.2	17.7	14.5	15.9	Cordova, Alaska	(2)	(2)	(2)	10.0
Westport, Wash.	24.0	21.1	18.5	15.0	Montauk, N.Y.	(2)	(2)	(2)	9.7
Point Pleasant, N.J.	10.9	10.5	11.5	13.3	Newport, Oreg.	14.0	14.5	10.4	9.5
Fort Bragg, Calif.	15.7	16.8	14.4	12.7	Rockland, Maine	13.4	10.7	12.3	9.4
Blaine, Wash.	8.1	10.1	10.3	12.5	San Francisco Area, Calif.	18.0	18.3	22.2	9.2
Lafitte-Barataria, La.	14.7	11.9	9.4	12.5	Astoria, Oreg.	15.0	15.7	11.2	9.2
Galveston, Texas	8.1	7.0	12.0	11.9	Eureka, Calif.	13.5	12.4	7.0	8.8
Montauk, N.Y.	(2)	(2)	(2)	10.9	Crescent City, Calif.	8.2	9.8	8.1	7.0
Apalachicola, Fla.	12.0	9.0	10.8	10.8	Oriental-Vandemere, N.C.	8.5	7.7	7.1	8.9
Delacroix-Yadloskey, La.	(2)	10.6	6.8	10.8	Blaine, Wash.	3.6	5.7	4.1	6.9
Ihwo-Chinook, Wash.	16.8	9.9	10.8	10.6	Westport, Wash.	10.0	8.5	9.8	6.6
Santa Barbara, Calif.	14.1	11.0	9.3	10.1	Coo's Bay-Charleston, Oreg.	18.2	14.3	8.3	6.4
Cape Charles-Oyster, Va.	7.5	6.5	9.2	9.9	Greenport, N.Y.	(2)	(2)	7.7	6.2
Aktutan, Alaska	40.6	33.4	33.7	9.4	Homer, Alaska	(2)	(2)	(2)	5.8
Port Huene, Oxnard, and Ventura, Calif.	48.1	36.4	22.7	9.4	Santa Barbara, Calif.	5.9	4.9	4.3	5.6
Chincocheague, Va.	9.0	7.1	12.3	9.3	Point Pleasant, N.J.	4.7	4.6	6.2	5.5
Grand Isle, La.	7.1	5.6	6.4	9.2	Anacortes-La Conner, Wash.	7.2	8.0	3.1	5.3
Freeport, Tex.	14.9	9.0	8.0	9.0	Aktutan, Alaska	29.2	15.6	10.1	5.1
Dalcomb, La.	(2)	(2)	(2)	8.6	Oriental-Vandemere, N.C.	4.6	7.9	9.2	4.9
Hampton Bays, N.Y.	(2)	(2)	(2)	8.2	Chincocheague, Va.	5.1	3.9	5.5	4.8
Fort Myers, Fla.	15.0	9.2	7.3	8.2	Hampton Bays, N.Y.	(2)	(2)	4.4	4.6

(1) Previously called San Pedro, Calif. (2) Not available. (3) Previously called Hampton-Norfolk, Va.

* Record. Record quantity was 848.2 million lb landed in San Pedro, Calif., in 1960.

Note:—Data for some ports are estimated. To avoid disclosure of private enterprise, the following ports were not included: Fernandina Beach, Fla.; Intracoastal City, Morgan City, and Berwick, La.; Chatham, Provincetown, and Sandwich, Mass.; Biloxi, Miss.; Southport-Calabash, N.C.; Newport, R.I.; and Reedville, Va.

It contains over 112,000 records. This database, coupled with recreational boat usage figures, could provide information on recreational boat accident rates. Database on tape at the Office of Boating Safety, USCG (G-BP-I) Gary Traub, Phone: (202) 267-0955.

Recreational Boating List of Fatalities (FATALS). This database contains the names, date, district, and state of recreational fatal accidents from 1981 through 1985. The database contains over 3,800 records. This database, coupled with recreational boat usage figures, could provide information on recreational boat accident rates. Database on tape at the Office of Boating Safety, USCG (G-BP-I) Gary Traub, Phone: (202) 267-0955.

Corps of Engineers Database. This database is the source for the CoE summary reports on Waterborne Commerce of the U.S. It is collected on all domestic transits by the CoE but maintained by MARAD. It separates the tonnage shipped by port, commodity, vessel type and time period. It does not place dollar values on cargo. Data may be aggregated by MARAD district, by year or by month. The database begins in 1976. These data would be useful to further refine the information on tonnage shipped domestically. Combined with dollar value information, it would show by port the economic value of the commodities shipped. It could also be used to show volume of transits through each waterway (sample in Table 4.6). Prepared by Division of Domestic Ocean Shipping, Office of Domestic Shipping, Maritime Administration, Mr. Bill Miller, Phone: (202) 366-4374.

Commodity Movement Annual (CMA). This database includes all the waterborne foreign imports and exports by major port. The data are divided by three vessel types, by carrier flag (U.S. or foreign) and by direction of shipping (inbound or outbound). The data include the dollar value and tonnage by commodity. These data would be useful to combine with the domestic shipping data to get the economic value of commodities passing through ports. The data are not useful for estimating transits because they are based on "shippings" into or out-of the country. One "shipping" may make many ports-of-call at U.S. ports (sample in Table 4.7). Prepared by the Office of Trade Studies and Subsidy Contracts, Maritime Administration, U.S. Department of

Table 4.6: Report for Year 1984

SHIPPING PORT	RECEIVING PORT	TYPE VESSEL	COMMODITY	SHORT TONS
NEW YORK	GUAM ISLAND	1	1442 SAND, GRAVEL AND CRUSHED ROCK	5
NEW YORK	GUAM ISLAND	1	2061 SUGAR	2
NEW YORK	GUAM ISLAND	1	2081 ALCOHOLIC BEVERAGES	36
NEW YORK	GUAM ISLAND	1	2099 MISCELLANEOUS FOOD PRODUCTS.	15
NEW YORK	GUAM ISLAND	1	2211 BASIC TEXT PROD EX TEXT FIBERS	33
NEW YORK	GUAM ISLAND	1	2491 WOOD MANUFACTURES, NEC	6
NEW YORK	GUAM ISLAND	1	2511 FURNITURE AND FIXTURES	50
NEW YORK	GUAM ISLAND	1	2621 STANDARD NEWSPRINT PAPER	12
NEW YORK	GUAM ISLAND	1	2631 PAPER AND PAPERBOARD	25
NEW YORK	GUAM ISLAND	1	2691 PULP, PAPER+PAPERBOARD PROD, NEC	127
NEW YORK	GUAM ISLAND	1	2831 DRUGS (BIG, MEDIC, BOTAN, PHARM)	1
NEW YORK	GUAM ISLAND	1	2841 SOAP, DETRG, CLN PREPS, PERF+COSM	9
NEW YORK	GUAM ISLAND	1	2851 PAINT, VARNISH, LACQUER, ENAMELS	1
NEW YORK	GUAM ISLAND	1	2891 MISCELLANEOUS CHEMICAL PRODUCT	27
NEW YORK	GUAM ISLAND	1	2917 NAPHTHA, MINERAL, SPIRITS, SOLVN	3
NEW YORK	GUAM ISLAND	1	2951 ASPHALT BUILDING MATERIALS	43
NEW YORK	GUAM ISLAND	1	2991 PETROLEUM AND COAL PRODUCTS NEC	105
NEW YORK	GUAM ISLAND	1	3011 RUBBER+MISC PLASTIC PRODUCTS	163
NEW YORK	GUAM ISLAND	1	3211 GLASS AND GLASS PRODUCTS	67
NEW YORK	GUAM ISLAND	1	3291 MISC. NONMETALLIC MINERAL PRODS	3
NEW YORK	GUAM ISLAND	1	3317 IRON + STEEL PIPE + TUBE	14
NEW YORK	GUAM ISLAND	1	3322 COPPER + COPPER ALLOYS ALL KDS	4
NEW YORK	GUAM ISLAND	1	3324 ALUMINUM + ALUM ALLOYS, UNWRKD	16
NEW YORK	GUAM ISLAND	1	3411 FABR METL PROD EXC ORD MACH	1
NEW YORK	GUAM ISLAND	1	3511 MACHINERY, EXCEPT ELECTRICAL	97
NEW YORK	GUAM ISLAND	1	3611 ELEC MACH, EQUIPMENT + SUPPLIES	137
NEW YORK	GUAM ISLAND	1	3711 MOTOR VEHICALS, PARTS + EQUIPMT	149
NEW YORK	GUAM ISLAND	1	3731 SHIPS AND BOATS	3
NEW YORK	GUAM ISLAND	1	3811 INSTRUMENTS PHOTO OPT, WAT, CLOC	1
NEW YORK	GUAM ISLAND	1	3911 MISC. PRODUCTS OF MANUFACTURING	4
NEW YORK	GUAM ISLAND	1	4112 MISCELLANEOUS SHIPMENTS, NEC	1,093
NEW YORK	GUAM ISLAND	1	TYPE VESSEL TOTAL	2,269
NEW YORK	GUAM ISLAND	4	2831 DRUGS (BIG, MEDIC, BOTAN, PHARM)	14
NEW YORK	GUAM ISLAND	4	2841 SOAP, DETRG, CLN PREPS, PERF+COSM	1
NEW YORK	GUAM ISLAND	4	2991 PETROLEUM AND COAL PRODUCTS NEC	6
NEW YORK	GUAM ISLAND	4	3511 MACHINERY, EXCEPT ELECTRICAL	4
NEW YORK	GUAM ISLAND	4	3711 MOTOR VEHICALS, PARTS + EQUIPMT	1
NEW YORK	GUAM ISLAND	4	4112 MISCELLANEOUS SHIPMENTS, NEC	24
NEW YORK	GUAM ISLAND	4	TYPE VESSEL TOTAL	50
			TOTAL TONS FOR RECEIVING PORT	2,319
			TOTAL TONS FOR SHIPPING PORT	2,319
PAULSBORO	PUERTO ARMUELLES	2	2914 DISTILLATE FUEL OIL	7,086
			TYPE VESSEL TOTAL	7,086

Table 4.7: Commodity Tonnage by Type Service and U.S. Port

REPORT NUM CMA O10P07 1984 CENSUS DATA - INBOUND LINER	U.S. PORT	TOTAL TONS	U.S. TONS	FOREIGN TONS	U.S. %	TOTAL VALUE	U.S. VALUE	FOREIGN VALUE	U.S. X
0101	PORTLAND ME.	37	37	0	37	95277	95277	0	95277
0102	BANGOR ME.	13	13	0	13	59122	59122	0	59122
0103	EASTPORT ME.	81678	5	81673	5	53029579	1540	53028039	53028039
0112	BAR HARBOR ME.	633	633	0	633	611800	611800	0	611800
0121	ROCKLAND ME.	760	760	0	760	760	760	0	760
0131	PORTSMOUTH N H.	6124	6124	0	6124	9360606	9360606	0	9360606
0152	SEARSPORT ME.	3362	3362	0	3362	808199	808199	0	808199
0401	BOSTON MA.	230382	2129	228253	1	576330688	8364132	567966556	576330688
0404	GLOUCESTER MA.	20954	5	20949	5	51656255	15088	51656255	51656255
0405	NEW BEDFORD MA.	6870	6870	0	6870	13229645	13229645	0	13229645
0406	PLYMOUTH MA.	25	25	0	25	43750	43750	0	43750
0408	SALEM MA.	349	349	0	349	68759	68759	0	68759
0502	PROVIDENCE R I.	24062	803	23259	3	62720346	184898	62535448	62720346
0601	BRIDGEPORT CONN.	19316	19316	0	19316	17210242	17210242	0	17210242
0603	NEW HAVEN CONN.	137754	3449	134305	3	174497652	5650160	168847492	174497652
0604	NEW LONDON CONN.	28304	28304	0	28304	30194450	30194450	0	30194450
0708	ALEXANDRIA BAY N.Y.	33	33	0	33	85848	85848	0	85848
0712	CHAMPLAIN-ROUSEFS POINT N	50	50	0	50	38919	38919	0	38919
0901	BUFFALO-NIAGARA FALLS N	1785	1785	0	1785	888832	888832	0	888832
0903	ROCHESTER N.Y.	14	2	12	14	31380	21917	9463	31380
0904	OSWEGO N.Y.	291	291	0	291	199796	199796	0	199796
1001	NEW YORK N.Y.	778595	1983315	5805280	25	24586119893	6223291930	18363877963	24586119893
1002	ALBANY N.Y.	92245	81850	92245	9	25596172	194434422	25596172	25596172
1101	PHILADELPHIA PA.	922602	243	840752	9	2124759637	194434422	276608	2124759637
1102	CHESTER PA.	243	243	0	243	276608	276608	0	276608
1103	WILMINGTON DEL.	208777	2567	206210	1	116925526	5967743	110957783	116925526
1105	PAULSBORO N.J.	1	1	0	1	11760	11760	0	11760
1107	CAMDEN N.J.	61178	29164	32014	48	104419650	57329124	47090526	104419650
1113	GLOUCESTER CITY N.J.	5355	5355	0	5355	5544402	5544402	0	5544402
1302	CAMBRIDGE MD.	8766	8766	0	8766	22242145	22242145	0	22242145
1303	BALTIMORE MD.	2446555	377136	2069419	15	5640663744	808351354	4832312390	5640663744
1401	NORFOLK VA.	952336	320127	632209	34	2897480952	725374857	2172106095	2897480952
1402	NEWPORT NEWS VA.	129896	123332	6564	95	156201988	136467911	19734077	156201988
1404	RICHMOND-PETERSBURG VA.	61654	14	61640	1	172231166	1086377	171144789	172231166
1501	WILMINGTON N.C.	203284	53648	149636	26	479942398	125155045	354787353	479942398
1511	BEAUFORT-MOREHEAD CITY N	12628	155357	12628	16	48958310	273717897	48958310	48958310
1601	CHARLESTON S.C.	959660	1874	804303	16	2679764525	273717897	2406046628	2679764525
1602	GEORGETOWN S.C.	1874	1874	0	1874	257491	257491	0	257491
1701	BRUNSWICK GA.	862	862	0	862	582540	582540	0	582540
1703	SAVANNAH GA.	1185375	314918	870457	27	2805030307	927509203	1877551104	2805030307
1801	TAMPA FL.	61958	169	61789	34	47889599	338799	47550800	47889599
1803	JACKSONVILLE FL.	269792	91905	177887	34	521639891	181768784	339871107	521639891
1814	ST PETERSBURG FL.	79	62	17	78	967524	829960	137564	967524
1816	PORT CANAVERAL	2639	24	2615	1	2347785	28942	2318443	2347785
1818	PANAMA CITY FLA.	4170	4170	0	4170	1732724	1732724	0	1732724
1819	PENSACOLA FLA.	922	922	0	922	1078985	1078985	0	1078985
1901	MOBILE AL.	144367	40035	104332	28	187932345	41467124	146465221	187932345
1902	GULFPORT MISS.	45045	19	45026	28	75544328	15870	75528458	75544328

Transportation, 400 7th St. S.W., Room 8117, Washington, D.C. 20590. Mr. Bob Brown, Phone: (202) 366-2286.

United States Oceanborne Foreign Trade Routes. This publication presents detailed information on cargoes moving on U.S.-foreign waterborne trade routes both in U.S.-flag and foreign flag vessels. Several appendixes provide data on tonnage and value of commodities passing through the top thirty U.S. ports, the U.S. coastal districts, and the historical annual tonnages and values. These data would be useful in showing trends in waterborne foreign trade. They must be coupled with domestic trends in order to be useful (sample in Table 4.8). Prepared by the Office of Trade Studies and Subsidy Contracts, Maritime Administration, U.S. Department of Transportation, 400 7th St. S.W., Room 8117, Washington, D.C. 20590. Mr. Bob Brown, Phone: (202) 366-2286.

CASMAIN Personnel Casualties (PCAS) and Vessel Casualties (CAS). These two databases consist of personnel and vessel casualties from September 1980 to the present for all commercial vessel accidents reported in U.S. waters. The data are available on data tape. CASMAIN lists casualties by nature, causes, vessel description, and waterway. Data are also available prior to 1980 in the PERCAS and VESCAS databases which began in 1963, but these data are less complete. Data are derived from Forms 2692 (Accident Report). A casualty as defined in the federal code is any occurrence that meets one of the following criteria: damage of \$1,500 or more; grounding; any accident that renders a vessel unseaworthy; any accident resulting in loss of life; or any injury that causes a seaman to be laid up for 72 hours or more. Reports on casualties are filed with local marine safety offices and are then investigated, with the results of the investigation being filed with Coast Guard Headquarters in Washington. The report is reviewed and entered into the file. Data in the file cover all U.S. flag ships regardless of location at the time of the casualty and all non-U.S. flag ships in U.S. territorial waters. Particulars of the data include: vessel ID and code; time of day of the accident; weather and sea conditions at the time of the accident; ships particulars; including its dimensions, gross tonnage (GT), and hull type; information on personnel; location of casualty of type of water body and specific geographical location; codes for the cause and contributing factors; and results of the casualty (i.e., the number of injuries, and es-

Table 4.8: U.S. Oceanborne Foreign Trade

Appendix G Table 1
 U.S. Oceanborne Foreign Trade
 Top Thirty U.S. Ports
 All Services
 Calendar Year 1983

Rank	U.S. Port	Thousands of Long Tons			
		Total Tons	Import Tons	Export Tons	Pct. 1/ Change
1	New York	46,306	41,496	4,810	- 5
2	Gramercy	44,483	13,093	31,390	20
3	Houston	36,270	16,518	19,752	-13
4	Norfolk	34,738	3,835	30,903	-27
5	New Orleans	32,641	10,723	21,918	-14
6	Philadelphia	19,804	15,985	3,819	-21
7	Baltimore	19,299	8,428	10,871	-42
8	Tampa	18,570	3,892	14,678	-21
9	Long Beach	17,913	7,018	10,895	- 2
10	Baton Rouge	17,518	5,557	11,961	-11
11	Beaumont	16,065	12,635	3,430	- 1
12	Corpus Christi	15,233	12,634	2,599	- 5
13	Texas City	14,215	13,635	580	-35
14	Destrehan	12,956	67	12,889	- 6
15	Portland, Oregon	12,854	1,691	11,163	12
16	Newport News	12,720	2,162	10,558	-36
17	Christiansted	12,276	12,081	195	-89
18	Marcus Hook	11,881	11,744	137	19
19	Los Angeles	10,900	5,492	5,408	-14
20	Pascagoula	9,679	9,541	138	-91
21	Tacoma	8,133	1,940	6,193	21
22	Freeport	8,031	7,514	517	-40
23	St. Rose	8,005	649	7,356	-20
24	Port Arthur	7,545	4,153	3,392	- 6
25	Savannah	7,373	3,681	3,692	-12
26	Galveston	7,335	909	6,426	20
27	Paulsboro	6,415	6,180	235	14
28	Wilmington, Delaware	6,307	6,259	48	-88
29	Mobile	6,099	1,892	4,207	-35
30	Seattle	3,964	1,759	2,205	-37
	All Other Ports	302,063	172,559	129,504	- *
	Total	630,412	327,616	302,796	-10

* - Less than 0.5 percent.

1/- Compared to Calendar Year 1982.

timate of the dollar damages, pollution, and whether or not there was a total loss). These databases will be useful for estimating commercial accident rates for each waterway when combined with transit and cargo information. Prepared by the Office of Marine Investigations, G-MMI-(3), USCG, 2100 2nd Street, SW, Washington, D.C. 20593. Mr. Tom Pettin, Phone: (202) 267-1430. (Updated Annually)

ATONIS. The Aids to Navigation Information System replaced the Standard Aids to Navigation Data System (SANDS). Contains information on each individual aid to navigation, including locations, signals provided and equipment used, type of aid (floating/fixed), access by water or land, and data on discrepancies from which discrepancy rates/MTBF and response/MTTR can be ascertained. Some historical data may be retrieved from review of SANDS.

USCG Annual Budget. Provides direct labor costs and numbers of personnel, "general detail" personnel and other overhead labor costs, capital and operating costs of ships, boats and aircraft, and the bases, depots, stations, and moorings from which they operate. Also includes breakdown of costs directly involved in aid to navigation hardware, R&D and other support manager program costs such as training.

WAMS Analyses and Aids to Navigation Operations Requests. WAMS analyses and Aids to Navigation Operations Requests (Forms 3213) include various information on justification (in terms of amount and size of traffic and cargo), and initial cost of new aids/upgraded aids or other improvements.

Port Access Route Study. (CGD 81-074) The purpose of this study was to determine any need for routing measures for vessels using U.S. ports. It includes information on coastal areas of the U.S., the volume of traffic following certain traditional routes, fishing vessels in established fishing grounds, and the risk to vessels from offshore developments such as oil and gas drilling rigs.

Map of Inland Freight Tonnage by Direction of Movement, Mississippi River, Selected Tributaries and Gulf Intracoastal Waterways. U.S. Army Corps of Engineers. Waterway traffic tonnage density map, by direction between key

geographical locations including ports, locks and terminals of improved waterways under U.S. Army Corps of Engineers administration. (Updated Annually)

U.S. Great Lakes Ports Statistics for Overseas and Canadian Waterborne Commerce. Saint Lawrence Seaway Development Corporation, 800 Independence Avenue., S.W., Washington, D.C. 20591. U.S. Census data for waterborne imports and exports for the U.S. Great Lakes Port Range is statistically tabulated by port, by foreign trade area, by dollar value, in short tons (2000 lb.), stating percent of total by type of vessel service. Tabulations are identical for imports and exports. (Updated Annually)

Waterborne Data Bank. Department of the Army. For exports and imports, this tape includes the total value (dollars) and total shipping weight (pounds) for all vessels and the value (dollars) and total shipping weight (pounds) for U.S. flag vessels. For imports, the tapes include the country of origin for U.S. flag vessels and the country of destination for all vessels. For exports, the tapes include the country of destination for U.S. flag vessels and the country of origin for all vessels. (CN091-CN099: 1973, CN101-CN105: 1971, CN125: 1975)

Inland Waterborne Commerce Statistics. American Waterways Operators, Inc. Reports on 27 major waterways including total amount of traffic and net tons of the major commodities transported. Contains comparative statistics on tonnage of commerce transported on inland waterways of the United States (exclusive of the Great Lakes) comparing most recent statistics with 20 previous calendar years, comparisons of the principal commodities transported; comparisons of coastal and coast-wise traffic, and comparisons of net tons and ton-miles of freight traffic transported by all modes for the most recent five years for which data are available. Tables show the length and depths of individual segments of the network of navigation channels; number of towboats, tugboats and barges in operation according to the latest available statistics; and a comparison of the number of vessels in operation for the most recent years of availability. (Updated Annually)

Revenue and Traffic of Class A and B Water Carriers (1938-Present), Statement 650. Interstate Commerce Commission. Semi-annual report on class A and B water carrier freight revenues, revenue tons and miles, and passenger revenues and numbers carried with comparative data for same period of previous year. Compiled from quarterly reports on form QWS. Contains one table presenting data for the following 5 marine regions: Atlantic and Gulf Coasts, Great Lakes, Mississippi River and Tributaries, Pacific Coast, Intracoastal, and by individual carriers within each region. (Updated Semi-Annually)

Casualty Returns. The Liverpool Underwriters Association. Each issue of statistics offers a summary of total world losses for the current year and 4 previous years, giving the number of ship casualties and the total of tonnage lost, total losses by nationalities, 5-year summary, losses by nature of casualty, and total losses by nature of casualty for 5 years. The monthly data give the vessel name, flag/port of registry, gross tonnage (GT), year built, owners (operators), voyage, cargo, and particulars of the casualty. These data are supplied in two categories: total losses and other important casualties. (Updated Monthly)

Distances Between U.S. Ports. National Ocean Survey. Report presenting tables showing nautical distances between U.S. coastal and inland waterway ports, including those of Puerto Rico, Virgin Islands, the Panama Canal, and Midway Islands. Also covers selected Canadian Great Lakes, St. Lawrence Seaway, and Pacific Ports. Distances are shortest routes of safe navigation, generally measured in nautical miles. (Updated Periodically)

American Association of Port Authorities (AAPA) Annual Handbook. The Handbook is available at no charge from the AAPA Office. It includes a listing of U.S. public and private ports and port authorities with the name of the port director, address, and phone number. Anyone interested in obtaining information on an individual port is advised to secure a copy of this handbook and to contact the port offices concerning their available data or publications. For example, the port of San Francisco publishes an annual ocean shipping handbook; the Port of Portland and the Port Authority of New York and New Jersey both prepare and distribute numerous reports on trade through the

ports, ship schedules, and facilities and services available at the ports.
(Updated Annually)

Bridges Over Navigable Waters of the United States. Coast Guard, Army Corps of Engineers. Contains a list of the locations and owner of each bridge over navigable waters of the United States, and gives such pertinent information as the distance from the mouth of the body of water it spans, type of bridge, clearance (horizontal and vertical), date plans were approved, and type of traffic traveling over the bridge. Issued in the following parts: Part 1) Atlantic Coast. Part 2) Gulf and Mississippi River System. Part 3) Great Lakes. Part 4) Pacific Coast.

Current Trends in Port Pricing (August 1978). Department of Commerce, Maritime Administration. Report on pricing policies of public ports and the trade-off between recovering costs and competing for cargo. Examines port usage charges, known as dockage (for ships) and wharfage (for cargo); and other charges for terminal leasing and use of facilities and services. Rates are current as of 1977, with selected changes from 1968. Data are primarily from interviews with managers at 28 ports in 4 coastal areas. Includes scattered tables and charts, most showing port usage charges compared to total vessel operating costs; typical dockage and wharfage charges, by coastal area, 1968 and 1977; port revenue deficiencies; and other port charges.

Domestic Oceanborne and Great Lakes Commerce of the U.S. Maritime Administration. Gives data for dry cargo ships and tank ships in two sections (shipping areas to receiving areas and receiving areas from shipping areas), by commodity and total tonnage. Summary charts give historical data.
(Updated Annually)

Guide to Port Entry. C.L. Pielow, Editor, Shipping Guides, Limited. Data provided for all the world's ports include the following: pilotage, anchorage, restrictions at specific ports, maximum size of vessel that the port is equipped to handle, health regulations, tugs, berthing, radio, radar, bridges and clearances, tanker facilities, fuel, repair facilities, drydocks, services, and port regulations and authorities.

Interstate Port Handbook. Vance Publishing Corporation. Gives information for each U.S. Coastal, Great Lakes, and inland waterway port on as many as 10 topics and a 1/2 page narrative. Describes the waterway systems in the U.S. by region, mileages of the inland river waterways, ports, docks and terminals, and controlling clearances of bridges, locks and dams. (Updated Bi-Annually)

Lloyd's Register of Shipping - The Casualty Information File. Lloyd's of London Press, Ltd. Lloyd's of London is the leading center for the collection and dissemination of shipping casualty information. Lloyd's register also has much casualty information on record. Research is now under way to link these data to provide an even more comprehensive casualty information service. The data include all ships totally lost, broken up, etc. during the quarter by flag, number, gross tonnage, type of casualty, and percentage of total tonnage; details of the casualties for each ship including the ship's name and year of build, type, voyage, cargo, circumstances and place, and date. (Updated Periodically)

Lloyd's Register of Shipping - The Register Book. Lloyd's of London Press, Ltd. Contains detailed particulars of all known sea-going merchant ships of 100 gross tonnage or above throughout the world (some 60,000 vessels), and includes all ships presently classed with Lloyd's register. This file is the source from which the Register Book, its supplements, and new entries are compiled. It is updated by a comprehensive data gathering and editing system which embraces official lists, shipping journals and newspapers. Included among the principal items: ships' current and former names, date of build, ship type, classification society, shipowner/manager, dimensions, flag and port of registry, propulsion, tonnages (gross/net/dead weight), speed and fuel consumption, engine power, shipbuilder/yard, number/engine builder, cargo carrying/handling facilities. (Updated Periodically)

Maintenance and Repair (M&R). Maritime Administration. This database is updated as material becomes available. The data elements include codes for vessel name, ship design, operator, region, trade route, voyage number, section, function cost, material, cause for repair, corrective action, group

summary, facility, facility location, repair region, manufacturer, cost, fleet type, calendar quarter, year, and termination date. (Updated as Needed)

Marine Insurance Information System (MII). Maritime Administration. The MII data base elements include the vessel ID code, vessel characteristics, home port, registry information, insurance carried, underwriter ID, insurance claims, contract price, construction cost, world market value, mortgage balance, replacement cost, book value, and war risk value. (Updated as Needed)

Operating Cost of Coast Guard Cutters (1951-). Coast Guard. Annual Report on Coast Guard Cutter operating costs, by cost item, individual vessel, and program. Contains preface and 3 tables listed below. (1) Service-wide average cost of Coast Guard Cutters (by class of unit and major items of cost, and by total and percent change). (2) Operating costs of Coast Guard Cutters by class of unit and major items of cost (by individual vessel, total, resource, and operating hours). (3) Service-wide summary of operating costs of Coast Guard Cutters by class of unit and programs. Cost items are pay and allowances of officers and enlisted personnel, fuel, other operating and maintenance costs; electronics program, vessel program, other. (Updated Annually)

Physical Waterway Characteristics. Army Corps of Engineers. This database includes statistical profiles of locks, channels, and bridges on U.S. waterways. The data were compiled by U.S. Army Corps of Engineer districts from data in existing records and publications for the fiscal year 1975. There are 52 elements of lock characteristics. The 31-channel characteristics include identification and location, general remarks, restricted navigation, standard low and high water data, channel maintenance, and structures and obstacles. Bridge characteristics are provided in 32 segments of data such as identification and location, general remarks, operational characteristics, channel, clearances, and restrictions on navigation. In 1979, five engineer pamphlets were published that contained the 1975 data. Access will also be provided through the Corps navigation computer database. Revision procedures have been arranged, but revision frequency has not been decided. (Updated Periodically)

AD-A173 705

SRA (SHORT RANGE AIDS TO NAVIGATION) RESOURCE
MANAGEMENT: MEASURES OF EFFECTIVENESS(U) MANDEX INC
SPRINGFIELD VA L GREENBERG ET AL. SEP 86 USCG-D-20-86
DTCF23-85-C-20078

2/4

UNCLASSIFIED

F/8 17/1

NL

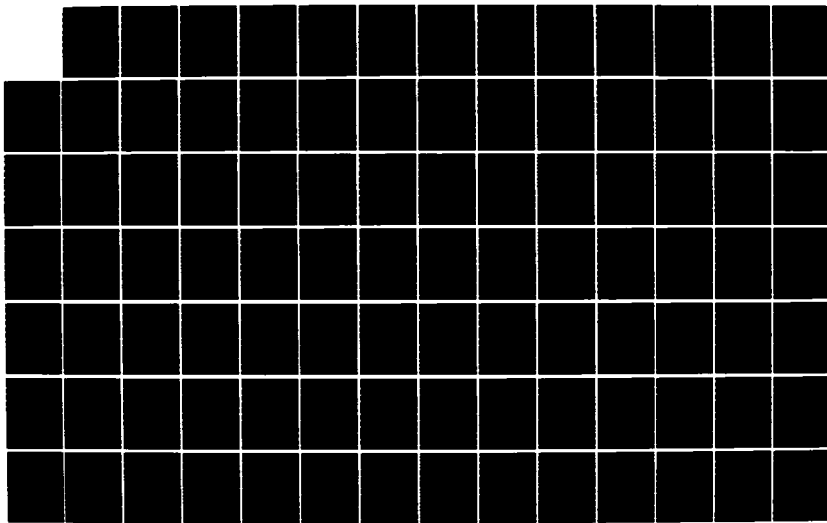

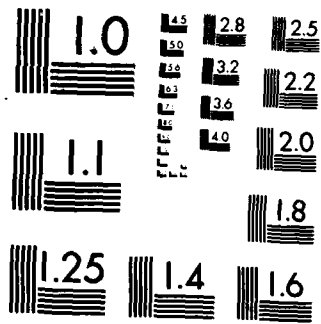

MICROCOPY RESOLUTION TEST CHART
NATIONAL BUREAU OF STANDARDS-1963-A

Polluting Incidents In and Around U.S. Waters. Coast Guard. The report contains data on discharges of oil, refuse, and other pollutants into navigable waters and contiguous zones of the U.S. Fourteen tables are included, with data for all incidents and for oil spills only. Particulars of the data are the number of incidents, the gallon volume of the spill, the percent of total by general area, the location of the incident, the type of material spilled, the source of the spill, the relative size of the discharge, and the incident month and cause. (Updated Annually)

National Waterway Study, 1980. Army Corps of Engineers. The study resulted in four major products: 1) a description of the nation's existing water transportation system, identifying the major physical and operational characteristics of U.S. waterways, ports and harbors, the major commodities being transported, and the types of carriers and shippers using these facilities; 2) an assessment of the water transportation systems capability to meet future needs, including the systems interrelationships with non-transportation needs such as flood control, irrigation, and recreation, 3) selection and analysis of alternative changes to the water transportation system; and 4) 49 recommendations to Congress. The scope included all U.S. waterways and ports with waterborne commerce, both domestic and foreign, water transportation as one mode of transportation and as one part of water resource use.

Losses and Scrappings. Maritime Administration. This publication contains a listing by country of all commercial vessels lost or scrapped during the year, and includes the total number of ships lost or scrapped, the year of build, gross tonnage (GT), dead weight tonnage (DWT), and average age of the ships in each class (freighters, combination carriers, containerships, and tankers). (Updated Annually)

Recreational Boating in the Continental United States in 1973: The Nationwide Boating Survey. Coast Guard. In order to expand and clarify existing information on recreational boating and provide measures of effectiveness of the boating safety program, a nationwide survey of 1973 boating activity was conducted by the U.S. Coast Guard. Using randomly-generated telephone exchanges, over 25,000 households were contacted and those dis-

covered to be boat-owning and/or containing a boat operator were interviewed. The results for each geographical area were appropriately weighted and combined to form state, regional, and national estimates of boating data. The analysis reveals that passengers on non-motorized boats have a greater risk of being involved in a fatal accident, while boaters on motorized craft have a greater chance of incurring a serious injury.

American Bureau of Shipping (ABS) Casualty Data. American Bureau of Shipping. In accordance with its function as a seaworthiness and marine plans classification society, the ABS provides casualty survey services to vessel owners. The following data are extracted from surveys for the computer input: file number, survey date, report number, year of ship's build, gravity of the problem, the ship's hull number, its tonnage, the name of the shipyard where built, the ship's name and type, the ship's flag, damage information, and a descriptive commentary of the casualty. (Frequency of Update: Ongoing)

Annual Report of the Secretary of Transportation on Hazardous Materials Control. Department of Transportation, Materials Transportation Bureau. The report includes a summary of hazardous materials incident reports involving death or injury by mode of transport, Coast Guard data on unintentional releases of hazardous materials aboard tank vessels, vessel casualties, waterfront casualties, and pollution responses; special permits and exemptions granted by mode of transportation, including a breakdown on those issued by the Coast Guard; hazardous materials regulations violations and enforcement actions; hazardous materials inspections of carriers, shippers, and container manufacturers; Coast Guard port and merchant marine inspections; commodities most frequently named in hazardous materials carriers incident reports; Coast Guard marine casualties involving bulk hazardous materials carriers for the fiscal year; and a listing of projects, publications, and other materials of the Coast Guard concerning hazardous materials. (Updated Annually)

Coast Guard Service-Wide Search and Rescue Statistics. Coast Guard. Contains 3 charts, summary table, and 3 tables showing responses and deaths and property loss prevented annually for the fiscal year and 5-year averages, for all districts, air stations, bases, patrol boats, groups/sections, and stations. (Updated Annually)

Marine Safety Information System (MSIS). Columbus Laboratory of Battelle, Inc. The MSIS was developed for the USCG by the Columbus Laboratory of Battelle, Inc. It is an interactive system, linking system users together as both suppliers and receivers of information. Within this framework, detailed safety profiles for vessels and facilities can be developed, analyzed, and compared; current status relative to regulatory actions can be generated; common areas can be detected; pending actions can be monitored; and administrative functions can be performed. Does not include causes of accidents. (Frequency of Update: On-going)

Motorboat Accident Statistics (MBA). Coast Guard. The system provides annual statistical summaries on motorboat accidents. The principle data elements are case number, date, state, country, cause, fatalities, injuries, operator age, vessel types, time, and environmental conditions. A magnetic tape is produced on a monthly basis to update the Office of Boating Safety management information system. Thirty-two annual reports are generated by this system. One of them is the Coast Guard Boating Statistics, required by the Federal Boat Safety Act of 1971. (Updated Monthly)

Statistics of Casualties. Coast Guard, Office of Merchant Marine. A statistical summary of commercial vessel casualties that were investigated by the Coast Guard marine inspectors. The public, industry, and the Coast Guard have used the findings of these investigations to establish standards and determine the need for legislation to improve the protection of safety of life and property at sea. Includes statistical data for 1963, 1965-71, and 1973-79.

Boating Statistics: Coast Guard. Reports boat numbering registration and boating accidents involving fatalities, injuries, or property damage exceeding \$100. Covers 50 states, D.C., Guam, Puerto Rico, the Virgin Islands, and American Samoa. The report includes an introduction and summary with text table showing fatalities and rates; 17 tables, listed below, and 7 charts; summary of coast guard auxiliary safety program activities; and glossary and facsimile of old and new accident reporting forms. 1) Numbering data by state. 2) Classification of numbered motorboats. 3) Numbered motorboats by propulsion and hull material. Accident Data - 4) Five year summary of

selected accident data by state. 5-7) Boating accidents, vessels involved in accidents (by type of casualty), and results of boating accidents (fatalities, injuries, and property damage). 8) Weather and water conditions (associated with vessels involved in accidents, fatalities and injuries). 9) Accident data by state (number of accidents, number of vessels and persons involved, and dollar amount of damage). 10) Types of accidents by state (number of vessels involved, with or without vessel casualty, and number of victims by drownings, other deaths or injury). 11) Jurisdiction of boating accidents by state. Detailed tables--(data are cross-tabulated by operators age and experience, boat type, hull material, length, propulsion, horsepower, and operation at time of accident). 12) Vessels involved in all accidents by principal cause. 13-14) Principal cause of fatalities and of injuries. 15-17) Vessels involved, fatalities, and injuries by type of casualty. Types of vessel casualty include grounding, capsizing, flooding, sinking, fires, collision, striking floating object, and other. Personal casualties include falls overboard or in boat, burns and scalds, being struck by boat or propeller, crushing or pinching, and other. (Updated Annually)

Operational Statistics System (OPSTAT) and Abstract of Operations. Coast Guard. The system is to produce statistical reports of aircraft, boats, and cutters for each district. These reports reflect the activities within current Coast Guard programs. The system is Coast Guard-wide. Principal data elements are cumulative hours expended for operation of aircraft, boats, and cutters within current Coast Guard programs, i.e., search and rescue. Reports include: Abstract of Operation Boat Reports (Quarterly-Annually), Abstract of Operation Aircraft/Maintenance (quarterly-annually, hardcopy), and Abstract of Operation Cutter Report (quarterly-annually, hardcopy). There is no query capability. (Updated Quarterly)

American Petroleum Institute. No databases currently available. Ms. Lois Sherman, Phone: (202) 682-8000.

5. ILLUSTRATIVE RESOURCE MANAGEMENT DECISION:
A BUOY TENDER FOR PUGET SOUND

5.1 The Decision Setting

In order to illustrate how the measures of effectiveness will be used in the Resource Management Tool (RMT) to make better resource allocation decisions, this section will show how the RMT can be used to analyze an example problem which actually confronted the Coast Guard in 1982: how to provide a buoy tender for Puget Sound.

Due to budget cuts, the old Lighthouse Service Tenders HOLLYHOCK and WALNUT were retired from service. HOLLYHOCK was homeported in Miami, Florida, and was not replaced. Servicing responsibility for her assigned buoys was assigned to other buoy tenders in the 7th District. WALNUT was homeported in San Pedro, California, as the only buoy tender in the 11th District. She was replaced by the 175-foot FIR, the only remaining Lighthouse Service Tender, which had tended aids to navigation in Puget Sound since she was commissioned. Although FIR had been homeported in Seattle, her buoys were reassigned to IRIS, homeported in Astoria, Oregon.

While there was no problem accomplishing scheduled work in Puget Sound after the reassignment of FIR, IRIS was not able to respond to discrepancies in the manner that local mariners had come to expect. In less than a year, Congress directed that the Coast Guard find a cost-effective way to replace the lost capability of FIR in Puget Sound.

The purpose of this example is to illustrate how the RMT, had it been available in 1982, could have aided the Coast Guard in analyzing this problem and in communicating the decision to Congress. The scope of the decision environment has been scaled down in order to focus understanding on the RMT and measures of effectiveness. Therefore, the following illustration is intended to demonstrate methodology, not to be an actual *complete* evaluation of the decision to select a buoy tender for Puget Sound. However, it represents a typical resource management decision for which the RMT will be ideally suited.

5.1.1 Background. The Coast Guard knew that it had a difficult problem to solve. Not only were there objective, economic costs and benefits to the mariner to consider, but reassignment of buoy tenders always caused an upheaval in the Coast Guard districts and the local communities which was not easy to quantify, but which usually cost something in the end. The Coast Guard had just been through a round of decommissionings and resource adjustments and was not eager to go back and face the pilots' associations, the Congress, and the district commanders with another change. Taking stock of the situation, no good solution seemed readily apparent.

Following the reassignment of FIR to the 11th District, the servicing forces in the 13th District consisted of the tenders and ANTs shown in Table 5.1.

<u>Servicing Unit</u>	<u>Length</u>	<u>Crew</u>	<u>Boats</u>	<u>Homeport</u>
USCGC Bayberry	65'	6	-	Seattle, WA
ANT Port Angeles	---	7	0	Port Angeles, WA
USCGC Iris (WLB)	180'	48	-	Astoria, OR
USCGC White Bush (WLM)	133'	23	-	Astoria, OR
ANT Astoria	---	7	2	Astoria, OR
ANT Coos Bay	---	6	1	North Bend, OR
USCGC Bluebell	100'	15	-	Portland, OR
ANT Portland	---	8	3	Portland, OR

Table 5.1: 13th District AtoN Servicing Forces

IRIS could be expected to be in CHARLIE status (not available for operations) 25 percent of the time. During these periods, BAYBERRY and ANT Port Angeles could provide secondary response only to those types of discrepancies to IRIS's buoys which did not require lifting the buoys from the water. WHITE BUSH was capable of lifting all but a few of IRIS's buoys, but the capability was severely limited to periods of good sea conditions, not only in Puget Sound, but also off the Washington coast while traveling to reach Puget Sound. When available, tenders from the 17th District in the area for shipyard availabilities could be used for discrepancy response. During the expected 75 percent of the time when IRIS would be available, steaming time in good weather from Astoria to Seattle was more than a day, and if IRIS

was servicing aids to navigation near the California border, steaming time was more than two days.

The AtoN servicing forces in other districts were also stretched thin. Other than WHITE BUSH, three of the 133-ft. WLMs were located in the northeast in the 1st District and the other 3 along the Gulf Coast in 7th and 8th Districts. The five 157-ft. WLMs were in the 3rd and 5th Districts along the east coast. All of these tenders had large numbers of assigned aids to navigation, many of which could not be serviced by deeper-draft vessels. The 180-ft. WLB fleet consisted of 17 tenders spread throughout eight districts in the continental United States (CONUS) and another 11 outside CONUS, including seven in the 17th District and three in the 14th District. Most of these vessels had multi-mission demands in addition to buoy tending, such as ice-breaking on the Great Lakes, search and rescue on the open seas, and fisheries patrolling.

5.1.2 Capabilities desired for a Puget Sound buoy tender. Puget Sound and Rosario Strait leading to it form a very deep and wide channel. A variety of commercial, recreational, and Naval vessels use the waterway, including cargo container ships, 125,000 DWT oil tankers, and Trident submarines. Fog is a major hazard in the channel and coastal areas along the approach have the worst bar conditions anywhere in the U.S.

The buoys assigned to IRIS in the Puget Sound included two 9-foot Lighted Sound Buoys. These buoys weigh about 13 tons. These and one other large buoy were moored with single or double 9- or 12-ton sinkers. In addition, IRIS was assigned another twenty-one 9- and 10-foot lighted buoys, weighing up to 19 tons, for which a Puget Sound tender would have discrepancy response responsibilities approximately 25 percent of the time.

Many of the Traffic Separation Scheme (TSS) buoys in Puget Sound were moored with synthetic mooring lines. Servicing these moorings requires special equipment known as SLIHANDS. While SLIHANDS is portable, the tender carrying it must be specially modified.

A great many of the buoys that would be assigned to a Puget Sound tender, as well as the buoys assigned to IRIS for which a Puget Sound tender would have some discrepancy response responsibility, were in "exposed" locations in terms of fetch and sea states. To service these aids to navigation and transit these waters, as well as those along the Washington and Oregon coasts, a tender would require considerable seakeeping capability. The large area to be covered also required a vessel manned for extended steaming.

5.2 Analysis Using the RMT Approach

The Coast Guard had many sources of data available to it including discrepancy rates, response times, operating costs, accident statistics, and the number of transits in each U.S. waterway. It also had indicators of Coast Guard morale, political pressures, user satisfaction, and many other intangible factors. However, it had no way of combining this information systematically in order to determine the total effectiveness of a potential solution. The measures of effectiveness defined in this report provide the means to make that linkage.

The measures of effectiveness can be combined in an MOE module of the RMT to yield a single measure of total effectiveness. This measure may be the expected dollar value of a proposed option. When some benefits of an option cannot be easily put into terms of dollars, then an approach known as multiattribute utility (MAU) may be used. A complete explanation of MAU is provided in Appendix B. The seven key steps of the MOE module, as they relate to the example decision of a buoy tender for Puget Sound, are as follows:

- *Problem Definition:* How can the Coast Guard provide a buoy tender for Puget Sound in the most cost-effective way?
- *Identification of Alternatives:* What are the feasible options from which the Coast Guard can choose to buy or relocate a buoy tender?
- *Review of Comparison MOEs:* What are the measures of effectiveness that are important in buying or shifting a buoy tender and which ones have little or no impact?
- *Evaluation of Each Alternative on the Comparison MOEs:* How does each alternative plan to locate a tender in Puget Sound score on each measure of effectiveness?

- *Prioritization of the Comparison MOEs:* Which measures of effectiveness are more important than others in choosing between alternative buoy tender purchase or relocation options?
- *Comparison of Alternatives:* Which alternative plan scores highest on all the measures of effectiveness combined?
- *Sensitivity Analysis:* Would the choice of a particular plan change if some assumptions or priorities were changed?

The remainder of this section will illustrate each step in turn. The result will be an understanding of how the measures of effectiveness can be used in an analysis of SRA resource management problems using the RMT approach.

5.2.1 Problem definition. Definition of the problem is the first step in the RMT approach. Framing the proper question at the beginning of an analysis saves time and effort later on. However, often a problem is not understood well enough at first to pose a well-defined problem statement. In these cases, it is useful to proceed with the analysis and return to this step from time to time until a clear problem definition emerges. In the example problem, the problem definition could be stated as "evaluate alternative ways to provide a buoy tender for Puget Sound."

5.2.2 Identification of alternatives. The normal use for the SRA measures of effectiveness and the RMT is for evaluation of a well-defined set of alternatives. For the example problem, a Puget Sound buoy tender should have the capability of either a WLM or WLB in order to perform adequate discrepancy response. The tender could come from servicing assets within the 13th District, from another district, or an additional tender could be acquired. In addition, FIR could be returned to Puget Sound and a tender from another district reassigned to the 11th District. After discussions with AtoN personnel from headquarters and the districts, the following seven alternatives could have been identified as feasible solutions to the problem:

Alternative A. Relocate IRIS to Seattle. Basing facilities already existed for a WLB tender in Seattle and this alternative might have been a relatively inexpensive way to reduce travel time to the many aids to navigation in Puget Sound. This would also have required the relocation of many of the families of the crew of 48 and might have had a poor effect on their morale.

Alternative B. Relocate WHITE BUSH to Seattle. Similar to Alternative A, this would have been a low-cost option to base the 133-ft. WLM tender in Puget Sound without disrupting servicing forces in other districts. Due to its smaller crew size of 23, it would also have had a smaller impact on morale. However, some of the aids to navigation in Puget Sound exceed the servicing capabilities of a WLM.

Alternative C. Shift a WLM from an east coast district to Seattle. This alternative would have relocated a 133-ft. WLM, probably from the 1st District, to provide additional capability to the 13th District. It would have required a long move for the crew and many of their families.

Alternative D. Shift a WLB from the 14th District to Seattle. Although the 14th District had only three WLBs, there was evidence that critical functions could be performed with two. A WLB would have provided all the servicing capability that FIR provided in Puget Sound.

Alternative E. Shift a WLM from the east coast to San Pedro and return FIR to Seattle. This approach would have fully restored the servicing capacity in Puget Sound. However, capability in the donor district and the 11th District may have diminished. It also involves moving families of two 23-man crews.

Alternative F. Shift a WLB from the 14th District to San Pedro and return FIR to Seattle. This alternative may have improved the situation in Puget Sound and the 11th District. As in the previous alternative, it would involve relocating most of two sets of crews and families.

Alternative G. Acquire an additional buoy tender to be assigned to Seattle. This could not be accomplished in a short time frame and would be costly. But, in the long run, it would certainly provide the best servicing of any alternative.

While this example will only consider these seven alternatives, the RMT would allow additional alternatives to be developed as needed. For example, after investigation of these options, it might be desired to compare the costs and benefits of relocating the tender to Port Angeles instead of Seattle.

5.2.3 Review of comparison MOEs. In determining which of the measures of effectiveness have a bearing on the problem, it is useful to review the outline structure of MOEs shown in Table 4.1. While a range of MOEs have been developed for the RMT in order to address any SRA resource management problem, the structure should be examined carefully to ensure that all important factors affecting the particular decision to be made are being considered. The RMT is flexible enough to allow a new MOE to be added if needed. Conversely, not all MOEs in the structure should be used for all decisions if they have no bearing on the problem. The goal is to develop a list of MOEs

that is as compact as possible without leaving out any that might help choose between alternatives (see Section 4.3.2 for detailed descriptions of MOEs).

For this example, five of the MOEs in the outline structure have been identified as having no impact on the selection of a buoy tender for Puget Sound:

1 3 1 1 *Non-Accident Costs.* None of the alternatives requires the mariner to take any special actions or purchase any equipment.

1 3 3 2 *Federal Government Interests.* None of the alternatives imposes any particular indirect costs or benefits on the Federal government other than those enumerated in the other MOEs.

1 3 4 2 *Environmental Interests.* None of the alternatives provides special environmental benefits except those that may be included under Economic Considerations.

1 3 4 3 *Historic Preservation.* None of the alternatives affects Historic Preservation.

2 1 3 *Research and Development Costs.* None of the alternatives affects R&D costs.

These MOEs are seen to have an insignificant impact on the ability to distinguish between alternatives. Therefore, they may be simply "zeroed out" of the structure for this analysis by evaluating their scores and weights as 0. The MOEs themselves, should be retained in the RMT in order to be used at a later time for other analyses.

The remaining list of MOEs is still quite considerable, yet it is important to be efficient in the analysis by focusing only on those which would make a difference to the choice of a solution. A practical approach to this step is to begin with only MOEs that have tangible economic impacts on the alternatives, measurable in dollars. By comparing the alternatives on these MOEs first, one or two alternatives may be seen to be far better than the others, reducing the effort needed to collect and analyze data on the other MOEs. Should no single alternative prove to be significantly better than the others using only economic MOEs, then the non-economic MOEs may be folded into the analysis as additional considerations. Of course, both economic and non-economic MOEs may be used from the beginning of the analysis if time and

resources are available. The economic and non-economic MOEs for the example are listed in Table 5.2.

5.2.4 Evaluation of each alternative on the MOEs. The evaluation of each alternative on only the economic MOEs may take the form of a cost-benefit analysis approach. The positive and negative economic impacts of each alternative, measured in dollars, are totaled and the alternative with the greatest net dollar value is selected. This approach assumes that dollar values may be placed on human lives lost through accidents (see Appendix C). This approach also assumes that all dollars are valued equally and may be substituted between MOEs. For example, one dollar of capital cost is assumed to be no different from one dollar of litigation cost. Although an analysis may require a more subtle definition of economic costs and benefits in some cases, the cost-benefit approach is usually the best way to begin.

For this example, Table 5.3 shows the net economic benefits and costs of each alternative. Costs are assumed to be "cost to the federal government," while costs to the mariner are expressed as negative benefits. The benefits and costs shown are hypothetical, but real figures would be calculated using other modules of the RMT.

From Table 5.3, it is not clear which alternative is the best. Alternatives F and G have the greatest net dollar values, but Alternatives D and B also have some positive net worth. The other alternatives seem so bad that further analysis of them may be unwarranted. In order to help discriminate between Alternatives B, D, F and G, the non-economic MOEs should be considered together with the economic MOEs.

Because the non-economic MOEs are not measured in terms of dollars, a common "scoring" system must be used for all MOEs to allow comparisons between alternatives. Both economic and non-economic MOEs usually have natural standard units of measure (e.g. dollars, hours, ton-miles, lives). However, sometimes a more subjective unit of measurement with verbal descriptions must be used (e.g. very bad, bad, good, excellent). Regardless of the unit of measure, a measurement scale must be developed for each MOE so that the alternatives may be "scored" on it. There are two kinds of "scoring" scales: ab-

Table 5.2: Outline Structure of MOEs

ECONOMIC

- 1 Benefits
 - 1 1 Safety
 - 1 1 1 Economic Considerations
 - 1 1 1 1 Commercial Users
 - 1 1 1 2 Recreational Boaters
 - 1 1 1 3 Government Users
 - 1 1 1 4 General Public
 - 1 1 2 Personal Safety
 - 1 1 2 1 Commercial Users
 - 1 1 2 2 Recreational Boaters
 - 1 1 2 3 Government Users
 - 1 1 2 4 General Public
 - 1 2 Timeliness
 - 1 2 1 Ship-Related Costs
 - 1 2 2 Consignor or Consignee Costs
- 2 Costs
 - 2 1 Coast Guard Costs
 - 2 1 1 Operating Expense (OE)
 - 2 1 2 Capital Costs (AC&I)
 - 2 2 Other Federal Government
 - 2 2 1 Litigation
 - 2 2 2 Other

NON-ECONOMIC

- 1 3 Other Benefits
 - 1 3 1 Mariner Interests
 - 1 3 1 2 User Satisfaction
 - 1 3 2 Coast Guard Interests
 - 1 3 2 1 Multimission Capability
 - 1 3 2 2 Organizational Impact
 - 1 3 2 3 Standard Measures of Performance
 - 1 3 3 Other Government Interests
 - 1 3 3 1 International
 - 1 3 3 3 State/Local Governments
 - 1 3 4 Public Interests
 - 1 3 4 1 Economy

Table 5.3: Example of Economic Analysis

	ALTERNATIVES (\$000)						
	A	B	C	D	E	F	G
<u>Net Economic Benefits</u>							
SAFETY							
Commercial Economic	0	+50	-80	+380	-130	+470	+710
Recreational Economic	-4	+14	-10	-4	+2	-4	+50
Government Economic	+87	+13	+13	+69	-5	+180	+161
General Public Economic	+3	+3	-4	+30	-4	+30	+30
Commercial Personal	-80	-50	+50	+280	+50	+320	+440
Recreational Personal	+10	+76	-12	+10	+43	+10	+210
Government Personal	+160	+140	-10	+40	-20	+60	+180
General Public Personal	+8	+8	0	+20	0	+20	+20
TIMELINESS							
Ship-Related Costs	-31	+26	+26	+312	-12	+292	+350
Consignor/Consignee Costs	<u>0</u>	<u>+46</u>	<u>0</u>	<u>+195</u>	<u>0</u>	<u>+207</u>	<u>+230</u>
TOTAL NET BENEFIT	+153	+326	-27	+1332	-76	+1585	+2381
<u>Net Economic Costs</u>							
COAST GUARD COSTS							
Operating Expenses (OE)	+400	+362	+512	+250	+550	+325	+1000
Capital Costs (Annualized)	0	0	0	0	0	0	+600
OTHER							
Litigation	<u>-100</u>	<u>-100</u>	<u>+300</u>	<u>-20</u>	<u>+300</u>	<u>-20</u>	<u>-500</u>
TOTAL NET COST	300	262	812	230	850	305	1100
BENEFIT S MINUS COST S	-147	64	-839	1102	-926	1280	1281

Note: The benefits and costs used in this example are hypothetical, but are consistent with judgments provided by several subject matter experts.

solute and relative. Both kinds of scales may be used in an analysis, as will be illustrated in the example below using four selected MOEs:

- COMMERCIAL ECONOMIC SAFETY BENEFITS (Measure 1.1.1.1);
- COMMERCIAL PERSONAL SAFETY BENEFITS (Measure 1.1.2.1);
- SHIP-RELATED TIMELINESS COSTS (Measure 1.2.1);
- ORGANIZATIONAL IMPACT ON THE COAST GUARD (Measure 1.3.2.2).

Under both of the scoring approaches, a benefit scale is defined from 0 to 100. These endpoint values are arbitrary, and are selected for convenience. Note that 0 does not imply no benefit. Rather, it can be viewed as a baseline, or threshold against which alternatives can be scored. In a similar fashion, the 100 point on the scale can be viewed as the point that represents 100% of the benefit that can be gained over threshold. All points in between these endpoints can be viewed as a proportionate gain in benefit value.

Absolute Scoring Scales. The first kind of scoring is the use of absolute scoring scales. In this method, the scales can be developed independently from the alternatives. The endpoints of each scale are determined in an absolute sense, and there is no requirement that any of the alternatives fall at the endpoints. In determining the endpoints, it is essential to consider the range of values that potential alternatives might span. If the defined endpoints are too close together, alternatives will be excluded. If too far apart, all alternatives will fall in too narrow a band of scores and the RMT will not be able to discriminate between them.

For the example problem of a tender for Puget Sound, Table 5.4 shows the scores for the bottom-level MOE of COMMERCIAL ECONOMIC SAFETY BENEFITS (Measure 1.1.1.1) which was developed using an absolute linear scale in thousands of dollars. The endpoints on the scale and the net annual economic benefit for each alternative may be determined using other components of the RMT. The endpoints are then given a score of "0" and "100" and the score for each alternative is interpolated proportionally between the endpoints. In this example, assume that the range for this MOE was -\$200,000 to +\$800,000.

<u>Alternative</u>	<u>Benefits (\$000)</u>	<u>Score</u>
Endpoint	+800	100
G	+710	91
F	+470	67
D	+380	58
B	+50	25
A	0	20
C	-80	12
E	-130	7
Endpoint	-200	0

Table 5.4: Commercial Economic Safety Benefits

The best alternative is G (+\$710,000) because the 13th District gains a WLB tender in the Puget Sound without any district losing capability. Alternatives D (+\$380,000) and F (+\$470,000) are almost as good because a WLB loss from the 14th District would have little impact there, but a WLB gain on the west coast would greatly improve capability. Alternative F is slightly better than D because a WLB is better for use in the 11th District coastal areas than FIR. The worst alternative is E (-\$130,000) because the improvement in Puget Sound from FIR is more than offset by the loss of WLM capability in an east coast district and ocean servicing capability in the 11th District. Alternative C (-\$80,000) is almost as bad as E because a WLM in the Puget Sound only improves capability slightly, while the loss of WLM capability in an east coast district is great. Alternatives A (negligible change) and B (+\$50,000) do not increase total capability very much, but relocating WHITE BUSH would be better than relocating IRIS because IRIS needs to cover the "exposed" ocean area down to southern Oregon and up the Columbia and Snake Rivers while WHITE BUSH has less distance to travel to service coastal AtoN from Puget Sound. These dollar values are merely illustrative, and do not reflect the real benefits that might result from an analysis using other modules of the RMT.

Another example of a MOE using an absolute scale is COMMERCIAL PERSONAL SAFETY BENEFITS (Measure 1.1.2.1). For this MOE, the scale is expressed in terms of expected lives saved and the economic worth of the lives in dollars (annualized at \$100,000 per life). The costs of non-fatal injuries may also be included. This scale would be based on another RMT module which provides the endpoints (5 lives saved or 5 lives lost) and also the potential lives

lost/saved by each alternative. Scores for each alternative are interpolated proportionally between the endpoints.

<u>Alternative</u>	<u>Annual</u> <u>Lives Lost/Saved</u>	<u>\$(000)</u>	<u>Score</u>
Endpoint	+5.0	+500	100
G	+4.4	+440	94
F	+3.2	+320	82
D	+2.8	+280	78
C	+ .5	+50	55
E	+ .5	+50	55
B	- .5	-50	45
A	- .8	-80	42
Endpoint	-5.0	-500	0

Table 5.5: Commercial Personal Safety Benefits

The greatest potential loss of life for commercial users occurs in areas where there are many fishing vessels and the water temperatures are cold. Therefore, benefits for each alternative differ from the economic benefits evaluated above. For commercial users, buying a new tender for Puget Sound is still the best alternative (G). However, the worst alternative is relocating IRIS (A) because the Columbia River area has a high density of small commercial fishing boats which would be at greater risk. Relocating WHITE BUSH (B) would also be very damaging because of the many small fishing ports along the coast. Shifting a WLM (C and E) would provide more capability on the west coast, but may be offset by some lost capability on the east coast. The 14th District does not have many fishing fatalities because there are fewer coastal hazards and warmer waters there, so shifting a WLB (D and F) would have little effect. The lives lost or saved for each alternative are merely illustrative, and do not reflect the real safety impacts that might result from an analysis using other modules of the RMT.

Relative Scoring Scales with Economic MOEs. The second kind of scoring is with a relative scale. Relative scoring requires that the alternatives be clearly specified. In relative scoring, for each MOE, the alternative that is "best" on the MOE is assigned a score of 100, while the "worst" alternative is assigned a score of 0. The range of such a scale thus measures the difference between alternatives--a score of 100 can be thought of as 100% of the potential improvement on a MOE over and above the baseline worst case which scored

0. Note that a score of 0 does not imply that the alternative has no value. Rather, it indicates that the alternative is the baseline for comparison. All other alternatives are scored on the 0 to 100 scale relative to how they compare with the endpoints.

As an example of relative scoring, consider the bottom-level MOE of SHIP-RELATED TIMELINESS BENEFITS (Measure 1.2.1). Delays in scheduled transit times cause additional dollar costs for ship owners. The net economic difference of reducing from or adding to the current delay times for each alternative is shown below in Table 5.6.

<u>Alternative</u>	<u>Benefit (\$000)</u>	<u>Score</u>
G	+350	100
D	+312	90
F	+292	85
B	+26	15
C	+26	15
E	-12	5
A	-31	0

Table 5.6: Ship-Related Timeliness

Ship-related timeliness is strongly affected by AtoN in areas that have poor weather patterns and narrow channels, such as the Columbia River in the 13th District and many areas in east coast districts. The 11th and 14th Districts generally have good weather and wide channels. While the best alternative is G, shifting a WLB to Puget Sound (D) almost accomplishes the same thing and shifting the FIR to Puget Sound with a WLB in San Pedro (F) is only slightly worse. At the other end of the scale, taking IRIS out of Astoria on the Columbia River (A) is the worst alternative. When ranges are out there, vessels will still travel, but at reduced speed. Shifting FIR to Puget Sound in Alternative E is good except that the benefit is overshadowed by minor lost WLM capability in the eastern district and major lost ocean servicing capability in the 11th District. Relocating WHITE BUSH (B) gains no real benefit, but causes no real loss, as does shifting an eastern WLM (C). Although these benefits are hypothetical, real benefits from decreasing transit delays would be obtained from the other modules in the RMT.

Relative Scoring Scales with Non-Economic MOEs. Another example of the use of a relative scale is the non-economic MOE of ORGANIZATIONAL IMPACT ON THE COAST GUARD (Measure 1.3.2.2). As described in Section 4.3.2, such impacts include personnel job satisfaction and morale, professional development and training, and self-image. Since data for this measure are sparse, scores for each alternative may have to be estimated by direct judgment. Later, if this MOE was important enough to be a decisive factor in the decision, the estimate could be refined with survey or interview data collected specifically for this purpose.

Although none of the alternatives affects personnel self-image, there is a difference in the number of personnel affected by each alternative. A simple verbal description scale is developed consisting of LOW, MEDIUM, and HIGH adverse impacts and each alternative is rated on each concern, as shown in Table 5.7.

<u>Alternative</u>	<u># Affected by Relocations</u>	<u>Dissatisfaction with Relocations</u>	<u>Retraining Required</u>
A	MED	MED	MED
B	LO	MED	MED
C	LO	MED	LO
D	MED	HI	MED
E	MED	MED	LO
F	HI	HI	MED
G	HI	MED	MED

Table 5.7: Coast Guard Organizational Impacts

Alternatives F and G would affect a high number of personnel (at least 96) because they would require reassignment of the equivalent of two WLB crews. Alternatives A (48 crewmen), D (48 crewmen), and E (71 crewmen) would affect a moderate number of personnel. Alternatives B and C would both require the relocation of only 23 crewmen and their families. It is assumed that personnel assigned to the 11th and 14th Districts would be highly dissatisfied to be reassigned to the Pacific northwest and that most other personnel generally dislike being asked to move their families. Retraining requirements would be low to medium for all alternatives, with alternatives involving WLMs having the least impact. These judgments about the organiza-

tional impacts of each alternative, may be made using assessment techniques described in Appendix E.

The next step is to scan the list of alternatives, identify the best and worst courses of action, and assign scores of 100 and 0 to them. The lowest combined set of adverse impacts would score highest on the scale, while the highest set of adverse impacts would score lowest. Therefore, Alternative C (LO, MED, LO) is assigned 100, while Alternative F (HI, HI, MED) is assigned 0. Scores might be directly estimated for the remaining alternatives by interpolating their value as compared to the endpoints of the scale. If all scoring intervals are equal, then an improvement on any concern from HIGH to MEDIUM or from MEDIUM to LOW is worth 25 additional points for that alternative. The results could be displayed on a value graph as shown in Figure 5.1.

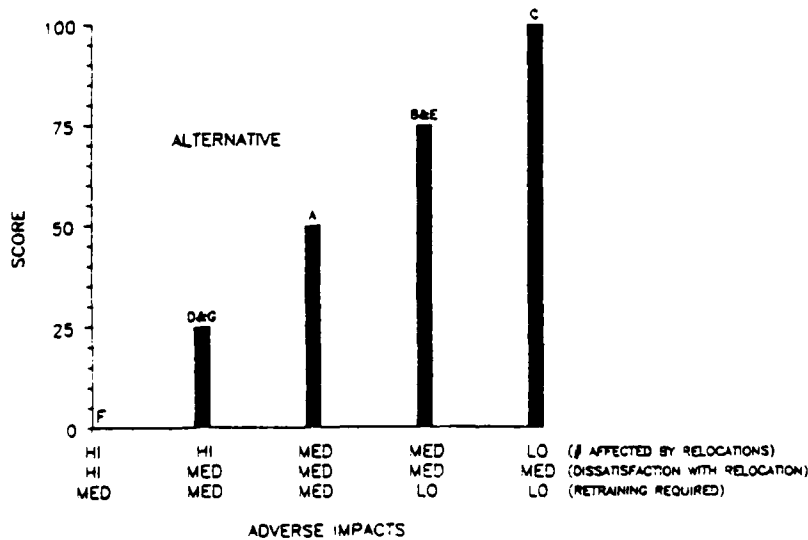

Figure 5.1: Organizational Impact on the Coast Guard

A value graph is simply a way to represent the changing marginal value of a measure of effectiveness. In the figure above, the marginal value does not change. However, if the MOE had changing marginal value, the resulting scores for each alternative might look like Figure 5.2. This figure would imply that for this MOE, the Coast Guard actually values a reduction from HIGH organizational impact to MEDIUM impact more than twice as much as a reduction from MEDIUM to LOW.

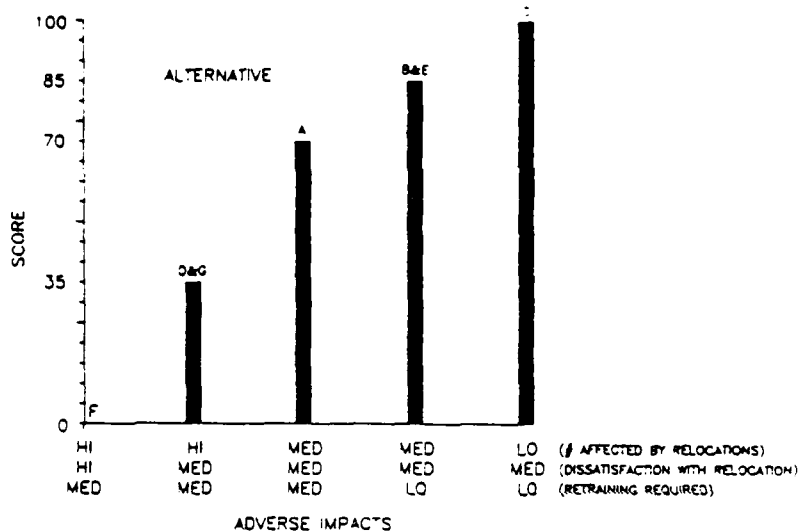

Figure 5.2: Value Graph for Organizational Impact on the Coast Guard

It is important to understand that for any MOE all segments of its scale need not have the same proportionate value. Value graphs may be used with a discrete verbal scale, as in Figure 5.2, or with a continuous scale, when they are called value curves. Value graphs, value curves, and techniques used to assess them are discussed in detail in Appendixes B and E. For the remainder of this example, assume that Figure 5.2 is used. All the alternatives may be scored on each remaining bottom-level comparison MOE using either the relative or absolute scoring procedures and the direct assessment of scores or a value graph. For a complete listing of all scores used in this illustrative example, see Table 5.8.

5.2.5 Prioritization of the comparison MOEs. In the scoring systems described above, an evaluation scale from 0 to 100 was developed for each MOE. However, each scale was defined independently of all others, so the resulting scores of the alternatives are not directly comparable. Some MOEs may carry more importance in the evaluation than others, and the range of the scales of equally important MOEs may be different. Therefore, a measure of the priority, or relative importance, of each MOE is necessary. This is accomplished through a weighting system.

Table 5.8: List of MOE Scores

Scores							Node
A	B	C	D	E	F	G	
							1 Benefits
							1 1 Safety
							1 1 1 Economic Considerations
20	25	12	58	7	67	91	1 1 1 1 Commercial Users
10	40	0	10	20	10	100	1 1 1 2 Recreational Boaters
50	10	10	40	0	100	90	1 1 1 3 Government Users
20	20	0	100	0	100	100	1 1 1 4 General Public
							1 1 2 Personal Safety
42	45	55	78	55	82	94	1 1 2 1 Commercial Users
10	40	0	10	25	10	100	1 1 2 2 Recreational Boaters
90	80	5	30	0	40	100	1 1 2 3 Government Users
40	40	0	100	0	100	100	1 1 2 4 General Public
							1 2 Timeliness
0	15	15	90	5	85	100	1 2 1 Ship-Related Costs
0	20	0	85	0	90	100	1 2 2 Consignor or Consignee Costs
							1 3 Other Benefits
							1 3 1 Mariner Interests
15	15	0	90	0	90	100	1 3 1 2 User Satisfaction
							1 3 2 Coast Guard Interests
10	25	0	50	0	50	100	1 3 2 1 Multimission Capability
70	85	100	35	85	0	35	1 3 2 2 Organizational Impact
0	0	0	100	0	100	100	1 3 2 3 Standard Measures of Performance
							1 3 3 Other Government Interests
100	100	100	0	100	0	100	1 3 3 1 International
0	25	50	50	50	50	100	1 3 3 3 State/Local Governments
							1 3 4 Public Interests
100	100	100	100	100	100	0	1 3 4 1 Economy
							2 Costs
							2 1 Coast Guard Costs
80	85	65	100	60	90	0	2 1 1 Operating Expense (OE)
100	100	100	100	100	100	0	2 1 2 Capital Costs (AC&I)
							2 2 Other Federal Government
50	50	0	40	0	40	100	2 2 1 Litigation
90	100	70	75	45	50	0	2 2 2 Other

The need for weighting holds for both relative and absolute scoring scales. In the former, the difference, or "swing", between the best and worst alternatives is the basis for weights, while in the later, it is the swing between the selected endpoints of each scale. In either case, if the true priorities are to be captured, the swing between the endpoints, as well as the importance of the MOE, must be considered. One of the more common approaches is to assign a weight of 100 to the most important swing at a MOE structure "node." Other weights are then assigned using ratio judgments--that is, if the swing on a MOE is judged to be twice as important as the swing on another MOE, the former would carry twice the weight of the latter.

For the example, the weights of the MOEs at each node in the MOE structure must be assessed. For the MOE for ECONOMIC CONSIDERATIONS (Measure 1.1.1), there are four bottom-level MOEs: COMMERCIAL USERS, RECREATIONAL BOATERS, GOVERNMENT USERS, and GENERAL PUBLIC. Since the endpoints of the net economic benefit scale for each MOE have already been determined, they might be listed as shown in Table 5.9.

<u>MOE</u>	<u>Range of Scale</u>
ECONOMIC CONSIDERATIONS	
COMMERCIAL	-\$200,000 to +\$800,000
RECREATIONAL	-\$ 10,000 to +\$ 50,000
GOVERNMENT	-\$ 5,000 to +\$180,000
GENERAL PUBLIC	-\$ 4,000 to +\$ 30,000

Table 5.9: Range of Scales for Economic Considerations

Since all the scales are in terms of dollars, and the assumption for the moment is that dollars of each MOE have the same value as dollars of any other MOE, all that is required is to weight the MOEs according to the differences between their endpoints. If the largest "swing" (COMMERCIAL) is assigned a weight of 100 for a difference of \$1 million, then RECREATIONAL should receive a weight of 6 for a swing of \$60,000, GOVERNMENT should receive 18.5 and GENERAL PUBLIC a weight of 3.4.

For comparison, the weights can be normalized to sum to 1.00 by adding the assigned weights and dividing each by the sum as shown below:

<u>MOE</u>	<u>Normalized Weight</u>
ECONOMIC CONSIDERATIONS	
COMMERCIAL	.78
RECREATIONAL	.05
GOVERNMENT	.14
GENERAL PUBLIC	.03

At each higher level node, MOEs may be weighted by summing the total of the "swings" at the lower level nodes, assigning the largest swing a weight of 100, calculating the ratios of the other MOEs, and normalizing to sum to one. For example, the total swing for ECONOMIC CONSIDERATIONS is \$1,279,000 while the total swing for PERSONAL SAFETY is \$1,442,000. If the latter is given a weight of 100, then the former should have a weight of 89. Normalized to sum to one, the weights for the components of SAFETY are as follows:

<u>MOE</u>	<u>Normalized Weight</u>
SAFETY	
ECONOMIC CONSIDERATIONS	.47
PERSONAL SAFETY	.53

Such combining of weights from the bottom level MOEs can also be performed on non-economic MOEs. While some non-economic MOEs may be directly "priced out" to find a dollar value (as the value of a life was priced out in Table 5.5), the relative weights between economic and non-economic MOEs may be used to imply the dollar values of the remaining non-economic MOEs. Table 5.10 shows a complete list of all weights used in the example.

5.2.6 Comparison of alternatives. After all alternatives have been scored and weights have been assigned to the MOEs, the combined measure of value can be determined for each alternative. Since the RMT uses independent MOEs (see Section 4.2.3), the combined value will be an additive combination of each score times its weight. For the example, the values in Table 5.11 show that Alternative G has the best combined value when considering only ECONOMIC CONSIDERATIONS.

Table 5.10: List of MOE Weights

1	Benefits	Wt=.50		
1 1	Safety	Wt=.49		
1 1 1	Economic Considerations		Wt=.47	
1 1 1 1	Commercial Users			Wt=.78
1 1 1 2	Recreational Boaters			Wt=.05
1 1 1 3	Government Users			Wt=.14
1 1 1 4	General Public			Wt=.03
1 1 2	Personal Safety		Wt=.53	
1 1 2 1	Commercial Users			Wt=.54
1 1 2 2	Recreational Boaters			Wt=.23
1 1 2 3	Government Users			Wt=.21
1 1 2 4	General Public			Wt=.02
1 2	Timeliness	Wt=.11		
1 2 1	Ship-Related Costs		Wt=.62	
1 2 2	Consignor or Consignee Costs		Wt=.38	
1 3	Other Benefits	Wt=.40		
1 3 1	Mariner Interests		Wt=.25	
1 3 1 2	User Satisfaction			Wt=1.00
1 3 2	Coast Guard Interests		Wt=.50	
1 3 2 1	Multimission Capability			Wt=.30
1 3 2 2	Organizational Impact			Wt=.60
1 3 2 3	Standard Measures of Performance			Wt=.10
1 3 3	Other Government Interests		Wt=.15	
1 3 3 1	International			Wt=.10
1 3 3 3	State/Local Governments			Wt=.90
1 3 4	Public Interests		Wt=.10	
1 3 4 1	Economy			Wt=1.00
2	Costs	Wt=.50		
2 1	Coast Guard Costs		Wt=.60	
2 1 1	Operating Expense (OE)			Wt=.55
2 1 2	Capital Costs (AC&I)			Wt=.45
2 2	Other Federal Government		Wt=.40	
2 2 1	Litigation			Wt=.30
2 2 2	Other			Wt=.70

MOE	Weight	Alternative Scores						
		A	B	C	D	E	F	G
ECONOMIC CONSIDERATIONS								
COMMERCIAL	.78	20	25	12	58	7	67	91
RECREATIONAL	.05	10	40	0	10	20	10	100
GOVERNMENT	.14	50	10	10	40	0	100	90
GENERAL PUBLIC	.03	20	20	0	100	0	100	100
COMBINED VALUE		24	24	11	54	6	70	92

Table 5.11: Combined Value of Economic Safety Benefits

The combined value for Alternative G is 92 and is equal to the score for COMMERCIAL (91) times the weight for COMMERCIAL (.78), plus the product of the score and weight for RECREATIONAL, GOVERNMENT, AND GENERAL PUBLIC benefits, or:

$$92 = (91 \times .78) + (100 \times .05) + (90 \times .14) + (100 \times .03).$$

The combined values calculated above may be used as scores in the evaluation of the next higher level MOE. For example, Table 5.12 shows that Alternative G is again the best alternative when considering all SAFETY benefits. See Appendix F for a complete listing of combined values.

MOE	Weight	Alternative Scores						
		A	B	C	D	E	F	G
SAFETY								
ECONOMIC CONSIDERATIONS	.47	24	24	11	54	6	70	92
PERSONAL SAFETY	.53	45	51	31	53	35	57	97
COMBINED VALUE		35	38	21	53	22	63	94

Table 5.12: Combined Value of All Safety Benefits

The weights and scores for all MOEs may eventually be combined into a single measure of value for BENEFITS and a single measure of value for COSTS for each alternative as shown in Table 5.13. The weights for benefits and costs have been assumed to be equal at this point, but may be adjusted later should the choice of the preferred alternative depend upon them.

MOE	Weight	Alternative Scores						
		A	B	C	D	E	F	G
OVERALL								
BENEFITS	.50	32	40	31	61	29	61	85
COSTS	.50	85	89	68	86	59	76	12
COMBINED VALUE		58	64	49	73	44	68	49

Table 5.13: Combined Value of All Benefits and Costs

A plot of the above table shows the tradeoffs between costs and benefits for each alternative. (A high value on the cost scale means that the alternative has low costs.) As shown below, the better alternatives -- those with the highest combined values in Table 5.13 -- score high on both the cost and benefit dimensions. However, the "best" alternative depends on the weights assigned to those dimensions, i.e., the relative importance of improving effectiveness versus keeping costs down.

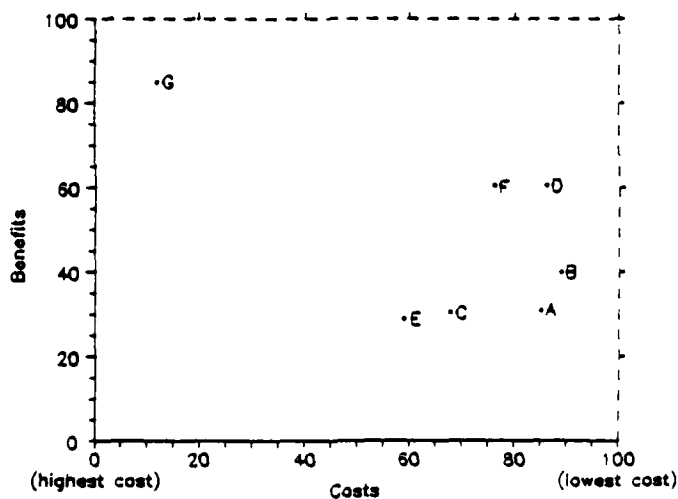

Figure 5.3: Costs vs. Benefits

Including the non-economic considerations, Alternative D (61, 86) may be a better solution than Alternative F (61, 76) or B (40, 89) because it provides the next to highest level of benefits at the next to lowest level of cost. Alternative G, on the other hand, provides even greater benefits at a greater cost. Thus, by including important non-economic factors in the analysis, the range of potential solutions has been effectively narrowed to two alternatives, D and G.

One final approach may help discriminate between these last two alternatives. While it was desirable to develop a value scale for each non-economic MOE, it was assumed that value scales were unnecessary for economic MOEs because a dollar should always be worth the same. However, if it is judged that to mariners, losing a dollar has a much greater proportional impact than gaining a dollar, then value scales are necessary. In order to express this "risk aversion" to monetary losses, utility scales, similar to value scales, may be developed for the economic MOEs (see Appendix C for a discussion of risk aversion).

In the example, for the MOE for COMMERCIAL ECONOMIC SAFETY BENEFITS (Measure 1.1.1.1), the utility curve is shown in Figure 5.4. This curve means that preventing a loss of \$200,000 is worth as much to the mariner as a gain of \$800,000. Therefore, the value of a dollar gained is only one-fourth the value of a dollar prevented from being lost.

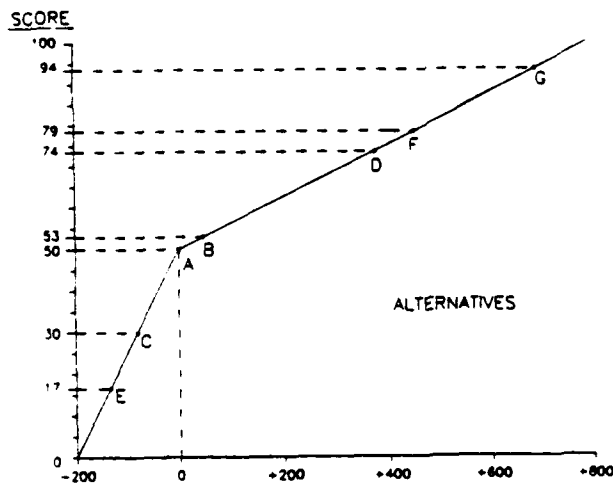

Figure 5.4: Value Curve for Commercial Economic Safety Benefits

After all economic MOEs have been expressed as utility curves, the combined values for the alternatives are as shown in Table 5.14:

MOE	Weight	Alternative Scores						
		A	B	C	D	E	F	G
OVERALL								
BENEFITS	.50	42	51	39	69	35	68	86
COSTS	.50	86	90	68	87	59	77	12
COMBINED VALUE		64	71	54	78	47	72	49

Table 5.14: Combined Value of All Benefits and Costs (revised)

A new plot of costs versus benefits for each alternative is shown in Figure 5.5:

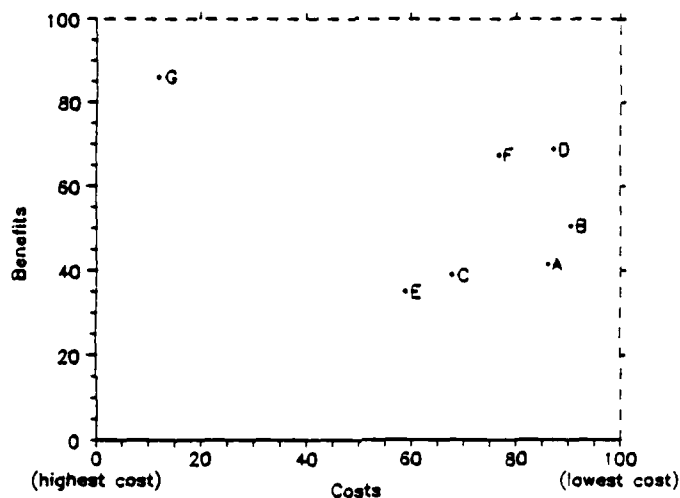

Figure 5.5: Costs vs. Benefits with "risk averse" Economic MOEs

Now it is clear that even with "risk averse" utility curves for the economic MOEs, Alternative D is still better than Alternative F. But Alternative G continues to yield more benefits if the Coast Guard is willing to pay the higher costs. At this point, a sensitivity analysis may help find a solution.

5.2.7 Sensitivity analysis. Before drawing any conclusions from the scores developed so far, it is useful to test the range of possible solutions through sensitivity analysis. It is possible to study the effects of changing scores, of using a different set of weights to represent a different point of view, or of posing a variety of other "what if" questions.

There are three major types of sensitivity analyses that may be used. First, the scores that have been assessed can be modified to determine if results change. Experience has shown that results are reasonably insensitive to minor changes in scores and that there is usually a high degree of confidence in the assessed values. Next, several weights can be changed and the overall scores recalculated. This is useful in examining large-scale changes to the RMT (such as weights of a different decision maker), but does not make it easy to isolate causes of change. A third sensitivity analysis is to vary one weight at a time and identify the regions where decisions change.

For the example, it might seem that the weight relative to BENEFITS given to the non-economic MOE for OTHER BENEFITS (.40) is too high. It is possible to examine the effects of letting this weight, called a local weight, vary from 0 to 1.00 as shown in Table 5.15. It should be understood that this is not the same as varying the cumulative weight, or the weight on OTHER BENEFITS relative to all other MOEs.

Weight on MOE OTHER BENEFITS	Overall Combined Value						
	A	B	C	D	E	F	G
.00	65	72	51	81	44	78	54
.10	65	72	51	80	45	76	53
.20	64	71	52	79	45	75	52
.30	64	71	53	79	46	74	50
Current .40	64	71	54	78	47	72	49
.50	63	71	54	78	48	71	48
.60	63	70	55	77	49	70	46
.70	63	70	56	77	49	68	45
.80	62	70	57	76	50	67	44
.90	62	69	57	75	51	66	43
1.00	62	69	58	75	52	64	41

Table 5.15: Sensitivity of Weight on OTHER BENEFITS

As the table shows, Alternative D is the dominant solution to the problem, regardless of the weight assigned to OTHER BENEFITS, although the MOE is seen to be a definite discriminator once it is included. Therefore, the concern over the .40 weight for the MOE is unwarranted.

A final sensitivity test may help select between Alternatives D and G. By varying the local weight of the importance of total BENEFITS versus COSTS

from 0 to 1.00, the analysis may show which alternative is most reasonable.

Weight on MOE BENEFITS	Overall Combined Value						
	A	B	C	D	E	F	G
.00	86	90*	68	87	59	77	12
.10	81	86*	65	85	57	76	19
.20	77	82	62	84*	54	75	27
.30	73	79	59	82*	52	74	34
.40	68	75	56	80*	49	73	42
.50	64	71	54	78*	47	72	49
.60	59	67	51	77*	45	72	56
.70	55	63	48	75*	42	71	64
.80	50	59	45	73*	40	70	71
.90	46	55	42	71	37	69	79*
1.00	42	51	39	69	35	68	86*

Table 5.16: Sensitivity of Weight on BENEFITS

As seen in Table 5.16, the asterisks indicate that as long as the importance of BENEFITS of the solution is not weighted more than four times the importance of the COSTS, then Alternative D, shifting a WLB from the 14th District to Seattle, is the preferred alternative. However, if the desire to produce effectiveness gains above this level is sufficiently strong, then Alternative G, purchase of a new tender should be chosen.

Just accounting for economic MOEs, the swings in COSTS total \$2,150,000 while the swings in BENEFITS total \$3,332,000, which would indicate weights of .39 and .61 respectively. Because in a tight budget environment, non-economic benefits probably would not add that much more weight to the total benefits, Alternative D appears to be the best alternative. However, making strong inferences about one- or two-point differentials in scores may be dangerous; more than a ten-point differential should safely discriminate among alternatives. It is essential to recognize that the numerical results of the evaluation process are not the ultimate goal of the RMT. Rather, the scores and weights are merely a reflection of the available information and judgments used as inputs. The numerical output should serve as a catalyst for discussion and revision of the inputs. A perfectly acceptable, and often desirable, outcome of the RMT will be a result that is not intuitively appealing. The beauty of the RMT is the ease with which such disagreements can be traced to specific rationale, and revised if appropriate. The output of the RMT is not

a decision--rather, it is a tool to identify principle issues, to focus further data gathering efforts, and to guide the decision-making process.

As demonstrated in this illustrative example, the RMT approach will be able to help solve difficult resource management decision problems. It helps the decision maker to identify critical MOEs, includes important intangible MOEs that might otherwise be excluded from the analysis, and spotlights MOEs for which the decision maker needs more information. In 1982, the Coast Guard had to make a decision on a buoy tender for Puget Sound and had no analytical tool which it could use to support its decision with numerical analysis or articulated judgments. The measures of effectiveness and use of the RMT will ensure that future resourcing decisions are based on the best possible information and are fully supportable.

6. WORKPLAN FOR TASKS 2 THROUGH 9

The major thrust of this project is to develop a predictive methodology capable of guiding future management decisions concerning the acquisition, deployment, and use of SRA program resources.

As outlined in the Statement of Work, there are many realms within which SRA resource management decisions may be made. These realms, and their relation to the tasks defined under this project, are as follows:

- Routine servicing policy (Task 2)
- Platform capabilities (Task 3)
- Discrepancy response criteria (Task 4)
- Servicing alternatives (Task 5)
- Staffing levels (Task 6)
- Multimission policy (Task 7)
- Short range aid (SRA)/radio-navigational aid (RA) tradeoffs (Task 8)

The decisions reached in these realms are highly interrelated. No realm is totally independent: any decision to engage in multimission operations limits routine servicing and discrepancy response time, any modification of routine servicing cycles may affect the rate at which discrepancies occur, any modification of existing platform capabilities may affect all of the above, and so on.

It is for this reason -- this high level of interdependence among functions -- that a ninth task, Development of an Analytic Model, has been added. The role of this model is to integrate the findings and relationships developed in Tasks 2 through 8 into a cohesive overall methodology, making use of the measures of effectiveness, modified as necessary, developed under Task 1.

The purpose of the analytic model, in brief, is to provide quantitative evidence capable of supporting decisions reached within any of the realms outlined above, all factors considered. This means that the decision must not only be beneficial (i.e., the predicted benefits exceed the predicted cost) but optimal (the decision reached is the "best" of all plausible alternatives).

Tasks 2 through 8 are the stepping stones leading to the development of the desired predictive methodology. Within each task, two sets of goals will be addressed:

- (1) Short-Term. -- To develop algorithms and perform analyses that will lead to better decision-making within the realm in question. (For example, under Task 2: for a given set of failure rates, platform capabilities, and discrepancy response criteria, what routine servicing cycle produces the greatest benefits for a fixed cost? Produces the least cost for a fixed set of benefits?)
- (2) Long-term. -- To study (a) the linkages that cause changes in one variable to affect all other variables, and (b) the linkage between those changes and the measures of effectiveness developed in Task 1.

Each task will, broadly speaking, consist of five subtasks:

Subtask 1 -- Study the process in question for the purpose of assessing both existing and future policy, practice, and capabilities.

Subtask 2 -- Define meaningful quantitative analyses needed to support SRA decision-making within the realm in question.

Subtask 3 -- Identify and gather the data (both empirical and, if necessary, subjective) needed to support those analyses.

Subtask 4 -- Propose reasonable and efficient methods for gathering data, not currently available, that could be used to support future analyses and/or decision-making.

Subtask 5 -- Conduct the analyses.

Concurrent with each task, effort will also be devoted toward integrating the results of that task into the Task 9 analytic model.

Fuller detail concerning each of these tasks is provided below.

Task 2 - Routine Servicing (and Maintenance) Demands

The demands on routine servicing have their genesis in the equipment which produces the signals that guide the mariner; these demands are further tempered by the environment in which the equipment is situated. Some of the equipment, such as lamps and primary batteries, must be considered as consumables since they are consumed by use and at some point must be replaced. Other equipment, such as buoy bodies, require extensive preventive maintenance from time to time in order to extend the life of these expensive components as a preferred alternative to costly catastrophic failure. Whether through "end of life" consumption or catastrophic failure, each component of the equipment has an associated mean-time-between-failure (MTBF) and some variability about that figure.

By its nature, there is a predictability to the MTBF that can be determined. Ideally all servicing and maintenance could be scheduled based on the expected life of equipment components. In practice, however, each equipment has a "key" component that governs the visit rate for purposes of servicing and maintenance. Moreover, not all discrepancies are random: some equipments suffer from "infant mortality" as part of a bathtub-shaped failure curve (in which the failure rate starts out initially high, subsequently declines and stabilizes, then rises as the equipment begins to wear out). Environmental phenomena such as heavy storms and winter ice and other abuses such as vandalism and careless users all combine to produce discrepancies in the system. The factors which affect decisions on the frequency of routine servicing are numerous and include the expectation of less than perfect equipment performance, i.e., equipments not technically in a failed state may nonetheless produce less than peak output.

Major short range AtoNs comprise approximately 1% of the inventory but, despite their small number, exert considerable influence on program resources as a whole and on a number of MOEs. Routine servicing demands for this category of AtoN must be emphasized.

Routine servicing and maintenance involves a number of costs. These include replacement equipment components as well as the cost of the people needed to perform the work, the tools they use, and their transportation to and from

the AtoN site (direct labor, materials and transportation costs) plus the organizational infrastructure which supports these items (overhead). Direct materials are only a small part of the total cost.

Different equipment components require different degrees of servicing support. For example, lamp replacement does not require the heavy lift capability needed to relieve a lighted buoy. Also, different kinds of AtoNs have different needs. That is, the maintenance and servicing needed for a Primary Seacoast Light is very much different from that of a small daybeacon.

Some routine servicing demands are not hardware related, e.g., position checks of floating AtoNs. These will also be identified and included in the Task report.

An earlier (Booz-Allen) study is the immediate initial reference in regard to the rationale for servicing intervals used today. An essential component of this task will be in-depth interviews with key people in the former Ocean Engineering branches, and quite likely, follow-up discussions at the National Aids to Navigation School. Project officers in the Navigation Systems Technology Branch can provide insight into future technological developments. ATONIS and SANDS provide the likely data bases for current and past experiences.

The work planned for Task 2 involves the following:

1. Conduct an assessment of both current and future equipment and servicing/maintenance policies.
2. Identify specific analyses needed to explore the impact of possible changes in equipment and/or policy.
3. Identify and gather needed data to the extent currently available.
4. Define mechanism(s) for gathering needed data not currently available.
5. Conduct analyses.

The analyses to be conducted will be determined in conjunction with the Coast Guard Project Officer and other interested CG personnel. In addition to the examples cited in Mandex's original Technical Proposal, consideration will be given to other near-term situations that may be identified during the Task 2 interviews. With the present realities of Gramm-Rudman-Hollings, one might look into the costs and benefits of Remote Control and Monitoring of Major (and other) Aids to Navigation, as an example to set forth a rationale to determine if there is in fact a benefit, and if so, to assess its relationship to the costs involved.

We intend through this task to explore the impact of changes in routine maintenance and servicing requirements upon selected measures of effectiveness, in particular system availability by class of AtoN. We intend also to investigate the extent to which routine maintenance actions are affected by environment and policy.

Key issues to be resolved either prior to or during this task include:

- o Is aid replacement/relocation considered part of routine maintenance? Sometimes?
- o To what extent is unscheduled (corrective) maintenance considered in developing workloads? Does this belong to Task 4, Response Criteria? Are false outages a problem? How to account for?
- o To what extent does environment or geography affect routine maintenance criteria and/or practice?
- o What are the ramifications of accelerating routine servicing schedules beyond currently established criteria?

Task 3 - Platform Capabilities

The platforms involved in the SRA program include vessels, vehicles and aircraft. Their purposes are to provide transportation and a mobile work site for servicing and maintenance personnel as well as replacement equipment and

tools. The salient features of the platforms are usually dictated by the kind of work needed to be done and where. The kind of work to be done (and its frequency) is a result of the needs of the equipment used at the AtoN sites as well as program policies relating to non-hardware requirements. The physical environment in which the platform operates both at the work site and enroute to and from it, are equally important. This task will be limited to defining platform capabilities of Coast Guard platforms only. Those platforms provided to the program by other government agencies and/or contractors will be considered as part of Task 5, Servicing Alternatives.

The costs associated with the platforms are formidable. Of all the platforms, the 28 180-ft WLB class buoy tenders are those receiving the greatest scrutiny, and deservedly so. With crews of half-a-hundred, they require half the field servicing personnel yet service only a tithe of the population of aids to navigation. Further, since only about a tenth of the crew is involved on-deck in servicing buoys during buoy operations, these WWII-vintage multi-purpose auxiliary vessels with buoy tending capability (which moreover spend 25% of their time in maintenance status to keep them running) are resources whose costs and efficiencies are understandably questioned. Due to their age alone, replacements for this class of buoy tender have been on the drawing boards for many years. Replacement, however, involves completing OMB's A-109 process. This class is also a natural starting point since it is used to service the largest buoys now in use.

The salient features of all platforms include considerations of minimal capabilities required to perform a given operation, such as hoisting capability for the largest weight buoys and moorings to be lifted, as well as characteristics such as speed and weather conditions in which it can operate.

All characteristics need to be identified, both those which are generic and those unique to buoy tenders, and, where appropriate, limiting values noted. Sources for this information will be within Coast Guard Headquarters (Naval Engineering Division, Marine Technology Division, A-76 Study Group, Office of Acquisition, and the Facilities Management Branch) and elsewhere (experiences of other National Lighthouse Authorities which have recently purchased new buoy tenders).

The steps in this task will be similar to those in Task 2. For the reasons stated above, major emphasis will be placed on the Offshore Buoy Tender but other platforms will not be neglected. The data assessment for this task will not be limited to the characteristics of the platforms but will also address the numbers and locations of the AtoNs to be serviced and/or maintained by platforms with common sets of operating characteristics. Some operating characteristics, such as speed, cannot be fully addressed within this task since the primary effect of platform speed is dependent on factors to be developed in other tasks. Thus, this task will develop the threshold values for salient features and linkages internal to this task. External linkages will be developed in later tasks.

Task 4 - Response Criteria

This task is related to Task 2 (Routine Servicing Demands) to the extent that routine servicing and maintenance can be used to reduce mean-time-between-failures. This task involves identifying the resources to be used in discrepancy response, their costs, and the policies that are currently being used or may be used in the future to correct discrepancies in the system.

Whereas reliability is significantly dependent upon MTBF, availability is inevitably affected by the criteria used to respond to outages and by the associated mean-time-to-repair (MTTR). In this regard, system management appears to have a great deal of flexibility. In reality, however, this flexibility is constrained by outside influences, e.g., cost, user satisfaction, and other measures of effectiveness.

In terms of system availability, tradeoffs are possible between component reliability and discrepancy response. That is, if the MTBF could, through improved equipment reliability, be doubled, then the MTTR could also be doubled to achieve the same availability figure. At that point, however, user satisfaction (another MOE) enters the picture. Doubling the MTTR may preserve system availability in a strictly numerical sense yet produce immense mariner dissatisfaction and other negative consequences (including increased legal exposure). The primary economic question underlying these tradeoffs is the cost of more reliable equipment versus the cost savings resulting from relaxed response

demands. There is a secondary economic question, however, and that is the cost of litigation resulting from outages that are (from the mariner's standpoint) unreasonably long. Finally, there is the non-economic issue of user satisfaction. All of these factors must ultimately be taken into account.

Apart from these secondary issues, tradeoffs involving discrepancy response time are more complex than a simple linear relationship involving availability. The mariner's knowledge of a long-standing discrepancy may, as shown in Figure 2-1, affect his decision-making process. Thus, a given level of availability resulting from high discrepancy rate/quick response time would impact chiefly on safety while the same level of availability resulting from low discrepancy rate/slow response time might be less favorable in terms of expediting traffic.

The algorithms/models developed in this task will be useful in assessing effects on both the internal and external MOEs, and the extent to which availability can usefully be used as a descriptor.

Another aspect of this task will be the development of the relationship between discrepancy response and costs to the mariner (for a given discrepancy rate). Application of this task will also ultimately be interactive with the previous task (Platform Capabilities). For example, in districts having low AtoN density (e.g., the 14th and 17th Districts), vessel speed will have a greater impact than in an area with higher concentrations of aids where vessel speed can be relatively insignificant compared to response policy.

Within the area of Response Criteria, all factors affecting the development of existing and possible future methods of responding to outages will be identified. These will include policies external to the Coast Guard which have had an effect on the methods developed to respond to discrepancies in the past as well as in the future.

In terms of interviewees, each branch of the Short Range Aids to Navigation Division and the Coast Guard Representative on the LALA Technical Committee on Availability and Reliability of Aids to Navigation will be included. ATONIS, SANDS, and the Broadcast/Local Notices to Mariners are obvious data bases concerning the status quo, but these do not include all of the pecuniary effects

on the user community or the Coast Guard. Examination of historical and financial documents relating to externally imposed limitations on personnel travel, transportation of material, vehicle mileages, etc., will be necessary to fully develop this task.

Policy statements on response criteria to be considered include:

- o Time-to-underway
- o Vessel/personnel standby policy -- published and practiced
- o Choice of platform/methods of responding
- o Published methods of quantifying field performance

Task 5 - Servicing Alternatives

Whereas Task 3 was concerned with varying the characteristics of buoy tenders and other platforms, Task 5 provides a much less constrained approach to how the platforms (or other resources) may be used for routine maintenance as well as discrepancy response.

One of the exercises the results of this task must be able to respond to is that of evaluating the feasibility of novel schemes, such as those proposed externally by OMB and the Congress. These include such schemes as double-crewing or the proposed use of commercially available surplus offshore supply vessels. In a similar vein, new concepts proposed either in-house or by industry for development, such as automated signal status and position audit schemes, could be evaluated in terms of their likely costs and benefits if successful, prior to their development.

Within this task, the shoreside maintenance functions will be set out and the effect of various alternatives included in the analysis.

Under this task, we will:

- o Identify all constraints -- hardware, platforms, personnel, organizational, political -- on the various servicing alternatives to be covered in this task.

- o Analyze the impact of various alternatives on selected appropriate MOEs, holding the MOEs constant and varying the constraints and vice versa.

The data needs for this task include:

- o Alternative maintenance schemes in use by field units
- o AtoN assignment lists
- o Instances of crossing District boundaries
- o Examples of routine/non-routine interdistrict cooperation
- o Experiences of multi-crew vessels
- o Discrepancy response methods used by other National Lighthouse Authorities
- o Methods used to perform shoreside maintenance functions
- o Identification of open and closed arenas
- o Effects of non-scheduled workload on routine servicing functions
- o Experience with contract maintenance
- o Limitations of climatology on maintenance alternatives
- o Limitations of district boundaries on waterway arenas

Task 6 - Staffing Levels

In addition to the examination of existing job task analyses mentioned in the proposal, we intend in this task to measure the effective output of the various staffs and field units by developing common terms of reference. The output of the various units can then be quantified and compared. Variations in personnel available in relation to workload at field units (Groups and ANTs) and District Branches will be studied.

The inputs and outputs of the organizations will be reduced to common usable measures. It may not be appropriate or useful to base this measurement on individual job task analysis, at least in the early stages but significant reliance will be placed on Planning Proposal 14-001-83 as an example of the types of work accomplished by a typical branch. Similar information will be developed for other units studied. The development of a methodology to measure organizational inputs ("costs of services") and compare these with the "outputs"

of the organization in commonly measured terms. These terms, which will necessarily require some adjustment to account for differences inherent in the conditions in which each organization is required to operate, would be sufficiently detailed to provide inputs to the MOEs. Job task analysis may be necessary in order to help develop the adjustment factors between units and will be used where necessary.

We believe this approach is appropriate because the data required for analysis should be readily available with little need for additional reporting and the method will take into account work performed outside of the formalized job tasks common to all similar units. We also believe that the analysis will be much more useful to management as a measure of the comparative productivity of the various field organizations. Thus, internal effects on the AtoN program as well as the effects of changes on the MOEs can both be evaluated.

During this task, reliance will be placed on information contained in a variety of sources, including but not limited to:

- o Aids to Navigation Administrative Manual
- o The Abstract of Operations
- o Standard Staffing Manual
- o Unit Organization Charts
- o AtoN Unit Assignment Lists
- o Unit Allowance Lists
- o Planning Proposal 14-001-83
- o USCG Program Operating Cost Report

Task 7 - Multimission Effects

In Task 7, we will examine the impact on the SRA program of decisions involving multimission operations.

In Task 1, the MOE framework that was developed included multimission effects as evaluation criteria. This provides a framework for evaluating policy decisions in Tasks 2-6 in terms of their impact on the ability to perform in multimission roles. Changes in staffing, or platforms, or servicing policies,

etc., were inputs, and the effect on multimission roles was one of several outputs.

In Task 7, the focus changes. Policy decisions on multimission roles are now the input, and effects on the SRA program in terms of other MOEs are the output. Some multimission roles can be scheduled (e.g., military training and interdiction patrols); other are reactive (e.g., search and rescue). Policy decisions regarding multimission roles can be examined for both scheduled and reactive roles.

The first step in Task 7 is to identify the decisions that can reasonably be evaluated. The types of issues that might typically be addressed include:

- o How many hours of military training time should be scheduled?
- o Should interdiction patrols be conducted only as a routine part of steaming toward AtoN assignments?
- o What are the implications of contracting out ice-breaking?
- o What would be the impact if other tasks such as marine science activities (MSA), cooperation with other agencies (COOP), public affairs (PIA), etc., were to be curtailed?
- o What would be the impact of reducing the number of SRA-dedicated Off-shore Buoy Tenders (OBTs)?

Next, we will develop models for measuring multimission effects. There are both intra-multimission effects in which the resources devoted to the various missions are traded off, and external effects in which resources devoted to multimission operations are at the expense of the SRA Program. These models will focus on the MOEs developed in Task 1. They will be highly data-driven, with The Abstract of Operations providing much of the needed statistical information. Additionally, the Coast Guard Service-Wide Search and Rescue Statistics (Reference No. 450 in the Transportation Statistics Reference File maintained by DoT's Transportation System Center) may contain useful information on SAR.

We have not come across data on multimission operations such as number of drug or fisheries arrests or number of military exercises supported; such data will need to be developed as part of this task.

The product of this task will be a multimission effects report that will describe models, algorithms, data sources, and additional data requirements. Additionally, as in the previous tasks, linkages with the Task 9 analytic model will be identified.

Task 8 - RA/SRA Tradeoffs

The purpose of this task is to provide a mechanism to evaluate the effect on the MOEs caused by differing combinations of radio and short-range aids to navigation.

Holding other components of the SRA program constant, a variety of radio-navigation/short-range configurations can be used in the harbor and harbor approach environment. Performance of the configuration will predictably vary in terms of many of the MOEs defined in Task 1. The ongoing Waterway Performance Study is providing one look at measuring performance from various short range and radio aid systems; these results will be incorporated into this task. In going beyond this study, Task 8 will focus on the critical MOEs such as cost, timeliness, and safety, and use these to compare directly the various RA/SRA alternatives under consideration.

Within the SRA program, the Government provides aid to navigation systems that may be classified as: (1) daytime visual, (2) nighttime visual, (3) audible, and (4) radar-based radio-electronic. In most cases, an aid station will include signals for more than one of these systems. The RA program provides other, longer-range, radio aids: radiobeacons, Loran-C and Omega for the present, and full-time satellite coverage will be provided some time in the future.

As in the previous tasks, Task 8 will use the MOEs developed in Task 1. First, a technology assessment of RA/SRA options will be performed. Working with appropriate personnel at Coast Guard headquarters (and possibly in the districts), we will specify decision options relating to different levels of

reliance on radio aids as opposed to short range aids. Different options might be specified for different operational settings. A major data source is expected to be the 1984 Federal Radionavigation Plans published by DoT and DoD.

Next, appropriate measures of effectiveness will be selected. Working again with appropriate Coast Guard personnel, we will review and refine MOEs developed in Task 1. First, we will select those MOEs that are appropriate for the RA/SRA tradoff analysis. These will be a subset of the MOEs developed in Task 1. Second, we will develop the measurement scales relating performances on measures to value. Scales will be refined, if necessary, to encompass the range of variations exhibited by the options and to reflect accurately the values of variations over the ranges. Third, we will review the importance weights across attributes and make any necessary adjustment (e.g., to reflect changes in the ranges).

Then, assessments will be made of the performance of the RA/SRA options against the selected MOEs. Assessments will incorporate all available data including the Waterway Performance Study and judgments of experts. This performance assessment may also use special-purpose models that will be developed to link RA/SRA decisions to characteristics of AtoN performance. As part of the analysis, we will identify future data sources for needed information that is not currently available.

Next, overall evaluations will be determined, sensitivities will be explored, and results will be documented. Analyses will be conducted to determine the sensitivities of evaluations to uncertainties in the data, differences of opinions, and changes in assumptions.

Finally, linkages with the Task 9 analytic model will be identified. Results will then be briefed to appropriate Coast Guard personnel and documented in a written RA/SRA Tradeoff report, due the end of the sixtieth month.

Task 9: Analytical Model

As previously stated, the purpose of Task 9 is to integrate all previous tasks and to present a systematic approach for supporting Coast Guard decisions

relating to the acquisition, deployment, and use of SRA resources. Based on knowledge gained in Tasks 2 through 8, the final product will be a resource management tool (RMT) that allows Coast Guard managers to reach decisions that can be supported through quantitative analysis, making use of decision-modeling techniques, empirical data, and where necessary, structured expert judgment.

While the final form of the model remains to be fully defined, it will consist in large part of the series of modules described in Chapter 2 (pages 2-6 through 2-8) of this report. Those modules, shown in block diagram form in Figure 6-1, focus mainly on the issues of safety and timeliness; their function is to predict the impact of SRA program decisions on (a) mariner safety and (b) transit delays, and to translate those impacts into economic terms. The RMT will incorporate these modules into a full-blown analytic model, in which all measures of effectiveness, both economic and non-economic, as well as those relating to dimensions other than safety and timeliness, are taken into account. The manner in which many of these steps will be accomplished was previously illustrated in Chapter 5 of this report.

The critical components of Task 9 include the following:

- o develop an overall resource management framework;
- o establish linkages between Tasks 2 through 8 and the overall framework;
- o refine linkages between Tasks 2 through 8 and the Task 1 MOEs;
- o implement the automated portions of the RMT on the USCG computer system making it compatible with the USCG C3 Standard Terminal or other computer system as specified by the Coast Guard;
- o demonstrate the RMT to USCG districts;
- o provide documentation on the RMT.

We anticipate no data requirements unique to Task 9; rather, Task 9 will use information gathered in Tasks 2 through 8. The Task 9 efforts should begin as

FIGURE 6-1. OVERVIEW OF SYSTEMS MODEL

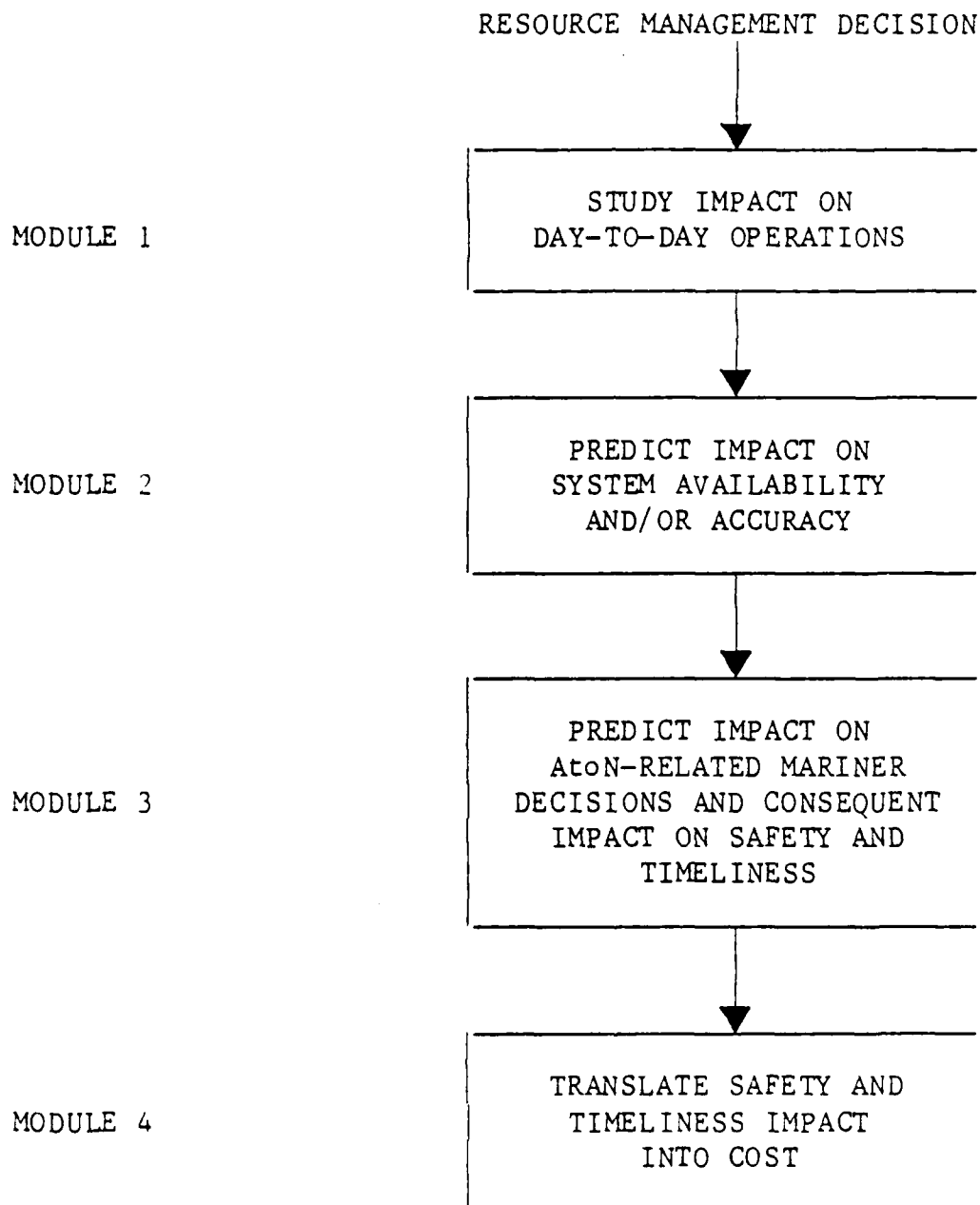

early as year 3 and continue in parallel with the remaining tasks. As each task is undertaken, we will examine the linkages between that task and the Task 9 product. Task 9 will in effect evolve along with its individual components. The degree of automation is uncertain at this time; however, we anticipate that the final model will involve a combination of automated modules developed as a result of Tasks 2 through 8, some off-line analysis, and an automated module to accomplish the multiattribute utility analysis (or equivalent) functions envisioned for Task 9.

APPENDIX A: TRIP REPORTS

This appendix includes, in chronological sequence, trip reports to the following Coast Guard District Offices:

		Page
CGD-9 (Cleveland)	4-5 Nov 1985	A-2
CGD-1 (Boston)	4-5 Dec 1985	A-6
CGD-7 (Miami)	16-17 Dec 1985	A-18
CGD-8 (New Orleans)	9-10 Jan 1986	A-24
CGD-3 (New York)	10-11 Feb 1986	A-40
CGD-2 (St. Louis)	19-20 Mar 1986	A-43
CGD-12 (San Francisco)	31 Mar-1 Apr 1986	A-59
CGD-14 (Honolulu)	2-4 Apr 1986	A-62
CGD-5 (Portsmouth)	29 May 1986	A-66
CGD-13 (Seattle)	9-10 June 1986	A-70
CGD-17 (Juneau)	11-13 June 1986	A-76

Visits to each office were accompanied by meetings with local or regional pilot groups and other user organizations. Also, on 9 Dec 1985, a special visit was made to the American Pilots Association headquarters in Washington, D. C. (page A-16).

TRIP REPORT

Meeting with 9th Coast Guard District, Cleveland, OH, 4-5 November 1985

4 November 1985

1. Kickoff Meeting, 8:30 AM

Capt. Leonard Garrett, Capt. Fred Kelley, Lt. Ray Smoyer, Lt. JG Benny DeVito, and Bill Craig

Major Purpose - introduce the MANDEX effort, generalized discussions of MOEs, specific discussions on 9th District.

In general, the 9th District is unique with respect to peak workloads in the late fall (decommissioning of aids) and early spring (commissioning of aids). In the district, USCG personnel are satisfied with the configuration of aids, are satisfied with the level of technology, and tend to focus on ensuring that the system works reliably. From a user point of view, the mariners look to see if the system works well which includes, "do they see the right aids" and "are the aids working correctly."

There was a feeling that, in trying to measure the effectiveness of the SRA system, there has never been a good handle on what benefit measures should be used, particularly with regard to intangible benefits. Rather, previous studies tended to institutionalize what was already known. Tools don't exist to evaluate service to mariners. However, there was a feeling that service wasn't suffering because, in the Great Lakes area, the system is not under pressure. Due to economic conditions, shipping is way down and the system hasn't changed much. Additionally, notices to mariners help mitigate any impacts, particularly for the commercial mariner. (The bulk of the group discussions focused on the commercial mariner rather than on the recreational boater.)

In attempting to outline specific measures of effectiveness, several general categories were identified:

- *Service to the Mariners* - Includes both commercial and recreational boaters; usually there is little praise for a job well done, but much noise if there are problems. In measuring this MOE, it is probably necessary to focus on choke points (e.g., St. Mary's River), since the real key to an effective SRA program is to tailor to the waterway. Questions that may be appropriate might include:
 - is the system adequate?
 - is the discrepancy rate and response adequate?
 - are mariners notified quickly of discrepancies?
 - are charts and light lists accurate?
 - are aids positioned accurately?
 - does the system remain static and predictable?
 - is the physical appearance of the system good?
 - is the system reliable?
 - are there excessive delays in transit?
 - are we able to extend the shipping window as widely as possible?
 - is the USCG receiving many complaints?
 - is litigation higher than it should be?
 - does any aid placement inhibit traffic or itself present a hazard to navigation?
 - what is the perception of risk?

- *USCG Concerns* - These tended to focus on discrepancy rates, response times, utilization of tenders, cost expended per aid, etc. While accident rates are also important, there has been little data available to measure things like number of accidents, where they occurred, why they happened, etc. Commercial accidents occur infrequently (but when they do, it's often at the northern end of Lake St. Clair). Other factors include:
 - is the relation with users co-operative or adversarial?
 - how is crew morale?
 - what is the physical appearance of the vessels? of the aids system?
 - can multi-mission requirements be met?
 - is training adequate?
 - what is the public relations impact?
- *Political Factors* - There was a strong sense that many cost-beneficial decisions are overridden by political issues. Examples given included the attempt to remove the *Acacia* and the *Mackinac*. The district can't afford to "win the battle" over a small issue and to "lose the war" on appropriations. One of the questions is, "what will be the impact of a USCG decision on the local community?"
- *Costs* - These presently are viewed from a USCG perspective. If the same system can be maintained for fewer dollars, this is good from a cost point of view. Measuring the costs has been difficult since there are often inconsistencies in reporting procedures.

2. Phone Conference with Captain David Freeborn, 1:15 PM

- a. The major theme coming from Capt. Freeborn was the focus on the user. This is critical and should be explored through channels such as International Ship Masters, Lake Carriers' Association, Dominion Marine Association, pilots organizations, etc.
- b. Capt. Freeborn felt that the emphasis on discrepancy response criteria does not do a good job of measuring against goals. There is no set of well defined standards that show how well the system performs now; therefore, it is difficult to determine how much improvement needs to be made.
- c. The USCG reporting system focuses on performance of units, performance of equipment, and the impact of training; it can't adequately measure the internal process.
- d. While relations with users are friendly and good rapport exists, there should be even more interface with the user (e.g., industry training programs).
- e. Better ties are needed between the USCG and the Corps of Engineers regarding aids to navigation.
- f. There is somewhat of a paradox in that the aids to navigation system was not established based on USCG requirements but rather on user requirements; yet, the user really doesn't know how the USCG can change the system.

5 November 1985

1. Lake Carriers' Association

George J. Ryan (President) and Gordon D. Hall

- a. The most important Coast Guard service to lake carriers is the servicing of aids through the navigation season. Actions such as year-round structures that would extend the season, which is weather-dependent, are the most welcomed. The schedule of buoy removal in fall is more important than placement in spring.
- b. All-weather capability is also important, and racons have been very well received. There are limits, however, to all-weather capabilities; pilots won't move if they can't see the bow, regardless of the aids.
- c. The major concern addressed by all-weather capability is the reduction of delay in shipping. Reduction of delay has a direct dollar impact. Individual major shippers keep track of dollar-per-hour delay costs, but these costs are not available from LCA. Fewer delays would allow shippers to plan inventory better.
- d. When considering improvements in the system, improvements in the choke points, which affect many carriers, are the important ones. Major choke points are the St. Mary's, Detroit, and St. Clair rivers.
- e. Lake carriers also feel that personnel safety is very important and that reduced chances of collision or grounding could be related directly to personnel safety.
- f. Congress seemed to listen most to safety and environmental arguments (especially concerning oil spills in ice), but these arguments could not always be made. For example, the decision to keep the Mackinac for icebreaking was based on economic arguments (both local economics and the steel industry).
- g. From the LCA perspective, the Coast Guard headquarter's accident records are less than adequate. However, useful information is often kept in the field, such as the "little black book" at the St. Mary's River district office. This information may provide some insights into the role of short-range aids in accidents. (As an aside, collisions in queues are extremely rare.)
- h. It would be difficult to make significant improvements in the Great Lakes because the system is so good now.
- i. The biggest discontent is the perception that the discrepancy rate is high now. This is based on an observation of a long list of discrepant aids in local notices to mariners. However, it is not clear that this perceived high rate has much impact on commercial traffic. The Coast Guard corrects critical aids promptly.

2. 9th District Information System

Lt. JG Benny DeVito and Lt. Ray Smoyer

- a. GLANDS, the Great Lakes version of ATONIS, keeps track of the aid inventory, equipment list, and discrepancy response. GLANDS will be tied in with ATONIS by spring of 1986.
- b. We were provided with samples of GLANDS data, which were explained.
- c. The 9th District currently has 3-4 years of good data, but insufficient resources to analyze them.
- d. Commercial accident data is maintained by "M" branch through the Marine Safety Information System (MSIS).

3. Buoy Tender Skipper

LCDR David Jones, skipper of USCGC SUNDEW (180' WLB)

- a. An important consideration in operating a buoy tender on the Great Lakes is to tailor the service to users' need. For example, recreational buoys are removed earlier than ones that serve the commercial mariner.
- b. Limiting factors on the SUNDEW are deck space and stability.
- c. Mariners appreciate most being called and consulted about buoy removal in the fall.
- d. The measures of effectiveness for a buoy tender are cost of servicing a given set of buoys (major controllable costs are fuel and batteries) and discrepancy rate (15% of discrepancies could be attributed to personnel error).
- e. An important attribute that is difficult to quantify is the extent to which the buoy tender skipper is a "good landlord" of the waterway as a whole.
- f. The SUNDEW is involved heavily in icebreaking (especially for about 2 weeks in the spring), and it spent 26 weeks in Bravo 6 for SAR (and several weeks in Bravo 2, during storm warnings).

TRIP REPORT

Organizations and Dates

Places: First Coast Guard District Operations Division, Boston, MA
Boston Fuel Transportation, Inc., Boston, MA
Boston Pilots Association, Inc., Boston, MA

Dates: 4, 5 December 1985

Members of Party

Karl Schroeder, G-DST-1
Leonard Greenberg, Mandex, Inc.
Jacob Ulvila, Decision Science Consortium, Inc.
Guy Clark, PharoLogic, Ltd.

Persons Visited

First Coast Guard District

CAPT Richard Rybacki, Chief of Staff
CAPT Douglas Thurnher, Chief of Operations
CAPT Steve Richmond, Chief of OAN
CAPT George Ireland, Chief, Marine Safety Division
LCDR Chet Motekaitis, Assistant Chief, OAN
LCDR Mike Slack, Assistant Chief, MSD
LTJG Ben Clough, OAN
LTJG Scott Krammes, OAN
Bob Potkay, OAN

Boston Fuel Transportation, Inc.

Dave Galman

Boston Pilots Association

Ed Mitchell
Joe Quarters

1. Meeting with First District Aids to Navigation Personnel, 4 December 1985

Capt. S. Richmond, LCDR C. Motekaitis, LTJG B. Clough, LTJG S. Krammes, and Mr. B. Potkay

- a. The general purposes of this meeting were to elicit views on measures of effectiveness, to solicit comments on the draft measures of effectiveness developed by the project team (25 November 1985), and to elicit information on ways in which the first district is unique. Specific changes to MOEs are shown in section 4 below, and appropriate references are given here.
- b. CGDI peculiarities are:
 - Rocky coast;
 - Ice and fog;
 - Many deep moors;
 - Change aids to ice buoys in the winter.
- c. In the first district, many buoys are removed "when endangered by ice." When icing conditions are possible, a buoy tender is usually standing by for a quick response. If icing does not occur, then it appears as though the cutter was not utilized. The measures should give credit for this (MOE 2.2).
- d. Icebreaking is different in the first and ninth districts. In the first district, the Cape Cod Canal is the major choke point that requires icebreaking. Other points are the Penobscot River, Nantucket, and Providence. Ice removal from buoys is also a big job. In addition, iced-over buoys cause an increase in discrepancies (including aids off-station or submerged) every winter. The 180' buoy tender is a good ice breaker in the first district (contrasted with the ninth, which has a special ice-breaking tug).
- e. Maintenance scheduling is critical to keeping up the aids to navigation function--at least one of the two 180' tenders should be in service at all time, and both should be in service during the ice season (December to March). Scheduling of maintenance is sometimes a problem.
- f. The 180' buoy tender is very important for training--both in the AtoN function and in providing at-sea and command experience to officers more generally (see MOE 2.4.3).
- g. Sometimes it is impossible to tell why a small buoy is needed until it is removed and a problem appears (e.g., increased groundings).
- h. Pleasure boaters cause the greatest problem, especially in fog, and fog is a problem in major pleasure boating areas (Penobscot Bay is especially bad). Many pleasure boaters don't even know that the local notice to mariners exists and many who do don't read it.
- i. Even in summer, the average water temperature may only be in the 50^os, and life expectancy is only a few hours in 55^o water. SAR requires quick response.
- j. Characteristics of channels change a lot with the tides. It is almost the case that there are two different coasts, one at high tide and one at low tide. Aids are set to a large extent by local knowledge and attempt to account for shifting bottoms.

- k. The first district must be concerned with international conventions and coordinating with Canadians (new MOE, see section 4). Nantucket is the main landfall for transatlantic commerce. IMO provisions do not recognize LORAN for position-fixing on traffic separation schemes; coordination requires consistency and reliability. Canadians want to get rid of sequence radio beacons.
 - l. The first district is heavily involved with the Navy in coastal defense (MARDEZ) war games. Both 180' cutter and 55' ANT boats are used in the first district. No funding is provided by the Navy for this activity. The Coast Guard would like to know more clearly where it fits into the national defense picture (new MOE and MOE 2.6.1).
 - m. Lighthouse maintenance is a significant effort in the first district, involving about 3 weeks a year for each tender (180' and 133'). The first district has the most lighthouses, and all 102 active lighthouses are potentially historic (new MOE). Some lighthouses are still manned, all will be unmanned by 1989.
 - n. Commercial mariners in the first district include cargo carriers, fishermen, and charter boat operators (MOE 1.1). Recently, the composition of commercial traffic has changed in the first district to more tugs and barges (especially oil barges).
 - o. In some locations, grounding rate may be a good indicator of the quality of the AtoN system.
 - p. When considering discrepancies, it is useful to distinguish the signal type, aid type (e.g., shore or floating), and location.
 - q. The marine information system costs about \$1500 to \$2000 a week during the peak boating season (1 April-1 November). NOAA and the Corps of Engineers account for about 25% of the input. About 5000 Local Notices to Mariners are sent out during the peak season (2000 commercial, 3000 pleasure).
2. Meeting with: Capt. G. Ireland, Chief, Maritime Safety Division
LCDR M. Slack, Chief, Port Safety Branch, 4 December 1985
- a. The objective of the aids to navigation system is to make the pilot's life easy:
 - require the minimum number of decisions;
 - make decisions easy.
 - b. A pilot is most worried about putting a ship aground--it's his reputation.
 - c. Time is money to shipping companies, and a big component is longshoremen. If they're called, they're paid, whether or not the ship has docked.
 - d. Pilots like buoys for navigation (racons in reduced visibility).
 - e. The daily cost of running a ship is about \$20,000 to \$50,000.
3. LTJG S. Krammes explained the computerized information system that is used in the first district and gave us a copy of the output, 5 December 1985.

4. Changes in the Draft Measures of Effectiveness

Several specific additions and clarifications to the draft measures of effectiveness (25 November 1985 version) were noted. These include the following (designated by outline code). A copy of the draft is attached.

- 1 Service to Mariners could include the MSC (may fit better under 1.3).
- 1.1 Include fishermen, cargo carriers, and charter boat operators among commercial users.
 - 1.1.1.2.1 Non-accident delay costs should include delay costs caused by other than specific incidents.
- 1.2 Recreational boaters use a large portion of the aids in the first district.
 - 1.2.1 Economic considerations of the recreational boater include boat damage, property damage, and equipment costs.
- 1.3 Government vessels include those operated by the Corps of Engineers.
 - 1.3.1 Economic considerations for government vessels include the costs of delays in getting to repair facilities.
- 2.1 The following might be added as a sub-category of USCG interests:
 - 2.1.4 Public comment on aids to navigation mission performance.
- 2.2 Resource utilization should allow for all maintenance, training, administration, and defense tasks.
 - 2.3.1 OE costs should include administrative and support costs and should include long-run as well as short-run costs.
 - 2.3.5 Training and recruitment costs should be added as a new category.
- 2.4 Competency level should be reflected somehow in USCG personnel implications.
 - 2.4.2 Morale should include fatigue and retention.
 - 2.4.3 Personnel development and training, including AtoN and general training, should be added as a sub-category of USCG personnel implications.
- 2.5.3 Fishing should be added as an example of law enforcement.
- 2.5.4 The icebreaking season in the first district is mid-December through the first of March.
- 2.5.5 Lighthouse maintenance and repair and support of the National Data Buoy Office (NOAA) and the Corps of Engineers' dredging operations are additional items of "other missions."

- 2.6 Administrative duties should be added as a new sub-category of USCG interests.
- 3.1 The effect of recreational boating activity should be included in the impact on the local economy.
- 3.4 Public image should be added as a sub-category of public interest. (This might be better placed under USCG interests.)
- 3.5 The boating industry (boat builders and boating support companies, such as marinas, yards, and repair facilities) is a group that should be singled out for treatment as a separate category under public interest. (This might be better treated as a new category with a single-digit outline code.)
- 3.6 Historic preservation should be added as a public interest sub-category.
- 4.3 Impact on national defense should be added as a sub-category of effects on other government agencies. (This might be better placed under public interest.)
- 7 International impacts should be added as a new category. This would have the following two sub-categories:
 - 7.1 Impact on IALA convention and on IMO.
 - 7.2 Coordination with other countries on territorial waters (e.g., Canada and Mexico).

5. Meeting with Dave Galman, Boston Fuel Transportation, Inc., 5 December 1985

- a. He has not heard many complaints about the present level of aid servicing, including discrepancy response.
- b. Pilots are concerned with safety, ship operators are concerned with economics.
- c. The broadcast notice to mariners is not sufficient for information--especially for ships at sea coming into a channel.
- d. A pilot uses the aids and has confidence in the system. He does not think that the Coast Guard has much of an icebreaking capability. Racon is very useful for big buoys in areas of heavy traffic, especially in conditions of poor visibility.
- e. He feels that the channels of communications between the Coast Guard and pilots are adequate if people want to use them, but use is not very high. A problem area is in accident reporting; an accident report that is filed with M does not always get to AtoN.
- f. Commercial interests will approach the Coast Guard directly and exhaust all other channels before going to Congress. Pleasure boaters go to Congress first.
- g. A particular problem was mentioned at Jacknife Ledge. Several outbound vessels have gone aground on this rock ledge that is in a turn at Fall River. This location could use a lighted aid.

6. Meeting with Boston Pilots Association, Inc., 5 December 1985

- a. There are no problems with AtoN in Boston Harbor.
- b. Rapport with the Coast Guard is good in all respects, including with the captain of the port. It would be useful to meet about twice a year to discuss aids to navigation (e.g., to talk about which buoys they could live without).
- c. The local and broadcast notices to mariners are very important and are used a lot by pilots.
- d. A racon would be very useful in Boston.
- e. If a buoy is reported out (to Group Boston), there is some delay in getting it fixed due to the time it takes communication to filter down USCG echelons.
- f. There is a bit of a problem in some channels where the first buoy is a second-class, unlighted one.
- g. The best location for a buoy is in the water at the edge of the channel (e.g., as opposed to ashore or back from the edge of the channel).
- h. Fall River channel is a daylight operation. It would not change to 24-hour operation even if it were lighted.
- i. The old Lighthouse Service had long-term dedicated AtoN personnel who the pilots knew and had confidence in--CG should consider same approach instead of rotating personnel every 2 to 4 years.

DRAFT MEASURES OF EFFECTIVENESS

(General, but tailored to Great Lakes where possible and appropriate.)

- 1 Service to Mariners. This is a measure of how well user needs are being satisfied. It includes commercial, recreational, and government vessels.
 - 1.1 Commercial users. Includes both ocean-going ships and Great Lakes ships. Of the US flag companies in the Great Lakes, 4 make up 75% of the traffic.
 - 1.1.1 Economic considerations--from the point of view of the commercial user.
 - 1.1.1.1 Accident-Related. Costs to a carrier involved in an accident (e.g., grounding, collision, ramming).
 - 1.1.1.1.1 Lost cargo. Dollar value of cargo lost/damaged due to an accident.
 - 1.1.1.1.2 Ship damage. Dollar value of damage to vessel due to an accident.
 - 1.1.1.1.3 Other accident. Other costs of an accident (e.g., cost of clean-up, cost of temporarily replacing lost carrying capacity).
 - 1.1.1.2 Non-Accident. Costs to carriers not involved in an accident.
 - 1.1.1.2.1 Delay. Costs due to delays that are caused by degradation of the aids to navigation system, by environmental conditions, or by specific incidents.
 - 1.1.1.2.1.1 Direct costs--Dollar value that can be directly attributed to the delay condition (e.g., cost of fuel, pay and allowances).
 - 1.1.1.2.1.2 Opportunity costs--Indirect costs of a delay (e.g., costs of rescheduling, changing inventory policy, making-up lost days).
 - 1.1.1.2.2 Length of operating season. Measures impact of decisions on how late aids can be removed and how early they can be returned to service.
 - 1.1.1.2.3 Routine costs. Normal operating, maintenance, and capital costs that may be affected by changes in the aids to navigation system.
 - 1.1.1.2.4 Other non-accident costs. Costs other than those shown above.
 - 1.1.2 Personnel safety--Relates to safety of the crews of the commercial vessels. May be in terms of injuries, deaths, lost days, etc.
 - 1.1.3 Other considerations--Includes miscellaneous factors not accounted for above.
 - 1.1.3.1 Confidence in the System. Measures impact of USCG decisions and practices on commercial mariners' confidence in the aids to navigation system.
 - 1.1.3.2 Appearance of the System. Measures impact of USCG decisions and practices in terms of how the commercial mariner physically views the system.

- 1.1.3.3 *Marine Information Communication.* Measures how well information is disseminated by the USCG and received by the commercial mariner of the status of the aids to navigation system; includes impact on broadcasts, notice to mariners, etc.
 - 1.1.3.4 *Accuracy.* Measures impacts of both how well are aids positioned and how up-to-date are the published charts and light lists.
 - 1.1.3.5 *Rapport with USCG.* Measures whether the client and USCG are operating in a cooperative versus adversarial role.
- 1.2 Recreational boater. Measures overall impact on recreational boaters who use a relatively small portion of the aids to navigation system in the Great Lakes.
- 1.2.1 Economic considerations--Economic impacts on recreational boaters (both accident-related and non-accident-related).
 - 1.2.2 Safety--Impacts on injuries and deaths among recreational boaters.
 - 1.2.3 Other--Impacts on recreational boaters other than economic and safety.
- 1.3 Government vessels. Impacts of USCG policies and practices on vessels operated by other units of government (e.g., U.S. Navy, NOAA, state governments).
- 1.3.1 Economic considerations--Economic impacts on government vessel operations (both accident-related and non-accident-related).
 - 1.3.2 Safety--Impacts on injuries and deaths among government vessel operators.
 - 1.3.3 Other--Other impacts on government vessel operators.
- 2 USCG Interests. Includes the USCG perception of how well the aids to navigation and other missions are performed; the costs associated with these missions; impacts on USCG personnel.
- 2.1 Aids to navigation mission performance. How well is the USCG conforming to stated policies and standards.
 - 2.1.1 Discrepancy rate--Number of discrepancies in a district per aid per year.
 - 2.1.2 Response time--Time from initial indication of discrepancy until a fix is in place; appropriate level is a function of discrepancy response factor (DRF).
 - 2.1.3 Quality of service--Includes aid placement, maintenance, and repair.
 - 2.2 Resource utilization. Measures how well USCG assets are being utilized (e.g., availability, hours in high readiness, hours in standby).
 - 2.3 Cost. Direct dollar costs to the USCG.
 - 2.3.1 OE cost--To operate and maintain the system; includes all recurring costs such as pay and allowances.
 - 2.3.2 Capital costs (AC&I)--Includes non-recurring costs (replacement of aids, SLEP, etc.).
 - 2.3.3 R&D costs--Research and development costs.

- 2.3.4 Cost of litigation--Includes both the direct legal expenses and liabilities incurred as a result of legal action.
- 2.4 Personnel implications. This measures non-cost related impacts on USCG personnel.
 - 2.4.1 Safety--Measures impact of crew safety during operations as a function of policy changes.
 - 2.4.2 Morale--Measures impact on crew morale as a function of policy changes (e.g., less liberty time, longer working hours, temporary dislocations from family).
- 2.5 Multi-mission capability. This measures the capability to perform missions other than aids to navigation.
 - 2.5.1 Military--This includes training and readiness to prepare for wartime deployment.
 - 2.5.2 SAR--Search and rescue operations.
 - 2.5.3 Law enforcement--In support of federal and local law enforcement agencies (e.g., immigration, drug traffic).
 - 2.5.4 Ice breaking--Breaking ice during frozen season; in Great Lakes, mostly during early spring.
 - 2.5.5 Other missions--Other roles as required; includes marine science activities (MSA), cooperation with other agencies (COOP), marine environmental response (MER), port environmental safety (PES), public affairs (PIA).
- 3 Public Interest. Measures impact of policy decisions on the public (non-mariner).
 - 3.1 Local economy. Measures impact of policy decisions on the local economy (e.g., affect on port city of cargo passing through it; the impact on a town if a vessel is decommissioned).
 - 3.2 Environment. Measures impact on the environment as a function of policy changes (e.g., pollution control).
 - 3.3 Public safety. Relates to impact on the public regarding hazardous cargo, etc.
- 4 Effects on Other Government Agencies. Includes both direct and indirect effects on federal, state, and local governments.
 - 4.1 Regulatory. Measures regulatory impacts on agencies (e.g., EPA).
 - 4.2 Other government costs. Resulting from Coast Guard actions.
 - 4.3 Other effects on government.
- 5 Political Consequences. Measures political implications that can affect USCG decisions (e.g., threat to appropriations if local Congressman is offended).

6 Risk. Measures chances of failing to achieve stated expectations.

6.1 Servicing risk. Chances of not providing the expected level of service associated with a policy decision.

6.2 Cost risk. Chances of exceeding expected costs associated with a policy decision.

6.3 Public risk. Chances of not meeting expectations in terms of impact on the public.

6.4 Other risk. Risk not included in other risk factors.

TRIP REPORT

Organization and Date

Place: American Pilots Association Headquarters, Washington, DC

Date: 9 December 1985

Members of Party

Karl Schroeder, G-DST-1
LT Chip Sharpe, G-NSR-1
Leonard Greenberg, Mandex, Inc.
Terry Bresnick, Decision Science Consortium, Inc.
Jacob Ulvila, Decision Science Consortium, Inc.
Guy Clark, PharoLogic, Ltd.
John Stanley, PharoLogic, Ltd.

Person Visited

CAPT Pat Neely, President of American Pilots Association

1. The purpose of the meeting was to solicit views of pilots on the effectiveness of the USCG's aids to navigation system.
2. CAPT Neely does not think that any port is being held back from development due to lack of aids to navigation or problems with the AtoN system. If the cargo is there, then aids will be added (usually built with private money and then turned over to the Coast Guard). He does not think that anyone would argue that an increase in aids (e.g., lights) would increase traffic.
3. The worst situation is to have an aid missing, especially at the entrance to a channel. In this case, there is the possibility that the aid is sunken and obstructing the channel. The risk (economic, safety, and environmental) is such that pilots are apt to wait for the Coast Guard to respond before transiting. Restoring the AtoN system after a storm is also a big problem. (He added, however, that the Coast Guard did a good job after a storm wiped out aids in the Houston Ship Channel).
4. Demurrage, the economic impact of delay, runs a couple of thousand dollars an hour for a cargo ship.
5. There is good rapport between pilots and the Coast Guard--from headquarters down to the districts: He communicates directly with the CG Office of Navigation (RADM Wojnar).
6. It is CAPT Neely's opinion that the Coast Guard is stretched a bit too thin now and cannot always cover enough area quickly enough.
7. CAPT Neely is worried about a decrease in service if the Coast Guard turns over AtoN duties to the private sector. Specific concerns include: quality of servicing of aids (especially large buoys), speed of discrepancy response (especially at night), and SAR response.
8. Information about discrepancies is almost as useful as fixing a discrepancy except for missing aids.
9. Pilots are most often the ones who report outages. They use the information in local and broadcast notices to mariners. He is satisfied with both of these.
10. Pilots are most upset when they cannot get a change made in the system at the local level. (The reason given is usually economic.)
11. He offered to put out a survey questionnaire to local pilots associations.

MEETINGS FOR FLORIDA TRIP, 16-17 DECEMBER 1985

A. Meeting with 7th District Aids to Navigation Personnel (Miami), 16 December 1985

Attendees: See attached list

1. Factors that make 7th district unique (particularly Miami)
 - 12-month season for residents
 - Large number of seasonal residents (transitory users)
 - Heavy drug traffic
 - Large number of cruise vessels
 - Benign weather, no ice, high use of solar aids (less maintenance, more vandalism)
 - Short entrance channels
 - Soft, forgiving bottom
 - Intracoastal waterway
 - Hurricane damage
 - More structures, with work done by construction tenders (84% fixed aids)

2. Specific comments on draft MOEs:
 - a. Commercial vessels include fishing boats, charter boats, underwater activities.
 - b. Insurance costs need to be included: Policies are not written on the basis of individual risk, but are written broadly.
 - c. Under routine costs (1.1.1.2.3): As aids change, quality and quantity of skills and equipment change; this is a real cost to commercial users.

3. In order to focus on MOEs, a hypothetical situation was selected, a scenario developed around it, and discussions were held on MOEs:

Situation - the WLB: SAGEBRUSH would not be available either through transfer or decommissioning.

Scenario:

 - Size and number of ANT teams would increase.
 - Remaining WLBs would be used in a round robin approach to service SAGEBRUSH's aids.
 - System would be made less tender-dependent:
 - reduce 180' workload
 - change some lighted aids to unlighted (backwater ports)
 - reduce size of some aids
 - replace some aids with fixed structures
 - use articulated beacons.
 - SAGEBRUSH currently does 40% AtoN, 60% other.
 - Eliminate tasks that are done merely because the vessel is there and available.
 - Reduce discretionary tasks.
 - 210s are planned for Puerto Rico in the future.

Impacts (MOEs)

- a. Political pressures (from Puerto Rico): Federal government is major employer, but impact on economy would be minor; local government may want real estate back.
 - b. Risks: Pilots would complain, as would large oil refineries.
 - c. Quality: Some degradation, longer to fix, minimum delays.
 - d. Other Missions: Greater presence in drug trafficking lanes due to round robin steaming; less time available to do other missions; SAR effectiveness decreases if aids are not maintained; there is an increase in apparent efficiency since only high-value missions will be performed (hot targets only).
 - e. Vessel Downtime: If a vessel goes down for repair, long lead times for repair can no longer be tolerated ("benevolent" downtime); these long lead times are a result of parts non-availability for aged ships and government contracting procedures; there will be high added costs to overcome downtime.
 - f. More accidents, higher costs of litigation.
 - g. More complaints.
4. Other comments:
- a. States should review costs and training requirements for licensing mariners; if skills could be improved, perhaps fewer aids would be required.
 - b. Education of mariners is important and is not done well now.
 - c. The goal is for large cutters to be doing 40% other missions; now AtoN is 15%, Law Enforcement is 75%.
 - d. Hard to measure effect of 48-hour response time; "partial discrepancies" are not distinguished from total discrepancies.
 - e. Only 1500-2000 people get local notice to mariners; broadcasts of discrepancies are both scheduled and unscheduled.
 - f. During hurricane season, there is severe damage to many aids; many are moved off-station. Aerial overflights are used to identify problems, and a priority list is established.
 - g. Primary sources of discrepancy information:
 - 1st - recreational boaters
 - 2nd - commercial
 - Last - routine patrols.False alarm rate is low.
 - h. Pilotage Rules Vary: Required for some classes of vessels; each state has own rules. Pilots groups exert leverage through lobbying.

- i. Cruise ships carry 50,000 people/week into the port; schedules are tight. Ships can be delayed by:
 - Safety and health reasons
 - Aids off-station
 - Channel closings (rare)--once every few years, an accident blocks the entrance.
- j. Congressional Complaints: Occur when someone tries to decrease the system, when marina operators are trying to get new aids; not many complaints on quality--pressures are self-imposed rather than external.
- k. When aids do not get fixed, it is due to lack of available resources or to human error (faulty communication).
- l. Some pressure is placed by yacht groups, boaters clubs, user associations in local groups, etc.
- m. Relations between USCG and pilots association is pretty good; mostly done at local level with little done at district level.

B. Meeting with Captain G.S. Duca (Chief of Staff, 7th District), 16 December 1985

- 1. Captain Duca feels that a comprehensive analysis of SRA program is required, and it must begin with a thorough understanding of what a buoy tender does.
- 2. The driving factor in AtoN decisions is cost to USCG and cost to the economy. The latter includes direct costs (collisions, rammings, groundings) and indirect costs (facilitation of navigation).
- 3. The costs incurred by the direct operator are usually passed on to the ultimate user, the "real public."
- 4. 90% of SAR work is within 3 miles of shore where there are not many aids.
- 5. Needs of recreational boaters should be placed above DoD needs (multi-mission).
- 6. There is slack in the system now; loss of assets (e.g., tenders) will cause people to speak up.
- 7. The AtoN system is a mature program based on years of experience; changes are incremental, based on empirical data.
- 8. It might help to look at the experiences of other countries.

C. Meeting with LTJG Neil Hurley (oan), 16 December 1985

- 1. There is minimal data available in the 7th district other than on aids inventory. This is used for assignment of aids to tenders.
- 2. Data is available through the USCG-wide MSO database.

3. Another source of information is the Practical Information Listing of Equipment and Servicing (PILES).

D. Meeting with Captain Dario Pedrajo, 17 December 1985

1. Captain Pedrajo is the President of the Florida State Pilots Association (Miami).
2. He believes the USCG is overloaded with other tasks and as a result, the AtoN mission is affected.
3. Over the last 15 years, there have been many changes in the characteristics of users:
 - More traffic;
 - Larger ships, larger turning circles;
 - before, 500'; now, 1000'
 - before, 2 tons; now 60-70 tons
 - before, 20' draft; now 30' draft.
4. If the USCG takes actions to increase discrepancy response time, the major factor would be increased risk of accident; there is often little room for error now; further decreases in the capability of the SRA system would reduce that margin even more. Under non-ideal conditions, accidents may occur.
5. When the system operates right, you can do more things, more safety; more ships can transit at the same time.
6. The Port of Miami is approaching saturation.

E. Meeting with Tampa Bay Pilots - Captain Fred D. Smith and Jerry Bacon, 17 December 1985

1. The AtoN system design has been improved greatly in the last 2 years in Tampa Bay.
2. If the system capability decreases significantly, there will be:
 - Many more groundings
 - Channel blockings
 - Traffic shut-downs.

However, it would take a very major capability decrease to cause this (i.e., they like their dedicated tender).

3. There now exists competition in state pilotage in Tampa Bay; there are pilots who are willing to take greater risks to get business; as a result, there are few delays caused by the SRA system.
4. In Tampa Bay, most inbound cargo is petroleum, phosphates outbound, by bulk carriers (around 5000 transits/year).

5. The major effect that changes as the system capability decreases is the "pucker factor" or margin for error (risk perception).
6. The USCG does a satisfactory job in AtoN:
 - Response time is not that great;
 - Many aids are not positioned correctly (system design does not mark channel, buoys do not always mark where intended);
 - USCG usually is not the one to detect off-station buoys.
7. There is a close working relationship between USCG and pilots; however, it was felt that the Captain of the Port Orders need to be enforced better by USCG.

F. Meeting with Captain Thomas W. Boerger (Marine Safety Office, Captain of the Port) and Captain Joseph Valenti (Tampa Port Authority Deputy Port Director), 17 December 1985

1. In Tampa Bay, condition of SRA system is unlikely to affect waterway status unless something very drastic occurs.
2. USCG philosophy is to leave judgments on risk up to the pilots. There is strong competition and risk perception varies greatly. There are few accidents.
3. Measures of effectiveness might include number of groundings and the subjective input of pilots and USCG personnel.
4. A large cruise ship might inject \$500K into the local economy on a typical Saturday afternoon.
5. It costs at least 10-15K/day to run a large ship.
6. A good source of information might be studies of economic worth conducted for many ports as well as MARAD reports (maritime administration).
7. The pressure point in any SRA system is when the pilots refuse to do anything. In Tampa Bay, the system would have to be very badly degraded before pilots would refuse work.
8. Not much accident data is available, and the little that is, is not aggregated; few accidents occur, none with serious consequences.
9. Competition is between ports. Ships will go to ports where it is less expensive and where there is less navigational risk.

Meeting at CGD7 on SRA Resource Management, 16 December 1985

Name	Organization	Phone Number
CAPT Alvin Cattalini	CCGD7 (Chief, OAN)	305-536-5722
CAPT Lloyd R. Lomer	D7, Chief Engineer	305-536-5667
LCDR Vince O'Shea	D7 (OAN)	305-536-5621
LCDR Joe Milo	D7 (ECV)	305-536-5661
LT Phil Centonze	CCGD7 (OAN)	305-536-5621
LT Larry Jaeger	Seventh District (ECV)	305-536-5637
Karl R. Schroeder	HQS R&D (G-DST-1)	202-426-1020
Guy Clark	PharoLogic	301-372-6972
Leonard Greenberg	Mandex, Inc.	703-442-3870
Terry Bresnick	Decision Science Consortium	703-790-0510

TRIP REPORT

Organizations and Dates

Organizations: Eighth Coast Guard District Operations Division, New Orleans, LA
Coast Guard Base, New Orleans
Board of Commissioners of the Port of New Orleans
Sea-Land Services, Inc.
Associated Branch Pilots
Associated Federal Coast Pilots
Crescent River Port Pilots Association
New Orleans-Baton Rouge Steamship Pilots Association
Compass Marine Services
American Waterways Operators, Inc.

Dates: 9-10 January 1986

Members of Party

Leonard Greenberg, Mandex, Inc.
Jacob Ulvila, Decision Science Consortium, Inc.
Guy Clark, PharoLogic, Ltd.

Persons Visited

Eighth Coast Guard District Operations

CAPT J.D. Sipes, USCGD8 (o)
CAPT D. Carey, USCGD8 (oan)
CDR S. Burgess, USCGD8 (dpl)
CDR P. Hill, USCGD8 (oan)
LT M. Rhodes, USCGD8 (projects)
LT T. Rolston, USCGD8 (dpl)
LTJG M. Crawley, USCGD8 (oan)

Coast Guard Base

CDR G.A. Bird, CO VTS NOLA
LCDR W.R. Jurgens, USCG Group New Orleans
LT R.E. Carson, USCG VTS NOLA
CWO K. Charney, CO USCGC WHITE HOLLY
CWO R.C. Escue, USCG Group New Orleans
CWO R. Hunt, CO USCGC PAMLICO
BMC E.W. Bird, XPO USCGC WHITE HOLLY
BMC R. Creegan, OinC ANT Venice
BMC T.L. McNatt, OinC ANT New Orleans
BM1 W.D. Dixon, XPO USCGC WHITE HOLLY
QM1 J. Huse, USCGC WHITE HOLLY
QM3 M. Davis, USCGC WHITE HOLLY

Board of Commissioners Port of New Orleans

W.S. Eckert, Port Deputy Assistant Executive Director, Marine Terminals

Sea-Land Services, Inc.

Capt. E.C. Savage, Senior Manager, Vessel Operations

Associated Branch Pilots

Capt. J. Michell

Associated Federal Coast Pilots

Capt. P. Hight

Crescent River Port Pilots Association

Capt. J.H. Anderson

New Orleans-Baton Rouge Steamship Pilots Association

Capt. M.E. Bowman

Capt. E.D. Daniels

Compass Marine Services

E. Conrad, President

American Waterways Operators, Inc.

J. Duke, V.P., Southern Region

1. Meeting at 8th District Headquarters

- a. The general purposes of this meeting were to elicit views on measures of effectiveness, to solicit comments on the draft measures of effectiveness developed by the project team (7 January 1986 version), and to elicit information on ways that the eighth district is unique. References below are to the MOEs (attached).
- b. USCGD8 is characterized by:
- Ocean, coastal, and river traffic;
 - Soft bottoms;
 - Man-made bayous, channel;
 - Locks;
 - Constant dredging;
 - Mix of traffic, including:
 - many tug boats (barge break-aways are a big problem)
 - fishing boats
 - other cargo carriers
 - Much hazardous cargo (petrochemical);
 - High knock-down of aids;
 - 3 distinctly different geographies:
 - Southern Louisiana
 - Texas
 - Florida panhandle
 - Mobile offshore drilling units;
 - Military shipyards;
 - Several ports, including two of the ports in the U.S. (New Orleans and Houston);
 - Weather problems
 - hurricanes
 - flood waters
 - Many private aids, especially placed by oil industry (2600 inspections are done on private aids in a year).
- c. Mobile offshore drilling units are scheduled to be inspected (as ships, by another unit of the Coast Guard) once a year. Now, these units are confined to a small geographical area, but they are spreading (esp. to Mobile, California, and New England).
- d. Sinkings or knock-downs of some aids occur about once a week (e.g., one particular buoy in Houston ship channel is out every 2 weeks, an important light on the Mississippi River has been out most of the last year and a half despite its being rebuilt).
- e. Cost of dredges should be considered. (MOE 1.1.1.1)
- f. Each group commander holds an AtoN conference annually. Attendance is down. Pilots are the most vocal group of users. (MOE 1.1.3.5)
- g. Recreational boaters do not use the AtoN system very much. Most recreational boating is in areas that are not marked by USCG-maintained aids (most recreational boating is in shallow waters, aids are mostly in shipping channels). (MOE 1.2)
- h. It is easy to tell the quality of the ANT team working aids just by looking. (MOE 1.1.3.2)
- i. VTS is a controversial subject on the Mississippi; users tend to be against it.

- j. Positioning is not necessarily determined by the USCG; local knowledge of the mariner plays a big part. Useful local knowledge positioning is affected by crew turnover. (MOE 2.4.2)
- k. Weather is a problem, but fatigue is not (under present operating conditions). Summer heat is sometimes a problem. (MOE 2.4.2)
- l. They do not think that proper credit is always given for long days the crew has to work. (MOE 2.2)
- m. Wrecks are a problem to fishing boats (there is a lot of shrimping in shallow water), and they require a quick response (usually from a 55' boat). (MOE 1.1.1.2, 1.1.2)
- n. A scenario worth analyzing is what would happen if one buoy tender were "painted white."
- o. Several concerns were expressed about contracting out the servicing of aids. These included:
 - The time necessary to let a contract;
 - Problems in positioning (two contracted ranges were built in the wrong places);
 - Response time to discrepancy report;
 - Discretionary authority to move aids (would the contractor have it?);
 - USCG inexperience in contracting;
 - Risk of a bad contract and inability of USCG to take over servicing from a contractor (once the resource is retired, there is no backup);
 - Contractor inability to record local knowledge (especially if contractors change on re-competitions).

(MOEs 1.1, 1.3, 2.1, 2.3.1, 2.5, 7)

- p. A Navy task force (including a battleship) may soon be stationed in Corpus Christi, Texas. This will increase the number of aids that will need to be serviced. (MOE 1.3)
- q. The Tennessee-Tombigbee waterway is currently marked by 200 to 300 aids. Aids are not standardized. A first-class petty officer ANT services this 600 miles of water.
- r. The number of construction tenders is driven by the rate of destruction of aids. If there were no destruction, the Coast Guard could get rid of half of the construction tenders. The Houston ship channel has one dedicated construction tender that is on Bravo Zero status. Buoys are replaced there within running time (6 to 12 hours), fixed structures are reconstructed within a week.
- s. Many of the broadcast notices to mariners are due to the transiting of mobile offshore drilling units (MODUs) which are larger than 50% of the channel's width. (MOE 1.1.3.3)
- t. The Local Notice to Mariner's mailing list is about 3000 to 3500. It is not reaching the recreational boater, who is not interested in it. It is getting to commercial mariners. In addition to the usual Local Notice, two special annual notices are issued: Special Local Notice to Mariners and notice of wrecks. A list of oil rigs is kept but not distributed, since it is available commercially. (MOE 1.1.3.3)
- u. Some critical aids are located at pipeline crossings, making them difficult to service safely. (MOE 2.4.1)

- v. Vandalism is high in the eighth district. (MOE 2.3.1)
- w. The following multi-mission activities were mentioned:
 - *Military* (MOE 2.6.1): Some mine counter-measure work; eighth district vessels used in Grenada;
 - *Law Enforcement* (MOE 2.6.3): AtoN resources respond but are not involved in dedicated patrols; a 133' is sometimes used as a "gas station for speed boats;"
 - *NOAA* (MOE 2.6.5) has three data buoys that are serviced by a 180' tender (133' in an emergency)--servicing is especially important during a hurricane.
- x. The eighth district is not much involved with international coordination (there is little need to coordinate with Mexico). They may be affected by a change in IALA standards for visual signals for oil rigs, which are to be phased in by 1989. (MOE 5.1, 5.2)
- y. Lighthouses are not a big concern in the eighth district, but have some impact. They do not now have a good inventory of who owns what. Most lighthouses are potentially historic due to age. Lighthouses are serviced by 180' tenders, construction tenders, or ANT teams; they are restored by contractors. (MOE 3.5)
- z. As staffing is reduced, administration suffers first. (MOE 2.5)
- aa. The Louisiana Offshore Oil Platform (LOOP) is a special problem that requires unique aids.

2. Meeting at Sea-Land Services, Inc. (Capt. E. Savage)

- a. The requirements to become a navigator of merchant ships is decreasing in the U.S. This results in less-qualified pilots and mates and makes the AtoN system more important.
- b. 85% of the container trade with the Port of New Orleans is through the Mississippi River Gulf Outlet (MRGO). A closing of the MRGO cuts off New Orleans from its most lucrative trade (one ton of containerized freight contributes about \$850 to the economy of a port, compared with about 30c a ton for bulk freight). (MOE 3.2)
- c. His estimate of the cost of delay is consistent with others that we have heard. (MOE 1.1.2.1)
- d. Present MRGO aids do not allow a ship to determine when it is precisely in the middle of a channel. This inhibits passing, due to safety considerations. A range would help. (MOE 1.1.1.2.1, 1.1.1.1, 1.1.2)
- e. He estimates that a lighted range in the MRGO would save about 187 hours a year in ship delays for Sea-Land alone. (MOE 1.1.2.1)
- f. Longshore gangs have three starting times a day: 8:00 AM, 1:00 PM, and 7:00 PM. Work that overlaps starting times is subject to standby and overtime charges. (MOE 1.1.1.2.1.1)

- g. He feels that the USCG views its mission as ensuring safety, not the facilitation of commerce (as in some other countries). Facilitation of commerce is also appropriate and important. (MOE 1.1.1.2.1, 1.1.3.5, 2.7)
 - h. He has asked for ranges in the MRGO every year without success (economics were the reason given).
 - i. One buoy out would not make much difference under good conditions, but could be critical to avoid a grounding in low visibility or if radar were out.
 - j. Beacons are generally preferred over buoys because of their fixed, precise location. However, beacons are not very useful if they are offset too far from the channel.
 - k. He feels that Japan and Germany have excellent AtoN systems and that the U.S. sometimes skimps, taking the cheap way out, which will prove to be more expensive in the long run. (MOE 2.3.1, 2.3.2)
 - l. The policy of the pilots is not to allow passing at night in the MRGO (Sea-Land makes 10 transits a week). See attached navigational guidelines dated 19 March 1984. This slows traffic, but is necessary for safety. (MOE 1.1.1, 1.1.2)
 - m. An additional cost of a delay is the increased fuel requirement to try and make up lost time steaming (e.g., in trips from Gulf to Europe). It takes \$60,000 in fuel oil to pick up 12 hours of steaming. (MOE 1.1.1.2.1)
3. Meeting at Coast Guard Base (Pilots and USCG Base personnel)
- a. Pilots raised the issue of user charges and expressed the opinion that charging pilots as well as vessels is double-charging and should be avoided. (MOE 1.1.1.2.3)
 - b. A range of fixed lights would be useful in the MRGO, especially the lower part.
 - c. Nighttime navigation in the MRGO is done looking two gates ahead (four lights). Unless lights are on at the same time, it is difficult to get into the middle of the channel--the problem is especially bad if a light is out. Given this difficulty, the pilots choose to delay traffic and retain safety (by not allowing passing at night). (MOE 1.1.1.2.1, 1.1.1, 1.1.2)
 - d. The USCG keeps records on vessel delays (VTS).
 - e. Pilots feel that local people should have a greater voice in the manner in which funds are used. They would be more likely to press their Congressmen for more AtoN funds, if they felt that they would have influence on how the funds would be used. They would also welcome advice on how to petition legislators effectively. (MOE 6, maybe new one under 1)
 - f. At a local level, the Coast Guard has been extremely helpful to pilots. (MOE 1.1.3.5)
 - g. Pilots have a preference for white lights over the IALA convention of red and green. White lights help in ship-to-ship communications (e.g., "don't meet me at the white light").

- h. Pilots felt that the USCG could do a better job of enforcing the maintenance of private aids and in requiring shielding of some background lights. (There are a total of about 25,000 private aids in the eighth district. The Mississippi River from Baton Rouge to New Orleans has about 1500 and below New Orleans, 400.)
 - i. Aids prevent accidents. Single aids are not critical, but groups of aids are. Pilots feel that once an aid is judged to be necessary, it should be maintained. It is impossible to determine when the state of the AtoN system causes an accident; it is only a contributing factor.
 - j. Pilots do not think that additional aids would increase the speed of traffic in the MRGO, but dredging would. However, better marking of shoals would permit larger-draft ships to transit safely and with confidence.
 - k. Pilots generally do not use the Broadcast Notice to Mariners (with the exception of an occasional coastal pilot). They use bridge-to-bridge and personal knowledge because they travel the route so frequently (about 2 runs a day). The Local Notice is useful.
 - l. LT Carson can provide data on hold-up time in the MRGO with three weeks' notice.
 - m. An important measure to consider is how much shipping business goes somewhere else due to deficiencies in the AtoN system. Where it goes is also very important.
 - n. There are a lot of individual differences among pilots in the way that they use aids. Pilots will not always agree on which aids are most important.
 - o. Entry-level merchant mariners are not well-examined on AtoN in the USCG's licensing program.
4. CWO R. Hunt gave us a guided tour of the construction tender USCGC PAMLICO.
5. Compass Marine Services (E. Conrad)
- a. He is advocating contracting maintenance on aids and thinks that a private contractor could get the job done more timely and economically.
 - b. When an aid is out, cargo is delayed and risk of an accident increases.
 - c. He thinks that the USCG does not care about industry's opinion on aids (e.g., what location for fixed lights), nor does he think that the USCG accounts properly for local conditions when specifying aids (preferring to make broad rules and apply them across-the-board).
 - d. Going to Congress doesn't help industry's cause--the USCG is regarded as a regulatory agency and complaints of those being regulated are not taken seriously.
 - e. He finds it difficult to communicate with the Coast Guard--people constantly rotate jobs and he cannot establish rapport.

- f. Tow boats are operated 24 hours a day, 7 days a week. If a tow boat is down 20 to 30 days a year, it is losing money.
 - g. Aids are important because tow boat operators rotate and are often in unfamiliar waters.
 - h. The Local Notice to Mariners is valuable, and the Broadcast Notice is more valuable. The Local Notice should be made available at more locations, such as locks.
 - i. Some areas, especially shoals, need aids.
 - j. Aids contribute mainly to the avoidance of damage cost.
 - k. A tug boat is paid about \$1/horse power/day.
6. Board of Commissioners of the Port of New Orleans (W.S. Eckert)
- a. Vessel traffic at the Port of New Orleans has doubled over the last ten years and quadrupled over the last twenty (see attached chart prepared by the Board of Commissioners of the Port of New Orleans).
 - b. The condition of the MRGO has stabilized except during big storms.
 - c. The MRGO could use more fixed aids, more radar reflectors, and ranges at the turn.
 - d. Pilots have recently relaxed some of their restrictions on transiting the MRGO. See attached navigational guidelines dated 19 March 1984.
 - e. The Board has information on what a ton of cargo (container and bulk) is worth to the economy--we may write for this information.
 - f. Even daytime traffic could be slowed by loss of aids in a continuous section (e.g., a two-mile stretch). In the MRGO there are few land markers.
 - g. They are working with CAORF on a simulation of the MRGO, and he suggested that we visit CAORF on our trip to New York.

Attachments:

- 1. Draft Measures of Effectiveness (7 January 1986).
- 2. Associated Branch Pilots and Crescent River Port Pilots--MRGO Waterway Navigational Guidelines (19 March 1984).
- 3. Mississippi River-Gulf Outlet and the Inner-Harbor Navigational Canal Statistical Update (14 November 1985).

DRAFT MEASURES OF EFFECTIVENESS

- 1 Service to Mariners. This is a measure of how well user needs are being satisfied. It includes commercial, recreational, and government vessels.
- 1.1 Commercial users. Includes ocean-going ships, Great Lakes ships, commercial river boats, fishermen, and charter boat operators.
- 1.1.1 Economic considerations--from the point of view of the commercial user.
- 1.1.1.1 Accident-Related. Costs to a carrier involved in an accident (e.g., grounding, collision, ramming).
- 1.1.1.1.1 Lost cargo. Dollar value of cargo lost/damaged due to an accident.
- 1.1.1.1.2 Ship damage. Dollar value of damage to vessel due to an accident.
- 1.1.1.1.3 Insurance. Changes in dollar cost of insurance due to accident.
- 1.1.1.1.4 Other accident. Other costs of an accident (e.g., cost of clean-up, cost of temporarily replacing lost carrying capacity).
- 1.1.1.2 Non-Accident. Costs to carriers not involved in an accident.
- 1.1.1.2.1 Delay. Costs due to delays that are caused by degradation of the aids to navigation system, by environmental conditions, by specific incidents, or by other causes.
- 1.1.1.2.1.1 Direct costs--Dollar value that can be directly attributed to the delay condition (e.g., cost of fuel, pay and allowances).
- 1.1.1.2.1.2 Opportunity costs--Indirect costs of a delay (e.g., costs of rescheduling, changing inventory policy, making-up lost days).
- 1.1.1.2.2 Length of operating season. Measures impact of decisions on how late aids can be removed and how early they can be returned to service (appropriate in Great Lakes).
- 1.1.1.2.3 Routine costs. Normal operating, maintenance, training, and capital costs that may be affected by changes in the aids to navigation system.
- 1.1.1.2.4 Insurance. Changes in dollar cost of insurance.
- 1.1.1.2.5 Other non-accident costs. Costs other than those shown above.
- 1.1.2 Personnel safety--Relates to safety of the crews of the commercial vessels. May be in terms of injuries, deaths, lost days, etc.
- 1.1.3 Other considerations--Includes miscellaneous factors not accounted for above.

- 1.1.3.1 *Confidence in the System.* Measures impact of USCG decisions and practices on commercial mariners' confidence in the aids to navigation system.
- 1.1.3.2 *Appearance of the System.* Measures impact of USCG decisions and practices in terms of how the commercial mariner physically views the system.
- 1.1.3.3 *Marine Information Communication.* Measures how well and how quickly information is disseminated by the USCG and received by the commercial mariner of the status of the aids to navigation system; includes impact on broadcasts, notice to mariners, etc.
- 1.1.3.4 *Accuracy.* Measures impacts of both how well are aids positioned and how up-to-date are the published charts and light lists.
- 1.1.3.5 *Rapport with USCG.* Measures whether the client and USCG are operating in a cooperative versus adversarial role.

1.2 Recreational boater. Measures overall impact on recreational boaters.

- 1.2.1 Economic considerations--Economic impacts on recreational boaters (both accident-related and non-accident-related), which include boat damage, property damage, and equipment.
- 1.2.2 Safety--Impacts on injuries and deaths among recreational boaters.
- 1.2.3 Other--Impacts on recreational boaters other than economic and safety.

1.3 Government vessels. Impacts of USCG policies and practices on vessels operated by other units of government (e.g., U.S. Navy, the MSC, NOAA, the Corps of Engineers, state governments).

- 1.3.1 Economic considerations--Economic impacts on government vessel operations (both accident-related and non-accident-related, including cost of delays in getting into repair facilities).
- 1.3.2 Safety--Impacts on injuries and deaths among government vessel operators.
- 1.3.3 Other--Other impacts on government vessel operators.

2 USCG Interests. Includes the USCG perception of how well the aids to navigation and other missions are performed; the costs associated with these missions; impacts on USCG personnel.

- 2.1 Aids to navigation mission performance. How well is the USCG conforming to stated policies and standards.
 - 2.1.1 Discrepancy rate--Number of discrepancies in a district per aid per year.
 - 2.1.2 Response time--Time from initial indication of discrepancy until a fix is in place; appropriate discrepancy response level (DRL) is a function of discrepancy response factor (DRF).
 - 2.1.3 Quality of service--Includes aid placement, maintenance, and repair.
 - 2.1.4 Public comment--Amount of public comment (favorable and unfavorable) on the aids to navigation system.

- 2.2 Resource utilization. Measures how well USCG assets are being utilized (e.g., availability; hours in high readiness, standby, maintenance, training, administration, and defense tasks).
- 2.3 Cost. Direct dollar costs to the USCG.
 - 2.3.1 OE cost--To operate, maintain, administer, and support the system; includes all short-term and long-term recurring costs such as pay and allowances.
 - 2.3.2 Capital costs (AC&I)--Includes non-recurring costs (replacement of aids, SLEP, etc.).
 - 2.3.3 R&D costs--Research and development costs.
 - 2.3.4 Training and recruitment--All costs of training and recruiting personnel.
 - 2.3.5 Cost of litigation--Includes both the direct legal expenses and liabilities incurred as a result of legal action.
- 2.4 Personnel implications. This measures non-cost related impacts on USCG personnel (including competence).
 - 2.4.1 Safety--Measures impact of crew safety during operations as a function of policy changes.
 - 2.4.2 Competency Level--Includes such factors as morale, fatigue, retention.
 - 2.4.3 Development and training--Measures impact on USCG personnel training, both AtoN and general.
- 2.5 Administrative capability. Measures the ability to perform administrative duties.
- 2.6 Multi-mission capability. This measures the capability to perform missions other than aids to navigation.
 - 2.6.1 Military--This includes training and readiness to prepare for wartime deployment.
 - 2.6.2 SAR--Search and rescue operations.
 - 2.6.3 Law enforcement--In support of federal and local law enforcement agencies (e.g., immigration, drug traffic, fishing).
 - 2.6.4 Ice breaking--Breaking ice during frozen season.
 - 2.6.5 Other missions--Other roles as required; includes marine science activities (MSA), cooperation with other agencies (COOP), marine environmental response (MER), port environmental safety (PES), public affairs (PIA), and all other Coast Guard missions not otherwise accounted for. (Support of the NOAA National Data Buoy (NDBO) program is included in MSA and COOP.)
- 2.7 Public image. Measures the effect on the USCG's public image.

- 3 Public Interest. Measures impact of policy decisions on the public (non-mariner).
 - 3.1 Boating industry. Measures the impact of policy decisions on the boating industry (e.g., boat builders and boating support companies such as marinas, yards, and repair facilities).
 - 3.2 Local economy. Measures impact of policy decisions on the local economy (e.g., effect on port city of cargo passing through it; the impact on a town if a vessel is decommissioned; the effect of recreational and charter boating on the local economy).
 - 3.3 Environment. Measures impact on the environment as a function of policy changes (e.g., pollution control).
 - 3.4 Public safety. Relates to impact on the public regarding hazardous cargo, etc.
 - 3.5 Historic preservation. Measures the impact on historical sites (such as historic lighthouses) of policy changes.
 - 3.6 National defense. Measures the impact of policy decisions on the national defense of the U.S.
- 4 Effects on Other Government Agencies. Includes both direct and indirect effects on federal, state, and local governments.
 - 4.1 Regulatory. Measures regulatory impacts on agencies (e.g., EPA).
 - 4.2 Other government costs. Resulting from Coast Guard actions.
 - 4.3 Other effects on government.
5. International Impacts. Measures the impacts of USCG policies on international agreements and international cooperation.
 - 5.1 IALA and IMO. Measures impacts on IALA and International Maritime Organization (IMO) conventions.
 - 5.2 International coordination. Coordination with other national governments (e.g., Canada and Mexico) on matters such as territorial waters.
- 6 Political Consequences. Measures political implications that can affect USCG decisions (e.g., threat to appropriations if local Congressman is offended).
- 7 Risk. Measures chances of failing to achieve stated expectations.
 - 7.1 Servicing risk. Chances of not providing the expected level of service associated with a policy decision.
 - 7.2 Cost risk. Chances of exceeding expected costs associated with a policy decision.
 - 7.3 Public risk. Chances of not meeting expectations in terms of impact on the public.
 - 7.4 Other risk. Risk not included in other risk factors.

MARCH 19, 1984

ASSOCIATED BRANCH PILOTS AND CRESCENT RIVER PORT PILOTS -- MRGO WATERWAY
NAVIGATIONAL GUIDELINES

Traffic on Mississippi River Gulf Outlet Waterway is coordinated by the Associated Branch Pilots and the Crescent River Port Pilots. All vessels should advise the pilot office of ETA, berth destination, vessel's length, beam, and fresh water draft 24 hours in advance if possible. The pilot office should be advised 24 hours in advance, if possible, of a vessel's ETD. Any changes in ETA/ETD should be relayed immediately to the pilot office.

The Crescent River Port Pilots and the Associated Branch Pilots will coordinate the arrival and sailing of vessels in a priority manner. If there are more than one vessel involved within a three hour span the greater amount of vessels shall have priority over the least amount of vessels arriving or sailing.

The Associated Branch Pilots recommend that no vessels pass or overtake between Buoy 1 and 2 and Light 62 whose overall length is greater than 600 feet or whose beam is greater than 85 feet or whose fresh water draft is greater than 30 feet.

The Associated Branch Pilots further recommend daylight only for vessels passing or overtaking between Light 62 and Light 78 whose overall length is up to but not exceeding 650 feet or whose beam is up to but not exceeding 96 feet or whose fresh water draft is up to but not exceeding 30 feet.

The Crescent River Port Pilots Association recommends that no vessel meet or overtake each other at night on MRGO between Light 78 and the Paris Road Bridge at MRGO, Mile 60.9 whose overall length is greater than 600 feet or whose beam is greater than 85 feet or whose fresh water draft is greater than 30 feet.

The Crescent River Port Pilots Association further recommends daylight only for vessels meeting or overtaking on the MRGO between Light 78 and the Paris Road Bridge at MRGO, Mile 60.9 whose overall length is up to but not exceeding 650 feet or whose beam is up to but not exceeding 96 feet or whose fresh water draft is up to but not exceeding 30 feet.

Daylight will be defined (as stated in the Nautical Almanac for the year 1984) as Civil Twilight at Lat. 30 N, changing on the first day of each month.

The Crescent River Port Pilots Association will notify the Captain of the Station of the Associated Branch Pilots of fog conditions on their route. Ships should not enter MRGO if the river pilots route has been closed due to fog.

The Associated Branch Pilots will notify the River Pilots Office Manager of fog conditions on their route. The river pilots will not leave the dock if the Associated Branch Pilots route has been closed due to fog.

These guidelines may be modified as changes in channel conditions, resulting from dredging improvements or to aids of navigation, allow.

Nothing in these coordination guidelines should be construed as limiting a pilot in his good judgment.

PRESIDENT: _____

CRESCENT RIVER PORT PILOTS ASSOCIATION

PRESIDENT: _____

ASSOCIATED BRANCH PILOTS

BOARD OF COMMISSIONERS OF THE PORT OF NEW ORLEANS
(A Unit of Local Government of the State of Louisiana)
INTER-OFFICE COMMUNICATION

TO: E. S. Reed, H. G. Joffray, DATE: November 14, 1985
H. R. Haar, H. R. Rauber,
P. Reeh, R. Hughes, B. Morse,
P. Gallwey, Trade Development Staff

FROM: G. Austin *G. Austin* CC: L. D. Watson

SUBJECT: Mississippi River-Gulf Outlet and
the Inner-Harbor Navigational Canal
Statistical Update

Attached is a recently updated report on oceangoing traffic using the Mississippi River-Gulf Outlet and the Inner-Harbor Navigational Canal.

Should you require any further information contact the Marketing Division.

GA/dd

Attachment

MISSISSIPPI RIVER GULF OUTLET
AND THE INNER-HARBOR NAVIGATIONAL CANAL
PORT OF NEW ORLEANS

<u>CALENDAR YEAR</u>	<u>MRGO AND IHNC TONNAGE OVER GENERAL CARGO PUBLIC FACILITIES</u>	<u>PERCENTAGE OF TOTAL GENERAL CARGO PUBLIC FACILITIES</u>
1984	2,352,600 Short Tons	37%

VESSEL PASSAGES - CALENDAR YEARS 1966 - 1984:

<u>YEAR</u>	<u>MRGO VESSELS</u>			<u>IHNC VESSELS</u>		
	<u>INBOUND</u>	<u>OUTBOUND</u>	<u>TOTAL</u>	<u>EASTBOUND</u>	<u>WESTBOUND</u>	<u>TOTAL</u>
1966	210	192	402	122	130	252
1967	251	228	479	103	126	229
1968	274	237	511	135	169	304
1969	287	286	573	157	120	277
1970	404	350	754	N.A.	N.A.	261
1971	381	387	768	N.A.	N.A.	242
1972	455	476	931	N.A.	N.A.	N.A.
1973	469	426	895	109	135	244
1974	480	427	907	133	164	297
1975	502	506	1,008	92	104	196
1976	527	484	1,011	81	141	222
1977	532	503	1,035	110	173	283
1978	726	695	1,421	128	162	290
1979	801	771	1,572	111	160	271
1980*	692	659	1,351	88	118	206
1981	756	722	1,478	33	64	97
1982	787	713	1,500	55	95	150
1983	780	670	1,450	47	143	190
1984	876	831	1,707	N.A.	N.A.	N.A.

*MRGO closed to vessel traffic July 22, 1980 through April 12, 1981 due to a chemical spill.

NOTE: Operations at the Public Bulk Terminal were temporarily suspended September 1980 through April 1981.

SOURCE: U. S. Army Corps of Engineers (Vessels)
Port of New Orleans (Tonnage)

PREPARED BY: Marketing Division
Port of New Orleans
November 14, 1985



MEETINGS for 3rd DISTRICT TRIP, 10-11 FEBRUARY 1986

10 February - Aids to Navigation Office

Attendees

CAPT Al Harrell, Chief, OAN
CDR Ernest Blanchard, OinC, National AtoN School
LT Victor Pounds, Operations, D-3 (OAN)
LT Paul Reid, Planning Officer, D-3 (OAN)
LTJG Spence Byrum, Assistant Planning Officer, D-3 (OAN)
LTJG Jeff Anderson, Positioning/Training Officer, D-3 (OAN)
QM1 Donald Driskell, Marine Information

Study Group

Karl Schroeder, US Coast Guard Research & Development
Leonard Greenberg, Mandex
Terry Bresnick, Decision Science Consortium, Inc.
John Stanley, PharoLogic Ltd.

1. Factors that make the 3rd district unique:
 - 2 very large ports (NYC, Philadelphia);
 - more political clout brought to bear;
 - all tenders are assigned ANTs;
 - Vice Admiral is present in the district;
 - large number of historical lighthouses (42);
 - 3 Corps of Engineers offices present (New England, New York, Philadelphia);
 - more bridges than most districts;
 - many pleasure boaters.
2. Reaction to WAMS and the Waterways Design Manual is very positive.
3. Professionalism and morale were recurrent themes. Now, cutter personnel are overworked and can't get things done as well as they would like. While professionalism is high, there was a sense that if response and servicing criteria are lowered, fewer people will recognize the importance of aids and choose AtoN as a career choice. One of the rewarding aspects of AtoN is that you can see the results of your work.
4. 3rd district waterways are considered to be safe. The USCG feeling was that mariners make heavy use of buoys, but fixed aids, lighthouses, and sound signals were not very useful. (This perception was contradicted in a later meeting that included pilots' associations.)
5. It is hard to get a handle on accurate percentages of time spent doing other missions since the Abstract of Operations form is often filled out incorrectly. (The form was recently changed to provide more useful information.) Some tenders are doing more enforcement work than AtoN.

6. The 3rd district does a lot of public service functions such as boating safety information, merchant marine documents, and regatta patrols.
7. Now less than 1% of aids are placed off-station; there is a reasonable tolerance for positioning and cutters stay on-station until the job is done correctly. ANT teams need more training and supervision. Most off-station aids are reported by pilots.
8. The use of "days underway" as an indicator of performance has serious problems. The standard of 170 days is somewhat arbitrary, and doesn't accurately reflect the way the job should be done.
9. During routine situations, it is unlikely that the types of decision that HQ will make (e.g., platforms, servicing alternatives) will be reflected in operations of the system. However, during exceptional circumstances (e.g., after a hurricane or when a cutter is down for maintenance), these effects will be noticeable.
10. If resources (e.g., WLBs) are reallocated, aids would have to be redistributed and the size of some aids would likely be reduced to permit servicing by smaller units.
11. Local notices to mariners are sent to 6500 recipients in the summer and about 5000 in the winter. Recipients include pilots, government agencies, and commercial users among others.

10 February - Meeting with Captain Richard Heym, Chief, VTS

1. Relative benefits to commercial users are the highest priority.
2. AtoN is a regressive system in regard to the boating public; that is, the more affluent get most of the benefits.
3. Fog signals provide more disbenefit than benefit because of noise.
4. There is useful carryover from experience in AtoN to VTS; six of the seven VTS officers in the 3rd district have AtoN background.
5. Political considerations may overwhelm other considerations when it comes to resource management of the AtoN system.

11 February

Attendees

LT Victor Pounds, Operations, D-3 (OAN)
Peter Tischbein, US Army Corps of Engineers (212-264-9059)
CAPT Doug Brown, Hudson River Pilots
CAPT Gregory V. Brooks, Exxon Shipping Co. (201-474-7181)
Russell F. Lindblad, Mobil Oil Corporation (212-883-5582)
Tom Costanzo, New York and New Jersey Port Authority (212-466-8009)
CAPT Robert Deane, Sandy Hook Pilots (718-448-3900)
CAPT D. Cassano, Hudson River Pilots
Derwood Hall, New York and New Jersey Port Authority (212-466-8009)

Study Group

Karl Schroeder, US Coast Guard Research & Development
Leonard Greenberg, Mandex
Terry Bresnick, Decision Science Consortium, Inc.
John Stanley, PharoLogic Ltd.

1. According to Hudson Pilots' Association, the Hudson River is unique in that there is a minimum USCG presence. It is almost considered to be a "backwater" area. There are few delays due to buoys, and the pilots use the shoreline points for navigation much more so than the buoy system. Pilots work close to the shoreline and generally work around the clock, and last year, there were on the order of 3 ships delayed due to weather. However, racons on bridges would be helpful.
2. Of the problems that do occur, most are caused by "outsiders" operating in an area in which they are unfamiliar. Pilots who regularly operate in the area have few problems.
3. Both Mobil and Exxon agreed that they would prefer to see more ranges (only 3 ranges now on the Hudson River). They recognized that this might have to come at the expense of some buoys. They particularly would prefer to see more ranges and buoys at turns. Both felt that it would be difficult to assess the criticality of aids (and outages) unless a very detailed scenario were painted. It might be difficult to get good information on delays, accidents, and costs since this information typically is proprietary, and the oil companies have little incentive to share such information. There is also little incentive to support actions that make pilots' jobs "easier" without having an impact on the corporate bottom line.
4. According to Sandy Hook Pilots' Association, the Raritan Bay needs more ranges (perhaps 3 structures). Ice is a problem here, and buoys need to be removed during heavy ice periods to prevent being destroyed. Pilots here do make use of buoys, especially during adverse weather conditions. The Pilots' Association has been trying to work with the district to evaluate criticality of current and proposed aids. Unlike sentiments expressed in the previous day's meetings, Sandy Hook Pilots like sound signals.
5. The NY Port Authority does not maintain detailed data on delays, accidents, etc. They suggested contacting individual companies such as Sea-Land. The State of New York tried to implement a tidal gauge system to help navigation, and has had a hard time finding sponsors. The Port Authority may have some good data on Port Elizabeth.
6. The Corps of Engineers has conducted some economic analyses tied in with design of channels that may be of useful reference. It was suggested that we contact Sam Tosi, Chief Planning Division (212-264-9219) to find out about obtaining these studies.
7. There was some discussion on dissemination of information. The Local Notice to Mariners should be looked at to see if it can be localized even further, if it can be shortened, if it can be sent out less frequently, etc. User meetings can be held to examine these issues. Much information is passed by word of mouth from pilot to pilot.
8. It was suggested that there is a need to develop a system for real-time bridge clearance information that will allow mariners to react to conditions at least an hour ahead of time.
9. Privatization of aids might be a worthwhile servicing alternative to investigate.

TRIP REPORT

Organizations and Dates

Organizations: Second Coast Guard District, St. Louis, MO
American Commercial Barge Line Company
Jeffboat, Inc.
The Waterways Journal, Inc.
Other attendees of Coast Guard/Industry Information Exchange ("Industry Day") -
see attached list

Dates: 19-20 March 1986

Members of Party

Karl Schroeder, USCG
Leonard Greenberg, Mandex, Inc.
Guy Clark, PharoLogic, Inc.
Jacob Ulvila, Decision Science Consortium, Inc.

Persons Visited

Second Coast Guard District
RADM B.F. Hollingsworth
CAPT E. O'Donnell
CDR T.C. Scheeser

Hon. R. Denson (administrative law judge)

American Commercial Barge Line Company
Capt. A.W. Cannava, Jr.

Jeffboat, Inc.
M.B. Ferris, Jr.

The Waterways Journal, Inc.
James V. Swift

Purposes

The purposes of this trip were to elicit information on ways that the second district is unique, to address the attendees at "Industry Day," to identify information to facilitate the quantification of measures of effectiveness (MOEs), and to solicit views and opinions on the MOEs.

A. Meetings at 2nd District Headquarters

- I. The second district is unique and is characterized by:
 - a. Geographically, covers the rivers in the western U.S. Operates only on rivers, both open rivers and pooled rivers.

- b. Floating aids in rivers are not charted. Channels in rivers change constantly, and the position of aids are changed frequently. Information about aid position is provided to mariners after each run, which are generally about ten days apart.
 - c. Aids are generally placed to mark a 9' channel depth at the lowest anticipated river level between runs (e.g., if river is dropping, then marking may be at 14' or 15' level).
 - d. During periods of flooding, floating aids are sometimes removed and fixed aids (generally 10'-20' Rohn towers) are sometimes moved before high water. A particularly troublesome point during floods is the confluence of the Upper Mississippi and Ohio rivers.
 - e. Most floating aids are 4th class buoys, a few are fast-water buoys, a few are lighted.
 - f. There is a high loss rate for buoys (5000 to 10,000 a year), and vandalism is high (shot guns, stolen batteries). Tow boaters also wipe out buoys sometimes.
 - g. A lot of AtoN effort is spent in cutting away brush from around aids.
 - h. Bridges are a problem, especially around St. Louis. The Eads bridge is particularly difficult. In addition, it is a historical bridge.
 - i. The second district is constituted in four groups.
 - 1. Group Upper Mississippi River (Upper Mississippi (above Cairo), Illinois, and Missouri Rivers).
 - 2. Group Ohio River (Ohio, Monongahela, and Allegheny Rivers).
 - 3. Group Tennessee River (Tennessee and Cumberland Rivers).
 - 4. Group Lower Mississippi (Lower Mississippi and Arkansas Rivers).It is proposed to combine the second and third groups.
 - j. In winter, the Missouri, Illinois, and Upper Mississippi (above St. Louis) are closed due to ice. The second district has no icebreaking capability.
 - k. Buoys are used mainly by towboaters. Little use is made by recreational boaters. Recreational boaters generally operate in pooled rivers.
 - l. The Lower Mississippi River poses the greatest problems:
 - large barges carrying most of the tonnage;
 - big changes in the river.
2. Communication and rapport with mariners is very good. Rapport is enhanced by having USCG personnel serve more than one tour of duty on the rivers (tender CO's generally have years on the river) and through such programs as "industry day." Coast Guard personnel ride tow boats and vice versa. Coast Guard personnel talk to mariners almost daily.

3. Broadcast notices to mariners are very important in the second district. They are used mostly to report discrepancies and large changes. Each Group office broadcasts in its local area.
4. The second district also issues a Channel Report after each run of a buoy tender (about 10 days). It describes where aids were placed during the run.
5. A WAMS study was completed on the Upper Mississippi (origin to mile 185) in November 1985. It lists all accidents on that part of the river.
6. Traffic on the river is a closed population of users. (For example, coastal operators or pilots would not pilot on the rivers.)
7. Relationships are good between USCG and Corps of Engineers (COE). The COE will distribute information for the USCG at locks and dams (e.g., a questionnaire about changes).
8. Aids are most important during times of low water. A barge could break apart if it hit the edge of the channel hard.
9. Since most of the positioning is done by local knowledge, it is important to have continuity in the officer-in-charge of a tender.
10. The Corps of Engineers records information on commodity movements in the river at each lock (check at Ft. Belvior).
11. There is very little multi-mission work in the second district--some SAR (mostly body searches for bridge jumpers) and a little ELT (drugs in the southern end of the district). 98% of the time, second district vessels are used in AtoN.
12. Second district information to ATONIS will not contain any positioning data (since aids are not assigned fixed stations), it will only contain inventories of aids. ATONIS is currently operational at the District level; implementation is intended at the Group level by adding C3s; ATONIS will not be at the Unit level.
13. The standard ATONIS format is not very well suited to information in the second district. They have received permission from headquarters for some deviations.
14. Discrepancy response is only applicable to shore-based aids in the second district. Floating aids are re-set every run (about every 10 days).
15. We received a copy of the Computerized AtoN Record Data System (CARDS) and ATONIS forms. Also received copies of district-wide buoy projections through 1987.

16. Sometimes service-wide policy does not fit well with second district requirements.
17. There were big accidents in St. Louis harbor in April 1983 and April 1984 at Eads Bridge and La Cleads Landing during high water. Each caused about \$8 million in damage and caused fires along the water front. There are collisions with bridges every 2 or 3 days in the second district, especially with 6 to 8 culprits.
18. The USCG conducted the following number of casualty and personnel investigations in 1981-1985:

<u>Year</u>	<u>Casualty Investigations</u>	<u>Personnel Investigations</u>
1981	826	115
1982	544	76
1983	596	37
1984	814	48
1985	831	63

19. The river tug boat and barge industries are doing poorly, and future prospects are not good. Shipping business on the rivers declined every year for the last several.
20. Industry representatives remarked that environmental damage and personal injuries were important factors to consider.
21. Industry does not want the MOE analysis to be used as a justification for imposing user charges.
22. Capt. Cannava of American Commercial Barge Line Co. offered to provide some information on delay costs at a later time and in response to a written request. He suggested that we contact Everett Johnson of Cargo Carriers (St. Genevieve, MO) for additional information.

Attachments

1. Second Coast Guard District Marine Information Exchange Agenda.
2. Charts used in Mandex presentation.
3. Coast Guard/Industry Information Exchange List of Attendees.

ATTACHMENT 1

SECOND COAST GUARD DISTRICT
MARINE SAFETY INFORMATION EXCHANGE
20 MARCH 1986

0800 Registration Opens
Coffee - Social Period

0900 Information Exchange Opens: Moderator - Captain Ralph Bartels

Opening comments and Introduction of speaker's: Captain Ralph Bartels

0915 Presentations:

- a. Ongoing Project to Assess the Effectiveness of the Short Range Aids to Navigation Program:
Mr. Leonard Greenburg, Mandex Inc., Vienna VA.
- b. Bridge issues affecting St. Louis Harbor:
Mr. Roger Wiebusch, CCGD2(cbr)
- c. Update on Green Navigation Buoys:
Commander Ted Scheeser, CCGD2(can)
- d. Overview of Port Safety and Marine Environmental Safety Programs:
Commander Robert Luchun, CCGD2(meps)

1100 Open period for questions/comments from the floor

1130 Break for lunch

1300 Presentations Continue:

- e. Update on Federal Regulations and Coast Guard Programs Affecting the Inland Marine Industry:
Lieutenant Commander Jim Koehler, CCGD2(mvs)
- f. Update on Licensing Regulations:
Lieutenant Keith Dabney, CG Marine Safety Office St. Louis

1430 Open Period for questions/comments from the floor

1600 Closing comments: Captain Ralph Bartels

- Note:
- 1. In addition to the "Open Periods", some time has been allowed at the end of each presentation for questions.
 - 2. In addition to the speakers, the Second District's Hearing Officer will be present to answer questions.

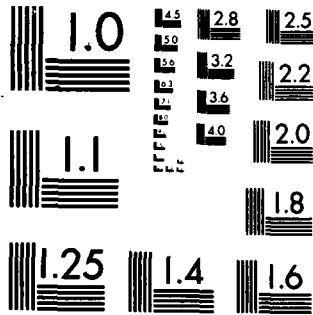

MICROCOPY RESOLUTION TEST CHART
NATIONAL BUREAU OF STANDARDS-1963-A

FIGURE 1 - PROJECT OVERVIEW

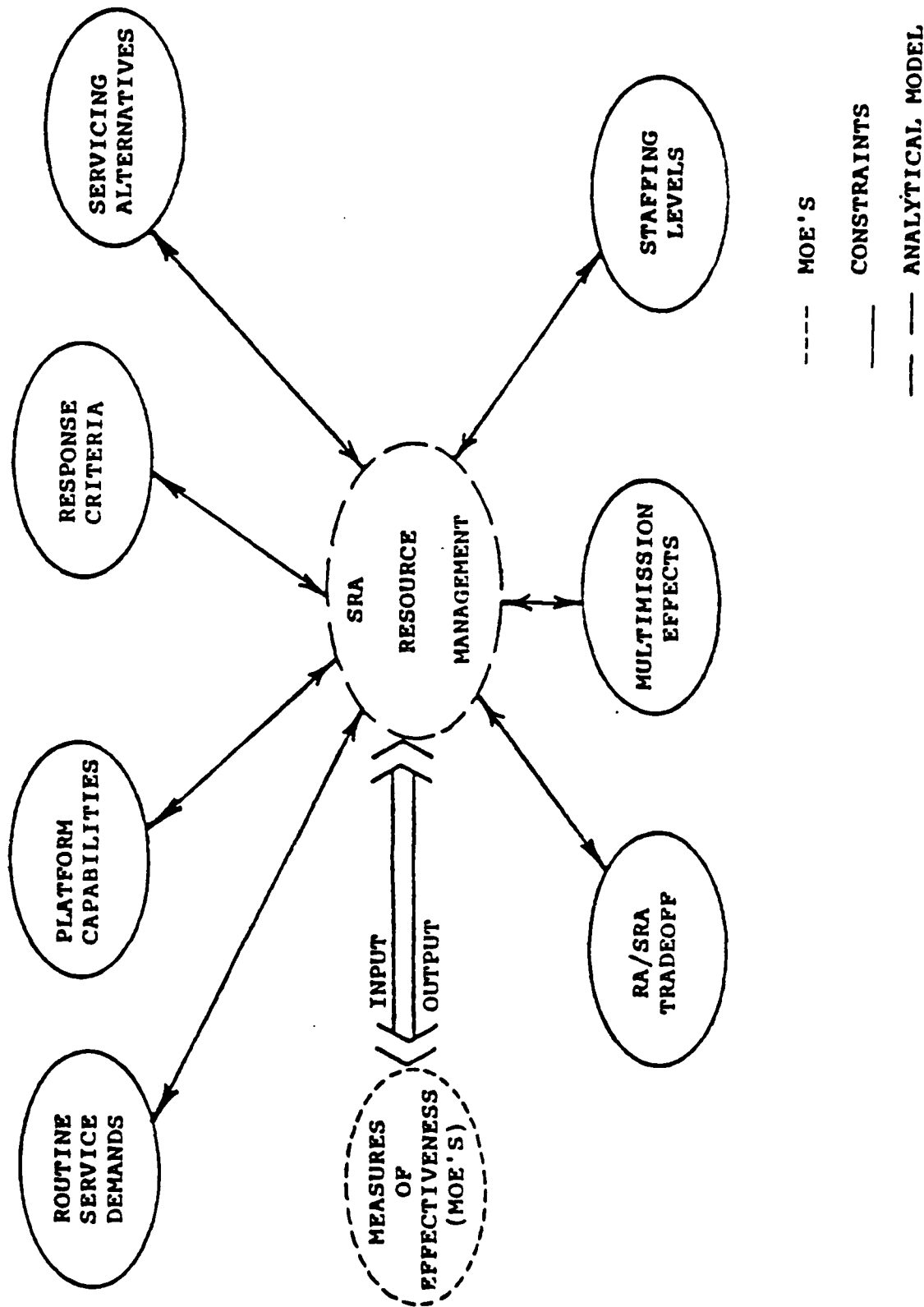

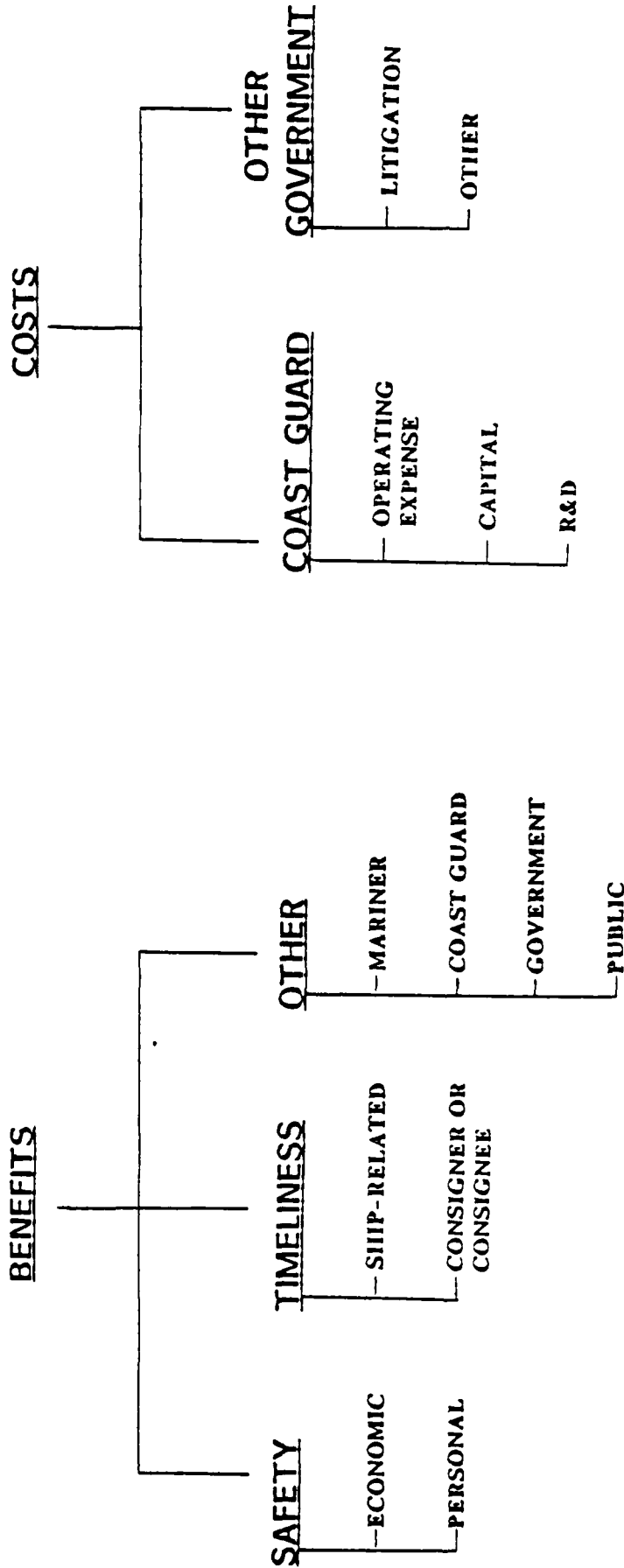

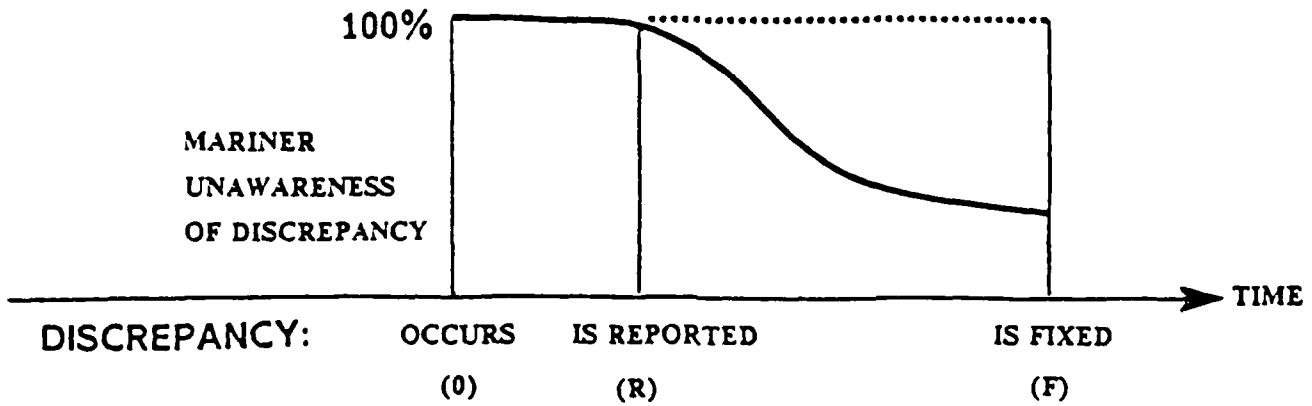

POSSIBLE CHANGE FACTORS

DISCREPANCY RATE

EQUIPMENT RELIABILITY
ROUTINE SERVICING POLICY
CREW STAFFING, TRAINING, AND COMPETENCE

TIME UNREPORTED (\overline{OR})

FAULT REPORTING CAPABILITY
MONITORING POLICY

RESPONSE TIME (\overline{RF})

DISCREPANCY RESPONSE CRITERIA
MULTI-MISSION CAPABILITY AND OTHER FACTORS
THAT AFFECT RESOURCE AVAILABILITY

MARINER AWARENESS

MARINE INFORMATION POLICY AND PRACTICE

SAFETY IMPACT
TIMELINESS IMPACT

AtoN REDUNDANCY

BOATS

PERSONNEL

RESOURCE
CONSTRAINTS

SRA POLICY
AND PRACTICE

MEASURES OF
PERFORMANCE

MEASURES OF
EFFECTIVENESS

ROUTINE SERVICING

DISCREPANCY RESPONSE
CRITERIA

TECHNOLOGICAL INNOVATION

STAFFING LEVELS

MULTI-MISSION EFFECTS

ETC.

DISCREPANCY RATE

TIME UNREPORTED

RESPONSE TIME

MARINER AWARENESS

ETC.

SAFETY

TIMELINESS

OTHER

ATTACHMENT 3

COAST GUARD/INDUSTRY INFORMATION EXCHANGE
LIST OF ATTENDEES
MARCH 1986

MARITIME INDUSTRY:

Agri-Trans Corporation, St. Louis, MO
R. Christer Broman
Billy R. Martin
Thomas L. Reeves

National Marine Service, Inc.
Jerry Dissault
Charlie Bohn
Cathy Otts

Mid-South Towing Co.
Don Salisbury
L. Wadlington

The American Waterways Operators, Inc.
Capt John Duke

Crouse Corporation
Lynn Sherrill

St. Louis Ship
Richard D. Rogers
Anthony G. Tobin

Tennessee Valley Towing, Inc.
Bill Dyer

Petrochem Services, Inc.
Joseph J. Smith
Thomas W. Knueven

Southern Towing Co.
Frank Stegbauer
Bill Stegbauer
Charles Southern
Frank Hollomon

Gateway Clipper Fleet
Zack J. D'Alesandro
Terry Wirginis

Mississippi Marine Towboat Corporation
Kenneth D. Griffin

Bi-State Development Agency
Darryl L. Thompson

Mid-America Transportation Company

J. A. Tinkey
John Snyder

River Terminal Operators Association

Victor E. Satter

Spartan Transportation Corporation

Gary L. Reeves
Omer C. Harpe, Jr.

Ory Bros. Marine Service of America, Inc.

John R. Ory
James S. Walter

Cargo Carriers - Minneapolis, MN

Ralph Vander Naillen
Dick DeSchepper
Katherine Merrill
Gerry Brown

Shell Oil Company

Mark Huff

Monsanto Chemical Company

G. W. Hazzard
R. L. Toler

Orgulf Transport, Inc.

Greg J. Menke

Ole Man River Towing

Dave Shaw

Cargo Carriers - St. Genevieve, MO

→ Everett Johnson
Jay Worthington
John Dover

Conti Carriers

Capt. Daniel Brock
John T. Ryan

Ingram Barge Company

Robert H. Livingston

The Waterways Journal, Inc.

James V. Swift
John E. Spenser
William K. Morrison

USS Chemicals Division of U.S. Steel Corporation

Richard L. Spaulding

Waterways Marine Incorporated

Charlie D. Embrey
Stan Nations

3M Company Traffic Control Materials

Jerry Barnwell

Riverway

Mike Lindgren
Bruce Hancock
Ray Sellers

Peavey Barge Lines

Floyd R. Goodman

Agrico Chemical Company

Don Malone

SCNO Barge Lines

Jeffrey N. Covinsky
Mark D. Mayfield
James M. Fox

HBC Barge

Fred Schulte

The Valley Line Company

Capt. Bob Gray
Mr. Larry Blazeovich

American Commercial Barge Line Company - Jeffersonville, IN

Paul Book

Tom Behringer

Norb Whitlock

Chris Brinkop

✓ Andy Cannava

Denny Hill

Tommy M. Seals

Koch Refining Company

Gary Lyon

Willow Towing, Inc.

Ferman A. Kellum, Jr.

Sue W. Kellum

Bunge Corporation

Bill Schmidt

Rick Sattler

Western Rivers Training Centers, Inc.

Betty S. Hutto

Mandex, Inc.
Leonard Greenberg

U.S. Coast Guard, Aids to Navigation Washington, D.C.
Karl Schroeder

Pharologic, Ltd.
Guy Clark

Decision Science Consortium
Jacob Ulvila

Caleb Brett USA
Daniel J. McIntyre
Bill Federle

Midland Enterprises
R. A. Paquin
G. T. Dyer

Iowa Marine Repair Corp.
Capt. Tom Edwards
Capt. Ken Stiltz

Delmar Marine, Inc.
Mark Knoy
Delbert Knoy

Missouri Barge Line Company, Inc.
Robert Nally
Leo Steger

Ashland Petroleum Company- Covington, KY
David L. Coriell

Triangle Refineries - Louisville, KY
James E. Snider

Material Sales Co., Inc.
Ralph T. Hoffmann
Alan F. Hauff

St. Louis Fuel
Jack R. Choumer

Economy Boat Store
Clyde Morris

Walker Boatyard Inc.
Kimble Lehman

Exxon
Elmer O. Worley

Opryland USA, Inc.

Nathan Cline
Bill Walker
Kent Redgrave
Chris Campbell
Capt. Edgar A. Poe

Mainstream Shipyards & Supply, Inc.

John W. Sansing
June Sansing

Shell Oil

C. R. Woodford
D. C. Moore

Paul's Towboat Employment Service, Inc.

H. Paul Striegel

Apex Oil Company/Petroleum Fuel and Terminal

Thomas E. Kniestedt
Gary Crader
Lloyd Lewis
Joe Lewis

McDonough Marine Service

Raymond S. Hackett III

Dravo Mechling Corporation

Jack Wershbaile

Igert, Inc.

Louis Igert III

Triangle Refineries - Houston, TX

Robert R. Crane

Streckfus Steamers Inc.

J. Thomas Dunn

Triangle Refineries - St. Louis, MO

Oliver Littleton

Luhr Brothers

Kenneth "Bud" Schmidt
Mike Habel
Bob Reece
Jim Baker

Material Service

Edward Senn
Jack Moore

Riverway Harbor Service

Donald S. Bruner
Harold E. Bruner

Harcon Barge Company

Bill Kinzeler
Don Rudd

Canal Barge Company

Captain Earl Daily

Pennwalt Corporation

Ray Belt

M/G Transport Services, Inc.

Vincent J. Wynne

Ashland Petroleum Co. - Cincinnati, OH

Lynn G. Ernst

Neare, Gibbs & Co.

Charles Hazelwood

Kiesel Marine Service, Inc.

Samuel Elder
Joel Hollocher

Ashland Petroleum Company - Ashland, KY

Zane G. Meek
Michael W. McFann

Union Carbide Corporation

Billy J. Bell
A. C. "Dutch" Hemme
P. A. Hart
F. W. Wyatt

StL Industries, Inc.

Terry Robinson

Exxon Shipping Co.

Doug Lambert

The Boswell Oil Company

Sylvia M. Jenks

BB Riverboats

Alan Bernstein

Cargo Carriers Incorporated - St. Charles, MO

Jerome P. Conrey

WJG Telephone Company

Mr. Alvin W. Pyle

Department of the Army Corps of Engineers - Memphis
Bill Gross

Missouri Portland Cement Company
Rick Bensinger

Louisiana Dock Company
J. C. Gee

✓ M. B. Ferris
(Aug)

Sun Oil Company
Jim Boswell

O'Daniels & Associates
Dennis O'Daniels

Air Products and Chemicals
James E. Outland

Jefferson Barracks Marine Service, Inc.
Robert Goodwin

Mt. Vernon Barge Service, Inc.
Arthur W. Bayer
Greg Serfert

Current Marine Service
Dick Kemmerer

Wilson Marine
Bill Wilson

U . Coast Guard, St. Louis, MO

RADM B. F. Hollingsworth
CAPT R. W. H. Bartels
CAPT J. D. Webb
CDR R. E. Luchun
CDR T. Josiah
CDR T. C. Scheeser
LCDR J. E. Koehler
LCDR T. B. Rodino
LCDR D. W. Cleaveland
LT W. R. Wheeler
LTJG D. L. Lersch
LT K. Dabney
LTJG M. DeVries
Mr. Roger Wiebusch
Mr. B. Flahart

TRIP REPORT

Meeting with 12th US Coast Guard District, San Francisco, CA

Dates: 31 March - 1 April 1986

Persons Visited: CDR Salvador Romo, Branch Chief (oan)
LT Jeff Way, Assistant Branch Chief
Wayne Till, Chief, Bridge Section
BMCS R. Whitman, AtoN TRA Team
QMC Wayne Floyd, Section Chief (Hydro)
QMI R. Lieberman, Hydro
CAPT William Walker, Hornblower Yachts, Inc.

Members of Party: Karl Schroeder, HQ, R&D, USCG
Leonard Greenberg, Mandex, Inc.
Guy Clark, PharoLogic, Ltd.
Terry Bresnick, Decision Science Consortium, Inc.

1. Unique aspects of 12th district
 - only a few points of entry
 - difficult bar conditions; heavy swells
 - a lot of fog; therefore a high percentage of aids are lighted
 - environmental issues are very visible
 - sensitivity to non-marine local population (e.g., sound signals, historical lighthouses)
 - many lighthouses (22); significance is out of proportion to need; many are leased to historical societies, but USCG still maintains them
 - no construction tenders
 - most traffic is bulk cargo, tankers (60% is petroleum)
 - heavy redundancy in aids, almost no truly critical ones (except perhaps 40' LNB in San Francisco); there are more aids per length of channel than in other districts
 - a lot of river navigation on the Sacramento River Deep Water Channel
 - the district has 1 WLB, 2 ANT teams (San Francisco, Rio Vista).

2. In this district (as in others), public policy forces USCG to retain aids that don't appear to be cost-effective. The district has very vocal, well organized recreational boaters. The largest group is the Pacific Interclub Yacht Association with 15000 member families and 320 member clubs; there are also several racing associations (both power and sail).

3. There is one major pilots' association (the San Francisco Bar Pilots' Association) and also, one smaller group (Humboldt Bay).

4. There are numerous port authorities in the district which compete heavily for cargo.

5. In the San Francisco Bay, the Captain of the Port exercises much control; due to heavy weather, he often must close the port, restrict traffic, or enforce strict regulations on hazardous cargo.

6. The VTS system is popular with mariners; participation is voluntary, but at the 95% level. It was felt that if it were made mandatory, it would be less well received. They are in the process of civilianizing the staff.
7. Fog signals are used more as obstruction markers rather than as navigational aids. There weren't many positive comments made about fog signals.
8. The USCG tender spends 30% of the time doing other missions; these primarily are military readiness and cooperation with other agencies such as NOAA.
9. In general, the media are favorable to the USCG; there are few congressional enquiries (12/year); there aren't too many problems with litigation.
10. As far as ability to maintain the AtoN system, things are going well and the system can respond adequately; even when WLB is in "Charlie status" most discrepancy response can be handled by ANT teams; however, despite the fact that there is a term contract for piledriving, the district considers response to down structures as too slow.
11. Data are available within the district on aid visits and discrepancies; the Army Corps of Engineers may have transit data and value of cargo data; the accident database is available through HQ.
12. The district is testing for contracting the system maintenance in the Sacramento and San Joaquinto area.
13. Local notice to mariners has a basic distribution of 3200, increasing during boating season.
14. Pilots go to anchor rather than travel in improperly marked channels (rivers).
15. Improved flasher reliability has occurred even though there have been no major technological changes; this is attributed to improved crew competency through better training.
16. AtoN school has had a noticeable positive impact on crew competency.
17. Heavy flooding conditions in Sacramento River deep water channel resulted in loss of whole system of aids. Suggestion was made that the model be able to deal with both complete system failures and individual aid failures.

Meeting with San Francisco Bar Pilots, 31 March 1986

Bar Pilots Attendees: Captain William W. Meyer (President)
Captain Carl Bowler

1. Dealings with the USCG on local AtoN are outstanding.
2. San Francisco is a 24 hr/day, 365 day/yr port.
3. On the rivers, there is no room for error in the AtoN system; it is hazardous to navigate upriver if aids are missing; aid outages can result in daytime transits only. This confirms statements made by the USCG district office.
4. Some of the aids are so sophisticated and expensive that there are no spares. There have been 3 times in the last four years when the Sacramento River was closed as a result of aid outages; there have been some lengthy delays in replacing aids ("Class A" aids such as #7), and during this period the risk of grounding goes up as does the pilots' level of concern.
5. Pilots would rather have slower, accurate discrepancy response (i.e., with experienced crews) rather than faster, inaccurate response.
6. It was suggested that we might want to talk to commercial carriers such as ARCO, PG&E, Crown-Zellerbach, Donter, Diablo (Pittsburgh), US Steel, and Dow Chemical.
7. Before pilots will rely on new "black box" aids to navigation, they must develop high levels of confidence in them; otherwise, they will be afraid to count on them.
8. CAPT Meyer felt the pilots shut down more for weather than for aid outages; CAPT Bowler felt that both causes of outages are closely linked--the point at which they shut down is linked to the distance between aids (contrast this with the USCG viewpoint of heavily redundant system).

Meeting with CAPT Stan Putzke, Director of Marine Operations
Crowley Maritime Corporation
San Francisco, CA

Date: 1 April 1986

1. What about the AtoN system does Crowley value?
 - *In port* - channel buoys and sea buoys are most important to validate references.
 - *Offshore* - SRA not needed; they have had radio-navigation for a long time; coastal aids are only needed when coming into port.

2. In general, if any single aid is lost, there is no impact because of electronic aids on the vessels.
3. Recreational boaters need smaller aids.
4. The USCG can do best by developing policies that will cut down the number of big cutters and staff; inroads can be made by using lighter aids that can be towed.
5. It is very hard to delete aids from the system because of "inertia."
6. A key to identifying which aids are really needed is to establish users fees.
7. CAPT Putzke doesn't feel that multi-mission arguments are valid to justify excessive resources.
8. There has been no organized effort towards privatization.
9. When the Sacramento River is closed, it costs Crowley approximately \$3000/boat/day.
10. It does not work to give collateral SRA duties to people doing other USCG jobs.

Meetings with 14th USCG, Honolulu, HA

Date: 2 April 1986

Persons Visited: CDR Richard Brandes, USCG, Chief, AtoN Branch (808-546-5107)
 LTJG Mitchell West, USCG, AtoN Branch (808-546-7130)
 LTJG Donald Noviello, USCG, AtoN Branch (808-546-7130)

Members of Party: Karl Schroeder, HQ, R&D, USCG
 Leonard Greenberg, Mandex, Inc.
 Guy Clark, PharoLogic, Ltd.
 Terry Bresnick, Decision Science Consortium, Inc.

- I. Unique aspects of 14th district:
 - only 554 aids, but vast distances to cover (200 buoys, less than 100 are lighted); high proportion of underway time (15 days to some aids);
 - due to distances, WLBs must be floating workshops to do what ANT teams normally do in a shop; tenders do what industrial shops would normally do;
 - use of divers for mooring inspections;
 - ANT teams need a lot of equipment support;
 - most cargo traffic is into Oahu, Hilo, and Kauai;

- in the southern part of the district, charts aren't very good;
- 35-40% of aids are maintained for military use only.

2. Multi-mission issues:

- WLBs are wartime resources, deployable to E. Asia;
- very little SAR (3 missions/year);
- law enforcement recovers 2¢ on the dollar in fines or seizures;
- supports NOAA data buoys (1 week/year/aid).

3. There is little in the way of accident data points; there is a Honolulu Harbor Accident Data Base, but there has been only 1 major accident in the last 20 years (it was due to pilot error); there is no good database on vessel activity.

4. Some delay can occur due to aid outages, but mostly in Micronesia; if all buoys and lights work, ship will enter at night, otherwise no; for tankers, there are many daylight-only harbors.

5. More consideration in planning the AtoN system is given to commercial shipping and fishing than to recreational boating.

6. Discrepancy response out of Hawaii is on a one-on-one basis; in the Philippines, we are trying to get local support from the Navy, but there isn't enough quality control; quarterly visits to Philippine aids are made by public works system.

7. It is hard to train other services to do AtoN; it is better to reduce the number of aids and to replace large buoys with easier to maintain aids (BASSWOOD and/or articulated beacons).

8. Local notice to mariners goes to 730 users on a weekly basis; it is small but critical. USCG is notified of outages primarily by commercial or military users.

9. The Design Manual doesn't work well in the 14th district because there are no long narrow channels.

10. Litigation is minimal; a good reference case would be Whitney Steamship.

Meeting with User Community

Date: 3 April 1986

Persons Visited: David E. Parsons, State Boating Mar. (808-548-2838)
Pat Torres, State Harbors Division (808-548-6711)
D.E. Gately, DOT, Harbors Division (808-548-6255)
CDR Richard W. Brandes, 14th USCG District (oan) (808-547-7130)
LCDR Richard Buckingham, USCGC SASSAFRAS (808-546-5189)
LTJG Mitchell D. West, 14th USCG District (oan) (808-546-7130)
LTJG Donald Noviello, 14th USCG District (oan) (808-546-7130)
William T. Crichton, Naval Station, Pearl Harbor (808-471-9093)
Tom Fujikawa, State Harbors, Design (808-548-2505)
Fred Nunes, State Harbors, Design (808-548-2505)

Members of Party: Karl Schroeder, HQ, R&D, USCG
Leonard Greenberg, Mandex, Inc.
Guy Clark, PharoLogic, Ltd.
Terry Bresnick, Decision Science Consortium, Inc.

1. The major impact of aid outages is on night operations; if lights are out, some vessels will wait until daylight to come in (submarines).
2. If the range on the main channel at Pearl Harbor is out, this can be critical; if both ranges are out, a pilot is needed; there is a problem with the Westlock range in that there are two similar parallel ranges.
3. Usually, the USCG learns of aid outages very quickly from commercial or military users.
4. Pilots prefer fixed aids for navigation, but buoys are more forgiving and cause less damage if a mistake is made.
5. Not many aids are associated with recreational boaters; not many pleasure boats come from outside areas; 2/3 of tourists get involved with water-related activities.
6. In considering the impact of delays, we must include landside costs (e.g., stevedores cost \$31/hr); no one in the group could remember a situation where delays in Honolulu were a result of aids.
7. Major shipping agents include Theo Davies Marine and Matson.
8. National Marine Fisheries Service may be able to provide costs/benefits associated with aids.
9. The Ocean Recreation Council of Hawaii represents recreational boaters; point of contact is Dr. Rose Pfund at U. of Hawaii Sea Grant Programs.

10. One of the costs to State and Local governments arising from USCG decisions is the cost of taking over maintenance.
11. Most recreational boaters don't get or read local notices to mariners, but the responsible ones do listen to broadcast notices.

Meeting with Hawaii Pilots' Association

Date: 4 April 1986

Person Visited: Captain David Lyman

Member of Party: Leonard Greenberg, Mandex, Inc.

1. Discussion was held concerning the conceptual model underlying the development of measures of effectiveness. Captain Lyman endorsed the notion of mariners being at risk primarily for safety until discrepancies are reported and at risk from both a safety and a timeliness standpoint thereafter, until the system is restored. He reinforced the notion that the nature and extent of the risk depends heavily on the degree of system redundancy, class of vessel, presence or absence of a pilot, weather, time of day, etc.
2. Honolulu has a narrow main ship channel. Significant costs can result if the channel is not cleared rapidly. He reinforced the statement made the previous day concerning the criticality of the ranges.
3. While buoys are guides at best, they are important to certain classes of vessels. The prevailing trade winds at Honolulu are on the order of 25 to 30 knots; under those conditions, carships or other vessels susceptible to winds would not travel at night without buoys.
4. Tugs and barges are another class of vessels in need of a system of buoys. Maintaining proper buoy location, however, may be a problem; buoys are sometimes moved by the barges.
5. Local notices to mariners are important to pilots, particularly for reporting proposed changes. Professionals (including some fishing vessel operators, but not all) use the notices to update their charts; recreational boaters do not.
6. The issue of whether an increase in discrepancy response time increases the safety risk linearly or exponentially was discussed. Captain Lyman noted that although the increase is (as Mandex had conjectured) linear, there comes a point at which that increase may not be acceptable. Specifically, during brief outages, the likelihood of a stranger unfamiliar with the waters blundering into trouble might be acceptably low; the longer the discrepancy remains unattended, however, the more unacceptable that likelihood becomes.

TRIP REPORT

Meeting with 5th District, Portsmouth, VA, 29 May 1986

Attendees

CAPT M.J. Moynihan, Chief, oan
LCDR George Detweiler, Assistant Chief, Aids to Navigation Branch
John R. Walters, Chief, Operations, Planning, and Hydrographic Section
John Hubard, Chief, Ocean Engineering Section

Study Group

Karl Schroeder, USCG Research and Development
Leonard Greenberg, Mandex, Inc.
Terry Bresnick, Decision Science Consortium, Inc.

1. Unique aspects of the 5th District:

- Covers a tri-state area which includes much of the Atlantic Intracoastal Waterway and Chesapeake Bay.
- Has both a sea coast environment as well as inland waterway environment; there are numerous inlets along the seacoast with heavy use by commercial fishermen and recreational boaters.
- 2 major ports (Baltimore, Hampton Roads) with the bulk of commercial traffic in coal, containerized shipping and general cargo; the area south of Richmond is a major deep water terminal (25').
- Morehead City, NC and Wilmington, NC have major cargo facilities and are increasing in traffic due to cheaper costs.
- Extremely heavy military port traffic--Norfolk Naval Base is largest in world; Morehead City is a major amphibious loadout point for Camp LeJeune.
- Many seasonal "snowbirds" transiting the area.
- District assets include:
 - 2 180' buoy tenders
 - 2 157' coastal buoy tenders (WLM)
 - 2 inland tenders (WLI)
 - 3 construction tenders (160', pusher tug/barge, 100' WLI, WLC class).
- Over 5500 aids including 9' buoys, 8' buoys, day beacons, lights, major lighthouses, radio beacons, LORAN stations, racons.
- Severe ice in winter, freezes harder and faster; 100-200 ice aids.
- Area is subject to severe hurricanes.

- Area waterways have a soft, forgiving bottom.

2. Major associations include:

- Virginia Pilots Association - large, lobbying force;
- Association of Maryland Pilots - very sophisticated (Capt. Mike Watkins, President);
- Wilmington Pilots;
- Morehead City Pilots;
- Independent licensed federal pilots;
- Hampton Roads Maritime Association (Capt. Jack Mace, Executive Vice President);
- Chesapeake Bay Yacht Association - not too vocal.

Relations with USCG are very good and non-confrontational; there is little competition among associations.

3. Pilots, especially on the inland waterways, operate with little margin for error regarding draft. The James River is winding, with many hazards; therefore, certain vessels can't move at night. Additional aids to extend the daytime length of the river would save demurrage costs.
4. The pilots' needs and Navy needs are not necessarily the same; pilots don't like unlighted buoys and prefer aids outside the channel.
5. Project to deepen Norfolk Harbor and the Cape Henry Channel will generate a requirement for more aids. May have to add ranges and racons.
6. Close coordination is required with Corps of Engineers (COE); COE maintains Waterways Commerce data; COE publishes general design memoranda for each waterway with a Corps project.
7. Local notice to mariners is sent to over 5000 people. About 1700 broadcasts were made thus far this year; 3,800 were made last year.
8. There are 2 manned lighthouses which will be automated by July. Sound signals are minimal and are not much of an aid to commercial vessels; however, recreational boaters like them.
9. WAMS is not being done; lack the necessary manpower.

Meeting with Hampton Roads Maritime Association, 29 May 1986

Attendees

Capt. Jack Mace (Executive Vice President, Hampton Roads Maritime Association)
Capt. Arthur Knudsen (US Licensed Docking Pilots)
Capt. Richard L. Counselman (President, Virginia Pilot Association)
Capt. Robert L. Jerns (USN, Director, Operations and Plans Staff, Commander Naval Base, Norfolk)
Mr. James Provo (Chairman, Vessel Owners, Agents and Operators)
Mr. Paul Horsboll (Operations Manager, Curtis Bay Towing Company of Virginia)
Mr. George Flanagan, General Manager, McAllister Brothers, Inc.)

1. The Hampton Roads Maritime Association provides a forum for all involved parties to exchange information and ideas. Members include representatives of Pilots Associations, steamship agents, touring companies, and the Services; everyone works well together.
2. The aids to navigation system is very good in the district; it would take a really bad situation to affect pilots since there is significant redundancy.
3. Litigation is a motivating force in USCG decisions; even if the USCG isn't at fault, they will be blamed. This has important implications for the resource allocation model.
4. Some people feel that nothing less than all aids fully operational is acceptable.
5. Freight rates are the lowest they've been in years; while the traffic is way down in terms of numbers of vessels, the value of the cargo and ships is way up. As a result, the number of accidents is lower, but the cost consequence of an accident if it occurs is high.
6. Groundings have become more of an issue in that more are reported, surveys are required, and it is not as easy to ignore.
7. For a PANAMEX sized vessel, a demurrage figure of \$4,300/day is current; several years ago, \$10-15K/day was reasonable. We need to be cautious about using today's figures since they may not be representative of a steady state.
8. For a large container ship, \$50K/day operating costs are a reasonable approximation.
9. As a general comment, it is hard to see green lights and green buoys.
10. The Navy has a specific concern in terms of harbor security; they could foresee doing away with visual aids and going to electronic aids.

11. Fog signals aren't needed by commercial vessels since they need two working radars; however, recreational boaters make use of them.

12. Members of the Association confirmed the excellent rapport with the Coast Guard.

TRIP REPORT

Organizations and Dates

9 June 1986

Columbia River Pilots
Foss Maritime Company
Knappton Maritime Corporation
Northwest Towboat Association
Port Angeles Pilots
Shaver Transportation Company
Tidewater Barge Lines

9-10 June 1986

Thirteenth Coast Guard District, Seattle, WA

11-12 June 1986

Seventeenth Coast Guard District, Juneau, AK

12-13 June 1986

Alaska Marine Highway

Members of Party

Karl Schroeder, USCG
Leonard Greenberg, Mandex, Inc.
Guy Clark, PharoLogic, Inc.
Jacob Ulvila, Decision Science Consortium, Inc.

Persons Visited

In Seattle:

Thirteenth Coast Guard District

RADM T.J. Wojnar (District Commander)
CAPT T. Nutting (oan)
CAPT T.F. McGrath (legal)
LT P.L. Stephenson (oan)
Mr. H. Metzger (oan)
CWO J. Lindeblad, Information Center

Columbia River Pilots

Capt. D. Kasch

Foss Maritime Company

Capt. P. Campbell
Capt. J. Niederhauser

Knappton Maritime Corporation

Capt. G. Comstock
Capt. N. Davis

Northwest Towboat Association

Capt. B. Taylor

Port Angeles Pilots

Capt. O.H. Abney

Shaver Transportation Company

Capt. M. Rine

Tidewater Barge Lines

Capt. M. Colburn

In Alaska:

Seventeenth Coast Guard District

CAPT W. S. Rich (Chief of Staff)
CDR J.S. Merrill (oan)
LCDR R. Winter (oan)
Mr. R. Seagrave (oan)

Alaska Marine Highway

Capt. K.J. Mitchell, Port Captain
Capt. C. Rice, Captain of the Malaspina
F. Meadors, C/M
C. Bates, 2M
J. Seefried, 3M

Purposes

The purposes of this trip were to elicit information on ways that the thirteenth and seventeenth districts are unique, to solicit opinions on the measures of effectiveness, and to observe parts of the AtoN system. This last purpose was met by riding the Alaska Marine Highway from Ketchikan to Juneau, including a night passage through the Wrangell Narrows.

For convenience in scheduling, the usual sequence of events was reversed in the 13th district. On the first day, following a courtesy visit to RADM Wojnar, a round table session was held with

representatives of seven pilots' and other user groups. This was then followed, continuing into the second day, by formal meetings with CGD-13 personnel.

A. Meetings with Users in the 13th District

1. A large containerized cargo vessel consists of about 15 units with cargo valued at \$75,000 to \$100,000 per unit.
2. 48 hours is too long to relight any range, but reflectors on the range boards would be useful until relit. There are ranges on the Columbia and Snake Rivers. Currently these use retroreflective material.
3. At times of poor visibility or difficult currents, vessels would be reluctant to travel without aids and this would hold up vessel traffic.
4. There is night travel on the Columbia River. If ranges are out, the vessels will still travel, but at reduced speed.
5. There are more and more container ships. Their costs of delay are easier to establish because they run on a schedule. A rough estimate is \$25,000 a day to operate the ship (this does not include any shore-side costs). A tug boat costs about \$3000 to \$4000 a day, and a gill net boat costs about \$2000 a day.
6. Bulk carriers are chartered and the agents would have cost figures. If a chartered ship does not show up on time, it is likely to lose the charter. It could also lose a customer (e.g., by a change to rail).
7. Safety is the number one concern of pilots. Risk depends on the amount of traffic.
8. Ship operators are best at describing the importance of aids.
9. In the thirteenth district, it is especially bad to have a combination of aids out.
10. Recreational boaters make heavy use of aids in the 13th district (e.g., to buoy hop in the Columbia River) but don't always use them properly. There are many more recreational than commercial boats. Recreational boats are a problem, especially on weekends; they block up commercial lanes.
11. Gill netters are a big problem during their season (about September). Occasionally, commercial vessels are forced to cut through the gill nets.

12. Commercial boaters get and use the Local Notice and find both the Local and Broadcast notices very useful. Recreational boaters do not use the Local Notice very much.
13. In the Upper Columbia River, bridges and fog are the biggest problems. Shippers work closely with the USCG to remove obsolete aids and get new ones. Additional racons would be useful inside of bridge piers.
14. In Puget Sound, the USCG has been very responsive. The AtoN system is very old and excellent. Pilots had some problems accepting VTS in the beginning (citations generated bad feelings), but they now feel that the system is excellent. From Point Defiance down, it seems to take longer to repair aids.
15. Tug boat operators think that the AtoN system is excellent overall. There have been very few incidents with aid problems. They would like to see more racons on buoys. Tug boats have a difficult time during gill net season and during regattas.
16. The AtoN system on the Snake River was established during a shortage of funds. Safety could not be retained if this system were reduced.
17. The Pilot Commission has public information on accidents.
18. They are suspicious about the use of a model to rate individual aids as a basis for dropping aids.
19. In the past few years, users were reluctant to ask for new aids because of budgetary constraints on the USCG.

B. Meetings with 13th District AtoN Personnel

1. A list of principal waterways was distributed (attached).
2. The 13th district has the worst bar conditions anywhere in the U.S.
3. They have studied articulated lights but cannot use them due to the height of tides and strength of currents.
4. Generally, commercial users do not need or use fog horns. Recreational boaters need them and ferry boat operators like them.
5. Commercial boaters are more organized and exert more pressure on the Coast Guard than do recreational boaters.

6. The Local Notice has about 2000 subscribers; six years ago, there were 4300. In an effort to keep costs down, subscriptions must be actively renewed each year. Pleasure boaters generally do not keep up with Local Notices and do not update their light lists.
7. A unique feature of the 13th district is the use of deep water moorings with synthetic lines. They work well.
8. The 13th district covers the west coast of the U.S. from Oregon to the Canadian border. It has three distinct types of waterways: coastal waters, the Columbia River System (Columbia and Snake Rivers), and the waters of Northwest Washington (Puget Sound and Rosario Strait).
9. Coastal waters of the 13th district are characterized by:
 - Large swells (30' to 40') from Japan cause bars.
 - Most commercial traffic is fishing and logging.
 - A lot of AtoN work on offshore islands is done by helicopter.
 - Power supply to the Cape Flattery light is a problem.
 - Willapa Bay is a very difficult port for maintaining aids due to rapid channel changes.
10. The Columbia and Snake Rivers are characterized by:
 - AtoN is serviced by a 180' inland tender based in Portland and an ANT.
 - Servicing may be contracted out for about 200 aids.
 - Shoaling is beginning around dams. The Corps of Engineers has been contacted, but is not experienced in dredging for navigation.
 - The primary cargo to Portland is grain.
11. Puget Sound and Rosario Strait are characterized by:
 - Very deep and wide channel.
 - Alaskan crude oil is shipped on 125,000 DWT tankers through Rosario Strait. Puget Sound has a variety of cargo in bulk and container ships.
 - There is a lot of military traffic--the Trident Submarine base as well as local Army and Air Force bases. Everett may get a Navy base.
 - The FIR, a 175' buoy tender and the oldest tender in the Coast Guard, is based in the 13th district. It has stability problems, cannot work 9' buoys, and must be careful working 8' buoys in coastal waters. It serves as a backup for the 180' tender, which is often in maintenance. It is not satisfactory for this role.
 - A 65' buoy boat, based in Seattle, functions as an ANT and is used for smaller aids.
 - Group Seattle has five automated lighthouses with caretakers.
12. Fog is a problem in Coastal and Puget Sound areas and fog signals are a big headache. Three lamplighters, soon to be replaced, turn them on and off. Ice can be a problem in rivers.

13. Lighthouses are mostly for coastal navigation, not to mark harbor entrances. There are 22 or 23 historic lighthouses in the 13th district, and they are in pretty good shape (with a couple of "disasters").
14. There are a lot of racons in the north and along the coast, but they are not used very much.
15. The FIR is used a lot in law enforcement--mostly offshore fisheries patrol--and it is also called on for pollution incidents. The IRIS is not used much in law enforcement. There is very little SAR use of tenders.
16. Tanker traffic is restricted to 125,000 DWT and there is a VTS to aid tanker traffic in Rosario Strait. Some tankers have problems with the current. There was an oil spill in Port Angeles harbor that involved AtoN.
17. They have good relations with the Canadians and "occasionally" coordinate with them.
18. Recreational boaters use the aids a lot. Communications with recreational boaters is especially through the Coast Guard auxiliary.
19. The great majority of light discrepancies are responded to the next day.
20. Data sources include: ATONIS, Corps of Engineers, Association of Ports on the Columbia River, and other ports. Ports are especially good sources for projections of traffic volumes.

C. Meetings with Other 13th District Personnel

1. Commercial boaters in the 13th District repair most of the aids that they damage. They report and pay for the others, and this is not a problem. The recreational boater is bad about paying for his damage.
2. The cost of litigation is difficult to determine. An admiralty attorney in private practice charges about \$150 an hour plus expenses.
3. Not many claims are filed for buoys that are off-station or lights that are out too long. The USCG is generally covered if notice is given and repairs are made within a "reasonable time." The USCG is in good shape if it follows its own guidelines. The USCG could be faulted if the aid is not maintained according to its maintenance schedule.
4. Once an aid is in place, that is evidence that it is needed. Justification is needed to remove an aid. Budgetary reductions have been held to be a valid basis for cutting some aids.

5. Cases of under \$25,000 can be settled at the district, those between \$25,000 and \$50,000 go to USCG Headquarters, and those over \$50,000 go to the U.S. Department of Justice.
6. A-76 contracting out is a big concern for potential liability, especially if the contractor does not provide maintenance that is up to Coast Guard standards.
7. The C3 system has good systems to support Fortran, Pascal, and C, but Basic does not run well (it is too slow).
8. They suggested that we may want to consider having any large model resident on a larger machine that could be accessed from a C3 terminal. An RFP is being prepared for the acquisition of the larger system, and a decision is expected within a year. The system is expected to be delivered and running before we begin Task 9. Preliminary specifications indicate that many machines will qualify technically. These include Digital Equipment Corporation's VAX as well as systems made by Prime, Data General, Hewlett-Packard, and others.

D. Meetings with 17th District Personnel

1. The 17th district has three distinct SRA systems: southeastern Alaska; central and western Aleutian Islands; and western mainland and north slope.
2. Southeastern Alaska is characterized by:
 - 35,000 square miles of water;
 - about 1000 aids;
 - 2 WLBs, a 65' WLI, Base Ketchikan (SAR, but does AtoN as well), ANT Southeast (flies to service all electronic aids in western mainland and north slope);
 - AtoN mission is similar to that in other CG districts;
 - AtoN resources are used about 100% in AtoN.
3. Central and western Aleutians are characterized by:
 - coverage extends 1000 miles;
 - about 500 aids, 250 of which are in Prince William Sound;
 - 4 WLBs, which are limited considering the area covered;
 - discrepancy response is in accordance with the intent but not necessarily the letter of the DRF; because of the large distances, response times are longer;
 - less user traffic than southeast;
 - less redundancy in aids.
4. Western mainland and north slope are characterized by:
 - 6 major lighthouses, 15 racons, and 39 minor aids;
 - aids are serviced by ANT Southeast, which is based in Ketchikan but is moving to Sitka;

- a few, highly skilled professional mariners are the only users of the AtoN system. They will travel with or without the aids;
 - discrepant aids tend to be fixed the next season (aids are not used much in the winter due to lack of traffic);
 - north slope aids are serviced once a year (batteries are replaced in the spring).
5. Political, rather than AtoN needs tend to drive the system now.
 6. In FY85, the 17th district started solar conversions, mostly in challenging locations. They had no problems. They expect 80% conversion by 1987 and 100% by 1988. Solar is not used above 60° latitude because there is almost no light at all in winter.
 7. The 17th district has had several years experience with contracting out the maintenance of aids. They have encountered some difficulties including: finding it difficult to evaluate the quality of bidders; having only a single bidder; and writing requirements in a way that screens out unqualified bidders.
 8. Most of the vessels are fishing boats, with some barges, oil tankers (especially into Valdez), cruise ships (Juneau expects 256 ships with about 220,000 people in 1986), and ships of the Alaska Marine Highway.
 9. High tides (up to 40 feet, 24 feet in southeast) are a problem in many of Alaska's waterways, and strong currents are a problem in other parts.
 10. Poor charting is a problem, and some waterways were not re-charted after the 1964 earthquake.
 11. Alaskan waterways have very irregular rocky bottoms with many pinnacles. Fathometers cannot be used effectively. There are some sandy bottoms toward the Aleutians but these are rare.
 12. Tenders perform an extensive amount of multi-mission work, in total about one ship-year a year, mostly on domestic fisheries' law enforcement around the short salmon and halibut seasons.
 13. Availability of aids tends to run at 99.0%.
 14. Response time is very important in some key waterways, including Wrangell Narrows, where every aid marks a pinnacle or a critical turn.
 15. There are about 1000-1500 subscribers to the weekly Local Notice to Mariners. Broadcast Notices occur at a rate of 2-3 per day. Only a small minority of mariners do not hear Broadcast Notices.

16. The Coast Guard now has a good working relationship with mariners, but this has not always been the case. Three years ago, relations were poor and mariners had the perception that their input had no influence on AtoN decisions. They were particularly upset by: 1) changing to IALA green, 2) downgrading some aids (including reducing the intensity of some lights), and 3) removing white lights. They were also upset that the only public hearings were in San Francisco. There are no organizations that speak for pilots.
17. 95% of the aids to navigation mark rocks or shoals. There are only 4 dredged channels in the district.
18. LORAN is used extensively in the west.
19. A possible example for illustrating the MOE tool is the case of False Pass. It is very dangerous if an aid is out, but most mariners (mainly fishing vessels) will use it anyway. Their livelihood depends on their catch during the short fishing season, and the alternative route, out and through Unimak Pass, adds 20 hours and is very dangerous.
20. Fog signals, of which there are about six in the district, are considered a waste of electricity. They are not used much and many are on remote lighthouses. Most aids with fog signals also have radio beacons, which also are not used very much.
21. Vessels are well-equipped in the 17th district. Recreational boats over 26' have radar; all commercial vessels have state-of-the-art navigational equipment.
22. Each year, 8 to 10 vessels are lost, with loss of life. They were usually overloaded.
23. The Civil Engineering office has good information about problem areas.
24. A unique feature of the 17th district is the Alaska Marine Highway, used for intercity transportation. The system has a \$63M/year budget and a fleet of boats.

E. Meetings with Capt. Kelly J. Mitchell, Alaska Marine Highway

1. The Alaska Marine Highway serves in some ways as the training ground for Alaskan pilots. They are hired away by industry, which pays much more than the State of Alaska.
2. Alaskan waters can be characterized in three zones: north, southwest, and southeast.
3. The north is characterized by:
 - the AtoN system is limited by ice conditions. Aids are seasonal and it is important to commerce that they are placed as soon as possible;
 - mariners rely on aids a lot;

- electronic aids are few and far between;
- Kodiak has no ice problem; it does have many users, and navigation might be improved by a VTS;
- Cook Inlet has extreme currents (4-5 knot cross-currents) and could be helped by a racon;
- Race Point, Fire Island, and McKinsey Narrows have a lot of commercial traffic that relies on ranges. Traffic will not travel without ranges in restricted visibility. This area could also use real-time tide information; they currently use NOAA tide tables to assure adequate (>10') clearance. An alternative would be to blast a channel so that there is no more shoaling.

4. Valdez is the main port in the southwest. It is characterized by:

- 24-hour a day operations;
- a hazardous rock before the turn, which is marked by a lighted range. If the light were out, vessels would continue but the chances of an accident would increase "drastically" (he would not quantify this statement);
- Captain Eldee of the southwest pilots would be very good to contact.

5. Southeast is characterized by:

- a lack of landfall aids;
- heavy mariner reliance on visual aids;
- two especially difficult waterways are Wrangell Narrows and Surges Narrows. Vessels will not transit with the ranges out.

6. Delays in arrival can be costly. Stevedore costs run about \$50 to \$75 an hour per person. A cargo ship generally requires two gangs of 16 men each, with a four hour minimum.

7. The Alaska Marine Highway carries several hundred thousand passengers a year, producing \$35 million in revenues. They also carry time-critical cargo such as frozen milk to the north and frozen fish to the south. Insurance costs \$1.8 to \$4 million a year.

8. Their operations are much affected by politics. Factions in Anchorage and Fairbanks would love to see the marine highway shut down to strengthen their bids to get the state capital moved from Juneau.

9. In some places, like Wrangell Narrows, they would like to see discrepant aids repaired immediately. In any waterway, if an aid is out for an extended period of time, the chances of an accident are increased due to the increased likelihood that someone with less local knowledge will try to get through.

F. Meetings with Captain and Crew of the Malaspina (Alaska Marine Highway). (Messrs. Greenberg and Ulvila rode the Malaspina from Ketchikan to Juneau, viewed the AtoN system--including a night passage through Wrangell Narrows--and interviewed key members of the crew.)

1. Color changes in AtoN, especially to IALA green (which does not contrast with either the background or the water), have made navigation more difficult. One of the crew members noted that the changes appeared to be arbitrary and made with no apparent reason, nor were mariners consulted prior to the change.
2. There is a problem with aids being changed back and forth; for example, a buoy being changed from white to red and back to white (several aids on chart 17382 in the general vicinity of 56°30' latitude and 133°40' longitude were especially noted). Resources could be better used in enhancing the system rather than in changing things that do not need to be changed.
3. Reducing the intensity of lights always harms navigation. Especially bothersome were the reduction at Sisters Island and the proposed reduction at Grand Island.
4. Also disturbing is the perception that a number of AtoN decisions are made "at desks," without any firsthand knowledge of the navigation problems.
5. Sometimes the information on aids in the Local Notice is in error. The crew does not make a change to the chart in ink until the change is reported in the Weekly Notice from the Defense Mapping Agency.
6. Many small boats use fog signals. Not everyone has LORAN and radar, and these systems break down.
7. Once a decision is made to transit Wrangell Narrows, the complete passage must be made. There is no way to turn back, slow down, or drop anchor.
8. There are problems with overtaking smaller vessels in Wrangell Narrows which transit in both directions. Many do not hear oncoming traffic in the daytime (at night, a light can be used to warn the other vessel).
9. There are 63 aids in Wrangell Narrows, all of which mark hazards or course changes. The bottom is all rocks.
10. Of foul weather conditions, snow is the worst. It may even cover a light in Wrangell Narrows. Sometimes a vessel can get into fog without warning. Lights are visible at distances of about .15 to .20 miles in fog. (Ranges are picked up half again as far as colored lights.)
11. Ranges in Wrangell Narrows mark courses leading into critical tight turns.
12. The aids in Wrangell Narrows were published in the 1920s or earlier and have remained essentially the same since then.

ATTACHMENT

PRINCIPAL DISTRICT 13 WATERWAYS

9 JUNE 1986

WATERWAY	PRINCIPAL PORTS	PROJECT DIMENSIONS	VESSEL SIZE	HAZMAT CARGO	PRINCIPAL CARGO
San Juan Strait	Bellingham Anacortes	Natural deep draft (wire dragged)	To 1,000 ft 125,000 DWT	Crude oil Petroleum byproducts Chemicals	Alaska crude oil Petroleum products Wood Wood byproducts
Skagit Sound	Everett Bremerton Seattle Tacoma Olympia	Natural deep draft Everett: 20'x150'x1.1M (priv dredged to 30') Olympia: 30'x300-500'x1.7M	To 900 ft (Avg 650)	Same as above Nuclear material	Petroleum products Wood byproducts Container products Food products Wood
Grays Harbor	Hoquiam Aberdeen Cosmopolis	30'x350'x9.9M 30'x350'x5.1M 30'x200'x2.3M	To 600 ft Tug & barge Fishing vsls	Oil	wood wood products
Columbia River (North to Portland)	Astoria Longview Kalama Portland	48'x2640'x5.5M (bar) 40'x600'x107.7M (to Portland, OR)	To 1,000 ft	Gasoline Distillate fuel Oil	wood wood products Grain
^{Spok} Columbia River (Portland to Lewiston)	Vancouver The Dalles Tri-Cities Lewiston	27'x300'x35.1M (to Bonneville Dam) Pooled Reservoirs No specific projects except Ice Harbor Cut (14'x250'x5M)	Tugs Towboats	Same as above	Same as above
Coos Bay	North Bend Coos Bay	35'x300'x9.9M 35'x400'x2.5M	To 600 ft Tug and barge Fishing vsls	Same as above	wood

APPENDIX B: MULTIATTRIBUTE UTILITY ANALYSIS

Multiattribute utility analysis (MAU) is an appropriate technique for combining measures of effectiveness (MOEs) to aid in decisions in which: (a) multiple factors, or attributes, are important; (b) no decision is clearly best on all factors; and (c) some factors (such as intangibles) are difficult to quantify. MAU models explicitly reflect the relative importance of each objective, and, therefore, the tradeoffs among them. By doing so, an MAU model enables an analyst or manager to develop a summary measure of value reflecting many kinds and degrees of impacts on these objectives. In the Coast Guard resource management tool, it will sometimes be important to trade off one measure against another to form overall or intermediate summary evaluations.

The key stages in an MAU approach are:

- identification of what is to be evaluated (alternatives or options).
- definition of the components, or attributes of value (what is important, e.g., measures of effectiveness);
- evaluation, or "scoring" alternatives on the attributes (how is each alternative rated on each attribute?);
- prioritization of the attributes of value (e.g., is cost more important than user satisfaction? how much more?);
- comparison of alternatives being evaluated (which alternative scores highest on all factors combined?);
- sensitivity analysis on assumptions and judgments (what if priorities change?).

Task 1 is concerned with establishing MOEs as a means to measure performance. The following paragraphs describe in some detail the steps required to apply MAU analysis using the MOEs to evaluate alternatives. This description is based on a hypothetical illustration that was used to illustrate MAU analysis in a project conducted for the Coast Guard by Mandex and DSC (Contract No. TCG-23-83-C-20080). Although the example is not an SRA resource decision, the techniques and methods are appropriate there as well. A brief

illustration of MAU analysis and other analysis methods for an SRA decision are given in Chapter 5. This appendix gives an expanded description of some technical issues. More detail on the illustration used in this appendix is contained in the project report "Analytic Methods for Assessing Recreational Boating Safety Effectiveness: A Users' Guide" (January 1984).

The hypothetical example evaluated personal flotation devices. Coast Guard boating safety statistics show that in 1982, 1178 people lost their lives in recreational boating accidents. Almost 90% of these deaths were the result of drowning. To reduce the number of such deaths, the Coast Guard had established standards and requirements for personal flotation devices. PFDs. Coast Guard analysts were tasked with examining the way that boaters evaluated several alternative PFDs with regard to major factors such as effectiveness and cost. The specific goal of the analysis was to provide a "macro" level evaluation of the alternative PFDs and to identify the major issues that affect boaters' choices. (Note that the scope of the sample problem is scaled down to illustrate techniques. The following analysis is not intended to be an actual evaluation of PFDs.)

B.1 Identification of Alternatives (MOEs)

In many cases, the alternatives to be evaluated are few and well-defined. In other cases, it becomes necessary to pare down the potential set of alternatives before detailed evaluation. This is often accomplished by a technique known as elimination by aspect. For example, in buying a car, few buyers fully evaluate all models. Rather, they eliminate many alternatives outright by specifying certain required and/or unacceptable aspects of the automobiles. This might include specifying a price range, a style (e.g., 2-door, convertible), a manufacturer, or even specific features (e.g., must have automatic transmission).

In generating options for cases where alternatives are not well defined, it is sometimes useful to focus on one characteristic that plays a major role in the decision. This characteristic is used to generate different alternatives as it runs through its range of potential values. For example, alterna-

tives can be characterized from least risky to most risky, cheapest to most expensive, easiest to implement to hardest to implement, etc.

For our sample problem, we initially defined the subset of potential PFDs that were to be evaluated. These were:

- (1) Inflatables (I);
- (2) Hybrid inflatables (HI);
- (3) Inherent buoyancy devices (IB);
- (4) Styled inherent buoyancy (SIB);
- (5) Ski belt (SB);
- (6) Seat cushions (SC).

B.2 Identification of Attributes

In determining the attributes, or factors, on which the alternatives will be judged, it is desirable that the set of attributes have the following characteristics:

- be comprehensive enough to account for most of what is important in evaluating the options, yet compact enough to be usable;
- be able to highlight the differences among options;
- be measurable and obtainable;
- reflect separate, nonoverlapping features to avoid double counting.

While it is desirable to satisfy the last characteristic, it is by no means required. It is possible to define evaluation factors that are dependent upon each other and interact in complex ways. However, most of the value of an MAU model can usually be obtained by using a simpler form in which each factor is independent of all other factors. If it is clear that two factors are not independent, but both are interacting, it is usually possible to define a single factor that incorporates the critical aspects of the dependent factors. (Notice that here we are addressing independence in the worth of an attribute; technical interdependencies are addressed in the definition of the alternatives.) The measures of effectiveness described in Chapter 4 are appropriate attributes for SRA resource decisions.

It is often desirable to define the attributes in a hierarchical fashion such that at the top of the hierarchy are broad, general attributes which get subdivided into more specific subattributes. Usually, the highest level attributes are too broad to be useful in scoring alternatives; thus, a rule-of-thumb for subdividing is to develop attributes at the lowest level of the hierarchy that can be measured readily. A simple hierarchical evaluation structure for the PFD evaluation example is shown in Figure B.1.

There are four major factors: effectiveness of the device, the usability of the PFDs by boaters, the durability of the PFDs themselves, and the costs of the PFDs. These factors are too broad. As a result, they were subdivided as indicated:

Effectiveness

- *HEAD-UP*: the ability to keep the head out of water for an unconscious boater;
- *ROUGH SEAS*: the ability to keep a conscious boater afloat in rough seas;
- *BUOYANCY*: the rated weight capacity of the device;
- *FAILURE RATE*: indicates potential for not doing the job for which it was intended (e.g., inflatable fails to inflate).

Usability

- *IMAGE*: measures how boaters perceive their own image of using the device;
- *ACCESSIBILITY*: the ability to store the device and get to it readily when needed;
- *COMFORT*:
 - *WEARABILITY* - measures how comfortable the device is to wear;
 - *INTERFERENCE* - indicates how much the device interferes with other activities such as fishing, sunbathing, etc

EXAMPLE FOR ILLUSTRATION ONLY

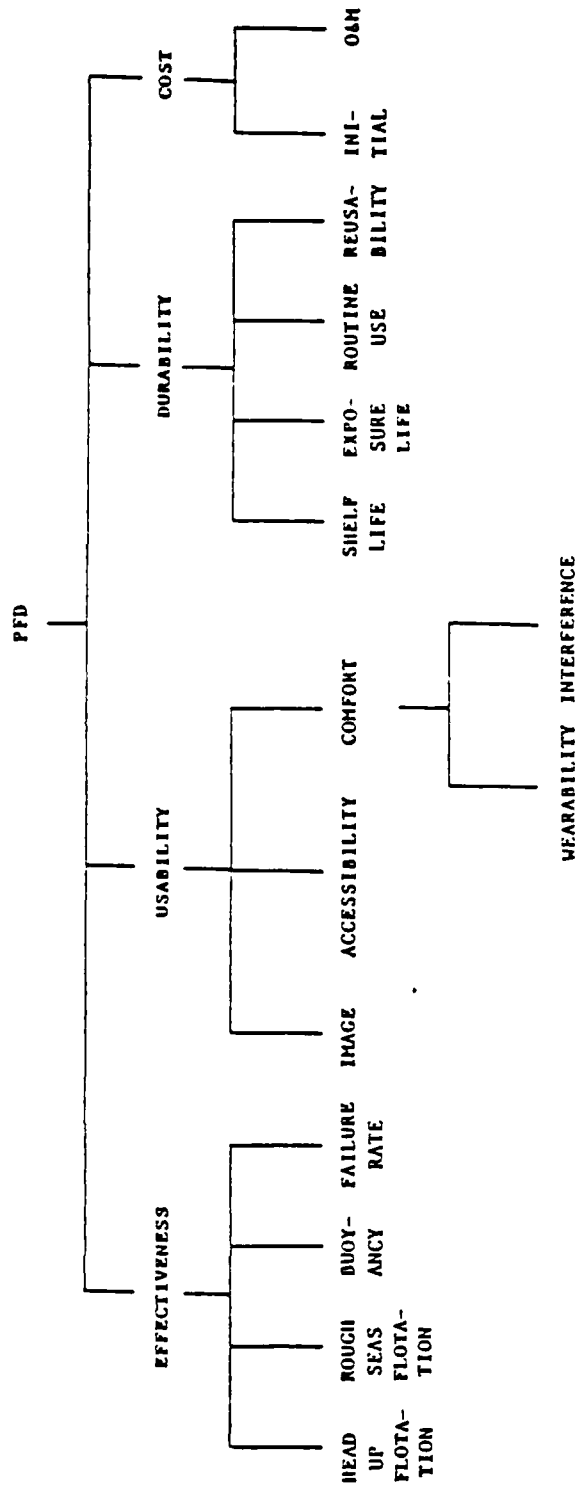

Figure B.1: PFD Evaluation Structure

EXAMPLE FOR ILLUSTRATION ONLY

Durability

- *SHELF LIFE*: how long can the PFD remain on the shelf unused before it begins to deteriorate?
- *EXPOSURE LIFE*: how long can the PFD be used and exposed to boating conditions before it begins to deteriorate?
- *ROUTINE USE*: how susceptible is the device to damage caused by routine use (e.g., straps tearing, punctures, etc.)?
- *REUSABILITY*: once used, is the ability to reuse the PFD impaired?

Cost

- *INITIAL PURCHASE COST*;
- *O&M COSTS*: costs to operate, maintain, and replace the PFD (over a 10-year period).

Each factor in the "tree" structure is referred to as a branch, and the places where branches meet are referred to as nodes. Note that there is no requirement that the number of levels of subdivision be the same throughout the structure, nor do all nodes necessarily have the same number of branches. The last level of subdivision results in branches that are called bottom-level attributes, or terminal branches. The terms "factors," "attributes," "branches," and "criteria," are generally interchangeable, and all are commonly found in the literature on MAU.

There is no theoretical limit to the number of levels of the hierarchy or the number of bottom-level attributes that can be developed as an MAU structure. However, as a general guideline, five levels are usually more than adequate. If in structuring the problem, the analyst has more than five levels, he should give serious consideration to regrouping attributes. A normal tendency for the beginner is to attempt to develop a "tree" with minute levels of detail to ensure that nothing is left out. The primary purpose of MAU is to differentiate among alternatives. Attributes that provide no contribution towards differentiation should be considered for elimination.

There are many techniques that can be used to develop the tree structure, but two are most prevalent--top-down structuring and bottom-up structuring.

In top-down structuring, the analyst first describes the highest-level attributes and then attempts to determine logical subdivisions. The analyst proceeds from general to specific until a level is reached that provides a reasonable measure of value. It is perhaps the easiest technique to use to develop a hierarchy quickly from scratch.

The bottom-up approach is more difficult to employ, but often results in a more discriminatory structure. The idea is to generate the lowest-level attributes by directly identifying measurable factors, and then logically grouping the factors into clusters that go from specific to general. One of the best ways to apply this approach is to begin by listing the advantages and disadvantages of each alternative. The lists for all alternatives are then combined into a single list of advantages and disadvantages. This list is then used to define the attributes and to group them into logical clusters. The bottom-up approach is less likely to miss an attribute inadvertently, but is more time-consuming and requires more experience than the top-down approach.

With either approach, the following issues are critical to remember:

- (1) At any node of attributes, the branches should be independent; all nodes should be independent of each other.
- (2) Minute detail is usually unnecessary; focus on attributes that discriminate among options. Typically, one-third of the bottom-level attributes account for 80-90% of the overall evaluation.
- (3) When properly used, differences in number of levels and differences in number of branches at nodes will not affect the results.
- (4) In determining if an attribute can be easily measured, it is not necessary that the attribute have an obvious *objective* measure that can easily be quantified. Measures that must be evaluated *subjectively* using expert judgments are equally valid and should be used. (Benefit assessment techniques are discussed in a later section).

B.3 Evaluation of Alternatives on Attributes

The next step is to evaluate each alternative on each attribute. As an example, consider the bottom-level attribute of DURABILITY--SHELF LIFE. This scale would have the obvious measure of years. The value scale will thus serve to assign a score to the number of years associated with an alternative. Suppose the following SHELF LIFE data are available on the options. (Note: All data used in this illustration are hypothetical):

<u>Option</u>	<u>SHELF LIFE (years)</u>
I	3
HI	5
IB	10
SIB	10
SB	6
SC	8

Assume that the value of SHELF LIFE is linear with time over the range of 3 years to 10 years. IB and SIB have shelf lives of 10 years; therefore, both score 100. Option I has a shelf life of 3 years and is given a score of zero. SB with a SHELF LIFE of 6 year should be 3/7 of the way from 0 to 100, or a score of 43.

Similarly, SC would score 71. All values can be shown on a value curve as in Figure B.2:

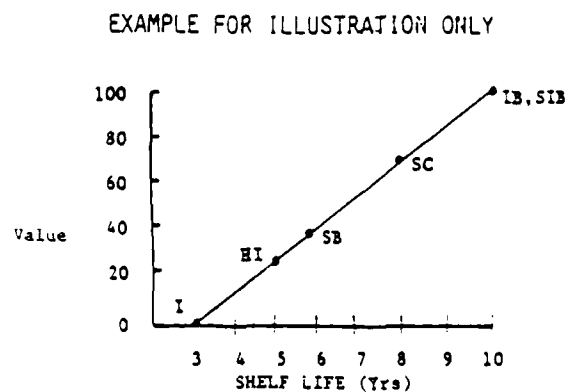

Figure B.2: Utility Curve for SHELF LIFE

There is no requirement that a value curve be linear. For example, on the factor BUOYANCY, it can be argued that the initial improvements in BUOYANCY over baseline have the most incremental value. Suppose BUOYANCY measures are as follows:

<u>Option</u>	<u>BUOYANCY (lbs)</u>
I	25
HI	25
IB	25
SIB	17
SB	5
SC	9

If the argument can be made that the eight pound difference in going from 9 to 17 sounds more important than the eight pound difference in going from 17 to 25 pounds, the value curve might look like the following:

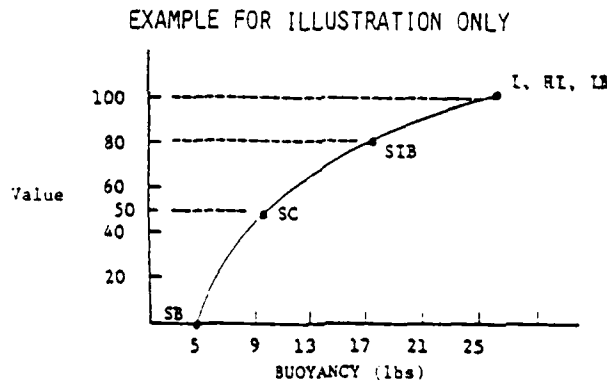

Figure B.3: Utility Curve for BUOYANCY

The value curve can, in fact, take on many different shapes. In many cases, value increases slightly or not at all until a threshold is reached and then it rises dramatically. It is also possible for value to rise up to a point and then drop off. These situations could lead to the following types of curves:

EXAMPLE FOR ILLUSTRATION ONLY

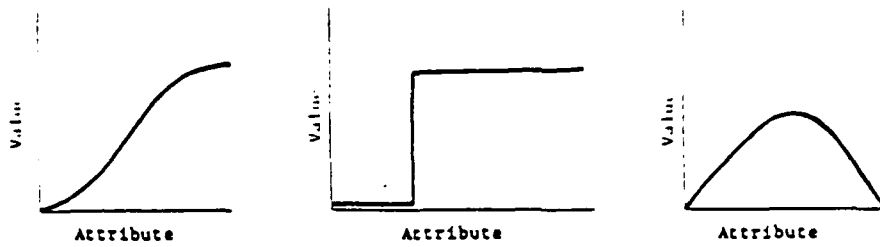

Figure B.4: Possible Shapes for Utility Curves

There is also no requirement that value curves be continuous. Often, the attribute should be measured in discrete terms. For example, the intangible factor INTERFERENCE could be represented as follows:

EXAMPLE FOR ILLUSTRATION ONLY

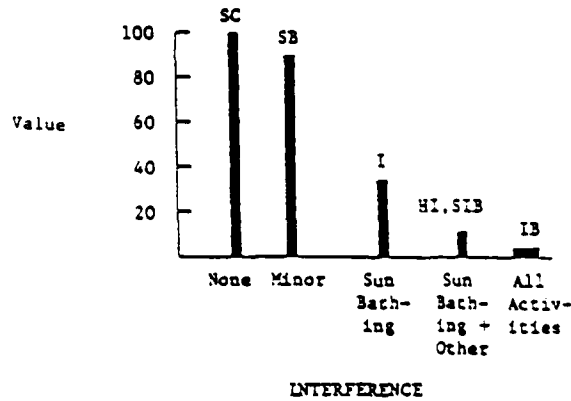

Figure B.5: Discrete Utility Curve for INTERFERENCE

Several important issues are worth noting. First, the horizontal axis for each factor is determined uniquely for that factor. Common sense and logic will dictate what the appropriate measure should be. Next, it should be apparent that it is not necessary to develop formally the value curves themselves. Once the logic behind the curves is apparent, scores can be directly assessed. Finally, the points on the horizontal axis must encompass the set of alternatives under consideration. If a new alternative is added that falls

outside the defined range, the endpoints must be redefined and new scores must be assessed.

Sometimes, there is not a good objective, readily quantified measure for an attribute. In these cases, verbal descriptions are used and related to the value scale. An example of this was shown in Figure B.5. Scaling terms such as High/Medium/Low, Yes/No, and Go/No are also frequently used to define these scales.

Scores for all alternatives on all bottom-level attributes are displayed using the previous tree structure as shown in Figure B.6. Recall that these scores are hypothetical and do not represent Coast Guard judgments. Rather, they have been developed by the authors to demonstrate key points of the methodology.

The discussion above described a relative scoring procedure. The second major approach to scoring is using absolute scoring procedures. In this method, the scales are developed independently from the alternatives. The endpoints of each scale are determined in an absolute sense. In determining the endpoints, it is essential to consider the range of values that potential options might span. If the defined endpoints are too close together, options will be excluded. If too far apart, all options will fall in too narrow a band of scores and the model will not discriminate adequately. Possible benchmarks for endpoints can include the following:

- current characteristics at the 0 point, ideal characteristics at the 100 point;
- characteristics less than current level at the 0 point. This allows value to be reduced on one attribute as a tradeoff for increased value in another;
- characteristics of other known, related systems as endpoints.

In the absolute scoring system, the scales are used in a similar fashion to the relative scoring system, but alternatives can fall anywhere on the scale. The value scales again can take a variety of forms and shapes, and a weighting system is required to compare one scale with another.

EXAMPLE FOR ILLUSTRATION ONLY

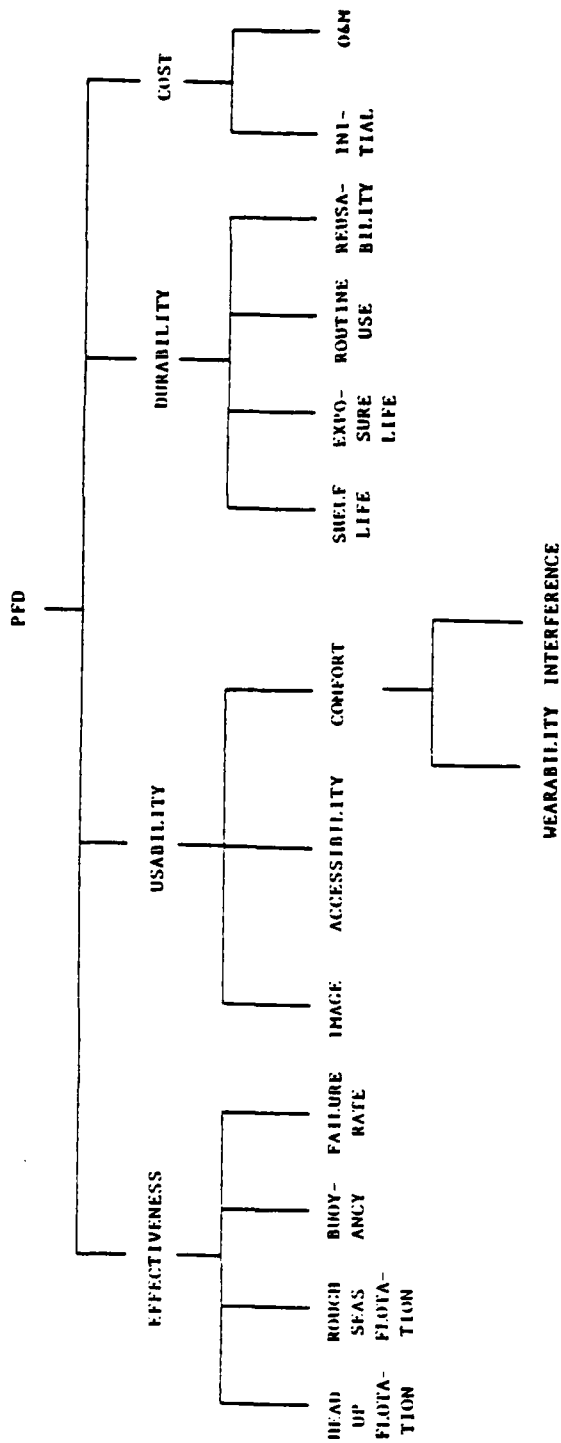

	50	50	100	0	50	100	40	30	0	0	0	0	36	12
I	50	60	100	10	20	80	10	15	29	17	20	10	12	0
II	100	100	100	70	0	0	0	0	100	100	100	100	25	100
III	5	25	80	100	75	20	50	15	100	67	90	100	0	81
IV	0	0	0	95	90	90	80	90	43	33	50	100	95	84
V	0	0	50	85	100	80	100	100	71	50	60	100	100	94

Figure B.6: PFD Evaluation Structure with Scores

EXAMPLE FOR ILLUSTRATION ONLY

The absolute scoring system usually provides results that are easily communicated, and provides a better reference frame of value than relative scales. On the other hand, an absolute system is more difficult to use, requires more expertise on the nature of the problem, and is more time consuming to develop. The absolute scoring system is often used in situations where alternatives are not well defined. In fact, it serves as a useful tool in developing feasible alternatives, and can be used to recommend where appropriate data are readily available.

B.4 Prioritization of Attributes (Weighting)

In the scoring systems described above, an evaluation scale from 0 to 100 was developed for each attribute. However, each scale is defined independently of all others, and the resulting scores are not directly comparable. In reality, some attributes carry more importance than others, and a measure of the priority, or relative importance, of each factor is necessary. This is accomplished through a weighting system. As with the scoring system, weightings are often judgmental, and different decision makers (or different organizational units) could have different sets of weights.

The most common perception of a weight is that it answers the question, "How important is attribute A relative to attribute B?" However, such a measure is often misleading. A more pertinent question to ask is, "How important is the difference in the range of values for attribute A versus the difference for attribute B?" The subtle difference in wording of these two questions is extremely important. The latter question includes both the importance of the attribute as well as the "swing" in the range of values on the attributes. As an example of this distinction, program costs may be very important in the abstract. However, if the cost scale is defined over a very small range, the change in cost over the range may be relatively unimportant compared with variations of other attributes. In this case, cost would receive a low weight. An appropriate set of weights would measure the importance of the differences in attribute scales rather than the importance of the attributes alone. For the remainder of this discussion, whenever the importance of an attribute is mentioned, we are referring to the "swing" importance.

Judgmental weight can be assessed top-down or bottom-up. Top-down weighting is easier and is more widely used. In the top-down approach, the analyst begins at the highest level node in the hierarchy, and assesses the relative differences among attributes. For the PFD example, the question might be asked, "How do differences in EFFECTIVENESS compare with differences in USABILITY, DURABILITY, and COST?" or, "Is it more important to get improved capability over baseline in USABILITY versus EFFECTIVENESS, DURABILITY, and COST?" A common approach is to assign a weight of 100 to the most important swing. Other weights are then assigned using ratio judgments--that is, if the swing on an attribute is judged to be twice as important as the swing on another attribute, the former would carry twice the weight of the latter. These assigned weights are then normalized to run to 1, for comparability in data calculations. In the PFD example, the following weights might be assigned. (Note: These weights do not represent Coast Guard assessments. They are hypothetical values developed by the authors.):

<u>Attribute</u>	<u>Assigned Weight</u>	<u>Normalized Weights (%)</u>
EFFECTIVENESS	100	40
USABILITY	37	15
DURABILITY	37	15
COST	70	30

Looking at USABILITY, these 15 points of normalized weight must be spread among the subfactors that make up USABILITY. There are three branches making up USABILITY--IMAGE, ACCESSIBILITY, and COMFORT. Rather than trying to allocate the 15 points, it is easier to assign weights to these subfactors using the same approach described above. The most important swing is given 100, ratio judgments are made for other swings, and the resulting numbers are normalized to sum to 1. Thus, at every node in the structure, the "local" weights will sum to 1. Assume that the USABILITY subfactor weights were judged as follows:

<u>Attribute</u>	<u>Assessed Weight</u>	<u>Normalized Weight (%)</u>
IMAGE	75	37.5
ACCESSIBILITY	25	12.5
COMFORT	100	50.0

This process would next be applied to the attribute COMFORT since it has subattributes of WEARABILITY and INTERFERENCE. Assigning weights would continue for all nodes in the structure.

A useful notion is that of cumulative weight of an attribute. The local weight refers to the weight of an attribute at its node in the hierarchy. Weights at each node sum to 100%. It is also useful to identify the weight of an attribute relative to the entire evaluation structure, its cumulative weight. The cumulative weight, or CUMWT, is the product of all normalized weights along the branches leading the attribute in question. To illustrate, the evaluation structure is repeated in Figure B.7 with hypothetical local weights shown for each attribute, as well as the CUMWT. To calculate the CUMWT for EFFECTIVENESS/ROUGH SEAS, multiply the local weights along the path to ROUGH SEAS, or 40% (for EFFECTIVENESS) times 10% (for ROUGH SEAS) which equals 4% (.04). Note that the sum of CUMWTS for all bottom-level is 100%. The interpretation of the .14 CUMWT for EFFECTIVENESS/HEAD-UP FLOTATION is that in terms of the entire evaluation, the importance of differences on that attribute accounts for 14% of the entire decision. As a further calibration check on the assigned weights, it is useful to list all bottom-level factors in order of decreasing CUMWT. This provides a basis for discussion and revision of the assessed weights. For the PFD example, this list would appear as follows:

<u>Bottom-Level Attribute</u>	<u>CUMWT</u>	<u>Sum of CUMWTs</u>
O&M COST	.165	.17
BUOYANCY	.15	.32
HEAD-UP FLOTATION	.14	.46
INITIAL COST	.135	.60
FAILURE RATE	.07	.67
ROUTINE USE	.06	.73
IMAGE	.056	.78
WEARABILITY	.045	.83
EXPOSURE LIFE	.045	.87
ROUGH SEAS FLOTATION	.04	.91
SHELF LIFE	.03	.94
INTERFERENCE	.03	.97
ACCESSIBILITY	.019	.99
REUSABILITY	.015	1.00

Note that 4 of the 13 attributes account for almost 60% of the weight.

EXAMPLE FOR ILLUSTRATION ONLY

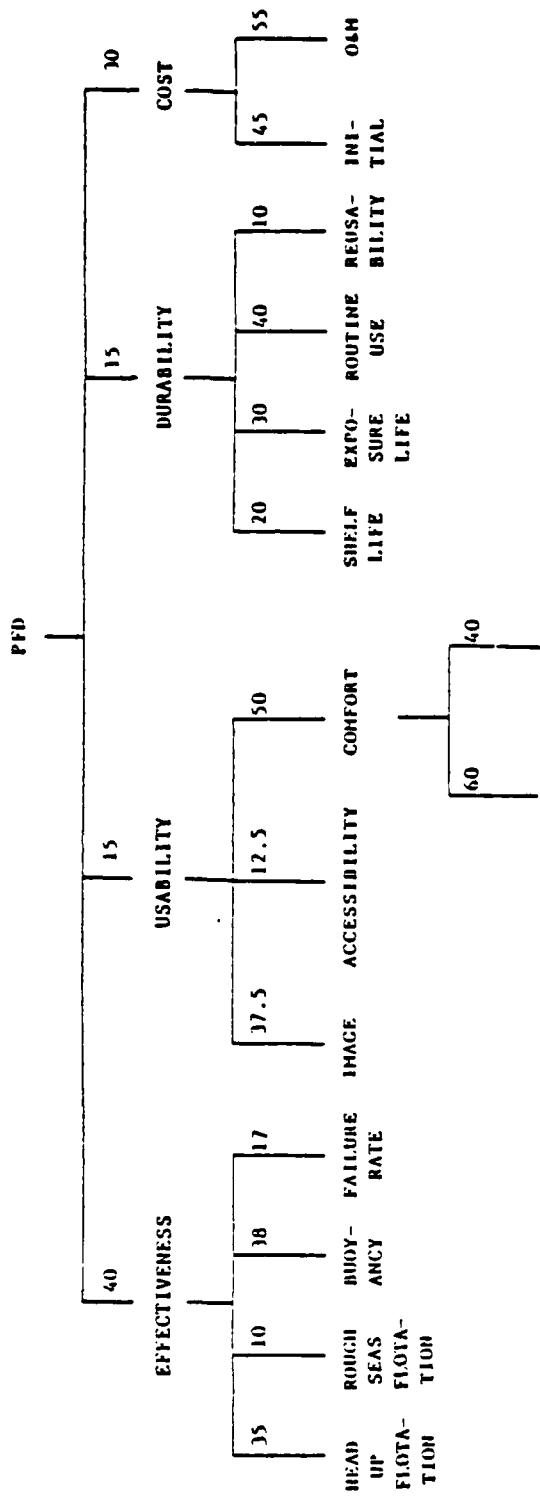

WEARABILITY INTERFERENCE

	CURR	.14	.04	.15	.07	.06	.02	.04	.03	.03	.04	.06	.01	.14	.17
I	50	50	100	0	50	100	40	30	0	0	0	0	0	38	12
III	50	60	100	10	20	80	10	15	29	17	20	10	10	12	0
LB	100	100	100	70	0	0	0	0	100	100	100	100	100	25	100
SIB	5	25	80	100	75	20	50	15	100	67	90	100	100	0	81
SB	0	0	0	95	90	90	80	90	43	33	50	100	100	95	84
SC	0	0	50	85	100	80	100	100	71	50	60	100	100	100	94

Figure B.7: PFD Evaluation Structure with Scores
Top-Down Weighting

EXAMPLE FOR ILLUSTRATION ONLY

Top-down weighting can be done quickly and with little computational difficulty. Its major disadvantage is that in making tradeoffs at the highest levels, it is sometimes difficult to conceptualize all of the things that are included in comparing differences among attributes. Using top-down weighting, it often happens that one "slips" back to the "abstract importance" measure of a factor rather than the more desirable "swing" importance.

A more complex alternative for assessing importance weights is the bottom-up approach. The analyst begins at the lowest-level attributes and works his way upwards by directly comparing lower-level attributes in one part of the structure with attributes in another part.

For example, in the PFD problem, the analyst could start with the EFFECTIVENESS node and elicit weights for HEAD-UP FLOTATION, ROUGH SEAS FLOTATION, BUOYANCY, and FAILURE RATE as before. Assume the weights are as follows:

<u>Attribute</u>	<u>Assessed Weight</u>
HEAD-UP	90
ROUGH SEAS	25
BUOYANCY	100
FAILURE RATE	45

The analyst next compares an attribute from another part of the structure with one of the weights. For example, assume BUOYANCY improvements (weighted as 100) are considered to be five times as important as INTERFERENCE improvements. The weight on INTERFERENCE would be one fifth that of BUOYANCY, 20. Since in this approach, the attributes are all being evaluated on a common scale, the weights as initially assessed can be compared directly. Similarly, suppose ACCESSIBILITY swings are judged to be half as important as ROUGH SEAS swings, and HEAD-UP FLOTATION is three times as important as WEARABILITY. This could imply a weight of 12.5 for ACCESSIBILITY and 30 for WEARABILITY.

The power of bottom-up weighting becomes evident as we move up the hierarchy. Since all bottom-level attribute weights are linked through measurement on a common scale, it is only necessary to add together the weights of the branches at each node to get the node weight. Thus, the weight

of EFFECTIVENESS is the sum of the weights of its components, or $90 + 25 + 100 + 45 = 260$. Similarly, COMFORT weight is the weight of WEARABILITY (30) plus INTERFERENCE (20), or 50. If the weight of IMAGE is assessed at three times that of ACCESSIBILITY (12.5), the weight of USABILITY would be 37.5 (IMAGE) + 12.5 (ACCESSIBILITY) + 50 (COMFORT) or 100. Similarly, we might judge INITIAL COSTS to be slightly less important than HEAD-UP FLOTATION (90) so we could assign a weight of 85. If differences in O&M COSTS are judged to be slightly more important than improvements in BUOYANCY (100), we might assign a weight of 105. Note that in making such judgments, the process is iterative and multiple comparisons are made as consistency checks.

In an oversimplified analogy, this can be compared to the process that an eye doctor follows in determining a prescription. Rather than asking "What is your vision?" (i.e., what is the weight of an attribute?), he asks, "Do you prefer lens A or lens B?" (i.e., is attribute A more important than B?). He then continues by making additional comparisons.

Bottom-up weighting is also more natural when comparing attributes measured in the same units or in determining weights by "pricing out." For example, if a number of attributes are measured in dollars, the weight reflects directly the value assigned to "different" dollars (e.g., a dollar to government being valued the same as, more than, or less than a dollar to commercial mariners). As another example, the weight on injuries compared with dollars reflects a "pricing out" of the dollar value of avoiding an injury. Bottom-up weighting is also the more natural way to incorporate parametric weighting guidelines, such as discounting cash flows over time at 10%.

Using a similar process for the rest of the structure, assume that weights have been assessed as shown in Figure B.8. All weights as shown are directly comparable. Next, at each node, we can normalize weights to sum to 100 and can calculate CUMWTS as before. The results are shown in Figure B.9. Note that for the purposes of this example, the results of both top-down and bottom-up weighting procedures are identical. In reality, it would be highly unlikely that this would occur. Perceptions change, many aggregate judgments are made implicitly, and there are few perfect judgment assessors in the world. However, results should be consistent. The key to this is the itera-

EXAMPLE FOR ILLUSTRATION ONLY

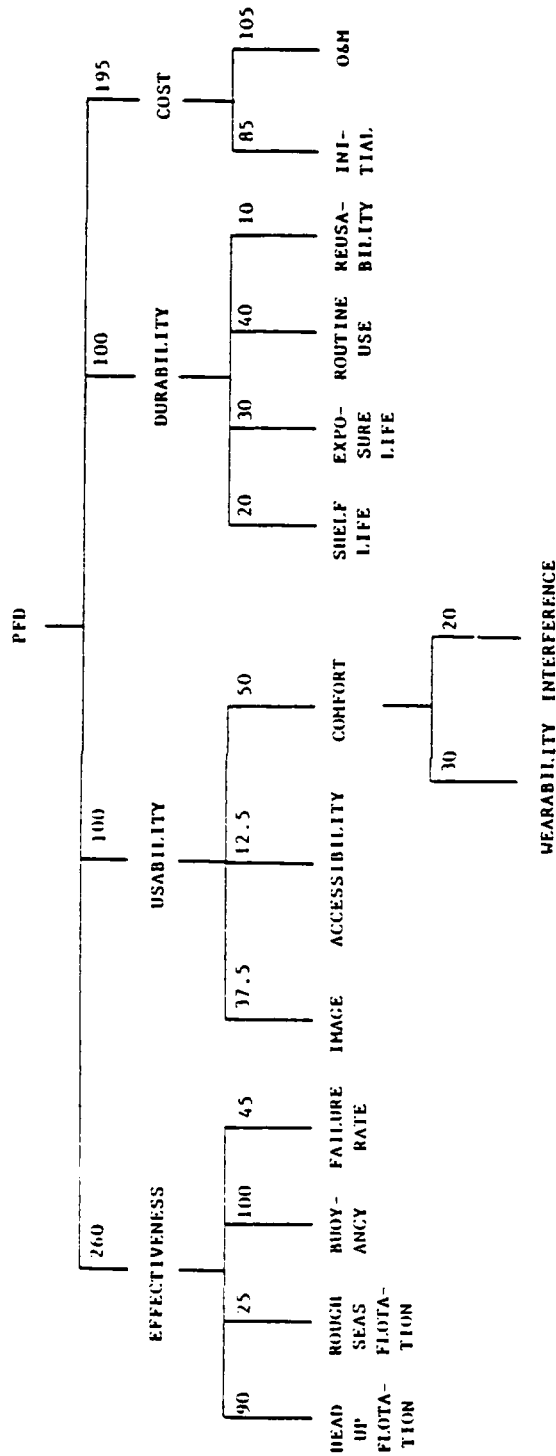

I	50	50	100	0	50	40	30	0	0	0	0	38	12
II	50	60	100	10	20	10	15	29	17	20	10	12	0
IB	100	100	100	70	0	0	0	100	100	100	100	25	100
SIB	5	25	80	100	75	20	15	100	67	90	100	0	81
SB	0	0	0	95	90	80	90	43	33	50	100	95	84
SC	0	0	50	85	100	80	100	71	50	60	100	100	94

Figure B.8: PFD Evaluation Structure with Scores
Bottom-Up Weighting (Unnormalized)

EXAMPLE FOR ILLUSTRATION ONLY

EXAMPLE FOR ILLUSTRATION ONLY

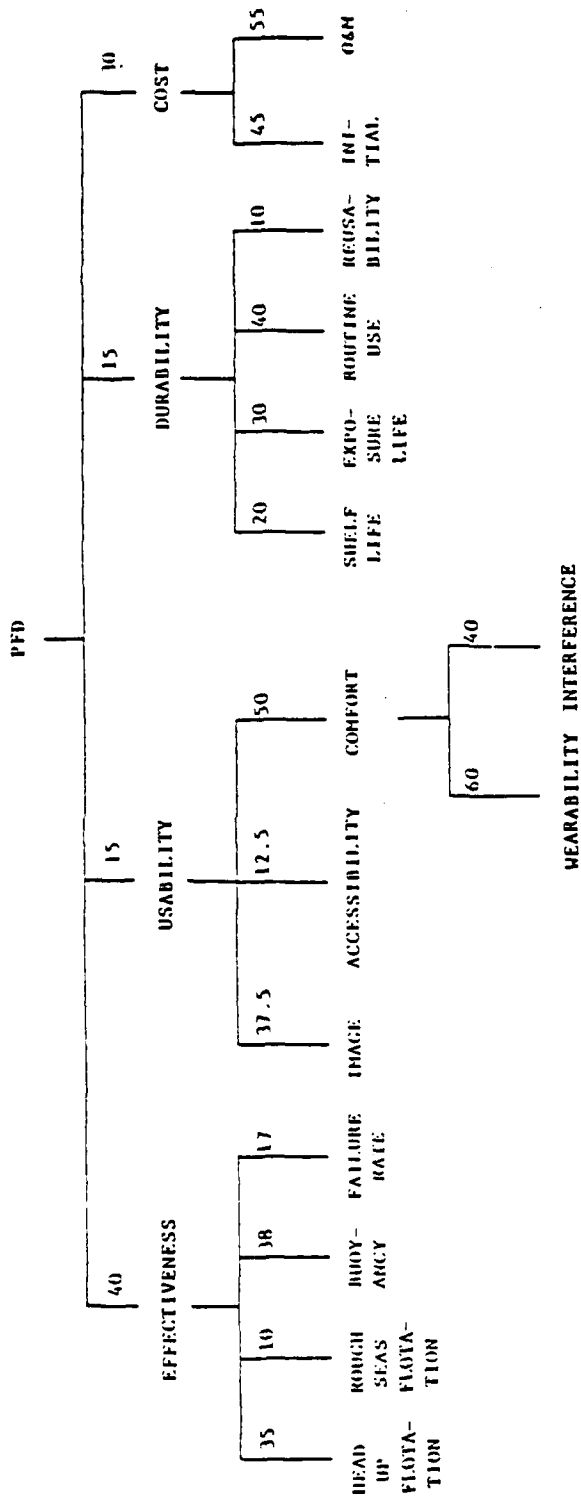

WEARABILITY INTERFERENCE

CUMMT	.14	.04	.15	.07	.06	.02	.04	.03	.04	.03	.04	.06	.01	.16	.17
I	50	50	100	0	50	100	40	30	0	0	0	0	0	38	12
II	50	60	100	10	20	80	10	15	29	100	17	20	10	12	0
IB	100	100	100	70	0	0	0	0	100	100	100	100	100	25	100
SIB	5	25	80	100	75	20	50	15	100	100	67	90	100	0	81
SB	0	0	0	95	90	90	80	90	43	90	33	50	100	95	84
SC	0	0	50	85	100	80	100	100	71	100	50	60	100	100	94

Figure B-9: PFD Evaluation Structure with Scores
Bottom-Up Weighting (Normalized)

EXAMPLE FOR ILLUSTRATION ONLY

tive process, the challenging of the final weights, and revision based on logical argument.

A combination of both bottom-up and top-down weighting usually works quite well. By using both techniques at different points in the weight process, greater consistency can be achieved.

B.5 Comparison of Alternatives

After all alternatives have been scored on the attributes, and weights have been assigned to the attributes, an overall evaluation for each alternative is determined. In an MAU structure with independent attributes, the overall score will be an additive combination of scores and weights. In more complicated structures, where attributes do interact, other combination roles are more appropriate. Multiplicative models are discussed in Section B-7. It is essential to recognize that the numerical results of the evaluation process are not the ultimate goal of the model. Rather, the scores and weights are merely a reflection of the judgments used as inputs. The numerical output should serve the analyst as a catalyst for discussion and revision of the model. A perfectly acceptable (and often desirable) outcome of the MAU model is a result that is not intuitively appealing. The beauty of the MAU model is the ease with which such disagreements can be traced to specific rationale, and revised if appropriate. As such, the computational algorithm should be presented in a form that allows such traceability.

Starting at the bottom-level nodes, a weighted-average score is calculated for each alternative. For example, the table below shows the calculations for the EFFECTIVENESS node.

EXAMPLE FOR ILLUSTRATION ONLY

NODE 1.1, EFFECTIVENESS		OPTION SCORES						
BRANCHES:	LOCAL WGT	I	HI	IB	SIB	SB	SC	CUMMT
1.1.1 HEAD-UP FLOTATION *	.35	50	50	100	5	0	0	.14
1.1.2 ROUGH SEAS FLOTATION*	.10	50	60	100	25	0	0	.04
1.1.3 BUOYANCY *	.38	100	100	100	80	0	50	.15
1.1.4 FAILURE RATE *	.17	0	10	70	100	95	85	.07
TOTAL	1.00	61	63	95	52	16	33	.40

Scores of each candidate are shown against each attribute (head-up flotation, rough seas flotation, buoyancy, and failure rate) in the table, and each attribute's weight is given in the "NODE WGT" column. In order to calculate the total score for any option on the EFFECTIVENESS node, the analyst must calculate the contributions that each branch makes toward the total score and add them together. (This is true since we assumed independent branches and an additive model.) For example, the score of option I on EFFECTIVENESS would be the score for I on HEAD-UP FLOTATION times the weight of HEAD-UP FLOTATION, plus the score for I on ROUGH SEAS FLOTATION times the weight of ROUGH SEAS FLOTATION, plus the score for I on BUOYANCY times the weight on BUOYANCY, plus the score for I on FAILURE RATE times the weight of FAILURE RATE. Using the number in Table B.1, this would be:

$$\text{SCORE(I)} = (50 \times .35) + (50 \times .10) + (100 \times .38) + (0 \times .17) = 61.$$

Similarly, the score for HI would be:

$$\text{SCORE(HI)} = (50 \times .35) + (60 \times .10) + (100 \times .38) + (10 \times .17) = 63.$$

In general, the score for an option i at a node would be:

$$\text{SCORE}(i) = \sum_j S_{ij} W_j$$

where S_{ij} = score for option i on attribute j;

W_j = weight of attribute j.

The bottom line of the table, labeled TOTAL, reflects the calculated score for each option on the node EFFECTIVENESS. The total CUMWT reflects the fact that EFFECTIVENESS represents 40% of the entire evaluation model. Note that on EFFECTIVENESS, IB scores highest at 95 while SB scores lowest at 16.

These evaluations are then carried to the next level and combined with the results of other nodes. The following table shows the calculations for the overall PFD node.

EXAMPLE FOR ILLUSTRATION ONLY

NODE I.O. PFD	LOCAL WGT	OPTION SCORES						CUMWT
		I	HI	IB	SI3	SB	SC	
1.1 EFFECTIVENESS	.40	61	63	95	52	16	33	.40
1.2 USABILITY	.15	49	24	0	49	87	98	.15
1.3 DURABILITY	.15	0	20	100	86	49	63	.15
1.4 COST	.30	24	5	66	45	89	97	.30
TOTAL	1.00	39	33	73	54	53	66	1.00

Notice that scores in the "EFFECTIVENESS" row are the same as in the "TOTAL" row of the previous table.

The TOTAL line says that IB scores highest followed by SC. The reasons why IB did well can be seen easily. It scored very high (95) on EFFECTIVENESS which was the criterion carrying the most weight. It was highest on DURABILITY, and moderate on COST. It was worst on USABILITY, but that factor carried a small weight. Similarly, if the analyst wanted to study why IB scored 95 on EFFECTIVENESS, he could look at the previous table to see where points were generated. (Note: These scores do not represent a Coast Guard evaluation of PFDs. They are hypothetical results used to illustrate MAU methodology.)

The general rules for interpreting scores are as follows:

- For a bottom-level factor, scores are entered directly;
- For any higher-level factor, scores are calculated using lower-level factors.

The numbers themselves are not the primary result. These numbers should serve to generate discussion and debate. They also highlight areas in which results are counterintuitive. Since the judgments behind the resulting numbers are easily traceable, disagreements can focus on specific issues rather than on overall results. When defending the model, if someone disagrees with a number, he should be able to provide strong enough rationale to counter-balance previous judgments. The output of the model is not a decision--

rather, it is a tool to identify principal issues, to focus further data-gathering efforts, and to guide the decision-making process. The analyst should hesitate in making strong inferences about one- or two-point differentials in score; however, more than a ten-point differential (on the 100-point scale) should safely discriminate among options. The analyst also can use the scores to determine if any options are dominated--that is, worse than another option on every attribute. In such a case, there is no combination of weights that will cause the dominated option to be preferred. Often, as part of the analysis, several areas are identified for further data-gathering and sensitivity analysis. All too often, effort is wasted in trying to obtain data on every possible aspect of a problem. It is far more efficient first to identify the critical issues and then gather data only on the factors that can affect the decision.

B.6 Sensitivity Analysis

Since assessments are often uncertain or subjective, it is desirable to perform sensitivity analyses on the model inputs. Often, in working with multiple sources of input, there are disagreements that may never be resolved. Rather than spend significant resources debating the issue, it is better to first determine if a change in the input affects the result. If not, there is little to be gained in further data collection and debate.

There are three major types of sensitivity analyses that are often used. First, the scores that have been assessed can be modified to determine if results change. Experience has shown that results are reasonably insensitive to minor changes in scores and that there is usually a high degree of confidence in the assessed values. Next, several weights can be changed and the overall scores recalculated. This is useful in examining large-scale changes to model (such as using weights for a different decision maker), but does not make it easy to isolate causes of change. A third sensitivity analysis is to vary one weight at a time and identify the regions where decisions change. Typically, one factor is chosen and its weight is allowed to vary from 0% to 100%. As the weight increases, the total weight of the other factors must decrease but the weights are kept in the same relative proportion to each other.

For example, as baseline, the weights for EFFECTIVENESS subfactors in the model were:

HEAD-UP FLOTATION	35%
ROUGH SEAS FLOTATION	10%
BUOYANCY	38%
FAILURE RATE	17%

The analyst can examine the effects of letting the weight of HEAD-UP FLOTATION vary from 0% to 100% of the evaluation. Since the model is linear, the score for any option as a function of HEAD-UP FLOTATION weight can be plotted on a graph of weight versus overall score. For example, the score for any option can be calculated as follows.

Whatever weight is chosen for HEAD-UP FLOTATION, the difference between that weight and 100% is reallocated among the other factors in strict proportion to their original ratio of 10:38:17. Thus, for each weight W_H , assigned to HEAD-UP FLOTATION, the remaining weights are calculated as follows:

$$W_R = \frac{10}{10+38+17} (1-W_H) = .15(1-W_H)$$

$$W_B = \frac{38}{10+38+17} (1-W_H) = .58(1-W_H)$$

$$W_F = \frac{17}{10+38+17} (1-W_H) = .26(1-W_H)$$

where the subscripts R, B, and F denote ROUGH SEAS FLOTATION, BUOYANCY, and FAILURE RATE accordingly.

The score for EFFECTIVENESS for alternative I may now be written in terms of W_H as follows:

$$\begin{aligned} \text{EFFECTIVENESS SCORE(I)} &= \text{Score for I on HEAD-UP FLOTATION} \times W_H \\ &+ \text{Score for I on ROUGH SEAS FLOTATION} \times W_R \\ &+ \text{Score for I on BUOYANCY} \times W_B \\ &+ \text{Score for I on FAILURE RATE} \times W_F \end{aligned}$$

$$\begin{aligned}
 &= 50 \times W_H + 50 \times .15 \times (1-W_H) + 100 \times .58 \times (1-W_H) \\
 &\quad + 0 \times .26 \times (1-W_H) \\
 &= 65.5 - 15.5 W_H.
 \end{aligned}$$

Similarly, scores for other options would be:

$$\begin{aligned}
 \text{SCORE (HI)} &= 69.6 - 19.6W_H \\
 \text{SCORE (IB)} &= 91.2 + 8.8W_H \\
 \text{SCORE (SIB)} &= 76.2 - 71.2W_H \\
 \text{SCORE (SB)} &= 24.7 - 24.7W_H \\
 \text{SCORE (SC)} &= 51.1 - 51.1W_H.
 \end{aligned}$$

These can be plotted as a function of W_H as shown in Figure B.10.

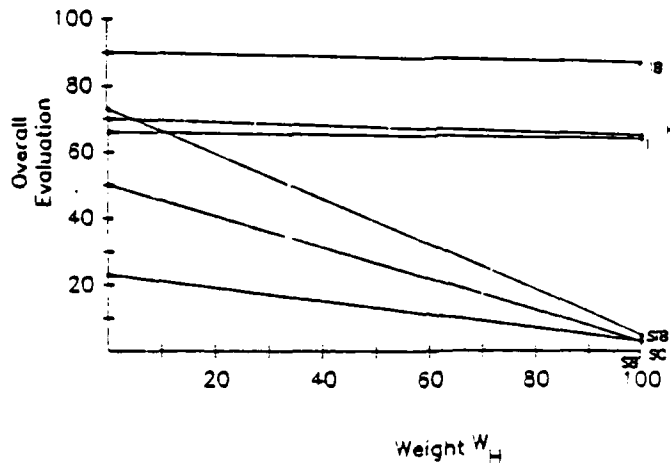

Figure B.10: Sensitivity on HEAD-UP FLOTATION

Since we want the option with the highest score, we select the option whose plotted line falls highest. IB is the dominant option on EFFECTIVENESS for any value of W_H .

We can perform a similar calculation at the highest level of the hierarchy on the weight of COST (W_C). Factors at node 1 include:

EFFECTIVENESS	40%
USABILITY	15%
DURABILITY	15%
COST	30%

For the moment, assume USABILITY and DURABILITY are not being considered, and tradeoffs are only being made on the basis of EFFECTIVENESS and COST. Then,

$$W_E = (1 - W_C)$$

where subscripts E and C refer to EFFECTIVENESS and COST.

The score for option C would be:

$$\begin{aligned} \text{SCORE(I)} &= \text{Score for I on EFFECTIVENESS} \times W_E + \text{Score for I on COST} \times W_C \\ &= 61 \times (1 - W_C) + 24 \times W_C \\ &= 61 - 37W_C. \end{aligned}$$

Similarly,

$$\begin{aligned} \text{Score (HI)} &= 63 - 58W_C \\ \text{Score (IB)} &= 95 - 29W_C \\ \text{Score (SIB)} &= 52 - 7W_C \\ \text{Score (SB)} &= 16 + 73W_C \\ \text{Score (SC)} &= 33 + 64W_C. \end{aligned}$$

These can be plotted as a function of W_C as follows:

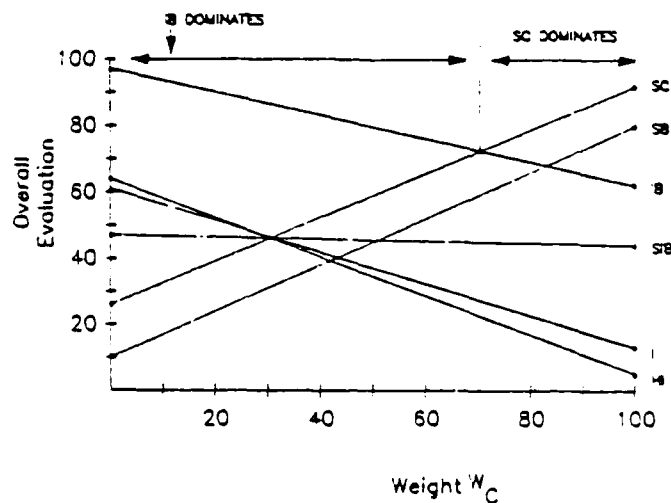

Figure B.11: Sensitivity to Cost

Initially, with W_C low, IB has the highest overall score. As W_C increases, SC becomes the dominant option. Under no set of weights for W_2 and W_C would SB, SIB, I, or HI be the preferred option. We can solve for the exact breakpoint by equating the expressions for the score for these two dominant options:

$$\begin{aligned}\text{SCORE (IB)} &= \text{SCORE (SC)} \\ 95 - 29W_C &= 33 + 64W_C \\ 93W_C &= 62 \\ \therefore W_C &= .67\end{aligned}$$

The sensitivity analysis shows that W_C must be decreased to .67 before the preferred alternative changes. Thus a debate as to whether W_C should be .10 versus .20 would not be worth much effort since the result is not affected.

Sensitivity analysis is perhaps the most important step in the MAU process. It helps to solidify subjective judgments and to identify critical areas for further study. It should be an integral part of all MAU analyses.

3.7 Complicating Factors and Extensions

This section will identify some of these more demanding modeling issues and will provide general references for further reading. Detailed explanation of these complications is beyond the scope of this effort.

There are occasions when it is not possible to restrict the criteria to be value-independent of each other without losing a good deal of information. In such cases, the hierarchical structure can include factors that interact, and a multiplicative (or more complicated) algorithm can be used to determine an overall score. The analyst should be aware that use of multiplicative models increases the modeling time and effort many fold, and often, the added accuracy provided by such a model is not justified by its costs. A common rule-of-thumb is known as the 80/20 rule: 80% of the results of an analysis can be achieved with 20% of the input effort. Many experts feel that developing a detailed multiplicative model is tantamount to spending the additional 30% of the input resources to achieve the final 20% of the results. Few deci-

sion makers are in a position to afford such luxury.

A detailed description of multiplicative and other forms of models and their uses can be found in *Decisions with Multiple Objectives: Preferences and Value Tradeoffs* by Keeney and Raiffa (1976).

The analysis described in preceding sections assumed some source of information. This could be measurement, statistical data, analytical models, or judgment. Often, when judgment is the source of information, more than one individual holds an opinion that should be represented in the analysis. In these cases, some thought should be given to determining the best way to elicit and use these opinions. This is described in Appendix E.

APPENDIX C: MODELS WITH PROBABILITY DISTRIBUTIONS

There are several ways that probability distributions may arise in a model or analysis. For example, probabilities may be estimated for the chances of an accident, the chances that a mariner would encounter a discrepant aid, or the distribution of damage costs given that an accident occurs. This appendix describes some of the ways that such probabilistic information might be incorporated into a given model. As with other parts of the analysis, the specific methods used and the level of detail modeled will vary from analysis to analysis depending on such factors as the availability of data, the range of decision alternatives, and the importance of individual MOEs (i.e., the level of detail may be different for different measures). This appendix addresses major issues in the use of probability distributions in evaluative models, but it does not provide a complete treatment of either probability theory or decision analysis. The reader is referred to standard textbooks on the subjects for more detailed information, such as Meyer (1970), Raiffa (1969), Brown, Kahr, and Peterson (1974), Keeney and Raiffa (1976), and Wagner (1970).

For many evaluations, it will be appropriate to use the expected value (mean) of a probability distribution on a measure to characterize impact. For example, the expected cost to a containerized cargo carrier given an accident may be an appropriate measure of the entire distribution of cost that might occur for this user in the event of an accident. Whether or not the mean is an appropriate summary descriptor of the distribution depends on the attitude toward risk that is appropriate to reflect in the analysis. The mean is an appropriate summary measure only if a "risk-neutral" attitude is appropriate. Loosely speaking, this means that the decision maker or decision-making organization is indifferent between being in a situation with risky consequences and being in a situation that has the mean consequence for sure. The mean is also appropriate only if the value scale is linear, for example, if each incremental dollar is worth the same. These two conditions derive from the fact that the expected value of a non-linear function of random variables is usually different from the same function of expectations, which is known as the fallacy of averages. (Other summary measures, such as the median or mode,

are strictly appropriate under even more difficult and implausible restrictions.)

There are three major ways that attitude toward risk taking might be incorporated into an analysis. These methods correspond to the major ways for conceptualizing the notion of "risk." In all three methods, risk is treated as an element of value and a "riskier" alternative is valued differently from a less risky alternative. The three methods treat risk as a deterministic feature of a value scale, as a probabilistic feature of a utility scale, or as an attribute in and of itself.

Consider the first two conceptualizations, probabilistic and deterministic. A probabilistic approach to risk could be accommodated in the method using either utility analysis or certainty equivalents. The theoretical basis for an analytic utility function is given by Pratt (1964) and its details are described in Brown, Kahr, and Peterson (1974). The deterministic treatment of risk might be characterized by a value that increases nonlinearly with an underlying measure (such as dollars or number of deaths). For example, this implies that the value of a dollar (or death) is not constant. This interpretation of risk attitude could be incorporated into the models through a nonlinear value function as discussed in Appendix B and illustrated in Section 5.2.6. Consider, for example, Figure C.1 which shows the possible functional relationships between number of deaths and societal cost (deterministic interpretation) or utility (probabilistic interpretation).

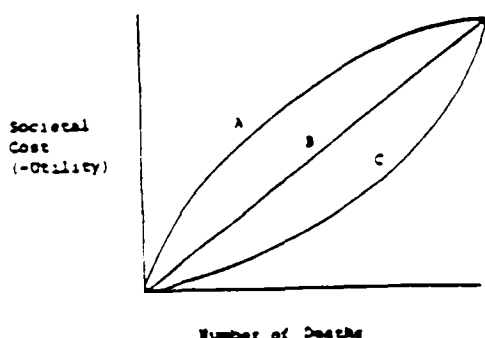

Societal Cost (Deterministic)

- A. Cost per death decreases as number of deaths increases
- B. Cost per death is constant
- C. Cost per death increases as number of deaths increases

Utility (Probabilistic)

- Risk seeking: $U(\bar{N}) < EU(\bar{N})$
- Risk neutral: $U(\bar{N}) = EU(\bar{N})$
- Risk averse: $U(\bar{N}) > EU(\bar{N})$

Figure C.1

The deterministic interpretation of curve A is that the cost per death decreases as the number of deaths increases, for example, 100 deaths has a societal cost that is less than 100 times that of one death. If curve A had been determined from answers to probabilistic questions, as discussed below, then it would represent a risk-seeking utility function. A risk-seeking utility function has the feature that, in a situation involving an uncertain number of deaths, the utility of the expected number of deaths is less than the expected utility for the uncertain number of deaths. (Note that the curve shows decreasing utility on the vertical axis.) Curve B's deterministic interpretation is that the cost per death is constant; societal cost increases linearly with number of deaths. For example, 100 early deaths is 100 times as costly to society as one death. Curve B's probabilistic interpretation is that of risk neutrality; the utility of an expected number of deaths is equal to the expected utility of the uncertain number. Curve C's deterministic interpretation is that the cost per death increases as the number of deaths increases. For example, 100 deaths has a societal cost of greater than 100 times the societal cost of one death. Curve C is a risk-averse utility function. The utility of an expected number of deaths is greater than the expected utility of the uncertain number.

Figure C.2 illustrates the probabilistic interpretation of risk attitude. Example 1 shows a choice between an alternative that would result in one death for certain and another one that would result in 100 deaths with a probability of .01 and in no deaths with a probability of .99. Notice that both alternatives result in an expected (mean) number of deaths equal to one. When faced with this choice, a risk-averse individual or group (curve C) prefers the alternative that results in one death for certain, other things, like costs, being equal. A risk-neutral individual (curve B) is indifferent between the alternatives, and a risk-seeking individual (curve A) prefers the one that results in the uncertain event. (Of course, all individuals would prefer to take neither, but this choice is not available.)

Example 1

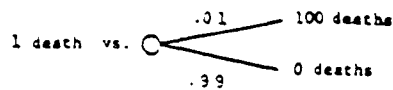

Example 2

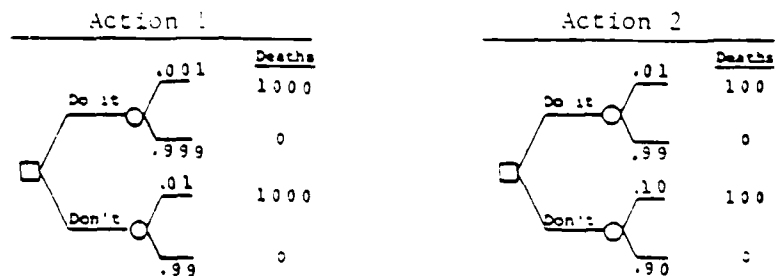

Figure C.2: Probabilistic Interpretation of Risk Attitude

Example 2 shows two actions that might affect safety, Action 1 and Action 2. Action 1 reduces the chance of a consequence of 1,000 deaths from .01 to .001. Action 2 reduces the chance of a consequence of 100 deaths from .10 to .01. Thus, each issue has the effect of reducing the expected (mean) number of deaths from 10 to 1, an expected reduction of 9 deaths. Action 1 is preferred by an individual whose utility for 1,000 deaths is less than 10 times the utility for 100 deaths. This is the case for the risk-averse individual whose utility function is like curve C of Figure C.1 (remember utility decreases in the vertical direction). A risk-neutral individual (curve B) is indifferent between the two actions. Action 2 is preferred by an individual whose utility for 1,000 deaths is greater than 10 times the utility for 100 deaths. This is the case for the risk-seeking individual, whose utility function is like curve A.

A third approach to incorporating risk perception and attitude into the method is to treat attitudes toward risk separately from the function of handling the value of outcomes or uncertainty. In this conceptualization, risk is a characteristic of an outcome that need not relate functionally to other consequences (such as death, injury, or property destruction). For example, Slovic, *et al.* (1980) concluded, from a study of eighteen characteristics of risk, that the catastrophic potential of an accident (e.g., an LNG tanker explosion) is a major determinant of the public's perception of, and attitude toward, a risk of a technology. This could be accommodated in the methodology by adding a measure to the MOEs to account for the extent to which the safety

issue addresses accidents with catastrophic potential. This method of dealing with risk perception and attitude could be handled especially well with the technique of multiattribute utility analysis described in Appendix B.

To incorporate any of these approaches to risk perception and attitude into the methodology requires answers to two questions: What is an appropriate risk function? and, Who should decide what is appropriate? Stokey and Zeckhauser (1978, p. 252) recommend that:

"...government policy makers should be relatively risk neutral unless either (1) the projects are so massive in scope that their risks are still consequential even though spread across the population, or (2) the projects concentrate benefits and costs on particular groups that are therefore strongly affected."

With very few exceptions, SRA resource decisions appear not to be of either nature. However, this will be determined better in Tasks 2-8 when the method is applied to SRA resource decision areas. If risk neutrality continues to appear appropriate, then means of probability distributions can be used, and such use will simplify both the assessment of impacts and the evaluation of alternatives.

If risk neutrality proves inappropriate, then the mean value is not an appropriate summary of a distribution. There are four methods that might then be used. First, the entire distribution of impact could be used. However, this will result in an unwieldy analysis except in the special case where one alternative being evaluated stochastically dominates another (Keeney and Raiffa, 1976, pp. 134-135). Second, expected values could be adjusted by "risk premiums" (which are positive for risk-averse decision makers, negative for risk-seeking ones). For example, in each case, an assessment would be made of how much of a premium the decision maker would be willing to pay to receive a certain impact rather than the uncertain distribution. This assessment is difficult to make precisely, but is often easy to approximate. In cases where an approximation will suffice, this is an excellent method. Third, a distribution might be represented by two parameters, such as mean and standard deviation or mean and central 90% credible interval. Together, the two parameters represent both central tendency and dispersion. A function would then be assessed to adjust the expected value based on the measure of

dispersion (standard deviation or credible interval). Risk aversion would be modeled by a larger reduction in expected value for larger dispersions. This method will work well in many applications. Fourth, a utility function could be assessed and used to calculate the expected utility of a distribution. This involves determining functions of the form illustrated in Figure C.1 generally by asking hypothetical "reference gamble" questions (Raiffa, 1969). Although the utility function approach is the soundest approach theoretically, it is the most difficult to apply in practice because of the difficulty in determining the utility function from responses to "reference gamble" questions. This method is justified only for the most important measures when a good deal of uncertainty exists and risk attitude is markedly risk averse or risk seeking. Depending on the degree of risk aversion or risk seeking, the extent of uncertainty, and importance of the MOE involved, any of the four methods might be used in the Resource Management Tool (RMT).

APPENDIX D: COST-EFFECTIVENESS TECHNIQUES FOR RESOURCE MANAGEMENT

D.1 Introduction

Cost-effectiveness techniques are appropriate for optimizing the allocation of resource (such as cost, personnel, cutters, etc.). The standard paradigm of the cost-effectiveness technique is to rank each candidate system based on its benefit-to-cost ratio. (The term "cost" is used generically to refer to any resource.) Then, if candidates are selected in order of this ratio until the budget is expended, the chosen ones will provide the greatest overall benefit that can be obtained within the budget. (This solution is approximate if the selection does not use the entire budget.) The benefit part of the ratio might be determined by a multiattribute utility analysis. Cost could be determined by an examination of budgeted or forecast cost.

A variant of this standard paradigm appears to be more useful to the types of resource management problem faced by the Coast Guard. It may be appropriate to consider alternatives formed by applying different levels of resource to different program elements. That is, decisions might be made as to the level of resource of each component rather than which programs to choose. A straightforward variation of the method handles this possibility by assessing incremental benefits and costs for different levels. This variant involves the following steps.

Step 1: Describe Programs and Assess Costs. The first step in the method is to describe each potential area for funding and estimate its costs. Descriptions should be as complete and concise as possible to aid in the assessment of both costs and benefits. In addition, to the extent possible, programs should be described in such a way that each is independent of the rest. This may lead to a combination, for purposes of this analysis, of otherwise separate programs. There are two important components of independence, technique independence and preferential independence, and the program descriptions should exhibit both. Technical independence is the ability to conduct a program separate from another. A project is preferentially independent if its value does not depend on the other projects. Dependencies are

accommodated in the analysis by representing the programs as different levels of a single program.

Funding areas that make up the resource mix for the SRA program include routine service demand policy, platform capabilities (configurations), response criteria policies, servicing alternatives, staffing levels, and multi-mission effects. These can each be described in terms of "levels" at which the area can be funded. A notional model structure is shown in Figure D.1.

Service Demand	Policy A	Policy B	Policy C	Policy D	Policy E
Platform Capabilities	Config. A	Config. B	Config. C	Config. D	
Response Criteria	Policy X	Policy Y	Policy Z		
Staffing	Level 1	Level 2	Level 3		
Multi-Mission Roles	Role 1	Role 2	Role 3	Role 4	

Figure D.1: Funding Areas and Levels

A resource mix is defined by selecting one "level" on each funding area. For example, a mix could include a service policy of replacing buoy batteries every 2 years, using service-life extended WLB class buoy tenders, requiring 12-hour response time for minor discrepancies, staffing at current levels, and allowing multi-mission training 3 days a month. Even in this small example, there are hundreds of combinations of levels, each representing a potential mix.

As part of this approach, costs must be determined for each level of each funding area.

Step 2: Describe Benefits. The second step in the method is to describe the benefit that the Coast Guard expects to obtain from each level of each area. The MOEs developed in Task 1 will provide the measure of benefit, while the relationships developed in Tasks 2 through 8 will provide the calculation mechanism. Both quantitative and qualitative MOEs will be used.

Benefit contributions might be assessed in a number of ways depending on the nature of the measure (e.g., whether or not it is easily characterized in natural units) and the availability of data and expert judgment. Sources of information include statistical data, analytic or simulation models, field experience and judgment. More detailed information on the assessment of benefits is contained in Appendix B.

Next, assessments are needed of how a program's value changes as the level of resource changes. Two patterns of benefit changes are most common, a decreasing incremental contribution and a linear contribution. These patterns are illustrated in Figure D.2. With decreasing incremental benefit, each higher level of funding adds less than a proportional benefit. With linear increased benefit, each higher funding level adds proportionately the same benefit. Another pattern is sometimes encountered which might be called a "dip". With this pattern, some lower funding levels provide proportionately less benefit than higher levels. This pattern is sometimes encountered when "placeholder" levels are proposed or when a funding area consists of complementary parts.

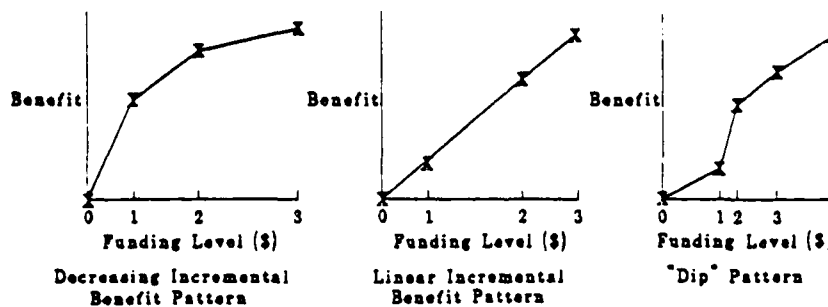

Figure D.2: Benefit Patterns

Step 3: Determine Cost-Effective Budget Allocations. The third step of the method is to use the assessed benefit contributions and costs to determine cost-effective allocations, those uses of resources that maximize benefit within budgets. Each of the possible mixes has a cost and benefit associated with it. When all mixes are plotted on cost-benefit axes, the result is as shown in Figure D.3. Note that for any given level of expenditure, maximum

benefit is achieved by selecting a mix along the frontier of the plotted area. The cost-effective order of increasing the levels of programs is determined by ordering the transitions between levels on the basis of their benefit-to-cost ratios. The transition with the highest ratio is first, the transition with the second highest ratio is second, and so forth. Choosing to fund the projects in this order ensures maximum benefit within a budget (Everett, 1967). (This statement is approximate if the allocation does not use the entire budget.) Although these calculations can be rather tedious, they lend themselves to computerization.

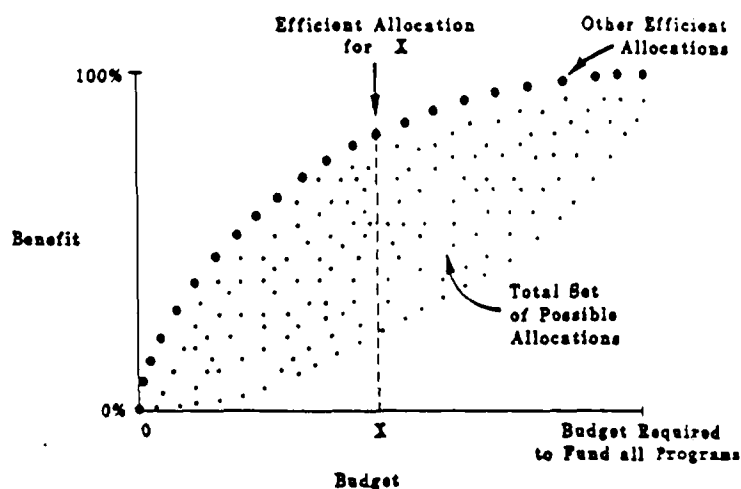

Figure D.3: Efficient Allocations

Step 4: Sensitivity Analysis. Often, components of the analysis, cost and benefit assessments, are not known precisely. In addition, some assessments are usually made judgmentally and are subject to disagreement. These conditions make it especially important to investigate the sensitivity of the results to variations in the input.

Several inputs might be varied: cost assessments, benefit assessments between programs, or benefit pattern assessments within programs. Each input influences the incremental benefit-to-cost ratio of transitions and thus influences the order of transitions and cost-effective programs at different budget levels. Sensitivity analyses might be conducted by varying groups of parameters and re-calculating results or by selectively investigating the ex-

tent that certain inputs would need to change in order to give a different result. An important set of sensitivity analyses to conduct is one that spans the range of opinions where there are disagreements. Often, disagreements are resolved when a sensitivity analysis shows that they make no difference in the final conclusion.

Another type of sensitivity analysis is provided by examining trial allocations or sets of funding levels for all projects. Comparing the benefit and cost of the trial allocations with that provided by cost-effective allocations can indicate areas for revision if the trial allocation is not efficient.

D.2 Example Problem

The following is a description of an application of the method to prioritize program funding alternatives as a basis for a one-year budget plan. The description is hypothetical in that the descriptions of attributes and programs are disguised. However, the analysis is based on an actual application of the method to aid in budget planning for a division of the Defense Nuclear Agency (Ulvila and Chinnis, 1983).

Table D.1 is a summary display of program scores on multiple attributes and weights for the attributes. In the example, twenty-two programs (labeled 1-22) were considered. Each program was evaluated on its contribution to each of eleven attributes (shown as "obj. a" through "obj. k"). These correspond to the attributes in an MAU analysis. Some attributes were indexed on objective, quantitative scales with natural units, and some were intangible or strictly judgmental. In cases where scales were strictly judgmental, a relative scale was developed and scores of 0 and 100 were defined by the programs. This was the case for objectives a, b, c, e, and f. The other objectives (d, g, h, i, j, and k) were scaled with natural units (e.g., dollars, months) and the 0 to 100 ranges were defined in those units. The programs do not necessarily exhibit scores that cover the full 0 to 100 ranges on those scales.

The weights shown correspond to tradeoffs across attributes. These weights represent the relative importance of the 0 to 100 point variations on

Table D.1: Program Scores and Attribute Weights

	a	b	c	d	e	f	g	h	i	j	k	"TARGET LEVEL"	COST	BENEFIT
weights:	0.12	0.08	0.14	0.14	0.12	0.08	0.08	0.06	0.06	0.06	0.04	0.10		
1)program 1	0	100	80	50	0	100	75	60	30	30	30	70	700	53
2)program 2	0	100	30	60	0	25	75	10	50	45	75	75	1000	41
3)program 3	0	100	90	55	20	50	50	30	50	75	60	60	800	51
4)program 4	0	100	20	90	0	90	85	40	50	80	75	75	800	52
5)program 5	0	100	50	50	0	75	75	60	50	50	65	65	1000	48
6)program 6	92	0	25	50	0	60	75	20	25	75	25	25	700	40
7)program 7	0	20	80	0	0	100	20	100	20	40	0	0	350	31
8)program 8	4	20	50	75	0	90	20	70	40	90	20	20	600	40
9)program 9	92	0	20	40	75	90	60	20	30	90	30	30	700	49
10)program 10	92	0	20	80	100	100	60	20	30	80	25	25	400	57
11)program 11	1	0	20	60	0	90	25	20	0	100	25	25	500	28
12)program 12	12	50	0	30	0	90	25	30	25	80	25	25	800	27
13)program 13	0	50	10	60	0	100	25	10	10	100	25	25	500	31
14)program 14	1	0	10	40	0	90	50	20	20	50	10	10	350	23
15)program 15	12	50	100	40	100	40	50	90	30	80	65	65	1000	60
16)program 16	2	30	10	30	0	75	50	50	30	90	75	75	600	33
17)program 17	100	20	30	60	20	90	50	40	20	50	75	75	300	52
18)program 18	0	20	80	0	0	100	50	80	0	100	0	0	350	33
19)program 19	11	0	20	60	0	90	35	25	0	100	50	50	275	32
20)program 20	1	20	10	65	0	35	60	15	50	100	50	50	300	32
21)program 21	92	20	30	40	0	0	75	10	90	75	40	40	600	41
22)program 22	1	10	0	40	0	100	0	30	30	60	0	0	300	20

Note: Weights and Benefits shown are rounded.

the objectives. The weights show, for example, that the 100 point variations on objectives c and d were judged to be equally most important. The 100 point variations on objectives a and e were next in importance, and each was about 85% (.12/.14) as important as objective c or d.

For each program, a score of 0 to 100 is shown against each attribute; these are the assessed contributions of "target level" programs, those levels with the "target level" costs shown. (Rationales for the scores were recorded where appropriate.) The "BENEFIT" column shows the overall weighted-average contribution of the "target level" program to the attributes. For example, BENEFIT of Program 2 is calculated as:

$$(.12)(0) + (.08)(100) + (.14)(30) + (.14)(60) + (.12)(0) + (.08)(25) + (.08)(75) + (.06)(10) + (.06)(50) + (.04)(45) + (.10)(75) = 41$$

(both weights and benefits are rounded in Table D.1).

Table D.2 shows the costs and benefits of different levels of funding for each program. For example, Program 1 is shown with three possible levels of funding, \$250,000, \$500,000, and \$700,000. The relative overall benefits of the three levels were assessed to be 55%, 80%, and 100% of the "target level" (Level 3). This gives a benefit pattern for Program 1 as shown in Figure D.4.

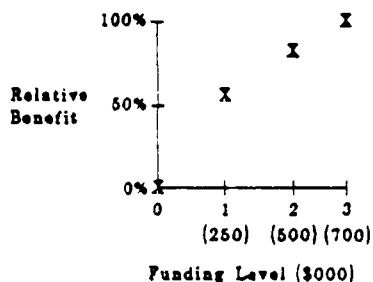

Figure D.4: Benefit Pattern for Program 1

The cost-effectiveness priority of the funding levels is determined by multiplying the relative benefit increases shown in Table D.2 by the ap-

Table D.2: Program Funding Levels

		Level			
		1	2	3	4
Program 1	Relative Benefit (%)	55	80	100	
	Cost (\$000)	250	500	700*	
Program 2	Relative Benefit (%)	37	62	87	100
	Cost (\$000)	250	500	750	1000*
Program 3	Relative Benefit (%)	25	50	100	
	Cost (\$000)	200	400	800*	
Program 4	Relative Benefit (%)	50	75	100	
	Cost (\$000)	400	600	800*	
Program 5	Relative Benefit (%)	15	50	100	
	Cost (\$000)	250	500	1000*	
Program 6	Relative Benefit (%)	45	80	100	
	Cost (\$000)	200	500	700*	
Program 7	Relative Benefit (%)	40	67	100	
	Cost (\$000)	50	100	350*	
Program 8	Relative Benefit (%)	20	50	100	
	Cost (\$000)	100	200	600*	
Program 9	Relative Benefit (%)	17	50	100	
	Cost (\$000)	100	250	700*	
Program 10	Relative Benefit (%)	45	80	100	
	Cost (\$000)	150	300	400*	
Program 11	Relative Benefit (%)	12	55	100	
	Cost (\$000)	50	250	500*	
Program 12	Relative Benefit (%)	40	80	100	
	Cost (\$000)	300	600	800*	
Program 13	Relative Benefit (%)	20	50	100	
	Cost (\$000)	100	250	500*	
Program 14	Relative Benefit (%)	10	60	100	
	Cost (\$000)	50	200	350*	
Program 15	Relative Benefit (%)	30	60	100	
	Cost (\$000)	300	600	1000*	
Program 16	Relative Benefit (%)	25	75	100	
	Cost (\$000)	100	400	600*	
Program 17	Relative Benefit (%)	66	83	100	
	Cost (\$000)	50	100	300*	
Program 18	Relative Benefit (%)	47	77	100	
	Cost (\$000)	150	250	350*	
Program 19	Relative Benefit (%)	20	100		
	Cost (\$000)	100	275*		
Program 20	Relative Benefit (%)	50	100		
	Cost (\$000)	100	300*		
Program 21	Relative Benefit (%)	45	85	100	
	Cost (\$000)	250	500	600*	
Program 22	Relative Benefit (%)	80	100		
	Cost (\$000)	200	300*		

**Target level*

appropriate weighted-average BENEFIT of Table D.1 and then dividing the product by the cost increments of Table D.2. The multiplication places the incremental benefits on a common scale, and the division determines the cost effectiveness.

Table D.3 shows the cost-effectiveness prioritization, an ordering of all level changes in decreasing order of incremental benefit to incremental cost. In the illustration, the most cost-effective program, considering its contribution across the multiple objectives, is Level 1 of Program 17. This is followed by Level 1 of Program 7, Level 2 of Program 17, Level 1 of Program 10 and so forth. Numbers in Table D.3 are rounded. In cases where a "dip" pattern appears, the "dip" is inefficient and the benefit-to-cost ratio is calculated for the double-transition that spans the dip. For example, at order 8 Program 19's funding moves from Level 0 to Level 2, bypassing the dip at Level 1.

Table D.3 also shows the total weighted-average contribution to attributes ("Total Benefit") and total cost of following the cost-effective order. At any given level of total budget, the most cost-effective combination of project fundings is given by taking all of the changes indicated in the prioritization down to that level. For example, the cost-effective use of a total budget of 1125 (\$1,125,000 in the illustration) is to fund the first nine transitions in the order shown. This results in the following set of project fundings:

Program 1	Level 1	\$250,000
Program 7	Level 2	\$100,000
Program 10	Level 2	\$300,000
Program 17	Level 2	\$100,000
Program 19	Level 2	\$275,000
Program 20	Level 1	\$100,000
All Others	Level 0	

Notice that, because of the way that program levels were defined, this order accounts for synergies and dependencies among the programs. Also notice that Table D.3 shows 60 cost-effective combinations over the entire range of budget possibilities from \$50,000 to \$12,925,000. This contrasts sharply with the total number of possible funding combinations of:

Table D.3: Cost-Effective Prioritization

ORDER	PROGRAM	LEVEL CHANGE	BENEFIT CHANGE	COST CHANGE	TOTAL BENEFIT	TOTAL COST	BENEFIT / COST
1	17)program 17	0> 1	34	50	34	50	.68
2	7)program 7	0> 1	12	50	46	100	.24
3	17)program 17	1> 2	9	50	55	150	.18
4	10)program 10	0> 1	26	150	81	300	.17
5	7)program 7	1> 2	8	50	89	350	.16
6	20)program 20	0> 1	16	100	105	450	.16
7	10)program 10	1> 2	20	150	125	600	.13
8	19)program 19	0> 2	32	275	158	875	.12
9	1)program 1	0> 1	29	250	187	1125	.12
10	10)program 10	2> 3	11	100	198	1225	.11
11	18)program 18	0> 1	15	150	214	1375	.10
12	18)program 18	1> 2	10	100	224	1475	.10
13	9)program 9	0> 2	25	250	248	1725	.10
14	6)program 6	0> 1	18	200	266	1925	.09
15	16)program 16	0> 1	8	100	275	2025	.08
16	22)program 22	0> 1	16	200	291	2225	.08
17	20)program 20	1> 2	16	200	307	2425	.08
18	8)program 8	0> 1	8	100	315	2525	.08
19	8)program 8	1> 2	8	100	323	2625	.08
20	18)program 18	2> 3	8	100	330	2725	.08
21	21)program 21	0> 1	18	250	348	2975	.07
22	14)program 14	0> 2	14	200	362	3175	.07
23	11)program 11	0> 1	3	50	366	3225	.06
24	4)program 4	0> 1	26	400	392	3625	.06
25	4)program 4	1> 2	13	200	405	3825	.06
26	4)program 4	2> 3	13	200	418	4025	.06
27	21)program 21	1> 2	16	250	434	4275	.06
28	3)program 3	0> 1	13	200	447	4475	.06
29	3)program 3	1> 2	13	200	460	4675	.06
30	3)program 3	2> 3	26	400	486	5075	.06
31	14)program 14	2> 3	9	150	495	5225	.06
32	13)program 13	0> 1	6	100	501	5325	.06
33	13)program 13	1> 2	9	150	511	5475	.06
34	13)program 13	2> 3	15	250	526	5725	.06
35	21)program 21	2> 3	6	100	532	5825	.06
36	2)program 2	0> 1	15	250	547	6075	.06
37	15)program 15	0> 1	18	300	565	6375	.06
38	15)program 15	1> 2	18	300	583	6675	.06
39	15)program 15	2> 3	24	400	607	7075	.06
40	8)program 8	2> 3	24	400	631	7475	.06
41	11)program 11	1> 2	12	200	643	7675	.06
42	16)program 16	1> 2	17	300	660	7975	.06
43	9)program 9	2> 3	25	450	684	8425	.06
44	1)program 1	1> 2	13	250	697	8675	.05
45	1)program 1	2> 3	11	200	708	8875	.05
46	11)program 11	2> 3	12	250	720	9125	.05
47	5)program 5	0> 2	24	500	744	9625	.05
48	5)program 5	2> 3	24	500	768	10125	.05
49	6)program 6	1> 2	14	300	782	10425	.05
50	17)program 17	2> 3	9	200	791	10625	.04
51	16)program 16	2> 3	8	200	800	10825	.04
52	2)program 2	1> 2	10	250	810	11075	.04
53	2)program 2	2> 3	10	250	820	11325	.04
54	7)program 7	2> 3	10	250	830	11575	.04
55	22)program 22	1> 2	4	100	834	11675	.04
56	6)program 6	2> 3	8	200	842	11875	.04
57	12)program 12	0> 1	11	300	853	12175	.04
58	12)program 12	1> 2	11	300	864	12475	.04
59	12)program 12	2> 3	5	200	869	12675	.03
60	2)program 2	3> 4	5	250	875	12925	.02

Note: Numbers in this table are rounded.

$$(3)^3 \times (4)^{18} \times (5) = 9,277,000,000.$$

Figure D.5 shows a plot of the percentage contributions and costs of cost-effective program combinations. For example, Table D.3 shows that after 21 transitions, a total benefit of 348 is attained at a total cost of \$2,975,000. This is plotted as point A on Figure D.5 since 348 is 40% of the total benefit attainable ($348/875 = .40$). Similarly, after 31 transitions, 57% ($495/875$) of the benefit is attained at a cost of \$5,225,000, which is plotted as point B.

D.3 Use of the Results

Results from applying the method described above can be used in many phases of resource management. The initial development of the analysis brings a focus to the whole resource planning process by delineating goals, objectives, and tradeoffs and by framing the contributions of the programs in terms of those goals and objectives. Exercising the analysis through sensitivity analyses can help to resolve disagreements. Even disagreements that are not resolved are at least clarified as to their causes (e.g., disagreements over facts or opinions).

A continuing use of the analysis can aid in adjusting the plan in responding to problems or opportunities. Budget adjustments and reprogrammings are an expected part of any resource planning process. The tools described above are especially well-suited to provide rapid responses to budget changes that are also based on a comprehensive consideration of alternatives. Since the approach generates and compares a wide range of possibilities in each program area, and a full range of cost-effective allocations, a budget change can be responded to by moving up the priority list of cost-effective allocations to respond to a budget cut or down the list to respond to an increase. The effects of these changes are already analyzed with respect to the contributions to all attributes.

New project opportunities that become available midway in the budget cycle can be readily compared with projects that have been analyzed. A new

PLOT OF TOTAL BENEFIT VS. TOTAL COST FOR EFFICIENT ALLOCATIONS

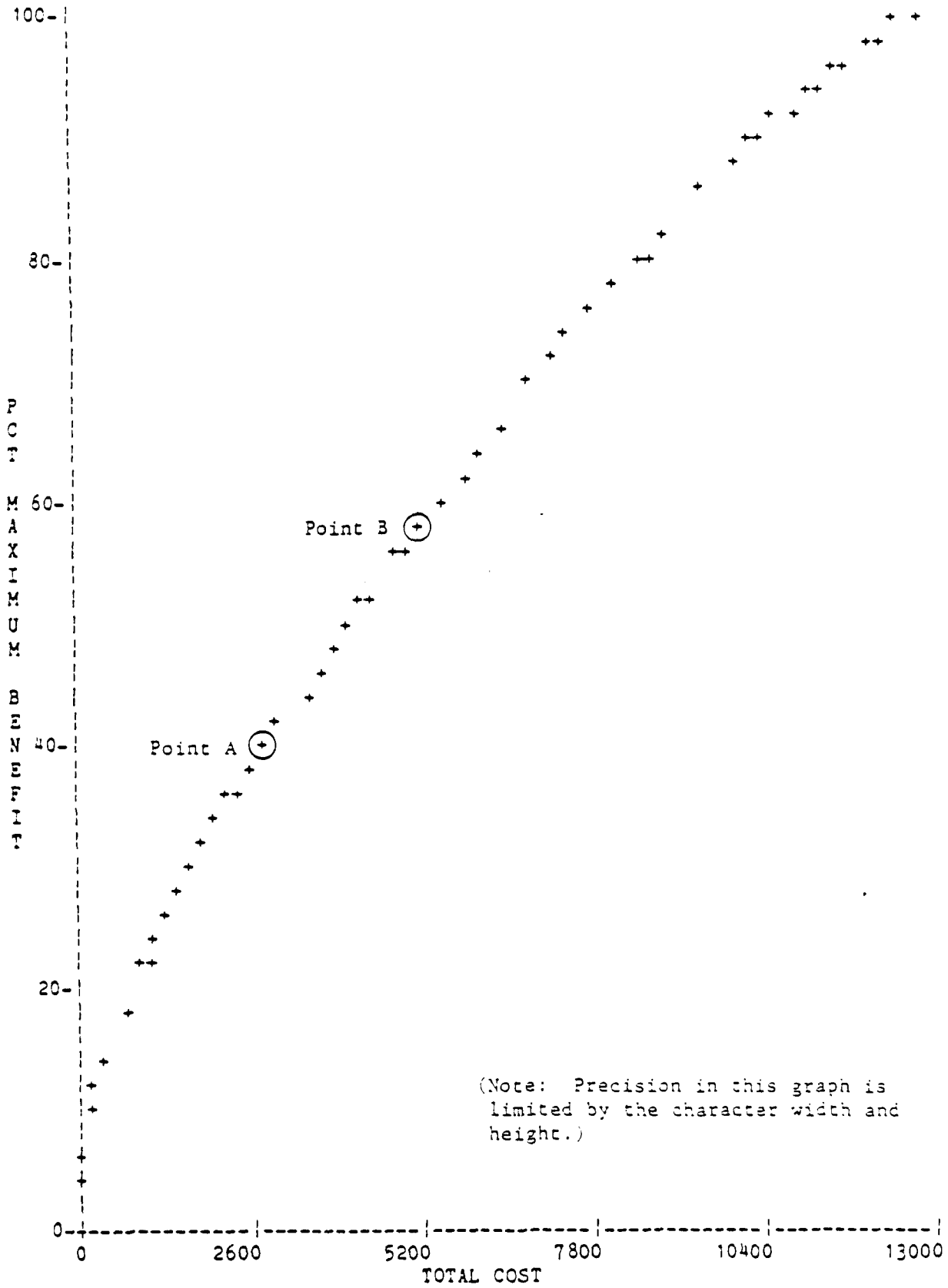

Figure D.5: Plot of Cost-Effective Priority

program is simply added as a new line-item or as a new level in an existing project. A comprehensive comparison of this program's opportunities with all others is provided with just an assessment of the new project against the attributes of value.

APPENDIX E: USE OF JUDGMENTAL ASSESSMENT TECHNIQUES

As mentioned in Appendix B, judgment is often required in the assessment of MOEs, either to supplement incomplete data or to substitute for non-existent data. Despite the application of careful elicitation techniques, the use of expert judgment for information is fraught with potential pitfalls, especially when it comes to eliciting probabilities and to eliciting information from groups. In this section, we describe some of these problems and some innovative techniques for overcoming them.

E.1 Probability Elicitation

Expert judgment will likely be the source of key pieces of information for a number of uncertainties modeled in some analyses. It is critical, then, that the methodology provide an accurate way to translate that judgment into a defensible, mathematical statement. An obvious way to translate an opinion into a probability is to simply ask the expert for a probability statement. However, research in the field of mathematical psychology has shown that the quality of probability judgment is sensitive to many factors and that probability assessors are commonly affected by many biases. For example, von Winterfeldt (1980) identified seventeen cognitive limitations that affect an individual's ability to provide accurate estimates of probability including:

- **Overconfidence.** A person is usually more confident of his assessments than his track record justifies;
- **Availability.** People tend to overestimate the likelihood of events that are "available," i.e., those for which relevant examples are easy to recall, and underestimate those for which recall is difficult;
- **Anchoring with insufficient adjustment.** People tend to estimate quantities by picking a readily available point and then making adjustments or error bounds; adjustments are usually too small.
- **Rounding.** People tend to use round numbers, especially to avoid the appearance of precision. They often use only a limited number of values to represent all judgments, forcing some events to be inadvertently regarded as the same.
- **Use of the whole scale.** People tend to spread their assessments over the entire range of the scale even if they should be more tightly grouped.

Fortunately, both experimental and applied work has been done on this problem. Based on experience and testing, the following guidelines have evolved for helping individuals make better judgmental assessments of probabilities. These can be applied to particular problems in the assessment of uncertainties.

- (1) Motivate the assessor. There is a problem in getting information from individuals if they are not motivated to provide the best assessments that they can. We will attempt to encourage such motivation both by taking the elicitation seriously and by showing the experts that their opinions are important.
- (2) Provide the experts with experience in probabilistic thinking. For those experts who are unfamiliar with estimating probabilities, we will use a series of simple exercises (which we have used successfully with executives and engineers) to promote familiarity with the ideas of probability. This may include experiences with such devices as standard reference gambles and probability wheels.
- (3) Carefully define what is being estimated. The more individual latitude that is allowed in defining the event or other parameter being assessed, the greater the error introduced.
- (4) Use several people to provide assessments. The collective ability of groups in providing assessments is generally greater than that of individuals, especially if different group members have different information. Effective group elicitation techniques are discussed below.
- (5) Use consistency checks. It is usually possible to get the same information by asking different questions. For example, probabilities can be assessed by asking for odds, relative likelihoods, or probability numbers. Seeking and resolving such inconsistencies improves the quality of assessments. This may also involve the use of graphical aids such as log-odds probability charts.
- (6) Point out common biases. If assessors are aware of commonly observed biases, such as overconfidence, availability bias, anchoring with insufficient adjustment, rounding, and use of the whole scale, they can more readily recognize their susceptibility to them and adjust their assessments accordingly.

E.2 Group Elicitation

Combining the judgments of several experts is often the best way to ensure the highest quality of assessments. This is especially true when different experts have different information, for example, when different people

are experts about different aspects of the problem. However, whenever individuals are combined into groups, group behavioral pressures affect the actions and responses of individuals. A number of methods have been devised to take advantage of the positive aspects of group behavior while minimizing the negative aspects. The range of group assessment techniques is characterized by three basic approaches: consensus groups, the nominal group technique, and the Delphi method (see Seaver, 1976).

The consensus group approach involves open group discussions aimed at producing a consensus view. Since a consensus group involves open, face-to-face discussions among group members, it is most susceptible to problems arising out of group dynamics. It also provides the opportunity for the greatest advantages from the group, since interactions are least constrained. The consensus group approach is most effective when the group members are motivated to cooperate to produce the best assessment. However, a skilled facilitator or analyst can often overcome problems introduced by combative group members. The facilitator controls the discussion, keeping it focused on the problem at hand, and keeps individuals from unduly monopolizing the discussion. A minor variation on the consensus group method is for an individual, such as an analyst, to solicit judgments from a limited number of respondents, develop an analysis from these judgments, and then hold a group meeting where this "strawman" analysis is reviewed and refined. We have found this variation to be especially effective in our experience. Of course, either version of the consensus group technique requires a group meeting, which might not always be possible.

At the other extreme from the consensus group technique are the mechanical methods for controlling group processes, such as the Delphi method. The Delphi method begins by having individuals give their opinions individually. Each respondent is then shown all responses but is not told who provided which response. Respondents are then allowed to revise their opinions. After the second round, the responses are averaged or the process is repeated one or more times before averaging. A key characteristic of the Delphi method is that individual group members remain anonymous. The Delphi method is most appropriate if the group is likely to be so combative that a small number of group members would inappropriately dominate a group meeting. It is also ap-

propriate if some group members could be expected to intimidate others (either intentionally or unintentionally) so that they do not give accurate responses. An added condition is that group members could be expected to have essentially the same information available for making the assessment, so that the exchanges that would result from group discussions could not be expected to contribute significantly to any individual's information base.

The nominal group technique is in-between the Delphi method and consensus groups. The nominal group technique involves the following procedure: individuals provide assessments silently in the presence of the group; all individual assessments are presented to the group without discussion; the group discusses each judgment for clarification, elaboration, and evaluation; individuals reconsider their judgments and provide new assessments; the process is repeated; and any remaining differences are resolved mathematically (e.g., by averaging the final responses). This method differs from Delphi in that responses are not anonymous and group members can interact. It differs from consensus groups in that the interactions are more controlled and all assessments are made individually. The nominal group technique is most appropriate with a combative group whose members have access to different sources of information (the group discussion allows for exchange of this information). In summarizing the results of the psychological research on these methods, Seaver (1976) concluded that:

Delphi, the most widely used of the behavioral methods, is also the most controversial. Experiments at Rand obtained generally favorable results, while other experimenters have been less enthusiastic. Other research has shown that actual face-to-face discussions improve results, contrary to a hypothesis underlying the development of the Delphi method. The nominal group method had proved to be a particularly successful approach. In direct comparisons between the nominal group method and the Delphi method, the nominal group has always done as well as Delphi and in most cases better.

Another way to combine assessments of individuals, of course, is to simply gather the individual estimates and combine them using some mathematical procedure (such as averaging). This avoids any group processes. Seaver (1976) reviewed the research on mathematical procedures and found, for example, that averaging the assessments of individuals produced improvements

over individual assessments. He also found, however, that group methods produced better results than purely mathematical combinations.

APPENDIX F: A BUOY TENDER FOR PUGET SOUND

The following data comprise the complete numerical analysis used in the illustrative example in Section 5.2. The data used in the example was developed by DSC and PharoLogic staff members, working together, to illustrate various techniques that may be applied to the development and use of an SRA Resource Management Tool. The data format is that of an envisioned computerized multiattribute utility model to be developed for the Coast Guard. There are two sections to the data.

Section 1 is a summary of all the weights and scores used in the analysis. Each node is indicated by an outline code number which corresponds to the measure of effectiveness number provided in the detailed description of the MOE in Section 4.3, except that the outline code number has an additional "1" in front of it. This additional "1" merely provides a code number for the overall analysis, including costs and benefits. The node outline code number is followed by a node "path" descriptor which gives a descending list of the names of each level category in the structure (see Figure 4.1) from "Overall" to the name of the node itself. The "greater than" character (>) means that the node to the left of the character is higher in the structure than the node to the right of the character. The subnodes at any particular node are listed underneath the outline code and path descriptor. The "*" or "u" after the subnode name indicate a bottom level subnode, which is a measure of effectiveness (MOE). The "*" means that the score for the MOE was assessed directly, while the "u" means that the MOE score was derived from a utility curve. After each subnode, the table lists its local weight (WT), the scores for each alternative (A through G), and its cumulative weight (CUMWT). The local weight is its weight relative to the other subnodes of that particular node, while the cumulative weight is its weight relative to all the subnodes at that level of the structure. The COMBINED value below each alternative is the sum of the weighted scores of the subnodes. Section 2 is a summary of the rationales used to generate the numerical analysis. In some cases, dollar figures were hypothesized for use in the example, while in other cases only a qualitative description was created. The node outline number and path descriptor for each node are the same as described above. The LATEST RECORDED SCORES are provided for each MOE which was directly assessed, while the LATEST

RECORDED VALUES are provided for each MOE which was assessed using a utility curve. The LATEST RECORDED WEIGHT is provided for all higher level nodes.

1 Overall

ATTRIBUTE	WT	A	B	C	D	E	F	G	CUMWT
1) Benefits	.50	42	51	39	69	35	68	86	.500
2) Costs	.50	86	90	68	87	59	77	12	.500
COMBINED		64	71	54	78	47	72	49	1.000

1 1 Overall>Benefits

ATTRIBUTE	WT	A	B	C	D	E	F	G	CUMWT
1) Safety	.49	54	57	33	70	31	76	96	.245
2) Timeliness	.11	0	41	33	91	19	91	100	.055
3) Other Ben	.40	38	48	48	62	44	52	71	.200
COMBINED		42	51	39	69	35	68	86	.500

1 1 1 Overall>Benefits>Safety

ATTRIBUTE	WT	A	B	C	D	E	F	G	CUMWT
1) Economic	.47	52	54	31	72	16	80	95	.115
2) Per Safety	.53	55	60	35	69	44	72	97	.130
COMBINED		54	57	33	70	31	76	96	.245

1 1 1 1 Overall>Benefits>Safety>Economic

ATTRIBUTE	WT	A	B	C	D	E	F	G	CUMWT
1) Commercial u	.78	50	53	30	74	17	79	94	.090
2) Recreation u	.05	29	64	0	29	52	29	100	.006
3) Government u	.14	74	54	54	69	0	100	95	.016
4) Gen Public u	.03	55	55	0	100	0	100	100	.003
COMBINED		52	54	31	72	16	80	95	.115

1 1 1 2 Overall>Benefits>Safety>PerSafety

ATTRIBUTE	WT	A	B	C	D	E	F	G	CUMWT
1) Commercial u	.54	42	45	55	78	55	82	94	.070
2) Recreation u	.23	53	68	0	53	61	53	100	.030
3) Government u	.21	94	89	25	61	0	67	100	.027
4) Gen Public u	.02	40	40	0	100	0	100	100	.003
COMBINED		55	60	35	69	44	72	97	.130

1 1 2 Overall>Benefits>Timeliness

ATTRIBUTE	WT	A	B	C	D	E	F	G	CUMWT
1) Ship-reltd u	.62	0	54	54	95	31	92	100	.034
2) Consigner u	.38	0	20	0	85	0	90	100	.021
COMBINED		0	41	33	91	19	91	100	.055

1 1 3 Overall>Benefits>OtherBen

ATTRIBUTE	WT	A	B	C	D	E	F	G	CUMWT
1) Mariner	.25	15	15	0	90	0	90	100	.050
2) USCG Int	.50	45	59	60	46	51	25	61	.100
3) Other Gov	.15	10	33	55	45	55	45	100	.030
4) Public Int	.10	100	100	100	100	100	100	0	.020
COMBINED		38	48	48	62	44	52	71	.200

1 1 3 1 Overall>Benefits>OtherBen>Mariner

ATTRIBUTE	WT	A	B	C	D	E	F	G	CUMWT
1) Non-Accid *	.00	0	0	0	0	0	0	0	.000
2) User Sat	*1.00	15	15	0	90	0	90	100	.050
COMBINED		15	15	0	90	0	90	100	.050

1 1 3 2 Overall>Benefits>OtherBen>USCGInt

ATTRIBUTE	WT	A	B	C	D	E	F	G	CUMWT
1) Multimisn *	.30	10	25	0	50	0	50	100	.030

2) Org Impact *	.60	70	85	100	35	85	0	35	.060
3) Stnd Meas *	.10	0	0	0	100	0	100	100	.010
COMBINED		45	59	60	46	51	25	61	.100

1 1 3 3 Overall>Benefits>OtherBen>OtherGov

ATTRIBUTE	WT	A	B	C	D	E	F	G	CUMWT
1) Internatnl *	.10	100	100	100	0	100	0	100	.003
2) Federal *	.00	0	0	0	0	0	0	0	.000
3) State/Locl *	.90	0	25	50	50	50	50	100	.027
COMBINED		10	33	55	45	55	45	100	.030

1 1 3 4 Overall>Benefits>OtherBen>PublicInt

ATTRIBUTE	WT	A	B	C	D	E	F	G	CUMWT
1) Economy	*1.00	100	100	100	100	100	100	0	.020
2) Environmnt *	.00	0	0	0	0	0	0	0	.000
3) Historic *	.00	0	0	0	0	0	0	0	.000
COMBINED		100	100	100	100	100	100	0	.020

1 2 Overall>Costs

ATTRIBUTE	WT	A	B	C	D	E	F	G	CUMWT
1) USCG Costs	.60	89	92	81	100	78	95	0	.300
2) Other Gov	.40	81	88	49	68	31	50	30	.200
COMBINED		86	90	68	87	59	77	12	.500

1 2 1 Overall>Costs>USCGCosts

ATTRIBUTE	WT	A	B	C	D	E	F	G	CUMWT
1) OE	u .55	80	85	65	100	60	90	0	.165
2) AC&I	u .45	100	100	100	100	100	100	0	.135
3) R&D	* .00	0	0	0	0	0	0	0	.000
COMBINED		89	92	81	100	78	95	0	.300

1 2 2 Overall>Costs>OtherGov

ATTRIBUTE	WT	A	B	C	D	E	F	G	CUMWT
1) Litigation	u .30	60	60	0	52	0	52	100	.060
2) Other Cost *	.70	90	100	70	75	45	50	0	.140
COMBINED		81	88	49	68	31	50	30	.200

1 Overall

LATEST RECORDED WEIGHT: 1.00

Benefits and costs are initially given equal weight because neither is considered to be more important at this time. In a tight budget environment, the costs of the alternatives would become much more important. In a period of close Congressional and public scrutiny of the SRA system, the benefits of the alternatives may become more important than the costs.

1 1 Overall>Benefits

LATEST RECORDED WEIGHT: .50

The relative swing weights in SAFETY and TIMELINESS are based on the dollar value of the ranges in the scales (\$2,721,000 and \$611,000). Together, these economic MOEs were judged to be 60 percent of the benefit value, and the non-economic MOE of OTHER BENEFITS was judged to be 40 percent.

1 1 1 Overall>Benefits>Safety

LATEST RECORDED WEIGHT: .49

Because of the smaller total swing of economic considerations (\$1,279,000) as compared with personal safety benefits (\$1,442,000), the ratio of weights is .47 for economic considerations and .53 for personal safety.

1 1 1 1 Overall>Benefits>Safety>Economic

LATEST RECORDED WEIGHT: .47

By a large margin, the most important swing occurs for the commercial users (\$1,000,000). The general public has the least important (\$34,000). Government users' swing is about five times that of the general public (\$185,000) while recreational boaters is about twice as much (\$60,000).

1 1 1 1 1 Overall>Benefits>Safety>Economic>Commercial

LATEST RECORDED VALUES IN \$(000):

A-20. B-25. C-12. D-58. E-7.0 F-67. G-91.

The best alternative is G because the 13th District gains a WLB tender in the Puget Sound without any district losing capability. Alternatives D and F are almost as good because a WLB loss from the 14th District would have little impact there, but a WLB gain on the west coast would greatly improve capability. Alternative F is slightly better than D because a WLB is better for use in the 11th District coastal areas than FIR. The worst alternative is E because the improvement in Puget Sound from FIR is more than offset by the loss of WLM capability in an east coast district and ocean servicing capability in the 11th District. Alternative C is almost as bad as E because a WLM in the Puget Sound only improves capability slightly, while the loss of WLM capability in an east coast district may be great. Alternatives A and B do not increase total capability very much, but relocating WHITE BUSH would be better than relocating IRIS because IRIS needs to cover the large ocean area down to southern Oregon while WHITE BUSH has less distance to travel

to service coastal A-to-N from Puget Sound.

1 1 1 1 2 Overall>Benefits>Safety>Economic>Recreation

LATEST RECORDED VALUES IN \$(000):

A-10.0 B-40.0 C-0.00 D-10.0 E-20.0 F-10.0 G-100.

Most recreational boaters use A-to-N serviced by WLMs. The best alternative is G and the worst is C as explained above. However, there are more recreational users in the Seattle area than in the rest of the 13th district. This means that relocating WHITE BUSH to better respond to small A-to-N discrepancies in Puget Sound would have little effect on other recreational users. All the other alternatives (A,D,E,and F) would improve capability in Puget Sound but would decrease capability elsewhere. Alternative E is slightly better than the others because the San Pedro area in the 11th District has many jetty buoys which could be handled better by the smaller WLM tender.

1 1 1 1 3 Overall>Benefits>Safety>Economic>Government

LATEST RECORDED VALUES IN \$(000):

A-50.0 B-10.0 C-10.0 D-40.0 E-0.00 F-100. G-90.0

The primary government user is the U.S. Navy. Puget Sound has a TRIDENT submarine base. San Diego has large Navy base. 14th District has Pearl Harbor. The best alternative is F because FIR would increase capability a bit in the 13th District, while a WLB has fewer weather restrictions than FIR for handling ocean AtoN which the Navy uses around San Pedro. The 14th District has extra ocean AtoN capacity, so would not lose much, if any, capability. Alternative G runs a close second place because the big improvement occurs in the 13th District. The worst alternative is E because a WLM would decrease capability for ocean AtoN at San Pedro and would decrease WLM capability in an east coast district, but provide no increase in Puget Sound's large AtoN capability. Alternatives B and C are slightly better than E because, while not improving Puget Sound capability, they do not decrease capability as much elsewhere. Relocating IRIS would improve capability only in Puget Sound with no loss to the rest of the district. Shifting a WLB from the 14th District to Puget Sound would improve capability there, but with a possible minor loss to the 14th District.

1 1 1 1 4 Overall>Benefits>Safety>Economic>GenPublic

LATEST RECORDED VALUES IN \$(000):

A-20.0 B-20.0 C-0.00 D-100. E-0.00 F-100. G-100.

Because it is more difficult to differentiate general public economic benefits, alternatives D, F and G were selected as being better than the rest and given the top score. This is because these alternatives added another tender to the commercial west coast without taking a tender from the equally commercial east coast. Many secondary general economic benefits might be felt by this action, including reducing environmental risk at the oil terminal at Port Angeles, increasing general safety in the highly visible VTS (vessel traffic system) in Puget Sound, maintaining smooth flow of commerce (including oil) to and from Alaska, and keeping the mouth of the Columbia River open to commercial traffic (timber, grain, etc.) There would be little general economic loss to the 14th district because it has several alternative ports in Hawaii and good weather most of the time. Alternatives C and E would be the worst because they take a tender from the busy east coast, increasing risk and

decreasing general economic contribution of the AtoN system there and offsetting improvements on the west coast. Alternatives A and B are slightly better than C and E only because small general economic improvements may be made within the 13th District by focusing assets on the more commercial Seattle area.

1 1 1 2 Overall>Benefits>Safety>PerSafety

LATEST RECORDED WEIGHT: .53

Commercial users' swing is the most important because of the many small fishing vessels which are affected (\$520,000). Recreational boaters also are at great risk of personal fatality injury or fatality, however, the swing is only about half of the commercial users' swing (\$222,000). Government users' swing is similar to the recreational boaters (\$200,000) and the general public swing is the least by far (\$20,000).

1 1 1 2 1 Overall>Benefits>Safety>PerSafety>Commercial

LATEST RECORDED VALUES IN \$(000):
A-42. B-45. C-55. D-78. E-55. F-82. G-94.

The greatest potential loss of life occurs in areas where there are many fishing vessels and the water temperatures are cold. Therefore, benefits for each alternative and class of user differ from the purely economic benefits evaluated above. For commercial users, buying a new tender for Puget Sound is still the best alternative (G). However, the worst alternative is relocating IRIS (A) because the Columbia River area has a high density of small commercial fishing boats which would be at greater risk. Relocating WHITE BUSH (B) would also be very damaging because of the many small fishing ports along the coast. Shifting a WLM (C and E) would provide more capability on the west coast, but may be offset by some lost capability on the east coast. The 14th district does not have many fishing fatalities because there are fewer coastal hazards and warmer waters there, so shifting a WLB (D and F) would have little effect.

1 1 1 2 2 Overall>Benefits>Safety>PerSafety>Recreation

LATEST RECORDED VALUES IN \$(000):
A-10.0 B-40.0 C-0.00 D-10.0 E-25.0 F-10.0 G-100.

Personal safety benefits for recreational users would be similar to the economic benefits (see 1 1 1 1 2).

1 1 1 2 3 Overall>Benefits>Safety>PerSafety>Government

LATEST RECORDED VALUES IN \$(000):
A-90.0 B-80.0 C-5.00 D-30.0 E-0.00 F-40.0 G-100.

Since the Navy is the biggest government user, large bases in cold water areas are the important consideration. Alternative G is the best, but large benefit gains could also be made by relocating IRIS or WHITE BUSH to Puget Sound (A and B). The worst alternatives would be to shift a WLM to the west coast from the mostly cold water east coast (C and E). Shifting a WLB from the 14th District would be better because of Hawaii's warmer water, but the large Naval base at Pearl Harbor is an important user.

1 1 1 2 4 Overall>Benefits>Safety>PerSafety>GenPublic

LATEST RECORDED VALUES IN \$(000):
A-40.0 B-40.0 C-0.00 D-100. E-0.00 F-100. G-100.

As in 1 1 1 1 4 above, personnel safety benefits to the public are difficult to discriminate between alternatives. However, areas with many bridges and ferries, such as the Pacific Northwest and the east coast, are more important. Because Alternatives D, F and G add a WLB to the west coast without taking from the east coast, these score the best. Alternatives C and E simply shift capability from the east coast to the west coast with no overall improvement. Some significant improvement could be made within the 13th district by relocating IRIS or WHITE BUSH from the Astoria area where there are few ferries and bridges to the Seattle area.

1 1 2 Overall>Benefits>Timeliness

LATEST RECORDED WEIGHT: .11

There is a difference between the swings for ship operators (\$381,000) and the cargo owners (\$230,000) that gives relative local weights of .62 and .38 respectively.

1 1 2 1 Overall>Benefits>Timeliness>Ship-reltd

LATEST RECORDED VALUES IN \$(000):
A-0.00 B-15.0 C-15.0 D-90.0 E-5.00 F-85.0 G-100.

Ship-related timeliness is strongly affected by AtoN in areas that have poor weather patterns and narrow channels, such as the Columbia River in the 13th District and many areas in east coast districts. The 11th and 14th districts generally have good weather and wide channels. While the best alternative is G, shifting a WLB to Puget Sound (D) almost accomplishes the same thing and shifting FIR to Puget Sound with a WLB in San Pedro (F) is only slightly worse. At the other end of the scale, taking IRIS out of Astoria on the Columbia River (A) is the worst alternative. Shifting FIR to Puget Sound in Alternative E is good except that the benefit is overshadowed by minor lost WLM capability in the eastern districts and major lost ocean servicing capability in the 11th District. Relocating WHITE BUSH (B) gains no real benefit, but causes no real loss, as does shifting an eastern WLM (C).

1 1 2 2 Overall>Benefits>Timeliness>Consigner

LATEST RECORDED VALUES IN \$(000):
A-0.00 B-20.0 C-0.00 D-85.0 E-0.00 F-90.0 G-100.

Timeliness is critical for perishable or high-value commodities such as fresh produce and electronic components. In addition, Seattle is "the" major seaport for almost all commodities going in and out of Alaska and has a very long channel. The Columbia River is the main artery for shipping apples and grain from the northwest. Some fresh produce is shipped from 11th District ports, but most goes by rail and truck. A high dollar amount of computer components enters the U.S. from the far east through L.A.-Long Beach, which has a very short channel. Most produce from Hawaii is canned before shipment, so is not time-sensitive. The best alternative is G, followed closely by D and F because of the large benefit gains in the Seattle area. Relocating IRIS (A) takes capability away from the Columbia River and gives it to Seattle for no net gain, while shifting a WLM to the west coast (C and E) takes away

minor capability from the east coast or L.A.-Long Beach and gives it to Seattle for no net gain. A relocation of WHITE BUSH (B) might provide some benefit through a more even distribution of assets in the 13th District.

1 1 3 Overall>Benefits>OtherBen

LATEST RECORDED WEIGHT: .40

Most of the importance for the mariner has been captured by other MOEs. Therefore, the swing weight for Coast Guard interests is at least twice that of the mariner. Other government and public interest swings are half as important as for the mariner. The swing weight for Coast Guard interests is the largest, not because Coast Guard interests are the most important, but mainly because the difference between the best and worst alternatives in other benefits to the users is small compared with the difference in benefits to the Coast Guard.

1 1 3 1 Overall>Benefits>OtherBen>Mariner

LATEST RECORDED WEIGHT: .25

There are no non-accident benefits, therefore all weight (1.00) goes to user satisfaction.

1 1 3 1 1 Overall>Benefits>OtherBen>Mariner>Non-Accid

LATEST RECORDED SCORES:

A-0 B-0 C-0 D-0 E-0 F-0 G-0

Pilots have sometimes refused to move certain classes of ships in a waterway because of the poor A-to-N system. In this case, no commodities were being prevented from being shipped, and none of the alternatives would decrease discrepancy response to such a poor level that pilots would refuse to move cargo.

1 1 3 1 2 Overall>Benefits>OtherBen>Mariner>UserSat

LATEST RECORDED SCORES:

A-15 B-15 C-0 D-90 E-0 F-90 G-100

Mariner satisfaction with the AtoN system is mainly manifested through the pilots organizations and the Congressional delegations. A very vocal and influential alliance of these groups comes from the Pacific northwest. A directive from Congress (under pressure from the Washington pilots association) to put a tender in Puget Sound is the cause of this analysis. Obviously, the users would like alternative G best. Barring a new tender, taking a WLB from the 14th District (D and F) would barely be noticed by the Hawaiian pilots and representatives. On the other hand, the powerful east coast pilots and congressmen would make any alternative which took away their tenders (C and E) very bad. Almost as bad would be the resentment within the 13th District between the Oregon and Washington groups that would result from alternatives A and B.

1 1 3 2 Overall>Benefits>OtherBen>USCGInt

LATEST RECORDED WEIGHT: .50

The swing in organizational impact is at least twice that of the swing in multimission capability, which is at least twice that of the swing in

AD-R173 705

SRA (SHORT RANGE AIDS TO NAVIGATION) RESOURCE
MANAGEMENT: MEASURES OF EFFECTIVENESS(U) MANDEX INC
SPRINGFIELD VA L GREENBERG ET AL. SEP 86 USCG-D-20-86
DTCF23-85-C-20078

4/4

UNCLASSIFIED

F/G 17/1

NL



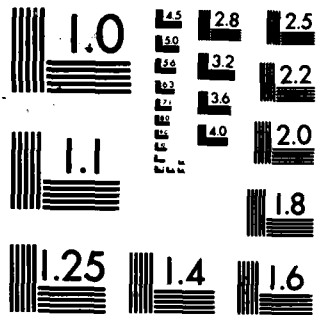

MICROCOPY RESOLUTION TEST CHART
NATIONAL BUREAU OF STANDARDS-1963-A

standard measures.

1 1 3 2 1 Overall>Benefits>OtherBen>USCGInt>Multimissn

LATEST RECORDED SCORES:

A-10 B-25 C-0 D-50 E-0 F-50 G-100

The best alternative is to add new multimission capability (G). Since the current emphasis for multimission capability is drug interdiction along the east coast, shifting a WLM to the west coast would be the worst alternative (C and E). Relocating IRIS (A) would have little effect because it would continue to perform mostly fishery zone patrolling and other ELT duties. Relocating WHITE BUSH would be slightly better because its primary multimission responsibility is SAR and there are more distress calls in the northern sector of the district than in the southern sector. But all ships have a SAR capability, so the effect of alternative B is small. While the 14th District WLMs perform mostly fisheries enforcement and drug interdiction, the capability to continue these multimissions would not be eroded by alternatives D and F.

1 1 3 2 2 Overall>Benefits>OtherBen>USCGInt>OrgImpact

LATEST RECORDED SCORES:

A-70 B-85 C-100 D-35 E-85 F-0 G-35

Organizational impact is a function of the number of crewmen affected, the morale effects, and the retraining required. The 7 alternatives were given a qualitative impact rating for each factor (LO, MED, HI), averaged, and converted to scores.

Alternative	No. of Crewmen	Dissatisfaction	Retraining
A	MED	MED	MED
B	LO	MED	MED
C	LO	MED	LO
D	MED	HI	MED
E	MED	MED	LO
F	HI	HI	MED
G	HI	MED	MED

1 1 3 2 3 Overall>Benefits>OtherBen>USCGInt>StndMeas

LATEST RECORDED SCORES:

A-0 B-0 C-0 D-100 E-0 F-100 G-100

The affect of the alternatives on the standard measures can be best estimated by looking at the primary measure-- discrepancy response rate (DRR). The baseline scores are estimated from the following:

District	#WLMs	#A-to-N	Coverage	Baseline Score
11th	1	220	200 miles	100
14th	3	500	8000 miles	0
13th	1	2000	500 miles	70
East Coast WLMs		350 ea	100 miles ea	100

All alternatives would leave the 11th district with the best DRR and the 14th with the worst DRR. Effects on the other districts are shown below:

District	A	B	C	D	E	F	G
13th	70	70	100	100	100	100	100
East Coast	100	100	70	100	70	100	100

TOTAL	170	170	170	200	170	200	200
NORMALIZED	0	0	0	100	0	100	100

1 1 3 3 Overall>Benefits>OtherBen>OtherGov

LATEST RECORDED WEIGHT: .15

While there are some international effects, the swing is very small compared with the swing for state and local government effects. There are no explicit federal government benefits.

1 1 3 3 1 Overall>Benefits>OtherBen>OtherGov>Internatnl

LATEST RECORDED SCORES:
A-100 B-100 C-100 D-0 E-100 F-0 G-100

International impacts would not be important. There would be some negative impact on the 14th District with alternatives D and F because the WLB would come from assets that cover the Trust Territories of the Pacific Islands (TTPI). When these islands gain independence, this impact will disappear.

1 1 3 3 2 Overall>Benefits>OtherBen>OtherGov>Federal

LATEST RECORDED SCORES:
A-0 B-0 C-0 D-0 E-0 F-0 G-0

No impacts defined at this time.

1 1 3 3 3 Overall>Benefits>OtherBen>OtherGov>State/Locl

LATEST RECORDED SCORES:
A-0 B-25 C-50 D-50 E-50 F-50 G-100

The best alternative is to buy a new tender (G). There would be a negative impact if IRIS was relocated (A) out of Astoria without replacement because its contribution to Astoria is more than would be the gain in Seattle. Relocating WHITE BUSH (B) would not be quite as bad. (If these were moved to Port Angeles instead, impact would be neutral.) The other alternatives are neutral on local impact.

1 1 3 4 Overall>Benefits>OtherBen>PublicInt

LATEST RECORDED WEIGHT: .10

There are no historic or environmental effects, so the entire local weight (1.00) is placed on economic effects.

1 1 3 4 1 Overall>Benefits>OtherBen>PublicInt>Economy

LATEST RECORDED SCORES:
A-100 B-100 C-100 D-100 E-100 F-100 G-0

Only Alternative G would require substantial investment by the public.

1 1 3 4 2 Overall>Benefits>OtherBen>PublicInt>Environmnt

LATEST RECORDED SCORES:
A-0 B-0 C-0 D-0 E-0 F-0 G-0

There are no environmental considerations in this decision.

1 1 3 4 3 Overall>Benefits>OtherBen>PublicInt>Historic

LATEST RECORDED SCORES:

A=0 B=0 C=0 D=0 E=0 F=0 G=0

There are no historic considerations in this decision.

1 2 Overall>Costs

LATEST RECORDED WEIGHT: .50

The swing in costs to the Coast Guard (\$1,350,000) is several times more important than the swing in litigation (\$800,000). Adding in the non-economic costs of ease of implementation to OTHER GOVERNMENT COSTS brings its weight up to .40.

1 2 1 Overall>Costs>USCGCosts

LATEST RECORDED WEIGHT: .60

While dollar for dollar, the importance of OE funds is as great as AC&I funds, the impact of the swing from the best to the worst alternative in OE costs (\$750,000) is slightly larger than impact on the AC&I budget of buying a new tender (\$600,000). There are no R&D costs to consider.

1 2 1 1 Overall>Costs>USCGCosts>OE

LATEST RECORDED VALUES IN \$(000):

A=80.0 B=85.0 C=65.0 D=100. E=60.0 F=90.0 G=0.00

The increase in the annual operating cost of the combined WLB and WLM fleets was estimated for each alternative. OE costs are mainly a function of the support costs of a base area and the steaming hours of the vessels. Qualitative descriptions were converted to costs.

Alternative	Cost of Area	Steaming Hours	Costs (\$000)
A	HI	MED	400
B	HI	MED	362
C	VERY HI	LO	512
D	LO	LO	250
E	VERY HI	LO	550
F	LO	LO	325
G	VERY HI	VERY HI	1,000

1 2 1 2 Overall>Costs>USCGCosts>AC&I

LATEST RECORDED VALUES IN \$(000):

A=100. B=100. C=100. D=100. E=100. F=100. G=0.00

Alternative G is the only one that requires AC&I funds: \$600,000 on an annualized basis.

1 2 1 3 Overall>Costs>USCGCosts>R&D

LATEST RECORDED SCORES:

A=0 B=0 C=0 D=0 E=0 F=0 G=0

There are no R&D costs.

1 2 2 Overall>Costs>OtherGov

LATEST RECORDED WEIGHT: .40

The swing between the best and worst alternatives in litigation costs is only about one half the swing between alternatives in terms of time and effort to implement.

1 2 2 1 Overall>Costs>OtherGov>Litigation

LATEST RECORDED VALUES IN \$(000):

A=50.0 B=50.0 C=0.00 D=40.0 E=0.00 F=40.0 G=100.

Alternative G is the best because it adds a new Coast Guard asset. Most litigation, however, is incurred on the east coast. Therefore, taking a WLM from the east coast districts would be the worst alternative (C and E). Since the 14th District has extra capacity and very little litigation, taking a WLB from that district would have almost no effect. Relocating within the 13th District would only be slightly worse.

1 2 2 2 Overall>Costs>OtherGov>OtherCost

LATEST RECORDED SCORES:

A=90 B=100 C=70 D=75 E=45 F=50 G=0

The other major cost is the time and effort needed to implement the alternatives. Relocating WHITE BUSH or IRIS to Seattle would be the easiest alternatives (A and B). The hardest to implement would be the procurement of a new tender (G). Shifting a tender between districts would be harder than relocating within a district (C and D). Shifting two tenders between districts would be even more difficult (E and F).

REFERENCES

Abstract of Operations. Washington, DC: Department of Transportation, U.S. Coast Guard, annual.

Additional billet in 14th District Aids to Navigation Branch. February 1983.

Aids to navigation in the deep draft waterway complex leading from the Gulf of Mexico to Baton Rouge. 8th Coast Guard District, January 1981.

Aids to navigation manual - Administration (Commandant Instruction M16500.7). Washington, DC: Department of Transportation, U.S. Coast Guard, 16 November 1981.

American Association of Port Authorities (AAPA) annual handbook. American Association of Port Authorities.

American Bureau of Shipping casualty data. American Bureau of Shipping, annual.

Analytic methods for assessing recreational boating safety effect: User's guide. Washington, DC: Department of Transportation, U.S. Coast Guard, January 1984.

A/N positioning (Briefing to Admiral Stewart by D. Nelson). Washington, DC: Department of Transportation, U.S. Coast Guard, 11 August 1977.

Annual report of the Secretary of Transportation on hazardous materials control. Washington, DC: Department of Transportation, Materials Transportation Bureau.

Armacost, LCDR R. *Good intentions about long range planning for short range aids to navigation*. February 1977.

AtoN Information System (ATONIS). Washington, DC: Department of Transportation, U.S. Coast Guard, periodic.

Audit of maintenance of navigational aids (Office of Inspector General Report R1-CG-4-053). Boston, MA: U.S. Coast Guard, annual.

Benefits of short range aids to navigation (SRA) system (Memorandum from G-CPE to G-CCS). Washington, DC: Department of Transportation, U.S. Coast Guard, 8 June 1981.

Benefits of short range aids to navigation (SRA) system (Memorandum). Washington, DC: Department of Transportation, U.S. Coast Guard, 8 June 1981.

Boating accident reporting (BAR) system (G-BP-I). Washington, DC: Department of Transportation, U.S. Coast Guard, Office of Boating Safety, periodic.

Boating statistics. Washington, DC: Department of Transportation, U.S. Coast Guard, annual.

Bridges over navigable waters of the United States. Washington, DC: U.S. Army Corps of Engineers.

Brown, R. V., Kahr, A.S., and Peterson, C.R. *Decision analysis for the manager.* New York: Holt, Rinehart, and Winston, 1974.

CASMAIN personnel casualties (PCAS) and vessel casualties (CAS) (G-MMI-(3)). Washington, DC: Office of Marine Investigations.

Casualty returns. England: The Liverpool Underwriters Association, ongoing.

Classification of aids to navigation according to their reliability. The Technical Committee on Reliability of Aids to Navigation, *IALA Bulletin* 1986/1.

Clingan, I.C. *Safety at sea - Its risk management.* Paper presented at 1985 IALA Conference.

Coase, R.H. *The lighthouse in economics.* *The Journal of Law and Economics*, 1974, 17.

Coast Guard action needed to promote safer marine transportation (Comptroller General Report CED-79-37). Washington, DC: Department of Transportation, May 21, 1979.

The Coast Guard IRM architecture (Draft). Washington, DC: Department of Transportation, U.S. Coast Guard, 18 April 1986.

The Coast Guard's programs of aids to navigation along Louisiana's coast could be more effective (Comptroller General Report CED-80-58). Washington, DC: Department of Transportation, U.S. Coast Guard, 11 April 1980.

Coast Guard service-wide search and rescue statistics (No. 450). Washington, DC: Department of Transportation, U.S. Coast Guard, annual.

Commodity movement annual (CMA). Washington, DC: Office of Trade Studies and Subsidy Contracts, Maritime Administration.

Corps of Engineers database. Washington, DC: U.S. Maritime Administration, Office of Domestic Shipping, ongoing.

Cost analysis of contractor serviced aids to navigation. Temple, Barker, and Sloane, Inc., August 1982.

Current trends in port pricing. Washington, DC: Department of Commerce, August 1978.

Design manual for restricted waterways. Washington, DC: Department of Transportation, U.S. Coast Guard, 1985.

Discount rates to be used in evaluating time distributed costs and benefits (OMB Circular A-94). Washington, DC: Office of Management and Budget, 27 March 1972.

Distances between U.S. ports (National ocean survey). Washington, DC: Department of Transportation, U.S. Coast Guard.

Dod should defer buying new TACAN equipment (GAO report). Washington, DC: Government Accounting Office, 12 November 1981.

Domestic oceanborne and Great Lakes commerce of the U.S. Washington, DC: U.S. Maritime Administration.

Economic analysis of investment and regulatory decisions (FAA-APO-82-1). Washington, DC: Federal Aviation Administration, January 1982.

Economic benefits of improved watertight subdivision for Great Lakes bulk carriers (Maritime Administration Report #1628-2-R1). Washington, DC, December 1978.

The economics of deepwater terminals. Washington, DC: Department of Commerce, 1972.

Economic values for evaluation of Federal Aviation Administration investment and regulatory programs (APO Bulletin 84-3). Washington, DC: Federal Aviation Administration, June 1984.

Economics of shipping practice and management. Extract of Chapter 5, "Economics of ship operation".

Everett, H, III. Generalized Lagrange multiplier method for solving problems of optimum allocation of resources. *Operations Research*, 1967, 399-417.

Feasibility study for remote monitoring of lighthouses. Fourteenth Coast Guard District, 18 December 1985.

Fisheries of the US, 1984. Washington, DC: US Department of Commerce, April 1985.

Great II - Upper Mississippi River: Main report and Executive Summary. Great River Environmental Action Team, December 1980.

IALA technical committee update. Harley Cleveland, 1986.

Information on the USCG decision to purchase the M/V cowslip vessel (CED-81-128). Washington, DC: General Accounting Office, June 25, 1981.

Information requirements analysis of Coast Guard operating systems. Advanced Technology, 10 September 1985.

Inland waterborne commerce statistics. American Waterways Operators, Inc., periodic.

Interstate port handbook. Vance Publishing Corporation.

Keeney, R.L., and Raiffa, H. *Decisions with multiple objectives: Preferences and value tradeoffs.* New York: Wiley, 1976.

Losses and scrappings. Washington, DC: U.S. Maritime Administration, periodic.

Lloyd's register of shipping--The casualty information file. London, England: Lloyd's of London, Ltd, periodic.

Lloyd's register of shipping--The register book. London, England: Lloyd's of London, Ltd, periodic.

Lloyd's weekly casualty reports. London, England: Lloyd's of London, periodic.

LNG site for Point Conception California: Maritime risk management procedures (Report 22-813-M). McMullen Associates, 19 March 1979.

Maintenance and repair (M&R). Washington, DC: U.S. Maritime Administration, periodic.

Marine insurance information system (MII). Washington, DC: U.S. Maritime Administration, ongoing.

Masse, S. Management information in the Coast Guard (Thesis). August 1971.

Marine safety information system (MSIS). Columbus, OH: Battelle, Inc., ongoing.

Mission need statement (MNS) of 27 Mar 1985 for the WLB/WLM capability replacement (Memorandum). Washington, DC: Department of Transportation, 27 March 1985.

Mobile ship channel - Waterways analysis and management. Eighth Coast Guard District, 4 February 1985.

Motorboat accident statistics. Washington, DC: Department of Transportation, U.S. Coast Guard, periodic.

MSIS data dictionary on the automated office system (USCG Manual). Washington, DC: Department of Transportation, U.S. Coast Guard, April 1986.

National waterway study. Washington, DC: U.S. Army Corps of Engineers, 1980.

Operating cost of Coast Guard cutters (Annual Report). Washington, DC: Department of Transportation, U.S. Coast Guard.

Operational statistics system (OPSTAT) and Abstract of Operations. Washington, DC: Department of Transportation, U.S. Coast Guard.

Physical waterway characteristics. Washington, DC: U.S. Army Corps of Engineers.

Pielow, C.L. (Ed). Guide to port entry. Shipping Guides, Limited.

Polluting incidents in and around U.S. waters. Washington, DC: Department of Transportation, U.S. Coast Guard, periodic.

Pollution incident reporting system (PIRS). Washington, DC: Department of Transportation, U.S. Coast Guard, ongoing.

Port Series reports. Ft. Belvoir, VA: Corps of Engineers Water Resources Support Center, periodic.

Port access route studies (CGD 81-074). Washington, DC: Department of Transportation, U.S. Coast Guard, periodic.

Pratt, J.W. Risk aversion in the small and in the large. *Econometrica*, January-April 1964, 32(1-2), 122-136.

Prototype waterways analysis of Green Bay, WI. Ninth Coast Guard District, 19 March 1985.

Quantification of A/N benefits (Memorandum). Washington, DC: Department of Transportation, U.S. Coast Guard, 17 December 1980.

Raiffa, H. *Assessments of probabilities* (Unpublished manuscript). Boston, MA: Harvard University, 1969.

Recreational boating in the Continental United States in 1973: The nationwide boating survey. Washington, DC: Department of Transportation, U.S. Coast Guard.

Recreational boating list of fatalities (FATALS). Washington, DC: U.S. Coast Guard, Office of Boating Safety, ongoing.

RCP Data Workbook. Washington, DC: Department of Transportation, U.S. Coast Guard, October 1984.

Report on the activities of the technical committee on the reliability and availability of aids to navigation. XIth Conference of the International Association of Lighthouse Authorities, 1985.

Revenue and traffic of class A and B water carriers (1938-Present) (Statement 650). Washington, DC: Interstate Commerce Commission.

Safety goals for nuclear power plants: A discussion paper (NUREG 0880). Washington, DC: U.S. Nuclear Regulatory Commission, February 1982.

Seaver, D.A. *Assessment of group preferences and group uncertainty for decision making*. Los Angeles, CA: University of Southern California, Social Science Research Institute, 1976.

Ship handling in narrow channels. Carlyle Plummer, 1978.

Short range aids to navigation study. Washington, DC: Department of Transportation, U.S. Coast Guard, June 1983.

Short range aids to navigation systems: Design manual for restricted waterways. Washington, DC: Department of Transportation, U.S. Coast Guard, June 1985.

Short range aids to navigation (Program Plan FY83-92). Washington, DC: Department of Transportation, U.S. Coast Guard.

Slovic, P., Fischhoff, B., and Lichtenstein, S. *Facts and fears: Understanding perceived risk*. In R.C. Schwing and W.A. Albers (Eds.), *Societal risk assessment*. NY: Plenum Press, 1980, 181-216.

Sponsor's requirements document: Buoy boat (Draft). Washington, DC: Department of Transportation, U.S. Coast Guard, Undated.

SRA - A logical model representing SRA-mission command and control (Technical Memorandum 4.8). Washington, DC: Department of Transportation, U.S. Coast Guard, 23 September 1983.

Statistics of accidents. Washington, DC: Department of Transportation, U.S. Coast Guard, Office of Merchant Marines, annual.

Statistics of casualties. Washington, DC: Department of Transportation, U.S. Coast Guard, Office of Merchant Marines, annual.

Stokey, E., and Zeckhauser, R. *A primer for policy analysis*. NY: W.W. Norton, 1978.

Study of Great Lakes vessel casualties and the impact of proposed US Coast Guard stability requirements. Marine Consultants and Designers, Inc., September 29, 1983.

Transportation lines of the United States (Report WRSC-TL-83 & 84). Washington, DC: U.S. Corps of Engineers, July 1985.

Transportation statistical reference file - Users Manual. Department of Transportation, 1983.

Ulvila, J.W., and Chinnis, J.O., Jr. *A method for allocating resources across R&D programs* (Technical Report 83-8). Falls Church, VA: Decision Science Consortium, Inc., December 1983.

U.S. Coast Guard annual budget. Washington, DC: Department of Transportation, U.S. Coast Guard.

U.S. Great Lakes ports statistics for overseas and Canadian waterborne commerce. Washington, DC: St. Lawrence Seaway Development Corporation.

US oceanborne foreign trade routes. Washington, DC: Maritime Administration, June 1985.

Use of basswood and articulated beacons in CGD. Washington, DC: Department of Transportation, U.S. Coast Guard, 14 September 1985.

von Winterfeldt, D. *Some sources of incoherent judgments in decision analysis*. Falls Church, VA: Decision Science Consortium, Inc., 1980.

Wagner, H.M. *Principles of operations research*. Englewood Cliffs, NJ: Prentice-Hall, 1970.

WAMS analyses and aids to navigation operations requests. Washington, DC: Department of Transportation, U.S. Coast Guard, ongoing.

Waterborne data bank (CN091-CN099, 1973; CN101-CN105, 1976; CN125, 1975). Washington, DC: Department of Transportation, U.S. Coast Guard.

Waterborne commerce of the United States (WRSC-WCUS-83-1,2,3,4,5). Washington, DC: U.S. Army Corps of Engineers, 1983.

Waterways analysis and management system (WAMS) (Commandant Instruction 16500.11). Washington, DC: Department of Transportation, U.S. Coast Guard, 4 September 1984.

Wood, W.C. *Nuclear safety - Risks and regulations.* Washington, DC: American Enterprise Institute for Public Policy Research, 1983.

END

12-86

DTIC