



AD-A170 732

HELICOPTER ICING SPRAY SYSTEM (HISS) EVALUATION AND IMPROVEMENTS

DAUMANTS BELTE
PROJECT ENGINEER

RALPH WORATSCHK
PROJECT ENGINEER

APRIL 1986

DTIC
ELECTRONIC
S AUG 6 1986
A

FINAL REPORT



DTIC FILE COPY

Approved for public release, distribution unlimited.

UNITED STATES ARMY AVIATION ENGINEERING FLIGHT ACTIVITY
EDWARDS AIR FORCE BASE, CALIFORNIA 93523

86 8 5 060

USAAEFA

DISCLAIMER NOTICE

The findings of this report are not to be construed as an official Department of the Army position unless so designated by other authorized documents.

DISPOSITION INSTRUCTIONS

Destroy this report when it is no longer needed. Do not return it to the originator.

TRADE NAMES

The use of trade names in this report does not constitute an official endorsement or approval of the use of the commercial hardware and software.

DISCLAIMER NOTICE

THIS DOCUMENT IS BEST QUALITY PRACTICABLE. THE COPY FURNISHED TO DTIC CONTAINED A SIGNIFICANT NUMBER OF PAGES WHICH DO NOT REPRODUCE LEGIBLY.

REPORT DOCUMENTATION PAGE		READ INSTRUCTIONS BEFORE COMPLETING FORM										
1. REPORT NUMBER USAAEFA PROJECT NO. 82-05-3	2. GOVT ACCESSION NO. AD-A170 732	3. RECIPIENT'S CATALOG NUMBER										
4. TITLE (and Subtitle) HELICOPTER ICING SPRAY SYSTEM (HISS) EVALUATION AND IMPROVEMENTS		5. TYPE OF REPORT & PERIOD COVERED FORMAL 1984-1985 ICING										
		6. PERFORMING ORG. REPORT NUMBER										
7. AUTHOR(s) DAUMANTS BELTE RALPH WORATSCHEK		8. CONTRACT OR GRANT NUMBER(s)										
9. PERFORMING ORGANIZATION NAME AND ADDRESS US ARMY AVN ENGINEERING FLIGHT ACTIVITY EDWARDS AIR FORCE BASE, CA 93523-5000		10. PROGRAM ELEMENT, PROJECT, TASK AREA & WORK UNIT NUMBERS 1K-2-DT-168-01-1K-1K										
11. CONTROLLING OFFICE NAME AND ADDRESS US ARMY AVIATION SYSTEMS COMMAND 4300 GOODFELLOW BOULEVARD ST. LOUIS, MO 63120-1798		12. REPORT DATE APRIL 1986										
		13. NUMBER OF PAGES 160										
14. MONITORING AGENCY NAME & ADDRESS (if different from Controlling Office)		15. SECURITY CLASS. (of this report) UNCLASSIFIED										
		15a. DECLASSIFICATION/DOWNGRADING SCHEDULE										
16. DISTRIBUTION STATEMENT (of this Report) Approved for public release; distribution unlimited.												
17. DISTRIBUTION STATEMENT (of the abstract entered in Block 20, if different from Report)												
18. SUPPLEMENTARY NOTES												
19. KEY WORDS (Continue on reverse side if necessary and identify by block number)												
<table border="0"> <tr> <td>Atomizer Performance</td> <td>Helicopter Icing</td> </tr> <tr> <td>Cloud Physics</td> <td>Ice Formation</td> </tr> <tr> <td>Drop Size Measurement</td> <td>In-Flight Simulation</td> </tr> <tr> <td>Evaporation</td> <td>Qualification Testing</td> </tr> <tr> <td>Flow Distribution</td> <td>Spray Tanker</td> </tr> </table>			Atomizer Performance	Helicopter Icing	Cloud Physics	Ice Formation	Drop Size Measurement	In-Flight Simulation	Evaporation	Qualification Testing	Flow Distribution	Spray Tanker
Atomizer Performance	Helicopter Icing											
Cloud Physics	Ice Formation											
Drop Size Measurement	In-Flight Simulation											
Evaporation	Qualification Testing											
Flow Distribution	Spray Tanker											
20. ABSTRACT (Continue on reverse side if necessary and identify by block number)												
<p>The US Army Aviation Engineering Flight Activity operates a modified CH-47C helicopter as an airborne spray tanker for helicopter qualification tests in artificial icing conditions. The operational performance and spray cloud characteristics of the Helicopter Icing Spray System were evaluated in the course of several test programs during the 1984 and 1985 icing seasons in Duluth, Minnesota. Configuration changes made during the first two phases of this program reduced previous spray system problems of water leakage, freezing,</p>												



DEPARTMENT OF THE ARMY
HEADQUARTERS, US ARMY AVIATION SYSTEMS COMMAND
4300 GOODFELLOW BOULEVARD, ST. LOUIS, MO. 63120-1798

REPLY TO
ATTENTION OF

AMSAV-E

SUBJECT: Directorate for Engineering Position on the Final Report of USAAEFA Project No. 82-05-03, Helicopter Icing Spray System (HISS) Evaluation and Improvement

SEE DISTRIBUTION

1. The purpose of this letter is to establish the Directorate for Engineering position on the subject report. The report documents Phase 3 of a three phase effort for improving the U.S. Army Aviation Engineering Flight Activity (USAAEFA) JCH-47C HISS. Phase 1 was completed and the structural dynamic characteristics of the JCH-47C with fiberglass rotor blades and a modified boom assembly were documented in AVSCOM letter, DRDAV-DI, 7 Oct 82, subject: USAAEFA Report, Helicopter Icing Spray System (HISS) Boom Structure Dynamic Evaluation with Fiberglass Blades, USAAEFA Project No. 82-05-1. Phase 2 was completed and the design, fabrication, installation, and flight testing of several modifications which were incorporated to improve system operation, simplify maintenance action and correct problems areas identified in earlier testing were documented in AVSCOM letter, AMSAV-E, 6 Dec 85, subject: USAAEFA Report, Helicopter Icing Spray System (HISS) Evaluation and Improvements, USAAEFA Project No. 82-05-2. The preceding reports were submitted to the Federal Aviation Administration (FAA). This report consolidates phases 1 and 2 and documents the phase 3 evaluation of the operational performance and spray cloud characteristics of the HISS during the 1984 and 1985 icing tests in support of U.S. Army, U.S. Navy, and U.S. Marine helicopter icing tests at Duluth Minnesota. This report is being provided to the FAA as a final report per Article V, Paragraph C of FAA/U.S. Army Interagency Agreement Number DTFA03-80-A-00199.

2. This Directorate agrees with the report conclusions and recommendations. Additional comments are provided relative to the report paragraphs as indicated below:

a. Paragraph 40: The conclusions presented document significant improvements made to the HISS capability in support of artificial icing tests. Most noteworthy was the successful operations to temperature below -20°C without encountering freeze up of the nozzles and a satisfactory spray pattern. While the drop mass concentration is improved and the useable upper limit water flow is improved, the artificial icing cloud still does not accurately reproduce the natural icing environment under all conditions. Additionally, the cloud dimensions need significant increases to allow immersing a complete helicopter and reduce overall test time. The current HISS configuration can only immerse the rotor systems and fuselages separately.

AMSAV-8

SUBJECT: Director for Engineering Position on the Final Report of USAAEFA
Project No. 82-05-3, Helicopter Icing Spray System (HISS) Evaluation
and Improvements

b. Paragraph 41: The recommendations require improvements which are beyond the capability of the current HISS. To provide for a HISS with a significantly improved capability the U.S. Army Aviation Systems Command has initiated an Improved Helicopter Icing Spray System (IHISS) program to meet future test requirements. The IHISS is expected to be operational in 1990-1991 timeframe and will consist of a palletized system capable of providing a spray cloud with the following characteristics:

- | | |
|---|-----------------------------|
| (1) Variable Liquid Water Content (LWC) | 0.15 to 2 gm/m ³ |
| (2) Variable Median Volumetric Diameter (MVD)
for any LWC from 0.15 to 2 gm/m ³ | 10 to 50 microns |
| (3) Drop Size Distribution (0 to -25 ⁰) | Natural Cloud
Spectrum. |
| (4) Ambient Temperature | +40 to -25 ⁰ C |
| (5) Pressure Altitude | 0 to 15000 ft. |
| (6) Airspeed | 60 to 150 KIAS |
| (7) Cloud Cross-Section Size at 150 ft.
to 200 ft. from the boom | 15 x 55 ft. |
| (8) Spray Endurance (1 gm/m ³ , 130 KIAS) | 30 min. |
| (9) Aircraft Endurance | 2 hr. |

3. The effort put forth by USAAEFA to improve the current HISS was outstanding and the modifications incorporated enhance the overall capability to conduct acceptable artificial icing tests. The IHISS should improve test productivity at least 100% as well as accurately duplicate natural icing conditions. Additionally, a palletized HISS will allow rapid removal and installation from one CH-47D to another thereby increasing HISS availability during periods of extended aircraft maintenance.

4. AVSCOM - Providing Leaders the Decisive Edge.

FOR THE COMMANDER



DANIEL M. McENEANEY
Director of Engineering

TABLE OF CONTENTS

	<u>Page</u>
INTRODUCTION	
Background.....	1
Test Objective.....	1
Description.....	1
Test Scope.....	3
Test Methodology.....	4
RESULTS AND DISCUSSION	
General.....	8
HISS Configuration.....	8
Spray Operations.....	9
Natural Cloud Characteristics.....	12
Spray Cloud Characteristics.....	14
Ice Accretions on Test Aircraft.....	19
CONCLUSIONS	
General.....	21
RECOMMENDATIONS.....	22
APPENDIXES	
A. References.....	23
B. Description - Helicopter Icing Spray System.....	25
C. Instrumentation - JU-21A Cloud Measuring Equipment....	35
D. Test Techniques and Data Analysis Methods.....	40
E. Photographs.....	43
F. Test Data.....	65
G. Letter Report, USAAEFA Project No. 82-05-1.....	76
H. Letter Report, USAAEFA Project No. 82-05-2.....	98
DISTRIBUTION	

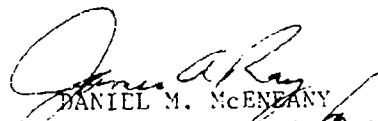

INTRODUCTION

BACKGROUND

1. The US Army Aviation Engineering Flight Activity (USAAEFA) operates a modified CH-47C helicopter as an airborne spray tanker for helicopter qualification tests in artificial icing conditions. The Helicopter Icing Spray System (HISS) was first used in 1973 (ref 1, app A) and has undergone numerous modifications to improve its capabilities. A dual-trapeze spray boom was incorporated in 1975 (ref 2), the original atomizers were replaced with Sonicore nozzles in 1979 (ref 3), and a gas-turbine bleed air source was added in 1981 (ref 4). Additional requirements were identified during the 1982 icing season, and the US Army Aviation Systems Command issued a test request (ref 5) to incorporate, document, and evaluate subsequent modifications as a three-phase effort. Phase 1 of this program consisted of a boom dynamics evaluation after an aircraft upgrade to fiberglass rotors (replacing the metal blades) and improved forward transmission and vibration dampers. Phase 2 reported on modifications to the water supply routing, emergency water jettison system, airframe maintenance provisions, and hydraulic systems. The Phase 1 and 2 reports are reproduced in appendixes G and H to provide a combined overview of current HISS status.

TEST OBJECTIVE

2. The objective of this program (Phase 3) was to evaluate operational performance and spray cloud characteristics of the HISS during the 1984 and 1985 icing operations in Duluth, Minnesota.

DESCRIPTION

3. The HISS, shown in photo A and further described in appendix B, is installed in a modified CH-47C helicopter (US Army S/N 68-15814). It consists of an internal water tank and an external spray boom assembly suspended beneath the aircraft from a torque tube through the cargo compartment. Hydraulic actuators rotate the torque tube to raise and lower the boom assembly. The boom is constructed of concentric metal pipe, forming an upper and lower trapeze located between two outrigger sections, with an overall tip-to-tip width of 60 ft. The outer pipe is the structural trapeze and boom assembly, and is pressurized with bleed air from the aircraft engines and an auxiliary power unit (APU). The inner pipe acts as the water passage. Water and bleed air are supplied to spray nozzles spaced along the boom to atomize the water and form the spray cloud. Water flow rate is controlled to vary the cloud liquid water content (LWC).

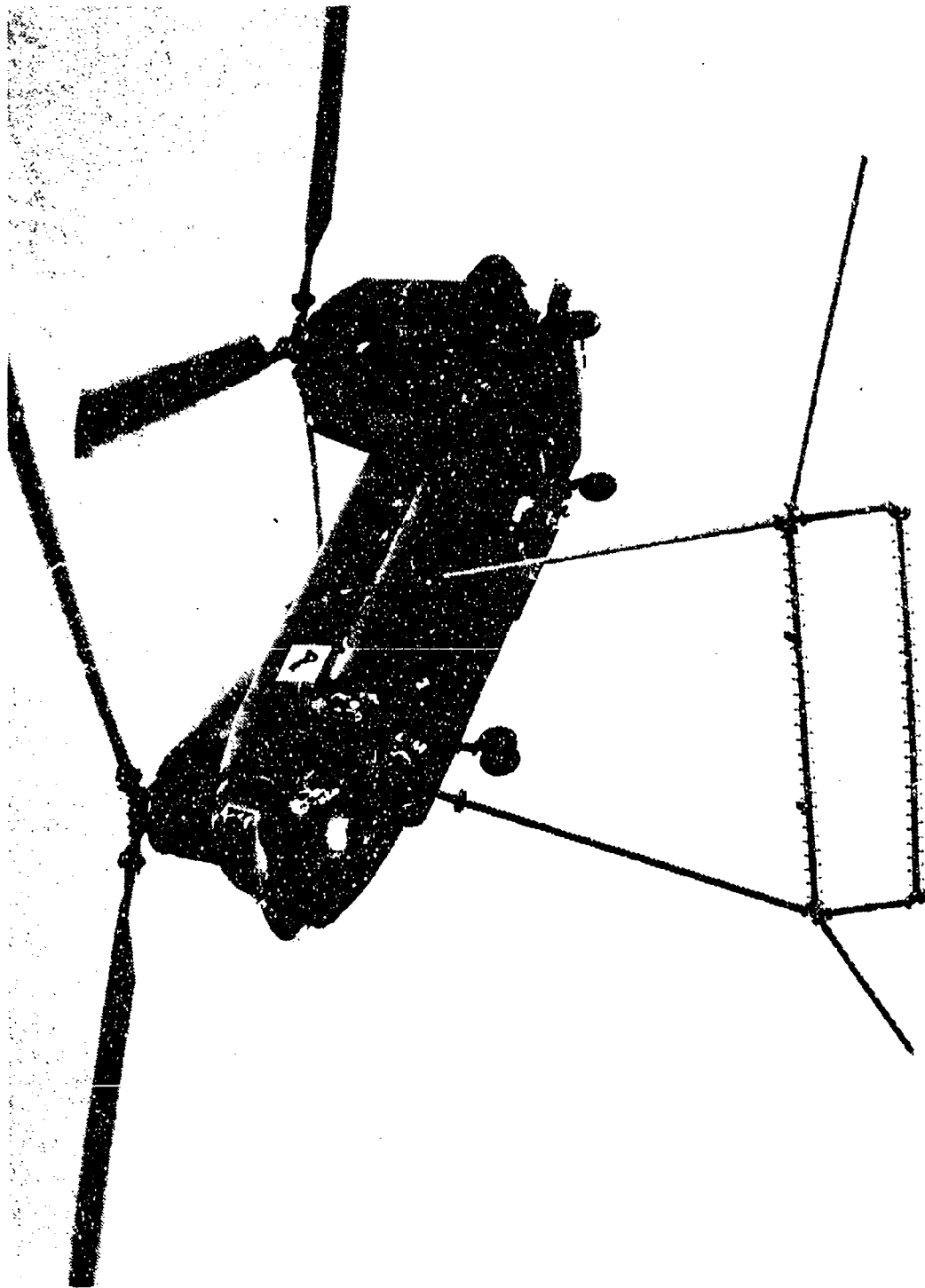

Photo A. JCH-47C Helicopter with HISS Installation

4. An aft-facing radar altimeter at the rear of the HISS allows positioning of test aircraft at a known standoff distance. A calibrated outside air temperature probe and a Cambridge dew point hygrometer provide ambient temperature and humidity measurement. Thermocouples and pressure transducers installed on the boom assembly allow inflight measurement of pressure and temperature for both boom air and water while spraying.

TEST SCOPE

5. The phase 3 evaluation was conducted during two icing seasons while the HISS flew artificial icing missions for several test programs in the vicinity of Duluth, Minnesota (field elevation 1429 ft). HISS icing operations consisted of 45 flights from 9 January to 19 March 1984, and 28 flights from 16 January to 22 March 1985. These were flown in support of the following eight test programs:

1984 - CH-53E Super Stallion (Naval Air Test Center Rep't RW-95R-84)

YEH-60A Quick Fix (USAAEFA Project No. 83-21)

UH-1H 2nd Generation Pneumatic Deicer Boot (Project No. 83-13)

UH-60A External Stores Support System (Project No. 83-22)

UH-1H Ice Shapes and Performance Degradation (Project No. 83-23)

1985 - SH-60B Seahawk (Naval Air Test Center Rep't RW-45R-85)

JU-21A Airfoil Section Array Ice Shapes (USAAEFA Project No. 83-01)

AH-64A Apache (Project No. 84-23).

Several of these programs conducted natural icing tests during the same period. Test results for the individual programs are contained in their own respective reports. This evaluation summarizes only the general artificial icing characteristics related to HISS performance while operating in their support.

6. The HISS configuration flown used 97 nozzles installed only on the trapeze sections. The outriggers were retained for structural reasons but were isolated from the water and bleed air supply. Test conditions covered a range of pressure altitude from 2700 to 11,400 ft, ambient temperature from -4.5 to -23.5°C, and airspeeds from 80 to 124 knots true airspeed. Water flow rates between 5 and 30 gallons per minute (gpm) were established to produce LWC values from 0.22 to 1.16 gm/m³ during icing

missions. Higher flow rates (up to 50 gpm) were used specifically for spray cloud calibration. Maximum loading condition used for takeoff was 47,900 lb gross weight with a longitudinal center of gravity from fuselage station (FS) 333 (aft) to 330.5 with 1450 gallons of water and full fuel or 1650 gallons water and aft auxiliary fuel tanks empty. Flight limitations contained in the aircraft operator's manual (ref 6, app A) and the airworthiness release (ref 7) were observed during testing.

TEST METHODOLOGY

7. The calibration aircraft used to sample the spray cloud was a JU-21A fixed wing aircraft (US Army S/N 66-18008) shown in photo B. Onboard instrumentation included two Particle Measuring Systems, Inc. (PMS) laser spectrometers (models FSSP-100 and OAP-200X), a Leigh MK 10 ice detector, a Cloud Technology, Inc. LWC sensor, a Rosemount total air temperature probe, and a Cambridge dew point hygrometer. The data acquisition system installed was a Small Intelligent Icing Data System for recording and processing the instrumentation signals. The particle counting and sizing capabilities of the PMS laser spectrometers provided a description of drop size distributions for diameters between 2 and 300 microns, and allowed a calculation of median volumetric diameter and LWC. A more detailed description of the aircraft and cloud measurement system is contained in appendix C, and the data analysis techniques are described in appendix D.

8. Operational icing missions were generally flown at a single test condition that was held constant throughout a given mission, while calibration flights were intended to measure a range of spray conditions. As shown in photo C, artificial icing missions consisted of flying a test aircraft in formation behind the HISS while keeping the aircraft immersed in the spray cloud approximately 180 ft behind the booms. Prior to cloud entry by the test aircraft, the JU-21A performed a cloud sampling maneuver (photo D) by immersing the laser spectrometers in the densest portion of the spray for approximately one minute to obtain a "cloud centered" average measurement of LWC and drop size distribution. Flights intended for cloud calibration repeated this maneuver at a number of flow rates ranging from 5 to 50 gpm. Additional standoff distances from 130 to 330 ft behind the booms (100 to 300 ft as measured by the aft-facing radar altimeter) were also evaluated, and vertical sweeps through the cloud were performed to measure spray variation within the plume. Appendix D describes the techniques used during these various test procedures in more detail.



Photo B. JU-21A Aircraft with Cloud Measuring Equipment



Photo C. In-flight Artificial Icing Test Formation



Photo D. JU-21A Performing Spray Cloud Sampling Maneuver

RESULTS AND DISCUSSION

GENERAL

9. Operational performance of the HISS as an airborne icing simulator and characteristics of the spray cloud were evaluated during the 1984 and 1985 icing seasons. These flights demonstrated that previous spray system problems of water leakage, freezing, and non-uniform flow patterns from the trapeze had been reduced. No substantial change was measured in drop size distribution of the spray. While the cloud produced peak drop concentrations in the desired range, it also contained a number of larger drops that do not normally occur in natural stratiform clouds. As a result, ice formations on test aircraft showed accordingly varied characteristics. Many aspects were quite realistic and compared favorably with natural accretions, to include formation of "double-horned" non-streamlined ice shapes on main rotor blades at -5°C .

HISS CONFIGURATION

10. Prior to the 1984 icing season, phase 2 of this project incorporated various improvements to the HISS installation that are fully described in appendix H. While this configuration was current for start of the 1984 icing season, additional changes were made both during icing operations and between the 1984-1985 seasons. This section discusses these subsequent modifications and their effects.

11. The initial 1984 icing flights with the "T" shaped water manifolds resulted in formation of ice on the upward facing rows of nozzles. As described in paragraph 17, the downward facing nozzles were not affected because of orientation differences and local airflow effects. The water feed lines for all nozzles on both upper rows were replaced with aluminum tubing curved to one side as shown in photo 1, appendix E. This curved tubing no longer projected directly behind the top row nozzle bodies, and ice formation on the water lines was eliminated.

12. One minor manifold change was made during the 1985 season. As shown in photo 2, the two left most manifolds of the lower trapeze were interconnected with flexible tubing to alleviate a flow irregularity described in paragraph 19. This modification did not significantly change the flow pattern from the outboard manifold, and was not implemented for the corresponding manifolds on the upper trapeze.

13. The control panel for the bleed air APU was originally attached to the APU enclosure forward of the spray boom torque tube, and

could only be operated from the front of the cargo compartment (1984). To allow access from the spray operator's station in the aft cabin, the panel was relocated (1985) behind the torque tube assembly and mounted to the right cabin wall near FS 270, as shown in photo 3. This permitted combined operation of the bleed air APU and the spray system controls by a single operator.

14. Water passages throughout the spray booms and support arms initially consisted of 1-1/2 inch diameter tubing. Previous tests (app H) suggested that flow behavior at low water flow rates (less than 10 gpm) might be improved by reducing the size of these passages. Between the 1984 and 1985 icing season, the tubing sections within the upper and lower trapeze were replaced by one inch diameter tubing, leaving the support arms unchanged. Subsequent modifications (after 1985 icing) also converted the remaining water passages to one inch. The smaller passages were intended to eliminate partially filled water lines at low flow rates, decrease delay times during flow adjustments, and allow more uniform delivery of flow among the nozzles. The tubing changes reduced total volume of water contained in the boom assembly from 8.0 gallons in 1984 to 5.8 gallons in 1985. With one inch tubing throughout, present volume is 3.6 gallons.

15. Rupture of bleed air hoses and malfunction of the water pump caused recurring difficulties during operation (para 16). To reduce incidence of such problems, these systems were modified after completion of the 1985 icing tests. The long sections of 2 inch flexible hose connecting the bleed air mixer assembly outlets with each of the boom entry points were replaced by 2 inch diameter stainless steel tubing, as shown in photo 4, appendix E. Short hose sections remained to connect the tubing gaps and accommodate line movement caused by rotation of the torque tube when raising and lowering the boom. The hydraulic motor driving the water pump was replaced with a larger unit better suited for sustained operation. A thicker mounting baseplate was installed to improve alignment, and the type of coupling between motor and pump was changed from one with press-fit neoprene bushings to one with sprockets and a roller chain connection. The replacement motor unit and coupling installation are shown in photos 5 and 6, appendix E. For comparison, the original assembly can be seen in photo 2, appendix H.

SPRAY OPERATIONS

16. The HISS attempted 73 icing spray flights during the 1984 and 1985 icing seasons in Duluth, Minnesota. Of these flights, 64 met icing aircraft test requirements as intended. Two of the

remaining nine missions were terminated prior to start of spray because of test aircraft problems, while the other seven experienced HISS equipment malfunctions. Water pump hydraulic motor failure occurred twice, and bleed air hose breakage terminated five missions (four of these before icing immersion). Under favorable weather conditions and aircraft availability, up to four complete spray flights have been accomplished in a single day. This section discusses various characteristics of the system that were observed during operation.

17. Differences in nozzle orientation to the airstream affected spray performance under icing conditions. When the boom assembly deployed to the down and locked position, the support arms hung from the aircraft at an angle aft of vertical, as shown in photo 7, appendix E. This angle is a function of rigging adjustment between the torque tube positioning arms, hydraulic actuators, and downlock struts. Some variation is possible whenever the trunnion mount assembly is removed and reinstalled during maintenance between icing seasons. The aft sweep causes the upward facing row of nozzles on each trapeze to incline slightly forward (into the airstream), and the downward facing rows somewhat aft. The 1984 icing season saw the first operational use of the "T" shaped water manifolds (app G), and initial flights consistently resulted in growth of small ice formations near the atomizer tips on the upward facing rows of nozzles (photo 8, app E). The downward facing rows remained clear. As seen closer in photo 9, a bridge of ice formed between the nozzle orifice and the water supply tube located directly behind the nozzle body. The local flow field behind each upward facing nozzle entrained some of the spray and deposited drops onto the water tube. These froze and formed a curved ice column that grew toward the nozzle orifice. The downward pointing nozzles faced the airstream at a different angle, and the spray projected clear of the tubing. As described in paragraph 11, this spray impingement was eliminated by modifying the water feed lines. Future spray system designs should maintain uniform nozzle orientation to the airstream to preclude inconsistent atomization characteristics between different groups of nozzles.

18. Except for the phenomenon described above, freezing and leakage at the nozzles and associated boom connections did not usually present a problem. The stainless steel "T" manifolds using high-pressure hydraulic tube fittings (MS-type) had been installed in response to earlier such problems (ref 4, app A), and effectively corrected the recurring leaks typical of the previous disk manifolds and plastic lines. Occasional ice formations that appeared on the boom could be traced to individual fittings and corrected by tightening. At temperatures colder than -15°C , a potential

for internal freezing at some manifold locations still existed if bleed air or water flow were interrupted. This was of some concern during the start of flow while initial adjustments were in progress to balance water output, particularly at low flow rates. At the colder temperatures, set-up times had to be short and delays kept to a minimum to avoid partial freeze-up. As a standard procedure (ref 3), bleed air was kept flowing through both air and water passages (bleed and purge) until actual start of water flow. To prevent cold-soaking the boom prior to engine start, an additional procedure was developed for operating the bleed air APU on the ground to flow hot air through the system while the JCH-47C was being towed from the hangar. In normal circumstances, spray operations can be conducted successfully at temperatures as low as -23°C without leakage or freezing of the boom assembly.

19. The 1984 icing season was the first operational use of separate throttling water valves for the upper and lower trapeze. Flow distribution and measured pressure characteristics throughout the boom resembled those seen during the pre-icing test flights at Edwards AFB, California (app H). The end manifolds of each boom immediately adjacent to the support arm water supply (extreme left on the lower trapeze and extreme right on the upper) displayed less consistent water flow than the rest of the trapeze. This became particularly evident at low flow rates when these two manifolds only operated intermittently. An attempt to smooth the flow pattern by interconnecting adjacent manifolds (para 12) did not produce appreciable change in performance. Installation of reduced diameter water tubing in a portion of the boom assembly between 1984 and 1985 (para 14) did not significantly alter overall operating characteristics, and spray performance for both seasons remained similar. The observed spray patterns produced by the trapeze assembly during operation are generally satisfactory.

20. As observed in the past, spray from the upper and lower trapeze sections merged to form a single cloud just forward of the test aircraft nominally positioned 180 ft behind the booms. Previously reported spray cloud dimensions (ref 3, app A) have been estimated as 36 ft wide and 8 ft deep in cross-section (without spray from the outriggers), and these remain valid as a representative average. Photos 10 and 11, appendix E show front and side views of the JU-21A in the spray cloud. Cloud dimensions are not large enough for complete coverage of a test aircraft, and separate immersion sequences were used for icing the rotor system and fuselage. Satisfactory icing operations were not attainable during turbulent air conditions since the presence of gusts disturbed the cloud behind the booms and precluded a stable immersion.

21. To produce a selected LWC, the HISS set its initial water flow rate to a calculated value derived from the physical relationship between water volume, airspeed, and cloud cross-sectional area that assumes a homogeneous spray dispersion and no water loss from evaporation:

$$\text{LWC} = \frac{1320.06 \times \text{flow rate}}{\text{airspeed} \times \text{area}}$$

Where:

LWC = gm/m³

flow rate = gallons/minute

airspeed = knots true airspeed (KTAS)

cross-sectional cloud area = ft²

1320.06 = conversion factor for units shown; water density taken as 1 gm/cm³

This function provides a calculated average for LWC over the entire cloud cross-sectional area. Small adjustments to the flow rate were often made once the JU-21A sampled the spray and obtained a measured value for LWC. Any significant deviation between the calculated average and the measured sample generally indicated the presence of some abnormal condition. The calculated average served as a useful cross-check for such factors as- very low humidity (high evaporation), nozzle blockage and flow imbalance (changes in cloud size and spray density), flowmeter inaccuracy, poor atomization (drop sizes outside measurement range), and laser spectrometer malfunction. If the LWC measurement could not be considered reliable, the calculated value was used to establish the test condition.

22. Radar activated red and yellow lights on the HISS provided visual cues to the test aircraft for maintaining standoff position. The lights did not provide information on relative motion, but indicated whether the aircraft was too close, too far, or within the proper distance zone. Pilot comments suggested that the ability to hold distance constant was affected by difficulty in judging the rate of closure. To improve future artificial icing operations, methods should be investigated to provide the test aircraft with an analog display of standoff distance.

NATURAL CLOUD CHARACTERISTICS

23. To evaluate how closely the artificial spray cloud simulates the natural icing environment, some baseline characteristics typical of natural clouds need to be defined. Figure 1,

appendix F shows drop size spectra from four representative stratiform cloud samples (A through D) obtained during natural icing test programs. Sample A was measured with a UH-1H helicopter in 1979 near St. Paul, Minnesota, and was originally presented as a natural cloud baseline in references 8 and 9, appendix A. It also appears in reference 3, which compares it with the first Sonicore nozzle results from the HISS. Sample B was obtained by the JU-21A near Salem, Oregon in 1982 (ref 1C). Samples C and D were measured during the 1984 Minnesota program in the vicinities of International Falls and Duluth, respectively. Combined, these samples illustrate the characteristics of stratiform clouds typically encountered during natural icing tests conducted by USAAEFA.

24. These normalized mass distribution spectra show the amount of LWC measured in each drop size class, divided by size increment of the measuring equipment (3 microns (μm) in case of the forward scattering spectrometer (FSSP), and 20 μm for the optical array probe (OAP)). The same data can be nondimensionalized by expressing the various drop diameters as a ratio of median volumetric diameter (MVD), and the LWC of each size class as a percentage of the total. Median rather than mean diameter is normally used to characterize drop populations, as it provides a more sensitive indicator of any water volume contained in the form of large drops. Figure 2 presents the previous four spectra in nondimensional format. This allows comparison of size distributions independent of specific values of LWC and MVD.

25. Two additional cases (E and F) are included in figure 2, appendix F. Case E shows nondimensional drop spectra presented by Langmuir in 1945 (ref 11, app A) and derived from icing "data that were obtained by R.M. Cunningham in an airplane" using the rotating multicylinder method. The discrete points on case E depict Langmuir's basic distribution. Additional distributions commonly used in the literature have been obtained by applying an exponent to the size ratio of the basic spectrum (powers of 0.0, 1.0, 1.5, 2.0, and 2.5). The second curve in case E shows one such alternate distribution, calculated by raising the basic spectrum to the 1.5 power. The curve using this exponent matches the natural cloud spectra more closely. The Langmuir distributions play a role in the National Advisory Committee for Aeronautics (NACA) icing research of that period, and appear in subsequent analyses (ref 12). A summary of the NACA icing investigations and published reports is given in reference 13. The final distribution (case F) shown on figure 2, appendix F is a composite of drop spectra A through D, and is intended to suggest a nominal baseline representative of natural icing cloud characteristics. This fairing does not differ from any of the previous

A through D curves by more than 5 percentage units of the LWC axis, and approximates the general shape of the Langmuir distributions. While other air mass types in different geographic areas may exhibit separate spectra, the composite curve shown by case F is typical of recent natural icing tests in stratiform clouds. The realism of the artificial cloud can be judged by how closely it resembles this natural cloud baseline. Efforts should be made to assemble a more varied data base of cloud spectra applicable to the helicopter icing environment.

SPRAY CLOUD CHARACTERISTICS

26. Cloud data from previous artificial icing programs using the Sonicore atomizers appear in references 3, 4 and 14, appendix A and were also obtained with spectrometer probes from the Particle Measuring Systems, Inc. (PMS) series. References 3 and 14 show initial HISS results with the Sonicore nozzles from 1980 and 1981, and reference 4 gives cloud measurements taken in 1982 after the APU bleed air source had been added. The LWC and MVD characteristics of the spray are presented in these reports and correlated with flow rate and location in the cloud.

27. In obtaining cloud measurements with the PMS probes, the FSSP alone normally suffices for natural clouds (drops smaller than 45 μ m), while both probes are required for the HISS in order to include the larger drop sizes. Malfunction of either probe precludes a valid HISS cloud measurement. Assorted problems were experienced with both PMS probes at various times during the 1984 and 1985 icing seasons. The malfunctions were often subtle and persistent, and sometimes several flights would elapse between initial indication of a difficulty and its resolution. The most insidious was an internal misalignment in the FSSP that caused the probe to undercount the number of drops. This error apparently originated partway through the 1984 season, and introduced a gradually worsening drift in probe accuracy that progressed through 1985. Its overall effect was to distort the measurements toward lower LWC and higher MVD values than actual. As a result, only a limited amount of the PMS data obtained is considered valid for spray cloud characterization. On-site diagnostic facilities for the cloud measuring equipment should be upgraded and a factory equivalent calibration and functional check performed prior to each icing season.

28. Measurements of LWC and MVD taken during "cloud centered" spray samples in 1984 are shown as a function of water flow rate in figures 3 through 6, appendix F. Airspeeds of 90 and 120 KTAS are presented separately. These points represent data averaged

over intervals lasting from 10 to 20 seconds selected from approximately one minute long stable immersions in the spray cloud. The LWC measurements (figs. 3 and 4) can be compared with the "calculated average" linear function (para 22) shown for each airspeed. The degree of agreement with the calculated line and the range of scatter are typical of those observed previously (refs 3 and 4, app A). The MVD data (figs. 5 and 6, app F) are taken from the same cloud samples and fall in a range between 34 and 75 μ m. For comparison, the 1980 results (ref 3, app A) showed a high concentration of data between 20 and 35 μ m, and the 1982 data (ref 4) ranged from 25 to 40 μ m MVD at flow rates below 13 gal/min, and 40 to 70 μ m at higher flow rates. While overlap exists with the previous range of values, the present MVD data tend to group toward the upper end of the size range. Even at low flow rates where the finest atomization should occur, no MVD's averaged below 34 μ m. This undesirable indication of larger drop sizes than seen in the past tends to shift the artificial cloud spectrum away from the nominal 15 to 25 μ m MVD range typically attributed to natural clouds. In view of the otherwise enhanced flow distribution characteristics of the spray system that were expected to improve atomization, this discrepancy cannot be readily explained. With some uncertainty in data quality introduced by instrumentation problems (para 27), substantive conclusions regarding any change of atomization performance cannot be drawn.

29. Examples of normalized spray cloud drop spectra are presented in figure 7, appendix F. For comparison with previous HISS data, case A is taken from reference 3, appendix A and shows a sample from 1980 with an MVD of 21 μ m. Cases B and C are from 1984 with MVD's of 35 and 55 μ m, respectively. These data were obtained from "cloud centered" samples and are one second records selected as representative of the average conditions. When compared with the natural cloud spectra of figure 1, appendix F differences are evident in slope and in shape near the apex. While the peak concentrations occur at reasonable values of drop size (15 to 25 μ m), the HISS distributions are considerably broader and include larger drop sizes above 50 μ m that do not normally occur in natural clouds. This is particularly evident at higher flow rates as in case C. Presence of these larger drops drives the MVD upward.

30. When the spectra are presented in nondimensional format (fig. 8), the contrast with the natural cloud data (fig. 2) is even more pronounced. The natural cloud spectra show a distinct peak exceeding 25% LWC near an MVD₀ ratio of one; the spray data do not peak as sharply or exceed 12% LWC, and significant amounts of LWC occur at size ratios in excess of two. Even when actual

MVD occurs at a comparable value ($21\mu\text{m}$ in case A) the quantity of LWC present in the form of larger drops has a marked effect on the distribution shape. The nozzle spray characteristics with available air and water pressure are such that some amount of undesirably larger drops are always generated, which skews the distribution. In general, the artificial cloud produces peak drop mass concentrations in the desired size range, but also contains a number of larger drops that are not characteristic of natural clouds.

31. Variability of spray composition within the cloud was measured during vertical sweep maneuvers. LWC and MVD were obtained over one-half second intervals while slowly climbing and descending through the cloud. Relative position between data points was estimated by assuming equally spaced increments during the traverse. Previous results have been summarized in references 3 and 4, appendix A, where LWC is presented as a smooth function of vertical location within the cloud. These curves were intended to suggest average trends based on combined data from a number of flights. Scatter of this LWC data varied among individual sweeps but generally remained within $\pm 0.2 \text{ gm/m}^3$. LWC increased from near zero (defining each cloud boundary) to a peak slightly below cloud center, and the maximum LWC exceeded the average taken over the entire cloud depth by a factor of 1.4 to 1.8, depending on flow rate. Generally similar trends were observed during this program. Figure 9, appendix F presents an example of vertical sweep data obtained in 1984. Consecutive values of LWC and MVD measured during a sweep in each direction are shown corresponding to estimated position in the cloud. Shape of the LWC curve is characteristic, and in this instance the maximum value occurs just above cloud center at a factor of 1.8 higher than the average value for the sample. The drop size data show an MVD range of 35 to $40\mu\text{m}$ in the central portion of the cloud, with smaller values near the top of the spray and higher values near the bottom. The lower 2 ft of the cloud show a marked increase in MVD occurring as LWC rapidly decreases, resulting from an absence of small drops rather than an increase in the number of large ones. At the very bottom of the cloud (near zero LWC), only two or three large drops registered on the PMS probes, resulting in a very large MVD. This pattern of MVD variation from top to bottom has also been previously reported and is characteristic of the spray cloud.

32. Additional measurements taken during this same spray condition are presented in figure 10. Time histories of LWC are shown for standoff distances of 130, 180 and 230 ft from the boom. This range of distances would normally represent the limits of test aircraft movement during formation flight while attempting to

maintain a constant 180 ft from the HISS. A steady "cloud centered" sample of 18 seconds was obtained in each case. In addition, the JU-21A deliberately input slight vertical motions (estimated at ± 2 ft) while sampling at the 180 and 230 ft distances to include a wider segment of the spray than during the "cloud centered" immersions. Figure 10 notes the average values of LWC and MVD for each of the sequences shown. At the 130 ft standoff, spray from the upper and lower trapeze had not quite merged to form a continuous cloud, and the measurement was taken centered in the lower plume. The data show gradually decreasing LWC and increasing MVD with standoff distance, which is consistent with an expanding plume and the effects of evaporation reducing the number of small drops more quickly than large ones. The amount of LWC variation seen during these time histories indicates the extent of scatter to be expected while obtaining cloud measurements. While the traces that include deliberate vertical movement show larger excursions between consecutive points than the "cloud centered" samples, total variation over the entire sample is not greatly affected (about 0.2 gm/m^3 bandwidth in these samples) and the averaged values are comparable. The averaging procedure used to define spray characteristics from "cloud centered" samples appears to yield reasonably consistent results within normal operating limits.

33. Flow rates higher than usual were also evaluated during this program. As observed previously, nozzle performance deteriorates markedly when water flow increases to a point where water pressure starts to approach available air pressure. When atomization broke down above 25 gpm in reference 3, appendix A drop spectra peaked around an $80 \mu\text{m}$ diameter instead of the usual $15\text{-}25 \mu\text{m}$ range. This effect presently occurs at about a 35 gpm flow rate (app H) when bleed air is supplied by both APU and aircraft engines. Flow rates were established up to 50 gpm, resulting in measured LWC values that exceeded 2 gm/m^3 at 120 KTAS. However, the large drop sizes and high MVD values (about $150 \mu\text{m}$) at such flow rates limit their realism for icing tests. Since drop diameters above $300 \mu\text{m}$ were probably present but not measured by the probes or considered in the MVD calculation, their inclusion would tend to increase MVD even further. The present operating air and water pressure characteristics indicate an upper usable limit of about 35 gpm to retain satisfactory spray atomization.

34. Relative humidity is known to influence the spray cloud characteristics, but accurately quantifying its effects by in-flight measurement has proven elusive. A natural cloud is saturated with a background relative humidity of 100%, representing a substantial presence of water in vapor form in addition to

the liquid drops that define LWC. For the -20° to 0°C temperature range, the saturation vapor represents from 0.9 to 4.8 gm/m^3 of additional moisture in the air (ref 15, app A). Spray from the HISS in a clear air environment introduces the desired LWC in the form of drops, but no control exists over the ambient vapor content (expressed by relative humidity). Evaporation of the spray cloud is the most apparent effect of low relative humidity. Calculations show that evaporation can noticeably alter both the drop size spectrum and LWC in one second, the approximate time interval between the spray boom and test aircraft at 120 KTAS. LWC loss leading to drop extinction occurs more rapidly for small drops than large ones, particularly affecting drops below $20\text{ }\mu\text{m}$. The overall decrease in LWC and increase in MVD depends on the original drop distribution, which varies with flow rate and location in the cloud. A general trend of lower LWC and higher MVD has been observed for data obtained over a wide humidity spread, and a statistical correlation was presented in reference 4. The 1984-1985 evaluation encountered an ambient humidity range from 20 to above 95%, but the majority of tests took place at conditions above 50%. Clearly defined variations attributed solely to humidity could not be isolated from other effects in the available data. Since icing simulation emphasizes drop sizes below $20\text{ }\mu\text{m}$ where evaporative effects are most severe, increased efforts should be made to identify and deal with the influence of humidity on cloud composition.

35. High humidity conditions (above 95%) produced visible effects during spray operations. The appearance of the generated cloud became more dense and noticeably restricted forward visibility from the test aircraft. This was attributed to a large increase in the number of very small drops, which was also indicated by an increase in formation of frost-like coatings on the test aircraft (para 38). In such conditions, condensation trails frequently appeared in the rotor systems of both the HISS and the test aircraft (photos 12 through 14, app E). The visible vortices from the blade tips of the HISS passed well above the test aircraft, and the condensation trails could assume dimensions and appearance comparable to the spray cloud. The spray cloud did not dissipate as quickly as at low humidity and sometimes persisted in the form of parallel rows of clouds remaining from earlier passes back and forth through the test area. On a few such occasions, an undersun reflection could be observed in the previous trails, an optical effect indicating that the supercooled water drops had glaciated and turned to ice crystals (ref 16, app A). Photos 15 and 16, appendix E show a HISS cloud trail (as observed from the ground) that persisted, increased in size, and acted as a catalyst for natural cloud growth.

ICE ACCRETIONS ON TEST AIRCRAFT

36. The various test aircraft flown in the HISS spray cloud during concurrent icing programs (para 5) provided an opportunity to compare ice formations between the natural and artificial environments. Drop trajectory and impingement studies indicate that the type of ice accretions produced depend strongly on drop sizes present in the cloud. Catch efficiency is related to inertial properties of different size drops, determining their ability to follow streamlines and make turns with the airflow. As described in paragraph 30, the HISS cloud contains a portion of its LWC in the small drop size range of natural clouds, but also contains an amount of larger drops (above 50 μm). Ice from the larger drops collects in a smooth layer over larger frontal areas of exposed surface than small drops, which tend to form localized accretion patterns projecting forward from stagnation regions. The mix of drop sizes found in the HISS spray gave rise to both types of ice formation. The HISS could provide extended immersions at high LWC's, which resulted in more massive ice formations of the large drop type than usually found in stratiform clouds at the test site. At the same time, however, the small drops in the spray distribution also produced ice formations with shapes and accretion characteristics very similar to natural cloud ice forms. These were particularly evident on aircraft surfaces where inertia of the large drops prevented their impact, such as rotor hub droop stops, UH-1H sideward facing inlet screens, and tailboom rivets. Future efforts to improve HISS performance should emphasize reduction of drop sizes to less than 50 μm diameter for increased realism of the ice formations.

37. One major area of uncertainty in the past had been the ability of the HISS to produce non-streamlined "double-horned" ice shapes, a type of formation characteristic at warmer temperatures (near -5°C). Such formations on rotor blades are known to be common in the natural environment, but doubts remained about the artificial cloud since larger drops tend to produce more streamlined shapes. On one flight (1985) at -5.0°C , ice was retained on the inboard portions of the AH-64A main rotor after landing, as shown in photo 17, appendix E. A very obvious "double-horned" cross section was apparent at the ice surface where the outboard portion had shed, demonstrating that the HISS is capable of producing non-streamlined ice accretions on rotor blades. This was the first time at such a warm temperature that sufficient rotor ice had been retained to allow direct examination, and this finding significantly improves the credibility of the HISS simulation. Additional examples of rotor icing generated by the HISS (1984) are given in reference 17, appendix A which used silicone molds

to replicate ice shapes from UH-1H rotor blades at temperatures from -11° to -22°C.

38. Various inferences regarding drop size can be drawn from the appearance and characteristics of the ice accretions. Photographs 18 through 25, appendix E illustrate additional types of ice formations encountered in natural and artificial conditions. One indication of small drop size is formation of ice on surfaces that exclude large drops by inertial sorting. Tailboom rivets and small irregularities along the sides of a fuselage are examples of such areas, as shown in photos 18 and 19 for natural and artificial icing encounters. Photo 19 includes ice along the edges of stickon insignia letters on the tailboom, and a frost-like coating that follows skin surface deflections. At high-humidity conditions behind the HISS (para 35) the frost-like coatings became very pronounced, which is attributed to an increase in the number of small drops. Photo 20 shows such an instance where even the bottom of the fuselage was covered, resulting in a heavier coating than observed during natural encounters.

39. Photos 21 and 22 compare natural and artificial ice formations on forward areas. While the artificial formations on the nose and drop tanks cover larger areas than in natural conditions (attributed to the presence of larger drops), the general shapes and locations of accretions are comparable. The sharply defined cutoff of ice formation below a horizontal hinge-line on the nose is evident in both photos. Ice had already shed from the FM antenna (aft of the cockpit door) in photo 22; a closer view with ice present is shown in photo 23. The feathery, forward growing formations seen here and in photos 24 and 25 are characteristic of desirable drop sizes. The outward-expanding formations from exposed fastener heads in photo 23 and scalloped formations on the angled strut in photo 24 are realistic shapes also indicating presence of small drops. Additional discussion comparing natural and artificial ice formations is given in reference 18, appendix A, which was a 1985 program to photographically document ice accretions on various test airfoil sections mounted in a fixture attached to the JU-21A.

CONCLUSIONS

GENERAL

40. Evaluation of HISS performance during the 1984 and 1985 icing seasons found that operational characteristics had improved as a result of the system modifications made during the first two phases of this program. The following conclusions were reached upon completion of the artificial icing tests:

a. Spray operations can be conducted successfully at temperatures as low as -23°C without leakage or freezing of the boom assembly (para 18).

b. The observed spray patterns produced by the trapeze assembly during operation are generally satisfactory (para 19).

c. The artificial cloud produces peak drop mass concentrations in the desired size range (15 to 25 μm), but also contains a number of larger drops that are not characteristic of natural clouds (para 30).

d. The averaging procedure used to define spray characteristics from "cloud centered" samples appears to yield reasonably consistent results within normal operating limits (para 32).

e. The present operating air and water pressure characteristics indicate an upper usable limit of about 35 gpm to retain satisfactory spray atomization (para 33).

f. The HISS is capable of producing non-streamlined ("double-horned") ice accretions on rotor blades (para 37).

RECOMMENDATIONS

41. The following recommendations are made:

a. Future spray system designs should maintain uniform nozzle orientation to the airstream to preclude inconsistent atomization characteristics between different groups of nozzles (para 17).

b. Methods should be investigated to provide the icing test aircraft with an analog display of standoff distance (para 22).

c. Efforts should be made to assemble a more varied data base of cloud spectra applicable to the helicopter icing environment (para 25).

d. On-site diagnostic facilities for the cloud measuring equipment should be upgraded and a factory equivalent calibration and functional check performed prior to each icing season (para 27).

e. Increased efforts should be made to identify and deal with the influence of humidity on cloud composition (para 34).

f. Future efforts to improve HISS performance should emphasize reduction of drop sizes to less than 50 μm diameter for increased realism of the ice formations (para 36).

APPENDIX A. REFERENCES

1. Final Report, USAASTA Project No. 72-35, *Helicopter Icing Spray System Qualification*, October 1973.
2. Final Report, USAAEFA Project No. 75-04, *Modified Helicopter Icing Spray System Evaluation*, March 1977.
3. Final Report, USAAEFA Project No. 79-02-2, *Helicopter Icing Spray System (HISS) Nozzle Improvement Evaluation*, September 1981 (N82-19208).
4. Letter, USAAEFA, DAVTE-TI, 22 June 1982, subject: Report. Helicopter Icing Spray System (HISS) Evaluation and Improvements, USAAEFA Project No. 80-04-2.
5. Letter, AVRADCOM, DRDAV-DI, 14 June 1982 (with revision, 13 August 1982), subject: Helicopter Icing Spray System (HISS) Evaluation and Improvements. (Test Request 82-05)
6. Technical Manual, TM 55-1520-227-10-2, *Operator's Manual, Army Model CH-47C Helicopter*, 29 May 1984, change 5 dated 4 September 1985.
7. Letter, AVRADCOM, DRDAV-D, 1 July 1982 (with revisions 13 July 1982 and 13 July 1983), subject: Airworthiness Release for Helicopter Icing Spray System (HISS) Boom Structural Dynamics Evaluation with Fiberglass Blades and Modified Spray Cloud Measurements, USAAEFA Project No. 82-05.
8. Technical Report, Meteorology Research Inc., No MRI 79 FR-1700, *Drop Size Characteristics of the USAAEFA (CH-47) Helicopter Icing Spray System During Simulated Icing Tests of the UH-1H*, 27 July 1979
9. Final Report, USAAEFA Project No. 78-21-2, *Microphysical Properties of Artificial and Natural Clouds and Their Effects on UH-1H Helicopter Icing*, August 1979.
10. Final Report, USAAEFA Project No. 81-21, *Limited Artificial and Natural Icing Tests of the OV-10 (Re-evaluation)*, June 1982.
11. Technical Report, General Electric Research Laboratory, No. RL-225, *Mathematical Investigation of Water Droplet Trajectories, December 1944-July 1945*, as published in "The Collected Works of Irving Langmuir, Volume 10, Atmospheric Phenomena", Pergamon Press Ltd, 1961.

12. Technical Report, NACA-TR-1215, *Impingement of Cloud Droplets on a Cylinder and Procedure for Measuring Liquid Water Content and Droplet Sizes in Supercooled Clouds by Rotating Multicylinder Method*, 1955 (N81-73119)
13. Technical Memorandum, NASA TM-81651, *Selected Bibliography of NACA-NASA Aircraft Icing Publications*, August 1981.
14. Technical Report, Meteorology Research Inc., No. MRI-81 FR-1813, *Natural and HISS Cloud Droplet Data as Sampled During the 1980-81 USAAEFA/St. Paul Field Program*, 1 September 1981.
15. Handbook, Smithsonian Miscellaneous Collections Volume 114, *Smithsonian Meteorological Tables*, Smithsonian Institution Press, sixth revised edition 1966.
16. Textbook, V.J. Schaefer and J.A. Day, *A Field Guide to the Atmosphere*, Houghton Mifflin Company, 1981.
17. Final Report, USAAEFA Project No. 83-23, *Evaluation of UH-1H Level Flight Performance Degradation Caused by Rotor Icing*, July 1984.
18. Final Report, USAAEFA Project No. 83-01, *Verification of U-21A Cloud Parameter Measurement Equipment and Comparison of Natural and Artificial Ice Accretion Characteristics on Rotor Blade Airfoil Sections*, to be published.
19. Handbook, All American Engineering Co., SM-280-B, *Installation, Operation, and Maintenance Instructions with List of Parts, Helicopter Icing Spray System (HISS)*, with Change 1, November 1974.
20. Technical Report, Meteorology Research Inc., No. MRI 82 FR-1858, *US Army Small Intelligent Icing Data System (Army SIIDS)*, 3 February 1982.

APPENDIX B. DESCRIPTION-HELICOPTER ICING SPRAY SYSTEM

1. The aircraft equipped with the HISS installation is a modified Boeing Vertol CH-47C helicopter with fiberglass rotor blades, US Army S/N 68-15814. It is a twin-engine, turbine powered tandem rotor helicopter with a gross weight limit of 48,000 lb. Power is provided by two Lycoming T55-L-11 series turboshaft engines. Each engine has an installed power rating of 3,750 shaft horsepower under standard day sea level conditions. Each rotor system is 60 ft in diameter and is equipped with three fiberglass blades of 32 in. chord. Normal operating rotor speed is 225 rpm. Fuselage length is 50 ft 9 in., and distance between rotor centerlines is 39 ft 2 in. A hydraulically powered loading ramp is located at the rear of the cargo compartment.

2. The HISS installation was initially developed under contract by the All American Engineering Co. in 1972, and is described in reference 19, appendix A. Side and rear view schematics of the present overall arrangement are shown in figure A. The aluminum water tank has an 1800 gallon capacity, and the deployed spray boom assembly is suspended 19 ft beneath the aircraft from a torque tube through the cargo compartment. Hydraulic actuators rotate the torque tube to raise and lower the boom assembly, and mechanical latches hold the boom assembly locked in either the fully deployed or retracted positions. The external boom assembly can be jettisoned from any position by explosive bolts at two joints on the boom support members. The internal water supply can be jettisoned by a cable-cutter cartridge arrangement which opens trap doors in the water tank over the aircraft cargo hook hatch. Controls for water jettison and boom deployment, retraction, and jettison are located in the cockpit.

3. The boom assembly consists of two parallel 27 ft trapeze sections with 5 ft vertical separators, and two 17.6 ft outriggers attached by 4-way junctions to the upper trapeze. When lowered, the outriggers are swept aft 20° and angled down 10° giving a tip to tip boom width of 60 ft. Skid plates at each corner of the lower trapeze allow a forward hover landing without damage to the boom or nozzles if the boom fails to retract. The boom is constructed of concentric metal pipe. The outer pipe (4 in. diameter) is the structural trapeze and outrigger assembly and provides a passage for bleed air. Water is pumped through the inner pipe at selected flow rates from the tank to the nozzles on the boom assembly. The water passages originally had a 1-1/2 inch diameter throughout. Between the 1984 and 1985 icing seasons, the water tube sections within the upper and lower trapeze were changed to one inch diameter. After the 1985 season, the remaining sections in the boom supports and cabin interior were also modified, converting the entire water system to one inch diameter. Thirty manifolds for distributing water to the nozzles are spaced approximately three ft apart along the boom exterior. Aircraft

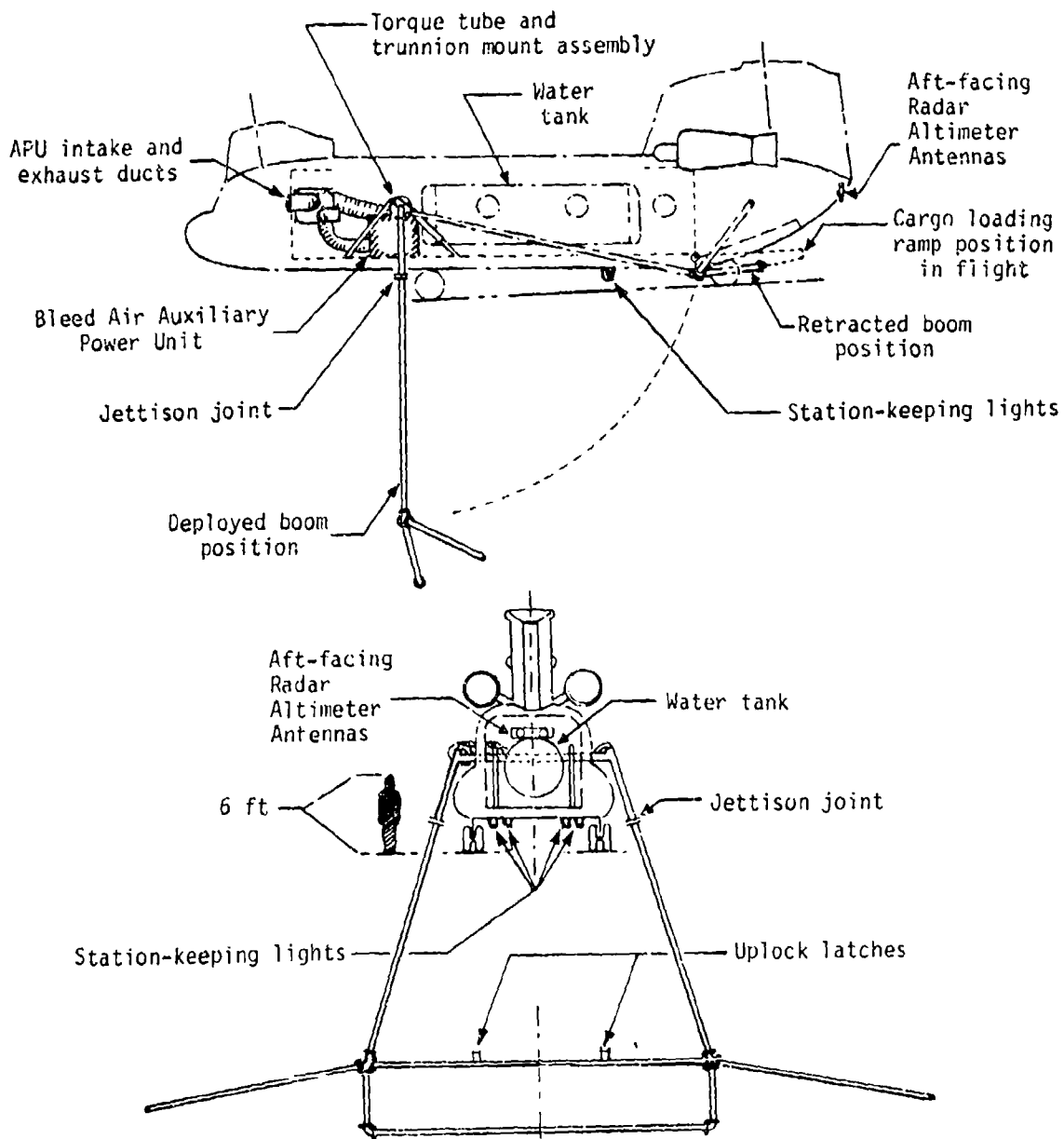

Figure A. Helicopter Icing Spray System
Side and Rear View Schematic

engine compressor bleed air and bleed air from a Solar T-62T-40C2 auxiliary power unit (APU) are supplied through the outer pipe to the nozzles for atomization. Figure B shows a schematic of the current air and water distribution system.

4. There are 172 nozzle receptacles on the boom surface, as shown in figure C. These receptacles are staggered to provide alternating upward and downward ejection ports every six inches. Because of available air pressure considerations only 97 locations on the center sections are normally used during icing operations. Sonic Development Corporation Model 125-H Sonicore nozzles (photo 1) have been installed since 1980. Air enters at the base of the nozzles and water from the side through connecting tubes from the manifolds. As installed on the boom, vertical distance between upward and downward facing nozzle orifices is 11 inches. Figure D shows a cutaway schematic of the air and water plumbing within the booms. Additional details of the various HISS components modified during phases 1 and 2 of this program are given in appendixes G and H.

5. Aft-facing radar altimeter antennas are mounted at the rear of the HISS to allow positioning the test aircraft at a known standoff distance. Analog displays are provided in the cockpit and the aft cargo compartment. The radar activates red and yellow lights mounted to the bottom of the HISS fuselage (photo 2) that act as visual cues for the test aircraft. The aft cargo ramp remains partially open while spraying to allow observation of the test aircraft from the rear of the HISS. A calibrated Rosemount air temperature probe and a Cambridge dew point hygrometer with cockpit displays provide accurate ambient temperature and humidity measurement. Thermocouples and pressure transducers are installed on the boom assembly at two locations (shown in fig. C) to allow inflight measurement of pressure and temperature for both boom air and water while spraying. A control and display panel is mounted on the right side of the cabin at fuselage station 120 at the opening to the aircraft heater unit compartment. As shown in photo 3, two selector switches are available to control three digital displays, two for pressure and one for temperature. These measurements were read and recorded manually. An operator's station at the rear of the HISS, shown in photo 4, provides control of various air, water, and hydraulic valves, and includes displays of water flow rate, upper and lower trapeze water pressure, pump outlet water pressure, and various hydraulic system pressures. Access is afforded to controls of the bleed air APU and the manual override uplock and downlock boom mechanisms. For photographic purposes during icing operations, dye added to the water imparts a yellow color to the ice (calcoicid uranine yellow 73, in approximate proportions of 7 oz per 1500 gallons).

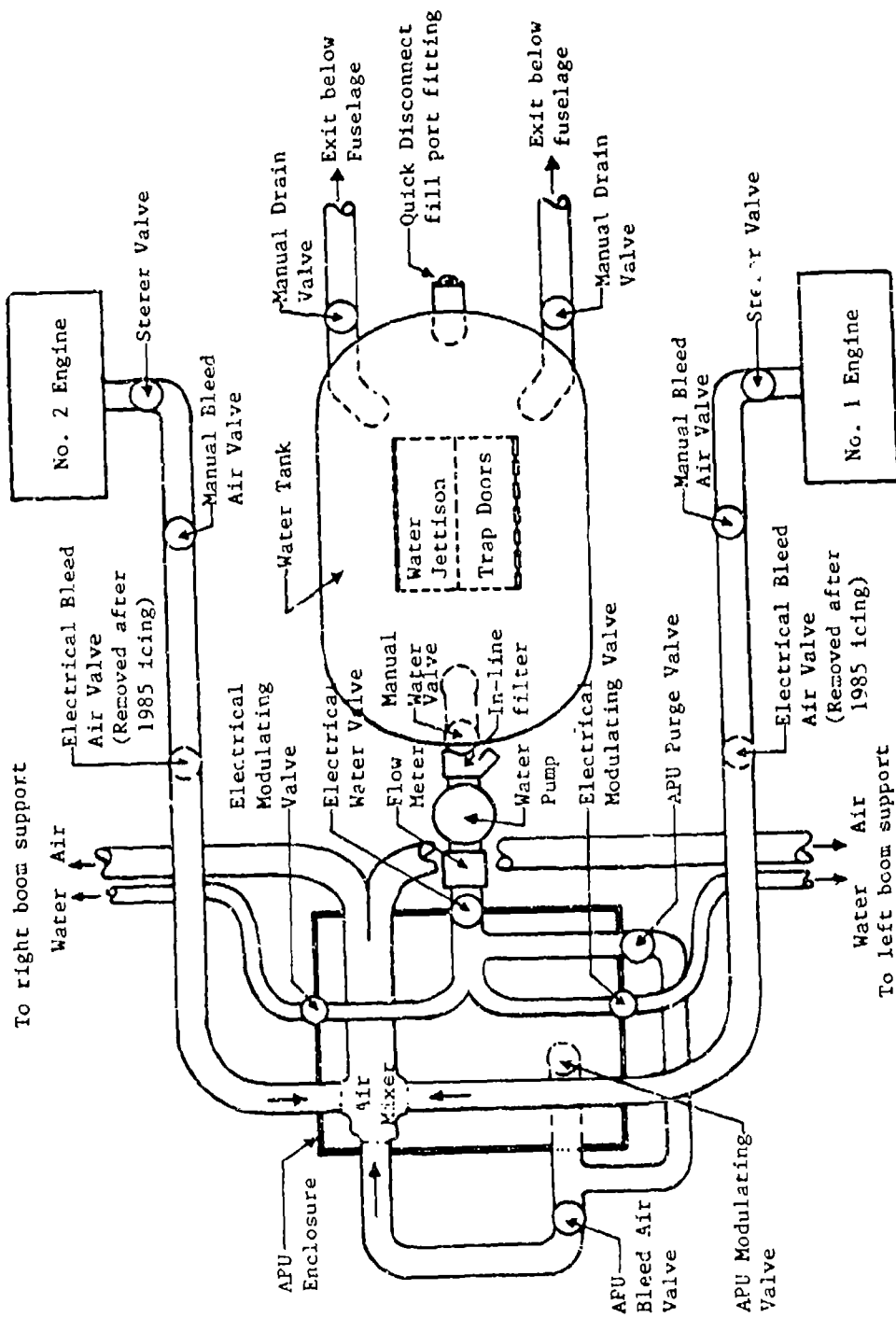
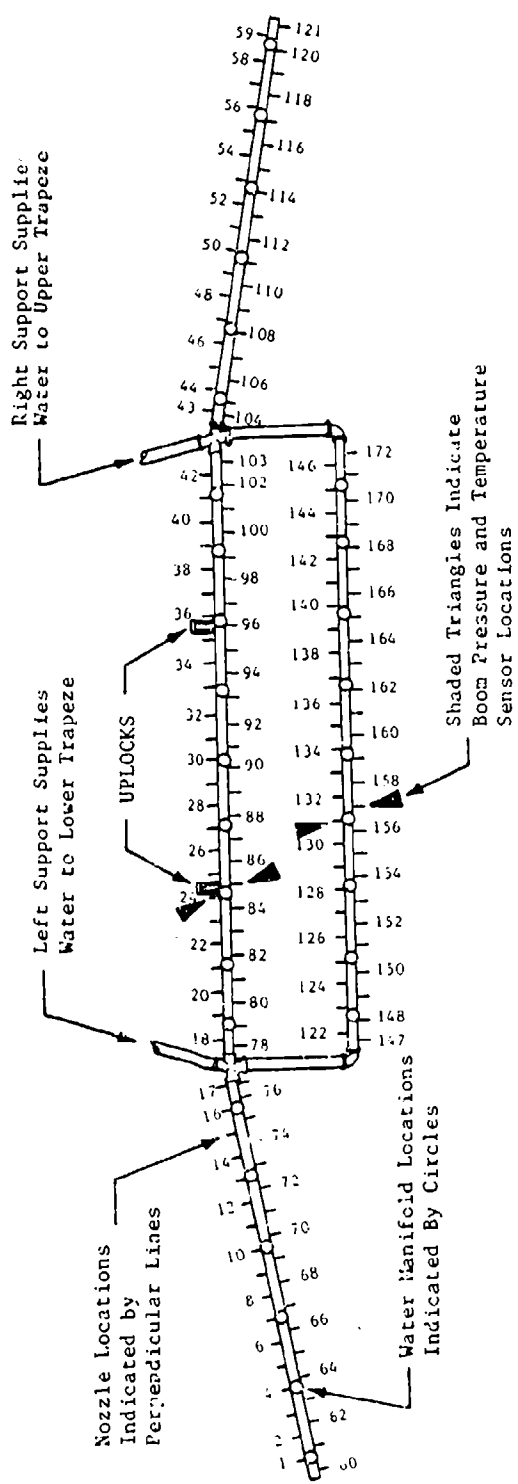

Figure B. Helicopter Icing Spray System Air and Water Distribution System



- NOTES: 1. As viewed from rear looking forward.
2. Total of 172 nozzle receptacles (35 per outrigger, 51 per trapeze)
3. Total of 30 water manifolds (6 per outrigger, 9 per trapeze)
4. Trapeze length 27 ft, overall tip-to-tip 60 ft.
5. Nozzles not installed on outriggers and location No's 24, 36, 85, 131, and 157

Figure C. Boom Assembly Nozzle and Water Manifold Provisions

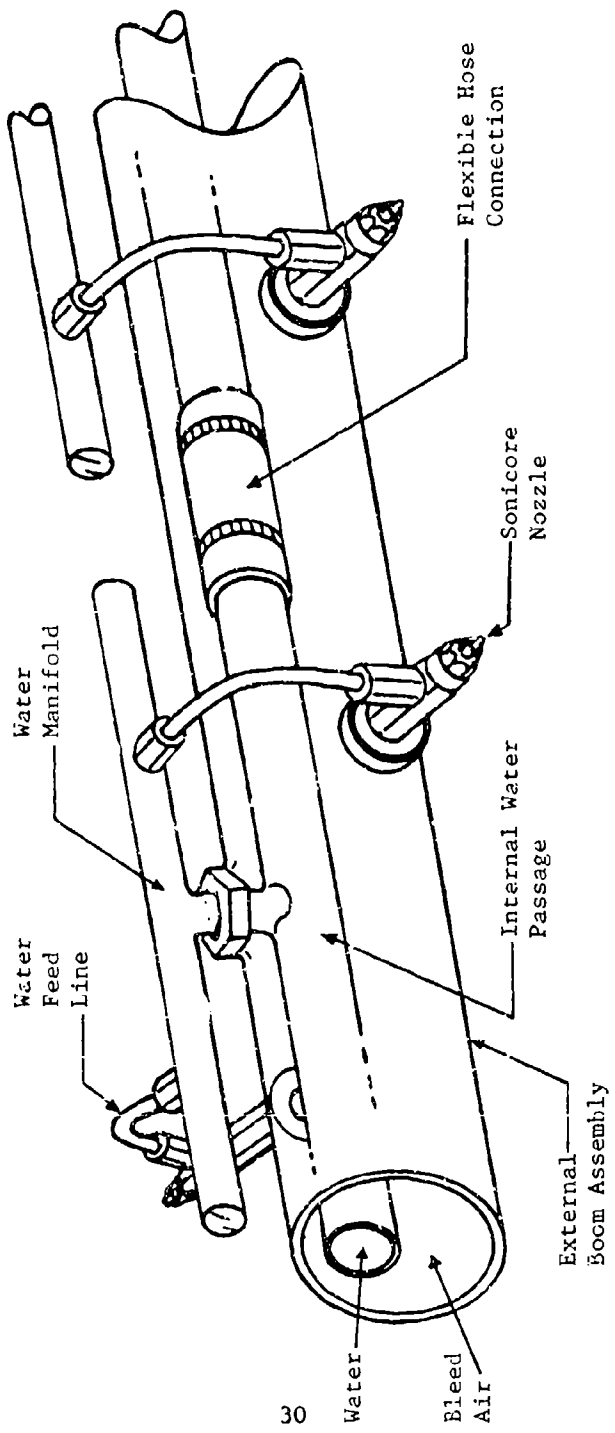

Figure D. Cutaway Schematic of Spray Boom Plumbing

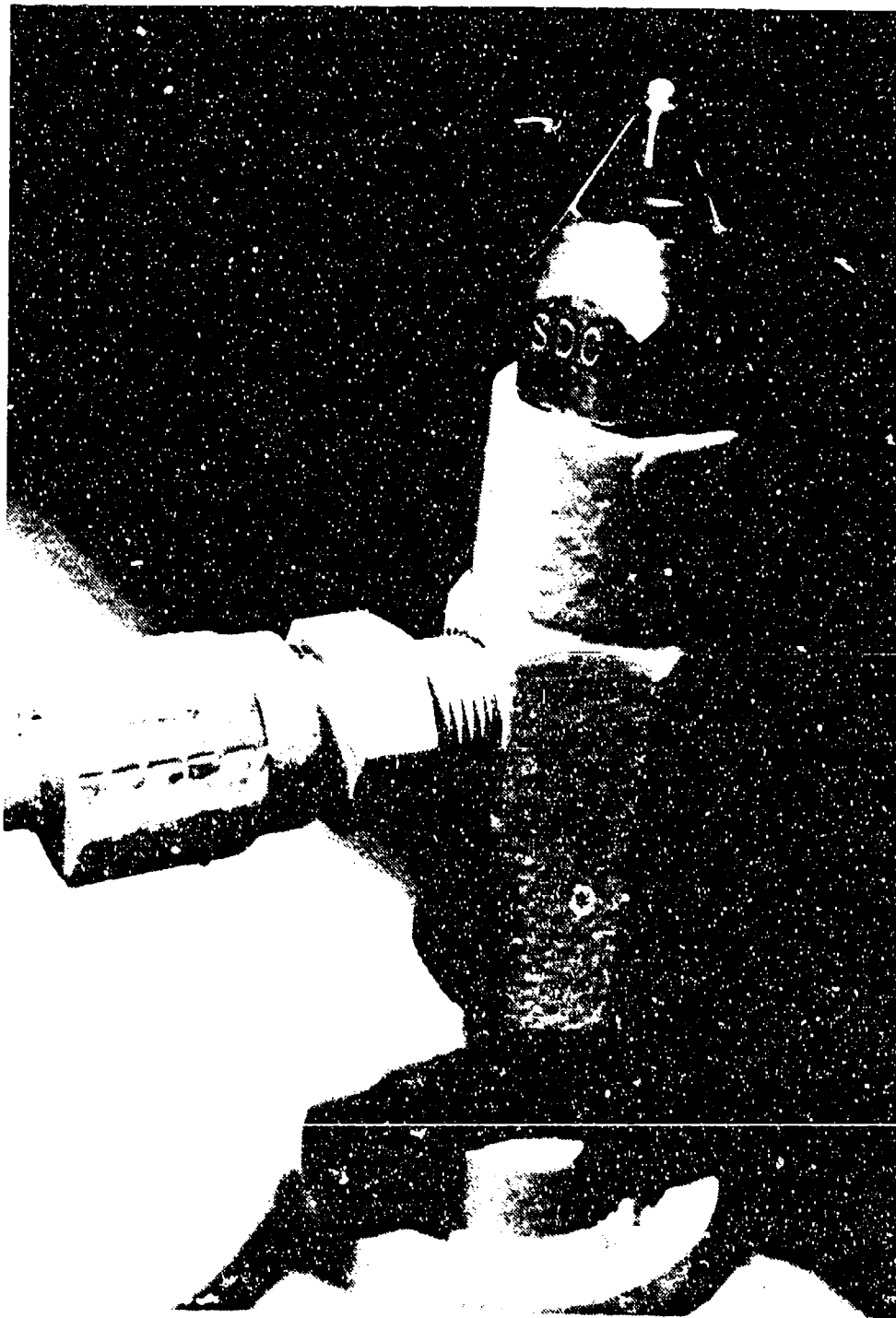

Photo 1. Soaic Development Corporation, Model 125-II
"Soaicore" Spray Nozzle



Photo 2. Red and Yellow Position Lights Mounted on HISS Fuselage

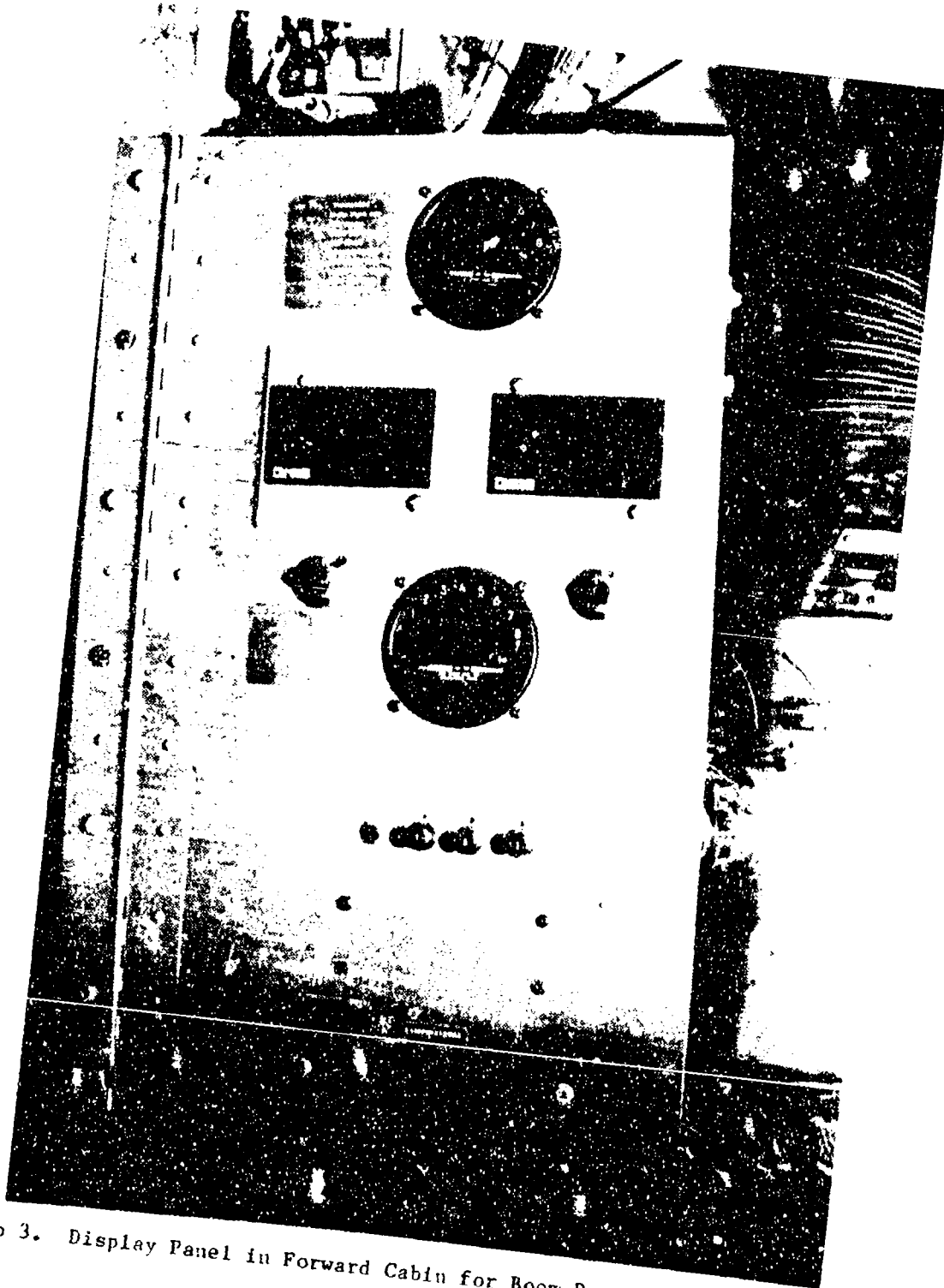

Photo 3. Display Panel in Forward Cabin for Boom Pressure and Temperature

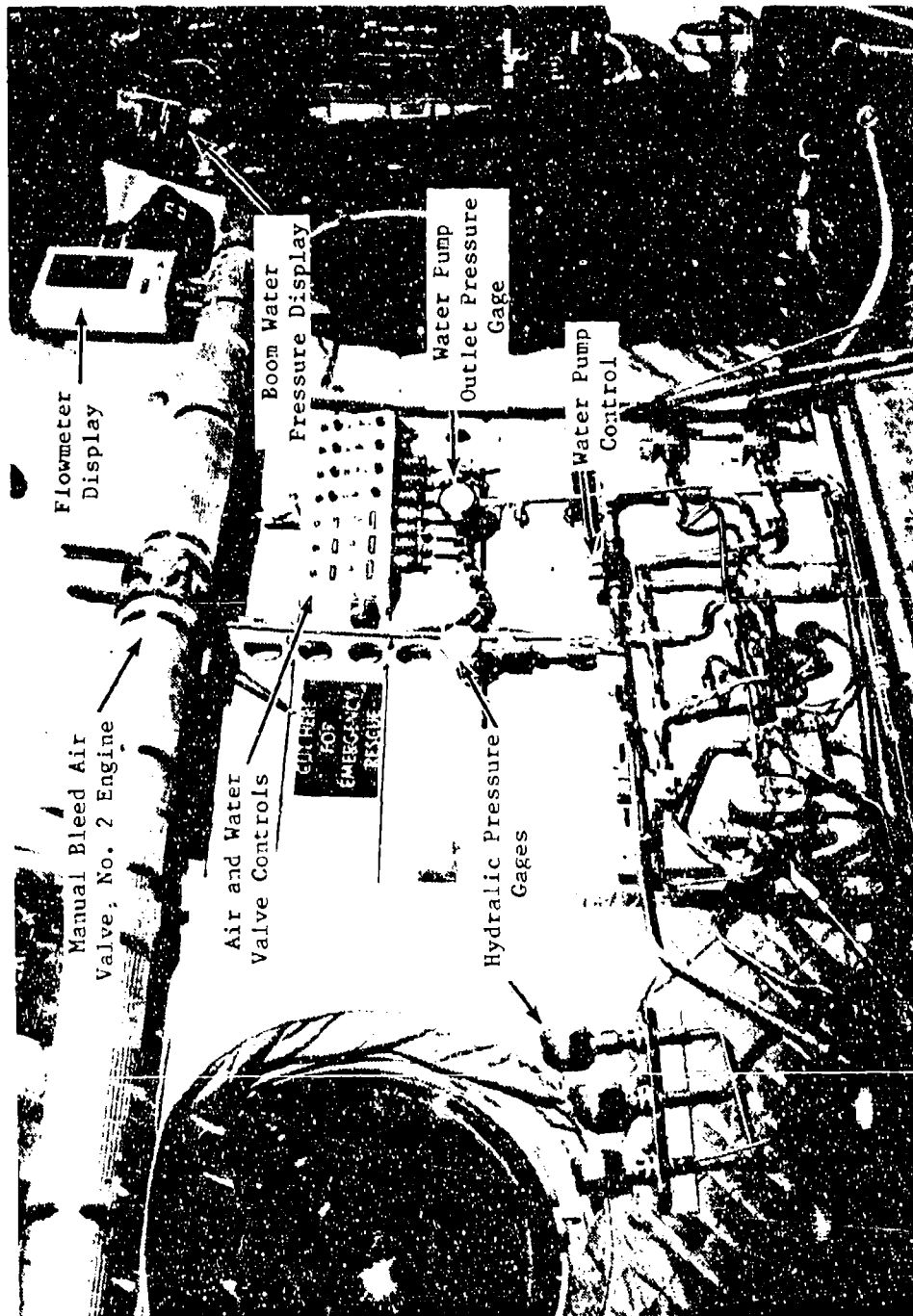

Photo 4. Operator's Station in Aft Cabin for Spray Control

APPENDIX C. INSTRUMENTATION

JU-21A CLOUD MEASURING EQUIPMENT

1. The aircraft used for icing cloud measurements was a JU-21A, US Army Serial No. 66-18008, manufactured by Beech Aircraft Corporation. It is an unpressurized, low-wing, all metal, twin engine airplane with retractable tricycle landing gear and a maximum takeoff weight of 9650 lb. The aircraft has a wingspan of 45 ft 10.5 in. and a nose to tail length of 35 ft 6 in. Power is provided by two T74-CP-700 (commercial designation PT6A-20) turbo-prop engines manufactured by Pratt and Whitney Aircraft/United Aircraft of Canada, Ltd. Each engine has an installed power rating of 550 shaft horsepower under standard day sea level conditions. The aircraft is certified for flight into moderate icing conditions, and incorporates electrothermal systems for anti-icing the windshield, pitot tube, stall warning vane, engine air inlet lip, fuel vents, and heater air inlet and deicing the propeller blades. Pneumatic boots are incorporated for deicing the wing leading edges outboard of the engine nacelles to 30 inches short of the wing tips, and the vertical and horizontal stabilizers. The engines are equipped with extendable ice vanes ahead of the compressor inlet for particle deflection, and an autoignition system to reignite combustion in case of flameout due to water ingestion or icing conditions.

2. The cloud measurement package installed on the JU-21A consisted of the following equipment: a Particle Measuring Systems, Inc. (PMS) forward scattering spectrometer probe (model FSSP-100), a PMS optical array cloud droplet spectrometer probe (model OAP-200X), Rosemount total temperature sensor and display, Cambridge model 137 chilled mirror dew point hygrometer and display, Leigh Mk 10 ice detector unit with digital display (1984 only), Cloud Technology Inc. model LWH-1 (Johnson Williams type) liquid water content (LWC) indicator system, and the Small Intelligent Icing Data System (SIIDS). Photo 1 shows the exterior of the aircraft with the probes in place, while photo 2 shows the interior instrumentation rack with displays.

3. The Leigh Mk 10 and Cloud Technology probes were not used to obtain HISS cloud data, as they did not provide a meaningful LWC measurement in the spray plume. This is attributed to the presence of large drop sizes in the spray beyond the design limits of these probes. In the natural cloud environment, these probes functioned properly and gave valid readings. Only the PMS spectrometer measurements were used for HISS LWC data. Each PMS probe projects a collimated helium-neon laser beam normal to the airflow across a small sample area. In forward flight, particles passing through the beam (sample area) are counted and measured into 15 size channels per probe, each probe operating over a different size range. While these probes are primarily intended as particle sizing devices, an LWC can be calculated from the



Photo 1. Cloud Measuring Instrumentation on JU-21A



Photo 2. SIIDS Display Rack

drop size measurement and number count within the sample volume relative to airspeed.

4. The FSSP-100 determines particle size by measuring the amount of light scattered into the collecting optics aperture as the particles pass through the laser beam. A pulse height analyzer compares the maximum amplitude of the scattering signal pulses with a reference voltage derived from a separate measurement of the illuminating light signal. The pulse height analyzer output is encoded to give the particle size in binary code, and resolves particle sizes from 2 to 47 μm into 15 equally spaced increments 3 μm wide. It is capable of sizing particles having velocities of 20 to 125 meters/sec (39 to 243 knots). A gate output signal provides a measure of particle transit time, and a velocity averaging counter and control system determines an average. The system automatically rejects particles with transit times less than average since these are susceptible to edge effect errors and result from particles passing through regions of less than maximum intensity. A laser beam width of 0.186 mm and depth of field of 2.76 mm provides a total sample area of 0.513 mm^2 (before velocity reject).

5. The OAP-200X determines particle size using a linear array of photodiodes to sense the shadowing of array elements. Particles passing through the field of view illuminated by its laser are imaged as shadowgraphs on the array and a flip-flop memory element is set if the photodiode elements are darkened. Size is given by the number of elements set by a particle's passage, the size of each array element, and the optical magnification. Magnification is set for a size range of 20 to 300 μm , and 24 active photodiode elements divide particles into 15 size channels, each 20 μm wide. It is capable of sizing particles with velocities of 5 to 100 meters/sec (10 to 194 knots). Depth of field, effective array width, and sample area vary with sensed particle size to a maximum of 61mm, 0.44mm, and 18.3 mm^2 , respectively.

6. The SIIDS was designed by Meteorology Research Inc. and is a data acquisition system programmed specifically for icing studies. A more complete description appears in the user's guide (ref 20, app A). It consists of four main components: a microprocessor, Techtran data cassette recorder, Axiom printer, and an operator control panel. The SIIDS has three operational modes: (1) data acquisition, in which averaged raw data are recorded on cassette tape and engineering units are displayed on the printer, (2) a playback mode in which raw averaged data read from the cassette are converted to engineering units displayed on the printer, and (3) a monitor mode used to set the calendar clock and alter programmed constants. During data acquisition, the operator may

select an averaging period of 1/2, 1, 2, 5, or 10 seconds. The following parameters are displayed on the SIIDS printer in engineering units.

- a. calendar: year, month, day, hour, minute and second
- b. pressure altitude (feet)
- c. airspeed (knots)
- d. outside air temperature ($^{\circ}\text{C}$)
- e. dew point ($^{\circ}\text{C}$)
- f. total LWC observed by the FSSP (gm/m^3)
- g. total LWC observed by both FSSP and OAP (gm/m^3)
- h. median volumetric diameter (μm)
- i. amount of LWC observed for each channel (total 30) of both probes (gm/m^3)

APPENDIX D. TEST TECHNIQUES AND DATA ANALYSIS METHODS

1. The JU-21A equipped with the Small Intelligent Icing Data System (SIIDS) package obtained HISS spray cloud measurements on flights intended for cloud calibration and in conjunction with artificial icing missions for test aircraft on other programs. Operational icing missions were generally flown at a single test condition that was held constant throughout a given mission, while the calibration flights measured a range of spray conditions. A crash/rescue helicopter accompanied each mission as an area chase and remained in visual contact with the test formation.

2. Artificial icing missions with a test aircraft consisted of flying in formation behind the HISS while keeping the aircraft rotor system or fuselage immersed in the spray cloud. The HISS flew at a constant airspeed between 80 and 120 knots true airspeed (KTAS) throughout the immersion, and attempted to maintain constant air temperature by gradually adjusting altitude as required. The test aircraft attempted to maintain a constant standoff distance of 180 \pm 10 ft from the spray booms, using the radar altimeter activated red and yellow position lights as visual cues. Radio calls from crewmembers in the rear of the HISS and the JU-21A close chase assisted in positioning the test aircraft laterally and vertically. When a change of direction was made to stay within the operating area, test formation was maintained and spray immersion continued during gradual turns at bank angles below 10°.

3. Prior to cloud entry by the test aircraft, the JU-21A assisted the HISS in establishing the desired flow rate and performed a cloud sampling maneuver to measure actual liquid water content (LWC) and drop size distribution. Initial flow rate was set to a value calculated from target LWC and airspeed (para 21, Results and Discussion section). The JU-21A observed the spray plumes emanating from the boom assembly to provide qualitative comments on evenness of flow distribution between the upper and lower trapeze. Notes were taken of any evident leaks, malfunctioning nozzles, or ice formations on the boom for post-flight maintenance inspections. For operation behind the HISS, the JU-21A configured to an approach (35%) flap setting. Just prior to cloud entry, all electrothermal ice protection systems were activated and engine ice vanes were extended. Once flow rate was stable and the spray plumes balanced, the JU-21A maneuvered to immerse the laser measuring spectrometers into the spray cloud at the nominal 180 ft standoff distance. The probes were held approximately centered in the densest portion of the cloud for about a minute while obtaining a continuous record of one second samples. Once a measured value for LWC was available, flow rate was adjusted as necessary to provide the target LWC. After this sample, the JU-21A repositioned to one side and the test aircraft entered the spray cloud to begin immersion.

4. On flights intended for cloud calibration, the JU-21A performed additional sampling maneuvers. The target airspeed for these tests was 120 KTAS. The HISS varied flow rates incrementally from 5 to 50 gal/min to produce a range of LWC values, and monitored spray boom air and water pressures. At each flow setting, a steady cloud-centered measurement was obtained by the JU-21A using the procedure just described. For selected flow rates, measurements were repeated at additional standoff distances from 130 to 330 ft behind the booms. Vertical sweeps through the cloud were also made using a half second data rate to measure variation of spray composition within the plume. The JU-21A initiated vertical sweeps from a centered position beneath the cloud, climbing slowly until the probes were above the cloud, and then descending to the starting point.

5. Cloud characteristics were derived from the SIIDS presentation of Particle Measuring Systems, Inc. (PMS) spectrometer data. All cloud parameters were computed from the particle number count, size classification, and size of air volume sampled, which depends on airspeed and probe type. A measured drop was assumed to lie in the center of its size class, although actual diameter may fall anywhere within the channel. A total of 30 size channels were available between both probes but only 28 were actually used. The two smallest channels of the optical array probe (OAP) (20 and 40 μm) were not included in the computation since they overlap the size range covered by the forward scattering spectrometer probe (FSSP). The SIIDS sums total volume of the drops sampled and provides a value for LWC contained in each size class (drop mass per channel for a one cubic meter sample volume); total sampled LWC results from summing the 28 size channels. Median volumetric diameter (MVD) is the drop size which divides the volume of the spray in halves, such that half the total water volume is contained in drops larger and half in drops smaller than this median diameter. If the mass contained in each channel is first converted to a percentage of the total mass and these percentages are added consecutively, the MVD occurs at the diameter where the cumulative sum reaches 50%.

6. The SIIDS data averaging intervals (sample accumulation rate) normally used were one second for the HISS cloud and ten seconds for the natural icing environment. A half second sample rate was used during vertical sweeps through the HISS cloud. The vertical sweeps were intended to determine spatial variation of LWC and MVD within the cloud. The lack of precise spatial references for correlation with probe data during the sweeps required making two assumptions: (1) the JU-21A moved through the cloud at a constant rate, and (2) the cloud boundaries were defined when the probes stopped registering a significant number

of drop counts (probes outside the cloud). These assumptions only permit an estimate of probe position relative to edges of the cloud, and do not provide data on actual cloud dimensions. Some discrepancies in the data could be expected for any given sweep because of cloud size relative to the measurement aircraft and the type of maneuver performed while flying in formation.

APPENDIX E. PHOTOGRAPHS

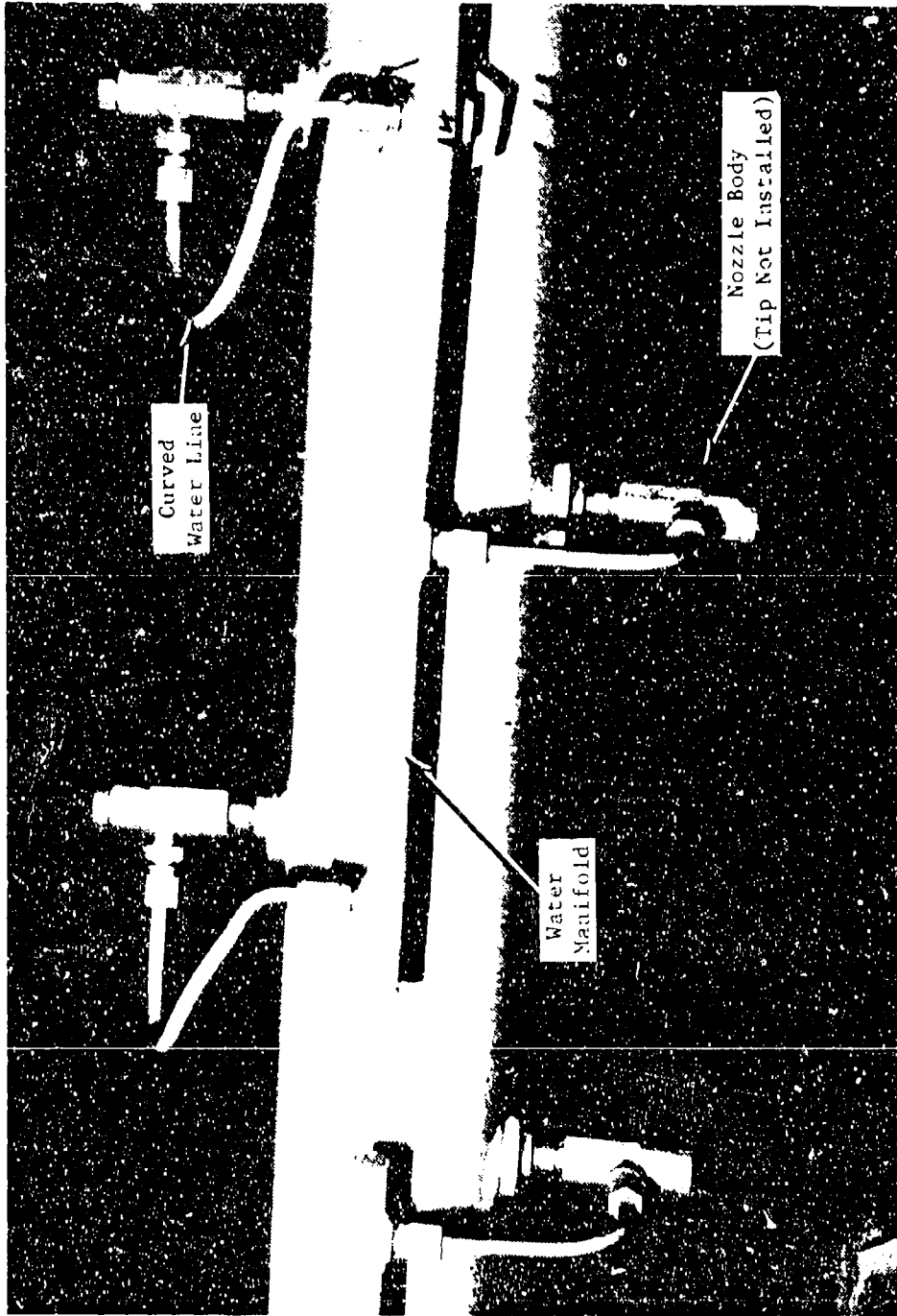

Photo 1. Curved Water Feed Lines Installed For Upward-Facing Nozzles

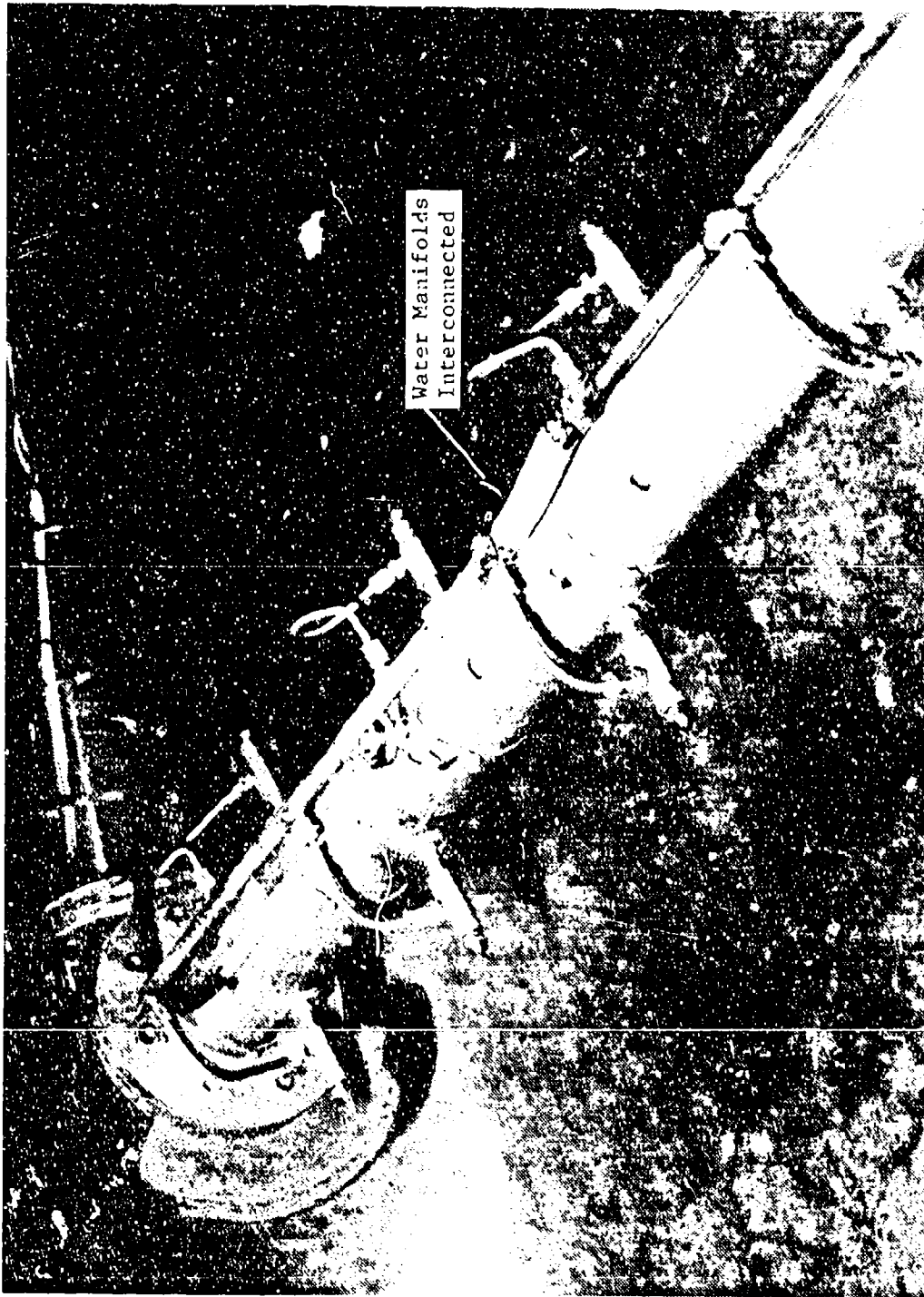

Photo 2. Interconnected Water Manifolds on Left End of Lower Trapeze

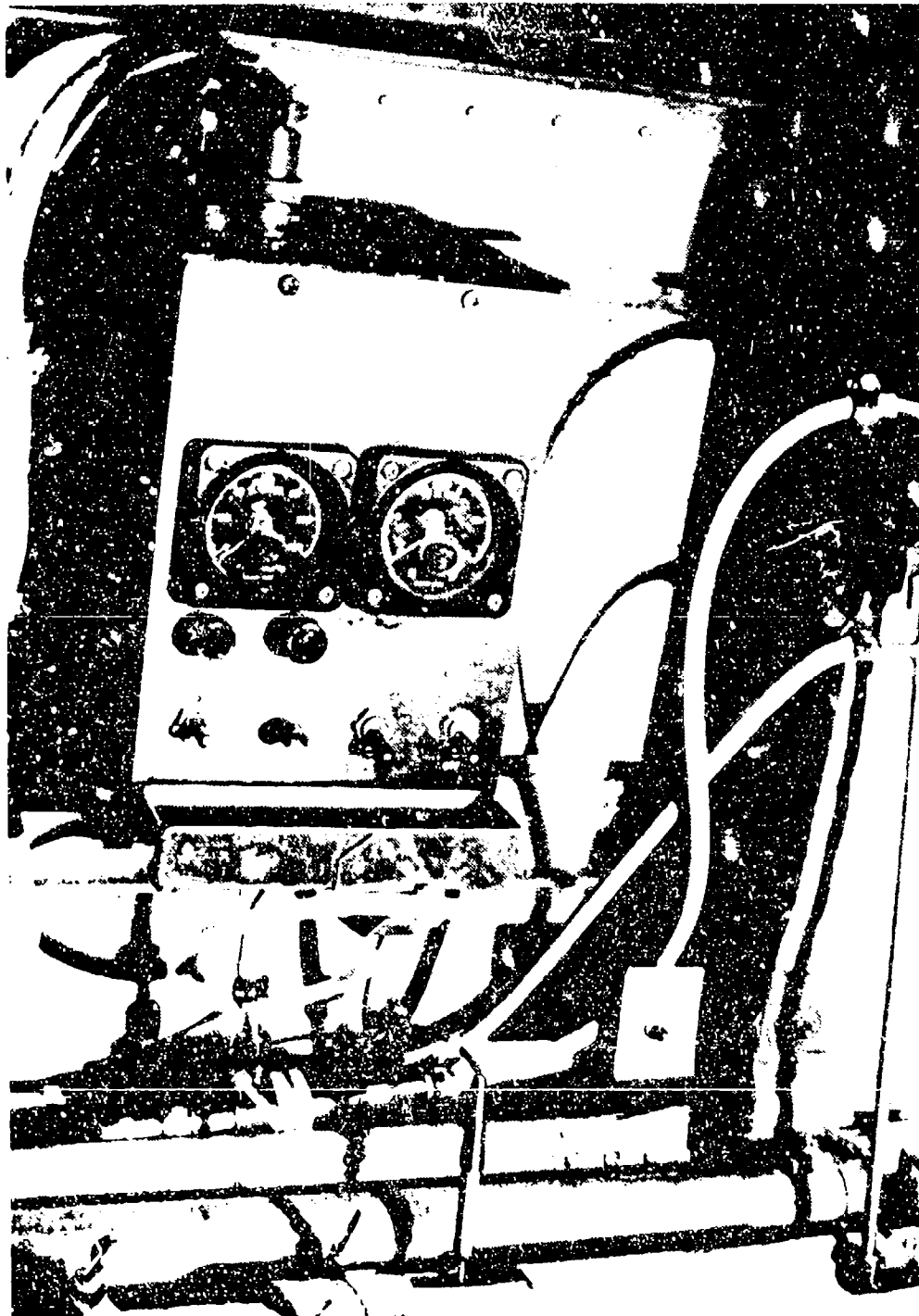

Photo 3. Bleed Air APU Control Panel Mounted to Cabin Wall

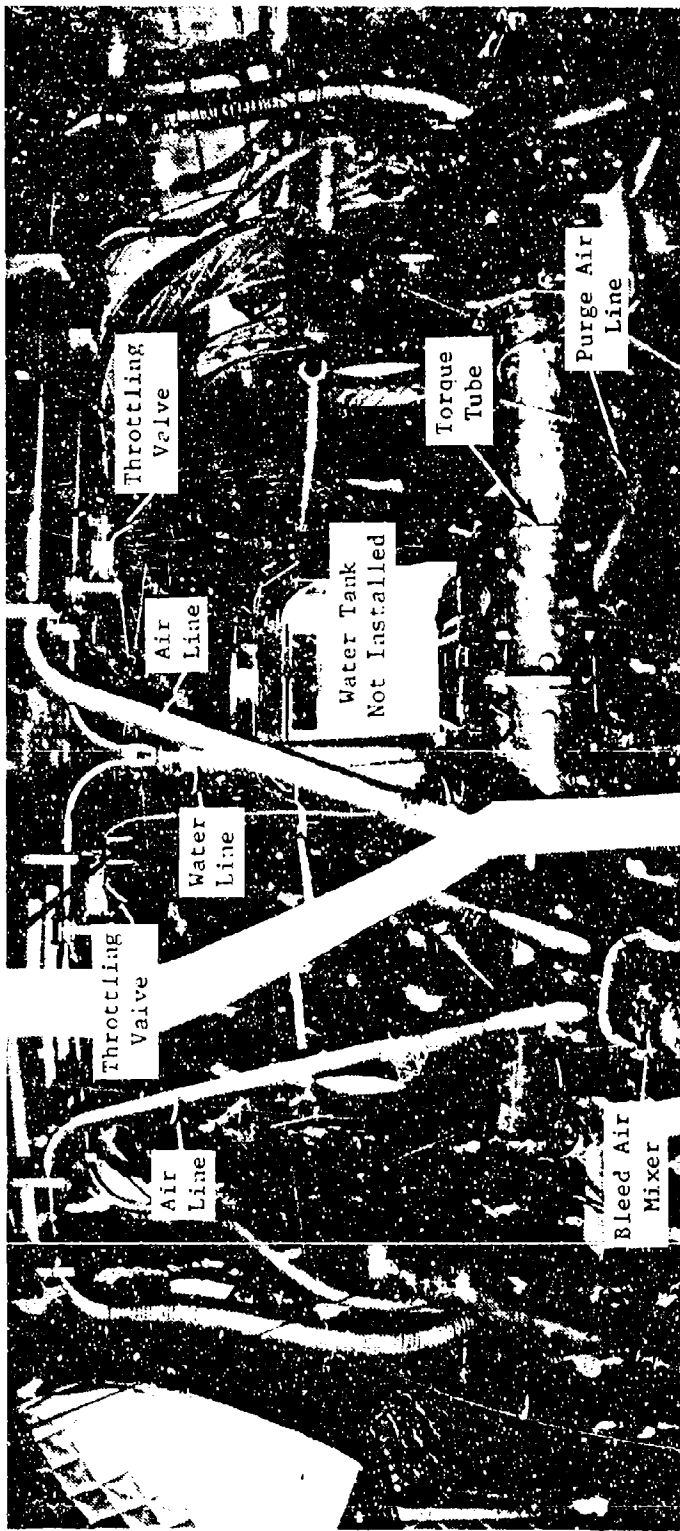

Photo 4. Stainless Steel Air Line Installation

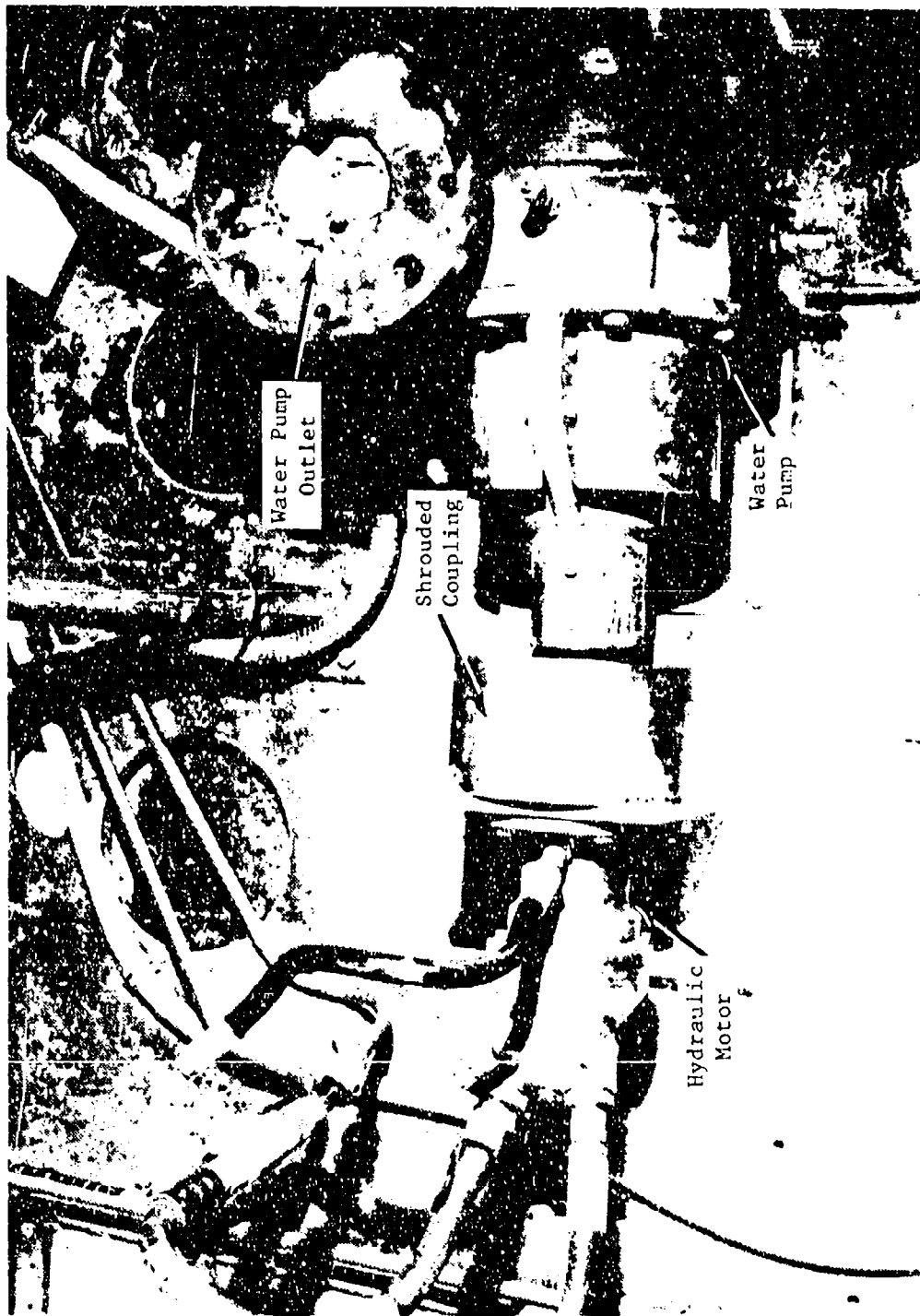

Photo 5. Hydraulic Motor and Water Pump Assembly

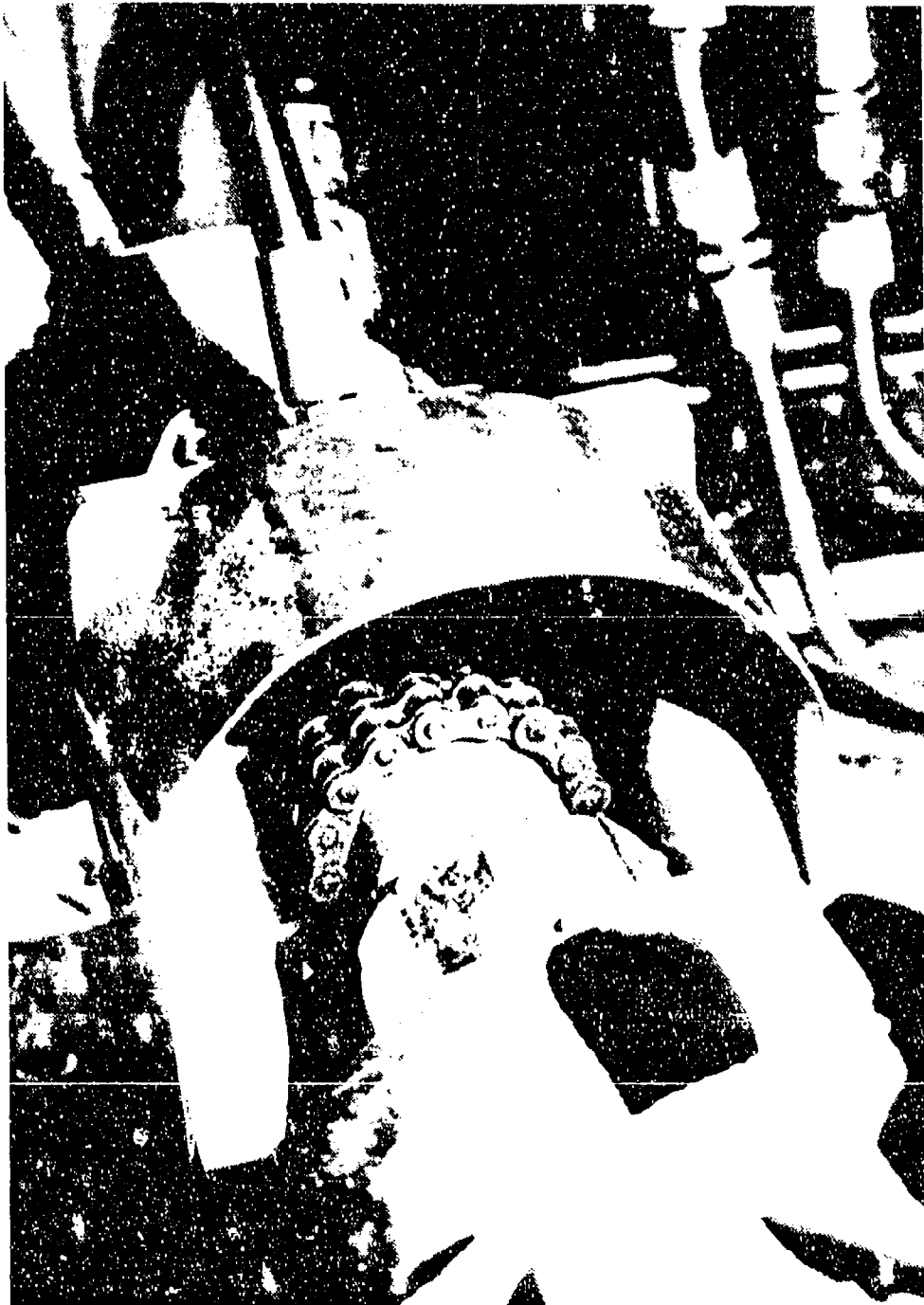
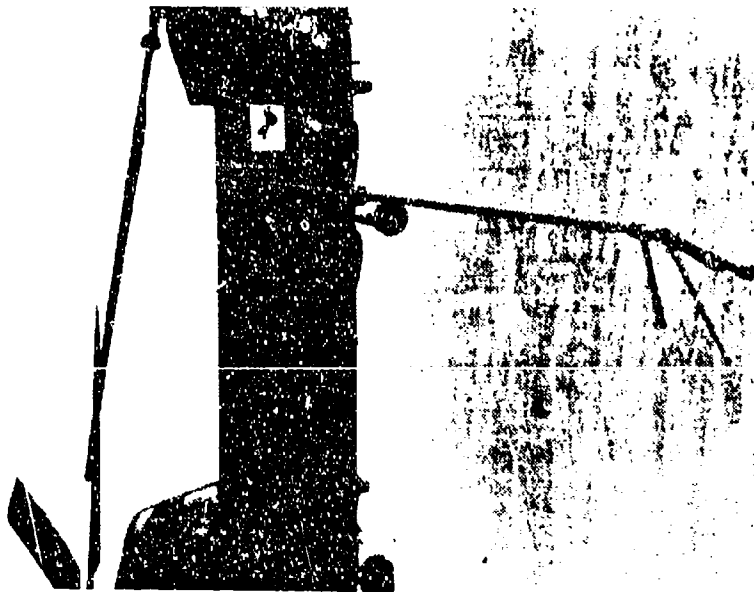
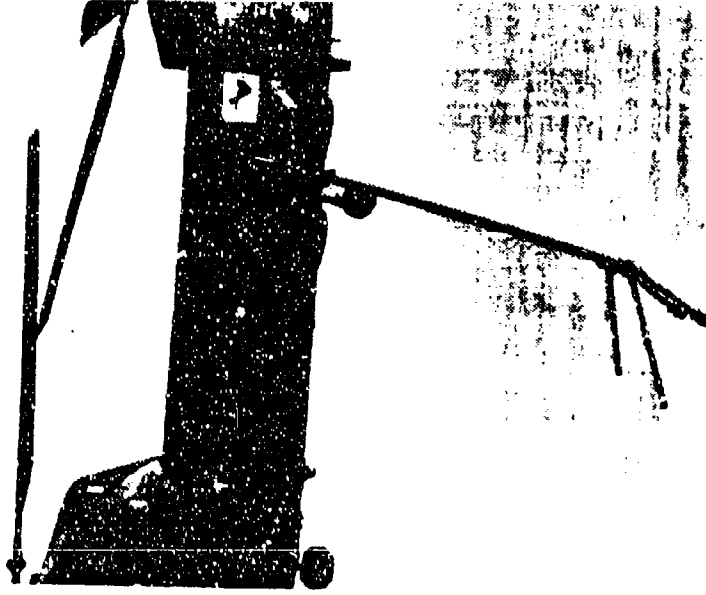

Photo 5. Roller Chain Coupling Between Hydraulic Motor and Water Pump



40 KCAS



140 KCAS

Photo 7. Boom Support Arm Rearward Deflection for Two Airspeeds

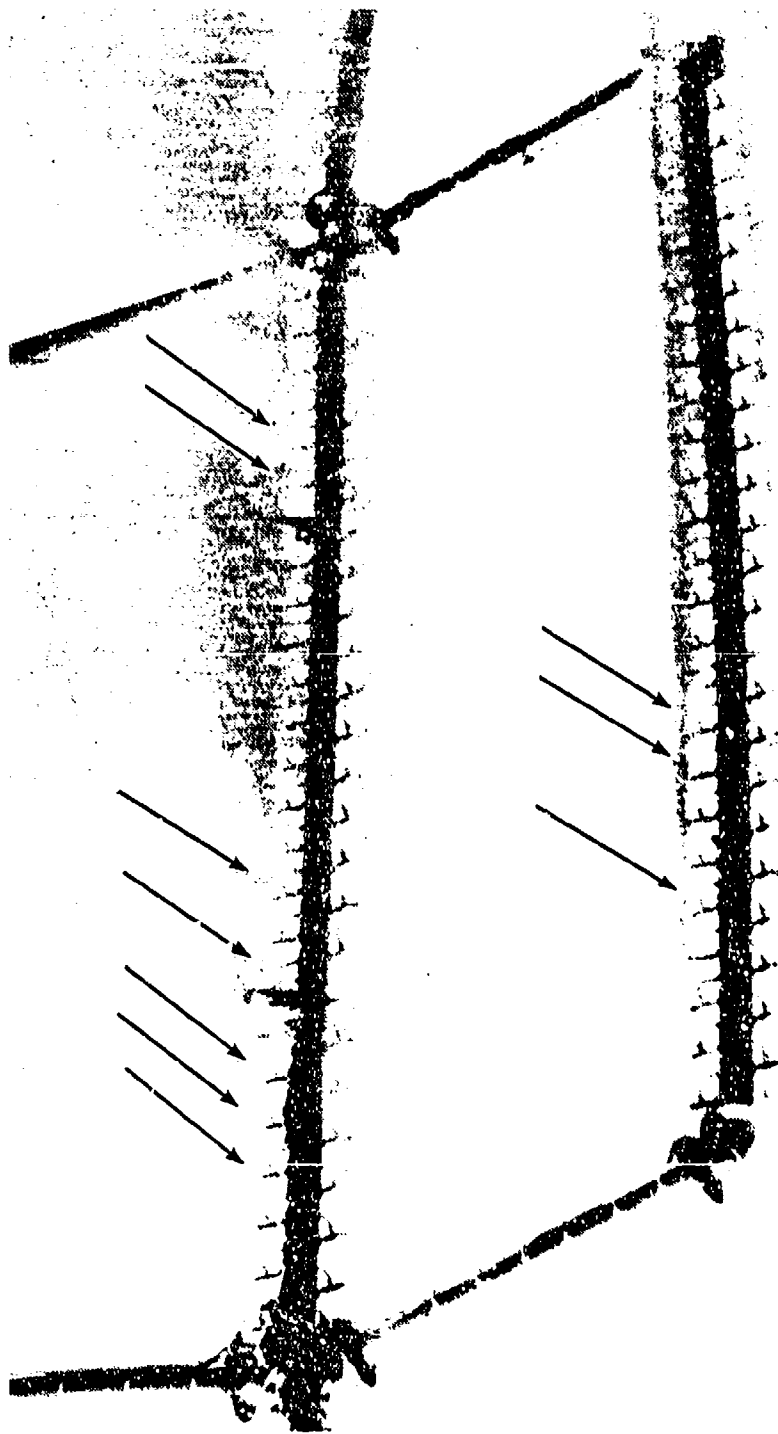

Photo 8. Ice Formations on Upward-Facing Nozzles

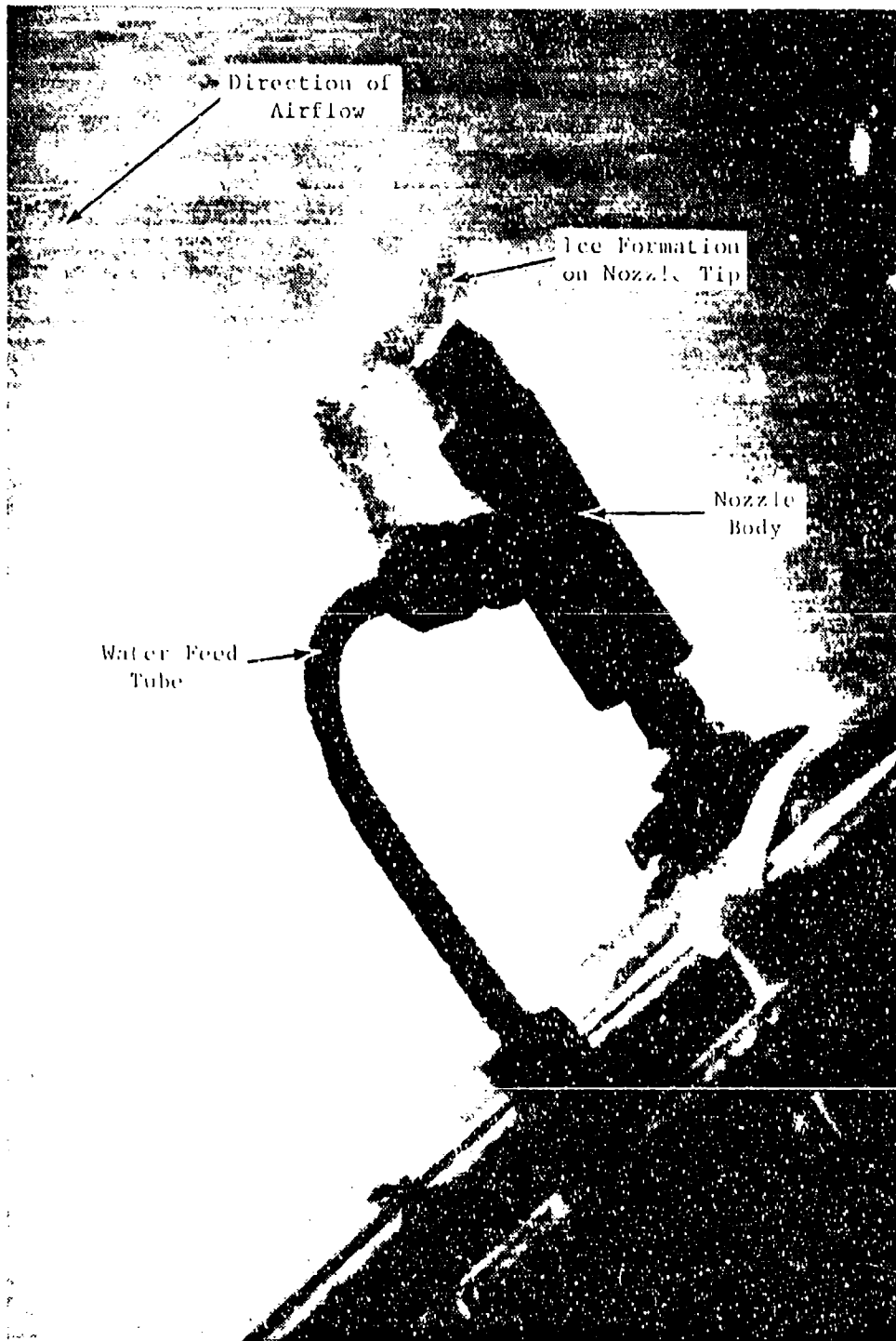

Photo 9. Ice Formation Between Atomizer Tip and Water Feed Tube

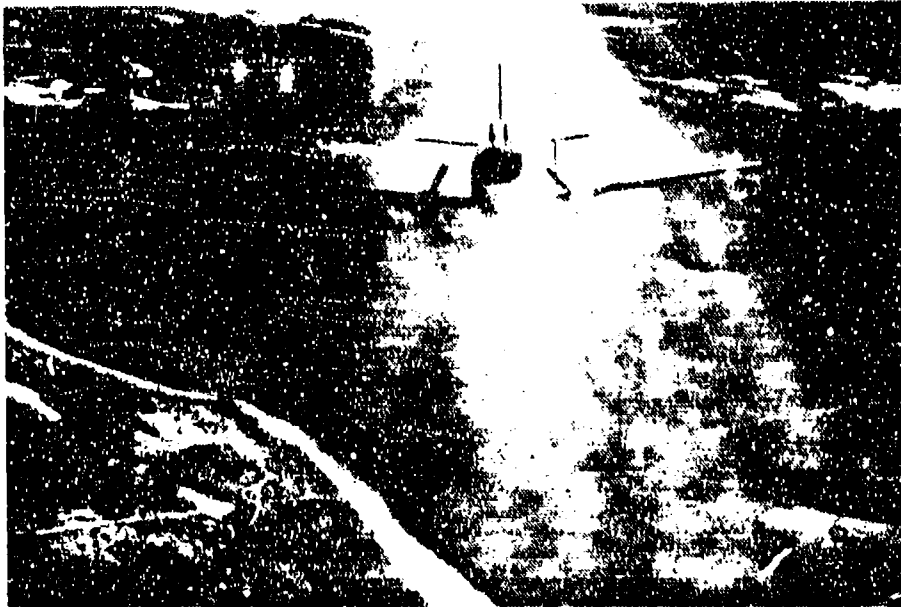

Photo 10. Front View of JU-21A in HISS Spray Cloud
(Wingspan = 45 ft 10.5 in.)

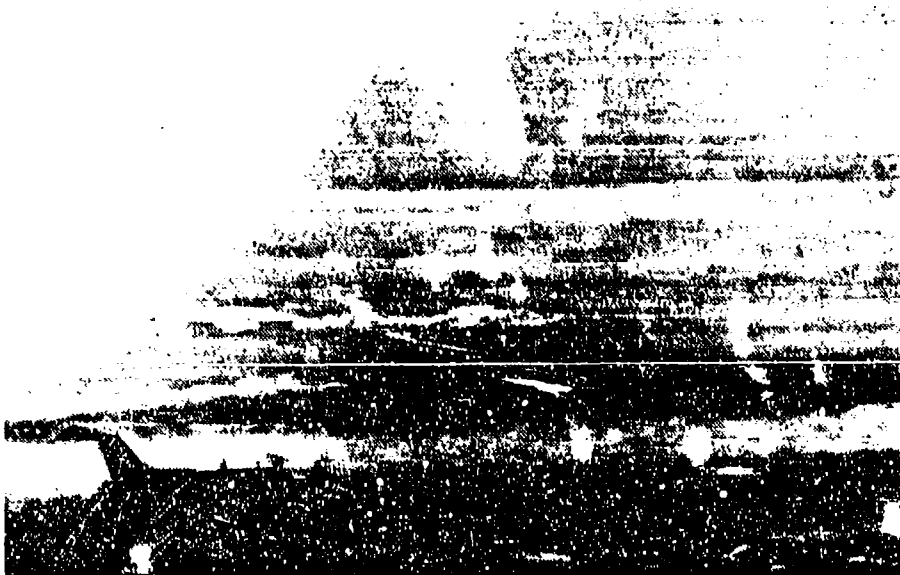

Photo 11. Side View of JU-21A in HISS Spray Cloud
(Total Height of Vertical Stabilizer = 3 ft 8 in.)



Photo 12. Condensation Trails Forming From HISS
Blade Tips at High Humidity (>95%)

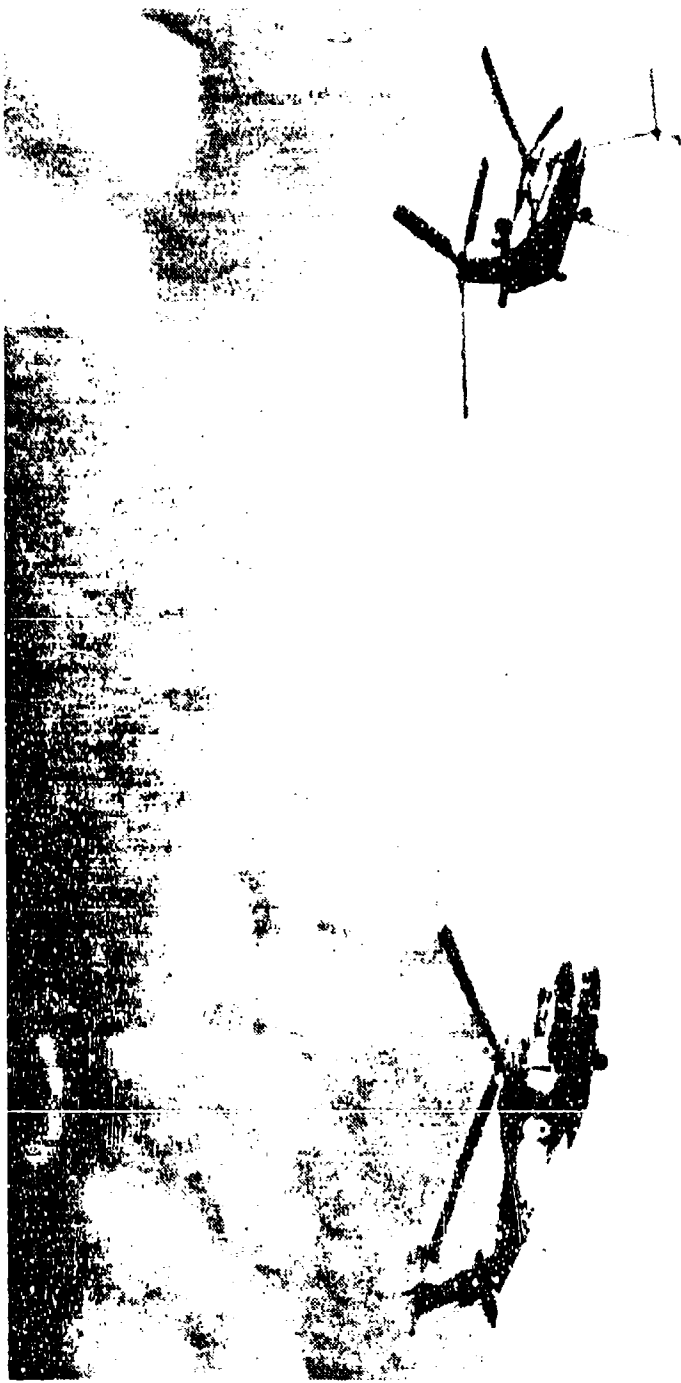

Photo 13. Trailing Vortices From Main Rotors
of HISS Passing Above Test Aircraft

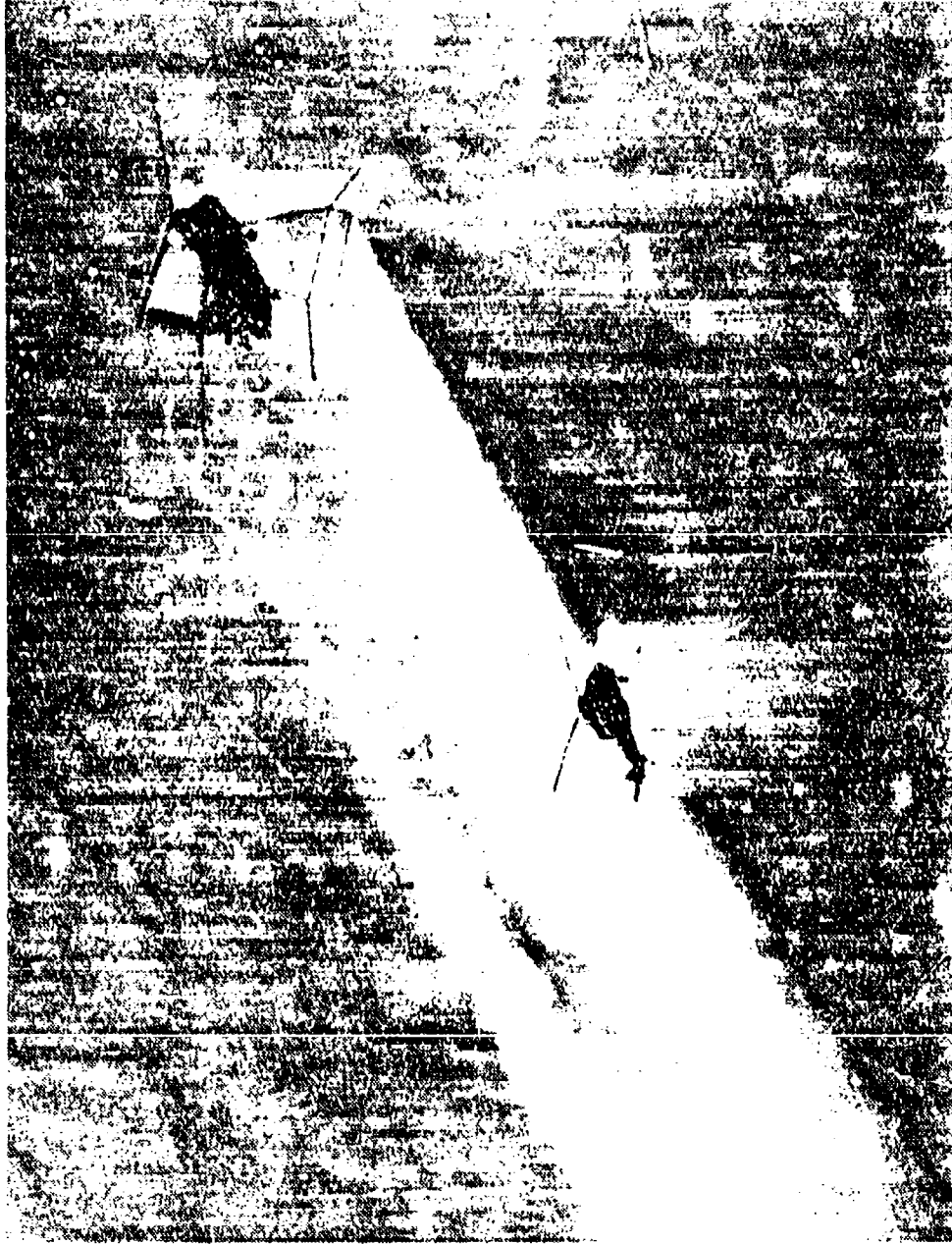

Photo 14. Expansion and Density Increase of Condensation Trails at
High Humidity (>95%)

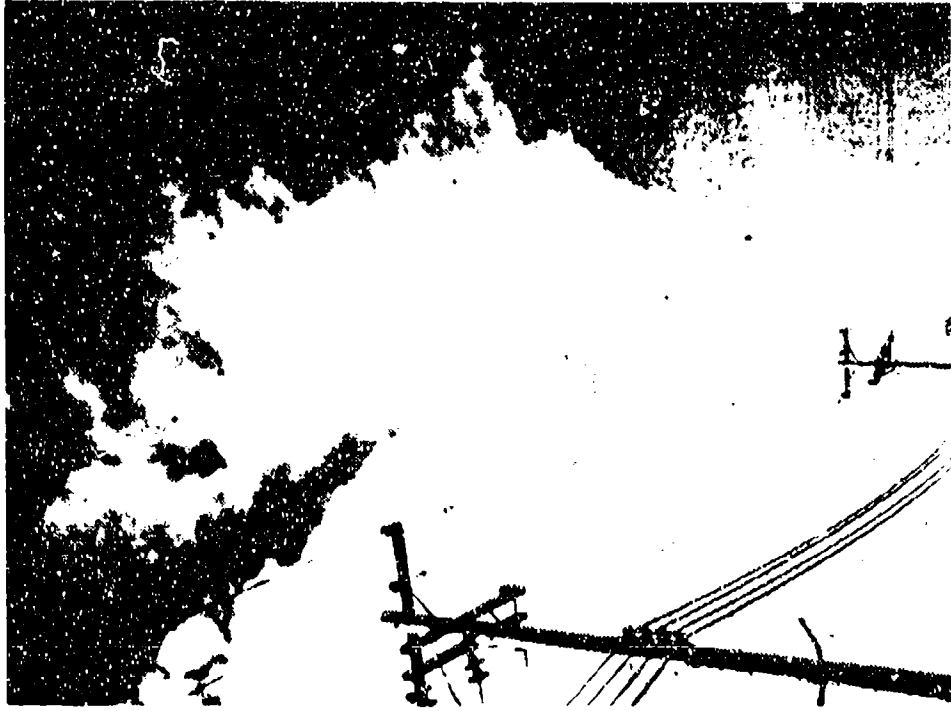

Photo 16. Natural Cloud Growth
Originating From HISS Cloud Trail

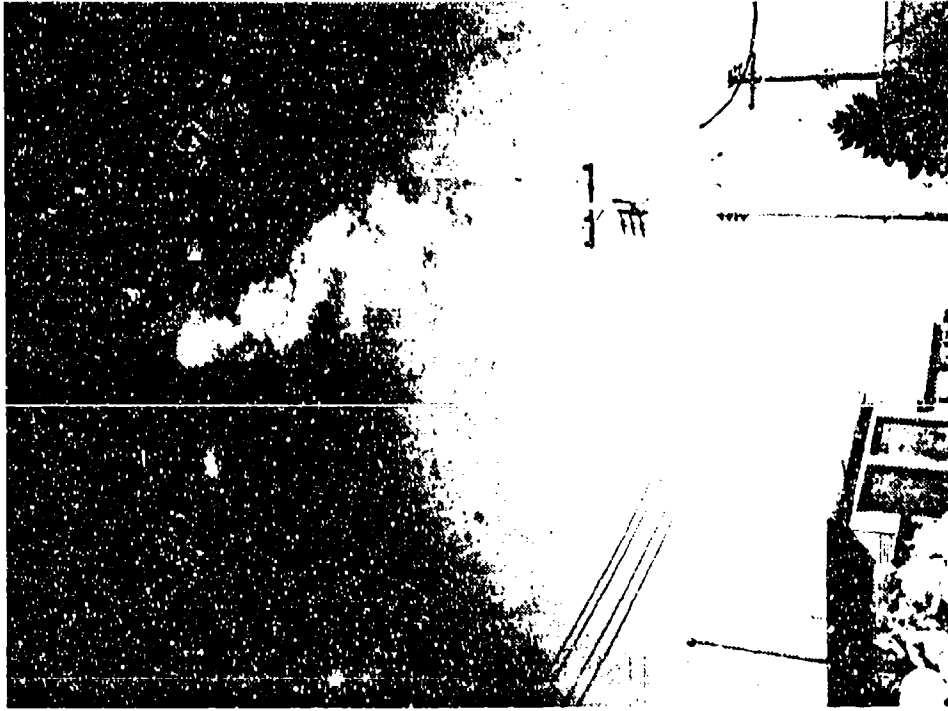

Photo 15. HISS Cloud Trail Remnants
as Seen From the Ground

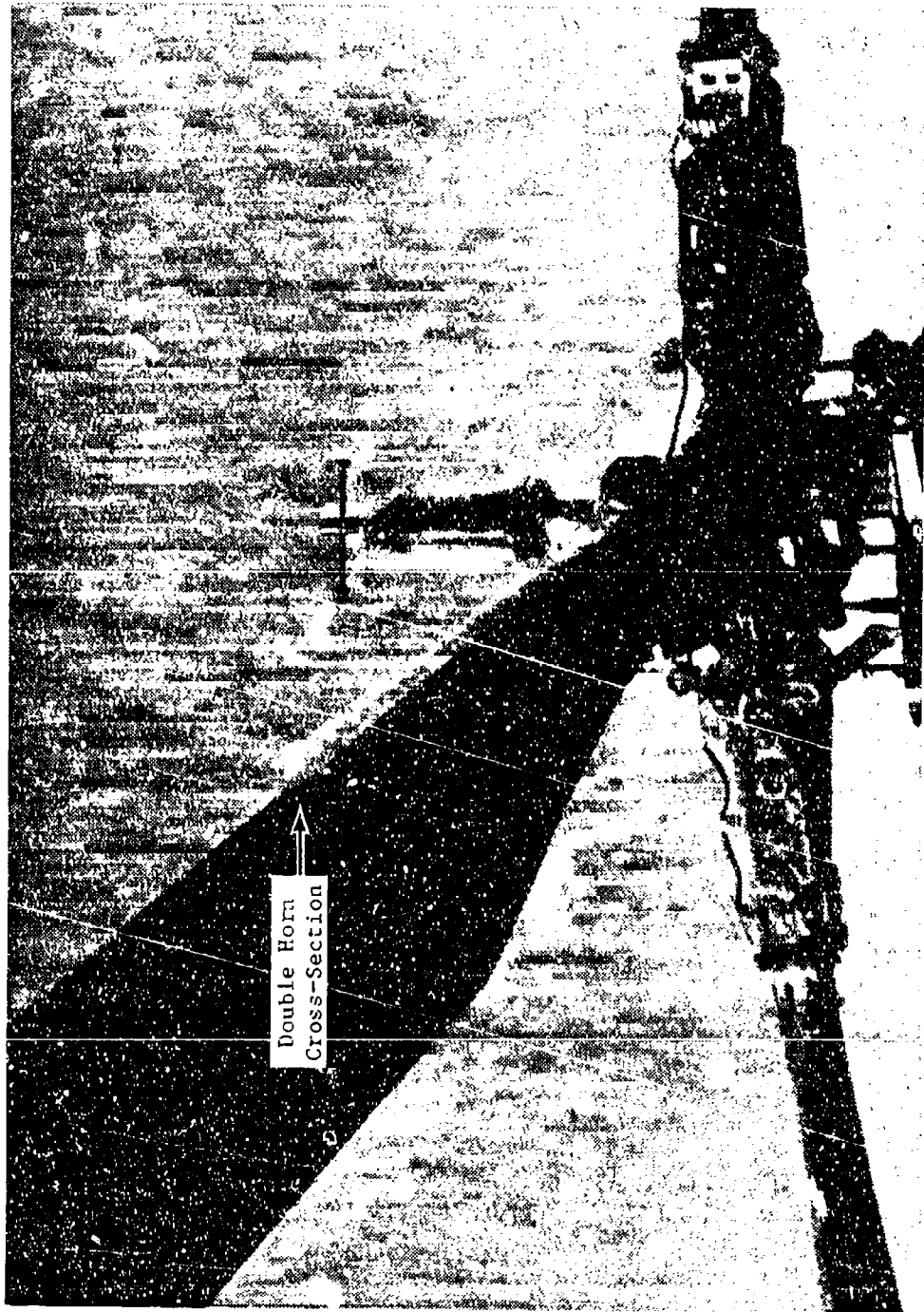

Photo 17. Artificial (HISS) Ice. "Double Horn" Shape on AH-64A Main Rotor After 22 Minutes at $1\text{gm}/\text{m}^3$, -5°C Ambient Temperature

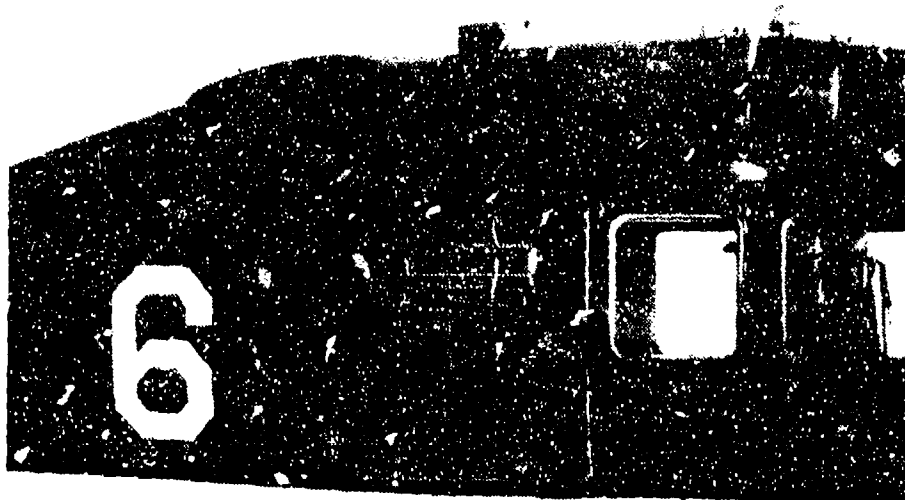

Photo 18. Natural Ice. Formation on Rivets Along Side of Fuselage (UH-60).

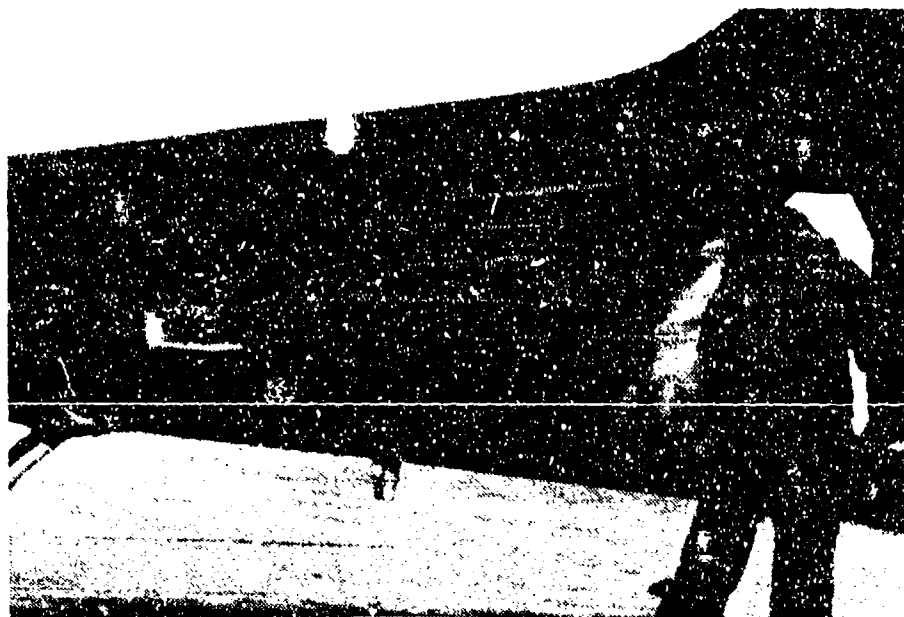

Photo 19. Artificial (RUSS) Ice. Formation on Tailboom Rivets (UH-60).



Photo 20. Artificial (HISS) Ice. Frost-Like Coating on Tailboom and Sides and Bottom of Fuselage at >95% Relative Humidity (UH-60; Bottom Half of Inboard Drop Tanks are Painted White, Rest of Airframe is Normally Dark)

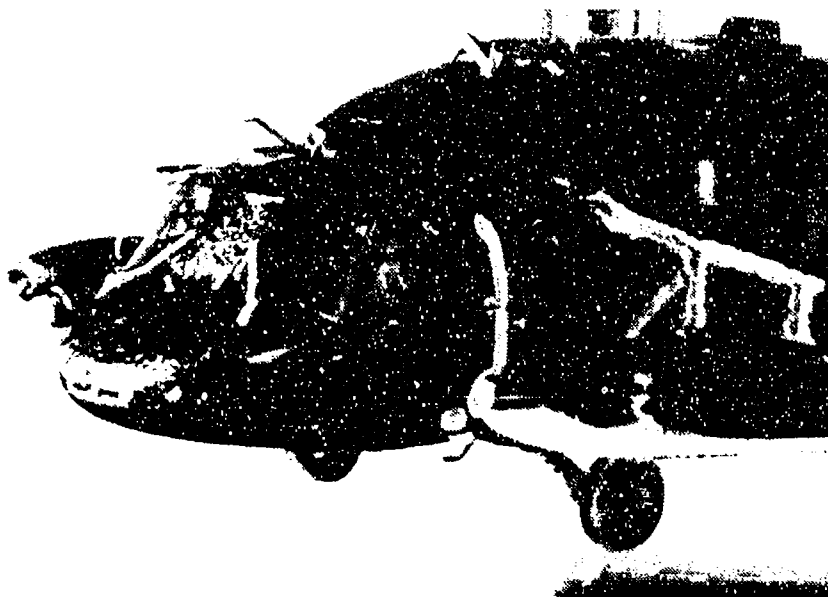

Photo 21. Natural Ice. Temperature -5.5°C ,
LWC $0.25\text{gm}/\text{m}^3$ at $26\ \mu\text{m}$ MVD, 107 KTAS



Photo 22. Artificial (HISS) Ice. Temperature -7.5°C ,
LWC $1.0\text{gm}/\text{m}^3$ at $62\ \mu\text{m}$ MVD, 120 KTAS

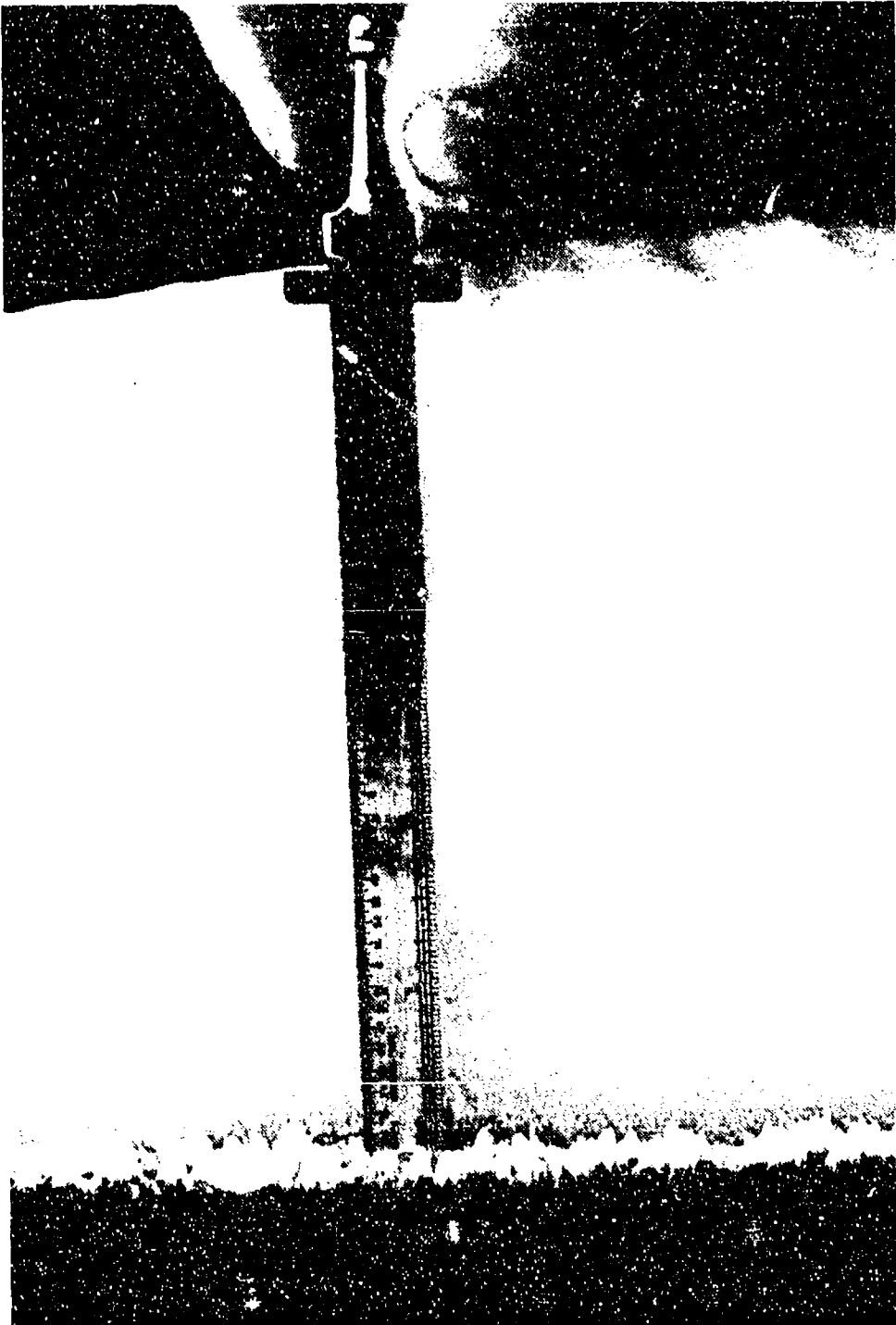

Photo 23. Artificial (HISS) Ice. Formation on FM Antenna of UH-60 Helicopter

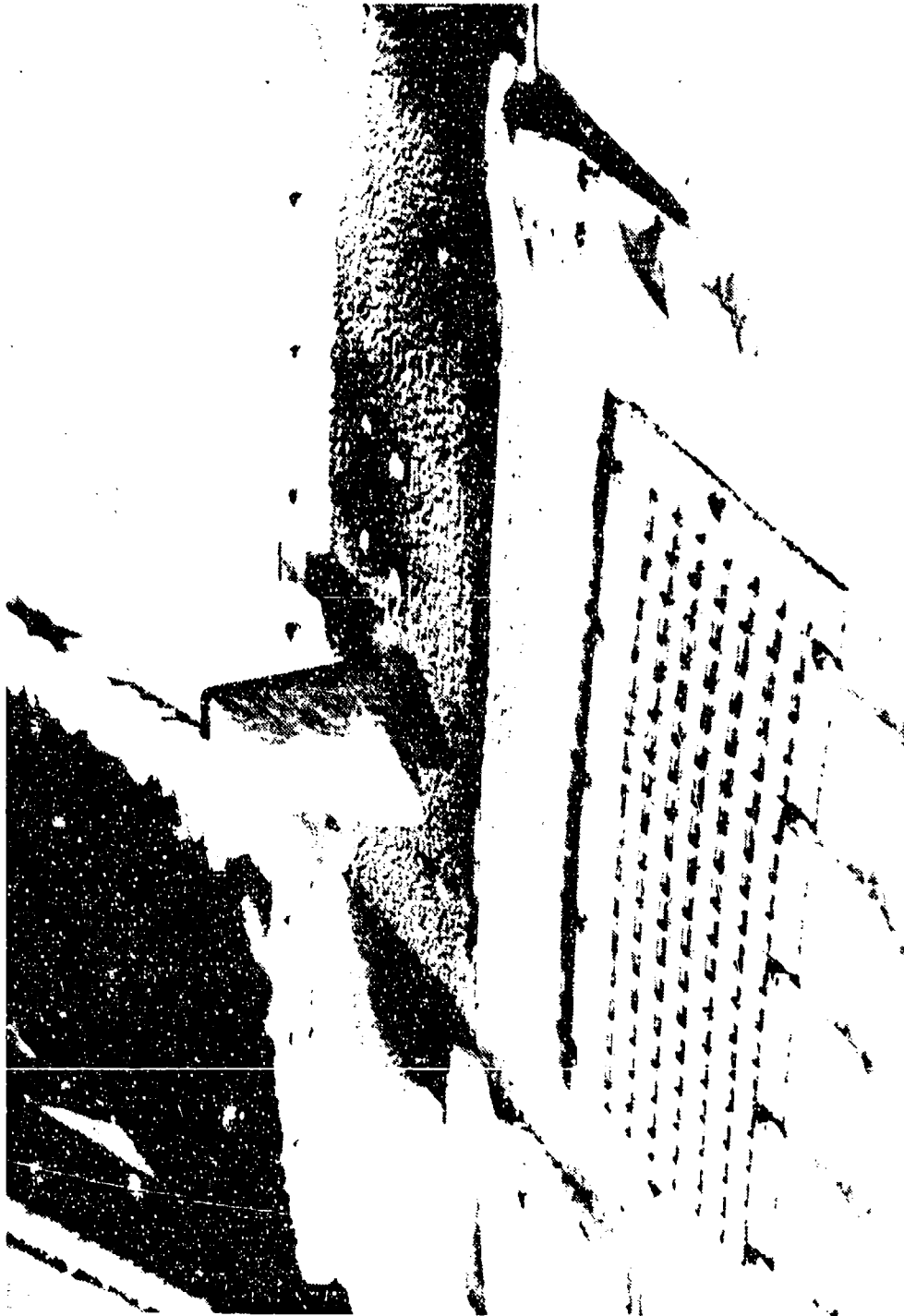

Photo 24. Artificial (HISS) Ice. Area Forward of Center Windshield (UH-60)



Photo 25. Artificial (HISS) Ice. Formation on Swept Landing Gear Strut (UH-60)

APPENDIX F. TEST DATA

FIGURE 1
 NATURAL STRATIFORM CLOUD
 DROP MASS DISTRIBUTIONS

NOTE: Data obtained using Particle Measuring Systems, Inc. laser spectrometers

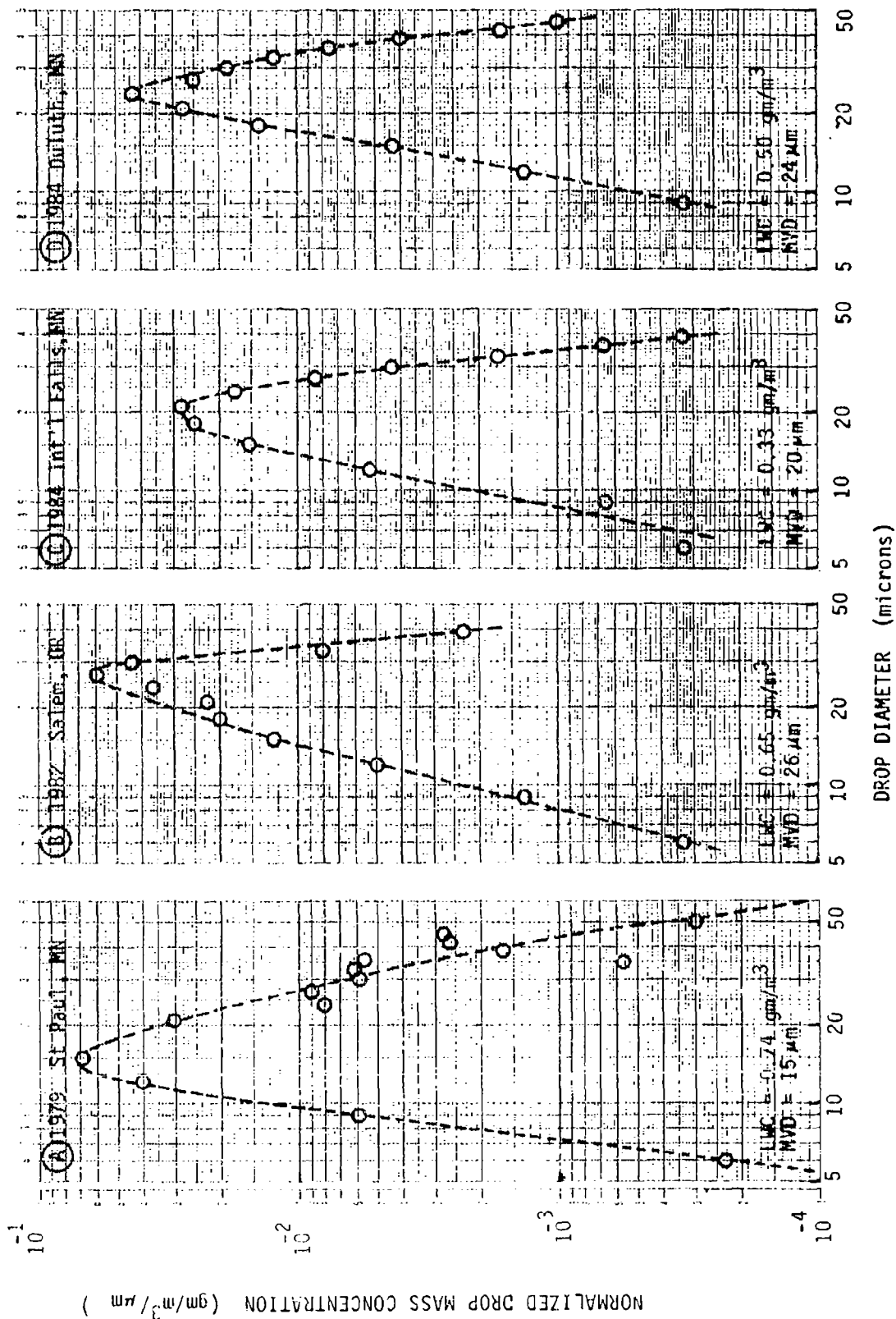

FIGURE 2
NATURAL STRATIFORM CLOUD
NONDIMENSIONAL DROP
MASS DISTRIBUTIONS

NOTE: Natural Cloud Distributions A - D Taken From Fig. 1

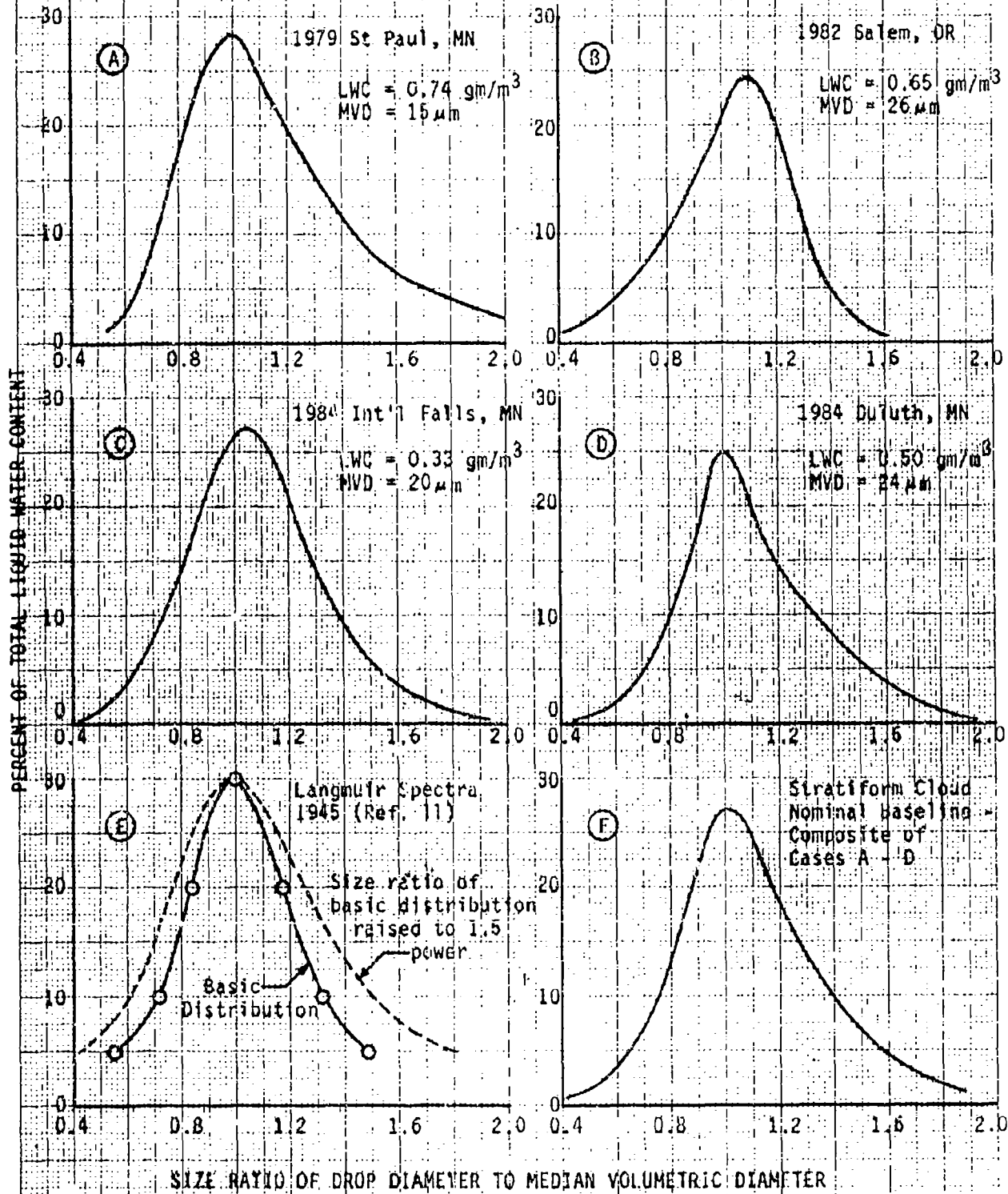
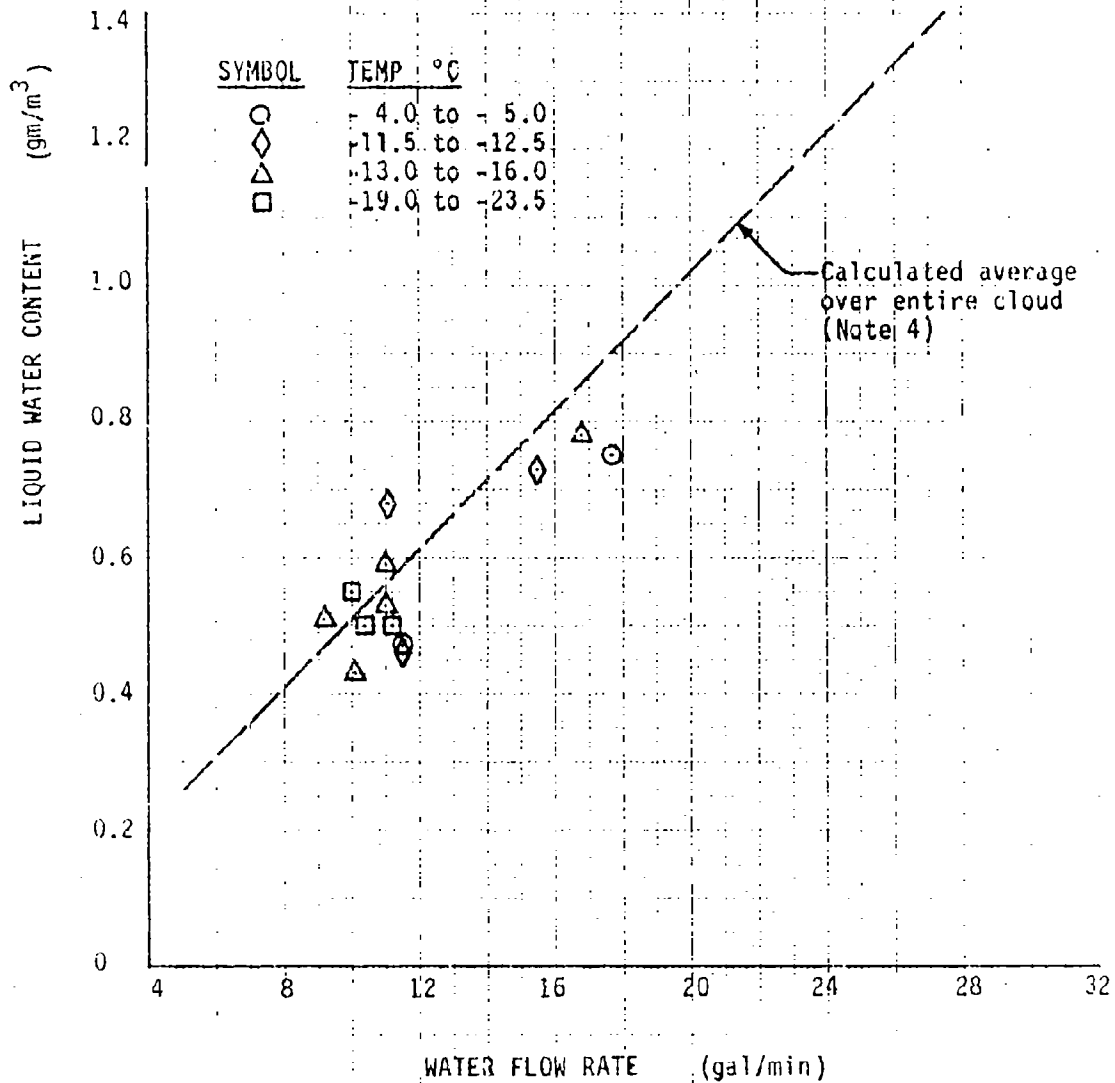

FIGURE 3
 WATER FLOW RATE AND LIQUID
 WATER CONTENT OF HISS SPRAY CLOUD

- NOTES: 1. 97 Sonicore nozzles installed on trapeze sections only
 2. Data obtained using Particle Measuring Systems, Inc laser spectrometers
 3. Measurements taken during stable immersions centered in spray cloud 180 ft behind spray boom
 4. Line shows calculated average for 8 x 36 ft cloud cross section at 90 KTAS (Para 21)
 5. Airspeed = 90 KTAS



**FIGURE 4
WATER FLOW RATE AND LIQUID
WATER CONTENT OF HISS SPRAY CLOUD**

- NOTES: 1. 57 Sensors were installed on trapeze sections only.
 2. Data obtained using Particle Measuring Systems, Inc. laser spectrometers.
 3. Measurements taken during stable immersions centered in spray cloud 180 ft behind spray booms.
 4. Line shows calculated average for 8 x 36 ft cloud cross section at 120 KTAS (Para 21).
 5. Airspeed = 120 KTAS.

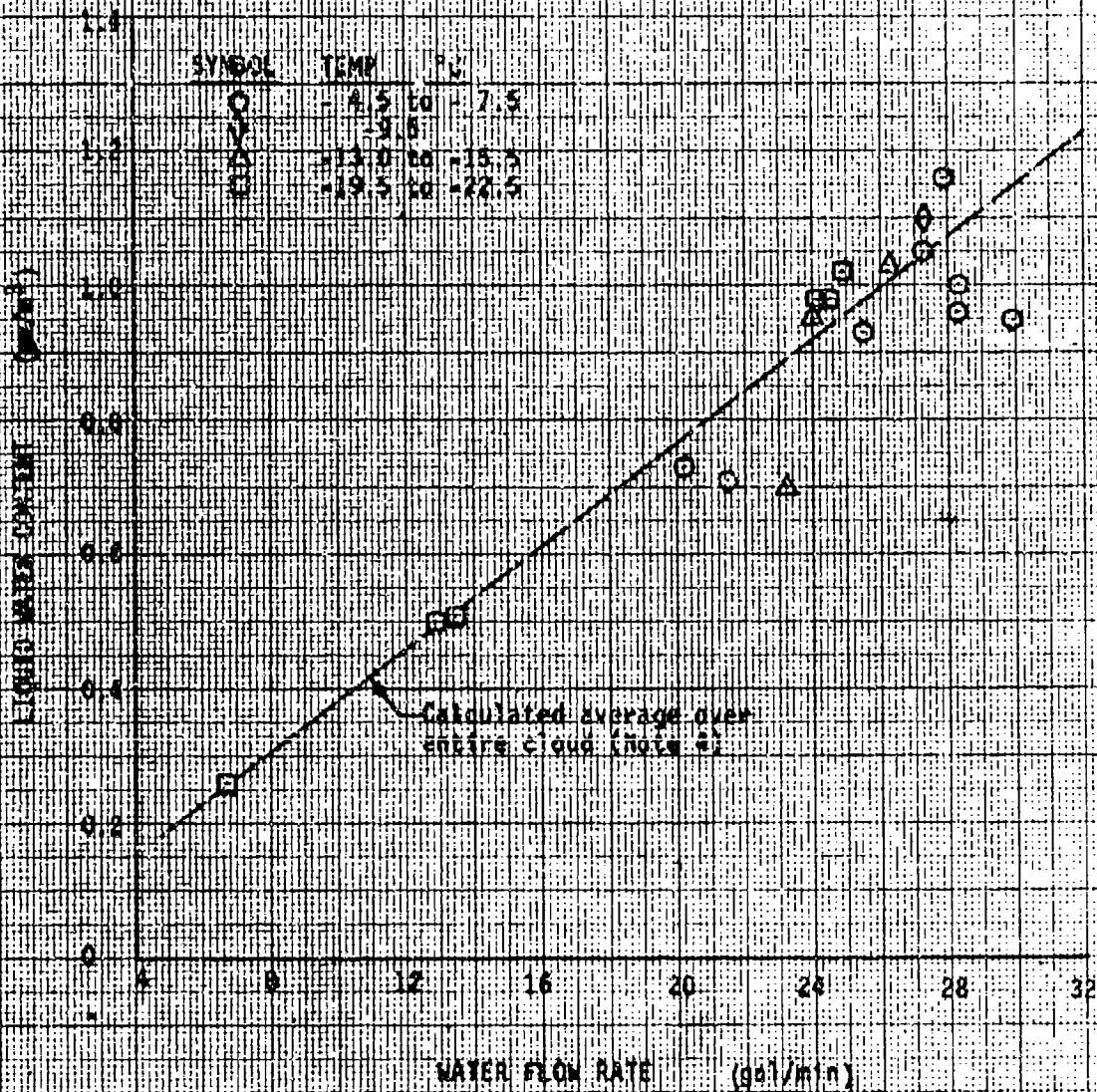

FIGURE 5
 WATER FLOW RATE AND DROP SIZE
 MEDIAN VOLUMETRIC DIAMETER OF HISS SPRAY CLOUD

- NOTES: 1. 97 Sonicore nozzles installed on trapeze sections only
 2. Data obtained using Particle Measuring Systems, Inc. Laser spectrometers
 3. Measurements taken during stable immersions centered in spray cloud 180° behind spray booms
 4. Airspeed = 90 KTAS

SYMBOL	TEMP °C
○	-4.0 to -5.0
◇	-11.5 to -12.5
△	-13.0 to -16.0
□	-19.0 to -23.5

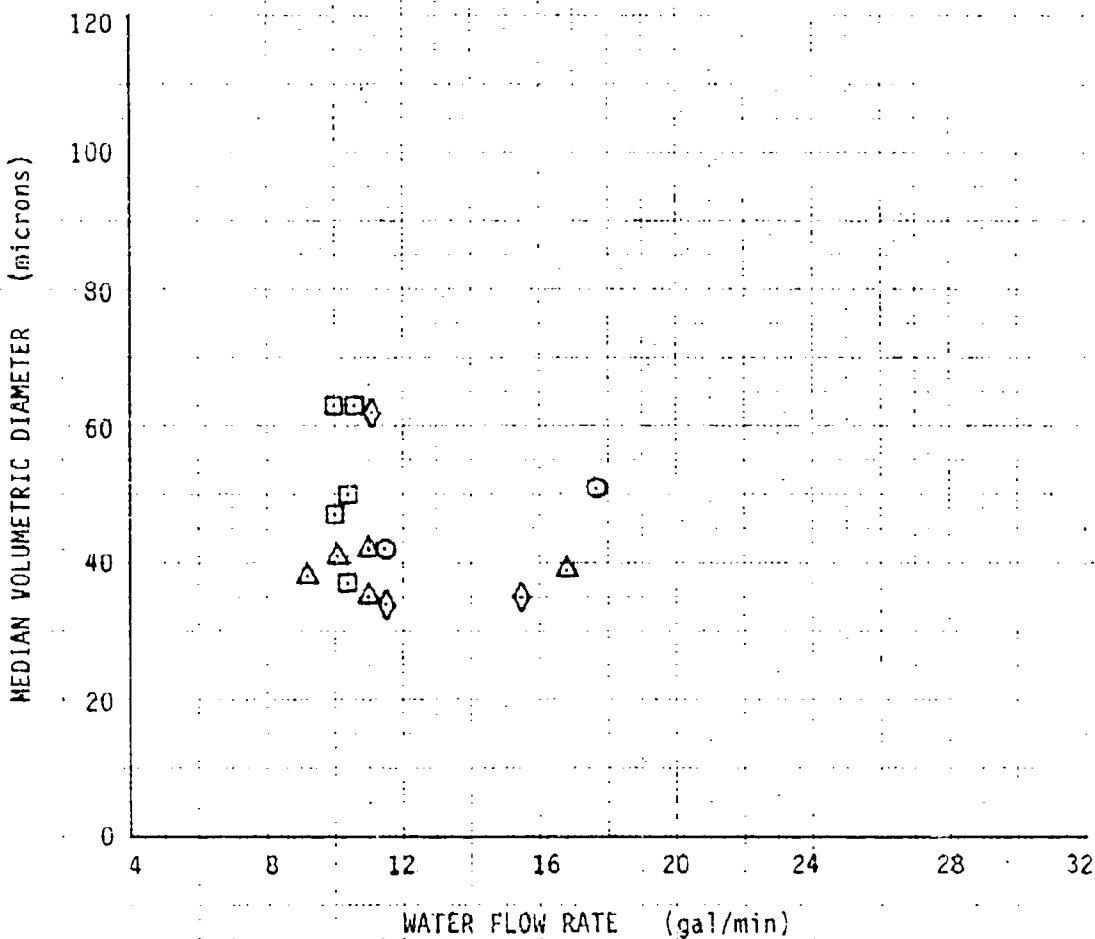

FIGURE 6
 WATER FLOW RATE AND DROP SIZE
 MEDIAN VOLUMETRIC DIAMETER OF HISS SPRAY CLOUD

- NOTES: 1. 97 Sonicore nozzles installed on trapeze sections only
 2. Data obtained using Particle Measuring Systems, Inc Laser spectrometers
 3. Measurements taken during stable immersions centered in spray cloud 180 ft behind spray booms
 4. Airspeed = 120 KTAS

SYMBOL	TEMP °C
○	- 4.5 to - 7.5
◇	-9.5
△	-13.0 to -15.5
□	-19.5 to -22.5

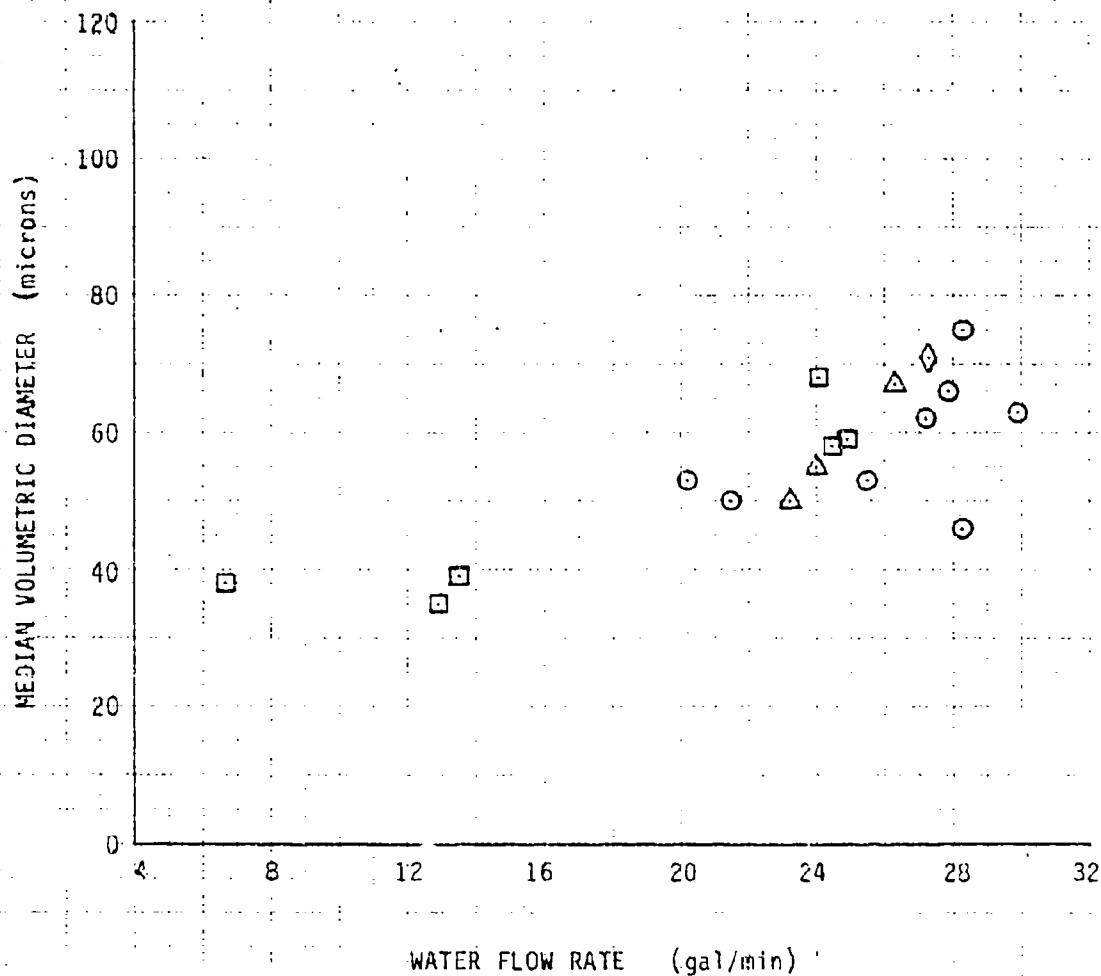

FIGURE 7
HELICOPTER ICING SPRAY SYSTEM
DROP MASS DISTRIBUTIONS

- NOTES: 1. 97 Sonicore nozzles installed on trapeze sections only
2. Data obtained using Particle Measuring Systems, Inc. laser spectrometers
3. Measurements taken 180 ft. behind spray booms

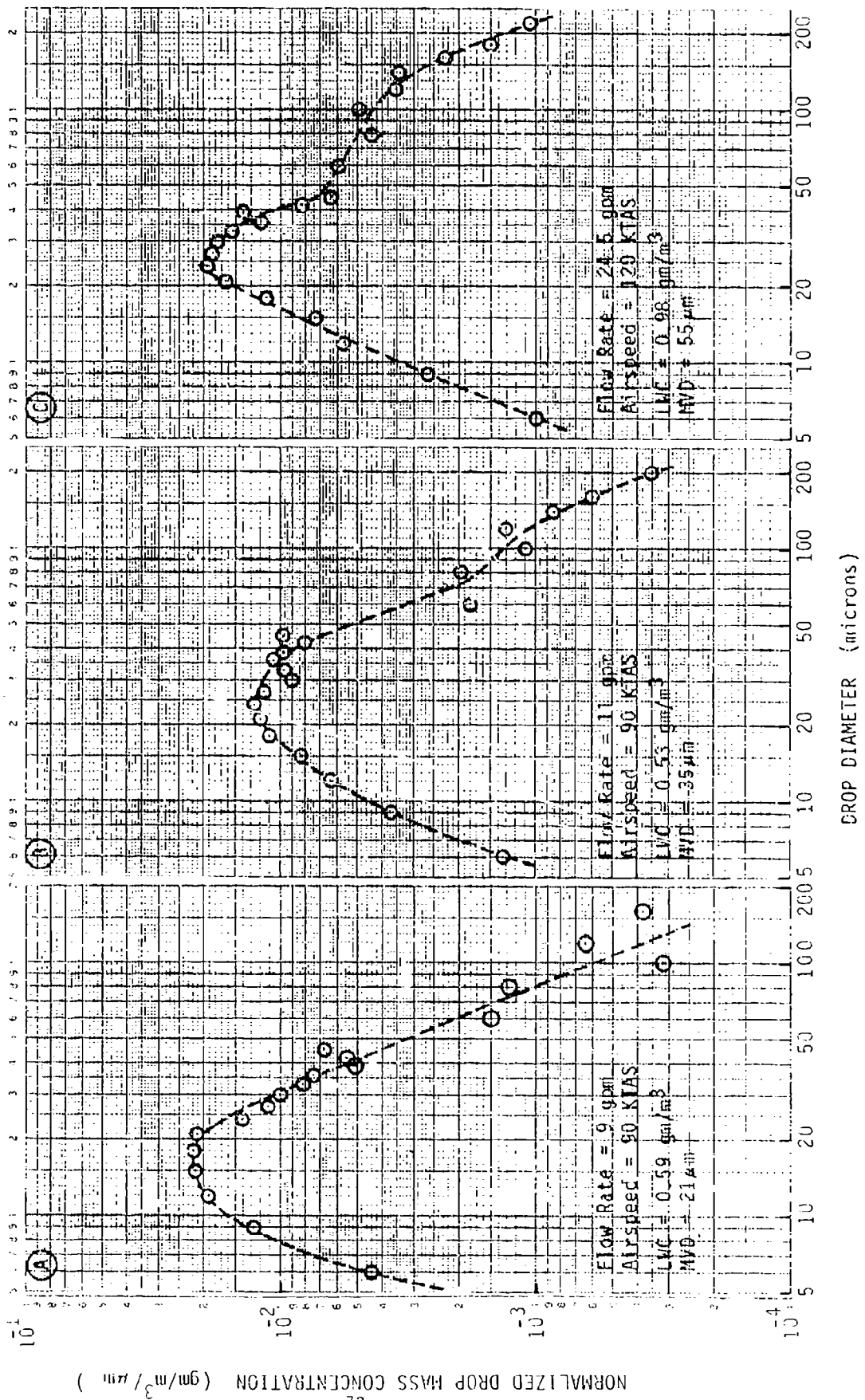

FIGURE 8
HELICOPTER ICING SPRAY SYSTEM
NONDIMENSIONAL DROP
MASS DISTRIBUTIONS

- NOTES: 1. 97 Sonicore nozzles installed on trapeze sections only
2. Artificial cloud distributions taken from Fig. 7

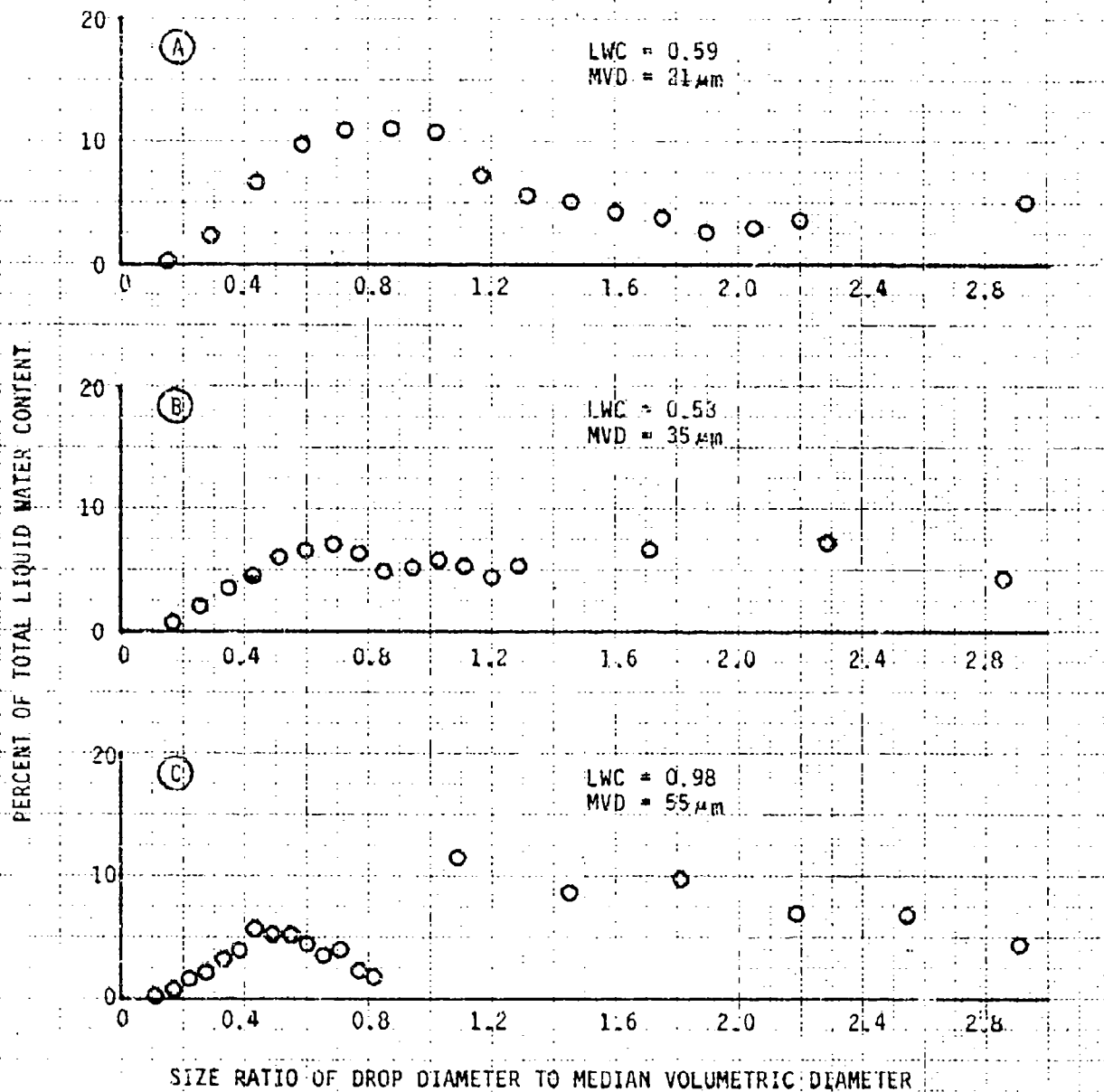

FIGURE 9
 HELICOPTER ICING SPRAY SYSTEM
 VERTICAL VARIATION OF CLOUD COMPOSITION

- NOTES: 1. 97 Sonicore nozzles installed on trapeze sections only
 2. Data obtained using Particle Measuring Systems, Inc laser spectrometers
 3. Half second sample rate during vertical sweeps
 4. Measurements taken 180 ft behind spray booms
 Airspeed = 120 KTAS
 Flow rate = 13 gpm

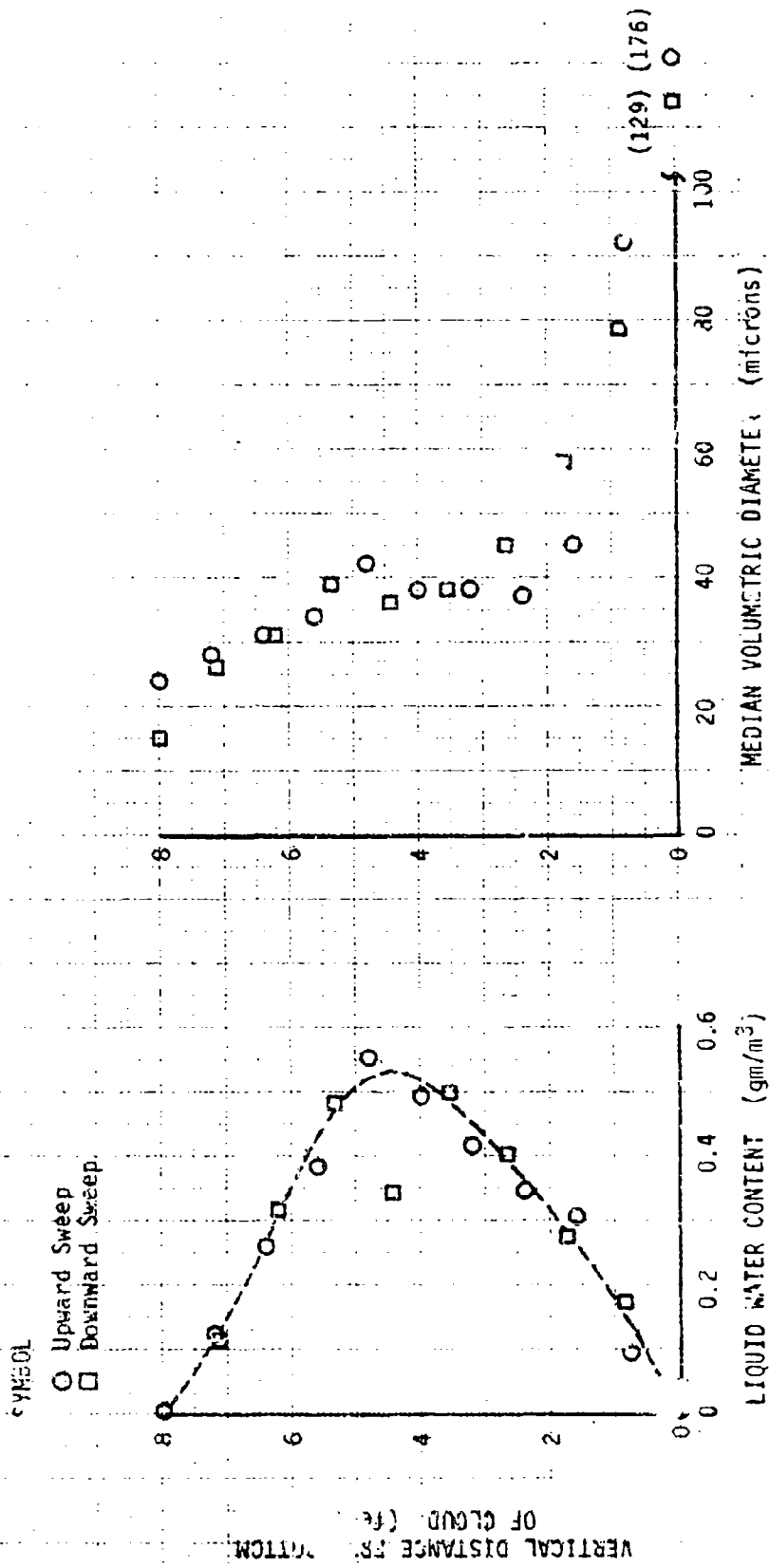
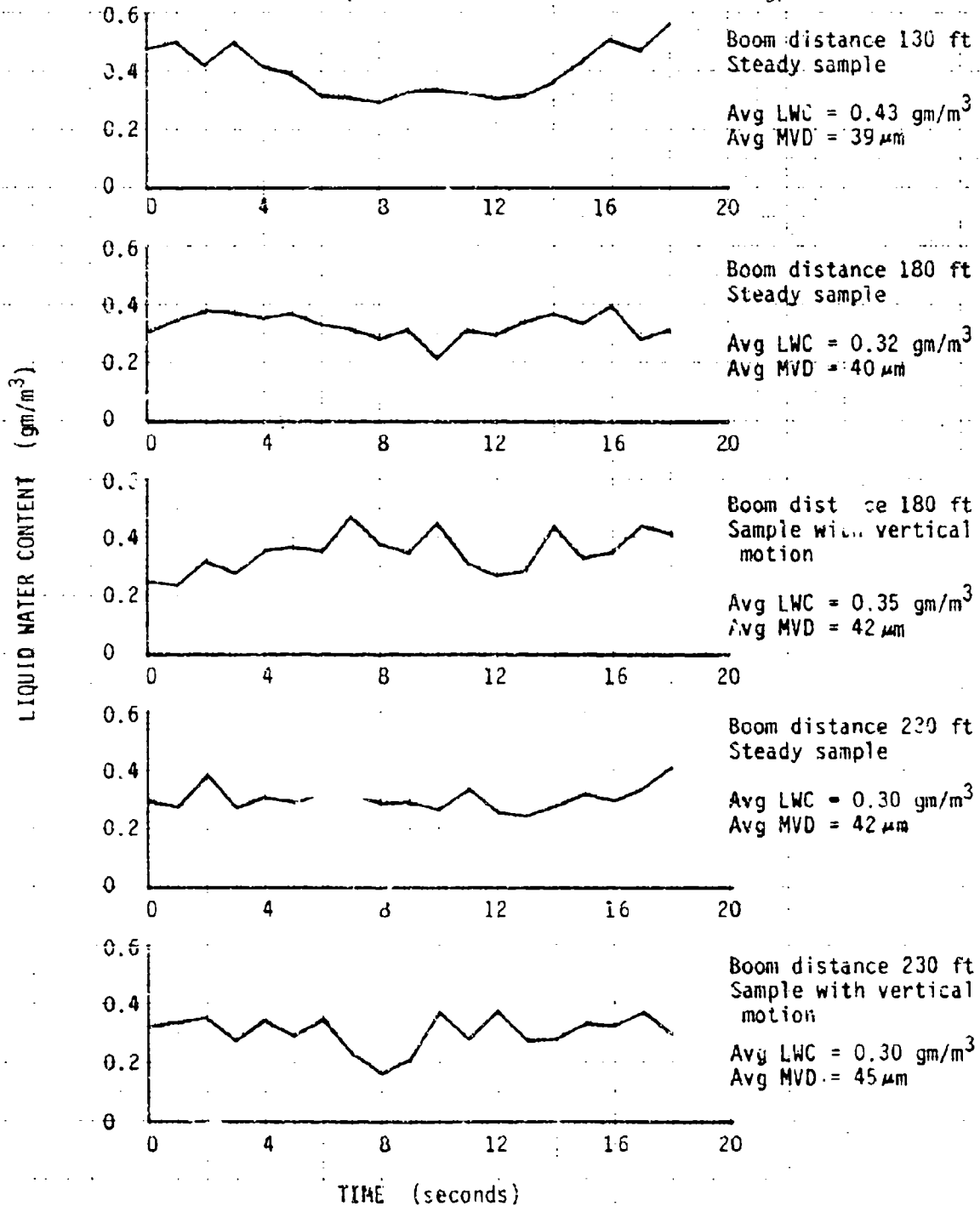

FIGURE 10
 HELICOPTER ICING SPRAY SYSTEM
 CLOUD SAMPLING TIME - HISTORIES

- NOTES: 1. 97 Sonicore nozzles installed on trapeze sections only
 2. Data obtained using Particle Measuring Systems, Inc laser spectrometers
 3. One-second sample rate during immersion
 4. Airspeed = 120 KTAS Flow Rate = 13 gpm



APPENDIX G. LETTER REPORT, USAAEFA PROJECT NO. 82-05-1



DEPARTMENT OF THE ARMY
U. S. ARMY AVIATION ENGINEERING FLIGHT ACTIVITY
EDWARDS AIR FORCE BASE, CALIFORNIA 93523

AUG 31 1982

DAVTE-TI

SUBJECT: Report, Helicopter Icing Spray System (HISS) Boom Structural Dynamics Evaluation with Fiberglass Blades, USAAEFA Project No. 82-05-1

Commander
US Army Aviation Research and
Development Command
ATTN: DRDAV-DI
4300 Goodfellow Boulevard
St. Louis, MO 63120

1. REFERENCES. a. Letter, USAAEFA, DAVTE-TI, 22 June 1982, subject: Report, Helicopter Icing Spray System (HISS) Evaluation and Improvements, USAAEFA Project No. 80-04-2.

b. Letter, AVRADCOM, DRDAV-DI, 14 June 1982, (with revision, 13 August 1982), subject: Helicopter Icing Spray System (HISS) Evaluation and Improvements. (Test Request)

c. Letter, AVRADCOM, DRDAV-D, 1 July 1982, (with revision, 13 July 1982), subject: Airworthiness Release for Helicopter Icing Spray System (HISS) Boom Structural Dynamics Evaluation with Fiberglass Blades and Modified Spray Cloud Measurements, USAAEFA Project No. 82-05.

d. Letter, USAAEFA, DAVTE-TI, 28 June 1982, (with revision, 15 July 1982), subject: Test Plan, Helicopter Icing Spray System (HISS) Boom Structural Dynamics Evaluation with Fiberglass Blades and Modified Spray Cloud Measurements, USAAEFA Project No. 82-05.

e. Letter, USAAEFA, DAVTE-TI, 4 June 1981, subject: Letter Report, Helicopter Icing Spray System (HISS) Evaluation and Improvements, USAAEFA Project No. 80-04.

2. INTRODUCTION. During April, 1982, the JCH-47C aircraft (US Army S/N 68-15814) in which the Helicopter Icing Spray System (HISS) is mounted, was modified by replacing the metal rotor blades with fiberglass rotor blades and subsequent reduction of rotor operating speed to 225 rpm. In addition, the US Army Aviation Engineering Flight Activity (USAAEFA) modified the existing HISS spray boom to eliminate bleed air/water leakage problems encountered during the 1982 artificial icing tests (ref 1a).

DAVTE-T1

SUBJECT: Report, Helicopter Icing Spray System (HISS) Boom Structural Dynamics Evaluation with Fiberglass Blades, USAAEFA Project No. 82-05-1

Improved water manifolds were fabricated and installed. To evaluate results of these modifications, the US Army Aviation Research and Development Command (AVRADCOM) tasked USAAEFA to conduct a limited HISS spray boom dynamics evaluation (ref 1b).

3. TEST OBJECTIVE. The objective of this test program was to determine the dynamic characteristics of the HISS spray boom.

4. DESCRIPTION. a. The HISS is installed in a modified CH-47C helicopter (US Army S/N 68-15814) and consists of an 1800 gallon internal water tank and an external spray boom assembly suspended 19 ft beneath the aircraft from a crosstube through the cargo compartment. Hydraulic actuators rotate the crosstube to raise and lower the boom assembly. Both the external boom assembly and internal water supply can be jettisoned in an emergency. For icing tests, a non-toxic, biodegradable dye is added to the water and imparts a yellow color to the ice.

b. The spray boom consists of two 27 ft center sections, vertically separated by 5 ft and two 17.6 ft outriggers attached to the upper center section. When lowered the outriggers are swept aft 20° and angled down 10° giving a tip to tip boom width of 60 ft. The boom is assembled of concentric metal pipe. Water is pumped at selected flow rates from the tank to the nozzles on the boom assembly through the inner pipe (1-1/2 in. diameter). Thirty manifolds for distributing water to the nozzles are spaced approximately 3 ft apart along the boom exterior. Aircraft engine compressor bleed air and bleed air from a Solar T-62T-40C2 bleed air APU are supplied through the outer pipe (4 in. diameter) to the nozzles to atomize the water. There are 172 nozzle receptacles on the boom surface. These receptacles are staggered to provide alternating upward and downward ejection ports every 6 inches. Sonic Development Corporation Model 125-H Sonicore nozzles were installed for this evaluation.

c. As a result of numerous air and water leaks encountered during the 1982 icing season, several modifications were made to the spray boom. All boom internal hoses were replaced with Flexfab, Inc. Turbo hose and clamped securely with hose clamps at all junctions. The water and air inputs to the top of the boom were modified as shown in photo 1, inclosure 1. The round water manifolds and plastic lines (photo 2) were replaced by T-section manifolds and stainless steel lines utilizing high pressure hydraulic (MS) fittings (photo 3). In addition, each of the four way junctions had two nozzles mounted on them by using specially fabricated brackets (photo 4).

5. TEST SCOPE. The test was conducted at Edwards Air Force Base, Calif. from 8 July to 20 July 1982. Six test flights were conducted for a total

DAVTE-TI

SUBJECT: Report, Helicopter Icing Spray System (HISS) Boom Structural Dynamics Evaluation with Fiberglass Blades, USAAEFA Project No. 82-05-1

of 6.4 productive hours. The tests were conducted at engine start gross weights between 34,160 and 48,200 pounds and corresponding longitudinal center-of-gravity locations of FS 326.0 and FS 331.8, respectively. Test pressure altitude was 6000 ft with a rotor speed of 225 rpm. The general test conditions and configurations are shown in table 1. The limits contained in the operator's manual and airworthiness release (ref 1c) were observed.

6. TEST METHODOLOGY. Flight test profiles were typical of the normal HISS mission and are described in the test plan (ref 1d). Test techniques are briefly described in the appropriate section of paragraph 7. Data were recorded on magnetic tape onboard the aircraft and telemetered to a ground station. Boom strain gage locations as well as test instrumentation are described in inclosure 2.

7. RESULTS AND DISCUSSION. a. General. Boom dynamics and stress data were acquired during level flight at airspeeds from 60 knots indicated airspeed (KIAS) to maximum airspeed for level flight (V_H) and in turns to 30° bank angle. Boom gust response was simulated by the introduction of pulse and doublet control inputs into each axis independently. No boom stress or dynamics problems were experienced during testing.

b. Boom Dynamics. The boom dynamics were evaluated with the various configurations of nozzles, manifolds, and gross weights shown in table 1. The boom gust response was evaluated using control pulse and doublet inputs at the primary HISS icing operations airspeed of 120 knots true airspeed (KTAS). Lateral and directional pulses had very little effect on the boom and response was either deadbeat or damped in 1 or 2 cycles. The response to a longitudinal doublet input was an asymmetric pendulum-type longitudinal oscillation. The largest boom tip deflections at 120 KTAS were on the order of +2 ft and were damped in 3 to 4 cycles. As previously observed, the boom displayed a 3/rev vibration (11.25 Hz) superimposed on the lower period dynamic response. The boom oscillatory response was adequately damped in all axes at all conditions tested. The boom dynamics were essentially unchanged from previous configurations and were acceptable.

c. Boom Stress. (1) Boom stresses were monitored at the conditions shown in table 1, using strain gages at the positions (J, E, D) shown in figure 1, inclosure 2. The data are presented as mean bending stress (vector sum of the bending stress in two axes) and alternating stress (one-half peak-to-peak stress in each axis). The lower horizontal cross tube (J) and the vertical tubes (E) are made of 6061-T6 aluminum and have steady-state and transient limits shown in the Goodman diagrams (figs. 1 and 2, incl 3). The upper horizontal cross tube and the outriggers (D) are

Engine Start Gross Weight (LB)	Longitudinal Center-of-Gravity Location (FS)	Avg Density Altitude (FEET)	Avg OAT (°C)	Water Volume On Board (GAL)	Manifold Configuration	Number of Nozzles Installed	Remarks
34160	326.0 (MID)	8000	19.0	0	T-section	154	Boom Up and Down
45840	330.1 (AFT)	8740	18.5	1400	T-section	154	Boom Up and Down
48200	331.8 (AFT)	8860	20.5	1600	T-section	1022	Boom Up and Down
46140	329.5 (AFT)	8680	18.5	1400	Round	1002	Boom Up and Down
38140	329.4 (MID)	9220	22.5	0	T-section	1002,3	Boom Up Only, Outriggers Removed ⁴

- ¹Rotor speed = 225 RPM
- ²Installed on boom center sections only
- ³Nozzle bodies only
- ⁴Ferry configuration

Table 1. Boom Stress and Dynamics Test Conditions¹

DAVTE-T1

SUBJECT: Report, Helicopter Icing Spray System (HISS) Boom Structural Dynamics Evaluation with Fiberglass Blades, USAAEFA Project No. 82-05-i

of 4130 N steel with an infinite ($N = 10^6$) life oscillatory limit of 21,629 psi.

(2) Comparative data for the T-section manifold (154 and 102 nozzles) and round manifold (100 nozzles) configurations with the boom down are shown in figures 1 through 3, inclosure 4. Similar comparisons were made with the boom up for these configurations as well as the ferry configuration (figures 4 through 6). The boom down data were acquired with a water flow rate between 7 and 15 gallons/minute. The stresses were primarily a function of airspeed with control inputs and turns producing minimal increases in alternating and mean stresses. The boom stresses were independent of the nozzle or manifold configuration and are satisfactory throughout the airspeed range tested.

(3) One flight was conducted with the outriggers removed to evaluate this as a potential ferry configuration. The boom center sections were configured with the T-section manifolds and 100 nozzle bodies. Previous testing with the boom outriggers removed had shown alternating stresses in the lower horizontal cross tube (J) to reach unacceptable levels at 146 KTAS (ref 1e). This was not the case during these tests as shown in figure 4, inclosure 4. The only restrictions to airspeed were caused by excessive aircraft-related vibrations encountered at V_H (137 KIAS). These vibrations reduced the maximum usable airspeed range to approximately 130 KIAS. The aircraft's cruise guide indicator had fewer excursions into the yellow band than with the outriggers installed and the boom up. No stress problems were encountered at any time during this test. This configuration should be authorized for ferrying the CH-47 with the HISS installed.

d. Boom Extension/Retraction. Previous tests had shown that the boom could be successfully extended and retracted at all airspeeds to 110 KIAS (ref 1a). To verify these results, the boom was extended and then retracted at 60 KIAS through 110 KIAS in 10-knot increments. The boom was successfully extended and retracted at all airspeeds through 100 KIAS, and exhibited the same characteristics as during previous testing. The boom was successfully extended at 110 KIAS, however during the retraction sequence, the mechanical locking struts (fig. . incl 1) moved far enough for the torque arms to clear the down lock, but not far enough to clear the barrel end of the struts. Under hydraulic pressure, the left locking strut buckled (photo 5, incl 1) and in so doing contacted and damaged one of the A-frame support members, while the right locking strut popped free of the torque arm. Once the torque arms were free of the obstruction, the retraction cycle continued without further incident. This retraction failure appears to be caused by improper strut actuator function rather than hydraulic stalling due to airspeed. To alleviate the possibility of another such occurrence, the strut actuators are being replaced and the

DAVTE-TI

SUBJECT: Report, Helicopter Icing Spray System (HISS) Boom Structural Dynamics Evaluation with Fiberglass Blades, USAAEFA Project No. 82-05-1

barrel ends of the struts are being tapered by USAAEFA to eliminate the ridge that obstructed the torque arms. Since an aircraft emergency may necessitate high speed boom retraction, boom extension/retraction tests through 120 KIAS should be accomplished.

8. CONCLUSIONS. The following conclusions were reached upon completion of this test program:

a. The boom dynamics were essentially unchanged from previous configurations and were acceptable under all conditions tested (para 7b).

b. The boom stresses were independent of the nozzle or manifold configuration and are satisfactory throughout the airspeed range tested (para 7c(2)).

c. The boom was successfully extended and retracted at all airspeeds through 100 KIAS (para 7d).

9. RECOMMENDATIONS. The following recommendations are made:

a. The CH-47 with the HISS installed should be authorized for ferrying with the outriggers removed and T-section manifolds and 100 nozzle bodies installed on the boom center sections (para 7c).

b. Boom extension/retraction tests through 120 KIAS should be accomplished. (para 7d).

10. AUTHORS. This report was prepared by Ralph Woratschek, project officer/engineer and MAJ Marvin L. Hanks, project pilot.

4 Incl
as

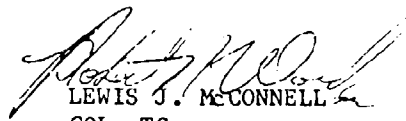
LEWIS J. McCONNELL
COL, TC
Commanding

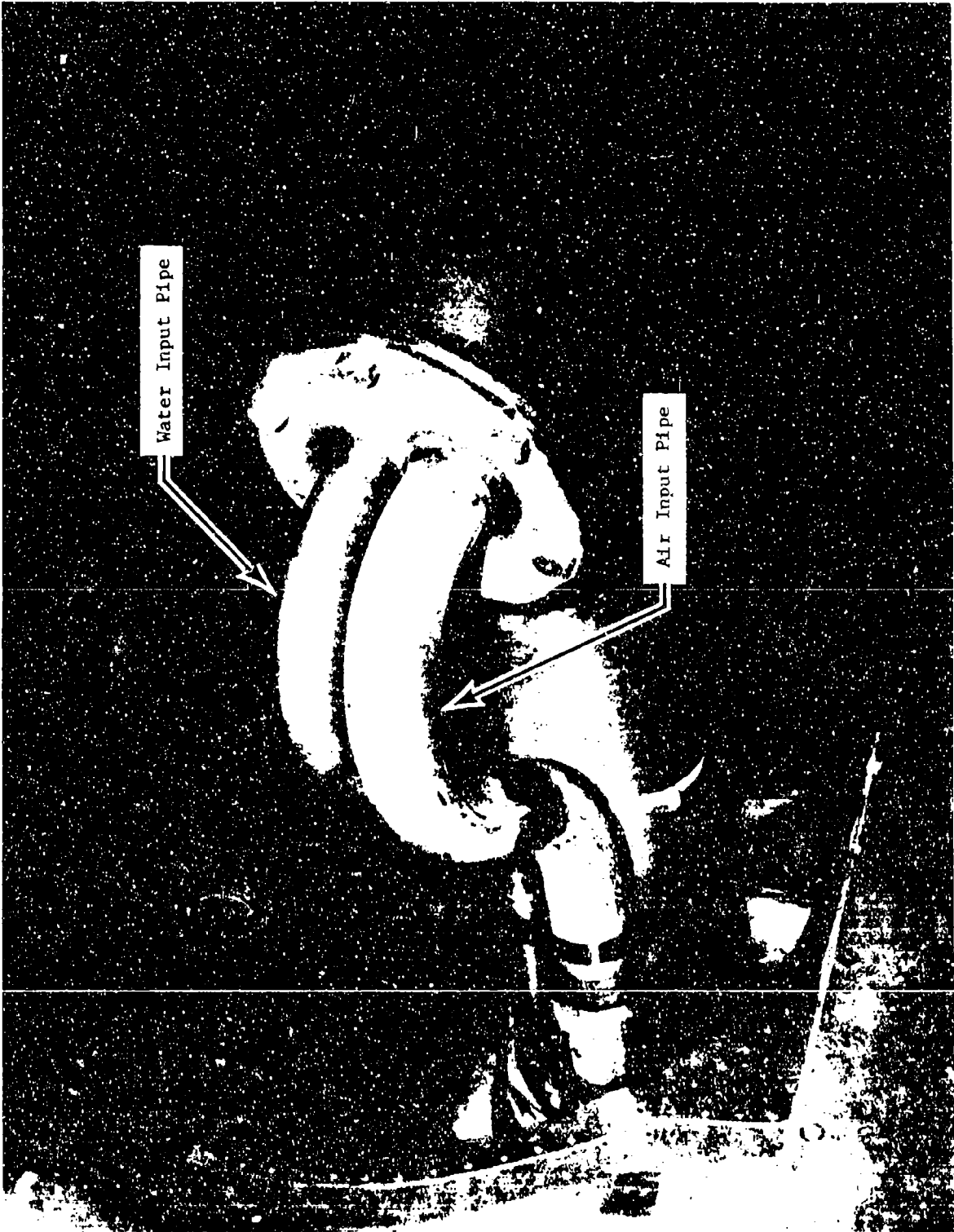

Photo 1. Modified Boom Air and Water Input Pipes

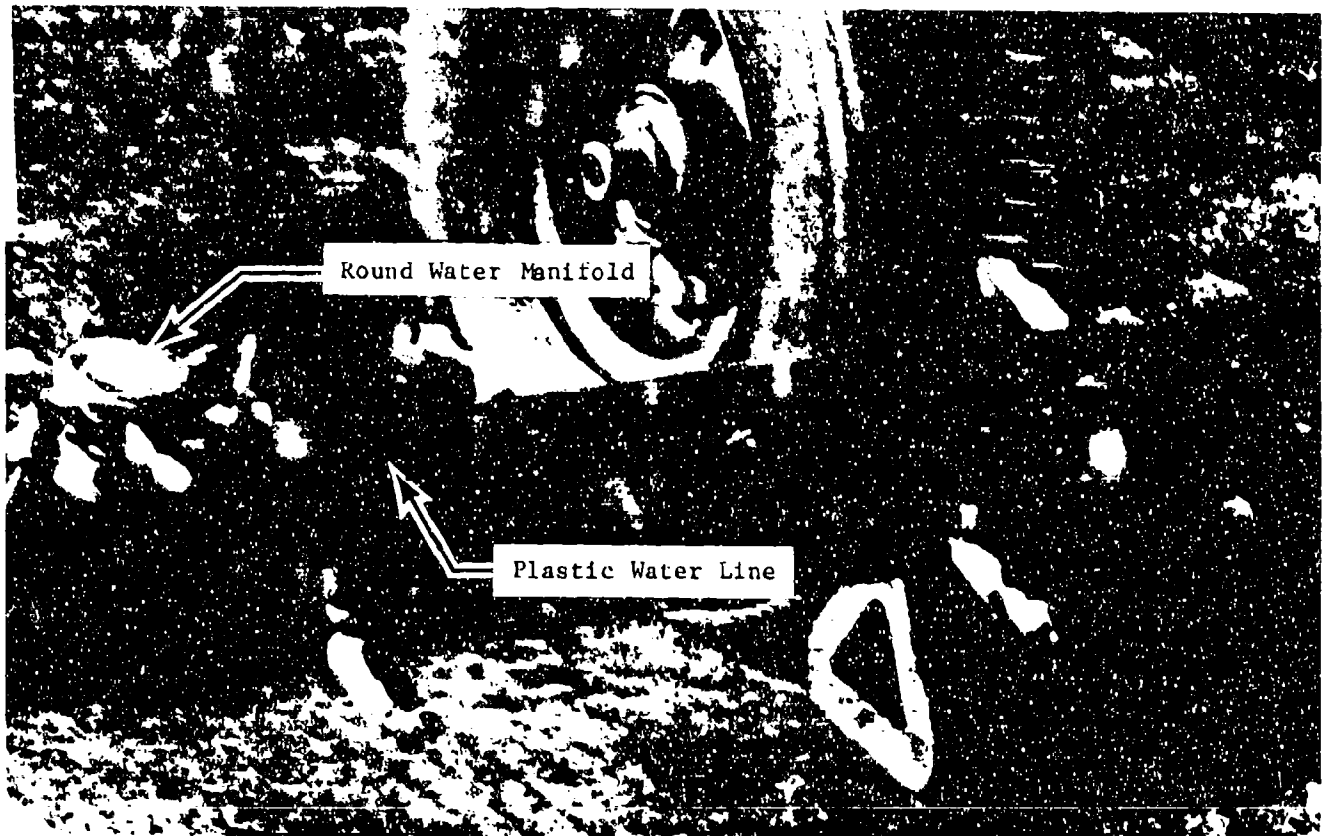

Photo 2. Round Water Manifolds and Plastic Lines

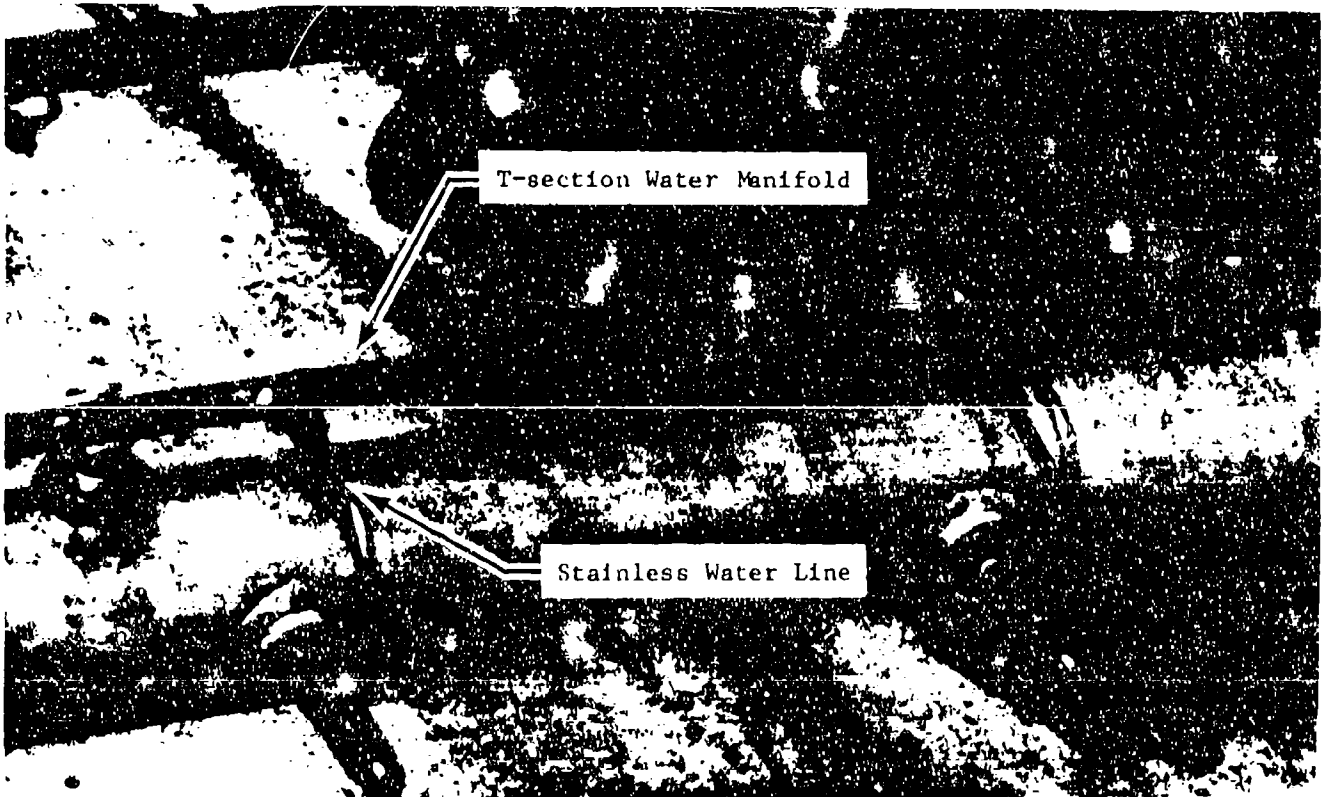

Photo 3. T-section Water Manifolds

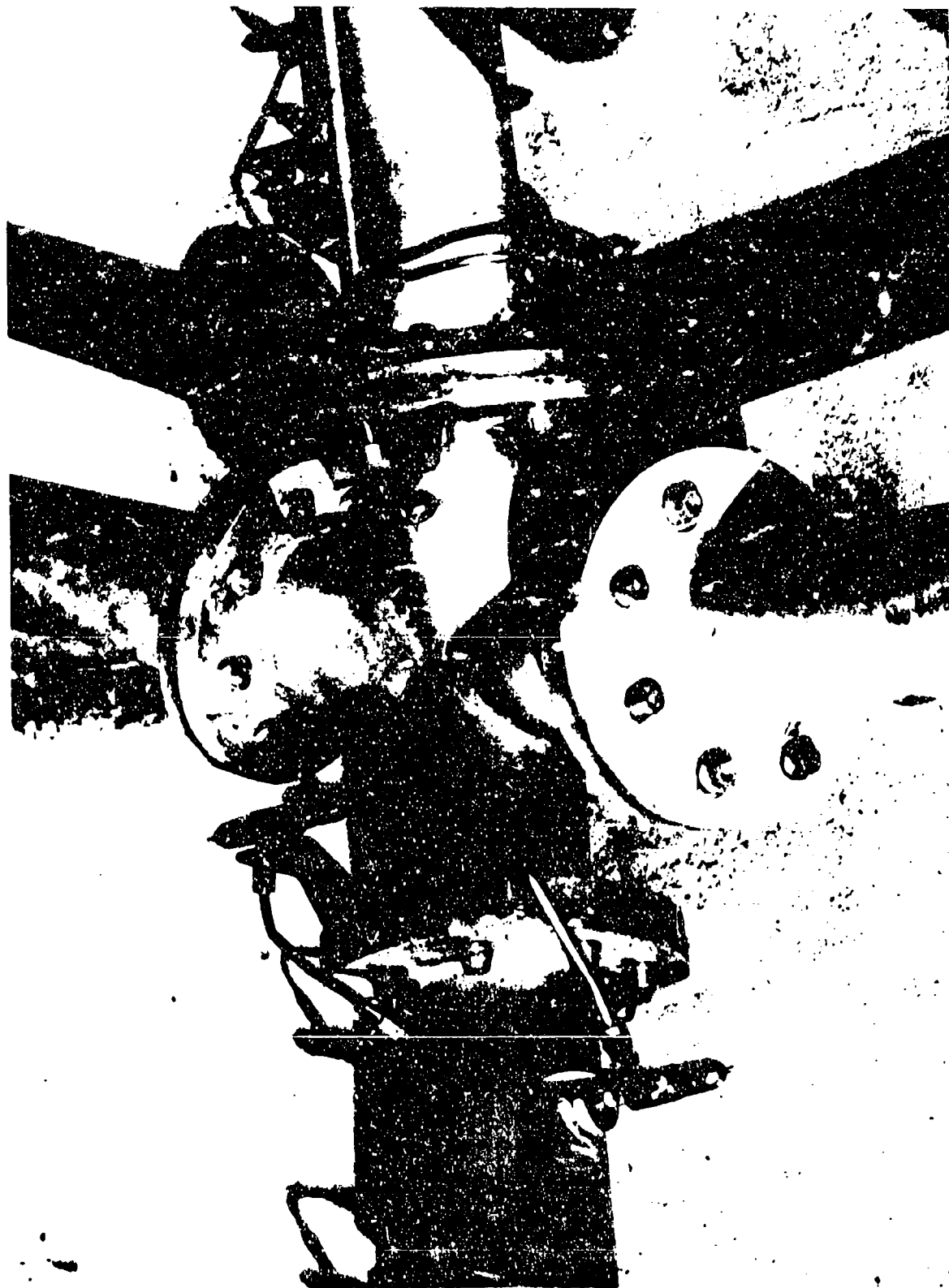

Photo 4. Four-way Junctions with Nozzles Installed

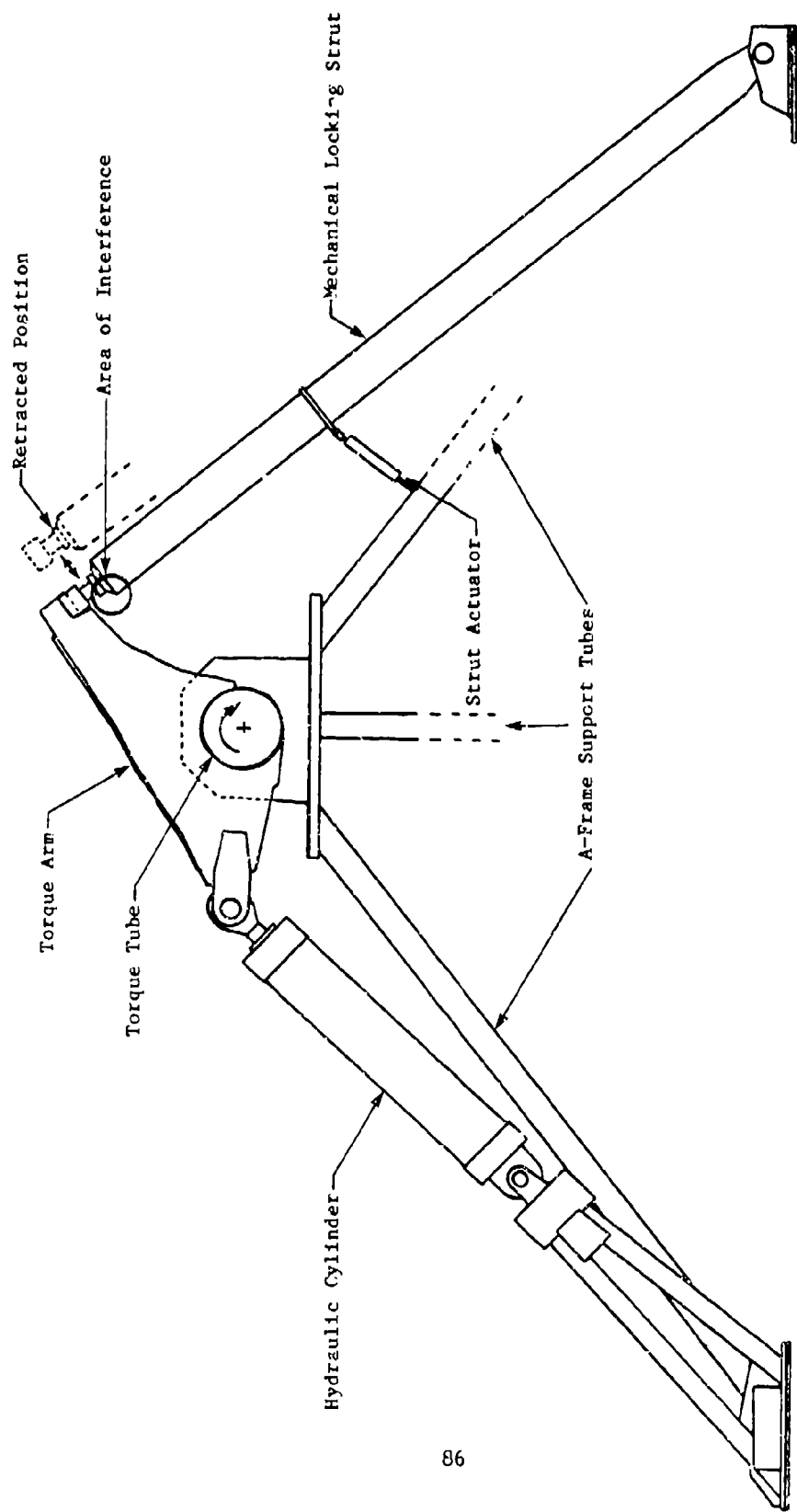

Figure 1 . Torque Tube and Trunnion Mount Assembly

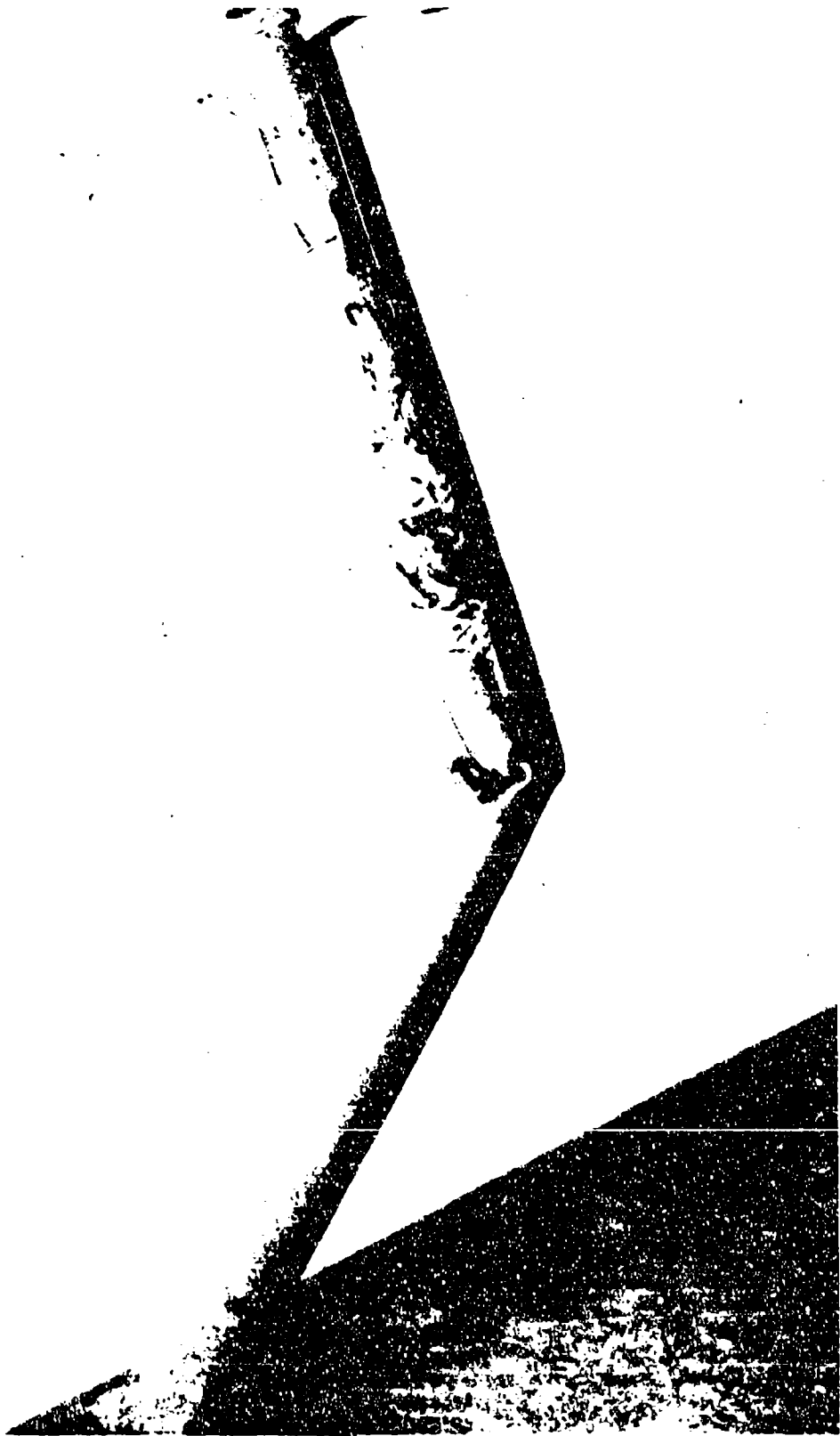
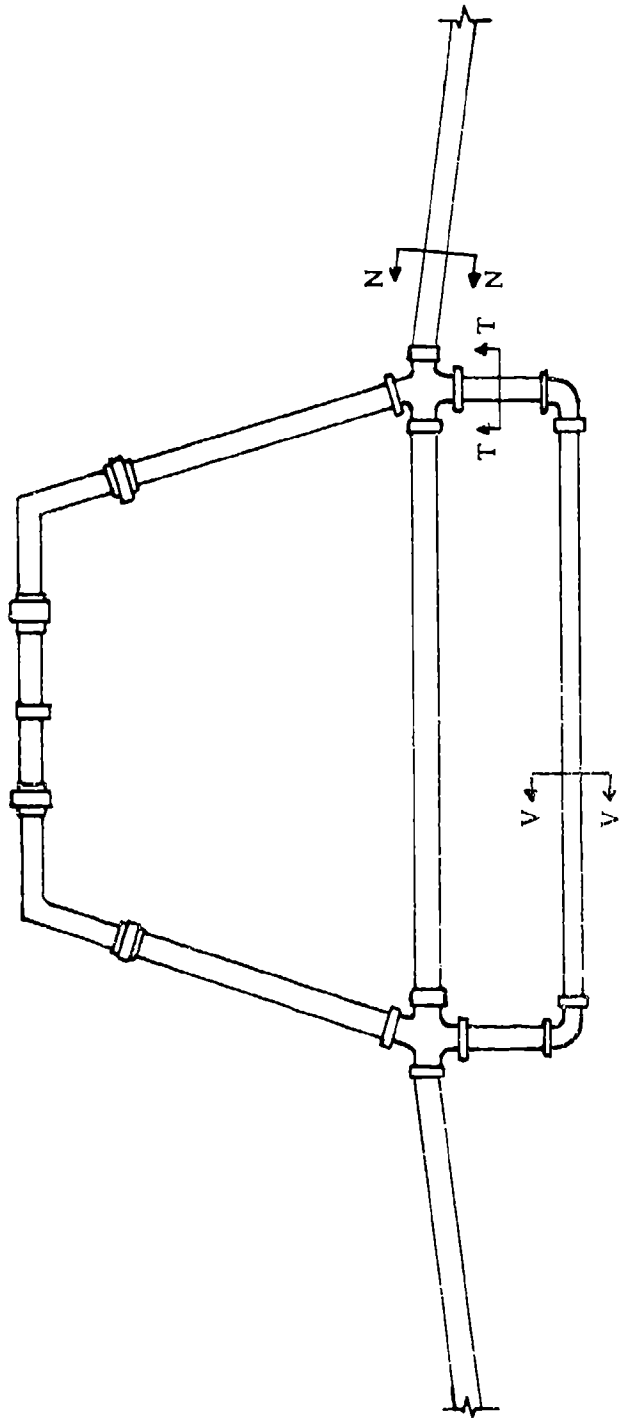

Photo 5. Buckled Left Locking Strut

INSTRUMENTATION

Digital and analog data were obtained from calibrated instrumentation and were recorded on magnetic tape. The instrumentation system consisted of various transducers, signal conditioning units, a ten-bit PCM recorder, and an Ampex AR 700 tape recorder. The data were telemetered to a ground station for loads monitoring. Figure 1 shows accelerometer and strain gage locations used for this test. The following parameters were recorded:

- Altitude
- Airspeed
- Main rotor speed
- Control positions
 - Longitudinal
 - Lateral
 - Directional
 - Collective
- Bending loads
 - DB_x (fore/aft)
 - DB_z (up/down)
 - EB_x (fore/aft)
 - EB_y (lateral)
 - JB_x (fore/aft)
 - JB_z (up/down)



Section V-V

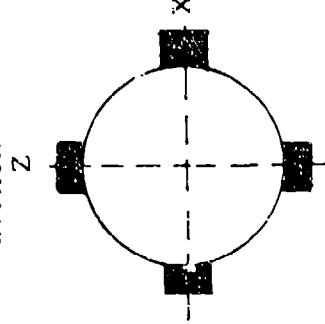

JB_x (fwd/aft)
JB_z (up/dwn)

LOCATION J

Section T-T

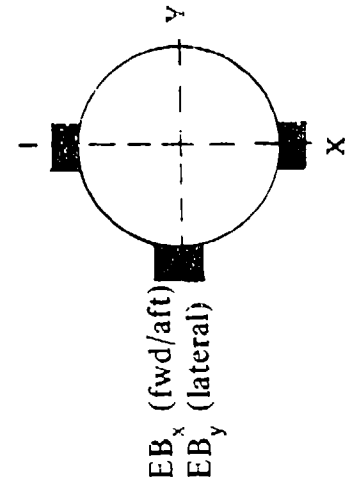

EB_x (fwd/aft)
EB_y (lateral)

LOCATION E

Section N-N

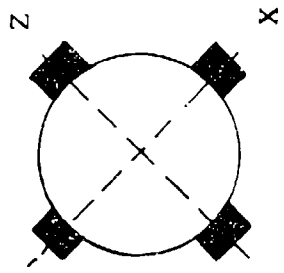

DB_z (up/dwn)
DB_x (fwd/aft)

LOCATION D

Figure 1. Spray Boom Instrumentation Schematic

FIGURE 1
 MODIFIED GOODMAN DIAGRAM
 FOR
 6061-T6 ALUMINUM

- NOTES:
1. 10% LIMIT FOR STEADY STATE MANEUVERS
 2. 10% LIMIT FOR TRANSIENT MANEUVERS
 3. USE FOR LOWER HORIZONTAL CROSS-TIME (STRAIN GAGE LOCATION = 1)

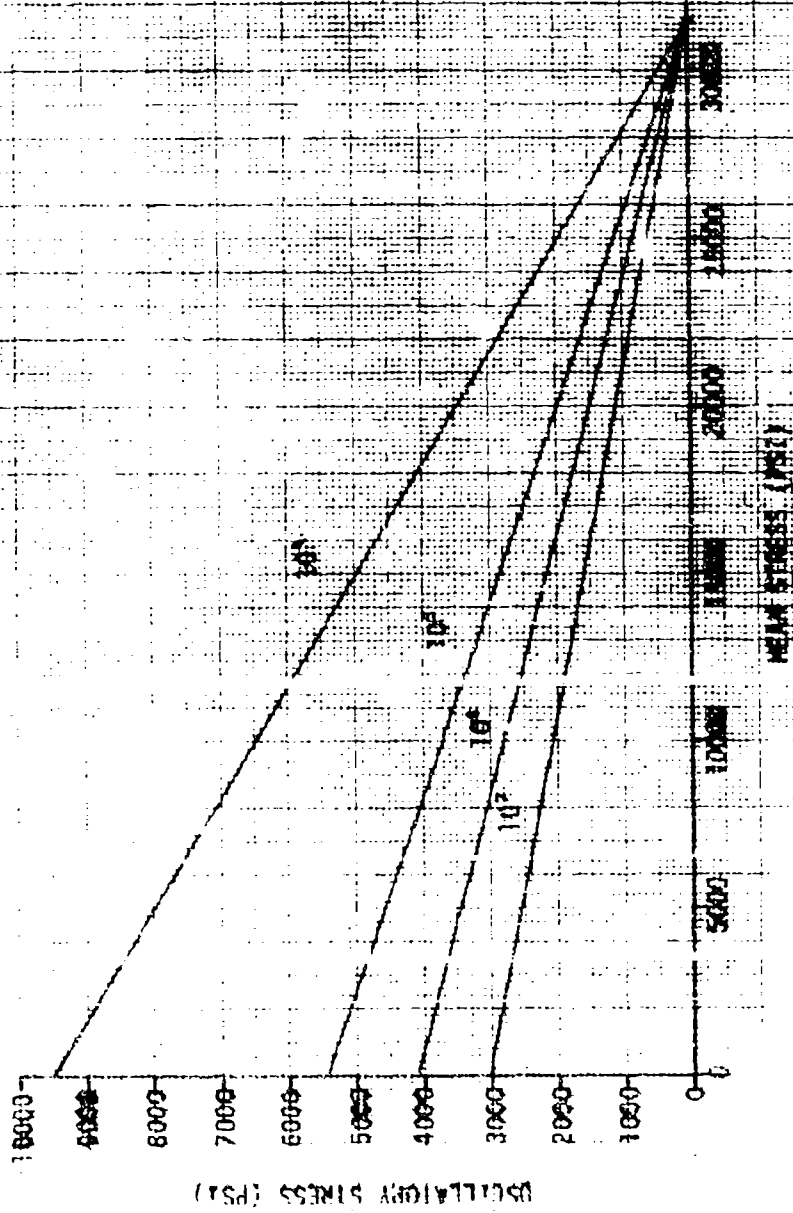

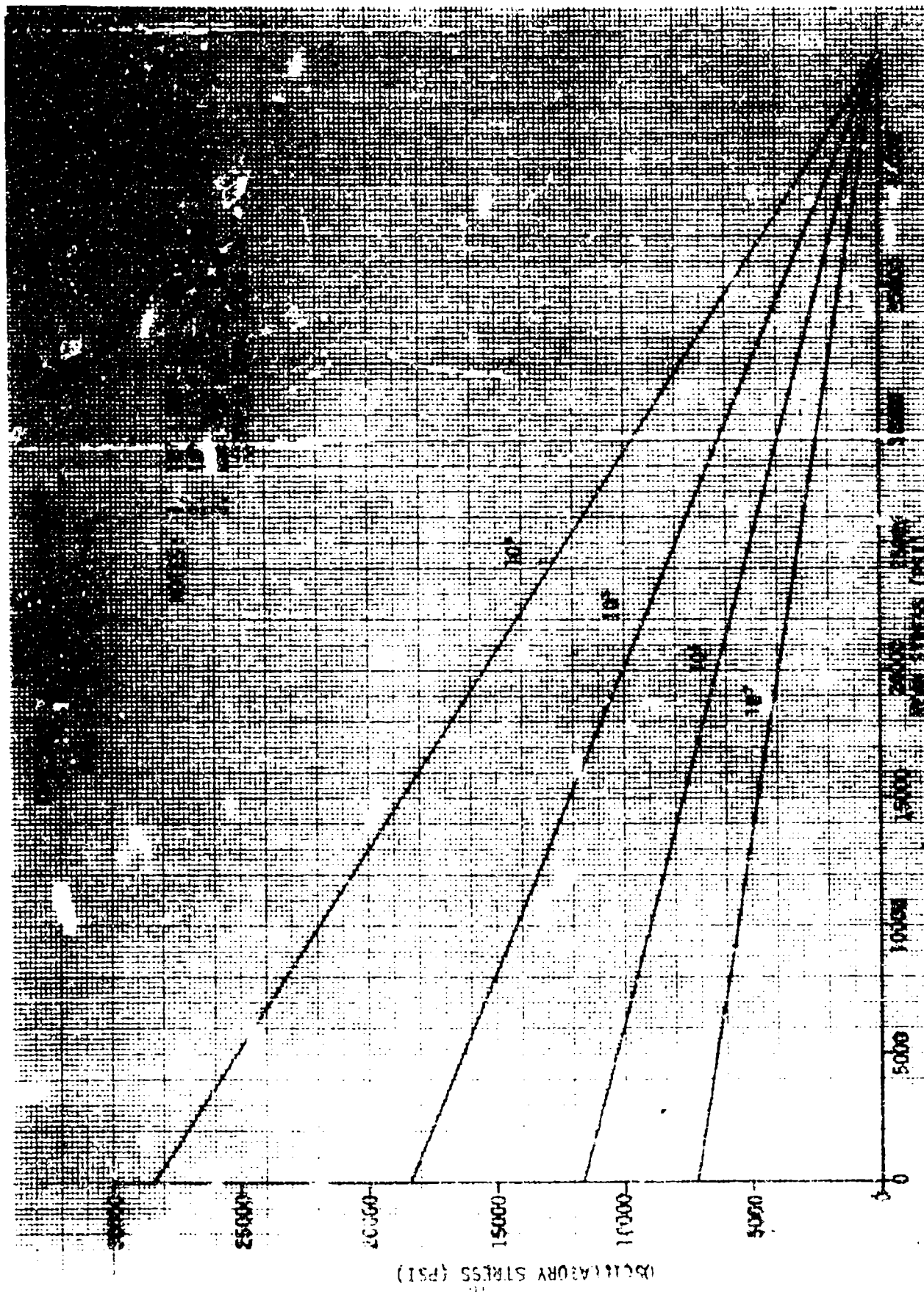

LABORATORY STRESS (PSI)

RESIDUAL STRESS (PSI)

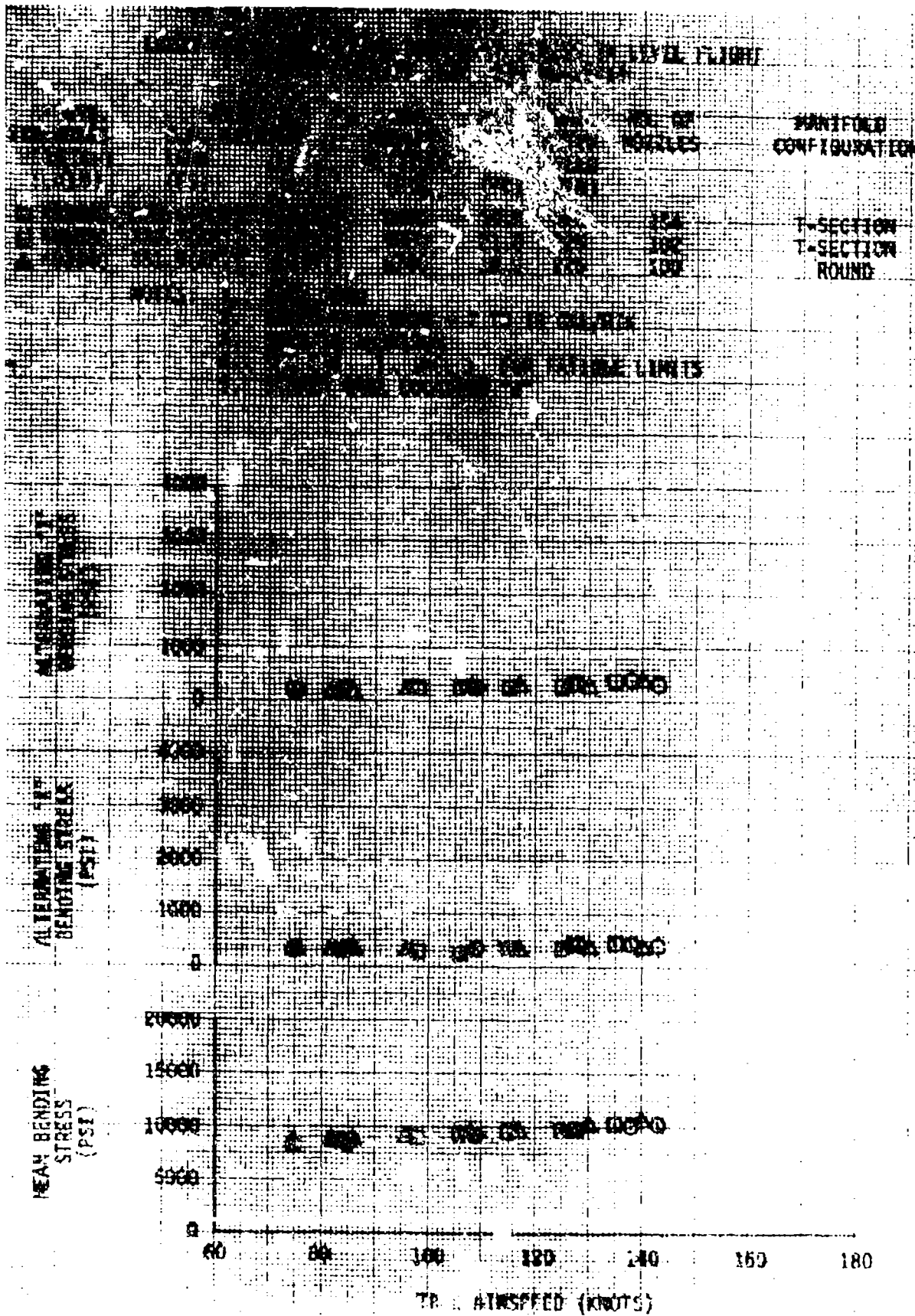

FIGURE 13

AVG. GROSS WEIGHT (LBS)	AVG. LOCATION (FT)	AVG. DENSITY (LBS/FT ³)	AVG. QTY	AVG. SIZE (IN)	AVG. NO. OF PARTICLES	AVG. CONFIRMATION
332.7	(AFT)	8020	81.5	7.5	102	T-SECTION
331.9	(AFT)	8740	88.5	7.5	100	T-SECTION

- NOTES:
1. WASH DOWN
 2. WATER FLOW RATE = 7 TO 10 GPM
 3. MILD STEEL
 4. STRAIN GAGE LOCATION "D"

ALTERNATE 13
 (SEE FIG. 13)

PERMANENT RECORD
 (SEE FIG. 13)

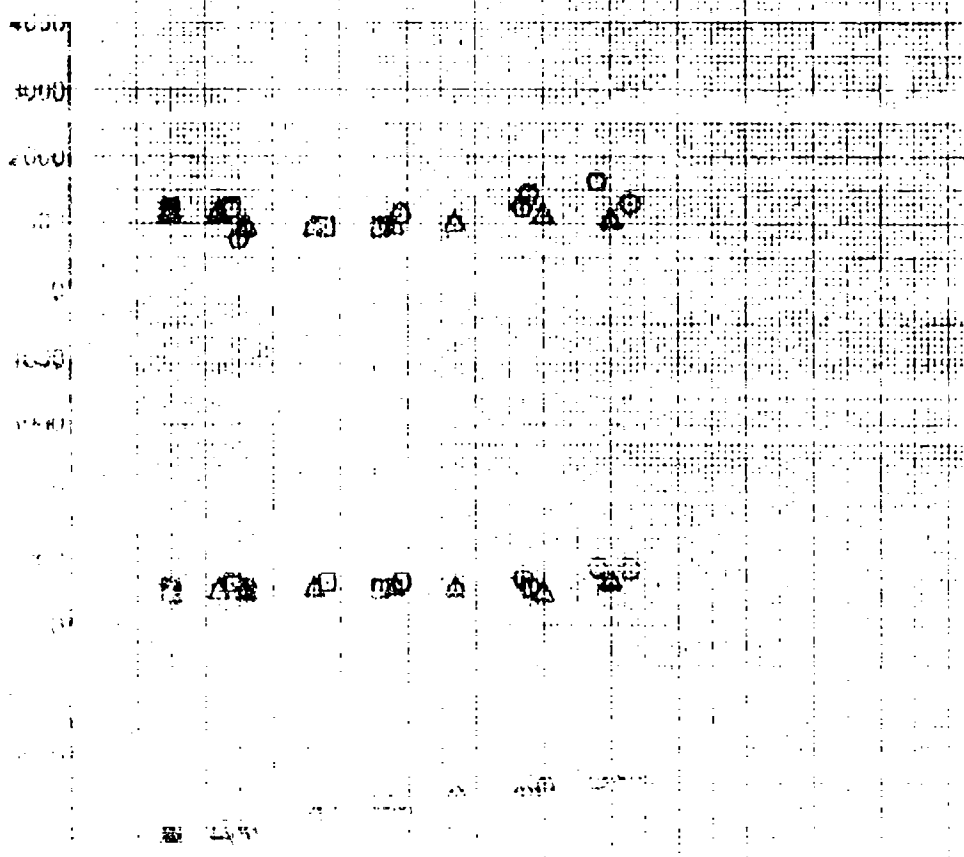
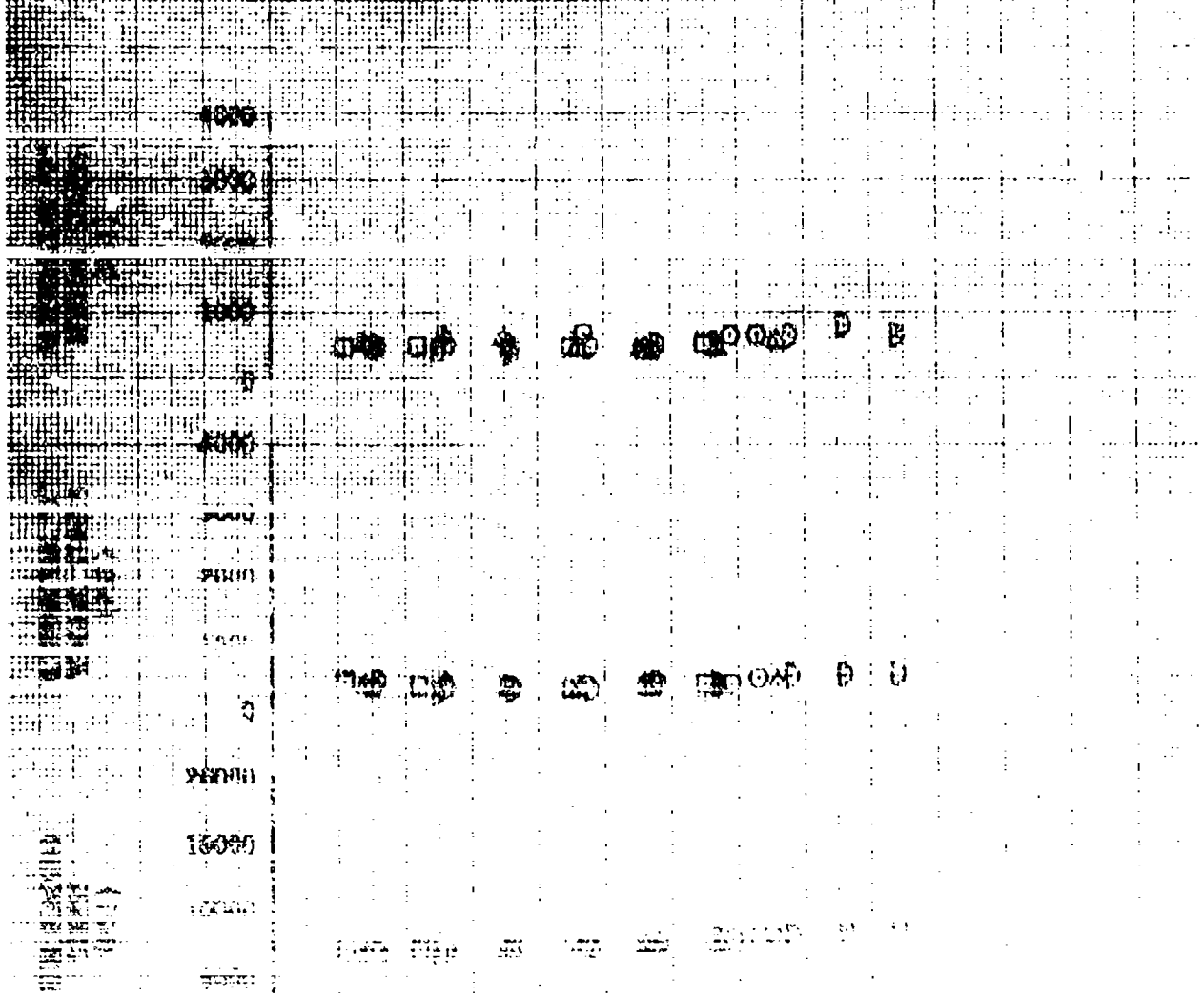

FIGURE 1

COMPOSITE-TUBE BOOM STRESS IN LEVEL FLIGHT

TEST NO.	LOADING RATE (G)	TIME (SEC)	NO. OF NOZZLES	MANIPULATION
1001	10.0	125	154	T-SECTION
1002	10.0	125	100	T-SECTION
1003	10.0	125	100	ROUND
1004	10.0	125	100	T-SECTION, OUTRIGGERS REMOVED

NOTE: 1. POINT OF LOAD OFF
 2. POINT OF FAILURE
 3. POINT OF FAILURE FOR FATIGUE LIMITS
 4. UPPER MARK LOCATION



TEST REPORT NUMBER: 57-65-14814
 DATE: 5/1/65

ITEM	NO.	DESCRIPTION	NO. OF TESTS	NO. OF FAILURES	NO. OF NOZZLES
C	10000	10000	100	25	150
D	10000	10000	100	25	100

TEST CONFIGURATION

F-SECTION

ARMED

I-SECTION, OUTRIGERS
 REMOVED

- NOTES:
1. DATA ON SPRAY GUN
 2. SOURCE OF MATERIALS
 3. FOR FATIGUE LIMITS
 4. STORAGE CASE LOCATION

ALTERNATING
 BENDING STRESS
 (PSI)

ALTERNATING
 BENDING STRESS
 (PSI)

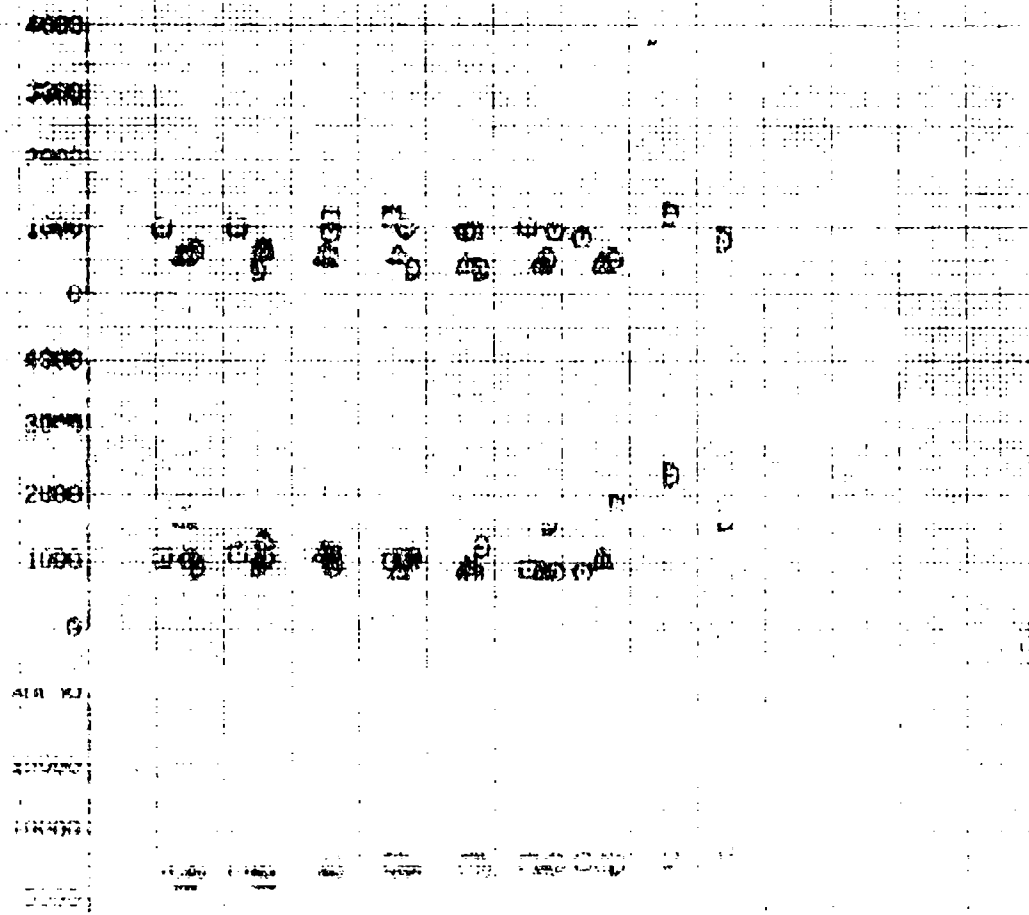

DATE	TIME	TYPE	LOCATION	DEPTH	TEMPERATURE	WIND	SEA	REMARKS
10/10/54	0800	Surf	10.5	21.5	154			
10/10/54	0800	Surf	10.5	21.5	154			
10/10/54	0800	Surf	10.5	21.5	154			

WIND: 0.0
 SEA: 0.0
 SURFACE TEMPERATURE: 21.5
 SURFACE SALINITY: 35.0

ALTIMETER: 101.1
 BAROMETER: 101.1
 (79.7)

ALTIMETER: 101.1
 BAROMETER: 101.1
 (79.7)

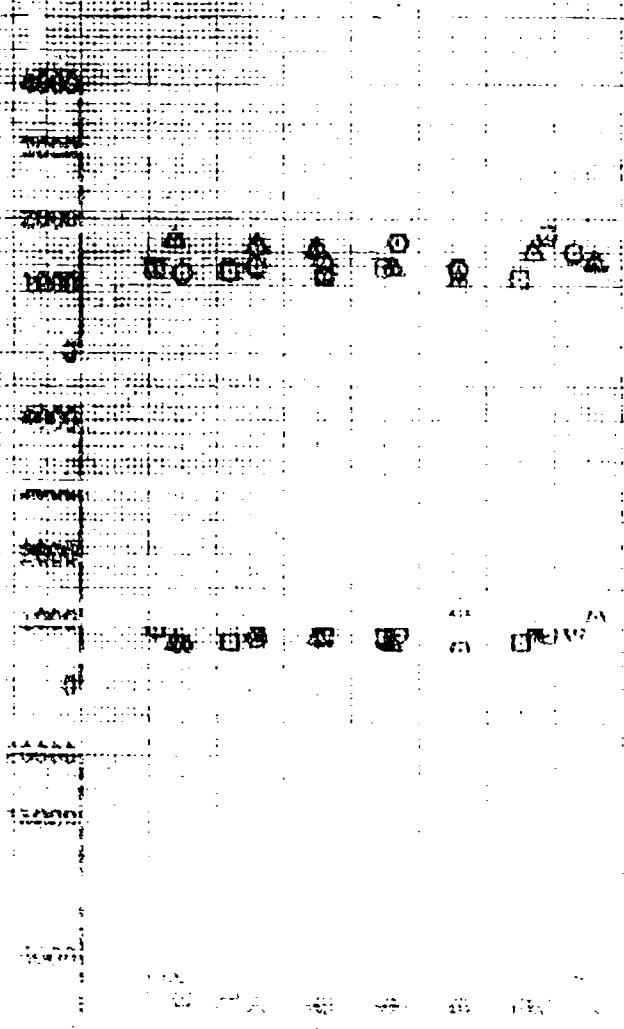

ALTIMETER: 101.1
 BAROMETER: 101.1
 (79.7)

APPENDIX H. LETTER REPORT, USAAEFA PROJECT NO. 82-05-2



DEPARTMENT OF THE ARMY
U.S. ARMY AVIATION ENGINEERING FLIGHT ACTIVITY
EDWARDS AIR FORCE BASE, CALIFORNIA 93523

REPLY TO
ATTENTION OF

OCT 22 1985

SAVTE-M

SUBJECT: Report, Helicopter Icing Spray System (HISS) Evaluation and Improvements. USAAEFA Project No. 82-05-2

Commander
US Army Aviation Systems
Command
ATTN: AMSAV-ED
4300 Goodfellow Blvd.
St. Louis, MO 63120-1798

1. REFERENCES. a. Final Report, USAAEFA Project No. 79-02-2, *Helicopter Icing Spray System (HISS) Nozzle Improvement Evaluation*, September 1981.
- b. Letter, USAAEFA, DAVTE-TI, 4 June 1981, subject: Letter Report, Helicopter Icing Spray System (HISS) Evaluation and Improvements. USAAEFA Project No. 80-04.
- c. Letter, USAAEFA, DAVTE-TI, 22 June 1982, subject: Report, Helicopter Icing Spray System (HISS) Evaluation and Improvement. USAAEFA Project No. 80-04-2.
- d. Letter, AVRADCOM, DRDAV-DI, 14 June 1982 (with revision, 13 Aug 1982), subject: Helicopter Icing Spray System (HISS) Evaluation and Improvements (Test Request).
- e. Letter, USAAEFA, DAVTE-TI, 28 June 1982 (with revision, 15 July 1982), subject: Test Plan, Helicopter Icing Spray System (HISS) Boom Structural Dynamics Evaluation with Fiberglass Blades and Modified Spray Cloud Measurements, USAAEFA Project No. 82-05.
- f. Letter, USAAEFA, DAVTE-TI, 31 August 1982, subject: Report, Helicopter Icing Spray System (HISS) Boom Structural Dynamics Evaluation with Fiberglass Blades, USAAEFA Project No. 82-05-1.
- g. Letter, AVRADCOM, DRDAV-D, 1 July 1982 (with revisions, 13 July 1982 and 13 July 1983), subject: Airworthiness Release for Helicopter Icing Spray System (HISS) Boom Structural Dynamics Evaluation with Fiberglass Blades and Modified Spray Cloud Measurements, USAAEFA Project No. 82-05.

SAVTE-M

SUBJECT: Report, Helicopter Icing Spray System (HISS) Evaluation and Improvements. USAAEFA Project No. 82-05-2

2. BACKGROUND. Since 1973, the US Army Aviation Engineering Flight Activity (USAAEFA) has used a JCH-47C as an airborne spray tanker for helicopter qualification tests in artificial icing conditions. As reported in reference 1a, the Helicopter Icing Spray System (HISS) nozzles were modified during 1979 by installing Sonic Development Corp. Model 125H Sonicore atomizers to improve drop size distribution and uniformity of liquid water content (LWC). The altered dynamics of the spray boom were subsequently investigated in 1980, as reported by reference 1b. In 1981 a gas turbine auxiliary power unit (APU) was installed as an additional bleed air supply for the atomizers. Reference 1c describes this modification, additional boom dynamics tests, and spray cloud measurements from the 1981-82 icing season. Various operational problems were encountered during that program, and a number of proposed modifications to improve the design were identified and reported at that time (encl 1). The aircraft (USA S/N 68-15814) was upgraded in April 1982 by replacing the metal rotor blades with fiberglass blades and changing the forward transmission and vibration dampers. This resulted in a change in rotor speed, and several modifications to the spray boom assembly were incorporated. The US Army Aviation Systems Command (AVSCOM) directed (ref 1d) USAAEFA to prepare a test plan (ref 1e) and conduct a 3-phase program to investigate boom dynamics (phase 1), incorporate and evaluate improvements to the spray system (phase 2), and determine spray system characteristics during icing operations (phase 3). The phase 1 boom dynamics evaluation is reported in reference 1f.

3. TEST OBJECTIVE. The objective of this program (phase 2) was to incorporate and document modifications designed to improve HISS operations, and to evaluate their effects on the spray characteristics.

4. DESCRIPTION. a. The HISS is installed in a modified CH-47C helicopter (US Army S/N 68-15814) and consists of an 1800 gallon internal water tank and an external spray boom assembly suspended 19 ft beneath the aircraft from a crosstube through the cargo compartment. Hydraulic actuators rotate the crosstube to raise and lower the boom assembly. Both the external boom assembly and internal water supply can be jettisoned.

b. The spray boom consists of two 27 ft trapeze center sections with 5 ft vertical separators and two 17.6 ft outriggers attached to the upper trapeze section by 4-way junctions. The outriggers are swept aft 20° and angled down 10°, giving a tip to tip boom width of 60 ft. The boom is assembled of concentric metal pipe. Water is pumped at selected flow rates from the tank to the nozzles on the boom assembly through the inner pipe (1.5 in. diameter). Thirty manifolds for distributing water to the nozzles are spaced approximately 3 ft apart along the boom exterior. Compressor bleed air from both aircraft engines and bleed air from a Solar T-62T-40C2 APU is supplied through the outer pipe (4 in. diameter) to the nozzles to atomize the water. There are 172 nozzle receptacles on the boom surface. These receptacles are staggered to provide

SAVTE-M

SUBJECT: Report, Helicopter Icing Spray System (HISS) Evaluation and Improvements, USAAEFA Project No. 82-05-2

alternating upward and downward ejection ports every 6 inches. Sonic Development Corporation Model 125-H Sonicore nozzles were installed for this evaluation.

5. TEST SCOPE. The various HISS modifications described in paragraph 7 were incorporated at USAAEFA during May 1982 to December 1983. Fourteen flights totalling 14.7 test hours were conducted at Edwards AFB, California, from July to December 1983. Flights were conducted to evaluate proper functioning of all modified components, to include the emergency water jettison system, boom extension and retraction provisions, and water flow and spray system operation and procedures. A smoke trail wake survey was also performed to identify interaction of the aircraft rotor wake on the spray cloud. Spray operations were conducted with two nozzle configurations on the boom: nozzles installed on the trapeze sections only (97 atomizers) and nozzles installed on the trapeze and inboard two-thirds of each outrigger (147 atomizers). Previous tests had shown that additional outrigger nozzles were ineffective because of the CH-47C rotor vortex. Engine start gross weight for the flights ranged from 31,160 to 46,060 lb at a center of gravity of fuselage station 334.4. Test pressure altitude was 6000 ft and the rotor speed was 225 rpm. The limits contained in the operator's manual and airworthiness release (ref 1g) were observed.

6. TEST METHODOLOGY. All system modifications described were incorporated by USAAEFA personnel. Coordination was accomplished with Boeing Vertol to obtain concurrence with modifications that impacted the airframe and hydraulic systems. AVSCOM was involved in approving proposed changes that affected aircraft systems, and was kept apprised of configuration status for airworthiness release purposes. Test techniques for the water jettison, spray operation, and smoke trail rotor wake flight tests are briefly described in the appropriate sections of paragraph 7. Data were hand recorded from aircraft cockpit gages and an instrumentation display of boom air and water pressures. Chase aircraft provided visual observations and photographic coverage during individual tests.

7. RESULTS AND DISCUSSION. a. General. A number of modifications were incorporated on the HISS to improve system operation, simplify maintenance, and correct several problem areas encountered during the 1981-82 icing season. The affected assemblies included the water supply routing, emergency water jettison system, airframe maintenance provisions, and hydraulic system. Performance of the modifications was evaluated during flight tests where all affected systems were operated. A smoke trail rotor wake survey was also conducted to define the downwash interaction with the spray cloud. Results are discussed in the following paragraphs.

b. Water System. (1) Several modifications were made to the water supply system for improved operation. Installation of the bleed air APU for the 1981-82 icing season to supplement aircraft engine bleed air for nozzle atomization

SAVTE-M

SUBJECT: Report, Helicopter Icing Spray System (HISS) Evaluation and Improvements, USAAEFA Project No. 82-05-2

resulted in higher boom air pressures and temperatures than previously experienced. This environment increased the air and water leakage throughout the boom system, causing uneven water delivery to various boom sections and recurring problems with respect to frozen nozzles and growth of ice formations on the boom. As described in reference 1f, the disk-shaped water manifolds and associated plastic tubing to the nozzles were replaced by stainless steel T-section manifolds, steel tubing, and high-pressure MS-type fittings. Photo 1 (encl 2) shows an outrigger equipped with these replacement manifolds. As before, each manifold supplies water for 4 to 6 nozzles, depending on specific location on the boom.

(2) Previous spray operations had shown that the interconnected water passages throughout the boom often resulted in visible differences of water output from the upper and lower trapeze sections. During 1981-82 icing, spray from the lower trapeze appeared twice as dense as from the upper boom. At some conditions, wide sections of the upper trapeze would not spray any water, or only spray in a pulsating manner. Such uneven flow distribution between the two sections degraded cloud depth, uniformity of LWC, and consistency of atomization. Separate water paths to the upper and lower booms were provided by selectively blocking the internal water passages with expandable rubber plugs, isolating the two booms from each other. Each vertical boom support then delivered water from the tank to only a single boom section. The left support supplied the lower trapeze (and left outrigger) and the right support supplied the upper trapeze (and right outrigger). Bleed air passages remained interconnected throughout the entire boom.

(3) Water routing from the tank outlet into the boom supports was considerably modified to improve access to individual components, simplify maintenance, and provide insulation from the cold environment of the aircraft cargo-hook belly hatch. The existing horizontally mounted turbine-type flowmeter had been subject to cavitation, freezing, and contamination by debris. It was replaced by a Fischer and Porter "Mini-Mag" flowmeter using the magnetic inductance principle and providing an unobstructed 1-inch diameter flow passage mounted vertically. The main supply outlet from the water tank was relocated to the forward part of the tank, and the water pump and associated plumbing were removed from the enclosed support cradle beneath the tank and located in an accessible area forward of it. Urethane insulation foam was then injected to fill the enclosed area formed by the support cradle beneath the tank. The water pump outlet now exits vertically upward into the flowmeter, as shown in photo 2. The stainless steel water line continues upward to a "Y" junction near the cabin ceiling, shown in photo 3, where the line splits into left and right arms routed toward each boom support arm, supplying the lower and upper trapeze sections, respectively. Separate electrical throttling valves were installed in each arm of the "Y". Flexible hose connected these arms to the steel tube sections at the boom entry points to accommodate line movement caused by rotation of the torque tube when the boom was raised and lowered. Photos 4

SAVTE-M

SUBJECT: Report, Helicopter Icing Spray System (HISS) Evaluation and Improvements, USAAEFA Project No. 82-05-2

and 5 show the hose routing for the boom retracted and boom deployed configurations, respectively. Transducers to measure water pressure in the upper and lower booms were installed and connected to indicators at the operator's station, allowing independent measurement of water flow to the upper and lower trapeze controlled by the right and left throttling valves. Photo 6 shows the instrumentation installed in the upper trapeze to measure both air and water pressure and temperature.

(4) Two manual valves were installed at the lower aft end of the water tank to allow draining water without having to pump it through the boom system or activate the emergency dump feature. These were connected to 3-inch diameter hoses leading into the aircraft floor through two panels just forward of the cargo ramp hinge line. Drain openings were installed in the belly of the aircraft directly beneath, as shown in photo 7. These drain valves allow a water flow rate of approximately 400 gal./min. As an additional filling port to the gravity feed opening on top of the tank, a 1.5 inch quick disconnect fitting was added to the lower rear of the tank to accept a 2-inch diameter fire hose.

c. Water Jettison System. (1) The emergency water jettison consists of two adjacent downward opening doors fitted in the lower portion of the water tank. These are normally held closed by steel cables in tension routed to a fixture on top of the tank. Cable-cutting cartridges can be electrically activated from the cockpit to sever the cables and allow the doors to swing open, resulting in a rapid water dump from the tank. The water then exits the aircraft through the cargo hook opening in the floor beneath the tank.

(2) The original doors had recurring leakage problems because of inability to adjust cable tension from outside the water tank, and were not located directly over the cargo hook opening in the floor of the aircraft. Water inside the aircraft had been a cause of magnesium floor panel corrosion. The jettison system was modified by providing new openings in the tank (photo 8) centered over the cargo hook opening and modifying the cable assembly. The new tank openings were enlarged by 50% to a total area of 1.5 ft², and new doors installed (photo 9). A strip of zinc chromate paste between the tank and the doors provided a watertight seal. A new cable routing incorporated a handle-equipped ratcheting winch to adjust tension on the closed doors (photo 10). Four-inch diameter vent holes with offset protective covers were added to the top of the water tank at each end. Additionally, two reinforced sheet aluminum doors were installed on the fuselage belly to cover the cargo hook opening (lower rescue hatch door), as shown in photo 11. These were attached by full-length piano hinges at the front and rear of the hatch. The forward door overlaps the rear, and is held in place with six spring-loaded latches and a 3/8-inch bungee. The doors remain normally closed, but swing open downward when subject to 100 to 125 lb force from above, as in the case of a water dump. The aft door then remains open until manually closed after landing.

SAVTE-M

SUBJECT: Report, Helicopter Icing Spray System (HISS) Evaluation and Improvements, USAAEFA Project No. 82-05-2

(3) An evaluation of the modified water jettison system was conducted to verify proper inflight operation and evaluate effects on flight characteristics. Following a ground test of the dump system (photo 12), inflight jettison tests with 1400 gallons onboard were performed in a hover at a nominal 10-ft wheel height (photo 13), level flight at 107 knots indicated airspeed (KIAS) (photo 14), autorotational descent at 100 KIAS (photo 15) and deceleration at 50 KIAS (photo 16). The flight conditions were chosen to represent the most likely emergency jettison situations, such as a level flight spray mission at 120 knots true airspeed (KTAS), an emergency descent from altitude, and an aborted takeoff. In each case, gross weight and cg was representative of a typical icing spray mission. The majority of the water drained from the tank within 15 seconds of activation, followed by a reduced flow for another 15 seconds until a residual trickle remained. Spray entered the aft ramp area only in the 107 KIAS level flight condition. Handling qualities and system operation were satisfactory in all cases.

d. Airframe Modifications. To permit maintenance inspections underneath the aircraft floor without removing the boom support torque tube and trunnion assembly, twelve 4" x 6" holes and inspection access covers for these were installed in the aircraft belly at locations spaced from FS 174 to 269, at left and right BL 39, as shown in photo 17. To facilitate lifting of floor panels without removing the HISS installation, the left and right outboard floor panels were cut and respliced at FS 150 and 285 just forward and aft of the torque tube base plate, as shown in photo 18.

e. Hydraulic System. The aircraft utility system provides power to the HISS hydraulics to run the water pump and raise and lower the boom assembly. The original configuration had lengthy line routings attached to the water tank support cradle. This system was removed and the controls and valves were relocated to a single panel installed on the right side of the aircraft between FS 400 and 440 at the operator's station, as shown in photo 19. A 25 cubic-inch accumulator was installed between the utility and HISS hydraulics to avoid pressure surges. Gauges were added at the operator's station to measure boom actuator, water pump, and return line pressures. A failure protection circuit was also incorporated to automatically shut off and isolate the HISS hydraulics from the aircraft utility system in case of HISS hydraulic fluid and pressure loss. Figures 1 and 2 (encl 3) illustrate the system operation during both boom transit and boom locked configurations.

f. Miscellaneous. (1) During previous testing (ref 1f), a boom retraction sequence at 110 KIAS resulted in damage to one of the boom downlock struts when it failed to remain clear of the torque arm as it began to rotate. New downlock strut hydraulic actuators were installed to keep the struts clear during the retraction cycle. A backup cable and pulley arrangement was attached from the uplock struts to a lever on the cabin floor to allow manually pulling both uplocks clear of the torque arm if the hydraulic actuators failed to

SAVTE-M

SUBJECT: Report, Helicopter Icing Spray System (HISS) Evaluation and Improvements, USAAEFA Project No. 82-05-2

function properly. In-flight boom deployment and retraction tests were done at 80, 100, 110 and 120 KIAS, with acceptable results at all conditions. Average time to lower the boom was approximately 55 seconds, and 40 seconds to raise it. Boom system deployment and retraction was satisfactory at airspeeds to 120 KIAS.

(2) The water tank support cradle rests on a wooden base and is secured to the cabin floor by steel cables and turnbuckles. The cable network originally connected five hard points on each side of the cradle at buttline (BL) 24.5 to two 10,000 lb and four 5000 lb cargo tie down points at BL 44 on the floor adjacent to the sides of the aircraft. To reduce interference with crew movement, the cables fastened to the 5000 lb tie downs were repositioned to attach to the next inboard row of seven tie downs at BL 20. Appropriately located holes were made in the wooden base to provide access to these inboard tie down points.

(3) The spray boom assembly in the retracted position prevents lowering the cargo ramp at the rear of the aircraft further than slightly above horizontal. Lowering the ramp beyond this angle in-flight would prevent the boom from retracting fully. A metal indicator was fastened to the side of the ramp to display this angle by alignment with an index mark above the cabin floor.

(4) Some modifications were made to the electrical systems to simplify existing circuitry and eliminate previously installed wire bundles that were no longer being used. Various wire routings for the boom hydraulic controls, cable cutter circuits, valve installations and APU controls were relocated to raise them above the floor and protect them from exposure to personnel movement and water leakage. Corresponding circuit diagrams were updated accordingly. A second VHF radio was installed in the aircraft and a roof mounted antenna was added at mid-fuselage.

g. Spray Tests. (1) In flight spray operation was evaluated using two nozzle configurations on the boom. One configuration (five flights) consisted of 97 nozzles mounted on the two trapeze sections only, with the outriggers isolated from the boom air and water supply by metal plates bolted between the boom flanges at the outrigger junctions. The second configuration (four flights) made use of the outriggers as well as the trapeze sections, adding 25 nozzles to the inboard two-thirds of each outrigger for a total of 147 nozzles. Selected water flow rates were established between 5 and 50 gallons per minute, and a chase aircraft visually observed the spray plume characteristics. Instrumentation included measurement of air and water pressures in the upper and lower boom center trapeze sections.

(2) A series of procedural and hardware modifications to the water passages were made between flights to improve the flow characteristics observed during operation. A "Y" fitting in the line past the flowmeter outlet split the water stream in two, directing half down through the left boom support into

SAVTE-M

SUBJECT: Report, Helicopter Icing Spray System (HISS) Evaluation and Improvements, USAAEFA Project No. 82-05-2

the lower trapeze, and half through the right support to the upper trapeze. Its intended function was to deliver equal amounts of water to each trapeze section at all flow rates. However, below a certain flow rate an imbalance occurred which tended to divert all the water into a single branch of the "Y" junction. This condition produced twice the desired flow and elevated water pressure from one boom section while the other section had zero flow and its empty water manifolds showed below ambient pressure (suction). This behavior is illustrated for both nozzle configurations in figure 3, which shows measured air and water pressures during the initial tests. The imbalance is apparent below 25 gal/min with the outriggers, and below 20 gal/min with just the trapeze.

(3) Electrically controlled throttling valves were placed downstream of the "Y" fitting outlets to allow modulating each water path, and water pressure indicators for the upper and lower booms were installed at the operator's station to show any imbalance. This arrangement allowed establishing a stable and balanced flow condition throughout the boom. However, operator technique as to sequence, timing, and magnitude of adjustments remained a significant factor for successful operation. At low flow rates, any disturbance interrupting the flow tended to trigger the imbalance, and caused the flow to funnel into a single boom support. Air and water boom pressures with flow rate in the final configuration are shown in figure 4. The various modifications incorporated to the spray system enabled producing a satisfactory spray cloud over the desired water flow range.

(4) Several characteristics of the system behavior were observed. An approximate lag of 15 seconds elapsed from valve adjustment to visible flow change at the booms. The chase aircraft was useful in estimating how evenly the mass flow was split between the upper and lower booms while establishing a desired flow rate. At 10 gal/min and below, the amount of air pressure supplied to the boom directly affected the ability to establish a balanced water flow. Satisfactory water flow below 10 gal/min could not be obtained consistently with full bleed air to the nozzles (APU plus both engines), while flow was readily balanced when just the APU was supplying air. Table 1 (encl 4) shows measured boom air pressure for both nozzle configurations with several air source combinations. An air pressure of 20 psig is considered the minimum acceptable for satisfactory atomization, with higher air pressures generating smaller drop sizes. With the outriggers included, both the APU and engines are required to provide enough air pressure. With just the trapeze, the APU alone is adequate and is the only source used below 10 gal/min.

(5) Water to the boom flows vertically downward through the boom support passages and makes an abrupt turn to enter the horizontal trapeze sections and outriggers. The water manifolds immediately adjacent to the turn do not receive as stable a flow as the remainder, and their nozzles tend to spray in a pulsating manner, particularly at low flow rates. This affects two manifolds

SAVTE-M

SUBJECT: Report, Helicopter Icing Spray System (HISS) Evaluation and Improvements, USAAEFA Project No. 82-05-2

when the trapeze sections are used and four manifolds when the outriggers are included. This phenomenon aggravates the gap in the spray at the 4-way junctions between the outriggers and the center trapeze when the outriggers are in use. Because of the lowered bleed air pressure available with the outriggers and the behavior of the nozzles adjacent to the 4-way junctions, only the trapeze sections should be used (without outriggers) for icing spray missions in the present configuration.

(6) The main water passages in the boom consist of 1.5 inch diameter tubing. These passages may not be completely filled with water at low flow rates, as indicated by the difficulty experienced in obtaining a balanced flow throughout the boom, the pulsing nozzles at manifolds where a right angle turn in the flow is made, and the time delay observed between flow adjustment and spray change. Future modifications should include reducing the size of the boom water passages to enable better spray performance at low flow rates without limiting the high flow rates.

h. Rotor Wake Survey. (1) To define interaction of the HISS rotor wake with the spray cloud, a flow visualization survey using smoke was conducted. The flow survey attempted to define the point where the downwash, as defined by smoke injected beneath the aft rotor, intersects the spray cloud and disturbs it with turbulence. A commercially available Compro Aviation "Drift Finder" smoke generator unit was installed in the aft cabin cargo ramp area as shown in photo 20. It consisted of a 3.5 gallon capacity tank and an electrically driven pump, with a flexible line routed to a nozzle installed in the CH-47C APU exhaust pipe in the aft pylon. When activated, the unit injected a flow of Texaco "Corvus-13" oil into the APU exhaust, producing a cloud of white smoke from the six inch diameter APU exhaust port located above the aft cabin cargo door opening (photo 21). The rotor wash would entrain and deflect the smoke downward in flight. Validity of the smoke as an indicator of rotor wash location was verified by flying a UH-60A helicopter at various standoff distances behind the HISS, as shown in photo 22, and noting when downwash turbulence could be felt affecting the main and tail rotor systems. A chase aircraft correlated relative position of the smoke to the UH-60A rotor systems when turbulence was perceived. The lower edge of the smoke cloud agreed reasonably well with the onset of turbulence.

(2) Side views of the HISS, smoke trail, and spray cloud taken from a chase aircraft are shown in photos 23 through 27. Airspeeds of 80, 90, 100, 120 and 130 KTAS were flown at an average gross weight of 44,000 lb, pressure altitude of 6000 feet, and ambient temperature of 13°C. Although a well defined horizon for reference does not appear on this series of photographs, the spray cloud trajectory can be seen to form a shallow downward curve at an angle below the horizontal. The angle increases with decreasing airspeed. These spray characteristics indicate the presence of flow field effects at the spray nozzle location on the boom assembly. Using two separate photos from each airspeed,

SAVTE-M

SUBJECT: Report, Helicopter Icing Spray System (HISS) Evaluation and Improvements, USAAEFA Project No. 82-05-2

figure 5 shows the average distance behind the booms that the smoke contacts the spray cloud. The CH-47C fuselage length of 50 ft 9 in. was used for scaling distances from the photographs. Figure 5 also shows the calculated distance for downwash interaction using simple momentum theory and an assumed horizontal spray sheet without downward deflection. The calculated distances are comparable to those measured on the photos around 90 KTAS but are considerably shorter at slower speeds, and increase much more rapidly at higher speeds than those observed during the smoke survey.

(3) Spray from the upper and lower trapeze merges at approximately 150 ft, and test aircraft try to maintain a standoff of 180 \pm 10 ft from the booms during icing immersions. The smoke survey indicated that this distance remains relatively free of rotor wash for the 90 to 120 KTAS airspeed range normally used for icing. The smoke trail at higher airspeeds suggested that the rotor wash distance does not increase much beyond 200 ft, indicating that greater standoff distances are not practical with the present boom configuration.

8. CONCLUSIONS. The following conclusions were reached upon completion of this test program:

a. The emergency water jettison system operation was satisfactory at all conditions tested (para 7c).

b. Boom system deployment and retraction was satisfactory at airspeeds to 120 KIAS (para 7f(1)).

c. The various modifications incorporated to the spray system enabled producing a satisfactory spray cloud over the desired water flow range (para 7g(3)).

9. RECOMMENDATIONS.

a. Only the trapeze sections should be used (without outriggers) for icing spray missions in the present configuration (para 7g(5)).

b. Future modifications should include reducing the size of the boom water passages to enable better spray performance at low flow rates (para 7g(6)).

10 AUTHOR. This report was prepared by Mr. Daumants Belte/Project Engineer, Autovon 350-2227, Commercial (805) 277-2227.

4 encl
as

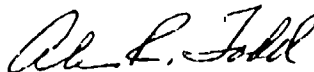
ALAN R. TODD
COL, AV
Commanding

DISPOSITION FORM

13 APR 1982

For use of this form, see AR 340-15; the proponent agency is TAGO.

REFERENCE OR OFFICE SYMBOL

DAVTE-M

SUBJECT

Trip Report: Helicopter Icing Spray System
Improvement Planning and OperationsTHRU: DAVTE-M
DAVTE-P
DAVTE-T
DAVTE-CT
DAVTE-S

FROM DAVTE-M

DATE Mr. Belte/s1/4708 CMT 1

TO: DAVTE-C
DAVTE-A

1. Trip Requirements:

- a. Order No. & Date: T.O. 3-29, 18 Mar 1982
- b. Place: Icing test site, St. Paul, MN
- c. Date: 21-27 March 1982
- d. Project No.: N/A
- e. Estimated Cost: Total \$845.
- f. Other travelers: None

2. Purpose of Travel: Observe HISS operations during the final week of icing in Minnesota and identify existing problem areas for correction prior to next icing season.

3. Itinerary: Los Angeles to St Paul MN, 21 Mar; return to Los Angeles 27 Mar 1982

4. Individuals Contacted: (AEFA personnel on site) LTC Ward, Chuck Blum, Henry Sanford, Ralph Woratschek, Vern Diekmann, MAJ Hanks, Bob Robbins, Don Stafford, SFC Senatore

5. Discussion of Problems: An in-house AEFA staff briefing was held on 17 Mar 1982 to outline HISS improvement planning and objectives, with emphasis on near-term and interim design efforts to upgrade the HISS until a replacement system becomes available several years downstream. This TDY to Minnesota came about as a result of this meeting, with the objective of evaluating present HISS operating procedures and problems on site, and assimilating them into a near-term plan for required modifications to improve the system for the 1982-83 icing season.

6. Significant actions: During the 5 working days spent in Minnesota, most phases of operational and maintenance procedures for the spray system were reviewed and observed. Included were 3 flights aboard the U-21 chase/cloud measurement aircraft and 5 flights aboard the HISS at both forward and aft cabin operator's stations. Discussions with icing project personnel and HISS crewmembers brought up a number of problems identified in the course of the icing season, and generated a number of ideas for problem correction and system improvement. Section 7 (Conclusions) describes these observations, and section 8 (Recommendations) outlines the proposed tasks that need to be accomplished this year for near-term improvement.

7. Conclusions:

a. Upper/Lower boom spray difference. A definite difference in water output exists between the upper and lower trapeze. Spray from the lower boom appears about twice as dense as the upper spray. At some conditions, wide sections of the upper trapeze do not produce any water at all, or only spray in a pulsating manner. This is presently the most significant

Encl 1

109

DA FORM 2496
AUG 80

PREVIOUS EDITIONS WILL BE USED

☆ U.S. G.P.O. 1980-665141/288

DAVTE-M

SUBJECT: Trip Report: Helicopter Icing Spray System Improvement Planning and Operations

drawback of the HISS end product, i.e., composition of the spray cloud. The uneven distribution of water to the nozzle array and the pulsing effect are plainly visible, and significantly degrade cloud quality as to cloud depth, uniformity of LWC, and droplet MVD. During project 80-04, (boom dynamics after first icing season with sonicore nozzles) it was noted that the "Y" junction that delivers water to the boom supports on each side does not do this evenly. Rotation of the "Y" from one side to the other between flights would alter spray density patterns. The additional APU air now available (with resulting new leaks) has seriously aggravated this condition. The proposed changes for water plumbing and routing into the booms must compare alternate methods to deliver equal amounts of water to the upper and lower trapeze (including flow paths, line size requirements, adjustable restriction of water to the lower boom, and possible use of a hydraulic flow splitter device) to identify a workable solution.

b. Water tank/pump/plumbing. The water tank and plumbing are another area needing major modification. The emergency water jettison doors on the tank bottom cannot be properly tensioned closed to prevent leakage. On two occasions this year, the doors were partially opened (by manually loosening the cables instead of operating the cable cutter) to reduce water load prior to precautionary landings. Since the cargo hook belly opening of the aircraft is not directly under the water doors, large quantities of water were released onto the aircraft floor (magnesium floor panel corrosion has been a recurring problem). A second means of manually draining water during flight needs to be incorporated. In flight, the belly opening allows a flow of cold ambient air into the cargo compartment. At a -15°C condition, temperature in the aft cabin was measured at 25°F (-4°C) and a constant flow of circulating air could be felt. The wind chill factor was the main source of crew discomfort instead of actual temperature. The water pump, turbine flowmeter, and sight gage fittings are all uninsulated and at floor level under the water tank (exposed to ambient airflow from the belly opening), and freezing in each of these has impaired spray operations. A needlessly long and complex routing of various size steel lines and clamped hose connectors has remained in place from previous configurations. The area around and beneath the water tank can be cleaned up to eliminate these problems by relocating the pump and flowmeter forward of the tank, rerouting and converting to hard-plumbed stainless steel tubing with MS fittings, relocating the tank jettison doors and modifying the cable cutters, and adding inspection panels on the aircraft belly. The open area under the tank can then be insulated and isolated from the cabin. Possible use of moveable aircraft belly doors (as used during one "B" model Chinook program) can also be explored.

c. Torque tube/support arm plumbing. The routing of air and water lines into the boom at the torque tube and top of support arms was reversed in Minnesota as an expedient to alleviate a leakage problem, and changes were made to tubing in the support arms. The torque tube seals as installed are inadequate. The torque tube fittings that plumb in air and water were originally designed for a different configuration, and need to be relocated and properly pointed to simplify routing, shorten line length, and save weight by eliminating items no longer necessary.

d. Tubing and flex hose within boom. The APU bleed air delivered to the boom is both hotter and at higher pressure than the engine bleed available in the past, and has caused several problems for the boom. A number of clamped pieces of rubber hose are used as connections to join sections of the interior concentric water line within the boom and support areas (i.e., where the plumbing first enters the boom, across the explosive bolt joints, and between each adjacent water manifold on the spray booms). These lines are subject to water flow while spraying and hot bleed air while purging. The hose sections deteriorate and leak, and the metal pipes are subject to corrosion (8 years of corrosion deposits have

DAVTE-M

SUBJECT: Trip Report: Helicopter Icing Spray System Improvement Planning and Operations

accreted). None of the metal tube ends have a bead around the rim for proper hose fit. All the rubber connections inside the boom were replaced with fresh hose in Minnesota, and some sections of tubing in the support arms were replaced with stainless steel. After five days of operation, the newly replaced hoses had hardened, and were only loosely held onto the metal tubes by the originally tight clamps. Since then, high temperature Turbohose (Flexfab Co.) has become available, and should better withstand these operating conditions.

e. Nozzle manifolds/plastic lines. The same elevated bleed air temperatures have caused continuing problems for the external boom manifolds and plastic tubes supplying water to the nozzles. It is no longer possible to maintain a completely leak-free connection between the brass fittings and plastic tubes, requiring increased maintenance and resulting in numerous leaks and formation of "popsicles" while spraying. Replacing the manifolds with proper size stainless steel "T" fittings that lead to a sectioned steel line running from one manifold to the next along the length of the boom exterior should provide tightly sealed connections to the nozzles, and not add any more line length than presently exposed to ambient air. Welded fittings would have to be fabricated onto the steel line sections to provide uniformly shaped leads to each nozzle. All joints would be of standard high-pressure MS fittings available from the inventory. Such a design would eliminate the present external manifold/plastic line set-up with most of its inherent problems. Provisions to drain water from the boom water lines could also be incorporated in this basic design change.

f. HISS instrumentation. Present instrumentation onboard the HISS has several shortcomings. The pressure transducers (boom, engine, and APU air and boom water) are of mixed absolute and gage pressure types. The delta pressure (static to total) transducers for engine and APU air (for mass flow) could not function at high temperature and did not work in Minnesota. The water pressure gage available to the spray operator in the aft cabin only measures pump outlet pressure. This can vary over a wide range at a given flow rate depending on individual adjustment of the hydraulic water pump setting and valve opening, and is not related to boom water pressure. Freezing of this gage has occurred. Resolution of the flowmeter is only 1 gallon per minute, and the rotary vane flowmeter has also experienced damage from freezing and required replacement. Flowmeter indicated values are presently off from actual by a factor of two. A "best" technique for setting up water flow to the boom does not exist, and displays available to the crew are not adequate to define a consistent method that would be repeatable from operator to operator. Centrally relocating present operator's indicators (flowmeter, radar altimeter, pump outlet pressure), adding new gages (boom and line pressure), replacing unsatisfactory sensors with more durable units (delta pressure, flowmeter of proper range and sensitivity) and defining operator procedure should allow repeatable and satisfactory spray system operation.

g. Electrical system. The HISS-related electrical wiring installed in the cabin area requires considerable rework to eliminate recurring problems. The APU and electrical valve wiring installation should be rerouted through protected runs off the floor (to avoid personnel movement and water on the floor), and various connectors and cannon plugs need replacement. Some excess electrical wiring from previous programs is still in place, and unknown wire bundles need to be traced, identified, and removed if no longer necessary. Color coding for positive identification and addition of test connectors for troubleshooting would simplify future operation. The boom-deployment and control box wiring from the cockpit also falls in this category, since modifications have been made, but functioning is still not entirely reliable. Size of this effort requires at minimum a full-time dedicated electronics technician until completion.

DAVTE-M

SUBJECT: Trip Report: Helicopter Icing Spray System Improvement Planning and Operations

h. Boom uplocks. The control circuitry to raise and lower the boom, and the uplock release and fasten mechanisms each require rework for satisfactory operation. The uplock mechanism has physically released one side of the boom on landing touchdown. The activating circuitry, microswitches, and manual cable release require careful operator timing and "feel", and are not entirely reliable.

i. Radios. The headset plug-in ICS box accepts jacks for 4 crewmembers at the rear of the HISS, but is not wired for FM transmit capability to allow direct communication with the test aircraft. This often prevents timely reporting of observed icing events affecting the test aircraft. Additionally, the VHF radio installed in the HISS has presented some difficulty in interfacing with frequencies of the commercial test aircraft using the HISS; installation of a second VHF unit would improve this situation.

j. Boom structure. Some indications of twisting at a wear point within the boom assembly have appeared during this icing season, and magnaflux or x-ray inspection of the boom should be performed before further use and modification of the boom. Since this would entail stripping the present coat of paint, the reapplied coat should be of better quality (epoxy) and color (black) for improved appearance to subdue the smudges and stains of normal operation.

k. Hydraulic failure protection. The utility hydraulics for boom operation are still directly tied in to the aircraft systems. A protection-circuit design exists and most of the required components are presently available. Approval from St. Louis for this modification has been pending and should be pursued and implemented.

l. Refueling. The 5000 gal. fuel tanker allows simultaneous use of 2 fueling hoses, each pumping at about 60 gal/min. Not counting time for repositioning the fuel truck from left to right sides of the aircraft halfway through refueling, the entire 806-gallon usable tank capacity of the HISS can be fueled in less than 7 minutes. This current procedure is fairly efficient and decreases turn-around time between flights.

m. Rewatering. A single fitting is installed on the top rear of the HISS water tank for taking on water. It must first be completely removed to add the chemical dye, then reinstalled to attach the water hose. The 90° bend in this fitting does not always return to the same position when screwed back in, and is usually angled off to one side where it interferes with water hose attachment. Since the water faucet inside the hangar is near the nose of the HISS, several turns of the hose are needed to route it into the aft cargo area of the HISS, where kinking can occur in the final several feet. Diameter inside the fitting is less than that of the hose and probably restricts maximum flow rate. This arrangement allows adding water at 75 to 80 gal/min, which requires about 18 minutes for a full water load of 1400 gals. Dual fittings (fore and aft) should be installed on the tank to allow procedural flexibility, and they should be sized and oriented to accept full flow of the water hose to reduce turnaround time.

n. Water temperature. Water temperature onboard the HISS tank remains constant at about 42°F. This was measured both for water coming out of the supply hose in the hangar, and for water drained from the HISS tank after an icing flight at -15°C (+5°F).

o. Water sight gages. The sight gage markings for the two plastic tubes on the water tank disagree with each other by as much as 300 gallons. Both the upper surface of the water tank and floor of the aircraft are horizontal on the ground (0° measured with a bubble protractor), and about 2° nose down measured in flight at 110 KIAS. The mid-tank sight gage

DAVTE-M

SUBJECT: Trip Report: Helicopter Icing Spray System Improvement Planning and Operations

is accepted as the more accurate of the two. At an OAT of -15°C water froze in the tubes where they plumb into the bottom of the tank and disabled the sight gages (no change in indicated water level), although visible water remained liquid where the gages are read.

p. Boom angle. When the boom is deployed in flight, the support arms are locked at some angle slightly swept back from vertical. Airborne photographs taken this year allowed measuring this angle relative to the aircraft (14.5 to 15°). The actual angle can vary from year to year depending on boom downlock adjustment when reinstalling the trunnion pallet.

q. Ramp position. The cargo ramp at rear of the HISS can only be lowered to some angle above horizontal before it prevents raising the boom assembly to the fully up and locked position. Painted lines to mark this angle wear out quickly, and can't be seen at present. This can be solved by fastening sheet-metal indicators.

r. Safety net. The safety net stretched across the rear HISS opening is a makeshift item and needs replacement as to proper fit and ease of use.

s. Maintenance. Use of the HISS has risen over recent icing seasons (increasing number of simultaneous icing projects), and both maintenance support and spare parts availability should be addressed prior to the next deployment. This season's effort in Minnesota resorted to a 2-shift operation to support as many as 4 attempted flights per day, as well as perform required maintenance and (sometimes major) unscheduled repairs to both the aircraft and spray system. Completing the routine aircraft phase maintenance as well as proposed HISS system modifications prior to next fall will require a greater level of maintenance effort than previously allocated to the HISS between icing seasons. The work should be scheduled to finish early enough (e.g., 1 October) to allow sufficient time for in-flight checkout to identify and correct problems, and to accumulate flight hours for crew training and procedure standardization. This aspect has been neglected in the past, with checkout of crews and systems being hurried after deployment to Minnesota. Spare parts availability, especially of one-of-a-kind HISS items, can impact the entire icing effort if a breakdown occurs. The concept of a dedicated parts van for aircraft and spray system items should be implemented. Critical spare items need to be identified (e.g. electric valves, nozzle components, instrumentation items) and procured. Some components of the All-American HISS design, such as the hydraulic actuators for the boom, were originally items obtained from surplus available in 1972. Replacements can no longer be found, and overhaul with substitute or specially fabricated parts is the only way to keep such components functioning. Commercially available modern items with similar capability should be identified to supersede these, and planning started for their replacement. Scheduled maintenance on the activity's other Chinook should be geared toward replacing systems components as they come due with parts that insure commonality with those on the HISS. Installing a chip light debris detection system to identify which specific plug was activated would improve turnaround time by eliminating inspection and draining/refill efforts needed just to locate the problem. In anticipation of outdoor maintenance at freezing temperatures in event of a forced landing (as occurred this year), a canvas/parachute cover for the aircraft should be obtained under which the crew can work while heated by Herman-Nelsons.

8. Recommendations: Based on the items discussed above, the tasks listed in inclosure 1 must be accomplished and can realistically be completed before next season with in-house capabilities (contingent on commitment of resources). These items listed represent the near-term solution; a concurrent effort is also needed to plan toward the major items for the intermediate phase (i.e., replacement water tank and replacement boom design) beyond next icing season.

DAVTE-M

SUBJECT: Trip Report: Helicopter Icing Spray System Improvement Planning and Operations

9. Action Required:

a. Workable preliminary designs already exist for most of the modifications proposed. Detailed follow-up at this time is required so that coordinated activity can commence upon return of the HISS from Ft. Campbell during the week of 19 April 1982.

b. Preparation of a cost estimate.

c. The proposed plumbing modifications are expected to correct existing shortcomings and be adequate to handle more than full output of the APU. Review and analysis of pressure, temperature and spray data just taken is required to properly evaluate the pending option of adding a second APU source.

d. The scope of the effort proposed here represents a sizeable commitment of in-house resources. An activity staff meeting is required to review the intended plan and agree on a course of action, to coordinate tasks, schedules, and manpower requirements among all participants involved, and to resolve the following areas: (1) time frame of the boom dynamics flight tests with the new fiberglass blades and lower rotor RPM, (2) coordination requirements with AVRADCOM in St. Louis, and relationship of the AEPA effort to the design study in progress (Boeing-Vertol) for interim improvements and HISS replacement.

1 incl
Planned Tasks for Near-Term
HISS Improvement

DAUMANTS BELTE
Aerospace Engineer

Planned tasks for near-term HISS improvement - 1982

- a. Water tank dump doors - relocate centered over belly opening
- b. Water jettison cable release - redesign/relocate
- c. Manual water dump - install new valve to drain water from tank (in-flight)
- d. Water pump - replace/relocate from beneath tank to fwd of tank
- e. Flowmeter - replace/relocate
- f. Incorporate method to deliver equal amounts of water to upper and lower booms.
- g. Interior water lines & hose connectors - reroute/replace w/1-1/2" stainless steel hard plumbing w/MS fittings
- h. Replace single aft filler fitting with fore and aft fittings sized to allow full hose flow
- i. Sight gages - apply consistent markings for water quantity
 - insulate connections to water tank
- j. Install belly inspection panels (req. St. Louis approval).
- k. Insulate/isolate area under water tank from crew cabin
- l. Investigate availability of moveable belly doors for aircraft
- m. Rework torque tube seals, relocate air and water entry pipes into boom (torque tube and upper support arm modification)
- n. Replace all boom interior hose connection with hi-temp Flexfab turbohose
- o. Weld rim heads on all pipe sections taking hose connections
- p. Disassemble boom components - magnaflux/x-ray for structural integrity
 - clean and apply anti-corrosion treatment to pipes
 - repaint (black epoxy)
- q. Boom manifolds - replace manifolds w/compatible sized "T" fittings
 - run sections of metal tubing along boom exterior w/individual lines to each nozzle (identical)
- r. Hydraulic failure protection circuit - install (req. St. Louis approval)
- s. Uplock mechanism - rework for reliability of mechanism & manual controls
 - microswitches & wiring
- t. Electrical systems - reroute wiring for APU & electric valves through protected runs off floor
 - check all connectors and cannon plugs, rebuild as required
 - trace and identify various unknown wire bundles
 - color code wiring & install test connectors for troubleshooting
 - rework cockpit boom control box and wiring for reliability
- u. Radios - add 2nd VHF to cockpit
 - add FM transmit capability to aft cabin ICS box
- v. Instrumentation - obtain durable pressure transducers (hi-temp)
 - replace flowmeter with more durable unit
 - obtain adequate replacement spares
 - identify requirements for operator's panel
- w. Operator procedure - develop repeatable technique using quantitative indicators
- x. Install sheet metal indicator for ramp position
- y. Install redesigned rear ramp safety net
- z. Fabricate canvas aircraft cover for outdoor maintenance
- aa. Install chip-light debris-detection system
- bb. Procure dedicated spare parts van & stock with critical items and high use parts

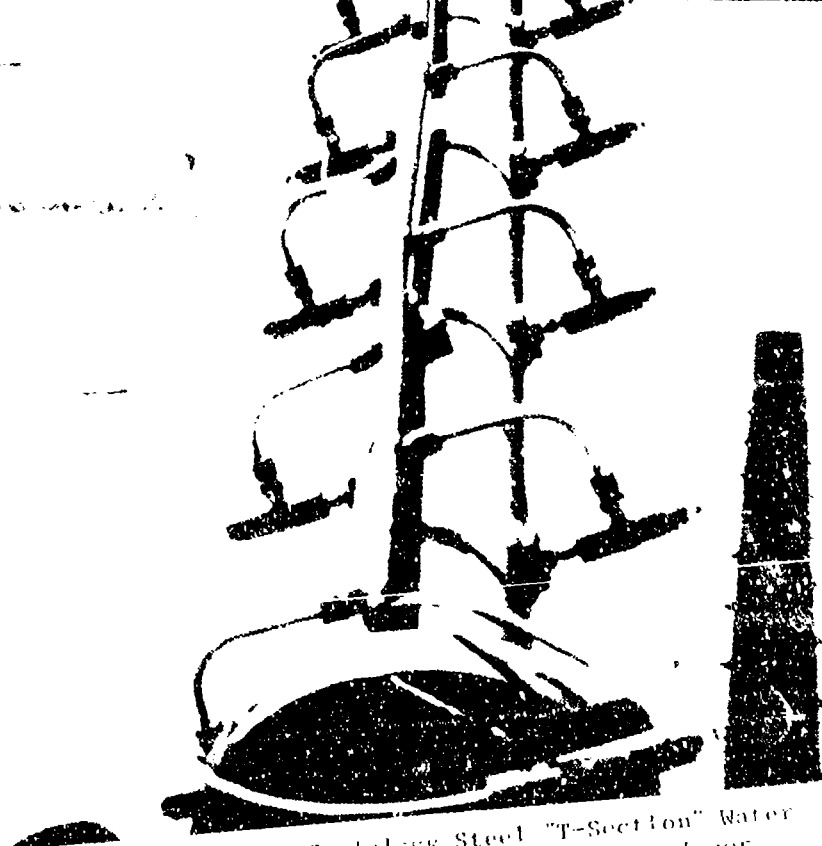
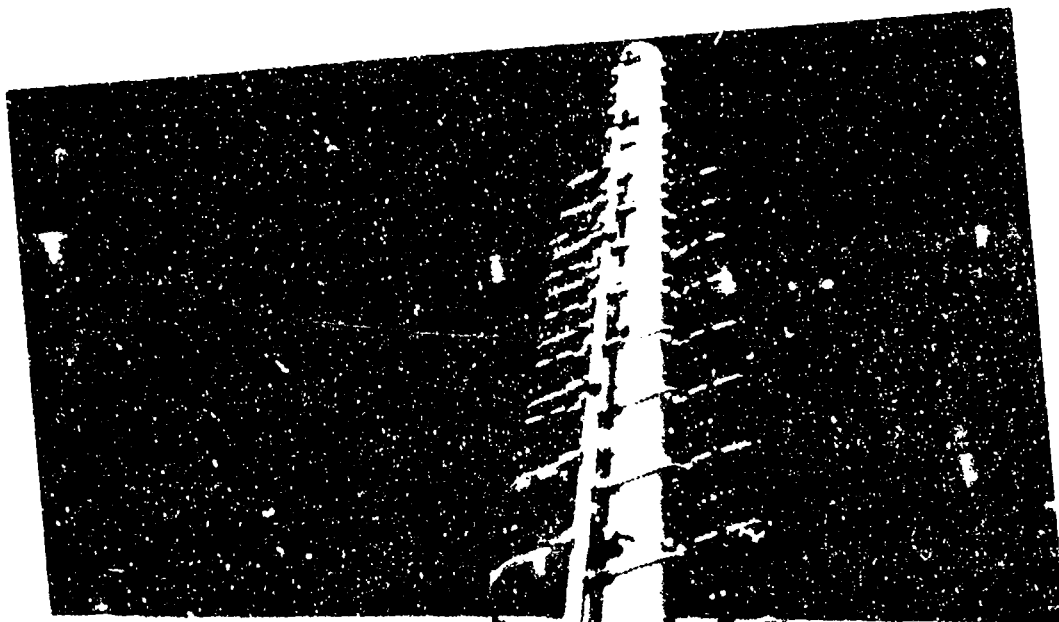

Photo 1. Stainless Steel "T-Section" Water Manifold. Installed on Left Outrigger



Photo 2. Water Pump and Flowmeter

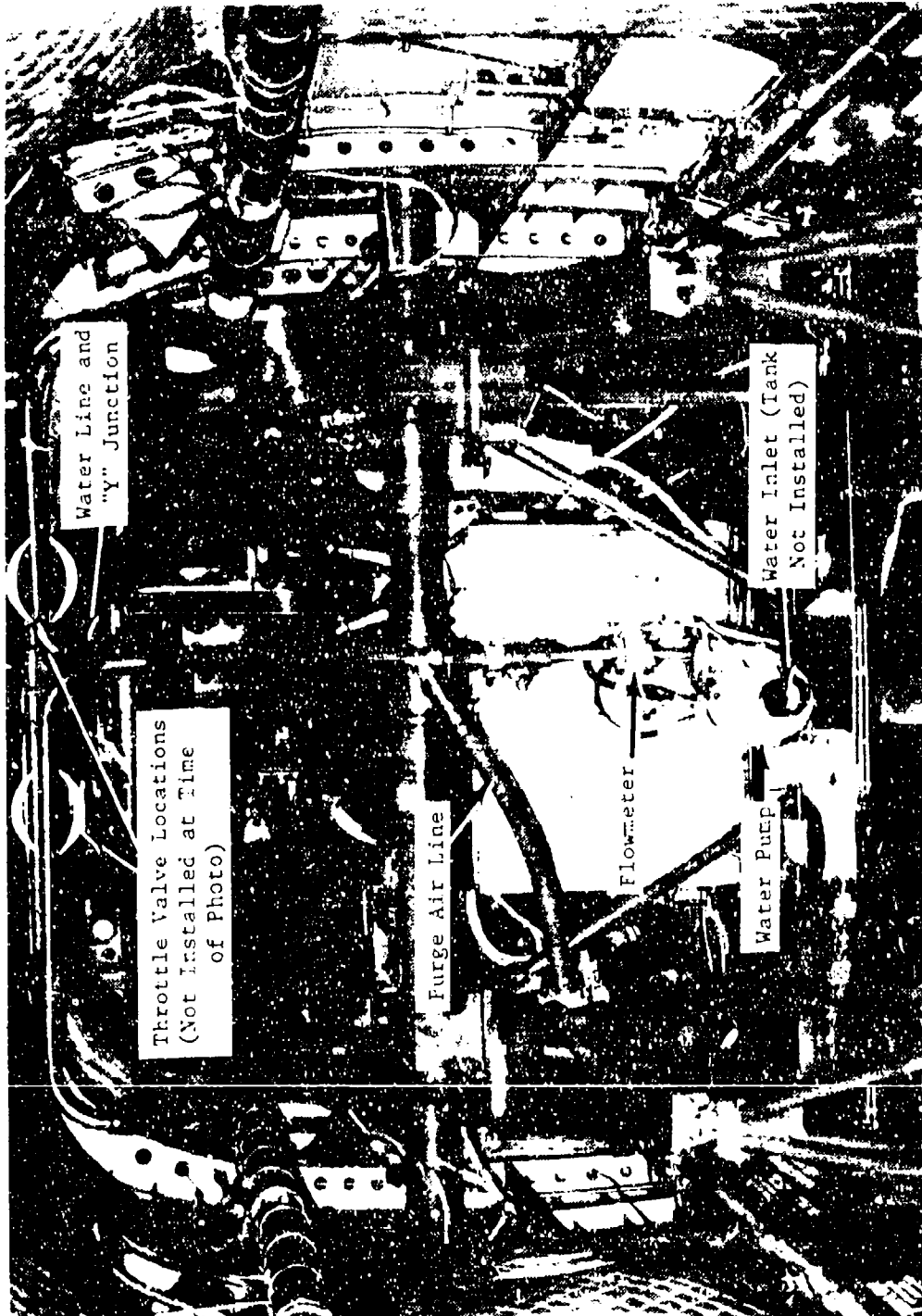

Photo 3. Water Line Routing

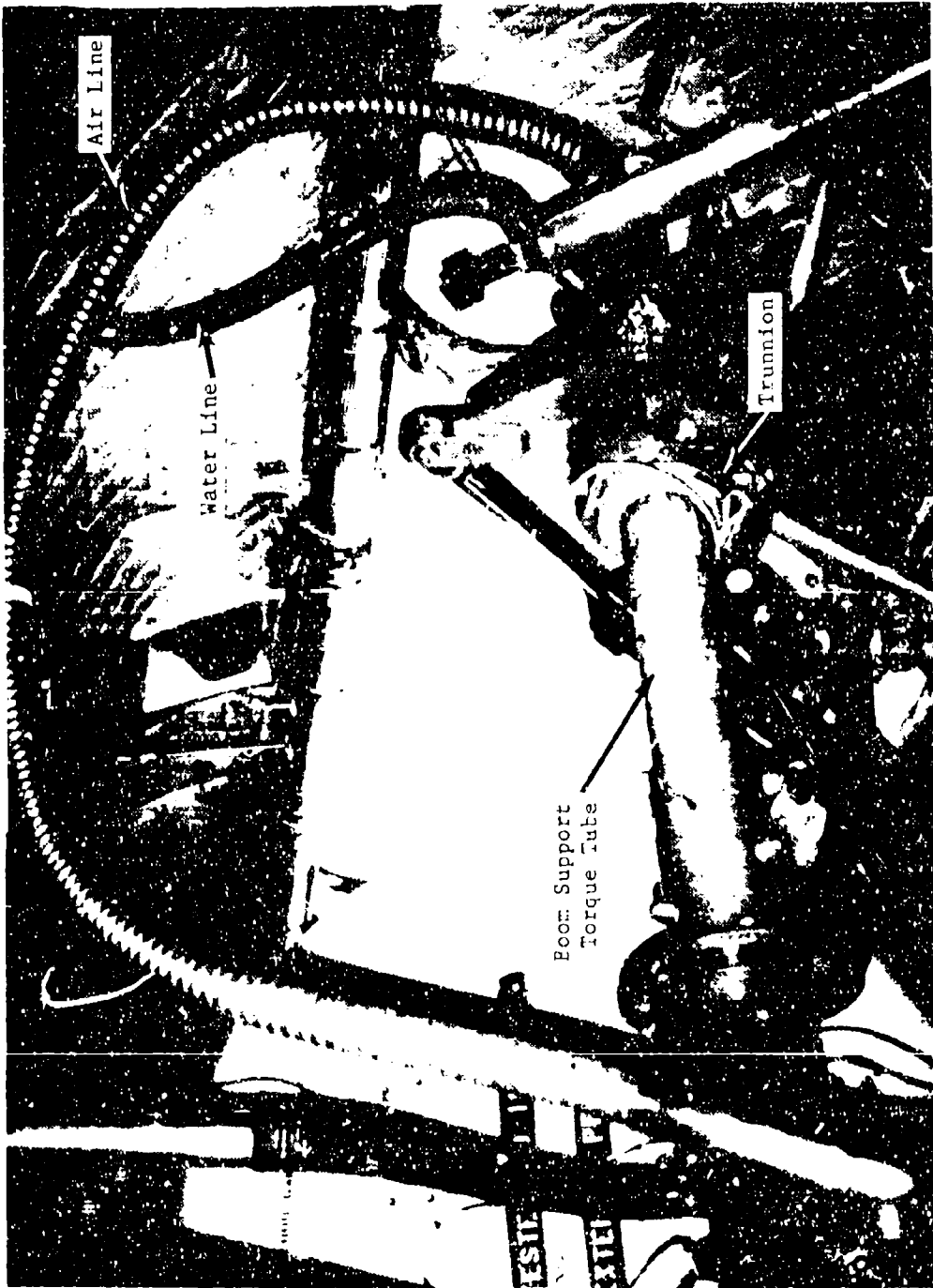

Photo 4. Water and Air Hose Routing (Boom Retracted)

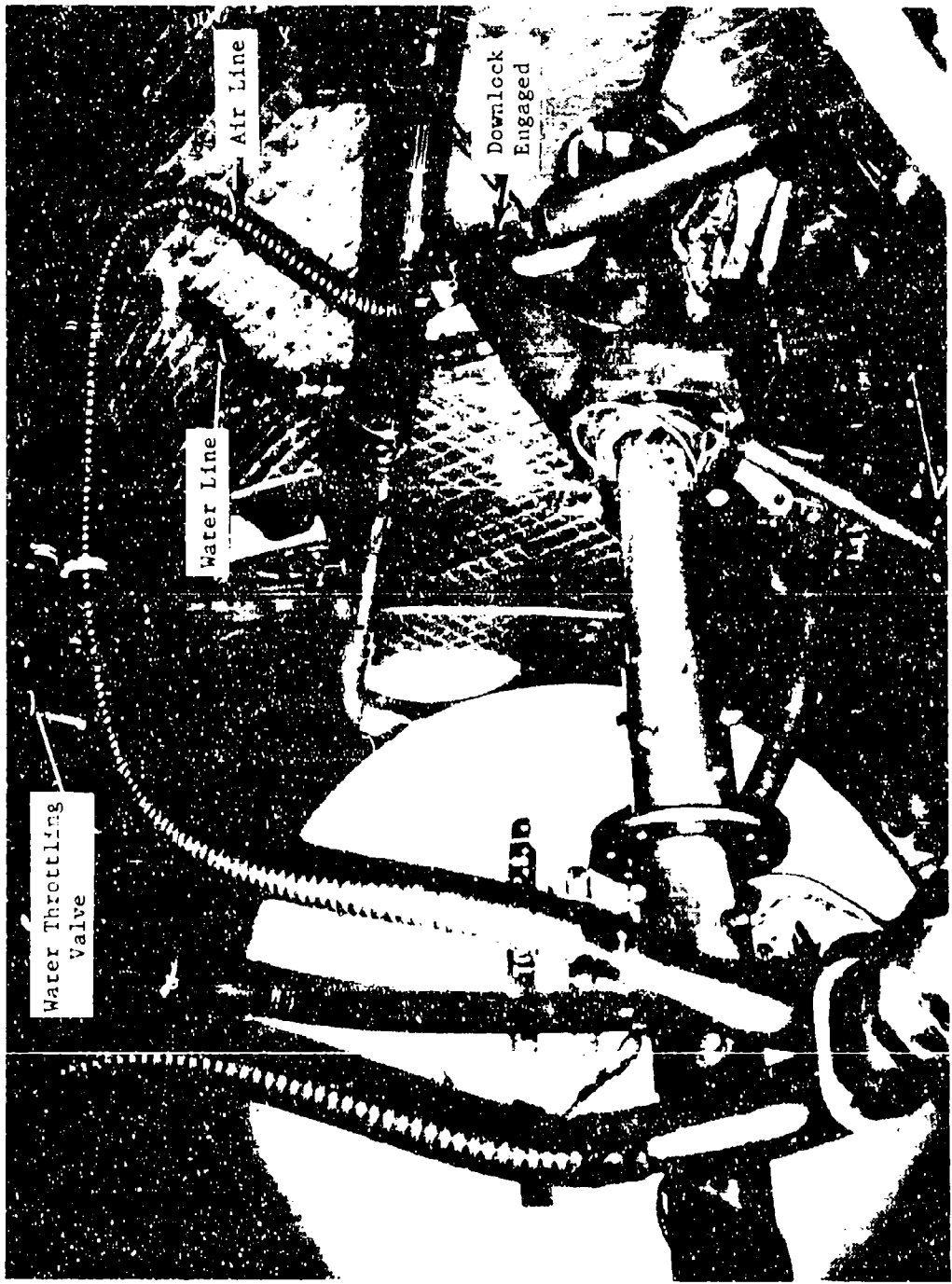

Photo 5. Water and Air Hose Routing (Boom Deployed)

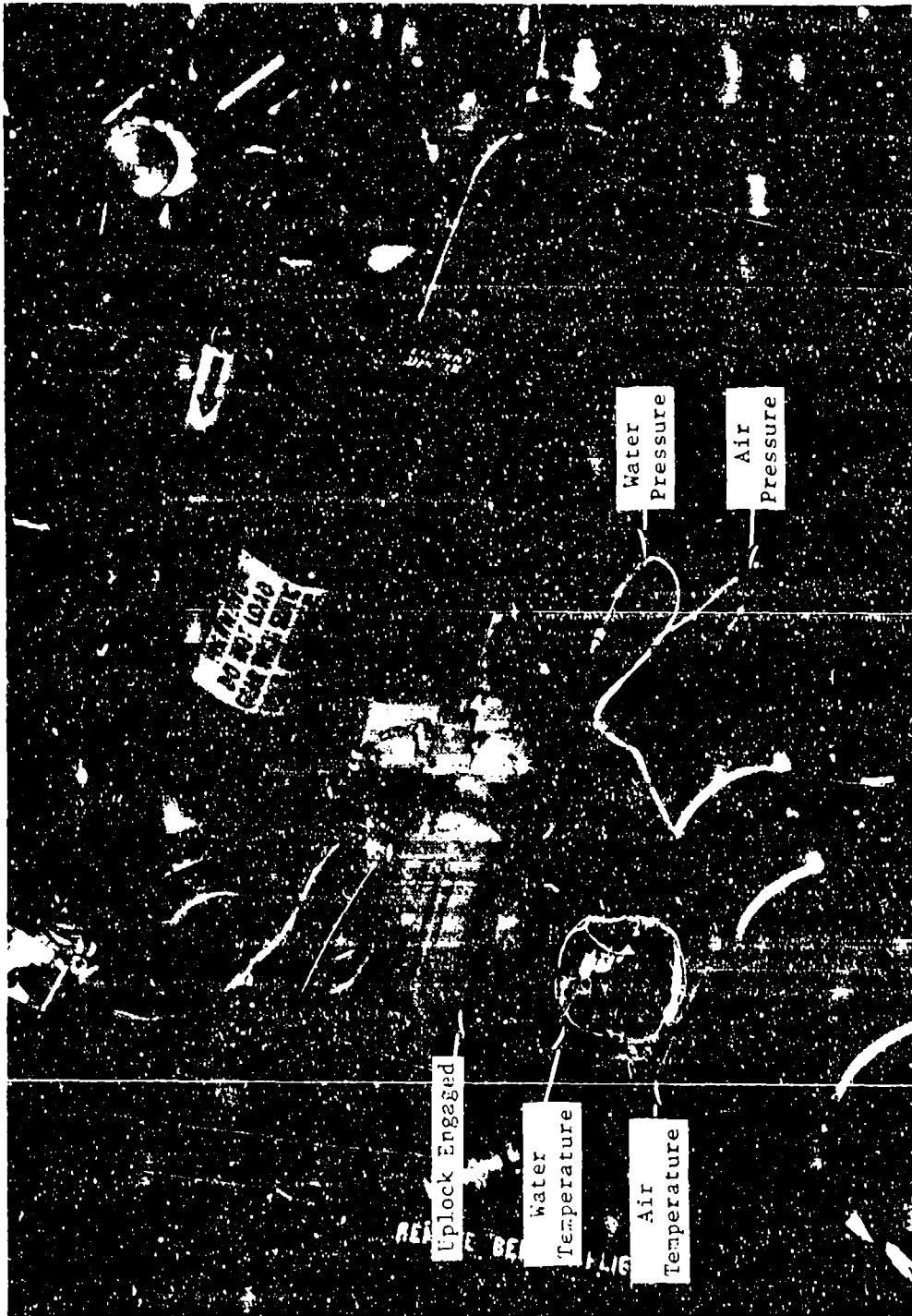

Photo 6. Upper Spray Boom Instrumentation

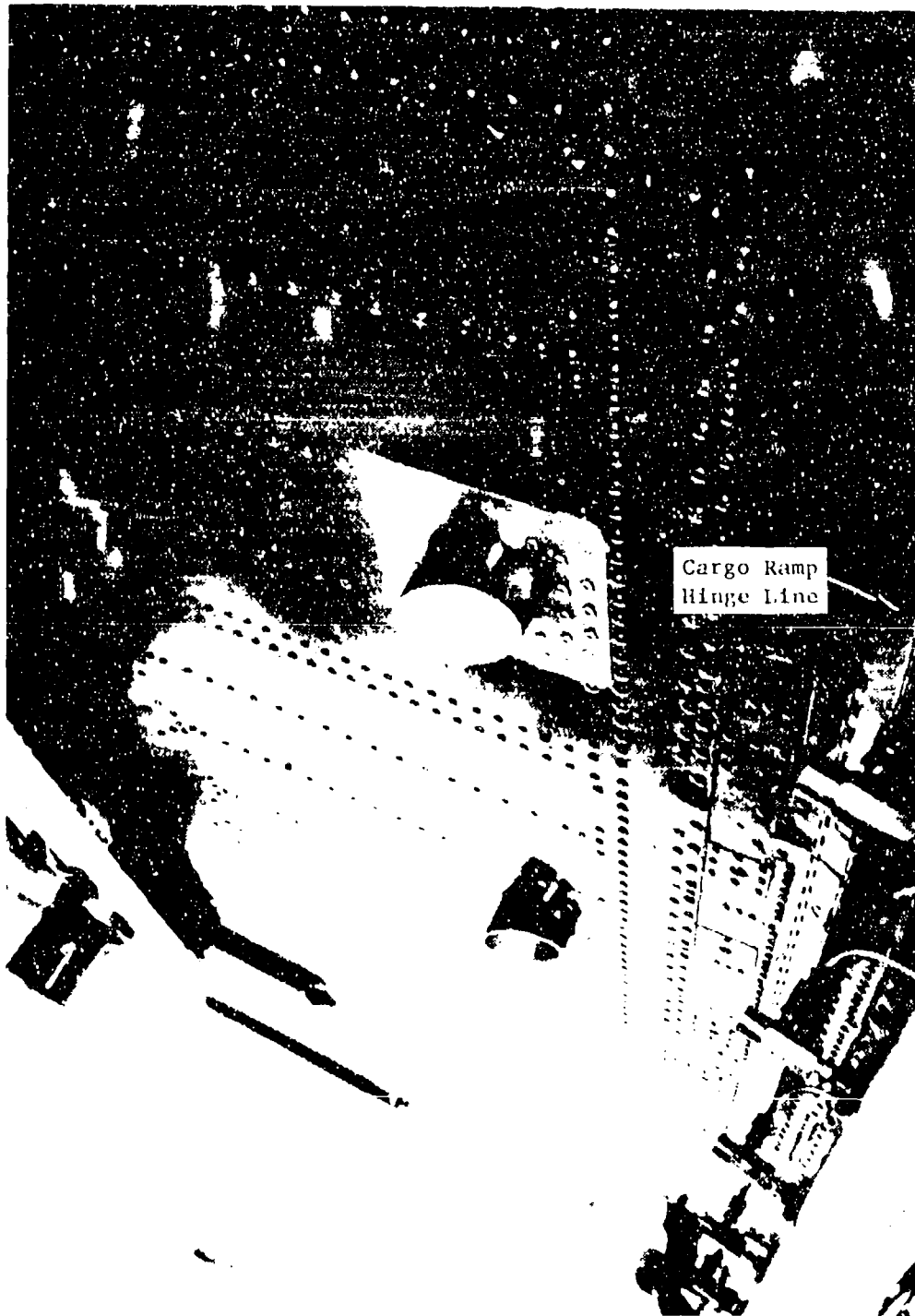

Photo 7. Water Drain Openings in Fuselage Skin



Photo 8. Water Tank Jettison Door Openings



Photo 9. Water Tank Jettison Door Installation

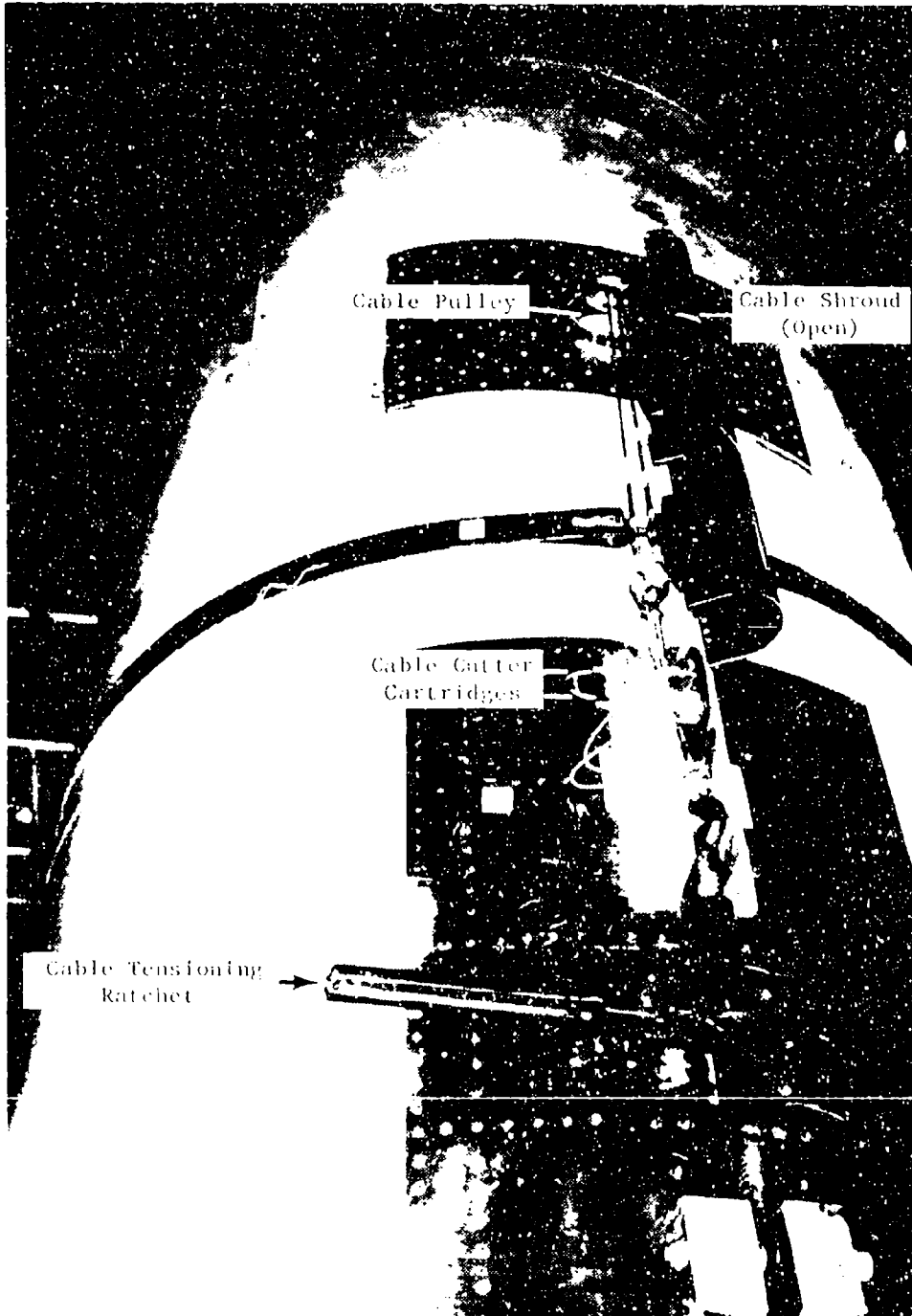

Photo 10. Jettison Door Retaining Cable Installation
on Top of Water Tank
125

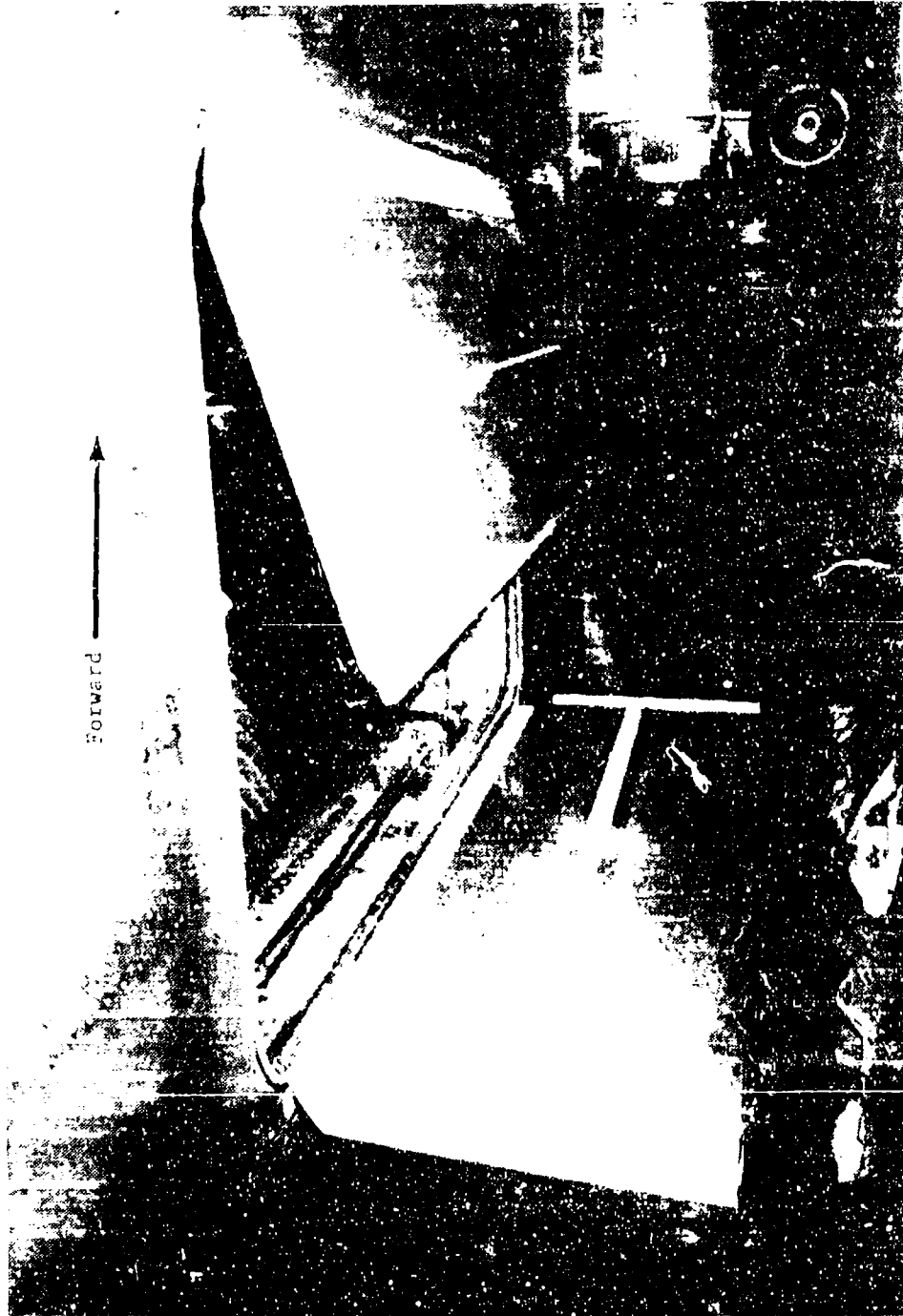

Photo 11. Trap Doors Beneath Cargo Hook Opening

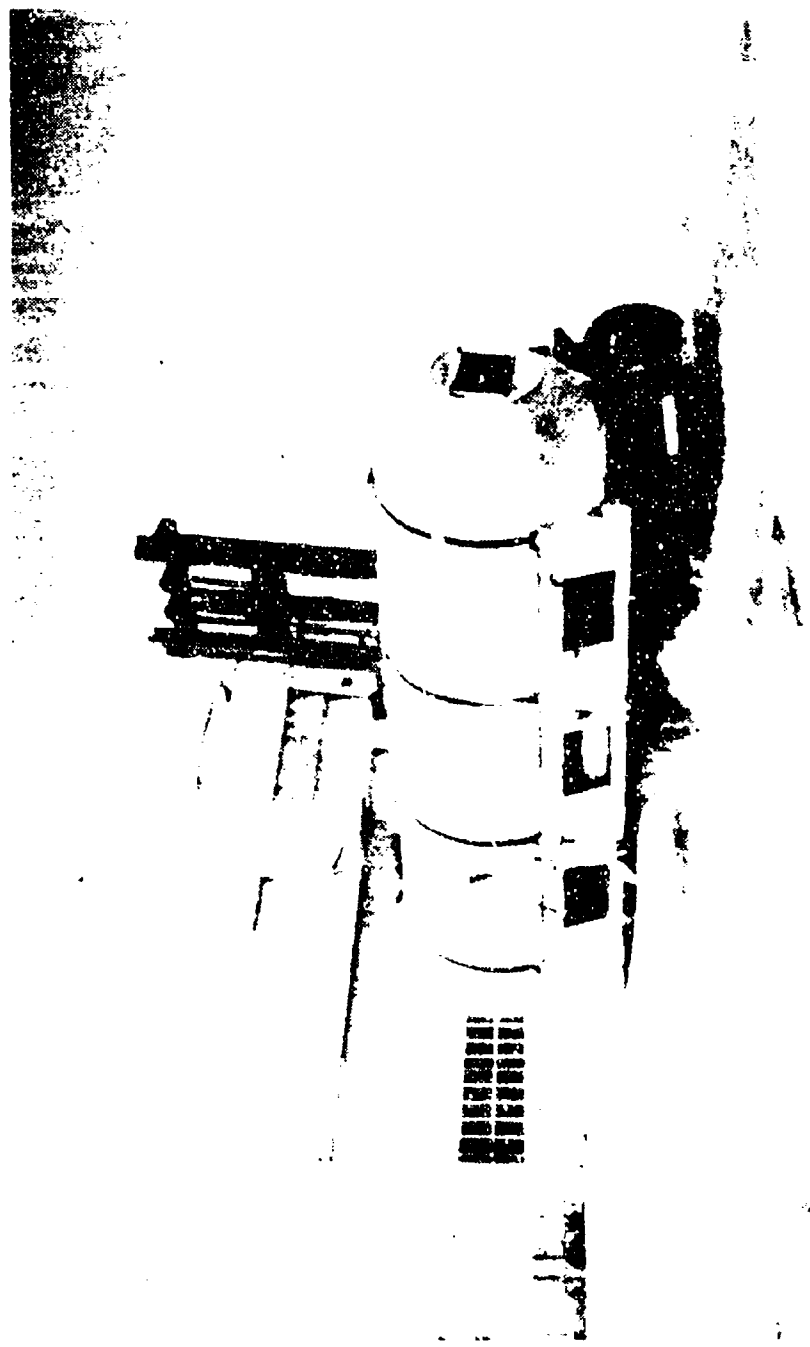

Photo 12. Water Jettison System Ground Test

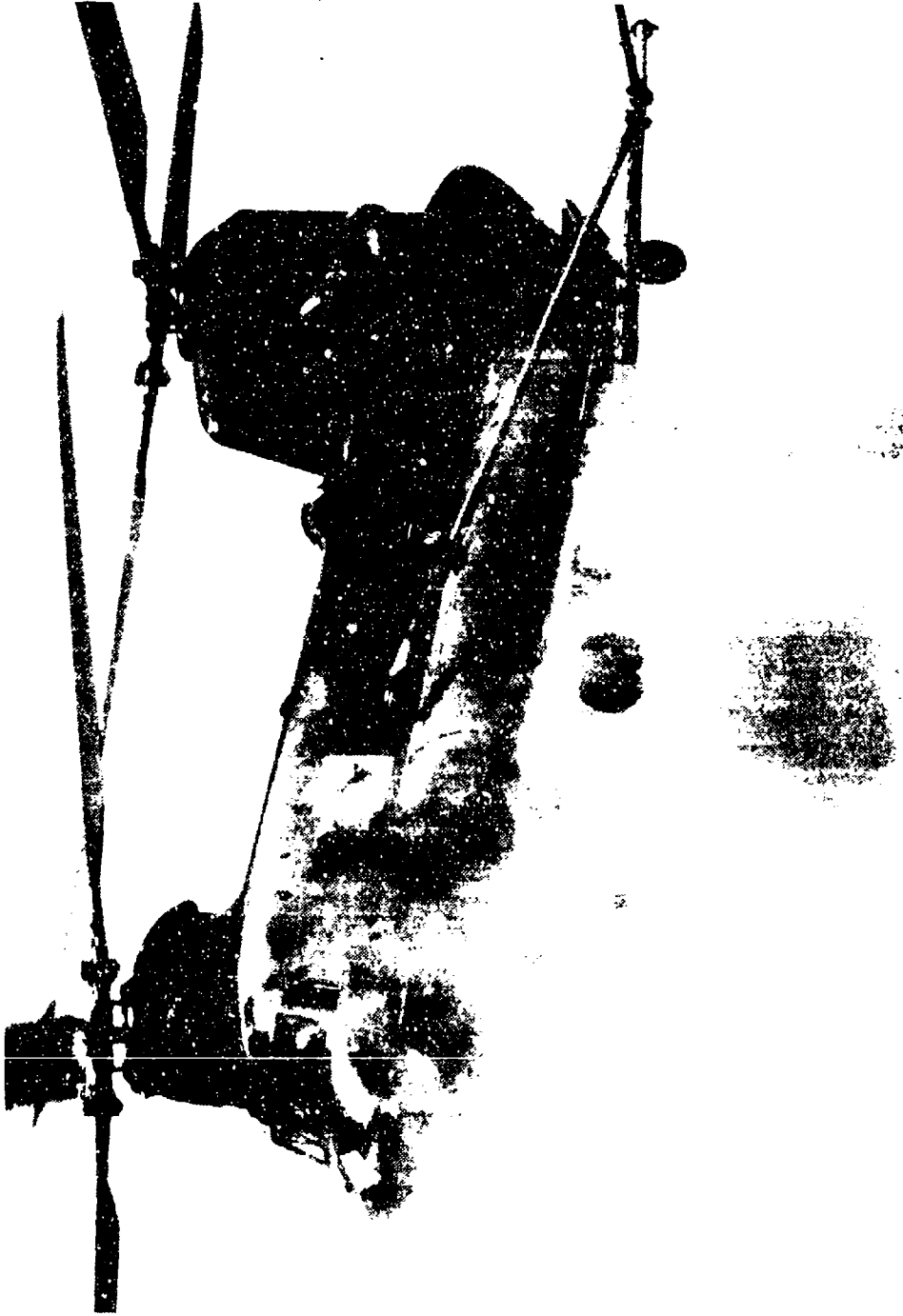

Photo 13. Water Jettison Test From Hover

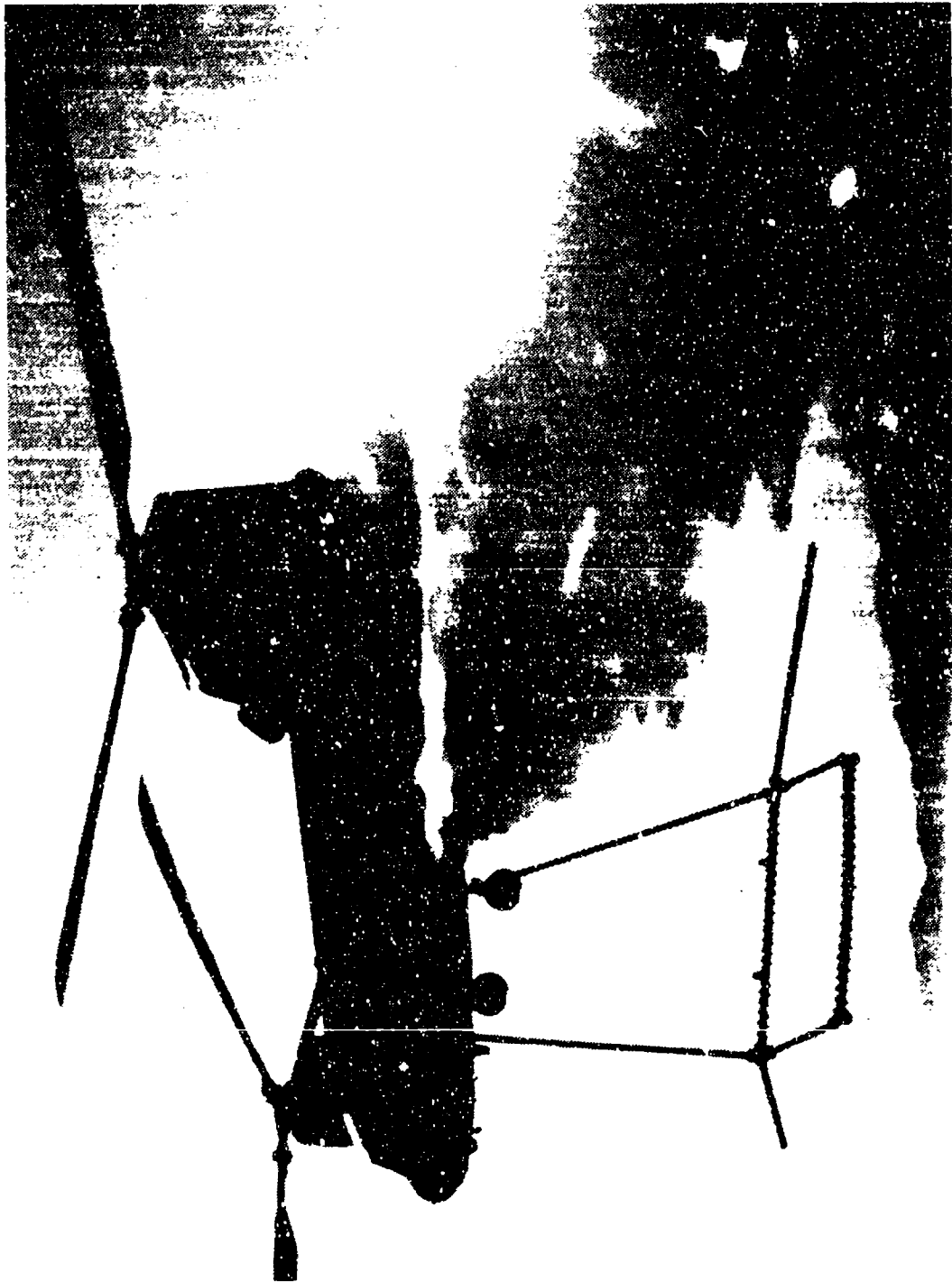

Photo 14. Water Jettison Test in Level Flight at 107 KIAS

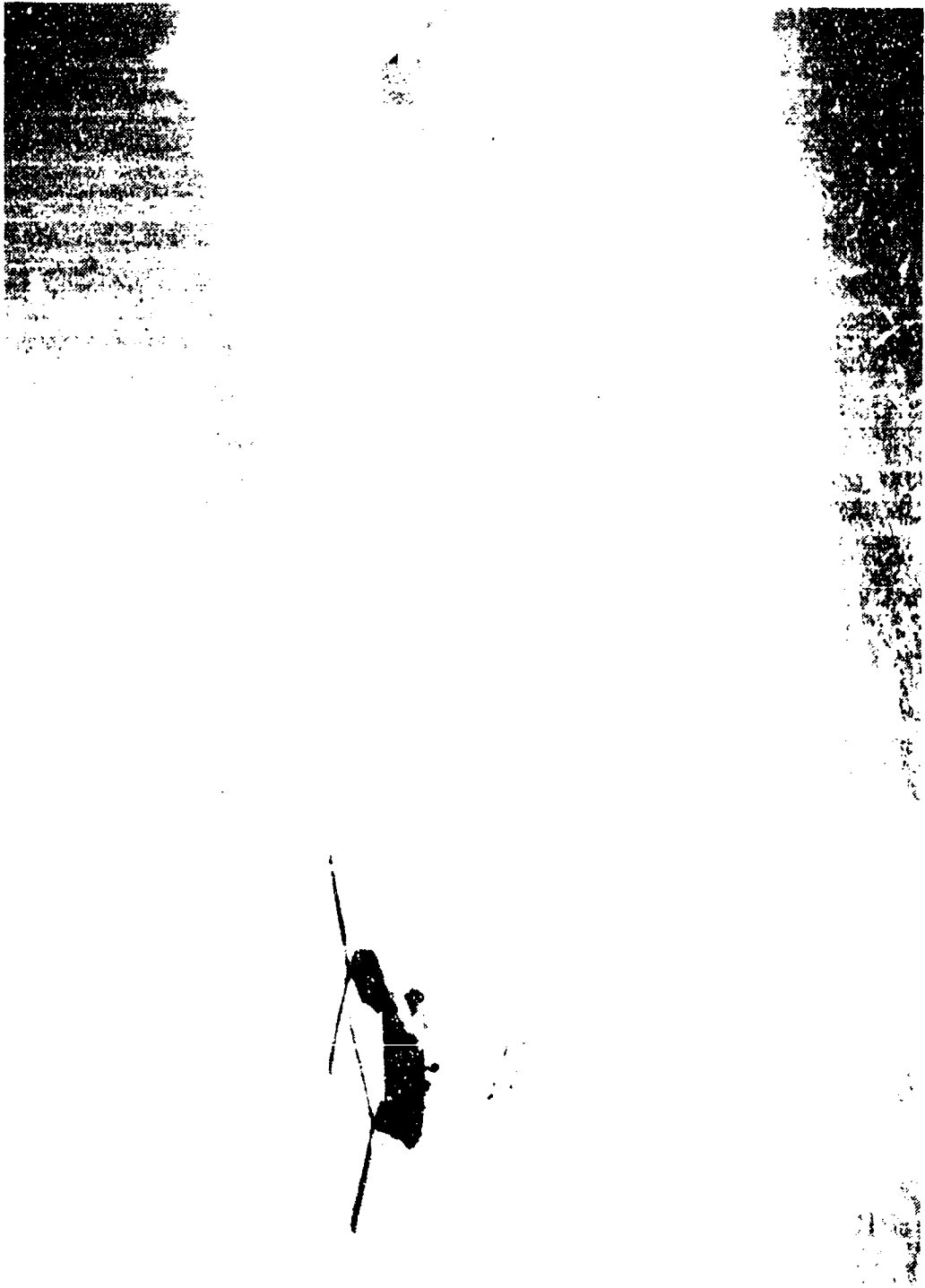

Photo 15. Water Jet/iscn Test in Autorotational Descent at 100 KIAS

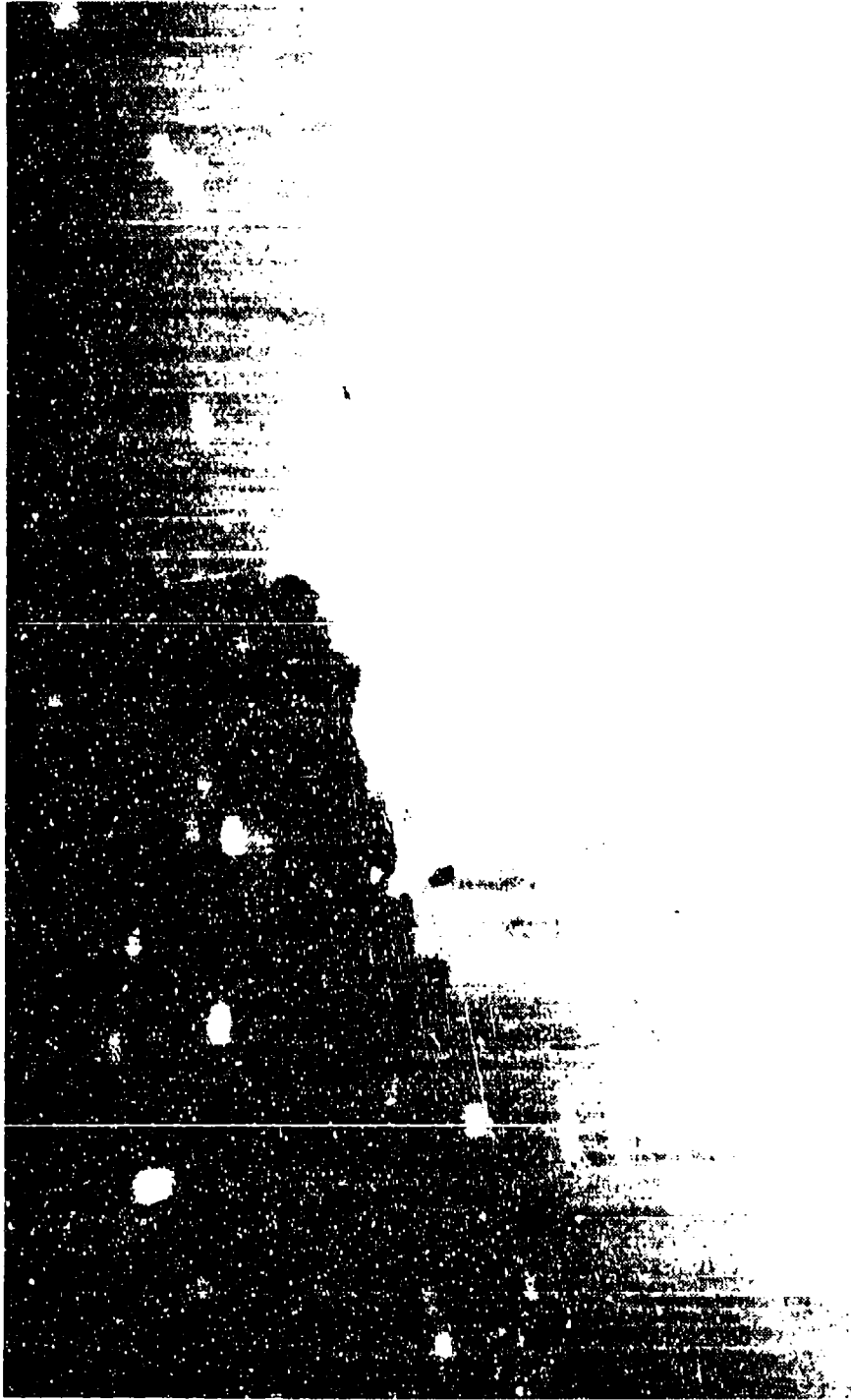

Photo 16. Water Jettison Test During Deceleration at 50 KIAS



Photo 17. Inspection Access Covers Added to Aircraft Belly

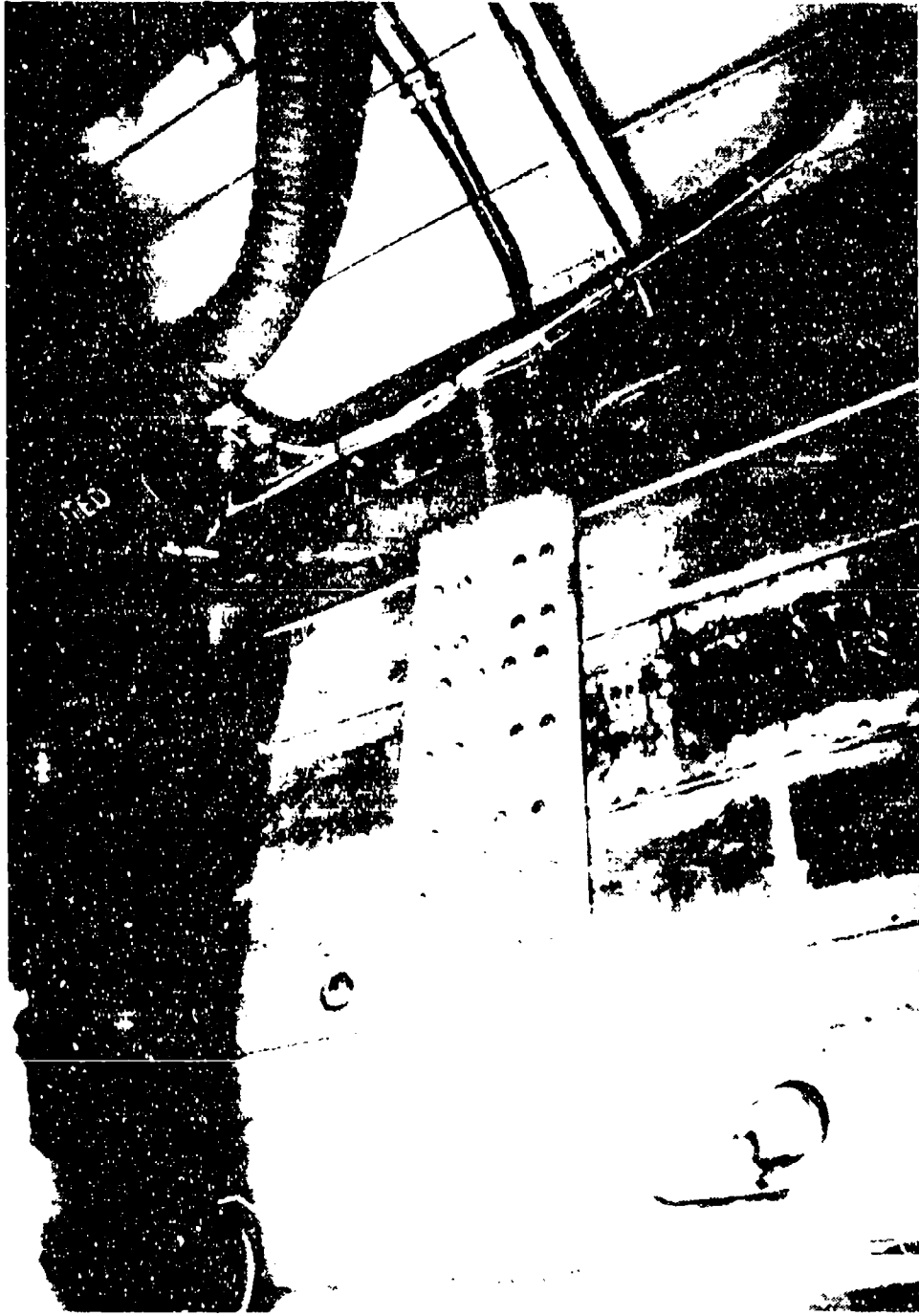

Photo 18. Floor Panel Splice at Fuselage Station 150

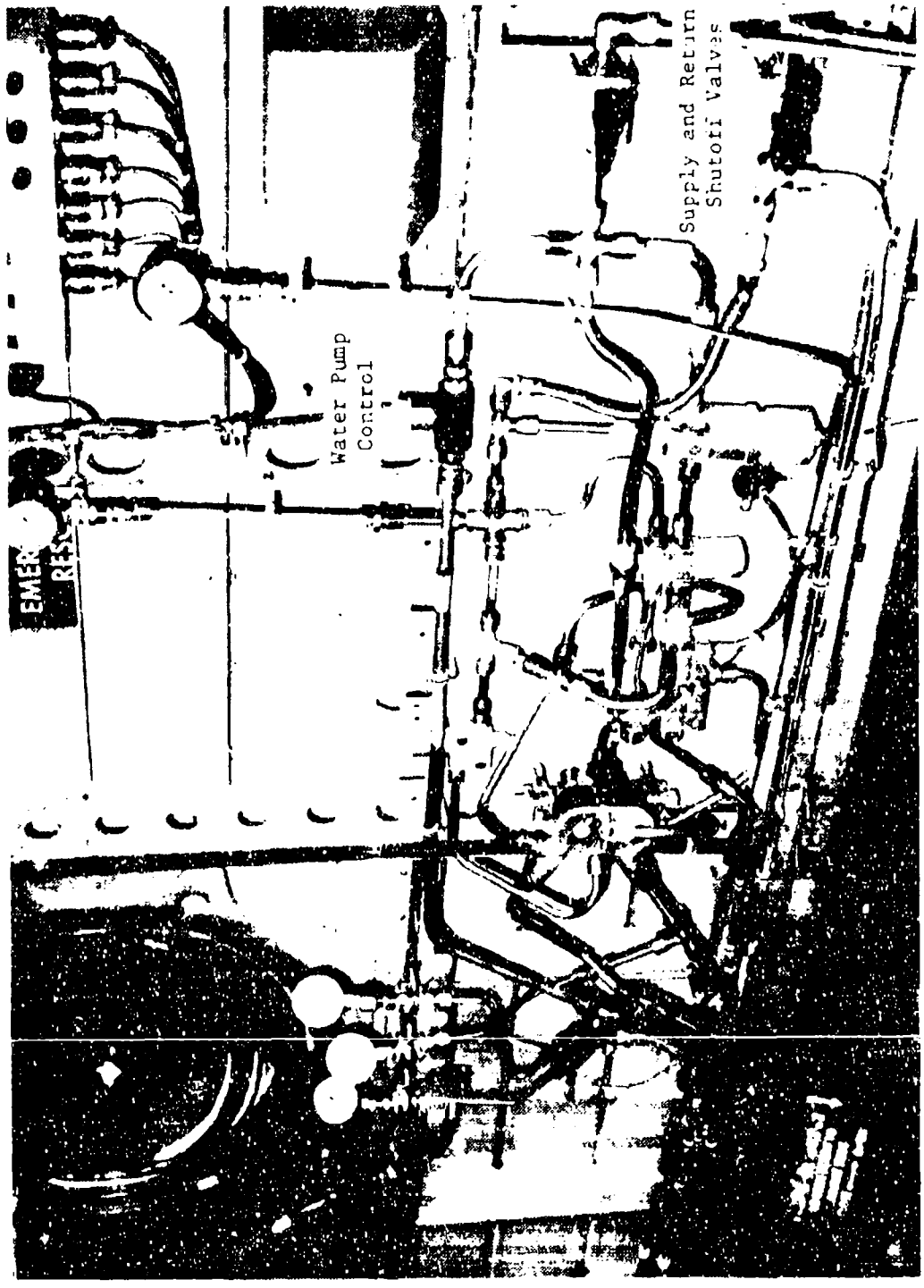

Photo 19. Modified Utility Hydraulic System Operator's Station

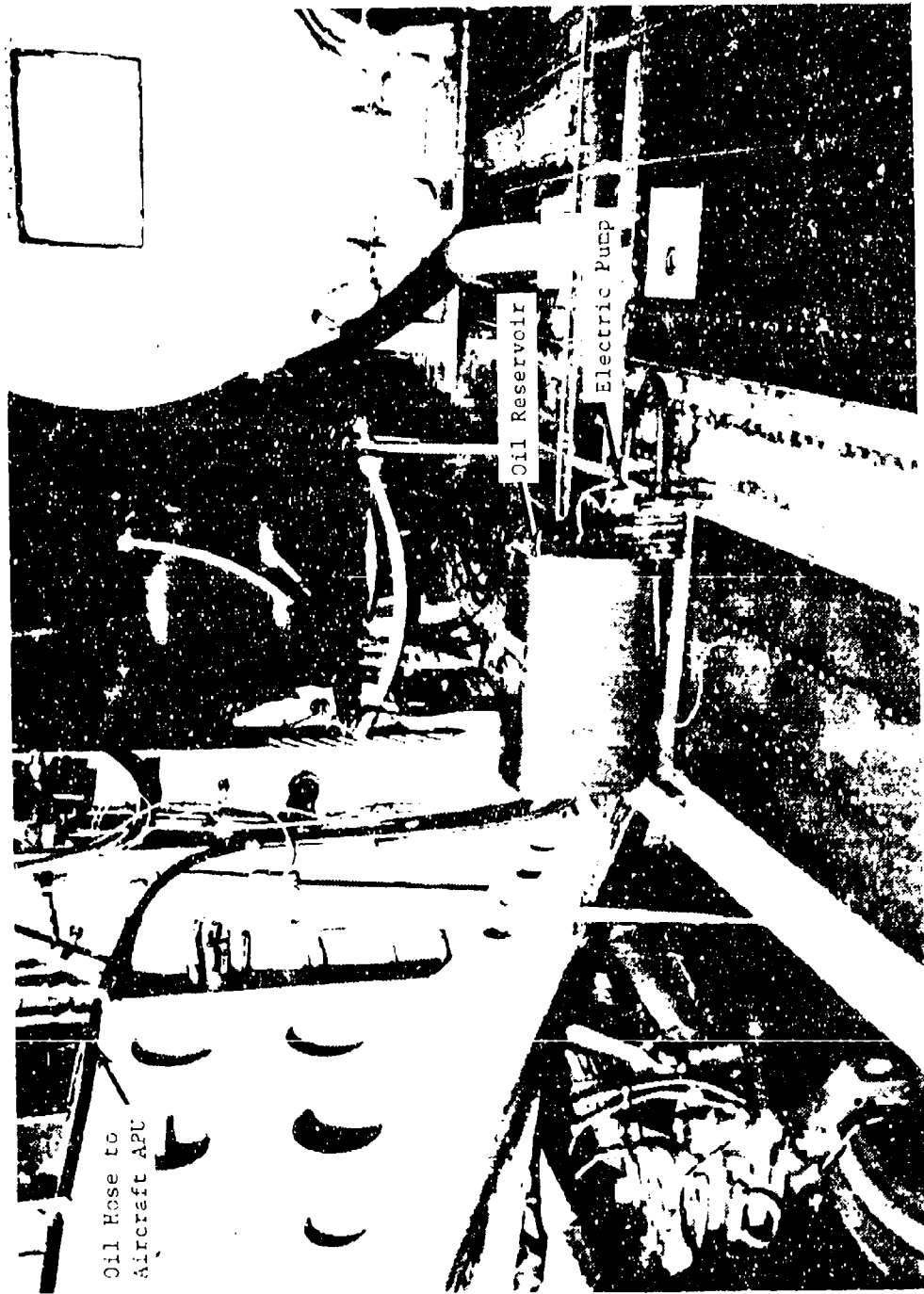

Photo 20. Smoke Generator Pump and Oil Reservoir

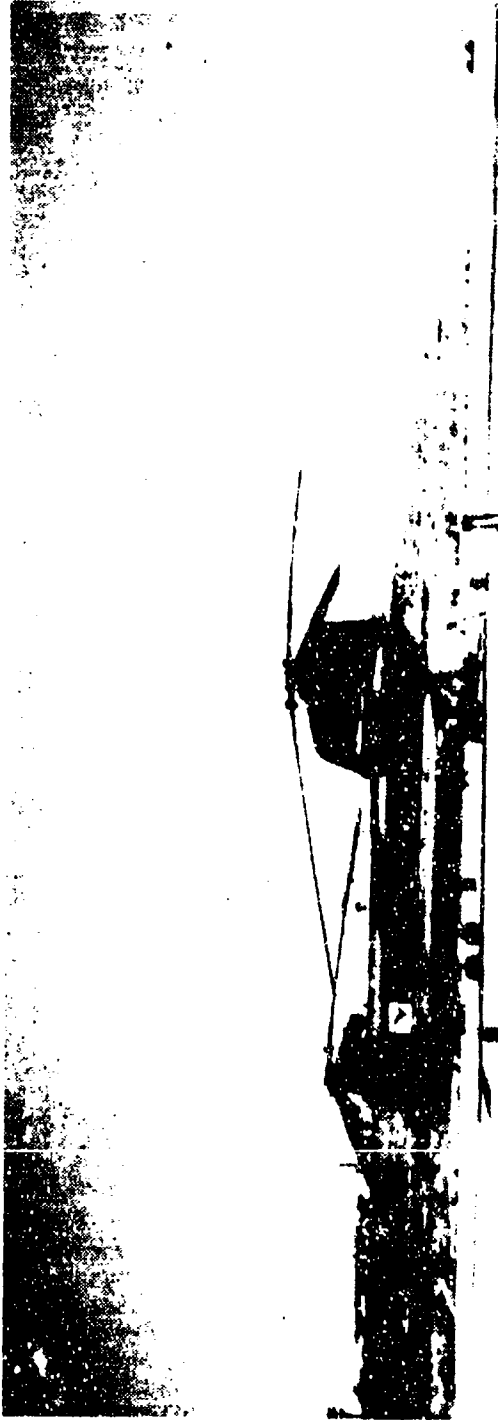

Photo 21. Ground Test of Smoke Generator in APU Exhaust

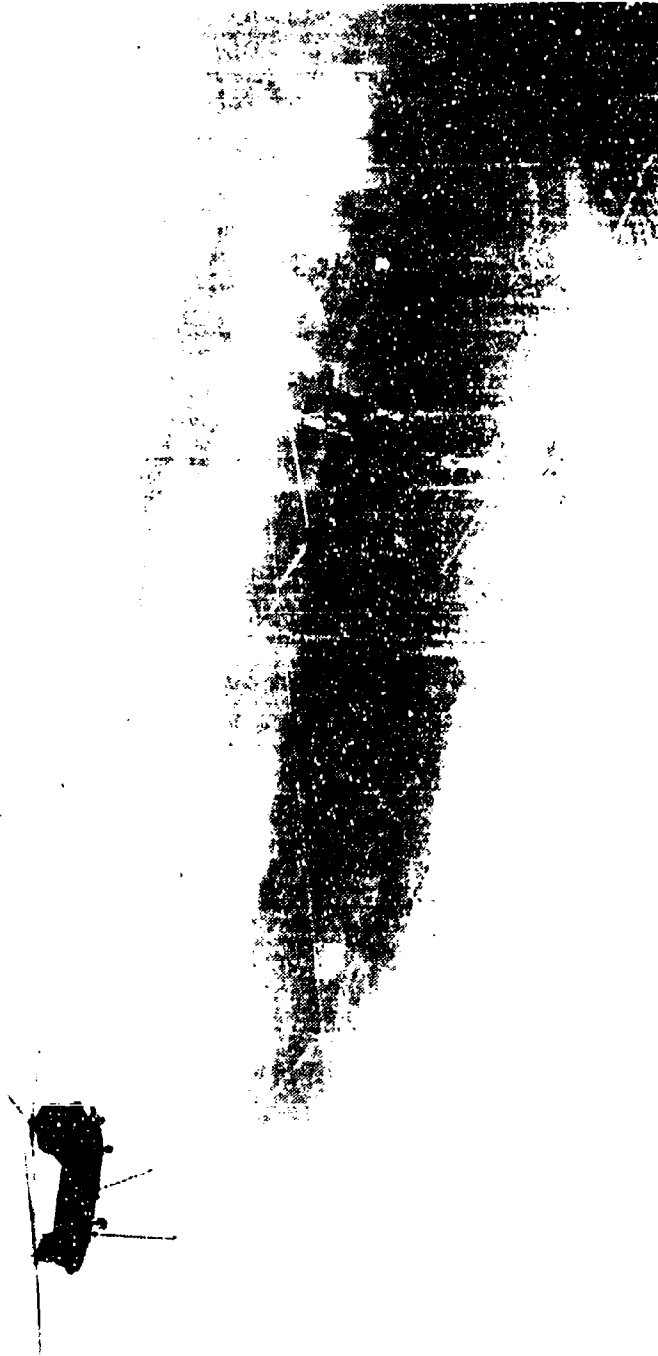

Photo 22. HISS and UH-60A Formation to Verify Smoke Trail and Rotorwash Turbulence

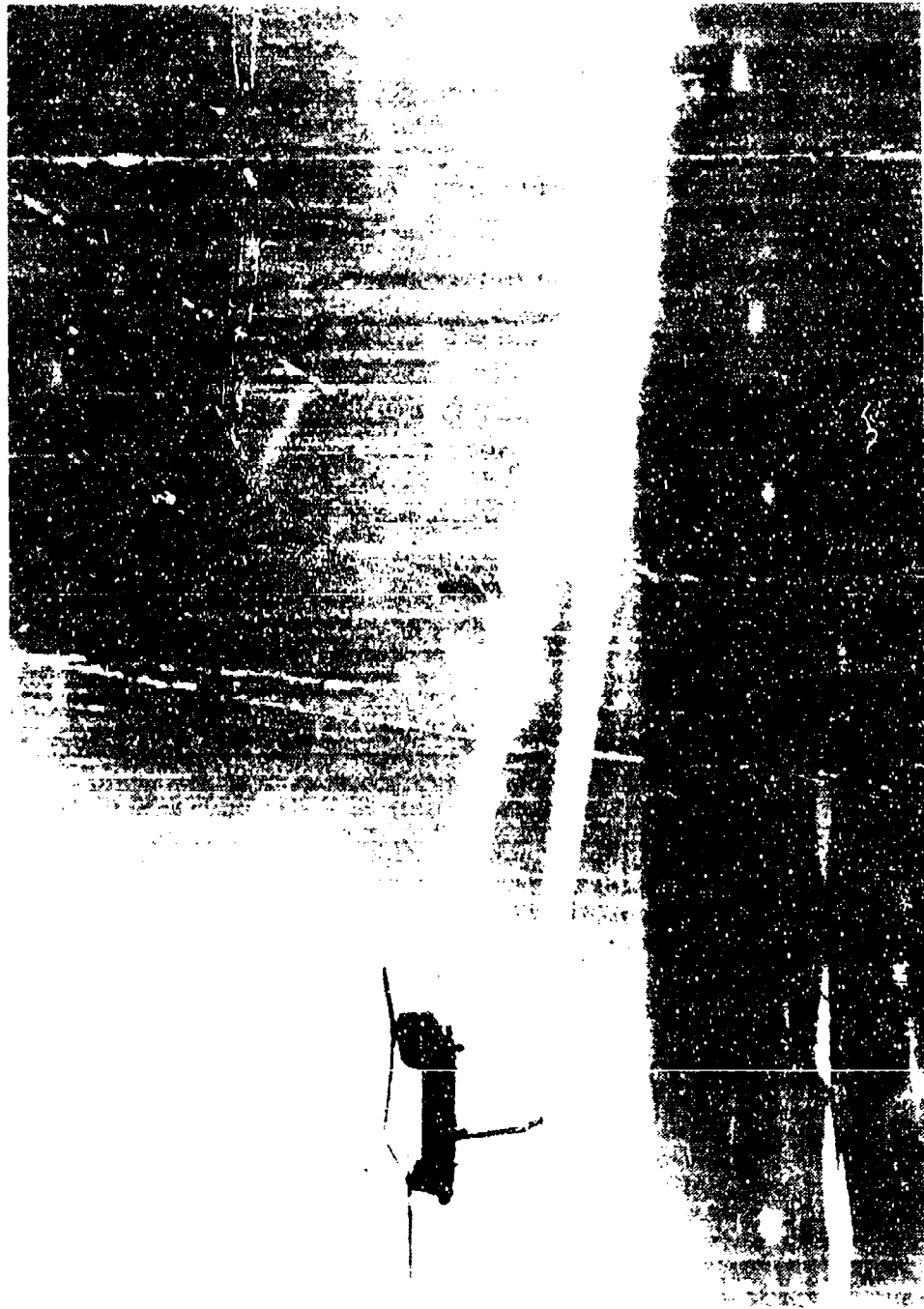

Photo 23. Spray Cloud and Smoke Trail at 80 KTAS



Photo 24. Spray Cloud and Smoke Trail at 90 KTAS

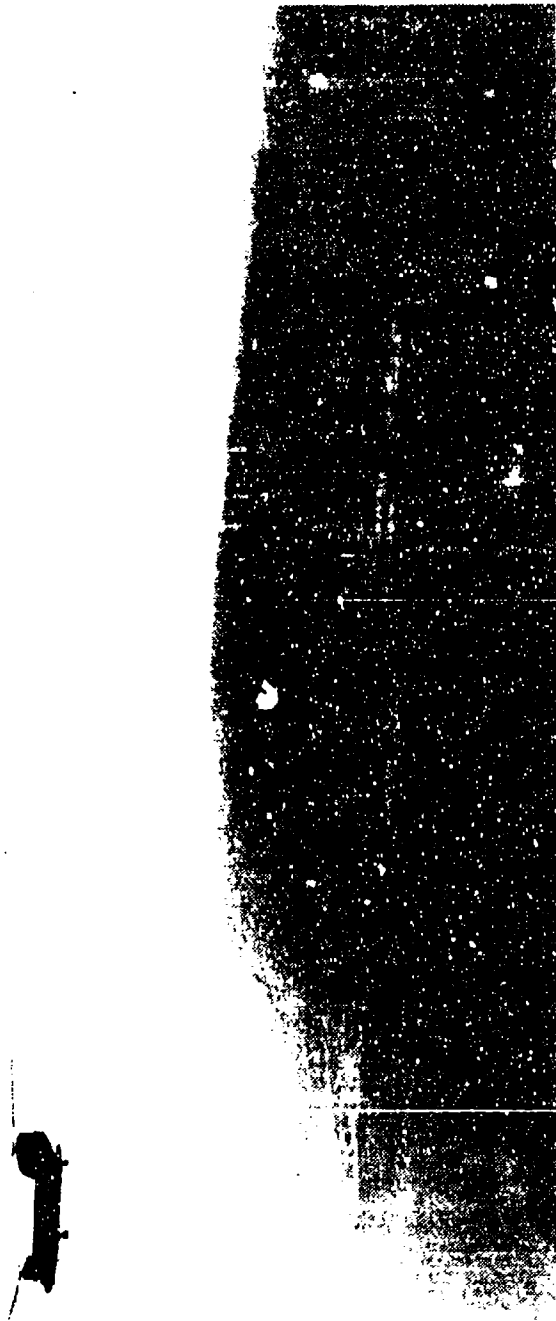

Photo 25. Spray Cloud and Smoke Trail at 100 KTAS

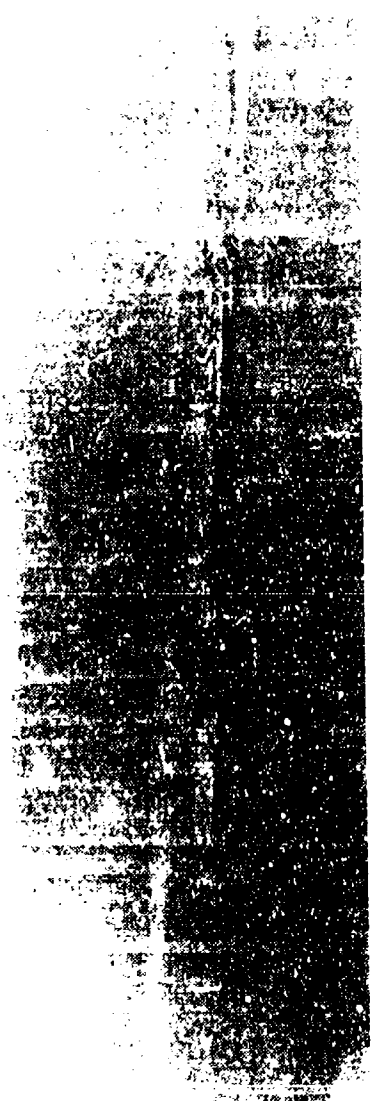
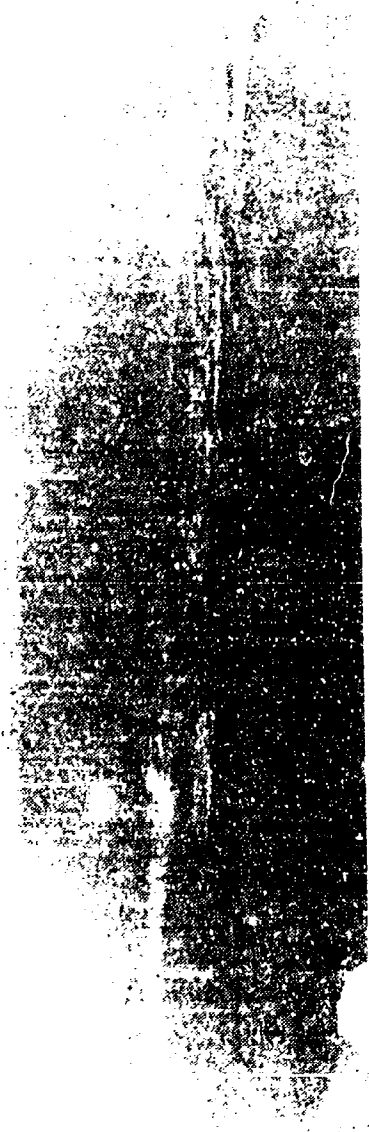

Photo 26. Spray Cloud and Smoke Trail at 120 KTAS



Photo 27. Spray Cloud and Smoke Trail at 130 KTAS



P. 26. Spray Cloud and Smoke Trail at 120 KTAS



Photo 27. Spray Cloud and Smoke Trail at 130 KTAS

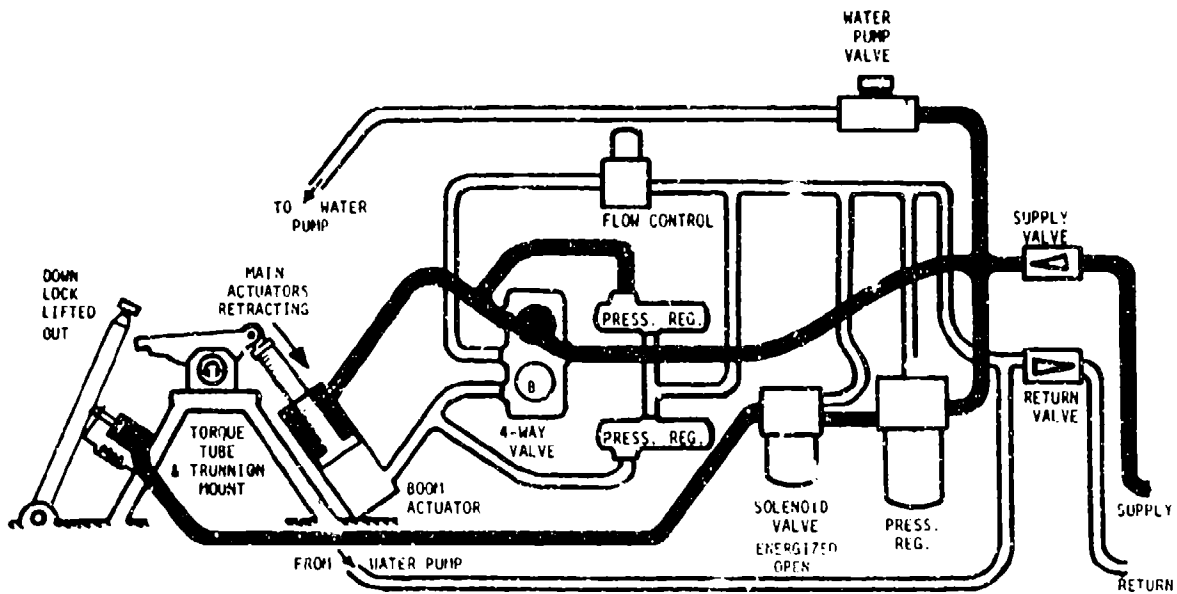

Boom Lowering (Deploying)

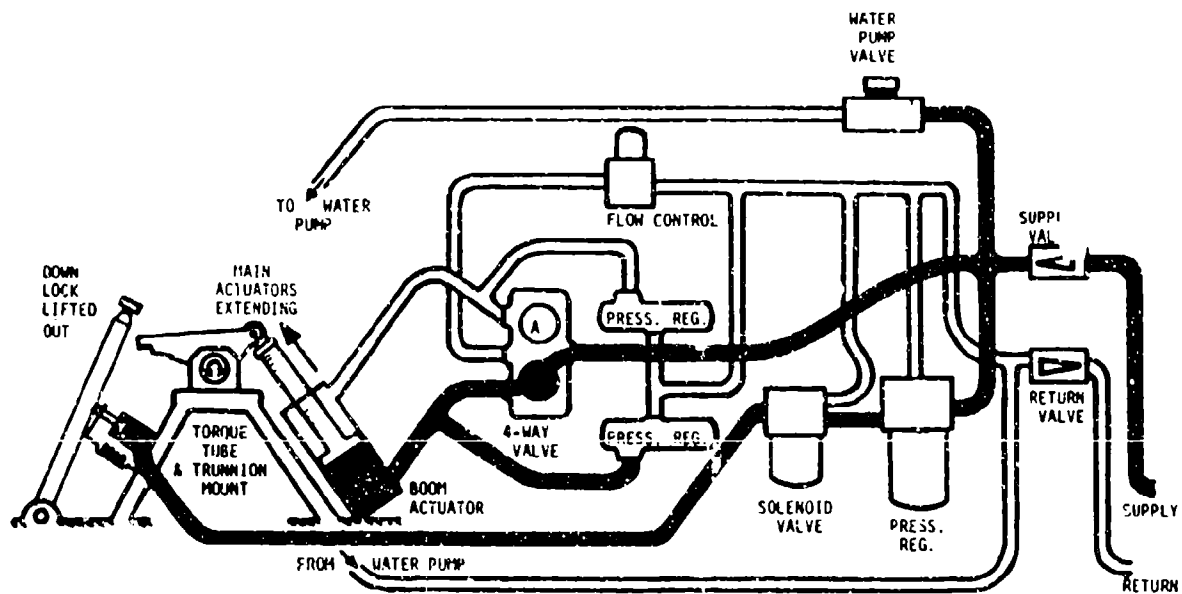

Boom Raising (Retracting)

Figure 1. Depiction of Utility Hydraulic System with Boom in Transit. Shaded Tubing Indicates Pressurized Lines.

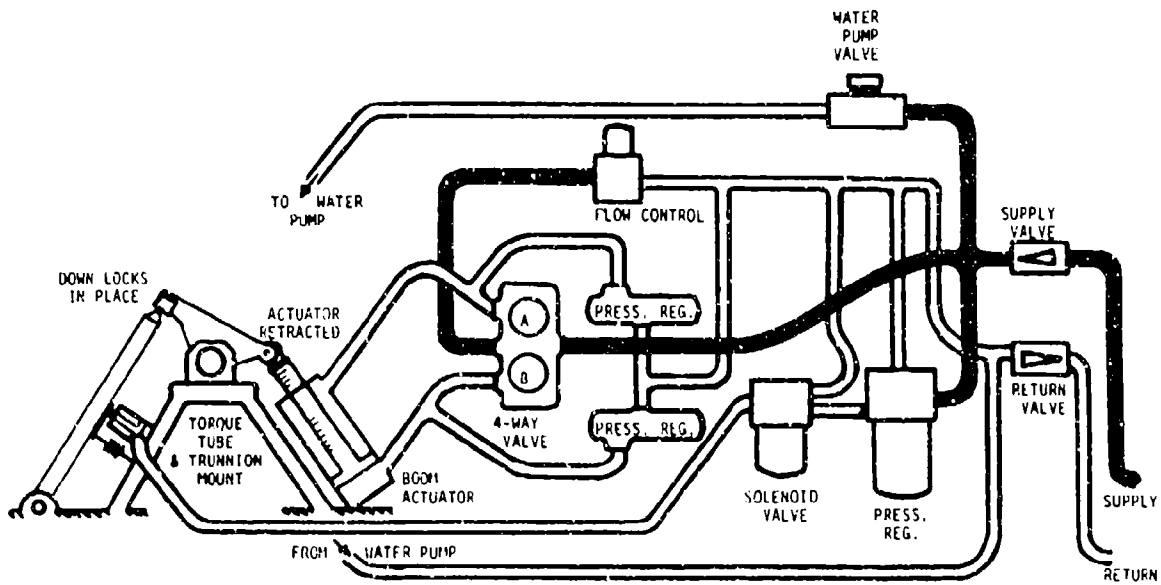

Boom Down and Locked (Deployed)

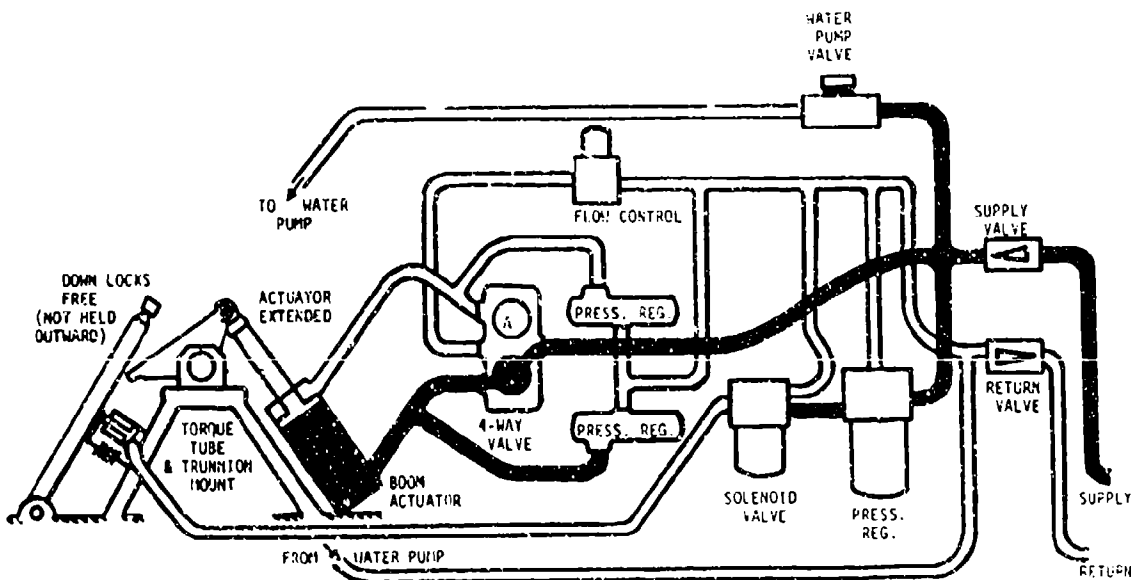

Boom Up and Locked (Retracted)

Figure 2. Depiction of Utility Hydraulic System with Boom Stationary. Shaded Tubing Indicates Pressurized Lines.

FIGURE 3
 HELICOPTER ICING SPRAY SYSTEM
 OPERATING AIR AND WATER PRESSURE
 JCF-47C/HISS USA S/N 68-15814

- NOTES: 1. Separate water paths to upper and lower booms, flow divided only by "Y" junction
 2. Sonicore model 125-HB nozzles installed
 3. Engines and APU used as air source
 4. Upper trapeze ---○---
 Lower trapeze ---□---

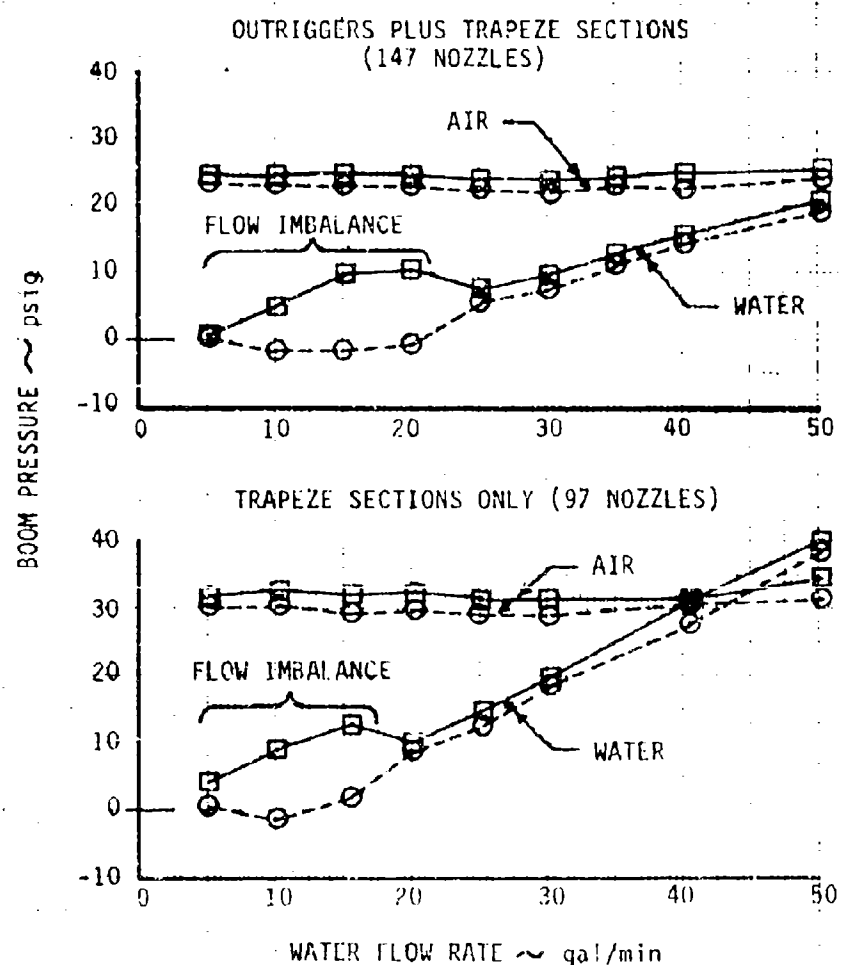

FIGURE 4
 HELICOPTER ICING SPRAY SYSTEM
 OPERATING AIR AND WATER PRESSURE
 JCH-47C/HISS USA S/N 68-15814

- NOTES:
1. Throttling water valves installed
 2. Separate water paths to upper and lower booms
 3. Sonicore model 125-HB nozzles installed
 4. Engines and APU used as air source except where indicated: APU only
 5. Upper trapeze ---○---
 Lower trapeze ---□---

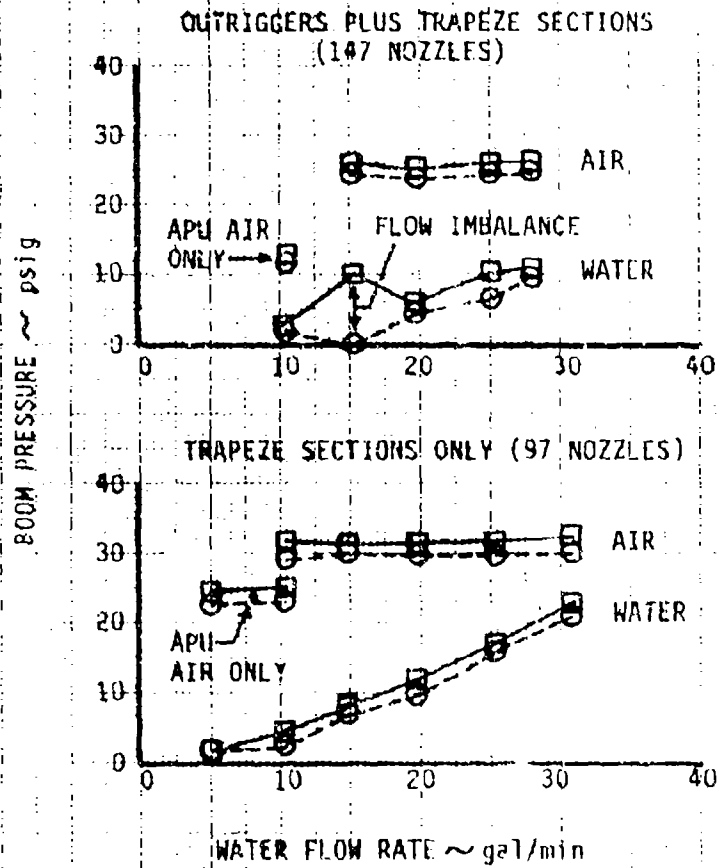

FIGURE 5
MISS SMOKE TRAIL
ROTOR WAKE SURVEY

CH-47C/HISS USA 37N 68-15814

- NOTES: 1. Average flight condition,
13°C temp, 6,000 ft press alt,
44,000 lb gross weight
2. Distances scaled from side
view photographs using CH-47C
fuselage as reference
3. Average of 2 photos per point

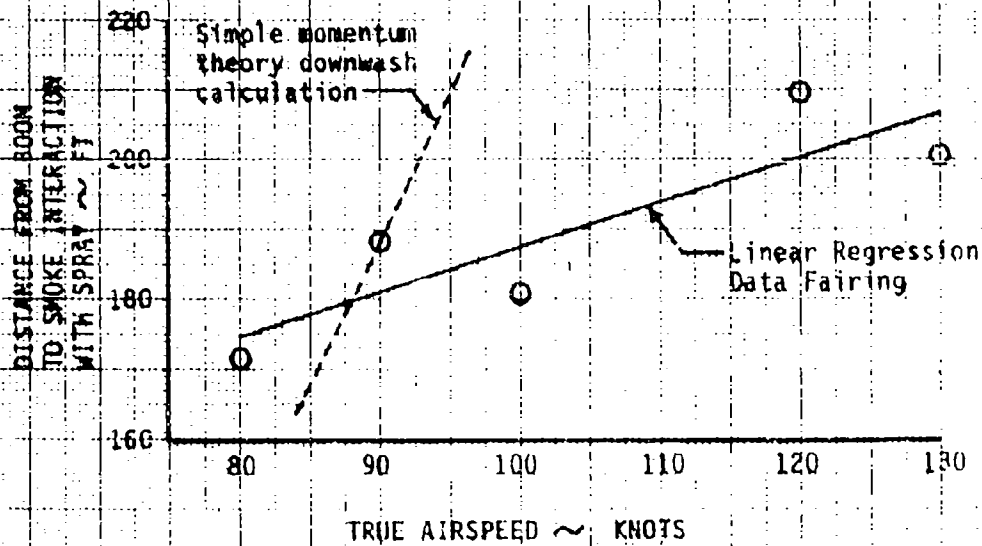

Table 1. Available Boom Air Pressure

Bleed Air Source	Boom Air Pressure ¹ (PSIG)	
	Trapeze Only ²	Trapeze Plus Outriggers ³
APU Only	23-1/2	12
APU plus one ENGINE	27	19-1/2
APU plus both ENGINES	30	24
Both ENGINES only	14	6-1/2
Single ENGINE only	3	2

NOTES:

¹Upper and lower boom values averaged; no water flow; average flight conditions: 100 KTAS, 5500 ft H_p, 10°C Ta, 50% Q_E.

²Upper and lower trapeze sections with 97 nozzles.

³Trapeze sections and both outriggers, 147 nozzles.

DISTRIBUTION

HQDA (DALO-AV, DALO-FDQ, DAMO-HRS, DAMA-PPM-T, DAMA-RA, DAMA-WSA)	6
US Army Materiel Command (AMCDE-SA, AMCDE-P, AMCQA-SA, AMCQA-ST)	4
US Army Training and Doctrine Command (ATCD-T, ATCD-B)	2
US Army Aviation Systems Command (AMSAV-8, AMSAV-ED, AMSAV-Q, AMSAV-MC, AMSAV-ME, AMSAV-L, AMSAV-N, AMSAV-GTD)	15
US Army Test and Evaluation Command (AMSTE-TE-V, AMSTE-TE-O)	2
US Army Logistics Evaluation Agency (DALO-LEI)	1
US Army Materiel Systems Analysis Agency (AMXSY-RV, AMXSY-MP)	6
US Army Operational Test and Evaluation Agency (CSTF-AVSD-E)	2
US Army Armor School (ATSB-CD-TE)	1
US Army Aviation Center (ATZQ-D-T, ATZQ-CDC-C, ATZQ-TSM-A, ATZQ-TSM-S, ATZQ-TSM-LH)	5
US Army Combined Arms Center (ATZL-TIE)	1
US Army Safety Center (PESC-SPA, PESC-SE)	2
US Army Cost and Economic Analysis Center (CACC-AM)	1
US Army Aviation Research and Technology Activity (AVSCOM) NASA/Ames Research Center (SAVRT-R, SAVRT-M (Library))	3
US Army Aviation Research and Technology Activity (AVSCOM) Aviation Applied Technology Directorate (SAVRT-TY-DRD SAVRT-TY-TSC (Tech Library))	2

US Army Aviation Research and Technology Activity (AVSCOM)	1
Aeroflightdynamics Directorate (SAVRT-AF-D)	
US Army Aviation Research and Technology Activity (AVSCOM)	1
Propulsion Directorate (SAVRT-PN-D)	
Defense Technical Information Center (FDAC)	2
US Military Academy, Department of Mechanics	1
(Aero Group Director)	
ASD/AFXT, ASD/ENF	2
US Army Aviation Development Test Activity (STEBG-CT)	2
Assistant Technical Director for Projects, Code: CT-24	
(Mr. Joseph Dunn)	2
6520 Test Group (ENML)	1
Commander, Naval Air Systems Command (AIR 5115B, AIR 5301)	3
Defense Intelligence Agency (DIA-DT-2D)	1
Federal Aviation Administration Technical Center (AWS-10GN)	3
Federal Aviation Administration Headquarters (Dick Adams)	1