

2

AD-A168 427

DTIC
SELECTE
JUN 10 1986
S D



AIR COMMAND AND STAFF COLLEGE

STUDENT REPORT

PROTOCOL HANDBOOK - A GUIDE
FOR THE BASE PROTOCOL OFFICER

MAJOR JO A. BALL

86-0180

"insights into tomorrow"

DTIC FILE COPY

DISTRIBUTION STATEMENT A
Approved for public release;
Distribution Unlimited

86 8 10 028
86 8 10 028

DISCLAIMER

The views and conclusions expressed in this document are those of the author. They are not intended and should not be thought to represent official ideas, attitudes, or policies of any agency of the United States Government. The author has not had special access to official information or ideas and has employed only open-source material available to any writer on this subject.

This document is the property of the United States Government. It is available for distribution to the general public. A loan copy of the document may be obtained from the Air University Interlibrary Loan Service (AUL/LDEX, Maxwell AFB, Alabama, 36112) or the Defense Technical Information Center. Request must include the author's name and complete title of the study.

This document may be reproduced for use in other research reports or educational pursuits contingent upon the following stipulations:

-- Reproduction rights do not extend to any copyrighted material that may be contained in the research report.

-- All reproduced copies must contain the following credit line: "Reprinted by permission of the Air Command and Staff College."

-- All reproduced copies must contain the name(s) of the report's author(s).

-- If format modification is necessary to better serve the user's needs, adjustments may be made to this report--this authorization does not extend to copyrighted information or material. The following statement must accompany the modified document: "Adapted from Air Command and Staff Research Report _____ (number) entitled _____ (title) by _____ (author) ."

-- This notice must be included with any reproduced or adapted portions of this document.



REPORT NUMBER 86-0180

TITLE PROTOCOL HANDBOOK - A GUIDE FOR THE BASE PROTOCOL OFFICER

AUTHOR(S) MAJOR JO A. BALL, USAF

FACULTY ADVISOR MAJOR TRACEY GAUCH, AGSC/EDP

SPONSOR LIEUTENANT COLONEL GILBERT L. MARTIN, HQ USAF/DAH

Submitted to the faculty in partial fulfillment of
requirements for graduation.

AIR COMMAND AND STAFF COLLEGE
AIR UNIVERSITY
MAXWELL AFB, AL 36112

REPORT DOCUMENTATION PAGE

1a. REPORT SECURITY CLASSIFICATION UNCLASSIFIED		1b. RESTRICTIVE MARKINGS	
2a. SECURITY CLASSIFICATION AUTHORITY		3. DISTRIBUTION/AVAILABILITY OF REPORT STATEMENT "A" Approved for public release; Distribution is unlimited.	
7b. DECLASSIFICATION/DOWNGRADING SCHEDULE		5. MONITORING ORGANIZATION REPORT NUMBER(S)	
4. PERFORMING ORGANIZATION REPORT NUMBER(S) 86-0180		5b. OFFICE SYMBOL (If applicable)	
6a. NAME OF PERFORMING ORGANIZATION ACSC/EDCC		7a. NAME OF MONITORING ORGANIZATION	
6c. ADDRESS (City, State and ZIP Code) MAXWELL AFB AL 36112-5542		7b. ADDRESS (City, State and ZIP Code)	
8a. NAME OF FUNDING/SPONSORING ORGANIZATION		9. PROCUREMENT INSTRUMENT IDENTIFICATION NUMBER	
8b. OFFICE SYMBOL (If applicable)		10. SOURCE OF FUNDING NOS.	
8c. ADDRESS (City, State and ZIP Code)		PROGRAM ELEMENT NO.	PROJECT NO.
11. TITLE (Include Security Classification) PROTOCOL HANDBOOK - A GUIDE FOR THE BASE		TASK NO.	WORK UNIT NO.
12. PERSONAL AUTHOR(S) Ball Jo A., Major, USAF		14. DATE OF REPORT (Yr., Mo., Day) 1986 APRIL	
13a. TYPE OF REPORT	13b. TIME COVERED FROM _____ TO _____	15. PAGE COUNT 131	
16. SUPPLEMENTARY NOTATION Item 11: PROTOCOL OFFICER			
17. COSATI CODES		18. SUBJECT TERMS (Continue on reverse if necessary and identify by block number)	
FIELD	GROUP	SUB. GR.	
19. ABSTRACT (Continue on reverse if necessary and identify by block number) This handbook is designed with the base protocol officer in mind; however, it covers a wide spectrum of protocol that can be helpful to any Air Force officer. The focus is on the most common areas that challenge the novice protocol officer. The handbook describes flag etiquette, ceremonies, social occasions, distinguished visitors protocol, aide-de-camp responsibilities, contingency funds, and a collection of odds and ends tips a protocol officer can use in his/her daily duties.			
20. DISTRIBUTION/AVAILABILITY OF ABSTRACT UNCLASSIFIED/UNLIMITED <input type="checkbox"/> SAME AS RPT <input type="checkbox"/> DTIC USERS <input type="checkbox"/>		21. ABSTRACT SECURITY CLASSIFICATION UNCLASSIFIED	
22a. NAME OF RESPONSIBLE INDIVIDUAL ACSC/EDCC Maxwell AFB AL 36112-5542		22b. TELEPHONE NUMBER (Include Area Code) (205) 293-2483	22c. OFFICE SYMBOL

PREFACE

This handbook was prepared for the officer who is just introduced to a job in protocol. The purpose of this guide is twofold: first, to provide an initial reference handbook for base protocol officers, and second, to recommend a library upon which to gather detailed instructions for every protocol occasion.

The idea for a handbook is nothing new. Several students at Air Command and Staff College have prepared projects with a protocol handbook in mind. Unfortunately, the reports do not always make it to the right place for Air Force publication and distribution. I was fortunate to meet Lieutenant Colonel Lee Martin HQ USAF/DAH who stated the AF/DA was interested in publishing a protocol guide for the many 70XX officers who found themselves in this special duty assignment for the first time without a clue what it involved. Captain Norman L. Watson who works in the same office with Colonel Martin had drafted a proposed protocol handbook in 1983 when he was stationed at Keesler AFB, Mississippi. Captain Watson had surveyed 70XX officers worldwide to get their opinions of a protocol handbook. He spent a lot of time and effort researching various regulations and books to build a thorough guide. The project was excellent; unfortunately, it was never finalized and published. With Captain Watson's permission and Colonel Martin's sponsorship, I set out to rejuvenate the project. I started with the proposed draft which includes specific detail from numerous Air Force regulations; many sections are used almost verbatim with changes only for brevity and clarity. Next I researched and extracted some good solid advice from numerous ACSC students who definitely knew their protocol. An invaluable contributor is Major Joyce K. Stouffer who last year wrote an excellent protocol handbook. I took bits and pieces from these projects and combined them with my own "lessons learned" from three years in protocol. Many ideas were blended. I am indebted to all the ACSC students who felt the subject of protocol needed to be studied and guidance provided, and to Captain Watson whose hard work in the draft is finally coming to fruition.

To help me through this task I was fortunate to have the expertise and support of Major Tracey Gauch. As my advisor, Major Gauch deserves a special word of thanks. Her expertise and positive attitude enabled me to follow through and accomplish my goal. Also, I couldn't have done anything without Jackie Partridge - a super gal who does spectacular typing. Finally, some words to all those who may question the priority of protocol in today's military -- as long as there is order and discipline in the services, there will be protocol.



Library Codes	
Dist	Avail and/or Special
A-1	

ABOUT THE AUTHOR

Major Jo Ball received her degree in History/English from the University of California, Los Angeles, and entered the Air Force in 1972. After Officer Training School, she learned to be an executive support officer, a trade that has taken her to many jobs at many bases in the past 14 years. She holds a Masters Degree in Public Administration from the University of Northern Colorado, and has completed Air Command and Staff College by seminar and Squadron Officer School by correspondence and residence. To her credit, she has been an operations administration officer, a flight commander at OTS, a chief of central base administration, the assistant executive officer to The Air Force Inspector General, and just recently was a congressional liaison officer in the Pentagon before coming to the Air Command and Staff College. She has been a protocol officer--both full and part-time. She served as the protocol officer to the 314th Air Division/Air Force Korea at Osan Air Base, Korea, and later went to Headquarters Tactical Air Command, Langley AFB VA, to serve at major command level as a protocol officer. While serving in the Pentagon, she was selected on numerous occasions to assist the Department of Defense Chief of Protocol on protocol functions for various visiting ministers of defense and their wives. Upon completion of ACSC, Major Ball has been selected for assignment to the International Affairs Division (CVAI), HQ USAF where she plans to further her protocol experience.

TABLE OF CONTENTS

Preface	iii
About the Author	iv
Table of Contents	v
List of Illustrations	ix
 CHAPTER ONE - INTRODUCTION	 1
 CHAPTER TWO - THE AMERICAN FLAG	 4
Historical Perspective	4
The US Flags	5
General Guidance	5
Half-Staff	6
When Carried for Ceremonies	6
Decorative Display	6
Relative Arrangements	7
Honors or Tributes	8
Lowering and Folding	17
Flags on Holidays	17
Conclusion	17
THE PLEDGE OF ALLEGIANCE TO THE FLAG	18
THE NATIONAL ANTHEM	18
THE AIR FORCE SONG	20
 CHAPTER THREE - SALUTES AND SALUTING	 21
Salutes by Flags	23
Saluting the United States Flag	23
Army or Navy Gun Salute	23
Conclusion	23
 CHAPTER FOUR - RANK AND PRECEDENCE	 24
Determining Precedence	25
When Seniority Determines Precedence	26
Rank and Precedence in Other Countries	27
Conclusion	27
 CHAPTER FIVE - OFFICIAL CEREMONIES	 31
CHANGE OF COMMAND CEREMONIES	31
Drill and Ceremonies	31
General Sequence of Events	31
Invitations	32
Change of Command Operations Plan (OPLAN)	32
Programs	32

CONTINUED

Reviewing Officer	33
Rehearsal	33
Necessary Materials	33
Other than Formal Review	33
AWARD, DECORATION, AND RETIREMENT CEREMONIES	45
General	45
Preparation	45
Procedures for Awards and Decoration Ceremonies	46
Order of Presentation	47
Recognition of Members Being Retired	48
THE MILITARY FUNERAL	52
Air Force Policy	52
TYPES OF FUNERAL CEREMONIES	53
General Considerations	53
Complete Air Force Funeral	53
Funeral Without Chapel Service	53
Graveside Service	53
Funeral Without Chapel Service	53
Graveside Service	53
Memorial Service	53
ITEMS OF INTEREST	54
Cannon Salute	54
Aviation Participation	54
The Flag	54
Checklist	54
RETREAT	56
Conclusion	56
CHAPTER SIX - ETIQUETTE AND OFFICIAL MILITARY ENTERTAINMENT	57
Introduction	57
Precedence	57
Proper Introductions	57
RECEPTIONS	58
Dress	58
Receiving Line	58
Flag Arrangement Behind the Receiving Line	59
Assistant Hosts and Hostesses	59
OFFICIAL LUNCHEONS	59
FORMAL DINNERS	60
INVITATIONS	60
SEATING: LUNCHEONS AND DINNERS	62
Arrangements	62

CONTINUED

Procedure	64
NAME TAGS	64
PLACE SETTING	64
PLACE CARDS	65
TOASTS	66
Ceremonial Toasts	66
ENTERTAINMENT	67
THE DINING-IN AND DINING-OUT	67
Introduction	67
Historical Background	67
Purpose	68
Dress	68
Planning the Dining-In	68
Seating	68
Conduct and Courtesies	69
Principal Officials	69
Ceremonies	69
Rules of Protocol	71
Awards	72
Sample Dining-In Agenda	72
Conclusion	72
CHAPTER SEVEN - HONORS ACCORDED DISTINGUISHED VISITORS	76
PROTOCOL RESPONSIBILITIES	76
POLICY ON CEREMONIAL HONORS	79
When Honors Will be Accorded	80
When Ceremonies May be Held	81
Meeting and Greeting Distinguished Visitors	81
Prior to Arrival by Automobile	82
Upon Arrival by Automobile	82
Visitors Traveling by Commercial Air	82
Prior to Arrival by Military Air	83
Ceremony on Arrival by Military Air of a DV Other Than the President	83
Ceremony on Departure of a DV by Military Air	88
Position of Staff Cars and Duties of Drivers	88
Conclusion	88
ESCORT OFFICERS	89
INTERNATIONAL DISTINGUISHED VISITOR TOURS	91
Introduction	91
Notification	91
Tour itinerary	91

CONTINUED

Briefings and On-Base Tours	91
Escort Officers	92
Entertainment	93
International Customs and Courtesies	94
Funds	94
Duties of Project/Escort Officers	94
Protocol Visit Checklist	95
Conclusion	97
CHAPTER EIGHT - AIDE-DE-CAMP FUNCTIONS	98
Position	98
Responsibilities and Procedures	98
Conclusion	100
CHAPTER NINE - FINANCIAL AND TRAVEL ARRANGEMENTS FOR COMMANDERS	101
Financial Arrangements	101
Travel Arrangements	101
CHAPTER TEN - USE OF CONTINGENCY FUNDS	105
General	105
Authorized Categories of Entertainment	106
Who May Be Entertained	106
What Expenditures Are Not Authorized	107
Personnel Authorized To Be Hosts	108
Conclusion	109
CHAPTER ELEVEN - POTPOURRI	110
Flexibility in Approach or Knowing Murphy's Law	110
The Art of Conversation	110
R.S.V.P.	111
Tan-Nosing	112
Automobile Plates for Air Force Commanders	112
Place of Honor	112
Calling Cards	113
Attention to Detail	113
Self-Confidence	116
Hard Work (Let's Get To It)	116
BIBLIOGRAPHY	118

CONTINUED

FIGURES

FIGURE 1	-	Flags on Stationary Flagstuffs	9
FIGURE 2	-	Display of the Flag at Half-Staff	10
FIGURE 3	-	Carrying Flags at Ceremonies	9
FIGURE 4	-	Position of Flags at Ceremonies	13
FIGURE 5	-	Flag Suspended From a Building	13
FIGURE 6	-	Flag Suspended Over Middle of Street	13
FIGURE 7	-	Position of Flag on a Speaker's Platform	13
FIGURE 8	-	Display of the Flag at Podium	14
FIGURE 9	-	Displaying US Flag in Group of Flags	14
FIGURE 10	-	Display of Flag in an Office	14
FIGURE 11	-	Position of Flags Flown from Same Halyard	15
FIGURE 12	-	Correct Method of Folding the US Flag	16
FIGURE 13	-	Unofficial List of Precedence in the US	28
FIGURE 14	-	Comparable Rank Among the Military Service	29
FIGURE 15	-	Diagram of Positions for Change of Command Ceremony	36
FIGURES 16	-	29 - Change of Command Ceremony - Steps 1 - 14	37-44
FIGURE 30	-	Retirement Information Form	50
FIGURE 31	-	Sample Semi-Engraved Invitation	61
FIGURE 32	-	Sample Dining-in Agenda	73
FIGURE 33	-	Protocol Function Checklist	75
FIGURE 34	-	Diagram of a Ceremony for Secretary of the Air Force ...	85
FIGURE 35	-	Diagram of a Ceremony for Major General or Rear Admirals	86
FIGURE 36	-	Visit Checklist	87
FIGURE 37	-	Travel Checklist	104
FIGURE 38	-	Automobile Plate for Base Commander	114
FIGURE 39	-	Automobile Plate for Wing Commander	114
FIGURE 40	-	Sample Calling Cards	115

Chapter One

INTRODUCTION

"Make one mistake and you're through!"
Anonymous General

Are you thinking about becoming a protocol officer or have you just been notified that you have a special duty assignment as a base protocol officer? If the answer is yes to either or both of these questions, don't panic. It is not unlikely that you as a 70XX, executive support officer or administrative officer, may find yourself in this position sometime during your Air Force career. The reason being the administrative officer is often chosen to fill this position. So, if you do find yourself being placed in this assignment or if you are considering following a protocol calling, step right up, because the job really is exciting and challenging. I can speak from experience, as I have been a protocol officer at base and major command levels, and assisted in protocol duties in the Department of Defense--Pentagon arena.

I did not know what the protocol job entailed when I volunteered for the position. Oh, I had dabbled in protocol when as a second lieutenant, I was selected to arrange an award ceremony. Luckily, someone helped me through the steps to organize and "muddle through" this basic ceremony. It really was not until I reported to my duty assignment and assumed the title of Protocol Officer that I realized there is a lot more to protocol than just setting up an award ceremony. There is more to being prepared for a protocol job.

There is no formal training to prepare one for protocol. You have to depend on a combination of using common sense, researching various protocol and etiquette literature, relying on Air Force Pamphlet (AFP) 900-1, Guide to Air Force Protocol, and being thrown into the frying pan learning from experience. I would like to provide an additional source of information to prepare a newly assigned protocol officer for many of the occasions that a base protocol officer faces - a simple, easy to understand guide to base protocol.

I realize there are all types of written sources a protocol officer can refer to in preparing for the duties. I will encourage you to seek out and learn as much as possible because protocol can be very complicated. What I am concerned with is providing you some general guidelines to get you started in the right direction without falling into any pitfalls. Then I'll

back up these rules with specific references, where you can get in-depth, quantitative information.

This guide is divided into specific chapters covering items of protocol you will have to know. You will be the one person looked to for the "expert" answers. I cover what I consider the spectrum of protocol functions from routine to highly specific--i.e. flag arrangement to commander's contingency fund. This guide is by no means a complete encyclopedia. I have included information I think will be helpful. To top it off, at the end, I added what I think is a helpful protocol reference library which includes AFP 900-1, multiple protocol books, and numerous Air Force regulations to "round out" your sources. Then why this guide? Do we need a simple accessible guide for the base protocol officer? I say yes, based not only on my personal experience, but also on the fact the Air Force Director of Administration (AF/DA) validated that need. In his meetings with 70XX officers worldwide, he recognized the request for specific guidance for Base Protocol Officers. There is no shortage of protocol reference material; the problem is funneling and digesting all the data into a useful, practical form. What is lacking is an easy-to-use guide prepared with the base protocol officer in mind. Therefore, AF/DA wanted such a guide. I'm honored to have prepared this guide, incorporating my ideas with the age-old tested rules of protocol.

I wanted to prepare this guide to help you because, like I said, I have been there. I learned the hard way, and if I can save you one black eye this book will be well worth it. One thing you will quickly learn in protocol, like it or not, people remember mistakes. You can do everything right and that's fine, but make one mistake and that memory remains. Another very important rule to remember, is proper protocol cannot ensure success, but improper protocol can well be the occasion for failure.

Now, don't get discouraged, because as I said in the beginning, protocol is exciting. This job will be one of your most challenging and maybe the most glamorous you will have in the Air Force. It is not for the shy or weak, but rather, it's for the strong at heart; it really brings out the best in you. So I say - try a protocol position, fine-tune your spit and polish, gain the confidence of your commander, and put yourself on the firing line. It's a challenge for any Air Force officer. Protocol can be easily understood and properly performed with some basic understanding and know-how. So what is protocol?

'Protocol' comes from a word the Greeks used to identify documents. But it now represents, in the complexity and change of the twentieth century, a body of social discipline without which the encounter of princes and presidents would have little relevance. For protocol brings to the meeting of world leaders a mixture of good manners and common sense which make effective communication possible.

Angier Biddle Duke
Former Chief of Protocol of the United States

The key is in the final words--"good manners and common sense." Therefore, to put it into basic terms for a base protocol officer--protocol is using your head and practicing proper etiquette you learned growing up with your family, and from practical experience and available protocol literature, to show the proper respect and recognition in a particular situation or ceremony. It's knowing and doing the right thing, at the right time, and in the right place in regard to rank, precedence, and recognition. There are specific rules of conduct and principle established over centuries of tradition that are followed to show courtesy and the order of mankind. As long as we are a civilized society, there will be rank and precedence as well as their recognition in a ceremony or special occasion. These established rules form the meaning of protocol.

Now that you understand what protocol is, where did it begin? To give you a foundation and, hopefully, make you feel more at ease with protocol, a historical perspective is most appropriate. Protocol has been part of human life for thousands of years. The sculptured reliefs on the ruined walls of Persepolis, for example, show the order of procession imposed on the tribute bearers at the court of Cyrus the Great 2,500 years ago. Protocol has also been a traditional mark of sophistication. President George Washington, who was his own Chief of Protocol, believed official formality and dignified etiquette were needed to gain respect for our new government and to enhance its authority. When asked what she considered to be the most important subject in the education of a king or queen, the late Dowager Queen Mary replied, "Manners." We know good manners are said to be the oil that greases the wheels of society, but far from being artificial, they are the natural attributes of a civilized person. John Quincy Adams was certainly in line with the authorities of protocol when he said common sense and consideration should be the basis of protocol.

A lack of proper customs and courtesies has, in fact, had its effect on society. Back in 1661, for instance, France and Spain came dangerously close to war over a matter of ambassadorial precedence. It occurred in London when after meeting the Swedish Ambassador, the French Ambassador, in his coach, tried to fall in behind the departing English royal coach. Because of precedence, sword combat soon ensued with the party accompanying the Spanish coach. The incident resulted in the ouster of the Spanish Ambassador and an ultimate redress from Spain.

Your understanding of protocol will be focused on daily activities of the commander - the recognition and proper respect shown to rank and position through proper etiquette. As you can see, protocol does have its place. In the Air Force, we see it in ceremonies, the hosting of distinguished visitors, parades, saluting, et al. And it is just such items that will be discussed in this handbook. In most cases, the base protocol officers must be concerned with ceremonies, and special occasions involving base leaders and visiting dignitaries. A good beginning is with the American flag since its proper recognition and handling is one of your primary duties and your "expertise" in all matters pertaining to the flag will be frequently referenced.

Chapter Two

THE AMERICAN FLAG

A basic protocol officer is expected to know flag etiquette and will be called upon to explain when and how the American flag should be flown. It is also helpful to understand the historical background; therefore, the following is general information to familiarize the protocol officer with the American flag history, etiquette, and custom. Included in this chapter, we will review the protocol of the Pledge of Allegiance and the National Anthem. Finally, we will discuss the Air Force song as a symbol of respect paid our service.

Historical Perspective

The first flags adopted by our Colonial forefathers were symbolic of their struggles with the wilderness of a new land. Beavers, pine trees, rattlesnakes, anchors, and various like insignia with mottoes such as "Hope," "Liberty," "Appeal to Heaven," or "Don't Tread on Me" were affixed to the different banners of Colonial America.

The Colonists' first flag to have any resemblance to the present day Stars and Stripes was the Grand Union flag, sometimes referred to as the "Congress Colors." It consisted of thirteen stripes, alternately red and white, representing the Thirteen Colonies with a blue field in the upper left-hand corner bearing the crosses of St. George and St. Andrew, signifying union with the mother country. This banner was first flown by the ships of the Colonial Fleet on the Delaware River in December 1775.

In January 1776, the Grand Union flag became the standard of the Colonial Army, which had come into being some months before--in June 1775. It was also carried by American Marines and Bluejackets, comprising an expeditionary force to the West Indies in 1776.

The present United States flag dates back to the Continental Congress where on 14 June 1777, a resolution was adopted that the flag would have thirteen alternating stripes of red and white, representing the thirteen original colonies of the Union. Each state was also to be depicted by a white star in a blue field which was intended to represent a new constellation in the development of the fledgling country. The original thinking was to add a new star and stripe every time a state came into the Union, but in 1818 when the flag had fifteen stripes, Congress decided to go back to the original thirteen, but keep adding stars for each new state. The colors of the flag are symbolic. Red is the traditional color of defiance, and white means purity. The blue field was taken from the edge of

Covenanter's Banner of Scotland, significant of the United States objection to British oppression.

The US Flags

These types and sizes of flags are authorized for use by the Air Force according to Air Force Regulation (AFR) 900-3, Department of the Air Force Seal, Organizational Emblems, Use and Display of Flags, Guidons, Streamers, and Automobile and Aircraft Plates:

1. Base. The flag is lightweight nylon bunting material, 8 x 17 feet. This is flown only in fair weather.
2. All-purpose flag. This flag is lightweight nylon bunting material, 5' x 9'6" or rayon bunting material 3 x 4 feet. The flag which is 5' x 9'6" is used as an interment flag and an alternate during bad weather. The flag which is 3 x 4 feet is used for outdoor display with flags of friendly foreign nations in arrival ceremonies for foreign dignitaries.
3. Ceremonial flag. The flag is rayon or synthetic substitute material, 4'4" x 5'6", trimmed on three edges with a rayon fringe 2½ inches wide.
4. Organizational. This flag is rayon or synthetic substitute material, 3 x 4 feet, trimmed on three edges with rayon fringe 2½ inches wide.
5. Boat. The flag is bunting material, without fringe, 2.37 x 4½ feet.

The Air Force flag is basically ultramarine blue in color. In the center is the Air Force Coat of Arms, which is encircled by stars and identifying scroll.

General Guidance

Title 36, United States Code (USC) Chapter 10, established the rules for proper use, display, and patriotic customs to be shown the United States flag. The US flag is displayed on an Air Force facility only according to these rules and customs. AFR 900-3 is your most useful guide in this area. However, some of its basic rules and customs are provided later for you.

Air Force members must show respect for the flag. Dependents or visitors on an Air Force facility are required to show due respect of the flag. Failure to do so renders them subject to exclusion from the facility.

Representations of the flag which are displayed on an Air Force facility in a manner or fashion which would disrupt the mission or detract from good order, discipline, or morale of Air Force members may be excluded from the facility by the commander. Persons who display representation of

the flag in such a manner may also be excluded from the facility by the commander.

Each Air Force installation is authorized to fly one installation flag from reveille to retreat. An additional flag staff and flag are authorized adjacent to each dependent school on the installation. Title 36, USC Section 174(a) permits the display of the flag for 24 hours a day to produce a patriotic effect if the flag is properly illuminated during the hours of darkness. Each installation is limited to one illuminated flag staff.

Half-Staff

Mourning is observed by flying the United States flag at half-staff which is defined as the position of the flag when it is one-half the distance between the top and bottom of the staff (Figure 1). When flown at half-staff, the flag is first hoisted to the peak and then lowered to the half-staff position. The flag must be raised to the peak before it is lowered for the day. Flags carried by troops are never carried at half-staff. On Memorial Day, the flag is displayed at half-staff until noon only, then raised to the top of the staff. By order of the President, the flag is also flown at half-staff on the death of principal leaders of the United States Government, and the Governor of a State, Territory, or Possession. The flag is displayed at half-staff according to Presidential instructions, order, or according to recognized customs or practices not inconsistent with law. Figure 2 contains a table indicating the persons entitled to this honor and the places and duration for the flag to be flown at half-staff. When in foreign countries and when the President directs, the United States flag is flown at half-staff at Air Force installations, whether or not the flag of another nation is flown at its peak alongside the United States flag. At no other time is the United States flag flown at a lesser height than other flags at the same location.

When Carried for Ceremonies

A United States flag is carried on all occasions of ceremony in which two or more squadrons participate representing a group, wing, air division, numbered air force, major command, or the Department of the Air Force. During the occasions, the flag is carried by a Color Guard. The position in line from right to left is the United States flag, then the Air Force flag, followed by the individual flag or flags, if appropriate (Figures 3 and 4). When carried by troops, Air Force flags correspond to the size of the United States flag.

Decorative Display

The following are the major decorative display rules:

1. When the United States flag is on a staff, the union of the flag is placed at the peak of the staff unless the flag is at half-staff.

2. When the flag is suspended from a building to another support, the union of the flag is hoisted out first and remains away from the building (Figure 5).

3. When the flag is displayed over the middle of a street, it is suspended vertically with the union to the north on a principally east and west street, or to the east on a principally north and south street (Figure 6).

4. When used on a speaker's platform, if the flag is displayed flat, it should be displayed above and behind the speaker (Figure 7). When displayed from a staff in a church or public auditorium, the flag is placed in the position of honor at the clergyman's or speaker's right as he or she faces the audience (Figure 8). Other flags on display are positioned to the left side of the speaker or to the right of the audience.

5. When displayed on aircraft or vehicles, the flag's union is always toward the front with stripes trailing.

6. When the flag is used to cover a casket, the union should be placed at the head and over the left shoulder (see AFR 143-1, Mortuary Affairs, for use and display of the flag during funeral services).

7. When the flag is suspended across a corridor or lobby in a building with only one main entrance, it should be suspended vertically with the union of the flag to the observer's left upon entering. If the building has main entrances on the east and west, the flag is suspended vertically near the center of the corridor or lobby with the union to the north. The union is placed to the east when the entrances are to the north and south. If there are entrances in more than two directions, the union should be to the east.

8. Concerning the use and display of flags in foreign countries, Air Force Commanders obtain instructions from the US Defense Attache in that country. In the absence of such an office, contact the senior Air Force officer on duty. These individuals formulate standardized instructions in keeping with existing treaties and arrangements agreeable to the host country. Inquiries relating to display of flags in foreign countries may be directed to Headquarters USAF, International Affairs Division (HQ USAF/CVAI), Washington D.C. 20330-5000.

Relative Arrangements

The following are the basic flag arrangement rules:

1. The United States flag with Air Force flags. See Figures 3, 4, 8, 9, 10, 11.

2. The United States flag with flags of foreign nations. When displaying flags of two or more nations, they are flown from separate staffs of equal height. International usage forbids the display of the flag of one nation above that of another nation in time of peace.

3. The United States flag with flag of states, cities, localities, or pennants of societies. When the United States flag is displayed as such, it is at the highest point in the group (Figure 9). If it is desired the flags be at the same level, the United States flag is given the position of honor which is at the flag's own right or the observer's left. Another flag or pennant is not placed above, or if on the same level, to the right of the United States flag. When these flags are flown from adjacent staffs, the United States flag is hoisted first and lowered last.

4. The United States flag in the procession with other flags. In a processions with another flag or flags, the United States flag is either on the marching right, or if there is a line of other flags, in front of the center of the line (Figure 4).

5. Crossed staff. When the flag is displayed with another flag from crossed staffs, the United States flag is on the right (observer's left), and its staff is in front of the staff of the other flag.

6. When the United States flag is displayed with other flags, the United States flag is always given the position of honor. The position of honor is the flag's own right or an observer's left. Any other flag displayed at the same time is to the observer's right, or the United States flag's left (Figure 10).

Honors or Tributes

The United States flag is not:

1. Dipped to any person or thing. Military organizational flags, state flags, and civilian organizational or institutional flags are dipped as a mark of honor.
2. Displayed with the union down except as signal of distress in instances of extreme danger to life or property.
3. Permitted to touch anything beneath it, such as the ground, the floor, merchandise, and so forth.
4. Carried flat or horizontally. It is always carried aloft and free.
5. Festooned, but allowed to fall and hang free.

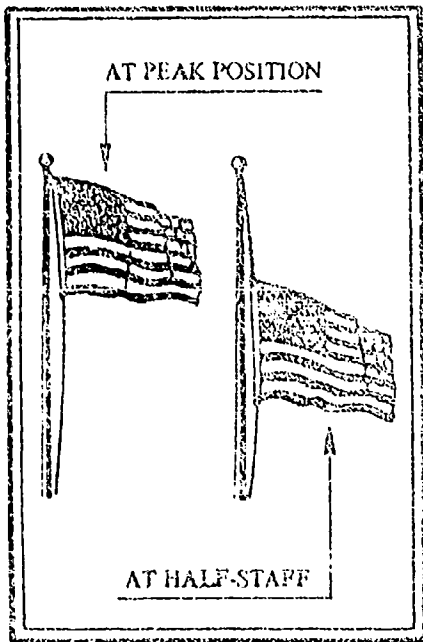

Flags on Stationary
Flagstaffs.

Figure 1

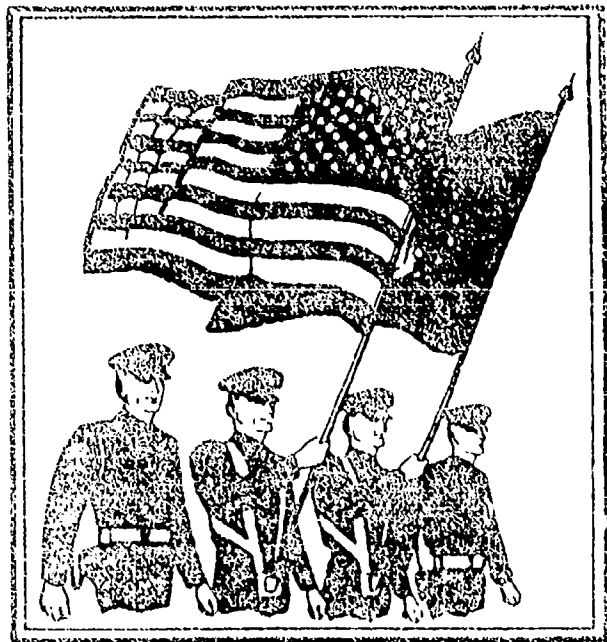

Carrying Flags at Ceremonies.

Figure 3

DISPLAY OF THE FLAG AT HALF-STAFF

(PUBLIC LAW 94-34*)

Occasion	Places	Period	Notice to Air Force Commander
Death of: President Former President President-Elect	All buildings, grounds, and naval vessels of the federal government in District of Columbia, throughout the United States and its territories and possessions; United States Embassies, Legations, and other facilities abroad including military facilities, naval vessels and stations.	30 days from date of death.	None. Commanders will comply on receipt of information 10 days from date of death through press, radio, television, or other news media.
Death of: Vice President Chief Justice of the United States Retired Chief Justice of the United States Speaker of the House of Representatives	All buildings, grounds, and naval vessels of the federal government in District of Columbia, throughout the United States and its territories and possessions.	10 days from date of death.	
Death of: Associate Justice of Supreme Court Secretary of Executive or Military Department Former Vice President President pro tempore of the Senate Majority Leader of the Senate Minority Leader of the Senate Majority Leader of House of Representatives Minority Leader of the House of Representatives		From day of death until interment.	

Figure 2

Death of Chairman of the Joint Chiefs of Staff Former Chairman of the Joint Chiefs of Staff	On all buildings, grounds, and naval ves- sels of the Department of Defense in the District of Columbia and throughout the United States and its territories and pos- sessions.	From the day of death until in- terment. (See Note 1)	
Death of: Chief of Staff, USAF Former Chief of Staff, USAF Air Force officers of five-star grade	Buildings and grounds under the jurisdic- tion of the Department of the Air Force.		
Death of: United States Senator United States Representative Territorial Delegate Resident Commissioner from the Corn- monwealth of Puerto Rico	All buildings, grounds, and naval vessels of the federal government in metropol- itan area of District of Columbia.	On the day of death and the following day.	
Death of: Governor of State or Territory	All buildings and grounds of the federal government located in the state, territory, or possession of the United States of the deceased governor.		
Death of other officials and foreign dignita- ries	To be displayed in such places according to orders or instructions as may be issued by or at the direction of the President, or according to recognized customs or prac- tices not inconsistent with law.	As directed by or at the di- rection of the President.	Headquarters USAF message (see note 2).
As directed by the heads of the several Depart- ments and Agencies of the government on occasions other than those listed above which they consider proper, and that suitable military honors be ren- dered as appro- priate.	Buildings, grounds, or naval vessels under jurisdiction of the appropriate De- partment head.	As directed by head of De- partment or Agency.	

Figure 2

Reproduced from
best available copy.

**SPECIAL AUTHORIZATION OF THE SECRETARY OF THE AIR FORCE
PRESIDENTIAL PROCLAMATION 3044.**

Death of commanders who were on active duty	Buildings and grounds which were part of the deceased's command.	From reveille to retreat on day of the funeral regardless of location of ceremony.	Headquarters concerned notifies other elements of the command.
Death of active duty Air Force four-star general officer	Buildings and grounds under jurisdiction of the Department of the Air Force.	From ^{5:00 AM} reveille to day of interment.	Headquarters USAF message.
	Buildings and grounds which were part of the deceased's command.	From day of death until interment.	Headquarters concerned notifies other elements of the command.
Death of retired Air Force four-star general	Buildings and grounds under jurisdiction of the Department of the Air Force.	From reveille to retreat on day of interment.	Headquarters USAF message.
Death of officers and airmen on active duty (except personnel in Detachment of Patient status at a USAF Hospital)	On buildings and grounds of their memorial service, funeral service, or duty station.	On the day of death or day following death. (Installation commanders may also half-staff the flag on the day of an on-base memorial or funeral service.)	Casualty officer concerned notifies appropriate commander (see note 3).
Death of civilians who die while employed by the Air Force (only if they are US citizens)	On buildings and grounds of their memorial service, funeral service, or duty station.	Installation commanders may half-staff the flag on day of death, day following death or day of an on-base memorial or funeral service.	Immediate supervisor or unit commander concerned notifies the installation commander (see note 4).

NOTES: 1. At joint installations or commands, the procedures prescribed by the responsible military commander or the Executive Agent are executed uniformly by all the US military units present.

2. Military commanders overseas should inquire of the United States Defense Attache at the US Embassy (see paragraph 3-3). Embassies have been advised, when necessary, to in turn con-

tact the State Department which will if necessary seek an opinion from the White House.

3. Commanders have the option to post the identity of the individual for whom the flag is half-staffed. The intent is to inform personnel why the flag is at half-staff.

4. If death of civilian occurs overseas, the casualty officer concerned notifies appropriate commander.

Figure 2

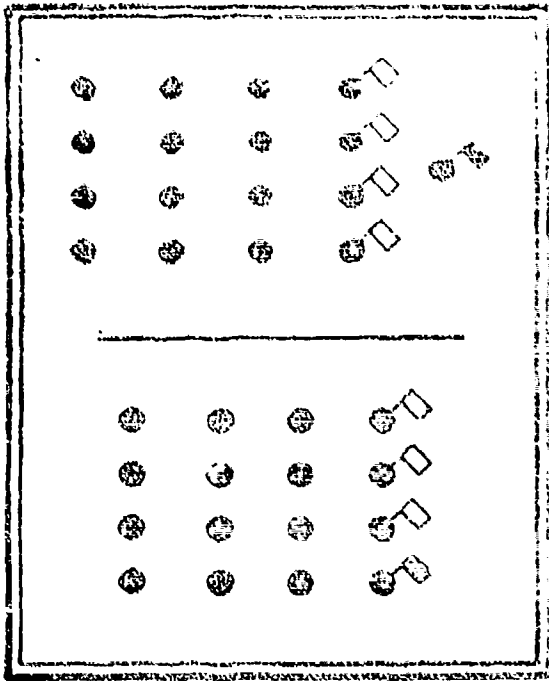

Position of Flags at Distances.

Figure 4

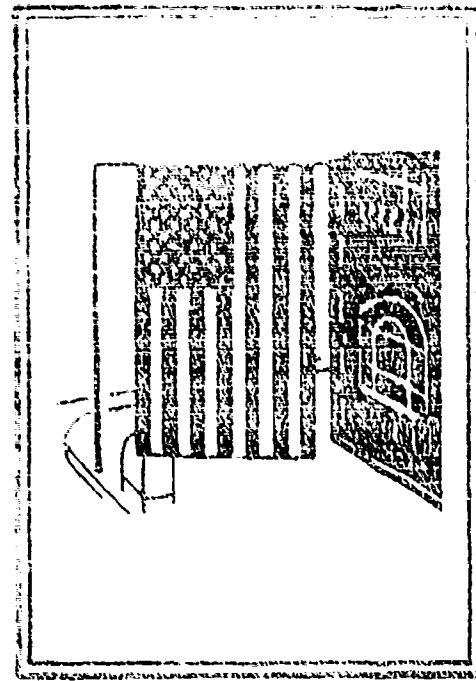

Flag Suspended From a Building.

Figure 5

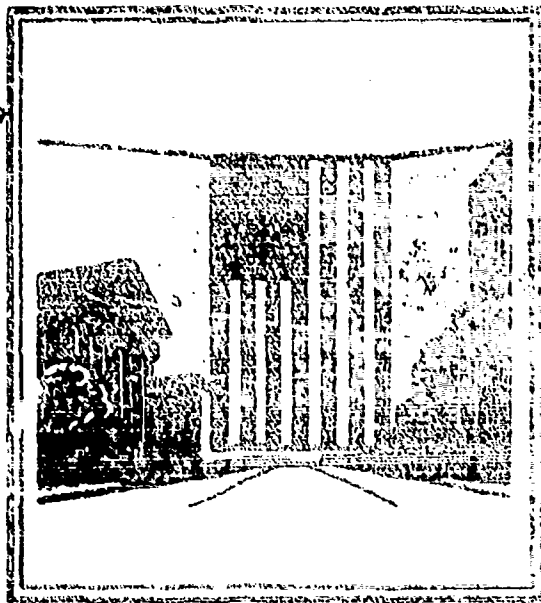

Flag Suspended Over a Street.

Figure 6

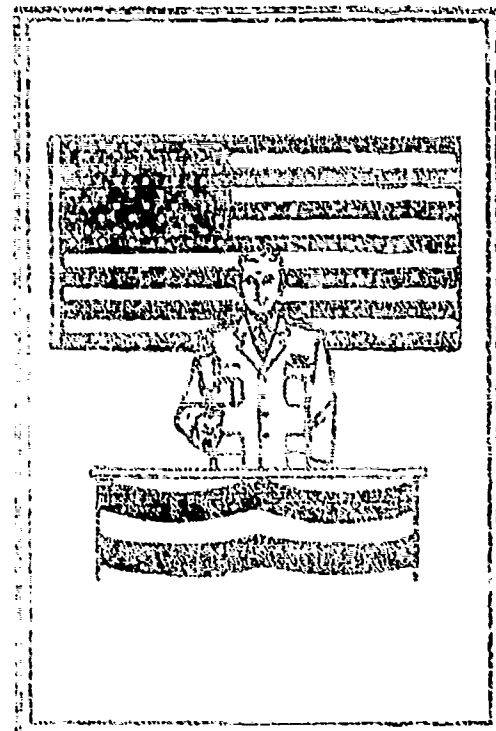

Position of Flag at Speaker's

Position.

Figure 7

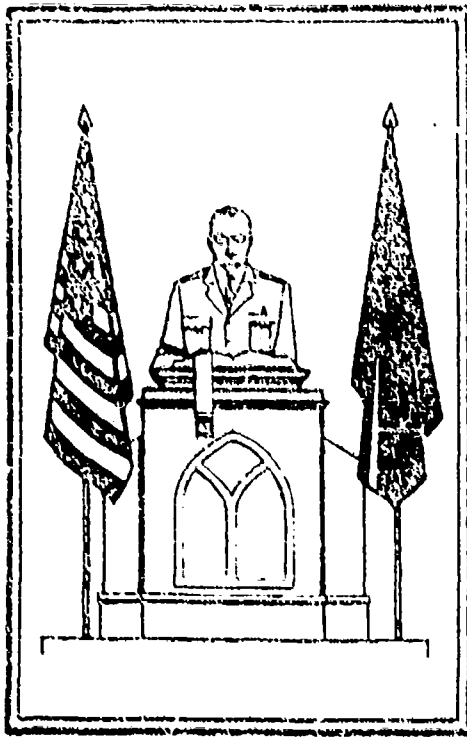

Figure 3-8. Display of the Flag in Chapel.

Figure 8

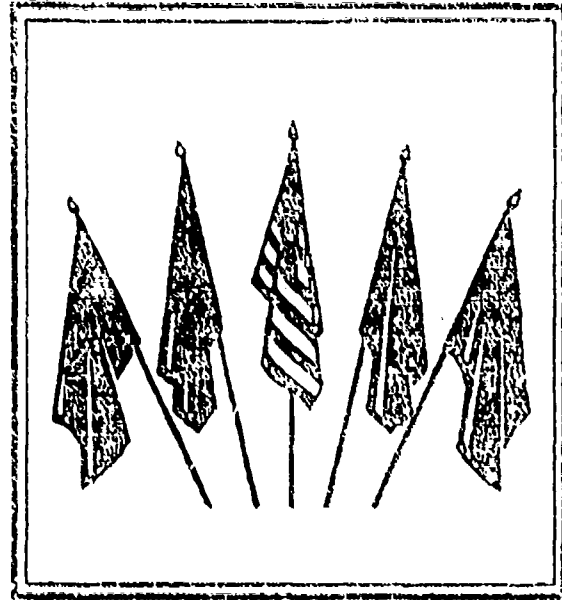

Figure 3-9. Displaying United States Flag in Group of Flags.

Figure 9

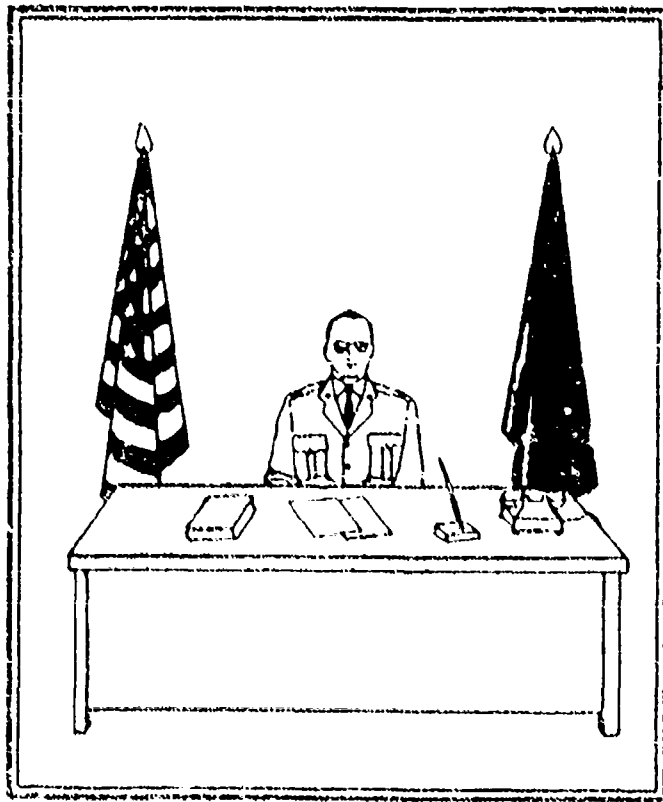

Figure 3-10. Display of Flag in an Office.

Figure 10

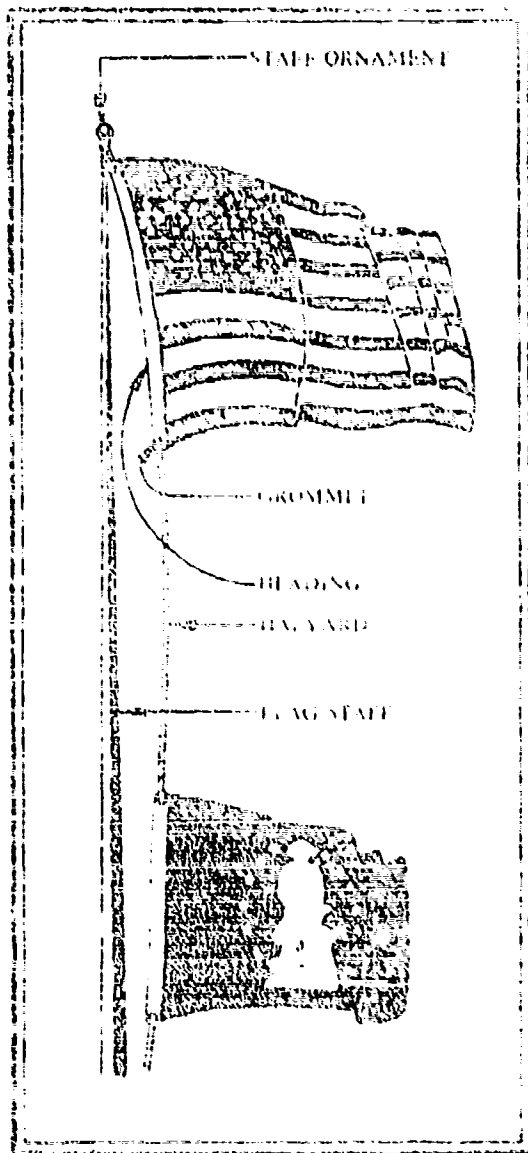
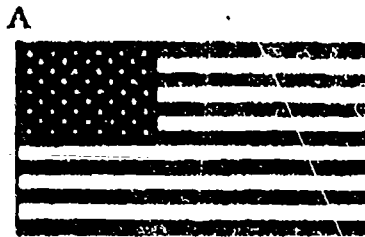

Figure 3-11 Position of Minuteman Flag
Taken from Same Reference.

CORRECT METHOD OF FOLDING THE
UNITED STATES FLAG

A--Hold the flag waist high.



B--Fold the lower striped section of the flag over the blue field.

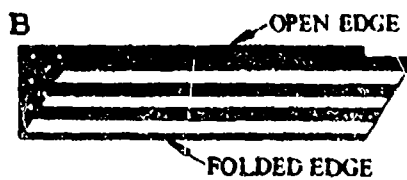

C--The folded edge (the edge nearest the reader in B) is then folded over to meet the open edge.



D--A triangular fold is then started by bringing the striped corner of the folded edge to the open edge.



E--The outer point is then turned inward parallel with the open edge to form a second triangle.



F--The triangular folding is continued until the entire length of the flag is folded in this manner.



G--When the flag is completely folded, only the blue field should be visible and it should be folded in the triangular shape of a cocked hat.



Figure 12

6. Used as a drapery of any sort such as an article of clothing, as a covering for a ceiling, on furniture, or for a vehicle.
7. Used as a receptacle for receiving or carrying any object.
8. Used as a covering for a statue or monument, but it may form a distinctive feature of the ceremony on unveiling a statue or monument.
9. Used for advertising purposes in any manner whatsoever. It is not embroidered on such articles as cushions, handkerchiefs, or similar items. It is not printed or otherwise impressed on paper napkins, boxes, or anything designed for temporary use and discard. Advertising signs are not to be fastened to a stand or halyard from which the flag is flown.
10. Fastened, displayed, used, or stored in any manner that permits it to be easily torn, soiled, or prevents display in any way.
11. Marked on, or should never have placed on it or attached to it, any mark, insignia, letter, word, figure, design, picture, or drawing of any kind.

Lowering and Folding

When the United States flag is lowered from the staff, no portion of it is allowed to touch the ground either in lowering or in folding. The flag is detached from the halyard and folded in the shape prescribed in Figure 12.

Flags on Holidays

The national flag may be displayed on all days when the weather permits, but it should especially be displayed on New Year's Day; Inauguration Day, 20 January; Martin Luther King's Birthday; Lincoln's Birthday; Washington's Birthday; Armed Forces Day, third Saturday in May; Memorial Day (half-staff until noon); Flag Day, 14 June; Independence Day, 4 July; Labor Day, first Monday in September; Columbus Day; Veterans Day; Thanksgiving Day, third or fourth Thursday in November; Christmas Day, 25 December; and such other days as may be proclaimed national holidays by the President.

Conclusion

Showing the proper respect and courtesy to the United States flag is a main responsibility of a protocol officer. The guideline provided above should help you understand this responsibility. AFR 900-3 is the Air Force bible on the flag, so refer to it for a detailed explanation. Next, we turn to some practical guidance on the Pledge of Allegiance to the US flag and the declaration of its reverence in the National Anthem.

THE PLEDGE OF ALLEGIANCE TO THE FLAG

"I pledge allegiance to the flag of the United States of America and to the Republic for which it stands, one Nation, under God, indivisible, with Liberty and Justice for all."

This wording of the pledge varies slightly from the original, which was drawn up in 1892 in the office of The Young's Companion magazine in Boston. It was first used on 12 October 1892 in the public schools in celebration of Columbus Day.

The pledge received official recognition by Congress in an Act approved on 22 June 1942. The phrase "under God" was added to the pledge by a Congressional Act on 14 June 1954. At that time, President Eisenhower said that, "In this way, we are reaffirming the transcendence of religious faith in America's heritage and future; in this way, we shall constantly strengthen those spiritual weapons which forever will be our country's most powerful resource in peace and war."

Honors to the flag during the Pledge of Allegiance are similar to those rendered during the playing of the National Anthem or "To the Colors" which you will read about later:

1. You do not recite the Pledge of Allegiance while in military formation or during military ceremonies.
2. At protocol functions, social, or sporting events:
 - a. When in uniform and outdoors, you stand at attention, face the flag, remain silent, and render the hand salute.
 - b. When in uniform indoors, you stand at attention, face the flag, but you do not salute; however, you may recite the Pledge of Allegiance if you wish.
3. When in civilian clothes (indoors or outdoors), you should stand at attention, face the flag, remove headdress with right hand, and place your right hand, holding the headdress, over heart and recite the pledge.

THE NATIONAL ANTHEM

The National Anthem is a declaration of reverence for and loyalty to the United States. On certain occasions, such as during inclement weather or when a band is not present for a retreat ceremony, "To the Colors" is played instead of the National Anthem. "To the Colors" is a bugle call sounded as a salute to the flag and symbolizes respect to the Nation and the flag in the same manner as the National Anthem. The flag and the United States are thought of as being the same; therefore, any time the National Anthem or "To the Colors" is played, the proper courtesy as described below must be rendered.

1. When in uniform in formation but not a part of a ceremony, the unit commander commands "Present Arms" when the National Anthem or "To the Colors" is played. The unit should be faced toward the flag before being given "Present Arms."

2. When in uniform but not in formation:

- a. Outdoors, at any ceremony where the US flag is present, come to attention, face the flag in the ceremony, and salute. At sports events, if the flag is visible, face the flag and salute. If the flag is not visible, face the band and salute in its direction. If the music is recorded, face the front and salute. During all other outdoor occasions, the same general principle is followed: come to attention and salute, facing the flag if visible, otherwise facing the music.
- b. Indoors, when the National Anthem or "To the Colors" is being played at the beginning or end of a program or sports activity, face the flag if it is present and take the position of attention. If no flag is present or visible, take the position of attention facing the music. Do not salute unless under arms.

3. When in civilian or athletic clothing outdoors, take the same action as when in uniform except that the manner of saluting is different. Military members remove their headdress with the right hand and hold the headdress at the left shoulder with the right hand over the heart. Members without hats, salute by standing at attention and placing the right hand over the heart.

4. When in civilian or athletic clothing indoors, stand at attention, but do not salute.

5. While in a vehicle during a flag ceremony, the driver brings the moving vehicle to a stop by the first note of the National Anthem or "To the Colors." The driver and passengers in the vehicle, remain seated at attention.

6. Air Force photographers and camera operators render appropriate honors outlined in these paragraphs, except when they are specifically assigned to photograph others rendering honors.

7. Flags and national anthems of friendly foreign countries are shown the same signs of respect.

Now that you are familiar with customs and courtesies showing the proper respect to the US flag through the Pledge of Allegiance and the National Anthem, let's turn to a song that pays tribute to the United States Air Force - the Air Force Song.

THE AIR FORCE SONG

As the National Anthem is symbolic of the United States, so also is the Air Force song symbolic of the Air Force and its military mission. Adopted from the Army Air Corps, the Air Force song symbolizes our loyalty for and confidence in an organization of professional military persons whose integrity is weighed in the balance of dedication to the American people and support of the United States Constitution. It is a means of expressing our camaraderie and esprit de corps.

From an etiquette point of view, the following apply:

1. Stand up during the playing of the Air Force song, except when it is heard while listening to a radio, watching television, or driving a vehicle.
2. When audience involvement is appropriate, it is proper to sing the Air Force song. Appropriate time would be at formal and informal social gatherings and ceremonies. When used as a recessional to a change of command ceremony, it would most likely not be appropriate to sing.

We've covered a great deal of detail on the American flag, the Pledge of Allegiance, the National Anthem, and the Air Force song. This second chapter was to give you a foundation on basic flag practices every protocol officer should be familiar with and use. Now let's move on to an examination of saluting - a basic courtesy that we all in the military services practice on a daily basis.

Chapter Three

SALUTES AND SALUTING

There are various schools of thought on the origin of the salute. One traces the custom to the days of chivalry when knights in armor met, each raised his visor to a friend so as to be identified. This was done with the right hand, the left hand being used to hold the horse's reins. Another possibility goes back to the days of the Borgia when assassinations by dagger were not uncommon. Then it was customary for men to approach each other with right hand raised, palm to the front, to show no dagger was concealed.

Whatever the origin, the salute is one of the oldest military traditions. It is a courtesy which is exchanged between members of the Armed Forces as both a greeting and a symbol of mutual respect. The basic rules regarding saluting are very simple (see AFR 30-1, Air Force Standards, and AFR 50-14, Drill and Ceremonies, for more details and illustrations):

1. You salute the President of the United States, all superior commissioned officers and warrant officers of the Armed Forces, and the officers of friendly foreign nations who are superior to you in rank. This means second lieutenants salute first lieutenants regardless of the myth of the "brotherhood of lieutenants."
2. You do not salute when indoors unless you are formally reporting to an officer superior to you or performing guard duty and wearing a side arm.
3. Both on and off base, you always salute when in uniform and outdoors, unless:
 - a. You are carrying articles (or a heavy object) in both hands which cannot be transferred to one hand, or cannot salute for another legitimate reason, such as an injury. In this case, an oral greeting should be exchanged such as "Good Morning, Sir or Ma'am."
 - b. You are in a designated "covered" area (see your organizational and echelon supplements to AFR 30-1, AFR 35-10, Dress and Personal Appearance of Air Force Personnel, and AFR 50-14 as appropriate).

- c. You are a member of a military formation or a work detail (only the senior member salutes).
 - d. You are attending a public gathering, such as a sports event.
4. You salute officers in US Government cars provided the car has a flag or metal standard which identifies the rank of the occupant (usually general officers and the wing and base commanders).
 5. Security Police performing traffic control salute officers in moving vehicles, if they recognize the occupant as an officer. (Exception: A salute is not required if doing so interferes with the security policeman's performance of duty. The driver of a vehicle in motion is not required to salute either, if doing so interferes with safety.)
 6. Saluting is not required if you are wearing civilian clothes, but it certainly is not prohibited.
 7. The salute is rendered at a distance at which recognition is easy, usually not more than 30 paces, and before the approaching person is closer than six paces.
 8. The salute is rendered only at a halt or walk. If running, one comes to a walk before saluting.
 9. The salute is never rendered with a pipe, cigar, or cigarette held in the mouth or right hand.
 10. If you are junior in rank, you salute first, and always hold the salute until it is returned.
 11. Always look at the person or Colors saluted.
 12. Don't have your left hand in your pocket when saluting.
 13. Never return a salute in a casual or superficial manner.
 14. When meeting a senior outdoors and engaging in conversation, salutes are exchanged, the conversation is completed, and salutes are again exchanged. (An airman in ranks, of course, only comes to attention and does not salute even though a conversation has occurred with an inspecting official.)
 15. If you, the senior in rank, are in the company of a junior officer, and an officer junior to you, but senior to the officer with you approaches, the salute will be initiated by the approaching officer who salutes you, the ranking officer. When you return the salute, the junior officer with you will salute simultaneously with you. The junior officer with you will hold

the salute until you and the approaching officer have dropped your salutes.

Salutes by Flags

The Air Force flag salutes by being dipped in all military ceremonies when the National Anthem or "To the Colors" is being played and when rendering honors. In marching, the Air Force flag salutes when six paces from the front of the person entitled to the salute. It resumes the carry when six paces beyond the person.

In passing in review, the Color Guard executes eyes right at the prescribed saluting distance at the command of the senior flag bearer, who commands, "Eyes Right" and "Ready Front." When the grade of the reviewing officer entitles that person to the honor, the Air Force flag salutes at the command "Right" and resumes the carry at the command "Front." All except the person on the right flank of the Color Guard executes eyes right.

The US flag is not dipped in salute, with one exception: Navy vessels upon receiving a salute of this type from a vessel registered by a nation formally recognized by the United States must return the compliment.

Saluting the United States Flag

Flags flown from stationary flag staffs on bases are saluted at reveille, retreat, and special occasions. Small flags and flags at half-staff are not saluted. Cased and folded flags are not saluted.

Military personnel passing an uncased US flag salute six paces before reaching the flag and hold the salute until they have passed six paces beyond it. Likewise, when an uncased US flag passes by, the salute is rendered six paces before the flag is even with the individual and held until the flag has passed six paces beyond him or her.

Army or Navy Gun Salutes

When gun salutes are fired at Army or Navy installations to honor a living person, all individuals in the ceremonial party salute, and spectators (including military) stand at attention. When gun salutes are fired on Independence Day and Memorial Day, all people present salute, facing the flag when visible or the sight of the saluting guns if the flag is not visible. In the Air Force, gun salutes are not fired at any ceremony including reveille and retreat.

Conclusion

Saluting is a basic courtesy that we, in all the military services, practice on a daily basis. We've looked at where saluting originated and some guidelines for its use. Remember, saluting is a show of proper respect and acknowledgement of another military member. It is a greeting to be rendered with honor and professionalism. Along with this show of respect, comes an understanding of rank and precedence - our next chapter.

Chapter Four

RANK AND PRECEDENCE

The whole idea of protocol centers around the fundamental rules of rank and precedence. It is critical that a protocol officer recognizes these rules and applies them appropriately. You will rely on precedence and rank to determine military procedures. The following guidance from AFR 35-54, Rank, Precedence, and Command, will help you to tackle this challenge.

Military rank is the relative position or degree of precedence given a military person. Rank marks station and confers eligibility to exercise command or authority in military service within the limits stated by law. When conferring rank, it is usually given individuals according to their office or grade in military service. There are exceptions, such as retired officers or officers with special assignments. Honorary titles of military rank cannot be awarded a civilian; however, those already earned will not be withdrawn.

Except in a special assignment by the President, or in the case of graduates of the Military Academies on active duty in the grade of second lieutenant, precedence, or relative rank among officers of the same grade in the active military service, including retired officer on extended active duty (EAD), is determined as follows:

1. By date of rank (DOR).
2. When DOR is the same, by total:
 - a. Active federal commissioned service.
 - b. Federal commissioned service.
3. When 1. and 2. above are the same:
 - a. Regular officers will proceed Reserve officers.
 - b. Regular officers will rank among themselves based on date of appointment as a Regular officer. If this date is the same, they will rank among themselves according to age with oldest taking precedence.
 - c. Reserve officers will rank among themselves by age, with the oldest taking precedence.
4. Graduates of the Air Force Academy. Second lieutenants not on a recommended list for first lieutenant, will rank among themselves in order of class standing.

Among airmen of the same grade on EAD, including retired airmen on EAD, precedence or relative rank is determined by:

1. DOR.
2. Total active federal military service date (TAFMSD) (AFR 35-3, Service Dates and Dates of Rank) when DOR is the same.
3. Age when 1. and 2. above are the same, with the oldest airman taking precedence.
4. Personnel serving in pay grade E-4 who have been appointed to noncommissioned officer (NCO) status (AFR 39-6, The Enlisted Force Organization) take rank and precedence over those who have not been so appointed. Within this special category of noncommissioned officer, precedence or relative rank is determined by:
 - a. Date of appointment (DOA) to NCO status.
 - b. DOR in grade E-4 when DOA is the same.
 - c. TAFMSD when a. and b. above are the same (AFR 35-3).
 - d. Age when a., b., and c. above are the same, with the oldest airman taking precedence.
5. Airman in grades above E-1 who are serving sentences of confinement are suspended from precedence and rank during that period, except for pay and allowances, and do not receive privileges not available to other prisoners (AFR 125-18, Operation of Air Force Correction and Detention Facilities).

Determining Precedence

An early attempt to provide an order of precedence among the heads of states was made in the 16th Century by the Pope, but sovereigns failed to observe it. Even at that time, some rules maintained that all crowned heads should be put on an equal basis. Time, of course, modified such an idea.

For nonofficial functions today, precedence or relative seniority is based on personal consideration, qualities, or attainments such as age, sex, relationship, and prominence of guests. One gives preference to the older woman, to the clergy, to those with scholastic achievement, and of course, to the guest of honor, or the one for whom the function is hosted. Likewise, a foreigner, an out-of-town guest, or one invited for the first time, might be accorded precedence over frequent guests, house guests, or relatives.

For official functions, there is some specific guidance, especially in the military where the Chairman of the Joint Chiefs of Staff outranks all officers of any branch of the Armed Services. Otherwise, the precedence of officers of the same or a comparable rank in all services is determined by the date of their appointment to the current rank. Retired military

personnel are ranked with, but after, their active duty counterparts.

When both military and civilian officials are involved, determining precedence becomes more complicated. As a general rule, top civilian officials, down to the secretaries of the military services, have precedence over any military person, regardless of rank. Matters of precedence become particularly complicated at the state, county, and municipal level; therefore, the establishment of hard and fast rules is virtually impossible. A safe rule is to work closely with the Air Staff and major command protocol officials for correct guidance.

In many foreign countries, ceremonial precedence is established under official governmental sanction. In the United States, it is based on local recognition of vested authority, and has developed primarily through customs and tradition. There is no absolute precedence list, because as positions are created, consolidated, or abolished, there are constant changes in the accepted list. Consequently, the US State Department does not release an official order of precedence. However, the list shown in Figure 13 is the one generally observed in diplomatic circles, and may be used safely at Air Force functions.

When Seniority Determines Precedence

In general, precedence between two officials of equal rank is determined by their length of service.

1. Diplomats. Between diplomats of equal rank, precedence is determined by the date on which their credentials were presented at the White House, not by the relative size and importance of their countries. A foreign official of equal rank with an American official, though, has preference over that official--this is the case whether the US is the host nation or when the US is responsible for protocol. No one person ever outranks our President under an American roof or anywhere else in this country.

2. Members of Congress. The Speaker of the House of Representatives outranks all member of Congress; otherwise, a Senator outranks a Representative regardless of length of service. Senators are ranked according to their length of service, except that the President pro tem of the Senate outranks all Senators. The precedence of Senators sworn in on the same day is determined alphabetically by their last names. The same rule applies to Representatives.

3. Spouses. A spouse is seated according to the rank of his/her spouse who has position or rank unless the spouse has a position of his/her own; then, the one with the highest position is the determining factor. For example, if a general's wife is also a Senator, she and her husband would both be accorded the precedence given to her position as Senator.

Rank and Precedence in Other Countries

In observing governmental, ecclesiastical, and diplomatic precedence in a foreign country, one of the general rules is military rank takes precedence over the principle of "courtesy to the stranger." However, this rule may not apply when the guest of honor is not the highest ranking guest. Methods of resolving this problem at a state dinner or at a mixed dinner are described in AFP 900-1. In some countries, ecclesiastical officials are given higher precedence than in others. In Roman Catholic countries, for example, a dignitary of the Church is more likely to take precedence over government and diplomatic officials than in predominantly Protestant countries.

Diplomatic precedence has been established by international agreement. Generally, the precedence of heads of diplomatic corps is determined by the length of service in that capital. For example, an Ambassador accredited in 1975 proceeds another accredited in 1982. These are only general rules on precedence. When specific problems arise, the local American Embassy is normally asked for the proper guidance.

The basic authorities for determining precedence are AFR 35-54 and AFP 900-1. For similar matters to those above and for determining precedence or relative rank of Reserve Commissioned Officers not on extended active duty, interservice seniority, and between US Foreign Service Officers and DOD officers, refer to AFR 35-54, Section A. For precedence of troops participating in a ceremony within the territorial jurisdiction of the United States, refer to AFR 50-14, Drill and Ceremonies Chapter 7. See Figure 14 for a comparable rank among the US Military Services.

Conclusion

This guidance on rank and precedence is general. If you need more specific advice, refer to the regulations listed above. The subject should not alarm you since a protocol officer establishes military procedures on rank and precedence. So, refer to your guidance regularly, especially when in doubt. Know your subject, and you won't find yourself in an embarrassing situation. We are ready now to proceed with the challenging task of official ceremonies. This is where you will really have to be on your toes. Official ceremonies are the "bread and butter" subjects for the base protocol officer.

Unofficial List of Precedence in the United States

The President of the United States	The Chiefs of Staff of the Army, the Navy, and the Air Force (ranked according to date of appointment)
The Vice President of the United States	The Commandant of the Marine Corps
The Speaker of the House of Representatives	15 star Generals of the Army and Fleet Admirals
The Chief Justice of the United States	14 star Secretary General, Organization of American States
Former Presidents of the United States	US Representatives to the Organization of American States
The Secretary of State	Director, Central Intelligence Agency
The Secretary General of the United Nations	Administrator, General Services Administration
Ambassadors of foreign powers	Director, United States Information Agency
Widows of former Presidents of the United States	Administrator, National Aeronautics and Space Administration
Ministers of foreign powers (chiefly of diplomatic missions)	Chairman, US Civil Service Commission
Associate Justices of the Supreme Court of the United States	Chairman, Atomic Energy Commission
The President's cabinet	Director, Defense Research and Engineering
The Secretary of the Treasury	Director of ACTION
The Secretary of Defense	Director, Office of Telecommunications Policy
The Attorney General	Administrator, Environmental Protection Agency
The Secretary of the Interior	Assistant to the President
The Secretary of Agriculture	Deputy Under Secretaries of State
The Secretary of Commerce	The Commandant of the US Coast Guard
The Secretary of Labor	Assistant Secretaries of the Executive Departments
The Secretary of Health, Education, and Welfare	Chief of Protocol
The Secretary of Housing and Urban Development	Members of the Council of Economic Advisors
The Secretary of Transportation	Active or Designate US Ambassadors and Ministers (leave rank, when in the United States)
Director, Office of Management and Budget	Under Secretaries of the Army, the Navy, and the Air Force (4 star) Generals and Admirals
The United States Representative to the United Nations	Assistant Secretaries of the Army, the Navy, and the Air Force (3 star) Lieutenant Generals and Vice Admirals
Members of the United States Senate	Former US Ambassadors and Ministers to foreign countries
Governors of States	Ministers of foreign powers (serving as ambassadors, not accredited)
Former Vice Presidents	Deputy Assistant Secretaries of the Executive Departments
Members of the United States House of Representatives	Counselors of Embassies or Legations of foreign powers
Chargés d'Affaires of foreign powers	Senior Civilian Officials, GS 18
The Under Secretaries of the Executive departments and the Deputy Secretaries	12 star Major Generals and Rear Admirals
Administrator, Agency for International Development	Senior Civilian Officials, GS 17
Director, United States Arms Control and Disarmament Agency	11 star Brigadier Generals and Commodores
The Secretaries of the Army, the Navy, and the Air Force	Senior Civilian Officials, GS 16
Chairman, Council of Economic Advisors	
Chairman, Council on Environmental Quality	
Chairman, Joint Chiefs of Staff	

Figure 13

COMPARABLE RANK AMONG THE MILITARY SERVICES

Army	Air Force	Navy
General	General	Chief Admiral
Lieutenant General	Lieutenant General	Vice Admiral
Major General	Major General	Rear Admiral
Brigadier General	Brigadier General	Commodore Admiral
Colonel	Colonel	Captain
Lieutenant Colonel	Lieutenant Colonel	Commander
Major	Major	Lieutenant Commander
Captain	Captain	Lieutenant
First Lieutenant	First Lieutenant	Lieutenant (Junior Grade)
Second Lieutenant	Second Lieutenant	Ensign
Chief warrant officer, W-4	Chief warrant officer, W-4	Chief warrant officer, W-4
Chief warrant officer, W-3	Chief warrant officer, W-3	Chief warrant officer, W-3
Chief warrant officer, W-2	Chief warrant officer, W-2	Chief warrant officer, W-2
Warrant officer, W-1	Warrant officer, W-1	Warrant officer, W-1
Cadet*		Midshipman

Pay Grade	Army	Air Force	Marine Corps	Navy
Special	Sergeant major of the Army	Chief master sergeant of the Air Force	Sergeant major of the Marine Corps	Master chief petty officer of the Navy
E-9	Sergeant major	Chief master sergeant	Sergeant major Master gunnery sergeant	Master chief petty officer
E-8	First sergeant Master Sergeant	Senior master sergeant	First sergeant Master sergeant	Senior chief petty officer
E-7	Platoon sergeant Sergeant first class Master sergeant ** Specialist seven	Master sergeant	Acting master sergeant*** Gunnery sergeant	Chief petty officer
E-6	Staff sergeant Sergeant first class** Specialist six	Technical sergeant	Acting gunnery sergeant** Staff sergeant	Petty officer first class
E-5	Sergeant Specialist five	Staff sergeant	Acting staff sergeant*** Sergeant	Petty officer second class
E-4	Corporal Specialist four	Sergeant Senior sergeant***	Acting sergeant** Corporal	Petty officer third class

E-3	Private first class	Airman first class	Acting corporal** Lance corporal	Seaman
E-2	Private	Airman	Private first class	Seaman apprentice
E-1	Private	Airman basic	Private	Seaman recruit

* Cadets are Presidential appointees and are officers in the constitutional sense. They do not have a military rank and neither outrank nor are they outranked by enlisted personnel. Cadets are not on active duty, are not saluted by enlisted personnel, and are not placed in supervisory positions over enlisted personnel. However, since they are officers in a constitutional sense, they hold a higher position than enlisted personnel for protocol purposes.

** Transitional title for those who held this grade continuously since 31 May 1958.

*** Transitional title for those holding pay grade continuously since 31 December 1958.

**** Grade title while serving in the Trainee or Apprentice Tier.

Figure 14 Continued

Chapter Five

OFFICIAL CEREMONIES

Official ceremonies are a major responsibility of a base protocol officer. Here is where you can make it, or stumble, and lose all your credibility! So look sharp, put on your thinking cap, and get ready to work. Ceremonies are events held to acknowledge a change of command, to honor distinguished persons, to accord distinctive honors to individuals on special occasions, to promote teamwork, or to demonstrate professionalism and proficiency. We will examine some of these ceremonies to get you on the right track on what you need to know as a base protocol officer. One of the most prominent ceremonies is the Change of Command.

CHANGE OF COMMAND CEREMONIES

Drill and Ceremonies

AFR 50-14 Drill and Ceremonies tells us that, when practical, the former commander should relinquish command to a successor at a parade or other appropriate ceremony. It is the former commander who determines the extent of the ceremony and is responsible for all arrangements, including the date, time, and adaptations to fit the local situation. It is courtesy to have the concurrence of the new commander and immediate superiors on the arrangements. As a rule, a change of command is not scheduled for a Saturday, Sunday, or national holiday. It should be noted here that the primary purpose of a Change of Command ceremony is to allow subordinates to witness the formality of command change from one officer to another. Therefore, the ceremony should be official, formal, brief, and conducted with great dignity.

At the formal parade ceremony attended by the commander of the higher echelon, the order is read directing the change of command after the presentation of decorations and awards, if scheduled; otherwise, the order is read after the National Anthem and "officers center" portion of the normal review sequence. AFR 50-14 can give you the best guidance on the formal change of command process.

General Sequence of Events

Here is a virtually "foolproof" order of events for a formal Change of Command ceremony:

1. Formation of the troops.

2. Presentation of troops and honors to the senior commander, when participating, and to the former commander.
3. Inspection of troops (if desired).
4. Presentation of decorations and awards (as applicable).
5. Formal change of command.
6. March in review.

Invitations

Preparing and mailing invitations is the responsibility of the outgoing commander. He or she is also responsible for ensuring invitations are sent to the "official family" which includes commanders, chiefs of staff, senior staff, etc., of all local units and activities as well as higher headquarters. The relief officer should have his/her guest list mailed in ample time (two to three weeks), and the officer being relieved should screen this list to avoid duplication.

Change of Command Operations Plan (OPLAN)

Prior to the ceremony, issue a change of command OPLAN. This OPLAN should have, as a minimum, the following:

1. Schedule of events (fair weather).
2. Diagram of ceremonial area (fair weather).
3. Schedule of events (inclement weather).
4. Diagram of ceremonial area (inclement weather).
5. Detailed list of services and equipment required or desired.

Programs

Printed programs can be very helpful to guests at the ceremony. Make sure to allow plenty of time to prepare and publish them. Consider including these things in the programs:

1. Command insignia, and/or a good picture of the unit's principle weapon system.
2. Schedule of events for the ceremony.
3. Brief biographies and photographs of both the outgoing and incoming commanders.
4. List of previous commanders and dates of command.

Reviewing Officer

The reviewing officer should be invited at least three weeks in advance to participate . A written invitation to the senior participant and guest speaker(s) is appropriate, but it's also a good idea to check on senior officer availability by phone first.

Rehearsal

A particularly complicated change of command ceremony almost always necessitates a full "dress rehearsal" at least five working days prior to the event. This is, of course, to allow enough time to work out any problems or awkward situations that might otherwise come up on the day.

Necessary Materials

You will need most or all of the following items for a successful Change of Command ceremony; in fact, you may want to make them part of an overall checklist.

1. Narration script.
2. Change of command and retirement orders.
3. Decorations (as required).
4. Decoration pillow.
5. Flags, bases.
6. Reserved seating tags.
7. Reserved parking area.
8. Printed programs.
9. Retirement certificates (as applicable).
10. Other specialized materials, as required.
11. Presentation roses for spouse (as appropriate).
12. Audio equipment.

Other than Formal Review (for those of you who want more detail)

Here is an example of a Change of Command ceremony by other than formal review as it is just such a ceremony for which you may be responsible in your protocol position. An acceptable ceremony could go as follows:

1. Master of ceremonies (usually the protocol officer) and guidon bearer (usually the unit's first sergeant or senior enlisted advisor) are in place on stage. (See figure 15)

2. Master of ceremonies calls the area to attention.
3. Posting of the Colors at center stage, with appropriate music, either live or recorded, if desired.
4. Senior commander, outgoing commander, incoming commander, in this order march to the stage one behind the other and post to the stage's left. (See Figure 16)
5. Playing of the National Anthem, live or recorded.
6. Senior commander, outgoing commander, incoming commander take their positions on center stage. (See Figure 17)
7. Presentations of decorations and/or awards to outgoing commander by higher echelon commander (master of ceremonies reads citations, gives medal/award to senior commander who presents it to outgoing commander, then senior commander assumes original position).
8. Master of ceremony reads order directing change of command.
9. Change of Command per se:
 - a. Commander and guidon bearer are in place. (See Figure 18)
 - b. Senior commander says, "Officer Center." Then the senior commander faces left and the incoming and outgoing commanders face right. (See Figure 19)
 - c. The incoming commander steps up to the left of the outgoing commander. (See Figure 20)
 - d. Outgoing commander takes unit guidon from guidon bearer and gives it to the senior commander. (See Figure 21)
 - e. The guidon bearer, as soon as he/she is relieved of the guidon, sidesteps right to be even with the senior commander. The senior commander who has received the guidon from the outgoing commander, gives it to the guidon bearer who is now in place. (See Figure 22)
 - f. The outgoing commander salutes the senior commander and says aloud, "Sir/Ma'am, I relinquish command." (See Figure 23)
 - g. The outgoing commander takes two steps straight back into the space previously occupied by the incoming commander. (See Figure 24)
 - h. The incoming commander takes two sidesteps to the right, into the space previously occupied by the outgoing commander. (See Figure 25)

- i. The incoming commander salutes the senior commander and says aloud, "Sir/Ma'am, I assume command." The senior commander returns the salute. The senior commander then takes the guidon from the guidon bearer and gives it to the incoming commander. (See Figure 26)
 - j. Once he/she is relieved of the guidon by the senior commander, the guidon bearer immediately sidesteps left to be even with the incoming commander. (See Figure 27)
 - k. The incoming commander immediately gives the guidon to the guidon bearer who is now in place. (See Figure 28)
 - l. The senior commander says "Post" and the commanders face right or left to once again face the troops. (See Figure 29)
 - m. The senior commander says to the troops, "At ease, please take your seats."
 - n. The incoming commander, outgoing commander, and guidon bearer go to parade rest.
10. Senior commander takes the podium and the master of ceremonies goes to the right of the stage. The senior commander speaks to the audience briefly on an appropriate topic relating to command and the new commander.
11. The senior commander presents the incoming commander to the troops. The senior commander goes to the right of stage. The incoming commander takes the podium and says a few appropriate words.
12. The incoming commander goes to the right of stage while the senior commander takes the podium. The senior commander gives the podium to the outgoing commander. The senior commander then joins the incoming commander at the right of stage.
13. The outgoing commander takes the podium, says a few farewell remarks, and then joins the senior commander and the incoming commander at the right of stage.
14. The master of ceremonies takes the podium and calls the area to attention.
15. The Colors are retrieved.
16. The senior commander, incoming commander, outgoing commander depart from right of stage (in that order) behind each other; the Air Force Song (if available) is played as they depart.
17. Once the commanders have left, the master of ceremonies states the time and place of the reception for the new commander and then dismisses the audience.

GB

MC

PODIUM

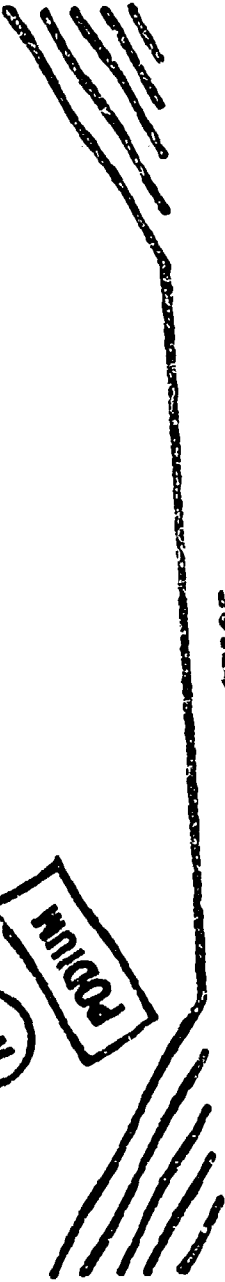

STAGE

Figure 15

LEGEND: MC == MASTER OF CEREMONIES

GB == GUIDON BEARER

SC == SENIOR COMMANDER

OC == OUTGOING COMMANDER

IC == INCOMING COMMANDER

o == GUIDON

FRONT

COLORS

GB

IC

DC

SC

MC

INCOLORED

STAGE

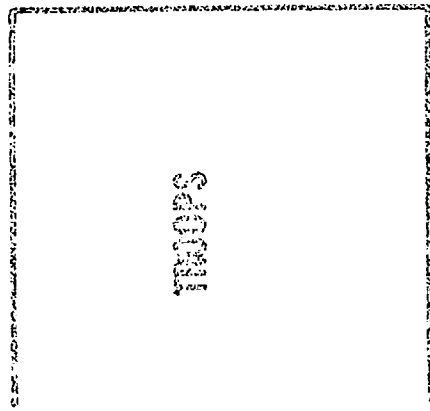
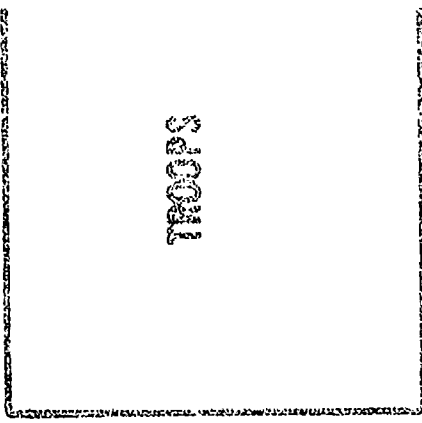

SC

SC

IC

Figure 10

FRONT

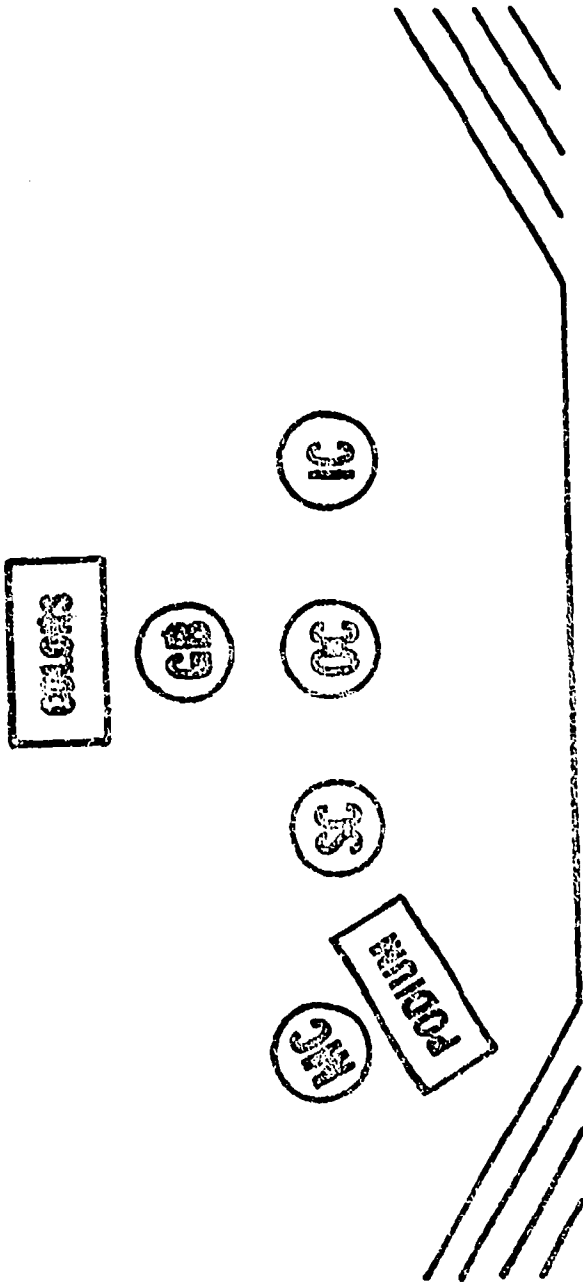

STAGE

FIGURE 17

FRONT

COLORS

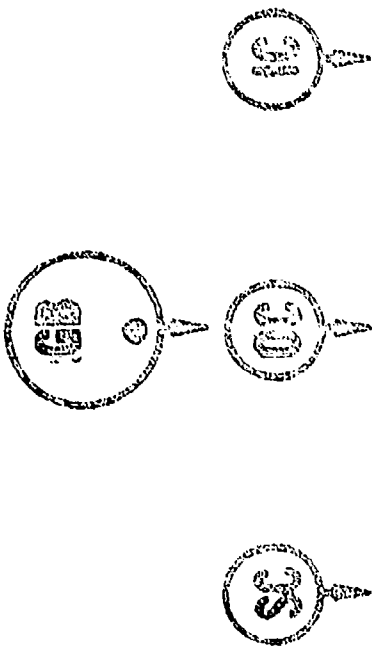

Figure 13
FRONT

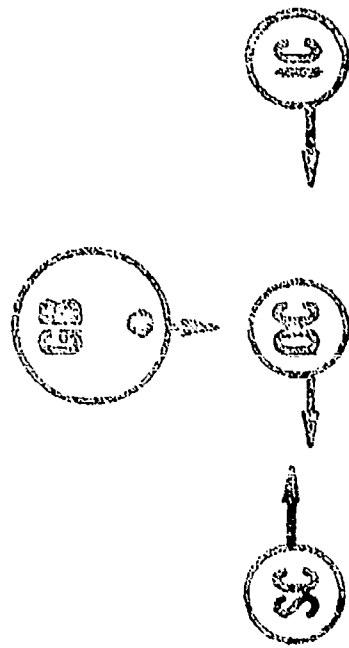
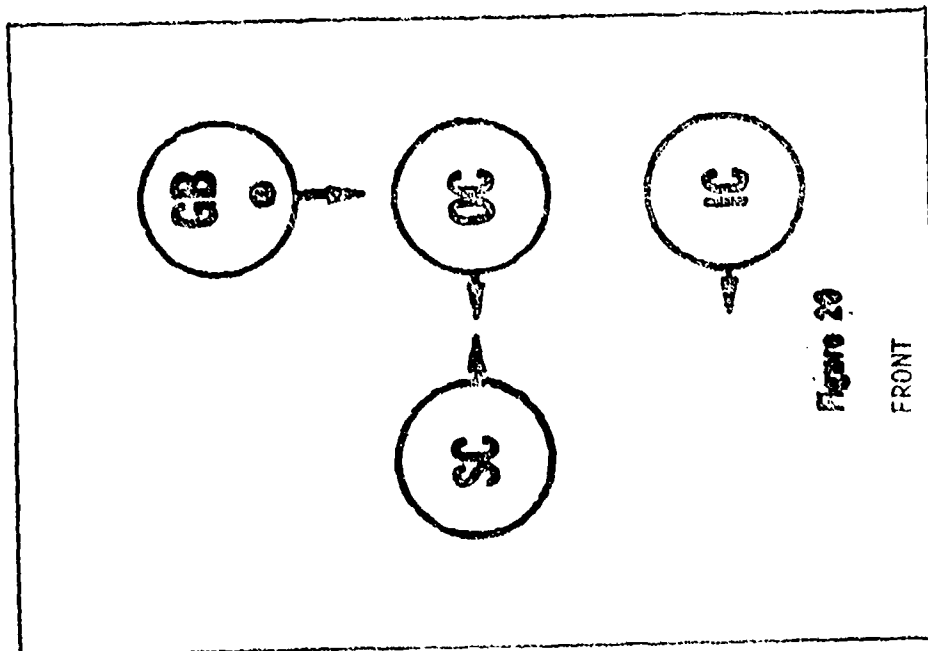
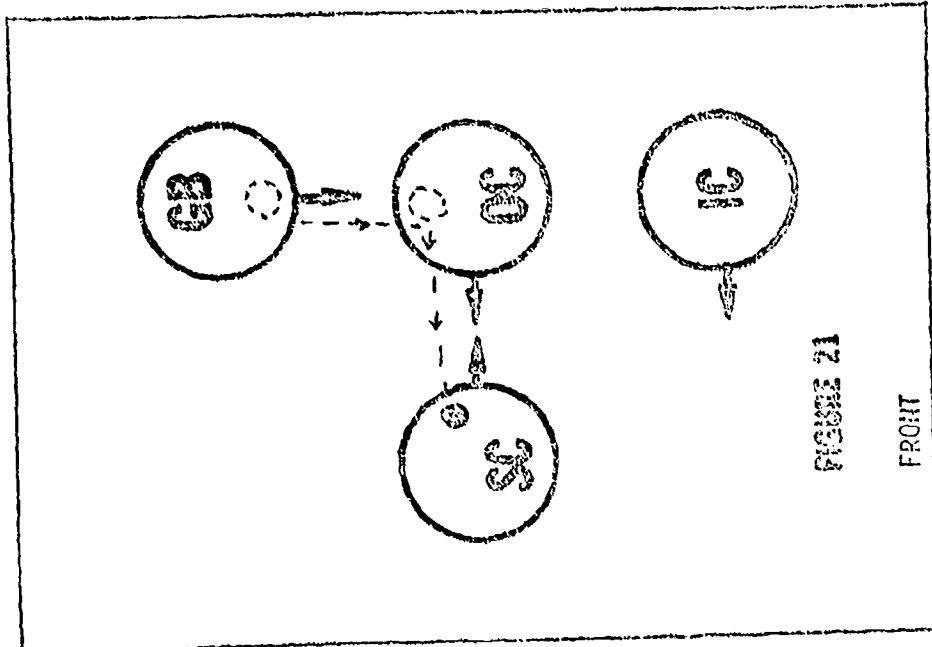
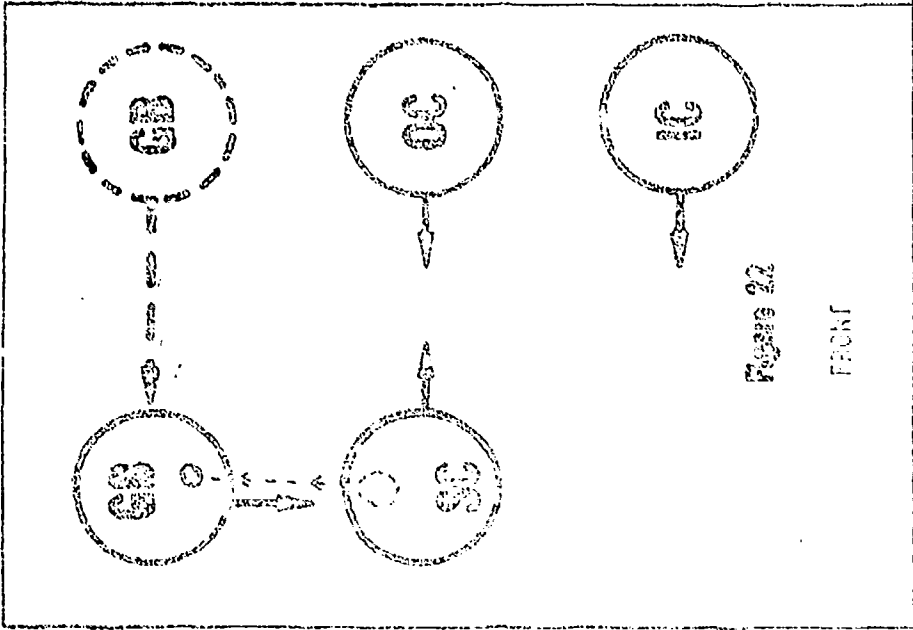
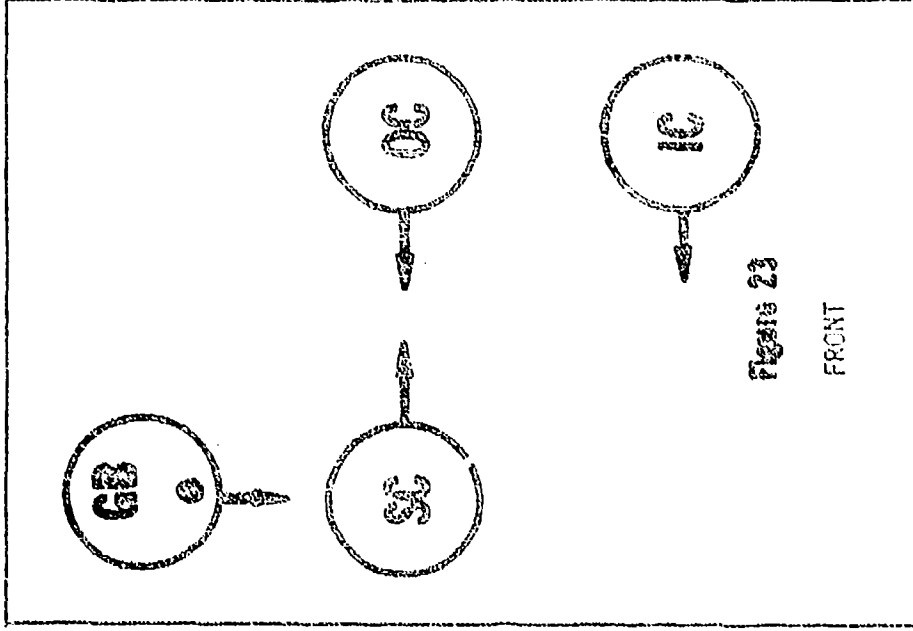
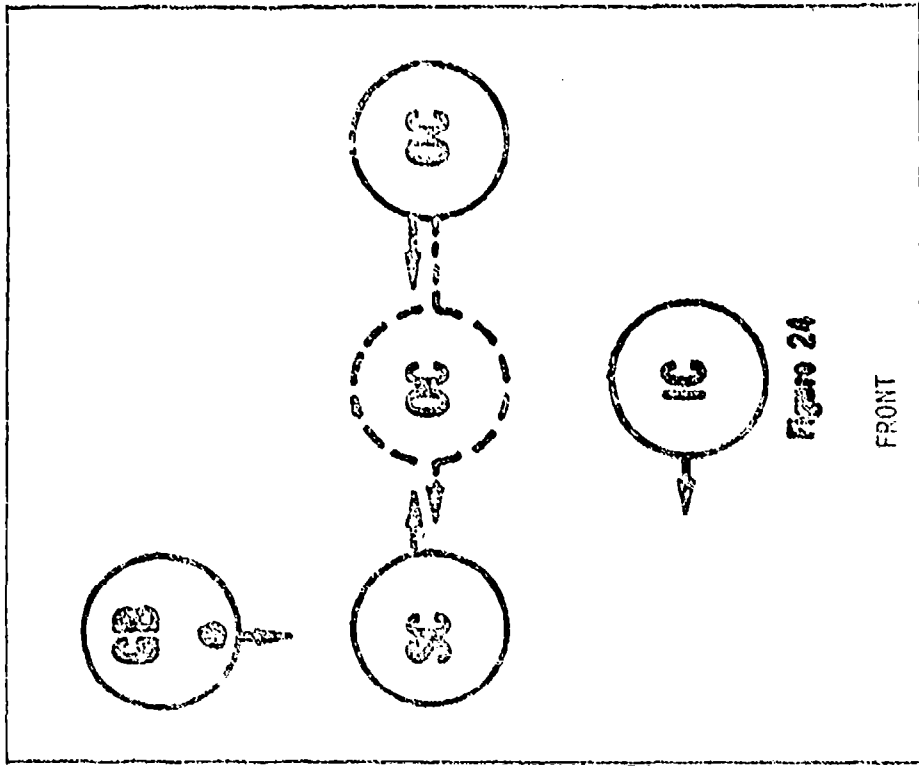
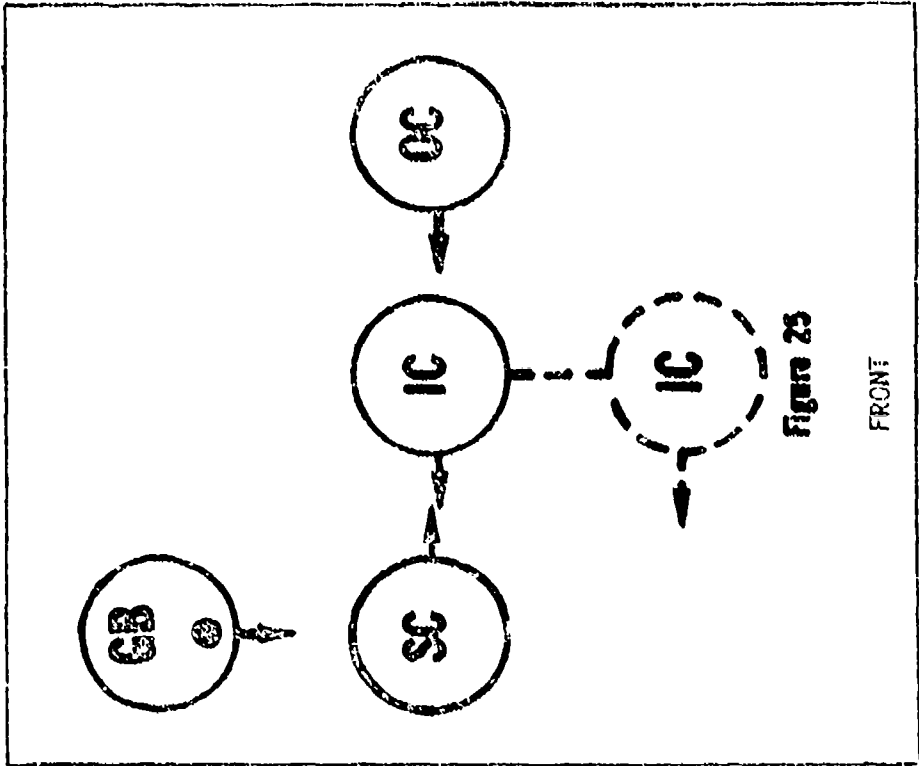

Figure 14
FRONT







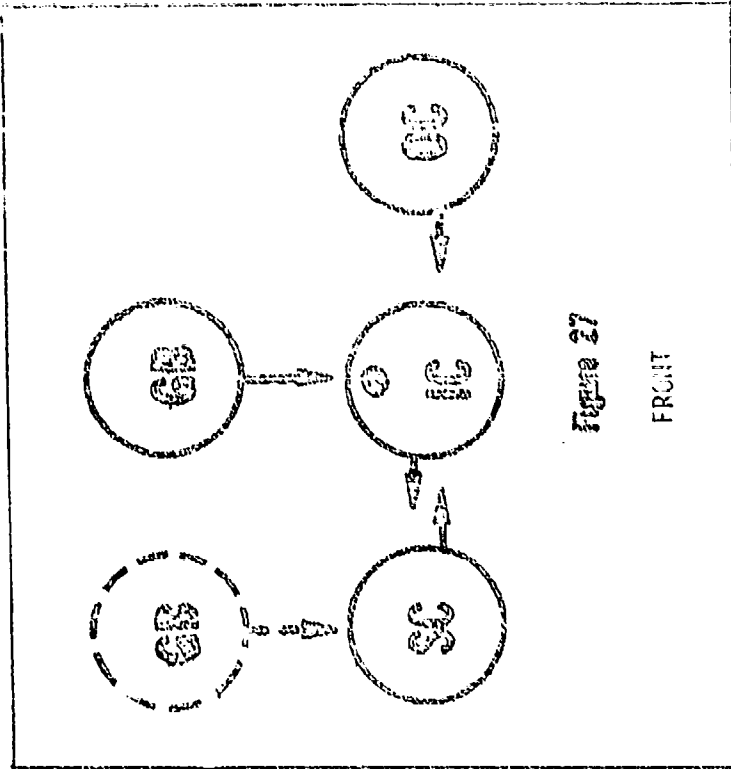

Figure 27

FRONT

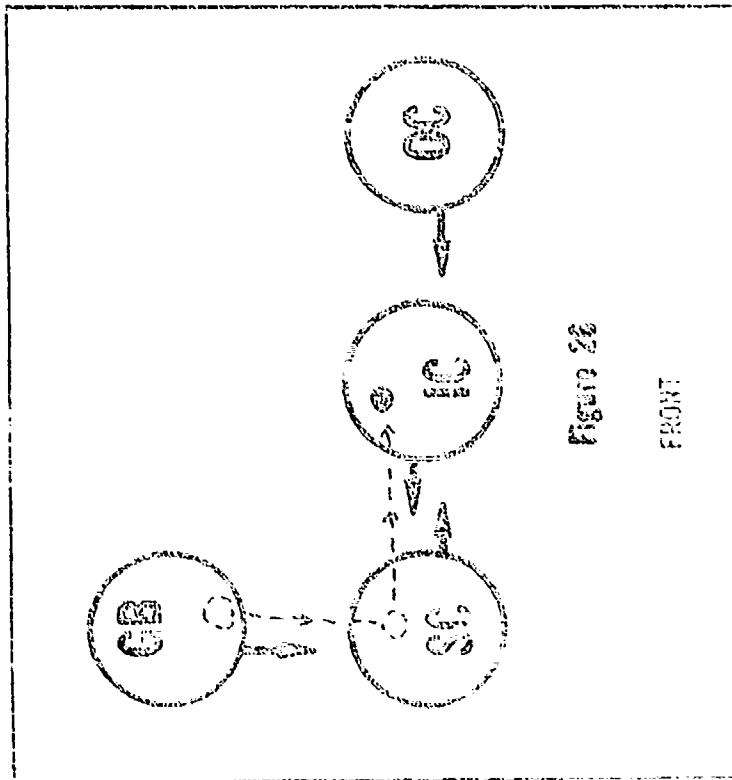
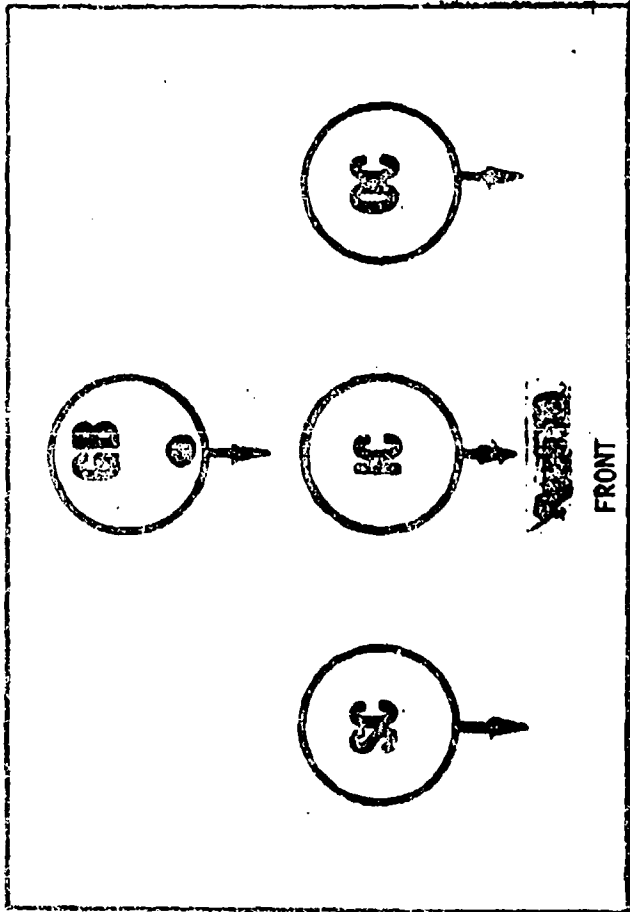
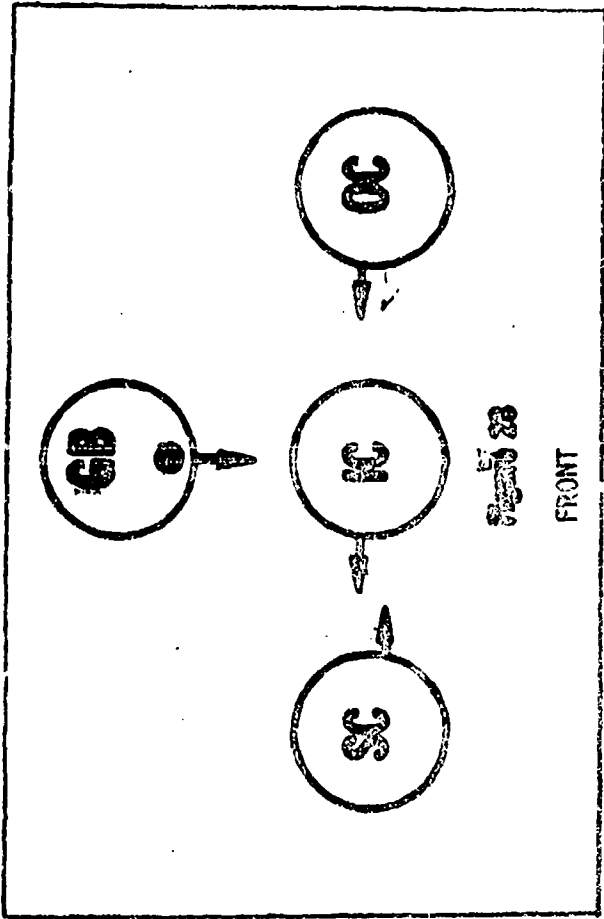

Figure 28

FRONT



The Change of Command ceremony is only one of the official functions for which you will be responsible. There are many others such as award, decoration, and retirement ceremonies which we will examine next.

AWARD, DECORATION, AND RETIREMENT CEREMONIES

General

An award, decoration, or retirement ceremony is an occasion in which the Air Force recognizes exceptional bravery, outstanding achievement, and accomplishment of long and honorable service, and the ceremony should be one which will reflect the high esteem in which the Air Force holds the individual. The retirement order or citation may be read, and the award or decoration may be presented at a formal review, or the ceremony may be held in an office or other suitable place. The occasion of an award, decoration, or retirement ceremony is one of great importance to the individual and to his or her family, and every effort should be made to ensure a ceremony which is meaningful and memorable.

The presentation of an award to the unit affords an excellent opportunity to enhance command and community relations. Therefore, it is a good idea to coordinate the ceremony with the Public Affairs office which should arrange for adequate public relations and publicity planning and coverage of the event. At a minimum, this should include photographing the event and submitting an article to the local or base paper detailing the event.

Although no specific procedures have been established for these ceremonies, they should be conducted with formality. The commander or his/her vice/deputy usually determines the type of ceremony for an award or decoration. A retiring member should be consulted as to whether he or she desires a formal ceremony. You will find the award ceremony is often held at a military parade or retreat ceremony. Whether a ceremony is formal or informal, relatives, friends, and co-workers should be encouraged to attend.

Preparation

To ensure coordinated effort, the following preparatory action should be taken. It will be the responsibility of the protocol officer (or the executive officer) to:

1. Determine who will be the awarding officer (usually the commander or the vice/deputy commander), the aide, and the master of ceremonies, and brief them to the extent necessary.
2. Ascertain the awarding officer's desires concerning time, date, and place of the ceremony. Make reservations immediately.
3. Contact the recipient to:

- a. Determine his/her availability on the date selected. If not available, ascertain a date suitable to the awarding officer and the recipient.
 - b. Ascertain if the recipient desires to have family members present at the ceremony.
 - c. Obtain the names of special guests to be invited.
4. Extend invitations to members of the recipient's family, and if desired, arrange transportation and appoint an escort. (Transportation and escorts are often arranged only for ceremonies involving posthumous awards.)
 5. Extend invitations to special guests and a limited number of friends and co-workers, notifying them of the date, time, and place of the ceremony and the prescribed uniform.
 6. Ensure the presentation room or other appropriate site is set-up, flags are in place, and the public address system is operative.
 7. Ensure all elements necessary to the ceremony are on hand and in order, the reader has a reading copy of each pertinent document, and the aide has the proper awards or that they are on the award table.
 8. Prepare autobiographical information on the recipient on a 5" x 8" card for the awarding officer.
 9. Arrange for a photographer and appropriate publicity.
 10. Ensure all principals, guests, etc., are notified to report to the place of the ceremony 15 minutes prior to the time scheduled for the ceremony.
 11. Brief all principals, guests, etc., on the ceremony protocol.
 12. Notify the awarding officer when all is in readiness and brief the final details.

Procedures for Awards and Decoration Ceremonies

The suggested and most generally followed procedure for awards and decoration ceremonies is outlined below. It is recommended that such ceremonies, when done at a Commander's Call, be done at the beginning of the Call so it receives first attention in the midst of the initial Call formalities.

Upon arrival, the recipient's family is escorted to the appropriate office where they will be briefed on the ceremony. They are then escorted to their position for the ceremony.

1. Have the master of ceremonies (usually the executive officer), aide, and members receiving decorations on stage, with the audience in their seats at zero hour.

2. The first sergeant, senior enlisted advisor, or appointed individual who is posted at the door, calls the area to attention when the commander enters. Suitable commands are:

- a. "Squadron Attention" for assemblies of all enlisted members or mixed assemblies of officers and enlisted.
- b. "Ladies and Gentlemen, the Commander" for assemblies principally involving officers of both genders.
- c. "Officer" or "Officer, the Commander" for assemblies principally involving officers of either gender or both genders.

3. The commander walks to the front and posts. The master of ceremonies begins by saying, "Attention to Orders," reads the award citation or the retirement order, as appropriate. If a retiree also receives an award, the citation is read first, the medal is pinned on, photographs are taken, and then the retirement order is read. During this time, the aide is standing by the awarding officer ready to hand over the award, the decoration, or the retirement certificate at the proper moment.

When the award or the retirement certificate has been presented, the recipient follows the lead of the awarding officer by shaking hands and acknowledging congratulatory remarks. As the ceremony ends, the recipient renders a final hand salute, and after final photographs have been taken, the awarding officer or the reader (master of ceremonies) announces that congratulations are in order and applause takes place. If the ceremony occurs at a Commander's Call, the Call continues at this point when the honoree takes his/her appropriate seat, usually reserved on the front row. If a reception is appropriate after the Commander's Call, it should be announced at the conclusion of the ceremony, but before the Call continues. It may also be briefly mentioned at the conclusion of the Commander's Call per se. If the ceremony is conducted apart from a Commander's Call or other on-going general military assembly, then it is usually appropriate for the honoree to take a convenient position after the presentation so the audience can file past and offer their congratulations.

Order of Presentation

If more than one medal is awarded, the first one presented is the medal of highest precedence. If the medals are identical, the highest ranking member is presented the medal first. (Example: A staff sergeant should receive a Bronze Star before a captain would be presented a Commendation Medal. If the captain also earned a Bronze Star, he or she would be the first honored.) The fact that a decoration recipient is receiving the same medal for the third or fourth time (i.e. oak leaf cluster) does not change the above order of presentation. (Example: A captain is receiving a

Commendation Medal for the third time at a ceremony where a major is receiving one for the first time; the presentation is made to the major first and then to the captain.)

Recognition of Members Being Retired

Tradition. Recognition of members who are retiring from a career of long and honorable service is one of the oldest traditions of military service. Each one should leave with a tangible expression of appreciation for his or her contribution to the Air Force and its mission, and with the assurance that he or she will continue to be a member of the Air Force family in retirement.

Responsibility. Commanders must ensure contributions of members who retire are carefully evaluated and recognized. Commanders will hold a retirement ceremony for all retiring members. The overseas commander should hold a retirement ceremony and present DD Form 363AF, Certificate of Retirement, at the overseas base for those going back to a base in the CONUS for retirement. If for military reasons, this can't be done at the overseas base, the ceremony will be held at the CONUS separation base. As part of the advance notice, the overseas CBPO must tell the CONUS CBPO if a ceremony should be held at the CONUS base. These instructions apply to personnel being retired under AFR 35-4, Physical Evaluation for Retention, Retirement, and Separation, and AFR 35-7, Service Retirements.

Ceremony. A formal ceremony is a courtesy that must be offered to all members. To a retiree, the retirement ceremony is the most important event in his or her career. The ceremony should be in keeping with the customs and traditions of the service and, preferably, be conducted by a general officer. Ceremonies held as part of formal military formations, such as retreat and parades, are encouraged when conditions permit. Relatives, friends, photographers, information service personnel, and local public relations representatives should be encouraged to attend. DD form 363AF and the Air Force Retired Lapel Button (AFR 900-48, Decorations, Service, and Achievement Awards, Special Badges, and Devices Chapter 12) are presented at the ceremony, along with any awards, decorations, honors, and/or letters of appreciation. Formal ceremony procedures must be followed in all cases, unless the member prefers otherwise. If the member does not want a formal ceremony, or for any reason (terminal leave, hospitalization) cannot be present for duty on the date of retirement, the Certificate of Retirement, letter of appreciation, retired lapel button, and any decorations are presented personally by the member's commander, or an officer designated by the commander, who expresses appreciation for the member's service. The retirement certificate should not be mailed to a retirement address unless the member asks that this be done, or if there is no other choice.

A Reserve member, who is entitled to retire in a permanent Reserve grade higher than the active duty grade he or she is serving in, may wear the uniform and insignia of the higher grade during the ceremony. Non-EAD members being retired or transferred to the Retired Reserve may take part in retirement ceremonies. If they are eligible, on the date of such transfer to the Retired Reserve or retirement, to receive retired pay under any

provision of law, they are given DD Form 363AF. If not, they are given AF Form 951, Certificate of Transfer to the Retired Reserve.

Letter of Appreciation. A letter of appreciation usually is given to members who retire with 30 years of active federal service. Those with less than 30 years' active service get a letter at the discretion of their commander. HQ USAF/MPG prepares the letter for general officers. All other letters are prepared by the commander or a senior officer of the member's unit. If the member is being advanced on retirement to a higher grade, the letter is addressed in the higher grade and is presented with the Certificate of Retirement. A letter is not prepared if the:

1. Member is retiring in place of demotion, elimination, or other administrative action; or
2. Member's service has been marred by administrative admonitions, punishment, reprimands, or mediocre performance.

Decorations and Awards. If a retiring member is to be recommended for a decoration, the commander should ensure the recommendation is sent in far enough in advance so , if approved, it may be presented at the retirement ceremony. The recommendation must reach the approving headquarter at least 60 days before the date of member's retirement. Retiring members who do not receive an award may want to have their ceremony separate from those who are receiving awards.

Checklist. Personnel who arrange for retirement ceremonies must keep in mind the retirement ceremony is an event of great significance to the member. Commanders must take an active part in the preparation and conduct of the ceremony. To help prevent error or oversight that might offend the retiree or leave a bad impression, the following checklist should be observed:

1. Determine the type of ceremony desired (formal or informal). The commander will schedule a formal ceremony and notify the member. If the member tells the commander that he or she does not want a formal ceremony, then an informal ceremony will be scheduled. Set the date, time, and uniform for participants.
2. Determine the status of award recommendations and ensure all award elements (that is, certificates, letters, medals) and the retirement certificate are available. Avoid using "dummy" elements that the retiree can't keep.
3. Make note of the ceremony date and time on the commander's calendar and advise him or her of details.
4. Prepare autobiographical remarks for commander's use on a 5" x 8" card.
5. Reserve room or other location for the ceremony.

RETIREMENT INFORMATION FORM

Please complete this form and return to CCP (Protocol) by _____.

NAME (Include nickname, if applicable): _____

RANK: _____

CURRENT DUTY TITLE: _____

OFFICE PHONE: _____ HOME PHONE: _____

WIFE'S NAME (Include nickname, if applicable): _____

NAMES (and ages) OF CHILDREN: _____

SPECIAL GUESTS WHO PLAN TO ATTEND THE CEREMONY: _____

INCLUSIVE DATES OF ACTIVE MILITARY SERVICE & TOTAL YEARS: _____

If you had a break in service, indicate dates. Indicate any inactive Reserve time, if applicable: _____

DATE AND SOURCE OF COMMISSION (Location): _____

PLEASE LIST ALL MILITARY ASSIGNMENTS (with brief summary of position and inclusive dates. Please do not use acronyms).

Figure 30

6. Ensure a public address system is available and working.
7. Announce ceremony in advance.
8. Arrange flight line "quiet time" if required.
9. Find out who and how many personal guests the retiree is inviting and arrange seating.
10. Prepare a printed program as appropriate.
11. Designate a person to read the citation or retirement order and provide elements to him or her in advance for practice.
12. Designate one person to be in charge of bringing all elements to the ceremony.
13. Arrange for photographer.
14. Determine requirements for flowers.

Figure 30 is an example of a retirement information form that is most helpful when filled in by the retiree. AFR 35-7 is the basic guide on Air Force retirements, and it contains additional information you will need on this subject. The following ceremony is an extension of recognizing a military member's or veteran's service to our country.

THE MILITARY FUNERAL

The military funeral ceremony is founded on tradition and represents our nation's appreciation for a member's service and sacrifice. The following is a brief presentation of the regulation and rules involved. AFR 143-1, Mortuary Affairs, provides detailed guidance.

Air Force Policy

The Air Force considers it a privilege to assist in the conduct of military funeral honors for active and retired members and veterans who served honorably in the Air Force. Honors will be furnished, consistent with available personnel and resources. Commanders at all echelons will place sufficient emphasis on this program to ensure honors are rendered accordingly. Each base is responsible for providing requested funeral honors support within the base's assigned geographical area, usually covered by the ZIP code. The wishes of the next of kin regarding the type and extent of honors to be furnished will be paramount, limited only by the capabilities of the base. Immediately after receiving the request to furnish military honors, the base mortuary officer obtains all pertinent information and makes appropriate preliminary arrangements.

TYPES OF FUNERAL CEREMONIES

General Considerations

Because so many variations of the basic ceremony are possible, no one ceremony can be prescribed that will be appropriate for all military funerals. The need for variation may be directed by a number of factors such as the physical layout of the area, the specific desires of the next of kin, and the time of the year. The different types of ceremonies available include - but are not limited to, the complete Air Force funeral, the complete ceremony less chapel service, graveside service, and the memorial service.

Complete Air Force Funeral

This ceremony is provided when all the required persons and equipment are available and when desired by the next of kin. Since there is specific protocol to be followed, it is imperative that you refer to AFR 143-1, Chapter 16 for guidance. Another guide is Service Etiquette, Chapter 40 that has step by step details to advise you.

Funeral Without Chapel Service

For this service, the procession usually forms at or near the entrance to the cemetery. The mortuary affairs officer supervises the transfer of the casket from the hearse to the caisson or makes provisions for the hearse to be included in the procession. While the casket is being transferred, the escort is brought to present arms and the honorary pallbearers uncover or salute as appropriate. The funeral procession then forms and proceeds as prescribed below.

Graveside Service

The military element (chaplain, body bearers, firing squad, and bugler) participating in the service are in position before arrival of the remains. Again there are specific steps to be followed and will be supervised by the mortuary affairs officer. Since this ceremony is most reverend, it is critical that the base protocol officer, if involved, has a plan to follow. There is no room for ignorance or error.

Memorial Service

Services are held in a chapel without the remains being present. Usually performed when the funeral service is held elsewhere, when large groups of people are involved and cannot attend the funeral, and if the remains are not recovered.

ITEMS OF INTEREST

Cannon Salute

The funeral of a flag or general officer (active or retired), which takes place at or near a military installation, will be marked with minute guns equal to the number to which the officer was entitled and will be fired at noon on the day of the funeral. The cannon salute corresponding to the grade of the deceased will be fired immediately after the benediction, followed by three volleys of artillery, guns firing simultaneously, or three volleys of musketry.

Aviation Participation

When there is aviation participation in a military funeral, it is timed so the airplanes appear over the procession while the remains are being taken to the grave. When the funeral is that of an aviator, it is customary for the airplanes to fly in a normal tactical formation less one aircraft, indicating the vacancy resulting from the loss of the deceased.

The Flag

The flag that covers the casket symbolizes the service of the deceased in the Armed Forces of the United States. The three volleys that are fired, according to ancient belief, are to scare away evil spirits. The playing of "Taps" over the grave marks the beginning of the last sleep and expresses confidence in an ultimate reveille to come.

If a service member dies while on active duty, the United States flag for the funeral ceremony is provided by the Air Force. However, if he or she dies as an honorably discharged veteran, the flag is provided by the Veterans Administration, Washington, D.C., and may be procured from the nearest post office. Postmasters require proof of an honorable discharge before issuing the flag for use at funeral ceremonies.

The flag is folded immediately after the sounding of "Taps." The body bearers hold the flag at the pall over the grave and fold the flag in the accustomed manner (Figure 12). The senior body bearer hands it to the chaplain or the officer in charge, who in turn presents it to the next of kin or a representative of the family.

Checklist

If you are in charge of a military funeral, you must have specific information in order to carry out the arrangements. To ensure accurate information, a checklist may include the following:

1. General Information
 - a. The name, grade, and serial number of the deceased.
 - b. Religious faith.
 - c. Name and address of funeral director.
 - d. Name and address of next of kin.

2. Personnel

- a. Chaplain of appropriate faith; name, grade, and serial number.
- b. Appropriate escort.
- c. Band, Color Guard (4 men), body bearers (6 or 8), honorary pallbearers (usually 6 to 10), firing squad (8), bugler.

3. Equipment

- a. Aerial escort.
- b. Caisson.
- c. Blank cartridges for funeral volleys.
- d. Interment flag for civilian funeral director.

4. Next of Kin

- a. What type of service is desired: time, date, location.
- b. The name, rank, address of service chaplain, or the name and address of civilian clergyman.
- c. Type of funeral procession, if desired.
- d. Honorary pallbearers, elected by family or command; their names, addresses, telephone numbers.
- e. The type of graveside ceremony: with volleys? "Taps?"
- f. Ceremonies by fraternal or patriotic organizations.
- g. Approximate number of relatives and friends attending services.
- h. Music: any particular compositions?

5. Civilian Funeral Director

- a. Name and location of cemetery, exact location of grave site.
- b. Time and date of interment services.
- c. Will he transport flowers from chapel to grave? Collect cards from flowers to be given to next of kin?

6. Miscellaneous

- a. Determine routes of march, positions, etc.
- b. Arrange for traffic control.
- c. Make certain equipment is ready at the right time and place.
- d. Ensure each person taking part in the funeral ceremony knows his/her duties.

RETREAT

The retreat ceremony serves two purposes; first, it signals the end of the official duty day, usually 1700, and second, the ceremony pays respect to the flag. The base commander normally designates the time for this ceremony. Traditionally, the bugle call, "Retreat," is sounded and is followed by the playing of either the National Anthem or "To the Colors." Everyone must stop whatever they are doing if they are outside and face the flag. During the bugle sound, stand at parade rest, then come to attention, and salute during the National Anthem or "To the Colors." If one is driving along in a car, the proper action is to stop and sit quietly until the music ends. Passengers in the car are expected to do the same.

Conclusion

You have now reviewed a few of the official ceremonies that take place on military installations. These ceremonies are a major responsibility of the base protocol officer. Ceremonies are not difficult, but they do require careful planning and thoughtful execution. By being prepared, paying attention to the details, and smoothly following a plan, you can ensure a successful ceremony. We are not through yet, we will now proceed to the social scene and official entertainment.

Chapter Six

ETIQUETTE AND OFFICIAL MILITARY ENTERTAINMENT

INTRODUCTION

An Air Force officer generally is familiar with the broad requirements of etiquette--the rules and forms prescribed by convention for socially acceptable conduct and behavior. As presented earlier, protocol is a code of established guidelines on proper etiquette and precedence which, when followed, lays the foundation for a successful event. Numerous books of etiquette are available to consult to learn the specific procedures for a particular social function. It behooves the protocol officer to keep informed on accepted social procedures, particularly as they are observed in the local community. Information on the rules of etiquette in this handbook, as adapted to the military organization, is provided in relation to official social functions primarily for the guidance of the protocol officer. Much of it, however, provides guidance to any officer both as a guest and host at a social function.

PRECEDENCE

One of the protocol officer's most important duties, as you have already read, is to determine in a given group of dignitaries (military, civilian, and foreign) "who outranks whom," and to ensure each dignitary is accorded the courtesies and honors rank and/or position entitled. In civilian circles, precedence is also observed at official functions; however, the prominence of the guest, his age, and achievements may determine his position in the order of precedence. At military official functions, including social activities, precedence is observed strictly on the basis of the individual's rank and/or position. In official circles, a wife is given the position of precedence commensurate with her husband's rank or position. Also, a woman who holds a position of prominence normally accorded honors in official circles is given the commensurate position of precedence, and her husband is given the same position.

PROPER INTRODUCTIONS

Normally, a man is introduced to a woman, such as "Polly, I'd like you to meet Colonel Such. Sir, this is my friend Polly Meyer." You honor the woman by saying her name first. There are three important exceptions to this rule, however. Firstly, ignore the "ladies first" tradition if the lady is your wife. The second exception is for introductions among members

of the armed forces, men and women, who are on duty or at official functions. Follow the rule of rank: the senior is named first--"Colonel Francis, I'd like you to meet Major Valerie Elbow, my Executive Officer. Major Elbow, this is Colonel Francis, our Air Base Group Commander." The third exception is when introductions involve the President of any country, a King, or Church dignitary. Two other general rules you should be familiar with are: (a) young people are presented to older people (barring rule of rank for military) and (b) a single person is normally introduced to a group.

RECEPTIONS

The reception is a popular social function in the service. Receptions can be large or small, take many forms, and serve many purposes. They are usually held in honor of someone such as a dignitary. They are also held to mark a special occasion such as an officer's retirement. The purpose is to have as many friends and acquaintances of the hosts meet the guest(s) of honor. A reception is somewhat more formal than a cocktail party, and there is always a receiving line. The hour is variable, depending on the occasion. It is normally held at any time over a two hour period between 1600 and 2300--1600 to 1800, 1700 to 1900, and 1800 to 2000 are the favored times. Often the reception held between the hours of 1800 and 2000 becomes a "reception buffet," and the menu may include, for example, such foods as sliced turkey, ham, roast beef, or lobster newburg, chicken a la king, a hot dip or two, and sometimes dessert. Beverages, including punch, are also served.

At a formal reception, punctuality is a must, and guests should arrive at the scheduled time and go through the receiving line. Just as arriving late is in bad taste, it is equally bad taste to partake of cocktails at a reception before going through the receiving line.

At less formal receptions and unless otherwise specified, guests may arrive and leave any time between the hours specified for the reception. There is no particular rule as to the length of time guests should stay at a reception. If the room is crowded, however, out of consideration for the other guests, they should stay no longer than an hour and may, of course, leave earlier. In this case, it is not necessary for guests to wait until the guest of honor, if there is one, has departed.

Dress

Usually, the host determines which uniform the officer shall wear. The spouses' attire is determined by the time of day. In the afternoon, a suit or simple dress will certainly be appropriate. After retreat or early evening, wear cocktail type clothing. The later the reception, the more formal the dress.

Receiving Line

The receiving line is formed from right to left as follows: first, the

protocol officer or aide followed by the host, the hostess, the ranking honored guest and spouse, the second ranking honored guest and spouse, etc. It is best to have neither less than three nor more than six in the line, excluding the protocol officer/aide, if possible; a greater number tends to restrain an optimum flow of guests.

At an official function, the protocol officer or aide stands nearest the door and a little to the side of the line, and announces the names of the guests as they start through the receiving line. (If possible, the protocol officer should be free to control the movement of the line and oversee the other details of the function.)

Guests should identify themselves to the announcer by their last name only, if name tags have not been provided. At an Air Force function, and at the White House, the man precedes his lady through the receiving line at official functions. No one should offer his hand to the announcer, since the announcer is not considered a member of the receiving line. Guests should limit their conversation with the members of the receiving line to a simple "How do you do?" or "Good afternoon," or "Good evening." They should move slowly, shaking hands, and greeting each member as they are presented. It is most important that guests move immediately from the end of the receiving line to the refreshment area, to make room for the guests following them.

Flag Arrangement Behind the Receiving Line

The US flag always precedes any other flag. If a foreign dignitary is being honored, his country's flag will be next, then the US department flag followed by the general's flag at the end.

Assistant Hosts and Hostesses

For large social gatherings, the protocol officer coordinates with the hostess in selecting junior officers and their spouses to act as assistant hosts and hostesses. These hosts and hostesses are stationed at the entrance to the building to greet and escort distinguished guests to the receiving line. In the reception area, the assistant hosts and hostesses introduce the guests to each other, see the guests are served, and help in other ways to ensure guests are welcomed. If the guests include distinguished persons other than the guest(s) of honor, local senior officers and their spouses are requested to ensure these guests are welcomed and personally escorted during the party.

OFFICIAL LUNCHEONS

Most official luncheons are held in honor of a visiting dignitary. These luncheons are often stag and frequently are termed working luncheons. However, when a dignitary's spouse attends, other spouses are to be invited.

The table arrangements and service are about the same as for an informal dinner. Three courses are customary, or four at the most.

Usually, food served at noon is lighter than that served at evening meals.

Place cards (see page 65) are a matter of convenience, and may be used for as few as eight or so guests. The table probably will be covered with a white cloth; however, coordinated colored cloth and napkins are fine and add to the setting of the luncheon. There should be a centerpiece, but no candles are used on luncheon tables. The first course is on the table when everyone sits down. Each course is served by waiters or waitresses.

FORMAL DINNERS

Today's formal dinner is what was termed semiformal in days when stewards or waiters were easily obtained. The main difference between today's formal dinner and the truly formal dinner is in the service: fewer waiters will serve fewer courses to the same number of people, and black tie is usually worn by the men, women in long dresses.

A table cloth of linen, damask, or lace may be used. The cloth should never overhang the table by more than 18 inches nor less than 12 inches unless it is intended to be floor length. The first course of soup or seafood usually is in place on the table when the guests sit down, but it is preferable that hot soup be served after guests are seated in order that it not get cold. Three or four courses are customarily served.

INVITATIONS

The semi-engraved invitation card simplifies the preparation and actual writing of invitations. These invitations require completing the guest's name, the time, place, dress, and occasion. They should be in the third person, in black ink with the date and time written completely. The dress is handwritten in the lower right hand corner. Honor guests are designated at the top of the card. The semi-engraved invitation is adaptable to most occasions; however, two other means of invitation are acceptable for informal social functions.

The telephonic invitation may be used for informal social functions, particularly to invite members of the command. When this form is used, a "To Remind" card should be sent upon acceptance. The "To Remind" is simply the semi-engraved invitation, completed in the same format as if it were an invitation, except the R.S.V.P. is lined through and "To Remind" written in the lower left hand corner. The invitation sent to a guest of honor only serves "To Remind," so it should not bear any indication of the purpose of the occasion.

There are certain occasions when the recipient of an invitation should be afforded more explanation than the semi-engraved card contains. Except for formal occasions, a personal letter of invitation signed by the commander is appropriate. An example would be an invitation to a guest lecturer which includes an invitation to dinner. In this case, the letter serves several purposes and upon acceptance a "To Remind" card is prepared.

In honor of Mrs. Choumoung Men, wife of the
Minister of National Defense, Republic of Vietnam



Mrs. Caspar W. Eisenberger
requests the pleasure of the company of
Captain Ball

at luncheon
on Thursday, the fourteenth of April
at half past twelve o'clock

To Remind
R.S.V.P.
699-7064

The Pentagon
River Entrance
Room 3E859

Figure 31

It is accepted practice in instances such as this to deliver the "To Remind" upon arrival at the command, rather than mail it separately.

Getting back to the invitation itself, "Regrets Only" in the lower left corner is used when negative responses are required. However, "R.S.V.P." meaning "please reply" is used if the invitation is for a meal, and/or acknowledgement. Also, in place of an "R.S.V.P.," a separate card may specify person (or office) and address to which replies are to be sent; or it may specify dress. Both of the response forms "R.S.V.P." and "Regrets Only" are correct; however, the first is preferred in official and diplomatic circles.

The only abbreviations used in a formal invitation are "Mr.," "Mrs.," "Dr.," and "R.S.V.P." . The word "junior" is spelled out with a small "j" unless the name of the person issuing the invitation is a long one, in which case "Jr." is correct.

Although the phrase, "request the pleasure of the company of" is used most frequently, the phrase, "request the honor of the company of" is the most appropriate choice on invitations issued by and to ambassadors and other high-ranking officials.

Envelopes for all invitations should be handwritten in black ink and addressed in the full name of the husband and wife unless the guest is single. (Example: Lieutenant Colonel and Mrs. John C. Smith)

Regardless of the occasion or form of invitation used, the invitation should be extended two weeks in advance. This permits the guest ample time to arrange his/her personal calendar and affords the protocol staff time to react to declinations, if necessary. Conversely, invitations must not be extended so far in advance so that the guest is unable to determine whether the schedule will permit attendance. Normally, three weeks is the earliest an invitation should be received. Figure 31 gives you an example of a semi-engraved invitation.

SEATING: LUNCHEONS AND DINNERS

Arrangements

For official luncheons and dinners, the protocol officer determines the seating arrangement, prepares a seating chart, and coordinates the chart with the host. The chart--a diagram of the table showing the location of each guest's seat--is usually displayed in the room where cocktails are served so guests may easily refer to it. In determining seating position, precedence is the protocol officer's first consideration; however, the final determination is made on the basis of experience, judgment, and common sense.

At an official dinner, according to precedence, at a rectangular table, the ranking lady is seated at the right of the host, and the ranking man at the right of the hostess. The second ranking lady is seated at the left of

the host, and the second ranking man at the left of the hostess. Then the third ranking lady is seated at the right of the highest ranking man, and the fourth ranking lady at the left of the second ranking man. The third ranking man is seated to the right of the ranking lady, and the fourth ranking man to the left of the second ranking lady. Thus, with a rectangular table, the lowest in rank will be seated nearest the center of the table. At an official luncheon when ladies are not included, the visiting dignitary is given the place of honor at the right of the host, depending on the shape of the table, or he may be seated directly across from the host. Also, if the guest of honor is outranked according to precedence by another guest, the senior guest may be seated at the right of the host, and the guest of honor placed across the table from the host. Examples of a seating arrangement are shown in AFF 900-1.

As stated above, the ranking lady is always seated to the right of the host and the ranking man to the right of the hostess. In seating the remaining guests, precedence is the guide, but other considerations may be determining factors. When foreign guests are included, for example, it is considered courteous to seat them between guests from the host country, even though the rank of the latter may be higher. Linguistic ability may be a deciding factor also in seating foreign guests. In seating guests without a protocol rating, age, prominence, and mutual interests may be considered, and these guests may be placed between those of official rank in the most congenial arrangement. If seating according to precedence results in a wife being next to her husband, the wife is moved.

A bachelor or widower entertaining with a dinner party may ask one of the lady guests to act as hostess to balance the table, or he may give prominence to the ranking man by asking him to sit as the co-host in the position normally occupied by the hostess.

At a mixed affair, an even number of guest couples allows a standard arrangement. When there are 6, 10, 14, or 18, etc., people seated at a table, the host and hostess sit at opposite ends of the table. Any multiples of four, such as 8, 12, 16, etc., mean the host and hostess cannot sit opposite each other without having to place two people of the same sex together. To avoid this, the hostess may give up her position at the end of the table and move one seat to the left, which places the male guest of honor opposite the host.

It is readily apparent that value judgments are a major determinant of an effective seating arrangement. Strict rules of precedence, such as man-woman-man-woman, cannot always be applied. One obvious solution often overlooked, is to add to the guest list as necessary and if space and other factors permit this, it can be a most effective solution. Other factors being stable, congeniality can be effectively applied. Rules of protocol should always be used, but when they are impractical, the protocol officer must be able to justify a particular seating arrangement. If the reasoning is sound, the seating will be successful.

Procedure

In proceeding to the dining area, the host leads the way with the ranking lady, and seats her to his right. The hostess, escorted by the guest of honor or the ranking man, enters last. In some cases, this procedure is changed; for example, when the guest of honor is a high-ranking diplomatic official or a governor, the hostess, with the guest of honor, enters first and is followed immediately by the host with the wife of the guest of honor or the ranking lady.

Each man escorts his dinner partner--usually the lady to be seated at his right--to the table. At large official functions, escort officers and aides ensure each man knows or is presented to his dinner partner. Also, the protocol officer may give each guest a small folded card containing dinner partner's names, or the guest may learn his dinner partner's name by checking the seating chart.

NAME TAGS

Name tags are recommended at large official social functions to provide individuals who are strangers to each other with the name and rank or position of persons with whom they may be engaged in conversation. Name tags also serve as an invaluable aid to the protocol officer, since unissued tags indicate guests who have not arrived. If inquiry reveals these guests will not attend, the protocol officer can take action early to rearrange the seating, change the seating chart, rearrange place cards, and remove excess dinnerware settings from the table, and thus eliminate empty places at the table. This rearrangement takes time, and the sooner it can be accomplished, the better, to avoid delaying the dinner. Any empty place at the table is an indication of thoughtlessness or lack of thorough planning, and is embarrassing to both the host and the guest of honor.

PLACE SETTING

An important rule to follow for setting the table is to avoid overcrowding. Allow at least 24 inches of table space for each person. The minimum place setting is the teaspoon, place knife, place fork, and salad or dessert fork. The next most needed pieces are the butter spreader and soup spoon. Other place setting pieces that are most commonly used are the cocktail-seafood fork, demitasse spoon, iced beverage spoon, and individual steak knives.

Silverware should be placed on the table in the order of its use, starting from the outside and working toward the plate. There are some basic rules for placing silver.

1. The silver, napkin, and plate are lined up approximately one inch from the edge of the table.

2. Forks are placed at the left of the plate, except the seafood fork which is placed at the right of the spoon, tines up.
3. Never place more than three forks on the table at any one time.
4. Knives and spoons are at the right of the plate with the blade of the knife facing in toward the plate.
5. Spoons for tea and coffee are placed on the saucer at the right of the handles before service.
6. Dessert spoons and/or forks are usually brought in on the dessert plate with the spoon at the right and the fork at the left of the plate.
7. The iced beverage spoon may be placed on the table at the right of the soup spoon or it may be laid above the plate with the handle of the spoon at the right.
8. The individual butter knife is usually placed across the top of the butter plate parallel with the edge of the table.

A china service consists of plates for breakfast, lunch, dinner, coffee and tea cups, serving dishes, and various sized plates for other purposes. The large flat plates are called dinner plates and are used for the main course. A smaller plate is used for a luncheon, and a plate smaller still may be used for dessert or salad. Various size plates are needed for butter, fruit, etc., and cups or bowls for soup. "Place plates" are the plates that are pre-set on a formal or semi-formal table when the guests sit down. No food is actually served on place plates.

PLACE CARDS

Place cards ensure each guest can easily find his or her place at the table. They also help the guests to identify persons seated next to them. Names on place cards should be large enough to be easily read by guests to the right and left, and the card should be placed above the plate in a position where it will not be disturbed. Place cards should be handwritten in black ink. They should show the fully spelled out title and last name of the guest. There is one exception: when the military title has two words, use the conversational title. For example, the place card for Major General Smith would read "General Smith." For designated senior officials, omit the name and use only the title. For example, "The Secretary of Defense" is correct. When the Air Force general officer place card is used, the rank of the host determines the card to use, even though the guest(s) may outrank him/her. If the host is not a general officer, plain white cards or those provided by most officers' clubs may be used.

TOASTS

A toast expresses good will toward others on a social occasion. This form of verbal greeting is rendered to the guest of honor by the officers who are hosting and participating in the affair.

In the 16th century, it became the custom in England to add toasted bread to drinks. The toast became saturated and sank to the bottom of the goblet and someone challenged "toast." It was necessary to drain the goblet to get to the toast. From this custom, the term "toast" came to be applied to a drink of honor proposed to some person during the course of a meal. Today, the toasts usually are proposed at the end of the dessert course. The toast usually begins with a welcome to the guest of honor. If the guest is accompanied by his or her spouse, reference may be made to the spouse, as well, during the toast.

The person offering the toast stands and raises a glass. The others, except the guest of honor, raise their glasses in salute to express good wishes or congratulations, and then drink to that salute. Those guests who do not drink alcoholic beverages should raise their glasses during the toast and merely touch the glass to their lips going through the motions of drinking without actually doing so. The guest of honor should neither raise a glass nor drink to the toast in his or her honor. After the toast has been proposed and made, the guest of honor may stand to thank the others and then may also offer a toast in return. However, it is not considered a breach of etiquette for a very high ranking officer or dignitary not to return the toast. The order and subject of all toast should be prearranged. In addition, the host should inform the guest of honor as to the nature of the toasts and when they will be offered. This is so the guest of honor may know what to expect and how to react.

Ceremonial Toasts

At an official dinner honoring a foreign dignitary, the host may propose a toast toward the end of the meal, to the sovereign or President of the guest's country. This toast is generally followed by the national anthem of the country. The guest of honor would respond with a toast to the President of the United States, followed by the National Anthem. If several nationalities are represented, the host may propose a toast collectively, naming the countries successively in order of seniority of the representatives present. The highest ranking representative would respond in behalf of all countries by proposing a toast to the President of the United States. Everyone drinks to a toast, except the individual to whom or to whose country or service the toast is proposed. Toasts to the head of state of a country are given as stated in the following example: At an official dinner for a high-ranking British official, hosted by an American officer, the host would rise during or after the dessert and say, "Ladies and gentlemen - to Her Majesty, Queen Elizabeth the Second." After the toast had been drunk and the guests were seated, the British official would respond by rising and saying, "The President of the United States." For specific customs of other countries it is recommended you contact the Air Force International Affairs Office (HQ USAF/CVAI) or the State Department.

ENTERTAINMENT

At the more formal dinner, the commander may wish to have some form of entertainment following dinner. This is an excellent time to serve liqueurs and if done effectively can serve as an excellent finale to an enjoyable evening. For purposes of the Air Force, no funds should be spent on after dinner entertainment. It is an extravagance unwarranted in these austere times. Moreover, excellent talent can usually be found among the command. The band is an excellent source. In this vein, a light musical presentation generally meets with ready acceptance. A singing group, talented soloist, or instrumental group can most often be successful. For foreign groups, a short, light film about the Air Force or aerospace project may be more appropriate. In any case, the entertainment must be light, designed to suit the guests, and brief, no longer than fifteen minutes. The protocol officer must always view the entertainment beforehand to ensure it is appropriate. A poor musical routine or inappropriate film can dampen a dinner party just as easily as it can enhance it. Now, we will examine a specific Air Force tradition that focuses on the peak of entertainment - the Dining-In and Dining-Out.

THE DINING-IN AND DINING-OUT

Introduction

The Dining-In and Dining-Out represent the most formal aspects of the Air Force social life. The Dining-In is the traditional form, and the term will be used throughout this chapter. However, most of the information applies equally to the Dining-Out. The Dining-In is a formal dinner for the officers of a wing, unit, or other organization. The Dining-Out is a relatively new custom which includes spouses and guests. You will find it very helpful to refer to AFP 30-6, Guide for an Air Force Dining-In for specific guidance.

Historical Background

The term Dining-In derives from an old Viking tradition of celebrating great battles and feats of heroes by formal ceremony. It is believed the custom spread to the English monasteries, was taken up by the early universities, and spread to the military with the appearance of the officers' mess. It is said that back in the early 1800s, when England was the reigning power in India, there was an English Army post where the Dining-In received its first impetus. It seemed the commander of this Indian outpost had officers under his command who lived on the post, had their own mess hall, but were never around for dinner. Since the local area was more interesting than the post officers' mess, the post commander found himself eating alone many nights. To bring the officers back to the mess and to create camaraderie, the post commander instituted a program whereby all officers would not only dine at least once a month in the mess, but they would dine in full military ceremony. This monthly event usually included a rum ceremony and toast to the Queen.

The late General H. H. "Hap" Arnold probably started the Dining-In tradition in the Army Air Corps during the 1930s when he presided over his famous "wing-dings." The association of American and British military personnel during World War II gave additional momentum to the growth of the custom in the United States Air Force. It was recognized that the ceremony provided situations where tradition and customs could play an important part in the life of military organizations. Fortunately the tradition of the Dining-In is very popular today. Air Force members recognize the important role these occasions play in preserving the tradition of our service.

Purpose

The purpose of the Dining-In is to bring together officers of a unit in an atmosphere of camaraderie, good fellowship, and social rapport. The basic idea is to enjoy yourself and the company of your fellow officers. This evening event is also an excellent means of saying farewell to the parting officers and welcoming newly arrived officers. Further, the Dining-In provides an opportunity to recognize individual and unit achievements. The Dining-In, therefore, is very effective in building high morale and esprit de corps.

Dress

The dress must be stated in the invitation. It usually is the mess dress for officers and long dinner dresses or evening clothes for female guests when attending a Dining-Out. Male civilians should wear appropriate black tie dinner dress.

Planning the Dining-In

Start early. Two to three months should be considered a safe time to start. Set a firm date, location, and general action plan. It is a good idea to appoint a planning committee. Make arrangements with the officers' club on room, date, time, and menu. The menu usually consists of four or five courses, with roast prime ribs of beef and Yorkshire pudding traditional but not a necessity. Two weeks to a month before the time set for the dinner, send out invitations to the guests who are not members of the mess. The semi-engraved card is often used for the invitations, or they may be handwritten or printed. Since this is a formal occasion, formal wording is used. For example, the wording for official guests should include the phrase "the honor of the presence of ..." but for personal guests, would read "the pleasure of the company of ..." or "...your company."

Seating

At a Dining-In, the guest of honor sits to the right of the president at the head table, with the next ranking guest on the president's left. Other guests are seated throughout the mess. The members of the mess are seated according to seniority, with Mr. or Madam Vice should be seated alone at the end of the room.

At a Dining-Out, the guest of honor's wife is seated to the right of the president, and the second ranking woman to his left. The president's wife is seated to the right of the guest of honor. The table should be set-up in a manner most suitable to the dining area. The head table usually is a long single table, but side tables may be placed down each end in a modified "E"--with no seats off center. No one should be seated across from those at the head table. It is important tables are not crowded, with everyone having plenty of elbow room.

Conduct and Courtesies

In an atmosphere of good cheer, each officer is encouraged to enjoy himself or herself to the fullest; however, as in all gatherings of officers, moderation is the key note to enjoyment. All members are encouraged to pay his or her respects to the guest of honor and to meet as many guests as time permits, without monopolizing the time of any one guest.

Principal Officials

The following are the principal officials of the Dining-In:

President. This officer is the center figure of the Dining-In. Normally the commander of the organization hosting the Dining-In, the president is charged with the responsibility of setting the date and place of the event, introducing the principal speaker and honored guests, proposing the first toast, ensuring the rules of protocol are observed, and closing the ceremony.

Mr. Vice/Madam Vice. Usually, the junior officer assigned as recorded on the latest officers' roster, or he/she may be selected for possessing wit and ability to speak. He/she assists the president by performing duties prescribed by the president. Members must be prepared to follow instructions given by either the president or Mr. Vice/Madam Vice. This official starts the cocktail period by opening the lounge, sounds the dinner chimes to summon the members and guests into the dining room, keeps the party moving, and is the last person to leave.

The Guest Speaker. The guest speaker's presentation is the traditional highlight of the evening. By custom, the speaker should be distinguished either as a military officer or official of the government. The speaker should be contacted well in advance and advised of the nature of the evening. Arrangements should be made for him/her, and other invited guests, as protocol and custom dictate.

Ceremonies

Members of the mess participate in three ceremonies of sufficient importance to warrant special designation here:

Presentation of the Colors. The colors are formally presented at the beginning of the Dining-In. When the president taps the gavel three times to call the mess to order, the color guard enters and comes to "Present

Arms." If desired, a bugler may sound "To the Colors" or the National Anthem may be played. The Color Guard then places the flags in their stands and departs. (This ceremony is only recommended when a trained Color Guard is available.) If the ceremony is not observed, the Colors are positioned before the members enter the dining room.

Wine Pouring Ceremony. If the wine pouring ceremony is observed, all members are seated after the invocation. Wine decanters are passed from hand to hand until all glasses are filled, never letting the decanters touch the table. When a decanter is empty, the officer holding the decanter hands it to a steward and receives a full one. After the initial toast, wine bottles may be placed on the table for subsequent toasts. (This ceremony is generally too time consuming for a Dining-In of large groups; therefore, wine may be poured prior to convening the mess and decanters placed on tables.)

Toasting. The custom of toasting is universal. It is believed that this custom came into wide acceptance after the effects of poisons were discovered. When two persons, who might be antagonists, drank from the same source at the same instance and suffered no ill effects, a degree of mutual trust or rapport was established. With this foundation laid, discussions could continue on a more cordial basis. Today, toasting is simple courtesy to the person honored. It is not necessary to drain the glass at the completion of each toast or even to sip the wine; a mere touch of the glass to the lips satisfies the ceremonial requirements. In our modern Air Force, glasses are definitely not smashed against the fireplace.

Toasts should be proposed in sequence and at intervals during the program of the evening. The president proposes the first toast, Mr./Madam Vice proposes all other prepared toasts. Gentlemen and officers stand to toast, but female guests remain seated to drink the toast unless it is considered a standing ovation. If still in doubt, the ladies should take their cue from the president's wife. The following is recommended:

1. After the invocation: "To the Colors;" "To the President of the United States;" "To the Secretary of the Air Force;" "To the Chief of Staff, USAF."
2. After the welcoming remarks: The president introduces the head table, and Mr./Madam Vice proposes a toast "To our honored guests,"; response, "Here, Here."
3. After recognition or awards; as appropriate.
4. After speech by Guest of Honor: Mr./Madam Vice proposes a toast, "To our Guest of Honor, _____."
5. Normally, toasts should be planned and approved in advance by the president. To avoid confusion the toasts and responses should be printed in the Dining-In program booklets placed at the tables. However, if a member does desire to propose a toast, he or she

should stand, saying, "Mr. President, I propose a toast." Upon being recognized by the president, the member states, "I propose a toast to _____." The president then raises a glass, a signal to the members to stand and repeat the toast: "To _____," with a response, "Here, Here."

Rules of Protocol

The following are basic rules of protocol for a dining-in:

1. Punctuality is mandatory. Each member should arrive at the bar no later than 10 minutes after the opening time to meet the guests before dinner. At the scheduled time or when the chimes are sounded for dinner, the members enter the dining room and stand at attention behind their chair at their appointed place at the banquet table. Drinks are not carried to the dining room.
2. The guests and president of the mess are the last to enter the dining room. The president formally calls the mess to order and continues according to the agenda. The president's welcoming remarks set the tone for the formal part of the agenda. Following a recess, the president introduces the guest of honor.
3. Smoking. From the time you enter the dining room until the "after burner" or "smoking lamp" is lit by the president, smoking is not permitted. The president usually lights the smoking lamp after most members have finished the main course.
4. If there is to be an informal portion of the dining-in, such as some form of entertainment, there should be a distinct break between the formal and informal portions. This can be readily accomplished by having the mess adjourn to the bar following the president's closing remarks. The dining room can then be cleared and prepared for the informal activities.
5. Each time the mess is adjourned or reassembled, the members stand until the persons at the head table have left the room or are seated.
6. Use of the Gavel. The president opens and closes and gains attention by rapping the gavel one time which signifies complete silence. Two raps of the gavel signifies a recess at the end of the dining-in.
7. Once the mess is open, members are not to leave the table or return without permission.
8. After the mess is adjourned, members are not to remain in the dining room until the guest of honor or the president has been seated. If there is a delay in their seating, the president may allow members to leave. Some unobtrusive signal, such as having a unit flag closed, is an appropriate means of notifying members the

Dining-In is over. Mr. Vice/Madam Vice is the last member to leave the Dining-In.

Awards

If individual and unit achievements are recognized, an appropriate ceremony is arranged. The ceremony takes place during the formal portion. A convenient time is immediately preceding the guest of honor's speech. Under no circumstances should any ceremony follow directly after the speech which should be the highlight of the Dining-In.

Sample Dining-In Agenda

Figure provides a sample agenda to help you understand the basic flow of events.

Conclusion

Whether attending or organizing a Dining-In, knowledge of the preceding information will be valuable to you. While a Dining-In is a formal dinner function for members of a military unit and selected guests, a Dining-Out on the other hand, is a formal dinner at which spouses and guests of unit members attend. AFP 30-6 is an excellent guide to ensure tradition and customs are followed. Finally, AFP 900-1 can give you some solid guidance in matters of social etiquette. It was designed specifically to cover such topics as guest lists, invitation formats, social functions, forms of address, et al. Figure 33 of this handbook is a very usable protocol function checklist which also is helpful in this area. Now we can proceed to what to do in behalf of distinguished visitors.

SAMPLE DINING-IN AGENDA

- 1900 Lounge opens.
- 1945 Lounge closes. Mr. Vice sounds the dinner chime. Members and guests proceed to the dining room and stand behind their chairs. The smoking lamp is out.
- 2000 The President calls the mess to order. The Color Guard posts the colors, the National Anthem is played, and the invocation is given.
- 2005 President: "Ladies and Gentlemen, I propose a toast to the Commander in Chief, the President of the United States."
- Response: "To the President."
- Mr. Vice: "Mr. President, I propose a toast to the Secretary of the Air Force."
- Response: "To the Secretary of the Air Force."
- Mr. Vice: "Mr. President, I propose a toast to the Chief of Staff, United States Air Force."
- Response: "To the Chief of Staff."
- Mr. Vice: "Mr. President, I propose a toast to the Commander in Chief, Strategic Air Command."
- Response: "To the Commander in Chief."
- 2010 The President seals the mess, makes concluding remarks, and introduces the guests.
- 2020 Mr. Vice: "Mr. President, I propose a toast to our guests." (Messers stand at attention.)

Response: "Hear, Hear".

- 2021 President invites the members of the mess to be seated. Dinner is served.
- 2050 Smoking lamp is lit when directed by the President.
- 2100 President announces recess. (Members quietly stand while the head table departs.)
- 2120 Mr. Vice sounds the chime. Members extinguish smoking material, return to the dining room, and remain standing until seated by the President.
- 2125 Coffee and tea are served. Smoking lamp is lit at the President's direction.
- 2130 Entertainment - "Crew Blues" and the "No-Notice Players".
- 2205 President introduces the Guest Speaker.
- 2210 Address by Major General John E. Brown. Following the address, Mr. Vice: "Mr. President, I propose a toast to our distinguished speaker."
- Response: "Hear, Hear".
- 2230 Closing remarks by the President. Presentation to the Guest Speaker. Colors are cased. The mess adjourns and the lounge opens.

Protocol Function Checklist

Date: _____ Guest(s) of Honor: _____

Time: _____ Host: _____

Function: _____ Project Officer: _____

Place: _____

() Announcement Board: _____

() Bar Time: _____ Type of Bar: _____ Food Time: _____

() Sufficient Bartenders and Bars (depending on the occasions): _____

() Billing: _____

() Candelabras: _____

() Color Scheme and Linen Colors: _____

() Decorations: _____

() Door Openers: _____

() Easel: _____

() Escorts: _____

() Flags: _____

() Flowers: _____

() Guest Book: _____

() Invitations to Guests: _____

() Menu: _____

() Microphone & Podium: _____

() Band/Music Selection: _____

() Name Tags: _____

() Napkins & Matches: _____

() Number of Attendees: _____ Estimate: _____ Final: _____

() Parking Arrangements: _____

() Gift for Guest Speaker (if appropriate): _____

() Photographer: _____

() Place Cards: _____

() Receiving Line: _____

() Room: _____

() Seating Charts: _____

() Table Set-up: _____

() Transportation: _____

Remarks: _____

Chapter Seven

HONORS ACCORDED DISTINGUISHED VISITORS

The protocol officer handles local arrangements for distinguished visitors (DV), whether military or civilian, domestic or foreign. AFR 900-6, Honors and Ceremonies Accorded Distinguished Persons, describes the honors and ceremonies to render distinguished persons at Air Force installations. This regulation stipulates the persons entitled to honors, states what honors will be accorded to and when, and explains where the ceremonies may be held.

The intent of honors is to extend a mark of courtesy to a DV. Honors will be accorded only the DV and not to personal representatives. A committee or delegation, therefore, is honored in the person of the senior or ranking member.

PROTOCOL RESPONSIBILITIES

The protocol officer functions as coordinator for visits of distinguished persons. Usually, most of the planning for a DV has been clearly defined and worked out by higher authority. The protocol officer's duty is to carry out the plan. Unfortunately, an inexperienced planner may not foresee the unexpected or any number of troublesome problems that might arise. The procedures outlined, are provided primarily for your guidance since you are charged with the responsibility of making all arrangements for the visit and ensuring all individuals concerned are informed of their responsibilities and duties in connection with the visit. Upon receiving notification of the impending visit of a DV, the protocol officer should:

1. Establish a status file folder with the following inputs as received.
 - a. Biographical information.
 - b. Copies of all correspondence and messages.
 - c. Restrictions on classified access/controlled areas.
 - d. Personal information on diet requests/restrictions, quarters, social affairs, tours, and briefings.

After the visit, save this information for planning future visits.

2. Get the commander's preference and desires for the upcoming visit by first sending appropriate communique (letter, memo,

staff summary sheet, etc.) to him/her detailing the pending visit. Include:

- a. Name and title of visitor.
 - b. Names/positions of visiting party.
 - c. Mode of travel with expected time of arrival.
 - d. Length of Visit.
 - e. Purpose of Visit.
 - f. Proposed items of interest (tour, briefing, entertainment).
3. Advise involved staff of upcoming visit.
 4. With the commander's guidelines preferences, develop an itinerary. Make a detailed schedule by including:
 - a. Arrival time, greeting party.
 - b. Honors (if appropriate).
 - c. Car seating plan.
 - d. Time sequence (block minute by minute); allow sufficient time for events. It is very important to allow time for breaks, transportation, and rest periods.
 - e. Courtesy calls.
 - f. Briefings.
 - g. Meals.
 - h. Social functions.
 - i. Participating base personnel and telephone numbers.
 - j. Escort officers and telephone numbers.
 - k. Quarters.
 - l. Departure time and mode of transportation.

When all plans have been coordinated and approved, publish an itinerary. It is also a good idea to reduce it to pocket size in order for the itinerary to be more manageable.

5. Consider preparing a separate itinerary and schedule of events for spouses in the visiting party, since their interests may differ from those of the official party.
 - a. Work closely with the commander's spouse to build the itinerary.
 - b. Determine the visitors' interests.
 - c. Arrange tours and briefings on family assistance programs, wives' club activities, family housing, and historical sites (pick places for which your area is known).
 - d. Allow time for shopping in stores sell fine American-made products. Fashion shows are popular.
 - e. Coordinate with each agency and store.

6. Distribute copies of the itineraries to all local personnel/spouses concerned. When time permits, send a copy of the schedule to the visitor prior to the arrival as a matter of courtesy. This action also gives the DV an opportunity to prepare for the visit and request changes if necessary.
7. Coordinate with the commander on the composition of the official greeting party which will meet the distinguished visitor.
 - a. Notify the individuals selected.
 - b. Keep them informed of the time and place of arrival of the distinguished visitor.
 - c. Ensure dignitaries (especially foreign visitors), are met and bade farewell by officers of equal rank, if possible. As a general rule, this requires that a general officer be present at the arrival and departure of a general officer on an official visit.
8. Make arrangements with senior staff officers for appointments and conferences.
9. Notify the public affairs office so news media and photographic coverage can be arranged, as appropriate.
10. Contact the billeting office to reserve appropriate accommodations for the visitor and members of the party.
 - a. Ensure rooms are in excellent condition including the heat, air conditioning, telephones, television, lights, drains (i.e. everything).
 - b. Coordinate with the commander on personal preferences for quarters conditions.
11. Arrange with the motor pool for transportation for the visitor.
 - a. Ensure all drivers of the members' official party are briefed regarding their schedules.
 - b. Provide them with exact directions so they can work independently if they become separated from the other cars in the group.
 - c. Dry run the desired route two days in advance of the arrival party.
 - d. Always have an alternate plan in mind in case the primary route is unavailable when needed.
12. Arrange for honor guard formations, guards, security police escorts, as appropriate and desired.

13. Schedule the conference room for briefings, as necessary, and notify the staff agencies involved in the briefings.

14. Select and brief escort officers or couples, as appropriate.

15. Ensure all personnel concerned are informed of the visitor's security clearance status and any restrictions regarding access to classified information and/or restricted or controlled areas.

16. If official entertainment is planned:

- a. Contact the officers' club or a caterer, and make necessary arrangements; consider dietary restrictions conveyed (with international visitors -- be aware of religious differences on food preparation and serving).
- b. Assist the official host in compiling the guest list.
- c. Prepare and send invitations.
- d. Prepare confirmed guest list, name tags, place cards, and seating chart, as appropriate.
- e. Arrange for flowers (corsages) for distinguished lady guests, and for individual official flags.

17. Prepare information folders for members of visiting party. The folders should contain:

- a. The local itinerary.
- b. The schedule of events.
- c. A list of room assignments.
- d. A roster of local general officers and other key personnel and services and their telephone numbers.
- e. A pamphlet describing the mission of the Air Force or base.
- f. An information sheet on points of interest in the local area.
- g. Invitations to social events.

POLICY ON CEREMONIAL HONORS

Honors and ceremonies are designed for greeting all DV's when they arrive and depart Air Force installations. According a person these honors does not bar additional or subsequent ceremonies, such as reviews or parades.

In general, honors and ceremonies are reserved for the President, Vice President, statutory appointees, and general flag officers of the United States military establishment, and foreign dignitaries.

When a DV (military or civilian) entitled to ceremonial honors is preparing for an official visit to an installation, he or she notifies the installation commander or his/her designated representative at least 30 days in advance, except in those few situations where advance clearance would impair the mission. If this advance timing cannot be met, the commanders concerned must be contacted as soon as possible. Such notification must include the general purpose of the visit, particular items or areas of interest to the person, and honors desired. Officials of the DOD and of the other military departments are expected to provide similar advance information. In the interest of economy and in order to conserve manpower resources, salutes, honors, or ceremonies for DOD general/flag officers will not be held unless specifically requested by the visitor. If requested, such honors are expected to serve some useful purpose, such as promoting international good will, maintaining national prestige, or improving morale. DOD general/flag officers of the other military departments are expected to conform to this practice.

The customary courtesies and appropriate assistance required to accomplish the mission will be extended to DV's. The commander or his/her designated representative should be present to greet a visiting official upon arrival.

There will be no official entertainment of DOD personnel visiting installations unless such entertainment would contribute to the mission of the visit in terms of promoting international good will, community relations, or morale. If the installation commander believes entertainment would help accomplish the mission, he/she arranges for it only after approval in advance by the official person. The visitor who originates a request for entertainment must reimburse the installation for the expense.

Only the ranking officer or civilian official authorized an official flag may have the flag or other special identifying insignia displayed on the aircraft, ship, or motor vehicle in which traveling. Such flags or insignia will not be displayed for other individuals on an assimilated rank basis. (See AFR 900-3 for use and display of individual flags.)

The International Affairs Division (CVAI), HQ USAF will in each instance issue guidance and any special instructions pertaining to honors and ceremonies to be accorded official foreign DVs in the CONUS.

Distinguished persons who are entitled to honors are shown in the Table of Honors found in Attachment 1 of AFR 900-6. That table includes those honors prescribed for statutory civilian and military officials of the Department of Defense. The table also includes commissioned officers through the President.

When Honors Will be Accorded

Unless otherwise directed, full honors must be accorded the President of the United States when he arrives at or departs from any Air Force installation, regardless of the day or hour.

Except for the President, honors are not accorded between retreat and reveille, on Sundays, or on national holidays (except Armed Forces Day and Independence Day), unless the officer directing the honors believes the occasion requires an exception. A DV arriving at an Air Force installation at a time honors are not accorded may be honored at a later time if desired.

When two or more persons entitled to honors arrive at or depart from an installation at the same time, only the senior receives honors. If they arrive or depart successively, honors are paid to each in turn, except that a senior must be notified before the installation accords honors to a junior.

Any official or officer holding two or more positions (civil or military), any one of which entitled him/her to honors, receives only the honors due the highest grade; he may not be honored in more than one capacity.

When Ceremonies May be Held

Ceremonies may be held at any assembly area, but arrangement of distances and timing must reflect dignity and a sense of protocol. If facilities are limited, such honors as are possible will be accorded. The site of the ceremonies must be controlled to avoid disturbance by intrusion of spectators.

Meeting and Greeting Distinguished Visitors

The following procedures apply, whether the distinguished visitor arrives by automobile, commercial air, or military air.

1. Honors are rendered as prescribed in AFR 900-6. When honors are scheduled, the senior greeting officer meets the visitor as he/she debarks and escorts him/her to the position to receive honors. (If a visiting dignitary's spouse is in the party, the senior greeting officer's spouse is also there to greet the debarking visitors and remains with the dignitary's spouse during the honors ceremony.) Upon completion of the ceremony, the senior greeting officer escorts the distinguished visitor through the receiving line, and they are followed by the visiting party members. (Figures 34 and 35).
2. The protocol officer, escort officer, and/or aides assist in processing baggage, clearing customs (as necessary), and delivering baggage to the billets of the visiting party.
3. The composition of the greeting party is important. Normally, one or more of the following greet distinguished visitors upon arrival when they are Deputy Chief of Staff, USAF, level or higher: at MAJCOM, the Commander, Vice Commander, or Chief of Staff; and at wings, the wing commander, one or more of his/her deputy commanders, and/or his/her executive; at bases, the base commander or vice commander. The protocol officer determines

by means of a memorandum who will comprise the greeting party. If none of the officers listed above are available, the protocol officer requests a general officer or the senior staff officer of the office of primary interest for the visit meet the dignitary. As a general rule, an officer of rank equal to that of the visitor is selected. The commander usually indicates those officers on the staff to be included in the greeting party. When spouses are in the visiting party, the spouses of the greeting officers are normally included in the greeting party.

Prior to Arrival by Automobile

The protocol officer will be responsible for the following:

1. Arrange for a security police escort vehicle to meet the visitor at the entrance to the base and lead the way to the designated area (where greeting party will meet the visitor). Prior to arrival, security police are provided the name and position of the visitor, the approximate time of arrival, and a description of the car in which the visitor will be traveling, to include the license number.
2. Coordinate with the security police on the route to be traveled from the base entrance to the designated area, and request the security police control traffic along the route, if considered necessary.
3. If honors are appropriate and space permits, arrange for the honor guard and band to be in place at or close to the designated area.

Upon Arrival by Automobile

The driver of the security police escort vehicle leads the way, gauging his/her speed to ensure the visitor arrives at the designated area as close as possible to the time expected, consistent with safety.

Upon completion of honors, if scheduled, the visitor and official party are escorted to the designated office or activity. If honors are not scheduled, the greeting party meets the dignitary, and they proceed to the office or activity the dignitary is to visit.

Visitors Traveling by Commercial Air

Normally, no formal greeting ceremonies are scheduled at the airport. The protocol officer adapts the plan to the circumstances of the DV's arrival. Usually, an officer of appropriate rank and/or position is designated to meet the visitor at the airport and provide escort to the base. The applicable instructions in the preceding paragraphs are followed for meeting and greeting the visitor at the base, rendering honors, et al.

Prior to Arrival by Military Air

Through base operations, track the aircraft's schedule to determine arrival time. At least 15 minutes before the estimated time of arrival of the visitor:

1. The protocol officer and the escort officer(s) meet at the flight line to make a final check to ensure everything is ready and coordinate last minute changes.
2. Automobiles, each with a planned seating arrangement, designated to carry specific members of the visiting party, are lined up in the order they will depart from the flight line. The car for the DV and the senior greeting officer is first, with the others following in order of seniority of passengers. Each driver is briefed on the destination of his/her passengers after leaving the flight line. (A copy of the itinerary should be furnished each driver.)
3. If honors are scheduled, the honor cordon, the honor guard, and the band should be in place.

Ceremony on Arrival by Military Air of a DV Other Than the President

The installation commander and receiving party stand close to the dignitary's anticipated point of arrival. The honor cordon consists of two lines of the prescribed number of airmen (shown in the Table of Honors in AFR 900-6), at normal intervals facing one another to form an aisle five paces wide. This aisle begins at, and extends behind and away from, the line on which the installation commander takes a position. The honor guard commander centers five paces beyond the end of the aisle of airmen. The Color Guard forms at normal intervals centered four paces behind the honor guard commander. If a band is available, it must be centered four paces to the rear of the Color Guard (see Figures 34 and 35). When additional flights of airmen are used for a special occasion considered appropriate by the installation commander, they are formed on the line with and on each flank of the band. Each additional flight will consist of not more than 28 airmen and honor flight commander. All members of the formation, except the aisle of airmen comprising the honor cordon, must face the designated point of arrival of the distinguished person's aircraft.

When the dignitary arrives, the aircraft must be directed to a selected position so the dignitary will be facing the formation when exiting the aircraft. As the aircraft nears its selected position, the band or a recording provides appropriate background music (see footnote 7 of the Table of Honors, AFR 900-6). The honor guard commander calls the formation to attention as the installation commander and receiving party come forward and salute the distinguished person. The installation commander then extends a greeting. Unless the distinguished person desires certain members of the official party to share the honors, none will participate.

The installation commander escorts the dignitary to a central position facing the Colors two paces from the line at which the aisle of airmen begins. The commander aligns himself/herself on the dignitary's left. If there are numerous members of the party to be honored, they form a line or lines behind the dignitary and the installation commander. The band or recorded music will cease as the dignitary nears the designated position. Upon signal from the installation commander, the honor guard commander orders "Present Arms." The band, or recorded music, presents Ruffles and Flourishes and the Honors march, during which all persons salute (see footnotes 2 and 3 of Table of Honors, AFR 900-6). The person receiving honors acknowledges them throughout the music by a personal salute. Personnel in uniform witnessing the ceremony, salute and face the person being honored. Men in civilian clothes also face the person being honored and salute by removing the hat with the right hand and holding the hat at the left shoulder with the right hand over the heart. Men without hats should salute by holding the right hand over the heart. Women in civilian clothes salute by placing the right hand over the heart without removing their hat, if worn. When the music stops, the honor guard commander commands "Order Arms."

Upon conclusion of honors and music, the installation commander gives the command, "Flight, Prepare for Inspection." At this command, the honor guard commander marches forward, halts three paces in front of the distinguished person, salutes, and states, "Sir/Ma'am, the honor guard is ready for inspection." The honor guard commander takes a position to the right of the distinguished visitor and guides the visitor through the inspection. The host takes a position to the rear of the distinguished visitor with the installation commander on the right (i.e. if host and installation commander are separate individuals). The band plays appropriate music during the inspection (see AFR 900-6, footnote 8, attachment 1). The route of the inspection begins with the file of honor airmen to the distinguished person's left, continues down this file, then proceeds in front of the band (between the Color Guard and the band), to inspect the other file of honor airmen. The band and Color Guard will not be inspected. At the end of the inspection, the honor guard commander escorts the DV back to the original position. When additional flights are used, the route of inspection must be expanded to include them. When the DV returns to the original position, the band ceases playing, and the honor guard commander must salute, do an about-face, and return to his/her original position.

The installation commander then escorts the DV to enter the designated staff car, which has been driven to a point in front of the honor guard commander. The honor guard commander commands "Present Arms." Only the honor formation salutes. As the DV enters the vehicle, the band plays appropriate background music. Members of the dignitary's party will be escorted through the aisle of airmen to their staff cars. After the last staff car departs from the vicinity, and the music has stopped, the honor guard commander commands "Order Arms" and dismisses the formation.

DIAGRAM OF A CEREMONY FOR MAJOR GENERALS OR REAR ADMIRALS

VIP Receiving Honors:

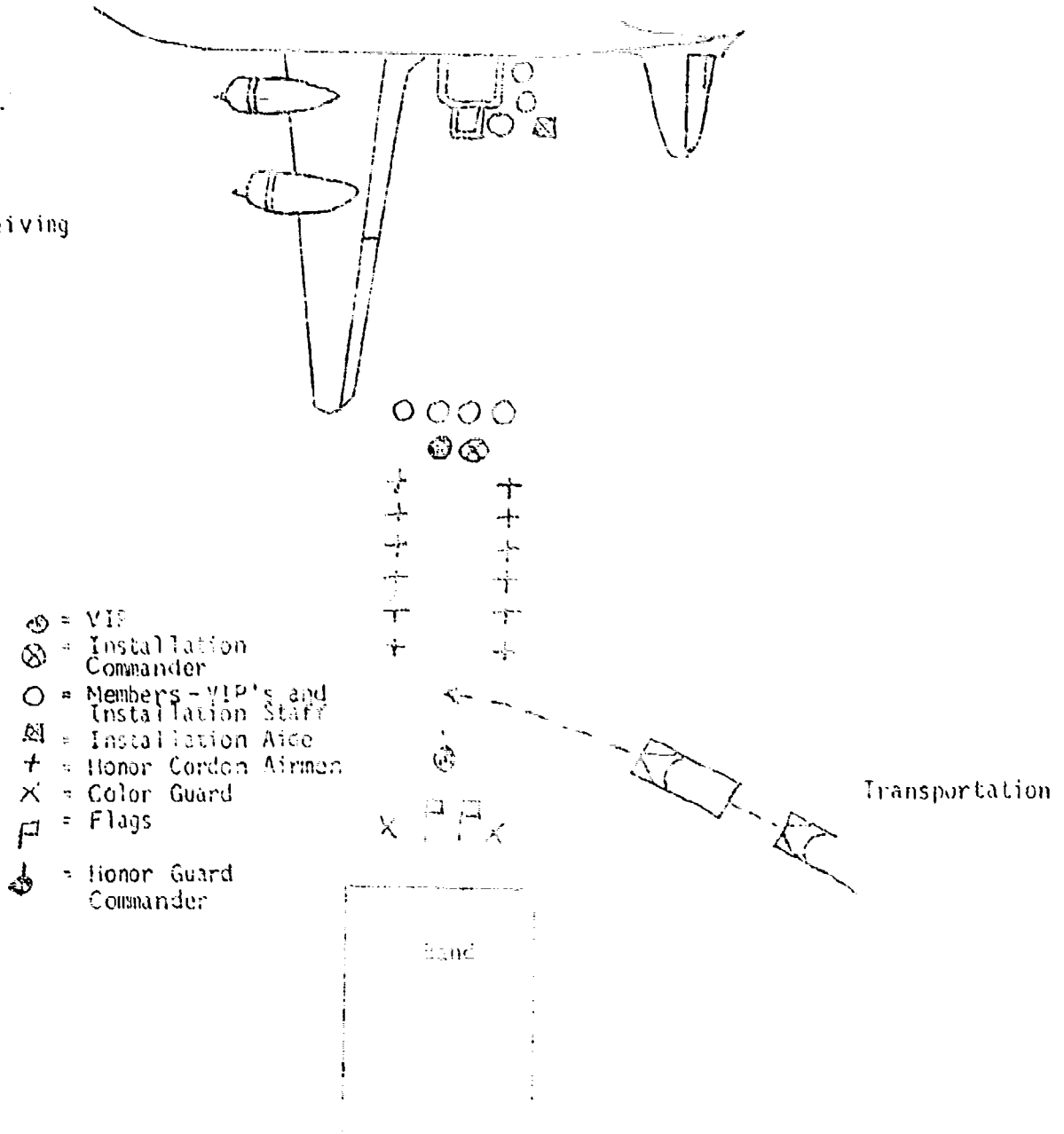

The above arrangements relative to the positions of the participants and the band may be adapted to fit local physical conditions. Additional flights may be added as desired.

DIAGRAM OF A CEREMONY FOR THE SECRETARY
OF THE AIR FORCE

Secretary of the Air
Force Receiving Honors:

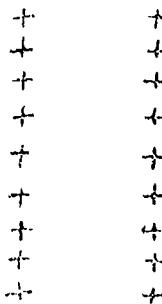
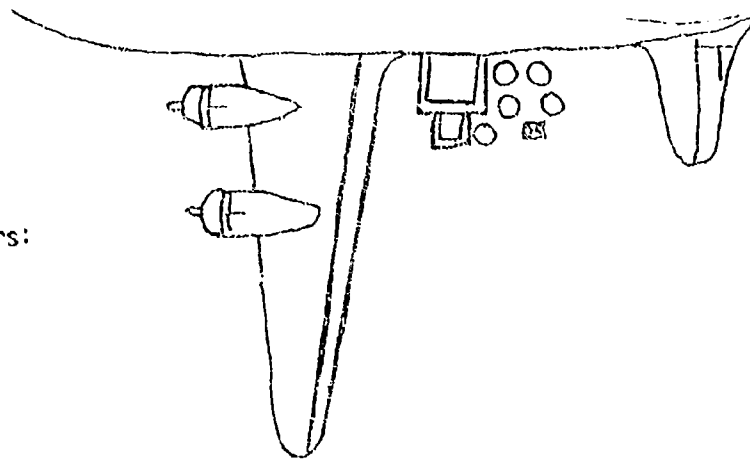

Legend

- ⊙ = Secretary
- ⊗ = Installation Commander
- = Members - VIPs and Installation Staff
- ⊠ = Installation Aide
- + = Honor Cordon of Airmen
- x = Color Guard
- ▣ = Flags
- ♠ = Honor Guard Commander

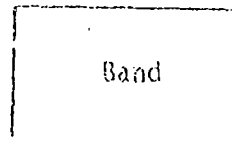
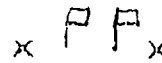
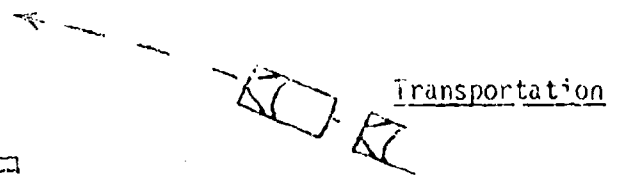

The above arrangements relating to transportation, band, and additional flights may be adapted to fit local physical layouts.

Figure 35

Visit Checklist

VIP: _____ POSITION: _____

DATE OF VISIT: _____ PURPOSE: _____

PROJECT OFFICER: _____ OFC SYM: _____ PHONE: _____

OTHERS ARRIVING WITH VIP: _____

UNIFORM: _____ BIOGRAPHY: _____

ITINERARY:

_____ Tentative itinerary prepared/distributed

_____ Final itinerary prepared/distributed

ARRIVAL:

_____ Commander Notified _____ Honor Guard notified _____
(place and mode) (as needed)

_____ Staff notified _____ Security Police notified _____
(as needed)

_____ Ground transportation arranged (vehicle dispatch, EXT _____
Request star plates (if general officer)

BRIEFINGS:

<u>Place</u>	<u>Time</u>	<u>Subject</u>	<u>Point of Contact</u>
--------------	-------------	----------------	-------------------------

- 1.
- 2.
- 3.
- 4.

_____ Conference room / slide flipper

_____ Attendees notified

_____ Name tags ordered for conference table (graphics: EXT _____)

_____ Seating Arrangement

_____ arrange for coffee, rolls, etc.

TOUR:

_____ Arrange transportation

_____ Arrange escort

MEALS:

_____ Location reserved (O'club: EXT _____)

_____ Attendees notified: _____

Ceremony on Departure of a Distinguished Person by Military Air

The ceremony on departure of a distinguished person is substantially the same as the ceremony on arrival, but in reverse. The honor formation is identical. The DV's car is driven to a point in front of the honor guard commander, who brings the formation to attention and salutes. The band plays appropriate background music (see AFR 900-6, footnote 7, attachment 1). The DV, accompanied by the installation commander, proceeds to the same place at which honors were rendered on arrival, and takes a position facing the Colors. Meanwhile, the members of the DV's party are escorted from their cars to the aircraft by a route outside the aisle of honor airmen. When the music stops, the honor guard commander commands "Present Arms." The band or recorded music then presents Ruffles and Flourishes and the Honors march, during which all persons salute (see AFR 900-6, footnote 2 and 3, attachment 1). The honor guard commander commands "Order Arms" when the music stops.

Upon conclusion of honors and music, the installation commander gives the command "Flight, Prepare for Inspection." The same inspection procedures prescribed above will then be followed. After the inspection, the installation commander escorts the DV to the aircraft and bids goodby. As the DV moves toward the aircraft, the band plays appropriate background music. After the DV and the official party have enplaned, the receiving party moves to a position between the airplane and the honor guard. Where space does not permit the honor formation to remain in position, the honor guard commander should issue the necessary orders to form the honor guard at a safe distance from the point of departure of the aircraft. Usually, closing ranks by the honor airmen will be sufficient. Only the installation commander salutes as the DV's airplane moves away.

Position of Staff Cars and Duties of Drivers

Drivers of staff cars for the DV and party will not salute during the ceremony. They must remain in their vehicles alert to move forward. The positions of the vehicles depend upon the location of the ceremony.

Conclusion

AFR 900-6 remains the authority on honors accorded DV's. It contains other very important matters, such as the specific protocol requirements for Presidential visits and protocol requirements upon the notification of a distinguished visitor's death. Commanders, for example, must render the honors and take other actions prescribed in AFR 900-6 upon receipt of official notice of information through radio, television, or other news media, of the death of any person entitled to such honors. In addition, Figure 36 is a very usable checklist for visits. By suitably modifying it to meet local needs, it could be very helpful to you.

ESCORT OFFICERS

An escort officer is normally assigned to each DV for the duration of his/her visit. The escort officer accompanies the visitor throughout the visit, except when circumstances indicate otherwise. Officers of all grades, lieutenant through colonel, may be selected as escorts. Compatibility of interests is a major consideration in the selection of the escort officer who, as the official representative of the commander, is expected to reflect the hospitality of the Air Force. The escort officer extends every courtesy, official and social, and overlooks no detail in making the visitor feel welcome. He handles all situations with tact, consideration, and courtesy, coupled with judgment and common sense. Sufficient numbers of escort officers are selected for each visiting party to ensure each visiting party member is given all practicable assistance and extended every reasonable courtesy during the visit. When the visiting party includes spouses, the spouses of the escort officers are requested to act as escorts for the visiting spouses. Escort officers and their spouses who are scheduled to act as escorts should contact the protocol officer for guidance and assistance considered necessary.

Procedures to be observed by the escort officer are:

1. Prior to the arrival of the DV:
 - a. The protocol officer briefs the escort officer (and the spouse, if acting as escort) on the various phases of the itinerary as they pertain to the individual who is to be escorted.
 - b. If the visitor is to be billeted in the distinguished visitor's quarters on base, the escort officer registers the guests at the billeting office. The protocol officer checks the quarters for readiness, and reports any discrepancies to the billeting office immediately for correction.
2. Upon arrival and during visit:
 - a. The escort joins the greeting party and, upon meeting the DV, introduces himself/herself and offers assistance for the period of the visit. If the commander is not a member of the greeting party, the senior escort officer extends the commander's greetings and best wishes. Upon completion of greetings, the escort accompanies the visitors to the next scheduled activity or to their quarters, as indicated on the itinerary. After escorting the visitors to their billets, the escort departs, unless circumstances indicate otherwise.

- b. At the first opportunity, the escort spouse should go over the itinerary with the visiting spouse. The escort should know about and inform the visiting spouse of any special activities taking place on the base or in the near vicinity, which might be of interest to the visitor. The escort should also offer to accompany the visitor on shopping or sightseeing tours, and make any other arrangements the guest may desire. If assistance is needed in making these arrangements, the protocol officer is the point of contact.
 - c. If the escort officer is invited to a social function in connection with escort duties, the escort reminds the visitor of the time, place, and type of dress for the occasion, and escorts the visitor to the function. Timeliness is important. If the visitor is delayed in meeting a commitment, the escort officer informs the host of the delay, with the reason. At any official social function, the escort ensures the visitor meets other dignitaries present. When the visiting dignitary is engaged with other dignitaries, the escort officer should excuse himself/herself gracefully, but remain visible in the near vicinity. (An escort spouse follows similar procedures in assisting a visiting spouse.)
3. Upon and after the visitor's departure:
- a. Shortly before the visitor is to depart, the escort officer contacts the billeting office to obtain billeting charges. If, as in the case of foreign dignitaries, billeting charges are to be paid from contingency funds, the escort follows the procedures specified by the protocol officer in the initial escort briefing. When the charges are not to be paid from contingency funds, the escort officer presents the bill to the DV or the appropriate member of his party for payment.
 - b. After the DV has departed, the escort officer briefs the protocol officer on any problems encountered during the visit and makes recommendations to improve procedures.

INTERNATIONAL DISTINGUISHED VISITOR TOURS

Introduction

Air Force bases are attracting increasing numbers of foreign visitors. The primary purpose of their visits usually is to observe the USAF and compare its operations to their own requirements. In addition, these visits provide an excellent opportunity to exchange ideas. Every effort is made to ensure foreign visitors return to their country with the best possible impression of the Air Force's activities, motivated (hopefully) to seek the cooperation of their governments with the United States. Since Air Force installations are often the center for foreign distinguished visitors, a little information on the run down for conducting foreign distinguished visitor tours is in order. For detailed guidance, refer to AFP 11-17, Guide to Conducting Foreign Distinguished Visitor Tours.

Notification

HQ USAF/CVAI notifies Air Force installations scheduled to be visited by foreign dignitaries sufficiently in advance to enable the commanders of the installations concerned to make suitable plans and arrangements. The initial notification is by alert message followed by the tour letter. The alert message gives the makeup of the party, the overall itinerary, general purpose of the visit, areas of interest to the visitor, and particular items of special instructions. It includes names, ranks, military positions, English speaking capabilities, honors to be rendered (usually accomplished in Washington D.C.), and instructions regarding security clearances. The tour letter, or guide for handling foreign visitors under the auspices of the USAF Tour Program, denotes special instructions for funds at each installation, guidance on photographic coverage, and any amplified explanation on the purpose of the visit and makeup of the official party. Attached to the tour letter will be the protocol data and biographical sketches of the official party.

Tour Itinerary

The itinerary for foreign dignitaries is based upon suggestions by the USAF representatives in the country concerned, the Air Attache, the Chief of the Air Force Section of the Military Assistance Advisory Group (MAAG), or the Chief of the Air Force Mission. It is compiled in HQ USAF/CVAI. The Air Ministry of the country involved may also request a visit to a specific installation.

Briefings and On-Base Tours

Planning for briefings and conducted tours of base activities should be carefully related to the objectives of the tour program as outlined in the alert message. The distinction should be recognized between the tour objectives of visits by air ministers or foreign chiefs of staff and visits by foreign air force officers sponsored under the Military Assistance Program (MAP).

Air ministers and foreign chiefs of staff are interested primarily in the broad aspects of USAF organization, training methods, operational procedures, and concepts of aerial warfare. Tours of this type are designated "Chief of Staff Tours." Any specific desire of the distinguished visitor should be stated in the alert message.

Tours conducted under MAP are known as "Map Orientation Tour/Distinguished Visitor" and rarely include a foreign chief of staff. However, the importance of MAP visitors should not be judged by their rank, but rather by the importance of the positions they hold in the air force of the country concerned. The purpose of the MAP Orientation Tour/Distinguished Visitor is to assist the visitors in obtaining maximum utilization and understanding of material and equipment furnished under MAP. As technicians, this group is interested in personnel indoctrination with USAF methods pertaining to organization, equipment, logistics, training, and operating techniques. When it is deemed desirable, advance information is provided indicating types of equipment furnished or programmed under MAP.

Tours of Air Force installations sponsored by an agency other than the Air Force are referred to as Other Agency Tours. Included are tours of guests of the Department of Army or Navy, Department of Defense, or the Joint Chiefs of Staff for which either of these agencies is assigned responsibility (Executive Agency) for all aspects of planning and execution. The type of visitor involved may vary from a chief of staff to a technician who is interested in only one facet of a particular program. Guidance as to special interests of visitors must be included in the alert message.

Briefings and demonstrations should be slanted toward the specialties represented by the job titles of the visitors, unless otherwise specified by the tour letter. Groups are usually composed of officers with no more than two primary fields of interest. Most visiting foreign nationals understand English when it is spoken slowly and simply. Briefing personnel should avoid the use of complex sentences, initials, and abbreviations in their lectures. The extensive use of visual aids, where possible, is recommended. Formal briefings should be short, concise, and given in the native language of the visitor, when possible. Reports prepared by escort officers reveal briefings soon become repetitious when they describe in detail the position of each base in the overall command organization. It is suggested that briefing officers present the MISSION and OPERATIONS of the base concisely, touching very lightly on details, unless visitor reaction indicates interest in a specific subject.

Escort Officers

All foreign dignitaries on tour of Air Force installations under the USAF Distinguished Visitors Tour Program are accompanied by an Air Force officer acting in behalf of the Secretary of the Air Force or the Chief of Staff. The officer is responsible for administrative and financial details of the tour and serves as interpreter when a language barrier exists. When possible, the escort officer is selected from those in training for assignment in the attache or mission system in the country concerned. The escort officer, therefore, usually has a personal as well as official

interest in the success of the visit, since it may eventually enhance his or her status when assuming duties in that country. Since benefits will accrue to the Air Force through the escort officer's contact with the visitors, this officer must be included in all events pertaining to the visit, including social functions. Commanders should assist the escort officer in fulfilling the visit mission, and are encouraged to solicit advice on any phase of the local itinerary.

Entertainment

When you plan entertainment for foreign dignitaries, try to take advantage of the most distinctive, positive aspects of the local area. This gives the guest wider exposure to the many forms of entertainment available in America. Special restaurants, museums, concerts, recreational areas, and shows vary from locality to locality; and if you have something unique and tasteful in your area, show it off. Since HQ USAF sponsors a high level official reception or dinner in Washington, other social functions should be smaller and less formal. These factors govern the allocation of entertainment funds. The following suggestions from escort officers' reports and from remarks made by the foreign visitors should be considered in planning entertainment:

1. Large cocktail parties at officers' clubs are discouraged. Visitors prefer small, more intimate gatherings such as small dinner parties with staff officers and their spouses. Visitors are particularly impressed by the home life of Americans, and appreciate being entertained in the home of the commander or his representative. If you have any questions on entertaining international dignitaries, contact HQ USAF/CVAI.
2. Regarding dinners, make sure persons of equal rank to the visitor attend, but also try to include foreigners or other guests of the same national or ethnic background as the dignitary. Guest lists should be varied from visit to visit to enable the maximum number of USAF officers and their spouses to participate in social functions. It should be remembered, however, that certain officers, because of their position or assignment, should be included in all functions. Officers who have served as Air Attache or in the MAAG of the country concerned should be included when possible.
3. Visitors enjoy participating in base functions which may not have been especially planned for them, for example, barbecues and picnics where sports clothes may be worn.
4. On weekends the visitors should be given an opportunity to shop and visit local points of economic, historical, and scenic interest such as ranches, farms, museums, and parks.
5. When the wife of a male foreign visitor accompanies him, a separate program of activities should be arranged, when appropriate, to permit her to observe activities of American women

and typical American home life, and to give her an opportunity to shop and sightsee in neighboring communities.

International Customs and Courtesies

In the case of foreign dignitaries, their customs with regard to religion, social, and other cultural taboos should be given careful considerations to avoid offense and embarrassment. You should familiarize yourself with some international customs and courtesies when hosting visiting foreign dignitaries. Take particular note to avoid serving combinations of veal and ham, or chicken and ham, both of which are unacceptable to Moslems and members of the Jewish faith. Fish is acceptable almost universally. It is always wise to have a variety of nonalcoholic beverages available to those who prefer them. Since each country has its own customs, it is appropriate to contact HQ USAF/CVAI for specific guidance.

Funds

Funding of tours for foreign dignitaries is the responsibility of HQ USAF or the agency for when the Air Force acts as Executive Agent. Funds are provided for minimum official expenditures on the basis of the visitor's rank and the objectives of the tour. Maximum funds available to each installation for official entertainment will be listed in the tour letter. The escort officer is not authorized to exceed the established limit nor to expend funds for other than specified purposes. The maximum fund citation given to a command or installation does not include the cost of quarters and rations which is paid separately by the escort officer. The escort officer should be given fully itemized bills in sufficient time to enable him/her to make payment before departure. The escort officer must be provided with guests lists for every function arranged for the visitor to comply with final accounting procedures. Occasionally an installation commander may be requested to provide funds from resources available to him. Such a request is an exception and is avoided whenever possible.

Duties of Project/Escort Officers

To ensure a successful visit, a local project/escort officer should be appointed to accompany foreign visitors during their stay. The officer so designated should be available for necessary liaison between the Air Force escort officer and base authorities, and should be able to provide the escort officer with services or requirements generated by the visit. The selection of the escort officer should not be based solely on the availability of a particular officer. Rather, choose an officer for this important duty very carefully and brief him or her on all facets of the schedule, problems that may arise, and methods to best solve potential problems. Briefings to the local escort officer should include these points:

1. The uniform requirements of each planned event. In addition, remind escorts that they must be in the correct uniform for each event.

2. If changes are made in the schedule of events, the local escort officer must notify the overall escort officer of these changes. Should the visiting dignitary have any special desires or requests, the overall escort officer should be aware of them.

3. Both escort and protocol officers should know where the short-notice dry cleaner is in the event of any mishaps so they can take care of any dry cleaning the dignitary may require.

4. In the event of an emergency, the escort must have the necessary reference material. Some of the emergencies that might arise include food requirements, transportation, medical needs, etc.

5. The local escort officer and protocol officer must be aware of the toasts that will be made at formal luncheons and dinners and of the appropriate responses. Also, if the dignitary desires to make any speeches or have a press interview, the commander must be apprised of these.

6. Arrange to have a female escort for a foreign dignitary's wife. When selecting this escort, consider her age, language capabilities, and position. The capabilities of the escort often prove to be very valuable to the guest.

Protocol Visit Check List

Prearrival preparations could consist of the following:

1. Arrange for honors (honor guard and band).
2. Arrange for transportation (including security police escorts, if applicable).
3. Plan official entertainment (including menu, cost, and guest list for commander's approval). Check itinerary to see if special provisions (i.e., foods and beverages) for those of varying culture and religious beliefs are required. Customs with regard to religious, social, and other cultural taboos should be considered to avoid offense and embarrassment to foreign dignitaries.
4. Send written instructions to the officer in charge of any dining or entertainment requirements. Include composition of visiting party, location desired, time, and date.
5. Arrange press coverage as appropriate.
6. Arrange for photography as desired.

7. Designate billeting arrangements. Provide billeting for the escort officer in the same building as the dignitary when possible; if not, make suitable transportation available to the escort.
8. If appropriate, secure information brochure or handouts which would be of special interest or assistance to the visitors.
9. Determine the following:
 - a. Method of reimbursement if applicable.
 - b. Method of payment for meals, VOQ charges, toll charges for telephone and telegraph, dry cleaning, laundry, etc.
10. Prepare local itinerary and notify responsible individuals or organizations. Inform responsible individuals of the distinguished visitor's particular interest in a subject or operation.
11. Schedule facilities for briefing of visitors.
12. Inform briefing officers of HQ USAF authorized disclosure and limitations. After the pre-arrival preparations have been completed, the project officer should list the persons and organizations to notify of the exact time of arrival of the distinguished visitor. The following should be included in the list for notifications:
 - a. Major organizations concerned.
 - b. Ceremonial elements.
 - c. Transportation facilities.
 - d. Members of the receiving party and aides.
 - e. Dining facility and billeting office.
 - f. Information officer.
13. Meet the guest upon arrival at base operations or at the appropriate commercial transportation terminal.
14. Furnish the HQ USAF escort officer copies of the base itinerary, as well as lists of names and positions of officers who the visitors will meet.
15. Give special attention to the transportation, dining, and recreational arrangements and needs of a dignitary's aide or aides. Foreign dignitaries usually travel with one or more aides from their own armed service. These individuals usually are officers of the highest caliber who will probably hold positions of authority in their countries in the future. They often form lasting impressions of the United States and its Air Force as well as the hospitality and treatment rendered.

16. Escort the guest to his/her quarters in the VOQ or to the hotel. Should the commander so desire, the host officer may escort the guest directly to the commander at his/her office or quarters.

17. Arrange a luncheon for the wife of a dignitary when the DV is to be given a stag luncheon. The wife's luncheon should be given by her American hostess or by the wife of another high ranking official. Not only should American officials' wives attend, but also the invitations should be extended to local notable citizens, such as those of the same national origin as the guest.

18. When official entertainment is planned, extend an invitation to the guests and accompany them to the function.

19. Arrange for private entertainment for the guest if there is no planned entertainment.

20. Arrange with the VOQ officer for payment of bill and checkout.

21. Before scheduled departure, obtain for the HQ USAF escort officer all receipted bills incident to the visit. Eliminate if possible, any necessity for the escort officer to absent himself/herself from the visiting party, and any necessity for the DV to settle accounts or to become involved in check-in or checkout procedures.

Conclusion

Your authoritative guidance for international DV tours is AFP 11-17. It contains specific guidance on other matters such as security clearances, honor, funds accommodations, press coverage, et al. Be sure to use it as your authoritative source. We will now focus on a specific duty that a protocol officer will encounter in one way or another - aide-de-camp.

Chapter Eight

AIDE-DE-CAMP FUNCTIONS

You may be wondering why I included a chapter on aide-de-camp functions in this guide to protocol. It is quite simple - you'll benefit by knowing about this particular officer since the aide is often a close companion either as a co-worker or as a visitor. Your job can be a lot easier if you understand and work in harmony with the aide. Most aides are worth their weight in gold since they, if they are experienced, can provide you important information that can make the general officer's visit/tour a success. Your primary duty is to assist the general or commander in any way you can.

Position

The duties of the aide-de-camp, or aide as he/she is commonly known in the Air Force, have differed widely at various times and in various military forces throughout history. The earliest aides were little more than orderlies who looked after the comfort and personal property of the commander in the field. On the other hand, some of Napoleon's aides were men of exceptional military ability who acted as his "eyes," and as interpreters of his mind to subordinate commanders. On occasion, they even exercised a delegated authority. The refinement of the staff concept in the modern military organization has tended to reduce the involvement of the aide in purely military matters. Indeed, in some services, notably the British, the aide is almost wholly occupied with social responsibilities. In the United States Air Force, the duties of the typical aide encompass a diverse, yet curiously homogeneous, grouping of military, social, and administrative responsibilities.

Responsibilities and Procedures

It is important for you to understand the responsibilities of an aide not only because of locally assigned generals, but also because of the number of visiting generals. Many of you will be working closely with a general's aide or may even be assigned to an aide position. These responsibilities and duties are true of a general's executive officer when he is not authorized an aide. Air Force officer aides are authorized only for general officers in command (or equivalent) positions. Joint positions and those outside the regular Air Force require by position authorization.

Entitlements are as follows:

1. General or lieutenant general - one lieutenant colonel.
2. Major general - one captain.
3. Brigadier generals are only authorized to use part-time additional duty officers from within existing resources. Special exception must be requested from the MAJCOM.

There are also a limited number of enlisted aides, and they are assigned based on the position and representational responsibilities of the general officer.

It is a special, voluntary assignment in which an officer may be selected because of his/her military appearance, judgment, personal integrity, ability to work with people, and his/her command of verbal and written communications. It is difficult to list the responsibilities of an aide because it all depends on the general officer, the mission of the unit, and the aide himself/herself. The following responsibilities and procedures are common ones in most aide positions.

The most important responsibility is to ease the demands which are made on the general's time. In the course of official duties, a general officer meets a very large number of people and is required to read a great deal of material. The aide can assist in making the time thus spent more productive. The aide, always guided by the desires of the general, must act as a sort of buffer. People seeking audiences with the general come to the aide over whose desk passes much of the printed material which the general will read. The adept aide will learn to distinguish the trivial from the significant and the important from that which is of little interest to the general. In these matters, the aide should be acutely perceptive of the general's interests. The general must never be shielded from vital information simply because it is unpleasant. When operating in this capacity, perhaps the greatest test is placed on the aide's ability to deal with people. When it is necessary to refer people to an appropriate staff agency or to a lower level of command, it must be done tactfully and diplomatically. The aide should carefully explain that the agency or person to whom they are referred is the best qualified to assist.

The aide will be commonly involved in social contacts. It may be with official receptions such as receiving lines, a New Year's Day reception, commander's call, a dining-in, etc. These social contacts may also involve various community relations such as speaking or appearance engagements for the general, formal parties et al. Knowledge of social forms and procedures is an important phase of the aide's activity. The nature of the aide's job demands a close working relationship with the protocol officer.

One of the most time consuming responsibilities of an aide is handling administrative details. The monitoring of appointments is one of the most important items in this area. The aide will also be reviewing incoming and outgoing correspondence for the general. The aide will work with the general's financial arrangements such as control of contingency (official)

funds. An aide may also handle at least a part of the general's personal money. This may happen when traveling because the aide normally pays the general's personal expenses. Funds for this purpose are usually provided by the general prior to departure from the place of assignment.

An aide has various responsibilities involving official travel. The aide will usually accompany the general; therefore, he/she will be responsible to make full preparation for and work closely with the general during the trip. Then, upon return from travel, the aide will ensure preparation of travel vouchers for the general, summarize notes taken on the trip for the general, and possibly prepare thank you notes for the general's signature for courtesies received while traveling.

Conclusion

This chapter on aide duties was to familiarize you with the various responsibilities required. You will work closely with aides, in fact, by the similarities in duties, you need to know this person very well. Both of your objectives is to help that commander/general.

Chapter Nine

FINANCIAL AND TRAVEL ARRANGEMENTS FOR COMMANDERS

Financial Arrangements

Various executive support officers, especially those in aide or protocol positions, will work closely with their commanders concerning certain financial situations. As you will read in the following chapter, commanders at such levels as wing/base, numbered air force, and major command have contingency funds available to defray expenses incurred by them for the official entertainment of prominent federal, state, and local officials. Each commander is personally responsible for properly using the funds and accurately reporting their use. The protocol officer should be familiar with these funds. This familiarity should include knowing the restrictions (your MAJCOM will place some of these restrictions) placed upon expenditures, administration procedures incidental to expenditure, and the balance remaining at all times. With this understanding, you will be able to alert the commander or general on the status of the funds. This will preclude obligating more money for a function than is available.

Travel Arrangements

Most general officers and numerous colonels are required by nature of their responsibilities to spend a considerable portion of their time in official travel. The aide will normally accompany the general on these official trips. While the colonel's executive officer may travel also, he/she will most probably just work in planning the trip. Responsibilities listed in the following text will depend on how much traveling your commander does and how closely you work with him/her in this area.

CT-39/C-21 Travel. USAF general officers and commanders frequently travel stateside on MAC's fleet of T-39/C-21 aircraft. These aircraft are operationally controlled by MAC/DOOF at Scott AFB, IL. It would be helpful for you to understand how the system operates, how to request transportation, and what to do if plans change in the middle of the trip. First, find out who your airlift validator is - in most cases, it is the secretary.

The validator is the only person in your headquarters from whom MAC will accept requests for T-39/C-21 travel. Oh, they may talk to you to give you general flight information; however, your requests for travel must be backed up with a request from the designated validator. Be sure you also understand the lead times required to support your general's or commander's movement. Provide a complete schedule and accompanying party list.

Even the best plans never go according to schedule. If you know of changes for airlift, let MAC/DOOF know. Tell the aircraft commander, relay through your home base, or call direct to Admin Airlift at AV 638-5851. The people at MAC/DOOF are very responsive and do a super job.

Prior to Departure. The first step in preparing for travel is to discuss the trip with the commander or general. Determine the itinerary, the duration, the purpose of the trip, and who will be escort. This information is necessary so you may have the TDY orders published (blanket TDY orders are often used) and the plans coordinated with all personnel concerned. Coordination is essential--with the people receiving the visit as well as with those making the trip. The people being visited should be notified as to the purpose of the trip, its duration, and personnel accompanying the general/commander. This coordination will ensure adequate facilities are provided for the needs and comforts of the general/commander and the official party during their visit. Furthermore, it will ensure key personnel are available at the destination to discuss any problem areas. The development of a check list is an excellent way to make sure "you do the right thing at the right time" before departing. Some questions that should be considered for inclusion on such a check list are:

1. Have electrical messages stating purpose and length of visit been sent to organizations to be visited?
2. Do the messages state rank, name, degree of security clearance, and assignment of personnel in the traveling party?
3. Do messages specify honors, if required, and indicate acceptable social and recreational activities?
4. Are the secretaries and the commander's spouse provided with a copy of the trip itinerary?
5. Are all personnel making the trip aware of the immunization and passport requirements?
6. Have personnel making the trip been notified as to clothing (military and civilian) requirements?
7. Have precautions been taken for safeguarding accompanying classified materials for duration of trip?
8. Has the aircraft crew been briefed?
9. Have inflight lunches been ordered?
10. Is biographical material (and picture if applicable) of key personnel at scheduled stops necessary?
11. For a general officer, will the general's flag be needed at the destination?

Needless to say, if you travel with the commander, you must be available at all times.

Upon Return. The duties performed by you upon completion of a trip are in accordance with the desires of your general/commander. However, these duties normally include:

1. Preparing of per diem voucher, filing a copy for record purposes.
2. Summarizing notes taken on the trip for the general/commander; presenting them in a readable form.
3. Being briefed by the secretary on things that happened while you were absent, and in turn, briefing the secretary on return about things of concern on the trip.
4. Posting the appointment calendar and book with new obligations.
5. Preparing, for the general's/commander's signature, thank you notes for courtesies received while traveling.

The preceding items are standardized to some degree; however, this listing may easily be expanded to fit your individual needs. Provided is a travel checklist (Figure 37) to assist you when and if you are called to arrange travel. Remember, your primary duty is to aid the general or commander in any way you can. When in doubt, ask. Next we look closely at contingency funds, and what you can and cannot do with them.

TRAVEL CHECKLIST

Before the Trip

- Plan itinerary
- Notify stations and MAJCOMs
- Get key personnel rosters
- Notification/permission of HHQ
- Honors to be accorded?
- VOQ/hotel reservations
 - Room and phone numbers
- Ground transportation
- Uniform requirements
 - Mess dress, winter, summer
 - raincoat
- Schedule and dress requirements for spouse
- Weather
- Take star/command flag along?
- Travel orders
- Brief aircraft commander
- Inflight meals, refreshments
- Departure and arrival times(local)
- No flowers, fruit baskets, etc.
- Point of contact at each station
- Arrange for admin services at enroute bases
- Coordinate security clearances with AFSSO
- Check reports from last base visit
- Awards and Decs; coordinate who has/brings medals, trophies, etc.
- Review itinerary with boss
- Command Post informed

Overseas Trips

- Consult the Foreign Clearance Guide
- Coordinate itinerary 45-60 days prior to trip--especially airlift and theater clearances
- Passports/visas/shots current?
- Check customs information
- Obtain speech/interview guidance from PAO
- Roster of key foreign dignitaries
- Predetermine if host country will accord honors
- Coordinate through protocol plaques, mementoes, etc., for foreigners
- Carry extra mementoes to give out

After the Trip

- Travel vouchers
- Letters of appreciation
- Record all gifts received

Figure 37

Chapter Ten

USE OF CONTINGENCY FUNDS

General

Funds at all levels and for all purposes are becoming increasingly harder to obtain and coming under closer scrutiny. Today's austere environment demands greater attention to the source and disbursement of funds, and protocol is no exception. As in other disciplines in the Air Force, a good budget and discrete use of available money is vital. Each year the Congress makes funds available in the DOD Appropriations Act for emergencies and extraordinary expenses (contingencies) which may be expended on the approval or authority of the Secretary of the Air Force.

Representation funds are used to maintain the standing and prestige of the United States by extending official courtesies to certain officials and dignitaries of the United States and foreign countries. The Secretary of the Air Force may authorize the use of representation funds for any purpose deemed appropriate which conforms to policy set by DOD. Unless otherwise specifically authorized by the Secretary or the designee, commanders may spend representation funds only for official entertainment or for other official purposes authorized in AFR 11-16, Contingency Funds.

All official entertainment must be in keeping with propriety as dictated by the occasion and, in all instances, must be conducted on a modest basis. Guest lists for such functions must be held to the minimum necessary to extend proper courtesy to the guest(s) of honor; however, when guests from outside the DOD are being honored, observe the following ratios of DOD personnel (including spouses or escorts) to non-DOD guests:

1. Parties of less than 30 persons - not more than 80 percent should be DOD personnel.
2. Parties of 30 or more persons - not more than 50 percent should be DOD personnel.

In meeting the above ratios, do not consider as honored guests, any personnel of other DOD activities or foreign military and civilian personnel assigned to major commands, separate operating agencies, and direct reporting units. Deviations of more than five percent from the maximum number of DOD participants paid from official representation funds require advance approval of the Secretary of the Air Force.

Authorized Categories of Entertainment

The following are authorized categories of entertainment:

1. Community Relations. Entertainment required to maintain civic or community relations. This category applies to both domestic and foreign communities in areas near Air Force installations.
2. International. Entertainment incidental to visits by distinguished foreign nationals in other than a community-relations context.
3. Public Relations. Entertainment incidental to a visit by a distinguished American citizen, as specified below ("Who may be Entertained," para 2), that may not be classified as community relations.
4. DOD Protocol. Entertainment incidental to a visit by DOD personnel, as specified below ("Who May be Entertained," para 3).
5. Other. Mementos, food, and refreshment purchases for inventory. Other miscellaneous current expenses that cannot be charged to a specific event classified under paragraph 1 through 4 above.

Who May Be Entertained

The following may be entertained:

1. Distinguished citizens, military officers, and government officials of foreign countries whose rank, position, function, or stature justify official entertainment.
2. Federal, state, and local officials--such as the President and Vice President of the United States, members of the Cabinet, members and professional staff personnel of the Congress, governors of states, mayors of cities, citizens' committees, and other distinguished or prominent citizens who have made a substantial contribution to the nation or DOD, and members of the news media on certain occasions.
3. If a commander considers it appropriate, these members of the DOD may be entertained at an Air Force installation. However, the entertainment must be limited to that which is minimally required to extend official courtesy when the DOD member is on an official visit to the field:

Office of the Secretary of Defense:

Secretary and Deputy Secretary of Defense
Under Secretaries of Defense

Assistant Secretaries of Defense
General Counsel, DOD
Inspector General, DOD
Assistant to the Secretary of Defense
Director, Program Analysis and Evaluation

Organization of the Joint Chiefs of Staff:

Chairman, Joint Chiefs of Staff
Director, Joint Staff
United and Specified Commanders

Military Departments:

Secretaries, Under Secretaries, and Assistant Secretaries of the Military Departments
Chiefs and Vice Chiefs of Staff of the Army and Air Force
Chief and Vice Chief of Naval Operations
Commandant and Assistant Commandant of the Marine Corps

Defense Agencies:

Directors, Defense Agencies
President, Uniformed Services University of the Health Services

4. As a general rule, entertainment of US Federal employees below the levels specified above and counterparts to these DOD officials listed above are not authorized without advanced approval of the Secretary of the Air Force.

5. When attending events honoring authorized individuals, costs may be paid for by members of their official party and other essential invitess as constrained by guest ratios. Separate events honoring spouses of visiting officials normally are not authorized unless related to the official purpose of the visit.

What Expenditures Are Not Authorized

The following expenditures are not authorized:

1. Expenses for retirement ceremonies and change of command for DOD personnel, unless specifically approved in advance by the Secretary of the Air Force.
2. Expenses solely for entertainment of DOD, Air Force, Army, Navy, or Marine Corps personnel unless authorized as stated above.
3. Entertainment of DOD personnel participating as guest speakers or lecturers, with the exception of those officials listed above.

4. Payment of membership fees or dues.
5. Expenses, other than authorized official entertainment, connected with conferences, conventions, seminars, or working groups, except when specifically approved in advance by the Secretary of the Air Force.
6. Expenses that are usually expected to be assumed as a personal obligation.
7. Purchase of gifts, mementos, tokens, souvenirs, seasonal greeting, and calling cards except under the following conditions;
 - a. No one memento costing more than \$165 may be purchased or presented. The total costs of mementos presented by any one DOD official to any one recipient may not exceed \$165.
 - b. Expenses eligible to be pro-rata costs of non-DOD authorized guests' participation in morale, welfare, and recreational activities may be paid from official representation funds, unless otherwise prohibited herein.
8. Expenses for classified projects or intelligence purposes.
9. Expenses eligible to be financed from other appropriated and non-appropriated funds with some requirements.
10. Repairs, maintenance, and renovation projects to enhance the appearance of DOD facilities.

Personnel Authorized To Be Hosts

Official representation courtesies on behalf of the United States Government may be extended by the Secretary of the Air Force, Chief of Staff and subordinate commanders who administer an approved official representation program. These officials may delegate the authority to host official functions at their discretion. However, invitations to foreign dignitaries to visit the United States at the expense of the Air Force may be extended only by the Secretary of the Air Force and the Chief of Staff, USAF.

CONCLUSION

Funds will become more and more difficult to obtain if present trends continue. Funds obtained under the provisions of AFR 11-16 are the primary source of money for protocol. The efficient protocol officer will carefully manage available monies always being cognizant of means to conserve and find the alternate sources available to him/her. However, the most effective vehicle for prudent management of protocol funds is a meaningful budget and detailed accounting procedures. Make sure your record keeping is crystal clear and completely accurate. Poor management in this vital area can only reflect adversely on the protocol officer and the commander. Let's think positive we are almost there. I plan to wrap up this handbook with a mixture of "tricks of the trade" or potpourri.

Chapter Eleven

POTPOURRI

Now you are ready to start your new duties. Stop! Let's just cover a few more "tricks of the trade" that can help you to be a better protocol officer. The following guidelines are an assortment of "things to put in your pipe" to think about and use as necessary. Nothing is in concrete, and so the best lesson to learn is to be flexible.

Flexibility in Approach or Knowing Murphy's Law

I can't tell you how many times as a protocol officer I had a plan of action that at the last minute had to be changed. It goes with the territory; the best laid plans.... The way to overcome these last minute changes or surprises is to be flexible and, therefore, have backup plans. First, be prepared with your primary plan and then, have contingency plans. Anticipate and don't lock yourself into concrete because in protocol anything can happen and usually does. Along with surprises comes Murphy's Law which is "if anything has a chance to go wrong, it does." This law is well known in protocol circles. I can tell you some personal horror stories where I have experienced Murphy's Law. The way to beat it is to anticipate and prepare. A protocol officer who is in control with a solid plan as well as a backup strategy, can react to any catastrophe.

The Art of Conversation

"The tongue is but three inches long, yet it can kill a man six feet high." This old Japanese proverb is often so very true. We as officers in the service of our country have chosen to be professional leaders. As such we are in a "fish bowl," as it were. We should, therefore, devote significant thought and effort to being proficient in general conversation. A good conversationalist always has something to say and says it well. A good protocol officer should be a good conversationalist with something interesting to talk about, neither overbearing in attitude nor irritating to the listeners. If you don't want to embarrass yourself, you might consider these general rules for conversationalists:

DO:

1. Have something to say--and say it well. A conversation started could be a new item, a movie personality, a recent, unusual incident or a brief amusing story.

2. Above all, be a good listener: this will actually put you at ease.
3. Use a moderate speaking tone.
4. Learn to remember names and faces: such actually draws people to you.
5. Develop the art of small talk: talking about nothing in particular, but never official subjects.
6. Talk with shy persons about their families, hobbies, special interests, thereby putting them at ease.
7. When a host/hostess, be a moderator and intervene in a monologue, a controversial discussion, a mute group, by changing the subject.

DO NOT:

1. Gossip.
2. Talk business (shop-talk) at a social gathering (unless you are discussing tomorrow's itinerary).
3. Replace wit with sarcasm or ridicule.
4. Dominate any conversation; silence, at times, is golden.
5. Interrupt others (This is so often violated. Many never listen to what another is saying, but only think of what they want to say; often such persons cut off others just to get in their two-cents worth.)
6. Contradict others.
7. Talk over anyone's head.
8. Talk down to anyone.
9. Be "syrupy"; insincere flattery is always in poor taste.
10. "Clam Up", a shy guest is a host's burden.
11. Exclude others from a conversational group.

R.S.V.P.

Nothing causes more gnashing of teeth than an unanswered R.S.V.P. The initials stand for the French response *s'il vous plait*, meaning "please reply." An R.S.V.P. on an invitation obliges you to respond as soon as possible. You may decline or accept the invitation, but you would be very rude if you didn't call at all.

Tan-Nosing

Tan-nosing is the art of sustained visibility to your superiors that proves neither over-revealing of your weaknesses, nor under-revealing of your strengths. In other words, it's brown-nosing with finesse.

An important element of any career is making sure our bosses know us well. If they don't know us well, our OERs won't receive the ratings or indorsements we truly deserve. So, one of our responsibilities is, in fact, to be known in a positive light by those who make the difference. All of our bases offer us several opportunities to do just that. Officer Club membership is perhaps the most obvious, but not just that. We need to be at the dining-in and the dining-out also. Those "hail and farewell" parties are for us as are the opportunities to volunteer for special duties such as an escort officer or additional duties such as a squadron or group public affairs officer.

As we apply ourselves, our hard work in our specific specialty will take care of itself but our visibility will be the key that unlocks senior officer recognition. The protocol officer will naturally be exposed to many senior officers. There is a chance for over-exposure. The key is to be available - in the background. Remember you are not a DV, but you are there to "make things happen" so practice the art of being "invisible," but in control.

Automobile Plates for Air Force Commanders

Plates, made of metal (6"x9") are authorized for display on Air Force vehicles by those persons listed in AFR 900-3, parag 3-12a and by Air Force wing and base commanders.

1. Wing level and above commanders are authorized an ultramarine blue background inscribed with the unit designation and the word "COMMANDER" in yellow. The commander's grade insignia in the appropriate color is illustrated in the center (Figure 39). This plate is procured locally.
2. Air Force base commanders are authorized an ultramarine blue background inscribed with words "BASE COMMANDER" in yellow. The base commander's grade insignia in the appropriate color is illustrated in the center (Figure 38). This plate is procured locally.

Automobile plates are displayed only when the car is in motion and occupied by the commander. Since they do often personally drive their staff cars on a frequent basis, the plate may remain bracketed and uncovered while the vehicle is parked.

Place of Honor

Traditionally, the right side has been considered the position of honor. Therefore, the person junior in rank always walks, rides, and sits to the left of the senior. It is the junior's responsibility to know

his/her place and maneuver into it with as little attention as possible. As a general rule, seniors enter an aircraft, automobile or boat last and leave first. This procedure may be reversed in entering a car at a left-hand curb. In such cases, the senior may enter first. This precludes the senior stumbling over the junior seated to the left. Since seniors are always accorded the most desirable seats, when three persons are in the back seat, the junior is in the middle, with the most senior on the right. In full cars, juniors sit in the front, and seniors sit in the back. In boats, a junior sits forward and a senior sits aft. When flying with a senior who is the pilot, you should be aboard in your designated position.

Calling Cards

Even though the tradition of making formal calls and the use of calling cards has declined over the years, they are still useful in many situations. You may have had little use for calling cards so far; however, your position as a protocol officer may change that since you will have contact in senior military and diplomatic circles. The following is useful information concerning the selection and use of calling cards.

1. Only engraved cards in black ink are correct.
2. The card should reflect good taste.
3. The card is similar in size to business cards used by civilians.
4. Formats for the card can vary somewhat; that is, rank and branch of service may be shown in different ways depending on personal preference. Figure 40 shows several examples.
5. No abbreviations are used on the card except "Jr." for "Junior" if the individual's name is long, otherwise Junior is spelled out. A first or second lieutenant uses only the word "Lieutenant".

These cards are helpful in introducing yourself and demonstrates your interest as a protocol officer in that individual.

Attention to Detail

This is the name of the game in protocol, and practicing it can make the difference between a mediocre and a good protocol officer. The thing to remember is that there are numerous details to each aspect of protocol whether it involves an official ceremony or a visiting dignitary. You need to watch the small items as well as the big picture. One way to be prepared is to always show up early for functions to double check arrangements. Don't leave any detail to chance, but rather "fine tune" your plan to cover all aspects. Pay attention to detail and you can eliminate mistakes.

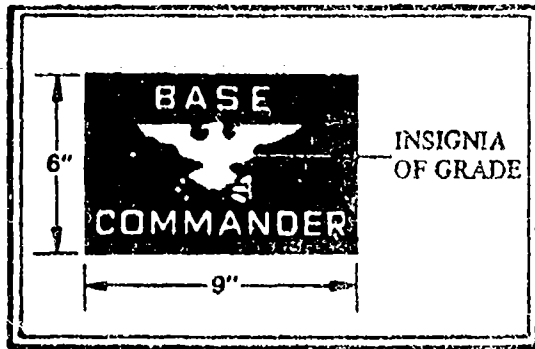

Figure 38 Automobile Plate for Air Force Base Commanders.

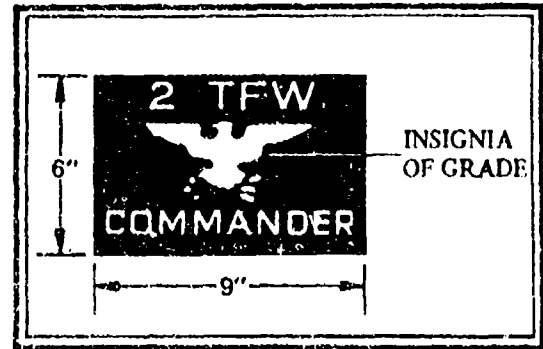

Figure 39 Automobile Plate for Air Force Commanders of Wings and Above.



Air Force Joint Program

GREGORY S. ANGELL
Captain, USAF
Exchange Officer

RAAF Amberley
APO San Francisco 96209
Phone: 011-61-7280 2636

RAAF Base Amberley
Queensland, 4305
Australia



Office of the Secretary
United States Air Force

JO A. BALL
Major, USAF
Office of Legislative Liaison

Colonel Richard J. Tiplady
Protocol Officer for Secretary
of Defense

The Pentagon - Suite 6D871
Washington, D.C. 20330-1420

202/696-7201
AV 228-7301

The Pentagon
Washington, DC 20301

202-697-7064

John Carl Brown

Lieutenant Colonel
United States Air Force

Captain James Lee Briggs

United States Maritime Service

Major Mary Ames Smith

United States Marine Corps

Figure 40

Self-Confidence

A protocol officer who radiates self-confidence can go far. I'm not talking about putting on a facade; I'm referring to self-confidence gained through hard work, lots of study, and professional achievements in the job. Since people will be looking to you for advice, it's best if you present the appearance of someone who knows his/her stuff. It takes time to feel confident in any job, so do your homework and learn all you can. Establish your credibility. If you do make a mistake, learn from it, and don't repeat it. As I said at the very start, a lot of protocol is plain common sense, so use your head. Think, act, and radiate self-confidence.

Hard Work (Let's Get To It)

The job of a protocol officer is not an easy one. It is a real challenge for any officer. Be prepared for long hours and for being a jack of all trades. The protocol officer is usually the first person to arrive (hours before a function begins or a visitor arrives), the expert with all the answers, the center of problem solving, the receptor of blame if anything goes wrong, and the last one to leave when the day is done. You no more have something completed or under control when another visit or function starts the process all over again. It's exciting; it's challenging. It can be glamorous when attending a formal dinner for a visiting ambassador, or it can be very unattractive when you are working in sub-freezing weather outside base operations, unloading heavy luggage, waiting for a DV whose arrival time is unknown. One thing, it never is boring! You may long for a quiet, normal day, but I've never seen any protocol officers who felt their duties were routine. Air Force protocol requires the best caliber of officers to enforce the many and varied rules and procedures involved. It takes a special person to meet the challenge. So whether you have heard the calling from within or you have orders from MPC, you have a very exciting job ahead. I hope this guide will serve as a tool to help you along the way. This guide is only the beginning; below is a list of the regulations and publications you will need to get detailed facts on protocol. Build a reference library to enhance and preserve your protocol credibility. You can add to the list as you progress. I wish you good luck, and watch out for Murphy's Law.

PROTOCOL REFERENCE LIBRARY

Service Etiquette, ed. by Swartz. Annapolis, Md: U. S. Naval Institute.

The Air Officers' Guide. Harrisburg, Pennsylvania: The Stockpole Company.

Radlovic., I., Monte. Etiquette and Protocol; a Handbook of Conduct in American and International Circles. New York: Harcourt, Brace.

Vanderbilt, Amy. The Amy Vanderbilt New Complete Book of Etiquette. Garden City, NY: Doubleday and Company, Inc.

AFR 10-1, Preparing Written Communications

AFR 7-4, Social Protocol Stationery

AFR 11-7, Air Force Relations with Congress

AFR 11-16, Contingency Funds - Miscellaneous Current Expenses - Official Representation - PEC 91515F

AFR 11-17, Guide to Conducting Foreign Distinguished Visitor Tours

AFP 30-1, Air Force Standards

AFP 30-6, Guide for an Air Force Dining-In

AFR 35-7, Service Retirements

AFR 35-10, Dress and Personal Appearance of Air Force Personnel

AFR 35-54, Rank, Precedence and Command

AFR 50-14, Drill and Ceremonies

AFR 143-1, Mortuary Affairs

AFP 900-1, Guide to Air Force Protocol

AFR 900-3, Department of the Air Force Seal, Organizational Emblems, Use and Display of Flags, Guidons, Streamers, and Automobile and Aircraft Plates

AFR 900-6, Honors and Ceremonies Accorded Distinguished Persons

OPNAVINST 1710.7 Social Usage and Protocol Handbook. Washington DC: Office of the Chief of Naval Operations.

BIBLIOGRAPHY

A. References Cited

Books

1. Gross, Mary Preston. The Officer's Family Social Guide. Chuluota, Florida: Beau Lac Publishers, 1985.
2. Kinney, A. J. and John H. Napier III The Air Officers' Guide. Harrisburg, Pennsylvania: The Stackpole Company, 1983.
3. Lott, James E. Practical Protocol, A Guide to International Courtesies. Houston, Texas: Gulf Publishing Company, 1973.
4. McCaffree, Mary Jane and Pauline Innis. Protocol The Complete Handbook of Diplomatic, Official, and Social Usage. Englewood Cliffs: Prentice-Hall Inc. 1977.
5. Radlovic, I Monte. Etiquette and Protocol - A Handbook of Conduct in American and International Circle. New York: Harcourt, Brace, 1959.
6. Swartz, Oretha D. Service Etiquette. 3d ed. Annapolis, Md.: United States Naval Institute, 1977.
7. Wier, Ester and Hickey, Dorot / Coffin. The Answer Book on Air Force Social Customs. Harrisburg, Pennsylvania: The Stackpole Company, 1959.
8. Wood, John R. and Serres, Jean. Diplomatic Ceremonial and Protocol. New York: Columbia University Press, 1970.

U. S. Department of the Air Force Publications

9. U. S. Department of the Air Force. Social Protocol Stationary. AF Regulation 7-4. Washington D.C.: Government Printing Office, April 1985.
10. U. S. Department of the Air Force. Preparing Written Communications. AF Regulation 10-1. Washington D.C.: Government Printing Office, March 1985.

CONTINUED

11. U. S. Department of the Air Force. Air Force Relations with Congress. AF Regulation 11-7. Washington D.C.: Government Printing Office, December 1983.
12. U. S. Department of the Air Force. Contingency Funds - Miscellaneous Current Expenses. AF Regulation 11-16. Washington D.C.: Government Printing Office, November 1980.
13. U. S. Department of the Air Force. Guide to Conducting Foreign Distinguished Visitor Tours. AF Pamphlet 11-17. Washington D.C.: Government Printing Office, October 1976.
14. U. S. Department of the Air Force. Distribution of the Congressional Directory. AF Regulation 11-33. Washington D.C.: Government Printing Office, November 1974.
15. U. S. Department of the Air Force. Air Force Standards. AF Regulation 30-1. Washington D.C.: Government Printing Office, May 1983.
16. U. S. Department of the Air Force. Guide for an Air Force Dining-In. AF Pamphlet 30-6. Washington D.C.: Government Printing Office, August 1983.
17. U. S. Department of the Air Force. Physical Evaluation for Retention, Retirement, and Separation. AF Regulation 35-4. Washington D.C.: Government Printing Office, September 1980.
18. U. S. Department of the Air Force. Service Retirements. AF Regulation 35-7. Washington D.C.: Government Printing Office, September 1981.
19. U. S. Department of the Air Force. Dress and Personal Appearance of Air Force Personnel. AF Regulation 35-10. Washington D.C.: Government Printing Office, September 1983.
20. U. S. Department of the Air Force. Air Force Rank, Precedence, and Command. AF Regulation 35-54. Washington D.C.: Government Printing Office, September 1981.
21. U. S. Department of the Air Force. Drill and Ceremonies. AF Regulation 50-14. Washington D.C.: Government Printing Office, April 1985.

CONTINUED

22. U. S. Department of the Air Force. Mortuary Affairs. AF Regulation 143-1. Washington D.C.: Government Printing Office, November 1980.
23. U. S. Department of the Air Force. State Official and Special Military Funerals. AF Manual 143-2. Washington D.C.: Government Printing Office, December 1965.
24. U. S. Department of the Air Force. Nonappropriated Fund - Basic Responsibilities, Policies, and Practices. AF Regulation 176-1. Washington D.C.: Government Printing Office, September 1983.
25. U. S. Department of the Air Force. Air Force Open Mess Program. AF Regulation 215-11. Washington D.C.: Government Printing Office, June 1985.
26. U. S. Department of the Air Force. Guide to Air Force Protocol. AF Pamphlet 900-1. Washington D.C.: Government Printing Office, Reprinted November, 1978 with Chg 1.
27. U. S. Department of the Air Force. Department of the Air Force Seal, Organizational Emblems, Use and Display of Flags, Guidons, Streamers, and Automobile and Aircraft Plates. AF Regulation 900-3. Washington D.C.: Government Printing Office, March 1985.
28. U. S. Department of the Air Force. Service Flag and Lapel Button. AF Regulation 900-5. Washington D.C.: Government Printing Office, July 1968.
29. U. S. Department of the Air Force. Honors and Ceremonies Accorded Distinguished Persons. AF Regulation 900-6. Washington D.C.: Government Printing Office, December 1965.
30. U. S. Department of the Air Force. Representation at Official Functions in Honor of or Sponsored by Foreign Nationals. AF Regulation 900-15. Washington D.C.: Government Printing Office, May 1985.
31. U. S. Department of the Air Force. Decorations, Service, and Achievement Awards, Unit Awards, Special Badges, and Devices. AF Regulation 900-48. Washington D.C.: Government Printing Office, March 1982.

CONTINUED

Official Documents

32. Baginsky, Vincent J. Handbook for Air Force Dining-In. Maxwell AFB: Air Command and Staff College Research Report #0130-81, 1981.
33. Benbough, Robert B. USAF Protocol Information Handbook. Maxwell AFB: Air Command and Staff College Research Report, May 1969.
34. Carr, Patrick J. Protocol Ceremonies and Customs - An Air Force Officer's Handbook. Maxwell AFB: Air Command and Staff College Research Report #83-0360.
35. Epting, James R. Handbook for the General Officer Aide-de-Camp. Maxwell AFB: Air Command and Staff College Research Report #82-0770.
36. Heck, Frederick B. II. Planning Guide for Formal Evening Functions. Maxwell AFB: Air Command and Staff College Research Report #1010-78.
37. Steininger, Warren L. Basic Protocol Guidelines. Maxwell AFB: Air Command and Staff College Research Report, May 1974.
38. Stouffer, Joyce K. Protocol Handbook. Maxwell AFB: Air Command and Staff College Research Report #85-2645.
39. Weise, Edward W. Walk to the Left - A Handbook for Air Force Aides. Maxwell AFB: Air Command and Staff College Research Report. 1945-1981.

Other Sources

40. Air Training Command Pamphlet, Protocol Primer. Undated.
41. OPNAVINST 1710.7 Social Usage and Protocol Handbook. Washington DC: Office of the Chief of Naval Operations, 1979.
42. Watson, Norman L. An Unofficial Handbook in Air Force Protocol. May, 1983.