

AD-A184 701

SURVEY PROBE INFRARED CELESTIAL EXPERIMENT (SPICE)(U)  
ROCKWELL INTERNATIONAL AMARIN CA DEFENSE ELECTRONICS  
OPERATIONS R C BERRY ET AL. JAN 86 C77-551/261

1/3

UNCLASSIFIED

AFBL-YR-86-0087 F19828-77-C-0648

7/8 17/8

AL

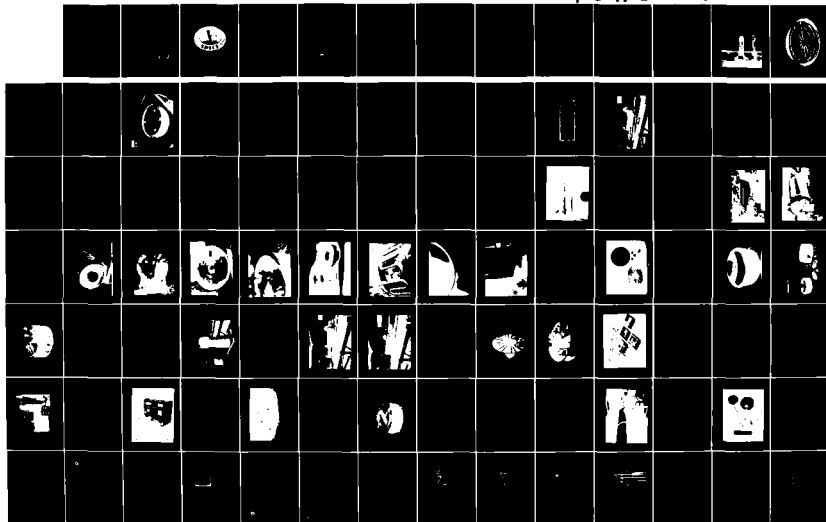

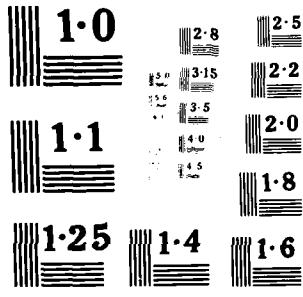

(1)

AFGL-TR-85-0087

# AD-A164 701

Survey Probe Infrared Celestial Experiment (SPICE)

R. C. Berry  
C. R. Madrid

Rockwell International  
3370 Miraloma Avenue  
P.O. Box 3105  
Anaheim, CA 92803

January 1985

Final Report  
June 1976 - August 1984

\*Original contains color  
plates: All DTIC reproductions  
will be in black and  
white\*

APPROVED FOR PUBLIC RELEASE; DISTRIBUTION UNLIMITED

AIR FORCE GEOPHYSICS LABORATORY  
AIR FORCE SYSTEMS COMMAND  
UNITED STATES AIR FORCE  
HANSCOM AIR FORCE BASE, MASSACHUSETTS 01731

DTIC  
SELECTED  
FEB 19 1986  
S D D

DTIC FILE COPY

86 2 18 178

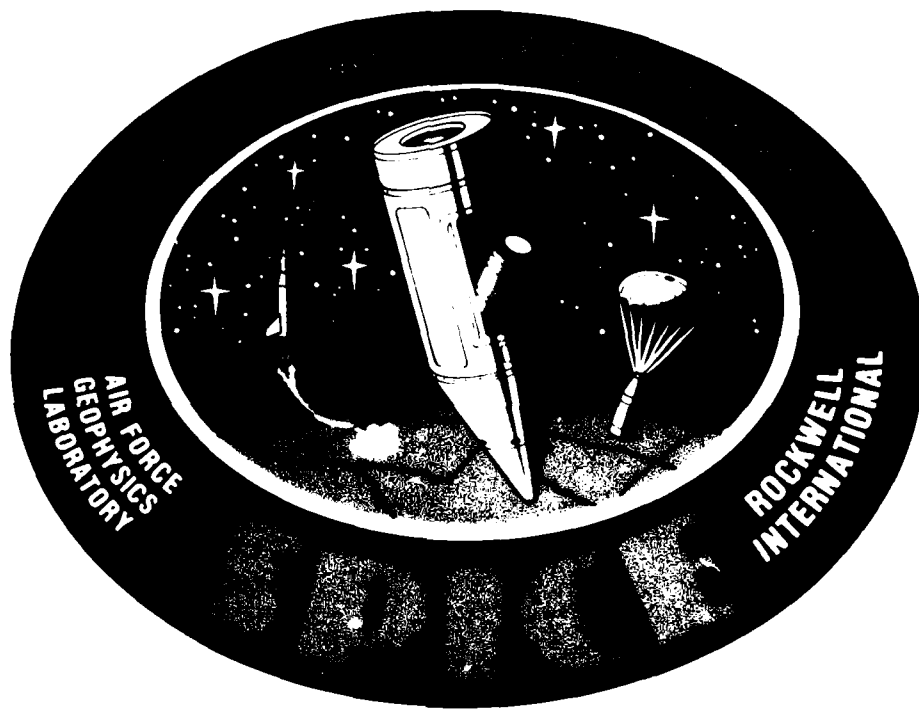

86 2 18 178

UNCLASSIFIED

SECURITY CLASSIFICATION OF THIS PAGE

AD-A164 701

## REPORT DOCUMENTATION PAGE

1a. REPORT SECURITY CLASSIFICATION <b>UNCLASSIFIED</b>		1b. RESTRICTIVE MARKINGS	
2a. SECURITY CLASSIFICATION AUTHORITY		3. DISTRIBUTION/AVAILABILITY OF REPORT Approved for public release; Distribution unlimited.	
2b. DECLASSIFICATION/DOWNGRADING SCHEDULE			
4. PERFORMING ORGANIZATION REPORT NUMBER(S)		5. MONITORING ORGANIZATION REPORT NUMBER(S) <b>AFGL-TR-85-0087</b>	
6a. NAME OF PERFORMING ORGANIZATION <b>Rockwell International</b>	6b. OFFICE SYMBOL (If applicable)	7a. NAME OF MONITORING ORGANIZATION <b>Air Force Geophysics Laboratory</b>	
6c. ADDRESS (City, State and ZIP Code) <b>3370 Miraloma Avenue, P. O. Box 3105 Anaheim, CA 92803</b>		7b. ADDRESS (City, State and ZIP Code) <b>Hanscom AFB Massachusetts 01731</b>	
8a. NAME OF FUNDING/SPONSORING ORGANIZATION <b>Air Force Geophysics Laboratory</b>	8b. OFFICE SYMBOL (If applicable)	9. PROCUREMENT INSTRUMENT IDENTIFICATION NUMBER <b>F19628-77-C-0049 - Final Report</b>	
8c. ADDRESS (City, State and ZIP Code) <b>Hanscom AFB, MA, 01731</b>		10. SOURCE OF FUNDING NOS.	
11. TITLE (Include Security Classification) <b>Celestial Experiment (SPICE) Survey Probe Infrared</b>		PROGRAM ELEMENT NO. <b>63428F</b>	PROJECT NO. <b>7670</b>
		TASK NO. <b>06</b>	WORK UNIT NO. <b>AI</b>
12. PERSONAL AUTHOR(S) <b>Berry, R. C. and Madrid, C. R.</b>			
13a. TYPE OF REPORT <b>Final Report</b>	13b. TIME COVERED <b>FROM Jun 76 to Aug 84</b>	14. DATE OF REPORT (Yr., Mo., Day) <b>1985 January</b>	15. PAGE COUNT
16. SUPPLEMENTARY NOTATION			
17. COSATI CODES		18. SUBJECT TERMS (Continue on reverse if necessary and identify by block number) <b>Infrared Sensors</b>	
FIELD	GROUP		
19. ABSTRACT (Continue on reverse if necessary and identify by block number) The HI HI STAR sensor was refurbished and the focal plane arrays modified to cover the spectral range from 8-30 um. The instrument was subsequently flown in January 1979 on an ARIES sounding rocket. The sensor was extensively damaged on recovery. The system was again refurbished and flown successfully from White Sands Missile Range, New Mexico in September. This report describes the details of the refurbishment and modification of the sensor system and the flight performance.			
20. DISTRIBUTION/AVAILABILITY OF ABSTRACT UNCLASSIFIED/UNLIMITED <input type="checkbox"/> SAME AS RPT. <input checked="" type="checkbox"/> DTIC USERS <input type="checkbox"/>		21. ABSTRACT SECURITY CLASSIFICATION <b>Unclassified</b>	
22a. NAME OF RESPONSIBLE INDIVIDUAL <b>Stephan D. Price</b>		22b. TELEPHONE NUMBER (Include Area Code) <b>(617) 861-4552</b>	22c. OFFICE SYMBOL <b>OPI</b>

DD FORM 1473, 83 APR

EDITION OF 1 JAN 73 IS OBSOLETE.

SECURITY CLASSIFICATION OF THIS PA

C77-551/201

SURVEY PROBE INFRARED CELESTIAL EXPERIMENT  
(SPICE)  
FINAL REPORT  
CONTRACT F19628-77-C-0049  
LINE ITEM 0002  
CDRL A008 AND A009

Prepared for  
Air Force Geophysics Laboratory  
Hanscom Air Force Base  
Massachusetts 01731

Prepared by

R. C. Berry/C. R. Madrid

APPROVED:

  
A. M. McDevitt  
Program Manager



**Rockwell International**

Defense Electronics Operations  
3370 Miraloma Avenue  
P O Box 3105  
Anaheim, California 92803

TABLE OF CONTENTS

	<u>Page</u>
1.0 Introduction . . . . .	1-1
2.0 SPICE I . . . . .	2-1
2.1 Telescope Assembly . . . . .	2-1
2.1.1 Front Cover and Background Plate . . . . .	2-1
2.1.2 Optics . . . . .	2-7
2.1.3 Mechanical Assembly . . . . .	2-12
2.2 Focal Plane . . . . .	2-15
2.3 Electronics . . . . .	2-20
2.4 PCM . . . . .	2-22
2.5 Integration Tests and Flight Support . . . . .	2-24
2.6 Post Flight Evaluation . . . . .	2-30
3.0 SPICE II . . . . .	3-1
3.1 Telescope Assembly . . . . .	3-1
3.1.1 Front Cover and Background Plate . . . . .	3-1
3.1.2 Mechanical Assembly . . . . .	3-3
3.2 Electronics . . . . .	3-13
3.3 AGE Equipment . . . . .	3-19
3.4 Focal Plane . . . . .	3-25
3.5 Integration Tests and Flight Support . . . . .	3-27
3.6 Post Flight Evaluation and Refurbishment . . . . .	3-28
3.6.1 Telescope Assembly . . . . .	3-28
3.6.2 Electronics . . . . .	3-31
3.6.3 Focal Plane . . . . .	3-31
3.7 System Tests at AFGL . . . . .	3-33



Accession For	
NTIS CRA&I	<input checked="" type="checkbox"/>
DTIC TAB	<input type="checkbox"/>
Unannounced	<input type="checkbox"/>
Justification	
By	
Distribution/	
Availability Codes	
Dist	Avail and/or Special
A-1	1

TABLE OF CONTENTS

Appendix A

SPICE II Electronic Test Report

Appendix B

VC409-0001 Pulse Code Modulator Specification - SPICE I

VC409-0001-21 Pulse Code Modulator Specification - SPICE II

Appendix C - Specifications

AA0209-103 Evacuation

AA0209-104 Cryogen Filling

AA0209-105 Leak Rate

AA0209-106 Hold Time

AA0209-107 Axis Determination

AA0209-111 O-Ring Installation

AA0309-026 Optical Component

Appendix D

C77-1108-201 Acceptance Test Procedure



TABLES

	<u>Page</u>
Table I . . . . .	2-11

FIGURES

Figure 2-1 . . . . .	2-2
Figure 2-2 . . . . .	2-3
Figure 2-3 . . . . .	2-4
Figure 2-4 . . . . .	2-6
Figure 2-5 . . . . .	2-8
Figure 2-6 . . . . .	2-10
Figure 2-7 . . . . .	2-13
Figure 2-8 . . . . .	2-14
Figure 2-9 . . . . .	2-16
Figure 2-10 . . . . .	2-17
Figure 2-11 . . . . .	2-18
Figure 2-12 . . . . .	2-19
Figure 2-13 . . . . .	2-21
Figure 2-14 . . . . .	2-23
Figure 2-15 . . . . .	2-26
Figure 2-16 . . . . .	2-27
Figure 2-17 . . . . .	2-28
Figure 2-18 . . . . .	2-29
Figure 2-19 . . . . .	2-31
Figure 2-20 . . . . .	2-32
Figure 2-21 . . . . .	2-33
Figure 2-22 . . . . .	2-34
Figure 2-23 . . . . .	2-35
Figure 2-24 . . . . .	2-36
Figure 2-25 . . . . .	2-37
Figure 2-26 . . . . .	2-38
Figure 3-1 . . . . .	3-2
Figure 3-2 . . . . .	3-4
Figure 3-3 . . . . .	3-5
Figure 3-4 . . . . .	3-6
Figure 3-5 . . . . .	3-8
Figure 3-6 . . . . .	3-9
Figure 3-7 . . . . .	3-11
Figure 3-8 . . . . .	3-12
Figure 3-9 . . . . .	3-14
Figure 3-10 . . . . .	3-15
Figure 3-11 . . . . .	3-16
Figure 3-12 . . . . .	3-20
Figure 3-13 . . . . .	3-22
Figure 3-14 . . . . .	3-24
Figure 3-15 . . . . .	3-26
Figure 3-16 . . . . .	3-30
Figure 3-17 . . . . .	3-32

## 1.0 INTRODUCTION

The Survey Probe Infrared Celestial Experiment (SPICE) Program is a refurbishment and modification to an Infrared System previously called Hi Hi Star Sensor System. The Hi Hi Star System had been designed, fabricated and tested under Air Force Contract F04701-71-C-0148. This system was flown on an Aerobee 350 vehicle that was launched from White Sands Missile Range (WSMR) in February 1974. Due to vehicle problems on this flight, there was an early re-entry that resulted in payload damage.

In December 1976, Rockwell International (RI) received the SPICE contract (f19628-77-C-0049) from the Air Force Geophysics Laboratory (AFGL). This contract was later modified to reflect changes necessary to interface with an ARIES vehicle instead of the previously planned Aerobee 350. The availability of the ARIES provides greater data collection time.

The SPICE Sensor System was launched from WSMR in January 1979. Due to vehicle problems, no sky map data were taken and the sensor system again sustained damage due to a landing estimated at approximately 150 gs.

The system was again refurbished and was launched from WSMR in September 1982. This flight went well with sky map data being collected and the payload successfully received.

C77-551/201

The system was returned to RI where it was cleaned and retested. Some minor modifications were completed and the system was delivered to AFGL. After delivery, system operation was verified and the unit is ready to support a flight. There are currently no plans for this flight at AFGL.

## 2.0 SPICE I

### 2.1 TELESCOPE ASSEMBLY

#### 2.1.1 Front Cover and Background Plate

During the vehicle re-entry of the Hi Hi Star flight, the front cover was lost and the retract mechanism badly damaged. A honeycomb type cover (Hi Hi Star duplicate) was fabricated and the retract mechanism refurbished. Later contract changes required that a redesigned cover also be provided. This was due to the use of an ARIES vehicle (Figure 2-1) for added flight data time. The new system would be linear along the roll axis whereas the old system was angular in the plane of the yaw axis. Due to these changes, a different mounting design was needed. The mount was to be attached to the cover using eight #10 screws. Because the addition of eight #10 screw holes would create a much greater chance of vacuum leak, it was decided not to modify the honeycomb cover. A solid aluminum ribbed cover was designed and fabricated (Figure 2-2). Guide pins were added to ensure correct alignment between the front cover, the outer housing, the background plate and the inner housing.

A new Blackbody Chopper Assembly was fabricated. Some design improvements were incorporated to reduce the thermal build-up that would occur within the chopper after a series of "BB Calibration" commands. An additional twisted pair of five mil pure gold wires were soldered from aft end of the solenoid plunger to the base of the assembly (see 11 in Figure 2-3). Layers of two mil indium were placed between each mating surface of the chopper assembly for a better thermal contact all the way to the cold background plate. The solenoid guide pin (anti rotation) was replaced on the inner cavity with a guide blade eliminating any tendency for the plunger to hang up or stall. The Chopper Assembly was installed into a Helium Test Dewar and tested under cryogenic conditions. All tendency for the chopper to hang up or stall or for the temperature to rise past the critical operating point had been eliminated.

C77-551/201

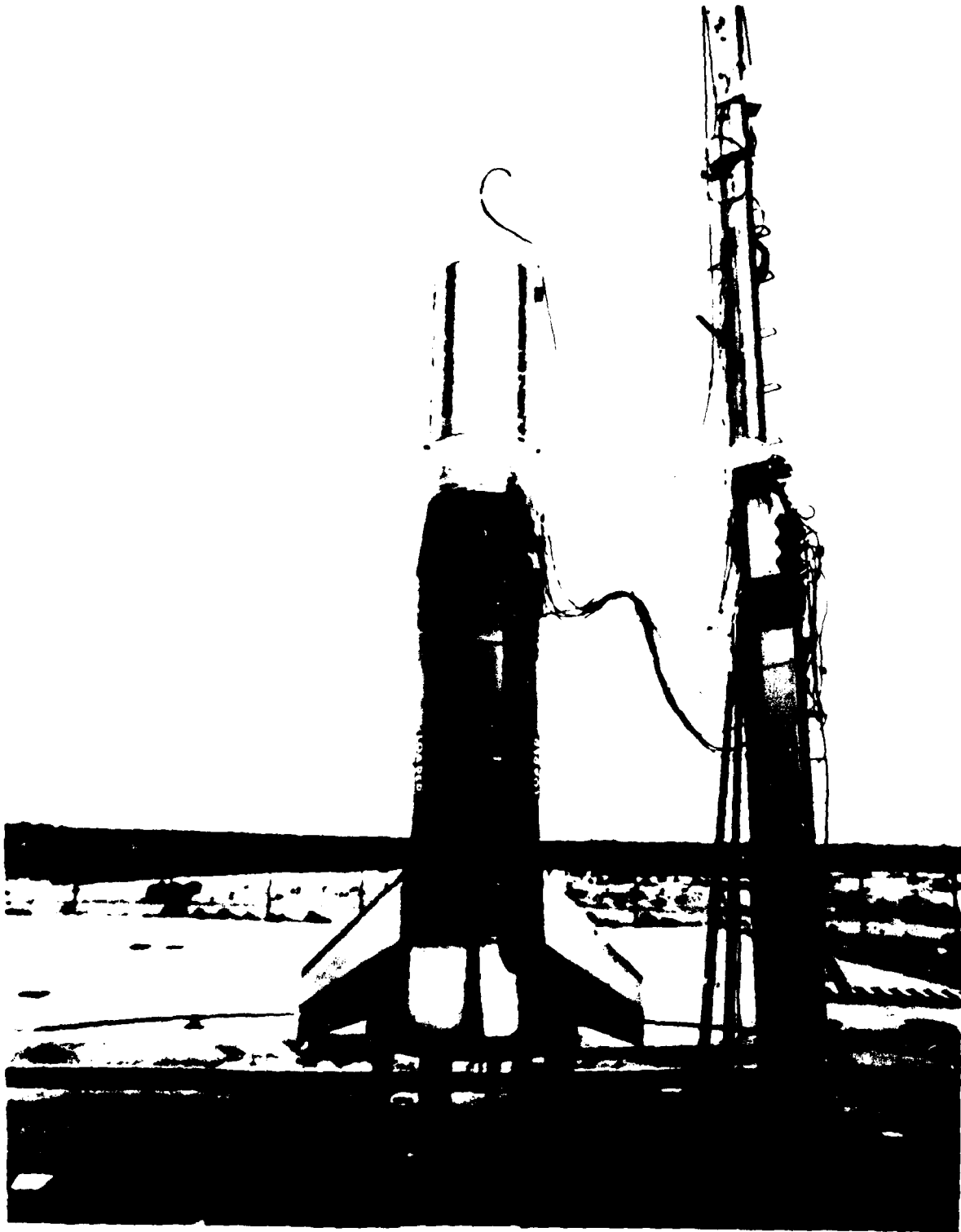

Figure 2-1

(77-551)201



Figure 2-2

C77-551/201

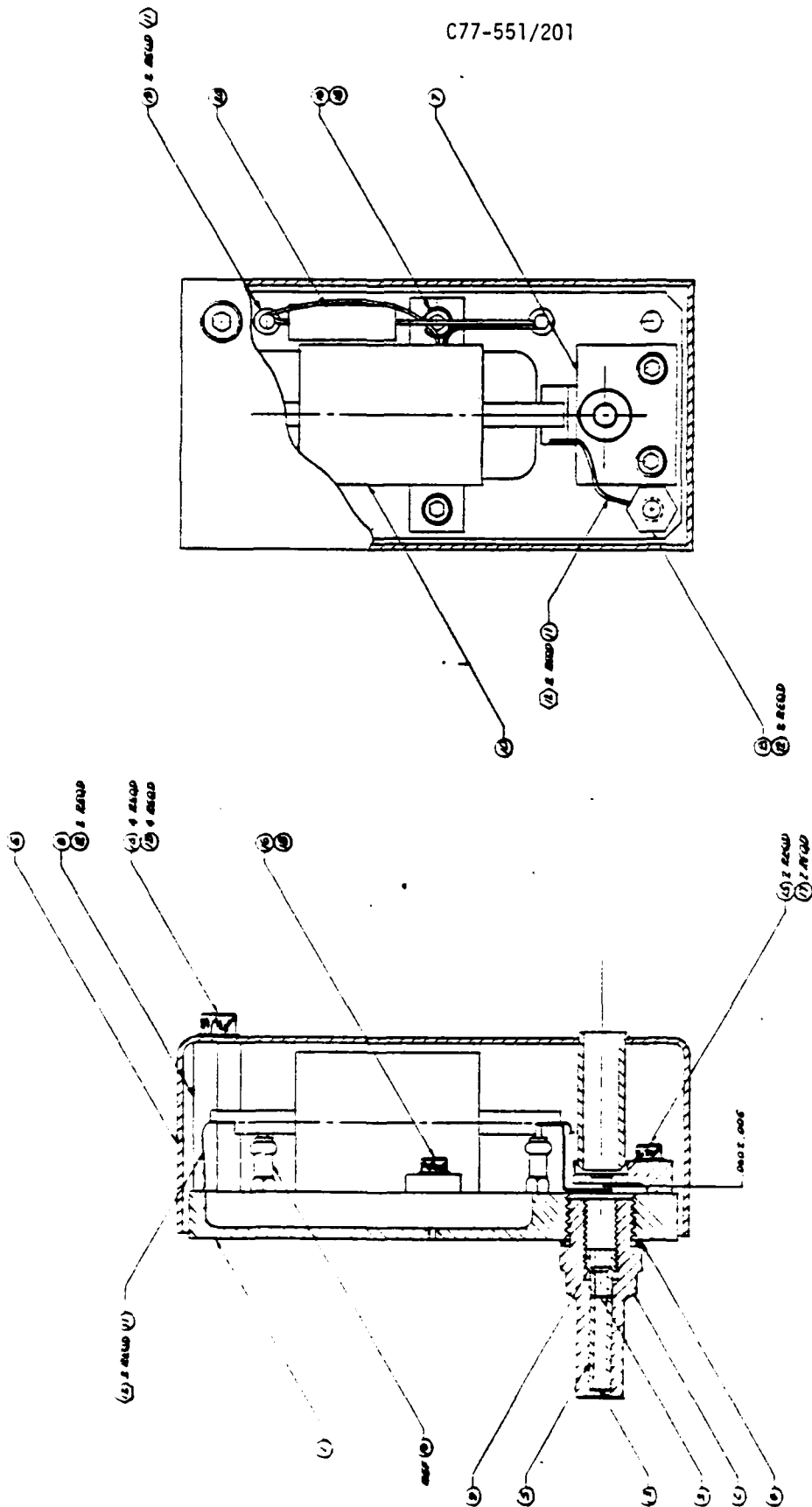

Figure 2-3

C77-551/201

A new background plate was required because the original was part of the cover assembly which was lost during premature re-entry of the Hi Hi Star payload. The background plate was fabricated per the existing drawings but instead of being hard wired to the front cover, a connector was installed between the two. This greatly facilitated assembly and disassembly. The previous background plate assembly was held together by interference tolerance but the new one was soldered together. This proved to be stronger and also permitted better heat transfer from the background plate through the spring fingers to the inner housing. New background plate hardware was built and the complete assembly was joined to the solid aluminum cover (see Figure 2-4).



C77-551/201

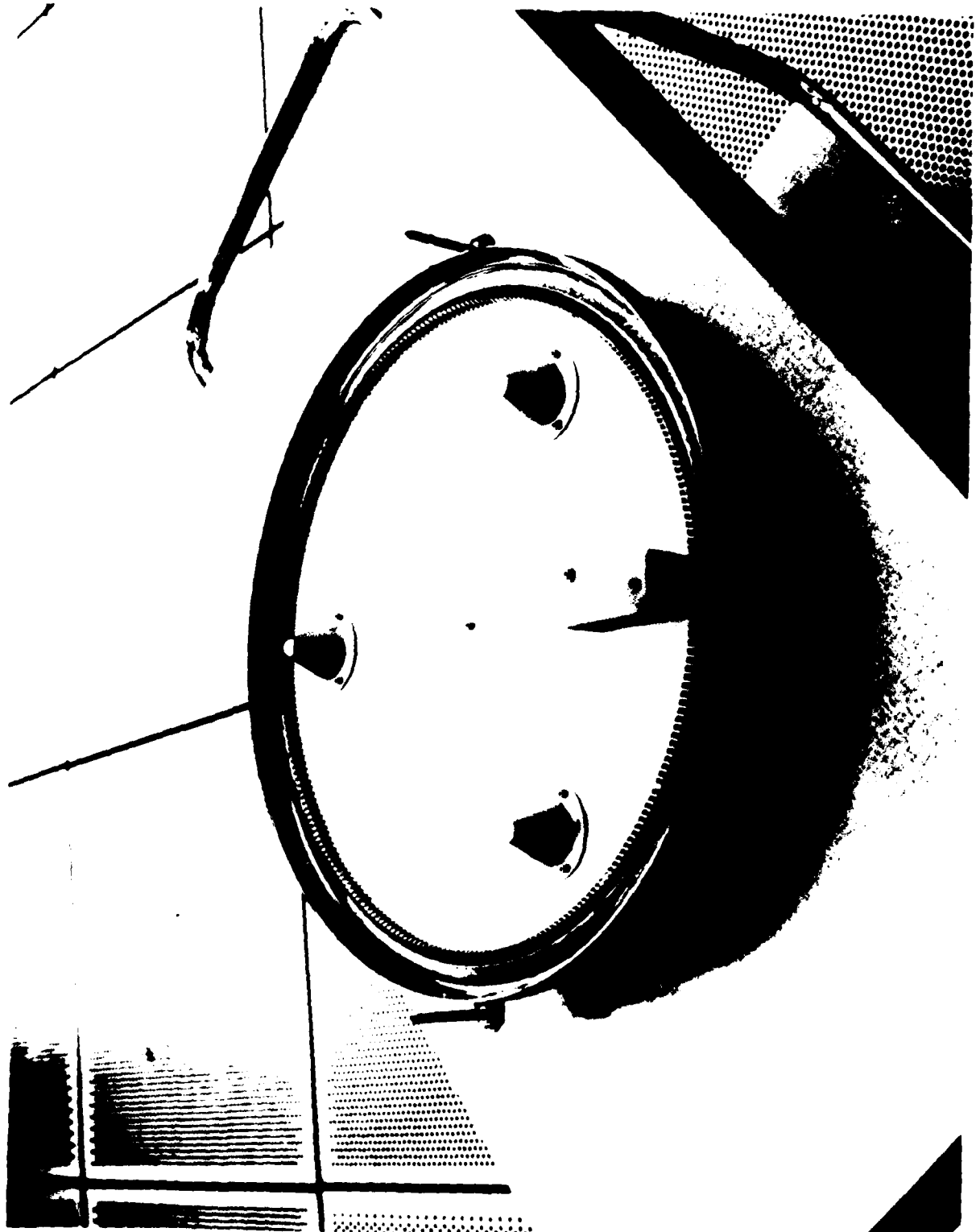

Figure 2-4

### 2.1.2 Optics

A measurement of the scattering characteristics of the sensor primary mirror was conducted. The purpose was to determine the cleanliness and to find if degradation had occurred since the measurement performed when the mirror polishing was completed.

The setup used to measure the mirror is shown in Figure 2-5. The basic elements of the setup includes the CO<sub>2</sub> laser source, the chopper, the attenuator box, the sensor rotary table, the mirror rotation platform, the sensor package and the lock-in amplifier. The attenuator box allows the power level to be adjusted in order to read the power level of the focused spot and the readings at various off-focus positions. The sensor rotary table allows the sensor to rotate about a spot directly under the illuminated mirror area. The mirror platform allows three dimensional adjustments of the mirror position as well as rotation of the mirror. The sensor package has a telescope with a 1" diameter aperture and a re-imaging section to restrict the viewing angle. A Helium cooled Hg-Ge detector is used as the sensing element. A lock-in amplifier phased to the chopper is used to increase sensitivity.

Readings were taken to determine the relative off-focus energy reflected from the mirror surface. The mirror was rotated to obtain the variation in off-axis readings at a given angle. These variations are an indication of the cleanliness experimental setup. The specular power,  $P_T$  is given by

$$P_T = \frac{V_{sp}}{R \tau_o} \quad (1)$$

where  $V_{sp}$  is the on-axis-focus spot voltage reading,  $R$  is the responsivity of the sensor in volts per watt and  $\tau_o$  is the transmission of the sensor's telescope. The off-axis voltage readings  $V_i$  can be represented by

$$V_i = \frac{A_M P_i A_T \tau_o R \cos \theta}{r^2 \pi} \quad (2)$$

where  $A_M$  is the area of the illuminated spot on the mirror,  $P_i$  is the reflected power density in watts/cm<sup>2</sup>,  $\theta$  is the off-focus angle,  $A_T$  is the collecting aperture of the sensor telescope and  $r$  is the distance from the mirror surface

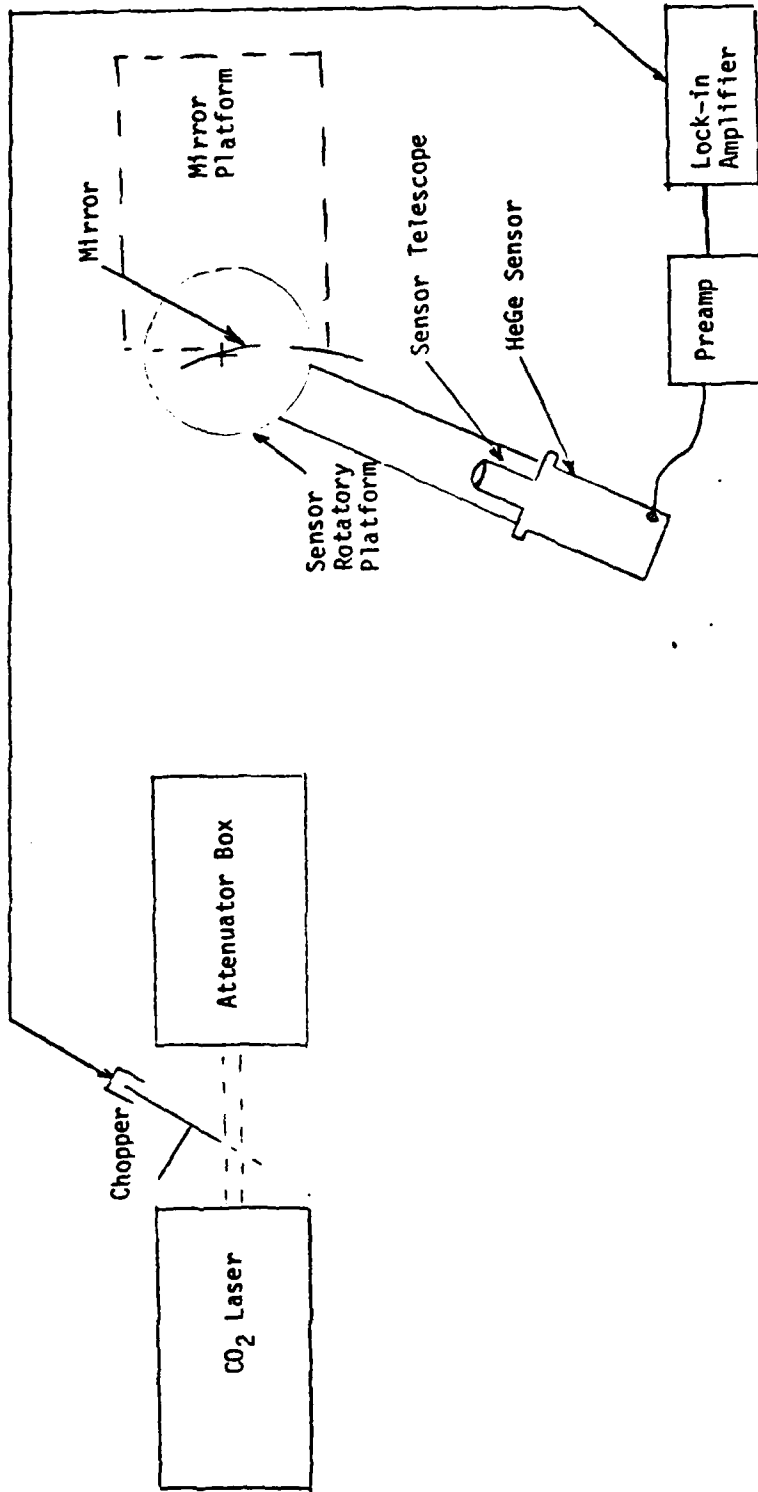

Figure 2-5 Experimental Setup for Scattering Measurement

to the collecting aperture. The scattered energy is assumed to be Lambertian, scattering into  $\pi$  steradians as a function of the cosine of the angle  $\theta$ . The quantity of interest is the coefficient of reflectance for the scattered energy. This coefficient,  $\rho$  will be per steradian and can be represented by

$$\rho = \frac{P_i A_M}{\pi P_T} \quad (3)$$

which by combining Equations 1, 2 and 3 can be written as

$$\rho = \left( \frac{V_i}{V_{sp}} \right) \frac{r^2}{A_T \cos \theta} \quad (4)$$

The values of  $V_i$  and  $V_{sp}$  are taken from the measured data in the log book. The diameter of the collecting aperture was 1 inch and the distance of the collecting aperture from the mirror was 16 inches. A plot of  $\rho$  versus the angle from the focused spot is given in Figure 2-6. This plotted data is also given in tabular form in Table 1. Examining the data obtained as the mirror was rotated at  $5^\circ$  off-focus indicates a random variation in readings which is indicative of small amounts of surface contamination found even on freshly cleaned mirrors. The variation was found to be .67 to  $7.53 \times 10^{-5}$ . Even a few dust particles can cause a relatively large variation at these levels. Highly contaminated mirrors show a higher and usually more even level of scattering.

In comparing the present scattering data with the previous scattering data (see Figure 2-6), it is concluded that the mirror scattering coefficient is similar.

C77-551/201

MIRROR SCATTERING DATA

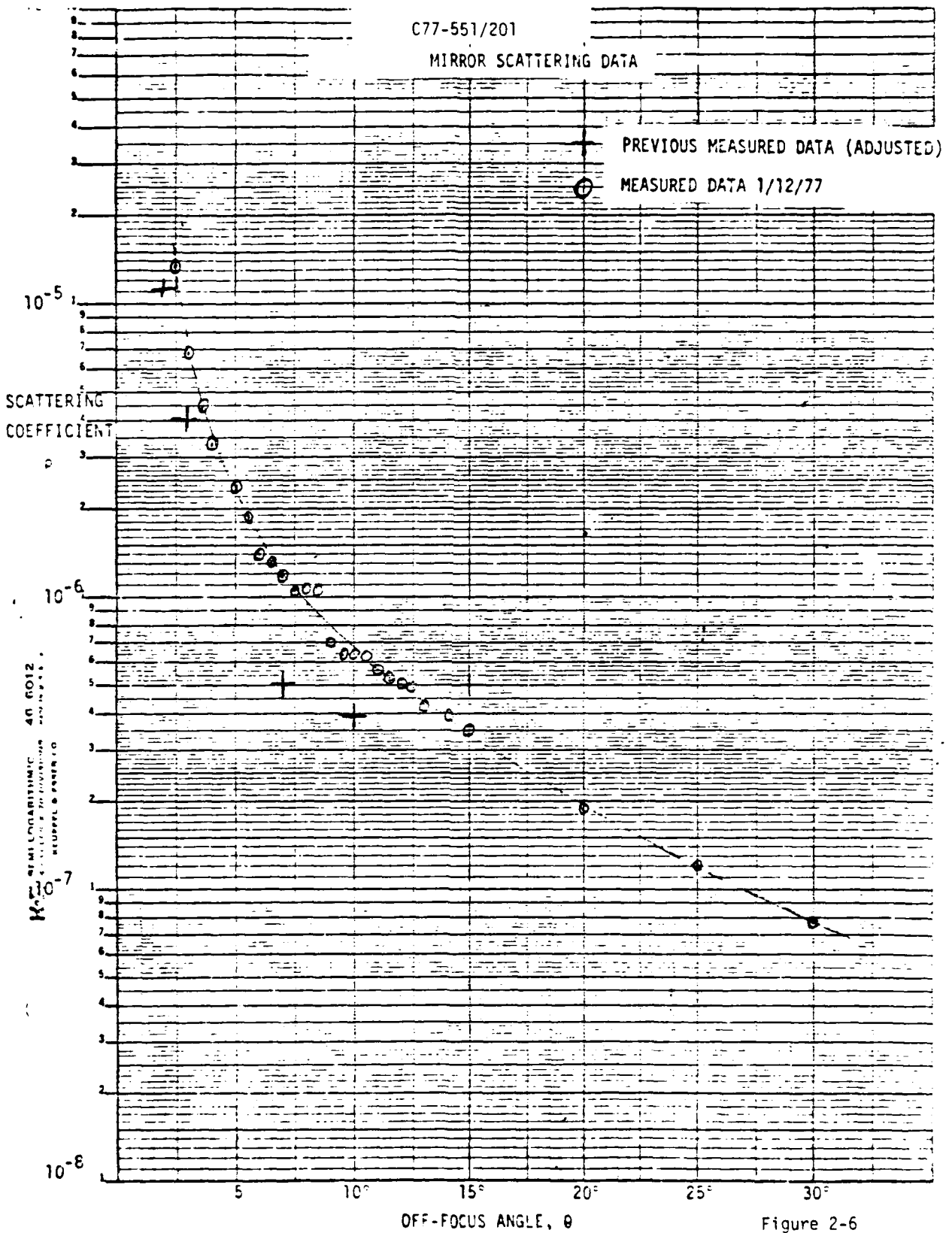

Figure 2-6

TABLE I  
MIRROR SCATTERING COEFFICIENTS

Off-Focus Angle  $\theta$  in Degrees

2.5	$1.33 \times 10^{-4}$
3.0	$6.98 \times 10^{-5}$
3.5	$4.47 \times 10^{-5}$
4.0	$3.36 \times 10^{-5}$
4.5	$3.07 \times 10^{-5}$
5.0	$2.37 \times 10^{-5}$
5.5	$1.90 \times 10^{-5}$
6.0	$1.40 \times 10^{-5}$
6.5	$1.34 \times 10^{-5}$
7.0	$1.17 \times 10^{-5}$
7.5	$1.06 \times 10^{-5}$
8.0	$1.06 \times 10^{-5}$
8.5	$1.07 \times 10^{-5}$
9.0	$7.07 \times 10^{-6}$
9.5	$6.27 \times 10^{-6}$
10.0	$6.28 \times 10^{-6}$
10.5	$6.23 \times 10^{-6}$
11.0	$5.67 \times 10^{-6}$
11.5	$5.42 \times 10^{-6}$
12.0	$5.13 \times 10^{-6}$
12.5	$5.01 \times 10^{-6}$
13.0	$4.22 \times 10^{-6}$
14.0	$3.90 \times 10^{-6}$
15.0	$3.51 \times 10^{-6}$
20.0	$1.90 \times 10^{-6}$
25.0	$1.22 \times 10^{-6}$
30.0	$7.71 \times 10^{-7}$

### 2.1.3 Mechanical Assembly

After stray radiation testing, the mirrors (4) were cleaned by Rockwell's Optical Department and telescope reassembly was started (Figure 2-7). Telescope assembly was performed in the Class 100 clean room in B/202 at Anaheim, California (Figure 2-8). The individual parts were detergent or solvent washed, deionized water or solvent rinsed, then dry nitrogen dried before installation. To facilitate assembly, various assembly tools were designed and fabricated. During this and previous assembly and disassembly, it was found that several unnecessary and precarious steps could be eliminated using the newly developed tools. A new alignment reticle was designed and installed using a white ceramic base with black lines. This unit was easier to see, and align to, than the old mirrored reticle. The superinsulation was washed in freon and hung out to dry. This was done after the individual sheets were cut. The cutting of the superinsulation for Hi Hi Star was done with a type of rolling pizza cutter. This method would leave slivers of mylar. It was found that a single edge razor blade was most efficient in performing this job. This supercleaning of the superinsulation also seemed to help the telescope assembly to attain a higher vacuum by removal of any machine oil or other contaminants on the mylar.

The assembly and testing of the SPICE telescope was performed using the applicable specifications for the job to be performed. These specifications were redlined and modified as required. The latest revision of all applicable specifications can be found in the Appendix to this document.

New longer cryogenic transfer were designed. These included a 45° angle at the telescope fill and exhaust port end to be compatible with the new Wentworth Institute Payload Telescope access port. These were fabricated by the Cryolab Corporation.

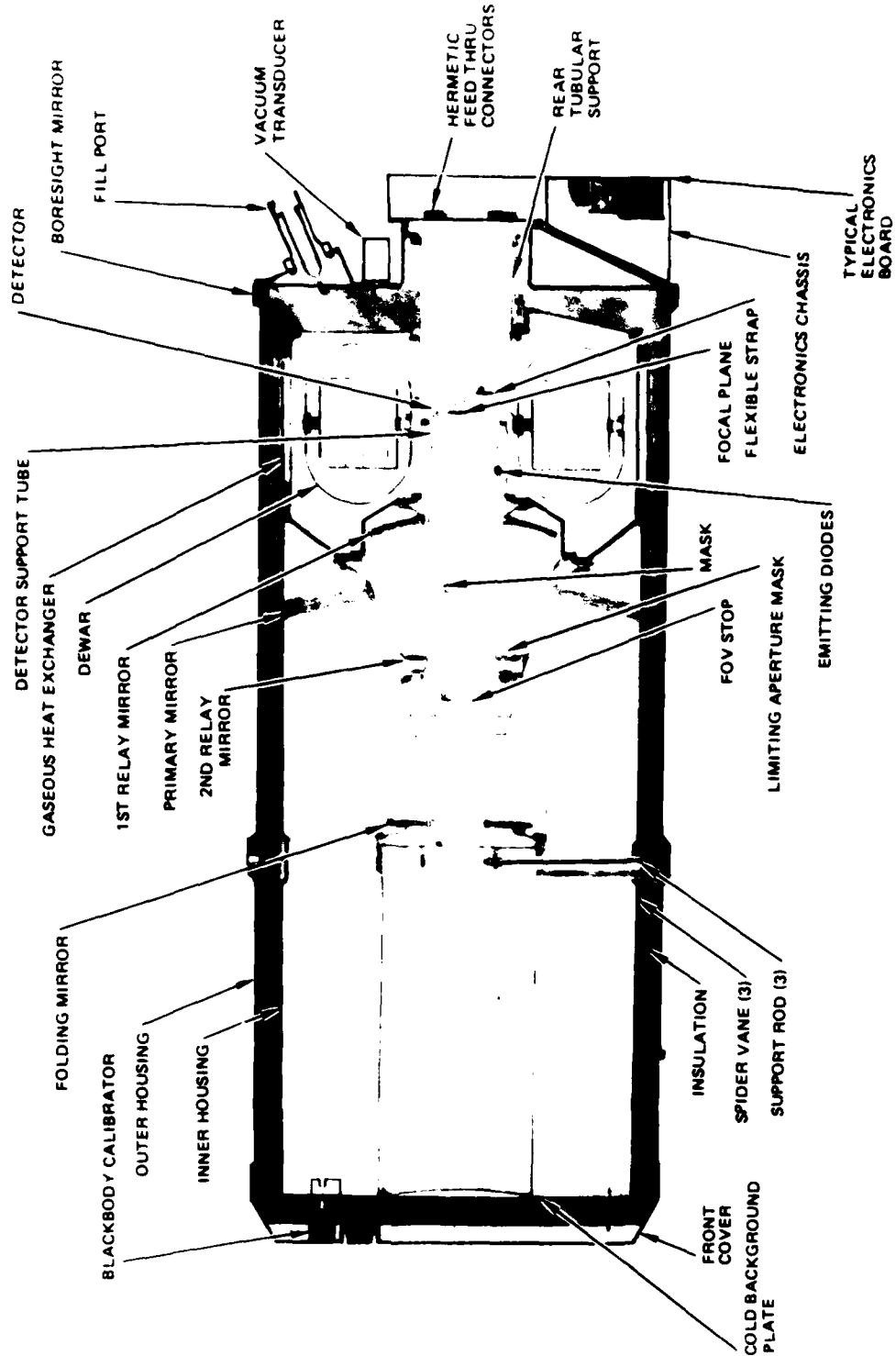

Figure 2-7





Figure 2-8

## 2.2 FOCAL PLANE

A new Focal Plane Assembly (FPA) was designed. The 54 element detector array utilized doped silicon detectors. The detector elements were mounted with the contacts parallel to the incoming radiation. The radiated surface uses transparent contacts as shown in Figure 2-9. The 54 detectors were divided into three (longband, midband, shortband) subarrays. The subarrays are filtered so that they respond to three adjacent parts of the infrared spectrum. The detectors are lined up into columns so that the adjacent channels overlap in the direction of scan (see Figure 2-10). Because the longband array is biased at a lower voltage, it had to be electrically isolated from the FPA. A sapphire isolator (Figure 2-11) was used because of its excellent thermal conductivity (0.3<sup>0</sup>K difference between longband and midband). The only drawback in using this material is that it is extremely brittle and it is necessary to replace it every time the FPA is reworked.

The low noise (siliconix G118) MOSFET preamps and 10<sup>10</sup> ohm load resistors are located in the FPA adjacent to its respective detector (Figure 2-12). The load resistors are a (ELTEX 102) metal oxide composition. After testing of FPA was completed at Anaheim, the unit was sent to Naval Oceans Systems Center for testing/verification of spectral response and NEP measurements.

The new FPA, like the previous one, is easily installed and removed from the telescope.

SPICE DETECTOR ELEMENT MOUNTING APPROACHES

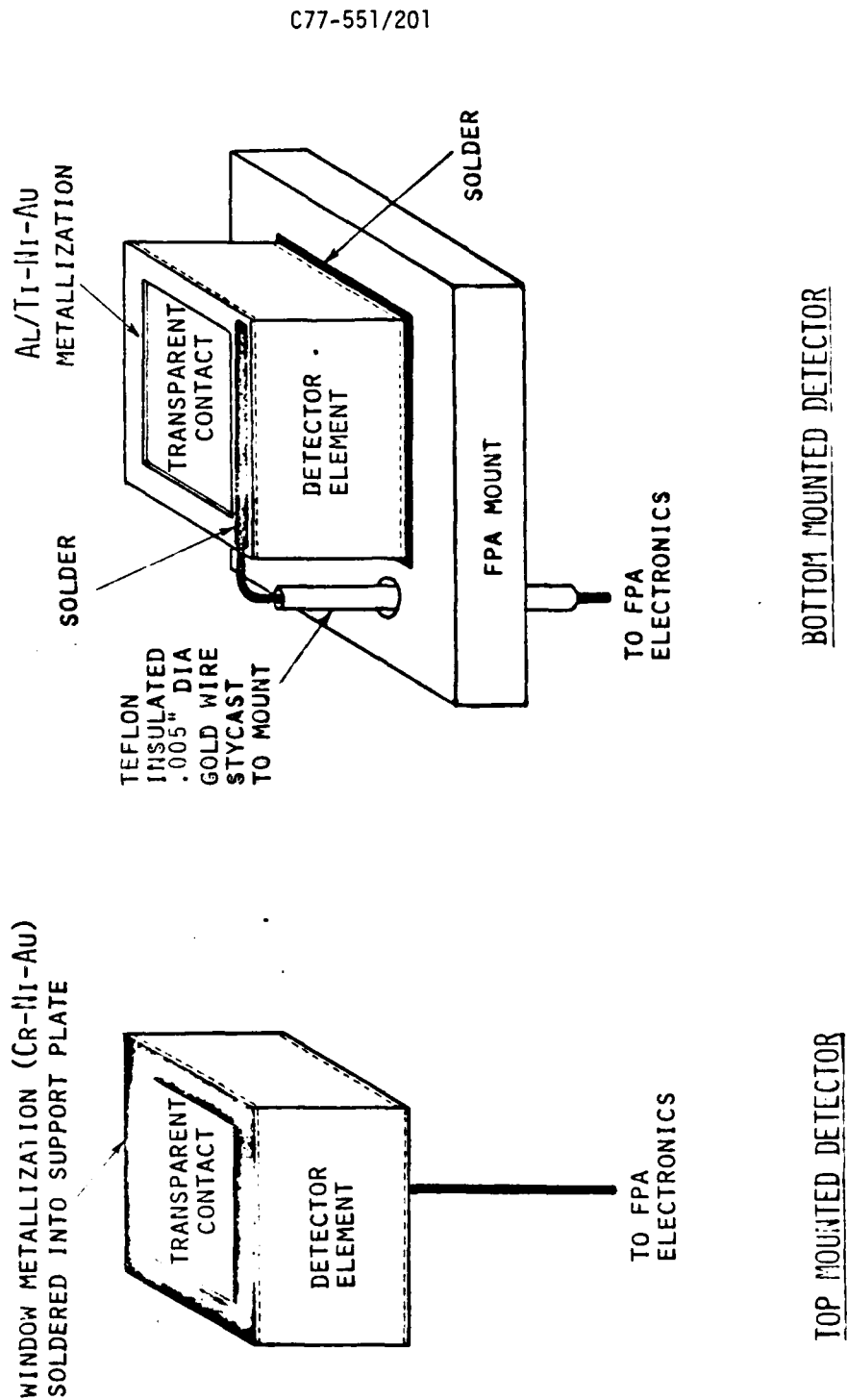

Figure 2-9

TOP VIEW OF NEW COLOR BAND ASSEMBLY

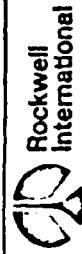
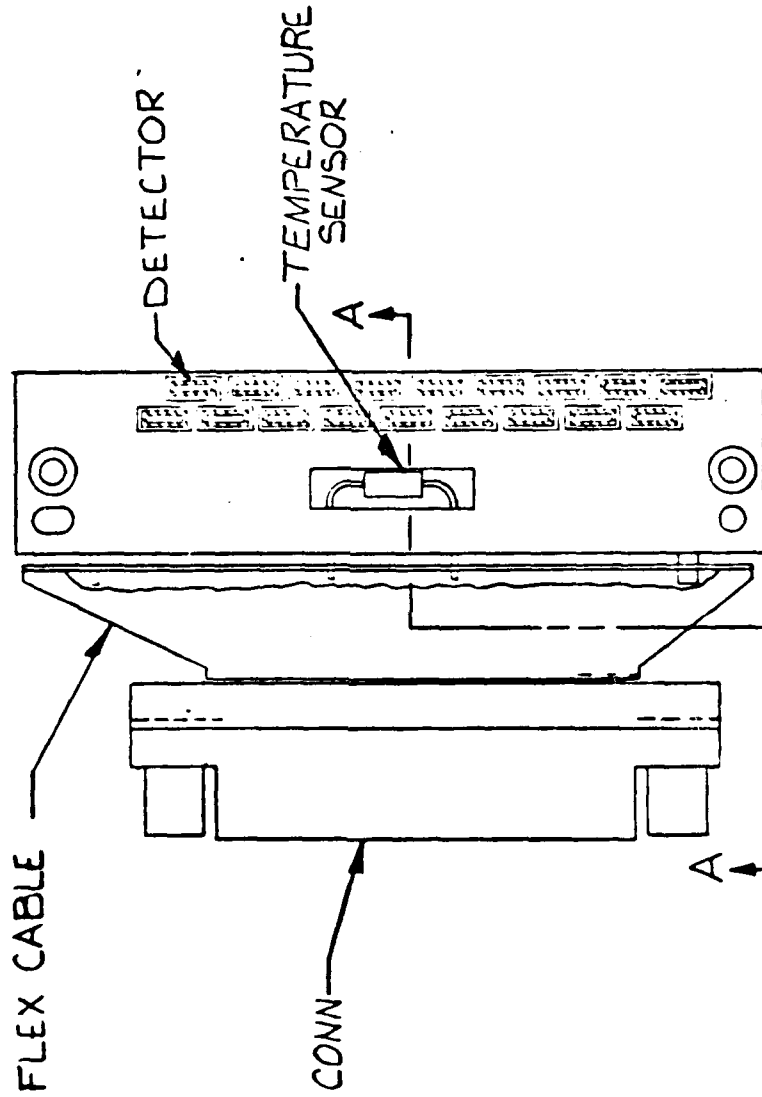

Figure 2-10

SPICE FPA SHOWING LONGBAND ELECTRICAL ISOLATION

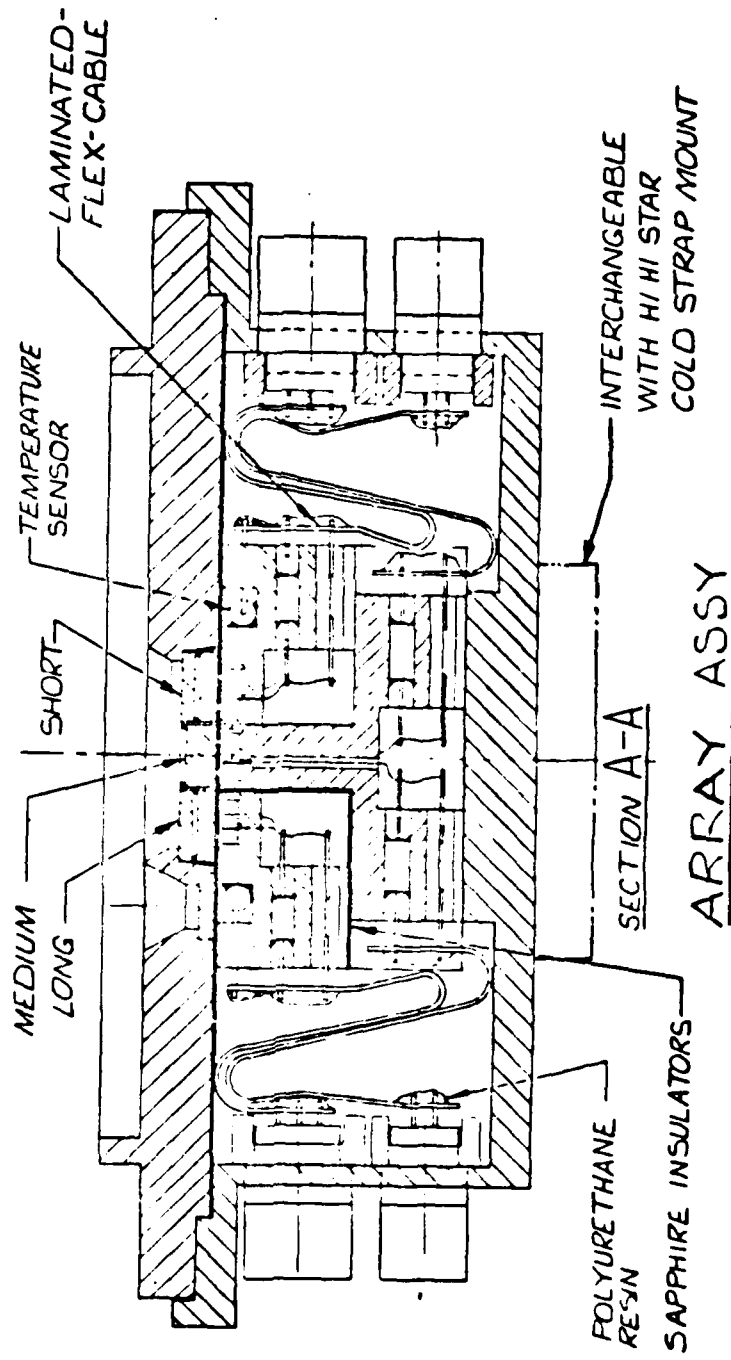

Figure 2-11

DETECTOR ELECTRONICS ON FOCAL PLANE INTERCONNECTIONS

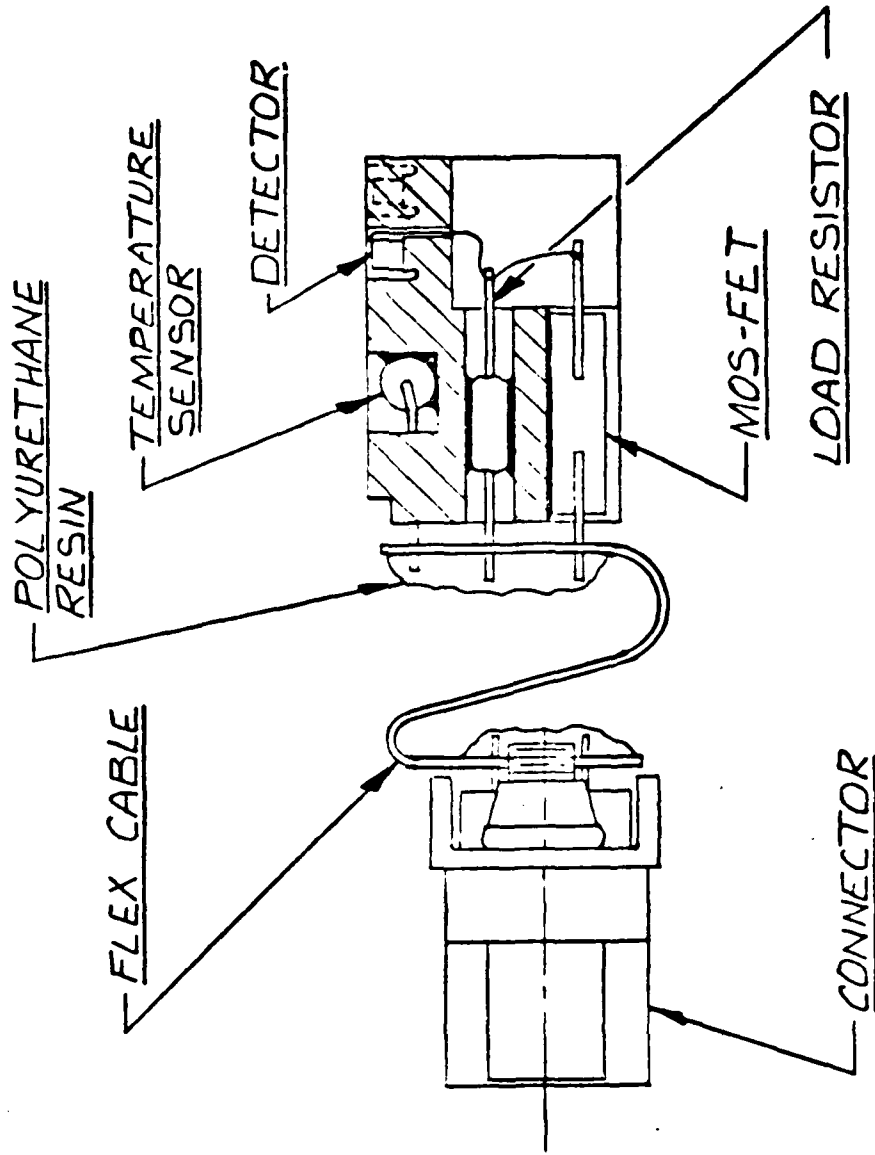

Figure 2-12

### 2.3 ELECTRONICS

Requirements for a new focal plane also made it necessary to redesign the post amplifiers (DSP's). The customer's requirements dictated the detector width of 2.5 arc minutes (0.727 mr). With the telescope's focal length of 30.55 inches, detector width = 0.0222 inches. The dwell time on each detector was calculated to be 2.78 ms. It was necessary to extend the bandwidth to 180 Hz. After investigating the feasibility of modifying the Hybrid Thin Film Circuits (HTFC's), it became apparent that this would not be compatible with the impending flight schedule. Instead, it was decided to make the modifications on the DSP modules. Following this rework, all of the channels were tested with input pulses of 2.78 ms duration whose amplitudes were varied from  $\pm 100$  microvolts to  $\pm 5.0$  volts. The DSP output symmetry in response to positive-going and negative-going pulses varied from channel to channel. A typical response (Figure 2-13) of the test was plotted.

The power supply regulator module was replaced prior to vibration testing. The original module had been thermally overstressed near the end of the Hi Hi Star flight. When the front cover assembly and retract mechanism were torn off of the telescope prior to the "cover install" command, the retract mechanism wiring was broken and exposed the chassis ground, signal ground, and +24 vdc to one another. This power was routed through the P/S regulator module causing its printed circuitry to overheat. The new P/S regulator module operated trouble free throughout the SPICE I Program.

C77-551/201

47 6212

30 MILES PER HOUR

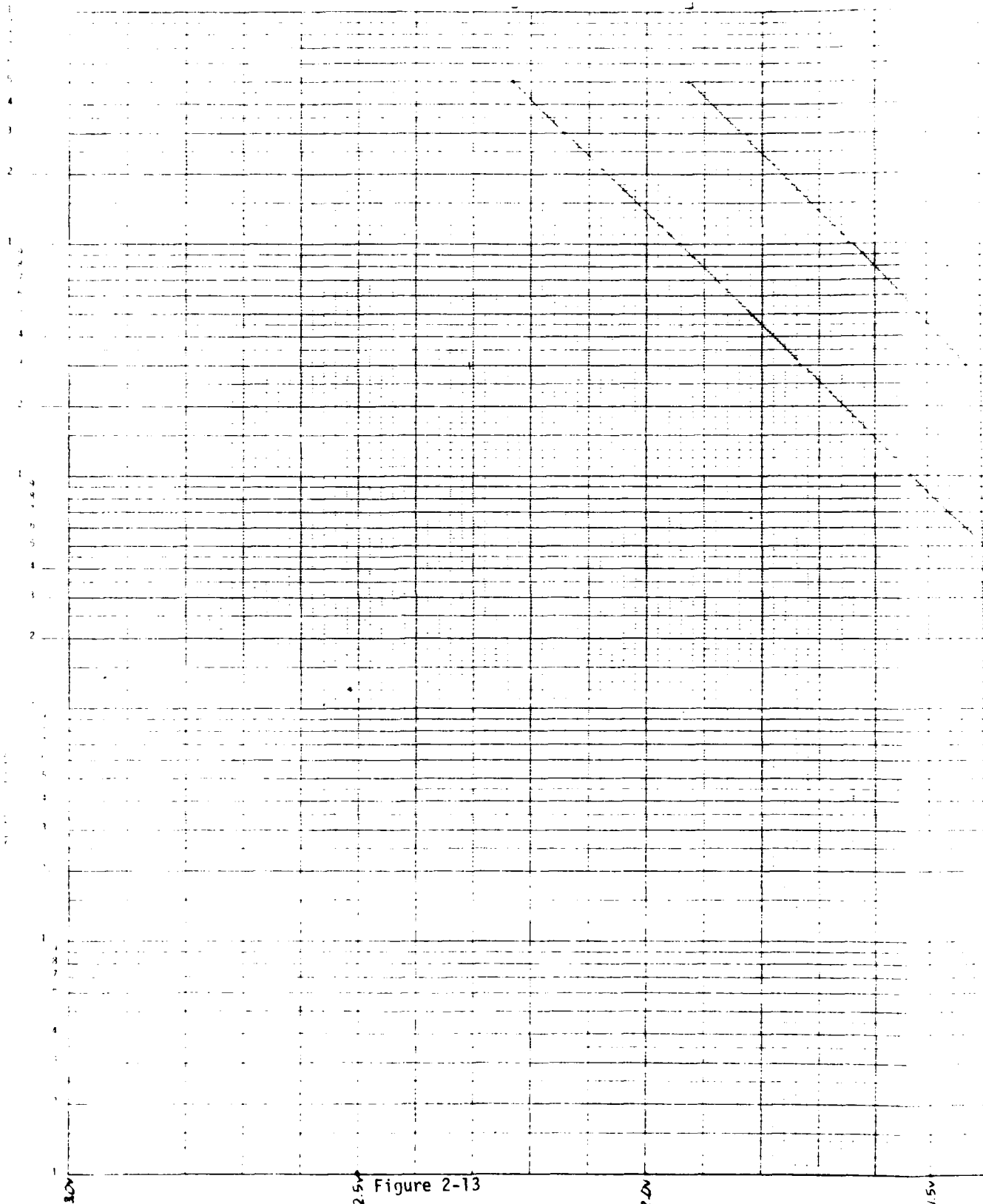

Figure 2-13  
2-21



LANGBAND CH1  
SPICE I DSP

+ INPUT  
2.78 ms pulse

- INPUT  
2.78 ms pulse

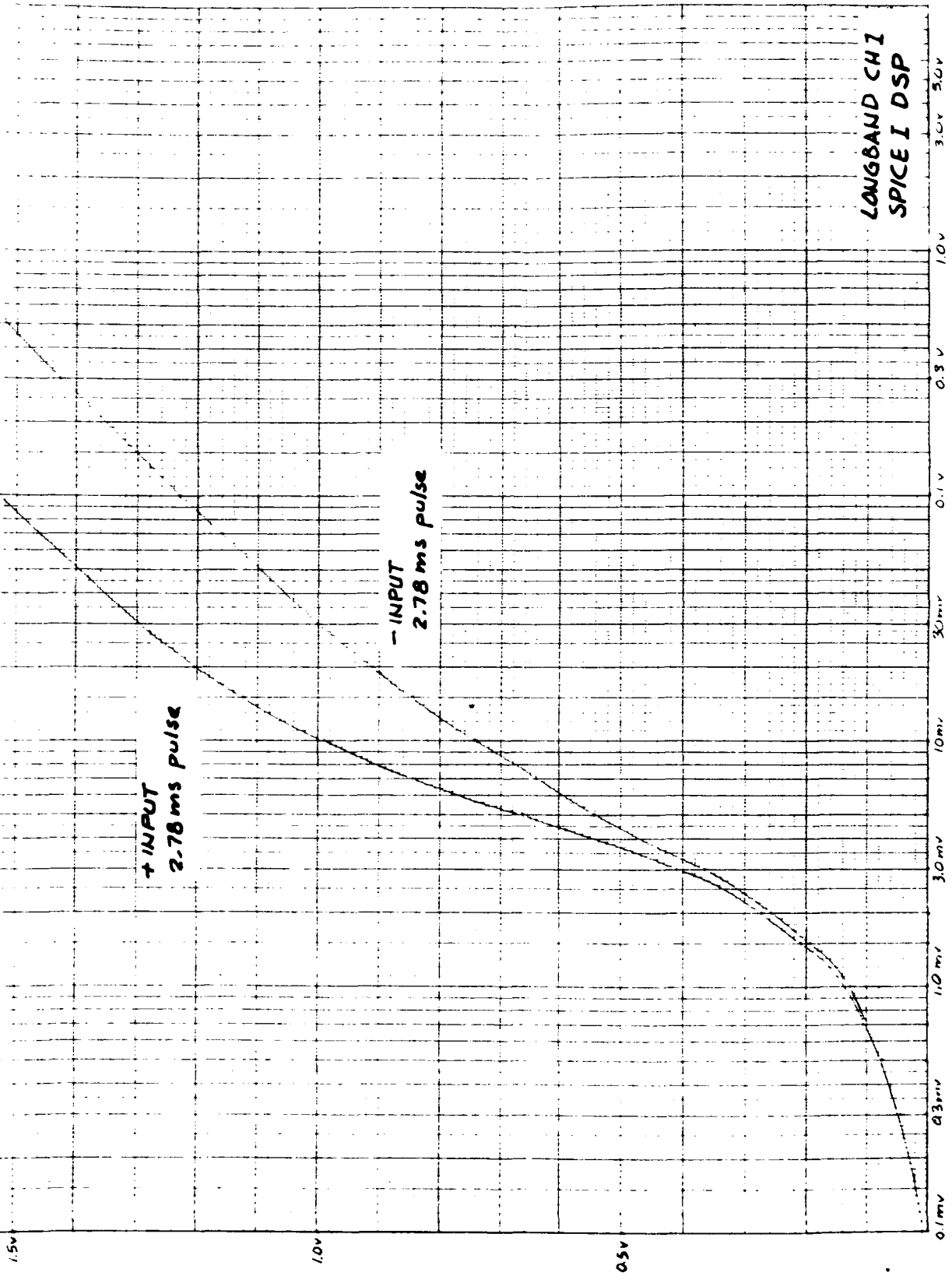

2.4 PCM

A new PCM encoder was required to support this program due to increased data rate. The (Hi Hi Star) Base Ten encoder was replaced by one manufactured by Teledyne Controls. One basic difference between them is that Base Ten sampled the detector outputs sequentially in one complete color band before sampling the next band (S1, S2, S3...L16, L17, L18) whereas the Teledyne unit sampled in alternate color bands (S1, M1, L1...S18, M18, L18). Another difference is the increased data rate. The Hi Hi Star rate was 245 kilobits per second versus 960 kilobits per second on SPICE I. The dc input range is zero to plus five volts dc. The electrical and physical interface was unchanged (Figure 2-14) as per specification.

The existing PCM decommutator (Base Ten) could not be made compatible to the new encoder requirements. A decommutator was obtained from Decom Systems Inc. (DSI). This new decom was delivered as part of the AGE console P/N 40523-509.

SPIICE PCM ENCODER ASSEMBLY

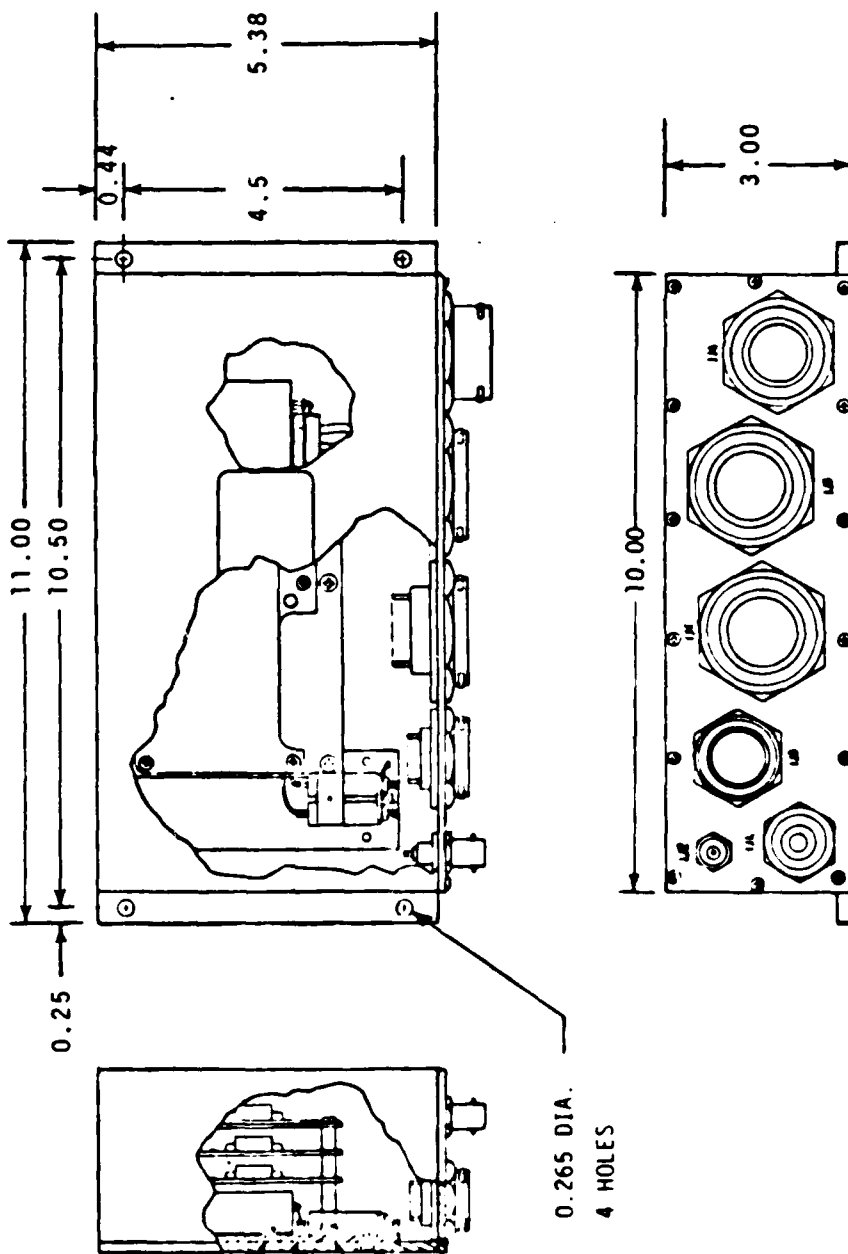

Figure 2-14

## 2.5 INTEGRATION TESTS AND FLIGHT SUPPORT

Testing of the SPICE sensor was completed in April 1978 with the unit being delivered to Air Force Geophysics Laboratory (AFGL) in Boston, Mass. A copy of the test report from the vibration tests which were conducted on the sensor prior to delivery is included as Appendix A.

Rockwell support was provided for the sensor during integration testing at AFGL from May 1978 until October 1978. The payload was shipped to White Sands Missile Range (WSMR) in October and support continued during integration and testing of the payload to the vehicle.

The telescope cooldown requires approximately sixteen hours and 140 liters of cryogenics. Once the telescope cryo system is capped off, the detectors can be maintained at a predetermined temperature for a minimum of six hours. All relevant housekeeping signals are telemetered out along with the detector information.

The electronics performed quite normal throughout this phase of the program. There were some temperature sensitive circuits which were corrected during integration tests at AFGL. Detector wideband noise comparisons in the following table were measured at A) Anaheim post vibration, B) AFGL first cooldown, C) WSMR t-43 min.

CH	SHORTBAND			MIDBAND			LONGBAND		
	A	B	C	A	B	C	A	B	C
1	53	235	20	36	21	18	45	27	27
2	46	11.5	20	33	26	17	65	190	48
3	40	12.0	20	47	49.5	17	59	29	40
4	49	10.0	15	41	26	20	50	29	17
5	31	24.0	19	36	29.5	20	34	27	20
6	34	11.0	17	32	* 2V	15	54	22	19
7	48	11.5	12	41	30.5	17	32	65	20
8	50	12.0	19	36	40.5	24	39	140	19
9	48	11.6	18	43	24.5	34	34	174	19
10	37	9.8	16	34	18.5	30	37	36	19
11	31	10.3	15	40	25	22	43	215	21
12	30	29.5	16	41	26.5	29	55	32	20
13	37	34	25	56	36.5	20	41	33	18
14	32	11.5	20	28	30	20	32	36	20
15	30	13.0	23	35	25.5	22	39	23	19
16	36	11.3	20	39	38	21	34	24	18
17	40	40.0	10	33	25	27	42	21	18
18	27	13.0	20	30	27.5	22	49	26	29
DC	38	13.7	205	83	97	73	83	117	09

\* All readings are in millivolts unless otherwise indicated.

The SPICE sensor system was launched aboard an ARIES vehicle on January 27, 1979 from WSMR (Figure 2-15). Due to vehicle problems, no sky mapping data were obtained. Sensor data with the front cover installed indicated the sensor system was operating properly. All vital signs, i.e., noise levels, temperatures, etc. were good including the emitter diode signals for all channels which were operated 75 seconds into the flight just prior to the time for cover removal.

The sensor operation was to be a sequence where the vehicle door is opened, the front cover removed and the sensor rotated out for data collection. Due to vehicle problems, the door did not open, therefore the remaining sequence did not occur.

During normal operation, the vehicle separates at Station 163 after engine burn-out (see Figure 2-16), then after re-entry, the nose cone is separated for the parachutes to come out of the recovery section allowing for a slow rate descent and landing with Station 163 down. This sequence occurred correctly except for problems resulting in damaged parachutes and a high rate of descent. When the vehicle landed, it collapsed from Station 163 to Station 155 due to impact with the ground (Figures 2-17 and 2-18). The star tracker, etc. which was installed in this area was driven back collapsing the cover removal screw jack assembly and bending the equipment platform next to the sensor to the point where it impacted the sensor forcing the sensor out towards the vehicle door.

C77-551/201

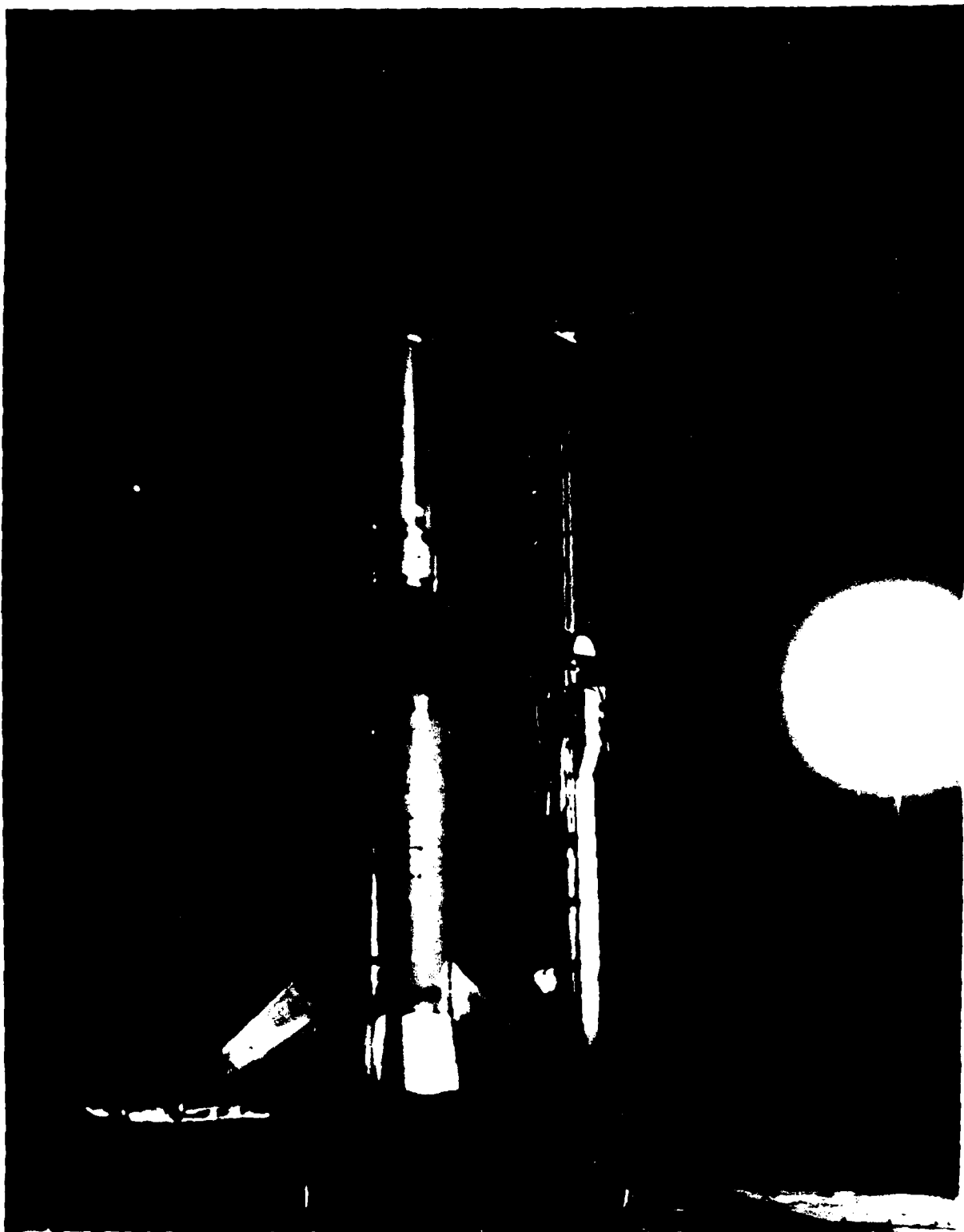
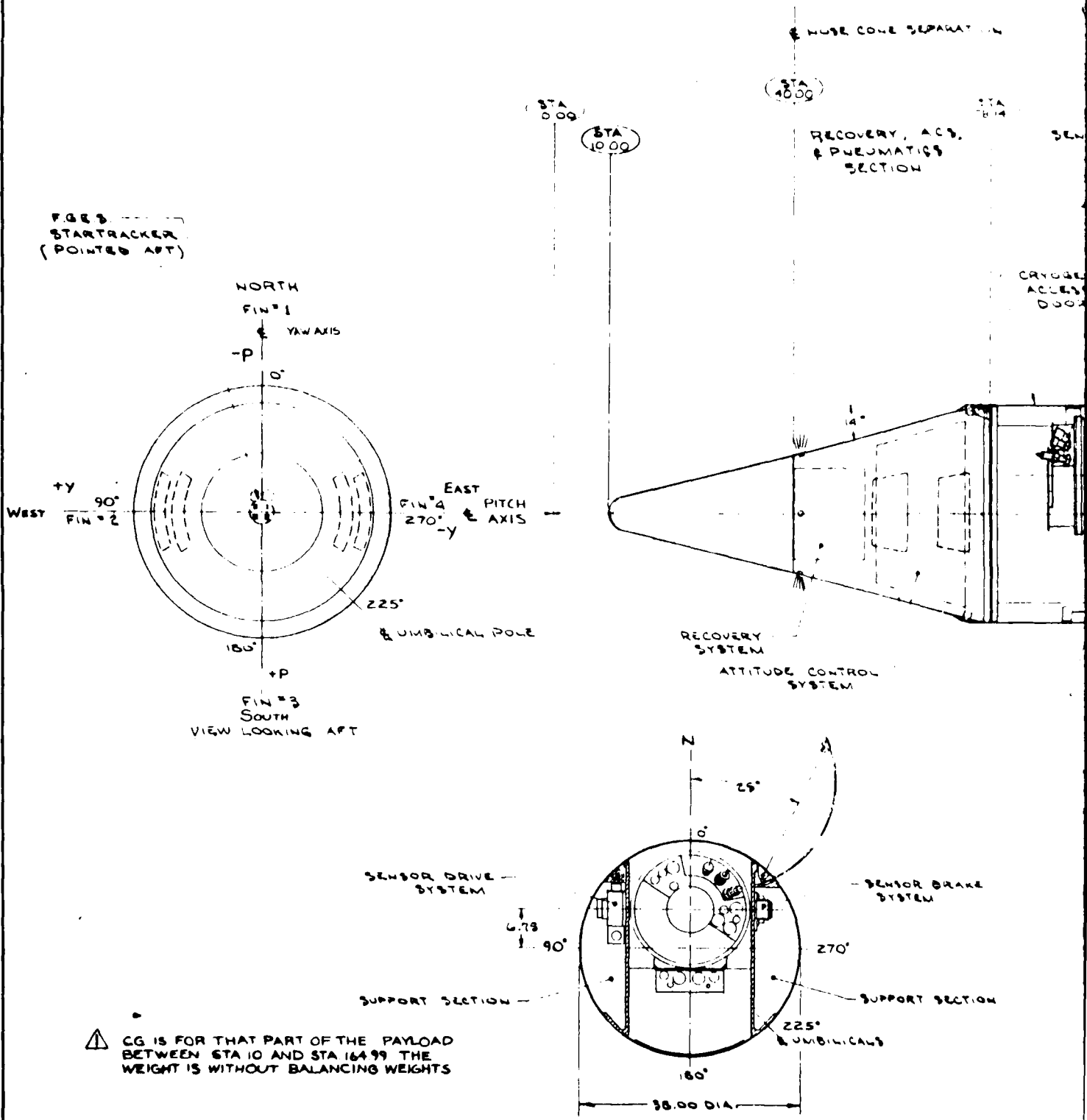

Figure 2-15

2-26



△ CG IS FOR THAT PART OF THE PAYLOAD BETWEEN STA 10 AND STA 16499 THE WEIGHT IS WITHOUT BALANCING WEIGHTS

Figure 2-16

SECTION A-A

D-984B

REVISIONS	
A	ISSUED
B	STA. NO. 1036
C	STA. NO. 1040
D	REVISED

PAYLOAD DEPARATION

STA 1036

CRYOGEN ACCESS DOOR

SENSOR BAKE SYSTEM

3 PORT SECTION

APC

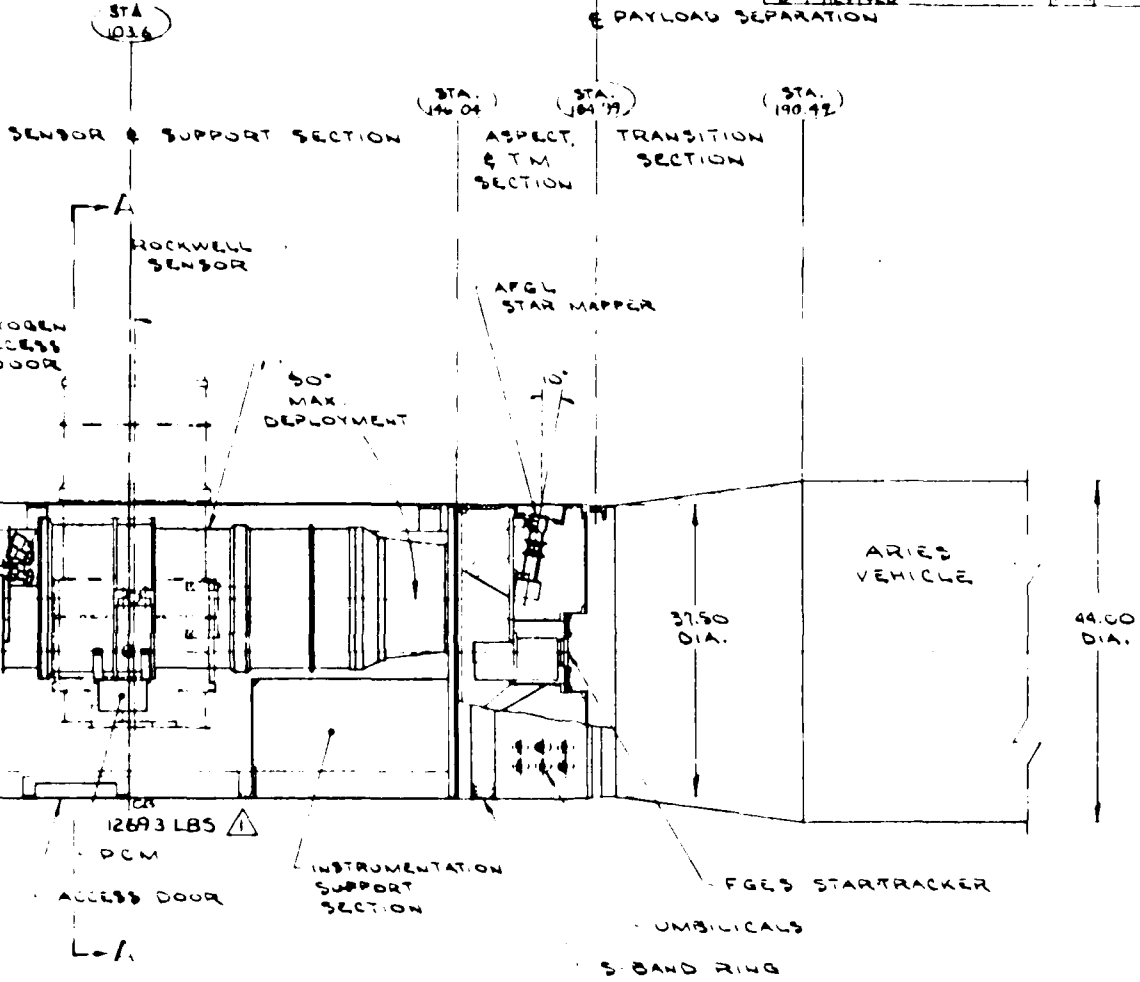

WENTWORTH INSTITUTE APC CONTRACT NO. -0211 BOSTON, MA 02110	DESIGNED <b>LEBLANC</b> CHECKED <b>LEBLANC</b> CHICAGO	DRAWN <b>CN STARK</b> DATE <b>4-7-77</b> NEXT ASSY	PROJECT <b>SPICE A24732-1</b> AEROSPACE INSTRUMENTATION DIVISION AIR FORCE GEOPHYSICS LABORATORY HANOVER, NH 03761
TOLERANCE UNLESS OTHERWISE NOTED DECIMAL .005 SURFACE .010 ANGULAR .030 BREAK SHARP EDGES AND CORNERS	SCALE <b>1/10</b> MATERIAL	CONFIGURATION <b>DRAWING - SPICE PAYLOAD</b>	<b>D-984B</b>



C77-591/201



Figure 2-17

C77-551/201



Figure 2-18

## 2.6 POST FLIGHT EVALUATION

The SPICE sensor and related equipment were shipped directly to Rockwell International at Anaheim for closer examination and evaluation. Upon first examination it looked like the telescope had been totaled (Figure 2-19). With closer inspection, however, the telescope seemed to have survived with a large percent of its components still in tact. The mirrors (all four) were all right. The focal plane array was okay. The outer housing was in good condition except for a few minor scratches. Although the electronics cover was damaged (Figure 2-20), the rear telescope cover was fine. The primary mirror support ring and all the optical cone assembly and its mirror were also all right. The inner housing had come loose and flew forward. This destroyed the cold background plate assembly (Figures 2-21 and 2-22), but the new solid aluminum front cover was repairable. The cryogen tank and heat exchanger assembly was badly damaged so that the tank (Figure 2-23) had to be replaced, but the heat exchanger frame was salvageable by replacing the flattened tubing (Figure 2-24). When the inner housing came forward, it sheared the support rods off at the outer housing (Figure 2-25). The inner housing was destroyed (Figure 2-26), and would have to be replaced.

C77-551/201

7900CF2 D



Figure 2-19

C77-551/201

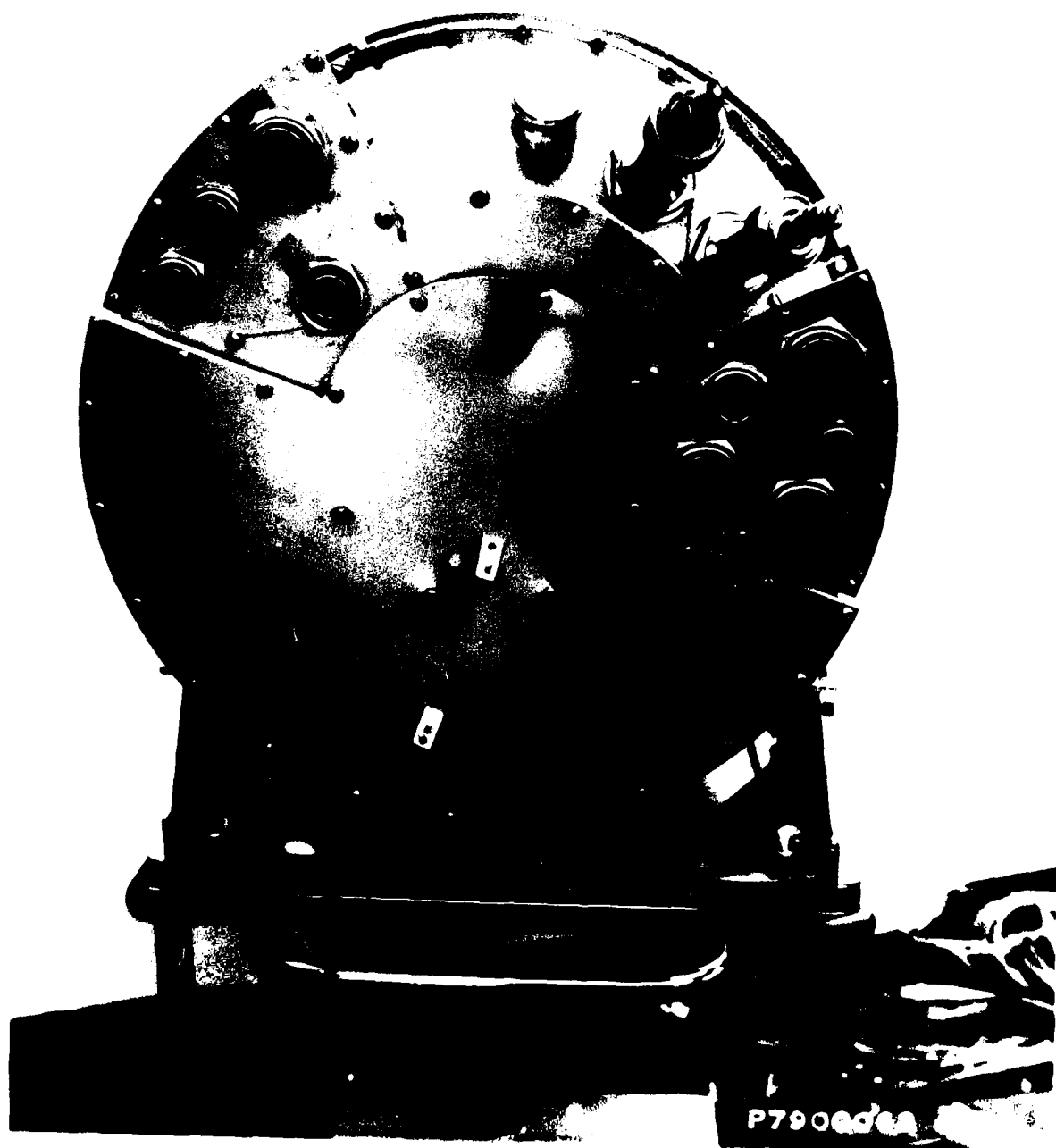

Figure 2-20

C77-551/201

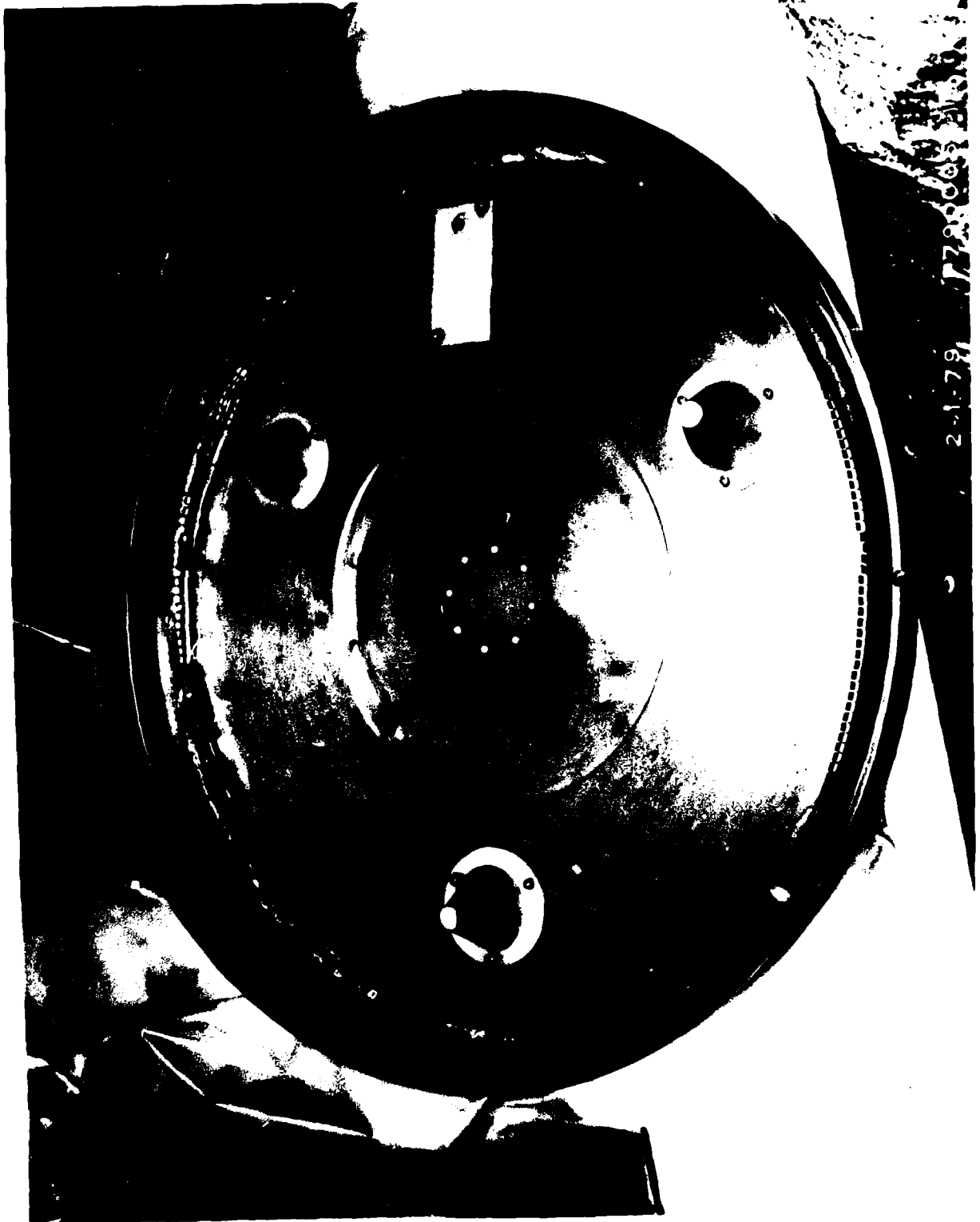
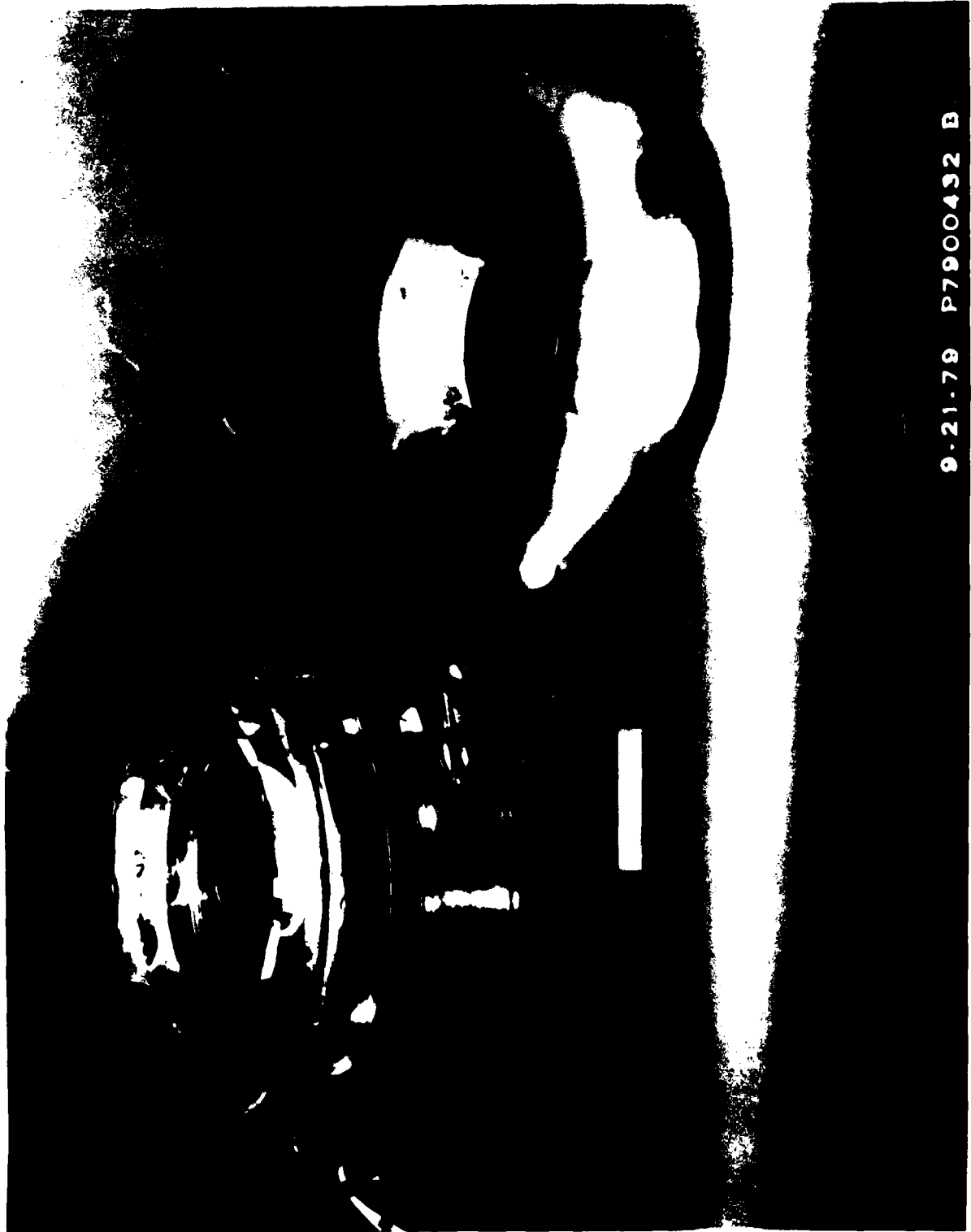

Figure 2-21

C77-551/201



Figure 2-22



9-21-79 P7900432 B

Figure 2-23





Figure 2-24

C77-551/201



Figure 2-25

C77-551/201



2-2-79 P7900063 H

Figure 2-26

### 3.0 SPICE II

#### 3.1 TELESCOPE ASSEMBLY

##### 3.1.1 Front Cover and Background Plate

The front cover was stripped of anodizing and the nickel plating on the o'ring lip. The cover was then straightened using a hydraulic press. This removed all of the warp or bending of the cover. The angled o'ring surface was machined down to ensure removal of slight imperfections (small dents), and to ensure a perfectly round lip. The "D" hole for connector 2J10 was damaged during impact, so it was machined out and a new one made and E.B. welded in place. The unit was then x-rayed for faults and when none were found, it was re-anodized and the front edge nickel plated. Rockwell's Optical Department lapped and polished the o'ring surface of the nickel plated front edge. A connector was installed and the assembly was tested and found to have no leaks. The blackbody was installed and wired to the connector. A strip connector was wired to the connector to accept the wire bundle from the cold background plate. New longer guide pins were fabricated and installed completing the front cover assembly.

The cold background plate assembly had to be almost completely refabricated (Figure 3-1). This included a new plate, spring fingers, outer ring pull off and push on support units. The only part that was recoverable was the blackbody chopper assembly. It had been completely dismantled, thoroughly cleaned and reassembled. The plate itself was sent to Cohen-Ebner of Brooklyn, New York to be gold plated over nickel plate, but with no copper, this produced a great finish on the plate. The ring, fingers, and plate were soldered together like the previous background plate. The wires from the two temperature sensors, and the blackbody chopper were terminated in the other half of the strip connector that was used on the front cover assembly.

(77-551 291)

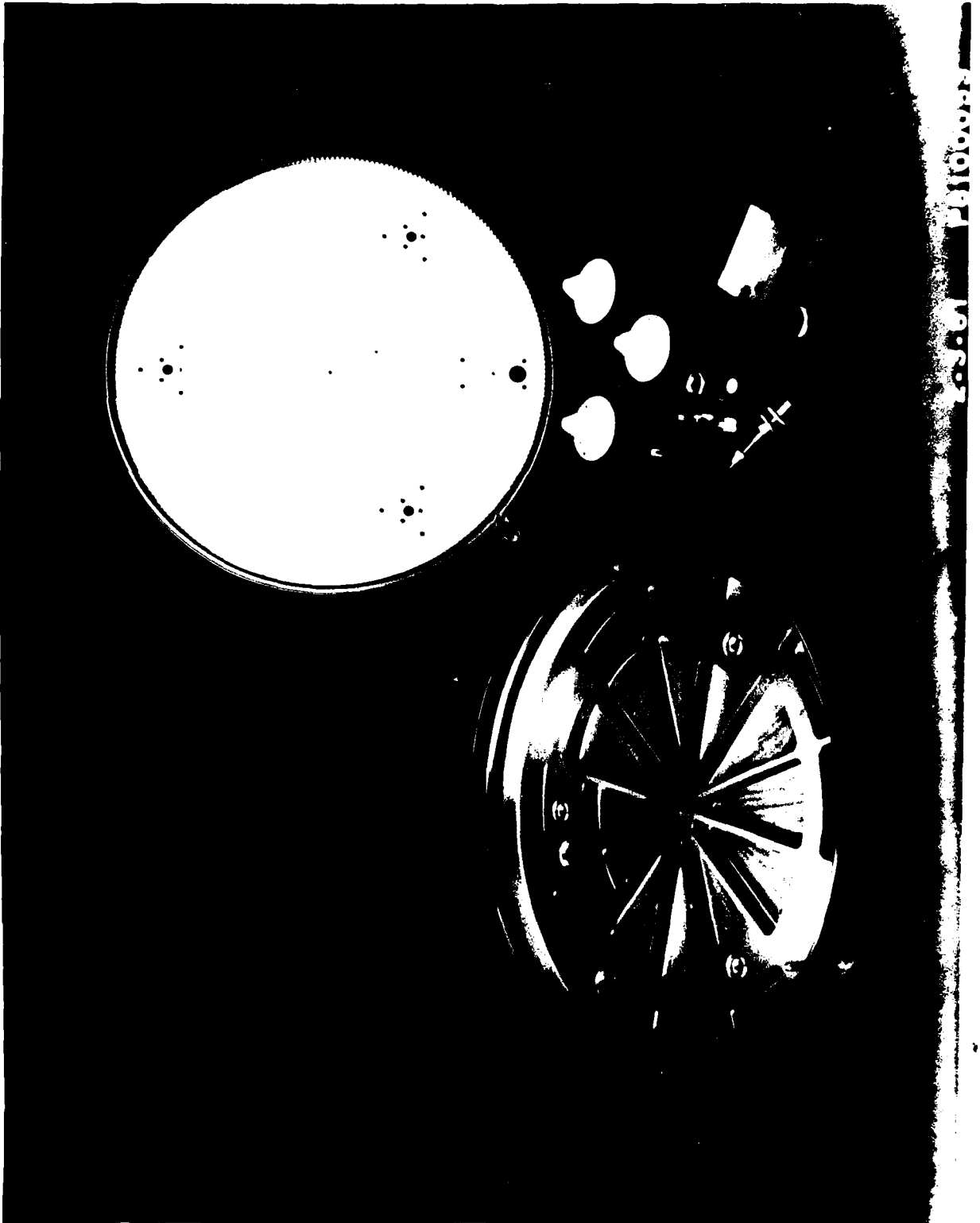

Figure 3-1

3-2

Fifty two sheets of superinsulation were cut, freon washed and installed between the cold background assembly plate and the front cover assembly. Four of these sheets were larger diameter so that they would bend up on the outer edge to cover the open ends of the other 48 layers. The two connectors were connected and the wires staked down, completing the front cover cold background plate assembly.

### 3.1.2 Mechanical Assembly

A new inner housing was built using the same construction methods as Hi Hi Star. When the housing was finished, it was a much cleaner item due to the fact that no test heaters or test only temperature sensors had been epoxyed on then removed to leave residue on the surface. The inner housing was then lapped at the front cover, primary mirror support ring and the folding mirror mating surfaces to make them flat and parallel to each other. The forward edge was then nickel plated where the cold background plate interfaces with the inner housing. The rest was grey anodized. The required temperature sensors (new) were then attached and the wires routed to a strip connector near the rear inner face surface.

The mirror support ring was examined and found to be all right. It was paper lapped to remove any burrs and parallelism was also checked. The unit was then thoroughly cleaned.

The new cryogen tank was built (Figure 3-2) according to existing drawings except for the upper and lower half toroids. Originally these were very thin stainless shells to keep the payload light. Because this isn't as important on the SPICE program, the new ones were made thicker so as to make the tank sturdier and less prone to vacuum leaks. The heat exchanger survived the impact except for the tubing. Again the original tubing was very thin nickel tubing used because of weight savings. Regular copper tubing was substituted resulting in a weight gain but also in a cost saving and heat transfer advantage (Figure 3-3). The copper tubing was silver soldered to the bulkhead. The parts were cleaned and assembled (Figure 3-4). Included in the assembly were new fill and vent lines, new dewar support, new rear support tube, and a new cold strap and sapphire isolator were installed with indium washers to the inside cold post of the tank.

C77-551/201

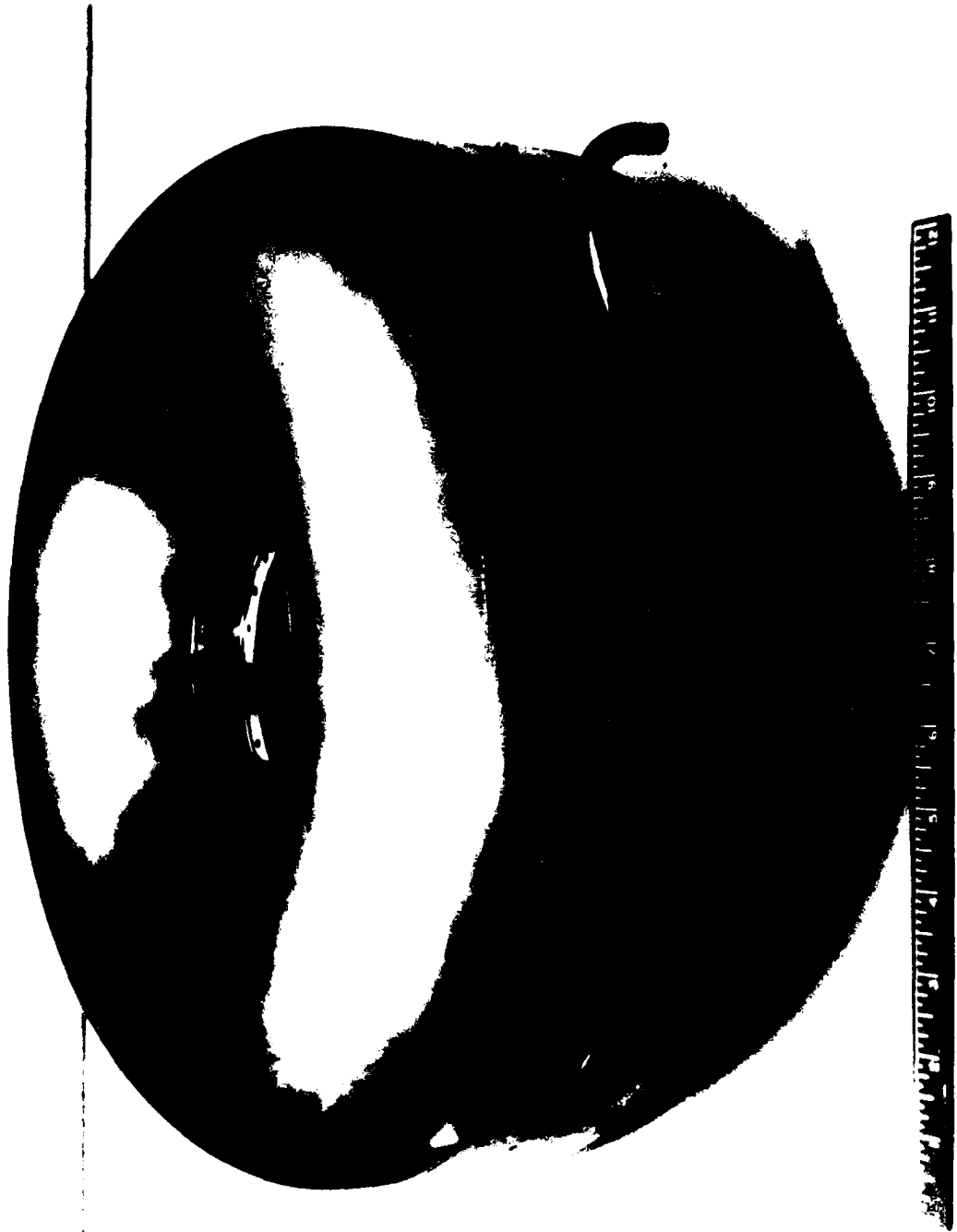

Figure 3-2

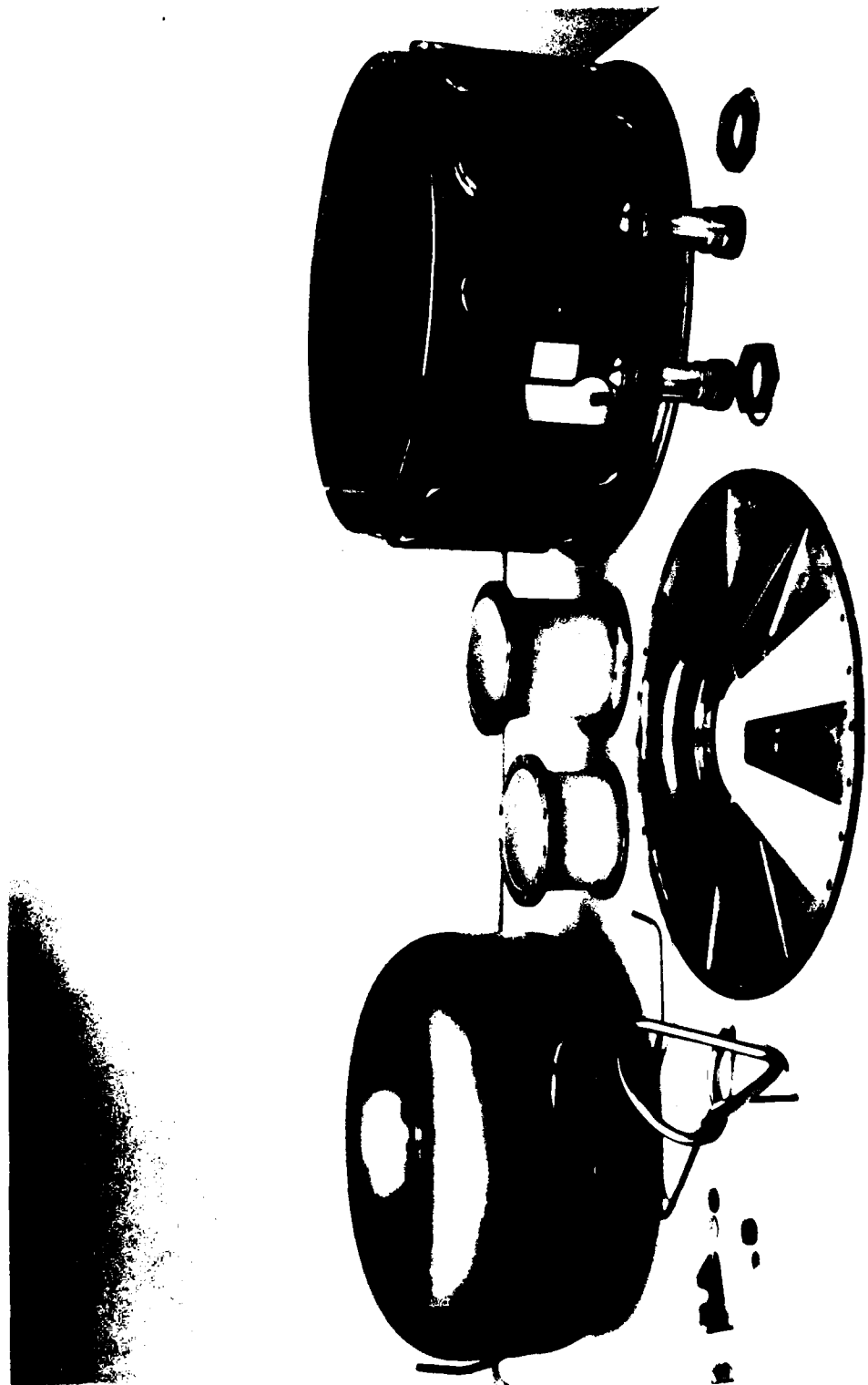

Figure 3-3



C77-551/201

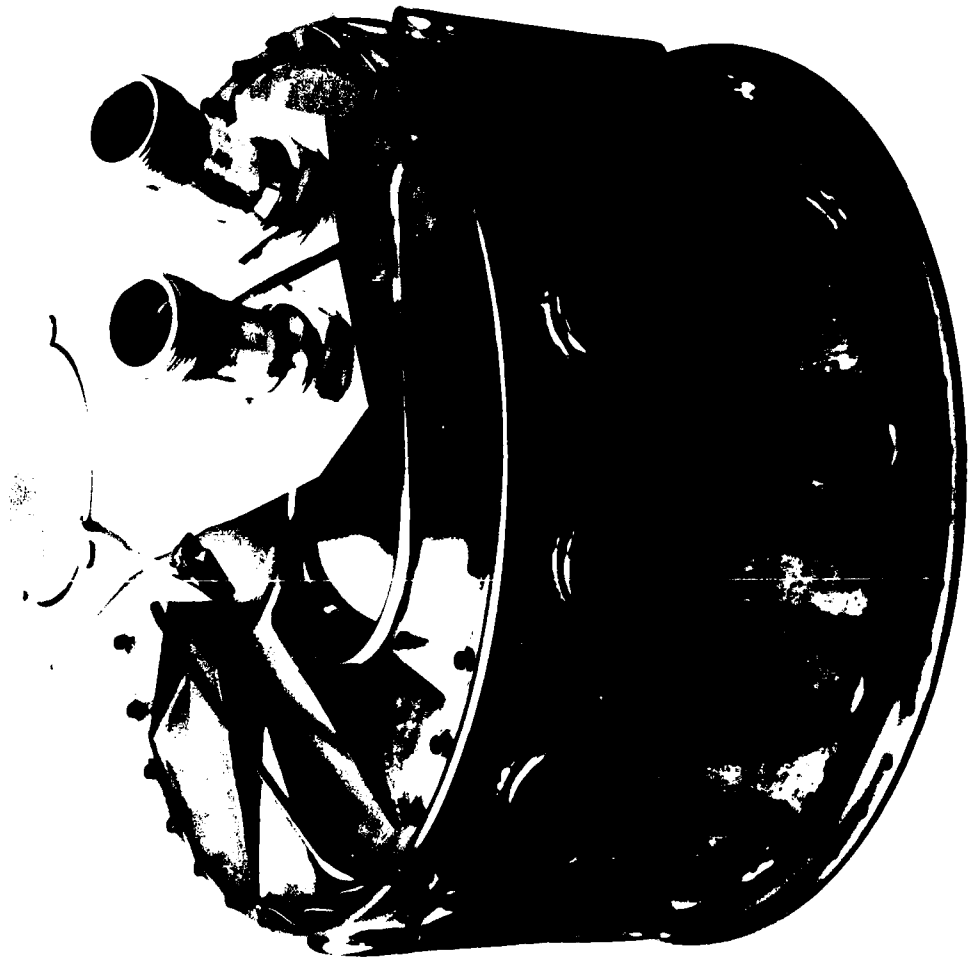

Figure 3-4  
3-6

All four mirrors were delivered to optics group for cleaning and inspection. All mounting surfaces were lapped to ensure flatness, then the mirrors were optically cleaned. The first relay with its stray radiation cylinder was installed onto the mirror support ring and the bolts safely wired. Next the second relay mirror and field mask were then attached to the mirror support cone. The baffle cone and rectangular field stop were also attached to the mirror support cone. All wiring and temp sensors were installed and properly routed during this assembly. The support cone and mirror assembly was then joined to the mirror support ring, and its screws safety wired. Lastly the primary mirror was installed on the mirror support ring.

The outer housing was cleaned and inspected. A slight dent was removed from over the front o'ring groove with a fine pumas stone. A 30° x 1/8 inch bevel was machined into the rear of the outer housing to facilitate o'ring insertion. The front opening was checked for roundness and found to be satisfactory. The outer housing temperature sensor (ambient) was wired to a two pin strip connector.

The folding mirror, its focusing shim and the folding mirror baffle were next installed with required temp sensor and wirings into the new inner housing (Figure 3-5). Next the mirror support ring assembly was installed onto the rear flange of the inner housing. Indium foil was placed between the two flanges to ensure proper heat transfer from the front of the telescope assembly through the mirror support ring. The detector baffle and detector support cylinder were then added to the assembly.

The cryogen tank and bulkhead assembly was then attached to the rear flange of the mirror support ring already on the inner housing. Required bolts were installed, torqued to specifications and then safety wired. Again indium foil was used between mounting surfaces to improve heat transfer. The 54 sheets of super insulation were added to the rear of the rear bulkhead and wrapped around the rear support tube. Then the rear cover is installed onto the rear support tube covering the super insulation. Figure 3-6 shows this complete inner assembly minus any super insulation. The new wiring and connectors can be seen as well as the wire stake-down method.



C77-551/201

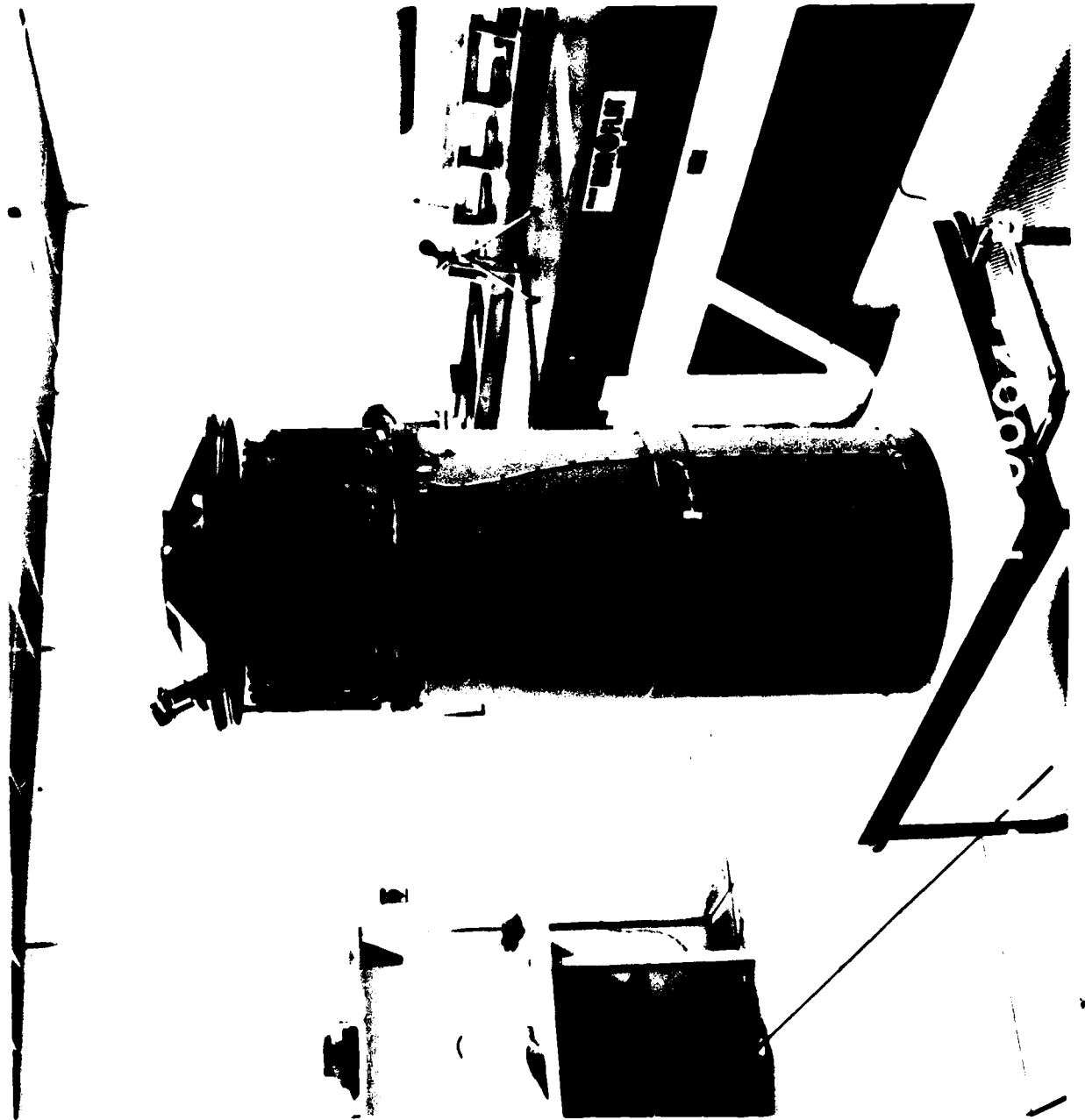

Figure 3-6

C77-551/201

Preparation for the assembly of the inner housing into the outer housing can be seen in Figures 3-7 and 3-8. Super insulation has not been installed in these photos as yet except for under the rear cover. Super insulation was then installed and the units mated together. The assembly fixture shown was designed for easy assembly and safety reasons.

C77-551/201

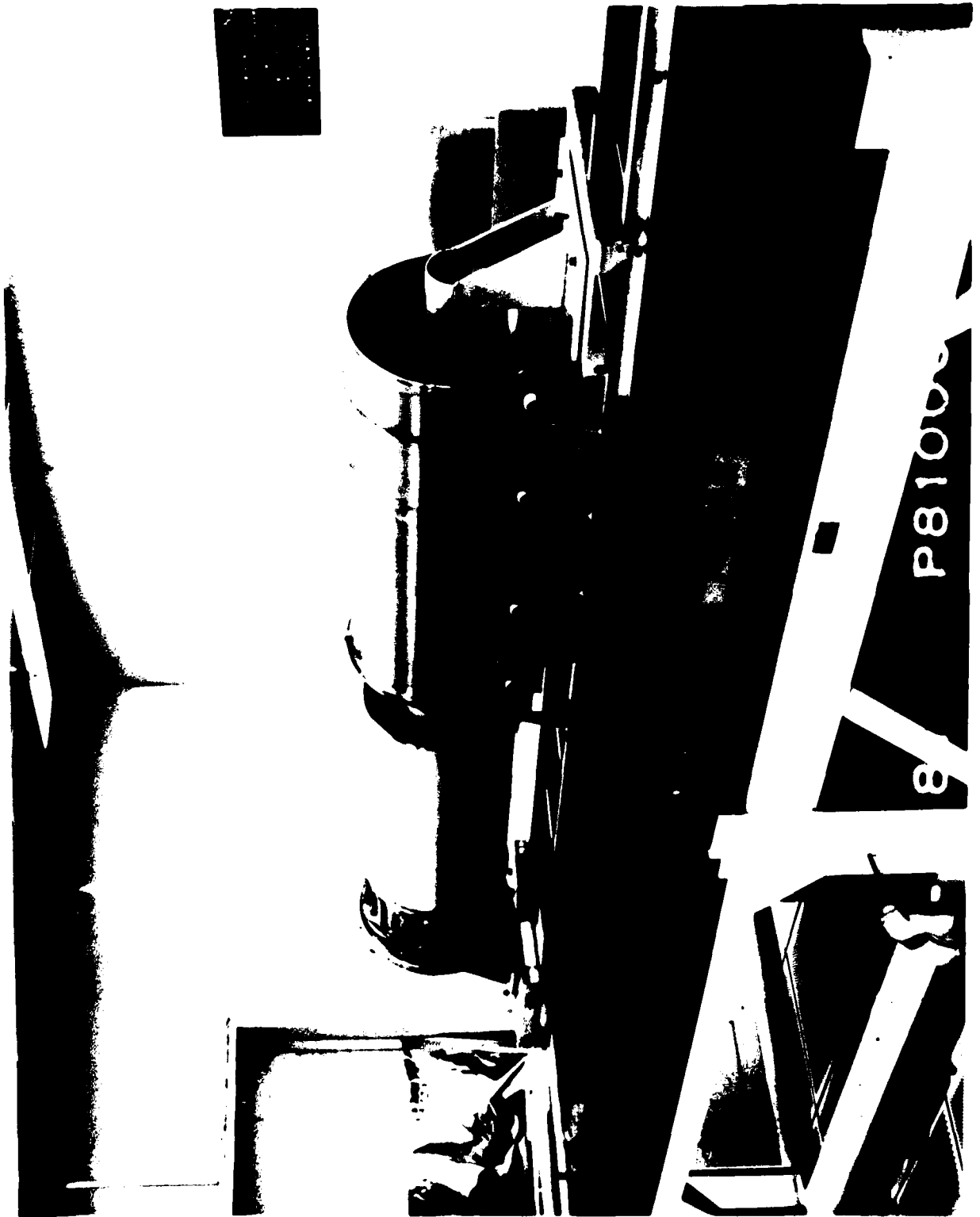

Figure 3-7

3-11

C77-551/201

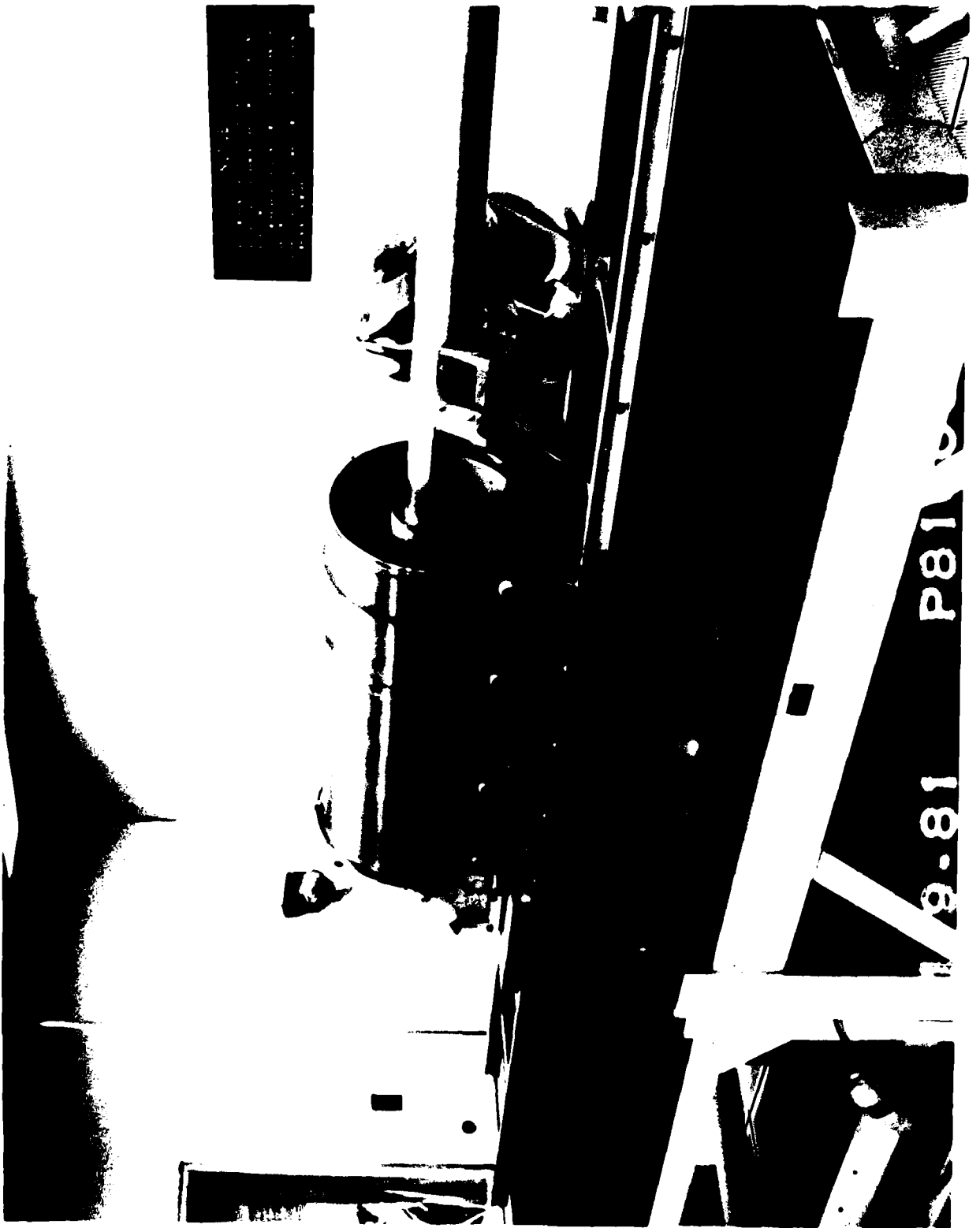

Figure 3-8

### 3.2 ELECTRONICS

A new electronics assembly was designed to replace the Hi Hi Star/SPICE I electronics. There were four basic differences between the two:

- 1) The entire electronics assembly is removable from the telescope. This facilitates assembly and test of both units. Also this configuration allows the efforts to occur concurrently rather than sequentially (Figure 3-9).
- 2) The circuit boards were plugged in rather than hardwired into the electronics assembly (Figures 3-10 and 3-11).
- 3) The Hybrid Thin Film Circuits (HTFCs) were plugged into the circuitboard rather than soldered into the board.
- 4) The Detector Signal Processor (DSP) modules incorporated linear gain (X100) post amplifier HTFC's in place of the linear-log amplifier HTFC's.

The signal channel gain in the SPICE I sensor was measured in the linear operational regime ( $e$  in  $\leq 1$  mv) at three frequencies: namely 4, 50 and 180 Hz. The mid band gain, i.e.,  $f = 50$  Hz, is summarized in the following table for each spectral band.

SPICE I Signal Channel Gain

Spectral Band	Mean Gain	Standard Deviation
SWL	165	6.3
MWL	170	5.7
LWL	143	4.9

For these gain values, the zilch noise background at the input of the PCM encoder should have been on the order of 7.8, 8.0, 6.7 mv in the SWL, MWL, and LWL bands, respectively.

Prior to the SPICE I flight, work was started on a linear amplifier design which would replace the existing linear-log amplifier used in the sensor.



C77-551/201

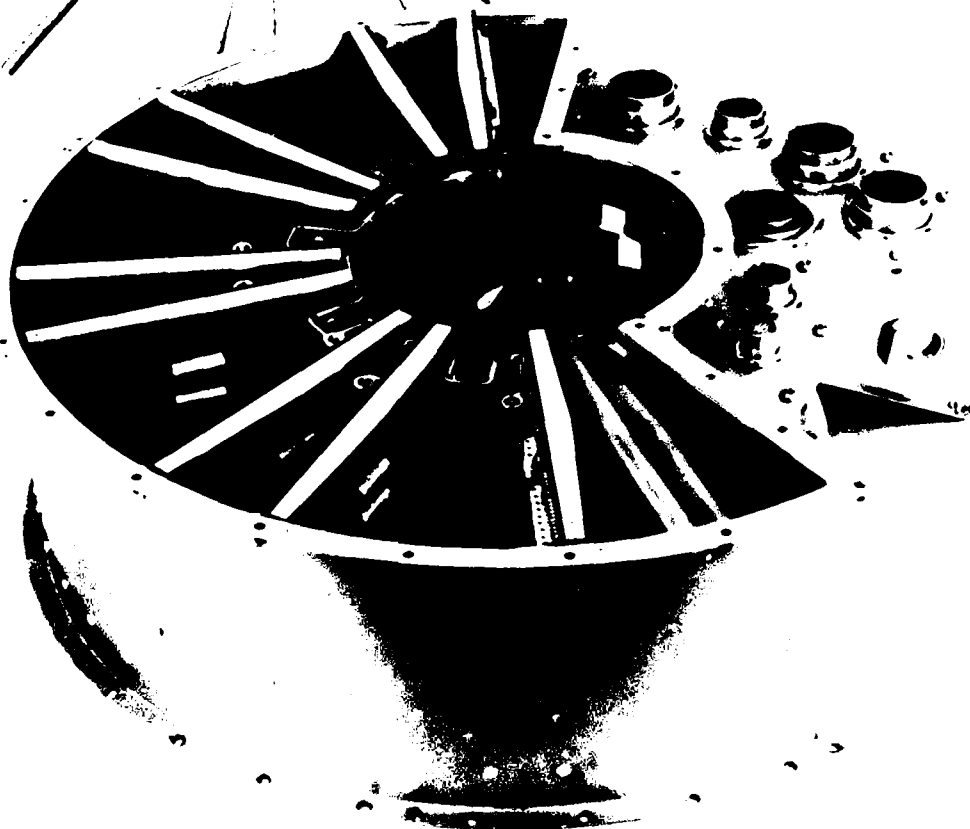

Figure 3-9

3-14

C77-551/201

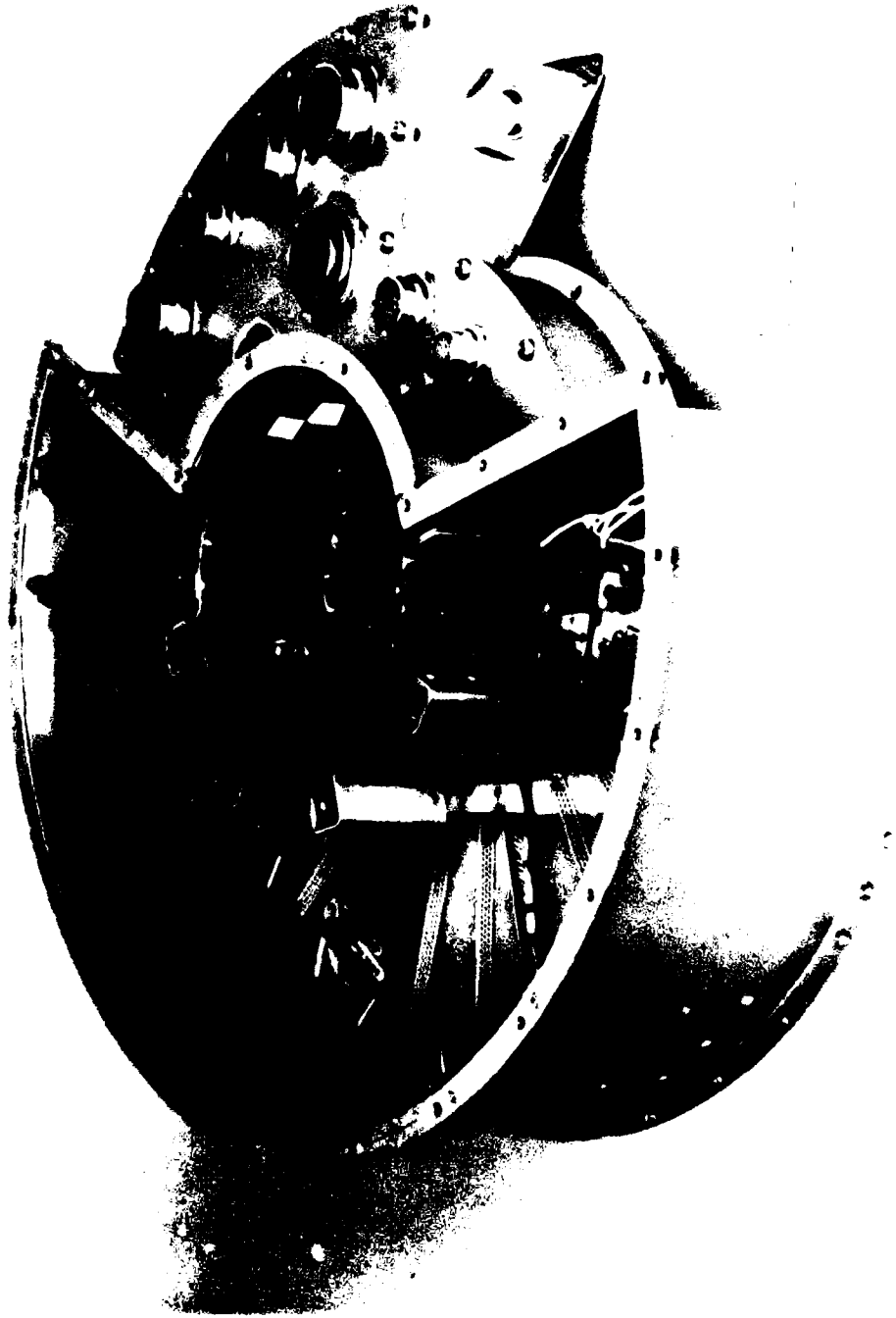

Figure 3-10

177-551 201



10-16-79 P7900470 E

Figure 3-11

The initial gain of this amplifier was adjusted such that the overall system gain was about 40. This gain value was established based on 1) a requirement that the RMS noise level be equal to the LSB of the PCM unit, and 2) initial theoretical noise estimates.

The predicted noise level at the PCM input was on the order of 6 mv. When the noise estimates were updated, the noise at the PCM input was predicted to be on the order of 1.8 to 2 mv -- a value which was not compatible with the gain levels of the PCM. To rectify this situation, the signal channel gain was increased to about 100.

The measured gain in each SPICE II channel is presented in the following table:

SPICE II Signal Channel Gain

Spectral Band	Mean Gain	Standard Deviation
SWL	102.6	0.52
MWL	102.4	0.54
LWL	102.8	0.42

The zilch background noise level at the PCM input should be on the order of 4.8 mv in each of the three spectral bands.

Up to this point, the detector irradiance and, hence, background noise has been assumed to be negligible. With the cover on, this will be the case in the short and mid wavelength bands. Such is not the case, however, in the long band. The predicted detector irradiance in this band is on the order of  $3.1 \times 10^9$  photons/cm<sup>2</sup>/sec. This translates into a noise level of about 8.0 and 5.6 mv at the PCM input for the SPICE I and II sensors, respectively. The total noise in the long band should be 10.4 and 8.0 mv for the two sensors.

The electronics assembly was functionally tested and then sent to AETL (Ogden Labs) in Fullerton, California for environmental testing (see AETL Job No. 973-3754 Appendix A).

The assembly was subjected to shock, acceleration, and vibration tests per AA0305-115. There were no physical or functional failures resulting from these tests.

SPICE II prime power requirements were less than in HHS/SPICE:

	SPICE II	HHS/SPICE	
DC Volts	Amps	Amps	Vent Gas Htr
+24	2.0	2.0	3.4A
-24	0.8	1.0	
+16	0.25	1.6	
-16	0.2	0.3	
+ 8	0.3	0.3	

A new PCM encoder made by Aydin-Vector was provided for the SPICE II project. This encoder was capable of accepting 0 to 10 volt signals as compared to the 0 to 5 volt limitation of the previous encoder. This encoder was delivered to the customer as part of the SPICE II system.

### 3.3 AGE EQUIPMENT

During the SPICE I project it became obvious that some changes were desirable on the existing HHS/SPICE AGE equipment. Because of changes to the sensor hardware and functions, several of the AGE panel meters, control switches and test points became non-applicable to the current sensor configuration. Also, the present decommutator unit would not fit in the original AGE console. The obsolete hardware was eliminated and the remainder was consolidated. This allowed space for the decom and for the installation of a higher capacity +28 volt power supply. The new console was made of aluminum so that it would be more mobile when used in the field.

The Power Supply Package (PSP) housing was also changed. The housing was made so that the AGE console could be stacked on top of it (Figure 3-12) during lab tests. The addition of casters made it more manageable when used around the launch pad. Air blowers inside the housing circulate cooling air to the SPICE sensor (External Power) power supplies to aid operating during extremely hot weather. Also, added to this console was the additional of test points that allow auxiliary power to be applied to the vent gas heater when less than the normal 24 vdc is required.

A roll-around cart that houses the AGE cables during shipping or storage can also be considered as AGE equipment. The six AGE cables which are each forty-two feet long are seldom used in their fully extended length so that it becomes necessary to coil and stow the excessive cable length. Normally only eight feet of cable is required, so the remaining cable is protected in its shipping container during integration and lab tests.

During pre-flight procedures in the launch facility, the telescope is filled with cryogens while positioned nose down in the payload. The telescope is designed to accept the most cryogens while in this attitude. While a ninety percent fill can be attained in one particular horizontal position, only vertically can a one hundred percent fill be realized. During telescope evacuation, cryogenic fill and testing the telescope might be moved from place to place. To facilitate this and to make the telescope more portable, a new "nose" cart was designed and built (Figure 3-12).

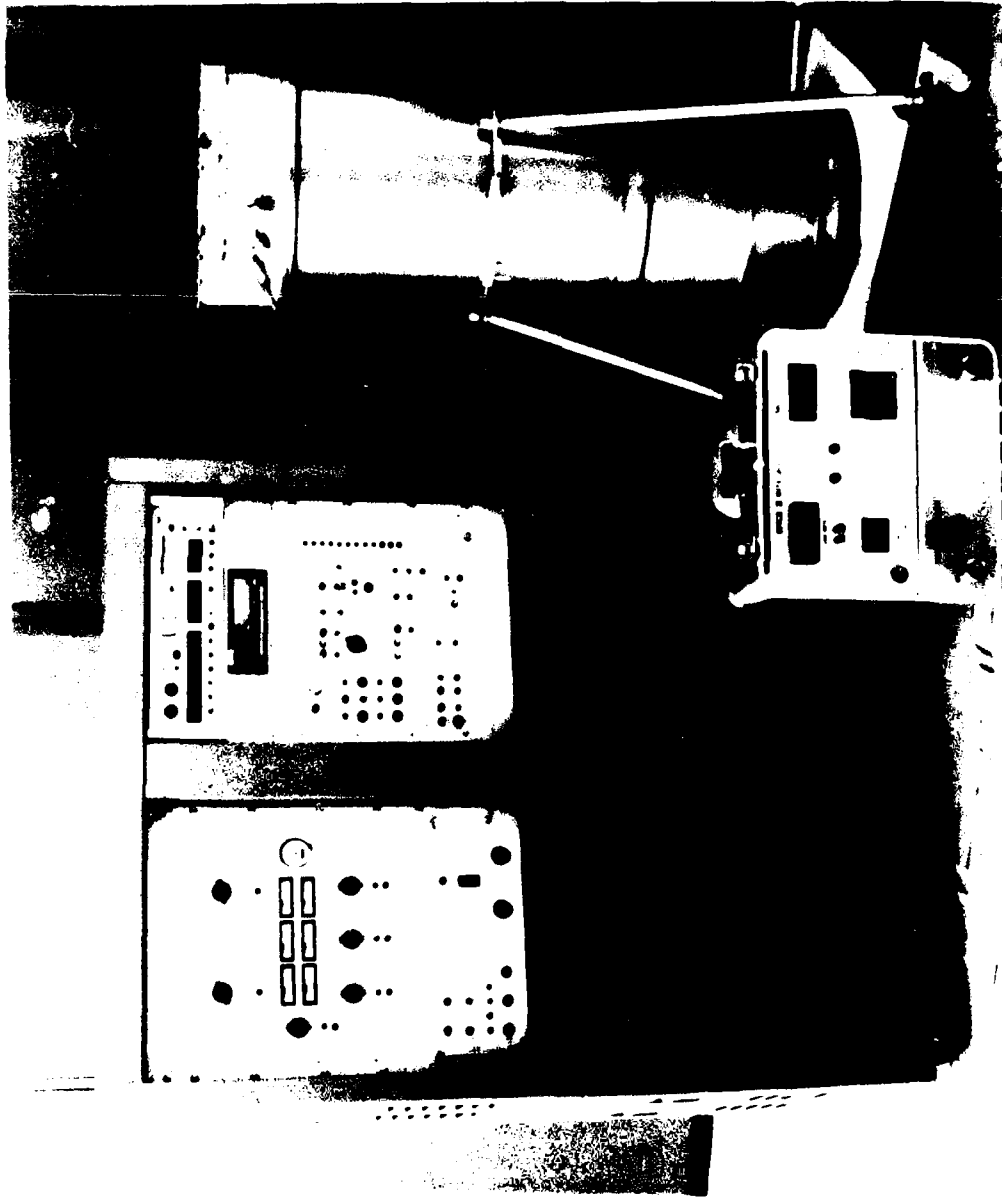

Figure 3-12

A new vent gas flowmeter and heater were fabricated. This new unit (Figure 3-13) indicates flow rates plus total flow of helium gas instantaneously on digital panel meters. The flowmeter is designed around a Matheson 8160-0415 flow transducer whose accuracy is  $\pm 1\%$  at  $70^{\circ}\text{F}$ . Because the measured gas will be extremely cold (during sensor cooldown), a gas heater becomes necessary. The heater unit itself consists of two 500 watt elements connected in parallel, the heater control is a triac controlled by a zero-voltage sensing I.C. (CA3059). The I.C. is enabled by the combined function of a thermister which senses the output gas temperature and a comparator which remains "on" as long as the transducer senses a flow of gas greater than four liters per minute.

This assembly measured gas flow up to 100 l/m and has controlled (at  $68^{\circ}\text{F}$ ) input gases whose temperatures have exceeded  $-240^{\circ}\text{F}$ . The input and output gas temperatures are digitally displayed.

A needle control valve in the panel is used to regulate the flow rate during cooldown.



C77-551/201



8-17-80

P8000213 J

Figure 3-13

C77-551/201

During each shipment of Hi Hi Star and SPICE I, some of the shipping containers had to be repaired or refabricated. This took time and money and a better shipping system was desired. Numerous container companies were contacted and one was authorized to build a set of seven customized storage and shipping containers. These containers proved to be very sturdy and about one tenth the cost of some that were investigated. They are made of a one half inch inner plywood box with hand layed fiberglass cloth (Figure 3-14).

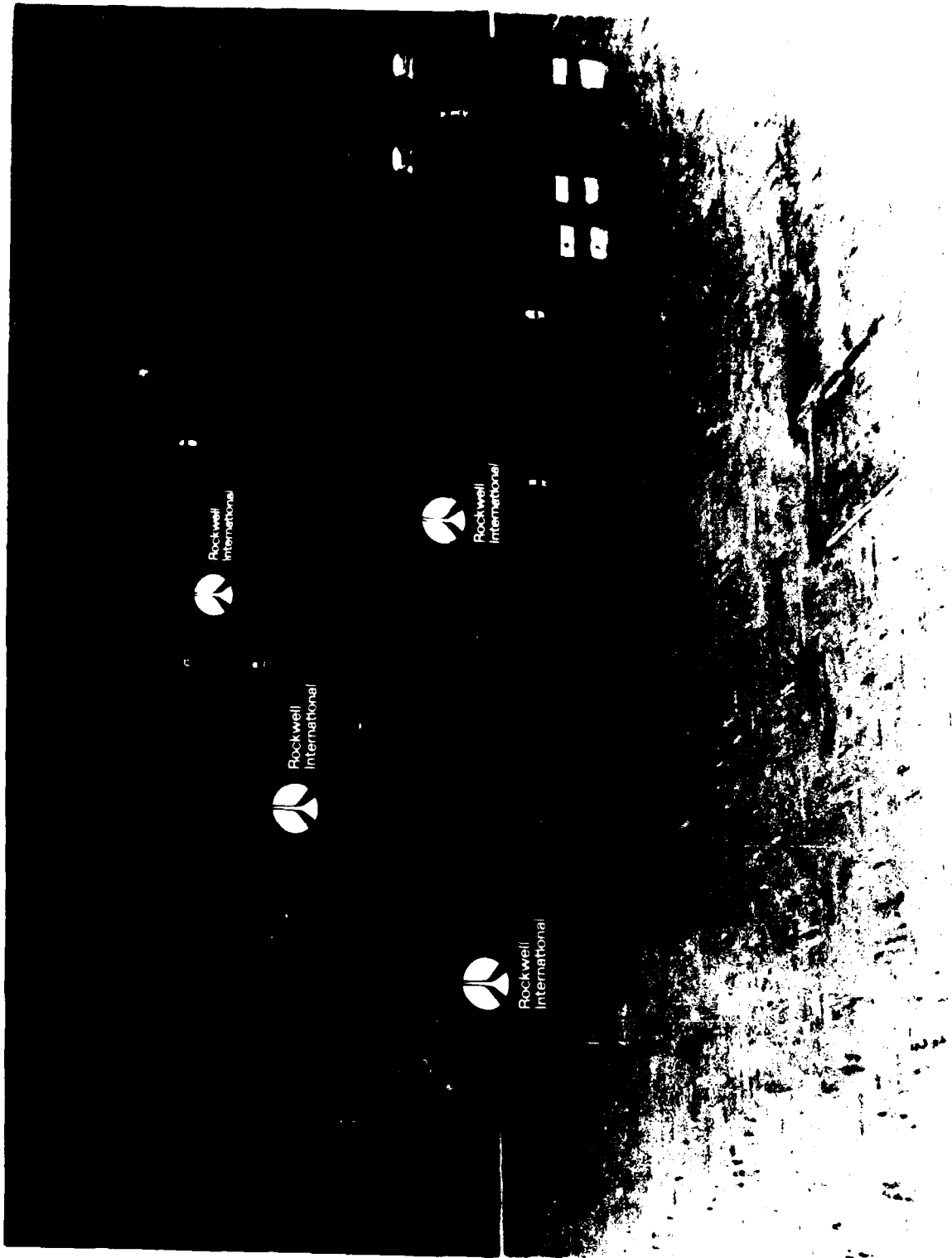

Rockwell  
International

Rockwell  
International

Rockwell  
International

Rockwell  
International

Figure 3-14

3.4 FOCAL PLANE

The SPICE Focal Plane Array (FPA) (Figure 3-15) was tested following the SPICE I flight. Two detectors (Sλ9 and Sλ14) were inoperative. After the rework and testing was completed, the FPA was delivered to NOSC for performance measurements. All the tested channels appeared to respond comparatively to the previous measurements. The FPA was returned from NOSC with the longband array inoperative. This problem was found to be in a flat cable and it was repaired. New cables were purchased when it became evident that some damage existed due to handling and rework of the Focal Plane. The new cables were not available in time to support the impending SPICE II launch schedule.

C77-551/201



Figure 3-15

### 3.5 INTEGRATION TESTS AND FLIGHT SUPPORT

The SPICE sensor was delivered to AFGL at Hanscom AFB on March 2, 1982 in preparation for the SPICE II experiment. Because of the desire to have a higher data rate PCM encoder, the Aydin-Vector encoder was not used. Instead a unit which was provided by Oklahoma State University was integrated into the system.

At AFGL, the SPICE sensor was cooled down five times including once in the horizontal position. Following each cold test, the sensor was warmed up and then a cover removal and sensor deployment sequencing test was performed.

The complete SPICE payload was vibrated and shock tested and followed by a functional test identical to the previbration tests. With all tests successfully concluded, the experiment was shipped to White Sands Missile Range (WSMR), New Mexico.

At WSMR the payload was integrated with the Attitude Control System (ACS). After cold testing the sensor and payload, an optical alignment of the entire payload was performed. The payload-vehicle separation unit was installed and then the entire assembly was spin-balanced just prior to installing it on top of the launch vehicle in the launch tower. Once on the tower, a dry run of the launch was performed.

The SPICE II Sensor System was launched aboard an ARIES vehicle on September 14, 1982 from WSMR. The flight went very well and data were recorded in all three bandwidths. Only midband, channel 9 appeared to be inoperative. There was a good recovery with no apparent damage to the payload.

### 3.6 POST FLIGHT EVALUATION AND REFURBISHMENT

#### 3.6.1 Telescope Assembly

After SPICE II flight, the sensor assembly, AGE, power supply, cables, and all related hardware were shipped to Rockwell International at Anaheim. The task was to check the condition of the telescope. On September 28, 1982, a post flight cooldown was performed. The telescope had not been opened since the September 14, 1982 flight. All housekeeping signals indicated that everything was normal - noise and signal (ED'S and BB) from detector channels appear normal. Channel 9 though was still inoperative. The detector array was removed and inspected and found to have very fine dust particles on it.

The dummy detector was installed in place of the operational one and a cold focus test was performed. It was discovered that the telescope was about .014 inches out of focus at the focal plane (.100 inch at the collimator focus). The telescope was dismantled and inspected and the fine particles found on the detector were also found on the mirror surfaces. The mirrors were submitted to Rockwell's Optical Department for cleaning and the particles captured in distilled water. A representative sample was submitted to Rockwell's Materials and Processes laboratory for identification.

These particles contained silicates, sulfates, and cellulose. The silicates and the sulfates apparently were derived from the soil in the area. The silicates were presumed to be sand and the sulfates were presumably derived from gypsum. The cellulose may have originated from wiping tissues or some other similar material.

After Post flight inspection and test, the telescope assembly including the mirrors was cleaned and re-assembled. Another cold focus test was performed. Again, the focus was out by the same amount, (.014 inches). A new folding mirror shim was made and another cold focus performed. This time the focus was right on target. Assembly and disassembly was now relatively easy (considering the complexity of the sensor). This was accomplished again with precise assembly tooling and experienced personnel since most of the crew had been on the Hi Hi Star and SPICE projects since the beginning.

At various intervals during assembly, all items requiring vacuum integrity were leak tested individually and in their respective subassemblies. The complete sensor assembly was tested for leaks. An optical quality and cold focus test was then performed on the sensor assembly but without the operational front cover and detector. The detector was installed into the sensor and the optical alignment test performed (figure 3-16). After the electronics assembly was mated to the sensor, several other tests were performed including the hold time and acceptance test. Copy of these tests will be found in the Appendix to this document.



C77-551/201



Figure 3-16

### 3.6.2 Electronics

Following the flight of SPICE II experiment, it was determined that the detector post amplifier gain should be reduced due to saturation of the amplifiers during flight. Also, the gain of the three background (dc amplifiers) channels was to be increased. All 54 detector channel DSP gains were changed from x100 to x40. The gain of the dc channels was increased by a factor of 15.

### 3.6.3 Focal Plane

The successful flight of the SPICE II experiment indicated that the FPA performance was as expected. Only midband Channel 9 was inoperative and the responsivity of the mid and shortbands was lower than had been calculated. The Channel 9 problem was due to an open circuit condition in one of the four FPA flat cables (Figure 3-17). The lowered responsivity may have been due to a reduction in bias voltage from 13.5 vdc to 6.76 vdc. This reduction in voltage was caused by an isolator (sapphire strip) breakdown.

Post flight requirements regarding the refurbishment of the FPA were accomplished. New flat cables and MOSFETS were purchased. The new cables were microscopically inspected to detect, if any, flaws existed in the circuitry. All cables were acceptable.

Two dozen new MOSFETS were tested to determine: noise, gain, output impedance. FET data on the following table typifies the results of all the units tests.

MOSFET G118 (Siliconix) NOISE READINGS

Freq. (Hz)	#1A	#2A	#3A	#4A	#5A	#6A
4	.25 $\mu$ V	.30 $\mu$ V	.30 $\mu$ V	.25 $\mu$ V	.25 $\mu$ V	.25 $\mu$ V
10	.18 $\mu$ V	.20 $\mu$ V	.20 $\mu$ V	.18 $\mu$ V	.18 $\mu$ V	.18 $\mu$ V
20	.12 $\mu$ V	.15 $\mu$ V	.12 $\mu$ V	.12 $\mu$ V	.12 $\mu$ V	.10 $\mu$ V
100	.08 $\mu$ V	.08 $\mu$ V	.06 $\mu$ V	.08 $\mu$ V	.06 $\mu$ V	.06 $\mu$ V
1K	.05 $\mu$ V	.05 $\mu$ V	.04 $\mu$ V	.05 $\mu$ V	.05 $\mu$ V	.04 $\mu$ V
Vs(V)	5.51	5.42	5.53	5.42	5.34	5.35
Output	8.5 mV	8.5 mV	8.5 mV	8.5 mV	8.5 mV	8.5 mV
Input	9.5 mV	9.5 mV	9.5 mV	9.5 mV	9.5 mV	9.5 mV
Gain	0.89	0.89	0.89	0.89	0.89	0.89
Z Out	0.622 m $\Omega$	0.622 m $\Omega$	0.622 m $\Omega$	0.622 m $\Omega$	0.565 m $\Omega$	0.565 m $\Omega$

075617-1

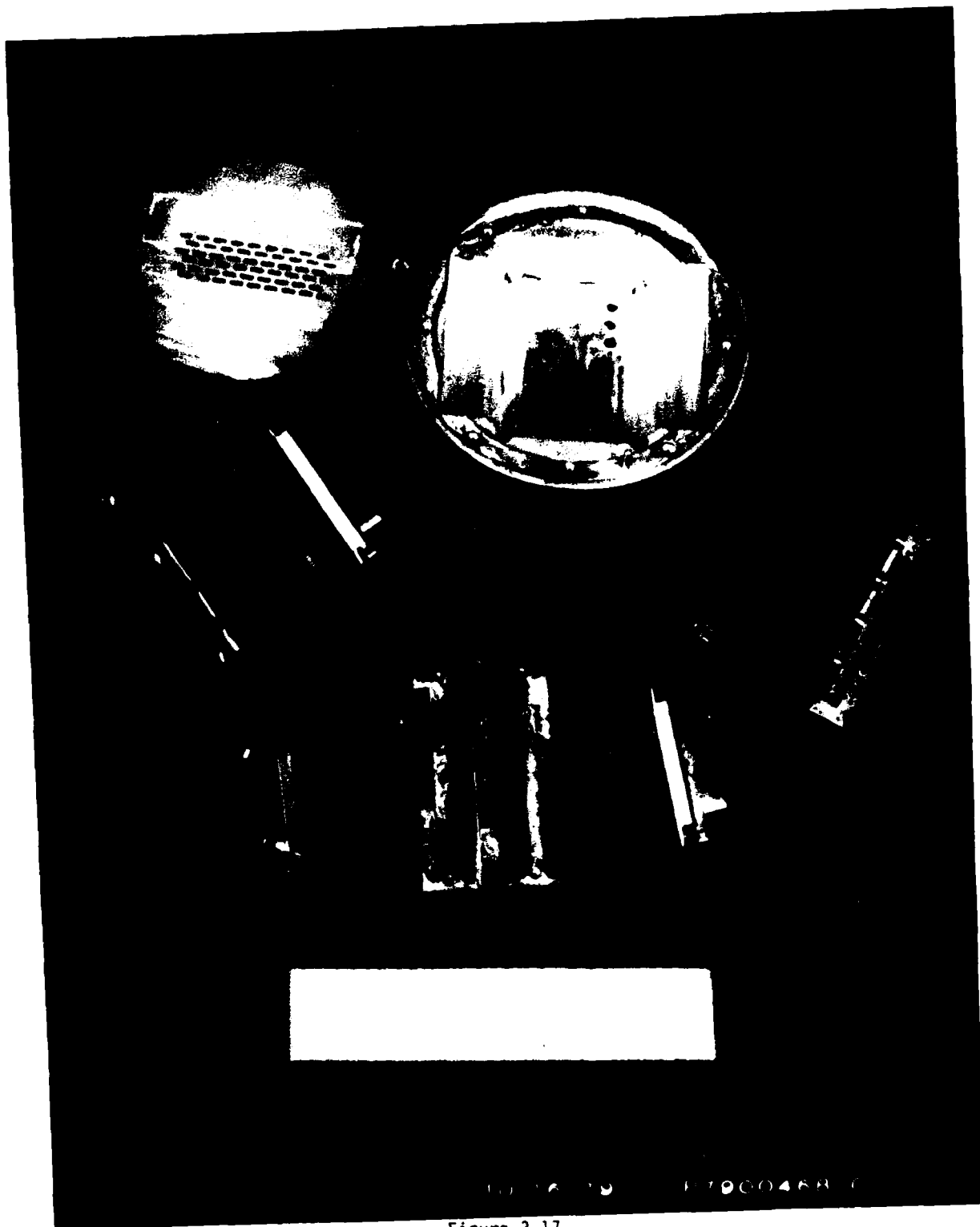

Figure 3-17

The detector subarrays were stripped of their MOSFETS, flat cables, and connectors. Newly tested G118 MOSFETS were bonded in place with Stycast epoxy. The new flat cables had new connectors soldered onto them. The FET gates were wired to the detector/load resistor junctions and then the flat cables were soldered onto the source side of the FETS. The longband and shortband subarrays were mounted onto the midband per drawing except that instead of using a sapphire isolator under the longband subarray, strips of alumina were epoxied onto the midband case. These strips (5 each) were located directly under the points of contact with the longband case. The top of each alumina strip was covered with indium. The longband case was lapped and measured to determine the alumina strip isolator thickness required. It was determined from these measurements that the previous sapphire isolator was at least 3 mils too thick, causing the longband case to protrude above the two other subarrays. This may have been a factor in the isolation failures of the past.

The detector array was completely assembled and tested. All channels were operating. The unit was then installed in the telescope where it was determined that the longband temperature was  $0.8^{\circ}\text{K}$  above that of the midband. The midband temperature is currently set at  $8.5^{\circ}\text{K}$ . The detector outputs are unchanged following four cooldowns at Anaheim.

### 3.7 SYSTEM TESTS AT AFGL

After completion of integration and acceptance tests at the Anaheim facility, the SPICE sensor was shipped to AFGL at Hanscom AFB on July 30, 1984. At Hanscom AFB the SPICE sensor was again cooled and tested. The test data was repeatable as compared to the testing done at Anaheim. Some additional testing of proposed circuit changes were also accomplished at this time. Upon completing the testing of the system, the SPICE sensor was bagged and stored in its shipping container.

While at AFGL, an experimental circuit was implemented to monitor the detector bias supply to the short and midbands. After five days of testing, it appeared that the monitor circuitry did not load down detector bias battery pack. Most important of all, it did not introduce any noise into the detector outputs. The detector noise was measured at the analog output of the decom via the Aydin-Vector encoder. The Bias Battery status was monitored on decom word 64, frame 14 (formerly used as Front Cover Temp). The circuit was left in the sensor electronics in a breadboard (non-flight) configuration per customer request pending further analysis.

C77-551/201

A P P E N D I X A

A-1



APPROVED ENGINEERING TEST LABORATORIES / 1536 EAST VALENCIA / FULLERTON, CALIFORNIA 92631 / TEL (714) 879 6110  
A NATIONAL TECHNICAL SERVICES COMPANY

7 September 1979

FULLERTON DIVISION REPORT NUMBER 973-3754  
Rockwell International, Electronic Systems Group  
Purchase Order Number A9EA-762389-E-907

- A. TESTS: Shock, Acceleration, Sinusoidal Vibration, and Random Vibration
- B. TEST ITEM: SPICE-II Electronics and Rear Cover Assembly, P/N 40150-509-1, S/N 001.
- C. SPECIFICATION: Autonetics Hi-Hi Star Sensor System Environmental Test Specification No. AA0305-115, Revision A (Redlined), Paragraphs 5.2.4.4, 5.2.4.3, and 5.2.4.2.3 thru 5.2.4.2.4
- D. RESULTS: This is to certify that the test item was subjected to the Shock, Acceleration, and Vibration Tests according to the above specification.

Rockwell International Electronic Systems Group representatives directed the testing, operated and monitored the test item during the Vibration and Acceleration Tests, performed physical inspections, and conducted required post tests.

There was no visible evidence of damage resulting from the tests.

Test data, equipment lists, and test setup photographs are attached.

APPROVED ENGINEERING TEST LABORATORIES

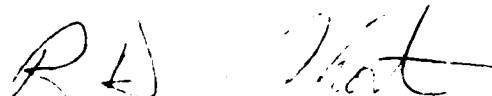
  
R. D. Short, Division Manager

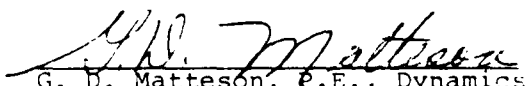
  
G. D. Matteson, P.E., Dynamics  
Department Supervisor

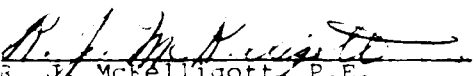
  
R. J. McKelligott, P.E.  
Quality Assurance Manager

DATE STARTED: 8/17/79  
 DATE COMPLETED: 8/17/79  
 TEST ENGINEER: BERRY F. MOORE  
 Q. A.: [ ]  
 G. S. I.: [ ]  
 Page 1 of [ ]

SHOCK TEST DATA SHEET  
 CUSTOMER: AUTONATICS  
 TEST ITEM: SPICE II Electronics Assembly  
 SPECIFICATION: AA0305-115 P/N 40150-509 S/N A001

TEMP.: [ ] HUMIDITY: [ ]  
 Amb. [ ]  
 ANTL JOB NO.: 973-3754

Type of machine used: Drop  Pendulum

Fixtured and Tested by Normal Mounting: YES  NO

\*\*\*  
 1 = Tested as Calibrated  
 2 = Sawtooth  
 3 = Half Sine

Drop Run No.	Wave Shape	Shock Level (G's)	Duration (m.s.)	Direction of Shock	Shocks Applied per Dir.	Visual Exam Post Test
2	50	6	6	**	1	yes
2	50	6	6		2	
2	46	6	6	**	1	O.K.
3						
4						
5						
6						

\*\* = Thrust Axis

TEST RESULTS: There appeared to be no damage to the Test Item due to the applied shock. The Customer performed all operational tests during and after the applied shock.

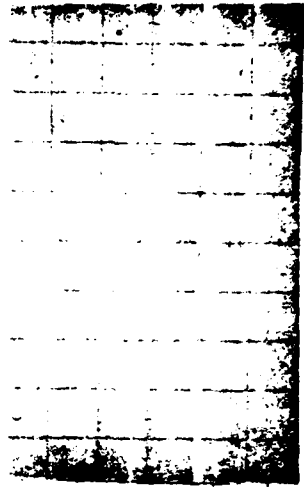

TEST RUN

Berry F. Moore  
 Berry F. Moore, Test Engineer

DATE STARTED: 8/17/79	SHOCK TEST DATA SHEET	TEST ENGINEER: Berry F. Moore
DATE COMPLETED: 8/17/79	CUSTOMER: Autonetics	Q.A.:
AETL JOB NO.: 973-3754	TEST ITEM: SPICE II Electronics Assembly	G. S. I.:

PHOTOGRAPH OF CALIBRATION TEST RUN

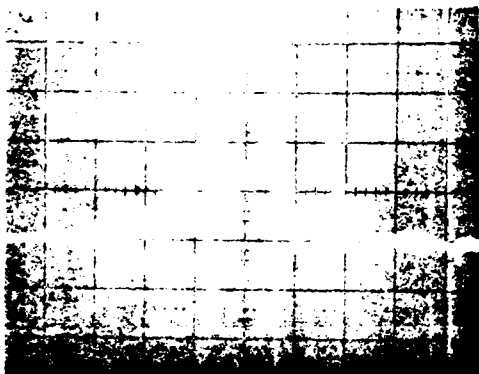

CALIBRATION

VERTICAL 16.6 g = 1 div.  
HORIZONTAL 2 ms = 1 div.

VALUE

LEVEL = 50 g  
DURATION = 6 ms

SHOCK TEST EQUIPMENT LIST

	<u>CALIBRATION</u>
1. Endevco Accelerometer, Model 2225, S/N TJ05, 0 to 20,000 g + 1.5% linearity, Control No. D-4275-F	Due 6-11-80
2. Endevco Accelerometer, Model 2252, S/N VB38, 0 to 5000 g + 1.5% linearity, Control No. D-4274-F	Due 6-7-80
3. Endevco Shock Amplifier, Model 2718A, 0/250/500/2500/5000/25,000/50,000, + or - 1.5% fs all ranges, Control No. D-4186-F	Due 12-6-79
4. Krohn-Hite Bandpass Filter, Model 330M, 0.2 to 20,000 cps, + 5% of setting, 24/octave attenuation, Control No. D-4187-F	Due 12-6-79
5. Hewlett Packard Storage Oscilloscope, Model 1223A with 15 MHz Amplifier, Control No. E-4291-F	Due 12-7-79
6. AETL 6-Foot Free Fall Drop Tower, Control No. D-4181-F	Prior to Test



**AETL**

DYNAMICS DIVISION



# DATA SHEET

ACCELERATION TEST

Customer: **AUTONETICS**  
**ELECTRONICS UNIT (SPICE II)**  
 Part No. **40150-509**  
 Spec. **M0305-115**  
 Para **5.2.4.3**  
 S/N **001**

Job No. **573-3754**  
 P.O. No. **A9-EATG2389**  
 Date **8-20-79**  
 Amb. Temp. **82°**  
 Photo **YES**  
 Test Med. \_\_\_\_\_

No	Serial No.	Axis	Rg (Inches)	RPM Required	RPM Actual	Accel Level (g) Required	Accel Level (g) Actual	Duration Required (Minutes)	Duration Actual (Minutes)	REMARKS
1	001	XXXX	162	65	65	20	20	2.0	2.0	AT CONCLUSION OF TEST NO DAMAGE WAS NOTED
2										
3										
4										
5										
6										
7										
8										
9										
10										
11										
12										

GENERAL TEST NOTES:

EQUIPMENT: **TACHOMETER NO. D43866, CENTRIFUGE NO. D41795, STOP WATCH NO. D4244E CAL DNE 131.80**

**DURING TESTING ELECTRONICS UNIT WAS FUNCTIONAL, MONITORING OF UNIT WAS PERFORMED BY CUSTOMER USING CUSTOMER FURNISHED EQUIPMENT.**

**A FUNCTIONAL TEST WAS PERFORMED FOLLOWING ACCELERATION THE ELECTRONICS UNIT PERFORMED SATISFACTORILY**

Tested By:                      Date: 8-20-79  
 Witness:                      Date: 8-22-79  
 Sheet No.                      of                       
 Approved:



APPROVED ENGINEERING TEST LABORATORIES  
A NATIONAL TECHNICAL SERVICES CO.

NTS

Date Started		Date Completed		Customer		AETL VIBRATION DATA													M.J.O.	
Day	Hour	F	Hz	Inch	G's Pk	Noted	ACC	MIN	Noted	Hz	G's Pk	Noted	Test Sequence	Output Frequency	Specimen Serial No.	Remarks	Units			
8-21-79	1338	AMB	10-50	-	1.5	THRUST	1.1	7.0	1	Plot #1	001	START SWEEP			40150-509-1					
			50-160	-	3.0															
			160-2000	-	5.0															
8-22-79	1311		5-43	5.1"/SEC	-	LAT.1	1.1	7.0	2	Plot #2	001	START SWEEP								
			43-250	-	3.5	(YAW)														
			250-2000	-	5.0															
8-22-79	1532	AMB	5-43	5.1"/SEC	-	LAT.2	1.1	7.0	3	Plot #3	001	START SWEEP								
			43-250	-	3.5	(PITCH)														
			250-2000	-	5.0															

*NOTE: CUSTOMER OPERATED TEST ITEM DURING VIBRATION WITH CUSTOMER SUPPLIED TEST EQUIPMENT, AND PERFORMED FUNCTIONAL CHECK UPON COMPLETION OF VIBRATION IN EACH AXIS.*

*ORIGINAL TO CUSTOMER*



VLD ENGINEERING TEST LABS

ASTM API

CUSTOMER: AUTOMETICS

ORDER NO: 973-3754

TEST ITEM: STAR SENSOR TELESCOPE

PART NO: 40150-509-1

SERIAL NO: 001

DATE: 8-31-79

SPLIT LEVEL: 5.0 G<sub>z</sub> PK

W/ ELEMENT NO: 1

AXIS: THRUST, RESP ACCEL AXIS

LOCATION: ON FIXTURE RING

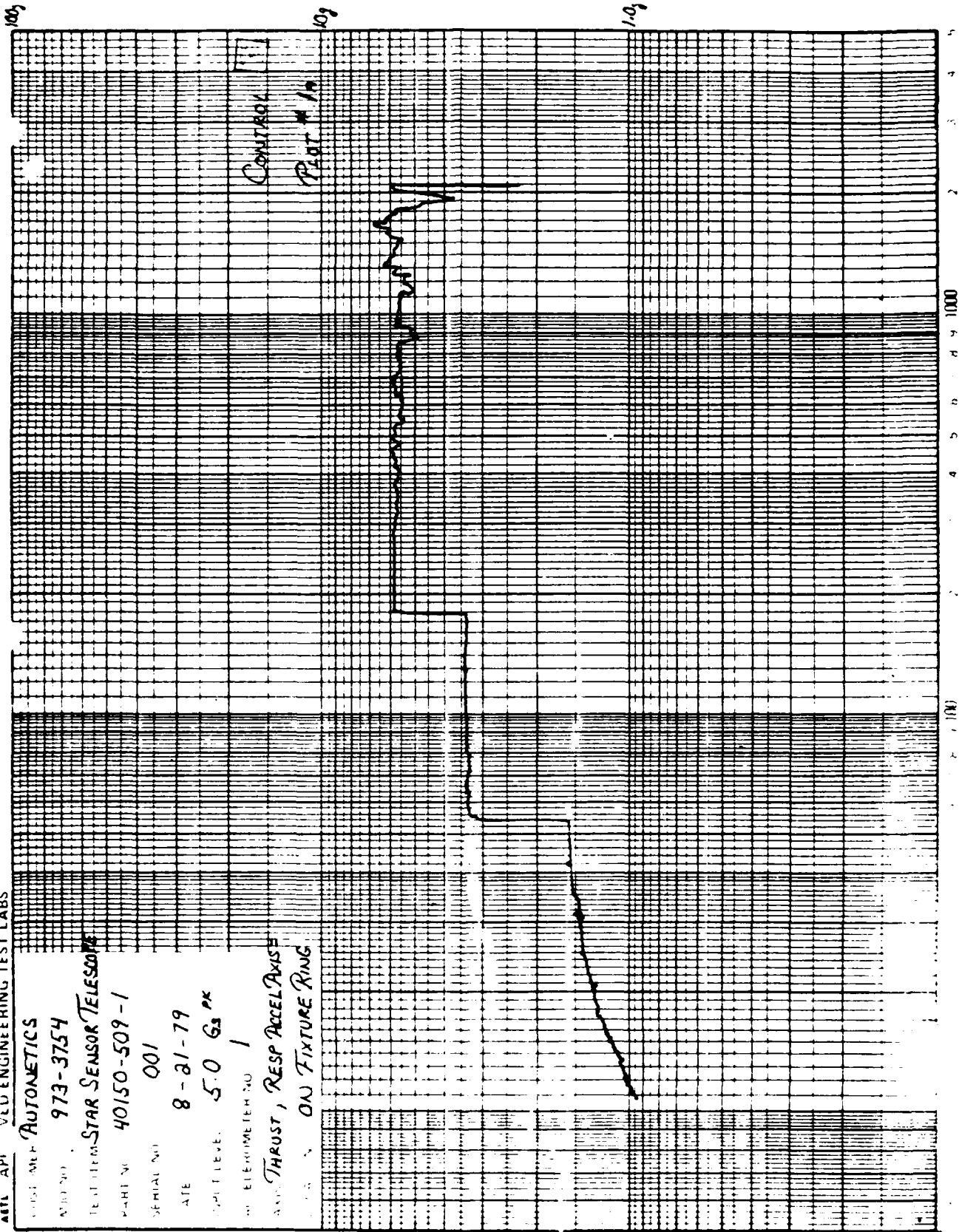

100

10

10

1000

100



AVE ENGINEERING TEST LABS

CUSTOMER AUTONETICS

PTO NO 973-3754

TEST ITEM STAR SENSOR TELESCOPE

PART NO 40150-509-1

SERIAL NO 001

DATE 8-21-79

INPUT LEVEL 5.0 G<sub>rms</sub> PK

ELECTROMETER NO 2

... THRUST, RESP ACCEL AXIS THRUST

LOCATION ON TOP CENTER OF ELECTRODYNAMICS

TABLE

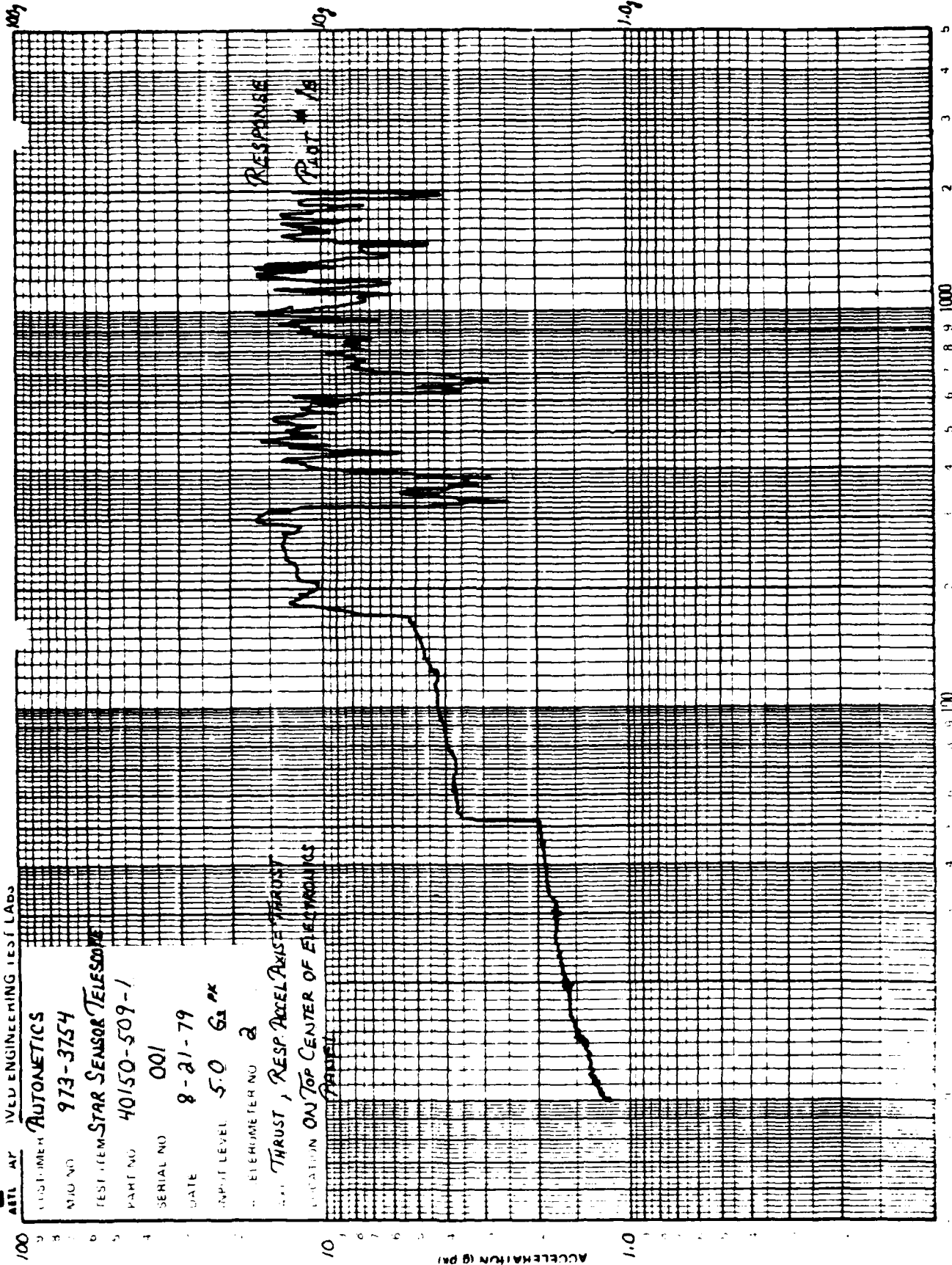

100

9

8

7

6

5

4

3

2

1

0

10

9

8

7

6

5

4

3

2

1

0

10

9

8

7

6

5

4

3

2

1

0

10

9

8

7

6

5

4

3

2

1

0

100

100

9

8

7

6

5

4

3

2

1

0

10

9

8

7

6

5

4

3

2

1

0

10

9

8

7

6

5

4

3

2

1

0

10

9

8

7

6

5

4

3

2

1

0



ARTL API VED ENGINEERING TEST LABS

CUSTOMER: **AUTONAUTICS**  
 M/F/I NO: **973-3754**  
 TEST ITEM: **STAR SENSOR TELESCOPE**  
 PART NO: **40150-509-1**  
 SERIAL NO: **001**  
 DATE: **8-21-79**  
 INPUT LEVEL: **5.0 G<sub>pk</sub>**  
 ELECTRICAL ITEM NO: **3**  
 TEST: **THRUST, RESP ACCEL AXIS**  
 LOCATION: **ON CONNECTOR PANEL**

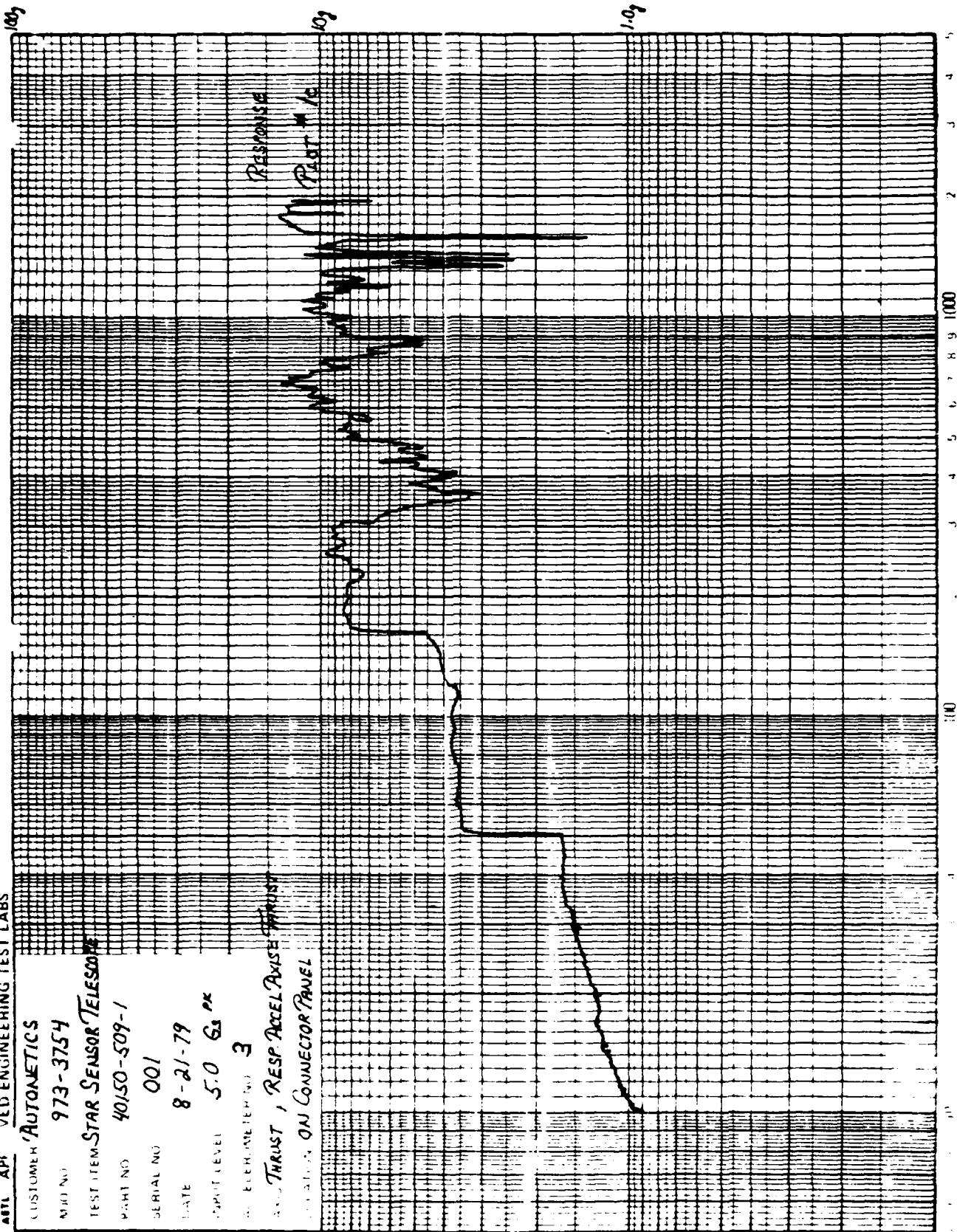

100  
 9  
 8  
 7  
 6  
 5  
 4  
 3  
 2  
 1  
 10  
 100  
 1.0

AL-101  
AERONAUTICAL ENGINEERING TEST LABORATORY

MANUFACTURER  
**AUTONETICS**

MODEL NO  
**973-3754**

TEST ITEM  
**STAR SENSOR TELESCOPE**

PART NO  
**40150-509-1**

SERIAL NO  
**001**

DATE  
**8-21-79**

INPUT LEVEL  
**5.0 G<sub>r</sub> PK**

ACCELEROMETER NO  
**4**

AXIS  
**THRUST, RESP. ACCEL. AXIS**

LOCATION  
**ON REAR COVER**

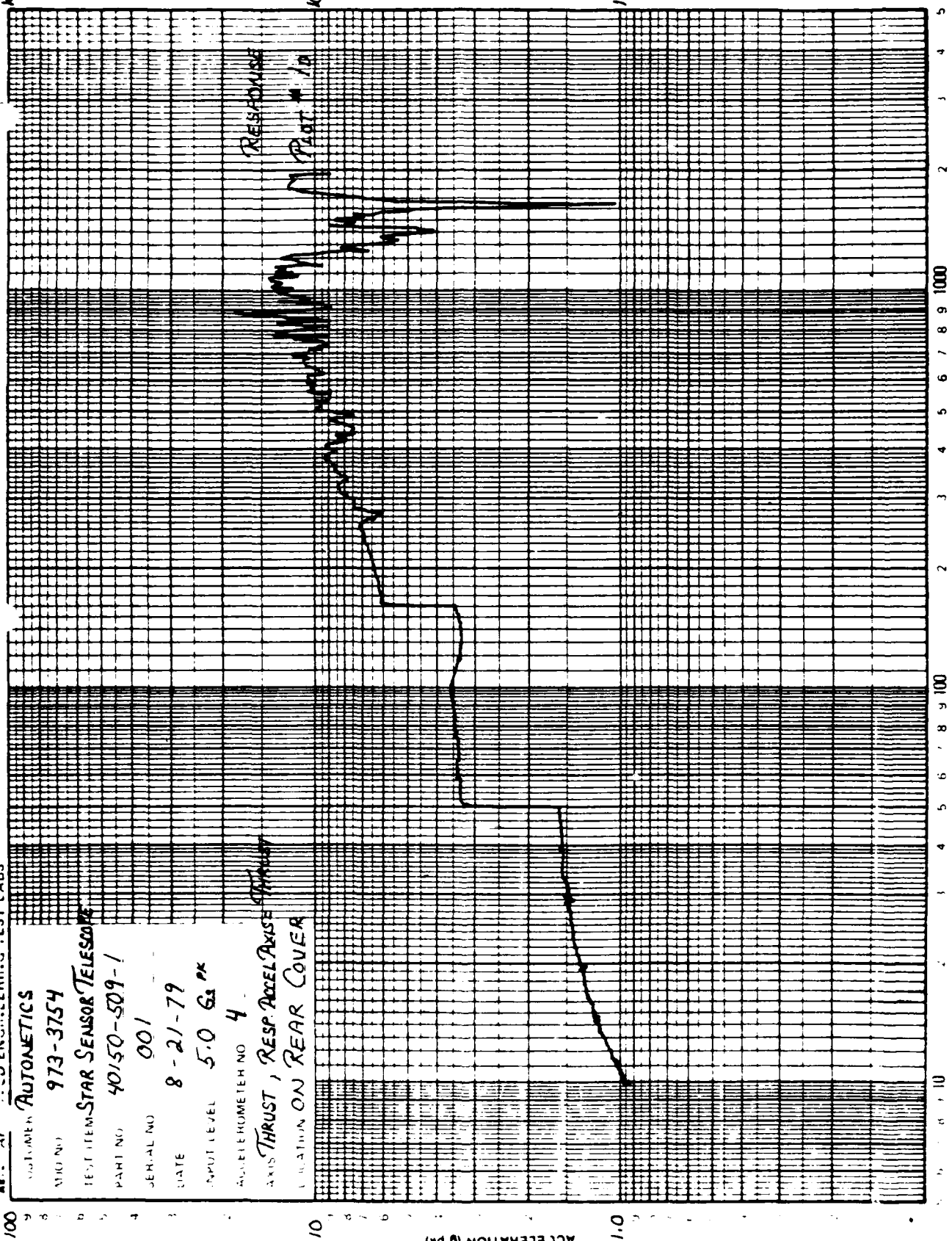

ACCELERATION (G PK)

6



ATEL APH VED ENGINEERING TEST LABS

100

CUSTOMER AUTONETICS

ORDER NO 973-3754

TEST ITEM STAR SENSOR TELESCOPE

PART NO 40150-509-1

SERIAL NO 0018

DATE 8-21-79

INPUT LEVEL 5.0 G<sub>r</sub> PK

ACCELERATION NO 5

AXIS THRUST, RESP ACCEL AXIS LAY

ORIENTATION ON SIDE OF ELECTRONICS

100

RESPONSE

Plot # 12

100

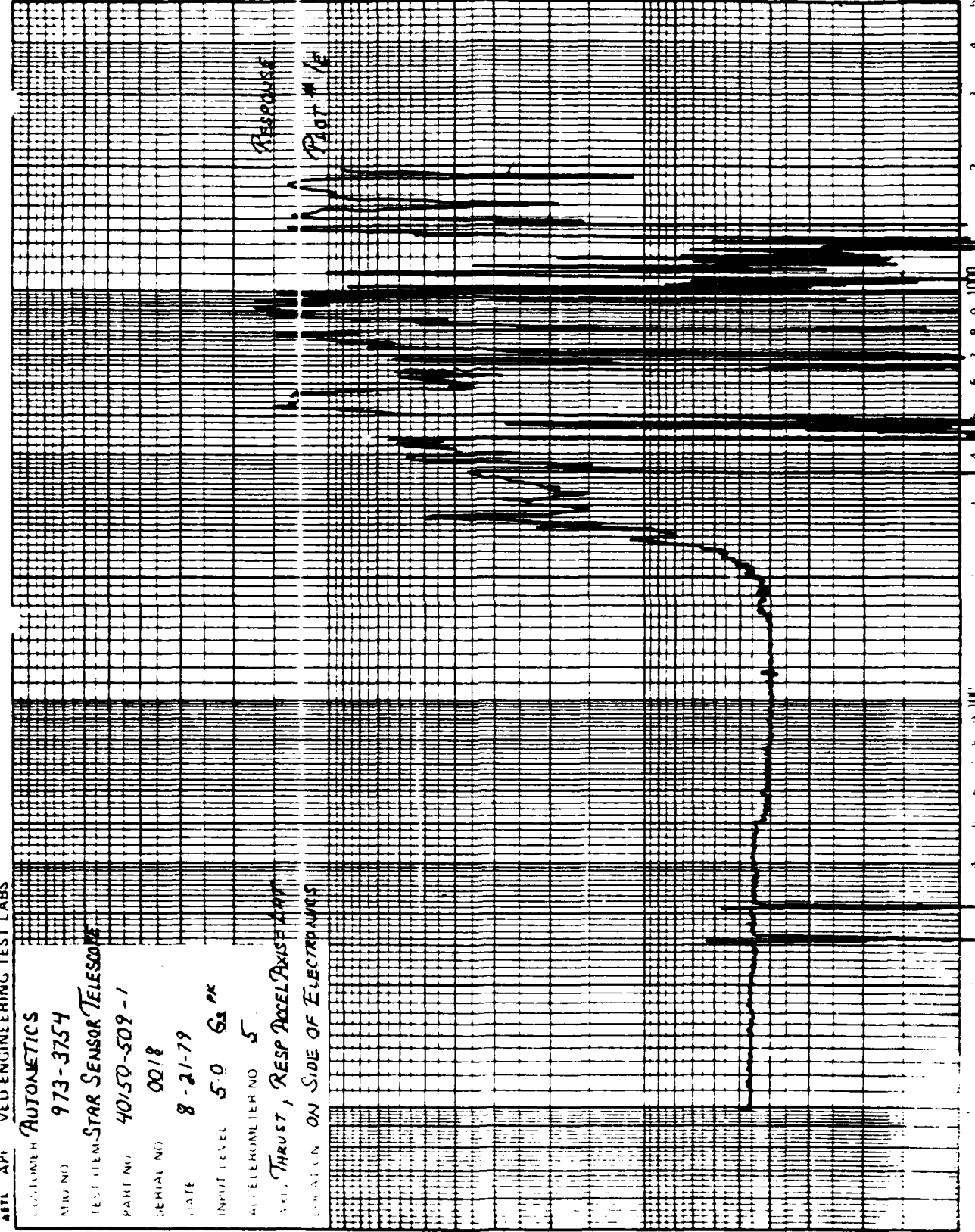

100

10

1.0



VED ENGINEERING TEST LABS

100  
1  
2  
3  
4  
5  
6  
7  
8  
9  
10

CUSTOMER: AUTOMETICS  
CITY/NO: 973-3754  
TEST ITEM: STAR SENSOR TELESCOPE  
PART NO: 40150-509-1  
SERIAL NO: 001  
DATE: 8-22-79  
SHIP LEVEL: 5G3 6g PK  
ACCELEROMETER NO: 1  
MOUNTING: YAW, RESP ACCEL AXIS  
LOCATION: ON END OF FIXTURE

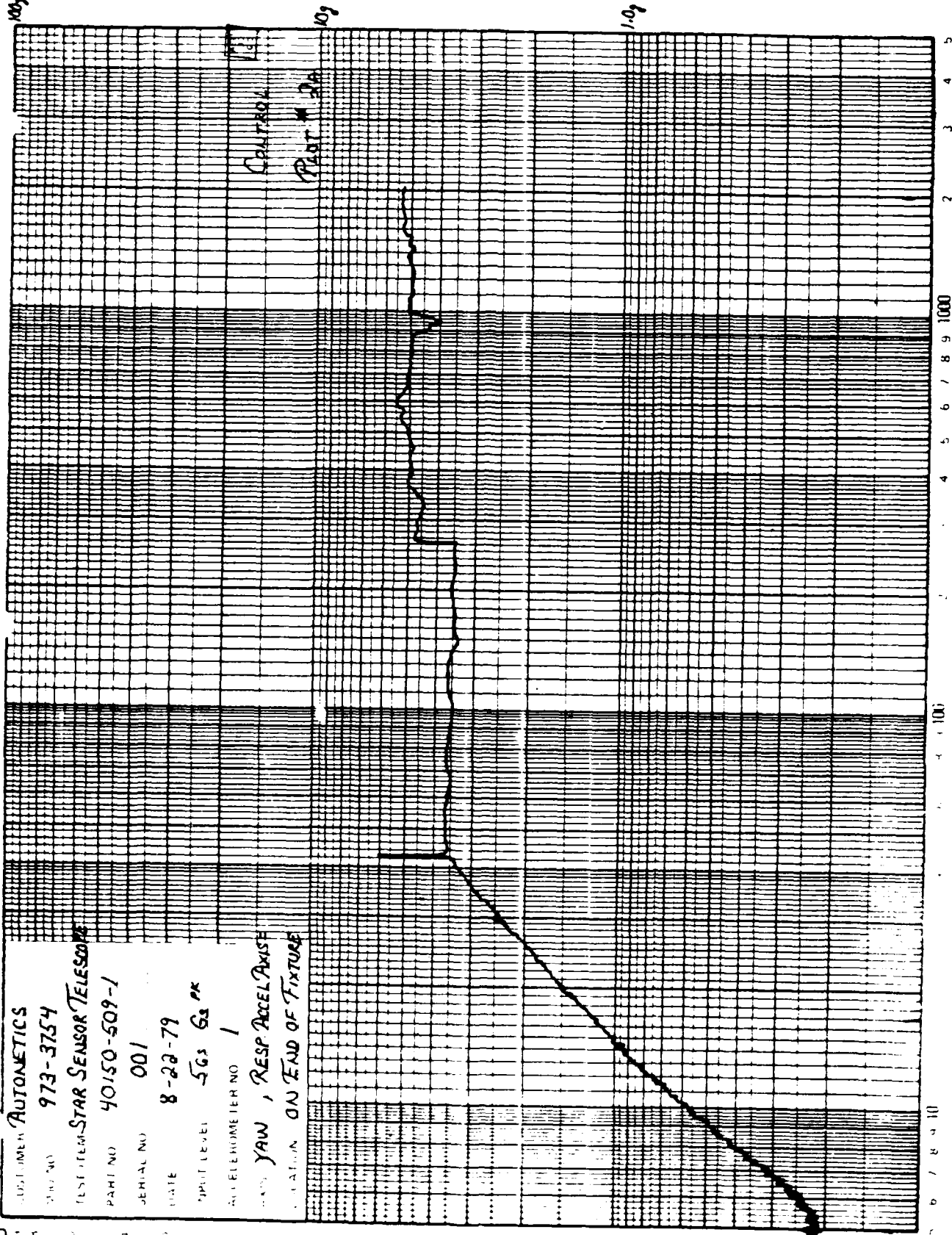

100  
1000





AVIONIC ENGINEERING TEST LABS

100  
9  
8  
7  
6  
5  
4  
3  
2  
1

TEST ITEM: AUTONETICS

973-3754

TEST ITEM: STAR SENSOR TELESCOPE

PART NO: 40150-509-1

SERIAL NO: 001

DATE: 8-22-79

CIRCUIT LEVEL: 5 GS PK

AVIONIC ENGINEER NO: 2

AXIS: YAW, RESP ACCEL AXISE YAW

LOCATION: UNDER NERTH ELECTRONICS

10  
9  
8  
7  
6  
5  
4  
3  
2  
1

AVIONIC ENGINEER NO: 2

RESPONSE

PLAT # 28

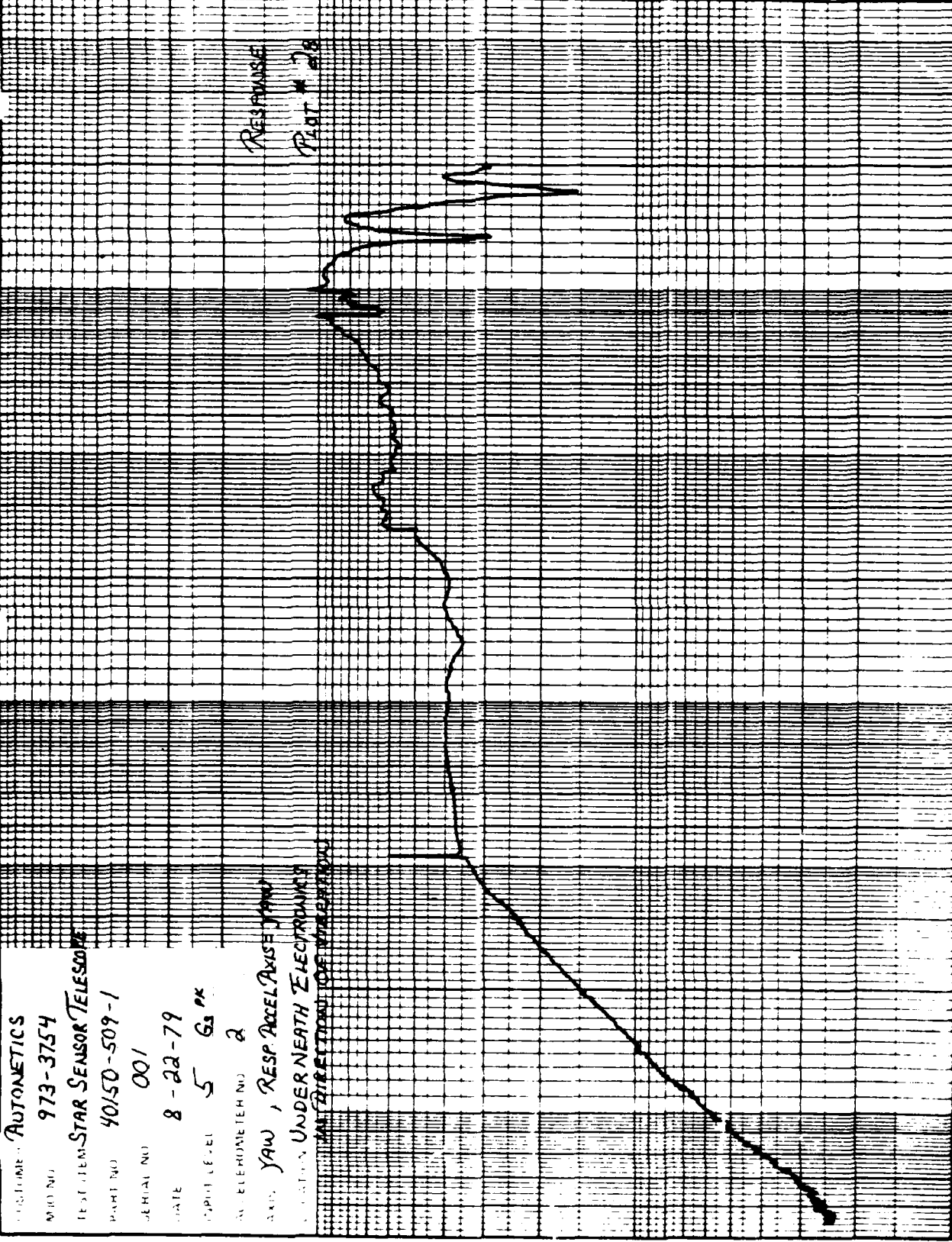

100  
9  
8  
7  
6  
5  
4  
3  
2  
1

TIME (MIN)

1 2 3 4 5

ACT ELECTRON 19 PSI

1.0

100

100

1.0



AVCO ENGINEERING TEST LABS

**AUTOMETRICS**

973-3754

TEST ITEM: STAR SENSOR TELESCOPE

PART NO: 40150-509-1

SERIAL NO: 001

DATE: 8-22-79

AMPL LEVEL: 5.0 GS PK

ACCELEROMETER NO: 3

AXIS: YAW, RESP AXEL AXISE YAW

ORIENTATION: ON TOP CENTER OF

JECT RODS

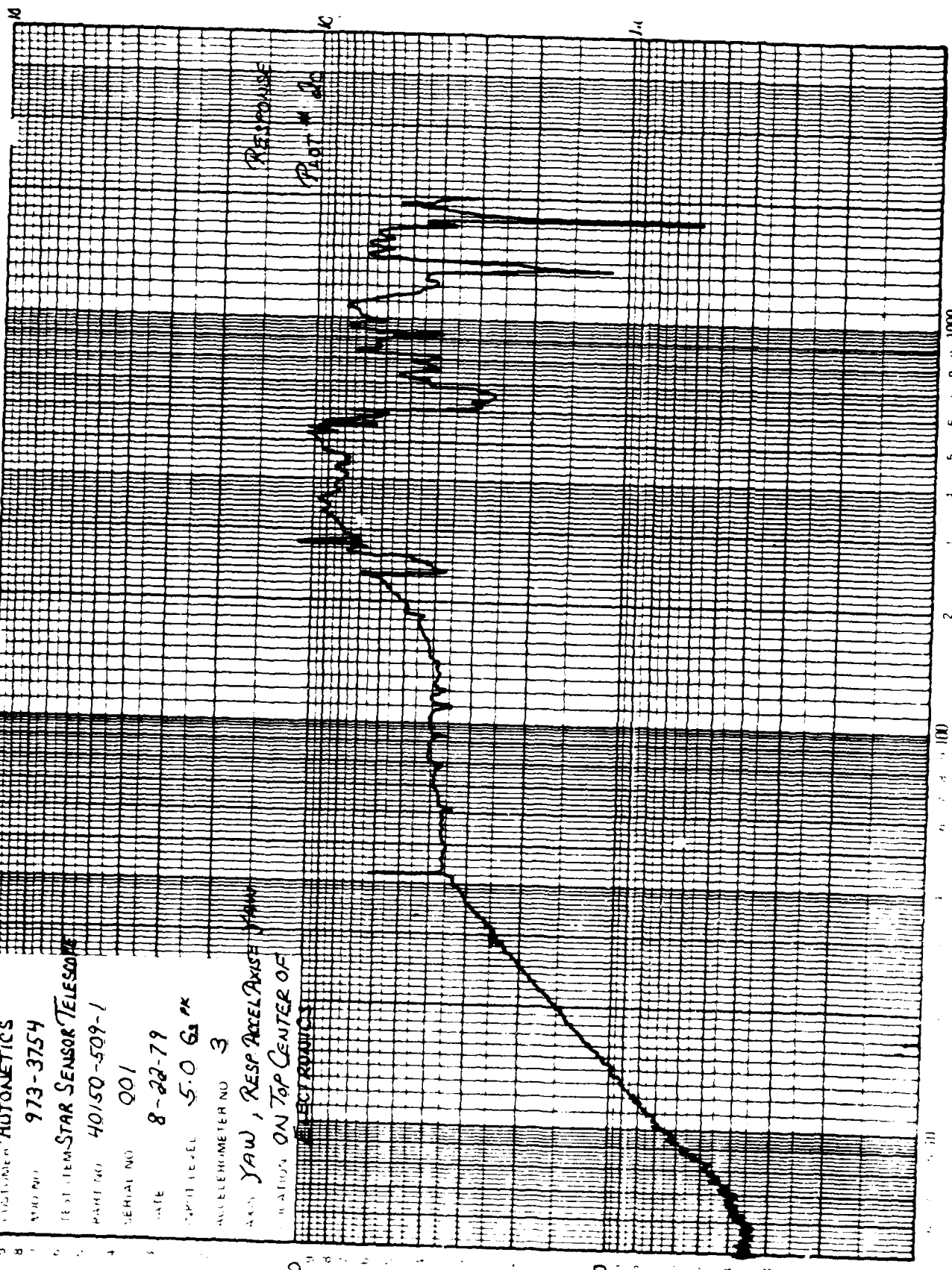

ACCELERATION (g PK)

1.0

RESPONSE

Plot # 20

AD-A164 701

SURVEY PROBE INFRARED CELESTIAL EXPERIMENT (SPICE)(U)  
ROCKWELL INTERNATIONAL AMMANEIN CA DEFENSE ELECTRONICS  
OPERATIONS R C BERRY ET AL JAN 85 C77-561/291  
AFOL-TR-85-0007 FIGURE-77-C-0009

2/3

UNCLASSIFIED

F/D 171E

ML

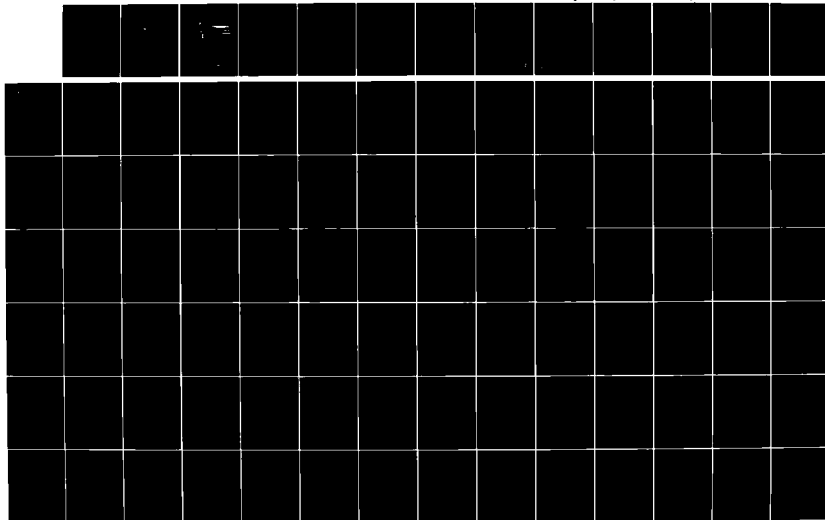

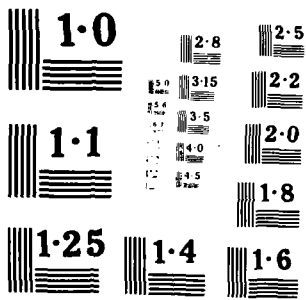



ATELL APH VED ENGINEERING TEST LABS

CUSTOMER AUTOMETICS

WORK NO 973-3754

TEST ITEM STAR SENSOR TELESCOPE

PART NO 40150-509-1

SERIAL NO 001

DATE 8-22-79

INPUT LEVEL 5.0 G<sub>rms</sub> PK

ACCELEROMETER NO 4

AXIS YAW, RESP ACCEL AXIS YAW

LOCATION ON CONNECTOR PANEL

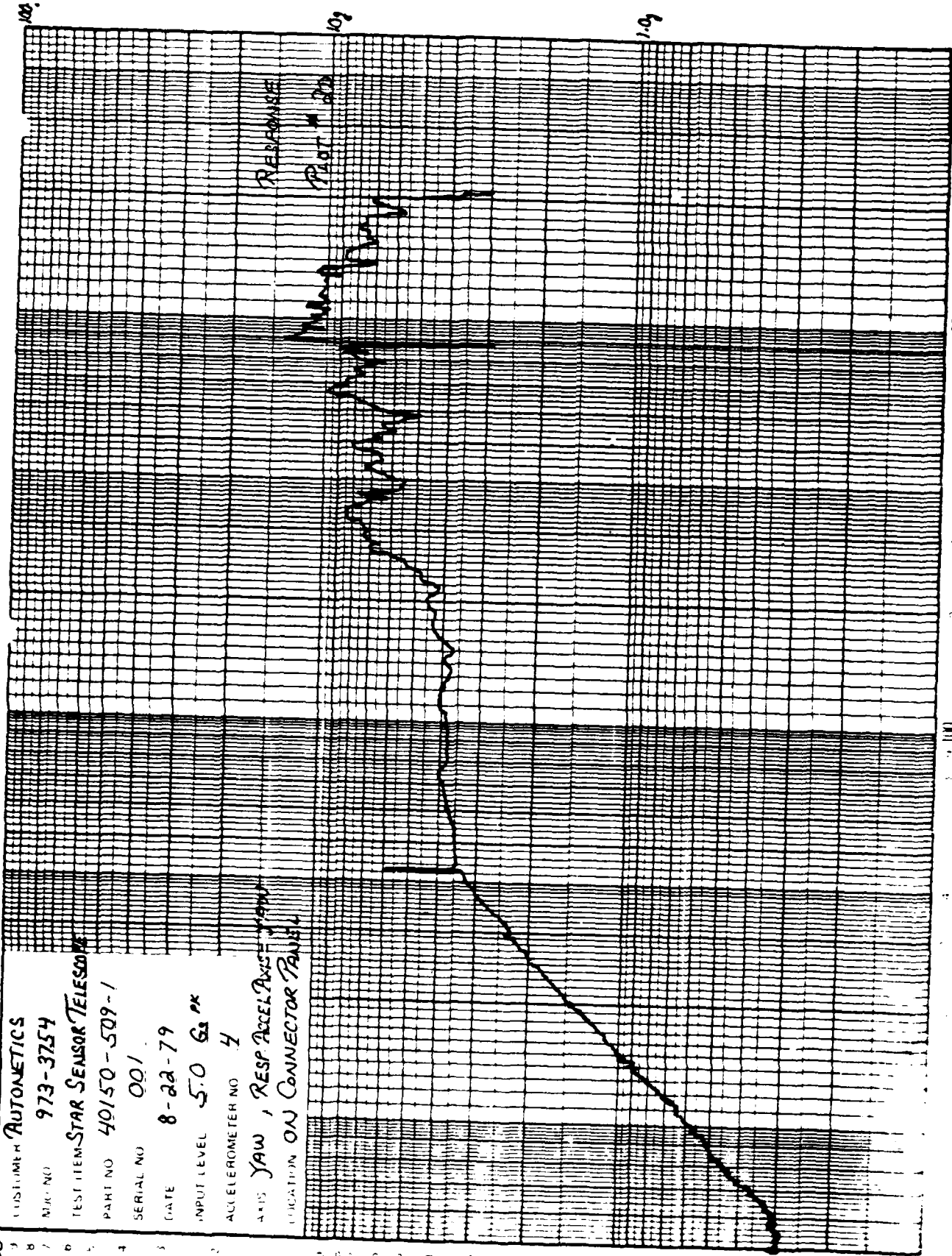

100

3

8

7

6

5

4

3

2

1

10

3

2

1

1.0

1.0

1.0

1.0

1.0

1.0

1.0

1.0

1.0

1.0

1.0

1.0

1.0

1.0

1.0

1.0

1.0

1.0

1.0

1.0

1.0

1.0

1.0

1.0

1.0

1.0

1.0

1.0

CUSTOMER  
**AUTONETICS**

MJO NO  
**973-3754**

TEST ITEM  
**STAR SENSOR TELESCOPE**

PART NO  
**40150-109-1**

SERIAL NO  
**001**

DATE  
**8-22-79**

INPUT LEVEL  
**5 GS PK**

ACCELEROMETER NO  
**5**

AXIS  
**YAW, RESP AXEL AXIS YAW**

LOCATION  
**ON BACK SIDE OF ELECTRONICS UNIT**

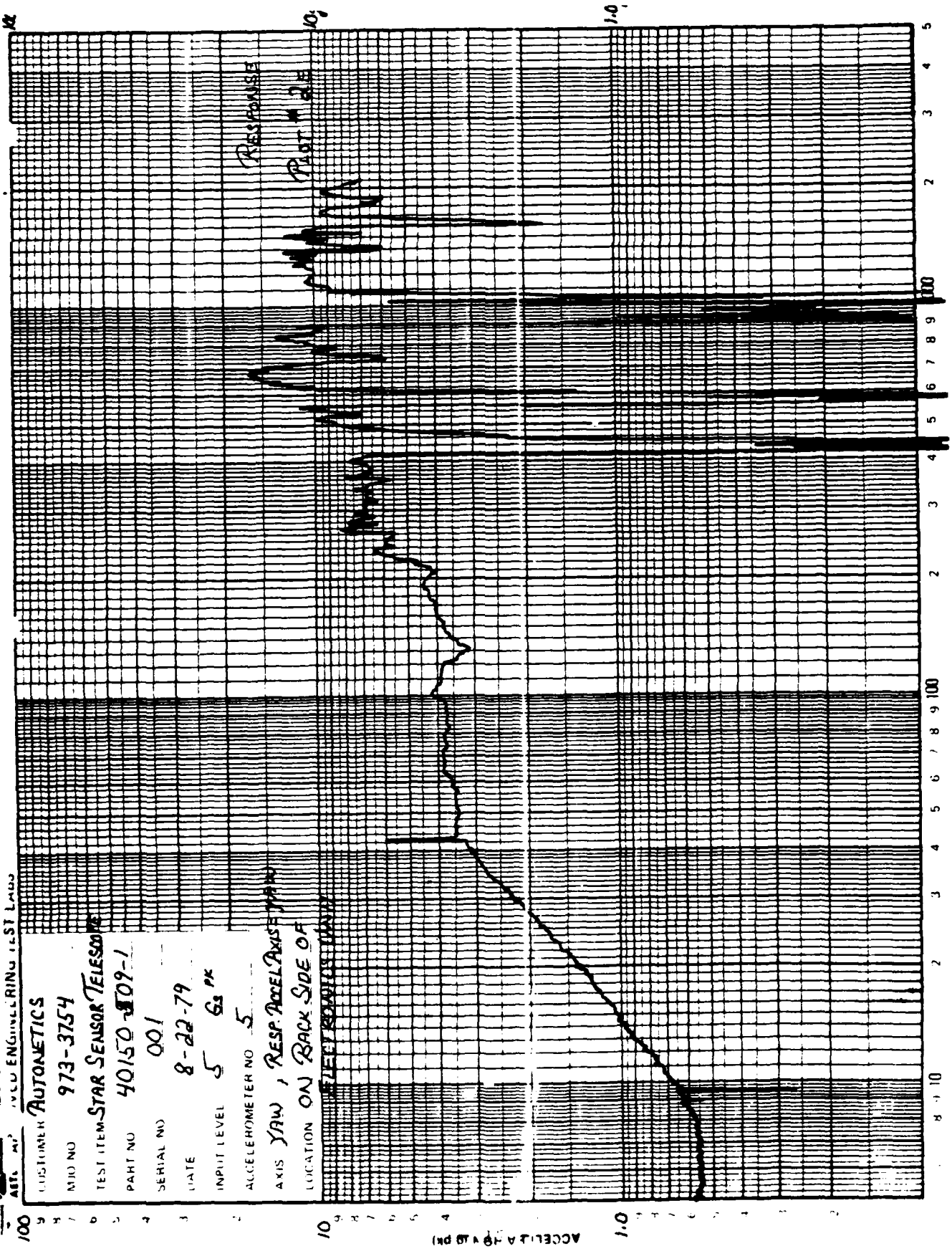

AVEL ENGINEERING TEST LABS

TEST ITEM AUTOMETICS

SERIAL NO 973-3754

TEST ITEM STAR SENSOR TELESCOPE

PART NO 40150-509-1

SERIAL NO 001

DATE 8-22-79

INPUT LEVEL 5.0 Gs PK

ACCELEROMETER NO 1

AXIS PITCH, RESP ACCEL AXIS

LOCATION ON END OF FIXTURE

ALIGN

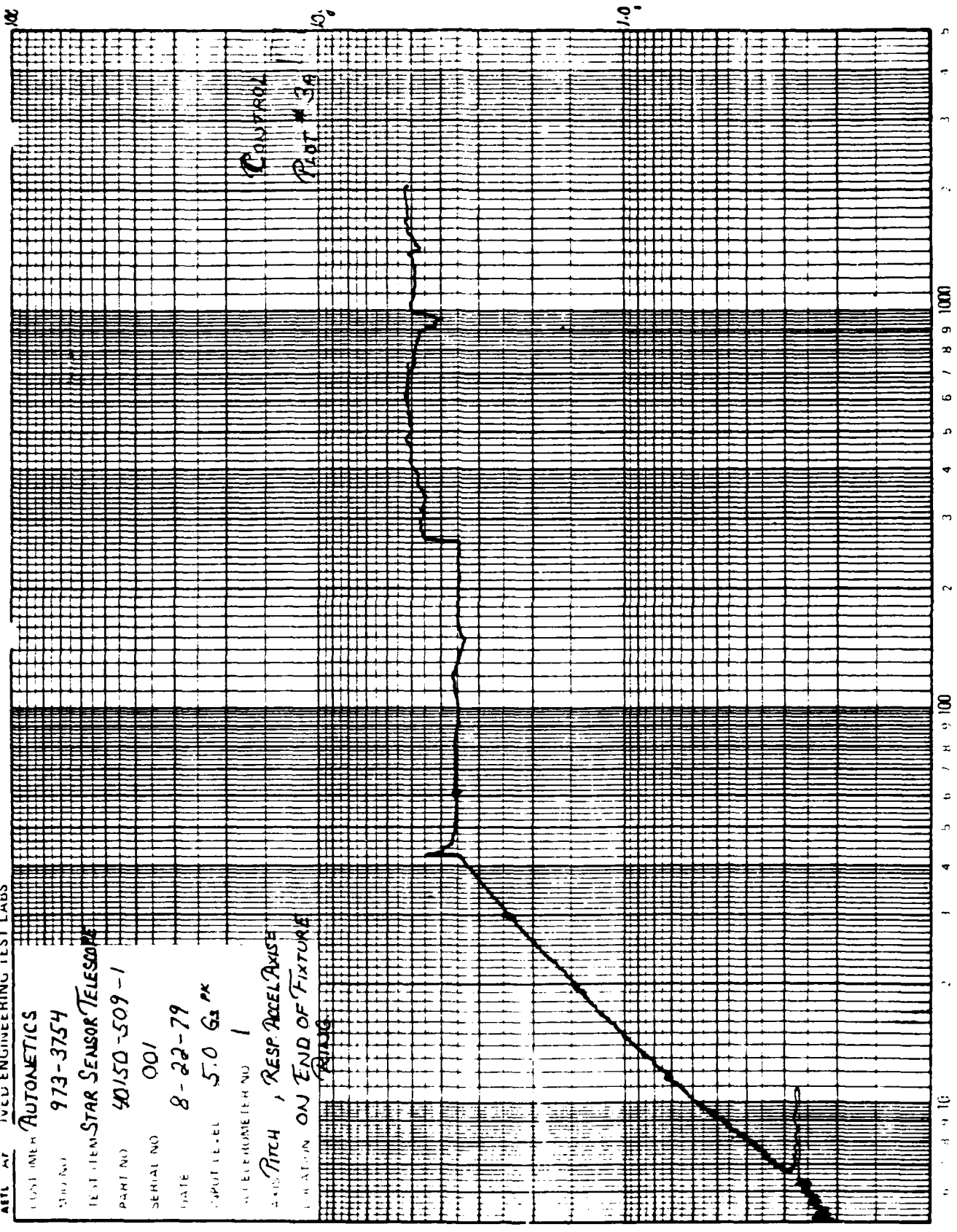

ACCELERATION (G)



AVIONIC ENGINEERING Dept. Labs

**AUTONETICS**

973-3754

**STAR SENSOR TELESCOPE**

40150-509-1

001

8-22-79

50 G<sub>r</sub> PK

TEST NO. 2

PITCH, RESP ACCEL AXISE PITCH

UNDERNEATH ELECTRONICS

IN DIRECTION OF VIEWING

100

100

100

FREQUENCY

PLOT # 3A

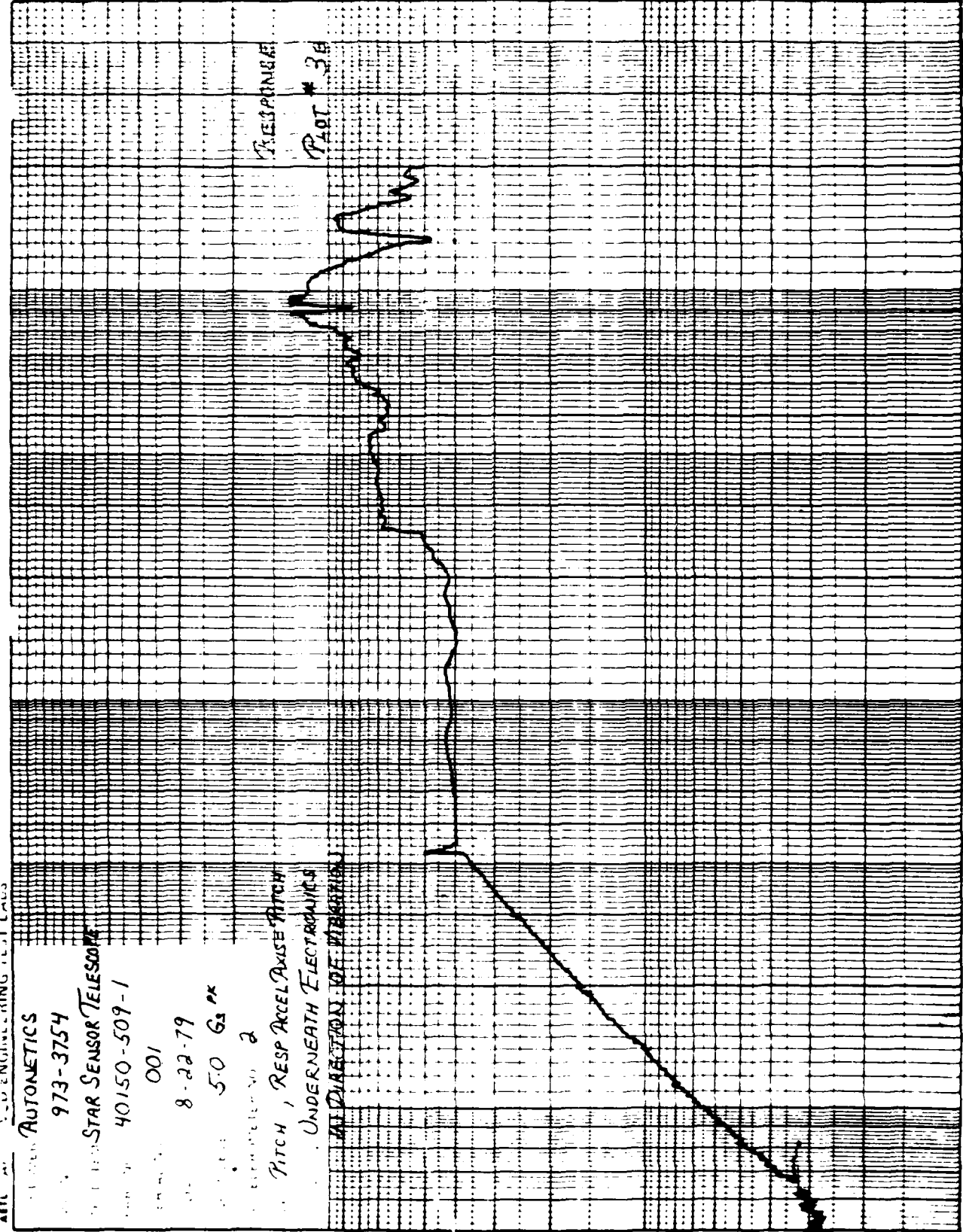

0 1 2 3 4 5 6 7 8 9 100

100

100

1.0





AVIATION ENGINEERING TEST LABS

**AUTOMETRICS**

973-3754

STAR SENSOR TELESCOPE

40150-509-1

001

8-22-79

5.0 Gs PK

3

PITCH, RESP ACCEL AXIS - PITCH

(ON) TOP CENTER OF ELECTRONICS

RETRACE

PLOT # 10

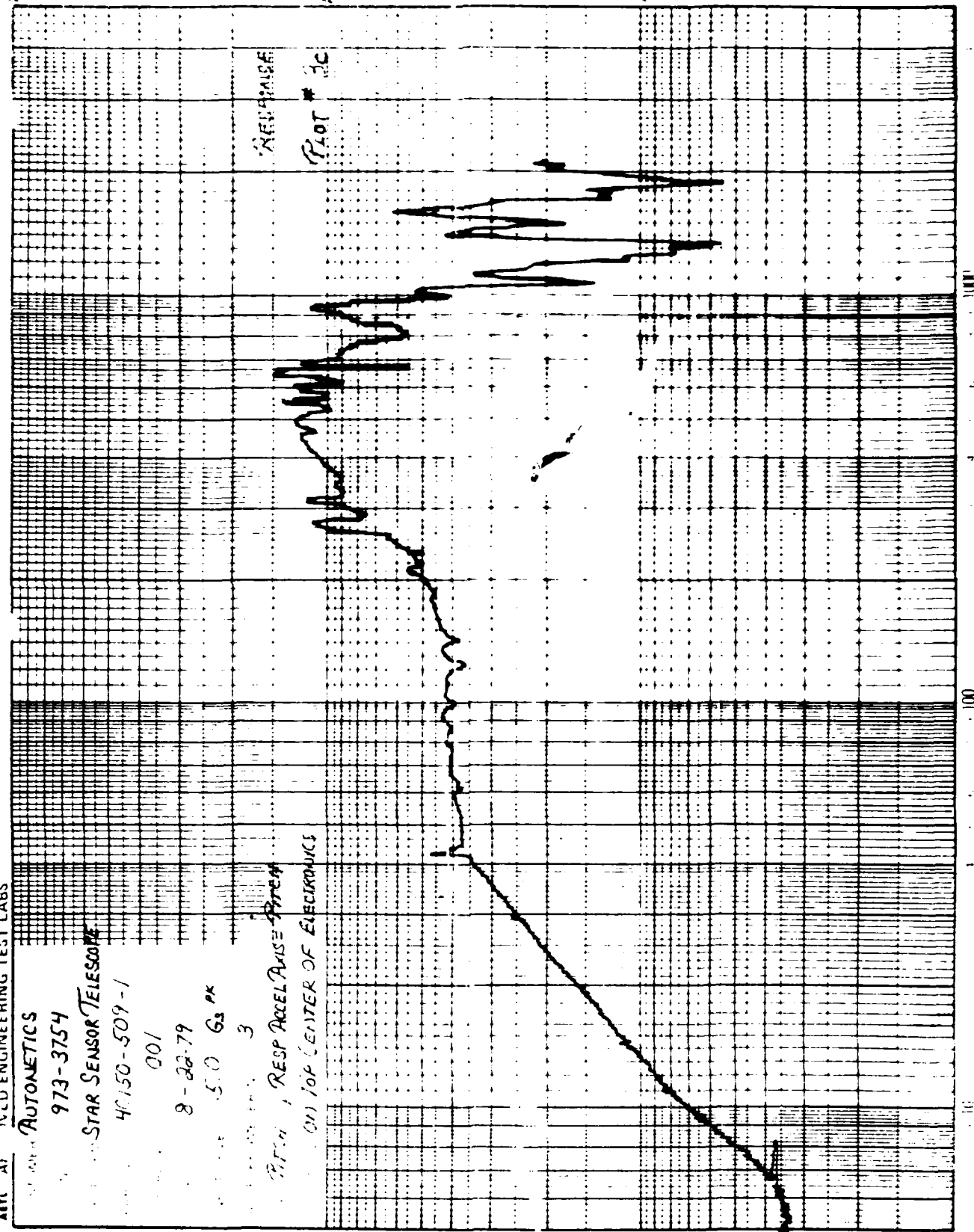



Autometrics Engineering Test Labs

AUTOMETRICS

973-3754

STAR SENSOR TELESCOPE

47157-5001

001

2-28-77

5.0 GS PK

4

RESP ACCEL PANEL #1111

TYPE 1A PANEL

Class Approved

Plot # 10

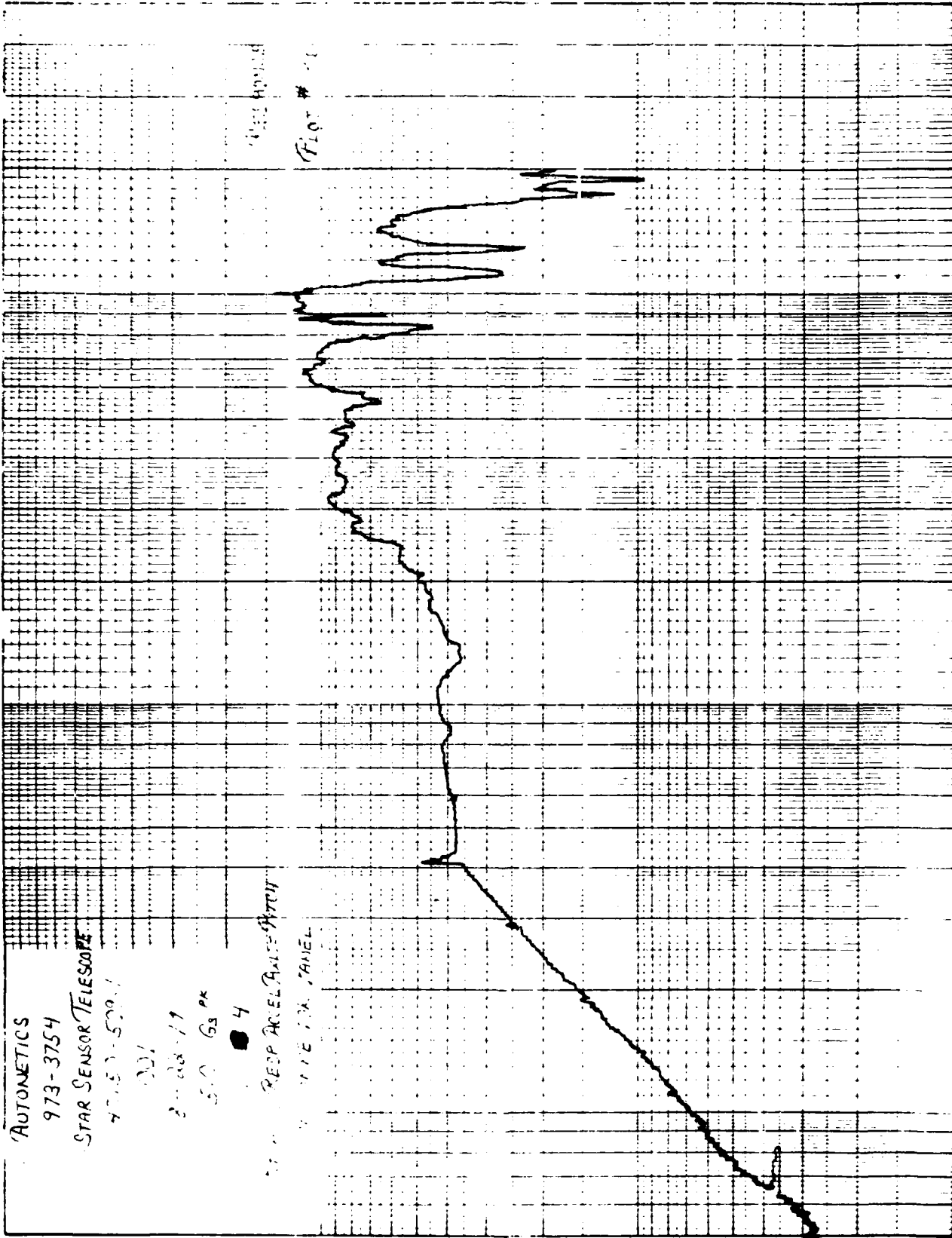

(100)

10

10



VED ENGINEERING TEST LABS

**AUTONETICS**

973-3754

**STAR SENSOR TELESCOPE**

40150-509-1

001

8-22-79

5.0 G<sub>pk</sub>

5

PITCH, RESP ACCEL AXIS

ON REAR OF ELECTRONICS

BAD CABLE - LOST DATA

RESPONSE

PLOT # 38

100g

10g

1.0g

100

10

1.0

1 2 3 4 5 6 7 8 9 1000 2 3 4 5 6 7 8 9 100 2 3 4 5 6 7 8 9 10



ROVED ENGINEERING TEST LABORATORIES  
AUXILIARY TECHNICAL SERVICES CO.

Date Started:		Customer		AETL VIBRATION TEST DATA		M.I.O.							
Day	Hour	Temp	Freq Bandwidth	P.S.D. Level	Roll Up	Roll Off	Accel Level	Duration	Axis	Test Sequence	Part No.	Specimen Serial No.	Remarks
F	Hz	G <sup>2</sup> /Hz	db/oct	db/oct	Grms	Sec	X, Y, Z	Noted	Noted	Noted	Noted	Noted	Units
8-21-79	1300	AMB	20-2000	.025	7.0	N/A	THRUST	1	1	1			EQUALIZATION
	1438		20-2000	.025	7.0	10	THRUST	2	—	—			RANDOM RUN
8-22-79	1200		20-2000	.05	9.9	N/A	LAT	3	3	3			EQUALIZATION
	1404		20-2000	.05	9.9	10	LAT-1	4	—	—			RANDOM RUN
8-22-79	1544	AMB	20-2000	.05	9.9	10	PITCH	5	—	—			RANDOM RUN

NOTE: CUSTOMER OPERATED TEST ITEM DURING VIBRATION WITH CUSTOMER SUPPLIED TEST EQUIPMENT, AND ALSO PERFORMED FUNCTIONAL CHECK OUT OF TEST ITEM UPON COMPLETION OF VIBRATION IN EACH AXIS.



AVIATION ENGINEERING TEST LABS

CLIENT: AUTONETICS  
PART NO: 973-3754  
TEST ITEM: STAR SENSOR TELESCOPE

GRMS

THRUST, RESP. ACCEL AXISE

EQUALIZATION  
Plot # 1

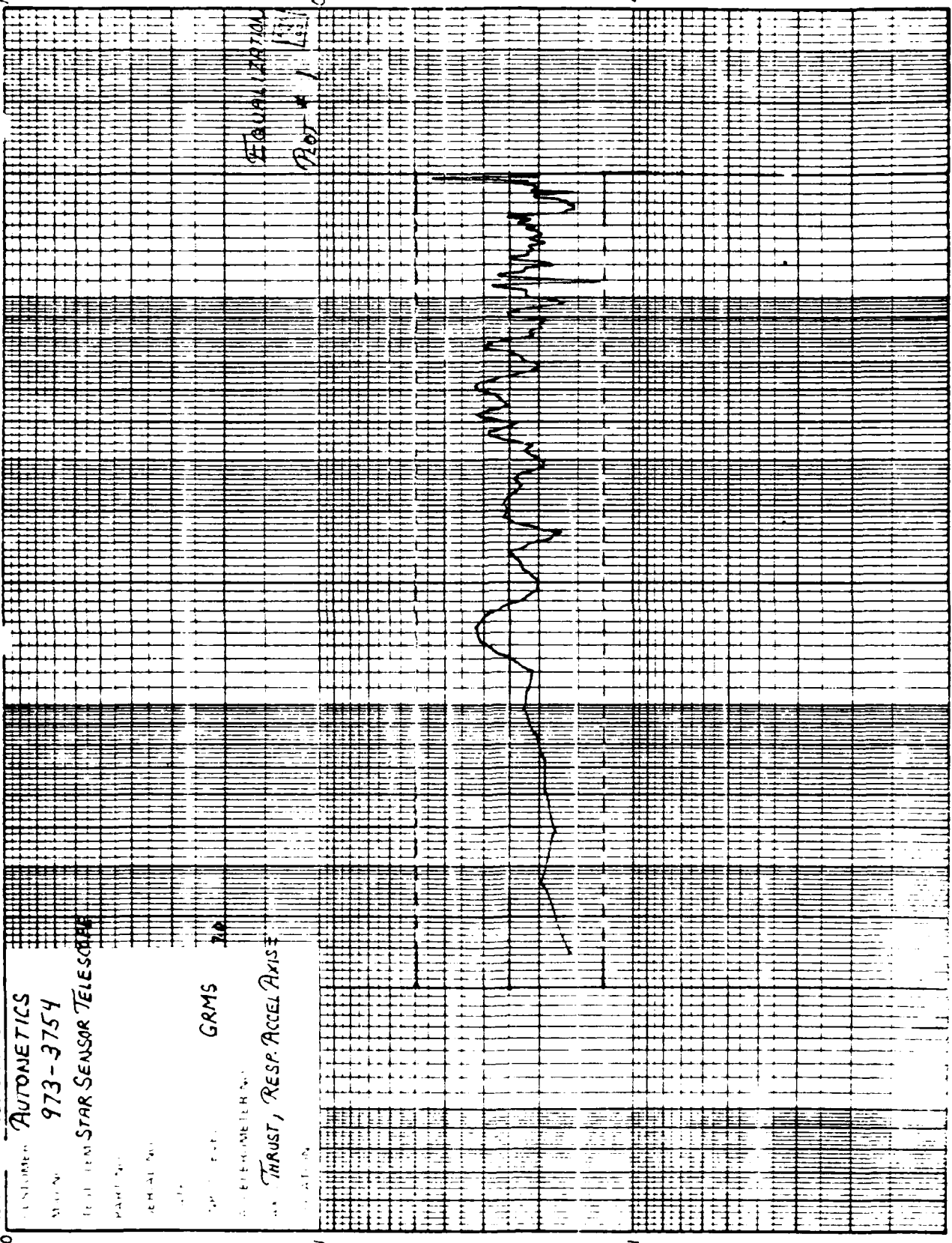

1.0  
0.1  
10  
100  
1000



QVED ENGINEERING TEST LABS

CUSTOMER: **AUTONETICS**  
 MFG NO: **973-3754**  
 TEST ITEM: **STAR SENSOR TELESCOPE**  
 PART NO:  
 SERIAL NO: **FIXTURE**  
 DATE: **8-22-79**  
 INPUT LEVEL: **9.9 GRMS**  
 ACCELEROMETER NO: **1**  
 AX: **LAT, RESP ACCEL AXIS**  
 LOCATION: **ON END OF RING**

EQUALIZATION  
 Plot # 3

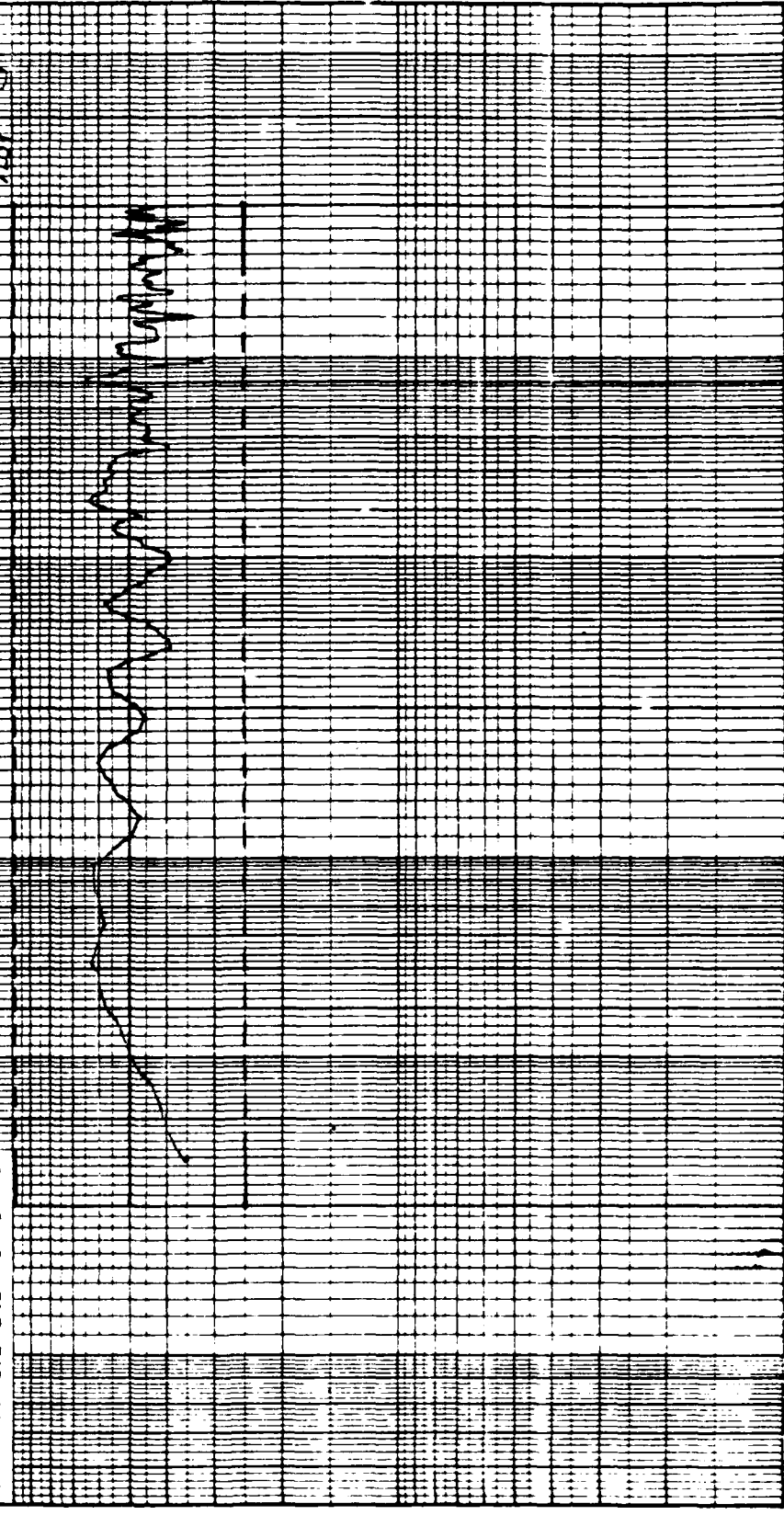

LOWER SPECTRAL DENSITY (G/Hz)



APPROVED ENGINEERING TEST LABORATORIES

EQUIPMENT LIST

<u>Description</u>	<u>Apparatus</u>	<u>Calibration</u>
<u>SINE VIBRATION</u>	Minerva Stop Watch, Model 0-60, AETL Control No. G-4121-F	12 months Due 10-25-79
	Bruel & Kjaer Automatic Exciter Control, Model 1025, AETL Control No. D-4025-F	6 months Due 9-12-79
	Bruel & Kjaer Accelerometers <u>Model No.</u> <u>Control No.</u>	6 months Due 9-3-79
	4335                    D-4393-F	
	4335                    D-4389-F	
	4335                    D-4392-F	
	4335                    D-4388-F	
	4335                    D-4391-F	
	Unholtz-Dickie Charge Amplifiers <u>Model No.</u> <u>Control No.</u>	6 months Due 2-13-80
	8PMCV                 D-4034-F	
	8PMC                    D-4042-F	
	8PMC                    D-4054-F	
	8PMCV                 D-4235-F	
	8PMCV                 D-4035-F	
	Esterline Angus X-Y Recorder, Model 575, AETL Control No. E-4335-F	12 months Due 7-18-80
	Moseley Log Converter, Model 60B, AETL Control No. D-4245-F	6 months Due 1-16-80
	MB Vibration Exciter, Model C210, AETL Control No. D-4019-F	Not Required
	MB Vibration Amplifier, Model 5140, AETL Control No. D-4021-F	Not Required
	CEC Tape Recorder, Model GR-2800, AETL Control No. D-4130-F	6 months Due 3-2-79



APPROVED ENGINEERING TEST LABORATORIES

EQUIPMENT LIST

<u>Description</u>	<u>Apparatus</u>	<u>Calibration</u>
<u>RANDOM VIBRATION</u>	Minerva Stop Watch, Model 0-60, AETL Control No. G-4121-F	12 months Due 10-25-79
	Ling ASDE-80 Equalizer Analyzer, AETL Control No. D-4120-F	Prior to Test
	Bruel & Kjaer Accelerometer, Model 4335, AETL Control No. D-4393-F	6 months Due 9-3-79
	Unholtz-Dickie Charge Amplifier, Model 8PMCV, AETL Control No. D-4034-F	6 months Due 12-13-80
	MB RMS Meter, Model N120, AETL Control No. D-4133-F	6 months Due 9-19-79
	Spectral Dynamics Real Time Analyzer, Model SD330, AETL Control No. D-4125-F	6 months Due 9-20-79
	Esterline Angus X-Y Recorder, Model 575, AETL Control No. E-4334-F	12 months Due 12-15-79
	MB Vibration Exciter, Model C210, AETL Control No. D-4019-F	Not Required
	MB Vibration Amplifier, Model 5140, AETL Control No. D-4021-F	Not Required





APPROVED ENGINEERING TEST LABORATORIES

EQUIPMENT LIST

<u>Description</u>	<u>Apparatus</u>	<u>Calibration</u>
<u>ACCELERATION</u>	Selco Tachometer, Model 727, AETL Control No. D-4386-F	6 months Due 1-31-80
	AETL Centrifuge, 15-foot Radius Arm, Control No. D-4179-F	Prior to Test
	Mentor Stop Watch, 0 to 15 min., + 1 second, AETL Control No. D-4124-F	12 months Due 1-31-80

C77-551/201

A P P E N D I X B

PREPARED BY	CODE IDENT NO 51215  <b>Missile Systems Division</b> <b>Rockwell International</b>  <b>SPECIFICATION</b>	NUMBER:	VC 409-0001
R. H. Weiss <i>RHW</i>		TYPE:	PROCUREMENT
APPROVALS		DATE:	April 7, 1977
<i>A. M. McDevitt</i> A. M. McDevitt		SUPERSEDES SPEC DATED	February 15, 1977
		REV LTR	A

TITLE: PULSE CODE MODULATION (PCM) ENCODER SPICE I

CONTENTS

- 1.0 SCOPE
- 2.0 APPLICABLE DOCUMENTS
- 3.0 REQUIREMENTS
- 4.0 QUALITY ASSURANCE PROVISIONS
- 5.0 PREPARATION FOR DELIVERY

CODE IDENT. NO. 94756

REVISIONS

VC 409-0001

LTR	DISPOSITION	D-S SOS	C GIC TO LC	DATE	APPROVED
	<input type="checkbox"/> 1 MAY BE REWORKED <input type="checkbox"/> 2 CANNOT BE REWORKED <input type="checkbox"/> 3 NONE				
	<b>DESCRIPTION</b>				
A	Paragraph 3.1.4.5 <u>was</u> Isolated Sync Output	3	II	4-7-77	<i>[Signature]</i>
	Paragraph 3.1.5 <u>was</u> Accuracy	3	II	4-7-77	<i>[Signature]</i>

**Rockwell International Corporation**  
**Missile Systems Division**  
 Columbus, Ohio 43216      Anaheim, Calif 92803

CODE IDENT NO 51215

NUMBER VC 409-0001	REVISION LETTER						PAGE 2
	A						

**1.0 SCOPE**

This specification establishes the requirements for the performance, design, and test of a Pulse Code Modulation (PCM) Encoder. The separately packaged and mounted encoder provides the interface with the signal-conditioned prime data and housekeeping signals, the vehicle's subcommutated housekeeping signals, and the telemetry transmitter in a space vehicle.

**2.0 APPLICABLE DOCUMENTS**

The following documents of the issue in effect on date of invitation for bids form a part of this specification to the extent specified herein. In the event of conflict between the requirements of this specification and the listed documents, the requirements of this specification shall govern.

**SPECIFICATIONS**

Military

MIL-E-8189E 1 September 1970	Electronic Equipment, Missiles Booster and Allied Vehicles, General Specification for
MIL-E-8983 12 February 1970	Electronic Equipment, Aerospace, Extended Space Environment, General Specification for

**STANDARDS**

Military

MIL-STD-143A 14 May 1963	Specifications and Standards Order of Precedence for the Selection of
MIL-STD-454B 10 June 1968	Standard General Requirements for Electronic Equipment, and Subsequent Change Notices
MIL-STD-461A 1 August 1968	Electromagnetic Interference Characteristics, Requirements for Equipment

Rockwell International Corporation  
Missile Systems Division  
Columbus, Ohio 43216      Anaheim, Calif. 92803

CODE IDENT NO 51215

NUMBER VC 409-0001	REVISION LETTER						PAGE 5
	A						

### 3.0 REQUIREMENTS

The requirements of the encoder are as follows:

1. Accept the analog and bilevel input signals as specified herein.
2. Supply as outputs a NRZ-M PCM encoded Signal, buffered test signals, and synchronization signals as specified herein.
3. Operate within the environments specified.
4. Be of minimum size and weight meeting the specification herein.

#### 3.1 Performance

##### 3.1.1 Input Signals

###### 3.1.1.1 Prime Data

There will be 55 analog, single-ended, high level prime data input signals to the minor frame, identified as words  $A_1$  through  $A_{55}$ .

###### 3.1.1.2 Vehicle Data

There will be 3 analog, differentially received, high level vehicle data input signals to the minor frame, identified as words  $A_{56}^1$  through  $A_{58}^1$ .

###### 3.1.1.3 Housekeeping/Diagnostic Data

The encoder shall have the capacity to accept single-ended analog and bilevel housekeeping/diagnostic data input signals to the subcommutated frames as follows. This capacity was selected to occupy two minor frame words as indicated in the data table and format programming.

54 Analog signal channels  
20 Bilevel signal channels

###### 3.1.1.3.1 The analog channels are identified as follows:

6 inputs,  $B_1$  through  $B_6$ , subcommutated  
into 2 minor frame words

48 inputs identified as  $C_3$  through  $C_{50}$ .

3.1.1.3.1.1 The 48 analog inputs include 9 spare channels. The number of spares may be adjustable for hardware/cost considerations.

Rockwell International Corporation  
Missile Systems Division  
Columbus, Ohio 43216      Anaheim, Calif. 92803

CODE IDENT NO. 51215

NUMBER VC 409-0001	REVISION LETTER						PAGE 4
	A						

3.1.1.3.2 The bilevel channels are identified as follows:

10 inputs occupy sub-frame word  $C_1$

10 inputs occupy sub-frame word  $C_2$ .

3.1.1.4 Each analog input channel shall accept a signal from 0.000 volts to +5.000 volts.

3.1.1.4.1 Any input signal under  $1/2$  the quantized level shall be 0 volts (binary code: 000000001). Any input signal over +5.000 volts shall be considered +5.000 volts.

3.1.1.5 Each bilevel input channel shall accept a signal from 0 to +5 volts.

3.1.1.5.1 An input voltage level less than +1.0 volt will initiate a "0" logic level.

3.1.1.5.2 An input voltage greater than +2.0 volts will initiate a "1" logic level.

3.1.1.6 Overvoltage

Each of the analog and bilevel input channels shall be capable of accepting an input overvoltage outside of the normal signal range to limits of from +15 volts to -15 volts.

3.1.1.7 Channel Crosstalk

Channel crosstalk shall be  $\pm 2.5$  millivolts or less for all signals to the limits of the specified input overvoltage.

3.1.1.8 Source Impedance

The encoder shall operate within specification for the input signal source impedances specified below.

3.1.1.8.1 The prime data input signals source impedances shall be 10 ohms maximum.

3.1.1.8.2 The vehicle data differential input signals source impedances shall be unbalanced from 0 to 6000 ohms.

3.1.1.8.3 All remaining bilevel and analog input signals shall have source impedances from 0 to 6000 ohms.

**Rockwell International Corporation**  
**Missile Systems Division**  
 Columbus, Ohio 43216      Anaheim, Calif 92803

CODE IDENT NO 51215

NUMBER VC 409-0001	REVISION LETTER						PAGE 5
	A						

3.1.1.9 Input Impedance

The input impedance during either sampling or non-sampling time shall be as follows:

    Analog Channels: 10 Megohm minimum  
 Bilevel Channels: 100 Kilohm minimum

3.1.1.10 Back Current

The input circuit back current during either sampling or non-sampling times shall be as follows:

    Analog channels: 0.1 microamperes maximum  
 Bilevel channels: 1.0 microamperes maximum

3.1.2 Output Signals

3.1.2.1 Output Code

3.1.2.1.1 The output code shall be serial, with NRZ-M programming logic, having the most significant bit first.

3.1.2.1.2 The output logic 1 voltage level shall be +4.5  $\pm$ 0.5 volts.

3.1.2.1.3 The logic 0 voltage level shall be +0.5  $\pm$ 0.5 volts.

3.1.2.1.4 The output shall be capable of driving a capacitively coupled load impedance of 50 K ohms or greater.

3.1.2.1.5 The encoder shall utilize 10 bits per word with no parity.

3.1.2.1.6 The output data list shall be:

DATA LIST

<u>WORD</u>	<u>SAMPLE RATE</u>	<u>INPUT CHANNELS</u>	<u>WORDS PER MINOR FRAME</u>
A	1500	55	55
A1	1500	5	5
S. ID	1500	-	4
B	93.75	6	2
C	46.875	18	-
C <sub>2</sub>	93.75	10	-
C <sub>1</sub>	93.75	10	-

Minor Frame Length: 64 words  
 Major Frame Length: 2048 words  
 Total Bit Rate: 960 K bps





**Rockwell International Corporation**  
**Missile Systems Division**  
Columbus, Ohio 43216      Anaheim, Calif 92803

CODE IDENT NO 51215

NUMBER	VC 409-0001	REVISION LETTER	A							PAGE	7
--------	-------------	-----------------	---	--	--	--	--	--	--	------	---

3.1.2.2 Output Sync Signals

3.1.2.2.1 A sync signal derived from the minor frame sync divided by 4 shall be provided at the houskeeping/diagnostic input signals' connector.

3.1.2.2.1.1 This signal shall be short circuit proof.

3.1.2.2.1.2 The logic 1 voltage level shall be between +3.0 and +5.0 volts and capable of supplying 400 microamperes.

3.1.2.2.1.3 The logic 0 voltage level shall be between 0.0 and +0.4 volts and capable of sinking 16 milliamperes.

3.1.2.3 Test Signals

3.1.2.3.1 The following test signals shall be provided at the multi-coaxial cable test connector:

- NRZ-level serial output
- Major frame sync
- Minor frame sync
- Pulse amplitude modulation (PAM)
- Word clock
- Bit clock

3.1.2.3.2 Each signal shall be buffered and short circuit proof and capable of delivering a signal through 1000 feet, or less, of 50 ohm coaxial cable.

3.1.2.4 Guard Shield Drive Signal

A signal shall be furnished to the vehicle data input signals' connector to drive a single guard shield encasing all differentia' input signals. The signal shall be of such magnitude and phase to effectively reduce the common mode voltages and resulting crosstalk errors.

3.1.3 Input Power

3.1.3.1 Supply Voltage and Current

3.1.3.1.1 The system shall operate from a supply voltage of +24 Vdc nominal with a range from +22 to +28 Vdc.

3.1.3.1.2 The maximum average power dissipation shall be 12 watts when operated at +24.0 Vdc.

Rockwell International Corporation  
Missile Systems Division  
Columbus, Ohio 43216      Anaheim, Calif 92803

CODE IDENT NO 51215

NUMBER VC 409-0001	REVISION LETTER A	PAGE 5
-----------------------	----------------------	-----------

3.1.3.2 Transients and Voltage Ripple

The encoder shall meet the transient overvoltage conditions and voltage ripple requirements specified in MIL-STD-461A for class ID equipment.

3.1.3.3 Input Voltage Polarity Reversal

Input voltage polarity reversal protection will be supplied. No damage to the encoder will occur through a reversal of input voltage polarity.

3.1.4 Grounding

The encoder shall have the following grounds (returns) electrically isolated from each other by a minimum of ten megohm.

3.1.4.1 Signal

3.1.4.2 Chassis

3.1.4.3 Power

3.1.4.4 Differential Input Signal

3.1.4.5 Deleted

3.1.5 Accuracy (For Analog Input Channels)

3.1.5.1 Quantization Uncertainty

The quantization error shall be  $\pm 1/2$  LSB. This is interpreted to represent a maximum possible error of  $\pm 2.5$  millivolts for a  $\pm 5$  volt high level signal.

3.1.5.2 Normal Signal Range Error

Each channel shall have  $\pm 5.0$  millivolts or less of worst case cumulative error from all other error sources when all input signals are within their normal range of from 0 to  $\pm 5$  volts.

3.1.5.3 Abnormal Signal Range Error

For any combination of input signal overvoltages to the limits specified herein, any channel shall not be affected beyond the channel crosstalk specified herein.

3.1.5.4 Setting Accuracy

The setting error shall be a non-random error of  $\pm 2.5$  millivolts or less.

**Rockwell International Corporation**  
**Missile Systems Division**  
 Columbus, Ohio 43216      Anaheim, Calif 92803

CODE IDENT NO 51215

NUMBER VC 409-0001	REVISION LETTER						PAGE 9
	A						

3.1.5.5 Common Mode Voltage Error

The differential channels shall have a common mode rejection (CMR) of 74 db or more from 0 to 2000 Hz. This represents a maximum additional error of  $\pm 0.5$  millivolts with the occurrence of a 5 volt common mode voltage.

3.1.6 Premodulation Filter

A premodulation filter with the following characteristics shall be incorporated. These parameters shall be easily adjustable.

Active, Low-Pass Filter:	Optimized for linear phase
5 db Cutoff Frequency:	0.8 times the nominal bit rate
Final Slope:	-36 db/octave or greater

3.1.7 Sampling Rate Stability

The clock frequency shall be easily changed to provide the capability of lower sampling rates. The sampling rate stability shall be 0.5 percent of the nominal rate.

3.1.8 Interface

The encoder shall be designed for the use of interconnecting cables and connectors.

3.1.8.1 Receptacles (Rockwell Supplied)

The receptacles specified below shall provide electromagnetic interference shielding as specified in MIL-STD-461A.

<u>Identification</u>	<u>Name</u>	<u>Receptacle</u>	<u>Manufacturer</u>
1J1	Power	JTN07RE8-44P(011) <sup>1</sup>	Bendix
1J2	TM Output	31-239-1050 <sup>1</sup>	Amphenol
1J5	Vehicle Data	JTN07RE14-18P(011)	Bendix
1J4	Prime Data	JTN07RE22-2PA(011)	Bendix
1J5	Housekeeping Data	JTN07RE22-2PB(011)	Bendix
1J6	Test Signals	PT07SE22-77S(011)	Bendix

NOTE: Output return routed through 1J1.

3.1.8.1.1 The wire lists below relate the pin connections required to the signals/words specified herein. Unused pins are not shown.

**Rockwell International Corporation**  
**Missile Systems Division**  
 Columbus, Ohio 43216      Anaheim Calif 92803

CODE IDENT NO 51215

NUMBER VC 409-0001	REVISION LETTER						PAGE 10
	A						

5.1.8.1.2 Power Connector 1J1 (4 pins)

<u>Pin</u>	<u>Signal</u>
1	Chassis Ground
2	+24 Vdc
3	+24 V Return
4	Sig Return, Serial Code

5.1.8.1.3 TM Output Connector 1J2 (Coaxial)

<u>Pin</u>	<u>Signal</u>
Center	Serial Code
Shield	EMI Shield tied to chassis

5.1.8.1.4 Vehicle Data Connector 1J3 (18 pins)

<u>Pin</u>	<u>Signal</u>
B	A <sup>1</sup> <sub>56</sub>
C	A <sup>1</sup> <sub>57</sub>
E	A <sup>1</sup> <sub>58</sub>
F	Guard Shield Drive
N	Return A <sup>1</sup> <sub>56</sub>
P	Return A <sup>1</sup> <sub>57</sub>
R	Return A <sup>1</sup> <sub>58</sub>

5.1.8.1.5 Prime Data Connector 1J4 (85 pins)

<u>Pin</u>	<u>Word A</u>	<u>Pin</u>	<u>Word A</u>	<u>Pin</u>	<u>Word A</u>	<u>Pin</u>	<u>Word C</u>
1	55	27	2	61	53	46	48
5	1	29	26	62	3	45	49
6	4	31	5	63	6	47	50
7	7	32	8	64	9		
8	10	33	11	65	12		
9	13	34	14	66	15		
10	16	35	17	67	21		
11	19	37	27	68	24		
13	22	38	35	69	18		
14	20	42	29	74	23		
15	28	43	32	75	30		
16	31	44	25	76	35		
17	34	59	47	77	36		
20	37	84	51	78	39		
22	40			79	42		
23	43	18	58	80	45		
24	46	57	41	82	48		
25	49	58	44	83	54		
26	52	60	50	85			

**Rockwell International Corporation**  
**Missile Systems Division**  
 Columbus, Ohio 43216      Anaheim, Calif 92803

CODE IDENT NO 51215

NUMBER VC 409-0001	REVISION LETTER						PAGE 11
	A						

3.1.8.1.6 Housekeeping Data Connector 1J5 (85 pins)

<u>Pin</u>	<u>Word</u>	<u>Pin</u>	<u>Word</u>	<u>Pin</u>	<u>Word</u>
1	C1				
5	SIG RET	30	C12	56	C41
6	C2	31	C13	57	B1
7	C1	32	C14	58	C2
8	C1	33	C15	59	B2
9	C2	34	C16	60	C2
10	C2	35	C17	61	B4
11	C31	36	C18	62	C2
12	C7	37	C19	63	B6
13	SIG RET	38	C20	64	C2
14	C1	39	C42	65	C28
15	SIG RET	40	C21	66	C2
16	C1	41	C44	67	C2
17	C1	42	C22	68	C2
18	C32	43	C1	69	B3
19	C1	44	C23	70	*C45
20	C8	45	C24	71	B5
21	C3	46	C25	72	*C46
22	C4	47	C26	73	C33
23	C5	48	C27	74	MINOR FR SYNC/ 4
24	*C6	49	C35	75	*C47
25	C9	50	C38		
26	*C30	51	C37		
27	C10	52	C39	83	C1
28	*C29	53	C43	84	C1
29	C11	54	C40	85	C34
		55	C36		

\*Spares

3.1.8.1.6.1 1J5 Bilevel Words

<u>Word</u>	<u>Bit</u>	1	2	3	4	5	6	7	8	9	10
C1	Pin No.	1	17	19	14	16	7	8	83	84	43
C2	Pin No.	58	67	60	62	64	66	10	6	9	68

3.1.8.1.7 Test Signals Connector 1J6 (7 coaxial)

<u>Coax</u>	<u>Signal</u>	<u>Coax</u>	<u>Signal</u>
A	NRZ-L output	D	minor frame sync
B	P/M	E	word clock
C	major frame sync	F	bit clock

**Rockwell International Corporation**  
**Missile Systems Division**  
Columbus, Ohio 43218      Anaheim, Calif 92803

CODE IDENT NO 51215

<b>NUMBER</b> VC 409-0001	<b>REVISION LETTER</b> A	<b>PAGE</b> 12
------------------------------	-----------------------------	-------------------

**3.2 Design and Construction**

**3.2.1 Mounting**

The encoder shall be designed to mount upon a flat surface.

**3.2.2 Maximum Envelope**

The maximum size, including connector protrusions, shall be contained within the rectangular dimensions: 4.0 inches high x 7.0 inches x 11.5 inches.

**3.2.3 Weight**

The weight of the encoder shall not exceed 7.0 pounds.

**3.2.4 Finishes**

Finishes shall be applied to all surfaces where required for protection against corrosion or other deterioration. The materials, finishes and protective coatings shall not impair the performance of the encoder. No subliming shall occur.

**3.2.5 Workmanship**

The encoder shall be constructed with a workmanship consistent with the requirements of MIL-STD-454B.

**3.2.6 Identification**

**3.2.6.1 Name Plate**

A name plate shall be provided. Complete identifying data will be specified at a later date.

**3.2.6.2 Receptacle Identification**

All receptacles shall be durably and legibly marked with the identification specified in paragraph 3.1.8.1.

**3.2.7 Electromagnetic Interference and Compatibility**

**3.2.7.1 Electromagnetic Interference**

The equipment shall meet the electromagnetic interference test requirements of MIL-STD-461A. Radio frequency spectrum characteristics shall meet the requirements stated in MIL-STD-440 and Supplement 1 for susceptibility.

**Rockwell International Corporation**  
**Missile Systems Division**  
Columbus, Ohio 43216      Anaheim, Calif 92803

CODE IDENT NO 51215

NUMBER VC 409-0001	REVISION LETTER						PAGE 13
	A						

**3.2.7.2 Interference Control**

Electromagnetic Interference (EMI) control shall be inherent in and concurrent with the design and development of all electrical and electronic equipment, components and assemblies. Information and functional signal spectrums shall be limited to the minimum compatible with functional requirements. Receivers of information and functional signals shall have a bandwidth only as wide as required to meet functional requirements. Propagation and coupling of EMI shall be minimized by component location, cable routing and judicious use of shielding. Packaging and installation of components, circuits, etc., shall be such as to minimize interference pickup and radiation. The maximum permissible levels of generated interference and minimum thresholds of susceptibility of each equipment shall be in accordance with MIL-STD-461A.

**3.2.8 Environmental Operating Conditions**

3.2.8.1 The encoder shall be designed to operate under the environmental service conditions listed herein.

3.2.8.1.1 Environmental qualification testing shall be performed by Autonetics. The vendor's proposal shall indicate the method and design approach to be utilized to assure qualification.

3.2.8.1.2 The encoder shall not exhibit microphonic effects during and following the environmental conditions listed herein.

**3.2.8.2 Temperature**

The encoder shall operate within specification between the temperature extremes of  $-20^{\circ}\text{C}$  to  $+50^{\circ}\text{C}$ .



**Rockwell International Corporation**  
**Missile Systems Division**  
 Columbus, Ohio 43216      Anaheim, Calif 92803

CODE IDENT NO. 51215

NUMBER VC 409-0001	REVISION LETTER						PAGE 14
	A						

**3.2.8.3 Altitude**

The encoder shall operate within specifications between the pressure extremes of sea level pressure to  $10^{-8}$  torr.

**3.2.8.4 Acceleration**

The encoder shall operate within specifications during and following an acceleration of 20g for 2 minutes in each of two (2) directions perpendicular to its 18.0 inch diameter plane.

**3.2.8.5 Vibration**

The encoder shall operate within specifications during and following vibration as follows.

**3.2.8.5.1 Sinusoidal Vibration**

A frequency survey (sinusoidal sweep) shall be conducted in each of three (3) mutually perpendicular axes at a rate of 2 octaves per minute.

<u>Axis</u>	<u>Frequency</u>	<u>Level</u>
Perpendicular	10 - 50 Hz	2.3 g
	50 - 160 Hz	4.5 g
	160 - 2000 Hz	7.5 g
Lateral 1 & 2	5 - 43 Hz	7.7 in/sec
	43 - 250 Hz	5.3 g
	250 - 2000 Hz	7.5 g

**3.2.8.5.2 Random Vibration**

Random vibration tests will be conducted in each of 3 mutually perpendicular axes as follows: 20 seconds per axis from 20 to 2000 Hz at  $0.056 \text{ g}^2/\text{Hz}$ .

**3.2.8.6 Shock**

The encoder shall operate within specifications during and following a shock test of 100 g for 6 milliseconds applied in each direction of its perpendicular axis.

**Rockwell International Corporation**  
**Missile Systems Division**  
Columbus, Ohio 43216      Anaheim, Calif. 92803

CODE IDENT NO 51215

NUMBER	VC 409-0001	REVISION LETTER	PAGE 15
		A	

**3.2.8.7 Axes Definition**

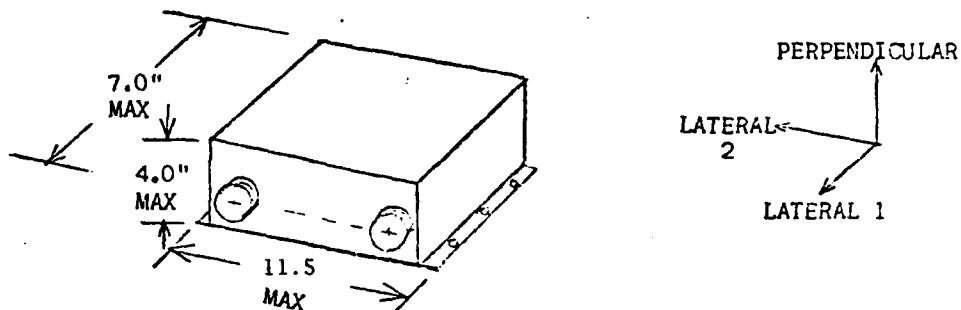

**4.0 QUALITY ASSURANCE PROVISIONS**

**4.1 Test and Evaluation**

4.1.1 The encoder shall be functionally tested for verification of its conformance to the specification herein.

**4.1.2 Acceptance Test Procedure (ATP)**

An acceptance test procedure and reports on subsequent data are required. The documentation shall be submitted to Autonetics for approval 30 days ARO.

4.1.2.1 The ATP shall include among its tests, provisions to verify compliance with the worst case crosstalk error and unbalanced source common mode rejection requirements specified herein.

**5.0 PREPARATION FOR DELIVERY**

**5.1 Data Package**

Three (3) complete sets of operating instructions, manuals and mechanical and electrical drawings shall be delivered with or before the encoder delivery. The exact contents of the data package shall be determined at a later date.

PREPARED BY	CODE IDENT. NO.: 94756 <b>Rockwell International Corporation</b> Autonetics Group  <b>SPECIFICATION</b>	NUMBER VC 409-0001-21
R. H. WEISS <i>R. H. Weiss</i>		TYPE PROCUREMENT
APPROVALS		DATE October 24, 1977
<i>A. M. McDevitt</i> A. M. McDEVITT		SUPERSEDES SPEC. DATED: October 3, 1977
		REV. LTR. A

TITLE PULSE CODE MODULATION (PCM) ENCODER SPICE II

CONTENTS

- 1.0 SCOPE
- 2.0 APPLICABLE DOCUMENTS
- 3.0 REQUIREMENTS
- 4.0 QUALITY ASSURANCE PROVISIONS
- 5.0 PREPARATION FOR DELIVERY

CODE IDENT. NO. 51215

REVISIONS

VC 409-0001-21

LTR	DISPOSITION	D-STATUS	C L O C I G	DATE	APPROVED
	<input type="checkbox"/> MAY BE REWORKED <input type="checkbox"/> CANNOT BE REWORKED <input type="checkbox"/> NONE				
	<b>DESCRIPTION</b>				
A	Paragraph 3.1.1.9 - Bilevel Channel Impedance was 100 Kilohm minimum	3	II		<i>R. Williams flm.</i>
	Paragraph 3 1.5.5 (CMR) was 74 db for additional error of <u>+0.5</u> millivolts	3	II		<i>R. Williams flm.</i>
	Paragraph 3.2.2 - Height was 4.0 inches	3	II		<i>R. Williams flm.</i>
	Paragraph 3.2.3 - Weight was 10 pounds	3	II		<i>R. Williams flm. 10/29/77</i>

# Rockwell International Corporation

CODE IDENT. NO. 94756

NUMBER	REVISION LETTER							PAGE
VC 409-0001-21	A						2	

## 1.0 SCOPE

This specification establishes the requirements for the performance, design, and test of a Pulse Code Modulation (PCM) Encoder. The separately packaged and mounted encoder provides the interface with the signal-conditioned prime data and housekeeping signals, the vehicle's subcommutated housekeeping signals, and the telemetry transmitter in a space vehicle.

## 2.0 APPLICABLE DOCUMENTS

The following documents of the issue in effect on date of invitation for bids form a part of this specification to the extent specified herein. In the event of conflict between the requirements of this specification and the listed documents, the requirements of this specification shall govern.

### SPECIFICATIONS

#### Military

MIL-E-8189E  
1 September 1970

Electronic Equipment, Missiles  
Booster and Allied Vehicles, General  
Specification for

MIL-E-8983  
12 February 1970

Electronic Equipment, Aerospace,  
Extended Space Environment, General  
Specification for

### STANDARDS

#### Military

MIL-STD-143A  
14 May 1963

Specifications and Standards Order  
of Precedence for the Selection of

MIL-STD-454B  
10 June 1968

Standard General Requirements for  
Electronic Equipment, and Subsequent  
Change Notices

MIL-STD-461A  
1 August 1968

Electromagnetic Interference  
Characteristics, Requirements for  
Equipment

Rockwell International Corporation

Marathon, Calif. 92803

CODE IDENT NO 51215

NUMBER	VC 409-0001-21	REVISION LETTER	A							PAGE	5
--------	----------------	-----------------	---	--	--	--	--	--	--	------	---

3.0 REQUIREMENTS

The requirements of the encoder are as follows:

1. Accept the analog and bilevel input signals as specified herein.
2. Supply as outputs a NRZ-M PCM encoded Signal, buffered test signals, and synchronization signals as specified herein.
3. Operate within the environments specified.
4. Be of minimum size and weight meeting the specification herein.

3.1 Performance

3.1.1 Input Signals

3.1.1.1 Prime Data

There will be 55 analog, single-ended, high level prime data input signals to the minor frame, identified as words  $A_1$  through  $A_{55}$ .

3.1.1.2 Vehicle Data

There will be 3 analog, differentially received, high level vehicle data input signals to the minor frame, identified as words  $A_{56}^1$  through  $A_{58}^1$ .

3.1.1.3 Housekeeping/Diagnostic Data

The encoder shall have the capacity to accept single-ended analog and bilevel housekeeping/diagnostic data input signals to the subcommutated frames as follows. This capacity was selected to occupy two minor frame words as indicated in the data table and format programming.

54 Analog signal channels  
20 Bilevel signal channels

3.1.1.3.1 The analog channels are identified as follows:

6 inputs,  $B_1$  through  $B_6$ , subcommutated into 2 minor frame words

48 inputs identified as  $C_3$  through  $C_{50}$ .

3.1.1.3.1.1 The 48 analog inputs include 9 spare channels. The number of spares may be adjustable for hardware/cost considerations.

# Rockwell International Corporation

CODE IDENT. NO. 94756

NUMBER VC 409-0001-21	REVISION LETTER A	PAGE 4
--------------------------	----------------------	--------

3.1.1.3.2 The bilevel channels are identified as follows:

10 inputs occupy sub-frame word  $C_1$

10 inputs occupy sub-frame word  $C_2$

3.1.1.4 Each analog input channel shall accept a signal from 0.000 volts to +10.000 volts.

3.1.1.4.1 Any input signal under 1/2 the quantized level shall be 0 volts (binary code: 000000001). Any input signal over +10.000 volts shall be considered +10.000 volts.

3.1.1.5 Each bilevel input channel shall accept a signal from 0 to +5 volts.

3.1.1.5.1 An input voltage level less than +1.0 volt will initiate a "0" logic level.

3.1.1.5.2 An input voltage greater than +2.0 volts will initiate a "1" logic level.

### 3.1.1.6 Overvoltage

Each of the analog and bilevel input channels shall be capable of accepting an input overvoltage outside of the normal signal range to limits of from +15 volts to -15 volts.

### 3.1.1.7 Channel Crosstalk

Channel crosstalk shall be +2.5 millivolts or less for all signals to the limits of the specified input overvoltage.

### 3.1.1.8 Source Impedance

The encoder shall operate within specification for the input signal source impedances specified below.

3.1.1.8.1 The prime data input signals source impedances shall be 10 ohms maximum.

3.1.1.8.2 The vehicle data differential input signals source impedances shall be unbalanced from 0 to 1000 ohms.

3.1.1.8.3 All remaining bilevel and analog input signals shall have source impedances from 0 to 1000 ohms.

# Rockwell International Corporation

CODE IDENT. NO. 94756

NUMBER VC 409-0001-21	REVISION LETTER A	PAGE 5
--------------------------	----------------------	--------

### 3.1.1.9 Input Impedance

The input impedance during either sampling or non-sampling time shall be as follows:

Analog Channels:      10 Megohm minimum  
Bilevel Channels:    50 Kiloohm minimum

### 3.1.1.10 Back Current

The input circuit back current during either sampling or non-sampling times shall be as follows:

Analog Channels:      0.1 microamperes maximum  
Bilevel Channels:    1.0 microamperes maximum

### 3.1.2 Output Signals

#### 3.1.2.1 Output Code

3.1.2.1.1 The output code shall be serial, with NRZ-M programming logic, having the most significant bit first.

3.1.2.1.2 The output logic 1 voltage level shall be  $+4.5 \pm 0.5$  volts.

3.1.2.1.3 The logic 0 voltage level shall be  $+0.5 \pm 0.5$  volts.

3.1.2.1.4 The output shall be capable of driving a capacitively coupled load impedance of 50 K ohms or greater.

3.1.2.1.5 The encoder shall digitize into 11 bits per word with no parity, but the MSB shall be inhibited, thus transmitting only 10 bits.

3.1.2.1.6 The output data list shall be:

#### DATA LIST

<u>WORD</u>	<u>SAMPLE RATE/SEC</u>	<u>INPUT CHANNELS</u>	<u>WORDS PER MINOR FRAME</u>
A	1500	55	55
A <sup>1</sup>	1500	3	3
S, I <sub>D</sub>	1500	--	4
B	93.75	6	2
C	46.875	48	--
C <sub>2</sub>	93.75	10	--
C <sub>1</sub>	93.75	10	--

Minor Frame Length:      64 words  
Major Frame Length:    2048 words  
Total Bit Rate:            960 K bps



Rockwell International Corporation

Whittier, Calif 92803

CODE IDENT NO 51215

NUMBER VC 409-0001-21	REVISION LETTER						PAGE 6
	A						

3.1.2.1.6.1 The three words designated S<sub>1</sub> S<sub>2</sub> S<sub>3</sub> are used for frame sync and shall have the code 1111101011 1100110011 0100000000 respectively.

3.1.2.1.6.2 The word designated I<sub>D</sub> is used for sub-frame identification.

3.1.2.1.6.3 A possible format is:

FORMAT PROGRAMMING

A <sub>1</sub>	A <sub>2</sub>	A <sub>3</sub>	A <sub>4</sub>	A <sub>5</sub>	A <sub>6</sub>	A <sub>7</sub>	- - -	A <sub>56</sub> <sup>1</sup>	A <sub>57</sub> <sup>1</sup>	A <sub>58</sub> <sup>1</sup>	B <sub>1</sub>	B <sub>2</sub>	S <sub>1</sub>	S <sub>2</sub>	S <sub>3</sub>	I <sub>D</sub>
.	.	.	.	.	.	.	.	.	.	.	B <sub>3</sub>	B <sub>4</sub>	.	.	.	.
.	.	.	.	.	.	.	.	.	.	.	B <sub>5</sub>	B <sub>6</sub>	.	.	.	.
.	.	.	.	.	.	.	.	.	.	.	C <sub>1</sub>	C <sub>2</sub>	.	.	.	.
.	.	.	.	.	.	.	.	.	.	.	C <sub>3</sub>	C <sub>4</sub>	.	.	.	.
.	.	.	.	.	.	.	.	.	.	.	C <sub>5</sub>	C <sub>6</sub>	.	.	.	.
.	.	.	.	.	.	.	.	.	.	.	C <sub>7</sub>	C <sub>8</sub>	.	.	.	.
.	.	.	.	.	.	.	.	.	.	.	C <sub>9</sub>	C <sub>10</sub>	.	.	.	.
.	.	.	.	.	.	.	.	.	.	.	C <sub>11</sub>	C <sub>12</sub>	.	.	.	.
.	.	.	.	.	.	.	.	.	.	.	C <sub>13</sub>	C <sub>14</sub>	.	.	.	.
.	.	.	.	.	.	.	.	.	.	.	C <sub>15</sub>	C <sub>16</sub>	.	.	.	.
.	.	.	.	.	.	.	.	.	.	.	C <sub>17</sub>	C <sub>18</sub>	.	.	.	.
.	.	.	.	.	.	.	.	.	.	.	C <sub>19</sub>	C <sub>20</sub>	.	.	.	.
.	.	.	.	.	.	.	.	.	.	.	C <sub>21</sub>	C <sub>22</sub>	.	.	.	.
.	.	.	.	.	.	.	.	.	.	.	C <sub>23</sub>	C <sub>24</sub>	.	.	.	.
.	.	.	.	.	.	.	.	.	.	.	C <sub>25</sub>	C <sub>26</sub>	.	.	.	.
.	.	.	.	.	.	.	.	.	.	.	B <sub>1</sub>	B <sub>2</sub>	.	.	.	.
.	.	.	.	.	.	.	.	.	.	.	B <sub>3</sub>	B <sub>4</sub>	.	.	.	.
.	.	.	.	.	.	.	.	.	.	.	B <sub>5</sub>	B <sub>6</sub>	.	.	.	.
.	.	.	.	.	.	.	.	.	.	.	C <sub>1</sub>	C <sub>2</sub>	.	.	.	.
.	.	.	.	.	.	.	.	.	.	.	C <sub>27</sub>	C <sub>28</sub>	.	.	.	.
.	.	.	.	.	.	.	.	.	.	.	.	.	.	.	.	.
.	.	.	.	.	.	.	.	.	.	.	.	.	.	.	.	.
.	.	.	.	.	.	.	.	.	.	.	.	.	.	.	.	.
.	.	.	.	.	.	.	.	.	.	.	.	.	.	.	.	.
.	.	.	.	.	.	.	.	.	.	.	.	.	.	.	.	.
A <sub>1</sub>	A <sub>2</sub>	A <sub>3</sub>	A <sub>4</sub>	A <sub>5</sub>	A <sub>6</sub>	A <sub>7</sub>	- - -	A <sub>56</sub> <sup>1</sup>	A <sub>57</sub> <sup>1</sup>	A <sub>58</sub> <sup>1</sup>	C <sub>49</sub>	C <sub>50</sub>	S <sub>1</sub>	S <sub>2</sub>	S <sub>3</sub>	I <sub>D</sub>

# Rockwell International Corporation

CODE IDENT. NO. 94756

NUMBER VC 409-0001-21	REVISION LETTER						PAGE 7
	A						

## 3.1.2.2 Output Sync Signals

3.1.2.2.1 A sync signal derived from the minor frame sync divided by four shall be provided at the housekeeping/diagnostic input signals' connector.

3.1.2.2.1.1 This signal shall be short-circuit proof.

3.1.2.2.1.2 The logic 1 voltage level shall be between +3.0 and +5.0 volts and capable of supplying 400 microamperes.

3.1.2.2.1.3 The logic 0 voltage level shall be between 0.0 and +0.4 volts and capable of sinking 16 milliamperes.

## 3.1.2.3 Test Signals

3.1.2.3.1 The following test signals shall be provided at the multi-coaxial cable test connector:

NRZ-L serial output

Major frame sync

Minor frame sync

Pulse amplitude modulation (PAM)

Word clock

Bit clock

3.1.2.3.2 Each signal shall be buffered and short-circuit proofed and capable of delivering a signal through 1000 ft, or less, of 50-ohm coaxial cable.

## 3.1.3 Input Power

### 3.1.3.1 Supply Voltage and Current

3.1.3.1.1 The system shall operate from a supply voltage of +24 vdc nominal with a range from +22 to +28 vdc.

3.1.3.1.2 The maximum average power dissipation shall be 12 watts when operated at +24 vdc.

# Rockwell International Corporation

CODE IDENT. NO. 94756

NUMBER	REVISION LETTER							PAGE 8
VC 409-0001-21	A							

### 3.1.3.2 Transients and Voltage Ripple

The encoder shall meet the transient overvoltage conditions and voltage ripple requirements specified in MIL-STD-461A for class ID equipment.

### 3.1.3.3 Input Voltage Polarity Reversal

Input voltage polarity reversal protection will be supplied. No damage to the encoder will occur through a reversal of input voltage polarity.

### 3.1.4 Grounding

The encoder shall have the following grounds (returns) electrically isolated from each other by a minimum of ten megohms.

#### 3.1.4.1 Signal

#### 3.1.4.2 Chassis

#### 3.1.4.3 Power

#### 3.1.4.4 Differential Input Signal

### 3.1.5 Accuracy (For Analog Input Channels)

#### 3.1.5.1 Quantization Uncertainty

The quantization error shall be  $\pm 1/2$  LSB. This is interpreted to represent a maximum possible error of  $\pm 2.5$  millivolts for a  $\pm 10$  volt high level signal.

#### 3.1.5.2 Normal Signal Range Error

Worst case cumulative error including crosstalk shall not exceed  $\pm 5$  millivolts  $\pm$  measured quantization setting error when all inputs are within the normal range of 0 to  $\pm 10$  volts.

#### 3.1.5.3 Abnormal Signal Range Error

Worst case cumulative error including crosstalk shall not exceed  $\pm 7.5$  millivolts  $\pm$  measured quantization setting error for any combination of input signal overvoltages.

#### 3.1.5.4 Quantization Setting Accuracy

The quantization level setting error shall be a nonrandom error of  $\pm 2.5$  millivolts or less.

# Rockwell International Corporation

CODE IDENT. NO. 94756

NUMBER VC 409-0001-21	REVISION LETTER A	PAGE 9
--------------------------	----------------------	-----------

### 3.1.5.5 Common Mode Voltage Error

The differential channels shall have a common mode rejection (CMR) of 68 db or more from 0 to 2000 Hz. This represents a maximum additional error of  $\pm 2.0$  millivolts with the occurrence of a 5-volt common mode voltage.

### 3.1.6 Premodulation Filter

A premodulation filter with the following characteristics shall be incorporated. These parameters shall be easily adjustable.

Active, Low-Pass Filter:	Optimized for linear phase
3 db Cutoff Frequency:	$0.8 \pm 0.08$ times the nominal bit rate
Final Slope:	-36 db/octave or greater

### 3.1.7 Sampling Rate Stability

The clock frequency shall be easily changed to provide the capability of lower sampling rates. The sampling rate stability shall be 0.5 percent of the nominal rate.

### 3.1.8 Interface

The encoder shall be designed for the use of interconnecting cables and connectors.

#### 3.1.8.1 Receptacles (Rockwell Supplied)

The receptacles specified below shall provide electromagnetic interference shielding as specified in MIL-STD-461A.

<u>Identification</u>	<u>Name</u>	<u>Receptacle</u>	<u>Manufacturer</u>
1J1	Power	JTN07RE8-44P <sup>1</sup>	Bendix
1J2	TM Output	31-239-1050 <sup>1</sup>	Amphenol
1J3	Vehicle Data	JTN07RE14-18P	Bendix
1J4	Prime Data	JTN07RE22-2PA	Bendix
1J5	Housekeeping Data	JTN07RE22-2PB	Bendix
1J6	Test Signals	PT07SE22-77S	Bendix

NOTE: Output return routed through 1J1.

3.1.8.1.1 The wire lists below relate the pin connections required to signals/words specified herein. Unused pins are not shown.

**Rockwell International Corporation**

CODE IDENT NO 51215

<b>NUMBER</b>	<b>REVISION LETTER</b>	<b>PAGE</b>
VC 409-0001-21	A	10

3.1.8.1.2 Power Connector 1J1 (4 pins)

<u>Pin</u>	<u>Signal</u>
1	Chassis Ground
2	+24 Vdc
3	+24 V Return
4	Sig Return, Serial Code

3.1.8.1.3 TM Output Connector 1J2 (Coaxial)

<u>Pin</u>	<u>Signal</u>
Center	Serial Code
Shield	EMI Shield tied to chassis

3.1.8.1.4 Vehicle Data Connector 1J3 (18 pins)

<u>Pin</u>	<u>Signal</u>
B	A <sup>1</sup> <sub>56</sub>
C	A <sup>1</sup> <sub>57</sub>
E	A <sup>1</sup> <sub>58</sub>
F	Guard Shield Drive
N	Return A <sup>1</sup> <sub>56</sub>
P	Return A <sup>1</sup> <sub>57</sub>
R	Return A <sup>1</sup> <sub>58</sub>

3.1.8.1.5 Prime Data Connector 1J4 (85 pins)

<u>Pin</u>	<u>Word A</u>	<u>Pin</u>	<u>Word A</u>	<u>Pin</u>	<u>Word A</u>	<u>Pin</u>	<u>Word C</u>
1	55	27	2				
5	1	29	26	61	53	46	48
6	4	31	5	62	3	45	49
7	7	32	8	63	6	47	50
8	10	33	11	64	9		
9	13	34	14	65	12		
10	16	35	17	67	15		
11	19	37	27	68	21		
13	22	38	35	69	24		
14	20	42	29	74	18		
15	28	43	32	75	23		
16	31	44	25	76	30		
17	34	59	47	77	33		
20	37	84	51	78	36		
22	40			79	39		
23	43	48	38	80	42		
24	46	57	41	82	45		
25	49	58	44	83	48		
26	52	60	50	85	54		

Rockwell International Corporation

CODE IDENT NO 51215

NUMBER VC 409-0001-21	REVISION LETTER A	PAGE 11
--------------------------	----------------------	---------

3.1.8.1.6 Housekeeping Data Connector 1J5 (85 pins)

<u>Pin</u>	<u>Word</u>	<u>Pin</u>	<u>Word</u>	<u>Pin</u>	<u>Word</u>
1	C1	30	C12	56	C41
5	SIG RET	31	C13	57	B1
6	C2	32	C14	58	C2
7	C1	33	C15	59	B2
8	C1	34	C16	60	C2
9	C2	35	C17	61	B4
10	C2	36	C18	62	C2
11	C31	37	C19	63	B6
12	C7	38	C20	64	C2
13	SIG RET	39	C42	65	C28
14	C1	40	C21	66	C2
15	SIG RET	41	C44	67	C2
16	C1	42	C22	68	C2
17	C1	43	C1	69	B3
18	C32	44	C23	70	*C45
19	C1	45	C24	71	B5
20	C8	46	C25	72	*C46
21	C3	47	C26	73	C33
22	C4	48	C27	74	MINOR FR SYNC/ 4
23	C5	49	C35	75	*C47
24	*C6	50	C38		
25	C9	51	C37		
26	*C30	52	C39	83	C1
27	C10	53	C43	84	C1
28	*C29	54	C40	85	C34
29	C11	55	C36		

\*Spares

3.1.8.1.6.1 1J5 Bilevel Words

<u>Word</u>	<u>Bit</u>	1	2	3	4	5	6	7	8	9	10
C1	Pin No.	1	17	19	14	16	7	8	83	84	43
C2	Pin No.	58	67	60	62	64	66	10	6	9	68

3.1.8.1.7 Test Signals Connector 1J6 (7 coaxial)

<u>Coax</u>	<u>Signal</u>	<u>Coax</u>	<u>Signal</u>
A	NRZ-L output	D	minor frame sync
B	PAM	E	word clock
C	major frame sync	F	bit clock

# Rockwell International Corporation

CODE IDENT NO. 94756

NUMBER VC 409-0001-21	REVISION LETTER							PAGE 12
	A							

## 3.2 Design and Construction

### 3.2.1 Mounting

The encoder shall be designed to mount upon a flat surface.

### 3.2.2 Maximum Envelope

The maximum size, including connector protrusions, shall be contained within the rectangular dimensions: 4.75 inches high x 7.0 inches x 11.5 inches.

### 3.2.3 Weight

The weight of the encoder shall not exceed 10 pounds.

### 3.2.4 Finishes

Finishes shall be applied to all surfaces where required for protection against corrosion or other deterioration. The materials, finishes and protective coatings shall not impair the performance of the encoder. No subliming shall occur.

### 3.2.5 Workmanship

The encoder shall be constructed with a workmanship consistent with the requirements of MIL-STD-454B.

### 3.2.6 Identification

#### 3.2.6.1 Name Plate

A name plate shall be provided. Complete identifying data will be specified at a later date.

#### 3.2.6.2 Receptacle Identification

All receptacles shall be durably and legibly marked with the identification specified in paragraph 3.1.8.1.

### 3.2.7 Electromagnetic Interference and Compatibility

#### 3.2.7.1 Electromagnetic Interference

The equipment shall meet the electromagnetic interference test requirements of MIL-STD-461A. Radio frequency spectrum characteristics shall meet the requirements stated in MIL-STD-449 and Supplement 1 for susceptibility.

# Rockwell International Corporation

CODE IDENT. NO. 94756

NUMBER	REVISION LETTER							PAGE	13
VC 409-0001-21	A								

## 3.2.7.2 Interference Control

Electromagnetic Interference (EMI) control shall be inherent in and concurrent with the design and development of all electrical and electronic equipment, components, and assemblies. Information and functional signal spectrums shall be limited to the minimum compatible with functional requirements. Receivers of information and functional signals shall have a bandwidth only as wide as required to meet functional requirements. Propagation and coupling of EMI shall be minimized by component location, cable routing and judicious use of shielding. Packaging and installation of components, circuits, etc, shall be such as to minimize interference pickup and radiation. The maximum permissible levels of generated interference and minimum thresholds of susceptibility of each equipment shall be in accordance with MIL-STD-461A.

## 3.2.8 Environmental Operating Conditions

3.2.8.1 The encoder shall be designed to operate under the environmental service conditions listed herein.

3.2.8.1.1 Environmental qualification testing shall be performed by Autonetics. The vendor's proposal shall indicate the method and design approach to be utilized to assure qualification.

3.2.8.1.2 The encoder shall not exhibit microphonic effects during and following the environmental conditions listed herein.

### 3.2.8.2 Temperature

The encoder shall operate within specification between the temperature extremes of -20°C to +50°C.

### 3.2.8.3 Altitude

The encoder shall operate within specifications between the pressure extremes of sea level pressure to  $10^{-8}$  torr.

### 3.2.8.4 Acceleration

The encoder shall operate within specifications during and following an acceleration of 20 g for two minutes in each of two (2) directions perpendicular to its 18.0 inch diameter plane.

### 3.2.8.5 Vibration

The encoder shall operate within specifications during and following vibration as follows.



# Rockwell International Corporation

CODE IDENT. NO. 94756

NUMBER VC 409-0001-21	REVISION LETTER A	PAGE 14
--------------------------	----------------------	---------

### 3.2.8.5.1 Sinusoidal Vibration

A frequency survey (sinusoidal sweep) shall be conducted in each of three (3) mutually perpendicular axes at a rate of two octaves per minute.

<u>Axis</u>	<u>Frequency</u>	<u>Level</u>
Perpendicular	10 - 50 Hz	2.3 g
	50 - 160 Hz	4.5 g
	160 - 2000 Hz	7.5 g
Lateral 1 & 2	5 - 43 Hz	7.7 in/sec
	43 - 250 Hz	5.3 g
	250 - 2000 Hz	7.5 g

### 3.2.8.5.2 Random Vibration

Random vibration tests will be conducted in each of three mutually perpendicular axes as follows: 20 sec per axis from 20 to 2000 Hz at 0.056 g<sup>2</sup>/Hz.

### 3.2.8.6 Shock

The encoder shall operate within specifications during and following a shock test of 100 g for 6 milliseconds applied in each direction of its perpendicular axis.

### 3.2.8.7 Axes Definition

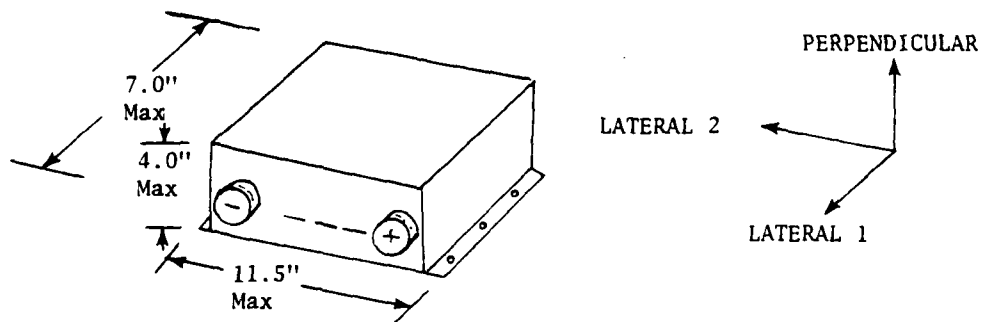

# Rockwell International Corporation

CODE IDENT. NO. 94756

NUMBER	REVISION LETTER							PAGE 15				
VC 409-0001-21	A											

## 4.0 QUALITY ASSURANCE PROVISIONS

### 4.1 Test and Evaluation

4.1.1 The encoder shall be functionally tested for verification of its conformance to the specification herein.

#### 4.1.2 Acceptance Test Procedure (ATP)

An acceptance test procedure and reports on subsequent data are required. The documentation shall be submitted to Autonetics for approval 30 days ARO.

4.1.2.1 The ATP shall include among its tests provisions to verify compliance with the worst case crosstalk error and unbalanced source common mode rejection requirements specified herein.

## 5.0 PREPARATION FOR DELIVERY

Three (3) complete sets of operating instructions, manuals, and mechanical and electrical drawings shall be delivered with or before the encoder delivery. The exact contents of the data package shall be determined at a later date.

C77-551/201

A P P E N D I X C

PREPARED BY	FSCM NO. 94756	NUMBER AA0209-103
R.C. BERRY	<b>Rockwell International Corporation</b>	TYPE
APPROVALS	Defense Electronics Operations — Anaheim Divisions	DATE September 14, 1984
<i>Reviewed 19 SEP 84</i>	<b>SPECIFICATION</b>	SUPERSEDES SPEC. DATED: September 20, 1971
		REV. LTR. A
		PAGE 1 of 5
TITLE SPICE SENSOR ASSEMBLY, A/N PART NUMBER 45800-701 EVACUATION INSTRUCTIONS		
<p>CONTENTS</p> <p>1.0 SCOPE</p> <p>2.0 APPLICABLE DOCUMENTS. MATERIAL AND EQUIPMENT</p> <p>3.0 REQUIREMENTS</p>		

# Rockwell International Corporation

FSCM NO 94756

NUMBER AA0209-103	REVISION LETTER	PAGE 2
	a	

- 1.0 SCOPE
- 1.1 This specification describes the equipment and procedures to perform SPICE SENSOR evacuation.
- 1.2 The SPICE SENSOR, in order to remain at the required lowered operating temperatures, must be evacuated to the lowest possible internal pressures.
- 2.0 APPLICABLE DOCUMENTS, MATERIAL AND EQUIPMENT
- 2.1 Documents Required by this Specification
- The following documents, to the extent indicated, form a part of this specification. In the event of any conflict between the requirements of this specification and the listed documents, the requirements of this specification shall govern.
- 2.1.1 Specifications
- Instructions Manual for Vacuum Pumping Station
- Rockwell International (RI)
- ST0117GA0001 Handling of Flammable and Dangerous Liquids and Chemicals
- Appendix A Handling of Inert Cryogenic Liquids
- 2.1.2 Drawings
- Autonetics Division of RI
- 45800-701 SPICE II Telescope Assembly
- 2.2 Documents Calling Out This Specification
- In the event of any conflict between the requirements of this specification and documents calling out this specification, the requirements of the documents calling out this specification shall take precedence.
- 2.2.1 Specifications
- Autonetics Division of RI
- AA0209-104 SPICE SENSOR ASSEMBLY Cryogen Filling Instructions
- 2.3 Material and Equipment
- Acceptable, precise results are contingent upon the use of equipment and material equivalent to that listed below. If the effectiveness and accuracy are not decreased, items equivalent to those listed below may be substituted, except for those marked with an asterisk.

# Rockwell International Corporation

FSCM NO 94756

NUMBER AA0209-103	REVISION LETTER A	PAGE 3
----------------------	----------------------	--------

2.3(Contd)	<u>ITEM NO</u>	<u>NO. REQUIRED</u>	<u>DESCRIPTION</u>
	1	1	Vacuum Pumping Station
	2	1	Telescope Cradle -EOL 1798-2451
	3	1	Vacuum Valve Operator
	4	1	Stainless Flexible Vacuum Line

### 3.0 REQUIREMENTS

#### 3.1 General Requirements

##### 3.1.1 Environmental Conditions

3.1.1.1 Operations required by this process shall be performed at an ambient temperature of 25 (+15 -05)C, a barometric pressure of 30 ± 2 inches of mercury, and relative humidity up to 50 percent room ambient.

##### 3.1.2 Safety Precautions

3.1.2.1 Handle flammable and dangerous liquids and chemicals in accordance with Specification ST0117GA0001.

3.1.2.2 Before applying pressure to a part under test or evacuating the vacuum system, personnel in the immediate area shall protect themselves against bodily harm by use of appropriate safety gear and/or apparel, or as otherwise directed by the Safety Department.

3.1.2.3 No connections or fittings shall be tightened, loosened, or opened while the test part is under pressure or the vacuum system evacuated unless specified to do so herein or by the applicable drawing or process specification.

##### 3.1.3 Equipment Considerations

3.1.3.1 The equipment shall be operated with the high vacuum station at least one foot from a wall to prevent restriction of the air cooling of the pump.

3.1.3.2 All fixed manifolding shall be as large in diameter and short in length as possible. All flexible tubing shall be capable of withstanding evacuation without collapse of the tubing. Line size and length shall be compatible with pump size to insure rapid evacuation time and cleanup rates. Consult the vacuum system operations and maintenance manual for details on pump speed and line size.

3.1.3.3 Whenever possible, the use of rubber in the vacuum system shall be kept at a minimum. Gland designs and gaskets shall be designed to expose a minimum amount of rubber to the vacuum system.

NOTE: Rubber will absorb helium gas causing contamination of the vacuum system.

# Rockwell International Corporation

FSCM NO 94756

NUMBER	REVISION LETTER							Page
AA0209-103	A						4	

3.1.3.4 The use of lubricants on seals in the vacuum system shall be held to a minimum by applying only a light film of a lower-vapor pressure type grease and removing excessive deposits by pulling the seal through the fingers several times.

NOTE: As in paragraph 3.1.3.5, grease will also absorb helium causing contamination of the vacuum system.

3.1.3.5 Ensure that vacuum station (1) is set up and has been operating for the length of time required by the manufacturer's operating manual.

## 3.2 Detailed Requirements

### 3.2.1 Evacuation of Telescope in Vacuum Chamber

3.2.1.1 Install telescope on cradle, EOL 1798-2451.

3.2.1.2 Roll telescope on cradle into vacuum chamber from holding fixture, EOL 1798-2450.

3.2.1.3 Connect required cryogen fill equipment and necessary test requirement if required.

3.2.1.4 Close both ends of vacuum chamber.

3.2.1.5 Start vacuum system roughing pump. In a few seconds roughing pump will lower pressure in vacuum chamber.

3.2.1.6 Continue with evacuating procedures per manufacturer's operating procedures.

3.2.1.7 Leave telescope on vacuum system for a minimum of 24 hours after telescope has reached an evacuation of  $2 \times 10^{-6}$  Torr as indicated on vacuum system.

### 3.2.2 Removing Telescope from Vacuum Chamber

3.2.2.1 Close telescope front cover.

3.2.2.2 Perform air release per manufacturer's operating procedures.

3.2.2.3 Open required end or ends of vacuum chamber.

3.2.2.4 Disconnect telescope from cryogen fill equipment or test equipment.

3.2.2.5 Roll telescope from vacuum chamber onto holding fixture, EOL 1798-2450.

3.2.2.6 Replace covers on vacuum chamber.

## Rockwell International Corporation

FSCM NO 94756

NUMBER	REVISION LETTER							PAGE 5
AA0209-103	A							

- 3.2.3 Alternate evacuation method.
  - 3.2.3.1 Install telescope on cradle (EOL 1798-2451) and cradle on holding fixture (EOL 1798-2449), or install telescope on nose cart (EOL 1798-2461)
  - 3.2.3.2 Install valve operator (3) and associated plumbing (4) on telescope.
  - 3.2.3.3 Position telescope adjacent to vacuum pump and connect the two together.
  - 3.2.3.4 Start vacuum system roughing pump. In a few seconds roughing pump will lower pressure in vacuum chamber.
  - 3.2.3.5 Open valve operator.
  - 3.2.3.6 Continue with evacuating procedures per vacuum station manufacturer's operating procedures.
  - 3.2.3.7 Leave telescope on vacuum system for a minimum of 24 hours after telescope has reached an evacuation of  $2 \times 10^{-6}$  Torr as indicated on vacuum system.
- 3.2.4 Removing Telescope from Vacuum System
  - 3.2.4.1 Close valve operator.
  - 3.2.4.2 Perform air release per manufacturer's operating procedures.
  - 3.2.4.3 Disconnect stainless flexible vacuum line from valve operator
  - 3.2.4.4 Remove valve operator from telescope.
  - 3.2.4.5 Place valve cap on telescope valve, ensuring that "O" ring is properly installed.
- 3.2.5 Returning the Telescope to Normal Pressure
  - 3.2.5.1 Ensure complete telescope has reached ambient temperatures.
  - 3.2.5.2 Before opening vent valve, ensure that only clean, dry nitrogen may enter telescope.
  - 3.2.5.3 Open vent valves slowly to ensure against telescope component damage.



PREPARED BY	FSCM NO. 94756	NUMBER AA0209-104	
R.C. Berry	<b>Rockwell International Corporation</b> Defense Electronics Operations — Anaheim Divisions  <h2 style="text-align: center;">SPECIFICATION</h2>	TYPE	
APPROVALS		DATE September 12, 1984	
<i>RC Berry</i> 12/14/84		SUPERSEDES SPEC. DATED: December 9, 1971	
		REV. LTR.      PAGE 1 of 7	
		B	
TITLE SPICE SENSOR ASSEMBLY, A/N PART NUMBER 45800-701 CRYOGEN FILLING INSTRUCTIONS			
<p><u>TABLE OF CONTENTS.</u></p> <p>1.0      SCOPE</p> <p>2.0      APPLICABLE DOCUMENTS,           MATERIAL AND EQUIPMENT</p> <p>3.0      REQUIREMENTS</p>			

# Rockwell International Corporation

FSCM NO 94756

NUMBER AA0209-104	REVISION LETTER							PAGE 2
	A	B						

## 1.0 SCOPE

This document describes the procedures for filling the SPICE Sensor Assembly with the required cryogens (liquified gas).

## 2.0 APPLICABLE DOCUMENTS, MATERIAL AND EQUIPMENT

### 2.1 Documents required by This Specification

The following documents, to the extent indicated, form a part of this specification. In the event of any conflict between the requirements of this specification and the listed documents, the requirements of this specification shall govern.

#### 2.1.1 Specifications

##### Rockwell Corporation

ST0117GA0001

Handling of Flammable and  
Dangerous Liquids and Chemicals

Appendix A

Handling of Inert Cryogenic Liquids

#### 2.1.2 Drawings

##### Autonetics Division of Rockwell

45800-701

SPICE II Telescope Assembly

### 2.2 Documents Calling Out This Specification

In the event of any conflict between the requirements of this specification and documents calling out this specification, the requirements of the documents calling out this specification shall take precedence.

#### 2.2.1 Specifications

##### Autonetics Division of Rockwell

AA0209-103

SPICE II Telescope Evacuation

### 2.3 Material and Equipment

Acceptable, precise results are contingent upon the use of equipment and material equivalent to that listed below. If the effectiveness and accuracy are not decreased, items equivalent to those listed below may be substituted, except for those marked with an asterisk.

# Rockwell International Corporation

FSCM NO 94756

NUMBER AA0209-104	REVISION LETTER	PAGE 3
	A B	

ITEM NO.	NO. REQ'D	DESCRIPTION
1	1	Fill Line 40520-509-5 (6 ft)
2	1	Exhaust Line 40520-509-7
3	1	Liquid Helium filled; GFE 100 or 500 Liter Dewar
4	2	Filter Extension 40522-509-3(12 inch) for 100L) 40522-509-5 (29 inch for 500L)
5	2	Dip Tube 40521-509-3
6	A/R	Vent Line, CRL
7	A/R	Gaseous Helium -Grade 4.5 pure helium with two stage regulator 3 and 4000 PSIG
8	1	Flowmeter, Brooks 1350-01 BIAAS
9	A/R	Gaseous Helium 1/2-inch Tygon Pressurization Line (o,825-14NG-LH)
10	1	Gas Cylinder Cart
11	1	Breakout Box 40554-509-1
12	1	Breakout Box 40555-509-1
13	A/R	Data Sheet, Cooldown & AGE Cooldown
14	2	Digital Voltmeter-(-5 volts in 0.001 steps) Fairchild Model 7050
15	1	Exhaust Gas Flow Meter Assy 10340-509
16	1	SPICE AGE Console 40523-509-1
17	1	SPICE AGE Power Supply 40543-509-1
18	14	SPICE AGE Cables
19	1	PCM Encoder

### 3.0 REQUIREMENTS

#### 3.1 General Requirements

##### 3.1.1 Environmental Conditions

3.1.1.1 Operations required by this process shall be performed at an ambient temperature of 25 (+15 -5)C, a barometric pressure of 30 ± 2 inches of mercury, and a relative humidity up to 50 percent room ambient.

3.1.1.2 The telescope during this procedure shall be protected at all times to ensure non-contamination either by protective bagging or by performance of the procedure in an area (clean room) capable of this type protection.

FORM NO. 7101 (REV. 10-60)

# Rockwell International Corporation

FSCM NO 94756

NUMBER AA0209-104	REVISION LETTER						PAGE 4
	A	B					

3.1.1.3 Filling procedures shall be performed in an area capable of removing cryogenic boil-off so as not to contaminate telescope with escaping gases.

### 3.1.2 Safety Precautions

3.1.2.1 Handle flammable and dangerous liquids and chemicals in accordance with Specification ST01170001.

### 3.2 Detailed Requirements

#### 3.2.1 Telescope Fill Operational Position (Vertical)

Note: If the telescope is to be filled in the horizontal position (interim testing), it shall be positioned so that the vent line is at 12 O'clock when viewed from the rear of the telescope.

3.2.1.1 Ensure that telescope is evacuated in accordance with Specification AA0209-103. A reading in the very low  $10^{-6}$  area or  $10^{-7}$  area is desirable.

Note: If telescope is not evacuated to a low enough pressure, frost or water vapor may form both outside and inside of the telescope and may damage components.

3.2.1.2 Connect, exhaust lines between telescope assembly and exhaust gas flow meter.

3.2.1.3 Connect breakout boxes to telescope

3.2.1.4 Insert dip tube into cryogen dewar.

3.2.1.5 Connect fill line to dip tube and to telescope fill port.

3.2.1.6 Using digital voltmeter, breakout boxes & data sheet, record warm readings.

3.2.1.7 Open dip tube cryogen valve

3.2.1.8 Pressurize cryogen supply to 3 to 4 PSIG, and adjust flow meter reading to 45 to 50 liters per minute.

3.2.1.9 Every hour record set of readings on data sheet. These will include temp. sensor resistance readings, flow rate in liters per minute, total flow and vent gas temperature.

3.2.1.10 Continue to monitor flow rate keeping it between 45 and 50 L/min

Note: These procedures will take about 16 to 20 hours to complete

3.2.1.11 When lines 5 thru 10 of data sheet cooldown indicate about 30 K<sup>2</sup> (about 50 to 60 thousand liters of gaseous helium) connect AGE console, PCM, and telescope together using AGE cables and turn on AGE power.

# Rockwell International Corporation

FSCM NO 94756

NUMBER AA0209-104	REVISION LETTER						Page 5
	A	B					

- 3.2.1.12 Remove exhaust line from exhaust gas flow meter, elevate end to allow helium plume to disipate.
- 3.2.1.13 Continue filling sensor with cryogenes until 10% indicator light under "Cryogen Liquid Level" on AGE Test Set comes ON. Record time and voltage on AGE data sheet.
- 3.2.1.14 Continue filling sensor with cryogenes until 60% indicator light under "Cryogen Liquid Level" on AGE Test Set comes ON. Record time and voltage.
- 3.2.1.15 Continue filling sensor until 100% indicator light under cryogen liquid level on AGE Test Set comes ON. Record time and voltage.
- 3.2.1.16 Continue filling sensor until helium plume splits into two parts.
- 3.2.1.17 Reduce pressurization on cryogen supply to 1 psi.
- 3.2.1.18 Disconnect exhaust line from sensor and connect exhaust heater assembly immediately (within 2 seconds or ice plug may occur).
- 3.2.1.19 Turn off dip tube cryogen valve.
- 3.2.1.20 Connect line from exhaust heater to exhaust gas flow meter.
- 3.2.1.21 Disconnect fill line from sensor and connect fill port plug assembly.
- CAUTION: Do not allow telescope to lose vacuum until it has reached ambient temperature. Loss of vacuum too soon may result in damage to components.
- 3.2.1.22 Secure cryogen supply dewar.
- 3.2.2 Refilling telescope - The telescope may be topped off (refilled) anytime before warm up by performing the following steps.
- 3.2.2.1 Remove exhaust heater assembly
- 3.2.2.2 Repeat step 3.2.1.2 leaving meter end elevated and not connected to meter.
- 3.2.2.3 Repeat step 3.2.1.4 if required.
- 3.2.2.4 Connect fill line to dip tube
- 3.2.3.5 Open dip tube cryogen valve
- 3.2.3.6 When helium plume appears at end of fill line. remove fill port plug assembly and insert fill line into telescope fill port.
- 3.2.3.7 Repeat steps 3.2.1.13 to 3.2.1.22.

# Rockwell International Corporation

FSCM NO 94756

NUMBER PAC208-104	REVISION LETTER B	PAGE 4
----------------------	----------------------	-----------

## DATA SHEET COOLDOWN DATE :

	TIME	24 HR	24 HR	24 HR	24 HR	24 HR	24 HR	24 HR	24 HR
	TEMP SENSOR	_____	_____	_____	_____	_____	_____	_____	_____
1	COLD STRAP	_____	_____	_____	_____	_____	_____	_____	_____
2	COOLING POST	_____	_____	_____	_____	_____	_____	_____	_____
3	HEAT EXCHANGE	_____	_____	_____	_____	_____	_____	_____	_____
4	DEWAR AMBIENT	_____	_____	_____	_____	_____	_____	_____	_____
5	OPT CONE MASK	_____	_____	_____	_____	_____	_____	_____	_____
6	OPT HSG, FWD EXP	_____	_____	_____	_____	_____	_____	_____	_____
7	OPT HSG, FWD OBS	_____	_____	_____	_____	_____	_____	_____	_____
8	CENTER TUBE EXP	_____	_____	_____	_____	_____	_____	_____	_____
9	CENTER TUBE OBS	_____	_____	_____	_____	_____	_____	_____	_____
10	SECOND MIRROR	_____	_____	_____	_____	_____	_____	_____	_____
11	DET PKG CONE	_____	_____	_____	_____	_____	_____	_____	_____
12	DET PKG REAR	_____	_____	_____	_____	_____	_____	_____	_____
13	PRIMARY MIRROR	_____	_____	_____	_____	_____	_____	_____	_____
14	OPT HSG MID	_____	_____	_____	_____	_____	_____	_____	_____
15	OPT HSG AFT	_____	_____	_____	_____	_____	_____	_____	_____
16	OPT HSG AMB	_____	_____	_____	_____	_____	_____	_____	_____
17	OUTER HSG	_____	_____	_____	_____	_____	_____	_____	_____
A8	BGP CENTER	_____	_____	_____	_____	_____	_____	_____	_____
CD	FRONT COVER	_____	_____	_____	_____	_____	_____	_____	_____
M	BGP EDGE	_____	_____	_____	_____	_____	_____	_____	_____
	VENT GAS (°F)	_____	_____	_____	_____	_____	_____	_____	_____
	FLOW LITER MIN	_____	_____	_____	_____	_____	_____	_____	_____
	FLOW TOTAL	_____	_____	_____	_____	_____	_____	_____	_____

Rockwell International Corporation

FSCM NO 94756

NUMBER	AA0209 - 104	REVISION LETTER	E							PAGE	7
--------	--------------	-----------------	---	--	--	--	--	--	--	------	---

DATA SHEET AGE COOLDOWN

DATE:

TIME											
FLOW RATE											
FLOW TOTAL											
DEWAR PRESSURE											
VACUUM											
VENT PRESSURE											
DET HTR PWP											
BB HTR PWP											
PRIMARY MIRROR											
ELECT HEAT SINK											
VENT GAS											
D S P HEAT SINK											
PWR SUP HEAT SINK											
CENTER TUBE EXP											
COLD STRAP											
CENTER TUBE OBSC											
OUTER HOUSING											
SECONDARY MIRROR											
DET PKG Lλ											
DET PKG CONE											
DET PKG Mλ											
DET PKG REAR											
DET PKG Sλ											
HEAT EXCHANGER											
OPT CONE MASK											
OPT HSG FWD EXP											
BACKGROUND PLATE											
OPT HSG FWD OBSC											
FRONT COVER											
COOLING POST											
BLACKBODY											

REV 10/72

	TIME	VOLTS
10		
60		
100		

PREPARED BY	FSCM NO. 94756 <b>Rockwell International Corporation</b> Defense Electronics Operations — Anaheim Divisions  <h2 style="text-align: center;">SPECIFICATION</h2>	NUMBER AA0209-105
R.C. Berry		TYPE
APPROVALS		DATE September 19, 1984
<i>[Signature]</i> 19 SEP 84		SUPERSEDES SPEC. DATED: September 20, 1971
		REV. LTR. A
TITLE SPICE SENSOR ASSEMBLY A/N PART NUMBER 45800-701-1 LEAK RATE TEST		
<p><u>TABLE OF CONTENTS</u></p> <p>1.0 SCOPE</p> <p>2.0 APPLICABLE DOCUMENTS, MATERIALS AND EQUIPMENT</p> <p>3.0 REQUIREMENTS</p>		



# Rockwell International Corporation

FSCM NO 94756

NUMBER	REVISION LETTER						PAGE 2
AA0209-105	A						

1. SCOPE

1.1 This specification describes the procedures for detecting leaks and measuring the size of those leaks.

1.2 The leak rate tests will be performed with the telescope filled with cryogenics to ensure that cryogenic fill will not affect the materials and equipment so as to disturb the tightness of the seals.

2. APPLICABLE DOCUMENTS, MATERIAL AND EQUIPMENT

2.1 Documents Required by this Specification

The following documents, to the extent indicated, form a part of this specification. In the event of any conflict between the requirements of this specification and the listed documents, the requirements of this specification shall govern.

2.1.1 Specifications

Rockwell International (RI)

ST01117GA0001 Handling of Flammable and Dangerous Liquids and Chemicals

Appendix A Handling of Inert Cryogenic Liquids

Autonetics, Division of RI

AA0209-103 SPICE SENSOR Evacuation

AA0209-104 SPICE SENSOR Cryogenic Filling

2.1.2 Drawings

Autonetics, Division of RI

45800-701 SPICE II Telescope Assembly

2.2 Documents Calling Out This Specification

In the event of any conflict between the requirements of this specification and documents calling out this specification, the requirements of the documents calling out this specification shall take precedence.

2.2.1 Drawings

Autonetics, Division of RI

45800-701 SPICE II Telescope Assembly

FORM NO 131 02 003 001

# Rockwell International Corporation

FSCM NO 94756

NUMBER AA0209-105	REVISION LETTER A	Page 3
----------------------	----------------------	--------

## 2.3 Material and Equipment

Acceptable, precise results are contingent upon the use of equipment and material equivalent to that listed below. If the effectiveness and accuracy are not decreased, items equivalent to those listed below may be substituted, except for those marked with an asterisk.

ITEM NO.	NO. REQUIRED	DESCRIPTION
1	A/R	Gaseous Helium - Grade 4.5 pure helium with two stage regulators 3 and 4000 PSIG
2	2	Flowmeter, Brooks 1350-01-B1AAS
3	A/R	Gaseous Helium 1/2-inch Tygon Pressurization Line (0.825 14NG-LH)
4	A/R	Gas Cylinder Cart
5	1	Vacuum Pumping Station
6	1	Vacuum Valve Operator
7	A/R	Vacuum Line - 2" Stainless Steel
8	1	Leak Detector with Calibrated Leak, Type SC4 Vacuum Electronics Corp.

## 3. REQUIREMENTS

### 3.1 General Requirements

#### 3.1.1 Environmental Conditions

3.1.1.1 Operations required by this process shall be performed at an ambient temperature of 25 (+15, -5)C, a barometric pressure of 30 ± 2 inches of mercury, and a relative humidity up to 50 percent room ambient.

3.1.1.2 The telescope during this procedure shall be protected at all times to ensure non-contamination either by protective bagging or by performance of the procedure in an area (clean room) capable of this type protection.

#### 3.1.2 Safety Precautions

3.1.2.1 Handle flammable and dangerous liquids and chemicals in accordance with Specification ST0117GA0001.

3.1.2.2 Before applying pressure to a part under test or evaluating the vacuum system, personnel in the immediate area shall protect themselves against bodily harm by use of appropriate safety gear and/or apparel, or as otherwise directed by the Safety Department.

# Rockwell International Corporation

FSCM NO 94756

NUMBER	REVISION LETTER						PAGE
AA0209-105	A					4	

- 3.1.2.3 No connections or fittings shall be tightened, loosened, or opened while the test part is under pressure or the vacuum system evacuated unless specified to do so herein or by the applicable drawing or process specifications.
- 3.1.3 Equipment Considerations
- 3.1.3.1 The equipment shall be operated with the helium leak detector at least one foot from a wall to prevent restriction of the air cooling of the diffusion pump.
- 3.1.3.2 All fixed manifolding shall be as large in diameter and short in length as possible. All flexible tubing shall be capable of withstanding evacuation without collapse of the tubing. Line size and length shall be compatible with pump size to ensure rapid evacuation time and cleanup rates. Consult the vacuum system operation and maintenance manual for details on pump speed and line size.
- 3.1.3.3 Operating and calibration procedures for the vacuum system shall conform to the applicable system operation and maintenance manual.
- 3.1.3.4 During operation of the leak detector vacuum system the cold trap shall be maintained at least half full of liquid nitrogen.
- 3.1.3.5 Whenever possible, the use of rubber in the vacuum system shall be kept at a minimum. Gland design and gaskets shall be designed to expose a minimum amount of rubber to the vacuum system.
- NOTE: Rubber will absorb helium gas causing subsequent contamination of the vacuum system.
- 3.1.3.6 The use of lubricants on seals in the vacuum system shall be held to a minimum by applying only a light film of a lower-vapor pressure type grease and removing excessive deposits by pulling the seal through the fingers several times.
- NOTE: As in paragraph 3.1.3.5 grease will also absorb helium causing contamination of the vacuum system.
- 3.1.3.7 Due to various types of contamination of a "background" reading may appear on the leak detector with the MSLD capped off from the test port station. This reading shall be considered excessive when it exceeds 10 percent of the lowest scale on the MSLD and action shall be taken to decontaminate the MSLD.
- 3.1.4 Calibration of Equipment
- 3.1.4.1 The calibrated leak(s) shall be used to determine the multiplication factor of the MSLD prior to test.

$$\text{Multiplication Factor} = \frac{\text{Calibrated Leak Rate (atm cc/sec)}}{\text{MSLD Reading}}$$

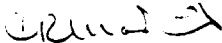

PREPARED BY	FSCM NO. 94756	NUMBER	
R. Berry	<b>Rockwell International Corporation</b> Defense Electronics Operations — Anaheim Divisions  <b>SPECIFICATION</b>	AA0209-106	
APPROVALS		TYPE	
 19 SEP 84		DATE	
		September 14, 1984	
		SUPERSEDES SPEC. DATED:	
	October 22, 1971		
		REV. LTR.	PAGE 1 of 6
		A	
TITLE      SPICE SENSOR ASSEMBLY A/N PART NUMBER 45800-701-1 HOLD TIME TEST			
<p><u>TABLE OF CONTENTS</u></p> <p>1.0 SCOPE</p> <p>2.0 APPLICABLE DOCUMENTS, MATERIAL AND EQUIPMENT</p> <p>3.0 REQUIREMENTS</p>			

# Rockwell International Corporation

FSCM NO 94756

NUMBER	REVISION LETTER							PAGE
AA0209-106	A						2	

## 1.0 SCOPE

1.1 This specification describes the equipment and procedures to perform a cryogen hold time test on the SPICE SENSOR under simulated operating conditions.

## 2.0 APPLICABLE DOCUMENTS, MATERIAL AND EQUIPMENT

### 2.1 Documents Required by this Specification

The following documents, to the extent indicated, form a part of this specification. In the event of any conflict between the requirements of this specification and the listed documents, the requirements of this specification shall govern.

#### 2.1.1 Specifications

##### Rockwell International (RI)

ST01117GA0001 Handling of Flammable and Dangerous Liquids and Chemicals

Appendix A Handling of Inert Cryogenic Liquids

##### Autonetics, Division of RI

AA0209-103 SPICE SENSOR Evacuation

AA0209-104 SPICE SENSOR Cryogenic Filling

AA0209-105 SPICE SENSOR Leak Rate Test

#### 2.1.2 Drawings

##### Autonetics, Division of RI

45800-701 SPICE II Telescope Assembly

### 2.2 Documents calling out This Specification

In the event of any conflict between the requirements of this specification and documents calling out this specification, the requirements of the documents calling out this specification shall take precedence.

#### 2.2.1 Drawings

##### Autonetics, Division of RI

45800-701 SPICE II Telescope Assembly

## Rockwell International Corporation

FSCM NO 94756

NUMBER AA0209-106	REVISION LETTER A	PAGE 3
----------------------	----------------------	--------

### 2.3 Material and Equipment

Acceptable, precise results are contingent upon the use of equipment and material equivalent to that listed below. If the effectiveness and accuracy are not decreased, item equivalent to those listed below may be substituted, except for those marked with an asterisk.

<u>ITEM NO.</u>	<u>NO. REQUIRED</u>	<u>DESCRIPTION</u>
1	1	Fill Line 40520-509-5 (6 ft)
2	1	Exhaust Line 40520-509-7
3	1	Liquid Helium filled; GFE 100 or 500 Liter Dewar
4	2	Filter Extension 40522-509-3 (12 inch for 100L) 40522-509-5 (29 inch for 500L)
5	2	Dip Tube 40521-509-3
6	A/R	Vent Line, CRL
7	A/R	Gaseous Helium - Grade 4.5 pure helium with two stage regulator 3 and 4000 PSIG
8	1	Flowmeter, Brooks 1350-01 BIAAS
9	A/R	Gaseous Helium ½-inch Tygon Pressurization Line (0,825-14NG-LH)
10	1	Gas Cylinder Cart
11	1	Breakout Box 40554-509-1
12	1	Breakout Box 40555-509-1
13	A/R	Data Sheet, Cooldown & AGE Cooldown
14	2	Digital Voltmeter - (-5 volts in 0.001 steps) Fairchild Model 7050.
15	1	Exhaust Gas Flow Meter Assy 10340-509
16	1	Vacuum Pumping Station
17	1	Vacuum Valve Operator
18	A/R	Vacuum Line - 2" Stainless Steel
19	1	Leak Detector with Calibrated Leak, Type SC4 Vacuum Electronics Corp.
20	1	SPICE AGE Console 40523-509-1
21	1	SPICE AGE Power Supply 40543-509-1
22	14	SPICE AGE Cables
23	1	PCM Encoder

# Rockwell International Corporation

FSCM NO 94756

NUMBER AA0209-106	REVISION LETTER					Page 4
	A					

## 3. REQUIREMENTS

### 3.1 General Requirements

#### 3.1.1 Environmental Conditions

3.1.1.1 Operations required by this process shall be performed at an ambient temperature of 25 (+15, -5)C, a barometric pressure of 30 ± 2 inches of mercury, and a relative humidity up to 50 percent room ambient.

3.1.1.2 The telescope during this procedure shall be protected at all times to ensure non-contamination either by protective bagging or by performance of the procedure in an area (clean room) capable of this type protection.

#### 3.1.2 Safety Precautions

##### 3.1.2.1 Safety Precautions

3.1.2.1 Handle flammable and dangerous liquids and chemicals in accordance with Specification ST0117GA0001.

### 3.2 Detailed Requirements

#### 3.2.1 Equipment Preparation

3.2.1.1 Evacuate telescope according to Specification AA0209-103.

3.2.1.2 Leak test telescope according to Specification AA0209-105.

3.2.1.3 Cool down telescope in vertical position according to Specification AA0209-104.

3.2.1.4 Prepare vent assembly for coupling to vent line at the end of the fill operation. Assembly consists of gas heater, absolute press relief valve and flowmeter in series. Gas vents outside the work area. Set flowmeter to zero.

3.2.1.5 At the completion of cool down and top off, remove transfer and vent lines and attach pressure relief valve to fill connector and vent assembly to vent connector, according to AA0209-104.

#### 3.2.2 Hold Time Test

3.2.2.1 As soon as the fill and vent assemblies are attached to the telescope according to 3.2.1.5, the hold time test has started. Start the clock.

3.2.2.2 Immediately turn Dewar Heater Sw to linear to pressurize the telescope.

3.2.2.3 Record set of readings from AGE console using AGE cooldown data sheet.



# Rockwell International Corporation

FSCM NO 94756

NUMBER	REVISION LETTER							PAGE 5
AA0209-106	A							

- 3.2.2.4 Completion of pressurization will be indicated by the start of flow (as read by the flowmeter).
- 3.2.2.5 Repeat step 3.2.2.3 every ½ hour.
- 3.2.2.6 Turn on detector preamps and detector temperature controller.
- 3.2.2.7 Perform detector preamp test per Integration test procedure.
- 3.2.2.8 After 4 hours the hold time test is completed. During this period the tank heater voltage shall not have dropped below 0.1 volts.
  
- 3.2.3 Equipment Removal
- 3.2.3.1 Remove vent assembly
- 3.2.3.2 Warm up cryogen system with room temperature helium flowing at a rate of 50 l/min until warm-up sensors indicate telescope is above 60°F. Do not open vacuum valve.
- 3.2.3.3 As soon as warmup has started, disconnect all electronics except warm-up sensors.
- 2.3.3.4 When telescope has warmed up, seal fill and vent connectors with their proper fittings.
- 3.2.3.5 Disconnect warm-up temperature sensors.

Rockwell International Corporation

PREPARED BY	FSCM NO. 94756	NUMBER	AA0209-107
R. C. Berry	<b>Rockwell International Corporation</b>	TYPE	
APPROVALS	Defense Electronics Operations — Anaheim Divisions	DATE	September 30, 1984
	<b>SPECIFICATION</b>	SUPERSEDES SPEC. DATED:	July 25, 1972
		REV. LTR.	PAGE 1 of 14
		B	

TITLE SPICE TELESCOPE ASSEMBLY AN/PN 45800-701-1  
YAW, PITCH, AND ROLL AXIS DETERMINATION

TABLE OF CONTENTS

- 1.0 SCOPE
- 2.0 APPLICABLE DOCUMENTS
- 3.0 REQUIREMENTS
- 4.0 QUALITY ASSURANCE
- 5.0 FIGURES

# Rockwell International Corporation

FSCM NO 94756

NUMBER AA0209-107	REVISION LETTER						PAGE 2
	B						

## 1.0 SCOPE

- 1.1 This specification describes the procedures and equipment required to boresight the SPICE Telescope Assembly.
- 1.2 The SPICE Telescope has two alignment mirrors, one attached to the outer rim, and one centered in the central obscuration portion of the telescope. The line of sight to these mirrors is defined as a line normal to the mirrored surface. A mirrored alignment ring is also provided which locates the telescope mounting plane.
- 1.3 The procedures herein provide the methods for establishing the directional relationship between the optical line of sight of the telescope (i.e., pitch, roll and yaw axis) and these mirrors.

## 2.0 APPLICABLE DOCUMENTS, MATERIAL AND EQUIPMENT

- 2.1 Documents required by this specification - the following documents, to the extent indicated, form a part of this specification. In the event of any conflict between the requirements of this specification and the listed documents, the requirements of this specification shall govern.

### 2.1.1 Specifications

#### Rockwell International Corporation (RI)

ST0117GA0001	Handling of Flammable and Dangerous Liquids and Chemicals
Appendix A	Handling of Inert Cryogenic Liquids
AA0209-0103	SPICE Sensor Evacuation
AA0209-0104	SPICE Sensor Cryogenic Filling

### 2.1.2 Drawings

#### Autonetics, Division of RI

45800-701-1	SPICE II Telescope Assembly
-------------	-----------------------------

### 2.3 Material and Equipment

Acceptable, precise results are contingent upon the use of equipment and material equivalent to that listed below. If the effectiveness and accuracy are not decreased, items equivalent to those listed below may be substituted except for those marked with an asterisk.

# Rockwell International Corporation

FSCM NO 94756

NUMBER AA0209-107	REVISION LETTER B	PAGE 3
----------------------	----------------------	-----------

<u>Item No.</u>	<u>No. Required</u>	<u>Description</u>
1	1	Collimator Large Aperture 16" or greater
2	1	Telescope Cradle EOL 1798-2450
3	1	Telescope Holding Fixture EOL 1798-2451
4	2	Granite Surface Plate
5	1	Theodolite Wild T3Am
6	1	Alignment Ring EOL 1798-2481
7	1	Yaw Axis Index Locator EOL 1798-2482
8	1	Front Test Cover EOL 1798-2447
<b>3.0      <u>REQUIREMENTS</u></b>		
<b>3.1      General Requirements</b>		
<b>3.1.1    Environmental Conditions</b>		
2.1.1.1	Operations required by this process shall be performed at an ambient temperature of 25 (+15-5)C, a barometric pressure of 30 + 2 inches of mercury, and a relative humidity up to 50 percent room ambient.	
3.1.1.2	Performance of this procedure shall be accomplished in a clean dust free area or steps shall be taken to ensure that no contamination shall affect the telescope assembly per R&D STD 209A, CLASS 1000.	
<b>3.1.2    Safety Precautions</b>		
3.1.2.1	Handle flammable and dangerous liquids and chemicals in accordance with Specification ST0117GA001.	
<b>3.2      Detailed Requirements</b>		
<b>3.2.1    Equipment Preparation</b>		
3.2.1.1	Assemble complete telescope except for operational cover.	
3.2.1.2	Install Front Test Cover.	
3.2.1.3	Evacuate Telescope per AA0209-0103.	
<b>3.2.2    Pitch and yaw axis determination.</b>		
3.2.2.1	Place telescope in front of large aperture collimator.	

FORM NO. 101-10-1-081

## Rockwell International Corporation

FSCM NO 94756

NUMBER	AA0209-107	REVISION LETTER	PAGE 4
		B	

- 3.2.2.2 Install and level theodolite on the vertical centerline of the telescope in the clear aperture below the horizontal centerline.
- 3.2.2.3 Focus collimator at infinity using an optically flat mirror which is full aperture of collimator.
- 3.2.2.4 Center the return image from the alignment block in the collimator field-of-view.
- 3.2.2.5 Illuminate interior of telescope with flashlight or similar light source.
- 3.2.2.6 Observe the fiduciary target through theodolite (placed in the direct position) and align theodolite reticle on the center of the target (View A Figure 1).
- 3.2.2.7 Fill sensor with cryogenics per AA0209-0104.
- 3.2.2.8 Repeat Step 3.2.2.6 and then read vertical and horizontal scales and record on Lines 1 and 15 of Worksheet 1.
- 3.2.2.9 Align theodolite on the projected collimator image.
- 3.2.2.10 Read vertical and horizontal scales and record on Lines 5 and 17.
- 3.2.2.11 Plunge and reverse theodolite.
- 3.2.2.12 Align theodolite on the projected collimator image.
- 3.2.2.13 Read vertical and horizontal scales and record on Lines 6 and 22.
- 3.2.2.14 Align theodolite on the center of the fiduciary target.
- 3.2.2.15 Read vertical and horizontal scales and record on Lines 2 and 20.
- 3.2.2.16 Complete computations using Worksheet 1 instructions.
- 3.2.2.17 Repeat Steps 3.2.2.8 through 3.2.2.16 until results of two sets of readings (Horizontal and Vertical) are within one minute.
- 3.2.2.18 Calculate horizontal and vertical means using values from two determinations.
- 3.2.2.19 Line 13 is telescope pitch axis boresight value. If value is negative, telescope optical line of sight to center of detector array is pointed down (amount recorded) in relation to a line normal to the face of the alignment mirror.  
  
If value is positive, the telescope line of sight is pointed up in relation to the alignment mirror.
- 3.2.2.20 Line 31 is telescope yaw axis boresight value.  
  
If value is more than  $180^{\circ} 00' 00.0''$ , the telescope optical line of sight is rotated clockwise (as viewed from above) by that amount, in relation to the alignment mirror,  
  
If value is less than  $180^{\circ} 00' 00.0''$  the telescope optical line of sight is rotated counter clockwise in relation to the alignment mirror.

FORM 300 (REV. 10-68)

# Rockwell International Corporation

FSCM NO 94756

NUMBER	AA0290-107	REVISION LETTER	PAGE
	B		5

- 3.2.2.21 Repeat Section 3.2.2 for central alignment mirror then proceed to Section 3.2.3.
- 3.2.3 Alignment ring alignment.
- 3.2.3.1 Telescope warmup may be initiated if desired.
- 3.2.3.2 Position the alignment on the rear flange of the telescope being careful not to disturb position of other images in collimator.
- 3.2.3.3 Place theodolite in the direct position so as to obtain both the alignment cube and alignment ring return images when adjusting the theodolite telescope.
- 3.2.3.4 Level theodolite.
- 3.2.3.5 Align theodolite on return image from the alignment ring.
- 3.2.3.6 Read vertical and horizontal scales and record on Lines 1 and 15 of Worksheet 1.
- 3.2.3.7 Align theodolite on return image from the alignment cube.
- 3.2.3.8 Read vertical and horizontal scales and record on Lines 5 and 17.
- 3.2.3.9 Plunge and reverse theodolite.
- 3.2.3.10 Align theodolite on return image from the alignment cube.
- 3.2.3.11 Read vertical and horizontal scales and record on Lines 6 and 22.
- 3.2.3.12 Align theodolite on return image from the alignment ring.
- 3.2.3.13 Read vertical and horizontal scales and record on Lines 2 and 20.
- 3.2.3.14 Complete computations using Worksheet 1 instructions.
- 3.2.3.15 Repeat Steps 3.2.2.25 through 3.2.2.35 until results of two sets of readings (Horizontal and Vertical) are within one minute.
- 3.2.3.16 Calculate horizontal and vertical means using values from two determinations.
- 3.2.3.17 Line 13 is alignment cube pitch axis LOS in relation to ring LOS. If value is negative, cube optical line of sight to center ring LOS is pointed down.
- 3.2.3.18 If value is positive, the cube line of sight is pointed up in relation to the ring LOS.
- 3.2.3.19 Line 31 is alignment cube, yaw axis line of sight in relationship to ring line of sight.
- 3.2.3.20 If value is plus the cube optical line of sight, it is rotated clockwise (as viewed from above) by that amount in relation to the alignment ring LOS.

Control Unit 131012-001

# Rockwell International Corporation

FSCM NO 94756

NUMBER	AA0209-107	REVISION LETTER						PAGE	6
		B							

- 3.2.3.21 If value is minus the cube optical line of sight, it is rotated counter clockwise in relation to the alignment ring line of sight.
- 3.2.3 Roll axis determination.
- 3.2.4.1 Install and level theodolite on the vertical centerline of the telescope in the clear aperture above the horizontal centerline (Figure 1).
- 3.2.4.2 Illuminate interior of telescope with flashlight or similar light source.
- 3.2.4.3 Observe detector array through theodolite (placed in the direct position) and align theodolite reticle on left edge of filter holder. (NOTE: The theodolite reverses the image seen so the left edge will appear on the right when viewed through the theodolite. The theodolite also inverts the image so lower end will appear to be on the top.)
- 3.2.4.4 Align theodolite reticle on lower left edge of filter mask.
- 3.2.4.5 Elevate theodolite telescope and observe run out of reticle from filter mask edge at upper end.
- 3.2.4.6 Roll telescope in cradle one half of runout.
- 3.2.4.7 Repeat Steps 3.2.4.4 through 3.2.4.6 until theodolite reticle follows edge of mask.
- 3.2.4.8 Position yaw axis index indicator on rear flange of telescope over yaw axis index mark, if telescope is so marked. If no mark is available, perform Steps 3.2.4.4 through 3.2.4.6 also for index tool. Rotate tool to obtain no runout.
- 3.2.4.9 Align theodolite on upper end of left edge of filter mask.
- 3.2.4.10 Read vertical and horizontal scales and record on Lines 1 and 10 of Worksheet 2.
- 3.2.4.11 Align theodolite on lower end of left edge of filter mask.
- 3.2.4.12 Read vertical and horizontal scales and record on Lines 5 and 13.
- 3.2.4.13 Plunge and reverse theodolite.
- 3.2.4.14 Align theodolite on lower end of left edge of filter mask.
- 3.2.4.15 Read vertical and horizontal and scales and record on Lines 4 and 14.
- 3.2.4.16 Align theodolite on upper end of left edge of filter mask.
- 3.2.4.17 Read vertical and horizontal scales and record on Lines 2 and 11.
- 3.2.4.18 Repeat Steps 3.2.4.8 through 3.2.4.17 using scribe line on index tool and new Worksheet 2.
- 3.2.4.19 Complete computations using instructions for Worksheet 2 for both sets taken.

# Rockwell International Corporation

FSCM NO 94756

NUMBER	AA0209-107	REVISION LETTER						Page 7
		B						

- 3.2.4.20 Repeat Steps 3.2.4.9 through 3.2.4.19 until results of two sets of readings for both mask and tool (Line 22, Worksheet 2) are within five minutes of arc.
- 3.2.4.21 Complete computations using Worksheet 2 instructions.
- 3.2.4.22 If value is plus the detector is rotated clockwise as viewed from the front of the telescope in relation to the index mark.
- 3.2.4.23 If value is minus the detector is rotated counter clockwise.
- 3.2.4.24 For every minute of arc difference between index tool scribe line and detector edge revolve index tool around telescope .0057 inches.
- 3.2.4.25 Repeat procedure until Line 27 is less than 10 minutes of arc. Apply index mark to telescope per 45990-701.

## 4.0 QUALITY ASSURANCE

### 4.1 Workmanship

4.1.1 Care shall be taken at all times to handle components so as not to contaminate or injure same.

### 4.1.2 Acceptance

4.2.1 If mark is to be applied during this procedure, index tool must be located less than 10 minutes of arc from vertical readings of detector mask edge (3.2.3.23).

4.2.2 Data maybe visually expressed using drawing on Page 14.



Rockwell International Corporation

FSCM NO 94756

NUMBER  
AA0209-107

REVISION LETTER

B

PAGE 8

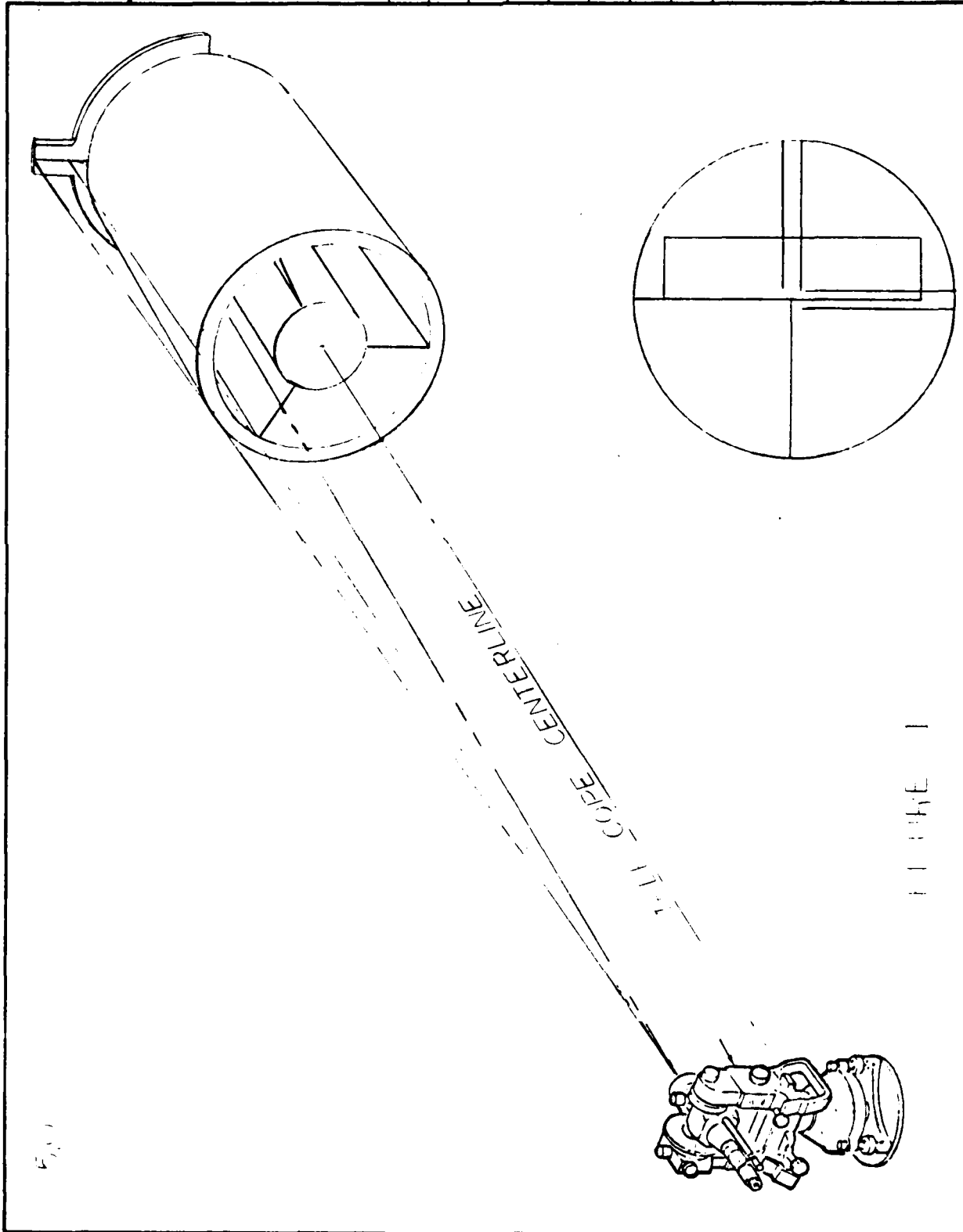

FIGURE 1

# Rockwell International Corporation

FSCM NO 94756

NUMBER AA0204-107	REVISION LETTER B	PAGE 9
----------------------	----------------------	--------

5.0                      WORKSHEET #1                      SET # \_\_\_\_\_ DATE \_\_\_\_\_

### VERTICAL

①	1	FIDUCIARY DIRECT	<input type="checkbox"/> -	RING	<input type="checkbox"/> +	
⑦	2	FIDUCIARY REVERSE				
	3	FIDUCIARY DIRECT	<input type="checkbox"/> +	RING	<input type="checkbox"/> -	
	4	RESULT (1-2 OR 2-3)				
③	5	COLLIMATOR DIRECT	<input type="checkbox"/> -	CUBE	<input type="checkbox"/> -	
⑤	6	COLLIMATOR REVERSE				
	7	COLLIMATOR DIRECT	<input type="checkbox"/> +	CUBE	<input type="checkbox"/> +	
	8	RESULT (5-6 OR 6-7)				
	9	ENTER LINE 4				
	10	RESULT (8+9) ALGEBRAICALLY				
	11	ENTER LINE 10 FROM SET #1				
	12	TOTAL (10+11) ALGEBRAICALLY				
	13	RESULT (12 ÷ 2) (MEAN)				

### HORIZONTAL

	14	CONSTANT (360°)			3 6 0 0 0 0 0
②	15	FIDUCIARY DIRECT (RING)			
	16	TOTAL (14+15) IF REQUIRED			
④	17	COLLIMATOR DIRECT (CUBE)			
	18	RESULT (16-17)			
	19	CONSTANT (360°)			3 6 0 0 0 0 0
⑧	20	FIDUCIARY REVERSE (RING)			
	21	TOTAL (19+20) (IF REQUIRED)			
⑥	22	COLLIMATOR REVERSE (CUBE)			
	23	RESULT (21-22)			
	24	ENTER LINE 18			
	25	TOTAL (23+24)			
	26	RESULT (25 ÷ 2)			
	27	FIDUCIARY OFFSET VALUE (-360° FOR CUBE & RING)			4 2 3 7.0
	28	RESULT (26-27)			
	29	ENTER LINE 28 FROM SET #1			
	30	TOTAL (28+29)			
	31	RESULT (30 ÷ 2) (MEAN)			

FORM NO. 2011-10-10-10000

Rockwell International Corporation

FSCM NO 94756

NUMBER	REVISION LETTER								PAGE 10
AA0209-107	B								

INSTRUCTIONS FOR WORKSHEET #1

VERTICAL

1. If value entered on line 1 is less than that of line 2 enter line 1 value on line 3.
2. Subtract line 2 from line 1 or line 3 from line 2, enter results on line 4.
3. Enter sign from line 1 or 3 in block in line 4 as applicable.
4. Repeat steps 1,2, and 3 for lines 5 through 8.
5. Enter results of line 4 with its sign on line 9.
6. Algebraically add lines 8 and 9 and enter result on line 10 with the appropriate sign.

HORIZONTAL

7. Note value on line 17, if value is greater than value on line 15 add  $360^{\circ}$  to line 15 and enter results on line 16.
8. Subtract line 17 from 16 or 15, enter results on line 18.
9. Repeat steps 8 and 9 for lines 19 through 23.
10. Enter line 18 value on line 24.
11. Add line 23 and line 24, enter results on line 25.
12. Divide line 25 value by 2 and enter results on line 26.
13. Subtract line 26 from line 27, (42' 37.0" for fiduciary,  $360^{\circ}$  for cube & ring), enter results on line 28.

Line 13 and 31 mean determinations.

VERTICAL

1. Enter line 10 from first set of readings on line 11 of second worksheet 1.
2. Add line 10 and line 11 algebraically and enter results on line 12.
3. Divide line 12 by 2, enter results on line 13.

HORIZONTAL

4. Enter line 28 from first set of readings on line 29 of second worksheet 1.
5. Add line 28 and 29, enter results on line 30.
6. Divide line 30 by 2, enter results on line 31.

# Rockwell International Corporation

FSCM NO 94756

NUMBER AA0209-107	REVISION LETTER B	PAGE 11
----------------------	----------------------	---------

5.0                      WORKSHEET #2                      SET # \_\_\_\_\_ DATE \_\_\_\_\_

MASK EDGE \_\_\_\_\_                      TOOL \_\_\_\_\_

### VERTICAL

①	1	UPPER EDGE DIRECT	
⑦	2	UPPER EDGE REVERSE	
	3	RESULT (1-2)	

⑤	4	LOWER EDGE REVERSE	
③	5	LOWER EDGE DIRECT	
	6	RESULT (4-5)    OR (5-4) FOR TOOL	
	7	ENTER LINE 3	
	8	TOTAL (6+7)    OR (7-6) FOR TOOL	
	9	CONVERT LINE 8 TO SECONDS	

### HORIZONTAL

②	10	UPPER END DIRECT	
⑧	11	UPPER END REVERSE	
	12	TOTAL (10+11)	

④	13	LOWER END DIRECT	
⑥	14	LOWER END REVERSE	
	15	TOTAL (13+14)	
	16	ENTER LINE 12	
	17	ENTER LINE 15 IF SMALLER THAN LINE 16	
	18	RESULT (15-16) <span style="border: 1px solid black; padding: 2px;">CCW -</span> OR (16-17) <span style="border: 1px solid black; padding: 2px;">CW +</span>	
	19	RESULT (LINE 18 ÷ 2)	
	20	CONVERT LINE 19 TO SECONDS	
	21	RESULT (LINE 9 ÷ 20)	
	22	ENTER ANGLE WHOS COT IS LINE 21	
	23	ENTER LINE 22 FROM SET #1	
	24	TOTAL (22+23) ALGEBRAICALLY	
	25	RESULT (LINE 24 ÷ 2)	
	26	ENTER LINE 25 FROM TOOL SET #2	
	27	RESULT (25-26) ALGEBRAICALLY	

FORM 100-211-100-1000

# Rockwell International Corporation

FSCM NO 94756

NUMBER AA0209-107	REVISION LETTER						PAGE 12
	B						

## INSTRUCTIONS FOR WORKSHEET #2

### VERTICAL

1. Subtract line 2 from line 1, enter results on line 3.
2. Subtract line 5 from line 4, (or line 4 from line 5 for tool), enter results on line 6.
3. Enter results of line 3 on line 7.
4. Add lines 6 and 7 (or subtract line 6 from line 7 for tool), enter total on line 8.
5. Convert line 8 value to seconds of arc, enter seconds value on line 9.

### HORIZONTAL

6. Add lines 10 and 11, enter total on line 12.
7. Add lines 13 and 14, enter total on line 15.
8. Enter line 12 value on line 16.
9. If line 16 is greater than line 15, enter the value of line 15 on line 17.
10. Subtract line 16 from line 15 or line 17 from line 16, as applicable, and enter result on line 18.
11. Enter sign as indicated, oine 15 - 16 will be minus (-), and 16 - 17 will be plus (+), in box to right.
12. Divide line 18 by 2, enter result on line 19.
13. Convert line 19 to seconds of arc, enter seconds value on line 20.
14. Divide line 9 by line 20, enter result on line 21.
15. Determine the angle whose cotangent is the value entered on line 21. Enter this angle on line 22 with the sign determined in step 11.
16. Repeat steps 1 through 15 for second set then proceed to step 17.
17. When two sets have been computed whose line 22 values agree within 5 minutes, enter the line 22 value from the first set on line 23 of the second set with its sign.
18. Algebraically add lines 22 and 23. Enter results on line 24 with the appropriate sign.

Rockwell International Corporation

FSCM NO 94756

NUMBER	REVISION LETTER						PAGE
AA 0209-107	B					13	

19. Divide line 24 by 2. Enter result on line 25 with its sign.
20. Repeat steps 1 through 19 for the Index Tool worksheets.
21. Enter line 25 from Index Tool's second set on line 26 of mask edge second set with its sign.
22. Algebraically subtract line 26 from line 25, enter result on line 27 with appropriate sign.

180 2 00 7 01 15 00 1 00 00 1

Rockwell International Corporation

FSCM NO 94756

NUMBER AA0209-1G7	REVISION LETTER B	PAGE 14
----------------------	----------------------	---------

SPICE ALIGNMENT  
(BOPE HEIGHT)

DATE .

HORIZONTAL  
(TOP VIEW - YAW)

INDEX  
MARK

--- CENTRAL  
MIRROR

ROTATIONAL  
(FRONT VIEW ROLL)

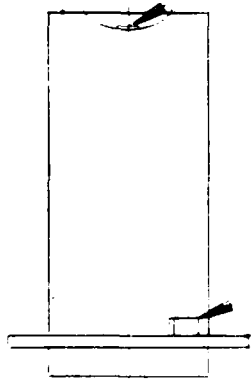

ALIGNMENT  
CUBE

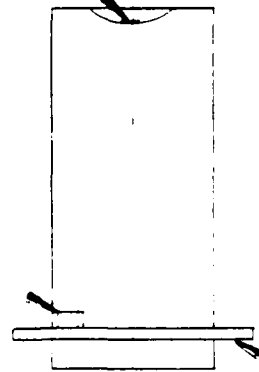

VERTICAL  
(SIDE VIEW PITCH)

ALIGNMENT  
CUBE

PREPARED BY	FSCM NO. 94756 <b>Rockwell International Corporation</b> Defense Electronics Operations — Anaheim Divisions  <h2 style="text-align: center;">SPECIFICATION</h2>	NUMBER	AA0209-111	
R. C. Berry		TYPE		
APPROVALS		DATE	September 30, 1984	
<i>[Signature]</i>		SUPERSEDES SPEC. DATED:	September 20, 1971	
		REV. LTR.	A	PAGE 1 of 3

**TITLE** SPICE II SENSOR ASSEMBLY, A/N PN 45800-701-1  
O-RING INSTALLATION INSTRUCTIONS

TABLE OF CONTENTS

- 1.0 SCOPE
- 2.0 APPLICABLE MATERIALS
- 3.0 GENERAL REQUIREMENTS
- 4.0 DETAIL REQUIREMENTS



# Rockwell International Corporation

FSCM NO 94756

NUMBER	AA0209-111	REVISION LETTER						PAGE	2
		A							

## 1.0 SCOPE

- 1.1 The purpose of this specification is to designate the materials and procedures to be used in the lubrication of O-rings for static sealing of assemblies in the telescope.
- 1.2 The materials and procedures outlined herein apply to O-rings as used in static sealing of assemblies when less than 30% compression is applied in O-ring installation.
- 1.3 The application of the procedure herein will facilitate installation of the o-rings to assure proper seating and sealing of mating surfaces.

## 2.0 APPLICABLE MATERIALS

- Item 1 Freon PCA
- Item 2 FS-1265 (300 Centistokes) - Dow Corning

## 3.0 GENERAL REQUIREMENTS

### 3.1 Cleaning

All surfaces in the sealing area shall be freed from grease cutting compounds, and other foreign materials by thoroughly cleaning with Freon Solvent, Type PCA.

### 3.2 Installation

3.2.1 The O-rings shall be cleaned, dried and coated with Dow-Corning FS-1265.

3.2.1.1 Wash O-rings in clean Freon Type PCA.

3.2.1.2 Allow O-rings to room dry for six hours (laminar flow bench).

3.2.1.3 Immerse O-ring in Dow Corning FS-1265 heated to  $150^{\circ}\text{F} \pm 100$  ( $65^{\circ}\text{C} \pm 5^{\circ}$ ) and soak for 16 hours.

NOTE: Steps 3.2.1.1 through 3.2.1.3 may be accomplished prior to actual use and the O-rings bagged until installation is required.

3.2.1.4 Semi-dry O-ring with light wipe with foam wipe. Do not removal all oil.

3.2.1.5 Case must be taken to avoid contaminants on the O-ring and its mating surfaces prior to installation.

3.2.2 The O-ring shall be firmly pressed into place to insure proper seating. If an instrument is used for this purpose, its surfaces which contact the O-ring shall not permit bruising or cutting.

3.2.3 O-rings shall be replaced each time that removal of O-ring is required.

Rockwell International Corporation

FSCM NO 94756

NUMBER	AA0209-111	REVISION LETTER						PAGE	3
		A							

4.0 DETAIL REQUIREMENTS

- 4.1 For sealing a joint between two surfaces, the assembly sequence shall be:
  - 4.1.1 Clean mating surfaces per 3.1
  - 4.1.2 Coat O-ring per 3.2.1
  - 4.1.3 Install O-ring in groove per 3.2.2.
  - 4.1.4 Fasten mating surfaces per drawing.

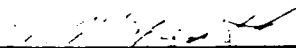
PREPARED BY	FSCM NO. 94756	NUMBER AA0309-026			
R. C. Berry	<b>Rockwell International Corporation</b> Defense Electronics Operations — Anaheim Divisions  <h2 style="text-align: center;">SPECIFICATION</h2>				
APPROVALS				TYPE	
				DATE September 30, 1984	
				SUPERSEDES SPEC. DATED: July 25, 1972	
	REV. LTR. B		PAGE 1 of 10		
TITLE SPICE SENSOR ASSEMBLY, A/N PART NUMBER 45800-701-1; OPTICAL COMPONENT POSITIONING, ALIGNMENT, FOCUSING, AND QUALITY TEST					
<p><u>TABLE OF CONTENTS</u></p> <p>1.0 SCOPE</p> <p>2.0 APPLICABLE DOCUMENTS, MATERIAL AND EQUIPMENT</p> <p>3.0 REQUIREMENTS</p> <p>4.0 QUALITY ASSURANCE PROVISIONS</p> <p>5.0 FIGURES</p>					

307

# Rockwell International Corporation

FSCM NO 94756

NUMBER	REVISION LETTER						PAGE
AA0309-026	B					2	

## 1.0 SCOPE

1.1 The optical components of the SPICE telescope are made to function at optimum distances between each element, if all mirrors, mounting components and spacing parts contract identically when subject to temperature changes a slightly larger or smaller (but correctly proportioned) system will result.

1.2 This specification describes the equipment and procedures for determining the dimension for final machining of the mirror mounting surfaces. This procedure will also determine the movement of the front edge of the inner housing relative to the other housing.

## 2.0 APPLICABLE DOCUMENTS, MATERIAL AND EQUIPMENT

2.1 Documents required by this Specification - The following documents, to the extent indicated, form a part of this specification. In the event of any conflict between the requirements of this specification and the listed documents, the requirements of this specification shall govern.

### 2.1.1 Specifications

#### Rockwell International Corporation (RI)

ST00117GA0001 Handling of Flammable and Dangerous Liquids and Chemicals

Appendix A Handling of Inert Cryogenic Liquids

AA0209-103 SPICE Sensor Evacuation

AA0209-104 SPICE Sensor Cryogenic Filling

### 2.1.2 Drawings

#### Autonetics, Division of RI

45800-701 Hi Hi Star Telescope Assembly

45814-701 Mirror Support Ring

45822-701 Cylinder, Support Detector - Telescope

45805-701 Housing, Inner-Telescope

45816-701 Cone, Support - Telescope

45823-701 Isolator, Thermal Detector - Telescope

45807-701 Shim, Folding Mirror

180-500-701-100000

# Rockwell International Corporation

FSCM NO 94756

NUMBER	AA0309-026	REVISION LETTER	PAGE 3
		B	

2.2 Documents Calling Out This Specification - In the event of any conflict between the requirements of this specification and documents calling out this specification, the requirements of the documents calling out this specification shall take precedence.

2.2.1 Drawings

Autonetics, Division of RI

45800-701 SPICE Star Telescope Assembly

2.3 Material and Equipment

Acceptable, precise results are contingent upon the use of equipment and material equivalent to that listed below. If the effectiveness and accuracy are not decreased, items equivalent to those listed below may be substituted except for those marked with an asterisk.

<u>Item No.</u>	<u>No. Required</u>	<u>Description</u>
1	1	Depth Micrometer
2	1	Granite Surface Plate
3	1	Installation Fixture, Telescope EOL 1798-2449
4	1	18-inch Optical Window
5	1	Base T3/Microscope EOL 1798-2454
6	1	Vacuum Turbo Pump System
7	1	Mass Spectrometer GE LC20
8	1	Heat Gun 1000 Watts
9	1	Front Test Cover EOL 1798-2447
10	1	Dummy Detector
11	As Required	Liquid Nitrogen Supply
12	5	Lapping Rings EOL 1798-2425
13	1	Set Parallel Bars
14	1	Fill Line 40520-509-7
15	1	Exhaust Line 40520-509-7
16	1	Liquid Helium filled: GFE 100 or 500 Liter Dewar
17	2	Filter Extension 40522-509-3 (12 inch) for 100L 40522-509-2 (29 inch for 500L)
18	2	Dip Tube 40521-509-3
19	A/R	Vent Line, CRL
20	A/R	Gaseous Helium - Grade 4.5 pure helium with two stage regulator 3 and 4000 PSIG
21	1	Flowmeter, Brooks 1350-01 BIAAS
22	A/R	Gaseous Helium 1/2 inch Tygon Pressurization Line (0.825-14NG-LH)
23	1	Gas Cylinder Cart
24	1	Breakout Box 40555-509-1

FORM 24 (REV. 10-1-60)

# Rockwell International Corporation

FSCM NO. 94756

NUMBER AA0309-026	REVISION LETTER B	PAGE 4
----------------------	----------------------	-----------

<u>Item No.</u>	<u>No. Required</u>	<u>Description</u>
25	A/R	Data Sheet, Cooldown
26	2	Digital Voltmeter(-5 volts in 0.001 steps) Fairchild Model 7050
27	1	Exhaust Gas Flow Meter Assy 10340-509
3.0	<u>REQUIREMENTS</u>	
3.1	General Requirements	
3.1.1	Environmental Conditions	
3.1.1.1	Operations required by this process shall be performed at an ambient temperature of 25 (+15 -5) <sup>o</sup> C, a barometric pressure of 30 + inches of mercury, and a relative humidity up to 50 percent room ambient.	
3.1.1.2	Operations 3.1.1.2 through 3.2.1.23 shall be performed after equipment has been rough cleaned but before final cleaning.	
3.1.1.3	Operations of 3.2.1 need not be performed in clean area, but needless contamination should be avoided. Operations of 3.2.2 and subsequent paragraphs will be performed in clean room or with telescope bagged for clean protection.	
3.1.2	Safety Precautions	
3.1.2.1	Handle flammable and dangerous liquids and chemicals in accordance with Specification ST0117GA0001.	
3.2	Detailed Requirements	
3.2.1	Measurement and machining of components	
3.2.1.1	Obtain mirror support ring, inner housing, support cone, thermal isolator and detector support cylinder.	
3.2.1.2	Lap first folding mirror mounting surface of inner housing flat to within 2 fringes at 6328A <sup>o</sup> housing.	
3.2.1.3	Lap surface "A" of inner housing parallel to first folding mirror mounting surface to within 20 seconds of ARC.	
3.2.1.4	Determine distance between surface "A" and first folding mirror mounting surface. Enter on Worksheet 1, Line 1.	
3.2.1.5	Lap surface "B" of support cone flat to within 2 fringes at 6328A <sup>o</sup> .	
3.2.1.6	Lap surface "A" of support cone parallel to surface "B" to within 20 seconds of ARC.	
3.2.1.7	Determine distance between surfaces A and B of support cone, enter on Worksheet 1, Line 4.	
3.2.1.8	Lap surface "A" of mirror support ring.	

TRG & REV. 01/11/01 (01/11/01)



# Rockwell International Corporation

FSCM NO 94756

NUMBER	REVISION LETTER						PAGE
AA0309-026	B					6	

- 3.2.1.19 Position inner housing vertically under a vertical collimator and obtain return image from flat positioned on mirror mounting surface.
- 3.2.1.20 Carefully install assembly of Step 3.2.1.18 on to surface "A" of inner housing.
- 3.2.1.21 Check parallelism between flat in inner housing and surface "F" of support ring.
- 3.2.1.22 Install assembly of Step 3.2.1.17 onto support ring.
- 3.2.1.23 Check parallelism between flat on inner housing and detector mounting surface on thermal isolator.
- 3.2.1.24 Disassemble and clean components.
- 3.2.2 Warm Focus Check
- 3.2.2.1 Assemble optical components and optical mounting components machined in Section 3.2.1.
- 3.2.2.2 Install and adjust dummy detector to proper position (.1310 behind mounting surface).
- 3.2.2.3 Install assembly in front of large aperture collimator.
- 3.2.2.4 Coaxialate telescope and collimator.
- 3.2.2.5 Set collimator at infinity mark.
- 3.2.2.6 Adjust dummy detector until return image in collimator is in focus.
- 3.2.2.7 Record amount of adjustment (revolutions and/or portions 1/8 turn 1/4 etc.)
- 3.2.2.8 Multiply revolutions determined in Step 3.2.2.7 by 0.025, result in axial movement of dummy detector (Focal Plane). The result must be less than .015 inches.
- 3.2.2.9 Adjust dummy detector clockwise one (1) revolution from position of 3.2.2.6.
- 3.2.2.10 Adjust collimator to focus return spot.
- 3.2.2.11 Measure and record movement of collimator focus adjustment barrel.
- 3.2.2.12 Repeat Step 3.2.2.9 through 3.2.2.11 until four revolutions clockwise from position of 3.2.2.6 have been completed then return to position of 3.2.2.6 and perform same procedure counter clockwise.
- 3.2.2.13 Divide results of Step 3.2.2.11 by 25 for movement of collimator focus adjustment barrel during each revolution of dummy detector. The results is the movement of the collimator adjustment barrel for .001 inch of telescope focal plane movement.



# Rockwell International Corporation

FSCM NO 94756

NUMBER AA0309-026	REVISION LETTER						PAGE 7
	B						

- 3.2.2.14 Plot results of 3.2.2.13 as in example of Figure 1.
- 3.2.3 Complete Focus Test
- 3.2.3.1 Assemble telescope using dummy detector, front test cover and rear test cover. Position dummy detector at .1310 behind detector mounting surface.
- 3.2.3.2 Repeat steps 3.2.2.3 through 3.2.2.5 then proceed to step 3.2.3.3.
- 3.2.3.3 Return dummy detector to starting position of step 3.2.3.1.
- 3.2.3.4 Close and evacuate telescope per AA0209-103.
- 3.2.3.5 Fill telescope per AA0209-104.
- 3.2.3.6 Monitor focal plane shift and inner housing shift during cooldown. Record time, temperature and focal plane shift (using collimator barrel movement and plot of Figure 1).
- 3.2.3.7 After 20 hours of cryogenic filling, monitor focal plane shift until no further movement of collimator barrel is detected.
- 3.2.3.8 If return image from dummy detector is in focus when collimator focusing barrel is within .050 inch of infinity setting proceed to step 3.2.4. If collimator focusing barrel is over .050 inch from the infinity setting continue with step 3.2.3.9.
- 3.2.3.9 Warm up telescope.
- 3.2.3.10 Dismantle telescope, remove dummy detector and thermal isolator from detector support cylinder, or remove folding mirror if required.
- 3.2.3.11 Machine surface "A" of detector support cylinder or add shim 45807-701 behind folding mirror to position focal plane at correct dimension of 0.1310 inch behind detector mounting surface. Folding mirror shim thickness is 1 to 7 of required detector movement.  
  
NOTE: Surface "A" of the detector support cylinder will only be machined once, from then on (or until a new detector support cylinder is made), only the folding mirror shim will be machined or made thicker.
- 3.2.3.12 Re-assemble and evacuate telescope using dummy detector and front test window.
- 3.2.3.13 Repeat steps 3.2.3.4 through 3.2.3.9.
- 3.2.4 Optical Quality Test
- 3.2.4.1 Note shape and size of spot through collimator eye piece.
- 3.2.4.2 Using retical determine size (in minutes of arc) of spot.
- 3.2.4.3 Rotate telescope and telescope cradel clockwise horizontally about front cover axis until outer scribe on dummy detector is in field of view.

FORM DRG 2112 REV 6 B1

# Rockwell International Corporation

FSCM NO 94756

NUMBER	AA0309-026	REVISION LETTER	PAGE	8
--------	------------	-----------------	------	---

- 3.2.4.4 Adjust collimator barrel until best focus is obtained and record collimator barrel position.
- 3.2.4.5 Repeat Steps 3.2.4.1 and 3.3.4.2. Spot will change from round disc to an ellipse.
- 3.2.4.6 Rotate telescope and telescope cradle counterclockwise about front cover axis until outer scribe on dummy detector is in field of view.
- 3.2.4.7 Repeat Steps 3.2.4.1 and 3.2.4.2.
- 3.2.4.8 Return telescope to center spot on dummy detector.

## 4.0 QUALITY ASSURANCE PROVISIONS

### 4.1 Workmanship

- 4.1.1 Care shall be taken at all times to handle components so as not to contaminate or injure same.

### 4.2 Acceptance

- 4.2.1 Cold focus position of collimator shall be within .050 inch of infinity setting (3.2.3.12) with dummy detector set at .1310 behind detector.
- 4.2.2 Actual spot size of return image in collimator eye piece, (3/2/4/2) shall be determined in the following manner:

Measured spot size, minus projected collimator spot size, and the result divided by two.

- 4.2.3 The resulting spot size from step 4.2.2 shall be less than three minutes.

### 4.3 Definitions

- 4.3.1 The following are definitions used on Worksheet 1:

- FFM - First Folding Mirror
- PM - Primary Mirror
- FRM - First Relay Mirror
- SRM - Second Relay Mirror

Rockwell International Corporation

FSCM NO 94756

NUMBER AA0309-026	REVISION LETTER						PAGE 9
	B						

WORKSHEET 1

1. FFM mounting surface to surface "A" of inner housing.
2. FFM mounting surface to PM mounting surface.
3. Result (1-2) req'd dimension from surface A to C of support ring.

4. SRM mounting surface to surface "A" of support cone.
5. SRM mounting surface to PM mounting surface.
6. Result (4-5) req'd dimension from surface C to D of support ring.

--

7. PM mounting surface to FRM mounting surface (req'd dimension from surface C to E of support ring).

8. Enter result from Line 3
9. Surface "A" to surface F of support ring.
10. Detector array mask to detector mounting surface
11. Surface B to detector mounting surface of thermal isolator
12. Total (8 + 9 + 10 = 11)



13. PM mounting surface to focal plain
14. Enter result from Line 12
15. Result (13 - 14) req'd dimension from surface A to C of support cylinder

Rockwell International Corporation

FSCM NO 94756

NUMBER 1007-10-01	REVISION LETTER								PAGE 10

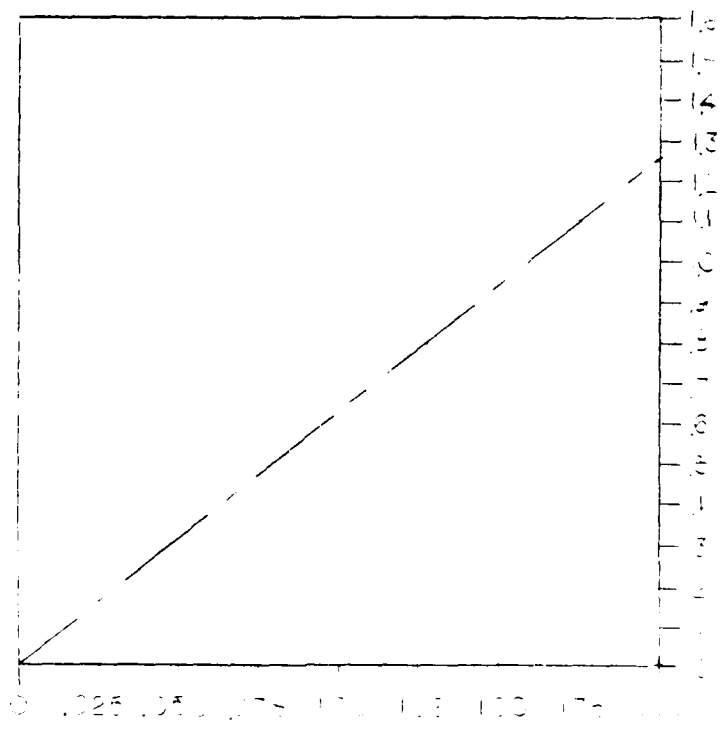
RO SPICE VS. COLLIMATOR



TELESCOPE

COLLIMATOR

1007-10-01-010

AD-A184 701

SURVEY PROBE INFRARED CELESTIAL EXPERIMENT (SPICE)(U)  
ROCKWELL INTERNATIONAL ANAHEIM CA DEFENSE ELECTRONICS  
OPERATIONS R C BERRY ET AL. JAN 85 C77-561/201  
AFGL-TR-85-0087 F18628-77-C-0048

3/3

UNCLASSIFIED

F/O 1998

DL

END
DATE
FORM
4-86
DTL

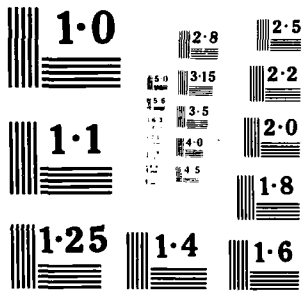

C77-551/201

A P P E N D I X D

D-1

<b>PREPARED BY</b>	<b>CODE IDENT. NO.: 94756</b>   <b>Autonetics</b> North American Rockwell  <b>SPECIFICATION</b>	<b>NUMBER</b>
A. M. McDevitt		C77-1108/201
<b>APPROVALS</b>		<b>TYPE</b>
A. M. McDevitt		<b>DATE</b>
		November 4, 1977
		<b>SUPERSEDES SPEC. DATED:</b>
		<b>REV. LTR.</b>
		<b>PAGE 1 of 29</b>

**TITLE**  
 SPICE PROGRAM ENVIRONMENTAL ACCEPTANCE TEST PROCEDURE

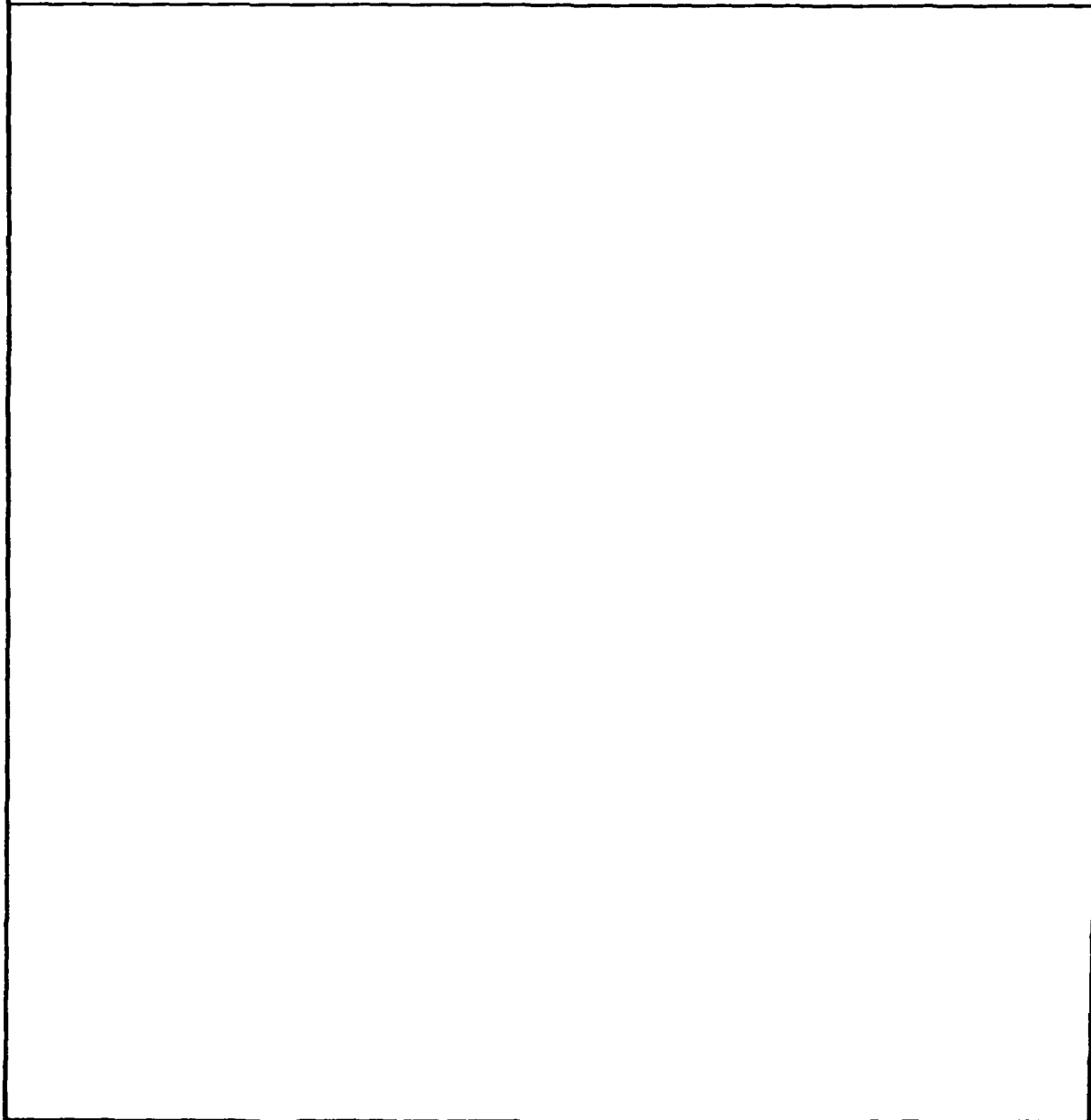



# Rockwell International Corporation

CODE IDENT. NO. 94756

NUMBER	REVISION LETTER	PAGE
C77-1108/201		i

## INDEX

1.0	INTRODUCTION	1
2.0	TESTS DEFINED IN THIS TEST PLAN	1
3.0	EQUIPMENT CONFIGURATION	1
4.0	APPLICABLE DOCUMENTS	1
5.0	TEST EQUIPMENT	2
6.0	BASELINE TESTS	2
6.1	Preliminary Setup	3
6.2	System Operation	5
6.3	Cryogen Fill	8
6.4	Detector Tests	9
7.0	ENVIRONMENTAL TEST	11
7.1	Portions of the Baseline Test required prior to and following the Environmental Test	11
7.2	Vibration Test	12
APPENDIX A		
	Data Sheets	14
APPENDIX B		
Figure 1	System Cables	21
Figure 2	Cryogen Fill	22
Figure 3	Sensor Axis	23
Figure 4	Accelerometer Location	24
APPENDIX C		
Table 1	SPICE Decom Signal Format	25

**Rockwell International Corporation**  
**Missile Systems Division**  
Columbus, Ohio 43216      Anaheim, Calif 92803

CODE IDENT NO 51215

<b>NUMBER</b> C77-1108/201	<b>REVISION LETTER</b> 	<b>PAGE</b> 1
-------------------------------	----------------------------	---------------

1.0      INTRODUCTION

This document contains the baseline and environmental test procedures that will be required for the Survey Probe Infrared Celestial Experiment (SPICE) Sensor System. The baseline test will verify system operation and establish a performance reference with a data bank of equipment operating parameters. The environmental test will insure proper system operation when the equipment has been exposed to simulated mission environment.

Prior to conducting the tests contained in the document, the system will have completed the engineering test phase.

2.0      TESTS DEFINED IN THIS TEST PLAN

- a. Baseline
- b. Vibration

3.0      EQUIPMENT CONFIGURATION

The system consists of two major assemblies.

- 1. Sensor P/N 45800-701
- 2. Pulse Code Modulator (PCM) P/N 2226050

4.0      APPLICABLE DOCUMENTS

- a. Sensor Assembly                      45800-701
- b. PCM                                      2226050
- c. Evacuation Procedure                AA0209-105
- d. System Interconnect Diagram       40356-509
- e. Contract Statement of Work
- f. Environment Test Methods            MIL-STD-810B C/N 1, 2 & 3
- g. AGE
  - (1) Sensor Control Panel              40555-509
  - (2) Vehicle Control Panel            40552-509
  - (3) PCM Control Panel                40545-509
  - (4) AGE Power Supply                40545-509

**Rockwell International Corporation**  
**Missile Systems Division**  
 Columbus, Ohio 43216      Anaheim, Calif. 92803

CODE IDENT NO 51215

NUMBER C77-1108/201	REVISION LETTER						PAGE 2

4.0      APPLICABLE DOCUMENTS - (Continued)

- (5) AGE Power Panel                      40538-509
- (6) Sensor Control Console              40523-509
- (7) Detector Output Panel                40530-509
- (8) Housekeeping Panel                  40540-509

5.0      TEST EQUIPMENT

The following commercial test equipment or equivalent will be required to conduct these tests. Special equipment such as Shaker Head, etc., are not listed here.

<u>NAME</u>	<u>MANUFACTURER/MODEL</u>
Oscilloscope	Tektronix - RM564
Plug-in	Tektronix - 3B5
Plug-in	Tektronix - 3A3
Camera	Tektronix - C27
Magnetic Tape Recorder	Honeywell - 7600

6.0      BASELINE TESTS

General baseline tests are operational system level tests conducted under ambient laboratory conditions to establish a performance reference and data bank of system operating parameters. The baseline tests are designed to verify all operational characteristics of the sensor system including interfaces with external equipments. These tests will be performed prior to subjecting the system to the environmental test. Portions of the tests will be performed prior to and following the environmental test. After environmental testing is complete, the full baseline will be repeated and the results compared with the pre-environmental baseline test.

The data will be recorded on data sheets provided as part of this document and retained as part of the data bank. The test data will be dated and signed by the Test Engineer.

**Rockwell International Corporation**  
**Missile Systems Division**  
 Columbus, Ohio 43218      Anaheim, Calif 92803

CODE IDENT NO 51215

NUMBER C77-1108/201	REVISION LETTER						PAGE 3

6.0      BASELINE TESTS - (Continued)

The baseline tests described herein may be changed or modified by the responsible Autometrics Test Engineer as necessary to fulfill the test objectives. The Test Engineer will redline a master copy of this procedure to record any such changes. The changes will be dated and initialized by the Test Engineer. The master copy will be retained as part of the data bank.

6.1      Preliminary Setup

6.1.1    The sensor shall be evacuated per Evacuation Procedure AA0209-103.

6.1.2    The AGE control functions shall be placed in the following initial conditions.

6.1.2.1    AGE Power Panel

DC

+28V	OFF
+15V	OFF

AC

115V	OFF
------	-----

6.1.2.2    AGE Control Panel

Power Supply Package Key	OFF (Full CW)
Detector Heater	DISABLE
Mirror Heater	OFF
Heater Exhaust	OFF
Heater Dewar	DISABLE (Rotary SW)
Cryogen Level	OFF (Rotary SW)

6.1.2.3    Vehicle Control Panel

System Power	OFF
Power Supply Package	OFF
RMVL INHB	ON

**Rockwell International Corporation**  
**Missile Systems Division**  
 Columbus, Ohio 43218      Anaheim, Calif 92803

CODE IDENT NO. 51215

NUMBER C77-1108/201	REVISION LETTER						PAGE 4

6.1.2.4    Decommutator (DSI Model 7103)

Input Code	NRZ-L
Bit Rate	No. 6
Bit Sync	NORMAL
Data	NORMAL
Clock	NORMAL
Bit/Wd	10
Wd/Fr	064
Frame Sync Pattern:	76571464000
Frame Sync Length:	30
Parity	OUT
FR/SFR	032
SFID - Location	
Word	004
MSB	05
SFID - Start	0
Display	DECIMAL
WORD OR FRAME	AS REQ'D
FRAME NO.	000
WORD NO.	063
Power	OFF

6.1.2.5    PCM Control Panel

PCM AGE Power	OFF
AGE Clock	OFF

6.1.2.6    Detector Output Panel

S Output	OFF (Rotary SW)
M Output	OFF (Rotary SW)
L Output	OFF (Rotary SW)

**Rockwell International Corporation**  
**Missile Systems Division**  
 Columbus, Ohio 43216      Anaheim, Calif 92803

CODE IDENT NO. 51215

NUMBER C77-1108/201	REVISION LETTER						PAGE 5

6.1.2.7 AGE Housekeeping Panel

Test Signals	OFF (Rotary SW)
Temperatures	OFF (Rotary SW)
Power Status	OFF (Rotary SW)

6.1.2.8 Digital Multimeter

Power	OFF
-------	-----

6.1.2.9 AGE Power Supply

Key	OFF (Full CW)
-----	---------------

6.1.3 Connect cabling as shown in Figure 1.

6.2 System Operation

6.2.1 Use the following switch sequence to turn system power ON

6.2.1.1 AGE Power Panel

AGE Power (115 V)	ON
DC Power	
(1) +28V	ON
(2) +15VV	ON

6.2.1.2 AGE Control Panel

Power Supply Package Key	ON (Full CCW)
--------------------------	---------------

6.2.1.3 Vehicle Control Panel

Power Supply Package	ON
System Power	ON

6.2.1.4 PCM Control Panel

PCM AGE Power	ON
---------------	----

6.2.2 Operation Verification

6.2.2.1 Turn the multimeter on, then read and record the following voltages

Rockwell International Corporation  
Missile Systems Division  
Columbus, Ohio 43216      Anaheim, Calif 92803

CODE IDENT NO 51215

NUMBER	REVISION LETTER	PAGE
C77-1108/201		6

6.2.2.1.1 Vehicle Control Panel

+8 Vdc  
-16 Vdc  
+16 Vdc  
-24 Vdc  
+24 Vdc

6.2.2.1.2 Housekeeping Panel

+10 Vdc  
+15 Vdc  
+16 Vdc  
+24 Vdc  
-15 Vdc  
-16 Vdc  
-24 Vdc

6.2.2.1.3 PCM Control Panel

+24 Vdc

6.2.2.2 Verify the following status lights.

6.2.2.2.1 AGE Power Panel

+28 Vdc      ON  
+15 Vdc      ON  
115 Vac      ON

6.2.2.2.2 AGE Control Panel

Cryogen LVL  
10%      OFF  
60%      OFF  
100%      OFF  
Mirror Heater      OFF  
Heater  
EXHST      OFF  
Dewar

**Rockwell International Corporation**  
**Missile Systems Division**  
 Columbus, Ohio 43216      Anaheim, Calif 92803

CODE IDENT NO 51215

NUMBER C77-1108/201	REVISION LETTER						PAGE 7

6.2.2.2.2. AGE Control Panel (Continued)

DISAB            ON  
 Linear           OFF  
 Full            OFF

WARNING

EXHAUST Heater OFF  
 Dewar Heater    OFF

PWR SUPPLY PKG    ON

Commands

INSTL            ON  
 RMVL            OFF

6.2.2.2.3 Vehicle Control Panel

Power

PWR SUPPLY PKG    ON  
 SYSTEM            ON

Commands

INSTL            ON  
 RMVL            OFF  
 RMVL INHB        ON

6.2.2.2.4 PCM Control Panel

PCM AGE Power    ON  
 AGE Clock        OFF

6.2.2.2.5 AGE Housekeeping Panel

System Status

RMVL            OFF  
 INSTL COMP      OFF  
 OP CMD          OFF  
 BBC             OFF  
 EDC             OFF  
 RMVL STAT      OFF



Rockwell International Corporation  
Missile Systems Division  
Columbus, Ohio 43216      Anaheim, Calif 92803

CODE IDENT NO 51215

NUMBER C77-1108/201	REVISION LETTER	PAGE 8
------------------------	-----------------	-----------

- 6.2.2.3 Read and record the "Launch Critical" meters on the AGE Housekeeping Panel and the voltage at the test pt.
- DET PKG FACE NUMBER ONE
  - HEAT EXCHANGER
  - REAR COVER
  - COLD BACKGROUND PLATE
  - POWER SUPPLY HEAT SINK
  - SENSOR VACUUM
  - DEWAR PRESSURE
- 6.2.2.4 Verify the elapsed time meter on the AGE Housekeeping Panel is running.
- 6.5 Cryogen Fill
- 6.3.1 Connect the cryogen fill equipment as shown in Figure 2. If the sensor is warm at the start of the fill, paragraph 6.3 must be completed. If the sensor is cold due to an earlier cryogen fill, proceed to paragraph 6.3.5 and bypass the integrated flow meter, etc.
- 6.3.2 Record the elapsed time meter reading.
- 6.3.3 Adjust the GHe pressure to obtain a vent flow rate of 50 to 60 liters per minute for the first four hours, then increase the flow rate to between 60 and 75 liters per minute until the Central Tube Exp temperature (Housekeeping Panel) is 1.2 Vdc.
- 6.3.4 At 30 minute intervals after the start of fill and until the fill has been completed, record to following:
- Time
  - Integrated Flow
  - Flow Rate
  - Housekeeping Panel:
    - Detector Package Face Number One
    - Heat Exchanger
    - Rear Cover
    - Cold Background Plate
    - Power Supply Heat Sink
    - Sensor Vacuum
    - Detector Package Face 2
    - Detector Package Rear

**Rockwell International Corporation**  
**Missile Systems Division**  
Columbus, Ohio 43216      Anaheim Calif 92803

CODE IDENT NO 51215

NUMBER	REVISION LETTER	PAGE
C77-1108/201		10

- 6.4.3 Record the DC level of the 18 L channels on the Detector Output Panel.
- 6.4.4 Connect the oscilloscope to detector channels S16 on the Detector Output Panel.
  - 6.4.4.1 Take a photograph of the noise.
  - 6.4.4.2 Actuate the EM Diode on the Vehicle Control Panel. Take a photograph of the emitter diode signal.
- 6.4.5 Connect the oscilloscope to detector channel M9 on the Detector Output Panel then repeat 6.4.4.1 and 6.4.4.2.
- 6.4.6 Connect the oscilloscope to detector channel L12 on the Detector Output Panel then repeat 6.4.4.1 and 6.4.4.2.
- 6.4.7 Connect the FM tape recorder to each of the 57 detector channels of the Detector Output Panel. Actuate the EM Diode on the Vehicle Control Panel and record at least one cycle of the emitter diode from each detector channel.
- 6.4.8 PCM Verification
  - 6.4.8.1 Turn ON the decommutator power.
  - 6.4.8.2 Dial word no. 005 and place word/frame switch in "word" position.
    - 6.4.8.2.1 Connect vehicle data 1 (PCM control panel) to the +8 Vdc (vehicle control panel). The decommutator will read  $1022 \pm 1$ . Disconnect the +8 Vdc.
    - 6.4.8.2.2 Short the input to vehicle data 1. The decommutator will read zero +1, -0.
  - 6.4.8.3 Connect the FM tape recorder to the decommutator analog output. Dial the appropriate word for each of the 57 detector channels (see Table 1). Actuate the EM diode on the Vehicle Control Panel and record at least one cycle of the emitter diode from each detector channel.
  - 6.4.8.4 Connect the oscilloscope to the decommutator analog output. Dial the appropriate word for detector channel S16.
    - 6.4.8.4.1 Take a photograph of the noise.
    - 6.4.8.4.2 Actuate the EM diode on the Vehicle Control Panel. Take a photograph of the emitter diode signal.
    - 6.4.8.4.3 Dial the appropriate word for detector channel M9 then repeat paragraphs 6.4.8.4.1 and 6.4.8.4.2.

Rockwell International Corporation  
Missile Systems Division  
Columbus, Ohio 43216 Anaheim, Calif 92803

CODE IDENT NO 51215

NUMBER C77-1108/201	REVISION LETTER	PAGE 9
------------------------	-----------------	--------

6.3.4 Housekeeping Panel - (Continued)

Opt Cone Mask  
Opt Hsg Fwd Exp  
Central Tube Exp  
Outer Housing  
Det Sig Procsr HS  
Blackbody  
Dewar Clg Post  
Det Pkg Face 3  
Det Pkg Cone  
Sec Mirror Support  
Opt Hsg Fwd Obs  
Central Tube Obs  
Front Cover  
Electronics Heat Sink  
Vent Gas

- 6.3.5 After the Central Tube Exp temperature is  $\geq 1.2$  Vdc, bypass the integrated flow meter with the vent gas. Then increase the GHe pressure to  $2.5 \pm .5$  lb. The pressure gauge on the dewar can be used for this setting.
- 6.3.6 Record the time and voltage when the 10% indicator lights. (AGE Control Panel)
- 6.3.7 Record the time and voltage when the 60% indicator lights. (AGE Control Panel)
- 6.3.8 Record the time and voltage when the 100% indicator lights. (AGE Control Panel)
- 6.3.9 After the 100% indicator lights reduce the GHe pressure to  $2.0 \pm .3$  lb. and continue cryogen flow for  $3 \pm 1$  minutes.
- 6.3.10 Use the AGE heater as required while capping the fill and vent line.
- 6.3.11 Record the amount of cryogen required to complete the fill.
- 6.4 Detector Tests
- 6.4.1 Record the DC level of the 18 S channels on the Detector Output Panel.
- 6.4.2 Record the DC level of the 18 M channels on the Detector Output Panel.

Rockwell International Corporation  
Missile Systems Division

Columbus, Ohio 43216      Anaheim, Calif 92803

CODE IDENT NO 51215

NUMBER C77-1108/201	REVISION LETTER	PAGE 11
------------------------	-----------------	------------

6.4.8.6 . Dial the appropriate word for detector channel L12 then repeat paragraphs 6.4.8.4.1 and 6.4.8.4.2.

6.4.8.7 Dial the appropriate word for all signals of word numbers 063 and 064 and frame numbers 004 through 028 that are listed in Table 1. Place word/frame switch in the Frame position. Record each signal level.

7.0 ENVIRONMENTAL TESTS

General

Prior to and following the environmental test, portions of the baseline tests will be completed. This will verify there is no degradation of operation due to the environmental test. The vibration test will be conducted at AETL in Fullerton, California.

7.1 Portions of the Baseline test required prior to and following the environmental test.

7.1.1 Repeat 6.1.

7.1.2 Repeat 6.2.

7.1.3 Repeat 6.3.

7.1.4 Repeat 6.4.4.

7.1.5 Repeat 6.4.5.

7.1.6 Repeat 6.4.6.

7.1.7 Actuate the EM Diode on the Vehicle Control Panel and use the oscilloscope to verify operation of each detector channel on the Detector Output Panel.

7.1.8 Repeat 6.4.8.1.

7.1.9 Repeat 6.4.8.2.

7.1.10 Repeat 6.4.8.4.

7.1.11 Repeat 6.4.8.5.

7.1.12 Repeat 6.4.8.6.

7.1.13 Repeat 6.4.8.7.

7.1.14 Actuate the EM Diode on the Vehicle Control Panel and use the oscilloscope to verify operation of each detector channel at the decommutator analog output.

**Rockwell International Corporation**  
**Missile Systems Division**  
 Columbus, Ohio 43218      Anaheim, Calif 92803

CODE IDENT NO 51215

NUMBER C77-1108/201	REVISION LETTER 	PAGE 12
------------------------	---------------------	------------

7.2      Vibration Test

General

The telescope assembly and PCM will be subjected to vibration tests in thrust, which is defined in Figure 3. Accelerometers will be mounted as defined in Figure 4. The response will be recorded on magnetic tape and X-Y plots will be produced for evaluation. The system will be cryogenically cooled and power will be applied for the test. Visual inspection shall be made to the equipment after the vibration test.

7.2.1      Sinusoidal Test

7.2.1.1      Install the vibration fixture on a slip table. The vibration fixture will be mounted to the shaker head for excitation in the thrust axis.

7.2.1.2      Install control accelerometers at the mounting points.

7.2.1.3      Equalize the vibration fixture and shaker head. Review the resulting X-Y plots prior to proceeding.

7.2.1.4      Install the telescope assembly and PCM.

7.2.1.5      Equalize the vibration fixture and the sensor. Review the resulting X-Y plots prior to proceeding.

7.2.1.6      Install the accelerometers for thrust axis vibration excitation. Refer to Figure 4.

7.2.1.7      Perform 6.1, 6.2 and 6.3 of the Baseline test.

7.2.1.8      Perform a frequency survey with the following conditions: \*

Type Signal	Sinusoidal
Frequency Range	5 to 2000 Hz
Sweep Range	≤ 4 octave/minute
Mtg. Point Max. Transmissibility	< ± 3 db
Crosstalk	< 3 db of input at all frequencies
Data	X-Y plots and FM tape of each accelerometer
10 to 50 Hz	1.5 g
50 to 160 Hz	5.0 g
160 to 2000 Hz	3.0 g

\* Perform a low "g" level run at 0.5 g and evaluate the X-Y plot prior to proceeding.

Rockwell International Corporation  
Missile Systems Division  
Columbus, Ohio 43216      Anaheim, Calif 92803

CODE IDENT NO 51215

NUMBER	REVISION LETTER	PAGE
C77-1108/201		13

7.2.2 Random Test

7.2.2.1 Repeat 7.2.1.1 through 7.2.1.7 for the thrust axis.

7.2.2.2 Perform the random vibration with the following conditions.

Frequency Range	20 to 2 KHz
Duration	10 seconds
Level	0.025 $g^2/Hz$

**Rockwell International Corporation**  
**Missile Systems Division**  
 Columbus, Ohio 43216      Anaheim Calif 92803

CODE IDENT NO 51215

NUMBER C77-1108/201	REVISION LETTER						PAGE 14

APPENDIX A

DATA SHEET

<u>Paragraph</u>	<u>Signal</u>	<u>Reading</u>	<u>Tolerance</u>
6.2.2.1.1	8 vdc	_____	8 vdc + .4 vdc
	-16 vdc	_____	-16 vdc + .8 vdc
	16 vdc	_____	16 vdc + .8 vdc
	-24 vdc	_____	-24 vdc + 1.2 vdc
	24 vdc	_____	24 vdc + 1.2 vdc
6.2.2.1.2	10 vdc	_____	4 vdc + .50 vdc
	15 vdc	_____	4 vdc + .50 vdc
	24 vdc	_____	4 vdc + .50 vdc
	-15 vdc	_____	4 vdc + .50 vdc
	-16 vdc	_____	4 vdc + .50 vdc
	-24 vdc	_____	4 vdc + .50 vdc
	+16 vdc	_____	4 vdc + .50 vdc
6.2.2.1.5	+24 vdc	_____	24 vdc + 1.2 vdc
6.2.2.3	Det. Pkg. Face Number One	_____	
	Heat Exchanger	_____	
	Rear Cover	_____	
	Cold Background Plate	_____	
	Power Supply Heat Sink	_____	
	Sensor Vacuum	_____	
	Dewar Pressure	_____	
6.5.2	Time	_____	

Rockwell International Corporation

CODE IDENT. NO. 94756

NUMBER C77-1108/201	REVISION LETTER	PAGE 15
------------------------	-----------------	---------

TIME																				
Integrated Flow																				
Flow Pate																				
Det Pkg Face 1 Temp																				
Heat Exchange Temp																				
Rear Cover Temp																				
Cold Background Temp																				
Power Supply H.S. Temp																				
Sensor Vacuum																				
Det Pkg Face 2 Temp																				
Det Pkg Rear Temp																				
Opt Cone Mask Temp																				
Central Tube Exp Temp																				
Outer Housing Temp																				
Det Sig Procsr H.S. Temp																				
Blackbody Temp																				
Dewar Clg Post Temp																				
Det Pkg Face 3 Temp																				
Det Pkg Cone Temp																				
Sec Mirror Temp																				
Opt HSG Fwd GSS Temp																				
Central Tube OBS Temp																				
Front Cover Temp																				
Electronics H.S. Temp																				
Vent Gas Temp																				
Opt HSG Fwd Exp																				

APPENDIX A  
6.3.4 Data Sheet



# Rockwell International Corporation

CODE IDENT. NO. 94756

NUMBER C77-1108/201	REVISION LETTER	PAGE 16
------------------------	-----------------	---------

DATA SHEET	APPENDIX A		
<u>PARAGRAPH</u>	<u>SIGNAL TIME</u>	<u>READING</u>	<u>TOLERANCE</u>
6.3.6	Time	_____	Not Applicable
6.3.6	10% Voltage Level	_____	6.2 ± 0.25 vdc
6.3.7	Time	_____	Not Applicable
6.3.7	60% Voltage Level	_____	6.2 ± 0.25 vdc
6.3.8	Time	_____	Not Applicable
6.3.8	100% Voltage Level	_____	6.2 ± 0.25 vdc
6.4.1	S1	_____	Not Applicable
	S3	_____	
	S3	_____	
	S4	_____	
	S5	_____	
	S6	_____	
	S7	_____	
	S8	_____	
	S9	_____	
	S10	_____	
	S11	_____	
	S12	_____	
	S13	_____	
	S14	_____	
	S15	_____	
	S16	_____	
	S17	_____	
	S18	_____	
6.4.1	S19	_____	

Rockwell International Corporation

CODE IDENT. NO. 94756

NUMBER C77-1108/201	REVISION LETTER	PAGE 17
------------------------	-----------------	---------

APPENDIX A

DATA SHEET

<u>PARAGRAPH</u>	<u>SIGNAL TIME</u>	<u>READING</u>	<u>TOLERANCE</u>
6.4.2	M1	_____	Not Applicable
	M2	_____	
	M3	_____	
	M4	_____	
	M5	_____	
	M6	_____	
	M7	_____	
	M8	_____	
	M9	_____	
	M10	_____	
	M11	_____	
	M12	_____	
	M13	_____	
	M14	_____	
	M15	_____	
	M16	_____	
	M17	_____	
	M18	_____	
6.4.2	M19	_____	Not Applicable

# Rockwell International Corporation

CODE IDENT. NO. 94756

NUMBER C77-1108/201	REVISION LETTER 	PAGE 18
------------------------	---------------------	---------

## APPENDIX A

### DATA SHEET

<u>PARAGRAPH</u>	<u>SIGNAL TIME</u>	<u>READING</u>	<u>TOLERANCE</u>
6.4.3	L1	_____	Not Applicable
	L2	_____	
	L3	_____	
	L4	_____	
	L5	_____	
	L6	_____	
	L7	_____	
	L8	_____	
	L9	_____	
	L10	_____	
	L11	_____	
	L12	_____	
	L13	_____	
	L14	_____	
	L15	_____	
	L16	_____	
	L17	_____	
	L18	_____	
6.4.3	L19	_____	Not Applicable
6.4.8.2.1	100%	_____	1022 ± 1
6.4.3.2.2	Zero	_____	0, +1, -0

**Rockwell International Corporation**  
**Missile Systems Division**

Columbus, Ohio 43216      Anaheim, Calif 92803

CODE IDENT NO 51215

NUMBER	C77-1108/201	REVISION LETTER		PAGE 19
--------	--------------	-----------------	--	---------

DATA SHEET  
 PARAGRAPH 6.4.8.7

APPENDIX A

WORD NO.	FRAME NO.	SIGNAL	READING
063	004	Dewar Pressure	_____
064	004	Sensor Vacuum	_____
063	005	Vent Pressure	_____
063	006	Electronics Heat Sink Temperature	_____
064	006	Vent Gas Temp	_____
063	007	DSP Heat Sink Temperature	_____
064	007	Power Supply Heat Sink Temperature	_____
063	008	Central Tube, Exposed, Temperature	_____
064	008	Rear Cover Temperature	_____
063	009	Central Tube, Obscured, Temperature	_____
064	009	Outer Housing Temperature	_____
063	010	Secondary Mirror Support Temperature	_____
064	010	Detector Package Face #1 Temperature	_____
063	011	Detector Package Cone Temperature	_____
064	011	Detector Package Face #2 Temperature	_____
063	012	Detector Package Rear Temperature	_____
064	012	Detector Package Face #3 Temperature	_____
063	013	Heat Exchanger, Forward Temperature	_____
064	013	Optical Cone, Mask, Temperature	_____
063	014	Optical Housing Forward, Exposed Temp.	_____
064	014	Background Plate, Center, Temperature	_____
063	015	Optical Housing, Fwd., Obscured, Temp.	_____
064	015	Front Cover Temperature	_____
063	020	Dewar Cooling Post #1 Temperature	_____
064	020	Blackbody Temperature	_____
063	022	Detector Heater Power	_____
064	022	Dewar Heater Power	_____
063	023	Blackbody Heater Drive	_____
064	023	Cover Motor Current (Spare)	_____

# Rockwell International Corporation

CODE IDENT. NO. 94756

NUMBER	REVISION LETTER	PAGE
C77-1108/201		20

DATA SHEET  
PARAGRAPH 6.4.8.7

APPENDIX A

WORD NO.	FRAME NO.	SIGNAL	READING
063	024	+24 Vdc	_____
064	024	-24 Vdc	_____
063	025	+16 Vdc	_____
064	025	-16 Vdc	_____
063	026	+15 Vdc	_____
064	026	-15 Vdc	_____
063	027	+10 Vdc	_____
064	027	-10 Vdc	_____
063	028	+ 8 Vdc	_____
064	028	+ 5 Vdc	_____

# Rockwell International Corporation

CODE IDENT. NO. 94756

NUMBER C77-1108/201	REVISION LETTER	PAGE 21
------------------------	-----------------	---------

## APPENDIX B

Figure 1

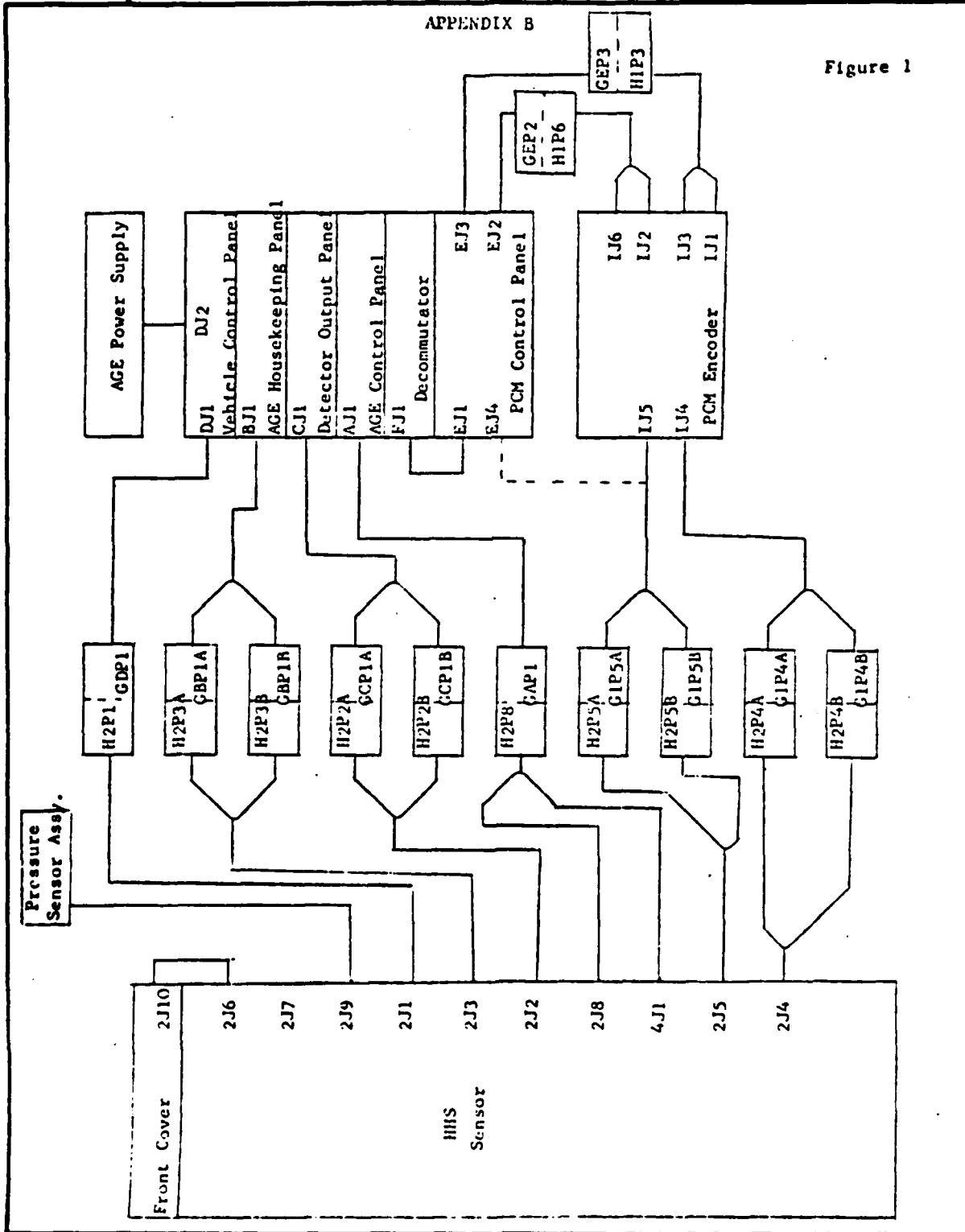

Rockwell International Corporation

CODE IDENT NO. 94756

NUMBER	REVISION LETTER	PAGE
C77-1108/201		22

APPENDIX B

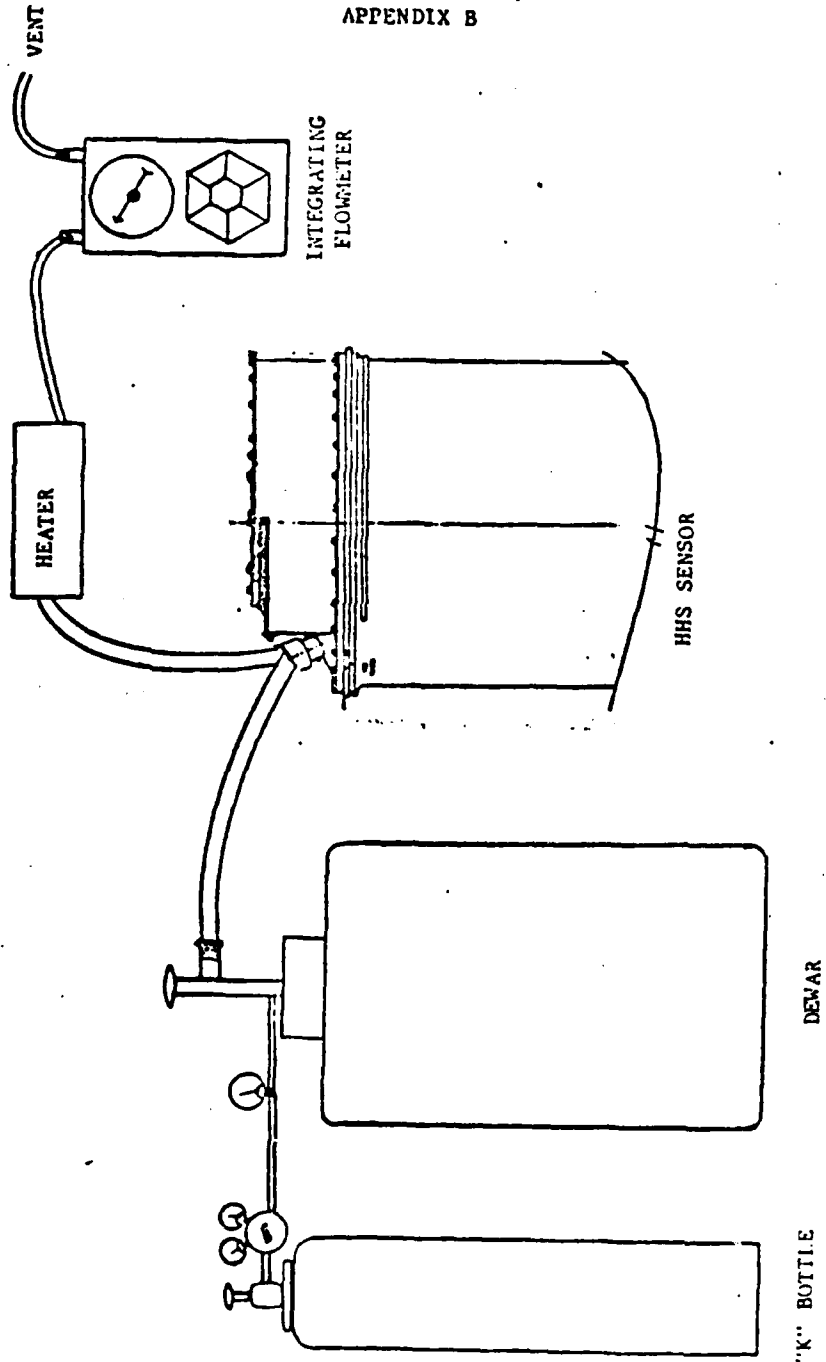

FIGURE 2

Rockwell International Corporation

CODE IDENT. NO. 94756

NUMBER C77-1108/201	REVISION LETTER								PAGE 23

APPENDIX B

FIG-28 TWO TO KEEP 3 PLACES  
EQUALLY SPACED FOR MARKING  
PURPOSES

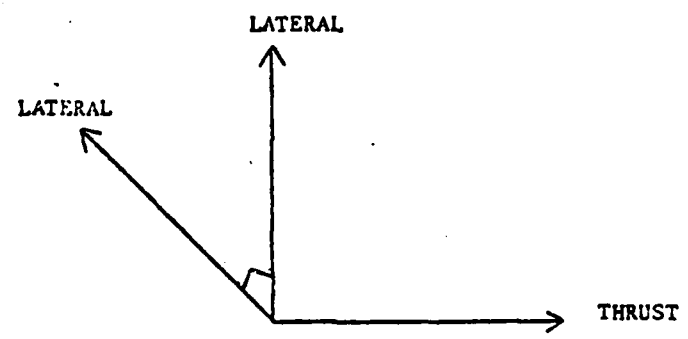
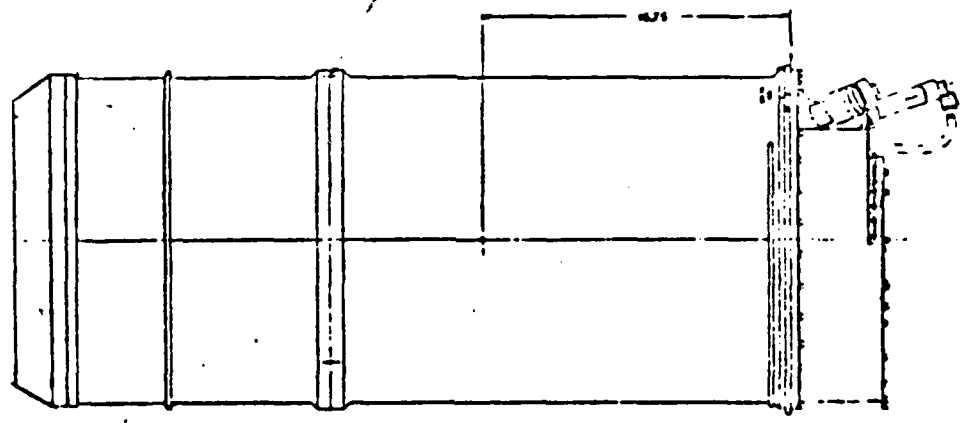

Figure 3



# Rockwell International Corporation

CODE IDENT. NO. 94756

NUMBER	C77-1108/201	REVISION LETTER	PAGE	24

## APPENDIX B

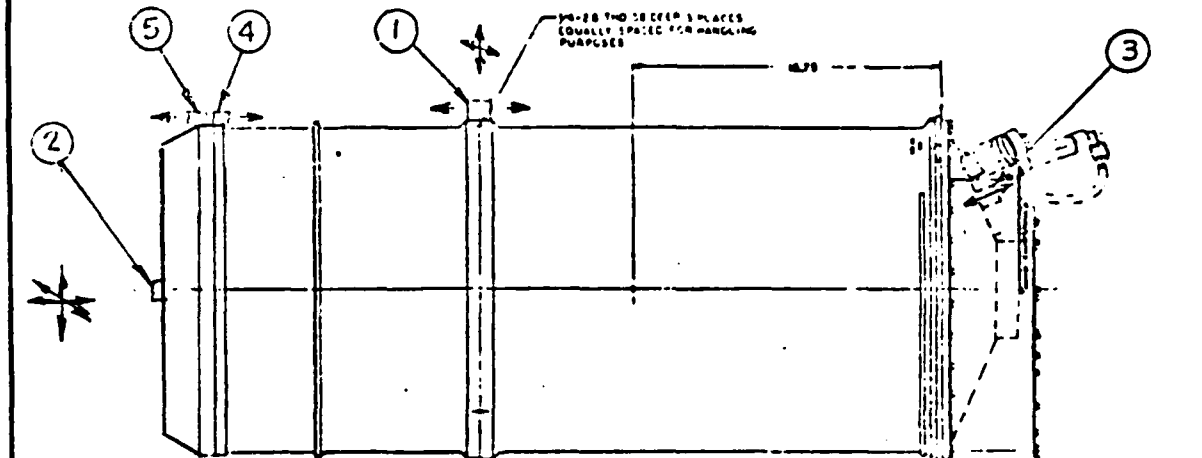

The following describes the location of the accelerometers for the Hi Hi Star Telescope Environmental Acceptance Vibration Test. In addition to the following accelerometers it is required that the input vibration fixture be monitored by a triad (three mutually orthogonal axes) accelerometer. The input axes of the triad accelerometer are to be aligned parallel with the three mutually orthogonal directions of vibration input.

1. Triad accelerometer located on the telescope outer housing support rod stiffening ring. This accelerometer is to be in a plane passing thru the telescope longitudinal axes (Line of Sight) and the center line of the cryogen fill port. The input axes of the triad accelerometer are to be aligned parallel with the three mutually orthogonal directions of vibration input.
2. Triad accelerometer mounted to the front cover ~~and~~ near the center line of the telescope. ~~This accelerometer is to be mounted near a flange of the cover removal mechanism to minimize secondary effects.~~ The input axes of the triad accelerometer are to be aligned parallel with the three mutually orthogonal directions of vibration input.
3. A single axis accelerometer mounted to the flange of the rear cover near the hermetic connector plate. This accelerometer is to be aligned with its input axis parallel to the longitudinal axis of the telescope.
4. A single axis accelerometer mounted to the front cover sealing flange of the outer housing. The accelerometer input axis is to be aligned parallel with the longitudinal axis of the telescope.
5. A single axis accelerometer mounted to the sealing flange of the front cover. This accelerometer is to be located directly opposite the accelerometer mounted to the front flange of the outer housing. The accelerometer input axis is to be aligned parallel with the longitudinal axis of the telescope.

Figure 4

# Rockwell International Corporation

CODE IDENT. NO. 94756

NUMBER C77-1108/201	REVISION LETTER 	PAGE 25
------------------------	---------------------	---------

## APPENDIX C

TABLE 1                      SPICE DECOM SIGNAL FORMAT

WORD NO.	FRAME NO.	SIGNAL
001	Not Applicable	Sync Word No. 1 (1111101011)
002	"	Sync Word No. 2 (1100110011)
003	"	Sync Word No. 3 (0100000000)
004	"	Subframe Identification (00000→11111)
005	"	Vehicle Data #1
006	"	Sensor Detector λ1 - S1
007	"	Sensor Detector λ2 - M1
008	"	Sensor Detector λ3 - L1
009	"	Sensor Detector λ1 - S2
010	"	Sensor Detector λ2 - M2
011	"	Sensor Detector λ3 - L2
012	"	Sensor Detector λ1 - S3
013	"	Sensor Detector λ2 - M3
014	"	Sensor Detector λ3 - L3
015	"	Sensor Detector λ1 - S4
016	"	Sensor Detector λ2 - M4
017	"	Sensor Detector λ3 - L4
018	"	Sensor Detector λ1 - S5
019	"	Sensor Detector λ2 - M5
020	"	Sensor Detector λ3 - L5
021	"	Sensor Detector λ1 - S6
022	"	Sensor Detector λ2 - M6
023	"	Sensor Detector λ3 - L6
024	"	Sensor Detector λ1 - S7
025	"	Sensor Detector λ2 - M7
026	"	Sensor Detector λ3 - L7
027	"	Vehicle Data #2
028	"	Sensor Detector λ1 - S8
029	"	Sensor Detector λ2 - M8
030	"	Sensor Detector λ3 - L8
031	Not Applicable	Sensor Detector λ1 - S9

# Rockwell International Corporation

CODE IDENT. NO. 94756

NUMBER C77-1108/201	REVISION LETTER						PAGE 26

## APPENDIX C

TABLE 1 SPICE DECOM SIGNAL FORMAT

WORD NO.	FRAME NO.	SIGNAL
032	Not Applicable	Sensor Detector $\lambda 2$ - M9
033	"	Sensor Detector $\lambda 3$ - L9
034	"	Sensor Detector $\lambda 1$ - S10
035	"	Sensor Detector $\lambda 2$ - M10
036	"	Sensor Detector $\lambda 3$ - L10
037	"	Sensor Detector $\lambda 1$ - S11
038	"	Sensor Detector $\lambda 2$ - M11
039	"	Sensor Detector $\lambda 3$ - L11
040	"	Sensor Detector $\lambda 1$ - S12
041	"	Sensor Detector $\lambda 2$ - M12
042	"	Sensor Detector $\lambda 3$ - L12
043	"	Sensor Detector $\lambda 1$ - S13
044	"	Sensor Detector $\lambda 2$ - M13
045	"	Sensor Detector $\lambda 3$ - L13
046	"	Sensor Detector $\lambda 1$ - S14
047	"	Sensor Detector $\lambda 2$ - M14
048	"	Sensor Detector $\lambda 3$ - L14
049	"	Vehicle Data #3
050	"	Sensor Detector $\lambda 1$ - S15
051	"	Sensor Detector $\lambda 2$ - M15
052	"	Sensor Detector $\lambda 3$ - L15
053	"	Sensor Detector $\lambda 1$ - S16
054	"	Sensor Detector $\lambda 2$ - M16
055	"	Sensor Detector $\lambda 3$ - L16
056	"	Sensor Detector $\lambda 1$ - S17
057	"	Sensor Detector $\lambda 2$ - M17
058	"	Sensor Detector $\lambda 3$ - L17
059	"	Sensor Detector $\lambda 1$ - S18
060	"	Sensor Detector $\lambda 2$ - M18
061	"	Sensor Detector $\lambda 3$ - L18
062	Not Applicable	Space Rate: 1500 SPS

# Rockwell International Corporation

CODE IDENT. NO. 94756

NUMBER C77-1108/201	REVISION LETTER	PAGE 27
------------------------	-----------------	------------

## APPENDIX C

TABLE 1                      SPICE DECOM SIGNAL FORMAT

WORD NO.	FRAME NO.	WORD IDENT.	SIGNAL
063	000 & 016	B1	Emitter Diode No. 1 Current
064	000 & 016	B2	"        "        No. 2 "
063	001 & 017	B3	"        "        No. 3 "
064	001 & 017	B4	"        "        No. 4 "
063	002 & 018	B5	"        "        No. 5 "
064	002 & 018	B6	Emitter Diode No. 6 Current
063	003 & 019	C1 Bit 1 (MSB)	Chopper Clock
"	"	"        C1 Bit 2	
"	"	"        C1 Bit 3	
"	"	"        C1 Bit 4	Blackbody Chopper Drive
"	"	"        C1 Bit 5	
"	"	"        C1 Bit 6	Cover Removal Status
"	"	"        C1 Bit 7	Cover Removal Command
"	"	"        C1 Bit 8	Cover Installation Complete
"	"	"        C1 Bit 9	Cover Removal Complete
063	003 & 019	C1 Bit 10 (LSB)	
064	003 & 019	C2 Bit 1 (MSB)	Emitter Diode No. 1 Status
"	"	"        C2 Bit 2	"        "        No. 2 "
"	"	"        C2 Bit 3	"        "        No. 3 "
"	"	"        C2 Bit 4	"        "        No. 4 "
"	"	"        C2 Bit 5	"        "        No. 5 "
"	"	"        C2 Bit 6	Emitter Diode No. 6 Status
"	"	"        C2 Bit 7	Emitter Diode Calibrate
"	"	"        C2 Bit 8	Blackbody Calibrate
"	"	"        C2 Bit 9	
064	003 & 019	C2 Bit 10 (LSB)	
063	004	C3	Dewar Pressure
064	004	C4	Sensor Vacuum
063	005	C5	Vent Pressure
064	005	C6	Primary Mirror Temp
063	006	C7	Electronics Heat Sink Temp

# Rockwell International Corporation

CODE IDENT. NO. 94756

NUMBER C77-1088/201	REVISION LETTER 	PAGE 28
------------------------	---------------------	---------

## APPENDIX C

TABLE 1

### SPICE DECOM SIGNAL FORMAT

WORD NO.	FRAME NO.	WORD IDENT.	SIGNAL
064	006	C8	Vent Gas Temp
063	007	C9	DSP Heat Sink Temp.
064	007	C10	Power Supply Heat Sink Temp.
063	008	C11	Central Tube, Exposed, Temperature
064	008	C12	Rear Cover Temperature
063	009	C13	Central Tube, Obscured, Temperature
064	009	C14	Outer Housing Temperature
063	010	C15	Secondary Mirror Support Temperature
064	010	C16	Detector Package Face #1 Temperature
063	011	C17	" " Cone Temperature
064	011	C18	" " Face #2 Temperature
063	012	C19	" " Rear Temperature
064	012	C20	Detector Package Face #3 Temperature
063	013	C21	Heat Exchanger, Forward Temperature
064	013	C22	Optical Cone, Mask, Temperature
063	014	C23	Optical Housing Forward, Exposed Temp.
064	014	C24	Background Plater, Center, Temperature
063	015	C25	Optical Housing, Fwd., Obscured, Temp.
064	015	C26	Front Cover Temperature
063	020	C27	Dewar Cooling Post #1 Temperature
064	020	C28	Blackbody Temperature
063	021	C29	Spare
064	021	C30	Spare
063	022	C31	Detector Heater Power
064	022	C32	Dewar Heater Power
063	023	C33	Blackbody Heater Drive
064	023	C34	Cover Motor Current (Spare?)
063	024	C35	+24 Vdc
064	024	C36	-24 Vdc

# Rockwell International Corporation

CODE IDENT. NO. 94756

NUMBER C77-1108/201	REVISION LETTER	PAGE 29
------------------------	-----------------	---------

## APPENDIX C

TABLE 1

### SPICE DECOM SIGNAL FORMAT

WORD NO.	FRAME NO.	WORD IDENT.	SIGNAL
063	025	C37	+16 Vdc
064	025	C38	-16 Vdc
063	026	C39	+15 Vdc
064	026	C40	-15 Vdc
063	027	C41	+10 Vdc
064	027	C42	-10 Vdc
063	028	C43	+8 Vdc
064	028	C44	+5 Vdc
063	029	C45	Spare
064	029	C46	Spare
063	030	C47	Spare
064	030	C48	Bkgrd $\lambda_1$ - SB
063	031	C49	Bkgrd $\lambda_2$ - MB
064	031	C50	Bkgrd $\lambda_3$ - LB

FILMED  
4-8