

MICROCOPY RESOLUTION TEST CHART
NATIONAL BUREAU OF STANDARDS-1963-A

14

DOT/FAA/PM-84/23

Program Engineering
and Maintenance Service
Washington, D.C. 20591

Structural Design Guidelines for Heliports

C.W. Schwartz
M.W. Witczak
R.B. Leahy

Department of Civil Engineering
University of Maryland
College Park, Maryland 20742

October 1984

Final Report

AD-A148 967

This Document is available to the U.S. public
through the National Technical Information
Service, Springfield, Virginia 22161.

DTIC FILE COPY

DTIC
ELECTE
JAN 04 1985
S
E



U.S. Department of Transportation
Federal Aviation Administration

84 12 27 066

NOTICE

This document is disseminated under the sponsorship of the Department of Transportation in the interest of information exchange. The United States Government assumes no liability for its contents or use thereof.

1. Report No. DOT/FAA/PM-84/23		2. Government Accession No.		3. Recipient's Catalog No.	
4. Title and Subtitle Structural Design Guidelines for Heliports. <i>FINAL RPT.</i>				5. Report Date October 24, 1984	
7. Author(s) C.W.Schwartz, M.W.Witczak, and R.B.Leahy				6. Performing Organization Code	
9. Performing Organization Name and Address Department of Civil Engineering University of Maryland College Park, MD 20742				8. Performing Organization Report No.	
12. Sponsoring Agency Name and Address U.S. Department of Transportation Federal Aviation Administration Program Engineering & Maintenance Service Washington, D.C. 20591				10. Work Unit No. (TRAIS)	
				11. Contract or Grant No. A01-80-10080	
				13. Type of Report and Period Covered Final Report 12/5/83 - 9/10/84	
				14. Sponsoring Agency Code APM-740	
15. Supplementary Notes Contract to: Systems Control Technology, Inc. 2326 S. Congress Ave., Suite 2-A West Palm Beach, Florida 33406					
16. Abstract Current structural design guidelines for heliports are analyzed using data obtained from the literature and from surveys of helicopter manufacturers, heliport design consultants, and heliport operators. Primary topics of interest in these analyses are the loads on heliport structures caused by helicopter hard landings, rotor downwash, and helicopter vibrations. A new analysis, based on reliability theory, is proposed for determining the helicopter hard landing load magnitudes appropriate for structural design. Results from this analysis indicate that the current FAA heliport structural design guidelines are adequate for medium to high volume heliports and conservative for low volume facilities. Additional analyses indicate that rotor downwash pressures and helicopter-induced vibrations are not critical loading conditions for most heliport structures. Guidelines for appropriate load combinations for heliport structural design are also presented.					
17. Key Words Heliports; Landing Loads; Gear Loads; Helicopter Downwash; Helicopter Vibrations			18. Distribution Statement This document is available to the U.S. public through the National Technical Information Service, Springfield, Virginia 22161.		
19. Security Classif. (of this report) Unclassified		20. Security Classif. (of this page) Unclassified		21. No. of Pages 116	22. Price

TABLE OF CONTENTS

	<u>Page</u>
NOTATION	-
1. INTRODUCTION	1
2. REVIEW OF TASK 1 FINDINGS	2
2.1 Literature Survey	2
2.2 Comparison of Existing Heliport Design Guidelines	3
2.3 Survey of Helicopter Manufacturers	6
2.4 Survey of Heliport Design Consultants	7
3. SURVEY OF HELIPORT OWNERS/OPERATORS	10
4. STRUCTURAL LOADS CAUSED BY HARD LANDINGS	16
4.1 Review of Current Practice	16
4.2 Structural Dynamic Load Magnification	22
4.3 Loads from Limit Load Drop Tests	25
4.4 Reliability-Based Approach to Hard Landing Loads	30
4.4.1 Basic Concepts	30
4.4.2 Statistical Analysis of Hard Landings	31
4.4.3 Formulation of Reliability Model for Hard Landing Loads	37
4.4.4 Results from the Reliability Model	43
4.5 Additional Comments on Hard Landing Load Magnitudes	48
4.6 Distribution of Landing Loads Through Landing Gear Components	50
4.7 Design of Landing Surface Against Punching Failure	50
5. DOWNWASH PRESSURES	53
5.1 Vertical Downwash	55
5.2 Horizontal Downwash	55
6. STRUCTURAL VIBRATIONS	70
7. OTHER STRUCTURAL LOADING CONDITIONS	74
7.1 Rooftop and Elevated Heliports	74
7.2 Ground Level Heliports	78
7.3 Load Combinations	80
8. SUMMARY OF STRUCTURAL LOADING GUIDELINES FOR HELIPORT DESIGN	80
8.1 Hard Landing Loads	80
8.2 Downwash Pressures	81
8.3 Structural Vibration	81
8.4 Load Combinations	82
9. SUGGESTIONS FOR FUTURE INVESTIGATIONS	82

TABLE OF CONTENTS (CONT.)

	<u>Page</u>
BIBLIOGRAPHY	84
APPENDIX A: Helicopter Dimensional Data	87
APPENDIX B: Survey Of Heliport Owners/Operators	96

Accession For	
NTIS GRA&I	<input checked="" type="checkbox"/>
DTIC TAB	<input type="checkbox"/>
Unannounced	<input type="checkbox"/>
Justification	
By _____	
Distribution/	
Availability Codes	
Dist	Avail and/or Special
A-1	



NOTATION

B	contact area width for skid gear
d	thickness of landing surface
DL	disk load
DLF	dynamic load factor
F_D	design hard landing load
F_P	peak landing gear load
$f_v(V)$	probability density function for v
$F_v(V)$	cumulative probability function for v
g	acceleration of gravity
HV	horizontal downwash velocity
HV_{Max}	maximum horizontal downwash velocity
l	contact area length for skid gear
LF	hard landing load factor
M	helicopter mass
m	number of helicopter operations at landing surface per year
MGW	maximum gross weight of helicopter
n	design life of landing surface, in years
N	total number of helicopter operations over life of heliport
P	static downwash pressure
P_o	total downwash pressure
P []	probability of event in []
R	rotor radius
R_{Hv}	HV/HV_{max}
RL	rotar lift factor

s	Shear stress
T	natural period of structure (first mode)
t_d	duration of loading
v	velocity (landing or downwash)
\bar{v}	mean landing velocity
v_D	design landing velocity
v_{HL}	threshold velocity for hard landing
v_o	vertical downwash velocity
x	horizontal distance from rotor hub
Z	height of rotor above ground
ρ_{SL}	density of air at sea level

1. INTRODUCTION

This final report summarizes the work performed by the Civil Engineering Department of the University of Maryland under subcontract No. T-0912, "Structural Design Guidelines for Heliports." This subcontract was in support of the SCT contract entitled "Guides for All-Weather Heliports," initiated under FAA Contract No. A01-80-C-10080, Task 2.

The overall objective of the subcontract was the development of structural design guidelines for heliport landing areas. Of major concern were helicopter induced structural loads due to hard landings, rotor downwash and vibrations.

The research effort consisted of two major tasks with specific elements and/or methodology of each as outlined below:

- I. Compilation, review and analysis of existing structural design criteria for heliports.
 - A. Literature review
 - B. Survey of helicopter manufacturers
 - C. Survey of heliport design consultants
 - D. Survey of heliport owners/operators
- II. Development of heliport structural design guidelines considering:
 - A. Hard landing impact loads
 - B. Rotor downwash
 - C. Structural vibrations
 - D. Heliport type and number of hourly movements (i.e., landings/takeoffs).

In view of the aforementioned tasks, this report includes eight additional chapters with major topics as follows:

2. Review of Task 1 Findings
3. Survey of Heliport Operators
4. Structural Loads Caused by Hard Landings
5. Structural Loads Caused by Rotor Downwash
6. Structural Vibrations
7. Other Structural Loading Conditions
8. Summary of Structural Loading Guidelines for Heliport Design
9. Suggestions for Future Investigations

2. REVIEW OF TASK 1 FINDINGS

As noted in the introduction, the focus of the Task 1 effort was twofold: the review and analysis of existing design criteria and structural loading data for heliport structures. To accomplish the goals of Task 1, a four part methodology was employed:

1. Literature Review
2. Survey of Helicopter Manufacturers
3. Survey of Heliport Design Consultants
4. Survey of Heliport Operators

The preliminary analyses of information from all sources suggested that rotor downwash and vibration loadings of heliport structures are considerably less significant than the impact loads from hard landings. The preliminary analyses also indicated that a precise yet simple method for determining the magnitudes of these hard landing impact loads for a wide range of helicopter types does not currently exist. Accordingly, the topic of hard landing impact loads became the number one priority of the Task 2 effort.

In the following subsections, the general findings from the Task 1 investigations are summarized. Specific Task 1 conclusions regarding hard landing loads, rotor downwash and structural vibrations are described in later sections of this report.

2.1 Literature Survey

To compile all relevant previous work on heliport loading considerations, a computerized literature search was made of several data bases: National Aeronautics and Space Administration (NASA), National Technical Information Service (NTIS) and Compendex/Engineering Index. The library collections at the Federal Aviation Administration, American Helicopter Association and University of Maryland were also reviewed. Selected references unavailable through those libraries or NTIS were obtained through the Interlibrary Loan Department of the University of Maryland.

Although the literature search resulted in a large number of citations, only a few were directly related to the objectives of this study. The relevant citations, listed in the bibliography at the end of the report, were divided into the following categories: existing design guidelines, landing gear/landing loads, rotor downwash and miscellaneous related topics. The information from these references is discussed as appropriate in later

sections of this report.

2.2 Comparison of Existing Heliport Design Guidelines

Three domestic and two foreign heliport design manuals were obtained during the Task 1 literature survey. The structural loading conditions for hard landing impact loads recommended by these manuals (including the recently revised LaDOT guide and FAA-AC 150/5390/1C draft issued in May and June of 1984, respectively) are summarized in Table 2.1. The minimum recommendations were found in the LaDOT and ICAO reports, which suggest hard landing loads equal to 1.5 times the percentage of static helicopter maximum gross weight (MGW) applied through each landing gear. The FAA and USCG guidelines are slightly more stringent, recommending 1.5 times the MGW to be applied through only two points (the main gear). The CAA recommendations are considerably more severe than any of the domestic guidelines. The CAA suggests hard landing impact loads of 2.5 times MGW, which is to be further increased in certain situations by a 1.3 structural response factor, yielding a total impact load factor of 3.25.

Additional differences among the current heliport design manuals are found in their recommendations for distributed live loads on the helideck. The FAA and ICAO guidelines recommend distributed live loads as dictated by the applicable local building codes. The LaDOT and USCG guidelines recommend a distributed live load of 40 psf and 42 psf, respectively; however, these live loads are to be treated as an alternate structural loading and are not combined with the hard landing loads. The CAA guideline recommends a 10 psf distributed live load to be applied simultaneously with their comparatively large hard landing loads.

The Uniform Building Code (UBC) for the general design of structures also contains recommended loading conditions for heliports. The UBC hard landing load recommendations are as follows: (a) for wheel-gear helicopters equipped with hydraulic shock absorbers, a single load equal to 0.75 times MGW applied over a 1 square foot contact area; or (b) for skid-gear helicopters, a single load equal to 1.5 times MGW applied over a 1 square foot contact area. In addition, the helideck must be designed for an alternate distributed live load of 100 psf (nominal). These UBC recommendations are thus either more or less severe than the FAA guidelines depending upon the type of landing gear and the size of the helideck.

	1 FAA GROUND LEVEL, ELEVATED ROOFTOP, OFFSHORE	2 LOUISIANA DOT AND DEVELOPMENT 3 AMERICAN PETROLEUM INSTITUTE OFFSHORE	4 U.S. COAST GUARD OFFSHORE	5 INTERNATIONAL CIVIL AVIATION ORGANIZATION GROUND LEVEL, ELEVATED, ROOFTOP, OFFSHORE	6 CIVIL AVIATION AUTHORITY GROUND LEVEL, ELEVATED, ROOFTOP, OFFSHORE	
HELICOPTER LOADS	STATIC	Gross weight applied equally through skid-type or float-type landing gear or through wheels of main landing gear	Gross weight applied equally through skid-type or float-type landing gear or through wheels of main landing gear	Gross weight applied equally through skid-type or float-type landing gear or through wheels of main landing gear	Gross weight applied equally through skid-type or float-type landing gear or through wheels of main landing gear	
	DYNAMIC/IMPACT	150% of the gross weight imposed equally through two contact points	150% of a percentage of the gross weight Percentage specified by the manufacture	Limit load established by the limit drop test in 14 CFR 29.725, or a load not less than 75% of the maximum weight taken on a square area of (1ft x 1ft) under each main landing gear applied anywhere on the helicopter deck area Stowed helicopter - maximum weight plus inertial forces from helicopter due to anticipated unit motions	150% of a percentage of the gross weight Percentage specified by the manufacture	2.5 x maximum take-off weight of the helicopter the above should be increased by a structural response factor dependent upon the natural frequency of the deck slab; this increase applies only to slabs with one or more freely supported edges; a minimum response factor 1.3 is recommended
	CONTACT AREA	Footprint of the main gear wheel or a point on the skid Data provided by manufacture	For multi-wheeled landing gears, sum of the areas for each wheel For float or skid, area of the float or skid around each support strut Data provided by manufacture		Footprint area of the tire required to support the load for any given tire pressure, or where applicable a landing skid	
	LOAD DISTRIBUTION	60-90% of gross weight through main gear If not specified by the manufacture, assume 85% of gross weight through main gear	In terms of percentage of gross weight specified by the manufacture			
	ADDITIONAL REMARKS REGARDING STRUCTURAL DESIGN	Design loads other than those applied by helicopter, such as snow, rainfall, wind, passengers and cargo, flight supporting equipment, additional weight of the heliport, etc., should be calculated in accordance with applicable building codes	Design Load a) Dead weight: weight of heliport decking, stiffeners, supporting structure and accessories b) Live load: uniformly distributed over entire heliport area including safety shelves; minimum of 40 lb/ft ² c) Wind load: determined in accordance with API RP 2A d) Helicopter landing load The heliport should be designed for at least the following combinations of design loads. a) Dead load + live load b) Dead load + design landing load c) Dead load + live load + wind load	Each helicopter deck must be designed to accommodate the loadings (static and dynamic) imposed by operation and storage of helicopters intended to use the facility as well as environmental loadings (wind, wave, water, snow, etc.) anticipated for the unit. Design analysis must be based on the dead load of the structure, existing stresses in the deck when it is an integral part of a unit's structure and each of the following loading conditions: a) Uniform distributed loading of 42 lb/ft ² applied to the helicopter deck area b) Helicopter landing impact loading c) Stowed helicopter loading	Live loads due to snow and traffic of personnel and equipment will be accounted for in accordance with local building codes	In addition to the static and dynamic loads imposed by the helicopter, the following loads should be included a) 5 KSN (10lb/ft ²) for snow, personnel, etc. b) horizontal lateral point load on the platform equivalent to 1.5 x maximum take-off weight of the helicopter c) dead load of structural members d) wind loading

TABLE 2-1. COMPARISON OF EXISTING HELIPORT DESIGN GUIDELINES

Table 2-1 (Cont.) - References

- 1) FAA AC 150/5390-1B
"Helicopter Design Guide"
22 August 1977.

FAA AC 150/5390-1C (draft)
"Helicopter Design Guide"
June 1984.
- 2) Louisiana Dept. of Transportation and Development
"Offshore Helicopter Design Guide"
March 1980.

Louisiana Dept. of Transportation and Development
"Offshore Helicopter Design Guide"
May 1, 1984.
- 3) American Petroleum Institute (API RP-21)
"Recommended Practice for Planning, Designing and Constructing
Helicopters for Fixed Offshore Platforms"
January 1983.
- 4) DOT US Coast Guard-Federal Register Vol. 43-No. 233, Part III
"Requirements for Mobile Offshore Drilling Units"
4 December 1978.
- 5) International Civil Aviation Organization (ICAO)
"Helicopter Manual" (replaces Aerodrome Manual, Part 6 - Helicopters)
- 6) Civil Aviation Authority, London, England
"Offshore Helicopter Landing Areas: Guidance on Standards"
1981.

2.3 Survey of Helicopter Manufacturers

The primary purpose of the survey of helicopter manufacturers was to obtain information relevant to the hard landing load condition for helicopters. Specifically, information in the following three categories was solicited:

- a) Aircraft weights and landing gear dimensional data for current and anticipated future helicopter models.
- b) Manufacturers' recommendations to customers on appropriate heliport design loads for their helicopters.
- c) Limit design loads for the landing gear for each helicopter model (The assumption is that these loads represent the maximum credible hard landing loads for the helicopter.)

Telephone conversations were held with engineering staff members and other representatives of Bell Helicopter, Sikorsky Aircraft, and Boeing-Vertol. Bell and Sikorsky helicopters comprise over 50% of the civilian rotorcraft fleet, and specific Sikorsky and Boeing-Vertol helicopter models represent the heaviest rotorcraft in civilian use.

Preliminary discussions with the manufacturers' representatives revealed that other useful information regarding helicopter landing loads could also be obtained from other sources. Accordingly, the following agencies were also contacted by telephone:

Federal Aviation Administration

- Rotorcraft Program Office (Washington, D.C.)
- Southwest Regional Office
- New England Regional Office

Helicopter Safety Advisory Conference

The results from these discussions will be described in the context of hard landing loads in Section 4.

One of the products of the subcontract work is an update of Appendix 1, "Helicopter Dimensional Data", in the current FAA Heliport Design Guide (AC 150/5390-1B and AC 150/5390-1C draft). In the May 1984 revision of the LaDOT Offshore Heliport Design Guide, the Helicopter Safety Advisory Conference (HSAC) updated the helicopter dimensional data. Rather than duplicating the HSAC efforts, their findings have been incorporated in this report as Appendix A.

2.4 Survey of Heliport Design Consultants

The current (1983) listing of heliport consultants was obtained from the Helicopter Association International. The activities of these consultants spanned a broad range: site selection, architectural and engineering design, environmental analysis, community public relations, licensing, and safety and security evaluations. From the list of twenty consultants, ten described as being involved in engineering design were contacted by telephone and asked to comment on the following items:

- a) type(s) of heliport designed
- b) type(s) of pavement typically used
- c) opinions regarding the conservativeness/unconservativeness of the FAA recommended design guideline of 150% x maximum gross helicopter weight (MGW) for dynamic hard landing loads.
- d) type and severity of structural/pavement distress due to helicopter operations
- e) opinions regarding the implementation of standardized helicopter categories
- f) *problems with vibrations on elevated structures due to helicopter landing and takeoff operations*
- g) *problems caused by rotor downwash*

Of the ten consultants contacted, two were involved in heliport planning and operation rather than structural design. One was no longer in business, and one was involved in the design of ambient wind measuring devices. The consultants' comments are summarized in Table 2-2. The most noteworthy comments include the following:

1. For all the different types of heliports designed (ground level, rooftop, elevated, offshore) rigid pavements were used exclusively, with the exception of prefabricated aluminum elevated structures, for which the landing deck consists of standard extruded aluminum beams. Furthermore, there were no reported instances of load associated pavement distress.
2. No problems with vibrations on rooftop or elevated structures were reported.
3. Problems associated with rotor downwash were limited to scattering of gravel on rooftop heliports, i.e., no structural problems due to

TABLE 2-2. RESULTS FROM TELEPHONE SURVEY OF HELIPORT CONSULTANTS

	Type of Heliport	Type of Pavement	ERT's 150 x 60ft for 1000 lbs	Parent District	Comments or other pertinent information	Problems with Heliport	Problems with Heliport
1	RoofTop	Rigid	150' not too conservative; Europeans use 200' x 60'	None	Design for a category of helicopters	None	Poor gravel. No structural problems
2	Ground level Elevated	Rigid	Appropriate	None	Design for a specific machine weight based on customer's needs	None	None
3*							
4	Ground level Elevated	Rigid	Appropriate	None	Design for a specific machine weight based on customer's needs	None	None
5*							
6*							
7	Ground level	Rigid	150' x 60ft Too conservative	None	Design for a specific machine weight based on customer's needs	None	None
8	Ground level RoofTop Elevated Offshore	Rigid	150' x 60ft too conservative	None	Category of specific weight	None	None
9*							
10	Ground level RoofTop Elevated Offshore	Rigid	Appropriate	None	Design for a specific machine weight based on customer's needs	None	None

* No comments received

TABLE 2-2 (CONT.)--REFERENCES

- | | |
|---|---|
| <p>1. ACI Division of Heliport Systems, Inc.
 Airport Park
 Morristown, NJ 07960
 Wm. E. Davis (201) 540-0011</p> <p>2. Aeronautical Consultant
 Drawer 807
 Hyannis, MA 02601
 Richard F. Hodgkins
 (617) 775-5838</p> <p>*3. Air Pegasus
 18 East 48th St., 2nd Floor
 NY, NY 10017
 Bud Shaw (212) 888-8585</p> <p>4. Certified Services, Inc.
 P.O. Box 1939
 Hammond, LA 70404
 Charles E. David
 (504) 345-3619</p> <p>*5. CH2M HILL
 Mid-Atlantic Regional Ofc.
 1941 Roland Clarke Place
 Reston, VA 22091
 Ronald F. Price
 (703) 620-5200</p> <p>*6. Helicopter Canada
 185 George Craig Blvd. NE
 Calgary, Alberta Canada T2E7H3
 Jon C. Pellow
 (403) 230-3200</p> <p>7. Hoyle, Tanner & Assoc. Inc.
 1 Technology Park
 Londonderry, NH 03053
 Stephen Bernardo
 (603) 669-5555</p> <p>8. Pan Am World Services, Inc.
 90 Moonachie Ave.
 Teterboro, NJ 07608
 John Meehan
 (201) 288-5218</p> <p>*9. TSI Inc.
 500 Cordigan Road
 P.O. Box 43394
 St. Paul, Minn. 55164
 Thomas F. Thornton
 (612) 483-0900</p> | <p>10. Vertical Aeronautics,
 International
 14225 Sylvan Street
 Van Nuys, CA 91401
 Lee Ambers
 (213) 901-1434</p> <p>Note: '*' indicates consultants who
 are either no longer in business
 or who are not involved in
 heliport structural design</p> |
|---|---|

rotor downwash were reported.

4. Though there was no opposition to designing for standardized helicopter aircraft categories, most consultants stated that they design according to the customer's needs, which usually are defined in terms of a specific helicopter and weight. The consultants also noted that for ground level rigid pavements, a minimum of six inches of Portland Cement concrete is required for all helicopters under 20,000 lb. (FAA AC 150/5320-6C); since there are very few civil aviation helicopters that exceed that weight, a rigid pavement design analysis is rarely required.
5. Four of the six consultants indicated that the FAA's guideline of 150% x MGW for the dynamic hard landing load seemed appropriate, with one consultant noting that the European standards recommend 200% x MGW. Two consultants suggested that the 150% x MGW was too conservative. None of the consultants, however, could offer any evidence or data to substantiate his opinion.

The major conclusions drawn from this survey were as follows: (a) downwash pressures and helicopter-induced structural vibrations are not critical structural design conditions; (b) hard landing impact loads are the critical structural loading conditions, but for certain helipad designs (e.g., rigid pavements for light helicopters) the current minimum requirements are more than adequate; and (c) there is a diversity of opinion regarding appropriate hard landing impact load magnitudes, but the differing opinions are rarely backed by substantiating evidence.

3. SURVEY OF HELIPORT OWNERS/OPERATORS

To assess the nature of load-associated pavement distress, preliminary conversations were held with representatives from the following helipad/heliport facilities: Maryland State Police, New York Port Authority, Bolling Air Force Base (Washington, D.C.) and the U.S. Army Waterways Experiment Station (Vicksburg, Miss). The only structural-related problem revealed in these conversations was the rutting of flexible (asphalt concrete) pavements under skid-gear equipped helicopters.

In a more comprehensive effort to assess the levels of load-associated pavement distress and problems caused by structural vibrations and rotor downwash in current heliport designs, a survey was made of 270 heliport

owners/operators in the United States. This survey solicited information in the following general categories: (a) type of helicopters and the frequency of their operation at the facility; (b) type and age of landing surface; (c) general and specific structural problems with the landing surface; (d) structural or other problems caused by helicopter vibrations; and (e) problems caused by rotor downwash. A copy of the survey form is included in Appendix B.

The 270 owners/operators surveyed were selected from the 1983 AIA Heliport Directory. A strong effort was made to obtain a representative geographic distribution of survey recipients. However, as more problems were anticipated with rooftop, elevated and offshore facilities, the survey distribution was biased toward these types of facilities; 60-70% of the survey forms were sent to rooftop, elevated, and offshore facilities, and the remaining 30-40% were sent to ground level facilities.

Of the 270 survey forms mailed, 40 were returned for insufficient or incorrect addresses. The remaining 230 forms were assumed to have reached their destinations; of these, 93 completed surveys were returned, yielding a response rate of 34%. As detailed in Table 3-1, the responses were roughly proportional to the number of surveys sent to each type of heliport facility; 35% of the responses were from ground level facilities and 65% were from rooftop, elevated, and offshore facilities.

The survey respondents represent a wide variety of heliport operations. As summarized in Figure 3-1, the number of helicopter operations per year reported by the respondents ranged from a few to over ten thousand. The distribution of operations by type of rotorcraft followed the general industry trend; as illustrated in Figure 3-2, the majority of operations are in the lightweight (less than 6000 lbs. maximum gross weight) helicopter class. However, a few respondents reported some operations (generally only a few operations per year) of heavy rotor craft greater than 20000 lb MGW.

A variety of landing surface types are also represented in the survey results. As detailed in Table 3-2, concrete and asphalt are the most widely used landing surfaces, accounting for 85% of the total reported in the survey, with steel, wood, and stabilized soil/turf comprising the remaining 15%.

The general results from the survey are summarized in Table 3-3; a more detailed listing of the survey results is given in Appendix B. A substantial majority of respondents--64%--reported no structural problems with their heliports. Only 3% of the respondents described their problems as

TABLE 3-1. SURVEY RESULTS: HELIPORT TYPES

<u>TYPE</u>	<u>PERCENT</u>
GROUND LEVEL	36%
ROOFTOP	54
OTHER ELEVATED	9
OFFSHORE	1

TABLE 3-2. SURVEY RESULTS: LANDING SURFACES

	<u>PERCENT</u>
CONCRETE (RIGID PAVEMENT)	63%
ASPHALT (FLEXIBLE PAVEMENT)	22
STEEL	5
WOOD	4
STABILIZED SOIL/TURF	4
UNSPECIFIED	1

TABLE 3-3. SURVEY RESULTS: GENERAL CHARACTERIZATION OF HELIPORT PROBLEMS

	<u>PERCENT</u>
"NO PROBLEMS"	64%
"MINOR"	14
"NORMAL"	16
"SIGNIFICANT"	3

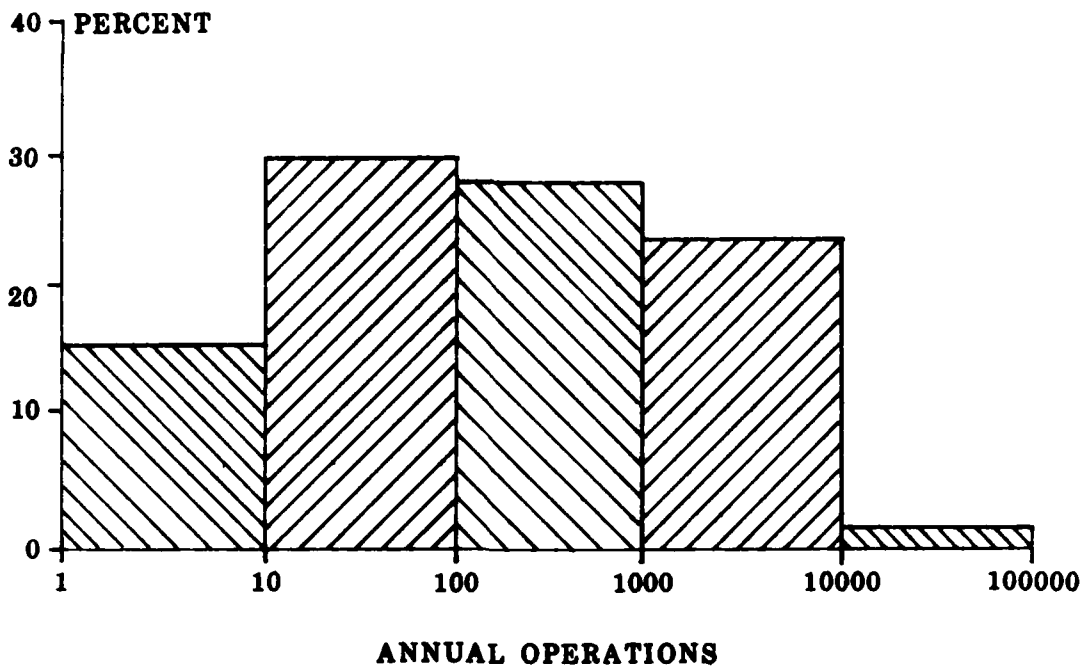

FIGURE 3-1. SURVEY RESULTS: FREQUENCY OF OPERATION

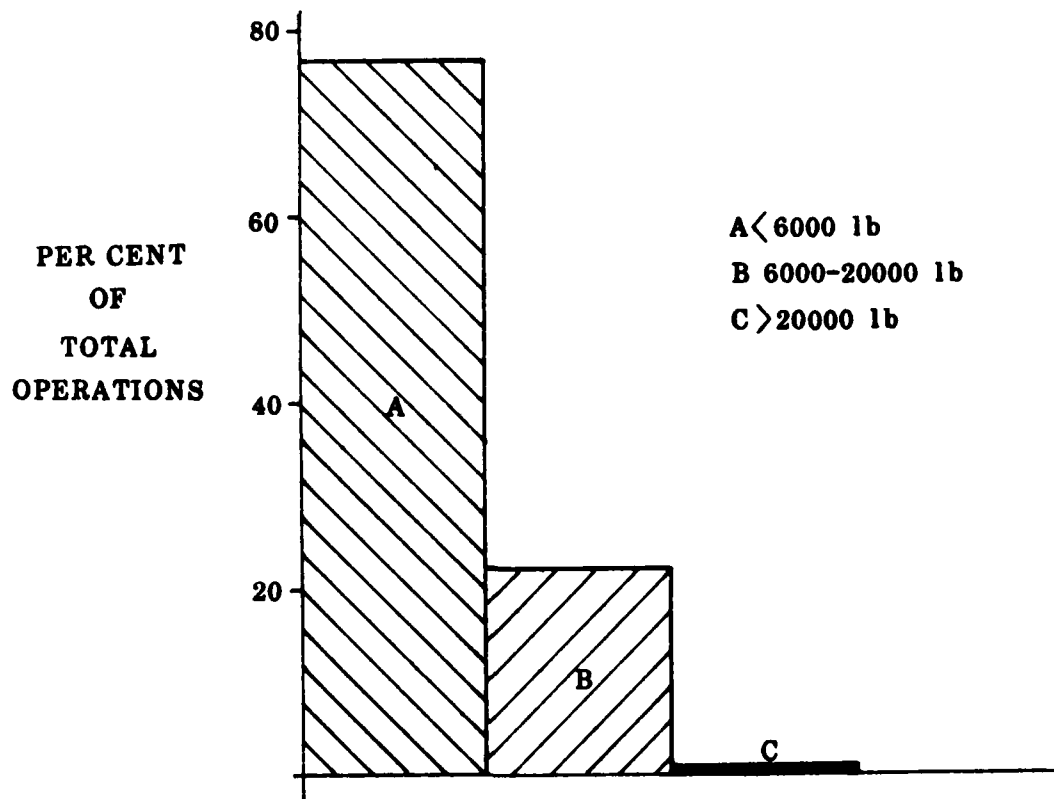

FIGURE 3-2. SURVEY RESULTS: OPERATIONS AS A FUNCTION OF HELICOPTER CATEGORY

"significant". A more detailed breakdown of the problems reported by the survey respondents is given in Table 3-4. Based on the results from the survey, the following noteworthy observations and conclusions can be made:

- (a) Pavement Distress. Eighty percent of the survey respondents indicated that, in terms of load associated landing pavement distress, there were "no problems" or only "minor problems". The most frequently mentioned distress categories for concrete landing pads were cracking, joint seal damage, and spalling; for asphalt surfaces, cracking and rutting.
- (b) Vibrations. The survey responses suggest that there are no significant vibration problems resulting from helicopter operations. Comments by the respondents were limited to the following.

- Vibrations caused loosening of exterior decorative (architectural) panels
- Vibrations were perceptible on the top floor of buildings housing rooftop helipads
- Vibrations were perceived to intensify pavement cracking

From a structural design viewpoint, the most significant of these comments is the suggestion that vibrations intensify pavement cracking. It is important to note, however, that cracking of asphalt and concrete pavements may be caused by the combination of load repetition (fatigue failure), environmental factors (e.g., freeze-thaw cycles) and construction quality (e.g., concrete curing, quality of aggregate). It is doubtful that the number of load repetitions on a helicopter landing surface approaches the fatigue life of the pavement. Consequently, we believe that the reported pavement cracking is primarily the result of poor construction and environmental factors rather than the result of helicopter vibrations.

- (c) Rotor Downwash. The survey comments indicate that there are no structural problems associated with rotor downwash. However, the survey comments do suggest that rotor downwash problems may require special consideration of the following points:
- Location and/or modification of roof vents to prevent helicopter engine exhaust fumes from entering the building's air conditioning system.

TABLE 3-4. SURVEY RESULTS: DETAILED PROBLEMS REPORTED BY HELIPORT OPERATORS

A. STRUCTURAL	NUMBER OF TIMES DISTRESS WAS SPECIFICALLY MENTIONED
1. CONCRETE (RIGID) PAVEMENTS	
- CRACKING	14
- JOINT SEAL DAMAGE	12
- SPALLING	11
2. ASPHALT (FLEXIBLE) PAVEMENTS	
- CRACKING	11
- RUTTING	8
B. VIBRATIONS	
- LOOSENING OF EXTERIOR DECORATIVE PANELS	2
- PERCEPTIBLE ON TOP FLOOR (ELEVATED PAD)	3
- INTENSIFICATION OF CRACKING	1
C. DOWNWASH	
- FUMES ENTERING A/C DUCTS	2
- GRAVEL SPREADING	2

- Selection of sufficiently coarse roofing gravel to prevent spreading due to downwash wind velocities.

In summary, the survey of heliport owner/operators did not reveal any significant levels of serious structural distress as the result of helicopter operations. This conclusion applies to the landing pavement performance and the effects of helicopter-induced vibrations and downwash pressures. None of the survey respondents reported any instances of severe structural failure (e.g., collapse of an elevated helipad); furthermore, we found no reference to any similar failures during our review of the heliport literature. Our overall conclusion from these observations is that current and past heliport design guidelines have specified adequate, and perhaps conservative, requirements for structural design.

4. STRUCTURAL LOADS CAUSED BY HARD LANDINGS

Our preliminary Task 1 investigations revealed that loads caused by hard landings are usually the critical structural loading condition for most heliport landing pads. In the following subsections, current practice for defining these landing loads is briefly discussed. In addition, a new method for determining the appropriate magnitude of helicopter hard landing loads is proposed and used to evaluate the adequacy of current practice.

4.1 Review of Current Practice

Hard landing loads are typically specified in terms of a "hard landing load factor", defined as a multiplicative factor applied to the maximum gross weight (MGW) of the helicopter. These loads are usually assumed to be distributed either equally through the two main landing gear or else in the same proportions as the static weight of the helicopter. For heliports servicing a variety of rotorcraft types, the hard landing loads will be governed by the largest helicopter expected to use the facility. Hard landing load factors specified by existing heliport design guidelines have already been reviewed in Section 2.2 and Table 2.1. These hard landing load factors range between 0.75 and 3.25, with a value of approximately 1.5 most commonly recommended (FAA, ICAO, LaDOT, USCG).

Despite the close agreement among many of the existing design guidelines, we found little hard evidence to substantiate their load recommendations. This is not to suggest that the existing guidelines are deficient; if

anything, our findings from the surveys of heliport design consultants and heliport owners and operators indicate that current loading specifications are more than adequate. The existing guidelines appear to be based largely on experience and consensus among the various guideline-writing organizations. This is a valid engineering approach, although it is often accompanied by an indeterminate degree of conservatism.

A study conducted by Sikorsky (Anonymous, 1973) supports in general terms a hard landing load factor of approximately 1.5. In the Sikorsky study, actual landing gear loads were measured during a hard landing after a simulated power failure while hovering at an altitude of approximately 3.5 feet. As shown in Figure 4-1, the maximum gear load factor measured during this test was 0.95g; the duration of this peak load was approximately one third of a second. From these data, the Sikorsky investigators concluded that "large helicopter alighting gear structures are designed to withstand from 1.25 to 1.5 times the static load on each wheel." From this conclusion and a consideration of the static load distribution within the landing gear, the Sikorsky investigators recommended a maximum landing load of 0.64 times MGW for each main gear (1.28 MGW total load) in a conventional (two main wheels and one tail wheel) landing gear configuration and a maximum landing load of 0.56 times MGW for each main gear (1.12 MGW total load) in a tricycle (two main wheels and one nose wheel) landing gear configuration. The paper goes on to recommend that "for structural helicopter platforms that are open on the underside, it is suggested that the foregoing factors be reduced by 25%."

Telephone conversations with Ed Nesbitt of Sikorsky confirmed the general conclusions drawn from this study. Instead of the 0.75 MGW per main gear hard landing load in the current FAA guidelines, Nesbitt recommends, based on Sikorsky's experiences with wheel gear helicopters, a hard landing load factor of 0.67 MGW per main landing gear. This load would be reduced by 25% for helidecks that are open on the underside. It is important to note that all of Sikorsky's recommendations are for wheel gear equipped helicopters only. Skid gears are stiffer and less energy absorbent than wheel gears and can thus be expected to apply different landing loads to the structure.

It should be noted here that all of the helicopter manufacturers provide landing gear load and geometry data for their helicopters. Examples of landing gear data sheets from Aerospatiale, Bell, and Sikorsky are given in Figures 4-2 through 4-4. In general, the landing gear data provided in these sheets

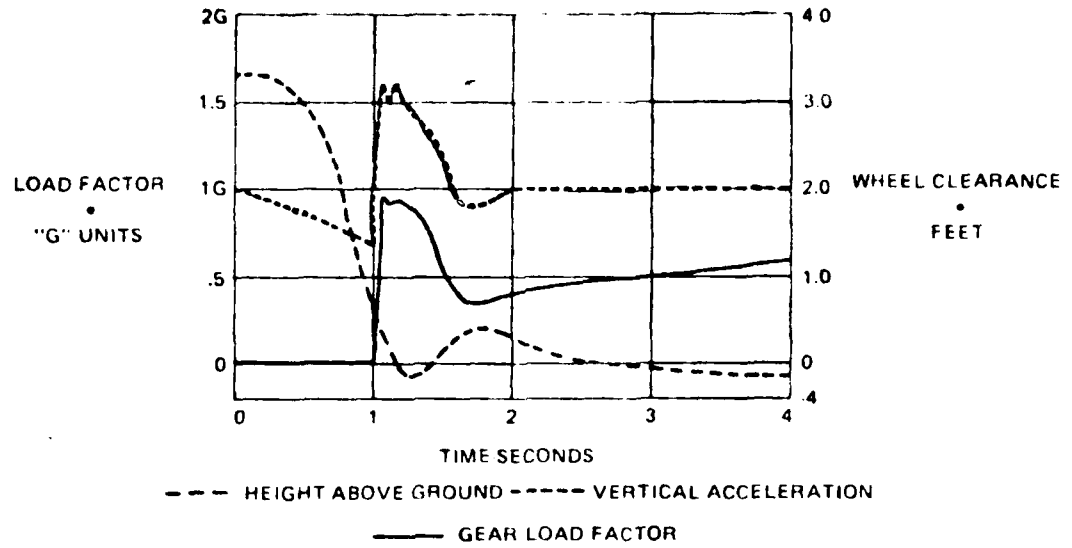
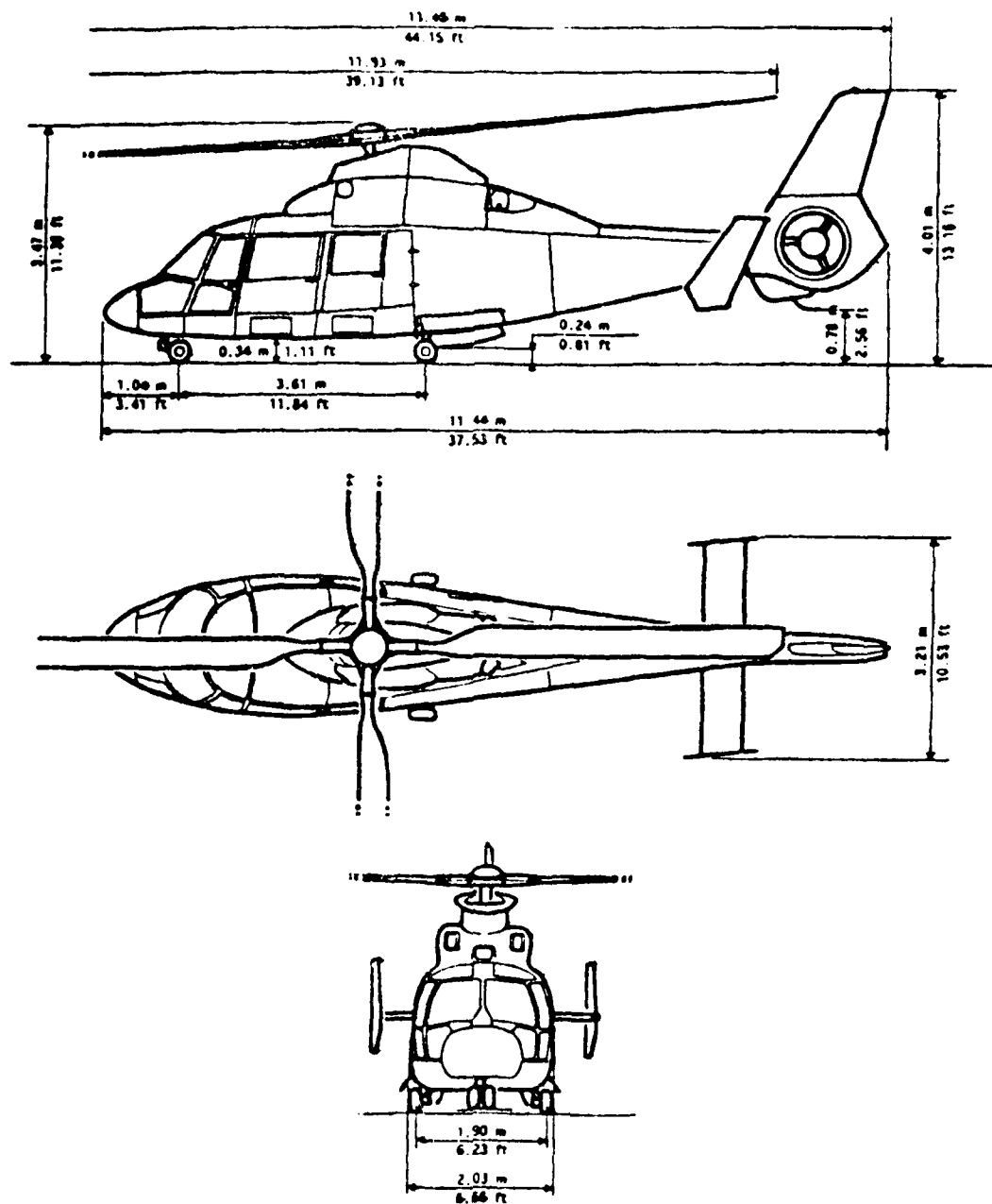

Figure 4-1. Helicopter Gear Load Forces After Power Failure While Hovering (Sikorsky, 1973)



AIRCRAFT DATA

SA365N

MAX GROSS WT	LANDING GEAR LOADING @ MAXIMUM GROSS WEIGHT			
	FWD. LOAD (LBS.)	AFT LOAD (LBS.)	CONTACT AREA PER GEAR LBS. PER SQUARE INCH	
8,487	1,867	6,620	FORWARD	AFT
			49.1*	100.3*
GEAR CONTACT AREA IN SQUARE INCHES	FORWARD	AFT	SKIDS	FIXED FLOATS
	19*	33*		

*Per Wheel

Figure 4-2. Typical Helicopter Data Sheet--Aerospatiale

HELIPORT DESIGN DATA

DIMENSIONS

BELL 214ST

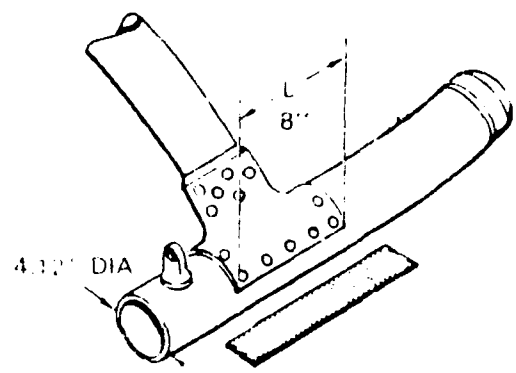
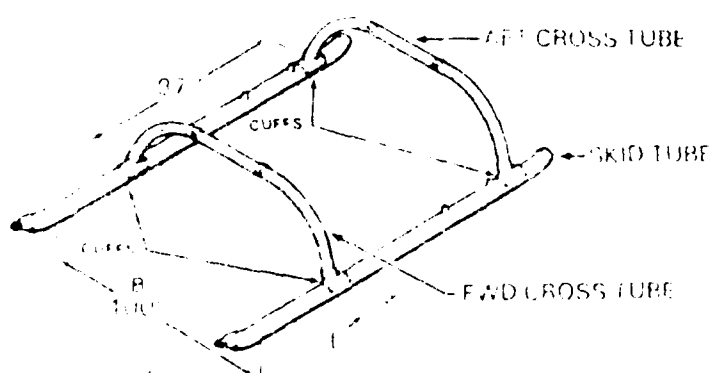
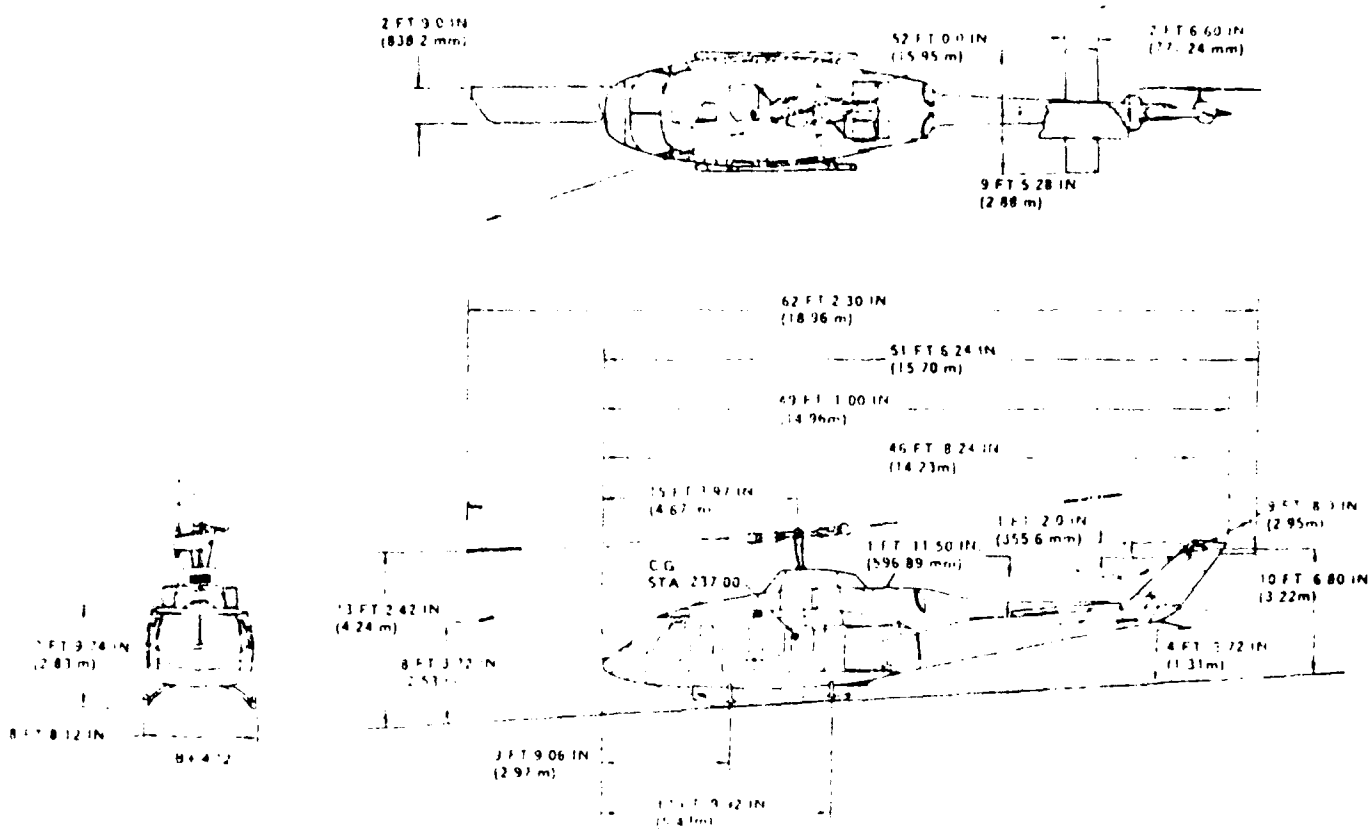

LANDING GEAR LOADING @ MAXIMUM GROSS WEIGHT 17 500 POUNDS
 BASED ON ONE "G" STATIC CONDITIONS AT AFT MOST STRUCTURAL CG LIMIT

GEAR TYPE	LOADING POUNDS		CONTACT AREA SQ IN		CONTACT PRES PSI	
	FORWARD	AFT	FORWARD	AFT	FORWARD	AFT
STD SKID	4864	12,636	24.7 X 2	24.7 X 2	98	256

Bell Helicopter **TEXTRON**

Figure 4-3. Typical Helicopter Data Sheet--Bell

SIKORSKY 76
HELICOPTER

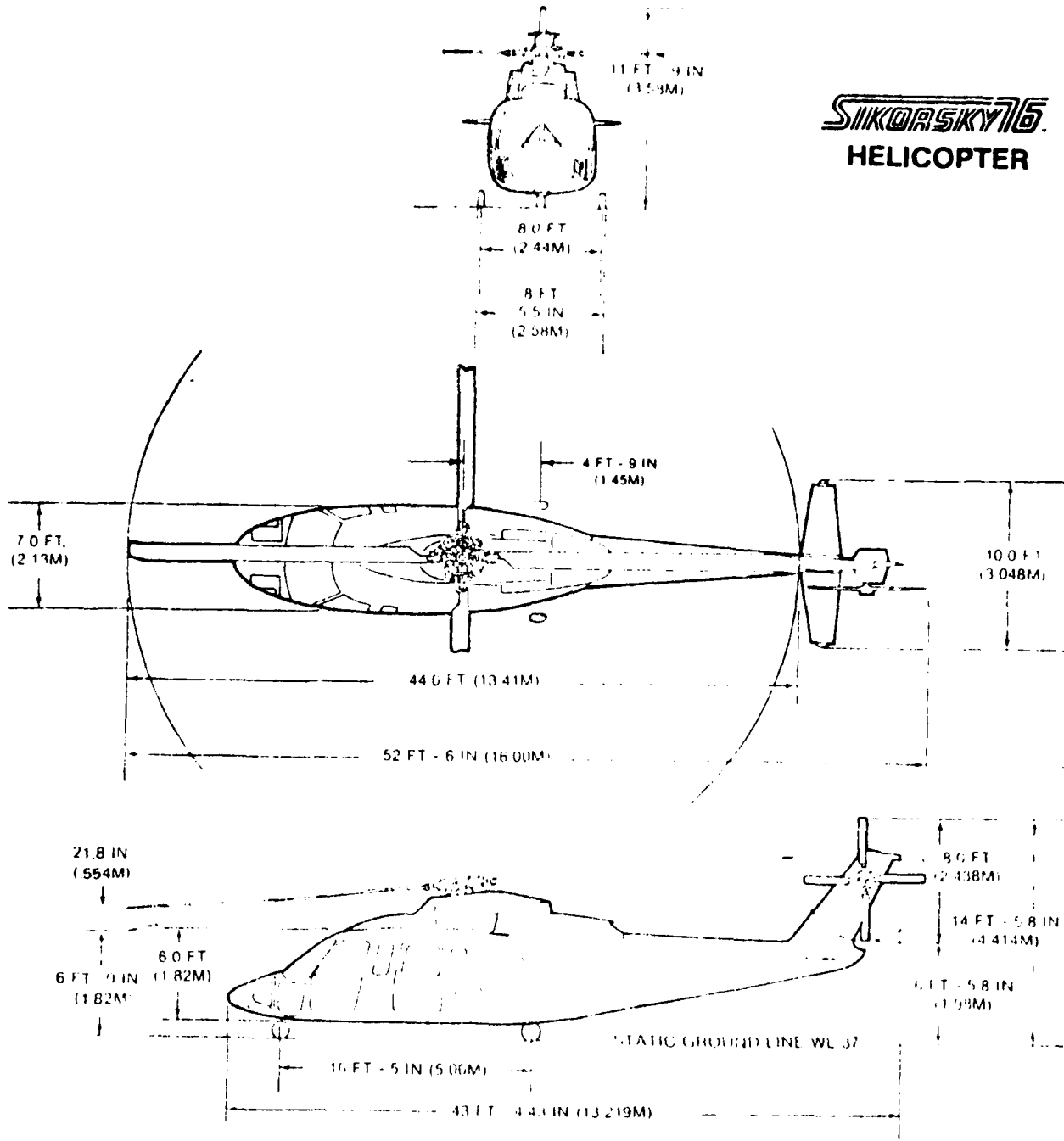

A I R C R A F T D A T A

MAX GROSS WT	LANDING GEAR LOADING @ MAXIMUM GROSS WEIGHT			
	FWD. LOAD (LBS.)	AFT LOAD (LBS.)	CONTACT AREA PER GEAR LBS. PER SQUARE INCH	
			FORWARD	AFT
10,300	2,600	7,700	136.84	80.2
GEAR CONTACT AREA IN SQUARE INCHES	FORWARD	AFT	SKIDS	FIXED FLOATS
	19.0	48.0	N/A	N/A

Figure 4-4. Typical Helicopter Data Sheet--Sikorsky

conforms to, and is most probably based on, current FAA design guidelines.

In summary, the major findings regarding current practice for specifying hard landing loads are as follows:

1. None of the heliport design consultants indicated any experiences of structural problems arising from the current FAA guidelines. Several of the consultants offered their opinions regarding the conservativeness/unconservativeness of the FAA guidelines, but no evidence was offered.
2. None of the heliport owners or operators surveyed reported any significant structural design problems with the landing surfaces at their facilities.
3. Although there was considerable variation between a few of the existing heliport design guidelines, nearly all of the domestic guidelines recommend a hard landing load factor of approximately 1.5.
4. There is little documented evidence substantiating the hard landing load recommendations in existing design guidelines. The existing guidelines appear to be based on experience and consensus, and the lack of structural problems encountered in the field suggests that the guidelines are somewhat conservative.

Regarding point 4, a quantitative analysis of appropriate hard landing load factors will be presented in Section 4.4.

4.2 Structural Dynamic Load Magnification

Helicopter hard landing loads are dynamic in nature and must be treated as such in the structural design of the landing surface. For example, the loads measured in the Sikorsky study described in the preceding section (Figure 4-1) are gear loads, i.e., the actual structural forces measured in the landing gear of the helicopter. These loads are the actual loads applied to the landing surface. These loads are not, however, the effective loads felt by the heliport structure; the loads applied by the helicopter landing gear will be further modified--either amplified or attenuated--by dynamic effects within the heliport structure, following the standard principles of structural dynamics (e.g., see Biggs, 1964). For practical design purposes, these dynamic effects are normally incorporated through application of a dynamic load factor (DLF). The purpose of the DLF is to convert the dynamic applied load to an equivalent static load producing the same stresses and/or

displacements in the structure. The magnitude of the DLF will be a function of the characteristics and duration of the loading and of the natural period of the heliport structure.

Except for the CAA design guidelines, there is no explicit consideration of dynamic structural load amplification effects in any of the existing heliport design guidelines. The CAA guideline recommends a DLF of 1.3 to be applied in a limited set of cases. However, as will be shown below, this value may be too low for many landing surfaces.

The topic of dynamic load magnification is also mentioned briefly in the Sikorsky study described previously:

"Additional conservatism arises because of the rapid nature of the application of the landing impact load, which [reaches] its peak value and is relieved in less than one-fifth of a second. Hence, the inertia of the mass of the platform structure itself has a cushioning effect on any bending stresses imposed on its membrane, as well as to the supporting beams underneath. This is analogous to the well accepted phenomenon that it is difficult to fail a heavy beam in bending simply by hitting it with a hammer or to fail a column by striking a blow on the end." (pg. 6)

The above statement is true only if the natural period of the landing platform (or pavement, for ground-level heliports) is significantly longer than the typical one-fifth second duration of the load application. The simple analysis described below can be used to investigate this point.

The first step in the analysis is the idealization of the loading applied by the helicopter landing gear during a hard landing. Considering the typical actual gear load vs. time history depicted in Figure 4-1, the idealized load vs. time curve shown in Figure 4-5 can be postulated. This load vs. time history is assumed to be independent of the dynamic response of the heliport landing structure. The two important characteristics of this curve are the peak load magnitude, F_p , and the peak load duration, t_d . After t_d , the peak load decreases to some lower plateau value that is a function of the rotor lift, RL, and the maximum gross weight of the helicopter, MGW, during the hard landing. The lower plateau portion of the curve after t_d can be neglected for the present analysis, leaving a pure impulse load of magnitude F_p and duration t_d .

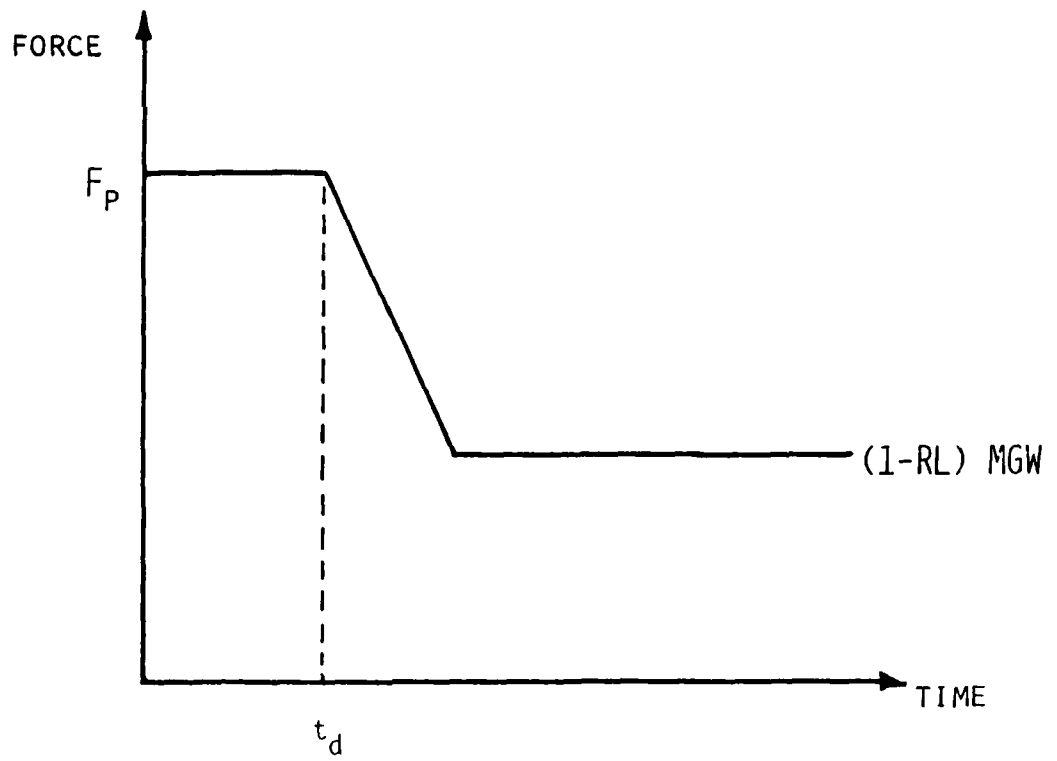

Figure 4-5. Idealized Gear Load vs. Time Curve for Hard Landing

As the second step in the analysis, the heliport landing structure is idealized as an equivalent single-degree-of-freedom dynamic system that is assumed to respond independently of the rotorcraft dynamics. Considering only elastic behavior for this system (the usual assumption for all structural design), a relationship for the maximum DLF for the structure for the given idealized load history can be developed; this relationship is plotted in Figure 4-6 (rectangular load), where the normalizing factor T on the horizontal axis is the natural period of the equivalent single-degree-of-freedom dynamic system.

The third step in the analysis is the estimation of the natural period of the equivalent single-degree-of-freedom dynamic system representing the landing platform structure. As a typical case, consider a one-way reinforced concrete slab having a 20 ft. span and a 25 ft. width in a rooftop heliport. Assuming a Bell 214 helicopter and using the FAA guidelines for hard landing loads, a rough design analysis can be performed: a 7 inch slab is required. Following standard approximate dynamic analysis techniques (e.g., Biggs, 1964, Chapter 5), this slab geometry produces a natural period of 0.15 to 0.20 seconds (depending upon how the mass of the helicopter is included in the calculations) for the equivalent single-degree-of-freedom system. A check of Figure 4-6 with $T=0.15$ to 0.20 seconds and $t_d=0.2$ seconds yields a DLF value of 2.0, the maximum value it can attain.

Obviously, other structural geometries and cases will produce different natural periods and therefore different DLF values. However, many of these other cases (e.g., pavements) will have shorter periods and thus the DLF will remain at its upper limit. The important point is that some structural cases will produce DLF values at the maximum, and consequently the dynamic load magnification effect cannot be ignored in any rational characterization of structural loads for the hard landing condition. In the absence of a more detailed dynamic analysis, engineering conservatism requires the use of a DLF value equal to 2.0.

4.3 Loads from Limit Load Drop Tests

One of the obstacles to the rational specification of hard landing loads is the absence of a precise definition of the hard landing condition itself. Is a landing which mildly jolts the passengers of the helicopter a "hard landing"? Or is a crash landing that destroys the landing gear and severely

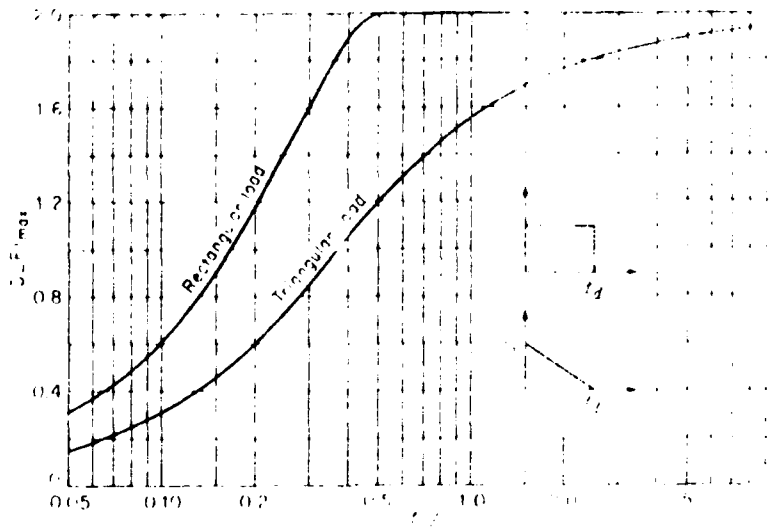

Figure 4-6. Maximum Response of One-Degree Elastic System (Undamped) Subjected to Rectangular Pulse Load Having Zero Rise Time (U.S. Army Corps of Engineers; from Biggs, 1964)

damages the aircraft fuselage a "hard landing"? Although most normal helicopter landings will produce negligibly small impact, abnormal landings can span a broad spectrum of velocities. Further complicating the problem is the variety of aircraft attitudes possible during abnormal landings. Clearly, some bounding definition is required for design purposes.

As part of FAA helicopter certification procedure, helicopter manufacturers are required to perform limit load drop tests on all landing gear in accordance with the relevant sections of Federal Aviation Regulations 27 and 29. Loosely speaking, the loads measured in the limit load drop tests represent the loads under which the landing gear begins to yield. Therefore, these loads should represent the maximum credible gear loads for the hard landing condition.

A comparison between limit load drop test values and current FAA hard landing load guidelines is given in Table 4-1 for skid gear equipped helicopters. Since the FAA design guidelines (column 4 in Table 4-1) are based on landing loads applied through two points (the main landing gear), it is most appropriate to compare these values with the limit load drop test values for the aft (main) gear only (column 5 in Table 4-1; combined aft gear). As shown in column 6 of the table, the ratio of actual measured loads to FAA recommendations is quite variable, ranging from a low of 0.75 to a high of 1.58 with an average value of 0.98. Column 7 of Table 4-1 shows the ratio of measured loads to maximum gross weight, which has an average value of 1.47.

Similar data for a sample of wheel-gear helicopters are given in Table 4-2. The ratios in columns 6 and 7 are again quite variable; the average ratio of measured combined main gear load to FAA recommendation is 0.85, and the average ratio of measured load to maximum gross weight is 1.28. These values are slightly lower than the corresponding values for skid-gear helicopters; one explanation for this is the greater compliance and energy absorption of wheel gears.

One possible cause for the variability of the individual data values is the diversity in the design of the landing gear for different helicopter models, i.e., differences in stiffness and/or energy absorption capacity. Another possible cause is variability in the limit load drop test procedure used by the individual manufacturers; the FAR requirements specify only maximum values for rotor lift and minimum drop heights. For example, Bell typically performs their tests with an assumed center of gravity location that

Table 4-1 Limit Load Drop Test Values for Skid-Gear Helicopters
 (Data Sources: LaDOT, 1980; FAA)

(1)	(2)	(3)	(4)	(5)	(6)	(7)
Manufacturer	Model	Maximum Gross Weight (lbs)	FAA Design Load Recommendation (lbs)	Limit Load (Main Gear) (lbs)	Ratio (5)/(4)	Ratio (5)/(3)
Bell	205-A-1	9500	14250	11399	0.80	1.20
	206-B	3200	4800	7624	1.58	2.38
	296L/L-1	4150	6225	6880	1.11	1.66
	212	11200	16800	19388	0.86	1.28
	214-B-1	12500	18750	14950	0.80	1.20
	214-ST	16500	24750	18637	0.75	1.13
	412	11500	17250	14123	0.82	1.23
	369HS	2550	3825	3244	0.85	1.27
	BK-105C	5070	7605	9730	1.28	1.92
				Average:	0.98	1.97

Table 4-2 Limit Load Drop Test Values for Wheel-Gear Helicopters
(Data Source: LaDOT, 1980)

(1) Manufacturers	(2) Model	(3) Maximum Gross Weight (lbs)	(4) FAA Design Load Recommendations (lbs)	(5) Limit Load (Main Gear) (lbs)	(6) Ratio (5)/(4)	(7) Ratio (5)/(3)
Bell	222	7650	11475	13406	1.17	1.75
Boeing Vertol	234	46142 ¹	69213	44480 ²	0.64	0.96
	107-11	19062 ¹	23593	33600	1.18	1.76
Helitech	S-55T	6260 ¹	9390	4000	0.43	0.54
Sikorsky	S-58T	13000	19500	12220	0.63	0.94
	S-61N/L	20500 ¹	30750	25800	0.84	1.26
	S-62	8000 ¹	12000	9800	0.82	1.22
Bell	2228	8250	12375	11554	0.93	1.40
	2145T	17500	26250	27800	1.06	1.59
				Averages:	0.85	1.23

Notes: 1. Based upon sum of static loads for all gear components.

2. Forward gear is the main gear for the BV 234.

is farther aft than permitted in the final version of the helicopter's flight manual. Sikorsky also indicated that they have in-house requirements for landing gear design that are often more stringent than the FAA minimum requirements.

Some caution must be exercised in the interpretation of the data in Tables 4-1 and 4-2. In particular, the close agreement of the FAA recommendations and the main gear limit load drop forces does not imply that the FAA recommended hard landing loads are meant to represent the limit load condition. The limit load drop values are gear loads while the FAA recommendations are effective structural loads. By the arguments presented in Section 4.2, the limit load values should be multiplied by the dynamic load factor to obtain equivalent structural loads. Assuming the maximum DLF of 2.0, the FAA recommended hard landing loads represent only one-half of the equivalent structural load for the limit load condition. Conversely, if the structure is to be designed to withstand the limit load condition, then the FAA recommendations should be doubled.

Given the satisfactory performance of heliports designed using the current FAA guidelines, it would be very difficult to justify a doubling of the FAA hard landing load factor. Moreover, this is not the only nor necessarily the proper conclusion to draw from the above discussion. A more correct interpretation is that the limit load drop condition, although valid for the design of the aircraft landing gear, is simply not a good definition of a "hard landing" for the purposes of heliport structural design. An alternative and more appropriate definition is presented in the next section.

4.4 Reliability-Based Approach to Hard Landing Loads

4.4.1 Basic Concepts

Ideally, we would like to define helicopter hard landing loads in terms comparable to those used to define other extreme structural loading conditions, e.g., floor, snow, and wind loads. The current trend in structural engineering is to define these types of loads using probabilistic reliability theory. (For a review of probability theory and reliability concepts, consult Benjamin and Cornell, 1970, a standard reference text.)

A fundamental axiom of reliability engineering is that we can never design any structure to be 100% "safe". Regardless of the magnitudes of the

design loads we specify for a structure, there will always remain a small but finite probability that the design loads will be exceeded. The goal of reliability engineering is to define a design load such that this probability of the load being exceeded, when combined with other uncertainties (e.g., material property strength, analysis accuracy, construction quality, etc.), will produce a structure with an acceptably small probability of failure.

As an example, consider snow loads for structures in northern climates. Roofs are not customarily designed to withstand the most severe snowfall that has ever been recorded in the past or that is ever expected in the future; instead, roofs are designed to withstand the largest snowfall expected during the lifetime of the structure. A building with a 50-year life would be designed to withstand a "50-year snowfall"; that is, a snowfall that on average occurs (or is exceeded) only once every 50 years.

Assuming that each year's snowfalls are independent from the next's, a snowfall magnitude that occurs (or is exceeded) on average only once every 'n' years has a probability of occurring (or being exceeded) within a single year equal to $1/n$. This simple fact from probability theory is the key to an appropriate definition of helicopter hard landing loads. If we design a heliport structure for an n-year snowfall or for n-year wind loads, then it is sensible to design this same structure for an "n-year hard landing". Each loading condition will then have the same probability of occurring or being exceeded within a single year ($1/n$); the structure will have a "balanced" reliability against all loading conditions.

4.4.2 Statistical Analysis of Hard Landings

Just as the magnitude of a 50-year snowfall is based upon a statistical analysis of historical snowfall records, the definition of an "n-year hard landing" requires a statistical analysis of helicopter landing characteristics. In particular, a probability density function (PDF) for hard landing gear loads is required; loosely speaking, the PDF describes the frequency with which some specified landing gear load occurs. Given this PDF, a design landing gear load having an annual probability of exceedence equal to $1/n$ can be determined.

Unfortunately, except for the limit load condition there is very little data available on the magnitudes of landing gear loads and even less on the relative frequencies with which these loads occur. More data are available on

landing velocities, however. As will be described in Section 4.4.3, these landing velocities can be converted into approximate landing velocities. Thus, a PDF for landing velocities is an acceptable starting point for the reliability analysis.

Ideally, the PDF for landing velocity will be based on measured data spanning a broad range of helicopter landing conditions from normal to crash. Unfortunately, such complete data do not appear to be available. However, data on the frequency and, to a lesser extent, impact velocity of hard landing accidents is available for civilian and military helicopter operations. These data, together with some reasonable assumptions, can be used to formulate the PDF for landing velocity.

The FAA and NTSB have compiled very detailed reports of civilian rotorcraft accidents for the period of 1980-81. Eliminating overlap between the two databases, a total of 217 hard landing accidents were recorded during the two year period. Only 94 of these accidents actually occurred at a designated helicopter landing surface; hence, the conditional probability of a hard landing occurring at a heliport given that a hard landing has occurred is only 0.433. Nevertheless, in all of the following discussion we will make the conservative assumption that all hard landings occur at heliports, i.e., the conditional probability is taken as unity.

Calculation of the probability of a hard landing accident requires knowledge of the total number of helicopter landings during the reporting period 1980-81. Although this number is not known, the FAA reports a total of 5.1 million flight hours during this period. Assuming some average number of helicopter landings per flight hour, the total number of flight hours can be converted to total landings for the period and, given the number of reported hard landing accidents, the probability of a hard landing accident can be computed. Table 4-3 summarizes these calculations for an assumed range of 0.5 to 4.0 landings per flight hour. The calculated probability of a hard landing varies between 10^{-4} and 10^{-5} , with 5.0×10^{-5} as a reasonable best estimate.

The probability of a hard landing accident is not sufficient to define the PDF for landing velocities needed in a structural reliability analysis. However, if a functional form for the PDF can be reasonably assumed, then the hard landing accident probability can be used for calibration. An exponential PDF is a convenient and realistic assumption for landing velocities for the following reasons: (a) based on physical reasoning, the frequency of very

Table 4-3 Range for Probability of A Hard Landing Accident

<u>Landings/Flight Hour (Assumed)</u>	<u>Total Landings</u> ²	<u>P [Hard Landing]</u> ³
0.5	2.55×10^6	8.5×10^{-5}
1.0	5.10×10^6	4.2×10^{-5}
2.0	10.20×10^6	2.1×10^{-5}
4.0	20.40×10^6	1.1×10^{-5}

Notes:

- (1) All data are for civilian rotorcraft operations during the period 1980-81.
- (2) Based on 5.1 million flight hours during 1980-81.
- (3) Based on accident data compiled by FAA and NTSB.

small landing velocities should be highest--e.g., in normal landings, which are by far the most frequent type of landing, the touchdown velocity approaches zero; (b) the exponential PDF is among the simplest and most commonly used distributions for this type of phenomenon, and there is no physical justification for using a more complex form; (c) since we will be dealing primarily with the upper tail of the distribution and since most other relevant distributional forms also have an exponential-like tail distribution, the precise distributional form used is relatively unimportant; and (d) the exponential PDF is mathematically convenient and easy to calibrate, given that it is a one-parameter distribution (i.e., defined entirely by its mean value).

The exponential PDF for landing velocities is depicted in Figure 4-7 and is given by the expression:

$$f_V(v) = (1/\bar{v}) \exp(-v/\bar{v}) \quad (4-1)$$

in which \bar{v} is the mean landing velocity. The probability of a hard landing, $P[\text{Hard Landing}]$, is equal to the integral of $f_V(v)$ from the hard landing threshold velocity, v_{HL} , to infinity--i.e., the shaded area under the tail in Figure 4-7.

The PDF in Figure 4-7 is defined in terms of two unknown quantities, \bar{v} and v_{HL} . The mean landing velocity \bar{v} is expected to be quite small, probably below 1 ft/sec (recall that the vast majority of helicopter landings will be normal, with touchdown velocities approaching zero). We can expect that the hard landing threshold velocity, v_{HL} , will probably be less than the limit load drop velocity of 6.3 ft/sec, but a more precise definition will require measured landing velocity data from actual hard landings. This information is not available in the civilian accident reports compiled by the FAA and NTSB. However, Christ and Symes (1981) have estimated these velocities for hard landing accidents of military helicopters; their findings are summarized in Figure 4-8. Over 50% of the military hard landing accidents occurred at impact velocities less than 5 ft/sec. Assuming that these data are applicable to civilian as well as military hard landings (in fact, it can be argued that civilian hard landings will on average occur at lower velocities than military landings), the threshold velocity v_{HL} in Figure 4-7 and Equation 4-1 will also be less than 5 ft/sec.

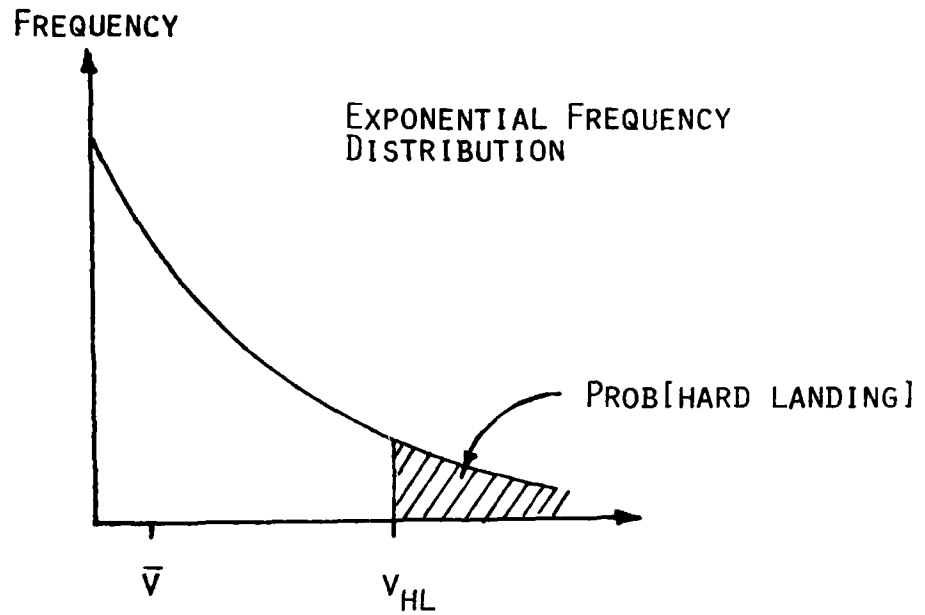

\bar{V} = AVERAGE LANDING VELOCITY

V_{HL} = THRESHOLD LANDING VELOCITY FOR HARD LANDING

Figure 4-7. Assumed Exponential Probability Density Function for Helicopter Landing Velocities

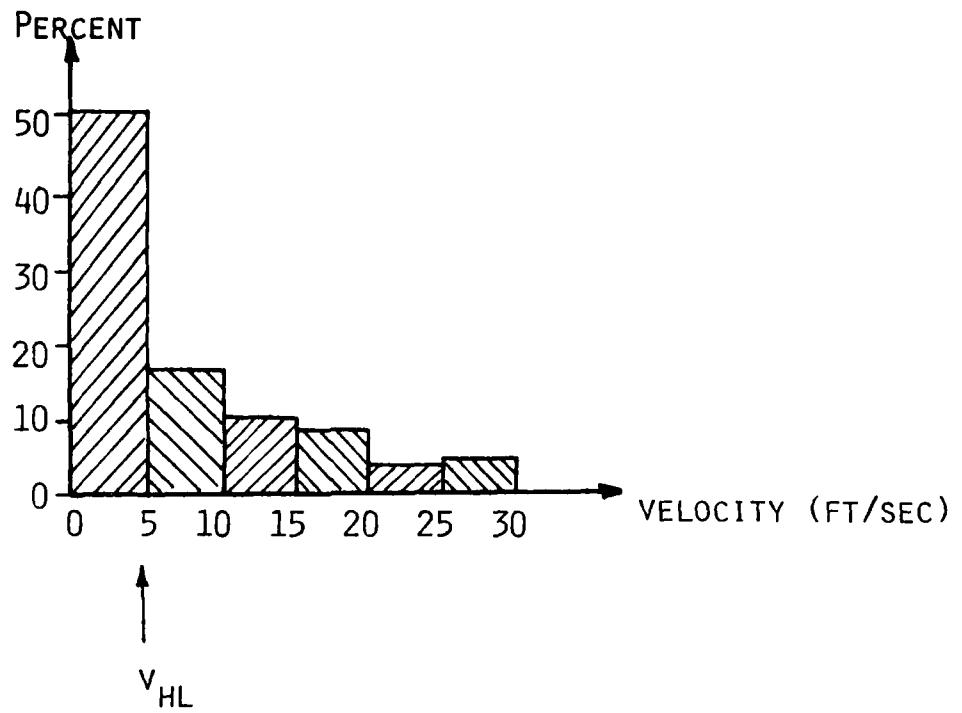

Figure 4-8. Histogram of Impact Velocities for Military Hard Landing Accidents (adapted from Christ and Symes, 1981)

Having this upper bound for v_{HL} , the exponential PDF parameter \bar{v} can be estimated. Computed values of \bar{v} for v_{HL} ranging between 1 and 5 ft/sec and $P[\text{Hard Landing}]$ ranging between 10^{-5} and 10^{-4} are summarized in Table 4-4. As indicated in the table, \bar{v} is relatively insensitive to $P[\text{Hard Landing}]$. The value of \bar{v} is more sensitive to v_{HL} , but \bar{v} still is limited to the narrow range of approximately 0.2-0.5 ft/sec, with 0.35 ft/sec being a reasonable best estimate.

The definition and calibration of the PDF given by Eq. 4-1 makes possible a rational reliability analysis of helicopter landing loads; this analysis will be described in more detail in the next section. However, it must be remembered that we have assumed the functional form for the PDF. Moreover, we have calibrated the PDF parameter based on very limited data confined to the tail of the distribution. In order to gain more confidence in this PDF, additional landing velocity data are required, especially for low velocity, i.e., normal, landings. This additional data will permit the verification of the assumed PDF functional form as well as enable a more accurate estimate of the mean velocity parameter \bar{v} .

4.4.3 Formulation of Reliability Model for Hard Landing Loads

Given the concept of an "n-year hard landing load" and a PDF for landing velocities, the formulation of a reliability model for hard landing loads is relatively straightforward. The major steps in the derivation are as follows:

1. From the PDF for landing velocities, determine a design velocity (v_D) that has a probability of $1/n$ of being exceeded within any one year; v_D will be a function of the mean landing velocity (\bar{v}) and the number of helicopter operations on the landing surface per year (m).
2. Convert v_D into an equivalent landing gear load; given the idealized gear load vs. time behavior shown in Figure 4-5 and an estimate of the peak load duration (t_d), the peak gear load (F_p) can be determined from a simple momentum analysis.
3. Apply an appropriate dynamic load factor (DLF) to the landing gear load to obtain an equivalent static design load, which can be converted to a hard landing load factor (LF).

In this analysis, the variables influencing the LF include: \bar{v} , the mean landing velocity, which in turn is affected by the assumed PDF form, v_{HL} , and $P[\text{Hard Landing}]$; n , the design life of the heliport; m , the number of

Table 4-4 Mean Landing Velocity vs. Hard Landing Threshold Velocity and Probability of Hard Landing for Assumed Exponential Frequency Distribution

V_{HL} (ft/sec)	P[Hard Landing]		
	1×10^{-5}	5×10^{-5}	1×10^{-4}
1	0.09	0.10	0.11
2	0.17	0.20	0.22
3	0.26	0.30	0.33
4	0.35	0.40	0.43
5	0.43	0.50	0.54

operations per year on the landing surface (it is assumed that half of these operations are landings and the other half are takeoffs); t_d , the peak load duration for the assumed gear load vs. time history; and DLF, the structural dynamic load factor, which is a function of t_d and the natural period of the landing surface (T). The reliability analysis derivation will be limited to the determination of the total hard landing load; the distribution of this load through the various components of the landing gear will be discussed later.

Design Velocity. The design landing velocity, v_D , is defined as that landing velocity having a probability of exceedence of $1/n$ during a single year. Alternatively, this definition states that the probability that all landing velocities during the year are less than v_D must equal $(1-1/n)$. Given the exponential PDF for landing velocity in Eq. 4-1, the probability that a single landing velocity is less than v_D can be expressed as:

$$P[v < v_D \text{ for single landing}] = F_V(v_D) \quad (4-2a)$$

$$= 1 - \exp(-v_D/\bar{v}) \quad (4-2b)$$

Assuming that landings are independent events, the probability that all landing velocities in a year are less than v_D can be expressed as:

$$P[v < v_D \text{ for all yearly landings}] = [F_V(v_D)]^{m/2} \quad (4-3a)$$

$$= [1 - \exp(-v_D/\bar{v})]^{m/2} \quad (4-3b)$$

Setting Eq. 4-3b equal to the desired probability level yields:

$$P[v < v_D \text{ for all yearly landings}] = [1 - \exp(-v_D/\bar{v})]^{m/2} = 1 - 1/n \quad (4-4)$$

in which m is the number of operations at the landing surface per year (assuming that one half are landings). Solving for v_D gives the required design landing velocity:

$$v_D = -\bar{v} \ln[1 - (1-1/n)^{2/m}] \quad (4-5)$$

A) 20 YEAR DESIGN LIFE

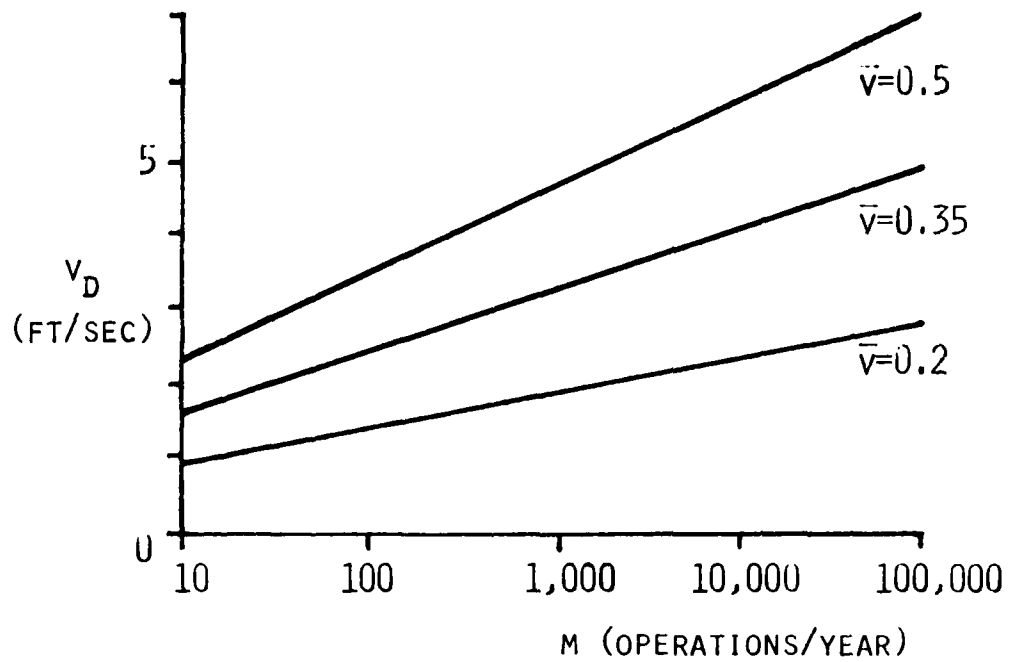

B) 50 YEAR DESIGN LIFE

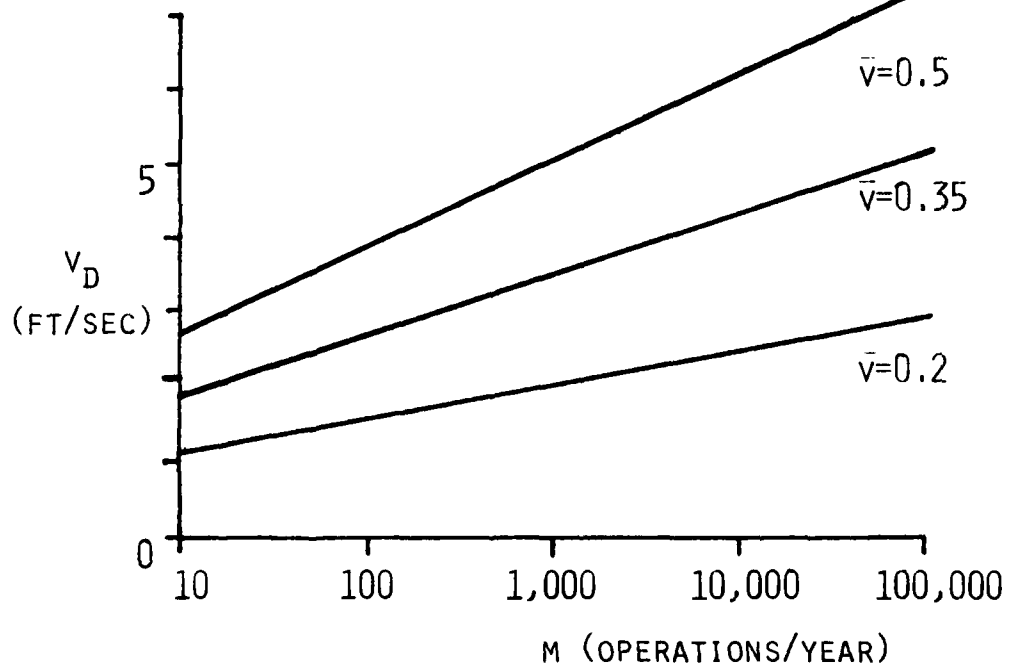

Figure 4-9. Variation of Design Landing Velocity with Operations per Year and Assumed Mean Landing Velocity

Figure 4-9 illustrates the variation of v_D with m for various combinations of n and \bar{v} . For most cases, v_D lies between the limits of 2.0 and 6.0 ft/sec. The design landing velocity is strongly dependent upon the number of operations per year (m), only moderately sensitive to the assumed mean landing velocity (\bar{v}), and relatively unaffected by the design life of the heliport (n).

Equivalent Gear Load. The landing gear load corresponding to the design landing velocity given by Eq. 4-5 can be estimated using a simple momentum analysis. Considering the idealized gear load vs. time curve shown in Figure 4-5 and ignoring the response past the peak load plateau, the impulse-momentum relation at landing is given by:

$$F_p t_d = M v_D \quad (4-6)$$

in which M is the mass of the helicopter. Since M equals MGW/g , where g is the acceleration of gravity, Eq. 4-6 can be rearranged as:

$$F_p = (MGW)v_D/(t_d g) \quad (4-7)$$

As discussed previously, studies by Sikorsky have determined that t_d is on the order of 0.25 to 0.3 seconds for wheel-gear helicopters under limit load drop test conditions (Figure 4-1). Although the value for t_d will vary from one model to the next, the Sikorsky estimate is probably representative for all wheel-gear helicopters. At landing velocities less than the limit load drop velocity (approximately 6.3 ft/sec), t_d will likely increase; nonetheless, we will use the limit load drop test values for t_d as a conservative approximation.

A corresponding range of t_d for skid-gear helicopters can be estimated by comparing the peak gear loads measured during limit load drop tests for both wheel-gear and skid-gear configurations. Under the same limit load landing velocities, two helicopters having the same landing weight (mass) will have the same landing momentum. This can be expressed as:

$$(F_p t_d / MGW)_{\text{wheel-gear}} = (F_p t_d / MGW)_{\text{skid-gear}} \quad (4-8)$$

Using the averages of columns 7 in Tables 4-1 and 4-2, Eq. 4-8 becomes:

$$1.28(t_d)_{\text{wheel-gear}} = 1.47(t_d)_{\text{skid-gear}} \quad (4-9)$$

Rearranging Eq. 4-9:

$$(t_d)_{\text{skid-gear}} = 0.87(t_d)_{\text{wheel-gear}} \quad (4-10)$$

The range of $t_d=0.25-0.3$ seconds for wheel-gear helicopters translates to a range of approximately 0.22-0.26 seconds for skid-gear aircraft. Thus, an overall range for t_d of 0.20-0.30, with a best estimate of 0.25 seconds, can be assumed to adequately represent all helicopter landing gear configurations.

Hard Landing Load Factor. As described in Section 4.4.2, the landing gear dynamic load must be multiplied by a dynamic load factor (DLF) to convert it to an equivalent static structural load for design purposes. The upper bound for the DLF for the idealized loading described in Figure 4-5 is 2.0, and as also described previously, many helicopter landing surfaces may have natural periods sufficiently short relative to the duration of the gear loading to attain this upper bound. Therefore, we will make the conservative assumption of $DLF=2.0$ for all landing surfaces in our analysis.

Multiplying the peak gear load from Eq. 4-7 by the DLF yields the following expression for the equivalent static design load, F_D :

$$F_D = 2(MGW)v_D/(t_d g) \quad (4-11)$$

This design load can be converted to the hard landing load factor, LF, by dividing Eq. 4-11 by the MGW of the helicopter:

$$LF = F_D/MGW = 2v_D/(t_d g) \quad (4-12)$$

Combining this equation with Eq. 4-5 produces:

$$LF = -2\bar{v}/(t_d g) \ln[1 - (1 - 1/n)^{2/m}] \quad (4-13)$$

Since n will be on the order of 20 to 50 years for most helicopter landing surfaces, $1/n$ will be small and Eq. 4-13 can be simplified using the binomial expansion:

$$LF \cong -2\bar{v}/(t_d g) \ln[2/(mn)] \quad (4-14)$$

The quantity mn represents to total number of operations over the lifetime of the landing surface. Defining this quantity as N :

$$LF \cong -2\bar{v}/(t_d g) \ln[2/N] \quad (4-15)$$

Equation 4-15 is the reliability-based expression for the hard landing load factor for heliport structural design. Note that Eq. 4-15 is limited to LF values greater than or equal to 1.0. Values for LF less than 1.0 imply that the hard landing load, in reliability terms, is less than the static weight of the helicopter; in this case, the static helicopter load is clearly the critical design condition.

4.4.4 Results from the Reliability Model

The hard landing load factor defined by Equation 4-15 is a function of three variables: the mean landing velocity, \bar{v} ; the duration of the peak gear load, t_d ; and the number of operations over the lifetime of the landing surface, N . The ranges and best estimates for these variables have already been discussed; they are summarized in Table 4-5. Equation 4-15 is also predicated on the assumption of an exponential PDF for landing velocity and the idealized gear load vs. time curve in Figure 4-5.

Similar to the case for the design landing velocity, LF is most sensitive to the number of operations on the landing surface. Figure 4-10 shows the variation of LF with N for the best estimate values of t_d and \bar{v} (as defined in Table 4-5). For all levels of operation, LF is less than the current FAA recommendation of 1.5, confirming the suspected conservatism of the FAA guidelines. For fewer than 200 thousand lifetime operations, the reliability analysis indicates that the static dead weight of the helicopter will be the critical design condition, with $LF=1.0$. At 10 million lifetime operations, the LF is still less than 1.35.

Figure 4-11 shows the influence of \bar{v} on LF . For the minimum estimate of \bar{v} , LF remains constant at 1.0 through 10 million operations. For the maximum estimate of \bar{v} , LF becomes greater than 1.0 at 6500 operations and exceeds the FAA guideline at 350 thousand operations. A similar plot showing the influence of t_d on LF is given in Figure 4-12; t_d has a less severe effect on

Table 4-5. Estimated Values for Parameters Influencing Hard Landing Load Factor (Equation 4-15)

<u>Parameter</u>	<u>Estimated Minimum</u>	<u>Estimated Maximum</u>	<u>Best Estimate</u>
\bar{v}	0.2 ft/sec	0.5 ft/sec	0.35 ft/sec
t_d	0.2 sec	0.3 sec	0.25 sec
N	N.A.	5×10^6	N.A.

Note: $g = 32.2 \text{ ft/sec}^2$

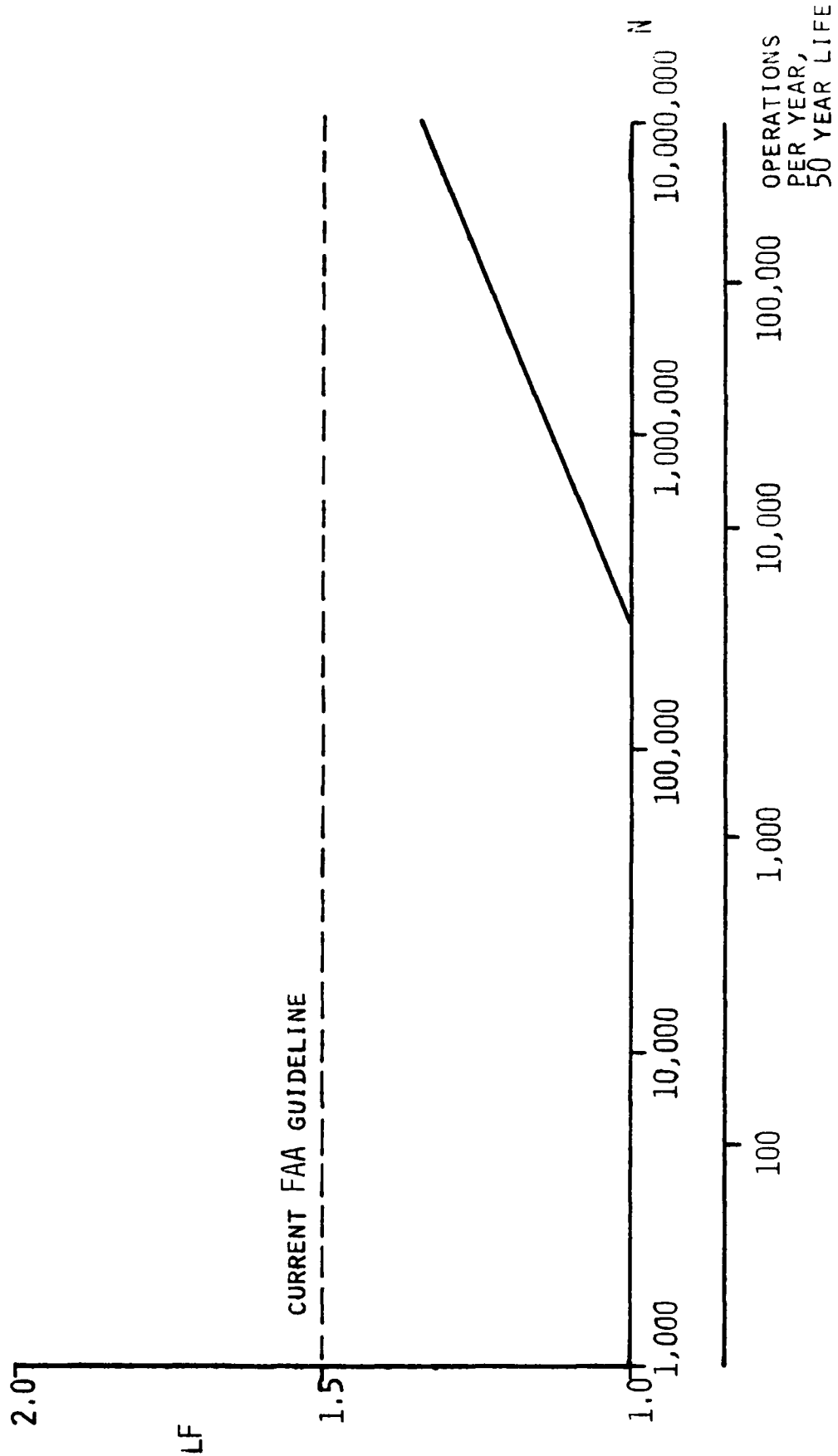

Figure 4-10. LF vs. N for Best Estimates of Parameters \bar{v} and t_d .

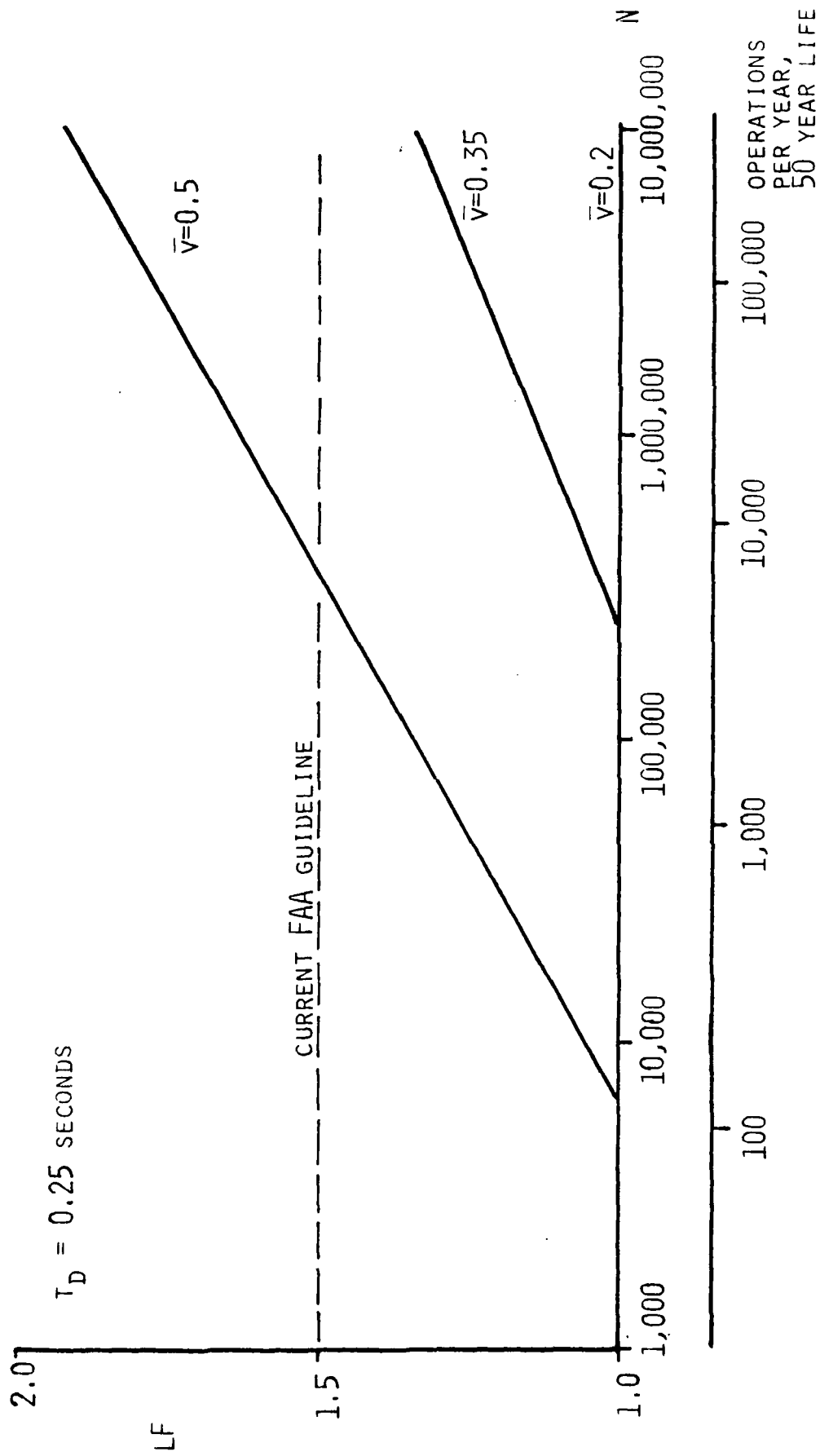

Figure 4-11. Influence of \bar{v} on LF.

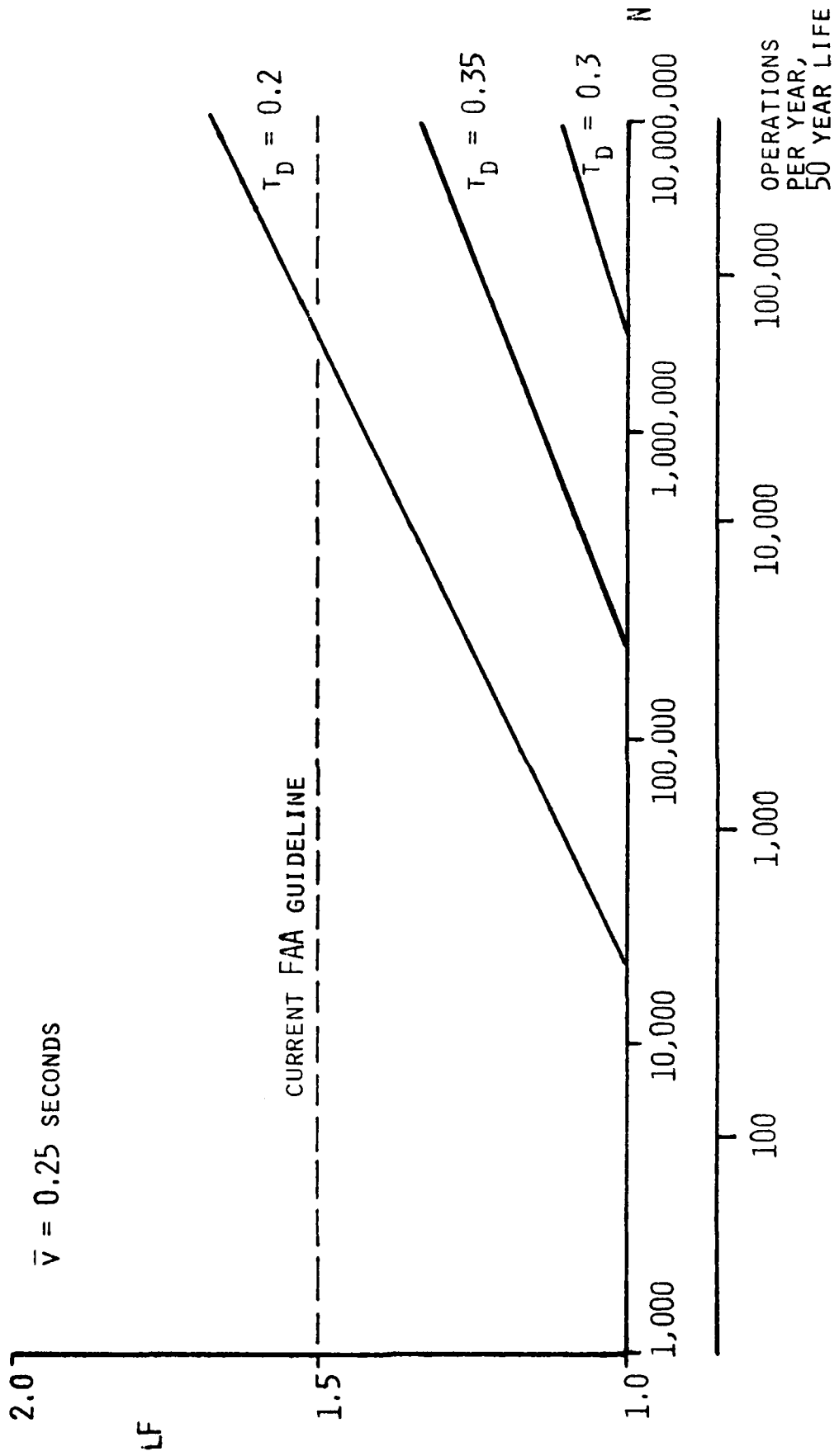

Figure 4-12. Influence of t_d on LF.

LF, at least within the range of values considered. For the minimum estimate of t_d , LF becomes greater than 1.0 at 2 million operations and remains well below the FAA guidelines. For the maximum estimate of t_d , LF becomes greater than 1.0 at 18 thousand operations and exceeds the FAA guideline at 2 million operations.

Conclusions drawn from these results from the reliability analysis are summarized as follows:

1. For all practical purposes, the reliability-based LF is smaller than the current FAA recommendations. The only exceptions to this occur at large numbers of operations for the extreme limits of t_d and \bar{v} . However, the conservative assumptions embedded in the reliability analysis--e.g., the assumptions that $P[\text{Hard Landing at Heliport} \neq \text{Hard Landing}] = 1.0$ and $DLF = 2.0$ for all cases--reduce the likelihood of these high LF values. Furthermore, heliports having large numbers of operations will primarily be large, commercial facilities; it is likely that the hard landing statistics for these types of facilities will be more favorable than the general civilian and military statistics used in the present study.
2. Below approximately 10,000 lifetime operations, hard landings cease to be the critical loading condition, and the static (parked) weight of the helicopter governs the structural design, with $LF = 1.0$.
3. In general, the results from the reliability analysis confirm the adequacy of the current FAA guidelines. The FAA recommendations appear to be only slightly conservative for heavily used heliports, although the conservatism increases for more lightly used facilities.
4. More data are required to narrow the ranges for t_d and especially for \bar{v} . More precise definitions of these variables will add confidence to any proposed reduction in the current FAA hard landing load guidelines.

4.5 Additional Comments on Hard Landing Load Magnitudes

The results from the reliability analysis of hard landing loads suggest that the current FAA guidelines are adequate for high volume heliports but may be conservative for less frequently used facilities. The available data are not sufficient, however, to permit a precise specification of a reduced hard landing load factor for these lower volume landing surfaces. To put the issue

of hard landing load factors into a proper perspective, it is instructive to consider the structural design consequences of different load factor magnitudes.

Consider the following typical structural layout for a new rooftop heliport. The landing structure is assumed to consist of 6 in. thick reinforced concrete one-way slabs with a width of 25 ft. and a span of 20 ft.; the slabs are supported on steel girders 25 ft. long. Further assume that the slabs and the long support girders are simply supported. The only live load assumed to act on the structure is a Bell 214ST helicopter, MGW=17500 lbs., treated as a single concentrated load acting at the center of the support girder. The minimum live load will thus be the static weight of the helicopter; a simple design calculation indicates that a W18x35 steel section will be required for the support girder. Considering a maximum live load equal to the FAA recommended hard landing load, a similar design calculation indicates that a W21x49 steel section will be required. Even under these very conservative design assumptions, the difference between the minimum load condition and the FAA hard landing load condition produces only a 40% increase in the steel required for the support girder.

Of course, all structural steel designers are interested in minimizing the amount of steel in their designs and would thus be eager to reduce this 40% hard landing "penalty". Note, however, that this 40% increase occurs only in the structural components most directly affected by the helicopter loads, i.e., the girders (and slabs) locally supporting the landing surface. As we progress farther from the landing surface, the influence of the helicopter loads on the overall loads for the various structural components will decrease, and the increase in steel (or reinforced concrete) to withstand the hard landing loads will also diminish in percentage terms. The implication of this argument is that the increase in overall structural cost due to the hard landing loads is comparatively small. Moreover, this increase in structural cost is likely to be insignificant compared to the total cost of the entire heliport.

Although the increase in cost associated with a load factor of 1.5 vs. 1.0 may be comparatively insignificant for new construction, there is one very important area where the precise magnitude of the load factor is critical: retrofitting of heliports or helistops on existing structures. The decision to construct a heliport or helistop on the roof of an existing building will

usually depend on whether the existing building structure has enough excess load capacity to sustain the additional loads imposed by the helicopter; increasing the load capacity to an existing building structure is usually too costly to be feasible. It is conceivable that there are many existing structures with enough excess load capacity to sustain a hard landing load factor of 1.0 but not enough to sustain a factor of 1.5. Thus, a precise determination of the correct hard landing load factor is critical for these projects.

One final comment must also be made regarding the magnitudes of hard landing loads. All existing design guidelines are based on experience with helicopters currently in service. Similarly, our reliability analysis for hard landing loads is also based to some extent on the characteristics (e.g., hard landing accident probabilities) of current helicopters. Advanced rotorcraft concepts presently under development will likely differ sharply from current rotorcraft models. Any design recommendations based on past experience must be applied cautiously to these new aircraft. Fortunately, most of the advanced rotorcraft concepts concern aerodynamics rather than landing gear, and therefore it is probable that future helicopter designs will exhibit hard landing characteristics broadly comparable to existing aircraft.

4.6 Distribution of Landing Loads Through Landing Gear Components

The reliability analysis described in the preceding section focused on the total load imparted to the structure by the helicopter during a hard landing. This total load will, in general, be divided among the landing gear components (i.e., main gear, nose gear, tail gear, etc.). Landing load distribution recommendations in existing heliport design guidelines typically specify an equal split of the hard landing load through the main gear (FAA) or a distribution in the same proportion as the distribution of static weight (LaDOT, ICAO).

A more rational analysis of the distribution of landing loads through the landing gear will require a coupled structural and aerodynamic analysis of the helicopter-structure system. This is a very complex problem requiring detailed knowledge of the landing gear and landing surface deformation characteristics, rotor lift forces, mass distribution of the helicopter, and landing approach attitude and speed. It is unlikely that a simplified, approximate analysis having general validity can be developed for this problem.

Given these analytical difficulties and the lack of any measured data for landing load distributions, the safest approach is to continue use of the recommendations in the existing design guidelines. These recommendations are based on experience at operating heliports; at this time, this experience represents the best data available.

4.7 Design of Landing Surface Against Punching Failure

In addition to withstanding the overall bending moments, shear forces, and axial loads caused by helicopter hard landings, a heliport landing surface must also sustain the local punching shear forces directly under the landing gear. This will be a concern only for rooftop and elevated landing surfaces; pavement foundations eliminate the punching shear problem for ground level landing surfaces. Design for punching shear is treated in all of the standard structural design codes (e.g., American Institute of Steel Constructors, American Concrete Institute). However, the simple analysis described below demonstrates that punching shear failures beneath a helicopter landing gear will not, in general, be the critical design consideration.

The most severe case for punching shear failure is a heavy helicopter equipped with a landing gear having a small contact area. Since skid gears have much smaller contact areas than wheel gears, the largest current skid-gear helicopter, a Bell 214ST having a MGW of 17,500 lbs., will be used for our example analysis. One difficulty with skid gear helicopters is that the gear contact area is poorly defined. Bell recommends that the footprint of the crosstube saddle, shown in Figure 4-13, be used as the gear contact area; this probably is a conservative assumption (i.e., the actual effective contact area is likely to be considerably larger). Using Bell's contact area recommendation, the current FAA hard landing load guidelines, and the assumption that the punching shear failure planes drop vertically from the edges of the gear contact area, the punching shear stresses, s , on the potential failure planes can be expressed as:

$$s = 1.5 (MGW/2) / [(2B + 2L)d] \quad (4-16)$$

in which d is the landing surface thickness. Substituting numerical values for our example analysis yields:

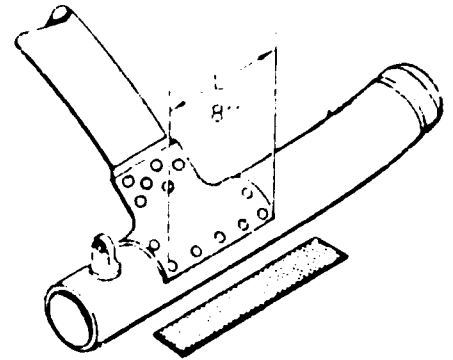
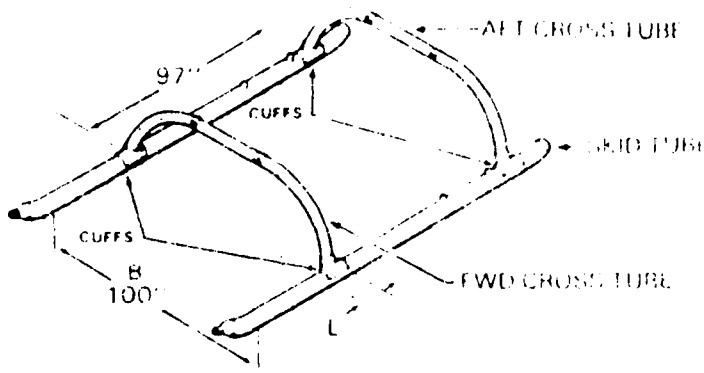

LANDING GEAR LOADING @ MAXIMUM GROSS WEIGHT — 17,500 POUNDS
 BASED ON ONE "G" STATIC CONDITIONS AT AFT MOST STRUCTURAL CG LIMIT

GEAR TYPE	LOADING POUNDS		CONTACT AREA SQ. IN.		CONTACT PRES. PSI	
	FORWARD	AFT	FORWARD	AFT	FORWARD	AFT
STD SKID	4864	12,636	24.7 X 2	24.7 X 2	98	256

Figure 4-13. Skid-Gear Contact Area for Bell 214ST Helicopter

$$s = 591.7 / d \text{ (psi)}$$

(4-17)

For an adequate structural design, s must be less than the allowable shear stress for the landing surface material. For A36 steel (standard structural steel), the allowable shear stress is 14,400 psi and thus a plate thickness of 0.04 in. is required; this is clearly much thinner than the actual plate thickness used in all existing heliport landing decks. For a concrete slab with a 4000 psi compressive strength and no shear reinforcement (the usual case for slabs), the allowable shear stress is approximately 120 psi, and thus a slab thickness of 4.9 in. is required. This thickness approaches, but is still likely less than, the slab thickness required to resist the overall slab bending moments. Local shear reinforcement, designed according to the standard ACI code procedure, may nevertheless be required.

A problem somewhat related to punching shear is rutting of flexible asphalt pavements under skid gear. This rutting problem was one of the few problems cited by heliport owners and operators in our survey. Rutting is not an instantaneous punching-shear type of phenomenon, however; rather, it is the product of time-dependent, viscoplastic deformation under constant load (a skid gear, in the case of heliport pavements). The best solution to this problem is to specify a rutting-resistant asphalt mix design; for high volume landing facilities, rigid portland cement pavements should be used in lieu of asphalt. Rutting may also pose a problem for turf landing surfaces, but these landing facilities are generally limited to very low volume operations.

5. DOWNWASH PRESSURES

Analogous to the general increase in wing loading for fixed-wing aircraft, helicopters have become heavier and faster with corresponding increases in disk loadings (Fradenburgh, 1958). With the increase in disk loads comes increased downwash velocities, which may be a concern in the design of some heliports. As most operational problems will occur when the helicopter is in the proximity of the landing pad, knowledge of downwash velocities and resulting horizontal and vertical downwash pressures during landing/takeoff operations are of particular concern.

TABLE 5-1. UNIFORM BUILDING CODE MINIMUM ROOF LIVE LOADS

TABLE NO. 23-C—MINIMUM ROOF LIVE LOADS¹

ROOF SLOPE	METHOD 1			METHOD 2		
	TRIBUTARY LOADED AREA IN SQUARE FEET FOR ANY STRUCTURAL MEMBER			UNIFORM LOAD	RATE OF REDUCTION r (Percent)	MAXIMUM REDUCTION R (Percent)
	0 to 200	201 to 600	Over 600			
1. Flat or rise less than 4 inches per foot. Arch or dome with rise less than one-eighth of span	20	16	12	20	.08	40
2. Rise 4 inches per foot to less than 12 inches per foot. Arch or dome with rise one-eighth of span to less than three-eighths of span	16	14	12	16	.06	25
3. Rise 12 inches per foot and greater. Arch or dome with rise three-eighths of span or greater	12	12	12	12	No Reductions Permitted	
4. Awnings except cloth covered ²	5	5	5	5		
5. Greenhouses, lath houses and agricultural buildings	10	10	10	10		

¹Where snow loads occur, the roof structure shall be designed for such loads as determined by the Building Official. See Section 2305 (d). For special purpose roofs, see Section 2305 (e).

²See Section 2306 for live load reductions. The rate of reduction r in Section 2306 Formula (6-1) shall be as indicated in the Table. The maximum reduction R shall not exceed the value indicated in the Table.

³As defined in Section 4506.

5.1 Vertical Downwash

Vertical downwash pressures can be taken as approximately equal to the disk load, (disk load = thrust / (3.14 x (rotor radius)²), which may range from 2.2 - 10.3 lb/ft² for a Rotorway Scorpion and Sikorsky Skycrane, respectively. As the majority of helicopters regularly flown weigh less than 6000 lb (FAA category A), typical disk loads are more commonly on the order of 4-6 lb/ft². For the Sikorsky S-76 (10,300 lb MGW), the disk load is 6.8 lb/ft², still well below the Uniform Building Code (UBC) minimum design roof load of 12 lb/ft² (Table 5-1).

5.2 Horizontal Downwash

Although vertical downwash pressures are not a critical structural loading condition, horizontal downwash pressures may be important in heliport design, particularly in urban areas where real estate is limited and expensive and structures may therefore need to be located close to the landing pad. Of primary concern is the maximum horizontal wind velocity and resulting wind loads.

Utilizing model and full scale data, maximum horizontal ground velocities (and therefore pressure, i.e. wind loads) can be determined for any disk load at any distance from the rotor hub. A detailed discussion of the horizontal velocity and pressure distribution is described below.

To determine horizontal velocity and its attenuation with distance from the rotor hub, both model and full scale data were studied. Model tests (Fradenburgh, 1958) were conducted with a 2-bladed, 2 ft-diameter rotor operating at a tip speed of approximately 600 ft/s. The rotor drive shaft was located above the rotor, thus providing unrestricted downward flow. Instrumentation consisted of rakes of conventional total and static tubes located at several positions below the rotor and on the ground, as well as static pressure taps in the ground surface. Velocity profiles were measured near the ground at three radial stations outboard of the blade tips. Maximum horizontal velocities twice the magnitude of the vertical velocity were measured at 1.5 radii from the center of rotation and at a rotor height-rotor radius (Z/R) ratio of 0.5, which corresponds to a helicopter with its landing gear on the ground. Therefore, the model data indicate that maximum horizontal velocities occur very near the ground surface at a distance of about 1.5 radii from the rotor hub and are approximately twice the vertical

velocity, v_0 , where

$$v_0 = \left[\frac{DL}{2\rho_{sL}} \right]^{1/2} \quad (5-1)$$

where

DL = disk load

ρ_{sL} = density of air at sea level

As part of a Corps of Engineers Waterways Experiment Station research effort (Leese, 1972; Leese and Knight, 1974; Leese and Carr, 1975) to predict the effect of rotor downwash on the ground surface and operating personnel, horizontal velocities generated by various Army helicopters were measured along and up to 6 ft above the ground surface. Measurements of downwash velocities during various operational modes were collected for OH-58A, OH-6A, AH-1G, UH-1H, UH-1M, CH-47 and CH-54 helicopters. The instrumentation array consisted of a number of wind velocity sensors mounted on vertical frames to obtain horizontal downwash velocities at 1 ft intervals up to a height of 6 ft above the ground.

Maximum horizontal velocities were measured at 0.3 ft above the ground at Z/R and X/R ratios of 0.5-0.75 and 0.9-1.7, respectively. As noted above, a Z/R ratio of 0.5 corresponds to a helicopter with its landing gear on the ground; X is the horizontal distance measured from the center of rotation. The Z/R and X/R ratios at which maximum velocities were measured in the full scale tests compare favorably with the model data, which recorded maximum velocities at Z/R = 0.5 and X/R = 1.5.

As seen in Figure 5-1, the full scale velocity for any disk load is approximately 1.5 times that predicted by the model data. It is reasonable to assume that the air flow beneath the model rotor is not impeded in any way as is the case for the full scale air flow. In the model, the flow contracts as it accelerates downward to a final wake diameter of about 71% of the rotor diameter. However, for the full scale velocity, the body of the helicopter forces this wake diameter to spread outward beyond the predicted 71% wake diameter; hence, a higher velocity is measured.

Shown in Figure 5-2 is a plot of horizontal velocity-to-maximum horizontal velocity ratio vs. distance from the rotor hub based on full scale data. This plot corresponds to a Z/R value of 0.5; i.e., when the landing

gear is on the ground. Based on the model and full scale data, the maximum horizontal velocity is defined as follows:

$$HV_{\max} = \left[\frac{4DL}{\rho_{sL}} \right]^{1/2} \quad (5-2)$$

where the terms are as previously defined. As is illustrated in Figure 5-2, the maximum horizontal velocity occurs at a distance of 40-50 ft from the rotor hub but drops off very quickly with increasing horizontal distance from the hub.

Given the maximum horizontal downwash velocity and the variation in velocity with distance, the horizontal wind load as a function of distance from the helicopter can be determined. The total pressure, P_o , is made up of static and dynamic components and can be expressed as follows:

$$P_o = P + \left[\frac{\rho_{sL} (HV)^2}{2} \right] \quad (5-3)$$

where

- P = static pressure
- $\frac{\rho_{sL} (HV)^2}{2}$ = dynamic pressure
- HV = horizontal velocity
- P_o = stagnation pressure (total pressure felt by the structure)

For $X/R \geq 1.5$, the static downwash pressure is negligible; hence the resulting wind load is equal to the dynamic pressure. From equation 5-2 the wind load for this condition may be expressed in terms of the disk load as follows:

$$P_o = P + \left[\frac{\rho_{sL} (HV)^2}{2} \right] \quad (5-4)$$

since $P = 0$

and $HV = (R_{HV})^2 \left[\frac{4DL}{\rho_{sL}} \right]^{1/2}$ (R_{HV} = ratio of HV/HV_{\max} from Figure 5-2)

thus: $P_o = (R_{HV})^2 \left[\frac{\rho_{sL}}{2} \right] \left[\frac{4DL}{\rho_{sL}} \right]$

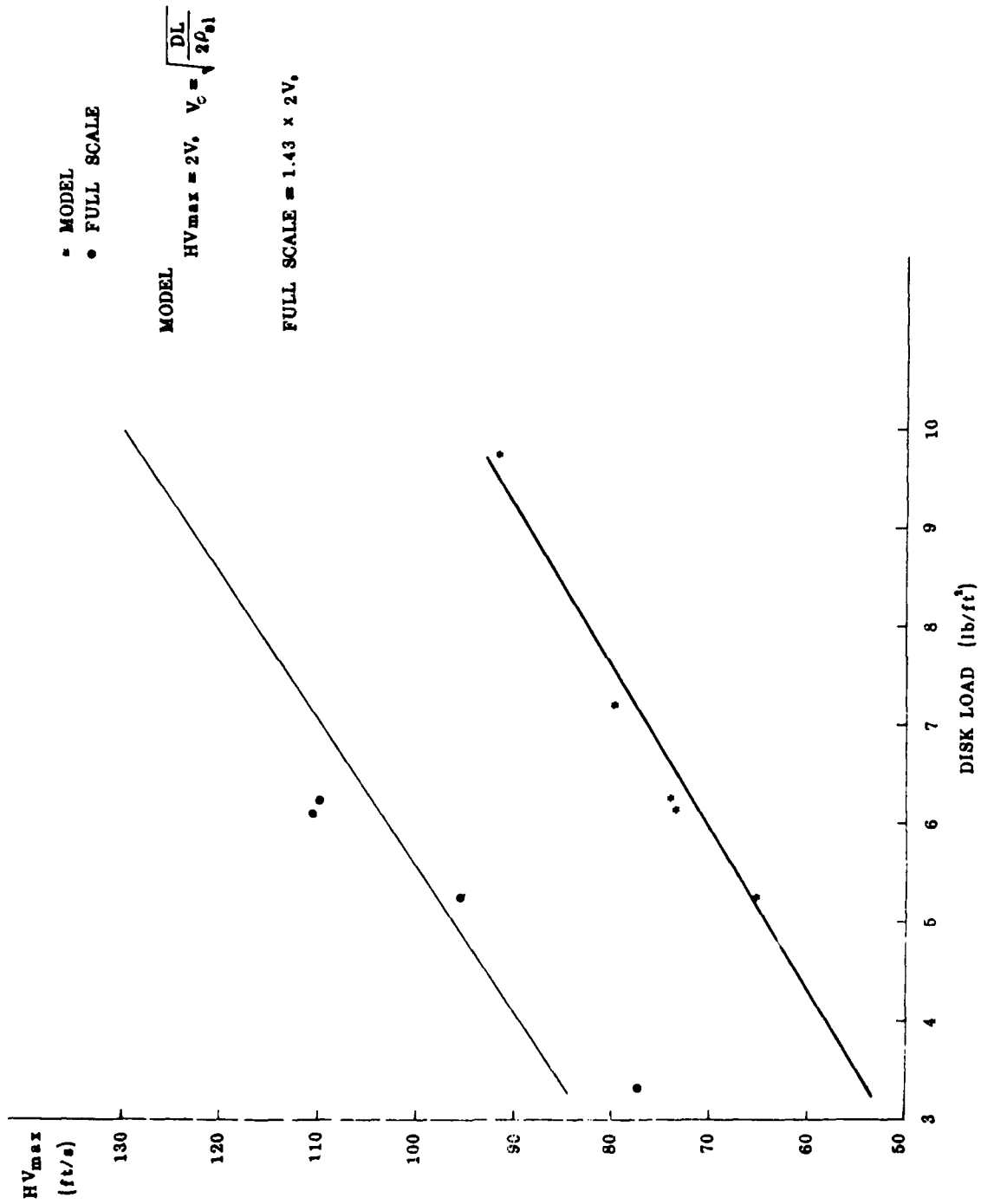

FIGURE 3-1. MAXIMUM HORIZONTAL VELOCITY AS A FUNCTION OF DISK LOAD

$$HV_{max} = \sqrt{\frac{4DL}{\rho_{a1}}}$$

		X(ft)						
		20	40	50	70	100	130	160
$\frac{HV}{HV_{max}}$.95	1.0	1.0	.8	.55	.50	.40

NB: for helicopter with landing gear on ground

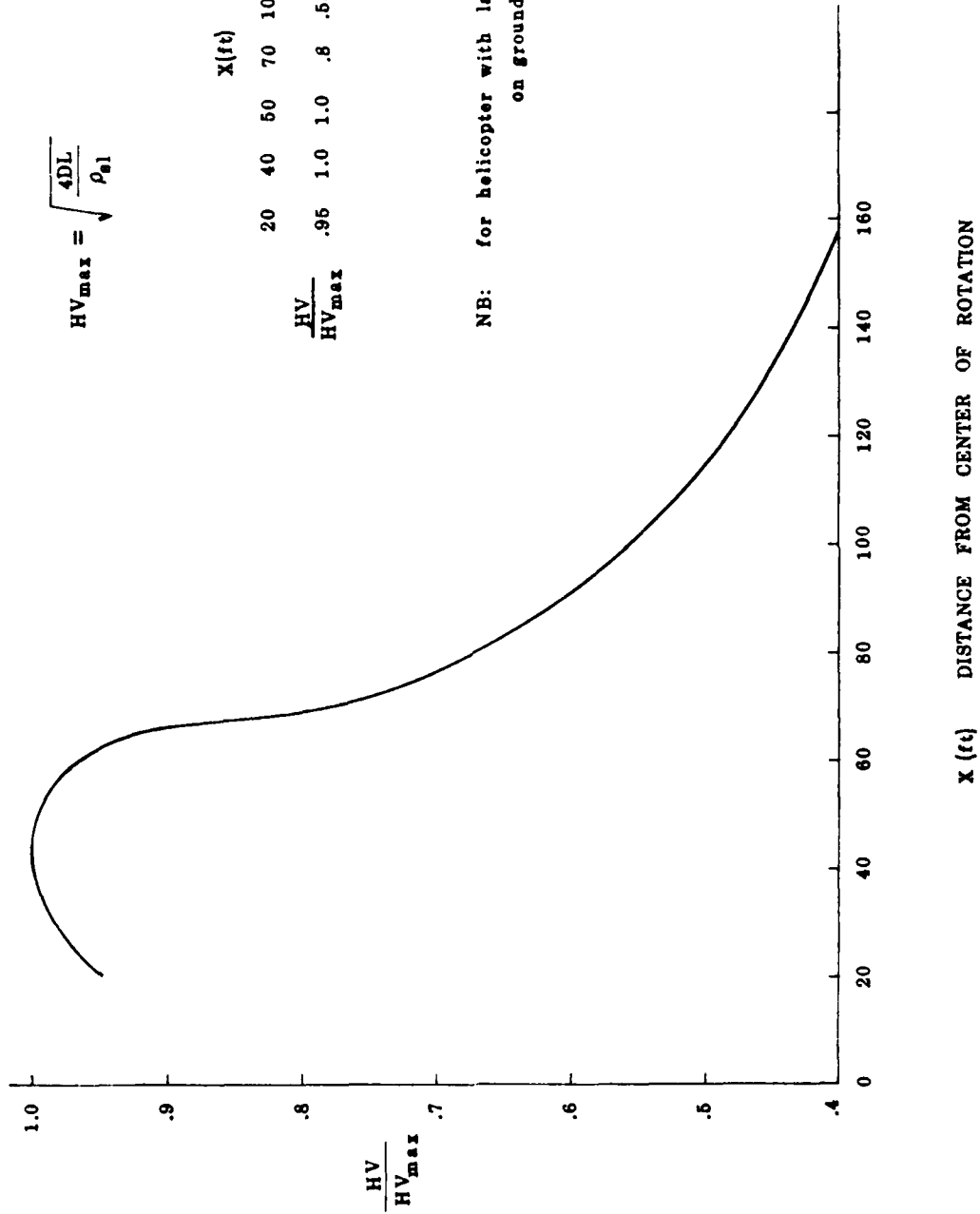

FIGURE 5-2. VARIATION IN HORIZONTAL VELOCITY WITH DISTANCE FROM ROTOR HUB

or:
$$P_0 = 2 \times (R_{HV})^2 \times DL \quad (5-5)$$

Shown in Figure 5-3 is the computed P_0/DL vs. X/R for a helicopter with its landing gear on the ground. As indicated by the figure, there is very good agreement between the full scale and model data. Figure 5-4 is an envelope curve representing the maximum P_0/DL at any X/R value. As illustrated in Figures 5-3 and 5-4, the maximum pressure of about $2.2 \times DL$ occurs at an X/R value of 1.5 but decreases rapidly with increasing values of X/R . A disk load of 9.78 lb/ft^2 (CH-54 at 39,800 lb) yields a wind load of 20 lb/ft^2 , which exceeds the allowable wind pressures specified by the Uniform Building Code for certain height zones in specific geographical areas (Table 5-2). However, the use of a CH-54 is generally limited to military applications where it is unlikely that wind load will be a major consideration. Perhaps more logical choices to demonstrate the magnitude of the wind loads are a Bell Long Ranger or Sikorsky S-76, which produce wind loads of 7.5 lb/ft^2 and 14 lb/ft^2 , respectively, both well within the UBC specifications.

Shown in Figure 5-5 is the variation in P_0/DL as a function of X/R for the Z/R values of 0.5, 1.0 and 1.5, which correspond to the following helicopter positions with respect to the ground surface: landing gear on the ground, in ground effect, and completely out of ground effect, respectively. From this figure it should be noted that the maximum or critical P_0/DL value does not always occur when the helicopter is on the pad. At X/R of 1.5 the maximum P_0/DL occurs when the landing gear is on the ground; however, at X/R of 2.5 the maximum P_0/DL occurs when the helicopter is completely out of ground effect. Accordingly, one may glean from Figure 5-5 that the maximum P_0/DL is dependent upon both the X/R values and the relative height of the helicopter above the ground surface. To clarify this concept, the envelope curve in Figure 5-6 has been drawn to show the maximum P_0/DL for any Z/R at any X/R , thus eliminating the need to consider the relative height of the helicopter with respect to the ground surface.

Shown in Figures 5-8 through 5-10 are P_0/DL ratios as functions of elevation H/R for various Z/R values at the X/R values of 1.5, 2.4 and 3.4 respectively. (A sketch clarifying the geometrical notation used for Figures 5-8 through 5-10 is included as Figure 5-7.) From these drawings it may be

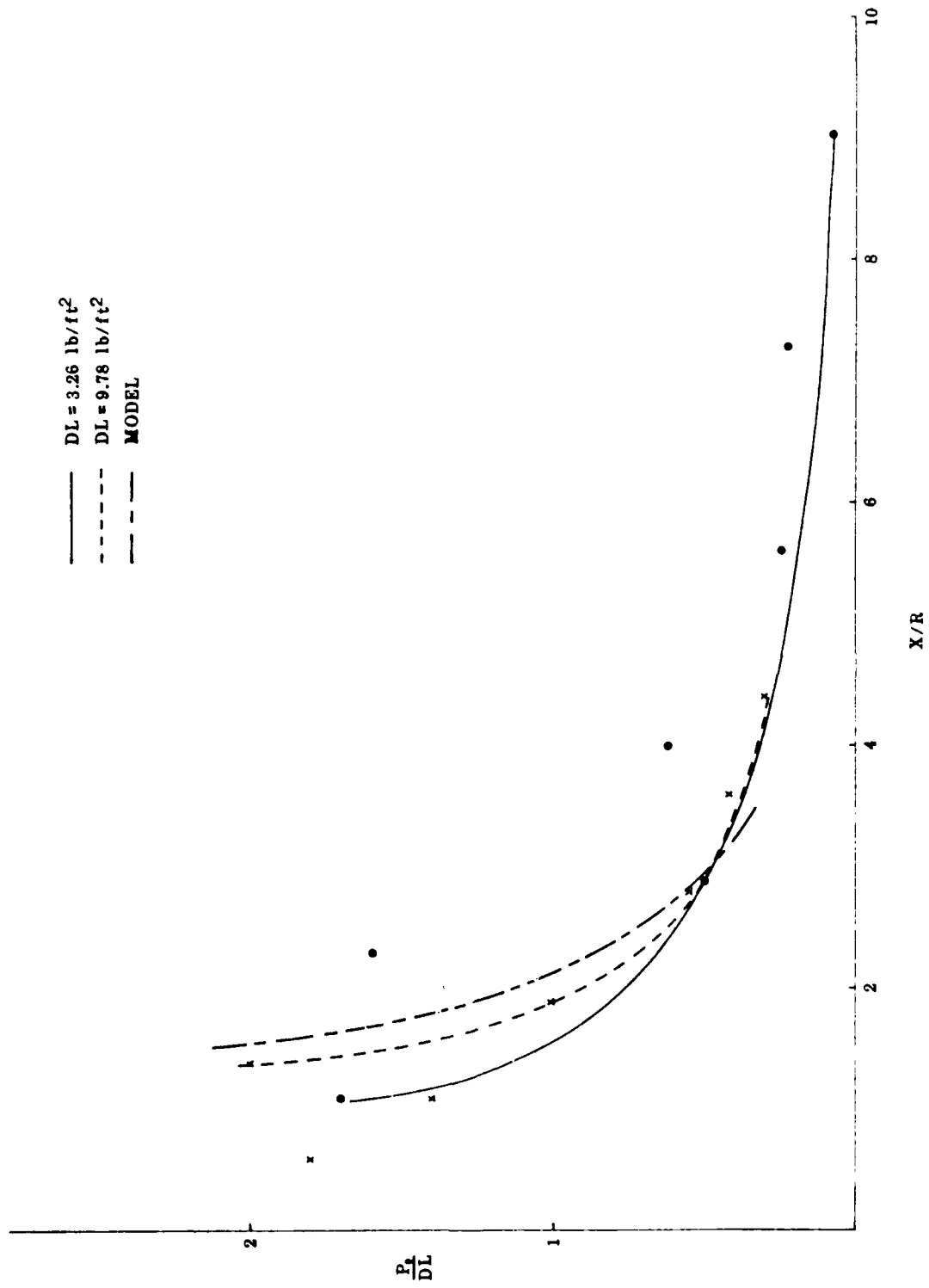

FIGURE 5.3 PRESSURE DISTRIBUTION FOR HELICOPTER WITH LANDING GEAR ON THE GROUND

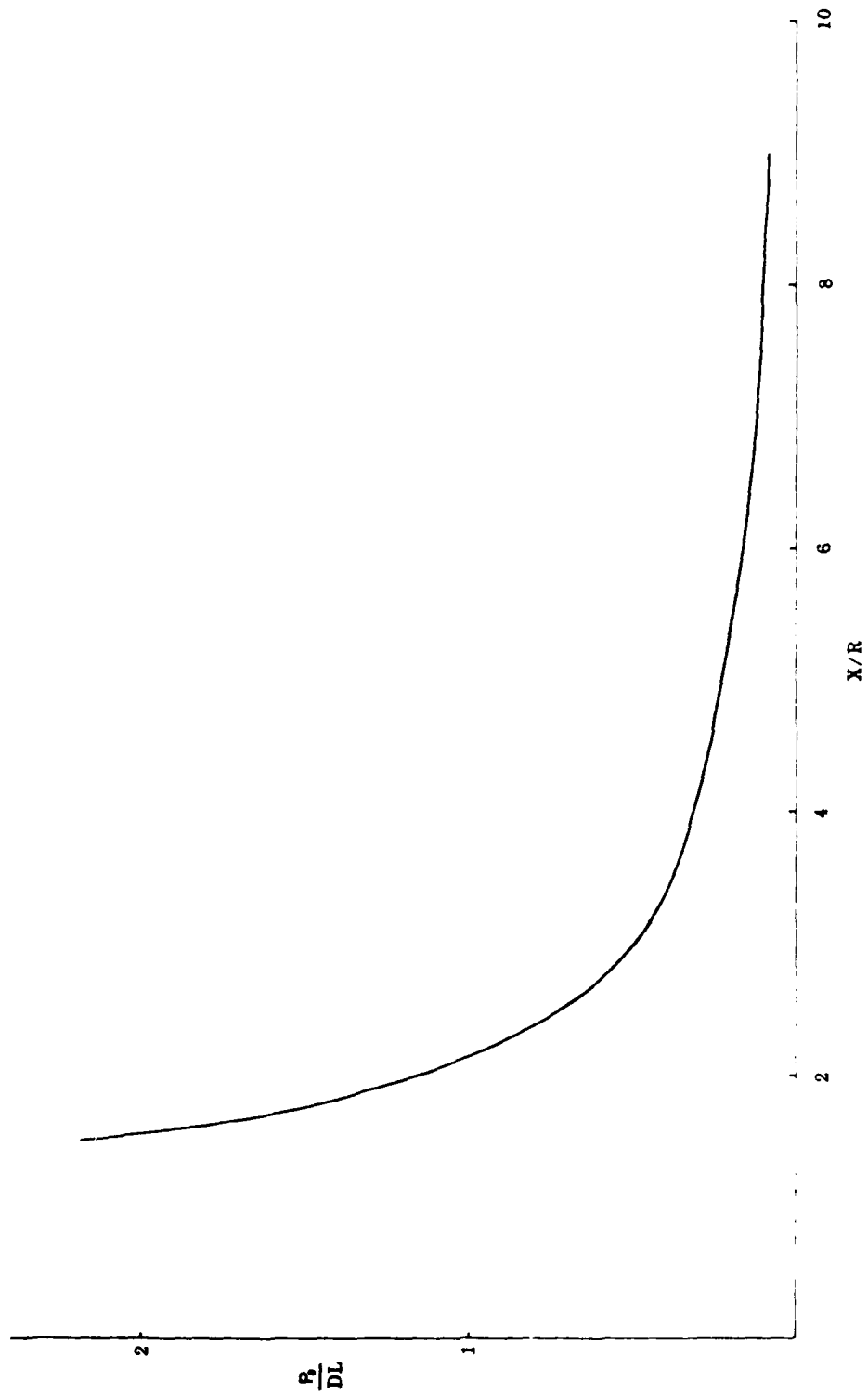

FIGURE 5-1. PRESSURE DISTRIBUTION FACTOR FOR HELICOPTER WITH LANDING GEAR ON THE GROUND

TABLE 5-2. UNIFORM BUILDING CODE WIND LOADS

TABLE NO. 23-F -- WIND PRESSURES FOR VARIOUS HEIGHT ZONES ABOVE GROUND*

HEIGHT ZONES (in feet)	WIND-PRESSURE-MAP AREAS (pounds per square foot)						
	20	25	30	35	40	45	50
Less than 30	15	20	25	25	30	35	40
30 to 49	20	25	30	35	40	45	50
50 to 99	25	30	40	45	50	55	60
100 to 499	30	40	45	55	60	70	75
500 to 1199	35	45	55	60	70	80	90
1200 and over	40	50	60	70	80	90	100

*See Figure No. 4. Wind pressure column in the table should be selected which is headed by a value corresponding to the minimum permissible, resultant wind pressure indicated for the particular locality.

The figures given are recommended as minimum. These requirements do not provide for tornadoes.

TABLE NO. 23-G -- MULTIPLYING FACTORS FOR WIND PRESSURES—CHIMNEYS, TANKS, AND SOLID TOWERS

HORIZONTAL CROSS SECTION	FACTOR
Square or rectangular	1.00
Hexagonal or octagonal	0.80
Round or elliptical	0.60

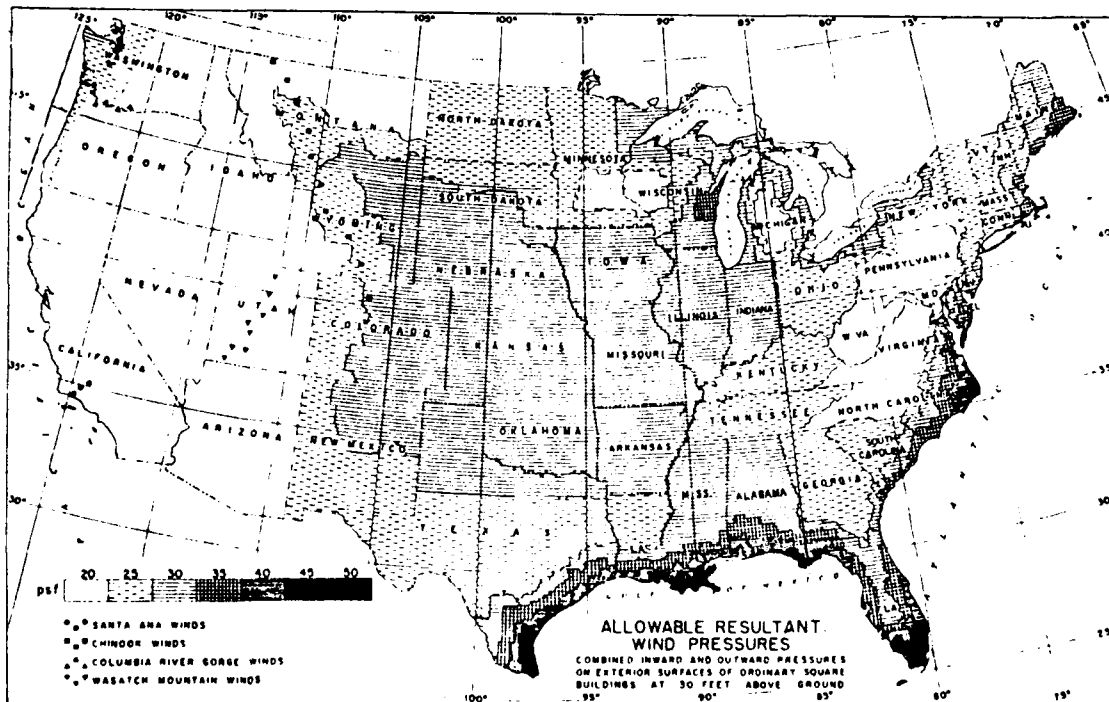

FIGURE NO. 4

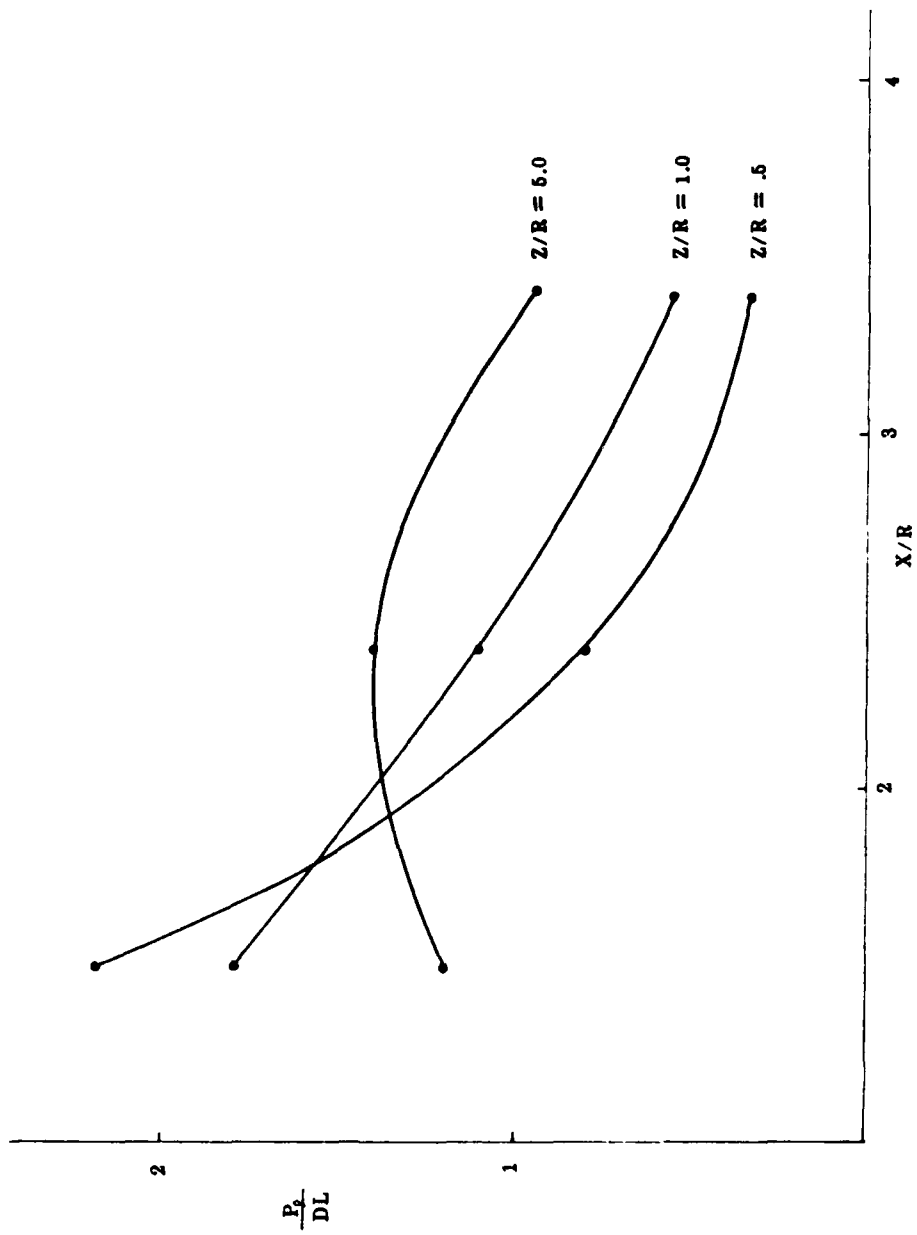

FIGURE 2. PRESSURE DISTRIBUTION AS A FUNCTION OF RADIAL OFFSET AND HEIGHT ABOVE THE GROUND SURFACE

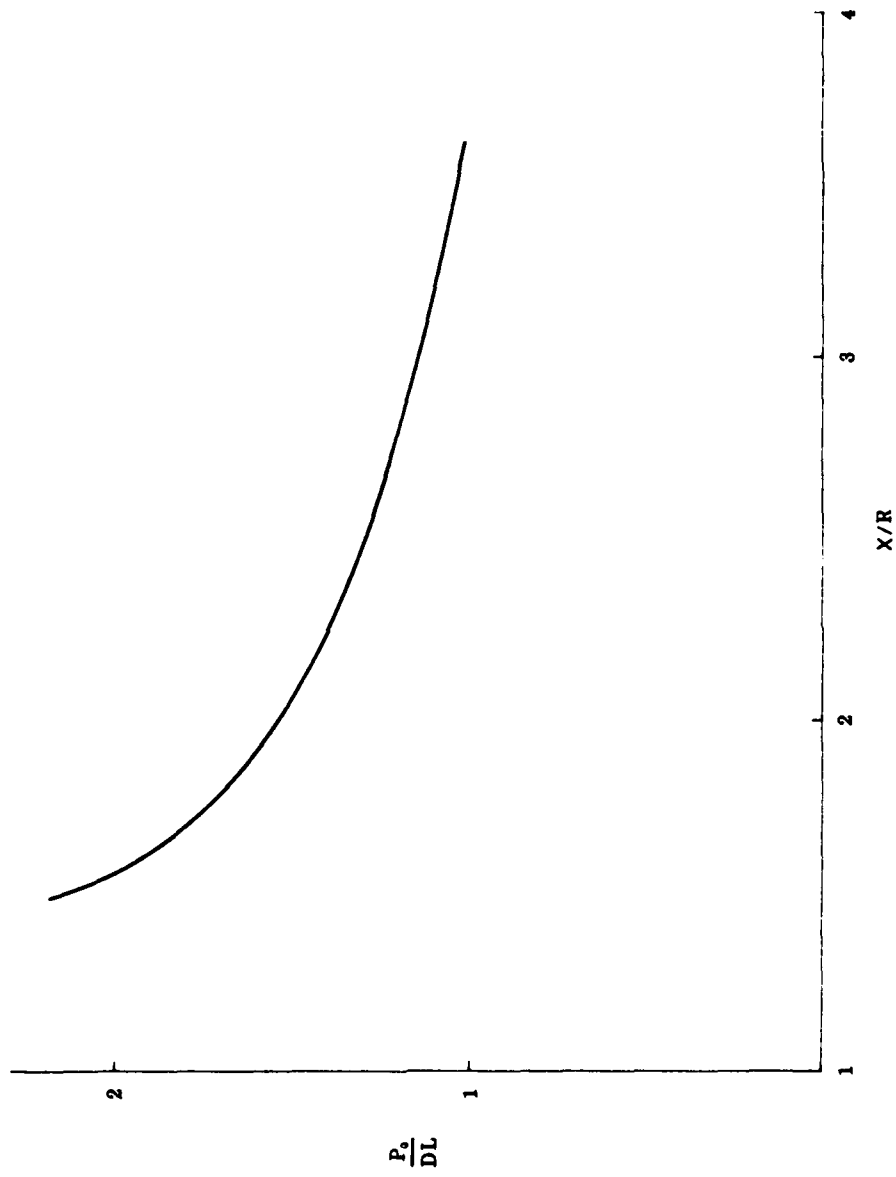
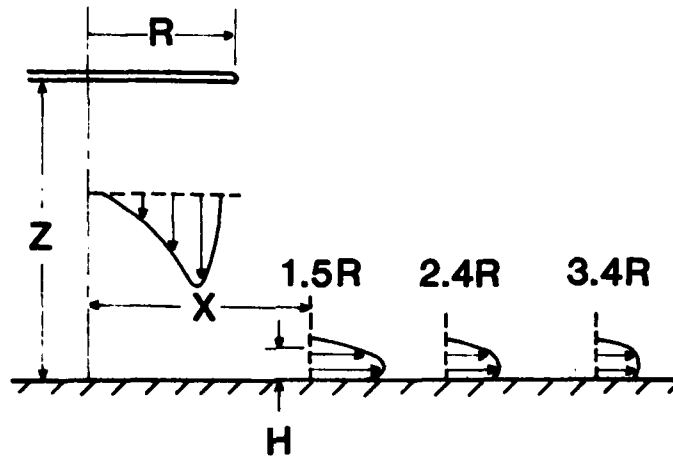

FIGURE 5-6. PRESSURE DISTRIBUTION ENVELOPE AS A FUNCTION OF RADIAL OFFSET



R = Rotor radius
 Z = height of rotor above ground
 X = horizontal distance from center of rotation
 H = height above ground

FIGURE 5-7. VELOCITY PROFILES ALONG THE GROUND
 (FROM FRADENBURGH, 1958)

$$\frac{X}{R} = 1.5$$

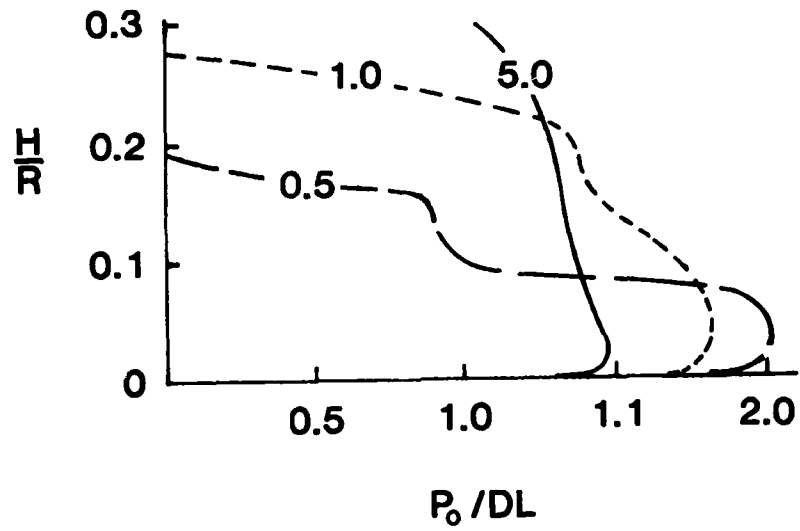

Z/R
0.5 ———
1.0 - - - -
5.0 ———

FIGURE 5-8. PRESSURE DISTRIBUTION NEAR THE GROUND SURFACE FOR $X/R = 1.5$
(FROM FRADENBURGH, 1958)

$$\frac{X}{R} = 2.4$$

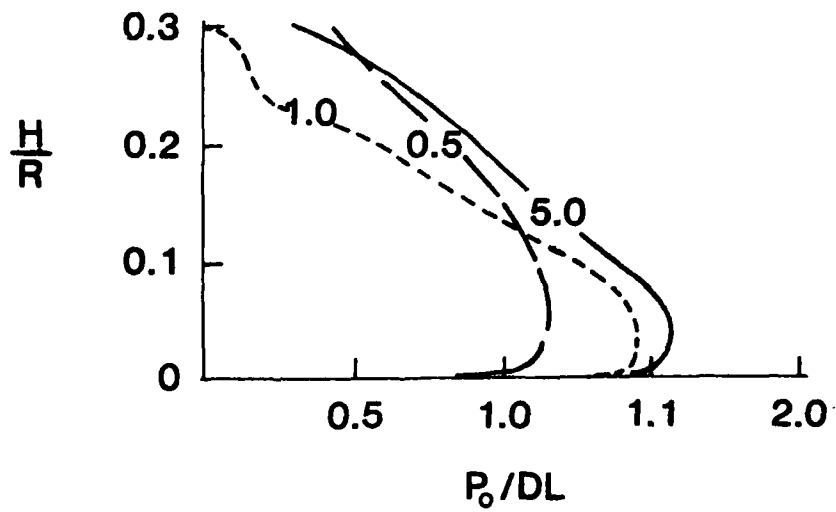

Z/R
0.5 — — — —
1.0 - - - - -
5.0 — — — —

FIGURE 5-9. PRESSURE DISTRIBUTION NEAR THE GROUND SURFACE FOR $X/R = 2.4$
(FROM FRADENBURGI, 1958)

$$\frac{X}{R} = 3.4$$

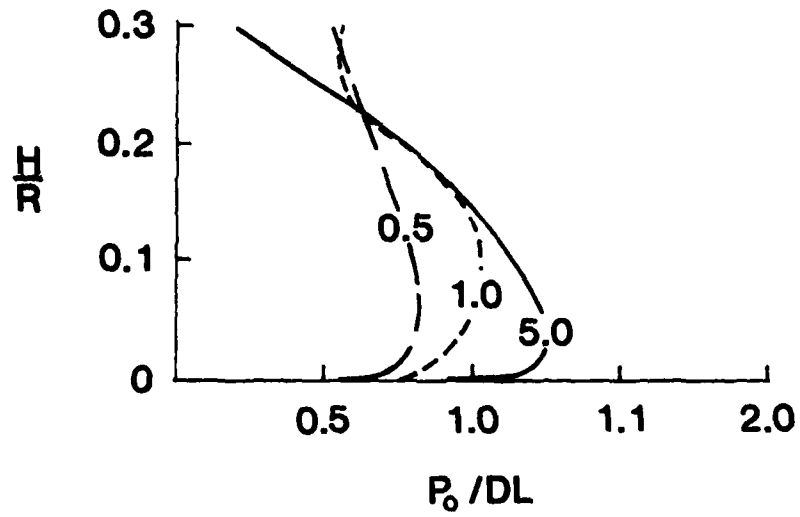

Z/R
0.5 ———
1.0 - - - -
5.0 ———

FIGURE 5-10. PRESSURE DISTRIBUTION NEAR THE GROUND SURFACE FOR $X/R = 3.4$ (FROM FRADENBURGI, 1958)

seen that horizontal downwash pressures may be high, but they are also very localized. As illustrated in Figures 5-8 through 5-10, the measured horizontal downwash pressures reach a peak value of $2 \times DL$ at the ground surface but decrease rapidly with height above the ground. For example, in Figure 5-8 for $Z/R = 0.5$, the measured horizontal downwash pressure at $H/R = 0$, i.e., the ground surface, is $2 \times DL$; at $H/R = 0.2$ however, the horizontal downwash pressure is almost zero. This same trend of higher localized horizontal downwash pressures near the ground surface is shown in Figures 5-9 and 5-10. In Figures 5-9 and 5-10, maximum pressure at the ground surface is only $1.0 - 1.1 \times DL$ and diminishes rapidly with increasing height above the ground surface.

In conclusion, both full scale and model data indicate that maximum horizontal ground pressures may approach $2.0 - 2.2 \times DL$ but drop off quickly with increasing distance from the rotor hub. For the more commonly flown helicopters in the civilian fleet (eq. Bell Long Ranger, Sikorsky S-76), wind loads may be on the order of $7-14 \text{ lb/ft}^2$, well within the UBC specifications for wind loads for structures. Survey responses, as noted in Appendix B, indicate that operational problems associated with rotor downwash are limited to the scattering of roof gravel and helicopter exhaust fumes entering rooftop circulation vents. Accordingly, rotor downwash will not be a critical load condition in the structural design of heliports.

All course, all of the discussion of downwash pressure distributions in this section is based on data from current, conventional helicopter models. It is likely that proposed advanced rotorcraft designs based on the X-wing, ABC, and tilt rotor concepts may exhibit significantly different rotor aerodynamics and therefore significantly different downwash pressure characteristics. However, any modification of the relations described in this section must await measurement data for these advanced concepts.

6. STRUCTURAL VIBRATIONS

Neither the heliport consultants and operators contacted by phone during Task 1 nor the survey responses of Task 2 indicated any significant problems due to vibrations. In addition, we were unable to find any literature references to this problem, although the topic of vibrations within the helicopter itself has been extensively studied.

Although not an issue for ground level landing pads, vibrations may be cause for concern for rooftop and elevated heliports. Problems caused by vibrations may be categorized as those related to structural integrity (overstress of structural members due to dynamic effects of vibrations), and serviceability (cracking of plaster and decorative masonry panels and annoyance of humans using the facility). Vibrations of the helideck may be caused by landing impact, machine vibrations transmitted through the landing gear, and rotor downwash.

As landing loads are not cyclic loads, vibrations resulting from landing impact are not a major concern; i.e., resonance of the structure is not a problem. Moreover, the dynamic structural effects of hard landing impact are already considered in the impact or hard landing load factor, which is intended to reicopter such that it literally "touches down," and there is no "impact" to be perceived by building occupants. Since hard landings are abnormal events, it is recommended that there be no special design criteria for hard-landing impact vibrations beyond those already incorporated in the dynamic load factor.

Vibrations transmitted through the gear typically occur during idle prior to takeoff and after landing. As the magnitude of the excitation force is small, vibrations are likely to be a problem only if resonance of the structure is reached. The occurrence of resonance depends on the excitation period, which is a function of the rotor shaft speed, and the response period, a function of the stiffness and mass of the structure. To estimate the likelihood of resonance occurring, one can consider the normal range of rotor speeds (rpm) and maximum response period of the structure. With helicopter rpm's ranging from 50-400 (350 being the optimal shaft speed) and the longest structural period for the landing surface of approximately 0.25 seconds, one observes in Figure 6-1 that resonance may occur under certain conditions. This resonance will likely be only a transient condition as the rotor accelerates/decelerates to/from maximum operating RPM, however. Furthermore, the dynamic load factors will not be as high as those shown in Figure 6-1 because structural damping, which is difficult to quantify, has not been incorporated in this analysis. For structures in which the occupants and/or contents are particularly sensitive to vibrations, the designer may choose to utilize some type of vibration isolation system (e.g., a "floating" slab for

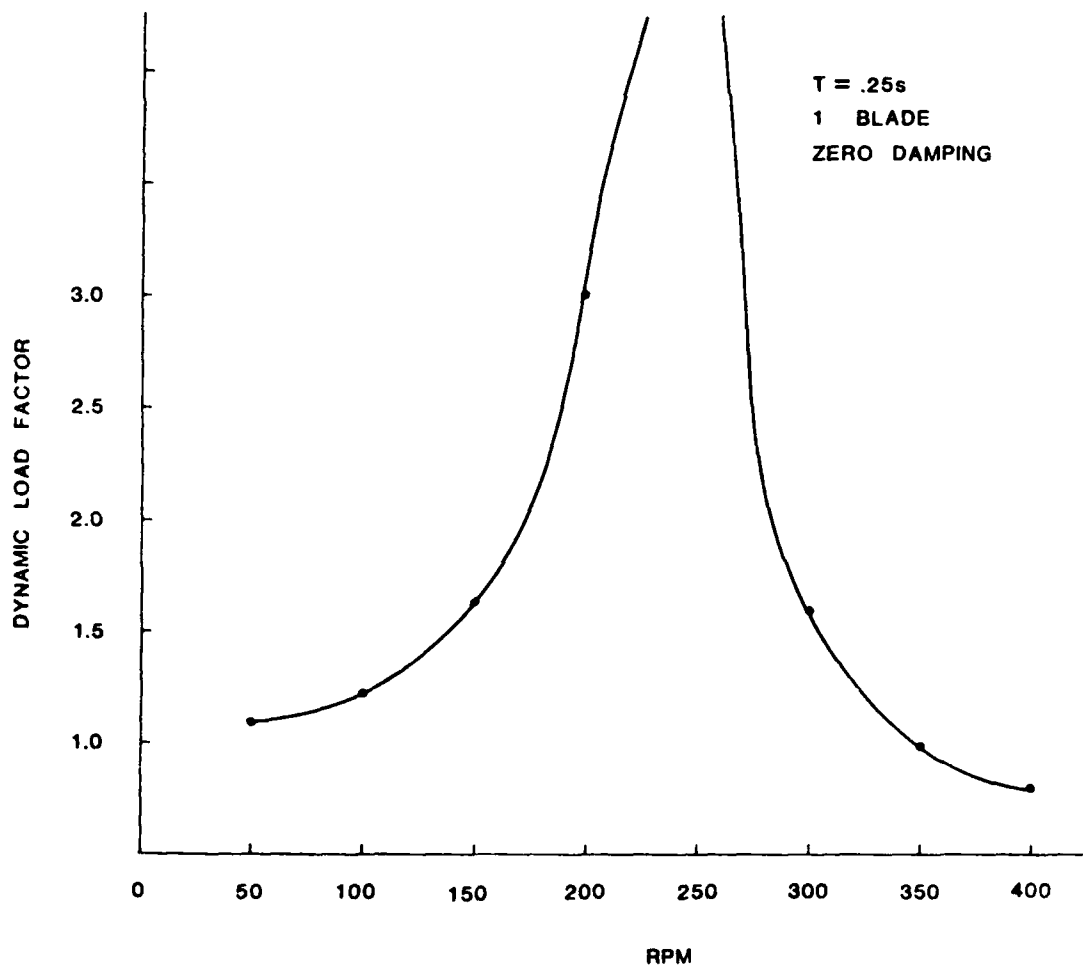

FIGURE 6-1. DYNAMIC LOAD FACTOR AS A FUNCTION OF SHAFT SPEED

the landing pad) similar to floating slab systems commonly used in subway rail systems.

The last component of induced structural vibrations in heliports is that generated by rotor downwash during takeoff and hover. The detailed model study by Fradenburgh (1958) described in the preceding section showed that most of the air for a rotor in ground effect is stagnant, i.e., there is no pulsating pressure field below the rotor, except near the edges of the rotor where it is of small amplitude. This pulsating pressure field near the rotor edges occurs only when the rotor is in ground effect and generating maximum downwash pressure at a peak operating speed of approximately 350 rpm. Excitation frequency in this case is the shaft rpm multiplied by the number of rotor blades per revolution. For 2-5 rotor blades at 350 rpm, the excitation frequency is 12-30 Hz and the excitation period is 0.03 - 0.08 seconds. As this excitation period is considerably smaller than the response period ($T = 0.25s$), no load magnification or resonance is likely to occur. Accordingly, downwash induced vibrations are not expected to be significant for the helideck and supporting structure.

The conclusions in the two preceding paragraphs are based upon the operating characteristics of current generation rotorcraft. However, they should also hold for the advanced rotorcraft concepts currently under development. In general, the advanced rotorcraft will produce vibrations of smaller magnitudes with higher rotor shaft speeds and higher blade velocities. Gear-transmitted vibrations may still cause a transient resonance condition as the rotor accelerates/decelerates to/from peak velocity, similar to generation rotorcraft. Rotor downwash-induced vibrations for advanced rotorcraft will have a shorter period than current models, however, resulting in even less likelihood of downwash-induced resonance of the comparatively long natural period heliport structure.

In summation, the impact effects of hard landings are already considered in the structural design. Although these vibrations may be disturbing to building occupants in rooftop heliports, they are likely to be perceived only in the abnormal event of a hard landing. Accordingly, no special design criteria are recommended for these vibrations. Downwash induced vibrations are not likely to be significant. Gear-transmitted vibrations may cause some resonance of the structure but the loads are small and damping should reduce the dynamic magnification somewhat. For added protection against vibrations,

the designer may choose to isolate the landing pad on a "floating" slab system.

7. OTHER STRUCTURAL LOADING CONDITIONS

It is the intent of this report to focus on the special loading conditions influencing the structural design of heliports that are due primarily to hard landings and rotor downwash. There are, however, other loading conditions to be considered, such as snow loads on rooftop or elevated heliports and equipment loads on ground level pads. These loads are usually specified by local building codes which are often based on national uniform building guidelines such as the Uniform Building Code (UBC), Building Officials and Code Administrators (BOCA), or by other government documents such as the FAA Advisory Circular 150/5320-6C, "Airport Pavement Design and Evaluation." These other loading conditions are detailed in the following sections.

7.1 Rooftop and Elevated Heliports

According to the UBC, snow loads may "be considered in place of the loads set forth in Table 23-C (included here as Table 5-1), where such loading will result in larger members or connections". Under normal heliport operating conditions the snow is removed from the landing pad and placed along the perimeter of the landing area such that the touchdown pad itself is not actually loaded by snow. However, provisions should be made for possible large accumulations of snow due to drifting. The hatched area in Figure 7-1 indicates regions where snow loads should be based on local information.

With respect to water accumulation the UBC states that the roof should be designed to support maximum loads including the possible ponding of water due to deflection. The deflection criteria are specified in UBC Tables 23-D and E (included here as Table 7-1).

Determination of uniformly distributed live load for rooftop and elevated heliports is analogous to that for floor design. Accordingly, heliports should be designed for unit loads comparable to those set forth in UBC Table 23-A (Table 7-2); specifically, 40 psf. The rationale for this value is based on several factors: The weight of the more commonly flown helicopters in the civilian fleet (3500-7000 lb) is comparable to that of a private car, and a distributed live load of 40-50 psf is commonly prescribed for parking garage structures. Furthermore, many existing heliport design guides cite values



Snow loadings in continental United States. From *Basic Statistical Summary: Technical Publication AAV-Doss 77-100*.
 May 15 1954

FIGURE 7-1. SNOW LOADINGS IN THE CONTINENTAL U.S.

TABLE 7-1. UNIFORM BUILDING CODE DEFLECTION CRITERIA

TABLE NO. 23-D—MAXIMUM ALLOWABLE DEFLECTION FOR STRUCTURAL MEMBERS*

TYPE OF MEMBER	MEMBER LOADED WITH LIVE LOAD ONLY (L.L.)	MEMBER LOADED WITH LIVE LOAD PLUS DEAD LOAD (L.L. + K D.L.)
Roof Member Supporting Plaster or Floor Member	$L/360$	$L/240$

*Sufficient slope or camber shall be provided for flat roofs in accordance with Section 2305 (f)

L.L. = Live load

D.L. = Dead load

K = Factor as determined by Table No. 23-E

L = Length of member in same units as deflection

TABLE NO. 23-E—VALUE OF "K"

WOOD		REINFORCED CONCRETE†	STEEL
Unseasoned	Seasoned‡		
1.0	0.5	$\{2 - 12(A_c/A_t)\} + 0.6$	0

†Seasoned lumber is lumber having a moisture content of less than 16 percent at time of installation and used under dry conditions of use such as in covered structures

‡See also Section 2609

A_c = Area of compression reinforcement

A_t = Area of nonprestressed tension reinforcement

TABLE 7-2. UNIFORM BUILDING CODE FLOOR DESIGN LOADS

TABLE NO. 23-A—UNIFORM AND CONCENTRATED LOADS

USE OR OCCUPANCY		UNIFORM LOAD ¹	CONCENTRATED LOAD
CATEGORY	DESCRIPTION		
1.	Armories	150	0
2.	Assembly areas* and auditoriums and balconies therewith	Fixed seating areas	50
		Moveable seating and other areas	100
		Stage areas and enclosed platforms	125
3.	Cornices, marquees and residential balconies	60	0 ²
4.	Exit facilities, public ³	100	0
5.	Garages	General storage and/or repair	100
		Private pleasure car storage	50
6.	Hospitals	40	1000 ²
7.	Libraries	Reading rooms	60
		Stack rooms	125
Manufacturing	Light	75	2000 ²
	Heavy	125	3000 ²
8.	Offices	50	2000 ²
9.	Printing plants	Press rooms	150
		Composing and linotype rooms	100
10.	Residential ⁴	40	0
11.	Rest rooms ⁵		
12.	Reviewing stands, grand stands and bleachers	100	0
13.	Schools	40	1000 ²
14.	Sidewalks and driveways	250	
15.	Storage	Light	125
		Heavy	250
16.	Stores	Retail	75
		Wholesale	100

¹See Section 2306 for live load reductions.

²See Section 2304 (c), first paragraph, for area of load application.

³See Section 2304 (c), second paragraph, for concentrated loads.

⁴Assembly areas include such occupancies as dance halls, drill rooms, gymnasiums, playgrounds, plazas, terraces and similar occupancies which are generally accessible to the public.

⁵Exit facilities include such uses as corridors and exterior exit balconies, stairways, fire escapes and similar uses.

⁶Residential occupancies include private dwellings, apartments, and hotel guest rooms.

⁷Rest room loads shall be not less than the load for the occupancy with which they are associated but need not exceed 50 pounds per square foot.

from 10-42 psf, indicating that live loads of this magnitude have been successfully used in the past. Should any heavy equipment (eg: maintenance, repair, snow removal, etc.) be permanently stored on the elevated or rooftop facility, the 40 psf figure should be increased as deemed appropriate by the design engineer.

1.2 Ground Level Heliports

The FAA Advisory Circular AC 150/5320-6C provides guidance for the design of airport pavements for fixed wing aircraft. As helicopter landing loads are much less severe than those imposed by fixed wing aircraft, FAA AC 150/5320-6C can also be used as a conservative guide for the design of heliport landing surfaces.

The design of ground level airport pavements for light aircraft is divided into three categories based upon the weight of the aircraft:

- A) less than or equal to 12,500 lbs.
- B) greater than 12,500 and less than 30,000 lbs.
- C) greater than 30,000 lbs.

For weight Classes A and B, flexible pavement thicknesses may be determined from Figure 7-2 (FAA AC 150/5320-6C); rigid pavements for weight category A require a minimum of 5 in. of Portland Cement concrete, and a minimum of 6 in. are specified for category B.

For airports serving aircraft with maximum gross weights in excess of 30,000 lbs. (Class C), the designer is referred to Chapter 3 of FAA AC 150/5320-6C. In either category, one should recognize that in many instances the loads imposed by ground support vehicles (e.g., refueling trucks) may be more severe than loads imposed by the aircraft.

The current FAA heliport design guide, FAA AC 150/5390-1B, has adopted 6 inches as the minimum requirement for rigid pavements for helicopters up to 20,000 lbs. maximum gross weight, based on the data derived from AC 150/5320-6C. However, given that helicopter loads are less severe than fixed wing aircraft loads, we recommend that all of the provisions in AC 150/5320-6C be followed for the design of helicopter landing pavements. This will result in pavement designs that are slightly less conservative than those specified by the current heliport design guideline.

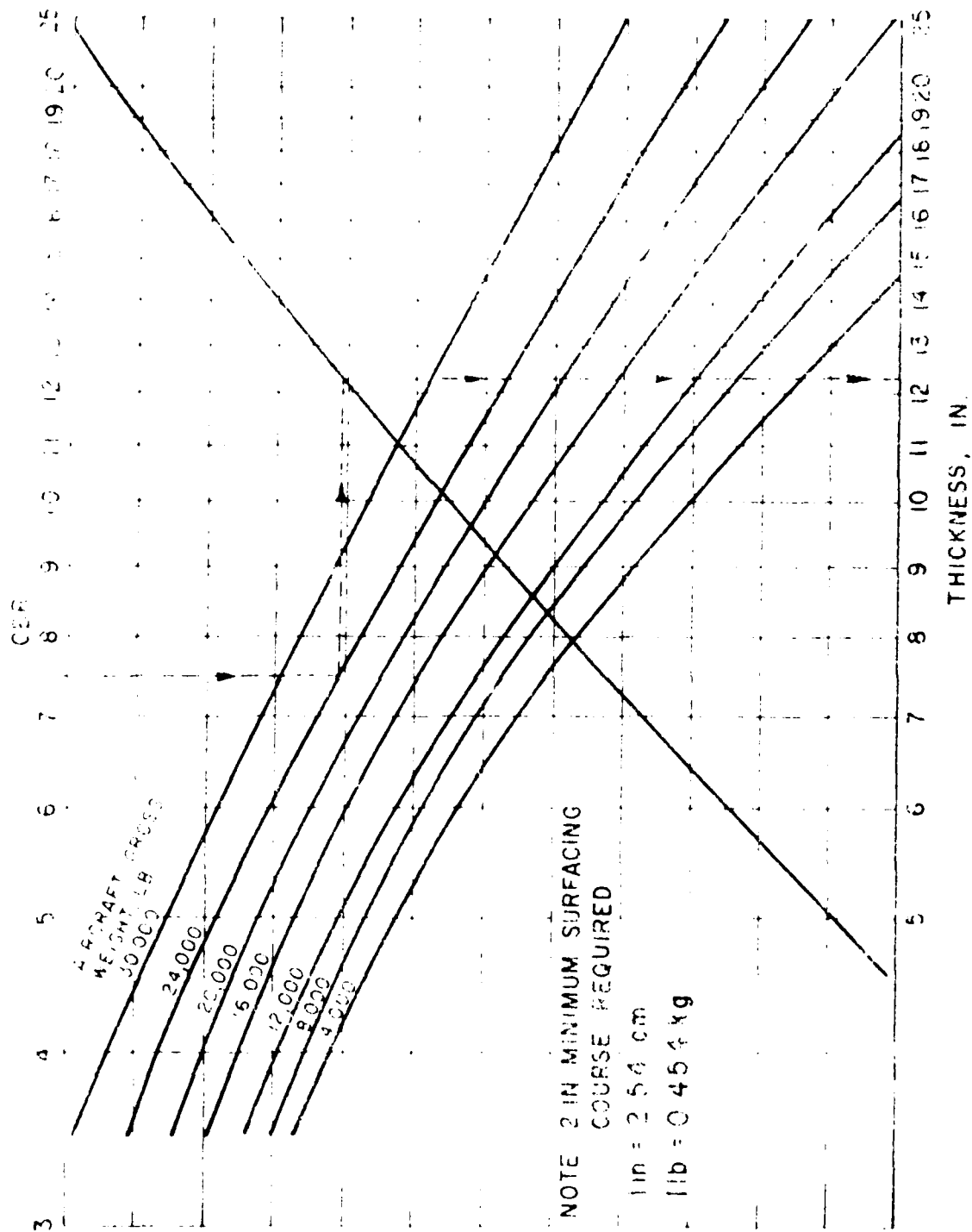

FIGURE 7.2 FAA DESIGN CURVE FOR FLEXIBLE PAVEMENT

7.3 Load Combinations

In view of the preceding sections, it is recommended that the heliport landing and parking areas be designed for the maximum stress induced by the following:

Landing Pad

- 1) dead load plus hard landing load
- 2) dead load plus snow load plus MGW of the helicopter (case of helicopter parked on landing pad during snowstorm)
- 3) dead load plus hard landing load plus snow load banked along perimeter of operations area
- 4) dead load plus uniformly distributed live load of 40 psf

Parking Area

- 1) dead load plus snow load plus MGW of helicopter(s)
- 2) dead load plus uniformly distributed live load of 40 psf

8. SUMMARY OF STRUCTURAL LOADING GUIDELINES FOR HELIPORT DESIGN

The following summary of loading guidelines is based on our review and analysis of the current state-of-the-art of heliport structural design. This summary is extremely condensed. The reader should consult the earlier sections in this report for the detailed justifications for these recommendations.

8.1 Hard Landing Loads

1. For heliports with a moderate to high operation frequency, the hard landing load recommendations in the current FAA guideline should continue to be used. Moderate to high operation frequency is defined here as more than 5,000 helicopter operations over the design lifetime of the landing surface.
2. For heliports with a low operation frequency, no increase for hard landing loads is required. The landing surface should be designed for the maximum gross weight of the largest helicopter expected to use the facility. Low operation frequency is defined here as fewer than 5,000 helicopter operations over the design lifetime of the landing surface.

Our study has indicated that the current FAA guidelines are slightly conservative for heavily used heliports and become more conservative as the

number of operations during the design life of the heliport decreases. However, the present paucity of data on helicopter landing velocities makes it difficult to apply with complete confidence the results from our reliability analysis. Consequently, at this time it is unwise to reduce the current guidelines for any but the most infrequently used facilities. As more data on helicopter landing characteristics become available in the future, it is expected that the hard landing load factor can be reduced for heliports having a moderate operation frequency and that the dividing line between low and moderate operation frequency can be increased.

8.2 Downwash Pressures

1. Vertical downwash pressures will not be a critical loading condition. For all current generation rotorcraft, the downwash pressures are less than the minimum roof loads prescribed by standard building codes.
2. In nearly all instances, horizontal downwash pressures will not be a critical loading condition for heliport structures. The horizontal downwash pressures for current generation rotorcraft are, with very few exceptions, less than the design wind loads prescribed by standard building codes. Downwash pressures may be locally large near the ground close to the rotor radius; if these pressures must be considered in the design of ancillary facilities at the heliport, the methodology outlined in Section 5 can be used for their calculation. The downwash pressures for advanced, high disk load rotorcraft can, as a first approximation, be extrapolated from the analysis presented in Section 5.

8.3 Structural Vibrations

1. The structural effects of vibrations caused by hard landings are already incorporated in the hard landing load factor. Since hard landings are abnormal events, no additional design precautions are required to minimize perceived hard landing vibrations in areas adjacent to or below the landing surface.
2. It is possible that gear transmitted vibrations during full power immediately before takeoff or after landing may cause resonance within an elevated or rooftop landing surface. The

resonance-inducing vibrations will generally be short in duration and small in amplitude and can thus be ignored for most structural designs. For vibration sensitive structures, the designer should perform a more detailed dynamic analysis of the structure and consider including vibration-isolating details (e.g., floating slabs) in the design.

3. Downwash-induced vibrations can be neglected in the structural design of the heliport.

8.4 Load Combinations

The heliport landing surfaces should be designed for the most critical of the following load combinations:

Landing Pad

- 1) dead load plus hard landing load
- 2) dead load plus snow load plus MGW of the helicopter (case of helicopter parked on landing pad during snowstorm)
- 3) dead load plus hard landing load plus snow load banked along perimeter of operations area
- 4) dead load plus uniformly distributed live load of 40 psf

Parking Area

- 1) dead load plus snow load plus MGW of helicopter(s)
- 2) dead load plus uniformly distributed live load of 40 psf

9. SUGGESTIONS FOR FUTURE INVESTIGATIONS

Our work under this subcontract has suggested several areas for further investigation:

1. Continued work on helicopter hard landings

- 1) Better characterization of the landing velocity vs. frequency of occurrence relation for helicopters. This will permit more confidence in the results from our reliability model for hard landings.
- 2) Investigation of the effect of approach attitude and other factors on helicopter hard landing loads. The major purpose of this study will be to determine whether there is any approach attitude that produces higher structural loads than the "load

through two main gear" condition. This study will require the analysis of both the helicopter dynamics and the structural response of the landing area.

- 3) Development of a more rational method for determining the landing gear contact area for skid gear helicopters. The current manufacturers guidelines are most probably conservative; a more rational calculation will require extensive, full scale testing of skid gear. This type of testing is most effectively performed by the manufacturers themselves.
- 4) Quantification of asphalt pavement rutting beneath skid gear helicopters, and development of methods for improving the rutting performance of asphalt landing surfaces. Asphalt pavement rutting was the only significant pavement distress problem discovered during our research.

B. Rotor Downwash

- 1) Investigation of the effect of rotor downwash on heliport personnel and/or passengers.
- 2) Appropriate sizing of gravel and other landing surface coverings to minimize blowing from helicopter downwash. This will require direct testing, most probably at an operational heliport.

C. Structural Vibrations

- 1) Perception of helicopter-induced vibrations in rooftop heliports by building occupants. Although helicopter-induced vibrations are small in magnitude, there have been reports of vibration perception by building occupants beneath rooftop facilities; this study would quantify the level of vibrations necessary for perception and propose methods for minimizing them.

BIBLIOGRAPHY

1. HELIPORT DESIGN GUIDES

Anonymous, "Helicopter Design Guide", FAA Advisory Circular 150/5390-1B, August 22, 1977.

Anonymous, "Helicopter Design Guide," FAA Advisory Circular 150/5390-1C (draft), June 1984.

Anonymous, "Offshore Helicopter Design Guide", Louisiana Department of Transportation and Development, March 1980.

Anonymous, "Offshore Helicopter Design Guide", Louisiana Department of Transportation and Development, May 1, 1984.

Anonymous, "Recommended Practice for Planning, Designing, and Constructing Helicopters for Fixed Offshore Platforms", American Petroleum Institute (APIRP 2L), January 1983.

Anonymous, "Requirements for Mobile Offshore Drilling Units", U.S. Coast Guard, Department of Transportation, 4 December 1978.

Anonymous, "Helicopter Manual", International Civil Aviation Organization, Montreal, Canada, First Edition, 1979.

Anonymous, "Offshore Helicopter Landing Areas: Guidance on Standards", Civil Aviation Authority, London, England, 1981. (NTIS #PB83-228874)

Anonymous, "Uniform Building Code", International Conference of Building Officials, Whittier, California, 1976.

Anonymous, "The BOCA Basic Building Code/1981", Building Officials and Code Administrators International, Inc., Homewood, Illinois, Eight Edition, 1980.

2. LANDING GEAR/LANDING LOADS

Anonymous, "Technical Aspects of Helicopter Structural Design and Operating Capabilities of the Helicopter", Sikorski Aircraft, October, 1973.

Free, F.W., "Helideck Design for Offshore Platforms", British Airways Helicopters Limited, Shell Aviation News, N450, 1978.

Anonymous, "Structural Considerations", Bell Helicopter Textron, Fort Worth, Texas.

Christ, D. and L.H. Symes, "Helicopter Landing Gear Design and Test Criteria Investigation", Report USAAVRADCOTR81-D-15, August, 1981. (NTIS #AD A105 512)

Crenshaw, B.M., "Development of an Analytical Technique to Predict Aircraft Landing Gear/Soil Interaction", Report No. AFFDL-TR-74-115, 1975. (NTIS #AD B003 790L)

Goodall, Ralph E., "Advanced Technology Helicopter Landing Gear", Report No. USAMRDL-TR-77-27, 1977, (NTIS #N78-19124)

Logan, A.H., "Analytical Investigation of an Improved Helicopter Landing Gear Concept", Report No. USAAMRDL-TR-76-19, 1976. (NTIS #AD A029 372)

Burdin, A.P. and Sviridov, N., "Helicopter Landing Pads", Report No. AST-11001-030-77-9, 1977. (NTIS #AD-B026 442L)

Anonymous, "Airworthiness Standards: Normal Category Rotorcraft", Federal Aviation Regulation 27, Federal Aviation Administration, Department of Transportation.

3. ROTOR DOWNWASH

Jenkins, B.Z., and Marks, A.S., "Rotor Downwash Velocities About the UH-1H Helicopter-Flight Test Measurements and Theoretical Calculations", Army Missile Research Development and Engineering Lab., Redstone Arsenal, Alabama, January 1975. (NTIS #AD-A008-965/6)

Leese, Grady, W., "UH-1H Downwash Velocity Measurements", Army Engineer Waterways Experiment Station, Vicksburg, Mississippi, August 1972. (NTIS # AD-Ap34 667/6)

Leese, Grady, W. and Carr, James W., "Materials Evaluation for Aircraft Blast and Helicopter Downwash Protection", Army Engineer Waterways Experiment Station, Vicksburg, Mississippi, June 1975. (NTIS #AD-A121 761/1)

Leese, Grady, W. and Knight, John T., "Helicopter Downwash Data", Army Engineer Waterways Experiment Station, Vicksburg, Mississippi, June 1974. (NTIS #AD-780 754/8)

Skujins, Ojars, "An Experimental Investigation of Rotor Forces and Flow Field in the Vicinity of a Step Ground Plane", West Virginia University, Department of Aerospace Engineering, July 1970. (NTIS #AD-711 955)

Fradenburgh, E.A., "Flow Field Measurements for a Hovering Rotor Near the Ground," paper presented at the American Helicopter Society Fifth Annual Western Forum, Los Angeles, California, September, 1958.

4. RELATED TOPICS

Anonymous, "AIA Directory of Heliports in the United States, Canada, Puerto Rico, and Directory of Hospital Heliports", Aerospace Industries Association, Washington, D.C., 1981.

Anonymous, "Airport Pavement Design and Evaluation", Advisory Circular 150/5320-6C, Federal Aviation Administration, Department of Transportation, December 1978.

Hodgkins, R.F., "Heliports", monthly (approximate) column in Rotor and Wing International magazine, 1983-present.

Braun, Joseph F. and Giessler, F. Joseph, "CH-54A Skycrane Helicopter Flight Loads Investigation Program", Army Aviation Material Labs, Ft. Eustis, Virginia, June 1966. (NTIS #AD-638 364)

Chestnutt, D., Bartek, L., Clay, L.F., and Braun, F.F., "UH-1B Helicopter Flight Loads Investigation Program", Army Aviation Material Labs, Ft. Eustis, Virginia, May 1966. (NTIS #AD634-502)

Studwell, Robert E., "Helicopter Dynamic Performance Program, Volume 1, Engineer's Manual", United Technologies Corp., Sikorsky Aircraft Division, Stratford, Connecticut, July 1980. (NTIS #AD-A088 474/2)

Taylor, M.J.H., and Taylor, J.W.R., "Helicopters of the World", Scribner, New York, 1978.

Vining, Ralph E., "Study of CH-53A Helicopter Flight Load Parameters", Naval Air Development Center, Warminster, Pennsylvania, September, 1971. (NTIS #AD-739-332)

Zinberg, L., "Flight Service Evaluation of Composite Components on the Bell Helicopter Model 206L: Design, Fabrication and Testing", Bell Helicopter Textron, Fort Worth, Texas, November 1982. (NTIS #N83-14169/7)

Anonymous, "Review of Rotorcraft Accidents, 1977-1979", National Transportation Safety Board, Department of Transportation, 1981. (NTIS #PB82-115601)

Biggs, J.M., Introduction to Structural Dynamics, McGraw-Hill, New York, 1964.

Benjamin, J.R. and C.A. Cornell, Probability, Statistics, and Decision for Civil Engineers, McGraw-Hill, New York, 1970.

APPENDIX A

Helicopter Dimensional Data

Extracted from the draft FAA AC 150/5390/1C (June 1984) and the Louisiana DOT Offshore Heliport Design Guide (May 1984), the appendix provides a current listing of helicopters by manufacture. The tabulated data include, as available, the following: helicopter dimensions; landing gear configuration and dimensions; maximum gross weight and distribution of weight forward and aft; gear contact area and disk load.

SCHEMATICS FOR APPENDIX A



HELICOPTER DIMENSIONS

S	PF	6-1	6-3	7-1	7-2	7-3	7-4	7-5	7-6	7-7

LANDING GEAR CONFIGURATION

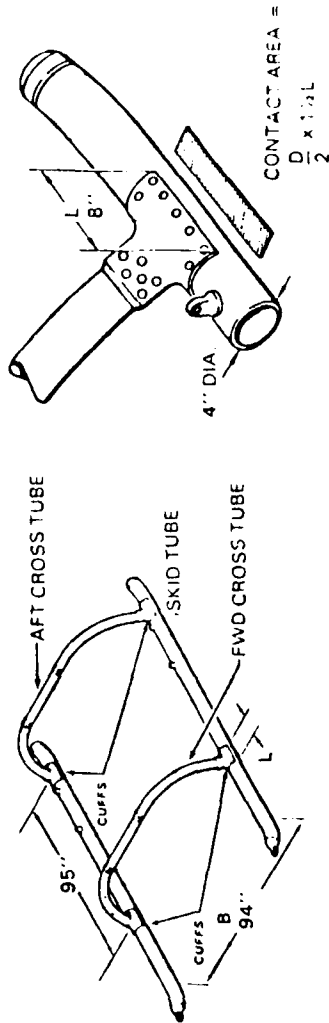

COMPUTATION OF SKID GEAR CONTACT AREA

$$\text{CONTACT AREA} = \frac{D \times L}{2}$$

HELICOPTER DIMENSIONAL DATA

Manufacturer	Model	Common Name	A (ft)	B (ft)	C (ft)	D (ft)	E (ft)	F (ft)
AUGUSTA	A-109A	II HIRANDO	42.9	10.9	35.1	6.6	7.0	2.3
AEROSPATIALE	315-B	LAMA	42.4	10.1	36.2	6.4		2.1
	318-C	ALOUETTE II	39.8	9.0	33.5	6.3		
	319-B	ALOUETTE III	42.1	9.3	36.1	6.3		
	330-B		59.6		49.5			
	339-J	PUMA	59.6	16.9	49.5	10.0	14.4	6.9
	341-G	GAZELLE	39.3	10.4	34.5		8.9	2.3
	360	DAUPHIN	44.1	11.5	37.7		10.0	
	360-C		44.1		37.7			
	350-B/D		42.7	10.3	35.1	6.1		2.3
	355-F		42.6	9.7	35.1	6.1		1.9
	365-N		44.2	11.4	39.1			2.6
	332-L		61.4	15.0	51.2	10.0		
	332-C		61.4	15.0	51.2	10.0		
	316-B		33.4	9.3	36.2	6.3		
BELL	47-G		43.6	9.3	37.0	5.3	3.5	3.5
	205-A-1		57.1	14.4	48.2	3.5	6.3	5.3
	206-B	JET RANGER	39.2	9.2	33.3	5.4	6.7	1.6
	206-L	LONG RANGER	42.5	11.7	37.0	5.2	6.2	2.9
	212	TWIN	57.3	14.4	48.0	3.5	7.0	4.4
	222		47.5	11.0	39.3	6.0	3.4	
	222-B		50.3	11.3	42.0	6.9	3.4	2.6
	222-J1		50.3	10.5	42.0	6.9	3.2	
	214-S1		62.2	14.2	52.0	3.7	3.2	
			62.2	14.2	52.0	3.7	3.2	
	412		56.1	13.5	46.0	8.6		6.5
	214-B	BIG LIFTER	60.2	13.5	50.0	9.6	9.4	3.7

AD-A148 967

STRUCTURAL DESIGN GUIDELINES FOR HELIPORTS(U) SYSTEMS
CONTROL TECHNOLOGY INC WEST PALM BEACH FL
C W SCHWARTZ ET AL. 24 OCT 84 DOT/FAR/PM-84/23

2/2

UNCLASSIFIED

A01-80-C-10080

F/G 1/5

NL



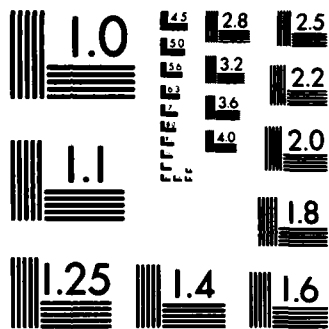

MICROCOPY RESOLUTION TEST CHART
NATIONAL BUREAU OF STANDARDS-1963-A

Manufacture Boeing	Model	Common Name	A (ft)	B (ft)	C (ft)	D (ft)	E (ft)	F (ft)
BOEING VERTOL	BO-105-C		38.8	10.1	32.2	6.2	9.0	6.1
	CH-47-234		99.0	19.0	60.0	60.0	11.0	16.2
	107-II		83.1	16.1	50.0	50.0	9.9	16.9
	179		59.5	16.6	49.0	10.2	8.0	6.4
BRANTLEY	B-2-B		28.0	6.8	23.7	4.3	4.8	3.0
AYNES	305		32.9	8.0	28.5	4.3	6.2	3.0
ENSTROM	F-28A/280	SHARK	39.0	9.0	32.0	4.7	6.0	3.1
	F-28C/280C	SHARK	39.0	9.0	32.0	4.7	6.0	3.1
FAIRCHILD	FH-1100		41.5	9.3	35.3	6.0	6.5	2.3
HILLER	UH-12-L	HILLER	40.7	10.1	35.4	5.5	10.0	3.3
	UH-12E/E-4	HILLER	40.7	10.9	35.4	5.5	10.8	4.0
HUGHES	269-NB	HUGHES 300	28.9	8.2	25.3	3.8	6.6	2.8
	269-C	HUGHES 300C	30.8	8.7	26.8	4.3	7.0	2.6
	369HS	HUGHES 500C	30.3	8.8	26.3	4.3	7.6	2.4
	369-D	HUGHES 500D	30.5	8.9	26.4	4.6	7.0	2.7
KAMEN	HH-43F	HUSKIE	47.0	19.3	47.0		7.2	2.3
ROTORWAY		SCORPION	27.6	7.3	24.0	3.6	6.5	3.1
MSB	105-CBS		38.8	9.8	32.3	6.2		
	BK 117	SPACE SHIP	42.7	10.9	36.1	6.2		
HELITECH	S-55T		62.2	15.3	53.0	8.8	8.2	6.5

HELICOPTER DIMENSIONAL DATA

Manufacture	Model	Common Name	A (ft)	B (ft)	C (ft)	D (ft)	E (ft)	F (ft)
SIKORSKY	S-58-T		65.8	15.9	56.0	9.5	11.4	6.4
	S-61N/L		73.0	18.6	62.0	10.6	12.3	8.3
	S-62		62.3	16.0	53.0	8.8	9.2	7.3
	S-64	SKYCRANE	88.5	25.4	72.3	16.0	13.2	9.3
	S-65C		88.2	24.9	72.3	16.0	10.3	8.8
	S-76		57.5	14.5	44.0	8.0	5.8	6.5
	S-78C		64.8	16.8	53.7	11.0	7.5	6.5
	S-55 A&C		62.3	12.5	53.0	8.8	10.3	6.5

HELICOPTER LANDING GEAR DATA

Manufacture	Model	Common Name	Landing Gear		G	H	I	Static MGW (lb)	Load		Gear Contact Area		Disk Load (lb/ft ²)
			Config.	Confg.					Fore (lb)	Aft (lb)	Fore (in ²)	Aft (in ²)	
AUGUSTA	A-109A II	HIRANDO	T-1		11.6	7.5	5727	1340	4327	14	22	5.6	
AEROSPATIALE	315-B	LAMA	S		10.8	7.8	5070	1927	3143	111 ²		4.9	
	318-C	ALOUETTE II	S		7.5		3650					4.2	
	319-B	ALOUETTE III	T-1		10.1	8.5	4960	1389	3571	46	46	4.8	
	330-B		T-1		13.3	8.0	16300	2608	13692	52	105	8.5	
	330-J	PUMA	T-2		13.3	7.8	16315	5547	10768	93 ³	83 ³	8.5	
	341-G	GAZELLE	S		5.6		3968	1310	2658	91 ²		4.2	
	360	DAUPHIN	T-4		23.7	6.5	6170	5183	987	33	19	5.5	
	360-C		T-4		10.9	7.9	6600	5544	1054	33	19	5.9	
	350-B/D		S		6.9		4299	2193	2106	86.5 ²		4.4	
	355-F		S		6.9		5071	2587	2484	86.5 ²		5.2	
	365-N		T-4		11.8	6.2	8487	1867	6620	19	33	7.1	
	332-L		T-2		17.3	9.8	18410	6536	11874	36	57 ³	8.9	
	332-C		T-2		14.7	9.8	18410	7364	11046	36	57 ³	8.9	
316-B		T-1		8.5		4850	1358	3429	46	46			
BELL	47-G		S		9.9	7.5	2950			6 ⁷	6 ⁷	2.6	
	205-A-1		S		12.1	9.0	9500	1900	7600	8 ⁷	8 ⁷	5.2	
	206-B	JET RANGER	S		8.3	6.3	3200	4 ⁶ 23	2577	13.5x2	13.5x2	3.7	
								5 ⁴ 68	2732	13.5x2	13.5x2	3.7	
								6 ⁴ 68	2732	13.5x2	13.5x2	3.7	
	206-L	LONG RANGER	S		9.9	7.7	4150	4 ¹ 192	2958	13.5x2	13.5x2	3.9	
								5 ¹ 129	3021	13.5x2	13.5x2	3.9	
								6 ¹ 129	3021	13.5x2	13.5x2	3.9	
	212	TWIN	S		12.1	8.8	11200	2463	8737	24x2	24x2	6.1	
								2492	8708	24x2	24x2	6.1	
								2492	8708	24x2	24x2	6.1	
	222		T-1		12.2	9.1	7850	1468	6382	18.9	31.8 ²	6.3	
	222-B		T-1		12.2	9.1	8250	1572	6678	19.1	32 ³	6.0	
222-UT		S		12.0	7.9	8250	2627	5623	24x2	24x2	6.0		
214-ST		T-3		9.3		17500	3900	13600	38.3	45 ³	5.8		
		S		8.7		17500	4864	12636	24.7x2	24.7x2	5.8		

HELICOPTER LANDING GEAR DATA

Manufacture Boeing	Model	Common Name	Landing Gear Config.	G (ft)	H (ft)	I (ft)	Static Load ¹ MGW (lb)	Load ²		Contact Area		Disk Load (lb/ft ²)
								For- (lb)	Aft (lb)	For (lb)	Aft (lb)	
BELL	412		S	12.1	8.7		11600	⁴ 2297	9303	24x2	24x2	4.7
								⁵ 2326	9274	24x2	24x2	4.7
								⁶ 2326	9274	24x2	24x2	4.7
	214-B	BIG LIFTER	S	12.1	8.6		16000			8 ⁷	8 ⁷	8.2
BOEING VERTOL	80-105-C		S	8.5			5070					6.2
	CH-47-234		Q-2	15.8	10.5	1.4	48500	28248	20252	98 ³	124 ³	8.6
	107-11		T-2	24.8	12.9	1.1	22000	6600	15400	25 ³	25 ³	11.2
	179		T-3	15.3	8.8	1.3	18700			82	82	
BRANTLEY	8-2-B		S		6.5		1670					3.7
HYNES	305		T-3	6.2	6.8		2900			18	18	4.5
ENSTROM	F-28A/280 SHARK		S	8.0	7.3		2150					2.7
	F-28C/280C SHARK		S	8.0	7.3		2200					2.7
FAIRCHILD	FH-1100		S	7.9	7.2		2750					2.5
HILLER	UH-12-L-4 HILLER		S	8.3	7.5		3100					3.3
	UH-12E/E-4HILLER		S	8.3	7.5		2800					2.9
HUGHES	269-NB	HUGHES 300	S	8.2	6.5		1670					3.3
	269-C	HUGHES 300C	S	8.2	6.5		2050	844	1206	11.3	11.3	3.6
	369HS	HUGHES 500C	S	8.1	6.8		2550					4.7
	369-D	HUGHES 500D	S	7.4	6.8		3000	981	2019	30	37.5	5.5
KAMEN	MH-43F	HUSKIE	Q-1	8.1	8.3		9150					2.64
ROTORWAY		SCORPION	S	7.5	5.1		1200					2.3
MBB	105-CBS		S		8.5		5291	1921	3370	14	14	6.5
	BK 117	SPACE SHIP	S		8.2		6283	2136	4147	16	16	6.1
HELITECH	S-55T		Q-1	10.5	11.0		7200	2160	5040	26	24	3.3

HELICOPTER LANDING GEAR DATA

Manufacture	Boeing	Model	Common Name	Landing Gear Config.	G (ft)	H (ft)	I (ft)	Static MGW (lb)	1		Gear		Disk Load (lb/ft ²)
									Load For (lb)	Aft (lb)	Contact For (lb)	Area Aft (lb)	
SIKORSKY		S-58-T		T-4	28.3	14.0		13000	11500	1500	80 ³	45	5.3
		S-61N/L		T-5	23.5	14.0		20500	17500	3000	58 ³	43	6.8
		S-62		T-4	17.8	12.2		7900	6900	1000	54	54	3.6
		S-64	SKYCRANE	T-1	24.4	19.8		42000			154	154	10.3
		S-65C		T-1	27.0	13.0	1.5	42000			154	154	10.3
		S-76		T-1	16.4	8.0		10300	2600	7700	19	48	6.8
		S-78C		T-4	28.9	9.0		20000			73	73	8.9
		S-55A C		Q-1	10.4	11.0		7200					3.3

FOOTNOTES FOR APPENDIX A

1. DYNAMIC LOAD = $LF \times MW$; SEE SECTION 4.4
2. GEAR CONTACT AREA (in^2): SKIDS - PER SIDE
3. GEAR CONTACT AREA (in^2): PER WHEEL
4. STANDARD SKID
5. HIGH SKID
6. EMERGENCY FLOAT
7. CONTACT LENGTH, L
CONTACT AREA = $D \times 1\frac{1}{2} \times L$

APPENDIX B

Survey of Heliport Owners/Operators

Contents:

- **Cover Letter**
- **Survey Questionnaire**
- **Tabulation of Survey Responses**

UNIVERSITY OF MARYLAND
COLLEGE PARK 20742

DEPARTMENT OF CIVIL ENGINEERING
COLLEGE OF ENGINEERING
(301) 454-2438

March 15, 1984

Typical Heliport Co.
1234 Industrial Blvd.
Houston, TX 54321

Dear Sir/Madam:

As part of a FAA sponsored research effort to update the structural design criteria for ground level and elevated heliports, the University of Maryland Department of Civil Engineering is reviewing data on load associated pavement distress caused by helicopter landing and take-off operations.

Enclosed is a very brief questionnaire regarding your heliport operation experiences that should take a few minutes to complete. Your response to this inquiry will be greatly appreciated by us in this endeavor.

Please return the completed questionnaire in the envelope provided. Thank you in advance for your time and cooperation in this matter.

Sincerely,

Charles W. Schwartz
Assistant Professor

HELIPORT OPERATOR SURVEY

1. Type of Heliport:

- Ground Level
- Rooftop
- Elevated
- Offshore

2. Largest Helicopter Which Uses The Facility:

Manufacturer _____

Model _____

Approximate number of operations (landing and take-off)
per year _____

3. Smallest Helicopter Which Uses the Facility:

Manufacturer _____

Model _____

Approximate number of operations(landing and take-off)
per year _____

4. Type of Pavement or Landing Surface:

- Rigid (Concrete)
- Flexible (Asphalt)
- Stabilized Soil/Turf
- Other (e.g. Wood, Steel, Aluminum) _____

5. Age of Pavement/Landing Surface _____

6. In your general opinion, how would you rate the overall performance to date of your heliport landing surfaces:

- No problem whatsoever
- Minor pavement/structural distress of no major concern
- Amount of pavement/structural distress considered normal
- Significant amount of distress present
- Pavement/structural distress considered a severe problem relative to maintenance and operational aspects

7. Shown below are several major pavement distress types that occur in rigid and flexible pavements. Please answer part (a) or part(b) as is applicable to your heliport and indicate, in ranked priority (1=most prevalent distress; 6=least prevalent distress), the actual distress present at your facility.

a) Rigid Pavement

Distress Types

- ___ Cracking
- ___ Joint seal damage: accumulation of soil or rocks in the joints
- ___ Spalling: pavement broken up into small, loose particles; dislodging of aggregate particles
- ___ Settlement or faulting: difference in elevation at a joint or crack
- ___ Pumping: ejection of material by water through cracks or joints
- ___ Polished aggregates

b) Flexible Pavement

Distress Types

 Cracking

 Raveling: wearing away of the pavement surface caused by dislodging of aggregate particles

 Rutting: surface depression in the wheel/skid path most noticeable after a rainfall when the wheel/skid paths are filled with water

 Swelling: upward bulge in the pavement surface

 Bleeding: film of bituminous material on the pavement surface which resembles a shiny, glass-like reflecting surface that usually becomes quite sticky

 Polished Aggregates

8. For rooftop, elevated, and offshore heliports only:

Please note any operational and/or maintenance problems (e.g. vibrations, structural distress) caused by helicopter landing and takeoff operations:

9. Please describe problems (if any) associated with wind effects induced by rotor downwash:

10. Any additional information and/or comments:

SURVEY RESPONSES

GROUND LEVEL	ROOF TOP	ELEVATED	OFFSHORE	OPERATING/YEAR		MODEL		LANDING SURFACE AGE	OVERALL PAVEMENT DISTRESS	DISTRESS TYPES	OPERATIONAL PROBLEMS	REMARKS
				LARGEST	SMALLEST	LARGEST	SMALLEST					
1.	1			10				Steel & 1 yr Wood	Minor Distress	none	none	none
2.	1			450	10	Bell 20 Long Rgr	Bell Jet Rgr	treated 20 yr wood on steel frame	Normal	rutting, cracking, raveling	wood structure grooved by skids	none
3. 1				100-150	4-5000	S-76	Bell Jet Rgr	Concrete	no problem	spalling		none
4. 1				1-8		CH-47		stabilized soil/ turf	no problem			
5.	1			10-50		Bell Jet Rgr		concrete	no problem	pumping (caused by contraction of heating elements)		none
6.	1			2		National Guard's largest		concrete	normal	joint seal damage		none
7.	1			150-300	same	Hughes 369D		concrete	no problem	joint seal damage, spalling		none
8.	1	(emergency only)				Military		asphalt	minor	cracking		none
9. 1				10,000		Puma/Bell 206-B		concrete	no problems	cracking		none
10. 1				2920/1500		Hughes 300C		concrete	no problems			none
11. 1				6000		Hughes 269C		concrete	normal	faulting joint seal damage		none
12. 1	1			14,6000		Bell Jet Rgr		concrete & reinf covered by aluminum asphalt	normal	all @ level 3		none
13	1			8000		A 355 D		concrete	no problems			"discernable vibrations"
14.	1			150-200/150-200		Bell 206	Bell 47	concrete	normal	cracking, spalling		none
15. 1				20/600		S-76	Bell 206 B	asphalt	minor	cracking, polished aggregate		none

GROUND LEVEL	ROOF TOP	ELEVATED	OFFSHORE	OPERATING YEAR		MODEL	LANDING SURFACE TYPE	SURFACE AGE	OVERALL PAVEMENT DISTRESS	DISTRESS TYPES	OPERATIONAL PROBLEMS	DOWNWASH PROBLEMS
				LARGEST	SMALLEST							
16.	1			5	325	Bell UH-1 Bell Rgr	concrete	7 yr	no problems		more vibrations than w/Rgr. Had to reseal the pad surface twice in 7 yrs (urethane seal coating)	none
17.	1			18		load limit 10,000lb. concrete	concrete	25 yr	no problems			
18. 1	1	1		848.4 hr.	2607.2 hr.	5-58 Hughes 300	concrete	13 yr	minor	joint seal damage		
19.	1			2	2	Hughes Bell OH-58	concrete	12 yr	no problems		17,18,19, none	
20. 1	1			20	900	Bell UH-1 Bell 2061-1	concrete	3 yr	no problems	joint seal damage cracking off landing	vibs on take-off	none
21. 1				20		Bell Jet Rgr	concrete	10 yr	no problems	joint seal damage	none	none
22. 1				500		Bell 47	stabilized soil/turf	18 yr	no problems			
23. 1				3			asphalt	10 yr	no problem			
24.	1 (emergency only)						wood					
25. 1	1			2500	3000	Hughes 5006 Hughes 3006	concrete	5 yr 12 yr	normal	joint seal damage	none	none
26. 1				1	3	Bell UH-1H AS-350 B	asphalt	3 yr	normal	cracking, rutting, raveling	none	none
27.		1		14		unknown	concrete	12 yr	no problem	slight cracking	none	none
28.	1			200		MBB 80 105	concrete	7 yr	no problem		exhaust fumes getting into AC vents	none
29.												
30.												

GROUND LEVEL	ROOF TOP	ELEVATED	OFFSHORE	OPERATING/YEAR		LARGEST	SMALLEST	MODEL	LARGEST	SMALLEST	LANDING SURFACE TYPE	AGE	OVERALL PAVEMENT DISTRESS		DISTRESS TYPES	OPERATIONAL PROBLEMS	DOWNWASH PROBLEMS
				LARGEST	SMALLEST								no problem	DISTRESS			
31	1	1		2000	500	Alouette 3198	Astar 3508	concrete	41 yr	no problem			none	none	"heating coils in concrete work great"	none	
32. no longer in service																	
33.	1			20	50	Long Rgr	Jet Rgr	asphalt	5 yr	no problem			cracking, swelling, rutting	none	none	none	
34.	1			1500		Bell 206 B		concrete	6 yr	no problem			maintenance free since constructed	none	none	none	
35. 1				400	500	Bell 206L	Hughes 500 C	concrete (4" thick on b" gravel base)	6 yr	no problem			none	none	none	none	
36.	1			4	730	Bell 222	Hughes 300 C	concrete	12 yr	no problem			none	none	none	40" solid wall sur- rounding the pad causes downwash to be in- tense	
37.	1			10	15	5-58	Bell Jet Rgr	concrete	5 yr	minor			joint seal dam- age, pumping	"flexing of roof has caused cracks in reflective coating"	none	none	
38.	1			30	2	Bell UH 1H	Bell 206 B	concrete	10 yr	no problem			not used since 79				
39. 1				6		Bell Jet Rgr		asphalt	8 yr	no problem			none	none	none	none	
40. 1				5		not specified		asphalt	9 yr	minor							
41. no longer in service (City of Pittsburgh)																	
42.	1			30	15	Huey	Bell	concrete	10 yr	no problem			none	none	none	none	
43. 1				15		Bell	Jet Rgr	asphalt	15 yr	no problem			none	none	none	none	
44. 1				2000+		Bell 206 B		asphalt	1 yr	significant distress			raveling, rutting	fuel spill- age, temps 90F	none	none	
45.				15-1700	2-300	Bell 206L-1	206 B	concrete	5 yr	normal			cracking	"via intensi- fier cracks"	none	none	

GROUND LEVEL	ROOF TOP	ELEVATED	OFFSHORE	OPERATING/YEAR		MODEL	LANDING SURFACE TYPE	AGE	OVERALL PAVEMENT DISTRESS	DISTRESS TYPES	OPERATIONAL PROBLEMS	DOWNWASH PROBLEMS
				LARGEST	SMALLEST							
46.	1			not used since 78			asphalt	10 yr				
47.	1			150	150	Chinook CH53 Bell 206 B	concrete	3 yr	no problems		none	none
48. 1	1			15	30	Bell 222	concrete asphalt	14 yr	no problems	cracking, spalling, cricing swelling	none	none
49. 1				24	70	Bell 212 S-76	asphalt	14 yr	no problem		none	none
50.		1		20	15	S58-T AS-3198 AS-Altoutte III	concrete	12 yr	no problem	all at level 6	none	none
51.	1			1		Bell Jet Rgr	concrete	15 yr	no problem			
52.	1			20-25	15	S-76 Bell Jet Rgr	concrete	11 yr	normal	cracking spalling	"vib notice- able on top floor	none
53.	1			4	5	S-58 Bell 206 L-1	concrete	10 yr	no problem	all at level 6	none	none
54. 1				12	20	S-76 Miller UH-12 D	concrete	6 mos	no problem			
55.	1			1250	250	80105 C85 AS- Altoutte III As-316 B	concrete	5 yr	no problem	all at level 6	"exhaust fumes into environmental control system"	
56.	1						concrete	15 yr	minor			
57. 1				300		Bell 206 B	concrete	12 yr	no problems	all at level 6		
58.	1			12			concrete	12 yr	no problems			
59. 1				150		Bell 206-L-1	asphalt	10 yr	minor	cracking, polished aggregate		
60.				15	720	Bell Jet Hughes 300C	concrete	10 yr	no problem	all at level 6		

GROUND LEVEL	ROOF TOP	ELEVATED	OFFSHORE	OPERATING/YEAR		MODEL		LANDING SURFACE TYPE	SURFACE AGE	OVERALL PAVEMENT DISTRESS	DISTRESS TYPES	OPERATIONAL PROBLEMS	DOWNDASH PROBLEMS
				LARGEST	SMALLEST	LARGEST	SMALLEST						
61	1			12	100	S-76	Bell 2068	concrete	7 yr	no problem			
62.		1		780 (medical emergencies)		Bell UH-1		concrete	20 yr	no problem		noise, vibrations, wind	
63.	1			10	20	Bell Jet Rgr		concrete GACO flex membrane	2 yr	normal	tearing of flex surface membrane (applied for waterproofing)		"roofing ballast must be 1 1/2" round rock to avoid movement ..vent caps solidly secured"
64.	1					AS-355F	Bell Jet Rgr	other (not specified)		no problems			
65.		1		1500		Bell 2068		Steel	15 yr	no problems	"steel ...holds up very well in Phoenix desert climate"		
66.	1			50		Bell 2068		concrete	1 yr	no problems	cracking		
67. 1				2-4	2160	Bell 204	Bell 47G	asphalt	4 yr	significant	rutting raveling, cracking	spreading gravel	
68.	1			150	100	Bell 204 UH-18	Bell 47G	wood blocks in sand	15 yr	no problems	raveling		
69. 1	1	1		25	3000	Bell 204	Bell 2068 Rgr	concrete asphalt turf	15 yr	minor	spalling, joint damage, cracking, rutting, raveling, cracking		
70.													
71	1			12	2000	CH-53	Bell 47G	concrete	2 yr	minor	cracking, spalling joint seal damage		none
72.	1			6	6	Bell 206L	Bell 2068	wood	8 yr	no problem	none	none	none
73.	1			1500		Bell 206 L		concrete	10 yr	normal	cracking	none	none
74.	1			15	10	Hughes 500	Hughes 300	concrete	15 yr	no problem	none	none	none

Copy available to DTIC down to permit full, legible reproduction.

GROUND LEVEL	ROOF TOP	ELEVATED	OFFSHORE	OPERATING/YEAR LARGEST	OPERATING/YEAR SMALLEST	MODEL LARGEST	MODEL SMALLEST	LANDING SURFACE TYPE	AGE	OVERALL PAVEMENT DISTRESS	DISTRESS TYPES	OPERATIONAL PROBLEMS	DOWNWASH PROBLEMS
75.	1					<3000 lb		concrete	12 yr	significant (can't keep roof around the pad water tight)	none	none	none
76.	1			10	1000	Huey military	Bolkow 80-105	concrete	7 yr	no problem	none	none	none
77. 1				100	20	Bell 206	Bell 209/212	asphalt	25 yr	minor	cracking		
78. 1				42,213 total		Bell 214-ST/2068		concrete asphalt	30 yr	normal	spalling, cracking rutting, swelling		
79. 1				16,699 total		Bell 214-ST/2068		concrete asphalt	18 yr	normal	spalling, cracking rutting, swelling		
80. 1				16,778		Bell 214ST/2068		concrete asphalt	40 yr	normal	spalling, cracking rutting, swelling		
81.	1			2 (emergency use only)				concrete	7 yr	no problems			
82. 1				10				stabilized soil	25 yr	no problems			
83	1			18		4000 lb		steel	13 yr	no problems			roof gravel blown
84. 1				3	6	Bell 47-G		concrete		no problems	all at level 6		
85.	1			350		Blackhawk		concrete	8 yr	minor	cracking, joint seal damage		exhaust fumes in AC system
86.	1			2	100	Sikorsky	Bell Jet Rgr	concrete	15 yr	normal	cracking, spalling	vib loosen exterior decor-ator panels	
87. 1				1	3	S-58	Bell 47G	concrete	6 yr	no problem			
88. 1				75	100	Military		concrete	3 yr	no problems			
89. 1	1			1800		Bell 206L	Bell 47	concrete asphalt		no problems	all at level 6	(rutting for asphalt pavement)	

GROUND LEVEL	ROOF TOP	ELEVATED	OFFSHORE	OPERATING/YEAR		MODEL		LANDING SURFACE TYPE	LANDING SURFACE AGE	OVERALL PAVEMENT DISTRESS	DISTRESS TYPES	OPERATIONAL PROBLEMS	DOWNWASH PROBLEMS
				LARGEST	SMALLEST	LARGEST	SMALLEST						
90.	1					Bell		concrete	5 yr	no problems			
91.	1			40				concrete	17 yr	no problems			
92.	1			1200	1300	Bell 222	Augusta	concrete	11 yr	normal	cracking, joint seal damage		
93.	1			25		UH 18	Hughes 500D	steel	11 yr	no problem			

END

FILMED

2-85

DTIC