

AD-A147 208

Research Product 84-04

BRADLEY INFANTRY FIGHTING
VEHICLE PROCEDURES GUIDE:
COMMANDER AND GUNNER

ARI Field Unit at Fort Benning, Georgia
Training Research Laboratory

February 1984

DTIC FILE COPY



U.S. ARMY RESEARCH INSTITUTE for the BEHAVIORAL and SOCIAL SCIENCES

Approved for public release; distribution unlimited

84 10 29 009

1984

[Handwritten signature]
A

**U. S. ARMY RESEARCH INSTITUTE
FOR THE BEHAVIORAL AND SOCIAL SCIENCES**

**A Field Operating Agency under the Jurisdiction of the
Deputy Chief of Staff for Personnel**

EDGAR M. JOHNSON
Technical Director

L. NEALE COSBY
Colonel, IN
Commander

Research accomplished under contract for
the Department of the Army

Mellonics System Development, Litton Systems, Inc.

Technical review by

SSGT Mark S. Vought
SSGT Paul R. Roberson

Accession No.
NTIS
...
...



AL

NOTICES

FINAL DISPOSITION: This Research Product may be destroyed when it is no longer needed. Please do not return it to the U.S. Army Research Institute for the Behavioral and Social Sciences.

NOTE: This Research Product is not to be construed as an official Department of the Army document in its present form.

UNCLASSIFIED

SECURITY CLASSIFICATION OF THIS PAGE (When Data Entered)

REPORT DOCUMENTATION PAGE		READ INSTRUCTIONS BEFORE COMPLETING FORM
1. REPORT NUMBER Research Product 84-04	2. GOVT ACCESSION NO. 10 A147 DC8	3. RECIPIENT'S CATALOG NUMBER
4. TITLE (and Subtitle) BRADLEY INFANTRY FIGHTING VEHICLE PROCEDURES GUIDE: COMMANDER AND GUNNER		5. TYPE OF REPORT & PERIOD COVERED Research Product
		6. PERFORMING ORG. REPORT NUMBER
7. AUTHOR(s) Margaret S. Salter	8. CONTRACT OR GRANT NUMBER(s) MDA 903-80-C-0545	
9. PERFORMING ORGANIZATION NAME AND ADDRESS Mellonics System Development, Litton Systems Inc., 1001 W. Maude Avenue, Sunnyvale, CA 94086		10. PROGRAM ELEMENT, PROJECT, TASK AREA & WORK UNIT NUMBERS 2Q263744A795
11. CONTROLLING OFFICE NAME AND ADDRESS U.S. Army Research Institute for the Behavioral and Social Sciences, 5001 Eisenhower Avenue Alexandria, Virginia 22333		12. REPORT DATE February 1984
		13. NUMBER OF PAGES 95
14. MONITORING AGENCY NAME & ADDRESS (if different from Controlling Office)		15. SECURITY CLASS. (of this report) UNCLASSIFIED
		15a. DECLASSIFICATION/DOWNGRADING SCHEDULE
16. DISTRIBUTION STATEMENT (of this Report) Approved for public release; distribution unlimited.		
17. DISTRIBUTION STATEMENT (of the abstract entered in Block 20, if different from Report)		
18. SUPPLEMENTARY NOTES For Driver Procedures see RP 84-03, and RN 84-61 for Evaluation Procedures Guide.		
19. KEY WORDS (Continue on reverse side if necessary and identify by block number) Procedure guides Job aid Fighting vehicles Infantry SPAS		
20. ABSTRACT (Continue on reverse side if necessary and identify by block number) A procedures guide was developed for critical tasks for Bradley Infantry Fighting Vehicle (M2) Commanders and Gunners. Tasks which are not compli- cated are presented in line-by-line form, with the names of tasks listed in the correct sequence. More complex tasks are presented in a flowchart format with decision trees at choice points. The steps within a procedure are sequenced, and the use of symbols highlights the subtasks. Warnings and cautions are presented, as well as indications to when vehicle indicator lights are critical. The terminology is identical to that found in the		

DD FORM 1473

EDITION OF 1 NOV 65 IS OBSOLETE

UNCLASSIFIED

SECURITY CLASSIFICATION OF THIS PAGE (When Data Entered)

UNCLASSIFIED

SECURITY CLASSIFICATION OF THIS PAGE(When Data Entered)

Item 20 (cont'd)

technical manual (TM 9-2350-250-10-2, Fighting Vehicle, Infantry, M2, Turret) and a table of contents is provided. Included in the guide are tasks associated with turret operation, ammunition loading and unloading, boresighting, weapons operation, and preventive maintenance checks and services. The guide is intended to be used as both a training supplement and as a job performance aid.

Research Product 84-04

**BRADLEY INFANTRY FIGHTING
VEHICLE PROCEDURES GUIDE:
COMMANDER AND GUNNER**

Margaret S. Salter
Mellonics Systems Development Division, Litton Systems, Inc.

Seward Smith, Contracting Officer's Representative

Submitted by
Seward Smith, Chief
ARI Field Unit at Fort Benning, Georgia

Approved as technically adequate
and submitted for publication by
Harold F. O'Neil, Jr., Director
Training Research Laboratory

U.S. ARMY RESEARCH INSTITUTE FOR THE BEHAVIORAL AND SOCIAL SCIENCES
5001 Eisenhower Avenue, Alexandria, Virginia 22333

Office, Deputy Chief of Staff for Personnel
Department of the Army

February 1984

Army Project Number
2Q263744A795

Training and Simulation

Approved for public release; distribution unlimited.

FOREWORD

The U.S. Army has begun introducing the Bradley Infantry Fighting Vehicle (M2) into mechanized infantry units, and has a major investment in training commanders, gunners, and drivers in the procedures of their respective positions. In support of this effort, the Army Research Institute initiated a research program to improve training and to develop procedures to maximize the operational effectiveness of the Bradley in combat.

In recognition of the complexity of the tasks required of BIFV crew members, the U.S. Army Infantry School requested that the Army Research Institute prepare a set of Procedures Guides which summarize the critical tasks for Bradley Commanders, Gunners, and Drivers. Tasks required of these crew members often dictate a specific sequence of actions designed to insure the safety of personnel, accomplish the mission, and safeguard the integrity of the equipment, or are so infrequently performed as to require a job aid for successful completion. Other tasks need to be cross-trained across squad members, or may require rapid familiarization for new crew members as a result of combat losses.

Responding to these task requirements, the Army Research Institute prepared a set of Procedures Guides to follow the same format as Procedures Guides developed by the Army Research Institute for the M1 Tank. The Bradley Guides are of compact size and allow for convenient updating as procedures change or new equipment becomes available. They include critical guidance on emergency procedures, proper use of the vehicle subsystems, and preventive maintenance checks. The intent is to provide each main crew member a position specific guide which, in addition to being technically correct, is more convenient to use than the technical manuals on board each vehicle.

The Commander and Gunner Guide was prepared according to these guidelines, and is being evaluated in the field by the Infantry School. Operational units and trainers are evaluating the guides both as training supplements and as job aids. Evaluation of this Commander and Gunner Procedures Guide and its companion Driver Procedures Guide RP 84-03 was undertaken in the institutional environment, and is available as Army Research Institute Research Note RN 84-61, Bradley Infantry Fighting Vehicle Procedure Guides: Evaluation.



EDGAR M. JOHNSON
Technical Director

ACKNOWLEDGEMENTS

Litton Mellonics Systems Development gratefully acknowledges the many contributions to this project by U.S. Army military and civilian personnel. Special thanks to:

- U.S. Army Research Institute, Fort Benning Field Unit

Dr. John C. Morey
Mr. Hal C. Strasel
Mr. Rick Moffat
Mr. Phil Hurst

- U.S. Army Infantry School, Directorate of Training and Doctrine

LTC George Hobson
SFC Notley P. Reavis, III
SSG Paul R. Roberson
SSG Mark S. Vought

- U.S. Army Infantry School, Weapons Gunnery and Maintenance Department

- Officers, NCOs, and students in the BIFV Commander and BIFV Gunner Courses

- U.S. Army Training Center, Infantry Training Group Officers, NCOs, and students in the BIFV Driver Course

GENERAL INFORMATION

This booklet contains BIFV Commander and Gunner Procedure Guides. Each guide is for a single activity and is matched to TM 9-2350-252-10-2 (Operator's Manual for Fighting Vehicle, Infantry, M2, Turret) or TM 9-2350-252-10-1 (Operator's Manual for Fighting Vehicle, Infantry, M2, Hull).

PURPOSE OF PROCEDURE GUIDES

The guides in this booklet will not take the place of the BIFV TM or training materials. They will help you remember long or difficult sets of procedures. In short, the guides will help to "jog your memory."

USE OF THIS BOOKLET

The Table of Contents (on the next page) lists the procedure guides in this booklet. Each guide gives you a step-by-step outline for completing an activity. The following will help you to better use each guide.

See P.

1. Some steps within a procedure guide are followed by a page number. On that page you will find a detailed breakdown of the step.

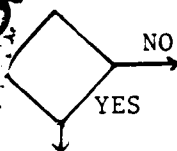

2. Some of the procedure guides include a question(s). Each question is stated inside a diamond shape. Your "yes" or "no" to the question will show you which path to follow.

STOP

3. Some steps within a procedure guide are followed by a box. In the box you will find more information on the step or a caution/warning.



4. Certain steps within a procedure guide require that a knob or switch be turned to a certain position. If that position is written like the symbol to the left, a light should also come on.

5. Master Checklists of all before, during, and after operations PMCS performed by crew members are included as an aid to the Commander's supervision of these activities.

CONTENTS

Page

I. TURRET OPERATION

Manual Mode 1
Power Mode:
 Traverse Turret 2
 Elevate and Depress Rotor 2
 Stab Mode 3-4
 TOW Operations 5
Turret Travel Lock 6
Runaway Engine - Immediate Action 7
Runaway Turret - Immediate Action 7
Override Hatch Switches - Immediate Action 8
Shut Down Turret 9
Operation in Extreme Cold 10
Operation in Extreme Heat 11

II. AMMUNITION - LOADING/UNLOADING

25mm Gun

Time 25mm Gun Feeder 12
Position 25mm Gun Bolt In Sear Position 13
Load 25mm Gun Feeder 14-16
Load/Reload 25mm HE Ammo 17-18
Load/Reload 25mm AP Ammo 19-20
Unload 25mm Gun Feeder 21-22
Unload/Stow 25mm HE Ammo 23-24
Unload/Stow 25mm AP Ammo 25-26

Coax Machinegun

Load/Reload 7.62mm Coax Machinegun Ammo 27
Unload 7.62mm Coax Machinegun Ammo 28
Clear Coax Machinegun 29

TOW Missile Launcher

Load/Reload TOW Launcher 30-31
Unload TOW Launcher 32

Smoke Grenade Launcher

Load/Stow/Reload Smoke Grenades 33
Unload/Stow Smoke Grenades 33

III. BORESIGHT

25mm Gun 34-35
Backup Sight 36
Coax Machinegun 37
Night Sight 37
TOW 38-39

CONTENTS

	Page
IV. ZERO	
25mm Gun	44
Coax Machinegun	41-42
V. 25mm GUN	
Fire 25mm Gun Manually	43
Fire 25mm Gun Power Mode	44-47
25mm Gun Misfires - Immediate Action	48-49
VI. COAX MACHINEGUN	
Fire Coax Machinegun Manually	50
Fire Coax Machinegun Power Mode	51-52
Coax Machinegun Fails to Fire - Immediate Action	53
Runaway Coax - Immediate Action	54
VII. TOW MISSILE SYSTEM	
Fire TOW Missiles	55-58
TOW Missile Misfires - Immediate Action	59-61
VIII. SMOKE GRENADES	
Launch Smoke Grenades	62
Smoke Grenades Fail to Launch - Immediate Action	63
IX. PREVENTIVE MAINTENANCE CHECKS AND SERVICES (PMCS)	
Commander - Before and During Operations; Weekly	64
Gunner - Before Operations	65
Gunner - During Operations	66
Deck Clearance System	67-68
ISU Operation	69-70
Dry Fire 25mm Gun	71-72
Dry Fire Coax Machinegun	73
Smoke Grenade Launcher Operation	74
TOW Launcher Operation	75-76
Stabilization Controls	77
Gunner - Weekly	78
X. MASTER CHECKLIST PMCS	
Before Operations	79-80
During Operations	81-82
After Operations	83
Weekly	84
Monthly	85

Operate Turret Manually

DO NOT OPERATE 25mm GUN AND TOW LAUNCHER IN MANUAL MODE AT THE SAME TIME

Traverse Turret Manually

1. TURRET TRAVERSE DRIVE SELECT LEVER . . . MOVE TO MANUAL POSITION
2. TRAVEL LOCK RELEASE
3. SPRING REMOVE FROM TURRET TRAVERSE HANDWHEEL
4. TURRET TRAVERSE MANUALLY
5. SPRING REINSTALL ON TURRET TRAVERSE HANDWHEEL
6. TURRET TRAVERSE SELECT LEVER MOVE TO POWER POSITION

Operate 25mm Gun Manual Elevation

7. GUN ELEVATION DRIVE SELECT LEVER MOVE TO MANUAL POSITION
8. SPRING REMOVE FROM GUN ELEVATION HANDWHEEL
9. 25mm GUN MANUALLY ELEVATE AND DEPRESS
10. SPRING REINSTALL ON GUN ELEVATION HANDWHEEL
11. GUN ELEVATION DRIVE SELECT LEVER MOVE TO POWER POSITION

Operate TOW Manual Elevation

12. TOW ELEVATION DRIVE SELECT LEVER MOVE TO MANUAL POSITION
13. SPRING REMOVE FROM GUN ELEVATION HANDWHEEL
14. TOW LAUNCHER MANUALLY ELEVATE AND DEPRESS
15. SPRING REINSTALL ON GUN ELEVATION HANDWHEEL
16. TOW ELEVATION DRIVE SELECT LEVER MOVE TO POWER POSITION

Operate Turret in Power Mode



TRAVERSE TURRET

1. DRIVER AND CARGO HATCH COVERS CLOSED OR POPUP POSITION
2. TURRET SHIELD DOOR CLOSED AND LATCHED
3. TURRET TRAVEL LOCK RELEASE
4. SEAT BELTS FASTEN

BOTH GUN ELEVATION SELECT LEVER AND TURRET TRAVERSE
SELECT LEVER MUST BE IN POWER MODE.

5. TURRET TRAVERSE DRIVE SELECT LEVER . . . MOVE TO POWER POSITION
6. TOW ELEVATION DRIVE SELECT LEVER . . . MOVE TO POWER POSITION
7. GUN ELEVATION DRIVE SELECT LEVER . . . MOVE TO POWER POSITION

MAKE SURE HATCH INTERLOCK
OVERRIDE SWITCH IS OFF

8. TURRET POWER SWITCH 
9. TURRET DRIVE SYSTEM SWITCH 
10. TURRET TRAVERSE
11. TURRET TRAVERSE AT HIGH SPEED - USE FAST
TURRET (SLEW) SWITCHES

CONTROL HANDLES SHOULD BE CENTERED BEFORE ENGAGING
OR RELEASING SLEW SWITCHES.

ELEVATE AND DEPRESS GUN ROTOR

12. GUN ROTOR ELEVATE AND DEPRESS
13. GUN ROTOR ELEVATE AND DEPRESS AT HIGH SPEED -
USE FAST TURRET (SLEW) SWITCHES

CONTROL HANDLES SHOULD BE CENTERED BEFORE ENGAGING
OR RELEASING SLEW SWITCHES.





OPERATE IN STAB MODE

DO NOT OPERATE TURRET IN POWER MODE IF GUN BARREL HAS BEEN REMOVED.

IF DRIVE MALF ANNUNCIATOR LIGHT COMES ON, RECYCLE TURRET DRIVE SYSTEM. IF LIGHT COMES ON AGAIN, SHUT DOWN TURRET POWER AND WAIT THREE MINUTES. IF LIGHT COMES ON AGAIN, NOTIFY ORGANIZATIONAL MAINTENANCE.

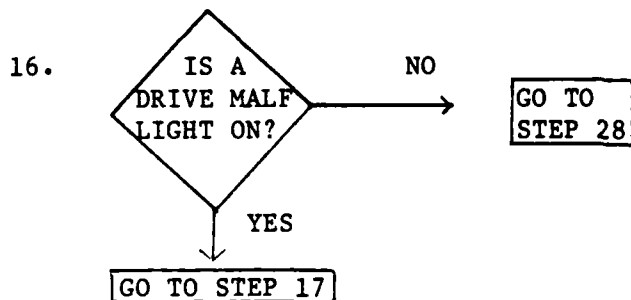
- 14. STAB SWITCH MOVE TO 
- 15. DRIVE MALF ANNUNCIATOR LIGHTS CHECK



- 17. STAB SWITCH MOVE TO OFF
- 18. TURRET DRIVE SWITCH MOVE TO OFF, THEN BACK TO 
- 19. STAB SWITCH MOVE TO 
- 20. DRIVE MALF ANNUNCIATOR LIGHTS CHECK

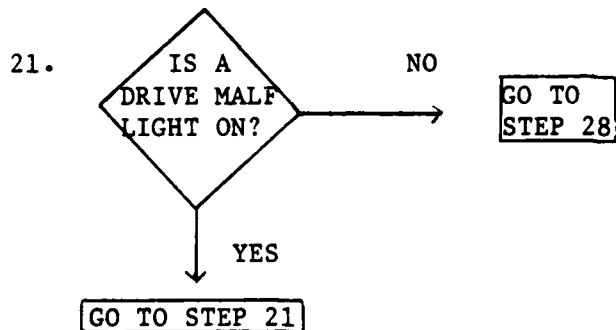

- 22. STAB SWITCH MOVE TO OFF
- 23. TURRET DRIVE SWITCH MOVE TO OFF
- 24. TURRET POWER SWITCH MOVE TO OFF - WAIT THREE MINUTES
- 25. TURRET POWER SWITCH MOVE TO 

- 26. TURRET DRIVE SWITCH MOVE TO
- 27. STAB SWITCH MOVE TO
- 28. DRIVE MALF ANNUNCIATOR LIGHTS CHECK

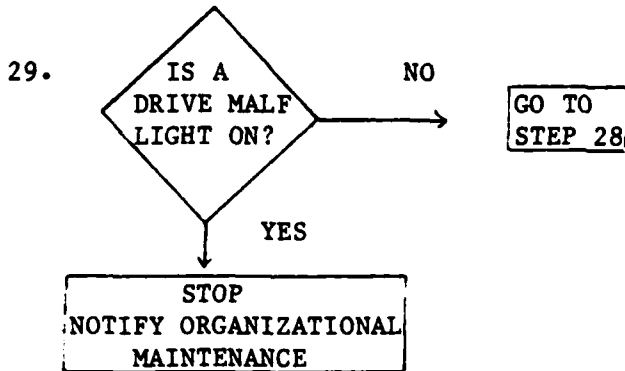
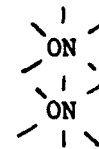

- 30. HE SS or AP SS BUTTON PRESS
- 31. TARGET SELECT THROUGH GUNNER'S EYEPIECE
- 32. RETICLE ALINE ON TARGET
- 33. STABILIZATION DRIFT CHECK

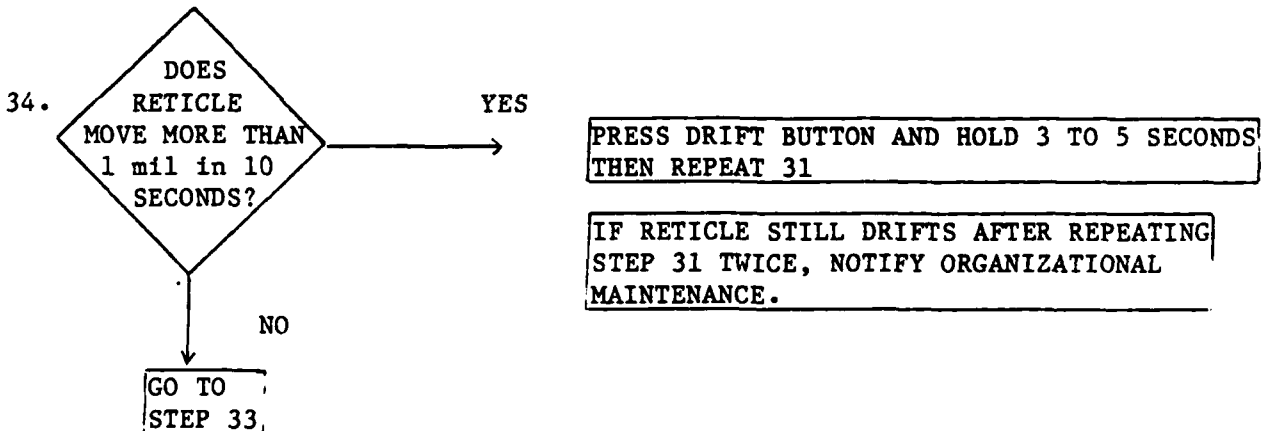

- 35. 25mm GUN FIRE AS REQUIRED
- 36. COAX MACHINEGUN FIRE AS REQUIRED
- 37. ARM-SAFE-RESET SWITCH MOVE TO RESET, THEN TO SAFE
- 38. STAB SWITCH MOVE TO OFF
- 39. TURRET TRAVERSE TO 6400 mils
- 40. TURRET DRIVE SWITCH MOVE TO OFF
- 41. TURRET POWER SWITCH MOVE TO OFF - DO NOT EXIT WITH POWER ON!
- 42. TRAVEL LOCK SET
- 43. SEAT BELTS RELEASE
- 44. TURRET SHIELD DOOR OPEN

Operate TOW Launcher In Power Mode

1. TOW LAUNCHER RAISE

- 1a. Launcher UP-DN Switch Move To Up
- 1b. Palm Switches Squeeze until Launcher Up Light comes 

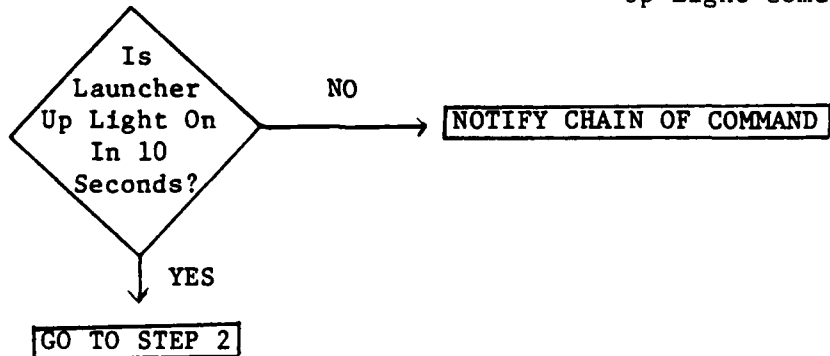

2. TOW LAUNCHER ELEVATE

- 2a. Palm Switches Squeeze and Hold
- 2b. Control Handles Rotate Until Launcher Reaches Position
- 2c. Control Handles Center
- 2d. Palm Switches Release

3. TOW LAUNCHER DEPRESS

- 3a. Palm Switches Squeeze and Hold
- 3b. Control Handles Rotate Until Launcher Reaches Position
- 3c. Control Handles Center
- 3d. Palm Switches Release

4. TOW LAUNCHER LOWER

- 4a. Launcher UP-DN Switch Move to Down
- 4b. Palm Switches Squeeze Until Launcher Stows Against Turret

IF LAUNCHER DOES NOT REACH STOW POSITION IN 10 SECONDS, NOTIFY CHAIN OF COMMAND

Operate Turret Travel Lock

TURRET TRAVEL LOCK MUST BE LOCKED WHEN YOU ENTER OR EXIT TURRET

1. TURRET TRAVEL LOCK SET IN LOCKED POSITION
2. TURRET TRAVERSE DRIVE SELECT LEVER MOVE TO MANUAL
3. SPRING REMOVE FROM HANDLE
4. TURRET TRAVERSE HANDWHEEL TURN SLOWLY —
5. TURRET TRAVERSE HANDWHEEL RELEASE
6. SPRING INSTALL ON HANDLE
7. TURRET TRAVERSE DRIVE SELECT LEVER MOVE TO POWER POSITION
8. TRAVEL LOCK LEVER RELEASE —

**PUSH ON TRAVEL LOCK LEVER
TO INSURE THAT TEETH MESH**

**PULL ALL THE WAY BACK TO
OPEN POSITION**

Runaway Engine - Immediate Action

- (D) 1. FUEL CONTROL OFF
- 2. GEAR SELECTOR NEUTRAL

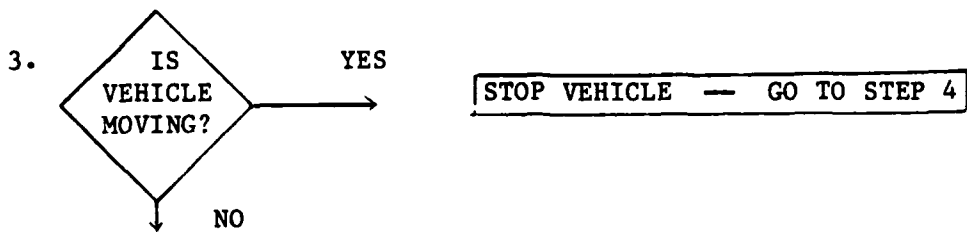

- 4. HAND BRAKE SET
- 5. TRIM VANE LOWER
- 6. POWER UNIT ACCESS DOOR OPEN
- 7. FUEL INLET HOSE PULL UP ON QUICK DISCONNECT
- 8. ORGANIZATIONAL MAINTENANCE NOTIFY

GUNNER CAN ALSO STOP RUNAWAY ENGINE BY TRAVERSING TURRET TO 4100 mils AND MANUALLY TURNING OFF MAIN FUEL SHUT OFF VALVE

Runaway Turret - Immediate Action

- 1. TURRET POWER SWITCH MOVE TO OFF
- 2. TURRET TRAVEL LOCK SET
- 3. ORGANIZATIONAL MAINTENANCE NOTIFY —

DO NOT OPERATE TURRET
IN POWER MODE.

Override Hatch Switches - Immediate Action

WHEN HATCH INTERLOCK OVERRIDE SWITCH IS ON, DO NOT FIRE GUNS
UNLESS ALL HATCH COVERS ARE CLOSED OR IN POP-UP POSITION AND
DO NOT FIRE TOW UNLESS ALL HATCH COVERS ARE CLOSED.

BE SURE TO MOVE HATCH INTERLOCK OVERRIDE SWITCH TO OFF BEFORE YOU LEAVE TURRET

1. HATCH INTERLOCK OVERRIDE SWITCH REMOVE — USE CROSS TIP
SCREWDRIVER
GUARD
2. HATCH INTERLOCK OVERRIDE SWITCH TURN ON
3. FAULTY HATCH INTERLOCK SYSTEM REPORT TO ORGANIZATIONAL
MAINTENANCE
4. HATCH INTERLOCK OVERRIDE SWITCH MOVE TO OFF WHEN SYSTEM
REPAIRED
5. HATCH INTERLOCK OVERRIDE SWITCH REINSTALL
GUARD

Shut Down Turret

1. GUN ELEVATE OR DEPRESS TO 0 mils
 2. TURRET TRAVERSE TO 6400 mils
 3. TURRET TRAVEL LOCK SET IN LOCKED POSITION
 4. TURRET TRAVERSE SELECT LEVER MOVE TO MANUAL
 5. TURRET TRAVERSE HANDWHEEL TURN SLOWLY WHILE PUSHING
TRAVEL LOCK LEVER
 6. NIGHT VISION PWR SWITCH INSURE OFF
 7. STAB SWITCH MOVE TO OFF
 8. TURRET DRIVE SYSTEM SWITCH MOVE TO OFF
 9. TURRET POWER SWITCH MOVE TO OFF
 10. BALLISTIC SIGHT COVER DOORS CLOSE
 11. COMMANDER'S HINGE LATCH HANDLE UNLOCK
 12. COMMANDER'S HATCH COVER INSURE IN POPUP POSITION —
- DO NOT CLOSE IN LEVEL POSITION**
13. COMMANDER'S HATCH COVER CLOSE
 14. GUNNER'S HATCH COVER RELEASE FROM LOCKED POSITION;
CLOSE
 15. COMMANDER'S AND GUNNER'S MOVE TO OFF
RADIO POWER SWITCH
 16. INTERCOM POWER CKT BKR SWITCH MOVE TO OFF
 17. TURRET SHIELD DOOR OPEN
 18. DOME LIGHTS OFF

Operation In Extreme Cold

DO NOT TOUCH COLD METAL WITH BARE SKIN

TURRET MOTORS AND LIVES CAN BE DAMAGED IF TURRET IS OPERATED IN EXTREME COLD. ALWAYS RUN ENGINE AND PERSONNEL HEATER. TURRET POWER DRAINS BATTERIES QUICKLY.

1. TURRET OPERATE MANUALLY WHEN ENGINE IS NOT RUNNING
 2. PMCS PERFORM ON A REGULAR BASIS
 3. 25mm GUN MANUALLY DEPRESS TO 50 mils —
- KEEP GUN BARRELS FREE OF ICE**
4. BALLISTIC SIGHT COVER DOORS KEEP CLOSED WHEN NOT IN USE
 5. VEHICLE COVER WITH TARPAULIN WHEN NOT IN USE
 6. COMMANDER'S AND GUNNER'S EYEPIECES COVER WITH RUBBER CAPS WHEN NOT IN USE
 7. SENSOR SELECT SWITCH SET TO NEUTRAL ON BRIGHT OR SNOWY DAYS
 8. FAN DEFOGGER SWITCH OPERATE WITH COVERS CLOSED TO MELT ICE FORMATIONS ON ISU WINDOWS
 9. FAN DEFOGGER OPERATE IF ISU WINDOWS FOG UP —
- DO NOT BREATHE ON EYEPIECES, UNITY WINDOWS AND PERISCOPES**
10. TOW MISSILE FIRE ONLY WHEN TEMPERATURE GREATER THAN -25° F (-31° C) AND TARGET CAN BE SEEN OR TRACKED THROUGH ISU
 - (H)11. ELECTRICAL CONNECTOR COVER REPLACE AFTER UNLOADING TOW MISSILE
 12. GRENADE LAUNCHER TUBES CHECK FOR ICE BUILD UP —

KEEP CAPS ON UNTIL READY TO FIRE

Operation In Extreme Heat

DO NOT TOUCH HOT METAL WITH BARE SKIN

TURRET ELECTRICAL MOTORS MAY OVERHEAT. IF DRIVE MALF ANNUNCIATOR LIGHT COMES ON, SHUT DOWN ELECTRICAL SYSTEMS FOR THREE MINUTES BEFORE RECYCLING POWER TO TURRET.

1. PMCS PERFORM ON A REGULAR BASIS —

KEEP GLASS, RUBBER AND LEATHER SURFACES CLEAN AND DRY TO REDUCE MOLD, MILDEW AND FUNGUS.
2. BALLISTIC SIGHT COVER DOORS KEEP CLOSED WHEN NOT IN USE
3. VEHICLE COVER WITH TARPAULIN WHEN NOT IN USE
4. COMMANDER'S AND GUNNER'S EYEPIECES . . . COVER WITH RUBBER CAPS WHEN NOT IN USE
5. SUN CHECK POSITION BEFORE USING ISU —

DO NOT LOOK DIRECTLY AT SUN THROUGH ISU
6. SENSOR SELECT SWITCH SET TO NEUTRAL ON BRIGHT SUNNY DAYS
7. TOW MISSILE FIRE ONLY WHEN TEMPERATURE LESS THAN 140° F (60° C) AND TARGET CAN BE SEEN OR TRACKED THROUGH ISU
- (H)8. ELECTRICAL CONNECTOR COVER REPLACE AFTER UNLOADING TOW MISSILE

Time 25mm Gun Feeder

1. FEED SELECT SOLENOID KNOB PUSH IN TO AP POSITION
2. 25mm GUN FEEDER CYCLE TO SEAR POSITION
 - 2a. Timer Release Lever Press In and Hold
 - b. Worm Gear Rotate Left; Release Timer Release Lever
 - c. Worm Shaft Nut Turn Left Until It Clicks and Timer Release Lever Pops Out
 - d. Feed Sprockets Check For Continuous 360° Movement
 - e. Rotor Check That Moves 1/3 Turn
 - f. No Back Clutches Check Rise and Drop

Worm Gear Will No Longer Move

3. BOLT POSITION INDICATOR CHECK --

IF NOT IN SEAR, NOTIFY ORGANIZATIONAL MAINTENANCE

4. FEED SELECT SOLENOID KNOB PULL OUT TO HE POSITION
5. STEPS 1 THROUGH 3 REPEAT

Position 25mm Gun Bolt In Sear Position

- 1. DRIVE SHAFT HANDLE INSURE HANDLE OUT
- 2. BOLT LOCK IN SEAR POSITION BY TURNING DRIVE SHAFT HANDLE FORWARD UNTIL IT STOPS

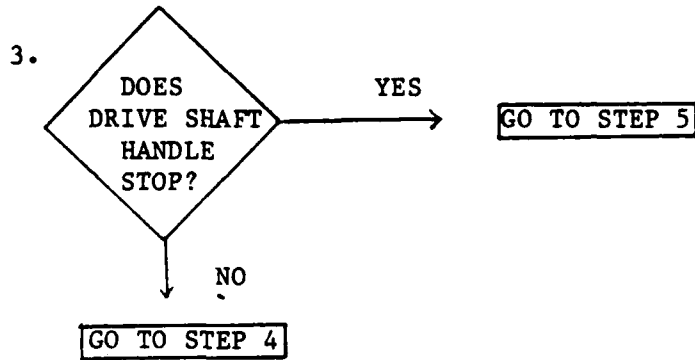

- 4. SEAR RETRACTOR LEVER RELEASE —
- 5. DRIVE SHAFT HANDLE CHECK LOCKED IN SEAR

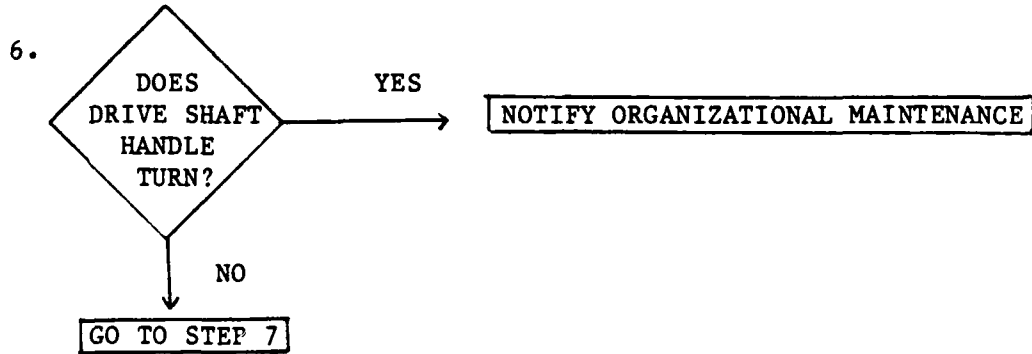

- 7. 25mm GUN FEEDER INSTALL

Load 25mm Gun Feeder

- 1. 25mm GUN GUARD AND COVER REMOVE AND OPEN
- 2. BOLT POSITION INDICATOR CHECK IN SEAR —

IF NOT IN SEAR, SEE TASK
TIME 25mm GUN FEEDER p.12

- 3. MANUAL SAFE HANDLE CHECK IN SAFE
- 4. 25mm GUN FULLY DEPRESS FOR HE AMMO
- 5. FEED SELECT SOLENOID KNOB PULL ALL THE WAY OUT TO HE POSITION
- 6. HE AMMO FORWARD TO 25mm GUN FEEDER

- 6a. 14mm Ratchet Wrench Put On Shaft of HE Forwarder, Handle Down
- b. Wrench Turn Left Until Lower Clutch Override Knob Starts To Come Out

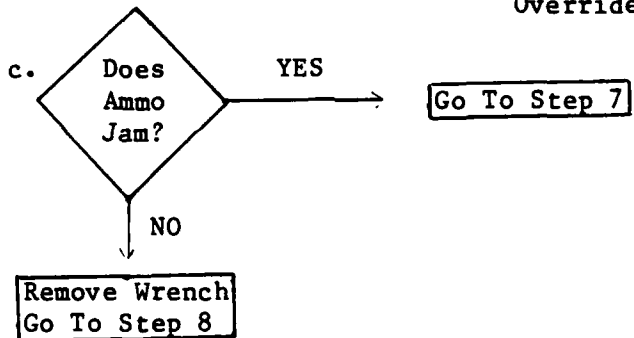

- 7. HE AMMO DOWNLOAD

- 7a. Wrench Apply Upward Pressure
- b. HE Release Handle Hold To Right While Moving Wrench To Right
- c. HE Release Handle Release
- d. Wrench Turn Right Until HE Release Handle Pops Back Into Place
- e. Above Steps Repeat Until HE Ammo Is Free From Feeder
- f. Step 6 Repeat

- 8. 25mm GUN FEEDER LOAD WITH TWO ROUNDS OF HE AMMO

- 8a. Wrench Put On Lower Feed Shaft Extension
- b. Wrench Turn To Left Until Lower Clutch Override Knob Goes In Second Time

KNOB WILL COME OUT 1/4 INCH AND
GO BACK AS EACH ROUND LOADED

- 9. HE AMMO REMOVE TENSION
 - 9a. Wrench Move to HE Ammo Forwarder
 - b. Wrench Turn To Left and Turn HE Release Handle To Right
 - c. Wrench Handle Turn To Right To Release Tension
 - d. Wrench Turn To Left Until HE Clutch Override Knob Is Fully Seated
 - e. Wrench Remove
- 10. FEED SELECT SOLENOID KNOB PUSH ALL THE WAY IN TO AP POSITION
- 11. 25mm GUN FULLY ELEVATE FOR AP AMMO
- 12. AP AMMO FORWARD TO 25mm GUN FEEDER
 - 12a. 14mm Ratchet Wrench Put On Shaft of AP Forwarder, Handle Down
 - b. Wrench Turn To Right Until Lower Clutch Override Knob Starts To Come Out

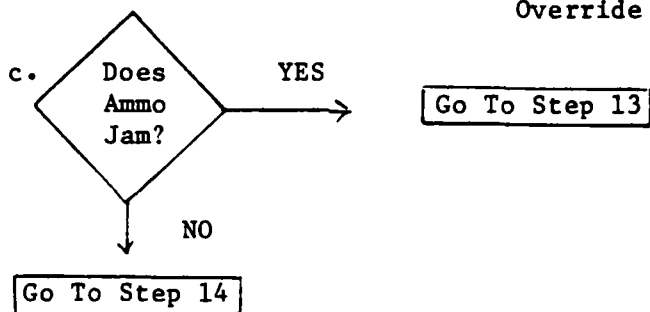

- 13. AP AMMO DOWNLOAD
 - 13a. Wrench Apply Upward Pressure
 - b. AP Release Handle Hold To Left While Moving Wrench To Straight Down Position; Release
 - c. Wrench Turn Left Until AP Release Handle Pops Back Into Place
 - d. Above Steps Repeat Until AP Ammo Is Free From Feeder
 - e. Step 11 Repeat
- 14. 25mm GUN FEEDER LOAD WITH ONE ROUND OF AP AMMO
 - 14a. Wrench Put On Upper Feed Shaft Extension
 - b. Wrench Turn To Left Until Upper Clutch Override Knob Goes In First Time

KNOB WILL COME OUT 1/4 INCH AND GO BACK AS EACH ROUND LOADED

15. AP AMMO REMOVE TENSION

- 15a. Wrench Move to AP Ammo Forwarder
- b. Wrench Turn To Right and Turn AP Release Handle to Left
- c. Wrench Turn To Left To Release Tension
- d. Wrench Turn To Right Until AP Clutch Override Knob Is Fully Seated
- e. Wrench Remove

16. 25mm GUN COVER AND GUARD CLOSE AND INSTALL

Load/Reload 25mm HE Ammo

- 1. ARM-SAFE-RESET SWITCH MOVE TO RESET, THEN SAFE
- 2. TURRET TRAVERSE TO HE LOAD POSITION
2150 mils
- 3. TURRET TRAVEL LOCK SET
- 4. TURRET DRIVE SWITCH MOVE TO OFF
- (H)5. TURRET SHIELD DOOR OPEN
- 6. 25mm AMMO CAN DOOR REMOVE
- 7. ACCESS DOOR REMOVE
- 8. LOADING RAILS INSURE CLEAN
- (H)9. HE AMMO CAN DOOR REMOVE
- 10. SQUAD SEATS STOW
- (H)11. HE AMMO BOXES UNSTOW FROM FLOOR AND RACKS;
STACK
- 12. SQUAD SEATS UNSTOW
- (H)13. FIRST AMMO BELT PREPARE — CHECK ROUNDS
- 14. SECOND AMMO BELT PREPARE
- 15. SECOND BELT REMOVE FIRST ROUND; THEN
JOIN TO FIRST BELT
- (H)16. AMMO BELT CHECK FOR MISALINED ROUNDS
- (H)17. AMMO BELTS JOIN AS REQUIRED
- (H)18. FIRST 44 ROUNDS LOAD IN AMMO CAN
- 17a. Ammo Belt Turn Over So Links Are On Top -
Rounds Should Point To Right
of Vehicle
- b. First Five Rounds Hang On Loading Rail, Double
Link First
- c. 19th Round Hang On Loading Rail
- d. Next 25 Rounds Count Out and Hang Both 24th
and 25th Rounds On Loading Rail
- 19. UPPER ROLLER RELEASE
- 20. AMMO BELT FORWARD

TURN RATCHET WRENCH UNTIL
19th ROUND DROPS OFF RAIL



- 21. UPPER ROLLER LOCK
- (H)22. NEXT GROUP OF ROUNDS LOAD INTO AMMO CAN - HANG 24
AND 25 ON RAIL
- (H)23. AMMO BELT LOOPS LIFT OVER BAFFLE
- (H)24. AMMO BELT LOOPS LIFT OVER ROLLER
- 25. AMMO BELT LOAD UNTIL AMMO CAN IS FULL
- 26. HE AMMO CAN DOOR INSTALL AND TURN HANDLE
- 27. ACCESS DOOR INSTALL AND TURN HANDLE
- 28. 25mm AMMO CAN DOOR INSTALL AND TURN HANDLE
- (H)29. HE-AP SELECTOR SWITCH MOVE TO HE
- (H)30. EMPTY AMMO CANS STOW
- 31. TURRET SHIELD DOOR CLOSE
- 32. TURRET DRIVE SWITCH MOVE TO 
- 33. TURRET TRAVEL LOCK RELEASE
- 34. TURRET TRAVERSE TO 6400 mils

Load/Reload 25mm AP Ammo

1. ARM-SAFE-RESET SWITCH MOVE TO RESET, THEN SAFE
 2. TURRET TRAVERSE TO AP LOAD POSITION
4350 mils
 3. TURRET TRAVEL LOCK SET
 4. TURRET DRIVE SWITCH MOVE TO OFF
 - (H)5. TURRET SHIELD DOOR OPEN
 - (H)6. AP AMMO CAN DOOR REMOVE
 7. LOADING RAILS INSURE CLEAN
 - (H)8. SQUAD SEATS STOW
 - (H)9. AP AMMO BOXES UNSTOW FROM FLOOR AND RACKS;
STACK
 - (H)10. SQUAD SEATS UNSTOW
 - (H)11. FIRST AMMO BELT PREPARE - CHECK ROUNDS
 - (H)12. SECOND AMMO BELT PREPARE
 - (H)13. LAST ROUND REMOVE FROM FIRST BELT
 - (H)14. SECOND BELT JOIN TO FIRST BELT
 - (H)15. AMMO BELT CHECK FOR MISALIGNED ROUNDS
 - (H)16. AMMO BELTS JOIN AS REQUIRED
 - (H)17. AMMO BELTS HANG FIRST DOUBLE LINKED ROUND
ON RAIL. THEN COUNT BELOW THE
RAIL AND HANG 24 AND 25 ON RAIL-
- ROUNDS SHOULD POINT TO THE LEFT
SIDE OF VEHICLE
18. SINGLE LINK END OF FORWARD — UNTIL AMMO CLEARS
AMMO BELT BOTTOM OF AP CAN
 19. AMMO BELT JOIN TO ROUND HANGING FROM
FEED CHUTE — IF RELOADING
 20. AMMO BELTS JOIN AS NEEDED



- 21. AP AMMO CAN DOOR INSTALL AND CLOSE
- (H)22. HE-AP SELECTOR SWITCH MOVE TO AP
- (H)23. EMPTY AMMO CANS STOW
- (H)24. TURRET SHIELD DOOR CLOSE
- 25. TURRET DRIVE SYSTEM SWITCH MOVE TO  ON
- 26. TURRET TRAVEL LOCK RELEASE
- 27. TURRET TRAVERSE TO 6400 mils

Unload 25mm Gun Feeder

PREPARE GUN FEEDER FOR UNLOADING

1. ARM-SAFE-RESET SWITCH MOVE TO RESET, THEN TO SAFE
2. TURRET TRAVEL LOCK SET
3. 25mm GUN GUARD AND COVER REMOVE AND OPEN
4. TURRET DRIVE SWITCH MOVE TO OFF
5. MANUAL SAFE HANDLE MOVE TO SAFE POSITION
6. COAX MACHINEGUN ACCESS DOORS OPEN
7. HE and AP LINKS DISCONNECT
8. COAX MACHINEGUN ACCESS DOORS CLOSE

REMOVE AP LINK EJECT CHUTE FROM 25mm GUN FEEDER

9. AP LINK EJECT CHUTE REMOVE FROM 25mm FEEDER
 - 9a. Latches Squeeze
 - b. Link Eject Chute Pull To Right, Away From 25mm Feeder
 - c. AP Links Disconnect
 - d. Link Eject Chute Pull Up and Left To Remove
 - e. AP Links Remove From AP Link Eject Chute and Discard
10. FEED SELECT KNOB PULL OUT TO HE POSITION

UNLOAD AP AMMO FROM 25mm GUN FEEDER

11. AP AMMO UNLOAD FROM 25mm GUN FEEDER
 - 11a. Ratchet Wrench Place On Upper Feed Shaft Extension With Handle Up and To Right
 - b. Upper Clutch Override Pull Out and Hold Knob
 - c. Ammo Links Guide Onto Stripper Rail
 - d. Ratchet Wrench Turn Until Last Round Clear of Feeder
 - e. Forward Release Lever Press To Release Tension As Needed
 - f. Upper Clutch Override Release Knob
 - g. Wrench Turn Left Until Upper Clutch Override Is Seated
 - h. Ratchet Wrench Remove



REMOVE HE LINK EJECT CHUTE FROM 25mm GUN FEEDER

12. HE LINK EJECT CHUTE REMOVE FROM 25mm GUN FEEDER
- 12a. 25mm Gun Manually Depress To Maximum Depression
 - b. Latches Squeeze
 - c. Link Eject Chute Pull To Right, Away From 25mm Gun Feeder
 - d. HE Links in Eject Chute Disconnect From HE Link In Feeder
 - e. Link Eject Chute Pull Down and Left To Remove
 - f. HE Links Remove From HE Link Eject Chute and Discard
13. FEED SELECT SOLENOID KNOB PUSH IN TO AP POSITION

UNLOAD HE AMMO FROM 25mm GUN FEEDER

14. HE AMMO UNLOAD FROM 25mm GUN FEEDER
- 14a. Ratchet Wrench Place On Lower Feed Shaft Extension With Handle Straight Down
 - b. Upper Clutch Override Pull Out and Hold Knob
 - c. Ammo Links Guide Onto Stripper Rail
 - d. Ratchet Wrench Turn Until Last Round Clear of Feeder
 - e. Forwarder Release Lever ... Press To Release Tension As Needed
 - f. Upper Clutch Override Release Knob
 - g. Wrench Turn Left Until Upper Clutch Override Is Seated
 - h. Ratchet Wrench Remove
15. 25mm GUN FEEDER REMOVE

REMOVE 25mm AMMO FROM 25mm GUN FEEDER

16. TIMER RELEASE ROD PUSH IN
17. WORM SHAFT NUT TURN TO LEFT UNTIL YOU HEAR TWO CLICKS AND ROUND DROPS INTO HELPER'S HAND

LISTEN FOR SOUND OF CLUTCHES FALLING BACK AND FEEDER GOING TO SEAR

18. 25mm GUN FEEDER TIME

Unload/Stow 25mm HE Ammo

1. HE LINK EJECT CHUTE REMOVE FROM 25mm GUN FEEDER
2. HE AMMO UNLOAD FROM 25mm GUN FEEDER
3. TURRET TRAVERSE TO 2150 mils
4. TURRET TRAVEL LOCK SET
5. TURRET DRIVE SWITCH MOVE TO OFF
- (H)6. TURRET SHIELD DOOR OPEN
- (H)7. HE AMMO CAN DOOR REMOVE
8. HE AMMO UNLOAD FROM HE FEED CHUTE
 - 8a. Ratchet Wrench Place On Shaft of Forwarder,
Wrench Handle To Left
 - b. Wrench Apply Upward Pressure
 - c. HE Release Handle Pull Up
 - d. HE Release Handle Hold Up While Moving Wrench
Straight Down
 - e. HE Release Handle Release
 - f. Wrench Turn Right Until Release Handle
Pops Back Into Place
 - g. Wrench Release
 - g. Steps a thru f Repeat Until Only Two Rounds
Visible in HE Feed Chute
9. HE AMMO MOVE ONTO LOADING RAIL
 - 9a. Ammo Can Access Door Remove
 - b. HE Round Nearest Grasp and Pull Onto Rail
Forwarder
 - c. Two Rounds Release From Feed Chute
 - d. Ammo Can Access Door Install
10. AMMO BELT PULL FROM CAN AND PLACE ON
VEHICLE FLOOR
- (H)11. 15th ROUND REMOVE
- (H)12. LINKS SEPARATE
- (H)13. LOOSE ROUND PLACE IN EMPTY DOUBLE LINKS
14. STEPS 11 THRU 13 REPEAT UNTIL ALL AMMO
SEPARATED INTO 15 ROUND BELTS



- 15. TWO 15 ROUND BELTS STOW IN HE AMMO BOX —
- REPEAT UNTIL ALL AMMO
STOWED IN BOXES
- 16. HE AMMO CAN DOOR INSTALL
- 17. HE AMMO STOW
- (H) 18. TURRET SHIELD DOOR CLOSE
- 19. TURRET DRIVE SWITCH MOVE TO 
- 20. TURRET TRAVEL LOCK RELEASE
- 21. TURRET TRAVERSE TO 6400 mils
- 22. TURRET TRAVEL LOCK SET
- 23. TURRET DRIVE SWITCH MOVE TO OFF
- 24. TURRET POWER SWITCH MOVE TO OFF
- (H) 25. TURRET SHIELD DOOR OPEN

Unload/Stow 25mm AP Ammo

1. AP LINK EJECT CHUTE REMOVE FROM 25mm GUN FEEDER
2. AP AMMO UNLOAD FROM 25mm GUN FEEDER
3. TURRET TRAVERSE TO 4350 mils
4. TURRET TRAVEL LOCK SET
5. TURRET DRIVE SWITCH MOVE TO OFF
- (H)6. TURRET SHIELD DOOR OPEN
- (H)7. AP AMMO CAN DOOR REMOVE
8. AP AMMO UNLOAD FROM AP FEED CHUTE
 - 8a. Ratchet Wrench Place On Shaft of Forwarder,
Wrench Handle To Right
 - b. Wrench Apply Upward Pressure
 - c. AP Release Handle Pull Up
 - d. AP Release Handle Hold Up While Moving Wrench
To Straight Down
 - e. AP Release Handle Release
 - f. Wrench Turn Left Until Release Handle
Pops Back Into Place
 - g. Steps a thru f Repeat Until Only Two Rounds
Visible in AP Feed Chute
9. AP AMMO MOVE ONTO LOADING RAIL
 - 9a. Access Area Reach In
 - b. AP Round Nearest Grasp and Pull Onto Rail
Forwarder
 - c. Two Rounds Release From Feed Chute
 - d. Wrench Remove From Shaft
10. AMMO BELT PULL FROM CAN AND PLACE ON
VEHICLE FLOOR
- (H)11. 15th ROUND REMOVE
- (H)12. LINKS SEPARATE
- (H)13. LOOSE ROUND PLACE IN EMPTY DOUBLE LINKS
14. STEPS 11 THRU 13 REPEAT UNTIL ALL AMMO
SEPARATED INTO 15 ROUND BELTS



- 15. TWO 15 ROUND BELTS STOW IN AP AMMO BOX —
- REPEAT UNTIL ALL AMMO
STOWED IN BOXES
- 16. AP AMMO CAN DOOR INSTALL
- 17. AP AMMO STOW
- (H)18. TURRET SHIELD DOOR CLOSE
- 19. TURRET DRIVE SWITCH MOVE TO — ON —
- 20. TURRET TRAVEL LOCK RELEASE
- 21. TURRET TRAVERSE TO 6400 mils
- 22. TURRET TRAVEL LOCK SET
- 23. TURRET DRIVE SWITCH MOVE TO OFF
- 24. TURRET POWER SWITCH MOVE TO OFF
- (H)25. TURRET SHIELD DOOR OPEN

Load/Reload 7.62 Coax Machinegun Ammo

IF LO AMMO LIGHT IS FLASHING, DO STEP 1
IF LOADING, START AT STEP 2

- 1. FORWARDER ACCESS DOOR OPEN - GO TO STEP 7
- 2. COAX MACHINEGUN ACCESS DOORS OPEN
- 3. MANUAL SAFETY SET TO SAFE
- 4. COVER ASSEMBLY AND FEED TRAY OPEN
- 5. CHAMBER INSPECT FOR ROUND
USE LIGHT IF NECESSARY

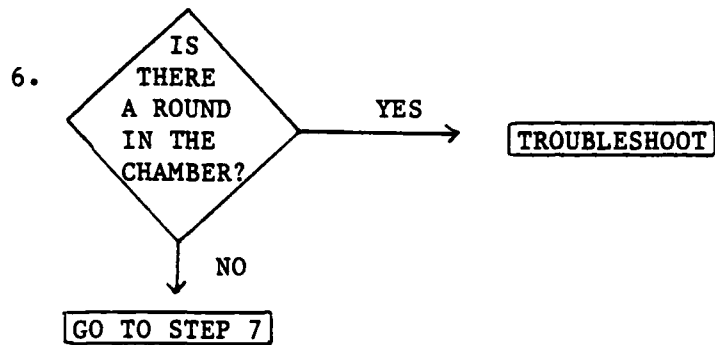

- 7. FOUR 7.62 AMMO CANS UNSTOW AND OPEN
- 8. AMMO BELT LOAD IN FIRST SECTION OF BOX - INSPECT ROUNDS
 - (H)8a. One Belt Remove and Inspect For Damage and Alignment
 - (H) b. Belt Pass to Gunner
 - c. Belt Feed Into Box, Folding Back and Forth
- 9. NEW AMMO BELT LINK TO FIRST
- 10. AMMO BELTS LINK AS NEEDED

FILL SECOND AND THIRD SECTIONS OF BOX; FILL TOP

IF RELOADING, GO TO STEP 11; IF LOADING GO TO STEP 13

- 11. LOAD AMMO BELT LINK TO AMMO BELT IN CHUTE
 - CLOSE FORWARD ACCESS DOOR
- 12. AMMO BELT FORWARD TO COAX MACHINEGUN
- 13. FEED TRAY CLOSE
- 14. AMMO BELT INSTALL ON FEED TRAY
- 15. COVER ASSEMBLY CLOSE
- 16. MACHINEGUN ACCESS DOORS CLOSE

Unload 7.62 Coax Machinegun Ammo

1. ARM-SAFE-RESET SWITCH MOVE TO RESET, THEN TO SAFE
2. TURRET DRIVE SWITCH OFF
3. MACHINEGUN ACCESS DOORS OPEN
4. BOLT INSURE TO REAR
5. MANUAL SAFETY INSURE IN SAFE
6. COVER ASSEMBLY OPEN
7. AMMO REMOVE
8. FEED TRAY OPEN - INSPECT CHAMBER AREA
TO INSURE CLEAR
9. FORWARDER ACCESS DOOR OPEN
10. COAX AMMO FORWARDER CLEAR
11. FORWARDER ACCESS DOOR CLOSE
12. EMPTY 7.62 AMMO CANS UNSTOW, OPEN
13. 100 ROUNDS OF 7.62 AMMO REMOVE FROM COAX AMMO BOX
14. AMMO BELT 100 ROUND STOW IN AMMO CAN
15. AMMO CANS FILL AND CLOSE
- REPEAT UNTIL AMMO STOWED
16. 7.62 AMMO CANS STOW

Clear Coax Machinegun

MAKE SURE MACHINEGUN IS POINTED DOWN RANGE AND PERSONNEL ARE CLEAR

1. COAX MACHINEGUN ACCESS DOORS OPEN
 2. CHARGER HANDLE PULL BACK FIRMLY
 3. MANUAL SAFETY MOVE TO SAFE POSITION
 4. COVER ASSEMBLY. OPEN
 5. AMMO BELT REMOVE FROM FEED TRAY
 6. FEED TRAY OPEN
 7. CHAMBER REMOVE ANY AMMO
- USE LIGHT IF NEEDED**
8. FEED TRAY CLOSE
 9. COVER ASSEMBLY CLOSE
 10. MANUAL SAFETY MOVE TO FIRE POSITION
 11. COAX MACHINEGUN DRY FIRE
 - 11a. Trigger Squeeze
 - 11b. Charger Handle Hold
 - 11c. Bolt Assembly Let Return Slowly
 12. CHARGER HANDLE PULL BACK FIRMLY
 13. STEP 11 REPEAT TO INSURE NO AMMO LEFT IN GUN
 14. COAX MACHINEGUN ACCESS DOORS CLOSE

Load/Reload Tow Launcher

- 1. TURRET TRAVERSE TO TOW LOAD POSITION
5950 mils
- 2. TOW LAUNCHER RAISE
- 3. TOW LAUNCHER ELEVATE TO 500 mils
- 4. TURRET DRIVE SWITCH MOVE TO OFF
- 5. TURRET TRAVEL LOCK SET
- (H)6. CARGO HATCH COVER OPEN TO TOW LOAD POSITION

TO LOAD MISSILES, GO TO STEP 7; TO RELOAD, GO TO STEP 8

- (H)7. DUST COVER REMOVE
- 8. TOW LAUNCHER PREPARE FOR LOADING BY
UNLOADING AND PULLING
DOWN LOADING HANDLES

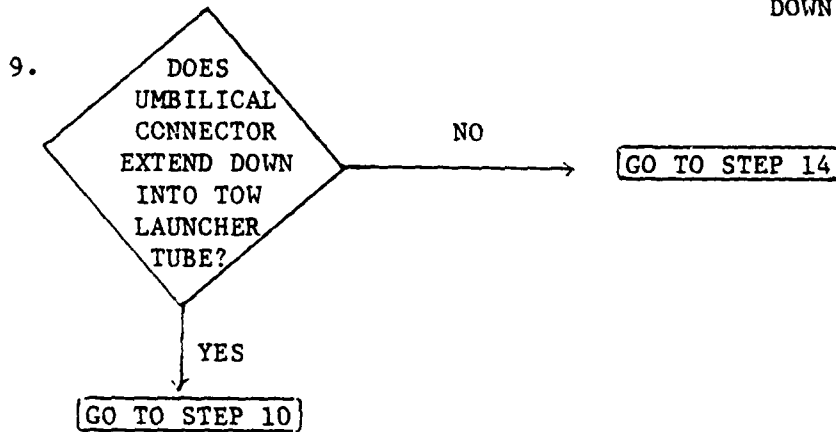

- (H)10. OBSTRUCTION OR DEBRIS REMOVE FROM TUBES
- 11. UMBILICAL CONNECTORS CHECK POSITION
- 12. ARM-SAFE-RESET SWITCH MOVE TO RESET, THEN TO SAFE

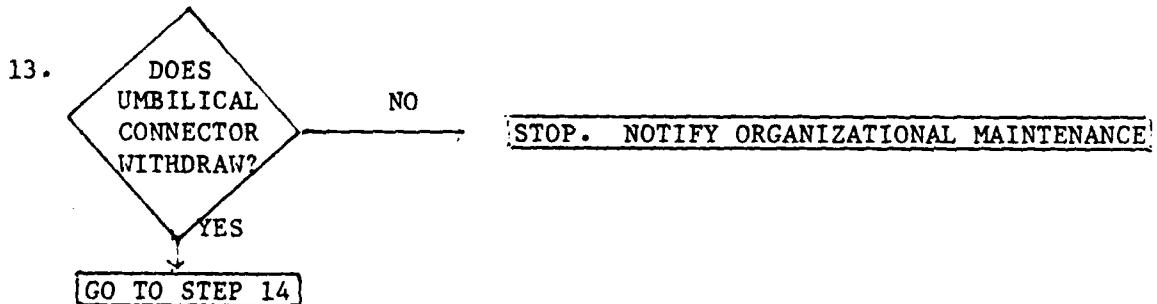

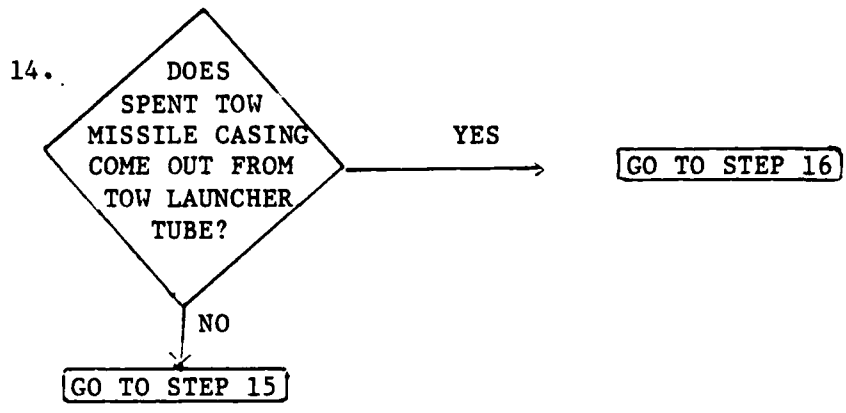

- (H)15. SPENT TOW MISSILE CASING PULL FROM TUBE AND DISCARD
- 16. TOW MISSILES UNSTOW FROM VERTICAL AND HORIZONTAL STOWAGE
- USE CAUTION. DO NOT LOAD DAMAGED MISSILES
- (H)17. FORWARD HANDLING RING REMOVE FROM NOSE END OF MISSILE
- (H)18. ELECTRICAL CONNECTOR COVER REMOVE FROM ELECTRICAL CONNECTOR - SAVE UNTIL MISSILES ARE FIRED
- 19. TOW MISSILE INSPECT FOR DAMAGE
- 20. TOW MISSILE LOAD INTO TOW LAUNCHER
- LUG CHANNELS IN LAUNCHER CAN GET OUT OF ALINEMENT AND BLOCK LOADING. PULL DOWN HARD ON LOADING HANDLE TO REALINE LUG CHANNELS.
- (H)21. CARGO HATCH COVER CLOSE AND NOFITY GUNNER

LAUNCHER UP INDICATOR LIGHT ON DOES NOT MEAN TOW SELECTED. TOW SELECT BUTTON MUST BE PUSHED TO SELECT TOW.

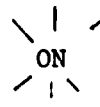
- 22. TRAVEL LOCK RELEASE
- 23. TURRET DRIVE SYSTEM SWITCH MOVE TO 
- 24. TURRET TRAVERSE TO 6400 mils
- 25. TOW LAUNCHER LOWER

Unload Tow Launcher

- 1. TURRET TRAVERSE TO 5950 mils
- 2. TOW LAUNCHER RAISE AND ELEVATE to 500 mils
- 3. TURRET DRIVE SYSTEM OFF
- 4. TURRET TRAVEL LOCK SET
- (H)5. CARGO HATCH COVER OPEN TO TOW LOAD POSITION
- 6. ENCASED TOW MISSILES INSPECT - HANDLE WITH CARE
- 7. ENCASED TOW MISSILES UNLOAD
 - 7a. Lock Handle Push Left and Hold
 - 7b. Loading Handle Pull Down

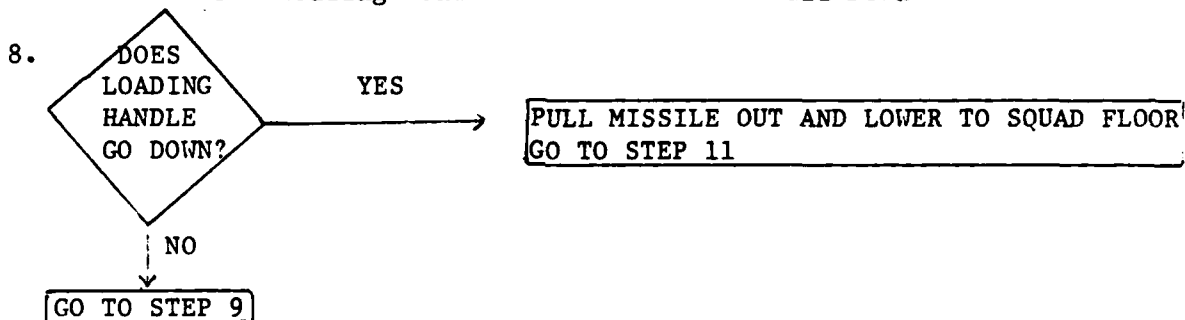

- 9. ARM-SAFE-RESET SWITCH MOVE TO RESET, THEN TO SAFE
WAIT 10 SECONDS
- 10. STEP 7 REPEAT

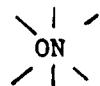
IF HANDLE STILL DOES NOT COME DOWN. NOTIFY ORGANIZATIONAL MAINTENANCE.
- 11. SECOND MISSILE UNLOAD - REPEAT STEP 7
- 12. ENCASED TOW MISSILES PREPARE FOR STOWAGE
 - 12a. Missiles Inspect
 - 12b. Handling Ring Install and Close Clamp
 - 12c. Connector Cover Install and Lock
- 13. ENCASED MISSILES STOW
- 14. LAUNCHER DUST COVER INSTALL
- (H)15. CARGO HATCH COVER CLOSE
- 16. TRAVEL LOCK RELEASE
- 17. TURRET DRIVE SWITCH 
- 18. TURRET TRAVERSE TO 6400 mils
- 19. TOW LAUNCHER LOWER

Load/Stow/Reload Smoke Grenades

SMOKE GRENADES MUST BE STOWED UPON RECEIPT
SINCE THERE IS NO INTERIOR STOWAGE FOR THEM.

LOAD AND STOW SMOKE GRENADES

1. TURRET DRIVE SWITCH MOVE TO OFF
2. TURRET POWER SWITCH MOVE TO OFF
- (H)3. RIGHT SIDE SMOKE GRENADE STOWAGE BIN . . OPEN
- (H)4. FOUR RUBBER CAPS REMOVE FROM RIGHT SIDE GRENADE LAUNCHER TUBES
5. EIGHT SMOKE GRENADES UNPACK FROM TWO AMMO CANS
6. FOUR SMOKE GRENADES STOW IN RIGHT SIDE SMOKE GRENADE STOWAGE BIN
- (H)7. FOUR SMOKE GRENADES LOAD INTO RIGHT SIDE GRENADE LAUNCHER TUBES; INSTALL CAPS
8. STEPS 3 THRU 7 REPEAT FOR LEFT SIDE

RELOAD SMOKE GRENADES

9. VEHICLE PREPARE - REPEAT STEPS 1 AND 2
- (H)10. EIGHT SMOKE GRENADES REMOVE FROM LEFT AND RIGHT SIDE SMOKE GRENADE STOWAGE BINS
11. EIGHT SMOKE GRENADES RELOAD IN LEFT AND RIGHT SIDE GRENADE LAUNCHER TUBES - INSTALL CAPS

Unload/Stow Smoke Grenades

1. TURRET DRIVE SWITCH MOVE TO OFF
2. TURRET POWER SWITCH MOVE TO OFF
- (H)3. RIGHT SIDE SMOKE STOWAGE BINS UNLATCH AND OPEN
- (H)4. FOUR RUBBER CAPS REMOVE FROM RIGHT SIDE GRENADE LAUNCHER TUBES
- (H)5. FOUR SMOKE GRENADES REMOVE FROM RIGHT SIDE GRENADE LAUNCHER TUBES
- (H)6. FOUR SMOKE GRENADES STOW IN RIGHT SIDE SMOKE GRENADE STOWAGE BINS; INSTALL CAPS
- (H)7. STEPS 4- 6 REPEAT TO UNLOAD AND STOW SMOKE GRENADES ON LEFT SIDE OF TURRET

Boresight Weapons System

DO NOT LOOK DIRECTLY AT SUN THROUGH ISU

1. ENGINE START
2. TURRET POWER SWITCH MOVE TO 
3. VEHICLE DRIVE TO WITHIN 1200 METERS OF TARGET (3960 feet) FACING TARGET
4. ENGINE STOP

TURN NIGHT VISION PWR SWITCH ON

5. BALLISTIC SIGHT COVER DOORS RAISE
6. RANGE CONTROL KNOB MOVE TO Ø
7. MAG SWITCH MOVE TO HIGH UNTIL IT CLICKS
8. SENSOR SELECT SWITCH MOVE TO CLEAR OR NEUTRAL
9. AP SS BUTTON PRESS EITHER AP SS OR HE SS CAN BE USED
10. STATUS INDICATOR CHECK THAT SELECTED AMMO APPEARS —

IF NOT, NOTIFY ORGANIZATIONAL MAINTENANCE

11. TURRET TRAVERSE DRIVE SELECT LEVER MOVE TO MANUAL POSITION
12. GUN ELEVATION DRIVE SELECT LEVER MOVE TO MANUAL POSITION
13. TOW ELEVATION DRIVE SELECT LEVER MOVE TO POWER POSITION —

DO NOT PUT TOW IN MANUAL POSITION

14. TURRET TRAVEL LOCK RELEASE
15. GUN RETICLE CENTER ON AIMING POINT OF TARGET
- (H)16. 25mm BORESIGHT ADAPTER AND TELESCOPE INSTALL - CAREFULLY
- (H)17. BORESIGHT TELESCOPE FOCUS ON TARGET

(H)18. ELEVATION CROSSHAIR IN ALIGN ON AIMING POINT
BORESIGHT RETICLE

GUNNER MANUALLY ELEVATE
OR DEPRESS GUN

(H)19. AZIMUTH CROSSHAIR IN ALIGN ON AIMING POINT
BORESIGHT RETICLE

GUNNER MANUALLY TRAVERSE
TURRET

20. BORESIGHT TELESCOPE CHECK ACCURACY BY ROTATING
90° TO RIGHT AND 90° TO LEFT

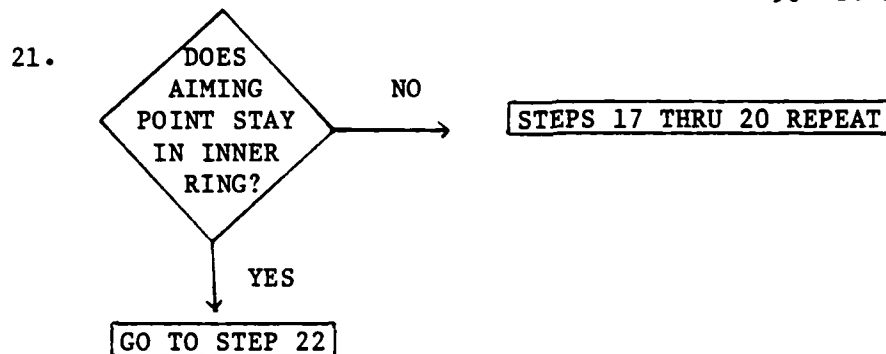

22. FOCUS BARREL TURN TO FOCUS RETICLE

23. GUN RETICLE CHECK ALIGNMENT

BORESIGHT AND GUN RETICLE
MUST BE ON SAME AIMING POINT

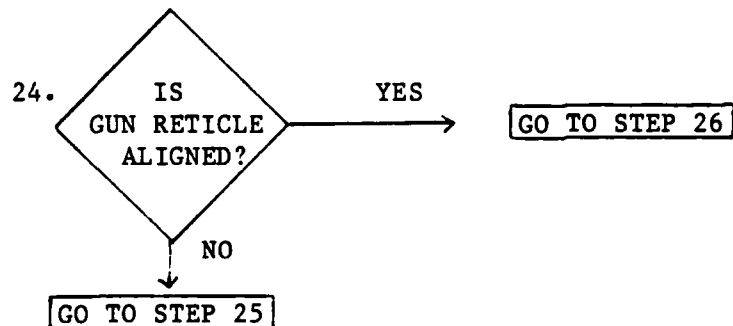

25. GUN RETICLE ALIGN

- 25a. Boresight Cover Lift
- b. EL Knob Turn To Align Elevation Crosshair
- c. AZ Knob Turn To Align Azimuth Crosshair
- d. Organizational Notify If Reticle Does Not Align
Maintenance
- e. Boresight Cover Close

Boresight Backup Sight

BACKUP SIGHT SHOULD BE BORESIGHTED IMMEDIATELY AFTER BORESIGHTING 25mm GUN.

- 26. BACKUP SIGHT EYEPIECE REPOSITION TO COMMANDER'S POSITION; LOCK
- 27. BACKUP SIGHT EYEPIECE FOCUS; FIND DIOPTRER SETTING
- 28. AIMING POINT IMAGE FIND IN RETICLE

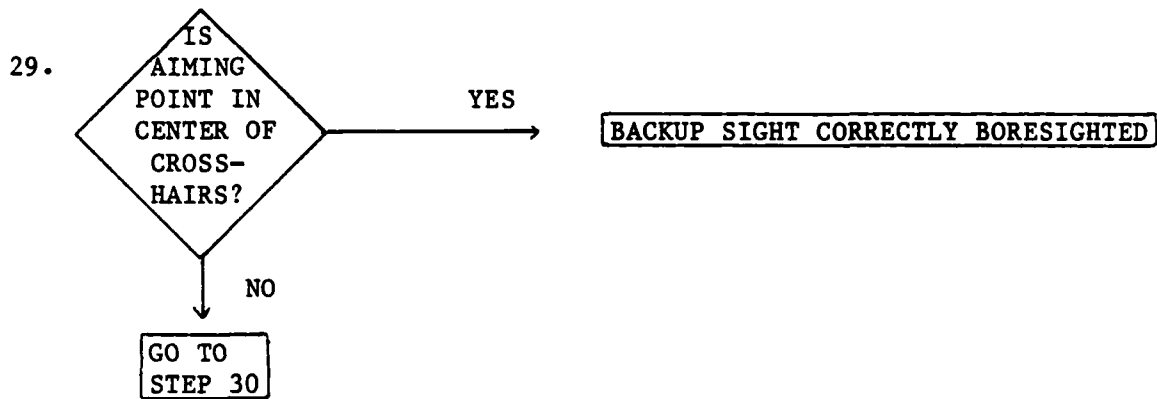

- 30. ELEVATION LINKAGE PERFORM ADJUSTMENT
 - 30a. Locknut Loosen
 - b. Sight Reticle Align Crosshair With Target
 - c. Thumbscrews Adjust

IF CROSSHAIR WILL NOT ADJUST TO HORIZONTAL LINE OF AIMING POINT CROSS, NOTIFY ORGANIZATIONAL MAINTENANCE.

- 31. HORIZONTAL ADJUSTMENT LOCK SCREW LOOSEN; TURN TO RIGHT OR LEFT
 - 32. AIMING POINT IMAGE CENTER
 - 33. HORIZONTAL ADJUSTMENT LOCK SCREW LOCK
 - 34. AIMING POINT IMAGE CHECK —
- IF NOT CENTERED, REPEAT STEPS 30-33.
- (H)35. BORESIGHT TELESCOPE AND ADAPTER REMOVE FROM BARREL

Boresight Coax Machinegun

- 36. 7.62 BUTTON PRESS
- 37. STATUS INDICATOR CHECK THAT 7.62 APPEARS —

IF NOT, NOTIFY ORGANI-
ZATIONAL MAINTENANCE
- (H)38. BORESIGHT ADAPTER AND TELESCOPE INSTALL
- (H)39. BORESIGHT TELESCOPE FOCUS ON TARGET
- 40. COAX MACHINEGUN ACCESS DOORS OPEN
- (H)41. AZIMUTH CROSSHAIR IN BORESIGHT. ALIGN ON AIMING POINT —
RETICLE

GUNNER MOVE AZ KNOB ON COAX
MACHINEGUN MOUNT LEFT OR RIGHT
- (H)42. ELEVATION CROSSHAIR IN ALIGN ON AIMING POINT —
BORESIGHT RETICLE

GUNNER MOVE EL KNOB ON COAX
MACHINEGUN MOUNT LEFT OR RIGHT
- (H)43. BORESIGHT TELESCOPE AND ADAPTER REMOVE FROM BARREL
- 44. COAX MACHINEGUN DOORS CLOSE

Boresight Night Sight To Day Sight

- 45. SENSOR SELECT SWITCH MOVE TO NIGHT
- 46. RETICLE BRIGHTNESS ADJUST KNOB TURN TO ADJUST
- 47. CON KNOB TURN TO ADJUST
- 48. FOCUS KNOB TURN TO FOCUS RETICLE
- 49. ELEVATION AND AZIMUTH ALIGN ON AIMING POINT WITH
CROSSHAIR NIGHT BORESIGHT EL AND AZ KNOBS
- 50. SENSOR SELECT SWITCH MOVE TO CLEAR OR NEUTRAL
- 51. GUN RETICLE CHECK ALIGNMENT ON AIMING
POINT
- 52. NIGHT VISION PWR SWITCH MOVE TO OFF



Boresight TOW Launcher

53. MAG SWITCH MOVE TO HIGH UNTIL IT CLICKS
54. SENSOR SELECT SWITCH MOVE TO CLEAR OR NEUTRAL
55. TOW LAUNCHER RAISE
56. TOW BUTTON PRESS - TOW TEST INDICATOR
LIGHT WILL COME ON
FOR 12 SECONDS.
57. TOW INDICATOR LIGHT CHECK ON
/ \ WHEN TEST LIGHT
GOES OUT / \
58. STATUS INDICATOR CHECK TOW APPEARS
- IF NOT, NOTIFY ORGANI-
ZATIONAL MAINTENANCE
59. TOW ELEVATION SELECT DRIVE LEVER MOVE TO MANUAL POSITION
60. GUN ELEVATION DRIVE SELECT LEVER MOVE TO POWER POSITION
- DO NOT PUT GUN IN MANUAL
POSITION
61. TURRET TRAVERSE DRIVE SELECT LEVER MOVE TO MANUAL POSITION
- (H)62. BORESIGHT TELESCOPE INSTALL CAREFULLY
63. TURRET TRAVEL LOCK RELEASE
- (H)64. BORESIGHT TELESCOPE FOCUS ON TARGET
- (H)65. AZIMUTH CROSSHAIR IN ALIGN ON AIMING POINT --
BORESIGHT RETICLE
- GUNNER MANUALLY TRAVERSE
TURRET AS NEEDED
66. ELEVATION CROSSHAIR IN. ALIGN ON AIMING POINT --
BORESIGHT RETICLE
- GUNNER MANUALLY DEPRESS OR
ELEVATE TOW LAUNCHER AS NEEDED
67. TOW RETICLE CHECK ALIGNMENT ON AIMING POINT

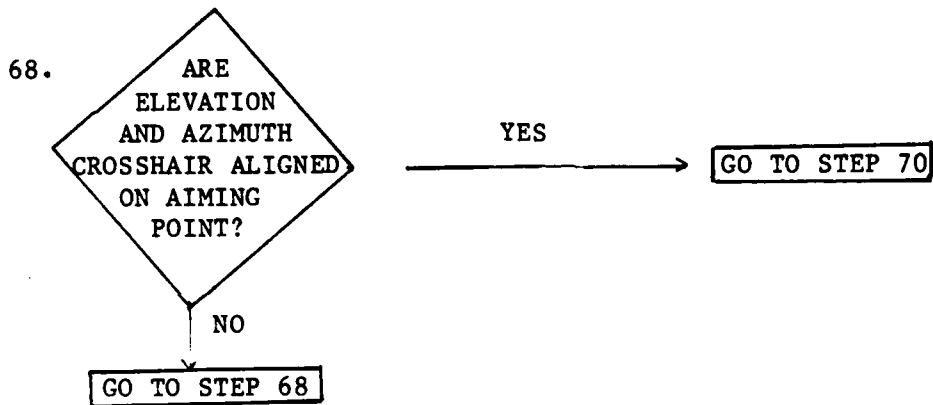

69. AZIMUTH CROSSHAIR CHECK —

IF NOT ALIGNED, NOTIFY ORGANIZATIONAL MAINTENANCE

70. ELEVATION CROSSHAIR ALIGN

- 70a. TOW Boresight Screw Using Screwdriver, Turn Until Elevation Crosshair Alines
- b. Screwdriver Remove —

IF AIMING POINT SHIFTS, NOTIFY ORGANIZATIONAL MAINTENANCE

71. TOW BUTTON PRESS

(H)72. BORESIGHT TELESCOPE REMOVE

73. TOW LAUNCHER LOWER

Zero ISU and 25mm Gun

1. TARGET SELECTED AT 1200 METERS
(3960 FEET)
2. RANGE CONTROL KNOB TURN TO 12
3. MAG SWITCH MOVE TO HIGH UNTIL IT CLICKS

USE AP AMMO AND AP SELECTOR SWITCH. IF USING TP-T IN AP SYSTEM, SELECTOR SWITCH MUST BE IN HE. USE AP SS BUTTON IF USING TP-T IN HE SYSTEM, SELECTOR SWITCH MUST BE IN HE AND HE SS BUTTON SELECTED

4. AP SS or HE SS (TP-T only) PRESS
5. TURRET TRAVERSE
6. 25mm GUN ELEVATE OR DEPRESS TO ALINE
RETICLE ON TARGET
7. ARM-SAFE-RESET SWITCH MOVE TO ARM
8. ONE ROUND FIRE AT TARGET

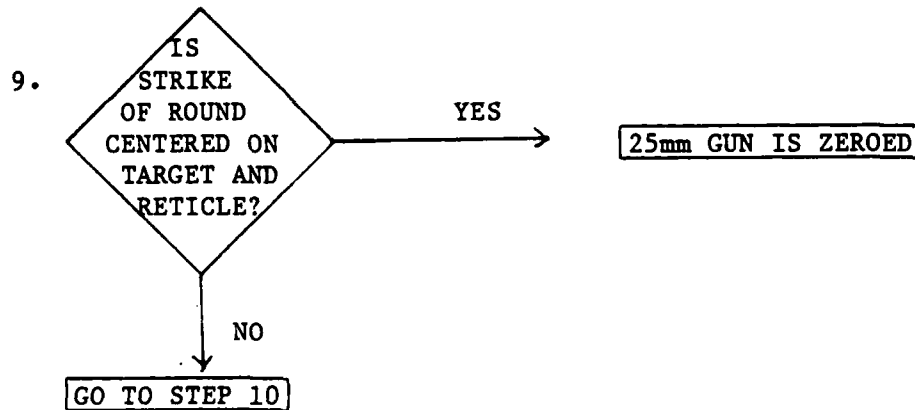

10. RETICLE ALIGN ON CENTER STRIKE OF ROUND
 - 10a. Gun Boresight Cover Open
 - 10b. EL Knob Turn To Align Elevation Crosshair
 - 10c. AZ Knob Turn To Align Azimuth Crosshair
 - 10d. Gun Boresight Cover Close
11. TURRET TRAVERSE
12. GUN ELEVATE OR DEPRESS TO ALIGN
RETICLE BACK ON TARGET
13. STEPS 8 AND 9 REPEAT UNTIL GUN IS ZEROED

IF GUN CANNOT BE ZEROED, NOTIFY ORGANIZATIONAL MAINTENANCE.

Zero Coax Machinegun

- 1. TARGET SELECTED AT 600 METERS
(1968 FEET)
- 2. RANGE CONTROL KNOB TURN TO 6
- 3. MAG SWITCH MOVE TO HIGH UNTIL IT CLICKS
- 4. COAX MACHINEGUN DOORS OPEN
- 5. MANUAL SAFETY CHECK POSITION

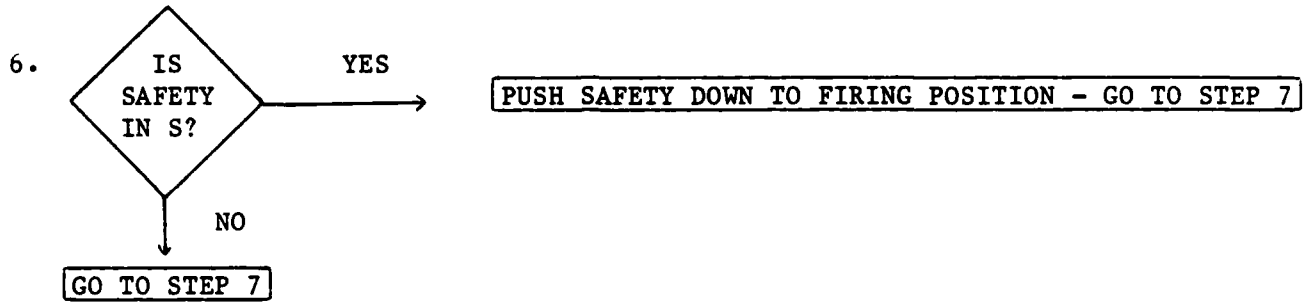

- 7. CHARGER HANDLE PULL BACK UNTIL BOLT LOCKS
TO REAR
- 8. COAX MACHINEGUN DOORS CLOSE
- 9. 7.62 BUTTON PRESS
- 10. TURRET TRAVERSE AS NEEDED TO ALIGN
RETICLE ON CENTER OF TARGET
- 11. GUN ELEVATE OR DEPRESS AS NEEDED
TO ALIGN RETICLE ON CENTER OF
TARGET
- 12. ARM-SAFE-RESET SWITCH MOVE TO ARM
- 13. MACHINEGUN FIRE SHORT BURST
- 14. STRIKES OF ROUND EXAMINE

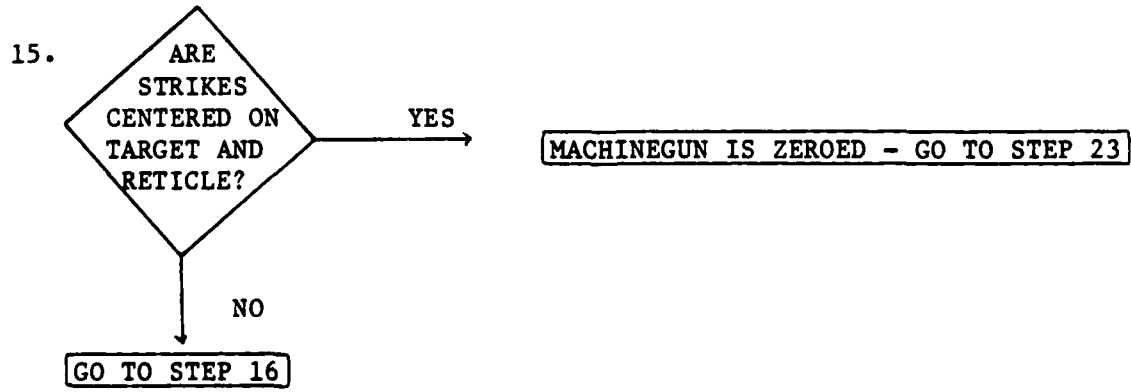

- 16. ELEVATION mils ESTIMATE mils BETWEEN STRIKES
AND CENTER OF RETICLE
- 17. AZIMUTH mils ESTIMATE mils BETWEEN STRIKES
AND CENTER OF RETICLE
- 18. COAX MACHINEGUN ACCESS DOORS OPEN
- 19. EL KNOB TURN TO ADJUST
- 20. AZ KNOB TURN TO ADJUST
- 21. COAX MACHINEGUN ACCESS DOORS CLOSE
- 22. STEPS 13 THROUGH 21 REPEAT UNTIL GUN IS ZEROED
- 23. COAX MACHINEGUN ACCESS DOORS OPEN
- 24. MANUAL SAFETY PUSH TO SAFE POSITION WITH
S SHOWING
- 25. COAX MACHINEGUN ACCESS DOORS CLOSE

Fire 25mm Gun Manually

DO NOT OPERATE TURRET IN POWER MODE WHILE MANUALLY FIRING 25mm GUN.

- 1. 25mm GUN GUARD AND COVER REMOVE AND OPEN
- 2. MANUAL SAFE HANDLE MOVE TO FIRE
- 3. SEAR RETRACTOR LEVER LOCK — CLICKS WHEN LOCKED
- 4. AP or HE AMMO SELECT AS REQUIRED
- 5. HANDCRANK ASSEMBLY INSTALL ON MANUAL DRIVE GEAR HUB
- 6. HANDCRANK ASSEMBLY TURN TO RIGHT TO DRY CYCLE GUN
- 7. BACKUP SIGHT USE TO ENGAGE TARGET
- 8. 25mm GUN FIRE

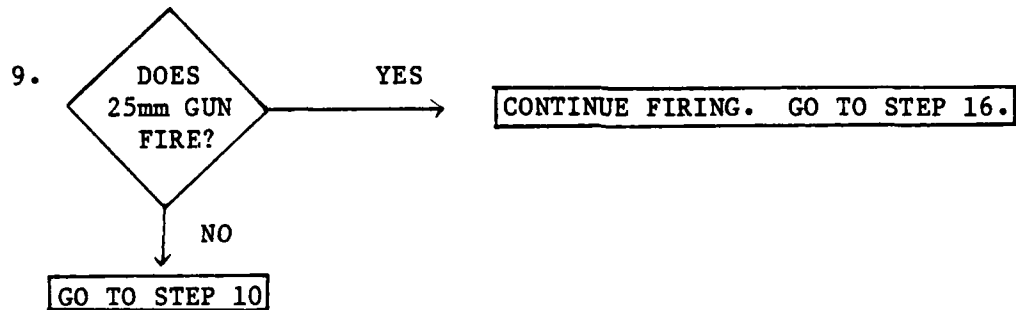

- 10. MANUAL SAFE CHECK
- 11. FEEDER HANDLE RAISE
- 12. SEAR RETRACTOR LEVER RELEASE
- 13. SEAR RELEASE PRESS IN AND HOLD
- 14. FEEDER HANDLE LOWER
- 15. BOLT CYCLE OUT OF MISFIRE POSITION

- 15a. Handcrank Assembly Turn Right One Half Turn
- b. Sear Release Release
- c. Handcrank Assembly Turn Until Bolt Locks In Sear Position —

BOLT POSITION INDICATOR WILL STOP IN SEAR.

- 16. HANDCRANK ASSEMBLY REMOVE
- 17. 25mm GUN COVER AND GUARD CLOSE AND INSTALL

DRY FIRE PROCEDURE SAME AS UNLOADED MANUAL FIRE

Fire 25mm Gun

IF STEPS ARE TAKEN OUT OF ORDER, GUN WILL NOT CYCLE PROPERLY. CHECK INDICATOR LIGHTS CAREFULLY.

1. DAY SIGHT OR NIGHT SIGHT PULL TO OPEN DOOR COVER HANDLE

NIGHT VISION PWR SWITCH ON ISU MUST BE MOVED TO ON 10 MINUTES BEFORE OPERATION

2. TURRET DRIVE SWITCH MOVE TO OFF
3. 25mm GUN GUARD AND COVER REMOVE AND OPEN
4. MANUAL SAFE HANDLE MOVE TO FIRE
5. 25mm GUN COVER AND GUARD CLOSE AND INSTALL

FIRST ROUND OF AMMO AFTER FEED CHANGE MAY FALL SHORT OR LONG. USE CAUTION.

6. AMMO SELECT AS REQUIRED
7. SEAR INDICATOR LIGHT CHECK

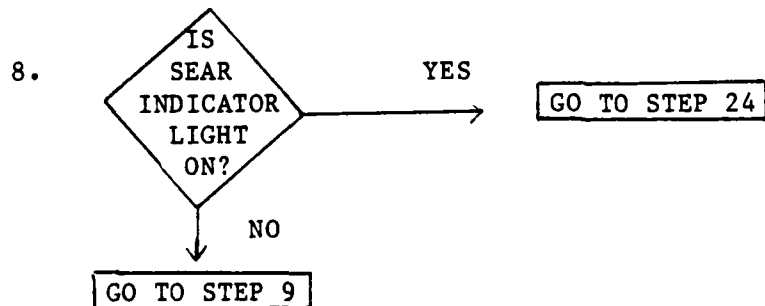

9. TURRET POWER SWITCH MOVE TO OFF
10. 25mm GUN GUARD AND COVER REMOVE AND OPEN
11. ELECTRICAL CONNECTOR ON FEEDER CHECK
12. FEEDER HANDLE CHECK LOCKED DOWN
13. SEAR INDICATOR CHECK IN SEAR

- 14. 25mm GUN COVER AND GUARD CLOSE AND INSTALL
- 15. TURRET POWER SWITCH MOVE TO 

IF 25 FDR MALF LIGHT COMES ON,
NOTIFY ORGANIZATIONAL MAINTENANCE.

- 16. SEAR INDICATOR LIGHT CHECK

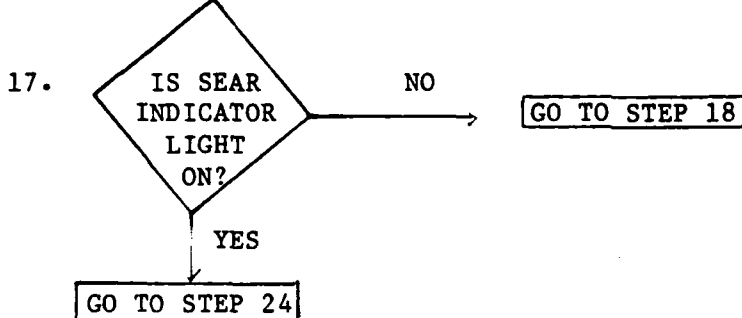

- 18. TURRET POWER OFF
- 19. ELECTRICAL CONNECTOR ON RECEIVER REMOVE - CHECK FOR BURNT OR DAMAGED PINS
- 20. FEEDER REMOVE CHECK FOR DAMAGE
- 21. INDICATOR CHECK IN SEAR
- 22. FEEDER REPLACE
- 23. SEAR INDICATOR LIGHT CHECK

IF NOT ON, NOTIFY ORGANIZATIONAL MAINTENANCE

- 24. TURRET DRIVE SWITCH MOVE TO 

IF FIRING DAY, GO TO STEP 25. IF FIRING THERMAL, GO TO STEP 26

- 25. SENSOR SELECT SWITCH MOVE TO CLEAR OR NEUTRAL -

GO TO STEP 33

- 26. NIGHT VISION POWER SWITCH MOVE TO ON - WAIT 10 MINUTES

- 27. SENSOR SELECT SWITCH MOVE TO NIGHT
- 28. NIGHT VISION PLRT SWITCH MOVE TO W/H OR B/H
- 29. CON KNOB TURN TO ADJUST
- 30. BRT KNOB TURN TO ADJUST
- 31. FOCUS KNOB TURN TO ADJUST NIGHT FOCUS
- 32. RET BRT KNOB TURN TO ADJUST



- 33. MAG SWITCH MOVE TO HIGH UNTIL IT CLICKS
- 34. STADIA LINES USE TO FIND TARGET RANGE
- 35. RANGE CONTROL KNOB TURN TO RANGE ESTIMATED IN STEP 34
- 36. TARGET APPLY APPROPRIATE SIGHT PICTURE
- 37. ARM-SAFE-RESET SWITCH MOVE TO ARM
- 38. 25mm GUN FIRE AT TARGET

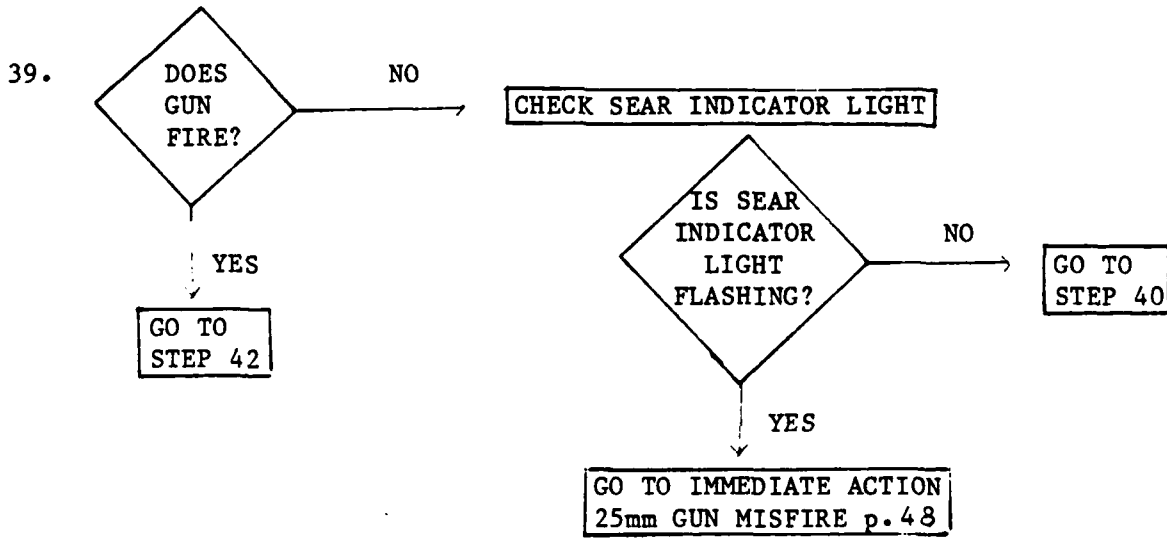

- 40. BOLT POSITION INDICATOR CHECK

GUN IS CONSIDERED HOT WHEN 100 ROUNDS HAVE BEEN FIRED IN 15 MINUTES

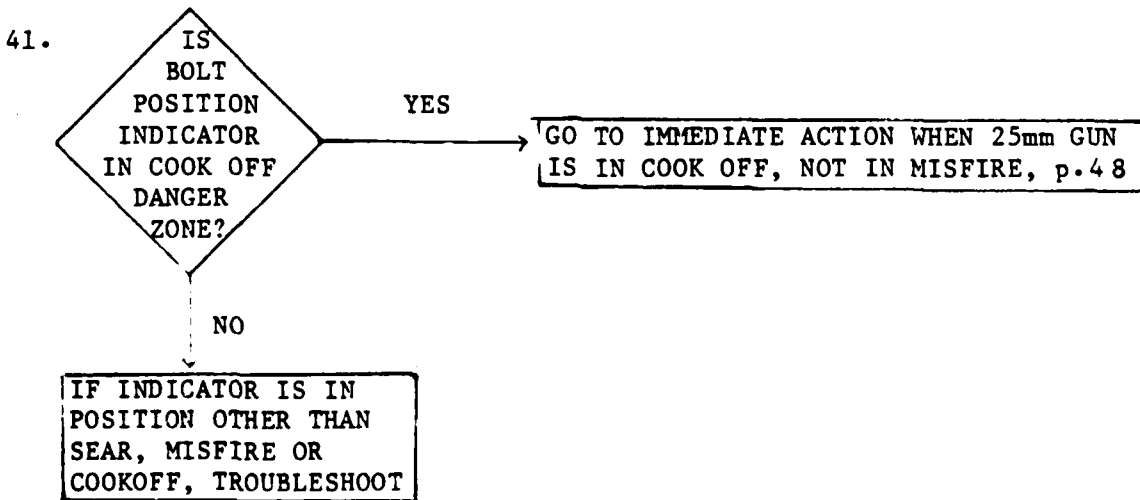

42. 25mm FDR MALF LIGHT. CHECK

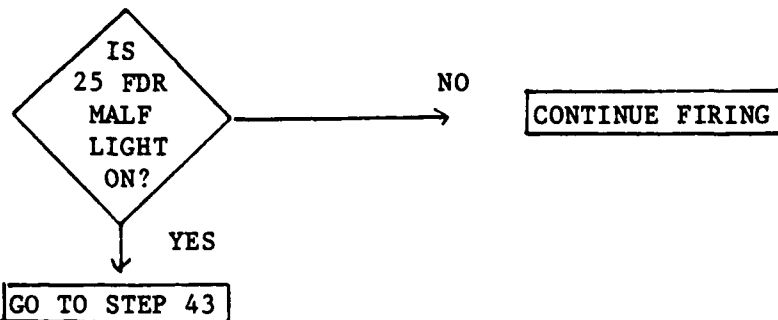

43. TURRET POWER SWITCH OFF

44. FEEDER CHECK FOR BINDING

45. INDICATOR CHECK IN SEAR

46. TURRET POWER SWITCH 

47. AMMO RESELECT AS REQUIRED

FIRST ROUND MAY FALL SHORT OR LONG AFTER AMMO FEED CHANGE IS MADE.

48. 25mm GUN FDR MALF LIGHT CHECK

49.

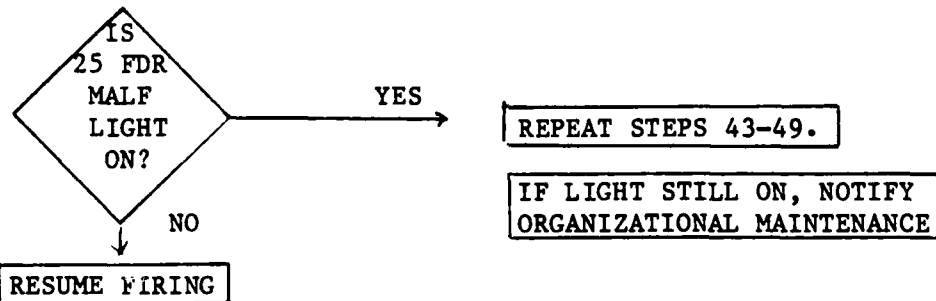

STEPS 50 THROUGH 57 SHOULD BE PERFORMED WHEN FIRING IS COMPLETED

50. ARM-SAFE-RESET SWITCH MOVE TO RESET, THEN TO SAFE

51. STAB SWITCH MOVE TO OFF

52. TURRET DRIVE SWITCH MOVE TO OFF

53. TURRET POWER SWITCH MOVE TO OFF

54. GUN GUARD AND COVER REMOVE AND OPEN

55. MANUAL SAFE ON

56. 25mm GUN CLEAR

57. GUN COVER AND GUARD CLOSE AND INSTALL

Immediate Action When 25mm Gun Misfires

MISFIRE COULD BE HANGFIRE. DO NOT IMMEDIATELY PRESS MISFIRE BUTTON.

IF GUN IS HOT, ALL SOLDIERS MUST EXIT VEHICLE.

GUN IS HOT ENOUGH FOR COOKOFF IF 100 ROUNDS HAVE BEEN FIRED WITHIN 15 MINUTES.

1. GUNNER'S TRIGGER SWITCHES RELEASE - **WAIT FOR 5 SECONDS**
2. SINGLE SHOT MODE SELECT IN AMMO YOU WERE FIRING
3. MISFIRE BUTTON PRESS
4. GUNNER'S TRIGGER SWITCHES SQUEEZE
5. SEAR INDICATOR LIGHT CHECK

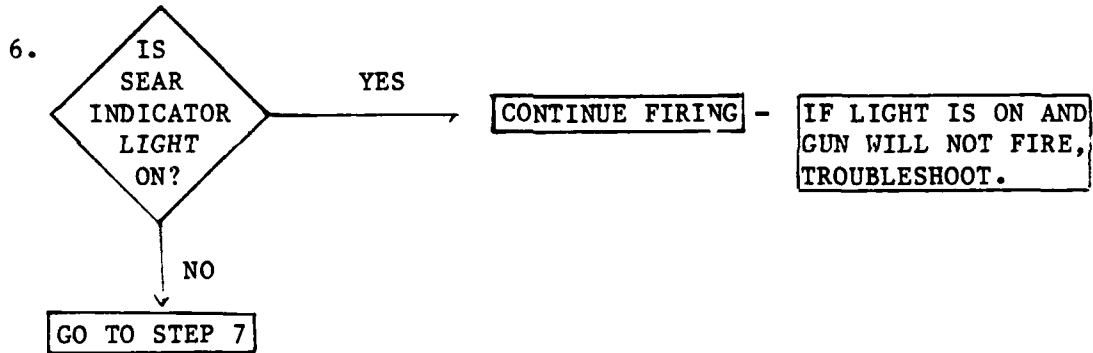

7. BOLT POSITION INDICATOR CHECK

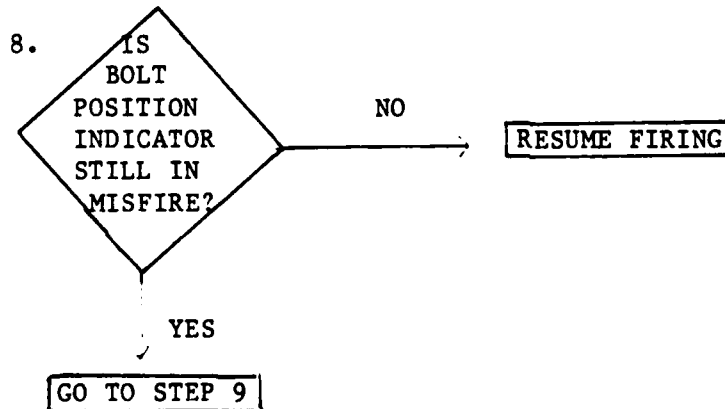

9. TEMPERATURE OF GUN

CHECK - **GUN IS HOT IF 100 ROUNDS HAVE BEEN FIRED IN 15 MINUTES**

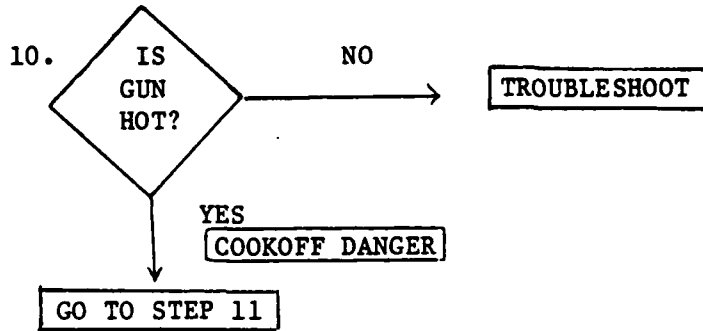

11. INTERCOM

TELL CREW AND DRIVER TO EXIT IMMEDIATELY

12. TURRET DRIVE SWITCH

OFF

13. TURRET POWER SWITCH

OFF

14. COMMANDER'S AND GUNNER'S HATCH COVERS

OPEN - COMMANDER AND GUNNER EXIT

STAY CLEAR OF VEHICLE FOR 30 MINUTES

15. COLD 25mm GUN

TROUBLESHOOT

Fire Coax Machinegun Manually

DO NOT OPERATE TURRET IN POWER MODE WHILE FIRING MANUALLY.
DO NOT FIRE COAX AND 25mm GUN AT THE SAME TIME. DRIVER AND
CARGO HATCHES SHOULD BE CLOSED BEFORE FIRING.

1. COAX MACHINEGUN ACCESS DOORS OPEN
2. CHARGER HANDLE PULL BACK UNTIL BOLT LOCKS
TO REAR
3. BACK-UP SIGHT USE TO ENGAGE TARGET
4. COAX MACHINEGUN FIRE
 - 5a. Manual Trigger Pull
 - b. Rounds Locate Strikes
 - c. Turret Traverse As Needed
 - d. Coax Machinegun Elevate Or Depress As Needed

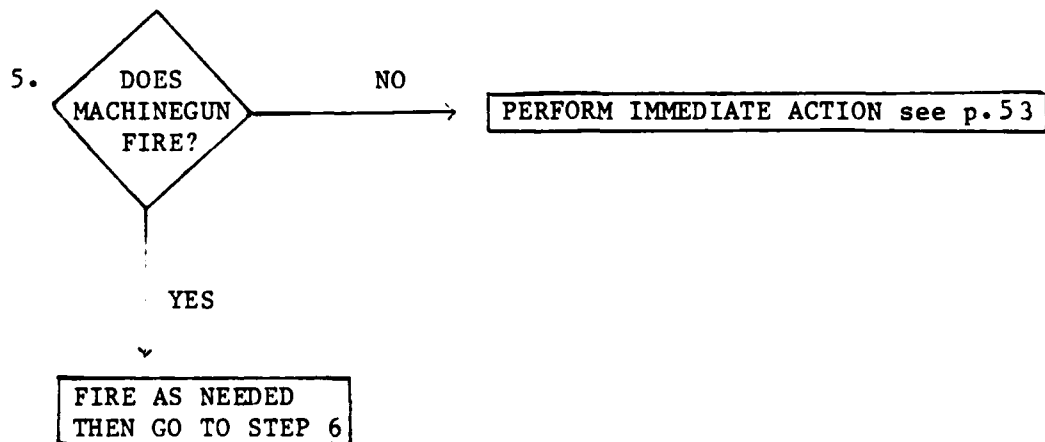

6. COAX MACHINEGUN CLEAR

Fire Coax Machinegun

- 1. COAX MACHINEGUN ACCESS DOORS OPEN
- 2. TURRET DRIVE SWITCH MOVE TO OFF
- 3. MANUAL SAFETY CHECK POSITION

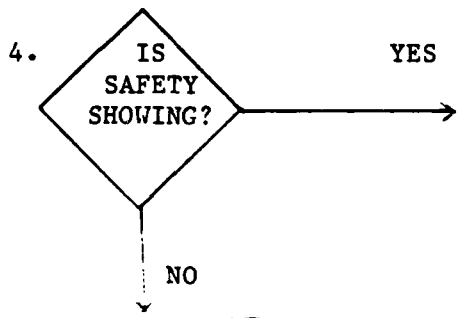

PUSH SAFETY DOWN TO FIRING POSITION
GO TO STEP 6

GO TO STEP 7

- 5. CHARGER HANDLE PULL BACK UNTIL BOLT LOCKS TO REAR
- 6. COAX MACHINEGUN ACCESS DOORS CLOSE
- 7. TURRET DRIVE SWITCH MOVE TO 
- 8. 7.62 BUTTON PRESS

DO NOT LOOK AT SUN THROUGH ISU

- 9. STATUS INDICATOR CHECK THAT 7.62 APPEARS
- 10. STADIA LINES FIND RANGE
- 11. RANGE CONTROL KNOB TURN TO RANGE ESTIMATED IN STEP
- 12. TARGET USE CORRECT SIGHT PICTURE
- 13. ARM-SAFE-RESET SWITCH MOVE TO ARM
- 14. TRIGGER AND PALM SWITCHES SQUEEZE TO FIRE

IF LO AMMO LIGHT FLASHES, EITHER STOP AND RELOAD OR PUSH LO AMMO OVRD BUTTON TO FIRE REMAINING AMMO

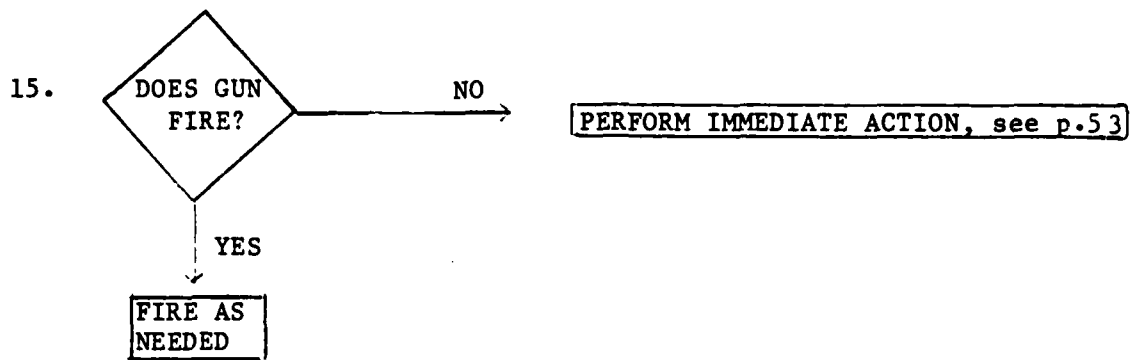

PERFORM STEPS 16-18 AFTER FIRING IS COMPLETED

- 16. ARM-SAFE-RESET SWITCH MOVE TO RESET, THEN TO SAFE
- 17. TURRET DRIVE SYSTEM SWITCH MOVE TO OFF
- 18. COAX MACHINEGUN CLEAR

Immediate Action When Coax Machinegun Fails To Fire

GUN IS HOT ENOUGH TO CAUSE COOKOFF IF 100 ROUNDS HAVE BEEN FIRED IN TWO MINUTES. IF GUN IS HOT, DO NOT INSPECT TRAY, REMOVE ROUND, OR RECHARGE GUN. CLOSE ACCESS DOORS AND LEAVE VEHICLE FOR 30 MINUTES.

- 1. ARM-SAFE-RESET SWITCH MOVE TO SAFE
- (C) 2. INTERCOM TELL CREW AND DRIVER TO EXIT IMMEDIATELY
- 3. TURRET DRIVE SWITCH MOVE TO OFF
- 4. TURRET POWER SWITCH MOVE TO OFF
- 5. COMMANDER'S AND GUNNER'S HATCH COVERS OPEN - COMMANDER AND GUNNER EXIT

STAY CLEAR OF VEHICLE FOR 30 MINUTES

- 6. VEHICLE REENTER AFTER 30 MINUTES
- 7. CHARGER HANDLE PULL BACK UNTIL BOLT LOCKS TO REAR

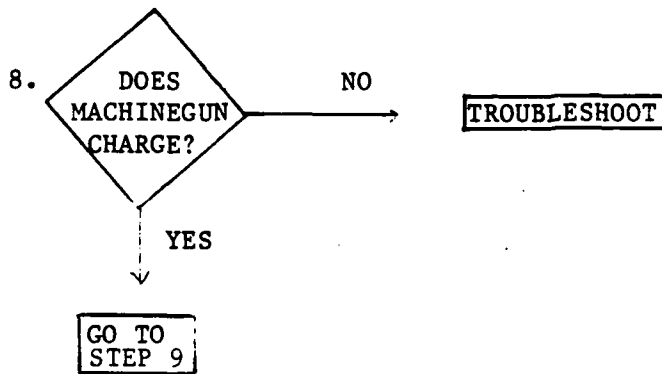

- 9. COAX MACHINEGUN ACCESS DOORS CLOSE
- 10. ARM-SAFE-RESET SWITCH MOVE TO ARM
- 11. COAX MACHINEGUN FIRE BY SQUEEZING TRIGGER AND PALM SWITCHES

IF GUN DOES NOT FIRE, TROUBLESHOOT

IF FIRING MANUALLY, OMIT STEPS 1, 2, 3, 4 AND 10 AND FIRE BY PULLING MANUAL TRIGGER

Immediate Action To Stop Runaway Coax

- 1. COAX MACHINEGUN KEEP POINTED DOWNRANGE
- (C)2. TURRET POWER SWITCH MOVE TO OFF
- (C)3. COAX MACHINEGUN STOP FROM FIRING
 - 3a. 7.62 Ammo Belt Grab, Twist and Hold To Stop Firing

IF 100 ROUNDS HAVE BEEN FIRED IN TWO MINUTES MACHINEGUN BARREL IS HOT

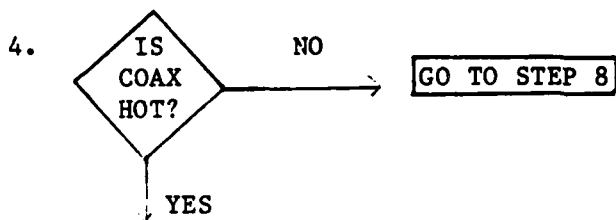

GO TO STEP 5

- (C)5. INTERCOM TELL DRIVER AND CREW TO EXIT IMMEDIATELY
- 6. COMMANDER'S AND GUNNER'S HATCH COVERS OPEN - COMMANDER AND GUNNER EXIT

STAY CLEAR OF VEHICLE FOR 30 MINUTES
- 7. VEHICLE REENTER AFTER 30 MINUTES
- 8. COAX MACHINEGUN CLEAR
- 9. 7.62 AMMO UNLOAD
- 10. ORGANIZATIONAL MAINTENANCE NOTIFY

Fire TOW Missiles

1. SLOPE INDICATOR CHECK

IF BUBBLE TOUCHING RED 10° RING, MOVE VEHICLE TO LEVEL GROUND.

IF THERMAL FIRING, TURN NIGHT VISION PWR SWITCH ON

2. TOW LAUNCHER RAISE

3. TOW BUTTON PRESS

4. TOW AND TOW TEST INDICATOR LIGHTS CHECK

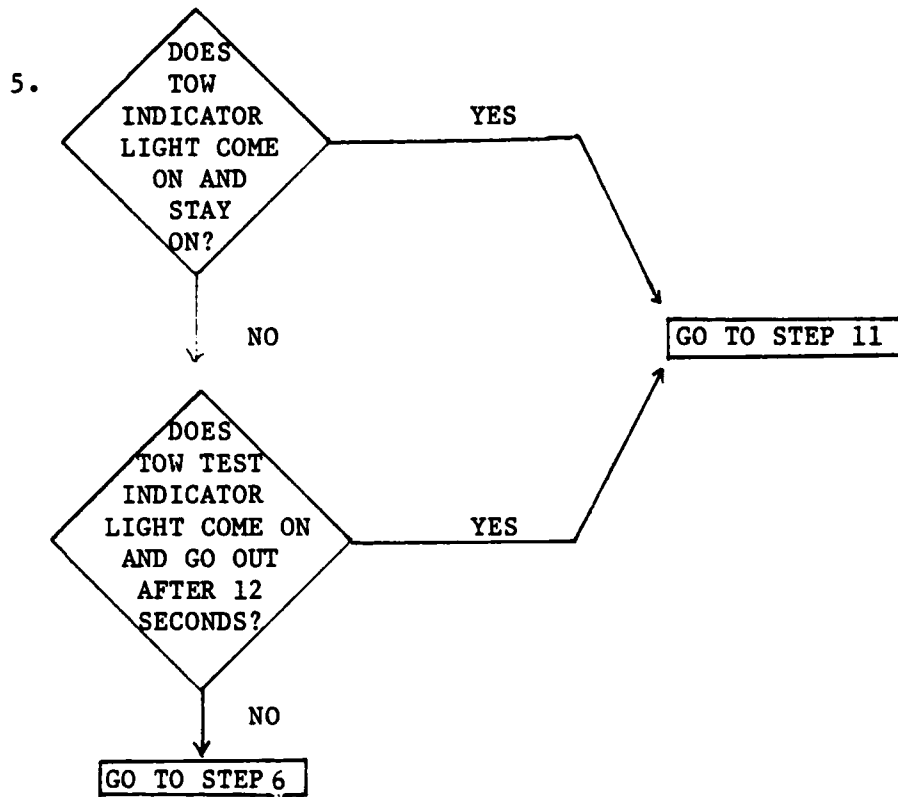

6. TOW CONTROLS CHECK - REPEAT STEPS 3-5

7. ANNUNCIATOR LIGHTS CHECK

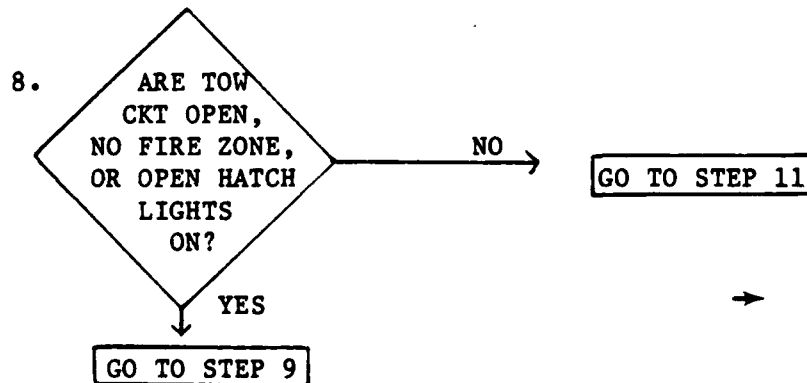

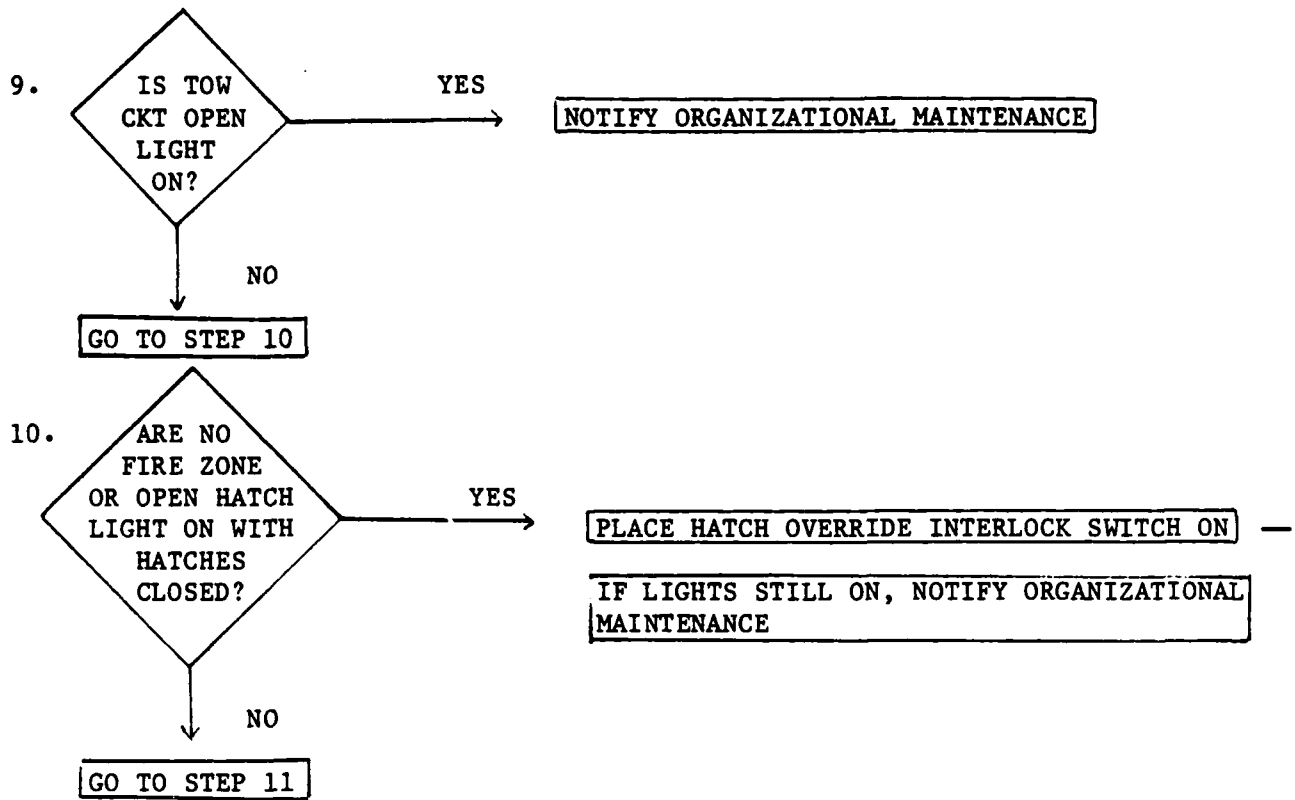

11. TOW CONTROL BOX RE-CHECK
ANNUNCIATOR LIGHTS

IF ANY LIGHTS ARE ON,
DO NOT FIRE TOW

FOR DAY FIRE, STEP 12

FOR THERMAL FIRE, STEP 13

12. SENSOR SELECT SWITCH MOVE TO NEUTRAL OR CLEAR, THEN GO TO STEP 18

DO NOT LOOK AT SUN THROUGH ISU

13. CON KNOB TURN TO ADJUST

14. BRT KNOB TURN TO ADJUST

15. RT BRT KNOB TURN TO ADJUST

16. FOCUS KNOB TURN TO FOCUS IMAGE NIGHT FOCUS KNOB

17. NIGHT VISION PLRT SWITCH MOVE TO W/H OR B/H

18. MAG SWITCH MOVE TO HIGH UNTIL IT CLICKS

MUST BE IN HIGH FOR TOW TO WORK

19. GUNNER'S EYEPiece CHECK FOR TOW STATUS INDICATOR

IF NOT PRESENT, NOTIFY ORGANIZATIONAL MAINTENANCE.

20. MISSILE TUBE BUTTON PRESS

DO NOT SELECT SECOND MISSILE WHILE FIRST IS IN FLIGHT OR FIRST WILL ABORT.

21. ARM-SAFE-RESET SWITCH MOVE TO ARM

22. RETICLE CROSSHAIRS CENTER ON TARGET

ALL PERSONNEL MUST BE INSIDE VEHICLE WITH HATCHES CLOSED.
DO NOT FIRE TOW THROUGH TREES OR BUSHES OR OVER WATER OR ELECTRICAL WIRES.

23. GUNNER'S TRIGGER AND PALM SWITCHES SQUEEZE AND HOLD

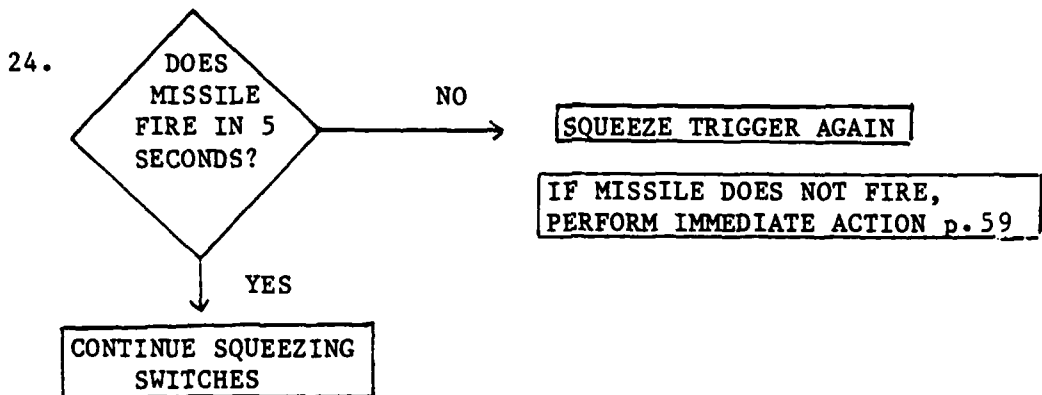

25. TARGET TRACK WITH GUNNER'S CONTROL HANDLES UNTIL IMPACT

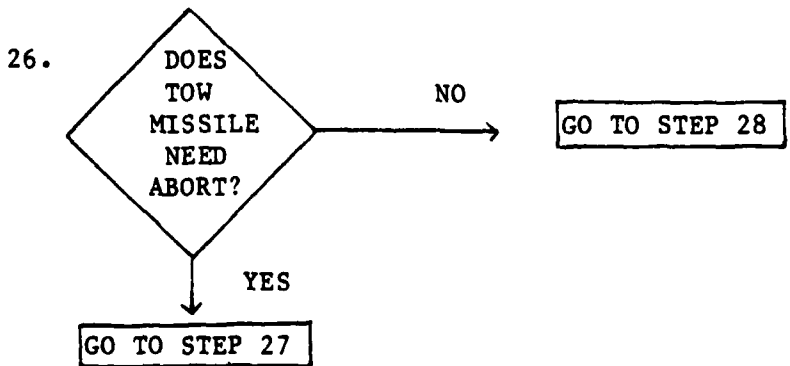

27. MISSILE FLIGHT PATH CHECK

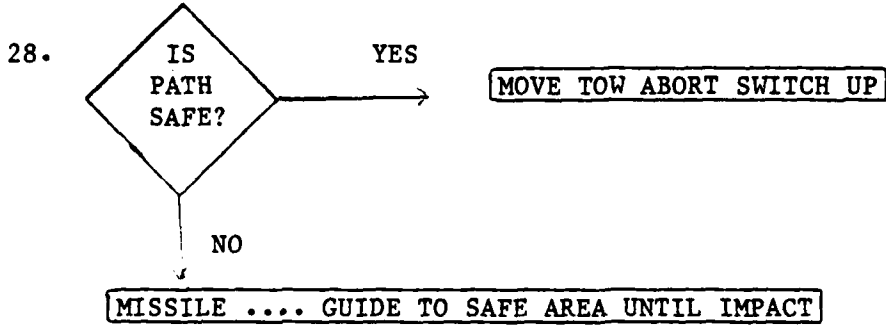

29. SECOND TOW MISSILE FIRE - REPEAT STEPS 20-27.

Immediate Action When TOW Missile Misfires

ALL VEHICLE PERSONNEL MUST STAY IN VEHICLE FOR 30 MINUTES AFTER FIRING ATTEMPT. HATCH COVERS AND RAMP CLOSED AND EVERYONE AWAY FROM BLAST AREA.

- (C)1. INTERCOM TELL CREW OF MISFIRE AND RE-FIRE ATTEMPT
- 2. ARM-SAFE-RESET SWITCH MOVE TO RESET, THEN TO SAFE
- 3. TOW BUTTON PRESS

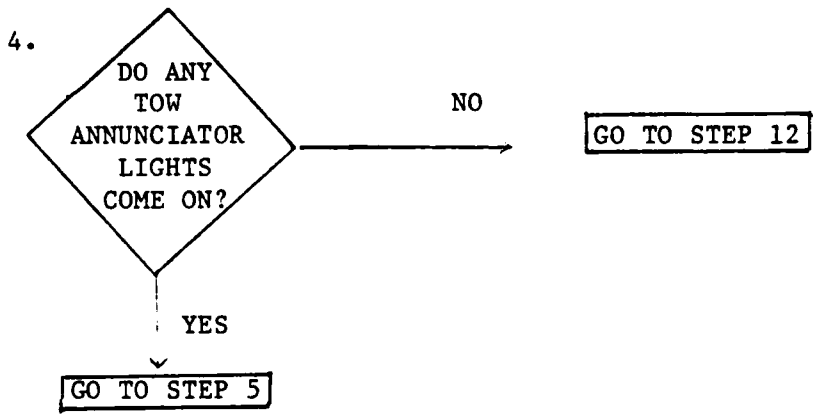

- 5. ARM-SAFE-RESET SWITCH MOVE TO RESET, THEN TO SAFE
- 6. TURRET DRIVE SWITCH MOVE TO OFF
- 7. TURRET POWER SWITCH MOVE TO OFF
- 8. TURRET SHIELD DOOR OPEN
- 9. TURRET COMMANDER AND GUNNER EXIT FOR 30 MINUTES
- 10. TURRET SHIELD DOOR CLOSE
- 11. ORGANIZATIONAL MAINTENANCE NOTIFY
- 12. MISFIRED TOW RESELECT
- 13. ARM-SAFE-RESET SWITCH MOVE TO ARM

ALL PERSONNEL MUST BE INSIDE VEHICLE WITH HATCHES CLOSED. DO NOT FIRE TOW INTO TREES OR BUSHES OR OVER WATER OR ELECTRICAL WIRES.

- 14. PALM AND TRIGGER SWITCHES SQUEEZE AND HOLD

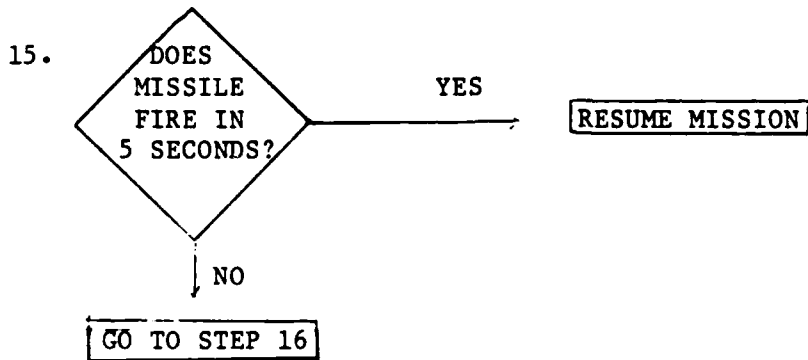

16. SECOND TOW MISSILE SELECT AND FIRE

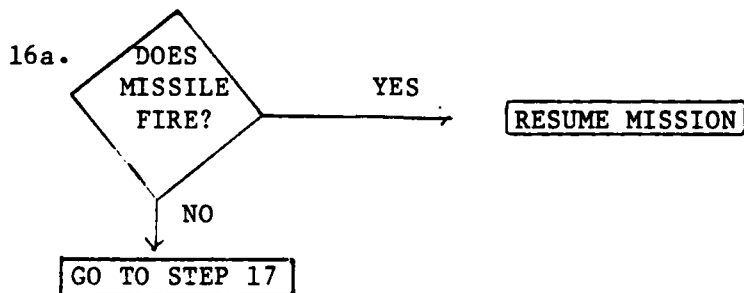

- 17. ARM-SAFE-RESET SWITCH MOVE TO RESET, THEN TO SAFE
- (D)18. VEHICLE POSITION SO THAT TRAVERSING TURRET AWAY FROM TROOPS
- 19. TURRET TRAVERSE TO 6400 mils — IF NEEDED
- 20. TURRET DRIVE SWITCH MOVE TO OFF
- 21. TURRET POWER SWITCH MOVE TO OFF
- 22. TURRET SHIELD DOOR OPEN
- 23. TURRET COMMANDER AND GUNNER EXIT
- 24. TURRET SHIELD DOOR CLOSE -- WAIT 30 MINUTES
- 25. TURRET SHIELD DOOR REOPEN
- 26. TURRET COMMANDER AND GUNNER RE-ENTER
- 27. TURRET POWER MOVE TO
- 28. TURRET DRIVE SYSTEM SWITCH MOVE TO

- 29. TURRET TRAVERSE TO 1600 OR 4800 mils
- 30. TOW LAUNCHER ELEVATE TO MAXIMUM ELEVATION
- 31. TURRET POWER SWITCH MOVE TO OFF
- (H)32. VEHICLE EXIT THROUGH RAMP ACCESS DOOR
(D)
- (D)33. HULL CLIMB ON TOP
- (D)34. TOW LAUNCHER UNLOCK
- (D)35. MISFIRED TOW MISSILE REMOVE FROM TOW LAUNCHER -
HAND MISSILE TO GROUND HELPER
- USE EXTREME CAUTION!
- (H)36. MISFIRED TOW MISSILE REMOVE TO SAFE PLACE

POINT MISSILE AND POSSIBLE BACKBLAST AWAY FROM VEHICLES, BUILDINGS AND PERSONNEL

- (H)37. MISFIRED TOW MISSILE MARK CLEARLY WITH STAKE AND
FLAG
- 38. EXPLOSIVE ORDNANCE DISPOSAL NOTIFY

Launch Smoke Grenades

CHECK THAT SOLDIERS ARE CLEAR OF LAUNCH AREA

CHECK CAPS REMOVED FROM TUBES

- | | |
|--------------------------------------|---------------|
| 1. MASTER POWER | ON |
| 2. TURRET POWER | ON |
| 3. FOUR HATCH COVERS | CLOSED |
| 4. GRENADE LAUNCHER SWITCH | MOVE TO ON |
| 5. TRIGGER BUTTON | PRESS TO FIRE |

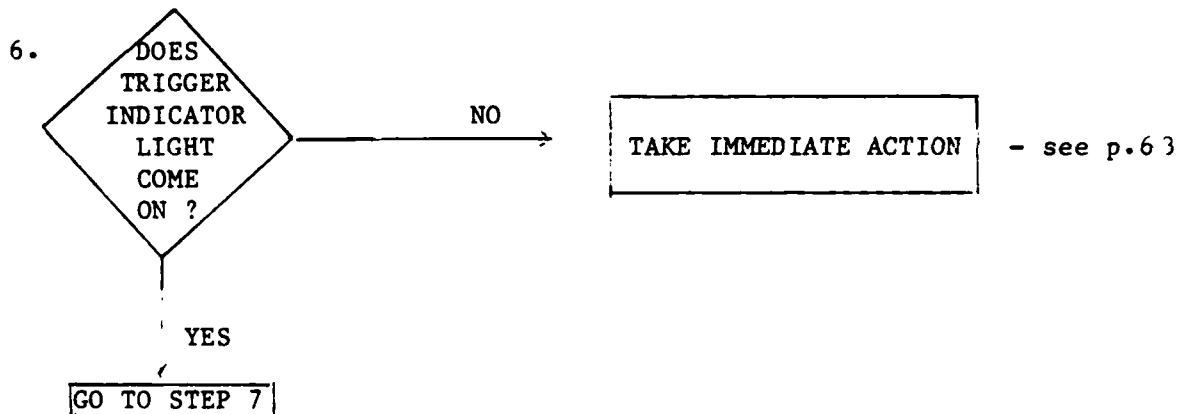

7. GRENADE LAUNCHER SWITCH MOVE TO OFF

CHECK TO SEE THAT ALL SMOKE GRENADES HAVE BEEN FIRED.
IF NOT, TAKE IMMEDIATE ACTION.

Immediate Action When Smoke Grenades Fail To Launch

KEEP TURRET POINTED DOWN RANGE.

- (C)1. INTERCOM MOVE VEHICLE TO SAFE AREA
- 2. GRENADE LAUNCHER SWITCH MOVE TO  ON
- 3. TRIGGER BUTTON PRESS TO FIRE

LOOK FOR SMOKE

- (C)4. COMMANDER'S HATCH COVER OPEN
- (C)5. LAUNCHERS CHECK

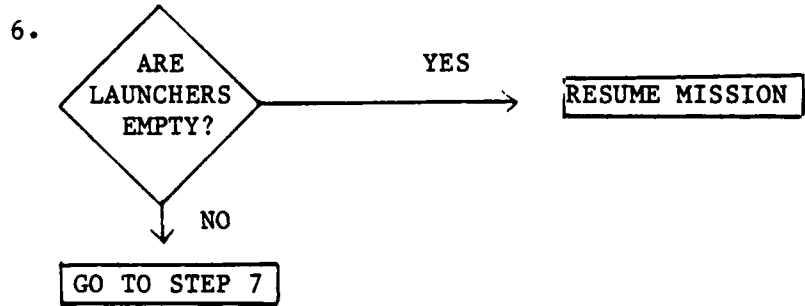

- 7. HELPERS EXIT VEHICLE
- (C)8. TURRET POWER SWITCH OFF
- 9. MISFIRED GRENADES REMOVE FROM LAUNCHER; MOVE TO SAFE AREA
- 10. CHAIN OF COMMAND NOTIFY

PMCS BRADLEY COMMANDER

BEFORE OPERATIONS CHECKS

SYSTEM	EQUIPMENT	CLEAN/CLEAR	DAMAGE/TAMPERING	IN PLACE	MISSING PARTS	OPERATION	STATUS	SECURE
COMMANDER'S STATION	SEAT		X			X		
	HATCH COVER		X			X		
	PERISCOPES	X	X					
	BLACKOUT COVERS		X	X				
COAX MACHINE-GUN (MAY BE DONE BY EITHER BC OR GUNNER)	ACCESS DOORS		X			X		X
	ACCESS DOOR HANDLES					X		
	ACCESS DOOR SEALS		X					
	AMMO FEED CHUTE		X					X
	FEED CHUTE LATCHES		X			X		X
	REAR GUN MOUNT	X	X					
	REAR GUN MOUNT BRACKET		X			X		
	BORESIGHT KNOBS	X				X		
	REAR MOUNTING PIN			X		X		
COMMUNICATIONS	RADIO					X		
	INTERCOM					X		

DURING OPERATIONS CHECKS

COMMANDER'S HANDLE	TURRET TRAVERSE					X		
	TURRET TRAVERSE FAST (SLEW)					X		
	25mm GUN ELEVATION/DEPRESSION					X		
ISU AND WEAPONS (CHECKS MADE WITH GUNNER)	ISU OPERATION					X		
	DRY FIRE 25mm GUN					X		
	DRY FIRE COAX MACHINEGUN					X		
	STABILIZATION CONTROLS					X		

WEEKLY PMCS CHECKS

COMMANDER'S	CUSHIONING PAD		X		X			
HATCH COVER	HATCH PIN LEVER			X		X		

PMCS BEFORE OPERATIONS - GUNNER

CHECK

LOCATION	SYSTEM	EQUIPMENT	CLEAN/CLEAR	DAMAGE/TAMPERING	IN PLACE	OPERATION	SECURE
TURRET INTERIOR	GUNNER'S STATION	SEAT		X		X	
		HATCH COVER		X		X	
		PERISCOPES	X	X			
		BALLISTIC SIGHT COVERS				X	
		ISU WINDOWS	X	X			
	25mm GUN	COVER	X	X			
		ZIPPLRS	X	X			
		BOLT POSITION INDICATOR	X	X			
		POWER CABLE		X			
		HE/AP FEED CHUTES		X			
		HE/AP LINK					
		EJECT CHUTES		X			
		25mm GUN					
		AFTER DRY FIRE		X			
	COAX MACHINE-GUN	ACCESS DOORS				X	X
		ACCESS DOOR HANDLES				X	
		ACCESS DOOR SEALS		X			
		AMMO FEED CHUTE		X			X
		FEED CHUTE LATCHES		X		X	X
		REAR GUN MOUNT	X	X			
		BRACKET		X		X	X
		BORESIGHT KNOBS	X			X	
	MANUAL OPERATIONS	REAR MOUNTING PIN			X	X	
		GUN ELEVATION DRIVE SELECT LEVER				X	
		GUN ELEVATION HANDWHEEL				X	
		TURRET TRAVERSE HAND WHEEL				X	
		TURRET TRAVERSE DRIVE SELECT LEVER				X	
		COMMUNICATIONS	RADIO/INTERCOM				X

PMCS DURING OPERATIONS - GUNNER

CHECK

LOCATION	SYSTEM	EQUIPMENT	CHECK							
			CLEAN/CLEAR	DAMAGE/TAMPERING	IN PLACE	LEAKS	MISSING PARTS	OPERATION	SECURE	STATUS
TURRET INTERIOR	INDICATOR LIGHTS	FAN-LAMP TEST/LAMP						X		X
		WEAPON CONTROL BOX						X		X
		TURRET POSITION INDICATOR						X		X
		TOW CONTROL BOX						X		X
		TURRET CONTROL BOX						X		X
	FANS	FAN-LAMP TEST/FAN						X		X
		GUN FANS						X		
		TURRET POWER INDICATOR LIGHT						X		X
	ISU COOL DOWN	TURRET POWER LIGHT						X		X
		NIGHT VISION POWER SWITCH						X		X
		CLOSED CYCLE COOLER						X		
	GUNNER'S HANDLES	TURRET TRAVERSE						X		
		TURRET TRAVERSE FAST						X		
		25mm GUN ELEVATION/DEPRESSION						X		
	DECK CLEARANCE SYSTEM	SYSTEM						X		
	ISU OPERATION	SYSTEM						X		
	25mm GUN	DRY FIRE						X		
	COAX MACHINE-GUN	DRY FIRE						X		
	SMOKE GRENADES	INDICATOR LIGHT						X		X
		TRIGGER LIGHT						X		X
	TOW LAUNCHER	SYSTEM						X		
	STABILIZATION CONTROLS	SYSTEM						X		X

NOTE: 25mm gun, coax machinegun, smoke grenade launcher and TOW missile launcher must be cleaned and inspected daily when used.

PMCS - Deck Clearance System

Report equipment not ready where * appears

1. DRIVER AND CARGO HATCH COVERS OPEN TO POP-UP POSITION

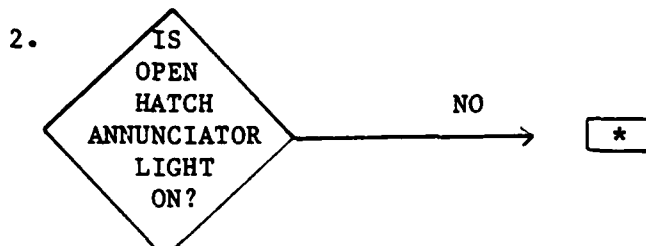

GO TO STEP 3

MAKE SURE HATCH OVERRIDE INTERLOCK SWITCH IS OFF

3. 25mm GUN DEPRESS TO -180 mils

4. TURRET TRAVERSE LEFT AND RIGHT IN FULL CIRCLE - IF TURRET DOES NOT MOVE*

5. 25mm GUN CHECK THAT IT ELEVATES AND DEPRESSES BY ITSELF WHEN PASSING OVER REAR DECK

6. 25mm GUN ELEVATE TO 0 mils

7. DRIVER'S HATCH COVER OPEN TO UPRIGHT POSITION

8. TURRET TRY TO TRAVERSE TO LEFT AND RIGHT



GO TO STEP 10

10. DRIVER'S HATCH COVER CLOSE

11. CARGO HATCH COVER OPEN TO UPRIGHT POSITION

12. TURRET TRY TO TRAVERSE TO LEFT AND RIGHT

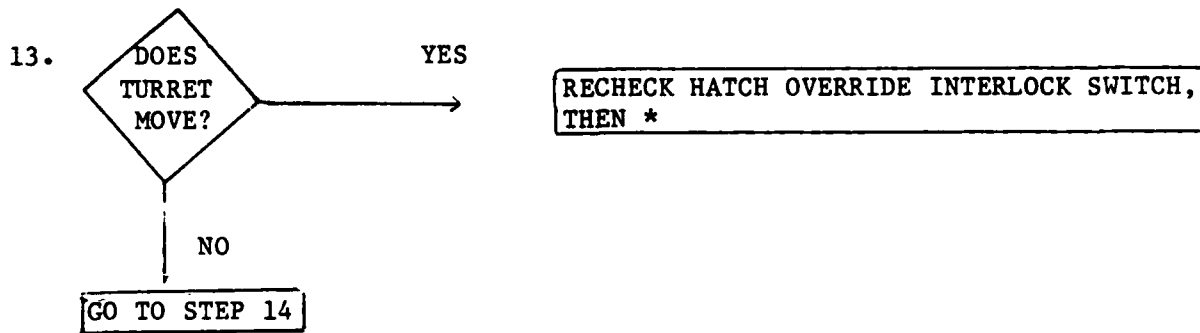

- 14. CARGO HATCH COVER CLOSE
- 15. TOW LAUNCHER RAISE AND TOW SELECTED
- 16. CARGO HATCH COVER OPEN

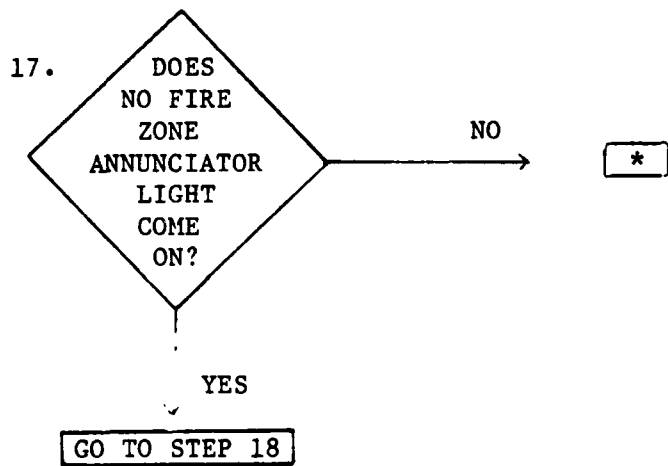



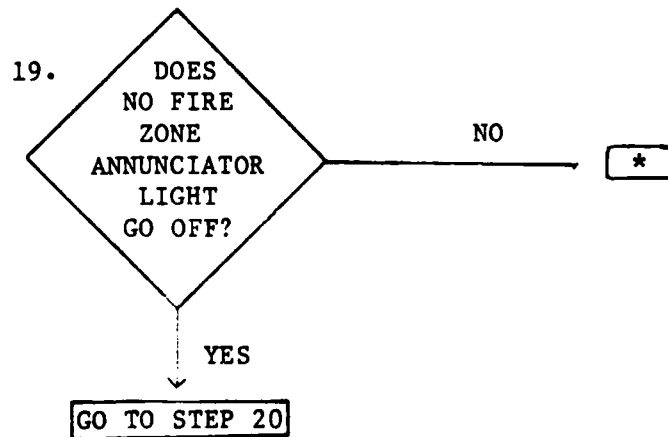

- 18. CARGO HATCH COVER CLOSE



- 20. TOW LAUNCHER LOWER

PMCS - ISU Operation

Report equipment not ready where * appears

1. NIGHT VISION PWR SWITCH ON
2. HE SS BUTTON PRESS -- HE SS INDICATOR LIGHT
WILL BE  ON 
3. RETICLE CHECK PRESENCE IN GUNNER'S EYEPIECE-
IF NOT PRESENT*
4. STATUS INDICATOR CHECK THAT READS HE - IF NOT HE
CHECK AMMO SELECT SWITCH, THEN *
5. MAG SWITCH MOVE TO HIGH UNTIL IT CLICKS
6. MAG SWITCH CHECK OPERATION - IF FAULTY*
7. SENSOR SELECT SWITCH MOVE TO NEUTRAL, THEN CLEAR;
CHECK OPERATION
8. RET BRT KNOB TURN TO LEFT AND TO RIGHT;
CHECK OPERATION
9. GUNNER'S DIOPTER (FOCUS BARREL) TURN; CHECK OPERATION - IF FAULTY*
10. COMMANDER'S DIOPTER (FOCUS BARREL) TURN; CHECK OPERATION - IF FAULTY*
11. RANGE CONTROL KNOB CHECK LAMP IS LIT; TURN FROM 0 TO 30
12. STATUS INDICATOR CHECK SAME AS RANGE CONTROL KNOB -
IF FAULTY*
13. VIEW CHECK RISES AS RANGE INCREASES -
IF FAULTY*
14. AP SS BUTTON PRESS -- AP SS INDICATOR LIGHT
WILL BE  ON 
15. RETICLE CHECK PRESENCE IN GUNNER'S EYEPIECE -
IF NOT PRESENT*
16. STATUS INDICATOR CHECK THAT READS AP - IF NOT AP
CHECK AMMO SELECT SWITCH, THEN *
17. RANGE CONTROL KNOB TURN FROM 30 TO 0

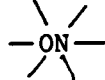

- | | |
|--|---|
| 17. STATUS INDICATOR | CHECK SAME AS RANGE CONTROL KNOB -
<u>IF FAULTY*</u> |
| 18. VIEW | CHECK FALLS AS RANGE DECREASES -
<u>IF FAULTY*</u> |
| 19. 7.62 BUTTON | PRESS — 7.62 INDICATOR LIGHT
WILL BE  — |
| 20. RETICLE | CHECK PRESENCE IN GUNNER'S EYEPIECE -
<u>IF NOT PRESENT*</u> |
| 21. STATUS INDICATOR | CHECK THAT READS 7.62 - <u>IF NOT 7.62*</u> |
| 22. RANGE CONTROL KNOB | TURN FROM 0 TO 10 |
| 23. STATUS INDICATOR | CHECK SAME AS RANGE CONTROL KNOB -
<u>IF FAULTY*</u> |
| 24. VIEW | CHECK RISES AS RANGE INCREASES -
<u>IF FAULTY*</u> |
| 25. SENSOR SELECT SWITCH | MOVE TO NIGHT |
| 26. NIGHT VIEW | CHECK PRESENCE IN GUNNER'S EYEPIECE -
<u>IF NOT PRESENT AFTER 10 MINUTES*</u> |
| 27. NIGHT VISION PLRT SWITCH | MOVE FROM W/H TO B/H; CHECK VIEW
CHANGES FROM WHITE ON RED TO
BLACK ON RED |
| 28. BRT KNOB | CHECK OPERATION - <u>IF FAULTY*</u> |
| 29. CON KNOB | CHECK OPERATION - <u>IF FAULTY*</u> |
| 30. RET BRT KNOB | CHECK OPERATION - <u>IF FAULTY*</u> |
| 31. FOCUS KNOB | CHECK OPERATION - <u>IF FAULTY*</u> |
| 32. NIGHT VISION PWR SWITCH | MOVE TO OFF |
| 33. SENSOR SELECT SWITCH | MOVE TO CLEAR - CHECK OPERATION -
- <u>IF FAULTY*</u> |

PMCS — Dry Fire Operation of 25mm Gun Report equipment not ready where * appears

- 1. TURRET DRIVE SWITCH OFF
- 2. TURRET POWER SWITCH OFF
- 3. 25mm GUN GUARD AND COVER REMOVE AND OPEN
- 4. MANUAL SAFE HANDLE MOVE TO SAFE - CHECK OPERATION
- IF FAULTY*
- 5. TURRET POWER SWITCH MOVE TO ON
- 6. TURRET DRIVE SYSTEM SWITCH ON
- 7. BOLT POSITION INDICATOR CHECK POSITION

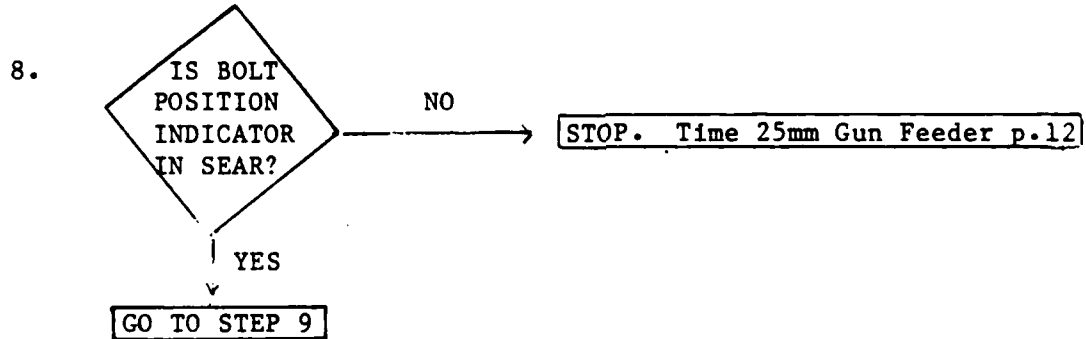

- 9. DRIVE SHAFT HANDLE CHECK MOVEMENT

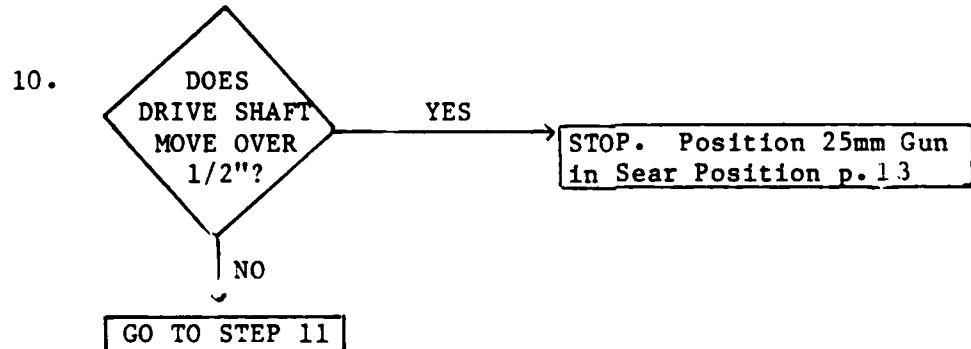

- 11. AP SS BUTTON PRESS
- 12. ARM-SAFE-RESET BUTTON MOVE TO ARM
- 13. SEAR INDICATOR LIGHT CHECK THAT ON - IF FAULTY*

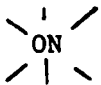
- 14. LO AMMO LOAD LIGHT CHECK FLASHING
- 15. LO AMMO OVRD BUTTON PRESS
- 16. LO AMMO, AP SS, SEAR INDICATOR LIGHTS . .  ON
- 17. GUNNER'S TRIGGER SWITCHES SQUEEZE
- 18. BOLT POSITION INDICATOR CHECK POSITION

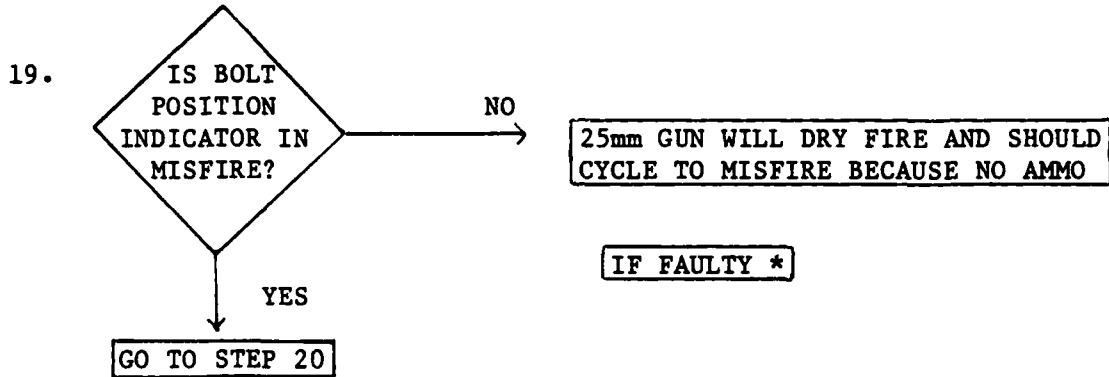

- 20. AP SS BUTTON PRESS
- 21. MISFIRE BUTTON PRESS
- 22. GUNNER'S TRIGGER SWITCHES SQUEEZE

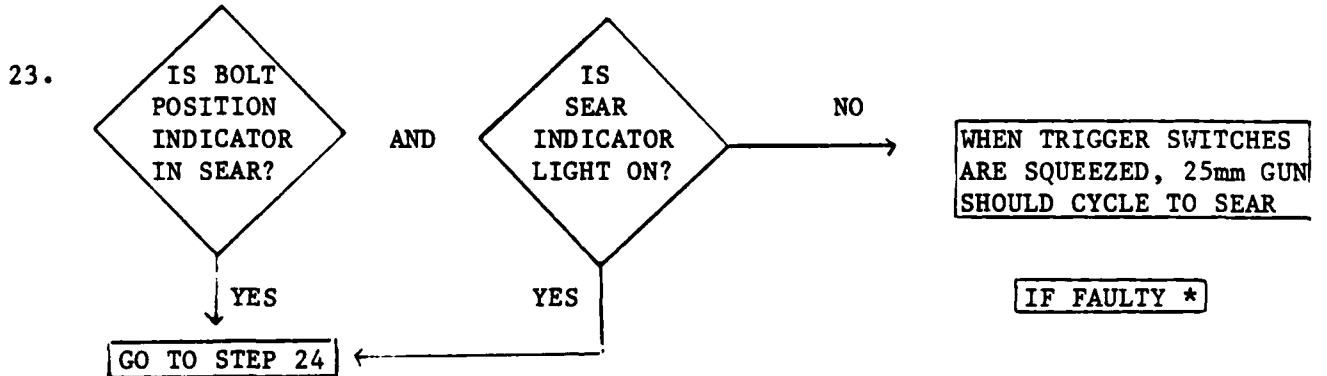

- 24. HE SS BUTTON PRESS
- 25. STEPS 12 THROUGH 23 REPEAT FOR HE SS
- 26. STEPS 11 THROUGH 25 REPEAT FOR COMMANDER'S HANDLE

PMCS - Dry Fire Operation of Coax
Machinegun

Report equipment not ready where * appears

BE CERTAIN THAT COAX IS UNLOADED AND FEED
CHUTE IS EMPTY

- 1. COAX MACHINEGUN ACCESS DOORS OPEN
- 2. MANUAL SAFETY MOVE TO FIRE; CHECK OPERATION
- 3. CHARGER HANDLE PULL BACK FIRMLY UNTIL LOCKS TO REAR; CHECK OPERATION
- 4. COAX MACHINEGUN ACCESS DOORS CHECK OPERATION - IF FAULTY*
- 5. 7.62mm BUTTON PRESS
- 6. 7.62mm LIGHT ON
- 7. ARM-SAFE-RESET SWITCH MOVE TO ARM
- 8. ARM LIGHT ON - IF NOT*
- 9. LO AMMO INDICATOR LIGHT CHECK FLASHING
- 10. LO AMMO OVRD BUTTON PRESS
- 11. LO AMMO INDICATOR LIGHT ON BUT NOT FLASHING
- (C)12. COAX MACHINEGUN ACCESS DOORS OPEN
- (C)13. CHARGER HANDLE PULL BACK - HOLD UNTIL LOCKS REAR
- 14. GUNNER'S TRIGGER SWITCHES SQUEEZE
- (C)15. CHARGER HANDLE MOVE SLOWLY FORWARD UNTIL BOLT SEATED

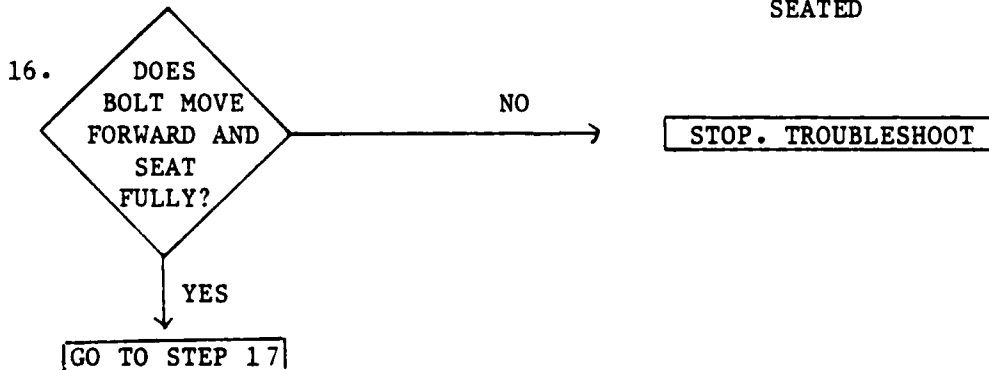

- (C)17. CHARGER HANDLE PULL BACK - HOLD UNTIL LOCKS REAR
- (C)18. COMMANDER'S CONTROL HANDLES PRESS TRIGGER AND PALM SWITCHES TOGETHER
- 19. STEPS 15 AND 16 REPEAT

PMCS - Smoke Grenade Launcher Operation

BE CERTAIN SMOKE GRENADE LAUNCHERS ARE EMPTY

1. GRENADE LAUNCHER SWITCH MOVE TO

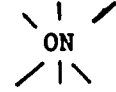

2.



NO



STOP DO NOT LOAD SMOKE GRENADES

YES



GO TO STEP 3

3. GRENADE LAUNCHER TRIGGER BUTTON PRESS

4.

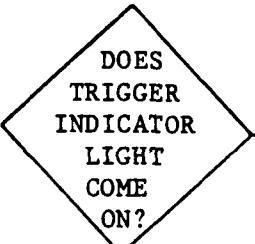

NO

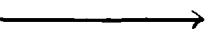

STOP DO NOT LOAD SMOKE GRENADES

YES



GO TO STEP 5

5. GRENADE LAUNCHER SWITCH MOVE TO OFF

PMCS - TOW Launcher Operation

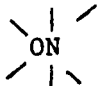
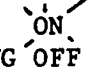
- 1. TOW LAUNCHER RAISE
- 2. MAG SWITCH MOVE TO HIGH UNTIL IT CLICKS
- 3. TOW BUTTON PRESS
- 4. TOW INDICATOR LIGHT CHECK THAT  ON AND STAYS  ON
- 5. TOW TEST INDICATOR LIGHT CHECK THAT  ON FOR 12 SECONDS BEFORE GOING OFF

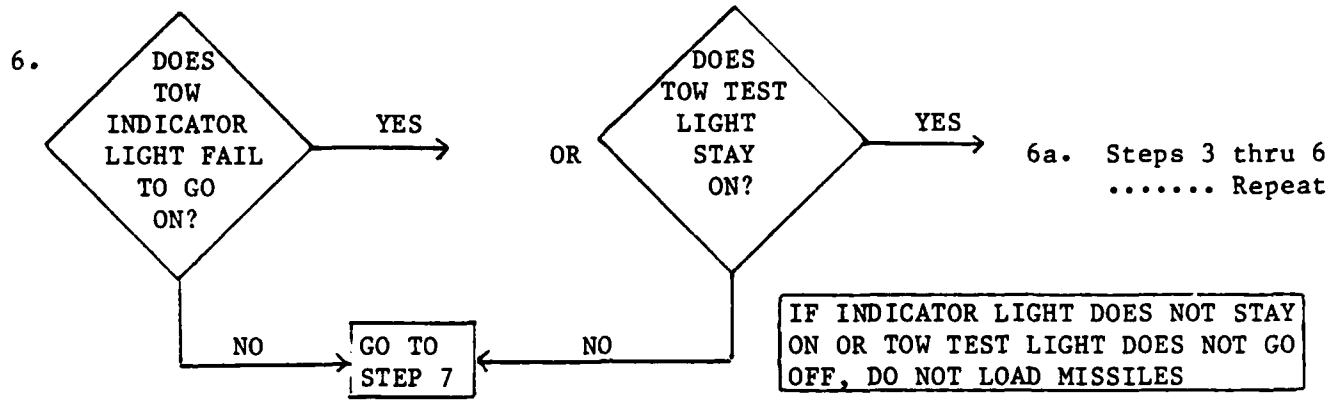

- 7. ARM-SAFE-RESET SWITCH MOVE TO ARM
- 8. TRCKR, CGE, PWR SUP LIGHTS CHECK THAT LIGHTS STAY OFF -
IF LIGHTS COME ON, DO NOT LOAD TOW MISSILES

- 9. ANNUNCIATOR LIGHT BOX CHECK LIGHTS

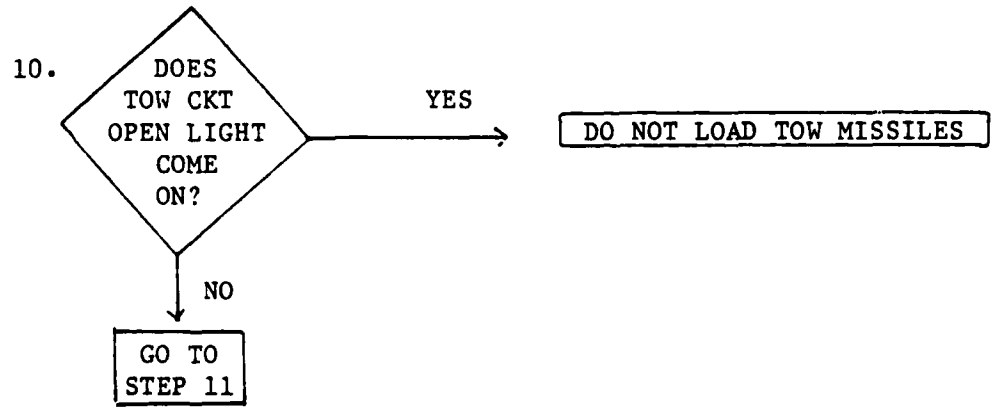

- 11. RETICLE CHECK PRESENCE IN GUNNER'S EYEPiece
- 12. STATUS INDICATOR CHECK READS TOW
- 13. MISSILE TUBE 1 BUTTON PRESS
- 14. MISSILE TUBE 1 LIGHT CHECK FLASHING

- 15. MISSILE TUBE 2 BUTTON PRESS
- 16. MISSILE TUBE 2 LIGHT CHECK FLASHING
- 17. TOW BUTTON PRESS
- 18. TOW INDICATOR LIGHT CHECK GOES OFF
- 19. TOW LAUNCHER LOWER UNTIL BANGING NOISE IS HEARD -
SEE STEP 20
- 20. LAUNCHER UP LIGHT CHECK GOES OFF

IF LAUNCHER DOES NOT BANG AGAINST SIDE OF TURRET, OR
IF LAUNCHER UP LIGHT STAYS ON, LOWER LAUNCHER MANUALLY

PMCS - Stabilization Controls

COMMANDER MAY OVERRIDE GUNNER'S HANDLES. TO RETURN CONTROL, GUNNER MUST CENTER GUNNER HANDLES, AND COMMANDER RELEASE PALM SWITCH

- | | | | | |
|----|--------------------------------------|--|----|-----------------|
| 1. | TURRET DRIVE SYSTEM SWITCH | MOVE TO | ON | WAIT 15 SECONDS |
| 2. | STAB SWITCH | MOVE TO | ON | |
| 3. | AP SS or HE SS BUTTON | PRESS | | |
| 4. | VEHICLE | STOP MOVEMENT | | |
| 5. | TARGET | SELECT BY LOOKING THROUGH GUNNER'S EYEPIECE | | |
| 6. | AP or HE RETICLE | ALINE ON TARGET WHILE SQUEEZING AND HOLDING PALM SWITCHES ON GUNNER'S OR COMMANDER'S CONTROL HANDLES | | |
| 7. | RETICLE | CHECK FOR DRIFT | | |

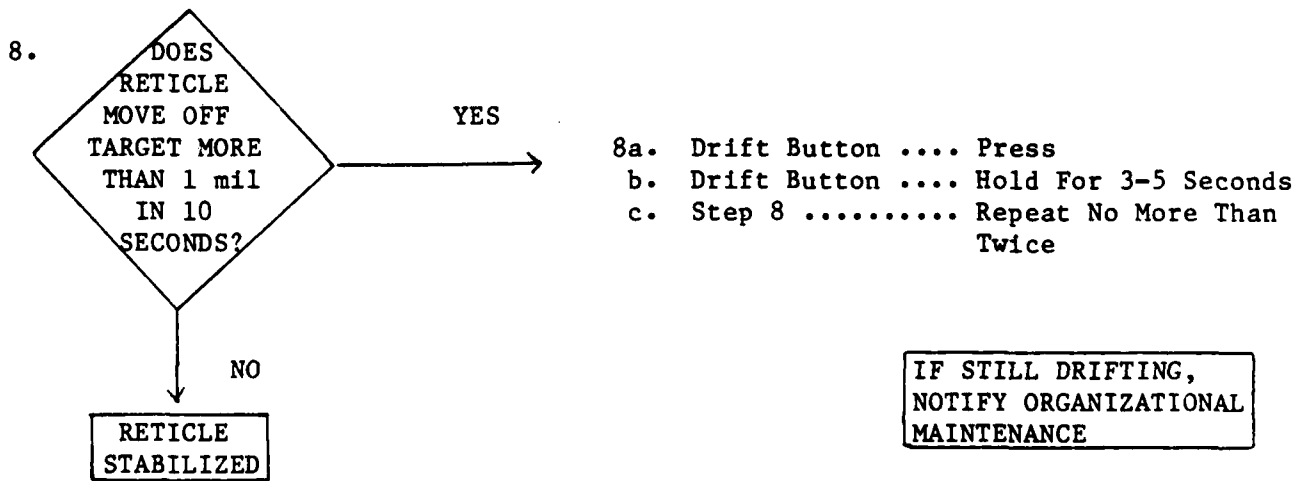

PMCS WEEKLY - GUNNER

NOTE: 25mm gun and coax machinegun must be cleaned, inspected, and lubricated weekly, whether fired or not. TOW launcher and smoke grenade launcher must be cleaned and inspected weekly, whether fired or not.

WEAPONS	REMOVE	DISASSEMBLE	CLEAN	INSPECT	LUBRICATE	ASSEMBLE	INSTALL
25mm GUN FEEDER	1st		X	X			4th
25mm GUN BARREL	2nd		X	X	X		3rd
25mm GUN RECEIVER	3rd		X	X	X		2nd
25mm TRACK AND BOLT ASSEMBLY	4th	X	X	X	X	X	1st
COAX MACHINEGUN	X	X	X	X	X	X	X
TOW MISSILE LAUNCHER			X	X			
SMOKE GRENADE LAUNCHER			X	X			

VEHICLE: INSPECT GUNNER'S HATCH COVER CUSHIONING PAD FOR CRACKS AND MISSING PIECES.

**BRADLEY COMMANDER MASTER CHECKLIST
PMCS BEFORE OPERATIONS**

LOCATION	SYSTEM	EQUIPMENT	CHECK										OPERATOR		
			CLEAN/CLEAR	DAMAGE/TAMPERING	IN PLACE	LEAKS	LEVEL	MISSING PARTS	OPERATION	POSITION	PRESSURE	SECURE		STATUS	
HULL EXTERIOR	SUSPENSION	ROAD WHEELS	X	X		X	X								S
		IDLER WHEELS	X	X		X	X								S
		SUPPORT ROLLERS	X	X		X	X								S
		SHOCK ABSORBERS						X							S
	VEHICLE	ALL	X	X		X		X						D,S	
	EXTERNAL FIRE SUPPRESSION	WIRES, SEALS		X	X			X					X		D
	FINAL DRIVE	HULL DRAIN PLUGS			X			X					X		D
	DRIVER'S HATCH	COVER		X				X	X						D
	ENGINE	SAFETY PIN			X			X	X				X		D
		TRANSMISSION OIL	X			X	X								D
TURRET EXTERIOR	EXTERIOR	ALL	X	X											S
		FRONT RING SIGHT	X	X											S
		ANTENNA MOUNT		X											S
		SHIELD DOOR		X					X						S
	TOW	LAUNCHER		X											S
		TUBES	X	X											S
		DUST COVER		X	X										S
	SMOKE GRENADE	RUBBER CAPS		X	X										S
		LAUNCHERS	X	X											S
		STOWAGE BINS	X	X											S
HULL INTERIOR	ENGINE	ENGINE OIL	X				X								D
		SWITCH							X	X				X	D
	FIRE SUPPRESSION (AUTOMATIC), SQUAD ENGINE AREA	WIRE, SEALS		X	X			X					X		D,S
		DISCHARGE LIGHTS												X	D,S
		PORTABLE EXTINGUISHERS		X	X							X			D,S
	SQUAD AREA	FRONT AND REAR HULL DRAIN PLUGS		X	X			X	X				X		S
DRIVER'S AREA		SEAT		X				X	X	X				D	
TURRET INTERIOR	DOORS	ALL	X	X											S
		TRAVEL LOCK		X					X						G
		HE AMMO CAN							X				X		S
		AP AMMO CAN							X				X		S
	COMMANDER'S STATION	SEAT		X					X						BC
		HATCH COVER		X					X						BC
		PERISCOPES	X	X											BC
BLACKOUT COVERS		X	X					X						BC	

BRADLEY COMMANDER MASTER CHECK LIST
PMCS BEFORE OPERATIONS

CHECK

LOCATION	SYSTEM	EQUIPMENT	CHECK										OPERATOR					
			CLEAN/CLEAR	DAMAGE/TAMPING	IN PLACE	LEAKS	LEVEL	MISSING PARTS	OPERATION	POSITION	PRESSURE	SECURE		STATUS				
TURRET INTERIOR	GUNNER'S STATION	SEAT		X						X						G		
		HATCH COVER		X						X							G	
		PERISCOPE	X	X													G	
		BALLISTIC SIGHT COVERS								X							G	
		ISU WINDOWS	X	X													G	
	25mm GUN	COVER	X	X													G	
		ZIPPER	X	X													G	
		BOLT POSITION INDICATOR	X	X													G	
		POWER CABLE	X	X													G	
		HE/AP FEED CHUTES		X										X			G	
		HE/AP LINK EJECT CHUTES		X											X		G	
		25mm GUN AFTER DRY FIRE		X						X							G	
		LOADING RAILS	X	X													G	
		COAX MACHINE-GUN	ACCESS DOORS								X				X			G or BC
			ACCESS DOOR HANDLES								X							G or BC
	ACCESS DOOR SEALS			X										X			G or BC	
	AMMO FEED CHUTE			X										X			G or BC	
	FEED CHUTE LATCHES			X						X				X			G or BC	
	REAR GUN MOUNT		X														G or BC	
	REAR GUN MOUNT BRACKET		X	X						X				X			G or BC	
	BORESIGHT KNOBS		X							X							G or BC	
	REAR MOUNTING PIN									X							G or BC	
	MANUAL OPERATIONS		GUN ELEVATION DRIVE SELECT LEVER								X							G
		GUN ELEVATION HANDWHEEL								X							G	
		TURRET TRAVERSE HAND WHEEL								X							G	
		TURRET TRAVERSE DRIVE SELECT LEVER								X							G	
	COMMUNICATIONS	RADIO								X							G and BC	
		INTERCOM								X							G and BC	

**BRADLEY COMMANDER MASTER CHECKLIST
PMCS DURING OPERATIONS**

CHECK

LOCATION	SYSTEM	EQUIPMENT	CHECK							OPERATOR	
			CLEAN/CLEAR	DAMAGE/TAMPERING	IN PLACE	LEAKS	MISSING PARTS	OPERATION	SECURE		STATUS
EXTERIOR	DRIVER'S HATCH	COVER		X					X		D
		SAFETY PIN			X				X	X	D
DRIVER'S COMPARTMENT	RAMP	RAMP	X	X					X		D
		INDICATOR LIGHT						X		X	D
		VOLTS						X		X	D
	INSTRUMENT PANEL GAGES	ENGINE COOLANT						X		X	D
		ENGINE OIL						X		X	D
		FUEL								X	D
	INSTRUMENT PANEL WARNING LIGHTS	COOLANT LEVEL						X		X	D
		TRANS OIL PRESS						X		X	D
		TRANS OIL TEMP						X		X	D
		FUEL FILTER	X					X		X	D
		AIR CLEANER CLOGGED						X		X	D
	PERISCOPES	LENSES	X	X	X						D
		BLACKOUT COVERS		X	X			X			D
	PERSONNEL HEATER	HEATER		X		X		X			D
		SQUAD DUCT AREA	X	X				X			D,S
		FUEL LINES/FITTINGS		X		X					D,G
	DRIVER'S CONTROLS	ACCELERATOR PEDAL							X		D
		GEAR SELECTOR							X		D
		STEERING YOKE							X		D
		VEHICLE BRAKES							X		D
SQUAD COMPARTMENT	SQUAD AREA	SEATS		X	X		X		X		S
		SEAT BELTS			X		X	X			S
		CARGO HATCH						X			S
		HATCH POSITION HANDLE						X			S
		PERISCOPES	X	X	X						S
		BLACKOUT COVERS		X				X			S
		FIRING PORT BALLS							X		S
TURRET INTERIOR	ISU COOL DOWN	TURRET POWER LIGHT						X		X	G
		NIGHT VISION POWER SWITCH						X		X	G
		CLOSED CYCLE COOLER							X		G

LISTEN FOR SOUND OF OPERATION



**BRADLEY COMMANDER MASTER CHECKLIST
PMCS DURING OPERATIONS**

CHECK

OPERATOR

BC=COMMANDER
D=DRIVER
G=GUNNER
S=OTHER

LOCATION	SYSTEM	EQUIPMENT	CHECK							OPERATOR	
			CLEAN/CLEAR	DAMAGE/TAMPERING	IN PLACE	LEAKS	MISSING PARTS	OPERATION	SECURE		STATUS
TURRET INTERIOR	INDICATOR LIGHTS	FAN-LAMP TEST/LAMP						X		X	G
		WEAPON CONTROL BOX						X		X	G
		TURRET POSITION INDICATOR						X		X	G
		TOW CONTROL BOX						X		X	G
		TURRET CONTROL BOX						X		X	G
	FANS	FAN-LAMP TEST/FAN						X		X	G
		GUN FANS						X			G
		TURRET POWER	DRIVE SYSTEM INDICATOR LIGHT						X	X	G
	COMMANDER'S HANDLE	TURRET TRAVERSE						X			BC
		TURRET TRAVERSE FAST (SLEW)						X			BC
		25mm GUN ELEVATION/DEPRESSION						X			BC
	GUNNER'S HANDLES	TURRET TRAVERSE						X			G
		TURRET TRAVERSE FAST (SLEW)						X			G
		25mm GUN ELEVATION/DEPRESSION						X			G
	DECK CLEARANCE SYSTEM	SYSTEM						X			G See p.67
	ISU OPERATION	SYSTEM						X			G,BC See p.69
	25mm GUN	DRY FIRE						X			G,BC See p.71
	COAX MACHINE-GUN	DRY FIRE						X			G,BC See p.73
	SMOKE GRENADES	INDICATOR LIGHT						X		X	G See p.74
		TRIGGER LIGHT						X		X	
	TOW LAUNCHER	SYSTEM						X		X	G See p.75
	STABILIZATION CONTROLS	SYSTEM						X		X	G,BC See p.77

**BRADLEY COMMANDER MASTER CHECKLIST
PMCS AFTER OPERATIONS**

LOCATION	SYSTEM	EQUIPMENT	CHECK											OPERATOR					
			CLEAN/CLEAR	DAMAGE/TAMPING	HEAT	IN PLACE	LEAKS	LEVEL	OPERATION	POSITION	PRESENCE OF WATER	STATUS	TENSION		WEAR				
HULL	FUEL	GAGE											X				D		
		FILTER	X				X					X					D		
	POWER UNIT ACCESS DOOR	BRACE		X						X							S		
		OIL	X				X	X			X						D		
	TRANSMISSION	OIL FILTER INDICATOR									X		X				D		
		COOLING	HOSES		X		X	X								X		D	
	COOLANT						X	X									D		
	BILGE AREA		X									X					D		
	RIGHT ANGLE FAN DRIVE		X				X										D		
	INTAKE SCREEN	SCREEN	X	X													D		
	FINAL DRIVE	OIL					X	X			X						D		
	ENGINE	HOSES, CLAMPS FITTINGS		X			X									X		D	
		OIL					X	X			X							D	
	DRIVER SUPERVISES SUSPENSION CHECKS	SUPERVISION	SHOCK ABSORBERS		X	X	X				X							S	
			ROAD WHEELS																
			IDLER WHEELS		X	X	X	X				X						X	S
			SUPPORT ROLLERS		X	X	X	X				X						X	S
			MOUNTING HOLES, FASTENERS															X	S
			HUBS		X	X	X	X	X				X						S
			SIGHT GLASSES	X	X														S
			TRACK		X												X	X	S
			TRACK ADJUSTER GREASE FITTING, BLEED VALVE		X		X	X											S
			TRACK PIN NUTS		X		X											X	S
TRACK GUARD		X		X											X	S			

NOTE: 25mm gun, coax machinegun, smoke grenade launcher and TOW missile launcher must be cleaned and inspected daily when used (G).

**BRADLEY COMMANDER MASTER CHECKLIST
PMCS WEEKLY**

NOTE: 25mm gun and coax machinegun must be cleaned, inspected, and lubricated weekly, whether fired or not. TOW launcher and smoke grenade launcher must be cleaned and inspected weekly, whether fired or not.

WEAPONS	REMOVE	DISASSEMBLE	CLEAN	INSPECT	LUBRICATE	ASSEMBLE	INSTALL
25mm GUN FEEDER	1st		X	X			4th
25mm GUN BARREL	2nd		X	X	X		3rd
25mm GUN RECEIVER	3rd		X	X	X		2nd
25mm TRACK AND BOLT ASSEMBLY	4th	X	X	X	X	X	1st
COAX MACHINEGUN	X	X	X	X	X	X	X
TOW MISSILE LAUNCHER			X	X			
SMOKE GRENADE LAUNCHER			X	X			

VEHICLE: INSPECT EMERGENCY BATTERIES (D), COMMANDER'S HATCH COVER (C), GUNNER'S HATCH COVER (G), RAMP HYDRAULIC SYSTEM (D), TORSION BARS (D,S), TRIM VANE (D,S).

**BRADY COMMANDER'S GUIDE MASTER CHECKLIST
PMCS MONTHLY**

CHECK

SYSTEM	EQUIPMENT	CLEAR/CLEAR	CHUNKING/SEPARATION	DAMAGE/TAMPING	LEAKS	LEVEL	MISSING PIECES	OPERATION	POSITION	STATUS	WEAR	OPERATOR
SUPERVISION	ROAD WHEELS		X	X							X	D, S
	SUPPORT ROLLERS		X	X							X	D, S
	IDLER WHEEL ARMS			X							X	D, S
	TRACK SHOE PADS		X				X				X	D, S
	DRIVE SPROCKET TEETH			X							X	D, S
	TRACK SHOES			X							X	D, S
	TRACK PIN NUTS			X			X		X		X	D, S
	RIGHT ANGLE FAN DRIVE	OIL	X			X	X					
EXTERIOR VEHICLE LIGHTS	ALL	X		X				X				D, S
BILGE PUMPS	SYSTEM	X		X	X			X				D
COOLING	PUMP BELT			X				X			X	D
	HOSE AND CONNECTIONS			X	X						X	D
FIRING PORTS	PLUGS						X	X	X			S
	HOSES			X	X			X			X	S
	BAGS			X				X			X	S
	FAN			X				X				S
	DUCT COVERS			X				X				S
PORTABLE FIRE EXTINGUISHERS	TAGS									X		S