

UNCLASSIFIED

SECURITY CLASSIFICATION OF THIS PAGE (When Data Entered)

REPORT DOCUMENTATION PAGE		READ INSTRUCTIONS BEFORE COMPLETING FORM
1. REPORT NUMBER	2. GOVT ACCESSION NO.	3. RECIPIENT'S CATALOG NUMBER
4. TITLE (and Subtitle) F/A-18 AN/APG-65 Radar Case Study Report (IDA/OSD R&M Study)		5. TYPE OF REPORT & PERIOD COVERED Final July 1982 - August 1983
7. AUTHOR(s) Paul F. Goree, IDA R&M Case Study Director		6. PERFORMING ORG. REPORT NUMBER IDA Record DocumentD-20 8. CONTRACT OR GRANT NUMBER(s) MDA 903 79 C 0018
9. PERFORMING ORGANIZATION NAME AND ADDRESS Institute for Defense Analyses 1801 N. Beauregard Street Alexandria, VA 22311		10. PROGRAM ELEMENT, PROJECT, TASK AREA & WORK UNIT NUMBERS Task T-2-126
11. CONTROLLING OFFICE NAME AND ADDRESS Office of the Assistant Secretary of Defense (MRA&L), The Pentagon Washington, D.C. 20301		12. REPORT DATE August 1983
14. MONITORING AGENCY NAME & ADDRESS (if different from Controlling Office) DoD-IDA Management Office 1801 N. Beauregard Street Alexandria, VA 22311		13. NUMBER OF PAGES 271
		15. SECURITY CLASS. (of this report) UNCLASSIFIED
		15a. DECLASSIFICATION/DOWNGRADING SCHEDULE N/A
16. DISTRIBUTION STATEMENT (of this Report) Approved for public release; distribution unlimited.		
17. DISTRIBUTION STATEMENT (of the abstract entered in Block 20, if different from Report) None		
18. SUPPLEMENTARY NOTES N/A		
19. KEY WORDS (Continue on reverse side if necessary and identify by block number) reliability, maintainability, readiness, case study, program structuring, lessons learned, F/A-18, APG-65, radar		
20. ABSTRACT (Continue on reverse side if necessary and identify by block number) This document records the activities and presents the findings of the F/A-18 AN/APG-65 Radar Case Study Working Group part of the IDA/OSD Reliability and Maintainability Study, conducted during the period from July 1982 through August 1983.		

RMI

ADA142103

LIBRARY
RESEARCH REPORTS DIVISION
NAVAL POSTGRADUATE SCHOOL
MONTEREY, CALIFORNIA 93943

LIBRARY
RESEARCH REPORTS DIVISION
NAVAL POSTGRADUATE SCHOOL
MONTEREY, CALIFORNIA 93943

IDA RECORD DOCUMENT D-20

F/A-18 AN/APG-65 RADAR
CASE STUDY REPORT
(IDA/OSD R&M STUDY)

Paul F. Goree
IDA R&M Case Study Director

DTIC
ELECTE
JUN 13 1984
A

August 1983

The views expressed within this document are those of the working group only. Publication of this document does not indicate endorsement by IDA, its staff, or its sponsoring agencies.

Prepared for
Office of the Under Secretary of Defense for Research and Engineering
and
Office of the Assistant Secretary of Defense
(Manpower, Reserve Affairs and Logistics)

This document has been approved for public release and sale; its distribution is unlimited.



INSTITUTE FOR DEFENSE ANALYSES

Approved for public release; distribution unlimited.

The work reported in this document was conducted under contract MDA 903 79 C 0018 for the Department of Defense. The publication of this IDA Record Document does not indicate endorsement by the Department of Defense, nor should the contents be construed as reflecting the official position of that agency.

IDA RECORD DOCUMENT D-20

**F/A-18 AN/APG-65 RADAR
CASE STUDY REPORT
(IDA/OSD R&M STUDY)**

Paul F. Goree
IDA R&M Case Study Director

August 1983



INSTITUTE FOR DEFENSE ANALYSES
1801 N. Beauregard Street, Alexandria, Virginia 22311

Contract MDA 903 79 C 0018

Task T-2-126

RELIABILITY AND MAINTAINABILITY STUDY

— REPORT STRUCTURE —

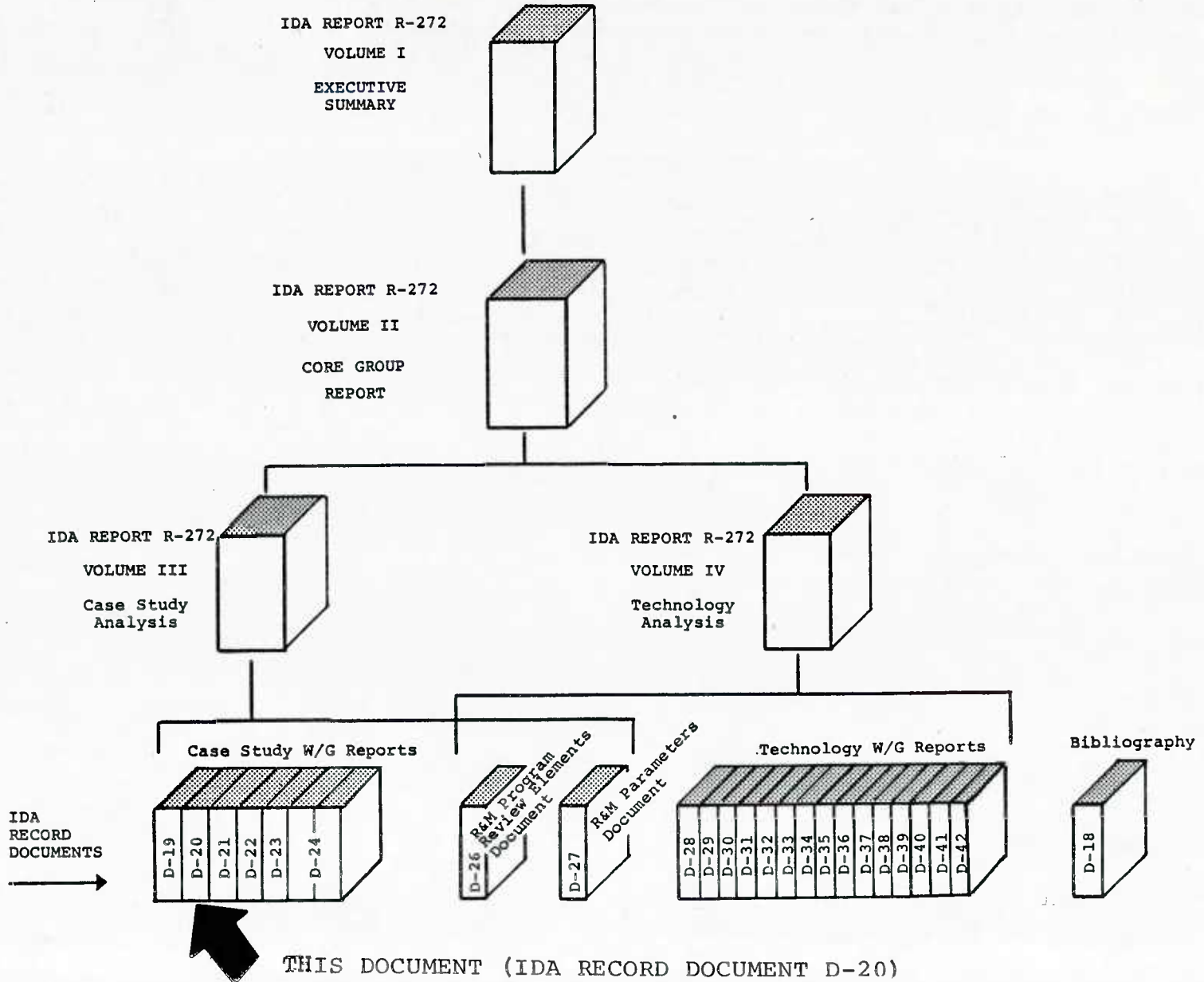

PREFACE

As a result of the 1981 Defense Science Board Summer Study on Operational Readiness, Task Order T-2-126 was generated to look at potential steps toward improving the Material Readiness Posture of DoD (Short Title: R&M Study). This task order was structured to address the improvement of R&M and readiness through innovative program structuring and applications of new and advancing technology. Volume I summarizes the total study activity. Volume II integrates analysis relative to Volume III, program structuring aspects, and Volume IV, new and advancing technology aspects.

The objective of this study as defined by the task order is:

"Identify and provide support for high payoff actions which the DoD can take to improve the military system design, development and support process so as to provide quantum improvement in R&M and readiness through innovative uses of advancing technology and program structure."

The scope of this study as defined by the task order is:

To (1) identify high-payoff areas where the DoD could improve current system design, development program structure and system support policies, with the objective of enhancing peacetime availability of major weapons systems and the potential to make a rapid transition to high wartime activity rates, to sustain such rates and to do so with the most economical use of scarce resources possible, (2) assess the impact of advancing technology on the recommended approaches and guidelines, and (3) evaluate the potential and recommend strategies that might result in quantum increases in R&M or readiness through innovative uses of advancing technology.

The approach taken for the study was focused on producing meaningful implementable recommendations substantiated by quantitative data with implementation plans and vehicles to be provided where practical. To accomplish this, emphasis was placed upon the elucidation and integration of the expert knowledge and experience of engineers, developers, managers, testers and users involved with the complete acquisition cycle of weapons systems programs as well as upon supporting analysis. A search was conducted through major industrial companies, a director was selected and the following general plan was adopted.

General Study Plan

- Vol. III ● Select, analyze and review existing successful program
- Vol. IV ● Analyze and review related new and advanced technology
- Vol. II (● Analyze and integrate review results
● Develop, coordinate and refine new concepts
- Vol. I ● Present new concepts to DoD with implementation plan and recommendations for application.

The approach to implementing the plan was based on an executive council core group for organization, analysis, integration and continuity; making extensive use of working groups, heavy military and industry involvement and participation, and coordination and refinement through joint industry/service analysis and review. Overall study organization is shown in Fig. P-1.

The basic case study approach was to build a foundation for analysis and to analyze the front-end process of program structuring for ways to attain R&M, mature it, and improve it. Concurrency and resource implications were considered. Tools to be used to accomplish this were existing case study reports, new case studies

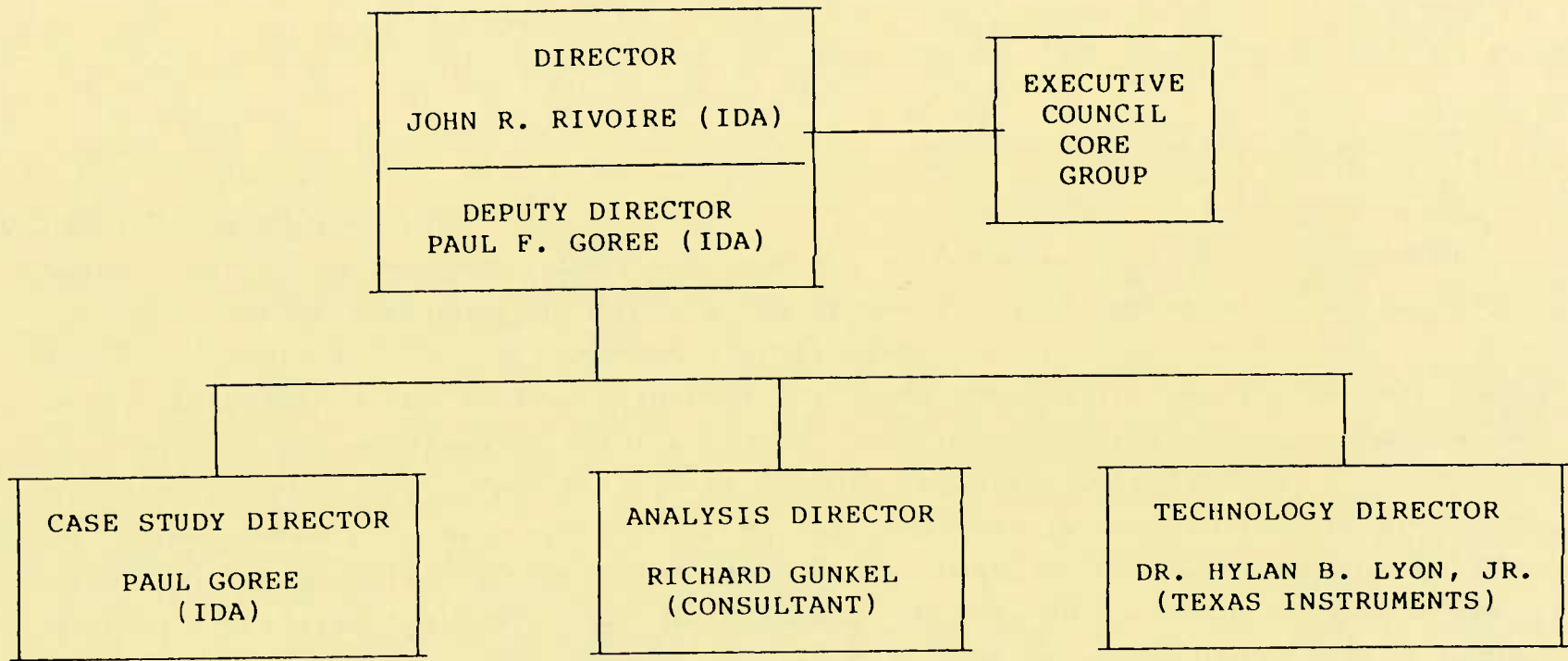

FIGURE P-1. Study Organization

conducted specifically to document quantitative data for cross-program analysis, and documents, presentations, and other available literature. In addition, focused studies for specific technology implications were conducted by individual technology working groups and documented in their respective reports. To accomplish the new case studies, the organization shown in Fig. P-2 was established.

In some areas where program documentation and records did not exist, the actual experience and judgement of those involved in the programs were captured in the case studies. Likewise, in the analysis process, the broad base of experience and judgement of the military/industry executive council members and other participants was vital to understanding and analyzing areas where specific detailed data were lacking.

This document records the program activities, details and findings of the Case Study Working Group for the specific program as indicated in Fig. P-2.

Without the detailed efforts, energies, patience and candidness of those intimately involved in the programs studied, this case study effort would not have been possible within the time and resources available.

The views expressed within this document are those of the working group only. Publication of this document does not indicate endorsement by IDA, its staff, or its sponsoring agencies.

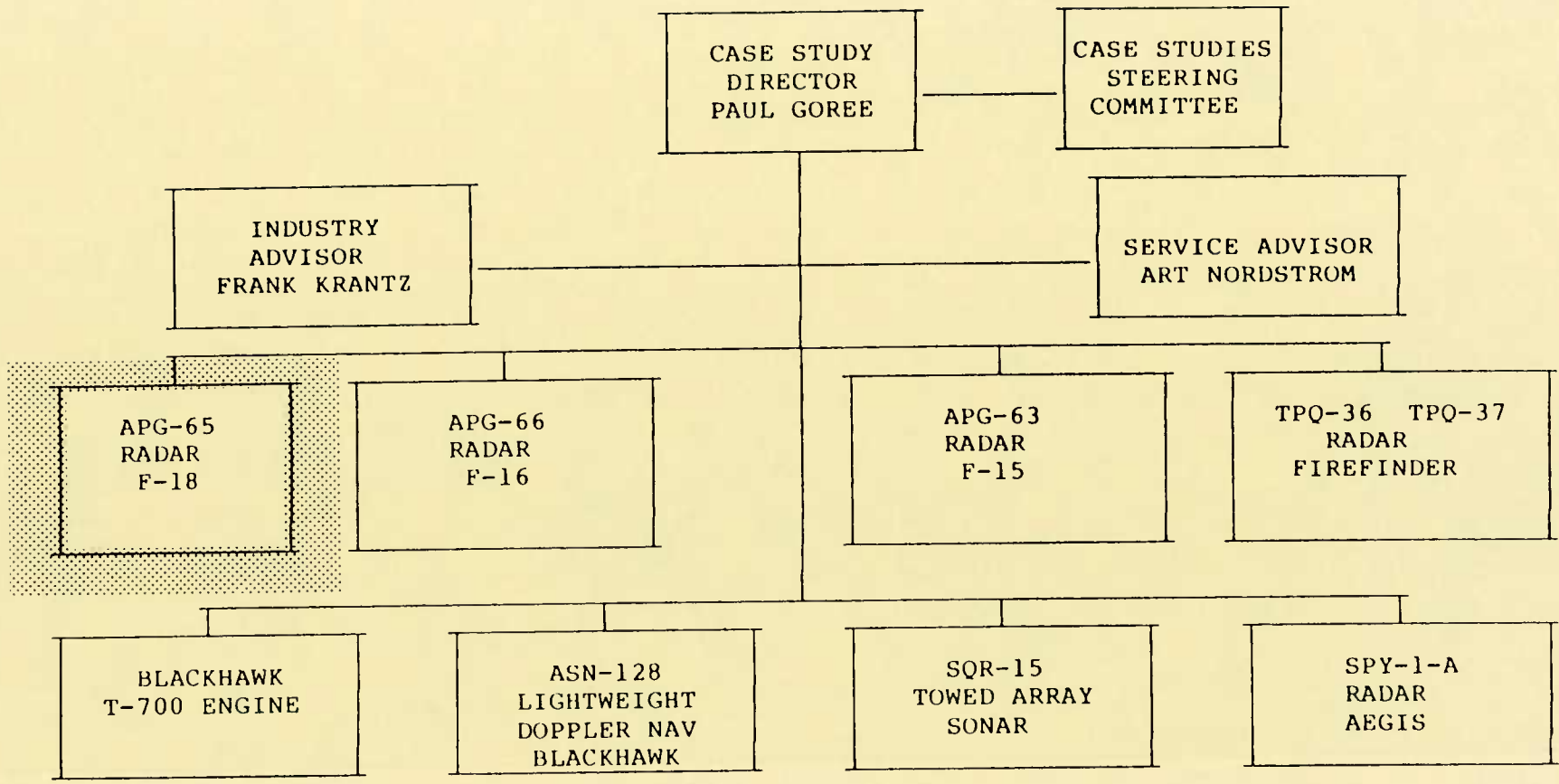

FIGURE P-2. Case Study Organization

F/A-18 AN/APG-65 RADAR

RELIABILITY AND MAINTAINABILITY CASE STUDY

F/A-18 APG-65 RADAR WORKING GROUP PARTICIPANTS

MCAIR

E.W. BAILEY	SUBSYSTEM MANAGER, F-18 RADAR/ATTACK SENSORS
G. FISHER	SECTION MANAGER, F-18 MAINTAINABILITY
W. LAUDEL	CHIEF ELECTRONICS ENGINEER
W.R. RUGGER	SECTION CHIEF, F-18 RELIABILITY
J. SLINKARD	TECHNICAL SPECIALIST, F-18 MAINTAINABILITY
E. TOD	SECTION CHIEF, F-18 RADAR

HUGHES

C.F. FARRELL	F-18 RADAR, RELIABILITY AND QUALITY
F.B. NELSON	F-18 RADAR PROGRAM MANAGER

IDA

P.S. GIBSON	- OSD/MRA&L
G.A. KUNZNICK	- IDA CONSULTANT
T.A. MUSSON	- IDA CONSULTANT

CASE STUDY OUTLINE

- INTRODUCTION 1
 - MISSION NEEDS 2
 - SYSTEM DESCRIPTION 16
 - PROGRAM SUMMARY 32
 - MEASURES OF SUCCESS 52

- PROGRAM ELEMENTS 65
 - CONTRACT 65
 - MANAGEMENT 103
 - DESIGN 121
 - MANUFACTURING 191
 - TEST AND EVALUATION 221

- SUMMARY AND LESSONS LEARNED 267

R&M PROGRAM REVIEW ELEMENTS

CONTRACT

1. R&M Requirements
2. Mission Profile Establishment
3. Life Profile Establishment
4. R&M Failure Definition
5. Incentives
6. Source Selection Criteria
7. LCC Consideration

MANAGEMENT

8. Planning Control & Emphasis
9. Monitor/Control of Subcontractors & Suppliers

DESIGN

10. Development of Design Requirements
11. Design Alternative Studies
12. Design Evaluation Analysis
13. Parts & Material Selection & Control
14. Derating Criteria
15. Thermal & Packaging Criteria
16. Computer Aided Design
17. Testability Analysis
18. BIT and ATE Performance
19. Features to Facilitate Maintenance

MANUFACTURING

20. - - ESS of Parts/Equipment
21. Failure Analysis/Corrective Action

TEST & EVALUATION

22. Design Limit Qualification Testing
23. Reliability Growth Testing
24. Demonstration Testing
25. Operational Test and Evaluation
26. Inservice Assessment

ABBREVIATIONS -- F-18

ACM	Air Combat Maneuver	FET	Field Effect Transistor
A/D	Analog to Digital	FH	Flight Hour
AFTA	Avionics Fault Tree Analyzer	FMD	Failure Maintenance Data
AGR	Air-to-Ground Range	FMEA	Failure Mode and Effects Analysis
ANT	Antenna	FMR	Frequency Modulation Ranging
APU	Auxiliary Power Unit	FP	Flatpack
BIT	Built-in-Test	FPM	Failures per Mission
CCM	Counter Countermeasures	FRB	Failure Review Board
CDR	Critical Design Review	FRS	Fleet Readiness Squadron
CFE	Contractor Furnished Equipment	FSD	Full Scale Development
CLEAR	Closed Loop Evaluation and Reporting	FSE	Fleet Supportability Evaluation
CMOS	Complementary Metal Oxide Semiconductor	FTT	Fixed Target Track
CW	Continuous Wave	GFE	Government Furnished Equipment
CWI	Continuous Wave Illuminator	GMTI	Ground Moving Target Indicator
D	Data	GMTT	Ground Moving Target Track
D&T	Design and Test	GPS	Ground Power Switch
DBSP	Doppler Beam Sharpening Patch	GSE	Ground Support Equipment
DBSS	Doppler Beam Sharpening Sector	GTWT	Gridded Traveling Wave Tube
DIP	Dual-In-Line Integrated Circuit Package	HAC	Hughes Aircraft Company
DLI	Deck-Launched Intercept	HOTAS	Hands on Throttle and Stick
DMMH/FH	Direct Maintenance Man Hours/Flight Hour	I	Integration
EAROM	Electronically Alterable Read Only Memory	I	Intermediate
ECL	Emitter Coupled Logic	IF	Intermediate Frequency
ECM	Electronic Countermeasure	IBA	Initial Bit Assessment
ECP	Engineering Change Proposal	IBIT	Initiated BIT
ECS	Environmental Control System	IC	Integrated Circuit
EM	Engineering Model	ICAP	Integrated Corrective Action Program
EMI	Electromagnetic Interference	ILS	Integrated Logistic Support
EMP	Electromagnetic Pulse	IMS	Information Management System
ESD	Electrostatic Sensitive Device	INS	Inertial Navigation Set
		I/O	Input/Output
		IOC	Initial Operating Capability
		IOT&E	Initial Operational Test and Evaluation

LCC	Life-Cycle Cost	Q	Quality
LVPS	Low Voltage Power Supply	QRB	Quality Review Board
M	Maintainability	R	Reliability
MAC	McDonnell Aircraft Company	R&M	Reliability and Maintainability
M/BIT	Maintainability/BIT	RBGM	Real Beam Ground Map
MDC	McDonnell Douglas Corporation	RCVR	Receiver
MEI	Maintenance Engineering Inspection	RDP	Radar Data Processor
MFHBF	Mean Flight Hours Between Failures	RDT	Reliability Development Test
MFHBMA	Mean Flight Hours Between Maintenance Actions	R/E	Receiver/Exciter
MHz	Megahertz	RF	Radio Frequency
MMH/FH	Maintenance Man Hours per Flight Hour	RFI	Radio Frequency Interference
MMP	Maintenance Monitor Panel	RSP	Radar Signal Processor
MP	Mission Profile	RWS	Range While Scan
MSI	Medium Scale Integration	S/N	Serial Number
MTBF	Mean Time Between Failures	SRA	Shop Replaceable Assembly
MTBUMA	Mean Time Between Unscheduled Maintenance Actions	SSS	Sea Surface Search
MTR	Mean Time to Repair	SST	Sea Surface Targeting
NASA	National Aeronautics and Space Administration	STT	Single Target Track
OH/FH	Operating Hour per Flight Hour	STTL	Schottky Transistor-Transistor Logic
OME	Operational Mission Environment	TA	Terrain Avoidance
PARAMP	Parametric Amplifier	TAAF	Test, Analyze, and Fix
PAX River	Patuxent River Naval Air Station, Maryland	T&E	Test and Evaluation
PBIT	Periodic BIT	TECHEVAL	Technical Evaluation
PCA	Physical Configuration Audit	TTL	Transistor-Transistor Logic
PD	Pulse Doppler	TWS	Track While Scan
PDC	Production Duty Cycle	TWT	Traveling Wave Tube
PDI	Pulse Doppler Illuminator	TX	Transmitter
PDR	Preliminary Design Review	VA	Attack Squadron
PRF	Pulse Repetition Frequency	VF	Fighter Squadron
PVU	Precision Velocity Update	VFO	Variable Frequency Oscillator
		VMFA	Marine Corps Fighter Attack Squadron
		VS	Velocity Search
		WRA	Weapon Replaceable Assembly
		XMTR	Transmitter

INTRODUCTION

45/3-2

MISSION NEEDS

RADAR REQUIREMENTS

Radar reliability is to a great extent driven by the aircraft mission requirements and the radar requirements, since these requirements determine system size, weight, power and complexity. The major factor is a requirement for all-weather air superiority, which determines detection range and radar missile compatibility factors. This need for longer range head-on detection in great measure determines transmitter size and power requirements. In addition, all-aspect, all-altitude detection determines waveform selection and complexity. These factors led to the selection of a high/med PRF transmitter design in the F/A-18. Detection range is also influenced to a great extent by antenna diameter and sidelobe characteristics. In the case of the F/A-18 radar, mission requirements and aircraft design resulted in an antenna size (antenna diameter is 26.625 inches) that did not require hydraulic drive and a roll gimbal resulting in a more reliable direct electrical drive approach. Another key area in determining detection range is receiver sensitivity. Historically, the requirement for a low receiver noise figure necessitated a parametric amplifier (PARAMP). In the case on the F/A-18, technology advancement allowed the required sensitivity to be met with a more reliable field effect transistor (FET) approach.

AIM-7F SPARROW missile compatibility is the other major factor in determining transmitter power requirements. On earlier aircraft (F-4) this compatibility was provided by the addition of a separate CW illuminator. The F-15 proved the feasibility of providing SPARROW compatibility using the high PRF pulse doppler waveform negating the need for a separate transmitter with its inherent reduction in system reliability. This concept has been adopted on the F/A-18. High PRF systems typically operated at 40-50% duty factors to meet detection range and missile requirements. The APG-65 uses range gating techniques which provide an equivalent capability but operate at a reduced duty factor (~33%) and thus provide resultant increase in reliability in range while search mode.

RADAR REQUIREMENTS

- SYSTEM SIZE, WEIGHT, POWER REQUIRED, AND COMPLEXITY
PRIMARILY DRIVEN BY MISSION REQUIREMENTS

- DETECTION RANGE
 - POWER REQUIREMENTS/WAVEFORM
 - ANTENNA DIAMETER
 - ELECTRIC VS. HYDRAULIC DRIVE
 - RECEIVER SENSITIVITY
 - PAR AMP VS. FIELD EFFECT TRANSISTOR (FET)

- MISSILE COMPATIBILITY
 - WAVEFORM
 - HIGH/MED PRF VS. MED PRF ONLY
 - DUTY FACTOR IN PDI
 - 40% VS. 10%

Air-to-ground resolution requirements on previous systems were met by "brute force" techniques of higher frequency or larger antenna diameter. In the APG-65 case, a resolution enhancement of 67:1 is provided by use of advanced doppler beam sharpening processing techniques which tends to increase system complexity but not to the level required by brute force techniques.

The F/A-18 requirement as a multi-mission aircraft necessitated the creation of highly complex digital signal processing which is provided by a fully programmable signal processor, which replaces the less reliable hard-wired machines used on previous programs. The multi-mission requirements also result in a significant increase in computer memory size requirements. In the APG-65 this is provided by a 256K 16-bit word disc memory with a much higher reliability than previous memory devices of equivalent capacity.

RADAR REQUIREMENTS (CONTINUED)

- RESOLUTION
 - FREQUENCY (REAL BEAM GROUND MAP)
 - ANTENNA DIAMETER (REAL BEAM GROUND MAP)
 - PROCESSING COMPLEXITY (DOPPLER BEAM SHARPENING)

- MULTIPLE MISSIONS
 - PROCESSING SPEED/COMPLEXITY
PROGRAMMABLE VS. HARDWIRED LOGIC
 - MEMORY CAPACITY

RADAR SYSTEM EVOLUTION

The F/A-18 aircraft and APG-65 radar were designed from the start for multi-mission capability. As a consequence the radar incorporates the latest performance features of current fleet fighter and attack aircraft, and a number of features not previously used in other operational systems. In the attack area the system incorporates many of the modes used on current Navy A-7 and A-6 aircraft and adds many additional modes (such as high resolution mapping) previously available only in special R&D programs.

In the fighter arena the APG-65 radar incorporates the main features of the radar on the F-4J that it replaces, has a track while scan mode first incorporated on the F-14, includes the Medium PRF waveform developed on the F-15 for all aspect capability, and adds additional features such as the raid assessment mode not available previously.

RADAR SYSTEM EVOLUTION

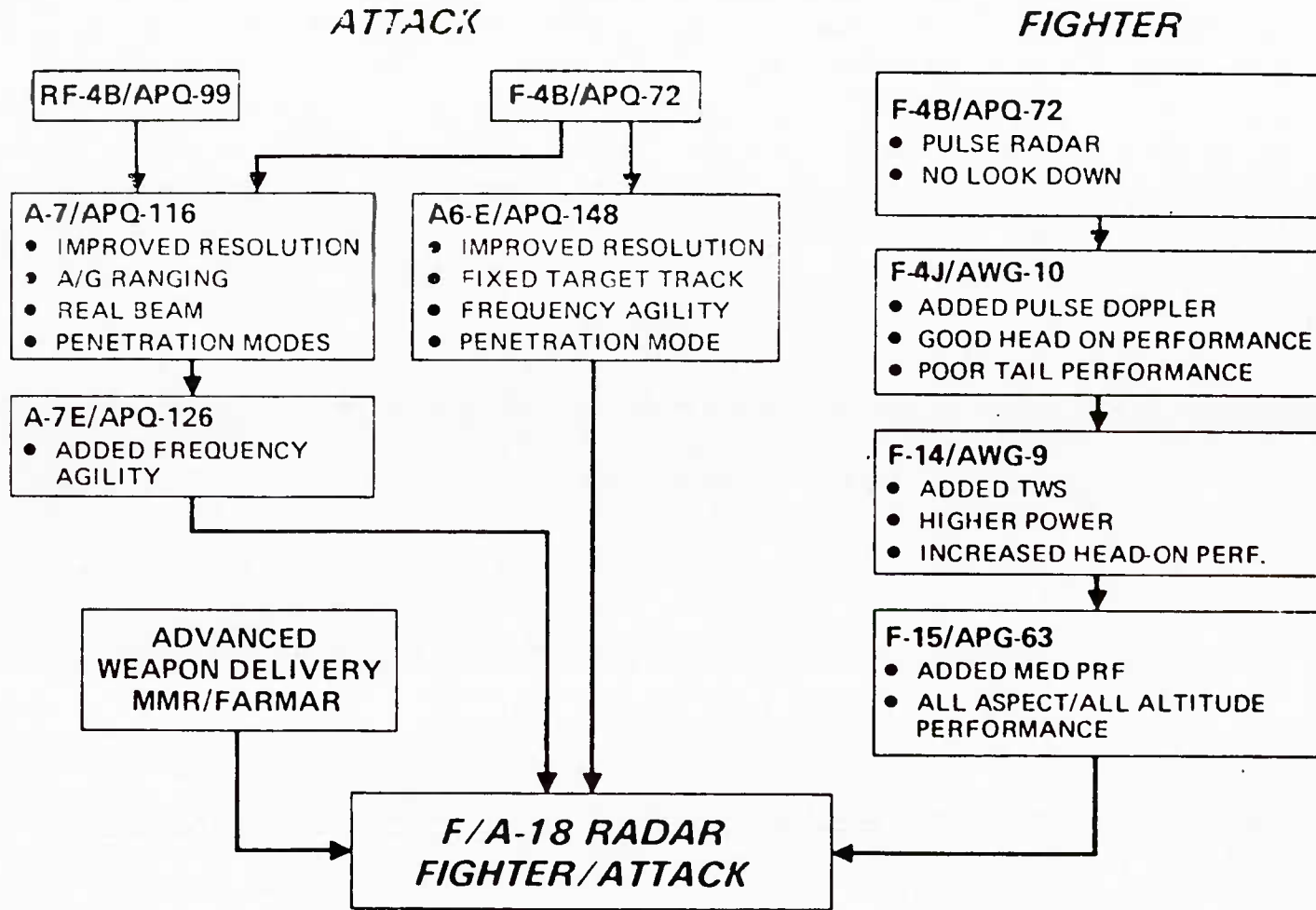

RADAR SET AIR-TO-AIR CAPABILITY

The APG-65 radar represents the latest step in pulse doppler radar development that started with the AN/AWG-10 radar for the F-4J. The AWG-10 was the first fighter system to use pulse doppler allowing head-on look down capability. This system retained the pulse search mode of conventional radars and had a boresight acquisition capability. Because of sidelobe clutter limitations, tail hemisphere look-down capability was limited. The AWG-10A shown is the latest version of this radar incorporating digital avionics and provides improvements over earlier versions of the AWG-10.

The AWG-9 system features a higher power transmitter and larger antenna for greatly enhanced head-on detection capability. This system includes a range-while-search and a track-while-scan (TWS) mode which, when coupled with the AIM-54 missile system, provides a multishot missile capability. To improve air combat maneuver (ACM) performance, a vertically scanning acquisition mode was incorporated.

The APG-63 radar was developed with a digital processor which provided a breakthrough in processing technology and allowed the development of the medium PRF waveform which, for the first time, allowed true all-aspect, all-altitude detection capability. The APG-63 also added a HUD acquisition mode for rapid automatic acquisition of targets within the head-up display field of view.

The F/A-18's APG-65 radar draws on all of this experience and contains a completely programmable signal processor which, when coupled with its basic high, medium, and low PRF transmission and receive capability and low sidelobe, narrow bandwidth antenna design, allows the incorporation of the best features of these systems. In addition, the technology developed for doppler beam sharpened ground mapping has been exploited to provide a unique air-to-air raid assessment capability against closely spaced targets.

RADAR SET AIR-TO-AIR CAPABILITY

- ALL ASPECT LOOK-UP/LOOK-DOWN DETECTION AND TRACK
 - INTERLEAVED HIGH AND MEDIUM PRFs IN RANGE WHILE SCAN (RWS) AND TRACK WHILE SCAN (TWS) MODES
- MULTIPLE TARGET TRACK IN TWS
 - RADAR MAINTAINS TRACK FILE OF 10 TARGETS (8 DISPLAYED)
 - TARGETS PRIORITIZED ON TIME TO GO
 - AUTOMATIC CENTERING OF AZIMUTH AND ELEVATION SCAN
 - STEERING AND LAUNCH PARAMETERS FOR TOP PRIORITY TARGET
- RAID DETECTION
 - TRACK POINT IS EVALUATED FOR MULTIPLE TARGETS IN FORMATION
- ECM DETECTION
 - RADAR PROVIDES ADVANCED ECM ASSESSMENT, ADVISORY AND CCM
- RAPID TARGET ACQUISITION IN COMBAT
 - AUTOMATIC ACQUISITION USING THREE SPECIAL SCANS - HUDACQ, VACQ AND BST
- PULSE DOPPLER ILLUMINATION
 - RF TARGET ILLUMINATION FOR MISSILE LAUNCH
- DESIGNED FOR SINGLE PLACE OPERATION
 - HANDS ON THROTTLE AND STICK (HOTAS) CONTROL
 - AUTO RADAR PARAMETER SELECTION WITH WEAPON SELECTION
 - UNCLUTTERED DISPLAYS

Some of the key air-to-air features of the APG-65 radar include all-aspect target detection in the presence of clutter, multiple target track with launch and steering information displayed for the top priority target. A raid assessment mode helps to determine if a multiple target cluster is being tracked and the advanced ECCM features provide for operation against ECM. In a close-in combat situation, the three air combat maneuver acquisition rasters provide for rapid radar lock-on. All this capability can be easily controlled using the Hands on Throttle and Stick (HOTAS) control and the uncluttered displays.

RADAR AIR-TO-GROUND MODES

The broad range of air-to-ground modes in the Hornet radar is illustrated in this chart. The combination of coherent frequency operation and programmable digital signal processing provides for real time azimuth doppler beam sharpening. This feature allows the radar to have variable effective beamwidths from 3.3° to 0.05° . The digital signal processing enables an accurate terrain avoidance mode including clearance plane determination. A sea surface targeting mode using adaptive thresholding is provided to enhance detection capability against surface targets such as Komar and Kynda. Coherent frequency techniques have also made it possible to realize a GMTI/GMTT mode with excellent sub-clutter visibility, more accurate air-to-ground ranging, and precise aircraft velocity measurements to aid in navigation and weapon delivery. Aircraft velocities in the velocity update mode are measured to within one foot per second allowing in-flight alignment of the Inertial Navigation Set (INS) and INS updates to reduce navigation errors.

AIR-TO-GROUND MODES

- REAL BEAM GROUND MAP (RBGM)
- DOPPLER BEAM SHARPENING SECTOR (DBSS)
- DOPPLER BEAM SHARPENING PATCH (DBSP)
- SEA SURFACE TARGETING (SST)
- PRECISION VELOCITY UPDATE (PVU)
- GROUND MOVING TARGET INDICATION (GMTI)
- TERRAIN AVOIDANCE (TA)
- FIXED TARGET TRACK (FTT)
- GROUND MOVING TARGET TRACK (GMTT)
- AIR-TO-GROUND RANGE (AGR)

MODE STATUS

AIR-TO-AIR

VS	OPERATIONAL
RWS	OPERATIONAL
TWS	OPERATIONAL
STT w/PDI	OPERATIONAL
ACM	OPERATIONAL
RAID	OPERATIONAL
SRT	OPERATIONAL
NCTR	PARTIAL
ECCM	PARTIALLY OPERATIONAL

AIR-TO-GROUND

RBGM	OPERATIONAL
DBS SECTOR	OPERATIONAL
DBS PATCH	OPERATIONAL
PVU	OPERATIONAL
AGR	OPERATIONAL
SSS	OPERATIONAL
TA	OPERATIONAL, IMPROVEMENT REQUIRED
GMTI	OPERATIONAL, IMPROVEMENT REQUIRED
GMTI/RBGM	OPERATIONAL, FURTHER DEVELOPMENT REQUIRED
FTT	OPERATIONAL
GMTT	OPERATIONAL, IMPROVEMENT REQUIRED

SYSTEM DESCRIPTION

AN/APG-65 RADAR SYSTEM

The APG-65 radar incorporates advanced technology to combine features into a 5 WRA system. This reduction in number of units from 19 WRAs on the F-14 (AWG-9), and 9 on the F-16 (APG-63) facilitates maintainability and improves the fault isolation capability.

The five WRAs are:

Low Sidelobe Planar Array Antenna is a 26.625 inch diameter antenna with direct electric drive. All electronic components are contained in an easily removable SRA, thus not requiring antenna removal for most failures. Antennas can be removed and replaced without requiring harmonization, thus reducing maintenance time.

Receiver/Exciter--This unit combines radar receiver, radar exciter, and all analog to digital conversion functions in a single unit.

Transmitter--The APG-65 transmitter is a liquid cooled design featuring a gridded TWT that provides low, medium, and high PRF waveforms and missile illumination.

Radar Data Processor--This is a general purpose computer containing a memory capacity of 256,000 16 BIT words (4 megabit) on a disc memory. This disc provides the program storage for both the 32K data processor and the 192K signal processor operating mode memories. This unit also contains the radar low voltage power supply.

Radar Signal Processor--This is a completely programmable special purpose processor operating at a 7.2 MHz rate to perform complex operations. It has a 192K word operating mode memory and contains a separate general purpose processor to allow parallel operations.

AN/APG-65 RADAR SYSTEM

- FIVE WRAs

LOW SIDELobe PLANAR ARRAY ANTENNA

RECEIVER/EXCITER

TRANSMITTER

RADAR DATA PROCESSOR

RADAR SIGNAL PROCESSOR

AN/APG-65 RADAR SYSTEM

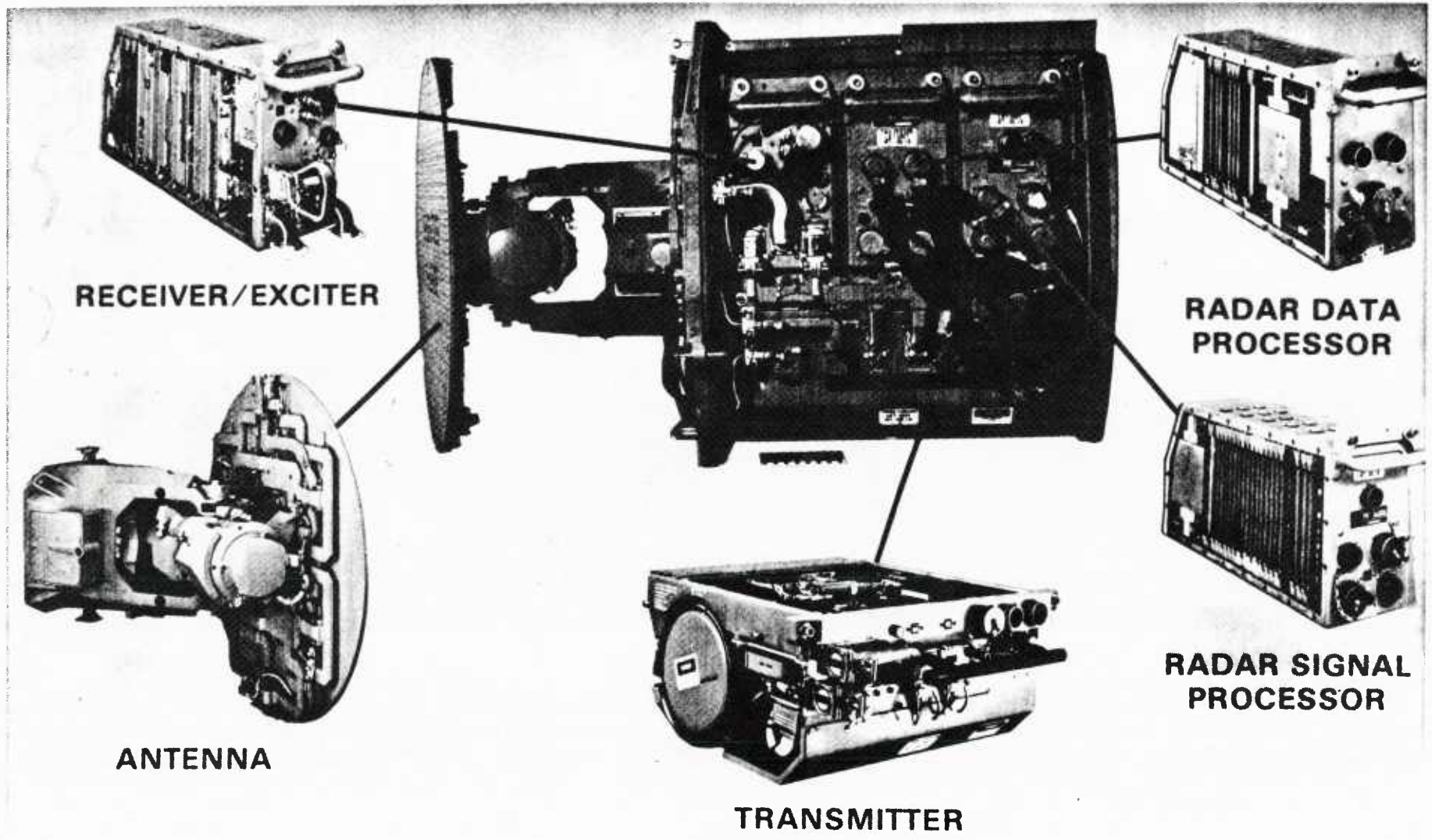

RADAR INSTALLATION

The APG-65 radar is installed in a vibration isolated rack configuration to protect the radar system from vibration created by the 20mm gun system. Due to this isolation design the radar remains at a relatively benign vibration level even during gunfire operations. This rack design also allows for easy maintenance. The radome swings to the side and the entire radar package can be rolled forward, allowing access to all WRA's from one side of the aircraft. The rack also contains an inherent gun gas and EMI shield to protect the radar WRA's from associated environmental factors. Electrical and cooling services are provided via a pantograph assembly allowing radar operation with the nose rack in extended position.

RADAR INSTALLATION

GENERAL: COMPATIBLE WITH BEYOND VISUAL RANGE AIM-7F
MISSILE, SHORT RANGE AIM-9 AND GUN DIRECTOR MODE
OPERATING RANGES FROM 200 FT. TO 160 NMI.
MULTI-WAVEFORM - FREQUENCY AGILE
FULL COMPLEMENT AIR/AIR AND AIR/GROUND MODES
WIDE AZ SCAN $\pm 70^\circ$ /WIDE ELEVATION TO 8 BARS
AUTOMATIC INITIALIZATION/ONE MAN OPERABLE

VOLUME: 4.37 FT³

WEIGHT: 343 LB (EXCLUDES RACK)

RELIABILITY: 106 HOUR DEMONSTRATED MTBF
(MIL-STD-781B)

MAINTAINABILITY: DEMONSTRATED 11.6 MIN.
FLIGHTLINE MTR

PARTS: 13,467

POWER: 9,500 WATTS

COOLING: AIR 2,782 WATTS
LIQUID 4,845 WATTS

KEY INSTALLATION ENVIRONMENTAL
CONSIDERATIONS:

PROXIMITY TO GUN (VIBRATION)
GUN GAS ENVIRONMENT
CARRIER LANDING

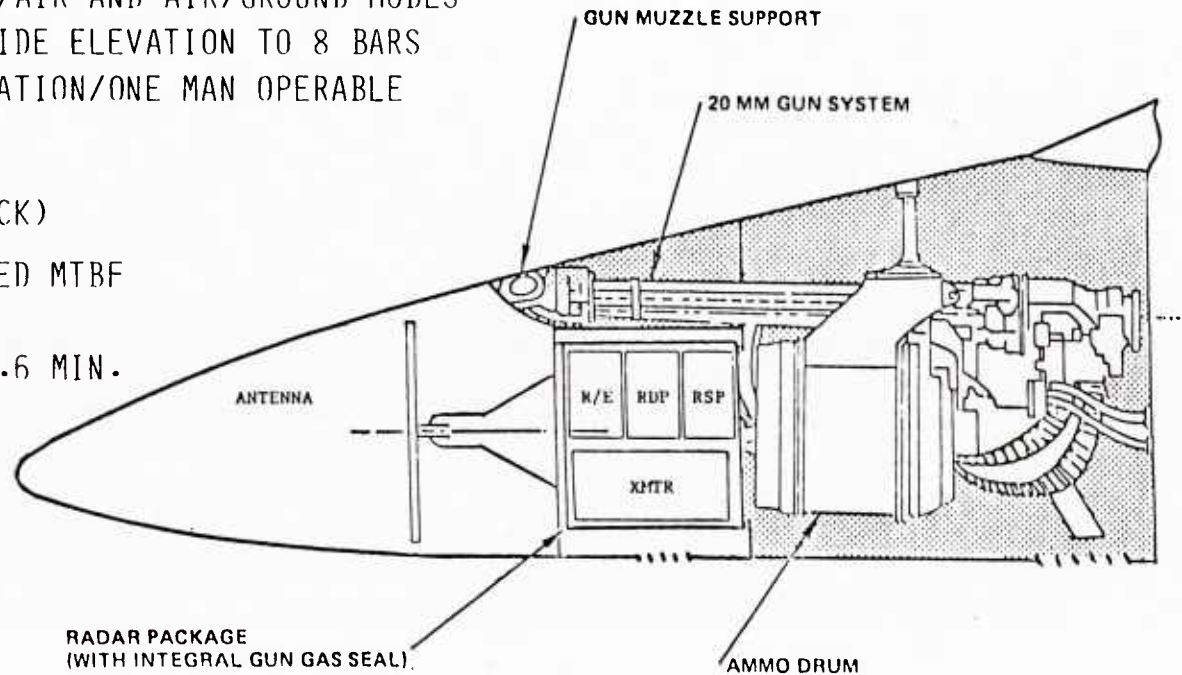

APG-65 RADAR SYSTEM PARAMETERS

The radar system consists of 5 weapon replaceable assemblies (WRA) and an isolation rack. The transmitter is liquid cooled and the other four units are cooled by forced air. The programmable radar signal processor contains the highest parts count and greatest heat dissipation and accordingly has the lowest MTBF allocation.

APG-65 RADAR SYSTEM PARAMETERS

	<u>MTBF</u>				<u>PARTS SUMMARY</u>			<u>DISSIPATION (WATTS)</u>	
	<u>WEIGHT (LBS)</u>	<u>VOLUME (FT³)</u>	<u>ALLO-CATED</u>	<u>PRE-DICTED</u>	<u>ICs</u>	<u>OTHER ELECT</u>	<u>TOTAL PARTS</u>	<u>AIR COOLED</u>	<u>LIQUID COOLED</u>
ANTENNA	84.2	N/A	700	1370	67	362	429	167	
TRANSMITTER	113.2	2.05	700	1130	154	1703	1857		4845
RCVR/EXCITER	45.9	.91	800	1110	49	1358	1407*	387.2	
RADAR SIGNAL PROCESSOR	55.0	.91	300	427	3964	2652	6616	1599.3	
RADAR DATA PROCESSOR	44.5	.91	600	835	1089	2224	3133	628.7	
RACK	109.4		4400	24500	--	34	34		
SYSTEM TOTAL	452.2	4.37	106	164	5325	8142	13467	2782	4845

*49 HYBRIDS

45A/3-5

MEMORY

The F-18 APG-65 radar contains more computer memory than any other current production fighter radar. This is due, in part, to the numerous radar modes and to the large storage requirements of the multi-mode programmable signal processor.

MEMORY LOADING

	CONSTANTS	ORDERS	WORDS
RSP			
A/A	6,896	16,786	60,702
A/G	2,164	14,961	48,129
BIT	252	3,936	12,336
EXEC/LOADER	0	562	1,686
FFT	1,024	0	1,536
TOTAL	10,336	36,245	124,389
RDP			
A/A		21,430	30,002
A/G		16,938	23,712
BIT		12,097	16,935
COMMON		5,075	7,104
TOTAL		55,540	77,753
DISC			
RSP		36,245	124,389
RDP		55,540	77,753
FLIGHT TEST			4,000
SPARES			4,300
TOTAL		91,785	210,442

MAJOR F-18 PROGRAM EMPHASIS

Reliability and maintainability were given equal program emphasis with performance and cost. The Navy offered MCAIR Life-Cycle-Cost incentives totaling 15 million dollars. A total of \$24 million was available for R&M incentives. MCAIR was permitted to offer R&M incentives to major subcontractors and make those awards an allowable contract cost.

R&M was elevated in program emphasis and the entire system was optimized for a proper balance.

MAJOR F-18 PROGRAM EMPHASIS

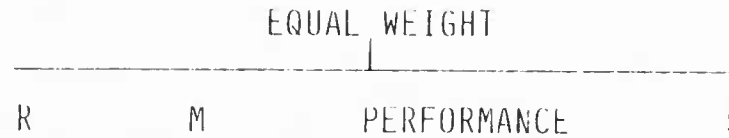

- PERFORMANCE IS DEFINED BY CONTRACT SPECIFICATIONS (AS-1291, SD-565-1)
- LIFE CYCLE DESIGN-TO-COST INCENTIVE
- RELIABILITY/MAINTAINABILITY INCENTIVE

OPTIMIZE FOR BEST BALANCE

RADAR RELIABILITY/MAINTAINABILITY FEATURES

- "RELIABILITY-BY-DESIGN" REQUIREMENTS IN CONTRACT INCORPORATE "ELEMENT WORST CASE ANALYSIS"
- SUBCONTRACTORS/BIDDERS KNEW MCAIR AND NAVY WERE SERIOUS AND WERE CONTINUALLY REMINDED DURING TECHNICAL COORDINATION MEETINGS, DESIGN REVIEWS, AND SPECIAL "AWARENESS" PRESENTATIONS
- RELIABILITY/MAINTAINABILITY DESIGN GUIDELINES WERE IMPLEMENTED BY MCAIR AND HUGHES
- RADAR ANALOG PROCESSING REPLACED BY DIGITAL PROCESSING
- ELECTRICAL RADAR ANTENNA DRIVE IN LIEU OF HYDRAULIC DRIVE
- IMPOSED OME DESIGN AND TEST ON RADAR
- REVISED ECS COOLING AIR SCHEDULE - LOWER PART OPERATING TEMPERATURES
- ADDED COOLING AIR OVERHEAT SENSORS TO PROTECT AGAINST TEMPERATURE OVERSTRESS
- EXTENSIVE USE OF LOW POWER PARTS (CMOS, SCHOTTKY) TO MINIMIZE HEAT RISE
- EXTENSIVE USE OF HYBRIDS, MSI, MICROPROCESSORS TO REDUCE PARTS COUNT
- STRINGENT PART DERATING REQUIREMENTS SPECIFIED IN PROCUREMENT SPECIFICATION
- COOLING AIR DIRECTED DOWN CENTER OF PCB FOR MINIMUM HEAT RISE AND MUCH LOWER JUNCTION TEMPERATURES

APG-65 MAINTAINABILITY PROGRAM FEATURES

A MCAIR maintainability engineer was assigned to the radar system and reported directly to the radar subsystem manager. The maintainability requirements for the aircraft installation and radar set were established via the maintainability design baseline document. These requirements were coordinated and approved by both the subsystem manager and equipment installation engineering. This document also serves as the basic document to initiate the in-house ILS process. The specific maintainability requirements, both qualitative and quantitative, were incorporated into the procurement specification which was the basic requirement for competitive procurement.

An incentive program was included as part of the radar subcontract to allow the supplier to receive a maintainability award which is based on measured field performance. In order to meet the maintainability requirements, built-in-test played a major role in the design of the radar.

A single point contact for maintainability was required at Hughes to provide a direct link between Hughes design engineering and MCAIR maintainability.

MAINTAINABILITY PROGRAM FEATURES

- MAINTAINABILITY RESPONSIBILITY ASSIGNED TO SUBSYSTEM MANAGERS
- MAINTAINABILITY CLOSELY TIED TO ILS
- MAINTAINABILITY DESIGN BASELINE ESTABLISHED REQUIREMENTS/GOALS
- MAINTAINABILITY INVOLVEMENT IN SUBCONTRACTING
- MAINTAINABILITY REQUIREMENTS QUANTIFIED
- MAINTAINABILITY INCENTIVES
- MAINTAINABILITY ON A PAR WITH PERFORMANCE
- MAINTAINABILITY INVOLVEMENT IN BIT PROGRAM
- MAINTAINABILITY SINGLE POINT OF CONTACT AT CUSTOMER

PROGRAM SUMMARY

APG-65 PROGRAM SUMMARY

Early in the program, the radar supplier, Hughes, was convinced that MCAIR was serious about R&M. This conviction was partially based upon the decisions that were made on the results of radar trade studies. This feeling was reinforced with contract financial incentives tied to challenging but achievable R&M requirements. Subsystem managers and individual designers were made personally responsible for reliability, maintainability, performance and cost parameters both at Hughes and MCAIR. These parameters were treated with equal emphasis in trade studies and design reviews. Technology was continuously monitored for potential reliability benefits and also for new threats such as ESD and EMP. Concurrency in testing extended the growth available through TAAF efforts. The F-18 pilot production concept allowed for rapid corrective action. Experience indicated that change flexibility is required for real growth in R&M.

Experience indicates that Physical Configuration Audit (PCA) should be established at the latest reasonable date to enhance the early incorporation of design changes. Additionally, change processing needs to be streamlined beyond PCA. Productivity programs should be encouraged since they can provide reliability, maintainability, and cost benefits. In selecting the right supplier, competition is an important element, and courage in selection (in the face of cost) is critical. The Navy "New Look" R&M program structure provided the framework for the radar program.

APG-65 PROGRAM SUMMARY

- R&M MOTIVATION EARLY IN THE PROGRAM
- DEFINITIVE REQUIREMENTS - CHALLENGING, BUT ACHIEVABLE
- DESIGNERS RESPONSIBLE FOR RELIABILITY, PERFORMANCE, MAINTAINABILITY, COST
 - DESIGN REVIEWS TREAT EACH WITH BALANCED EMPHASIS
- MONITOR TECHNOLOGY FOR PROGRESS AND NEW THREATS TO R&M
 - ESD/EMP
- CONCURRENCY PROVIDES BENEFITS IF:
 - CONTRACTOR SUPPORT FOR INITIAL FIELD INTRODUCTION IS PROVIDED
 - EXTEND THE GROWTH ACHIEVABLE THROUGH TAAF EFFORTS

APG-65 PROGRAM SUMMARY (CONTINUED)

- GROWTH IN R&M DEMANDS CHANGE FLEXIBILITY
 - PILOT PRODUCTION CONCEPT ALLOWS RAPID CORRECTIVE ACTIONS
 - ESTABLISH PHYSICAL CONFIGURATION AUDIT (PCA) POINTS AT LATEST REASONABLE POINT
 - STREAMLINE ECP PROCESSING
- PRODUCTIVITY PROGRAMS SHOULD BE ENCOURAGED
 - COST AND R&M BENEFITS
- SELECT THE RIGHT SUPPLIER
 - COURAGE IN THE SELECTION PROCESS (IN THE FACE OF COST)
 - COMPETITION IS IMPORTANT
- NAVY R&M PROGRAM - NEW LOOK - PROVIDES THE FRAMEWORK

AIRFRAME SYSTEM R&M FEATURES TO IMPROVE RADAR AVAILABILITY

In previous aircraft designs, inadequate safeguards in the design allowed the radar to be operated on the ground without cooling air, due to lack of ground cooling carts or improper maintenance. This resulted in overheating of the equipment, causing premature failures. On-board cooling fans were incorporated in the F-18 to eliminate this potential problem from the F-18 design.

A requirement was imposed on MCAIR to demonstrate a 20.0 minute radar remove and replace time with a crew size of 1.8. During the maintenance engineering inspection conducted in February 1980, a 11.6 minute remove and replace time was demonstrated with a crew size of 1.5.

Maximum use of BIT for the radar, coupled with modular construction reduced the need for ground support equipment and handling fixtures at the organizational level. These features decrease the down time required for radar maintenance and improve radar availability.

Ground power switching, which was first incorporated on the F-15 radar, was carried over to the F-18 radar. This allowed the maintenance man to select the systems to power up during maintenance, thus eliminating excessive operating time on the radar and improving the mean flight hours between failure.

AIRFRAME SYSTEM R&M FEATURES TO IMPROVE RADAR AVAILABILITY

- GROUND COOLING FANS PROVIDE AIR FLOW IMMEDIATELY ON POWER UP
 - HISTORICALLY, GROUND COOLING CARTS ARE AVOIDED BY MAINTENANCE PERSONNEL, RESULTING IN THERMAL STRESS ON EQUIPMENTS
 - GROUND FANS PROVIDE NECESSARY AIR FLOW FOR MOST MAINTENANCE WITHOUT GROUND CARTS
- AIRCRAFT INSTALLATION ALLOWS QUICK REMOVAL AND REPLACEMENT OF RADAR WRAs
- EXTENSIVE USE OF BUILT-IN-TEST MINIMIZES TROUBLESHOOTING TIMES (NO GROUND SUPPORT EQUIPMENT)
- GROUND POWER SWITCHING ALLOWS SELECTIVE GROUND OPERATION - ELIMINATES UNNECESSARY RUN TIME

GROUND POWER SWITCHING

One design objective on the F-18 was to minimize the operating time of the avionics. The less ground operating time per flight hour of the aircraft, the fewer failures per flight will be experienced. Reduction of ground operating time was achieved through effective BIT rapidly isolating to WRAs and through ground power switching (GPS). GPS is mechanized such that on initial a/c power turn-on, all avionics are off. Manual switch positioning is required for any avionic operation. The selective switching eliminates unnecessary radar operation during checkout of other avionics.

The reduction of operating hours per flight hour (OH/FH) results in fewer failures for a given number of flights or flight hours.

GROUND POWER SWITCHING (GPS)

HIGHER SYSTEM AVAILABILITY

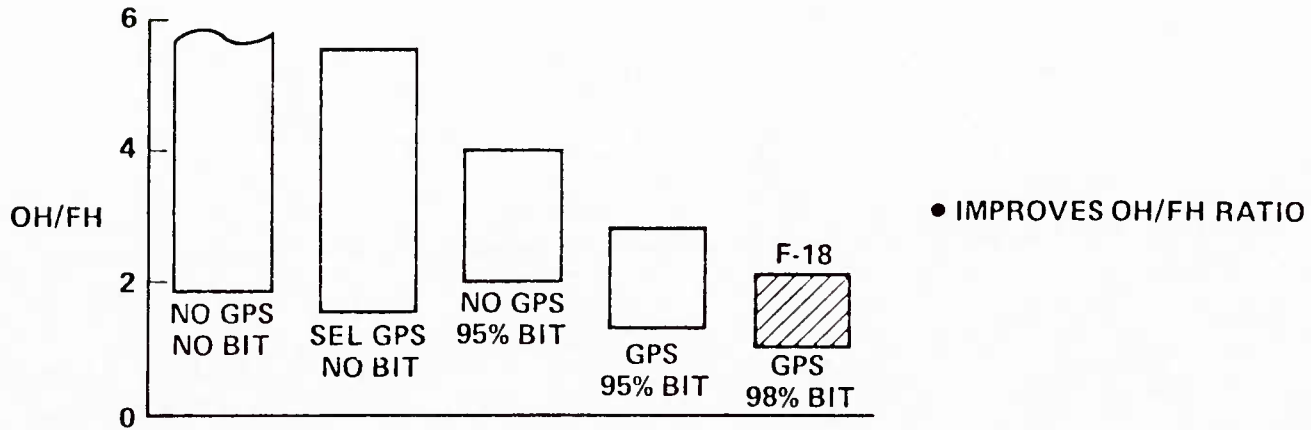

• RESULTS IN INCREASED FLIGHT HOURS/FAILURE

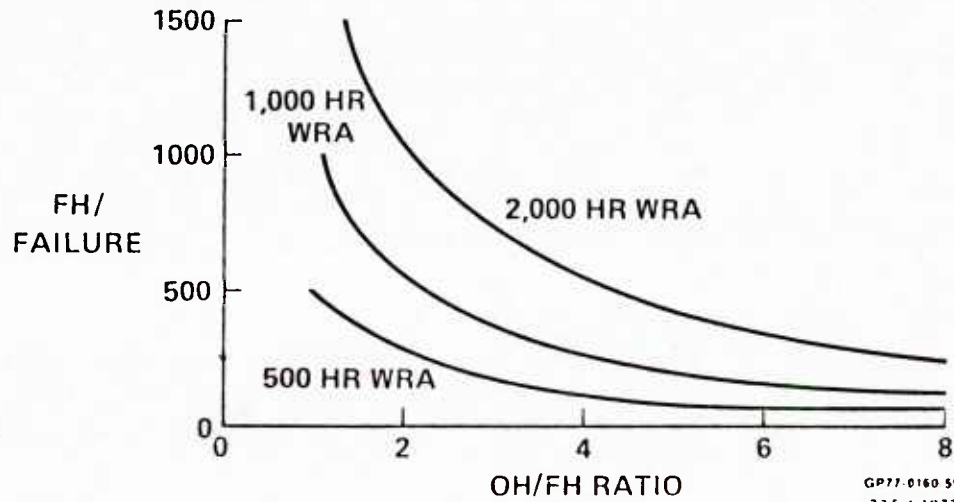

GP77-0160 59
23 Feb 1977

R&M GROWTH

- R&M REVIEW BOARD DURING DEVELOPMENT
- DEVELOPMENTAL TEST, ANALYZE AND FIX
- R&M MONITORING DURING INITIAL TRAINING SQUADRON USE
- SPECIAL BIT MONITORING TEAM
- CONTRACTOR SUPPORT OF INITIAL INTRODUCTION PHASES CRITICAL FOR FEEDBACK TO SUSTAIN R&M GROWTH
- SUPPLIER PROCEDURES FOR COORDINATION/EVALUATION OF DATA FROM ALL MANUFACTURING SOURCES - INITIAL PARTS SCREEN TO FINAL ACCEPTANCE
- INTEGRATED CORRECTIVE ACTION PROGRAMS (ICAP)
- FIELD/MCAIR/SUPPLIER COORDINATION POINT
- MAXIMUM GROWTH - KEEP INITIAL APPLICATIONS COMPATIBLE WITH CONFIGURATION CHANGES

PROGRAM ELEMENTS

The APG-65 radar program was structured to test and evaluate those elements that constituted the largest design/reliability risk early in the program. Special element development tests were performed on the disc memory and GTWT during 1977. The first engineering models entered testing in late 1977. Lab and environmental testing and reliability development testing were structured to test areas of high potential risk early. A 1/2 life vibration test and exposure to gunfire vibration testing were performed early in the test program. Temperature cycling to the extreme temperature environments was also performed early to ensure no latent design defects were present.

PROGRAM ELEMENTS

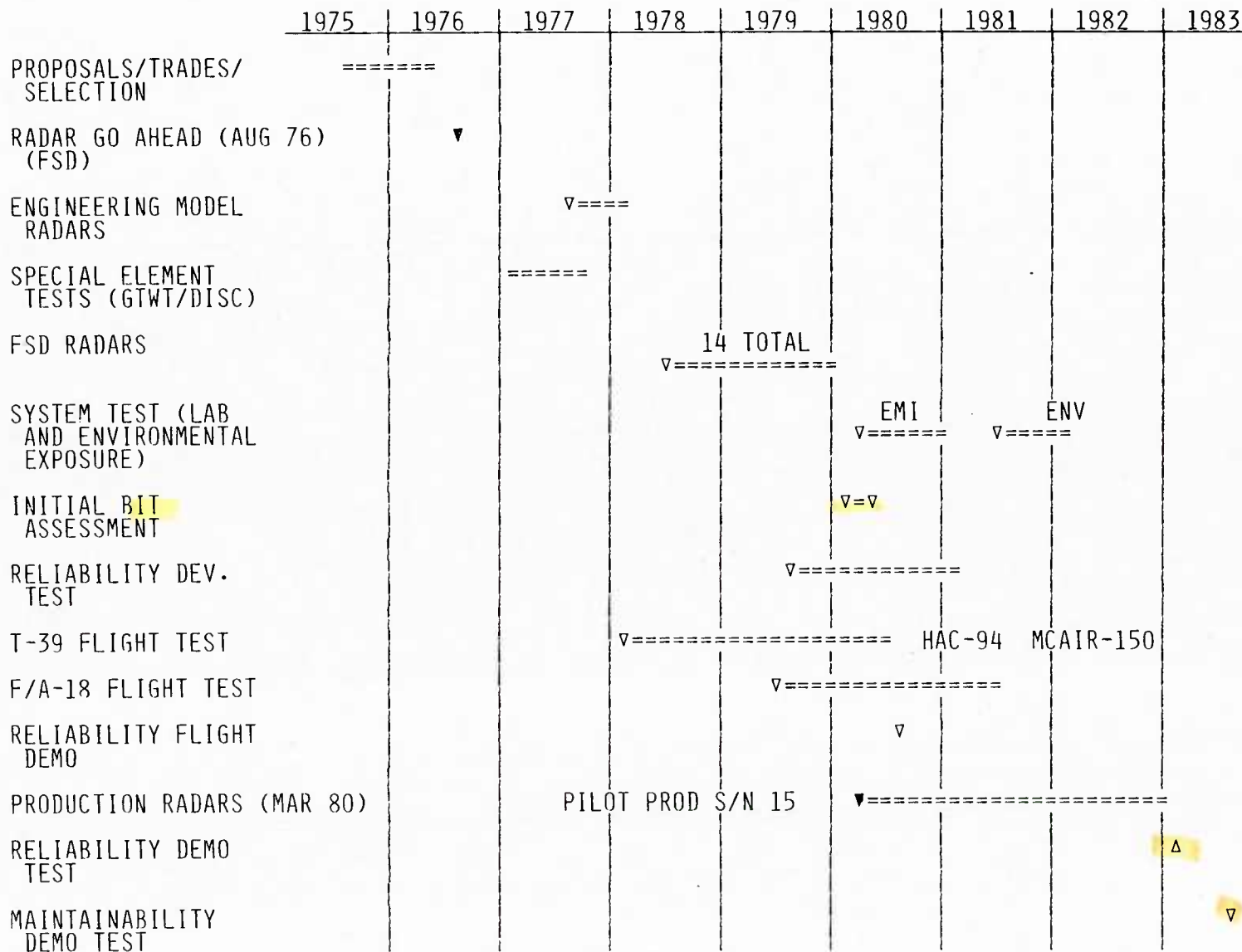

PROGRAM ELEMENTS

The APG-65 radar program began in 1975 with proposals being considered from seven radar contractors. In early 1976, Hughes Aircraft and a team consisting of Westinghouse and Norden were chosen as finalists. In August of 1976 the Hughes Aircraft design was selected. Testing began on key elements (gridded traveling wave tube, disc memory, etc.) in early 1977 and system level testing on engineering models (EM) began in late 1977. Design of these (EM's) was started prior to contractor go-ahead as part of the Hughes head-start program. Flight testing of an EM radar began in March of 1978 using a modified T-39D radar test bed. In August of 1978, the first of 14 full-scale development (FSD) radars began flight development, which continued until mid-1982 on both the T-39 and F-18 aircraft.

Key reliability milestones include reliability development testing, starting in September, 1979, and 50 flight (100 hour) aircraft reliability demonstration in October, 1980 which was completed with no radar failures and the 106-hour radar reliability demo which was completed in January 1983. During this test, 2 radars were run for a total of 149 hours to a MIL-STD-781 environment with no radar failures.

NAVY FLIGHT AND SUPPORT TEST ELEMENTS

During the radar development phase, a number of assessments and evaluations were conducted. During these tests, Navy pilots and maintenance personnel evaluated system performing reliability and maintainability aspects of the radar. Comments written by Navy personnel were then submitted to MCAIR/Hughes for possible incorporation in design changes and reevaluated during subsequent exercises. While some R&M improvements were incorporated as the result of the exercises, the several conclusions were that the radar met all R&M criteria at each stage of the assessment.

NAVY FLIGHT AND SUPPORT TEST ELEMENTS

NAVY PRELIMINARY ASSESSMENTS:	T-39	OCT 1978 JUL 1979
NAVY PRELIMINARY EVALUATION:	F/A-18	OCT 1979 MAR 1980 OCT 1980
NAVY PARTICIPATION FLIGHTS:	F/A-18	MAR 1980 - 28 JAN 1981
IOT&E (INITIAL OPERATIONAL TEST AND EVALUATION)	F/A-18	27 OCT 1980 - 28 JAN 1981
NAVY TECHEVAL:	F/A-18	MAR 1982
OPEVAL:	F/A-18	3 MAY - 4 OCT 1982 1628 FLIGHT HOURS OPERATIONAL EMPLOYMENT
	RESULT:	R&M MET ALL CRITERIA

F-18 RADAR RELIABILITY AND MAINTAINABILITY EVENTS

	1976	1977	1978	1979	1980	1981	1982	1983
GTWT AND DISC TESTING	=====							
REL GROWTH TEST						9		6
EMI						=====		
ENVIRONMENTAL QUAL							9	
INITIAL BIT ASSESSMENT					=			===
REL QUAL TEST #1 WAIVED								
#2								
50 REL DEMO FLIGHTS								12 1
5-19 NOV 80								==
M DEMO (PLANNED)								
START EM RADARS JAN 76			Δ					
GO AHEAD (FSD) AUG 76			Δ					
IDR OCT 76								
CDR (AVIONICS) JUN 77			▲					
FIRST T-39 EM MAR 78				Δ				
FIRST T-39 FSD AUG 78					Δ			
FIRST F-18 JUN 79					Δ			
PCA (S/N 27) JUN 81							Δ	
PROD GO-AHEAD MAR 79 (S/N 27)				▲				
1ST PROD DELIV. JUN 81 (S/N 27)							Δ	
1ST PROD FLT JUL 81 (S/N 27) IN F-17							Δ	
1ST PROD FLT AUG 82 (S/N 55 1ST FLEET A/C F-37) (PREVIOUS S/N IN TRAINING A/C)								Δ

PRE-PROD	14	(1-14)
PILOT PROD	11	(15-25)
LIMITED PROD	29	(26*-55)
*S/N 26 GSE CHECKOUT AT HAC		

EM	=	ENGR MODEL
S/N	=	SET NUMBER
A/C	=	AIRCRAFT NO
IDR	=	INITIAL DESIGN REVIEW

DEVELOPMENTAL RADAR ALLOCATION

Originally, 16 full-scale development radars were requested. However, to reduce program's cost, this number was reduced to 14. In addition, the equivalent of about 2-1/2 additional engineering model radars were manufactured. Of the 14 FSD units, systems #5, #6, and #12 were allocated to reliability development and environmental test.

DEVELOPMENT RADAR ALLOCATION

<u>INITIAL</u>		<u>FINAL</u>	
<u>SET</u>	<u>ALLOCATION</u>	<u>SET</u>	<u>ALLOCATION</u>
1	SELLER BENCH	1	TESTBED
2	TESTBED	2	SELLER BENCH
3	MCAIR BENCH	3	MCAIR BENCH
-	WRA SPARES	-	WRA SPARES
4	ENVIRONMENTAL TEST	4	SHIP 5 (F-5)
5	ENVIRONMENTAL TEST	5	RELIABILITY DEVELOPMENT TEST
6	RELIABILITY DEVELOPMENT TEST	6	ENVIRONMENTAL TEST
7	RELIABILITY DEVELOPMENT TEST	7	PAX BENCH
8	MCAIR DATA	8	SHIP 3 (F-3)
9	SHIP 3 (F-3)	9	SHIP 7 (TF-1)
10	SHIP 5 (TF-1)	10	SHIP 8 (F-7)
11	PAX BENCH	11	FLIGHT TEST SUPPORT
12	FLIGHT TEST SUPPORT	12	ENVIRONMENTAL TEST
13	SHIP 8 (F-7)	13	SHIP 10 (TF-2)
14	FLIGHT TEST SUPPORT	14	SHIP 11 (F-9)
15	SHIP 10 (TF-2)		
16	SHIP 11 (F-9)		

MEASURES OF SUCCESS

APG-65 RADAR RELIABILITY SUCCESS

The chart shows three of the notable milestones for the F/A-18 radar. The MIL-STD-781B reliability demonstration test had no failures in 149 operating hours (during that time there were no WRA removals or repairs).

APG-65 RADAR RELIABILITY SUCCESS

- NOVEMBER 1980
100 FLIGHT HOUR DEMONSTRATION IN A/C F-9 AT PAX RIVER
- NO RADAR FAILURES
- JANUARY 1983
FORMAL RELIABILITY DEMONSTRATION (MIL-STD-781B)
- 106 HOUR MTBF DEMONSTRATED
- SEPTEMBER 1982 - FEBRUARY 1983 (REFER TO PAGE 263)
FLEET AVERAGE
- 4275 HRS ACCUMULATED
- MTBF 24 HOURS

F-18 RELIABILITY DEMONSTRATED IN FLIGHT (NOVEMBER 1980)

F/A-18 Number 9 flew the 50 Reliability Demonstration flights in 100.5 flight hours between 5 and 19 November 1980 at Patuxent River. During this period, equipment failures and aircraft mission reliability performance were monitored by MCAIR and Navy personnel. Aircraft 9 is the final F/A-18 FSD aircraft and represented the configuration closest to the production article with systems improvements incorporated consistent with cost and schedule constraints. All flights were flown by MCAIR pilots and followed air-to-ground, air-to-air or ferry/familiarization profiles. The demonstration was performed at the highest fly rate possible within the constraints of pilot availability and Navy support. Of the 50 flights, the first 20 were dedicated to an air-to-ground profile, the second 20 to an air-to-air profile, and the last 10 to a ferry/familiarization profile. The air-to-ground and air-to-air profiles incorporated simulated combat segments near the middle of the mission and the ferry/familiarization flights incorporated a NAVAID penetration, GCA pattern, and two touch-and-gos. During two air-to-ground flights, live gunfire and bomb drops with MK-82SE inert bombs were performed on a practice target. Live gunfire was also performed on two air-to-air flights.

At the completion of the 50 flights, all aircraft maintenance data were reviewed by a joint Navy/MCAIR Review Board. During the demonstration, nine Contractor Furnished Equipment (CFE) and three Government Furnished Equipment (GFE) failures occurred. These failures are as follows: CFE--Left Wing Outboard Fuel Probe; Hydraulic Line, Right AMAD Bay; Broken Wire, Right Fire Detection System; Clogged Hydraulic Filter; Maintenance Signal Data Recorder; Cockpit Cooling Fan; INS; Left Trailing Edge Flap Actuator; Stores Management Set Decoder Station 4; GFE--Left Engine (A/B Pump and Line Leak); AIM-9 Launcher Nitrogen Leak; Right Engine Slow Start.

F-18 RELIABILITY DEMONSTRATED IN FLIGHT (NOVEMBER 1980)

- FLEW 50 FLIGHTS USING AIRCRAFT F-9 - 100 FLIGHT HOURS IN 15 DAYS
 - 20 AIR-TO-AIR, 20 AIR-TO-GROUND, 10 FERRY FLIGHTS
 - DROPPED BOMBS ON 2 FLIGHTS AND FIRED-OUT GUN ON 4 FLIGHTS
 - NAVY CREWS MONITORED ALL GROUND AND FLIGHT OPERATIONS

- RELIABILITY DEMONSTRATED
 - 5 FLIGHTS PER AIRCRAFT PER DAY ON 3 OCCASIONS
 - FLEW 25 CONSECUTIVE TOTAL AIRCRAFT FAILURE-FREE FLIGHT HOURS
 - RADAR OPERATED WITHOUT FAILURE THE ENTIRE TEST (100 FLIGHT HOURS)
 - AIRCRAFT REQUIREMENT 3.7 MFHBF
 DEMONSTRATED 8.4 MFHBF
 - DEMONSTRATED AIRCRAFT PROBABILITY OF MISSION SUCCESS = 0.96
(ONLY 2 MISSION FAILURES - NONE WERE RADAR)

- NAVY PILOTS FLEW TWO FLIGHTS AT CLOSE OF 50 FLIGHT DEMO TO VERIFY AIRCRAFT STATUS - ALL SYSTEMS UP

F-18 AIRCRAFT 3M ANALYSIS

An analysis was made in an attempt to correlate field measurements being made by MCAIR to reported 3M data. The analysis revealed that approximately 54% of the events that 3M classified as failures in the MFHBF computation were classified as inherent failures by MCAIR. Major areas of difference as interpreted by MCAIR occurred as a result of MCAIR team follow-up in determining secondary failures, and externally induced failures.

F-18 AIRCRAFT 3M ANALYSIS

<u>MAINTENANCE EVENTS</u>	<u>% OF TOTAL EVENTS</u>
INHERENT FAILURES	54.4
UNDOCUMENTED SECONDARY FAILURES	12.8
UNDOCUMENTED INDUCED FAILURES	16.8
NON-PRODUCTION CORRECTED	9.6
DUPLICATE COUNT	5.8
MISDOCUMENTED SUPPORT ACTION	<u>0.6</u>
	100 %

DATA FROM FEBRUARY 1981 THROUGH 4 MAY 1982

ALL LEMOORE AIRCRAFT

HUGHES ANALYSIS OF APG-65 FIELD RELIABILITY

VFA 125

<u>PERIOD</u>	<u>FLIGHT HOURS</u>	<u>RADAR HOURS</u>	<u>MEAN RADAR HOURS BETWEEN</u>		
			<u>REMOVALS</u>	<u>RADAR REPAIRS</u>	<u>PRIMARY FAILURES</u>
1981	922	1106	14	27	42
JAN/JUN 82	2406	2887	19	29	48 (EST)*†
JUL/DEC 82	4011	4813	24	41	59 (EST)*

APPROACHING 1 MONTH BETWEEN REMOVALS, 2 MONTHS BETWEEN PRIMARY FAILURES.

*DETAILED ANALYSIS OF 1981 AND PRIOR SHOWS 40% OF FAILURES ARE NON-PRIMARY, I.E., MAINTENANCE-RELATED.

†PRIMARY MTBF BY WRA: TX=208, R/E=192, ANT=333, RSP=385, RDP=200

F/A-18 YUMA DEPLOYMENT

The Navy has been and is continuing to conduct a series of F-18 deployments to remote sites. These deployments involve intensive flying schedules of both air-to-air and air-to-ground missions. The most recent deployment at this writing was January 1983. A MCAIR field team was in place at Yuma, Arizona, to monitor nine of the deployed eighteen aircraft for R&M. The F-18 radar exhibited high reliability with 96% of 300 flights requiring no radar removals. Only one of the WRAs returned to NAS Lemoore for I level repair retested good.

F/A-18 YUMA DEPLOYMENT

- MOST RECENT OF MANY NAVY DEPLOYMENTS SIMULATING OPERATIONAL UTILIZATION
- 4 JANUARY TO 28 JANUARY 1983
 - TRAINING SQUADRON DEPLOYMENT TO YUMA
 - 18 AIRCRAFT, 613 FLIGHTS, 650 FLIGHT HOURS
 - 9 AIRCRAFT WERE R&M MONITORED (~300 FLIGHTS)
- 3 OF THE 9 AIRCRAFT, 78 FLIGHTS, 83.2 FLIGHT HOURS REQUIRED NO RADAR MAINTENANCE ACTIONS
- 96% OF FLIGHTS HAD NO RADAR REMOVALS
 - 1 WRA RETURNED FOR I LEVEL MAINTENANCE WAS RETESTED-OK. THIS WAS A MEASURED 300 SORTIES PER UNNECESSARY REMOVAL

RADAR BIT DEVELOPMENT STATUS

The built-in-test software program (Tape 101B) was released for field use in October, 1982. This program was essentially complete at time of issue. Subsequent to tape release, areas were uncovered in which program refinement was required. These changes are currently being flight evaluated and will be incorporated in the next scheduled program release.

The software program in the F-18 radar consists of about 30,000 16-BIT words and performs 106 separate tests during periodic BIT (present mode) and 321 tests during initiated BIT in which the entire radar is exercised either by pilot action or automatically when the system is turned on.

RADAR BIT DEVELOPMENT STATUS

RADAR BIT DEVELOPMENT DEVELOPMENT ESSENTIALLY COMPLETE WITH TAPE 101B

PERIODIC BIT 106 TESTS

INITIATED BIT 321 TESTS

PROGRAM REVIEW ELEMENTS

CONTRACT

- R&M REQUIREMENTS
- MISSION PROFILE ESTABLISHMENT
- R&M FAILURE DEFINITION
- INCENTIVES
- SOURCE SELECTION
- LCC CONSIDERATION

BASIC CONTRACT ELEMENTS

The contract for the F-18 radar addressed reliability and maintainability in the following ways:

- a. The instruction for proposal preparation emphasized the part that would be played by the reliability/maintainability program in the supplier selection process.
- b. The equipment specification defined R&M requirements, testing, growth factors, derating requirements, and second tier documents.
- c. The purchase order contained the life cycle cost structure, design-to-cost structure, and incentives for R&M.
- d. The supplier data requirements list imposed MCAIR data reporting requirements for R&M.
- e. The general management requirements included provisions for corrective action, retrofit, test failure notification, FMEA procedure.

APG-65 RADAR
BASIC CONTRACT ELEMENTS

- INSTRUCTIONS FOR PROPOSAL PREPARATION
 - EMPHASIZED PART PLAYED BY RELIABILITY/MAINTAINABILITY PROGRAM IN SELECTION
- EQUIPMENT PROCUREMENT SPECIFICATION
 - DEFINED R&M REQUIREMENTS, TESTING, GROWTH FACTORS, DERATING REQUIREMENTS, SECOND TIER DOCUMENTS
- PURCHASE ORDER
 - LIFE-CYCLE COST STRUCTURE, DESIGN-TO-COST STRUCTURE, INCENTIVES FOR R&M
- SUPPLIER DATA REQUIREMENTS LIST
 - IMPOSED MCAIR DATA REPORTING REQUIREMENTS
- GENERAL MANAGEMENT REQUIREMENTS
 - CORRECTIVE ACTION, RETROFIT, TEST FAILURE NOTIFICATION, FMEA PROCEDURE

BASIC CONTRACT ELEMENTS - SECOND TIER

The second tier of contract documents in the MCAIR/Hughes contract included a number of documents that had direct impact on APG-65 R&M. These documents included design guidelines processes and policy, test and evaluation standards and requirements, preferred parts lists, and required failure reporting policy.

This list indicates the documents and their MCAIR document numbers.

APG-65 RADAR
BASIC CONTRACT ELEMENTS

- SECOND TIER R&M DOCUMENTS
 - (A3807) RELIABILITY DESIGN GUIDELINES - AVIONICS
 - (A3374) F/A-18 PREFERRED PARTS
 - (A3376) OPERATIONAL MISSION ENVIRONMENT (OME) -
VIBRATION REQUIREMENTS
 - (A3380) SUBCONTRACTOR MAINTAINABILITY TEST STANDARDS
 - (A3382) TEST COMPATIBILITY DESIGN REQUIREMENTS
 - (A3710) MATERIALS AND PROCESSES
 - (A3672) FASTENER USAGE POLICY
 - (A3711) CORROSION PREVENTION AND CONTROL PLAN
 - (A1215) PACKAGING
 - (A3712) NONDESTRUCTIVE TEST PLAN REQUIREMENTS
 - (A4150) CLOSED LOOP EVALUATION AND REPORTING
 - (A4241) THERMAL DESIGN AND EVALUATION
 - (A4300) RELIABILITY DEVELOPMENT TESTING

CONTRACTUAL ASPECTS AIMED AT IMPROVED RADAR R&M

The subcontract for the APG-65 radar contained a number of features aimed at improved radar R&M.

Design requirements for R&M included a stringent part derating requirement. This was based on the NASA guidelines but in many instances, such as IC temperatures and transistor power, even tougher levels were required. A detailed set of reliability design guidelines was also utilized.

A Test-Analyze-and-Fix (TAAF) program included a reliability development test. The TAAF philosophy was followed in all the radar testing with failure analysis and corrective action for all failures. The emphasis on estimating MTBF from these tests was replaced with an atmosphere of uncovering every possible weakness.

Many test requirements were placed upon the supplier: reliability development, initial BIT assessment and maintainability BIT demonstration. During these tests each component or test failure required analyzing and a corrective action taken. Retesting was required in many cases.

The final test of the supplier's performance was a field measurement of the procurement specification quantitative values. These were accomplished at 2500 and 9000 flight hours; 2500 at NATC PAX River Maryland, 9000 at NAS LeMoore California. An incentive existed for each milestone.

CONTRACTUAL ASPECTS AIMED AT IMPROVED RADAR R&M

DESIGN REQUIREMENTS

- SPECIFIC DESIGN REQUIREMENTS INCLUDING DERATING CRITERIA
- RELIABILITY DESIGN GUIDELINES

TEST-ANALYZE-AND-FIX (TAAF) PROGRAM

- RELIABILITY DEVELOPMENT TEST REQUIREMENTS
- INITIAL BIT ASSESSMENT
- M/BIT DEMONSTRATION

R&M GUARANTEES DEMONSTRATED

- MTBF
- MMH/FH
- MFHBMA

INCENTIVES - UP TO 5% OF FSD PURCHASE ORDER PRICE

- DURING MIL-STD-781B LAB DEMONSTRATION - MTBF
- DURING FLIGHT DEMONSTRATION
 - MFHBF
 - MMH/FH
 - MFHBMA

LABORATORY AND FLIGHT DEMONSTRATIONS

The F/A-18 program required that R&M be demonstrated both at the equipment level and the aircraft level.

Demonstrations and evaluations to comply with the quantitative requirement were required in the Navy to MCAIR and MCAIR to Hughes contracts. The ability to meet the on-aircraft requirements was demonstrated by MCAIR during the 2500 flight hour evaluation at NATC Pax River and by the Navy during the 9000 flight hour evaluation at NAS Lemoore. The intermediate level maintainability demonstration, along with the final bit evaluation, is scheduled at Hughes Aircraft Company later this year (1983).

These contractual R&M demonstration requirements will be summarized on the next three charts.

LABORATORY AND FLIGHT DEMONSTRATIONS

- FIRM R&M GUARANTEES AT BOTH AIRCRAFT AND RADAR LEVEL
- DEMONSTRATIONS AT EQUIPMENT LEVEL AT HUGHES
- DEMONSTRATIONS AT AIRCRAFT LEVEL DURING FLIGHT TEST PROGRAM

APG-65 RADAR RELIABILITY DEMONSTRATION

The radar reliability demonstration requirement was specified as a three-phase MTBF growth requirement. The quantitative MTBF requirements in the MCAIR subcontract to Hughes were slightly higher than the MTBFs stated in the Navy contract to McDonnell. Test Phase #1 which was to use the first pre-production units was waived so the test radars could be used in the TAAF Reliability Development Test, thereby testing the recently implemented FSD corrective actions under operational mission environments. The second phase (at the point of 50-75 production units) exceeded the 85 hr requirement and went on to meet the requirement of the final phase (106 hrs MTBF), potentially eliminating the need for the third test.

APG-65 RADAR RELIABILITY REQUIREMENTS

- THREE PHASE PRODUCTION RELIABILITY GROWTH REQUIREMENT

<u>PHASE</u>	MTBF REQUIREMENT		<u>DEMONSTRATION POINT</u>	<u>RESULTS</u>
	<u>NAVY/MAC</u>	<u>MAC/HAC</u>		
#1	60	64	INITIAL UNITS	WAIVED
#2	80	85	#50-#75	>106 HRS
#3	100	106	#125	---

- PHASE #2 RESULTS >106 HOUR MTBF
- AHEAD OF SPECIFIED GROWTH PLAN

MAINTAINABILITY REQUIREMENTS

The maintainability requirements imposed on the radar supplier included suballocating to the radar a portion of the total air vehicle requirements.

The MTBUMA, MTTR, and DMMH/FH were all demonstrated requirements. The MTTR was demonstrated during the maintenance engineering inspection in February 1980. The MTBUMA and DMMH/FH were demonstrated during the field 2500-hour evaluation at NATC-Pax River, MD, and the 9000 FH evaluation at NAS-LeMoore, CA.

The basic Navy maintainability requirements (NAVAIR AR-10 and MIL-STD-1472 including BIT) were redefined and incorporated into the procurement specification for the radar. These design requirements were integrated with other requirements based on past experience.

APG-65 RADAR MAINTAINABILITY REQUIREMENTS

MTBUMA(FH)	40.0 FLIGHT HOURS (NOT LESS THAN)
MTRR	0.20 HOURS ("0" LEVEL)
DMMH/FH	0.26 HOURS (TOTAL "0" + "1")
BUILT-IN-TEST	"PERIODIC" BIT SHALL DETECT AT LEAST 90% OF ALL FAILURES OF THE SELECTED EQUIPMENT OPERATING MODE "PERIODIC + INITIATED" BIT SHALL DETECT AT LEAST 98% OF ALL EQUIPMENT FAILURES
INITIAL BIT ASSESSMENT	CONSISTS OF INSERTING ONE AT A TIME A TOTAL OF 500 NON-DESTRUCTIVE FAILURE SIMULATIONS. THE NUMBER OF UNDETECTED FAILURES SHALL NOT EXCEED 3.
MAINTAINABILITY DEMONSTRATION	DEMONSTRATION OF FAILURE DETECTION, ISOLATION, MEAN TIME TO REPAIR SHALL BE CONDUCTED PER TEST PLAN
AR-10 REQUIREMENTS	REDEFINED AND INCLUDED IN RADAR PROCUREMENT SPECIFICATION
OTHER DESIGN FEATURES FOR MAINTAINABILITY	<ul style="list-style-type: none">• ALL WRA LIQUID COOLING, WAVE GUIDE AND ELECTRICAL CONNECTIONS SHALL BE OF THE QUICK RELEASE TYPE. LIQUID COOLANT CONNECTORS ARE SELF-SEALING TYPE.• THE RADAR PACKAGE SHALL BE CAPABLE OF BEING EXTENDED USING THE EFFORT OF ONE PERSON STANDING ON THE GROUND• ACCESS TO THE ANTENNA SHALL NOT REQUIRE RACK EXTENSION• CAPTIVE WRA MOUNTING FASTENERS

BUILT-IN-TEST REQUIREMENTS

The basic NAVAIR AR-10 requirements were redefined and incorporated into the radar procurement specification to assure that MCAIR would, as a minimum, meet or exceed the MCAIR built-in-test requirements to the Navy. As a direct fallout of incorporating a comprehensive BIT program employing digital circuits, SRA isolation can be accomplished by inspecting the fail flags stored within the processor memory.

APG-65 RADAR BUILT-IN-TEST REQUIREMENTS

- INITIATED BIT
98% FAULT DETECTION
99% FAULT ISOLATION (TO WRA)
- PERIODIC BIT
90% FAULT DETECTION
90% FAULT ISOLATION (TO WRA)
- FALSE ALARM RATE <1%

BIT TEST PLAN

The number of trials for the maintainability/BIT demonstration is determined by the system MTBF at a 95% confidence level. The faults are randomly selected and proportionally distributed to each WRA based on the WRA failure rates. A minimum of 95 faults with zero (0) test failures (all faults detected and isolated) is considered passed. If a test failure occurred, an additional 30 faults with zero test failures are required in order to pass. If, at the completion of this demonstration, 338 tests, a point within the accept region is not obtained, fixed/retest of the test failures is required.

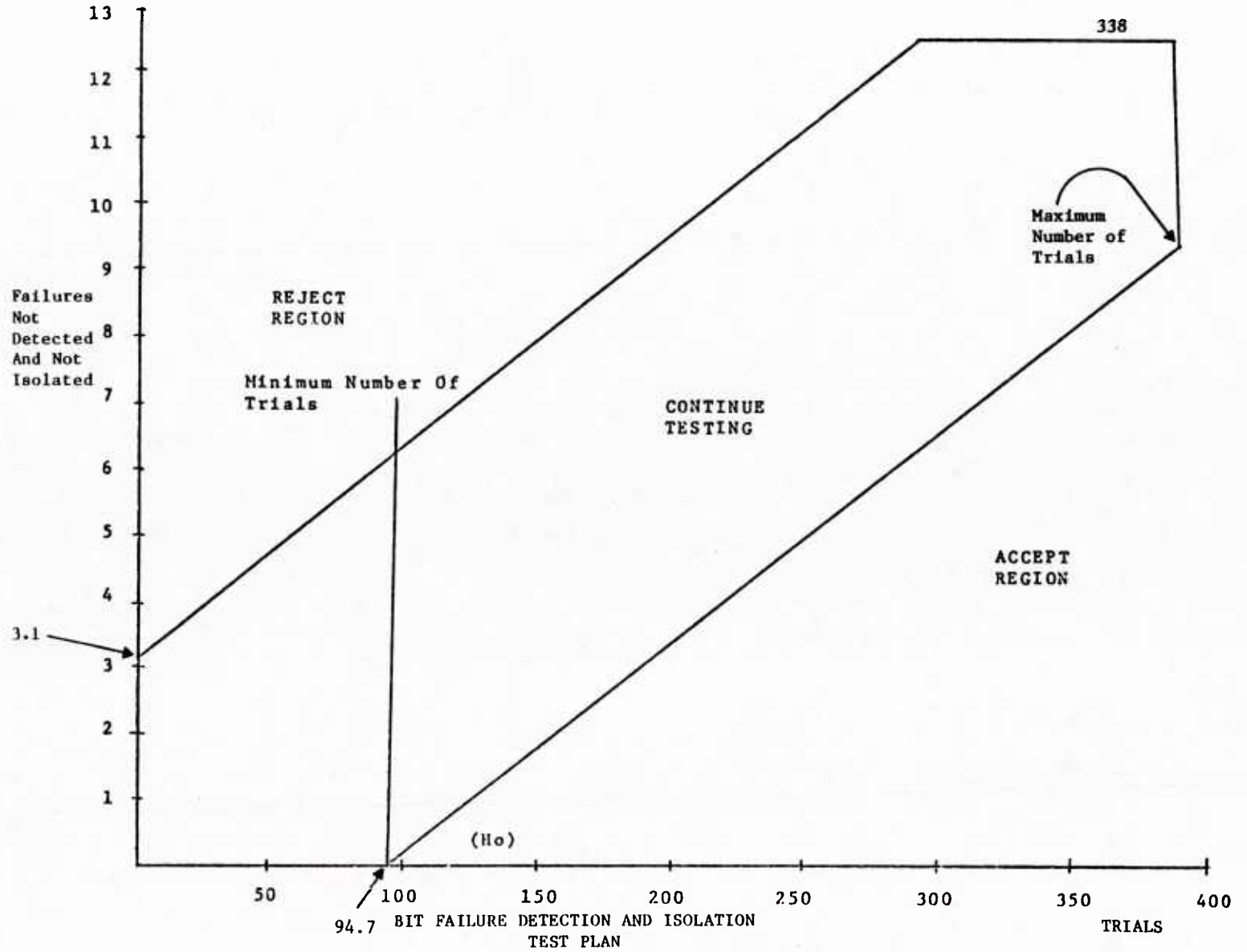

Emphasis was placed on designing and testing to the "real-world" environments. Operational Mission Environment (OME) was used to define the F/A-18 operating conditions and took precedence over less severe environmental specifications. This real-world environment was first applied as design constraints and then used to set the test limits.

The implementation of a realistic Operational Mission Environment (OME) as a basis for design and test requirements is a key Hornet program initiative which contributes to improved equipment reliability. Traditional design and test requirements have, in many instances, been inadequate in representing field operating stresses. As a result, the real-world operating environment contributes to failure modes that were not considered during design, nor discovered and corrected during demonstration tests. To solve this problem, realistic training and combat mission profiles were selected as the basis for a detailed operating environment of the airplane. As the first step in the OME process, twelve training missions (based on training syllabus requirements, squadron surveys, and pilot experience) and six critical combat missions (based on the Hornet Operational Requirement) were defined. A frequency of occurrence for each mission was then established for Navy Fighter, Navy Light Attack, and Marine Fighter/Attack squadrons, as well as ship/shore and combat/training sortie ratios. Allowances were included for combat maneuvers, occasional transient excursions beyond the design flight envelope, ground operation, and handling and storage conditions. The resulting OME definition formed the basis for establishing expected flight load, vibration, temperature, altitude, humidity, acoustic, salt, and dust conditions. Critical design points from the OME became "design-to" requirements for all Hornet equipment. Thus, design and test conditions tailored to the expected environment were derived and imposed in the procurement specifications. OME conditions were used in the radar reliability development test. Accelerated testing approaches were developed to "time-compress" the design life testing to achieve test span reductions and cost economics.

F-18 MISSION PROFILES (MP)
IN DESIGN AND TEST (D&T)

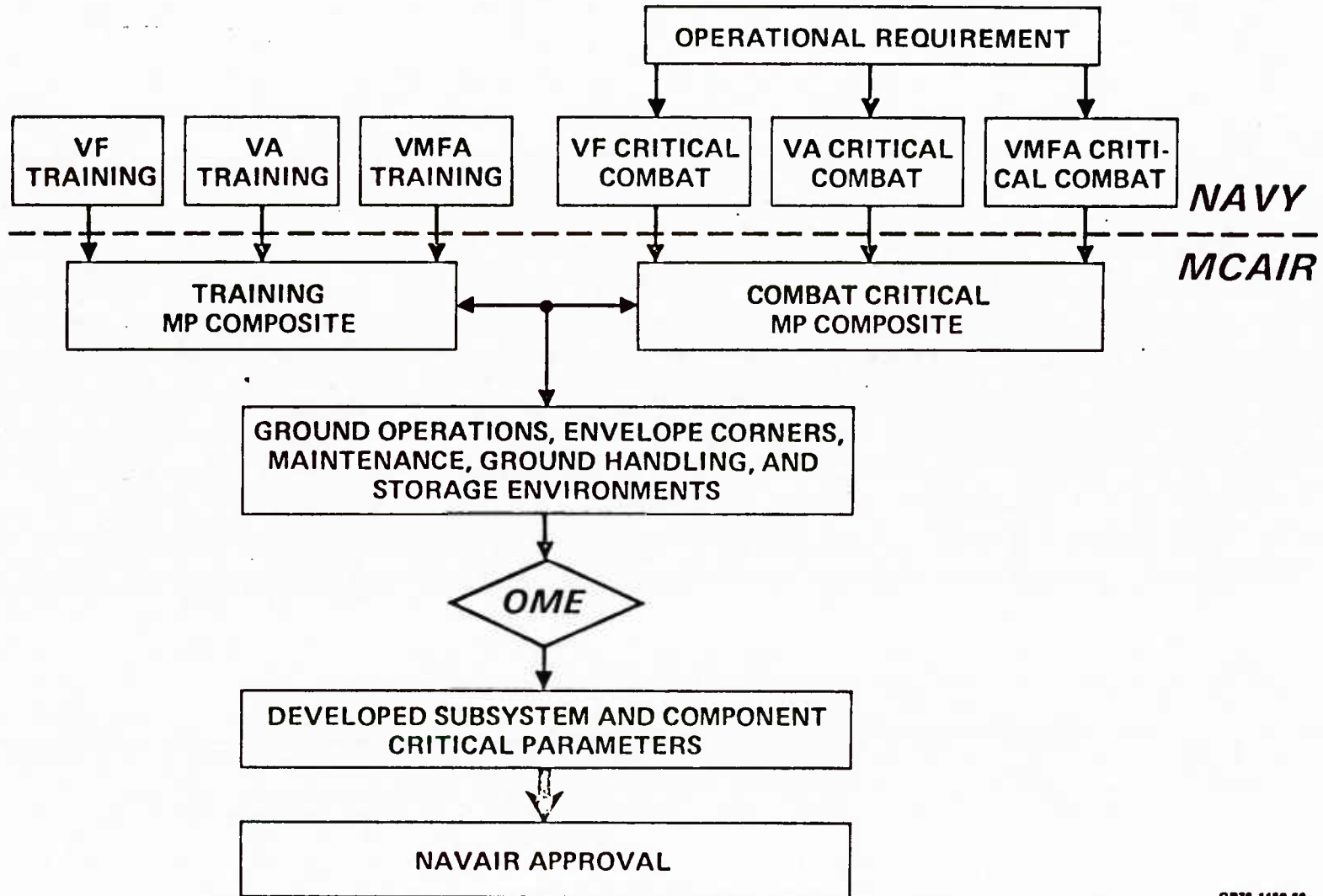

F-18 DESIGN MISSION MIX

TYPE SQUADRON/MISSION	VF	VA	VMFA
% OF PROCURED FORCE	25	43	32
TRAINING MISSION DISTRIBUTION (SURVEYS AND TRAINING REQ'MTS) 88%			
STRIKE ESCORT	7.5	-	5.0
BARRIER CAP	10.8	-	10.0
FIGHTER CAP	6.5	-	6.0
DECK LAUNCHED INTERCEPT (DLI)	1.0	-	1.0
AIR COMBAT TRAINING/ACM	20.9	12.0	20.0
AIR INTERCEPT TRAINING	20.0	5.0	-
INTERDICTION/CLOSE AIR SUPPORT	12.0	27.0	30.0
LOW LEVEL NAVIGATION/STRIKE	-	15.0	17.0
CARRIER QUALIFICATION	3.0	3.0	2.0
FIELD CARRIER LANDING PRACTICE	9.0	9.0	9.0
FERRY/FAM/INSTRUMENTS	9.3	24.0	-
SURFACE SUBSURFACE SEARCH	-	5.0	-
TOTAL	100%	100%	100%
COMBAT CRITICAL MISSIONS 12%	DISTRIBUTION FOR CONSERVATIVE DESIGN		
STRIKE ESCORT	75.0	-	40.0
DLI AGAINST BOMBERS (SAME PROFILE AS T4)	25.0	-	25.0
SUPERSONIC MEDIUM ALTITUDE ATTACK	-	5.0	5.0
SUPERSONIC HIGH ALTITUDE ATTACK	-	15.0	-
HIGH SUBSONIC LOW ALTITUDE ATTACK	-	10.0	10.0
SUBSONIC MEDIUM ALTITUDE ATTACK	-	70.0	20.0

F-18 OPERATING HOUR SUMMARY

	SINGLE MISSION	F-18 SERVICE LIFE
FLIGHT HOURS	1.877	6000.0
ADDITIONAL ENGINE OPERATING HOURS	0.563	1800.0
● MISSION RELATED (TAXI, TAKEOFF, ETC)	(0.522)	(1667.2)
● OTHER (MAINTENANCE, TRIM, ETC)	(0.041)	(132.8)
OPERATING HOURS FOR MAINTENANCE	0.630	2013.9
● APU OPERATING	(0.530)	(1694.2)
● EXTERNAL POWER	(0.100)	(319.7)
TOTAL	3.070	9813.9

GP76-1150-53

SUMMARY

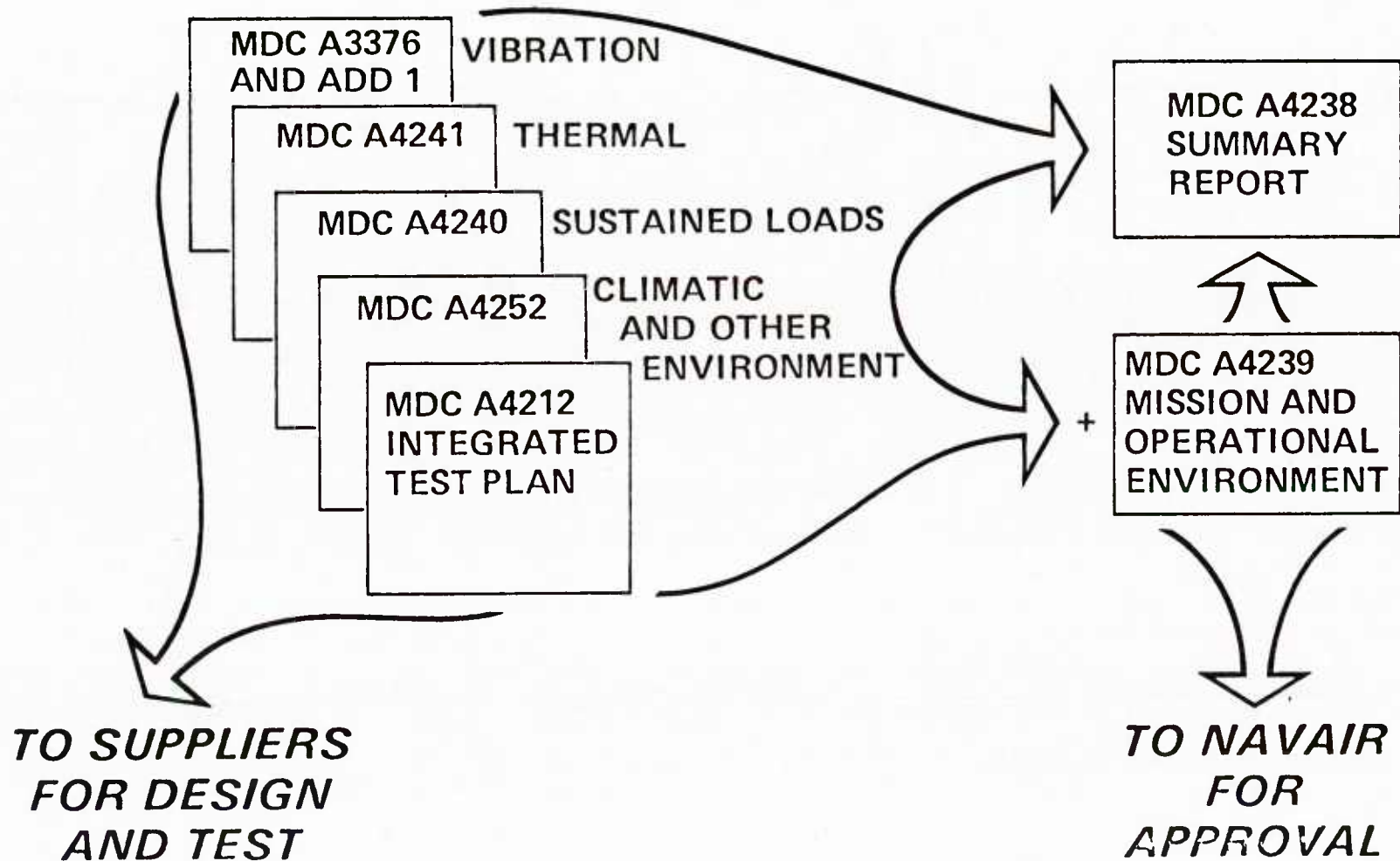

RELIABILITY FAILURE DEFINITION

Reliability failure definitions were established for the various test/measurement aspects of the F-18 program. Reliability demonstration testing basically used the ground rules of MIL-STD-781 and AR-34. Field teams were deployed both during full-scale development (FSD) and deployment. Ground rules during FSD included provisions for making a failure non-relevant if a fix had been identified prior to the field occurrence. (This approach was a compromise between counting all failure occurrences until the fix was implemented and not counting repeats of known problems.) This method projected the reliability that could be expected on the production aircraft.

RELIABILITY FAILURE DEFINITION

- RELIABILITY DEMONSTRATION
 - MIL-STD-781B "RELIABILITY TESTS: EXPONENTIAL DISTRIBUTION"
 - AR-34 "GENERAL REQUIREMENTS FOR FAILURE CLASSIFICATION FOR RELIABILITY TESTING"

- RELIABILITY MEASUREMENT DURING FLIGHT TEST AND OPERATION
 - MCAIR/NAVAIR MEMORANDUMS OF AGREEMENT
 - FSD - NON-RELEVANT IF FIX PREVIOUSLY IDENTIFIED
 - PRODUCTION - ALL RELEVANT

R&M AWARD FEE STRUCTURE

An incentive award fee was issued as part of the basic contract to provide MCAIR an opportunity to gain awards based on demonstrated aircraft performance in the areas of R and M. These award fees were then structured to allow major suppliers to participate in the R&M incentive.

The reliability features of the radar to be demonstrated were MTBF and MFHBF. The maintainability features were MMH/FH (O-Level Unscheduled), DMMH/FH (O&I Total) and MFHBMA (O-Level). These requirements were selected to be demonstrated during the production reliability test, the 1200 FH, 2500 FH, and 9000 FH periods. The incentive award fee was structured to provide 60% of the total award pool to reliability and 40% maintainability.

APG-65 RADAR RELIABILITY INCENTIVE AWARDS

The table shows the radar reliability incentive earned to date. The 1200 flight hour evaluation was based on cumulative data beginning at first flight and allowed almost no credit for corrective actions. The 2500 flight hour milestone was fulfilled by the 50-flight, aircraft reliability demonstration. The production reliability demonstration was the MIL-STD-781B test conducted at Hughes.

APG-65 RADAR

R&M INCENTIVE AWARD FEE STRUCTURE

- MAXIMUM AWARD = 5% OF FSD PURCHASE ORDER COST
- WEIGHT CONSTRAINTS ON RELIABILITY AWARDS
- QUALITATIVE LIFE CYCLE COST CONSTRAINT ON MAINTAINABILITY AWARDS

R&M PARAMETERS		MAXIMUM AVAILABLE AWARD FEE AS PERCENT OF R&M AWARD POOL			
		PRODUCTION RELIABILITY TESTING (MIL-STD-781B)	1200 FH	2500 FH	9000 FH
RELIABILITY 60%	MTBF	30	9	--	--
	MFHBF	--	-	21	--
MAINTAINABILITY 40%	MMH/FH (O-LEVEL, UNSCHED)	--	4	6	--
	DMMH/FH (O&I, TOTAL)	--	-	8	12
	MFHBMA (O-LEVEL)	--	-	4	6
TOTAL		30	13	39	18

APG-65 RADAR RELIABILITY INCENTIVE AWARDS

The table shows the radar reliability incentive earned to date. The 1200 flight hour evaluation was based on cumulative data beginning at first flight and allowed almost no credit for corrective actions. The 2500 flight hour milestone was fulfilled by the 50 flight, aircraft reliability demonstration. The production reliability demonstration was the MIL-STD-781B test conducted at Hughes.

APG-65 RADAR RELIABILITY INCENTIVE AWARDS

	<u>MTBF</u>			<u>MFHBF</u>			<u>% AWARD RECEIVED</u>
	<u>THRESHOLD</u>	<u>100%</u>	<u>ACTUAL</u>	<u>THRESHOLD</u>	<u>100%</u>	<u>ACTUAL</u>	
1200 FLIGHT HOURS	58	96	37	--	--	--	0
2500 FLIGHT HOURS	--	--	--	53	88	100	100
PRODUCTION R DEMO	85	106	>106	--	--	--	TBD

9000 HOUR MAINTAINABILITY INCENTIVE AWARD

The 9000 flight hour maintainability evaluation was conducted by VFA-125, the first fleet readiness squadron (FRS), at NAS-LeMoore, California. The maintenance was performed by fleet personnel and observed by MCAIR and Naval Air Test Center monitors. The maintenance was documented by squadron maintenance personnel on Navy VIDs/MAFs (OPNAV 4790/60). The data from four production aircraft was used.

During this time VFA-125 made three deployments, two to MCAS-Yuma, AZ, and one to NAS-Fallon, NE. A total of 924 flight hours were accumulated on these four aircraft.

APG-65 RADAR

9000 HR MAINTAINABILITY INCENTIVE AWARD

MMH/FH (ORGANIZATIONAL/INTERMEDIATE-LEVEL) FOR 9,000 FLIGHT HOURS

REQUIRED - .280 MMH/FH
DEMONSTRATED - .227 MMH/FH
% IMPROVEMENT - 19%
AWARD - MAXIMUM (12% OF TOTAL R&M AWARD POOL)

MFHBMA (ORGANIZATIONAL-LEVEL) FOR 9,000 FLIGHT HOURS

REQUIRED - 36.7 MEAN FLIGHT HOURS BETWEEN MAINTENANCE ACTION
DEMONSTRATED - 42.0 MEAN FLIGHT HOURS BETWEEN MAINTENANCE ACTION
% IMPROVEMENT - 16%
AWARD - (19% OF MAINTAINABILITY AWARD, 88% OF LOGISTICS
BIAS AWARD)

TOTAL 9,000 FLIGHT HOURS MAINTAINABILITY INCENTIVE
AWARD - 80.3% OF AWARD AVAILABLE

SOURCE SELECTION

The importance of R&M was clearly established with potential suppliers during numerous briefings, specific proposal preparation instruction, and firm, demanding specification requirements. This importance was reinforced by requiring specific data in each proposal. The data included analysis of and justification for any exceptions to reliability guidelines and derating criteria. Examples of analysis techniques including FMEAs and predictions were also required. It was made clear that R&M was a total program concept and that R&M evaluation would be conducted in all key areas of the proposal including design, manufacturing, management, and contracts. Numerous special trade studies of alternative configurations required the input of the potential suppliers. These activities supported the emphasis on R&M during negotiation.

SOURCE SELECTION

- 1) CLEARLY ESTABLISH IMPORTANCE OF R&M
 - A) BRIEFINGS
 - B) REQUEST FOR PROPOSAL INSTRUCTIONS
 - C) HARD SPECIFICATION REQUIREMENTS
- 2) REINFORCE IMPORTANCE WITH SPECIFIC DATA REQUIRED IN PROPOSALS OVER AND ABOVE
 - A) CLEAR SUMMARY OF EXCEPTIONS ANTICIPATED TO
 - RELIABILITY GUIDELINES
 - DERATING CRITERIA
 - ANALYSIS TECHNIQUES
 - TRADE STUDIES
- 3) R&M EVALUATION CONDUCTED IN ALL KEY PROPOSAL AREAS
 - DESIGN
 - MANUFACTURING/PRODUCTION PLANS
 - MANAGEMENT
 - CONTRACTUAL

NOT JUST THE R&M PROPOSAL VOLUMES
- 4) BUYER PERFORMANCE DURING NEGOTIATIONS SUPPORTS R&M EMPHASIS
 - REACTION TO SPECIFIC R&M EXCEPTIONS/DEVIATIONS BALANCE IN RELATION TO OTHER FACTORS
 - REACTION TO CONFIGURATION AND TRADE STUDY SELECTIONS
 - IMPLEMENTATION OF KEY R&M PROPOSED INITIATIVES AS CONTRACTUAL REQUIREMENTS
 - SPECIAL TESTS

MANAGEMENT

MANAGEMENT

- MANAGEMENT EMPHASIS
- MANAGEMENT CONTROL

MANAGEMENT EMPHASIS

All program participants at all levels must be made aware of the importance of R&M. This especially includes the designers both at MCAIR and the suppliers. With many informal R&M trade-offs taking place daily on the drawing boards, the individual designers have to be aware of the importance of R&M.

MANAGEMENT EMPHASIS

- NAVY BRIEFINGS ON R&M NEW LOOK
 - MCAIR MANAGEMENT AND SUBSYSTEMS MANAGERS
 - POTENTIAL SUPPLIERS

- MCAIR/NAVY
 - POTENTIAL SUPPLIERS
 - VISITS TO KEY SUPPLIERS PLANTS - BRIEFINGS TO MANAGEMENT AND RESPONSIBLE DESIGN ENGINEERS

RESULTS: ESTABLISHED MANAGEMENT EMPHASIS
ESTABLISHED DESIGNER LEVEL EMPHASIS

NAVY PROGRAM REVIEWS

Navy program monitoring and sustained emphasis on R&M was evident by the number of meetings shown in the figure. Special emphasis and attention was provided by the Assistant Deputy Chief of Naval Material for RM&O. These meetings not only communicated the Navy's interest in R&M but brought senior contractor management into the meetings.

In the early reviews, the Navy required that R&M be addressed in the reviews by the contractor subsystem manager. This reinforced the idea that R&M was part of the responsibility of the subsystem managers and designers.

NAVY PROGRAM REVIEWS AT MCAIR FOR R&M

NOV 5-6, 1975	R&M DESIGN REVIEW RADM FOXGROVER, ADM SEYMOUR, W. WILLOUGHBY
JAN 19-22, 1976	R&M DESIGN REVIEW
FEB 3-4, 1976	R&M REVIEW
MAR 3, 1976	BIDDER INFORMATION CONFERENCE RADM FOXGROVER, W. WILLOUGHBY
APR 2, 1976	R SPECIALTY DESIGN REVIEW
MAY 1976	INITIAL DESIGN REVIEW
AUG/SEP 1976	R SPECIALTY DESIGN REVIEW
DEC 6, 1976	R&M DESIGN REVIEW RADM JESSON, CAPT LENOX, W. WILLOUGHBY
SEP 1977	DETAIL DESIGN REVIEW
JAN/FEB/MAR 1977	R SPECIALTY DESIGN REVIEW
MAR 1, 1977	R&M PROGRAM REVIEW
APR 19-22, 1977	CRITICAL DESIGN REVIEW CAPT CARRUTH
MAR 13, 1978	R PROGRAM REVIEW
JUL 24, 1978	R PROGRAM REVIEW

(Continued)

During the present program phase emphasis has been concentrated on Navy operational reviews, but Reliability coordination and Technical coordination between NAVAIR, MCAIR and Hughes has continued.

NAVY PROGRAM REVIEWS AT MCAIR FOR R&M (CONTINUED)

DEC 12-13, 1978	R&M PROGRAM REVIEW
AUG 16, 1979	R&M PROGRAM REVIEW
SEP 24, 1979	R&M REVIEW - CAPT LENOX
JAN 27, 1980	PREPRODUCTION RELIABILITY DESIGN REVIEW - W. WILLOUGHBY, RADM JESSON, CAPT LENOX, CONDUCTED AT WASHINGTON, DC

FEBRUARY 1980 TO PRESENT

- TECHNICAL COORDINATION MEETINGS AT MCAIR/HUGHES - BIMONTHLY
- NAVY OPERATIONAL AND MAINTENANCE REVIEW - QUARTERLY SINCE JANUARY 1982
- NAVY/MCAIR R&M REVIEWS - SEMIANNUAL



OME AND YOUR APPROACH TO DESIGN AND TEST

- THE OME SPECS AND DOCUMENTS ARE THE MCAIR/USN BEST ESTIMATE OF WHAT YOUR EQUIPMENT WILL SEE IN SERVICE
- THE FLIGHT DEMONSTRATION PROGRAM WILL SIMULATE OPERATIONAL USAGE
- WE WILL ALL BE JUDGED IN THE FLIGHT DEMO PROGRAM
- THE SUCCESS OF OUR PROGRAM DEPENDS ON OUR PERFORMANCE DURING THE FLIGHT DEMONSTRATION

TAKE IT SERIOUSLY

DON'T DESIGN TO PASS SOME LAB TESTS
OUR F-18 WON'T FLY IN A LAB

MANAGEMENT CONTROLS

Collocation of R&M engineers with design engineers at MCAIR provided for effective coordination and communication throughout the program.

MANAGEMENT CONTROLS

- REQUIREMENTS/RESPONSIBILITY FLOW TO DESIGNER LEVEL
 - AWARE OF ALL REQUIREMENTS
 - EQUAL RESPONSIBILITY FOR PERFORMANCE/RELIABILITY/MAINTAINABILITY/COST (QUAD CHARTS) REPORTING AT ALL REVIEWS

- SCHEDULES AND MILESTONE CONTROL

- COLLOCATION OF R&M ENGINEERS WITH DESIGN ENGINEERING AT MCAIR

RADAR SET

WBS 1340.01

SUBSYSTEM MANAGER: L.A. LEMKE

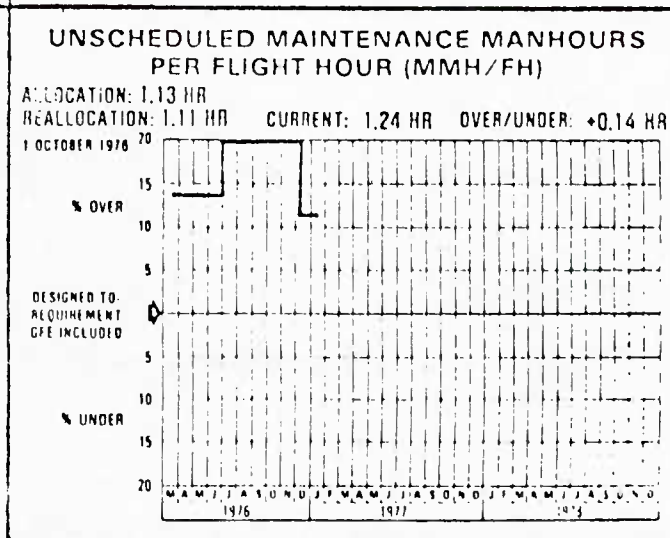
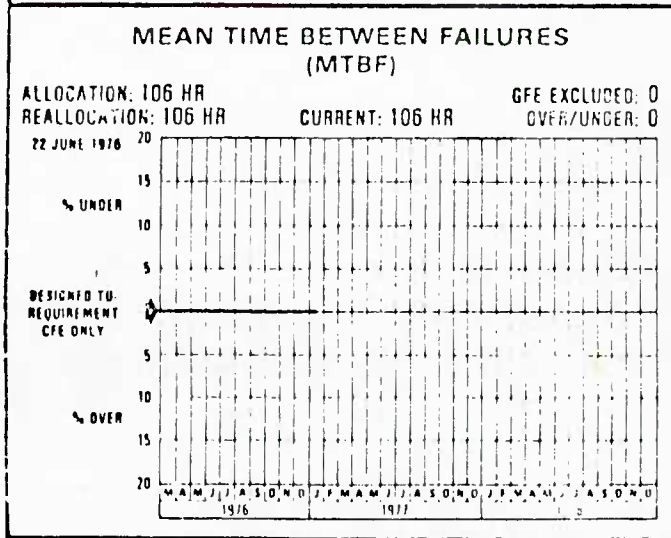
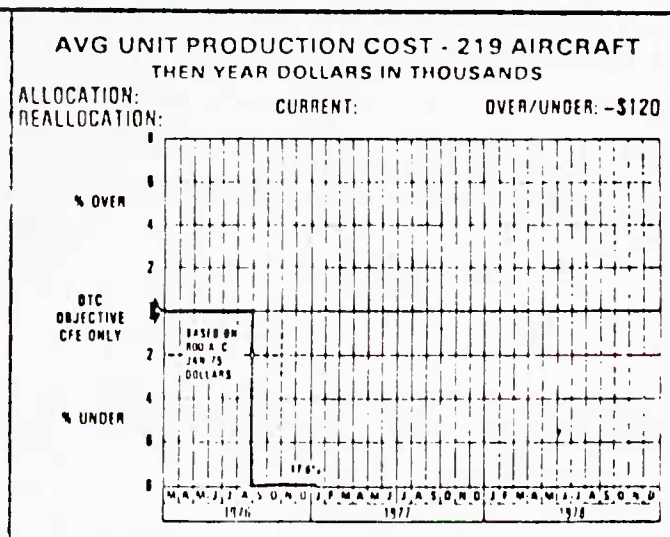
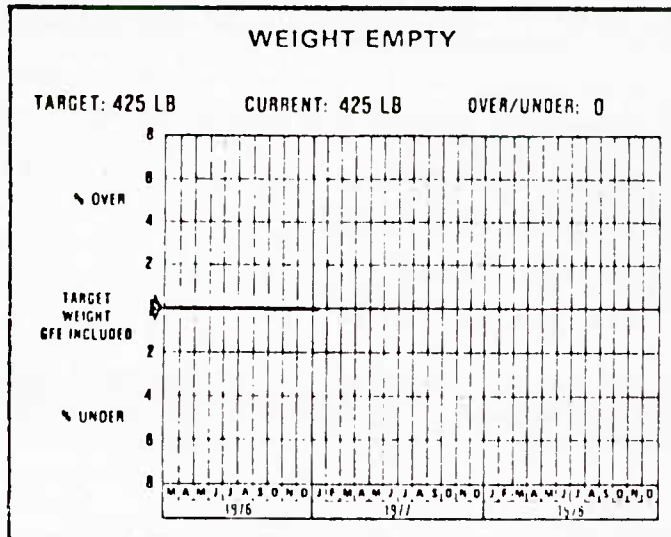
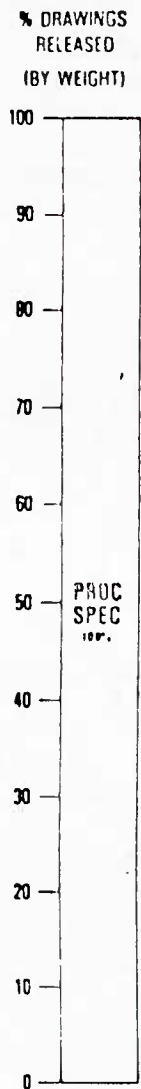

WRA: RADAR SIGNAL PROCESSOR

REA: E. B. CLAPP

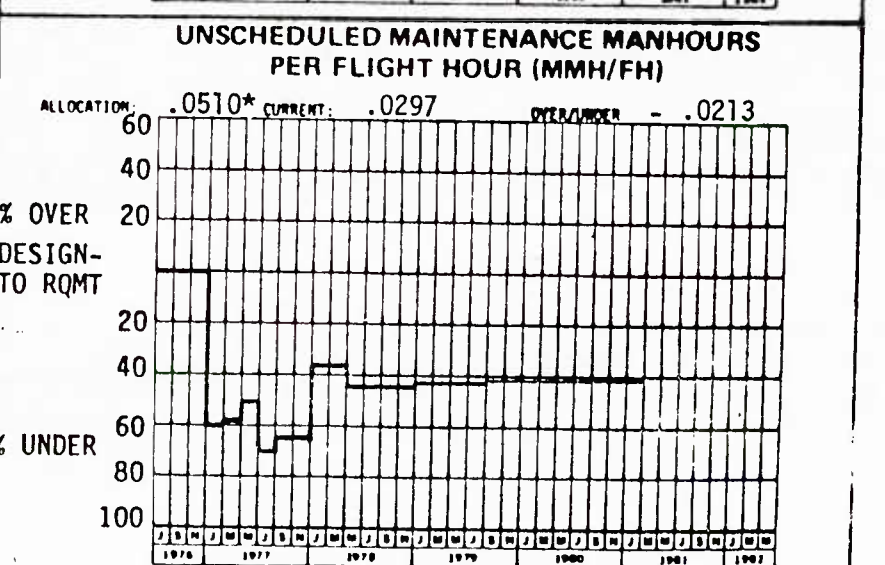
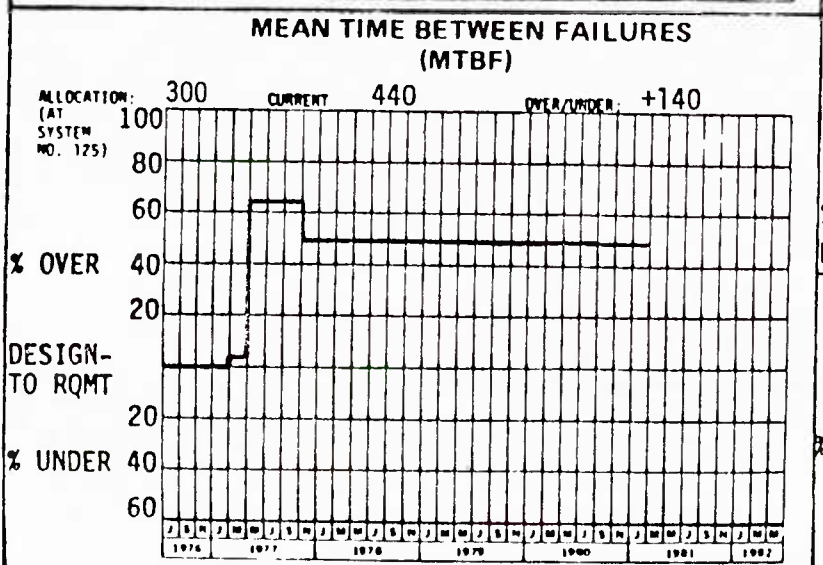
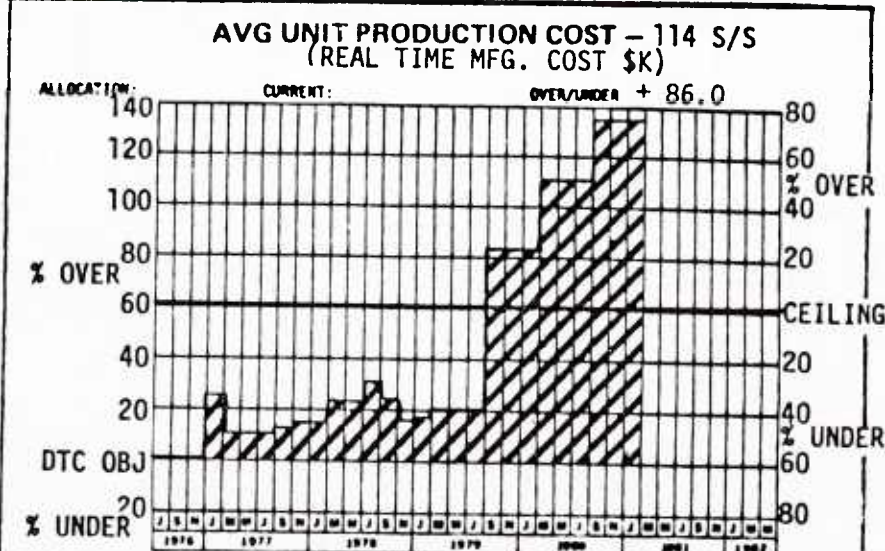
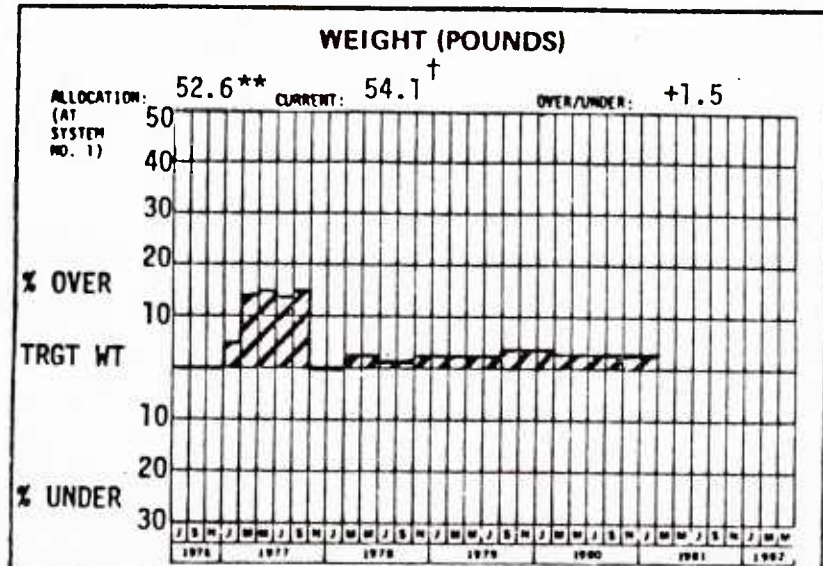

* REALLOCATED 9/77
 ** REALLOCATED 10/77

[†] PRODUCTION UNIT NO. 5 ACTUAL

FORMALIZED REQUIREMENTS TO IMPROVE CONTROL

	1976	1977	1978
	J A S O N D	J F M A M J J A S O N D	J F M A M J J A S O N D
REL DESIGN REQUIREMENTS	Δ		
REL & QUAL PROGRAM PLAN		Δ	
CRITICAL ITEMS PLAN		Δ	
INTEGRATED CORRECTIVE ACTION PROGRAM			Δ
FAILURE REVIEW BOARD			Δ
QUALITY REVIEW BOARD			Δ
FAILURE DATA MANAGEMENT			
FSD FAILURE REPORTING		Δ	
MFG DATA ACQUISITION			Δ
DATA COMPILATION		Δ	
DATA ANALYSIS			Δ
ASSEMBLY SCREENS		Δ	
COMPONENT QUALITY REQUIREMENTS			Δ
MFG TROUBLESHOOTING			Δ

CRITICAL ITEM RELIABILITY CONTROLS

The purchase order included specific requirements for a variety of measures directed at R&M assurance. Hughes established formal internal requirements documents containing detailed procedures for implementing these purchase order provisions. The following chart indicates that these requirements were selectively passed on to suppliers of key elements/devices within the radar.

CRITICAL ITEM RELIABILITY CONTROLS

RELIABILITY CRITICAL ITEM	PART NUMBER	WRA	FAILURE MODE AND EFFECTS ANALYSIS	WORST CASE ANALYSIS	TEMPERATURE SCREENING	VIBRATION SCREENING	ACCEPTANCE TESTING AT TEMP EXTREMES	DEVELOPMENT TESTING	VENDOR RELIABILITY PREDICTION	SPECIFY HIGH RELIABILITY PARTS	DERATING REQUIREMENTS	FAILURE ANALYSIS AND REPORTS	CORRECTION OF DEFICIENCIES
TRIPLER COUPLER	259295	XMT		✓	X	PERI- ODIC			X	X	X	X	X
FLAT LEAKAGE MONITOR	259361	XMT		✓	X	PERI- ODIC			X	X	X	X	X
LINEARIZED ATTENUATOR	259296	XMT		✓	X	X	X		X	X	X	X	X
ROTARY JOINTS	259351 259352	ANT		✓			X	X	X			X	X
NULL SWITCH	259445	ANT	✓		X	X	X	X	X	X	X	X	X
GYRO	259270	ANT		✓	X			X	X	X	X	X	X
GROUND MAP SWITCH	3556927	ANT	✓	✓						X	X	X	X
CHANNEL SELECT SWITCH	259446	ANT	✓	✓	X		X	X	X	X	X	X	X
TORQUE MOTORS	259349 259350	ANT	✓	✓	X				X			X	X
SELECTED HYBRIDS	VARIOUS			✓	X			X				X	X

X = REQUIREMENT ✓ = COMPLETED

JULY 1977

DESIGN

DESIGN

- DESIGN OVERVIEW
- DESIGN TRADE STUDIES
- PREDICTIONS AND ANALYSES
- DESIGN GUIDELINES
- PARTS AND DERATING
- BUILT-IN-TEST

TECHNOLOGY UTILIZATION THAT IMPROVED RELIABILITY

The keys to the achievement of the reliability specified for the APG-65 radar are the same keys which permit the achievement of the dual-mission, multimode performance capabilities: The capability to perform high speed, wide dynamic range analog-to-digital conversion of the radar return coupled with the availability of low cost, low power, high density, high speed digital devices enables the fully programmable processing of air/air and air/ground radar returns in addition to the previously implemented digital processing of target data and radar control functions. In effect, software complexity has been substituted for many discrete analog processing circuits. The other items listed represent additional examples of reliability enhancement resulting from technology advances.

APG-65 RADAR DESIGN - TECHNOLOGY KEYS TO RELIABILITY

- HIGH SPEED, 12 BIT DIGITAL-ANALOG CONVERSION
 - PLUS HIGH SPEED DIGITAL PROCESSING
 - CONVERTS ANALOG HARDWARE TO SOFTWARE
- LOW NOISE FET REPLACES PARAMETRIC AMPLIFIER
- PERMANENT MAGNET GRIDDED TRAVELLING WAVE TUBE
- GUNN DIODE LOCAL OSCILLATOR
- PDI VS. SEPARATE CW MISSILE ILLUMINATOR
- 4 MBIT DISC BULK MEMORY
- ELECTRIC DRIVE ANTENNA
- HIGH EFFICIENCY COOLING FOR LOW COMPONENT TEMPERATURES

DESIGN HIGHLIGHTS FOR IMPROVED R&M

The features noted here are examples of design choices which provide R&M benefits in addition to cost, weight and performance benefits. Some of these features were directly specified in terms of R&M requirements, while others were selected as a result of mechanization trade studies.

APG-65 RADAR - DESIGN HIGHLIGHTS FOR IMPROVED R&M

- LOW PARTS COUNT - 13,500 PARTS
- ANTENNA FEATURES:
 - ELECTRICAL DRIVE
 - NO TACHOMETERS
 - NO BORESIGHT REQUIRED UPON ANTENNA REPLACEMENT
 - NO ROLL GIMBAL
 - REMOVABLE SERVO PART OF ANTENNA ASSEMBLY
 - ALL DIGITAL INTERFACE
 - FAN/PENCIL BEAM AND NULL HORN SWITCHES
 - ANTENNA ARRAY - VIBRATION ISOLATION
- THERMAL DESIGN - 60°C TYPICAL JUNCTION TEMPERATURE
- GUN DIODE LOCAL OSCILLATOR
- FET RECEIVER LOW NOISE AMPLIFIER

APG-65 RADAR DESIGN HIGHLIGHTS FOR IMPROVED R&M (CONTINUED)

- NOSE PACKAGE WRAs ISOLATED FROM GUN GAS
- SRA, MOTHERBOARD ORIENTATION - VERTICAL (LIQUID WATER PROTECTION)
- HIGH VOLTAGE ARCING PROTECTION (FARADAY SHIELDS)
- LOW POWER IC LOGIC USED TO REDUCE JUNCTION TEMPERATURES (SCHOTTKY, LOW POWER SCHOTTKY, TTL)
- MEMORY - SPERRY MAGNETIC DISK, 156K 16 BIT WORDS
- GRIDDED TWT - PERMANENT MAGNET FOCUS, BEAM SCRAPER
- RADAR SIGNAL PROCESSOR - SOFTWARE REPROGRAMMABLE
- THREE ENGINEERING MODEL DEVELOPMENT SETS COMPLETED BEFORE DELIVERY OF FIRST FSD RADAR SET
- ALL WRAs REMOVABLE FROM GROUND LEVEL - NO STANDS REQUIRED
- NO ADJUSTMENT REQUIRED ON WRA REPLACEMENT

MCAIR considered the Hornet reliability requirements as being especially challenging and implemented many actions in the management, design, and test areas to ensure that these requirements would be achieved. The MCAIR subsystem manager responsibilities in the reliability area were delineated and reliability engineers were integrated into the design process. By collocating the reliability specialists with the subsystem managers and designers, all design details could be reviewed for reliability impact, resulting in maximum influence on the evolving design. Also, an extensive formal trade study process was used to evaluate any significant proposed changes to the baseline design. All trade studies were evaluated for reliability and maintainability impacts, along with the usual performance, weight and cost impacts. (Over 400 formal trade studies were completed during the design phase.) Periodic design reviews at suppliers, at MCAIR, and with the Navy, provided final assurance that reliability was being adequately considered in the design process.

Many of the accepted standard approaches to ensuring high equipment reliability are utilized on the Hornet program. Examples of these established techniques include reliability design-to-allocations, periodic assessment of status for each subsystem manager, failure mode and effects analysis, an approved parts list, selective use of Sneak Circuit Analysis, and use of a Closed Loop Evaluation and Reporting (CLEAR) system to report and track all equipment failures.

APG-65 DESIGNED-IN RELIABILITY AND MAINTAINABILITY

- R&M SPECIALISTS INPUTS AT DESIGN STAGE
 - TRADE STUDIES
 - REVIEW AND COMMENT SHEETS
 - MONITORING AND REPORTING
 - INTERNAL DESIGN REVIEWS
- ALLOCATIONS TO DESIGN LEVEL
- FIRM DESIGN GUIDELINES
- FIRM DERATING CRITERIA SPECIFIED
- DESIGN TO MEET F/A-18 OPERATIONAL MISSION ENVIRONMENT
- ANALYSIS TOOLS
 - FAILURE MODES AND EFFECTS ANALYSIS
 - STRESS ANALYSIS
 - SNEAK CIRCUIT ANALYSIS
- STANDARD PARTS PROGRAM

F/A-18 RELIABILITY DESIGN GUIDELINES

Extensive reliability design guidelines were established for all F-18 avionics. These guidelines were required to be reviewed in depth as part of the potential supplier proposal effort. Any exception required approval by MCAIR and all other elements of the guidelines became specification requirements when the contract was awarded. Hughes accepted the objectives of the guidelines with only a few minor exceptions. Later in the program, specific elements of the guidelines, such as the derating criteria, were made requirements of the radar procurement specification and the basic document remained a guideline.

F/A-18 RELIABILITY DESIGN GUIDELINES
AVIONIC EQUIPMENT

OBJECTIVE: DESIGN TO HIGH RELIABILITY STANDARDS FROM THE OUTSET

GUIDELINE (93 PAGES) ENCOMPASSES:

- ELECTRONIC PARTS
- ELECTRICAL/MECHANICAL PARTS
- ELECTRONIC PACKAGING
- MISCELLANEOUS PARTS
- PARTS DERATING
- DESIGN PRACTICES
- TESTING

GUIDELINE IMPLEMENTATION:

- HUGHES ACCEPTED
THE OBJECTIVES OF THE GUIDE-
LINES WITH ONLY A FEW SPECIFIC
MINOR EXCEPTIONS

TRADE STUDIES

The following two charts provide selected examples of mechanization trade studies performed during the preliminary design of the APG-65 radar. In general, cost, size, weight, performance, reliability and maintainability were considerations in each trade-off. In the great majority of cases, the selected mechanization provided a reliability advantage (often in addition to advantages in several of the other areas noted) over the other mechanizations considered.



F-18 TRADE STUDY STATUS

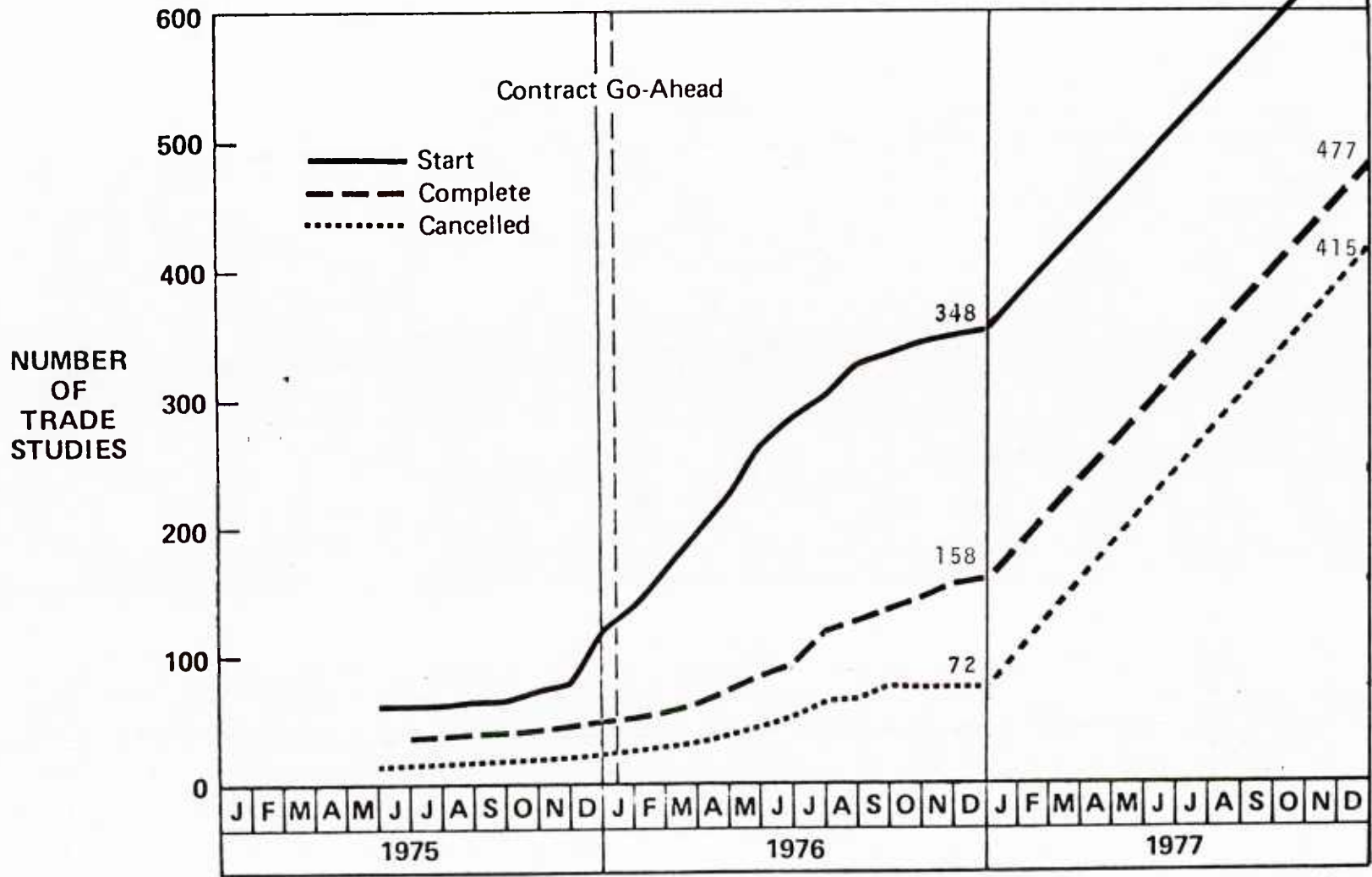

GP77-0002-1

MECHANIZATION TRADE STUDIES

<u>WRA</u>	<u>FUNCTION</u>	<u>SELECTED MECHANIZATION</u>		<u>ALTERNATE MECHANIZATION</u>	
		<u>DESCRIPTION</u>	<u>WRA MTBF</u>	<u>DESCRIPTION</u>	<u>WRA MTBF</u>
ANTENNA	GIMBAL DRIVE	DIRECT ELECTRIC DRIVE	1430	HYDRAULIC DRIVE	556
	GIMBAL	NO ROLL AXIS		ROLL GIMBAL	
RECEIVER/ EXCITER	RF PREAMP	FET	690	PARAMP	404
	PD TWT DRIVE	GUNN OSCILLATOR		MULTIPLIER CHAIN	
	CLUTTER PROCESSING	SOFTWARE		ANALOG HARDWARE	
TRANSMITTER	TWT DRIVE CONTROL	AUTO SATURATION	1630	CONSTANT DRIVE	944
	COOLING, DIELECTRIC	LIQUID		GAS, SOLID, LIQUID	
RADAR SIGNAL PROCESSOR	LOGIC MECHANIZATION	STTL DUPLEX	355	ECL SIMPLEX	154
	MODULE COOLING, PARTS PACKAGE	FLOW THRU, FLAT PACK		EDGE COOL, DIP	
RADAR DATA PROCESSOR	PROGRAM MEMORY	MAGNETIC DISC	690	EAROM	517

PULSE DOPPLER VS CW ILLUMINATION

One significant trade study performed during the proposal was the use of radars high PRF pulse doppler waveform in lieu of a separate continuous wave (CWI) illuminator. This addition of the CWI would have required 0.6 cu. ft. of space and increased system weight by 34 pounds. The reliability would have been adversely affected with a predicated decrease in system MTBF by about 6 hours. Since no significant performance advantages were present with CW illumination, this feature was eliminated.

TRADE STUDY - USE OF PD ILLUMINATION INSTEAD OF CW ILLUMINATOR

DELTA IMPACT FOR ADDITION OF CW ILLUMINATOR

- WEIGHT - 34 POUND INCREASE
- VOLUME - 0.6 CUBIC FOOT INCREASE
- RELIABILITY - 6 HOUR MTBF DECREASE ON SYSTEM
- PERFORMANCE - NO DIFFERENCE

FLATPACK (FP) VERSUS DUAL-INLINE (DIP) IC PACKAGE TRADE STUDY

FLATPACK PROVIDES A 2/1 RELIABILITY ADVANTAGE AND AND 2/1 VOLUME ADVANTAGE OVER DUAL-INLINE IC PACKAGE. BOTH ADVANTAGES STEM FROM THE FLOW-THRU HEAT EXCHANGER MODULE CORE UTILIZED WITH THE FLATPACK PACKAGE. THIS MECHANIZATION REQUIRES SUBSTANTIALLY LESS VOLUME AND PROVIDES MUCH LOWER COMPONENT OPERATING TEMPERATURES THAN ARE OBTAINABLE WITH THE EDGE COOLED CARD MECHANIZATION WHICH MUST BE EMPLOYED WITH THE DIP PACKAGE. THE FOLLOWING TABLE SUMMARIZES THE SIX CONFIGURATIONS STUDIED.

DESIGN	MAXIMUM NUMBER OF IC LOCATIONS PER MODULE ¹	SIZE, INCHES H W PITCH	COMPONENT PACKAGE TYPE ²	COOLING METHOD	IC TC (°C) ³		MTBF HOURS ⁴		NUMBER OF MODULES REQUIRED ¹	NUMBER OF MODULE CONNECTOR PINS ⁵	TOTAL NUMBER OF INTERCONNECTIONS REQUIRED ⁶	UNIT WEIGHT, POUNDS ⁷	UNIT VOLUME, FEET ³ ⁷
					MEAN	MAXIMUM ³	UNIT	SYSTEM ⁴					
A	80	8.0 x 6.0 x 0.35	DIP	EDGE	75	92	158	94	98	120	102,144	83.3	1.86
B	75	8.5 x 5.0 x 0.35	DIP	EDGE	75	102	158	94	85	180	102,780	82.2	1.83
C	80	4.8 x 3.8 x 0.60	FP	FLOW THROUGH	66	76	289	128	80	152	93,984	56.1	1.40
D	99	9.0 x 6.0 x 0.35	DIP	EDGE	72	106	167	97	49	240	102,980	78.6	1.86
E	168	5.0 x 6.0 x 0.60	FP	FLOW THROUGH	60	76	327	136	29	250	87,020	47.7	0.83
F 18	252	6.0 x 6.0 x 0.60	FP	FLOW THROUGH	66	76	365	140	19	304	82,814	48.2	0.83

NOTES

¹ EACH LOCATION IS FOR ONE 16 PIN INTEGRATED CIRCUIT (IC). THE BASELINE RSP DESIGN REQUIRES 3830 ICs. 212 OF THESE ICs ARE 24 PIN PACKAGES. EACH 24 PIN PACKAGE REQUIRES ONE AND ONE HALF 16 PIN LOCATIONS. THEREFORE, EACH DESIGN REFLECTS A CONSTANT RSP IC REQUIREMENT OF 3938 LOCATIONS. MODULE COUNT WAS BASED ON A CONSTANT 82 PERCENT UTILIZATION OF THESE LOCATIONS.

² DIP IS DUAL IN LINE, FP IS FLATPACK.

³ MEAN/MAXIMUM CASE TEMPERATURE (°C) FOR AN ASSUMED UNIFORM HEAT LOAD OVER THE MODULE BASED ON AN AVERAGE MODULE IC POPULATION OF 83 PERCENT AND AN AVERAGE IC THERMAL DISSIPATION OF 200 MW. USING F 18 DESIGN POINT COOLING AIR OF 242 POUNDS/MIN/IN², 82°F INLET, 180°F EXIT, AND 2.75 INCHES H₂O. ALL OF THE ABOVE DESIGNS ARE AMENABLE TO IMPLEMENTATION WITH SPECIFIED PRESSURE DROP. THE DIFFERENCES IN IC CASE TEMPERATURES (MEAN AND MAXIMUM) SHOWN REFLECT THE EFFECT OF THERMAL FLOW BACK (HEAT SPREADING) WHICH RESULTS FROM THE DIFFERENT LENGTHS OF HEAT EXCHANGERS NECESSARY FOR EACH DESIGN. IN ALL EDGE COOLED CASES, MODULES WERE ORIENTED SO THAT THE SHORTER DIMENSION, RATHER THAN THE LONGER DIMENSION, AS SHOWN IN FIGURE E 1, WAS BETWEEN THE HEAT EXCHANGERS. THIS RESULTS IN THE SHORTEST POSSIBLE THERMAL PATH.

⁴ PARTS COUNT ARE ASSUMED CONSTANT, AND NO CONSIDERATION WAS TAKEN FOR RELATIVE NUMBERS OF INTERCONNECTIONS, THUS, THE PRINCIPAL RELIABILITY FACTORS ARE PACKAGE ENCLOSURES (DIP, FP) AND MEAN COMPONENT CASE TEMPERATURES.

⁵ STANDARD FORK AND BLADE SHP CONNECTORS WITH 0.1 INCH SQUARE GRID FOR EITHER A WIRE WRAPPED OR MULTILAYER ETCHED CIRCUIT MOTHERBOARD.

⁶ ONE SOLDER JOINT FOR EACH COMPONENT AND CONNECTOR LEAD PLUS ALL MODULE TO MODULE INTERCONNECTIONS NEEDED TO IMPLEMENT EACH DESIGN.

⁷ UNIT VOLUME AND WEIGHT FOR MODULE DESIGNS (LESS POWER SUPPLY) IMPLEMENTED IN A CROSS SECTION THAT IS COMPATIBLE WITH THE F 18 INSTALLATION ENVELOPE, BUT ALLOWING THE FORE AND AFT DIMENSIONS TO GROW.

DESIGN RELATED ANALYSES

- BLOCK DIAGRAM AND MATH MODEL
- ALLOCATIONS AND PREDICTION
- STRESS ANALYSIS
- ENVIRONMENTAL ANALYSIS
- FAILURE MODES AND EFFECTS ANALYSIS
- SNEAK CIRCUIT ANALYSIS
- PERIODIC DESIGN REVIEWS

ANALYSIS RESULTS
F-18 RADAR RELIABILITY DESIGN ANALYSES

<u>ANALYSIS</u>	<u>APPLICATION</u>	<u>RESULTS</u>
FAILURE MODES & EFFECTS	WRA INPUT/OUTPUT	GROUND RADIATION-WEIGHT ON WHEELS LOGIC ADDED
	CRITICAL-VULNERABLE ITEMS	DISC MOTOR START - FIRM- WARE ADDED RECEIVER PROTECTION - ADDITIONAL BIT ADDED
SNEAK CIRCUIT	LVPS, TRANSMITTER (NO RF), ANTENNA SERVO	COMPLETE - NO MAJOR PROBLEMS, DRAWING CHECK
WORST CASE	CRITICAL DESIGN ITEMS AND FUNCTIONS	ECL TEMPERATURE GRADIENTS TIMING CLOCK SKEW NOISE FIGURE
THERMAL & ELECTRICAL STRESS	DERATING COMPLIANCE	INITIAL - 42 OVERTEMP CURRENT - 17
	COMPONENT SELECTION	INITIAL - 111 OVERSTRESSED CURRENT - 76
	MTBF PREDICTION	

TABLE 4-2. PROJECTED RELIABILITY

	MIL-HDBK-217B Predicted MTBF	Adjusted for 4K MOSRAM Industry Data	"K" Factor	Projected MTBF	Allocated MTBF
Antenna	1,370 →		1.6	860	700
Transmitter	1,128 →		1.7	665	700
Receiver/Exciter	1,110 →		1.4	790	800
Radar Data Processor	832	1,210	1.3	930	600
Radar Signal Processor	426	570	1.3	440	300
Equipment Rack	43,800 →		5.0	8,800	8,000
Waveguide Assemblies	<u>55,600</u> →		<u>2.0</u>	<u>27,800</u>	<u>10,000</u>
Total	164	195	1.42	137	106

MTBF PREDICTION PER MIL-HDBK-217B IS 164 HOURS

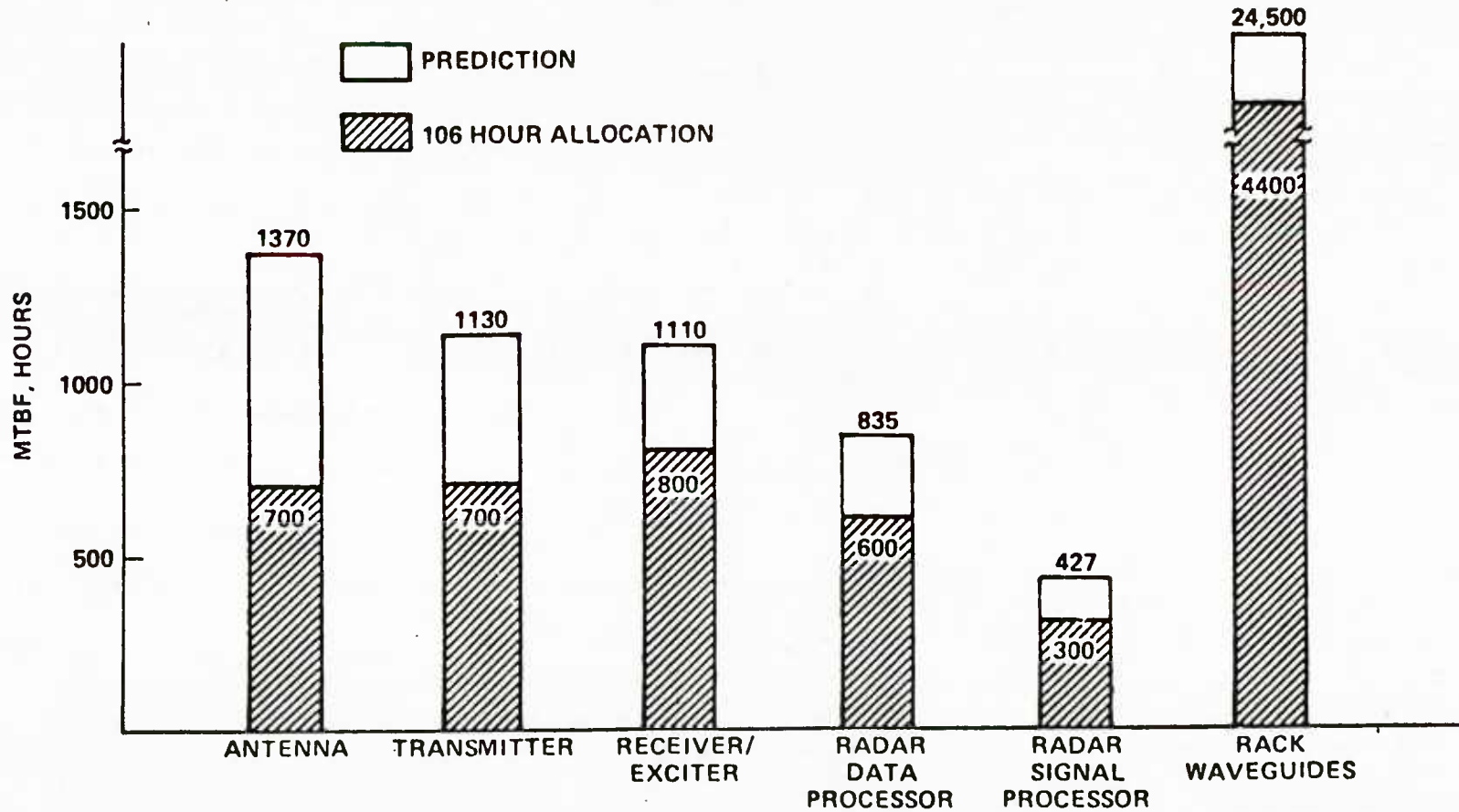

PREDICTED FAILURE RATE BY PART TYPE (ROUND NUMBERS)

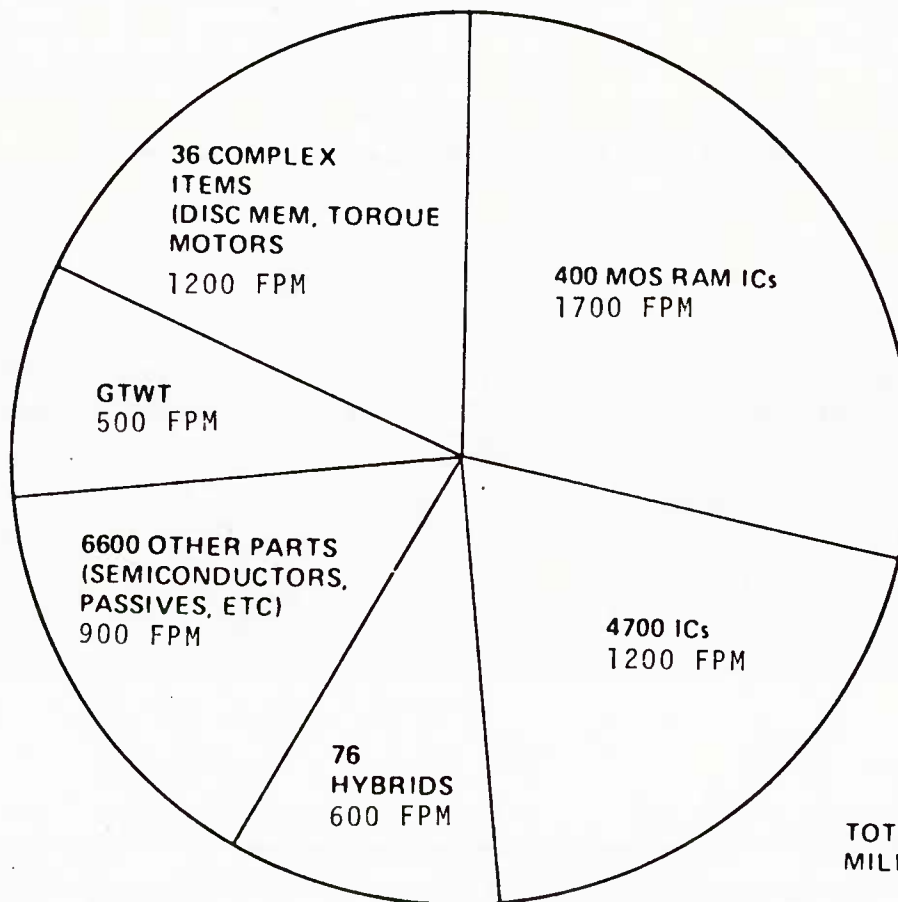

F-18 RADAR

TOTAL ~ 6100 FAILURES PER
MILLION HOURS (FPM)

JULY 1977

THERMAL ANALYSIS AND DESIGN

Following the design process to minimize the parts count, and a selection/screening process to obtain good quality parts, the single most important factor affecting reliability is good thermal management. This becomes doubly important in that military applications traditionally supply smaller quantities of cooling air and at higher temperatures than their commercial counterparts. To meet the low component operating temperatures dictated by reliability requirements, Hughes has developed a unique thermal design concept, applied first to the F-15 radar and then refined still further on the F/A-18 radar.

This concept consists of a lightweight aluminum heat exchanger sandwiched between two multilayer printed wiring boards. Cooling air passes directly through the core and is referred to as a "flow-through" module. This concept provides an extremely short thermal path to the component, being equal to the thickness of the printed circuit board itself. Experience has shown that this technique reduces the average temperature of the board mounted components by 15° to 20°C below that offered by alternate cooling schemes.

A computerized thermal model of the module is developed early in the design phase to provide rapid evaluation and optimization of the component layout for minimum temperatures.

The thermal model is augmented by a library of parts potentially selectable by the circuit designers and contain thermal impedance information (junction to case).

As the circuit design and product design evolves (i.e., identification and layout of parts), specialized forms are filled out stipulating the type and location of ICs on the module surface. This information, along with the previously generated thermal model and library of parts, permits a computerized thermal analysis to be performed in short order--before the product design is frozen.

The result is an identification of each component's temperature listed in tabular form, in addition to displaying a 3-dimensional thermal map. Hot spots are eliminated by repositioning hot components to cooler areas.

45B/7-39

The component layout of a module is reconfigured several times during the design phase as the result of the rapid thermal analysis capabilities, thus allowing optimization of the thermal design before the drawings are complete and ready for release.

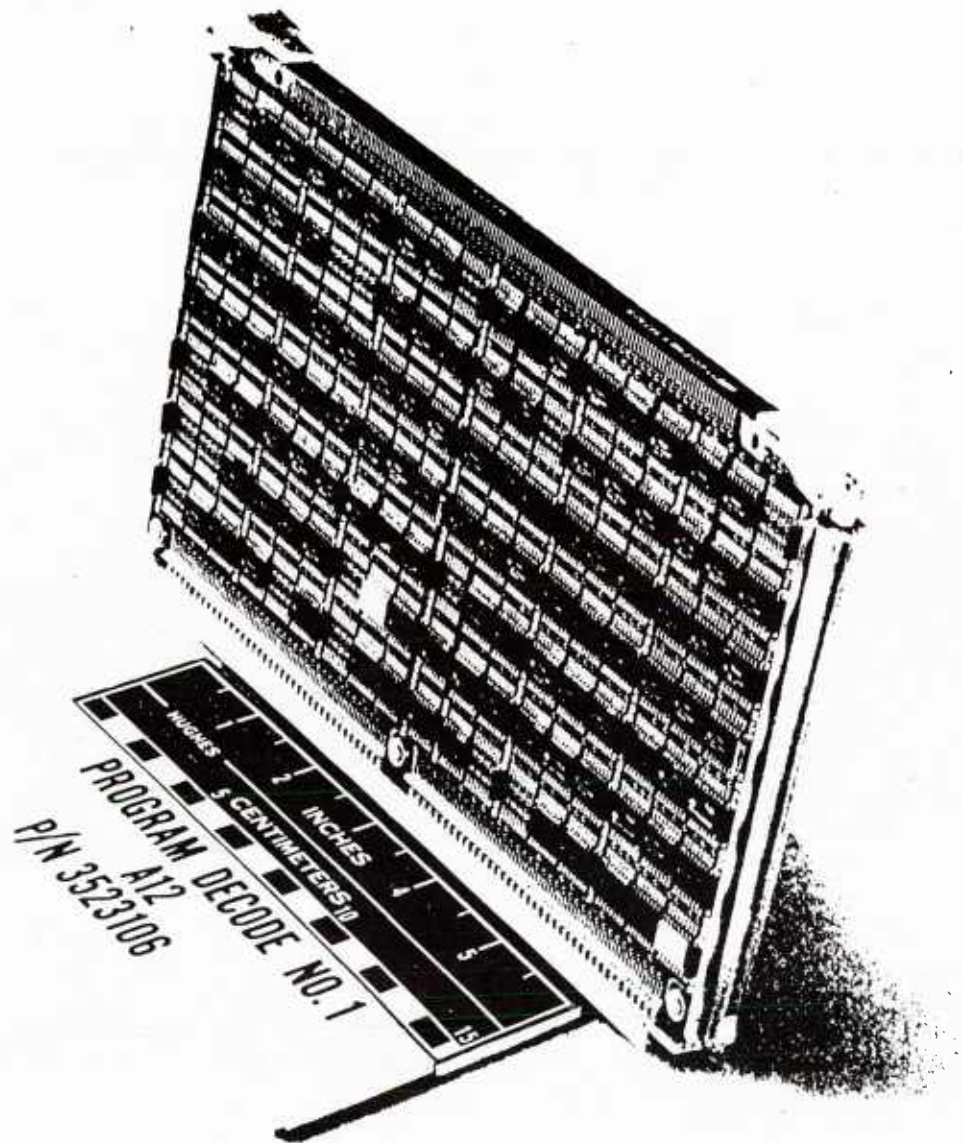

APG-65 RADAR PARTS AND DERATING

The baseline for F-18 parts derating requirements was the NASA guidelines. As part of pre-award trade studies, standard derating guides were requested from all potential avionic suppliers. Based upon results received, the NASA guidelines were modified and made more stringent. The specifics of this derating criteria are shown on the next few charts. Analysis was conducted in conjunction with reliability stress analysis and prediction and documented. Any deviation required justification.

An extensive part control program has been in effect throughout the program. Elements of the program included the MCAIR-established, NAVAIR-approved, Preferred Part List, a parts control board with membership from all major suppliers (including Hughes), and approved parts lists for each equipment.

APG-65 RADAR PARTS AND DERATING

- PARTS DERATING
 - HARD REQUIREMENTS
 - TIGHTER THAN NASA GUIDELINES

- PARTS CONTROL PROGRAM
 - PREFERRED PARTS LIST
 - NAVAIR APPROVED

 - PARTS CONTROL BOARD

 - EQUIPMENT PARTS LIST
 - SUBMITTALS TO MCAIR FROM HUGHES
 - HIGH PERCENT HI-REL, STANDARD PARTS

COMPONENT DERATING REQUIREMENTS

The component derating requirements were made a part of the radar procurement specification and were imposed at specific cooling conditions. The derating requirements encompassed microcircuits, hybrids, transistors, resistors, diodes, relays, capacitors and switches.

COMPONENT DERATING REQUIREMENTS

<u>PART TYPES</u>	<u>POWER* DERATING</u>	<u>VOLTAGE DERATING</u>	<u>CURRENT DERATING</u>	<u>MAX JUNCTION TEMPERATURE</u>	<u>OTHER</u>
<u>MICROCIRCUITS</u>					
TTL				110°C	DIGITAL FANOUT 0.80
CMOS				90°C	
OTHER				100°C	
<u>HYBRIDS</u>					
				105°C	
<u>TRANSISTORS</u>					
GENERAL	0.30	0.60	0.50	100°C	
POWER	0.30	0.60	0.50	105°C	
<u>RESISTORS</u>					
	0.50				
<u>DIODES</u>					
	0.30	0.50	0.50	100°C	
<u>CAPACITORS</u>					
		0.50			

*POWER DERATING FACTOR MUST BE APPLIED TO RATED POWER AT TEMPERATURE:

$$P(T_{OPER}) = P_{RATED} \times \frac{T_{MAX} - T_{OPER}}{T_{MAX} - T_{RATED}}$$

F-18 PARTS DERATING

MICROCIRCUITS			
Type	Derating Factor*		Parameter
	Open Mounting	Enclosed/Encapsulated, Wg	
Digital	.80	.70	Fanout/ Output Current
	.75	.75	Supply Voltage
	.75	.75	Operating Freq.
	90°C Max	90°C Max	C/705 Junct. Temp.
	100°C Max	100°C Max	Junction Temp.
Linear, Hybrid	.80	.80	TTL Junct. Temp.
	.75	.65	Supply Voltage
	.75	.75	Output Current
	.75	.75	Operating Freq.
	100°C Max	100°C Max	Junction Temp.
	105°C Max	105°C Max	Hybrid Junct. Temp.
DERATE FOR FOLLOWING END-OF-LIFE DRIFT CHARACTERISTICS:			
	±0.5mV	±0.5mV	Input Offset Volt.
	2.0µA	2.0µA	Input Bias Current
	2.0%	2.0%	Input Offset Current
	±1%	±2%	Open Loop Gain
Voltage Regulator	.80	.80	Input Voltage
	.75	.60	Output Current
	.60	.50	Power
	100°C Max	100°C Max	Junction Temp.
* = Allowable Change Factor			

TRANSISTORS			
Type	Derating Factor*		Parameter
	Open Mounting	Enclosed/Encapsulated, Wg	
General Purpose	.30	.15	Power
	.50	.50	Current
	.60	.60	Voltage
	100°C Max	100°C Max	Junction Temp.
Power	.30	.10	Power
	.50	.50	Current
	.60	.60	Voltage
	100°C Max	100°C Max	Junction Temp.
Switching	.30	.20	Power
	.50	.50	Current
	.60	.60	Voltage
	100°C Max	100°C Max	Junction Temp.
Field Effect	.20	.15	Power
	.50	.50	Current
	.60	.60	Voltage
	100°C Max	100°C Max	Junction Temp.
Unijunction	.30	.15	Power
	.50	.50	Current
	.60	.60	Voltage
	100°C Max	100°C Max	Junction Temp.

RESISTORS	
Resistor Type	Derating Factor* (Power)
Composition (CBC)	.5
Film Insulated (NLR)	.5
Film (NRC, NMR, NMR)	.5
Accurate Wirewound (AOR)	.5
Power Wirewound (PWR)	.5
Chassis Wirewound (RER)	.5
Variable Wirewound (STR)	.7 (Current)
Variable Non-wirewound (RJR)	.7 (Current)

DIODES			
Type	Derating Factor*		Parameter
	Open Mounting	Enclosed/Encapsulated, Wg	
General Purpose, Switching	.30	.15	Power
	.50	.50	PIV
	.50	.30	Surge Current
	.50	.60	Forward Current
	100°C Max	100°C Max	Junction Temp.
Rectifier, SCR	.30	.15	Power
	.50	.50	PIV
	.50	.30	Surge Current
	.50	.60	Forward Current
	100°C Max	100°C Max	Junction Temp.
Varactor	.50	.30	Power
	.75	.75	Breakdown Voltage
	.75	.60	Forward Current
	100°C Max	100°C Max	Junction Temp.
Zener	.30	.15	Power
	.50	.60	Forward Current
	.50	.50	Zener Current
	100°C Max	100°C Max	Junction Temp.
Reference	.30	.15	Power
	.50	.60	Forward Current
	.50	.50	Ref. Current
	100°C Max	100°C Max	Junction Temp.

**Zener/Reference Current should be limited to no more than

$$I_Z = .5 (I_{Z_{max}} + I_{Z_{min}})$$

RELAYS	
Type of Load	Derating Factor* (Switching Current)
Resistive	.75
Inductive	.60
Motor	.20
Filament	.10
Capacitor	.75

CAPACITORS	
Coilwinding Type	Derating Factor* (Voltage)
Ceramic	.50
Glass	.60
Pica	.50
Plastic or Paper Plastic	.50
Solid Tantalum	.50

SWITCHES	
Type of Load	Derating Factor* (Switching Current)
Resistive	.75
Inductive	.60
Motor	.20
Filament	.10
Capacitor	.75

*Derating Factor = Maximum Allowable Stress / Rated Stress

QP77-0004 03

INTEGRATED CIRCUITS JUNCTION TEMPERATURE DISTRIBUTION

The following two charts show, for each of several group of components, the distribution of operating temperatures for that group of components. Overlaid on that distribution is a curve of failure rate versus operating temperature for a typical part within that group of components. For example, in the case of TTL devices, the mean junction temperature is shown to be 70°C, some 40°C below the 110°C limit for that class of parts. It is also shown that the failure rate of a typical device in that group is nearly 50% higher at 110°C than at 70°C.

INTEGRATED CIRCUITS JUNCTION
TEMPERATURES DISTRIBUTION

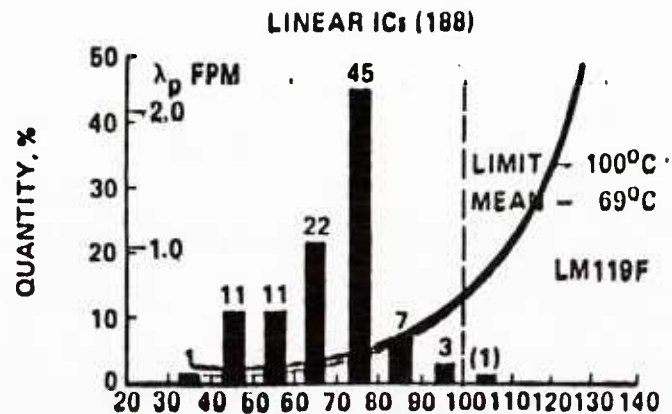
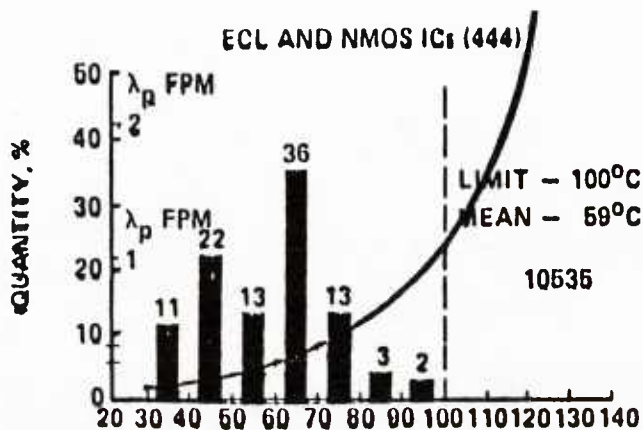

SAMPLE IC FAILURE RATES vs JUNCTION TEMPERATURE

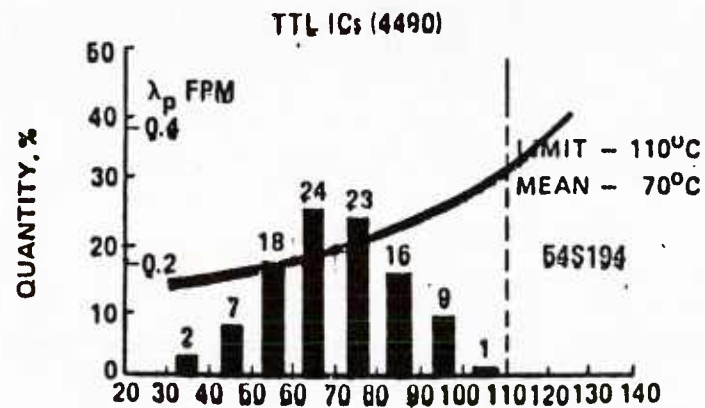
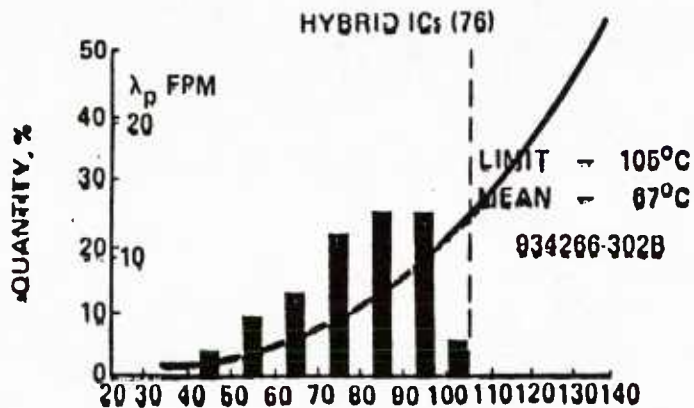

JUNCTION TEMPERATURE, °C

JUNCTION TEMPERATURE, °C

JULY 1977

SEMICONDUCTORS JUNCTION TEMPERATURES DISTRIBUTION

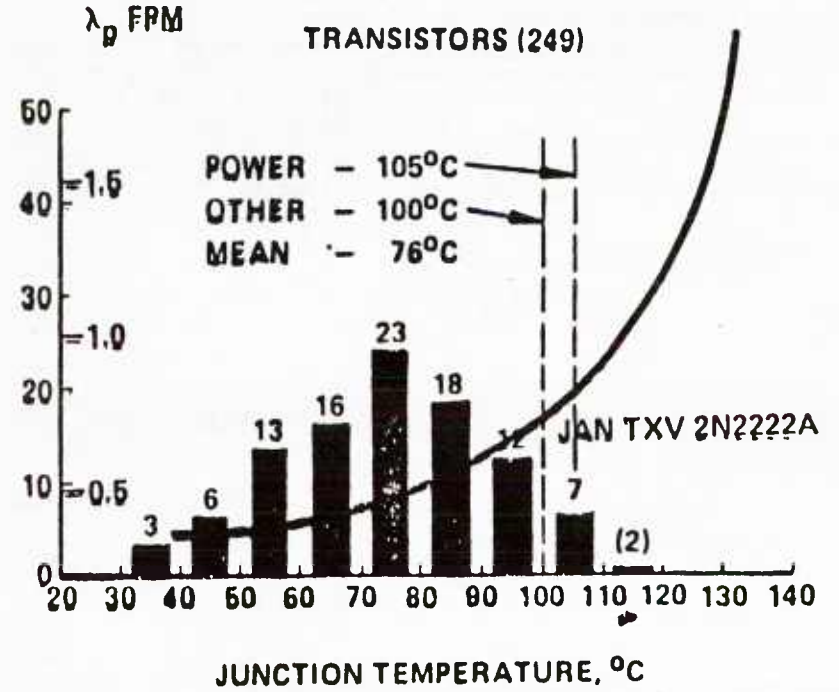
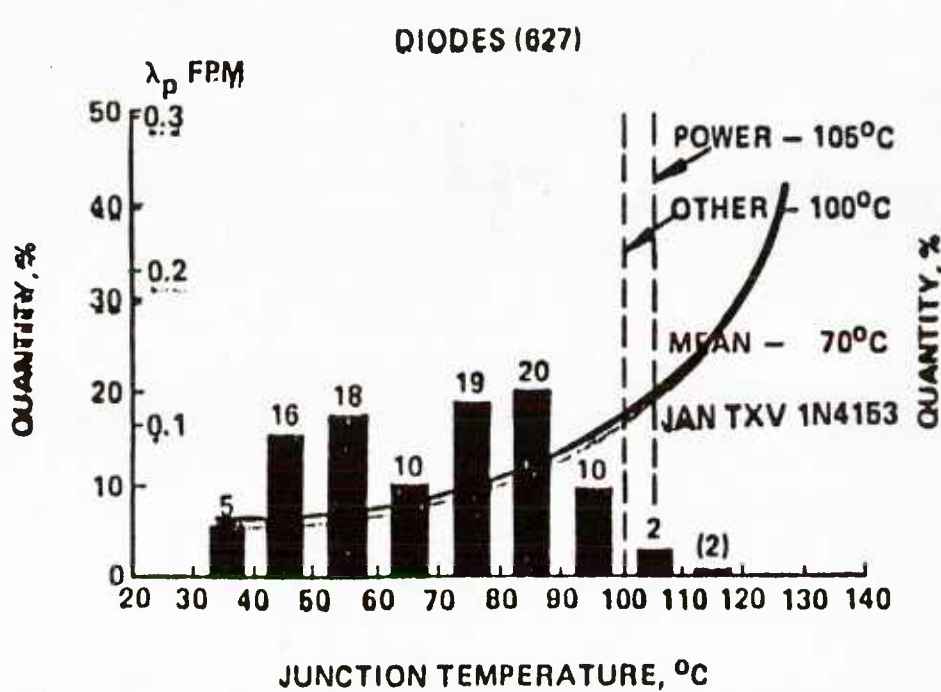

SAMPLE SEMICONDUCTORS FAILURE RATES vs JUNCTION TEMPERATURE

ELECTRICAL STRESS DERATING
COMPLIANCE SUMMARY

NUMBER OF COMPONENTS EXCEEDING ELECTRICAL DERATING LIMITS BY 3%

PART TYPE	PARAMETER	R DESIGN REVIEW STATUS	CORRECTIVE ACTION	UNDER REVIEW	RESIDUAL
TRANSISTORS	COLLECTOR VOLTAGE	5	3	0	2
	COLLECTOR CURRENT	4	3	1	0
DIODES	REVERSE VOLTAGE	25	0	13	12
	FORWARD CURRENT	0	0	0	0
CAPACITORS	DC VOLTAGE	32	2	17	13
RESISTORS	POWER	28	13	6	9
CHOKES	CURRENT	11	11	0	0
TOTALS		105	32	37	36
				73	

JULY 1977

DERATING EXCEPTION STATUS

	1 March 1977 Data Item - E-14.03		Current (May 1979)	
	Overstressed	Over Temperature	Overstressed	Over Temperature
Transmitter	38	5	28	0
Receiver/Exciter	7	16	0	3
Antenna	0	2	0	0
Radar Signal Processor	0	0	0	0
Radar Data Processor	0	0	0	0
Power Supply Function*	66	19	47	16
SUBTOTAL	111	42	75	19
RADAR TOTAL	153		94	
* Power supply parts not included in respective WRA entries above.				

DETAILED DERATING EXCEPTIONS

<u>Transmitter Derating Exceptions</u>									
Part	Circuit Symbol	Part Number	Parameter	Rated Value	Derating Reqmt	Actual Stress Value	Actual Stress Ratio	Corrective Action/Deviation Rationale	
Assembly: 3515420 SRA: 3515400									
Capacitor	C4	p/o 910041-1B	V _{DC}	400V	0.4	210V	0.52	These 400 volt mylar capacitors were developed for use on the F-18 program. They are high potted to 800 volts (twice rated value). Lack of room in the faraday box prevents using a capacitor with a higher voltage rating.	
Capacitor	C5	p/o 910041-1B	V _{DC}	400V	0.4	250V	0.625		
Capacitor	C6	p/o 910041-0B	V _{DC}	400V	0.4	250V	0.625		
Capacitor	C7	p/o 910041-0B	V _{DC}	400V	0.4	210V	0.52		
Assembly: 3515475 SRA: 3515400									
Diode, HV Rectifier	CR2	925214-1B	PIV	10KV	0.5	5700V	0.57	These 10KV high voltage rectifiers were developed for use on the F-18 program. Full derating of high-voltage components would not be practical in terms of cost or size, and the 0.57 stress ratio is not considered excessive for these parts. The vendor tests breakdown voltage to 11. KVDC on these parts. The 10KV rating is the point at which leakage current is specified.	
Diode, HV Rectifier	CR3	925214-1B	PIV	10KV	0.5	5700V	0.57		
Diode, HV Rectifier	CR4	925214-1B	PIV	10KV	0.5	5700V	0.57		
Diode, HV Rectifier	CR5	925214-1B	PIV	10KV	0.5	5700V	0.57		
Diode, HV Rectifier	CR8	925214-1B	PIV	10KV	0.5	5700V	0.57		
Diode, HV Rectifier	CR9	925214-1B	PIV	10KV	0.5	5700V	0.57		
Diode, HV Rectifier	CR10	925214-1B	PIV	10KV	0.5	5700V	0.57		
Diode, HV Rectifier	CR11	925214-1B	PIV	10KV	0.5	5700V	0.57		
SRA: 3515510									
Resistor	R1	RER75F5R11P	Power	30W	0.5	17.6W	0.59	R1 and R2 must together dissipate 35.2 watts. This power is divided between these two RER75 30-watt chassis-mount parts, which are the largest resistors available on the F-18 PPL. Their case temperature is held to 119°C. There is no room in the module to add a third resistor, and the 0.59 stress ratio is not considered excessive.	
Resistor	R2	RER75F5R11P	Power	30W	0.5	17.6W	0.59		
SRA: 3515510									
Capacitor	C6	910040-4B	V _{DC}	350V	0.4	210V	0.6	These metallized mylar capacitors were developed for use on the F-18 program. They are burned in at 425 VDC at 100°C. Lack of room prevents using a capacitor with a higher voltage rating.	
Capacitor	C7	910040-4B	V _{DC}	350V	0.4	210V	0.6		
Assembly: 3515514 SRA: 3515510									
Transistor	Q46	JANTXV2N5303	V _{DC}	80V	0.6	54V	0.675	JANTX 2N5038, a 90-volt part (on the F-18 PPL), was considered for this application, but rejected for two reasons: A) 2N5038 has a higher θ_{JC} which would result in a higher junction temperature. B) 2N5038 is not presently used anywhere in the F-18 radar. The slight improvement in voltage derating offered by the 2N5038 does not justify its use to this application.	
Transistor	Q47	JANTXV2N5303	V _{CC}	80V	0.6	54V	0.675		

DETAILED DERATING EXCEPTIONS (Continued)

TRANSMITTER DERATING EXCEPTIONS (Continued)

PART	CIRCUIT SYMBOL	PART NUMBER	PARAMETER	RATED VALUE	DERATING REQMT.	ACTUAL STRESS VALUE	ACTUAL STRESS RATIO	CORRECTIVE/ACTION DEVIATION RATIONALE
<u>SRA: 3515390</u>								
CAPACITOR	C1	910034-1B	V _{DC}	400V	0.4	270V	0.675	These 400-volt PVF ₂ capacitors were developed for use on the F-18 program. They are hi-potted to twice the rated voltage. Lack of room in the switching regulator module prevents using a capacitor with a higher voltage rating.
CAPACITOR	C2	910034-1B	V _{DC}	400V	0.4	270V	0.675	
CAPACITOR	C3	910034-1B	V _{DC}	400V	0.4	270V	0.675	
CAPACITOR	C4	910034-1B	V _{DC}	400V	0.4	270V	0.675	
CAPACITOR	C5	M39022/01-1477	V _{DC}	600V	0.4	280V	0.47	The 0.47 stress ratio for this polycarbonate capacitor is not considered excessive and does not justify development of a larger type.
DIODE, RECTIFIER	CR4	JANTXVIN541B	PIV	400V	0.5	270V	0.675	The possibility of developing a non-standard part for this application is being investigated. The MIL-SPEC calls for a breakdown voltage test to 440 volts.
DIODE, RECTIFIER	CR5	JANTXVIN541B	PIV	400V	0.5	270V	0.675	
DIODE, RECTIFIER	CR9	JANTXVIN541B	PIV	400V	0.5	270V	0.675	
CAPACITOR	C10	910040-4B	V _{DC}	350V	0.4	210V	0.6	This 350-volt metallized mylar capacitor was developed for use on the F-18 program. They are burned in at 425VDC at 100°C. Lack of room prevents using a capacitor with a higher voltage rating.
DIODE RECTIFIER	CR3	925436-1B	PIV	500V	0.5	270V	0.54	SA7429(925436) is a 500-volt power rectifier, developed specifically for this application. A stress ratio of 0.54 is considered acceptable.

DETAILED DERATING EXCEPTIONS (Continued)

TRANSMITTER DERATING EXCEPTIONS (Continued)

PART	CIRCUIT SYMBOL	PART NUMBER	PARAMETER	RATED VALUE	DERATING REQMT.	ACTUAL STRESS VALUE	ACTUAL STRESS RATIO	CORRECTIVE/ACTION DEVIATION RATIONALE
<u>ASSEMBLY: 3515392 SRA: 3515390</u>								
CAPACITOR	C5	M83421/01-0168P	V _{DC}	400V	0.4	210	0.52	M83421/01-168B is a 400-volt polycarbonate capacitor which sees an actual stress of 210 volts. There is no room on the A8A1 printed-circuit board for a higher-voltage capacitor. We do not feel that the 0.52 stress ratio is a reliability risk, particularly since there is essentially no AC ripple on the part.
<u>LOW VOLTAGE POWER SUPPLY (RDP) DERATING EXCEPTIONS</u>								
<u>SRA: 351520</u>								
CAPACITOR	C2	910034-1B	V _{DC}	400V	0.4	270V	0.67	Prior applications in F-14 & F-15 do not show a high failure rate. The part is burned in at 500V. A higher rated part would involve a weight and volume penalty.
CAPACITOR	C3	910034-1B	V _{DC}	400V	0.4	270V	0.67	
CAPACITOR	C4	910034-1B	V _{DC}	400V	0.4	270V	0.67	
CAPACITOR	C7	CMR06F222JODP	V _{DC}	500V	0.4	270V	0.54	Part is only marginally overstressed and is not considered excessive.
CAPACITOR	C9	910035-1B	V _{DC}	300V	0.4	160V	0.53	Applied voltage is regulated DC with low ripple. Weight and volume penalty for higher rated part are severe. The overstress is not considered excessive.
CAPACITOR	C14	CMR06F222JODP	V _{DC}	500V	0.5	320V	0.64	Parts still provide 180 volts of safety margin.
CAPACITOR	C15	CMR06F222JODP	V _{DC}	500V	0.5	320V	0.64	

DETAILED DERATING EXCEPTIONS (CONTINUED)

Low Voltage Power Supply (RDP) Derating Exceptions (Cont'd.)								
Part	Circuit Symbol	Part Number	Parameter	Rated Value	Derating Reqmt	Actual Stress Value	Actual Stress Ratio	Corrective Action/Deviation Rationale
SRA: 3515210 (con't)								
Capacitor	C27	M39003/01-2541	V _{DC}	20V	0.9	11V	0.55	Overstress is not considered excessive to justify a higher rated part.
Capacitor	C28	M39003/01-2541	V _{DC}	20V	0.5	11V	0.55	
Capacitor	C36	M39014/02-1340	V _{DC}	100V	0.5	64V	0.64	Volume restrictions prevent application of a higher rated part.
Capacitor	C38	905570-91B	V _{DC}	50V	0.5	30V	0.6	Overstress is not considered excessive to justify a higher rated part.
Capacitor	C40	905570-91B	V _{DC}	50V	0.5	30V	0.6	
Transistor	Q7	928883-1B	V _{CC}	450V	0.6	320V	0.71	Higher rated power transistor do not have the Switching speed required in the design.
Transistor	Q8	928883-1B	V _{CC}	450V	0.6	320V	0.71	
Transistor	Q9	928883-1B	V _{CC}	450V	0.6	320V	0.71	
Transistor	Q10	928883-1B	V _{CC}	450V	0.6	320V	0.71	
Diode	CR8	JANTXV1N5418	PIV	400V	0.5	270V	0.67	Design has 130 volts of safety margin. Prior applications on F-14 and F-15 does not indicate a problem.
Diode	CR9	JANTXV1N5418	PIV	400V	0.5	270V	0.67	
Diode	CR18	925436-1B	PIV	500V	0.5	270V	0.54	Part is only slightly overstressed which is not considered excessive.
Diode	CR29	JANTXV1N5418	PIV	400V	0.5	320V	0.8	The applied voltage is regulated. Higher rated part does not have the recovery time desired in the circuit.
Diode	CR32	925111-502B	Power	50W	0.3	17.9W	0.36	Part is only slightly overstressed. Junction temperature is predicted to be 80°C.
Diode	CR34	925111-502B	Power	50W	0.3	21.9W	0.44	Component junction temperature is predicted to be 70°C.
Inductor	L1	986249-1B	Current	8A	0.7	6A	0.75	Weight and volume penalty prevent use of higher rated part. (Actual currents will be measured to verify predictions.)
Inductor	L5	986255-3B	Current	12A	0.7	10A	0.83	
Inductor	L6	986265-1B	Current	60A	0.7	55A	0.92	
Assembly: 3515231 SRA: 3515210								
Diode	A4CR25	JANTXV1N5418	T _J	175°C	100°C	104°C	--	A copper ground plane is being designed to be added to circuit board to reduce junction temperatures.
Diode	A4CR26	JANTXV1N5418	T _J	175°C	100°C	104°C	--	
Diode	A4CR28	JANTXV1N5418	T _J	175°C	100°C	104°C	--	

DETAILED DERATING EXCEPTIONS (Continued)

LOW VOLTAGE POWER SUPPLY (RDP) DERATING EXCEPTIONS

PART	CIRCUIT SYMBOL	PART NUMBER	PARAMETER	RATED VALUE	DERATING REQMT.	ACTUAL STRESS VALUE	ACTUAL STRESS RATIO	CORRECTIVE/ACTION DEVIATION RATIONALE
ASSEMBLY: 3515231 SRA: 3515210 (con't)								
DIODE	A4CR29	JANTXVIN541B	T _J	175°C	100°C	104°C	-----	
DIODE, ZENER	A4VR2	JANTXVIN3826A	T _J	175°C	100°C	112°C	-----	
ASSEMBLY: 3515240 SRA: 3515240								
CAPACITOR	C14	M39002/01-01-2529	V _{DC}	20V	0.5	11V	0.55	Overstress is not considered excessive to justify a higher rated part.
ASSEMBLY: 3515266 SRA: 3515250								
RESISTOR	A3R8	RNC6H4021FS	Power	0.125W	0.4	0.06w	0.48	Overstress is not considered excessive to justify a higher rated part.
ASSEMBLY: 3515290 SRA: 3515250								
DIODE RECTIFIER	A4CR26	JANTXVIN541B	T _J	175°C	100°C	106°C	-----	A copper ground plane is being designed to be added to circuit board to reduce junction temperature.
DIODE RECTIFIER	A4CR27	JANTXVIN541B	T _J	175°C	100°C	106°C	-----	
DIODE RECTIFIER	A4CR28	JANTXVIN541B	T _J	175°C	100°C	106°C	-----	
DIODE RECTIFIER	A4CR29	JANTXVIN541B	T _J	175°C	100°C	106°C	-----	
RESISTOR	A4RE81	RCR20G151JS	Power	0.5W	0.5	0.32W	0.64	Overstress is not considered excessive to justify a higher rated part.
CAPACITOR	A4C18	M39003/01-2523	V _{DC}	20V	0.5	10.9V	0.54	
SRA: 3515250								
CAPACITOR	C1	CMR06F222JODP	V _{DC}	500V	0.5	320V	0.64	Parts provide 180 volts of safety margin. Cost, weight and volume prevent application of a higher rated part.
CAPACITOR	C3	CMR06F222JODP	V _{DC}	500V	0.5	320V	0.64	
CAPACITOR	C102	910034-1B	V _{DC}	400V	0.5	270V	0.67	Parts are burned in at 500V. Size and weight would increase significantly for a higher rated part.
CAPACITOR	C103	910034-1B	V _{DC}	400V	0.5	270V	0.67	
CAPACITOR	C103	910034-1B	V _{DC}	400V	0.5	270V	0.67	

DETAILED DERATING EXCEPTIONS (Continued)

LOW VOLTAGE POWER SUPPLY (RDP) DERATING EXCEPTIONS

PART	CIRCUIT SYMBOL	PART NUMBER	PARAMETER	RATED VALUE	DERATING REQMT.	ACTUAL STRESS VALUE	ACTUAL STRESS RATIO	CORRECTIVE/ACTION DEVIATION RATIONALE
CAPACITOR	C108	CMR06F472JODP	V _{DC}	500V	0.5	270V	0.54	Overstress is not considered excessive to justify a higher rated part.
TRANSISTOR	Q3	928883-1B	V _{CC}	450V	0.6	320V	0.71	High voltage transistors with adequate speed and current rating are not available at higher voltage ratings.
TRANSISTOR	Q4	928883-1B	V _{CC}	450V	0.6	320V	0.71	
TRANSISTOR	Q5	928883-1B	V _{CC}	450V	0.6	320V	0.71	

DETAILED DERATING EXCEPTIONS (CONTINUED)

Low Voltage Power Supply (RSP) Derating Exceptions								
Part	Circuit Symbol	Part Number	Parameter	Rated Value	Derating Reqmt	Actual Stress Value	Actual Stress Ratio	Corrective Action/Deviation Rationale
SRA: 3513250 (con't)								
Diode, Rectifier	CR1	JANTXVIN5418	T _J	175°C	100°C	104°C	--	Overstress is not considered excessive. Thermal measurements and power dissipations are being made to verify prediction.
Diode, Rectifier	CR2	JANTXVIN5418	T _J	175°C	100°C	104°C	--	
Diode, Rectifier	CR4	JANTXVIN5418	T _J	175°C	100°C	102°C	--	
Diode, Rectifier	CR5	JANTXVIN5418	T _J	175°C	100°C	102°C	--	
Diode	CR6	JANTXVIN5418	PIV	400V	0.5	320V	0.8	The applied voltage is regulated. Higher rated parts do not have the recovery time desired in the circuit.
Diode	CR7	JANTXVIN5418	PIV	400V	0.5	320V	0.8	
Diode, Rectifier	CR8	925434-1B	Power	200W	0.3	82W	0.41	Overstress is not considered excessive. Thermal measurements and power dissipations are being made to verify prediction.
			T _J	150°C	100°C	105°C	--	
Diode, Rectifier	CR9	925434-1B	Power	200W	0.3	82W	0.41	
			T _J	150°C	100°C	105°C	--	
Diode, Rectifier	CR105	925079-503B	T _J	150°C	100°C	107°C	--	Thermal measurements are being made to verify prediction.
Diode, Rectifier	CR109	JANTXVIN5418	PIV	400V	0.5	270V	0.67	Higher rated parts do not have speed required in the circuit.
Diode	CR114	JANTXVIN5418	PIV	400V	0.5	270V	0.67	
Diode, Rectifier	CR121	925436-1B	PIV	500V	0.5	270V	0.54	Overstress is not considered excessive to justify a higher rated part.
Inductor	L101	986249-1B	Current	8A	0.7	6A	0.75	Weight and volume penalty prevent use of a higher rated part.
Inductor	L105	986255-3B	Current	12A	0.7	10A	0.83	
Receiver/Exciter Derating Exceptions								
Assembly: 3515806 SRA: 3515790								
Integrated Circuit	ASU3	932710-1B	T _J	150°C	100°C	103°C	--	Overstress is not considered excessive. A larger power dissipating IC is not available.

F-18 PARTS CONTROL STATUS

PART TYPES

761	APPROVALS
2	LIMITED APPROVALS
11	REPEATED APPROVALS
11	AT NAVY
0	IN-PROCESS
3	REJECTION-REPLACE MIL PART
17	REJECTION-DATA/APPLICATION
48/23	EXCLUDED/DELETED
876	TOTAL PART TYPES REQUESTED REQUIRING 2,028 TRANSACTIONS

ELECTROSTATIC SENSITIVE DEVICE (ESD) CONTROL PROGRAM

Use of digital systems and state-of-the-art components for the F-18 avionics systems, and the rapid development of new technology components required a method to mark and identify ESD components and their next higher assemblies. The basic requirements were incorporated into the radar procurement specification in 1978 to provide a means to mark and identify the radar ESD items.

MCAIR's internal process specification was approved for use in February 1979 with a special purchase order condition issued to the supplier to identify packaging instruction for ESD components and next higher assemblies.

All radar ESD components and their next higher assemblies have been integrated into the MCAIR ILS data requirements and support functions to identify the packaging, test, and handling requirements for the Navy. These initial requirements were imposed on our supplier to assure that the reliability of the radar will not be compromised due to degraded devices or latent failures resulting from ESD damage.

ELECTROSTATIC SENSITIVE DEVICE (ESD) CONTROL PROGRAM

- MARKING AND IDENTIFICATION OF ESD COMPONENTS AND NEXT HIGHER ASSEMBLY REQUIREMENTS INCORPORATED INTO F/A-18 AVIONIC PROCUREMENTS (1978)
- INTERNAL PROCESS SPECIFICATION APPROVED FOR USE AT MCAIR (PS 20725 DATED FEB. 1979, REV. A ISSUED NOV 1982)
- PACKAGING INSTRUCTIONS ISSUED UNDER SPECIAL PURCHASE ORDER CONDITIONS (1979)
- IDENTIFICATION OF ESD COMPONENTS AND NEXT HIGHER ASSEMBLIES, PACKAGING, TEST, AND HANDLING REQUIREMENTS INCORPORATED INTO THE ILS SUPPORT FUNCTIONS FOR NAVY SUPPORT

BUILT-IN-TEST

REQUIREMENTS

PERIODIC

INITIATED

FAULT DETECTION

90%

98%

FAULT ISOLATION (TO WRA)

90%

99%

FALSE ALARM RATE

1%

1%

TESTS IMPLEMENTED

106

321

- MINIMAL TEST-ONLY COMPONENTS
- PROGRESSIVE TEST FLOW
- CAPABILITY FOR SRA LEVEL FAULT ISOLATION

BIT REQUIREMENTS

PERIODIC BIT (P-BIT)

DETECT >90% OF FAULTS -- NOT DETECTED <10%

ISOLATED >90% OF FAULTS DETECTED -- 81% DETECTED AND ISOLATED

DETECTED - DETECTED AND ISOLATED -- DETECTED BUT NOT ISOLATED <9%

INCORRECT ISOLATION <1% OF DETECTED AND ISOLATED -- <.81% INCORRECTLY ISOLATED

P-BIT AND INITIATED BIT (I-BIT)

DETECT >98% -- NOT DETECTED <2%

ISOLATE >99% OF FAULTS DETECTED -- >97% DETECTED AND ISOLATED

DETECTED - DETECTED AND ISOLATED -- DETECTED BUT NOT ISOLATED <2%

INCORRECT ISOLATION <1% OF DETECTED AND ISOLATED - <.97% INCORRECTLY ISOLATED

BIT DESIGN

A general block diagram of the radar subsystem is shown on this chart. The radar equipment is made up of five major WRAs. There are the Radar Data Processor (RDP), the Radar Signal Processor (RSP), Receiver/Exciter (R/E), Transmitter (XMTR), and Antenna (ANT).

The Radar Data Processor contains the general purpose computer and the Low Voltage Power Supply (LVPS). The data processor manages the entire radar, controls the modes, executes BIT and contains all the nonvolatile memory for the radar. The data processor controls all communication with the Mission Computer through the avionics multiplexer (A-Mux), and it communicates to the remainder of the radar through two radar multiplexer (R-Mux) channels, one to the RSP and the other to the remaining radar units.

The RDP is the first unit tested in IBIT and it is then used to test each of the succeeding units which lie in the path of radar data flow. The low voltage power supply section of the RDP is designed to remain on under all safe operating conditions and failures. This is done to permit BIT to operate and find the system failure. If the RDP is inoperative because of some essential LVPS failure, the fault indicator in the RDP is automatically set.

The Radar Signal Processor (RSP), which is tested next, is a high-speed digital processor whose architecture and organization have been optimized for the radar signal processing task. Its programs are loaded from the RDP. The core of the machine is tested by loading in test data and programs, operating them and having the RDP evaluate the results. In addition, the RSP input/output circuits, which interface with units other than the RDP, have self-test capability to verify the RSP control over the units and the RSP ability to receive data from them correctly. The main interface of this type is with the Receiver/Exciter.

BIT DESIGN

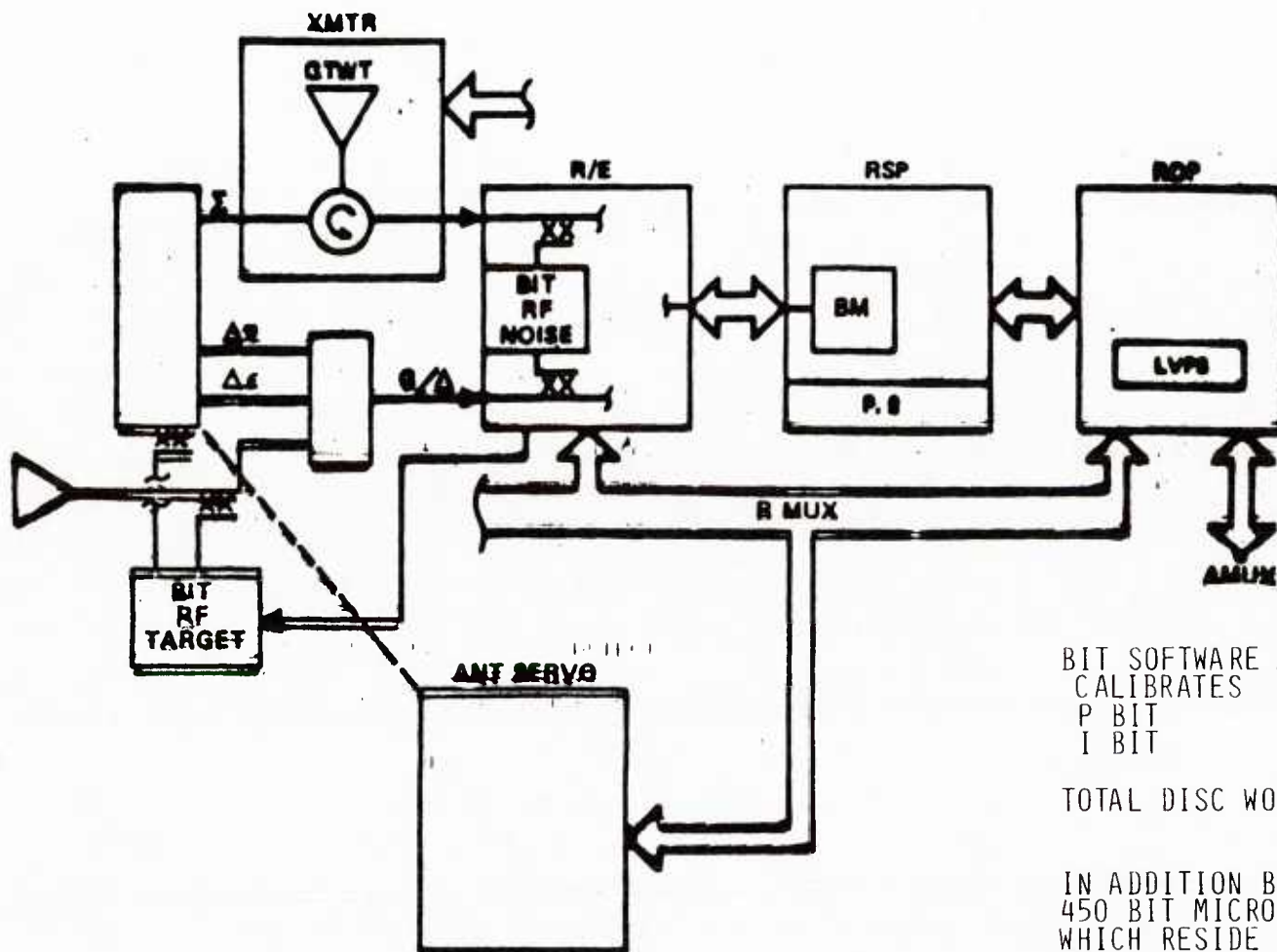

BIT SOFTWARE ALLOCATIONS

CALIBRATES	3,755
P BIT	1,480
I BIT	25,501

TOTAL DISC WORDS 30,736

IN ADDITION BIT INCLUDES ABOUT 450 BIT MICRO-INSTRUCTIONS WHICH RESIDE IN THE RDP IOC AND PROMS

GENERAL RADAR BLOCK DIAGRAM

BIT DESIGN (Continued)

The Receiver/Exciter unit, which is tested after the RSP, provides the RF drive to the transmitter, receives two channels of received RF from the Antenna and performs RF, IF and analog signal processing and A/D conversion. The tests of the Receiver/Exciter utilize signals derived from the Transmitter Drive, which are inserted into the Antenna, where the signals split into each of the receiver input channels. These test signals are processed through the Receiver and then evaluated by the previously tested RSP and RDP. In the performance of these tests the Antenna RF processing is also tested.

The Transmitter is tested mainly by turning it on and having it radiate into a dummy load during IBIT. It is also monitored by PBIT during tactical operation when it radiates out the antenna.

The antenna servo function is managed completely by the RDP. The servo tests consist largely of exercising the servo functions and having the RDP monitor and evaluate the results.

The test building block approach starts with the self-tested RDP and tests additional functions one at a time. When a function passes its test, it is used to test the next function. This process adds a minimum of test hardware, permits more qualitative testing than added special-purpose hardware and adds least to cost, weight and failure rates.

The test data are evaluated to isolate faults to the defective WRA, and the results are made available to the Mission Computer.

BIT IMPLEMENTATION

- CALIBRATES RFI VFO
 A/D BIAS FMR
 PHASE AND GAIN ZERO RANGE
- EXECUTED PERIODICALLY DURING TACTICAL OPERATION
- IN GENERAL, A SIGNAL IS INJECTED INTO THE FRONT END OF THE SYSTEM AND THE DOWNSTREAM RESULTS ARE MONITORED AND SAVED FOR LATER USE BY THE PROCESSORS IN COMPENSATING FOR TOLERANCE BUILD-UP AND ENVIRONMENTAL EFFECTS .
- THE RESULTS OF THE CALIBRATIONS ARE USED BY PERIODIC BIT TO PROVIDE AN INDICATION OF END-TO-END SYSTEM OPERATION AND TO INDICATE MAJOR MALFUNCTIONS AND OUT-OF-TOLERANCE CONDITIONS
- THE CALIBRATES DO NOT PROVIDE FAULT ISOLATION

895 RSP INST - DISC WORDS (RSP) 2685

1070 RDP INST - DISC WORDS (RDP) 1070

—————
TOTAL 3755

BIT IMPLEMENTATION

- PERIODIC BIT EXECUTIVE R/E
 ANTENNA RDP
 TRANSMITTER RSP

- EXECUTED PERIODICALLY DURING TACTICAL OPERATION

- THREE TYPES OF PERIODIC TESTS PERFORMED:
 - (1) BACKGROUND TESTS - COMPOSED OF FIRMWARE AND SOFTWARE ROUTINES WHICH TEST THE RDP WHILE IT IS NOT ACTIVELY ENGAGED IN THE EXECUTION OF THE TACTICAL PROGRAM

 - (2) WRA I/O TESTS - CONSISTS OF A SERIES OF INTERROGATIONS WHICH ARE PERFORMED ON EACH WRA AS IT IS BEING SERVICED BY THE TACTICAL SOFTWARE, I.E., R-MUX SERVICING OF THE ANTENNA, TRANSMITTER AND R/E AND RSP I/O SERVICING

 - (3) EVALUATION OF CALIBRATION RESULTS

- P BIT (INCLUDING THE RESULTS OF THE CALIBRATIONS) DETECTS 90% OF THE SYSTEM FAILURES AND ISOLATES 90% OF THESE TO THE WRA

1480 RDP INST - 1480 DISC WORDS

BIT IMPLEMENTATION

- INITIATED BIT SUPERVISOR (RDP) R/E
 EXECUTIVE (RSP) ANTENNA
 RDP TRANSMITTER
 RSP
- INTERRUPTS TACTICAL OPERATION AND USES A BUILDING BLOCK APPROACH WHICH TESTS ADDITIONAL FUNCTIONS ONE AT A TIME
- THE RDP IS TESTED FIRST USING FIRMWARE AND SOFTWARE SELF-TESTS
- THE RSP SELF-TEST IS THEN PERFORMED UNDER THE SUPERVISION OF THE RDP
- THE R/F IS THEN EXERCIZED AND TESTED BY THE RDP AND RSP
- THE ANTENNA SERVO IS EXERCIZED AND ITS RESPONSE EVALUATED BY THE RDP
- THE TRANSMITTER IS TESTED BY MONITORING ITS OPERATION INTO A DUMMY LOAD DURING BIT AND BY ADDITIONAL QUALITATIVE RF TESTS UTILIZING THE R/E AND RSP
- I BIT DETECTS 98% OF THE SYSTEM FAILURES AND ISOLATES 99% OF THESE TO THE WRA

5,540 RSP INST - DISC WORDS	16,620
8,881 RDP INST - DISC WORDS	8,881
	<hr/>
TOTAL	25,501

F-18 RADAR BIT DEVELOPMENT PROGRAM

The F-18 specification imposed NAVAIR document AR-10 (Maintainability of Avionics Equipment and Systems). The primary requirement within AR-10 is BIT fault detection and isolation. This was added to the radar procurement specification as a design requirement. Hughes was required to submit data items and perform tests to verify compliance. The first was an analytical verification, based on WRA, SRA and component failure rate. It was required to show that the design would detect and isolate to the required percentages.

The next step was to take a look at the early design through the initial BIT assessment. Faults were inserted into an operational system (302) and only three test failures were allowed for a test complete, all test failures above three require analysis, fix and retest. The same type test was combined with the maintainability demonstration which will be conducted later this year (1983).

Also, a BIT detection requirement was added to the reliability development test (RDT). During the RDT, a failure of the BIT to detect a failure or occurrence of a false alarm required an analysis and fix.

During the F-18 flight test program at NATC-PAX River, Maryland, BIT was evaluated on those aircraft containing radar systems. This evaluation continued at VFA-125 (NAS-LeMoore) with MCAIR and NAVAIR personnel working together to define problem areas. These evaluations have resulted in additional improvements which are currently being evaluated by NAVAIR at both NAS-LeMoore and MCAS-E1 Toro.

*O - I Level ?
USE of BIT*

F-18 RADAR BIT DEVELOPMENT PROGRAM

- FIRM SPECIFICATION REQUIREMENTS BACKED WITH FORMAL DEMONSTRATION
- ANALYTICAL VERIFICATION
- INITIAL BIT ASSESSMENT (IBA) TEST
- DEVELOPMENT COMBINED WITH RELIABILITY DEVELOPMENT TESTING
- COMBINED MAINTAINABILITY AND BIT DEMONSTRATION
- DEDICATED SYSTEMS DEVELOPMENT AIRCRAFT
- INTEGRATED BIT SYSTEM DEVELOPMENT ON FULL UP AIRCRAFT

APG-65 BUILT-IN-TEST (BIT) IMPLEMENTATION

Two types of BIT are implemented into the APG-65 radar system: periodic and initiated. Periodic BIT is automatically performed at timed intervals during normal system operation and does not require operator participation. Initiated BIT is a more extensive test and is commanded to start by the operator. This test may also require some operator participation. Both types of BIT are analyzed and tested.

Although the radar requirements are only to detect and isolate to the faulty WRA, the system is capable of going beyond this to the SRA level. This is a potential which needs further study.

Haha!

what about I
level SRA fault
isolation?
you've already got
the tests!

See page 62, 31
78-SRA BIT FLAGS

APG-65 BUILT-IN-TEST IMPLEMENTATION

TEST DURING OPERATION

PERIODIC BIT

106 TESTS CONDUCTED

EXTENSIVE SPECIAL TEST FOR ISOLATION

INITIATED BIT

321 TESTS CONDUCTED

REQUIREMENT: ISOLATE TO WRA

CAPABILITY: ISOLATION TO MANY SRAs

POTENTIAL: ISOLATION TO MORE SRAs

APG-65 BIT ANALYTICAL VERIFICATION

MCAIR required the supplier to submit a BIT analytical verification data item on how he proposed to mechanize his BIT architecture within the radar to meet the procurement specification requirements. This data item was submitted early in the program and contained sufficient information for MCAIR to assess the supplier's BIT design approach. This data item is submitted for MCAIR approval and is used as a tool to guide the supplier in his BIT design.

APG-65 BIT ANALYTICAL VERIFICATION

INCLUDES AS A MINIMUM:

- A DESCRIPTION OF EQUIPMENT AND BIT OPERATIONS, INCLUDING FUNCTIONAL BLOCK DIAGRAMS, SOFTWARE FLOW DIAGRAMS, AND METHOD OF IMPLEMENTING BIT FOR EACH EQUIPMENT FUNCTION
- ADVANTAGES THAT MAY BE GAINED FROM TESTS USING OTHER INTERFACING AVIONICS
- DESCRIPTION AND JUSTIFICATION FOR ANY BIT INHIBIT OR SYSTEM INTERRUPTION REQUIREMENTS DURING ORGANIZATIONAL MAINTENANCE OR IN-FLIGHT
- DETAILED DESCRIPTION OF BIT METHODS USED (MULTIPLEX TERMINAL TEST, TEST DISPLAY, CANNED TEST CONDITION, ETC.) AND RECOMMENDATIONS FOR ADDITIONAL METHODS IF DESIRED
- TECHNICAL JUSTIFICATION FOR NON-COMPLIANCE OF IN-FLIGHT (PERIODIC) BIT PERFORMANCE ALONG WITH ACHIEVABLE LEVELS

BIT ANALYTICAL VERIFICATION (CONTINUED)

- DESCRIPTION OF THE EQUIPMENT'S ABILITY TO PROVIDE OUTPUTS FOR DISPLAY OF DEGRADED PERFORMANCE
- THE TIME REQUIRED TO DETERMINE A GO OR NO-GO CONDITION OF THE EQUIPMENT IN EACH OF THE BIT OPERATING MODES
- A DETAILED LIST OF EACH SIGNAL (FUNCTION, PARAMETER, ETC.) USED BY THE EQUIPMENT TO DETERMINE AN EQUIPMENT FAILURE, ALONG WITH ITS APPLIED ACCEPT/REJECT LIMIT AND EXCEED TIME CRITERIA
- THE RATIONALE FOR THE SELECTION OF EACH ITEM IN ABOVE LIST
- A DESCRIPTION OF THE METHOD OF ADJUSTING THE ACCEPT/REJECT LIMITS AND EXCEED TIME TOLERANCES FOR PREPRODUCTION EQUIPMENT
- JUSTIFICATION FOR USE OF WRA FAILURE INDICATOR OTHER THAN THAT SPECIFIED

APG-65 RADAR BIT DATA AT THE FLIGHTLINE

The radar BIT design requirements were established and incorporated into the MCAIR procurement specification. An important factor for developing the radar system's BIT was data management. The BIT design was followed from the start of the program through a sequence of tests and demonstrations which started with the analytical verification, initial BIT assessment, test-analyze-and-fix, maintainability demonstrations, factory and field data, and reliability demonstrations. The management of data accumulated during these tests allowed MCAIR and the supplier to assess BIT performance and implement improvements into the radar system BIT design.

The design of the radar BIT allows deployment of aircraft to remote sites with no organizational level ground support equipment required for support of the radar. Rapid fault detection and isolation coupled with ease of removal and replacement increased the availability of the radar for flight. The potential of reducing test station loading could be realized by taking advantage of the processing capability of the radar. MCAIR developed an organizational level test set (AFTA--Avionics Fault Tree Analyzer) which can access the radar's BIT fault data stored in memory. With the development of a fault tree for the radar, SRA isolation is possible using the AFTA via the 1553 MUX BUS. On aircraft, SRA isolation could result in reduced test station loading, improved WRA availability, and a reduction in requirements for WRA spares.

As a result of the radar's digital processing capability a special relay mode is provided for beyond BIT troubleshooting. This stored data can be called up on the digital display indicators in the cockpit to assist the maintenance personnel to isolate faults which were not detected or isolated by BIT.

APG-65 RADAR BIT DATA AT THE FLIGHTLINE

- ESTABLISH BIT DETECTION/ISOLATION REQUIREMENTS
- BIT DATA MANAGEMENT IS IMPORTANT FOR ASSESSING BIT PERFORMANCE
- SHOP LOADS CAN BE REDUCED BY ISOLATING TO MANY SRAs
 - AVAILABILITY IMPROVED
 - DEPLOYMENTS TO REMOTE BASE SIMPLER
 - POTENTIAL REDUCTION OF SHOP GSE
 - REDUCTION IN SPARE WRA ASSETS

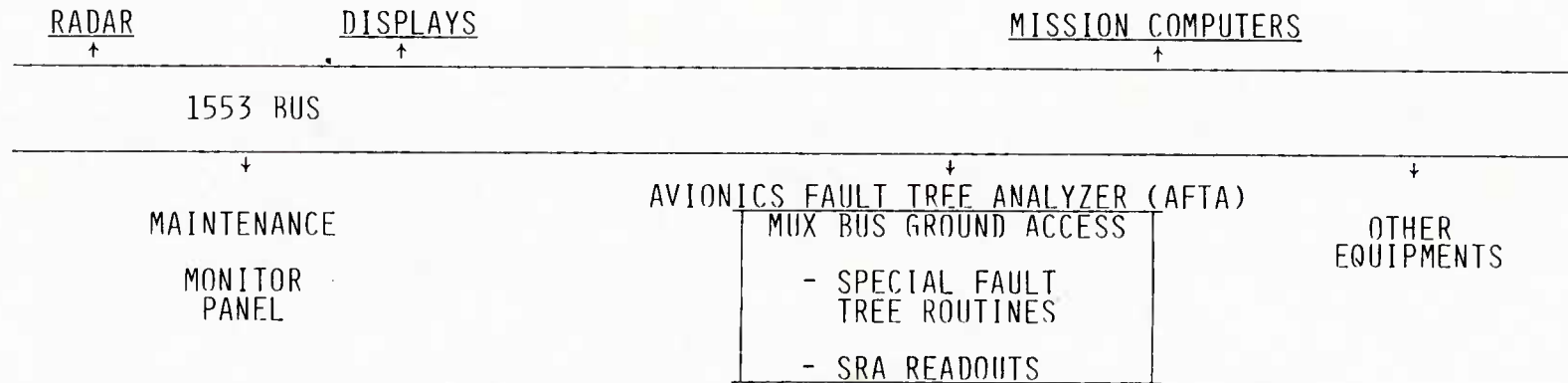

RADAR DATA ON THE MUX BUS (RELAY MODE)

- SPECIAL MESSAGES FOR WRA FAILS
- SPECIAL MESSAGES FOR MORE THAN 300 PIECES OF BIT DATA
- DATA STORED IN NONVOLATILE MEMORY TO REFLECT FLIGHT DATA

45A/13-4

APG-65 RADAR
BIT DATA AVAILABLE TODAY

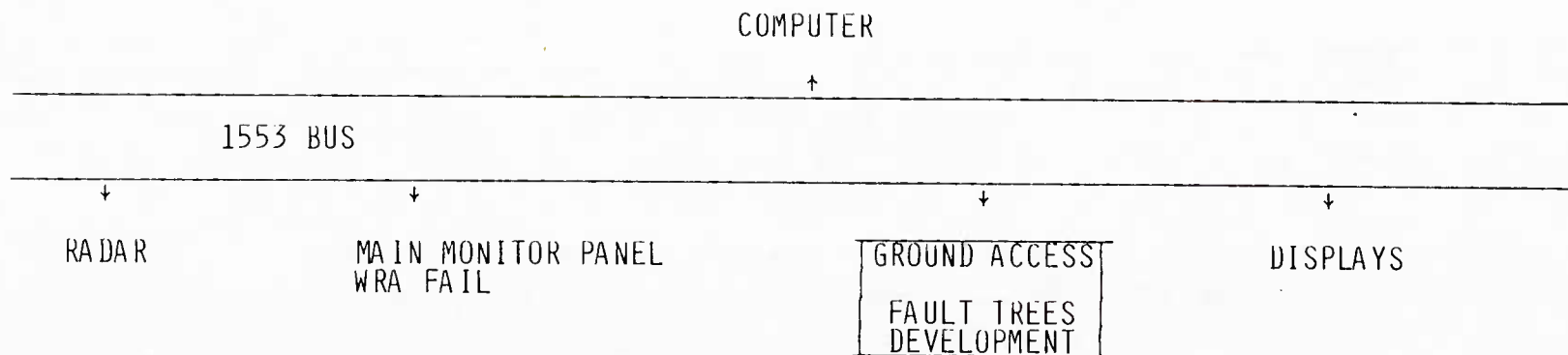

DATA IN RADAR NONVOLATILE MEMORY:

ACCUMULATED PERIODIC-BIT MATRIX: ALL P-BIT EVENTS DURING FLIGHT

INITIATED BIT MATRIX: LAST I-BIT MATRIX STATUS OR CURRENT STATUS IF CLEARED

OPERATIONAL BIT MATRIX: LAST MATRIX FROM TURN-ON TEST SEQUENCE

A) RELAY MODE - GROUND USE

- CALLS UP FAIL INDICATIONS IN ANY AVAILABLE MATRIX

- PROVIDE RADAR ISOLATION ASSESSMENT

- HISTORY AND CURRENT STATUS

B) MEMORY INSPECT

- ADDRESS ANY MEMORY LOCATION

- ADDRESS VOLATILE MEMORY

- CURRENT STATUS

MANUFACTURING

MANUFACTURING

- STRESS SCREENING
- FAILURE REPORTING AND CORRECTIVE ACTION
- INTEGRATED CORRECTIVE ACTION PROGRAM (ICAP)
- COST REDUCTION

PRODUCTION CONTROLS TO ENSURE APG-65 RELIABILITY

- COMPONENTS
 - 100% TEST-AT-TEMP (ICs & HYBRIDS)
 - MINIMIZE DEFECTS BEFORE STARTING ASSEMBLY
 - PIN TEST (CAVITY DEVICES)
 - LEAK TEST (ICs & HYBRIDS)
 - SUPPLIER SURVEILLANCE
- ASSEMBLY SCREENS
 - SRA, WRA, BURN-IN
 - CULL ASSEMBLY DEFECTS & RESIDUAL PART DEFECTS BEFORE THE COUNTING STARTS
- REPAIR RULES
 - PIECE PART REPLACEMENT
 - ASSURE UNIFORM SCREENING
 - FAULT VERIFICATION
 - ACCURATE CAUSE DETERMINATION
 - RESOLVE INTERMITTENTS AND "UNKNOWN" BEFORE THE COUNTING STARTS
- FAILURE DATA
 - EXACTLY WHAT, EXACTLY WHERE
 - PROGRAM IDENTIFICATION BY ANALYSIS OF VALID STATISTICS
 - AUTOMATION
 - EVALUATION OF SCREENS
 - RAPID RESPONSE, REDUCED ERROR RATE, REDUCED COST OF ACQUISITION
- MANAGEMENT
 - QUALITY REVIEW BOARD
 - MANAGEMENT REVIEW OF QUALITY CORRECTIVE ACTION PROCESS

45C/1-8

APG-65 RADAR MANUFACTURING SCREENING

This chart describes the screening applied today to APG-65 parts, assemblies, WRAs and the radar set. The following points should be noted:

- These procedures are significantly different from those imposed at the beginning. Much was learned from experience and the contract provided flexibility.
- Evolution is toward shorter minimum screens but longer failure-free intervals. The use of "failure-free" cycle requirements allows shorter screening on units with no screening failures and imposed additional screening time on units that are experiencing screening failures. The radar subcontractor objective is to complete screening at the WRA level. This avoids problem of radar set burn-in with unequal numbers of spare WRAs.
- 100% IC incoming screen at Hi/Lo temperature was added part way through program based upon other F/A-18 supplier experience.
- WRA screen profiles changed to match extremes of burn-in.
- The duration of the "failure-free" screens are automatically adapted to the manufacturing learning curve. As design, component and manufacturing problems are resolved, there are fewer failures and fewer attempts are required to complete the failure-free interval. The average number of cycles needed to complete 5 failure-free has decreased from over 10 to less than 7.
- Spare WRA's get complete burn-in. Spare SRA's get slave tested in a WRA after SRA screening and test.

45B/4-1

MANUFACTURING SCREENING

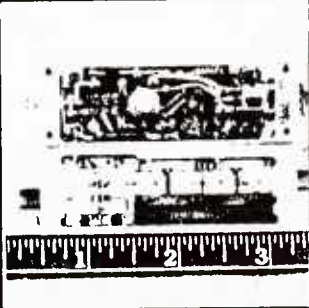
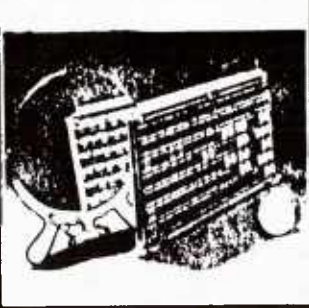
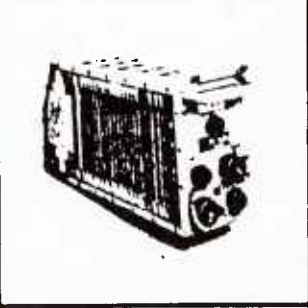
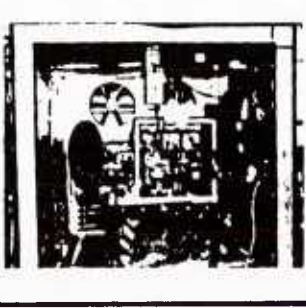
	PARTS	SRAS	WRAS	BURN-IN
				
TEMPERATURE	-65°C TO +150°C	-60°C TO +95°C	-55°C TO +55°C	-54°C TO +46°C
RATE OF CHANGE	15°C/MIN	15°C/MIN	15°C/MIN	5°C/MIN
CYCLES	10	46	12	5
DURATION	0.5 HRS	24 HRS	24 HRS	35 HRS
ON-TIME	NONE	NONE	13 HRS	25 HRS
FAILURE-FREE	N/A	N/A	3 CYCLES	5 CYCLES
TEST-AT-TEMP	100%	FUNCTIONAL TEST AT ROOM TEMP	100%	100%
VIBRATION	NONE	NONE	6g RMS RANDOM	2g SINE
DURATION	N/A	N/A	20 MIN	10 MIN/HR
FAILURE FREE	N/A	N/A	20 MIN	COMBINED WITH TEMP

F-18 SCREENING PROGRAM

EFFECTIVENESS DATA: INDUSTRY/GOVERNMENT STUDIES

NAVY MANUFACTURING SCREENING PROGRAM: NAVMAT P-9492

TEMPERATURE

RANDOM VIBRATION

- F/A-18 IMPLEMENTATION:
- HARD REQUIREMENTS AT RADAR SYSTEM LEVEL
 - POTENTIAL SUPPLIER PROGRAM WAS A MAJOR PART OF SOURCE SELECTION
 - LOWER LEVEL SCREENS CONTROLLED VIA SUPPLIER DRAWINGS
 - HEAVY SUPPLIER INCENTIVE TO IDENTIFY PROBLEMS EARLY IN THE TEST CYCLE
 - FLEXIBILITY TO RAPIDLY IMPROVE SCREENING TECHNIQUES (EARLY SYSTEM LEVEL TEST TRANSMITTER PROBLEMS RESULTED IN IMMEDIATE SCREEN CHANGES - RESOLVED PROBLEMS AT LOWEST LEVEL)

APG-65 RADAR SCREENING/BURN-IN REQUIREMENTS

• PRE-BURN-IN WRA/SRA SCREENING REQUIREMENTS

	<u>SRA SCREENING</u>	<u>WRA SCREENING</u>
NO. CYCLES	46	3-4
TIME/CYCLE (HRS)	0.5	6
TOTAL TIME (HRS)	23	18-24
TEMPERATURE	-60° TO 95°C	-55° TO 57°C
TEMP RATE OF CHANGE	15°C/MINUTE	15°C/MINUTE
VIBRATION	NONE	6G RANDOM, 3-AXIS, 20 MIN., FAILURE FREE
POWER	OFF	ON/OFF 1-3 TIMES/CYCLE
FUNCTIONAL TEST	PRIOR TO TEMP. CYCLING AND AFTER INSTALLATION IN WRA	DURING VIBRATION AND AND TEMPERATURE CYCLING

• SPARE WRA/SRA SCREENING REQUIREMENTS

<u>SRA SCREENING</u>	<u>WRA SCREENING</u>
PRODUCTION TEST AND WRA CHECKOUT	PRODUCTION TEST AND SYSTEM LEVEL CHECKOUT

• SRA REPLACEMENT DURING BURN-IN

RESET WRA CYCLE COUNT TO ZERO. SRA MEETS SRA SCREENING
REQUIREMENTS ABOVE

TRANSMITTER SCREENING PROFILE

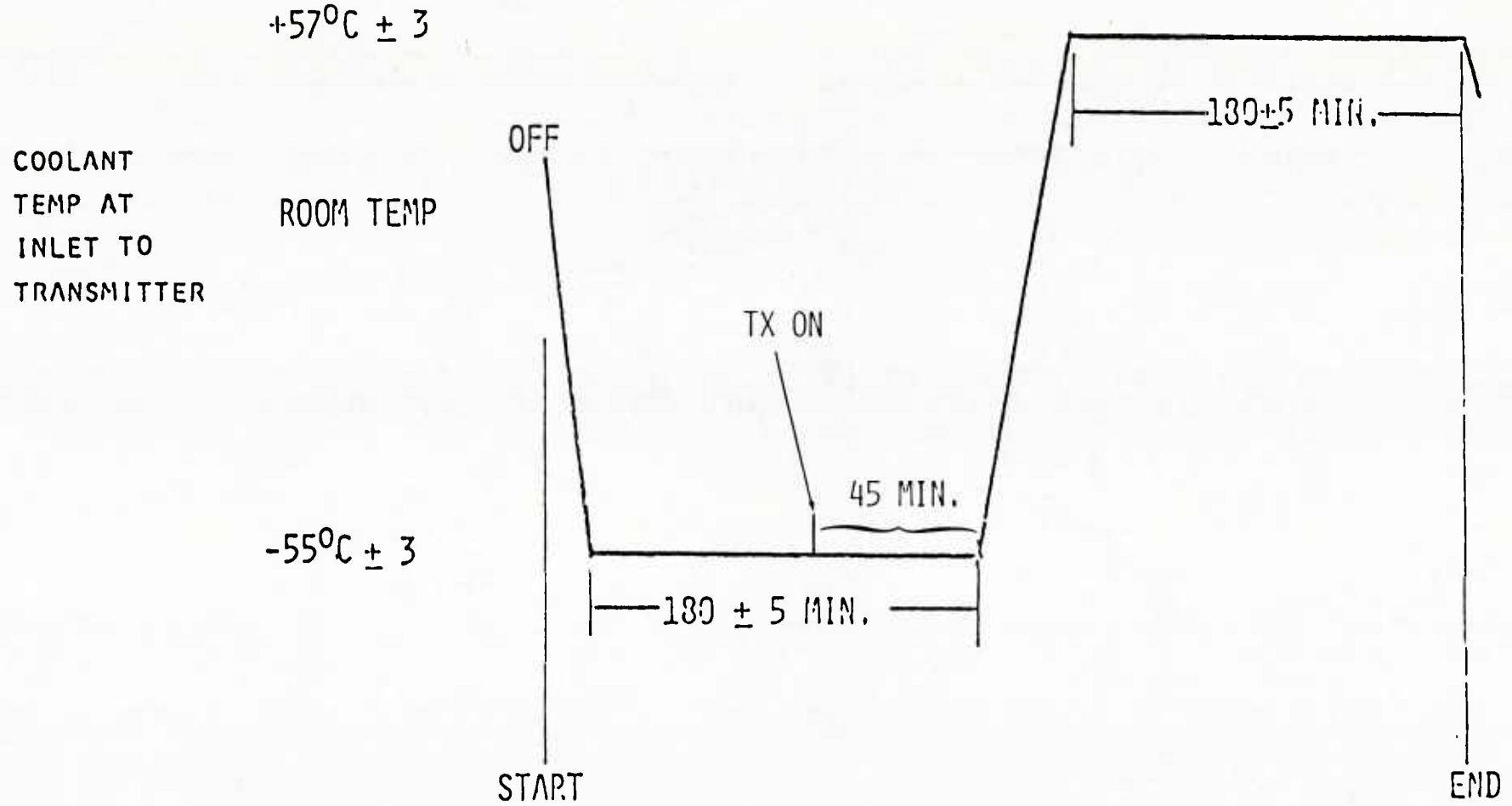

AIR COOLED WRA SCREENING PROFILE

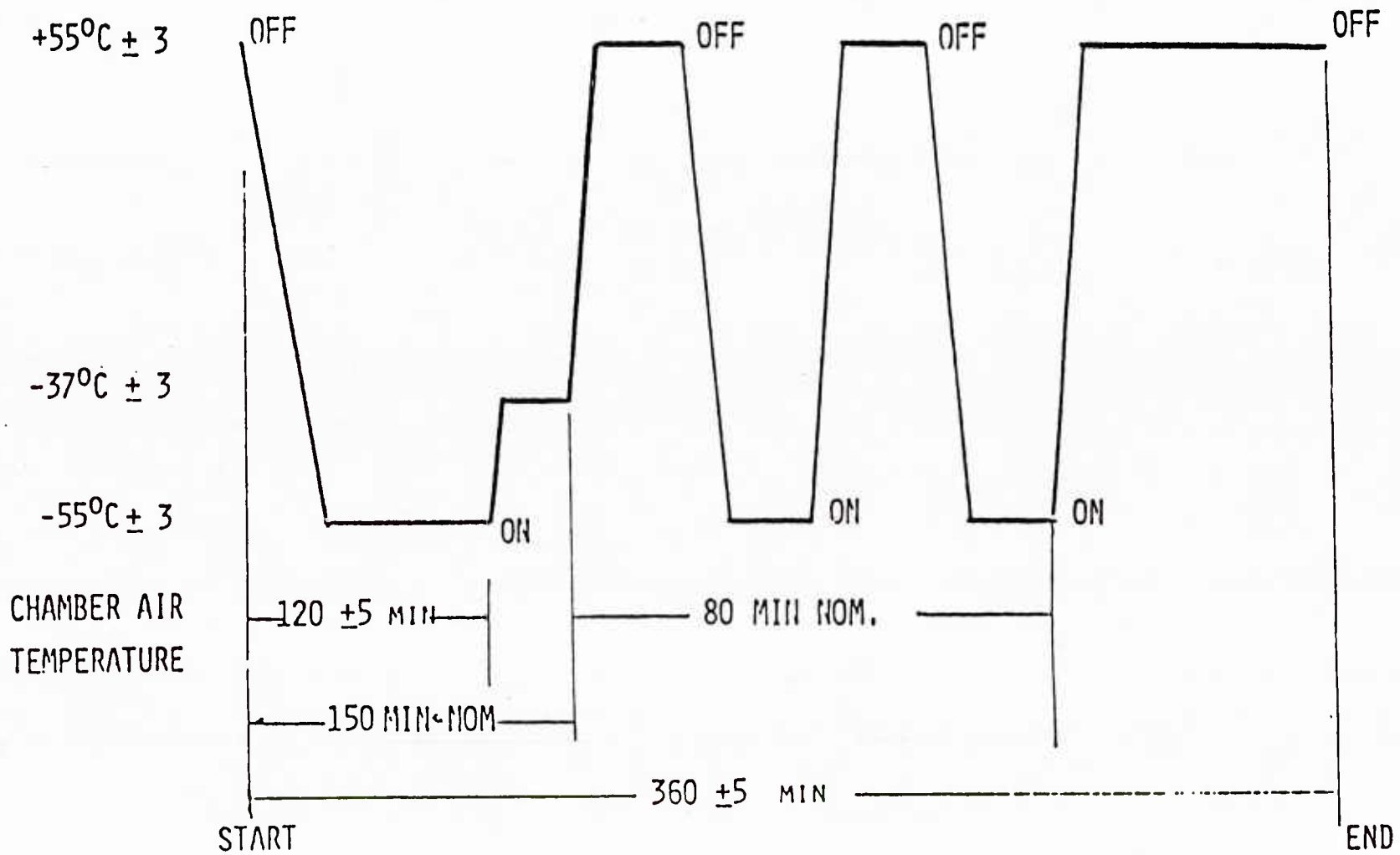

COOLING AIR PRESSURE, IN INCHES OF H₂O, AT HOT DWELL:

WRA	MAX	MIN
2.2	2.8	2.2

APG-65 FAILURE MONITORING/CORRELATION/CORRECTIVE ACTION SYSTEM

NEEDS:

- THOROUGH DATA SYSTEM FOR FAILURES AT ALL LEVELS OF MANUFACTURING CYCLE
- RAPID FEEDBACK TO PROGRAM RELIABILITY/QUALITY ASSURANCE CONTROL POINT
- IDENTIFICATION OF AND TRENDS CORRELATION WITH FIELD DATA TO IDENTIFY RAPID CORRECTIVE ACTION

IMPLEMENTATION:

- AUTOMATED DATA ENTRY/RETRIEVAL SYSTEM FOR ENTRY AT MANUFACTURING STATIONS FROM SRA TEST THROUGH SYSTEM TEST
- DATA MANAGEMENT PROGRAMS TO CORRELATE AND PRESENT DATA FOR PROGRAM ACTION

CLEAR (CLOSED-LOOP EVALUATION & REPORTING) SYSTEM

Evolution of the CLEAR system began with the F-15 Eagle program around 1970. The reliability (R), maintainability (M), and quality (Q), requirements for that aircraft were more stringent and required more data to be collected than any previous programs. As a result, a team was assembled and the CLEAR system was developed and implemented on the F-15 program.

The ability of the system to supply the data needs of all three disciplines, R, M, and Q was given prime consideration, since up to that time each discipline was inputting and processing essentially the same data in different systems. Uniform reporting of future projects and the elimination of duplication of effort were major design goals.

In 1976 MCAIR was awarded the contract by the Navy to develop the F/A-18 Hornet Aircraft. A primary requirement of the Hornet program was to provide an aircraft with a significant reduction in LCC over current Navy systems. Intensified corrective action programs, expanded failure reporting coverage and R and M demonstrations dictated the need for some improvement in the CLEAR system. The improvements primarily involved modifications to the reporting procedures along with a redesign of the on-aircraft (organizational level) reporting forms. These changes enabled CLEAR to more closely emulate the Navy 3M (Maintenance, Material, Management) system.

CLEAR (CLOSED-LOOP EVALUATION & REPORTING) SYSTEM

- MCAIR SYSTEM FOR COLLECTING NON-CONFORMANCE, MAINTENANCE AND FAILURE INFORMATION WITH COMPUTER REPORTING FOR ANALYSIS AND PRODUCT UPGRADING

- DEVELOPED FOR F-15 AND IMPROVED FOR F-18 USAGE
 - ✓ SUPPLIER TESTS

 - ✓ MCAIR BENCH & QUAL TESTS

 - ✓ PILOT SQUAWKS

 - ✓ ON/OFF AIRCRAFT REPAIRS

 - ✓ SUPPORT OF CUSTOMER TESTS

Data Reporting

This covers a very wide area from defects found during manufacture of hardware, through assembly, testing and often continues for a period of time during field usage of the end product. The reporting also covers a wide geographical area in that its data are collected from MCAIR in-house and remote site operations and from many of the hardware suppliers. However, reporting is predominately a manual operation where people (inspection, manufacturing, engineering) fill out forms which follow the equipment to various work areas where additional information is added. Completed copies of the forms are then sent to the data center for input to the automated system.

Data Input

The data input section of the system has experienced the most recent and significant change by adding an on-line staging file computerized entry system. The staging file is a basic information management system (IMS) program which replaced the less efficient manual coding/key-punching input method.

Processing

The major portion of the user needs are still being satisfied by processing against the combined data base originally established during the initial design of CLEAR. Each project has two main IMS hierarchical structured files; the FMD (failure maintenance data) file, and the FMD index file which contains index pointers to enable selections and exclusions of particular segments of data. There are also several wrap-around sequential files used

CLEAR FORMS

ROBBINELL AIRCRAFT COMPANY FLIGHT RECORD WORKSHEET CLEAR FORM A

1. AIR. SER. NO. 2. PILOT 3. HOUR NO. 4. AIRCRAFT TYPE 5. FLIGHT NO. 6. DATE

7. TIME L/T 8. TIME 9. ALTITUDE 10. WIND 11. REFERENCE 12. OBSERV 13. FLIGHT IN 14. COMMENTS

15. ALIGNMENT DATA
 1. MODE () 2. MODE () 3. MODE ()
 4. STANDBY MODE
 5. INITIAL LAT
 6. INITIAL LONG
 7. ALTITUDE

16. FAULT	17. TIME OF FLIGHT	18. REPAIRS	19. PILOT
NO.	START	END	NO.
1			
2			
3			
4			

20. SIGNATURE 21. DATE

22. EMPLOYER'S SIGNATURE 23. DATE

24. EMPLOYER'S NAME 25. ADDRESS 26. CITY 27. STATE 28. ZIP

ROBBINELL AIRCRAFT CO. ARMY MAINTENANCE NONCONFORMANCE RECORD CLEAR FORM B MNR

1. MODEL 2. A/C OR TWO B/R 3. OPS DEPT./LOC 4. FLT STATUS 5. ENTRY NO 6. PAGE

7. MAINTENANCE REQUIRED / NONCONFORMANCE 8. DATE

9. DESCRIPTION

10. ACTION

11. REPAIR / CHECKOUT

12. EMPLOYER'S SIGNATURE 13. DATE

14. EMPLOYEE NO. & DATE

15. REMOVED PART NO. SERIAL NO.

16. INSTALLED PART NO. SERIAL NO.

17. TIME 18. DATE

NOTE: SPACE IS INCLUDED TIME FOR ONE HOUR UP FAULT ISOLATION AND REPLACEMENT CHECKOUT AND ONE HOUR DOWN TIME.

ROBBINELL AIRCRAFT COMPANY CLEAR FORM C

1. NAME	2. TITLE	3. CODE	4. OFFICE	5. EXT. NO.	6. EXT. NO.	7. EXT. NO.	8. EXT. NO.	9. EXT. NO.	10. EXT. NO.	11. EXT. NO.	12. EXT. NO.	13. EXT. NO.	14. EXT. NO.	15. EXT. NO.	16. EXT. NO.	17. EXT. NO.	18. EXT. NO.	19. EXT. NO.	20. EXT. NO.

21. SIGNATURE 22. DATE

23. SIGNATURE 24. DATE

25. SIGNATURE 26. DATE

27. SIGNATURE 28. DATE

29. SIGNATURE 30. DATE

31. SIGNATURE 32. DATE

33. SIGNATURE 34. DATE

35. SIGNATURE 36. DATE

37. SIGNATURE 38. DATE

39. SIGNATURE 40. DATE

41. SIGNATURE 42. DATE

43. SIGNATURE 44. DATE

45. SIGNATURE 46. DATE

47. SIGNATURE 48. DATE

49. SIGNATURE 50. DATE

51. SIGNATURE 52. DATE

53. SIGNATURE 54. DATE

55. SIGNATURE 56. DATE

57. SIGNATURE 58. DATE

59. SIGNATURE 60. DATE

61. SIGNATURE 62. DATE

63. SIGNATURE 64. DATE

65. SIGNATURE 66. DATE

67. SIGNATURE 68. DATE

69. SIGNATURE 70. DATE

71. SIGNATURE 72. DATE

73. SIGNATURE 74. DATE

75. SIGNATURE 76. DATE

77. SIGNATURE 78. DATE

79. SIGNATURE 80. DATE

81. SIGNATURE 82. DATE

83. SIGNATURE 84. DATE

85. SIGNATURE 86. DATE

87. SIGNATURE 88. DATE

89. SIGNATURE 90. DATE

91. SIGNATURE 92. DATE

93. SIGNATURE 94. DATE

95. SIGNATURE 96. DATE

97. SIGNATURE 98. DATE

99. SIGNATURE 100. DATE

CLEAR REPORTING DURING FLIGHT TESTING

The reporting cycle begins when the pilot worksheet, CLEAR form A, is filled out. Included on the form are certain facts about the flight, take-off times, landing times and so on. Also included is a list of "Squawks" encountered by the pilot during the flight.

After debriefing is complete the form A is routed to the inspection office where a separate form B is prepared for each pilot squawk. This form is used to document all data concerning the aircraft (organizational level) repairs. If the repairs can be made on the aircraft without removing a unit for additional test and/or repairs, the form B is completed stamped-off, and routed to the data center for input to the system.

If it is necessary to remove a unit for test and/or repair, a form C is initiated to record the off-aircraft (intermediate level) test and repair data. This form is attached to the hardware and both are taken to the bond room for disposition of the hardware. The hardware and a copy of the form are then sent to the test/repair area. Here one of three things normally happens. The equipment checks good, minor problems are found and repaired, or the failure is confirmed but cannot be repaired locally. The results of the test/repair are recorded and the hardware and form are returned to the bond room. Good equipment will be returned to the aircraft or stores, and defective equipment is returned to the supplier for repair.

CLEAR

USE OF CLEAR FORMS DURING FLIGHT TESTING



SUPPORT SCHEDULED
MAINTENANCE MANHOURS

RECORDED ON OPIS:

- SERVICING SUPPORT
- PHASED MAINTENANCE
- SCHEDULED MAINTENANCE

FLIGHT SQUAWK GROUND SQUAWK

CLEAR FORM A

CLEAR FORM B/FR

CLEAR FORM B/MNR

CLEAR FORM C

BOND ROOM

EQUIPMENT AND CLEAR FORM C - COPY 3 TO REPAIR AREA

FOR DELAYED REPAIRS OF FLT/GND SQUAWK:

- ORIGINAL FORM B IS CLOSED
 - FORM B-DDIR IS INITIATED
- WHEN REPAIRS ARE MADE
- NOTE 1 PROCEDURE APPLIES

NOTE 1

- IF REPAIRS MADE ON AIRCRAFT
 - CLEAR FORM B COMPLETED
- IF REPAIRS REQUIRE EQUIPMENT REMOVAL
 - CLEAR FORM B COMPLETED
 - CLEAR FORM C INITIATED

WHEN EQUIPMENT SENT TO SUPPLIER FOR REPAIR

- SUPPLIER COMPLETES COPY 4 OF CLEAR FORM C PER DATA ITEM 001.02
- AND -
- SUPPLIER COMPLETES FAILURE ANALYSIS/CORRECTIVE ACTION REPORT PER DATA ITEM E 14.09

IF UNIT CHECKS GOOD OR REPAIRS COMPLETED INHOUSE:

- COMPLETE COPY 3 (BENCH TEST AND REPAIR)
- RETURN (EQUIPMENT AND FORM) TO BOND ROOM

- OR -

IF REPAIRS ARE NOT COMPLETED INHOUSE:

- COMPLETE COPY 3 (BENCH TEST)
- RETURN (EQUIPMENT AND FORM) TO BOND ROOM

ICAP

The MCAIR integrated corrective action program committee has been in operation on the F-18 radar since program inception. This team meets bi-weekly and consists of representatives from the various disciplines involved in assuring the system meets its reliability, maintainability, and quality requirements. During the course of this program many problems have been reviewed. Sixty two of these were of sufficient magnitude to require formal documentation and reporting. Of these 62 problems, 6 are now (1983) open and being monitored.

INTEGRATED CORRECTIVE ACTION PROGRAM (ICAP)

- OBJECTIVE: TO IMPLEMENT EARLY CORRECTIVE ACTION BASED ON REVIEW OF FAILURE DATA
- TEAM MEMBERS: ELECTRONIC ENGINEERING
RADAR LAB
MANUFACTURING PLANNING
RELIABILITY
QUALITY ASSURANCE
MAINTAINABILITY
HUGHES REP AT MCAIR
- PREPRODUCTION: REVIEW FAILURE DATA FROM TESTS AT HUGHES (BURN-IN, RELIABILITY DEVELOPMENT, ENGINEERING TESTS), FLIGHT DEVELOPMENT (PAX RIVER), AND EQUIPMENT TESTS AT MCAIR
- PRODUCTION: REVIEW FAILURE DATA FROM TEST FLIGHTS AT MCAIR AND NAVY FLEET FAILURES
- ICAP PROBLEM STATUS, F-18 RADAR
 - TOTAL PROBLEMS IDENTIFIED - 62
 - OPEN PROBLEMS - 6

INTEGRATED CORRECTIVE ACTION PROGRAM

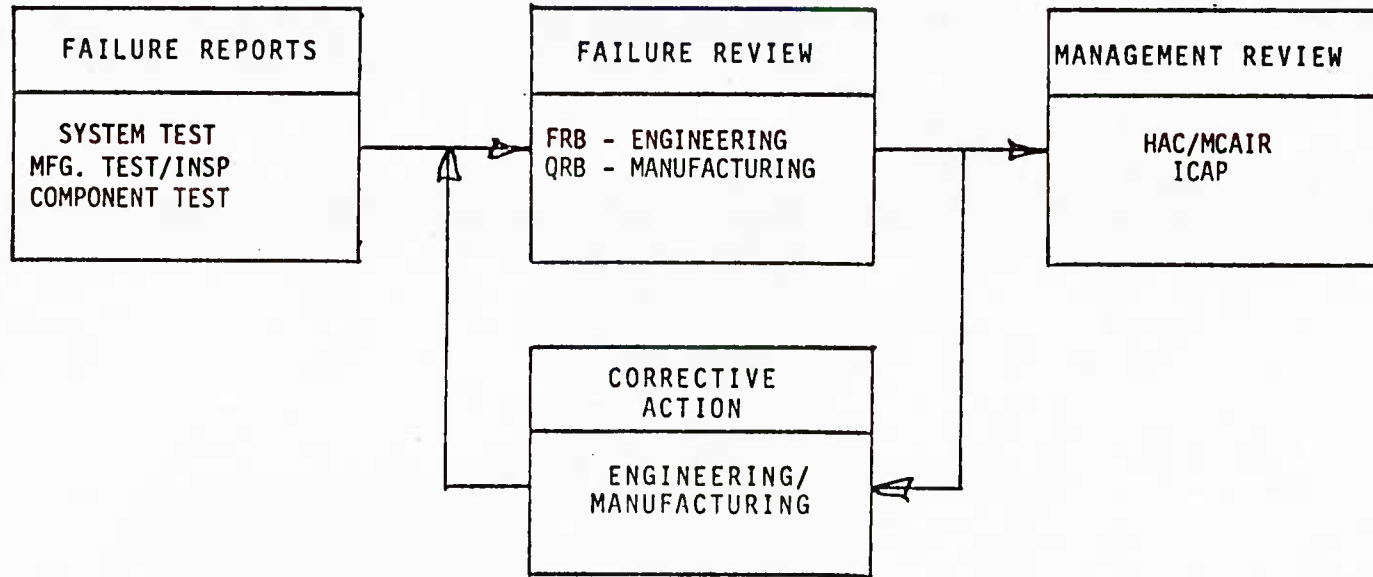

- o PROGRAM MANAGEMENT PARTICIPATION
- o FORMAL INSTRUCTIONS

MCAIR/SUPPLIER INTEGRATED CORRECTIVE ACTION PROGRAM

OPEN PROBLEM STATUS

REPORT NO. 46
 DATE DEC 82
 PAGE 01-1

P.B. NO. 74-870052

P/N 3525000 NOMENCLATURE RADAR SYSTEM

PROB NO	REPORTED		PROBLEM DESCRIPTION	FIELD FAILURES	PRIORITY	ACTION PENDING TO CLOSE PROBLEM			
	BY	DATE				AGENCY	DESCRIPTION	DUE	COMPLETED
51	MCAIR	01-14-82	Transmitter Casting Ruptured.	1 (Could affect all sys.)		MCAIR	RCP CCP 382 sent to MCAIR.		
55-A	MCAIR	06-02-82	LVPS 4A22 and 7A1. MCAIR has experienced (17) 4A22 and (21) 7A1 nonconformances from Jan thru May 1982.			HUGHES	HAC Engineering investigation LVPS 7A1 is now ICAP 55-A. LVPS 4A22 is now ICAP 55-B.		
55-B	MCAIR	10-21-82				MCAIR			
56	MCAIR	08-05-82	High Voltage Pwr. Supply SRA 1A2 has numerous failures at LeMoore and St. Louis. Specific failures on (5) SRA 1A2A2, P/N 928883-1B Transistors	Approx. 14 failures Jan thru July 82		HUGHES	HAC Engineering investigation		
57	MCAIR	08-27-82	Sticking (075) Racks caused by gun gas residue.	Approx. 12 failures to date		HUGHES	Engineering on hold to re-evaluate design for weight reduction.		
58	MCAIR	08-27-82	Transmitter drops through guide rails. Guide rails bend down allowing TX. to fall off the guide rails during removal.	Approx. 3rd failure to date		HUGHES	Change to strengthen rails required. Evaluating other possible designs to reduce weight. Change per ECR 8036381/ECA 489381.		
59	MCAIR	09-15-82	SRA 2A7 Ref. OSC, P/N 3515820-XX is a low reliability item.	Approx. 18 failures to date		HUGHES	Engineering investigating.		
60	MCAIR	09-15-82	SRA 2A10 Digital Module P/N 3575240-XX is a low reliability item.	Approx. 15 failures to date		HUGHES	Engineering investigating.		
62	MCAIR	10-29-82	16K IC P/N 932864-001B low reliability item in Opt (3) radar equip.	Approx. 16 SRA failures to date		HUGHES	Engineering investigating.		

MCAIR/SUPPLIER INTEGRATED CORRECTIVE ACTION PROGRAM

PROBLEM STATUS

P.S. NO. 74-870052

REPORT NO. 45

DATE NOV 82

P/N 3525000

PAGE _____

NOMENCLATURE RADAR SYSTEM

PROB NO.	PROBLEM DESCRIPTION	REPORTED DATE	RESPONSIBILITY FOR		STATUS/ DATE	REMARKS
			REPT & FOLLOW-UP	CORRECTIVE ACTION		
1	Motor Amp 3472426 Failures	1-22-9	MCAIR	Hughes	CLD OCT 82	Improvements via ECA 474386-1A.
2	Ch1 Sel Switch 259446 Failures	1-22-9	MCAIR	Hughes	CLD APR 80	Improvements via CCPs 192, 230 & 242.
3	"XMTR-CAL" Fails (Pulse Spikes)	1-22-9	MCAIR	Hughes	CLD APR 80	Design change (CCP083) @ 011, S/N 016.
4	CAP. M39014/02-1419 Failures	2-05-9	MCAIR	Hughes	CLD JAN 80	No action-investgtn neg-fails subsided.
5	Coolant Leaks @ Xatr Inlet	2-06-9	MCAIR	Hughes	CLD OCT 79	'O'ring mat'l changed @ 011, S/N 016.
6	Waveguide/array screws loosen	2-28-9	MCAIR	Hughes	CLD OCT 79	Loctite on screws @ 031, S/N 016.
7	Intermittent 900Hz signal	2-28-9	MCAIR	Hughes	CLD APR 80	031 flex cables redesigned @ S/N 016.
8	Multilayer Board shorts & opens	3-21-9	MCAIR	Hughes	CLD APR 80	Optical aids in use - Ongoing actions.
9	Chain Reaction Failures	3-21-9	MCAIR	Hughes	CLD OCT 79	No action - HAC feels design is adequate.
10	Breakage of Module Extractors	3-21-9	MCAIR	Hughes	CLD OCT 81	Stronger extractor material @ Set 055.
11	GTWT, P/N 259255 - Low Power	3-26-9	MCAIR	Hughes	CLD APR 80	Improved design/assembly techniques.
12	Coax Connect. Fatigue (3537479)	3-30-9	MCAIR	Hughes	CLD JUN 81	Right-angle connector at Rack LEY088.
13	W/G Clamp 918356 Failures	7-11-9	MCAIR	Hughes	CLD SEP 81	Caution note added to Tech Orders.
14	No Thermal Bond at Hybrids	7-11-9	MCAIR	Hughes	CLD DEC 79	Assy/Insp improvements incorporated.
15	Transistor 928883-1B Failures	7-13-9	MCAIR	Hughes	CLD APR 80	Improvements via CCPs 175, 221 & 226.

MCAIR/SUPPLIER INTEGRATED CORRECTIVE ACTION PROGRAM

PROBLEM STATUS

REPORT NO. 45
DATE NOV 82
PAGE _____

P.S. NO. 74-870052

P/N 3525000

NOMENCLATURE RADAR SYSTEM

PROB NO.	PROBLEM DESCRIPTION	REPORTED DATE	RESPONSIBILITY FOR		STATUS/ DATE	REMARKS
			REPT & FOLLOW-UP	CORRECTIVE ACTION		
16	Cover Fastener Assy Separates	8-07-9	MCAIR	Hughes	CLD APR 80	Improved fastener @ Set No. 024 (OPT II).
17	Semi-rigid W/G Assy Damage	8-08-9	MCAIR	Hughes	CLD APR 80	Design change (CCP167) @ 075, S/N 013.
18	Failure of Flex Cable Assys	9-10-9	MCAIR	Hughes	CLD APR 80	Design changes via CCP138/185 & ECA474347.
19	Non-constraint of Shld Wires	9-07-9	MCAIR	Hughes	CLD FEB 80	Mfg. Planning for 041/681 revised Nov 79.
20	Module Ident Markings not Clear	9-19-9	MCAIR	Hughes	CLD APR 80	Mech. design change @ Set 024 (OPT II).
21	Capacitor 910034-1B Failures	10-11-9	MCAIR	Hughes	CLD SEP 81	Improved capacitor-CCP 346/Set 055 (OPT 3).
22	IC P/N 932775-1B Failures	11-21-9	MCAIR	Hughes	CLD APR 80	100% Screen @ Rec Insp - Low & High Temp.
23	IC 932749-1B Failures	1-21-0	MCAIR	Hughes	CLD APR 80	100% Screen @ Rec Insp - Low & High Temp.
24	Ant Conn Jackscrew Maint Fails	12-17-9	MCAIR	Hughes	CLD APR 80	Design change to slot bolts @ 031 S/N 027.
25	Filter 930482/483 Failures	1-22-0	MCAIR	Hughes	CLD JAN 82	Improved capacitor construction-D/C 8133.
26	Transistor 928185-504B Failures	1-22-0	MCAIR	Hughes	CLD MAR 80	Design change (CCP241) @ 011, S/N 027.
27	IC 932777-1B Failures	1-24-0	MCAIR	Hughes	CLD APR 80	100% Screen @ Rec Insp - Low & High Temp.
28	Part Failures from Xmtr Arcing	2-15-0	MCAIR	Hughes	CLD JUL 81	Design Change - CCP 196/241/278/298.
29	O11 Cover Fasteners Separate	2-05-0	MCAIR	Hughes	CLD APR 80	Improved fastener @ O11 No. 027 (Opt II).
30	Pantograph P/N 3537480 Problems	3-07-0	MCAIR	Hughes	CLD JUL 80	Improvements initiated @ Rack No. 015.

MCAIR/SUPPLIER INTEGRATED CORRECTIVE ACTION PROGRAM

PROBLEM STATUS

P.S. NO. 74-870052

REPORT NO. 45

DATE NOV 82

P/N 3525000

PAGE _____

NOMENCLATURE RADAR SYSTEM

PROB NO.	PROBLEM DESCRIPTION	REPORTED DATE	RESPONSIBILITY FOR		STATUS/ DATE	REMARKS
			REPT & FOLLOW-UP	CORRECTIVE ACTION		
31	Rack Hdwe Rust/Worn Markings	3-11-0	MCAIR	Hughes	CLD NOV 80	Screening checks at Rec Insp added.
32	Pattern Fail of IC 932180-502B	3-18-0	Hughes	Hughes	CLD JUL 80	Transferred to ICAP No. 28.
33	Equipment Soldering Defects	4-24-0	MCAIR	Hughes	CLD JUL 80	Remedial measures initiated @ Sys 011.
34	Reversed 7A1C102-Dwg Error	5-13-0	MCAIR	Hughes	CLD JUN 80	Drawing error corrected.
35	Antenna Boresight Null Shifts	5-20-0	MCAIR	Hughes	CLD AUG 80	Mech design change to 3597823 @ KQQ020.
36	Pattern Fail of IC 932751-1B	6-11-0	Hughes	Hughes	CLD DEC 80	Circuit redesign - 16K RAM - at System 060.
37	Boresight Error Accum. O/T	6-13-0	MCAIR	MCAIR	CLD SEP 81	Improved Mfg procedures & alignment tool.
38	Antenna Scan bumper failures	8-21-0	MCAIR	Hughes	CLD SEP 80	Mech design change @ Sys 027.
39	XMTR Conn Jackscrew-Maint Fails	10-22-0	MCAIR	Hughes	CLD JAN 81	Mat'l change (1A2)-7/64 jackscrews-1A6/7.
40	Wire Damage Within 041/681 WRAs	10-22-0	MCAIR	Hughes	CLD AUG 81	Protective tape added to wire bundles.
41	Damaged Rack Retaining Bolts	01-16-1	Hughes	Hughes	CLD JAN 82	Mech change - EO 27630 @ Set 128.
42	Coolant Fitting 05P08 Pops Off	01-22-1	MCAIR	MCAIR	CLD DEC 81	Various improvements - See INCAP Rpt No. 34
43	Clocking of Connectors 4J3/7J6	03-12-1	MCAIR	Hughes	CLD MAY 81	Retrofit Instructions 3624293 corrected.
44	Bad Shld Termination-EMI Plugs	04-14-1	MCAIR	Hughes	CLD MAY 81	Planning/Inspection revised & OJT added.
45	Coax Connection Fatigue - 01P08	05-07-1	MCAIR	Hughes	CLD JUN 81	Automatic crimping tool at Rack LEM034.

MCAIR/SUPPLIER INTEGRATED CORRECTIVE ACTION PROGRAM

PROBLEM STATUS

P.S. NO. 74-870052

P/N 3525000

REPORT NO. 45

DATE NOV 82

PAGE _____

NOMENCLATURE RADAR SYSTEM

PROB NO.	PROBLEM DESCRIPTION	REPORTED DATE	RESPONSIBILITY FOR		STATUS/ DATE	REMARKS
			REPT & FOLLOW-UP	CORRECTIVE ACTION		
46	Contact B/T Array/Conn Housing	08-17-81	MCAIR	Hughes	CLD OCT 81	Increased bumper thickness @ 031 No. 55.
47	Inconsistent SRA ASD Markings	09-09-81	MCAIR	Hughes	CLD AUG 82	Decrease in failures noted.
48	System Hangs Up in ORT Mode	11-06-81	MCAIR	Hughes	CLD MAR 82	New Software tape (OPF-100A)
49	Short Screws in Equipment Rack	11-23-81	MCAIR	Hughes	CLD JAN 82	Increased screw length @ Set 055.
50	Coolant Lines Abraid Cable Assy	11-23-81	MCAIR	Hughes	CLD JAN 82	Spiral sleeving added @ Set 055.
51	Transmitter Casting Rupture	01-14-82	MCAIR	Hughes	OPEN	
52	Bolt Assy. P/N 971259-1C	03-15-82	MCAIR	Hughes	CLD OCT 82	New Ring Design.
53	Low Volt. Power Supplies	03-15-82	MCAIR	Hughes	CLD MAR 82	Additional Filtering added @ Set 055.
54	Memory Alterations	04-14-82	MCAIR	Hughes	CLD OCT 82	CCP 385 Retrofit @ 55 and up.
55	LVPS 4A22 and 7A1	06-02-82	MCAIR	Hughes	OPEN	
56	High Volt Pwr. Supp 1A2	08-05-82	MCAIR	Hughes	OPEN	
57	Sticking (075) Racks	08-27-82	MCAIR	Hughes	OPEN	
58	TX Drops through Guide Rails	08-27-82	MCAIR	Hughes	OPEN	
59	SRA 2A7 High Fail Rate Item	09-15-82	MCAIR	Hughes	OPEN	
60	SRA 2A10 High Fail Rate Item	09-15-82	MCAIR	Hughes	OPEN	
61	SRA 1A7 High Fail Rate Item	09-15-82	MCAIR	Hughes	CLD OCT 82	Zener Diode added @ 55 and up.

MCAIR/SUPPLIER INTEGRATED CORRECTIVE ACTION PROGRAM

PROBLEM STATUS

P.S. NO. 74-870052

REPORT NO. 45

DATE NOV 82

P/N 3525000

NOMENCLATURE RADAR SYSTEM

PAGE _____

PROB NO.	PROBLEM DESCRIPTION	REPORTED DATE	RESPONSIBILITY FOR		STATUS/ DATE	REMARKS
			REPT & FOLLOW-UP	CORRECTIVE ACTION		
62	16K IC Low Rel. Item	10-29-82	MCAIR	Hughes	OPEN	

INTERPLAY BETWEEN COST REDUCTION AND QUALITY/RELIABILITY

- HEAVY DIRECT LABOR WORK PACKAGES
 - COST/PRODUCTIVITY
 - QUALITY/CONSISTENCY
 - RELIABILITY

- COUNTER WITH AUTOMATION
 - AUTOMATIC COMPONENT INSERTION/TEST/SOLDERING
 - AUTOMATED TEST
 - AUTOMATED INSPECTION

RECOMMENDATION: SUPPORT SUPPLIER PRODUCTIVITY INITIATIVES

- MANUFACTURING TECHNOLOGY
- TECHNOLOGY MODERNIZATION

TEST DEFECT TRENDS

The following two charts are extracts from a manufacturing management report showing the progress in several categories of problems which result in SRA test failures for each of two groups of SRA's (machine-built and hand-built). The improvement in each major problem area is shown in the charts.

DEFECTS PER UNIT (DPU)

2

JAN 81



JUL 81



DEC 81



MAY 82



F/A 18 RADAR TEST DEFECT TRENDS

HAND BUILT MODULES

JAN 1981 TO MAY 1982

1

0

COMP DEFECT

WIRE ERROR

WRG/POL/MSG

SOLDER

MISC.

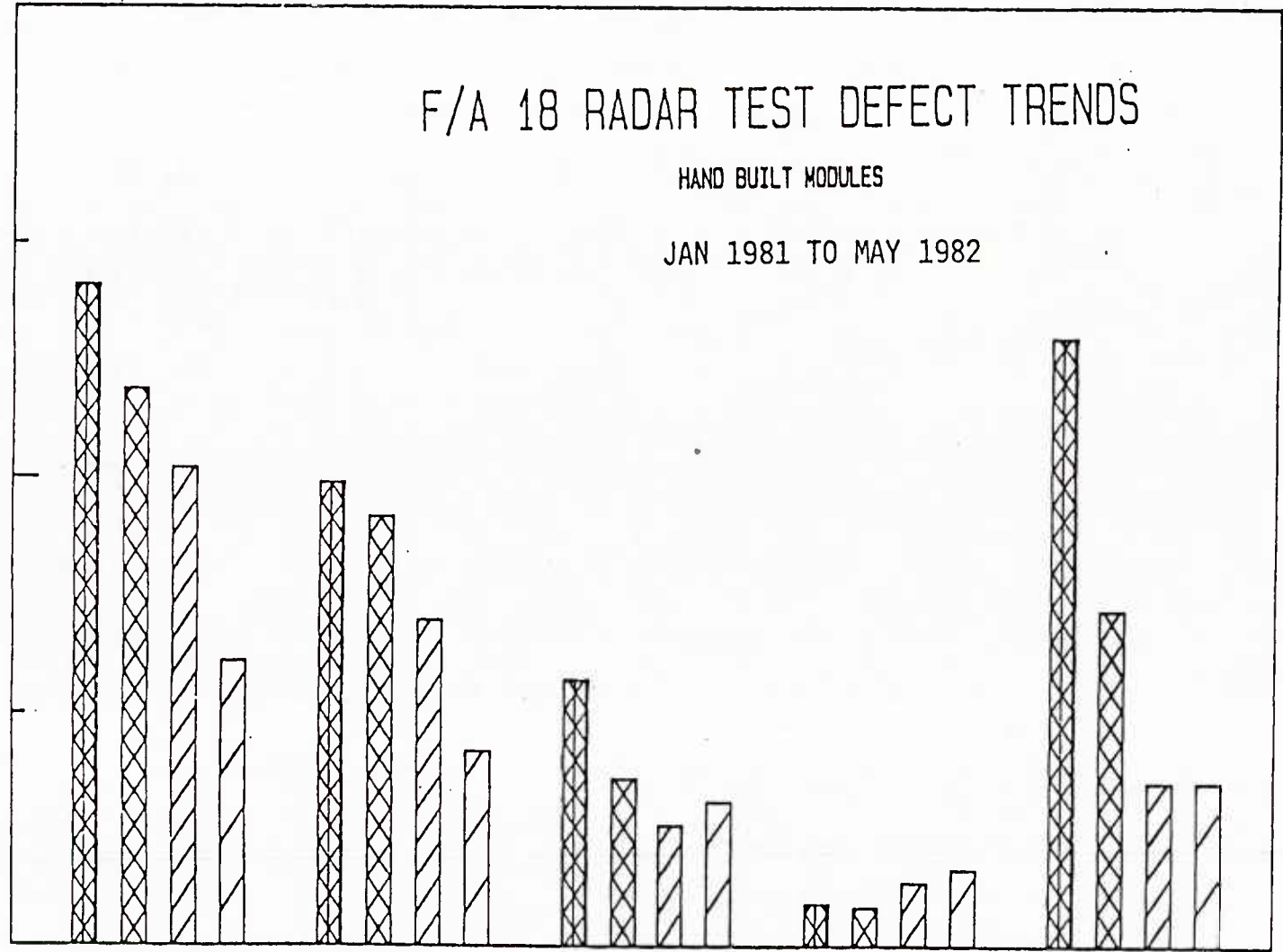

DEFECTS PER UNIT (DPU)

3

JAN 81



JUL 81



DEC 81



MAY 82

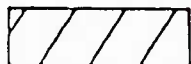

F/A 18 RADAR TEST DEFECT TRENDS

MACHINE BUILT MODULES

JAN 1981 TO MAY 1982

2

1

0

COMP DEFECT

WIRE ERROR

WRG/POL/MSG

SOLDER

MISC.

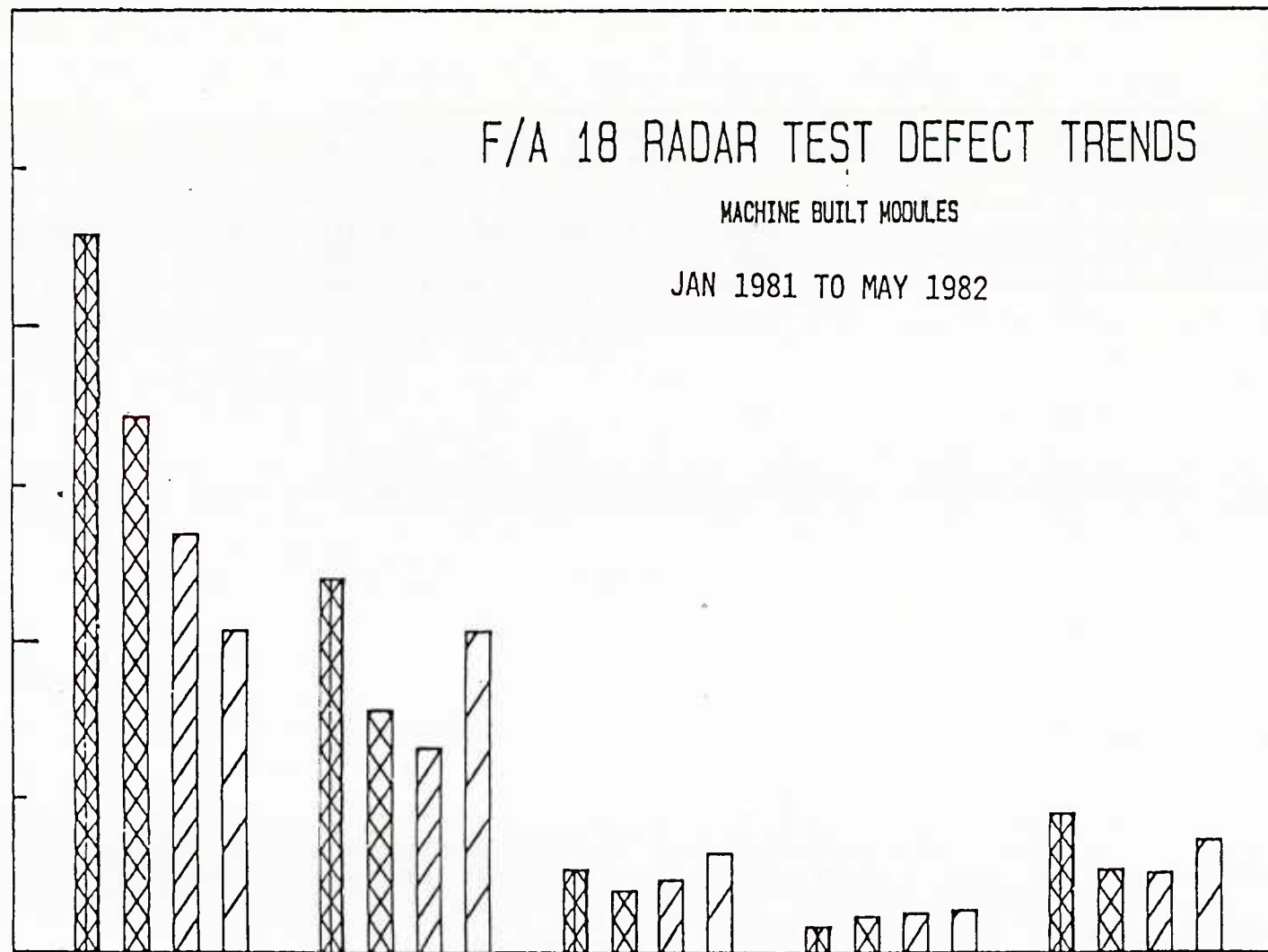

TEST AND EVALUATION

TEST AND EVALUATION

- T&E APPROACH
- RELIABILITY DEVELOPMENT TEST
- RELIABILITY DEMONSTRATIONS
- INITIAL BIT ASSESSMENT
- MAINTAINABILITY DEMONSTRATION
- IN-SERVICE R&M ASSESSMENT

The F/A-18 Test and Evaluation program was purposely integrated and interleaved with many of the individual tests building on one another. Test Analyze and Fix (TAAF) was a philosophy which acted as an umbrella over the entire test program. All failures were analyzed and followed-up for necessary corrective action.

TEST AND EVALUATION

- 1) INTRODUCTION - EVERYTHING IS TEST, ANALYZE AND FIX (TAAF)
- 2) ELEMENT DEVELOPMENT TEST
 - PROPOSALS IDENTIFIED ITEMS REPRESENTING RELIABILITY RISK
 - MCAIR REVIEWED DURING PROPOSAL EVALUATION - ADDED ITEMS WHERE NECESSARY
 - MEMORANDUM OF AGREEMENT NEGOTIATED TO DEFINE SPECIFIC TESTS
 - IMPLEMENTED AFTER SOURCE SELECTION UPON CONTRACT AWARD
- 3) RELIABILITY DEVELOPMENT TEST
 - ORIGINAL DEFINITION WAS MIL-STD-781
 - DURING PROPOSAL PRELIMINARY OPERATIONAL MISSION ENVIRONMENT (OME) PRICED AS OPTION
 - FINAL OME NEGOTIATED AS OPTION TO PURCHASE ORDER
 - OME OPTION EXERCISED
- 4) LABORATORY DEMONSTRATION TESTS
 - ORIGINAL DEFINITION TO MIL-STANDARDS AND F/A-18 UNIQUE FACTORS
 - FINAL OME NEGOTIATED AS OPTION TO PURCHASE ORDER
- 5) ACCEPTANCE TESTING INCLUDING BURN-IN
 - BASED ON MIL-STD-781
 - IMPROVED ON FSD AND PRODUCTION

TEST AND EVALUATION (CONTINUED)

- 6) BUILT-IN-TEST FUNCTIONAL TESTING
 - o COMBINED INITIAL BIT ASSESSMENT AND PARTIAL MAINTAINABILITY DEMONSTRATION TEST
- 7) MAINTAINABILITY DEMONSTRATION TESTING
- 8) DEVELOPMENT FLIGHT TESTING
- 9) SPECIAL TESTING
 - o 100 FLIGHT HOUR RELIABILITY DEMONSTRATION TEST
 - o 1200 FLIGHT HOUR/2500 FLIGHT HOUR/9000 FLIGHT HOUR
- 10) NAVY TESTING
 - NAVY PRELIMINARY EVALUATIONS (FLIGHT-RELIABILITY MONITORED)
 - INITIAL OPERATIONAL TEST AND EVALUATION (RELIABILITY/MAINTAINABILITY/AVAILABILITY EVALUATED)
 - NAVY TECHNICAL EVALUATION (TECHEVAL)
 - OPERATIONAL TEST AND EVALUATION

CONCURRENCY OF TESTING

The APG-65 radar program had a great deal of test concurrency. To meet cost and schedule constraints this concurrency was required; this, however, usually results in increased risk. To minimize this risk, certain actions were taken. To minimize the retrofit threat, high stress testing was performed early in the program, and the results of all testing was utilized in a total test, analyze, and fix concept. The expeditious feed-back of information from the various tests allowed design changes to be incorporated early in the program.

To accomplish a development program with a large amount of concurrency it was deemed necessary that the program management be given the flexibility to use available assets to meet the various elements of the development program.

CONCURRENCY IN TESTING

A TOTAL TAAF CONCEPT

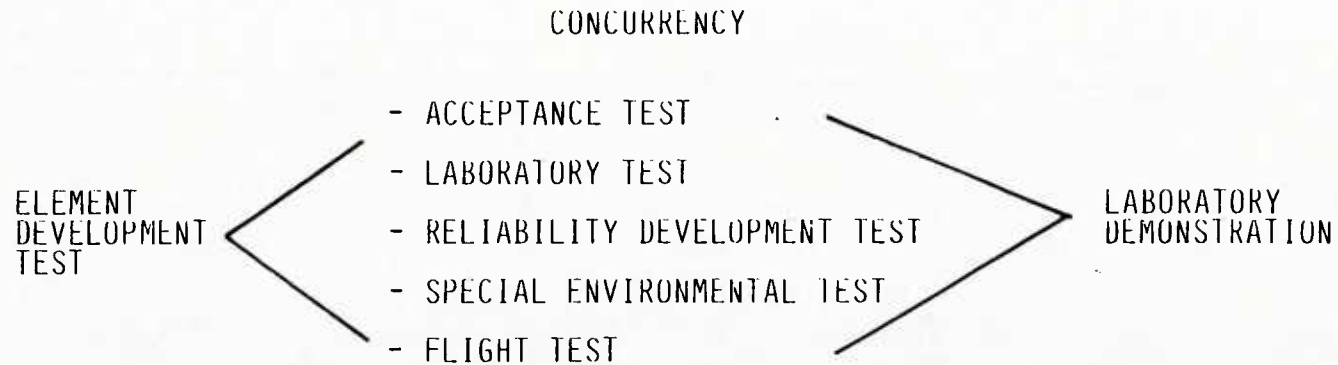

- CONCURRENCY - DEMANDS TOTAL PROGRAM DEDICATION TO TEST, ANALYZE, AND FIX
 - RECOGNIZES THAT DEDICATED RELIABILITY DEVELOPMENT TEST IS ONLY AN ELEMENT OF RELIABILITY GROWTH
 - RECOGNIZES FLEXIBILITY IN ASSET UTILIZATION

F-18 RADAR
RELIABILITY DEVELOPMENT TESTS

Reliability development tests were performed on preproduction radar set numbers 5 and 13 and production set numbers 19 and 22 for a total of 1591.8 hours. The functional exercising of the sets in the environment consists of operating in Velocity Search (VS), Range While Search (RWS) and Real Beam Ground Map (RBGM), and running Initiated BIT. Periodically, throughout reliability development testing, a performance test is run at room ambient conditions, which is designed to detect failures that cannot be detected in the environment.

The environment during this test is an operational mission environment divided among three sets; one set dedicated to reliability development and the two environmental laboratory demonstration (lab demo) sets. It requires full-life vibration on one set (consisting of half-life and four 750 flight-hour vibration periods), and four 750 flight-hour vibration periods on one of the lab demo sets; 340 cycle As, high/low temperature stress test (half of which are with altitude); 100 cycle Ds, high-temperature stress test; and mission profiles consisting of 551 tropical day cycles, 30 hot day cycles, 37 cold day cycles, and standard day cycles as required to meet the total test time of 3800 hours.

F-18 RADAR
RELIABILITY DEVELOPMENT TEST

- TEST UNITS: 1 UNIT DEDICATED TO RELIABILITY DEVELOPMENT TEST (RDT)
2 UNITS USED FOR RDT AND ENVIRONMENTAL DEMONSTRATION TESTS
3800 "ON" HOURS
- ENVIRONMENT:
 - VIBRATION: - FULL LIFE (6000 FLIGHT HOURS EQUIVALENT) ON ONE SET AND HALF-LIFE ON A SECOND SET)
 - INCLUDES SINE CYCLE AND RANDOM GUNFIRE AND NON-GUNFIRE LEVELS, 3-AXES
 - TOTAL VIBRATION TIME, 240 HOURS
 - THERMAL: - THERMAL CYCLE STRESS (340 CYCLES, 680 HOURS "ON" TIME, ONE-HALF WITH ALTITUDE)
 - MAXIMUM CONTINUOUS SEA-LEVEL THERMAL TEST (100 CYCLES, 400 HOURS)
 - MISSION PROFILES (SIMULATED FLIGHT THERMAL CONDITIONS AND GROUND CONDITIONS BEFORE AND AFTER FLIGHT)
 - TROPICAL DAY (551 CYCLES, 1653 HOURS)
 - HOT DAY (30 CYCLES, 90 HOURS)
 - COLD DAY (37 CYCLES, 111 HOURS)
 - STANDARD DAY (APPROXIMATELY 200 CYCLES, 600 HOURS AS REQUIRED TO MEET REQUIRED TOTAL TEST TIME)

F/A-18 RADAR

RELIABILITY DEVELOPMENT TEST SCHEDULE

1979												1980												1981											
M	A	M	J	J	A	S	O	N	D	J	F	M	A	M	J	J	A	S	O	N	D	J	F	M	A	M	J	J	A	S	O	N	D		

PLANNED RELIABILITY DEVELOPMENT TEST SCHEDULE

|=====|

ACTUAL RELIABILITY DEVELOPMENT TEST SCHEDULE

|=====|

S/N 005

1/2 LIFE VIB. THERMAL
|=====|=====|

S/N 013

THERMAL 1/4 LIFE VIB.
|=====|=====|

S/N 022

THERMAL
|=====|

S/N 019

THERMAL
|=|

ALL TEST TIME IS TAAF TIME

The F-18 radar reliability development test (RDT) did not yield a significant number of new problems, the primary reason being that data from all radar testing was analyzed for problems and necessary corrective action. Significant amounts of ground and airborne testing were being conducted prior to the formal start of the RDT. Two points of significance are:

1. For effective reliability growth, all test data must be utilized for Test-Analyze-and-Fix (TAAF).
2. An early start of formal RDT will increase the yield of significant new information from the test.

ALL TEST TIME IS TAAF TIME

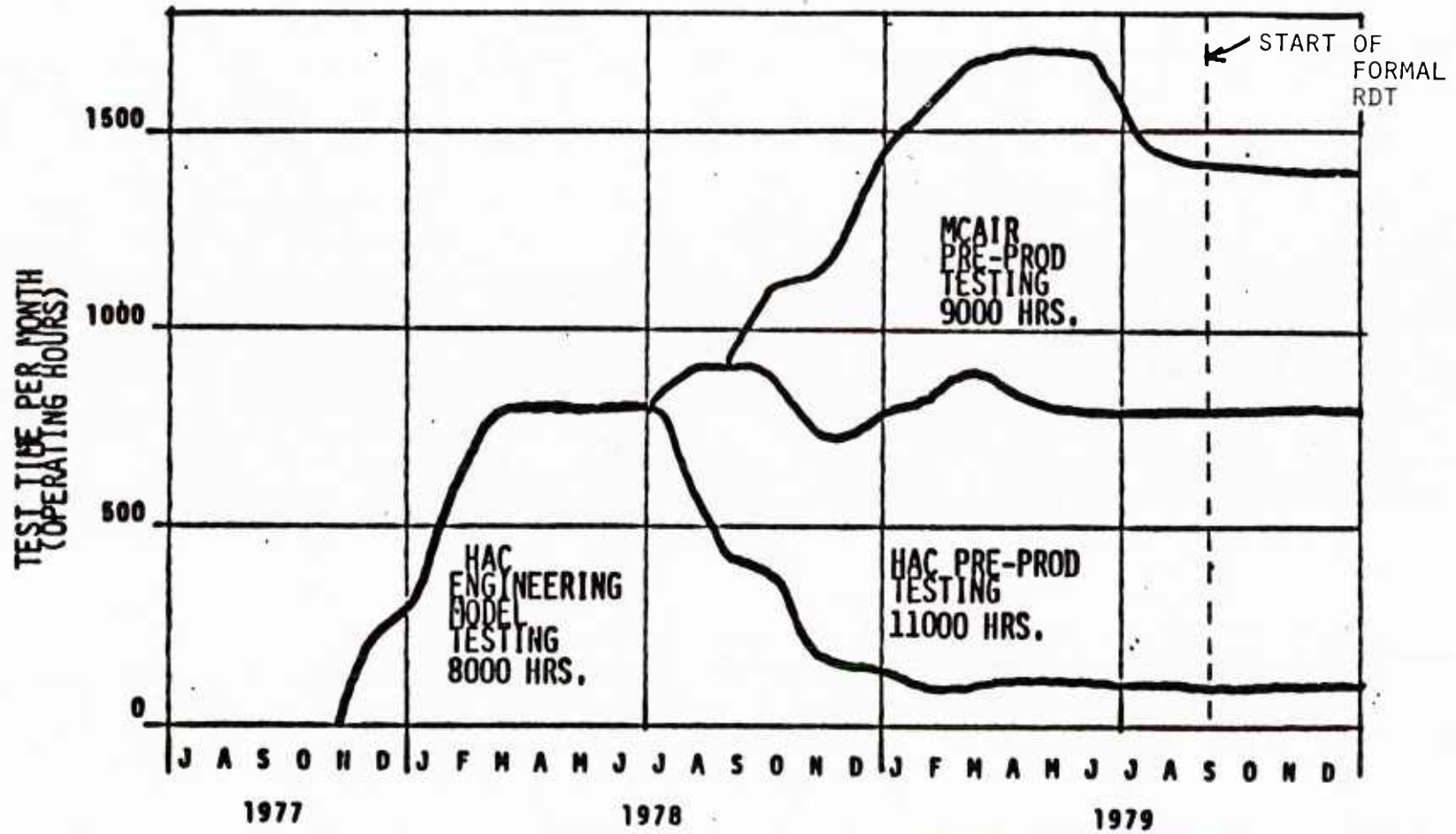

F-18 RADAR
RELIABILITY DEVELOPMENT TEST

<u>REQUIRED</u>	<u>COMPLETED</u>	<u>FAILURES</u>	<u>FIX COMPLETE</u>
S/N 5 (REL DEV) HALF-LIFE VIB, 750 FLT. HR. VIB (4), MISSION PROFILES	770.4	71	63
S/N 19	434.5	8	8
S/N 13 (LAB DEMO) EMC, HUMIDITY RAIN, EXPLOSION, SAND & DUST, SALT FOG; (REL DEV) MISSION PROFILES, VIB., CYCLE A, CYCLE D - INTERSPERSED IN LAB DEMO	62.5	16	8
S/N 22	324.4	16	7
TOTAL	1591.8	111	86

NOTE: RELIABILITY DEVELOPMENT TESTING HAS BEEN SUSPENDED IN ORDER THAT ENVIRONMENTAL QUALIFICATION CAN BEGIN BECAUSE THE SAME RADAR SETS ARE USED FOR BOTH TESTS

STATUS AS OF 11 SEP 1981

F-18 RADAR

RELIABILITY DEVELOPMENT TEST PROGRESS CHART

<u>ITEM</u>	<u>FAILURE LEGEND</u>	<u>ITEM</u>	<u>FAILURE LEGEND</u>
1	(1) HANDLE UNBONDED ON RDP, RSP AND R/E	31	(25) BROKEN WIRE (RDP)
4	(2) LOOSE RESISTOR & CAPACITOR (R/E)	32	(26) RESOLDERED CONNECTION 1A8R5 (TX)
5	(3) DISC LOOSE (RDP)	33	(27) SOLDER CONNECTIONS (RSP)
8	(4) BROKEN RESISTOR (R/E)	35	(28) WAVEGUIDE CRACKED
9	(5) BROKEN CAPACITOR (R/E)	36	(29) GTWT & XFMR (TX)
10	(6) BROKEN WIRE (R/E)	37	(30) BAD SOLDER CONNECTION 1A8A1 (TX)
11	(7) WIRE BROKEN AT CONN (RDP)	38	(31) WASHERS CRACKED (RACK)
12	(8) ION PUMP POWER SUPPLY (TX)	39	(32) PIN SHEARED, BALL BEARING RACE LOOSE (RACK)
13	(9) AZ CAGE TEST FAIL (ANT)	40	(33) DISPLAY INFORMATION LOST
14	(10) POWER SUPPLY HANDLE BROKEN (RDP)	40.1	(34) REF OSC OVEN TEMP (R/E)
15	(11) THREE CAPACITORS BROKE LOOSE FROM MOUNTING (RDP)	41	(35) IC ON 3A1A3 (ANT)
17	(12) DOUBLER ON MOTHERBOARD BROKE LOOSE (RDP)	42	(36) CAP. 910034 (TX)
18	(13) WIRE BROKEN TO FAULT INDICATOR (RDP)	43	(37) PWB SHORTED (RSP)
19	(14) CAPACITOR 1A2A5C1, P/N 39014/02 (TX)	49	(38) LOOSE WIRES (RACK)
20	(15) RECTIFIER 1A2A5CR14, P/N 925214-1B (TX)	51	(39) EMI FILTER (RSP)
20.1	(16) RDP DISC, WIRE BROKEN (RDP)	52	(40) R13, R20, CR3 ON 1A8 (TX)
21	(17) P-BIT, PHASE/GAIN INCORRECT SIGNAL LEVEL (ANT)	55	(41) SHORTED PWB (RDP)
23	(18) P-BIT, ANT SCAN FAIL (ANT)	56	(42) IC A1A1U5 ON 7A1 (RDP)
24	(19) LOOSE LVPS BUS BAR (RDP)	57	(43) LVPS 4A22 TESTED GOOD (RSP)
25	(20) FLEX HARNESS (TX)	58	(44) 7A8 SOLDER DEFECT (RDP)
26	(21) CONNECTOR WASHER MISSING (RACK)	59	(45) REMOVED 7A8 ROK (RDP)
27	(22) EXTRACTOR/RETAINER PIN BROKEN (RDP)	60	(46) 7A6 TESTED GOOD (RDP)
29	(23) 1A5Q1 & PRESS. SW FAILED (TX)	60.1	(47) LVPS ARC (RDP)
30	(24) A10 SOCKET PROTECTOR (R/E)	62	(48) REG TESTED GOOD (RDP)
		63	(49) TRANSISTORS ON 7A1 (RDP)
		64	(50) BENT PIN ON 7A8 (RDP)
		66	(51) 4A22 PWB OPEN (RSP)
		67	(52) 2 RES. & 2 XSTRS (TX)
		68	(53) BURNED SPOT ON 2A8 (R/E)
		69	(54) BONDING REMOVED (R/E)

45/13-9

F-18 RADAR

RELIABILITY DEVELOPMENT TEST PROGRESS CHART (CONTINUED)

<u>ITEM</u>	<u>FAILURE LEGEND</u>	<u>ITEM</u>	<u>FAILURE LEGEND</u>
70	(55) 4A10 TESTED GOOD (RSP)	104	(86) ANT, AZ/EL SCAN FAIL
71	(56) 4A9 TESTED GOOD (RSP)	105	(87) PROBLEM NOT DUPLICATED (ANT)
72	(57) SOLDER DEFECT, 7A5 (RDP)	105.1	(88) WAVEGUIDE BROKEN
73	(58) COOLANT O-RING (TX)	105.2	(89) SYSTEM HUNG UP
74.1	(59) IC ON 4A1 (RSP)	106	(90) PHASE/GAIN & AZ/EL FAIL
75	(60) SHORT ON 2A10 (R/E)	109	(91) NO RF IN HPRF OR PDI
76	(61) MODULE TESTED GOOD (RDP)	110	(92) RSP INTERNAL IOC FAIL
77	(62) IC REPLACED (RSP)	114	(93) SAT. CONT. LOOP PROBLEM
79	(63) 7A1 TESTED GOOD (RDP)	115	(94) SOFTWARE I/O PROBLEM
80	(64) 2A8 REPAIRED (R/E)	116	(95) NO RF OUTPUT
81	(65) IC ON 7A4 (RDP)	117	(96) FAILED TO OPERATE
82	(66) RIVETS BROKEN	119	(97) HV GRID FAULT
83	(67) AFT ROLLER STOPS BROKE	120	(98) A/D BIAS FAULT
84	(68) NO BIT TARGETS	122	(99) PWR SUPP SHUT DOWN
85	(69) XTAL OSC ON 4A3 (RSP)	123	(100) EL TORQ AMP FAIL
87	(70) 1A5 TRANSISTORS (TX)	124	(101) WAVEGUIDE CRACKED (R/E)
88	(71) GUIDE BUSHING (RSP)	124.1	(102) 1A5 PWR SHORT (TX)
89	(72) SOLDER DEFECT (TX)	127	(103) RDP WILL NOT POWER UP
90	(73) RSP WILL NOT PWR UP	128	(104) RDP WILL NOT POWER UP
91	(74) IC ON 1A8A1 (TX)	129	(105) RDP WILL NOT POWER UP
92	(75) 4A1 TESTED GOOD (RSP)	130	(106) NO RF POWER OUTPUT
93	(76) PROBLEM NOT DUPLICATED (TX)	131	(107) WAVEGUIDE BROKEN
94	(77) 1-1C, 1-RS. NET., 4A1 (RSP)	132	(108) LOOSE CONNECTION (R/E)
95	(78) 7A6 TESTED GOOD (RDP)	133	(109) TX DUMPED
96	(79) 4A10 CONNECTOR (RSP)	134	(110) PHASE/GAIN GAIN FAIL
97	(80) RDP FAILED	136	(111) TX FAILED
98	(81) FLEX WIRING (TX)		
99	(82) RE - WILL NOT START		
100	(83) TX BIT FAULT		
103	(84) PROBLEM NOT DUPLICATED (R/E)		
103.1	(85) AZ TORQ. AMP FAIL		

45/13-10

RDT ENVIRONMENTAL PROFILES

The next two charts present examples from the six thermal profiles that were employed during Reliability Development Testing (RDT). The profiles were developed based on MCAIR studies of expected mission mix and aircraft worldwide distribution.

The first chart, Tropical Day Mission Profile, presents a sequence in which the aircraft checks are made and taxiing for take-off (0 to 20 minutes), the second phase is flight (20 to 140 minutes) and the last is taxiing and ground maintenance (140 to 180 minutes).

The second chart, Cycle A Stress Test, subjects the equipment to low and high environmental extremes and at a rapid rate of change between the extremes to determine if there are weaknesses related to high rates of change of temperature.

CYCLE A STRESS TEST

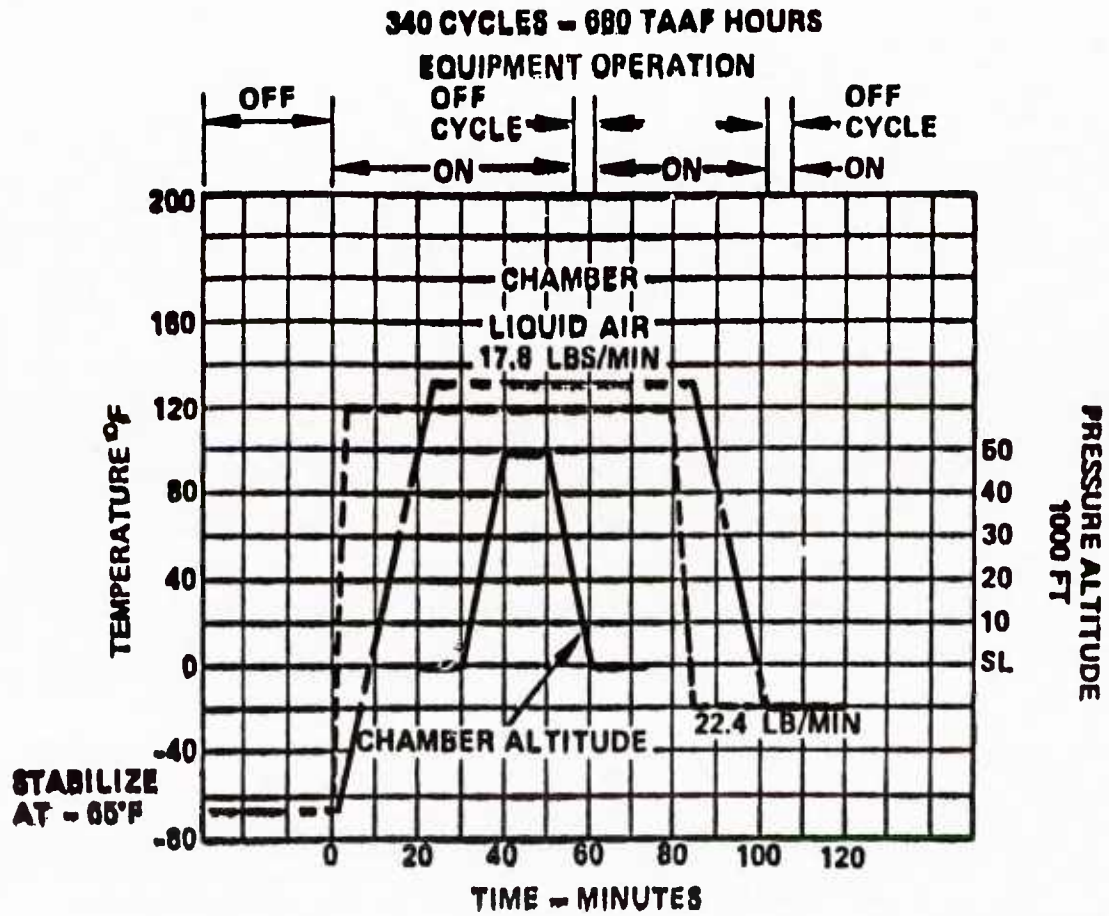

NOVEMBER 1977

TROPICAL DAY MISSION PROFILE

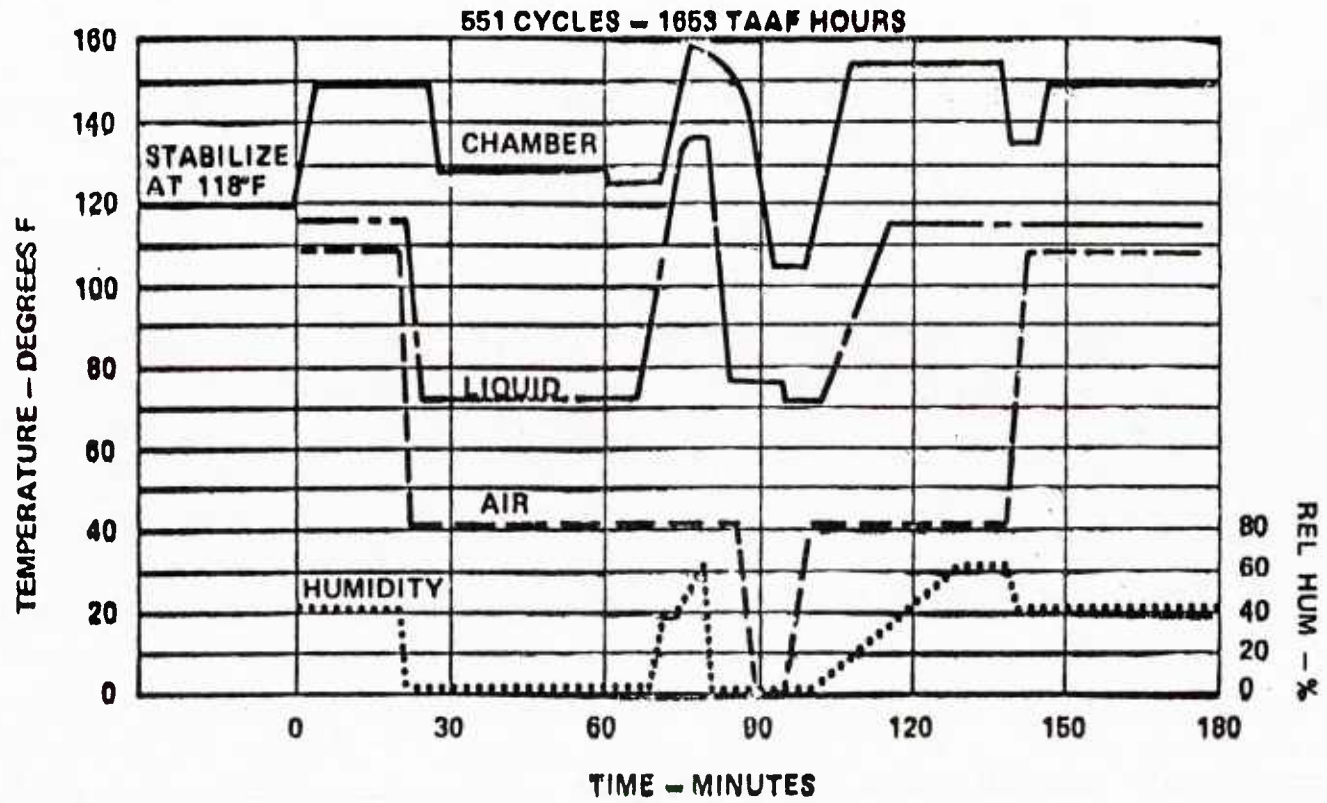

NOVEMBER 1977

RADAR RELIABILITY DEMONSTRATION

In November 1980, a MCAIR-Navy team performed a 50 flight, 100 hour demonstration of the F/A-18 aircraft reliability. This demonstration, performed with aircraft F9 and APG-65 radar set number 19, was completed in 15 days without a radar failure of any kind. The demonstration included air-to-air, air-to-ground and ferry missions; the 20mm gun was fired on 4 flights and bombs were dropped on 2. Five flights per day were accomplished on 3 occasions. Navy pilots flew 2 additional flights at the conclusion of the demonstration, also without radar failure of any kind.

APG-65 RADAR RELIABILITY DEMONSTRATION - LABORATORY

- JAN 1983
- RADAR SERIAL NUMBERS 85 AND 94
- 149 OPERATING HOURS, ZERO FAILURES
- RADAR EXCEEDED CURRENT (OPTION III) 85 HR MTBF REQUIREMENT
- RADAR PASSED NEXT YEAR'S (FY'82) 106 HR MTBF REQUIREMENT
- CHAMBER DOOR NEVER OPENED DURING TEST
- NO MAINTENANCE PERFORMED, NO REPAIRS REQUIRED DURING TEST
- OPERATIONAL IMPLICATIONS - NO MAINTENANCE REQUIRED IN 4 MONTHS OF FLYING IN ENVIRONMENTAL EXTREMES

ESTIMATED F/A-18 RADAR RELIABILITY DEVELOPMENT TEST COSTS PER HOUR

TEST DURATION	1600 HRS	
HAC TEST COST (EXCLUDING RADAR SETS)		\$1,000,000
MCAIR COSTS (2 MAN YEARS D/346 AND D/311)		\$260,000
		<hr/>
		\$1,260,000

- PER HR TEST COST (WITHOUT UNIT COST) = $\$1,260,000 \div 1600 = \787.00

COST OF 2 RADAR (FSD) SETS	\$1,521,000
	1,260,000
	<hr/>
	\$2,781,000

- PER HR TEST COST (INCLUDING UNIT COST) = $\$2,781,000 \div 1600 \times \$1,730.00$

ESTIMATED F/A-18 RADAR RELIABILITY DEMONSTRATION TEST COSTS PER HOUR

TEST DURATION	149 HRS	
HAC TEST COST (EXCLUDING RADAR SETS)		\$392,000
MCAIR COSTS (2 MAN YEARS D/346 AND D/311)		130,000
		<hr/>
		\$522,000

- PER HR TEST COST (WITHOUT UNIT COST) $\$522,000 \div 149 = \$3,500.00$

REFURBISH CHARGES FOR 2 RADARS $\$42,600$

- PER HR TEST COST (INCLUDING REFURBISH) = $\$564,600 \div 149 = \$3,790.00$

RADAR INITIAL BIT ASSESSMENT (IBA)

The initial BIT assessment (IBA) test is an early hardware and software evaluation of the supplier's BIT design. These tests were conducted in May 1980 prior to the reliability development test.

The chart indicates the number of faults inserted in each WRA, the number and percent detected, and the number and percent that were isolated.

Notes 3, 4, and 5 indicate that improved results were predicted for the later configuration of the radar.

RADAR INITIAL BIT ASSESSMENT (IBA)

COMPLETED MAY 16, 1980

IBA FAULTS (NOTE 1)

	<u>INSERTED</u>	<u>DETECTED</u>	<u>% DETECTED</u>	<u>ISOLATED</u>	<u>% ISOLATED (NOTE 2)</u>
RADAR SIGNAL PROCESSOR (RSP)	106	105	99.06	103	98.10
RADAR DATA PROCESSOR (RDP)	49	36 (NOTE 3)	73.47	35	97.22
ANTENNA	46	42	91.30	42	100.00
TRANSMITTER	30	29	96.67	28	96.55
RECEIVER/EXCITER	55	47 (NOTE 4)	85.45	19	40.43
RADAR SET	16	14 (NOTE 5)	87.50	6	42.86
	—	—	—	—	—
TOTALS	302	273	90.4	233	85.35

NOTE 1 - NUMBER OF FAULTS SELECTED WAS DETERMINED ON THE BASIS OF PREDICTED WRA FAILURE RATE

NOTE 2 - % ISOLATED BASED ON FAULTS DETECTED.

NOTE 3 - ESTIMATE THAT 4 ADDITIONAL RDP FAULTS WOULD HAVE BEEN DETECTED IF THE 4 MEGABIT DISK AND SOFTWARE WERE AVAILABLE.

NOTE 4 - ESTIMATE 8 ADDITIONAL FAULTS WOULD HAVE BEEN DETECTED IF THE FMR SOFTWARE/HARDWARE WAS AVAILABLE.

NOTE 5 - ESTIMATE 2 ADDITIONAL FAULTS WOULD HAVE BEEN DETECTED IF THE FMR SOFTWARE/HARDWARE WAS AVAILABLE.

AN/APG-65 RADAR REMOVAL AND REINSTALLATION

The specification for the AN/APG-65 required that each radar WRA be replaced in 20 minutes or less with a crew size of 1.8. This included the time from access through function check, less delay times. During the maintenance engineering inspection (MEI), conducted at MCAIR-St. Louis in February 1980, this requirement was demonstrated. The times demonstrated averaged 11.6 minutes, 8.4 minutes better than the requirement.

AN/APG-65 RADAR REMOVAL & REINSTALLATION

- DEMONSTRATED AT MAINTENANCE ENGINEERING INSPECTION (MEI)
FEBRUARY 1980
- SPECIFICATION REQUIRED 20 MINUTES
DEMONSTRATED 11.6 MINUTES
- INCLUDED (FOR EACH WRA):
 - ACCESS
 - DISCONNECTION
 - REMOVAL
 - REINSTALLATION
 - RECONNECTION
 - FUNCTIONAL CHECK

APG-65 MAINTAINABILITY/BIT DEMONSTRATION PLAN

The Maintainability/BIT Demonstration, which will be conducted later this year (1983), is the final laboratory demonstration of the BIT capability. The test will consist of inserting from 95 to 338 faults into the various radar WRAs and measuring the number detected and isolated correctly to the failed WRA. The faults will be distributed among the WRAs based on WRA failure rate.

APG-65 MAINTAINABILITY/BIT DEMONSTRATION PLAN

- THE M BIT DEMONSTRATION WILL BE CONDUCTED AT THE HUGHES AIRCRAFT COMPANY FACILITIES BEGINNING IN THE LATTER HALF OF 1983
- THE TEST WILL CONSIST OF INDUCING FAULTS INTO THE SYSTEM AND MEASURING THE ABILITY OF BIT TO DETECT AND ISOLATE THE FAULTS
- THE MINIMUM NUMBER OF FAULTS SHALL BE SELECTED FROM A CANDIDATE LIST OF NOT LESS THAN 388 FROM WHICH 95 TO 338 WILL BE INSERTED
- THE NUMBER OF FAULTS SHALL BE DISTRIBUTED AMONG THE WRAs BASED ON THE WRA FAILURE RATE

IN-SERVICE BIT ASSESSMENT

The Navy's concern for BIT effectiveness in the fleet led to the formation of a joint MCAIR/NAVAIR BIT assessment team. The assessment covered a one-year period from November 1981 through November 1982 at three different locations on the West Coast: LeMoore, China Lake, and Pt. Mugu. The results led to changes in equipment software which were incorporated in F37 and up aircraft. The Navy is continuing their assessment to determine the effectiveness of the new software. MCAIR's involvement in this continuing assessment is now being negotiated.

IN-SERVICE BIT ASSESSMENT
NOVEMBER 1981 TO OCT 1982

	1981												1982												FLIGHT HOURS	RADAR BIT EVENTS
	J	F	M	A	M	J	J	A	S	O	N	D	J	F	M	A	M	J	J	A	S	O	N	D		
<u>LEMOORE</u>																										
5 AIRCRAFT	=====																								924.0	46
4 AIRCRAFT	=====																								612.1	24
6 AIRCRAFT	=====																								237.3	15
																									<u>1773.4</u>	
<u>CHINA LAKE</u>																										
4 AIRCRAFT	=====																								220.2	13
<u>PT MUGU</u>																										
2 AIRCRAFT	=====																								219.3	10

- BIT FIXES INCORPORATED INTO F-37
- FINAL REPORT SUBMITTED TO NAVY FEBRUARY 1983
- FOLLOW-ON BIT ASSESSMENT IN NEGOTIATION

R&M ASSESSMENTS DURING FLIGHT DEMONSTRATION

The major R&M assessment points took place at the 1200 flight-hour point, at the end of 2500 FH and at the end of 9000 FH. All data from the beginning of flight testing up to 1200 FH was utilized for the first evaluation, with no credit being given for after-the-fact corrective action. The second major milestone took place at the 2500 FH point with aircraft F-9 flying a special 50-flight reliability demonstration program. The latest milestone was a maintainability evaluation which took place at Lemoore Naval Air Station. This evaluation covered four aircraft over a period of 6 months and ended at approximately the 9000 FH point.

R&M ASSESSMENTS DURING FLIGHT DEMONSTRATION

To evaluate the R&M performance, assessment points and locations were selected and mutually agreed to by MCAIR and NAVAIR. The first three (i.e., 1200 FH, 2500 FH and 50 flight) demonstrations were conducted at NATC Pax River, Maryland. During these periods maintenance was performed by MCAIR. The fourth evaluation, 9000 flight-hour, was conducted at NAS LeMoore, California. Maintenance for this period was performed by VFA-125, the first Navy fleet readiness squadron. The last evaluation, fleet supportability evaluation, will be conducted during the first part of 1985. The location is not yet firm. However, maintenance will be performed by the Navy or Marines.

IN-SERVICE FAILURE ASSESSMENT IS CRITICAL TO R&M GROWTH

In order to obtain an early assessment of the R&M problems, identify corrective actions, and evaluate the effectiveness of design changes, it was deemed necessary to have R&M personnel on site. Normal data retrieval from systems such as the Navy 3M does not allow for timely and accurate problem identification. The F-18 program included joint MCAIR and NAVAIR on-site monitoring at both Pax River and NAS LeMoore. This effort will continue into Eleet Supportability Evaluation (FSE), where logistics as well as design problems will be evaluated.

IN-SERVICE FAILURE ASSESSMENT IS CRITICAL TO R&M GROWTH

- FSD AIRCRAFT: PAX RIVER
 - SCORE: MCAIR/NAVY TEAM ON SITE TO EVALUATE EACH MAINTENANCE ACTION FOR RELEVANCY. SUBSYSTEM MANAGER AND CONTRACTOR ASSISTED FORMAL REVIEW BOARD IN ASSESSMENT OF CORRECTIVE ACTION.
 - CORRECTIVE ACTION: CHIEF ELECTRONIC ENGINEER PRESIDED OVER FAILURE REVIEW TEAM CONSISTING OF SUBSYSTEM MANAGER, EQUIPMENT ENGINEER, AND RELIABILITY ENGINEER TO REVIEW EVERY RELEVANT AND PENDING FAILURE. PURPOSE OF THE REVIEW WAS TO DETERMINE WHICH FAILURES REQUIRED ADDITIONAL FOLLOW-UP.

- PRODUCTION AIRCRAFT: NAS LEMOORE
 - EVALUATION: R&M TEAM ASSIGNED TO INITIAL TRAINING SITE TO IDENTIFY PROBLEMS AND DETERMINE OPERATIONAL RELIABILITY. PROGRAM VISIBILITY PROVIDED, NOT AVAILABLE THROUGH 3M.

RELIABILITY/MAINTAINABILITY STAFFING FOR REMOTE SITES
 (NUMBERS OF PEOPLE)

		<u>R</u>	<u>M</u>	<u>I</u>	<u>D</u>
• PATUXENT RIVER, MD 1200 AND 2500 HR EVALUATION	NOV 78 THROUGH OCT 80	4	4	-	3
• NAS LEMOORE, CA 9000 HR EVALUATION	NOV 81 THROUGH MAY 82	3	3	-	3
• NAS LEMOORE, CA BUILT-IN-TEST EVALUATION	JAN 82 THROUGH SEP 82	-	2	2	1
• NAS LEMOORE, CA FOLLOW-ON R&M TRACKING	JAN 83 THROUGH SEP 83	2	2	-	1
• FLEET SUPPORTABILITY EVALUATION LOCATION - TBD	JAN 85 (ESTIMATED)	3	3	-	3

R - RELIABILITY

I - INTEGRATION

M - MAINTAINABILITY

D - DATA

PERIOD - SEP 82 THROUGH FEB 83
 DATE - 18 APR 83

RELIABILITY AND MAINTAINABILITY SUMMARY
 FOR SELECTED EQUIPMENTS

NAMSO 4790.A7298-01
 PAGE 84
 ACFT - F/A-18A

AIRCRAFT - F/A-18A

WUC	NOMENCLATURE	ACTIVITY	TOTAL FLIGHT HOURS	TOTAL MAINT ACTIONS	MFHBMA	ML1 REPAIR FAILURE	TOTAL FAILURE	MFHBF	UNSCH MAINT MAN HOURS	MAINT M/H PER F/H	M/H PER MAINT ACT	EMT PER MAINT ACT
742G6	AS3254/APG65 ANTENNA	VX-4	215	6	35.8	1	3	71.7	24	.109	3.9	3.1
		VX-4/VX-5 F18 O	449	3	149.7	0	3	149.7	18	.039	5.8	5.2
		TOTAL	4,275	36	118.8	1	11	388.6	214	.050	5.9	4.2
742G7	MT4955/APG65 ELECTRICAL EQUIPM	VFA-125	2,900	22	131.8	8	8	362.5	39	.013	1.8	.9
		TOTAL	4,275	22	194.3	8	8	534.4	39	.009	1.8	.9
742GA	AS3424/APG65 ANTENNA	VMFA-314	390	1	390.0	1	1	390.0	6	.015	6.0	3.0
		VFA-125	2,900	6	483.3	3	3	966.7	14	.005	2.3	1.3
		TOTAL	4,275	7	610.7	4	4	1,068.8	20	.005	2.8	1.5
742GG	NOMENCLATURE UNAVAILABLE	VFA-125	2,900	1	2,900.0	0	0	-.-	4	.001	4.2	2.1
		TOTAL	4,275	1	4,275.0	0	0	-.-	4	.001	4.2	2.1
742G9	NOC	VFA-125	2,900	3	966.7	0	3	966.7	11	.004	3.7	3.7
		VX-4	215	1	215.0	0	1	215.0	2	.009	2.0	2.0
		VX-4/VX-5 F18 O	449	1	449.0	0	1	449.0	8	.018	8.0	6.0
		TOTAL	4,275	5	855.0	0	5	855.0	21	.005	4.2	3.8
TOT 742GO	AN/APG65 RADAR SET	VMFA-314	390	55	7.1	2	8	48.8	227	.582	4.1	2.2
		VFA-125	2,900	415	7.0	26	111	26.1	2,583	.891	6.2	5.0
		VX-4	215	50	4.3	7	20	10.8	282	1.313	5.6	4.0
		VX-5	321	27	11.9	2	11	29.2	358	1.115	13.3	10.9
		VX-4/VX-5 F18 O	449	48	9.4	2	28	16.0	410	.914	8.5	7.5
		TOTAL	4,275	595	7.2	39	178	24.0	3,861	.903	6.5	5.1
742L6	NOMENCLATURE UNAVAILABLE	VFA-125	2,900	1	2,900.0	0	0	-.-	6	.002	6.0	6.0
		TOTAL	4,275	1	4,275.0	0	0	-.-	6	.001	6.0	6.0
TOT 742LO	NOMEN UNAVAILABLE	VFA-125	2,900	1	2,900.0	0	0	-.-	6	.002	6.0	6.0
		TOTAL	4,275	1	4,275.0	0	0	-.-	6	.001	6.0	6.0
742N1	NOMENCLATURE UNAVAILABLE	VMFA-314	390	1	390.0	0	0	-.-	2	.005	2.0	1.0
		TOTAL	4,275	1	4,275.0	0	0	-.-	2	.000	2.0	1.0
TOT 742NO	NOMEN UNAVAILABLE	VMFA-314	390	1	390.0	0	0	-.-	2	.005	2.0	1.0
		TOTAL	4,275	1	4,275.0	0	0	-.-	2	.000	2.0	1.0
74310	NOMENCLATURE UNAVAILABLE	VX-4/VX-5 F18 O	449	1	449.0	1	1	449.0	1	.002	1.0	.5
		TOTAL	4,275	1	4,275.0	1	1	4,275.0	1	.000	1.0	.5
TOT 74310	NOMEN UNAVAILABLE	VX-4/VX-5 F18 O	449	1	449.0	1	1	449.0	1	.002	1.0	.5
		TOTAL	4,275	1	4,275.0	1	1	4,275.0	1	.000	1.0	.5
74364	NOMENCLATURE UNAVAILABLE	VFA-125	2,900	1	2,900.0	0	1	2,900.0	2	.001	2.0	2.0
		TOTAL	4,275	1	4,275.0	0	1	4,275.0	2	.000	2.0	2.0
TOT 74360	NOMEN UNAVAILABLE	VFA-125	2,900	1	2,900.0	0	1	2,900.0	2	.001	2.0	2.0
		TOTAL	4,275	1	4,275.0	0	1	4,275.0	2	.000	2.0	2.0

APG-65 RELIABILITY MANUFACTURING VERIFICATION TEST

Initial requirements for reliability manufacturing verification test included an all equipment Production Duty Cycle (PDC) test. As production increased it was decided to evaluate a sample test rather than testing all equipment. During pilot production approximately 50% of the radar sets underwent PDC testing. No difference in reliability was identified between tested and untested radar sets. This indicated that PDC testing was not necessary on every radar set. PDC testing is now performed on one out of ten radar sets, or one radar set per month, whichever is less. The PDC test adds a significant cost to each radar set and sample testing results in significant program savings.

The continuing sample PDC test will assure that the production program maintains the reliability of the radar and test data will be tracked for indication of any negative trends.

In January 1983, the first formal laboratory demonstration of APG-65 reliability was successfully completed. The demonstration was performed to verify the intermediate MTBF requirement of 85 hours specified for production radars 51-124. The test, performed on radar sets numbers 85 and 94, was completed without failure, repair or other maintenance on the radar. A total of 149 consecutive failure-free hours were accumulated during continuous exposure to worst-case high and low temperature operating conditions. This is equivalent to over four months of service use without maintenance and was sufficient to satisfy the requirement to demonstrate a 106 hour MTBF. This early achievement of the MTBF specified for radars serial number 125 and up qualified Hughes for the maximum incentive fee award and could result in elimination of the next demonstration planned for set 125 and an associated cost savings.

APG-65 RADAR RELIABILITY MANUFACTURING VERIFICATION TEST

- TEST CRITERIA
 - SAMPLE: ONE RADAR PER TEN SYSTEMS OR ONE PER MONTH
 - ENVIRONMENT: TEST LEVEL F OF MIL-STD-781B
 - ACCEPTANCE CRITERIA: REJECT LINE OF TEST PLAN II
 - TEST TIME: FIFTY HOURS PER RADAR SYSTEM TESTED

- OBJECTIVE
 - VERIFY MAINTENANCE OF RADAR RELIABILITY PERFORMANCE THROUGHOUT PRODUCTION PROGRAM
 - TRACK FOR NEGATIVE TRENDS

SUMMARY AND LESSONS LEARNED

SUMMARY AND LESSONS LEARNED

LESSONS LEARNED - DESIGN

APG-65 FAILURE MODES AND EFFECTS ANALYSIS (FMEA)

- ACROSS THE BOARD REQUIREMENT FOR FMEA TO PIECE PART LEVEL IS NOT COST EFFECTIVE
- PIECE PART LEVEL ANALYSIS IS NECESSARY ON SAFETY ITEMS (FLIGHT CONTROL, STORES MANAGEMENT, ELECTRICAL SYSTEM), CRITICAL ITEMS, AND SELECTIVE SRAs
- PRIME CONTRACTOR NEEDS LATITUDE IN DETERMINING DEPTH

*So he can
Sell more SE?*

LESSONS LEARNED - DESIGN
APG-65 R&M DESIGN RELATED ANALYSES

	<u>EFFECTIVENESS</u>		
	<u>LOW</u>	<u>MED</u>	<u>HIGH</u>
• BLOCK DIAGRAM AND MATH MODEL		X	
• ALLOCATIONS AND PREDICTIONS		X	
• STRESS ANALYSIS			X
• OME ENVIRONMENTAL ANALYSIS			X
• FAILURE MODE AND EFFECTS ANALYSIS			
- CRITICAL ITEMS			X
- WRA LEVEL			X
- SELECTIVE SRA LEVEL			X
- 100% PIECE PART LEVEL	X		
• SNEAK CIRCUIT ANALYSIS	X		
• TEST ANALYZE AND FIX PROGRAM			X
• FAILURE ANALYSIS AND CORRECTIVE ACTION PROGRAM			X
• FAILURE REVIEW BOARD			X

LESSONS LEARNED - TESTING

Start environmental test early and consider a combination of "Reliability Development" and "Environmental Qualification" tests. Use "OME" and accelerated stress in lieu of MIL-Spec test environments.

Use all failure data for TAAF, including preproduction manufacturing test failures (especially screening and burn-in). Consider projected growth based on patterns/fixes identified, rather than number of test hours, to establish end point for dedicated TAAF testing (TAAF continues on all remaining test and later on field data). Efficient dedicated environmental test and fix requires spares. Effective TAAF must include contractual provisions for field R&M assessment and management review.

All-equipments production reliability test and formal reliability demonstrations are very expensive. Benefits of both are potentially available through careful monitoring/analysis of screening and burn-in failures and enforcement of "fix pattern failures" clause.

A measure of production reliability is necessary.

A "retrofit-on-repair" vehicle is badly needed for simple but important fixes in the field. The incorporation of design changes into production units can experience lengthy delays after PCA.

LESSONS LEARNED - TESTING

- START ENVIRONMENTAL TEST EARLY. CONSIDER COMBINATION OF "RELIABILITY DEVELOPMENT" AND "ENVIRONMENTAL QUALIFICATION" TESTS
 - USE "OME" AND ACCELERATED STRESS IN LIEU OF MIL-SPECS
- USE ALL FAILURE DATA FOR TAAF, INCLUDING PREPROD MANUFACTURING TEST FAILURES (ESPECIALLY SCREENING AND BURN-IN)
 - CONSIDER PROJECTED GROWTH BASED ON PATTERNS/FIXES IDENTIFIED, RATHER THAN NUMBER OF TEST HOURS, TO ESTABLISH END POINT FOR DEDICATED TAAF TESTING (TAAF CONTINUES ON ALL REMAINING TEST AND LATER ON FIELD DATA)
 - EFFICIENT DEDICATED ENVIRONMENTAL TEST AND FIX REQUIRES SPARES
 - EFFECTIVE TAAF MUST INCLUDE CONTRACTUAL PROVISIONS FOR FIELD R&M ASSESSMENT AND MANAGEMENT REVIEW
- ALL-EQUIPMENTS PRODUCTION RELIABILITY TEST AND FORMAL RELIABILITY DEMONSTRATIONS ARE VERY EXPENSIVE
 - BENEFITS OF BOTH ARE POTENTIALLY AVAILABLE THROUGH CAREFUL MONITORING/ANALYSIS OF SCREENING AND BURN-IN FAILURES AND ENFORCEMENT OF "FIX PATTERN FAILURES" CLAUSE
- A "RETROFIT-ON-REPAIR" VEHICLE IS BADLY NEEDED FOR IMPORTANT FIXES IN THE FIELD
- A MEASURE OF PRODUCTION RELIABILITY IS NECESSARY

LESSONS LEARNED - TESTING

The objectives and results of all testing during FSD should be applied to TAAF. The environmental qualification and dedicated TAAF testing should be combined and be comprised of a combination of realistic operational profiles and accelerated stress exposure. This testing must be done very early in the program and the results should be combined with those of the manufacturing screening and burn-in to identify failure patterns. In this way the number of dedicated test articles can be reduced (however, ample spares are essential for efficient environmental testing). Screening and burn-in of each article provides information not obtainable through protracted testing of a few samples. That is margin problems and quality variations which are exposed by burn-in may not show up in testing just a few samples. Burn-in also exposes "new" design margin problems which are inadvertently introduced with configuration changes.

The APG-65 radar program experience supports this view:

- Great majority of failure patterns identified thus far were first seen in burn-in
- As a result, the planned test time was greatly reduced
- Several new problems associated with a configuration change package at serial number 55 were revealed by burn-in and corrected prior to aircraft delivery
- The results of environmental qualification and TAAF, which were partially combined, showed that further integration would be possible

LESSONS LEARNED - TESTING

MAKE ALL TESTING TAAF & STREAMLINE DEVELOPMENT TEST

- COMBINE ENVIRONMENTAL QUAL & (DEDICATED) TAAF
USING OME AND ACCELERATED STRESS
- DO ENVIRONMENTAL TEST EARLY AND UTILIZE BURN-IN
RESULTS

LESSONS LEARNED - TEST

Reduced test time for Reliability Development can be pursued if a Test Analyze and Fix philosophy is being applied to all testing and also if a flight test program is running concurrently with the RDT. A measuring stick to apply to the RDT test results is to watch the corrective action being accomplished per unit of time. Thresholds for measuring that parameter can be determined and utilized for judgment in suspending the test.

A two-phase test, first starting with early development test units, then changing to initial production units, allows the program to start early, run efficiently, and then test the corrective action incorporated.

Emphasizing the aspect of uncovering failures instead of measuring MTBF leads to the most open communication of problem areas.

An accelerated test, utilizing the corner of the environmental envelope, allows for better test efficiency than spending a lot of test time at the normal operating points. A danger with this approach is going overboard on the extremes and accelerations and causing unnecessary problems.

LESSONS LEARNED - TEST

APG-65 RELIABILITY DEVELOPMENT TEST

- CONSIDER REDUCED TEST TIME - 3,800 HRS SPECIFIED, 1,600 HRS ACTUAL
- CONSIDER TWO PHASE TEST -
 - PRE-PRODUCTION UNITS
 - INITIAL PRODUCTION UNITS
- DON'T STOP TEST TO INCORPORATE DESIGN CHANGES, TEST IN PARELLEL WITH CHANGES
- EMPHASIZE TAAF NATURE OF TEST
- DE-EMPHASIZE MTBF MEASUREMENT
- CONSIDER ACCELERATED TEST VS. OME FOR RDT
- ACCOMPLISH HIGHER STRESS TEST FIRST

APG-65 LESSONS LEARNED

- ENCOURAGE TOTAL TAAF (TEST ANALYZE AND FIX) CONCEPT

- PROVIDE TOOLS - FAILURE REPORTING
COORDINATION OF DATA FROM ALL TEST SOURCES
FAILURE ANALYSIS/CORRECTIVE ACTION

- MAINTAIN SOME FLEXIBILITY - DON'T OVERLOAD CAPACITY TO CONDUCT
FAILURE ANALYSIS - SOME SCREENING BY PROGRAM MANAGEMENT

- MAINTAIN BALANCED EMPHASIS ON CORRECTIVE ACTIONS FOR
RELIABILITY/PERFORMANCE/MAINTAINABILITY PROBLEM AREAS

- ON UTILIZATION OF RELIABILITY DEVELOPMENT TEST
 - CONVENTIONAL WISDOM: TEST, FAIL, STOP, DESIGN CHANGE, CONTINUE TEST

 - PROBLEM: INEFFICIENT

 - RECOMMENDATION: ALLOW TESTING IN PARALLEL WITH DESIGN ACTION
FIND MORE PROBLEMS SOONER

LESSONS LEARNED - MANUFACTURING

Manufacturing burn-in, with an extended failure-free period, can provide all of the benefits of formal reliability demonstrations whether they be a sample test or an all-equipment test, both of which were originally specified for the APG-65 radar. The formal demonstrations attempt to measure the absolute value of MTBF. This requires elaborate procedures and preparations such that failure "relevance" can be established. That is, so that the true cause of each failure can be proven so as to separate failures chargeable to test equipment or procedural faults, maintenance or troubleshooting errors, damage, etc. This approach tends to be very expensive. The extended failure-free burn-in conversely eliminates emphasis on "blame" for "relevant" failures while providing a strong supplier motivation to eliminate or minimize all causes of burn-in failure to reduce costs.

The fact that burn-in does not yield an absolute value MTBF measurement need not be of concern. Once the design has been verified, the on-going reliability is maintained by quickly fixing any new pattern failures which may arise; this is an inherent result of the failure-free burn-in procedure.

LESSONS LEARNED - MANUFACTURING

EXPLOIT BURN-IN TO SUPPLANT PRODUCTION RELIABILITY DEMONSTRATION

- ALL-EQUIPMENTS DEMO INCOMPATIBLE WITH FACTORY EQUIPMENT
- FORMAL SAMPLE DEMO EXPENSIVE/UNNECESSARY

F/A-18 RELIABILITY LESSONS-LEARNED

- ESTABLISH DESIGN-CENTERED, COLLOCATED TEAM
- TAKE TRADE STUDIES SERIOUSLY AND CONSIDER RELIABILITY IMPACTS
- CONSIDER RELIABILITY EQUALLY WITH OTHER PERFORMANCE AND COST PARAMETERS IN MAJOR PROCUREMENT DECISIONS
- CONCENTRATE ON DESIGN SIMPLICITY, PARTS DERATING, IMPROVED COOLING
- USE OME TO DESIGN AND TEST THE EQUIPMENT
- EMPHASIZE TEST ANALYZE AND FIX ASPECT OF RDT
- APPLY "TAAF" TO EARLY AIRCRAFT FLIGHT TESTING, USING OPERATIONAL GROUND RULES
- DEMONSTRATE RELIABILITY AT THE AIRCRAFT LEVEL
- NEGOTIATE RELIABILITY DOLLAR INCENTIVES WITH CUSTOMER AND MAJOR SUBCONTRACTORS

APG-65 MAINTAINABILITY LESSONS LEARNED

- ESTABLISH EFFECTIVE DESIGN/LOGISTICS INTERFACE
- MAKE SUBSYSTEM MANAGERS RESPONSIBLE
- ESTABLISH REALISTIC DESIGN-TO REQUIREMENTS
- USE REVIEW AND COMMENT SHEETS FOR COMMUNICATION TO DESIGN ACTIVITIES
- USE TRADE STUDIES TO BALANCE DESIGN AND MAINTAINABILITY/LOGISTICS CONSIDERATIONS
- USE A CREDIBLE SIMULATION MODEL TO TRACK OPERATIONAL READINESS PERFORMANCE
- PROVIDE A PROGRESSIVE BIT DEVELOPMENT/VERIFICATION PROGRAM

MORE LESSONS LEARNED

- AMPLE SPARES AND PARALLEL TEST/FIX ESSENTIAL FOR EFFICIENT TAAF
- INTEGRATE BIT DEVELOPMENT WITH TAAF
- PROVIDE ON-SITE CONTRACTOR SUPPORT THROUGH INTRODUCTION TO COMPLETE TAAF R AND M
- PIECE PART LEVEL FMEA AND SNEAK CIRCUIT ANALYSIS HAVE LIMITED EFFECTIVENESS FOR RADAR
- CAREFUL ANALYSIS FOR NOISE/TRANSIENT SUSCEPTIBILITY OF TRIP-CIRCUITS HAS HIGH PAYOFF
- VECP PROGRAMS PROVIDE R&M BENEFITS

APG-65 BIT RECOMMENDATIONS

- INITIAL - ESTABLISH FULL UP BIT HARDWARE/SOFTWARE DESIGN (EMPHASIZE EARLY HARDWARE/SOFTWARE DEVELOPMENT) REQUIREMENTS
- DEVELOPMENT - ANALYSIS (STRATEGIES TO MINIMIZE FALSE ALARMS AND CNDs)
- INITIAL BIT ASSESSMENT (FAULT INSERTIONS)
 - TAAF CONCEPT - USE ALL TEST SOURCES (FAILURE MODES EXPERIENCED IN OPERATIONAL ENVIRONMENT)
 - EMPLOY A SINGLE THREAD, CLOSED LOOP DATA SYSTEM TO ENSURE AND TRACK SYSTEM MATURATION
 - DEVELOP A MIXTURE OF AUTOMATIC AND MANUAL DIAGNOSTICS TO ENSURE ACHIEVEMENT OF 100% DIAGNOSTICS CAPABILITY
- PRODUCTION - USE AND TRACK BIT CAPABILITY TO ESTABLISH CONFIDENCE IN BIT. MATURE BIT SOFTWARE
- GROWTH - CONTRACT PROVISIONS FOR BIT GROWTH, ON-SITE EVALUATION

