

ADA137825

AD 

NATICK/TR-81/021

20030108187

**STUDY TO DETERMINE THE CB THREAT  
AND DEFINE ALTERNATIVE CREW  
PROTECTION SYSTEMS FOR THE ADVANCE  
ATTACK HELICOPTER (AAH) (VOL. I)**

by

George C. Rannenberg

Hamilton Standard Div., United Technologies Co

**DTIC**  
SELECTED  
FEB 13 1984

Contract No. DAAK60-79-C-0136

June 1981

DTIC FILE COPY

APPROVED FOR PUBLIC RELEASE;  
DISTRIBUTION UNLIMITED.

**UNITED STATES ARMY**  
**NATICK RESEARCH AND DEVELOPMENT LABORATORIES**  
**NATICK MASSACHUSETTS 01760**

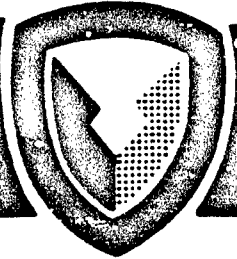

**Clothing and Equipment Division**  
**Clothing, Equipment and Materials**  
**Engineering Laboratory**

84 02 13 012

## **REPRODUCTION QUALITY NOTICE**

**This document is the best quality available. The copy furnished to DTIC contained pages that may have the following quality problems:**

- **Pages smaller or larger than normal.**
- **Pages with background color or light colored printing.**
- **Pages with small type or poor printing; and or**
- **Pages with continuous tone material or color photographs.**

**Due to various output media available these conditions may or may not cause poor legibility in the microfiche or hardcopy output you receive.**

**If this block is checked, the copy furnished to DTIC contained pages with color printing, that when reproduced in Black and White, may change detail of the original copy.**

(This document contains  
blank pages that were  
not filmed)

Approved for public release; distribution unlimited.

Citation of trade names in this report does not constitute an official indorsement or approval of the use of such items.

Destroy this report when no longer needed. Do not return it to the originator.

UNCLASSIFIED

SECURITY CLASSIFICATION OF THIS PAGE (When Data Entered)

REPORT DOCUMENTATION PAGE		READ INSTRUCTIONS BEFORE COMPLETING FORM
1. REPORT NUMBER NATICK/TR-81/021	2. GOVT ACCESSION NO. AD-A137825	3. RECIPIENT'S CATALOG NUMBER
4. TITLE (and Subtitle) STUDY TO DETERMINE THE CB THREAT AND DEFINE ALTERNATIVE CREW PROTECTION SYSTEMS FOR THE ADVANCED ATTACK HELICOPTER (AAH) (VOL. 1)		5. TYPE OF REPORT & PERIOD COVERED Final Report for Period 1 Oct 79 - 1 Dec 80
		6. PERFORMING ORG. REPORT NUMBER AAH-CB-07 (CEMEL - 238)
7. AUTHOR(s) George C. Rannenberg	8. CONTRACT OR GRANT NUMBER(s) DAAK60-79-C-0136	
9. PERFORMING ORGANIZATION NAME AND ADDRESS Hamilton Standard Division United Technologies Corporation Windsor Locks, CT 06096	10. PROGRAM ELEMENT, PROJECT, TASK AREA & WORK UNIT NUMBERS Reimbursable Order	
11. CONTROLLING OFFICE NAME AND ADDRESS US Army Natick R & D Laboratories (NLABS) NARADCOM - CEMEL Natick, MA 01760		12. REPORT DATE 1 December 1980
		13. NUMBER OF PAGES
14. MONITORING AGENCY NAME & ADDRESS (if different from Controlling Office)		15. SECURITY CLASS. (of this report)
		15a. DECLASSIFICATION/DOWNGRADING SCHEDULE
16. DISTRIBUTION STATEMENT (of this Report) Cleared for public release; distribution unlimited.		
17. DISTRIBUTION STATEMENT (of the abstract entered in Block 20, if different from Report)		
18. SUPPLEMENTARY NOTES		
19. KEY WORDS (Continue on reverse side if necessary and identify by block number) CHEMICAL WARFARE                      PROTECTIVE CLOTHING                      PROTECTIVE GARMENTS BIOLOGICAL WARFARE                      FLIGHT CREWS                                      MASK VENTILATION CHEMICAL/BIOLOGICAL WARFARE              HELICOPTERS                                      DECONTAMINATION PROCEDURES THREAT    ADVANCED ATTACK HELICOPTER CB THREAT    CB AGENTS		
20. ABSTRACT (Continue on reverse side if necessary and identify by block number) A chemical biological threat is defined and applied to the Advanced Attack Helicopter as presently designed. Conclusions are reached regarding the safety and mission effectiveness of the helicopter against this threat. Various change options to improve the chemical/biological characteristics of the Advanced Attack Helicopter are evaluated and recommendations made.		

UNCLASSIFIED

SECURITY CLASSIFICATION OF THIS PAGE(When Data Entered)

19. FILTER SYSTEM TO REDUCE CABIN CONTAMINATION  
LIQUID COOLED GARMENT AND RELATED EQUIPMENT

<b>Accession For</b>	
NTIS GRA&I	<input checked="" type="checkbox"/>
DTIC TAB	<input type="checkbox"/>
Unannounced	<input type="checkbox"/>
Justification	
By _____	
Distribution/ _____	
Availability Codes	
Dist	Avail and/or Special
ALL	



UNCLASSIFIED

SECURITY CLASSIFICATION OF THIS PAGE(When Data Entered)

## SUMMARY

The course of this study was to first investigate and define the expected chemical/biological (CB) challenge, and then to combine it with the helicopter mission to produce the CB threat which could be expected to confront the AAH. Various optional means were then investigated by which the CB defense capability of AAH could best be improved to withstand this CB threat. Each of these optional changes to the AAH was then evaluated for chemical and biological safety, effect on overall mission effectiveness, and penalty to the helicopter in terms of weight, cost, and installation feasibility.

A simplified summary of the conclusions and results of the study are as follows:

1. It is concluded that the present (1980-1985 time frame) individual respiratory protective devices and protective garments, are adequate for essentially zero flight crew casualty operation from exposure to CB agents, providing the flight crew starts the mission inside a properly fitted clean protective ensemble, and that proper personnel decontamination procedures are utilized.
2. However, in order to avoid an unacceptable loss in mission effectiveness due to thermal stress, it is concluded that a liquid-cooled vest undergarment should be added to the CB protective clothing ensemble for the AAH flight crew. In addition, equipment needed to provide the required cooled fluid should be added to the present AAH environmental control system. (ECS).
3. It is also concluded that provisions should be added to each crew station for forced ventilation of the mask with cool dry air from the cabin ECS supply duct, in order to reduce the hazard of an improperly fitted mask, and to provide cooling of the face area.

4. Finally, it is concluded that a collective CB filter system, with cabin overpressure, should be added to the AAH in order to reduce cabin contamination level and to increase safe utilization time when the mask is not worn.

The recommendations of this study are that, (1) the conclusions of this study should be implemented by proceeding into a design phase of the AAH CB protection system components; and (2) an actual prototype system should be fabricated, tested, and evaluated to determine the final configuration of a production system for use with the AAH.

1. PREFACE

The Army's intent in authorizing this study was to develop a document to help define, and optimally integrate, a crew CB protection system for the Advanced Attack Helicopter (AAH). This document should be of significant benefit to the AAH Project Management (AAH-PM) for future planning and/or procurement purposes

The study, awarded to Hamilton Standard on 28 September 1979 by the U.S. Army Natick Research and Development Command,\* Natick, Massachusetts, was performed under the direction of Mr. Vincent Iacono of the Natick facility.

Many sources were consulted during the data gathering phase of the study, and therefore an attempt was made at each contributing facility to coordinate Hamilton Standard's request for data and the Army's response, through a single individual. This helped greatly in assuring that the data sources consulted were appropriately qualified, and also assured that the data was provided to Hamilton Standard in a timely fashion. These facilities, and the men who provided this coordinating function are as follows:

Mr. Vincent Iacono	NARADCOM-CEMEL	Natick R&D Command, Natick, MA
Mr. Julius Romano	AAH PMO	Army Aviation Program Office, St. Louis, MO
CPT Timothy Savage	U.S. Army	USAVN Center, Fort Rucker, AL
Mr. Matthew Hutton	Chem Systems Lab	Aberdeen, MD
CPT Paul Garrett	Human Engr. Lab	Aberdeen, MD
Mr. William Barlow	Chief Aero/ Thermodynamics	Hughes Helicopters Culver City, CA
Dr. Matthew L. Herz	NARADCOM-ORSAO	Natick R&D Command, Natick, MA
Dr. Jeffrey Manickas	"	"

\* Renamed U.S. Army Natick Research and Development Laboratory, 1980.



Hamilton Standard personnel performing this program were:

Mr. George C. Rannenberg	Principal Engineer and author of final report
Mr. Mark M. Hultman	Chemical Analysis Engineer
Mr. Philip F. Heimlich	Design Engineer
Mr. John R. Nason	Thermodynamic Analysis Engineer
Mr. Thaddeus E. Burr	Asst. Program Manager.
Mr. Alfred O. Brouillet	Program Manager

TABLE OF CONTENTS

	<u>PAGE</u>
SUMMARY	1
PREFACE	2
TABLE OF CONTENTS	5
LIST OF ILLUSTRATIONS	8
LIST OF TABLES	9
1. THE CB CHALLENGE	11
(a) CB Munition Systems	11
(1) Categories of Agents Considered	11
(2) Chemical Agents Not Considered	15
(3) Munitions Used for Deployment of Chemical Agents	16
(4) Biological Weapons	17
(5) The Chemical Threat Environment	20
(b) The Effects of Chemical Agents on Humans	21
(1) General Toxicity of Agents	21
(2) Eye Toxicity Effect on AAH Crew	22
(3) Toxicity of Biological Agents	23
(c) Ambient CB Environment Expected to Confront AAH	24
(d) AAH Mission Profile	27
(1) Derivation of "Standard Helicopter Combat Day"	27
(2) Derivation of "Helicopter CB Day"	29
(e) CB Environment Inside Present AAH Helicopter	32
2. INDIVIDUAL CB DEFENSE CAPABILITY	33
(a) Suitability of Available Respiratory Protective System Against Agents Considered	33
(1) Agents Handled by Respiratory Protective System	33
(2) Usage Life of Respiratory Protective System	35
(b) Crew Protection Provided By The Porous, Carbon- Impregnated Suit	38
(1) Agent Protection Afforded Wearer	38
(2) Usage Life of Suit	39
(c) Description of Available CB Protective Garments	41
(d) Value of Chemical Alarms in AAH Defense	45
3. PRESENT AAH CB DEFENSE CAPABILITY	51
(a) Present AAH Components Affecting CB Defense	51
(b) Effect of Chemical Agents on AAH Equipment	53
(c) Decontamination of AAH Cabin	54
(1) Decontamination of Chemical Agents	54
(2) Decontamination of Biological Agents	59

TABLE OF CONTENTS (CONTINUED)

	<u>PAGE</u>
4. THE THERMAL STRESS PROBLEM	60
(a) Improved Chemical Resistance And Resultant Increased Thermal Stress	60
(b) Thermal Stress in Helicopters Predating CB Warfare	62
(c) Thermal Problem Faced by the Existing CB Protection System	64
(1) Heat Transfer Characteristics of the CB Protective Ensemble	64
(2) Thermal Mission Adopted for Purpose of Thermal Analysis	66
(d) Thermal Stress Analysis of the Flight Crew	70
(1) Thermal Stress Analysis Method Used	70
(2) Computer Results of Thermal Stress Analysis	74
(3) Thermal Stress Increases With Crew Leaving Helicopter	81
(4) Effect of Moisture in the Ambient on AAH Thermal Problem	82
(5) Unzipped Protective Suit, Or New More Open Clothing for Reduced Thermal Stress	84
(e) Evaluation of Alternate Approaches to Providing Adequate Flight Crew Cooling	85
(1) Candidate Cooling Options	85
(2) Selection of Liquid Cooled Vest Design Parameters	89
(3) Liquid Cooled Vest Growth Potential for Use Outside AAH	92
5. CREW SAFETY VERSUS CB PROTECTION LEVEL	93
6. EFFECT OF IMPROVING AAH DEFENSE ON AIRFRAME AND SYSTEMS	96
(a) Description of Current AAH Environmental Control System	96
(b) Addition of CB Suit Cooling Function to the ECS	102
(c) Addition of Capability for Ventilated Facepiece Mask	108
(d) Addition of an Overpressure Collective Filter System to the ECS	111
(1) Closing Off Cabin Leakage Areas	111
(2) Change of Forward Electronic Cooling To An Ambient Air Source	114
(3) Change to a Recirculation ECS And Its Advantages	118
(4) Advantages of a Single Replaceable Collective Assembly	125
7. ESTIMATED COST TO THE HELICOPTER VERSUS CB PROTECTION LEVEL	129
8. LOSS IN HELICOPTER MISSION EFFECTIVENESS VERSUS CB PROTECTION LEVEL	132
9. CONCLUSIONS	136
10. RECOMMENDATIONS	142
11. REFERENCES	143

TABLE OF CONTENTS (CONTINUED)

<u>APPENDIX</u>		<u>PAGE</u>
A	Photographs and Simplified Specifications of CB protective Garment Options suitable for AAH Helicopter Crewman	145
B	Heat Burden Assessment in Support of the AAH Helicopter CB Study	166
	TITLE FOR VOLUME 2	180
	GLOSSARY OF ABBREVIATIONS AND ACRONYMS	184

LIST OF ILLUSTRATIONS

<u>FIGURE</u>	<u>TITLE</u>	<u>PAGE</u>
1	Expected GD Evaporation Concentrations with time Throughout a Contaminated Environment, Deposition of 3 g/m <sup>2</sup>	25
2	Standard Helicopter Combat Day	28
3	AAH Cabin GD Concentration with and without Collective Protection as a Function of Time From Entering Agent Cloud	48
4	AAH Cabin GD Dosage Due to Cabin Influx Before Diverter Valve Shuts	49
5	Comparison of Uniforms for Hot/Dry Environment	75
6	Comparison of Uniforms for Warm/Moist Environment	76
7	Comparison of Heat Rejection Requirements vs. Capability for a Warm/Moist Day	78
8	Comparison of Environments for Crew in CB Attire	83
9	Liquid Cooled Garment Performance	90
10	General View of Current AAH ECS Components	97
11	Current AAH Airflow Paths	99
12	Location of Existing ECS in AAH Helicopter	100
13	Revised AAH Airflow Paths, CB Suit Cooling Provision Added	103
14	Liquid Coolant/Pump Package	104
15	Existing System with Coolant/Pump and Ventilated Mask Provision Added	109
16	AAH Cabin Floor, Leakage Areas	112
17	Revised AAH Airflow Paths, Collective Filter and Recirculation Overpressure System Added	120
18	Collective Filter/Protective Valves Concept	122
19	Existing System with Collective Filter, Recirculation Overpressure System, Coolant Pump Package, and Ventilated Mask Provision Added	124
20	Single Replaceable Assembly, APS Plus Valves Plus CB Filter	126

LIST OF TABLES

<u>TABLE</u>	<u>TITLE</u>	<u>PAGE</u>
1	Seven Types of Agents Considered in this Report	12
2	Chemical Agent Nomenclature	13
3	Original Design Objectives of Army CB Mask Assembly	23
4	Performance Test Acceptance Criteria - M10A1 Canister	34
5	(U) M10A1 Charcoal Life For G-Agent	36
6	Protective Ensemble Development Areas	36
7	Typical Response Time of Dry Sensor Chemical Detector Alarm	46
8	Recommended Decontaminants for Individual Chemical Agents on Materiel	55
9	Clothing Characteristics	65
10	Mission Profile for Thermal Analysis	67
11	Computer Program Input Data Required	73
12	Effects of Clothing and Environmental Conditions on Body Heat Storage	80
13	Comparison of AAH Cooling Concepts for Personal CB Undergarment	88
14	Flight Crew Safety vs. CB Protection Level	95
15	Estimated Cost to Helicopter vs. CB Protection Level	130
16	Loss in Helicopter Mission Effectiveness vs. CB Protection Level	133
17	Conclusions of Study Regarding Preferred CB Protection Level	137

1. THE CB CHALLENGE

(a) CB MUNITION SYSTEMS

(1) Categories of Agents Considered

The following is an unclassified version of this section of the report, which is available in Volume 2 (classified Secret).

Seven types of chemical agents, considered to be representative of those confronting the AAH (Reference 6), are classified by their effect on humans and are considered in this study to be the specification agents against which defense capabilities of the AAH should be evaluated. The seven types of agents are summarized in Table 1. Specific chemical names and symbols for warfare agents are presented in Table 2.<sup>1</sup> The following is a discussion of these agents.

Vomiting and irritant agents are used primarily to harass target personnel. Specific chemical names and additional information on these types of agents, and also on incapacitating agents are provided in the classified Appendix C of this report.

Blood and choking agents are colorless and are non-persistent. A non-persistent agent is one which disperses rapidly because of a high vapor pressure. Evaporation rates are very high and these agents show an advantage when it is desired to occupy an area soon after an attack. These agents cause coma, convulsion, and death if a high enough concentration is inhaled.

For the blister agent Distilled Mustard (HD), and the nerve agents Tabun, Sarin, Soman(G) and O-Ethyl S-2-Dl Isopropyl Amino Ethyl Methyl Phosponothiolate (V) complete body protection is required. Blister agent, also known as mustard, is often delivered in a thickened form which poses a lingering threat to troops. Mustard, while primarily known for its blister causing property, also damages the eyes, blood vessels, and respiratory tract.

<sup>1</sup> Planning and Conducting Chemical, Biological, Radiological and Nuclear Defense Training. Army Field Manual FM 21-48, June 1973.

TABLE 1 - SEVEN TYPES OF AGENTS CONSIDERED IN THIS REPORT

TYPE OF AGENT	HOW USUALLY ADMINISTERED	MEANS OF ADMINISTRATION	EFFECTS ON MAN	EFFECTS ON HORSE	DATE OF ACTION	PHYSIOLOGICAL CHARACTERISTICS		PROTECTIVE MEASURES	IDENTIFICATION BY AGENT CHARACTERISTICS IN THE FIELD	
						FIELD AID	IDENTIFICATION		SMELL/TASTE	CHARACTERISTICS
GAS	Amorphous or granular	Aerosol agent which is administered by direct contact with the eyes and upper respiratory tract.	Irritation, burning, tearing, itching, coughing, sneezing, and watery discharge from the eyes.	Irritation and burning of the respiratory tract.	Very rapid by inhalation; slow through skin.	None needed	None needed	Protective mask and protective clothing	Colorless	GA--Gases
	Colorless									
LIQUID	Liquid droplets	Aerosol agent which is administered by direct contact with the eyes and upper respiratory tract.	Irritation, burning, tearing, itching, coughing, sneezing, and watery discharge from the eyes.	Irritation and burning of the respiratory tract.	Rapid	None needed	None needed	Protective mask and protective clothing	Colorless	GL--Liquids
	Colorless									
SOLID	Tablets (Gases)	Aerosol agent which is administered by direct contact with the eyes and upper respiratory tract.	Irritation, burning, tearing, itching, coughing, sneezing, and watery discharge from the eyes.	Irritation and burning of the respiratory tract.	Rapid	None needed	None needed	Protective mask and protective clothing	Colorless	GS--Solids
	Colorless									
LIQUID	Liquid (Gases)	Aerosol agent which is administered by direct contact with the eyes and upper respiratory tract.	Irritation, burning, tearing, itching, coughing, sneezing, and watery discharge from the eyes.	Irritation and burning of the respiratory tract.	Rapid	None needed	None needed	Protective mask and protective clothing	Colorless	GL--Liquids
	Colorless									
SOLID	Tablets (Gases)	Aerosol agent which is administered by direct contact with the eyes and upper respiratory tract.	Irritation, burning, tearing, itching, coughing, sneezing, and watery discharge from the eyes.	Irritation and burning of the respiratory tract.	Rapid	None needed	None needed	Protective mask and protective clothing	Colorless	GS--Solids
	Colorless									
LIQUID	Liquid (Gases)	Aerosol agent which is administered by direct contact with the eyes and upper respiratory tract.	Irritation, burning, tearing, itching, coughing, sneezing, and watery discharge from the eyes.	Irritation and burning of the respiratory tract.	Rapid	None needed	None needed	Protective mask and protective clothing	Colorless	GL--Liquids
	Colorless									

1. All agent symbols are used in this figure only for convenience and for reference. For details on chemical agent and riot control agent characteristics, see SI 3-215.

2. Symbols of chemical agents, such as nerve agents and choking agents, are to be used.

3. Although irritant agents are not considered chemical agents, they have been used routinely in combat.

REFERENCE: FM 21-40



TABLE 2. CHEMICAL AGENT NOMENCLATURE

Category of agent	Agent symbol	Agent nomenclature
Smoke	ZC	HC mixture. Mixture of aluminum, zinc oxide, and hexachloroethane.
	FS	Sulfur trioxide-chlorosulfonic acid solution.
	CS	O-chlorobenzalmononitrile.
Riot control	CEI	Micropulverized CS. O-chlorobenzalmononitrile.
	CM	Chloroacetophenone.
Riot control agent solvents	TOP	Tri-(2-ethylhexyl) phosphate.
	TEP	Tributyl phosphate.
	PG	Propylene glycol.
Incapacitating	BS	Quinacridyl benzoate.
Blister agent simulant	MR	Melasses residuum.
Blister	H	Mustard. 2,2'-dichloroethylethyl sulfide.
	HD	Distilled mustard. 2,2'-dichloroethylethyl sulfide.
	HT	Mustard-T mixture. (Similar to HD but with a lower freezing point)
	HN	Nitrogen mustard. 2,2'-dichloroethylethylamine.
	L	Lewisite. Dichloro-(2-chlorovinyl)arsine.
	CX	Phosgene oxime.
Choking	CG	Phosgene. Carbonyl chloride.
Blood	AC	Hydrogen cyanide.
	CK	Cyanogen chloride.
Nerve	GA	Tabun. Dimethylaminoethylphosphorochloridate.
	GB	Sarin. Methylisopropoxyfluorophosphine oxide.
	GD	Soman. Methylphenacyloxyfluorophosphine oxide.
	VX	O-Ethyl S-(2-diisopropylaminoethyl) methylphosphonothioate.

REFERENCE: FM21-48

Nerve agents GA, GB, GD and VX kill at very low dosages. They act not only by inhalation, but also percutaneously. Even at trace dosages the eyes are adversely affected by narrowing and dimming of the field of vision. The nerve agents are often thickened with organic solvents or polymers to increase casualties by penetration of the protective ensemble, and to obtain slower dissipation into the atmosphere. Penetration is dependent upon the size of the liquid drops and the vapor pressure. Increasing the liquid drop sizes by adding thickener increases the amount of agent and the time the agent is on the suit.

(2) Chemical Agents Not Considered

Certain chemical agents which are known to effectively circumvent the standard Army CB filter concept were not considered, since previous studies have shown their reduced toxicity requires such large delivered tonnages that they are inferior to other weapons systems.

Certain chemical agents, such as carbon monoxide or ammonia, will not be removed either by activated carbon, or by particulate filtration in the current canister. However, the relatively low toxicity of these agents makes them extremely difficult to deliver in lethal quantities. Previous studies have shown such agents to be inferior to common high explosives as weapons, and therefore they have not been considered in this study.

Other chemical agents such as metallic carbonyls are toxic enough to be considered, but no practical means of delivering a dispersal fine enough to pass through the particulate filter was uncovered in this study.

At any rate the development of agents which circumvent the current canister would undoubtedly only cause a revision of the canister to take place to provide a defense against them. There is no assurance that the specific construction of the current canister will remain unchanged, but rather it is assumed in this study that the defense concept of the chemical filter is sound and that revisions to the specific internal construction of the throwaway portion will be made when required.

(3) Munitions Used for Development of Chemical Agents

Chemical and biological warfare agents are delivered by a variety of means, including artillery, rockets, bombs, missiles, land mines, and direct spray from aircraft and helicopters.

The content of this paragraph is classified, and is available in Vol. 2 which is classified Secret.

(4) Biological Weapons

Biological weapons employing living microorganisms, were considered limited by their inability to pass through mask particulate filters.

The objective of using biological weapons is to reduce the ability of military personnel to fight. While biological weaponry is also used to cause disease of animals and plants and to cause deterioration of materials, the primary focus in this study is on the reduction of the AAH crew's fighting ability.

Biological agents consist of living micro-organisms including bacteria, rickettsia and viruses. These agents are affected by their environment, with some easily destroyed by sunlight in a matter of hours, while others remain infectious after several hours.

The effects of antipersonnel biological agents are the same as those associated with specific diseases such as typhoid, influenza, diphtheria, etc. The severity of the disease produced depends upon the dosage received, the route of entry into the body, defenses that the body may already have against the agent, the speed and type of treatment, and the ability of the agent to break down normal body defenses and interfere with normal body functions.

With all biological agents, there is considerable delay between the time an agent enters the body, and the point at which symptoms of disease appear. This is commonly referred to as the incubation period which, due to its inexactness, is expressed as a range. This time range can be altered in several ways.

Excessive doses of the agent may shorten the incubation period and also change the course of the disease. An abnormal route of entry for the agent may result in a gross change in symptoms of the disease, such that it cannot

be recognized by a physician. An example of an abnormal route of entry would be through a cut or wound, rather than orally. Also, the synergistic effects of two or more agents may so completely mask or alter the symptoms of each that the resulting set of symptoms may not be associated with either agent.

The three normal openings in the body through which a biological agent may enter are the respiratory tract, broken skin, and the digestive tract. Biological agents entering the respiratory tract are passed easily into the blood stream and circulated throughout the body. The unbroken skin provides excellent protection against biological agents, however, vectors such as insects may infect individuals percutaneously to produce serious diseases. The only remaining openings in the body are associated with the digestive tract, and biological agent entry via this route is unlikely but not impossible.

Factors such as body immunity, light, temperature, and moisture affect the infectious ability of biological agents. The ultraviolet component of sunlight kills most biological agents. Increasing the temperature causes most agents to die more rapidly. Finally, low relative humidity causes organisms to die more rapidly than high humidity conditions.

Dispersal of biological agents can be made by pumping a slurry, or "soup" laden with agent, through spray nozzles. As the carrier liquid (water for example) evaporates, the droplets get smaller and the concentration of agent in the droplet increases. As the carrier disappears, the remaining portion approaches its smallest possible dispersal size. It is in this smallest possible delivery size that the maximum danger is reached, because of the increased possibility of passing through the particulate filter portion of the CB defense system. This study considers that this lower limit in effective agent size was greater than 1 micron, and that the particulate filter in the canister is an adequate defense.

In a like manner the dispersal of biological agents can be made by surrounding an explosive with a powder of finely ground dried agent. Again there are practical limits to the smallest size biological agent particle which can be delivered, and this study considers that this lower limit in size was greater than 1 micron and that the particulate filter in the canister is an adequate defense.

Biological agents also tend by their nature to be long response time weapons, much like strategic bombing, rather than weapons which would be considered to bring down a helicopter. This being the case one would expect biological agents to be used against more permanent staging areas and larger bases, rather than on the helicopter versus tank battlefield.

(5) The Chemical Threat Environment

The rates at which various munitions must be delivered to a target to produce significant casualties is known, and therefore a model battlefield situation was constructed for use in this study.

This chemical warfare battlefield model is classified Secret and is available in Volume 2.



(b) THE EFFECTS OF CHEMICAL AGENTS ON HUMANS

(1) General Toxicity of Agents

The following is an unclassified version of this section of the report. A classified version is available in Volume 2, which is classified Secret.

Chemical agents vary in toxic effect depending upon dosage. The various chemical concentrations of nerve agents and blister agents which produce varying degrees of symptoms are discussed in detail in Volume 2. Meteorological effects on agent effectiveness are also considered.

The basic conclusion of this section is that even very low concentrations of nerve agent are detrimental to the vision of the AAH pilot, and therefore, the protective mask must be worn at all times. While these agents are also effective percutaneously, the dosages of G-agent and H-agent expected inside a clean AAH are not sufficient to warrant wearing of the CB protective clothing ensemble by the crew. The possibility of liquid contamination outside the AAH, however, makes wearing the suit necessary since the suit cannot be put on and taken off inside the helicopter. The suit is also necessary for safety inside a contaminated cabin.

## (2) Eye Toxicity Effect on AAH Crew

Detailed information on pilot's baseline performance versus performance when his eyes are affected by chemical agent was not available, but its absence does not affect the conclusions of this study because this study assumes a very conservative concentration to be unacceptable. A quantitative evaluation of reduction in pilot performance vs. chemical agent dose was not considered in this study. The dose of agent required for onset of miosis (eye performance degradation) or inflammation has been established over a broad range, but evaluating the onset of eye degradation to specific pilot performance and mission effectiveness is more difficult. For purposes of this study it has been assumed that any pilot miosis results in a mission casualty. That is to say, any observable miosis will cause the mission to be aborted, even though the crew and helicopter will most likely survive.

It has been conservatively assumed in this study that a dosage of 0.5 mg-min/m<sup>3</sup> is sufficient to produce eye effects which could reduce pilot performance. Reduction in pilot performance does not occur immediately if the time in which this dose is accumulated is short because miosis can occur up to several minutes after the dosage level has been absorbed. It is believed that the use of such a conservative dosage limit is desirable in that it provides a form of safety factor, or safety margin, which should be used in a study of this type.

The use of countermeasures or antidotes by the flight crew appears impractical insofar as miosis prevention is concerned. Antidote injections, for example, are of no use to a helicopter pilot in preventing or curing miosis, because side effects result in an unacceptable reduction in the capability of the pilot. Such countermeasures can save lives, but do not preserve full capability of the pilot while doing so, and therefore cannot be a viable method of protection for the AAH crew.

(3) Toxicity of Biological Agents

No significant data on biological warfare agents with regard to their dispersal means, effect, or dosage was uncovered in the reference material made available for this study. Likewise the only significant data uncovered regarding defense against biological agents is discussed in Section 1 (a)(4).

It is therefore concluded that such information is beyond the security classification of this study. However, lack of this data has no effect on the conclusions of this report, providing the biological penetration data of Table 3 of this report are correct.

**TABLE 3 ORIGINAL DESIGN OBJECTIVES OF ARMY CB MASK ASSEMBLY**

**THE MASK ASSEMBLY SHALL PROTECT THE FACE, EYES AND RESPIRATORY TRACT FROM FIELD CONCENTRATIONS OF CHEMICAL AND BIOLOGICAL AGENTS.**

**CAPABILITY OF THE RESPIRATORY CHEMICAL FILTER SHOULD PROTECT THE WEARER FROM A MINIMUM OF 15 ATTACKS WITH G-TYPE AGENTS. A CHEMICAL ATTACK IS DEFINED AS AN EXPOSURE TO 1000 MG/M<sup>3</sup> CONCENTRATION FOR 20 MINUTES**

**PROTECTION CAPACITY OF THE RESPIRATORY CHEMICAL FILTER SHOULD BE ADEQUATE FOR AT LEAST ONE ATTACK WITH BLOOD AGENTS.**

**AEROSOL PROTECTION BY PARTICULATE FILTER:**

**CHEMICAL PENETRATION - 0.01% MAX.  
NUCLEAR PENETRATION - 0.01% MAX.  
BIOLOGICAL PENETRATION - 0.0001% MAX.**

**LIQUID PROTECTION THROUGH MASK SURFACE MATERIALS:**

**6 HOURS PROTECTION FROM LIQUID AGENTS SUCH AS MUSTARD, THICKENED SOMAN, AND VX**

**VAPOR DIFFUSION PROTECTION THROUGH MASK SURFACE MATERIALS:**

**6 HOURS PROTECTION FROM MUSTARD, THICKENED SOMAN, AND VX.**

**ALL THE ABOVE DESIGN OBJECTIVES ARE MET OR EXCEEDED BY THE MASK ASSEMBLY CONSIDERED IN THIS STUDY.**

**REFERENCE FOR THIS TABLE:**

**REQUIRED OPERATIONAL CHARACTERISTICS OF  
THE NEW PROTECTIVE MASK. RECEIVED FROM  
CSL ON 11/27/79.**

(c) AMBIENT CB ENVIRONMENT EXPECTED TO CONFRONT AAH

Vapor concentration and dosage levels expected to be encountered by the AAH are highly dependent upon the type of munition employed, meteorological conditions, and terrain factors. Vapor and liquid agent environments are dependent upon temperature, lapse rate, wind speed, relative humidity, precipitation, terrain, and height of detonation. While many of these factors apply primarily to ground level concentrations and dosages, they will also have an important influence upon the CB environment experienced by the AAH. This discussion of meteorological effects on the CB environment is primarily concerned with the lower one hundred meters of the atmosphere.

Temperature has a strong effect on the persistence of deposited chemical agents. Figure 1 shows the vapor levels remaining after a deposition of 3 g/m<sup>2</sup>, as a function of time after deposition at three different temperatures.<sup>2</sup>

Also shown in Figure 1 is the fact that lower temperatures cause lower concentrations to persist for a longer time period, while high temperatures cause higher concentrations to persist for much shorter time periods, tending to equalize the total concentration times time (CXT) exposure. In general, high ambient air temperatures favor high casualty rates for unmasked troops, and cold temperatures favor delayed casualties from liquid penetration of the suit. This is a generalized appraisal based on the available information. The effects of lower temperatures on toxic munitions are extremely complex and difficult to generalize.

Temperature gradient with altitude (lapse rate) is important in determining the rate of dissipation of CB agents, and also is important in distributing the chemical deposition. A high lapse rate distributes agents much more rapidly. An inversion lapse rate, in which the air near the surface is cooler than that above, does not allow the agents to dissipate vertically, thereby trapping high concentration of agents near the ground. Because of this

<sup>2</sup> Chemical Agent Decontamination Study.  
Joint Technical Coordinating Group for Munitions Effectiveness  
January 1976. (Secret Report)

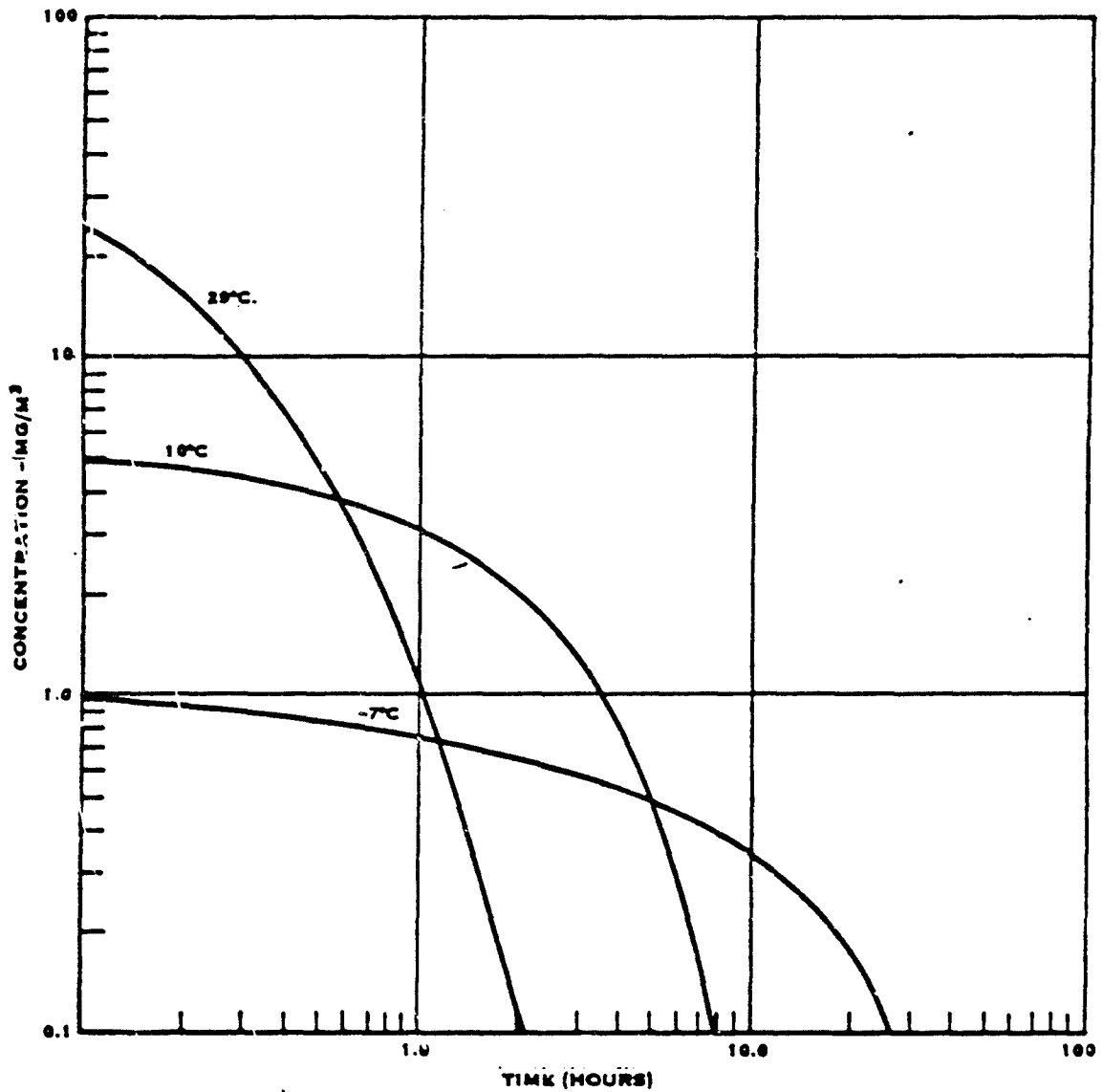

FIGURE 1 EXPECTED GD EVAPORATION CONCENTRATIONS WITH TIME THROUGHOUT A CONTAMINATED ENVIRONMENT, DEPOSITION OF  $3g/m^2$

phenomenon, temperature inversion conditions are normally considered ideal for a chemical attack.

Wind has the large effect on chemical agent dispersion that one would expect. Small area non-persistent chemical attacks are most effective when winds do not exceed 5 knots (9.3 km per hr). For large area attacks it is most desirable to have wind speeds less than 15 knots (27.8 km per hr). In view of the generally higher concentration near ground level, the wind created by the AAH downwash during hover will probably tend to reduce concentrations and dosages in the vicinity of the AAH by mixing relatively agent-free air from above with chemically contaminated air below. This effect may be reversed if the AAH is within 10 meters of the ground due to higher evaporation rates of liquid agents incurred by the impingement of the downwash on the ground.

Terrain exerts considerable influence on chemical agent clouds. In general, higher concentration of agents tend to accumulate in valleys, depressions, and foxholes. The AAH pilot should avoid such areas if feasible. Rough ground, including that covered by brush, tall grass, or trees, impairs the dispersion of chemical agents, and less agent would be encountered if the helicopter is set down upwind in the most open, highest area possible.

Height of detonation varies depending upon the type of munition and atmospheric conditions. They can be detonated barometrically or set to explode on impact. Detonation is normally set from 0 to 100 meters. With the AAH mission occurring primarily within the lower 100 meters of the atmosphere, agent concentrations and dosages occurring outside the AAH may be just as high as at ground level, and for this reason no differentiation will be made between agent concentrations occurring during flight and those encountered on the ground during rearming/refueling.

(d) AAH MISSION PROFILE

(1) Derivation of "Standard Helicopter Combat Day"

The following is an unclassified version of this section of the report. A classified version is available in Volume 2, which is classified Secret.

As part of the specification for the contract of this study, the Army supplied a detailed time-line for a single combat flight,<sup>3</sup> which was then expanded as part of this study to what is referred to as a "Standard Helicopter Combat Day". The resulting AAH mission profile used in this study is shown in Figure 2. The mission is considered to begin at the time the crew leaves the protective enclosure and to end at the time the crew exits the AAH upon return to base. After a preflight briefing of 41 minutes, the crew is transported to the helicopter, a journey which takes 11 minutes. After arrival at the AAH, 67 minutes are spent in preflight checks. Take-off itself takes six minutes. Actual flight time after becoming airborne is 77 minutes for a single flight, making total time from leaving the protective enclosure to returning from the first flight (including post-flight briefing) 181 minutes. We will assume for purposes of this study that six such flights in sequence constitute a "Standard Helicopter Combat Day", and therefore the total mission time for the crew, measured from leaving the protective enclosure to egress from the AAH upon return to base, is slightly less than twelve hours.

The "Standard Helicopter Combat Day" profile selected for this study assumes that the AAH crew is already suited at the start of the day and has not yet entered suit decontamination procedures which are available at the end of the day's mission. Suit donning and doffing factors are identical to those faced by all other elements of the Army, and therefore are not covered in this study of the AAH. It is further assumed that if a crewmember is contaminated with liquid agent while refueling or rearming, that adequate

<sup>3</sup> Hunfeld Tactical Mission, Supplement to AH WSTE A Report Data. (Unclassified) which is enclosure 2 of letter from Robert Eaton to AAH Program Manager, dated 12 December 1978.

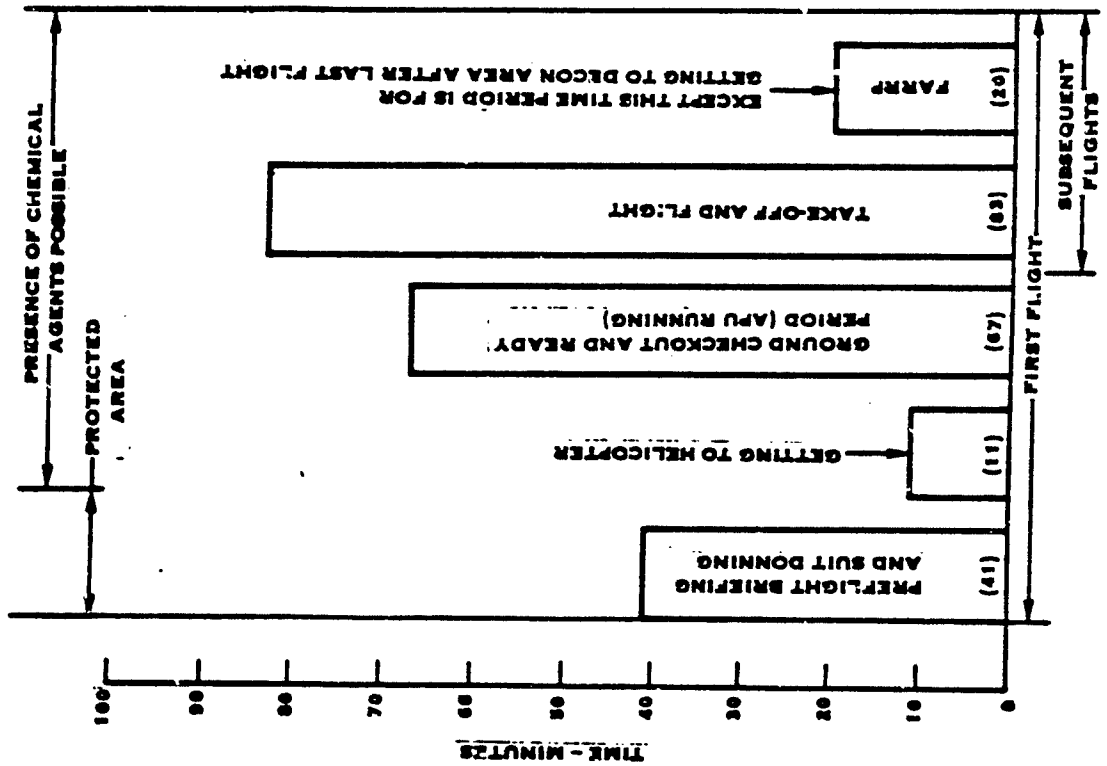

TOTAL NUMBER OF FLIGHTS PER DAY FOR A SINGLE FLIGHT CREW IS ASSUMED TO VARY FROM 2 FOR "SUSTAINED" BATTLE CONDITION, TO 6 FOR "ALL OUT" BATTLE CONDITION:

FLIGHTS PER DAY	ACCUMULATED TIME IN CB GARB	CREW TIME PER FLIGHT	
		INSIDE AAH	OUTSIDE AAH
1	222 MIN.	180 MIN.	31 MIN.*
2	328 MIN.	83 MIN.	20 MIN.
3	426 MIN.	83 MIN.	20 MIN.
4	531 MIN.	83 MIN.	20 MIN.
5	634 MIN.	82 MIN.	20 MIN.
6	737 MIN.	83 MIN.	20 MIN.
	TOTAL	565 MIN.	131 MIN.

\*EXPOSURE POSSIBILITY BEGINS WITH TRANSPORTATION TO HELICOPTER.

REFERENCE: ITEM 2, PARA. F-2, CONTRACT DAAK66-79-C-0136 (MODIFIED BY HAMILTON)

FIGURE 2 - STANDARD HELICOPTER COMBAT DAY



measures will be taken before the crewmember re-enters the AAH. Failure to decontaminate such a liquid agent from a crewmember could result in death to the affected person, due to the fact that agent trapped between the suit and seat is prevented from evaporating, and in fact may be pressed through the porous suit material. This makes a rather strong case for the improved safety of the totally impermeable suit in spite of its somewhat more severe heat rejection problems. In any case, such decontamination problems are also faced by all other elements of the Army, and therefore, are not specifically covered in this study of the AAH.

(2) Derivation of "Helicopter CB Day"

The following is an unclassified version of this section of the report. A classified version is available in Volume 2, which is classified Secret.

The "Standard Helicopter Combat Day" established in Section 1.(d)(1) was superimposed with an estimate of the CB environment to produce what is referred to as a "Helicopter CB Day", for purposes of evaluating the CB defense characteristics of the AAH.

While a clear definition of a single flight was made available for the study, a clear definition of the number of flights made consecutively in one day was not made available. Therefore, the concept of a "Standard Helicopter Combat Day" was adopted by Hamilton Standard as described in Figure 2. In order to proceed with the concept of a "Helicopter CB Day", it has been assumed that CB exposure will exist on and off, without warning, during 50% of the flight time of the "Standard Helicopter Combat Day".

The in-flight CB exposure is assumed to consist of flights through clouds of G-agent, mustard, or blood agent (cyanogen chloride). The most probable attack scenario described in Section 1.(a)(5) was adopted as representative of typical exposure levels during flight. While it is possible to encounter G-agent concentrations as high as  $350 \text{ mg/m}^3$  for very short periods of time and some types of attack can produce vapor concentration as high as  $10,000 \text{ mg/m}^3$  for brief periods of time, it will be assumed that the AAH will more typically be exposed to a maximum continuous concentration of G-agent of  $25 \text{ mg/m}^3$  when on the ground at the FARRP.

While the assumptions made here may exaggerate the possibilities of CB exposure, it is important that a purposely severe threat be chosen to evaluate the capability of the available protective devices. The assumption of a 12-hour mission with six hours at this relatively high CB exposure is felt to meet this requirement.

As shown in Figure 2, the first flight of the day requires almost double the time in the AAH as do subsequent flights due to the requirement for pre-flight checks. Sixty-seven (67) minutes of the first flight is spent on the ground with the AAH crew aboard. Pre-flight checks are followed by the first 83-minute flight. For the first flight, 11 minutes are spent getting to the AAH, and 20 minutes are spent at the FARRP, for a total of 31 minutes during which the AAH crew may be exposed to the chemical threat outside of the vehicle.

Considering the above, total flight time for the day is 498 minutes (565 minus 67), and with the 50% exposure ground rule, this means 249 minutes of potential CB exposure. For 33.5 minutes, the crew could be exposed to 25 mg/m<sup>3</sup> prior to take-off, and finally they could be exposed to 65.5 minutes of 25 mg/m<sup>3</sup> outside the AAH and at the FARRP. For purposes of estimating typical life of the personal respiratory filter, it has been assumed that each CB day will consist of exposure 100% of the time at the FARRP at 25 mg/m<sup>3</sup> (100 minutes), and 50% of the time in flight (249 minutes) at concentrations experienced in flight. The above defines the "Helicopter CB Day" which Hamilton Standard considered in this study.

It turns out that the severity of the above design condition for evaluating the chemical protection capability is relatively unimportant. There is such a large safety factor margin for both the suit and the respiratory devices, using the above design criteria, that one is forced to conclude that the primary chemical danger does not come from the expected AAH mission, but rather from improperly fitted equipment, physical contact with liquid agent, and battle conditions in which no suitable decontamination facilities are available. The adequacy of the existing CB ensemble for the threat of the expected mission is more thoroughly described in Sections 4.(a) and 4.(b).

(e) CB ENVIRONMENT INSIDE PRESENT AAH HELICOPTER

The following is an unclassified version of this section of the report. A classified version is available in Volume 2, which is classified Secret.

Without collective chemical or particulate control added to the AAH, lethal dosages of CB agents will enter the cabin through the normal-air supply system and by infiltration; however interior levels will be considerably attenuated compared to external levels.

The AAH cabin volume attenuates external concentrations of agents; however, lethal levels of agents rapidly build up. Total dosages for G-agents experienced by the crew are far above the lethal level for inhalation and thus the protective mask must be worn at all times in a CB theater. G-agent or HD dosages, however, are not high enough to warrant the wearing of CB protective garments by the crew when inside a clean AAH cabin unless there is contamination by liquid droplets.

2. INDIVIDUAL CB DEFENSE CAPABILITY

(a) SUITABILITY OF AVAILABLE RESPIRATORY PROTECTIVE SYSTEM AGAINST AGENTS CONSIDERED

(1) Agents Handled by Respiratory Protective System

The standard M10A1 cartridge, when installed in a properly fitted mask, protects the wearer from all chemical agents considered in this study. A properly fitted mask protects the face, eyes, and respiratory tract of the wearer from chemical and biological agents through the use of particulate filtration for aerosol and particle removal, and activated impregnated carbon for toxic gas removal. The protective mask is equipped with an expendable charcoal canister/filter which has an adequate capacity to protect the wearer from at least 15 severe chemical attacks with G-type agents.

The basic operational requirements met by the mask are summarized in Table 3. The basic requirement is to provide protection from fifteen chemical attacks with G type agents, where a chemical attack is defined as an exposure to a concentration of 1000 mg/m<sup>3</sup> for 20 minutes. In reality the mask is capable of protecting against much higher concentrations as demonstrated by the test results shown in Table 4. In addition, the protective mask will protect from vapor and liquid penetration of the rubber mask material itself for a minimum of six hours when worn with a protective hood.

While virus particles are normally extremely minute, it is assumed in this study that they must be disseminated through the use of a vector or some carrier agent capable of providing nutrients. None of these carrier agents was considered in this study to be smaller than 1.0 micron (see Section 1.(a)(4)), nor are any droplets of thickened agent considered less than 0.3 microns.

The pleated filter used in the charcoal canister is designed to remove 99.99% of all particulate matter 0.3 micron and larger in size.

**TABLE 4. PERFORMANCE TEST ACCEPTANCE CRITERIA - M10A1 CANISTER**

AGENT	TEST CONCENTRATION	MIN. LIFE	CXT
GB (SARIN)	4,000 ± 200 MG/m <sup>3</sup>	75 MIN.	300,000 MG-MIN/M <sup>3</sup>
CK (CYANOGEN CHLORIDE)	4,000 ± 200 MG/m <sup>3</sup>	30 MIN.	120,000 MG-MIN/M <sup>3</sup>
AC (HYDROCYANIC ACID)	10,000 ± 500 MG/m <sup>3</sup>	*N.R.	
CG (PHOSGENE)	20,000 ± 500 MG/m <sup>3</sup>	*N.R.	
SA (ARSINE)	10,000 ± 500 MG/m <sup>3</sup>	*N.R.	

\*NO SPECIFIC TIME REQUIREMENT FOR THESE AGENTS.

**REFERENCE FOR THIS TABLE:**

REQUIRED OPERATIONAL CHARACTERISTICS  
OF THE NEW PROTECTIVE MASK  
RECEIVED FROM C.S.L. ON 11/27/79

(2) Usage Life of Respiratory Protective System

The M10A1 cartridge protective assembly has the capacity to provide protection for a large number of chemical encounter missions of the type selected for the "Helicopter CB Day" described in Section 1.(d)(2). The M10A1 cartridge has the capacity to sorb a minimum G-agent dosage of 300,000 mg min/m<sup>3</sup>. Traversing one CB event, as defined in Section 1.(a)(5), results in crew exposure to the dosage levels shown in the unclassified figures

of classified Volume 2. With these unclassified figures, calculations were made for dosage per each of these events for various assumed aircraft speeds. This was then combined with the mission of Figure 2 as described in Section 1.(d)(2). Table 5 shows this comparison between dosage per CB event, dosage per mission, and M10A1 cartridge chemical capacity. Only a very small fraction of the G-agent capacity of the cartridge is used on what is considered in this study to be a heavy CB day.

Considering that the maximum concentration of G-agent rarely exceeds 300 mg/m<sup>3</sup>, and that the minimum capacity of the canister is 300,000 mg min/m<sup>3</sup>, the wearer may survive for more than 16 hours (1000 minutes) even when experiencing the maximum possible concentration attainable.

Although the M10A1 cartridge has a great excess of capacity for G-agents, there is a limitation when exposed to the non-persistent agent cyanogen chloride (CK). Minimum design CxT for this agent is 120,000 mg min/m<sup>3</sup>. Saturation of CK at 20°C is approximately 3000 mg/m<sup>3</sup>; however, maximum actual concentrations experienced on the battlefield are more likely to be on the order of 300 mg/m<sup>3</sup>. Canister life under these latter conditions would be only 6.6 hours. At the above saturated concentration, canister life would be only 40 minutes. In short, the canister is capable of withstanding a severe chemical attack with blood agents; however, if it is believed that a severe attack with blood agents has occurred, the canister should be changed as soon as possible.

TABLE 5 . (U) M10A1 CHARCOAL LIFE FOR G-AGENT

VELOCITY (KNOTS)	DOSAGE PER EVENT	NUMBER OF EVENTS IN ONE CB DAY	TOTAL DOSAGE FLIGHT	DOSAGE ON GROUND	TOTAL DOSAGE	MASK CAPACITY* (CB DAYS)
	MG-MIN M <sup>3</sup>		MG-MIN M <sup>3</sup>	MG-MIN M <sup>3</sup>	MG-MIN M <sup>3</sup>	
40	18.4	61	1122.4	2475	3597	83
90	7.1	138	980	2475	3455	87
120	5.3	184	975	2475	3450	87
130	5.0	199	955	2475	3470	86

\*WHERE A STANDARD "HELICOPTER CB DAY" CONSISTS OF 249 MINUTES FLIGHT TIME, AND 100 MINUTES GROUND TIME PER DAY AT 25 MG/M<sup>3</sup> CONCENTRATION.



No data defining the storage capacity of the M10A1 cartridge for bacteriologically active dust was discovered during this study. It is assumed, however, that this is not a limiting factor for the assembly, provided that the expendable cartridge is changed as recommended by the manufacturer. Storage capacity for biological and other aerosols and dusts is limited only by the added breathing resistance such loading imposes on the wearer.

In view of the fact that there is at this time no practical way to assess cartridge life remaining, it is important that the cartridge be changed in accordance with applicable training manuals or other official guidance.

(b) CREW PROTECTION PROVIDED BY THE POROUS, CARBON-IMPREGNATED SUIT

(1) 'Agent Protection Afforded Wearer

The standard available CB protective overgarment, when properly fitted, will protect the AAH crew from all chemical and biological agents considered in this study.

The content of the remainder of this section is classified and is available in volume 2 which is classified Secret.

(2) Usage Life of Suit

The standard available CB protective garment is overdesigned in chemical resistance for the AAH crew compared to some other Army occupations; therefore, its life for the AAH flight crew will usually be limited by wear and cleaning.

The primary purpose of the CB protective overgarment is to protect the wearer from the direct impact of liquid droplets. This is accomplished through an activated carbon impregnated material which adsorbs vapors emitted on the exterior surface of the cloth in the vicinity of the wetted site.

Suit degradation is caused by the accumulation of excreted body oils and perspiration which accumulate in the protective material. Oils or solvents of any kind are suspected of rendering the suit ineffective by wicking through the carbon impregnated suit and carrying agent with it. The effects of oils and solvents are still being evaluated.

The suit has been found capable in tests of providing adequate vapor and liquid protection after 14 days of normal wear in battlefield conditions. Allowable wear time for the less active AAH crewmember could therefore be longer than 14 days, however, 14 days is the longest test verified wear period. Contamination of the suit at any time during the allowable wear period is grounds for replacement or cleaning. Replacement of the suit is recommended within 6 hours of contamination. The effect of laundering the CB protective overgarment or protection level is still being evaluated.

Thickened GD or VX agents which are specifically used to cause casualties by protective suit penetration have low vapor pressures and a high potential for material penetration via vapor diffusion. Therefore, these agents will have a more deleterious effect on useful suit life than exposure to gaseous agents.

In summary, the CB protective overgarment protects the wearer for up to 14 days of continuous wear, protecting the wearer from both the vapor and liquid threats. The suit is replaced when either 14 days of continuous wear have accumulated, or within 6 hours if the suit has been contaminated by a CB attack or by oil droplets.

(c) DESCRIPTION OF AVAILABLE CB PROTECTIVE GARMENTS

A complete array of flightworthy CB garments suitable for the AAH flight crew exists. But they must be considered "first generation" equipment since the special requirements of airmen have already made apparent the need for certain improvements.

There are options available, and many different combinations of CB attire are possible for the AAH crew, but the following is what might be referred to as the baseline CB attire for the 1980-1985 time frame:

- a) Underwear (T-shirt, drawers, socks)
- b) Two-piece chemical protective suit (overgarment)
- c) One-piece fire-resistant coveralls
- d) Armored vest
- e) XM-29 CB protective mask
- f) M-9 Aviators CB protective hood
- g) SPH-4 flight helmet
- h) Butyl gloves with cotton liners
- i) Nomex flight gloves
- j) Standard boots
- k) Butyl footwear covers

The use of cold weather clothing as part of the CB ensemble may not be necessary for the AAH flight crew, because the chemical protective suit is worn over the aircrew clothing and provides thermal insulation as well as chemical protection. A brisk cold day is necessary to remove body heat, if any significant physical work is being done, as is discussed in detail in Section 4.(d).

A brief specification and photograph of each of the CB protective clothing options is shown in Appendix A. The chemical defense characteristics of the respiratory protective system are covered in Section 2.(a). The chemical defense characteristics of the suit are covered in Section 4.(2).

Helicopter operation does not in itself result in any new requirements for CB garments, but it does point up the inherent deficiencies. These deficiencies can never be completely eliminated, but certainly can be improved upon. One such example is bulkiness. It is impossible to have clothing without some bulk. But bulkiness around the waist of an infantry truck driver might be without consequence, whereas bulkiness around the waist of a helicopter pilot could block off his view of instruments in a waist high console. Bulkiness in the glove of an infantry truck driver could be without consequence, whereas it could interfere with operation of a circuit breaker panel on a helicopter, and so on. Examples of reduced agility and dexterity are:

- a) widened fingers interfering with operation of switches
- b) feet slipping from pedals and bulky for good pedal operation
- c) ties, straps, and bulky folds catching on levers and other cockpit protrusions

Interference of the mask with vision is undoubtedly a more critical matter for the AAH flightcrew than for many other Army occupations. Unimpeded vision and rapid reflexes are obviously essential to survival when flying near the earth between trees. There are several ways in which this visual impairment can take place, for example:

- a) reduction of field of view by mask
- b) distortion of image by the mask lens
- c) inability to hold eye at proper focal length for gun sight, night vision apparatus, telescopic sight, etc.
- d) inability to remove sweat from the eyes
- e) fog on the mask lens, particularly on the inside where it cannot be removed.

Another area of concern is that of physical discomfort to a degree which can cause distraction, headache, nausea, dizziness, and disorientation.

Examples of causes of this kind of discomfort are:

- a) excessive pressure against the head or face
- b) eye strain from vis. 1 distortion
- c) improper breathing rate, resulting in higher or lower oxygen levels than desired, caused by voluntary breathing effort required to overcome respiratory system pressure drop. XM-30 series mask pressure drop is low enough to reduce this to be a minor problem.
- d) inability to reject body heat, with resultant artificially induced fever. This heat rejection problem is described in detail in Section 4.(d).

Improvements in ease of donning and doffing are continuously being evaluated. The difficulty is, of course, that chemical safety requirements must predominate over convenience in opening and closing access points.

Fire resistance requirements, not unique to airmen, are of tremendous importance. In spite of design improvements to reduce the fire hazard in helicopters, flame resistant clothing still represents the flight crew's best chance of surviving fire. With the current baseline CB attire, the helicopter crew faces a dilemma. The fire resistant coveralls are most effective as the outermost clothing layer. But unfortunately bulkiness of the chemical suit makes the ensemble more comfortable with the fire coveralls inside even though the carbon filled foamed overgarment is not fire resistant. A Product Improvement Proposal (PIP) is in process to develop a fire resistant overgarment, but no improvement is expected in its bulky configuration or ability to dissipate body heat in warm environments.

Many different approaches are being considered in effort to alleviate the factors discussed above. A brief summary of these development approaches together with respective areas of improvement, currently being considered by the Army Natick Labs, is shown in Table 6.

TABLE 6 . PROTECTIVE ENSEMBLE DEVELOPMENT AREAS

CLOTHING ITEM IMPROVEMENT	DEVELOPMENT APPROACH	AREA OF IMPROVEMENT								
		VISION	FIRE RESISTANCE	AGILITY, DEKTERITY	DONNING, DOPPING	CHEMICAL SAFETY	BODY HEAT REACTION	EASE OF DECON OR LONGER LIFE	LESS EXPENSIVE	CHEAP ENOUGH TO BE DISPOSABLE
COOLED VEST	LIQUID PASSAGE VEST TO BE WORN UNDER CHEMICAL PROTECTIVE VEST						X			
SINGLE GLOVE COMBINING FIRE RES. AND CHEM. SAFETY	THIN GLOVE INHERENT FIRE RESISTANT MATERIAL		X	X	X			X		
MATERIAL OF SUIT FIRE RESISTANT	MOLEX AS OUTER LAYER AND FIRE RESISTANT FOAM OF TUIT MATERIAL		X	X	X		X	X		
ALLOWING MASK LENS TO PUSH IN TO ACCOMMO-DATE GUNNERS SIGHT, ETC.	FLEXIBLE PERIPHERY OF LENS, VARIABLE THICKNESS LENS	X								
IMPERMEABLE COVERING FROM SHELTER TO AIRCRAFT	IMPERMEABLE COVER TO PROTECT THE CLOTHING UNTIL ENTERING AIRCRAFT.						X		X	X
HIGHLY PERMEABLE FINE RESISTANT CHEMICAL PROTECTIVE MATERIALS	LINER SYSTEM		X	X		X		X	X	X
HOOD	PERMEABLE HOOD FOR XM SERIES MASK		X	X	X	X		X	X	X
FOOTWEAR	GOOD FITTING FOOTWEAR COVERS ON INHERENTLY AGENT RESIS-TANT FOOTWEAR		X	X	X	X		X	X	
OVERGARMENT	LIGHTWEIGHT, HIGHLY PERMEABLE, FIRE RESISTANT		X	X	X	X	X	X	X	



(d) VALUE OF CHEMICAL ALARMS IN AAH DEFENSE

The availability of suitable alarms can improve crew safety and mission effectiveness by allowing more utilization time of the helicopter with the crewman in the "mask-off" mode.

Available alarms are expected to be development derivatives of the current M43 alarm. The M43 series alarms are about 6" x 6" x 8", (15.2x15.2/20.3 cm) in size, can operate on 28 VDC power, and weigh about 6.5 lb (3.0 kg). The M43 responds quickly to high concentrations, and slower to low concentrations. Typical response characteristics for a "dry sensor" alarm of the type expected to be available in the time period of this study are shown in Table 7.

Alarm systems are of little value to the crew of an unprotected helicopter who fly into a thick agent cloud with masks off. Encountering cloud concentrations on the order of 350 mg/m<sup>3</sup> would result in unacceptable interior concentrations, and lead to a rapid dosage buildup to the eye effect dosage, before a mask could be donned. To illustrate this response time problem let us return to the artillery attack model presented in Section 3.1.5. Upon flying into the most dense (centerline) concentrations, the crew will be alerted to a G-agent presence in about 1.8 seconds, when traveling at 90 knots (167 km per hr). Unless the crew can don their masks within about 8 seconds, eye defects will be inevitable. The 8-second time availability is optimistic because it assumes that there is no lag time in the sampling line between the outside of the AAH and the alarm. Even with these typical levels of agents, there is insufficient time to don a mask, and higher concentrations make even less time available. It should be pointed out that the development of faster alarm response at high agent concentrations cannot influence the response time problem for a cabin without collective protection. Even a zero time alarm response would give the crew only about two seconds more, or 10 seconds to don their masks instead of 8 seconds.

**TABLE 7 TYPICAL RESPONSE TIME OF DRY SENSOR CHEMICAL DETECTOR ALARM**

CONCENTRATION OF AGENT	TIME TO TRIP ALARM		DOSE TO TRIP ALARM	
	VOLATILE: G AGENTS	VISCOUS: VX AGENTS	VOLATILE: G AGENTS	VISCOUS: VX AGENTS
0.3 MG/M <sup>3</sup>	4 SEC	6 SEC	0.02 $\frac{\text{MG-MIN}}{\text{M}^3}$	0.03 $\frac{\text{MG-MIN}}{\text{M}^3}$
1.0 MG/M <sup>3</sup>	2.5 SEC	2.5 SEC	0.042 $\frac{\text{MG-MIN}}{\text{M}^3}$	0.042 $\frac{\text{MG-MIN}}{\text{M}^3}$
10 MG/M <sup>3</sup>	1.5 SEC	1.5 SEC	0.25 $\frac{\text{MG-MIN}}{\text{M}^3}$	0.25 $\frac{\text{MG-MIN}}{\text{M}^3}$

REFERENCE: FROM UNCLASSIFIED DATA PROVIDED BY  
 CS DETECTION ALARM DIVISION  
 CSL, ABERDEEN (FEB. 13, 1966)

Since alarms cannot materially affect the ability to fly "mask off" in a helicopter without collective protection, it is concluded that alarms are primarily of use in unprotected helicopters for masked crewmembers to sound the alarm to others who are behind or downwind.

In a helicopter with a collective filter system however, alarms have several potential uses. An alarm sensing ambient air agent concentration may be used to automatically divert incoming ambient airflow to the cabin to go through a CB filter. Shut off dampers are necessary on the inlet and outlet of CB filters to protect them from everyday vapors and dusts which would otherwise contaminate them and make them worthless when an actual CB agent attack occurs. Construction of these dampers, or valves, is discussed further in Section 6.(d)(3). An alarm sensing ambient air concentration can be used to automatically trigger the motion of these dampers from the position of protecting the CB filter to the position of forcing all incoming air through the filter. The same actuator can also be used by the flight crew to manually actuate the dampers.

Figure 3 shows cabin concentration versus time for both an unprotected cabin and a cabin with a collective filter for the model battlefield gradient concentrations of Section 3.A.e and a helicopter speed of 90 knots, (167 km pr hr).  
Note on Figure 3 that the current unprotected cabin with all fresh air responds very quickly, as shown by the left hand curve. The right hand curve responds slower at first, even though the air is not going through the filter, because only about 25% of the airflow is fresh and the remainder is recirculated as described in Section 6.(d)(3). After the alarm trips and activates the filter, the cabin concentration starts to decline, as shown.

Figure 4 shows the accumulated dose received by the flight crew for the same ambient concentrations, when the collective system is automatically

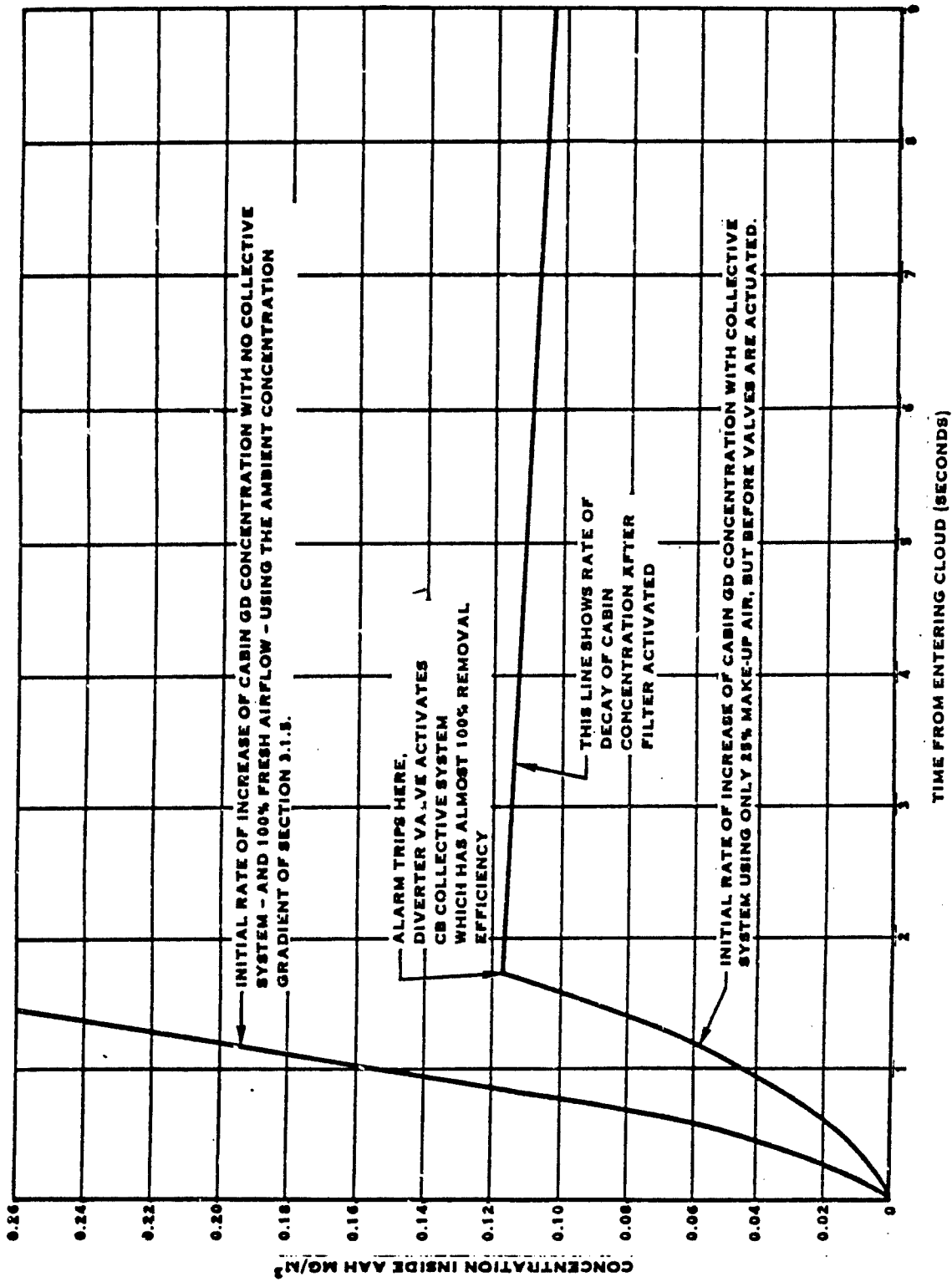

Figure 3 AAH CABIN GD CONCENTRATION WITH AND WITHOUT COLLECTIVE PROTECTION AS A FUNCTION OF TIME FROM ENTERING AGENT CLOUD

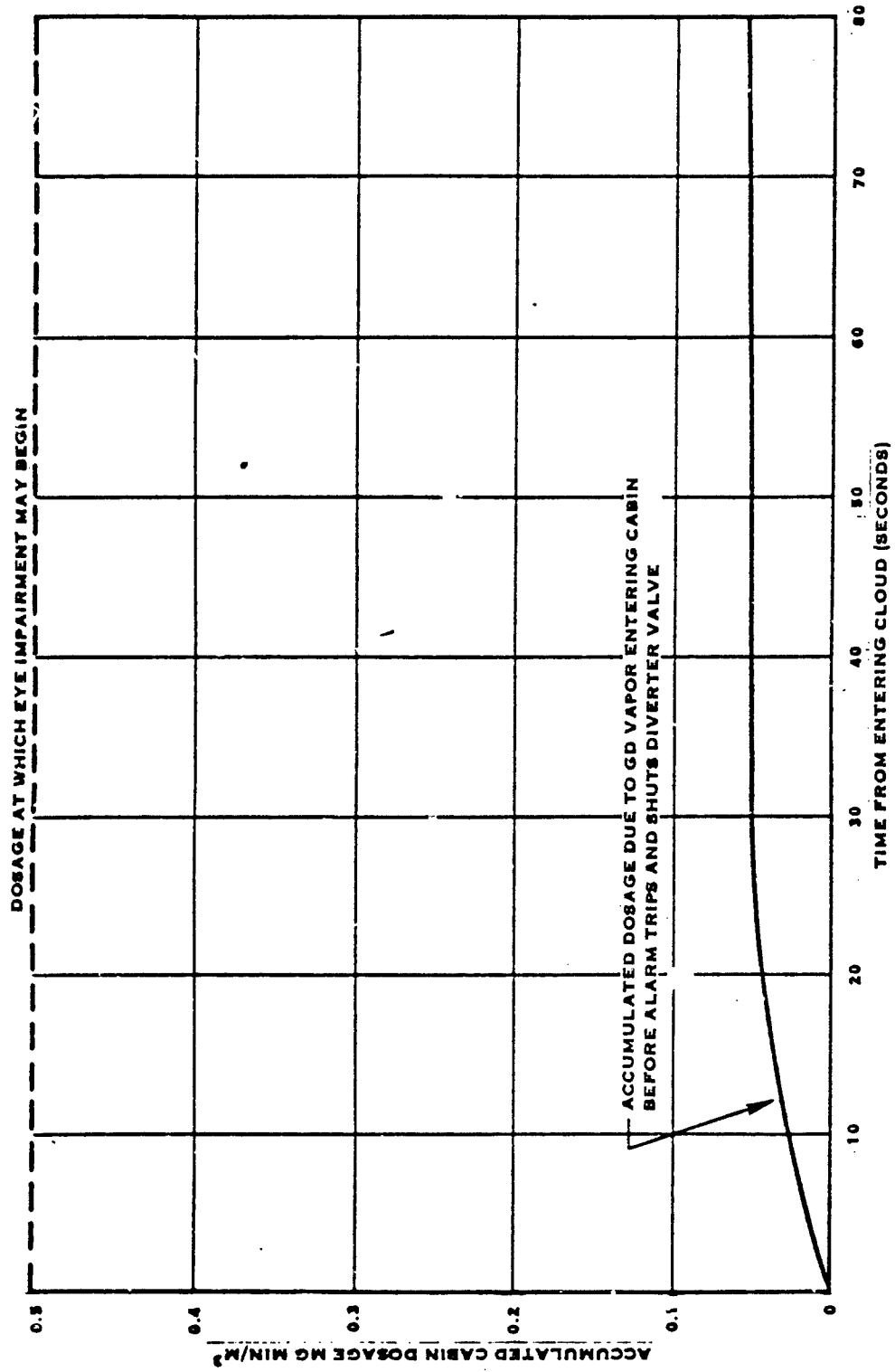

FIGURE 4 AAH CABIN GD DOSAGE DUE TO CABIN INFLUX BEFORE DIVERTER VALVE SHUTS

activated by an ambient air alarm. Only about one tenth of the dose required for miosis will be received. Obviously it is quite possible to fly into extremely high concentrations in which unacceptable doses could be received if the filter system is not activated prior to entering the cloud. However, adding the automatic provision adds only a wire, and possibly a relay, if both a collective system and an alarm are already installed. This small additional cost significantly adds to overall system safety when agents are unexpectedly encountered with the CB filter in the non-activated mode.

Another use for an alarm is to indicate cabin air concentrations rather than ambient air concentrations. A single alarm could be located inside the AAH and sample both outside ambient air and inside cabin air by utilizing air tubing at the inlet and outlet of the alarm case. Two sets of air tubing could be used with a selector damper so that either inside or outside air could be sampled. The major problem, which could be a limiting factor in the usefulness of alarms on AAH, is the difficulty of decontaminating the alarm and its air sample tubing after an exposure to thickened agent. A clean assembly would provide the response characteristic shown in Table 7 for its first exposure. Once contaminated, however, it is not clear that subsequent signals would be accurate enough to be of value. In other words, a clean alarm would be capable of "sounding the alarm" but would not necessarily be able to sound the "all clear" inside the cabin. The use of two alarms, one inside the cabin and one in the ambient, would somewhat reduce the problem of contaminated alarms, but not entirely, since the alarm in ambient air could still receive thickened agent.

The changes to the AAH recommended in Section 10 of this study are unaffected by alarm performance, but the availability of sensitive, accurate, and reliable alarms can improve safety and improve mission effectiveness by allowing increased safe utilization of the helicopter in a "mask off" condition.

### 3. PRESENT AAH CB DEFENSE CAPABILITY

#### (a) Present AAH Components Affecting CB Defense

There are no components in the present AAH specifically designed for CB warfare, although the particulate filter currently installed will remove a significant portion of large particles and aerosols.

The filter system currently installed on the cabin air induction system was not designed to remove chemical agents, but rather was designed to remove dust. It is an assembly consisting of multiple cyclone separators, each about 3/4" (1.9 cm) in diameter, assembled in parallel to form the complete filter. Performance achieved is removal of about 90% of particles over 20 microns in size. Dust in a helicopter is a major problem due to the rotor downwash during slow vertical descent. The presently installed dust separator is the result of many years of development and is presumably satisfactory for its intended purpose. But unfortunately, thickened agents and aerosols will certainly be trapped in it to a considerable degree. Besides trapping these agents for later out-gassing, performance as a dust filter could be adversely affected by thickened agents. These agents will clog dust outlet passages and generally coat internal surfaces. Decontamination would be extremely difficult due to the small complex flow passages, and so replacement of the active filter element seems the only solution. A new less expensive design would be required if contaminated elements were to be thrown away.

A more detailed description of the present AAH Environmental Control System is given in Section 6(a).

There is one potential CB defense characteristic of the AAH environmental control system which could conceivably prove to be important, and which merits further investigation. This is the fact that all air supplied to the cabin is momentarily raised to 450°F, (232°C) as it goes through the shaft-driven

compressor to the cooling unit. Reference material available for this study does not discuss a degradation in toxicity of chemical or biological agents when exposed to this kind of sudden, short duration, high temperature condition.<sup>4-9</sup> Nevertheless, further testing might reveal that some agents are detoxified when subjected to the high temperature.

---

<sup>4</sup> See reference 1, p. 11.

<sup>5</sup> See reference 2, p.24.

<sup>6</sup> Chemical, Biological, Radiological, and Nuclear Defense.  
US Army Field Manual FM-40, May 1971.

<sup>7</sup> Chemical Reference Handbook.  
U.S. Army Field Manual FM 3-8, Jan. 1967.

<sup>8</sup> John D. Weiss, Director  
U.S. Army Human Engineering Laboratory  
Aberdeen, Maryland  
Letter from G. Rannenberg, subj; Effect of CB garb on Helicopter Mission Effectiveness, 12 March 1980.

<sup>9</sup> G. Rannenberg, ltr from, U.S. Army Aviation Center, Ft. Rucker, AL.,  
22 Jan. 1980 (Secret).



(b) EFFECT OF CHEMICAL AGENT ON AAH EQUIPMENT

Chemical agents can adversely affect vehicle equipment, particularly plastic surfaces, and therefore coatings to provide protection without altering equipment function are under development.

Adsorption of chemical agents into the surface of plastics and paints has been well investigated, and new surface finishes are being developed to combat it. The present AAH cabin interior, including consoles, floor, etc., is a black acrylic lacquer.<sup>10</sup> This finish should be changed in the future to one of the new Army polyurethane finishes being developed especially for their resistance to adsorption of chemical agents. For detailed information on these finishes one should contact CSL Aberdeen for a copy of a designer's handbook now being prepared.

Damage to transparent canopy surfaces by both agents and decontamination compounds is extremely likely unless steps are taken to prevent it. A surface finish originally developed to improve scratch resistance of transparent plastics has proved to significantly reduce both adsorption of agents into the surface, and preservation of visual properties. There is some reduction in light transmission due to the coating but its use appears necessary. Detailed information on these coatings for transparent surfaces are also included in the above-mentioned handbook.

The effect of chemical agents on dielectric properties of electronic components is a concern, but no information on this was made available for the study. In addition there is the possibility of agents specifically designed to disrupt electronic equipment. This subject is beyond the scope of this study, but should specific filters be required in the future to protect electronics cooled by ambient air, such filter requirements could conceivably impact the cabin environmental control system.

<sup>10</sup> Military Specification, MIL-L-46159, Lacquer Acrylic, Low Reflective, 2 Dec 1976.

(c) DECONTAMINATION OF AAH CABIN

(1) Decontamination of Chemical Agents

Recommended chemical agent decontaminants, while not practical to use on complex equipment, may be practical for the cockpit floor, foot pedals, etc. But heat soak with clean hot air may ultimately prove to be the only practical cabin decontamination technique, due to the sensitivity of complex instruments and electrical gear to decontaminants.

One summary chart of recommended decontaminants for different chemical agents is shown on Table 8.<sup>11</sup> This reference is not specifically devoted to aircraft aluminum structures but its content is summarized below. The solution DS2 referred to is a clear solution consisting of 70% diethylenetriamine, 28% ethylene glycol monomethyl ether, and 2% sodium hydroxide. The solution is not highly corrosive to metals, but it will slowly corrode aluminum, cadmium, tin, and zinc with prolonged contact. The solution softens and removes new paint, discolors old paint, softens leather, and will damage rubber, woolens, and synthetics. DS2 reacts rapidly with GD and HD with sufficient contact time (30 minutes) in the temperature range of 10 to 50°C. DS2 is inactivated by water. The usual technique in decontaminating surfaces with DS2 is to apply the liquid with a mop or broom, allow it to set for 30 minutes and then to flush with water.

The solution STB referred to in Table 8 stands for "Super Tropical Bleach". It is a white powdery mixture of chlorinated lime and calcium oxide. Freshly prepared STB contains 30% available chlorine, however it unfortunately evolves chlorine during storage. STB is also corrosive to metals and fabrics. STB decontaminates mustard, lewisite and G-agents. It is normally mixed to give a slurry containing 40 parts bleach and 60 parts water by weight. Decontamination is effected by swabbing the slurry on a

<sup>11</sup> See reference 2, p.24.

TABLE 8. RECOMMENDED DECONTAMINANTS FOR INDIVIDUAL CHEMICAL AGENTS ON MATERIEL.

Chemical agents	Decontaminants <sup>1</sup>	Remarks
G-agents (GA, GB, GD) .....	Slurry, hot soapy water, alkali solution <sup>2</sup> D82, or components of the M18 kit.	STB and GA produce toxic vapors; in confined areas steam and ammonia should be used.
V-agents .....	★D82, slurry, 5-percent sodium hypochlorite solution, or components of the M18 kit.	Liquid V-agents do not evaporate rapidly or freeze at normal freezing temperatures. Absorbed, V-agents remain toxic for some time.
Mustards (H, HD, HN, HQ, HT) ....	★STB, slurry, D82, components of the M18 kit.	Dry STB on liquid mustard produces flame and toxic vapors. In sealed container, stable up to 10 years.
Lewisite (L), mustard-lewisite mixture (HL), phenyldichloroarsine (PD), ethyldichloroarsine (ED), methyldichloroarsine (MD).	★STB, slurry, D82, water, or caustic soda.	Decontamination products are toxic, fairly stable, nonvolatile, and insoluble in water. Alkali solutions <sup>2</sup> destroy vesicant properties.
Phosgene oxime (CX) .....	Large amounts of water or D82 ..	Liquid above 89° F. Readily soluble in water.
Phosgene (CG) .....	Water followed by alkali solution <sup>2</sup> or D82.	CG liquid below 47° F.
Cyanogen chloride (CX, hydrocyanic acid (AC)).	Sodium hydroxide solution or D82 .	CK liquid below 55° F.
Adamsite (DM) .....	Slurry or D82 .....	AC liquid below 77° F.
Diphenylchloroarsine (DA), diphenylcyanarsine (DC).	Alkali solution <sup>2</sup> or D82 .....	Aeration is sufficient in the field.
CS .....	Water or 5-percent sodium bisulfite solution.	Aeration is sufficient in the field.
Chloroacetophenone (CN), CN solution (CNB, CNC, CNS <sup>3</sup> ).	Hot sodium carbonate solution, hot sodium hydroxide, or hot soapy water.	Aeration is sufficient for vapors.
White phosphorus (WP) or plasticized white phosphorus (PWP).	Water or copper sulfate solution ..	Water extinguishes burning WP; copper sulfate prevents further burning.
Sulfur trioxide-chlorosulfonic acid (FS).	Alkali solution <sup>2</sup> water followed by alkali solution <sup>2</sup> or hot soapy water.	Corrosive to metals when moist; acidic, destroys nylon and paint.
Titanium tetrachloride (FM) .....	Water or alkali solution <sup>2</sup> .....	Corrosive to metals.
HC mixture (HC) .....	Water or alkali solution <sup>2</sup> .....	No decontamination required for vapor. High concentrations toxic.
BZ .....	Hot soapy water .....	.....

<sup>1</sup> Decontaminants are listed for chemical agents in liquid or solid state. In addition to decontaminants listed, aeration is effective for most chemical agents (vapors and light contamination) except V-agents. Screening meshes generally require no decontamination except aeration.

<sup>2</sup> Ten-percent solution of caustic soda, washing soda, baking soda, or household ammonia; 5-percent solutions are recommended for fabrics to include canvas and leather (para 5-2a).

<sup>3</sup> In closed spaces, sodium sulfite is used for CNS.

REFERENCE: FM 3-8

surface. For decontamination of boots, it is mixed in the ratio of two parts bleach and three parts soil for use in "shuffle boxes", in which the crew would presumably "shuffle" before entering the helicopter. The Earth STB mixture is also useful for spreading under equipment that has been decontaminated to neutralize any agent flushed from the equipment during decontamination procedures.

"High test bleach" is similar to STB and contains a minimum of 70% calcium hypochlorite. HTB is recommended for decontaminating individuals and personal protective equipment.<sup>12</sup> Six ounces of HTB and six ounces of detergent are dissolved in 12 gallons of water to make 12 gallons of decontaminating solution. New solutions must be replaced daily during an alert because of chlorine loss.

Another excellent source of procedures for decontaminating aircraft interiors is TM 3-220.<sup>13</sup> Paragraph 35f of this TM calls for the use of hot, soapy water or self-emulsifying degreasing solvent to remove chemical contamination. To be more specific, a non-ionic detergent is best, considering the problem of non-ferrous metals, electrical equipment, and electronics. A non-ionic detergent has the advantages of being both non-conductive and a better surface displacement agent, and does not leave a residue.

Also, whenever aqueous solutions are used on or near electrical circuitry, it is advisable to treat these areas with a drying agent such as 1-butanol (from a spray can) to displace the water.

The following detergents have been recommended:

- a. NSN 7930-00-249-8036, Detergent, General Purpose

<sup>12</sup>See reference 2, p.24.

<sup>13</sup>TM 3-220; Chemical, Biological, and Radiological (CBR) Decontamination; Department of the Army, Nov 1967.

- b. NSN 7930-00-634-1362, Detergent, General Purpose
- c. NSN 7930-00-515-2477, Detergent, General Purpose

These are generally recommended for decon because of their high alkalinity, which destroys G-agents. These detergents are suitable for aircraft interior decon, but may lead to unacceptable corrosion of bare metal areas and electrical short circuits because of their ionic nature.

To avoid these possible problems, and to take advantage of the superior surface displacement properties of non-ionic detergents, the following is recommended:

- a. NSN 7930-00-282-9699, Detergent, General Purpose (Liquid, Non-ionic) MIL-D-16791E, Type I (Water-soluble, Non-ionic). The detergent is mixed with water at a concentration of 1 ounce per gallon.
- b. 1-Butanol in a spray can, standard lab item

Other methods of decontaminating equipment include the use of heat and weathering. It is in this last area, heat and weathering, that the most practical approach to decontaminating the AAH cabin probably lies.

Heat increases the rate of any chemical reaction. An old fashioned rule of thumb is that the rate of a chemical reaction doubles for each 10°C. Weathering is the term used to describe the relatively slow chemical decomposition process which takes place at room temperature. However, it takes too long to be a practical decontamination technique at room temperature. But the AAH cabin already has the built-in capability to heat the cabin to 160°F with the APU running, and with electric equipment shut off. Theoretically the cockpit equipment can withstand 160°F without damage, providing it is not operating. Only testing can determine how practical this decontamination technique can

be for the AAH cabin, but it appears to have considerable promise. The technique is ever more attractive with the collective filter system of Section 6.(d) added to the AAH, because the cabin would be continually washed with a flow of hot filtered clean air.

All in all, the state of the art of decontamination appears quite primitive. This is one reason that Hamilton Standard recommends a collective chemical protection system for the AAH. The best decontamination technique is undoubtedly to keep the agent out in the first place.

(2) Decontamination of Biological Agents

Recommended biological agent decontaminants appear practical and easy to apply because of their aerosol nature.

The AAH cockpit may be decontaminated by an ethylene oxide-fluorinated hydrocarbon mixture. Four 12-ounce dispensers are used for the 100-cubic-foot of the AAH cabin when it requires bacteriological decontamination. A contact time of six hours is sufficient to decontaminate. Vapors of formaldehyde may be substituted for the above mixture if necessary.

The fact that these approved techniques appear to work,<sup>14</sup> without actually scrubbing cabin interior surfaces, makes decontamination of biological agents appear a much simpler matter than decontamination of chemical agents.

<sup>14</sup>See reference 6, p. 52.

#### 4. THE THERMAL STRESS PROBLEM

##### (a) IMPROVED CHEMICAL RESISTANCE AND RESULTANT INCREASED THERMAL STRESS

Design features which have improved the chemical resistance of CB clothing over the last 25 years have inherently led to a reduced ability of the body to reject heat to the environment, thereby resulting in increased thermal stress.

Man, as well as all other mammals, is basically cooled by evaporation when in a hot day ambient environment. Conduction heat transfer only aggravates the problem when the ambient temperature is greater than the skin temperature, and left unchecked, can cause a fever. Thus evaporative cooling must not only cool the metabolic heat generated inside the body, but must also cool any heat conducted into the body from its surroundings. This is particularly critical where the outside surface of the clothing is heated by direct sunshine, as is the case under the AAH canopy. If there is not enough evaporative cooling taking place to accomplish this cooling, the result is an artificially induced fever, and eventually death.

A common misconception of the operation of the protective suit is that a porous suit will vent evaporated sweat, while not allowing outside vapors to enter. Actually the evaporated sweat directly vented from inside the suit to outside is of minor cooling value, and occurs primarily by the slow process of diffusion. The majority of the evaporative cooling is actually achieved by pumping dry air from outside the suit into the wetted skin area where this air increases in humidity to the saturation point at about 27°C (80°F) (which is the skin temperature necessary to remove body heat), and then continuously replacing this saturated air with dry air. For example, the heat which must be removed by sweat evaporation from AAH crew is typically 73 watts (250 Btu/hr). This ideally requires that 67.3 liters per minute (135 cubic feet per hour) of perfect dry outside air be drawn into the wetted area where



it must be completely saturated at 27°C (80°F) and then pumped out to the ambient so it can be replaced by another charge of dry air. Since each cubic foot of air is not dry to start with in humid weather, and since only a portion of the air will be completely saturated before it is pumped out, and since some of the evaporated sweat goes to cool the outside of the suit instead of the body, the volume of air which really needs to be pumped is many times the ideal listed above.

This pumping of dry air in and saturated air out is accomplished by wind across the suit, or by body motion changing the volume of air trapped inside the suit. This pumping must cause a pressure differential across the material of the suit, which in turn pumps the air through. All other leakage paths around cuffs, zippers, and so on have been carefully sealed as a defense against chemical agents. In practice, a sufficient flow of air is very often not pumped through the suit, and the result is thermal stress.

(b) THERMAL STRESS IN HELICOPTERS PREDATING CB WARFARE

For 15 years, helicopter design has been incorporating increased use of refrigeration equipment to alleviate thermal stress. The addition of a chemical warfare requirement just makes the problem worse.

Fifteen years ago studies were conducted describing the heat stress problems encountered by Army air crewmen flying missions in hot climates. Following reports of heat stress in the OV-1 Mohawk reconnaissance aircraft during flights over Vietnam in June 1966, an Army study concluded there was a need for in-flight drinking water, increased cockpit ventilation, and lighter clothing to reduce crew discomfort and restore homeostatic conditions.<sup>15</sup> "Homeostatic Conditions" is a medical term used to describe normal body temperature without an artificially induced fever.

Another study was conducted by the Army to determine heat stress levels in the cockpit of the AH-1G Hueycobra helicopter.<sup>16</sup> This study concluded that an air conditioner is required for effective pilot performance in hot sunny environments.

As a result of these heat stress problems associated with previous aircraft, the AAH design incorporates an environmental control system (ECS). However, because of the high engine power and weight penalty associated with the addition of this type of system, it is only marginally acceptable in providing cooling for the crew in normal flight clothing, and is therefore inadequate for use with CB clothing. Cabin air temperature can be as high as 29.4°C (85°F), with dew point temperatures up to 15.6°C (60°F). These conditions coupled with a high solar heat load through the large transparent canopy require that practically all of the metabolic body heat of the flight crew be rejected by evaporation of perspiration from the skin surface. In standard flight clothing, the crewman might be expected to have the ability to open the clothing and enhance the evaporative heat loss to help maintain his body temperature at an acceptable level.

<sup>15</sup>R.J. Joy; Heat Stress in Army Pilots Flying Combat Missions in the Mohawk Aircraft in Vietnam; Aerospace Medicine, Vol. 38, No. 9, September 1967.

<sup>16</sup>J. Breckenridge and C. Levell; Heat Stress in the Cockpit of the Huey Cobra Helicopter; Aerospace Medicine, Vol. 41, No. 6, June 1970.

In practice this is seldom done by a helicopter crew because zipped up clothing is a major factor in survivability in the event of fire. When clothed in CB attire, the same situation exists, as well as increased chemical risk if the CB clothing is left unfastened.

The degree of body temperature rise which can be tolerated by the helicopter crew is less than can be tolerated by many other Army occupations, because of the high degree of visual acuity and quick reflexes required to fly an AAH mission. A helicopter crewman can suffer little degradation in performance due to heat stress without seriously jeopardizing the mission, the helicopter, and his life.

Another study conducted by the Army assessed heat stress problems of Combat Vehicle Crewman (CVC) in CB protective clothing.<sup>17</sup> This study concluded that without a means of active cooling, crewmen in combat vehicles in a hot environment will suffer significant heat stress casualties.

As a result of the above trend in increased awareness of potential thermal stress problems for the AAH crew, a thermal stress study was performed for the AAH crewmen as part of this study. The objectives were: To evaluate the present CB protective clothing over the anticipated mission profile, to compare the thermal stress of the crew in CB attire against the standard flight suit and other reference clothing ensembles, to identify thermal stress problems and evaluate potential solutions, and to recommend selected approaches. As a design goal, it was decided that the crew should be capable of performing the consecutive multiple combat flights of Section 1.(d)(1) without having to abort any part of the mission due to thermal stress.

<sup>17</sup>M. Herz, P. Brandler, A. Freeman, R. Byrne; Assessment of Chemical Warfare Protective Clothing; Natick/TR-80/002. Oct. 1979 AD-C022447L (Secret Report).

(c) THERMAL PROBLEM FACED BY THE EXISTING CB PROTECTION SYSTEM

(1) Heat Transfer Characteristics of the CB Protective Ensemble

While there are some options available in design details of the suit configuration expected to be available in the 1983-1985 time period, the heat transfer characteristics of the CB clothing are firm enough to proceed with a thermal analysis.

To evaluate the thermal stress effects of CB attire, it was necessary to compare the results of analysis conducted, using the same mission profile and environmental conditions, with various other clothing ensembles. Detailed descriptions of the existing CB protective systems are presented in Section 2.(c). Table 9 presents a description of the four clothing ensembles considered in the thermal stress analysis along with the clo and  $i_m/clo$  values for each. Also included are approximate values of solar heat load. The data contained in Table 9 were obtained from the U.S. Army Natick Research and Development Command and are consistent with their recent study of CB protection for Combat Vehicle Crewmen.<sup>18</sup>

As previously mentioned, it is assumed for the thermal analysis that full CB protective clothing including mask, hood, boots, and gloves are worn throughout the mission, since any mission phase may be subject to the CB threat.

<sup>18</sup>See reference 17, p.63.

TABLE 9 CLOTHING CHARACTERISTICS

	TROPICAL COMBAT UNIFORM	STANDARD FLIGHT SUIT	CB ATTIRE	IMPERMEABLE SUIT
<b>CLOTHING ENSEMBLE:</b>				
UNDERWEAR (T-SHIRT, DRAWER, SOCKS)	X	X	X	X
LEATHER BOOTS	X	X	X	X
HELMET	X	X	X	X
TROPICAL FATIGUES	X			
ONE-PIECE FIRE-RESISTANT COVERALLS		X	X	X
ARMORED VEST		X	X	X
NOMEX FLIGHT GLOVES		X	X	X
MASK AND HOOD		X	X	X
TWO-PIECE CHEMICAL PROTECTIVE OVERGARMENT (CHARCOAL IMPREGNATED)			X	
BUTYL GLOVES WITH COTTON LINERS			X	X
BUTYL FOOTWEAR COVERS			X	X
IMPERMEABLE BUTYL SUIT				X
<b>CHARACTERISTICS:</b>				
INSULATION RESISTANCE - CLO	1.43	1.74	2.64	2.64
$1 \text{ CLO} = 0.18 \frac{\text{M}^2 \cdot ^\circ\text{C}}{\text{KCAL/HR}}$ $\left( = 0.88 \frac{\text{FT}^2 \cdot ^\circ\text{F}}{\text{BTU/HR}} \right)$				
PERMEABILITY INDEX RATIO $i_m$ /CLO $i_m \approx 0.5$ FOR CLOTHED MAN $i_m = 0$ FOR NO EVAPORATION	0.34	0.21	0.10	0.05
SOLAR HEAT LOAD - WATTS (COMBAT MISSION PHASE)	128	110	65	65

(2) Thermal Mission Adopted For Purpose of Thermal Analysis

The AAH mission, for purposes of thermal stress analysis, consists of superimposing the helicopter environments of Section 6.(a) with the mission time line of Section 1.(d)(1).

The AAH "Standard Helicopter Combat Day" described in Section 1.(d) was used as the basis for thermal stress calculations. Mission phases with similar activity levels were grouped together to minimize the number of work periods that had to be considered. A summary of the mission phases is presented in Table 10.

For purposes of the thermal stress analysis, the mission begins after the preflight briefing, which is assumed to be conducted in a CB protected shelter location. The crew starts the mission fully dressed in CB protective clothing, since it is assumed that the point of departure is subject to CB attack. After transport to the helicopter, the crew performs a preflight checkout. During this checkout period the APU is operating and provides the cockpit with air conditioning. However, this period favors crewman cooling because preflight activity should include a walk-around, preflight inspection where APU operation will not assist in crewman cooling. Following checkout a combat flight is made, terminating at the FARRP for refueling and rearming. Up to six additional combat flights may be flown before returning to the debriefing area and decontamination. But to simplify the computer program analysis, only two consecutive combat flights were considered because, by the end of two flights, either the crewmen will reach an acceptable equilibrium condition that will be maintained throughout additional flights, or an unacceptable percentage of heat casualties will occur, making additional flights impossible.

Following the first combat flight, it was assumed that each crewman would remain in the air-conditioned helicopter cockpit while a ground crew performed

TABLE 10 . MISSION PROFILE FOR THERMAL ANALYSIS

MISSION PHASE/ACTIVITY	DURATION MINUTES	METABOLIC RATE WATTS	AIR VELOCITY M/SEC	AMBIENT CONDITIONS			
				HOT/DRY ENVIRONMENT TEMP - °F	RH - %	WARM/MOIST ENVIRONMENT TEMP - °F	RH - %
TRANSPORT TO HELICOPTER	15	30	0.3	120	5	100	85
CHECK-OUT - APU START TO ENGINE START ENGINE CHECK-OUT FLY TO COMBAT	85	109	1.0	85	14	85	42
COMBAT	44	130	1.0	85	14	85	42
FLY TO FARRP REARM & REFUEL FLY TO COMBAT	53	107	1.0	85	14	85	42
COMBAT	44	130	1.0	85	14	85	42
FLY TO FARRP	17	107	1.0	85	14	85	42
REARM & REFUEL BY FLIGHT CREW	20	816	0.3	120	5	100	85

the refueling and rearming. This favors crewman cooling, as in actuality at least one crewman will exit the aircraft to assess battle damage and to supervise rearming and refueling. However, following the second combat flight, it was assumed that each crewman left the cockpit and participated in the refueling and rearming task. This represents an estimated average thermal situation.

The performance of the .AAH environmental control system was obtained from Hughes Aircraft, and is fully defined in Section 6.(a). Temperature and humidity conditions for each mission phase are included in Table 10. They are presented for the two ambient design cases, hot/dry, and warm/moist. Both ambient environments were evaluated in order to understand the differences between them.

For mission phases where the crew is outside the helicopter an air velocity of 0.1 m/sec (0.33 ft/sec) was assumed, which represents still air with natural convection. In the cockpit, the environmental control system provides air at a velocity of approximately 1.2 m/sec (4 ft/sec). However, the crewmen are seated in chairs that surround them on three sides and they wear an armor chest plate, both of which shield a considerable amount of body area from air movement. For this reason, a reduced effective air velocity in the cockpit of 0.33 m/sec (1 ft/sec) was used. This is approximately equivalent from a heat transfer point of view to an air velocity of 1.2 m/sec (4 ft/sec) over half of the total body area. At any rate, air velocity does not have a large effect on body heat loss as will be discussed in detail later. Air velocities for each mission phase are shown in Table 10. It was assumed that all of the solar flux is transmitted through the canopy and none is reflected. The total solar heat load on the crewman is a function of the exposed projected body area, which was assumed to be equivalent to the crewman standing when



outside the helicopter and seated when inside with a solar angle of 60 degrees. In both cases, it was assumed the solar flux was on the profile rather than full face. Resulting values of solar heat load on the crewman are also a function of the clothing absorbtivity and transmittance as calculated by the computer program.

Metabolic heat rates for the activity levels associated with each mission phase were estimated by personnel from the U.S. Army Research Institute of Environmental Medicine, Natick, Massachusetts specifically for this study. These values are shown in Table 10 for each mission phase. Values used are consistent with those in the recent Army Combat Vehicle Crew CB Study.<sup>19</sup>

<sup>19</sup>See reference 17., p. 63.

(d) THERMAL STRESS ANALYSIS OF THE AAH FLIGHT CREW

(1) Thermal Stress Analysis Method Used

The best analytical method currently available for evaluation of thermal stress is the "Natick Thermal Stress Model" computer program. There is some concern over details which could affect its accuracy, but not to a degree which could affect the conclusions of the analysis.

An advanced version of the "Goldman Thermal Stress Model" developed at the U.S. Army Research Institute for Environmental Medicine at Natick was used to evaluate the thermal stress on the AAH crewman. The analytical techniques used, with the exception of solar radiation, are described in a paper by Berlin et al. (1975).<sup>20</sup> The effects of solar radiation and the methods of calculating these loads on the crewmen were presented by Breckenridge and Goldman at ASHRAE in 1972.<sup>21</sup>

The thermal stress model uses a Fortran computer program to determine body heat storage over any defined work period. It calculates the effect of heat storage on deep body (rectal) temperature and resultant heart rate, and then determines the percentage of thermal stress casualties based on these values. A "thermal casualty" is defined as a crewman who is physically incapacitated by body temperature to a degree that makes him unable to complete the mission.

The percent thermal casualties is directly related to rectal temperature, with negligible mission abortions at rectal temperatures below 38.8°C (101°F) and 100% mission abortions at a rectal temperature of 41.1°C (106°F). It is assumed that the percent of mission abortions (thermal casualties) increases linearly between these two values.

Net body heat gain is calculated by the computer program based on the balance between metabolic heat generation and heat exchange with the environment. The metabolic heat generation is a program input and is a function of activity

<sup>20</sup>H. Berlin, L. Stroschel /n and R. Goldman, A computer program to predict energy cost, rectal temperature, and heart rate response to work, clothing and environment. ED-SP-75011, Edgewood Arsenal, Aberdeen Proving Ground, Maryland, November 1975. AD-A026 112.

<sup>21</sup>J. Breckenridge and R. Goldman, Human solar heat load. Presented at ASHRAE Semi-annual Meeting. New Orleans, Louisiana. Paper No. 2218, January 1972.

level. Heat exchange with the environment includes convection, radiation, and evaporative heat transfer. Convective heat transfer is the loss or gain in heat from the body surface through the clothing (by conduction) to the ambient air flowing over the body at a given velocity. The rate at which heat is transferred is a function of the insulating properties of the clothing expressed in units called "clo", the ambient air temperature, and air velocity.

Radiation heat gain consists primarily of a solar heat load through the helicopter canopy. Direct, diffused, and terrain-reflected sunlight as well as solar angle, crewman's position and orientation to the sun are considered.

Evaporative heat loss considers the amount of heat transfer by evaporation of perspiration from the body surface. The rate of evaporation is a function of the permeability ( $i_m$ ) of the clothing.

A series of work and rest periods was constructed that represents as nearly as possible the AAH mission. The calculated values of rectal temperature, heart rate, and percent casualties are then plotted. One program limitation that became evident during this study was the inability of the program to connect work periods without introducing intermediate rest periods. This is necessary to allow calculated body conditions to stabilize in the computer before the next transient condition is started.

In addition, some work periods were extended by the program in order to stabilize conditions that resulted from previous work periods. This artificial modification in the mission time line in order to use the analytical program available is discussed more thoroughly in Section 4.(e).

Another possible limitation of the program is the basis of the analysis on rectal temperature only, without regard to how long this rectal temperature has existed. It appears logical that there should be some effect of the

duration of the fever included in the casualty analysis. That is to say, an induced fever of 38.8°C (101°F) should be considered much more damaging to the pilot's capabilities if it lasted three hours than if it lasted one hour. This is not the case in the present analysis, and so it is concluded that the program results could be quite optimistic. Since the conclusion is reached that supplementary cooling is required, the optimism of the calculation has no significance.

A list of computer program inputs is shown in Table 11.

TABLE 11 COMPUTER PROGRAM INPUT DATA REQUIRED

<u>INPUT PARAMETERS</u>	<u>UNITS OF INPUT PARAMETERS</u>
<b>AMBIENT CONDITIONS:</b>	
DRY BULB TEMP	°C
RELATIVE HUMIDITY	%
SOLAR HEAT LOAD	WATTS
AIR VELOCITY	M/SEC
AIR VELOCITY MODIFIER FOR BODY MOTION	-
<b>HUMAN CHARACTERISTICS:</b>	
HEIGHT	CM
WEIGHT	KG
BODY SURFACE AREA	M <sup>2</sup>
POSTURE	-
<b>MISSION CONDITIONS:</b>	
METABOLIC RATE	WATTS
GEOGRAPHICAL LOCATION	-
SOLAR ANGLE	-
ACCLIMATIZATION	DAYS
DURATION OF WORK PERIOD	MIN.
<b>CLOTHING ENSEMBLE:</b>	
INSULATION RESISTANCE	CLO
PERMEABILITY RATIO ( $i_m/clo$ )	1/CLO
<b>INITIAL CONDITIONS:</b>	
RECTAL TEMP	°C
HEART RATE	BEATS/MIN.
SKIN TEMP	°C

## (2) Computer Results of Thermal Stress Analysis

The use of existing individual CB protection systems were found by the analysis to result in an unacceptable number of heat casualties, particularly for consecutive multiple flights.

Computer cases were run for both ambient environments of Table 10 (hot/ dry and warm/moist), and for all four clothing ensembles of Table 9.

Conditions within the cockpit are design point conditions for the environmental control system and do not represent actual measured values. If these environmental control system design conditions are not met with actual hardware under actual operation, the cockpit environment will be more severe and the results of this study will be optimistic.

Summary curves of rectal temperature and casualty probability for all the cases run are shown in Figures 5 and 6. Figure 5 presents data on all four uniforms for the hot/dry environment, while Figure 6 presents the same data for the warm/moist environment. In either environment, the casualty probability is unacceptably high before the end of the second flight when the crew is in CB attire, indicating the need for supplemental cooling. The actual initial rate of climb for the rectal temperature will be higher than depicted here due to walkaround preflight inspection. The thermal stress problem will also be more severe than depicted after the first combat flight when one crewmember leaves the aircraft to assess battle damage and to supervise rearming and refueling.

The marginal design of the helicopter environmental control system is evidenced by Figure 6 where a small (5%) mission casualty probability is shown for the standard flight uniform buttoned up for flame resistance in the warm/moist environment. In this study, the standard flight uniform also included a CB protective mask and hood. Without wearing these items, the thermal casualty probability would be reduced to zero.

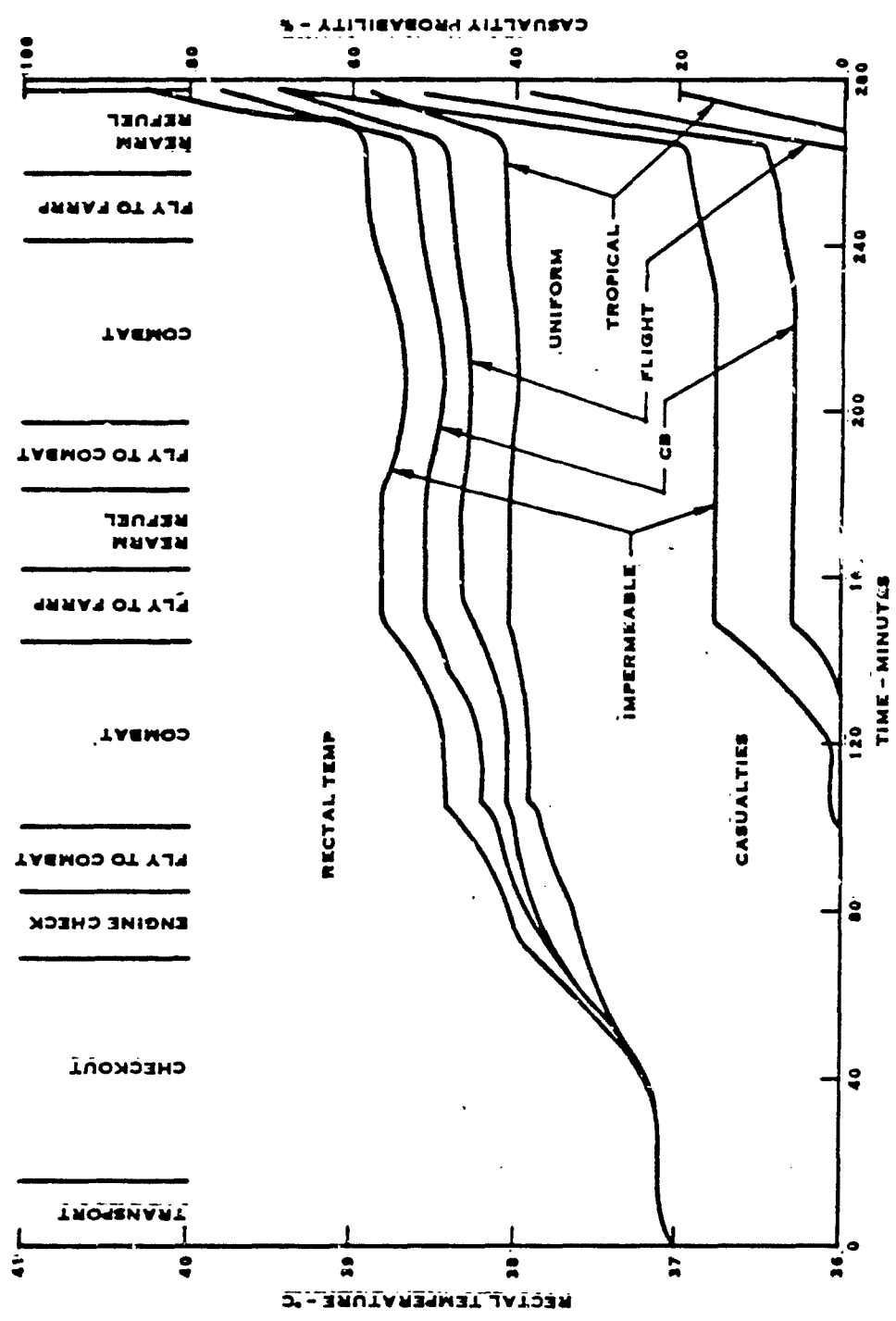

FIGURE 5 . . . COMPARISON OF UNIFORMS FOR HOT/DRY ENVIRONMENT

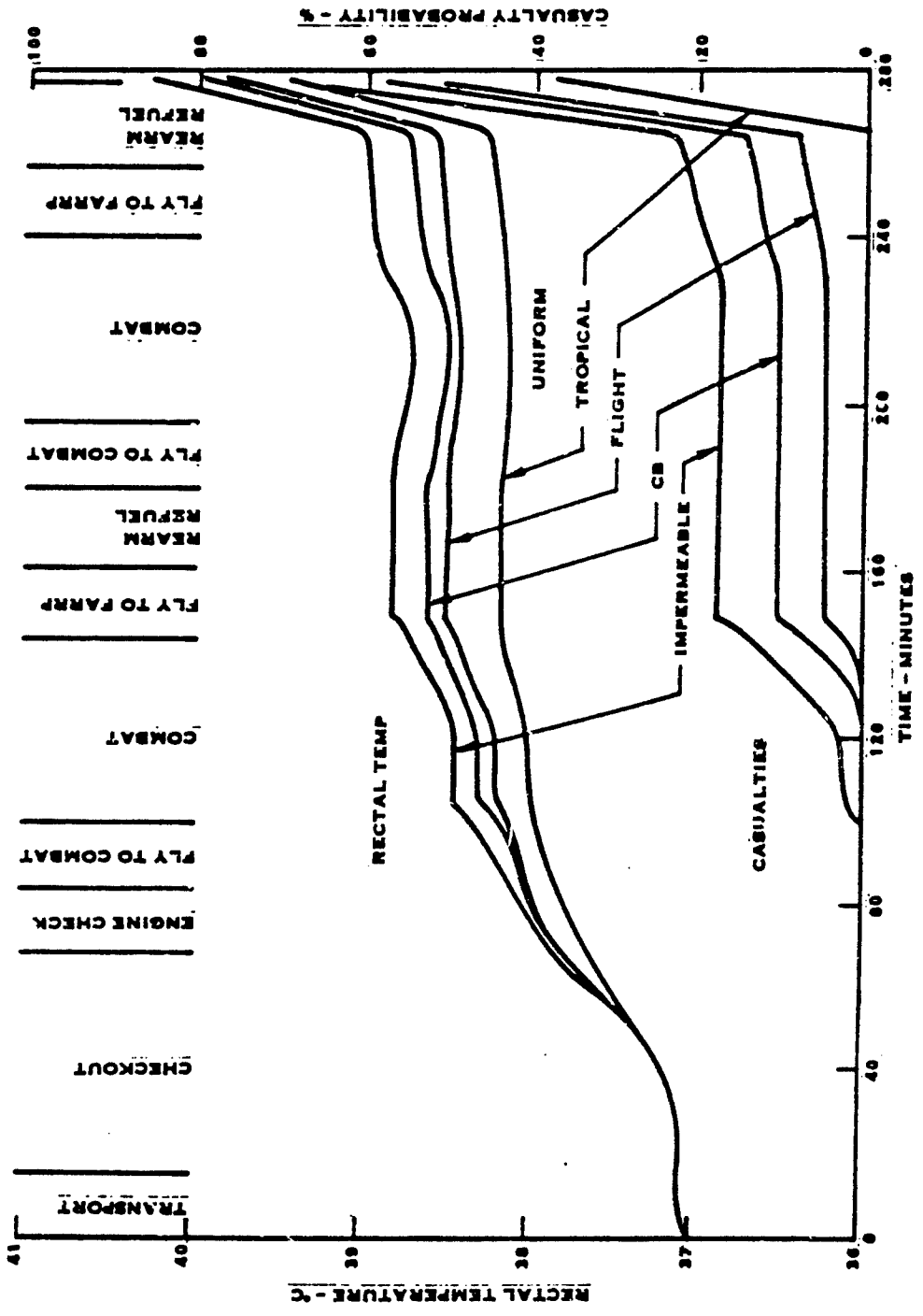

FIGURE 6 COMPARISON OF UNIFORMS FOR WARM/MOIST ENVIRONMENT



A hypothetical impermeable butyl suit was considered to assess the effects of reduced permeability on heat stress. The butyl suit would theoretically be less expensive, give greater CB protection, and would be easier to decontaminate. The results of this calculation are that the impermeable suit would have slightly higher (19% vs 11%) thermal casualty probability during the second consecutive flight due to zero evaporation of sweat.

The tropical combat uniform buttoned up for flame resistance was used for comparison purposes. It represents the coolest uniform from a thermal stress standpoint. No casualties are suffered in either environment through two consecutive flights with the crew in this uniform.

Figure 7 shows a comparison of the required heat rejection versus the heat loss capability of each clothing ensemble for the combat mission phase in the warm/moist environment. Since the majority of heat loss is by evaporation, the heat loss was plotted vs permeability ratio ( $i_m/clo$ ). As can be seen, both the impermeable suit and the CB attire fall far short of rejecting the required amount of heat. The difference between the required heat rejection and the clothing heat rejection capability is the rate at which heat is stored in the body. The curve also shows that the standard flight suit falls somewhat short of providing the required heat rejection if the crewman is masked. When the crew is unmasked, as would be the case in a non-CB theater, the standard flight suit would just provide the required heat rejection. The tropical combat uniform provides more than enough heat rejection. The variation in required heat rejection values is due to the different amounts of solar heat absorbed by each uniform. With the crew in CB attire, the rate at which heat is stored in the body is 111 watts during a combat flight. Heat will be stored at lesser rates during other mission phases. The heat

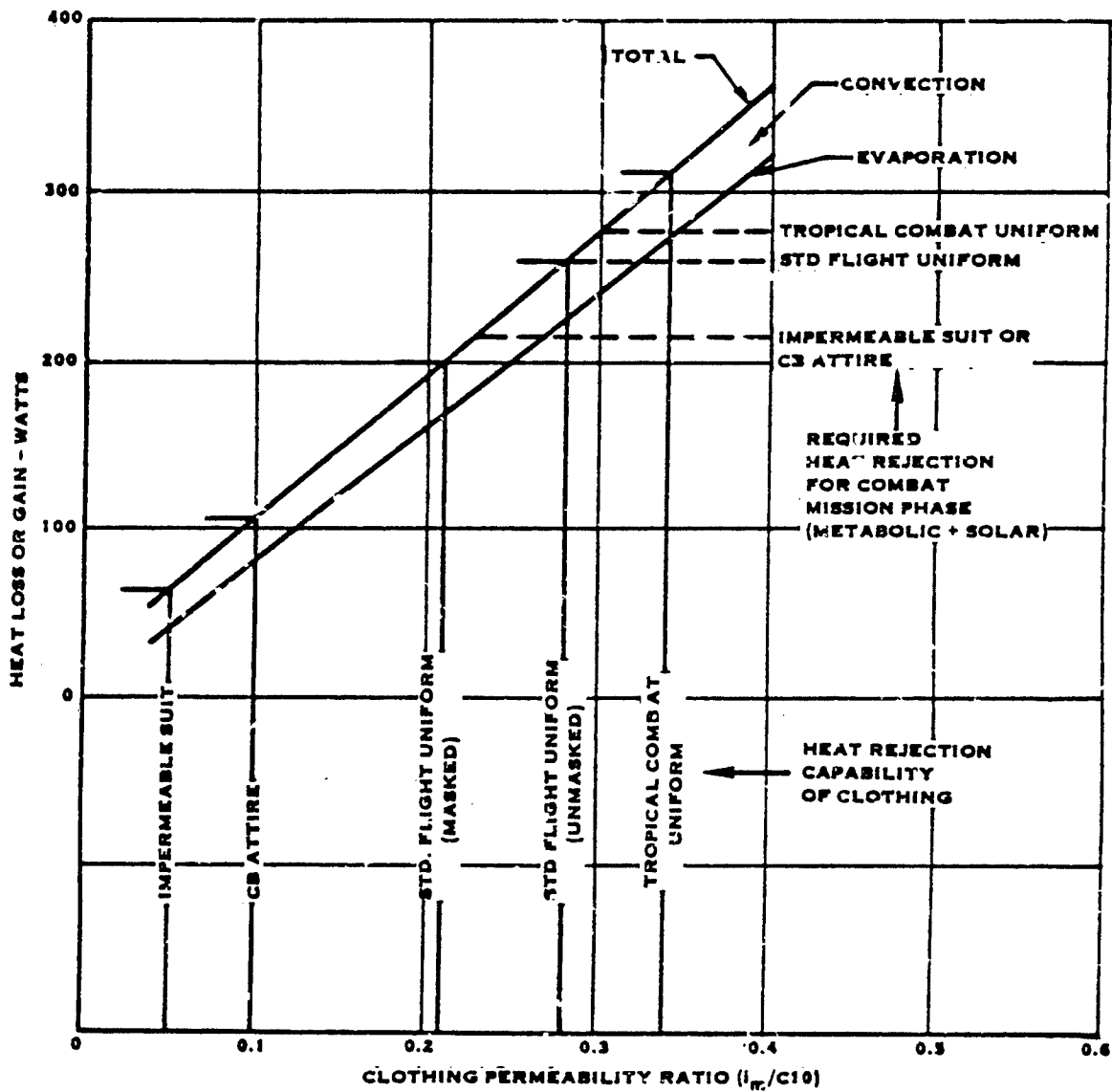

FIGURE 7 . COMPARISON OF HEAT REJECTION REQUIREMENT VS. CAPABILITY FOR A WARM/MOIST DAY

storage value of 111 watts is used in Section 6.(a) to establish requirements for supplemental heat rejection system designs.

In an effort to determine which parameters have the most significant effect on heat rejection, a sensitivity study was conducted with the crew in CB attire during a combat flight. Large changes were assumed in clothing and environmental parameters, each considered individually, and the improvement in heat rejection evaluated. Table 12 presents the results of this study. None of the changes come close to providing enough additional heat rejection to eliminate the body heat storage of 111 watts for this mission phase. In addition, the changes that provide the greatest improvement are not practical solutions. Therefore, it is concluded that the elimination of body heat storage can only be provided by the addition of a supplemental cooling means underneath the clothing next to the crewman's body.

In running the thermal stress computer program, a slight modification to the desired mission profile was necessary due to a peculiarity of the program discussed previously. This added 15 minutes to the desired timeline as shown on the actual computer generated plots included in Appendix B. This time difference is not significant from a thermal stress standpoint and will not change any of the conclusions of the study. Therefore, it was removed from all of the summary curves presented in this Section, and appears only in Appendix B.

**TABLE 12 . EFFECTS OF CLOTHING AND ENVIRONMENTAL CONDITIONS ON BODY HEAT STORAGE**

<u>CHANGE IN PARAMETER</u>	<u>HEAT REJECTION</u>	<u>REQUIRED HARDWARE CHANGE</u>
<b>CLOTHING</b>		
50% REDUCTION IN INSULATION - CLO FROM 2.64 TO 1.32 CLO	16	} { CHANGES WITHOUT REDUCING CB PROTECTION WOULD REQUIRE AN ADVANCE IN THE STATE OF THE ART OF CB PROTECTIVE CLOTHING DESIGN
100% INCREASE IN PERMEABILITY - $I_{cl}/CLO$ FROM 0.11 TO 0.22 1/CLO	81	
<b>ENVIRONMENT (WARM/MOIST)</b>		
25°F REDUCTION IN AIR TEMPERATURE FROM 85 TO 60°F	36	} { MAY REQUIRE TWICE THE COOLING CAPACITY OF ECU RESULTING IN LARGE WEIGHT AND POWER PENALTY TO HELICOPTER.
2.7°F REDUCTION IN DEW POINT FROM 66 TO 39°F	20	
400% INCREASE IN AIR VELOCITY FROM 1 TO 4 FT/SEC	3	IMPROVEMENT IS NEGLIGIBLE
100% REDUCTION IN SOLAR HEAT LOAD FROM 66 WATTS TO ZERO	65	} { WOULD REQUIRE REFLECTIVE COATING ON CANOPY. WOULD RESULT IN REDUCED NIGHT VISION AND LOSS OF CAMOUFLAGE. COATING REMOVED DURING DECONTAMINATION OR REFLECTIVE OUTER GARMENT.

BODY HEAT STORAGE DURING COMBAT IS 111 WATTS.

(3) Thermal Stress Increases with Crew Leaving Helicopter

Heat casualties will result even sooner if the AAH crew leaves the helicopter in CB attire for such activities as rearming and refueling between flights.

Following the second combat flight cycle, the crew leaves the helicopter to perform the rearming and refueling procedures themselves. As can be seen from Figures 5 and 6, extremely high casualty probabilities exist for all uniforms and both environments. In CB attire, the rectal temperature rises at a rate of  $0.105^{\circ}\text{C}/\text{min}$  ( $0.189^{\circ}\text{F}/\text{min}$ ). Over the rearm/refuel period of 20 minutes, this results in a total rectal temperature rise of  $2.10^{\circ}\text{C}$  ( $3.78^{\circ}\text{F}$ ). This is sufficient to cause significant thermal stress casualties (28%) even if the crew starts from a resting condition with a normal rectal temperature of  $37^{\circ}\text{C}$  ( $98.6^{\circ}\text{F}$ ). It is therefore, concluded that the flight crew is not capable of performing rearming and refueling tasks at the normal work rate, without raising body temperature to a degree that the mission will have to be aborted during the next flight. Likewise, ground crews face a similar thermal stress condition, which although not covered in this study, will have to be resolved in order to maintain scheduled turnaround time at the FARRP.

The flight crew is in much better condition to exit from the helicopter and participate in the rearming and refueling if supplemental cooling is provided in the helicopter. If the supplemental cooling means is sufficient to maintain a normal crewman body temperature before exiting, at the FARRP, and has the capacity to cool the body back down to normal following the rearming and refueling procedure, the crewmen can participate in this operation at metabolic rates up to 330 watts for the 20-minute period.

(4) Effect of Moisture in the Ambient on AAH Thermal Problem

There is not a significant difference to the flight crew between the two hot day critical environments, the hot/dry environment or the warm/moist environment.

Figure 8 , shows a body temperature comparison between the two environments with the crew in CB attire. The actual initial rate of climb for the rectal temperature will be higher than depicted here due to walk-around preflight inspection. The thermal stress problem will also be more severe than depicted after the first combat flight when one crewmember leaves the aircraft to assess battle damage and to supervise rearming and refueling. The differences between the two environments are small as evidenced by Figure 8 . This is because the crew spends most of its time in the cockpit, where the environment is conditioned. In the warm/moist ambient environment the cockpit humidity is slightly higher, resulting in slightly higher heat stress casualties due to the lower (22%) evaporative cooling potential. However, at the activity levels considered, the difference is small. In Figure 8, the rectal temperature curves are quite similar and the casualty probability is only slightly higher for the warm/moist environment (11% vs 8%).

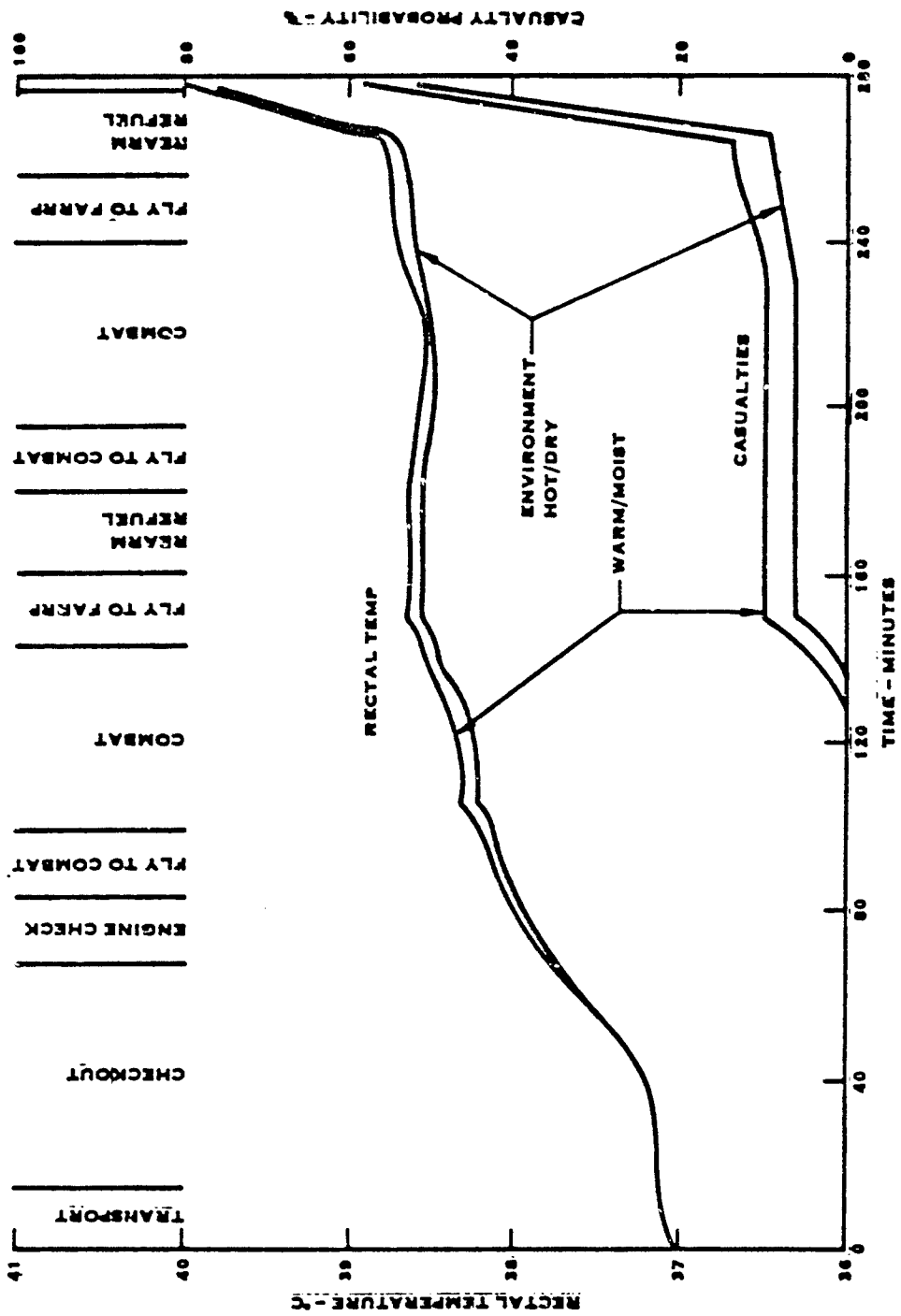

FIGURE 3 COMPARISON OF ENVIRONMENTS FOR CREW IN CB ATTIRE

(5) Unzipped Protective Suit, or New More Open Clothing For Reduced Thermal Stress

Unfastening and leaving open portions of the protective suit was considered as a method of reducing thermal stress where a collective system is used. This would require a collective CB protection system that maintains a positive pressure in the vehicle. Without positive pressure, the toxic vapor hazard in the vehicle will become equal to the hazard outside the vehicle.

If a collective CB protection system is used and the cockpit is free of CB agents, then the mask, hood and butyl gloves might be removed and the CB protective overgarment unzipped and loosened to improve evaporative heat transfer. This would reduce the thermal casualty probability somewhat. However, since cooling is marginal with the standard flight suit, it is apparent that an unacceptably high number of thermal stress casualties would still exist, and the resulting reduced individual chemical protection even inside a cockpit with collective protection is assumed to be an unacceptable risk.

The present CB attire was designed for an infantryman operating outdoors. In the helicopter cockpit, the concentration of CB agents will be considerably lower than outdoors. Therefore, it might be possible to design a new protective clothing ensemble that provides a lower but adequate level of protection for the crew in the cockpit, and that will also allow for improved cooling and eliminate the need for a liquid cooled vest. Additional chemical protection would then have to be provided for operations outside the helicopter. One way would be to use a lightweight, disposable, impermeable attire thrown over the pilot as he goes to and from the helicopter. The trouble with this solution is that it compromises chemical safety, and furthermore causes psychological problems as well. It would appear that the very high risk to which helicopter pilots are already exposed makes such a solution inappropriate, but this is a judgment and not amenable to analysis. The development of such disposable attire for evaluation should certainly be considered.



(e) EVALUATION OF ALTERNATE APPROACHES TO PROVIDING ADEQUATE FLIGHT  
CREW COOLING

(1) Candidate Cooling Options

Various approaches to flight crew cooling were considered such as lowering the helicopter cabin temperature, cooling the hood vs. cooling the torso by a vest, liquid coolant vs. air coolant, and so on.

The brute force approach of lowering cabin temperature to about 18°C (65°F) was considered. Unfortunately the helicopter crew is in a plastic bubble "greenhouse", with transparent surfaces almost down to waist level. Also, armor plate sections which are positioned to provide as much protection as possible from flying metal objects also prevent large portions of the body from receiving air motion created by the ECS. These dead-air spaces would be still in direct sunlight, and clothing surface temperatures would be warm to the touch. Also the armor plate would bake in a closed, parked helicopter and would reach about 54°C (130°F). The crew would then get into the cabin, sit on, and be surrounded by this heavy weight of hot armor.

Analysis shows the cooled cabin approach to be already marginal at best. In addition, comments of crewmen dressed in CB protective equipment indicate severe body temperature problems in transport aircraft, which do not have nearly as complete a greenhouse effect and no local hot armor. The brute force approach of very low cabin temperatures is deemed unacceptable.

Cooling of the hood, that is to say portions of the head and neck, were also considered. Obtaining steady contact between the skin and liquid-cooled garment surface is next to impossible in this part of the body because of flexibility and bending in the neck area. Also, calculation shows that there would be insufficient contact area available to remove the desired amount of localized heat without causing an extremely cold neck. Direct air cooling with dry clean air is a more practical approach for the neck area. This is because direct contact of air with the body will cool by evaporation

of perspiration, which of course would not take place using a member between the skin and a cooled garment surface. Unfortunately a supply of cool dry air, completely clean of chemical agents is not available. A new and separate CB filter system just for a cooled hood would be large, bulky, wasteful of fan pumping power and would involve chemical risk. Also, it could provide chemically dangerous openings for agents to enter when the crew is disconnected from the system.

By cooling only the torso, or chest, there would be sufficient area to cool the body without excessively low skin temperature. The chest has no joints, so that the only flexibility required in the vest would be in the direction of increasing and decreasing diameter of the chest caused by breathing. This may be easily accomplished by an elastic section, thus allowing the heat transfer portion to be non-stretch plastic with liquid-cooled panels.

Air cooling rather than liquid cooling is a possibility for the vest, but again would have to be open loop, and thus would require a new and separate CB filter system. A closed-loop air system is prohibitively large, since a pound of air has about 100 times the volume of a pound of water. An air-cooled vest also has a problem when the coolant flow is inoperative or not connected, because the man wearing the vest would then have another excellent insulation gap around his chest, further reducing his ability to reject heat. The liquid-cooled vest has 23 times the conductivity of the air-cooled vest, when there is no coolant flow. Furthermore, although it is not needed for the AAH, the liquid concept lends itself quite well to future development such as using a self-contained icepack outside the helicopter.

The air-cooled suit using direct contact with the body and evaporative cooling does have the disadvantage of a fan and filter, but on the other hand it has a potential advantage for the wearer to enjoy prolonged periods outside the AAH. This

potential advantage is that the evaporative cooling feature makes it possible to cool with ambient air directly, with no refrigeration required. Since operation outside the AAH would be of relatively short duration for the AAH crew, and since refrigeration is already available inside the AAH, this potential advantage would be of little value. However, the air-cooled suit might be advantageous with infantry or other vehicles, and may have other potential applications where refrigeration is not available.

A summary of the above discussion and rationale for selection of the liquid cooled vest for AAH is presented in tabular form on Table 13.

	AIR COOLED UNDERGARMENT				LIQUID COOLED UNDERGARMENT COOLING BY CONDUCTION THROUGH IMPERMEABLE MEMBRANE
	AIR CONTACT WITH BODY - EVAPORATIVE COOLING		COOLING BY CONDUCTION THROUGH IMPERMEABLE MEMBRANE		
	OPEN LOOP	CLOSED LOOP	OPEN LOOP	CLOSED LOOP	
THERMAL PERFORMANCE	BEST	BEST	WORST	WORST	GOOD
CHEMICAL SAFETY	FAIR	FAIR	BETTER	BETTER	BEST
SIZE AND WEIGHT OF AAH PORTIONS OF SYSTEM	BIG	BIGGER	BIGGEST	BIGGEST	SMALLEST

88 >

TABLE 13 COMPARISON OF AAH COOLING CONCEPTS FOR PERSONAL CB UNDERGARMENT

## (2) Selection of Liquid-Cooled Vest Design Parameters

The liquid-cooled vest approach would provide each crewman with a simple liquid transport garment worn under the uniform which conductively cools the torso. Liquid would circulate through flexible umbilicals from the vest to a heat exchanger in the helicopter environmental control system where heat is rejected to the cockpit cold air supply. Temperature control would be provided by a normal diverter valve located in the umbilical near each vest. The valve would allow liquid to flow through or bypass around the vest. This method of temperature control is simple and reliable. A quick disconnect would provide the interface between the umbilical and the vest. Liquid cooling would provide full protection against CB agents, since there is no communication with the environment. Water, with perhaps some propylene glycol for protection against freezing, would be the best choice for a cooling fluid from a heat transport standpoint. It would provide the most cooling with the least flow requirement and is readily available.

A liquid-cooled vest suitable for this application is currently under development at the U.S. Army Natick Research and Development Command. (See Appendix A.) It is constructed of six-mil-thick polyurethane coated-nylon, with heat-sealed flow paths. The material is not bulky and is highly flexible allowing it to conform easily to the body for comfortable wear and effective heat transfer. A description of the equipment that must be added to the helicopter to support the liquid cooled vest is provided in Section 6.(b).

Figure 9 shows curves of heat rejection for the vest and also for a cooled vest plus cooled hood vs water inlet temperature with a water flow rate of 24 kg/hr (53 lb/hr). This testing was conducted by the U.S. Army Research Institute of Environmental Medicine, Natick, Massachusetts using a copper mannequin to simulate the crewman clothed in full CB protective attire.

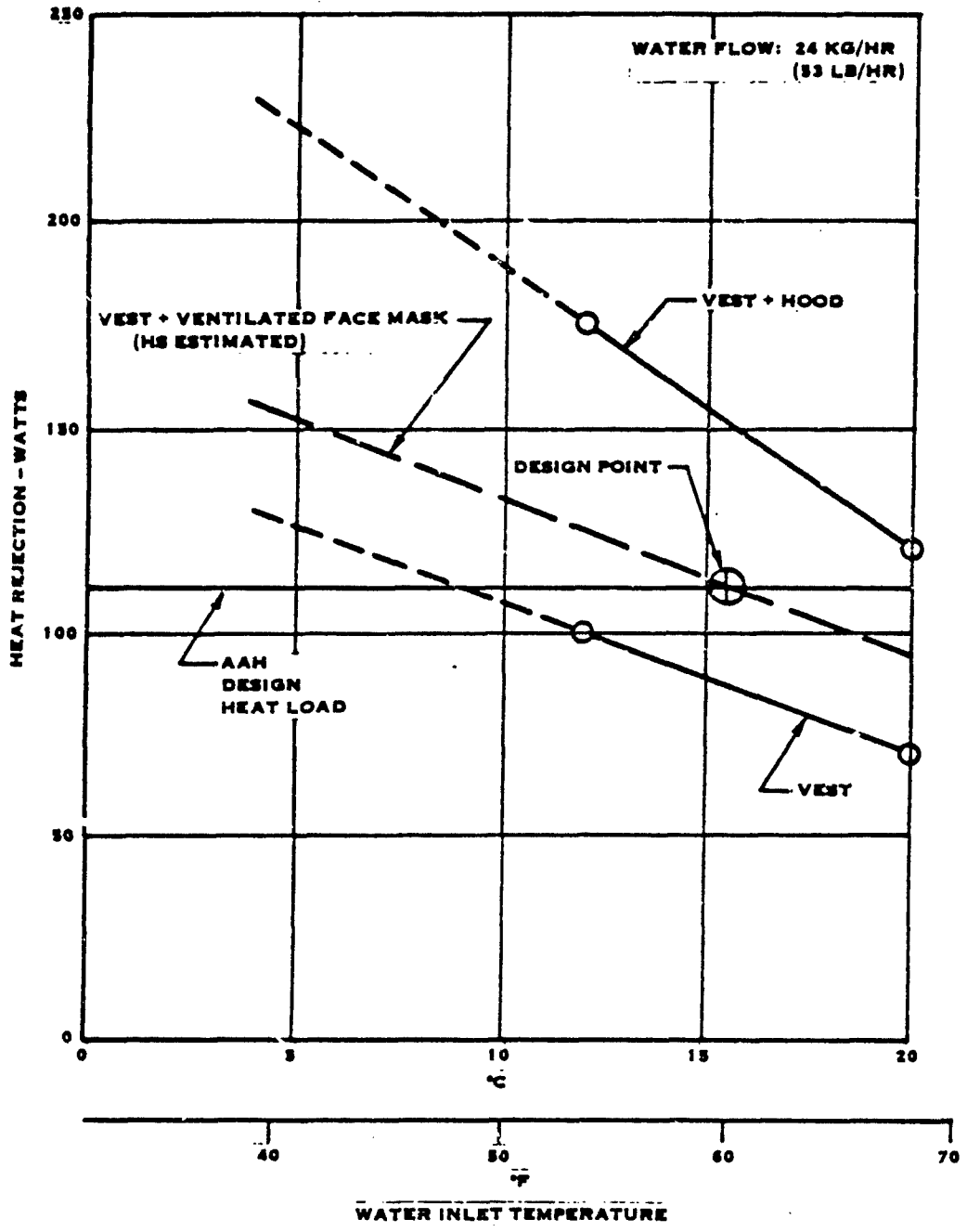

**FIGURE 9 . LIQUID COOLED GARMENT PERFORMANCE**

Also included in Figure 9 is an estimated heat rejection curve for the vest alone, and a curve showing the expected cooling provided by the ventilated face mask. The cooled vest plus ventilated face mask has almost as much heat removal as the cooled vest plus cooled hood and is much easier to implement on the AAH.

The baseline cooling design point for the liquid cooling loop in the helicopter was taken from Figure 9 for the vest plus ventilated mask. This design point heat load for the AAH crewman is 111 watts (see Section 4.(c)(2). This requires a water inlet temperature into the vest of 15.6°C (60°F).

(3) Liquid-Cooled Vest Development Growth Potential for Use Outside AAH

The liquid-cooled vest concept enables development of a self-contained unit, using an ice pack or other compatible heat sink for extended periods outside the helicopter. The same liquid-cooled vest recommended here for use in the AAH helicopter can also be used when crewmen are outside the helicopter performing rearming and refueling tasks, when in transit to or from the helicopter, and during briefing and decontamination operations.

There are a number of heat sinks, compatible with the liquid-cooled vest, presently under investigation by the U.S. Army Natick Research and Development Command for combat vehicle crewmen. These include small Freon refrigeration systems that can be used within a vehicle, while operating from vehicle power. These units can service up to four crewmen. Also under investigation is an individual ice pack that can provide up to two hours of cooling outside the vehicle.

Another possibility to extend the crew's usefulness outside the helicopter would be to provide long umbilicals connected to liquid coolant ports on the external surface of the helicopter. This would allow the crewmen to leave the cockpit, close the door to prevent CB agents from entering the cockpit and perform tasks at reasonably high activity levels in the immediate vicinity of the helicopter.

This subject of cooled vest development potential deserves future attention, but is not within the scope of this present study of AAH CB protective systems.



## 5. CREW SAFETY VERSUS CB PROTECTION LEVEL

There are two threats to helicopter crew safety in a CB environment; one is the direct poisoning action of the CB agent, the other is degeneration of functional capability caused by inability to reject body heat.

The direct poisoning action of CB agents is discussed in Sections 1. to 3. The net result is that the crew must have both the mask and suit on for safety outside the helicopter. Inside a clean helicopter, the use of mask alone has risk but is probably acceptable. However, since there is no practical way to get the suit on and off inside the helicopter, the crew is forced to have the suit on inside the helicopter as well. The safety of mask alone in the helicopter becomes a moot point once it is concluded that the suit is needed anyway for operation outside the helicopter.

The inability of the crew to adequately reject body heat in CB clothing has been well known for years, but an exact evaluation is made difficult by the following variables:

1. There is a considerable range of thermal tolerances between individuals.
2. There is a considerable thermal tolerance range for the same individual, due to health, diet, and fatigue factors.
3. Cooling capacity of the porous suit is very much a function of "pumping" dry air in and saturated air out of the suit, by body motion and local wind level.
4. There are undoubtedly individual differences in characteristics of suit material such as pressure drop, wettability, surface tension of the fibers, previous cleaning practices, previous exposure to sweat, and so on.

In spite of the above variables, the analysis of the crew body heat rejection problem described in Section 4 of this report is adequate to make a crew safety evaluation, and the net result is that supplemental cooling for the crew is essential. There is considerable inaccuracy in predicting exactly how long the average pilot can withstand an artificially generated fever before his reduced physical responses represent an unacceptable risk, but this study concludes that this is a moot point. Since cooling is necessary it would be foolish not to provide enough. The cooled vest provision resolves the problem regardless of the uncertainty regarding the severity of the problem.

A summary chart of crew safety versus the various potential change level options to the helicopter is shown in Table 14. Note that the shaded entries on the table are unacceptable from a safety standpoint. If a particular defense category is unacceptable from the chemical safety standpoint, it is of no consequence if it is acceptable in thermal safety. Likewise, if a particular category is unacceptable from a thermal safety standpoint, it is of no consequence if it is acceptable in chemical safety. There are shaded entries in the "mask only" column of Table 14, and also shaded entries in the "mask plus suit" column. Only the column labeled "mask plus suit plus cooled vest" is acceptable from a safety point of view, and each change step to the helicopter improves safety so that the lower right hand corner of Table 14, is preferred for safety.

TABLE 14. FLIGHT CREW SAFETY VS. CB PROTECTION LEVEL

CHANGE "STEPS" TO HELICOPTER TO REDUCE CB HAZARD		FLIGHT CREW SAFETY LEVEL									
STEP #	DESCRIPTION OF STEP	SAFETY CATEGORY	MASK ONLY		MASK PLUS SUIT			MASK PLUS SUIT PLUS COOLED VEST			
			OUTSIDE HELICOPTER	INSIDE HELICOPTER	OUTSIDE HELICOPTER	INSIDE HELICOPTER	OUTSIDE HELICOPTER	INSIDE HELICOPTER	OUTSIDE HELICOPTER	INSIDE HELICOPTER	
01	HELICOPTER AS IS	CHEMICAL	CHEMICAL CASUALTY	SAFE USUALLY IF CABIN CLEAN	ACCEPTABLE	ACCEPTABLE	ACCEPTABLE	ACCEPTABLE	ACCEPTABLE	ACCEPTABLE	ACCEPTABLE
		THERMAL	—	—	ACCEPTABLE ON HOT DAY FOR SHORT PERIODS ONLY	MISSION ABORTED DUE TO THERMAL STRESS	—	—	—	—	—
02	SUIT COOLING PROVISION ADDED	CHEMICAL	CHEMICAL CASUALTY	SAFE USUALLY IF CABIN CLEAN	ACCEPTABLE	ACCEPTABLE	ACCEPTABLE	ACCEPTABLE	ACCEPTABLE	ACCEPTABLE	ACCEPTABLE
		THERMAL	—	—	ACCEPTABLE ON HOT DAY FOR SHORT PERIODS ONLY	MISSION ABORTED DUE TO THERMAL STRESS	ACCEPTABLE	ACCEPTABLE	ACCEPTABLE	ACCEPTABLE	ACCEPTABLE
03	VENTILATED MASK PROVISION ADDED	CHEMICAL	CHEMICAL CASUALTY	SAFE USUALLY IF CABIN CLEAN	ACCEPTABLE	ACCEPTABLE	ACCEPTABLE	ACCEPTABLE	ACCEPTABLE	ACCEPTABLE	ACCEPTABLE
		THERMAL	—	—	ACCEPTABLE ON HOT DAY FOR SHORT PERIODS ONLY	REDUCED THERMAL STRESS, BUT MISSION STILL ABORTED	ACCEPTABLE	ACCEPTABLE	ACCEPTABLE	ACCEPTABLE	ACCEPTABLE
04	COLLECTIVE FILTER SYSTEM ADDED, VENTILATED MASK "OFF"	CHEMICAL	CHEMICAL CASUALTY	SAFER THAN ABOVE	ACCEPTABLE	ACCEPTABLE	ACCEPTABLE	ACCEPTABLE	ACCEPTABLE	ACCEPTABLE	ACCEPTABLE (WITH ALARM) IF CABIN CLEAN AT START
		THERMAL	—	—	ACCEPTABLE ON HOT DAY FOR SHORT PERIODS ONLY	REDUCED THERMAL STRESS, BUT MISSION STILL ABORTED	ACCEPTABLE	ACCEPTABLE	ACCEPTABLE	ACCEPTABLE	BEST
05	COLLECTIVE FILTER SYSTEM ADDED, VENTILATED MASK "ON"	CHEMICAL	CHEMICAL CASUALTY	SAFER THAN ABOVE	ACCEPTABLE	ACCEPTABLE	ACCEPTABLE	ACCEPTABLE	ACCEPTABLE	ACCEPTABLE	BEST, LEAST CABIN DECON EFFORT NECESSARY
		THERMAL	—	—	ACCEPTABLE ON HOT DAY FOR SHORT PERIODS ONLY	REDUCED THERMAL STRESS, BUT MISSION STILL ABORTED	ACCEPTABLE	ACCEPTABLE	ACCEPTABLE	ACCEPTABLE	ACCEPTABLE

6. EFFECT OF IMPROVING AAH CE DEFENSE ON AIRFRAME AND SYSTEMS

(a) DESCRIPTION OF CURRENT AND ENVIRONMENTAL CONTROL SYSTEM

Environmental control for the AAH cabin and electronics compartments is provided by an open air cycle refrigeration unit powered by the accessory drive gear box. It is adequate for its original purpose of simultaneously providing crew cooling and adequate cooling for long avionics life, but adaptability to chemical warfare was not an original design consideration.

Major elements of the AAH Environmental Control System (ECS) are shown in the general view of Figure 10. Ambient air is drawn into the system inlet through a fuselage inlet and then into the air particle separator (APS) which is a multiple element type centrifugal dust separator. The air then enters the shaft driven compressor (SDC), which is a gear-box-mounted, single-stage centrifugal compressor, where it is raised to about 365 kPa (53 psia) and 232°C (450°F). The SDC does double duty, since it also serves as the compressed air source for the pneumatic turbine starter used to start the main helicopter engines. When the engines are not running, the gear box and SDC are driven by an on-board small gas turbine auxiliary power unit (APU). Thus the environmental control system is powered by the APU until the engines start, after which it is powered by the main engines.

The air, having been compressed by the SDC, then enters the Environmental Cooling Unit (ECU), which is a simple cycle turbomachine with a fully regenerative condenser for water separation. The turbomachine utilizes its cooling turbine power to drive a fan to pull ambient air through the ECU primary heat exchanger, and thus reject the compressor heat to the ambient air.

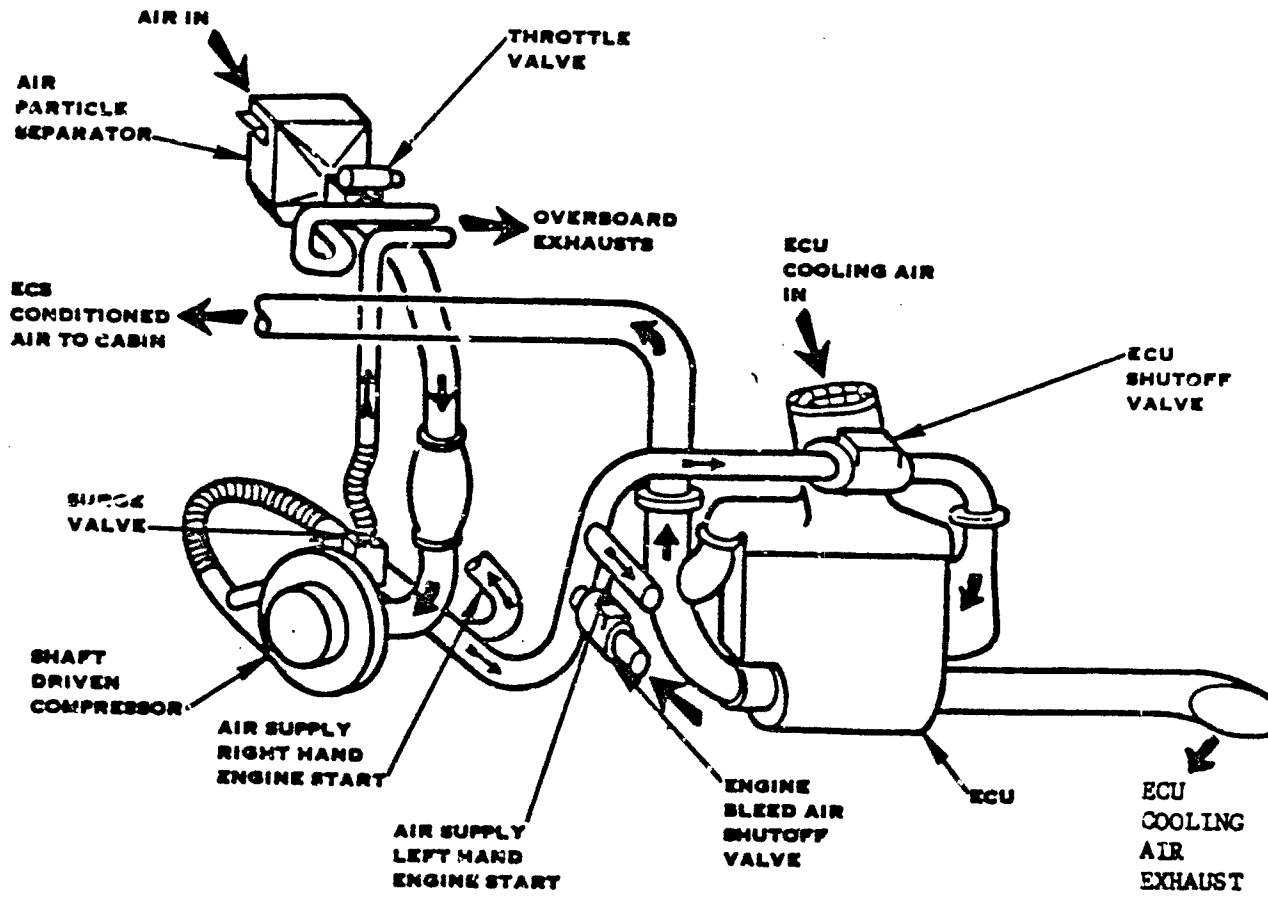

FIGURE 10 GENERAL VIEW OF CURRENT AAH ECS COMPONENTS

The cooling turbine discharge air is then mixed by the cabin supply air temperature control with hot compressor discharge air in whatever proportion is necessary to provide the cabin with the cabin supply air temperature selected by the crew.

The cooling system not only cools the cabin, but the forward avionics and turret compartment as well. The system is designed to obtain maximum utilization of available cooling capacity by utilizing cabin discharge air as the air inlet source for the equipment cooling fans. A schematic of the airflow paths of the current AAH is shown on Figure 11. In addition to being at a low temperature, the use of cabin discharge air also provides a dust and grit-free source of air for equipment cooling.

A view of the AAH helicopter showing the location of major elements of the existing ECS is shown on Figure 12.

Pertinent performance data on the system at its "pull down" design point, is as follows:

Ambient Inlet Conditions:

Ambient Absolute Humidity = 0.026 kg/kg

Air Flow Rate = 10.4 kg/min (23 lb/min)

Ambient Air Temperature = 37.7°C (100°F)

Cooling Unit Outlet Conditions:

Cabin Supply Absolute Humidity = 0.000857 kg/kg

Cabin Supply Air Dry Bulb Temperature = 9.2°C (48.5°F)

"Pull Down" Cooling Capacity (Ambient Minus Cooling Unit Outlet):

Q sensible = 4.98 kW (17,000 Btu/hr)

Q latent = 6.65 kW (22,700 Btu/hr)

Q total = 11.6 kW (39,700 Btu/hr)

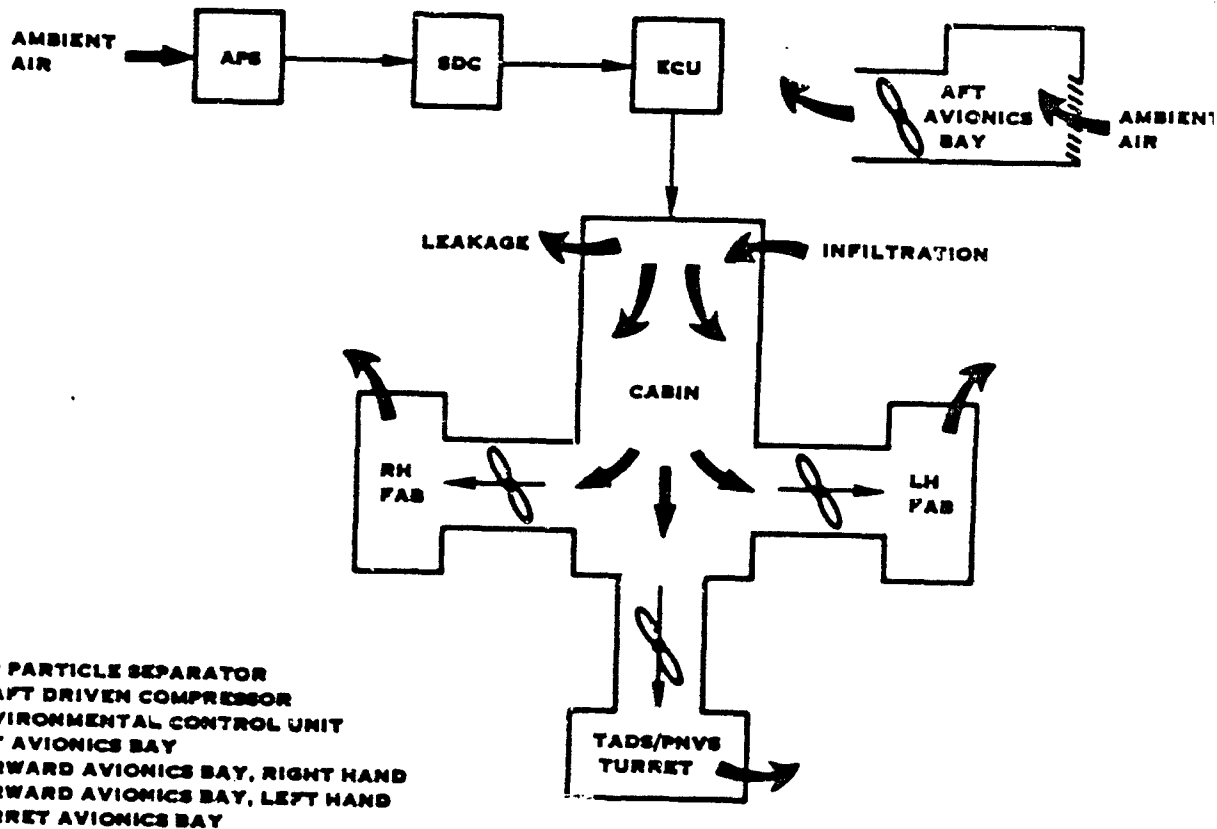

FIGURE 11 . CURRENT AAH AIRFLOW PATHS

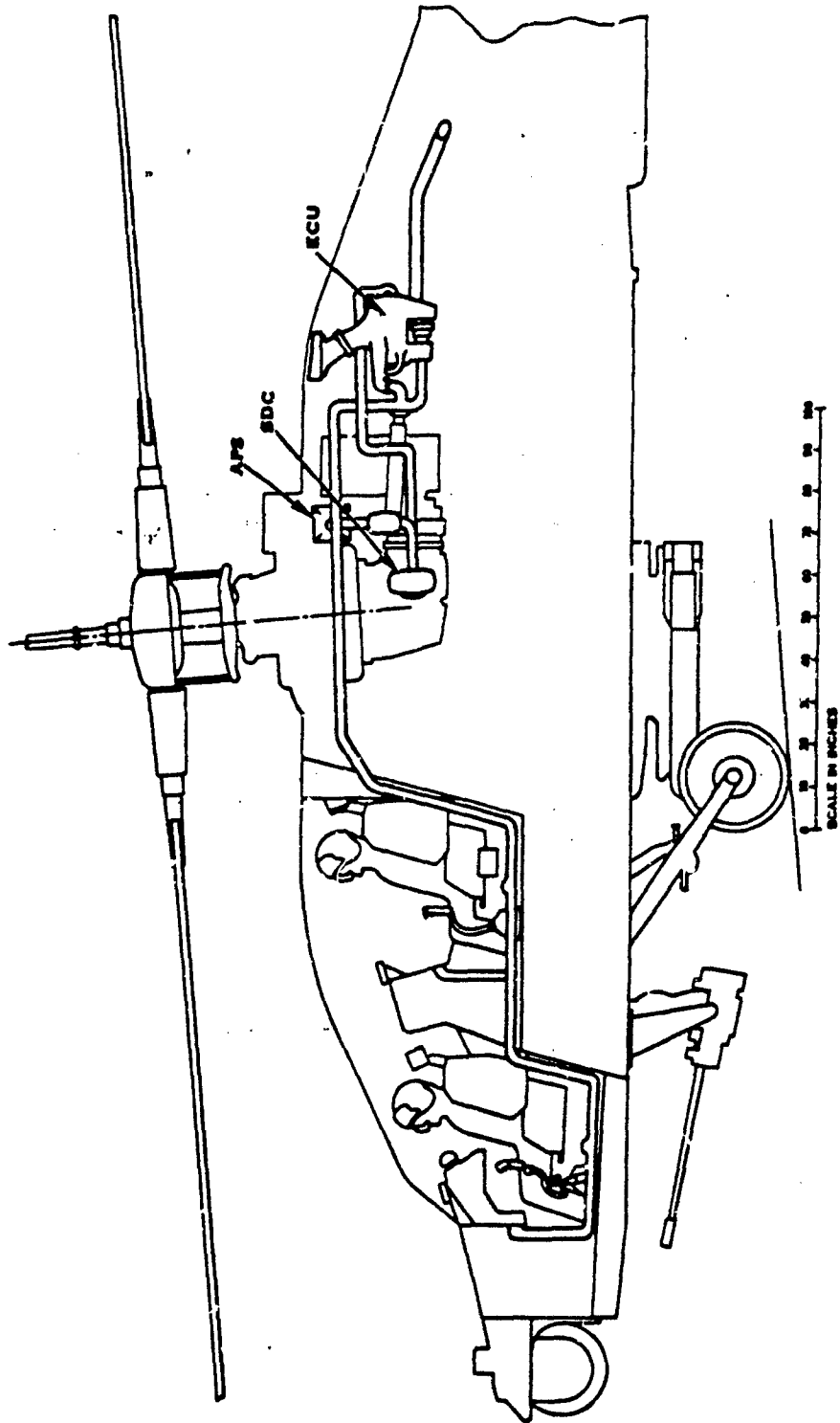

FIGURE 12 . LOCATION OF EXISTING ECS IN AAH HELICOPTER



Input Shaft Power:

SDC power used by ECU = 37.3 kW (50 shp)

SDC input shaft speed (uses integral single stage gear) = 12,250 RPM

The shaft driven compressor (SDC) weighs about 13.6 kg (30 lb), part of which is chargeable to the engine start system because of its dual role as a necessary part of the main engine starter.

The environmental control unit (ECU) weighs approximately 9 kg (20 lb), and has a total "pull down" cooling capacity of 11.6 kW (3.3 tons cooling). The resulting specific weight of the cooling unit of 0.77 kg/kW (6.1 lb/ton cooling) is extremely light, but as a result the power required to drive it is quite high, 37.3 kW (50 shp). The resulting coefficient of performance (COP) of the cooling system is about 0.31. Additional fuel flow consumed by the main engine to overcome the shaft power drain of the ECS is approximately 10 kg fuel per hr (22 lb fuel per hr).

(b) ADDITION OF CB SUIT COOLING FUNCTION TO THE ECS

Only a minor change to the current AAH environmental control system is necessary to use the existing cabin air supply duct as the cooling source for liquid cooled vests needed by the crew under their CB clothing.

The fact that the AAH already has a cabin cooling system makes the task of providing for the liquid cooled vests a relatively simple matter. Liquid returning from the suits is cooled by passing through a small liquid-to-air heat exchanger, mounted on a section of the cabin air supply duct, and then the cooled liquid is pumped back again through the vests. The AAH airflow paths with the suit cooling provision added are shown in Figure 13. For purposes of evaluating the feasibility and desirability of the concept, a preliminary design of such a liquid cooling system has been made. The purpose of this preliminary design was to obtain trade-off weights and costs, without optimizing design details. A cross-section of this liquid cooling unit is shown in Figure 14.

Referring to Figure 14, one notes that the system contains an independent liquid loop for each crewman. Each loop consists of a liquid-to-air heat exchanger, a coolant storage tank and fill cap, a recirculation pump, and the necessary fluid lines and fittings to interface with the cooling vest of the CB ensemble suited crewman. Coolant from the crewman enters the liquid cooling unit package at the coolant inlet header. As the coolant passes through the heat exchanger, it dissipates the crewman-induced heat load to the air circuit conductively through radial fins to the cabin supply air. The coolant then enters the coolant storage tank in which entrained gas bubbles are removed by gravity separation. After the coolant leaves the coolant storage tank, it passes through the centrifugal pump, which provides the motive force for coolant recirculation, and then returns to the crewman to complete the cycle.

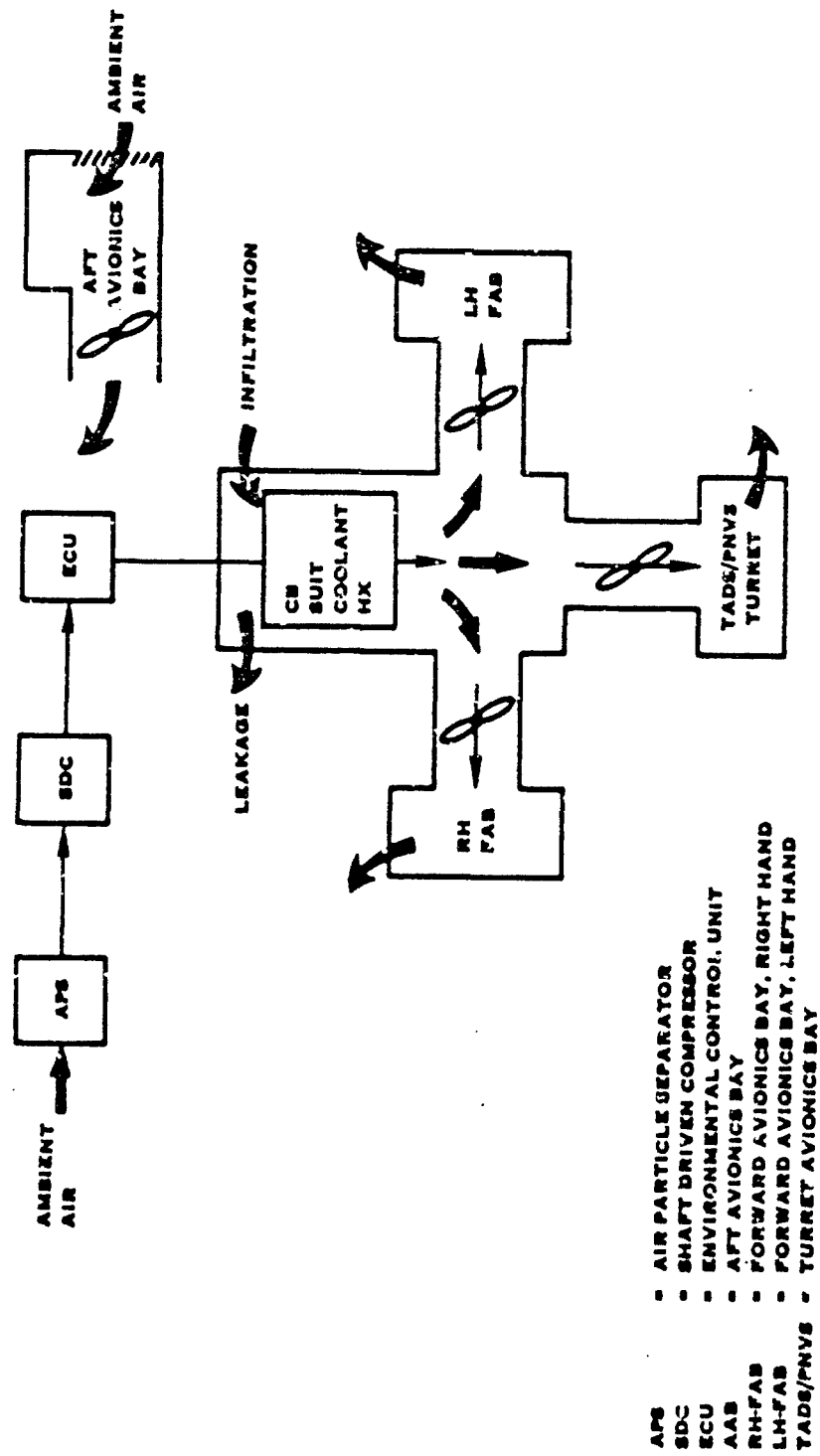

FIGURE 13. REVISED AAH AIRFLOW PATHS, CB SUIT COOLING PROVISION ADDED

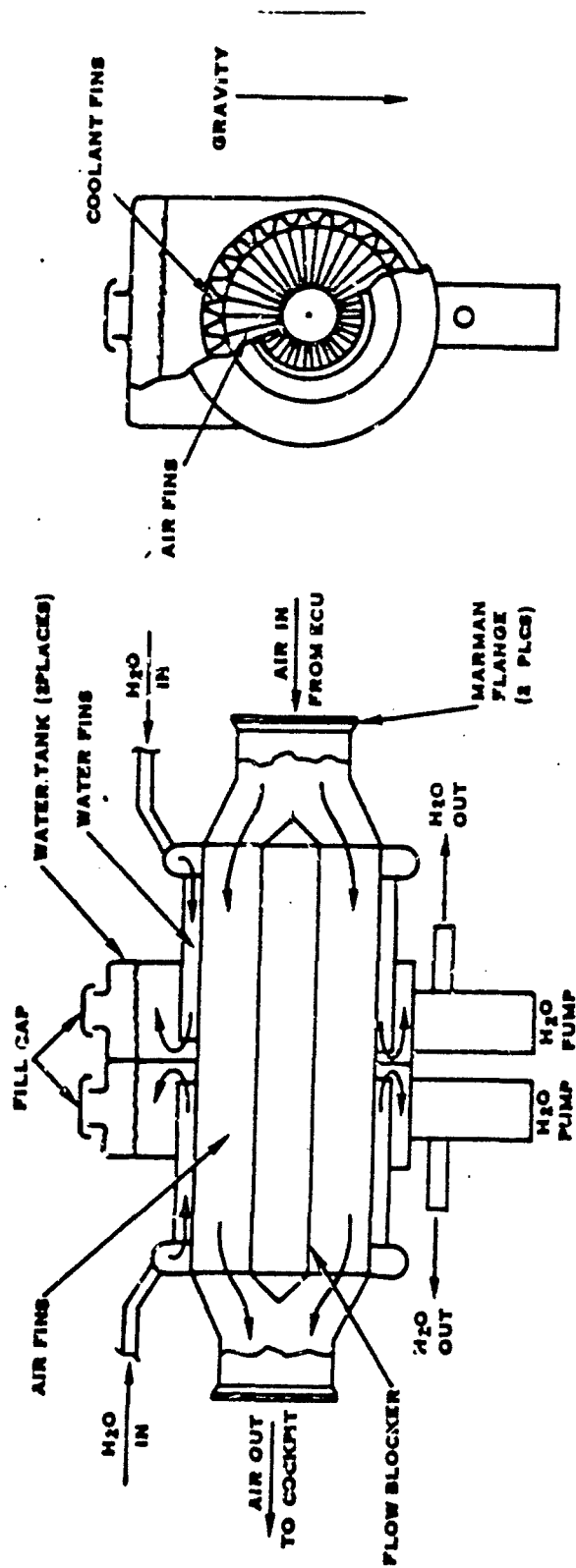

FIGURE 14 - LIQUID COOLANT/PUMP PACKAGE

Crewman thermal comfort is maintained by a manually operated liquid bypass control valve located at the cooling vest quick disconnect. The valve allows the crewman to bypass any desired portion of the coolant flow around the cooling vest as a function of heat load. In addition, the crew can select any desired cabin air supply temperature, as described in Section 6.(a).

The liquid cooling unit is conceived as an integrated package assembly. The package structure is formed from the combination of the two liquid-to-air heat exchangers and the two coolant storage tank assemblies into a composite brazed and welded aluminum unit. The package located in the cooled air makeup line to the cockpit downstream of the Environmental Control Unit (ECU), is line-mounted via Marman flanges at each end of the air side portion of the heat exchanger. The cooling unit package location in the helicopter is shown in Figure 15.

The unit is sized to dissipate a maximum heat load of 110 watts (378 Btu/hr) per crewman. For this condition, the cabin supply air side temperature rise is 1.6°C (3°F) total for both heat exchangers at sea level hot day. Cabin supply air flow is 23 PPM with a heat exchanger inlet air temperature of 1.7°C (35°F).

A cooling turbine discharge air temperature of 1.7°C (35°F) is used, rather than the 9.2°C (48.5°F) value of Section 6.(a) because the fresh air latent load is reduced to 25% of the present latent load by use of cabin air recirculation, as described in Section 6.(d)(3). Even considering the pressure drop of a collective filter at the SDC inlet and a liquid heat exchanger at the ECU discharge, the ECU discharge temperature is capable of being as low as the automatically controlled lower temperature limit of 1.7°C (35°F) to prevent ice.

The unit is sized to provide a liquid coolant temperature leaving the heat exchanger of 15.5°C (60°F) for a coolant flow per vest of 24 kg/hr (53 lb/hr). The crew body temperature which results from supplying the crew liquid cooled vests with this 60 F fluid is described in Section 4.(a)(2).

The air side of the heat exchanger is conceived as having a single air flow pass with 18 radially oriented 1.0-inch (2.5-cm) high fins nestled between the flow blocker and the inside of the duct wall. The duct diameter in the area of the heat exchanger is increased to 6-inch (15.2-cm) diameter to provide room for the required area of finning and to minimize air side pressure drop. The water side heat exchanger has 13 fins per inch (-5 fins per cm) of circumference, which are longitudinally oriented.

The coolant tank allows for thermal expansion and contraction, a convenient means of line deaeration, and provides sufficient additional coolant for makeup due to leakage and charging of the crewman's cooling vest in case it should initially be dry. The pumps are self-priming by virtue of their being located at the bottom of the coolant storage tanks. It is recommended that a nontoxic coolant additive such as propylene glycol be used to prevent coolant system freeze-up at low temperature conditions.

Two separate liquid loops, and two liquid pumps were considered in this preliminary design because it was possible to obtain data on a prototype pump assembly being used at Natick in feasibility testing of a single vest system. By using one of these pumps for each crewman, the AAH system would have commonality with other single vest applications. Also, control and other interaction between the two fluid loops is avoided, which is sensible for a prototype or initial system design.

It is recommended that an actual design of this liquid cooling unit be performed in a follow-on design phase of this program. At that time, component level trade-offs will involve the selection of a production pump configuration and heat exchanger type. The pump configuration trade-off includes the consideration of pump types ranging from centrifugal to positive displacement and the method of how it is driven. The final pump will likely be electrically driven, although mechanical or air-driven designs should be considered. Various heat exchanger types such as tube-in-tube, tube of shell, tube-in-fin, and plate-fin should also be considered, along with various methods of providing an extended heat transfer surface.

Various system level trade-offs should be considered, such as whether the cooling loop for each crewman should be independent or dependent, and if dependent whether they should be in parallel or in series. Consideration should also be given to the question of need for a backup pump or pumps for system reliability.

The final system packaging approach to be determined in a follow-up design phase may incorporate an integrated structural design similar to the preliminary design shown here, or it may utilize a separate frame on which the individual system components are mounted. Also, the overall package may be line-mounted utilizing Marman flanges, as shown, or bulkhead-mounted with flexible connections for the ducting.

(c) ADDITION OF CAPABILITY FOR VENTILATED FACEPIECE MASK

Only a minor change to the AAH ECS cabin air supply ducting is necessary to provide an individual hose and damper for each crewmember to select cool, dry air for forced ventilation of the mask.

Even though the XM-30 type mask has a low pressure drop to be overcome by breathing muscles, there is still a degree of nuisance associated with any breath powered device. This nuisance is significantly reduced by forced ventilation of the mask, since no negative pressure need be created to breathe in, only the positive pressure to breath out remains. Also there is a definite improvement in problems related to sweat getting in the eyes because of the extra flow of cool dry air which passes through the mask. These advantages of a forced ventilated mask are discussed in Section 8.

An additional safety feature of the ventilated mask is that the lack of a negative pressure under the mask makes it impossible to draw CB agents around an improperly fitted mask, such as could occur if hair, or a bit of wire or clothing should protrude into the seal area. This forgiveness of error in improperly donning the mask could be important during battle conditions.

The present AAH cabin air distribution system has exhibited a considerable non-uniformity of cabin temperature between the head and feet of the crew. The preliminary design of this study adds a new cabin air supply duct down the left side canopy frame to provide a more uniform cabin temperature, by delivering cooling air up in the "greenhouse" region at the top of the cabin. This new duct is also used as the source of air for the flexible tubes providing air for the ventilated facepiece masks. This is shown in the helicopter view of Figure 15.



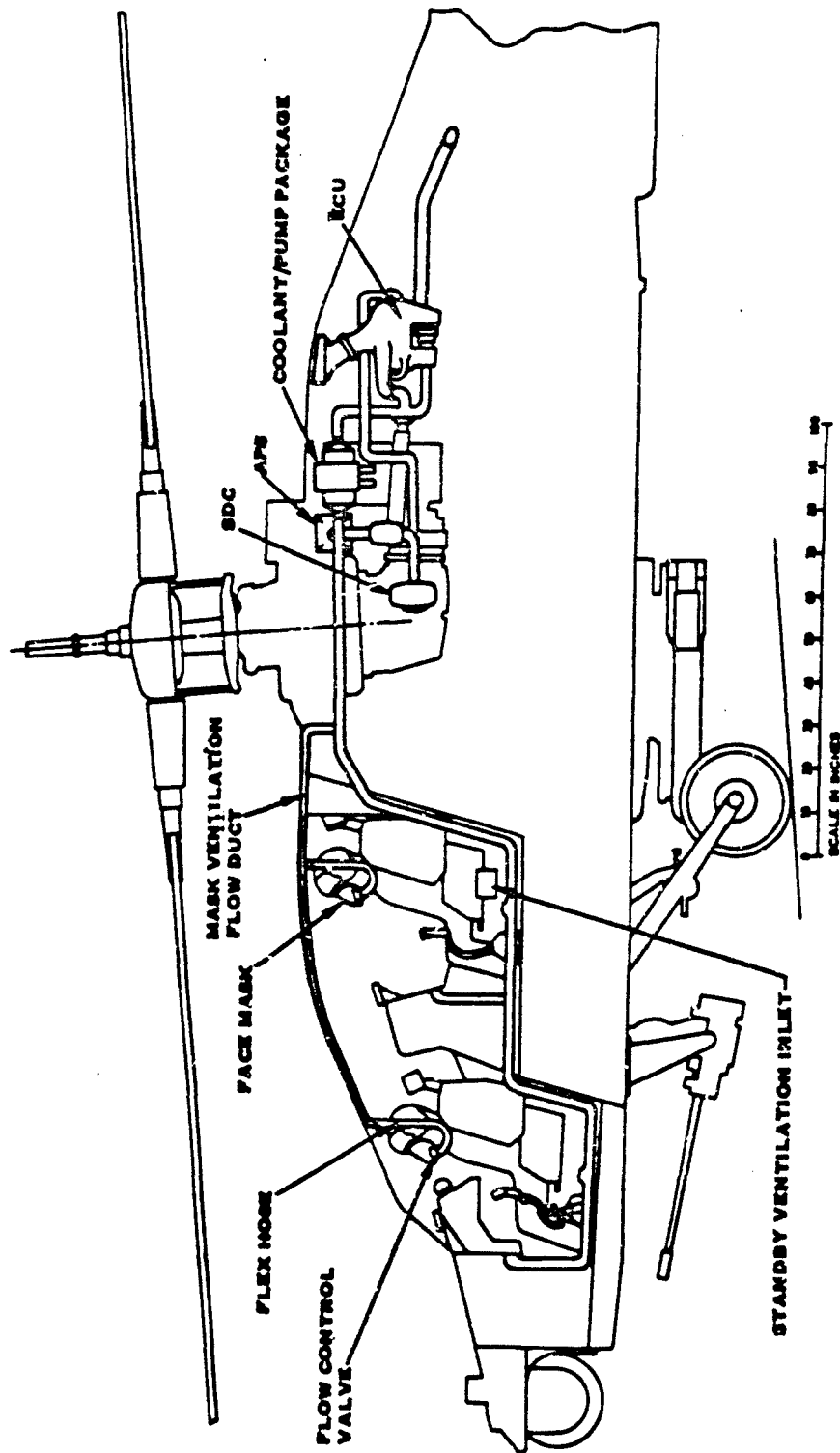

FIGURE 15 EXISTING SYSTEM WITH COOLANT/PUMP AND VENTILATED MASK PROVISION ADDED

This suggested arrangement will have to be reevaluated for an actual design, but does appear advantageous. This recommendation also solves the problem of what to do with the flexible hoses when they are not in use; they merely hang down from the duct running along the canopy frame. If the canisters are waist-mounted, rather than cheek-mounted as shown, a supply air source along the console may be preferred. (See also photographs on pages 159 and 161 of Appendix A for comparison.) In any case, an easy-break connection is required at the canister, since sudden egress must not be impeded by a solid connection requiring attention to disconnect.

(d) ADDITION OF AN OVERPRESSURE COLLECTIVE FILTER SYSTEM TO THE ECS

(1) Closing Off Cabin Leakage Areas

To provide an overpressure cabin it will be required that substantially all leakage areas be sealed, particularly those in the cockpit floor.

A schematic representation of those cabin leakage areas that exist in the AAH cockpit floor are shown in Figure 16. An estimate of the total exposed leakage area in the present AAH design totals about 12 in<sup>2</sup> (77.4cm<sup>2</sup>). In order to insure a cabin pressure above ambient, all unnecessary leakage areas must be minimized. The electrical wiring openings may be closed either by the addition of bulkhead type electrical connectors, or by rubber molded grommets having premolded holes for the wire passages. Grommets may also be used to seal off the hydraulic line openings. The rudder pedal slots, pedal adjustment slots, collective control, cyclic control, and the throttle control openings will all have to be covered with molded rubber boots. These boots must be protected against inadvertent damage so that leakage control is maintained during service and maintenance procedures for the life of the helicopter. Although the AAH was not designed with pressurization in mind, it is likely that most areas can be controlled with techniques commonly used in pressurized aircraft, and that special rubber boots will suffice where problems unique to the AAH occur. A summary of current openings, and their leakage areas, is as follows:

<u>LEAKAGE SOURCE</u>	<u>APPROXIMATE LEAKAGE AREA</u>
Rudder Pedal Slots	1 in <sup>2</sup> (6.5 cm <sup>2</sup> )
Rudder Pedal Adj. Slots	3 in <sup>2</sup> (19.4 cm <sup>2</sup> )
Collective Control	0 in <sup>2</sup> (0 cm <sup>2</sup> )
Cyclic Control	0.25 in <sup>2</sup> (1.6 cm <sup>2</sup> )
Throttle Control	3.00 in <sup>2</sup> (19.4 cm <sup>2</sup> )
Wiring Openings (C.P.G. Floor)	1 in <sup>2</sup> (6.5 cm <sup>2</sup> )

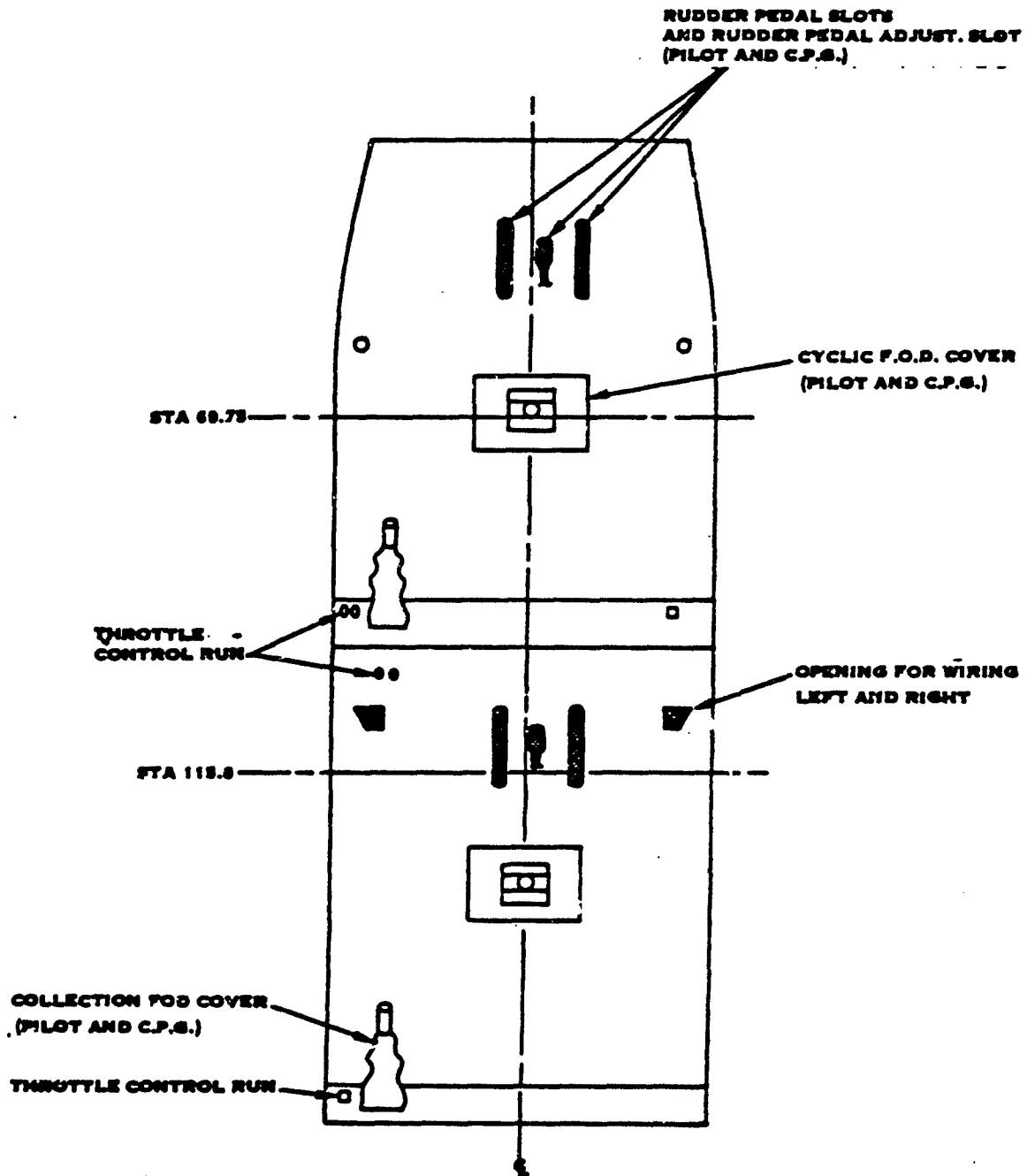

FIGURE 16 AAH CABIN FLOOR, LEAKAGE AREAS

Wiring Openings (Pilots Floor)	3 in <sup>2</sup> (19.4 cm <sup>2</sup> )
Hydraulic Line Openings	1 in <sup>2</sup> (6.5 cm <sup>2</sup> )

Since it is possible to seal a cabin too well, it follows that it must be possible to dangerously overpressurize it, since the pressurization source is not a fan but rather is a high-pressure compressor. For this reason, it is assumed in this study that a simple pressure relief control will be necessary. This control should hold the cabin at a few inches of water, which should be high enough to prevent infiltration and low enough not to damage the canopy or structure. Actual flight tests in simulated agent will be necessary to confirm the cabin pressure levels required to prevent infiltration. Also, actual pressurization ground tests may be necessary to determine if structural stiffening is required to prevent unacceptable deflection of flat surfaces or structure, once the necessary pressure level has been determined. Furthermore, leakage reduction may cause decontamination problems and this should also be tested with simulants.

(2) CHANGE OF FORWARD ELECTRONIC COOLING TO AN AMBIENT AIR SOURCE

To provide overpressure of the AAH cabin dictates that a large portion of the forward avionics be changed to ambient air cooling, as is current practice in the AAH aft avionics compartment.

Actually in the present AAH, the forward avionics fans suck much more flow out of the cabin than leaks out through holes. Sealing the cabin by itself therefore, cannot provide a dependable overpressure. The present cabin flow balance is approximately as follows for the normal cabin inflow of 23 lb/min: (10.44 kg/min)

Flow out through right hand avionics fan	=	8 lb/min (3.63 kg/min)
Flow out through left hand avionics fan	=	8 lb/min (3.63 kg/min)
Flow out through forward avionics and turret fan	=	5 lb/min (2.27 kg/min)
Flow out through leakage holes	=	2 lb/min (0.91 kg/min)
TOTAL	=	23 lb/min (10.44 kg/min)

Since the fan flows listed above are all nominal calculated values, it would not be surprising if flight tests of the present AAH prototypes showed a scattering of negative as well as positive cabin pressures.

Since the largest "leaks" to ambient of cabin air inflow are the electronic cooling fans, these fans must be changed to take their air supply from the ambient, so that cabin inflow air may be used to provide overpressure. AAH electronic cooling requirements are basically per MIL-E-5400 (slightly revised for AAH).<sup>22</sup> This specification being applicable, the electronics being purchased for AAH are already capable of being adequately cooled using 120°F (49°C) outside air, rather than the cooler cabin discharge air now being supplied. Fortunately the avionics fans have already been purchased with this possibility in mind, and have two sets of field windings. One set of windings results in the higher fan RPM necessary to properly cool the avionics with 120°F (49°C) supply air, so that no change to the fans is necessary, only a wiring change is needed.

<sup>22</sup> Military Specification, MIL-E-5400, Electronic Equipment, Airborne. General Specification for 31 Oct 1975. Definition of the CB Threat to the AAH. M.J.R. F. Williams.

Incidentally, the peak temperatures experienced inside the electronic boxes are probably higher using cabin discharge air for cooling than they will be using ambient air for cooling. The expected advantage of using cool cabin air for electronic cooling is realized only for a steady state cabin temperature situation. In practice, the cooling system is designed for temperature "pull down" that occurs when a helicopter that has been parked in the summer sun is put into service. Cabin temperatures can be up to 50°F (28°C) higher than ambient temperatures in this situation, and it takes a long time to cool the cabin down to even ambient temperatures, because of heat stored in the cabin armor and structure. Therefore the ambient cooling source recommendation of this study should not noticeably affect equipment reliability insofar as maximum electronic component temperatures are concerned. Stability and accuracy of electronic circuitry should not be noticeably affected either, since the actual component temperature range experienced should be about the same, or even reduced.

A major problem with using ambient air for electronic cooling is the large amount of dust and grit which can completely envelop a helicopter operating from a dry dirt road. The aft electronics compartment was originally designed for ambient air cooling, and of course other helicopters also use ambient air. But clean air is a definite advantage for electronic life and maintenance, and the AAH will unfortunately be forced to give up this advantage. Probably the worst problem incurred in going to ambient air for cooling is the turret, with its numerous close tolerance mechanical fits, such as slides, gears, and bearings, which can be highly sensitive to grit. The turret fan pressure rise is already 20" (50 cm) of H<sub>2</sub>O, and adding a filter could cause development difficulty and delay. It might therefore be best to continue to keep the turret mechanical area cooled by cabin discharge air to avoid the development problems of dust shields, at least for the first production models.

All the electronic boxes now cooled by cabin discharge air are installed just outside the cabin shell. Some are installed on shelf-like racks along the lower sides of the cabin. Some are mounted to the outside of the cabin wall. In all cases it would be a simple matter to feed dust-free cooling air via a local flex tube to any local hot-spot in the electronics requiring special cooling or very clean air. Such tubes would pick up cabin discharge air from the cabin wall adjacent to the affected electronic box. The tubes would be short and light, and need not be removed with the equipment. Any flow taken from the cabin for electronic cooling would, of course, have to be replaced by taking into the system a like amount of ambient air through the collective filter, as discussed in Section 6.(d)(3).

Further study should be undertaken to confirm the suitability of ambient air for electronic cooling with respect to agents specifically designed to disrupt avionics. The public press, such as Aviation Week, has referred to an airborne dispersal of very small conductive filaments as posing a potential threat to unencapsulated close tolerance electronic components, such as micro-processors. The data provided for this study made no mention of these agents, yet their use could still be a possibility. The defense against such agents can be accomplished by local particulate filtration at the "black box", or by collective filtration. Such an electronics filtration requirement could have a large effect on the design of the CB defense system.

In Sections 3.(b) and 3.(c)(1) the subject of chemical decontamination of electronics is discussed. Due to the primitive state of such decon techniques, the best decon method for electronics appears to be heat soak simultaneously with clean air being pumped through. Certainly the less agent that is allowed into the equipment in the first place, the easier decon will be. Conversely, shifting electronics from cabin discharge air to ambient air for cooling



will result in a major increase in electronics contamination with chemical agents. The effect of this on decon time is not known, and so no decision can be made at this point that CB filters need to be installed for electronic equipment. If CB filtration for avionics is absolutely necessary, then the present AAH system of using cabin discharge air for electronic cooling may be correct, and the collective filter system could be made large enough to handle cabin overpressure and electronic airflow requirements simultaneously. This study, however, proceeds under the assumption that helicopters are so weight sensitive that the crew and cabin must be protected from agents, but that equipment outside the cabin shell must live with the chemical environment. Except for local electronic equipment hot spots, as mentioned above, the collective system of this study will protect only the crew in the cabin from agents, on the basis that this is the lightest, least expensive, and minimum logistical approach. The trade-off between reduced payload of ordnance which can be carried versus weight of equipment added to protect equipment installed outside the cabin from agents is beyond the scope of this study.

### (3) Change to Recirculation ECS and Its Advantages

Conversion of the forward avionics equipment to ambient air cooling makes possible a recirculation type ECS system, with the CB filter sized to remove agents from only the "make-up" air.

The amount of fresh make-up air which must be brought in through the collective filter is exactly equal to the sum of that which leaks out through holes and seals in the cabin wall, plus the amount purposely taken from the cabin to locally provide cool clean air for equipment mounted outside the cabin.

Even if the cabin were sealed perfectly, the system could still not utilize 100% recirculation, because some fresh airflow through the cabin is necessary to prevent buildup of carbon monoxide and possible smoke or odor. This minimum flow requirement will not be a problem, however, because the fresh airflow of any practical design will be more than enough for carbon monoxide removal.

For purposes of proceeding with the preliminary design of a collective filter system, it has been assumed that the ambient make-up flow required for both over-pressure and local cool clean air supply to equipment outside the cabin will total 2.7 kg/min (6 lb/min). In other words, of the 10.5 kg/min (23 lb/min) total cabin flow, the amount fresh is 2.7 kg/min (6 lb/min) and the amount recirculated is 7.8 kg/min (17 lb/min), or about 25% fresh and 75% recirculated. This is a somewhat arbitrary judgment based on reducing cabin leakage to a low value, and cooling a large portion of the avionics with ambient air. The filter size and weight used in this trade-off study is based on the above make-up flow, and of course designing for a higher flow would result in a corresponding increase in filter size and weight.

The revised flow path schematic of the AAH system with the recirculation overpressure system added is shown in Figure 17. Referring to the figure, note that the forward avionics equipment is shown converted to ambient air cooling. Cabin discharge air is ducted back to the SDC inlet, where it joins the ambient make-up air flow which has gone through the APS and collective CB filter. A cabin pressure regulator (CPR) is located in the cabin return line, or on the cabin wall at the inlet to the cabin return line. This CPR is set to provide a cabin pressure adequate to prevent infiltration of CB agents into the cabin, while at the same time preventing cabin overpressure which could cause structural damage. In case of enemy fire opening up holes in the cabin wall, or in case of defective leaking seals, the CPR will go toward the closed position and continue to increase fresh airflow through the CB filter to maintain the cabin pressure required for CB safety. Even though the CB filter is sized for a nominal flow of 2.7 kg/min (6 lb/min), the filter will remove agents from a much higher flow at some loss in efficiency and with a higher pressure drop.

An alternate arrangement using a fixed geometry system of orifices to determine cabin pressure as well as the amount of fresh air brought in through the filter, does not have the flexibility that the CPR has to properly handle off-design operating conditions. It is because of this that a CPR is recommended.

Referring to Figure 17, note that isolation valves are shown at the inlet and outlet of the CB filter, so that ambient air entering the system may bypass the CB filter for operating conditions in which the CB filter is not needed. These shutoff dampers are necessary to seal off the CB filter element and protect it from contamination by everyday vapors and dusts which otherwise could contaminate the filter and make it worthless for use in an actual CB agent attack.

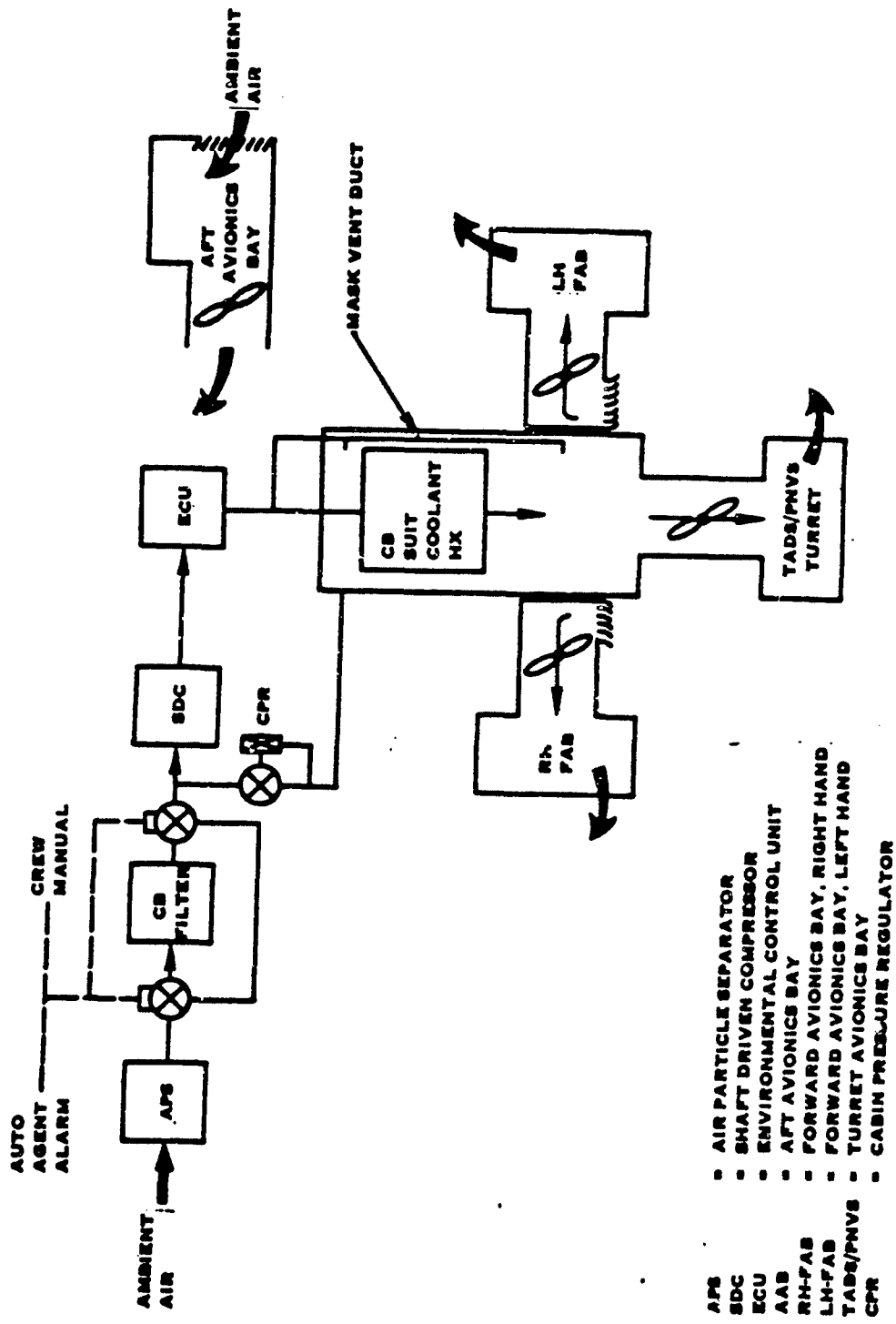

- APS - AIR PARTICLE SEPARATOR
- SDC - SHAFT DRIVEN COMPRESSOR
- ECU - ENVIRONMENTAL CONTROL UNIT
- AAB - AFT AVIONICS BAY
- RH-FAB - FORWARD AVIONICS BAY, RIGHT HAND
- LH-FAB - FORWARD AVIONICS BAY, LEFT HAND
- TADS/PNVS - TURRET AVIONICS BAY
- CPR - CABIN PRESSURE REGULATOR

FIGURE 17 REVISED AAH AIRFLOW PATHS, COLLECTIVE FILTER AND RECIRCULATION OVERPRESSURE SYSTEM ADDED

Automatic control of these damper valves by chemical alarms is discussed in Section 2.(d). The crew may also manually position these damper valves. Pilot judgement should be used to avoid unnecessarily hovering in dust conditions which could cause unnecessary dust contamination of the filter when the CB filter system is activated. Flight tests will be required to determine how much operation hovering over a dusty road can be tolerated to avoid completely filling the fine pleated multi-pore particulate filter, and making it useless for biological and other fine aerosol defense. Once the pleated multi-pore filter pressure drop exceeds its design value, it will rip to pass the airflow and become ineffective as a filter. To prevent this, an override could be added to the CPR to limit filter pressure drop to a maximum acceptable value by automatically reducing pressurization flow into the cabin. This increases the possibility of agent infiltration through the cabin walls, but is certainly less hazardous than a ripped filter.

A view of the collective filter assembly with its protective valves is shown in Figure 18. The CB filter element, scaled to fit the interior of the AAH, contains 15 pounds (6.8 kg) of activated carbon. The filter is an axial flow configuration utilizing inlet and outlet screens and a porous preloading pad. The sides of the filter assembly utilize an aluminum sheet metal design with stiffening webs to provide structural rigidity. Inlet and outlet bolt flanges allow attachment of the biological and dust filter on the inlet to the activated carbon filter and to the outlet flow distribution header on the outlet side.

The biological and dust filter utilizes a pleated multipore filter with an outer frame of aluminum sheet metal utilizing stiffening webs. Inlet and outlet bolt flanges provide for attachment to the gas filter and the inlet header to the complete assembly.

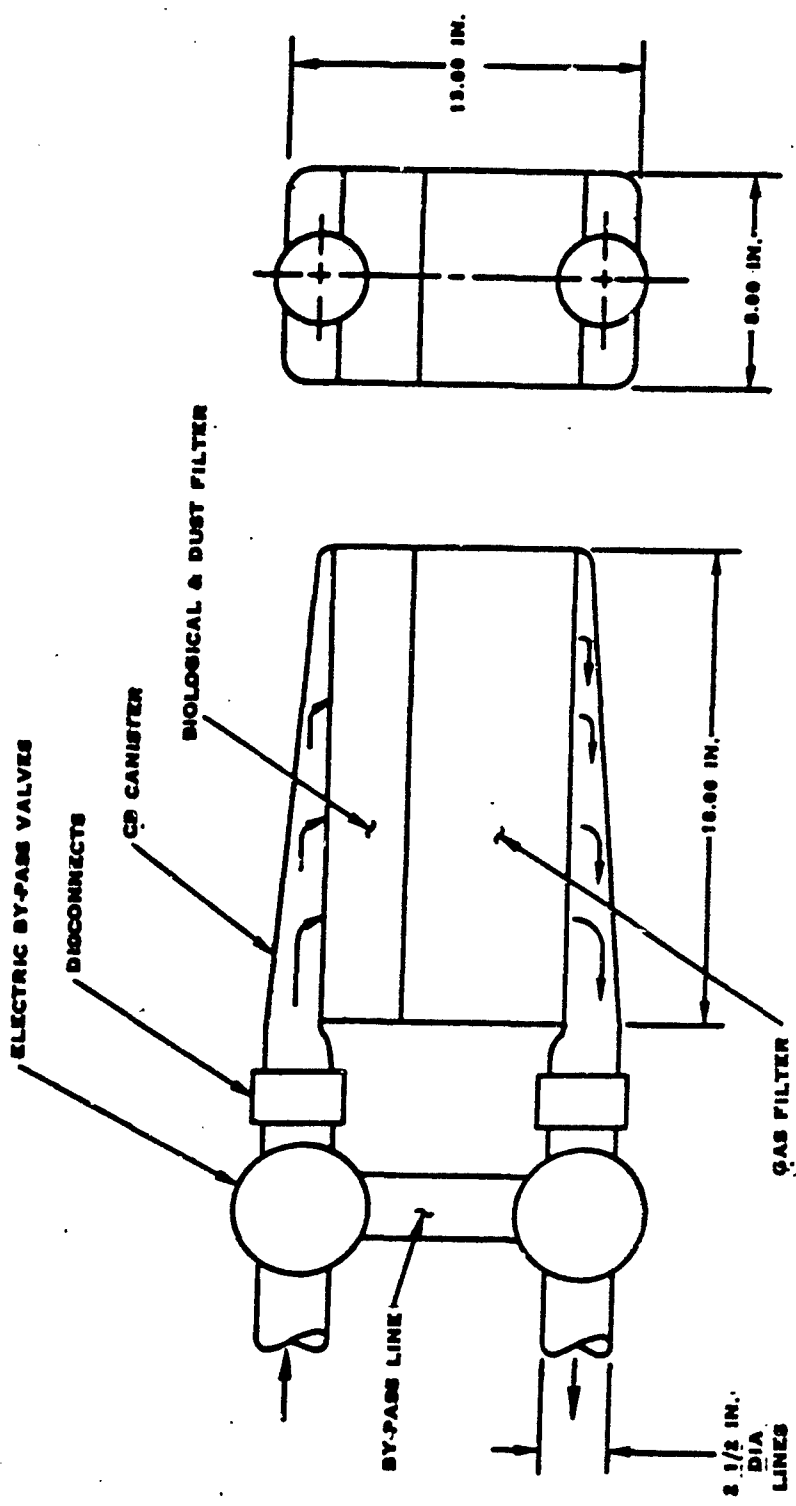
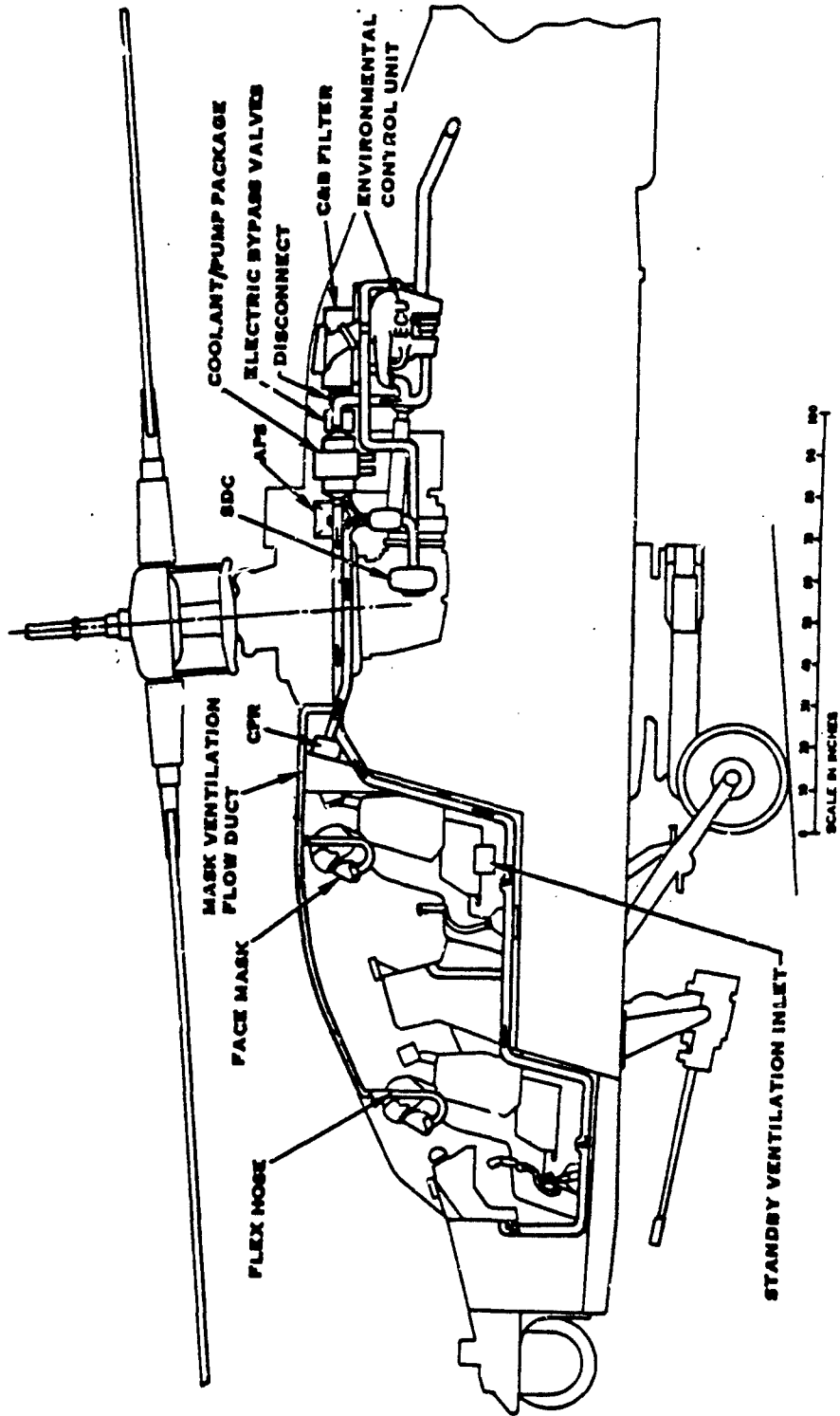

FIGURE 18 COLLECTIVE FILTER/PROTECTIVE VALVES CONCEPT

The filter package is shown located in the helicopter in Figure 19. It is located aft of the helicopter engine directly over the auxiliary power unit (APU). The package configuration requires a maximum package height of 8 inches (20.3 cm) to fit between the APU and the outside contour of the helicopter. The two filters are packaged axially in series with a large face area to limit pressure drop. The inlet and outlet header configuration provides good flow distribution.

In the packaging configuration shown, it is assumed that the filter protective bypass valves are configured as two rotary spool valves, with an interconnecting duct, mechanically linked together and driven by a pneumatic actuator (triggered by a solenoid valve) utilizing 50 psi (345 kPa) air from the SDC. Response time to open is 1 second maximum and closing is achieved mechanically by a spring. It is assumed that the inlet and outlet disconnects are simple "tube-in-tube", with radial "O" rings to provide for positive sealing. The disconnects do not actually transfer package loads, however, the male half is trapped inside of the female half. The sealing "O" rings are retained on the male canister side of the package and are normally replaced during canister replacement.



**FIGURE 19** EXISTING SYSTEM WITH COLLECTIVE FILTER, RECIRCULATION OVERPRESSURE SYSTEM, COOLANT PUMP PACKAGE, AND VENTILATED MASK PROVISION ADDED



#### (4) Advantages of a Single Replaceable Collective Assembly

Unfortunately it will be impossible to prevent agent contamination of the ducting between the APS and CB filter, so that the CB filter package concept shown in Figure 18 does not lend itself to safe or easy replacement when contaminated, and contaminated ducts will remain in the helicopter. Removing the CB filter element for replacement is going to expose the ground crew to agents, since the inlet duct to the element can be contaminated. Removal of the disposable filter element from the APS, after it is contaminated with thickened agents, is equally difficult.

In order to improve the safety of filter servicing, and to greatly reduce the time and skill required for filter servicing, a single replaceable assembly concept was investigated as shown in Figure 20. Referring to this figure, note that an integral housing simultaneously acts as the air manifolds, damper valve housings, and mounting frame for both the centrifugal coarse APS filter and the CB filter elements. There is no inlet duct leading to the APS, because the APS inlet face becomes the outer surface of the helicopter. The entire suitcase shaped assembly is inserted through a rectangular hole in the skin, and is latched in by skin-mounted, quick-release camloc fasteners. The assembly slides in like a drawer to rest on contact points inside the helicopter. One single interface rubber seal exists at the point leveled "Air to helicopter" in Figure 20. Figure 20 is not an actual design, but is rather an illustration of the concept. For example, the levers on an actual design would probably be installed inside the connecting manifold, rather than outside as shown. At this point air leaving the assembly joins the helicopter air duct upstream of the cabin recirculation return air junction. The plane of this interface rubber seal is also the location of the output arm of the helicopter-mounted actuator for the dual filter protective valves. The actuator stays in the helicopter when the assembly is removed. The actuator output arm acts through the interface air opening to press on the spring-loaded lever system which operates the damper valves. The spring is loaded to hold the dampers shut against the inlet

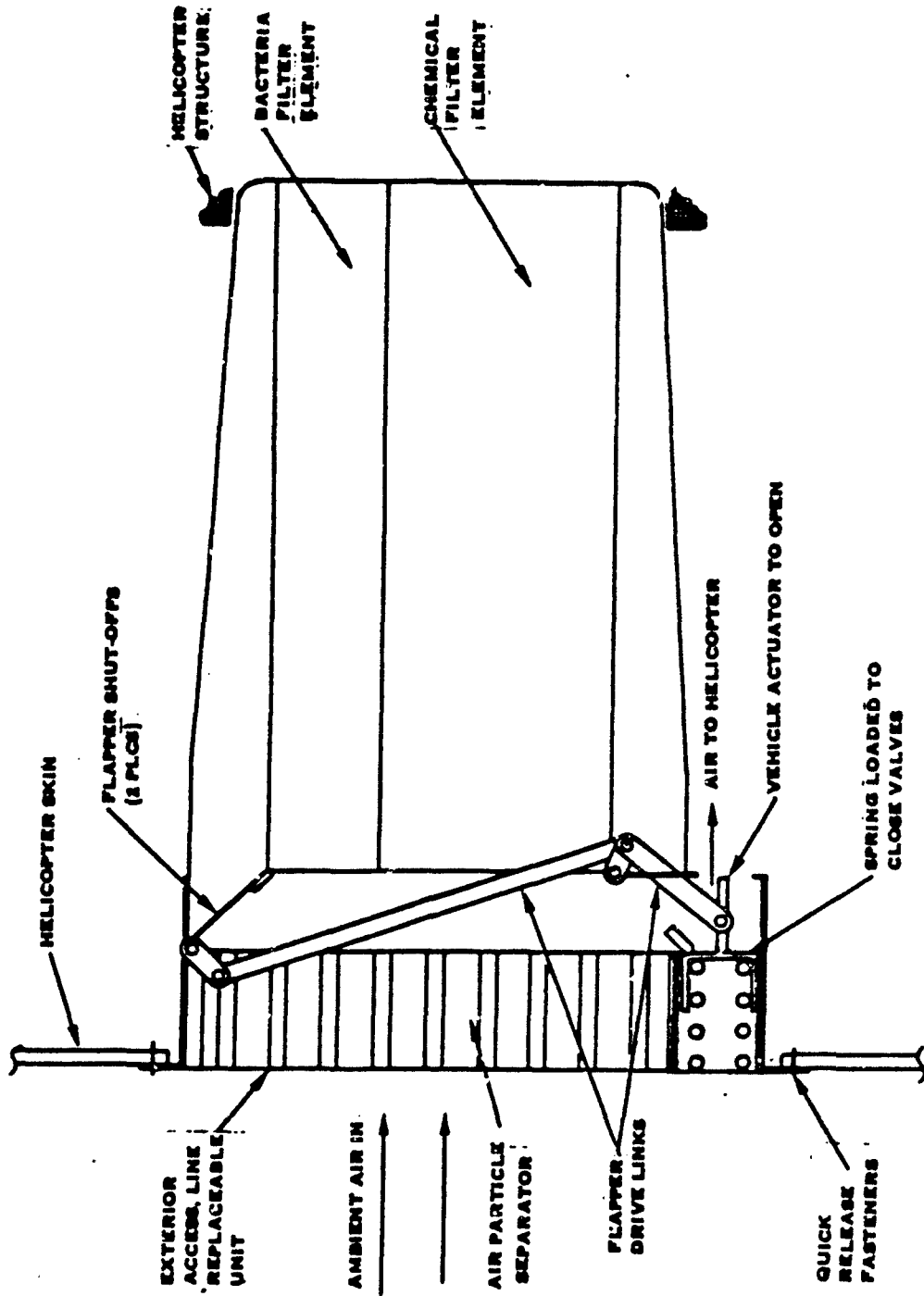

FIGURE 20 - SINGLE REPLACEABLE ASSY, AFS PLUS VALVES PLUS CB FILTER

and outlet of the CB filter element to protect it from contamination during shipment, storage, and in flight, prior to the time it is needed for actual CB defense. The actuator could be a single pneumatic piston, since 344 kPa (50 psia) is always available if the engine or APU are running.

When the damper valve actuator is not activated, the CB filter is covered and ambient air only goes through the APS to the helicopter ducting. When the damper valve actuator is activated, the CB filter is uncovered and the lower damper continues to swing to cover the bypass opening around the CB filter, so that all the entering ambient air must pass through both the APS and the CB filter in series.

The logic of the single replaceable assembly concept is that the replaceable elements, perhaps common to other Army applications, would be installed into the single assembly at the operations base. A lesser number of replaceable assemblies peculiar to AAH would be stocked at the FARRP and other advanced positions. After a pitched battle situation, complete assemblies could be collected, the frames decontaminated and new elements installed by ground personnel without tying up the helicopter. Safety would be improved and helicopter turnaround time and servicing skill reduced. Whether the logistic disadvantage of stocking the required number of assemblies is justified is beyond the scope of this study, but the concept has appeal.

If a clean replaceable assembly were not available, the worst that could happen is that the assembly would be removed from the helicopter and the replaceable elements changed outside the helicopter, right there on the spot, without decontaminating the frame. This is probably not any less safe than the concept of changing the two elements separately inside the helicopter, without utilizing a single replaceable assembly.

The safety and service advantage of the single replaceable unit concept stands by itself, even if no stock of replaceable assemblies is maintained. If additional assemblies are not available, the ground crew removes the contaminated assembly, unlatching and sliding it out like a suitcase, to replace the filters and return the same assembly to service. While there is considerably more skill and time required to return the same assembly to service, compared to having replacements available, the concept still appears desirable compared to installing the two filters separately inside the helicopter.

The single replaceable assembly concept does not appear to add any significant weight to the helicopter, because the compactness of the single unit approach reduces interconnecting duct weight and volume. Also there is only one interface connection with the helicopter duct system, instead of three, and no access doors, in the usual sense, are necessary.

## 7. ESTIMATED COST TO THE HELICOPTER VERSUS CB PROTECTION LEVEL

In order to evaluate CB protection level options, estimates of cost, weight, and maintenance have been made for each of the CB defense options considered in this report. A summary table of these costs is shown in Table 15. Included are initial cost, weight, and life and maintenance support.

The estimated weights of Table 15 are based on weights of the hardware assemblies listed. The trade-off component costs listed are calculated using typical aircraft preliminary design practice. Estimated weights are multiplied by appropriate aircraft average costs, which are somewhat higher than expected procurement cost of the components themselves in order to reflect the helicopter manufacturer's added costs. These costs may be considered estimates of the increase in delivered cost of the helicopter with these components added. They are hopefully set high enough that the trade-off study will not encourage unjustified additions to the helicopter. The constants used to calculate these trade-off costs are listed on the bottom of Table 15.

Any weight added to the helicopter must result in either less ordnance carried or less fuel carried. No attempt is made here to consider the increase in helicopter fleet cost incurred by reducing ordnance carried, or of reducing helicopter range to accommodate the weight increase of these CB protective options.

Referring to Table 15, the change steps to reduce the CB hazard to the AAH are listed down the left side. Step #1 is the baseline, or helicopter "as is". Step #2, which is the addition of a suit-cooling provision, is absolutely essential. As discussed in Section 6.4, the mission effectiveness becomes unacceptable after only two flights in a hot day environment without additional crew cooling. Estimated weight addition to the helicopter (vest not included) for the suit cooling provision is (5.3 kg) 11.7 lbs for the concept described in Section 6.(b). Trade-off cost is \$2,927.

TABLE 15 ESTIMATED COST TO HELICOPTER VS CB PROTECTION LEVEL

CHANGE "STEPS" TO HELICOPTER TO REDUCE CB HAZARD		DESCRIPTION OF STEP	DESCRIPTION OF HARDWARE ASSEMBLIES ADDED	ESTIMATED WEIGHT LB	TRADE-OFF COST*	ESTIMATED LOGISTICS REPLACEMENT LIFE
STEP #	DESCRIPTION OF STEP					
01	HELICOPTER AS IS		BASELINE	0	0	-
02	SUIT COOLING PROVISION ADDED		1. HEAT TRANSFER/ RESERVOIR 2. LIQUID PUMPS 3. LIQUID LINES AND FITTINGS 4. H <sub>2</sub> O SUBTOTAL	4.0 4.4 1.1 3.2 11.7	1000 1760 167 - 2027	UNLIMITED 2000 HRS UNLIMITED - -
03	VENTILATED MASK PROVISION ADDED		1. AIR TUBING, DAMPERS AND FITTINGS	1.8	228	UNLIMITED
04	COLLECTIVE FILTER SYSTEM ADDED		1. CLOSE LEAKS IN FLOOR 2. RECIRCULATION DUCTING 3. CABIN PRESSURE VALVE 4. REPLACEMENT CAN FILTER ELEMENTS 5. HEADERS AND PACKAGING 6. BYPASS VALVES 7. REPLACEABLE AIR PARTICULATE SEPARATOR ELEMENT SUBTOTAL	3.0 1.5 5.0 20.8** 4.8 4.0 3.8 48.0	750 228 2000 TBD** 678 1600 TBD - 5230	- UNLIMITED 5000 HRS ONCE PER CB ENCOUNTER UNLIMITED 1000 CYCLES ONCE PER CB ENCOUNTER
	TOTAL PENALTY			59.2	8402	

\*TRADE-OFF COST CALCULATED AT  
 1) \$150/LB FOR DUCTS, HEADERS AND STATIC COMPONENTS  
 2) \$250/LB FOR HEAT TRANSFER BRAZED ASSEMBLIES  
 3) \$400/LB FOR PUMPS, VALVES, OTHER MOVING PART COMPONENTS  
 \*\* INCLUDES 18 LBS OF ACTIVATED CHARCOAL AT \$6.30/LB

Change Step #3 is the addition to the helicopter of provisions for ventilated masks. This provision is light, (0.7 kg) 1.5 lb , plus some additional weight if a new cabin air supply duct is added as discussed in Section 8.3. Trade-off cost of the flex air tubing, dampers, and fittings is \$225.

Change Step #4 is the addition of the collective filter system utilizing overpressure and recirculation, as described in Section 6.(d). Estimated weight of the components without the replaceable elements is 21.5 lb (9.8 kg). The replaceable elements weigh an additional 23.5 lbs (10.7 kg), for a total weight of 45 lbs (20.4 kg). Trade-off cost is \$5,250 without replaceable elements.

Logistics problems related to the various CB protection levels are almost non-existent, except for the replaceable CB filter elements. Here the selected concept of 25% fresh air and 75% recirculated air has cut size, weight, and cost of the elements about as far as practical.

## 8. LOSS IN HELICOPTER MISSION EFFECTIVENESS VERSUS CB PROTECTION LEVEL

The CB Threat to the AAH has been defined and the loss in AAH helicopter mission effectiveness due to CB protective devices has been quantitatively assessed by HEL Aberdeen,<sup>23,24</sup> and numbers assigned to the five most predominant causes of this loss. This assessment is shown in tabular form in Table 16. It is very useful because it attempts to evaluate the mission effectiveness improvement which would result for the AAH, with each of the change step options considered in this report. It should be noted that the term "loss in mission effectiveness" used in this report is defined as the percent increase in number of helicopter combat hours that must be assigned to a given battle area to achieve the same result as would have been achieved had the crew not been encumbered with any CB protective devices.

The change step options to the helicopter are listed down the left side of Table 16. Step #1 is the baseline which exists with the current helicopter, "as is". The table indicates that the mission must be aborted after two consecutive hot day flights because of the crew heat rejection problem described in Sections 4 and 5.

Change Step #2, the addition of a crew suit-cooling provision reduces the loss in mission effectiveness to 19% for the "Standard Helicopter Combat Day" of Section 1.(d). Ten percent of this 19% loss is caused by interference effect of the mask on vision and gunsights. This is a well known problem, and considerable effort is being expended toward its solution. A detailed review of the mask-gunsight interface problem warrants a separate specialized document on the subject. Corrective measures are being developed and evaluated to reduce this effect. The 10% degradation number shown in Table 16 for mask interference is merely our estimate of that which would be achieved utilizing corrective measures now in process. Surprisingly, even though crew body

<sup>23</sup>See reference 7, p.52.

<sup>24</sup>See reference 6, p.52.



Table 16 LOSS IN HELICOPTER MISSION EFFECTIVENESS\* VS. CB PROTECTION LEVEL

STEP #	DESCRIPTION OF STEP	CAUSE OF LOSS IN HELICOPTER MISSION EFFECTIVENESS	ESTIMATED % LOSS IN OVERALL MISSION EFFECTIVENESS*	
			12 HOUR "STANDARD HELICOPTER COMBAT DAY," PER SECTION 3.4	24 HOUR (-) BATTLE SCENARIO, PER SECTION 3.4
01	HELICOPTER AS IS: (MASK PLUS SUIT)	1. EXTREME THERMAL STRESS DUE TO INABILITY TO REJECT BODY HEAT 2. INTERFERENCE EFFECT OF MASK ON VISION AND GUNSIGHT 3. SWEAT IN EYES, FOG ON INSIDE OF MASK-GLASS 4. ANNOYANCE FROM SELF POWERED RESPIRATORY SYSTEM 5. LOSS OF DEXTERITY DUE TO GLOVES, BOOTS, AND BULK	MISSION ABORT DUE TO THERMAL STRESS AFTER 2 FLIGHTS	SAME AS 12 HOUR DAY AT LEFT
02	SUIT COOLING PROVISION ADDED: (MASK PLUS SUIT PLUS COOLING VEST)	1. EXTREME THERMAL STRESS DUE TO INABILITY TO REJECT BODY HEAT 2. INTERFERENCE EFFECT OF MASK ON VISION AND GUNSIGHT 3. SOME SWEAT IN EYES, VERY HOLDING NORMAL BODY TEMP BUT FACE STILL IN UNCOOLED GREENHOUSE 4. ANNOYANCE FROM SELF POWERED RESPIRATORY SYSTEM 5. LOSS OF DEXTERITY DUE TO GLOVES, BOOTS, AND BULK	9% 13% 5% 1% 3%	30%** 10% 5% 1% 3%
03	VENTILATED MASK PROVISION ADDED: (MASK PLUS SUIT PLUS COOLING VEST PLUS VENTILATED MASK)	1. EXTREME THERMAL STRESS DUE TO INABILITY TO REJECT BODY HEAT 2. INTERFERENCE EFFECT OF MASK ON VISION AND GUNSIGHT 3. SWEAT IN EYES ELIMINATED, BUT EYES NOW CAN BE OVERDRIED 4. ANNOYANCE FROM SELF POWERED RESPIRATORY SYSTEM 5. LOSS OF DEXTERITY DUE TO GLOVES, BOOTS AND BULK	19% TOTAL LOSS 6% 10% 5% 1% 3%	49% TOTAL LOSS 36%** 10% 5% 1% 3%
04	COLLECTIVE FILTER SYSTEM ADDED: (SUIT, PLUS COOLING VEST, BUT MASK "OFF"). MASK "ON" SAME AS 03 ABOVE.	1. EXTREME THERMAL STRESS DUE TO INABILITY TO REJECT BODY HEAT 2. MASK INTERFACE 3. LOSS OF DEXTERITY DUE TO GLOVES, BOOTS, AND BULK	19% TOTAL LOSS 6% 9%*** 3%	49% TOTAL LOSS 36%** 9%*** 3%

\*THE TERM "LOSS IN HELICOPTER MISSION EFFECTIVENESS" USED IN THIS REPORT IS DEFINED AS THE PERCENT INCREASE IN NUMBER OF HELICOPTER COMBAT HOURS MUST BE ASSIGNED TO A GIVEN BATTLE AREA TO ACHIEVE THE SAME RESULT AS WOULD HAVE BEEN ACHIEVED HAD THE CREW NOT BEEN ENCUMBERED WITH ANY CB PROTECTIVE DEVICES.

\*\*THIS 30% LOSS IN MISSION EFFECTIVENESS ON A HOT DAY IS CAUSED BY THE DEGRADATION OF THE FLIGHT CREW EFFECTIVENESS AFTER SPENDING 12 HOURS OR MORE OUTSIDE THE A/H AFTER 12 HOURS OF FLIGHT, DUE TO INABILITY TO REACH THE PLANNED DECON AND REST AREA. THE 30% NUMBER MAY BE HIGH, BUT IS INCLUDED AS A REMINDER THAT THE A/H CREW FACES THE SAME PROBLEMS, OUTSIDE THE A/H, AS THE REST OF THE ARMY.

\*\*\*THIS 9% LOSS IN MISSION EFFECTIVENESS PRESUPPOSES THAT A CABIN ALARM INDICATES NO AGENT, UNRESOLVED PROBLEMS OF MASKING IN THE A/H COCKPIT IN FLIGHT ARE MADE DIFFICULT BY REQUIREMENT FOR FULL PILOT ATTENTION TO FLIGHT DUTIES.

temperature is kept normal by the cooled vest, there is still a 5% sweat-moisture problem in the eye area, due to the greenhouse effect of the sun causing local heating. Annoyance from the lung-powered respiratory protective system is indicated to be down to a 1% problem, because of the low-pressure-drop advanced design of the XM-29 mask. Loss of dexterity due to bulk, boots, and gloves is estimated to cause a 3% loss in mission effectiveness.

Change Step #3, the addition of a ventilated mask provision is not shown to be important in improving mission effectiveness. As indicated, the third cause of loss in mission effectiveness, having to do with mask vision problems, is essentially unchanged at 5%. Without the ventilated mask provision the 5% loss was due to sweat associated problems. With the ventilated mask provision added, the sweat problem has been replaced with a problem of "overdried eyes" due to the velocity of cool dry air. The conclusion is that it is going to be extremely difficult to completely eliminate visual problems associated with wearing a mask, and that forced ventilation may be desirable for chemical safety or other reasons, but that it is not justified on the grounds of improved vision.

Change Step #4, addition of a collective filtration system for the cabin, can only affect helicopter mission effectiveness if it enables the crew to operate with their masks off. When this is the case, the only remaining loss in mission effectiveness is loss of dexterity due to bulk, gloves, and boots, of 3%. The helicopter operating conditions under which a collective filter system allows the crew to operate "mask off" is discussed in Section 4.4 and Section 11.

Note that the far right hand vertical column of Table 10 lists severe losses in mission effectiveness which can occur if the crew is forced into a second day of battle without having reached the planned decon and rest area after the first day's battle. Inclusion of this on the chart is a reminder that the AAH crew, when outside the AAH, faces many of the same chemical warfare problems as are faced by the rest of the Army. The 24+ hour scenario with 12 hours outside the vehicle results in the requirement for a permeable suit. The impermeable suit, while chemically safer, aggravates the thermal stress problem for periods when cooling provisions are not available, and therefore was not considered further in this study. There are no known options in the design of the AAH CB defense system which can affect this, except that the liquid-cooled vest is amenable to use outside the AAH as discussed in Section 4.(e)(3).

## 9. CONCLUSIONS

The conclusions of this study were derived from the body of the report and summarized in Table 15. For more detail refer to the specific tables listed below:

- Flight crew safety versus CB protection level is summarized in Table 12. (Page 80.).
- Weight versus CB protection level is summarized in Table 13. (Page 88.).
- Helicopter mission effectiveness versus encumbrance of various CB protection levels is summarized in Table 16. (Page 133).

Referring to Table 17 note that step #1, leaving the helicopter as is, is unacceptable due to the thermal stress which causes mission abortion after two flights.

Step #2, adding a provision to the helicopter for a cooled suit, is concluded to be needed. There is still a 19% loss in mission effectiveness due to crew encumbrance by CB garb, but the mission of six consecutive flights can now be achieved without mission abort. The cost of 11.7 lb (5.3 kg) and \$2,927 trades off very favorably for increasing the crew capability from two to six flights during a battle day.

Step #3, adding a provision for ventilated masks, is concluded to add to the safety margin to a degree that trades off favorably against its low cost of 1.5 lbs (0.7 kg) and \$225. While mission effectiveness is still down 19% due to encumbrance of the CB garb, chemical safety is improved and sweat evaporation from the eye area may be selected when desired by the crew. The improvement to safety is not dramatic, but the cost is low, thereby making the conclusion firm.

TABLE 17 CONCLUSIONS OF STUDY REGARDING PREFERRED CB PROTECTION LEVEL

CHANGE "STEPS" TO HELICOPTER TO REDUCE CB HAZARD		FLIGHT CREW SAFETY (FROM TABLE 7.0)	LOSS IN MISSION EFFICIENCIES (FROM TABLE 10.0)	COST TO HELICOPTER (FROM TABLE 9.0)	OVERALL CONCLUSION
STEP	DESCRIPTION OF STEP				
01	HELICOPTER AS IS: (MASK PLUS SUIT)	UNACCEPTABLE DUE TO THERMAL STRESS	ABORT MISSION AFTER 2 CONSECUTIVE FLIGHTS ON HOT DAY	ZERO	UNACCEPTABLE (CONCLUSION FIRM)
02	SUIT COOLING PROVISION ADDED: (MASK PLUS SUIT PLUS COOLING VEST)	ACCEPTABLE	10%	11.7 LB - \$2027	SUIT COOLING PROVISION SHOULD BE ADDED TO AAM (CONCLUSION FIRM)
03	VENTILATED MASK PROVISION ADDED: (MASK PLUS SUIT PLUS COOLING VEST PLUS VENTILATED MASK)	SAFER THAN ACCEPTABLE	10%	1.5 LB - \$225	VENTILATED MASK PROVISION SHOULD BE ADDED TO AAM (CONCLUSION FIRM)
04	COLLECTIVE FILTER SYSTEM ADDED: (SUIT PLUS COOLING VEST, BUT MASK "OFF")	ACCEPTABLE, IF CABIN NOT CONTAMINATED	3%		
04	COLLECTIVE FILTER SYSTEM ADDED: (SUIT PLUS COOLING VEST, MASK "ON")	MOST SAFE, LEAST CABIN DECON EFFORT NECESSARY	10%	45 LB - \$5250 PLUS LOGISTICS OF FILTER REPLACEMENT	COLLECTIVE FILTER SYSTEM SHOULD BE ADDED TO AAM (CONCLUSION FIRM ENOUGH TO PROCEED TO FLIGHT TEST EVALUATION)

Step #4, adding a collective filter provision to the helicopter, does the following things:

1. It makes "mask-off" operation adequately safe for use in a theater where CB warfare is imminent but not presently employed.
2. It greatly reduces the risk of "mask-off" operation in a theater in which CB warfare is being waged, for flights during which CB agents are not expected.
3. During all out CB battle conditions it provides the obvious safety advantage of providing double protection of personal as well as collective protection systems in series.
4. It significantly reduces the amount of cabin contamination which will result from sustained CB battle conditions.

The cost of 45 lbs. (20.4 kg) and \$5,250 plus logistics of filter replacement must be traded-off against the the combat flight hours in which loss in mission effectiveness is reduced from 19% to 3% by "mask-off" operation, and by reduced cabin decontamination effort. The answer to the trade-off is not obvious, primarily because the first two advantages listed above can only be realized if the cabin is clean, but this study concludes in favor of the collective system.

The following is a detailed breakdown of the conclusions reached, together with a reference to the section in the report in which there is further description and substantiation:

CONCLUSION REACHED	DESCRIBED IN SECTION	FIRMNESS OF CONCLUSION
<p>1. The safety of available (1980-1985 time frame) respiratory devices and protective garments is adequate for essentially zero casualty operation from CB agents, providing the crew starts the mission inside a clean, properly fitted garment, and that proper personnel decon is available.</p>	1 & 2	Firm
<p>2. Development of certain features in the protective ensemble will improve safety and/or mission effectiveness for AAH.</p>	Table 6	Firm
<p>3. The ability of the AAH flight crew to dissipate body heat is inadequate on a hot day, unless supplemental cooling is provided under the CB suit.</p>	4(d)(2) & 4(d)(3)	Firm
<p>4. The preferred configuration for cooling the AAH crew under their CB suits is by means of liquid cooled vests.</p>	4(e)(2)	Firm

CONCLUSION REACHED	DESCRIBED IN SECTION	FIRMNESS OF CONCLUSION
5. The preferred configuration for the liquid cooling components in the AAH is a concentric cylinder packaging concept, integral with the cabin air supply duct.	6.(b)	Not firm, but adequate as a baseline concept with which to enter the design phase.
6. A provision for forced mask ventilation should be added to AAH.	6.(c)	Firm, because of safety improvement.
7. An overpressure collective filter system should be added to AAH. If a collective system is added, the conclusions below apply:	3.(c)(1).3 6.(d)7. 9.	Not completely firm, because conclusion hinges on trade-off judgement factors.
8. Change a portion of the electronic cooling to ram air cooling, and utilize cabin recirculation in order to reduce weight and logistics of the collective filter system.	6.(d)(2)	Firm
9. A cabin pressure control of cabin recirculation flow is necessary to prevent structural damage to the helicopter caused by excessive overpressure.	6.(d)(1)	Not firm, but adequate as a baseline concept with which to begin the design phase.



CONCLUSION REACHED	DESCRIBED IN SECTION	FIRMNESS OF CONCLUSION
10. A replaceable element should be developed for the cyclone type coarse particulate filter used upstream of the CB filter.	3.(d)&6.(d)	Firm, because logistics of throwing away complete assemblies is unacceptable.
11. The CB element portion of the collective filter system should be protected by dampers from inadvertent contamination during non-CB operation.	6.(d)(3)	Firm
12. The CB filters should be activated automatically by an agent alarm sensor, as well as manually by the flight crew.	2.(d)	Not firm, but adequate as a baseline with which to enter the design phase.
13. A single replaceable unit concept should be used for the collective filter system, containing dampers, manifolds, and throwaway elements. The non-throwaway portions are reusable.	6.(d)(4)	Not firm, but adequate as a baseline concept with which to enter the design phase.

## 10. RECOMMENDATIONS

It is recommended that the conclusions of this study (summarized in Section 9) be implemented by proceeding into a design phase, with the objective of producing drawings suitable for fabrication of a complete set of prototype CB defense components for possible installation and flight evaluation in an AAH helicopter.

The literature shows very little design or operational experience appropriate for helicopters in the suit cooling and collective filter systems that are recommended. If the AAH is to be updated for CB warfare, then actual flight tests of a prototype system are necessary for the design of a production CB protection system.

REFERENCES

- Breckenridge, J. and Goldman, R., Human Solar Heat Load. Paper No. 2218 presented at ASHRAE Meeting, New Orleans, La., Jan 1972.
- Breckenridge, J. and Levell, C., Heat Stress in the Cockpit of the AH-IG Huey Cobra Helicopter. Aerospace Medicine, Vol. 41, No. 6, June 1970.
- Berlin, H., Stroschein, L. and Goldman, R., Edgewood Arsenal, Aberdeen P.G., Md., Nov 1975.
- Chemical Agent Decontamination Study. Joint Technical Coordinating Group for Munitions Effectiveness, Jan. 1976. (Secret Report).
- Chemical, Biological, Radiological and Nuclear Defense. U.S. Army Field Manual, FM-40, May 1971. (this has been superseded by revision of 14 Oct 1977).
- Chemical Reference Handbook. U.S. Army Field Manual, FM 3-8. Jan 1967.
- Herz, M., Brandler, P., Freeman, A., Byrne, R. Assessment of Chemical Warfare Protective Clothing. TR 80-022. Oct 1979. AD-C022447L (Secret Report).
- Hunfield Tactical Mission. Supplement to AH WSTE A Report Data. (Unclassified). Which is inclosure 2 of letter from Robert Eaton to AAH Program Manager, dated 12 Dec 1978.
- Joy, R. J., Heat Stress in Army Pilots Flying Combat Missions in the Mohawk Aircraft in Vietnam. Aerospace Medicine, Vol. 38, No. 9. Sept 1967.
- Military Specification, MIL-L-46159, Lacquer, Acrylic, Low Reflective, 2 Dec 1976.
- Planning and Conducting Chemical, Biological, Radiological and Nuclear Defense Training. Army Field Manual FM 21-48, June 1973.
- Rannenberg, G. ltr. from, 22 Jan 1980 (Secret)., U.S. Army Aviation Center, Ft. Rucker, Al.
- TM 3 - 220, Chemical, Biological and Radiological (CBR) Decontamination, Dept. of the Army, Nov 1967.
- Weisz, John D., Director, U.S. Army Human Engineering Laboratory, Aberdeen, Md, Rannenberg, G., letter from., 12 Mar 1980, Effect of CB Garb on Helicopter Mission Effectiveness.
- Williams, F., Military Specification, MIL-E-5400, Electronic Equipment, Airborne. General Specification for 31 Oct 1975. Definition of the CB Threat to the AAH.

APPENDIX A

PHOTOGRAPHS AND SIMPLIFIED SPECIFICATIONS  
OF CB PROTECTIVE GARMENT OPTIONS SUITABLE  
FOR AAH HELICOPTER CREWMAN

Item Name: Coveralls for Army Aviation Crewmen

Climatic Category According to QSTAG 200 Within Which the Item is Intended To Be Used: A-1, A-2, B-1, B-2, and B-3

Concept of Use: The coverall is intended to provide flight personnel protection from flash fires and comfort in temperatures above +20°C (68°F).

Description of Item: The coveralls are unlined with a slide fastener front closure, a bi-swing back, hook and pile fastener tape adjustments for the waist and sleeves and a slide fastener on the bottom of each leg. There are two breast patch pockets, a combination utility and pencil pocket on left sleeve, two thigh patch pockets, a knife pocket with a lanyard on the left thigh, two lower leg patch pockets and a multiple pencil compartment pocket on the right lower leg patch pocket. Except for the knife pocket, all pockets have slide fastener closures.

Materials Used: 148 g/m<sup>2</sup> (4.3 oz/yd<sup>2</sup>) high temperature resistant, non-melting nylon plain weave fabric.

Color: Sage Green 1524

Weight: 1 kg (2.2 lb )

Size Range:

20 sizes	36	38	40	42	44	46	48
	S	S	S	S	S	S	
	R	R	R	R	R	R	R
	L	L	L	L	L	L	L

Cost: \$59.00

Additional Remarks: Specification: MIL-C-83141 Coveralls, Flyer's, Men's, Summer, Fire-Resistant

NSN:  
8415-00-043-8380 (series)



COVERALLS FOR AVIATION CREWMEN

Item Name: Suit, Chemical Protective - Coat and Trousers (Overgarment)

Climatic Category According to QSTAG 200 Within Which The Item Is Intended To Be Used: All climatic categories where chemical protection is required.

Concept of Use: The overgarment will be issued as individual clothing to troops in combat zones forward of brigade rear boundary. It will be worn in all environments when under imminent threat of a chemical attack and after chemical operations have been initiated. It is worn over environmental clothing and body armor.

Description of Item: The overgarment is a two-layer, two-piece garment consisting of coat and trousers. The coat has a short standup collar, a full length zipper opening covered by a double protective flap, elastic sleeve closures and two outer pockets located at chest level. The trousers have a fly front, two cargo pockets with flaps, adjustable waist tabs, suspender loops and zipper closures on the outside of each leg which are covered by protective flaps.

Materials Used: The outer layer is a NYCO fabric treated with a nondurable water repellent to repel liquid agents. The inner layer is a charcoal impregnated foam/nylon tricot laminate which absorbs chemical agents.

Color: The outer layer is OG 107.

Dimensions: Packaged overgarment (size medium) measures approximately 30 x 23 x 8 cm (12 x 9 x 3 inches).

Weight: 1.8 kg (4 lbs) per overgarment (size medium).

Size Range: XXX-Small, XX-Small, Medium, Large, X-Large, XX-Large.

Cost: \$35.00 per overgarment.

Additional Remarks: The overgarment is issued to combat troops operating in forward areas. It was developed for troops that do not have access to any type of decontamination procedures. The overgarment is designed to protect the environmental clothing from contamination. When contaminated, the overgarment is discarded and replaced.

Specification: MIL-S-43926; Suit, Chemical Protective

NSN:  
8415-00-177-5007 (series)



SUIT, CHEMICAL PROTECTIVE-COAT AND TROUSERS (OVERGARMENT)



**Item Name:** Clothing Outfit, Chemical Protective (Shirt, Trousers, Socks and Gloves)

**Climatic Category According to QSTAG 200 Within Which The Item Is Intended To Be Used:** All climatic categories where chemical protection is required.

**Concept of Use:** The Clothing Outfit, Chemical Protective is issued to the individual soldier for an initial two-week wear for liners and one week wear for gloves and socks. The liners are worn under the outer layer of standard environmental clothing.

**Description Of Item:** The outfit consists of XXCC<sub>3</sub> treated liners, shirt and trousers; 3 pair chemical protective, cushion sole socks; and 1 pair chemical protective cotton gloves. All items in the clothing outfit are packaged in a polyethylene bag.

**Materials Used:** The shirt and trouser liners are made of 280 g/m<sup>2</sup> (8.2 oz/yd<sup>2</sup>) (8.2 oz/yd<sup>2</sup>) cotton sateen.

**Color:** Liners - OG 107  
Gloves - OG 109  
Socks - OG 408

**Dimensions:** A packaged clothing outfit measures approximately 38 x 31 x 15 cm (15 x 12 x 6 inches).

**Weight:** 2.2 kg (4 lbs. 15 oz) per outfit (medium size)

**Size Range:** X-Small, Small, Medium, Large, X-Large

**Cost:** \$28.60 per clothing outfit.

**Additional Remarks:** The clothing outfit requires field decontamination and retreatment in the event it becomes contaminated. Unlike the troops in forward areas, rear troops have access to field decontamination and retreatment facilities. The clothing items can be reimpregnated by the individual using the Decontaminating and Reimpregnating Kit, M-13, or can be reimpregnated in field laundry operation. This system was reclassified Standard LCC-8 on 7 Oct. 76. However, it will be used until such time as the gloves and socks in the outfit, and the Glove and Sock Set supplies have been exhausted. At that time a new Clothing Outfit, Chemical Protective (Shirt and Trousers only) will become available.

**NSN:**  
8415-00-782-3240

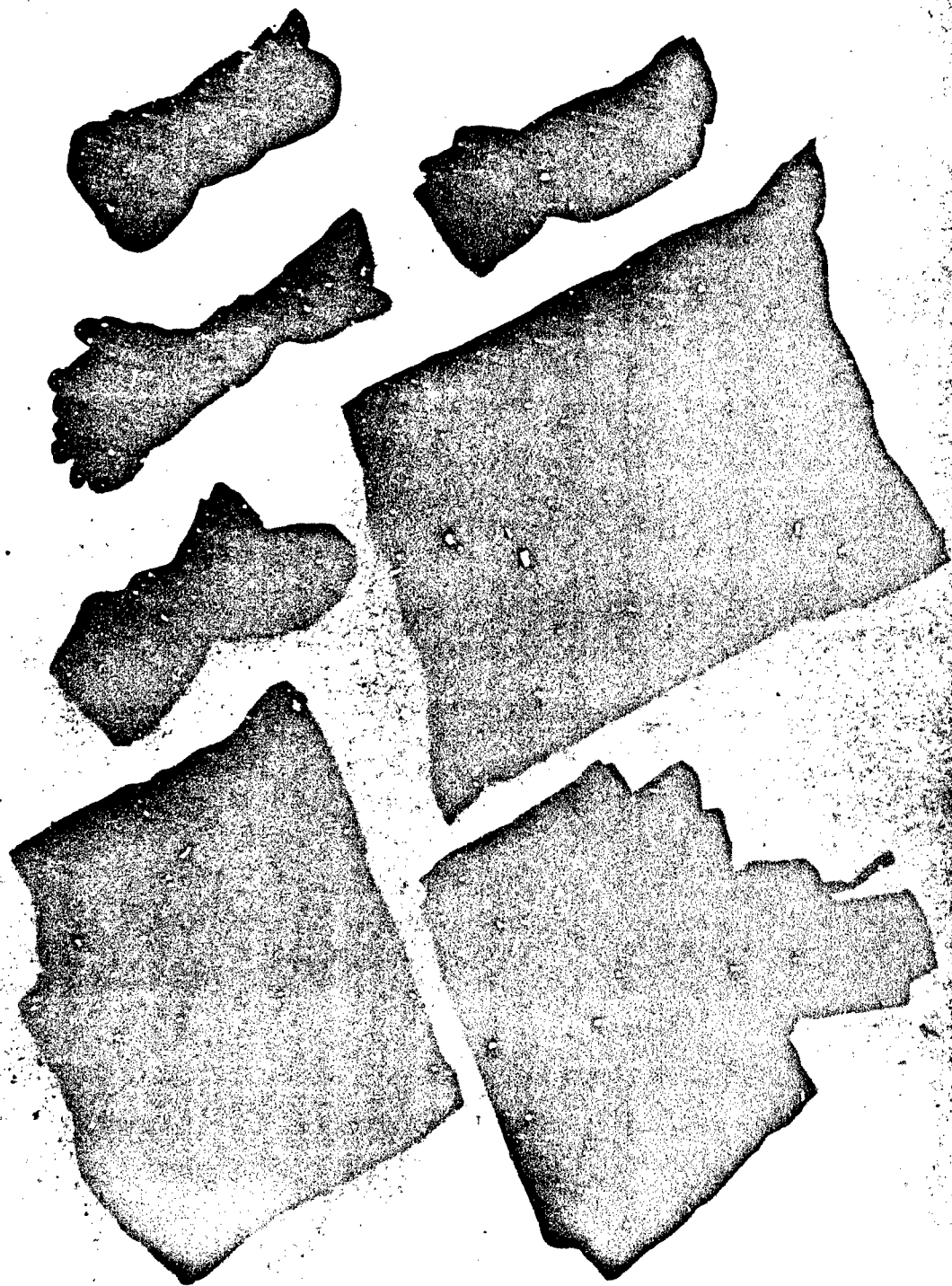

CLOTHING OUTFIT, CHEMICAL PROTECTIVE (SHIRT, TROUSER'S, SOCKS AND GLOVES)

Item Name: Gloves, Combat Vehicle Crewman's, Summer

Climatic Category According to QSTAG 200 Within Which The Item Is Intended To Be Used: To be worn in the same climatic zones as the Shirt and Trousers, Combat Vehicle Crewman (CVC) LIN T03002/X35980.

Concept of Use: To be worn by ground combat vehicle crewman to provide the hands of these persons additional and essential flame protection and increase of the confidence level and survivability in the event of conflict.

Description Of Item: The leather is a perspiration and water resistant cattlehide or horsehide leather; the fabric is a high temperature resistant knitted polyamide simplex cloth.

Color: The leather is black. The fabric is Olive Green 106.

Weight: 57 grams (2 ozs.) per pair (approx.)

Size Range: 7 Sizes - Sizes 5-11

Cost: \$11.50 per pair

Additional Remarks: LP/P DES 13-78, 27 Sep 78, Limited Production Purchase Description for Gloves, Combat Vehicle Crewman's, summer.

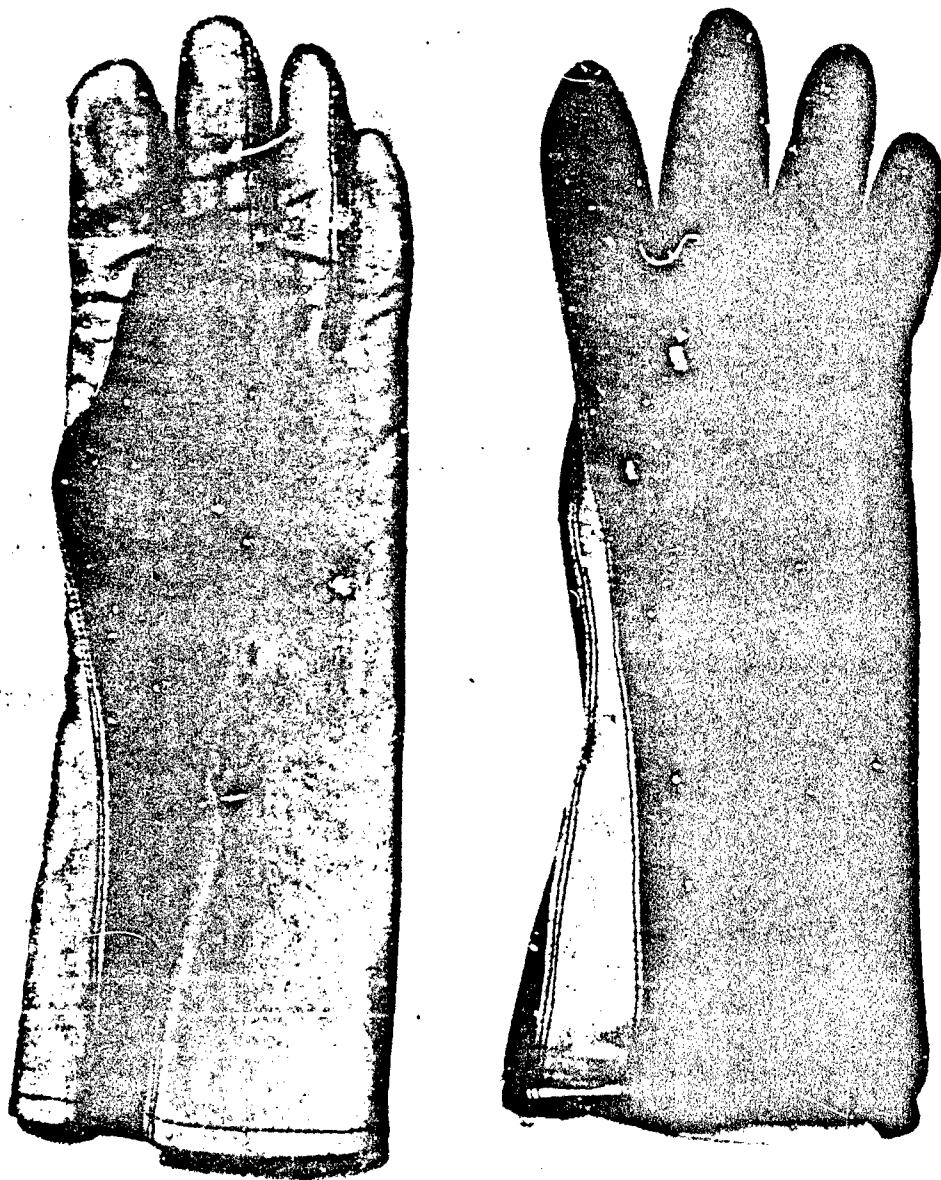

GLOVES, COMBAT VEHICLE CREWMEN'S, SUMMER

Item Name: Glove Set, Chemical Protective

Climatic Category According to QSTAG 200 Within Which The Item Is Intended To Be Used: All climatic categories where chemical protection is required.

Concept of Use: The gloves are used for protection of the hands in a CB environment. For maximum durability the standard leather glove is to be worn over the CB glove.

Description Of Item: The outer impermeable items are five finger gloves manufactured in a right and left hand configuration. The gloves are shaped to follow the natural curvature of the hand in a relaxed position. The inner permeable five finger gloves are ambidextrous.

Materials Used: The impermeable outer gloves are unsupported butyl rubber 0.6 mm (0.025 inch thickness). The inner gloves are cotton (3.4 oz/yd<sup>2</sup>).

Color: The outer gloves are black, and the inner gloves are white.

Dimensions: The minimum outer glove length is 36 cm (14 inches).

Weight: .17 kg (6 ozs.) for a complete glove set - size small.

Size Range: 4 sizes (S, M, L, XL) for the outer gloves, and 2 sizes (S, M) for the inner gloves.

Cost: \$5.00 per set

Additional Remarks: Specification: MIL-G-43976; Glove Set, Chemical Protective

NSN:  
8415-01-033-3517 (series)



GLOVE SET, CHEMICAL PROTECTIVE

Item Name: Gloves and Socks Set, Chemical Protective

Climatic Category According to QSTAG 200 Within Which The Item Is Intended To Be Used: All climatic categories where chemical protection is required.

Concept of Use: The gloves and socks set will be issued along with the Suit, Chemical Protective and as a replacement item for the Socks and Gloves, Chemical Protective in the Clothing Outfit, Chemical Protective until such time as the new standard Glove Set, Chemical Protective and Footwear Covers, Chemical Protective (overboots) become available.

Description Of Item: The set consists of 3 pair of XXCC3 treated socks and 1 pair of XXCC3 treated gloves.

Materials Used: Gloves - cotton knit  
Socks - 50% wool, 30% nylon, 20% cotton

Color: Gloves - OG 109  
Socks - OG 408

Dimensions: A packaged Gloves and Socks Set measures approximately 25 x 13 x 8 cm (10 x 5 x 3 inches).

Weight: A packaged set (size medium) weighs 0.54 kg (1 lb. 3 ozs.)

Size Range: X-Small, Small, Medium/Large

Cost: \$9.03 per set

Additional Remarks: NSN:  
8415-00-151-6505 (series)

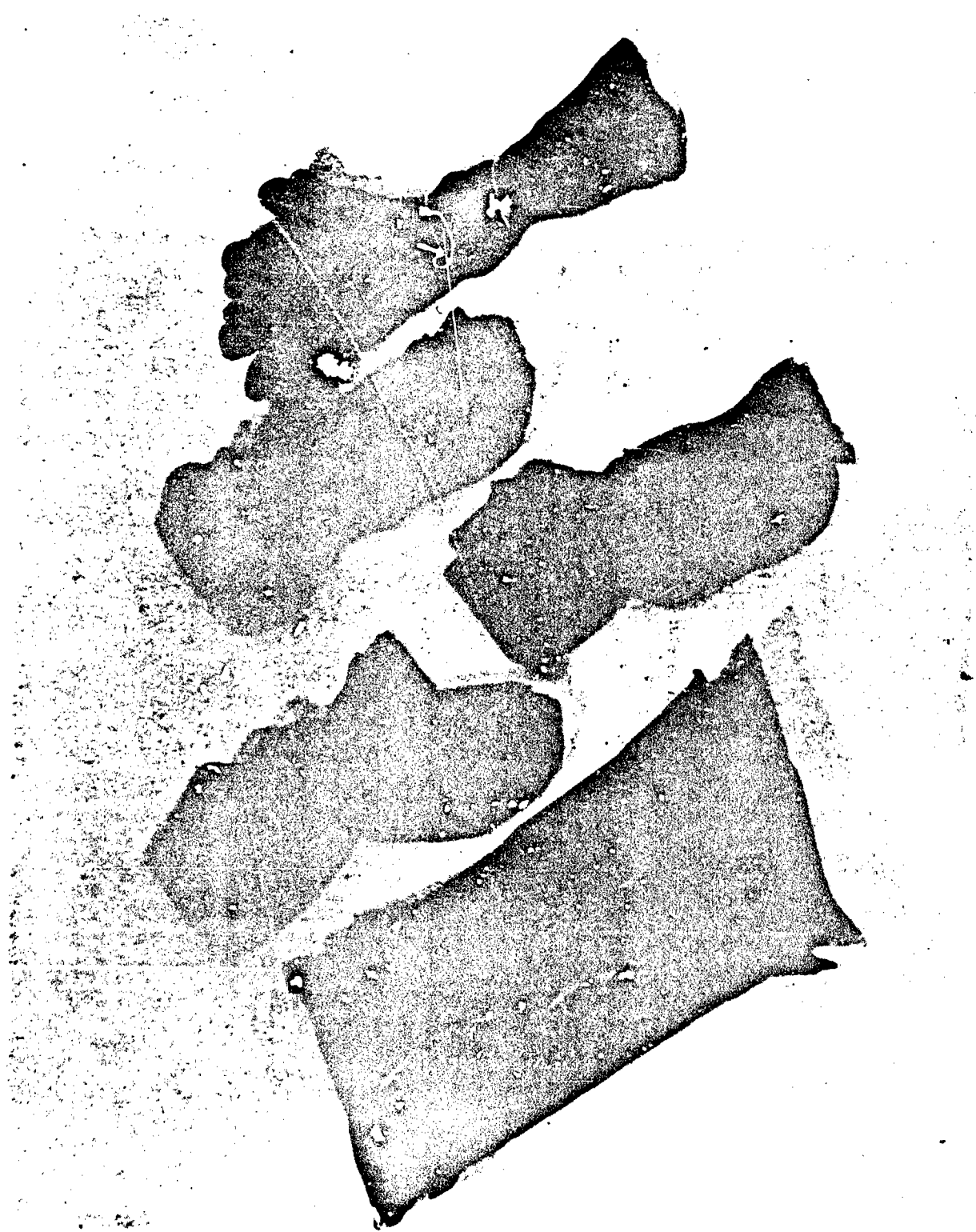

GLOVES AND SOCK SET, CHEMICAL PROTECTIVE



Item Name: Footwear Cover, Chemical Protective (Over Boots)

Climatic Category According to QSTAG 200 Within Which The Item Is Intended To Be Used: All climates where chemical protection is required.

Concept of Use: The footwear cover provides protection against chemical agents.

Description Of Item: Approximately 41 cm (16 inches) high with a grommet and lace closure.

Materials Used: Unsupported butyl sheet rubber with a pre-molded, non-slip butyl rubber sole.

Color: Black

Weight: 0.41 kg (14.5 ounces ) per boot

Size Range: One size

Cost: \$10.00

Additional Remarks: Specification: LP/P.DES 17-76; Footwear Cover, Chemical Protective

NSN:  
8430-01-021-5973

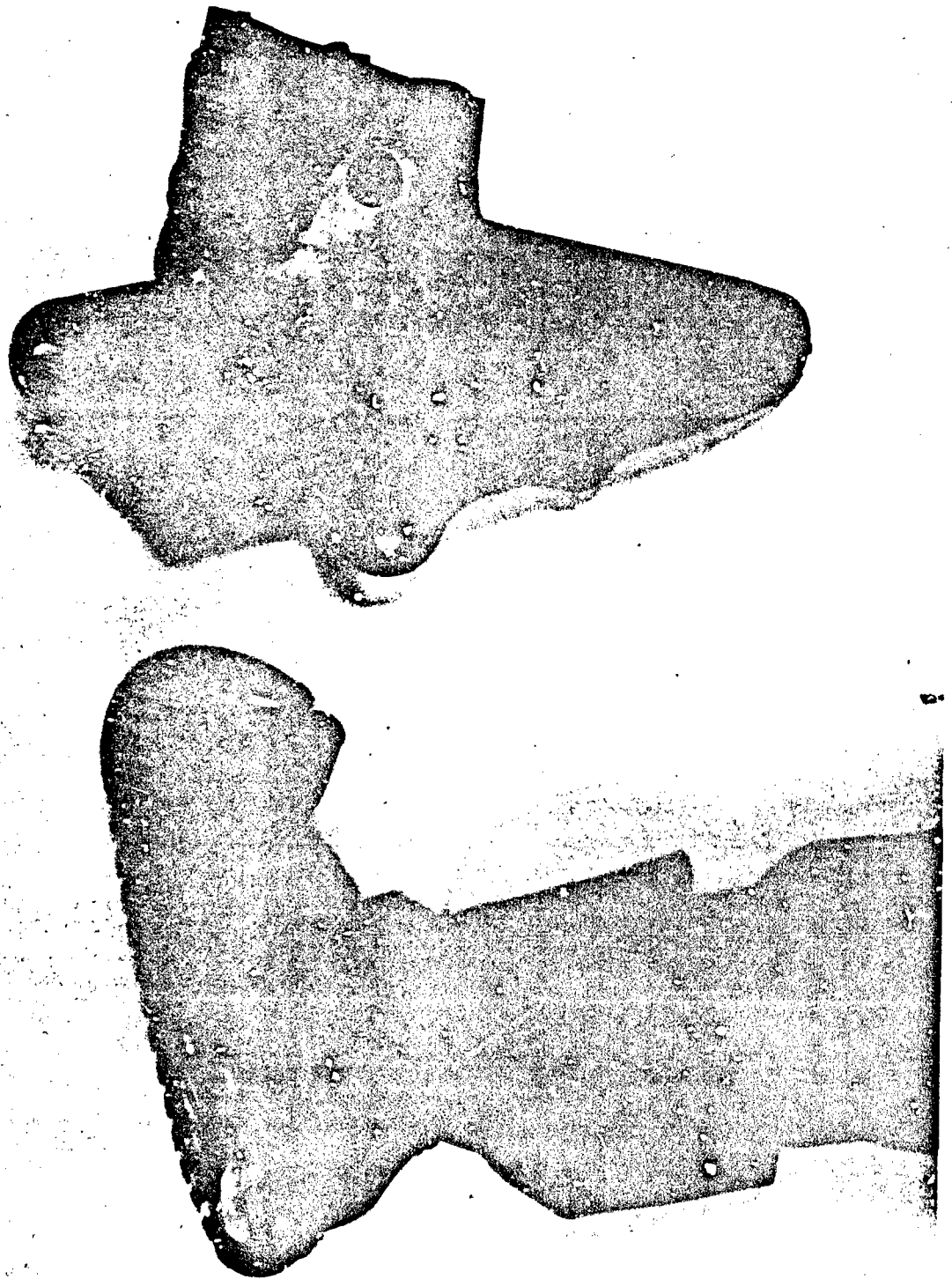

FOOTWEAR COVER, CHEMICAL PROTECTIVE (OVERBOOTS)

Item Name: SPH-4 Flight Helmet

Concept of Use: The helmet provides protection of head as well as positioning of earphones and microphones.

Description Of Item: Standard Army aviator's helmet, without modifications specifically made for CB warfare.

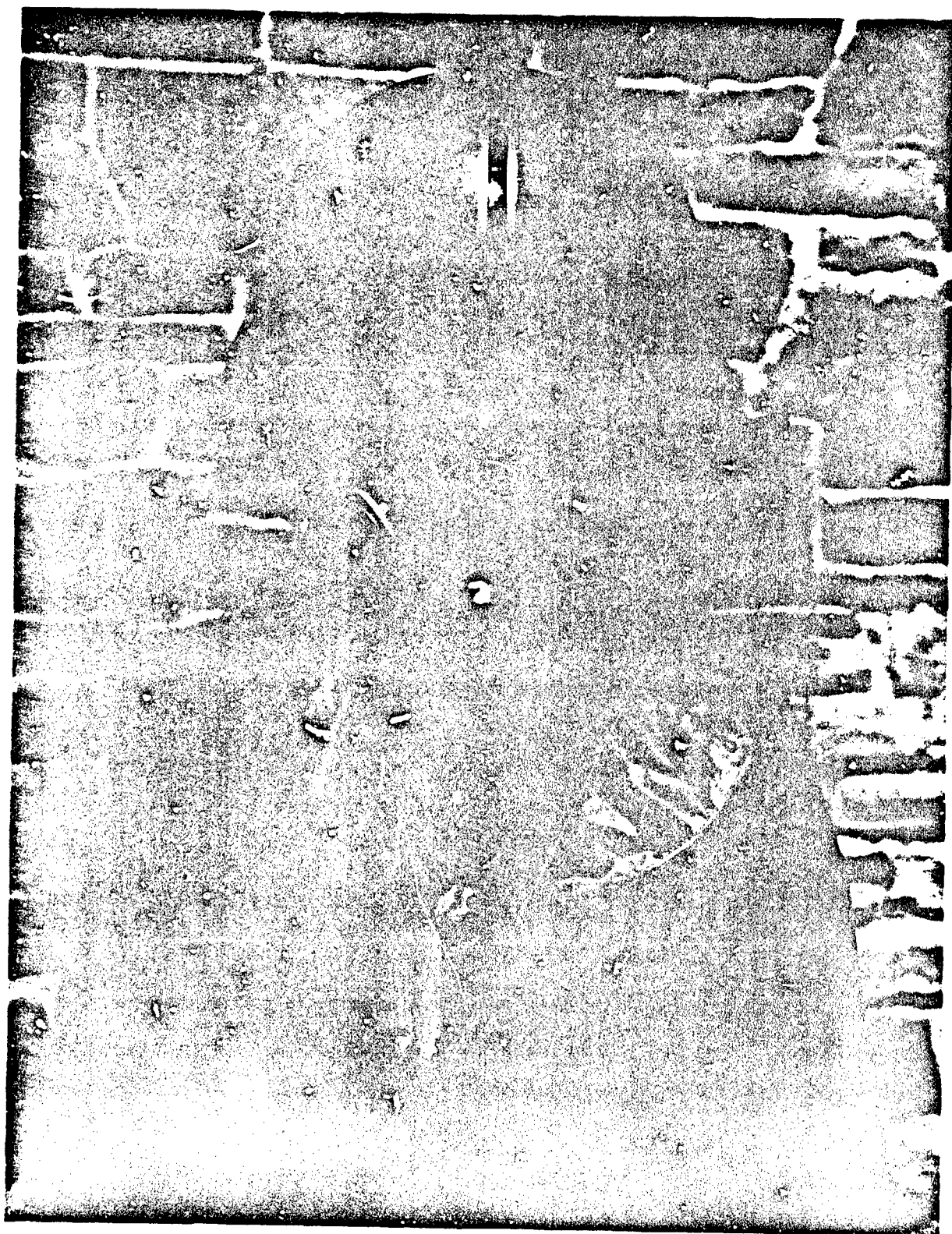

AVIATOR WEARING: XM-29 MASK  
SPH-4 FLIGHT HELMET  
M-9 CB PROTECTIVE HOOD  
(HOOD UNDER HELMET)

Item Name: Protective Hood M-9

Concept of Use: Specifically for use by Army aviators in CB mode, worn under or over SPH-4 flight helmet. Covers head and neck of wearer. Protects areas of skin not covered by the mask against vapors, aerosols, and droplets of chemical and biological agents.

Description Of Item: Zippers down front from chin to middle of chest. Lift-a-dot snaps on each side of mask at cheekbone positions the hood, and an electric edge around periphery seals and secures hood to the mask face piece.

Materials Used: Butyl rubber coated with nylon cloth. Material is compatible with decon solutions.

Item Name: XM-29 CB Protective Mask

Concept of Use: Provides filtered air for breathing, as well as CB protection and visual lens for eyes. Provides moisture removal from face by sweat evaporation into air being breathed.

Description: Lens design and flexibility of lens material, allows flexing to position lens for focal length compatible with optical sights. Material is largely silicone, with a transparent coating on lens to prevent absorption of agents, and harden surface to prevent scratches. Canister may be directly mounted on cheek, or waist mounted with inter-connecting flex tube.

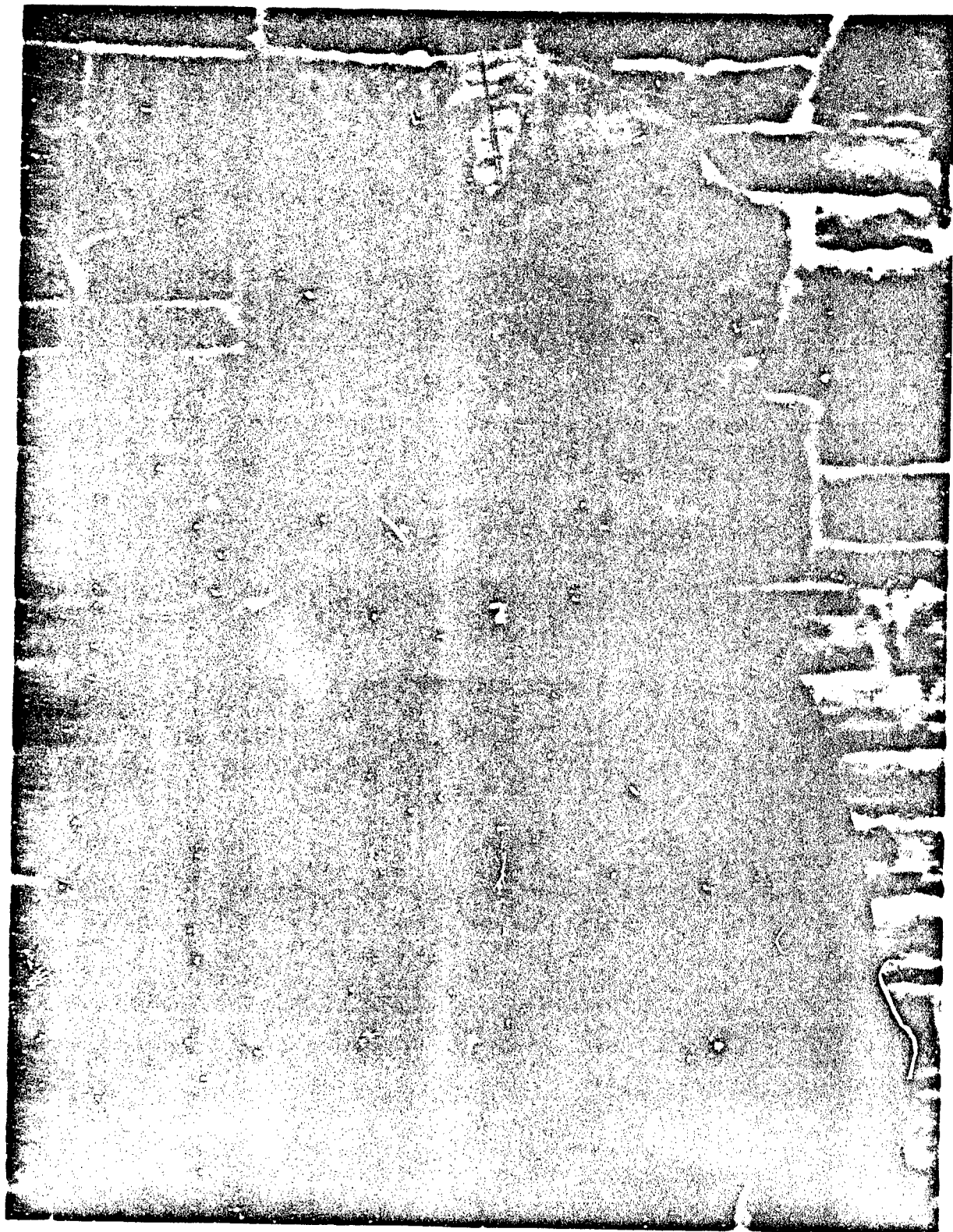

AVIATOR WEARING: XM-29 MASK  
SPH-4 FLIGHT HELMET  
M-9 CB PROTECTIVE HOOD  
(HOOD OVER HELMET)

Item Name: Liquid Cooled Vest

Climatic Category: Necessary for the crews of certain vehicles under the chemical protective overgarment, in hot-moist or hot-dry climates.  
To Be Used: Use optional in cold climates.

Concept of Use: The liquid cooled vest will be issued to helicopter airmen and others in combat zones where the chemical protective overgarment is issued, and where a supply of cooled liquid is available. It is used where a high work level must be maintained in direct sunlight, or particularly high surrounding air temperature.

Description Of Item: The liquid cooled vest has a front zipper entrance for easy donning and doffing. It consists of an efficient liquid transport manifold attached to a stretchable power net material. These materials are not bulky and are highly flexible for good comfort and no degradation to the wearer's mobility. Built into the manifold is a network of parallel liquid flow channels, which permit an even circulation of fluid. When the vest is worn, these channels are in close contact to the surface of the body resulting in high conductive heat transfer between the surface of the manifold and the body. A short umbilical with a quick release disconnect permits the inlet and outlet liquid flow from the available cooled liquid source to circulate through the vest. The quick release disconnect is designed not to leak fluid when disconnected and to release easily in the event of an emergency egress from the cockpit.

Materials Used: The liquid transport manifold is constructed from two thin layers of polyurethane coated nylon. Each layer of material is less than 6 mils in thickness. The stretchable power net is spandex.

Status: This item is under development and is expected to be available in the 1983-1985 time period.

Estimated Unit Cost: It is estimated that this item, less disconnect hardware and in production of 500 or more, will cost less than \$100 per vest.

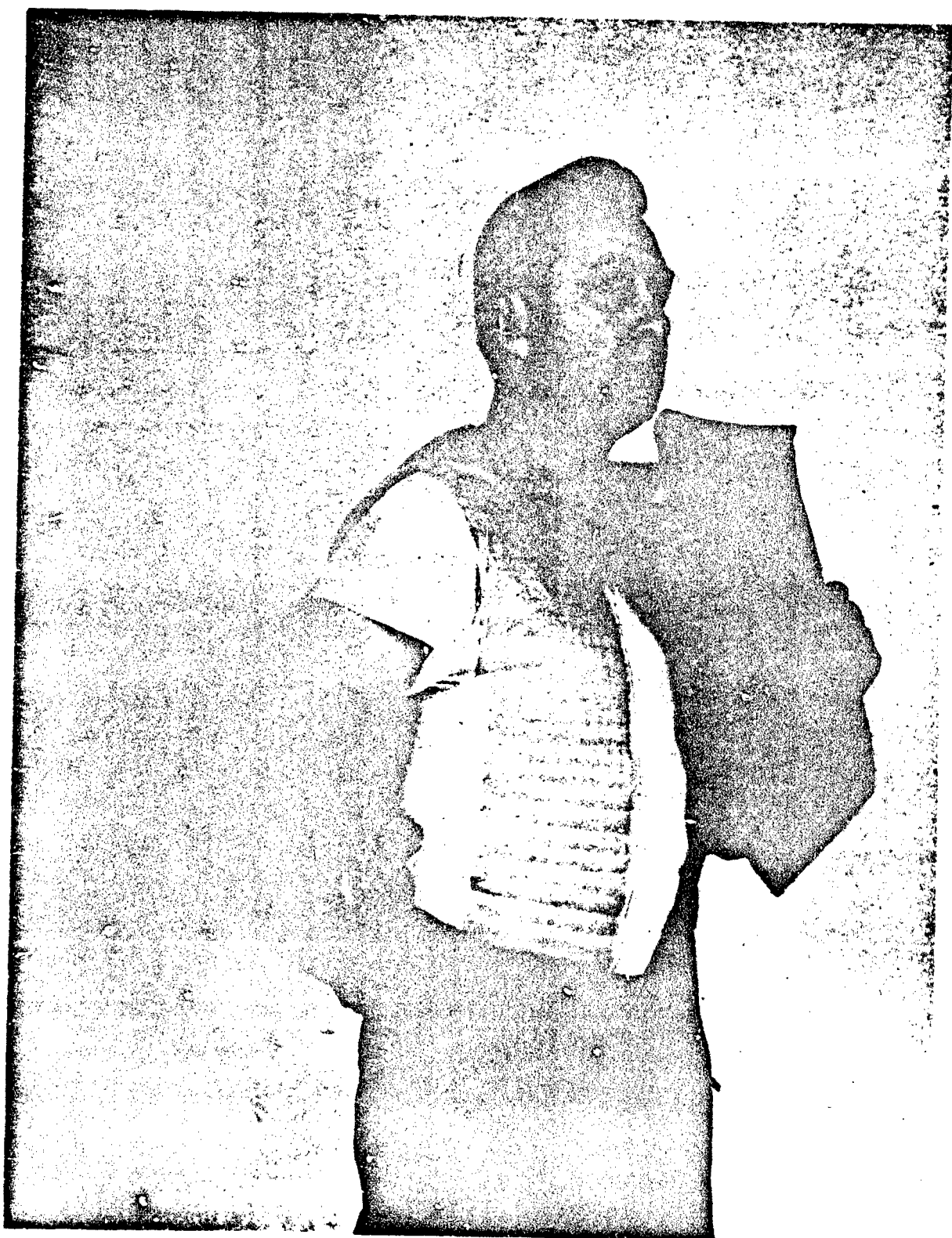

LIQUID COOLED VEST



APPENDIX B

HEAT BURDEN ASSESSMENT

This assessment has been prepared in response to a request from John Nason of the Hamilton Standard Division of United Technologies dated January 23, 1979. The results have been coordinated by Mr. Vincent Iacono, NLABS-CEMEL.

The assessment models the stated mission profile of the AAH crewman against four standard uniform ensembles in a tropical and a desert environment to allow a comparison of the physiological effects resulting from individual heat burden.

Conducted by:

Jeffrey Manickas  
Mathew L. Herz  
OR/SAO at NARADCOM (NLABS)  
Natick, MA 01760

(20 February 1980)

Table B-1

AAH Mission Profile

<u>Activity</u>	<u>Time (min)</u>	<u>Cumulative Time (min)</u>	<u>Work Load (Watts)</u>	<u>Environment</u>
Transport to Aircraft	15	15	90	Ambient <sup>a</sup>
Checkout	69	84	109	Cockpit <sup>b</sup>
Fly to Combat	16	100	109	"
Combat	44	144	150	"
Fly to FARRP	17	161	109	"
Rearm/Refuel	20	181	107	"
Fly to Combat	16	197	107	"
Combat	44	241	150	"
Fly to FARRP	17	258	107	"
Rearm/Refuel	20	278	516	Ambient <sup>a</sup>

<sup>a</sup>Ambient Sea Level - Desert 120°F and 5% relative humidity or Warm/moist 100°F and 63% relative humidity both with 0.3 ft/sec wind speed.

<sup>b</sup>Cockpit Sea Level - Desert 85°F and 14% relative humidity or Warm/moist 85°F and 42% relative humidity both with 1.0 ft/sec wind speed.

TABLE B-2

Heat Casualty Calculations for AAH Mission Profile in Desert and Tropic Environments

Environment	Clothing Ensemble	Equilibrium Values <sup>a</sup>				After Rearm/Refuel	
		Risk (%)	Rectal Temp (°C)	Heat Stress (Kcal/hr)	Risk (%)	Rectal Temp (°C)	Heat Stress (Kcal/hr)
Desert <sup>b</sup>	Tropical	0.0	38.0	58	21.1	38.96	114
	Airman (CVC Summer)	0.0	38.3	76	39.3	39.36	137
	Full CB	6.4	38.5	87	52.2	39.82	164
	Impermeable	15.4	38.7	99	69.7	40.30	192
Warm/Moist <sup>c</sup>	Tropical	0.0	38.2	70	38.4	39.44	142
	Airman (CVC Summer)	4.8	38.4	81	53.0	39.84	165
	Full CB	10.0	38.5	87	58.1	39.98	173
	Impermeable	17.4	38.7	99	68.5	40.27	190

<sup>a</sup>Equilibrium Values are increased at the beginning of second combat mission and approximate the values which would result from several continuous combat/rest cycles.

<sup>b</sup>Desert Environment with ambient conditions 120°F, 5% relative humidity and 85°F, 14% RH in cockpit.

<sup>c</sup>Warm/Moist Environment with 100°F, 63% relative humidity ambient and 85°F, 42% RH in cockpit.

Table B-3

Calculated Equilibrium Rectal Temperature (in excess of 37°C)

For AAH Mission Profile

<u>Environment</u>	<u>Clothing Alternative</u>			
	<u>Tropical</u>	<u>Airmen</u>	<u>Full CB</u>	<u>Impermeable</u>
Desert	1.0	1.3	1.5	1.7
Warm/Moist	1.2	1.4	1.5	1.7

Analysis of Variance

	<u>SS</u>	<u>df</u>	<u>Mean Square</u>	<u>F-Ratio</u>	<u>Significance</u>
Weather	0.01125	1	0.01125	2.45	NSD
Clothing	0.38375	3	0.1279	27.91	98% Probability
Error	0.01375	3	0.004583		
Total	0.40875	7			

Conclusions:

1. Cannot reject the hypothesis that there is no environmental effect.
2. Significant differences exist in clothing effects (most likely due to varying levels of permeability, etc.).

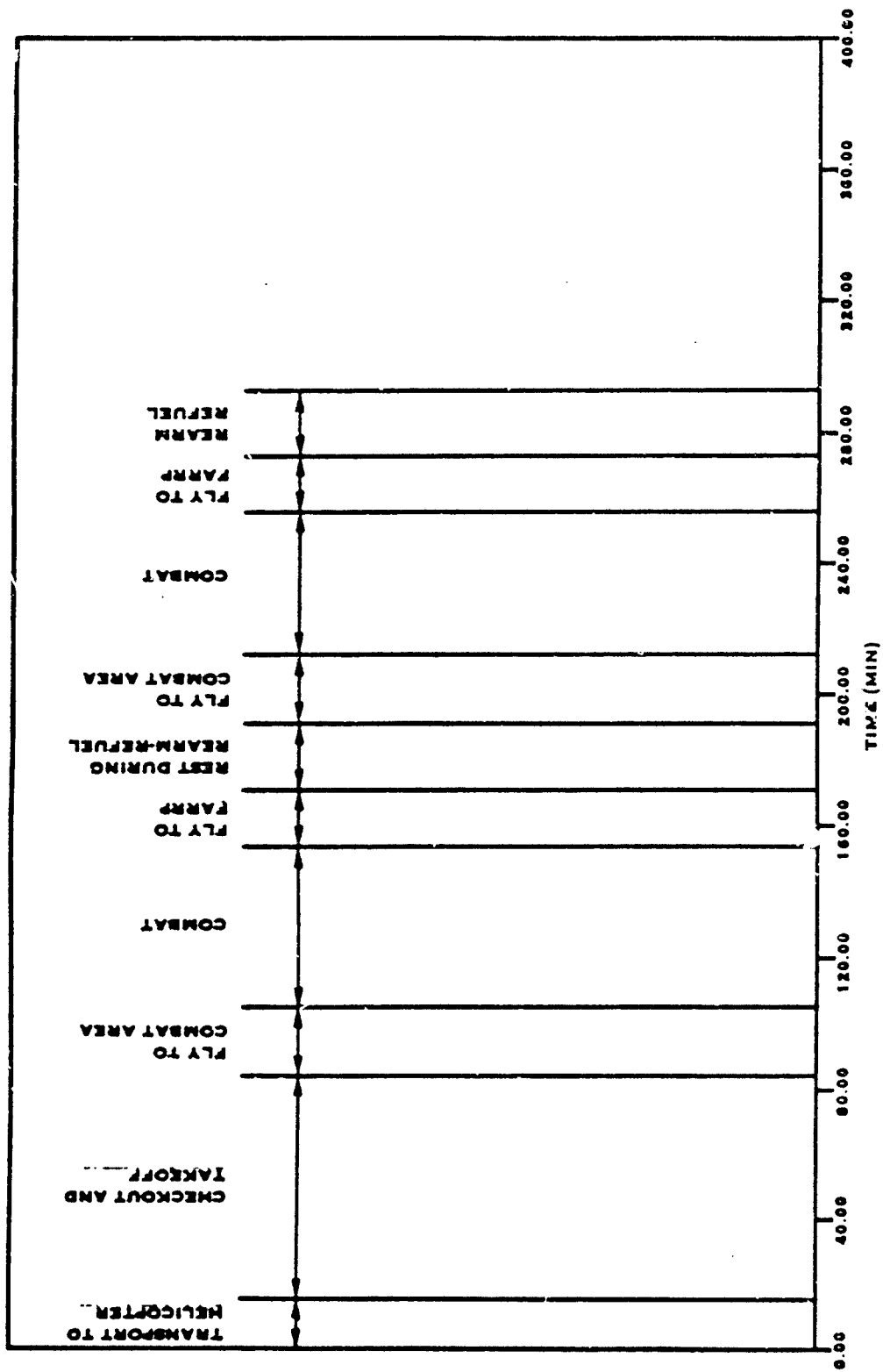

TIME-LINE USED IN HEAT CASUALTY ASSESSMENT CURVES OF THIS APPENDIX.  
 (ADAPTED FROM "STANDARD HELICOPTER COMBAT DAY" OF SECTION 1.d.1.  
 OF REPORT TO WHICH THIS APPENDIX IS ATTACHED.

# HEAT CASUALTY ASSESSMENT

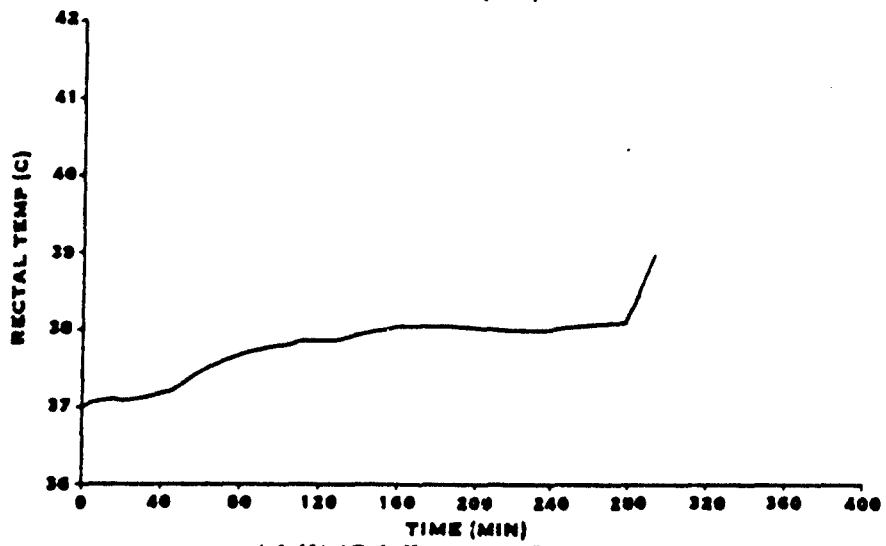
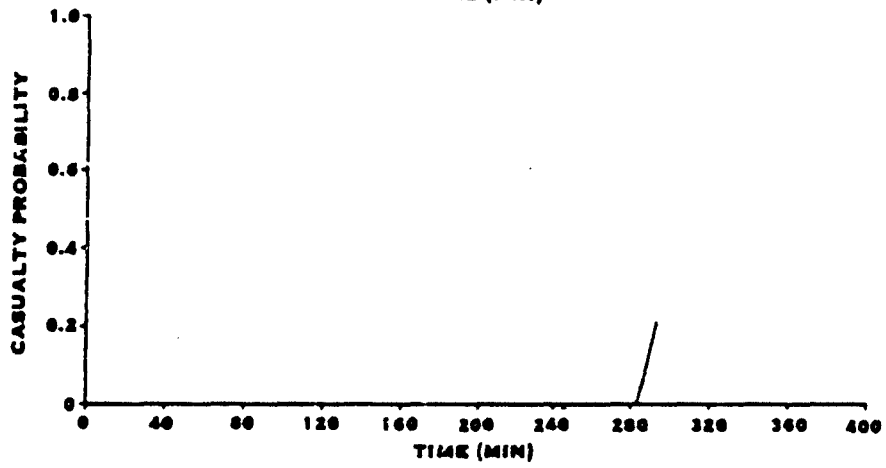
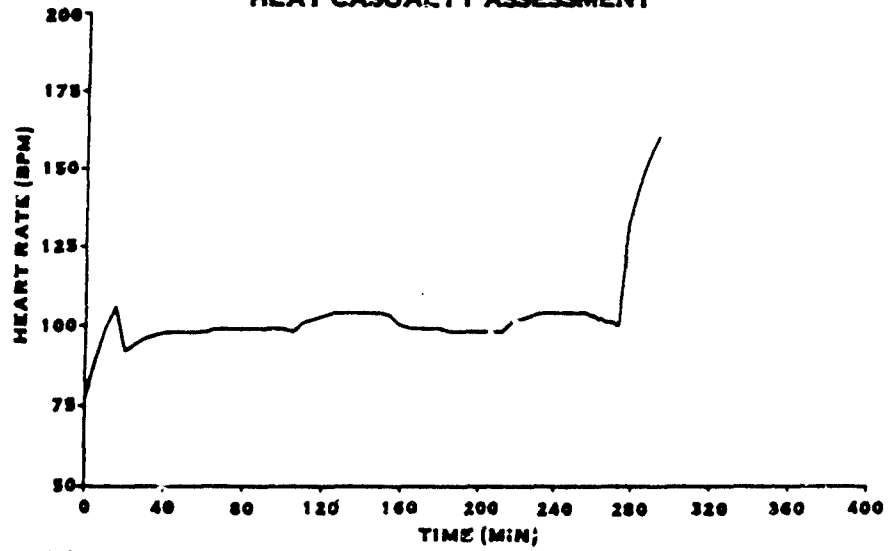

TROPICAL UNIFORM • DESERT ENV (120°F 5% HUM)

# HEAT CASUALTY ASSESSMENT

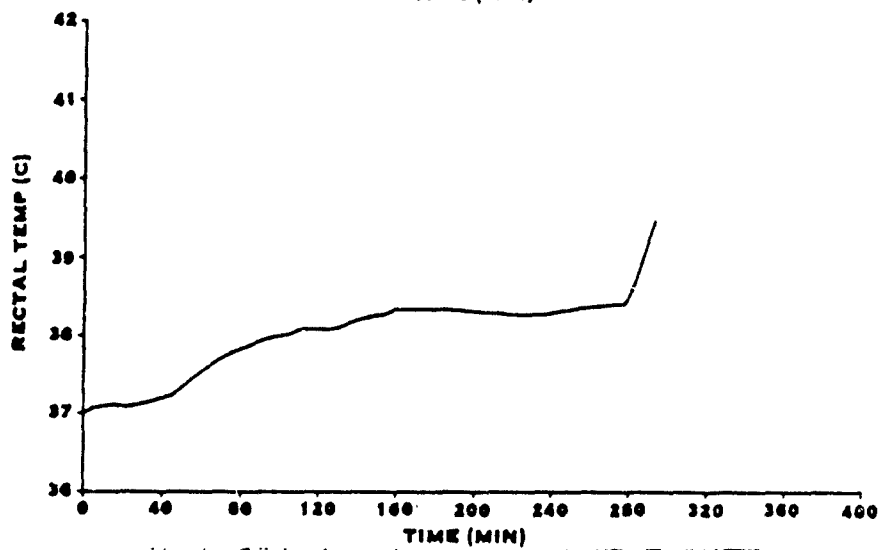
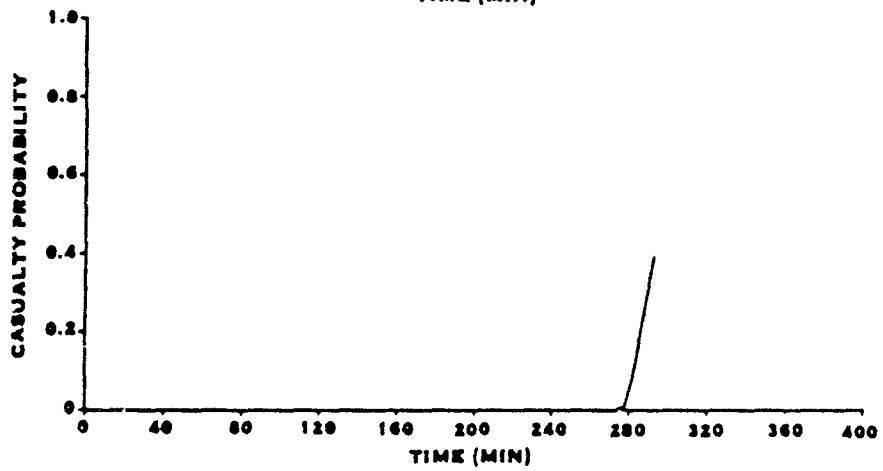
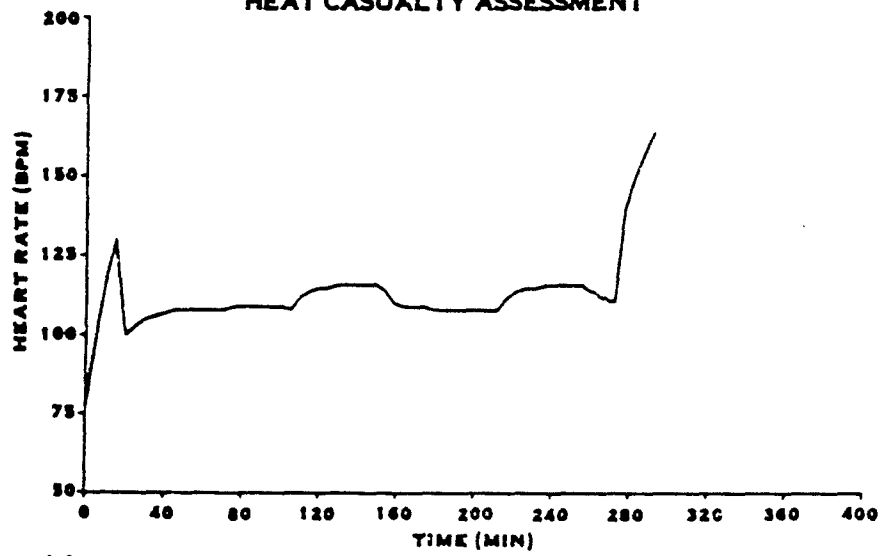

CVC SUMMER UNIFORM \* DESERT ENV (120°F - 1% HUM)



# HEAT CASUALTY ASSESSMENT

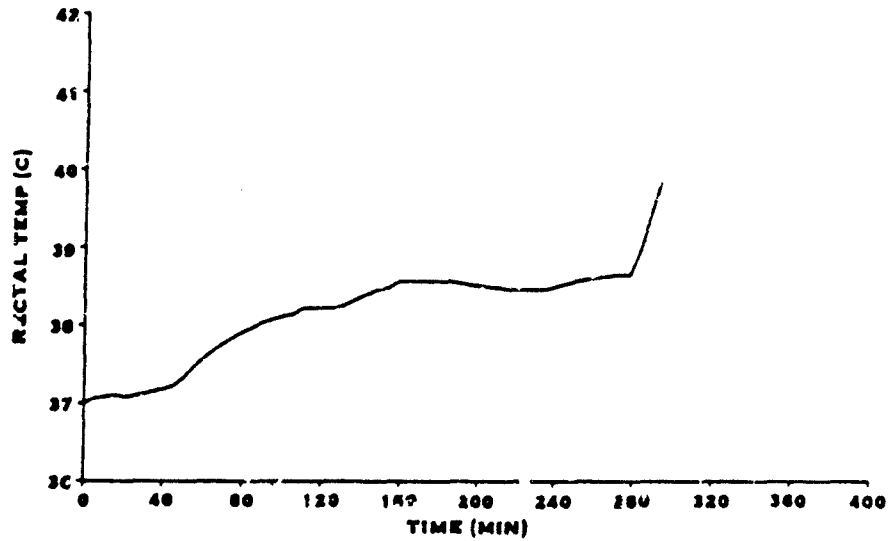
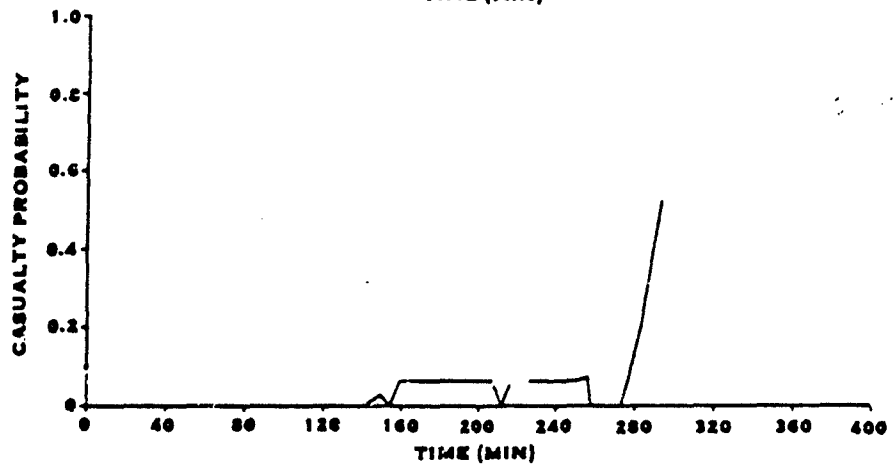
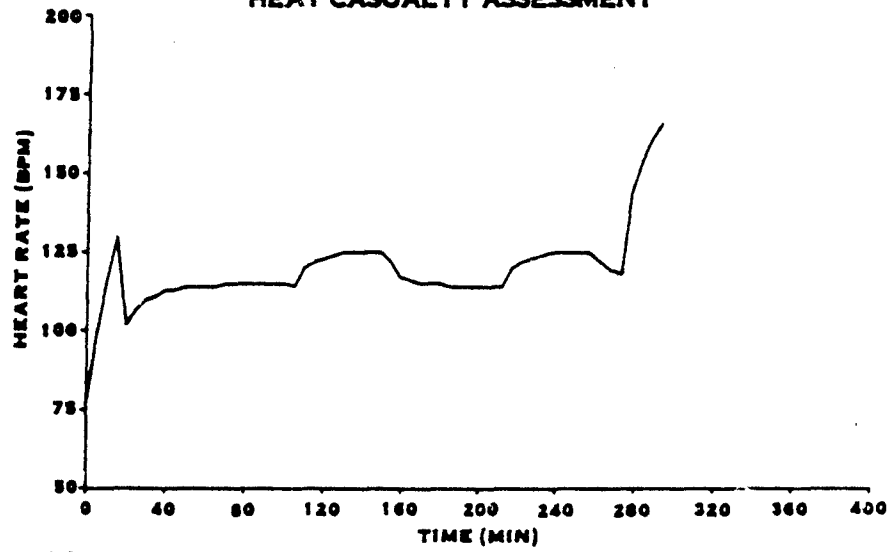

FULL CB ATTIRE • DESERT ENV (120°F 5% HUM)

# HEAT CASUALTY ASSESSMENT

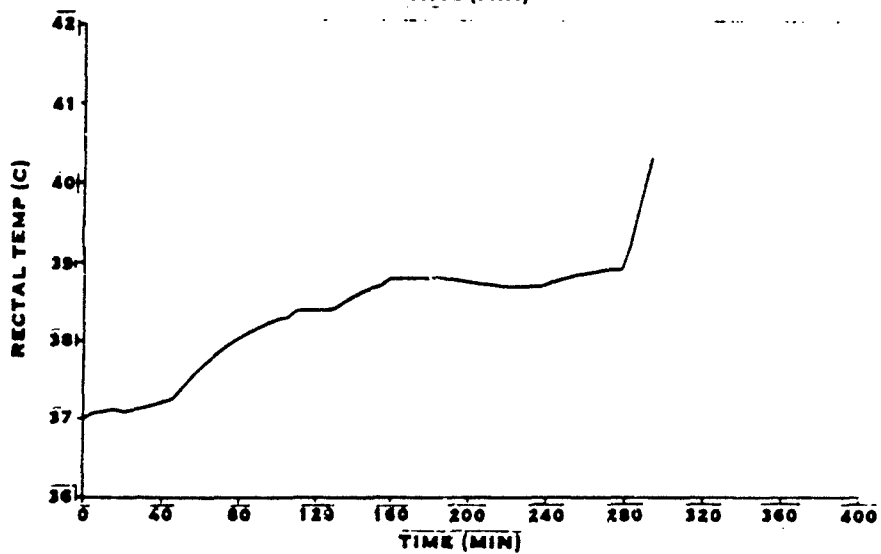
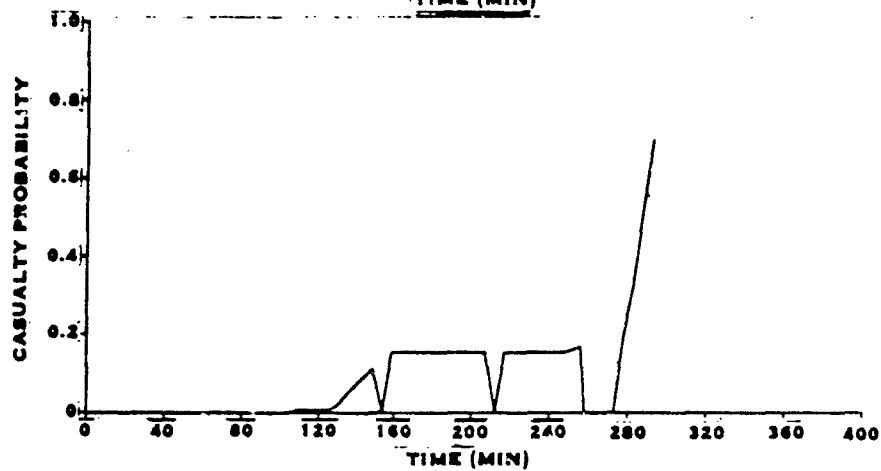
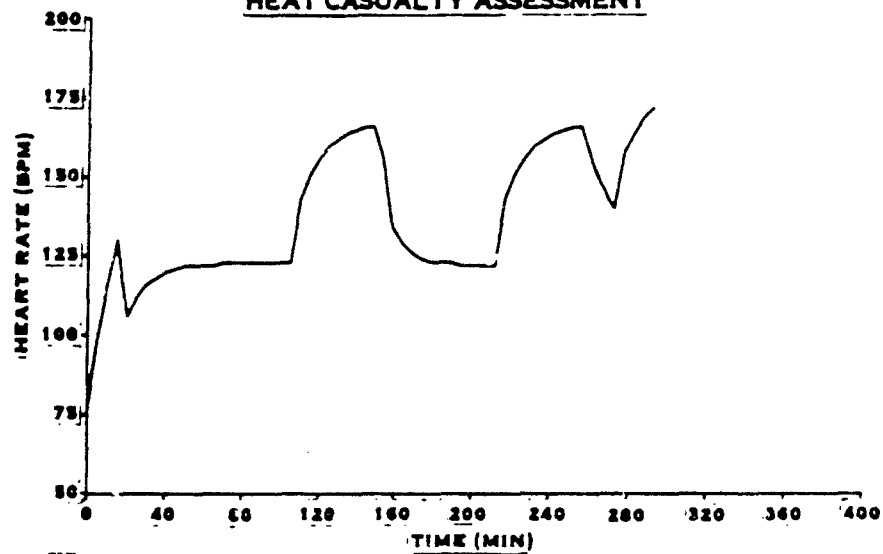

IMPERMEABLE SUIT • DESERT ENV (120°F 5% HUM)

# HEAT CASUALTY ASSESSMENT

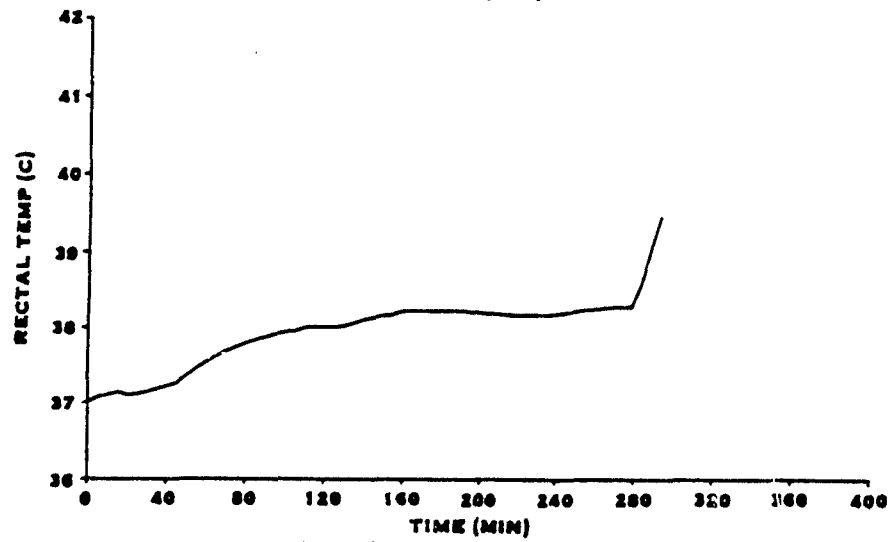
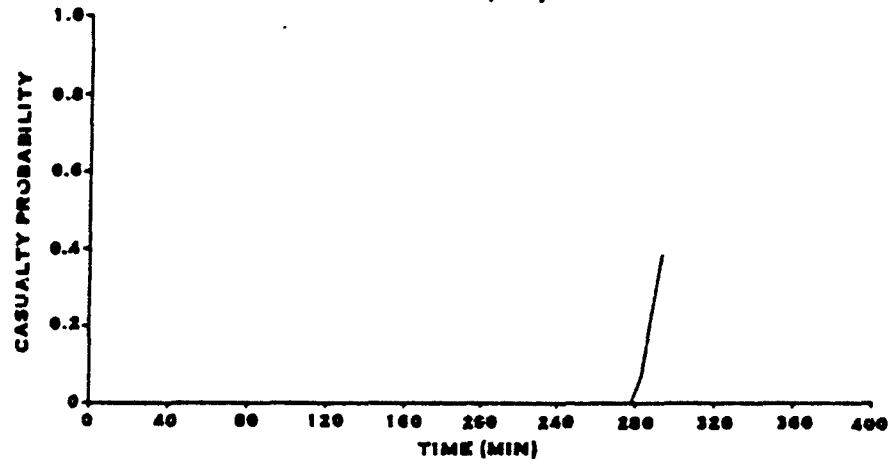
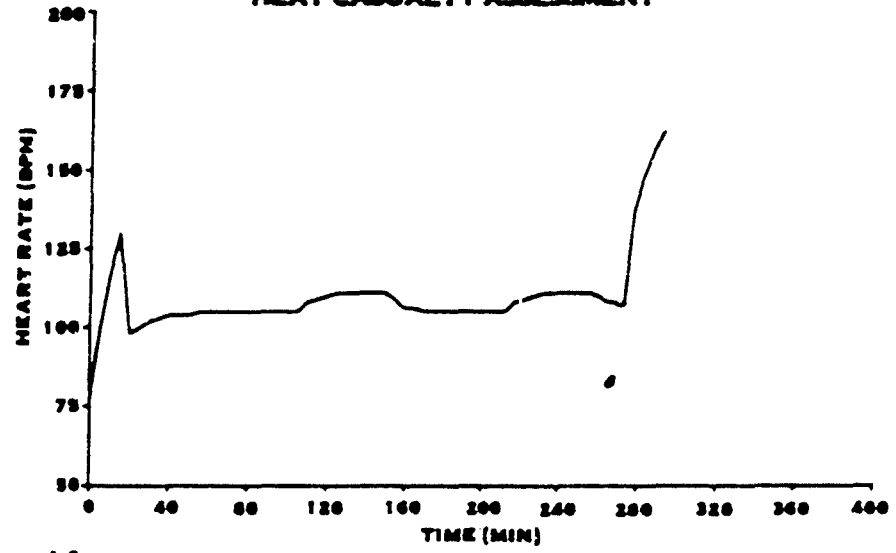

TROPICAL UNIFORM • WARM/MOIST ENV (100°F 63% HUM)

# HEAT CASUALTY ASSESSMENT

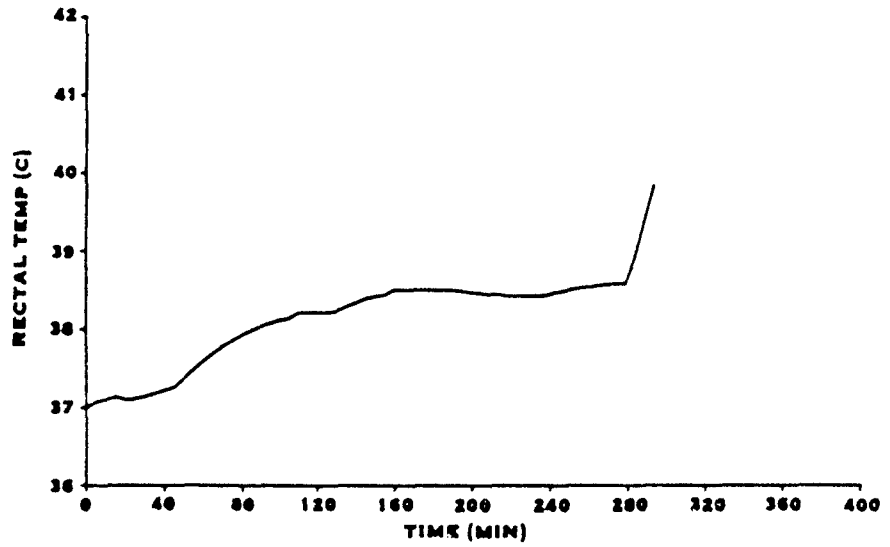
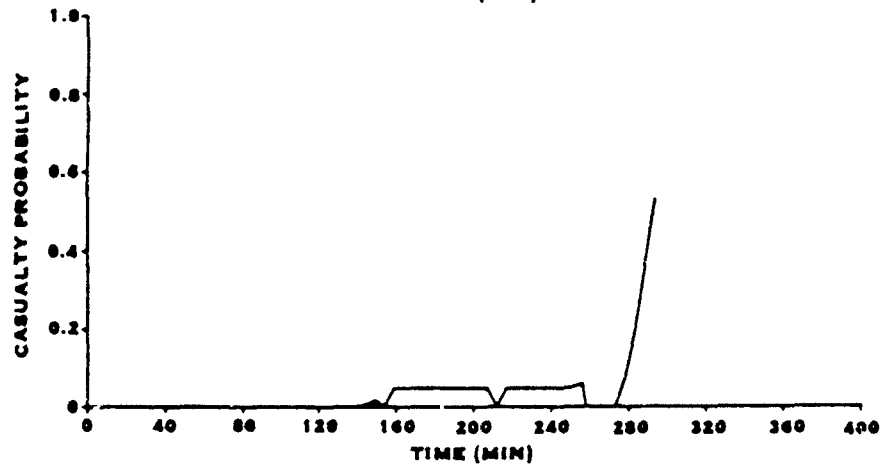
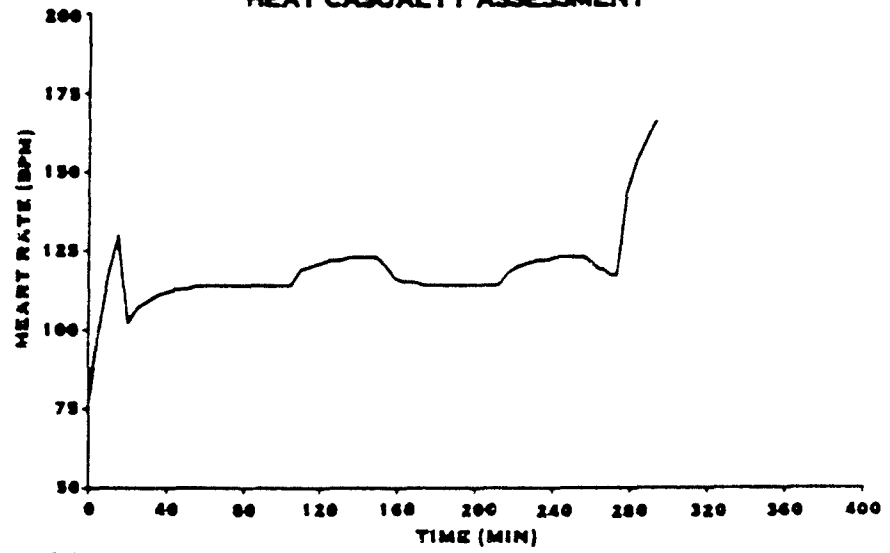

CVC SUMMER UNIFORM • WARM/MOIST ENV (100°F 63% HUM)

# HEAT CASUALTY ASSESSMENT

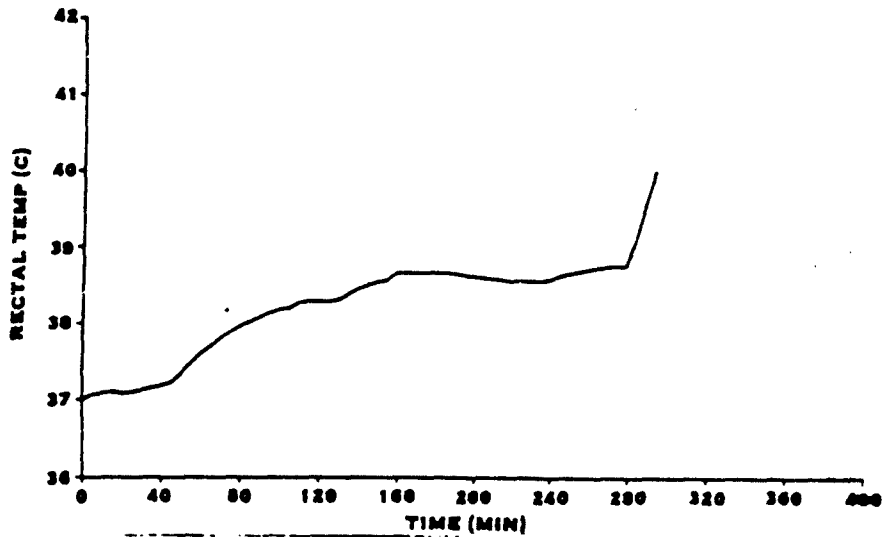
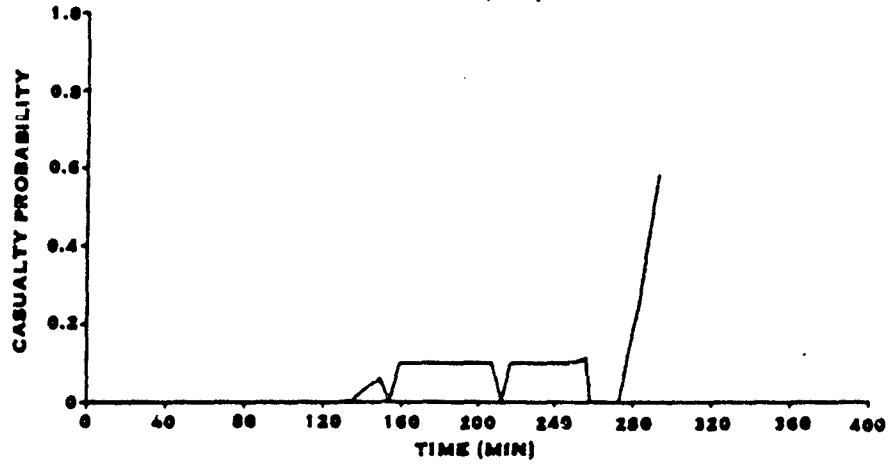
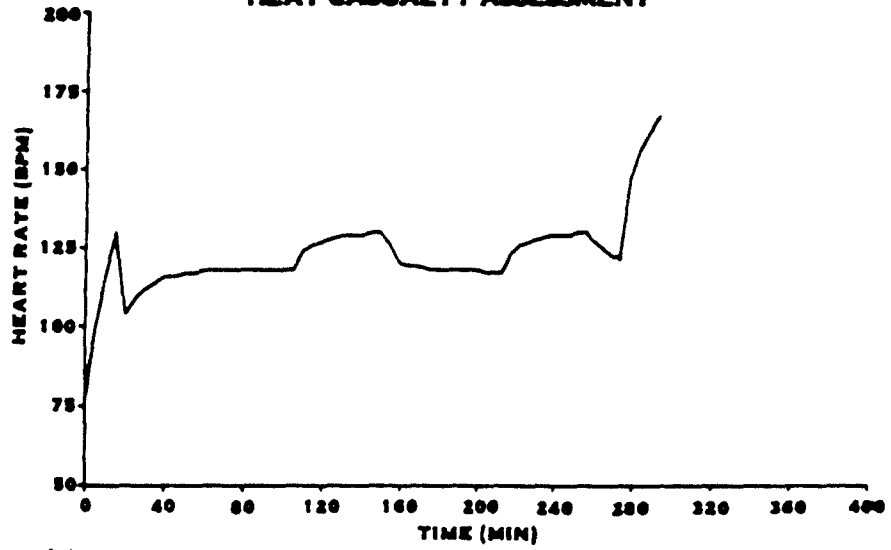

FULL CB ATTIRE • WARM/MOIST ENV (100°F 63% HUM)

# HEAT CASUALTY ASSESSMENT

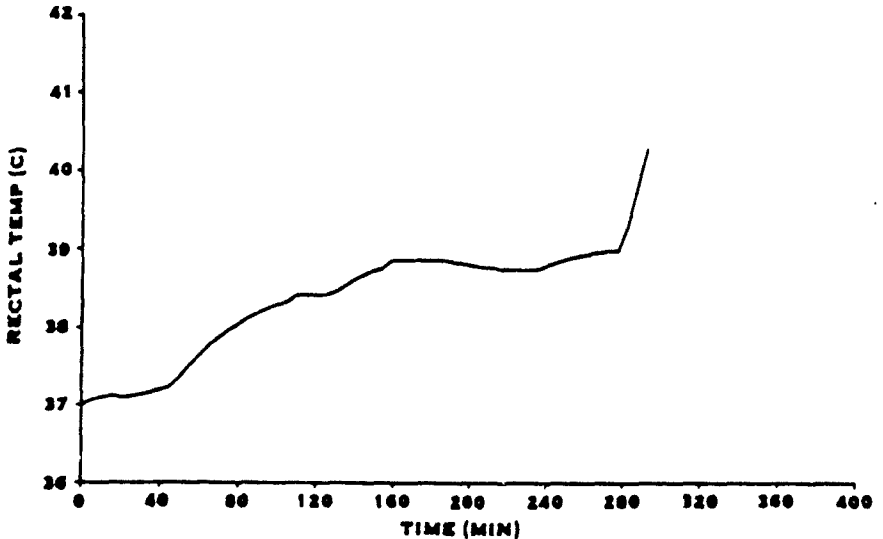
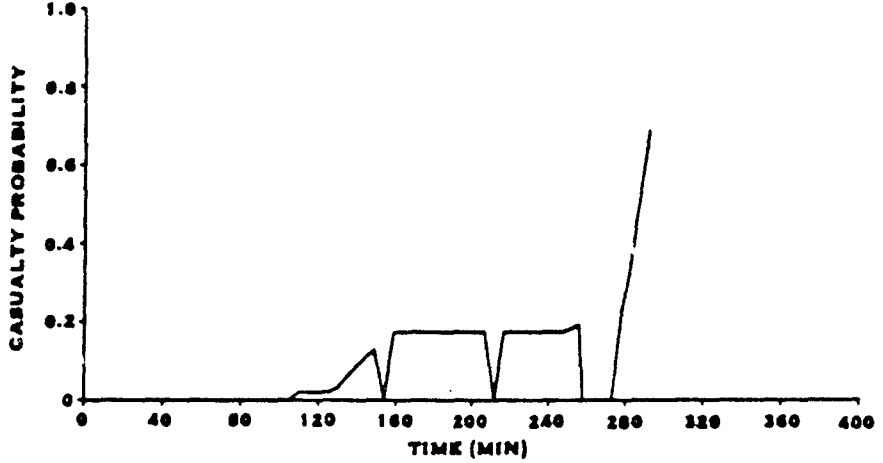
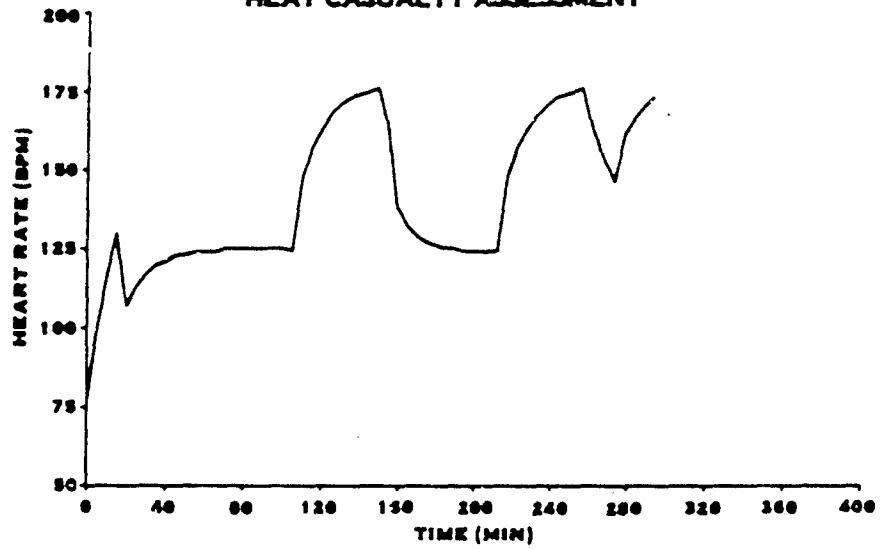

IMPERMEABLE SUIT • WARM/MOIST ENV (100°F 63% HUM)

TITLE FOR VOLUME 2

STUDY TO DETERMINE THE CB THREAT AND DEFINE ALTERNATIVE CREW PROTECTION SYSTEMS FOR THE ADVANCED ATTACK HELICOPTER (AAH) Vol. 2 (U).

GLOSSARY OF ABBREVIATIONS AND ACRONYMS

AAH	Advanced Attack Helicopter
APS	Air Particle Separator
APU	Auxiliary Power Unit
CB	Chemical and Biological
CEMEL	Clothing, Equipment & Materials Engineering Laboratory
CK	Cyanogen Chloride
clo	Unit of measurement for clothing insulation resistance
COP	Coefficient of Performance
C.P.G.	Co-pilot Gunner
CPR	Cabin Pressure Regulator
CSL	Chemical Systems Laboratory (Aberdeen, MD)
CVC	Combat Vehicle Crewman
DS2	Decontaminant Solution for GD and HD Agents
ECS	Environmental Control System
ECU	Environmental Cooling Unit
FARRP	Forward Area Refueling and Rearming Point
G-Agents (GA, GB, GD)	Nerve Agents
HD	A blister agent (Mustard)
HEL	Human Engineering Laboratory (Aberdeen, MD)
HS	Hamilton Standard
HTB	High Test Bleach
HX	Heat Exchanger
$i_m$	Unit of measurement for clothing permeability
NARADCOM (NLABS)	Natick Research and Development Laboratories
PIP	Product Improvement Proposal
PM	Program Manager
PMO	Program Management Office
PPM	Parts Per Million
R&D	Research and Development
RH	Relative Humidity
SDC	Shaft Driven Compressor
STB	Super Tropical Bleach
USAVN	U.S. Army Aviation
VX	A thickened G-agent



DISTRIBUTION LIST

Mr. Bernard Corona Director US Army Human Engineering Laboratory Aberdeen Proving Ground, AD 21005 (1)	A. R. Jeffers Aeronautical Systems Division Wright Patterson AFB, OH 45433 (1)
T. J. Cox/CPT Wert, Commanding Officer Office of the Commander Aeronautics System Division Wright-Patterson Air Force Base Dayton, Ohio 45433 (2)	LTC Lesko Office of the Commander US Army Training and Doctrine Command Fort Monroe, VA 23651 (1)
Mr. Robert Linsley/Mr. Matthew Hutton/ Mr. John Buddemeyer Office of the Commander Chemical Systems Laboratory US Army Armament Research and Development Command Aberdeen Proving Ground, MD 21010 (3)	Darold Frink/Ozzie Svaeri/Roger Rhodes Office of the Commander US Army Mobility Equipment Research & Development Command Fort Belvoir, VA 22060 (3)
Mr. William Curatolo Office of the Commander US Army Armor Center & School Fort Knox, KY 40121 (1)	CDR. Robert A. Margulies Commander, MC, USN Naval Submarine Medical Research Laboratory Naval Submarine Base Groton, CT 06340 (1)
Mr. William Kracov/Col. Jessie James Office of the Commander US Army Material Development & Readiness Command 5001 Eisenhower Ave. Alexandria, VA 22333 (2)	LTC Stahlman Commander US Army Nuclear and Chemical Agency 7500 Backlick Rd. Springfield, VA 22150 (1)
SFC Doherty Office of the Commander US Army Missile and Munitions Center and School Redstone Arsenal Huntsville, AL 35809 (1)	MAJ. William Stuck Program Manager Advanced Attack Helicopter, DARCOM 4300 Goodfellow Blvd. St. Louis, MO 63120 (1)
LT. Dombrowsky Detachment 63/MMWC Indian Head, MD 20640 (1)	Mr. J. Romano Dept. of the Army Proj. Mgr. for Advanced Attack Helicopter US Army Materiel Command P.O. Box 209 St. Louis, MO 63166 (1)
CPT Martin J. Fisher Office of the Superintendent Academy of Health Sciences US Army Material Division Fort Sam Houston, TX 78234 (1)	Mr. T. Nolan/Mr. John Branden Office of Director US Army Material Systems Analysis Activity Aberdeen Proving Ground, MD 21005 (2)

DISTRIBUTION LIST (Cont'd)

MAJ. Ronald Benson/Mr. Ray Birringer/  
CPT Savage/MAJ. Webb  
Office of the Commander  
US Army Aviation Center  
Fort Rucker, AL 36362 (4)

Mr. R. Boynton  
Office of the Commander  
US Army Foreign Science and Technology  
Center  
Charlottesville, VA 22907 (1)

LT. Chatelain  
USMC Development Center  
Air Branch (109-2)  
Quantico, VA 22134 (1)

Milton Dubay, Sr. Prog. Eng./  
COL. Brake/I. G. Andrew H. Anderson,  
Commander  
Office of the Commander  
US Army Tank Automotive Research &  
Development Command  
Warren, MI 48090 (3)

INTERNAL DISTRIBUTION LIST

Technical Library, NLABS	(2)
Marine Liaison Officer, NLABS	(1)
Air Force Liaison Officer, NLABS	(1)
Technical Documentation Office	(2)
ARIEM	(2)