

AD-A131 036

AIRCRAFT FATIGUE - WITH PARTICULAR EMPHASIS ON
AUSTRALIAN OPERATIONS AND RESEARCH(U) AERONAUTICAL
RESEARCH LABS MELBOURNE (AUSTRALIA) J Y MANN APR 83
ARL/STRUC-TM-361

1/1

UNCLASSIFIED

F/G 1/3

NL

END
SERIAL
9 83
DTIC

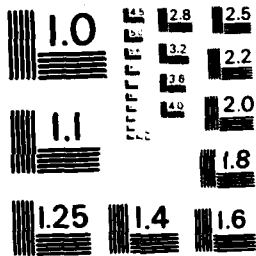

MICROCOPY RESOLUTION TEST CHART
NATIONAL BUREAU OF STANDARDS - 1963-A

ARL-STRUC-TECH-MEMO-361

AR-J02-947

12



ADA131037

DEPARTMENT OF DEFENCE
DEFENCE SCIENCE AND TECHNOLOGY ORGANISATION
AERONAUTICAL RESEARCH LABORATORIES
MELBOURNE, VICTORIA

Structures Technical Memorandum 361

AIRCRAFT FATIGUE - WITH PARTICULAR EMPHASIS ON
AUSTRALIAN OPERATIONS AND RESEARCH

J.Y. MANN

Approved for Public Release

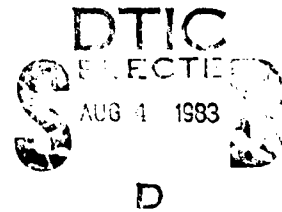

DTIC FILE COPY

(C) COMMONWEALTH OF AUSTRALIA 1983

COPY No

APRIL, 1983

83 08 3 . 095

Accession For	
NTIS BRAS1	X
DIC TAB	
Unannounced	
Justification	
By	
Distribution/	
Availability Codes	
Dist	A

AR-002-947



DEPARTMENT OF DEFENCE
 DEFENCE SCIENCE AND TECHNOLOGY ORGANISATION
 AERONAUTICAL RESEARCH LABORATORIES

Structures Technical Memorandum 361

AIRCRAFT FATIGUE - WITH PARTICULAR EMPHASIS ON
 AUSTRALIAN OPERATIONS AND RESEARCH

by

J.Y. MANN

This Technical Memorandum forms the basis for the 9th
 Plantema Memorial Lecture to be presented by the author at the
 biennial meeting of the International Committee on Aeronautical
 Fatigue (ICAF) at Toulouse, France in May 1983.



© COMMONWEALTH OF AUSTRALIA

POSTAL ADDRESS: Director, Aeronautical Research Laboratories,
 P.O. Box 4331, Melbourne, Victoria, 3001, Australia.

SUMMARY

The crash of a Dornier Merkur aircraft in Germany in 1927 was the first recorded instance of an in-flight structural fatigue failure. Australia was to experience its first aircraft structural fatigue failure in 1945.

Great distances between the major commercial and industrial centres (which are scattered throughout Australia), a favourable topography and usually good climatic conditions have combined to produce a strong interest in aviation and have resulted in Australia having a very high utilization rate of both commercial and private aircraft.

Concern with the problem of aircraft structural fatigue in the mid-1940's led to an ongoing research program on aircraft fatigue at the Aeronautical Research Laboratories which has continued with the support of the Australian civil aviation authority and the Royal Australian Air Force. Full-scale structural fatigue tests have been carried out on the structures of nine different aircraft including fighters, trainers and a small transport, and these activities have been supplemented by research on aircraft loadings, fatigue life assessment and the fatigue behaviour of materials and components.

This paper traces the history of aircraft structural fatigue until the establishment of the Aeronautical Research Laboratories in 1939, and then deals more specifically with Australian contributions from then until the present time. These reflect both the "lead-the-fleet" situation for civil aircraft and the desire to operate some military aircraft for lives well in excess of their original design lives.

CONTENTS

	<u>PAGE NO.</u>
1. INTRODUCTION	1
2. AIRCRAFT FATIGUE - PRE-1940	2
3. AIRCRAFT STRUCTURAL FATIGUE IN THE FIRST TEN YEARS OF ARL - 1940 TO 1950	5
4. AUSTRALIAN EXPERIENCES IN THE PERIOD 1951 TO 1960	11
5. 1961 TO 1965 - A PERIOD OF EXPANSION	20
6. THE EMERGENCE OF NEW TECHNOLOGIES - 1966 TO 1979	25
7. THE 1980's AND BEYOND	39
8. CONCLUDING REMARKS	43
ACKNOWLEDGEMENTS	45
REFERENCES	46
TABLES	
FIGURES	
DISTRIBUTION LIST	
DOCUMENT CONTROL DATA	

1. INTRODUCTION

Australia is a large continent with a mainland coastline of over 33,500 km and an area which would accommodate most of Europe (Fig. 1). European settlements were founded in Australia in the late 18th century, and over the past 200 years towns and cities have been established within Australia at scattered locations throughout the length and breadth of the continent.

At the present time (1981 census) about 60% of the relatively small total population of 14,576,000 persons is concentrated in the capital cities of the seven states which are all located around the coast and in the Australian capital, Canberra, which is inland (Table 1). Some 75% of the population resides within an easy drive of a coastal beach. The great distances between the commercial and industrial centres around the southern and eastern coasts of Australia and between the new large-scale mineral developments in the west and north of the country, compared with the distances between some of the major cities in Europe, are given in Table 2. As examples, compare the direct distances Melbourne-Perth (2,707 km) and Melbourne-Brisbane (1,376 km) with those from London to Moscow (2,510 km) and London to Rome (1,440 km).

By the 18th century the stage coach was well established in Europe as a means of transport over road systems which had been in existence for hundreds of years. However, at the start of the 19th century roadways in Australia were just being established and the carriage of passengers and goods over the long distances between the widely dispersed centres of population was mainly by ship. These large distances within Australia (often traversing inhospitable countryside with few towns), the generally much less well developed road and rail transport systems relative to Europe, a favourable topography with mountain ranges having a maximum peak of only 2230 m^{*}, and usually good climatic conditions have all combined within the 20th century to encourage the development of a strong interest in and reliance upon both commercial and private aviation within Australia. Similarly, in a defence situation aircraft are essential for both coastal surveillance and the rapid deployment of troops to widely dispersed centres. Air ambulance and medical services also play a major role in outback Australia.

It is not my intention to discuss the development of aviation within Australia as this subject has been very adequately covered elsewhere¹⁻⁴; but rather to briefly trace the history of aircraft structural fatigue and, more

* Compare with Mt. Blanc (France) 4810 m, Mt. Rosa (Switzerland) 4634 m and the Zugspitze (West Germany), 2963 m.

particularly, its implications in the operation of civil and military aircraft in this country.

2. AIRCRAFT FATIGUE - PRE-1940

About 150 years ago, long before the exploitation of power-driven heavier-than-air flying machines for civil and military uses, several very astute engineers in England, France and Germany recognized that some unexpected fractures of mechanical components in service were the result of repeated or vibrational loadings. In 1839 it was the French military engineer Poncelet⁵ who first used the word "fatigue" - a term which is now in common use to describe this method of failure - and shortly afterwards (in 1843) another French engineer by the name of Arnoux was reported⁶ to have suggested that the life of axles of mail-coaches operating on French highways should be limited to about 75,000 English miles to avoid such failures*. This was probably the first recorded application of the 'safe-life' approach to combat fatigue.

In the first half of the 19th century the new steam-locomotive railway systems had started to replace the stage coach for the surface transport of mails, freight and passengers. Some 13 years after the opening in England (in 1830[#]) of the first public steam locomotive railway in the world, accidents involving fractures in the axles of rolling stock were being discussed⁸. In the next decade these provided the impetus for more detailed investigations and research into the phenomenon⁹. However, it was also realised that the cyclic loadings associated with the passage of trains over the cast and wrought iron bridges of that period could introduce the problem of fatigue into engineering structures^{10,11} and affect their safety. Thus, even as long ago as the mid-19th century the relevance of fatigue as a problem associated with both structures and the transport industry had been established, and it was this same general problem which, some 100 years later in 1951, led to the formation of the International Committee on Aeronautical Fatigue (ICAF)¹².

The fatigue problem in aircraft has manifested itself in many ways - in primary and secondary structures, landing gear, engines and propellers, control systems, and various fittings. According to Boggs et al¹³ the famous Wright aeroplane of 1903 was not immune, as the engine of this aircraft suffered the fatigue cracking of a propeller shaft and later¹⁴ failures in a strut fitting and warping-wire pulley bracket.

* In a later work⁷ the safe operating life was stated to be 70,000 km (43,400 miles).

The first steam locomotive railway was opened in Australia at Melbourne in September 1854.

Most of the early concern with fatigue in aircraft and associated research in the first 20 years of this century - a period before the advent of civil airlines for the regular carriage of passengers - related, however, to non-structural items. These included control cables¹⁵, propeller shafts¹⁶, engine valve springs¹⁷, connecting rods¹⁸, crankshafts¹⁹ and other mechanical items²⁰. Because of low flying speeds and the good glide characteristics of the aircraft of that time any accident which may have resulted from such failures usually did not unduly jeopardise the safety of the occupants, and the main concern in taking remedial action was to prevent a recurrence of the failure and to provide increased reliability of operation. This was commonly achieved by improved quality control, surface finish or minor redesign²¹.

A very significant exception to the attention being directed at the time towards the fatigue of mechanical components in aircraft was a series of full-scale structural tests²² carried out in 1912 at the Royal Aircraft Factory (now the Royal Aircraft Establishment), Farnborough, England on a B.E.2 biplane (Fig. 2). These tests included an investigation into the fatigue of the wooden wing spar, in which the wing was mounted on a wall (in a similar way as it would be fixed to the aircraft fuselage), loaded statically to double its normal working load and then warped mechanically through the extreme range of movement 360,000 times*, after which the test was stopped. At that stage no failure had been observed. It is likely that the relatively good resistance of wooden structures to the action of repeated loadings (which has been demonstrated since that time^{23,24}) was a contributing factor to the lack of identified structural fatigue problems in the aircraft of that period. However, 'nuisance' fatigue failures continued to occur in wires and fittings, and effort was directed towards improving the fatigue characteristics of such items.

An interesting coincidence, from the Australian viewpoint, is that two B.E.2a aircraft (delivered in February 1914 to the Central Flying School at Point Cook, near Melbourne) together with three other aircraft, formed the nucleus from which the Royal Australian Air Force (RAAF) developed²⁵. According to Isaacs²⁶ these aircraft experienced a number of forced landings because of the fracture of engine components and other items.

Douglas in 1918²⁷ referred to the deterioration of the ultimate strength of metal mainplanes by vibration, and proposed that, during static testing, an

* This was considered to represent about 200,000 miles of flying and, at an average rate of usage of 1500 miles per annum, an average life of over 130 years.

of-balance oscillator should be mounted on the wing to reproduce slipstream induced vibrations. However, it was the tragic crash with the loss of six lives of a Dornier Merkur high-wing monoplane (Fig. 3(a)) of the German airline Lufthansa near Schleiz in Eastern Germany in September 1927^{28,29} which focussed attention on fatigue as being a potential problem in aircraft structures. This accident, which resulted from the failure of a wing to strut fitting (Fig. 3(b)), led to an extensive program of research at the Deutsche Versuchsanstalt fuer Luftfahrt (DVL) in Berlin²⁹ on the fatigue of full-scale wing spars made of wood, steel and duralumin²³. On 17 June 1929, the 'City of Ottawa'^{*}, a Handley-Page W.10 aircraft operated by Imperial Airways, was lost in the English Channel together with seven lives as the result of the fatigue failure of an engine connecting rod stud³⁰; and on 27 July 1934 a Swissair Curtiss Condor biplane crashed near Tuttelingen in Germany with the loss of eleven lives³¹ because of the failure of a wing strut. These accidents provided further evidence that the aircraft fatigue problem was not under control.

The research at the DVL on the fatigue of aircraft structures²³ and materials³² was the foundation from which developed the well-known multi-load-level program-load test of Gassner^{33,34}, and other structural fatigue research in both Germany³⁵ and the United States of America³⁶⁻³⁸. It is of interest to note, however, that the early US interest in structural fatigue was with airships^{36,39} and not aeroplanes. A variety of aircraft fatigue failures is illustrated in the first Chapter of Reference 40.

By the year 1939, the few instances of in-flight structural fatigue failures which had been documented and others which had occurred in the secondary structures of aircraft were usually regarded as either exceptional events or as imposing annoying delays and added operational and maintenance costs. However, Walker⁴¹ has since made the point that the recognition of a fatigue failure requires adequate diagnosis, and that fatigue may have been the primary cause of many accidents which were either unexplained or at the time attributed to other causes because of the lack of suitable failure analysis tools. Nevertheless, the potential problem was still either largely disregarded or not widely acknowledged and, as a result, structural design requirements were still based almost entirely on static strength and stiffness criteria.

Aircraft engineers in both Europe³⁵ and the USA³⁷ who had recognized the problem realised that two essential features in design to resist fatigue failure

* One of the other three aircraft of this type operated by Imperial Airways was named the 'City of Melbourne'.

were, firstly, a thorough knowledge of the nature (magnitudes and frequency of occurrence) of the repeated loads introduced into the structure during service by engine and slipstream vibrations, atmospheric turbulence, manoeuvres, landing and taxiing and, secondly, a complete understanding of the response of structural members to such variable loadings. Systematic research on loads measurement and loads statistics had been undertaken in Germany^{23, 42-44} concurrently with structural fatigue testing, and similar work had also been undertaken in the United States⁴⁵. Even in 1939 the requirements of the ideal instrument for measuring flight loads were defined by Arnstein and Shaw³⁸ as :

"it should record directly the maximum tensile and compressive stresses ever reached, and the numbers of cycles of different ranges or stresses. It should be completely automatic and not interfere with the normal operation of the craft. It should be connected at all times and not require attention more than a few times a year. It also must be reasonably cheap, light and accessible so that a number of them can be used without excessive expense".

At that time there was also an awareness^{23,36} that the fatigue performance of structural members was considerably inferior to that of the materials from which they were constructed. The steady development of aircraft with higher cruising speeds (which introduced a greater number of loadings per flying hour), higher wing loadings, higher gross weight and increased design stresses⁴⁶, coupled with increased and more severe utilization (associated in part with greater reliability of engines and other mechanical components, and more "all-weather" navigational aids), the demands for longer economic structural lives and the use of materials of increasing ratio of static to fatigue strength, were seen by some³⁸ as creating new and serious problems in the design and safe operation of aircraft.

This was the situation with aircraft fatigue when the Division of Aeronautics of the Council for Scientific and Industrial Research (now the Aeronautical Research Laboratories (ARL) of the Department of Defence) was established early in 1939 at a site in Melbourne to meet the testing and research requirements of the civil aviation industry and those of military aviation in Australia⁴⁷⁻⁴⁹.

3. AIRCRAFT STRUCTURAL FATIGUE IN THE FIRST TEN YEARS OF ARL - 1940 TO 1950

During World War 2 (1939 to 1945) the Division of Aeronautics worked with the RAAF and the local aircraft industry on operational, design and manufacturing problems. These included fatigue tests on welded steel tubing⁵⁰ used in the structures of some locally-built aircraft. Investigations were also carried out on service fatigue failures in aircraft engine crankshafts⁵¹ and propeller blades⁵²⁻⁵⁴. The last investigation referred to⁵⁴ was into the cause of the

crash of a RAAF Bristol Beaufort bomber in July 1945 with the loss of the crew of two, and was the first documented fatal crash of a RAAF aircraft because of fatigue failure. However, it was the in-flight loss of a wing from an all-wooden Australian-built De Havilland DH.98 Mosquito fighter-bomber of the RAAF in June 1944 which led to the initiation of structural fatigue research at ARL.

The years 1943 to 1950 were the formative years in the fields of aircraft structural fatigue testing and research in Australia. In providing this summary of Australian contributions in this period I do not wish to convey the impression that concern with the problem was unique to Australia. Extremely valuable contributions (some of which will be referred to) were being made by workers in other countries and, clearly, the experiences of those overseas were recognized in the formulation of the Australian approach to the problem.

Mr. H.A. Wills, the first Head of the then Structures and Materials Section of the Division of Aeronautics, was one of those who foresaw that the main criterion for the safe operation of aircraft structures in the future would be fatigue performance rather than static strength behaviour, and that this consideration would limit their economic service lives. Although the Mosquito accident was subsequently shown⁵⁵ to have been the result of a defective glued joint and not structural fatigue, the investigation into the cause of the accident involved the static strength testing of full-scale wings using a specially developed loading system consisting of whiffle-trees and hydraulic jacks. The potential of this newly developed hydraulic system for the rapid and automatic application of repeated loads to full-scale aircraft structures was soon realised⁵⁶ and a series of fatigue tests on Mosquito wings (Fig. 4) at a cyclic frequency of 5 cpm followed^{24,57} at the Division of Aeronautics to provide information in a field in which little or no reliable experimental data were available. These tests were (to the author's knowledge*) the first carried out in any country on complete full-scale wings using hydraulic actuators as the basis for the loading system.

On 31 January 1945, during the period of the Mosquito investigations, the Stinson A2W aircraft VH-UYY (Fig. 5) en route from Melbourne to Broken Hill lost its port wing in gusty weather and crashed at Redesdale in Victoria[#] with the loss of ten lives. This was the result of fatigue failure at a defective fish-mouth

* It is possible that some of the structural test programs carried out prior to this by aircraft companies included fatigue tests but, if so, the information was not widely disseminated.

At the time of the accident this aircraft had flown 13,763 hours⁵⁸.

welded joint in the tubular steel tension member of the main spar of the outer wing⁵⁹, and provided a tragic revelation within Australia of the aircraft structural fatigue problem. Although the fatigue of welded steel tubular joints in aircraft sub-structures had received some attention in both Germany and the USA (see, for example, References 60-62), it was concluded from the laboratory investigation of the wreckage of the Stinson that neither the defective weld^{*} nor a number of other fatigue cracks in other parts of the structure could have been detected by the then normal methods of visual inspection. It also focussed attention on the need for adequate inspections of aircraft structures by both magnetic particle and radiographic methods at appropriate intervals during their service lives.

The crash of the Stinson provided the catalyst for the now Structures Division of ARL, under the guidance of Mr. Wills and with the support of the RAAF, the Australian Department of Civil Aviation (DCA) and civil aircraft operators to plan a comprehensive program of research into aircraft fatigue including the measurement of flight loads experienced by aircraft under Australian operational conditions, the response of elastic structures to atmospheric turbulence, and the laboratory fatigue testing of full-scale structures, typical joints, small components and notched specimens. In December 1946 the local awareness of the general problem of fatigue was highlighted when an International Symposium on The Fatigue Failure of Metals⁶⁴ was held at the University of Melbourne. At this Symposium - which was claimed to be the first on the subject in the English-speaking world - 30 papers were presented of which five dealt specifically with various aspects of the aircraft fatigue problem.

As structural loads resulting from atmospheric turbulence were considered to make the major contribution to fatigue damage in civil aircraft structures (in contrast to manoeuvre loads in combat aircraft) a survey of the available literature on turbulence and gust spectra was undertaken early in 1946. However, as this information was mostly applicable to conditions in Europe and the USA, some doubts were raised regarding its relevance to aircraft operating under Australian flying conditions. A procedure for calculating the fatigue life of an aircraft structure was enunciated⁶⁵ and a program of flight measurements was commenced⁶⁶. This program was aimed at the collection of statistical information on gust loads under a variety of meteorological conditions and involved the

* Nearly 25 years after the Stinson crash ARL carried out a comprehensive series of fatigue tests⁶³ on fish-mouth welded joints in chromium-molybdenum steel because of a serious fatigue problem in the structure of the Beech 18, then operating in Australia.

installation of NACA V-g recorders* in civil aircraft operating on major scheduled routes within Australia⁶⁷ and on RAAF aircraft flying both within in Australia⁶⁸ and between Australia and Japan⁶⁹. Much of the ARL work on aircraft loads measurement in the period 1947 to the early 1950's which involved Douglas DC-3 and DC-4 aircraft and Bristol Freighter aircraft was summarised by Hooke⁷⁰ and for some years provided basic flight load spectra for the fatigue life estimation of aircraft operating in Australia.

At the conclusion of World War 2 a number of wings from the CA-12 Boomerang fighter (Fig. 6(a)) designed by Commonwealth Aircraft Corporation (CAC), Melbourne were made available for fatigue research. In contrast to the Mosquito wings these were an all-metal wing, basically of conventional riveted aluminium alloy sheet construction with formed spars and stressed skins. Commencing in late 1947 twelve Boomerang wings were fatigue tested under a variety of constant-amplitude conditions to establish an S/N curve for this full-size aircraft structure covering a life span from about 100 cycles to over 1.6×10^6 cycles. Eight wings were tested in the hydraulic-loading rig previously used for the Mosquito (by then redesigned and operating at about 15 cpm), and four in a rig (Fig. 6(b)) which employed a mechanical oscillator to vibrate the wings at close to their resonant frequency of about 750 cpm. The resonant testing rig allowed millions of low-amplitude loads to be applied in a relatively short time and provided an appreciation of the fatigue damage caused by such cyclic loads in the long-time operation of aircraft. These tests, which were completed in 1949,⁷¹ clearly confirmed the greatly inferior fatigue performance of a large metal structure relative to that of its simple joints and unnotched material. They also emphasized the serious reductions in the fatigue strength of metal wings caused by stress concentrations such as cut-cuts, riveted and bolted joints, as compared with the findings from the tests on the adhesive-bonded wooden wings of the Mosquito which appeared to be highly resistant to fatigue and for which the ultimate static strength was not appreciably reduced by some thousands of applications of a load within the limits of +25% to +90% of the ultimate failing load.

A survey of the problem of the life of aircraft structures had been presented by Wills in a paper⁷² read before the Institution of Engineers, Australia in September 1947, and in a later paper⁷³ presented at the 2nd International

* Although the information provided by these instruments was very limited compared with modern flight-loads measuring systems (particularly regarding the frequency of occurrence of low loads) they produced valuable statistics relating to medium and high accelerations associated with gusts and manoeuvres in both the positive and negative directions.

Aeronautical Conference held in New York in May 1949 he included the results of the fatigue tests on Boomerang wings. In these papers a method for estimating the fatigue life of an aircraft structure was outlined and areas were defined in which additional studies were needed if the dangers of structural fatigue failure were to be minimised. Ten years after Arnstein and Shaw³⁸ stipulated the requirements for an ideal flight loads measuring instrument, Wills⁷² reiterated that the direct measurement of strain fluctuations using a statistical counter was essential to advance progress in aircraft fatigue life estimation.

Although details were not made public until some years after the end of World War 2, about 20 Royal Air Force (RAF) Vickers - Armstrong Wellington twin-engined bombers were lost with their crews in the UK alone in the years 1942 to 1944 because of fatigue failures in serrated joints of the tubular steel spar (both top and bottom booms) of the wing just outboard of the engines^{74-77*}. The mean life of aircraft which crashed because of this type of failure was estimated to be 320 flying hours, with some crashing after only 180 hours. Failures in the tailplanes of the Hawker Typhoon fighter^{78,79} led to the conduct of a series of fatigue tests⁸⁰ on that particular structure (to a maximum life of 6209 cycles) at the Royal Aircraft Establishment (RAE). Presumably it was those or similar problems which prompted the installation of V-g recorders in a number of British military^{81,82} and civil aircraft⁸³ in the 1942 to 1945 period, and the increasing effort in Britain towards an understanding of the behaviour of aircraft structures under fatigue loadings⁸⁴⁻⁸⁷.

The events which have taken place since that time have not supported the contentions of Williams in 1946⁷⁸ and 1950⁷⁹ that the fatigue problem was not as serious as first thought, that there was no likely requirement for a full-scale structural fatigue test and that a structure which satisfied the ultimate load test would be strong enough to withstand any repeated loads encountered in service. There was clearly a difference of view between Williams and others^{84,87} who proposed that structures and structural elements should be subjected to a "standard" single load-level fatigue test consisting of a 1 g steady load and a superimposed fluctuating load (corresponding to a relatively small percentage of the ultimate load) for some millions of load cycles[#].

* The report Reference 74 was first drafted in August 1948.

These proposals were followed by those of Walker⁸⁸ and led to the development of the RAE Fatigue Criterion which specified the fatigue loading conditions as 1 g \pm 7.5% of the ultimate design load in the 50 ft/sec gust case at design cruising speed for 2 X 10⁶ cycles⁸⁹.

Reference has already been made to the paper by Bland and Sandorff published in 1943⁴⁶ who discussed the concept of designing aircraft structures for a specified or guaranteed finite service fatigue life rather than for an infinite life. This analysis was followed by those of Putnam⁹⁰, Wills⁷² and Williams⁷⁸ all of which were somewhat similar. In 1947 Lundberg⁹¹ proposed a series of fatigue safety factors for both primary and secondary structure, taking into account such aspects as the probability of a crack being detected before it reached a critical size.

The work of Bleakney³⁷ on the fatigue behaviour of aluminium wing beams was continued⁹² in conjunction with fatigue tests on smaller specimens cut from them - again the marked difference in the fatigue performance of the large pieces of structure and the smaller specimens was demonstrated. Instances of service fatigue failures in the tail sections of military aircraft and laboratory tests to verify methods of repair were given by Jewett and Gordon in 1945⁹³, while an analysis of service failures in the structural components of a number of aircraft is contained in Reference 94. An interesting finding by Arnstein⁹⁵ in 1946 was that the fatigue life of aluminium girders could be increased appreciably by pre-stressing them in tension to cause yielding at points of high stress concentration. A very significant contribution to the full-scale structural testing of aircraft wings was contained in a paper by Pierpont published in 1947⁹⁶. This described fatigue tests (in a hydraulic loading system) on two wings from a Beechcraft Model 35 Bonanza in which gust, manoeuvre and landing loads (four levels in each condition) were applied to verify a minimum life of 10,000 hours for the wing. The author expressed the belief that such full-scale fatigue tests would be the best method of establishing the long-time safety of the aircraft; the point also made by Wills⁷² that the most conclusive experiment to determine the response of a structure to fluctuating loads would be to conduct a fatigue test on the complete structure.

On 29 August 1948 the crash of a Northwest Airlines Martin 2-0-2 near Winona, Minnesota after only 1321 flying hours with the loss of 37 lives was apparently the first major aircraft accident in the United States resulting from structural fatigue failure. This resulted from extensive fatigue cracking in the lower boom of the front spar of the port wing at a joint between the centre section and outer wing⁹⁷⁻⁹⁹ as shown in Fig. 7. Although it was reported that the aircraft which crashed was flying through a severe thunderstorm at the time, fatigue cracks were subsequently found at similar locations in the spars of three other 2-0-2's; and a disturbing feature of the accident was that the 2-0-2 wing had been subjected to a full-scale fatigue test (single-load-level at a high alternating load range) before it entered airline service⁹⁹.

Further data obtained from the comprehensive program of gust loads measurement undertaken by the National Advisory Committee for Aeronautics (NACA) were published in 1944¹⁰⁰ and much of the NACA work was summarised in a paper¹⁰¹ presented at a Symposium on the Fatigue and Fracture of Metals held in 1950. Although most of the gust load measurements up to 1950 were made using V-g recorders it was appreciated⁷² that these instruments provided a rather indirect method of determining both the atmospheric gust spectrum and the resulting loads introduced at any location in a particular structure, because of assumptions relating to the aeroelastic response of the structure to turbulence and the load transfer characteristics within the structure.

4. AUSTRALIAN EXPERIENCES IN THE PERIOD 1951 TO 1960

In the early 1950's accidents involving three types of civil aircraft operating on regular airline routes demonstrated, as never before, that the fatigue problem in aircraft structures was more than an academic question and that it imposed a real threat to the safe operation of civil aircraft. These were the crash of a De Havilland DH.104 Dove (VH-AQO) in October 1951 near Kalgoorlie in Western Australia with the loss of seven lives because of the in-flight separation of the port wing^{99,102} after the aircraft had flown about 9,000 hours; the loss of a Vickers Viking at Mtara, Tanganyika, Africa in March 1953 resulting from the fatigue failure of a joint in the lower spar of the wing (after about 8,800 hours) which claimed 13 lives^{99,103}; and the accidents involving two De Havilland Comet aircraft over the Mediterranean Sea in January and April 1954 with a total of 56 lives lost because of pressure cabin fatigue^{99,104}. Fatigue problems in the wings, fuselage and tails of fifteen US military aircraft (including fighters, bombers, transports and trainers) in the 1952 to 1959 period which resulted in major accidents are referred to by Caldara¹⁰⁵. The most serious of these were three accidents in 1958 involving the Boeing B-47 bomber*.

It is not intended to dwell on the accidents which occurred in Europe and the USA, as relevant aspects of these have been adequately covered by Williams⁹⁹ at the 1965 ICAF Symposium and in more recent times by Campbell¹⁰⁶⁻¹⁰⁸, but rather to highlight two accidents in Australia and New Zealand. Nevertheless, in the years 1951 to 1960 there was much written throughout the world on the problem

* One is accustomed to thinking of aircraft structural fatigue as more of a problem with civil rather than military aircraft because of the much shorter operational lives of the latter - currently about 10:1. However, a comparison of the number of Typhoon and Wellington failures during World War 2 and the almost equal number of reported civil and military aircraft lost because of structural fatigue failures in the 15 years after the war finished¹⁰⁶ do not support this contention.

of aircraft structural fatigue - some representative examples being References 109-125, and there were at least five Conferences/Symposia devoted specifically to this subject including the first ICAF Symposium held at Amsterdam in 1959¹²⁶⁻¹³⁰. These writings were not only a clear indication of the concern being expressed with the growing problem of structural fatigue, but showed the effort being directed to understanding and overcoming it. In so doing they also provided a valuable record of:

- (i) the uncertainties in relying on the "safe-life" concept to maintain structural airworthiness without either weight or economic penalties (particularly when single spars were used to carry most of the bending loads);
- (ii) the early development of the so-called "fail-safe" design philosophy¹³¹ with the attendant use of redundant, multi-spar or multi-load-path structures;
- (iii) the increased reliance on regular inspections of the structure to detect fatigue cracks and monitor their rate of propagation¹¹⁶; and
- (iv) the assessment of the residual static strengths of cracked structures.

The crash of Dove VH-AQO in 1951 was the result of a fatigue crack which had developed from a rivet hole in the centre section wing spar lower boom (Fig. 8) - a non-redundant member made of the Al-Zn-Mg alloy D.I.D.363. VH-AQO had been manufactured in 1946 and for most of its life of about 9,000 hours had flown over arid country with a relatively severe gust pattern¹⁰². At the time another Dove aircraft (VH-AZY) operating on similar routes to the crashed aircraft had logged 8,515 hours, while a third Dove (VH-AQP) had accumulated 5,400 hours^{132,133}. No other aircraft of this type anywhere else in the world had a life exceeding 3,000 hours. After the accident the two other Doves were grounded and inspection of the main spars carried out. These revealed that VH-AZY had cracks at both the port and starboard ends of its centre-section boom at about the same positions as in the crashed aircraft. The wing structures of both the Dove and the Martin 2-0-2 were similar in that the spar booms were of Al-Zn-Mg alloys and carried all of the bending loads; and it was ironical and significant that these accidents involved the first two civil aircraft for which, during the design stage, a serious experimental effort (including full-scale wing testing) had been made to assess the fatigue life of the structures^{86,99,102}.

With hindsight of course, it is quite clear that the fatigue testing conditions adopted for the tests were not well suited to provide the assurances of fatigue performance which were hoped for - the alternating load level used for the 2-0-2 being too high⁹⁹ and that for the Dove being too low¹³⁴.

It was particularly significant that these events occurred during the period that ARL had extended its research on the fatigue behaviour of full-scale alluminium-alloy structures by undertaking a major investigation using surplus wings from North American P51-D Mustang fighters, the construction of which was regarded as a typical representation of the then current riveted stressed-skin aircraft design practice. Commencing in July 1950 and over the next 12 years some 222 Mustang half wings* were fatigue testes under a variety of loading conditions¹³⁵. An advantage in using these wings was that they were about the same size as those of the Boomerang which had been tested previously and thus the various hydraulic and vibration fatigue testing rigs could be reused with a minimum of modifications⁵⁵. It would be appropriate at this stage to restate the primary objectives of the Mustang program for, without doubt, this is by far the most comprehensive experimental fatigue investigation ever carried out on a single type of aircraft structure. Furthermore, it was one of the few investigations with basic research objectives in contrast to the many investigations since then relating to structural product development or to satisfy airworthiness requirements for particular types of aircraft. Others included the tests on Curtiss C-46 Commando wings¹³⁶⁻¹³⁹, Gloster Meteor 4 tailplanes¹⁴⁰ and Percival Provost wings^{141,142}.

The main objectives of the Mustang wing test program were^{143,144}:

- (a) to observe the behaviour of a typical wing structure subjected to repeated loading and obtain information on various aspect of fatigue failures;
- (b) to determine the complete alternating load - mean load diagram for a full-scale wing of typical rivet construction;
- (c) to correlate the fatigue strength of a complete structure with notched fatigue data on the component materials;
- (d) to examine the form of the frequency distribution of fatigue life, and obtain the fatigue life for given probability levels; and
- (e) to investigate the effect of preloading on the fatigue characteristic of the structure.

Detailed findings were presented in a series of ARL Reports and the information summarised in four papers by Johnstone and Payne^{55,144-146}. These tests on Mustang wings clearly provided a very large data base relating to the fatigue

* These included wings manufactured in both the USA and Australia; some brand new, most with relatively little flying, a few with over 500 hours operational service.

behaviour of full-scale aluminium alloy aircraft structures, and provided the basis for the alternating stress-mean stress diagram shown in Fig. 9. When used in conjunction with an appropriate cumulative damage hypothesis, this enabled predictions to be made of the fatigue lives of aircraft structures under a range of flight loading conditions. The constant-amplitude Mustang tests also indicated that the logarithmic normal distribution provided a good approximation to the frequency distribution of fatigue lives for such structures, and that a figure of 0.20 was a conservative estimate of the standard deviation of log. life¹⁴⁶. The benefits of static preloading (which reduced the effective value of stress concentrations by plastic deformation) were again demonstrated by tests which showed that the value of preload which provided a maximum relative increase in fatigue life was 80% to 85% of the static UFL.

Thus, when the Dove crashed in Western Australia in October 1951, ARL had available information from the Boomerang wing fatigue tests and some 40 results from tests on Mustang wings, together with RAE data on the fatigue behaviour of Typhoon and Meteor tailplanes, and a start had been made to express these data in a generalised form. There was also a significant amount of gust loads information derived from V-g recorders fitted to DC-3 aircraft flying on Western Australian routes⁶⁷. A unique opportunity was therefore provided to assess methods of life estimation by comparing the actual service life of the Dove with the life which might be predicted from the best available full-scale structural fatigue data and a representative load spectrum. However, there was a need to supplement the flight loads data from the V-g recorders with some on the occurrence of small gusts, and this was done by reference to American sources¹⁰⁰. A correction was also necessary to account for the differences in the materials used in the Dove (DTD 363) and the Mustang (24S-T) structures. This was done by comparing the relative fatigue strengths of both riveted joints and notched specimens of 24S-T and 75S-T aluminium alloys, the latter being somewhat similar to DTD 363. The results of the analysis¹⁴⁷ indicated a fatigue life for the Dove wing of between 3,200 and 12,200 hours (mean 8,000 hours), which was in remarkably close agreement with the service life of 9,000 hours experienced by the crashed aircraft. A further finding from the analysis was that if the structure had been manufactured from 24S-T rather than the higher static strength Al-Zn-Mg aluminium alloy the fatigue life might have been three to five times greater. Subsequently, fatigue test data obtained overseas on Dove centre-section booms indicated that the fatigue properties were inferior to that indicated by the data originally used by ARL. Based on the later data the estimated mean fatigue life was less than calculated previously and only about half that of the aircraft which crashed^{132,133}. The Dove centre section tension boom was redesigned by the manufacturer to increase its safe life.

A significant feature in Australian operations which was highlighted by the Dove crash was the very high utilization of civil transport aircraft compared with that in other countries. About that time Australian utilization rates as high as 3,000 to 4,000 flying hours per year were not uncommon¹³³ - much greater than in most other parts of the world. This feature, combined with the general policy of the major local airlines to be among the first to re-equip with new types of aircraft, resulted in Australian operators often being in the unenviable position of having "lead-the-fleet" aircraft in terms of flight hours. Typical examples of such aircraft included the Douglas DC-6, Bristol 170 Freighter, Lockheed L188 Electra, Vickers Viscount 700, Boeing 727-100, Fokker F-27 Friendship and a number of small aircraft typified by the Beech Queenair. The potential which these circumstances provided for an acceleration of fatigue related problems and the maintenance of airworthiness in the future was clearly recognized by the Australian DCA. Guided by the findings of the Dove investigations, they immediately undertook a detailed study of all types of Regular Public Transport (RPT) aircraft on the Australian register, firstly to identify the most fatigue-critical areas of the structures, secondly to establish structural safe-lives, and thirdly (if necessary) to initiate action to correct structural deficiencies and ensure the continued safe operation of the aircraft. The latter required the replacement of major components in aircraft of several types involving the operators in a great deal of work and expense. At the same time the generation of statistical gust loads information for Australian routes was accelerated by the fitment to a variety of RPT and freight carrying aircraft of V-g recorders, and counting instruments (such as the RAE Counting Accelerometer¹¹³ and RAE Fatigue Meter) which provided much more accurate information over a wide range of gust accelerations. The aircraft included the Bristol 170 Freighter¹⁴⁸, Douglas DC-6¹⁴⁹ and Vickers Viscount¹⁵⁰. The scope of the program at that time can be seen from Fig. 10¹³³.

Australia is, essentially, an importer and operator of aircraft rather than an aircraft designing and manufacturing country. Although a number of types of small civil and military aircraft have been manufactured within Australia under licence since the late 1930's there have, during the past 30 years, been very few aircraft wholly designed and manufactured locally. These have included only two multi-engined transports - the de Havilland Drover (which was based on the Dove) and the Government Aircraft Factories (GAF) Nomad. In the period 1950 to 1960 aircraft used on schedule domestic routes were almost exclusively of American or British origin. Two of the major functions of an airworthiness authority are to prescribe safety requirements for aircraft and to ensure that they are complied with. However, recurring difficulties have been experienced

by both the civil and military airworthiness authorities in Australia because of their lack of involvement with imported aircraft in the design and development stages, in obtaining detailed structural stressing information, and in ensuring that (from the Australian viewpoint) a satisfactory approach was taken to minimise the probability of in-service fatigue failures during the design life of the aircraft. This was particularly so when Australian experiences had indicated that the fatigue requirements of the certification authorities in the country of origin were inadequate or non-existent.

Following the proposals of Pugsley⁸⁴, Fisher⁸⁷ and Walker⁸⁸ for the verification of fatigue design criteria for wings by a single-load-level test, consideration was given in Australia to establishing a rationale for the specification of an "Airworthiness Fatigue Test" for aircraft structures. Rather than basing the magnitude of the alternating test load on an arbitrarily defined fraction of the ultimate failing load or arbitrarily defined gust load case it was initially proposed that this load should be selected to correspond to the gust velocity which, theoretically, would cause the most fatigue damage to the particular structure under consideration^{134,147}. The object was to initiate and develop a structural fatigue failure within a predetermined number of cycles, but it was envisaged that successively higher alternating load steps could be used (if necessary) until a failure occurred¹⁵¹.

However, the multiplicity of fatigue failure sites which had appeared in Mustang wings during constant-amplitude tests provided additional concern about relying on the results of one or two single-load-level tests to adequately represent a complex loading sequence or even reveal the most fatigue-sensitive parts of the structure. Because of these considerations and doubts as to the validity of cumulative damage hypotheses to predict fatigue lives, Langford^{152,153} proposed that the safe-lives of fatigue-critical components of wings should be determined by a multi-load-level test. His two proposals were either a random loading sequence representing a gust spectrum, or a three-load-level test modelled after the Gassner program-load test³⁴. The middle load was selected as that estimated to cause the maximum fatigue damage, with the maximum and minimum loads corresponding to gust velocities of respectively 8 ft/sec greater than and 5 ft/sec less than the middle load. It was postulated that the total number of cycles of load at each load level should each produce one third of the damage at the failure location in the wing. Such a test was envisaged as being suitable both as an airworthiness acceptance test and as a method of comparing contending design details. In commenting on Langford's proposals, Woodgate¹⁵⁴ questioned the retention of the "safe-life" approach and emphasised

the importance of the fatigue damage introduced in civil transport aircraft wings by the ground-air-ground cycle, and that the effects of this very important loading case should be recognized in the development of an airworthiness fatigue test.

The original objectives of the Mustang program were extended to include multi-load-level tests (program and random loading) under symmetric (gust) and asymmetric (manoeuvre) spectra, the effects of ground-air-ground cycles, comparisons of various life estimation methods and an investigation into the residual static strength of fatigue-cracked wings. Some of the loading sequences used (which include the three-load-level 'Airworthiness' test and a representation of the ARL 24-load-level random gust load sequence) are illustrated in Fig. 11. The results were summarised by Payne in Reference 146 and, among other things, showed that the simple three-load-level test and random gust sequence test were equivalent as regards fatigue lives for all types of failure observed in the structure. Further detailed information was published in References 155-160.

The importance of landing loads had been recognized as a probable cause of the Wellington wing failures⁸⁹ and work in the mid-1950's¹¹⁹ had shown that the ground-air-ground (GAG) cycle made a large contribution to the fatigue damage in transport aircraft wings. This knowledge, and other information available to Woodgate in 1955¹⁵⁴ indicated that the ramifications of the GAG cycle in the fatigue life of aircraft structures should be more fully explored. By September 1957 a suitable experimental program (with particular reference to the Vickers Viscount) had been developed by Trans-Australia Airlines (TAA), DCA and ARL for the fatigue testing of both simple specimens and Mustang wings. Again, it was the fatal crash (loss of four lives) of a Bristol 170 Freighter in New Zealand in November 1957⁹⁹, because of a fatigue failure in the lower boom of the outer wing front spar joint, which provided graphic evidence of the significance of this loading case. The aircraft had flown only 7,900 hours but, in that time, had made 13,000 landings. Flights, rather than hours flown, were then proposed as the criterion for fatigue life assessment.

One of the problems in accounting for the contribution of the GAG cycle to the total fatigue damage in a cumulative damage summation is the interpretation of this particular cycle in relation to the other loads in the spectrum. The simple approach of considering the GAG cycle as a once per flight cycle with upper and lower limits of the lg steady flight condition and at-rest on-ground condition respectively was shown to predict negligible damage. For calculating

fatigue damage in fighter aircraft Mangurian and Brooks¹¹⁹ had proposed that the GAG cycle should be assessed as the load variation from the on-ground condition to that corresponding to the mean value of the critical in-flight manoeuvre load which (on a statistical basis) would occur once per mission. The proposal put forward by ARL was that, for transport aircraft, the GAG cycle should be accounted for by basically combining the on-ground load with the maximum positive gust load (or loads) occurring in the spectrum*. Although the actual life reduction with the GAG cycle was much greater for wings (4:1) than for small specimens[#] (2:1), the last approach resulted in close agreement between predicted and experimental lives for both Mustang wings¹⁵⁶ and small notched specimens^{161,162}. The influence of the GAG cycle was also investigated by Gassner and Horstmann¹⁶³ whose conclusions were similar to the findings of the ARL work.

One of the significant observations from the ARL full-scale wing fatigue tests was the development of fatigue cracking at different locations of the structure as the test progressed. The airworthiness fatigue test proposals of Langford^{152,153} envisaged that any fatigue cracks which were detected during the test should be repaired by a method which would result in a minimum amount of load redistribution in the structure so that, by the termination of the test, all of the fatigue-critical components in the structure would be identified. A preliminary investigation of the philosophy of "progressive repair" was carried out on a Mustang wing¹⁶⁴ and it was demonstrated that satisfactory repairs for this purpose could be achieved by using conventional riveted aluminium alloy patches, laminated adhesive bonded glass-fibre cloth and adhesive bonded aluminium sheet.

The opportunity was provided to further investigate the airworthiness fatigue test and the progressive repair philosophy when, associated with the high utilization of the aircraft in Australia, a requirement developed to determine an extended life for the Dove wing under local operating conditions and evaluate the fatigue performance of modifications which had been incorporated since the introduction of the type. For this purpose a five-load-range program-load test was developed in which, in addition to three load ranges representing the gust loads, two additional load ranges were introduced. One of these was a very low load range which, theoretically, would cause no fatigue damage and

* This procedure for the successive pairing of the numerically greatest positive and negative loads irrespective of their position in the overall sequence was designated, by ARL, the H_1 cumulative damage Hypothesis.

These tests involved chains of specimens in which up to ten specimens were connected in series.

the second represented the GAG loading case. Tests were conducted in a resonant vibration rig operating at an average cyclic frequency of about 8 Hz, with the object of eventually producing a major unreparable failure. The test article consisted of the two outer wings from aircraft VH-AWB which had previously seen approximately 13,600 hours flying on Western Australian routes, connected through a dummy centre section structure which incorporated the aircraft tension boom. The test was eventually terminated after a total life (service plus equivalent service on test) of over 130,000 hours because of failure in the main spar tension boom of the outer wing. During the test some 60 cracks were detected and either monitored or repaired (including the use of adhesive-bonded patches), and a total of 15 centre section booms from Dove and Drover aircraft (of both the original and a heavier-section redesign) had been fatigue cracked¹⁶⁵. The cracked booms were subsequently tested statically to determine their residual strengths¹⁶⁶. The variability in the locations of fatigue cracks in the structure confirmed that, as a whole, it had to be regarded as "safe-life".

Concurrently with the routine collection of flight loads data for civil aircraft, ARL continued with the determination of flight loads information for RAAF aircraft. These included Mustang¹⁶⁷, de Havilland DH.115 Vampire¹⁶⁸, Freighter¹⁶⁹ and English Electric Canberra¹⁷⁰. The data derived from flight loads measurements on the Canberra provided a good illustration of the influence of type of mission and geographical location on the severity of aircraft loadings (Fig. 12).

In 1959, the year of the First ICAF Symposium - "Full-scale fatigue testing of aircraft structures" - Australia was formally admitted to ICAF and contributed two papers to the Symposium. The first by Payne¹⁴⁶ on the fatigue testing of wings has already been referred to; the second by Ferrari et al.¹⁷¹ of the Australian DCA discussed a probabilistic approach to the life of fail-safe wing structures. At this Symposium Barrois¹⁷² outlined the French philosophy on the fatigue testing of aircraft structures, while Larre¹⁷³ and Vallet¹⁷⁴ described the special installation at the Etablissement Aeronautique de Toulouse for the full-scale fatigue testing of the Sud-Aviation SE-210 Caravelle and the comprehensive testing program for the structure. A paper was also presented by van Beek¹⁷⁵ dealing with the fatigue testing of a very well-known aircraft on Australian civil routes - the Fokker F.27 Friendship.

5. 1961 TO 1965 - A PERIOD OF EXPANSION

Following the concern of the Australian civil aviation authorities in the mid to late 1950's, the DCA provided considerable financial and manpower support for the conduct of research at ARL on the fatigue of materials and structures and in the conduct of general airworthiness investigations. These involved additional effort on the measurement of flight loads, the derivation of reliable methods for predicting the service fatigue lives of structures, and work on crack propagation rates, residual static strengths and inspection intervals. A procedure for assessing the fatigue life of an aeroplane was put forward by Barnard and Hooke in 1961¹⁷⁶, and further discussed by Hooke in 1964¹⁷⁷.

The early work at ARL on flight loads measurement was largely directed at obtaining generalised loads and gust information under local operating environments. However, it became increasingly apparent that if, for the purpose of life estimation, such data were extrapolated to a specific type of aircraft on which no loads measurements had been made then the associated uncertainties could provide additional penalties in terms of either increased operating costs (or other restrictions) or a reduction in safety. This led to an increasing emphasis on the collection of flight loads data for each particular type of aircraft on which a fatigue life estimation under Australian conditions was required. Although the routine collection and analysis of data for large transport aircraft continued at ARL¹⁷⁸, this activity (and the life assessment of civil aircraft in Australia) was eventually absorbed by DCA¹⁷⁹ in collaboration with the National Aeronautics and Space Administration (NASA), and ARL's efforts were directed more particularly towards the life assessment of military aircraft and specific problems with the loads measurement on aircraft engaged in agricultural operations. The RAAF aircraft from which Fatigue Meter and V-g data were collected included the Lockheed Neptune maritime reconnaissance aircraft, Lockheed Hercules transport, de Havilland Vampire, North American Sabre fighter, and the GAMD Mirage IIII which entered service with the RAAF in 1964.

One of the first aircraft on which a fatigue-life assessment was made was the Canberra, the flight loads measurements on which have already been referred to¹⁷⁰. Based on these measurements a simple arithmetical damage formula was derived for progressively calculating (from Fatigue Meter readings) the fatigue life consumed by the structure in various roles¹⁸⁰ and this allowed the aircraft to be safely operated by the RAAF into the 1980's. However, it was probably the promulgation (in the United Kingdom in late 1960) of the relatively short safe-life of 2000 hours for the Avro Lincoln bomber which accelerated

the interest in Australia in the fatigue of military aircraft. At that time some RAAF Lincolns had already exceeded 2000 hours and others were approaching that life.

At the time when the Lincoln was being withdrawn from service a fatigue life analysis of the locally built de Havilland DH.115 Vampire MK.35 trainer indicated that the safe-life of the wing was insufficient to meet the RAAF requirements. Furthermore, because of minor differences in the construction of Vampires produced in Australia and in the United Kingdom there were some doubts as to the effectiveness (in RAAF aircraft) of a life-improvement modification which had been incorporated in RAF Vampires. As a consequence a full-scale fatigue testing program on the Vampire structure (Fig. 13(a)) was undertaken at ARL. Although the original purpose of the test was essentially the same as the Dove test in that it was to provide an assurance of structural airworthiness and validate repairs/modifications for extending the life, it was unique in ARL's experience as being the first time that a complete structure (wings and fuselage) had been used in the Laboratories for fatigue testing. The six-load-range program load sequence (3560 cycles per program) employed for the majority of the ARL tests was based on that used for tests made on Vampire wings in the United Kingdom, but with load levels changed to more closely correspond to the Australian load spectrum. Tests were also made at ARL using a random loading sequence. Ground and flight tests on a specially instrumented aircraft were also carried out to determine the strains at critical locations in the structure¹⁸¹ and to ensure that the correct flight strains were reproduced in the fatigue test articles. During the investigation 23 half wings and two fuselages were fatigue tested, twelve individual failure sites identified, and repairs or replacements incorporated as appropriate^{182,183}. An extensive testing program to evaluate a proposed life-enhancement modification was also undertaken¹⁸⁴. Among the findings of these investigations were the following:

- a. under program loading or random loading there was no significant difference in the mean lives to failure of either spar booms or notched specimens;
- b. after the equivalent of 41,219 and 67,238 flying hours respectively the two wooden fuselages to which had been attached the 23 half wings showed no signs of wood or glue deterioration; and
- c. under fatigue loadings blind Chobert rivets were not an effective way of connecting sheet to a heavy section.

The variety of fatigue failures in both aluminium and steel structural components of the Vampire provided the opportunity for utilizing the fractographic analysis techniques developed by Ryder at RAE¹⁸⁵, to study the fractures of aluminium alloy specimens¹⁸² and to determine fatigue crack propagation rates in some fractured structural items¹⁸⁶⁻¹⁸⁸. A typical example is shown in Fig. 13(b).

Concurrently with the tests on the Vampire structure, ARL undertook (commencing in 1963) an airworthiness fatigue test on the Cessna 180 mainplane at the request of the RAAF (Army operations) and the DCA (agricultural flying). Two wings were fatigue tested. The first was fitted with strain gauges and used in a flight test program to determine the strains induced in fatigue critical parts of the structure by specific service manoeuvres. It was then removed from the aircraft and subjected to a six-load-range program-loading test in the laboratory which was based on a combination of the most severe aspects of usage of the aircraft in civil, military and agricultural operations. During the fatigue tests progressive repairs were carried out on both wings and the tests terminated by failure in the main spar adjacent to the strut attachment at test spectrum lives of 15,230 and 17,840 hours respectively¹⁸⁹. These tests provided considerable insight into the general fatigue behaviour of light aircraft structures. It is of interest to note that in March 1964 the fatigue tests on Dove, Vampire and Cessna 180 were being conducted concurrently at ARL.

The Commonwealth Aircraft Corporation (CAC) CA-25 Winjeel entered service as the RAAF piston-engined basic trainer during 1951. In conjunction with the manufacturer, ARL undertook a fatigue life analysis of the structure¹⁹⁰ which indicated that the chordwise centre wing bolt/angle joint was critical. To provide more specific fatigue data for this particular part of the structure a six-load-range program-load fatigue test was carried out on a representative specimen¹⁹¹. This allowed an adequate safe-life to be assigned to the joint. Some aircraft (with up to 8150 hours) are still in service.

The Canberra, Vampire, Cessna 180 and Winjeel were, however, only four of the aircraft types in the RAAF fleet, and the RAAF requirement in the early 1960's to establish the safety under fatigue loadings of their other types created a task for which ARL did not have the resources to undertake in the time available. In order to expedite the structural fatigue analyses of RAAF aircraft the more engineering aspects of the life-assessment activities (including structural loadings, stress analysis, the identification of fatigue-critical areas within the structure and preliminary life predictions for such

areas) were undertaken by CAC (mainly) and Hawker de Havilland; with ARL concentrating on the measurement of flight strains, the derivation of flight loads spectra, the conduct (if required) of airworthiness fatigue tests, fatigue data acquisition, and background research on the overall problem. The active co-operation between ARL and CAC in this general field has been maintained since that time, and has been particularly important in relation to the Mirage 1110.

The longest and most intensive investigation undertaken in Australia into the fatigue life of an aircraft under local operating conditions involved the Mirage 1110; in the first phase that of estimating the safe service life and then some 15 years later in the development of refurbishment techniques for extending the life. This aircraft was manufactured under licence in Australia mainly at the Government Aircraft Factory (GAF) - the prime contractor - and CAC. In total 116 aircraft were delivered to the RAAF, 100 fighters and 16 dual trainers.

A preliminary fatigue analysis of the structure carried out at ARL in 1965 indicated that under RAAF operating conditions, particularly the ground-attack role, the fatigue-life of some parts of the structure might be inadequate. As a result a major investigation involving ARL, CAC and the RAAF was undertaken in which, during fabrication on the CAC production line, a wing was fitted with electrical resistance strain gauges and temperature sensors together with the associated wiring. Altogether, over 280 strain gauges (some inside the integral wing tanks), other transducers to measure temperature and acceleration and the ARL-designed Gust Probe, were fitted to the flight test aircraft A3-76 (Fig. 14). Comprehensive ground calibrations of the instrumented airframe were carried out and, over a period of four years some 200 flights (providing over 100 hours of flight-data) were made under a wide variety of loading and environmental conditions and strains measured in the wings, fin, fuselage and nose undercarriage. The information derived from these special flights enabled relationships to be established between the strains and accelerations for all the normal flight and landing configurations and, together with the load-spectrum data provided from Fatigue Meters fitted to other RAAF Mirages in normal squadron usage, enabled more refined estimates to be made of the safe-lives of various parts of the structure under Australian operating conditions. One of the problems encountered was in translating Fatigue Meter accelerations into strains at particular parts of the structure, as the transformation coefficients were found to be complicated functions of load level, altitude and airspeed. Nevertheless, a life-estimation formula was developed which accounted (approximately)

for the altitude, airspeed and aircraft mass at which Fatigue Meter readings were recorded and so allowed the proportion of the safe fatigue-life consumed by individual aircraft to be estimated from the Fatigue Meter readings.

As with the larger public transport aircraft, the long distances between centres of interest, generally favourable flying conditions and time savings compared with available ground transportation systems have combined to encourage the use of light aircraft for business, charter, survey, private and club flying. In the 1960's most light aircraft operating in Australia had been designed and certified to requirements which did not specify any fatigue substantiation. However, records which indicated a growing incidence of structural fatigue defects, particularly in aircraft engaged in agricultural flying operations caused some concern to DCA¹⁹². In such operations aircraft were used mainly for top dressing with fertilizers, seeding and insecticide/herbicide spraying - the aircraft frequently operating from rough strips. The nature of these operations which included a high frequency of take-offs and landings, low-altitude flying conditions, and a large number of relatively high manoeuvre loadings imposed severe fatigue loadings on the structure. The stresses introduced in the wing spar flanges of an aircraft in a typical agricultural operation are shown in Fig. 15¹⁹³. Additional concerns with aircraft used in agricultural flying were that initially (at least) they were adaptations of basic designs intended for some other purpose and that they were usually operated at gross weights in excess of their original design weights¹⁹².

A preliminary estimate made in 1960¹⁹⁴ of the fatigue life of a typical light aircraft used in the crop-dusting role indicated that the safe lives of aircraft used in such operations could be quite low. As a consequence DCA and ARL (with the co-operation of different operators) undertook a program primarily involving the fitment of Fatigue Meters (but in some cases the measurement of flight strain histories) to at least five different types of light aircraft with a particular objective of defining the load spectrum for aircraft used in agricultural operations. Some of the flight loads information on agricultural aircraft had been obtained¹⁹⁵, and special flight trials of the Cessna 180 under Army and agricultural roles were well advanced, when the concern of DCA was tragically demonstrated by fatal crashes involving two de Havilland Beaver aircraft while cropdusting. Both occurred near Armidale in New South Wales and resulted from fatigue failures in wing/strut lug fittings. The first in September 1963 after 3,400 hours and the second in July 1964, after 1,153 hours. These events were even more disturbing because a previous life assessment¹⁹⁵ and indicated safe-lives in the agricultural role of 5300 hours ($P_f = 0.01$) and

3,800 hours ($P_f = 0.001$). The results of the various loads investigations involving agricultural aircraft were summarised by Foden in a paper¹⁹⁶ presented at the 1967 ICAF Symposium held in Australia. One significant finding, which has been emphasised by O'Brien¹⁹³, was the differences in the loads spectra experienced by a particular type of aircraft because of pilot techniques. This is illustrated in Fig. 16. According to O'Brien this alone could represent a difference of 5:1 in the fatigue life of aircraft of the same type.

As the understanding of the properties of the atmosphere is important in the determination of the flight loads and fatigue design of aircraft (particularly transport aircraft), ARL collaborated with the RAE and other establishments in an investigation into the nature, severity and geographic distribution of clear air turbulence at high altitude (in or near the tropopause). This project was codenamed TOPCAT and the trials took place between July and October 1963 using a fully instrumented Canberra fitted with a gust probe. The trials were based at Salisbury in South Australia and search flights were made over a large portion of the Australian continent where high altitude turbulence had been predicted. The project included 41 flights of which 17 were successful in encountering turbulence ranging from slight to severe. The size of the turbulent areas was determined and their severity measured, thus allowing a power spectral analysis to be made of gust velocity which could be compared with the theoretical energy distribution. Details of this investigation are contained in References 197 and 198.

Australia was again involved in clear air turbulence research in 1966 when a collaborative program codenamed "HICAT" was undertaken with the United States Air Force. This program included flights of a Lockheed U-2 aircraft in the jet stream over the Australian continent at altitudes of from about 50,000 ft to 70,000 ft. The major findings of this investigation¹⁹⁹ were that such turbulence may exceed 160 km in dimension and persist for at least two hours, that the terrain some 60,000 ft below flight level appeared to influence the nature of the clear air turbulence, and horizontal temperature gradients of several degrees in a few kilometers may occur in the turbulent region.

6. THE EMERGENCE OF NEW TECHNOLOGIES - 1966-1979

A complementary project to those involving high altitude clear air turbulence was the investigation, by ARL, of low level turbulence using the instrumented RAAF Mirage III aircraft A3-76 fitted with the locally designed gust probe (Fig. 14). Although the initial objective in using the probe was to determine the gust response functions of the Mirage, its potential for obtaining valuable

information relating to the structure of atmospheric turbulence was exploited in numerous flights through severe turbulence over both rugged mountainous terrains at altitudes as low as 500 ft and also in thunderstorms²⁰⁰.

Since the mid-1960's ARL has played a decreasing role in the routine collection (for example, using Fatigue Meters) and the analysis of flight loads data on both civil and military aircraft - the civil activities being handled by DCA (with an emphasis on General Aviation aircraft) and a large part of the military aspects being undertaken by the RAAF themselves, CAC or Hawker de Havilland. Nevertheless, ARL has maintained a very active interest in the measurement of flight strains, mainly as a method for determining structural load distributions and as a precursor to the conduct of fatigue tests on particular aircraft, but also in relation to the development of instrumentation specifically for the in-flight fatigue damage monitoring of the critical parts of the structures of individual aircraft on a "tail-number" basis²⁰¹. A major step in the realisation of an airborne strain-measuring system which Wills envisaged in 1948⁷² was the proposal put forward by Ford and Patterson²⁰² for a small strain-range-pair counter. This concept, which became known as the Aircraft Fatigue Data Analysis System (AFDAS), was developed at ARL to the prototype stage, and production was then undertaken by British Aerospace Australia Ltd. In its current form (Fig. 17) the system consists of eight strain gauge or other electrical transducers; a solid-state airborne strain-range-pair-counter (4.5 kg); a ground-based interrogator, display and cassette recording unit; and a strain-range-pair fatigue damage translator. A particular application seen for such an instrument was in the measurement of loads (eg. fin loads) not usually relatable to the normal accelerations measured by Fatigue Meters installed at the centre-of-gravity of the aircraft. The introduction of AFDAS into RAAF aircraft has been discussed by Millhouse²⁰³. Another flight recording system developed at ARL was the Aircraft Flight Trials Recording and Analysis System (AFTRAS). This provides a facility for the airborne recording of up to 255 channels of data. Prototype development was completed in 1979.

A consequence of the high utilization of civil aircraft in Australia (which was associated initially with the "safe-life" structures common in the 1950's and 1960's) was the need for careful consideration of the implications of the statistical variability in fatigue life. Although the subject of variability in fatigue life and the form of its probability distribution were of great academic interest, one problem of considerable practical importance was that of translating a mean life (derived either by analysis or by fatigue testing) into a safe operating life. While the "scatter factor" used for this purpose had to

be sufficiently high to ensure that the probability of in-flight fatigue failure was reduced to an acceptable level, it was realized that the arbitrary imposition of a large factor could seriously affect the economic operation of an aircraft. Thus, the interpretation of structural fatigue data and the nomination of safe-lives and inspection intervals have been a long-standing interest of ARL²⁰⁴⁻²⁰⁹ and DCA^{116,171}.

One basic feature in the safe-life approach is the validity of assumptions relating to the distribution function of fatigue life, particularly the shape of the distribution at the lower tail. The data derived from ARL's extensive fatigue testing program on Mustang wings - presented at the 1961 ICAF Meeting²⁰⁴ - showed that the log. normal distribution was a reasonable approximation for complete structures and components down to probabilities of failure of 0.01 or 0.005. The studies of variability associated with the Mustang work also provided a firm foundation when the relatively simple "safe-life" concept was supplemented by the fail-safe, safety-by-inspection and damage-tolerance philosophies of structural design - all of which required that a minimum static strength be demonstrated by a structure containing a crack of prescribed dimensions. Neither the simple *safe-life* or *fail-safe* approaches to in-flight safety take into account the fundamental question of the increasing probability (risk) of structural failure with increasing service life when cracking may be progressively weakening the structure. The paper by Shaw¹¹⁶ was an early attempt to quantify the fail-safe approach, while Ferrari et al¹⁷¹ developed a procedure for estimating the risk of failure. Nevertheless they did not consider the variability in crack propagation rates and residual strength.

ARL has taken an active part in the development of the reliability approach to structural fatigue²¹⁰⁻²²⁰. In this approach (which makes use of representative residual strength and fatigue crack propagation data) the increasing risk of failure in a structural component as a function of service life as the crack propagates can be calculated for any prescribed load spectrum, taking into account the variability in static strength during crack growth and the variability in crack propagation rates²¹⁷. It requires an appreciation of the impossibility of achieving absolute safety, and agreement regarding acceptable risk. The reliability approach provides a quantitative solution to both the fail-safe and safe-life philosophies and has been developed to provide a method for establishing inspection intervals on the basis of an acceptable risk of failure per hour. The optimum procedure (Fig. 18) would be continuous inspection so that cracks are always limited to the detectable size. However, as this is usually not feasible in practice inspections are carried out at prescribed

intervals to limit the risk to the specified value. When the calculated risk rate reaches the maximum acceptable level from the viewpoint of structural safety an inspection is carried out. If the component is not inspectable (eg. safe-life) it is withdrawn from service at that life. If cracks of a size larger than some arbitrary size are detected the component should be removed from service; if cracks of less than this size are detected the interval to the next inspection must be re-assessed; if no cracks are detected, the risk of failure is reduced to that for continuous inspection. Thus, the risk of failure per hour will vary between that for continuous inspection and the specified maximum risk. Various aspects of the derivation of reliability models have been coordinated and refined into a computer program coded Numerical Evaluation of Reliability Functions (NERF)²²². Nevertheless, it should be noted that to successfully apply the quantitative reliability approach a considerable amount of reliable input data are needed, particularly as regards probability density functions covering, for example, fatigue crack propagation rates and the static strength characteristics of cracked structure.

Concurrently with ARL's work on the reliability aspects of structural safety Ford²²³⁻²²⁶ has been developing a general mathematical theory of structural fatigue under random loading which incorporates the features of a two-stage process of pre-crack damage (to crack initiation) and fatigue crack propagation occurring either at one or several (possibly interacting) locations simultaneously.

Although problems with aircraft undercarriages made of high-strength steel had been encountered, ARL's experience with aircraft structures until the late 1960's had been almost exclusively related to those made of aluminium alloys. Among the few structural exceptions were the early Stinson A2W structure of tubular steel, steel fittings at structural joints, and Vampire fuselage cross tubes. In the early 1960's DCA became very concerned about a serious (but non-fatal) accident with a Beech 18 which experienced a fatigue failure of the centre-section lower spar tube, and a spate of fatigue cracks found in the spars of other aircraft of this type. The centre section was made from welded 4130 steel tubing fully heat treated to a UTS of 1100 MPa (160,000 psi) after welding of the assembly. Despite the fact that some 8,000 of these aircraft were built over a 25 year period no fatigue data for such a welded heat treated construction had been determined²²⁷. On behalf of DCA, ARL undertook a fatigue testing program on specimens representative of the welded joints⁶³ in the structure and the data were used to convince both the manufacturer and the original certifying authority that the aircraft was seriously fatigue-prone.

The decisions in 1966 to replace the ageing Winjeel and Vampire trainers with the Aeronautica Macchi MB.326H jet trainer, and the Canberra bomber with the General-Dynamics F-111C strike-bomber had a major impact on the thrust of ARL's research over the next decade. A total of 87 Macchi MB.326H aircraft was procured by the RAAF and Royal Australian Navy, most of these being manufactured under licence in Australia with CAC being the prime contractor. Twenty-four F-111C aircraft were ordered, all of which were completely manufactured in the United States.

In the Macchi the centre-section spar booms were made of a high strength steel (similar to SAE 4340) heat treated to an ultimate strength of 1090 MPa (158,000 psi); while in the swing-wing F-111C (Fig. 19(a)) a number of major structural components including the wing carry-through structure and wing pivot fittings were made of D6AC steel heat treated to the ultra-high-strength (UHS) of 1590 MPa (230,000 psi). The use of UHS steels in aircraft flight structures was, at that time, virtually a new technology as they were quite different from aluminium alloys in their fabrication methods and properties²²⁸.

The investigation into the fatigue lives of the Macchi MB.326H structural components under Australian operating conditions (undertaken by ARL in conjunction with CAC) involved the flight testing of two specially strain-gauged aircraft to check the strains in the fin, tailplane, wing and centre section. Subsequent life estimates indicated that, under the RAAF spectrum of usage the lower spar boom in the wing centre section (a non-redundant member) was fatigue-critical - in particular a number of small holes used for the attachment of brackets. As the spar booms were progressively replaced at the expiration of their safe-lives by a later design of larger section, they were made available to ARL to explore the feasibility of both maintaining their airworthiness and of extending their lives by operating them on a "safety-by-inspection" basis, rather than on the original "safe-life" basis. A comprehensive investigation was undertaken on these booms which involved the determination of fatigue crack propagation rates under multi-load-level sequences and their residual static strengths, the development of suitable NDI techniques, and the application of reliability analysis for deriving inspection intervals*. This investigation showed that the fatigue crack growth rate in the spars was slow and that the critical crack size was considerably greater than the minimum size of crack which could be reliably detected using ultrasonic methods or the magnetic

* In parallel with the ARL tests on centre-section booms a full-scale wing fatigue test under an Australian spectrum was carried out by Aeronautica Macchi at Varesa, Italy.

rubber inspection (MRI) technique which had been developed by General Dynamics of Fort Worth, USA. The implementation of the "safety-by-inspection" philosophy relied firstly on ultrasonic inspection techniques to detect fatigue cracks at holes with the bolts in situ (and subsequently monitor their growth rates), and secondly on the confirmation of the crack indications (with bolts removed*) by means of a removable magnetic rubber plug cast in the hole. Cracks with a surface length as small as 0.05 mm could be detected in this way and spars were withdrawn from service at a crack length of 5 mm. Reliability theory was used to define the inspection intervals (which were not unacceptably short) and the maximum tolerable crack size. The "safety-by-inspection" philosophy provided considerable economic advantages in extending the total life of a boom well beyond the previously adopted safe-life without reducing the level of in-flight safety. This life was further extended by progressively reaming out the hole in steps until the cracks were removed - this being determined by monitoring the crack shape after the taking of successive magnetic rubber casts. It was established that (providing the nett section was not significantly reduced) the removal of the cracks plus a further 0.25 mm depth of metal would remove the residual fatigue damage. Various aspects of the investigation relating to the Macchi MB.326H are covered in References 229 and 230.

Almost co-incident with the handing over of the first of the Australian F-111C to the RAAF in September 1968 was the failure (in the United States) of an F-111 test article at a very early stage of a full-scale structural fatigue test. Irrespective of the political implications of this event it created a major technical problem in identifying the cause of the failure and then in ensuring that it could be satisfactorily overcome. In Australia, this led to firstly, the setting up at ARL of a special Scientific Advisory Panel to support the RAAF; secondly, to a comprehensive assessment of the F-111C fatigue life under the projected Australian operating conditions (particularly in transposing from the United States Air Force (USAF) to RAAF usage); thirdly, the undertaking of a testing and analytical program to investigate the fatigue behaviour (particularly fatigue crack propagation rates and variability in fatigue life); and fourthly, an investigation of the applicability of non-destructive inspection techniques for monitoring the structural safety of the aircraft. The seriousness of the problem was further demonstrated in December 1969 by the crash of a USAF F-111A resulting from a small manufacturing flaw in a wing pivot fitting, and this caused concern that the F-111C might not have

* For this purpose the original Jo-bolts (which provided a slight interference-fit) were subsequently replaced by clearance-fit fasteners which could be readily removed to inspect the holes.

been able to satisfy the performance requirements of the RAAF. Australia indicated that it was unwilling to accept delivery of the F-111C until all doubts about its structural integrity and combat performance had been resolved, but as an interim measure agreed to the lease of 24 Phantom F4E aircraft.

The ARL fatigue testing program necessitated the construction of a $\pm 450,000$ lbf electro-hydraulic machine for the multi-load-level testing of large complex specimens (Fig. 19(b)) comprising a channel section of D6AC steel to which aluminium alloy side plates were attached by Taper-Lok bolts. This specimen represented the critical section of the wing-carry-through-box (WCTB). Tests at ARL on fourteen of these specimens (and further fatigue tests in the United States on similar specimens and full-scale test articles) which were supported by extensive NDI monitoring confirmed that very small critical crack sizes would have to be contended with in D6AC steel, and that fatigue crack growth in this material was very sensitive to the presence of aggressive chemical environments introduced during fabrication or in service²³¹⁻²³⁴. Initially a safe-life approach had been proposed to ensure structural integrity, but as the results of the various fatigue tests indicated a standard deviation of log. life to final failure of up to 0.2^{231} (which was considerably greater than that of 0.08 for aluminium alloy structures tested under the same type of load spectrum²⁰⁶), and there was concern that potentially serious cracks might be missed during NDI, an alternative approach to certifying and maintaining the airworthiness of the structure was adopted. Thus, the concept of damage-tolerance evolved in which the principles of elastic fracture mechanics were used to predict critical crack sizes under various flight conditions, and then to demonstrate the integrity of each airframe by subjecting it (before delivery) to a static cold-proof test at $-40^{\circ}\text{C}^{235}$. Because of the lower fracture toughness (and hence smaller critical crack size) of D6AC at -40°C than at higher temperatures, a non-failure gave added assurance of adequate static strength at normal operating temperatures. As with the Macchi, the structural reliability approach could then be used to predict inspection intervals for selected critical areas of the structure and the service life intervals at which the cold-proof test should be repeated - again, the crack detection capability of NDI was an integral part of this approach. Other aspects of the ARL research on the fatigue of UHS steels are given in References 236 and 237, the latter covering a collaborative USAF/ARL investigation on the corrosion fatigue of Taper-Lok bolted joints in D6AC steel.

In March 1973 the RAAF finally took delivery of its first F-111C, and among the many modifications incorporated in this and the remaining 23 Australian

aircraft was a redesigned WCTB*. The F-111C is capable of operating over a range of configurations (weight, stores, wing-sweep angle) and type of flying (speed, altitude, mission type). A Service Life Monitoring Program (SLMP) was developed by ARL, the RAAF and CAC based on a procedure used by the USAF. This employs a computer-based system to process and analyse data derived from the continuous recording of significant flight parameters, to estimate the stress history at a number of selected structural "control points", and hence to calculate fatigue damage and monitor the life. The SLMP program has been implemented by CAC, but is backed by extensive NDI to which ARL Materials Division made a major contribution in the development of techniques, eg. the in-situ detection of cracked Taper-Lok bolts and cracks in bolt holes. One of the RAAF F-111C's which was returned to the USA after 2181 hours for a repeat cold-proof test failed during loading because of defects, including some which had developed in the upper surface of the wing pivot fitting. This event has vindicated the repeated proof-load approach to structural integrity.

During 1972 it became apparent that the service loading spectrum for the RAAF Mirage IIIIO (which had been established from Fatigue Meters fitted to squadron aircraft) was such that the previously estimated safe-lives for some parts of the structure were marginal relative to a longer life-of-type required by the RAAF for this aircraft - the life required also exceeded the manufacturer's design safe-life. It was therefore considered that the conduct of a full-scale fatigue test was justified to firstly provide a refinement in the estimate of safe-life and the required confidence to continue operating the aircraft on a "safe-life" basis; and secondly to identify fatigue-critical locations and develop inspection procedures and (if necessary) repair schemes.

The test article consisted of a starboard wing which had accumulated some 1729 flying hours²³⁸. After the fitment of strain-gauges and calibration in a series of ground loading and flight tests it was mounted on a reaction frame (dummy fuselage) and subjected to a complex flight-by-flight loading sequence in a multi-jack servo-hydraulic loading rig controlled and monitored by a PDP-11 computer^{238-240#}. The test loading sequence was derived from Fatigue Meter

* It is of interest to note that in April 1965, at a meeting to consider the future service life of the RAAF Canberras, it was stated that this aircraft was not expected to remain in service after the F-111C entered service - the Canberra was eventually phased out of RAAF service in 1982!

Some 33 years after Johnstone's paper on the strength testing of aircraft wings⁵⁶ and his own work on the fatigue of Typhoon tailplanes⁸⁰, Townshend (now at ARL) reviewed the development of aircraft structural testing to the time of the Mirage fatigue test²⁴¹.

records and the continuous recording of flight loads (covering a variety of typical RAAF missions) using specially instrumented aircraft which have been referred to previously. Fifty-five "flight-types" were formed into the sequence of 500 manoeuvre and gust flights (including ground loads) each of about one hour's duration²⁴². The test was carried out (with regular monitoring of the test article by NDI) on a 24 hours per day, seven days per week basis at an average testing rate of 12 simulated flights per hour. Considerable engineering support for the Mirage wing test was provided by CAC.

At a test life of about 15,000 flights a relatively large fatigue crack was detected at the bolt hole of an anchor nut in the lower skin panel (tank door) used for attaching the fixed fairing to the wing, and minor cracks were found at several other locations including an inboard rear flange bolt hole of the main spar. In service the skin crack would have allowed loss of fuel and would have been repaired, but in the test it was allowed to propagate. The test terminated with the sudden failure of the main spar under a 7.8 g load after 32,372 flights²³⁸, the final failure having initiated from the bottom of a blind hole used for attaching the fixed fairing. A detailed fractographic analysis of the fracture surface enabled the fatigue crack propagation rates to be established and correlated with those predicted using fracture mechanics principles²⁴³. A post-failure inspection also revealed a number of other fatigue cracks (most relatively small) throughout the structure²³⁸. The fatigue life demonstrated by the test was such as to clear the wing of the Mirage III structure to the then required RAAF life-of-type. However, since the test article comprised only a starboard wing, no test information was obtained on the fatigue quality of other parts of the airframe.

During the conduct of the ARL Mirage III wing test close contact was maintained with the Eidgenössisches Flugzeugwerk (F+W), Switzerland who were setting up a structural fatigue test on a complete Mirage IIIS airframe. It was hoped that this test would both confirm the results of the ARL test on the Mirage IIIO wing and also validate, by test, the safe-lives for other parts of the structure. Initial fatigue damage in both the Swiss and the Australian tests occurred as skin cracking from a fairing fastener attachment hole. Previous successful experiences at ARL with the use of adhesive-bonded glass fibre patches¹⁶⁴ and boron fibre reinforced plastic (BFRP) patches²⁴⁴ to retard or inhibit crack growth in aircraft structures and components led to the design of a suitable patch for this region²⁴⁵. However, the installation of the fairing hole crack patch on RAAF service aircraft became of secondary importance when cracks (associated with fuel leakage) were found at the adjacent fuel decant area of

several wings. A suitable multi-layer BFRP patch (Fig. 20) was designed and incorporated as a routine field repair on the RAAF Mirage fleet²⁴⁵⁻²⁴⁷.

However, of even greater concern to the safe operation of the RAAF Mirage fleet was the failure of the port wing in the first F+W Mirage test at a life much less than would have been predicted from the result of the ARL wing test and associated strain measurements²⁴⁸. The Swiss wing test failure, which originated at a bolt hole on the front flange, was subjected to a detailed fractographic examination at ARL²⁴⁹. A tear-down inspection of the Swiss test wings gave positive indications of fatigue cracks at a number of other bolt holes including the innermost bolt holes of the rear flange of the main spars, and showed the need to improve the fatigue performance in these locations if the life-of-type specified by the RAAF was to be achieved. The result of these findings was the setting up of a cooperative Tripartite investigation between ARL/RAAF, F+W and Avions Marcel Dassault (AMD-BA) which included comprehensive ground-loading strain surveys and flight trails, fatigue tests on small specimens representing the various fatigue-critical locations in the spar, and the continuation of the full-scale fatigue test at F+W²⁵⁰ with a starboard RAAF Mirage IIIIO wing (2190 hours service) and port Swiss Mirage IIIS wing (510 hours service)*. After a relatively short test life cracks were found at the innermost bolt holes of the rear lower flanges of the main spars of both wings. This finding initiated a fleet-wide inspection of the corresponding holes in the wings of both the RAAF and Swiss Mirage fleets, which confirmed the presence of cracks in these locations in a large number of wings. Thus, instead of maintaining the initial concept of carrying out the refurbishment of the wings to meet the required life-of-type at a time when there was virtually no fatigue cracking, the problem developed into that of extending the lives of spars which had already developed significant fatigue cracks in service. An extensive testing program to investigate various options for reworking fatigue-cracked holes was carried out at ARL, some results from which are given in Reference 250. Satisfactory extensions in fatigue life were obtained by reaming-out the cracks at the bolt holes and fitting interference-fit bushes.

The technique of interference-fit bushing²⁵⁰ was used as a repair for the RAAF and Swiss wings in the F+W test article and has been adopted as the basic system of refurbishment for extending the fatigue lives of the wing main spars of the RAAF Mirage IIIIO fleet. Nevertheless considerable thought has been given to the continued operation of the Mirage III structure on the "safe-life"

* BFRP were applied to the fairing hole regions of both wings and the decant hole of the RAAF wing after about 1170 simulated flight hours.

basis to which it was originally designed. Monitoring of crack growth in the spar bolt holes of individual aircraft until they could be released for factory refurbishment and provision for crack monitoring through the bushes by making them of stainless steel is clearly contrary to the basic concept of "safe-life", but acceptable if a safety-by-inspection philosophy was followed. Without the results of a full-scale structural test to failure on the complete airframe the major problems in adopting the latter philosophy for the whole Mirage structure revolve around uncertainties (in detail) as to the most fatigue-critical locations and, even if these were known, whether access could be provided to carry out NDI with adequate sensitivity and reliability. Associated economic and safety questions, with a fleet as large as the RAAF Mirage, are those of the extent of the inspections needed either on one aircraft or throughout the fleet. A major failure in fuselage frame 26 of the Swiss test article early in 1982, and subsequent inspections of both the test article and fleet aircraft, has at least provided the basis for making a more rational assessment of the service life of the remainder of the Mirage 111 airframe.

From the Australian viewpoint two major considerations in airworthiness are: (i) whether a new aircraft type has sufficient initial life for its intended Australian role and usage - this problem is magnified because most aircraft on the Australian register are designed to foreign requirements, and (ii) whether a current aircraft type can have its certificated service life economically and safety extended under a similar role or a completely different role.

In this regard it is of interest to reflect on the forecasts of aircraft service lives some 30 to 40 years ago. According to Nissen³⁵ by 1938 several Junkers G.24 civil passenger aircraft had flown up to 7,000 hours of their estimated life of 10,000 hours, and some Junkers Ju.52 operated by Lufthansa had exceeded 6,000 flying hours. Although Tye¹¹¹ has mentioned that only rarely did the most used civil aircraft prior to World War II have lives exceeding 10,000 hours, Teed²⁵¹ has stated that by the 1940's period two Handley-Page Hannibal transport aircraft had flown upwards of 12,000 hours and three Short Empire class flying boats had exceeded 15,000 hours. Lives exceeding 20,000 hours have been indicated by Shuler¹⁰⁹ for some Boeing aircraft. Pugsley^{81,252} in 1945/1946 was speaking of the life of a heavy bomber as 1,000 to 2,000 hours, and that of a civil transport some 10 to 20 times greater - eg. 20,000 hours. In his paper to the 2nd International Aeronautical Conference in 1949 Wills⁷³ suggested that the life to be aimed at should exceed the longest possible service lifetime of an aircraft of a certain type, and

noted that 40,000 to 50,000 hours might be reasonable for an aircraft such as the Douglas DC-3. By 1951 actual lives in this order for the DC-3 and of over 25,000 hours for the Lockheed Model 18 were quoted by Shuler¹⁰⁹.

According to Gardner²⁵³ utilization rates of 2,000 to 4,000 hours per annum were being realised by aircraft which had a predicted useful life of 15 to 20 years. In 1952/1953 aircraft lives of 30,000 hours were being proposed^{88,111,112} as design criteria for civil aircraft, but Gardner⁷⁴ even suggested an upper limit of 50,000 hours. For fighter aircraft Munier¹¹⁸ proposed a life of 4,000 hours. A French viewpoint expressed by Cornillon²⁵⁴ in 1956 was that, for a probability of failure of 0.001, the minimum life for a fighter should be 1,000 hours, for bombers and military transports 5,000 hours, and for civil transports 20,000 hours. At the same time Giddings²⁵⁵ forecast that a civil transport might be expected to fly some 30,000 to 40,000 hours over a period of 10 years, and a figure of 30,000 hours over this period was also an early criterion used for the SE-210 Caravelle¹⁷⁴ in 1959. It is now commonplace (in purchase contracts with operators) for transport aircraft manufacturers to guarantee their aircraft against fatigue problems in primary structure for at least 30,000 flights, and of interest to note that the retirement life of the Fokker F.27 has now been extended to 90,000 hours. During the last 20 years the required service lives of both civil and military aircraft has been extended to 20 to 25 years, which can represent lives in excess of 60,000 flying hours for a civil aircraft and from 6,000 to 8,000 hours for a military combat aircraft²⁵⁶⁻²⁵⁸. This situation is reflected in the Australian military scene where the RAAF have a requirement for a 20 year service life and 8,000 hours structural fatigue life for the new Australian-designed basic trainer.

According to Torkington²⁵⁹ in 1980 "a survey of 19 major airlines showed that 55% of their total fleet of 2542 aircraft were over 10 years old, many having a total flying hours figure never envisaged at the time of their certification". The problem of maintaining and extending the airworthiness of ageing aircraft without undue economic penalties or loss of operational effectiveness - in the words of Butler²⁶⁰ the "rehabilitation of fatigue-weary structures" - has been of long-standing concern to the Australian civil aviation authorities in the operation of civil aircraft because of the "lead-the fleet" situation which they have faced on a number of occasions²⁶¹. It is also clearly exemplified, in military aircraft, by Australian experiences with the Mirage III. "Long-life aircraft structures" was the theme for a convention organized by the Royal Aeronautical Society in London in May 1980²⁶². This topic of long service life is one of increasing worldwide importance in both

the civil^{261,263}, and military fields because of the high unit cost of modern aircraft and long lead times in their procurement, changing operational roles which sometimes results in the ageing aircraft being subjected to a more severe fatigue environment than they experienced in their early life²⁶⁴, and (in retrospect) the adequacy or relevance of structural loads or fatigue test information acquired during the initial development of the particular aircraft type. Furthermore, the degradation of a long-life aircraft structure because of the development of multiple defects, corrosion/stress corrosion, deterioration of bonded joints, undetected cracks or damage, inadequate repairs or untested modifications may cause the fatigue and fracture resistance of the structure to be changed to such an extent that the original airworthiness substantiation and inspection procedures (based on a structure in the new unmodified condition) may not be adequate to ensure the continued safe operation of the aircraft (Ref. 261). This last point is well demonstrated in the case of the RAAF F-111C, MB.326H and Mirage IIIO where fatigue-cracked "safe-life" structures are now being maintained airworthy through a "safety-by-inspection" approach.

Problems of particular concern to the civil aviation authority in Australia during the last 15 years have been the continuing occurrence of fatigue-type defects in light aircraft and the associated fatigue certification of the smaller General Aviation aircraft. Some individual aircraft in local operations have utilization rates approaching those of the larger RPT aircraft and have accumulated total lives of over 10,000 hours¹⁷⁹. It should also be noted that, despite the relatively flat terrain of Australia, the atmospheric gust environment experienced by aircraft operating within this country is quite severe and this augments the high utilization rate in creating a relatively rapid accumulation of fatigue damage. Prior to the early 1970's few of these imported aircraft were required to comply with any fatigue substantiation in their country of origin. As a result, in January 1970, the Australian airworthiness certification requirements for General Aviation aircraft were amended to include a requirement for structural fatigue substantiation for aircraft not exceeding 5,700 kg gross weight^{179,259}. Since then, retirement lives or fail-safe inspection procedures for aircraft operating under Australian conditions have been promulgated for 85 types of General Aviation aircraft - ranging from small single-engined types to pressurized twins. In most cases the promulgated lives differ from those in their country of origin, and have even exceeded 15,000 hours.

Other recurring fatigue problems which have been experienced with light and General Aviation aircraft in particular (but not exclusive to), relate to

propeller blades and hubs, undercarriages and landing wheels. During the past 12 years some 13 in-flight propeller failures have occurred in Australia resulting in three fatal crashes. Numerous propellers have been withdrawn from service because of the detection of major fatigue cracks in blade shanks and hubs. In addition to adopting safe-lives for specific propeller assemblies, the approach of the Department of Aviation (DoA) to overcome this problem has been to develop specialised NDI procedures (particularly eddy current techniques for propeller blade retention areas), to require improved maintenance procedures in the overhaul of propellers, and for the operators to pay careful attention to accidental damage (for example, by stone impact) and the degradation of protective coatings. The latter are of considerable significance because of the large numbers of unsealed airstrips and rough fields from which light aircraft operate. These conditions also lead to fatigue problems with undercarriages and landing wheels.

Fatigue failures of landing wheels are quite common in Australia for both RPT and General Aviation aircraft. For example the GAF Nomad suffered some 32 wheel failures in about 18 months, leading to the introduction of re-designed and heavier wheels. In the case of RPT aircraft one DoA study²⁶⁵ showed that 90% of Boeing 727-200 main landing wheels would develop fatigue cracks with a probability of greater than 95% before 8000 landings. Such findings were used by the DoA to argue at the US Federal Aviation Administration for higher fatigue design standards for aircraft wheels. Although landing wheels are essentially "safe-life" items they are maintained in service on a "safety-by-inspection" basis and again eddy current techniques are widely used in Australia for this purpose. It is of interest to note that the further growth of fatigue cracks in the landing wheels of the Macchi MB.326H has been successfully prevented by the use of BFRP patches developed by ARL^{244,266}.

During the past decade the fatigue of helicopters has received increasing attention by DoA. Although, in terms of numbers, they constitute a minority in the Australian Register of Aircraft (i.e. only about 3%) they attract a disproportionate amount of time and effort in the area of airworthiness control - about 10% of all Australian Airworthiness Directives relate to helicopter fatigue problems. Although only two fatal fatigue-initiated accidents have occurred in Australia (involving a Bell 47 in 1966 and a Bell 204B in 1968²⁶⁷) there have been many non-fatal accidents involving float cross-tubes, main rotor yokes and trunnions, rotor blades and other components. These have necessitated the retirement lives for particular components to be reduced from those originally promulgated.

The period 1966 to 1979 was one of great activity in Australia both in aircraft structural fatigue research and aircraft structural airworthiness developments, and included the holding of the 5th ICAF Symposium at Melbourne in May 1967. However, it was not without its share of tragedy because of five fatal accidents caused by structural fatigue. The worst of these was the crash of a Vickers Viscount 700 near Port Hedland in Western Australia on 31 December 1968 with the loss of 26 lives following the in-flight failure of the lower main spar boom of the starboard wing at a boom life of 8,090 flights - the prescribed boom retirement life at the time was 11,400 flights. This failure resulted from an incorrectly shaped interference-fitted bush which had escaped detection. A new retirement life of 7,000 flights was specified by the manufacturer and the British Air Registration Board, but in Australia all Viscounts of this type were withdrawn from service.

Although the topics discussed thus far have related mainly to the measurement of aircraft loadings, structural fatigue testing and life assessment, these research activities at ARL have been supported by a considerable effort in both the Structures and Materials Divisions of the Laboratories to determine the effects of metallurgical, processing, design and environmental variables on the fatigue behaviour of aircraft materials and components, to study methods of life estimation under complex load histories, to develop techniques for fatigue testing, to investigate basic mechanisms of fatigue failure and to undertake failure investigations for both the civil and military aviation authorities. Some aspects of this work were reviewed at a symposium on aircraft structural fatigue held in Melbourne during October 1976²⁶⁸.

7. THE 1980's AND BEYOND

Overall, in all categories, 90 to 95% of the 6835 aircraft currently on the Australian civil register are of foreign design and manufacture. The percentage for military aircraft is at least as great. Australia is not in the position to compete with well-established companies overseas in the design and development of medium-size and large RPT aircraft or sophisticated military combat aircraft, and even in the light aircraft field design and production could not be justified on local sales alone. Nevertheless, there have been three aircraft types which have reached quantity production in recent years (and a fourth is in the design/development stage) all of which require structural fatigue substantiation.

The Victa Airtourer - a two-seat, fully-aerobatic, piston-engined aircraft - was manufactured in Australia from July 1962 to February 1966 before

manufacturing rights were acquired by New Zealand Aerospace Industries Ltd (NZAIL). After the redesign of a later development of the Airtourer (the Aircruiser) the CT4 Air Trainer was evolved and was ordered by the RAAF as a primary trainer. A preliminary fatigue analysis carried out by ARL indicated that the centre-section joint of the main spar was likely to be fatigue-critical, and a modification was proposed. This was investigated by testing two simulated spars²⁶⁹ and changes were incorporated in the RAAF CT4A production aircraft. The CT4A entered RAAF service in 1975. In line with the RAAF policy to substantiate the fatigue life of the whole airframe was the requirement to carry out comprehensive flight-strain measurements. An aircraft instrumented with nearly 70 strain gauges and other transducers was statically calibrated and then over 40 flights made under representative training missions. The data thus acquired have enabled the fatigue test loadings for the wing, empennage and undercarriage to be deduced, and Fatigue Meter records from squadron aircraft have allowed the load spectrum under manoeuvres, gusts and landings, and the mission mix to be derived. The flight-by-flight fatigue test to be carried out on the structure will be controlled by a PDP-1144 computer and is scheduled to commence in the first half of 1983.

Nomad is a twin turbo-prop, unpressurized transport aircraft (mainly of riveted sheet construction) which is designed and manufactured by the Government Aircraft Factories (GAF), Melbourne. It has STOL capabilities for operation from unprepared airfields. Of the estimated production run of 170 aircraft, 135 have been delivered and are being used both locally and overseas in military, geophysical, medical and surveillance roles. In order to establish the safe fatigue life for the airframe in both civil and military roles a full-scale flight-by-flight airworthiness fatigue test was commenced at ARL in August 1976. Of particular concern was the fatigue damage induced in the structure by operations from unprepared airfields. The test article consisted of a port wing, wing strut, stub wing and the centre section of the fuselage (Fig. 21). Until the end of 1982 a total of 137,986 simulated flights of about one hour duration had been achieved. During the test many fatigue cracks (most relatively minor) were detected using a variety of NDI methods in the main wing, stub wing and fuselage. In such cases, conventional aluminium alloy patch repair schemes were developed with the view to catering for the limited repair facilities available in geographically remote areas. However, in some cases (where the cracking was considered to be non-representative of service occurrence), BFRP patches were applied. Three major failures have occurred, one being in the upper wing strut fitting at 79,837 flights (for which the fitting was replaced) and the other two in the stub-wing front spar. That in

the lower cap was repaired using an external bridging strap; the other in the upper cap was detected at 104,000 flights. The crack was allowed to propagate, but at 137,986 flights the test was stopped because the crack was considered to have reached a critical size.

The Transavia PL-12 Airtruk (Fig. 22) is a single seat, piston engined agricultural aircraft of rather unusual configuration. It is a twin tailboom sesquiplane with a short, stubby fuselage. The cockpit is located above the engine, with the hopper behind. This arrangement allows for easy loading from the rear. Some 112 aircraft have been manufactured since production commenced in 1966 and of these 75% have been exported - to New Zealand, Thailand, Malaysia, Taiwan, South Africa, Denmark and Yugoslavia. Aircraft have also been delivered to the USA and to Spain for evaluation. The latest model has an agricultural maximum weight for take-off of 1925 kg and the maximum structural hopper load is 907 kg. Wing spars are of welded fabricated sheet steel construction, and safe lives (derived by conservative analysis) of 11650 and 8680 hours have been promulgated for the main and stub wings respectively. A fatigue test program has been proposed to verify these lives.

In mid-1982 a contract for the design and development of a new RAAF basic trainer was awarded to the Australian Aircraft Consortium (AAC). This 2/3 seat turbo-prop aircraft is being designed using damage-tolerance and durability procedures, and one of the prototype airframes will be subjected to a durability test for two design service lifetimes (16,000 hours). ARL will be heavily involved in the acquisition of the fatigue and fracture data needed for the design analyses and in the conduct of the structural tests. The new trainer is expected to enter RAAF service in 1987/88 and to remain in use until the year 2008.

ARL's interest in non-metallic composite materials has extended over more than ten years, and various applications (particularly relating to the patching of cracks and the use of these materials as reinforcements) have already been referred to^{244-247,266}. A comprehensive survey presented by Hardrath as the 6th Plantema Memorial Lecture²⁷⁰ indicated the potential of advanced composite materials as primary structural members in future aircraft, and further applications were outlined by Chaumette²⁷¹ at the 1981 ICAF Meetings. Australia's decision to purchase the McDonnell-Douglas F/A-18 to replace the ageing RAAF Mirage fleet provided additional impetus for ARL to extend its interests in the structural applications of advanced composites. Figure 23 indicates the extent to which graphite/epoxy composites are used in the F/A-18

- these representing about 10% of the structural weight. Thus in one respect the ARL Structures Division has, in 40 years, turned the full circle - from fibrous wooden structures in the 1940's to advanced fibre composite structures in the 1980's - and it is of interest to recall the "editorial" which appeared in a 1956 issue of Aircraft Engineering²⁷² in which (referring to the ARL Mosquito tests) the use of non-metallic composites was seen as a method for avoiding the problem of fatigue in aircraft. Two consequences of the increased local interest in these materials was the presentation of a lecture series on composite materials at ARL in November 1981²⁷³, and the setting up of an investigation into the properties of carbon fibre reinforced plastic box beams. There appears to be no doubt that the longer-term operational experience with such materials in the structures of military and civil aircraft (advanced composites are used extensively in the Boeing 767 with which an Australian airline is re-equipping) will generate additional research within Australia. One potential problem which has been recognized is that of the damage tolerance of composite structures²⁷⁴.

In addition to powered aircraft the Department of Aviation in Australia is taking an increasing interest in the fatigue lives of both metal and fibreglass gliders. Again, the basic reasons are the popularity of gliding, favourable flying conditions and very high utilization rates (up to 1700 hours per annum), which have resulted in some gliders operated in Australia being the world leaders in terms of flying hours. Such utilization rates are much greater than envisaged by the design codes with the result that a number of gliders have been retired from service on reaching their promulgated safe-lives of about 3000 hours. Flight loads measurements using Fatigue Meters have been made using two Blanik L.13 gliders and two Janus gliders to define load spectra, and a full-scale fatigue test is being planned at the Royal Melbourne Institute of Technology on a Janus wing to refine airworthiness criteria for these types of aircraft and evaluate the effectiveness of major repairs.

Over a number of years the Materials Division at ARL has provided considerable support to both military and civil aviation operations in Australia and to the fatigue testing of structures by the development and application of specialised NDI procedures^{275,276}. Some of these, including ultrasonic, eddy current and magnetic rubber techniques have already been referred to. With the current emphasis on "safety-by-inspection", "damage-tolerance" and "retirement-for-cause" philosophies the role of inspection has assumed an even greater importance in the safe operation of aircraft. One technique in which ARL has taken a special interest in recent years is that of Acoustic Emission

(AE), particularly because of the potential of this method for in-flight fatigue crack growth monitoring. Following the encouraging application of AE during the laboratory fatigue testing of Macchi MB.326H spar booms and the promising correlation of AE signals with crack indications obtained using ultrasonic and magnetic rubber techniques, an AE monitoring system was developed by Battelle Pacific Northwest Laboratories, USA for installation in a RAAF Macchi MB.326H aircraft²⁷⁷. Subsequently, ARL contracted Battelle Pacific Northwest to design AE equipment and undertake crack growth monitoring in the main spar of the RAAF Mirage III wing during fatigue testing at F+W, with a view to developing airborne equipment suitable for continuous in-flight monitoring and its eventual application as an airworthiness validating system²⁷⁷.

Investigations at ARL into the fatigue cracking of structural components of the Mirage III and F-III have involved the extensive use of fractography to interpret the loading conditions causing crack propagation, and to derive fatigue crack propagation rates. The analysis of the spar fracture in the ARL fatigue test on the Mirage III wing²⁴³ provided a basis for the development of a computer-based technique of quantitative fractography which embraced inputs of a crack growth equation and stress intensities for successive crack front positions. This enabled a computer plot of striation markings to be matched with those on the fracture surface. This technique of deductive fractography has been successfully extended to the analysis of cracks in the structures of service aircraft, knowing the Fatigue Meter history of the particular structure and a "calibration" crack growth curve derived from a representative multi-load-level fatigue test. The recent heavy demands for quantitative fractography has led to the development of a semi-automatic system for data acquisition, reduction and presentation. It consists of an optical metallographic microscope fitted with digital micrometer drums and coordinate counters which input to a magnetic tape storage, microcomputer and digital plotter. This technique has allowed crack propagation characteristics to be determined in hours compared with weeks using conventional manual systems, and will be an extremely valuable tool for the future because of the major requirement for crack propagation data in damage-tolerant design.

8. CONCLUDING REMARKS

It is now some 40 years since the publication of the first ARL report⁵⁰ relating to the fatigue problem in aircraft and the commencement of the first of a number of fatigue tests on full-scale structures carried out in the Laboratories during that period i.e. Mosquito, Boomerang, Mustang, Dove, Cessna 180, Vampire, Mirage, Nomad and Airtrainer. The continuity of effort in

structural fatigue testing and the various related aspects of aircraft loadings and material response to repeated loadings is a reflection of the foresight of H.A. Wills in recognizing the importance of the fatigue problem in a country which, in the second half of the 20th century, would rely heavily on air transport.

Coupled with the high utilization of aircraft in Australia the civil aviation authorities have been and still are acutely aware of their responsibility in anticipating structural fatigue problems before they occur. In many cases, operators in other parts of the world have looked towards the experiences of those in Australia in the structural engineering management of their fleets. Furthermore, structural fatigue of non-powered aircraft is now making a significant impact on their continued safe operation. In the military area Australia has been among the first operators to experience the problems of new technologies (eg. UHS steels in the F-111), while some RAAF aircraft - both bombers and trainers - have accumulated well in excess of 5,000 hours. Both the Macchi MB.326H and the Mirage III (which have undergone life-extension refurbishments) are being operated to lives much greater than their original design lives. This has only been possible by a major effort in the areas of NDI and the development of fatigue life-enhancement procedures.

An indication of the effort within Australia which has been directed towards the aircraft structural fatigue problem can be gauged by the resources deployed. Although a substantial part of the work of Materials Division at ARL is directly related to the life-cycle management of aircraft structures, the effort is relatively small compared with that of the Structures Division where some 70% of the staff of about 80 scientists and engineers are closely associated with the problem in either loads measurement, fatigue life assessment, or the fatigue testing of materials, components and structures. Structural fatigue concerns more staff at ARL than any other single subject. About 25% of the structural airworthiness activities of the Department of Aviation are directly related to the fatigue problem. Life assessment and monitoring of RAAF aircraft is also a major activity of CAC. No small part of the effort which has been expended in Australia on the aircraft fatigue problem has been consequent upon the long lines of communication between the local operators and airworthiness authorities on the one hand and the aircraft manufacturers in Europe and the USA on the other, and the associated difficulties of access to detailed design and test information - particularly for long calendar-life aircraft.

There is no doubt that the problem of aircraft structural fatigue has had a very great impact on the direction of research and the safe-operation of aircraft within Australia during the last 40 years. The contributions which have been made towards a solution of the problem could not have occurred without the close co-operation of many people representing ARL, RAAF, DoA, operators and aircraft manufacturers within Australia.

But what of the future? Fatigue of aircraft structures - perhaps now in its guise of "durability and damage tolerance" - is still a major consideration in the design of the next generation of military combat aircraft and civil transports. Although service lives of 8,000 hours and 60,000 hours respectively are currently being anticipated, past experience suggests that during the 20 to 30 years over which they might be expected to operate there will be a requirement to extend their lives even further. The potential of fibre composites for the selective reinforcement and repair of aircraft components and structures has been demonstrated both in Australia and overseas. Perhaps their more widespread application in the future will be the answer to the "rehabilitation of fatigue-weary structures" of the 21st century.

ACKNOWLEDGEMENTS

During my 36 years of ARL I have had the privilege of working with Mr. H.A. Wills, Mr. W.W. Johnstone, Dr. ...O. Payne, Dr. F.H. Hooke and Mr. C.A. Patching and I would like to acknowledge their contributions to aircraft fatigue research in Australia. I have had helpful discussions with friends and colleagues in the Australian aircraft industry and their considerable support in the preparation of this paper is gratefully acknowledged. Particular thanks are expressed to Mr. K.R.A. O'Brien and Mr. C. Torkington of DoA and Mr. F.W. Austin of TAA for the provision of relevant information. The willing co-operation of the ARL Library staff, in particular the Senior Librarian Ms A. Forbes, and the staff of the Photographic Section is also much appreciated. Sincere thanks are given to Mrs. F.E. Wood-Davies for the preparation of the illustrations.

Acknowledgement is also made to various people for providing the following photographs used in this paper:

- Fig. 2 - Mr. P. Malone, ARL
- Fig. 3(a) - Mr. H.V. Krause, Lufthansa German Airlines, Melbourne
- Fig. 5 - Mr. G. Mc.A. Job, "Aircraft", Melbourne
- Fig. 6(a) - Mr. K.J. Kennedy, CAC
- Fig. 8 - Dr. I. Lamborn, Materials Research Laboratories, Melbourne
- Fig. 22 - Mr. J.C. Corby, Transavia Division, Transfield Pty Ltd, Sydney.

REFERENCES

1. Hudson Fysh, W. Australia in Empire air transport. Jnl Roy. Aero. Soc., vol. 50, Jan. 1946, pp. 21-72.
2. Coombes, L.P. Aeronautical development in Australia and its potential contributions to the British Commonwealth. Jnl Roy Aero. Soc., vol. 61, no. 554, Feb. 1957, pp. 69-102.
3. Davies, R.E.G. A history of the world's airlines. London, Oxford University Press, 1964.
4. Carroll, B. Australian aviators - an illustrated history. North Ryde, Cassell Australia Limited, 1980.
5. Poncelet, J.V. Introduction a la mecanique industrielle. physique ou experimentale. Paris, Imprimerie de Gauthier-Villars, 1870.
6. Edwards, H.H. Wrought iron axles. Jnl Franklin Inst., 3rd series, vol. 5, no. 3, March 1843, pp. 204-206.
7. Morin, A. Lecons de mecanique pratique-resistance des materiaux. Paris, Librairie de l'Hachette et Cie, 1853 [pp. 348-354].
8. Rankine, W.J.M. On the causes of the unexpected breakage of the journals of railway axles; and on the means of preventing such accidents by observing the law of continuity in their construction. Min. Proc. Instn civ. Engrs, vol. 2, session 1843, 1842-1843, pp. 105-108.
9. Woehler, A. Versuche zur Ermittlung der auf die Eisenbahnwagen - Achsen einwirkenden Kraefte und der Widerstandsfaehigkeit der Wagen-Achsen. Z. Bauw., vol. 10, 1860, pp. 583-616.
10. Report of the Commissioners appointed to inquire into the application of iron to railway structures. London, Her Majesty's Stationery Office, Command Paper 1123, 1849.
11. Fairbairn, W. Experiments to determine the effect of impact, vibratory action and long-continued changes of load on wrought iron girders. Phil. Trans., vol. 154, 1864, pp. 311-326.
12. Branger, J. The International Committee on Aeronautical Fatigue (ICAF), its foundation, growth and today's philosophy. Aircraft fatigue - design, operational and economic aspects. [Editors: J.Y. Mann and I.S. Milligan]. Sydney, Pergamon Press Australia, 1972, pp. 1-11.
13. Boggs, B.C.; Mondol, N.K.; McQuown, R.E. and Anderson, J.G. Digital and analogue computer equipment and its application to in-house testing. Use of computers in the fatigue laboratory. ASTM STP 613, Oct. 1976, pp. 2-26.
14. Schriever, B.A. Keynote address - Symposium on fatigue of aircraft structures. Proc. Symposium on fatigue of aircraft structures. W.A.D.C. tech. Rep. no. 59-507, Aug. 1959, pp. 4-7.
15. Simmons, L.F.G. The fatigue of stranded steel wire cables. Advis. Comm. Aero. Rep. Memo. no. 160, Jan. 1915.

16. Report on the fracture of a propeller shaft submitted by the Air Department of the Admiralty. Advis. Comm. Aero. Rep. Memo. no. 215, July 1915.
17. Simmonds, L.F.G. Investigation of the fracture of exhaust springs. Advis. Comm. Aero. Rep. Memo. no. 241, March 1916.
18. Hankins, G.A. Alternating stress tests of aluminium alloys. Advis. Comm. Aero. Light Alloys Sub-Committee Rep. no. 12, July 1917.
19. Stanton, T.E. and Batson, R.G.C. The effect on the resistance to fatigue of crankshafts of a variation on the radius of curvature of fillets. Advis. Comm. Aero. Internal Combust. Engine Sub-Committee Rep. no. 15, Oct. 1917.
20. Johnson, J.B. and Daniels, S. Study of some failures in aircraft plane and engine parts. Trans. Amer. Soc. Steel Treat., vol. 2, no. 12, Sept. 1922, pp. 1167-1176, 1212.
21. Johnson, J.B. Fatigue of aircraft parts. Aviation, vol. 30, no. 18, Aug. 1931, pp. 462-464 and no. 9, Sept. 1931, pp. 542-546.
22. O'Gorman, M. Report on the precautions taken as to the strength of details on the B.E. class of aeroplanes; with appendices. Tech. Rep. Advis. Comm. Aero. for Year 1913-14. London, HMSO, 1915, pp. 308-352.
23. Hertel, H. Dynamische Bruchversuche mit Flugzeugbauteilen. Z. Flugtech., vol. 22, no. 15, 14 Aug. 1931, pp. 465-474 and no. 16, 28 Aug. 1931, pp. 489-502. English translation: NACA tech. memo. no. 698, Jan. 1933.
24. Johnstone, W.W. Static and repeated load tests on "Mosquito" wings. CSIR Div. Aero. Rep. SM.104, Sept. 1947.
25. Parnell, N.M. and Lynch, C.A. Australian Air Force since 1911. Brookvale, NSW, J.W. Books Pty. Ltd., 1976.
26. Isaacs, K. Military aircraft of Australia. Part 6 - Royal Aircraft Factory B.E.2a. Aircraft, vol. 51, no. 9, June 1972, pp. 30-35.
27. Douglas, W.D. Methods employed at the Royal Aircraft Establishment for the experimental determination of the ultimate strength of aeroplane structures. Advis. Comm. Aero. Rep. Memo. no. 476, June 1918.
28. Brenner, P. Dynamische Festigkeit vom Flugzeug-Konstruktionsteilen. Luftfahrtforschung, vol. 3, no. 3, 17 April 1929, pp. 59-65.
29. Hertel, H. Ermuedungsfestigkeit der Konstruktionen. Berlin, Springer-Verlag, 1969. (see page 610).
30. Fatigue and the Channel air disaster. Iron Coal Trades Rev., vol. 119, 26 July 1929, p. 123.
31. The Swiss accident. Aeroplane, vol. 47, 8 Aug. 1934, p. 180.
32. Brenner, P. Baustofffragen bei der Konstruktion von Flugzeugen. Z. Flugtech., vol. 22, no. 21, 14 Nov. 1931, pp. 637-648.

33. Gassner, E. Ueber bisherige Ergebnisse aus Festigkeits-Versuchen im Sinne der Betriebsstatistik. Berichte no. 106 Lilienthal Gesellschaft fur Luftfahrtforschung, Jan. 1939, pp. 9-14. English translation: NACA tech. memo. no. 1266, May 1950.
34. Gassner, E. Festigkeitsversuche mit wiederholter Beanspruchung im Flugzeugbau. Luftwissen, vol. 6, no. 2, Feb. 1939, pp. 61-64. English translation: NACA tech. memo. no. 1087, Aug. 1946.
35. Nissen, O. Festigkeitsfragen bei der Gestaltung neuzeitlicher Flugzeuge. Jb. dtsh. Luftfahrtf., 1938, pp. 158-163. English translation: Aircr. Engng. vol. 12, no. 140, Oct. 1940, pp. 293-295, 306.
36. Goodyear-Zeppelin Corporation. Preliminary fatigue studies on aluminum alloy aircraft girders. NACA tech. note no. 637, Feb. 1938.
37. Bleakney, W.M. Fatigue testing of wing beams by the resonance method. NACA tech. note no. 660, Aug. 1938.
38. Arnstein, K. and Shaw, E.L. Fatigue problems in the aircraft industry. Metals and Alloys, vol. 10, no. 7, July 1939, pp. 203-209.
39. Hobrock, R.H. Some problems of the materials and methods of joining used in strong light structures. Publ. Daniel Guggenheim Airship Inst., no. 3, 1935, pp. 64-88.
40. Battelle Memorial Institute. Prevention of the failure of metals under repeated stress. New York, John Wiley and Sons, 1941.
41. Walker, P.B. Aircraft fatigue from the general engineering standpoint. Proc. Internat. Conf. fatigue of metals. London, Institution of Mechanical Engineers, 1956, pp. 672-676.
42. Keussner, H.G. Beanspruchung von Flugzeugfluegeln durch Boeen. Z. Flugtech., vol. 22, 1931, pp. 579-586 and pp. 605-615.
43. Kuessner, H.G. Haeufigkeitsbetrachtungen zum Ermittlung der erforderlichen Festigkeit von Flugzeugen. Luftfahrtforschung, vol. 12, no. 2, 16 May 1935, pp. 57-61.
44. Kaul, H.W. Die erforderliche Zeit- und Dauerfestigkeit von Flugzeugtragwerken. Jb. dtsh. VersAnst. Luftf., 1938, pp. 195-209. English translation: NACA tech. memo. no. 992, Oct. 1941.
45. Rhode, R.V. Gust loads on airplanes. SAE J1, vol. 40, no. 3, March 1937, pp. 81-88.
46. Bland, R.B. and Sandorff, P.E. The control of life expectancy in aircraft structures. Aeronaut. Engng Rev., vol. 2, no. 8, Aug. 1943, pp. 7, 9, 11, 13, 15-16, 21.
47. Coombes, L.P. Aeronautical research in Australia. Aircraft, vol. 24, no. 4, Jan. 1946, pp. 15-18, 40, 42 and no. 5, Feb. 1946, pp. 24-26, 46, 48, 50.
48. Coombes, L.P. Aeronautical research in Australia. Aircr. Engng, vol. 21, no. 243, May 1949, pp. 140-143, 152.

49. Aeronautical Research Laboratories. 40 years of aeronautical research - a history of ARL 1939-1979, Oct. 1979.
50. Johnstone, W.W. Fatigue tests on flash-welded chrome-molybdenum steel tubing. CSIR Div. Aero. S&M Note 50, Feb. 1943.
51. Osborn, C.J. Fatigue failure of a Gipsy VI crankshaft. CSIR Div. Aero. S&M Note no. 88, Dec. 1943.
52. Edwards, A.R. Examination of failed airscrew blade. CSIR Div. Aero. S&M Note no. 73, May 1943.
53. Greenaway, H.T. Fatigue failure of Hamilton-Standard propeller blade. CSIR Div. Aero. S&M Note no. 137, April 1945.
54. Greenaway, H.T. Failure of Curtiss electric airscrew. CSIR Div. Aero. S&M Note no. 142, Aug. 1945.
55. Johnstone, W.A. and Payne, A.O. Aircraft structural fatigue research in Australia. Fatigue in aircraft structures. [Editor: A.M. Freudenthal]. New York, Academic Press, 1956, pp. 427-448.
56. Johnstone, W.W. Review of current methods for strength testing of aircraft wings. Aust. Council Aero. Rep. no. ACA-28, Sept. 1946.
57. Johnstone, W.W. Repeated load tests on a Mosquito wing. CSIR Div. Aero. S&M Rep. no. 59, April 1946.
58. Osborn, C.J. The fatigue of welded steel tubing in aircraft structures. The failure of metals by fatigue. Melbourne, Melbourne University Press, 1947, pp. 290-308.
59. Osborn, C.J. Examination of failures in Stinson Model A wing structure. CSIR Div. Aero. S&M Note no. 134, March 1945.
60. Bollenrath, F. and Cornelius, H. Zeit- und Dauerfestigkeit einfach gestalteter metallischer Bauteile. Z. Ver. dtsh. Ing., vol. 84, no. 24, 15 June 1940, pp. 407-412. Weld. J., vol. 20, no. 3, March 1941, pp. 159s-160s.
61. Buckwalter, T.V. and Horger, O.J. Fatigue strength of welded aircraft joints. Weld. J., vol. 21, no. 11, Nov. 1942, pp. 525s-539s.
62. Buckwalter, T.V. and Horger, O.J. Fatigue strength of welded aircraft joints. Weld. J., vol. 23, no. 1, Jan. 1944, pp. 50s-58s.
63. Harris, F.G. and Rowan, R.W. Axial load fatigue tests on chromium-molybdenum steel tubing with welded fish-mouth type splices. Dept. Supply, Aero. Res. Labs Rep. no. ARL/SM.323, March 1969.
64. The failure of metals by fatigue. Melbourne, Melbourne University Press, 1947.
65. Hooke, F.H. and Wills, H.A. A procedure for the calculation of the endurance strength of aircraft structures. CSIR Div. Aero. S&M Note no. 152, April 1947.

66. Hooke, F.H. and Wills, H.A. A programme of flight load research. CSIR Div. Aero. Rep. SM.87, Feb. 1947.
67. Hooke, F.H. V-g recorder results from a DC-3 aircraft operating between Perth and Darwin. CSIR Div. Aero. Rep. SM.135, July 1949.
68. Hooke, F.H. Load frequency measurements on a Lincoln aircraft. CSIR Div. Aero. Note SM.150, Jan. 1947.
69. Hooke, F.H. V-g recorder results from a Dakota operating between Australia and Japan. CSIR Div. Aero. Rep. SM.111, April 1948.
70. Hooke, F.H. Gust research with V-g recorders on Australian routes. Dept. Supply, Aero. Res. Labs Rep. ARL/SM.241, April 1955.
71. Johnstone, W.W.; Patching, C.A. and Payne, A.O. An experimental determination of the fatigue strength of CA-12 "Boomerang" wings. Dept. Supply Aero. Res. Labs Rep. no. SM.160, Sept. 1950.
72. Wills, H.A. The life of aircraft structures. J. Instn Engrs Aust., vol. 20, no. 10, Oct. 1948, pp. 145-156.
73. Wills, H.A. The life of aircraft structures. Proc. 2nd Internat. Aeronaut. Conf. New York, Institute of Aero. Sciences, 1949, pp. 361-403.
74. Gardner, H.H. Part one of final report on experience of fatigue at Weybridge. Ministry of Supply S&T Memo. no. 10/54, Nov. 1954.
75. Owen, J.B.B. Service failures in aircraft structures associated with fatigue, repeated or dynamic loads. Aero. Res. Coun. Rep. Memo. no. 2688, 1952.
76. Stephenson, B.E. Fatigue properties of joints. Metal fatigue [Editor: J.A. Pope]. London, Chapman and Hall, Ltd., 1959, pp. 283-294.
77. Jenkins, P. Structural failures in Wartime ... and some solutions. Air Enthusiast, no. 11, 1979, pp. 42-48.
78. Williams, D. Strength of aircraft in relation to repeated loads. Royal Aircr. Establ. Rep. no. S.M.E. 3386, Sept. 1946.
79. Williams, D. Strength of aeroplanes in relation to repeated loads. Aeronaut. Q., vol. 1, pt 4, Feb. 1950, pp. 291-304.
80. Oaks, J.K. and Townshend, P.H. Fluctuating load tests of Typhoon tail planes. Royal Aircr. Establ. Rep. no. S.M.E. 3354, Dec. 1945.
81. Pugsley, A.G. Modern experimental work on aeroplane structures. Jnl Royal Aero. Soc., vol. 49, 1945, pp. 566-598.
82. Hain Taylor, R. Some preliminary results from V-g recorders installed in military and civil aircraft. Aero. Res. Coun. Rep. Memo. no. 2610, 1952.
83. Hain Taylor, R. A summary of V-g recorder results for civil aircraft. Royal Aircr. Establ. Tech. Note no. S.M.E. 368, July 1946.
84. Pugsley, A.G. The specification of test loads. Aircr. Engng, vol. 17, no. 202, Dec. 1945, pp. 352-353.

85. Pugsley, A.G. The behaviour of structures under repeated loads. Jnl Royal Aero. Soc., vol. 51, no. 441, Sept. 1947, pp. 715-720.
86. Fisher, W.A.P. Repeated loading and fatigue tests on a D.H. 104 (Dove) wing and fin. Royal Aircr. Establ. Tech. Note no. Struct. 32, Dec. 1948.
87. Fisher, W.A.P. A comparison of the endurance of various aircraft structures under fluctuating loading. Royal Aircr. Establ. Rep. no. Struct. 45, July 1949.
88. Walker, P.B. Design criterion for fatigue of wings. Jnl Royal Aero. Soc., vol. 57, no. 505, Jan. 1953, pp. 12-18.
89. Stephenson, B.E. Fatigue in aircraft design. Jnl Royal Aero. Soc., vol. 57, no. 513, Sept. 1953, pp. 584-589.
90. Putnam, A.A. An analysis of life expectancy of airplane wings in normal cruising flight. NACA Rep. no. 805, 1945.
91. Lundberg, Bo. "Bear-up" requirements for aircraft. Aero Digest, vol. 55, no. 6, Dec. 1947, pp. 56-58, 120-122.
92. Brueggeman, W.C.; Krupen, P. and Roop, F.C. Axial fatigue tests of 10 airplane wing-beam specimens by the resonance method. NACA Tech. Note no. 959, Dec. 1944.
93. Jewett, F.D. and Gordon, S.A. Repeated load tests - some experimental investigations on aircraft components. Proc. Soc. expl. Stress Analy., vol. 3, no. 1, 1945, pp. 123-130.
94. Davis, D.M. Fatigue failures of aircraft parts - their cause and cure. Aeronaut. Engng Rev., vol. 5, no. 1, Jan. 1946, pp. 15-23.
95. Arnstein, K. Fatigue failures in aircraft. Proc. Soc. expl. Stress Analy., vol. 3, no. 2, 1946, pp. 124-130.
96. Pierpont, W.G. Fatigue tests on major aircraft structural components. Proc. Soc. expl. Stress Analy., vol. 4, no. 2, 1947, pp. 1-15.
97. 2-0-2 report - CAB experts blame Winona crash on structural failure of left wing. Aviation Week, vol. 49, no. 17, 25 Oct. 1948, p. 16.
98. Aircraft design through service experience. U.S. Dept. Commerce, C.A.A. Tech. Man. no. 103, Sept. 1953. (see page 81).
99. Williams, J.K. The airworthiness approach to structural fatigue. Fatigue design procedures. [Editors: E. Gassner and W. Schuetz]. London, Pergamon Press, 1969, pp. 91-138.
100. Rhode, R.V. and Donely, P. Frequency of occurrence of atmospheric gusts and of related loads in airplane structures. NASA Adv. Restrict. Rep. no. ARR L4I21, Nov. 1944.
101. Dryden, H.L.; Rhode, R.V. and Kuhn, P. The fatigue problem in airplane structures. Fatigue and fracture of metals. [Editor: W.M. Murray]. New York, John Wiley and Sons, 1952, pp. 18-51.

102. Australian accidents - Dove structural failure. Aviation Safety Dig., no. 2, Oct. 1953, pp. 20-24.
103. Reports on the accident to Vickers Viking aircraft no. VP-YEY which occurred in the vicinity of Mtara, Handeni District, Tanganyika, on the 29th March, 1953. Dar es Salaam, Government Printer, 1954.
104. Civil aircraft accident - report of the Court of Inquiry into the accidents to Comet G-ALPY on 10th January, 1954 and Comet G-ALYY on 8th April, 1954. London, H.M.S.O., 1955.
105. Caldara, J.D. The impact of metal fatigue mishaps in the U.S. Air Force. Proc. symposium on fatigue of aircraft structures. W.A.D.C. tech. Rep. no. 59-507, Aug. 1959, pp. 8-30.
106. Campbell, G.S. A survey of fatal aircraft accidents involving metal fatigue - final report. Natn Aero. Establ. Canada LTR-ST-1219, 1 Dec. 1980.
107. Campbell, G.S. A note on fatal aircraft accidents involving metal fatigue. Internat. J. Fatigue, vol. 3, no. 4, Oct. 1981, pp. 181-185.
108. Simpson, D.L. and Campbell, G.S. Worldwide catastrophic fatigue-related aircraft accidents for aircraft types on the Canadian civil register. Natn Aero. Establ. Canada LTR-ST-1327, 14 Dec. 1981.
109. Shuler, W.T. Fatigue problems in transport aircraft. Aero Engng Rev., vol. 10, no. 6, June 1951, pp. 20-26.
110. McLaren, R. High speed aircraft structure fatigue. Aero Digest, vol. 63, no. 3, Sept. 1951, pp. 100-108.
111. Tye, W. Fatigue and the airworthiness engineer. Aeroplane, vol. 82, no. 2127, 25 April 1952, pp. 490-492.
112. Walker, P.B. The fatigue situation for civil aircraft. Aeroplane, vol. 82, no. 2127, 25 April 1952, p. 493.
113. Taylor, J. Measurement of gust loads in aircraft. Jnl Royal Aero. Soc., vol. 57, Feb. 1953, pp. 78-88.
114. Walker, P.B. Estimation of the fatigue life of a transport aircraft. Jnl Royal Aero. Soc., vol. 57, no. 514, Oct. 1953, pp. 613-617.
115. Kennedy, A.P. A method for determining the "safe" life of an aircraft wing from fatigue test results. Jnl Royal Aero. Soc., vol. 58, no. 521, May 1954, pp. 361-366.
116. Shaw, R.R. The level of safety achieved by periodic inspection for fatigue cracks. Jnl Royal Aero. Soc., vol. 58, no. 526, Oct. 1954, pp. 720-723.
117. Carl, R.A. and Wegeng, T.J. Investigations concerning the fatigue of aircraft structures. Proc. ASTM, vol. 54, 1954, pp. 903-928.
118. Munier, A.E. Fatigue of combat aircraft. Aero Digest, vol. 70, no. 4, April 1955, pp. 54, 56, 58.

119. Mangurian, G.N. and Brooks, P.D. Effect of operational factors on structural fatigue in fighter aircraft. S.A.E. Trans., vol. 63, 1955, pp. 531-544.
120. Gassner, E. The problem of fatigue strength in aircraft structures. Aircr. Engng, vol. 28, no. 329, July 1956, pp. 228-234.
121. Taylor, J. Fatigue loading actions on transport aircraft. Proc. internat. conf. fatigue of metals. London, Institution of Mechanical Engineers, 1956, pp. 650-657.
122. Harpur, N.F. Fail-safe structural design. Jnl Royal Aero. Soc., vol. 62, no. 5, May 1958, pp. 363-376.
123. Atkinson, R.J. Aircraft fatigue - a survey of current thought. Proc. 7th Anglo-American Aeronautical Conf. New York, Inst. Aeronaut. Sci., 1960, pp. 10-33.
124. Lundberg, Bo K.O. How safe is fail-safe? Shell Aviat. News, no. 270, Dec. 1960, pp. 14-19.
125. Troughton, A.J. Relationship between theory and practice in aircraft structural problems. Jnl Royal Aero. Soc., vol. 64, no. 599, Nov. 1960, pp. 653-667.
126. Freudenthal, A.M. [editor]. Fatigue in aircraft structures. New York, Academic Press, 1956.
127. Fatigue of aircraft structures. ASTM Spec. Tech. Publ. no. 203, Nov. 1957.
128. Proceedings of the symposium on fatigue of aircraft structures. W.A.D.C. Tech. Rep. no. 59-507, Aug. 1959.
129. Symposium on fatigue of aircraft structures. ASTM Spec. Tech. Publ. no. 274, June 1960.
130. Plantema, F.J. and Schijve, J. [editors]. Full-scale fatigue testing of aircraft structures. Oxford, Pergamon Press, 1961.
131. Lundberg, Bo K.O. The quantitative statistical approach to the aircraft fatigue problem. Full-scale fatigue testing of aircraft structures. [Editors: F.J. Plantema and J. Schijve]. Oxford, Pergamon Press, 1961, pp. 393-412.
132. Hooke, F.H. and Langford, P.S. Australian research in the fatigue and life assessment of aircraft structures. Aust. Aero. Res. Comm. Rep. A.A.R.C. 34, 1955.
133. Hooke, F.H. and Langford, P.S. Australian work on aircraft fatigue and life evaluation. Aircr. Engng, vol. 28, no. 334, Dec. 1956, pp. 408-414.
134. Wills, H.A. Structural fatigue and airline safety. Aircraft, vol. 30, no. 9, June 1952, pp. 18-21, 54.

135. Bruton, R.A. and Patching, C.A. Structural fatigue testing. Aircraft structural fatigue. Dept. Defence, Aero. Res. Labs Rep. ARL-STRUCT-363/ARL-MAT-104, April 1977, pp. 179-202.
136. McGuigan, M.J. Interim report on a fatigue investigation of a full-scale transport aircraft wing structure. NACA Tech. Note no. 2920, April 1953.
137. McGuigan, M.J.; Bryan, D.F. and Whaley, R.E. Fatigue investigation of full-scale transport-airplane wings: Summary of constant-amplitude tests through 1953. NACA Tech. Note no. 3190, March 1954.
138. Whaley, R.E.; McGuigan, M.J. and Bryan, D.F. Fatigue-crack-propagation and residual-static-strength results on full-scale transport-airplane wings. NACA Tech. Note no. 3847, Dec. 1956.
139. Whaley, R.E. Fatigue investigation of full-scale transport-airplane wings: Variable-amplitude tests with a gust-loads spectrum. NACA Tech. Note no. 4132, Nov. 1957.
140. Raithby, K.D. and Longson, J. Some fatigue characteristics of a two spar light alloy structure. Royal Aircr. Establ. Rep. no. STRUCT. 195, Jan. 1956.
141. Parish, H.E. Fatigue test results and analysis of 42 piston Provost wings. Scient. Tech. Memo. no. 1/65, April 1965.
142. Ward, A.P. and Parish, H.E. Fatigue test results and analysis of 26 piston Provost wings tested under random loading and their comparison with block programme test results from similar specimens. Scient. Tech. Memo. no. 5-74, Oct. 1974.
143. Kepert, J.L. and Payne, A.O. Interim report on fatigue characteristics of a typical metal wing. Dept. Supply, Aero. Res. Labs Rep. A.R.L./SM.207, Jan. 1955.
144. Payne, A.O. An investigation into the fatigue characteristics of a typical 24S-T aluminium alloy wing. Proc. internat. conf. fatigue of metals. London, Institution of Mechanical Engineers, 1956, pp. 641-649.
145. Johnstone, W.W. and Payne, A.O. Determination of the fatigue characteristics of "Mustang" P51D wings. Aero. Res. Consult. Comm. Rep. no. A.R.C.C. 30, June 1953.
146. Payne, A.O. Determination of the fatigue resistance of aircraft wings by full-scale testing. Full-scale fatigue testing of aircraft structures. [Editors: F.J. Plantema and J. Schijve]. London, Pergamon Press, 1961, pp. 76-132.
147. Hooke, F.H. Preliminary note on the fatigue life of an aeroplane constructed of high strength aluminium alloy under Australian operating conditions. Dept. Supply, Aero. Res. Labs SM Tech. Memo. no. 28, Jan. 1952.
148. Baum, Q. and Hooke, F.H. Counting accelerometer results from a Bristol "Freighter" aircraft operating in South-Eastern Australia. Dept. Supply, Aero. Res. Labs Note ARL/SM.207, Aug. 1953.

149. Higgs, M.G.J. Analysis of flight loads on DC-6 aircraft obtained with counting accelerometers in Australia. Dept. Supply, Aero. Res. Labs Note ARL/SM.269, March 1961.
150. Bruce, G.P. and Hooke, F.H. Flight loads on "Viscount" aircraft in Australia. Dept. Supply, Aero. Res. Labs Rep. ARL/SM.284, Nov. 1961.
151. Hooke, F.H. Life of aircraft structures from the research viewpoint. Aero. Res. Consult. Comm. Rep. no. A.R.C.C. 21, June 1953.
152. Langford, P.S. Fatigue of aeroplane structures from the viewpoint of an airworthiness authority. Aero. Res. Consult. Comm. Rep. no. A.R.C.C. 20, June 1953.
153. Langford, P.S. An airworthiness fatigue requirement for civil aeroplane wings. Aust. Aero. Res. Comm. Rep. no. A.A.R.C. 35, Nov. 1955.
154. Woodgate, B.G. Some notes on a proposed airworthiness requirement for wing structural fatigue life. Aust. Aero. Res. Comm. Rep. no. A.A.R.C. 53, Nov. 1955.
155. Payne, A.O. Random and programmed load sequence fatigue tests on 24ST aluminium alloy wings. Dept. Supply, Aero. Res. Labs Rep. no. ARL/SM. 244, Sept. 1956.
156. Mann, J.Y. and Patching, C.A. Fatigue tests on "Mustang" wings and notched aluminium alloy specimens under random gust loading with and without ground to air cycle of loading. Dept. Supply, Aero. Res. Labs Note ARL/SM.268, March 1961.
157. Patching, C.A. Fatigue in aircraft structures. Jnl Instn Engrs Aust., vol. 34, no. 9, Sept. 1962, pp. 205-214.
158. Parry-Jones, G. Fatigue crack propagation in Mustang wings. Dept. Supply, Aero. Res. Labs Rep. no. ARL/SM.289, June 1962.
159. Jost, G.S. The fatigue of 24S-T aluminium alloy wings under asymmetric spectrum loading. Dept. Supply, Aero. Res. Labs Rep. no. ARL/SM.295, Feb. 1964.
160. Jost, G.S. and Lewis, J.A. A comparison of experimental and predicted fatigue lives of Mustang wings under programmed and random loading. Dept. Supply, Aero. Res. Labs Rep. no. ARL/SM.300, Dec. 1964.
161. Finney, J.M. and Mann, J.Y. Fatigue behaviour of notched aluminium alloy specimens under simulated random gust loading with and without ground-to-air cycles of loading. Fatigue of aircraft structures. [Editors: W. Barrois and E.L. Ripley]. Oxford, Pergamon Press, 1963, pp. 151-177.
162. Finney, J.M. and Vann, A. Axial load fatigue behaviour of 7178-T6 aluminium alloy notched specimens under three different loading spectra. Dept. Supply, Aero. Res. Labs Rep. ARL/SM.307, Nov. 1965.
163. Gassner, E. and Horstmann, K.F. The effect of the ground to air to ground cycle on the life of transport aircraft wings which are subject to gust loads. Royal Aircr. Establ. Libr. Transl. 933, Feb. 1961.

164. Kepert, J.L. Determination of fatigue prone areas in an aircraft wing using a progressive repair technique. Dept. Supply, Aero. Res. Labs Note ARL/SM.246, May 1958.
165. Ellis, R.; Graff, D.G. and Mitchell, B.J. Dove wing fatigue test. Dept. Supply, Aero. Res. Labs Note ARL/SM.408, May 1974.
166. Ellis, R. and Graff, D.G. Residual strength tests on Dove centre section tension booms. Dept. Supply, Aero. Res. Labs Note ARL/SM.345, Oct. 1969.
167. Ferstat, Q. V-g records from "Mustang" aircraft in training. Dept. Supply, Aero. Res. Labs Note 192, Sept. 1951.
168. Bacon, N.E. V-g records from Vampire aircraft in training. Dept. Supply, Aero. Res. Labs Note ARL/SM.217, Aug. 1955.
169. Bacon, N.E. V-g recorder results from a Bristol Freighter aircraft operating in South Australia. Dept. Supply, Aero. Res. Labs Note ARL/SM.223, Nov. 1955.
170. Bruce, G.P. Interim note on flight loads on RAAF "Canberra" aircraft. Dept. Supply, Aero. Res. Labs Note ARL/SM.263, Feb. 1960.
171. Ferrari, R.M.; Milligan, I.S.; Rice, M.R. and Weston, M.R. Some considerations relating to the safety of "fail-safe" wing structures. [Editors: F.J. Plantema and J. Schijve]. Full-scale fatigue testing of aircraft structures. Oxford, Pergamon Press, 1961, pp. 413-426.
172. Barrois, W. The philosophy of fatigue tests on large dimension aircraft structures. Full-scale fatigue testing of aircraft structures. [Editors: F.J. Plantema and J. Schijve]. Oxford, Pergamon Press, 1961, pp. 239-253.
173. Larre, R. Installation developed for full-scale fatigue testing of the SE-210 "Caravelle" aircraft. Full-scale fatigue testing of aircraft structures. [Editors: F.J. Plantema and J. Schijve]. Oxford, Pergamon Press, 1961, pp. 254-277.
174. Vallat, P. "Caravelle" complete structure fatigue test development and analysis. Full-scale fatigue testing of aircraft structures. [Editors: F.J. Plantema and J. Schijve]. Oxford, Pergamon Press, 1961, pp. 278-310.
175. van Beek, E. Full-scale fatigue tests on the Fokker "Friendship". Full-scale fatigue testing of aircraft structures. [Editors: F.J. Plantema and J. Schijve]. Oxford, Pergamon Press, 1961, pp. 326-344.
176. Barnard, J.M.H. and Hooke, F.H. General procedure for fatigue life assessment of an aeroplane. Dept. Supply, Aero. Res. Labs Note ARL/SM.273, Nov. 1961.
177. Hooke, F.H. Operating loads and safe life estimation of aircraft in Australia. J. Instn Engrs Aust, vol. 36, no. 1-2, Jan.-Feb. 1964, pp. 1-8.

178. Visick, J. Variability of flight loads on a Viscount aircraft due to route, month and altitude. Dept. Supply, Aero. Res. Labs Rep. ARL/SM. 308, Nov. 1965.
179. O'Brien, K.; Torkington, C.; Benoy, M. and Douglas, R. Fatigue certification of general aviation aircraft in Australia. S.A.E. Pap. no. 720311, March 1972.
180. Hooke, F.H. and Jost, G.S. Formula for assessment of fatigue life of Australian Canberra aircraft. Dept. Supply, Aero. Res. Labs Rep. ARL/SM 285, Nov. 1961.
181. Barnard, J.M.H. and Gee, S.W. Flight tests on Vampire Mk 35 trainer aircraft. Dept. Supply, Aero. Res. Labs Note ARL/SM.275, Aug. 1962.
182. Patching, C.A. and Mann, J.Y. Comparison of an aluminium alloy structure with notched specimens under programme and random fatigue loading sequences. Fatigue design procedures. [Editors: E. Gassner and W. Schutz]. Oxford, Pergamon Press, 1969, pp. 395-432.
183. Bruton, R.A. and Patching, C.A. Fatigue testing of Vampire wings. Dept. Defence Aero. Res. Labs Rep. ARL-STRUCT-378, June 1979.
184. Mann, J.Y. and Harris, F.G. An investigation of the fatigue performance of three types of aircraft skin/spar boom fastening systems. Dept. Defence Aero. Res. Labs Rep. ARL/SM.350, Sept. 1974.
185. Ryder, D.A. Some quantitative information obtained from the examination of fatigue fracture surfaces. Royal Aircr. Establ. Tech. Note MET.288, Sept. 1958.
186. Barnard, J.M.H. and Hooke, F.H. Fracture study as an aid to fatigue evaluation. Dept. Supply, Aero. Res. Labs Tech. Memo. ARL/SM.123, Oct. 1963.
187. Barnard, J.M.H. and Agar, E.M. Safe fatigue life predictions of Vampire wing components. Dept. Supply, Aero. Res. Labs Note ARL/SM.289, March 1964.
188. Hooke, F.H. Fatigue fracture in aircraft structures. Fracture. [Editor: C.J. Osborn]. Melbourne, Melbourne University Press, 1965, pp. 236-256.
189. Benoy, M.B.; Verinder, F.E. and Maddock, T.S. Fatigue tests on the Cessna 180 wing and strut. Dept. Supply, Aero. Res. Labs Rep. ARL/SM. 318, Oct. 1967.
190. Barnard, J.M.H. Safe life prediction on Winjeel aircraft: wing, empennage and rear fuselage. Dept. Supply, Aero. Res. Labs Rep. ARL/SM.302, April 1965.
191. Foden, P.J. and Rowan, R. Interim report on the fatigue test of a Winjeel wing joint test specimen. Dept. Supply, Aero. Res. Labs Note ARL/SM.328, July 1968.
192. Milligan, I.S. Structural fatigue in agricultural aircraft. Third Australian Agricultural Aviation Symposium. Wagga, New South Wales, Nov. 1960.

193. O'Brien, K.R.A. Ag. aircraft life is in pilots hands. Aircraft, vol. 47, no. 3, Dec. 1967, pp. 28-29, 48.
194. Jost, G.S. and Lacey, G.C. Safe life estimates of the de Havilland "Beaver" wing-strut attachment. Dept. Supply, Aero. Res. Labs Tech. Memo. ARL/SM.98, Nov. 1960.
195. Patterson, A.K. Further note on flight loads on a Beaver aircraft on agricultural operations. Dept. Supply, Aero. Res. Labs Note ARL/SM.277, Oct. 1962.
196. Foden, P.J. Agricultural aircraft flight loads: typical spectra and some observations on airworthiness. Aircraft fatigue - design operational and economic aspects. [Editors: J.Y. Mann and I.S. Milligan]. Sydney, Pergamon Press Australia, 1972, pp. 221-240.
197. Burns, A. and Rider, C.K. Project Topcat-power spectral measurements of clear air turbulence associated with jet streams. Royal Aircr. Establ. Tech. Rep. 65210, Sept. 1965.
198. Rider, C.K. Project Topcat: a study of the gust velocity power spectra for six flights in clear air turbulence. Dept. Supply, Aero. Res. Labs Rep. ARL/SM.317, Aug. 1967.
199. Rider, C.K. and Thomson, M.R. Clear air turbulence in the Australian stratosphere. Dept. Supply, Aero. Res. Labs Note ARL/SM.362, Jan. 1971.
200. Rider, C.K.; Thomson, M.R. and Verinder, F.E. Measurement of extreme mechanical turbulence during low level flights of Mirage A3-76. Dept. Supply, Aero. Res. Labs Rep. ARL/SM.333, May 1971.
201. Emmerson, A.J. The value and difficulty of individual aircraft fatigue monitoring. Fatigue life of structures under operational loads. [Editors: O. Buxbaum and D. Schuetz]. LBF Rep. no. TR-136, Nov. 1977, pp. 2.3/1-2.3/29.
202. Ford, D.G. and Patterson, A.K. A range pair counter for monitoring fatigue. Dept. Supply, Aero. Res. Labs Tech. Memo. ARL/SM.195, Jan. 1971.
203. Millhouse, J.L. Introduction of direct strain monitoring as the primary source of usage data for RAAF fatigue damage and crack growth computations. Aircraft fatigue in the eighties. [Editors: J.B. de Jonge and H.H. van den Linden]. Netherlands, National Aerospace Laboratory, 1981, pp. 2.2/1-2.2/34.
204. Ford, D.G.; Graff, D.G. and Payne, A.O. Some statistical aspects of fatigue life variation. Fatigue of aircraft structures. [Editors: W. Barrois and E.L. Ripley]. Oxford, Pergamon Press, 1963, pp. 179-208.
205. Hoskin, B.C. and Ford, D.G. Scatter factors in aircraft fatigue life estimation. Dept. Supply, Aero. Res. Labs Note ARL/SM.350, April 1970.
206. Jost, G.S. and Verinder, F.E. A survey of fatigue life variability in aluminium alloy aircraft structures. Dept. Supply, Aero. Res. Labs Rep. ARL/SM.329, Feb. 1971.

207. The interpretation of the scatter factor. Dept. Supply, Aero. Res. Labs Note ARL/SM.373, Feb. 1972.
208. Mann, J.Y. Some phenomenological aspects of scatter in fatigue. Dept. Supply, Aero. Res. Labs Rep. ARL/SM.342, Nov. 1972.
209. Jost, G.S. and Costolloe, S.P. Fatigue life variability in aluminium alloy aircraft structures. Dept. Defence, Aero. Res. Labs ARL-STRUC-REP-381, Jan. 1980.
210. Payne, A.O. Reliability approach to structural airworthiness. Aircraft, vol. 45, no. 1, Oct. 1965, pp. 16-20.
211. Ford, D.G. and Grandage, J.M. Approximate life distribution of cracked structures with random risks. Dept. Supply, Aero. Res. Labs Note ARL/SM.363, March 1971.
212. Hooke, F.H. The fatigue life of safe life and fail-safe structures. A "state-of-the-art review". Dept. Supply, Aero. Res. Labs Rep. ARL/SM.334, June 1971.
213. Hooke, F.H. Analysis of safe fatigue life and safe inspection intervals by reliability and conventional theory. Dept. Supply, Aero. Res. Labs Rep. ARL/SM.335, July 1971.
214. Grandage, J.M. and Payne, A.O. A probabilistic approach to structural design. Dept. Supply, Aero. Res. Labs Rep. ARL/SM.337, Feb. 1972.
215. Payne, A.O. A reliability approach to the fatigue of structures. Probabilistic aspects of fatigue. ASTM STP 511, July 1972, pp. 106-155.
216. Diamond, P. and Payne, A.O. Reliability analysis applied to structural tests. Advanced approaches to fatigue evaluation. NASA SP-309, 1972, pp. 275-332.
217. Grandage, J.M. and Payne, A.O. The reliability approach to the safety of airframes. Conference on the application of probability theory to structural design. Institution of Engineers, Australia, Nov. 1974, pp. 104-119.
218. Hooke, F.H. Probabilistic design and structural fatigue. Dept. Defence Aero. Res. Labs Rep. ARL/SM.352, Nov. 1974. Aeronaut. Jnl, vol. 79, no. 774, June 1975, pp. 267-273.
219. Hooke, F.H. Aircraft structural reliability and risk theory - a review. Dept. Defence Aero. Res. Labs Rep. ARL/STRUCT-REP-363, ARL/MAT-REP-104, April 1977, pp. 299-344.
220. Payne, A.O. and Graham, A.D. Reliability analysis for optimum design. Engng Fract. Mech., vol. 12, 1979, pp. 329-346.
221. Payne, A.O. The fatigue of aircraft structures. Engng Fract. Mech., vol. 8, 1976, pp. 157-203.

222. Mallinson, G.D. On the genesis of reliability models. Dept. Defence Support Aero. Res. Labs ARL-STRUCT-REP-393, July 1982.
223. Ford, D.G. A unified theory of structural fatigue. Dept. Supply, Aero. Res. Labs Rep. ARL/SM.338, May 1972.
224. Ford, D.G. Safe fatigue lives: the theory and practice of various estimators and confidence bounds. Dept. Supply, Aero. Res. Labs Rep. ARL/SM.344, April 1973.
225. Ford, D.G. The development of the theory of structural fatigue. Dept. Defence Aero. Res. Labs Rep. ARL/STRUC-REP-363, ARL/MAT-REP-104, April 1977, pp. 269-298.
226. Ford, D.G. Reliability and structural fatigue in one-crack models. Dept. Defence, Aero. Res. Labs ARL-STRUC-REPORT-369, July 1978.
227. Simpson, R. A literature survey on the fatigue properties of welded chromium-molybdenum steel tubing. Dept. Supply, Aero. Res. Labs Note ARL/SM.304, March 1966.
228. Simpson, R. and Harris, F.G. Fatigue of ultra-high strength steels - a survey of the literature. Dept. Supply, Aero. Res. Labs Note ARL/SM.378, June 1972.
229. Gratzer, L.R. Generation of a representative load sequence for the fatigue testing of Macchi MB326H spar booms. Dept. Defence, Aero. Res. Labs ARL-STRUC-NOTE-450, Jan. 1979.
230. Howard, P.J. The prediction of aircraft life from full scale and component test results. Structural fatigue as a design factor. [Editor: A. Maenhaut]. Belgium, Aeronautics Administration, 1979, pp. 3.3/1-3.3/28.
231. Jost, G.S. Fatigue tests on ultra high strength steel structures (Humphries specimens). Dept. Supply, Aero. Res. Labs Rep. ARL/SM.347, March 1974.
232. Kemsley, D.S.; Ryan, N.E. and Jost, G.S. Environmental effects on fatigue crack initiation and propagation in ultra-high strength steels. Problems with fatigue in aircraft. [Editors: J. Branger and F. Berger]. Emmen, Swiss Federal Aircraft Establishment, 1975, pp. 2.3/1-2.3/41.
233. Kemsley, D.S. The fatigue behaviour of an ultra-high strength steel as influenced by water vapour content and temperature of an air environment. Engng Fract. Mech., vol. 10, no. 4, 1978, pp. 709-722.
234. Mann, J.Y. and Kemsley, D.S. The effects of very dry and fully water saturated air environments on the fatigue life of D6AC steel under constant and variable amplitude loading sequences. Corrosion, vol. 35, no. 10, Oct. 1979, pp. 465-471.
235. Hinders, U.A. F-111 design experience - use of high strength steel. AIAA Pap. no. 70-884, 1970.

236. Jost, G.S. and Esson, G.P. Fatigue of D6ac steel specimens - means and variability under programmed loading. Dept. Supply, Aero. Res. Labs Rep. ARL/SM.349, April 1974.
237. Harmsworth, C.L.; Kemsley, D.S. and Finney, J.M. US/Australia collaborative research project on corrosion fatigue in D6AC steel joints. Air Force Materials Lab. Tech. Rep. AFML-TR-78-150; Aero. Res. Labs Rep. ARL-STRUC-REPORT-370/MAT-REPORT-108, Dec. 1978.
238. Howard, P.J.; Patching, C.A. and Payne, A.O. Life estimation by parametric analysis. Problems with fatigue in aircraft. [Editors: J. Branger and F. Berger]. Emmen, Swiss Federal Aircraft Establishment, 1975, pp. 4.3/1-4.3/28.
239. Ludowyk, C.J. and Moody, E.S. Application of electro-hydraulic control to wing fatigue testing. Dept. Defence, Aero. Res. Labs Note ARL/SM.412, Nov. 1974.
240. Moody, E.S. A computer-based instrumentation system for structural fatigue testing. Dept. Defence, Aero. Res. Struct. Note 420, Nov. 1975.
241. Townshend, P.H. From sandbags to servo systems: the development of aircraft structural testing. Conference Papers. Diamond Jubilee Conference, Institution of Engineers, Australia, 1979, Event No. 502.2.
242. Howard, P.J. Development of a load sequence for a structural fatigue test. Aircraft structural fatigue. Dept. Defence, Aero. Res. Labs ARL-STRUC-REPORT-363/ARL-MAT-REPORT-104, April 1977, pp. 137-148.
243. Anderson, B.E. and Goldsmith, N.T. Prediction of crack propagation in Mirage wing fatigue test spar. Dept. Defence, Aero. Res. Labs ARL-STRUC-NOTE-448/ARL-MAT-NOTE-124, April 1978.
244. Baker, A.A. and Hutchison, M.M. Fibre composite reinforcement of cracked aircraft structures. Aircraft structural fatigue. Dept. Defence, Aero. Res. Labs ARL-STRUC-REPORT-363/ARL-MAT-REPORT-104, April 1977, pp. 419-457.
245. Jones, R. and Callinan, R.J. Structural design of BFRP patches for Mirage wing repair. Dept. Defence, Aero. Res. Labs ARL-STRUC-NOTE-461, July 1980.
246. Baker, A.A.; Callinan, R.J.; Davis, M.J.; Jones, R. and Williams, J.G. Application of BFRP crack patching to Mirage III aircraft. Proc. 3rd Internat. Conf. on Composite Materials. Paris, 1980, pp. 1424-1438.
247. Baker, A.A. Boron fibre reinforced plastic patching for cracked aircraft structures. Aircraft, vol. 60, no. 12, Sept. 1981, pp. 30-35.
248. Graham, A.D.; Grandage, J.M.; Rider, C.K. and Thomson, M.R. Comparison of the ARL and Swiss Mirage fatigue test lives using ARL strain survey data. Dept. Defence, Aero. Res. Labs ARL-STRUC-NOTE-478, July 1981.
249. Goldsmith, N.T. Fractographic examinations relevant to the F&W Mirage fatigue test. Dept. Defence, Aero. Res. Labs ARL-MAT-Tech-Memo-371, Aug. 1978.

250. Mann, J.Y.; Kälin, R. and Wilson, F.E. Extending the fatigue life of a fighter aircraft wing. Aircraft fatigue in the eighties. [Editors: J.B. de Jonge and H.H. van der Linden]. Netherlands, National Aerospace Laboratory, 1981, pp. 1.7/1-1.7/42.
251. Teed, P.L. The fatigue of aircraft. Metal fatigue. [Editor: J.A. Pope]. London, Chapman and Hall Ltd. 1959, pp. 262-282.
252. Pugsley, A.G. Repeated loading of structures. The failure of metals by fatigue. Melbourne, Melbourne University Press, 1947, pp. 64-72.
253. Gardner, H.H. Structural problems of advanced aircraft. Jnl Royal Aero. Soc., vol. 56, April 1952, pp. 221-260.
254. Cornillon, J. Some remarks on the French approach to the problems of fatigue. Fatigue in aircraft structures. [Editor: A.M. Freudenthal]. New York, Academic Press, 1956, pp. 317-322.
255. Giddings, H. The extent of the fatigue problem in aircraft design. Fatigue in aircraft structures. [Editor: A.M. Freudenthal]. New York, Academic Press, 1956, pp. 347-375.
256. Baillie, I.L.G. and Soper, W.P.C. Design philosophy for airframes. Forging and properties of aerospace materials. London, Metals Society, 1978, pp. 8-23.
257. Kirkby, W.T.; Forsyth, P.J.E. and Maxwell, R.D.J. Design against fatigue - current trends. Aeronaut. Jnl, vol. 84, no. 829, Jan. 1980, pp. 1-12.
258. Charnley, J. Materials and aeronautics, Aerospace, vol. 9, no. 2, Feb. 1982, pp. 16-23.
259. Torkington, C. Fatigue problems old and new. Aircraft, vol. 59, no. 10, July 1980, pp. 8-11, 26.
250. Butler, J.P. The rehabilitation of fatigue-weary structure. Fatigue of aircraft structures. ASTM STP no. 203, Nov. 1957, pp. 29-46.
261. O'Brien, K.R.A.; Torkington, C.; Benoy, M.B. and Douglas, R.B. The impact of long service on the fatigue of transport aircraft-airworthiness aspects. Fail-safe aircraft structures. Tech. Rep. Royal Aircr. Establ. 73183, March 1974, vol. 2, pp. 3.3/1-3.3/30.
262. 1980 Spring Convention - Long-life aircraft structures. London, Royal Aeronautical Society, May 1980.
263. Torkington, C. and Young, G.E.F. The role of the airworthiness authority and the airline in the continued operation of older transport aeroplanes. Structural fatigue as a design factor. [Editor: A. Maenhaut]. Belgium, Aeronautics Administration, 1979, pp. 2.3/1-2.3/17.
264. Campbell, G.S. and Williams, D.P. Aircraft fatigue problems caused by inadequate knowledge of loads. Natl Aeronaut. Establ. LTR-ST-1379, 13 May 1982.

265. Young, P.J. Reliability analysis of bead seat radius cracks in Boeing 727/200 main wheels. Dept. Aviation Rep. R-1/79, Sept. 1979.
266. Baker, A.A. A summary of work on applications of advanced fibre composites at the Aeronautical Research Laboratories, Australia. Composites, vol. 9, no. 1, Jan. 1978, pp. 11-16.
267. Tragedy at Barracouta. Aviation Safety Dig., no. 57, July 1968, pp. 1-7.
268. Aircraft structural fatigue. Dept. Defence, Aero. Res. Labs ARL-STRUC-REP-363/ARL-MAT-REP-104, April 1977.
269. Ford, D.G. CT4A spar boom fatigue tests - results and implications. Dept. Defence, Aero. Res. Labs ARL-STRUC-REPORT-379, Oct. 1979.
270. Hardrath, H.F. Advanced composites - the structures of the future. Fatigue life of structures under operational loads. LBF-Report no. TR-136, 1977, pp. 1.1/1-1.1/42.
271. Chaumette, D. Pressing the composites into service. Aircraft fatigue in the eighties. [Editors: J.B. de Jonge and H.H. van den Linden]. Netherlands, National Aerospace Labs, 1981, pp. 3.2/1-3.2/24.
272. Fatigue down under. Aircr. Engng, vol. 28, no. 334, Dec. 1956, p. 407.
273. Hoskin, B.C. and Baker, A.A. [Editors]. Lectures on composite materials for aircraft structures. ARL-STRUC-REP-394/ARL-MAT-REP-114, Oct. 1982.
274. Davis, M.J. and Jones, R. Damage tolerance of composites. Proc. Internat. Conf. Fracture Mechanics Technology [Editors: G.C. Sih, N.E. Ryan and R. Jones]. 1982.
275. O'Brien, K.R.A., Hollamby, D.C., Bland, L.M. and Glanvill, D.W. Crack detection capability of non-destructive inspection methods in relation to the airworthiness of aircraft. Problems with fatigue in aircraft. [Editors: J. Branger and F. Berger]. Emmen, Swiss Federal Aircraft Establishment, 1975, pp. 7.2/1 - 7.2/57.
276. Scott, I.G. NDI and the detection of fatigue. Aircraft structural fatigue. Dep. Defence Aero. Res. Labs. ARL-STRUC-REPORT-363/ARL-MAT-REPORT-104, April 1977, pp. 255-267.
277. Scott, I.G., Scala, C.M., Cousland, S.McK. and Rose, I.R.F. The use of acoustic emission as an airworthiness criterion. Metals Forum, vol. 5, no. 3, 1982, pp. 167-178.

TABLE 1 - POPULATIONS OF AUSTRALIAN CAPITAL CITIES
(June 1981 census)

Canberra (National capital)	238,379	Adelaide	882,520
Sydney	2,874,415	Perth	809,033
Melbourne	2,578,527	Hobart	128,603
Brisbane	942,636	Darwin	56,482

TABLE 2 - AIR DISTANCES AND TRAVEL TIMES

AUSTRALIA				EUROPE	
Centres	Air distance (km)	Travel time ⁺		Centres	Air distance (km)
		Air (hours. minutes)	Rail (hours)		
Melbourne - Canberra	470	0.45	*	Paris-Frankfurt	470
- Sydney	707	0.55	13	Paris-Munich	690
- Brisbane	1376	1.35	28+*	London-Rome	1140
- Adelaide	643	0.50	13	Frankfurt-Vienna	620
- Perth	2707	3.35	*	London-Moscow	2510
- Darwin	3131		Ø		
- Launceston	476	0.40	14 [#]	Paris-Zurich	480
Sydney - Canberra	237	0.30	*		
- Brisbane	747	0.55	15	London-Zurich	770
- Perth	3284	4.20	64	Amsterdam-Damascus	3260
- Darwin	3154		Ø		
- Adelaide	1166	1.45		Paris-Rome	1095
Adelaide - Perth	2120	2.50	44	Amsterdam-Athens	2170
- Alice Springs	1316	1.45	24	London-Vienna	1260
- Darwin	2619	3.30	Ø	London-Athens	2550

* requires change of train; # by passenger ferry

Ø no train service; + for these figures the average travel time by rail is about 16 times that by air.

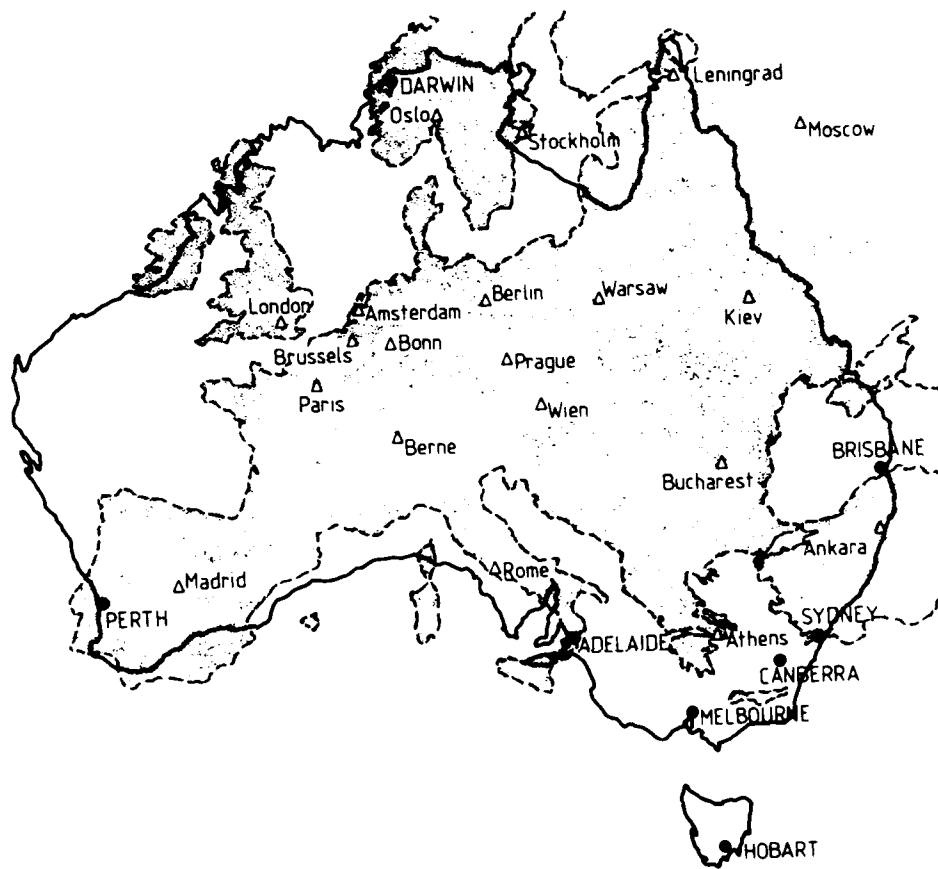

LAMBERT CONFORMAL CONIC PROJECTION

FIG. 1 COMPARATIVE SIZE OF AUSTRALIA AND EUROPE



FIG. 2 B.E. 2a AT CENTRAL FLYING SCHOOL, POINT COOK (NEAR MELBOURNE) IN 1914

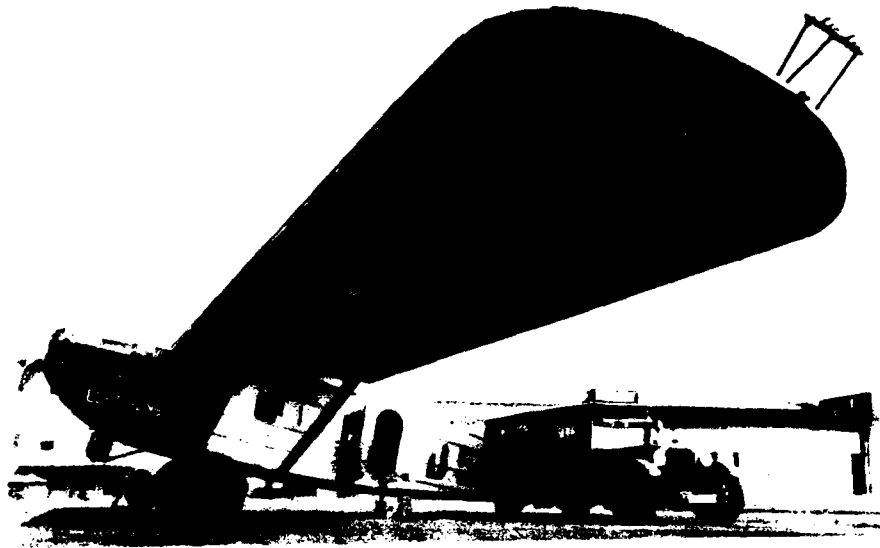

FIG. 3(a) LUFTHANSA DORNIER "MERKUR"

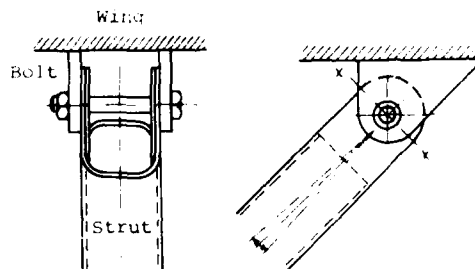

FIG. 3(b) DORNIER "MERKUR" WING/STRUT ATTACHMENT (Ref.)

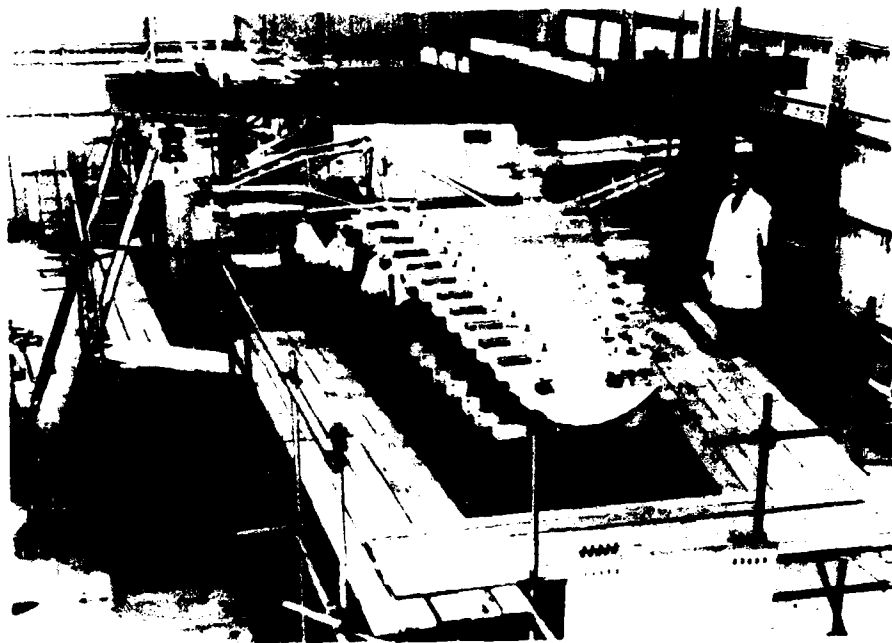

FIG. 4 "MOSQUITO" WING TEST RIG

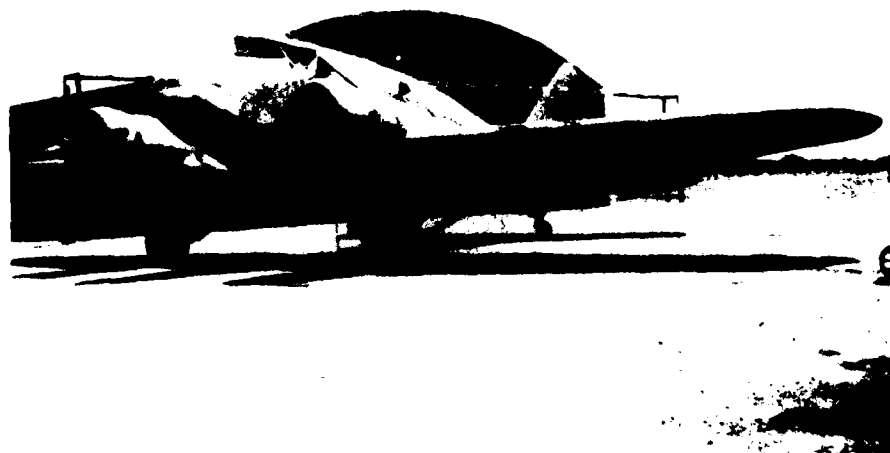

FIG. 5 STINSON A2W (VH-UYY)

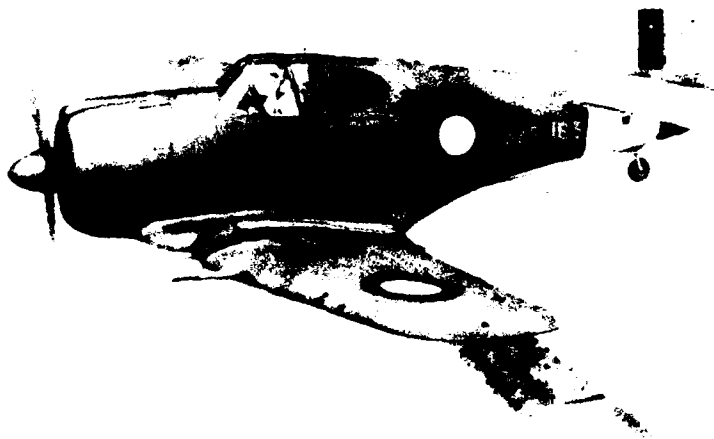

FIG. 6(a) CAC CA-12 "BOOMERANG"

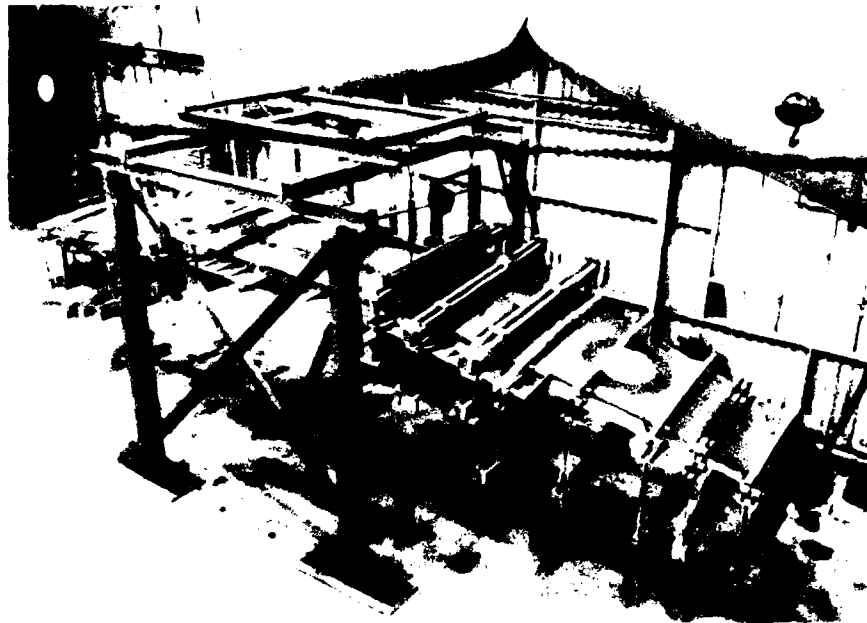

FIG. 6(b) "BOOMERANG" VIBRATION FATIGUE TEST RIG (WITH A2W WINGS IN BACKGROUND)

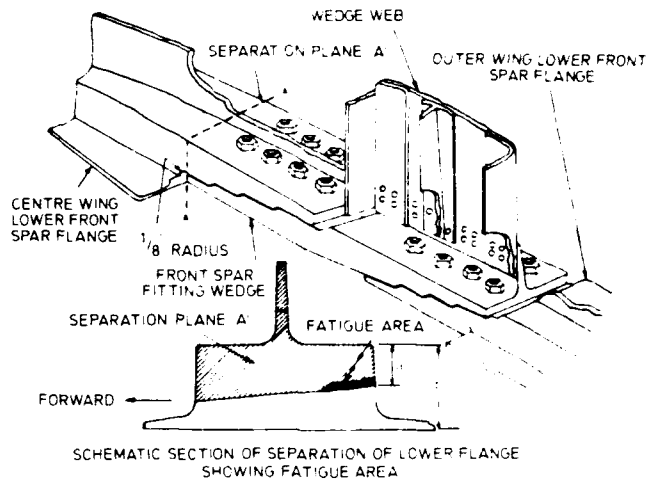

FIG. 7 MARTIN 2-0-2 WING ROOT FITTING FATIGUE FAILURE (Ref.)



FIG. 8 FATIGUE FAILURE IN SPAR BOOM OF "DOVE" VH-AQQ

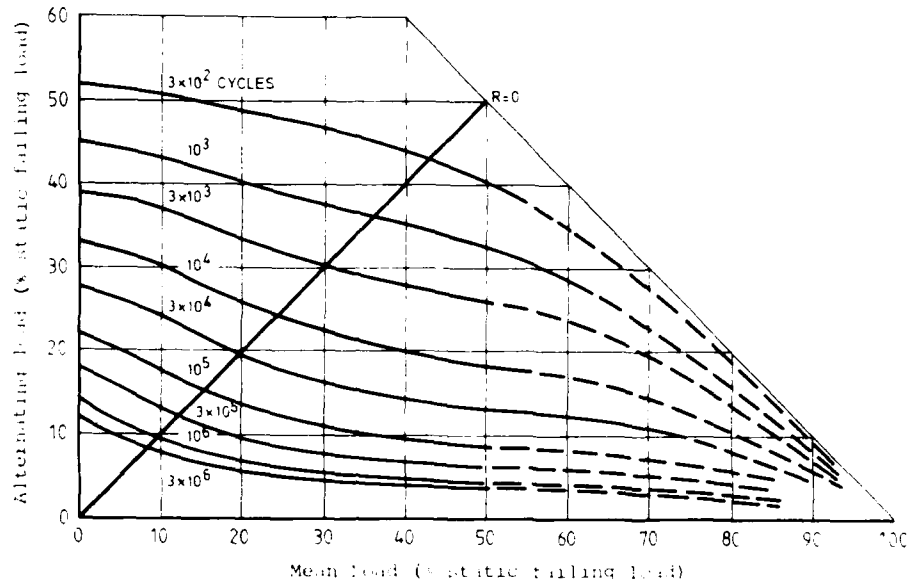

FIG. 9 ALTERNATING LOAD - MEAN LOAD DIAGRAM FOR MUSTANG WING FINAL FAILURE

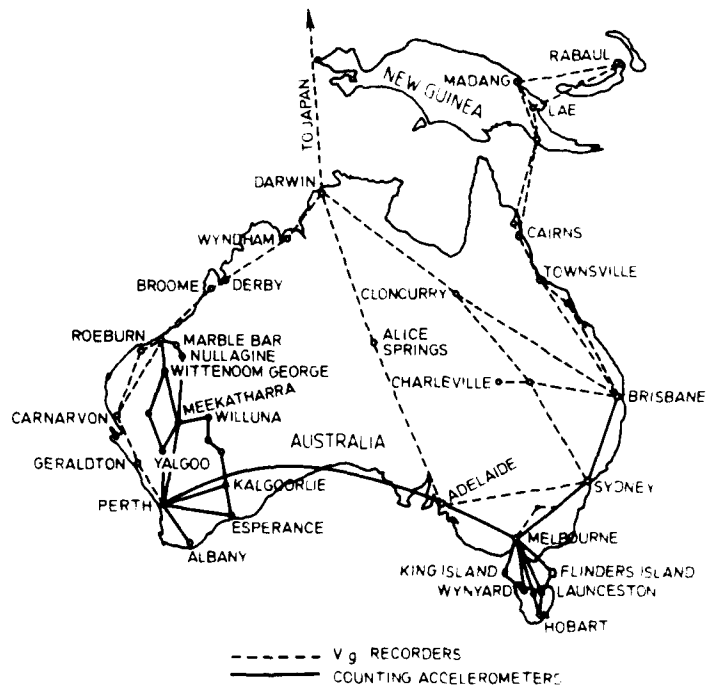
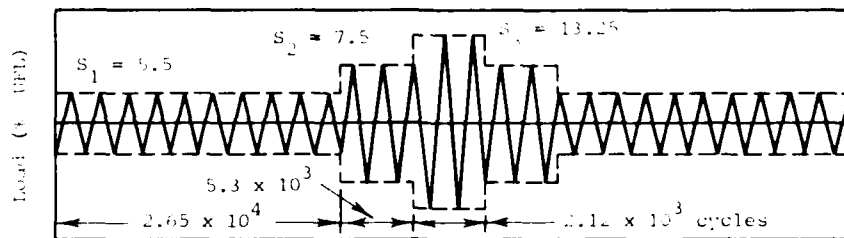
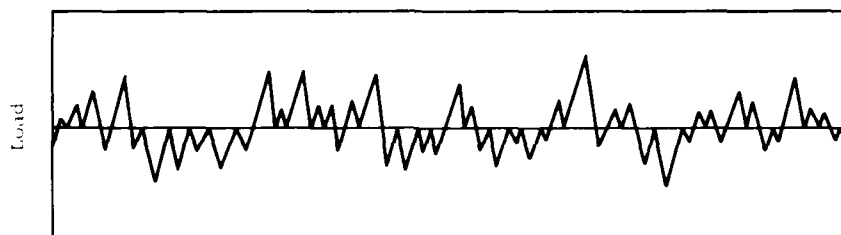

FIG. 10 FLIGHT LOADS MEASUREMENTS, AUSTRALIAN ROUTES-EARLY 1950's (Ref. 10)



(a) Program block 3-load-level test (vibration rig)



(b) Typical random gust load sequence (hydraulic rig)

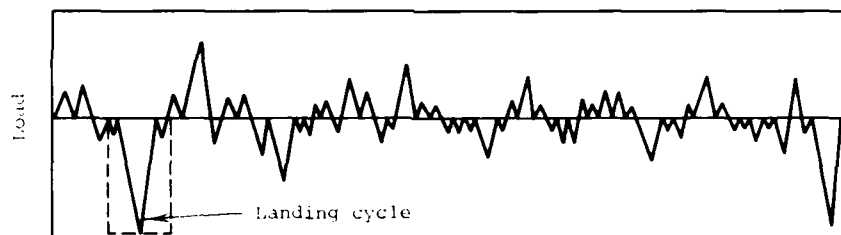

(c) Typical ground-air-ground cycle/gust load sequence (hydraulic rig)

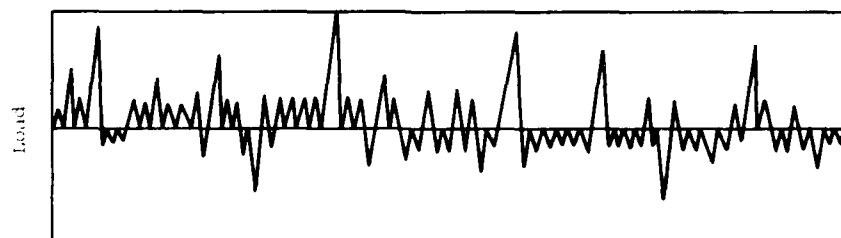

(d) Typical manoeuvre load sequence (hydraulic rig)

FIG. 11 EXAMPLES OF VARIOUS MULTI-LOAD-LEVEL SEQUENCES USED DURING MUSTANG WING INVESTIGATIONS

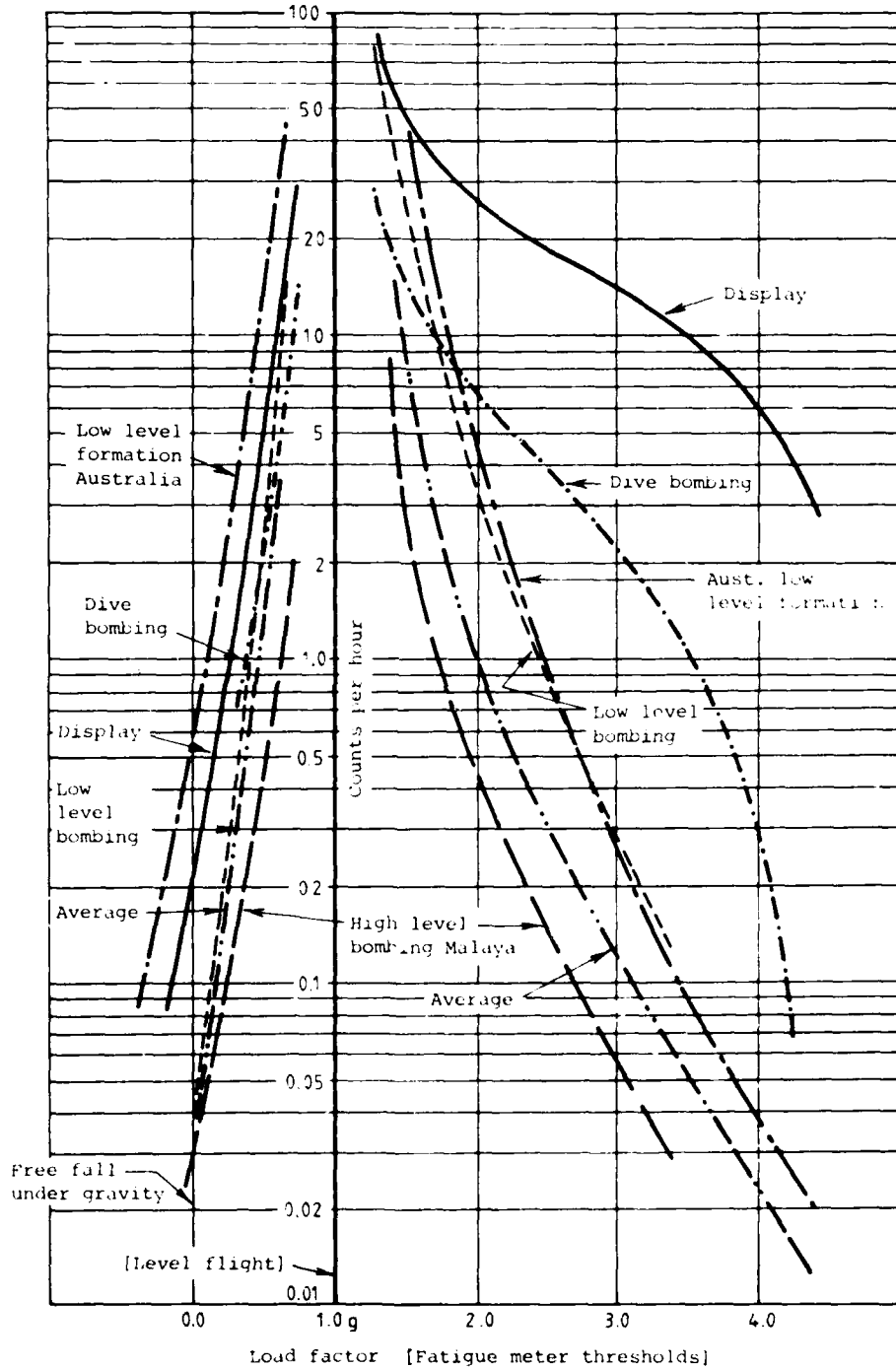

FIG. 12 LOAD-FREQUENCY CURVES FOR R.A.A.F. CANBERRA AIRCRAFT (Ref. 10)

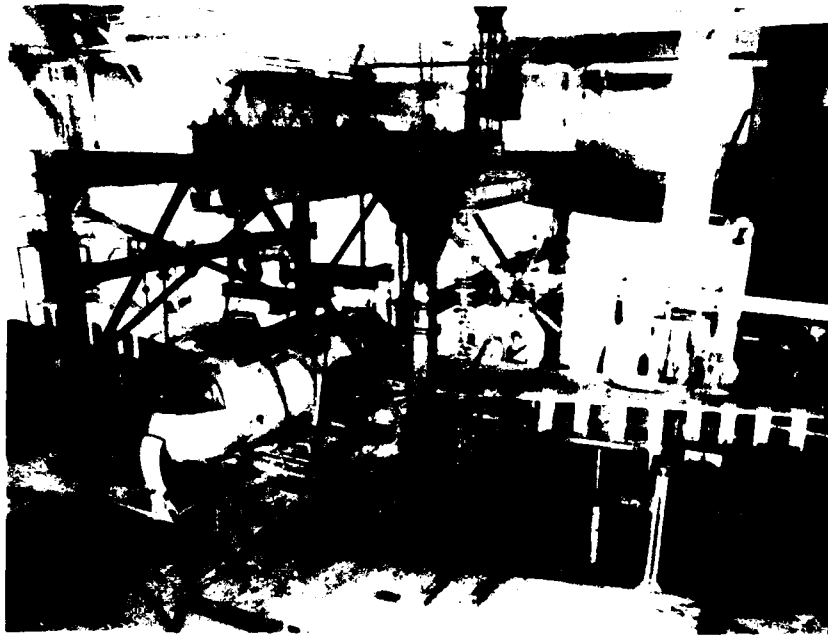

FIG. 13(a) "VAMPIRE" FULL-SCALE FATIGUE TEST RIG, WITH "DOVE" WING IN FOREGROUND (Ref. ...)

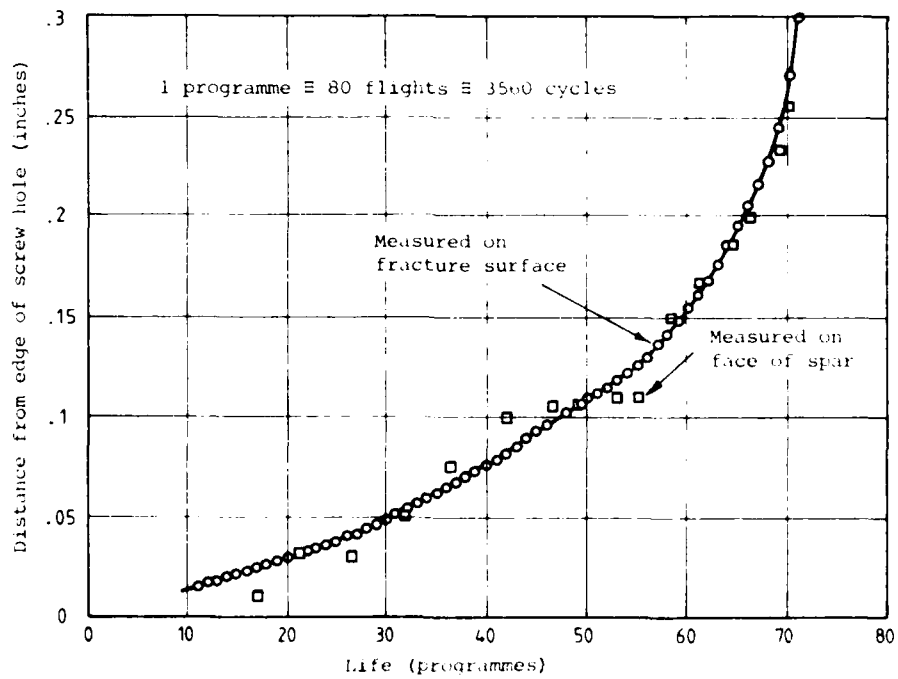

FIG. 13(b) CRACK LENGTH VERSUS LIFE, "VAMPIRE" SPAR (Ref. ...)

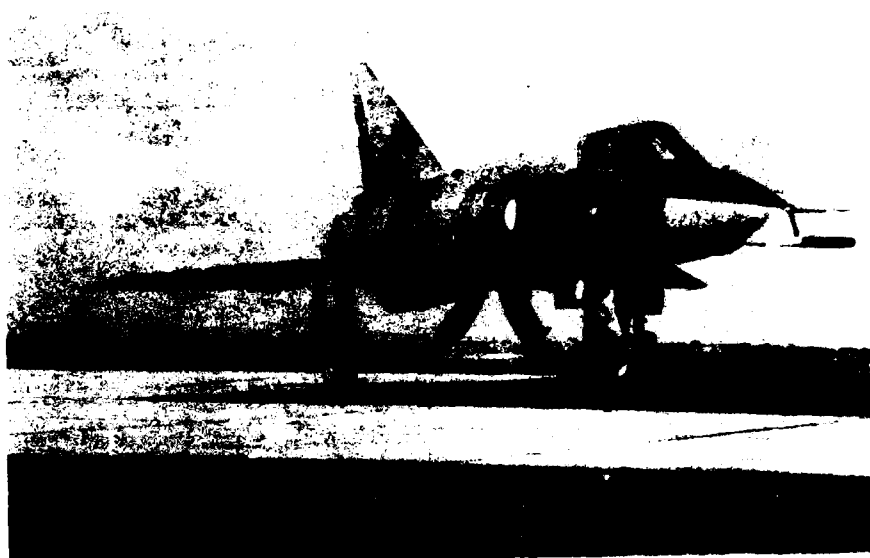

FIG. 14 RAAF MIRAGE AIRCRAFT A3-76 SHOWING ARL DESIGNED GUST PROBE

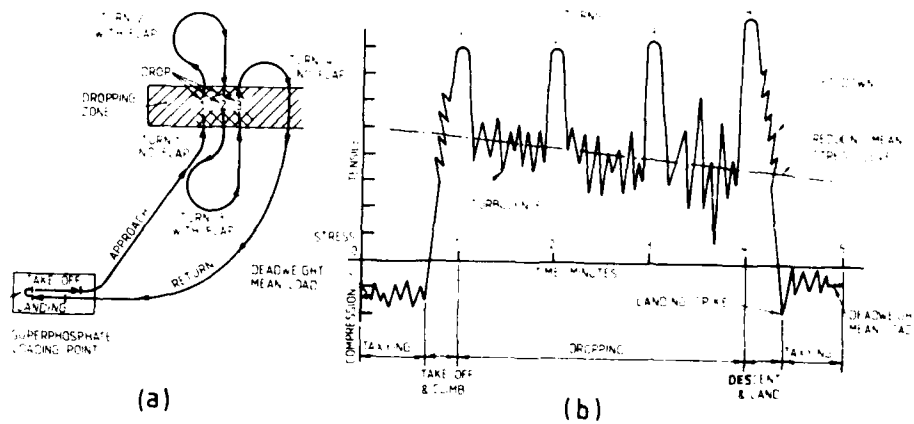

FIG. 15 (a) TYPICAL FLIGHT PATH FOR AERIAL AGRICULTURE OPERATIONS
 (b) STRESS-TIME PROFILE ON WING SPAR FLANGES FOR AIRCRAFT
 AT VARIOUS STAGES OF OPERATION (Ref. 10)

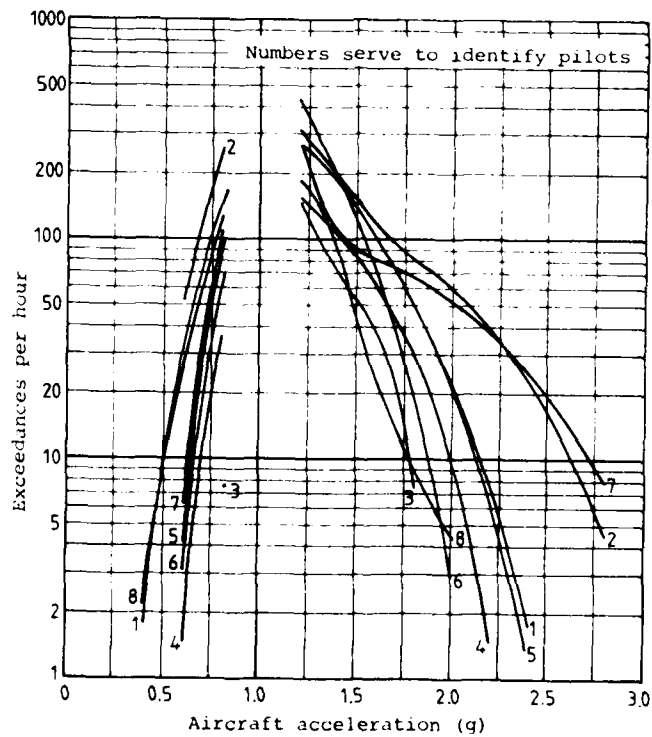

FIG. 16 VARIABILITY IN LOAD HISTORY CAUSED BY DIFFERENT PILOTS
 IN THE SAME AIRCRAFT (Ref. 10)

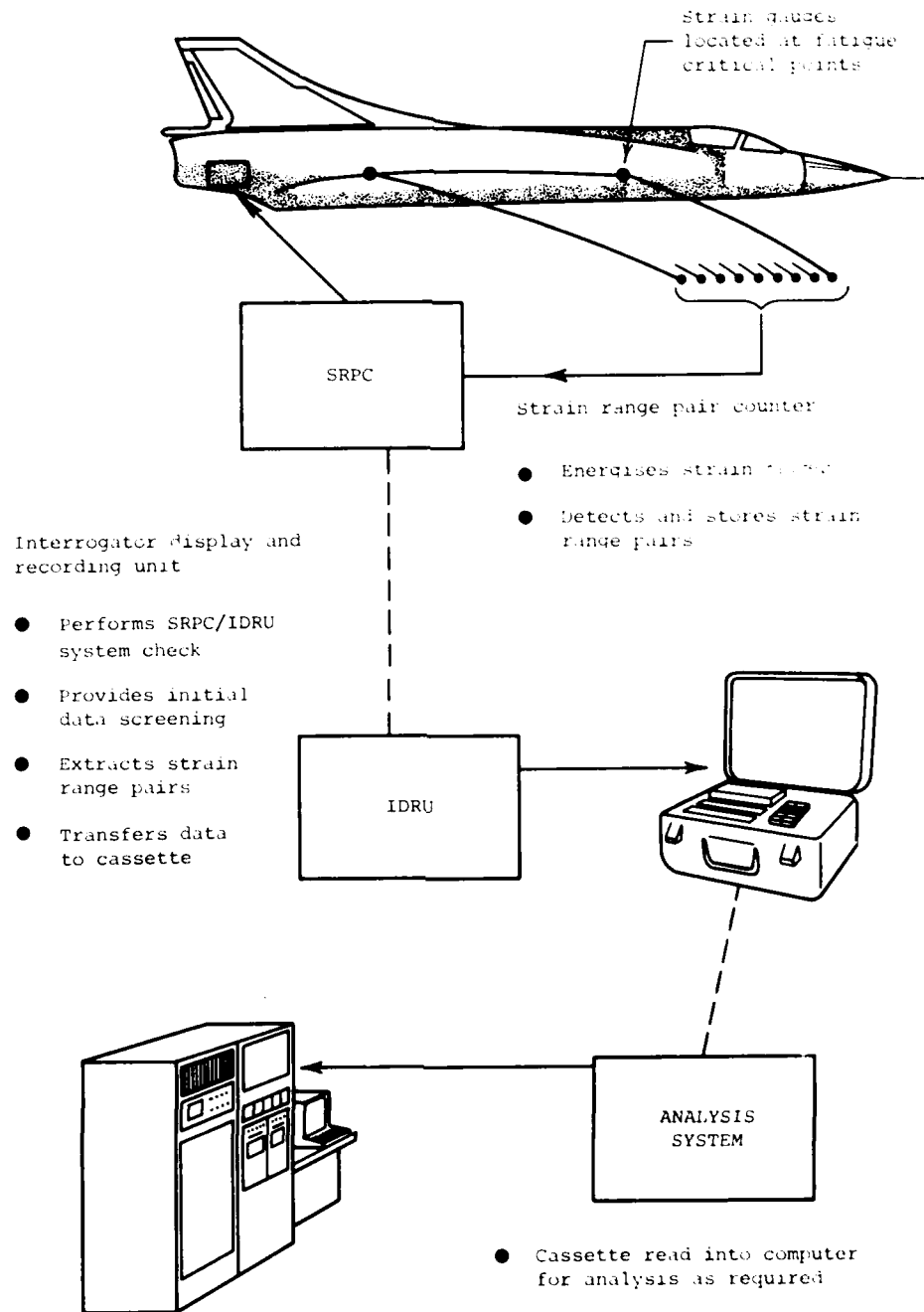

FIG. 17 THE AIRCRAFT FATIGUE DATA ANALYSIS SYSTEM (AFDAS)

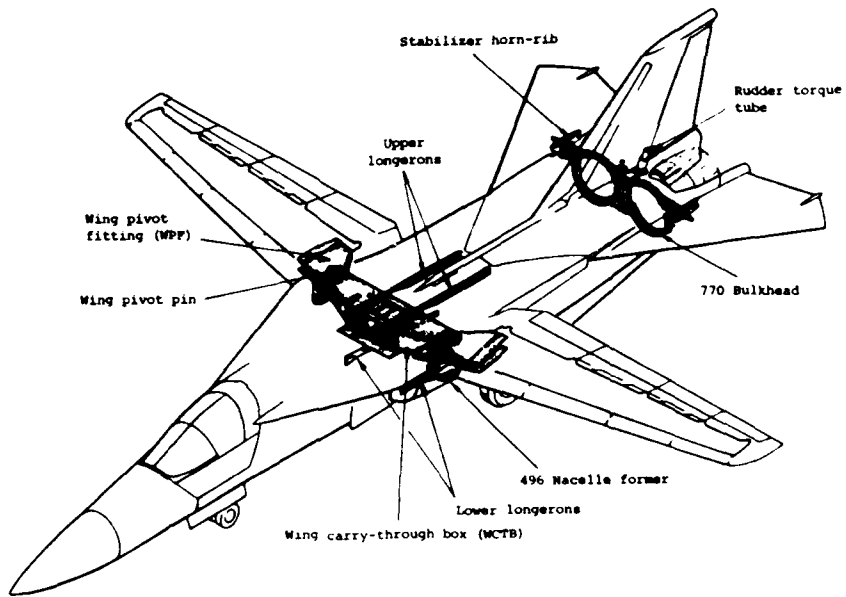

FIG. 19(a) D6AC STEEL STRUCTURAL MEMBERS IN F-111

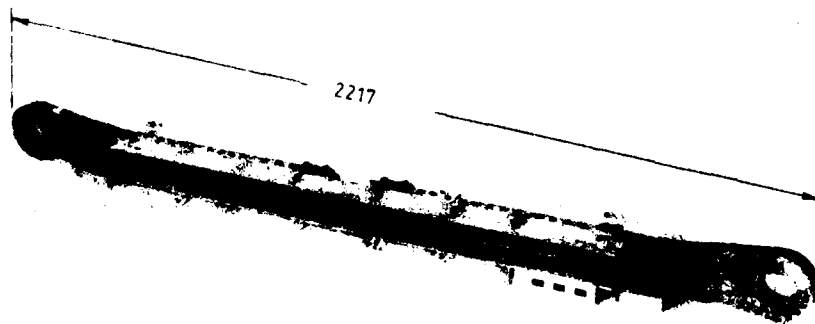

FIG. 19(b) D6AC STEEL "HUMPHRIES" SPECIMEN

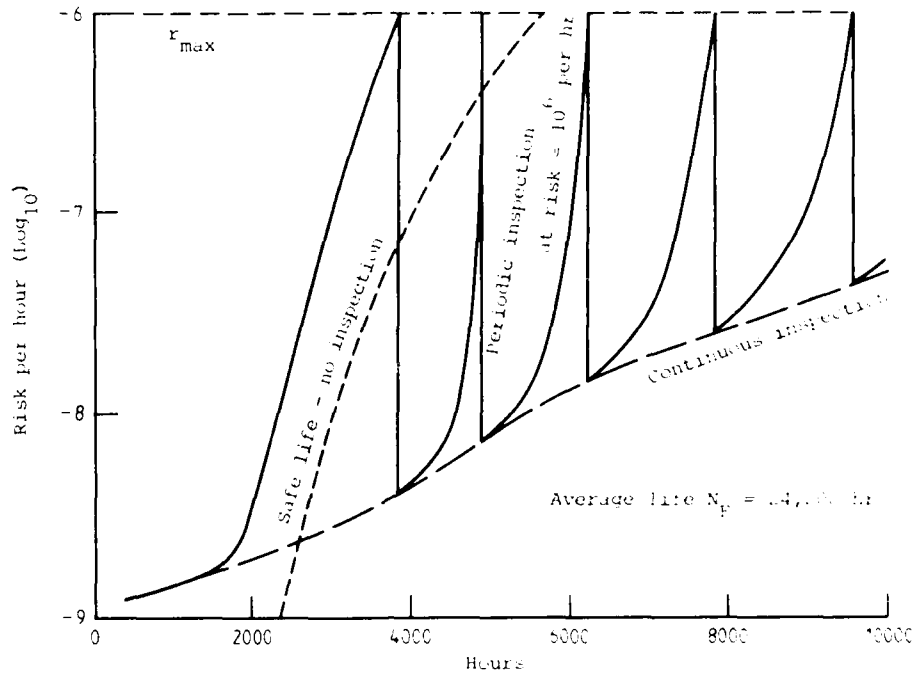

FIG. 18(a) RISK PER HOUR vs LIFE

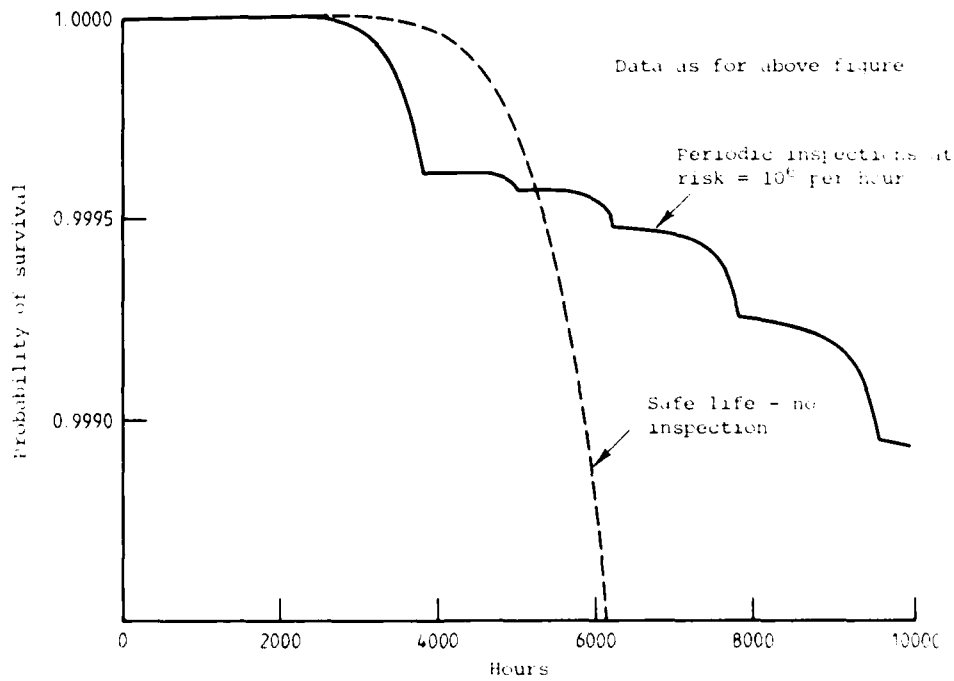

FIG. 18(b) PROBABILITY OF SURVIVAL vs LIFE (ref. 1)

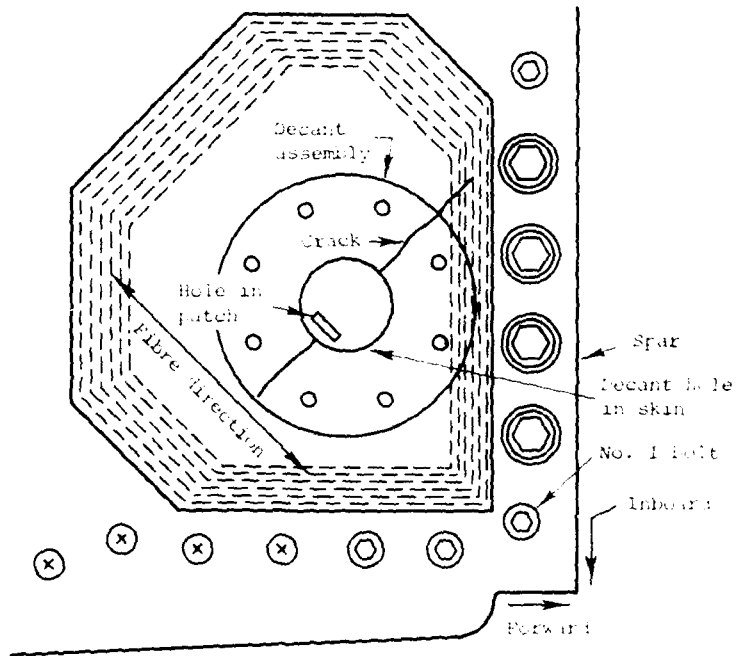

FIG. 20 BFRP PATCH FOR MIRAGE DECANT HOLE FATIGUE CRACKING

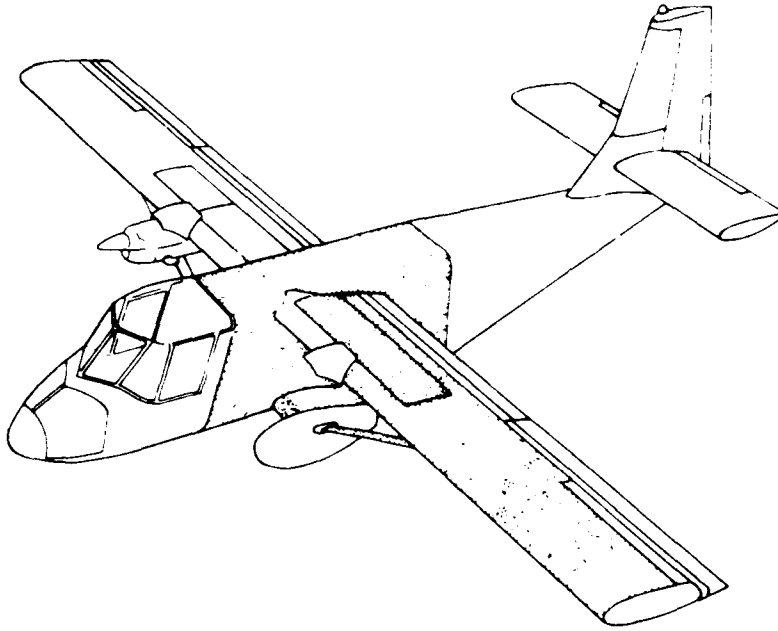
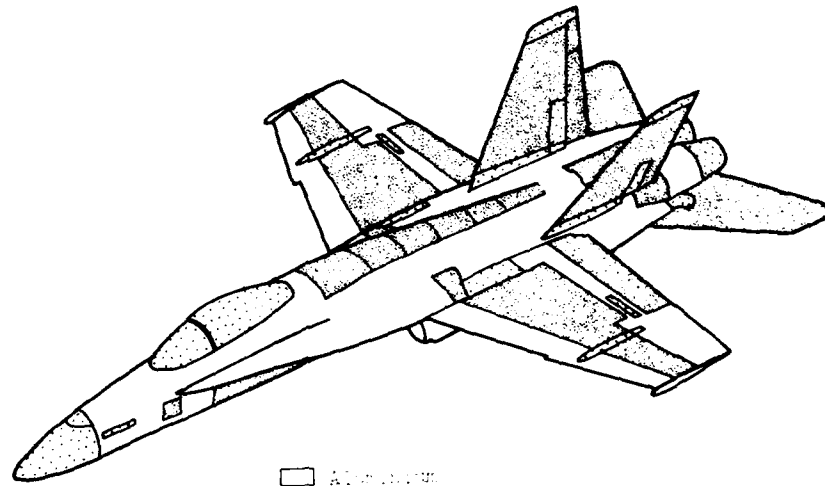

FIG. 21 GAF "NOMAD N22" (Shaded area shows extent of structural fatigue test article)



FIG. 22 TRANSAVIA "AIRTRUK" AGRICULTURAL AIRCRAFT



- Aluminum
- ▨ Invar/Epoxy
- ▩ Graphite/Epoxy Composites

FIG. 23 F/A-18, INDICATING APPLICATIONS OF GRAPHITE/EPOXY COMPOSITES

DISTRIBUTION

AUSTRALIA

Department of Defence

Central Office

Chief Defence Scientist)
Deputy Chief Defence Scientist) (1 copy)
Superintendent, Science and Technology Programmes)
Controller, Projects and Analytical Studies)
Defence Science Representative (U.K.) (Doc Data sheet only)
Counsellor, Defence Science (U.S.A.) (Doc Data sheet only)
Defence Central Library
Document Exchange Centre, D.I.S.B. (17 copies)
Joint Intelligence Organisation
Librarian H Block, Victoria Barracks, Melbourne

Aeronautical Research Laboratories

Director
Library
Superintendent - Structures
Divisional File - Structures
Superintendent - Materials
Author: J.Y. Mann
J.G. Sparrow
G.S. Jost
J.M. Finney
B.C. Hoskin
D.G. Ford
E.S. Moody
R. Jones
C.K. Rider
J.L. Kepert
C.A. Patching
L.M. Bland
A.A. Baker
Dr A.O. Payne (retired)
Dr F.H. Hooke (retired)
Dr L.P. Coombes (retired)
Mr H.A. Wills (retired)
Mr W.W. Johnstone (retired)

Materials Research Laboratories

Director/Library

Defence Research Centre

Library

Navy Office

Navy Scientific Adviser
Directorate of Naval Aircraft Engineering

.../contd.

DISTRIBUTION (CONTD.)

Army Office

Army Scientific Adviser
Engineering Development Establishment, Library

Air Force Office

Air Force Scientific Adviser
Director General, Aircraft Engineering - Air Force
Director of Aircraft Engineering - Air Force
Director General, Technical Plans - Air Force
AIRENG 5
AIRENG 5A
HQ Support Command [SENGSO]

Department of Defence Support

Government Aircraft Factories

Manager
Library

Department of Aviation

Library
Flying Operations and Airworthiness Division
Mr K.R.A. O'Brien, Melbourne
Mr C. Torkington, Canberra
Mr R.B. Douglas, Canberra
Mr S. Woodbury, Canberra
Air Safety Division, Mr I.S. Milligan, Melbourne

Statutory & State Authorities and Industry

Trans-Australia Airlines
Mr F.W. Austin, Engineering Director
Library
Qantas Airways Limited
Ansett Airlines of Australia, Library
Ansett Transport Industries Ltd, Mr R. Alexander
Lufthansa German Airlines, Mr Hans V. Krause
Swissair Pty Ltd, Mr G. Franklin
Mr G. McArthur Job, Editor 'Aircraft'
Commonwealth Aircraft Corporation
Library
Mr K.J. Kennedy (Manager Aircraft Factory No. 1)
Hawker de Havilland Aust. Pty Ltd, Bankstown, Library

Universities and Colleges

Adelaide	Barr Smith Library
Melbourne	Engineering Library
Monash	Hargrave Library Professor, I.J. Polmear, Materials Engineering

.../contd.

DISTRIBUTION (CONTD.)

Universities and Colleges (contd.)

Newcastle	Library
New England	Library
Sydney	Engineering Library
N.S.W.	Metallurgy Library
Queensland	Library
Tasmania	Engineering Library
Western Australia	Library
R.M.I.T.	Library
	Mr H. Millicer

SPARES (90 copies)

TOTAL (179 copies)

Department of Defence
DOCUMENT CONTROL DATA

1 a AR No AR-002-947	1 b Establishment No ARL-STRUC-TECH-MEMO-361	2 Document Date April, 1983	3 Test No
4 Title AIRCRAFT FATIGUE - WITH PARTICULAR EMPHASIS ON AUSTRALIAN OPERATIONS AND RESEARCH		5 Security a document: UNCLASSIFIED b title c abstract U U	6 No Pages 63
		7 No Refs 277	
8 Author(s) J.Y. MANN		9 Downgrading Instructions	
10 Corporate Author and Address Aeronautical Research Laboratories, P.O. Box 4331, Melbourne, Vic. 3001		11 Authority (as appropriate) a Source b Security c Downgrading d Approval	
12 Secondary Distribution of this document: Approved for Public Release. <small>Overseas enquirers outside stated limitations should be referred through ASDIS, Defence Information Services Branch, Department of Defence, Campbell Park, CANBERRA ACT 26</small>			
13 a This document may be ANNOUNCED in data bases and available services available to: No limitations			
13 b Citation for other purposes (ie casual announcements) may be permitted unrestricted permitted permitted			
14 Descriptors Flight loads General aviation aircraft Fatigue tests Military aircraft Fatigue (materials) Aircraft structures History Australia Research Aviation accidents		15 COSAT Group 0103 0504 1113	
16 Abstract This Technical Memorandum forms the basis for the 9th Plantema Memorial Lecture to be presented by the author at the biennial meeting of the International Committee on Aeronautical Fatigue (ICAF) at Toulouse, France in May 1983. It traces the history of aircraft structural fatigue until the establishment of the Aeronautical Research Laboratories in 1939, and then deals more specifically with Australian contributions in research and development from then until the present time. These reflect both the "lead-the-fleet" situation for civil aircraft within Australia and the desire to operate some military aircraft for lives well in excess of their original design lives.			

This page is to be used to record information which is required by the Establishment for its own use but which will not be added to the DISTIS data base unless specifically requested.

16 Abstract (Contd)		
17 Imprint Aeronautical Research Laboratories, Melbourne.		
18 Document Series and Number Structures Technical Memorandum 361	19 Cost Code 20 0003	20 Type of Report and Period Covered
21 Computer Programs Used		
22 Establishment File Ref(s)		

END

DATE
FILMED

9 - 83

DTI