

PHOTOGRAPH THIS SHEET

AD-F400 017

AD A127320

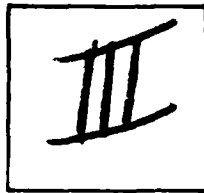

LEVEL

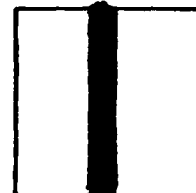

INVENTORY

# LANCE Handbook: Firing Team Leader's

DOCUMENT IDENTIFICATION

WLXXLH HB Mar. 83

### DISTRIBUTION STATEMENT A

Approved for public release  
Distribution Unlimited

### DISTRIBUTION STATEMENT

ACCESSION FOR	
NTIS	GRA&I <input checked="" type="checkbox"/>
DTIC	TAB <input type="checkbox"/>
UNANNOUNCED	<input type="checkbox"/>
JUSTIFICATION	
BY <i>Per Ltr. on file</i>	
DISTRIBUTION / AVAILABILITY CODES	
DIST	AVAIL AND/OR SPECIAL
<i>A</i>	

DISTRIBUTION STAMP

**DTIC ELECTE**

**S** APR 20 1983 **D**

**D**

DATE ACCESSIONED



83 04 19 238

DATE RECEIVED IN DTIC

PHOTOGRAPH THIS SHEET AND RETURN TO DTIC-DDA-2

AD-F400017

WLXLH  
HB  
Mar 83

# LANCE

## HANDBOOK

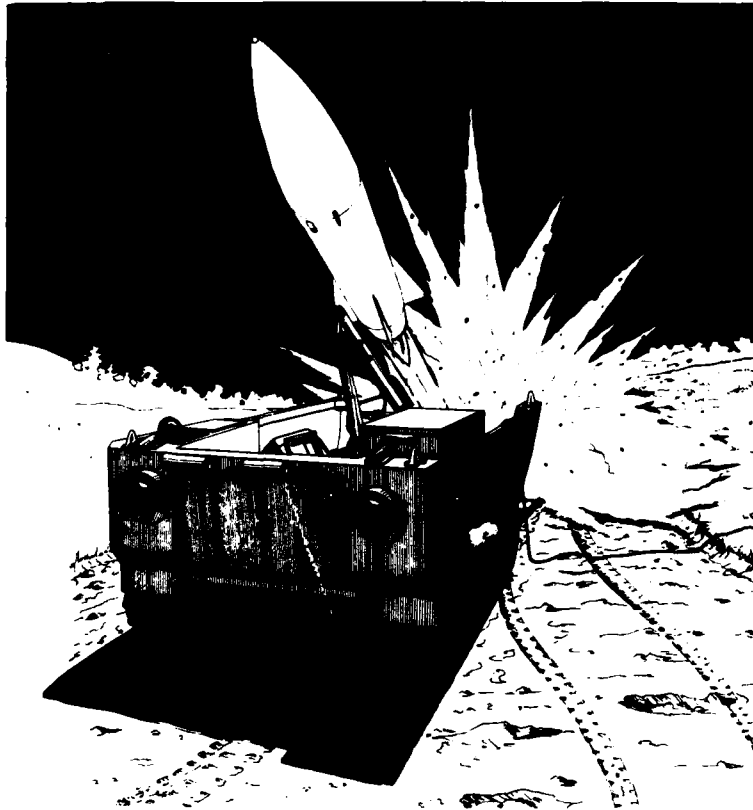

### FIRING TEAM LEADER'S

US ARMY  
FIELD ARTILLERY SCHOOL  
Weapons Department  
Fort Sill, Oklahoma

**DISTRIBUTION STATEMENT A**

Approved for public release;  
Distribution Unlimited

## TABLE OF CONTENTS

		Paragraph	Page
Chapter 1.	<b>INTRODUCTION</b>		
	Firing Team Organization . . . . .	1-1	1-1
Chapter 2.	<b>CRITICAL LANCE PUBLICATIONS</b>		
	Army Regulations . . . . .	2-1a	2-1
	Field Manuals . . . . .	2-1b	2-1
	Technical Manuals . . . . .	2-1c	2-2
	Technical Bulletins . . . . .	2-1d	2-4
	Supply Catalogs . . . . .	2-1e	2-4
	Miscellaneous . . . . .	2-1f	2-4
Chapter 3.	<b>SYSTEM CHARACTERISTICS</b>		
	Warhead Characteristics . . . . .	3-1a	3-1
	Missile Capabilities . . . . .	3-1b	3-1
Chapter 4.	<b>LANCE AMMUNITION</b>		
	Nuclear Special Ammunition Company . . . . .	4-1a	4-1
	Ammunition Operations . . . . .	4-1b	4-1
	Ammunition Maintenance . . . . .	4-1c	4-2
Chapter 5.	<b>FIRING OPERATIONS</b>		
	Reconnaissance . . . . .	5-1	5-1
	Mission Data Verification . . . . .	5-2	5-1
	Communications . . . . .	5-3	5-2
	Security . . . . .	5-4	5-2
	Advance Party Operations . . . . .	5-5	5-2
	Alternate Method . . . . .	5-6	5-3
	Safety . . . . .	5-7	5-4
	Techniques . . . . .	5-8	5-5
	Firing Team Leaders Checklists . . . . .	5-9	5-6
Chapter 6.	<b>A &amp; T OPERATIONS</b>		
	Ammunition Resupply . . . . .	6-1	6-1
	Mating . . . . .	6-2	6-1
	Vehicle Positioning . . . . .	6-3	6-2
	Big Top . . . . .	6-4	6-3
	Transloads . . . . .	6-5	6-4
	Tiedown Straps . . . . .	6-6	6-4
	Key Points . . . . .	6-7	6-5
	Safety . . . . .	6-8	6-5
	Techniques . . . . .	6-9	6-6
	Preparation Checklists . . . . .	6-10	6-8
	Torque Requirements . . . . .	6-11	6-11
Chapter 7.	<b>NUCLEAR RELEASE</b>		
	Nuclear Control Orders . . . . .	7-1a	7-1
	Team Leader Actions . . . . .	7-1b	7-1

W7483

	Paragraph	Page
<b>Chapter 8. BATTLE DRILL</b>		
Purpose . . . . .	8-1a	8-1
Resource Requirements . . . . .	8-1b	8-1
Sequence of Events . . . . .	8-1c	8-2
Time . . . . .	8-1d	8-3
Benefits . . . . .	8-1e	8-3
Battle Drill Checklist . . . . .	8-1f	8-3
<b>Chapter 9. COMMAND AND CONTROL</b>		
Methods of Fire . . . . .	9-1a	9-1
Response Posture . . . . .	9-1b	9-1
Authority to Mate . . . . .	9-1c	9-2
Extensions . . . . .	9-1d	9-2
Key Points . . . . .	9-1e	9-2
<b>Chapter 10. SURVEY</b>		
Firing Point Survey . . . . .	10-a	10-1
Firing Point Verification . . . . .	10-b	10-1
Key Points . . . . .	10-c	10-2
<b>Chapter 11. SURVIVABILITY</b>		
Enhance Your Survivability . . . . .	11-1	11-1
<b>Chapter 12. EMERGENCY DESTRUCTION</b>		
Authority . . . . .	12-1a	12-1
Priority . . . . .	12-1b	12-1
Emergency Destruction . . . . .	12-1c	12-2
Actions After Destruction . . . . .	12-1d	12-2
Key Points . . . . .	12-1e	12-3
ED Safety . . . . .	12-1f	12-4
ED Training Differences . . . . .	12-1g	12-5
Demolition . . . . .	12-1h	12-6
<b>Chapter 13. AIRMOBILE OPERATIONS</b>		
Preparations . . . . .	13-1	13-1
Air Transport . . . . .	13-2	13-1
Execution . . . . .	13-3	13-2
Airmobile Slings . . . . .	13-4	13-2
Example (External) Mission . . . . .	13-5	13-3
<b>Chapter 14. LOCAL DIRECTIVES</b>		
Lead Wire Seals . . . . .	14-1a	14-1
Pal Unlock/Lock (T1533-2) . . . . .	14-1b	14-2
DD 1150, EML and IRC . . . . .	14-1c	14-2
<b>Chapter 15. NUCLEAR TRAINING DIFFERENCES</b>		
M511E1 Container Exterior . . . . .	15-1a	15-1
M511E1 Container Lid Removed . . . . .	15-1b	15-2
Inside Parameter and Quick Access Covers . . . . .	15-1c	15-3
M240 WHS Suspended Above Container . . . . .	15-1d	15-3

	Paragraph	Page
<b>Chapter 16. NAICP</b>		
Purpose . . . . .	16-1a	16-1
Definitions . . . . .	16-1b	16-1
NAIC . . . . .	16-1c	16-1
Emergency Measures . . . . .	16-1d	16-2
<b>Chapter 17. NBC DEFENSE</b>		
Battery Level NBC Organization . . . . .	17-1a	17-1
Chemical Agents . . . . .	17-1b	17-2
Mission Oriented Protective Posture . . . . .	17-1c	17-2
Key Points . . . . .	17-1d	17-3
<b>Chapter 18. COMMON MISTAKES</b>		
Firing Operations . . . . .	18-1a	18-1
A&T Operations . . . . .	18-1b	18-2
<b>Chapter 19. DESERT OPERATIONS</b>		
Consumption of Fuel . . . . .	19-1a	19-1
Weather . . . . .	19-1b	19-1
Map Reading . . . . .	19-1c	19-1
Camouflage . . . . .	19-1d	19-1
Radio Communications . . . . .	19-1e	19-2
Light and Noise Discipline . . . . .	19-1f	19-2
Medical . . . . .	19-1g	19-2
Maintenance . . . . .	19-1h	19-2
Typical Operations . . . . .	19-1i	19-2
Canvas . . . . .	19-1j	19-2
Survey . . . . .	19-1k	19-3
Lance Operations . . . . .	19-1l	19-3
<b>Chapter 20. SUBARCTIC OPERATIONS</b>		
Subarctic Weather . . . . .	20-1a	20-1
Environmental Effect on Personnel . . . . .	20-1b	20-1
Behavioral Effects and Psychological Adjustment . . . . .	20-1c	20-1
Medical Problems . . . . .	20-1d	20-1
Maintenance . . . . .	20-1e	20-2
Vehicles . . . . .	20-1f	20-2
Communications . . . . .	20-1g	20-2
Employment . . . . .	20-1h	20-3
Camouflage and Concealment . . . . .	20-1i	20-3
Navigation . . . . .	20-1j	20-3

# CHAPTER 1

## INTRODUCTION

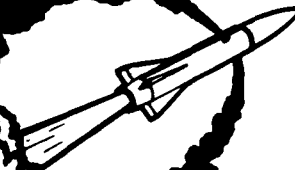

1-1. As a Lance Firing Team Leader you will be entrusted by the President of the United States with the ultimate of all responsibilities--the successful launch of a reliable NUCLEAR missile. No challenge is greater or more demanding!

a. There is a close, inherent relationship between a firing section and an Assembly & Transport Section in combat. As a result, leaders and soldiers must be knowledgeable in both areas whether the firing battery is organized into firing teams or into separate platoons. This handbook is specifically designed to assist an individual in gaining such experience. It incorporates valuable techniques and information not found in Lance technical manuals.

b. Although several Lance battalions employ the firing team concept, no references exists that depict its organization. The following is provided for your benefit (if appropriate).

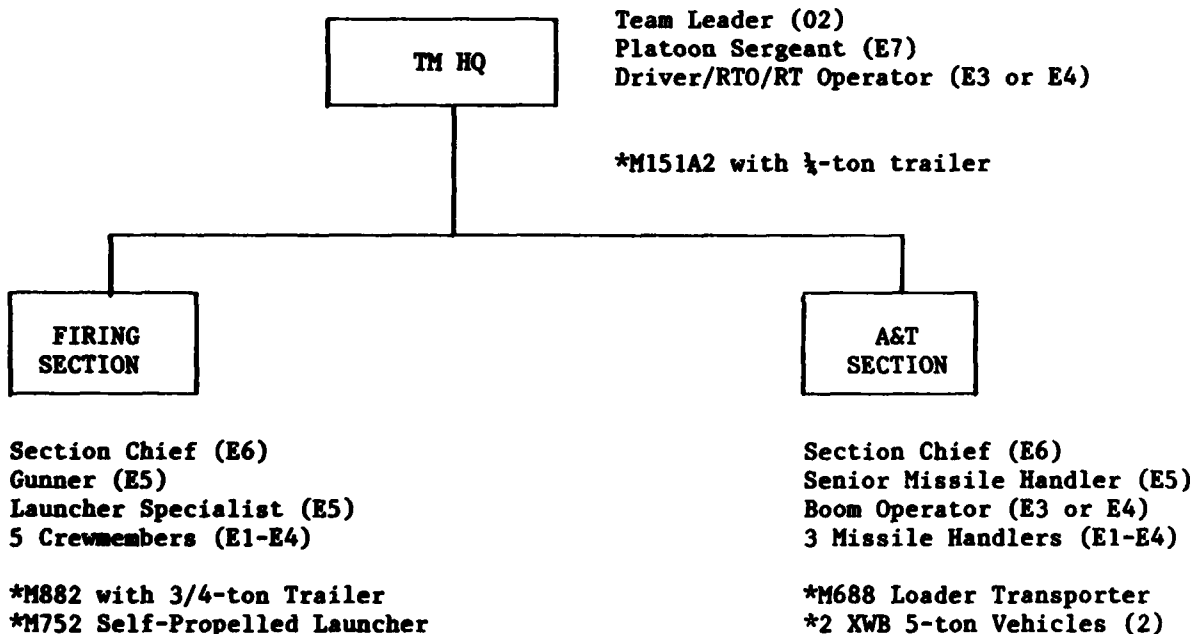

**NOTES:** (1) Seldom will the team possess the number of personnel or rank shown.  
(2) One team per firing battery will usually have the additional responsibility of either the M234 Mobility kit or the A&T Platoon Headquarter's XLWB 5-ton vehicle.

# CHAPTER 2

## CRITICAL LANCE PUBLICATIONS

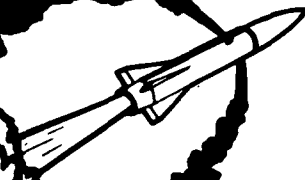
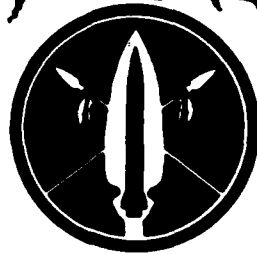

2-1. Your ability to make sound decisions will depend on your knowledge of the LANCE system. Become familiar with each manual and continually review them. Don't procrastinate! Technical and tactical proficiency will require many hours of individual study.

a. ARMY REGULATIONS (AR)

AR 50-5 . . . . . NUCLEAR SURETY.

Study this regulation. It contains excellent information on the Personnel Reliability Program (PRP), nuclear transport, and Nuclear Accident Incident Control Procedures (NAICP). Appendix D is a checklist for Courier Officers.

AR 50-109 . . . . . SAFETY RULES for the OPERATION of the LANCE  
NUCLEAR WEAPON SYSTEM.

These 9 safety rules are important! Commit them to memory.

AR 700-65 . . . . . NUCLEAR WEAPONS and NUCLEAR WEAPONS MATERIALS.

Good information on accountability and custodian procedures of nuclear weapons. Shows how to properly prepare DD Form 1150.

b. FIELD MANUALS (FM)

FM 5-25 . . . . . EXPLOSIVES and DEMOLITIONS.

Review this manual for specifics after studying the emergency destruction procedures given in the Battalion Field SOP.

FM 6-42 . . . . . FIELD ARTILLERY BATTALION, LANCE.

This manual sets forth doctrine pertaining to the organization, tactics, techniques, and procedures used by the LANCE Battalion in combat.

FM 6-42-1(C) . . . . . FIELD ARTILLERY BATTALION, LANCE.

Read this supplement.

FM 6-141-2(C) . . . . . FIELD ARTILLERY TARGET ANALYSIS and WEAPON  
EMPLOYMENT: NONNUCLEAR.

Provides concise information on nonnuclear LANCE casualty effectiveness and material damage capability. Read pages 6-3 through 6-5.

FM 100-50 . . . . . OPERATIONS for NUCLEAR CAPABLE UNITS.

Become familiar with this manual, especially chapter 4.

FM 101-60-18(C) . . . . . JOINT MUNITIONS EFFECTIVENESS MANUAL FOR GM-52C.

This manual provides information on the effectiveness of nonnuclear LANCE on various targets. Your Bn S2 has this manual.

FM 101-31-3(S) . . . . . STAFF OFFICER'S FIELD MANUAL: NUCLEAR WEAPONS EMPLOYMENT DATA.

This is an important manual on the employment of nuclear LANCE on the battlefield. It is critical that you become familiar with chapter 2. This chapter provides information on WHS yields and expected system response.

c. TECHNICAL MANUALS (TM)

TM 9-1115-485-12 . . . . . OPERATOR and ORGANIZATIONAL MAINTENANCE (PRELAUNCH PROCEDURES).

Covers receipt, unpackage, mate, transport, PAL, prefire, disarm and emergency procedures associated with the M234 Series Nuclear Warhead Section. STUDY this manual.

TM 9-1115-485-12-1 (FOUO) . . OPERATOR and ORGANIZATIONAL MAINTENANCE (Supplement) for the M234E3 and M240E3.

Includes important information on the M234E3 WHS and the new Command Disable System (CDS).

TM 9-1115-485-12-2 (CFRD) . . OPERATOR and ORGANIZATIONAL MAINTENANCE (Supplement) for the M234E1 and M234E2 WHS's.

This is easy to remember. Memorize it!

TM 9-1115-485-20P . . . . . ORGANIZATIONAL MAINTENANCE REPAIR PARTS and SPECIAL TOOL LISTS for the M234E1/2 WHS.

Reference only.

TM 9-1336-489-12 & P . . . . . OPERATOR and ORGANIZATION MAINTENANCE: WHS M251 and M201.

Covers receipt, unpackage, mate, and prefire inspections of the M251 HE Warhead Section.

TM 9-1375-213-12 . . . . . DEMOLITION MATERIALS.



Excellent information on the individual characteristics of demolition materials.

TM 9-1410-485-12 . . . . . OPERATOR and ORGANIZATIONAL MAINTENANCE:  
M5 MMA AMMUNITION.

This is the A & T Section's bible. STUDY it thoroughly!

TM 9-1425-485-10-1 . . . . . SYSTEM DESCRIPTION for LANCE GUIDED MISSILE  
SYSTEM.

To become truly knowledgeable of the LANCE system this manual is required reading.

TM 9-1425-485-10-2 . . . . . LANCE FIRING OPERATIONS.

This is the Firing Sections bible. STUDY it thoroughly!

TM 9-1425-485-12 . . . . . OPERATOR and ORGANIZATIONAL MAINTENANCE:  
LANCE LAUNCH AREA EQUIPMENT.

Describes maintenance requirements for the M752 self-propelled launcher, M740 LZL,  
Monitor Programmer and M91 Firing Device.

TM 9-1430-485-12 . . . . . OPERATOR and ORGANIZATIONAL MAINTENANCE:  
AZIMUTH LAYING SET.

Use this manual to conduct inventories and perform checks and adjustments on the  
Gunner Sight Unit (GSU), Remote Theodolite (RT) and Test Target (TT).

TM 9-1450-485-10 . . . . . OPERATING MANUAL for CARRIER, GUIDED MISSILE  
EQUIPMENT: M667 LANCE.

Concentrate on PMCS procedures and vehicle characteristics.

TM 9-1450-485-12 . . . . . OPERATOR and ORGANIZATIONAL MAINTENANCE:  
LANCE HANDLING EQUIPMENT.

Describes maintenance requirements for the M688 loader transporter, M234 mobility  
kit, M22 sling beam and M38 tripod hoist.

TM 39-0-1A . . . . . NUMERICAL INDEX TO JOINT ATOMIC WEAPONS  
PUBLICATIONS.

Use this manual to stay current on nuclear weapons publications. It is updated every  
four months.

TM 39-50-8(C) . . . . . EMERGENCY DESTRUCTION of NUCLEAR WEAPONS.

Emergency destruction procedures given in the battalion field SOP are extracted from  
this manual.

TM 39-T436-2 . . . . . OPERATION and MAINTENANCE INSTRUCTION: T436B  
POWER SUPPLY and T431 BATTERY CHARGER MONITOR.

Use this manual to properly maintain your T436 battery. Service battery is responsible  
for charging and discharging.

TM 39-T1533-2 . . . . . OPERATION and MAINTENANCE INSTRUCTION:  
T1533 PORTABLE DECODER.

This manual is simple to understand. Memorize all procedures and warnings given in chapter 6. Know the purpose of the T1528.

TM 55-1425-485-15-1 . . . . . TRANSPORTABILITY GUIDANCE, LANCE MISSILE SYSTEM.

Become familiar with this manual. Concentrate on external transport requirements of a LZL with an HE missile by a CH-47 helicopter.

TM 750-244-4-1 . . . . . DESTRUCTION of EQUIPMENT to PREVENT ENEMY USE, LANCE.

Gives priority list for destruction of LANCE peculiar equipment. READ IT!

d. TECHNICAL BULLETINS (TB)

TB 9-1100-803-15 (FOUO) . . . ARMY NUCLEAR WEAPONS EQUIPMENT RECORDS and REPORTING PROCEDURES.

Shows how to properly prepare DA 2409 (EML) and DA 2404 when associated with a nuclear weapon. This manual is critical during a Technical Validation Inspection (TVI).

TB 385-2 . . . . . NUCLEAR WEAPONS FIREFIGHTING PROCEDURES.

Important information on safety and control of a nuclear weapon involved in a fire.

TB 9-1410-485-10(C) . . . . . EMERGENCY REMOVAL of the SAFE ARM COVER LOCK ASSEMBLY.

Know this procedure!

e. SUPPLY CATALOGS (CS)

SC 1375-94-CL-P02 . . . . . DEMOLITION EQUIPMENT

Lists emergency destruction equipment that your team should possess.

SC 4935-95-CL-A67 . . . . . TOOL KIT, GUIDED MISSILE: MISSILE MATING, LANCE.

Use this as a guide during inventory of your A & T section.

SC 5180-95-CL-A65 . . . . . TOOL KIT, SPECIAL WEAPONS, ORGANIZATIONAL MAINTENANCE, LANCE.

Use this as a guide during inventory of your A & T section.

f. MISCELLANEOUS

ARTEP 6-595

Concentrate on those tasks associated with the firing platoon and A & T platoon. Know the standards that must be achieved.

#### BATTALION FIELD SOP

This manual standardizes the battalion tactical operations. Become familiar with it as soon as possible.

#### BATTALION POLICY and PROCEDURE MANUAL

This manual gives administrative guidance for battalion garrison and field operations.

#### BATTALION SPECIAL WEAPONS SOP

This manual gives administrative guidance for special weapons. Become familiar with it as soon as possible.

## CHAPTER

# 3

## SYSTEM CHARACTERISTICS



3-1. A team leader's ability to accomplish a mission will depend on his thorough knowledge of the limitations and capabilities of the Lance system. TM 9-1425-485-10-1 and FM 6-42 will provide you this knowledge.

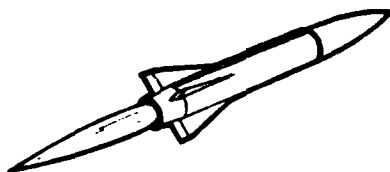

### a. WARHEAD CHARACTERISTICS

(1) The M251 high-explosive (HE) warhead section consists of 825 BLU 63B bomblets which are released at a preset height of burst. The M251 WHS is effective against lightly armored materials and personnel. See Lance - Joint Munitions Effects Manual (C).

(2) The M251A1 HE warhead section is an improved version of the M251 WHS and contains a payload of approximately 580 M74 fragmentation grenades. These grenades have a lower dud rate and improved fragment penetration capability.

(3) Yield and effects of the M234 series nuclear warhead can be found in FM 101-32-2 (S). The battalion S2 maintains this manual.

### b. MISSILE CAPABILITIES

The Lance missile provides the corps commander with an effective, long-range, all-weather, day/night, nuclear/conventional weapon system. It has excellent range capabilities.

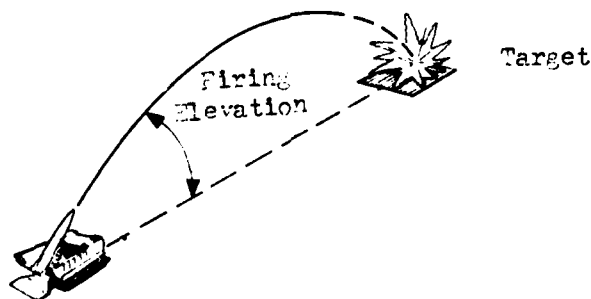

Launcher

NONNUCLEAR

← 8km Range 75km →

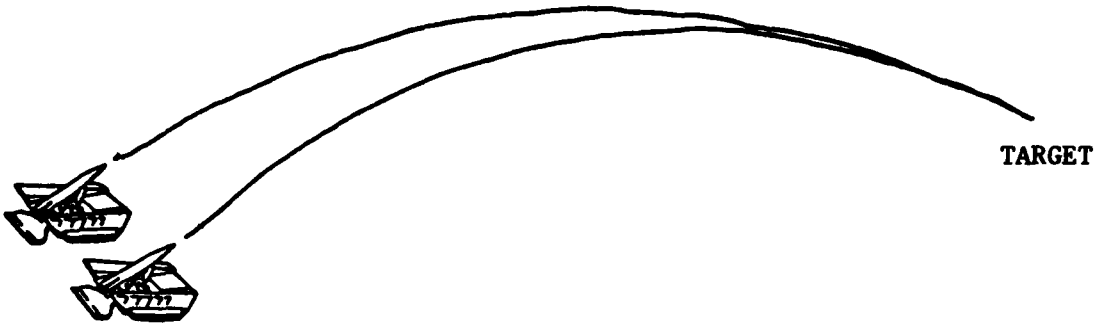

LAUNCHER ALTITUDE 1000m

NUCLEAR

← 8km Range 115km →



LAUNCHER ALTITUDE 1000m

TARGET

If the firing point or launcher is greater than 1,000 meters, the maximum ranges are extended to 81km for nonnuclear and 133km for nuclear.

# CHAPTER 4

## LANCE AMMUNITION



4-1. The resupply of missiles to the firing batteries is one of the most vital combat service support operations performed.

### a. NUCLEAR SPECIAL AMMUNITION COMPANY

The nuclear special ammunition company is responsible for maintaining all Lance-peculiar ammunition including control surfaces, main missile assemblages, nonnuclear and nuclear warheads. Two companies are normally assigned to support a corps and each is capable of establishing one or more SASPs. Refer to FM 9-6 for additional information.

### b. AMMUNITION OPERATIONS

When a LANCE battalion requires resupply of missile items, the nuclear weapon logistic element at corps will direct a nuclear special ammunition company to position sufficient stocks at a SASP locaton to support the request. At a coordinated time, the battalion's ammunition platoon will rendezvous with the SASP to conduct resupply. The ammunition platoon will then perform all required inspections to insure reliability of resupplied missile ammunition prior to delivery to firing batteries. Refer to FM 100-50 and your battalion field SOP for additional information.

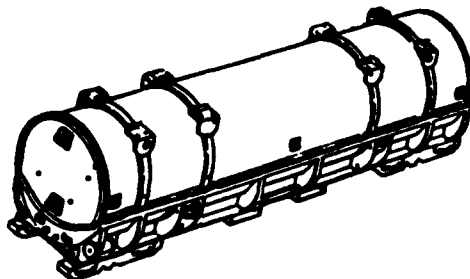

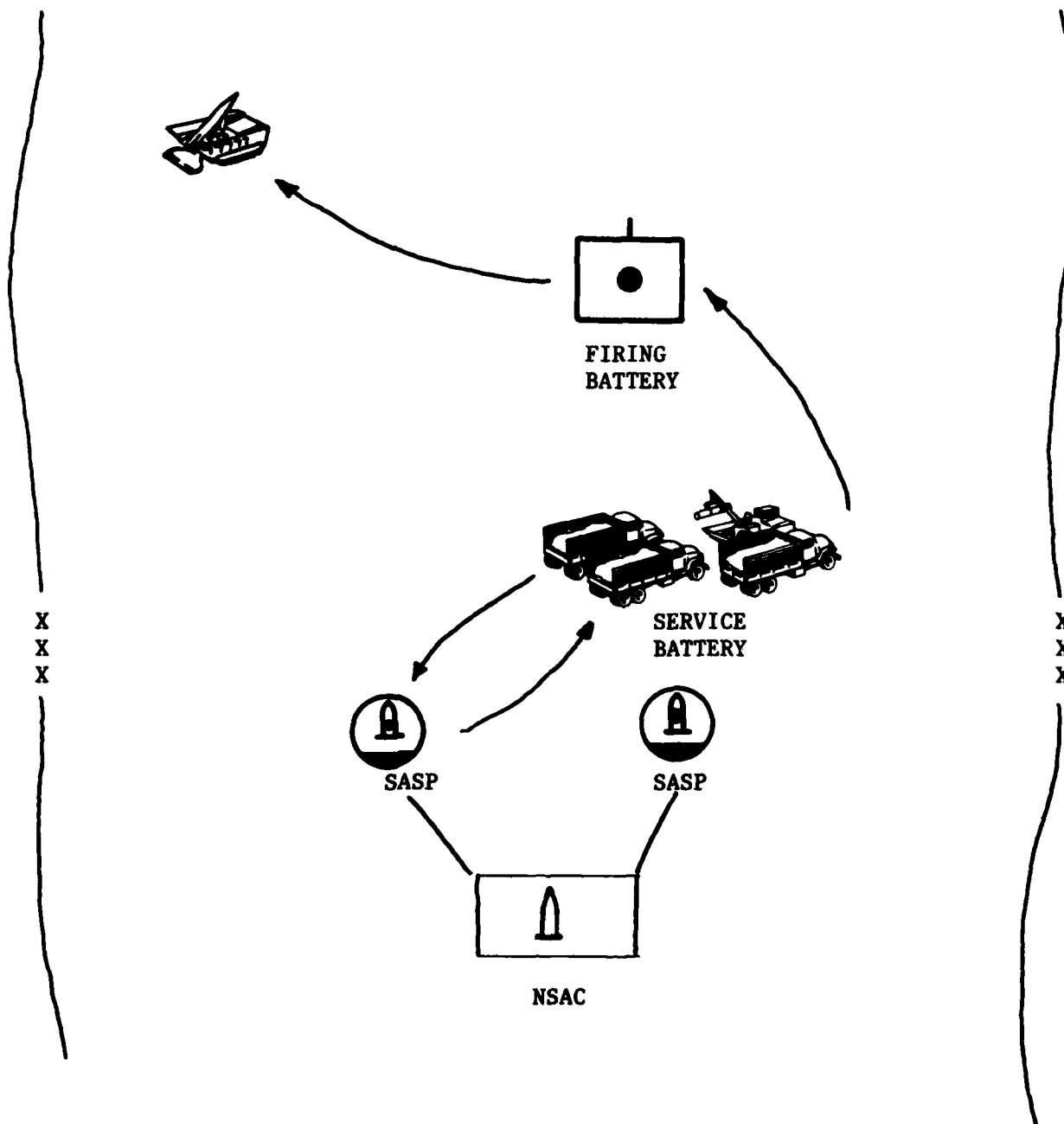

c. AMMUNITION MAINTENANCE

A Lance missile maintenance technician (warrant officer, MOS 214G) is assigned to service battery and is responsible for providing guidance and assistance to team personnel on ammunition maintenance. Normally, during tactical operations, a faulty missile will be removed from the launcher immediately and replaced with a serviceable one, rather than attempting maintenance. Unserviceable missile components are returned to the SASP as a defective class V item. Refer to TM 9-1410-485-12 and TM 9-1115-485-12 for turn in procedures.

# CHAPTER

# 5

## FIRING OPERATIONS

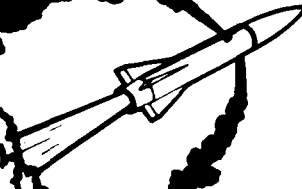

### 5-1. RECONNAISSANCE

Firing point reconnaissance is a critical responsibility of the team leader. Many fire missions have been jeopardized because the team was unable to find the firing position or occupied a point that was unusable. Prior reconnaissance cannot be over emphasized; it must take precedence over eating and sleeping.

When possible, the section chief and instrument operator should accompany the team leader on reconnaissance. As a minimum, the following should be accomplished:

- a. Selection of primary and alternate routes to the firing position.
- b. Reconnaissance of potential rendezvous areas for transload.
- c. Selection of the best hide area adjacent to the firing position.
- d. Verification of firing point survey. Refer to chapter 10 for specific guidance.
- e. Sweep of the firing point to insure it can be occupied and is free of hazards.
- f. Check communications with your FDC.
- g. Check slope using gunner's quadrant or compass.

### 5-2. MISSION DATA VERIFICATION

Fire mission data must be verified with firing point survey information immediately upon receipt from FDC. It requires only a few seconds and involves simple subtraction, using the mnemonic TFOOL (Take the Fire Out of the Old Lady).

Procedure:

1623.67 mils ..... Azimuth of the orienting line from survey data card.  
-0245.31 mils ..... Azimuth of fire from fire mission data sheet.

1378.36 mils ..... Equals the orienting angle indicated on the fire mission data sheet ( $\pm 0.5$  mils).



Failure to verify fire mission data can result in the launch of an unreliable round. The fact that the missile can be laid DOES NOT insure it is properly oriented towards the target.

### 5-3. COMMUNICATIONS

a. Nuclear Fire Mission: If communications are lost anywhere in the chain of command, the round will not be fired. Absolute control must be maintained over a nuclear weapon up until launch since a sudden change in the tactical or political situation may dictate "termination." Once the missile has been laid, the team leader must check with FDC to insure the mission is still a GO before firing.

b. Nonnuclear Fire Mission: If communications are lost, the decision to fire will be based upon command guidance. Normally, a nonnuclear TOT mission will be fired if communications are lost after the team occupied the firing point.

### 5-4. SECURITY

The launcher is extremely vulnerable during firing operations so effective security becomes critical. Capitalize on the following techniques:

a. Conduct a thorough sweep of the firing position prior to occupation by the launcher.

b. Emplace the M60 machine gun in a position which covers the most likely enemy avenue of approach. Remember maximum effective range is 1100 meters.

c. As a fire mission is being conducted, have crewmembers, who are waiting to perform a particular task, face outward from the SPL with their weapon.

d. Before evacuating to the firing pit for firing, deploy a security force to the opposite side of the SPL to provide all-around security. Insure that they position themselves within the safety fan and at the proper distance, Ref: TM 9-1425-485-10-2.

### 5-5. ADVANCE PARTY OPERATIONS

Use of an advance party can greatly enhance a team's ability to accomplish a follow-on mission. Their objective is to prepare the second firing point for rapid occupation by the launcher following a transload. Depending on team strength, organization normally consists of the team leader, platoon sergeant and RT operator. A typical advance party sequence of events is as follows:

a. Upon launch of the first round, the team leader secures the azimuth tape, used to position the SPL for firing, and departs with the advance party for the second firing point.

b. Enroute to the second point, the team leader insures that the LT is preparing for transload at the rendezvous location. Additionally, he verifies that fire mission data verifies with firing point survey.

c. Upon arrival at the point, the team leader directs the driver to position the vehicle in the woodline and as close to the orienting station (OS) as possible.

d. The entire advance party conducts a rapid sweep of the firing position. If firing point survey was not verified during reconnaissance, the team leader does so at this time.

e. As the RT operator unloads and positions the RT and TT for set-up, the platoon sergeant and team leader establishes the azimuth of fire with the azimuth tape. Establishing the azimuth of fire first allows for an unexpected early arrival of the SPL.

f. The TT and RT are set-up, leveled and verified as a joint effort.

g. The ORA is placed on the RT and the initial deflection is checked for accuracy. If the floating firing point method is being used, the azimuth stake can be repositioned to insure an initial deflection of 0000.00 mils (time permitting).

A well trained advance party can prepare a firing point from arrival to RT deflection check in 10 minutes or less. If SPL march order and transload are executed properly, 10 minutes is all that an advance party will have in which to prepare the point before the SPL arrives.

#### 5-6. ALTERNATE METHOD

During firing point occupation, terrain may preclude laying operations from being accomplished. In such situations, the alternate method may allow the mission to still be successfully completed by reversing the EOL and OS stations. This technique will not work every time because it depends on the location of the initial EOL in relationship to the launcher.

When the alternate method is used, 3200.00 mils must be added or subtracted from the original orienting angle (ORA). The new ORA will be used to lay the missile. The azimuth of fire does not change!

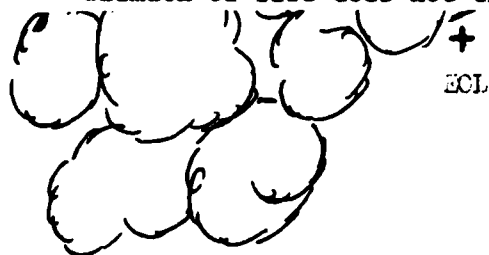

Orienting Angle = 4423.67 mils

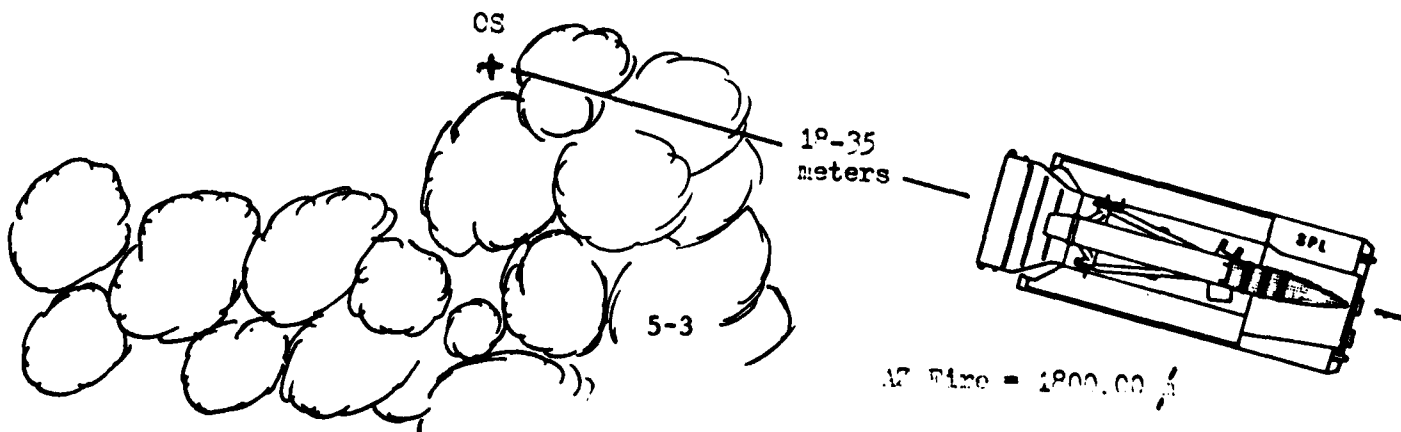

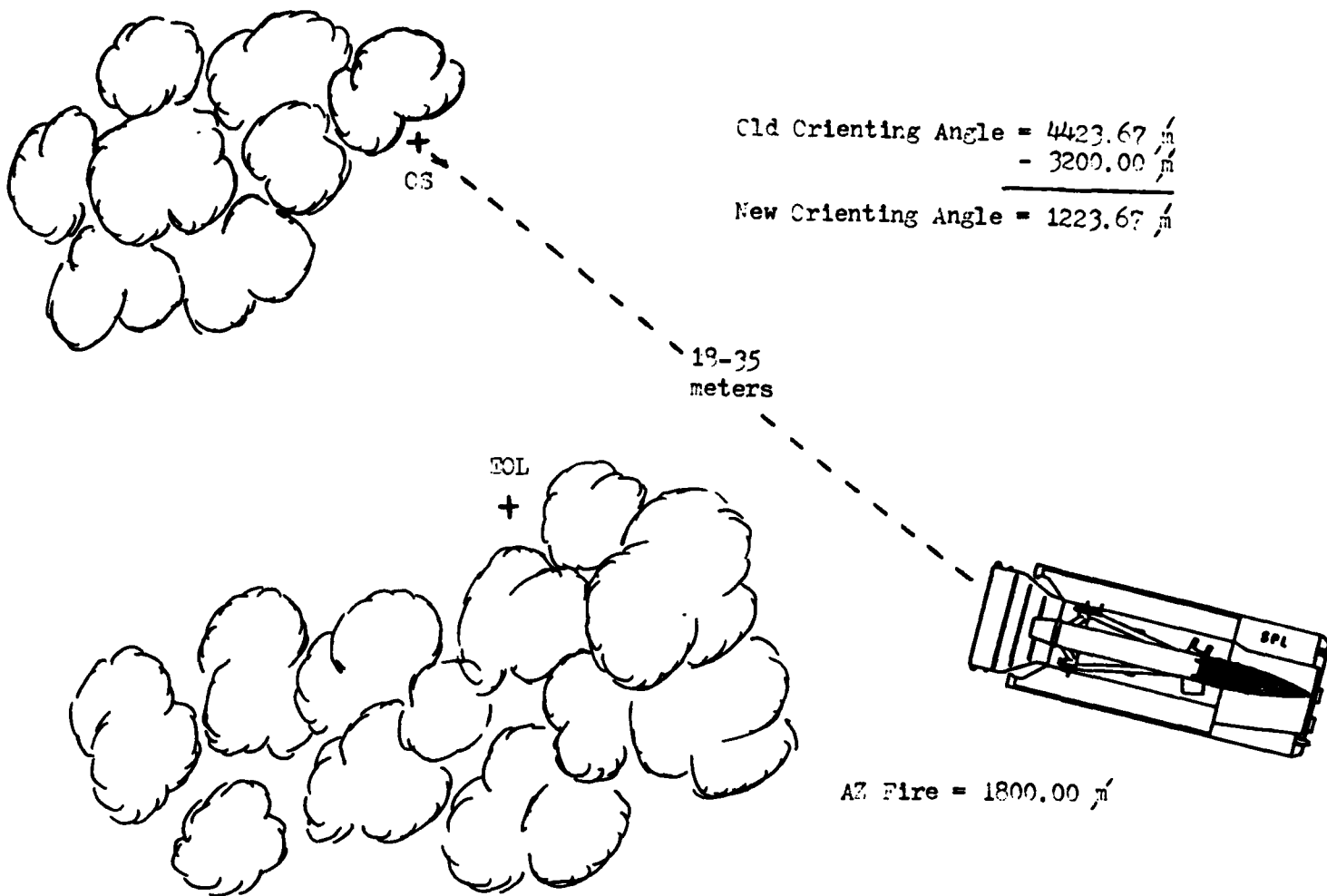

#### 5-7. SAFETY

A team leader must be familiar with all safety instructions given in TM 9-1425-485-10-2. The following amplifying guidance is provided for your benefit:

- a. Memorize the nine safety rules listed in AR 50-109.
- b. Know the first aid procedures and hazards of the MMA propellants, UDMH and IRFNA.
- c. Never extract the upper rod of the APU until all personnel are cleared from the danger area behind the missile.
- d. Before conducting emergency power operations, insure that the J1 quick disconnect cable has been disconnected from the NICAD battery.
- e. Follow the firing sequence given in TM 9-1425-485-10-2. Never arm the MMA safe-arm igniter before the safe-arm check has been performed.

## 5-8. TECHNIQUES

a. Use the firing team leader's checklists to prepare for fire missions and transloads.

b. When establishing the azimuth of fire, emplace the azimuth tape  $1\frac{1}{2}$  steps to the left of the firing point hub. This will greatly facilitate positioning of the SPL by allowing the driver to see the tape as he pulls over the hub.

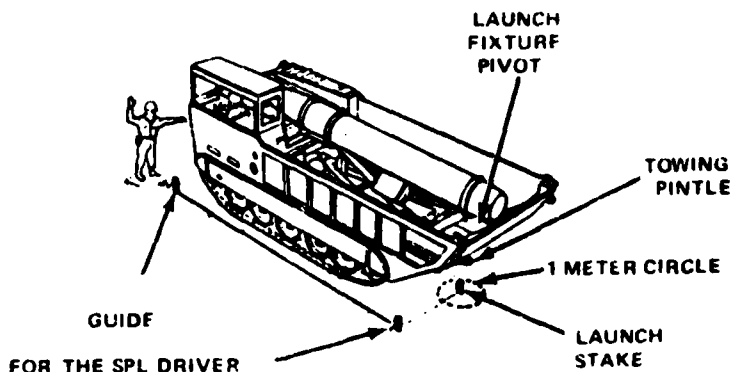

The launcher can be more accurately positioned in azimuth and only one man is needed as a guide.

c. If time permits, conduct a mated missile checkout prior to a fire mission. It's your only assurance that the mission will be successful.

d. Stow bows and covers on the SPL stowage arms prior to firing operations. Don't allow your team to be delayed in departing the point after firing by having to pick them up. Your team's survival depends on how fast they can depart. Bows and covers can be reinstalled in a hide area once the SPL has cleared the danger area (approx 1km).

e. During an emergency destruction, evacuate all Lance critical equipment; i.e., IGSU, FD and MP, if time permits. These items are hard to replace.

f. Keep two azimuth tapes available. One will invariably be left at a previous firing point.

g. In preparation of a nuclear pulse; i.e., a TOT mission followed by an ASAP, choose two firing points along a common route and fire the first mission from the farthest firing point from the battery area. This not only allows the team to position the LT for transload as they travel to the first firing point, but provides the firing section chief an opportunity to physically see the locations of the second firing point and transload area.

5-9. FIRING TEAM LEADERS' CHECKLISTS

a. TASKS PRIOR TO DEPARTING FOR A FIRING POINT OR HIDE AREA

- |    |  |     |    |
|----|--|-----|----|
| 1. | COMMUNICATIONS . . . . .   | YES | NO |
|    | Make radio check with FDC prior to departing area.<br>NOTE: Firing team should carry a RC-292 at all times.  |     |    |
| 2. | RECONNAISSANCE . . . . .   | YES | NO |
|    | All firing points and hide areas should be reconned prior to occupation.<br>NOTE: Verify survey during recon, if possible.   |     |    |
| 3. | MATED MISSILE CHECKOUT . . . . .   | YES | NO |
|    | If time permits, perform a mated missile checkout to insure that the system is functioning properly (the firing device and monitor programmer checkout is performed in conjunction with the mated missile checkout). |     |    |
| 4. | NIGHT LIGHTING EQUIPMENT . . . . .   | YES | NO |
|    | Insure that all night lighting equipment for the gunner sight unit (GSU), remote theodolite (RT), and test target (TT) is present and operational.   |     |    |
| 5. | PROTECTIVE CLOTHING/BREATHING APPARATUS. . . . .   | YES | NO |
|    | Insure that protective clothing and breathing apparatus are present when operating near MMA.   |     |    |

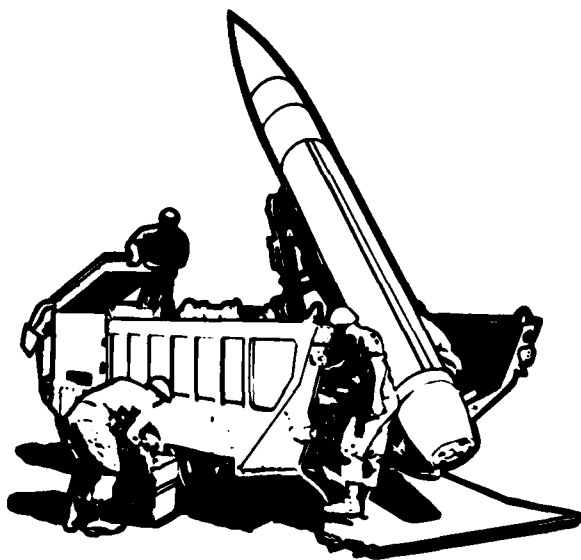

b. TASKS PRIOR TO TRANSLOADING A MISSILE ROUND FROM THE A & T SECTION

- |    |  |     |    |
|----|--|-----|----|
| 1. | <p><b>NICAD BATTERY</b> . . . . .</p> <p>Should be fully charged or within charging limits (weekly or 5 hours of operation). Remember to disconnect the power cable from the monitor programmer (MP) before charging.</p> <p>NOTE: Charging should be accomplished while traveling.</p>  | YES | NO |
| 2. | <p><b>VEHICLE SLAVE CABLE</b> . . . . .</p> <p>Should be readily available for NICAD charging and emergency power operations.</p> <p>NOTE: J1 quick disconnect cable must be disconnected from the NICAD before emergency power operations.</p>  | YES | NO |
| 3. | <p><b>CHECKS AND ADJUSTMENTS</b> . . . . .</p> <p>Gunner Sight Unit (GSU) _____ Bi-weekly</p> <p>Gunner Quadrant _____ Bi-Weekly</p> <p>Remote Theodolite (RT) _____ Monthly</p> <p>Test Target (TT) _____ Monthly</p> <p>NOTE: Perform checks and adjustments when there is a temperature change of 40 degrees F or more.</p> | YES | NO |
| 4. | <p><b>MAP (1:50,000)</b> . . . . .</p> <p>Acetated with location of firing points, hide areas, and rendezvous points.</p> <p>NOTE: Coordinate scale should be used for verifying grid locations.</p>   | YES | NO |
| 5. | <p><b>M-2 COMPASS</b> . . . . .</p> <p>Properly declinated.</p> <p>NOTE: The M-2 compass can be used to check the slope of the SPL/LZL to insure it is within a 5 degree/88 mil tolerance.</p>   | YES | NO |
| 6. | <p><b>AZIMUTH TAPE</b> . . . . .</p> <p>White engineer tape (approx 22 ft in length for ease of recovery) works best, especially at night.</p>   | YES | NO |
| 7. | <p><b>FIRE MISSION FORMAT</b> . . . . .</p> <p>Sufficient acetated copies available (2-3).</p>   | YES | NO |
| 8. | <p><b>CEOI</b> . . . . .</p> <p>Insure that everyone is aware of the current challenge and reply.</p>  | YES | NO |

9. APPROPRIATE MANUALS AND REFERENCES . . . . . YES NO
- FM 5-25 TM 9-1410-485-12  
 FM 6-42 TM 9-1425-485-10-2  
 TB 9-1100-803-15 TM 9-1425-485-12  
 TM 3-4240-212-14&P TM 9-1450-485-10  
 TM 9-1115-485-12 TM 9-T1533-2  
 TM 9-1290-200-14&P TM 39-50-8  
 TM 9-1336-489-12&P  
 Battalion Field SOP
- NOTE: This is not an all inclusive list, but only some of the more important manuals.
10. EMERGENCY DESTRUCTION KIT . . . . . YES NO
- Detonation Cord  
 Time Fuze  
 Fuze Igniters and Matches  
 Crimpers  
 Electrical Tape  
 Blasting Caps  
 Sandbags
- NOTE: Blasting caps should not be carried near troops. Sandbag in a trailer when possible.
11. TRANSPORT LOCKPIN . . . . . YES NO
- Insure transport lockpin is present.  
 NOTE: Accountability of the transport lockpin is critical from launch until SPL is reloaded.
12. LAUNCHER SPECIALIST TOOL KIT . . . . . YES NO
- Insure that the transport lockpin extractor is present, plus additional screwdrivers to assist in removing/ installing control surfaces.
13. SPARE MONITOR PROGRAMMER . . . . . YES NO
- Confirm current calibration. If spare monitor programmer is not available contact FDC to make necessary coordination.
14. EXTRA BA-30 BATTERIES . . . . . YES NO
- The gunner should carry 6 spare BA-30s at all times.  
 NOTE: For cold weather BA-30/30s should be used.
15. RATIONS . . . . . YES NO
- As necessary.

c. TASKS DURING TRANSLOAD OF A MISSILE ROUND FROM THE A&T SECTION

- |     |  |     |    |
|-----|--|-----|----|
| 1.  | SHORT UMBILICAL CABLE . . . . .<br>Insure exchange of short umbilical cable.   | YES | NO |
| 2.  | CONTROL SURFACES . . . . .<br>Insure exchange of empty control surface containers<br>for new control surfaces.<br>NOTE: M29 (Large) - Nuclear WHS<br>M30 (Small) - HE WHS  | YES | NO |
| 3.  | LEAD WIRE SEALS . . . . .<br>Should receive extra lead wire seals for MMA disarm<br>procedures.  | YES | NO |
| 4.  | DA FORM 2404 . . . . .<br>Should receive DA Form 2404s on the MMA, WHS, and<br>control surfaces being transloaded.   | YES | NO |
| 5.  | NUCLEAR WEAPONS CUSTODIAN AND COURIER OFFICER ORDERS . . .<br>Should be in your possession.<br>NOTE: The platoon sergeant and section chief should<br>also be on orders.   | YES | NO |
| 6.  | H 4267 KEY . . . . .<br>Always in the possession of the senior person in<br>charge.  | YES | NO |
| 7.  | DD 1150 HAND RECEIPT . . . . .<br>Indicates change in custody of the nuclear WHS from<br>the A&T platoon to the firing team.   | YES | NO |
| 8.  | DD 3161 HAND RECEIPT . . . . .<br>Indicates change in custody of MMA, control surfaces,<br>and ED material from the A&T platoon to the firing<br>team.   | YES | NO |
| 9.  | YELLOW RIBBON TO THE W31U CABLE . . . . .<br>If an authenticated warning order/fire mission<br>has <u>not</u> been received, the yellow ribbon will<br>be used to secure the disconnected W31U cable<br>in the WHS.                  | YES | NO |
| 10. | EQUIPMENT MAINTENANCE LOG (EML) AND<br>INSPECTION RECORD CARD (IRC) . . . . .<br>The EML should reflect the correct serial numbers of<br>the MMA and WHS. The IRC should indicate the proper<br>status of the WHS (locked/unlocked). | YES | NO |



- |     |   |     |    |
|-----|---|-----|----|
| 11. | T1533-2 PAL DECODING DEVICE . . . . .   | YES | NO |
|     | Whether or not the firing team will carry the T1533-2 will depend on battery SOP.   |     |    |
|     | NOTE: For L&L missions take the T436 battery with you as the T1533-2 power source. Insure DA Form 2404s are present for the T1533-2 and T436.   |     |    |
| 12. | COMMAND DISABLE CARD . . . . .  | YES | NO |
|     | Effective CDS cards should be in the possession of key firing team personnel (team leader, platoon sergeant, section chiefs). During nuclear operations an individual with a CDS card should be in close proximity. |     |    |
| 13. | SAFE-ARM LOCKING MECHANISM . . . . .  | YES | NO |
|     | Must be installed on the MMA prior to mating of a nuclear WHS. In critical situations the senior person in charge can make the decision to launch the round without the aerodynamic access cover.                   |     |    |
|     | NOTE: The aerodynamic access cover should be kept inside the safe-arm lockbox and the key in the possession of the senior person in charge.   |     |    |
| 14. | M2A3/M2A4 SHAPE CHARGES . . . . .   | YES | NO |
|     | The A&T platoon receives the shape charges (plus a 10% overage) from the ammo supply point, then transfers to the firing section on DD Form 3161.   |     |    |

## CHAPTER

# 6

## A&T OPERATIONS

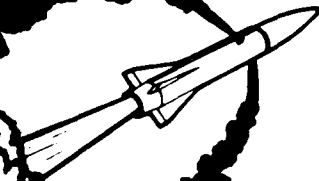

### 6-1. AMMUNITION RESUPPLY

The A&T section will perform necessary inspections to insure the reliability of missile rounds prior to their transfer from the service battery ammunition platoon.

- a. Nuclear Warheads: Refer to TM 9-1115-485-12 for inspection procedures. If time is critical, it is necessary only to check for warhead container integrity, (markings) serial number/model designator against 1150, humidity indicator, and for presence of nine lead wire seals.
- b. Nonnuclear Warheads: Refer to TM 9-1336-489-12&P for inspection procedures. Normally, only the integrity of the warhead container, serial number, and lead wire seals are checked prior to unpackage operations.
- c. Missile Main Assemblage: Refer to TM 9-1410-485-12 for inspection procedures. As a minimum, the MMA container head cover should be removed and the following checked: Log Book, short umbilical cable, shorting plug, and safe-arm igniter. The MMA leak indicators must indicate a safe condition before performing any inspection.

Empty warhead, MMA and control surface containers will be returned to service battery when being resupplied new rounds. The most expedient way of doing this is to have the empty containers loaded on ELWB 5-ton trucks and simply exchanging vehicles with the resupply convoy.

### 6-2. MATING OPERATIONS

There are three basic ways in which to mate a Warhead Section (WHS) to a missile main assemblage (MMA): on the SPL, on the LT, and in a MMA container on the ground. The advantages and disadvantages of each technique should be considered when choosing the best way to mate. Terrain, vehicle availability, and crew training will affect this decision.

The following information is provided for your benefit.

- a. Mate on the SPL: Upon initial pick up of Lance ammunition, mating the first round on the SPL provides the quickest and easiest way to ready the firing section for missions.

b. Mate on the LT: Mating the second round on the right side of the LT affords the quickest way to prepare the LT for resupply of the SPL. Round must be transferred to left side after mating, if fording operations have to be done.

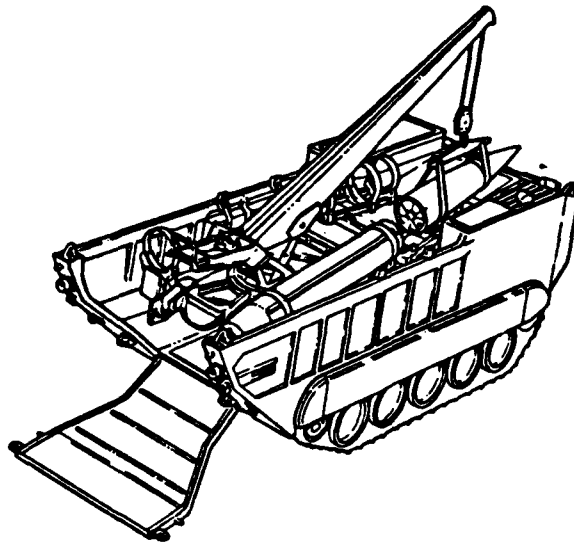

Whether or not the third round is mated on the left side of the LT should depend upon the mission requirement.

c. Mate on the Ground: Mating on the ground requires the MMA container to be downloaded. Although it is the easiest way to mate, it necessitates the transloading of an entire missile round from the MMA container to the LT/SPL. When conducted under the limited space of a "BIG TOP," this transload can be a difficult operation to accomplish.

	ADVANTAGES	DISADVANTAGES
SPL	<ul style="list-style-type: none"> <li>-- Quickest way to ready the SPL for firing</li> <li>-- Easy operation to perform</li> </ul>	<ul style="list-style-type: none"> <li>-- SPL must be available</li> <li>-- Requires a large mating area</li> </ul>
LT	<ul style="list-style-type: none"> <li>-- Quick operation to perform</li> <li>-- Eliminates transload of an entire missile round</li> </ul>	<ul style="list-style-type: none"> <li>-- Requires the most training</li> </ul>
Ground	<ul style="list-style-type: none"> <li>-- Easiest mate operation to perform</li> </ul>	<ul style="list-style-type: none"> <li>-- Time consuming</li> <li>-- Requires downloading of WHS and MMA containers</li> <li>-- Requires an entire missile to be transloaded</li> </ul>

### 6-3. VEHICLE POSITIONING

When performing an A&T operation, judicious vehicle positioning can minimize effort, decrease operation time, and minimize safety hazards. Always take whatever time is necessary to select the best positions of vehicles as affected by terrain,

type operation to be performed, and equipment status. Refer to TM 9-1410-485-12 for guidance but don't limit your team to only those positions given.

An alternate method in positioning the SPL for mating is given below.

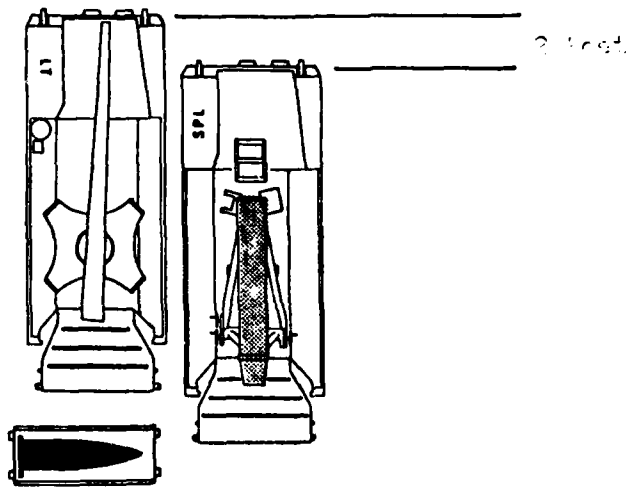

The LT must be forward of the SPL by approximately two feet to allow the boom to reach the forward end of the launch fixture.

#### 6-4. BIG TOP

The employment of the "BIG TOP" camouflage net enhances the survivability of a Lance Firing Battery by effectively concealing missile assembly. Its use, however, tremendously restricts the A&T section in both height and area available to conduct operations.

The following guidance is provided for your benefit.

a. Proper positioning of vehicles under the "BIG TOP" is critical. Positioning vehicles too far to one side can inhibit the traverse of the LT boom and create unnecessary safety hazards.

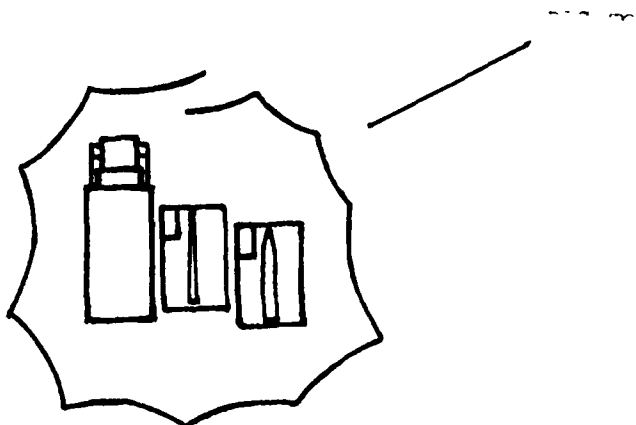

The time the A&T section takes to position vehicles correctly will be saved three-fold during the operation.

b. To strengthen the "BIG TOP" against high winds, place two center poles together (taped every three feet) to form a center pole. Position it between the ELWB 5-ton and the LT just behind the cab.

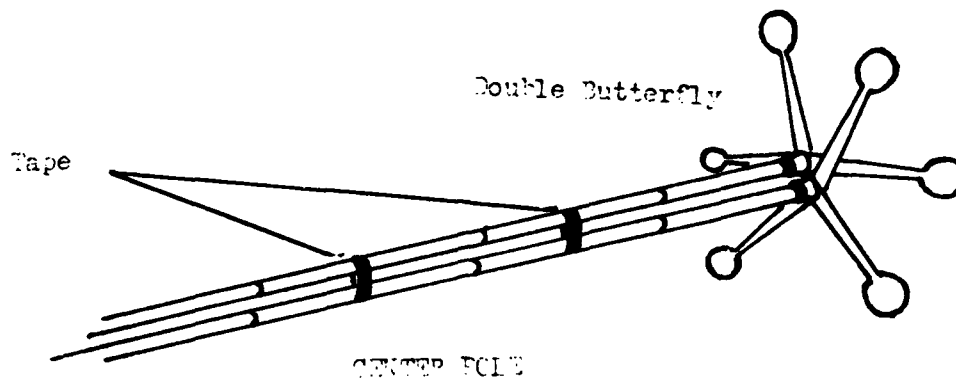

The double butterfly of the center pole will provide a large area in which to unstack containers off the ELWB 5-ton.

**NOTE:** The camouflage net pole positioned on the M38 handling unit pedestal will still be needed to add height to the net.

c. Tape a helmet liner to the end of the boom to prevent the camouflage net from becoming snagged during traverse.

d. Position entry control guards jut inside the entrance to the "BIG TOP". This will conceal their presence and increase their control of entry into the area.

#### 6-5. TRANSLOADS

The transload of a missile round is not the only exchange that occurs when resupplying a SPL. A new short umbilical cable and control surfaces must also be transferred. Additionally, if a nuclear round is transloaded, the firing section will need the H4267 key and safe-arm cover lock assembly key. Use the FIRING TEAM LEADER'S CHECKLIST (Tasks to be accomplished during transload) to insure that a transload is executed properly.

Because of the use of training rounds, realistic transloads are seldom practiced. Usually the missile round is lifted only a few feet off the SPL launch fixture and then lowered to simulate a transload. The exchange of control surfaces or a new short umbilical is often overlooked. As a result, firing teams are trained incorrectly and critical items are often forgotten by the firing section when an actual transload is performed. Avoid this problem by stressing the exchange of all critical items during transloads (simulated or not). The Lance Battle Drill provides an excellent tool to accomplish transload training.

#### 6-6. TIEDOWN STRAPS

Tiedown straps are used to secure Lance ammunition on load carrying vehicles for movement. Serviceability and marking requirements are given in TM 9-1115-485-12.

a. Tiedown straps must be marked with the "unpacked date" near the hook end of the long strap.

b. Straps exceeding 36 months of the "unpackage date" must be marked with a two-inch wide YELLOW band on both sides near the date.

Only straps which fall within 36 months of the "unpacked date" may be used in securing nuclear loads. Straps which are still serviceable and do not meet this criteria can be used to tiedown training nuclear and nonnuclear loads, MMAs, and emergency destruction materials.

NOTE: In order to eliminate the requirement to use the Battalion's War Reserve (WR) tiedown straps for inspections, SURETY INFORMATION LETTER NUMBER 48 (August 1980) permits the use of serviceable straps which exceed the 36 month criteria to be used during TVIs for movement of training weapons simulated to be WR.

#### 6-7. KEY POINTS

a. Insure that torque wrench calibration is monitored closely. The use of a torque wrench whose calibration is void is a major deficiency during a Technical Validation Inspection (TVI).

b. Whenever a WHS, MMA or control surface is being inspected, the senior person in charge must be immediately notified once a rejectable item has been found. He is responsible for determining what actions are to be taken.

c. In a tactical environment, the Field Storage Location (FSL) is positioned in the center of the battery area. This provides for enhanced security of the stored nuclear rounds.

d. Know all LT emergency operating procedures given in TM 9-1450-486-12. Inevitably, your A&T section will have to use them to continue a mission.

#### 6-8. SAFETY

A team leader must be thoroughly familiar with all safety instructions given in TM 9-1410-485-12. The following amplifying guidance is provided for your benefit.

a. Always use four guide ropes when conducting any lift operations involving the LT; i.e., transloads, mating, demating, container downloading, etc.

b. Insure that the ELWB 5-ton is properly parked when conducting loading or unloading operations. The parking depends on the model. Refer to the proper manual for the vehicle you have.

c. Never allow the A&T section to enter a MMA storage area without first checking all propellant leak indicators for a safe condition.

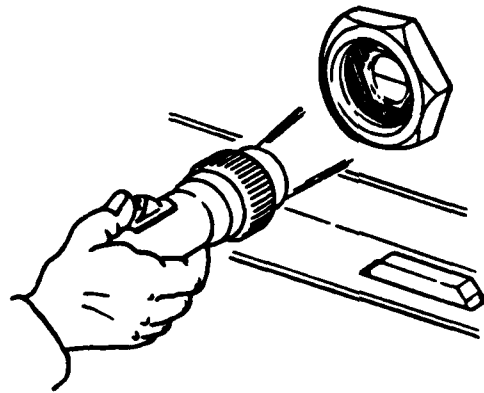

Leak Indicator

- d. Know the first aid procedures and hazards of the MMA propellants, UDMH and IRFNA.
- e. Breathing apparatuses and protective suits must be properly marked and readily accessible when conducting any operations involving a MMA. They should never be positioned so close to a MMA storage area that they would be unusable if a leak occurred.
- f. Memorize the 9 safety rules listed in AR 50-109.

#### 6-9. TECHNIQUES

- a. To facilitate stacking of WHS and MMA containers, reverse the side boards of the ELWB 5-ton. The troop seats, when lowered, will provide a walking platform around the outside of the vehicle cargo bed.
- b. Transloads can be accomplished quickly when the missile is positioned on the right side of the LT.

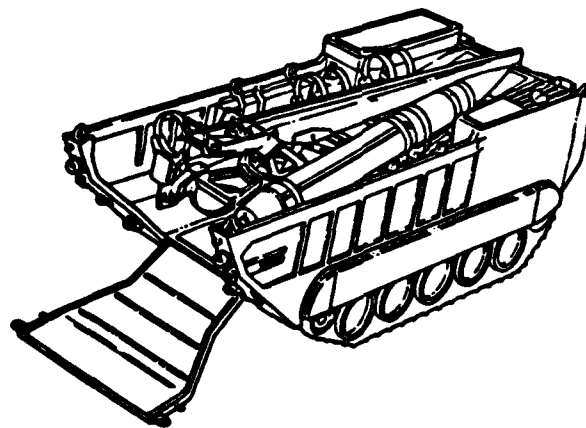

Transloading a missile from the right side avoids interference with the LT cab top and allows the SPL driver to rapidly position the SPL next to the LT (unassisted).

c. During nuclear assembly operations, be prepared to use either the T436B power supply or vehicular power to perform PAL unlock. Depending on how MMA and WHS unpacking progresses, one power source will prove faster than the other.

d. Use two 13/16 inch sockets when performing WHS unpacking or mating. This will allow two WHS T-head bolts to be loosened or tightened simultaneously thus decreasing assembly time.

e. In order to keep an accurate count of personnel within the exclusion area (FSL), make a set of numbered flip-cards to be used by the entry control guards. The guards simply flip a card for each individual entering the FSL (the number showing on the card reflects the number of people inside).

f. Use precut and precapped initiating systems to increase emergency destruction responsiveness. See chapter 12 for specific guidance.



## 6-10. PREPARATION CHECKLISTS

### a. M511E1 CONTAINER

1. Are the nine (9) lead wire seals in place on the container?
2. Are the lead wire seals on the records container threaded through the wing nuts securing the container?
3. Are the H-4244 wrenches (2) and the EML (2409)/IRC stored in the records container?
4. Are the markings correct?
5. Is the humidity indicator plug/card serviceable?
6. Is the container clean? Are both drain plugs present?
7. Is the container hardware present and stored IAW TM 9-1115-485-12?
8. Is the H-4267 key stored in its bracket?
9. Is the inside of the container clean?
10. Is the right amount of fresh desiccant (64 units) present in the container?
11. Is a serviceable protection strip installed in the container hold down strap between the strap and the WHS?
12. Is the NSN covered with missile tape?
13. Are all (22) Tee-head bolts engaged?
14. Is the container damaged to extent that damage exists to the WHS?

### b. M240 WHS

1. Does the serial number agree with the container and EML?
2. Are all the markings correct? Check critical markings with a measuring tape.
3. Is the WHS clean?
4. Does the WHS PAL status agree with the IRC?
5. Are the GO-NO GO indicator/able-disable indicator and T-handle in the Go/able and zero positions?
6. Are all switches in the "SAFE" position?
7. Are access covers in serviceable condition?
8. Is the yellow ribbon and cap installed on the top knob of the M42 sequential timer?

9. Are the A7P2 connector of the W74U cable and the yellow ribbon installed and the W74U cable stowed (disconnected) properly?
10. Is the J2 connector cover installed?
11. Is the connector cover and yellow ribbon installed on the connector at station 100?
12. Is the W53W cable connected to the A2J2 connection on the WHS?

c. M599 CONTAINER

1. Is the interior clean and in good condition?
2. Is the sling strap hook present?
3. Is the short umbilical cable present and properly stowed?
4. Does the exterior lack structural integrity; i.e., cracks, gouges, bends, dents, etc.?
5. Are all (30) tee-head bolts engaged?
6. Are (2) tie bars and stacking bolts present and secured?
7. Are all container markings correct?
8. Are both drain plugs present?
9. Are both propellant leak indicators (one at each end of container) white? Four (4) leak indicators should be present in the spare leak indicator container.
10. Has the container been secured with lead wire seals?
11. Is the LOG book updated and positioned on the shipping cover?

d. M6 MMA

1. Does the serial number agree with the LOG book and ammunition data card (DD 1650)?
2. Are all the markings correct? Check critical markings with a measuring tape.
3. Is the MMA clean; i.e., no dirt, fungus, etc.?
4. Is the SPGG igniter SAFE-ARM mechanism in the SAFE position?
5. Is the APU upper rod with the green warning ribbon installed?
6. Is the G&C cover positioned properly (not upside down) on the forward end of the MMA?
7. Is the umbilical connector shorting plug present?
8. Are the aft launch supports or latching ramps damaged or missing?

9. For MMAs with a structural boattail:

- a. Is the purging valve securely mounted?
- b. Are all (3) retaining screws secured to the boattail?

## 6-11. TORQUE REQUIREMENTS

1. M544 WHS CONTAINER WITH M251
  - Tee-head Bolts (22) . . . . . 35 ( $\pm 5$ ) ft-lb
  - Swing Bolts - Station 100 (4) . . . . . 75 ( $\pm 10$ ) ft-lb
  
2. M511 WHS CONTAINER WITH M234
  - Tee-head Bolts (22) . . . . . 35 ( $\pm 5$ ) ft-lb
  - WHS Hold Down Strap Bolts (4) . . . . . 30 ( $\pm 5$ ) ft-lb
  - Swing Bolts - Station 100 (4) . . . . . 75 ( $\pm 10$ ) ft-lb
  - Dessicant Access Cover Bolts (10) . . . . . 100 ( $\pm 5$ ) in-lb
  - Humidity Indicator . . . . . 22 ( $\pm 2$ ) ft-lb
  
3. M599 MMA CONTAINER WITH M5
  - Tee-head Bolts (30) . . . . . 35 ( $\pm 5$ ) ft-lb
  - Yoke Assembly Bolts (8) . . . . . 50 ( $\pm 10$ ) ft-lb
  - Shipping Cover (G&C) Bolts (4) . . . . . 15 ( $\pm 5$ ) ft-lb
  
4. MATING WHS AND MMA
  - Swing Bolts - WHS . . . . . 125 ( $\pm 10$ ) ft-lb
  
5. MOBILITY KIT
  - Swing Bolts - Towbar . . . . . 1200 ( $\pm$ ) 96  
in-lb
  
6. L3L
  - Swing Bolts - Towbar . . . . . 1200 ( $\pm$ ) 96  
in-lb
  - Shock Absorbers . . . . . 1200 ( $\pm$ ) 96  
in-lb
  - Trailing Arm Assemblies . . . . . 1200 ( $\pm$ ) 96  
in-lb
  
7. LAUNCHER FIXTURE
  - Securing Bolts . . . . . 1200 ( $\pm$ ) 96  
in-lb

**Note:** The launch fixture should be torqued after a missile round has been transloaded to the launch fixture.

## CHAPTER

# 7

## NUCLEAR RELEASE

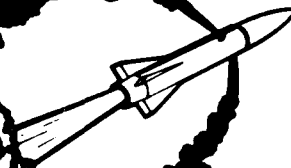

7-1. The ultimate objective of the employment of nuclear weapons is to terminate a conflict at the lowest level of hostilities on terms acceptable to the United States and its allies.

### a. NUCLEAR CONTROL ORDERS

Release, or the authority to use nuclear weapons, will be conveyed to FDC through an authenticated nuclear control order originating from the national command authority. This order will provide specific guidance and the necessary information necessary to override positive launch controls, such as the permissive action link (PAL) installed on all Lance nuclear warheads.

### b. TEAM LEADER ACTIONS

(1) Once a nuclear control order has been received by FDC, it is critical that you become immediately aware of its instructions. As the final controlling factor in the launch of a nuclear weapon, you must know:

- (a) The time frame in which nuclear rounds are to be employed.
- (b) The type yields authorized.
- (c) The number of rounds authorized to launch.

(2) Insure that your team is in a high state of readiness and is aware of what is to transpire. Remember, until an authenticated fire mission is received and receipt and authentication of a nuclear control order conveying release, the W31U cable remains disconnected. REF: AR 50-109

(3) Discuss with your commander the actions that you should take in the event your team loses communications during the mission.

(4) The use of nuclear weapons may result in like retaliation. Refamiliarize your team with the proper actions to take during a nuclear attack.

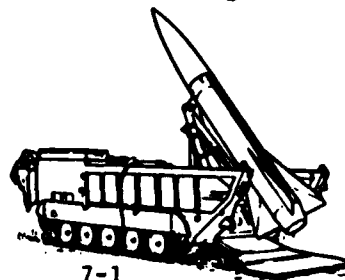

## CHAPTER

# 8

## LANCE BATTLE DRILL



8-1. Since 1980, the firing team battle drill has formed the basis for nuclear operations training for the firing team. It now is a standard drill and is often used for team competitions and certification evaluations prior to ASP firing.

### a. PURPOSE

The firing team battle drill was designed to emphasize critical tasks that would be required when a team has been fully committed to support a nuclear pulse; two rounds within an hour.

### b. RESOURCE REQUIREMENTS

(1) Personnel. This drill does not require a team to be at full strength. It is noted that teams are seldom at more than 70 percent of assigned strength available for training, nor can we plan on fighting at full strength.

(2) Equipment. Along with normal TOE section equipment, the following items are required:

- (a) one M6 MMA in container
- (b) one M240 WHS in container
- (c) one set of large control surfaces in containers
- (d) one set of empty M597 containers
- (e) SPL with all ground support equipment
- (f) LT with sling beam and guide ropes
- (g) one XLWB 5-ton vehicle
- (h)  $\frac{1}{2}$ -ton truck with radio
- (i) M880 5 $\frac{1}{4}$ -ton truck
- (j) LWSS for A&T exclusion area.

(3) Training Area. To stress realism, the battle drill must be conducted in a field environment.

(a) An entire battery position need not be established. However, the A&T exclusion area that would be established within a battery position is required.

(b) Two firing points, separated by a minimum of three kilometers, must be established. A survey card and computed nuclear firing data will be needed for each point.

c. SEQUENCE OF EVENTS

(1) Team vehicles, equipment and personnel assembled in the team/battery area.

(2) Team leader reports "Team prepared for drill."

(3) Performance of PMCS on team vehicles and equipment to be used.

(4) Tiedown inspection of ELWB 5-ton loaded with nuclear WHS and MMA.

(5) Reconnaissance of two firing points and a LT rendezvous location by the team leader (concurrent with assembly of round).

(6) Inspection and unpackage of MMA and nuclear WHS.

(7) Assembly of nuclear round and transload to LT.

(8) PAL unlock (may be conducted during unpackage of WHS).

(9) Departure of firing team from battery/team area.

(10) Arrival of LT at rendezvous location. Arrival of firing section at first firing point.

(11) Positioning of firing section at first firing point in a "prepare for march order" configuration; i.e., launch truss at firing elevation, firing device reeled to firing pit, control surface containers empty, crew at firing pit, etc.

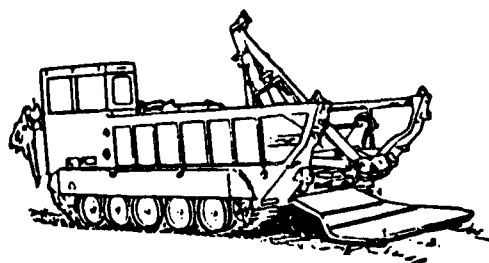

(12) March order given to firing section.

(13) Departure of team leader/advance party for second firing point.

(14) Departure of firing section for transload with LT at rendezvous area.

(15) Preparation of second firing point by team leader/advance party.

(16) Arrival of SPL at rendezvous area and transfer of nuclear round, control surfaces, short umbilical cable, etc.

(17) Departure of SPL for second firing point. LT returns to team/battery area or follow SPL.

(18) Second firing point screened, verified, and prepared for SPL arrival; i.e., RT and TT set up, azimuth of fire established, etc.

(19) SPL arrives

(20) Fire mission

(21) March order

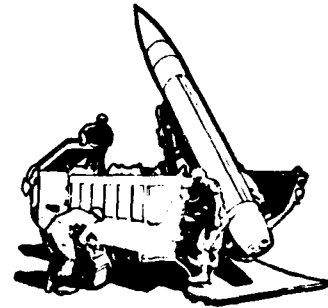

d. TIME

The firing team battle drill is designed to be accomplished in 4 hours or less. Time begins when the team leader reports "Team prepared for drill" and ends when the SPL is pulled off the point following march order of the second mission. A good team will complete this drill in 2½ hours or less. Only 30 minutes will be allotted to conduct PMCS.

e. BENEFITS

(1) The battle drill creates an intense, high pressure environment in which a team must operate. As a result, it provides a true test of a team's ability to conduct a successful nuclear pulse.

(2) The drill encourages cooperation between the firing section and A&T section on a grand scale. The benefit is crossed-trained 15D personnel.

(3) The drill incorporates a realistic transload which requires the actual transfer of a missile, short umbilical cable, control surfaces, and locking box cover. As a result, teams quickly learn the inadequacies of simulated transload training.

(4) Evaluation of the PMCS portion of the drill provides the team leader with an effective tool in assessing operator competence.

(5) The drill demands effective command and control at every level within the team. The team leader is forced to depend on his section chiefs.

f. BATTLE DRILL CHECKLIST

The following is a checklist designed to assist a Firing Team in conducting the LANCE BATTLE DRILL. It should be used in conjunction with the FIRING TEAM LEADERS CHECKLIST to maximize preparation efforts.





(1) A&T SECTION

1. M6 MMA and M599 Container
  - a. Log book in canvas bag (with DD 1650 Ammo Data Card and 1150's and/or 3161's).
  - b. Shorting plug.
  - c. Aerodynamic access cover.
  - d. Lead-wire seal on safe-arm igniter.
  - e. Upper rod of APU with green ribbon.
  - f. Sling strap hook in M599 container.
  - g. Short umbilical cable with protective boot.
  - h. Uncontaminated leak indicator on container.
  
2. M240 WHS and M511 Container
  - a. NSN (part No) taped.
  - b. EML and IRC in records container (EML should reflect that a receipt and verification inspection has been performed; IRC should reflect a locked WHS).
  - c. Two H4244 wrenches in records container.
  - d. Nine lead-wire seals present.
  - e. J1 yellow ribbon to station 100 present.
  - f. W31U cable yellow ribbon present.
  - g. W31U cable disconnected.
  - h. WHS settings "safe."
  - i. H4267 WHS key present in bracket.
  - j. 64 units of dissicant present.
  - k. Warhead locked.
  - l. WHS GO/NO GO indicator in GO position.
  - m. CDS able/disable in able position.
  - n. Plastic protective strip present under/over forward cradle support.
  - o. M511 container drain plugs present.
  - p. WHS cradle support T-head bolts torqued to 30 ( $\pm 5$ ) ft-lbs.
  - q. PAL cable installed on AlJ2 connector.
  - r. Container T-head bolts torqued to 35 ( $\pm 5$ ) ft-lbs.
  
3. M32 Control Surfaces
  - a. Latch pins present.
  - b. Jam clip.
  - c. Clean and paint, if necessary.
  
4. Tools and Equipment
  - a. M22 sling beam assembly.
  - b. Fourguide ropes.
  - c. Wood safety device (Jones Board).
  - d. Safe-arm igniter cover lock assembly with key.
  - e. T1533 portable decoder.
  - f. T1528 test adapter.
  - g. Spare humidity indicators.
  - h. Mating tool kit (complete).
  - i. Special weapons tool kit (complete).
  - j. All torque wrenches calibrated.
  - k. Extra lead-wire seals.
  - l. Missile tape.
  - m. Sandbags (for ED).
  - n. Fire extinguishers (serviceable with updated green tags).

- o. Water cans.
- p. ED materials (complete and dug-in).
- q. Flame & spark producing items box.
- r. TA 312 and DR-8.
- s. PRC 77 radio.
- t. Fire fighting equipment.
- u. Protective suits and breathing apparatus.
- v. Field tables.
- w. Chock blocks.
- x. Shoring material between WHS and MMA containers.
- y. Tow cable on M688 LT.
- z. Slave cable.
- AA. Dunnage.
- BB. Instant indicator of number of people in exclusion area (flip cards).
- CC. Four quarts of OHT.
- DD. Extra OE products.
- EE. Tie-down staps.

5. Vehicles

- a. One 5-ton ELMB wth OVM.
- b. One M688 LT with OVM.

6. Manuals and Paperwork

- a. EML and IRC.
- b. Valid DD Form 1150.
- c. DA 2404s on all equipment.
- d. CDS cards.
- e. -10 manuals for all vehicles.
- f. TM 9-1425-485-10-2.
- g. TM 9-1115-485-12.
- h. TM 39-T1533-2.
- i. TM 39-50-8 (C).
- j. Field SOP.
- k. FM 5-25.
- l. FM 6-42.
- m. FM 100-50.
- n. TB 9-1100-803-15 (FOUO).
- o. TM 9-1410-485-12.
- p. TM 9-1425-485-12.
- q. TM 9-1450-486-12.

(2) FIRING SECTION

1. Tools and Equipment

- a. Monitor programmers (2).
- b. Firing device.
- c. IGSU with accessories.
- d. Remote theodolite with accessories.
- e. Test target with accessories.
- f. Empty set of M597 control surface containers.
- g. Compass and binoculars.
- h. Map.
- i. Azimuth tape.
- j. Fire extinguishers.
- k. Water cans.

- l. ED materials, 3161 (complete and secured; blasting caps can be carried in  $\frac{1}{4}$ -ton trailer).
- m. Extra BA-30 batteries.
- n. VRC-46 radio.
- o. RC 292 antenna.
- p. CDS card.
- q. 1150 for round from A&T to Firing Section.
- r. CEOI and operations code book.
- s. Fire mission format.
- t. Launcher specialist tool bag (complete).
- u. Tow cable for M752 SPL.
- v. Slave cable.
- w. Missile tape.
- x. Sandbags (for ED).

2. Vehicles

- a. One M752 SPL with OVM.
- b. One M882 wth OVM.
- c. One  $\frac{1}{4}$ -ton with trailer.

## CHAPTER

# 9

## COMMAND AND CONTROL

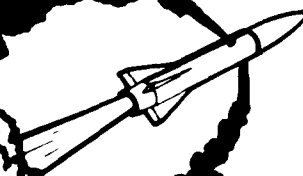

9-1. Due to its massive destruction potential and its greater range capability, a Lance battalion is normally assigned the mission of general support. This mission allows the corps commander to exercise maximum control of the system's capabilities-- both nuclear and nonnuclear.

### a. METHODS OF FIRE

(1) TOT. Time-on-Target is the most effective method for engaging targets. It allows for the simultaneous attack of targets and exerts maximum control of firing teams.

(2) ASAP. Time sensitive targets may be attacked through the use an ASAP mission with a not later than (NLT) time to fire. Although reponsiveness is increased, it does not allow for the massing of fires. To achieve a desired effect on target a short-fuzed TOT will be used by battalion FDC in lieu of ASAP.

(3) PULSE. When a high volume of fire is required in a short period of time, a TOT followed by an ASAP/NLT mission will be assigned. This method is used in support of nuclear operations.

### b. RESPONSE POSTURE

(1) Because the firing team has a limited mated missile carrying capability, judicious management of the type of rounds available becomes critical. As a result, various response postures are used to provide the corps commander with the capability to rapidly engage targets by adjusting the ratio of nuclear to nonnuclear weapons positioned on SPLs and LTs.

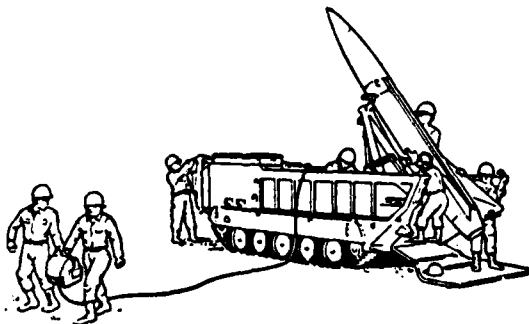

PHASE	POSTURE	SPL	LT	
1	Max HE	HE	HE	HE
2	Increased NUC	HE	HE	NUC
3	Immediate NUC	NUC	NUC	HE
4	Max NUC	NUC	NUC	NUC

(2) The above phases reflect, but are not necessarily limited to, actions of all firing teams. If the commander deems it appropriate, different response postures could be assigned to individual batteries within a battalion. For example: One battery within a battalion may be in a maximum nuclear posture while the other two batteries may be in an increased nuclear posture in order to provide continuous nonnuclear support.

(3) With missiles on the SPL and LT, a change in the firing team's response posture may require significant planning and coordination. Often it will be necessary to demate or transload one round in order to mate or transload a desired round to the SPL or LT. To minimize this effort, always have an empty MMA container readily accessible to facilitate the switching of rounds within the team.

c. **AUTHORITY TO MATE**

Before a Lance battalion can mate a nuclear warhead, authority to mate must be granted by a unified or specified commander, Ref: AR 50-109. Authority to mate nonnuclear rounds may be granted by the corps commander.

d. **EXTENSIONS**

When a firing team underestimates travel time or experiences technical difficulties, an extension to a TOT mission may be needed. Because a request for extension must be approved at corps, considerable time will be necessary to receive an answer. A request for extension of less than 15 minutes is considered unrealistic.

e. **KEY POINTS**

(1) Keep battery FDC advised of your team's status at all times. In turn, keep yourself abreast of the current situation and command guidance by checking with FDC each time your team returns to the battery area.

(2) Never delay in requesting an extension. Be decisive and send the request as early as possible.

(3) Few situations will be encountered that a team leader cannot solve through cleverness and imagination.

# CHAPTER 10

## SURVEY

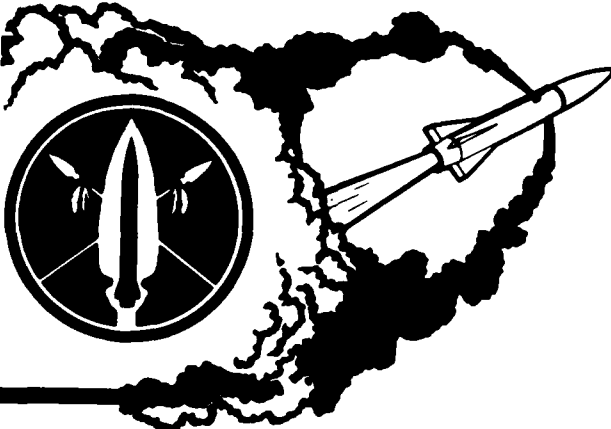

10-1. Although Lance can be an extremely accurate nonnuclear weapon, its effectiveness is often degraded by the inaccuracies of its survey. Errors as slight as 1 mil in direction or 100 meters in location can result in a complete target miss.

### a. FIRING POINT SURVEY

The accuracy of a firing point will depend upon the location of survey control points (SCPs) and the amount of time available to establish survey control prior to occupation by the firing section.

(1) When survey control is available (either through trig lists, or as provided by a topographic unit), firing points can be established using procedures that will insure an accuracy ratio of 1:1000 meters for position closure,  $\pm 2$  meters in altitude, and an orienting azimuth (AZ-OL) accurate to  $\pm 0.3$  mils.

(2) When survey control is not available, as in most areas of the world, the firing position must be map spotted for location. During daylight hours, this normally produces a location error of 50-60 meters when using a 1:50,000 scale map (at night this error is greater). Directional control is seldom a problem, since units are authorized a SIAGLE which can determine azimuths to a 0.3 mil accuracy.

### b. FIRING POINT VERIFICATION

In extended combat, survey accuracy will degrade rapidly. Often, survey control points will be unavailable and survey parties will have to rely upon questionable map spotting techniques as well as upon fatigued personnel. Nevertheless, as a team leader, you have final responsibility for insuring that a firing point is accurately surveyed before launch.

Take the following actions prior to occupation of a firing point by the firing section:

(1) Verify that the grid location indicated by the survey card is the actual location of the firing point. It should be within  $\pm 50$  meters when using a 1:50,000 scale map.

(2) Verify that the azimuth to the end of the orienting line (AZ-OL) is correct by using a declinated M2 compass. The reading should be within  $\pm 30$  mils; which is the average accuracy of a M2 compass under ideal conditions.

(3) Insure that the distance between the OS and EOL is between 35 and 70 meters.

(4) Insure that the ground slope does not exceed 5 degrees.

If any of the above requirements are not met, the firing point is unusable and would result in an unreliable launch. Notify battery FDC immediately.

c. KEY POINTS

(1) Develop a close working relationship with the two survey parties in the battery. Educate them so that they understand how to best establish a firing point to suit your needs; i.e., adequate cover and concealment, trafficability, and slope less than 5 degrees. Provide survey constant feedback on their efforts.

(2) Never depend solely on a survey diagram to locate a firing point. Often the diagram will be incorrectly drawn or out of scale. Use a map.



# CHAPTER 11

## SURVIVABILITY

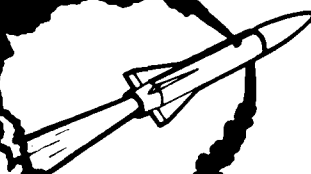

11-1. The mission of a Lance firing team does not end with the successful launch of a missile round. It must also survive to fire again.

### a. ENHANCE YOUR SURVIVABILITY!

(1) Camouflage your equipment immediately upon occupation of a new battery area. Lance-peculiar vehicles should be the first items to be camouflaged. The sighting of a SPL, LT or XLWB 5-ton will quickly identify the unit as Lance.

(2) Never travel until bows and covers are in place on the SPL and LT. The obvious presence or absence of a missile will not only draw undue attention but may provide the threat with valuable intelligence information.

(3) Minimize exposure outside a camouflage net. Upon returning to the battery area, never leave your LT or SPL exposed; no matter how short the stay. Time your operations so that the team is not exposed unnecessarily; i.e., don't pull over a firing point too early when there is no reason to do so.

(4) Insure that all reflective vehicle surfaces are covered when under nets or in hide areas. This includes windshield, mirrors, and headlights.

(5) If your A&T section uses the "BIG TOP" camouflage net, lower the net upon completion of each operation. The excessive height is a tremendous signature.

(6) Avoid returning to a previously occupied firing point. The point can be compromised whether or not a round was fired.

(7) Never leave the battery area without NBC protective suits. If not quickly accessible, they are of little benefit.

(8) Radio transmissions should not exceed eight seconds in duration. This will inhibit radio intercept and jamming.

(9) Rapid departure from a firing point after launch is critical. Don't delay by taking the time to reinstall bows and covers on the SPL. This should be done in a hide area a kilometer away.

(10) Insure that the M60 machine gun is employed effectively during firing operations.

# CHAPTER 12

## EMERGENCY DESTRUCTION

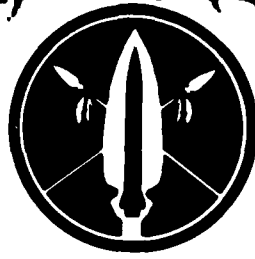

12-1. A team leader must be intimately familiar with procedures for the emergency destruction of Lance warhead sections and associated components. Refer to the following manuals for guidance:

TM 9-1115-485-12  
TM 9-1115-485-12-2 (C)  
TM 9-1300-206  
TM 9-1375-213-12  
TM 39-50-8 (C)  
TM 750-244-4-1  
FM 5-25

### a. AUTHORITY

The decision to initiate destruction will be made by the appropriate responsible individual as indicated below:

(1) When normal communications exists, the authority to destroy will be received and properly authenticated from the next higher headquarters.

(2) In the absence of normal communications or when circumstances do not allow sufficient time to request or receive authority, the decision to destroy, will be made by the custodial officer or in his absence, the senior United States' person in the custodial chain.

### b. PRIORITY

When the decision to destroy nuclear weapons is made, destruction will be accomplished in the following order of precedence:

(1) War reserve nuclear weapons and related components. Refer: TM 750-244-4-1.

(2) Associated classified materials and records.

(3) Training weapons and related training components.

(4) Unclassified tools, test and handling equipment.

Note: In emergency situations, all components and test equipment can be destroyed by placing the items against the WR weapon to be destroyed.

c. EMERGENCY DESTRUCTION (ED)

(1) Command disablement, emergency disablement, or demolition may be required to prevent capture, unauthorized tactical use, or compromise of system design when:

(a) The team position or convoy is about to be over-run.

(b) The team is unable to evacuate a part or all of its warheads during withdrawal.

(2) Command Disablement. The Lance nuclear warhead is equipped with a command disable system (CDS) which provides for the nonviolent disablement of the warhead section.

(3) Emergency Disablement. The decision to perform nonviolent emergency disablement will be made by the custodian or by higher authority in accordance with appropriate command guidance. Ref: TM 9-1115-485-12-2 (C). This supplementary means of disablement will prevent temporary, unauthorized tactical use of the nuclear warhead.

(4) Violent Destruction. The nonelectric dual initiating system is the primary method to be used in an emergency destruction, except when time or the tactical situation does not permit. In order of precedence, the two authorized methods of violent destruction are:

(a) Demolition. Whenever possible, command disablement of the Lance nuclear warhead will be conducted in conjunction with demolition.

(b) Burning. This is the least desired method and does not assure destruction. Command disablement or disconnection of the W31U cable is a prerequisite to use burning as an alternate method of destruction.

Note: Command disablement (CDS) alone will not be used unless the situation does not permit destruction by demolition or burning.

d. ACTIONS AFTER DESTRUCTION

(1) Immediately after ED has been completed, make an inspection to determine that all weapons and components have been destroyed. Observation by helicopter is the desired mode for this inspection; however, field glasses may be used. The T-2 theodolite may be used in lieu of field glasses. Transmit findings to higher headquarters.

(2) If destructon involves a nuclear weapon, a NAIC report must be initiated IAW AR 50-5 through battalion headquarters. Additionally, a certificate of destruction must be prepared and submitted to the accountable officer (Battalion S4) on DD Form 1150; listing the ERDA part number, method of destruction, and serial number of WHS.

e. KEY POINTS

(1) Each firing section should have one complete set of ED materials. This includes materials for the replacement of unserviceable items.

(2) Each A&T section should have sufficient ED materials (plus a 10% overage) for complete destruction of each nuclear warhead in the FSL. Additionally, there must be adequate ED materials to allow the LT to properly conduct a nuclear resupply of a firing section.

(3) ED materials should be transported on mission vehicles only if operational necessity so dictated.

(4) ED materials in the FSL will be dug in, placed on dunnage and protected from the environment. Blasting caps will be kept a minimum of 25 feet from all other explosives and will not be carried in close proximity of troops.

(5) All emergency destructions will be coordinated with other units by the senior man present. The section should provide for defensive security and evacuate as many vehicles and weapons as possible prior to executing the destruction. If time permits, evacuate as much Lance-peculiar equipment as possible; i.e., IGSU, MP and firing device.

(6) Team leaders must insure that sufficient personnel are trained and are available to execute ED. Avoid committing personnel to perimeter defense to the point where they cannot be disengaged to execute an ED order.

(7) Control of a nuclear weapon must be maintained until destruction is assured. Essential personnel should position themselves no farther than the maximum effective range of their weapons (460 meters) during evaluation.

(8) The use of precut and precapped initiating systems will greatly increase your response time to an ED order. See TM 9-1375-213-12 for handling instructions.

(9) Igniters and blasting caps must be secured in order to prevent unauthorized destruction of the WHS.

f. ED SAFETY

All personnel handling explosives must be thoroughly familiar with ammunition safety standards. The following precautions are provided for your benefit:

(1) All explosive items will be handled with care, insuring they are not subjected to shock, undue heat, or open flame.

(2) Do not allow smoking, open flame, spark or flame producing items within 50 feet of explosives.

(3) Explosives should not be subjected to direct sunlight or moisture longer than is necessary to complete an operation.

(4) Blasting caps and explosives will not be stored or transported together under normal circumstances. Refer to TM 9-1300-206 for exceptions.

(5) Keep blasting caps sandbagged until required for use. Precut/precapped initiating systems will be kept in sealed, waterproof plastic bag (1 pr) and sandwiched between cushioning material in a metal container.

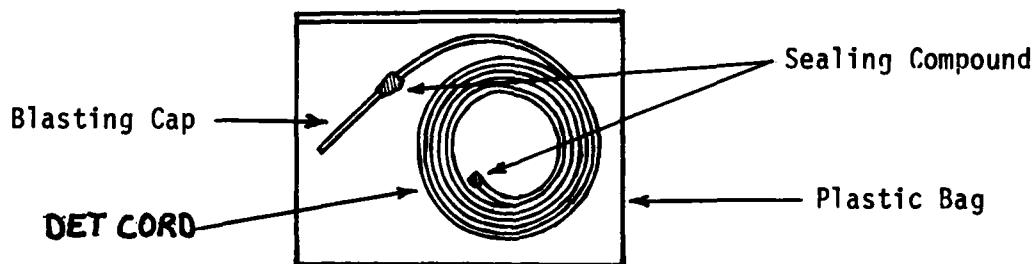

(6) Crimping and test burning should be accomplished at a minimum of 25 feet from other explosives.

(7) No more than two qualified personnel should be permitted to examine a misfire.

g. ED TRAINING DIFFERENCES

(1) M60 Igniter

(a) The igniter would be OD in color with yellow markings.

(b) The safety pin would be attached to the body of the igniter by a piece of string.

(2) Time Fuze, M700

(a) The blue plastic coating may be dark green in color or it may be a reddish-brown material type coating.

(b) There may be a single yellow band at one (1) foot or eighteen (18) inch intervals and double yellow bands at five (5) feet or ninety (90) inch intervals.

(c) It would come packed in fifty (50) foot reels.

(3) Detonating Cord

(a) The coating would be white or OD plastic.

(b) It would have a white chemical core.

(c) It would come packed in one hundred (100) foot reels.

(4) M2A3, 15 lb Shape Charge

(a) It would be OD in color with yellow markings.

(b) It would have an OD fiberglass stand off.

(c) There would be a piece of tape covering the cap well.

(d) It would be packed in a wooden crate with two (2) charges per crate.

(5) M7 Blasting Cap, Nonelectric

(a) The caps would not have any holes in the skin.

(b) The live caps would be silver or copper in color.

(c) The open end of the caps would be slightly flared.

h. DEMOLITION

A dual nonelectric initiating system will be used to destroy nuclear weapons mated or unmated. Procedures for testing, checking, emplacing and firing of this system are contained in TM 39-50-8 (C).

(1) Dual Nonelectric Initiating System for Single Warheads.

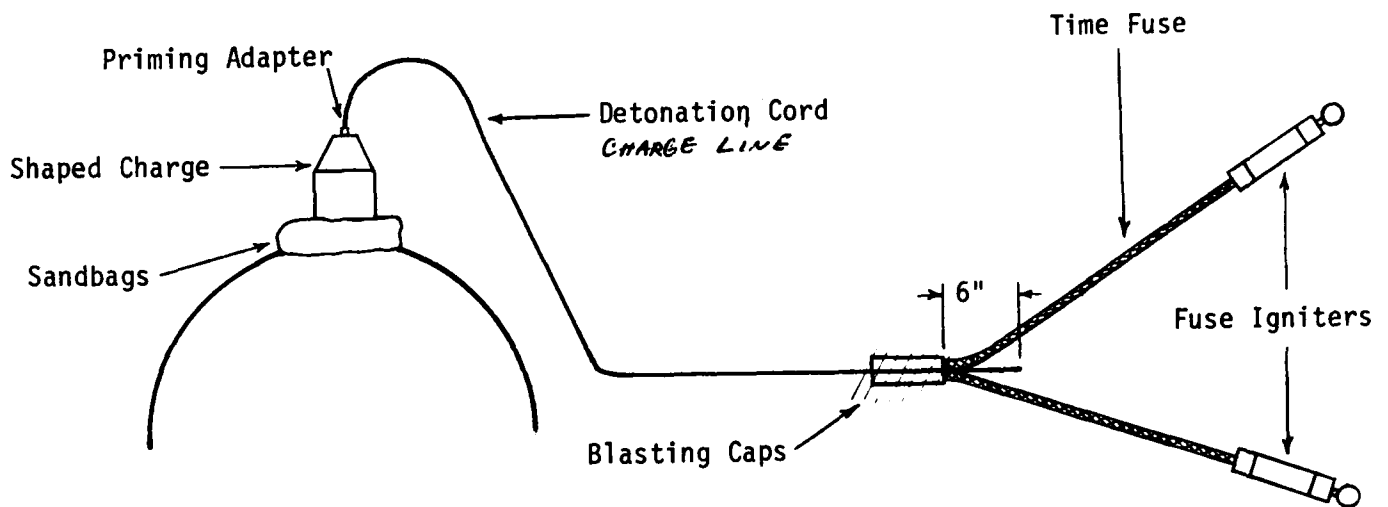

(2) Dual Nonelectric Initiating System for Multiple Warheads in a FSL.

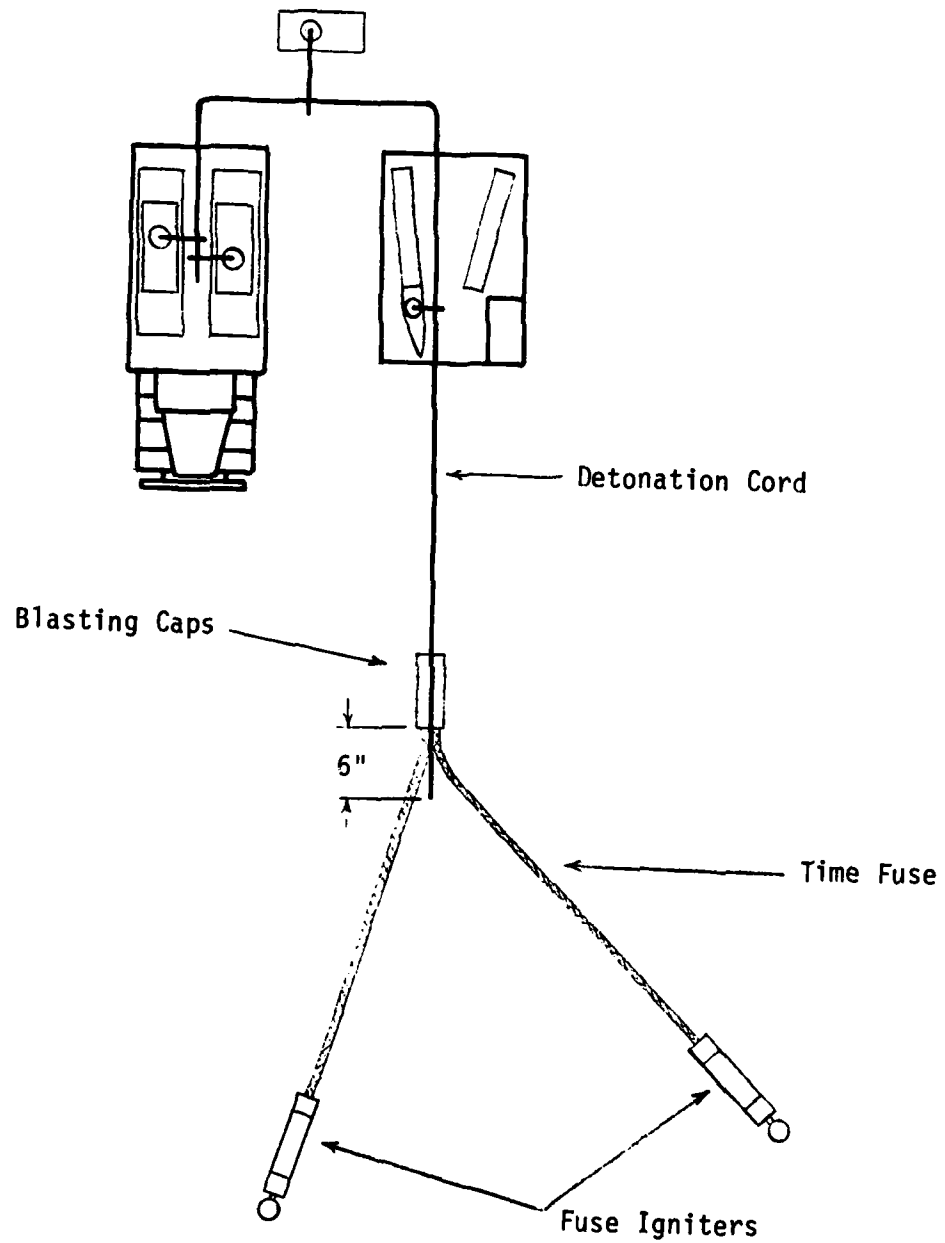



(3) Dual Nonelectric Initiating System for Multiple Warheads in a Convoy.

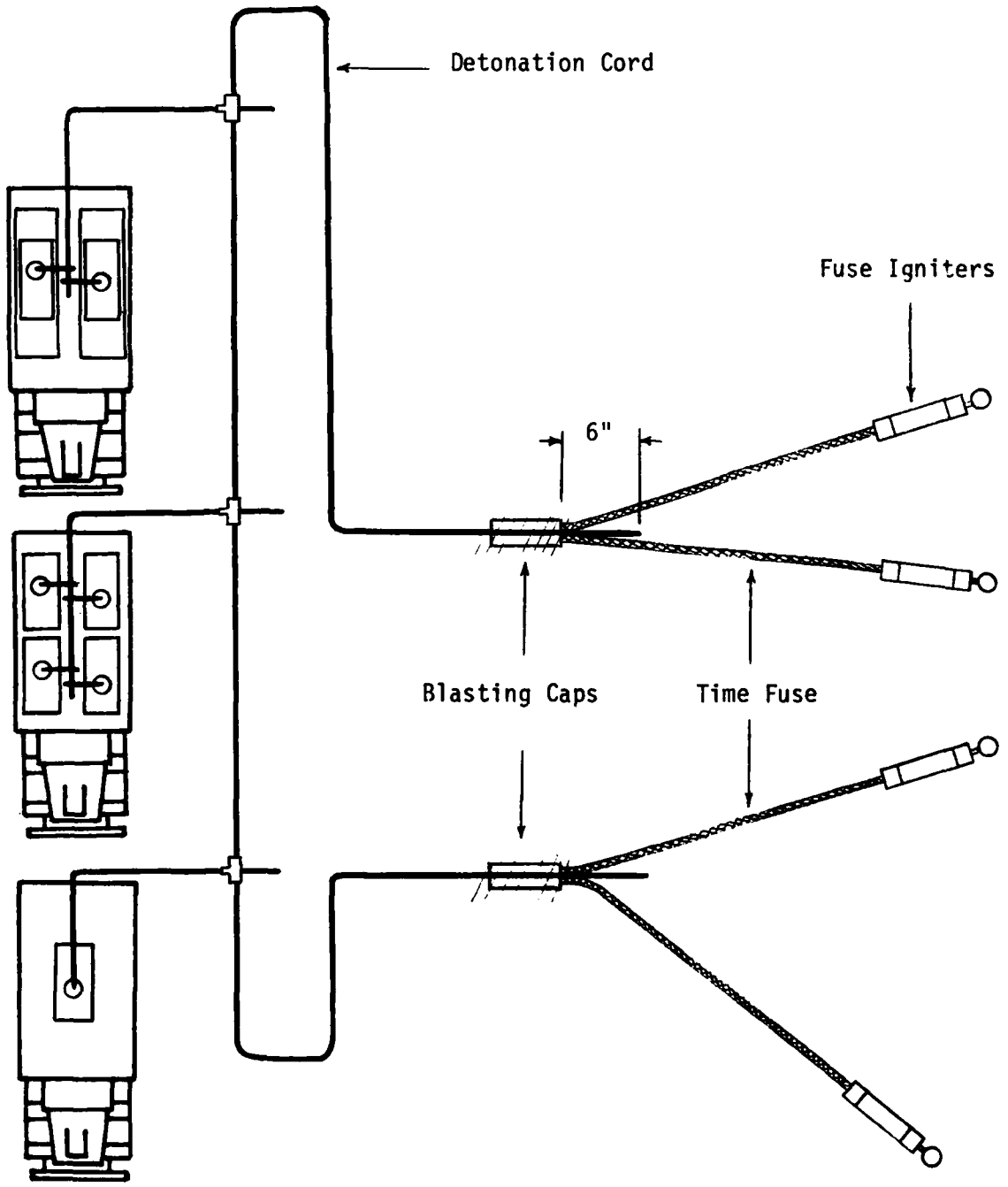

# CHAPTER 13

## AIRMOBILE OPERATIONS



### 13-1. PREPARATION

In preparation for a Lance airmobile operation, the basic planning sequence outlined in FM 57-35 should be considered. This is an inverse planning sequence and is generally accomplished in four phases: planning, loading, movement, and occupation. Begin by asking yourself the following questions:

- a. What is the method of fire; i.e., TOT or ASAP?
- b. What types of aircraft are available to support the operation?
- c. How is firing point survey to be established? Will a forward artillery unit establish the point or must battery survey accompany the mission?
- d. Will the team be able to communicate with FDC during the mission? If not, what controlling element does the team communicate with?

### 13-2. AIR TRANSPORT

The technical aspects of an airmobile operation can be found in TM 55-1425-485-15-1. There are two basic ways to airmobile an L $\bar{Z}$ L with missile.

a. Internal Load: This is the most preferred method because it enhances survivability by allowing the CH-47 helicopter to fly fast and unrestricted to the firing point. However, extraction of the empty L $\bar{Z}$ L is best accomplished by external loading--it's faster.

Note: An L $\bar{Z}$ L with missile can be loaded and tied down internally in less than 20 minutes. It can be extracted from the CH-47 at the firing point in less than six minutes.

b. External Loading: Although often used, it is the least desired method. Not only does it restrict the helicopter in flight but transmits to everyone within sight that a missile is being carried.

### 13-3. EXECUTION

An airmobile fire mission is carried out in four phases.

- a. Leader's Reconnaissance: When possible, an aerial reconnaissance of the firing position should be made. This allows the team leader to not only select the best firing point location but gives him the ability to effectively brief his team.
- b. Advanced Party. The purpose of the advance party is to prepare the firing point for occupation by the LZL. If survey must be established a minimum of 50 minutes will be needed. Organization will depend on the type of helicopter available, but will usually consist of the team leader, section chief, gunner, launcher specialist, RT operator, survey personnel, and FDC computer. Use of the CH-47 is most desired for it permits a  $\frac{1}{2}$ -ton vehicle with VRC-46 to be taken. The  $\frac{1}{2}$ -ton can be used to power the SIAGL and to position the LZL in rough terrain. A large advance party allows the fire mission to be started quickly upon the arrival of the LZL.
- c. Main Body. The platoon sergeant, remaining firing crew, and LZL with missile will be transported to the firing position by CH-47 (which may have been used to transport the advance party). The A&T section assists in tiedown if the LZL is carried internally, and hooks up if the LZL is carried externally. After arrival at the firing position, the CH-47 will depart for a holding area and await instructions.
- d. Extraction. Once the fire mission is completed, the empty LZL is prepared for external loading. Simultaneously, the firing crew loads equipment (including the  $\frac{1}{2}$ -ton) and boards the CH-47. Hook up of the LZL can be done through the use of the internal hook-up system or by an individual. If an individual is used to hook up, and alternate aircraft will be needed to pick him up.

### 13-4. AIRMOBILE SLINGS

Airmobile slings are vital to the battalion's capability to conduct airmobile missions and must be properly maintained when issued to the firing batteries. Keep the following requirements in mind!

- a. Store in a dry, protected area.
- b. Prior to usage, slings must be inspected for burns, tear, punctures, or cuts.
- c. Chain leg slings have no predetermined service life. However, every six months they must be inspected by a parachute rigger possessing MOS 43E and if found serviceable, a new date will be stamped on each sling. At no time will slings be used after six months without being properly inspected, Ref: TM 55-450-19.

### 13-5. TECHNIQUES-ORGANIZATION-EXECUTION (Example)

#### a. LEADER'S RECONNAISSANCE

(1) Use smoke to indicate your position and wind direction for arriving helicopter, OH-58.

(2) For simultaneous missions, both team leaders should accompany the battalion air coordinator on reconnaissance.

(3) Inform the pilot of the frequency to use, area to reconnaissance (grid), responsibility to act as relay during fire mission, and requirement to pick up hook-up man during extraction.

(4) Have maps marked to show flight path and location of LZ.

(5) Reconnoiter the route to the LZ, the firing position, and a holding area for the CH-47.

(6) Firing point selection:

(a) Capitalize on terrain (concealment). Keep the floating firing point method in mind.

(b) Knowing the azimuth of fire, select the best locations for OS, EOL, and firing pit. Picture the fire mission in your mind at that location so that set up is to your advantage. Example: the TT should be placed on the same side as the firing pit to facilitate firing.

(7) Reconnoiter quickly.

#### b. FIRING TEAM ACTIONS DURING LEADER'S RECONNAISSANCE.

(1) LZL prepared for external loading. It should be kept in the woodline until pick up. It is important that the control surfaces (in containers) be mounted on the M740 LZL when conducting either internal or external missions.

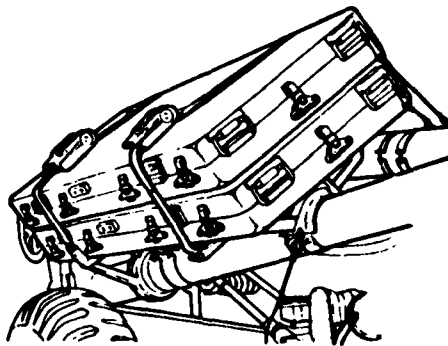

If they are secured on board the CH-47 separately, the crew chief may be unable to view through the bottom of the aircraft for hook-up of the LZL during extraction.

(2) Personnel prepared with smoke canister to direct landing of CH-47.

(3) Equipment readied for departure.

(a)  $\frac{1}{2}$ -ton vehicle loaded with spare MP, slave cable, SIAGLE, TI-59 calculators, FDC manuals, RC 292 and spare packing materials. Vehicle antenna must be tied down.

(b) Weapons and personnel equipment checked.

c. ARRIVAL OF CH-47 AT PZ

(1) If the team leader has not returned from reconnaissance, the platoon sergeant makes contact with the pilot and explains the operation.

(2) A 3" X 5" card is provided the pilot indicating vital mission information.

EXAMPLE 3" X 5" CARD

1. Frequencies and call signs to be used.
2. LZ grid location and hold area grid location.
3. Airmobile Organization.
  - a. Advance party personnel/equipment load information.  
9 PAX  
1  $\frac{1}{2}$ -ton vehicle (internal)
  - b. Main body personnel/equipment load information.  
6 PAX  
1 LZL with HE missile (7,400 lbs external)
4. Anticipated time period aircraft will be needed.

Notes: (a) Insure that the aircraft crew chief knows how the firing point will be marked. This will assist him in placing the LZL where the team wants it.

(b) Insure that the pilot understands that the main body must arrive at the LZ 50 minutes after the advance party was unloaded.

(c) Inform the pilot to land in the holding area to await completion of the fire mission. Use a predetermined time for the CH-47 to return for pick up because he has no communications capability when on the ground.

(3)  $\frac{1}{2}$ -ton vehicle is loaded and tied down. Back the vehicle in so it can be quickly unloaded at the firing position.

(4) Personnel should not load the aircraft until they are briefed by the team leader.

d. TEAM LEADER BRIEFING

(1) The team leader briefs the advance party on the occupation of the firing point.

- (a) How the CH-47 will land in relationship to terrain.
- (b) Who should sit on which side of the aircraft for exiting.
- (c) Where the  $\frac{1}{2}$ -ton vehicle should go after unloading.
- (d) Where survey should place OS and EOL.
- (e) Where the M60 machine gun should be placed for security.

(2) Briefs main body on time they should depart for LZ. The main body should arrive 50 minutes after the advance party to give them time to prepare the point.

e. ADVANCE PARTY DEPARTS FOR FIRING POSITION

Team leader leads CH-47 to LZ and directs where to land.

- (1) Use aircraft headphones so that you can talk to the pilots.
- (2) Ask to sit in the crew chief's seat between both pilots to facilitate coordination.

f. ADVANCE PARTY ACTIONS AT FIRING POSITION

- (1) Personnel exit aircraft IAW team leaders briefing.
- (2)  $\frac{1}{2}$ -ton vehicle exits into woods near OS position.
- (3) Security established - M60 emplaced.
- (4) Communications established.
- (5) Survey established - use  $\frac{1}{2}$ -ton to power SIAGL.
- (6) Fire mission data computed. Check data by using two TI-59 calculators.
- (7) Verify data with firing point. Subtract azimuth of fire from the azimuth to the orienting line. Refer to chapter 5.
- (8) Mark the firing point with engineer tape.

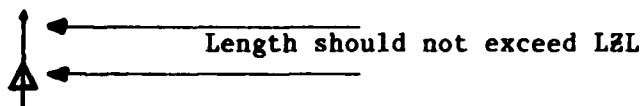

The section chief will direct CH-47 in positioning the LZL over the point.

(9) Set-up RT and TT. Check initial deflection! Insure they will not blow over when the CH-47 arrives at the firing point.

(10) Use survey to provide security after point is established. Insure they are at a safe distance from firing point (100 meters) since they will remain there until the missile is fired.

g. MAIN BODY DEPARTS FOR LZ

(1) Upon visual contact of CH-47 (returning after unloading the advance party), position the LZL for pick up.

(a) The nose of the missile should point into the wind.

(b) Wheel brakes should be disengaged.

(c) Caster wheels should be 6 inches from tow bar.

(2) CH-47 lands, picks up main body.

(3) Hook-up man is not part of the airmobile element. He will not go with main body.

(4) Establish communications with the advance party as soon after departure as possible.

h. MAIN BODY ARRIVAL

(1) Upon visual sighting, position section chief to guide LZL over stake.

(2) Individuals should be holding down the RT and TT as aircraft approaches. Turbulence will disturb them otherwise.

Note: After Ch-47 departs, recheck both instruments (RT and TT).

(3) Have the  $\frac{1}{2}$ -ton vehicle started and ready to be used to position LZL if necessary.

(4) Once the LZL is released, everyone except survey (who are on security) helps to untie and position the LZL along the azimuth of fire.

Note: Remember to save the packing material. It may be needed to resling the LZL if the round cannot be fired.

i. FIRE MISSION

(1) Once the LZL is positioned, the fire mission is started immediately. The main body should be unloading during this time and running towards the LZL. FDC personnel can help lower the LZL jack stands.

(2) During the mission, FDC personnel can be used to untangle the airmobile sling. They should position it to the front of the LZL in preparation for extraction.

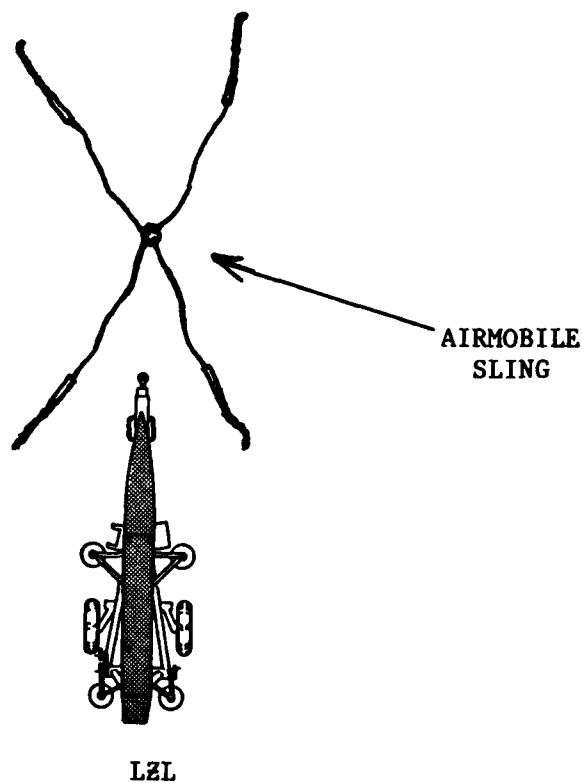

(3) The CH-47 should depart to the hold area. Instruct him to be in the air again 45 minutes after he departs the firing point.

j. EXTRACTION

- (1) Instruct the CH-47 to land for loading.
- (2) Resling the LZL and load the  $\frac{1}{2}$ -ton vehicle. Everyone should be utilized.
- (3) Load all personnel in the CH-47 except for one individual to be used to hook-up the LZL.
- (4) The OH-58 used by the battalion airmobile coordinator picks up the hook-up man after the LZL is picked up.



# CHAPTER 14

## LOCAL DIRECTIVES

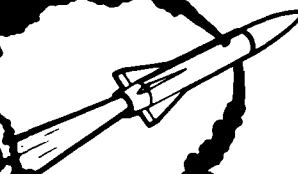
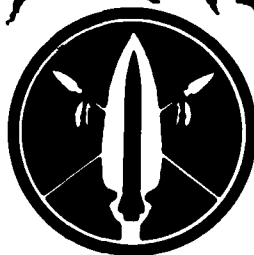

14-1. When actions during a technical operation require a subjective judgment or specific commander's guidance, the manual will refer to Local Directives. Three common directives are listed in this chapter.

a. **MISSING OR BROKEN LEAD WIRE SEALS During a Receipt Inspection or Unpackage Operation.**

If any of the NINE lead wire seals on the M511E1 shipping and storage container are discovered to be missing or broken, take the following actions:

(1) If missing or broken seals can be accounted for, note on DA 2404 and reseal.

(2) If seals are missing or broken and the unit cannot account for each one, accomplish the following:

(a) Note on DA 2404.

(b) Records Container Unsealed: Insure for presence of EML, IRC and H4244 wrenches.

(c) Quick Access Cover Unsealed: Inspect warhead and internal panels IAW TM 9-1115-485-12 for physical evidence of tampering.\*

(d) Container Flange Unsealed: Should one seal be missing or broken and there is no evidence of tampering, replace seal. Should both seals be missing or broken, remove the cover and inspect IAW TM 9-1115-485-12. Perform a status check and compare with IRC.\*

(e) External PAL Connector Unsealed: Perform a status check. If status agrees with the IRC, reseal and continue the mission. If status does not agree, notify the accountable officer (Battalion S4).

(f) Dessicant Access Cover Unsealed: Remove cover and inspect for damage or tampering if both seals are missing. Replace seals.\*

**\*NOTE:** Should evidence of tampering or damage be discovered, immediately notify the accountable officer. If damage meets rejection criteria, reject the warhead

section. If damage is insignificant or can be repaired by the unit, continue the mission.

b. PAL UNLOCK-LOCK OPERATIONS

The following flow diagram is designed IAW TM 9-1115-485-12 and TM 39-T1533-2 and will prove extremely valuable in understanding what actions should be taken during PAL operations.

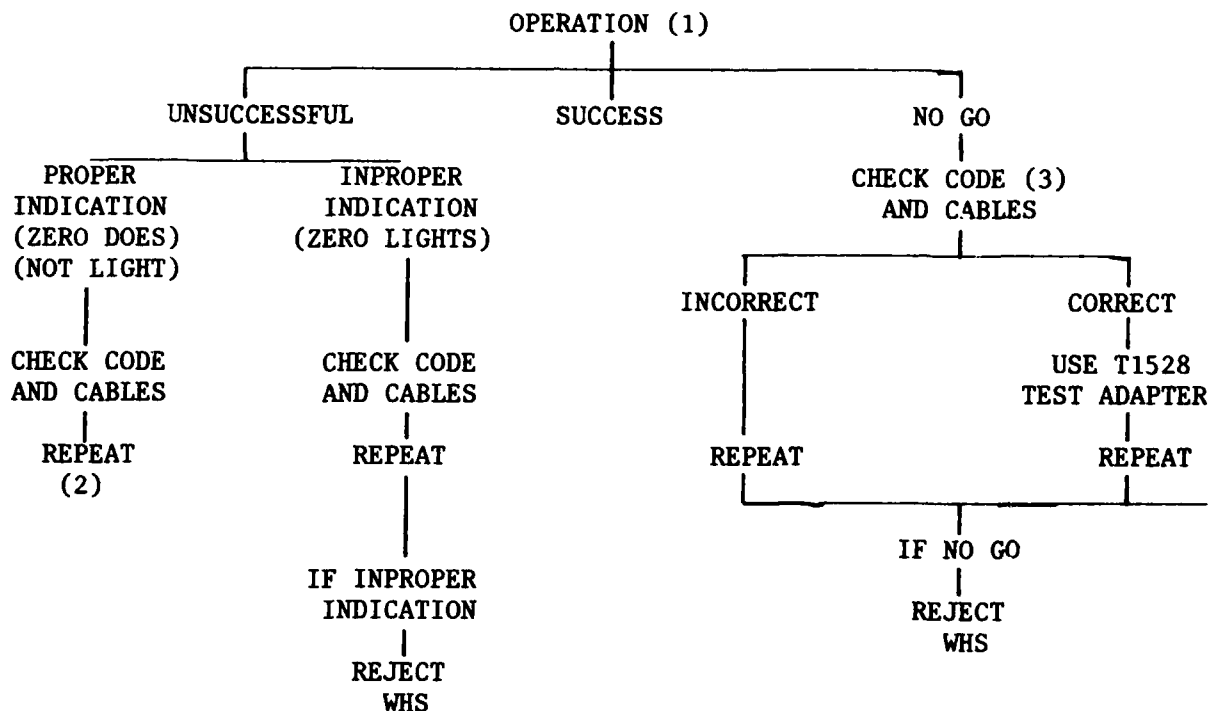

(1) The primary power source for the T1533 portable decoder will be vehicular. The T436B power supply will be used as a back-up and/or alternate power source.

(2) Number of attempts are determined by type of WHS.

(3) The primary reason for receiving a NO GO is due to an improper cable connection, usually the WHS connector.

c. DISPOSITION OF ASSOCIATED PAPERWORK TO A NUCLEAR WARHEAD

(1) DD 1150 HAND RECEIPT

(a) Reference: AR 700-65

(b) Purpose: Used to transfer custody of nuclear weapons and nuclear components when the designated individual is no longer capable of controlling movement of, and access to, nuclear weapons and nuclear components in his custody.

(c) DISTRIBUTION:

(1) Transfers between an accountable officer and a custodian.

- a. Original: Returned to the accountable officer after signing blocks 10 and 11.
- b. Copy 1: Retained by the receiving custodian as a custody receipt.

(2) Transfers between custodians under the jurisdiction of a single accountable officer.

- a. Original: Forwarded to the accountable officer after signing blocks 10 and 11.
- b. Copy 1: Returned to the old custodian.
- c. Copy 2: Retained by the new custodian as a custody receipt.

(d) Final Action: Upon expenditure or destruction of a nuclear weapon, a new DD 1150 should be prepared and forwarded to the accountable officer (Battalion S4) with the appropriate entry ..... "I certify that the Nuclear Warhead, serial number 27, was expended/destroyed on 2 March 1983. (Signature)."

(2) SC 5700C Inspection Record Card (IRC).

(a) References: TM 39-25-7, TM 39-T1533-2 and TM 9-1115-485-12.

(b) Purpose: Used to provide a complete record of actions involving either the Permission Action Link (PAL) or the Command Disable System (CDS) of a nuclear warhead.

(c) Distribution: The IRC is maintained with the nuclear weapon at all times; either in the records compartment of the M511E1 container or in the possession of the senior person in control of the nuclear weapon.

(d) Example Entries:

- (1) Status Check (T1533) Operational Code (locked).
- (2) Status Check (T1533) Operational Code (unlocked).
- (3) Unlock (T1533) Operational Code (unlocked).
- (4) Locked (T1533) Operational Code (locked).
- (5) Command Disable System Activated.
- (6) Logistical CDS Code Changed to Tactical CDS Code (BY35).
- (7) CDS Panel Recoded (Unit's Temporary Code).
- (8) CDS Recoded, Tactical Code (BU77).

(e) Final Action: The IRC will be destroyed IAW TM 9-1100-803-15 (FOUO) upon expenditure or destruction of the nuclear weapon. Usually, commanders will require that the IRC be forwarded along with the EML to the Battalion S2 for destruction.

(3) DA 2409 Equipment Maintenance Log (EML).

(a) References: TM 9-1100-803-15 (FOUO).

(b) Purpose: Used to provide a complete maintenance history of a nuclear weapon or nuclear component.

(c) Distribution: The EML is maintained with the nuclear weapon at all times; either in the records compartment of the M511E1 container or in the possession of the senior person in control of the nuclear weapon.

(d) Example Entries:

- (1) Pre-issue Inspection.
- (2) Storage Monitoring Performed.
- (3) Humidity Indicator Card Replaced.
- (4) Dessicant Replaced.
- (5) Verification Inspection.
- (6) Receipt Inspection.
- (7) GO/NO GO Indicator Activated.
- (8) Command Disable System Activated.
- (9) Rejection of the WHS.

(e) Final Action: The EML will be destroyed IAW TM 9-1100-803-15 (FOUO) upon expenditure or destruction of the nuclear weapon. Usually, commanders will require that the EML be forwarded along with the IRC to the Battalion S2 for destruction.

# CHAPTER 15

## NUCLEAR TRAINING DIFFERENCES

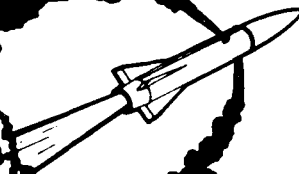

15-1. The use of training rounds requires all firing teams to emphasize nuclear training differences. Additionally, chapter 8 of AR 50-5, NUCLEAR SURETY, necessitates that these differences be pointed out during the Battalion's Nuclear Technical Validation Inspection (TVI).

To minimize confusion and disruption, point out these nuclear differences as you come to them during an unpackage operation of a training nuclear WHS:

a. M511E1 CONTAINER EXTERIOR

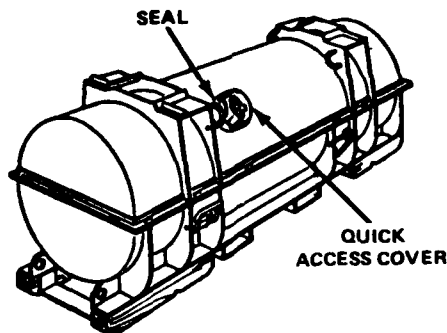

M511 CONTAINER FOR  
THE LIGHT WHS

(1) The six bronze squares on the trainer would be yellow in color on the nuclear WHS container.

(2) DOT nomenclature "EXPLOSIVE PROJECTILE" would appear on the top side and forward end.

(3) The NSN 1115-00-157-363 would not appear. Instead, one of the following part numbers would be present:

PN 8880001 (M234)

PN 9237600 (M234E1)

PN 9237700 (M234E2)

PN 9237830 (M234E3)

b. M511E1 CONTAINER LID REMOVED

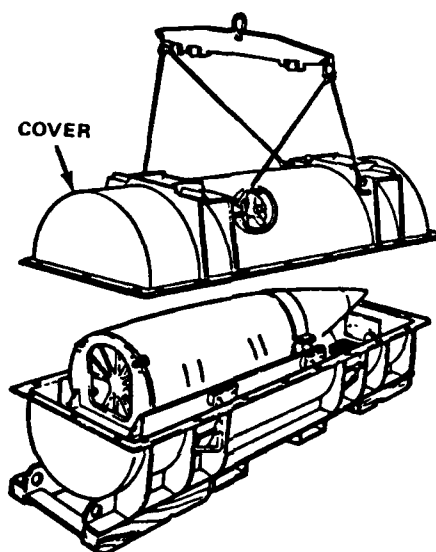

(1) The W53U cable connected to the Warhead PAL receptacle would be a W58U cable on the nuclear round. Gold tape denotes a training item.

(2) The four bronze squares would not appear on the nuclear round.

(3) Four yellow squares would appear 90 degrees apart and 8 inches from station 100 on the nuclear WHS.

(4) The word "INERT" would not appear on top of station 100 on the nuclear WHS.

(5) The model designator above the parameter access cover would reflect a M234 Series WHS instead of M240, the trainer.

(6) Ablative coating would cover the nuclear warhead case sections C and D. The screws around the access doors would not be visible.

(7) A maintenance access door would be present above the quick access door. It is not on the trainer.

(8) More boltwell covers would appear evenly spaced around case sections B and C.

c. INSIDE PARAMETER AND QUICK ACCESS COVERS

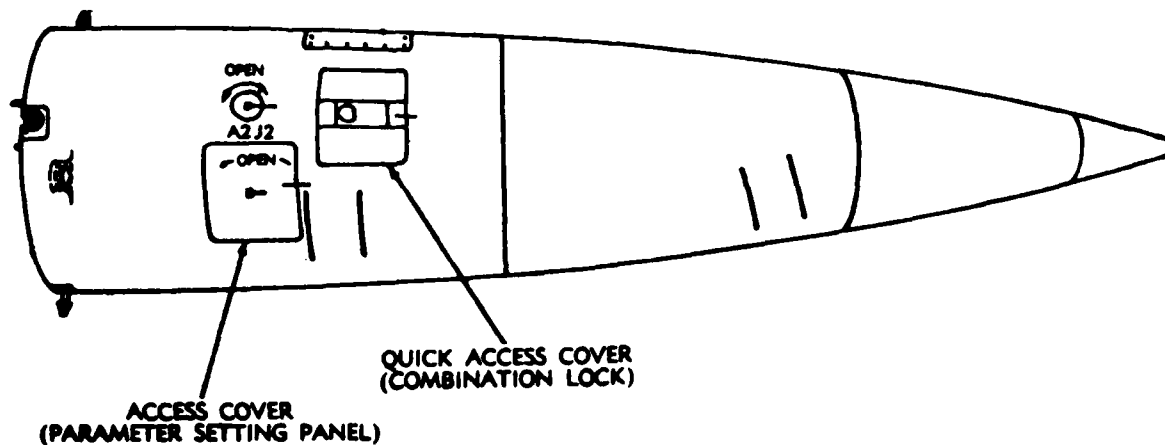

(1) The W74U cable that is on the trainer would be a W31U cable. Gold tape denotes a training item.

(2) The parameter and CDS assembly panels would not be bronze in color as they are on the trainer.

(3) The GO/NO GO indicator reset handle found on the trainer would not be present. The red color around the indicator would not be visible when in the GO position.

(4) CDS reset handle would not be present on the nuclear warhead.

(5) CDS "T" handle lanyard found on the trainer would not be present.

d. M240 WHS SUSPENDED ABOVE CONTAINER

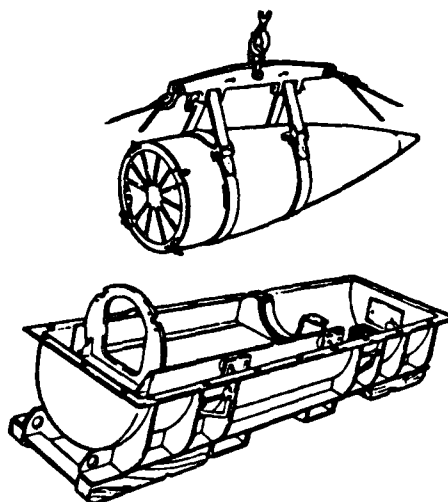

(1) Three drain holes would not appear in the bottom of case sections B, C, and D on the nuclear WHS.

(2) Two vent holes would appear in the upper portion of station 100.

(3) The rear adapter plate at station 100 would not be round on the nuclear WHS.





16-1. Direct enemy action, vehicle and aircraft accidents, handling accidents, and fires all offer potentially hazardous situations for nuclear weapons. Team leaders must be prepared to act swiftly and correctly in the event of such catastrophes.

a. PURPOSE of Nuclear Accident and Incident Control.

- (1) Minimize injury and loss of life - civilian and military.
- (2) Minimize interference with military operations--delaying a nuclear capable unit from performing its mission or restricting mobility of units in the vicinity of the accident.
- (3) Secure classified information and material.

b. DEFINITIONS

(1) Nuclear Accident: Any unplanned occurrence involving loss or destruction of, or serious damage to, nuclear weapons or their components which results in an actual or potential hazard to life or property.

(2) Nuclear Incident: Any unexpected event involving damage to a nuclear weapon or their components which involves no immediate danger to life or property but represents an increased risk of possible explosion or radioactive contamination. A nuclear incident can be further distinguished by either the possibility of the event becoming public knowledge or having political or international implications.

c. NAIC REPORTING

(1) A nuclear accident or incident will be reported immediately to higher headquarters. The report will provide a narrative description of the event by the fastest means available, usually by unclassified voice to battalion. The report will include time and location of occurrence, the unit responsible, and identification of the nuclear system involved.

(2) To facilitate prompt reporting, the following flagwords and descriptions have been established by AR 50-5:

- PINNACLE/NUCFLASH Nuclear War Risk Accident
- (1) Accidental or unauthorized nuclear detonation.
  - (2) Accidental or unauthorized launch of a nuclear-capable missile in the direction of, and/or having the capability to reach, the USSR or Warsaw Pact.
- PINNACLE/BROKEN ARROW Nuclear Weapon Accident
- (1) Nonnuclear detonation or burning of a nuclear weapon.
  - (2) Radioactive contamination.
  - (3) Seizure, theft, or loss of a nuclear weapon, including jettisoning.
  - (4) Public hazard, actual or implied.
- BENT SPEAR Nuclear Weapon Significant Incident
- (1) Evident damage requiring major repair.
  - (2) Striking of nuclear weapon by lightning.
  - (3) When it is known or suspected that a nuclear weapon has been partially or fully armed.
  - (4) When there is a possibility of adverse public reaction or release of information to the news media.
  - (5) Attempted or actual penetration or degradation of the security of a nuclear weapon site or convoy.
  - (6) A threat, actual or implied, of an attempt to seize a nuclear weapon or a threat to attack or inflict damage to storage site or security forces.
- DULL SWORD Nuclear Weapon Minor Incident
- (1) Evident damage which Army organizations are authorized to repair.
  - (2) Damage, loss, or destruction of a nuclear type training weapon.
  - (3) Unauthorized acts which degrade the safety, security or reliability of a nuclear weapon or trainer.
  - (4) Failure of a permissive action link (PAL) to unlock or lock.
  - (5) A nuclear-capable missile system accident in flight which does not meet the definition of PINNACLE/NUCFLASH.

d. EMERGENCY MEASURES

Becomes familiar with NAIC emergency measures as given in your battalion SOP. Detailed operations can be found in FM 3-15, Nuclear Accident Contamination Control.

- (1) Immediate actions to be taken.
  - (a) Rescue of injured personnel.
  - (b) First aid.

- (c) Evacuation of injured
- (d) Firefighting (See TB 385-2)
- (e) Notification of higher headquarters and request for assistance; i.e., EOD, fire department, etc.

(2) Additional actions, when possible.

- (a) Marking the accident site and restricting movement into the area.
- (b) Warning units downwind if radiation or chemical (UDMH or IRFNA) hazards exist.
- (c) Determining status of weapon(s) or components for a follow-up message as required by AR 50-5.

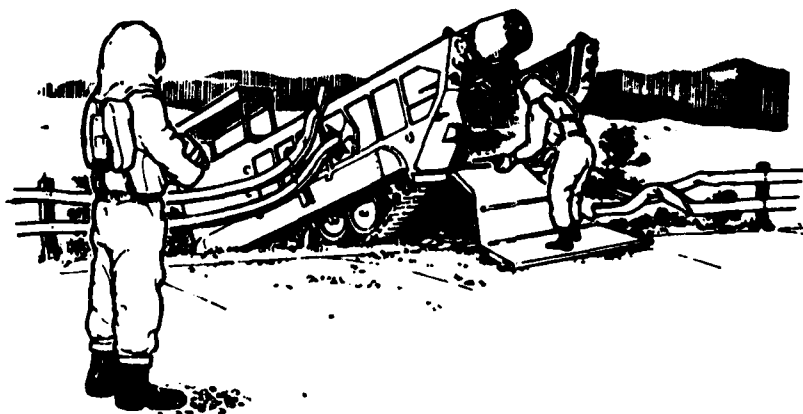

# CHAPTER 17

## NBC DEFENSE



17-1. In a future war the United States may confront the best-trained and best-equipped Army in the world in Chemical Warfare . . . The Soviet Union.

a. **BATTERY LEVEL NBC ORGANIZATION** . . . . . FM 21-40.

Battery personnel are appointed on an additional duty basis to perform NBC defense functions. Refer to FM 21-40.

(1) The NBC Control Party consists of an NBC Officer, NBC NCO, and an NBC Enlisted Alternate. They should be school trained and are responsible for unit NBC proficiency. The Control Party supervises all NBC Defense Teams within the battery.

(2) The Radiological Survey and Monitoring Teams consist of two men per team for each dose-rate radiac meter authorized the battery. The teams which use the IM-174A/PD radiacmeter are responsible for both survey/monitoring operations and marking contaminated areas. The team which uses the AN/PDR-27 radiac set is responsible for the monitoring of personnel after decontamination and for determining if supplies of food and water must be destroyed. Refer to FM 3-12 for detailed procedures.

(3) The Chemical Agent Detection Teams consists of two men per chemical agent detector within the battery. The teams which possess the M256 Detector Kit (issued one per section) are responsible for determining the presence of all known nerve, blister, and blood agents. The teams which use the M8 Automatic Chemical Agent Alarm are responsible for the early warning of nonpersistent and persistent threat agents when they are in vapor or inhalable aerosol form. Refer to FM 21-40 for further information.



b. CHEMICAL AGENTS

The following table is provided as a quick reference in the identification of common chemical agents. Refer to FM 3-9 for detailed information.

SYMBOL	AGENT NAME	TYPE	DURATION	CHARACTERISTICS
AC	HYDROGEN CYANIDE	BLOOD	NONPERSISTENT	COLORLESS VAPOR; ALMOND ODOR
CK	CYANOGEN CHLORIDE		NONPERSISTENT	COLORLESS VAPOR; NO ODOR
CG	PHOSGENE	CHOKING	NONPERSISTENT	COLORLESS VAPOR; CUT-GRASS ODOR
CX	PHOSGENE OXINE	BLISTER	PERSISTENT	COLORLESS DROPLETS; SHARP ODOR
HD	DISTILLED MUSTARD		PERSISTENT	YELLOW DROPLETS; GARLIC ODOR
HL	MUSTARD LEWSITE		PERSISTENT	DARK, OILY DROPLETS; GARLIC ODOR
HN	NITROGEN MUSTARD		PERSISTENT	DARK, OILY DROPLETS; FISHY ODOR
L	LEWSITE		NONPERSISTENT	DARK DROPLETS; GERANIUM ODOR
GA	TABUN	NERVE	PERSISTENT	COLORLESS VAPOR; FRUITY ODOR
GB	SARIN		NONPERSISTENT	COLORLESS VAPOR; NO ODOR
GD	SOMAN		PERSISTENT	COLORLESS VAPOR; FRUITY ODOR
VX	V-AGENT		PERSISTENT	COLORLESS AMBER VAPOR

Note: Persistency will vary due to weather and type delivery system used. Humid conditions will cause most agents to dissipate quickly while cold conditions will increase an agent's persistency.

c. MISSION-ORIENTED PROTECTIVE POSTURE (MOPP)

MOPP is a flexible system of protection against chemical agents. It requires a soldier to wear individual protective equipment consistent with the chemical threat, the work rate imposed by the mission, and the temperature.

A commander and his staff have a wide range of choices of chemical protection for their units, from no protection at all to full protective clothing and equipment MOPP 4.

<u>MOPP level</u>	<u>Overgarment</u>	<u>Over boots</u>	<u>Mask/Hood</u>	<u>Gloves</u>
1	Worn (NOTE A)	Carried	Carried	Carried
2	Worn (NOTE A)	Worn	Carried	Carried
3	Worn (NOTE A)	Worn	Worn (NOTE B)	Carried
4	Worn (CLOSED)	Worn	Worn (CLOSED)	Worn

NOTE A: Overgarment worn open or closed based on temperature and work rate.

NOTE B: Hood worn open or closed based on temperature and work rate.

MOPP 1 and 2 include those items that take the longest to put on, provide the greatest area protection and create the fewest task degradation problems. Items in MOPP 3 and 4 create the most heat loading and the greatest task degradation but can be more quickly donned. The MOPP levels assume no protection other than individual protective equipment.

d. KEY POINTS

- (1) Become familiar with FM 21-40, NBC defense.
- (2) Demand that each soldier in your team is capable of administering correct first aid procedures for nerve, blood, and blister agents. FM 21-41, Individual NBC Defense, is an excellent pocketsize guide on first aid.
- (3) Individual protective suits should be easily accessible at all times. Never depart the battery area without them!
- (4) Insure that your team is trained in the use of the M256 detection kit. It's simple to use but often overlooked.
- (5) Either the Team Leader or Platoon Sergeant should carry an IM 93/UD dosimeter. It is your only method by which to measure the total nuclear radiation (GAMMA) dose received by your team.
- (6) Insure that each soldier in your team who wears glasses has eye inserts made for his protective mask.
- (7) Memorize the requirements of each MOPP level and insure that your team can take the appropriate actions with minimal directions.
- (8) Performing firing operations under MOPP conditions is a significant challenge to any team. It poses unique problems for both the Gunner and the RT Operator due to the poor visibility when wearing the protective mask. Insure your team trains sufficiently to overcome these handicaps.
- (9) Both the Team Leader and Platoon Sergeant should keep an NBC Warning and Reporting System Card (GTA 3-6-2) on them to receive and send NBC reports.
- (10) Know what actions to take before, during, and after a nuclear or chemical attack. FM 21-40 is the best reference.

# CHAPTER 18

## COMMON MISTAKES



18-1. Certain mistakes are often repeated, again and again. This chapter highlights the most common of these mistakes, as noted by numerous ARTEP and TVI evaluations.

a. FIRING OPERATIONS (Reoccurring mistakes)

(1) Failure to verify fire mission data with firing point survey information.

(2) Removal of the safe-arm locking mechanism from the MMA prior to authorization under AR 50-109 (Safety Rules).

(3) Failure to maintain two-man control over the firing device once a GO is received in the "launch" mode.

(4) Arming of the safe-arm igniter prior to conducting a safe-arm check.

(5) Failure to check the leak indicator, humidity indicator and locking arm assemblies once the launcher has been emplaced over the firing point.

(6) Failure to release the traverse brake prior to conducting laying operations.

(7) Failure to lock the traverse brake after laying operations have been completed.

(8) Failure to insure that control surfaces are properly locked into place with safety clips engaged.

(9) Failure to insure that the MP is in the "off" position prior to connecting the short umbilical cable.

(10) Rear missile strap removed prior to elevating the missile to 100 mils.

(11) Suspension lockout (SLO) not engaged during fire operations.

(12) Short umbilical cable not inspected prior to connection to the MMA.

(13) T-2 theodolite improperly leveled; RT not rotated through 6400 mils to insure plate level is within one vial.

(14) Emergency destruction materials not accessible when carrying a nuclear round.

(15) Moving the SPL prior to installing the travel lock pin after a transload operation.

(16) Operational checks and adjustments not routinely conducted on the gunner's quadrant.

(17) EML and IRC not in the possession of the senior individual in charge of a nuclear round.

b. A&T OPERATIONS (Reoccurring mistakes)

(1) Failure to install the safe-arm locking mechanism on the MMA prior to mating to a nuclear warhead.

(2) Hearing protection not being worn when the handling unit is in operation.

(3) Torque wrenches out of calibration.

(4) Breathing apparatus and protective suits not properly marked.

(5) MMA leak indicators not checked before a majority of the crew enters the storage area.

(6) Personnel passing their hands or feet under a suspended load during an operation.

(7) MMA serial numbers not verified with DD 1650 Ammunition Card, during unpackage operations.

(8) Personnel smoking within 50 feet of an MMA.

(9) Insufficient guide ropes being used during transload operations.

(10) Tension released on sling prior to torquing T-head bolts during mating operations.

(11) Underside of warhead section not inspected once sling straps are removed after mating.

(12) Protective clothing not present, or not kept at a safe distance during operations with a MMA.

(13) Chock blocks not used with the ELWB 5-ton when rounds are being unloaded or loaded.

(14) Lance ammunition not properly secured with tie down straps on the ELWB 5-ton.

(15) Tie down straps not ratcheted with  $1\frac{1}{2}$  turns of strap when securing Lance ammunition.



# CHAPTER 19

## DESERT OPERATIONS

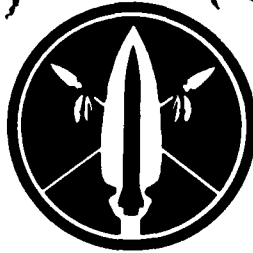

19-1. Conditions encountered in the desert will have a profound effect on Lance operations. The 1973 war in the Middle East clearly demonstrated that weapon systems not properly utilized will surely be destroyed.

This chapter highlights the experiences of two Lance battalions during desert exercises at White Sands, New Mexico. Refer to FM 90-3 for additional information.

a. **CONSUMPTION OF FUEL** is twice the normal rate. Large distances between units and firing points, combined with slow speed, high engine RPM and reduced traction in the sand results in the use of VAST amounts of both diesel and mogas.

b. **DESERT WEATHER** is a significant influence on personnel. Temperature changes of 50° F per day are normal. A 30° F change within 30 minutes of sundown is not unusual. Feet become numb quickly in the cold sand. Team leaders must be cautious of both heat and cold injuries in the same day. Soldiers must be encouraged to drink large amounts of water to avoid dehydration. Even during winter months, water consumption will be three times higher than normal. An average team will consume 8-10 gallons of water per soldier a day.

c. **MAP READING** is a tremendous challenge until leaders and drivers adjust to the uniqueness of the desert environment. If distant land marks are not visible, constant attention must be paid to prevent becoming lost. A "10 minute cat-nap" at night can result in a hopeless situation until daylight. Even though maps may be accurate, distances as shown on a map are often 25 to 40 percent farther when driving due to constant movement around and over sand dunes. Reliance must be placed on vehicle odometer readings and the M2 compass to successfully navigate in the desert.

d. **CAMOUFLAGE** is critical in a desert where natural hide areas do not exist. The Light Weight Screening System (LWSS) is effective and blends well into the desert if the "winter" side is used. However, the nets must be kept as low as possible or they extend beyond the top of sand dunes and are easily visible from long distances. Height of nets is by far the most significant signature when seen from the ground. When viewed from the air, the diameter is the most significant. Other keys to easy unit location are RC 292 antennas (too high and distinct), black smoke from diesel engines and prominent, heavily used roads.

e. RADIO COMMUNICATIONS are exceptional in the desert. There is nothing to block electrical line of sight for either FM or AM. Distances of 20 miles between FM "whip" antennas are sometimes attained. However, RC 292 antennas should still be used for reliable communications over extended distances.

f. LIGHT and NOISE DISCIPLINE is critical to survival at night. From the top of a sand dune a flashlight can be seen for 5 miles on an average night. A diesel engine can be heard for a mile in all directions.

g. MEDICAL problems require constant attention. Nose-bleed is common during the first few weeks in the desert until the body becomes accustomed to the dry climate. Precautions must be taken to prevent sunburn, frost bite and heat stroke in the same day. Most injuries can be avoided by insuring that soldiers wear adequate clothing and drink plenty of water.

h. MAINTENANCE of vehicles and equipment is aggravated by extended travel distances, sand, reduced traction, extreme temperature changes and dust in filters. Roads are seldom flat, twisting in both the horizontal and vertical plane. As a result, great stress is placed on tires, U-joints, steering-gear boxes, track tension and vehicle cross members. For every mile driven, stress is doubled and maintenance requirements are tripled. M880 series vehicles perform poorly even on roads.

i. TYPICAL OPERATIONS present new challenges in the desert.

(1) The short tent pegs are worthless in securing tents and camouflage nets in the loose sand. The long wooden pegs are needed, and they will often pull out in a light wind.

(2) Sand not only reduces vehicle traction but creates significant problems for artillery instrument operators. Shifting of the sand makes set up and leveling of the SIAGL and T-2 theodolite difficult.

(3) Oil should not be used on exposed surfaces as it only collects sand and dust. Weapons require little maintenance other than dusting.

(4) Soldiers become fatigued more quickly in sand due to difficulty when walking in sand.

(5) Dining and maintenance facilities should be placed upwind from any roads to reduce sand and dust contamination.

(6) Battery internal wire must be buried a minimum of 6 inches or it will quickly become entangled in wheels and tracks of vehicles due to the loose sand. Overheading is impossible.

j. CANVAS on vehicles is a necessity for Lance operations due to sand, dust, heat and cold. Without canvas, personnel effectiveness may be reduced as much as 20 percent within 48 hours. Electronic and optical equipment may be reduced 10 percent.

k. ACCURATE SURVEY is a considerable challenge in the desert. During the day, map spotting a firing point to within even 100 meters is difficult and at night an impossibility. Traverse operations are feasible but extremely slow due to rough terrain. Moreover, vast distances to be covered in a desert offensive and limited control points make traverse a limited solution. PADS appears to be the best answer. Directional control is not a problem when using either SIAGL's or astronomical survey (skies often clear both day and night).

1. LANCE OPERATIONS which are significantly affected by the desert:

(1) Normally, a launcher departs the battery position and occupies a "hide area" near the firing point to conduct last minute checks prior to firing. Hide areas do not exist in a desert environment; therefore, this tactic must be altered. Either the firing team must carry camouflage nets with them to establish a "hide area" or they must time their departure from the battery to minimize exposure. The use of an advance party by the firing team was found to enhance both survivability and responsiveness.

(2) Desert operations are characterized by rapid movement, large sectors of responsibility and 6400 m defense. As a result, Lance must use the "floating firing point" technique. This will not only increase firing team responsiveness but will insure a 6400 m capability.

(3) Lance needs a relatively flat area (slope not to exceed 5 degrees) to conduct technical operations. Although from a macro view the desert is flat, at micro level flat places are difficult to find. As a result, firing points must be chosen carefully.

(4) Movement of stacked rounds on the ELWB 5-ton is difficult and hazardous in the desert. The vehicle's high center of gravity combined with reduced traction in the sand results in very dangerous driving conditions.

(5) Reliance on airmobile operations to engage out-of-range targets is considerable due to the vast distances covered in a desert offensive. Airmobile operations will be the norm rather than the exception.

# CHAPTER 20

## SUBARCTIC OPERATIONS



20-1. Conditions encountered in the subarctic regions will have a profound effect on LANCE operations.

This chapter deals with the characteristics found in the subarctic regions. For further information refer to FM 90-11, (TBP) Cold Weather Operations and FM 90-6 Mountain Operations. Mountain operations must be considered when performing operations in Subarctic operations.

### a. SUBARCTIC WEATHER

Subarctic weather is characterized by extreme cold, deep snow and long nights during the winter months. The summer months have long periods of daylight. The spring is the worst time of year because the thaw causes the ground to become saturated, roads become flooded-often disintegrating-and low-lying areas are turned into a morass of mud.

### b. ENVIRONMENTAL EFFECTS OF PERSONNEL

If soldiers are subjected to heavy work following rapid transport from sea level to an elevation of 4200 meters, it is likely that 60 percent of them will become ill and may become ineffective. After months in a high altitude environment, 70 percent of sea level work capacity standards may be attained by acclimatized troops. For operations above 2500 meters acclimatization is required.

### c. BEHAVIORAL EFFECTS AND PSYCHOLOGICAL ADJUSTMENT:

Listed below are some of the behavioral effects that may occur in unacclimatized personnel.

- (1) Increased errors in performing simple mental arithmetics.
- (2) Decreased ability for sustained concentration.
- (3) Deterioration of memory.
- (4) Decreased vigilance.
- (5) Increased irritability.

d. MEDICAL PROBLEMS

Medical problems require constant attention. Sunlight in moderate amounts is not injurious to health, but harmful effects can be produced by excessive exposure to ultraviolet radiation. Exposute to ultraviolet light at high elevations is generally greater than at sea level because of the clear atmosphere and the reflection from glaciers and snowfields. Snow reflects about 75 percent of the sun's rays. Excessive exposure can result in snow blindness. During the actual period of exposure, there is no sensation other than brightness to warn the soldier. Snow blindness can be prevented by consistent use of proper sunglasses or goggles. The freezing of some parts of the body caused by exposure to extreme temperatures is a constant hazard when the wind is strong. High altitude increases the chance of frostbite by reducing the flow of blood to the extremities. The "Buddy System" is one of the prime prevention of frostbite. Leaders must be constantly familiar with the wind chill factor chart.

e. MAINTENANCE

In cold weather operations, personnel must expend considerable time and energy in self-preservation, and the efficiency of personnel in the operation and maintenance of equipment is reduced accordingly. Sluggish operation, malfunctions, and broken parts are common. Maintenance will consume a large proportion of the total effect since more time is required to perform tasks, and increased quantities and types of maintenance equipment are needed to support combat operations. Regardless of the difficulties involved, all prescribed maintenance procedures must be followed. Special fuels and lubricants as well as specified winterizing should be available and pretested for operability. Problems can be held to a minimum by:

- (1) Using only approved lubricants for cold weather operations.
- (2) Firing weapons at a reduced rate until parts are warmed up.
- (3) Keep working parts as free of snow and ice as possible.
- (4) Carrying additional spare parts on or with each launcher.
- (5) Training personnel in probable stoppage caused and the application of immediate action.

f. VEHICLES

Typical problems which can accure are:

- (1) Engines fail to start.
- (2) Inadequate power from batteries.
- (3) Improper lubrication because of thickened oil.
- (4) Seals and hoses leak or crack.
- (5) Fuel filters and lines clog up with ice crystals.
- (6) Suspension systems fail as metal becomes brittle.

(7) Cooling systems freeze.

(8) Tires become rigid, causing flat spots or cracks in sidewalls.

g. COMMUNICATIONS

Radio communications in a Lance battalion are significantly influenced by atmospheric activity such as magnetic storms, Aurora borealis (northern lights) and ionospheric disturbances, which are common to subarctic regions. Line of sight communication such as FM and VHF are only slightly affected because they do not depend on the atmosphere for transmission. The higher frequencies are affected more than lower frequencies. While extreme cold impairs the operations of electrical components that make up radio sets, its most serious effect on the batteries used to power certain radios such as the AN/PRC 77 and AN/GRA-39. For these radios, only batteries designed for cold weather operations should be used. Most of the units' radios will operate satisfactorily in northern regions if proper maintenance procedures are followed with special emphasis placed on operator preventive maintenance.

h. EMPLOYMENT

Lance operations in the subarctic regions will be largely impaired by mountains which are associated with this region. In mountainous terrain, particularly under winter conditions, it will be difficult to prepare suitable battery and firing positions. Firing positions should be prepared prior to occupation whenever possible. The possibility of firing into mountain peaks between the target and launch point should be considered when choosing firing points in valleys or low-lying areas. Conversely, firing from altitudes above 1000 meters increases the maximum range of the system. To enhance Lance mobility in mountains, it will be necessary to use helicopter aircraft as much as possible. During the summer months, long periods of daylight permit enemy observation practically around the clock further compounding the problem of undetected unit movement and survivability.

i. CAMOUFLAGE AND CONCEALMENT

The principles of camouflage and concealment apply although standard camouflage nets and paint patterns are unsuitable during the winter. Camouflage above the timberline requires special equipment which must be obtained.

j. NAVIGATION

Navigation in the mountains is made more difficult because of inaccurate mapping, magnetic attraction affecting compass accuracy, and the irregular direction you must travel. White outs and grey outs cause a loss of depth perception, which increases the possibility of becoming lost and increases driving hazards.

Prior to conducting operations in northern regions, it is imperative that intensive training programs be inaugurated to familiarize personnel with the effects of extreme cold weather on personnel health and survivability. Personnel must be familiar with the effects of extreme cold on metals, plastics, glass, canvas, paint, POL, individual and crew-served weapons.