

AD A 1 25576

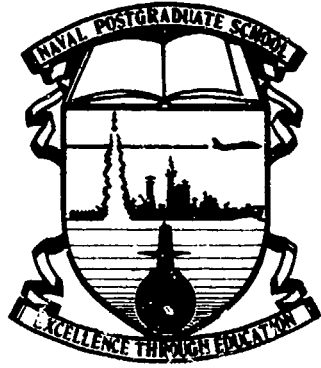

RADAR CROSS SECTION LECTURES

by

**DISTINGUISHED
PROFESSOR ALLEN E. FUHS**
Department of Aeronautics

DTIC
SELECTED
MAR 14 1983

A

DTIC FILE COPY

This document has been approved
for public release and sale
with unlimited distribution

NAVAL POSTGRADUATE SCHOOL
MONTEREY, CALIFORNIA
93940

88 02 02 035

RADAR CROSS SECTION LECTURES

by

Distinguished Professor Allen E. Fuhs
Department of Aeronautics
Naval Postgraduate School
Monterey, CA 93940
(408)646-2948
AV 878-2948

MAR 14 1983

A

INTRODUCTION

These notes were developed while the author was on Sabbatical at NASA Ames Research Center during FY 1982. The lectures were presented to engineers and scientists at NASA Ames in March-April 1982. In August 1982, the RCS lectures were presented at General Dynamics Fort Worth Division.

To thoroughly cover the content the following time schedule is required:

<u>LECTURE</u>	<u>HOURS LECTURE TIME</u>
I,	1.5
II,	3.0
III	1.5
IV	1.0

LECTURE I. INTRODUCTION TO ELECTROMAGNETIC SCATTERING

1. Level of Complexity
2. Features of EM Wave
3. What Is RCS?
4. Magnitude of Radar Cross Section
5. Polarization and Scattering Matrix
6. Inverse Scattering
7. Geometrical Versus Radar Cross Section
8. Polarization and RCS for Conducting Cylinder
9. Far Field vs Near Field
10. Influence of Diffraction on EM Waves
11. Relation of Gain to RCS
12. Antenna Geometry and Beam Pattern
13. Radar Cross Section of a Flat Plate
14. Wavelength Regions
15. Rayleigh Region
16. Optical Region
17. Mie or Resonance Scattering



Approved for	
NEED TO BE	<input checked="" type="checkbox"/>
FOR	<input type="checkbox"/>
Use of	<input type="checkbox"/>
<i>Full file</i>	
Abstract of	
Available Codes	
A	

A. E. FUHS ¹

Before discussing RCS, a perspective is given on the complexity of problems to be encountered. A measure of complexity is the tool required for numerical solution. The tools span from slide rule to CRAY computer.

Since these lectures are prepared mainly for the aerodynamicist, typical aerodynamics problems are given along with classes of RCS problems. The lectures provide sufficient information which allows back-of-envelope calculations in the "Southwest" corner of the graph. The lectures discuss in a descriptive way the scientific problems in the "Northeast" corner.

TYPE OF PROBLEM

MIE SCATTERING
COMPLEX SHAPE
3-D, viscous, transonic,
turbulent, unsteady
e.g. helicopter blade

RAYLEIGH SCATTERING
COMPLEX SHAPES

OPTICAL REGION
MULTIPLE SCATTERERS
NO INTERACTION

Potential Flow; Complex Shapes

ANY SCATTERING
WHERE SEPARATION
OF VARIABLES CAN
BE USED

SIMPLE SHAPES
e.g. SPHERES
OPTICAL or RAYLEIGH
Prandtl-Meyer Flow
Oblique Shocks

A. E. FUHS

SLIDE RULE HP41CV HP85 IBM360 CDC7600 CRAY

FEATURES OF EM WAVE

0 Wavelength $\lambda = c/f$

c = speed of EM wave = $3E8$ m/sec

f = frequency, Hz

0 Electric and Magnetic Fields*

- orientation related to antenna (source)

- $E = ZH$; $Z = (\mu/\epsilon)^{1/2}$ ohms

0 Polarization

- orientation of the electric vector \vec{E}

- polarization may be important in determining magnitude of RCS

0 Energy and Power*

energy density = energy/volume = $\frac{1}{2}(\epsilon E^2 + \mu H^2)$ = Joules/m³

flux of energy = power/area = $\vec{S} = \vec{E} \times \vec{H}$ = Watts/m²

power ~ (amplitude squared)

0 Interference

field vectors add vectorially; may cause cancellation of waves

*J. C. Slater, Microwave Transmission, Dover, 1959.

ELECTROMAGNETIC RADIATION

POYNTING VECTOR

$$\vec{S} = \vec{E} \times \vec{H} \quad \frac{\text{watts}}{\text{m}^2}$$

$$\lambda = \frac{c}{f}$$

$$\text{POWER} \sim (\text{AMPLITUDE})^2$$

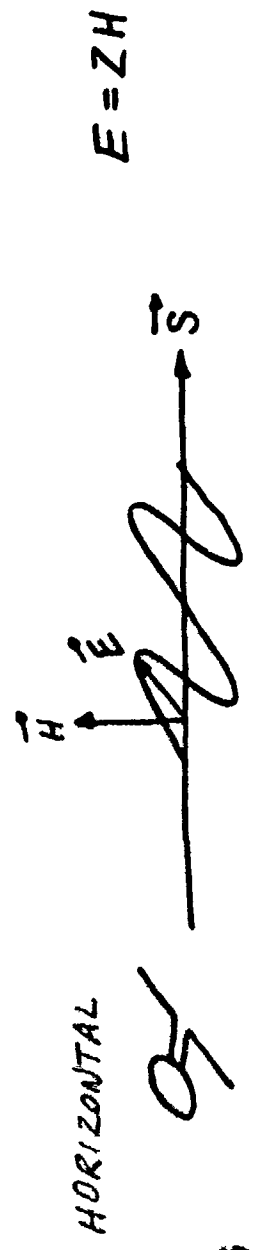
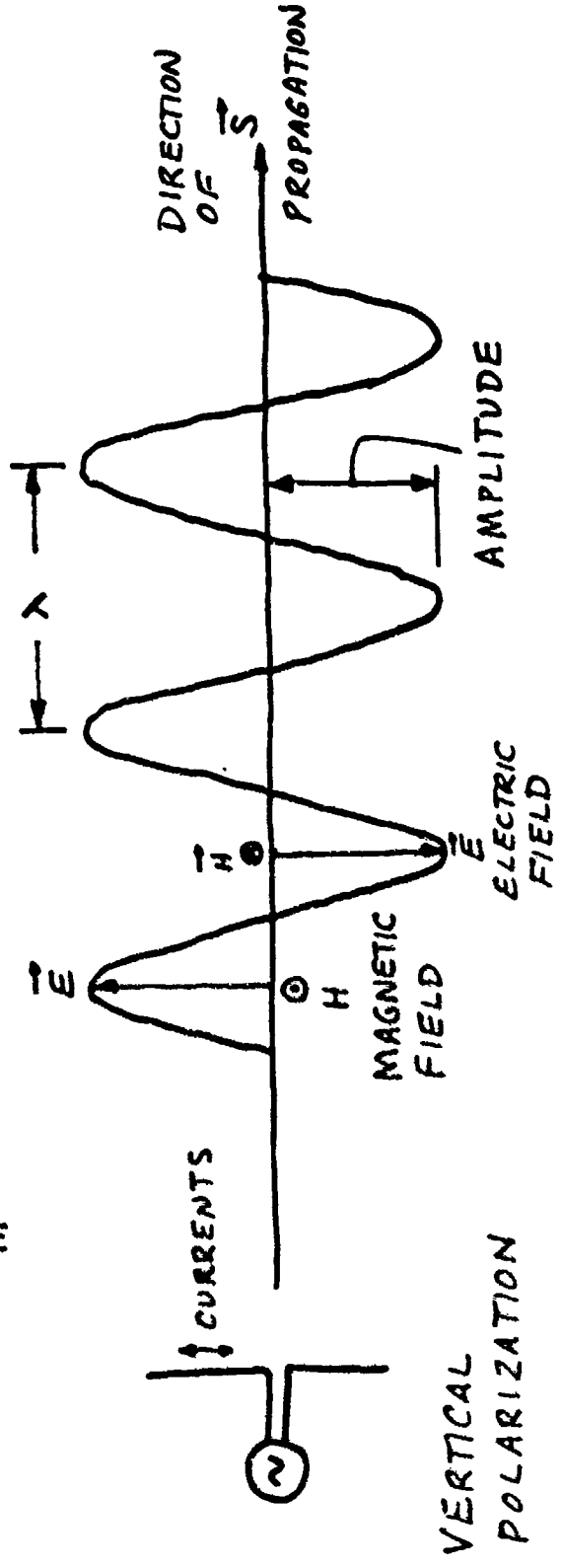

A. E. FUHS ³

What is RCS?

- 0 The RCS of any reflector may be thought of as the projected area of equivalent isotropic (same in all directions) reflector. The equivalent reflector returns the same power per unit solid angle.
- 0 RCS is an area.
- 0 Meaning of RCS can be seen by arranging σ in form:

$$\frac{\sigma I_1}{4\pi} = I_R R^2$$

σI_1 = power intercepted and scattered by target, Watts

$\sigma I_1 / 4\pi$ = power scattered in 4π steradians solid angle, Watts/steradian

$I_R A_R$ = power into receiver of area A_R , Watts

$\Omega = A_R / R^2$ = solid angle of receiver as seen from target, steradian

$I_R A_R / \Omega$ = power reflected to receiver per unit solid angle, Watts/steradian

$I_R A_R / (A_R / R^2) = I_R R^2$ = power reflected to receiver per unit solid angle, Watts/steradian

- 0 Meaning of limit

R is distance from target to radar receiver.

E_1 , H_1 , and I_1 are fixed.

E_R and H_R vary as $1/R$ in far field.

I_R varies as $1/R^2$ in far field.

Hence, σ has a limit as $R \rightarrow \infty$.

WHAT IS RADAR CROSS SECTION, RCS?

COMPLEX SHAPE



SAME
RCS

SPHERE



$$\sigma = \pi a^2 \text{ meter}^2$$

$$\sigma = \lim_{R \rightarrow \infty} 4\pi R^2 \left| \frac{E_r}{E_i} \right|^2$$

EQUIVALENT SPHERE

$$\sigma = \lim_{R \rightarrow \infty} 4\pi R^2 \left| \frac{H_r}{H_i} \right|^2$$

$$\sigma = \lim_{R \rightarrow \infty} 4\pi R^2 \frac{I_r}{I_i}$$

I_i = irradiance = power density

= intensity = watts/m²

A. E. FUHS

$$\sigma = \frac{\left[\frac{\text{power reflected to receiver}}{\text{solid angle}} \right]}{\left[\frac{\text{incident power density}}{4\pi} \right]}$$

$$\frac{1}{R^2} = \frac{\text{steradian}}{\text{area}}$$

A. E. FUHS 4

Magnitude of Radar Cross Section

- 0 RCS can be expressed in terms of area.
- 0 Since RCS is an area, you can check your formulas for RCS for dimensions; the formulas should always have dimensions of length squared.
- 0 The square meter is usually used as a reference to express σ as a relative value using decibels. An example of calculation

Given $\sigma = 28 \text{ db}_{\text{sm}}$, what is σ in m^2 ?

$$\sigma(\text{m}^2) = 10^{28\text{db}_{\text{sm}}/10} = 631 \text{ m}^2$$

Given $\sigma = 0.34 \text{ m}^2$, what is σ in db_{sm} ?

$$\sigma(\text{db}_{\text{sm}}) = 10 \log_{10}(0.34) = - 4.7 \text{ db}_{\text{sm}}$$

- 0 Some typical values are shown for various objects. Also the magnitude of creeping waves or traveling waves from an aircraft is shown. When the RCS due to direct reflection is reduced, RCS from other wave scattering phenomena may become important.

MAGNITUDE OF RADAR CROSS SECTION

A. E. FUHS

Magnitude in terms of area

σ in units of meter²

Relative magnitude in terms of db_{sm}

$$db_{sm} = 10 \log_{10} \left(\frac{m^2 RCS}{1.0 m^2} \right)$$

Typical values of RCS

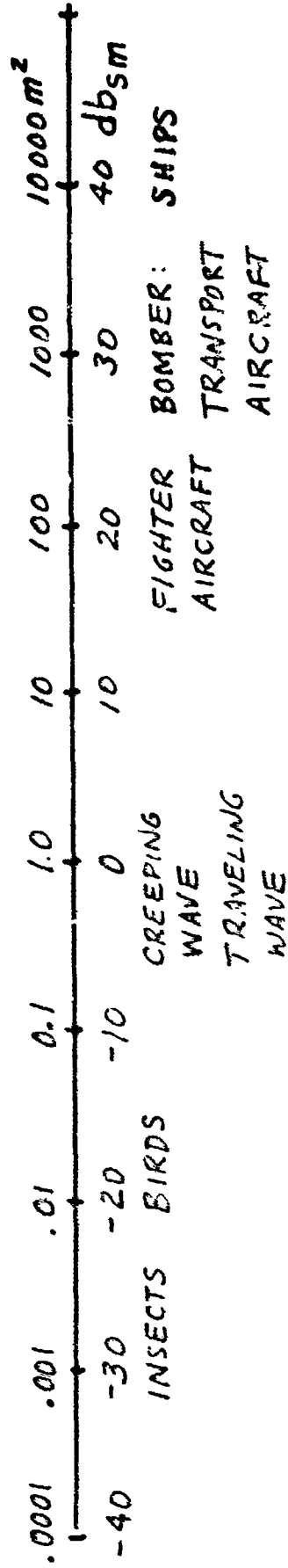

POLARIZATION AND SCATTERING MATRIX

- 0 The elements of scattering matrix have both phase and amplitude

$$a_{HH} = |a_{HH}| \exp j \phi_{HH}$$

- 0 For monostatic radar (transmitter and receiving antennas are colocated or very close together)

$$a_{VH} = a_{HV}$$

The expression is not true for bistatic radar.

- 0 Polarization of wave is specified by stating orientation of electric field vector E.
- 0 Cross polarization occurs when target changes the polarization of reflected wave compared to incident wave.
- 0 Polarization may be specified by orientation of E relative to a long distance of target, e.g., a wire. In this case, the notation

$$\sigma_{\parallel} \text{ and } \sigma_{\perp}$$

is used.

- 0 Usually $\sigma_{\parallel} > \sigma_{\perp}$.

POLARIZATION AND SCATTERING MATRIX

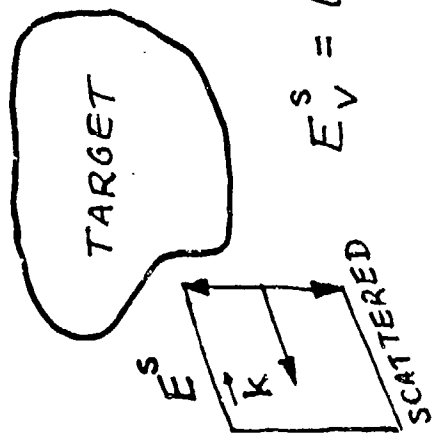
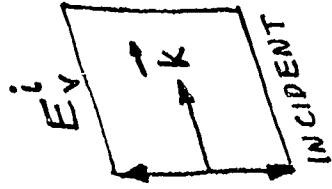

$$E_V^s = a_{VV} E_V^i$$

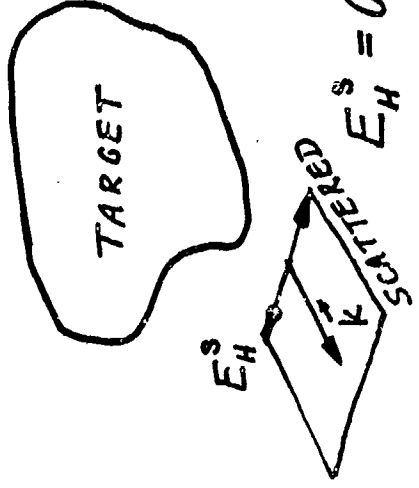
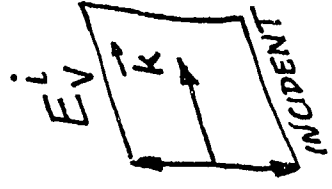

$$E_H^s = a_{HH} E_H^i$$

CROSS POLARIZATION

$$\begin{Bmatrix} E_H^s \\ E_V^s \end{Bmatrix} = \begin{vmatrix} a_{HH} & a_{HV} \\ a_{VH} & a_{VV} \end{vmatrix} \begin{Bmatrix} E_H^i \\ E_V^i \end{Bmatrix}$$

$$\sigma_{HH} = 4\pi R^2 |a_{HH}^i|^2$$

H Horizontal

V Vertical

A. E. FUHS

INVERSE SCATTERING

- 0 To quote from Professor Kennaugh* on the subject of inverse scattering:

"One measure of electromagnetic scattering properties of an object is the radar cross section (RCS) or apparent size. In the early days of radar, it was found that rapid variation of RCS with aspect, radar polarization, and frequency complicate the relation between true and apparent sizes. As measurement capabilities improved, investigations of the variation of RCS with these parameters provided the radar analyst with a plethora of data, but few insights into this relation. In the present context, such data are essential in determining the physical features of a distant target, rather than an annoying radar anomaly."

- 0 Inverse scattering provides a nonimaging method to determine target size, shape, etc.
- 0 By appropriately processing the backscattered waveforms or target signature observed in radar receivers, different target shapes may be discriminated and classified.
- 0 Stealth implies denial of detection; an expanded concept for stealth implies control of backscattered waveform, thereby denying information about target size, shape, etc.

*Edward M. Kennaugh, "Opening Remarks, Special Issue on Inverse Methods in Electromagnetics," IEEE Transactions on Antennas and Propagation, Vol. AP-29, March, 1981.

INVERSE SCATTERING

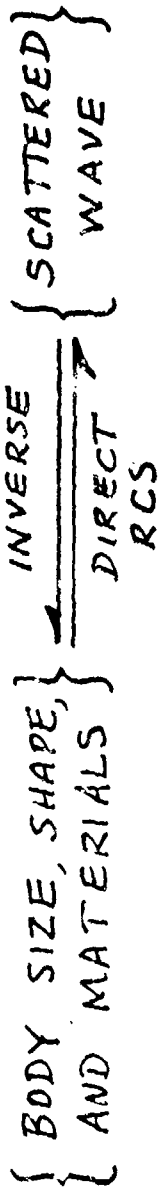

A. E. FUHS

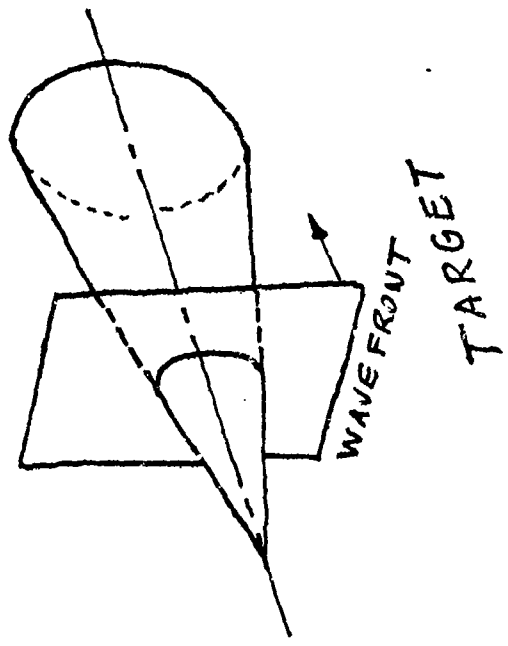
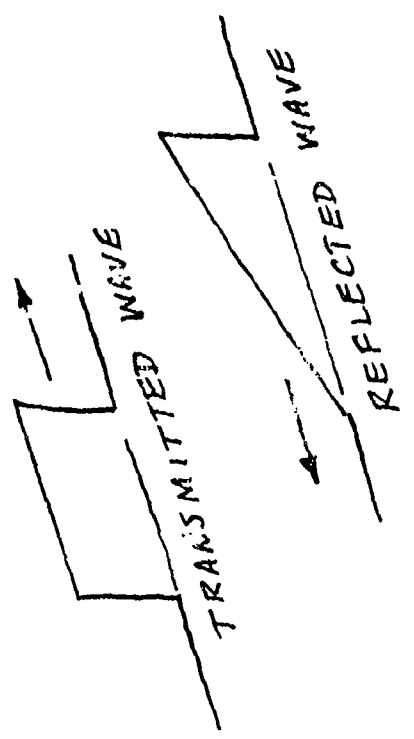

GEOMETRICAL VERSUS RADAR CROSS SECTION

0 Sphere. The two areas are drawn to scale. For a sphere,

$\sigma = \pi a^2$ independent of wavelength in optical region. Solve for a:

$$a = \text{SQR}(\sigma/\pi) = 0.56 \text{ meter}$$

0 Square Flat Plate. Consider a frequency of 8.5 GHz which corresponds

to $\lambda = 0.035 \text{ m} = 3.5 \text{ cm}$. The cross section for a flat plate is

$$\sigma = \frac{4\pi A^2}{\lambda^2} = \frac{4\pi[(0.1 \text{ m})^2]}{(0.035)^2} = 1 \text{ m}^2$$

0 Aircraft Broadside. The aircraft may have a panel which is normal to the wave vector \vec{k} . A large RCS results due to reflection from the panel.

0 Low RCS Aircraft Broadside. By a combination of RCS reduction methods, the aircraft has a smaller RCS than projected area.

GEOMETRICAL VERSUS RADAR CROSS SECTION

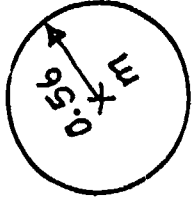

SPHERE

RCS 1 m^2

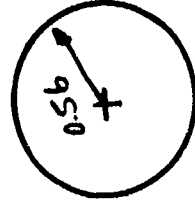

PROJECTED AREA 25 m^2



AIRCRAFT BROADSIDE

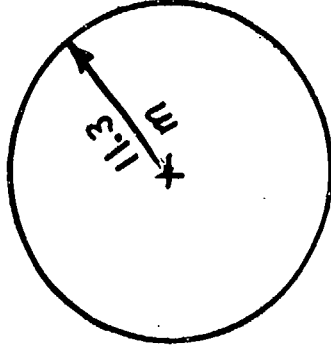

RCS 400 m^2

SQUARE FLAT PLATE

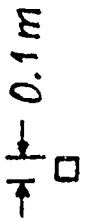

RCS 1 m^2

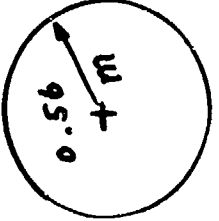

PROJECTED AREA 80 m^2

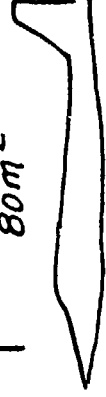

LOW RCS AIRCRAFT BROADSIDE

RCS 9 m^2



RADIUS 1.7 m

A. E. FUHS

A. E. FUHS ⁸**POLARIZATION AND RCS FOR CONDUCTING CYLINDER**

- 0 When λ is smaller than a , polarization is not important for magnitude of RCS.
- 0 The three regions based on relative size of λ compared to a are shown.
In both Rayleigh and optical regions, the RCS varies smoothly with changing λ .
In the Mie region, also known as resonance region, the RCS varies rapidly with changing λ . In optical region, σ_{\parallel} and σ_{\perp} converge to kaL^2 .
- 0 Cylinders with small ka are used for radar chaff.
- 0 A cylinder can be used as a model for estimating RCS of the leading edge of a wing or rudder.
- 0 Mie region occurs where circumference of cylinder, i.e., $2\pi a$, is nearly equal to wavelength, λ .
- 0 The values of ka for which cylinder diameter, d , equals λ and for which cylinder radius, a , equals λ are shown in the graph.

POLARIZATION AND RCS FOR CONDUCTING CYLINDER

$$ka = \frac{2\pi a}{\lambda}$$

SEE ALSO VIEWGRAPH 2-15

$$\sigma = kaL^2 \text{ OPTICAL}$$

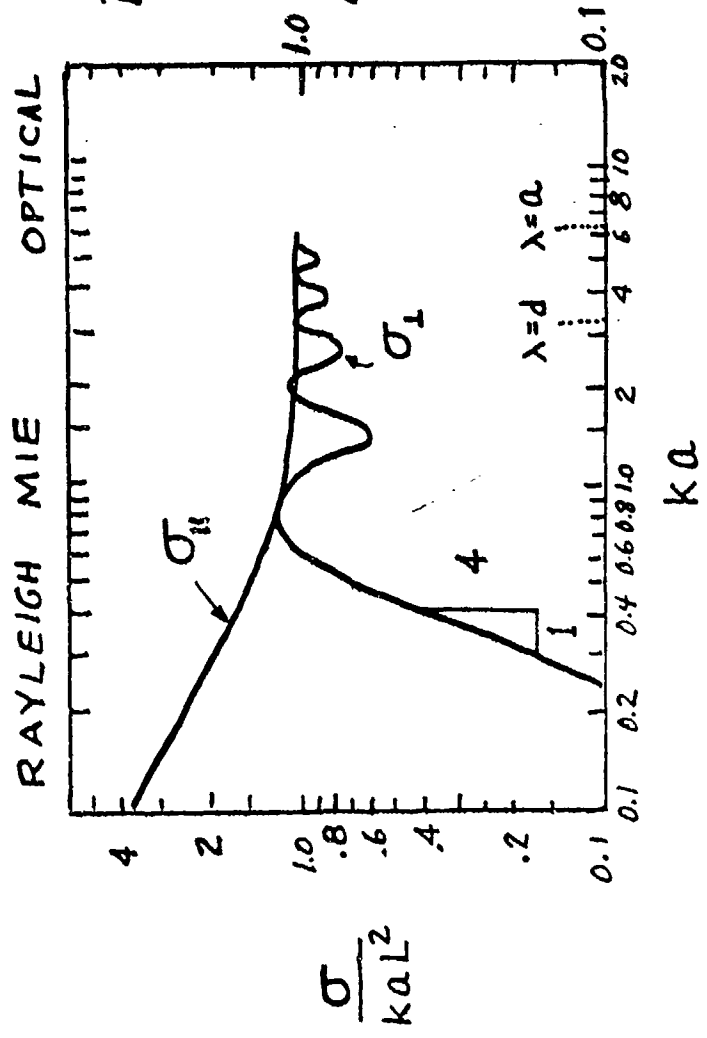

A. E. FUHS

A. E. FUHS⁹

FAR FIELD vs NEAR FIELD

- 0 The symbol f refers to a fraction of a wavelength. In far field, the variation in phase is small over a distance L .
- 0 In far field, the incident wave can be considered to be a plane wave.
- 0 The radiation from a dipole illustrates far field and near field for microwaves.

$$E_{\theta} = \frac{Mk^3}{4\pi\epsilon} \exp[j(\omega t - kr)] \sin \theta \left[-\frac{1}{kr} + \frac{j}{(kr)^2} + \frac{1}{(kr)^3} \right] \quad \text{NEAR FIELD}$$

$$E_{\theta} = -\frac{Mk^3}{4\pi\epsilon} \exp[j(\omega t - kr)] \sin \theta \frac{1}{kr} \quad \text{FAR FIELD}$$

M = dipole moment

ϵ = electric inductive capacity

k = $2\pi/\lambda$

ω = $2\pi f$ (f is frequency here)

θ = polar angle in polar coordinates

j = square root of minus one

FAR FIELD VS NEAR FIELD

RADAR CROSS SECTION APPLIES
TO FAR FIELD

FAR FIELD AND NEAR FIELD HAVE
SIMILAR MEANINGS IN OPTICS AND
RADAR

IN OPTICS, FRESNEL DIFFRACTION
OCCURS IN NEAR FIELD. FRAUNHOFER
DIFFRACTION OCCURS IN FAR FIELD

FOR MICROWAVES, FIELD VECTORS
DECAY AS $1/R$ IN FAR FIELD.

COMPLEXITY OF EM FIELDS IS
LESS IN FAR FIELD

A. E. FUHS

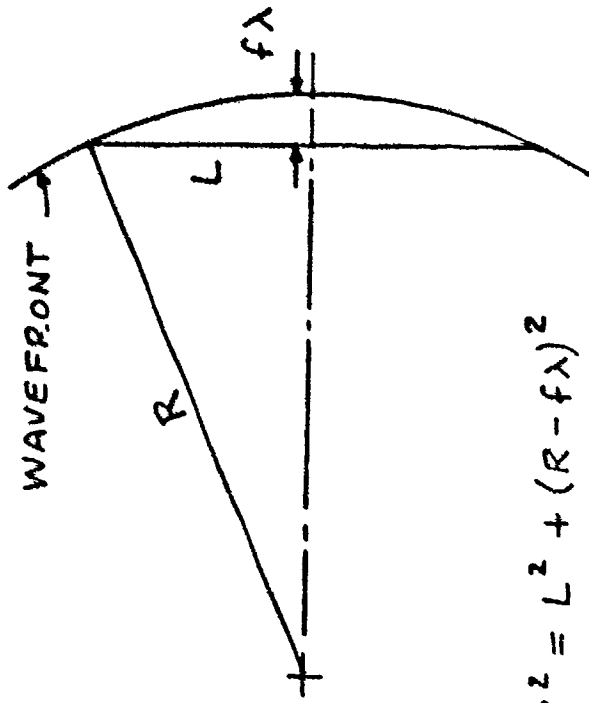

$$R^2 = L^2 + (R - f\lambda)^2$$

$$f = \frac{L^2}{2\lambda R} \ll 1 \quad \text{FOR FAR FIELD}$$

$$R = \frac{L^2}{2\lambda f} = \text{DISTANCE TO FAR FIELD}$$

INFLUENCE OF DIFFRACTION ON EM WAVES

- O On the left-hand side is a barrier with a small hole D . The waves are moving toward the right. The diffracted waves are nearly circular with center at hole.
- O A large value of λ/D yields a beam which diverges.
- O On the right-hand side, the hole D is much larger than a wavelength. The beam is transmitted through the barrier with little divergence.
- O A small value of λ/D yields a narrow beam from an antenna.

INFLUENCE OF DIFFRACTION ON EM WAVES

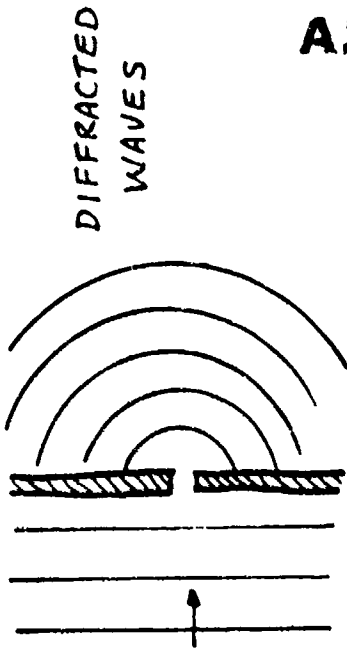

LARGE λ/D

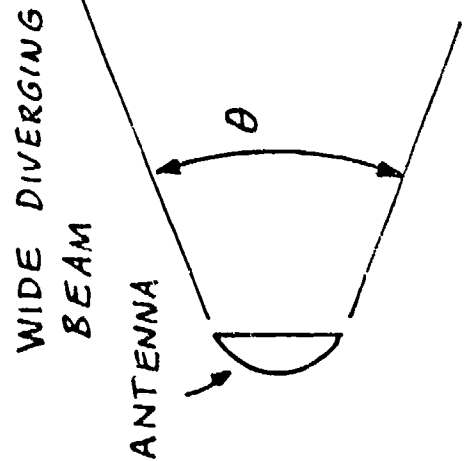

WIDE DIVERGING BEAM

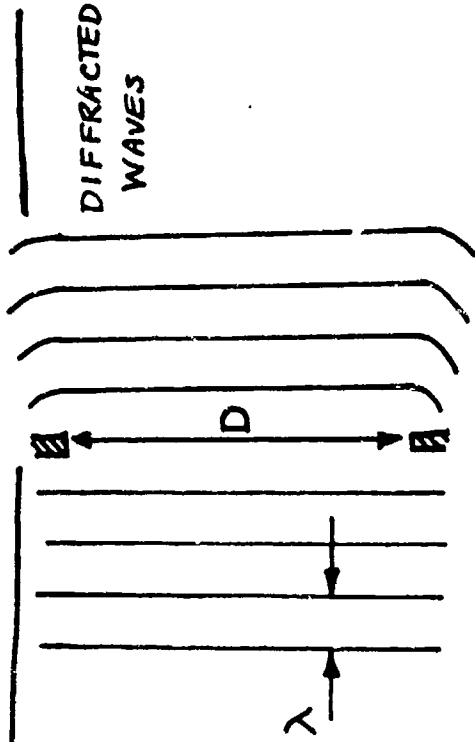

SMALL λ/D

NARROW BEAM

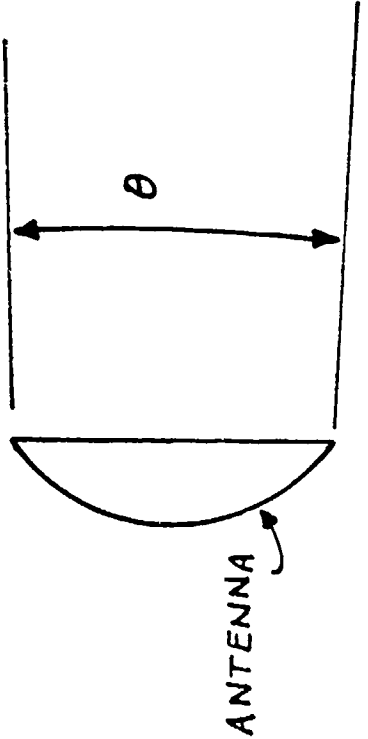

A. E. FUHS

$$\theta \sim \frac{\lambda}{D}$$

RELATION OF GAIN TO RCS

- 0 In the optical region, i.e., where ka is large, a formula can be written for RCS involving gain and reflecting area. The formula is given in the viewgraph.
- 0 Gain is a ratio of two solid angles. For a sphere, the solid angle is 4π steradians. If the wave is confined to a beam due to an antenna, the power is concentrated in the beam. Gain indicates the extent the power is concentrated in the beam.
- 0 To find the solid angle of the beam, the relation $\theta = C\lambda/D$ is used. C is a constant and usually has value $2/\pi$.
- 0 The reflecting area is the surface area between two wavefronts spaced $\Delta\lambda$ apart. Surface area outside the volume defined by the two wavefronts does not return radiation in a direction toward the radar antenna.
- 0 Derivation of the equation for gain:

Consider the beam from an antenna to be a cone with half angle $\theta = 2\lambda/\pi D$.

At a range R , the cone has a base with radius r . The value of r is given by

$$r = \theta R$$

The area of the beam, A_b , at range R is πr^2 . In terms of θ and the diffraction formula

$$A_b = \frac{4\lambda^2 R^2}{\pi D^2}$$

The solid angle of the beam is

$$\Omega = \frac{A_b}{R^2} = \frac{4\lambda^2}{\pi D^2}$$

By definition

$$G = \frac{4\pi}{\Omega} = \frac{4\pi}{\lambda^2} \cdot \frac{\pi D^2}{4} = \frac{4\pi A}{\lambda^2}$$

where A is the area of the antenna.

RELATION OF GAIN TO RCS

VALID IN OPTICAL
REGION

$$\sigma = GA$$

$$RCS = GAIN \cdot REFLECTING AREA$$

GAIN

$$G = \frac{4\pi}{\Omega} \frac{\text{steradians}}{\text{steradians}}$$

Ω = solid angle of beam

$$G = \frac{4\pi A}{\lambda^2}$$

$$\sigma = \frac{4\pi A^2}{\lambda^2}$$

REFLECTING AREA

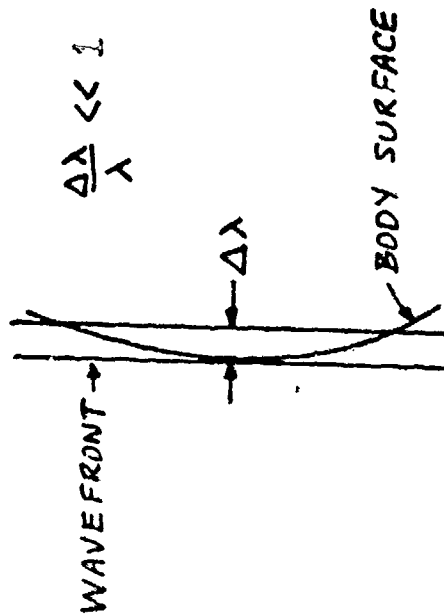

REFLECTING AREA IS SURFACE
AREA BETWEEN TWO WAVEFRONTS
SPACED $\Delta\lambda$

A. E. FUHS

A. E. FUHS 12

ANTENNA GEOMETRY AND BEAM PATTERN

- 0 A circular antenna produces a circular beam of radius r .
- 0 An elliptical antenna produces an elliptical beam. Due to diffraction, the long dimension of the antenna, L_a , is at right angles to long dimension of the beam, $\theta_e R$. The long dimensions of the antenna and beam are crossed. Note that $\theta_e > \theta_a$ and $L_a > L_e$.
- 0 The reason antennas are important to RCS is that the circular antenna is equivalent to a circular disc. The circular antenna is the source for a plane wave from an aperture in the form of a circle. Consider an incident plane wave reflected from a circular disc. The result is a plane wave from an aperture (the disc) in the form of a circle. Hence, the reflecting area is equivalent to an antenna. Antennas have side lobes. The radiation reflected by a flat plate or a disc has the same side lobes as an antenna of same shape.

ANTENNA GEOMETRY AND BEAM PATTERN

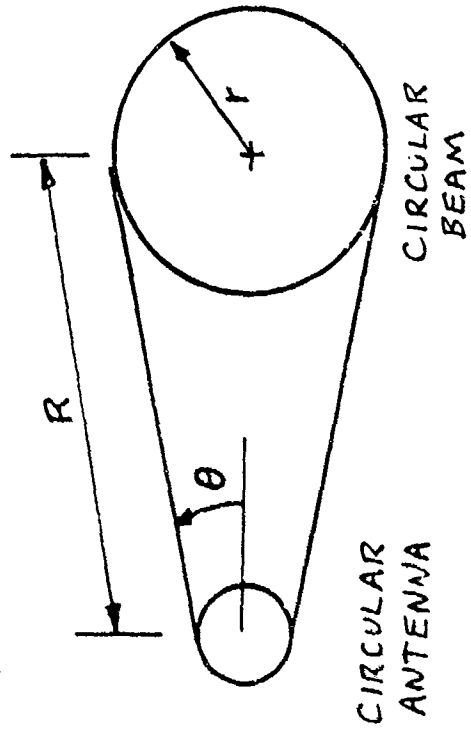

$$r = \theta R$$

$$r = \frac{2\lambda R}{\pi D}$$

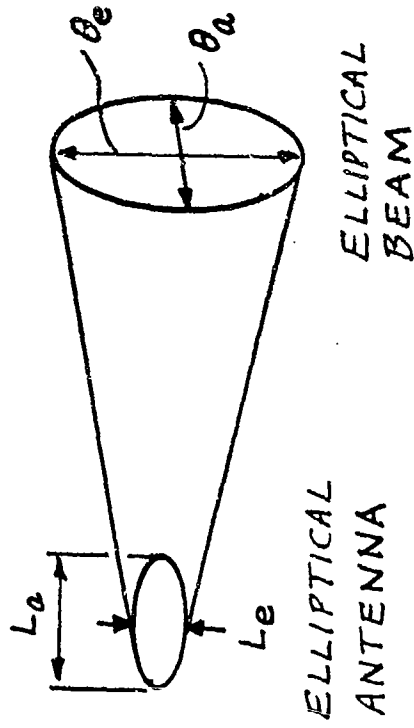

$$\theta_a \sim \frac{\lambda}{L_a}$$

$$\theta_e \sim \frac{\lambda}{L_e}$$

a azimuth
e elevation

RADAR CROSS SECTION OF A FLAT PLATE

0 The RCS of a flat plate is obtained from

$$\sigma = GA$$

where A equals the plate area, A_p .

0 Three different geometries leading to a series of wavefronts moving to the right are illustrated. The beam in the far field is identical for the three cases illustrated.

0 The shape of the flat plate does not influence the value of σ so long as the smallest dimension of the plate is much longer than a wavelength.

0 A test for whether or not the formula applies is accomplished by comparing λ and the square root of A_p . The result must be

$$\lambda \ll \sqrt{A_p}$$

RADAR CROSS SECTION OF A FLAT PLATE

$A_p = \text{Area of flat plate}$

$$\sigma = \frac{4\pi A_p^2}{\lambda^2}$$

VALID IN OPTICAL REGION

A. E. FUHS

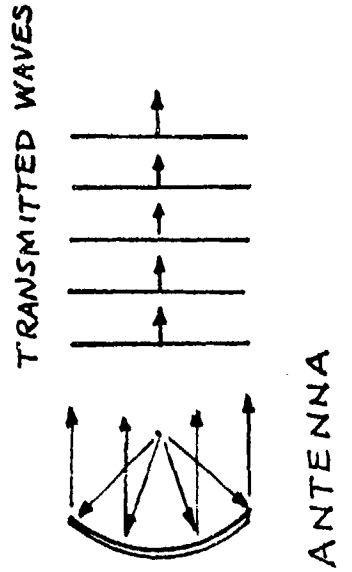
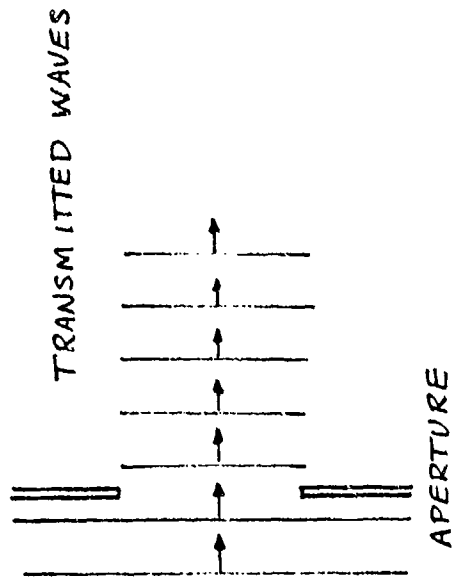
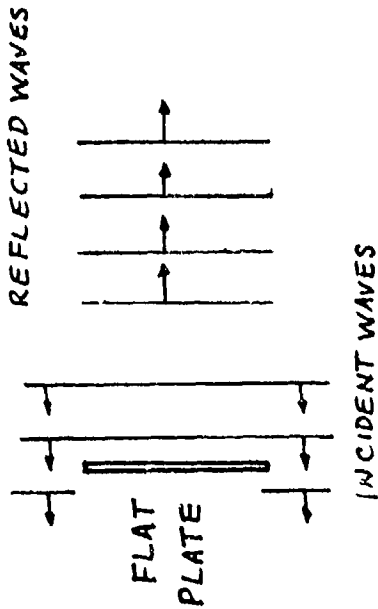

WAVELENGTH REGIONS

- 0 Recall $k = 2\pi/\lambda$; consequently

$$ka = \frac{2\pi a}{\lambda}$$

a is a characteristic dimension of the body.

- 0 A complex shape such as an aircraft may have components spanning all three regions. For example, the wing leading edge may be in the optical region while a gun muzzle may be in the Rayleigh region.
- 0 The region where $ka \approx 1$ is known as Mie region or as the resonance region. Resonance may occur between creeping waves and the specular reflected waves. The numerous wiggles characteristic of the resonance region may be due to the resonance.
- 0 The resonance region is difficult to analyze. In the Rayleigh region, series expansions using ka as an expansion parameter can be accomplished. In the optical region, the expansion parameter is $1/ka$. The series expansion technique is not useful for the Mie region. For Rayleigh scattering, the leading term in an expansion may be the electrostatic field.

WAVELENGTH REGIONS

$ka \ll 1$

RAYLEIGH

$$\sigma \sim \lambda^{-4}$$

σ vs ka smooth

$$\sigma \sim (\text{Volume})^2$$

$ka \approx 1$

MIE (RESONANCE)

σ vs ka many wiggles
difficult theoretically

$ka \gg 1$

OPTICAL

σ vs ka smooth

σ may be independent
of wave length

RAYLEIGH REGION

- 0 An oblate ellipsoid of revolution is shown in the figure. When the distance in the axial direction is small, the oblate ellipsoid models a disc like a penny. For this case, F is not near unity.
- 0 A prolate ellipsoid of revolution is shown in the viewgraph. When the distance along the axis is emphasized, a wire can be modelled. In that case, F is not near unity.
- 0 For smooth bodies which do not deviate too much from a sphere, the RCS is independent of polarization or aspect angle.
- 0 The formula for σ can be tested for a sphere. For a sphere

$$\sigma/\pi a^2 \approx 0.1 \text{ when } ka \approx 0.33$$

Assume $F = 1.0$. Then, since $V = 4\pi a^3/3$

$$\sigma = \frac{4}{\pi} k^4 \left(\frac{4\pi}{3} a^3\right)^2 = \frac{64}{9} (ka)^4 \pi a^2$$

Inserting the value for ka , one finds

$$\sigma/\pi a^2 = 0.084$$

which is close to the accurate value.

RAYLEIGH REGION

$$\sigma = \frac{4}{\pi} k^4 V^2 F^2$$

V = volume of target

$$k = 2\pi/\lambda$$

F = shape factor

$F \approx 1.0$ FOR ELLIPSOIDS WHICH ARE NOT FLAT

$F \approx 1.0$ FOR ROUNDED SMOOTH OBJECTS

$F \neq 1.0$ FOR ANY BODY WHERE ONE DIMENSION GREATLY EXCEEDS ANOTHER

$\sigma = \sigma$ (ASPECT ANGLE, POLARIZATION) WHEN ONE DIMENSION GREATLY EXCEEDS ANOTHER

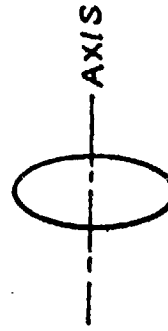
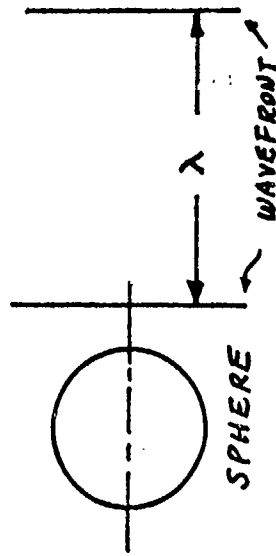

OBLATE ELLIPSOID



PROLATE ELLIPSOID

A. E. FUHS

OPTICAL REGION

0 One can apply the formula $\sigma = \pi\rho_1\rho_2$ to a sphere. In that case $\rho_1 = \rho_2 = a$.

Hence,

$$\sigma = \pi a^2$$

which is the anticipated result.

0 Optical approximation has the greatest use to calculate specular returns and the associated sidelobes.

0 Optical approximation may fail when there is a surface singularity such as an edge, a shadow, or a discontinuity in slope or curvature. Surface singularities may cause second-order effects which include creeping and traveling waves. When specular returns are weak, the RCS may be dominated by creeping or traveling waves.

OPTICAL REGION

RAY TRACING CAN BE USED TO ESTIMATE σ

A SMOOTH CURVED SURFACE NORMAL TO THE INCIDENT WAVE VECTOR \vec{k} WILL GIVE SPECULAR REFLECTION (MIRROR LIKE)

AN EQUATION FOR CROSS SECTION IS

$$\sigma = \pi \rho_1 \rho_2$$

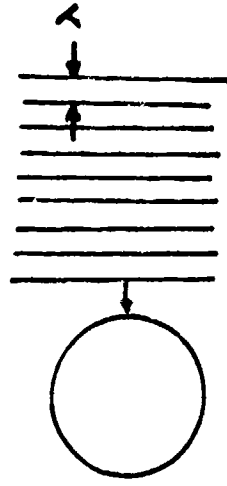

WHERE ρ_1 AND ρ_2 ARE RADII OF CURVATURE OF SURFACE.

REFLECTIONS OCCUR WHERE $\vec{k}_i \cdot \vec{n} = -k_i$.

GEOMETRICAL THEORY OF DIFFRACTION APPLIES IN OPTICAL REGION.

A. E. FUIS

MIE OR RESONANCE SCATTERING

To satisfy electrical boundary conditions on a body, a grid with nodes spaced at a small fraction of a wavelength, say $\lambda/6$, is needed. For the optical region where $\lambda \ll a$, the number of grid points is very large. However, for the resonance or Mie region, the value of λ is near a dimension of the body. Fewer grid points are needed in the resonance region than in the optical region.

MIE SCATTERING

SIMPLE GENERALIZATIONS FOR σ ARE NOT POSSIBLE
FAVORABLE FOR NUMERICAL TECHNIQUES; FEWER GRID POINTS
NEEDED

IMPULSE-RESPONSE TECHNIQUE MAY BE APPLICABLE

MAY OBTAIN RESULTS IN MIE-REGION BY TAKING MORE
TERMS IN $1/k_a$ SERIES EXPANSION; EXTEND OPTICAL
REGION TOWARD MIE-REGION

GEOMETRY OF BODY IS CRITICAL FACTOR

VERY FEW ANALYTICAL SOLUTIONS IN RESONANCE-REGION

A. F. FULTON

LECTURE II. RADAR CROSS SECTION CALCULATIONS; RADAR RANGE EQUATION

1. Physical Optics
2. Radar Range Equation 1
3. Radar Range Equation 2
4. Radar Range Equation 3
5. Burnthrough Range
6. RCS for Simple Shapes
7. Calculation of "Flat Plate" Area
8. Why RCS for Sphere Does Not Depend on λ
9. Wavelength Dependence of Specular Reflection
10. Wavelength Dependence Using Flat Plate σ
11. Wavelength Dependence Using P. O. Integral
12. Radar Cross Section of a Sphere
13. Addition of Specular and Creeping Waves
14. Derivation of $\sigma = \pi \rho_1 \rho_2$
15. Radar Cross Section for Wires, Rods, Cylinders and Discs
16. Radar Cross Section of Circular Disc of Radius, a --Linear Scale
17. Radar Cross Section of Circular Disc of Radius, a --Decibel Scale ($f = 12$ GHz)
18. Radar Cross Section of Circular Disc of Radius, a --Decibel Scale ($f = 2$ GHz)
19. RCS of Dihedral
20. Determination of RCS for Dihedral
21. Sample Calculation of RCS for a Dihedral
22. Calculated Dihedral RCS for $-30^\circ < \theta < 120^\circ$
23. Data for a Dihedral at 5.0 GHz
24. Creeping Waves
25. Traveling Waves
26. RCS of Cavities
27. Retroreflectors
28. RCS of Common Trihedral Reflectors
29. Vector Sum for Radar Cross Section
30. Radar Cross Section for Two Spheres
31. Sample Output for Two-Spheres Model
32. Radar Cross Section and Antennas

A. E. FUHS

PHYSICAL OPTICS

- 0 The symbol I is irradiance, Watts/m².
- 0 The value of I_0 is I at $\theta = 0$.

$$\lim_{\theta \rightarrow 0} \frac{I}{I_0} = \left[\frac{ka\theta}{ka\theta} \right]^2 = 1$$

- 0 Using the Kirchhoff Integral, which is a technique used in physical optics, the radar cross section is obtained.
- 0 A vocabulary guide is given since optics people use different words than microwave people.

References are as follows:

J. M. Stone, Radiation and Optics, McGraw Hill, New York, 1963.

J. W. Crispin, Jr., and K. M. Siegel, Editors, Methods of Radar Cross Section Analysis, Academic Press, New York, 1968.

PHYSICAL OPTICS

VOCABULARY GUIDE

OPTICS	RADAR
IR RADIANCE	POWER DENSITY
APERTURE	TARGET
OBSERVING PLANE	ANTENNA

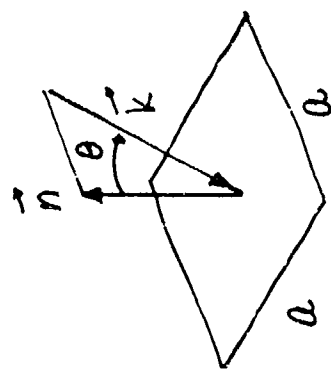

APPLICATION OF KIRCHHOFF INTEGRAL TO FRAUNHOFER DIFFRACTION GIVES

$$\frac{I}{I_0} = \left[\frac{\sin(ka \sin\theta)}{ka \sin\theta} \right]^2$$

STONE
PAGES 172-173

RADAR CROSS SECTION FOR SQUARE FLAT PLATE

$$\frac{\sigma}{\sigma_0} = \left[\frac{\sin(ka \sin\theta)}{ka \sin\theta} \right]^2$$

CRISPIN-SIEGEL
PAGE 122

RADAR RANGE EQUATION 1

- 0 By using the dimensions, one can understand the various steps in the derivation.
- 0 Symbols have the following definitions:
 - P = radar transmitter power, Watts
 - G = antenna gain
 - R = range, i.e., distance from radar to target, meters
 - Ω = solid angle
- 0 Note that atmospheric attenuation is neglected.

RADAR RANGE EQUATION 1

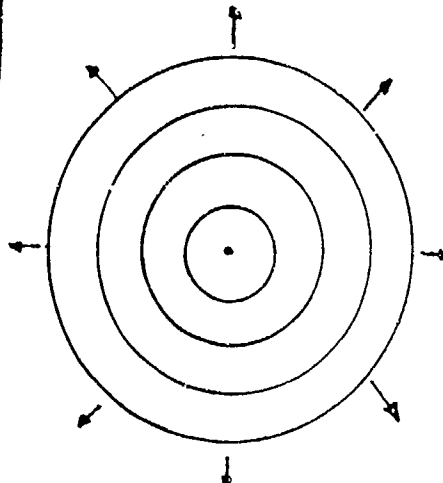

$$\frac{\text{POWER}}{\text{STERADIAN}} = \frac{P}{4\pi}$$

ISOTROPIC RADIATION

$$\Omega = \frac{A}{R^2} = \text{STERADIAN}$$

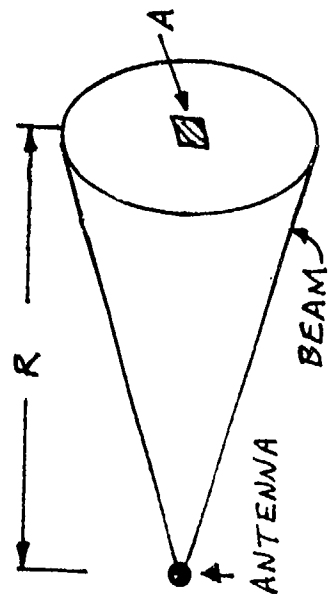

POWER THROUGH A IS

$$\frac{\text{POWER}}{\text{STERADIAN}} = \frac{PG}{4\pi} \frac{A}{R^2}$$

POWER PER UNIT AREA IS

$$\left\{ \frac{\frac{\text{POWER}}{\text{STERADIAN}}}{\text{AREA}} \right\} = \frac{PG}{4\pi} \frac{1}{R^2}$$

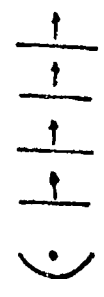

ANTENNA GAIN, G

POWER CONCENTRATED BY ANTENNA

A. E. FUHS

A. E. FUHS 3

RADAR RANGE EQUATION 2

- 0 Note that RCS has units of an area and is used as the area which intercepts outgoing radar power.
- 0 The signal, S, has units of power.
- 0 Note that $1/R^2$ is (steradian/unit area).

A. E. FUHS

RADAR RANGE EQUATION 2

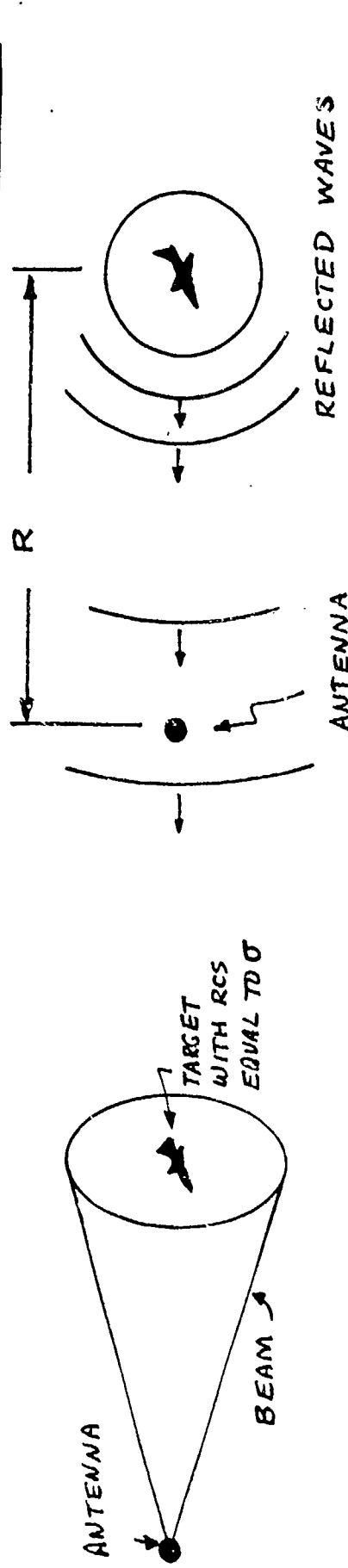

$$\text{POWER REFLECTED} = \frac{PG \sigma}{4\pi R^2}$$

$$\frac{\text{POWER REFLECTED}}{\text{STERADIAN}} = \frac{PG \sigma}{4\pi R^2} \frac{1}{4\pi}$$

A_0 = ANTENNA AREA

$\Omega = \frac{A_0}{R^2}$ = SOLID ANGLE OF ANTENNA AS SEEN FROM TARGET

$$\left\{ \begin{array}{l} \text{POWER RECEIVED BY} \\ \text{ANTENNA} \end{array} \right\} = \left(\frac{\text{POWER REF}}{\text{STERADIAN}} \right) (\text{STERADIAN})$$

$$S = \text{SIGNAL} = \frac{PG \sigma}{4\pi R^2} \frac{1}{4\pi} \frac{A_0}{R^2}$$

ANTENNA GAIN AND AREA

$$A_0 = \frac{G \lambda^2}{4\pi}$$

A. E. FUHS

RADAR RANGE EQUATION 3

- 0 Detection range does not necessarily equal R_0 .
- 0 Using logarithmic differentiation, one can show that

$$\frac{\Delta R_0}{R_0} = \frac{1}{4} \frac{\Delta P}{P} + \frac{1}{2} \frac{\Delta A}{A} + \frac{1}{4} \frac{\Delta \sigma}{\sigma} - \frac{1}{2} \frac{\Delta \lambda}{\lambda} - \frac{1}{4} \frac{\Delta N}{N}$$

- 0 A 40 per cent reduction in σ causes only a 10 per cent reduction in range.
- 0 The formula for relative detection ranges is useful. An example:

Radar power is doubled. How much does the reference range increase?

$$\frac{R_2}{R_1} = \left[\frac{P_2}{P_1} \right]^{1/4} = (2)^{1/4} = 1.189$$

Range increases by 19 per cent for a 100 per cent increase in power.

A. E. FUHS RADAR RANGE EQUATION 3

$$S = \frac{PG}{4\pi} \frac{\sigma}{R^2} \frac{1}{4\pi} \frac{G\lambda^2}{4\pi}$$

$$S = \frac{PG^2\lambda^2\sigma}{(4\pi)^3 R^4}$$

EXPRESS S IN TERMS OF ANTENNA AREA

$$G = \frac{4\pi A}{\lambda^2}$$

$$S = \frac{P}{(4\pi)^3} \frac{(4\pi)^2 A^2 \lambda^2 \sigma}{\lambda^4 R^4}$$

$$S = \frac{PA^2\sigma}{4\pi\lambda^2 R^4}$$

INTRODUCE NOISE N TO FORM SIGNAL-TO-NOISE RATIO

$$\frac{S}{N} = \frac{PA^2\sigma}{4\pi\lambda^2 R^4 N}$$

A REFERENCE RANGE IS THAT RANGE AT WHICH S/N = 1.0

$$R_0 = \left\{ \begin{array}{l} \text{RANGE FOR} \\ \text{UNITY S/N} \end{array} \right\} = \left[\frac{PA^2\sigma}{4\pi\lambda^2 N} \right]^{\frac{1}{4}}$$

RELATIVE DETECTION RANGES

$$\frac{R_2}{R_1} = \left[\frac{P_2 A_2^2 \sigma_2 \lambda_1^2 N_1}{P_1 A_1^2 \sigma_1 \lambda_2^2 N_2} \right]^{\frac{1}{4}}$$

BURNTHROUGH RANGE

0 Symbols have definitions as follows:

A_r	radar antenna area, m^2
A_j	jammer antenna area, m^2
A_{br}	area of radar beam at jammer, m^2
A_{bj}	area of jammer beam at radar, m^2
θ_j	angle of jammer beam, radians
θ_r	angle of radar beam, radians
S_j	signal at radar due to jammer, Watts
S_r	Signal at radar due to reflected power from target which is carrying jammer, Watts
P_r	radar power, Watts
P_j	jammer power, Watts
R	range, meters
λ	wavelength, meters
σ	RCS of target which is carrying jammer, m^2

0 Obviously both radar and jammer must be on same λ .

0 Note that S_j varies as R^{-2} .

0 Note that S_r varies as R^{-4} .

0 A narrow beam for jammer is not practical since this implies jammer must be aimed. Hence A_j is small.

0 Note that R_b varies as $\text{SQR}(\sigma)$.

0 For penetrating aircraft, a small value of R_b is desired.

BURNTHROUGH RANGE

A. E. FUHS

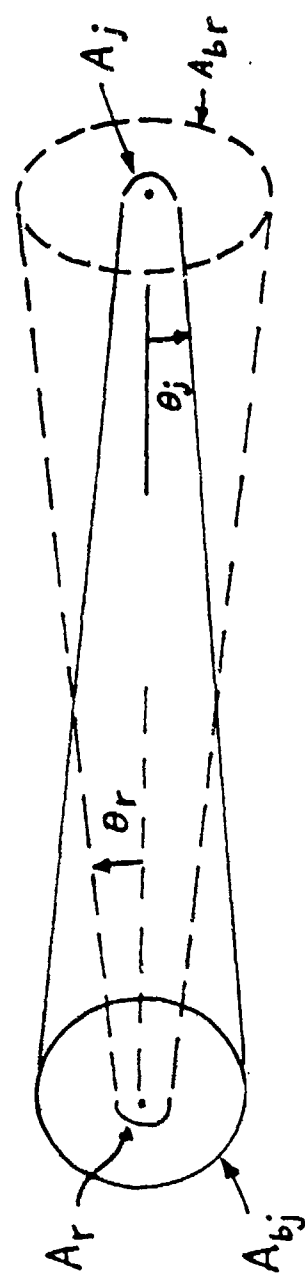

RADAR

$$\theta_j = \frac{2\lambda}{\pi D_j} ; \theta_r = \frac{2\lambda}{\pi D_r}$$

BEAM AREAS

$$A_{bj} = \pi r_j^2 = \pi (\theta_j R)^2 = \frac{4\lambda^2 R^2}{\pi D_j^2} = \frac{\lambda^2 R^2}{A_j}$$

$$A_{br} = \frac{\lambda^2 R^2}{A_r}$$

SIGNAL DUE TO JAMMER

$$S_j = \frac{P_j A_r}{A_{bj}} = \frac{P_j A_r A_j}{\lambda^2 R^2}$$

JAMMER

SIGNAL DUE TO RADAR OPERATION

$$S_r = \frac{P_r A_r^2 \sigma}{4\pi \lambda^2 R^4}$$

BURNTHROUGH DEFINITION

$$S_r = S_j$$

BURNTHROUGH RANGE

$$R_b = \left[\frac{P_r A_r \sigma}{P_j A_j 4\pi} \right]^{1/2}$$

RCS FOR SIMPLE SHAPES

- 0 The direction of the incident wave is specified by \vec{k} which is usually parallel to an axis for the simple cases considered here.
- 0 The equations are valid only in optical region where $ka \gg 1$.
- 0 The cone and paraboloid extend to infinity. σ is due to scattering at the tip for a cone and blunt nose for a paraboloid.
- 0 Compare the RCS for a sphere and a paraboloid. What do you notice?
- 0 The prolate (cigar shaped) ellipsoid of revolution has a RCS less than a sphere of radius b . Rewrite formula for σ as

$$\sigma = (\pi b^2)(b/a)^2 = (\text{RCS OF SPHERE OF RADIUS } b)(b/a)^2$$

As ratio b/a decreases, the radius of curvature at the nose decreases; σ decreases. Interpret the result in terms of

$$\sigma = \pi \rho_1 \rho_2$$

- 0 The circular ogive is tangent to a cylinder. The cylinder must extend to infinity. Note RCS is same for a cone and an ogive. RCS is due to scattering by the tip.

RCS FOR SIMPLE SHAPES

VALID IN OPTICAL REGION

A. E. FULS

SPHERE

$$\sigma = \pi a^2$$

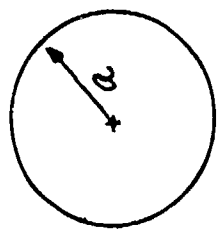

CONE

$$\sigma = \frac{\lambda^2}{16\pi} \tan^4 \delta$$

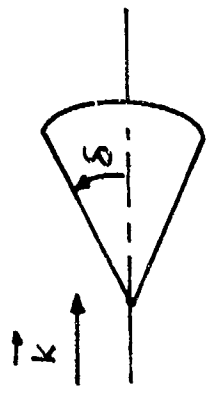

CONE EXTENDS TO INFINITY

PARABOLOID

$$\sigma = 4\pi \xi^2$$



PARABOLOID EXTENDS TO INFINITY

PROLATE ELLIPSOID OF REVOLUTION

$$\sigma = \frac{\pi b^4}{a^2}$$

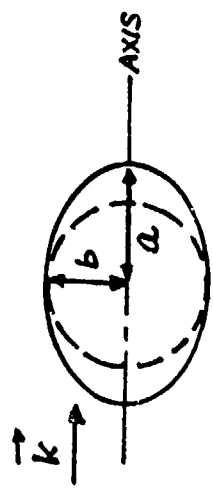

CIRCULAR OGIVE

$$\sigma = \frac{\lambda^2}{4\pi} \tan^4 \delta$$

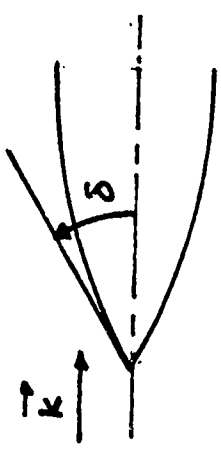

CIRCULAR DISC ; RADIUS a

$$\sigma = \pi a^2 \left[\frac{J_1(2ka \sin \theta)}{\tan \theta} \right]^2$$

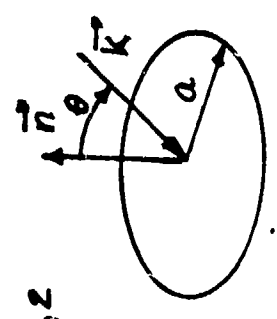

A. E. FUHS 7

CALCULATION OF "FLAT PLATE" AREA

- 0 To use the formula

$$\sigma = \frac{4\pi A_p^2}{\lambda^2}$$

one must evaluate A_p .

- 0 The method for determining A_p is shown for two cases, a sphere and a cylinder. The quantity F is a small number, and $F\lambda$ is a small fraction of a wavelength.
- 0 The cross section for a sphere does not depend on wavelength.
- 0 The cross section for a cylinder decreases as λ increases.
- 0 One can understand the dependence of σ on λ in terms of diffraction.
- 0 The reflecting area, A_p , is much smaller than the projected area of the body.

CALCULATION OF "FLAT PLATE" AREA

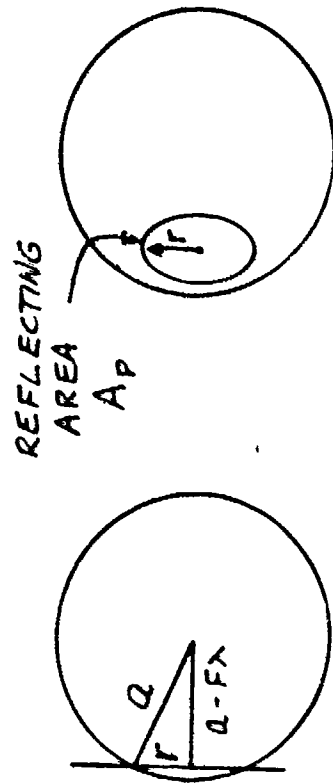

MERIDIAN PLANE

PERSPECTIVE

$$a^2 = (a - F\lambda)^2 + r^2$$

$$r = \sqrt{2Fa\lambda}$$

$$A_P = \pi r^2$$

$$\sigma = \frac{4\pi A_P^2}{\lambda^2} = 4\pi^2 F^2 a^2 = \pi a^2$$

THEREFORE

$$F = \frac{1}{4\pi}$$

A. E. FUHS

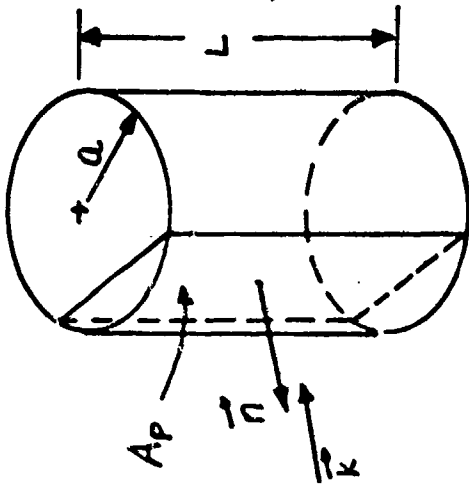

$$A_P = 2\pi L = 2L\sqrt{2Fa\lambda}$$

$$\sigma = \frac{4\pi [2L\sqrt{2Fa\lambda}]^2}{\lambda^2}$$

$$\sigma = 16FkaL^2 = kaL^2$$

THEREFORE

$$F = 1/16$$

WHY RCS FOR SPHERE DOES NOT DEPEND ON λ

0 The symbols have the following meaning:

r = radius of reflecting area, meters

A = reflecting area, m^2

θ = angle of reflected beam

Ω = solid angle of reflected beam

P = reflected power, Watts

0 In words the result, $\sigma_2 = \sigma_1$, can be expressed as follows:

As λ decreases, the reflected power decreases. However, the angle of the reflected beam, which is due to diffraction, decreases also. The changes in reflected power and solid angle of the reflected beam compensate for each other. As wavelength decreases, reflected power decreases; however, the reflected power is in a smaller reflected beam.

0 Exercise for the Motivated Reader.

Using viewgraphs 7 and 8, repeat the analysis for a cylinder. Show that

$$\frac{\sigma_2}{\sigma_1} = \frac{\lambda_1}{\lambda_2}$$

WHY RCS FOR SPHERE DOES NOT DEPEND ON λ

A. E. FUHS

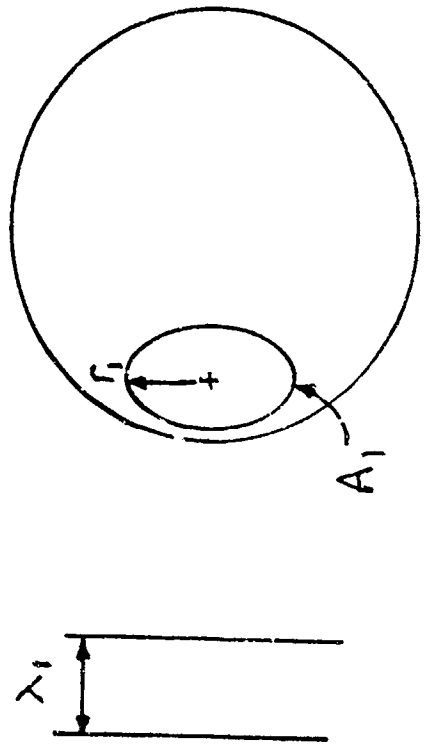

RADII OF REFLECTING AREAS

$$\frac{r_2}{r_1} = \left(\frac{\lambda_2}{\lambda_1} \right)^{1/2} = \frac{1}{2}$$

ANGLE OF REFLECTED BEAM

$$\frac{\theta_2}{\theta_1} = \frac{\lambda_2}{\lambda_1} \frac{D_1}{D_2} = \frac{\lambda_2}{\lambda_1} \frac{r_1}{r_2} = \frac{2}{4} = \frac{1}{2}$$

FROM DEFINITION OF RCS

$$\frac{\sigma_2}{\sigma_1} = \frac{P_2}{P_1} \frac{\Omega_1}{\Omega_2} ; \Omega \sim \theta^2$$

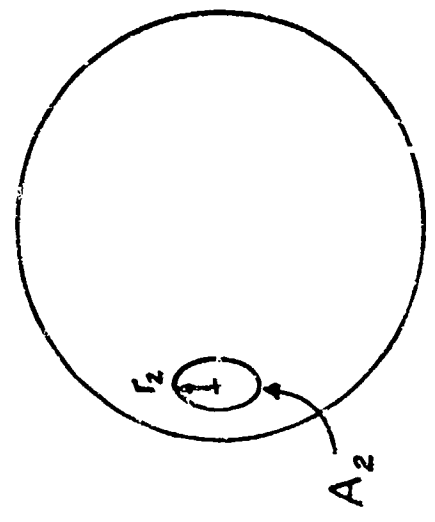
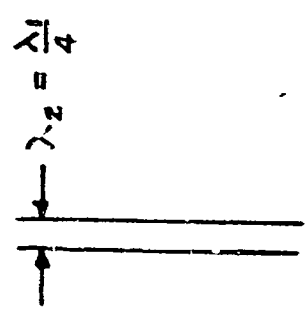

SOLID ANGLE VARIES AS SQUARE OF BEAM ANGLE, REFLECTED POWER VARIES AS THE REFLECTING AREA

$$\frac{\sigma_2}{\sigma_1} = \frac{A_2}{A_1} \frac{\theta_1^2}{\theta_2^2} = \frac{r_2^2}{r_1^2} \frac{\theta_1^2}{\theta_2^2} = \left(\frac{1}{2} \right)^2 \left(\frac{1}{2} \right)^2 = 1.0$$

THEREFORE σ DOES NOT DEPEND ON λ

WAVELENGTH DEPENDENCE OF SPECULAR REFLECTION

0 In the optical region, the RCS for various geometrical shapes varies with λ .
The variation is due to specular reflection.

0 The variation for a sphere was discussed by viewgraph 7.

0 The variation of σ with λ can be understood by using

$$\sigma = \pi \rho_1 \rho_2$$

0 The flat plate, cylinder, and ellipsoid can be understood in terms of

$$\sigma = \frac{4\pi A^2}{\lambda^2}$$

0 The variation of A_p with λ determines variation of λ .

WAVELENGTH DEPENDENCE OF SPECULAR REFLECTION

$\sigma \sim \lambda^n$. USE $\sigma = \pi P_1 P_2$ TO ORGANIZE CASES

VALUE OF n	VALUE OF P_1	VALUE OF P_2	EXAMPLES
-2	INFINITE	INFINITE	FLAT PLATE
-1	INFINITE	NONZERO, FINITE	CYLINDER
0	INFINITE	ZERO	WEDGE
0	NONZERO, FINITE	NONZERO, FINITE	ELLIPSOID
1	NONZERO, FINITE	ZERO	CURVED EDGE
2	ZERO	ZERO	TIP OF CONE

A. E. FUHS

WAVELENGTH DEPENDENCE USING FLAT PLATE σ

- 0 For a flat plate, $\rho_1 = \rho_2 \rightarrow \infty$. Hence A_p does not change with λ .
- 0 For a cylinder, $\rho_1 \rightarrow \infty$ and ρ_2 is finite and nonzero.
- 0 For a sphere, $\rho_1 = \rho_2$ and both are finite and nonzero.

WAVELENGTH DEPENDENCE USING FLAT PLATE σ

$$\sigma = \frac{4\pi A_p^2}{\lambda^2}$$

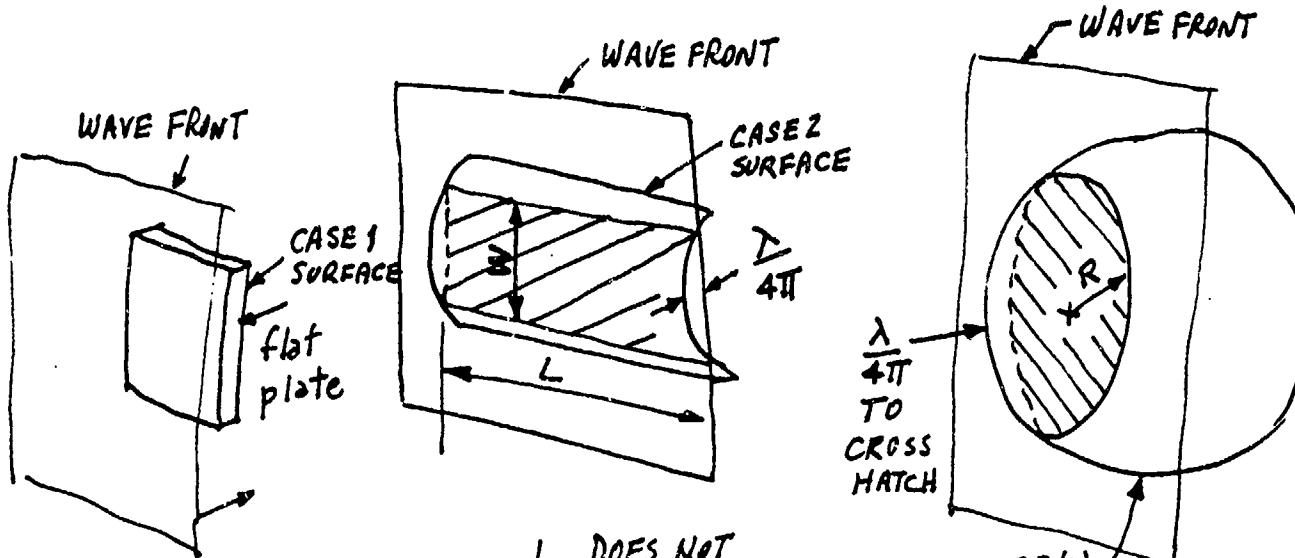

A_p does not depend on λ

$$\sigma \sim \lambda^{-2}$$

L DOES NOT DEPEND ON λ

W VARIES AS $\sqrt{\lambda}$

$$A_p \sim \sqrt{\lambda}$$

$$\sigma \sim \lambda^{-1}$$

CASE 3(b) SURFACE

$$A_p = \pi R^2$$

$$R \sim \sqrt{\lambda}$$

$$A_p \sim \lambda$$

$$\sigma \sim \lambda^0$$

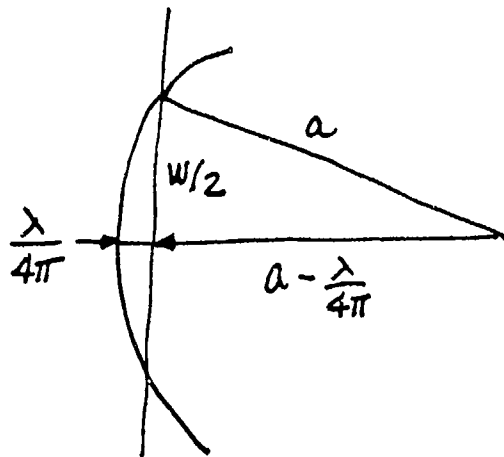

$$a^2 = \left(a - \frac{\lambda}{4\pi}\right)^2 + \left(\frac{w}{2}\right)^2$$

$$w \sim \sqrt{\lambda}$$

A. E. FUHS

WAVELENGTH DEPENDENCE USING P. O. INTEGRAL

- 0 P. O. = Physical Optics
- 0 The wedge, curved wedge, and cone have at least one zero value for radius of curvature. These can be understood in terms of the formula for σ which is based on an integration of $\partial A / \partial \rho$ along the direction of incident wave motion.
- 0 In this viewgraph, ρ is the distance along the direction of incident wave propagation.
- 0 The equation for σ is somewhat analogous to the equation for supersonic potential function. See page 237 of Liepmann and Roshko.*

*H. W. Liepmann and A. Roshko, Elements of Gas Dynamics, Wiley, New York, 1957.

WAVELENGTH DEPENDENCE USING P.O. INTEGRAL

$$\sigma = \frac{k^2}{\pi} \left[\int e^{2ik\rho} \frac{dA}{d\rho} d\rho \right]^2$$

EQUATION (1) PAGE 299 CRISPIN and SIEGEL "METHODS OF RADAR CROSS SECTION ANALYSIS", ACADEMIC PRESS, 1968

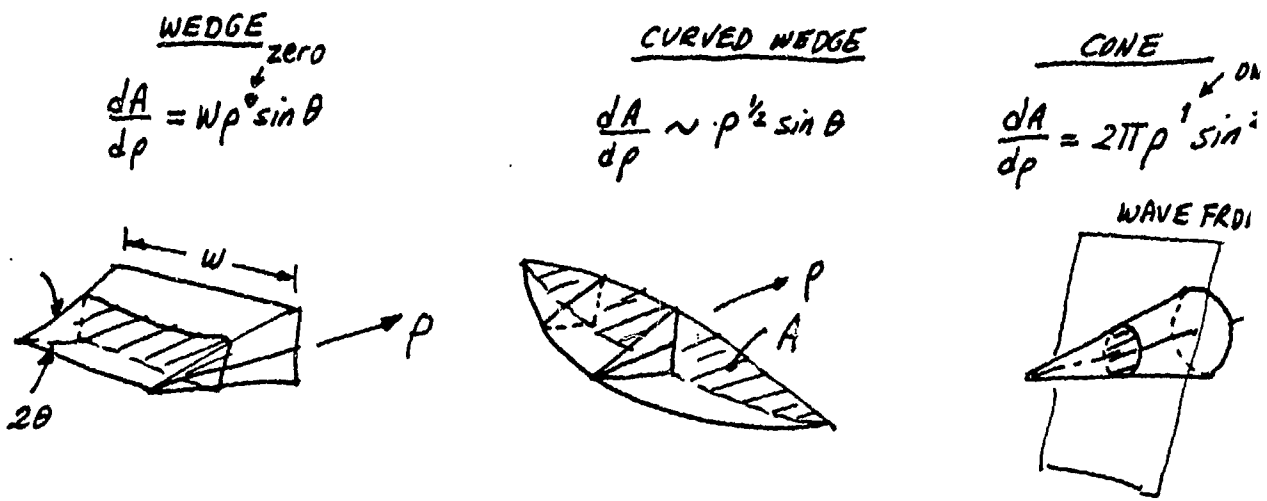

$$\frac{dA}{d\rho} = C\rho^n$$

$$\sigma = \frac{k^2}{\pi} \left[\int e^{2ik\rho} C\rho^n d\rho \right]^2$$

$$\sigma = \frac{k^2}{\pi} \left[\frac{1}{k^{n+1}} \int e^{2ik\rho} C(k\rho)^n d(k\rho) \right]^2$$

$$\sigma = \frac{k^{-2n}}{\pi} \left[\int e^{2iz} C z^n dz \right]^2 \quad z = k\rho$$

$$k = 2\pi/\lambda$$

$$\sigma \sim \lambda^{2n}$$

A. E. FUR

RADAR CROSS SECTION OF A SPHERE

- 0 The formula valid in Rayleigh region

$$\frac{\sigma}{\pi a^2} = \frac{64}{9} (ka)^4$$

comes from Lecture 1, Viewgraph 15.

- 0 In the optical region, σ_o is independent of ka ; subscript "o" refers to optical region.
- 0 In the MIE or RESONANCE region, the cross section is the sum of two contributions. Electric fields add vectorially; power does not add.

Hence the formula

$$\sigma = [\sqrt{\sigma_o} \pm \sqrt{\sigma_c}]^2$$

applies only at maxima or minima of the curves. At other locations a phase angle is required.

- 0 The meaning of the word "resonance" now becomes apparent. When the specular and creeping waves have the correct relative phase, one gets "resonance" or an addition of the two waves.
- 0 At point 1, which is a maximum in Mie region, ka is nearly 1.0. Hence

$$\frac{\sigma_c}{\pi a^2} \approx 1.03$$

RADAR CROSS SECTION OF A SPHERE

A. E. FUHS

RAYLEIGH

$$\sigma = (\pi a^2) \left(\frac{64}{9} (ka)^4 \right)$$

$$\frac{\sigma}{\pi a^2} = \frac{64}{9} (ka)^4$$

OPTICAL

$$\sigma_0 = \pi a^2$$

MIE

CREeping WAVE (CRISPIN PAGE 128)

$$\frac{\sigma_c}{\pi a^2} \approx 1.03 (ka)^{-5/2}$$

AT MAX OR MIN

$$\sigma = \left[\sqrt{\sigma_0} \pm \sqrt{\sigma_c} \right]^2$$

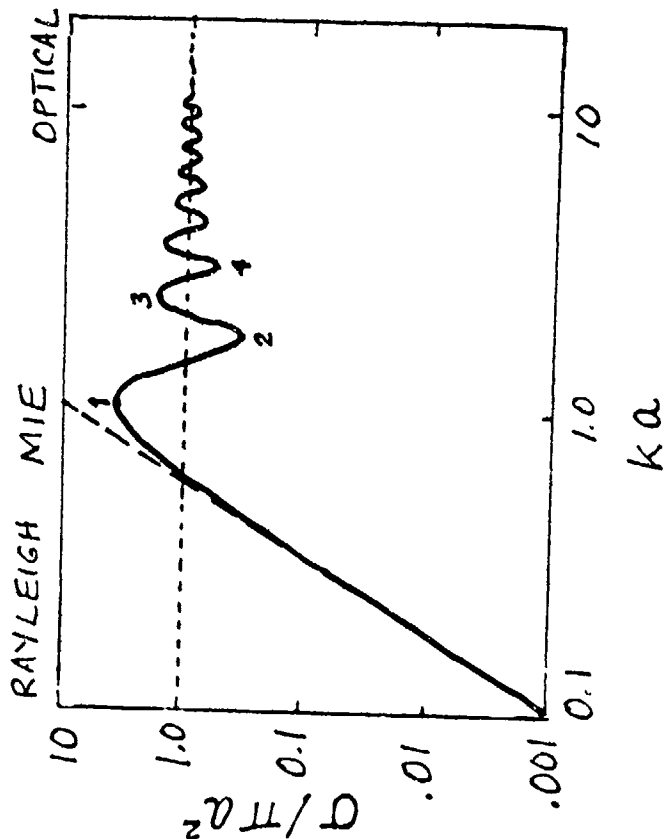

ADDITION OF SPECULAR AND CREEPING WAVES

- 0 One can calculate σ for the maximum at point 1 of RCS wave

$$\sigma_c/\pi a^2 = 1.03$$

$$\sigma_o/\pi a^2 = 1.00$$

$$\frac{\sigma}{\pi a^2} = [\sqrt{\sigma_c/\pi a^2} + \sqrt{\sigma_o/\pi a^2}]^2 = 4.06$$

In terms of db, precise calculations show that the cross section is 5.7 db high at point 1. For the calculations here

$$\sigma_{db} = 10 \log_{10}(4.06) = 6.09$$

which is close.

- 0 At the minimum at point 2 on the curve $ka = 1.8$

$$\frac{\sigma_c}{\pi a^2} = 1.03(1.8)^{-2.5} = 0.237$$

$$\frac{\sigma}{\pi a^2} = [\sqrt{1.0} - \sqrt{0.237}]^2 = 0.263$$

which is close to value of 0.28

- 0 In summary, the wiggles in the RCS curve in the Mie region are due to constructive or destructive interference between specular reflected and creeping waves.

ADDITION OF SPECULAR AND CREEPING WAVES

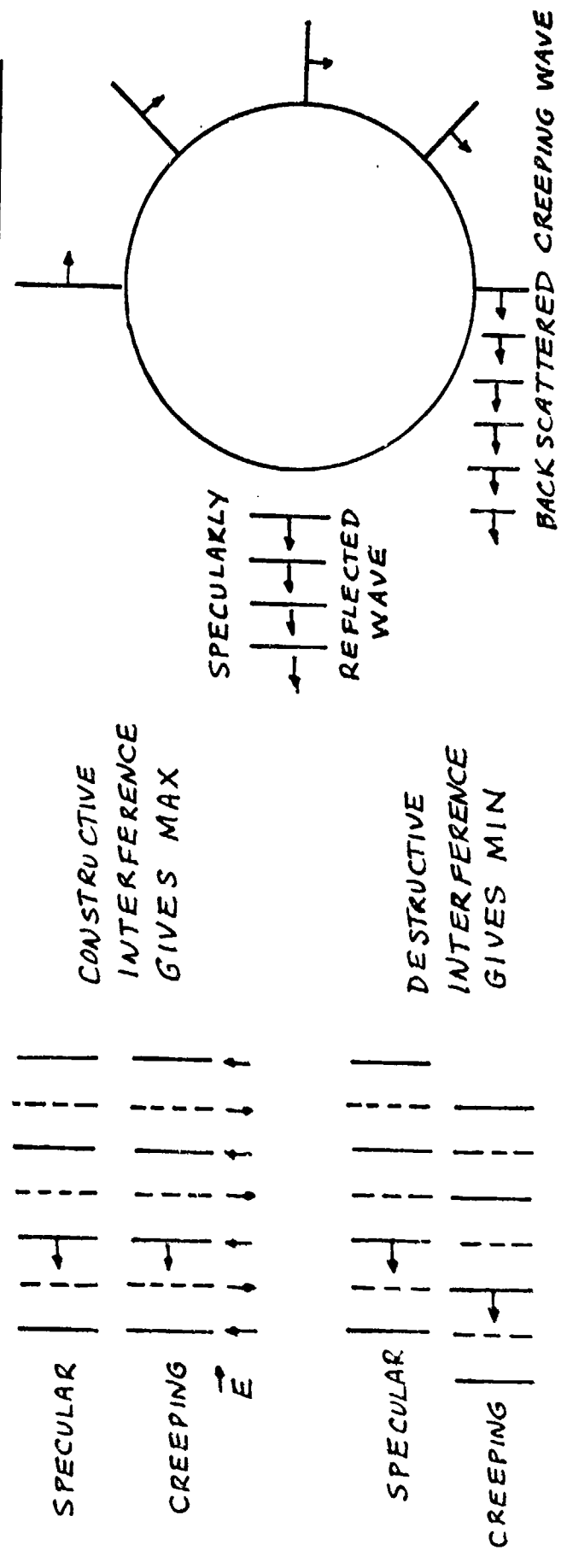

A. E. FUHS

DERIVATION OF $\sigma = \pi \rho_1 \rho_2$

- O ΔS arclength along the reflecting surface
 - $\Delta \theta$ angle subtended by ΔS from center for radius R
 - ΔS_r arclength along the reflected wavefront
 - \vec{k}_i propagation vector for incident wave
 - \vec{k}_r propagation vector for reflected wave
 - R radius of curvature of the reflected wavefront
 - ρ radius of curvature of reflecting surface
 - Ω solid angle formed by reflected wavefront
 - P_i incident power, Watts
 - P_r reflected power, Watts
- O The fact that the angle associated with ρ , i.e., $\Delta \theta_1/2$, is one-half of the angle associated with R , i.e., $\Delta \theta_1$, is an important fact.
 - O In the derivation of the equation, one uses the definition of RCS.

DERIVATION OF $\sigma = \pi P_1 P_2$

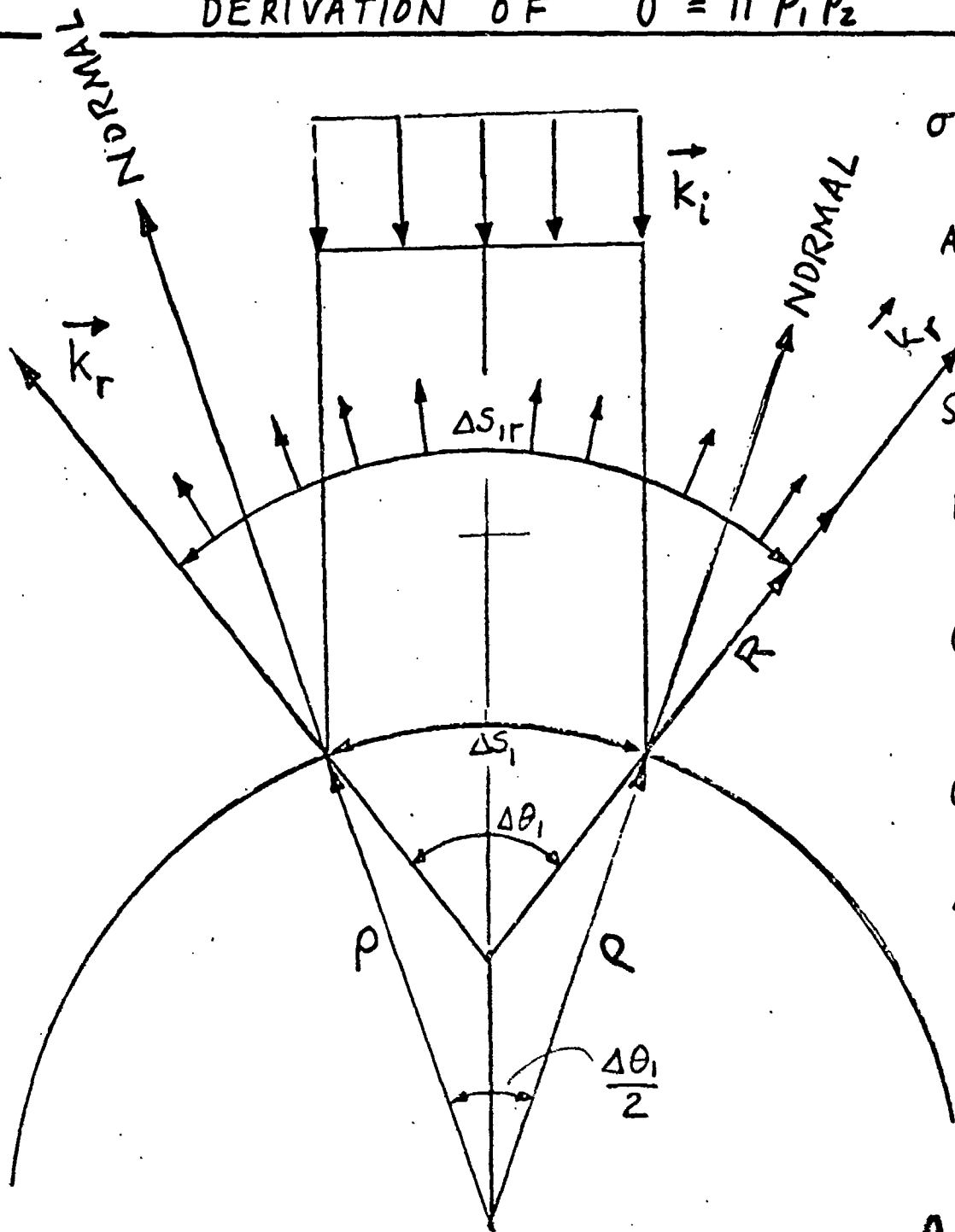

$$\sigma = \frac{P_r / \Omega}{P_i / 4\pi A}$$

$$A = \Delta S_1 \Delta S_2$$

$$\Omega = \frac{\Delta S_{1r} \Delta S}{R^2}$$

$$P_r = P_i$$

$$\sigma = \frac{\left\{ \frac{P_r R^2}{\Delta S_{r1} \Delta S_r} \right\}}{\left\{ \frac{P_i}{4\pi \Delta S_1} \right\}}$$

$$\sigma = 4\pi R^2 \frac{\Delta S_1}{\Delta S_{r1}^2}$$

$$\Delta S_1 = \rho \frac{\Delta\theta_1}{2}$$

$$\Delta S_{r1} = R \Delta\theta$$

$$\sigma = \pi P_1 P_2$$

$\rho =$ RADIUS OF CURVATURE

A. E. FUH

RADAR CROSS SECTION FOR WIRES, RODS, CYLINDERS AND DISCS

- 0 The problem has three characteristic lengths, i.e., a , L , and λ , and two ratios, i.e., $ka = 2\pi a/\lambda$ and L/λ .
- 0 The values of L/λ and ka determine the RCS.
- 0 Consider a reference square area which is λ on each side. The various geometrical figures have the λ -square drawn to indicate relative sizes of ka and L/λ .
- 0 The $(L/\lambda) - (ka)$ plane has been divided into three regions. In the upper left where $L/\lambda \gg 1$ and $ka \gg 1$, the polarization of the wave is not important. In the corner near the origin where $L = a$ and $ka \ll 1$, polarization is not important. In between these two regions, polarization is important, and one needs both σ_{\parallel} and σ_{\perp} to be complete.

RADAR CROSS SECTION FOR WIRES, RODS, CYLINDERS AND DISCS

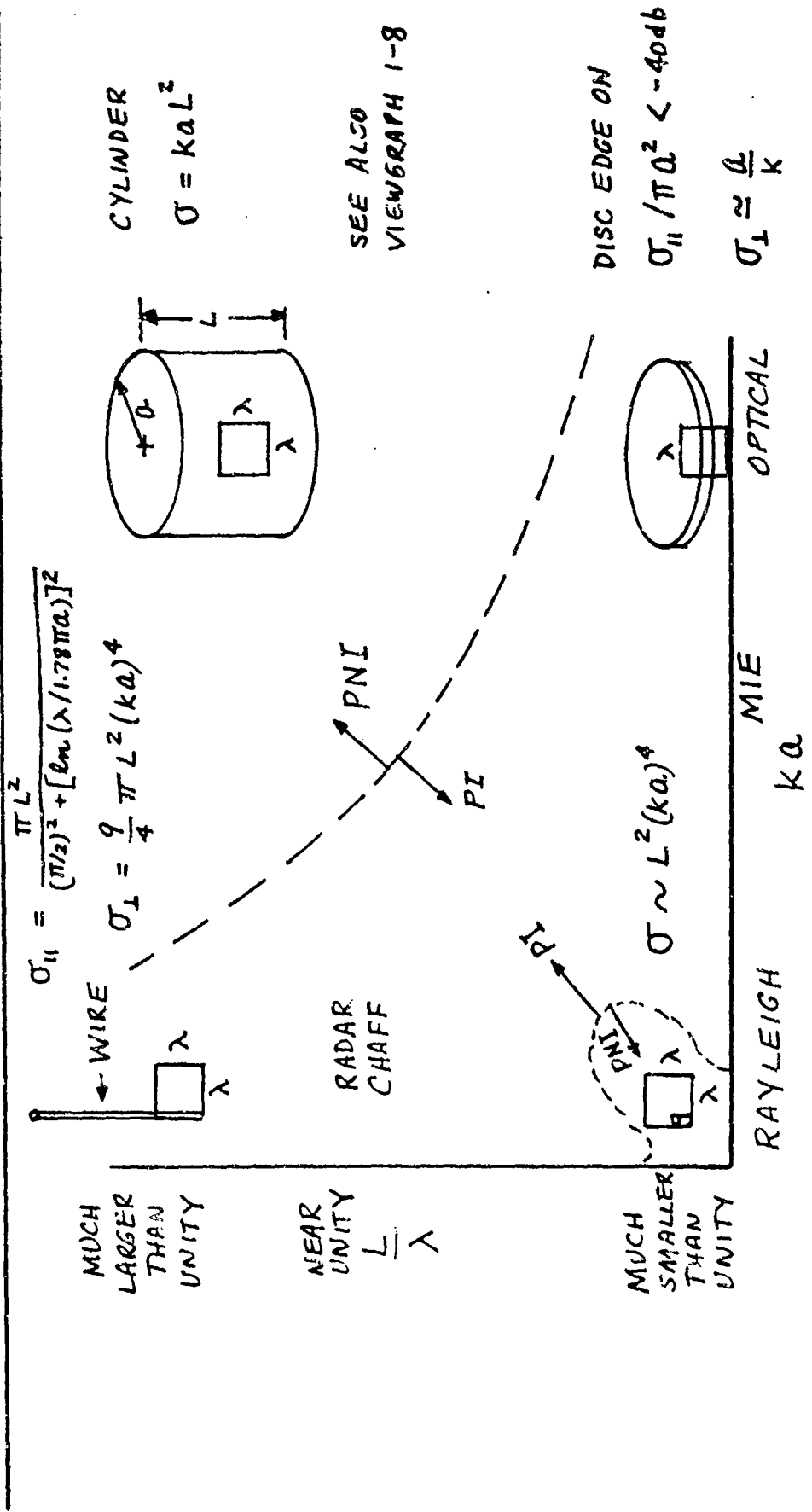

PI = Polarization important

PNI = Polarization Not Important

A. E. FUHS

RADAR CROSS SECTION OF CIRCULAR DISC OF RADIUS, a

LINEAR SCALE

0 The RCS of a circular disc has been calculated.

0 To evaluate the formula, one needs to know frequency and disc radius.
These values are given.

0 A disc with an area of

$$A = \pi r^2 = \pi(0.4572)^2 = 0.66 \text{ m}^2$$

yields a cross section of almost 9000 m^2 at 12 GHz.

0 The linear scale of σ illustrates the big change in σ as frequency increases.
The width of the reflected beam becomes much narrower as frequency increases.

RADAR CROSS SECTION OF CIRCULAR DISC OF RADIUS, a
 LINEAR SCALE

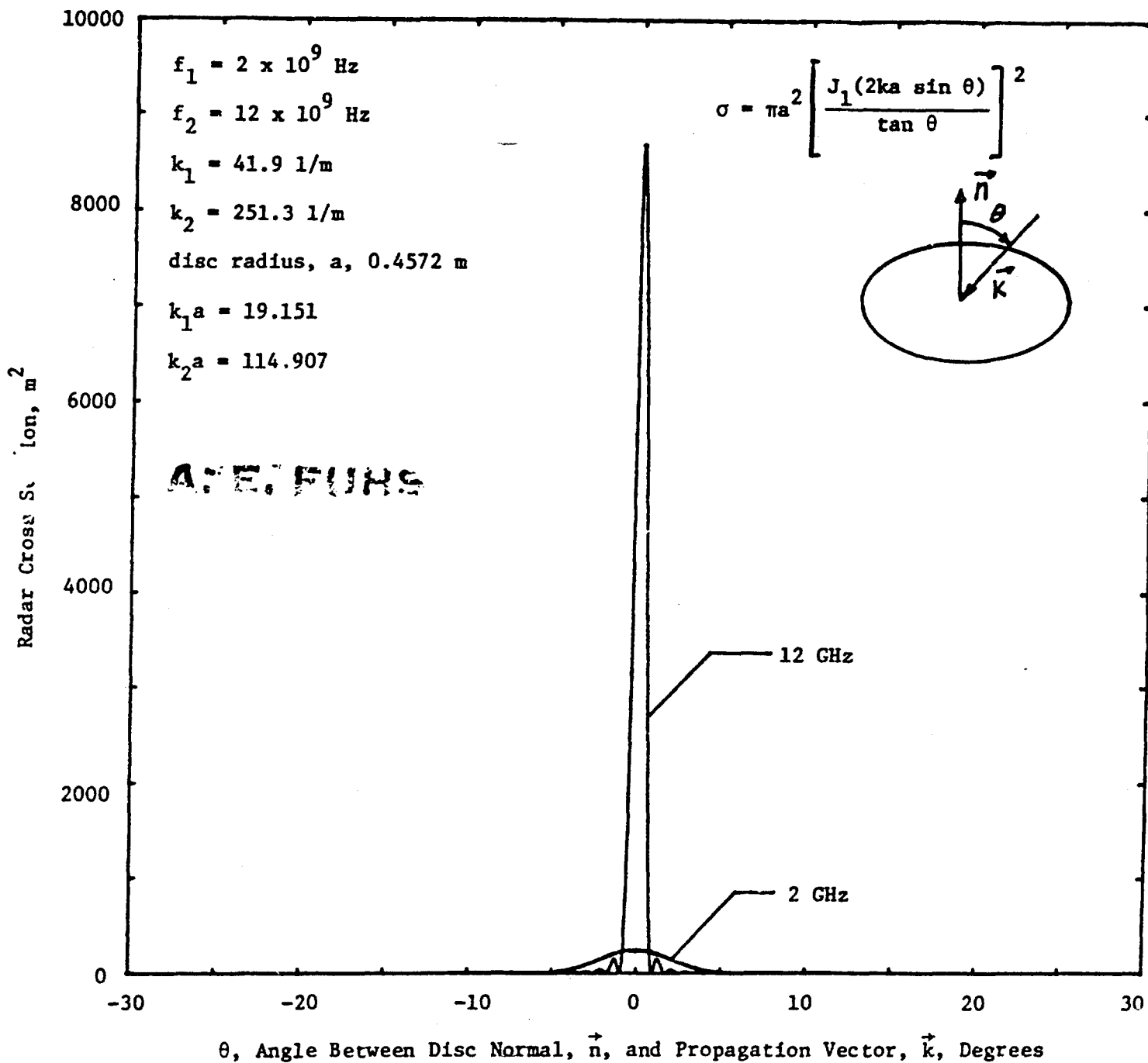

A. E. FUHS 17

RADAR CROSS SECTION OF CIRCULAR DISC OF RADIUS, a

DECIBEL SCALE

0 When db_{sm} is used as a value for RCS, the sidelobes become more apparent.

For $f = 12$ GHz, the main lobe of the beam is about 2° wide.

RADAR CROSS SECTION OF CIRCULAR DISC OF RADIUS, a

DECIBEL SCALE

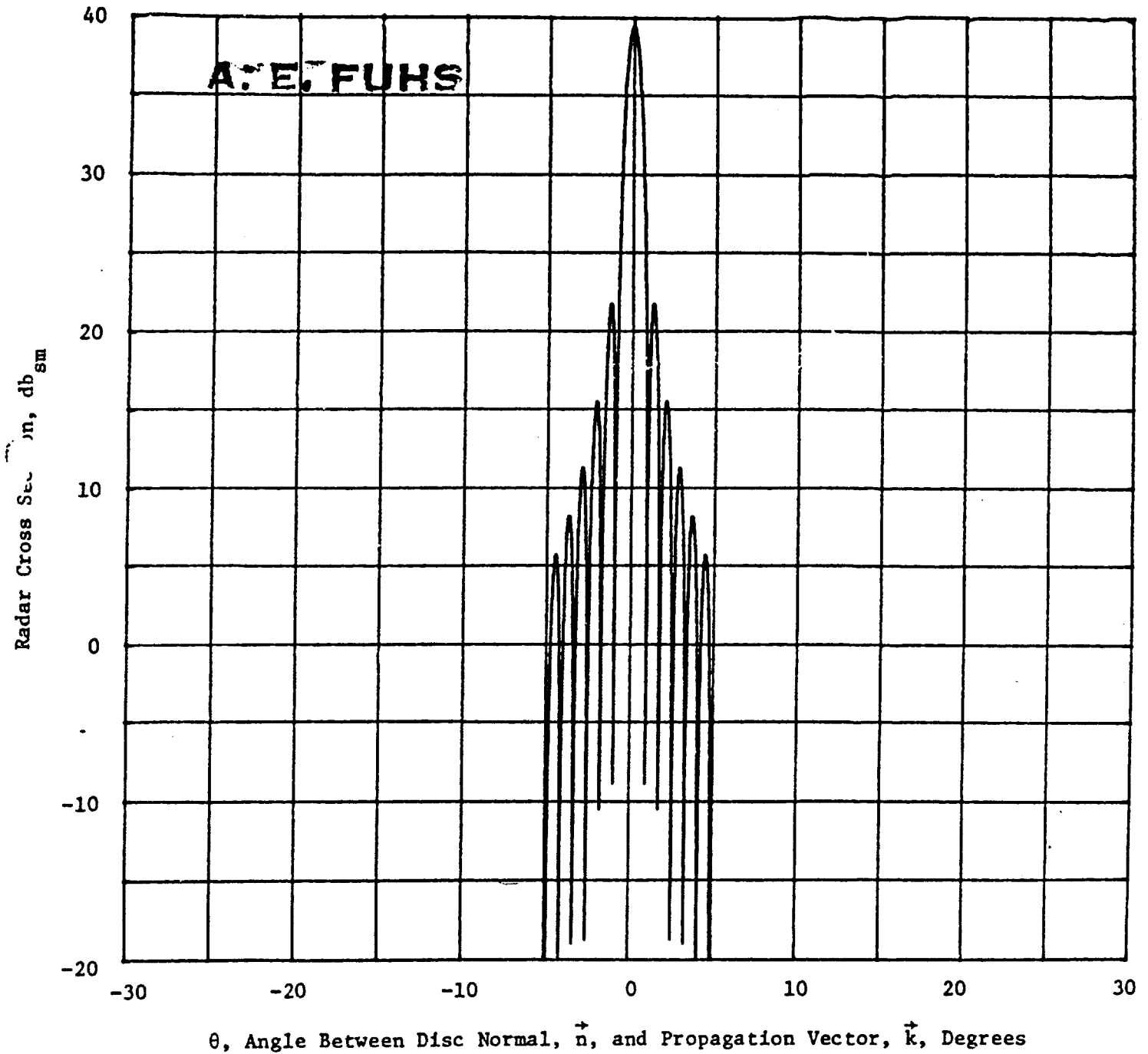
 $a = 36 \text{ inches} = 0.457 \text{ meter}$ $f = 1.2 \text{ GHz}$ 

RADAR CROSS SECTION OF CIRCULAR DISC OF RADIUS, a

DECIBEL SCALE

- 0 The side lobes at $f = 2$ GHz cannot be seen in the plot using a linear scale; see viewgraph 16. However, with the decibel plot, the side lobes are evident. At 2 GHz, the main lobe is almost 12° wide.

RADAR CROSS SECTION OF CIRCULAR DISC OF RADIUS, a

DECIBEL SCALE

$a = 36 \text{ inches} = 0.457 \text{ meters}$

$f = 2 \text{ GHz}$

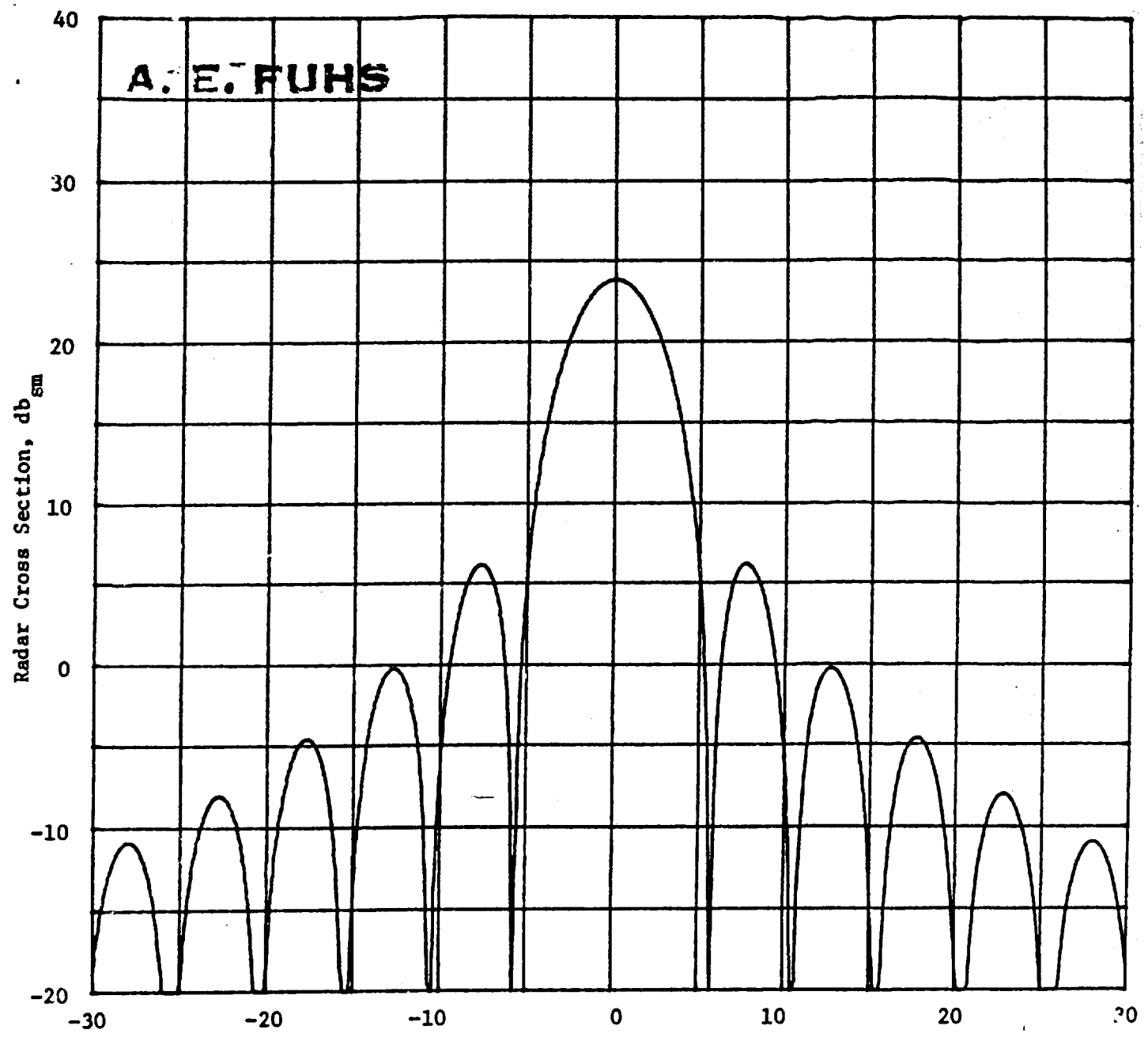

θ , Angle Between Disc Normal, \vec{n} , and Propagation Vector, \vec{k} , Degrees

RCS OF DIHEDRAL

- 0 The radar cross section is due to different surfaces when viewing angle changes. Starting at $\theta = 0^\circ$, the surfaces contributing to the RCS will be noted.
- 0 Near 0° . The plate P_2 and the edge E_1 are the main contributors. Consider \vec{E} perpendicular to edge E_1 . The RCS for E_1 can be modelled as a wire using RCS from viewgraph 15. The flat plate P_2 can be modelled using RCS from viewgraph 1.
- 0 Between 0° and 90° . The dihedral forms a retroreflector. In this region, use formula for the retroreflector.
- 0 Near 90° . Ditto for 0° ; however, use E_2 and P_1 .
- 0 Between 90° and 135° . Both plates P_1 and P_2 contribute to RCS. Once again, use RCS formula from viewgraph 1.
- 0 Between 135° and 180° . In this region the fact that the two plates P_1 and P_2 form a 90° -wedge becomes important. The symbol FW_s means use the finite wedge formulas with plate $\overline{P_1}$ in shadow.
- 0 Near 180° . Plate P_2 is (almost) normal to incident wave. A large RCS results due to flat plate P_2 .
- 0 Between 180° and 270° . Use formulas for finite wedge with both surfaces of wedge exposed. Subscript e means both surfaces are exposed.
- 0 Between 270° and 360° . Already discussed due to symmetrically located regions.

DETERMINATION OF RCS FOR DIHEDRAL

- 0 The largest RCS occurs when θ is 45° as seen in left-hand side of viewgraph.
- 0 One uses the flat plate formula to calculate RCS.
- 0 When θ is not equal to 45° , A_p can be found by a topological trick. Rotate the dihedral about an axis parallel to \vec{k} and passing through the dot on the corner line. Area common to both the initial and rotated dihedral is A_p . The angle θ is identical to θ used in the preceding viewgraph.

DETERMINATION OF RCS FOR DIHEDRAL

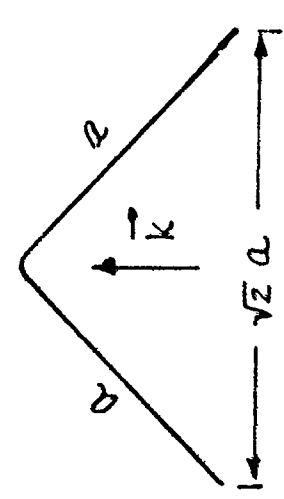

$$\sigma_{45} = \frac{4\pi A_p^2}{\lambda^2} = \frac{4\pi \left[\frac{(\sqrt{2}a)^2}{\lambda^2} \right]^2}{\lambda^2}$$

$$\sigma_{45} = \frac{8\pi a^4}{\lambda^2}$$

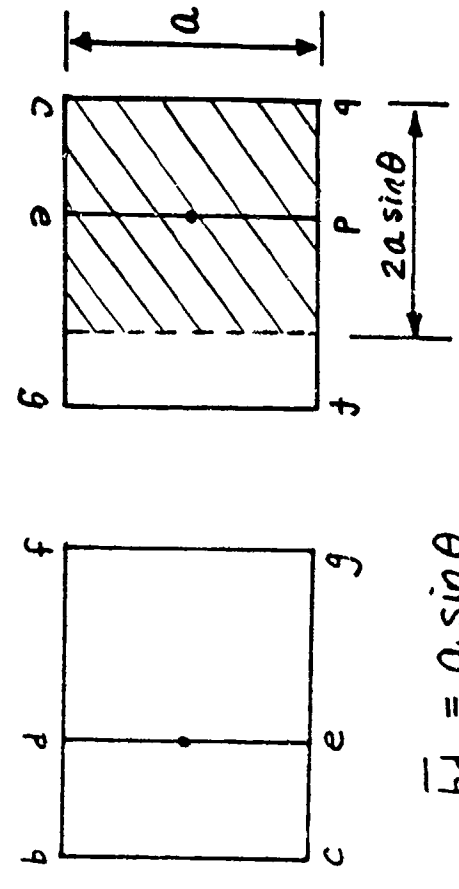

$$\overline{bd} = a \sin \theta$$

$$A_p = (2a \sin \theta)(a)$$

$$\sigma(\theta) = \frac{16\pi a^4 \sin^2 \theta}{\lambda^2} \quad 0 \leq \theta \leq 45^\circ$$

USE $(90^\circ - \theta)$ FOR $45^\circ \leq \theta \leq 90^\circ$

$$\frac{\sigma(\theta)}{\sigma_{45}} = 2 \sin^2 \theta$$

A. E. FURS

SAMPLE CALCULATION OF RCS FOR A DIHEDRAL

- 0 The cross section due to retroreflection from dihedral, i.e., $\sigma(\theta)$, and the cross section from flat plate, i.e., σ_{FP} , were added using the formula shown. The formula implies both reflected waves have the same phase angle.

81

21

SAMPLE CALCULATION OF RCS FOR A DIHEDRAL

$$\sigma = \left[\sqrt{\sigma(\theta)} + \sqrt{\sigma_{FP}} \right]^2$$

A. E. FUHS

$$-30^\circ \leq \theta \leq 120^\circ$$

$$\sigma(\theta) = \frac{16\pi a^4 \sin^2 \theta}{\lambda^2}$$

$$\sigma_{FP} = \frac{4\pi a^4}{\lambda^2} \left[\frac{\sin(ka \sin \theta)}{ka \sin \theta} \right]^2$$

$$\sigma_E = \frac{9}{4} \pi a^2 (kt)^2$$

σ_E WAS FOUND TO BE MUCH
SMALLER THAN $\sigma(\theta)$ OR σ_{FP} .
 σ_E WAS NOT INCLUDED IN
THE CALCULATION.

INPUT VALUES

$$f = 5.0 \text{ GHz}$$

$$a = 0.914 \text{ meters}$$

$$t = \lambda / 85$$

$$\lambda = 0.06 \text{ m}$$

CALCULATED DIHEDRAL RCS FOR $-30^\circ < \theta < 120^\circ$

- 0 The peak at $\theta = 0^\circ$ is due to flat plate P_2 . The peak at $\theta = 45^\circ$ is due to retroreflection by the dihedral. The peak at $\theta = 90^\circ$ is due to flat plate P_1 . For $90^\circ < \theta < 120^\circ$, the cross section is due to plates P_1 and P_2 .
- 0 This curve should be compared with the curve in the following viewgraph.

CALCULATED DIHEDRAL RCS FOR $-30^\circ < \theta < 120^\circ$

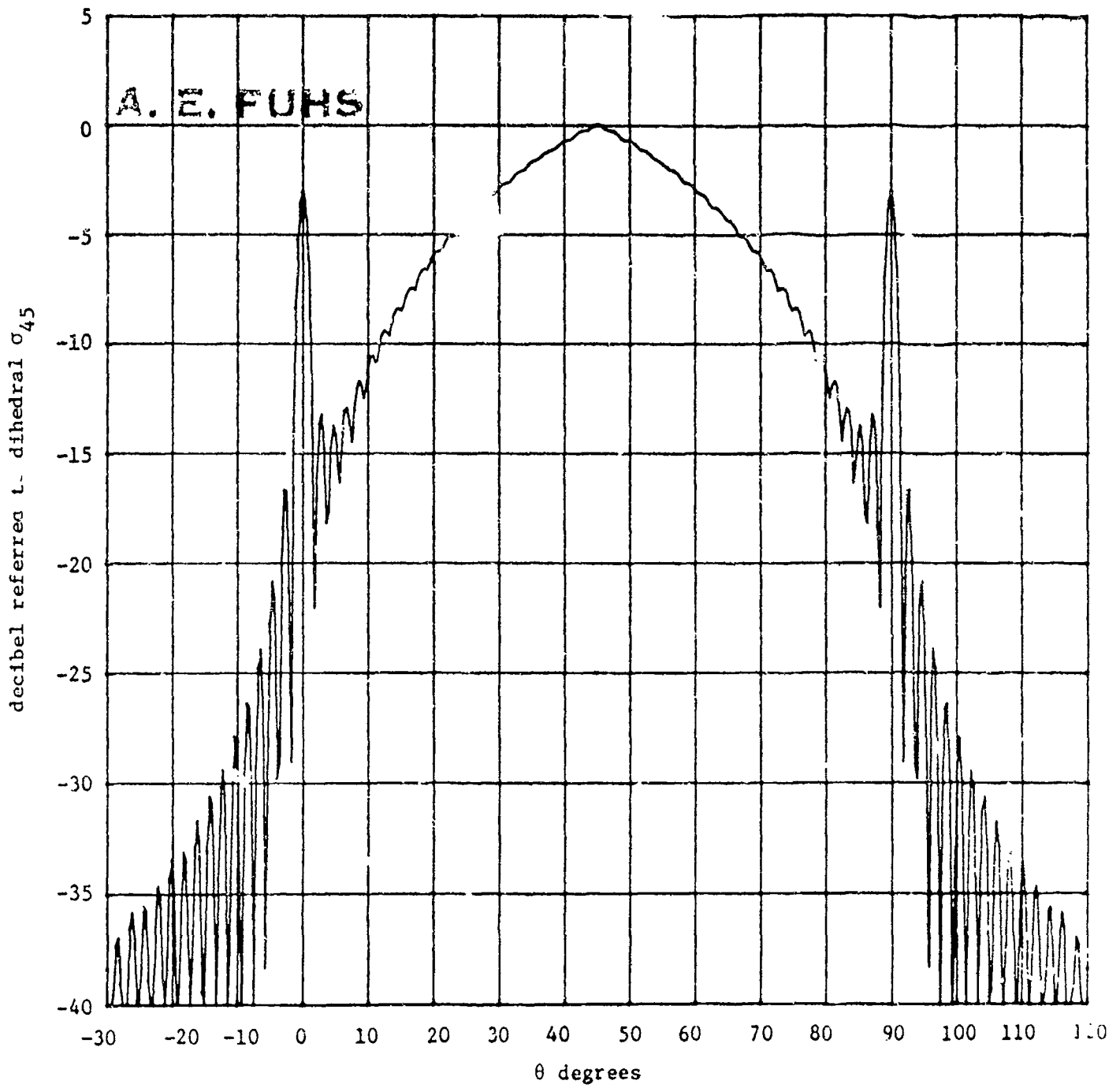

DATA FOR A DIHEDRAL AT 5.0 GHz

- 0 The simple model given in viewgraph 21 provides accurate results except for the dip at 45° .

DATA FOR A DIHEDRAL AT 5.0 GHz A. E. FUHS

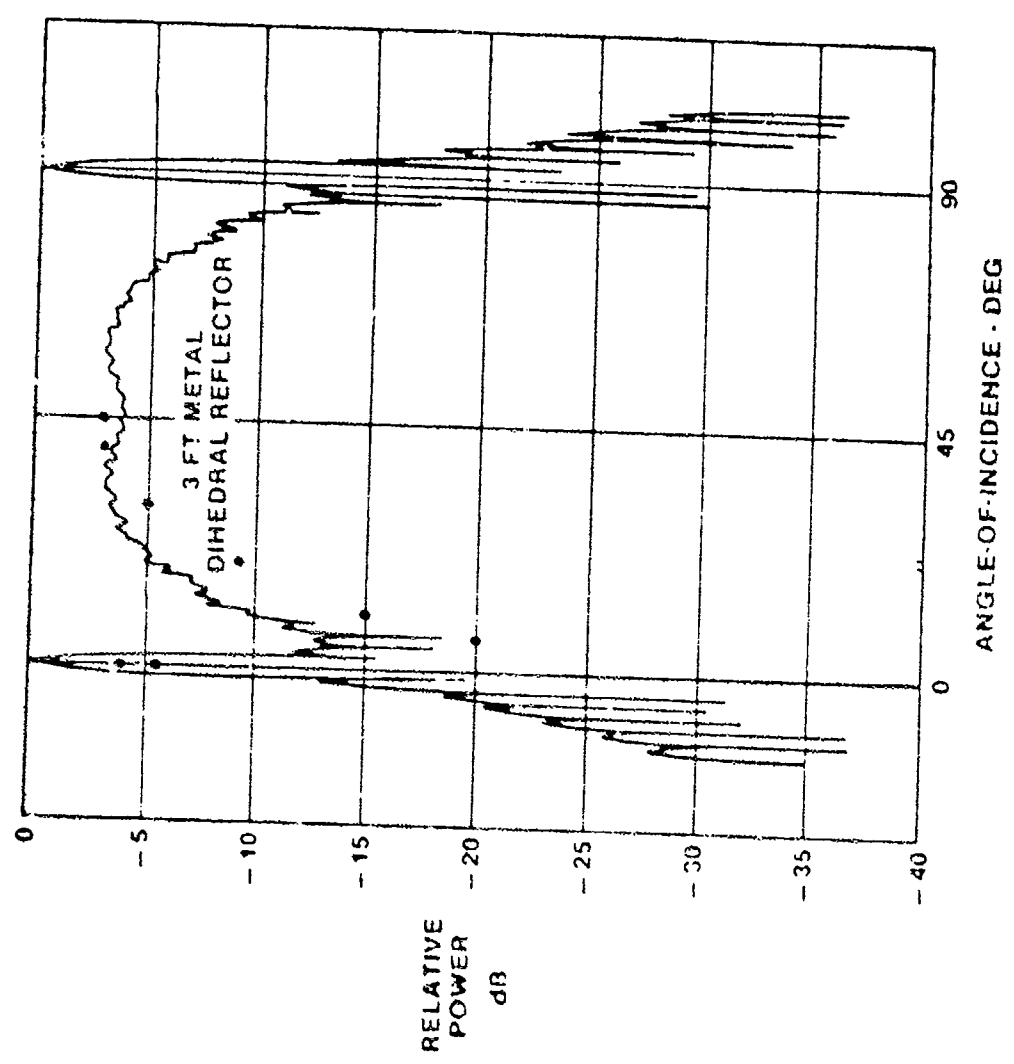

BLACK DOTS ARE A FEW CALCULATED POINTS

THE CALCULATED CURVE AGREES WELL WITH THE CURVE TO THE LEFT EXCEPT FOR THE RCS AT $\theta = 45^\circ$.

THE WIGGLES, THE TRENDS, THE MAGNITUDES, THE SPIKES AT 0° AND 90° ALL AGREE. HENCE CORRECT

PHENOMENA ARE INCORPORATED IN MODEL. THE DIP AT 45° INDICATES SOMETHING MISSING IN THE MODEL.

\vec{E} PERPENDICULAR TO DIHEDRAL EDGES E_1 AND E_2

CREEPING WAVES

0 Creeping waves usually yield smaller RCS than specular reflection.

In case of sphere, σ_c was as large as the specular return for $ka \approx 1$.

0 Creeping waves are important for smooth blunt bodies such as spheres, cylinders, and ellipsoids.

CREEPING WAVES

A. E. FUHS

A RAY TANGENTIAL TO
A SMOOTH OBJECT
EXCITES CREEPING
WAVES.

CREEPING WAVES ARE
ENCOUNTERED IN THE
MIE OR OPTICAL REGION.

WAVES ARE LAUNCHED AT
SHADOW BOUNDARY (RAYS ARE
TANGENT TO SURFACE) OF AN
OBJECT, CREEPING WAVES EMERGE

AT THE OPPOSITE SHADOW BOUNDARY
AS SHOWN, CREEPING WAVES PROPAGATE CLOCKWISE
AND COUNTERCLOCKWISE.

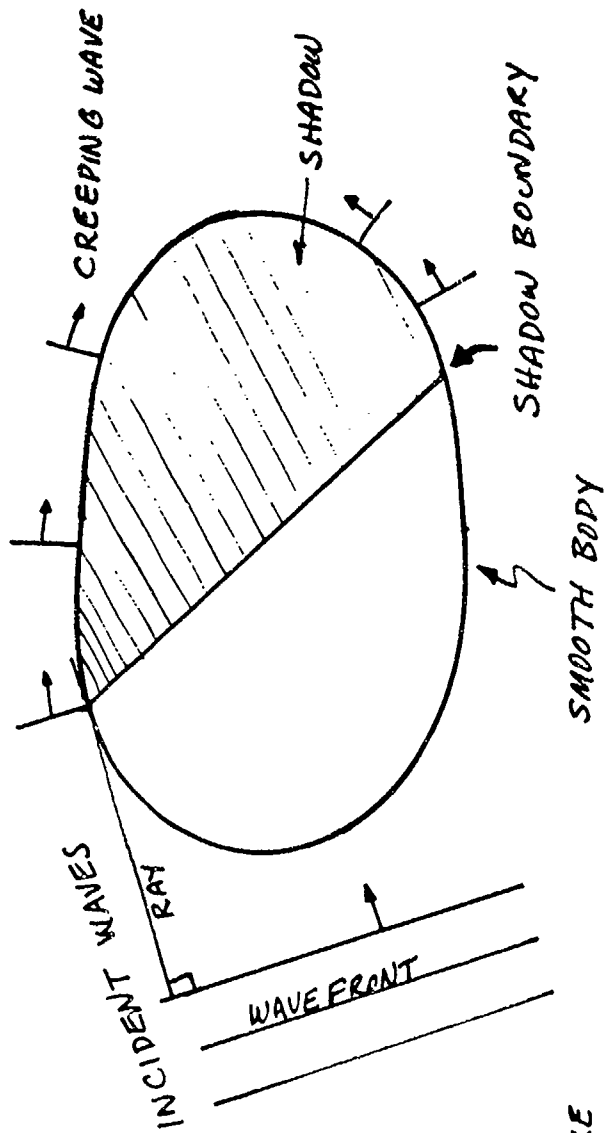

CREEPING WAVES ARE
ASSOCIATED WITH CURRENTS
IN THE BODY IN THE
SHADOW REGION.

TRAVELING WAVES

- 0 Body acts like a traveling wave antenna.
- 0 Formula for RCS due to wire for $L = 39\lambda$ and $a = \lambda/4$.

$$\frac{\sigma}{\lambda^2} = (8.5E - 4) \left[\frac{\sin \theta}{1 - \cos \theta} \sin[124.5(1 - \cos \theta)] \right]^4$$

$\theta = 0$ is for \vec{k} parallel to wire. At $\theta \approx 8^\circ$, the value of σ/λ^2 attains a value of about 10.

- 0 The conditions for excitation of traveling waves are noted, namely long, thin bodies with near nose-on incidence of waves.
- 0 Bodies with dielectrics favor excitation of traveling waves.

TRAVELING WAVES

A. E. FUHS

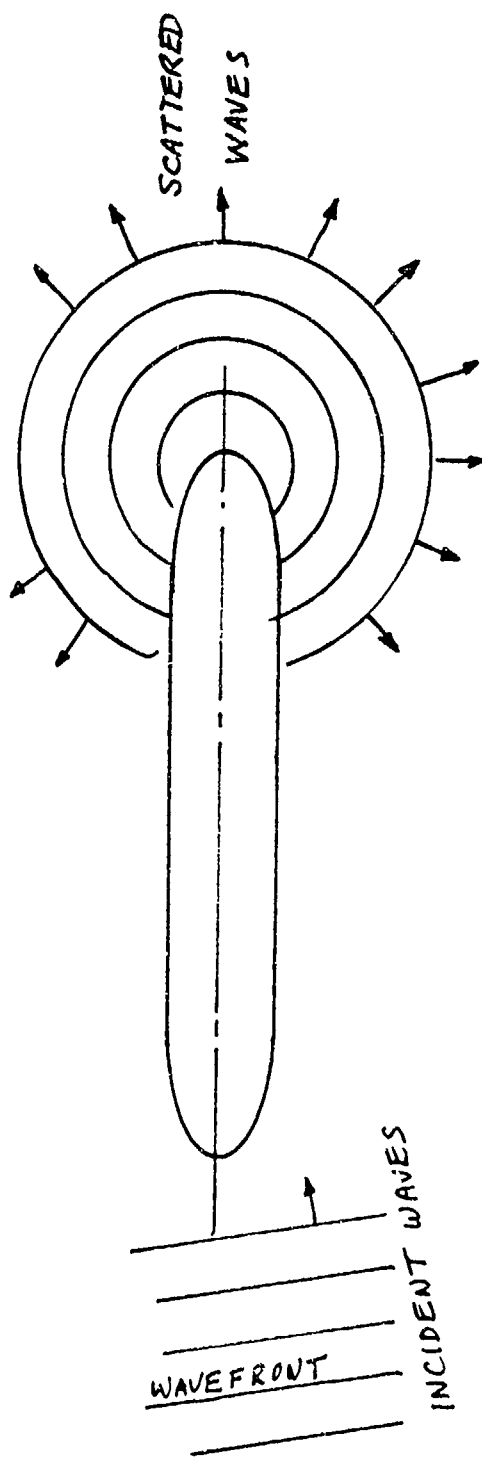

LONG THIN BODY SUCH AS WIRES, PROLATE ELLIPSOIDS, AND OGIVES
 NEAR NOSE-ON INCIDENCE
 \vec{E} VECTOR IN-PLANE OF PAPER
 BACK SCATTERED WAVES EMANATE FROM REAR OF BODY

RCS OF CAVITIES

- 0 The flat plate model gives an order-of-magnitude estimate of the inlet, exhaust, or radar cavity.
- 0 Fenestrated radomes may be opaque at some radar frequencies avoiding problem of transparent radome and exposure of radar cavity.

RCS OF CAVITIES

RADOME MAY BE TRANSPARENT AT RADAR FREQUENCIES

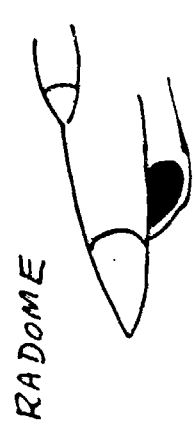

RADOME

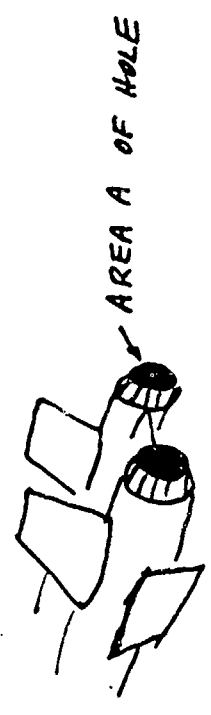

ENGINE EXHAUSTS

ENGINE INLET

- PROBLEM IS COMPLEX
 - RCS IS DETERMINED BY WHAT IS IN THE HOLE
 - CAVITIES HAVE INTRINSIC HIGH RCS
- AS A SIMPLE MODEL USE FLAT PLATE

$$\sigma = \frac{4\pi A^2}{\lambda^2}$$

FOR VARIATION WITH ANGLE θ

$$\frac{\sigma}{\sigma_0} = \left[\frac{\sin(kd \sin\theta)}{kd \sin\theta} \right]^2$$

A. E. FULTS

RETROREFLECTORS

0 Use of retroreflectors

- drones

- sail boats

- navigation buoys

0 Looking at retroreflectors, RR, on sail boats in Monterey Bay showed that almost every one was installed wrong if the radar was on another ship.

One plate of the RR usually was mounted horizontally which is wrong.

0 Retroreflectors are inadvertently designed into a vehicle causing very large RCS.

0 Retroreflectors were left on the moon by the astronauts.

RETROREFLECTORS

A. E. FUHS

$$\sigma = \frac{4\pi A^2}{\lambda^2}$$

PROBLEM IS TO FIND A.
 USE ROTATION ABOUT \vec{k}
 FOR INCIDENT WAVE, \vec{k} IS
 AREA AFTER ROTATION IS A
 HATCHED AREA

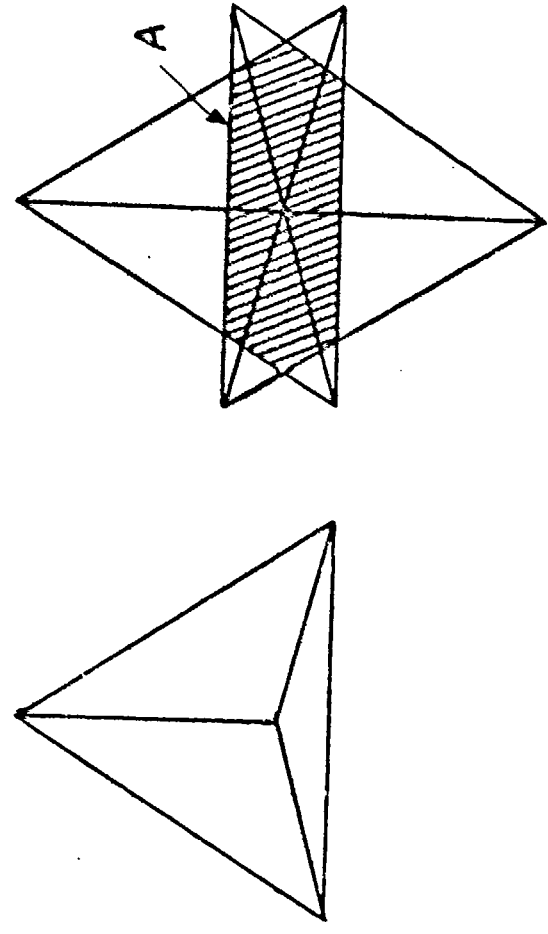

RAY'S ARE REFLECTED FROM ALL THREE SURFACES.
 RETROREFLECTORS DO NOT WORK WITH BISTATIC RADAR.

RCS OF COMMON TRIHEDRAL REFLECTORS

0 Consider the corner to form x,y,z coordinate system.

The angle of a symmetrically located vector can be found by

$$\cos^2 \theta_x + \cos^2 \theta_y + \cos^2 \theta_z = 1.0$$

$$\theta_x = \theta_y = \theta_z = \theta$$

$$\theta = \arccos(1/\sqrt{3}) = 54.736^\circ$$

RCS OF COMMON TRIHEDRAL REFLECTORS

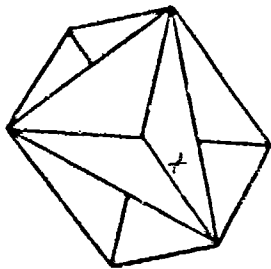

$$\sigma = \frac{1}{3} 4\pi \frac{\lambda^4}{\lambda^2}$$

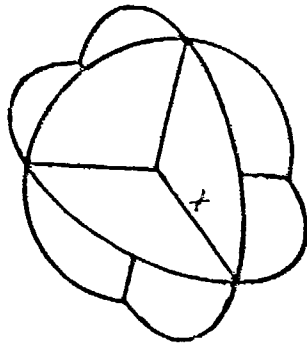

$$\sigma = 15.611 \frac{\lambda^4}{\lambda^2}$$

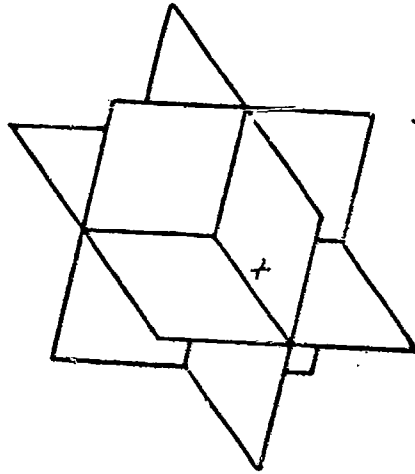

$$\sigma = 3 \frac{4\pi \lambda^4}{\lambda^2}$$

SQUARE REFLECTOR
HAS 9 TIMES LARGER
 σ THAN TRIANGULAR
REFLECTOR.

ONE CAN DERIVE THE RCS USING METHODS OUTLINED.
POSITION A VECTOR IN THE CORNER SO THAT THE THREE
DIRECTION COSINES ARE EQUAL. MOUNT THE REFLECTOR
SO THAT THE VECTOR POINTS TOWARD RADAR

VECTOR SUM FOR RADAR CROSS SECTION

- 0 The radar cross section for multiple scatterers can be found using the equation. In the equation, the sum is from first to m-th scattering object.
- 0 The equation contains phase information which may lead to cancellation.
- 0 The symbols have the following definitions:

σ_k radar cross section of k-th object

d_k distance from k-th object to radar receiver

λ wavelength of radar

E_r electric field in reflected wave

E_{rk} electric field in reflected wave due to k-th object

- 0 Since radar waves make round trip, a difference $\Delta d = \lambda/4$ gives a phase change of $\lambda/2$ which is 180° phase. A 180° phase causes cancellation. A difference $\Delta d = \lambda/2$ yields a phase of λ ; the reflected waves are in phase and add.

VECTOR SUM FOR RADAR CROSS SECTION

$$\sigma = \left[\sum_{k=1}^m \sqrt{\sigma_k} \exp\left(\frac{j4\pi dk}{\lambda}\right) \right]^2$$

ORIGIN OF $\sqrt{\sigma_k}$

$$\sigma = \left\{ \frac{\text{power reflected}}{\text{steradian}} \right\} / \left\{ \frac{\text{incident power}}{4\pi \text{Area}} \right\}$$

Reflected power $\sim E_r^2$

$$RCS \sim E_r^2 \sim \sigma$$

$$E_{rk} \sim \sigma_k^{1/2}$$

E_r = reflected electric field vector

E_r has amplitude and phase

at receiver, electric fields, E_{rk} ,

add vectorially

ORIGIN OF 4π

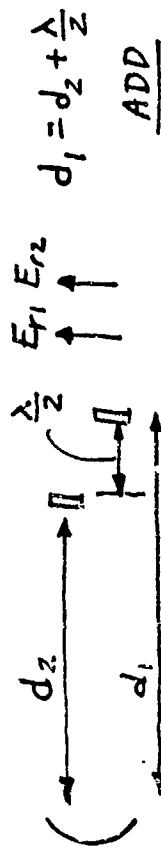
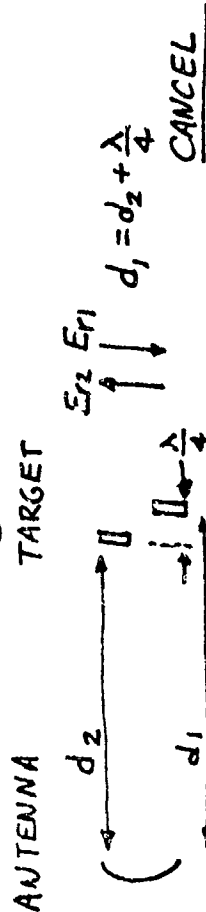
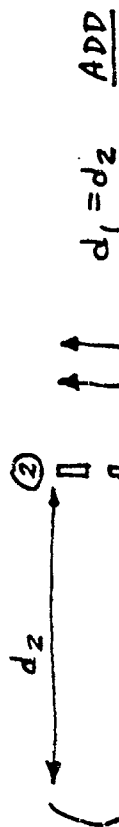

RADAR WAVES MAKE ROUND TRIP

RADAR CROSS SECTION FOR TWO SPHERES

- 0 A variety of features of RCS can be illustrated with the two-sphere model.
- 0 Vector addition of E

Assume $f = 1$ and $\theta = 90^\circ$; then $\sigma = 4\sigma_1$.

The cross section is 4 times that of one sphere!

- 0 Influence of spacing ℓ relative to λ . Assume $f = 1$.

$$\frac{8\pi\ell}{\lambda} \cos \theta = 0 \text{ or } 2n\pi \quad \text{a maximum occurs}$$

$$\frac{8\pi\ell}{\lambda} \cos \theta = (2n - 1)\pi; n = 1, 2, 3, 4, \dots \quad \text{a minimum (zero) occurs}$$

As ℓ/λ increases, the number of maxima increases.

- 0 Influence of unequal RCS for scattering centers (i.e., spheres not same size)

$$f = 1/4 \qquad E_2 = 1 \qquad E_1 = 1/4$$

$$E_{\max} = 1 + 1/4 = 5/4 \qquad E_{\min} = 1 - 1/4 = 3/4$$

$$\sigma_{\max} = (5/4)^2 = 1.56 \qquad E_{\min} (.75)^2 = 0.56$$

- 0 Influence when λ/ℓ or ℓ/λ are not integers

- interference still occurs

- angular location of interference peaks are shifted

- large σ at $\theta = 0^\circ$ is modified

- 0 When spheres are broadside to wave, the greatest sensitivity of RCS to a change in θ occurs, i.e.

$$\frac{\partial \sigma}{\partial \theta} \text{ is largest}$$

- 0 When spheres are on a line parallel to \vec{k} , the least sensitivity of RCS to a change in θ occurs, i.e.

$$\frac{\partial \sigma}{\partial \theta} \text{ is smallest}$$

RADAR CROSS SECTION FOR TWO SPHERES

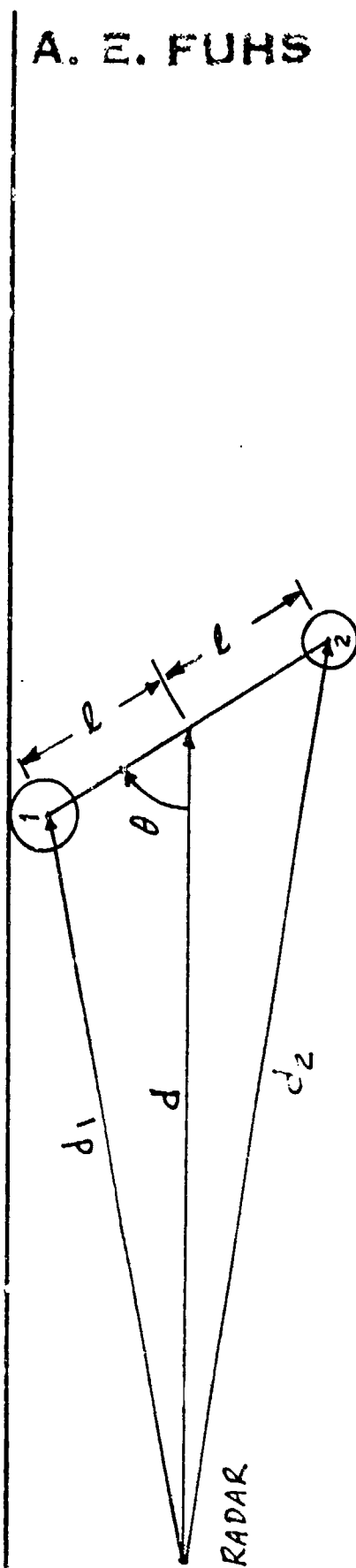

A. E. FUHS

$$d_1^2 = d^2 + l^2 - 2dl \cos \theta$$

$$d_1 \approx d - l \cos \theta$$

$$d_2 \approx d + l \cos \theta$$

DIFFERENT SIZE SPHERES CAN BE USED.

$$\sigma_1 = f^2 \sigma_2$$

FOR CASE ILLUSTRATED ABOVE, $f > 1.0$

$$\sigma = \sigma_1 \left[e^{i \frac{8\pi}{\lambda} (d - l \cos \theta)} + 2f e^{i \frac{4\pi}{\lambda} (d_1 + d_2)} + f^2 e^{i \frac{8\pi}{\lambda} (d + l \cos \theta)} \right]$$

$$\frac{\sigma}{\sigma_1} = \left\{ R^2 + I^2 \right\}^{1/2}$$

$$R = 2f + (1 + f^2) \cos \left[\frac{8\pi l}{\lambda} \cos \theta \right]$$

$$I = (f^2 - 1) \sin \left[\frac{8\pi l}{\lambda} \cos \theta \right]$$

SAMPLE OUTPUT FOR TWO-SPHERES MODEL

0 The RCS due to two spheres was calculated. Plotted is σ/σ_1 as a function of θ . When θ is 90° , the spheres are broadside to the waves. The spheres are oriented as shown in the drawing. A non-integer spacing was selected; $2d = 0.714\lambda$.

0 The figure on the left-hand side is for $f = 1$, i.e., both spheres are the same size. Broadside to the incident waves, σ/σ_1 is equal to 4. When $\theta = 0$, the RCS does not decrease to zero. At $\theta = 0^\circ$, the phase angle between the electric vectors is

$$(2)(0.71)(360) - 360 = 151.2^\circ$$

Since the phase angle is not 180° , the RCS does not vanish.

0 The figure on the right side has the same spacing for the spheres. However, the relative sphere size has been changed since $f = 1/2$. In fact, the RCS of one sphere is only f^2 or $1/4$ as large. The RCS does not vanish at any value of θ due to destructive interference.

SAMPLE OUTPUT FOR TWO-SPHERES MODEL

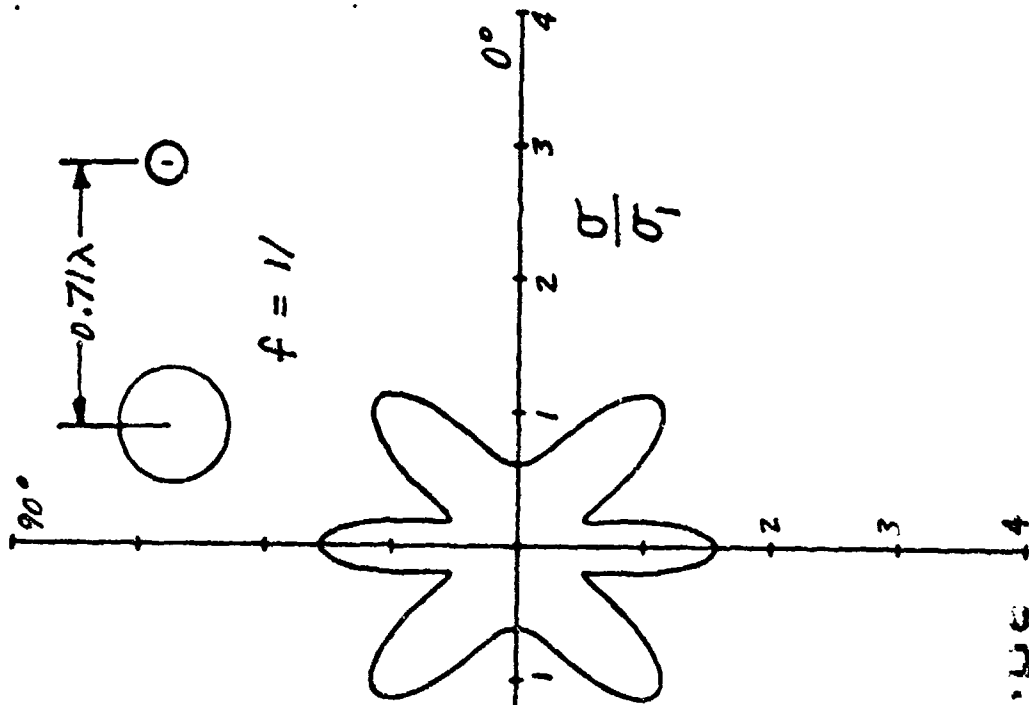
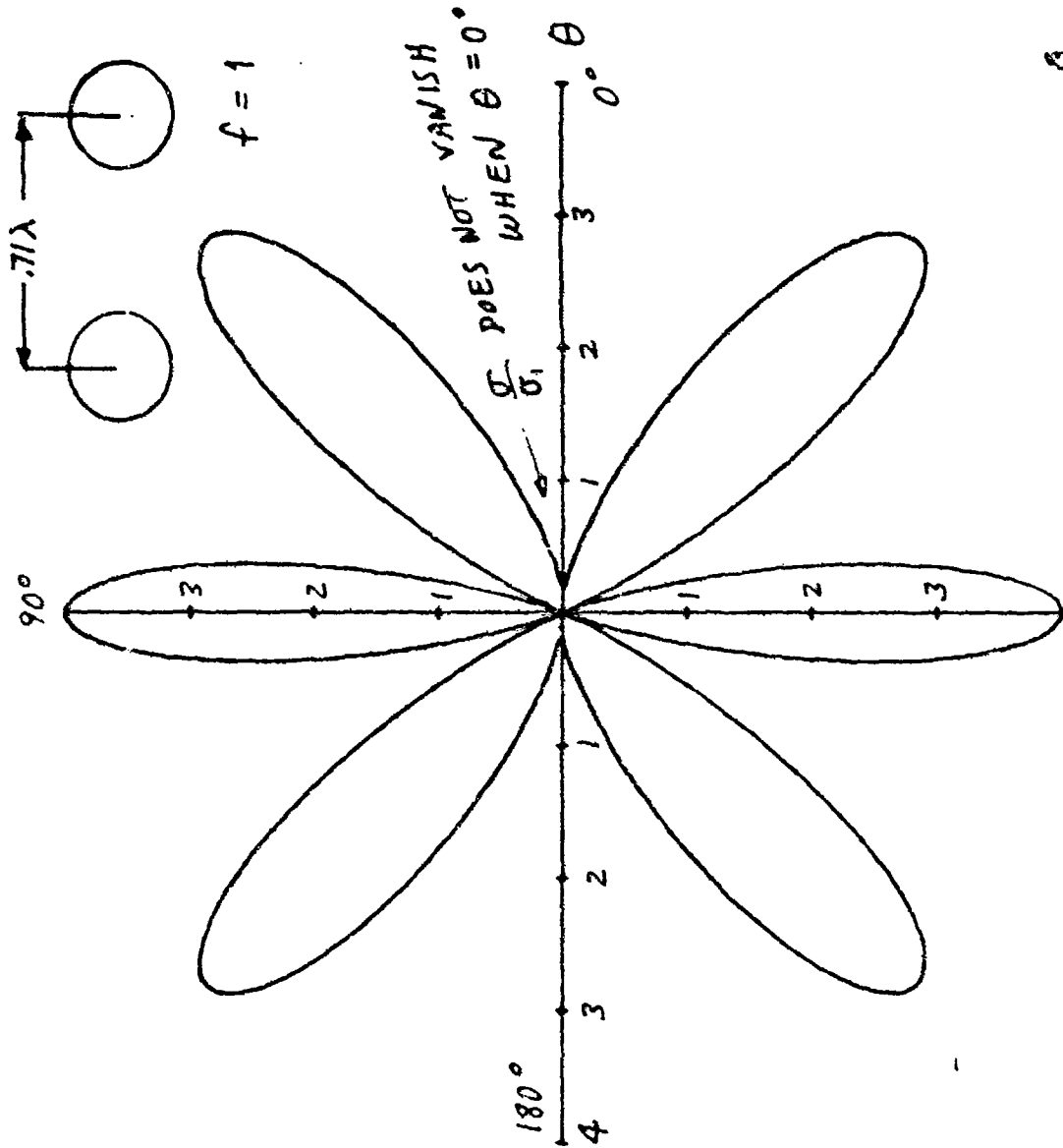

RADAR CROSS SECTION AND ANTENNAS

- O When the flat plate is illuminated at an angle α off the normal, the (monostatic) radar does not see the main lobe.
- O The (monostatic) radar receives the $N = 3$ sidelobe for the case illustrated.
- O Note that the angle off the normal α is one-half of the angle of the $N = 3$ lobe from the main lobe, i.e.

$$\beta = 2\alpha$$

RADAR CROSS SECTION AND ANTENNAS

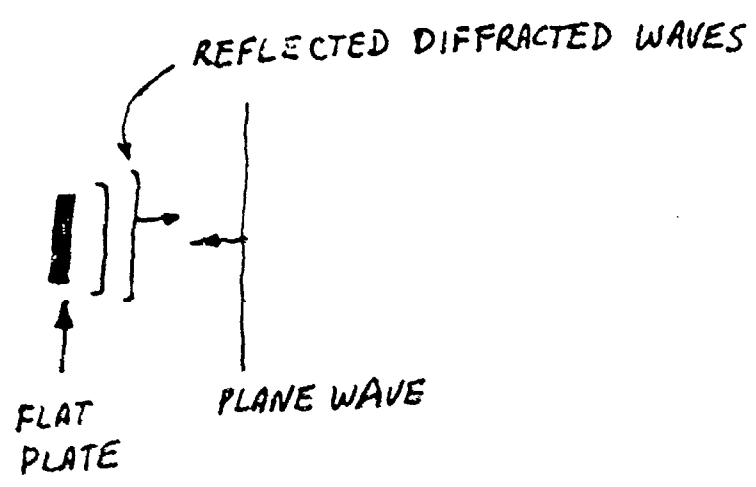
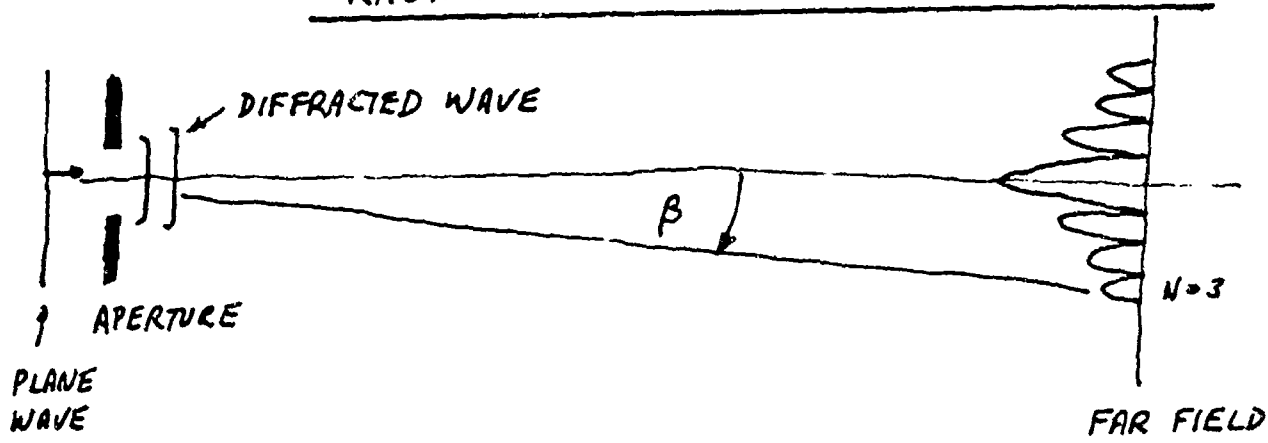

DITTO ABOVE

A: E. FUHS

$$2\alpha = \beta = 2\theta$$

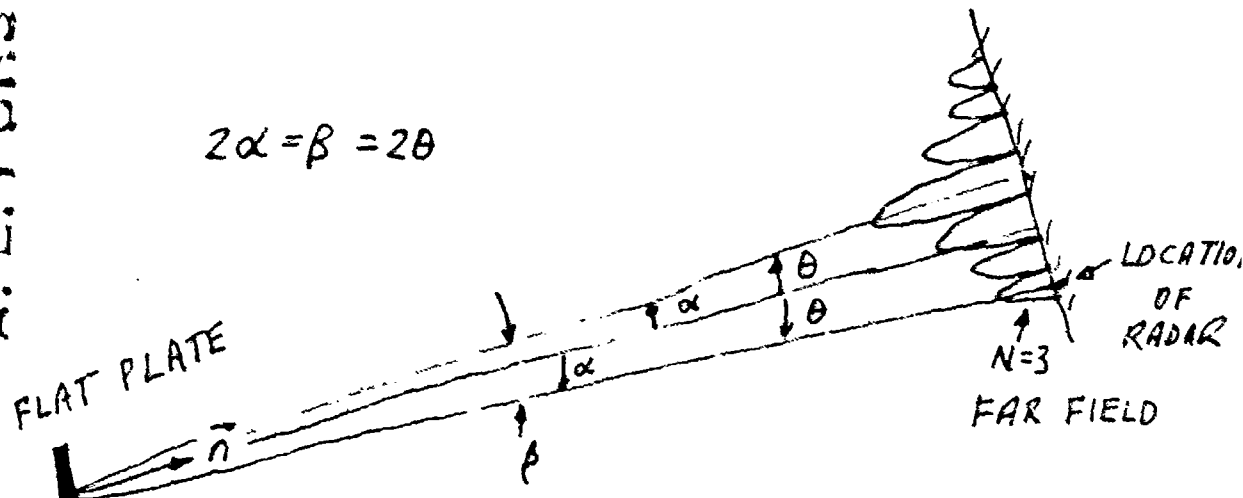

MONOSTATIC RADAR SEES $N=3$ LOBE

BISTATIC RADAR WITH ANGLE β SEES MAIN LOBE

LECTURE III. AIRCRAFT DESIGN AND RADAR CROSS SECTION

1. Origin of Electromagnetic Wave Scattering
2. Contributors to Aircraft Radar Cross Section
3. Relative Size of Contributors to RCS
4. Aircraft at Visible and Microwave Frequencies
5. Fire Fox MIG-31
6. Plan Form Fire Fox MIG-31
7. Gross Features of RCS for Fire Fox MIG-31
8. Antenna Scattering
9. Radar Cross Section Reduction
10. Impedance Loading
11. Shaping to Reduce Radar Cross Section
12. Do's and Don't's for Shaping to Achieve Low RCS
13. Radar Absorbing Material, RAM
14. Practical Aspects of RAM
15. Construction Materials
16. Radar "Hot Spots"
17. Payoff of Reduced Radar Cross Section

A. E. FUHS

ORIGIN OF ELECTROMAGNETIC WAVE SCATTERING

SPECULAR. Mirror-like reflection. Lobes occur due to diffraction. Main contribution occurs when $\vec{k}_i \cdot \vec{n} = -k_i$, i.e., wavefronts are tangent to surface. \vec{k}_i is wave propagation vector which is normal to incident wavefront.

DIFFRACTION. A discontinuity occurs, and electromagnetic (EM) boundary conditions must be satisfied. The scattered wave is necessary to satisfy the boundary conditions.

TRAVELING WAVE. A long thin body with near nose-on incidence may cause traveling waves. Along the body, EM scattering may occur due to

- surface discontinuity
- change in material, e.g., metal to plastic
- end of body

CREEPING WAVE. Waves which propagate in the shadow region of smooth bodies are creeping waves.

CHANGES IN EM BOUNDARY CONDITIONS. As the incident wave propagates along the surface of the body, the EM boundary conditions are satisfied by currents in body. Whenever a change in EM boundary conditions occurs, scattering results.

Examples are:

- gaps and edges
- surface discontinuities in slope, curvature, etc.
- change in surface materials

ORIGIN OF ELECTROMAGNETIC WAVE SCATTERING

A. E. FUHS

SPECULAR

MIRROR LIKE

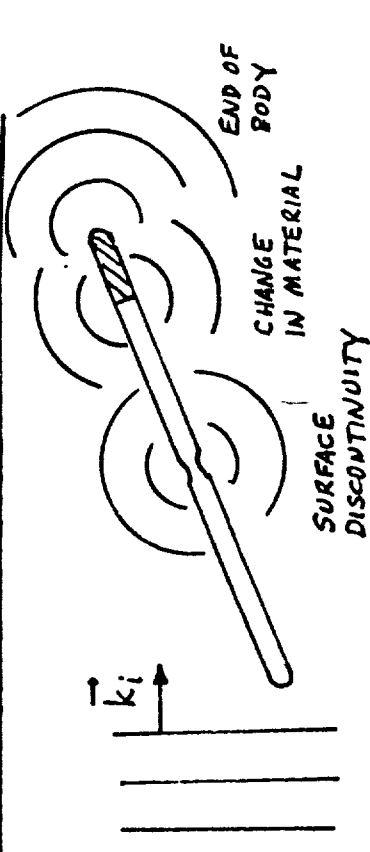
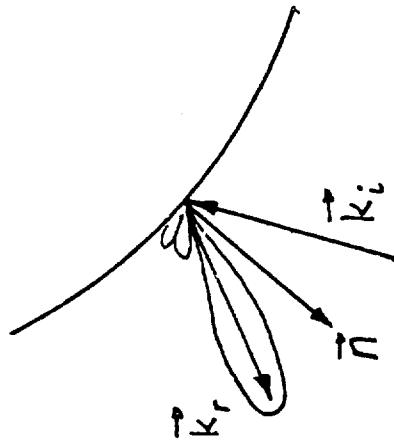

TRAVELING WAVE

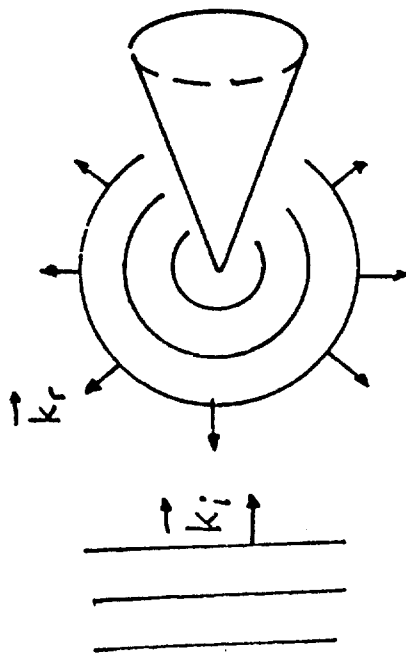

DIFFRACTION

TIP OF CONE, EDGE OF WEDGE

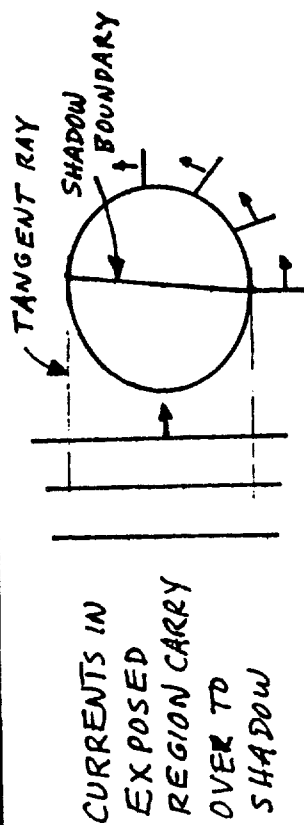

CREeping WAVE

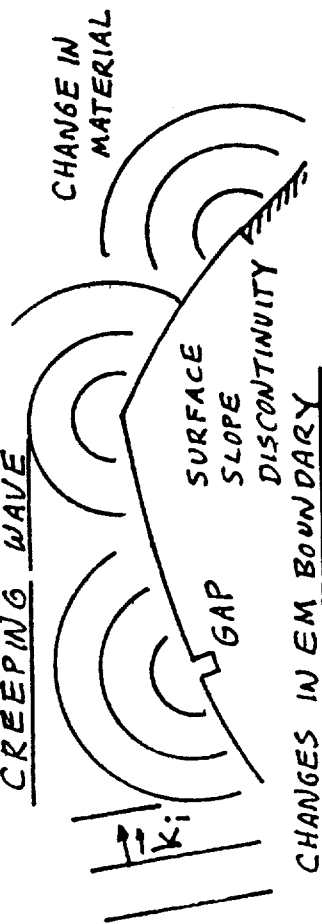

CONTRIBUTORS TO AIRCRAFT RADAR CROSS SECTION

- (1) RADOME. If radome is transparent, then radar wave "sees" inside the cavity containing A/C radar. Black boxes inside may form retroreflectors. If radome is opaque, then tip diffraction may occur.
- (2) A smooth rounded surface may have a creeping wave for the \vec{k}_1 shown.
- (3) Cockpit is a cavity and may be a large contributor to RCS.
- (4) The propagation vector \vec{k}_1 is about tangent to surface. The incident wave encounters an edge which is a scattering device.
- (5) Multiple reflections may occur. This may be more important for bistatic radar.
- (6) Large flat areas may cause glints. "Flat" is in quotes because a surface may have $\rho \gg \lambda$ and appear to be flat. ρ is radius of curvature.
- (7) Ordnance and drop tanks contribute to RCS.
- (8) Edge diffraction (like a wedge) occurs at sharp leading edges and trailing edges. Sharp is $\rho \ll \lambda$. Blunt is $\rho = \lambda$ or $\rho > \lambda$. Blunt edges use a cylinder as model.
- (9) Inlet cavities may give very large RCS.
- (10) The rudder and elevator may form a right angle dihedral which acts as retroreflector.

CONTRIBUTORS TO AIRCRAFT RADAR CROSS SECTION

THINK OF AIRCRAFT AS A PORCUPINE
 WITH NORMAL VECTORS \vec{n} . \vec{n} IS
 NORMAL TO SURFACE. WHERE EVER
 \vec{n} AND \vec{k}_i ARE PARALLEL EXPECT
 BIG RCS.

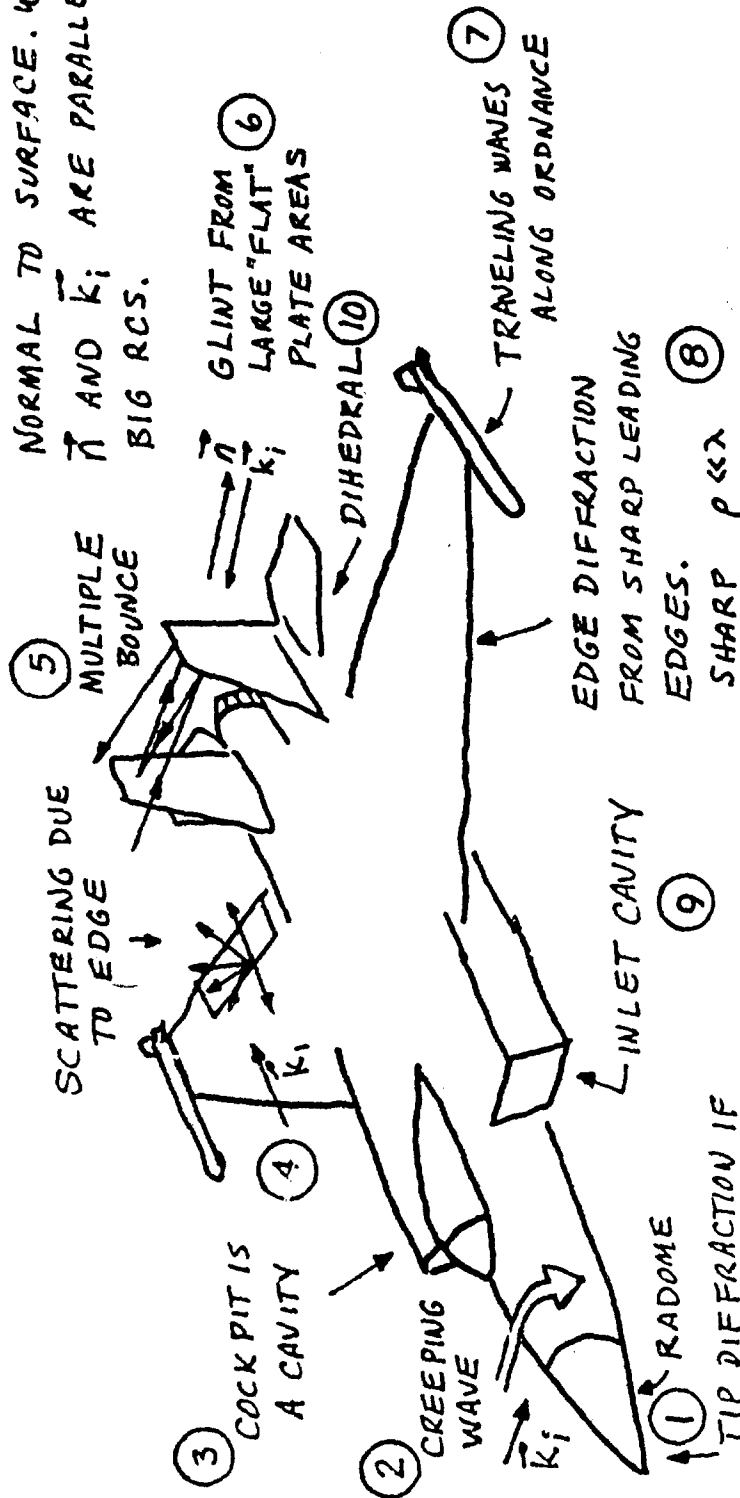

A. E. FUHS

CAVITIES ARE PRIMARY
 SOURCE OF RCS

TIP DIFFRACTION IF
 OPAQUE TO EM WAVES,
 OTHERWISE CAVITY
 IS TRANSPARENT

RELATIVE SIZE OF CONTRIBUTORS TO RCS

ORDNANCE. Missile may have own radar which can have large RCS.

RUDDER-ELEVATOR DIHEDRAL may be big due to action of retroreflector.

EXHAUST. Waves can propagate within the cavity and reflect from internal parts.

RUDDERS. RCS is small except for glint at broadside.

WING. RCS is small except when viewed so as to see "flat" area.

INLET FOR APU. The inlets for APU, air conditioning ducts, and gun exhaust gas ports can be large in certain direction.

COCKPIT. Big contributor to RCS.

GUN MUZZLE. Scattering is due to surface discontinuities.

RADOME. Big antenna inside acts like a cat's eye in the dark.

FUSELAGE. Recall $\sigma = \pi \rho_1 \rho_2$. Usually ρ_1 and ρ_2 are small compared to ρ of wing upper or lower surface.

RELATIVE SIZE OF CONTRIBUTORS TO RCS

SIZE OF RCS DEPENDS ON ASPECT ANGLE. MAGNITUDE STATED IS FOR MAXIMUM RCS FROM THE ITEM.

A. M. FUCHS

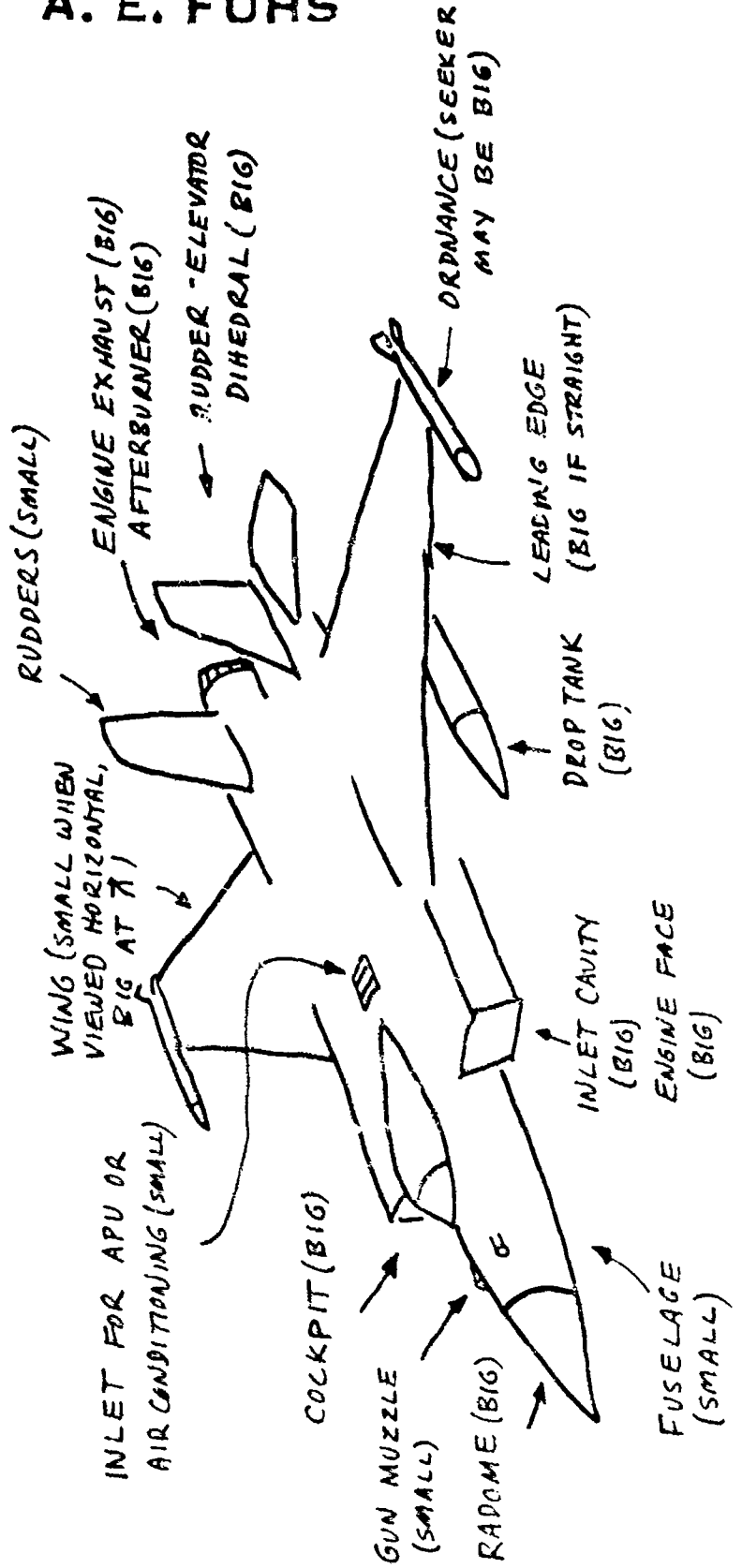

AIRCRAFT AT VISIBLE AND MICROWAVE FREQUENCIES

- 0 The EM boundary conditions and the wave equations are shown. The equation for free space is

$$\nabla^2 \vec{E} + k_0^2 \vec{E} = 0$$

For propagation inside dielectrics, change k_0 to k_1 .

- 0 Three major cavities are illustrated:

aircraft radar cavity

engine inlet cavity

cockpit cavity

AIRCRAFT AT VISIBLE AND MICROWAVE FREQUENCIES

A. E. FUHS

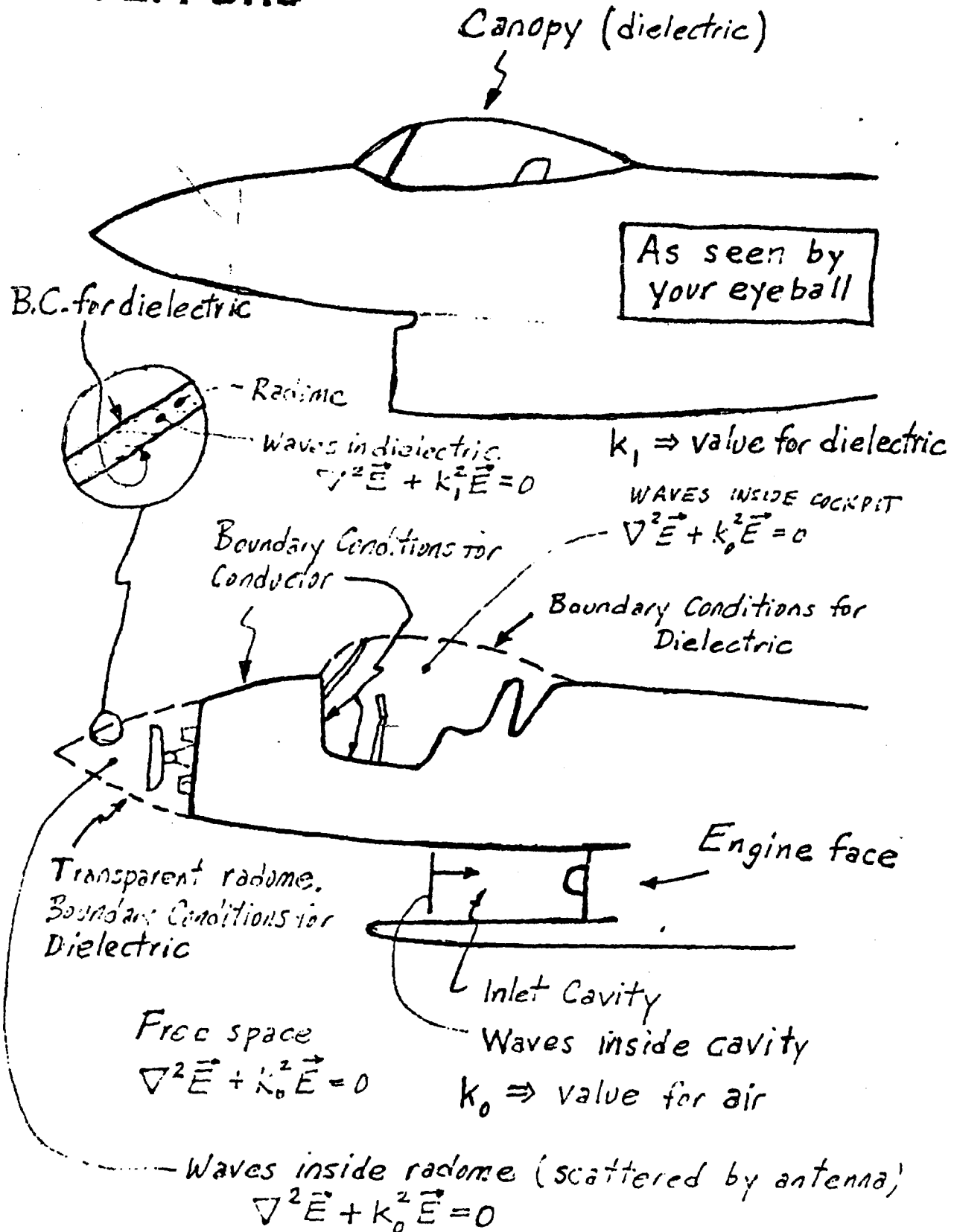

FIRE FOX MIG-31

- 0 As an example of estimating RCS for an aircraft, the MIG-31 Fire Fox will be used.
- 0 Some of the gross features of the RCS for the aircraft can be obtained from formulas discussed earlier.
- 0 The Fire Fox was designed, not for Mach 6, but for movie audiences. Low RCS and good L/D were not requirements. The design requirement was to look "mean."

Note: The comments for viewgraph 6 start here.

PLAN FORM FIRE FOX MIG-31

The assumed plan form is shown. The plan form can be verified now that the MIG-31 is in U. S. hands.

Assume the following:

wing span, 30 m	length, 28 m	radar frequency, 12 GHz	Wavelength, 0.025 m
-----------------	--------------	-------------------------	---------------------

The RCS will be estimated in the plane of the plan form. One views the aircraft from nose-on ($\theta = 0^\circ$) moving clockwise to starboard wing tip ($\theta = 90^\circ$). The various scattering components are identified.

FIRE FOX MIG-31

A. E. FUHS

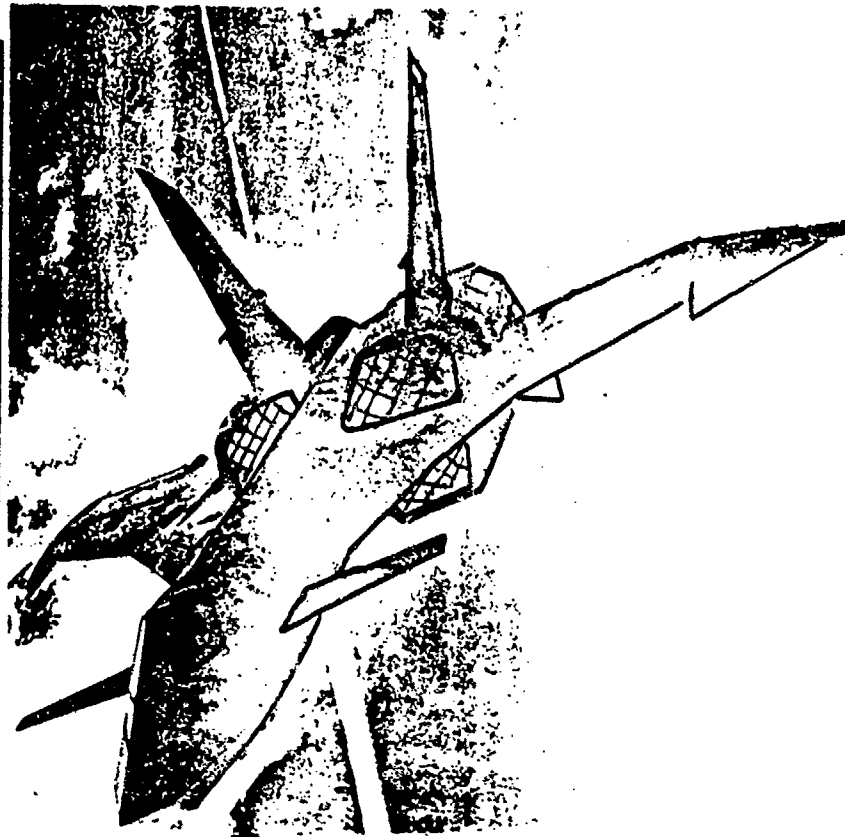
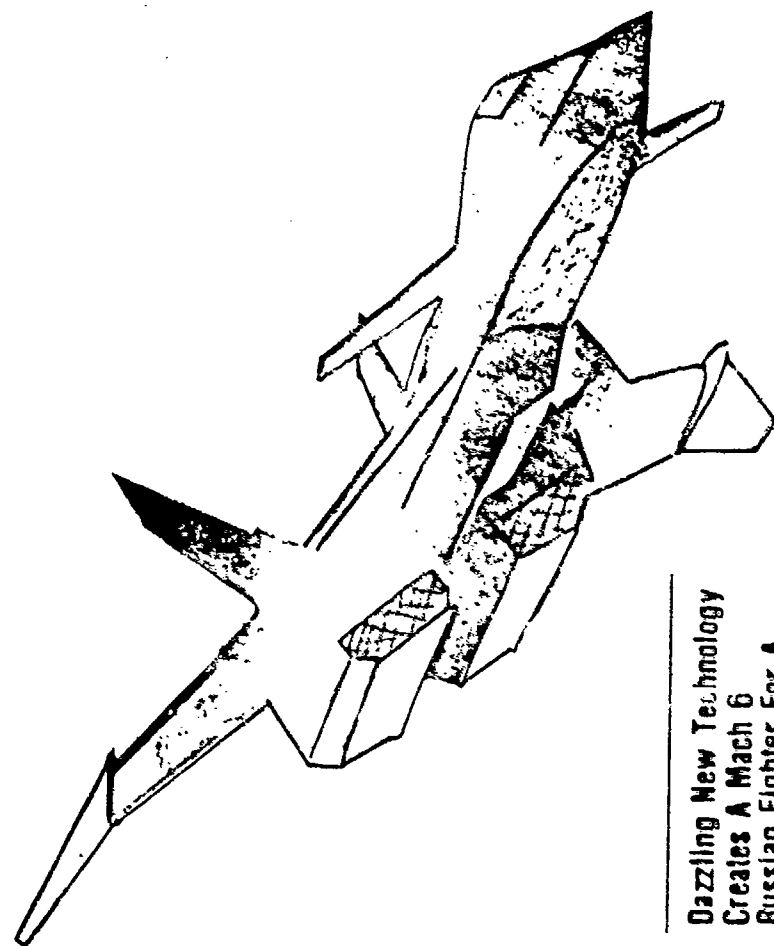

Dazzling New Technology
 Creates A Mach 6
 Russian Fighter For A
 Gripping Spy-Adventure
 Film. And This Dramatic
 Break-Through In
 Believable Special Effects
 May Be The Key To
 Producing Future Aviation
 Epics!

NOSE-ON $\theta = 0^\circ$

Tip Diffraction: The tip of the fuselage appears to be a wedge. Formulas for finite wedges are quite complex and are outside the realm of a back-of-an-envelope calculation. Based on calculations for tip diffraction for cones, σ may not be too important. However, this should be verified.

Engine Inlets: There are four engine inlets which will be modelled as flat plates with size 0.7 m x 1.8 m for each.

$$\sigma_1 = \frac{4\pi A^2}{\lambda^2} = \frac{4\pi(0.7 \times 1.8)^2}{(.025)^2} = 32000 \text{ m}^2 = 45 \text{ db}$$

One can estimate the width of the main lobe from

$$\frac{\sigma}{\sigma_0} = \left[\frac{\sin(ka \sin \theta)}{ka \sin \theta} \right]^2$$

The first zero occurs when $ka \sin \theta = \pi$.

$$\theta = \arcsin(\pi/ka) = 1.02^\circ$$

The lobe is very narrow.

To add the four inlets, use the equation from Lecture 2, viewgraph 29. If phase angles for the waves returned from the four inlets are all zero, then the addition formula becomes

$$\sigma = [4\sqrt{\sigma_1}]^2 = 16\sigma_1$$

The RCS for all four inlets is 57 db.

LEADING EDGE OF STARBOARD CANARD

The LE has a sweep of 20° . The LE can be modelled as a wire. The assumed dimensions are $L = 3.8$ m (length of LE on MIG-31) and radius of $a = 0.01$ m. For these values

$$\sigma_1 = \frac{9}{4} \pi (3.8)^2 (251.3 \times 0.01)^4$$

$$\sigma_1 = 4072 \text{ m}^2 = 36 \text{ db}_{sm}$$

The preceding equation appears in viewgraph 15 of Lecture 2. To estimate width of main lobe, one can use the same formula as used for the inlet. Wires have a lobe structure similar to a flat plate.

$$\frac{\sigma}{\sigma_0} = \left[\frac{\sin(kL \sin \theta)}{kL \sin \theta} \right]^2$$

The first zero in RCS occurs when

$$kL \sin \theta = \pi$$

or where $\theta = 0.2^\circ$ when $L = 3.8$ m. The second peak occurs at

$$\theta = \arcsin\left(\frac{3\pi}{2kL}\right) = 0.28^\circ$$

The value of the second peak is 34 db_{sm}.

The other comment is that the lobes are very, very narrow.

PLAN FORM FIRE FOX MIG-31

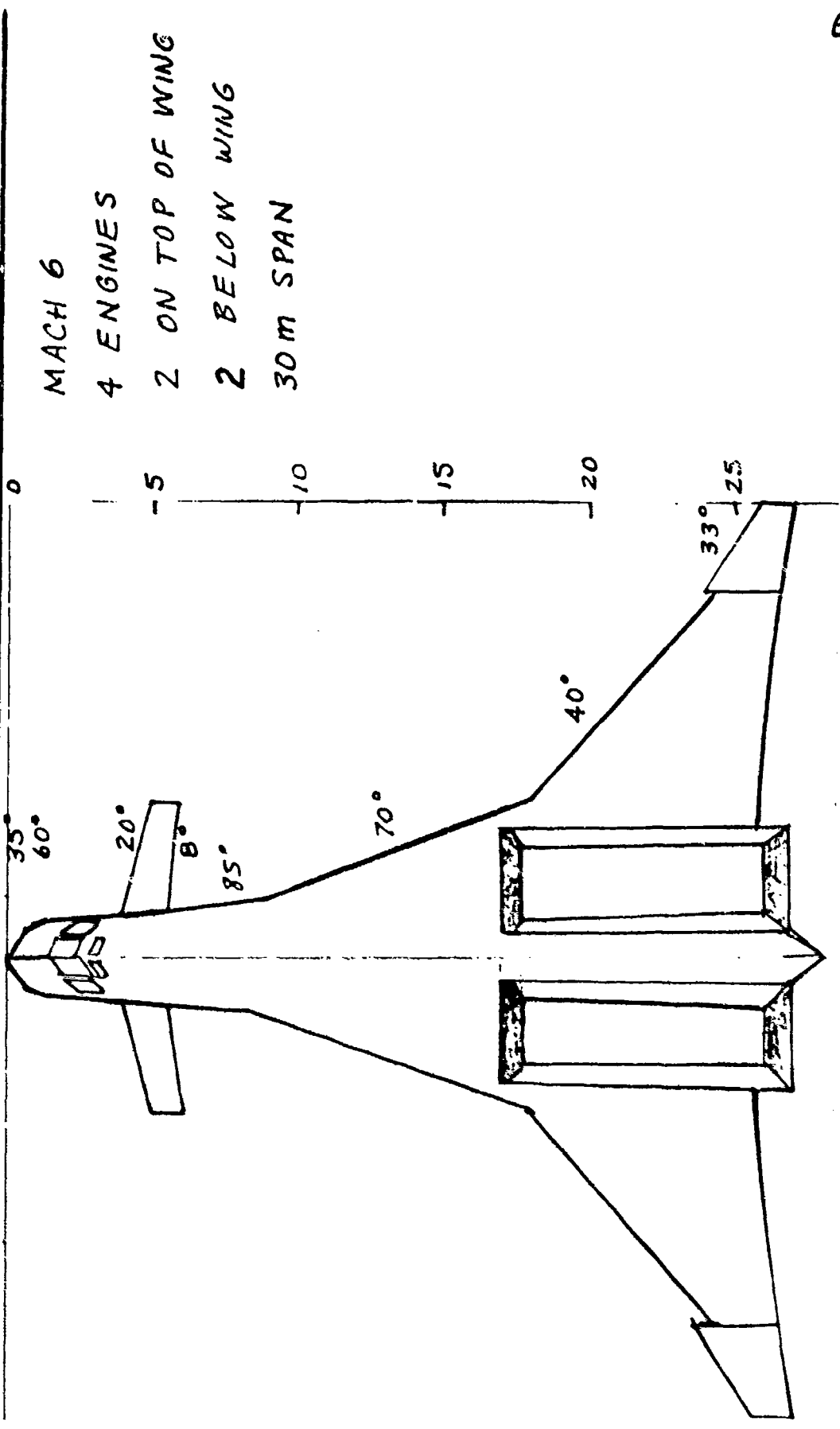

7

GROSS FEATURES OF RCS FOR FIRE FOX MIG-31

Continuing the calculations, the other leading edges were evaluated as follows:

Sweep	L, m	a, m	σ, m^2	σ, db_{sm}
33°	3.5	0.02	55300	47
40°	10	0.02	450000	56
70°	9	0.02	366000	55
90° (wing tip)	1.2	0.01	406	26

FUSELAGE

The fuselage has a normal vector at an angle of $\theta = 85^\circ$. Assume $\rho_1 = 3$ m and $\rho_2 = 10$ m. From

$$\sigma = \pi \rho_1 \rho_2 = 94 m^2 = 20 db$$

one finds the RCS for fuselage.

TRAILING EDGE OF PORT WING

The TE of port wing is normal to the incident waves from $\theta = 170^\circ$. Modelling the TE as a wire with $L = 12$ m and $a = 0.01$ m, the following results were obtained

$$\sigma = 404000 m^2 = 46 db_{sm}$$

The large RCS is due to high radar frequency.

4-ENGINE EXHAUSTS AT $\theta = 180^\circ$

The calculation for inlet was repeated with assumed dimensions of 0.8 m x 2.0 m. The result is

$$\sigma = 823550 m^2 = 47 db_{sm}$$

The RCS have been plotted. The various σ_k should be added using the formula given in Lecture 2, viewgraph 29.

NOTE

A note about values of RCS is appropriate. The leading edges scale as

$$\frac{\sigma_2}{\sigma_1} = \left(\frac{\lambda_1}{\lambda_2}\right)^2$$

Since the wavelength is small, the value of RCS is large. At $\lambda = 1.0$ m, the cross sections would be reduced by a factor of $(0.025/1.0)^2 = 6.25E-4$ or - 32 db. One could subtract 32 db_{sm} from each value shown for LE or TE if λ were 1.0 m.

GROSS FEATURES OF RCS FOR FIREFOX MIG-31

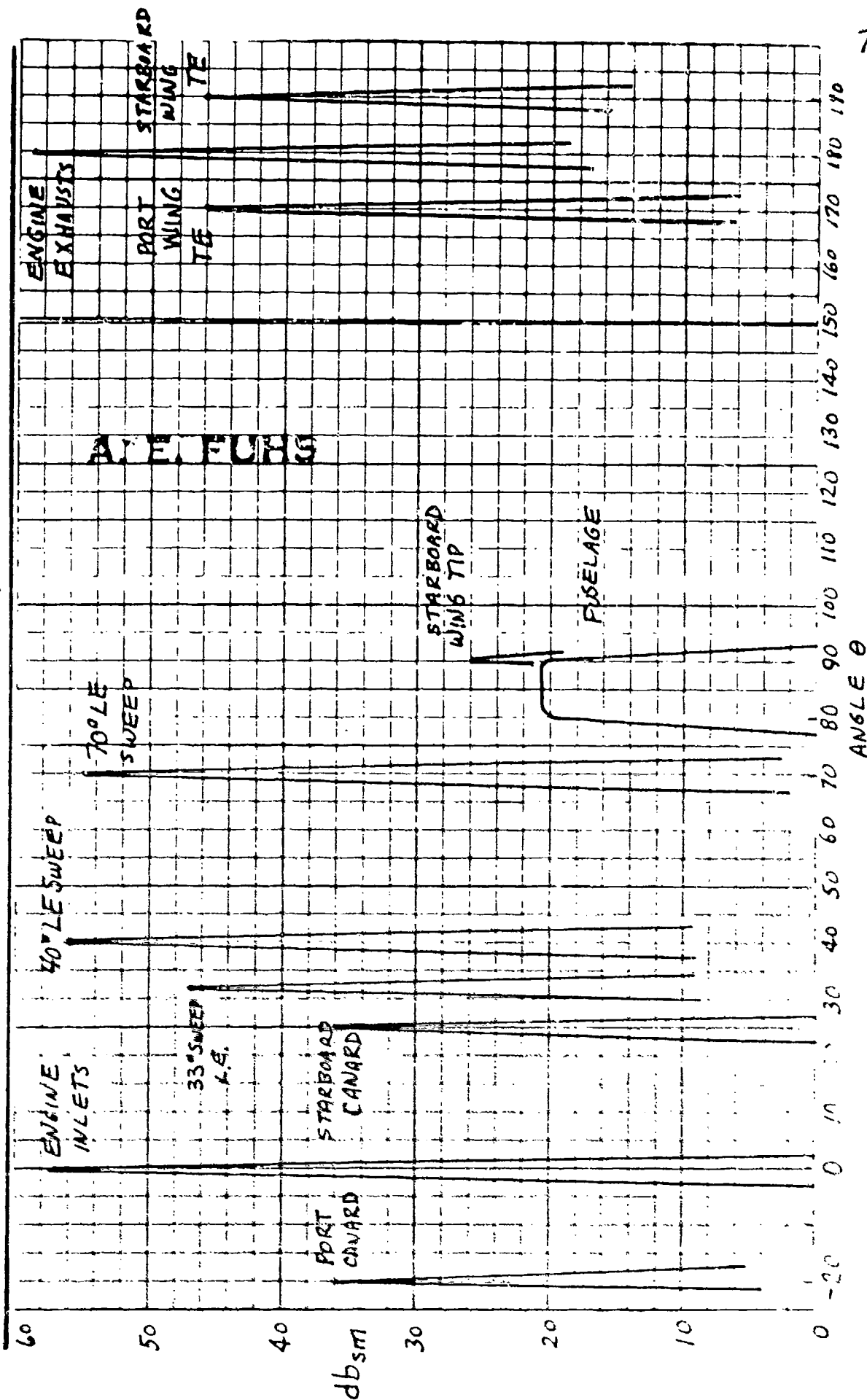

ANTENNA SCATTERING

- 0 Structural Scattering Term is due to currents induced in the antenna surface and is independent of antenna load impedance.
- 0 Antenna Scattering Term is due to current induced at the antenna load terminals. An antenna launches a plane wave from the antenna focus when radiating. The power moves outward from focal point to beam. When radar illuminates the antenna with plane waves, the power moves to the focus. The antenna feed system has a certain impedance. Depending on the impedance of the feed, the waves may or may not be re-radiated.
- 0 The RCS of an antenna is given by

$$\sigma = [\sqrt{\sigma_s} + \sqrt{\sigma_e} \exp i\psi]^2$$

where σ_s is RCS of structural scattering term and σ_e is the effective echo area of antenna. The phase angle between σ_s and σ_e is ψ . The value for σ_e is, for certain specific conditions,

$$\sigma_e = \frac{\lambda^2}{4\pi} G^2$$

where G is antenna gain at λ . As an estimate, one can use

$$\sigma = \frac{\lambda^2 G^2}{\pi}$$

for antenna RCS.

- 0 As an example, consider an antenna with a gain G of 100 at $\lambda = 0.5$ m. The RCS of the antenna is estimated to be

$$\sigma = \frac{(0.5)^2 (100)}{\pi} = 8 \text{ m}^2$$

ANTENNA SCATTERING

THE RADOME MAY BE TRANSPARENT TO THE INCIDENT RADAR WAVES.

THE ANTENNA OF AIRCRAFT RADAR MAY HAVE LARGE RCS

THE REFLECTION FROM AN ANTENNA IS ANALOGOUS TO REFLECTION OF LIGHT FROM CAT'S EYES AT NIGHT.

TWO TERMS IN CROSS SECTION OF AN ANTENNA

- STRUCTURAL SCATTERING TERM

- ANTENNA SCATTERING TERM

SCATTERING PATTERN FOR ANTENNA SCATTERING TERM IS PRECISELY

THE SQUARE OF THE ANTENNA RADIATION PATTERN.

A. M. FULIS

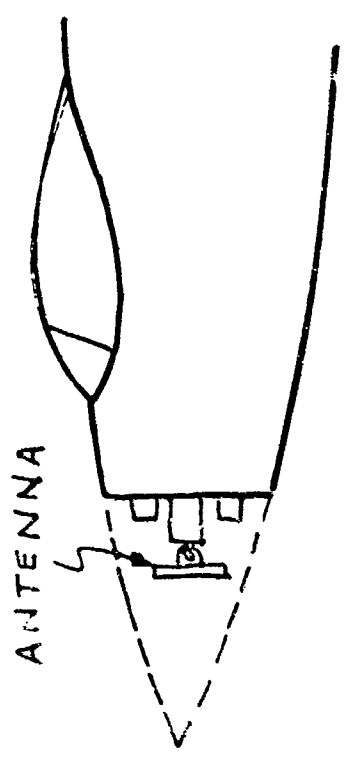

RADAR CROSS SECTION REDUCTION

- 0 SHAPING implies control of geometry so as to reduce RCS.
- 0 RAM is material used to match wave impedance of free space or to absorb the EM wave energy.
- 0 IMPEDANCE LOADING consists of passive or active elements added at appropriate locations to control RCS.

RADAR CROSS SECTION REDUCTION

A. E. FUHS

SHAPING

RADAR ABSORBING MATERIALS

IMPEDANCE LOADING

TO ENHANCE RCS ONE USES RETROREFLECTORS

TO DECREASE RCS ONE USES ONE OF THE THREE METHODS LISTED ABOVE

Japan's Ministry of International Trade and Industry will allow Tokyo Denki Kagaku Kogyo to sell its ferrite paint to the U.S. The ministry has determined that export of the radiation-absorbing paint would not violate Japanese arms-export regulations because the product has uses other than military. The paint has been used to prevent tall buildings from interfering with television reception.

IMPEDANCE LOADING

- 0 On the left-hand side is the case of a loaded pair of cylinders. By correct choice of Z_L , the load impedance, the RCS is reduced by 35 db.
- 0 On the right-hand side is the case of a pair of circular ogives back-to-back. The incident waves are arriving from the left when $\theta = 0^\circ$. A wire with length $\lambda/4$ is added to the tail end of the body. The wire causes a major reduction in RCS for $0 < \theta < 45^\circ$. This is an example of scattering by traveling waves when θ is small. A relatively minor change makes a very large change in RCS.
- 0 For simple cases, one may be able to exploit the method. Application of impedance loading to complex shapes may not be obvious.

IMPEDANCE LOADING A. E. FUHS

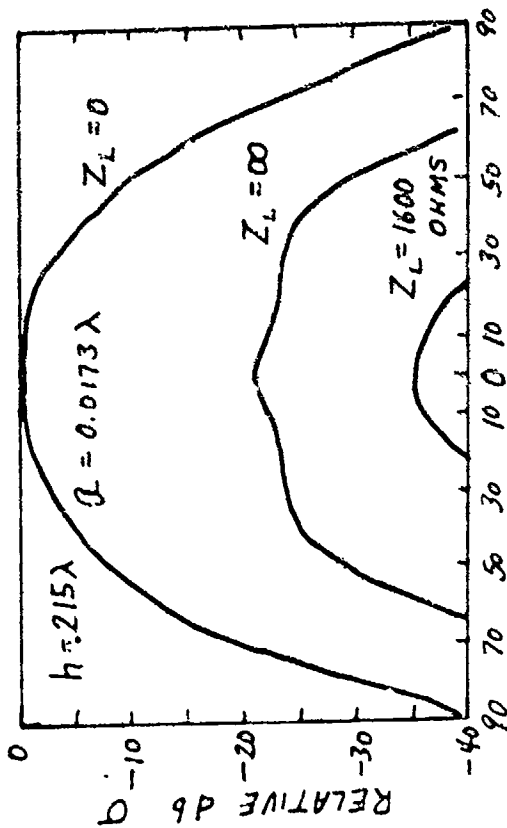

θ degrees off normal

THEORETICAL CURVES SHOWN, EXPERIMENTAL DATA CLOSE.

σ DECREASED BY 35dB

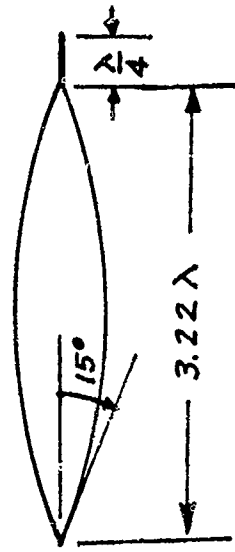
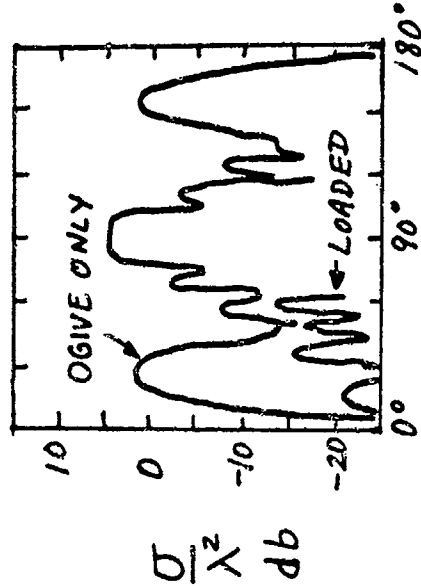

REDUCTION DUE TO $\lambda/4$ WIRE AT $\theta = 180^\circ$ END OF BACK-TO-BACK OGIVES.

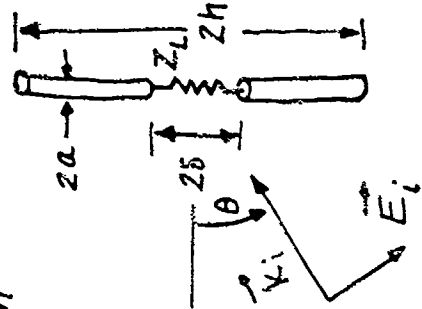

SHAPING TO REDUCE RADAR CROSS SECTION

- 0 The direction of incident radar waves is an important consideration. If the aircraft will be illuminated from below, put engines on top of the wing.
- (1) SHIELD INLETS. The inlets can be shielded by the fuselage. Locating the engines on top when radar is below A/C will help. If engine performance permits the use of wire mesh over the inlet, the RCS can be reduced. Mesh spacing is small fraction of λ .
 - (2) CANT RUDDERS INWARD. The surface normal vector \vec{n} is moved upward. The big RCS which occurs when \vec{k}_i and \vec{n} are parallel will occur only when radar is above the A/C. Also when a rudder-elevator combination is used, the retroreflector of the dihedral is avoided.
 - (3) SHIELD NOZZLES. The comments for inlets apply.
 - (4) ROUND WING TIPS. Use the formula $\sigma = \pi \rho_1 \rho_2$. A rounded wing tip has small ρ_1 and ρ_2 .
 - (5) CANT FUSELAGE SIDES. This tips the surface normal \vec{n} upward. For low RCS, do not have \vec{n} pointing toward the radar!
 - (6) BLEND COMPONENTS. Waves are scattered by discontinuities in slope, curvature, etc. Blending minimizes the geometrical discontinuities.
 - (7) MINIMIZE BREAKS AND CORNERS. Any shape resembling a retroreflector is bad. As shown in viewgraph 1, gaps scatter EM waves.
 - (8) PUT ORDNANCE LOAD INSIDE AIRCRAFT. This would make both the aerodynamicists and radar engineers happy. However, internal storage may not be possible. Drag equals $qC_D A$. Internal storage may give large A.
 - (9) ELIMINATE BUMPS AND PROTRUSIONS. The comments of items (6) and (7) apply here. Use retractable covers over gun parts.
 - (10) USE BANDPASS RADOME. An opaque radome at the search radar wavelength eliminates this problem.
 - (11) USE LOW PROFILE CANOPY. Ever since the SPAD, aviators want to see. Dog-fights require good visibility. Having said that, a low profile canopy with gold plating will have much lower RCS. The thin layer of gold (or other metal) plated on the canopy screens out microwaves.
 - (12) SWEEP LE. The A/C is frequently illuminated by a search radar from nose-on aspect. A swept LE is one way to reduce RCS. There are two philosophies in regard to LE shape. A straight LE concentrates a big RCS in a narrow lobe. If the search radar is never in that lobe, the A/C cannot be detected because of LE return. A curved LE spreads a smaller RCS over a wide angle. Although RCS is spread over a large angle, RCS is small.

FINAL NOTE: Think of A/C as a porcupine with surface normal vectors \vec{n} as quills. Don't have any quills pointing toward radar!

SHAPING TO REDUCE RADAR CROSS SECTION

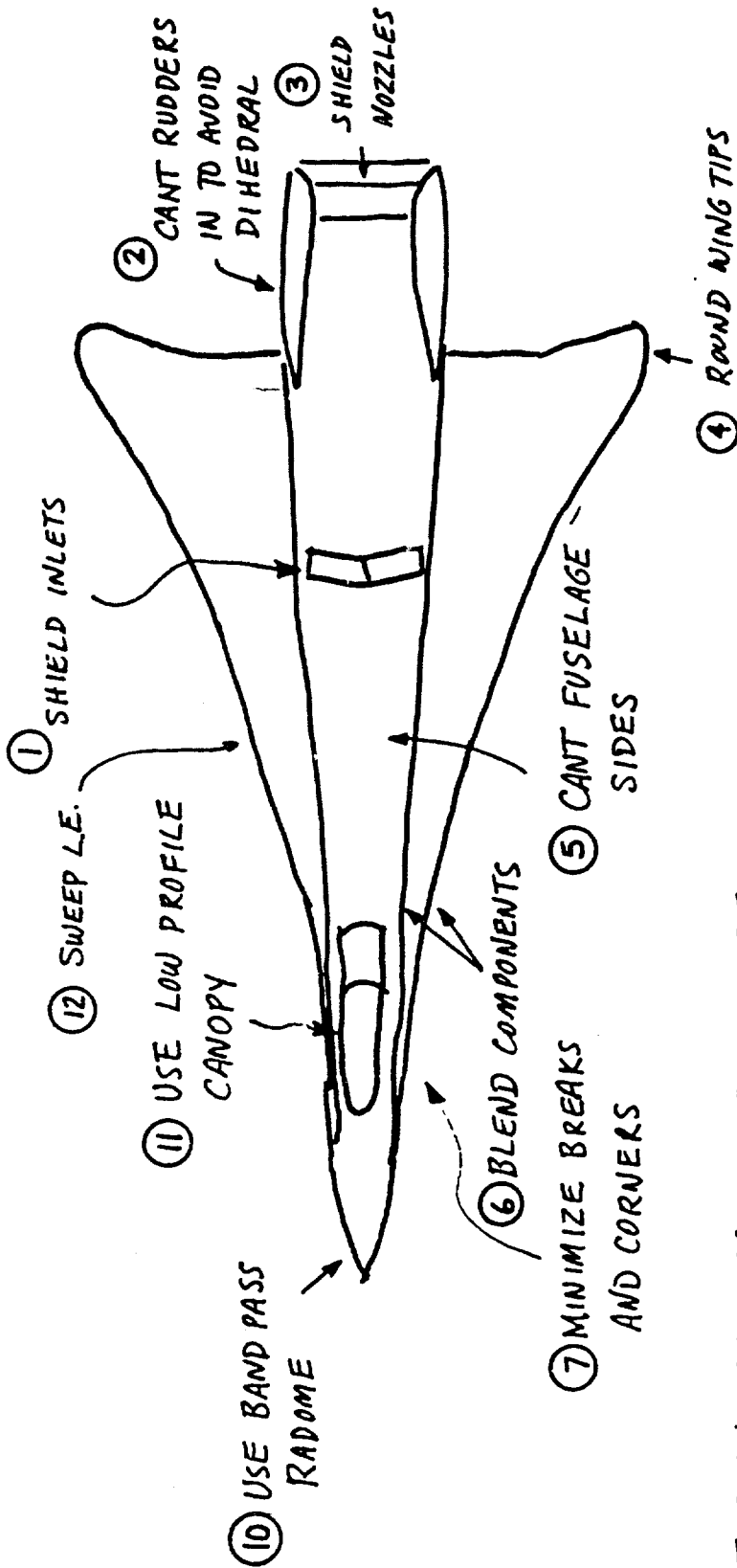

A. E. FURS

- ⑧ PUT ORDNANCE LOAD INSIDE AIRCRAFT
- ⑨ ELIMINATE BUMPS AND PROTRUSIONS

LOW RCS ← TRADEOFF → AERODYNAMIC PERFORMANCE =

DO'S AND DON'T'S FOR SHAPING TO ACHIEVE LOW RCS

- 0 The aircraft designer may not be able to heed all the advice.
- 0 Ship superstructures are classic examples of built-in retroreflectors.

DO'S AND DON'T'S FOR SHAPING TO ACHIEVE LOW RCS

DO'S

Do consider: are you designing for monostatic or bistatic radar

Do (for $L/\lambda > 1.0$) make body like an isotropic scatterer. This avoids RCS spikes

Do make surfaces convex with double curvature. Think

$$\sigma = \pi \rho_1 \rho_2$$

DON'T'S

Don't make any retroreflectors inadvertently

Avoid large flat areas.

Avoid 90° intersections of flat areas

Avoid cavities exposed to radar

Avoid discontinuities in

conducting path. EM waves induce currents in vehicle skin.

Don't concentrate currents by having electrical discontinuities.

RADAR ABSORBING MATERIAL, RAM

- O The probability of achieving the stated goal for RAM is rather remote.
- O The book of Ruck, et al.*, provides a detailed discussion of RAM.

*George T. Ruck, Editor, Radar Cross Section Handbook, Volume 2, Plenum Press, New York, 1970.

RADAR ABSORBING MATERIAL, RAM

ABSORB MICROWAVES

- Convert wave energy to heat
- similar to I²R loss

RADAR ABSORBING MATERIALS

- narrow band (resonant)
- wide band

PERFECT RAM

- has impedance of free space

$$Z_0 = \sqrt{\mu_0/\epsilon_0} = 377 \text{ Ohms}$$

- if $Z = Z_0$, waves are not reflected

TYPES OF ABSORBING MATERIALS

lossy dielectrics with finite conductivity (microwave oven)

lossy magnetic; ferrites are an example

REDIRECTION OF INCIDENT WAVE

Some RAM do not absorb but redirect the incident waves.

GOAL FOR RAM

- paint like
- broad band
- insensitive to polarization
- insensitive to aspect angle

PRACTICAL ASPECTS OF RAM

In addition to electromagnetic properties, RAM must have other favorable physical properties.

PRACTICAL ASPECTS OF RAM A. E. FUHS

WEIGHT

weight reduces A/C performance

COSTS

costs to design

costs to install

costs to maintain

THICKNESS

RAM robs volume from volume-limited

Vehicles

STRUCTURAL STRENGTH

adequate strength to withstand rigors

(e.g. RAM on helicopter blade)

ENVIRONMENT

is RAM hygroscopic?

does RAM peel off in rain?

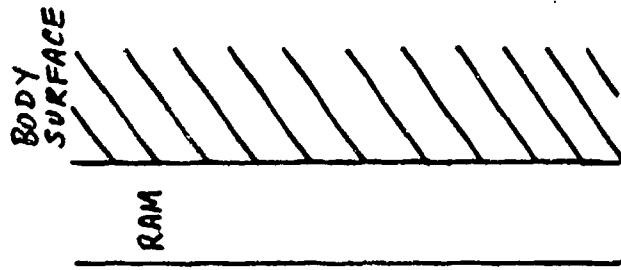

CONSTRUCTION MATERIALS

- EMP is electromagnetic pulse from exoatmospheric nuclear explosions.
- The attrition rate for Mosquito bomber was low.
Factors, such as speed and twin-engines as well as low RCS, may have contributed to the low rate.
- The trend is toward composite materials. Mixed structures, such as wings with composite skins and aluminum spars, may have high RCS due to reflection from spars.

CONSTRUCTION MATERIALS A. E. FUHS

METALS HAVE HIGH ELECTRICAL CONDUCTIVITY

- high conductivity means high reflectivity
- high conductivity, protection for EMP

LOW CONDUCTIVITY MATERIALS

- plywood Mosquito bomber in WWII had low RCS
- internal metal parts reflect (eg. engine, wiring, pumps)
- composite materials have low electrical conductivity

MIXTURE OF MATERIALS

- mixture of metals and nonconducting scatter at joints
- examples include canopy, window parts, radomes

RADAR "HOT SPOTS"

- 0 Many of the sources of "hot spots" have been discussed already.
- 0 Estimate the RCS of the trihedral corner reflector in the cockpit. Use the formula from Lecture 2, viewgraph 28:

$$\sigma = \frac{12\pi X^4}{\lambda^2}$$

Assume $X = 0.2$ m and $\lambda = 0.5$ m.

$$\sigma = \frac{12\pi(0.2)^4}{(0.5)^2} = 742 \text{ m}^2 = 29 \text{ db}_{\text{sm}}$$

BIG!

RADAR "HOT SPOTS"

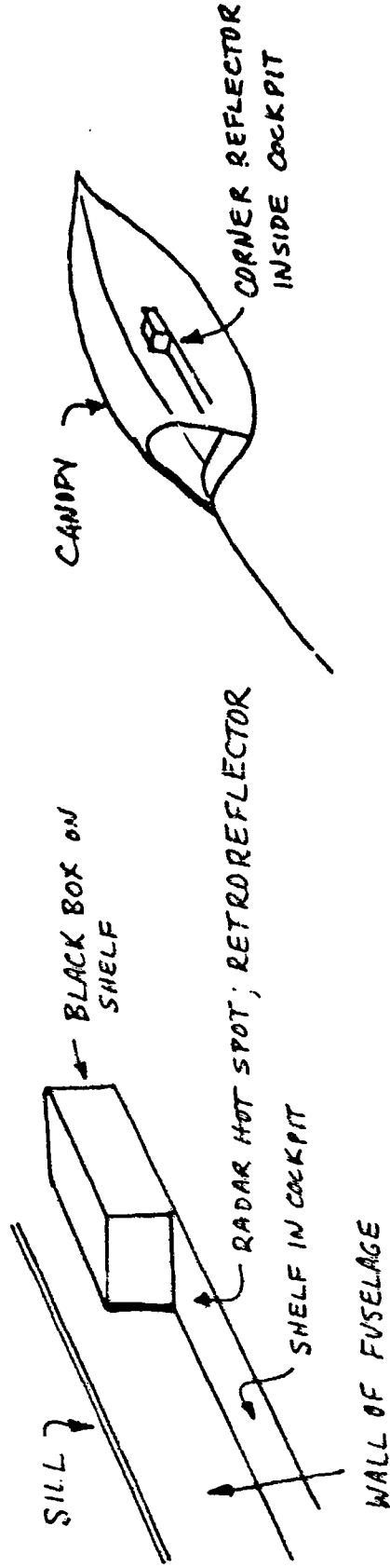

"HOT SPOT" IS A LOCALIZED AREA WHERE RETRODIRECTIVE REFLECTION OCCURS. "HOT SPOTS" MAY NOT BE ANTICIPATED. THE EXAMPLE ABOVE WAS NOT ANTICIPATED.

EXAMPLES INCLUDE

- air inlets
- engine nacelles
- pylons
- cockpits
- radar antennas

PAYOFF OF REDUCED RADAR CROSS SECTION

- 0 An air search radar may have a specification to be able to search so-many m^3 /sec of space. If the RCS is reduced, the volume search rate decays rapidly.

PAYOFF OF REDUCED RADAR CROSS SECTION

DECREASE DETECTION PROBABILITY

RANGE $\frac{R_2}{R_1} = \left(\frac{\sigma_2}{\sigma_1}\right)^{1/4} = (0.10)^{1/4} = 0.56$

SEARCH AREA

$\left(\frac{R_2}{R_1}\right)^2 = \left(\frac{\sigma_2}{\sigma_1}\right)^{1/2} = (0.56)^2 = 0.32$

SEARCH VOLUME

$\left(\frac{R_2}{R_1}\right)^3 = \left(\frac{\sigma_2}{\sigma_1}\right)^{3/4} = (0.56)^3 = 0.18$

JAMMING POWER FOR FIXED BURNTHROUGH

$\frac{P_2}{P_1} = \frac{\sigma_2}{\sigma_1} = 0.10$

DECREASE IN BURNTHROUGH RANGE

$\frac{R_2}{R_1} = \left(\frac{\sigma_2}{\sigma_1}\right)^{1/2} = (0.10)^{1/2} = 0.32$

A SURFACE SEARCH RADAR HAS A FIGURE-OF-MERIT OF HOW MUCH AREA/TIME CAN BE SEARCHED, A DECREASE OF σ BY 0.1 DECREASES THE SURFACE SEARCH RADAR FIGURE-OF-MERIT TO 32%.

AN AIR SEARCH RADAR SEARCHES VOLUME/TIME. REDUCING σ TO 0.1 * σ REDUCES VOLUME SEARCH TO 18%.

A. E. FUHS

LECTURE IV. SOLUTION TECHNIQUES

1. Maxwell's Equations
2. Solution for Scattered Field
3. Solutions to Maxwell's Equations
4. Separation of Variables
5. Geometric Optics
6. Geometrical Theory of Diffraction
7. Physical Optics
8. Impulse Approximation
9. Numerical Methods for Radar Cross Section
10. Applicability of Sum-of-Components Model for RCS Calculation

A. E. FUHS

MAXWELL'S EQUATIONS

The symbols have the following definitions:

E	electric field intensity, volts/m
H	magnetic field intensity, ampere-turn/m
D	electric displacement, coulomb/m ²
B	magnetic induction, webers/m ²
ρ	charge density, coulomb/m ³
J	current density, amperes/m ²
ϵ_0	permittivity of free space, farad/m
μ_0	permeability of free space, henry/m
k_0	free space propagation constant, 1/m

MAXWELL'S EQUATIONS

GENERAL

$$\nabla \times \vec{E} = -\frac{\partial \vec{B}}{\partial t} \quad (1)$$

$$\nabla \cdot \vec{B} = 0 \quad (3)$$

$$\nabla \times \vec{H} = \vec{J} + \frac{\partial \vec{D}}{\partial t} \quad (2)$$

$$\nabla \cdot \vec{D} = \rho \quad (4)$$

TARGETS ARE LOCATED IN FREE SPACE WHICH IS ASSUMED TO BE CHARGE-FREE, ISOTROPIC, AND HOMOGENEOUS RELATE D and B to E and H

$$\vec{D} = \epsilon_0 \vec{E} \quad \vec{B} = \mu_0 \vec{H} \quad (5-6)$$

MAXWELL'S EQUATIONS IN FREE SPACE

CAN BE MANIPULATED INTO WAVE-EQUATION FORM

$$\nabla^2 \vec{E} + k_0^2 \vec{E} = 0 \quad (7)$$

$$\nabla^2 \vec{H} + k_0^2 \vec{H} = 0 \quad (8)$$

TIME DERIVATIVES HAVE BEEN REPLACED BY $\partial(\)/\partial t = -i\omega$. ALSO

$$k_0^2 = \omega^2 \mu_0 \epsilon_0 \quad (9)$$

THE OPERATOR $\vec{\nabla}(\)$ IS

$$\vec{\nabla}(\) = \nabla(\nabla \cdot \vec{F}) - \nabla \times \nabla \times (\)$$

IN CARTESIAN COORDINATES, THE VECTOR EQUATIONS (7) AND (8) BECOME THREE SCALAR EQUATIONS. AN EXAMPLE

$$\nabla^2 E_x + k_0^2 E_x = 0 \quad (10)$$

WHERE E_x IS X-COMPONENT OF ELECTRIC FIELD.

SOLUTION FOR SCATTERED FIELD

0 The symbols have the following definitions:

q_s surface charge density, coulomb/m²

K surface current density, amperes/m

0 Additional boundary conditions apply at infinity.

SOLUTION FOR SCATTERED FIELD A. E. FUHS

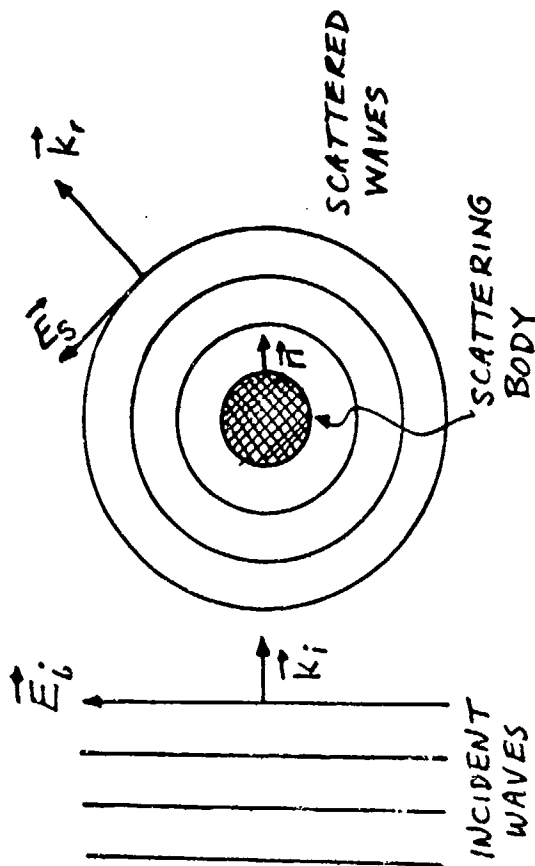

TOTAL FIELD IS SUM OF
INCIDENT PLUS SCATTERED
FIELD

$$\vec{E}_t = \vec{E}_i + \vec{E}_s \quad (11)$$

TOTAL FIELD MUST SATISFY
ELECTROMAGNETIC BOUNDARY
CONDITIONS ON SURFACE OF
BODY. FOR PERFECT CONDUCTOR

THE ELECTROMAGNETIC BOUNDARY
CONDITIONS (EMBC) ARE

$$\vec{n} \cdot \vec{H}_t = 0 \quad (12) \quad \vec{n} \cdot \vec{E}_t = \rho_s / \epsilon_0 \quad (14)$$

$$\vec{n} \times \vec{H}_t = \vec{K} \quad (13) \quad \vec{n} \times \vec{E}_t = 0 \quad (15)$$

LOOK AT (15). LET $\vec{n} = \vec{e}_z$

AND $\vec{E}_t = \vec{e}_x E_{xt} + \vec{e}_y E_{yt} + \vec{e}_z E_{zt}$.

ONE FINDS

$$-\vec{e}_x E_{yt} + \vec{e}_y E_{xt} = 0$$

WHICH LEADS TO

$$E_{yt} = E_{ys} + E_{yi} = 0$$

AT SURFACE

$$E_{ys} = -E_{yi}$$

SOLUTIONS TO MAXWELL'S EQUATIONS

- 0 Scattering of electromagnetic waves is a haven for the applied mathematician!

SOLUTIONS TO MAXWELL'S EQUATIONS

EXACT SOLUTIONS

- separation of variables; boundary value problems
- orthogonal coordinates

INTEGRAL FORMS OF MAXWELL'S EQUATIONS

- Stratton - Chu integrals
- vector Green's function

APPROXIMATE TECHNIQUES

- geometrical optics
- geometrical theory of diffraction
- physical optics and stationary phase
- impulse
- Fock

NUMERICAL TECHNIQUES

- direct solution of Maxwell's equations
- sum-over-components
- hybrid

A. E. FULS

SEPARATION OF VARIABLES

0 More than a dozen orthogonal coordinate systems have been discovered.

SEPARATION OF VARIABLES

ONE COORDINATE SURFACE OF BODY INTO THREE FUNCTIONS. IN THE PROCESS

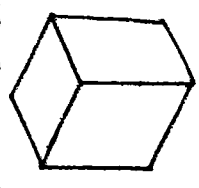

CARTESIAN

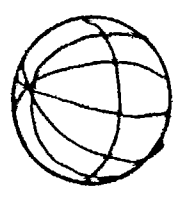

SPHERICAL



SPHERICAL



CYLINDRICAL

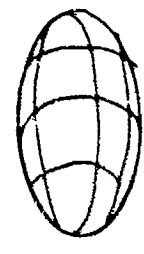

CONFOCAL ELLIPTIC

ON COORDINATE (e.g. $r = \text{constant}$) IS THE BODY.

EXAMPLE IN CARTESIAN

$$E(x, y, z) = X(x) Y(y) Z(z)$$

{ PARTIAL } → { ORDINARY }
{ DIFF. EQ. } { DIFF EQ }

MANY DOUBLE INFINITE SUMS OF SERIES RESULTS

$$E(x, y, z) = \sum_n \sum_m (\text{TERMS})_{nm}$$

COMPUTER USEFUL TO EVALUATE BIG SUMS.

A. E. FUHS

GEOMETRIC OPTICS

- 0 Geometrical optics accounts for transmission through radomes by using Snell's laws.

GEOMETRIC OPTICS

AS NAME IMPLIES TECHNIQUE ADAPTED FROM OPTICS.

REQUIREMENT FOR GEOMETRIC OPTICS

$$L \gg \lambda$$

WHERE L IS SIZE OF SCATTERING OBJECT, ALSO CALLED TARGET.

CORRESPONDS TO "OPTICAL REGION."

GEOMETRICAL OPTICS DEALS WITH RAYS AND WAVEFRONTS.

DIFFRACTION DOES NOT OCCUR IN GEOMETRICAL OPTICS.

SPECULAR REFLECTION IS A GEOMETRICAL OPTICS CONCEPT

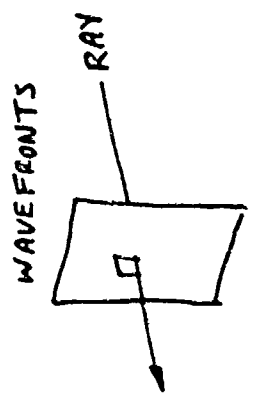

THE EQUATION

$$\sigma = \pi p_1 p_2$$

COMES FROM GEOMETRICAL OPTICS. TECHNIQUES TO CALCULATE p_1 AND p_2 BECOME IMPORTANT.

A. E. FUHS

GEOMETRICAL THEORY OF DIFFRACTION

- 0 By introducing phase angle as well as amplitude, the features of diffraction can be incorporated into the theory.
- 0 Geometrical theory of diffraction is an ad hoc method without firm theoretical foundation; it does work, however.

3

GEOMETRICAL THEORY OF DIFFRACTION

GEOMETRICAL OPTICS FAILS TO
ACCOUNT FOR EDGES, TIPS,
CORNERS, WEDGES, TANGENT POINTS,
AND SHADOW REGIONS.

PHASE ANGLES ARE ASSOCIATED
WITH RAYS.

TECHNIQUE GIVES GOOD RESULTS
FOR PROBLEMS ENUMERATED
ABOVE

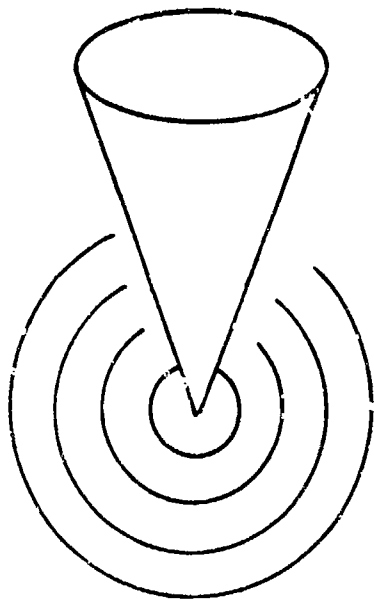

SCATTERING BY TIP CAN BE
HANDLED BY GEOMETRICAL THEORY
OF DIFFRACTION.

A. E. FUHS

PHYSICAL OPTICS

0 Physical optics involves integrals. The solutions are in terms of integrals.

PHYSICAL

OPTICS

A. E. FUHS

PHYSICAL OPTICS RECOGNIZES
WAVE NATURE OF EM RADIATION.

DIFFRACTION AND INTERFERENCE
ACCOUNTED FOR.

PHYSICAL OPTICS SYNONYMOUS
WITH "KIRCHHOFF INTEGRAL" &

"HUYGENS PRINCIPLE"

PHYSICAL OPTICS PROVIDES THE
INTENSITY OF RADIATION, WATTS/M²,
IN EITHER NEAR FIELD OR FAR
FIELD.

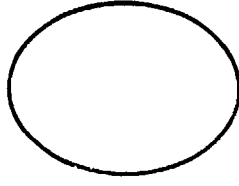

DISC REFLECTS
PLANE WAVE

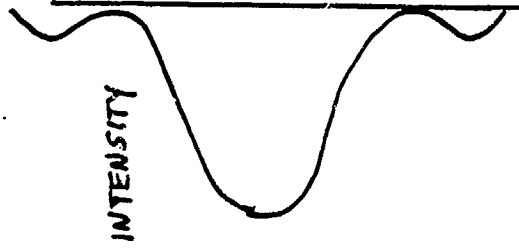

FAR FIELD

VARIATION OF INTENSITY IS DUE TO
DIFFRACTION AND INTERFERENCE.
FLAT PLATE, DISC, WIRE, OFF-NORMAL
CAN BE SOLVED USING PHYSICAL
OPTICS

IMPULSE APPROXIMATION

0 Impulse approximation is important to the problem of inverse scattering.

IMPULSE APPROXIMATION

OTHER TECHNIQUES USE MONOCHROMATIC WAVE. VARIATION OF SCATTERING IS NOT EXPLOITED.

INCIDENT WAVE IN IMPULSE METHOD IS A DELTA FUNCTION IN TIME.

BACKSCATTERED WAVE HAS ALL FREQUENCY COMPONENTS. THE SCATTERED WAVE IS MEASURED AS A FUNCTION OF TIME.

BY FOURIER TRANSFORM IN TIME, THE RESPONSE AS A FUNCTION OF FREQUENCY IS OBTAINED

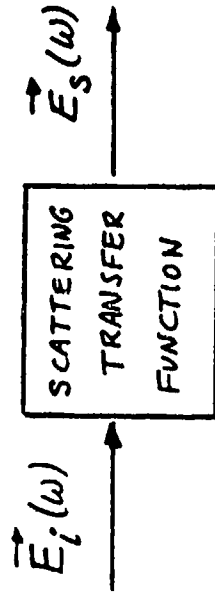

LINEAR-SYSTEM VIEWPOINT

THE SCATTERING MATRIX ELEMENTS ARE DETERMINED LEADING TO RADAR CROSS SECTION

NUMERICAL METHODS FOR RADAR CROSS SECTION

- 0 Numerical Methods are either in primary role or in secondary role.
- 0 The most common approach to machine calculation of RCS is the Sum-of-Components.
- 0 Direct solution of Maxwell's equations is handicapped by computer capability.

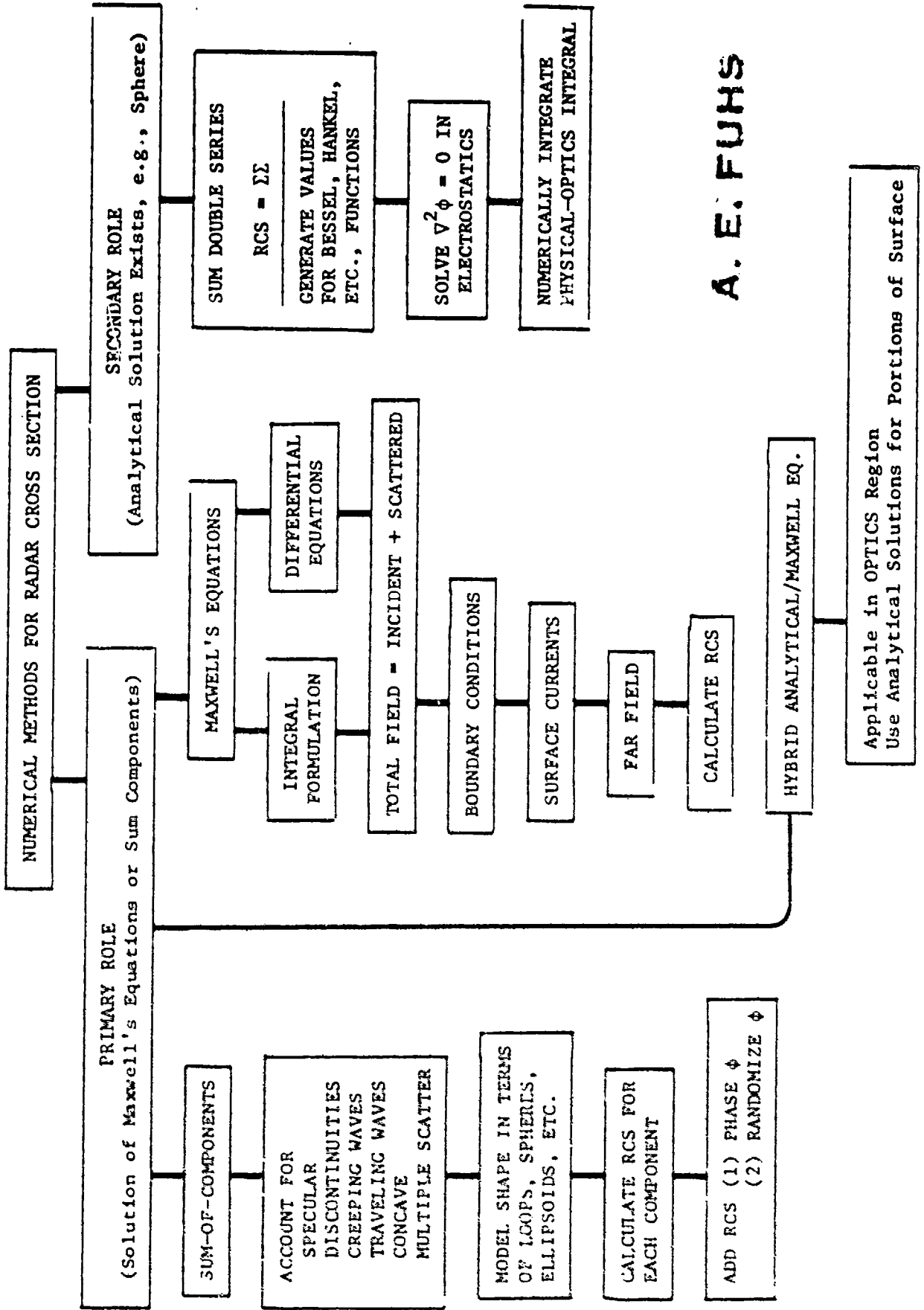

A. E. FUHS

APPLICABILITY OF SUM-OF-COMPONENTS MODEL FOR RCS CALCULATION

- C Even though $kL \gg 1.0$, where L is for overall aircraft size, for parts of the aircraft $k\ell \approx 1.0$ or $k\ell \ll 1.0$ may occur. Hence, solutions must span all three frequency ranges. ℓ is the size of a subcomponent of the aircraft.

A. E. FUHS

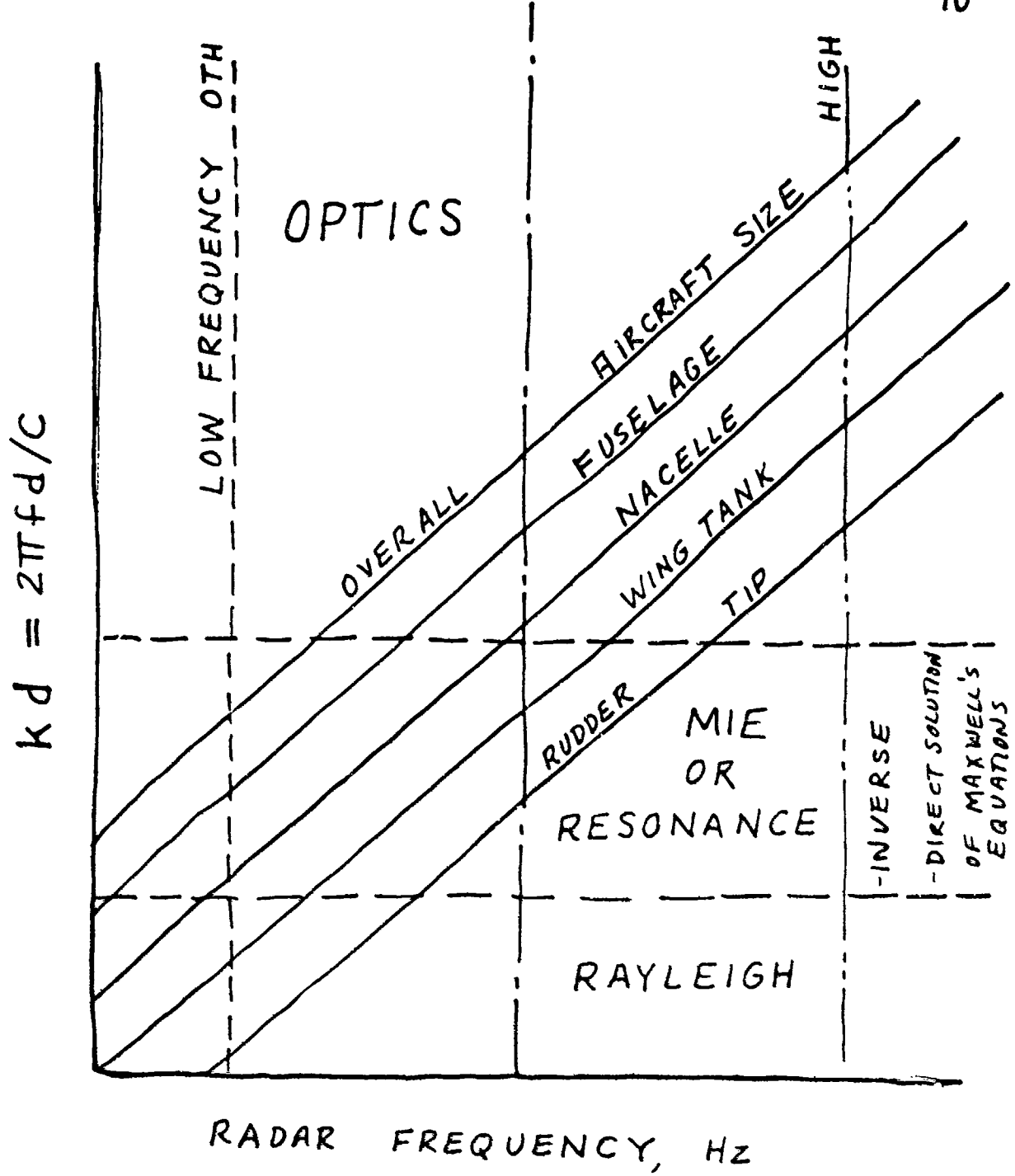

APPLICABILITY OF SUM-OF-COMPONENTS MODEL FOR RCS CALCULATION.