

MICROCOPY RESOLUTION TEST CHART
NATIONAL BUREAU OF STANDARDS-1963-A

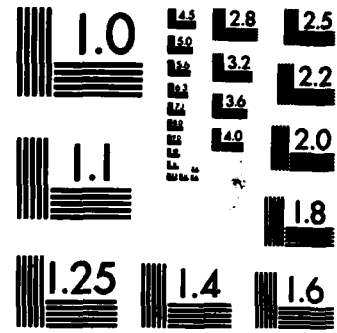

MICROCOPY RESOLUTION TEST CHART
NATIONAL BUREAU OF STANDARDS-1963-A

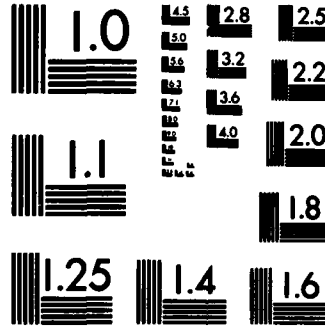

MICROCOPY RESOLUTION TEST CHART
NATIONAL BUREAU OF STANDARDS-1963-A

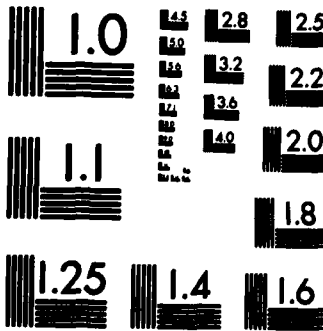

MICROCOPY RESOLUTION TEST CHART
NATIONAL BUREAU OF STANDARDS-1963-A



MICROCOPY RESOLUTION TEST CHART
NATIONAL BUREAU OF STANDARDS-1963-A



SSC-313
(SL-7-28)

AD A120599

**SL-7 RESEARCH PROGRAM
SUMMARY, CONCLUSIONS
AND RECOMMENDATIONS**

DTIC
ELECTRIC
0031 002

STRUCTURE COMMITTEE

1961

82 10 21 082

SHIP STRUCTURE COMMITTEE

The SHIP STRUCTURE COMMITTEE is constituted to prosecute a research program to improve the hull structures of ships and other marine structures by an extension of knowledge pertaining to design, materials and methods of construction.

RAdm Clyde T. Lusk, Jr. (Chairman)
Chief, Office of Merchant Marine
Safety
U. S. Coast Guard Headquarters

Mr. P. M. Palermo
Executive Director
Ship Design & Integration
Directorate
Naval Sea Systems Command

Mr. W. N. Hannan
Vice President
American Bureau of Shipping

Mr. J. Gross
Deputy Assistant Administrator for
Commercial Development
Maritime Administration

Mr. J. B. Gregory
Chief, Research & Development Staff
of Planning & Assessment
U.S. Geological Survey

Mr. Thomas W. Allen
Chief Engineering Officer
Military Sealift Command

LCdr D. B. Anderson, U.S. Coast Guard (Secretary)

SHIP STRUCTURE SUBCOMMITTEE

The SHIP STRUCTURE SUBCOMMITTEE acts for the Ship Structure Committee on technical matters by providing technical coordination for the determination of goals and objectives of the program, and by evaluating and interpreting the results in terms of structural design, construction and operation.

U. S. COAST GUARD

Capt. R. L. Brown
Cdr. J. C. Card
Mr. R. E. Williams
Cdr. J. A. Sanial
LCdr D. B. Anderson, Secy.

NAVAL SEA SYSTEMS COMMAND

Mr. R. Chiu
Mr. J. B. O'Brien
Mr. W. C. Sandberg
Lcdr D. W. Whiddon
Mr. T. Nomura (Contracts Admin.)

MARITIME ADMINISTRATION

Mr. N. O. Hammer
Dr. W. M. Maclean
Mr. F. Seibold
Mr. M. Touma

NATIONAL ACADEMY OF SCIENCES SHIP RESEARCH COMMITTEE

Mr. A. Dudley Haff - Liaison
Mr. R. W. Rumke - Liaison

SOCIETY OF NAVAL ARCHITECTS & MARINE ENGINEERS

Mr. A. B. Stavovy - Liaison

WELDING RESEARCH COUNCIL

Mr. K. H. Koopman - Liaison

MILITARY SEALIFT COMMAND

Mr. Albert Attermeyer
Mr. T. W. Chapman
Mr. A. B. Stavovy
Mr. D. Stein

AMERICAN BUREAU OF SHIPPING

Dr. D. Liu
Mr. I. L. Stern

U. S. GEOLOGICAL SURVEY

Mr. R. Giangerelli
Mr. Charles Smith

INTERNATIONAL SHIP STRUCTURES CONGRESS

Mr. S. G. Stiansen - Liaison

AMERICAN IRON & STEEL INSTITUTE

Mr. R. H. Sterne - Liaison

STATE UNIV. OF NEW YORK MARITIME COLLEGE

Dr. W. R. Porter - Liaison

U. S. COAST GUARD ACADEMY

LCdr R. G. Vorthman - Liaison

U. S. NAVAL ACADEMY

Dr. R. Battacharyya - Liaison

U. S. MERCHANT MARINE ACADEMY

Dr. Chin-Bea Kin - Liaison

Member Agencies:

*United States Coast Guard
Naval Sea Systems Command
Military Sealift Command
Maritime Administration
United States Geological Survey
American Bureau of Shipping*



**An Interagency Advisory Committee
Dedicated to Improving the Structure of Ships**

Address Correspondence to:

**Secretary, Ship Structure Committee
U.S. Coast Guard Headquarters, (G-M/TP 13)
Washington, D.C. 20593**

SR-1279

1981

This report is one of a group of Ship Structure Committee Reports which describe the SL-7 Instrumentation Program. This program, a jointly funded undertaking of Sea-Land Service, Inc., the American Bureau of Shipping and the Ship Structure Committee, represents an excellent example of cooperation between private industry, regulatory authority and government. The goal of the program is to advance understanding of the performance of ships' hull structures and the effectiveness of the analytical and experimental methods used in their design. While the experiments and analyses of the program are keyed to the SL-7 Containership and a considerable body of the data developed relates specifically to that ship, the conclusions of the program will be completely general, and thus applicable to any surface ship structure.

The program includes measurement of hull stresses, accelerations and environmental and operating data on the S.S. Sea-Land McLean, development and installation of a microwave radar wavemeter for measuring the seaway encountered by the vessel, a wave tank model study and a theoretical hydrodynamic analysis which relate to the wave induced loads, a structural model study and a finite element structural analysis which relate to the structural response, and installation of long-term stress recorders on each of the eight vessels of the class. In addition, work is underway to develop the initial correlations of the results of the several program elements.

Results of each of the program elements are being made available through the National Technical Information Service, each identified by an SL-7 number and an AD- number. A list of all SL-7 reports available to date is included in the back of this report.

This report documents a review of the SL-7 research program with a summary of each aspect and outside ancillary projects; presents a set of conclusions, and makes recommendations for further analysis of some data.



**Clyde T. Lusk, Jr.
Rear Admiral, U.S. Coast Guard
Chairman, Ship Structure Committee**

1. Report No. SSC-313 (SL-7-28)		2. Government Accession No.		3. Recipient's Catalog No.	
4. Title and Subtitle SL-7 Research Program Summary, Conclusions and Recommendations				5. Report Date August 1981	
				6. Performing Organization Code	
7. Author(s) Karl A. Stambaugh and William A. Wood				8. Performing Organization Report No. SR-1279	
9. Performing Organization Name and Address Giannotti & Associates, Inc. 703 Giddings Avenue, Suite U-3 Annapolis, Maryland 21401				10. Work Unit No. (TRAI5)	
				11. Contract or Grant No. DTCG-23-80-C-20025	
12. Sponsoring Agency Name and Address U.S. Coast Guard Office of Merchant Marine Safety Washington, D.C. 20593				13. Type of Report and Period Covered Technical Report 8/14/80 - 8/10/81	
				14. Sponsoring Agency Code G-M	
15. Supplementary Notes Contract monitored by: Ship Research Committee National Academy of Sciences Washington, D.C.					
16. Abstract From its first inception, the SL-7 containership program represented a milestone in maritime history. The SL-7s advanced the state of the art in such areas as design, classification, construction and ship operations. It was indeed fortunate when the opportunity presented itself for the Ship Structure Committee to participate in a research program for the full-scale measurement of hull girder stresses on these vessels. Like the SL-7 vessels themselves, the full-scale measurement program has become a milestone itself. The report that follows, ^e SL-7 Research Program: Summary, Conclusions and Recommendations, reflects mainly upon the technical content of the program. This report contains an evaluation of the SL-7 research program according to four main elements, namely, Full-scale Instrumentation, Model Testing Techniques, Analytical Techniques and Hull Girder Load Criteria Analysis. Conclusions are derived from the evaluation with emphasis on how the program results may benefit future programs of similar nature. The report contains appendices summarizing the relevant SL-7 research program documentation and describing the data recorded on the S.S. SEA-LAND McLEAN that should aid future data users. At this time, it appears obvious that the SL-7 program has been a tremendous success. The massive amounts of full-scale hull response data that have been recorded will undoubtedly be a most valuable source of data for researchers, designers and students for many years to come. The program has greatly increased our knowledge and understanding of the sea and the ships that sail on it. As a program involving many disciplines within the marine industry, it has fostered a spirit of cooperation and communication within the industry. These long-term benefits represent the real success of the SL-7 research program.					
17. Key Words Ship Research Ship Structures Structural Analysis Ship Response and Instrumentation			18. Distribution Statement research program.		
19. Security Classif. (of this report)		20. Security Classif. (of this page)		21. No. of Pages 138	22. Price

METRIC CONVERSION FACTORS

Approximate Conversions to Metric Measures

Symbol	When You Know	Multiply by	To Find	Symbol
LENGTH				
in	inches	2.5	centimeters	cm
ft	feet	30	centimeters	cm
yd	yards	0.9	meters	m
mi	miles	1.6	kilometers	km
AREA				
sq ft	square inches	6.5	square centimeters	cm ²
sq ft	square feet	0.09	square meters	m ²
sq yd	square yards	0.8	square meters	m ²
sq mi	square miles	2.6	square kilometers	km ²
acres	square miles	0.4	hectares	ha
MASS (weight)				
oz	ounces	28	grams	g
lb	pounds	0.45	kilograms	kg
	short tons (2000 lb)	0.9	tonnes	t
VOLUME				
cup	teaspoons	5	milliliters	ml
fl oz	tablespoons	15	milliliters	ml
qt	fluid ounces	30	milliliters	ml
pt	cup	0.24	liters	l
qt	quarts	0.95	liters	l
gal	gallons	3.8	liters	l
cu ft	cubic feet	0.03	cubic meters	m ³
cu yd	cubic yards	0.76	cubic meters	m ³
TEMPERATURE (exact)				
°F	Fahrenheit temperature	5/9 (after subtracting 32)	Celsius temperature	°C

Approximate Conversions from Metric Measures

When You Know	Multiply by	To Find	Symbol	
LENGTH				
millimeters	0.04	inches	in	
centimeters	0.4	inches	in	
meters	3.3	feet	ft	
kilometers	1.1	yards	yd	
	0.5	miles	mi	
AREA				
square centimeters	0.16	square inches	in ²	
square meters	1.2	square yards	yd ²	
square kilometers	0.4	square miles	mi ²	
hectares (10,000 m ²)	2.5	acres	acres	
MASS (weight)				
grams	0.035	ounces	oz	
kilograms	2.2	pounds	lb	
tonnes (1000 kg)	1.1	short tons	short tons	
VOLUME				
milliliters	0.03	fluid ounces	fl oz	
liters	2.1	quarts	qt	
	1.06	gallons	gal	
liters	0.26	gallons	gal	
cubic meters	35	cubic feet	ft ³	
cubic meters	1.3	cubic yards	yd ³	
TEMPERATURE (exact)				
°C	Celsius temperature	9/5 (then add 32)	Fahrenheit temperature	°F



* 1 in. = 2.54 (exactly). For other exact conversions and more detailed tables, see NBS Inc., Publ. 286, Units of Weight and Measure, Price \$2.25, SO Catalog No. C1310-286.

CONTENTS

	<u>Page</u>
1.0 <u>INTRODUCTION</u>	1
2.0 <u>BACKGROUND</u>	1
2.1 INFLUENCE OF PRIOR WORK LEADING TO THE SL-7 RESEARCH PROGRAM	2
2.2 DESIGN OF THE SL-7 CONTAINERSHIP	2
3.0 <u>REVIEW AND SUMMARY OF THE SL-7 RESEARCH PROGRAM</u>	3
4.0 <u>EVALUATION OF THE SL-7 RESEARCH PROGRAM</u>	11
4.1 EVALUATION OF INDIVIDUAL SL-7 PROJECTS	11
4.2 SUMMARY OF THE SL-7 RESEARCH PROGRAM EVALUATION	11
4.2.1 <u>Full-Scale Instrumentation</u>	11
4.2.2 <u>Model Testing Techniques</u>	55
4.2.3 <u>Analytical Prediction Techniques</u>	55
4.2.4 <u>Load Criteria, Analysis and Development</u>	56
4.3 OVERALL EVALUATION OF THE SL-7 RESEARCH PROGRAM	57
5.0 <u>RECOMMENDATIONS</u>	59
6.0 <u>EPILOGUE, THE SL-7 CONTAINERSHIP</u>	61
7.0 <u>ACKNOWLEDGEMENTS</u>	61
8.0 <u>REFERENCES</u>	62
<u>APPENDIX A - SUMMARIES OF REFERENCES 1 - 34</u>	A- 1
<u>APPENDIX B - SL-7 RESEARCH PROGRAM DATA BASE DESCRIPTION</u>	B- 1

LIST OF FIGURES

	<u>Page</u>
Figure 2-1	Midship Section of the SL-7 Class Containership 4
Figure 2-2	SL-7 Body Plan, Stem and Stern Outlines and Curve of Sectional Areas 5
Figure 3 1	Representation of an Open-Decked Ship 8
Figure 4-1	SL-7 Data Comparison 14
Figure 4-2	Hatch Deflection Measurements from the Calibration Experiment Performed on the SL-7 SEA-LAND McLEAN 16
Figure 4-3	Comparison of 4 RMS Estimates from the OWHS Radar with Corrected 4 RMS Estimates from the Tucker Meter: All Intervals .. 20
Figure 4-4	Comparisons of 4 RMS Estimates from the OWHS Radar with Corrected 4 RMS Estimates from the Tucker Meter: Intervals Plotted are Restricted to Those for Which the Radar Spectrum Area above the Low-Frequency Integration Cutoff is Greater than 80% of Total 20
Figure 4-5	Histograms of Scratch-Gauge Data Measured on the SL-7 Resource 23
Figure 4-6	Miscellaneous Details of Scratch Records 24
Figure 4-7	Illustration of Scratch-Mark Equivalent to Complex Time History of Stress 25
Figure 4-8	Comparison of SL-7 Stresses at Frame 178 During Positive Torsion 29
Figure 4-9	Representative Loading Applied to the Steel Structural Model . 30
Figure 4-10	Hatch Distortion vs. Stresses in Transverse Box at Fr. 178, Port Side-Section B due to Torsional and Lateral Moments for the SL-7 Containership 32
Figure 4-11	Stress Distribution due to Wave-Induced Vertical Bending Fr. 142-146 Second Loading Case 33
Figure 4-12	Stress Distribution due to Lateral Bending and Torsional Moments Fr. 142-146 Second Loading Case 33
Figure 4-13	Midship Vertical Wave Bending Moments and Wave Phase Lag, 180° Heading 35
Figure 4-14	Midship Vertical Wave Bending Moments and Wave Phase Lag, 0° Heading 36
Figure 4-15	Midship Torsional Wave Bending Moments and Wave Phase Lag, 30° Heading 37
Figure 4-16	Midship Torsional Wave Bending Moments and Wave Phase Lag, 240° Heading 38
Figure 4-17	Midship Vertical Wave Bending Moments and Phase Lag, 180° Heading 41
Figure 4-18	Midship Vertical Wave Bending Moments and Phase Lag, 0° Heading 42

LIST OF FIGURES (cont'd)

	<u>Page</u>
Figure 4-19 Midship Vertical Wave Bending Moments and Phase Lag, 30° Heading	43
Figure 4-20 Midship Torsional Wave Bending Moments and Phase Lag, 240° Heading	44
Figure 4-21 Comparisons of Structural Model Tests and Finite-Element Calculations for the SL-7 Containership, Loading Case 1 ...	46
Figure 4-22 Comparisons of Structural Model Tests and Finite-Element Calculations for the SL-7 Containership, Loading Case 2 ...	47
Figure 4-23 Comparisons of the Wave Time History Measured on the SEA-LAND McLEAN and the Regular Wave Representations (Condition 15 - Voyage 32W - Tape 145 - Index 18 - Interval 5 - Run 405)	51
Figure 4-24 Comparisons of the Wave Time History Measured on the SEA-LAND McLEAN and the Regular Wave Representations (Condition 16 - Voyage 32W - Tape 145 - Index 29 - Interval 50 - Run 450)	51
Figure 4-25 Comparison of the Calculated and Measured Midship Vertical Bending Stresses (Sensor LVB), Wave Condition 15	52
Figure 4-26 Comparison of the Calculated and Measured Midship Vertical Bending Stresses (Sensor LVB), Wave Condition 16	52



SEARCHED	INDEXED
SERIALIZED	FILED
FBI	
Dist	Avail and/or Special
A	

LIST OF TABLES

	<u>Page</u>
TABLE 2-1 CHARACTERISTICS OF S.S. SEA-LAND McLEAN	6
TABLE 3-1 SUMMARY OF SL-7 RESEARCH PROJECT USING THE SL-7 DATA OR AS REPRESENTATIVE HULL TYPE	10
TABLE 4-1 EVALUATION OF THE SL-7 RESEARCH PROGRAM	12

1.0 INTRODUCTION

The SL-7 is an eight-ship class of high-speed containerships conceived owned and operated by Sea-Land Services, Inc. (Sea-Land) in both North Atlantic and Pacific trade routes. A research program involving these ships was initiated by Sea-Land, the American Bureau of Shipping (ABS) and the Ship Structure Committee (SSC), with additional projects funded by the United States Coast Guard and the United States Navy. The program represents an excellent example of cooperation among private industry, classification societies and government. The goal of the program was to advance the understanding of ship structural performance and the effectiveness of analytical and experimental methods used in design. A long-range goal of the program was to obtain information for reaching the SSC's goal for the development of rationally-based system load criterion for the design and analysis of ship hull structures. While the full-scale measurements, model experiments, and analyses performed as part of this program were keyed to the SL-7 class containerships, many of the conclusions of the program can be generalized and applied to other surface ships. This report includes a summary of the overall program, outlines some of the details of the program planning, describes the correlation, comparison and validation efforts, and finally, addresses recommendations for further analysis of the SL-7 program data base.

This report is organized into four basic sections. The first section presents the background leading up to the initiation of the SL-7 research program. The second part presents a review and summary of the SL-7 research program and describes the program elements and general goals of SSC that form the common thread for the program. The second section is intended to provide the reader with some insight as to the relationships between the various program elements. The third part of the report contains an evaluation of the research program documented in References 1-34, relative to the program goals and objectives, and an overall summary of the conclusions is presented based on the evaluation of the research program. The fourth and final part of the report presents the recommendations which may be derived from the SL-7 research program.

Two Appendices are included which provide background information pertinent to the evaluation, conclusions and recommendations. Appendix A contains individual summaries of References 1 through 34, and Appendix B contains a description of the full-scale data base of ship response information recorded on the S.S. SEA-LAND McLEAN.

2.0 BACKGROUND

The SL-7 research program has deep roots in the research history of the SSC. This program was preceded by other programs which included extensive model tests, computer analyses and full-scale data collection and analysis. In fact, most of the full-scale vessel instrumentation technology in use today was developed under the sponsorship of the SSC. In planning for the SL-7 Research Program Summary, Conclusions and Recommendations, it was necessary to review the reports of the preceding related programs in order to provide a basis from which the SL-7 research program

has evolved. Many of these prior programs have had a profound impact and influence in the formulation of methods for full-scale ship data acquisition, in stimulating related research in the private sector, and in advancing the state of the art for ship design.

2.1 INFLUENCE OF PRIOR WORK LEADING TO THE SL-7 RESEARCH PROGRAM

The background research that preceded the SL-7 research program is discussed in detail by Siekierka, et al in SSC-257 (5). It is from this background that the SL-7 research program has evolved. The following is a synopsis of the influence of these studies on the elements of the SL-7 program:

1. Previous full-scale instrumentation programs have provided valuable ship hull load and response data that facilitated the development and validation of design methods and techniques. However, a quantitative description of the wave environment was lacking.
2. The analytical techniques for predicting ship bending moments due to waves have not been validated directly using full-scale data because of the absence of accurate wave information in previous full-scale programs. The wave data are essential to further develop load-prediction techniques and to achieve a greater confidence in the results of the predictions.
3. The full-scale stress data that have been collected are helpful in examining load design criteria for ships similar to those for which stress data are available but cannot provide direct guidance in designing different types of ships.
4. A technique has been developed for extrapolating full-scale ship wave-induced bending moment data and is based on environmental data encountered by the ship in question. This technique may also be used to synthesize bending moment data by using model test results or computational analysis and provides the designer with a valuable tool in predicting wave-induced bending moments.
5. The ship structural load criteria presented in SSC-240 (35) needed further validation and development for use with different ship types and varying types of load conditions.

2.2 DESIGN OF THE SL-7 CONTAINERSHIP

The concept of a high-speed containership was conceived by Sea-Land in the late 1960s. At the time, fossil fuel was still relatively inexpensive, and it appeared that the high-speed containerships were the way of the future for cargo transport. The design of the SL-7 was begun in early 1969 by Sea-Land, J.J. Henry, and The Netherlands Ship Model Basin (NSMB).

The structural design considerations for the SL-7 class of containerships were presented by Boylston (36) and represented the state of the art at the time in applying design tools and methods. During the initial

tigations, the application of modern design methods was still in its infancy and consequently the analyses commenced at a simple level, building more sophistication as the work progressed.

Design bending moments were determined statically on a wave equal to ship length and of a height equal to $2.2 L^{0.4} = 30$ ft. It was determined that the hogging moments were larger than the sagging moments by a factor of about 4 (36). A dynamic analysis was conducted based on the methods presented by Grim and Schenzle (37). The torsional rigidity of the containership was also considered in the design stages, where the torsional moment was determined using the procedure outlined by deWild (38).

Currently with the determination of the wave loading, a coarse mesh finite-element model of the ship was developed. This was one of the early attempts to model a whole ship. The structural analysis showed that deck structure in way of the engine space and transverse bulkheads between each deck limited the torsional-induced warping and deflection of the hull girders thus minimizing the torsional deflections at the hatch corners near the ship's quarter points. The resulting midship section as constructed is shown in Figure 2-1. The body plan is presented in Figure 2-2. An additional finite-element analysis was conducted with a much finer mesh as part of an extensive vibration analysis.

Series of model studies was conducted at the NSMB (36) with emphasis on hull form development and resistance. Seakeeping tests were also conducted and measurements were obtained for ship motions, accelerations and relative motions at the bow and stern in irregular seas corresponding to wind force Beaufort 8 in the North Atlantic (significant wave height 12.5 ft. and average period 8.5 sec.) approaching from ahead, the bow quarter, abeam, and the stern quarter. The relative motion data indicated that for this sea state no water would be shipped over the foredeck. However, emergence was not experienced and it was concluded that slamming would be minimal in Beaufort 8 seas.

There were 8 vessels of the SL-7 class constructed at three different foreign shipyards, which included Rotterdam Dockyard, A.G. Weser, and Stahl Nordseewerke. The vessels were:

S.S. SEA-LAND McLEAN	S.S. SEA-LAND FINANCE
S.S. SEA-LAND GALLOWAY	S.S. SEA-LAND MARKET
S.S. SEA-LAND TRADE	S.S. SEA-LAND RESOURCE
S.S. SEA-LAND EXCHANGE	S.S. SEA-LAND COMMERCE

Principal characteristics of the lead ship of the SL-7 class, the SEA-LAND McLEAN (McLEAN), are shown in Table 2-1.

BACKGROUND AND SUMMARY OF THE SL-7 RESEARCH PROGRAM

The three-phase SL-7 research program was proposed by Sea-Land and ABS before the SSC became involved. Sea-Land was interested in instrumenting the first ship of the class, the McLEAN, in order to validate design demands and procedures, while ABS was interested in conducting finite-

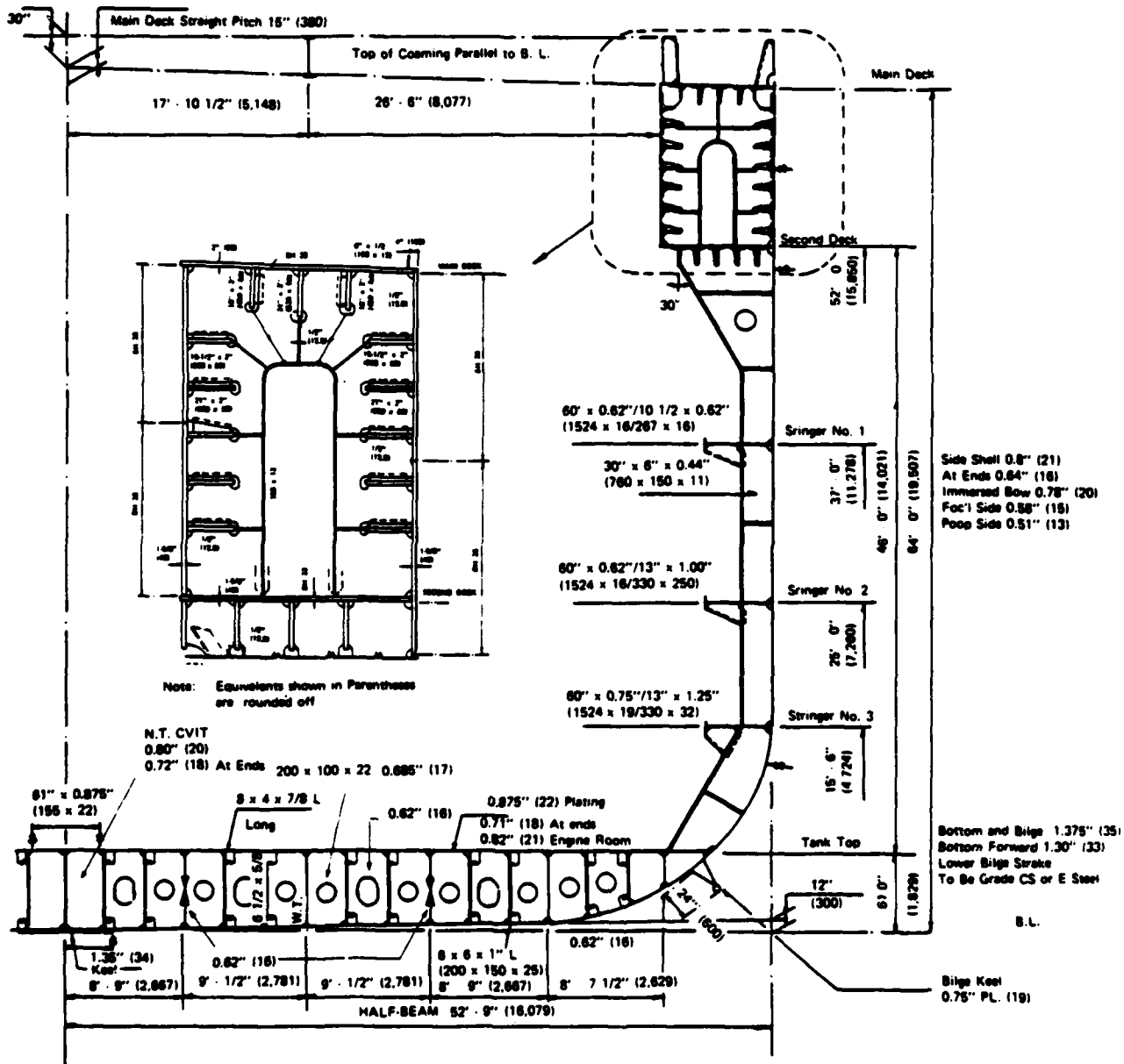

Figure 2-1 Mid-Ship Section of the SL-7 Class Containership

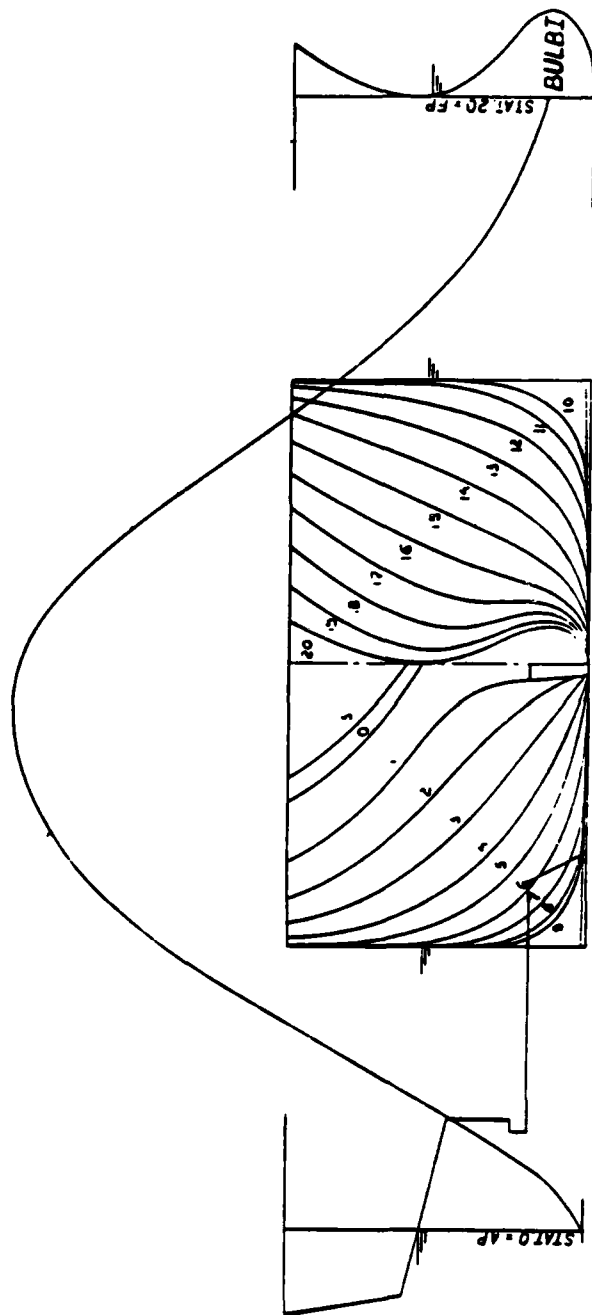

Figure 2-2 SL-7 Body Plan, Stem and Stern Outlines and Curve of Sectional Areas

TABLE 2-1
 CHARACTERISTICS OF S.S. SEA-LAND McLEAN

Name:	SEA-LAND McLEAN
Builder:	Rotterdam Dry Dock (Hull 330)
Class:	SL-7 Containership
Length, overall	946' 1½"
Length, between perpendiculars	880' 6"
Beam, molded	105' 6"
Depth to main deck, aft \bar{Q}	69' 9"
Depth to main deck, forward \bar{Q}	65' 3"
Camber from \bar{Q}	1' 3"
Draft, design	30' 0"
Draft, scantling	33' 0"
Dead weight - long tons	27,315
Displacement (34' 0" draft) - long tons	50,315
Machinery	Two separate cross-compound stem turbines driving two propeller shafts (Bunker C oil)
Shaft Horsepower-maximum continuous, both shafts	120,000
Propeller RPM	135
Speed, maximum, knots	33
Center of gravity - full load	399.32' forward of aft perpendicular 42.65' above base line
Section modulus, FR 186, top:	1,745 x 10 ⁶ in ³
Section modulus, FR 186, bottom:	2,166 x 10 ⁶ in ³
Neutral axis, FR 186	342.5 in above base line
Fuel oil Capacity (98% full)	5384 LT
Salt water Ballast Capacity	9656 LT

	<u>Container Capacity</u>		
	<u>8' x 8.5' x 35'</u>	<u>8' x 8.5' x 40'</u>	<u>Total</u>
Below deck	554	140	694
Above deck	342	60	402
TOTAL	896	200	1,096

element analyses and structural model tests in order to exercise and validate their relatively new finite-element computer program, DAISY. SSC eventually became involved in the project and supplied additional funds and technical guidance through a Project Advisory Committee of the National Academy of Sciences/National Research Council.

Several design-related problems prompted the initiation of the SL-7 research program. Each participant, Sea-Land (designing, building and operating), ABS (classification), and SSC (research), had specific interest goals to achieve through participation in the program.

The specific design features of interest to Sea-Land were primarily in areas of stress concentration at the hatch corners where the ship transforms from a flexible open box to a rigid closed box structure and where the transverse box girders interact with the longitudinal box girders. These locations are represented in Figure 3-1. They were also of special interest since the diagonal displacements of hatch openings subsequently caused large stresses at the girder intersections and problems with the hatch cover seals.

One of the primary goals relative to SSC's objectives for the full-scale portion of the SL-7 research program was stated in Siekierka in SSC-257, Reference 5, "The results of the wave-induced stress measurements (on the McLEAN) will be compared with model and computer analytical data. The ultimate aim is to secure sufficient confidence in the calculation procedure, so that model testing and full-scale data collection may be eliminated." Further applications of full-scale data discussed in the following sections will consider Siekierka's statement as one of the primary objectives of the full-scale instrumentation installed on the SL-7 class of ships.

As stated by Chazal in SSC-252 (39), the overall goal of the SSC for the SL-7 research program was to "either develop or provide supporting evidence for rational design methods for ships." Fundamental to any rational design method is the ability to characterize the actual structure using predictive techniques such as mathematical analysis or model testing. With either method, correlation factors must be applied which relate the predicted results to the actual full-scale structure. Determining these correlation factors and refining the predictive techniques are implicit objectives of research into ship structural design methods. Within this framework and the historical background presented, the SL-7 research program was developed with the following four distinct elements:

1. A full-scale instrumentation project consisting of measurement of hull stresses, rigid-body accelerations and environmental data, and long-term extreme strain recorders.
2. Use of model-testing techniques for the prediction and validation of ship dynamic and static loads and responses.
3. Development and validation of analytical tools and techniques for ship motion, load and response characteristics, including finite-element computer programs.

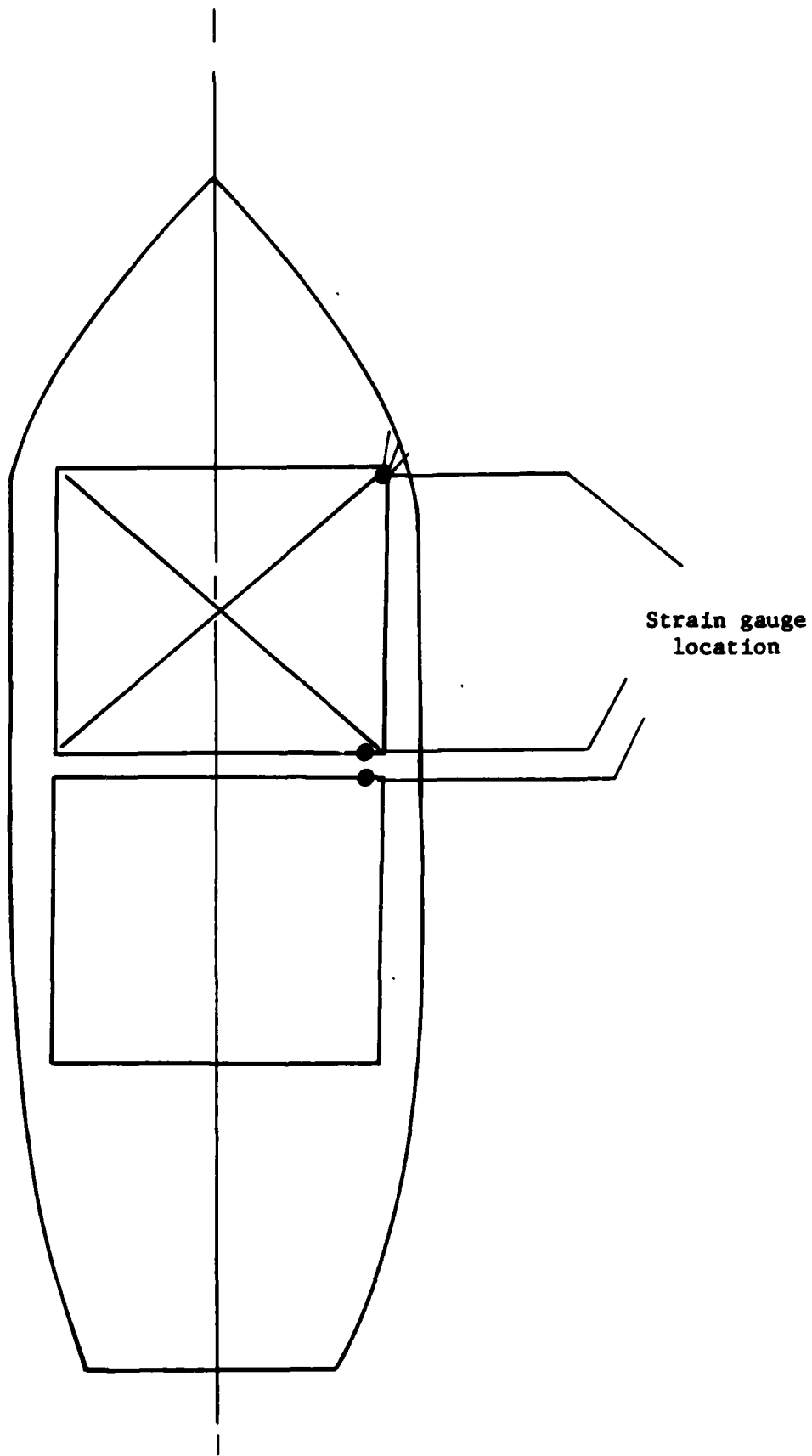

Figure 3-1 Representation of an Open-Decked Ship

4. Development and analysis of lifetime hull girder load criteria for ship structural design based on statistical evaluation of full-scale data.

In subsequent sections of this report, each of these elements, their interrelationships and impact on design methods, will be summarized and evaluated with respect to the program's objectives and goals.

The SL-7 research program as initially conceived contained specific individual projects to implement the broad program elements.

1. A full-scale instrumentation program was proposed to obtain full-scale measurement of seaway loads and response. This included the design and installation of an instrumentation system, the calibration and operation of this system, and reduction and analysis of selected amounts of data.
2. A series of hydrodynamic model tests were proposed to investigate wave-induced vertical, horizontal and torsional bending in the hull girder.
3. A model test was proposed to measure stresses and deflections of a small-scale structural model under separate and combined torsion and bending.
4. An analytical analysis was to be conducted which included the use of a finite-element program, DAISY, to analyze the structural response of the SL-7 containership.
5. A theoretical hydrodynamic analysis was to be performed applying the SCORES computer program for predicting the loads and response of the SL-7 containership in regular waves.

It should be emphasized that prior to completion of the full-scale instrumentation data reduction and analysis, the other program elements were initiated. The relationships between projects listed above are described in SSC-257 (5), which includes a description of the planning effort involved in the validation and verification of load, motion and response predictions. Not all of the recommendations for research presented in SSC-257 (5) were funded, and several were integrated into one project. As the program evolved, it developed into a more extensive program which included further analysis of data obtained from the initial program and development of additional related projects. These follow-on projects continued the validation and development efforts and full-scale data reduction that had begun in the initial part of the SL-7 research program.

Most of the results of the SL-7 related research projects have appeared as SSC reports. Summaries of all SL-7 related project reports and technical papers are presented in Appendix A. Some SL-7 related projects have received separate Coast Guard, Navy, or ABS sponsorship. The projects which will be evaluated in this report are listed in Table 3-1. A description of the McLEAN data base is presented in Appendix B. This

TABLE 3-1

SUMMARY OF SL-7 RESEARCH PROJECT USING THE SL-7 DATA OR AS REPRESENTATIVE HULL TYPE

SL-7 PROGRAM ELEMENTS	PROJECT	ORIGIN (location of data)	ASSOCIATED REFERENCES
Full Scale Instrumentation	Hull response measurement on the SL-7 SEA-LAND McLEAN	Teledyne Engineering Services	1, 7, 8, 9, 10
	Shipboard wave measurement systems on the SL-7 SEA-LAND McLEAN	Teledyne Engineering Services	10
		Naval Research Lab	13
		Stevens Institute of Technology	14-23*
	Scratch gauge data on the SL-7 class containerships (including the McLEAN)	Teledyne Engineering Services	25
		Giannotti & Assoc., Inc.	31*
Model Testing Techniques	1/140th Scale model tests of the SL-7	Stevens Institute of Technology	2
	Steel structural model tests of the SL-7	University of California, Berkeley	11
	PVC rigid vinyl structural model tests of the SL-7	David Taylor Naval Ship Research & Development Center	6
	Open water model tests of the SL-7	University of California, Berkeley	26,27
	Hull pressure model tests of the SL-7	University of Michigan	**
Analytical Techniques	SCORES computer simulations of the SL-7	Oceanics, Inc.	4, 12
	DAISY Finite Element Analysis of the SL-7	American Bureau of Shipping	3, 24, 30
	Time domain computer simulation of capsizing for the SL-7	University of California, Berkeley	26,28,29
Hull Girder Load Criteria Analysis	Examination of service stress data (includes the SL-7 as a ship type)	Stevens Institute of Technology and Rosenblatt & Son, Inc.	33*
	Evaluation of full scale wave loads (includes the SL-7 as a ship type)	HS-1 Panel, SNAME	34*
	Fatigue load spectra development for ship hulls	Giannotti & Assoc., Inc.	32*

* Based on full scale data obtained from Teledyne Engineering Services

** No document has been published to date.

description presents a summary of the data acquisition, data reduction methods, and data formats.

4.0 EVALUATION OF THE SL-7 RESEARCH PROGRAM

This section provides an overall evaluation of the SL-7 research program. Section 4.1 discusses the validity and usefulness of the results derived from each project in the four main program elements described in Table 3-1. Section 4.2 summarizes the evaluation, conclusions and contributions made by each project in the four main program elements. Section 4.3 presents an overall evaluation of the SL-7 research program.

4.1 EVALUATION OF INDIVIDUAL SL-7 PROJECTS

Evaluations of each of the projects listed in Table 3-1 have been categorized according to the four main elements of the SL-7 research program and are summarized in Table 4-1. The contributions of each project in achieving the SL-7 program goals are summarized with respect to development of specific structural design methods, motion and load measurement and prediction techniques, and rational hull girder load criteria. In many cases, the evaluations of individual researchers are presented with additional comments on overall observations, assumptions, limitations and applications of the projects considered. Special attention is given to the lessons learned from the SL-7 research projects that may be of benefit to future data users and those considering other programs of a similar nature.

4.2 SUMMARY OF THE SL-7 RESEARCH PROGRAM EVALUATION

This section presents a summary of the SL-7 research program evaluation which includes the primary observations obtained from the evaluations of each individual report (References 1-34) presented in Section 4.1. As per the individual evaluations, the summary is organized according to the four elements of the SL-7 research program.

4.2.1 Full-Scale Instrumentation

Although the McLEAN data base has several limitations, it still represents a major source of full-scale data for use by the marine community in general. The major limitations of the McLEAN data base have been indicated in the evaluation section and include the lack of an initial mean stress datum prior to departure for each voyage (the gauges were zeroed prior to departure and no record of the initial mean stress was kept), the inadequacy of motion measurement devices (roll and pitch pendulums), and the unreliability of measured wave data. The latter limitation of the data base severely limits further applications relative to verification of analytical prediction techniques. The research plan outlined by Siekierka in Reference 5 was heavily oriented to using the McLEAN data base for validation purposes. The wave-measurement limitation has precluded the achievement of this goal. It is also interesting to note that the research plan did not include hull girder load criteria analysis and development even though the data collection techniques were heavily oriented toward gaining a substantial statistical sample.

TABLE 4-1
EVALUATION OF THE SL-7 RESEARCH PROGRAM
 Element: FULL-SCALE INSTRUMENTATION

Report Title SSC No. Ref. No. Pub. Date	Structural Design Methods Specific to the SL-7 and Containerships in General	Measurement and Prediction of Ship Load, Motion and Stress	Rational Hull Girder Load Criteria Analysis and Development Including Statistical Evaluation of Data
Design and Installation of a Ship Response Instrumentation System Aboard the SL-7 Class Containership S.S. SEA-LAND WLEEAR SSC-276 Reference (1) 1974	<ul style="list-style-type: none"> • Many of the instrument locations were intended to provide design information to Sea-Land directly. • Sea-Land obtained data to make assessment of: <ul style="list-style-type: none"> (a) Hatch covers and comings (b) Deck cutouts (c) Cell guides and transverse bulk head structure (d) Container design (e) Internal container cargo restraint systems (f) Habitability in forward and aft houses (g) Deck and shell loadings in bow area (h) Rigid on-deck container securing system • No documentation on the data or results obtained by Sea-Land is available to the general public at this time. 	<ul style="list-style-type: none"> • No loads per se were measured on the SL-7, only response. Measurement of the wave environment was attempted using a Tucker wave meter and a radar wave meter. The measurement of wave environment was intended to facilitate comparisons between full scale and analytical predictions. See the following discussion of References (13) - (23) and summaries in Appendix (A) for an evaluation of the meter systems. • The angular motions measured on the SL-7 were obtained from pendulums. Accelerations of the pendulum produced measurement errors. (See discussion in Reference (23) for further evaluation.) • Strain-gauge locations represented the state of the art in strain-gauge placement with inputs by ABS, SSC advisors and Sea-Land. However, there is minimal documentation on the rationale involved with instrumentation selection, placement, purpose, and data reduction required. It is therefore difficult to fully evaluate the instrumentation system installed on the SEA-LAND McLEARN with limited (com'') 	<ul style="list-style-type: none"> • The data collection techniques were heavily oriented toward obtaining a statistical data sample and were not necessarily compatible with validation of analytical techniques or obtaining information for development of design methods.

TABLE 4-1 (cont'd)
EVALUATION OF THE SL-7 RESEARCH PROGRAM
 Element: FULL SCALE INSTRUMENTATION

Contribution of the Study in Achieving the SL-7 Research Program Goals			
Report Title SBC No. Ref. No. Pub. Date	Structural Design Methods Specific to the SL-7 and Containerhips in General	Measurement and Prediction of Ship Load, Motion and Stress	Rational Hull Girder Load Criteria Analysis and Development Including Statistical Evaluation of Data
Continuation of Reference (1) SL-7 Instrumentation Program Background and Research Plan SBC-237 Reference (5) 1976	<ul style="list-style-type: none"> A significant feature of the test plan outlined in the report is that it did not include plans to develop methods for containerhip design. 	<p>documentation of specific objectives and requirements for data acquisition and reduction. This information, if available, would be of great benefit for future full-scale instrumentation programs of a similar nature. For example, the information could aid in the determination of strain-gauge instrumentation placement without going through the deliberations that must have taken place in deciding the placement of strain gauges on the SEA-LAND McLEAN.</p> <ul style="list-style-type: none"> The report presents a research plan, developed by a few individuals and reviewed by the Project Advisory Committee of SSC, that is oriented directly at the validation of analytical prediction techniques. An overall chart of the plan is presented in Figure 4-1. The overall plan for validation was very good; but was dependent on obtaining an accurate picture of the wave environment actually encountered in order to obtain a validation of analytical prediction techniques. 	<ul style="list-style-type: none"> A significant feature of the test plan is that it did not include plans to develop or analyze the SL-7 containerhip load criteria or evaluate the SL-7 data statistically.

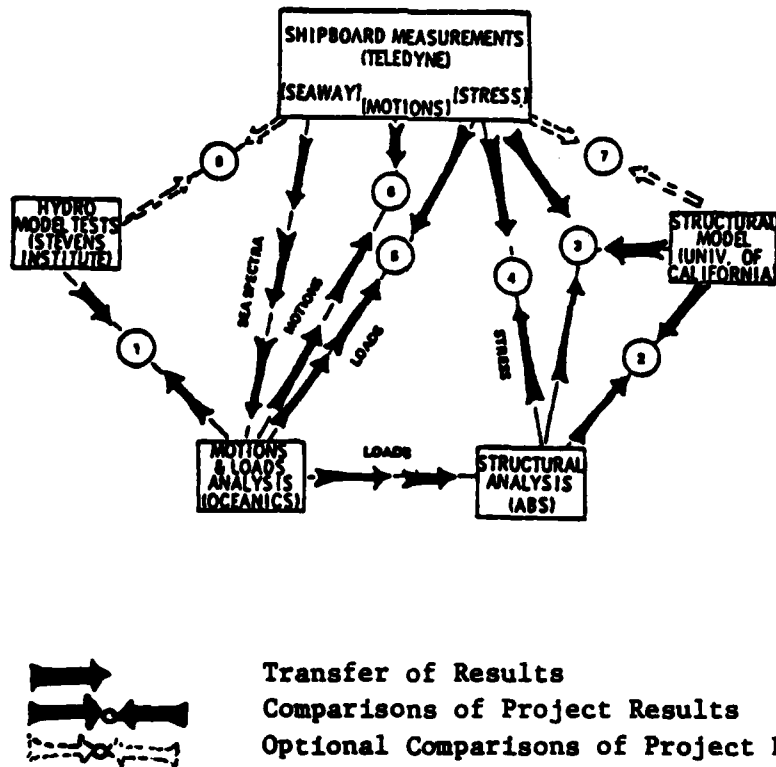
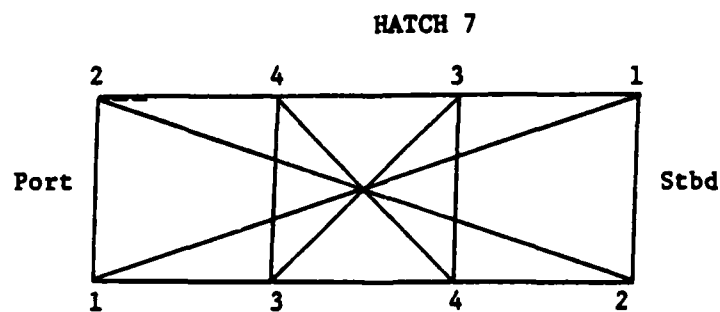

Figure 4-1 SL-7 Data Comparison

TABLE 4-1 (Cont'd)
 EVALUATION OF THE SL-7 RESEARCH PROGRAM
 Element: FULL-SCALE INSTRUMENTATION

Contribution of the Study in Achieving the SL-7 Research Program Goals			
Report Title SSC No. Rev. No. Pub. Date	Structural Design Methods Specific to the SL-7 and Containerhips in General	Measurement and Prediction of Ship Load, Motion and Stress	Rational Hull Under Load Criteria Analysis and Development Including Statistical Evaluation of Data
<p>Static Structural Calibration of Ship Response Instrumentation System Aboard the SEA-LAMP McLEAM SSC-263 Reference (7) 1976</p> <p>First Seacon Results from Ship Response Instrumentation Aboard the SL-7 Class Containerhip S.S. SEA-LAMP McLEAM in North Atlantic Service SSC-264 Reference (8) 1976</p>	<ul style="list-style-type: none"> During the calibration experiment, hatch deflections were measured as a result of a known loading to infer a relationship between hatch deflection and measured stresses. This information was useful in inferring a hatch displacement from seaway-induced stresses. Figure 4-2 from that report presents the results of inferring deflections from stresses. This information was to aid in the design of hatch covers which are sensitive to torsional-induced stresses. Minimal data are presented in this report; in fact, only a minimal amount of data have been reduced to date. This is substantiated by Table B-1 presented in Appendix (B). Additional data reduction is required before the data would be in a form useful to a designer or researcher. 	<ul style="list-style-type: none"> The data obtained from the calibration experiment was used to aid in the validation of the ABS finite-element program DAIST. The discussion of that report (Reference 24) presents an evaluation of the calibration experiment results. This is strictly a data format presentation report. The data presented in the report do not contribute to validation efforts. 	<ul style="list-style-type: none"> Some of the data presented in the report are oriented toward statistical evaluation of data (see Figure B-9 of this report). However, the data that are presented against Beaufort Number are inconvenient for validation use.

<u>Condition</u>	<u>Direction</u>	<u>Measurement</u>	<u>Cumulative Change</u>
4	1-1	96' 4 3/4"	0
4	2-2	96' 4 9/16"	0
4	3-3	50' 5"	0
4	4-4	50' 4 1/4"	0
5	1-1	96' 4 5/8"	- 1/8
5	2-2	96' 4 5/8"	+ 1/16
5	3-3	50' 4 3/4"	- 1/4
5	4-4	-*	-*
6	1-1	96' 4 3/8"	- 3/8
6	2-2	96' 4 15/16"	+ 3/8
6	3-3	50' 4 11/16"	- 5/16
6	4-4	-*	-*



* Reading not taken due to safety considerations.

Figure 4-2 Hatch Deflection Measurements from the Calibration Experiment Performed on the SL-7 SEA-LAND McLEAN

TABLE 4-1 (cont'd)
EVALUATION OF THE SL - 7 RESEARCH PROGRAM

Element: FULL-SCALE INSTRUMENTATION

Contribution of the Study in Achieving the SL - 7 Research Program Goals			
Report Title SSC No. Ref. No. Pub. Date	Structural Design Methods Specific to the SL - 7 and Containerhips in General	Measurement and Prediction of Ship Load, Motion and Stress	Rational Hull Girder Load Criteria Analysis and Development Including Statistical Evaluation of Data
Second Season Results from Ship Response Instrumentation Aboard the SL-7 Class Con- tainerhip S.S. SEA-LAND McLEAN in North Atlantic Service SL-7-9 Reference (9) 1976	<ul style="list-style-type: none"> Comments presented for Reference (8) apply. Comments presented for Reference (8) apply. Stress data were recorded at the forward hatch cutru. Here fatigue cracks were observed. These data are available and could be used for fatigue analysis and development of methods to avoid hatch corner fatigue damage. However, the data have not been reduced or analyzed to date. 	<ul style="list-style-type: none"> Comments presented for Reference (8) apply. Comments presented for Reference (8) apply. 	<ul style="list-style-type: none"> Comments presented for Reference (8) apply. Data were recorded while the McLEAN was settling on the blocks during drydocking. However, this information has not been analyzed. Comments presented for Reference (8) apply.
Third Season Results from Ship Response Instrumentation Aboard the SL-7 Class Con- tainerhip S.S. SEA-LAND McLEAN in North Atlantic Service SL-7-10 Reference (10) 1976	<ul style="list-style-type: none"> Comments presented for Reference (8) apply. Stress data were recorded at the forward hatch cutru. Here fatigue cracks were observed. These data are available and could be used for fatigue analysis and development of methods to avoid hatch corner fatigue damage. However, the data have not been reduced or analyzed to date. 	<ul style="list-style-type: none"> Comments presented for Reference (8) apply. 	<ul style="list-style-type: none"> Comments presented for Reference (8) apply.
A Report on Shipboard Wave- height Radar System SL-7-11 Reference (11) 1976	<ul style="list-style-type: none"> Comments presented for Reference (8) apply. 	<ul style="list-style-type: none"> This report documents the radar wave meter obtained from NRL and used on the McLEAN. The report presents a brief discussion on the required data analysis needed to obtain a true wave height from a moving ship. However, the specific limitations of the system were not foreseen at the system design level. 	<ul style="list-style-type: none"> Comments presented for Reference (8) apply.

TABLE 4-1 (cont'd)

EVALUATION OF THE SL-7 RESEARCH PROGRAM

Element: FULL-SCALE INSTRUMENTATION

Contribution of the Study in Achieving the SL-7 Research Program Goals			
Report Title SSC No. Ref. No. Pub. Date	Structural Design Methods Specific to the SL-7 and Containerhips in General	Measurement and Prediction of Ship Load, Motion and Stress	Rational Hull Girder Load Criteria Analysis and Development Including Statistical Evaluation of Data
Original Radar and Standard Tucker Wavemeter SL-7 Container- ship Data Reduction and Correlation Sample SSC-277 Reference (14) 1978 Wavemeter Data Reduction Method and Initial Data for the SL-7 Containership SSC-278 Reference (15) 1978 Radar and Tucker Wavemeter Data from S.S. SEA-LAND McLEAN; Voyage 32 - SL-7-16 Reference (16) 1978 Voyage 33 - SL-7-17 Reference (17) 1978 Voyage 34 - SL-7-18 Reference (18) 1978 Voyages 35 and 36E - SL-7-19 Reference (19) 1978 Modified Radar and Standard Tucker Wavemeter SL-7 Container- ship Data SL-7-20 Reference (20) 1978 Radar and Tucker Wavemeter Data from S.S. SEA-LAND McLEAN; Voyage 60 - SL-7-21 Reference (21) 1978 Voyage 61 - SL-7-22 Reference (22) 1978		<ul style="list-style-type: none"> References (14) through (22) present data reduction procedures and the subsequent data reductions. The discussion of the results appears in Reference (23) which is discussed next. 	

TABLE 4-1 (cont'd)

EVALUATION OF THE SL-7 RESEARCH PROGRAM

Element: FULL-SCALE INSTRUMENTATION

Contribution of the Study in Achieving the SL-7 Research Program Goals	
Report Title SSC No. Ref. No. Pub. Date	Rational Hull Girdler Load Criteria Analysis and Development Including Statistical Evaluation of Data
<p>Structural Design Methods Specific to the SL-7 and Containments in General</p>	<p>Measurement and Prediction of Ship Load, Motion and Stress</p>
<p>Results and Evaluation of the SL-7 Containment Radar and Tucker Wavecrest Data SSC-280 Reference (23) 1978</p>	<p>This report contains a detailed description and evaluation of the wavecrest systems used on the SEA-LAND McLEAN. The author, (Daisell), appropriately concluded: "The evidence strongly suggests that neither of the wave measuring systems (Tucker and Radar) can be regarded as a standard by which the performance of the other may be judged." This is illustrated by typical comparisons of wavecrest systems shown in Figures 4-3 and 4-4. The conclusions and recommendations of Reference (23) present a discussion of how the systems may be improved. The conclusions and recommendation are presented in the summary of Reference 23 in Appendix (A). It is unfortunate that the wave data recorded on the SEA-LAND McLEAN were determined unreliable. These data were to be an integral part of the total research program (outlined in SSC-257 SL-7-5) and were a necessary part of the validation of analytical predictions and model tests. Recall one of the objectives of the SL-7 program presented in Section 3.1 was, specifically, to perform such validations.</p>

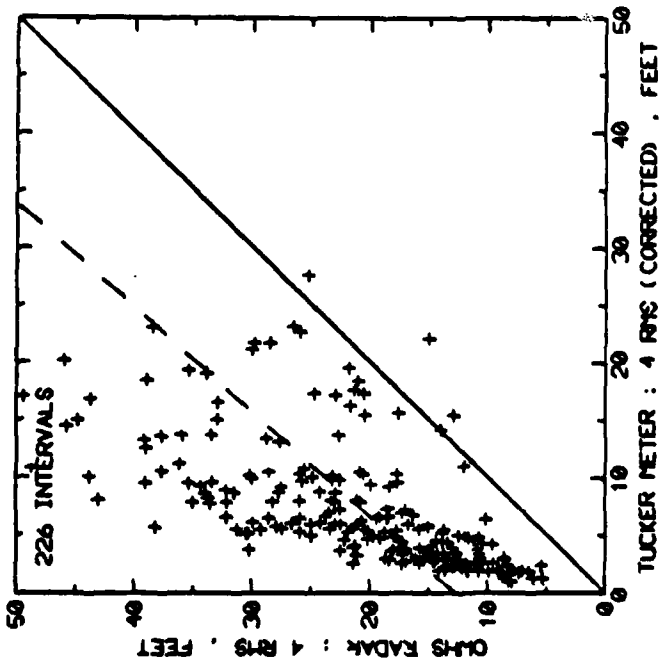

Figure 4-3 Comparison of RMS Estimates from the OMHS Radar with Corrected 4 RMS Estimates from the Tucker Meter: All Intervals

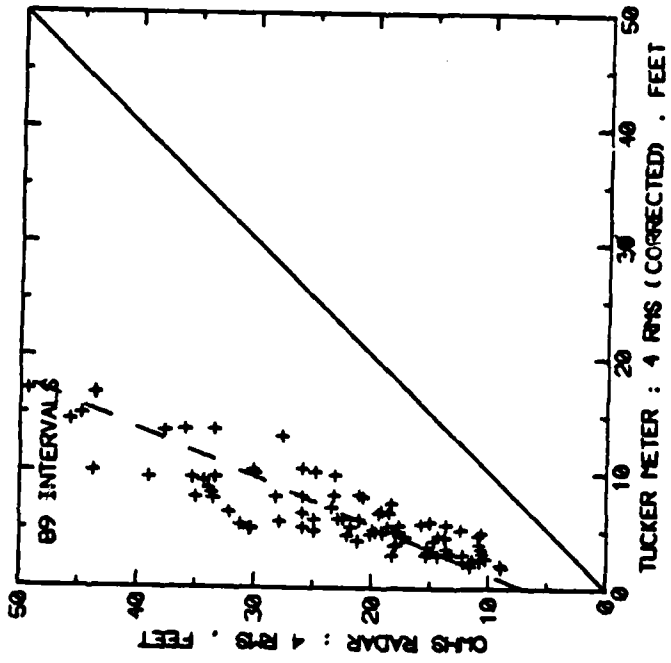

Figure 4-4 Comparison of 4 RMS Estimates from the OMHS Radar with Corrected 4 RMS Estimates from the Tucker Meter; Intervals Plotted are Restricted to Those for which the Radar Spectrum Area above the Low-Frequency Intergration Cutoff is Greater than 80% of Total

TABLE 4-1 (cont'd)
EVALUATION OF THE SL-7 RESEARCH PROGRAM

Element: FULL-SCALE INSTRUMENTATION

Contribution of the Study in Achieving the SL-7 Research Program Goals			
Report Title SSC No. Ref. No. Pub. Date	Structural Design Methods Specific to the SL-7 and Containerships in General	Measurement and Prediction of Ship Load, Motion and Stress	National Hull Girder Load Criteria Analysis and Development Including Statistical Evaluation of Data
Results of the First Five 'Data Years' of Extreme Stress Scratch Gauge Data Collected Aboard Sea-Land's SL-7s SSC-286 Reference (25) 1979			<ul style="list-style-type: none"> This report presents data analysis of the scratch gauges for each of the 8 ships in a Microgram form (see Fig. 4-5). This data presentation format is not readily compatible with the statistical evaluation techniques which require some type of weather classification. Of specific note is the fact that project records of the weather conditions encountered were kept for only the first three seasons of operation for the SEA-LAND McLEAM; however, the scratch gauges were operating on all 8 ships of the class for a total of 7 years each. There are weather observations contained in the ships' log books for the other cases, but as of this time that information has not been released.
Evaluation of SL-7 Scratch Gauge Data Reference (31) September 1980		<ul style="list-style-type: none"> The authors of Reference (31) point out very appropriately that the scratches produced by the mechanical devices every 4 hours represent the sum total of the structural response of many types of loads. This is illustrated in Figures 4-6 and 4-7. One scratch line can represent the response from the following types of loads: (cont) 	<ul style="list-style-type: none"> The conclusions by Oliver (Ref. 31) indicate that the scratch gauge data may be used in conjunction with load-combination techniques to obtain probabilistic distributions of combined loads over the 4-hour recording period. Extrapolation of these scratches for a lifetime experience (cont)

TABLE 4-1 (cont'd)

EVALUATION OF THE SL-7 RESEARCH PROGRAM

Element: FULL-SCALE INSTRUMENTATION

Report Title SSC No. Ref. No. Pub. Date	Contribution of the Study in Achieving the SL-7 Research Program Goals		
	Structural Design Methods Specific to the SL-7 and Containerships in General	Measurement and Prediction of Ship Load, Motion and Stress	National Hull Girder Load Criteria Analysis and Development Including Statistical Evaluation of Data
Continuation of Reference (31)		<ol style="list-style-type: none"> 1. Still-water bending due to weight and buoyancy. 2. Bending due to the ship's own wave train. 3. Wave-induced bending. 4. Dynamic loads, including slamming, whipping and springing. 5. Thermal effects. <p>• Since the scratches do not represent the wave-induced bending moment alone, they are not appropriate for use as an alternative to more complex continuous assessment sensors if the objective is to calibrate analytically or statistically predicted structural responses from wave-induced loads only.</p>	<p>of scratches forms a complete picture of the ship response from all loads.</p>

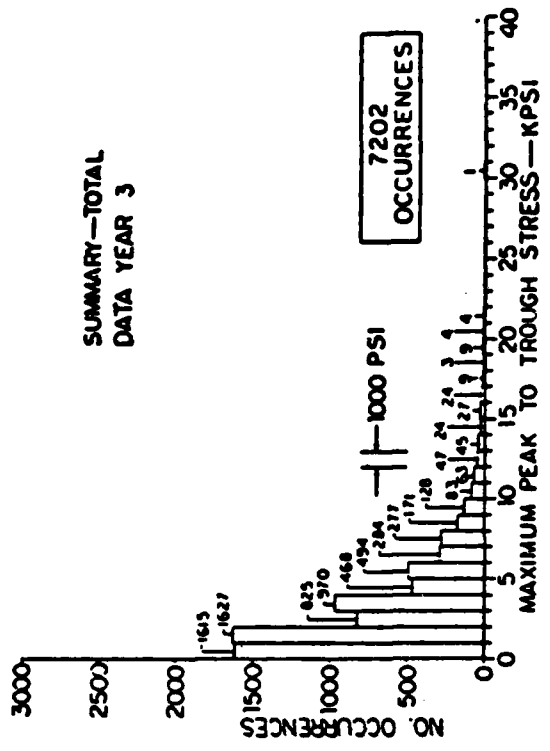
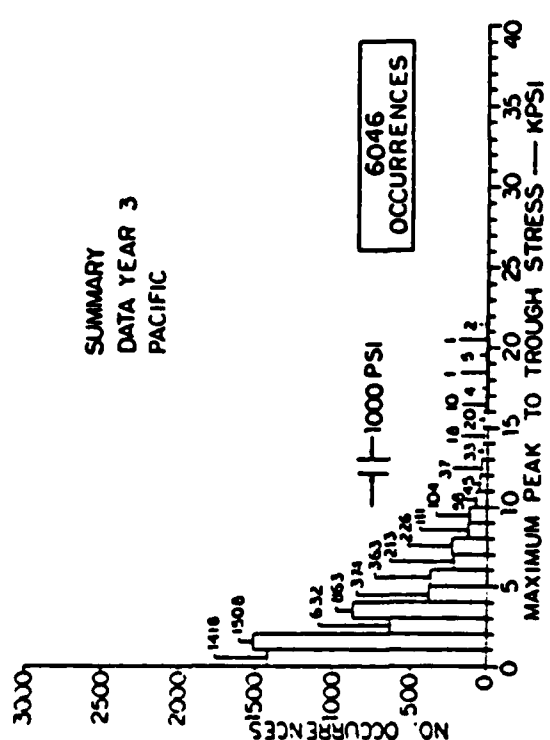
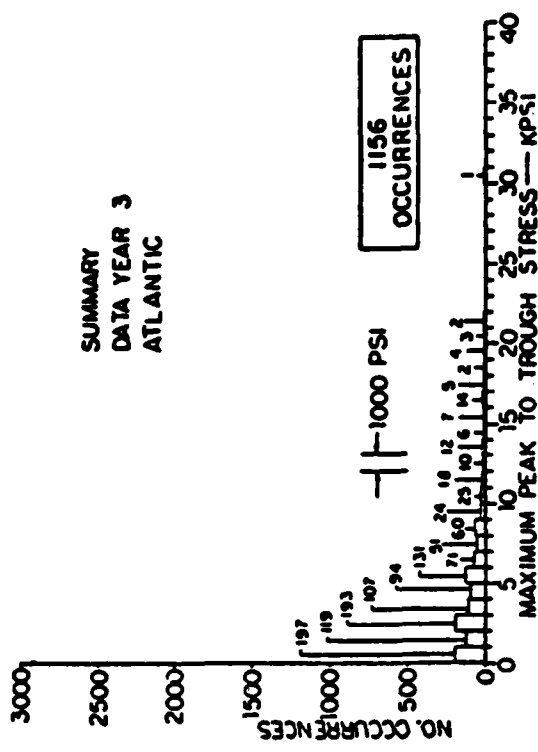
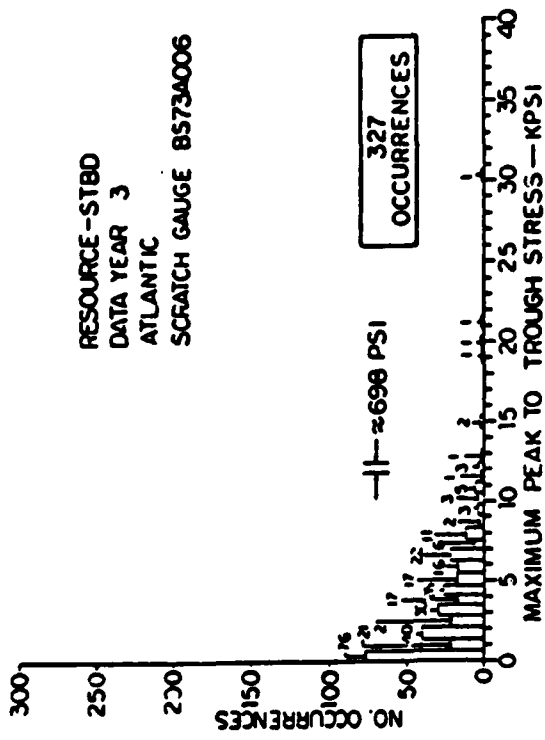

Figure 4-5 Histograms of Scratch-Gauge Data Measured on the SL-7 RESOURCE

Paper Tape Record of Scratch Marks

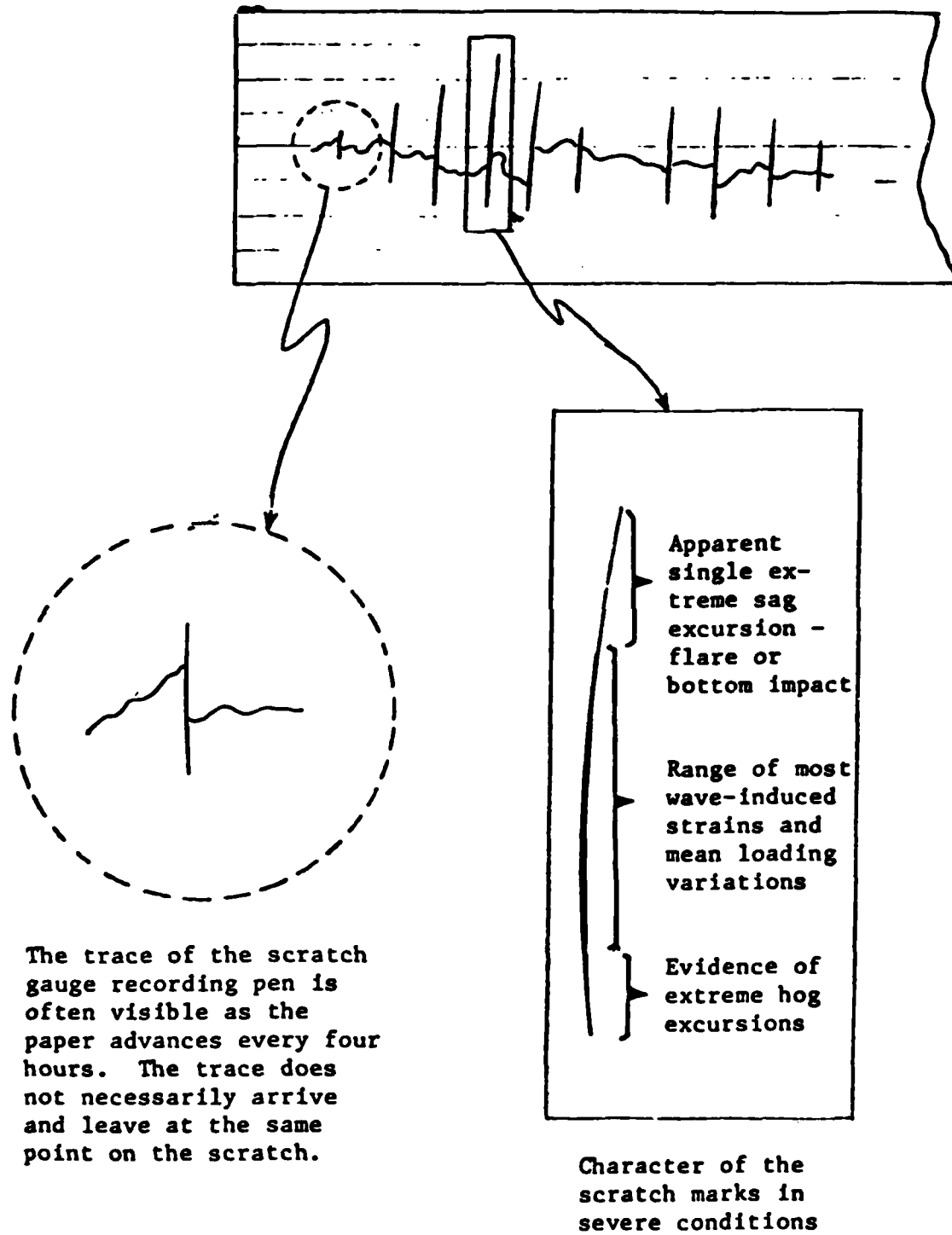

Figure 4-6 Miscellaneous Details of Scratch Records

TIME HISTORY OF STRESS

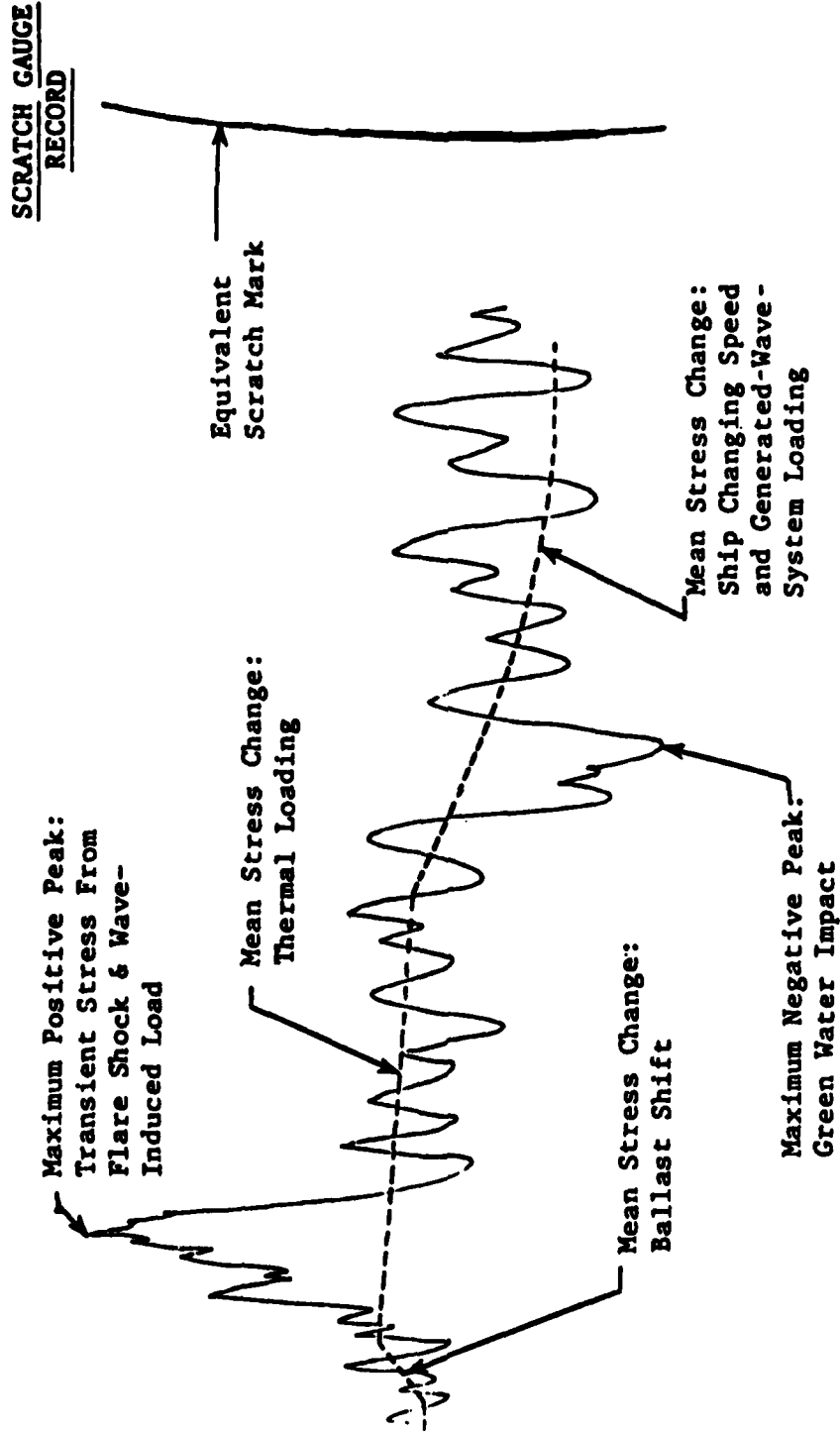

Figure 4-7 Illustration of Scratch Mark Equivalent to Complex Time History of Stress.

TABLE 4-1 (cont'd)
 EVALUATION OF THE SL-7 RESEARCH PROGRAM
 Element: MODEL TESTING TECHNIQUES

Report Title SSC No. Ref. No. Pub. Date	Structural Design Methods Specific to the SL-7 and Relationships in General	Contribution of the Study in Achieving the SL-7 Research Program Goals	Rational Hull Under Load Criteria Analysis and Development Including Statistical Evaluation of Data
Wave Loads in a Model of the SL-7 Containment Barring at Oblique Headings in Regular Waves SSC-239 Reference (2) 1974		<ul style="list-style-type: none"> The results of the (small) 1/140th scale model tests of the SL-7 containment were used primarily to aid in the validation of the SCORSS computer program. Further discussion of the model test results is presented in the evaluations of References (4) and (12). The model was small and self-controlled. Some problems were encountered with the directional control of the model; however, it was felt by the investigators that the difficulties were of secondary concern. The measured heave of the model was suspect when results were analyzed due to a possible error in the calibration of the heave pot, possibly producing a heave response in error by a factor of two. 	
Verification of the Rigid Vinyl Modeling Techniques SSC-250 Reference (6) 1976		<ul style="list-style-type: none"> The researchers that investigated the vinyl structural modeling technique concluded that the rigid vinyl model reduced construction efforts and it also enabled a slightly more complete representation of complex structural shapes and details as shown in Figure 4-8 as compared to the steel model (cont) 	

TABLE 4-1 (cont'd)
 EVALUATION OF THE SL-7 RESEARCH PROGRAM
 Element: MODEL TESTING TECHNIQUES

Contribution of the Study in Achieving the SL-7 Research Program Goals			
Report Title SSC No. Ref. No. Pub. Date	Structural Design Methods Specific to the SL-7 and Containments in General	Measurement and Prediction of Ship Load, Motion and Stress	National Hull Girders Load Criteria Analysis and Development Including Statistical Evaluation of Data
Continuation of Reference (6) Structural Tests of SL-7 Ship Model SSC-769 Reference (11) 1977		<p>shown in Figures 4-21 and 4-22. The authors of Reference (6) also point out that both vinyl and steel models do not adequately represent areas of stress concentration and structural joints.</p> <ul style="list-style-type: none"> • The steel model was loaded at a finite number of locations rather than applying distributed loads as would occur in the real ship as depicted in Figure 4-9. • The model plating thickness was larger than the scale ratio would indicate thus resulting in a torsionally stiffer model that does not adequately represent the warping stress induced by torsional loads. • The steel model did not represent stress concentrations adequately because of model size limitations and model welds that were not stress relieved. • The steel structural model tests were used primarily to generate structural response data used to validate an analytical finite-element model as discussed in Reference (30). (con't) 	

TABLE 4-1 (Cont'd)

EVALUATION OF THE SL-7 RESEARCH PROGRAM

Element: MODEL TESTING TECHNIQUES

Contribution of the Study in Achieving the SL-7 Research Program Goals			
Report Title SSC No. Ref. No. Pub. Date	Structural Design Methods Specific to the SL-7 and Containerhips in General	Measurement and Prediction of Ship Load, Motion and Stress	Rational Hull Girder Load Criteria Analysis and Development Including Statistical Evaluation of Data
Continuation of Reference (11) Capsizing Experiments with a Model of a Fast Cargo Liner in San Francisco Bay Reference (27) January 1972		<p>and the vinyl structural model described in Reference (6).</p> <ul style="list-style-type: none"> This program identified the possible benefits of open-water model tests for studying rare phenomena. Traditional towing tanks have a limited capability of producing realistic short-created seas of sufficient severity and duration of test runs necessary to produce rare events that would be required, especially in following seas where the frequency of wave encounter is low. No indication was given relative to the representative nature of wave spectrum existing during testing in the San Francisco Bay as compared to open ocean wave spectrum. This report does not relate directly to the SL-7 program goals, but describes the open water model testing techniques which were later applied to capsizing experiments of an SL-7 model (26). 	

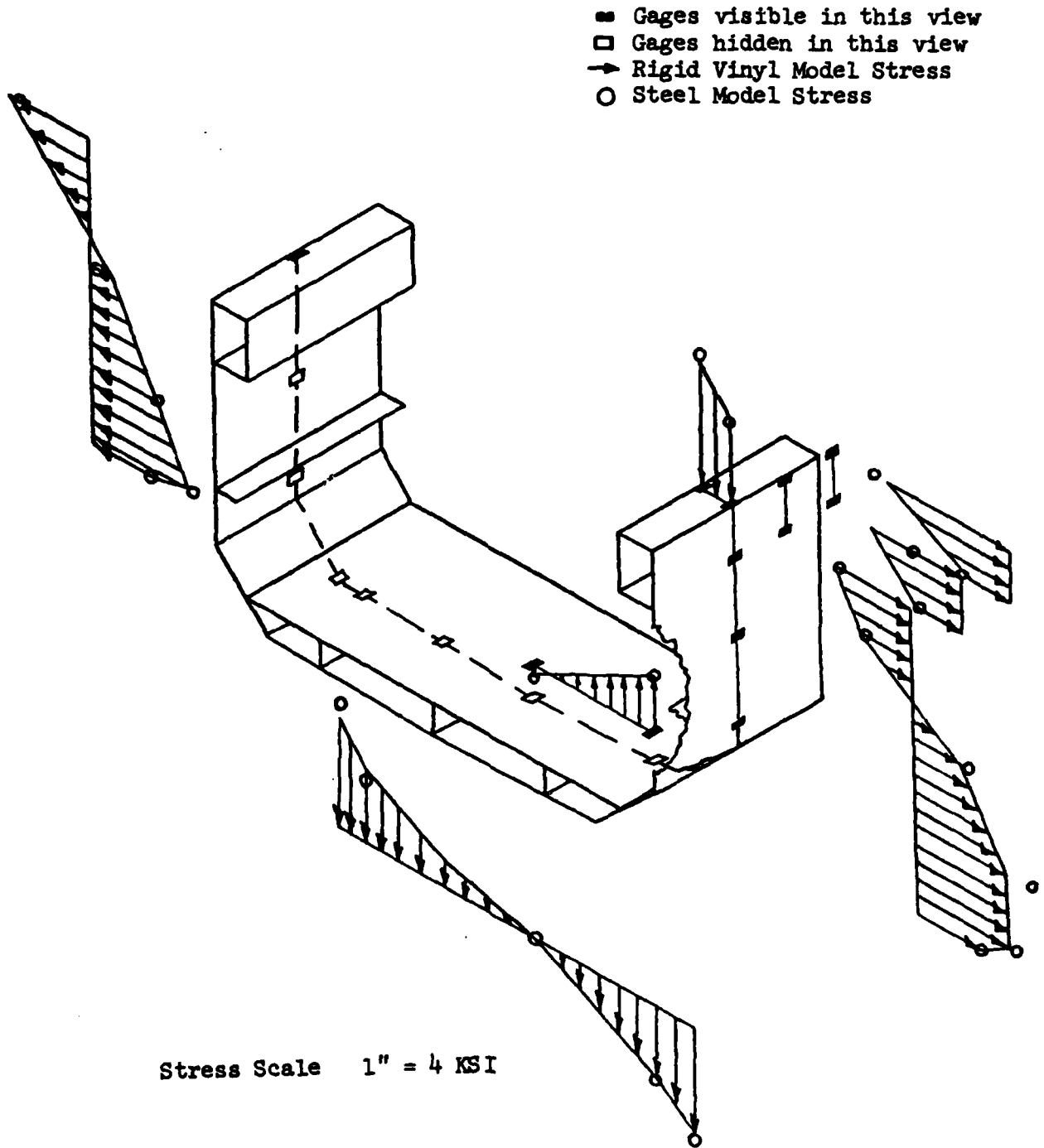
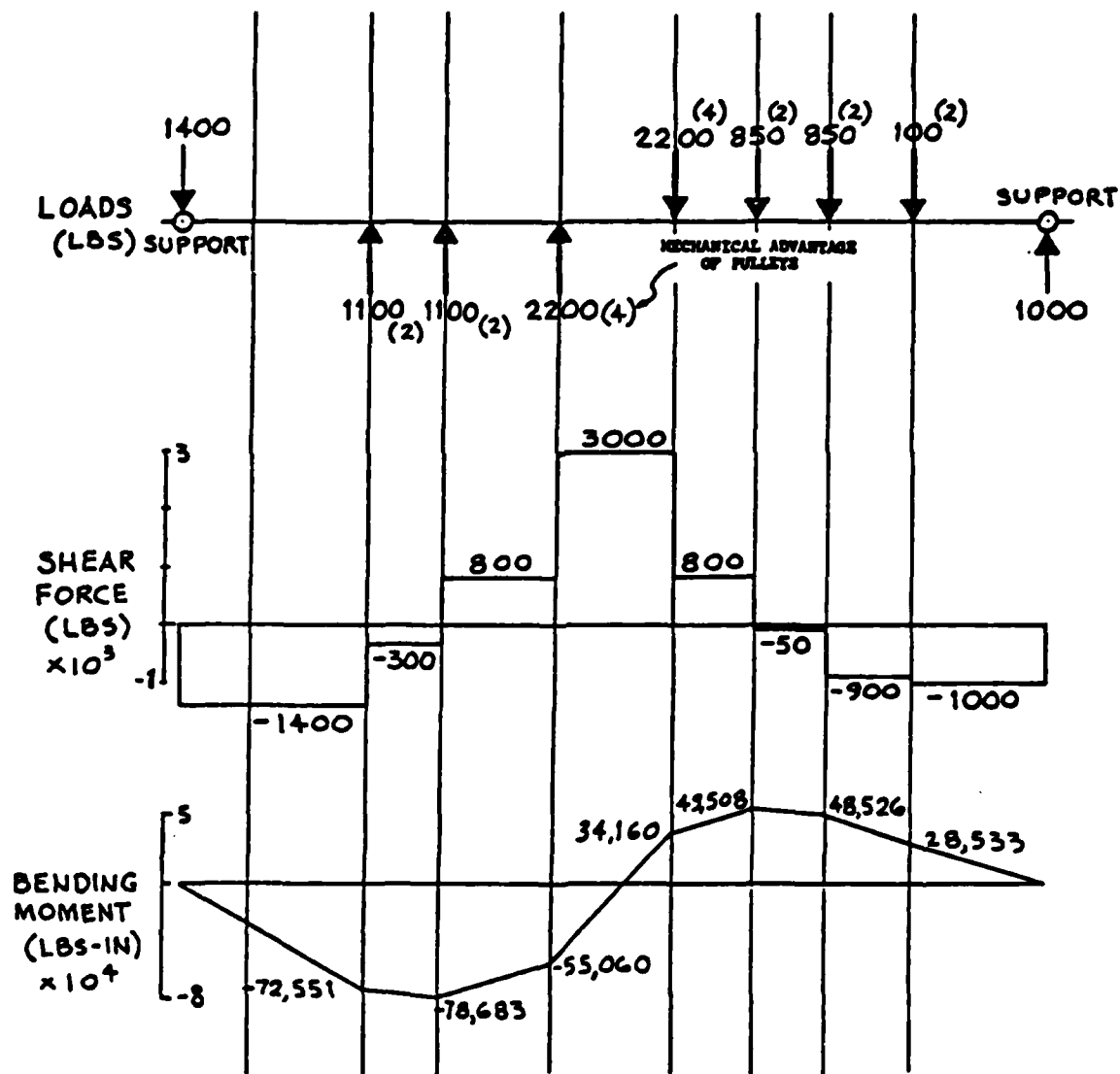
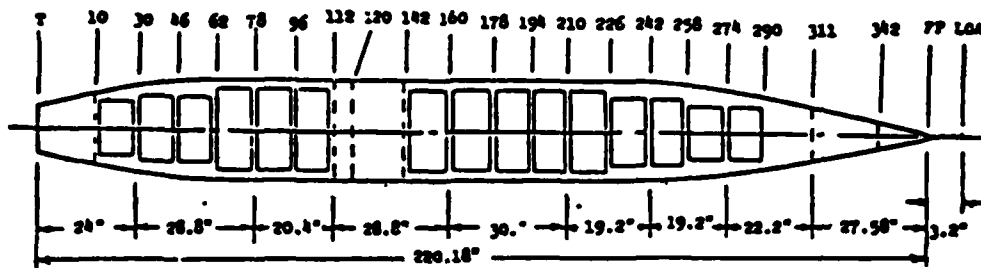

Figure 4-8 - Comparison of SL-7 Stresses at Frame 178 during Positive Torsion



Date of Experiment 6 July 1972

Figure 4-9 Representative Loading Applied to the Steel Structural Model

TABLE 4-1 (cont'd)
EVALUATION OF THE SL-7 RESEARCH PROGRAM

Element: ANALYTICAL TECHNIQUES

Report Title SSC No. Ref. No. Pub. Date	Contribution of the Study in Achieving the SL-7 Research Program Goals		
	Structural Design Methods Specific to the SL-7 and Containerhips in General	Measurement and Prediction of Ship Load, Motion and Stress	Rational Hull Girder Load Criteria Analysis and Development Including Statistical Evaluation of Data
<p>Structural Analysis of SL-7 Containerhip Under Combined Loading of Vertical, Lateral and Torsional Moments Using Finite Element Techniques SSC-243 Reference (3) 1974</p>	<ul style="list-style-type: none"> The structural analysis of the SL-7 using the finite-element computer program was used to generate data to infer a relationship between hatch deflection and predicted stresses at the transverse girder and longitudinal girder intersections. These data as depicted in Figure 4-10 were intended to provide a relationship between hatch distortions, measured stresses in the seaway on the McLEAM, and the seaway conditions producing the loadings. However, the relationships were not pursued in the open literature beyond the information presented in Reference (6) and represented here in Figure 4-10 The stress distribution at the forward hatch corner cutouts resulting from vertical bending and lateral and torsional bending. Examples of the stress distributions at the hatch corner cutouts are shown in Figures 4-11 and 4-12. 	<ul style="list-style-type: none"> The structural analysis presented in Reference (6) represented the first of a series of steps to exercise the AIS, DAISY finite-element computer program. As a first step it produced data that aided in the selection of strain gauge locations on the McLEAM. However, this information is limited in total scope. The report does not discuss how the loading for the containerhip was developed. A description of the procedure would be most useful for others contemplating a similar finite-element analysis, even though it was not a primary objective of the report. 	

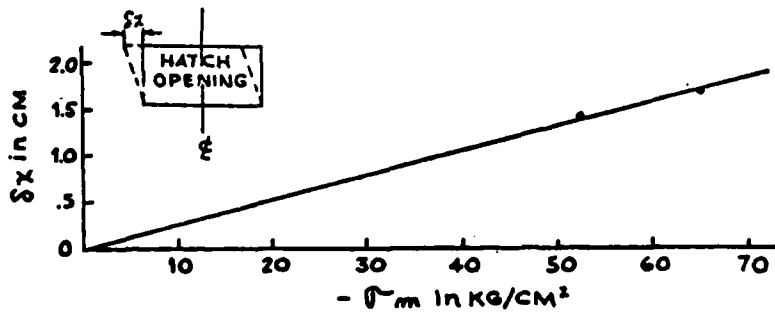
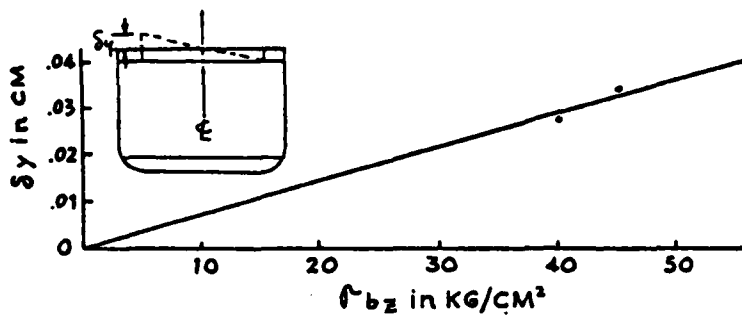
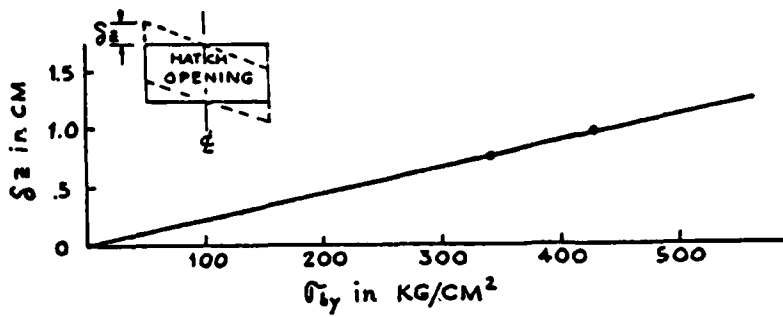

Figure 4-10 Hatch Distortion vs. Stresses in Transverse Box at Fr. 178, Port Side-Section B Due to Torsional and Lateral Moments For the SL-7 Containership

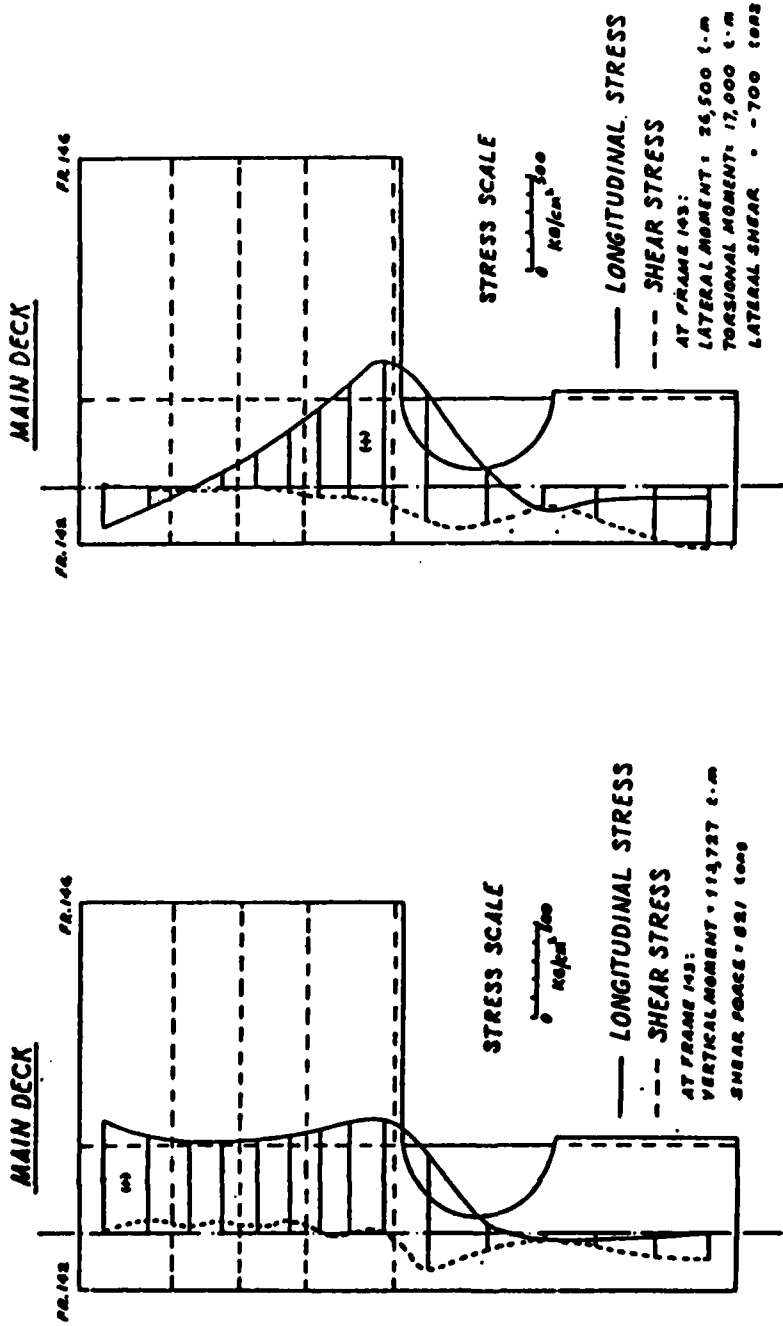

Figure 4-11 Stress Distribution Due to Wave-Induced Vertical Bending Fr. 142-146 Second Loading Case

Figure 4-12 Stress Distribution Due to Lateral Bending and Torsional Moments Fr. 142-146 Second Loading Case

TABLE 4-1 (cont'd)
EVALUATION OF THE SL-7 RESEARCH PROGRAM

Element: ANALYTICAL PREDICTIONS

Report Title SSC No. Ref. No. Pub. Date	Contribution of the Study in Achieving the SL-7 Research Program Goals		
Structural Design Methods Specific to the SL-7 and Containerhips in General	Measurement and Prediction of Ship Load, Motion and Stress	Rational Hull Girder Load Criteria Analysis and Development Including Statistical Evaluation of Data	
<p>Theoretical Estimates of Wave Loads on The SL-7 Containerhip in Regular and Irregular Seas SSC-246 Reference (4) 1974</p>	<p>The comparisons of model test data (Reference 2) and SCORES computer program results were not as good as had been hoped. Examples of comparisons for head, quartering and following seas appear in Figures 4-13 through 4-16. The lack of agreement between theory and experiment was attributed to the following factors:</p> <ol style="list-style-type: none"> 1. Influence of higher forward speed of the containerhip (Proude number effect). 2. In following seas, the theory is considered to be very tentative due to the low encounter frequencies. 3. Lateral plane wave loads are highly dependent upon adequate representation of ship roll response with non-linear roll damping, which is not represented in a linear/ship motions program. <p>The limitation in SCORES theory led to the extension of the theory as described in Reference (12).</p>		

Vertical Moment Amplitude
Wave Amplitude

Heavy Displacement

- o Experiment (V=30 KTS)
- Experiment (V=25 KTS)
- Theory (V=25 KTS)
- - - Theory (V=30 KTS)

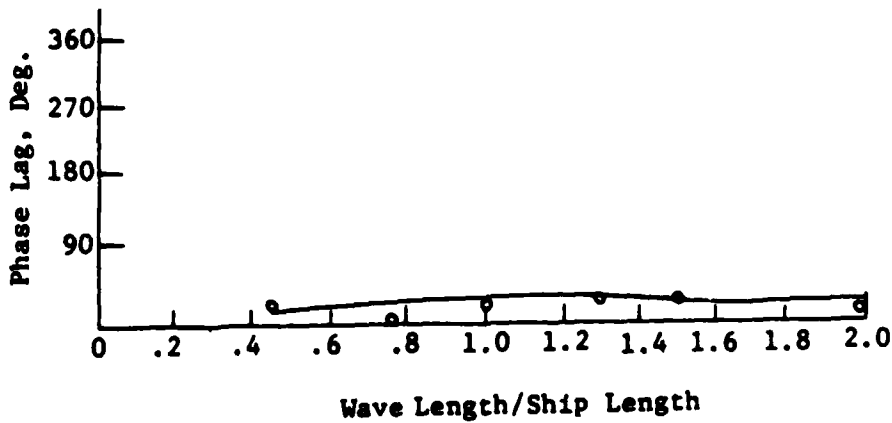
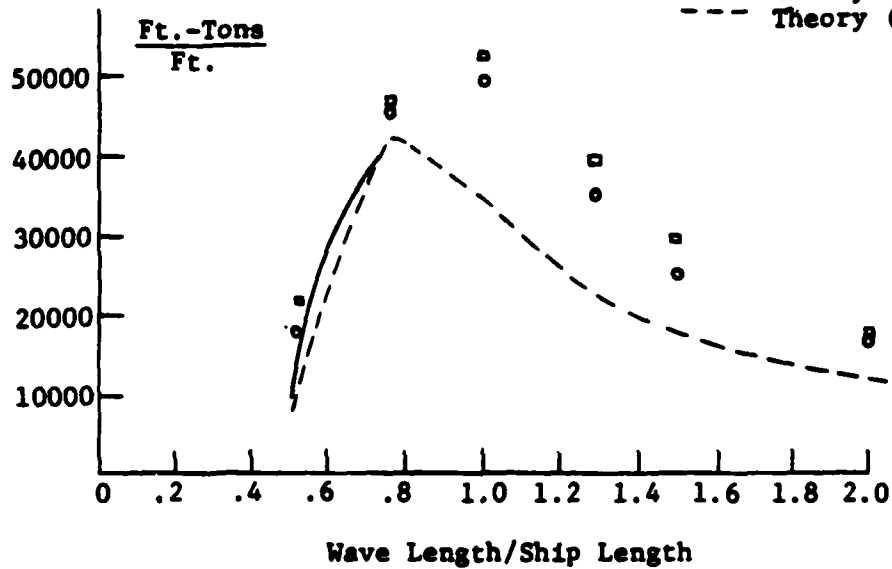

Figure 4-13 Midship Vertical Wave Bending Moments and Wave Phase Lag, 180° Heading

Vertical Moment Amplitude
Wave Amplitude

Light Displacement

- Experiment (V=25KI)
- Experiment (V=30KI)
- Theory (V=25KI)
- - - Theory (V=30KI)

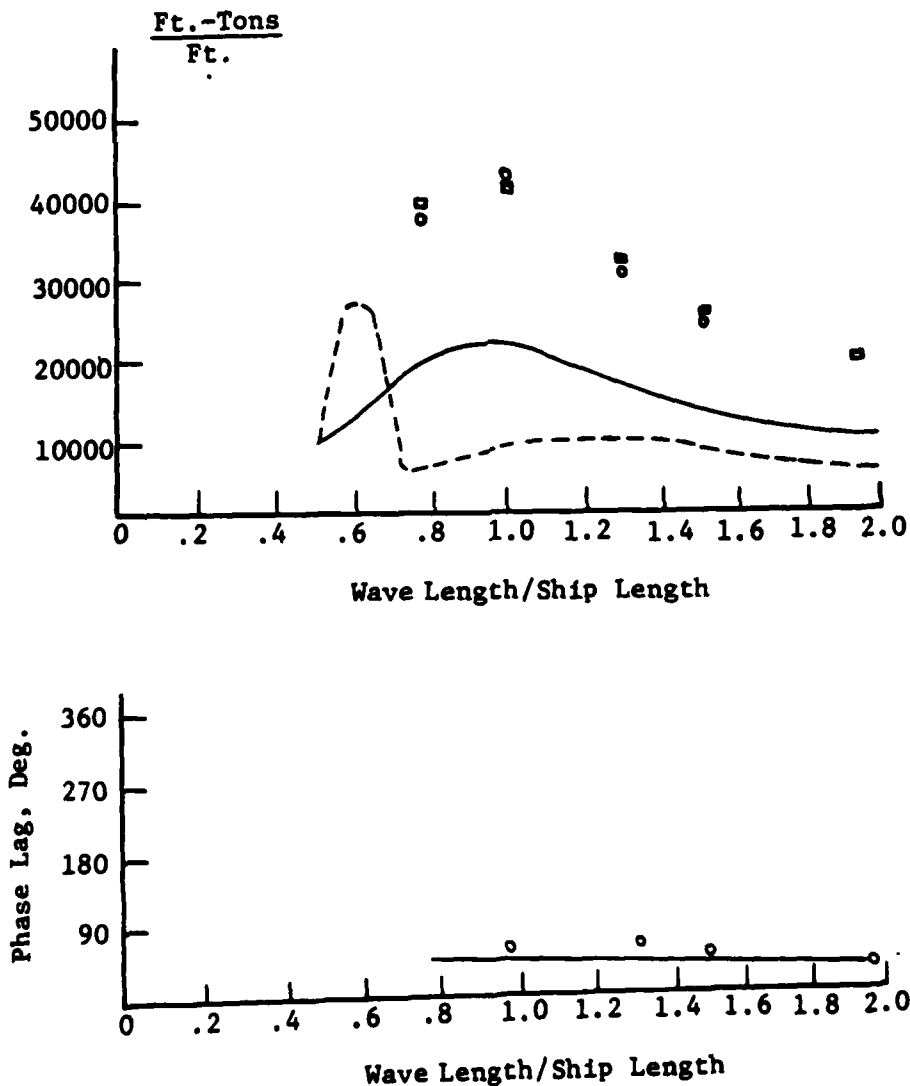

Figure 4-14 Midship Vertical Wave Bending Moments and Wave Phase Lag, 0° Heading

Heavy Displacement

- Experiment (V=30KTS)
- Experiment (V=25KTS)
- Theory (V=25KTS)
- - - Theory (V=30KTS)

Torsional Moment Amplitude
Wave Amplitude

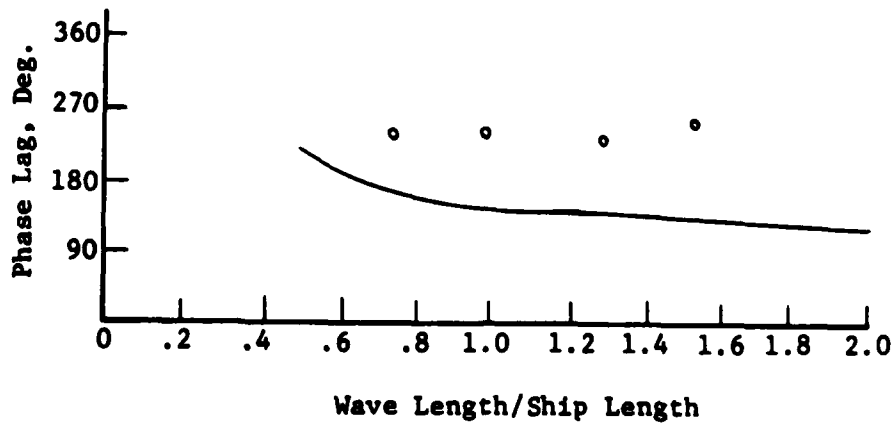
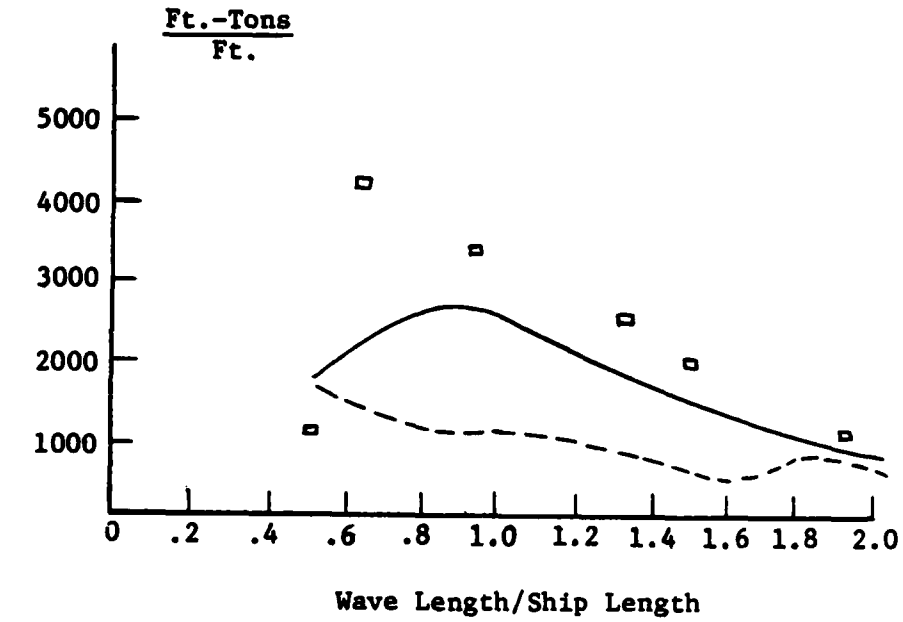

Figure 4-15 Midship Torsional Wave Bending Moments and Wave Phase Lag, 30° Heading

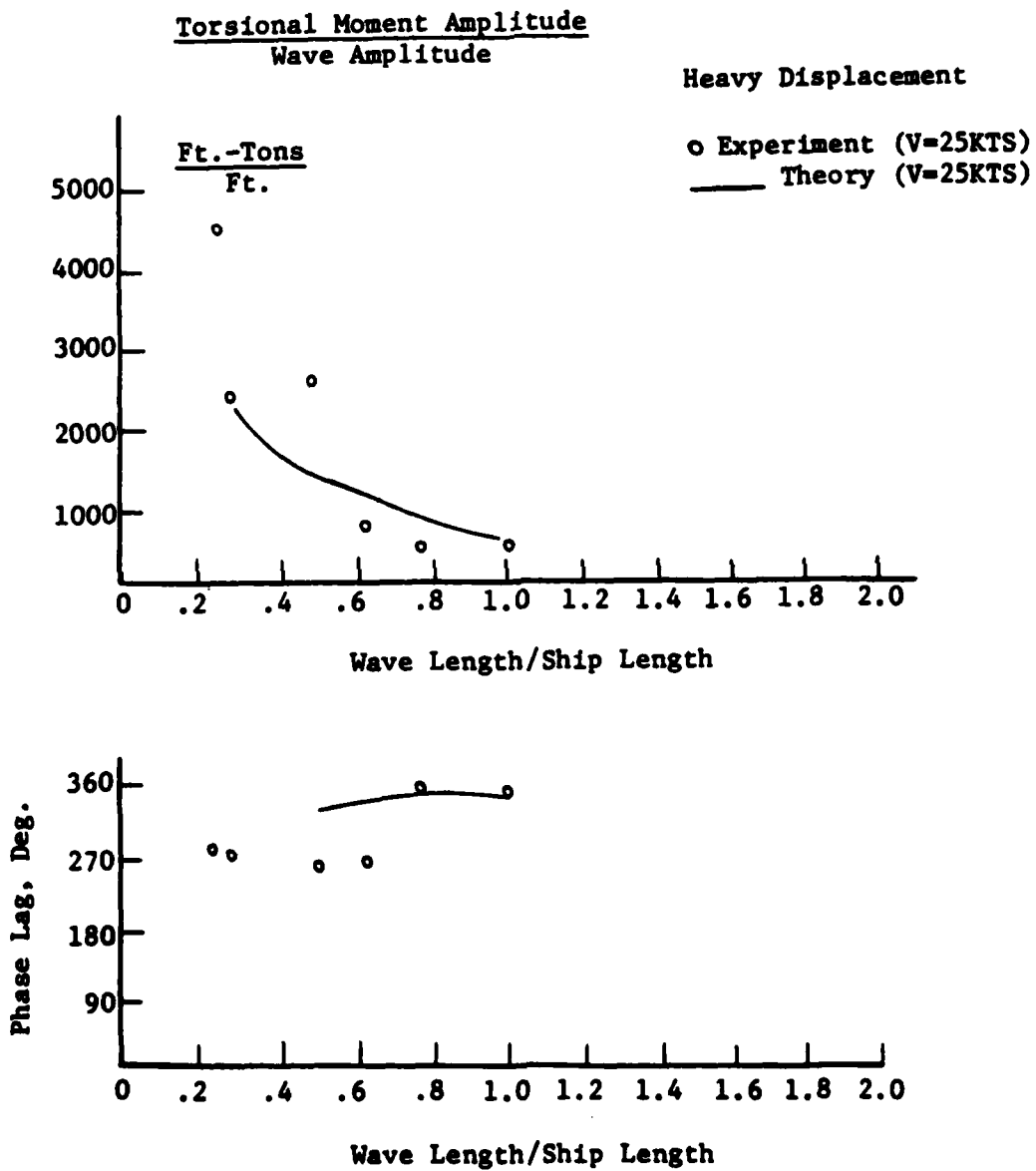

Figure 4-16 Midship Torsional Wave Bending Moments and Wave Phase Lag, 240° Heading

TABLE 4-1 (cont'd)
EVALUATION OF THE SL - 7 RESEARCH PROGRAM
 Element : ANALYTICAL TECHNIQUES

Report Title SBC No. Ref. No. Pub. Date	Structural Design Methods Specific to the SL-7 and Containerships in General	Contribution of the Study in Achieving the SL-7 Research Program Goals	Rational Hull Girder Load Criteria Analysis and Development Including Statistical Evaluation of Data
A Correlation Study of SL-7 Containership Loads and Motions - Model Tests and Computer Simulation SBC-271 Reference (12) 1977		<ul style="list-style-type: none"> • This project extended the basic theory presented in Reference (4) in several areas which include: <ol style="list-style-type: none"> 1. Incorporation of close-fit techniques for development of hydrodynamic coefficients instead of the Lewis-form method originally employed. 2. Incorporation of speed-dependent terms in the equations of motion. 3. Influence of rudder deflection in ship structural response. 4. Incorporation of the effects of surge in the equations of motion. 5. Investigation into the effects of non-linear role in ship response. Examples of the influence of each of these extensions to the SCORES theory are presented in the report. Several of the figures are represented here and indicate an improvement in predictions for midship vertical bending and midship torsional bending. (See Figures 4-17 through 4-20.) • The effects of model testing procedures on model response were indicated and would benefit future comparisons between model tests and theoretical predictions. As a result, (cont) 	

TABLE 4-1 (cont'd)
EVALUATION OF THE SL-7 RESEARCH PROGRAM
 Element: ANALYTICAL TECHNIQUES

Contribution of the Study in Achieving the SL-7 Research Program Goals			
Report Title SSC No. Ref. No. Pub. Date	Structural Design Methods Specific to the SL-7 and Containerships in General	Measurement and Prediction of Ship Load, Motion and Stress	Rational Hull Girder Load Criteria Analysis and Development including Statistical Evaluation of Data
Continuation of Reference (12)		<p>it was recommended that larger models and better test apparatus for the measurement of response of the model in oblique seas be used.</p> <p>At this stage of development, the SCORES computer program represented the state of the art in predicting ship load and response. The computational method was limited to the basic assumptions of linear theory.</p>	

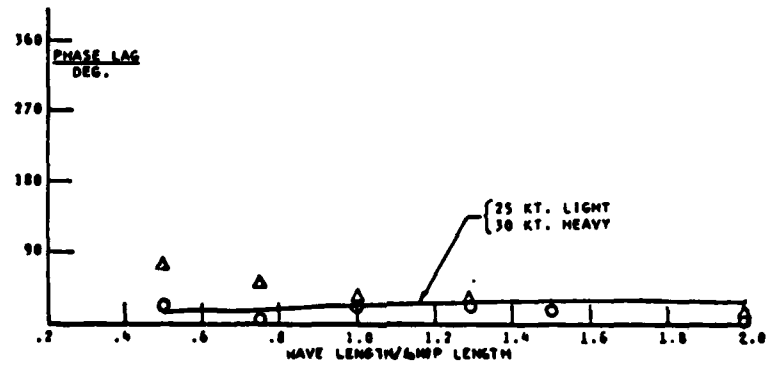
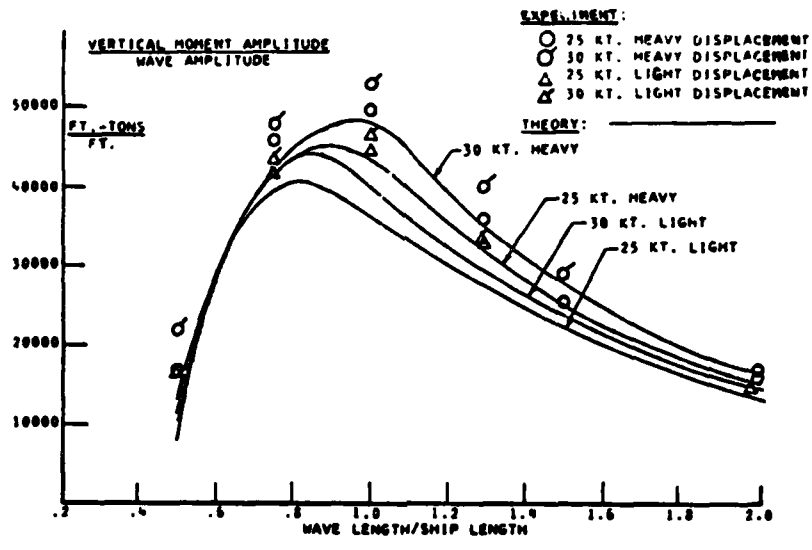

Figure 4-17 Midship Vertical Wave Bending Moments and Phase Lag, 180° Heading

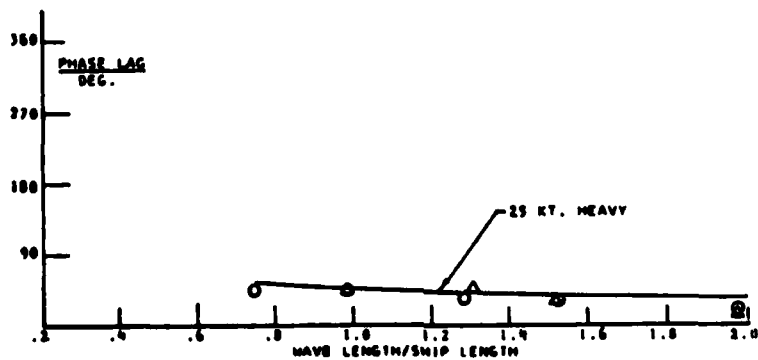
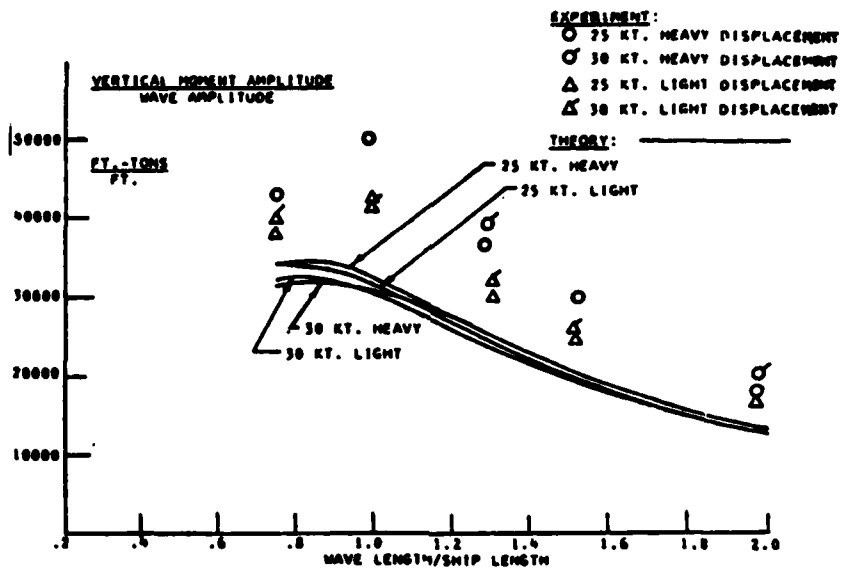

Figure 4-18 Midship Vertical Wave Bending Moments and Phase Lag, 0° Heading

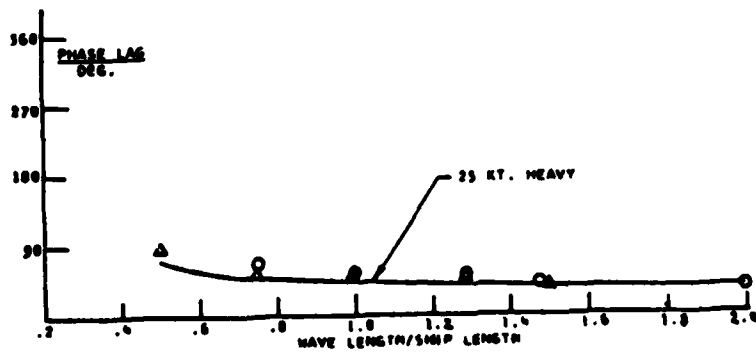
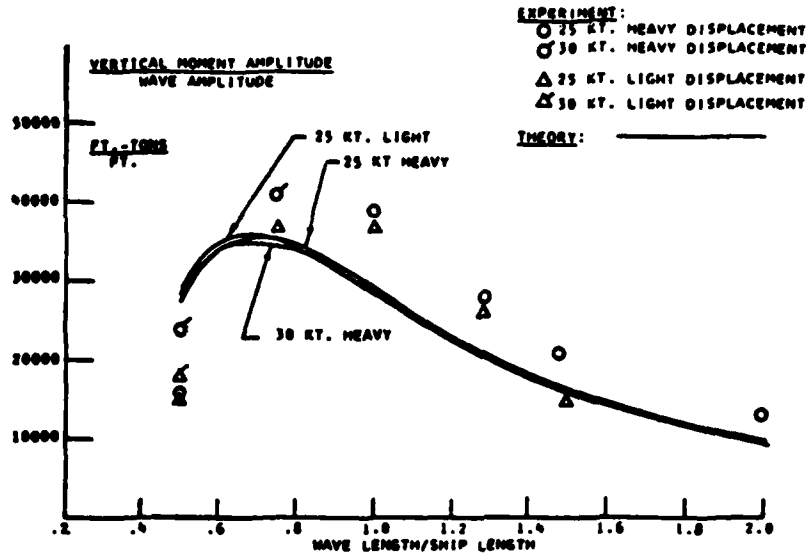

Figure 4-19 Midship Vertical Wave Bending Moments and Phase Lag, 30° Heading

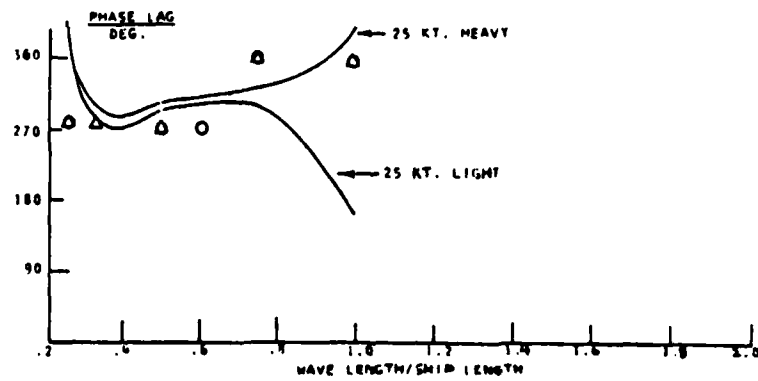
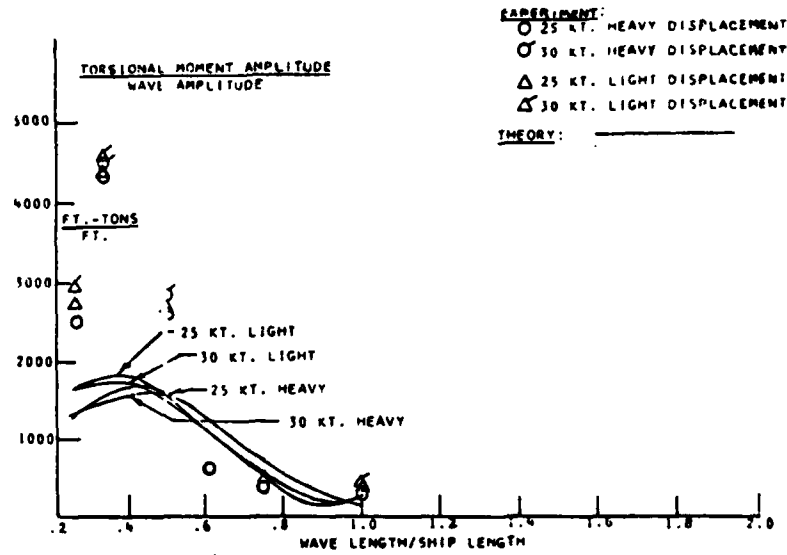
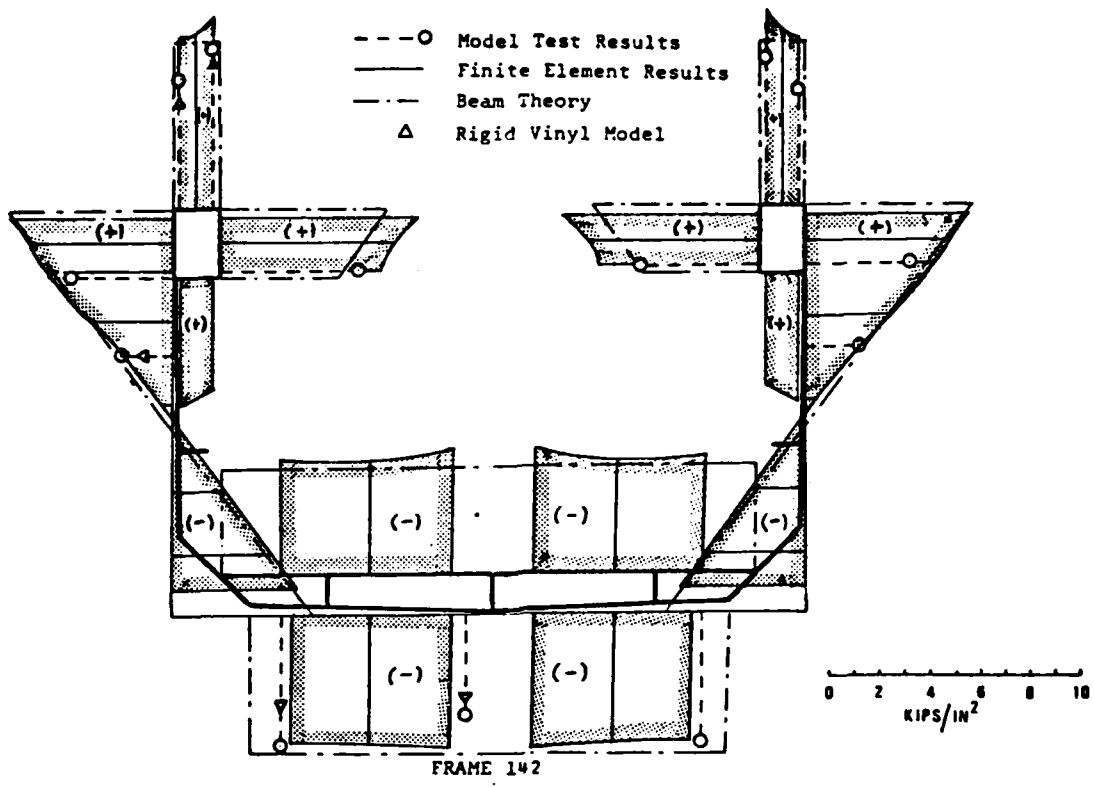

Figure 4-20 Midship Torsional Wave Bending Moments and Phase Lag, 240° Heading

TABLE 4-1 (cont'd)
EVALUATION OF THE SL - 7 RESEARCH PROGRAM

Element: ANALYTICAL PREDICTIONS

Report Title SSC No. Ref. No. Pub. Date	Contribution of the Study in Achieving the SL - 7 Research Program Goals	Rational Hull Girders Load Criteria Analysis and Development Including Statistical Evaluation of Data
<p>Structural Analysis of a Container Ship Steel Model Comparison with the Test Results Reference (30) November 1976</p>	<p>Structural Design Methods Specific to the SL-7 and Containerships in General</p> <ul style="list-style-type: none"> Standard beam-theory calculations were included in the analysis for pure bending vertical and agree well as would be expected. The vertical bending comparisons are shown in Figure 4-21. No beam-theory calculations were included for the torsional loading cases. The results would have shown that most formulas are unreliable with non-prismatic beams. The authors of Reference (30) indicated that the finite-element analysis would cost approximately half as much as the steel structural model experiment. The implications of the magnitude of cost for both types of analysis indicate that simple methods to predict the primary torsional response of open-decked ships are required. The recommendations presented in Reference (30) contain valuable design suggestions that were obtained from the finite element analysis. The recommendations are reproduced in the summary of Reference (30) in Appendix (A). 	<p>Measurement and Prediction of Ship Load, Motion and Stress</p> <ul style="list-style-type: none"> The comparisons of results between structural models (steel and vinyl) and finite-element models represented a step in the development, validation and refinement of the finite-element technique. The finite-element model compared quite well with the steel and vinyl models as can be seen in Figures 4-21 and 4-22. However, the models were loaded by discrete loading bars and did not represent the distributed loadings experienced by the ships encountered in the real environment. The magnitude of stresses presented in Figures 4-21 and 4-22 are relative to the loading and structural models. This is also compounded by the fact that the model scantlings were also much larger than the scale ratio would indicate. The development of the finite-element model is not described in detail. However, most structural analysts are interested in the actual modeling of the ship's structure.



(d)

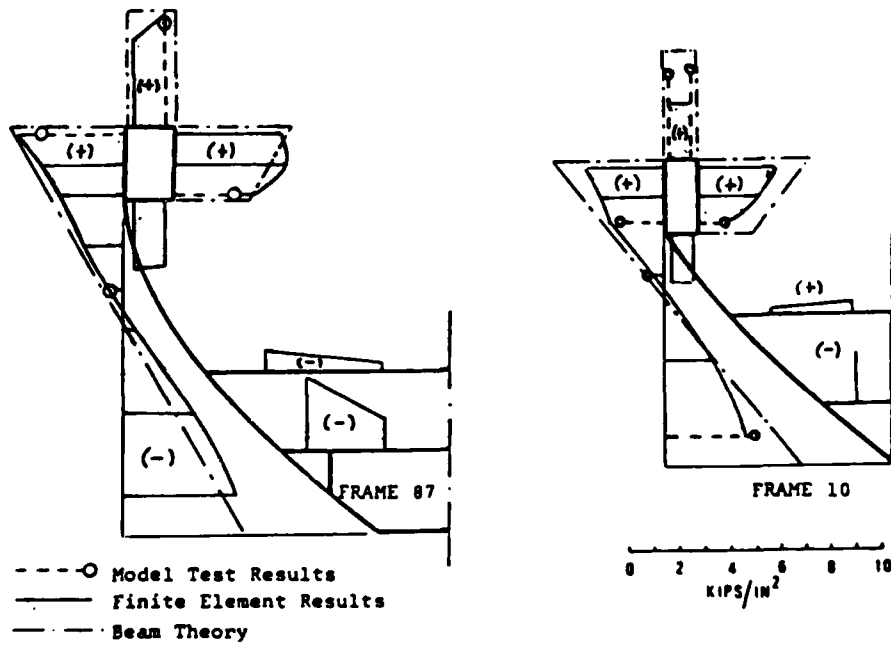

(e)

(f)

Figure 4-21 Comparisons of Structural Model Tests and Finite-Element Calculations for the SL-7 Containership, Loading Case 1.

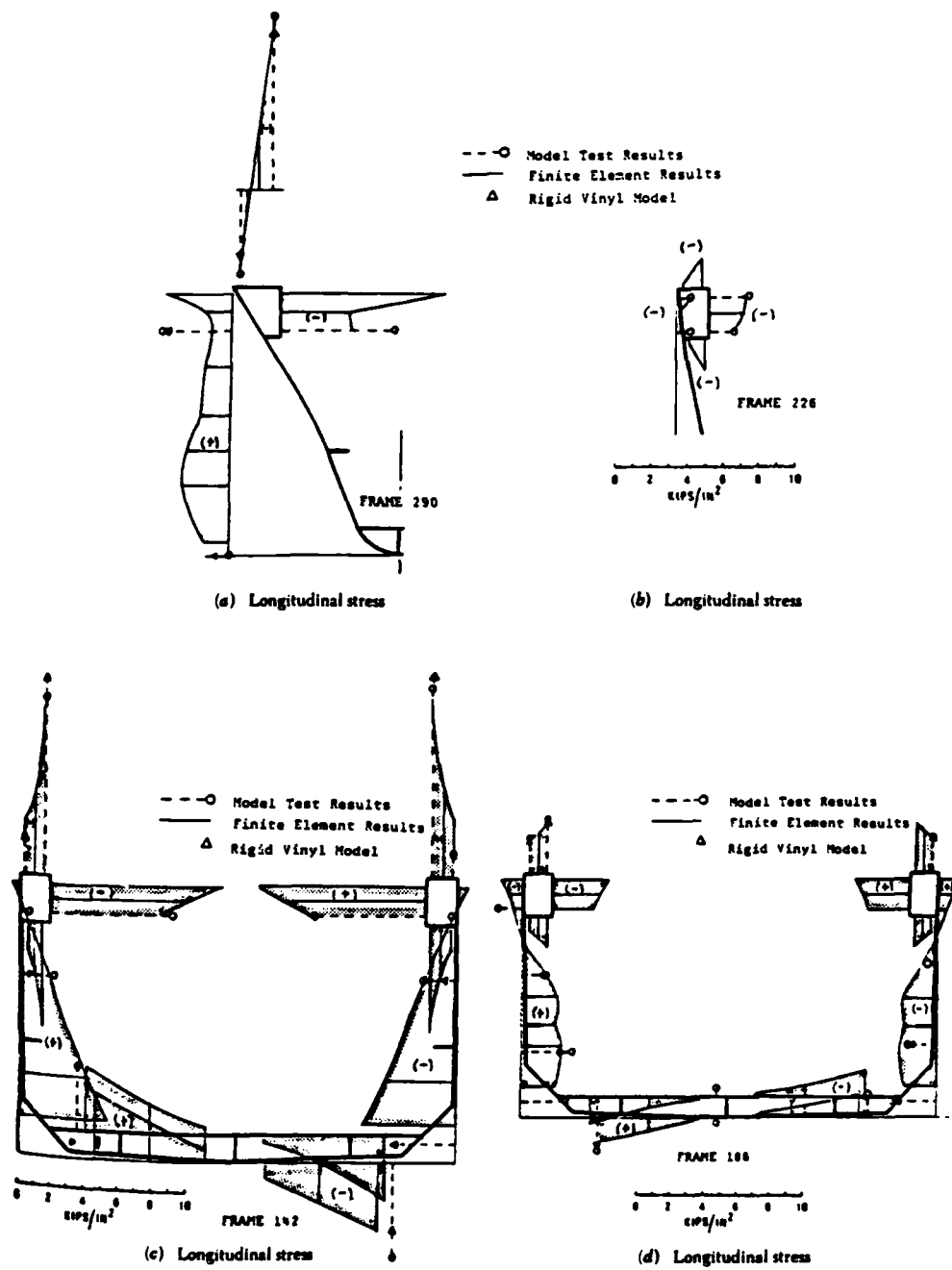

Figure 4-22 Comparisons of Structural Model Tests and Finite-Element Calculations for the SL-7 Containership, Loading Case 2.

TABLE 4-1 (cont'd)
EVALUATION OF THE SL-7 RESEARCH PROGRAM
 Element: ANALYTICAL PREDICTIONS

Contribution of the Study in Achieving the SL-7 Research Program Goals			
Report Title SSC No. Ref. No. Pub. Date	Structural Design Methods Specific to the SL-7 and Containerships in General	Measurement and Prediction of Ship Load, Motion and Stress	National Hull Girder Load Criteria Analysis and Development including Statistical Evaluation of Data
Comparison of Stresses Calculated Using the DAISY System to Those Measured on the SL-7 Containership Program SSC-282 Reference (24) 1979	<ul style="list-style-type: none"> The combination of ship loading prediction techniques with the finite-element techniques represents a significant tool for the structural analyst but the effort involved in this type of analysis would be prohibitive for routine application at this point in time. However, the technique could be employed to develop a simplified design method that would be useful to ship designers. 	<ul style="list-style-type: none"> The authors concluded that the comparisons between calculated and measured stresses for the dockside calibration were inconclusive because of significant temperature differentials during the test and low magnitudes of applied loads. They also recommended that for future tests complete temperature data be recorded and that appreciable mechanical strains be generated in the structure. A modified version of the SCORES program was used in conjunction with a special post processor to generate hydrodynamic data for the DAISY finite-element program. This effort represented the only significant attempts to compare analytical results to the full-scale data measured on the SEA-LAND McLEAN. The comparisons of measured stress and predicted stress are overshadowed by the reliability of full-scale wave data. Figures 4-23 and 4-26 show that the wave data required modification before it could be used as input for the load prediction techniques. The corresponding stress comparisons are shown in Figures 4-25 and 4-26. The (cont.) 	

TABLE 4-1 (cont'd)
EVALUATION OF THE SL-7 RESEARCH PROGRAM

Element: ANALYTICAL PREDICTIONS

Report Title SSC No. Ref. No. Pub. Date	Structural Design Methods Specific to the SL-7 and Containerships in General	Measurement and Prediction of Ship Load, Motion and Stress	Rational Hull Girder Load Criteria Analysis and Development Including Statistical Evaluation of Data
<p>Continuation of Reference (24)</p> <p>Ship Motions and Capsizing in Astern Seas Reference (26) June 1974</p>		<p>comparisons between measured and predicted were concluded to be generally good by the authors of Reference (24). Discrepancies between measured and predicted data are quite evident in the results. Although the comparisons are overshadowed by the poor quality of input wave data, the techniques represent a forward step in structural analysis of ships in a seaway and utilize the full-scale data base in the manner that was originally intended.</p> <p>• The predictions of capsizing of ships in following seas developed for the SL-7 using both linear strip theory and time domain analysis with comparisons of model and predicted motions indicate that linear strip theory can only broadly outline areas of speed, heading, and ship characteristics which may lead to trouble, and that the inclusion of non-linear effects in the linear theory still would not provide adequate description of the capsizing phenomena.</p> <p>(cont)</p>	

TABLE 4-1 (cont'd)
EVALUATION OF THE SL-7 RESEARCH PROGRAM

Element: ANALYTICAL PREDICTIONS

Contribution of the Study in Achieving the SL-7 Research Program Goals			
Report Title SAC No. Ref. No. Pub. Date	Structural Design Methods Specific to the SL-7 and Contiships in General	Measurement and Prediction of Ship Load, Motion and Stress	National Hull Girder Load Criteria Analysis and Development Including Statistical Evaluation of Data
Continuation of Reference (26)		<ul style="list-style-type: none"> The authors conclude that the numerical simulations of large amplitude motions of a ship in following and quartering seas in general resemble the motions of the model under similar sea conditions. However, no direct comparisons between model and numerical simulations are presented for evaluation. These references present the background and development of theory for the numerical simulations of ship capsizing in following seas. The studies do not relate directly to the SL-7 program as initially conceived but do contribute to the development of motion prediction techniques. Some comparisons of theory and model tests are presented in Reference (26) but no comparisons have been made for full-scale data. The original purpose for the development of a numerical simulation and comparisons with model tests was to aid in the analysis of ship-stability criteria. The implementation and impact of the theory on stability criteria for ships has not been introduced to date. 	
<p>A Time Domain Solution to the Motions of a Steered Ship in Waves Reference (28) November 1972</p> <p>Development of a Time Domain Simulation for Ship Capsizing in Following Seas Reference (29) October 1973</p>			

LOG BOOK DATA			
DATE AND TIME	01-10-74 2403		
POSITION	43-29 N 24-51 W		
COURSE AND SPEED	250 . 10.9 KNOTS		
SEA STATE	7		
WAVE HEIGHT	25 FEET		
REL DIR	2 PORT		
SWELL HEIGHT	20 FEET		
REL DIR	2 PORT		
---- VISUAL WEATHER / COMMENTS ----			
OCAST /			
WAVE HEIGHT STATISTICS (FEET)			
	TUCKER/DYN.	HEAD/RADAR	
P-T SAMPLE SIZE	98	70	121
MAXIMUM HEIGHT	15.9	43.4	57.2
10TH HIGHEST HTS	15.0	39.8	39.7
3RD HIGHEST HTS	13.2	33.8	32.5
4.0 RMS SPECTRA	13.3	34.8	32.5

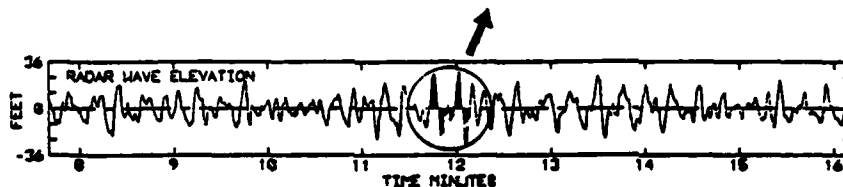
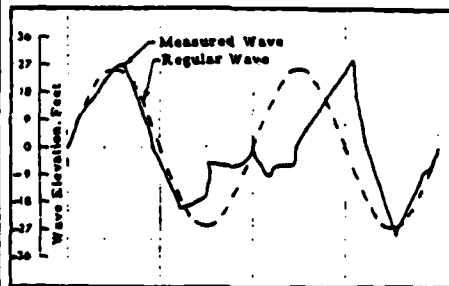

Figure 4-23 Comparisons of the wave time history measured on the SEA LAND McLEAN and the regular wave representations (Condition 15 - Voyage 32W - Tape 145 - Index 18 - Interval 5 - Run 405)

LOG BOOK DATA			
DATE AND TIME	01-12-74 1638		
POSITION	41-07 N 40-08 W		
COURSE AND SPEED	245 . 20.1 KNOTS		
SEA STATE	9		
WAVE HEIGHT	25 FEET		
REL DIR	2 STRD		
SWELL HEIGHT	20 FEET		
REL DIR	2 STRD		
---- VISUAL WEATHER / COMMENTS ----			
OCAST /			
WAVE HEIGHT STATISTICS (FEET)			
	TUCKER/DYN.	HEAD/RADAR	
P-T SAMPLE SIZE	229	179	222
MAXIMUM HEIGHT	8.3	0.9	88.6
10TH HIGHEST HTS	5.9	7.8	33.7
3RD HIGHEST HTS	4.6	6.4	26.4
4.0 RMS SPECTRA	5.5	6.2	27.4

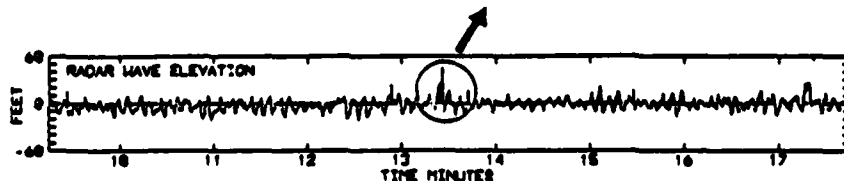
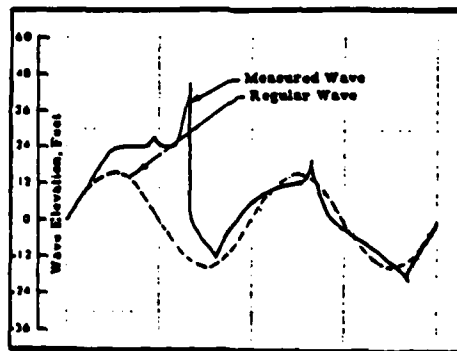

Figure 4-24 Comparisons of the wave time history measured on the SEA LAND McLEAN and the regular wave representations (Condition 16 - Voyage 32W - Tape 145 - Index 29 - Interval 50 - Run 450)

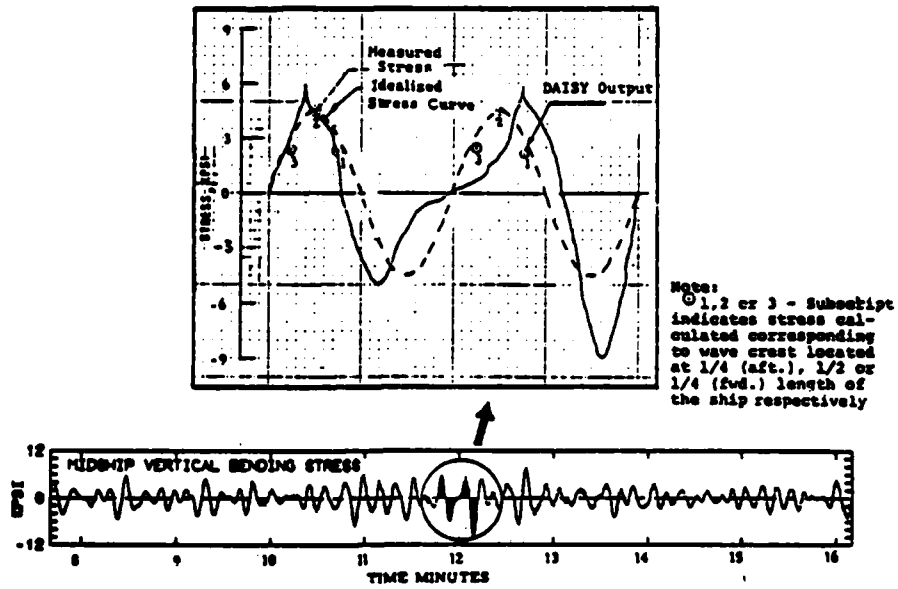

Figure 4-25 Comparison of the calculated and measured mean midship vertical bending stresses (Sensor LVB), Wave Condition 15

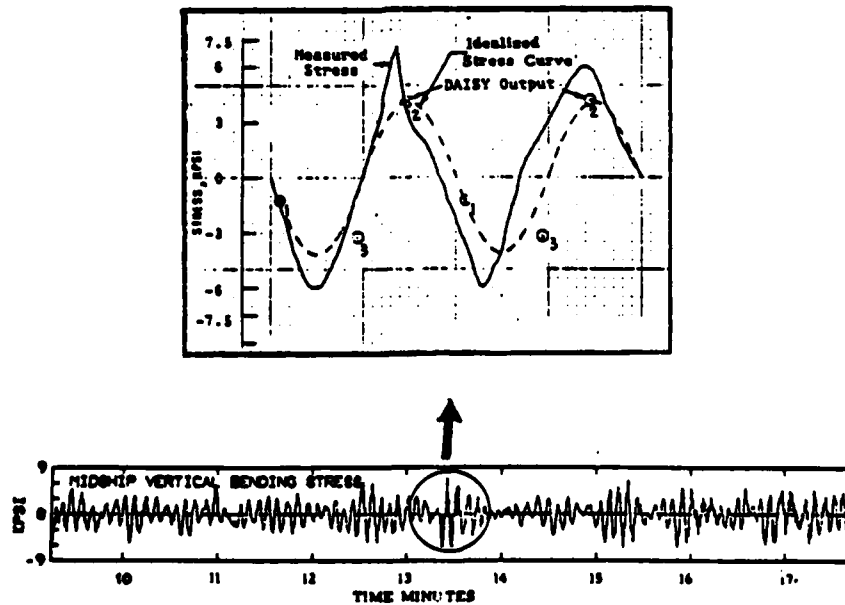

Figure 4-26 Comparison of the calculated and measured mean midship vertical bending stresses (Sensor LVB), Wave Condition 16

TABLE 4-1 (Cont'd)
 EVALUATION OF THE SL-7 RESEARCH PROGRAM
 Element: LOAD CRITERIA

Contribution of the Study in Achieving the SL-7 Research Program Goals			
Report Title SSC No. Ref. No. Pub. Date	Structural Design Methods Specific to the SL-7 and Containerships in General	Measurement and Prediction of Ship Load, Motion and Stress	Rational Hull Girder Load Criteria Analysis and Development Including Statistical Evaluation of Data
<p>Fatigue Load Spectra Development for Ship Hulls Reference (32) September 1960</p> <p>Examination of Service and Stress Data of Three Ships for Development of Hull Girder Load Criteria SSC-287 Reference (33) 1979</p>	<ul style="list-style-type: none"> A basic approach was outlined in this reference for the development of a fatigue load spectra using analytical and statistical techniques. This approach at present appears to be quite cumbersome for general ship structural design applications. 	<ul style="list-style-type: none"> In the instrumentation procedure, the strain gauges were reset to zero prior to each departure with no record kept of the offset. Thus, initial mean stress information was lost. The lack of this information proved to be a limitation in interpreting the strains measured on the McLEAN. Several recommendations were presented to obtain the initial mean stress as part of future full-scale instrumentation programs. 	<ul style="list-style-type: none"> Fatigue load spectra were developed using the SEA-LAND McLEAN data base and applying the basic approaches described in SSC-240 (Reference 35). The fatigue load spectra were developed using probabilistic techniques with additional work indicated to develop ship structural combined response methods. A special technique was presented for combination of the low-frequency wave-induced stresses and high-frequency wave-induced stresses for application to fatigue analysis. The study examined and evaluated several statistical distributions which describe the nature of both low-frequency and high-frequency wave-induced loads for three different types of ships. The variability of statistical distribution was indicated for the types of loads considered. This variability implies that no single statistical distribution is adequate to describe the statistical nature of ship structural loading. (con't)

TABLE 4-1 (cont'd)
EVALUATION OF THE SL-7 RESEARCH PROGRAM

Element: LOAD CRITERIA

Report Title SEC No. Ref. No. Pub. Date	Contribution of the Study in Achieving the SL-7 Research Program Goals		
	Structural Design Methods Specific to the SL-7 and Constabships in General	Measurement and Prediction of Ship Load, Motion and Stress	National Hull Girder Load Criteria Analysis and Development Including Statistical Evaluation of Data
Continuation of Reference (33) Evaluation of Full-Scale Wave Loads Reference (34)		<ul style="list-style-type: none"> Several particular recommendations were presented in the reference for the measurement of loads, motions and stresses, and are applicable to future research programs. The recommendations are presented in the summary of this reference in Appendix (A). 	<ul style="list-style-type: none"> No life-time loads were developed to evaluate the existing load criteria for the three types of ships considered. The reference presents data indicating trends in ship bending moments inferred from measured strain. The trends are presented for various ship types (including the SL-7), weather encountered, trade routes, and relevant hull parameters. This information could be useful for the design of similar ships; however, the data presented as Root Mean Square RMS data with no extrapolations to life time loads or design loads presented.

The three load criteria studies (32, 33, 34) conducted "after the fact" represented beneficial applications of the McLEAN data base. Generally, the data reduction and analysis of the McLEAN data did not appear to have the vigor that is characterized by the data acquisition (see Table B-1). The demand for the McLEAN data has been minimal to date. The lack of demand should not reflect the usefulness of full-scale McLEAN data. The data obtained from the McLEAN represents one of the most extensive full-scale instrumentation projects conducted to date and should be utilized as a source of data as determined applicable by a would-be researcher. The SSC should be alert to this data base for future applications. The documentation of the McLEAN full-scale data base has been included in several references. Appendix B provides a summary that describes the McLEAN data base for future data users. Limited documentation pertaining to the rationale and engineering involved with the instrumentation, selection, placement, data acquisition and reduction requirements restricts full evaluation of the instrumentation system with regard to the original objectives and goals for the program.

The research plan outlined by Siekierka in SSC-257 (5) did not include plans to develop methods for containership design. Many of the instrumentation locations on the McLEAN were intended to provide design information to Sea-Land directly. The documentation of the SL-7 research program (1-34) indicates the problem areas pertaining to containership design, in certain instances, and are included in the evaluation tables (4-1). However, the resolution of the design problems and development of design methods has not been documented in the open literature. Elbatouti (30) did present several valuable recommendations for the design of containerships obtained from the DAISY finite-element analysis, and these are included in the summary of Reference 30 in Appendix A.

4.2.2 Model Testing Techniques

The hydrodynamic and static structural model tests that were conducted as part of the SL-7 research program provided the major source of data for the validation of analytical prediction techniques. The model tests provided response data from a quantified loading source; thus, response comparisons can be made on a standard basis. There are indications from the researchers who made the comparisons between model tests and analytical predictions that there is room for improvement in the model testing procedures for both the hydrodynamic and static structural model tests. These improvements are indicated in the summary of analytical techniques.

4.2.3 Analytical Prediction Techniques

Generally the development and validation of analytical prediction techniques has been one of the most beneficial products of the SL-7 research program. Although the validation has been based primarily on comparison with model testing data, both SCORES and DAISY represent structural analysis tools that were not validated prior to the SL-7 research program. The complete validation of SCORES and DAISY against full-scale SL-7 data has been limited to date and over-shadowed by the reliability of the wave

environment measurement from the McLEAN. The comparisons between analytical predictions and McLEAN data represented the primary goal for the McLEAN data according to SSC-257 (5). The full realization of this goal with regard to McLEAN data does not appear to be obtainable from existing data, in view of the conclusions presented by Dalzell in Reference 23.

The procedures used by ABS to obtain input information to the DAISY finite-element computer program from a modified version of the SCORES ship motion and loads computer program represent a major first step in combining the two procedures. The finite-element computer programs should provide an excellent method for structural analysis from wave-induced loadings; however, the versions of SCORES that are available to the general public do not produce the information needed as input to the finite-element programs. Although the combination of hydrodynamic and finite-element computer programs are presently extremely involved, refinement and simplification of the techniques will eventually be extremely valuable tools to the ship structural analyst.

4.2.4 Load Criteria, Analysis and Development

ABS (24) determined that their hull girder load criteria for the SL-7 was adequate, based on their comparisons between the DAISY finite-element computer program and full-scale data. However, the existence of fatigue cracks at the forward hatch on the SL-7 indicates that the hull girder design had deficiencies from a ship operator's standpoint. The load criteria studies (33, 34, 35) were not included in the original SL-7 research plan, but were additional studies that used the McLEAN data base for appropriate applications. Generally the studies evaluated in Section 4.1 have shown that the statistical techniques necessary to develop a complete picture of ship structural response throughout the ship's lifetime are quite complex. The studies indicate that the number of variables involved in quantifying the total ship structural response are numerous and difficult to separate, for example, the response from various types of bending moments from ship loading, the ship's wave train, thermal effects, and the various loads induced by wave encounters.

To date, the full-scale SL-7 data have been used to aid in the development of a rational load and design criteria. However, as these studies indicate, considerable effort is still required to develop design criteria or design methods using statistical techniques. Additional effort is required to define statistically all the types of hull structural loadings (various wave-induced loads, mean stresses, thermal stresses, etc.) for various ship types. The probabilistic techniques have been successful in evaluating existing load criteria but as a pure design method is formidable in its total scope in the view of today's average structural analyst.

The methods for the development of a rational hull girder load criterion using a statistical combination of loads from all the various sources was originally presented in SSC-240 (35). The method was reexamined in SSC-287 (33); however, the evaluation was inconclusive and validation of the statistical technique as a design method remains incomplete.

4.3 OVERALL EVALUATION OF THE SL-7 RESEARCH PROGRAM

The goals and objectives of the SL-7 research program have met with varying degrees of success.

The load criteria applied in the design of the SL-7 primary hull structure has been found to be adequate by the American Bureau of Shipping. The occurrence of fatigue cracks at the forward hatch corners has been reported (10). (In fact, in the absence of a detailed damage survey it is likely that such cracks may have occurred at other hatch corners.) The presence of such cracks is known to have been a concern of the operators, Sea-Land Service, Inc. The inference is that from an operations point of view the criteria used for the design of the SL-7 structure requires re-examination. In a negative sense, the fact that the SL-7 program has illustrated this deficiency may be considered a success. The program has provided valuable full-scale data, some of which has already been analyzed by ABS for the development of structural detail design methodologies which may be applied to the design of high-stress concentration areas, such as those encountered on the SL-7 class ships (43).

The validation of hydrodynamic ship load and response prediction techniques has also met with varied success. Three types of model tests have been used to produce data for validation of analytical techniques. These include hydrodynamic structural, static structural and open-water model tests. The information produced by the model tests has been valuable in validation of the SCORES (hydrodynamic load and response prediction), DAISY (finite-element computer program), and USCG time domain (hydrodynamic load and response prediction for capsizing in following seas) computer programs with additional testing indicated in all instances.

ABShas conducted comparisons of their DAISY finite-element program and the full-scale data obtained from the McLEAN. This comparisons involved the development of hull pressure information (from a version of the SCORES program and special post-processor) and input into the finite-element program. However, the wave environmental data obtained from the McLEAN which was used as input for the analytical simulations has been found to be suspect. Although the analytical techniques have been validated against the model tests, comparisons against full-scale SL-7 data have not been extensive or conclusive enough to consider the techniques validated as part of the present SL-7 research program. The unreliability of the wave data severely limits the further application of full-scale McLEAN data for the validation of analytical techniques.

There will be a continuing demand for full-scale data that will be used for validation of analytical techniques. Several SSC projects have been developed to obtain additional full-scale data for a wide range of applications. Many of these projects are in the planning stages and many of the projects are still speculative. The projects that will require additional full-scale data for validation efforts are second-generation ship motion and response simulations. The USCG experience described in this report indicates a general trend toward time domain simulations for rare or extreme events by the community in general. SSC is currently

sponsoring the development of an advanced ship motion computer simulation program (SSC Project SR-1277) which will include nonlinear effects. Several efforts are also underway to develop specialized programs to predict loads and responses of the ship to bottom slamming and deck wetness. At some point in time these analytical techniques will require additional full-scale data which will provide the criteria against which all techniques for predicting structural response must be judged. Hopefully, these programs will be able to use the SL-7 experience as a modeling base. The future programs that will require full-scale data will ideally require some qualitative measure of the wave environment.

The STEWART J. CORT program (44) is currently investigating the effects of springing in Great Lakes ore carriers and has benefited from the SL-7 program in considering the evaluation of the wave-meter systems. The STEWART J. CORT research program is also following a specialized trend that will probably be indicative of future research programs. It was organized specifically to obtain Response Amplitude Operators (RAOs) for springing response analysis. This trend will very likely continue for validation of specialized analytical techniques for predicting slamming loads and loads from green water on deck, etc. for the wide range of future needs. Future programs will require planning efforts for specialized needs relative to instrumentation types, data acquisition techniques, and data reduction required. The SL-7 research program has shown that the data-acquisition requirements for obtaining a statistical sample of strain data are not necessarily compatible with the amount of quality data actually needed for validation of analytical prediction techniques, and that this potential conflict should, in the future, be resolved at the planning level.

Several overall observations, apparent in reviewing the SL-7 research program that pertain to instrumenting ships in general, are presented here. The costs that the owners of the vessel must absorb for calibration periods, delays, etc., are such that the goals of any program may be compromised. Accordingly:

1. Instrumentation should be installed and calibrated during construction, dry-dock or lay up.
2. Proper planning of the calibration experiment and voyage data-taking phases is essential.

A body such as SSC is a good coordination group; however, the prime contractor project should not necessarily be an organization primarily interested in instrumentation. Ideally, a naval architecture firm should be employed to coordinate the interests of SSC, ABS, ship designers, builders, researchers and owners. Initially, ABS coordinated much of the SL-7 Research Program and, therefore, derived most of the benefits. One central head or leader, that ideally is technically equipped and has a vested interest in the final product, is needed to provide consistent overall direction.

RECOMMENDATIONS

Following recommendations are derived from the summary and conclusions presented in the previous sections, and do not include the numerous other recommendations presented in the SL-7 reports.

The research plan outlined in SSC-257 by Siekierka (5) was not fully implemented. Further implementation is not recommended due to the limitations (as determined by Dalzell in Reference 23) of wave environmental data from the McLEAN instrumentation project.

The deficiencies of the wave environmental data limit further use of the McLEAN full-scale data for validation of analytical procedures for predicting wave-induced loads. Therefore, no further validation efforts in this area are recommended.

The SL-7 Research Program data base, including the full-scale McLEAN data base described in Appendix B, represents one of the most extensive data bases obtained to date. It is recommended that maintenance of this data base by the SSC be continued and that the SSC utilize the data base as the specific needs and applications arise.

It is not recommended that a detailed research plan for further use of the McLEAN data be developed; however, it is recommended that the SSC advertise and direct ship researchers, designers and builders to the SL-7 data base as the demand for full-scale data, model test data and analytical simulation results arise. The SL-7 data base is extremely useful but it should be left to the individual researcher to decide on the applicability of the data base to their specific needs. For example, the McLEAN data base may lend some insight into the ranges of strain-rate studies concerned with structural strains and those induced from drydocking, or fatigue cracking studies. It would be the responsibility of the SSC to be alert to the existence of the present McLEAN full-scale instrumentation data base and advertise its availability. All of the possible uses of the McLEAN data are too numerous to list here. Several types of analyses of McLEAN data are presented in Appendix B. Examples of further analysis of McLEAN data include:

- The highest hull girder stresses ever measured on the ships instrumented by TES occurred on the forward hatch of the McLEAN (79,000 psi P-T). The circumstances surrounding their occurrence would be extremely interesting.
- The data recorded at the forward hatch corner above radial cracks were observed and could possibly provide a data base for future fatigue analysis programs. However, these data are still in analog form, as recorded, and have not been analyzed in a useable form for fatigue analysis.
- The correlation of seaway stresses and hatch opening deflections originated by Sea-Land has not been completed and published in

the open literature. This information was intended to aid Sea-Land in the design of transverse box girders and hatch cover seals (see discussion in Table 4-1).

- Development of long-term statistical distributions of wave-induced stresses obtained from amidship vertical bending and hatch corners. The long-term statistical distributions would be developed on the same basis (i.e. Beaufort Number, etc.) and may provide insight into the long-term effects of stress concentrations on existing hull girder load criteria. This could also be conducted for various headings to isolate torsional effects.
5. Generally the documentation on the individual SL-7 research projects has been exceptional in describing the work reported. However, a detailed documentation of the planning effort involved in the full-scale element of the SL-7 research program would be beneficial to future research programs of a similar nature. References 1 and 5 contain a brief summary of the instrumentation purpose; however, no published document contains a detailed description of the planning efforts involved with the full-scale instrumentation element of the SL-7 research program. Information on the engineering effort and rationale involved in instrumentation selection, instrumentation placement, data acquisition and the required data reduction is very limited in published SSC documents. This information, if available to the research community, would be of great benefit for future full-scale instrumentation programs of a similar nature. For example, the information could aid in the determination of strain-gauge instrumentation placement without going through the deliberations that must have taken place in deciding the placement of strain gauges on the McLEAN. It is recommended that the SSC collect and publish information relating to the engineering effort and planning of the SL-7 program, if available. In fact, the lesson to be learned from this program is that all future similar programs should be preceded by a published full-scale instrumentation test plan.
 6. The results of the SL-7 research program indicate strongly that additional development of wave measurement systems is needed. An improved SL-7 wave-measurement system has recently been utilized as part of the STEWART J. CORT (43) research program; however, experience at this time has been limited to lower sea states. Further development of wave-measurement systems may be required for large seaways and at higher speed ranges before validation of existing or new analytical techniques can be completed. It is recommended that development and verification of such wave-measurement systems be continued actively in anticipation of future full-scale tests.
 7. It is recommended that McLEAN cargo, ballast and consumable loading conditions that existed upon departure for the various voyages where data were recorded be obtained from Sea-Land Services, Inc. and incorporated as part of the McLEAN data base.

8. It is recommended that future full-scale instrumentation programs provide a means for recording the initial mean stress upon departure for each voyage. This information is necessary for future load criteria analysis and development, in particular still-water bending moment information.
9. The only scratch-gauge data recorded on 8 ships of the SL-7 class that have supplementary project logbook data are those corresponding to the first three data seasons on the McLEAN. It is recommended that an investigation be conducted as to the availability of ships' logbook information to supplement the scratch-gauge data recorded on other ships. This information would be obtained from Sea-Land and maintained with the scratch-gauge data at Teledyne Engineering Services in Waltham, Massachusetts.
10. It is recommended that a survey be conducted to provide insight into the extent of damage sustained by the SL-7s during their service as commercial containerships. The damage survey would include the documentation of the circumstances surrounding the voyages when damage occurred.

6.0 EPILOGUE, THE SL-7 CONTAINERSHIP

At the present time (1981), the SL-7 containership is being phased out of commercial service. The cost of oil has risen from \$2 a barrel to \$35 a barrel since the time these ships were designed, and this high-speed capability is no longer economical. The trends toward high speed in commercial cargo ships which developed in the late 60s and 70s are beginning to phase out. The United States Navy is considering purchase of the SL-7 containerships for military logistic support applications, although when the class was designed, such an application was not considered in the structural design. Often ships will shift to other services, carry different cargo, or travel different routes than were initially considered when they were designed, and such may be the case for the SL-7 class. Under these conditions, the load criteria used in the original design of the SL-7 containerships may no longer be applicable.

Although the demand for high-speed containerships has diminished in recent years, the majority of the conclusions and recommendations of this program are applicable to open-decked ships as well as other ship types.

7.0 ACKNOWLEDGMENTS

The authors would like to acknowledge the work of the researchers involved in the SL-7 program. The summary, conclusions and recommendations of this report have been influenced to a large degree by the work of others involved in the program and are offered recognizing the benefits of hindsight.

8.0 REFERENCES

1. Fain, R.A., "Design and Installation of a Ship Response Instrumentation System Aboard the SL-7 Class Containership S.S. SEA-LAND McLEAN," 1974, SL-7-1, SSC-238, AD 780090.
2. Dalzell, J.F. and Chiocco, J.J., "Wave Loads in a Model of the SL-7 Containership Running at Oblique Headings in Regular Waves", 1974, SL-7-2, SSC-239. AD 780065.
3. Elbatouti, A.M., Liu, D. and Jan, H.Y., "Structural Analysis of SL-7 Containership Under Combined Loading of Vertical, Lateral and Torsional Moments Using Finite Element Techniques," 1974, SL-7-3, SSC-243. AD A002620.
4. Kaplan, P., Sargent, T.P. and Cilmi, J., "Theoretical Estimates of Wave Loads on the SL-7 Containership in Regular and Irregular Seas," 1974, SL-7-4, SSC-246. AD A004554.
5. Siekierka, W.J., Johnson, R.A. and CDR Loosmore, C.S., USCG, "SL-7 Instrumentation Program Background and Research Plan," 1976, SL-7-5, SSC-257. AD A021337.
6. Rodd, J.L., "Verification of the Rigid Vinyl Modeling Techniques: The SL-7 Structure." 1976. SL-7-6, SSC-259. AD A025717.
7. Boentgen, R.R. and Wheaton, J.W., "Static Structural Calibration of Ship Response Instrumentation System Aboard the SEA-LAND McLEAN," 1976, SL-7-7, SSC-263. AD A031527.
8. Boentgen, R.R., Fain, R.A. and Wheaton, J.W., "First Season Results from Ship Response Instrumentation Aboard the SL-7 Class Containership S.S. SEA-LAND McLEAN in North Atlantic Service," 1976, SL-7-8, SSC-264. AD A039752.
9. Wheaton, J.W. and Boentgen, R.R., "Second Season Results from Ship Response Instrumentation Aboard the SL-7 Class Containership S.S. SEA-LAND McLEAN in North Atlantic Service," 1976, SL-7-9. AD A034162.
10. Boentgen, R.R., "Third Season Results from Ship Response Instrumentation Aboard the SL-7 Class Containership S.S. SEA-LAND McLEAN in North Atlantic Service," 1976, SL-7-10. AD A034175.
11. Webster, W.C. and Payer, H.G., "Structural Tests of SL-7 Ship Model," 1977, SL-7-11, SSC-269. AD A047117.
12. Kaplan, P., Sargent, T.P. and Silbert, M., "A Correlation Study of SL-7 Containership Loads and Motions - Model Tests and Computer Simulation," 1977, SL-7-12, SSC-271. AD A049349.
13. Chen, D. and Hammond, D., "A Report on Shipboard Waveheight Radar System," 1978, SL-7-13. AD A053379.
14. Dalzell, J.F., "Original Radar and Standard Tucker Wavemeter SL-7 Containership Data Reduction and Correlation Sample," 1978, SL-7-14, SSC-277. AD A062394.
15. Dalzell, J.F., "Wavemeter Data Reduction Method and Initial Data for the SL-7 Containership," 1978, SL-7-15, SSC-278. AD A062391.
16. Dalzell, J.F., "Radar and Tucker Wavemeter Data from S.S. SEA-LAND McLEAN - Voyage 32," 1978, SL-7-16. AD A057154.
17. Dalzell, J.F., "Radar and Tucker Wavemeter Data from S.S. SEA-LAND McLEAN - Voyage 33," 1978, SL-7-17. AD A057155.
18. Dalzell, J.F., "Radar and Tucker Wavemeter Data from S.S. SEA-LAND McLEAN - Voyage 34," 1978, SL-7-18. AD A057156.

19. Dalzell, J.F., "Radar and Tucker Wavemeter Data from S.S. SEA-LAND McLEAN - Voyages 35 and 36E," 1978, SL-7-19. AD A057157.
20. Dalzell, J.F., "Modified Radar and Standard Tucker Wavemeter SL-7 Containership Data," 1978, SL-7-20, SSC-279. AD A062393.
21. Dalzell, J.F., "Radar and Tucker Wavemeter Data from S.S. SEA-LAND McLEAN - Voyage 60. 1978. SL-7-21. AD A057004.
22. Dalzell, J.F., "Radar and Tucker Wavemeter Data from S.S. SEA-LAND McLEAN - Voyage 61." 1978. SL-7-22. AD A057005.
23. Dalzell, J.F., "Results and Evaluation of the SL-7 Containership Radar and Tucker Wavemeter Data," 1978, SL-7-23, SSC-280. AD A062392.
24. Jan, H.Y., Chang, K.T. and Wojnarowski, M.E., "Comparison of Stresses Calculated Using the DAISY System to Those Measured on the SL-7 Containership Program." 1979. SL-7-24, SSC-282.
25. Fain, R.A. and Booth, E.T., "Results of the First Five 'Data Years' of Extreme Stress Scratch Gauge Data Collected Aboard SEA-LAND's SL-7's," 1979, SL-7-25, SSC-286.
26. Oakley, Jr., O.H., Paulling, J.R. and Wood, P.D., "Ship Motions and Capsizing in Astern Seas," 10th Symposium on Naval Hydrodynamics, Office of Naval Research, June 1974.
27. Haddara, M.R., Kastner, S., Magel, L.F., Paulling, J.R., Perez y Perez, L., Wood, P.D., "Capsizing Experiments with a Model of a Fast Cargo Liner in San Francisco Bay," prepared for the U.S. Coast Guard under Contract No. DOT-CG-84, 549-A, January 1972.
28. Perez y Perez, L., "A Time Domain Solution to the Motions of a Steered Ship in Waves," Report No. CG-D019-73, prepared under Contract No. DOT-CG-84, 549-A, November 1972.
29. Bovet, D.M., "Development of a Time Domain Simulation for Ship Capsizing in Following Seas" Report No. CG-D-28-74, October 1973.
30. Elbatouto, A.M.T., Jan, H-Y, Stiansen, S.G., "Structural Analysis of a Containership Steel Model and Comparison with the Test Results," SNAME Transactions, November 1976.
31. Oliver, J.C., "Evaluation of SL-7 Scratch Gauge Data," Giannotti & Associates, Inc., Draft Final Report to SSC, September 1980.
32. Giannotti, J.G., "Fatigue Load Spectra Development for Ship Hulls," for Teledyne Engineering Services, Inc., September 1980.
33. Dalzell, J.F., Maniar, N.M, Hsu, M.W., "Examination of Service and Stress Data of Three Ships for Development of Hull Girder Load Criteria," SSC-287, 1979.
34. Zubaly, R., "Evaluation of Full-Scale Wave Loads," SNAME, Panel HS-1.
35. Lewis, E.V., Hoffman, D., MacLean, W.M., Van Hooff, R., Zubaly, R.B., "Load Criteria for Ship Structural Design," SSC-240, 1973. AD 767389.
36. Boylston, J.W., deKoff, D.J., Muntjewerf, J.S., "SL-7 Containerships: Design, Construction and Operational Experience," SNAME, Trans. 1974.
37. Grim, Q. and Schenzle, P., "The Prediction of Torsional Moment, Horizontal Bending Moment and Horizontal Shear Force on a Ship in Waves," Proceedings, IMAS69, Section 3.
38. de Wilde, G., "Structural Problems in Ships with Large Hatch Openings," International Shipbuilding Progress, Vol. 14 (1967), No. 149 (Jan.) and No.150 (Feb.), pp. 7-33, 73-83.
39. Chazal, E.A., LCDR, Goldberg, J.E., Nachtsheim, J.J., Rumke, R.W., Stavovy, A.B., "Third Decade of Research Under the Ship Structure Committee," SSC-252, 1976, AD A021290.

40. Fain, R.A., Cragin, J.Q. and Schofield, B.H., "Ship Response Results from the First Operational Season Aboard the Container Vessel, S.S. BOSTON," Ship Structure Committee, Report No. SSC-212, 1970.
41. Johnson, A.E., Flaherty, J.A., Walters, I.J., "A Method for Digitizing, Preparing and Using Library Tapes of Ship Stress and Environment Data," SSC-236, 1973. AD 767388.
42. Johnson, A.R., Flaherty, J.A., Walters, I.J., "Computer Programs for the Digitizing and Using of Library Tapes of Ship Stress and Environment Data," SSC-237, 1973. AD 768863.
43. Stainsen, S.G., Jan, H.Y., and Liu, D., "Dynamic Stress Correlation for the SL-7 Containership," SNAME Trans. 1979.
44. Hammond, D., "Great Lakes Wave Height Radar System," USCG Report No. CG-D-6-80, 1977. AD A083647.

APPENDIX A

SUMMARIES OF REFERENCES 1-34

TITLE/SSC REPORT NO. (Ref. 1)

Design and Installation of a Ship Response Instrumentation System Aboard the SL-7 Class Containership S.S. SEA-LAND McLEAN, SSC 238 (SL-7-1).

DESCRIPTION

This report describes the transducers, cabling, signal-conditioning, and recording elements of the instrumentation system installed aboard the SL-7 containership S.S. SEA-LAND McLEAN. It includes a detailed summary of the strain-gauge bridge circuits, locations of all transducers, and a description of the various operating modes and options available for recording data from more than 100 strain gauges, accelerometers and motion sensors. This document contains a detailed description of the instrumentation package installed on the S.S. SEA-LAND McLEAN. Tables II and III of Reference (1) provide a brief summary of the rationale involved in the instrumentation selection and purpose.

AUTHOR'S FINDINGS, CONCLUSIONS AND RECOMMENDATIONS

None presented in this report.

TITLE/SSC REPORT NO. (Ref. 2)

Wave Loads in a Model of the SL-7 containership Running at Oblique Headings in Regular Waves SSC-239 (SL-7-2)

DESCRIPTION

This report describes the 1/140-scale segmented model tests of the SL-7 containership where the measurements included vertical, lateral and torsional wave bending moments, and vertical and lateral shear forces at two model sections. The model had balances between segments that were instrumented with strain gauges to infer torsional, lateral and vertical bending moments from strain measurements. The model response and motions were measured along with the waves or loading function. A set of 4-bladed propellers driven by an electric motor and rudder activated automatically were also included in the model design.

The two model loading conditions, estimated while the ships were under construction as being typical ship loadings, consisted of one full load and one ballast configuration.

The testing program contained four parts:

- (1) Smooth-water runs to measure moments and shears induced by the ships wave train.
- (2) Smooth-water tests to determine the effects of the ship's roll response at zero speed and one forward speed.
- (3) Smooth-water runs to generate an approximate response to rudder motions.
- (4) Regular wave runs at seven headings, two ship speeds, and various wave frequencies and heights.

The model was self-propelled through a ship speed range of 24 to 32 knots at seven headings in regular waves with lengths between .25 and 2.0 times the ship's length between perpendiculars. The results are presented in charts of load or motion amplitude with ship heading speed and loading conditions as parameters.

AUTHOR'S FINDINGS, CONCLUSIONS AND RECOMMENDATIONS

The primary objective of this investigation was to obtain three components of wave bending moment and two components of wave shear force at two sections of a high-speed containership. This was accomplished for the significant ship-wave headings. In addition, coordinated data were obtained of the model motions.

In advance of results of correlations of the present data with theory, no positive recommendations were made as to the necessity of further testing.

TITLE/SSC REPORT NO. (Ref. 3)

Structural Analysis of SL-7 Containership Under Combined Loading of Vertical, Lateral and Torsional Moments Using Finite-Element Techniques, SSC-243 (SL-7-3)

DESCRIPTION

This document describes the analysis of the SL-7 container vessel hull structure using the DAISY finite-element computer program. The ship, loaded with containers and placed in oblique quasi-static regular waves, is subject to combined vertical, lateral and torsional loads. Stress distributions particularly in the deck region are presented and investigated from the analysis using the reduced-element substructure feature in the program. Fine-mesh analyses are also presented at different locations of the ship. The computed stresses are discussed in connection with the placement of strain-gauge instrumentation on the SEA-LAND McLEAN.

AUTHOR'S FINDINGS, CONCLUSIONS AND RECOMMENDATIONS

The author presented several conclusions pertaining to the structural response of an open-decked containership. These observations include:

- (1) A relationship between hatch distortion and the transverse box stress distribution in this area suggested the linearity of the stress pattern.
- (2) The Navier Beam Hypothesis as applied to the open-deck box girder appeared to be adequate in predicting the primary response of the containership under pure vertical bending moments.

The interpretations of the stress results at the proposed locations of some strain gauges on the SEA-LAND McLEAN are made. Early output of the finite-element results had helped in the determination of the final location of some gauges.

TITLE/SSC REPORT NO. (Ref. 4)

Theoretical Estimates of Wave Loads on the SL-7 Containership in Regular and Irregular Seas, SSC-246 (SL-7-4)

DESCRIPTION

This report describes the application of the SCORES computer program for predicting ship structural response of the SL-7 containership in waves. Comparison is made between the computer and model tests of the SL-7 (reported in SSC 239 SL-7-2) in regular waves in predicting vertical, lateral and torsional moments, and vertical and lateral shears at two sections and heave, pitch and roll. Regions where the theory and model experiment do not agree have been pointed out and some means of correction or extension of the theory is discussed.

Additional computations were conducted for the SL-7 containership at numbers typical to operating conditions. These results are presented in the form of both frequency responses for regular waves as well as rms for irregular seas.

AUTHOR'S FINDINGS, CONCLUSIONS AND RECOMMENDATIONS

According to the author, the theory provided an adequate representation of ship response within the limitations of the strip theory. The lack of agreement between theory and experiment was evident for:

- (1) The influence that higher forward speed presented (Froude number effect)
- (2) Following seas, where theory is considered to be tentative due to low encounter frequencies.
- (3) Lateral plane wave loads that are highly dependent upon adequate representation of ship roll response with nonlinear roll damping which is not represented in a linear/ship motions program.

It was also concluded that the strip theory represented the state of the art in ship motions and loads computations and was consistent with all other available ship motion analyses applicable to wave responses.

TITLE/SSC REPORT NO. (Ref. 5)

SL-7 Instrumentation Program Background and Research Plan, SSC-257 (SL-7-5)

DESCRIPTION

This report presents an overview of the SL-7 research program up to 1976. It presents the experimental background upon which the program was based, the major features and expected outputs of the program, and some preliminary conclusions drawn from the research results obtained from the SL-7 research program up to the time the report was written. A research plan is also outlined for the possible data correlations and their consequences.

AUTHOR'S FINDINGS, CONCLUSIONS AND RECOMMENDATIONS

The author recommended a research plan based on the projects that had already been conducted as part of the initial research plan (projects presented in SL-7 documents 1 through 4), and additional follow on studies to be conducted as part of the SL-7 Research Program.

TITLE/SSC REPORT NO. (Ref. 6)

Verification of the Rigid Vinyl Modeling Technique: The SL-7 Structure,
SSC-259 (SL-7-6)

DESCRIPTION

This report describes the applications of the rigid vinyl structural modeling technique to the hull structure of the SL-7 containership, and a comparison of the model with its steel counterpart (described in SL-7-11) under equivalent load conditions.

AUTHOR'S FINDINGS, CONCLUSIONS AND RECOMMENDATIONS

The authors concluded that the use of rigid vinyl as the modeling material reduced construction efforts, improved the representation of complex structural shapes and details and offered reduction of experimental efforts due to ease of handling and convenient load magnitudes. Analysis of torsional stresses on both the steel and vinyl models revealed that areas of high-stress concentration can be misrepresented by strain gauge results simply because of the range of stresses present in a small area. Based on the results obtained from the structural model tests, it was concluded that essentially the same information was retrieved from the experimental programs of the steel model and the rigid vinyl model.

TITLE/SSC REPORT NO. (Ref. 7)

Static Structural Calibration of Ship Response Instrumentation System
Aboard the SEA-LAND McLEAN, SSC-263 (SL-7-7)

DESCRIPTION

This document reports the results of the dock side calibration of the strain-gauge portion of the ship response instrumentation installed on the SEA-LAND McLEAN SL-7. The experiment was intended to facilitate comparisons of measured stresses with calculated values resulting from known changes in loading, and thus verify the instrumentation system performance. The details of the experiment are presented in SSC-263 (7) for the loading conditions described below:

- (1) Dockside initial loading condition, with full load of containers in the hold and on deck, except beneath hatches 3, 10 and 14.
- (2) (Due to schedule constraints Condition No. 2 was deleted from the calibration experiment.)
- (3) Deck containers on Hatches 1 through 4 and 12 through 15.
- (4) Remaining deck containers on Hatches 5 through 11 removed.
- (5) Approximately one-half of containers removed from starboard side of Hatches 1 through 7 from the port side of Hatches 8 through 15, generating a torsional moment. Hatch covers placed asymmetrically to contribute to the torsional moment.
- (6) Completion of unloading described in Condition 5. This represents the maximum torsional load.
- (7) Nominally empty ship except for one propeller, 47 long tons loaded into Hatch 3 and one propeller in Hatch 4, all hatch covers on.

Calculations of vertical bending moment and torsional moment for each condition were provided by the ABS and the related stress changes have been compared with the measured values. In addition to the calibration of strain gauges, the diagonal displacement of a selected hatch opening was measured in an attempt to calibrate the hatch deflection with measured strain.

AUTHOR'S FINDINGS, CONCLUSIONS AND RECOMMENDATIONS

The following general conclusions were drawn by the authors based on the data gathered during the calibration experiment.

- (1) Measured changes in midship vertical longitudinal bending stress were consistently 80 percent of the calculated changes. Because of possible differences between the as-constructed and the theoretical (minimum scantling) section modulus upon which the calculations were

based, this correlation is reasonable and indicates further that the load/response characteristic is linear and that data acquisition and reduction techniques do not contain any significant systematic errors.

- (2) Data are presented relating response to applied loads, making possible the development of proportionality constant.
- (3) Stress levels achieved during the calibration were in most cases small relative to maximum measured seaway stress variations, and thermal conditions were not constant over the duration of the experiment. Therefore, extrapolations of loads by proportionality should be undertaken with caution.
- (4) The maximum observed stress change for the calibrations loadings (10,200 psi, sensor SYA, during the torsion loading, condition 4 to condition 6) occurred at the starboard aft corner of Hatch No. 9, just forward of the aft house. Other hatch corners at stations where hatch width changes are encountered exhibited high shear stresses near the stress relief cutouts. The hatch corners, therefore, are probably the most highly stressed parts of the structure.

REPORT NO. (Ref. 8)

ason Results From Ship Response Instrumentation Aboard the SL-7
tainership S.S. SEA-LAND McLEAN in North Atlantic Service,
(SL-7-8)

ION

ort contains selected examples of data, with evaluation and dis-
, collected during the first season on board the S.S. SEA-LAND

Data collection began with west bound Voyage 1 on October 8,
terminated with the east bound passage of Voyage 12 on April 5,
A total of 80 data tapes were recorded containing in excess of
eparate data recording intervals from more than 100 transducers.

ons include a brief description of the types of data collected,
sentation, selected comparisons of stresses with sea state and
of time histories of selected response data from all transducers
ected portions of a rough voyage.

FINDINGS, CONCLUSIONS AND RECOMMENDATIONS

qualitative observations are presented by the authors based on
ysis of selected types of data for the first season of operation;
this was not a detailed data analysis report and no conclusions
mmendations were offered.

TITLE/SSC REPORT NO. (Ref. 9)

Ship Response Instrumentation Aboard the SL-7 Containership S.S. SEA-LAND McLEAN, Results from the Second Operational Season in North Atlantic Service.

(This report is not a SSC published document and is available from National Technical Information Service) SL-7-9.

DESCRIPTION

This report contains selected examples of data, with evaluation and discussions, collected during the second season on board the S.S. SEA-LAND McLEAN. Data collection began with East bound voyage 25 on September 22, 1973. With the exception of Voyage 27 Westbound, the ship was manned until March 31, 1974. The total number of individual recording intervals of data was 60,941. On October 29, 1973 the SEA-LAND McLEAN entered drydock after unloading in Rotterdam. Continuous recordings were made during the time the ship was sitting on the blocks.

Discussions include a brief description of the types of data collected, data presentation, selected comparisons of stresses with sea state, and selected examples of time histories of response data.

AUTHOR'S FINDINGS, CONCLUSIONS AND RECOMMENDATIONS

This report did not contain detailed data analysis and no conclusions or recommendations were offered.

The highlight of the report is the presentation of selected heavy weather data for the second season which included a unique slam which resulted in a total (including whipping) estimated midship bending stress excursor at 53,600 PSI.

TITLE/SSC REPORT NO. (Ref. 10)

Ship Response Instrumentation Aboard the SL-7 Containership S.S. SEA-LAND McLEAN, Results from the Third Operational Season in North Atlantic Service

(This report is not a SSC published document and is available from the National Technical Information Service (SL-7-10)).

DESCRIPTION

This report contains selected examples of data, with evaluation and discussions, collected during the third season on board the S.S. SEA-LAND McLEAN. Data collection began with North Atlantic Voyages 59-61 during the period 17 January 1975 to 17 March 1975.

A significant amount of new strain-gauge instrumentation was installed for the third season data acquisition program. The location of this gauging was based on observations of damage incurred in the first two years of vessel operation. Specifically, radial cracks from the forward and some aft hatch corners and green water set-down of forecastle and flare plating had been experienced. In an attempt to characterize the loading in these areas, additional strain gauges were added.

Discussions include a brief description of the types of data collected, data presentation, selected comparisons of stresses with sea state, and selected examples of stress time histories of response data.

AUTHOR'S FINDINGS, CONCLUSIONS AND RECOMMENDATIONS

This report did not contain detailed data analysis and no conclusions or recommendations were offered. A few qualitative observations were presented including the observation that the highest peak-to-through stress measured was 79,000 psi on the forward hatch corner circumferential gauge (FyB).

TITLE/SSC REPORT NO. (Ref. 11)

Structural Tests of SL-7 Ship Model, SSC 269 (SL-7-11)

DESCRIPTION

This report describes a steel structural 1/50th scale model test program for the SL-7 containership, the development of the model, and test results.

The objectives of the SL-7 structural model tests were to:

- (1) Provide a more comprehensive view of the structural deflections and stresses for various component loadings than obtained from real ship data. (Prior to this study, no full-scale programs measured ship loading.)
- (2) Provide sufficient information with which to check and validate the finite-element calculations for typical ship structures.
- (3) Investigate the effect of warping restraint afforded by closed sections of the hull on torsional response.

The investigation included the development of the model size, material and construction. The scaling laws were examined and model particulars selected were based on this analysis.

The model was constructed of light gauge steel. As a result of several practical considerations, it was found necessary to increase the thickness of the structural components to reasonable commercial sizes to reduce the number of structural parts, thus simplifying the three-dimensional form of the ship hull. Several of the girders and stiffeners were taken together and were represented by one component with an equivalent cross section, while areas of the small plate stiffeners were included in the area of the plating. The structural model was loaded by means of calibrated weights, through a pulley and lever system, applied at a finite number of transverse bulkheads to provide a good distribution of load through loading bars. Discrete vertical, longitudinal and twisting loads were introduced to the model through the loading bars.

AUTHOR'S FINDINGS, CONCLUSIONS AND RECOMMENDATIONS

The investigators concluded that:

- (1) It was possible to develop a satisfactory, relatively small-scale model, but it was necessary to have the plating thickness slightly larger than the scale ratio would indicate.
- (2) Because of construction procedures and availability of standard steel plate sizes, it was not possible to include all of the structural

complexity of the full-scale ship in the model. The secondary structure was omitted and much of the primary structure was simplified.

- (3) The results indicated that the pure vertical bending results were comparable with elementary beam theory.
- (4) The tests of horizontal bending showed that elementary beam theory produced comparable results; however, the strains were quite small and not as well defined as for vertical bending.
- (5) The response of the ship to pure torsion indicated that bow, stern and machinery box structure were effective in restraining the ship's hull girder warping.
- (6) The vertical shear pattern appeared to have the correct shape and met the proper boundary conditions at the keel and deck edges. It was concluded by the researchers that the model welds were not capable of representing stress concentrations.

TITLE/SSC REPORT NO. (Ref. 12)

A Correlation Study of SL-7 Containership Loads and Motions Model Tests and Computer Simulations, SSC 271 (SL-7-12)

DESCRIPTION

A correlation study was carried out (for the SL-7 containership) by comparing results for structural loads and motions in waves obtained from model tests with computer calculations. The different aspects that could affect computer predictions were examined via further computations and analyses in order to determine their influence on the output data. Similarly, an examination of the possible effects that influence the model test data was made. The main objective of this study was to determine the capabilities of both test methods for prediction purposes.

Comparisons were made between theoretical predictions and results for other related ship models for which test data are available. Consistency of various results obtained is used as a basis for assessing the degree of validity of any particular method, as well as determining the exact difference in results due to various mechanisms that influence both the theory and experiments. Improvements in the theoretical model leading to an extended SCORES theory are described, together with comparisons of a range of available data for the SL-7 and other ships. These areas of extended theory include:

- (1) Incorporation of the Frank close-fit techniques for development of hydrodynamic coefficients instead of the Lewis form method originally employed
- (2) Incorporation of speed-dependent terms in the equations of motion
- (3) Influence of rudder deflection in ship structure response
- (4) Incorporation of the effects of nonlinear roll on ship response

The influence of each of these extensions to the SCORES theory are presented in the report.

AUTHOR'S FINDINGS, CONCLUSIONS AND RECOMMENDATIONS

The authors concluded that the different elements considered to modify the basic theory had negligible effects except for the addition of certain speed-dependent terms in the equations of motion that result in the extended SCORES theory. The authors also concluded that this theoretical model has shown good correlation with model-test data for conventional ships, another large, fast containership similar to the SL-7, and also for the SL-7 vertical-plane responses. The extended SCORES theory can be used over the entire range of conditions, with sufficient accuracy at low encounter frequencies, and does not require special treatment of

hydrodynamic forces just for that region in order to provide adequate vertical-plane load predictions.

It was found that the major problem for correlation of the SL-7 lateral-plane responses occurs in quartering-seas where large roll motions occur. However, the model testing procedures in these areas were also questioned.

The recommendations for further work in the area of SL-7 data correlation included:

- (1) Further model studies carried out in the quartering-sea range, preferably with a large model and/or special test apparatus that would be more suitable to "tender" ship models with directional control problems.
- (2) A more detailed determination should be made of the model roll static and inertial properties prior to the tests to insure consistency of the resulting values.
- (3) The roll-decay tests should be made with more information on time histories of motion presented, allowing more precise analysis of damping parameters (linear and non-linear), as well as using more than one method of initial roll disturbance as a means of checking repeatability of decay characteristics.

TITLE/SSC REPORT NO. (Ref. 13)

A Report on Shipboard Waveheight Radar System. This report is not a published SSC document and may be obtained from the National Technical Information Service in Microfiche (SL-7-13)

DESCRIPTION

This report describes the microwave shipboard wave height radar sensor developed by the Naval Research Laboratory for measuring the ocean wave spectra and installed on the S.S. SEA-LAND McLEAN. The report presents a detailed description of the electronic instrumentation and data acquisition used by the system. The report also presents a brief description of the corrections needed in measuring absolute wave heights from a moving vessel.

AUTHOR'S FINDINGS, CONCLUSIONS AND RECOMMENDATIONS

The objective of this report was to discuss the utilization of the microwave sensor on a moving vessel for measuring the open ocean wave spectra. No significant findings, conclusions or recommendations were presented.

TITLE/SSC REPORT NO. (Ref. 14)

Original Radar and Standard Tucker Wavemeter SL-7 Containership Data
Reduction and Correlation Sample, SSC-277 (SL-7-14)

DESCRIPTION

This report is the first in the series of 10 and involves the initial stages of the work to analyze and correlate the wave data obtained from the two wavemeter systems installed on the S.S. SEA-LAND McLEAN. Specifically, this report documents the several decisions and methods thought necessary in conversion of the raw data from its original analog form to digital form, the sampling and calibration of data from the second (1973-1974) season, and a summary of initial results. It was apparent from this initial work that large amounts of information (data) is needed before an absolute wave height measurement may be obtained.

AUTHOR'S FINDINGS, CONCLUSIONS AND RECOMMENDATIONS

No conclusions or recommendations are presented in this report. A summary of findings, conclusions and recommendations appear in SSC 280 (SL-7-23).

TITLE/SSC REPORT NO. (Ref. 15)

Wavemeter Data Reduction Method and Initial Data for the SL-7 Container-ship, SSC-278 (SL-7-15)

DESCRIPTION

This report is the second of a 10 document series on the verification and correlation of the wavemeter data obtained from the SL-7 SEA-LAND McLEAN. It describes part of the work involved to reduce data, to develop and implement corrections as were found necessary and feasible, and to correlate and evaluate the final results from the two wavemeters installed on the S.S. SEA-LAND McLEAN. It documents some background analyses, as well as those which were necessary to develop the needed corrections to the raw digitized wavemeter data. Implementation of the results of the various analyses in a second data reduction stage is also discussed. The second stage of data reduction consisted primarily of efforts to obtain a point spectra from a moving ship and define the transformations needed to correct the wave measurements which include ship motions.

AUTHOR'S FINDINGS, CONCLUSIONS AND RECOMMENDATIONS

No conclusions or recommendations are presented in this report. A summary of findings, conclusions and recommendations appear in SSC 280, (SL-7-23).

TITLE/SSC REPORT NO. (Ref. 16)

Radar and Tucker Wavemeter data from SEA-LAND McLEAN Voyage 32, (SL-7-16)
(This is not a SSC designated document.)

DESCRIPTION

This report is the third of a 10 document series on the verification and correlation of the wavemeter data obtained from the SL-7 SEA-LAND McLEAN. The report presents reduced wavemeter and amidship bending stress data in the form of time histories and spectral plots for the recording intervals of voyage 32. The corresponding logbook data are also presented.

AUTHOR'S FINDINGS, CONCLUSIONS AND RECOMMENDATIONS

This document is strictly a data report. No conclusions or recommendations are presented in this report. A summary of findings, conclusions and recommendations appears in SSC 280 (SL-7-23).

TITLE/SSC REPORT NO. (Ref. 17)

Radar and Tucker Wavemeter Data from SEA-LAND McLEAN Voyage 33, (SL-7-17)
(This is not a SSC designated document.)

DESCRIPTION

This report is the fourth of a 10 document series on the verification and correlation of the wavemeter data obtained from the SL-7 SEA-LAND McLEAN. The report presents reduced wavemeter and amidship bending stress data in the form of time histories and spectral plots for the recording intervals of voyage 33. The corresponding logbook data are also presented.

AUTHOR'S FINDINGS, CONCLUSIONS AND RECOMMENDATIONS

This document is strictly a data report. No conclusions or recommendations are presented in this report. A summary of findings, conclusions and recommendations appears in SSC 280 (SL-7-23).

TITLE/SSC REPORT NO. (Ref. 18)

Radar and Tucker Wavemeter Data from SEA-LAND McLEAN Voyage 34, (SL-7-18)
(This is not a SSC designated document.)

DESCRIPTION

This report is the fifth of a 10 document series on the verification and correlation of the wavemeter data obtained from the SL-7 SEA-LAND McLEAN. This report presents reduced wavemeter and amidship bending stress data in the form of time histories and spectral plots for the recording intervals of voyage 34. The corresponding logbook data are also presented.

AUTHOR'S FINDINGS, CONCLUSIONS AND RECOMMENDATIONS

This document is strictly a data report. No conclusions or recommendations are presented in this report. A summary of findings, conclusions and recommendations appears in SSC 280 (SL-7-23).

TITLE/SSC REPORT NO. (ref. 19)

Radar and Tucker Wavemeter Data from SEA-LAND McLEAN Voyages 35 and 36E,
(SL-7-19)
(This is not a SSC designated document.)

DESCRIPTION

This report is the sixth of a 10 document series on the verification and correlation of the wavemeter data obtained from the SL-7 SEA-LAND McLEAN. This report presents reduced wavemeter and amidship bending data in the form of time histories and spectral plots for the recording intervals of voyages 35 and 36E. The corresponding logbook data are also presented.

AUTHOR'S FINDINGS, CONCLUSIONS AND RECOMMENDATIONS

This document is strictly a data report. No conclusions or recommendations are presented in this report. A summary of findings, conclusions and recommendations appears in SSC 280 (SL-7-23).

JSC REPORT NO. (Ref. 20)

1 Radar and Standard Tucker Wavemeter SL-7 Containership Data,
(SL-7-20)

TION

port is the seventh of a 10 document series on the verification
relation of the wavemeter data obtained from the SL-7 SEA-LAND

This report presents the methods used to convert raw data from
iginal analog form to digital form, the sampling and calibration
from the third season (1974-1975) of the wave data obtained from
wavemeter systems installed on the S.S. SEA-LAND McLEAN.

5 FINDINGS, CONCLUSIONS AND RECOMMENDATIONS

clusions and recommendations are presented in this report. A
of findings, conclusions or recommendations appears in JSC 280
3).

AD-A120 599

SL-7 RESEARCH PROGRAM SUMMARY CONCLUSIONS AND
RECOMMENDATIONS(U) GIANNOTTI AND ASSOCIATES INC
ANNAPOLIS MD K A STANBAUGH ET AL. AUG 81 SR-1279
SSC-313 DTCG-23-80-C-20025

2/2

UNCLASSIFIED

F/G 12/1

NL

END

FORM

1

SEP

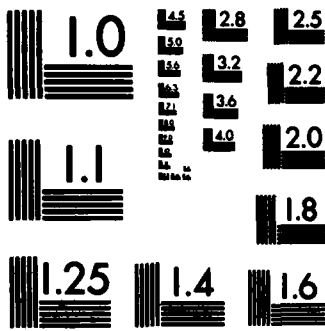

MICROCOPY RESOLUTION TEST CHART
NATIONAL BUREAU OF STANDARDS-1963-A

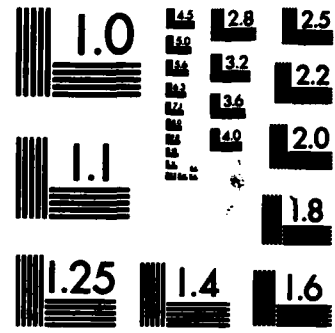

MICROCOPY RESOLUTION TEST CHART
NATIONAL BUREAU OF STANDARDS-1963-A

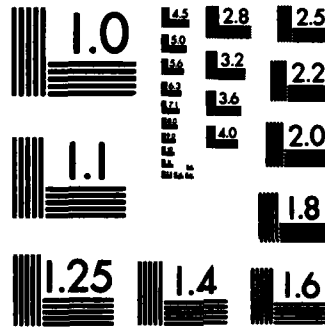

MICROCOPY RESOLUTION TEST CHART
NATIONAL BUREAU OF STANDARDS-1963-A

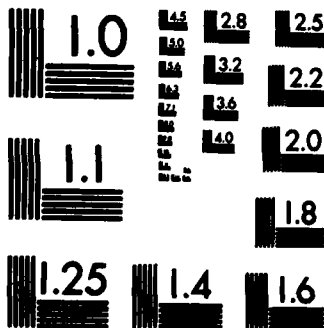

MICROCOPY RESOLUTION TEST CHART
NATIONAL BUREAU OF STANDARDS-1963-A

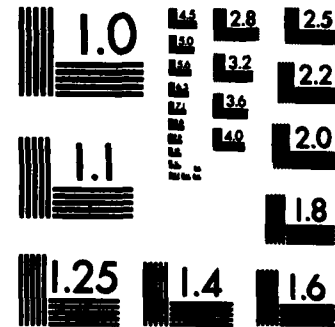

MICROCOPY RESOLUTION TEST CHART
NATIONAL BUREAU OF STANDARDS-1963-A

TITLE/SSC REPORT NO. (Ref. 21)

Radar and Tucker Wavemeter data from SEA-LAND McLEAN Voyage 60, (SL-7-21)
(This is not a SSC designated document.)

DESCRIPTION

This report is the eighth of a 10 document series on the verification and correlation of wavemeter data obtained from the SL-7 SEA-LAND McLEAN. This report presents reduced wavemeter and amidship bending data in the form of time histories and spectral plots for the recording intervals of voyage 60. The corresponding logbook data are also presented.

AUTHOR'S FINDINGS, CONCLUSIONS AND RECOMMENDATIONS

This document is strictly a data report. No conclusions or recommendations are presented in this report. A summary of findings, conclusions and recommendations appears in SSC 280 (SL-7-23).

TITLE/SSC REPORT NO. (Ref. 20)

Modified Radar and Standard Tucker Wavemeter SL-7 Containership Data,
SSC 279 (SL-7-20)

DESCRIPTION

This report is the seventh of a 10 document series on the verification and correlation of the wavemeter data obtained from the SL-7 SEA-LAND McLEAN. This report presents the methods used to convert raw data from its original analog form to digital form, the sampling and calibration of data from the third season (1974-1975) of the wave data obtained from the two wavemeter systems installed on the S.S. SEA-LAND McLEAN.

AUTHOR'S FINDINGS, CONCLUSIONS AND RECOMMENDATIONS

No conclusions and recommendations are presented in this report. A summary of findings, conclusions or recommendations appears in SSC 280 (SL-7-23).

TITLE/SSC REPORT NO. (Ref. 22)

Radar and Tucker Wavemeter Data from SEA-LAND McLEAN Voyage 61, (SL-7-22)
(This is not a SSC designated document.)

DESCRIPTION

This report is the ninth of a 10 document series on the verification and correlation of wavemeter data obtained from the SL-7 SEA-LAND McLEAN. This report presents reduced wavemeter and amidship bending data in the form of time histories and spectral plots for the recording intervals of voyage 61. The corresponding logbook data are also presented.

AUTHOR'S FINDING, CONCLUSIONS AND RECOMMENDATIONS

This document is strictly a data report. No conclusions or recommendations are presented in this report. A summary of findings, conclusions and recommendations appears in SSC 280 (SL-7-23).

TITLE/SSC REPORT NO. (Ref. 23)

Results and Evaluation of the SL-7 Containership Radar and Tucker Wavemeter Data, SSC 280 (SL-7-23).

DESCRIPTION

This report presents the findings, conclusions and recommendations obtained from the correlation and verification of the wavemeter data from the SL-7 SEA-LAND McLEAN. This report is the last of a 10 document series on the analysis of the data obtained from a Tucker wavemeter and radar wavemeter. The analysis included reduction of raw data in order to correlate and evaluate the final results from the two wavemeters. In carrying out this work, it was necessary to at least partly reduce several other channels of data recorded on the SL-7 SEA-LAND McLEAN, so that, as a by-product, reduced results were obtained from midship bending stress, roll, pitch and two components of acceleration on the ship's bridge. The additional data reduction was necessary primarily to obtain an absolute wave height measurement from a moving ship. The midship bending stress was used to generate stress RAO's which formed a basis for comparisons of the wave data obtained for the two wavemeter systems and model test data.

AUTHOR'S FINDINGS, CONCLUSIONS AND RECOMMENDATIONS

The conclusions and recommendations presented in this report are quite lengthy, but are very pertinent relative to the overall SL-7 research program and future programs of similar nature. No attempt has been made to summarize the conclusions and recommendations presented by the author which are included here in their entirety.

CONCLUSIONS

"The wave instrumentation included in the SL-7 program included a new system (the OWHS radar) and an old system (the Tucker meter). The basic minimum objective of the present project was to produce estimates of encountered wave variance or rms from the data produced by each system, and most of the work necessary in the present project was in support of this objective. Beyond this, the final objectives of the present program involved comparisons of results from the two wave measuring systems and the resolution of differences where possible. This latter objective has been addressed in the present report, and is the primary subject of the conclusions to follow.

- "(1) The evidence strongly suggests that neither of the wave measuring systems can be regarded as a standard by which the performance of the other may be judged.
- "(2) In the present application to a large, high-speed ship, it appears that quite significant errors in the Tucker meter output may be attributed to the characteristics of the analog double integration of acceleration. Improvements to this part of the system seem feasible within present technology. If the radar estimates happen to be closer to reality than the Tucker estimates, the existing corrections to the Tucker meter output for the attenuation of dynamic pressure with depth and for interference with the waves by the ship are considerably in error. If this is true, there appears no alternative to full-scale calibration trials for the calibration of the system.
- "(3) There appear to be a number of deficiencies in the installed OWHS radar system. Some of these produce errors of a magnitude which is impossible to assess because some significant pieces of information are missing. One of these deficiencies had the effect of reducing the apparent reliability of the radar system to quite low levels during the period of greatest interest (severe wave conditions). However, it appears that all of the problems perceived in the system may be significantly reduced by less than heroic measures.
- "(4) The source of error common to both systems has to do with the problems of double integration of low-frequency acceleration data. In the present application, the speed of the ship and the prevailing weather together tend to produce encountered wave components of extremely low frequency as much as half the time. These components are lost in the Tucker analog integration and not always successfully handled by the data reduction system employed for the radar data.
- "(5) There is a wide, systematic difference between the rms encountered waves (and the wave spectra) as measured by the radar and by the Tucker systems.
- "(6) Estimates of significant wave height from neither system correlate particularly well with visual estimates. Relative to visual estimates the radar results are too high and the Tucker meter estimates are too low.

- "(7) An indirect comparison of the wave spectra estimated by the two systems was made by deriving apparent midship stress response operators, and comparing these results with model test data for the SL-7 class ship. These comparisons suggest that the radar wave estimates are too high and the Tucker estimates too low. Quantitatively, however, if the Tucker meter wave estimates are correct, both the model test data as well as contemporary theory for wave-induced bending moments have to be in error by a factor of about three. If it is agreed that contemporary theory and model test techniques are better than this, the evidence suggests that the radar system, despite its known deficiencies, is closer to reality.

RECOMMENDATIONS

- "The present recommendations involve only the question of what might be done to improve results obtained with the systems which have been discussed -- under the assumption that installation of these systems is contemplated in the same, or another, large high-speed ship. Implicit in this assumption is that the overall theoretical limitation of either system is accepted. This overall limitation is that under the most ideal conditions only the encountered scalar spectrum of wave elevation can be produced.
- "Although the evidence is by no means conclusive, the present investigator's opinion is that the Tucker meter is not a good choice for installation in a ship of the size and speed of the SL-7 class. However, should such an installation be required, it is recommended that the double integration and computing circuits of this system be re-worked. The frequency where serious phase and amplitude distortion occurs in the double integration should be much lower than it was in the present full-scale program. It may be that the most practical approach would be to record both pressure and acceleration, and carry out an after-the-fact data reduction procedure similar to that employed for the radar. With or without a re-working of the electronics, there appears no real alternative to the full-scale calibration approach to the ship-wave interference effects upon the pressure head. Such trials are recommended for any installation in large, high-speed ships.
- "As noted in the conclusions, the radar system installed in the present program appears to have had a number of deficiencies. Despite these, it is the opinion of the investigator that the radar-based system is preferred for installation in large high speed ships. A check of results against a believable standard would still be required.
- "In the sense used here, the "radar system" includes more than just the radar unit itself. The various motion transducers and the data reduction procedure must be considered as part of the system as well. The perceived deficiencies appear to be largely curable. They may be considered under three main headings, as follows:

"1. The Radar Unit

Questions about the internal behavior and physics of the radar unit (how it could be bettered as a radar; if when a valid return is sensed is the indicated range correct; the nature of the physical circumstances under which return signal is lost, etc.) are all items which are beyond both the scope of the present project and the competence of the investigator. All the perceived deficiencies with the unit appear consistent with the output logic employed to deal with occasional return signal loss. Because it is necessary to know the length of the slant range vector when computing its vertical component, the output logic of the unit should be changed so that this information is not lost during a voyage -- irrespective of any return signal loss problem. The approach recommended is to hold the last valid range in the output register until the next valid range is acquired. It is suspected from the data in hand that the lapse of time between signal loss and re-acquisition is ordinarily relatively short. The effect on the data of the above recommendation would be to produce "notches" or flats in the time history. Small notches would introduce mostly high-frequency noise which is far preferable in data reduction to the ultra low-frequency noise injected by the logic of the present unit. Large "notches" or flats of long persistence would be relatively easy to see visually, or to detect by computer.

"2. Angles

To a fair degree of approximation the angle transducers of the pendulum type used in the present program are equivalent to body fixed lateral accelerometers. They are sensitive to both rotation and acceleration. The basic recommendation in this area is to measure angles properly -- either implicitly or explicitly. In the context of the radar system, this might be accomplished in two ways. One option is to mount a vertical accelerometer on the antenna and gyrostabilize both. In this case, the accelerometer output would be correct with respect to true vertical and the slant range would be related to its vertical component by a constant factor. The second option would be to mount a gyrostabilized vertical accelerometer in the radar pedestal. In this case, the accelerometer output would also be correct with respect to true vertical, and it would appear feasible within current state of electronic and microprocessor technology to make a continuous three dimensional vector correction to the slant range using the indicated angles from the gyro. It is felt that over and beyond the technical improvement, the resources expended in improving and automating the angle corrections could well be repaid in reduced costs of data handling and processing due to the fewer channels which would then be involved.

"3. Accelerations and Double Integration

In the final analysis, the phaseless double-integration scheme employed in the present data reduction was not sufficiently sophisticated. It was unable to handle ultra low frequencies as well as could be desired. However, the basic problem was that the extraordinarily good acceleration resolution required in some situations was not present in the data. According

"to the results, it appears that if the same scheme was to be used over again, the acceleration signal out of the recording medium should have a resolution approaching ± 0.002 g. With analog magnetic tape as the recording medium, this resolution might be approached in those cases where it is most needed (mild following or quartering seas) by the use of automatic gain control and the elimination of the one "g" signal bias included in the present vertical acceleration data. It should also be noted that the accelerometers used in the present application were probably not capable of this small a resolution.

"While better acceleration resolution would go a long way toward improving the estimation of the vertical displacement of the radar unit, it should be emphasized that any scheme involving discontinuous data samples has a low-frequency limit below which a proper job cannot be done. Perhaps, there is a practical continuous double-integration scheme which does not produce phase shifts. However, the present investigator's recommendation would be to defer an extraordinary amount of effort on this problem and to accept possible errors in quartering and following seas until such time as any second generation radar system can be fully accepted in the head and bow sea situation."

TITLE/SSC REPORT NO. (Ref. 24)

Comparisons of Stresses Calculated Using the Daisy System to Those Measured on the SL-7 Containership Program, SSC-282, SL-7-24

DESCRIPTION

This report compares stresses calculated using the ABS/DAISY finite-element program with those measured on board the SL-7 SEA-LAND McLEAN containership. This work was undertaken to verify the analytical procedures used in assessing the strength of ships in a seaway. Comparisons and evaluation are performed for four different and progressively more severe technical conditions: dockside calibration, RMS stresses in head seas and instantaneous stresses in head and oblique seas.

The wave environment which formed the basis for the comparisons of full-scale stress data and the analytical simulations was determined based on recorded signals from the wave radar system; however, at the time the correlation and verification study (SSC 280, SL-7-23) had not been completed. Once the wave environment was determined, the ABS/SHIPMOTION and ABS/DYNPRE computer programs were used to predict ship motions, wave loads and hydrodynamic pressures for input to the finite-element structural model. The ABS/SHIPMOTION program is a revised version of SCORES. ABS/DYNPRE which is an extended subroutine (post processor) of the SHIPMOTION program calculates the hydrodynamic pressure distribution on the wet surface of a ship's hull. The finite-element model consisted of a three-dimensional course-mesh and a fine mesh used to determine the stress distribution at selected strain-gauge locations.

AUTHOR'S FINDINGS, CONCLUSIONS AND RECOMMENDATIONS

- (1) The overall comparison between calculated and measured stresses for the dockside calibration is generally inconclusive because of significant temperature differentials during the test and the low magnitudes of the applied loads. However, good agreement between the calculated and measured stresses was obtained when thermal effects were small. For future calibration tests, it is recommended that complete temperature data be recorded and that appreciable mechanical strains be generated in the structure.
- (2) The comparison of calculated and measured RMS stresses in head seas is generally satisfactory, using both the spectrum analysis approach and the equivalent regular wave approach. The correlation using the former approach which takes into account the variation in response to different wave frequencies, shows better agreement than that obtained from the latter approach. However, it should be noted that the spectrum analysis approach is valid only near the midship section where the wave-induced stresses are generally in direct proportion to wave heights.

- (3) The agreement of calculated and measured instantaneous stresses in head seas is generally good; the calculated stress amplitudes agree well with the mean values of the measured stresses over a time-span of two complete encounter cycles.
- (4) The agreement of calculated and measured instantaneous stresses in oblique seas is also generally good for the wave conditions considered.
- (5) Based on the results obtained from this project, it can be concluded that the existing analytical tools for predicting wave loads and structural responses are suitable to assess the overall strength of the hull girder. All the measured stress data reduced to date from the SL-7 instrumentation program and all the calculated hull-girder stresses from the present study were found to be of low magnitude. Consequently, no modifications to the present hull girder strength standard are deemed necessary.
- (6) Regarding the structural responses, the ABS/DAISY system in its present form is considered satisfactory for performing static analyses for either quasi-static or dynamic loads.
- (7) In order to assess the strength of local structures and also to improve the current methodology, further research is deemed necessary to improve the calculation method for external pressures (possibly verified by model experiments) and to improve the ship motion program (SCORES) to account for three-dimensional effects and possibly for non-linear effects with respect to wave heights.

TITLE/SSC REPORT NO. (Ref. 25)

Results of the First Five "Data Years" of Extreme Stress Scratch-Gauge Data Collected Aboard SEA-LAND's SL-7s, SSC-287 (SL-7-25)

DESCRIPTION

This report describes the installation, calibration and data acquisition of scratch gauges mounted on each of the 8 ship class of SEA-LAND's SL-7s. Preliminary data reduction is described. The data are presented in histogram form for the various ships, years and routes (Pacific and North Atlantic). No attempt was made to analyze the data or categorize the scratches according to weather encountered.

AUTHOR'S FINDINGS, CONCLUSIONS AND RECOMMENDATIONS

This report did not contain detailed data analysis and no conclusions or recommendations were offered.

TITLE/SSC NO. (Ref. 26)

"Ship Motions and Capsizing in Astern Seas". This is not a SSC or SL-7 document but is a paper presented at the 10th Symposium on Naval Hydrodynamics, Office of Naval Research, June 1974.

DESCRIPTION

This report describes the analytical and experimental study of ship motions and capsizing in following seas conducted at the University of California, Berkeley for the U.S. Coast Guard. Extensive tests were conducted using two radio-controlled models in the wind-generated seas of San Francisco Bay. The models were the AMERICAN CHALLENGER class of cargo ship and the SL-7 class containership. Comparisons of the experimentally determined motions with a linear strip theory prediction are presented for both types of ships. A time-domain, numerical simulation program for motions and capsizing was used to investigate motions in a variety of wave conditions and was compared to the experimental results.

AUTHOR'S FINDINGS, CONCLUSIONS AND RECOMMENDATIONS

The analysis of linear and quasi-linear one-dimensional roll models revealed motion anomalies not apparent from the usual nonlinear ship motion theory. The authors concluded that linear ship motion can only broadly outline areas of speed, heading, and ship characteristics which may lead to trouble. Classical ship motion theories which are augmented by some nonlinear terms may reveal phenomena, not apparent in results of linear theory, which may lead to severe motion. The ability to predict capsizing is still not available through such theories.

TITLE/SSC REPORT NO. (Ref. 27)

Capsizing Experiments with a Model of a Fast Cargo Liner in San Francisco Bay. This is not a SSC or SL-7 designated document, but is a Coast Guard Report.

DESCRIPTION

This report describes a program of model testing in the open waters of San Francisco Bay. The program had as its objective the study of ship motion problems including capsizing and control performance in a heavy seaway. The equipment, testing techniques, and data acquisition and processing are described. Some preliminary results from simple statistical analyses of the data are also given.

AUTHOR'S FINDINGS, CONCLUSIONS AND RECOMMENDATIONS

Observations of the behavior of a model of the AMERICAN CHALLENGER class of cargo ships have enabled the authors to identify three categories of capsizing: low-cycle resonance, pure loss of stability, and broaching. All three modes are strongly influenced by the reduction of the ship's stability when a wave crest is amidship and all are most likely to occur in a following to quartering seaway.

The conclusions consisted primarily of an evaluation of the instrumentation used to power and control the model and data-collecting techniques applicable to open-water model testing.

TITLE/SSC REPORT NO. (Ref. 28)

"A Time-Domain Solution to the Motions of a Steered Ship in Waves." This is not a SSC or SL-7 designated document, but is a Coast Guard Report Number CG-D-19-73.

DESCRIPTION

The problem of ship motions in waves is formulated in the time domain by means of a convolution integral which relates the ship motion response to arbitrary exciting forces, under the assumption that the response is linear. The convolution integral is evaluated numerically to obtain the ship motions at discrete intervals of time.

Frequency independent nonlinearities of arbitrary form are incorporated into the model by considering them as part of the arbitrary exciting forces. Nonlinearities with time lag, such as those arising from rudder motions, are particularly amenable to this treatment. Nonlinearities that are functions of the instantaneous motions of the ship are approximated by continuously extrapolating the ship motions. Thus, one is able to include frequency-dependent linear force terms in what amounts to a stepwise solution of the nonlinear equation of motion, a capability not available in the conventional direct numerical integration techniques exemplified by, e.g. Runge-Kutta.

AUTHOR'S FINDINGS, CONCLUSIONS AND RECOMMENDATIONS

The author concluded that the numerical techniques for simulating the steered motion of a ship moving through a random seaway hold promise as a tool for studying the behavior of ships in severe wave conditions where large amplitude ship motions exist.

The recommendations included:

- (1) Additional nonlinear terms including nonlinear roll restoring moment with wave effects to improve the prediction at large roll angles, and nonlinear coupling between roll and heave or pitch.
2. A more precise determination of the terms in the convolution integral is needed with experimental verification. These experiments should include the measurement of impulse forces and responses, and wave exciting forces and responses.

TITLE/SSC REPORT NO. (Ref. 29)

"Development of a Time-Domain Simulation for Ship Capsizing in Following Waves." This is not a SSC or SL-7 designated report, but is a U.S. Coast Guard Report Number CG-D-28-74.

DESCRIPTION

This report describes the development of a time-domain computer simulation for ship capsizing in following waves. A survey of the recent literature in this field is presented. The formulation of the present approach is discussed, along with computer program limitations and assumptions. The program developed is used to study the phenomenon of low-cycle roll resonance as demonstrated by a two-dimensional section forced heave motion and by a fast cargo liner in following waves, both regular and irregular. The effect on capsizing tendency of variations in ship characteristics, initial conditions, and wave conditions is investigated. Qualitative comparisons of results with open water model experiments of the AMERICAN CHALLENGER class of cargo ships is presented. Finally, the potential application of this program to the determination of merchant vessel stability criteria is discussed, and recommendations are made for further work.

AUTHOR'S FINDING, CONCLUSIONS AND RECOMMENDATIONS

The authors found the qualitative agreement between time-domain simulations results and the results from the AMERICAN CHALLENGER open water model tests to be encouraging. The authors further concluded that the program in its current form can be used to simulate capsize situation quite accurately under pure following wave conditions.

The recommended improvements to the time-domain simulations included a more sophisticated numerical integration technique and the investigation of non-linear roll damping effects.

The authors recommended that the program be used to determine critical regions of operation from the stability point of view which would help establish effective stability safety standards for all vessels.

TITLE/SSC REPORT NO. (Ref. 30)

"Structural Analysis of a Containership Steel Model and Comparison with the Test Results." This is not a SSC published document. This document is presented in SNAME Transactions, 1976.

DESCRIPTION

This paper presents the comparisons of the steel and vinyl models of the SL-7 containership hull and a finite-element static analysis using the model test loads. A coarse mesh model of the hull was developed and a fine-mesh analysis for different parts of the deck structure was also presented. The hull was tested under vertical, lateral and torsional moments. Stress distributions, particularly in the deck region, are presented and investigated from the different types of analysis.

Estimations based on beam theory are also presented for the pure vertical bending cases.

AUTHOR'S FINDINGS, CONCLUSIONS AND RECOMMENDATIONS

The authors concluded that the finite-element model used to represent the steel model in the study was considered satisfactory for examining response of a hull girder to both bending and torsional loads. A model of finer mesh is required for determining the distribution of warping stresses, in comparison with that of bending stresses. They also observed that the installation of a heavy faceplate around the cutout on the deck at a hatch corner can help to reduce significantly the stress concentration factor for the structure configuration.

The author recommended that:

- (1) In the design of containerships, more attention should be paid to the torsional rigidity distribution along the hull.
- (2) Future attempts should be focused on establishing simple methods to estimate the hatch opening distortion as a function of the distribution of torsional moments and the basic structural configuration of the vessel.
- (3) Finite-element analyses of containership structures should be continued until a simple and reliable method is established for the prediction of torsional response of open deck hull girder. This is especially true for local structural details, such as hatch corners and connections near deck openings and other structural discontinuities.
- (4) Full-scale measurements aboard the SEA-LAND McLEAN were collected for three years. Correlation between the analytical results and the full-scale measurements would be beneficial in establishing guidelines for future designs.

TITLE/SSC REPORT NO. (Ref. 31)

Evaluation of SL-7 Scratch-Gauge Data (This report will be published as a SSC document, but exists as a Draft Final Report, Project SR-1268).

DESCRIPTION

This report describes the evaluation of the scratch-gauge data taken aboard all eight of the SL-7 class of containerhips. This project assesses the value and application potential of the scratch-gauge data base. The primary objectives of the project were to evaluate SL-7 scratch-gauge data as a basis for extreme load prediction, to determine correlations with electrical strain-gauge data recorded on the SL-7 SEA-LAND McLEAN, and to recommend when and how many scratch gauges can be recovered for placement aboard other ships. The study also investigated a wide spectrum of applications of the scratch-gauge data and the gauges themselves. The data analysis included:

- (1) Discussion of the measurement phenomena including what types of loadings are represented by the scratch-gauge recorders.
- (2) Statistical analysis of scratch-gauge data for all eight SL-7 containerhips in Pacific and Atlantic oceans. The statistical analysis included examination of the data with respect to statistical extreme prediction models.
- (3) Comparisons of the electrical strain gauges to the scratch gauges and evaluation as a possible alternative to electrical strain gauges.
- (4) Miscellaneous applications that include tracking of mean stress, short term statistics and the effects of corrosion.

AUTHOR'S FINDINGS, CONCLUSIONS AND RECOMMENDATIONS

The author presents several conclusions and recommendations that are pertinent to the applications of scratch gauges. In summary they include:

- (1) The scratch-gauge recorders produce data that represent the sum total of experience of strain that results from various types of ship loadings (i.e. mean stress, wave-induced stresses, whipping, thermal effects, etc.)
- (2) The scratch-gauge data easily lends itself to the various methods of statistical inferences described in the report. The extreme values derived can provide guidance to design of similar ships or structural modifications to the existing SL-7 class. This is contingent upon ship service under operation and environmental conditions similar to those under which the scratch data was acquired.
- (3) The scratch-gauge data can be used as an alternative to electrical strain instrumentation if total combined load is sought. The data

cannot be used to predict wave-induced loading only or to validate methods which theoretically predict only wave-induced loads.

- (4) The scratch-gauge data records provide a way to track mean stress over a long period of time. However, there are significant difficulties involved with such a procedure.

The author's recommendations included the possible future use of the scratch gauges and scratch-gauge data already obtained. These included possible use for other SSC projects on Still Water Bending Moment Determination and Ship Structures Loading in Extreme Waves.

TITLE/SSC REPORT NO. (Ref. 32)

Fatigue Load Spectra Development for Ship Hulls. This information will become part of a report that will be published as an SSC Document, Project SR-1254, "Fatigue Considerations in View of Measurement Load Spectra."

DESCRIPTION

This report describes several methods for developing load spectra applicable to fatigue testing. The primary purpose of the study was to develop a method for selecting fatigue load spectra for ships and to use the spectra as input to fatigue crack-growth analysis. Additional information is presented for the development of a long-term combined statistical stress distribution which would then represent a total picture of the stresses experienced by the ship during its lifetime. Consequently, the resulting distribution can be used for fatigue analysis. The method for development of load spectra for ship hulls was illustrated using the SL-7 SEA-LAND McLEAN midship bending stress data base.

AUTHOR'S FINDINGS, CONCLUSIONS AND RECOMMENDATIONS

The conclusions and recommendations included:

- (1) The state of initial mean stress in the SL-7 has been lost by the zeroing procedure and upon departure for each voyage in an effort to avoid signal saturation. It is recommended that future instrumentation programs incorporate a procedure for recording the magnitude of the gauge reading before it is zeroed.
- (2) The development of long-term statistical stress distribution based on observed wave height, Beaufort number, wind speed, or sea state, has obvious disadvantages which could be minimized if accurate wave height information was available.
- (3) The Root Mean Square (RMS) of the high-frequency wave-induced stresses should be calculated and incorporated as part of the presentation in the summary sheets.
- (4) Further analysis should be conducted to develop a rigorous method for combining the mean stresses (initial, varying, thermal, etc.) with the long-term statistical stress distributions for the wave-induced stresses. The method developed here represents a reasonable "first-cut" approach to the problem.
- (5) An investigation should be conducted to determine in what manner the high- and low-frequency wave-induced long-term statistical stress distributions may be combined so that they are representative of combined stresses which in turn affect the fatigue life of a ship's structure.

- (8) The combined long-term statistical stress distributions do not retain the stress peak-to-trough sequencing information present in measured stress time histories. This is a major disadvantage in utilizing a combined long-term statistical stress distribution to investigate the crack-growth retardation phenomenon.

TITLE/SSC REPORT NO. (Ref. 33)

Examination of Service and Stress Data of Three Ships for Development of Hull Girder Load Development, SSC 287.

DESCRIPTION

This is a follow-on project to SSC 240, "Load Criteria for Ship Structural Design," which proposed methods for the estimation and superposition of the primary loads and performed sample calculations for one conventional dry cargo ship. It involved the following bending moments:

- still-water due to weight and buoyancy
- ship's own wave train
- quasi-static wave-induced, vertical and lateral combined
- dynamic loads, including slamming, whipping and springing
- thermal effects

In this report, the service and full-scale stress data of three larger and/or faster ships (including the SL-7 SEA-LAND McLEAN) are examined for the purpose of the eventual development of hull-girder criteria. The purpose of this study was to analyze the service experience of three types of ship, which included a large, high-speed containership (SL-7), an oceangoing dry bulk carrier, and a very large crude carrier (VLCC). The examination is limited to extreme midship bending moment loads which are related to the ultimate strength.

AUTHOR'S FINDINGS, CONCLUSIONS AND RECOMMENDATIONS

The authors concluded that the still-water bending moments can be determined probabilistically; however, considerable additional information on loading conditions must be gathered in order to determine the statistical distributions. They also indicated that additional effort is required to determine the suitable probabilistic expression and the synthesis of a method for including the contribution of vibration to the extreme load.

TITLE/SSC REPORT NO. (Ref. 34)

Evaluation of Full-Scale Wave Loads. This is not a SSC published document; it was prepared for Panel HS-1, SNAME.

DESCRIPTION

The results of midship bending stress measurements made on 22 ships (including the SL-7 SEA-LAND McLEAN) of various types have been converted to a bending moment coefficient, (based on RMS stress for given recording intervals) plotted and compared. Trends of wave bending moment with ship type, trade route, length and fullness are shown.

AUTHOR'S FINDINGS, CONCLUSIONS AND RECOMMENDATIONS

The conclusions summarized the observed trends and made several recommendations for future stress-data measurements. The author recommended that future full-scale stress measurement systems be of the computer self-contained type presently in use for operational hull response monitoring. It was also recommended that regardless of the instruments used in making full-scale measurements, it is imperative that the trade route, speed, ship-to-wave heading, wave height observation and ship loading condition be routinely recorded with all measured data. The recommendations included a discussion pertaining to the information needed to calibrate the stress prediction methods that have been developed to date. These recommendations were brief but are pertinent to future research programs.

- (1) Comparison of long-term (ship-lifetime) extrapolation of measured stress data with long-term predictions using available statistical prediction methods.
- (2) Use of full-scale measurements made simultaneously with nearby wave-buoy measurements.
- (3) Development of reliable shipboard wave-data instrumentation when placed aboard ships along with stress instrumentation.

APPENDIX B

SL-7 RESEARCH PROGRAM DATA BASE DESCRIPTION

B.1 RESEARCH PROGRAM, DESCRIPTION OF THE DATA BASE

The information presented in the references listed in Table 3-1 forms the basic description of the total SL-7 research program data base. The majority of the documents are available from the National Technical Information Service (NTIS) in Springfield, Virginia. Each document is relatively complete with respect to the individual program. The full-scale instrumentation portion of the program is generally of greatest interest to the marine research and development community since it represents one of the most extensive instrumentation programs undertaken to date. The objective of summarizing the SL-7 data base is to provide information for designers and researchers contemplating the applicability of the data base to other projects and to those planning similar full scale instrumentation programs.

Technically, the instrumentation package installed on the SEA-LAND McLEAN consisted of hull structural response instrumentation, environmental wave data collection instrumentation and the extreme stress instrumentation. The latter two elements of the response instrumentation have been designated separate entities by SSC and the data collected were also presented as separate projects. In this report, the same organization will be followed with discussion of the analysis and reduction of environmental wave data and scratch gauge data in the evaluation section. In this section, the data base obtained from the full-scale hull structural response instrumentation package installed aboard the SEA-LAND McLEAN will be described.

Responsibility for the design and installation, operation of the system, and the collection of data on the SEA-LAND McLEAN was assigned to Teledyne Engineering Services (TES) of Waltham, Massachusetts. The instrumentation package of the SEA-LAND McLEAN, a descendant from the BOSTON instrumentation program (40), also designed by Teledyne, has additional, more complex measurement requirements. A description of the system and its installation is contained in SSC-238 (1).

The design and installation phase took place during the period prior to the ship entering service. Data collection began in September 1972 and continued for three sequential winter seasons in the North Atlantic.

The primary information objectives to be met through the shipboard measurements were as follows:

- (1) Midship vertical bending stresses of the deck, neutral axis and tank top of the midship section.
- (2) Torsional shear stresses.
- (3) Principal stresses at hatch corners.

- (4) Vessel pitch and roll.
- (5) Gross hull accelerations.
- (6) Accelerations of forward and aft deckhouses.
- (7) Longitudinal stresses at the deck and tank top of the forward end of the cargo hold.

Figure B-1 depicts the general instrumentation layout on the SEA-LAND McLEAN and References 1 and 5 contain detailed descriptions of the instrumentation sites and locations. The data from the instrumentation channels were supplemented by logbook entries of observed environmental and operational conditions, such as wave height estimates made by ship's officers, who had been instructed on wave observation techniques as part of a training program prior to serving on the SL-7s.

The outputs of all the various sensors were not recorded continuously because space and fund limitations dictated that only two fourteen channel tape recorders be installed. One recorder was dedicated to record 13 channels of data always from the same sources. The other recorder was used for 13 independent channels of data in four different modes of operation for a total of 52 channels of information from cyclically selected sources. The fourteenth channel on both recorders was reserved for compensation. Data were recorded for a total of two hours out of every four hours of ship operation. During this period, the cyclical recording mode operated on a one-half hour interval for two hours out of every four hour recording cycle. These one-half hour periods were then assigned index numbers. See Figure B-2 which shows the calibration and data recording sequence. The channel assignments and recording modes are indicated in Reference 1. During periods of high seaway loads, the data were recorded continuously. This type of additional recording mode was actuated when certain pre-set strain levels were exceeded.

A significant amount of new strain-gauge instrumentation was installed for the third season of data acquisition (10). The location of this gauging was based on the observation of damage incurred in the first two years of vessel operation. Specifically, radial cracks from the forward and some aft hatchcorners, green water set-down of the forecastle deck, and deformation of some bow flare plating had been experienced. In an attempt to characterize the loading in these areas, additional strain gauges were added. This instrumentation was included in the rotational schedule of the cyclical recorder. The strain information obtained from the gauges located in the area of the radial cracks could provide valuable data upon which fatigue studies could be based. However, at this time the data have not been reduced or analyzed and exist only in analog form as does the vast majority of data collected aboard the SL-7 SEA-LAND McLEAN.

Several important features about the data should be mentioned. The stresses, motions and accelerations were inferred from the analog voltage signal using appropriate calibrations at the start of each recording interval. See Figure B-3 for a typical strain recording. The strain measurements are not

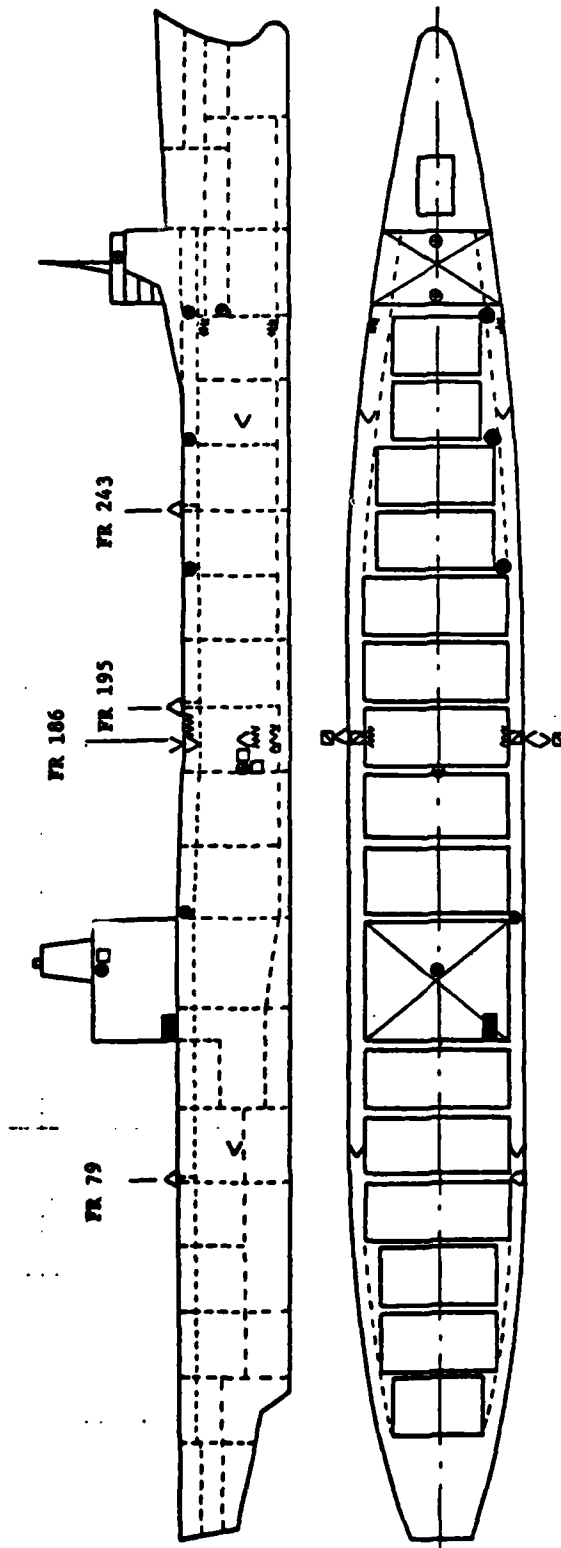

- ⊕ Bidirectional Accelerometer
- Pitch & Roll Pendulum
- ▣ Longitudinal Vertical Bending Element
- ∇ Torsional Shear Gage
- < Shear Gage
- ∩ Longitudinal Stress Gage
- △ Transverse Girder Gage
- Three Arm Rosette
- ∧ Midship Torsional Shear Element
- ⊠ Longitudinal Horizontal Bending
- ### Hull Longitudinal Strain

LEGEND

FIGURE B-1 GENERAL SENSOR LAYOUT AS INSTALLED ON THE
ON THE SL-7 SEA-LAND McLEAN

Figure B-2

THE STRESS RECORDING TECHNIQUES USED BY TELEDYNE ENGINEERING SERVICES
ON THE SL-7 SEALAND McLEAN

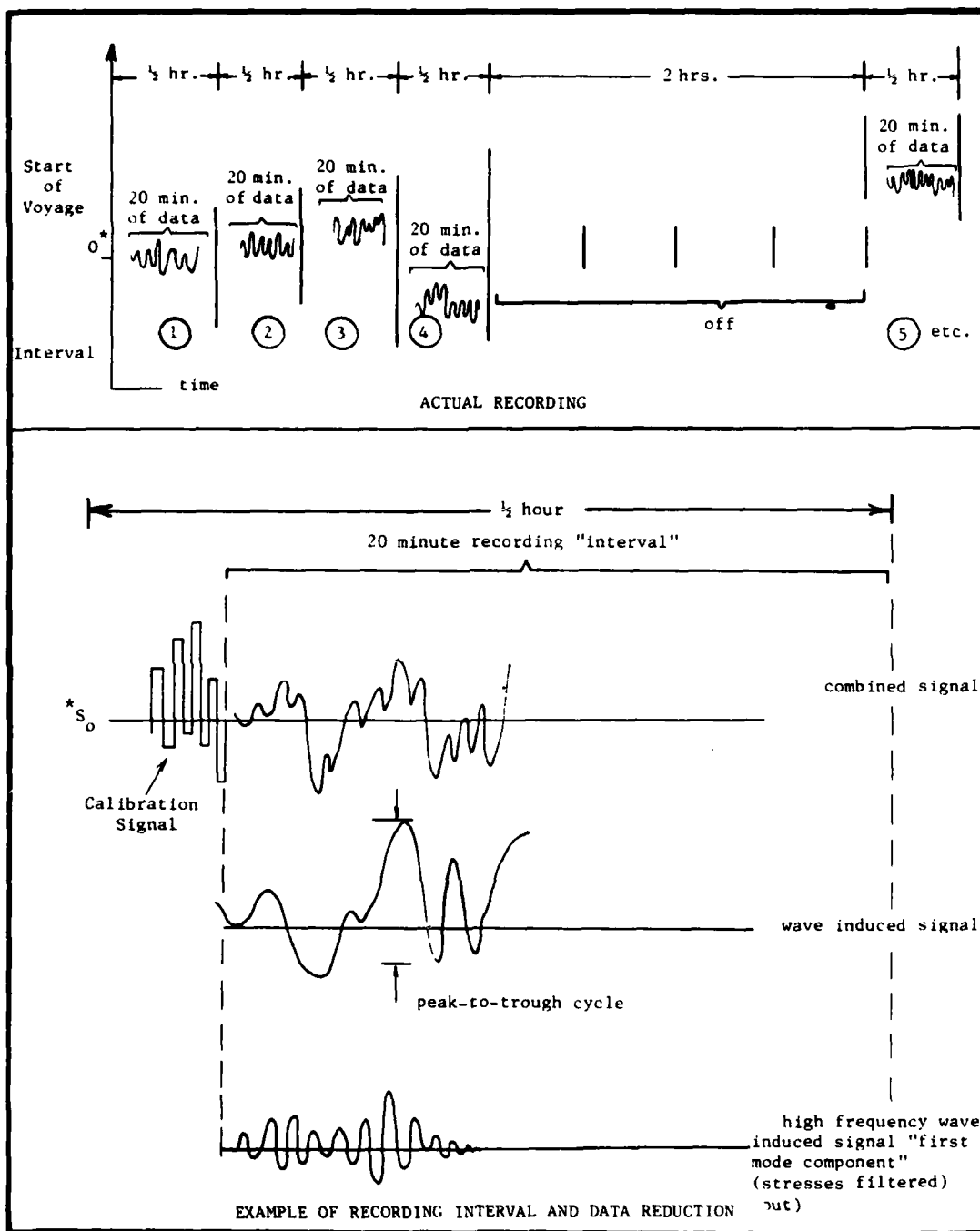

* Mean stress level was calculated from data and referenced to the start of the voyage when gauges were zeroed. Shifts in the mean stress were recorded after the gauges were zeroed.

absolute levels of stress in the structure, but rather the relative dynamic strain. The absolute value of strain includes, in addition, the combination of residual strains present at the time the strain gauges were installed. No method of reconstructing these residual strains is available.

The dynamic strains do not include the still water or initial mean strain resulting from cargo and/or ballast loading upon departure for each voyage because the strain gauges were zeroed to avoid signal saturation and no provision was made for recording the initial mean stress levels. This information is not available in any form for analysis. (This is an extremely important point if comparisons are to be made with static calculation of wave-induced bending moments.) After the vessel left port for a voyage, the gauges did record the varying mean strain which was made up of changes in ballast, consumables, fluid speed and thermal effects. An example of this may be seen in the upper part of Figure B-2 for the recording intervals 1-5 showing different mean strain levels for each interval.

Each 30-minute measurement interval is preceded by calibration signals and zero reference information as shown in the lower part of Figure B-2. The mean strain level for each 30-minute interval was computed for each of the strain channels reduced. This mean stress varied from interval to interval.

The wave-induced stresses fluctuated about the varying mean stress during a given 30-minute recording interval. The wave-induced stresses consisted of two basic components; the stresses that were induced by the waves occurring at approximately the frequency of wave encounter, and the stresses superimposed on the wave-induced stresses which are at or near the first mode hull girder response frequency. These high-frequency stresses are a result of impulsive loadings due to a representation of both the low-frequency and high-frequency wave-induced stresses appearing in the lower part of Figure B-2.

Large amounts of stress data have been obtained from the SL-7 full-scale instrumentation program. The method used in data collection is oriented heavily toward collecting large amounts of data to form a substantial statistical sample. In fact, the data collection and reduction techniques were a carry-over from previous full-scale instrumentation programs in which the objective was to obtain a large statistical sample so that the data could be extrapolated statistically to form a lifetime loading picture and thus aid in evaluating existing load criteria (L/20 wave, etc.).

B.2 SL-7 INSTRUMENTATION DATA REDUCTION AND ANALYSIS

The SEA-LAND McLEAN instrumentation data collection program generated raw data in two forms:

- (1) Magnetic 14-track tapes containing analog strain, sca characteristics and ship operating parameter signals
- (2) Manually recorded logbook data describing sea, wind, wave, and weather conditions at four-hour intervals.

Two formats were available for display of analog data. For quick ship-board review, each channel could be played back on an oscillograph at relatively high speed, with a low paper speed. The resultant compressed time-history hard copy record could be reviewed to observe signal peaks, relative levels, and overall variations. However, details of the wave form could not be seen. After returning the analog tapes to Teledyne, a more detailed review of selected data channels could be conducted using expanded time-history hard-copy oscillographic records made at slower tape speeds which preserve the details of wave form.

Procedures and computer programs described in References 41 and 42 were used to place the logbook data into digital form, to digitize selected channels of analog data, and to collate these sets of digital data onto digital library tapes. Subsequently, summary tapes were prepared which contained reduced transducer signals in digital form. These summary tapes were derived from the library tapes to facilitate data review and parametric analysis. The summary tapes contain the logbook information and reduced data for each interval. The reduced interval data consists of the Root-Mean-Square (RMS) of the Peak-to-Through (P-T, see Figure B-2) wave-induced stress, maximum P-T wave-induced stress, number of zero crossing wave-induced cycles, maximum P-T first mode stress and number of "bursts" of higher frequency transients per interval. Table B-1 displays the SEA-LAND McLEAN instrumentation program data in its various formats as it exists in the Teledyne SL-7 library. It is noted that with each succeeding season, fewer channels of analog data have been digitized. An interview with Teledyne personnel revealed that each season fewer channels were digitized simply because of the lack of requests for the previous season's digitized data.

For each transducer signal listed in Table B-1, the following describes in greater detail exactly what data are contained on its associated digital library tape(s). Since most large-magnitude stress records, especially those associated with slamming and similar dynamic events, can be separated into two components - wave-induced and first-mode two-noded vibration (i.e. whipping or springing) - and since each of these components can be characterized by its frequency, appropriate filtering arrangements can be applied to isolate each phenomenon's contribution to the overall stress record. Such a procedure was used in processing the SEA-LAND McLEAN analog records. On playback, the analog signal was filtered through a low-pass filter with a 2 Hz cutoff to eliminate high frequency vibratory effects and other noise; the remaining signal was then processed in three ways:

- (1) Through a 0.56 Hz to 2 Hz band pass filter to isolate the first mode component (the first-mode frequency of the SEA-LAND McLEAN at normal operating load is 0.80 Hz).
- (2) Through a 0.01 Hz to 0.22 Hz band pass filter and two subsequent 0.22 Hz low pass filters to isolate the wave-induced component.
- (3) Unfiltered to yield combined wave-induced and first mode-signals.

This filtering process is pictured graphically in Figure B-3.

TABLE B-1
 S. S. SEA-LAND McLEAN
 SUMMARY OF INSTRUMENTATION PROGRAM DATA AND DATA FORMATS
 THAT ARE PRESENTLY AT TELEDYNE ENGINEERING SERVICES

DATA ACQUISITION SEASONS	ANALOG TAPES/LOGBOOK	DIGITAL LIBRARY TAPES	SUMMARY TAPES
<u>SEASON I</u> <ul style="list-style-type: none"> • OCT 72 - APR 73 • Voyages 1 - 12 	<ul style="list-style-type: none"> • 80 Analog Tapes • Full Set of Logbook Data 	<ul style="list-style-type: none"> • 8 Analog Channels Digitized <ul style="list-style-type: none"> - <u>Longitudinal Vertical Bending</u> - <u>Torsional Shear Midships</u> - Roll - Pitch - Forward Acceleration - Vertical - Longitudinal Horizontal Bending - Shear Forward Port - Shear Forward Starboard • All Logbook Data Digitized 	<ul style="list-style-type: none"> • One Summary Tape per digitized channel which contains interval summary data and logbook data. (an example of summary tape output is shown in Figure B-9)
<u>SEASON II</u> <ul style="list-style-type: none"> • SEP 73 - MAR 74 • Voyages 25 - 38 	<ul style="list-style-type: none"> • 94 Analog Tapes • Full Set of Logbook Data 	<ul style="list-style-type: none"> • 3 Analog Channels Digitized <ul style="list-style-type: none"> - <u>Longitudinal Vertical Bending</u> - <u>Torsional Shear Midships</u> - Forward Acceleration - Vertical • All Logbook Data Digitized 	<ul style="list-style-type: none"> • One Summary Tape per digitized channel which contains interval summary data and logbook data. (an example of summary tape output is shown in Figure B-9)
<u>SEASON III</u> <ul style="list-style-type: none"> • JAN 75 - MAR 75 • Voyages 59 - 61 	<ul style="list-style-type: none"> • 34 Analog Tapes • Full Set of Logbook Data 	<ul style="list-style-type: none"> • 1 Analog Channel Digitized <ul style="list-style-type: none"> - <u>Longitudinal Vertical Bending*</u> • All Logbook Data Digitized 	<ul style="list-style-type: none"> • One Summary Tape per digitized channel which contains interval summary data and logbook data. (an example of summary tape output is shown in Figure B-9)

*The longitudinal vertical bending stress is the only stress information reduced to digital form for all data acquisition seasons.

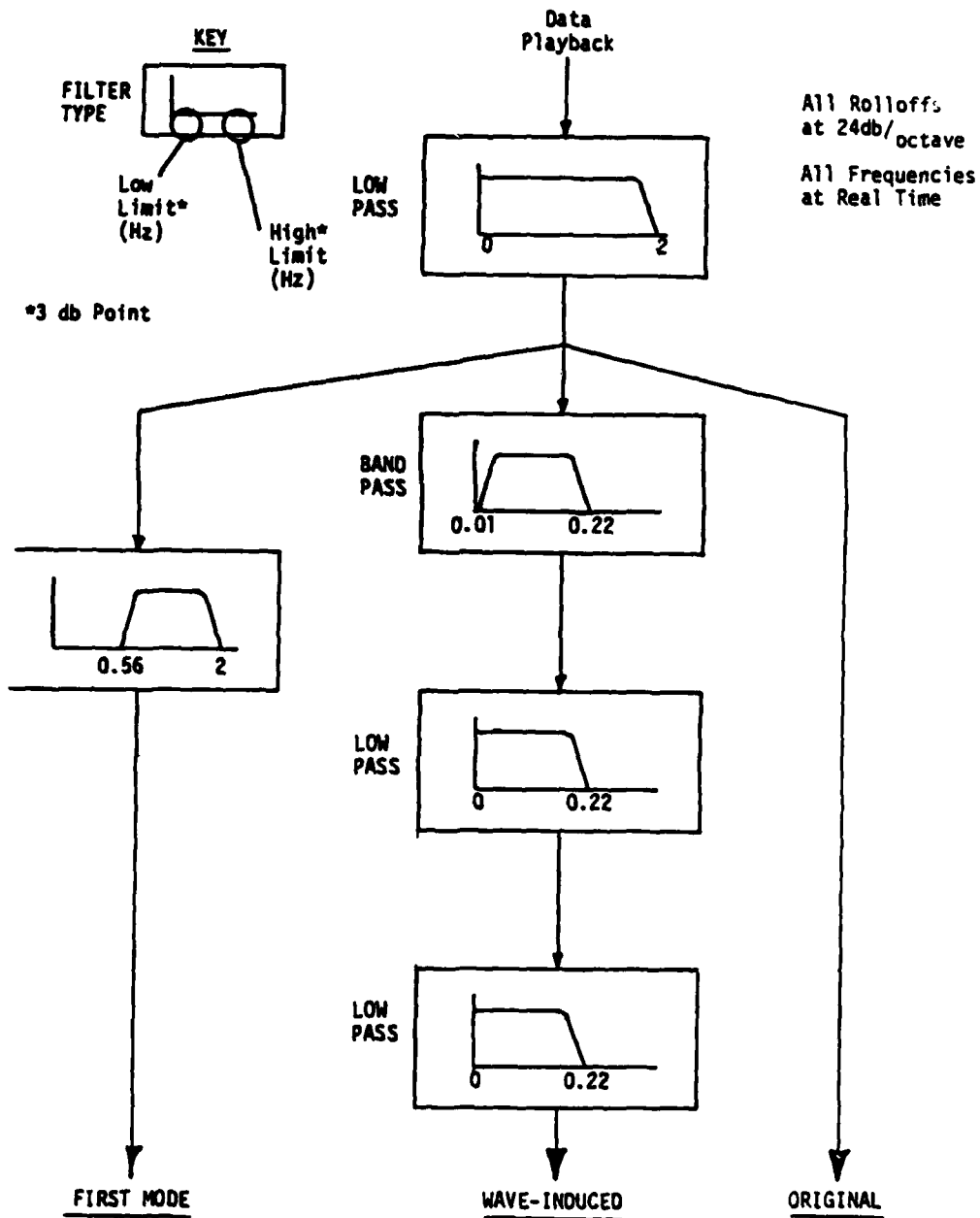

Figure B-3 FILTERING PROCESS USED BY TELEDYNE ENGINEERING SERVICES FOR ANALOG SIGNAL DIGITIZING FOR DATA OBTAINED ON THE SL-7 SEA-LAND McLEAN Reference 8

The three analog signals were then digitized at a sampling rate of 10 readings per second. Since only the first 20 minutes of each interval is processed, each of the three filtered signals (wave-induced first mode, and combined) generated 12,000 data points per interval. These sets of 12,000 data points comprise the digital transducer record. The computer program which generates the basic digital data record conducts additional calculations and operations to produce the digital library tape. A flow chart showing the digital library tape generation process is shown in Figure B-4.

For the wave-induced component, P-T values are calculated, stored, the number of P-T values counted and the RMS value of P-T wave-induced stress for the interval is calculated. The mean value of stress for the interval relative to the first interval of the pass (where a pass is a complete voyage's record for that transducer) is determined. Each P-T value is compared to the previous maximum and the maximum P-T value for the interval is retained. These values are stored as interval summary data.

The first-mode stress P-T data were calculated. When a predetermined threshold value of 600 psi was reached, the "burst" was initialized and counted, then the maximum P-T value for the interval was recorded.

Next, the digitized transformer data and the interval summaries are merged with the digitized logbook data. This process of generating the digital library tapes is summarized in Figure B-4.

To facilitate efforts such as parametric studies, where various logbook parameters are keyed to summary data, significant efficiency in tape reading can be achieved if the basic digital waveform records (12,000 point data sets) are deleted from the tape in use. To this end, summary tapes have been produced from the Library Tapes by deleting the digital records of wave-induced, first mode, and combined analog signals. The remaining information, interval summary information and logbook data is then available in a compact format for parametric-type analysis. The summary tape information is indicated on Figures B-4 and B-5.

The various examples of data presentation formats indicated in Figure B-5 are examples of the data processing capabilities of Teledyne. Table B-1 summarizes the channels of full-scale data that have been reduced to date. Figures B-6 to B-11 present examples of the various data formats in additional detail. An example of stress time history for the longitudinal vertical bending stress (LVBS) is shown in Figure B-6. This information was produced from the analog signal as recorded on the SEA-LAND McLEAN. An example of a project logbook entry form is shown in Figure B-7. This information was later digitized for further use in computer analyses. Figure B-8 depicts a sample of the digital library tape where the digitized logbook data and digitized P-T stress information are presented for a given 20 minute interval of recorded data. A selected example of the summary tape information is presented in Figure B-9. The summary tape contains index information, logbook information and reduced interval data for a given channel of interest. This information may be obtained from Teledyne in computer print-out form and represents a manual method for access to the data that has been digitized

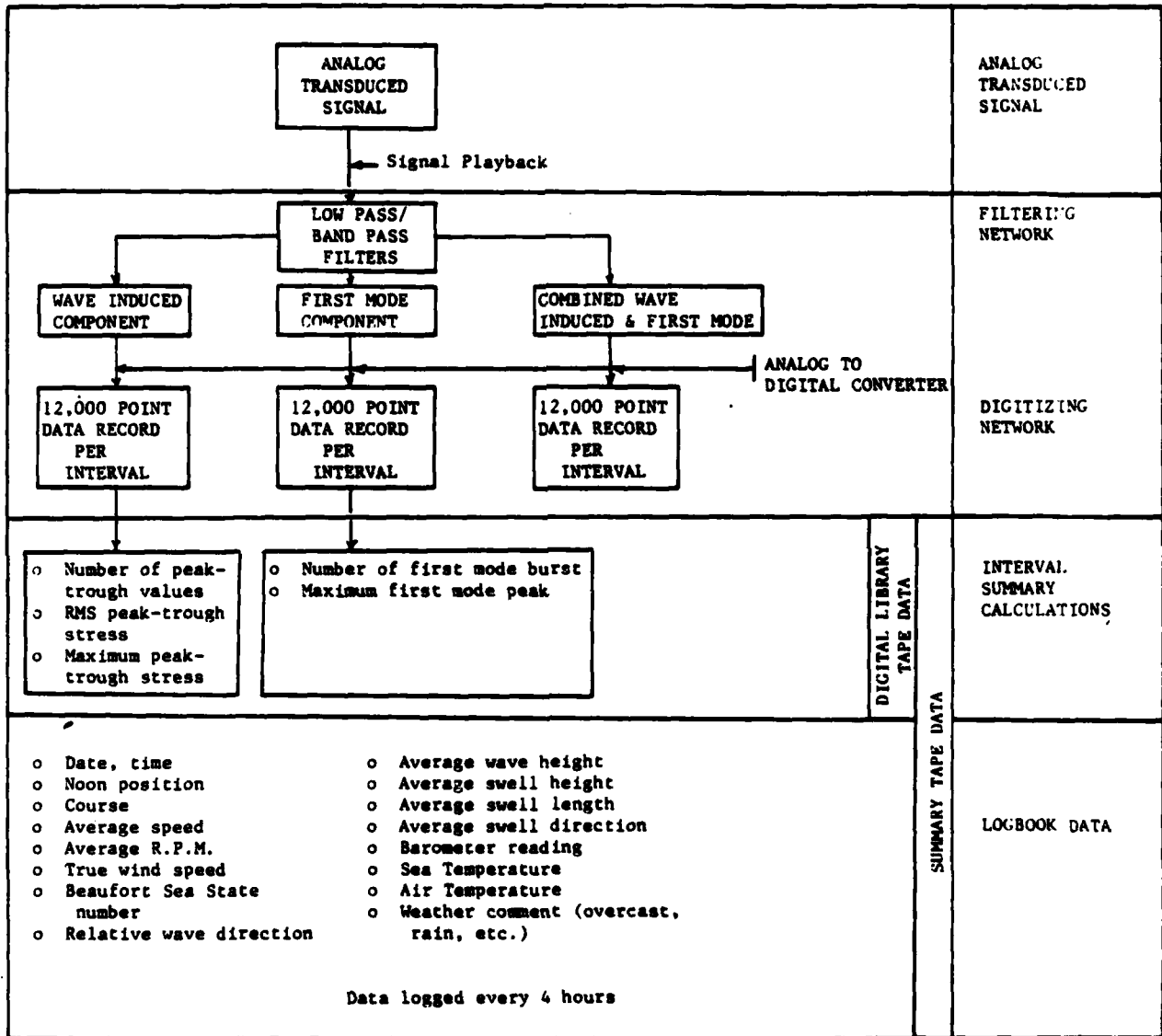
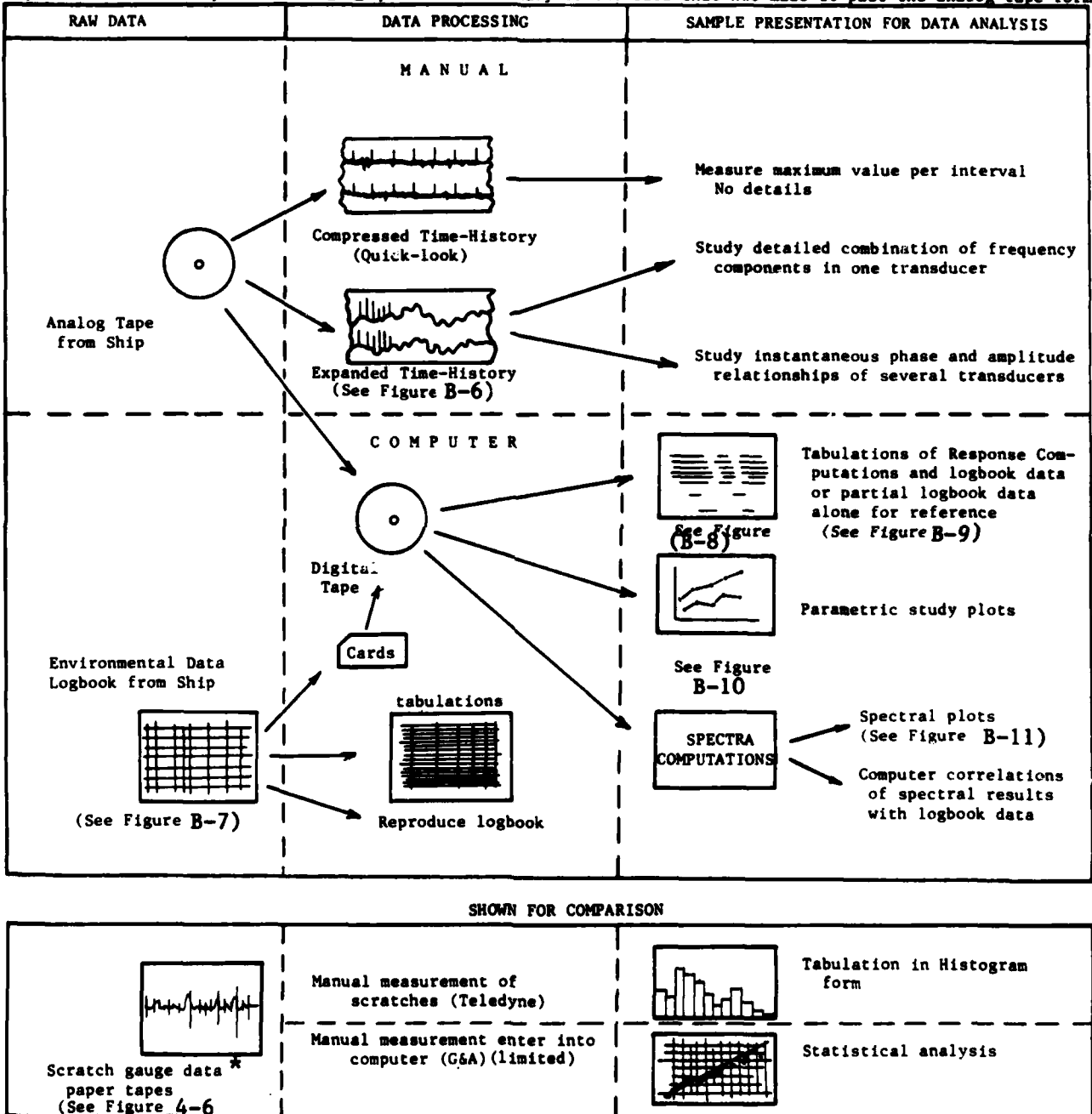

Figure B-4 Generation of Digital Library and Summary Tapes

Figure B-5

EXAMPLE OF DATA PRESENTATION FORMATS

The data formats indicated here are the presentation of the present data processing capabilities of Teledyne. Table B-1 presents a summary of the data that has made it past the analog tape form.



* The Logbook entries at Teledyne are for the scratch gauge data recorded for the first three seasons on the SL-7 SEA-LAND McLEAN only.

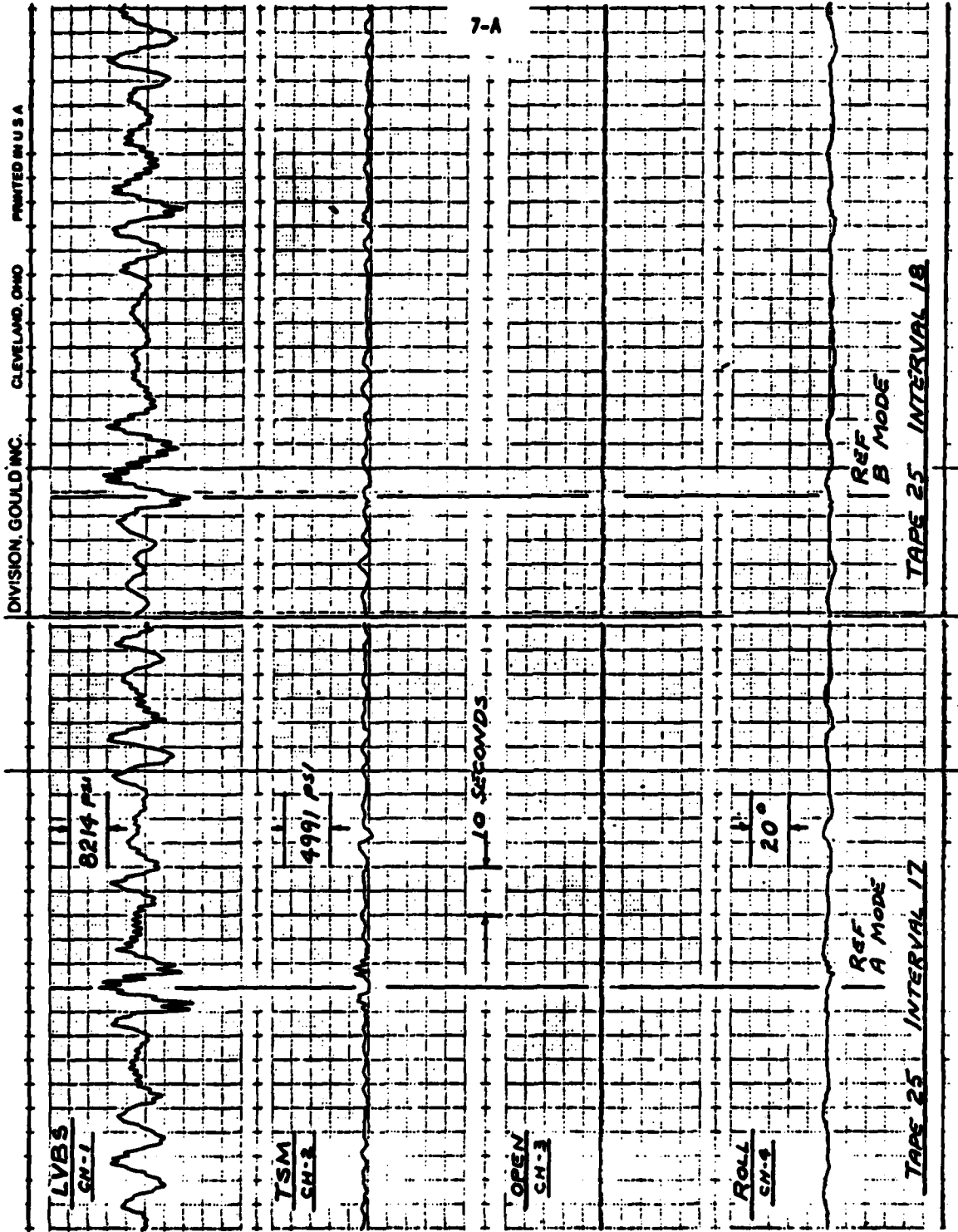

Figure B-6 Sample Stress Time History Recorded on the SEA-LAND McLEAN

DATA LOG

Issue: 12/2/68

6 Index No.	21 SWELL			22 Barometer Reading	23 Sea Temp.	24 Air Temp.	25 Weather	26 Initials	27 WATCH FOR FALSE START (Change of Course, Change of Speed, Change of Ballast, Slaming, Change Tape, Reel Number) (Wave buoy launching)
	21a Avg. Height'	21b Avg. Length	21c Relative Direct.						
1	2-3'	5-600'	0	30.10	54	48/47	CLDY RAIN	ETB	TAPE # 21 & 22 RUB = 1,2,3,4 - GSB = 1,2,3,4 FDH ACCCEL. & F.T.G.
2	10'	5-600'	45° NE	30.08	52	58/45	O'CAST		
3	10'	600'	45° NE	30.30	62	52/48	CLDY		
4	10-12	600	45° NE	29.97	64	57/57	P'CLDY		
5	10-12	600	45° NE	29.93	68	53/52	O'CAST RAIN		SHIP'S PITCHING - IN-LAND ISSUES - LIGHT ROLL SPRAY OVER HULL & DECK FIRST TIME SEEN THIS TYPE
6	12-15	600	45° NE	29.80	67	55/52	O'CAST		
7	12-15	600	37° NE	29.77	65	54/52	P'CLDY		
8	12-15	600	37° NE	29.63	68	53/51	CLDY		P'ISM & SILENT ROLL SPRAY FROM TOP OF BOW
9	10-12	600	31° NE	29.48	64	53/52	CLDY		
10	10-12	600	31° NE	29.50	64	58/55	O'CAST		RSA - 5-6-7-8 GSA - 5-6-7-8 F HLG
11	10-12	600	35° NE	29.38	64	63/60	CLDY		
12	8-10	500	45° NE	29.48	64	62/60	CLDY		
13	8-10	500	53° NE	29.50	64	64/63	P'CLDY		LEAD TAPE # 21 & 22
14	8-10	500	31° NE	29.51	66	61/60	P'CLDY		START TAPE # 23 & 24
15	6-8	500	31° NE	29.63	66	64/63	O'CAST		

Reference 8

Figure B-7 Sample Logbook Entry

DIGITAL TAPE 3 MCLAN 1973-1974 SEASON MIDSHIP VERTICAL BENDING CHANNEL 1
 SEA LAND MCLAN 32601-00-7401-14-748REVENHAVEN TO ELI/3ETH TAPES 143, 146 AND 147
 NUMBER OF CYCLES = 102

ANALOG LOGBOOK
 TAPE INDEX
 NUMBER NUM DATE LATITUDE SHIPS COURSE SHIPS PROP RPM REL WIND DIR SECS REL WAVE PD SECS SWELL DIR SWELL LENGTH FEET SEA TEMP WEATHER

TRIP INTERVAL NUM	TIME GMT	LONGITUDE	SHIPS SPEED KTS	SEA STATE	REL WIND SPEED KNOTS	WAVE HAVENAVE MT FEET	REL WAVE DIR SECS	SWELL DIR SWELL LENGTH FEET	BARDM INCH	AIR TEMP											
MCLAN 17 035	01-13-74	1600	40-17 N	056-29 W	274	121-0	09	45	20	0105	0400	29.96	03V								
32W 004																					
WAVE INDUCED PEAK TO TROUGH INFORMATION																					
3792	4325	3021	2103	4021	4088	3199	1147	5302	4458	3021	4117	1910	1362	4517	4858	4858	4858	4858	4858	4858	4858
2873	4746	7717	0013	4532	6947	12783	11479	6858	3625	4858	6421	3332	2221	5273	6458	7569	3318	1105	1105	1105	1105
6517	5762	1896	3910	2340	4043	5095	6458	7569	3318	4858	2251	2918	1607	1836	4769	1807	4665	6243	6243	6243	6243
4304	5362	6073	2606	3229	7800	9228	4769	1807	4665	6243	1422	3140	3258	4304	6073	9154	3806	5273	5273	5273	5273
6013	3792	1584	7909	6050	9613	9154	6991	0754	3806	5273	6976	7287	4769	4304	1584	6066	3199	1451	1451	1451	1451
4369	7213	4340	2844	1866	3614	6606	5332	4814	3199	1451	1629	4200	2488	4177	7111	4503	3081	4577	4577	4577	4577
4177	5688	8724	2844	5125	7110	4503	2398	2062	3081	4577	2784	3251	3792	4177	11819	4577	2488	2488	2488	2488	2488
4177	2728	2014	9524	10205	10205	4577	3555	3436	2488	4577	4088	3332	4917	4177	1896	2621	3199	3792	3792	3792	3792
8398	7035	4503	1896	4036	5747	3406	6139	2621	3199	3792	2666	1186	6095	4177	2881	6991	3096	3096	3096	3096	3096
2133	1896	1036	1659	2281	3643	3347	7436	6991	6991	3096	3081	1777	888	2133	1896	2916	1792	1792	1792	1792	1792
2133	6932	11020	1599	4917	3703	5688	2488	2102	2916	1792	4947	2932	3496	2133	6932	2370	1303	1303	1303	1303	1303
2044	1777		6125	1836	4710	2903	2784	2370	1303	2133	1777	1777	3140	2044							

Figure B-8 EXAMPLE OF PEAK TO TROUGH DATA REDUCTION OF SL-7 SEA-LAND MCLAN MIDSHIP VERTICAL BENDING STRESS

SUMMARY 1ADP MCLEAN 1973-1974 SEASON MIDSHIP VERTICAL BENDING CHANNEL 1
 PAGE 69A

ANALOG TAPE NUMBER	LOGBOOK INDLX NUM	DATE	LATITUDE	TIME GMT	LONGITUDE	SHIP'S COURSE	SHIP'S SPEED KTS	SEA STATE	WIND DIR	WAVE DIR	WAVE PERIOD SECS	WAVE LENGTH FT
MCLEAN143	32V 005	01-08-74	51-39 N	2000	002-07 E				035P	45	10	
MCLEAN143	32V 016	01-08-74	51-39 N	2000	002-07 E				035P	45	10	
MCLEAN143	32V 019	01-08-74	51-39 N	2000	002-07 E				035P	46	10	
MCLEAN143	32V 020	01-08-74	51-39 N	2000	002-07 E				035P	46	10	
MCLEAN143	32V 021	01-08-74	51-39 N	2400	002-07 E	233	123.7	00MP	00MP	40	10	
MCLEAN143	32V 022	01-08-74	51-39 N	2400	002-07 E	233	123.7	00MP	00MP	40	10	
MCLEAN143	32V 023	01-08-74	51-39 N	2400	002-07 E	233	123.7	00MP	00MP	40	10	
MCLEAN143	32V 024	01-08-74	51-39 N	2400	002-07 E	233	123.7	00MP	00MP	40	10	
MCLEAN143	32V 025	01-09-74	51-39 N	0400	002-07 E	233	131.6	149S	149S	30	08	
MCLEAN143	32V 026	01-09-74	51-39 N	0400	002-07 E	233	131.6	149S	149S	30	08	
MCLEAN143	32V 027	01-09-74	51-39 N	0400	002-07 E	233	131.6	149S	149S	30	08	
MCLEAN143	32V 028	01-09-74	51-39 N	0400	002-07 E	233	131.6	149S	149S	30	08	
MCLEAN143	32V 029	01-09-74	51-39 N	0800	002-07 E	233	131.9	104S	104S	40	12	
MCLEAN143	32V 030	01-09-74	51-39 N	0800	002-07 E	233	131.9	104S	104S	40	12	
MCLEAN143	32V 031	01-09-74	51-39 N	0100	002-07 E	233	131.9	104S	104S	40	12	
MCLEAN143	32V 032	01-09-74	51-39 N	0800	002-07 E	233	131.9	104S	104S	40	12	

Figure B-9 PARTIAL SUMMARY SHEET - SL-7 SECOND SEASON

SUMMARY TAPE MCLEAN 1973-1974 SEASON MIDSHIP VERTICAL BENDING CHANNEL
PAGE 090

REL SWELL LENGTH DIR FEET	SEA TEMP	WEATHER	MAX P-T-O-T STRESS PSI	NUMBER OF BUNSTS	COMMENTS		
SWELL INCH FEET	BAROM INCH HG	AIR TEMP	NUMBER CYCLES ---HAVE IND--- 1ST MODE	RMS STRESS PSI	MAX STRESS PSI	MEAN STRESS PSI	
035P 010 0400	29.66	E OCAS1	188	9146	37	2114	BACK IN AUTO OPERATION
035P 010 0400	29.66	E OCAS1	188	8809	311	2696	BACK IN AUTO OPERATION
036P 010 0400	29.66	E OCAS1	176	8931	61	2481	BACK IN AUTO OPERATION
035P 010 0400	29.66	E OCAS1	186	12187	59	4536	BACK IN AUTO OPERATION
008P 010 0400	29.63	E PT CLOY	179	9644	48	4534	222
008P 010 0400	29.63	E PT CLOY	171	12187	58	4573	206
008P 010 0400	29.63	E PT CLOY	163	12861	61	4986	262
008P 010 0400	29.63	E PT CLOY	171	10839	60	3830	-338
014S 010 0500	29.36	E OCAS1	164	6574	17	2481	176
014S 010 0500	29.36	E OCAS1	164	6717	12	1907	237
014S 010 0500	29.36	E OCAS1	167	8227	18	2206	306
104S 010 0500	29.76	E CLOY	179	6924	25	2062	-261
104S 010 0500	29.76	E CLOY	188	9023	60	2880	MOD 10 HEAVY PITCH
104S 010 0500	29.76	E CLOY	178	8870	51	3807	MOD TO HEAVY PITCH
104S 010 0500	29.76	E CLOY	187	7943	60	3247	MOD TO HEAVY PITCH
104S 010 0500	29.76	E CLOY	187	3701	44	3094	MOD TO HEAVY PITCH

Fig. 3-9 (con't) PARTIAL SUMMARY SHEET - SL-7 SECOND SEASON,
VOYAGE, 32W

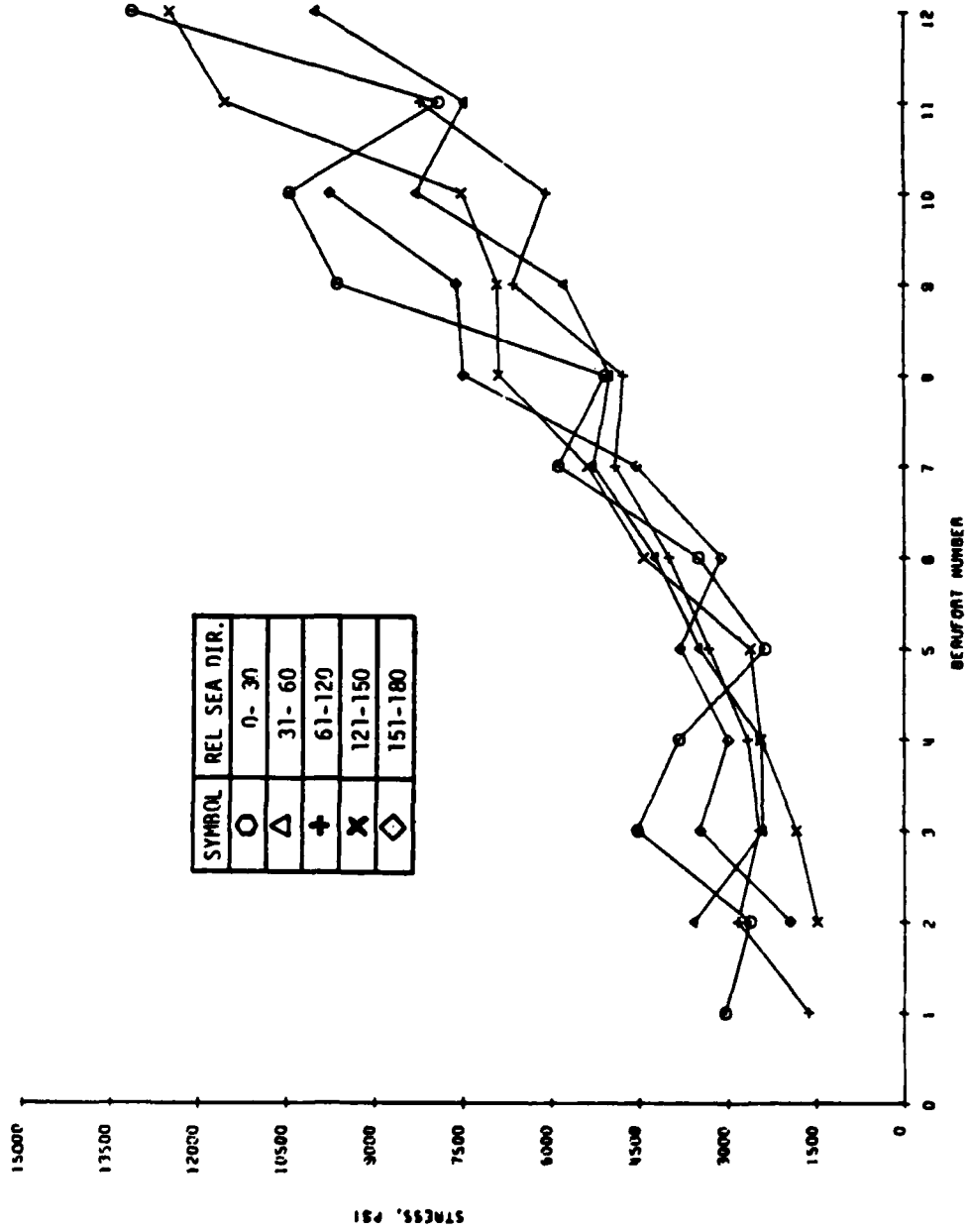

Figure B-10 (Reference 9)

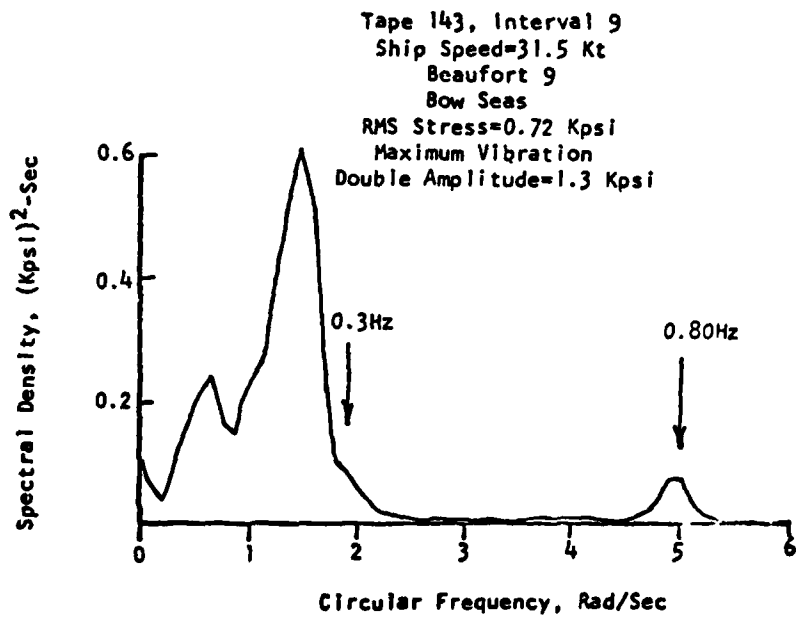

Figure B-11 Sample Stress Spectrum: SL-7

Reference 33

thus far (see Table B-1 for the types and amounts of data that have been reduced to date). Parametric plots may also be obtained from the Summary Tape information. A sample parametric plot is shown in Figure B-10. Figure B-11 depicts a stress spectrum calculated for a recording interval.

After digitizing and reducing the analog data to library and summary tapes, various data presentation formats may be utilized to facilitate analysis. These formats fall into three categories:

- (1) tabulation of the transducer and/or logbook data
- (2) parametric study plots
- (3) spectra computations

These tabulations can be a full listing of logbook or transducer data or can be parametrically selected based on specified input criteria with specified files of output generated. The parametric study plots can be generated for summary data plotted against any parameter, such as Beaufort number, and classified into five subgroups based on a parameter such as ship speed or relative wave direction. In addition to the parametric plots, tabulations may also be generated. Spectra computations can be conducted using the unfiltered digitized transducer record. Figure B-5 summarizes the various data-presentation formats discussed above. Samples of these formats, except spectral analysis, are presented in the three SL-7 seasonal reports, References (8), (9) and (10).

Teledyne is currently under contract to the United States Coast Guard to maintain the SL-7 data base. This contract is strictly a maintenance contract with very limited funds for additional data analysis. When assessing the SEA-LAND McLEAN data base, inquiries should be addressed through the Secretary of The Ship Structure Committee for approval before contacting Teledyne Engineering Services, Inc.

At this point, it would be appropriate to discuss the full scale SL-7 data that has not been reduced. The majority of the strain information has not been examined in any detail. In fact, the majority of the strain data is still in the analog form as recorded (see Table B-1). This unreduced strain data includes:

- (a) The longitudinal vertical bending stress amidship from individual port and starboard strain gauges.
- (b) The strain data obtained by "run bys" at several hatch corners to obtain the stress distribution at the respective locations.
- (c) The strain information taken at several transverse box girders and longitudinal box girder intersections. These data were recorded so that the longitudinal warping restraint could be inferred at the transition from open hatch to closed section at the forward deck house and the "S" bending due to torsional loads experienced by the ship.
- (d) Quarter point shear and torsional shear.

The demand for these data by the design and construction community has been minimal to non-existent even from researchers who originally requested the data. Therefore, the recommendations for further data analyses should be viewed in that light. Although these data are design specific and represent the SL-7 containership design, the data may also be applicable to open-decked containerships in general. Torsional effects on the containership's hull are of particular interest to containership designers.

ABS did analyze data obtained from several locations as part of the validation of the DAISY finite-element computer program. The comparisons involved the prediction of wave-induced stresses and was based on the wave data recorded on board the SEA-LAND McLEAN. Any correlations of any of the data obtained from the SEA-LAND McLEAN instrumentation with the measured wave data would not be well founded.

Many types of data analysis are possible other than those that would involve the measured wave data directly. The log book information contains observed wave height, sea state and wind speed information that may provide a basis for categorizing the data, etc. The lack of wave data for comparative purposes is a major setback; however, semi-quantitative analysis could be conducted based on Beaufort number, etc. Examples of further data analysis could include:

- (1) Analysis of the instantaneous distributions of wave-induced stresses obtained from the "rub-bys" around hatch corners for various heading and wave height groups. This would yield information on the distribution of stresses about the hatch corners that result from torsional bending, etc. This could also be done for the gauge locations at transverse girders to investigate the effects of torsion.
- (2) Development of long-term statistical distributions of wave-induced stress obtained from amidship vertical bending and hatch corners, etc. The long-term statistical distributions would be developed on the same basis (i.e. Beaufort number, etc.), and may provide insight into the effects of stress concentrations, etc., on existing load criteria. This could also be conducted for various headings to isolate torsional effects, etc.
- (3) Several studies indicate that additional data reduction of the high-frequency wave-induced stresses is required. This information would be useful for future load-criteria examination, if deemed necessary by SSC. The exact type of data reduction needed depends on the intended use. A minimum data reduction would include the RMS and number of cycles for each interval of data for the high-frequency wave-induced stresses.
- (4) The SSC has shown interest in the SEA-LAND McLEAN data base for the determination of strain rates. It must be remembered that the wave-induced strain rates experienced by the SEA-LAND McLEAN would be higher in head seas and lower in following seas than is typical due to the high speed capabilities of the SEA-LAND McLEAN. The strain data recorded aboard the SEA-LAND McLEAN results from several types of loading sources. These sources may be identified and strain rates determined accordingly. However, additional data reduction may be required to conduct the analysis,

especially in regard to the high-frequency wave-induced stresses. Additional consideration should also be given to the definition of 'typical' strain rate for the SEA-LAND McLEAN. Does typical refer to average for the existing data (three seasons) or average expected for the SEA-LAND McLEAN ? These are the types of questions that need to be answered before the applicability of the SEA-LAND McLEAN may be determined.

- (5) The data recorded at the forward hatch corner where radial cracks were observed would provide a data base for future fatigue analysis programs. However, these data are still in analog form, as recorded, and has not been analyzed in a useable form for fatigue analysis.

SHIP STRUCTURE COMMITTEE SL-7 REPORTS TO DATE

- SL-7-1, (SSC-238) - *Design and Installation of a Ship Response Instrumentation System Aboard the SL-7 Class Containership S.S. SEA-LAND McLEAN* by R. A. Fain. 1974. AD 780090.
- SL-7-2, (SSC-239) - *Wave Loads in a Model of the SL-7 Containership Running at Oblique Headings in Regular Waves* by J. F. Dalzell and M. J. Chiocco. 1974. AD 780065.
- SL-7-3, (SSC-243) - *Structural Analysis of SL-7 Containership Under Combined Loading of Vertical, Lateral and Torsional Moments Using Finite Element Techniques* by A. M. Elbatouti, D. Liu, and H. Y. Jan. 1974. AD-A002620.
- SL-7-4, (SSC-246) - *Theoretical Estimates of Wave Loads on the SL-7 Containership in Regular and Irregular Seas* by P. Kaplan, T. P. Sargent, and J. Cilmi. 1974. AD-A004554.
- SL-7-5, (SSC-257) - *SL-7 Instrumentation Program Background and Research Plan* by W. J. Siekierka, R. A. Johnson, and CDR C. S. Loosmore, USCG. 1976. AD-A021337.
- SL-7-6, (SSC-259) - *Verification of the Rigid Vinyl Modeling Techniques: The SL-7 Structure* by J. L. Rodd. 1976. AD-A025717.
- SL-7-7, (SSC-263) - *Static Structural Calibration of Ship Response Instrumentation System Aboard the SEA-LAND McLEAN* by R. R. Boentgen and J. W. Wheaton. 1976. AD-A031527.
- SL-7-8, (SSC-264) - *First Season Results from Ship Response Instrumentation Aboard the SL-7 Class Containership S.S. SEA-LAND McLEAN in North Atlantic Service* by R. R. Boentgen, R. A. Fain, and J. W. Wheaton. 1976. AD-A039752.
- SL-7-9, *Second Season Results from Ship Response Instrumentation Aboard the SL-7 Class Containership S. S. SEA-LAND McLEAN in North Atlantic Service* by J. W. Wheaton and R. R. Boentgen. 1976. AD-A034162.
- SL-7-10, *Third Season Results from Ship Response Instrumentation Aboard the SL-7 Class Containership S. S. SEA-LAND McLEAN in North Atlantic Service* by R. R. Boentgen. 1976. AD-A034175.
- SL-7-11, (SSC-269) - *Structural Tests of SL-7 Ship Model* by W. C. Webster and H. G. Payer. 1977. AD-A047117.
- SL-7-12, (SSC-271) - *A Correlation Study of SL-7 Containership Loads and Motions - Model Tests and Computer Simulation* by P. Kaplan, T. P. Sargent, and M. Silbert. 1977. AD-A049349.
- SL-7-13, *A Report on Shipboard Waveheight Radar System* by D. Chen and D. Hammond. 1978. AD-A053379.
- SL-7-14, (SSC-277) - *Original Radar and Standard Tucker Wavemeter SL-7 Containership Data Reduction and Correlation Sample* by J. F. Dalzell. 1978. AD-A062394.
- SL-7-15, (SSC-278) - *Wavemeter Data Reduction Method and Initial Data for the SL-7 Containership* by J. F. Dalzell. 1978. AD-A062391.
- SL-7-16, *Radar and Tucker Wavemeter Data from S. S. SEA-LAND McLEAN - Voyage 32* by J. F. Dalzell. 1978. AD-A057154.
- SL-7-17, *Radar and Tucker Wavemeter Data from S. S. SEA-LAND McLEAN - Voyage 33* by J. F. Dalzell. 1978. AD-A057155.
- SL-7-18, *Radar and Tucker Wavemeter Data from S. S. SEA-LAND McLEAN - Voyage 34* by J. F. Dalzell. 1978. AD-A057155.
- SL-7-19, *Radar and Tucker Wavemeter Data from S. S. SEA-LAND McLEAN - Voyages 35 and 36* by J. F. Dalzell. 1978. AD-A057157.
- SL-7-20, (SSC-279) - *Modified Radar and Standard Tucker Wavemeter SL-7 Containership Data* by J. F. Dalzell. 1978. AD-A062393.
- SL-7-21, *Radar and Tucker Wavemeter Data from S. S. SEA-LAND McLEAN - Voyage 60* by J. F. Dalzell. 1978. AD-A057004.
- SL-7-22, *Radar and Tucker Wavemeter Data from S. S. SEA-LAND McLEAN - Voyage 61* by J. F. Dalzell. 1978. AD-A057005.
- SL-7-23, (SSC-280) - *Results and Evaluation of the SL-7 Containership Radar and Tucker Wavemeter Data* by J. F. Dalzell. 1978. AD-A062392.
- SL-7-24, (SSC-282) - *Comparison of Stresses Calculated Using the DAISY System to Those Measured on the SL-7 Containership Program* by H-Y Jan, K-T Chang, and M. E. Wojnarowski. 1979. AD-A069031.
- SL-7-25, (SSC-286) - *Results of the First Five "Data Years" of Extreme Stress Scratch Gauge Data Collected Aboard SEA-LAND's SL-7's* by R. A. Fain and E. T. Booth. 1979. AD-A072945.
- SL-7-26, (SSC-304) - *SL-7 Extreme Stress Data Collection and Reduction* by E. T. Booth. 1981.
- SL-7-27, (SSC-311) - *Evaluation of SL-7 Scratch-Gauge Data* by J. C. Oliver. 1981.
- SL-7-28, (SSC-313) - *SL-7 Research Program Summary, Conclusions and Recommendations* by K. A. Stambaugh and W. A. Wood. 1981.

SHIP RESEARCH COMMITTEE
Maritime Transportation Research Board
National Academy of Sciences - National Research Council

The SHIP RESEARCH COMMITTEE has technical cognizance of the interagency Ship Structure Committee's research program.

Mr. A. D. Haff, Chairman, *Consultant, Annapolis, MD*
Prof. A. H.-S. Ang, *Civil Engrg. Dept., University of Illinois, Champaign, IL*
Dr. K. A. Blenkarn, *Research Director, Offshore Technology, Amoco Production Company, Tulsa, OK*
Mr. D. Price, Sr. *Systems Analyst, National Oceanic and Atmospheric Administration, Rockville, MD*
Mr. D. A. Sarno, *Manager-Mechanics, ARMCO Inc., Middletown, OH*
Prof. H. E. Sheets, *Dir. of Engineering, Analysis & Technology, Inc., Stonington, CT*
Mr. J. E. Steele, *Naval Architect, Quakertown, PA*
Mr. R. W. Rumke, *Executive Secretary, Ship Research Committee*

The SHIP DESIGN, RESPONSE, AND LOAD CRITERIA ADVISORY GROUP prepared the project prospectus and evaluated the proposals for this project.

Mr. J. E. Steele, Chairman, *Naval Architect, Quakertown, PA*
Mr. J. W. Boylston, *Consulting Naval Architect, Giannotti & Associates, Inc., Annapolis, MD*
Prof. R. G. Davis, *Assistant Professor of Naval Architecture, Dept. of Marine Engrg., Texas A&M University, Galveston, TX*
Mr. P. W. Marshall, *Civil Engineering Advisor, Shell Oil Company, Houston, TX*
Prof. R. Plunkett, *Dept. of Aerospace Engrg. and Mechanics, University of Minnesota, Minneapolis, MN*
Mr. C. B. Walburn, *Assistant Naval Architect, Bethlehem Steel, Corp., Marine Division, Sparrows Point, MD*

The SR-1279 *ad hoc* PROJECT ADVISORY COMMITTEE provided the liaison technical guidance, and reviewed the project reports with the investigator.

Mr. J. E. Steele, Chairman, *Naval Architect, Quakertown, PA*
Mr. A. D. Haff, *Consultant, Annapolis, MD*
Mr. P. M. Kimon, *EXXON International Co., Florham Park, NJ*
Mr. A. C. McClure, *Alan C. McClure Associates, Inc., Houston, TX*
Dr. W. R. Porter, *V.P. for Academic Affairs, State University of New York, Maritime College, Bronx, NY*

SHIP STRUCTURE COMMITTEE PUBLICATIONS

These documents are distributed by the National Technical Information Service, Springfield, VA 22314. These documents have been announced in the Clearinghouse Journal U. S. Government Research & Development Reports (USGRDR) under the indicated AD numbers.

- SSC-300, *Summary of Nondestructive Inspection Standards for Heavy Section Castings, Forgings, and Weldments* by R. A. Youshaw. 1980. AD-A099119.
- SSC-301, *Probabilistic Structural Analysis of Ship Hull Longitudinal Strength* by J. C. Daidola and N. S. Basar. 1981. AD-A099118.
- SSC-302, *Computer-Aided Preliminary Ship Structural Design* by A. E. Marsow and A. Thayamballi. 1981. AD-A099113.
- SSC-303, *Fatigue and Fracture Toughness Characterization of SAW and SMA A537 Class I Ship Steel Weldments* by J. F. Souak, J. W. Caldwell, and A. K. Shoemaker. 1981.
- SSC-304, *SL-7 Extreme Stress Data Collection and Reduction* by E. T. Booth. 1981.
- SSC-305, *Investigation of Steels for Improved Weldability in Ship Construction - Phase II* by B. G. Reisdorf and W. F. Domis. 1981.
- SSC-306, *Experimental Program for the Determination of Hull Structural Damping Coefficients* by P. Y. Chang and T. P. Carroll. 1981.
- SSC-307, *Evaluation of Fracture Criteria for Ship Steels and Weldments* by A. W. Pense. 1981.
- SSC-308, *Criteria for Hull-Machinery Rigidity Compatibility* by W. I. H. Budd, S. V. Karve, J. G. de Oliveira, and P. C. Xirouchakis. 1981.
- SSC-309, *A Rational Basis for the Selection of Ice Strengthening Criteria for Ships - Vol. I* by J. L. Coburn, F. W. DeBord, J. B. Montgomery, A. M. Nawwar, and K. E. Dane. 1981.
- SSC-310, *A Rational Basis for the Selection of Ice Strengthening Criteria for Ships - Vol. II - Appendices* by J. L. Coburn, F. W. DeBord, J. B. Montgomery, A. M. Nawwar, and K. E. Dane. 1981.
- SSC-311, *Evaluation of SL-7 Scratch-Gauge Data* by J. C. Oliver. 1981.
- SSC-312, *Investigation of Internal Corrosion and Corrosion-Control Alternatives in Commercial Tankships* by L. C. Herring, Jr. and A. N. Titcomb. 1981.
- SSC-313, *SL-7 Research Program Summary, Conclusions and Recommendations* by K. A. Stambaugh and W. A. Wood. 1981.

END

FILMED

10 00