



*Handwritten mark*



AD A119543

DEPARTMENT OF DEFENCE SUPPORT  
DEFENCE SCIENCE AND TECHNOLOGY ORGANISATION  
AERONAUTICAL RESEARCH LABORATORIES  
MELBOURNE, VICTORIA

Aerodynamics Technical Memorandum 339

A SET OF FLIGHT DYNAMIC EQUATIONS FOR  
AIRCRAFT SIMULATION

P.H. HALL\*

DTIC  
ELECTIC  
SEP 24 1982  
H

Approved for Public Release

\*Lieutenant P.H. Hall is an officer of the  
RAN and is on attachment to ARL.

DTIC FILE COPY

(C) COMMONWEALTH OF AUSTRALIA 1982

COPY No

82 09 24 070

JUNE, 1982

DEPARTMENT OF DEFENCE SUPPORT  
DEFENCE SCIENCE AND TECHNOLOGY ORGANISATION  
AERONAUTICAL RESEARCH LABORATORIES

Aerodynamics Technical Memorandum 339

A SET OF FLIGHT DYNAMIC EQUATIONS FOR  
AIRCRAFT SIMULATION

by

P.H. HALL\*

SUMMARY

DTIC  
ELECTE  
SEP 24 1982  
S H D

The six degrees of freedom dynamic equations of aircraft motion have been documented in this Memorandum for use in aircraft simulations at ARL. Earth axes are chosen for the integration of the force equations, and body axes for the integration of the moment equations. The use of quaternions to calculate aircraft altitude and associated direction cosines is described. This Memorandum also contains a brief description of an atmospheric data subroutine for use in aircraft simulation.



© COMMONWEALTH OF AUSTRALIA

POSTAL ADDRESS: Chief Superintendent, Aeronautical Research Laboratories,  
P.O. Box 4331, Melbourne, Victoria, 3001, Australia.

\* Lieutenant P.H. Hall, RAN is on attachment to ARL.

CONTENTS

	<u>PAGE NO.</u>
1. INTRODUCTION	1
2. DEFINITION OF AXES SYSTEMS USED IN THE SET OF EQUATIONS	1
2.1 Earth Axes	1
2.2 Body Axes	2
2.3 Stability Axes	2
2.4 Air-path Axes	2
3. SELECTION OF AXES FOR INTEGRATION OF EQUATIONS	2
3.1 Force Equations	2
3.2 Moment Equations	3
4. AIRCRAFT ATTITUDE DETERMINATION	3
5. AXES TRANSFORMATION	5
6. EQUATIONS OF MOTION	5
6.1 Force Equations	5
6.2 Moment Equations	8
7. ATMOSPHERIC DATA	9
8. CONCLUSION	10

REFERENCES

NOTATION

FIGURES 1 & 2

DISTRIBUTION LIST

DOCUMENT CONTROL DATA



Accession For	
DTIC GRA&I	<input checked="" type="checkbox"/>
DTIC TAB	<input type="checkbox"/>
Unannounced	<input type="checkbox"/>
Justification	
By _____	
Distribution/	
Availability Codes	
Dist	Avail and/or Special
A	

## 1. INTRODUCTION

In August 1981, a research program was initiated at ARL, under Royal Australian Navy sponsorship, to study the dynamic behaviour of V/STOL aircraft. The study will be based on a six degrees of freedom simulation of a military jet V/STOL aircraft, programmed using the Advanced Continuous Simulation Language (ACSL)\* on the ARL DEC System-10 computer.

Important aspects of the simulation are the derivation of the basic dynamic equations of aircraft motion, and the selection of suitable reference axes systems. Based on current practice, earth axes were chosen for the integration of the force equations, and body axes for the integration of the moment equations. In addition, the quaternion parameters were chosen for the calculation of the Euler angles.

This Memorandum provides a documentation of the basic six degrees of freedom dynamic equations of motion for use in aircraft simulations. The axes systems used in the set of equations are defined in section 2, while section 3 discusses the selection of axes systems for integration. The use of quaternions in determining aircraft attitude and performing axes transformations is dealt with in sections 4 and 5 respectively. The equations of motion are derived and listed in section 6, and summarized in figure 2. Section 7 provides a brief note on the source of atmospheric data and lists the atmospheric models which have been incorporated.

## 2. DEFINITION OF AXES SYSTEMS USED IN THE SET OF EQUATIONS

All axes systems are assumed to be orthogonal, right-handed triads, and are shown in figure 1.

### 2.1 Earth Axes ( $X_E, Y_E, Z_E$ )

The origin is at a point fixed on the earth's surface, typically at the runway threshold and on the centreline ( $R_T$ ). The X-axis points North; the Y-axis East; and the Z-axis 'down' toward the centre of the earth. It is assumed that the earth is flat and non-rotating, such that the earth axes are regarded as an inertial frame.

---

\* Mitchell & Gauthier Associates, Inc.

## 2.2 Body Axes ( $X_B, Y_B, Z_B$ )

Body axes are fixed on the aircraft with the origin located at the aircraft centre of gravity. The aircraft is assumed to be rigid, with the X-axis parallel to the horizontal fuselage reference line and pointing 'forward'; the Y-axis pointing to starboard (right); and the Z-axis 'downward'.

## 2.3 Stability Axes ( $X_S, Y_S, Z_S$ )

Stability axes are a special set of body axes used primarily in the study of small disturbances from a steady reference flight condition. Aerodynamic data are frequently presented in stability axes. These axes are displaced from the body frame by the angle of attack,  $\alpha$ , such that the X-axis in the steady-state is aligned with the projection of the relative wind vector on the aircraft plane of symmetry; the Y-axis points to starboard; and the Z-axis 'downward'.

## 2.4 Air-Path Axes ( $X_W, Y_W, Z_W$ )

Air-path axes differ from body axes by the angle of attack,  $\alpha$ , and the angle of sideslip,  $\beta$ . The transformation from body to air-path axes is accomplished as shown in figure 1, by first pitching through  $-\alpha$ , to coincide with the stability axes, and then yawing through  $\beta$ . The origin is located at the aircraft centre of gravity and the X-axis is aligned with the relative wind vector.

Note: When the wind velocity components are zero, the air-path axes coincide with the flight-path axes as defined by Fogarty and Howe [3]. Etkin [2] refers to the air-path axes as the air-trajectory reference frame (or wind axes).

## 3. SELECTION OF AXES FOR INTEGRATION OF EQUATIONS

There are good reasons to use mixed axes systems when studying the many measurements and observations of vehicle motion. The various options are discussed by Etkin [2] and other authors, such as Fogarty and Howe [3], and McFarland [5].

### 3.1 Force Equations

In recent years there has been a trend away from the use of body axes for the computation and integration of force equations. Flight-path axes do have definite benefits in terms of computer scaling and computation speed [3]. However, where these factors are not of over-riding importance, the selection of earth axes is becoming quite common.

For the proposed V/STOL aircraft studies, the earth axes system was selected for the computation and integration of the translational equations of motion for the following reasons:

- (i) it gives commonality with the axes system chosen by both RAE Bedford and NASA Ames in their simulation programs [1,5];
- (ii) it is the logical choice for modelling an aircraft operating from a moving ship, since there is a need to refer the forces and motion of both vehicles to a common reference frame; and
- (iii) it avoids the complications which exists with other axes systems when considering the presence of winds and turbulence, as highlighted by McFarland [5].

### 3.2 Moment Equations

The body axes system is the natural choice for the solution of the rotational equations of motion because of the important advantage of constant moments of inertia when calculating the moments and angular motion of the aircraft.

## 4. AIRCRAFT ATTITUDE DETERMINATION

The attitude of an aircraft is defined in terms of the traditional Euler angles,  $\psi$  (heading angle),  $\theta$  (pitch attitude), and  $\phi$  (roll, or 'bank' angle). In order to avoid the problems associated with the singularity in the Euler 'rate' equations, which occurs when  $\theta = \pm 90^\circ$ , quaternion components [7] or direction cosines may be used in the integration step.

Quaternion components were chosen for the following reasons:

- (i) their time derivatives are always finite and continuous, whereas those of the Euler angles possess singularities;
- (ii) the computations remain accurate as  $\theta$  approaches  $90^\circ$ ;
- (iii) it is a four parameter method consisting of four integrations with one constraint equation, whereas direction cosines, in principle, require nine integrations and six constraint equations.

The quaternion components are expressible in terms of Euler angles as follows:

$$\begin{aligned}
 \tau_0 &= \cos\phi/2 \cos\theta/2 \cos\psi/2 + \sin\phi/2 \sin\theta/2 \sin\psi/2 \\
 \tau_1 &= \sin\phi/2 \cos\theta/2 \cos\psi/2 - \cos\phi/2 \sin\theta/2 \sin\psi/2 \\
 \tau_2 &= \cos\phi/2 \sin\theta/2 \cos\psi/2 + \sin\phi/2 \cos\theta/2 \sin\psi/2 \\
 \tau_3 &= \cos\phi/2 \cos\theta/2 \sin\psi/2 - \sin\phi/2 \sin\theta/2 \cos\psi/2
 \end{aligned}
 \tag{1}$$

The quaternion component time derivatives are given by,

$$\begin{aligned}
 \dot{\tau}_0 &= -1/2 (P\tau_1 + Q\tau_2 + R\tau_3) \\
 \dot{\tau}_1 &= 1/2 (P\tau_0 - Q\tau_3 + R\tau_2) \\
 \dot{\tau}_2 &= 1/2 (P\tau_3 + Q\tau_0 - R\tau_1) \\
 \dot{\tau}_3 &= -1/2 (P\tau_2 - Q\tau_1 - R\tau_0)
 \end{aligned}
 \tag{2}$$

where P,Q,R are angular velocity components about body axes, and

$$\tau_0^2 + \tau_1^2 + \tau_2^2 + \tau_3^2 = 1
 \tag{3}$$

Failure to normalize the quaternion components at each iteration can result in the integration becoming unstable.

Euler angles may be derived from the quaternion components by using the following relationships,

$$\phi = \tan^{-1} \left[ \frac{\tau_2\tau_3 + \tau_0\tau_1}{\tau_0^2 + \tau_3^2 - 1/2} \right] = \tan^{-1} \left[ \frac{M_3}{N_3} \right]
 \tag{4}$$

$$\theta = \tan^{-1} \left[ \frac{\tau_0\tau_2 - \tau_1\tau_3}{[(\tau_0^2 + \tau_1^2 - 1/2)^2 + (\tau_1\tau_2 + \tau_0\tau_3)^2]^{1/2}} \right] = \tan^{-1} \left[ \frac{-L_3}{(L_1^2 + L_2^2)^{1/2}} \right]
 \tag{5}$$

$$\psi = \tan^{-1} \left[ \frac{\tau_1\tau_2 + \tau_0\tau_3}{\tau_0^2 + \tau_1^2 - 1/2} \right] = \tan^{-1} \left[ \frac{L_2}{L_1} \right]
 \tag{6}$$

The initial Euler angles are used to determine the initial quaternion components, which are in turn used to calculate the direction cosine parameters for use in axes transformation computations. The quaternion components are updated at each iteration, using equation



(2), such that the direction cosines are recalculated for use in the equations of motion, while the Euler angles are calculated as output data only.

### 5. AXES TRANSFORMATION

Transformation of a set of variables from body axes to earth axes (or vice-versa) is conveniently achieved by use of direction cosines [6], which are obtained in terms of the quaternion components by the following relationships,

$$\begin{aligned}
 L_1 &= 2 (\tau_0^2 + \tau_1^2) - 1 \\
 L_2 &= 2 (\tau_1 \tau_2 + \tau_0 \tau_3) \\
 L_3 &= 2 (\tau_1 \tau_3 - \tau_0 \tau_2) \\
 \\ 
 M_1 &= 2 (\tau_1 \tau_2 - \tau_0 \tau_3) \\
 M_2 &= 2 (\tau_0^2 + \tau_2^2) - 1 \\
 M_3 &= 2 (\tau_2 \tau_3 + \tau_0 \tau_1) \\
 \\ 
 N_1 &= 2 (\tau_1 \tau_3 + \tau_0 \tau_2) \\
 N_2 &= 2 (\tau_2 \tau_3 - \tau_0 \tau_1) \\
 N_3 &= 2 (\tau_0^2 + \tau_3^2) - 1
 \end{aligned} \tag{7}$$

### 6. EQUATIONS OF MOTION

Figure 2 is a summary of the overall six degrees of freedom dynamic equations for the case of a flat earth.

#### 6.1 Force Equations

The aerodynamic force components are frequently computed along stability axes, and the propulsive force components are usually supplied in body axes. The resolutes along stability axes are:

$$\begin{aligned}
 F_{XS} &= X_P \cos \alpha + Z_P \sin \alpha + X_A \\
 F_{YS} &= Y_P + Y_A \\
 F_{ZS} &= Z_P \cos \alpha - X_P \sin \alpha + Z_A
 \end{aligned} \tag{8}$$

The total force components in earth axes are obtained by the transformation of the forces in stability axes, using direction cosines, and the addition of the gravitational force component, as shown by equation (9). 'g' is assumed constant such that the calculated altitude in figure 2 is the geopotential height, as used in standard atmosphere calculations.

$$\begin{aligned} F_{XE} &= (L_1 \cos \alpha + N_1 \sin \alpha) F_{XS} + M_1 F_{YS} + (N_1 \cos \alpha - L_1 \sin \alpha) F_{ZS} \\ F_{YE} &= (L_2 \cos \alpha + N_2 \sin \alpha) F_{XS} + M_2 F_{YS} + (N_2 \cos \alpha - L_2 \sin \alpha) F_{ZS} \\ F_{ZE} &= (L_3 \cos \alpha + N_3 \sin \alpha) F_{XS} + M_3 F_{YS} + (N_3 \cos \alpha - L_3 \sin \alpha) F_{ZS} + W \end{aligned} \quad (9)$$

The components of acceleration with respect to the earth are obtained simply from the dynamic equations:

$$\begin{aligned} \dot{V}_{NE} &= F_{XE}/m \\ \dot{V}_{EE} &= F_{YE}/m \\ \dot{V}_{DE} &= F_{ZE}/m \end{aligned} \quad (10)$$

where  $m$  is the aircraft mass, and virtual mass effects are ignored.

The velocity components of the aircraft relative to the earth are obtained from the direct integration of equation (10). The components of the wind velocity relative to the ground are then added, giving the velocity components of the aircraft relative to the air mass;

$$\begin{aligned} V_N &= V_{NE} - V_{WN} \\ V_E &= V_{EE} - V_{WE} \\ V_D &= V_{DE} - V_{WD} \end{aligned} \quad (11)$$

The components of the aircraft velocity vector relative to the air, in body axes, are derived using equations (7) and (11), as shown by equation (12).

$$\begin{aligned} U_B &= (L_1 V_N) + (L_2 V_E) + (L_3 V_D) \\ V_B &= (M_1 V_N) + (M_2 V_E) + (M_3 V_D) \\ W_B &= (N_1 V_N) + (N_2 V_E) + (N_3 V_D) \end{aligned} \quad (12)$$

The resultant velocity (or True Airspeed) of the aircraft is then:

$$V_{TAS} = (U_B^2 + V_B^2 + W_B^2)^{1/2} \quad (13)$$

The angles of attack,  $\alpha$ , and sideslip,  $\beta$ , are also determined using equations (12) to (15);

$$\alpha = \tan^{-1} [U_B/U_B]; \text{ in the range } \pm 180^\circ \quad (14)$$

$$\beta = \tan^{-1} [V_B/(U_B^2 + W_B^2)^{1/2}]; \text{ in the range } \pm 90^\circ \quad (15)$$

or 
$$\beta = \sin^{-1} [V_B/V_{TAS}] \quad (16)$$

Time derivatives of these angles are required in the aerodynamic force and moment calculations. Adequate estimates can be obtained from polynomial fits to the current values and those from a few preceding time steps. Tomlinson [8] uses a quadratic fit to estimate  $\dot{\alpha}$  and  $\dot{\beta}$ .

e.g. 
$$\dot{\alpha}(t) = \frac{\alpha(t-2\Delta t) - 4\alpha(t-\Delta t) + 3\alpha(t)}{2\Delta t} \quad (17)$$

Flight-path parameters are derived directly from the earth axes velocity vector components using equations (18) to (20):

Ground speed,

$$V_{GR} = (V_{NE}^2 + V_{EE}^2)^{1/2} \quad (18)$$

Flight-path angle,

$$\gamma = \tan^{-1} [-V_{DE}/V_{GR}] \quad (19)$$

Angle of track, east of north

$$\chi = \tan^{-1} [V_{EF}/V_{NE}] \quad (20)$$

The positional coordinates of the aircraft's centre of gravity are derived by integrating the earth axes velocity vector components:

Distance travelled North,

$$\dot{x} = V_{NE} \quad (21)$$

Distance travelled East,

$$\dot{y} = V_{EE} \quad (22)$$

Altitude,

$$\dot{ALT} = -V_{DE} \quad (23)$$

The additional parameter of aircraft range is calculated using the definition:

$$R_G = (x^2 + y^2)^{1/2} \quad (24)$$

Linear accelerations at the aircraft's centre of gravity (in units of 'g'), are calculated by transforming the linear accelerations in earth axes (equation (10)) to body axes, using equation (7), and dividing by 'g'. Linear accelerations at the pilot's head and elsewhere (e.g. for accelerometers) can then be derived as required by the user.

### 6.2 Moment Equations

The total moments acting on an aircraft consist of aerodynamic and powerplant components. The powerplant components which include gyroscopic moments due to powerplant rotors, and thrust alignment moments, are normally given in body axes. The aerodynamic moments are, like the aerodynamic forces, frequently given in stability axes [3]. If the aerodynamic moments are given in body axes, the simplification of equation (25) is obvious (i.e. set  $\alpha=0$ ).

$$\begin{aligned} L &= L_A \cos\alpha - N_A \sin\alpha + L_P \\ M &= M_A + M_P \\ N &= L_A \sin\alpha + N_A \cos\alpha + N_P \end{aligned} \quad (25)$$

If it is assumed that the aircraft has a plane of symmetry, such that the products of inertia  $I_{yz}$  and  $I_{xy}$  are zero, then the body axes angular accelerations can be calculated by using equation (26).

$$\begin{aligned} \dot{P} &= L.C_1 + N.C_2 + (P.C_3 + R.C_1) Q \\ \dot{Q} &= M.C_5 + (R^2 - P^2) C_6 + R.P.C_7 \\ \dot{R} &= N.C_8 + L.C_2 + (P.C_9 - R.C_3) Q \end{aligned} \quad (26)$$

where

$$\begin{aligned}C_0 &= I_{XX} I_{ZZ} - I_{XZ}^2 \\C_1 &= I_{ZZ}/C_0 \\C_2 &= I_{XZ}/C_0 \\C_3 &= C_2 (I_{XX} - I_{YY} + I_{ZZ}) \\C_4 &= C_1 (I_{YY} - I_{ZZ}) - C_2 I_{XZ} \\C_5 &= 1/I_{YY} \\C_6 &= C_5 I_{XZ} \\C_7 &= C_5 (I_{ZZ} - I_{XX}) \\C_8 &= I_{XX}/C_0 \\C_9 &= C_8 (I_{XX} - I_{YY}) + C_2 I_{XZ}\end{aligned}$$

The constants  $C_0$  to  $C_9$  are evaluated during initialization.

The aircraft angular velocity components may then be obtained by integrating equation (26).

#### 7. ATMOSPHERIC DATA

Ambient atmospheric temperature ( $T_{amb}$ ), pressure ( $P_{amb}$ ), and density ( $\rho$ ), are obtained as a function of altitude from a subroutine version of the program, ATMOS.PHH.

ATMOS.PHH calculates the variation of atmospheric properties with altitude and has an altitude range from zero to 100,000 feet. There are six options available to the user; selection being made by setting the flag "KEYAIR" in accordance with Table 1.

ATMOS.PHH can be easily modified to calculate temperature/pressure/density ratios, Mach number and speed of sound if required. The criteria required to calculate the ARDU Tropical Atmosphere are those presented by Kipp [4].

TABLE 1: ATMOSPHERE OPTIONS OF ATMOS.PHH		
KEYAIR	ATMOSPHERE	DATA REQUIRED
1(default)	ICAO Standard Atmosphere	ALT
2	ICAO Sea Level conditions at all times	-
3	Off-Standard ICAO	ALT, TDAY, QNH, HAFR
4	ARDU Tropical Atmosphere	ALT
5	ARDU Sea Level conditions at all times	-
6	Off-Standard ARDU	ALT, TDAY, QNH, HAFR

8. CONCLUSION

The basic six degrees of freedom dynamic equations of aircraft motion have been documented in this Memorandum for use in aircraft simulations at ARL. The earth axes system was selected for the integration of the force equations, and the body axes system for the integration of the moment equations. Quaternion components have been used to calculate Euler angles and direction cosines. A routine for calculating atmospheric variables has been provided.

## REFERENCES

1. Cooke, R.A. "Standard Sets of Axes, Units and Identifiers for Use in the Software for the RAE Air Combat Simulator".  
RAE TM FS-307, January 1980
2. Etkin, B. "Dynamics of Atmospheric Flight".  
Wiley, 1972
3. Fogarty, L.E. and Howe, R.M. "Computer Mechanization of Six-Degree of Freedom Flight Equations".  
NASA CR-1344, May 1969
4. Kipp, G.W. "A Computer Program to Produce Atmospheric Data for Aircraft Performance Calculations".  
ARL/ME TM-367, April 1975
5. McFarland, R.E. "A Standard Kinematic Model for Flight Simulation at NASA-Ames".  
NASA CR-2497, January 1975
6. Potter, J.E., Stern, R.G., Smith, T.B. and Sinha, P. "Digital Flight Control Research".  
NASA CR-2433, August 1974
7. Robinson, A.C. "On the Use of Quaternions in Simulation of Rigid-Body Motion".  
WADC TR 58-17, December 1958
8. Tomlinson, B.N. "SESAME - A System of Equations for the Simulation of Aircraft in a Modular Environment".  
RAE TR-79008, January 1979

## NOTATION

ALT	altitude (ft, m)
$C_i$ (i=0,9)	inertia constants
$F_{XE}, F_{YE}, F_{ZE}$	applied forces in earth axes (lbf, N)
$F_{XS}, F_{YS}, F_{ZS}$	applied forces in stability axes (lbf, N)
g	gravitational constant (32.174 ft/s <sup>2</sup> , 9.81 m/s <sup>2</sup> )
HAFR	height of the airfield reference point above MSL (ft, m)
$I_{XX}, I_{YY}, I_{ZZ}, I_{XZ}$	moments and product of inertia (lb ft <sup>2</sup> , Kg m <sup>2</sup> )
KEYAIR	flag to select desired atmosphere in ATMOS.PHH
L,M,N	total moments (ft-lbf, N-m)
$L_A, M_A, N_A$	aerodynamic moments (ft-lbf, N-m)
$L_P, M_P, N_P$	powerplant moments (ft-lbf, N-m)
$L_i, M_i, N_i$ (i=1,3)	direction cosines
MSL	mean sea level
m	aircraft mass (lb, Kg)
Pamb	ambient atmospheric pressure (lbf/ft <sup>2</sup> , N/m <sup>2</sup> )
P,Q,R	angular velocity components about body axes (rad/s)
QNH	airfield pressure altitude above MSL (millibars)
$R_G$	aircraft range (ft, m)
$R_T \hat{e}$	centreline of runway threshold
Tamb	ambient atmospheric temperature (C)
TDAY	ambient air temperature at airfield reference point (C)
$U_B, V_B, W_B$	body axes velocity components (ft/s, m/s)
$V_{GR}$	aircraft ground speed (ft/s, m/s)
$V_N, V_E, V_D$	components of airspeed in earth axes (north, east, down) (ft/s, m/s)
$V_{NE}, V_{EE}, V_{DE}$	components of velocity relative to earth (ft/s, m/s)
$V_{TAS}$	true airspeed (ft/s, m/s)
$V_{WN}, V_{WE}, V_{WD}$	components of total wind velocity relative to earth (ft/s, m/s)
W	aircraft weight i.e. $W = mg$ (lbf, N)

.../cont.



## NOTATION (CONT.)

$X_A, Y_A, Z_A$	aerodynamic forces (drag, sideforce, lift) (lbf, N)
$X_B, Y_B, Z_B$	body axes reference frame
$X_E, Y_E, Z_E$	earth axes reference frame
$X_P, Y_P, Z_P$	propulsive forces (lbf, N)
$X_S, Y_S, Z_S$	stability axes reference frame
$X_W, Y_W, Z_W$	air-path axes reference frame
$x, y$	positional coordinates (ft, m)
$\alpha$	angle of attack (rad.)
$\beta$	angle of sideslip (rad.)
$\gamma$	flight-path angle, or 'angle of climb' (rad.)
$\delta_a, \delta_e, \delta_r$	control surface deflections: aileron, elevator rudder (rad.)
$\theta, \phi, \psi$	Euler angles of pitch, roll (bank) and yaw (heading) (rad.)
$\rho$	air density (lb/ft <sup>3</sup> , Kg/m <sup>3</sup> )
$\tau_i$ (i=0,3)	quaternion components
$\chi$	angle of track, east of north (rad.)

### Subscripts

amb	ambient
A	aerodynamic contribution
B	body axes
E	earth axes
P	powerplant contribution
S	stability axes
W	air-path axes
$W_N, W_E, W_D$	North, East and Downwards wind velocity

A dot over a variable denotes the first derivative with respect to time.

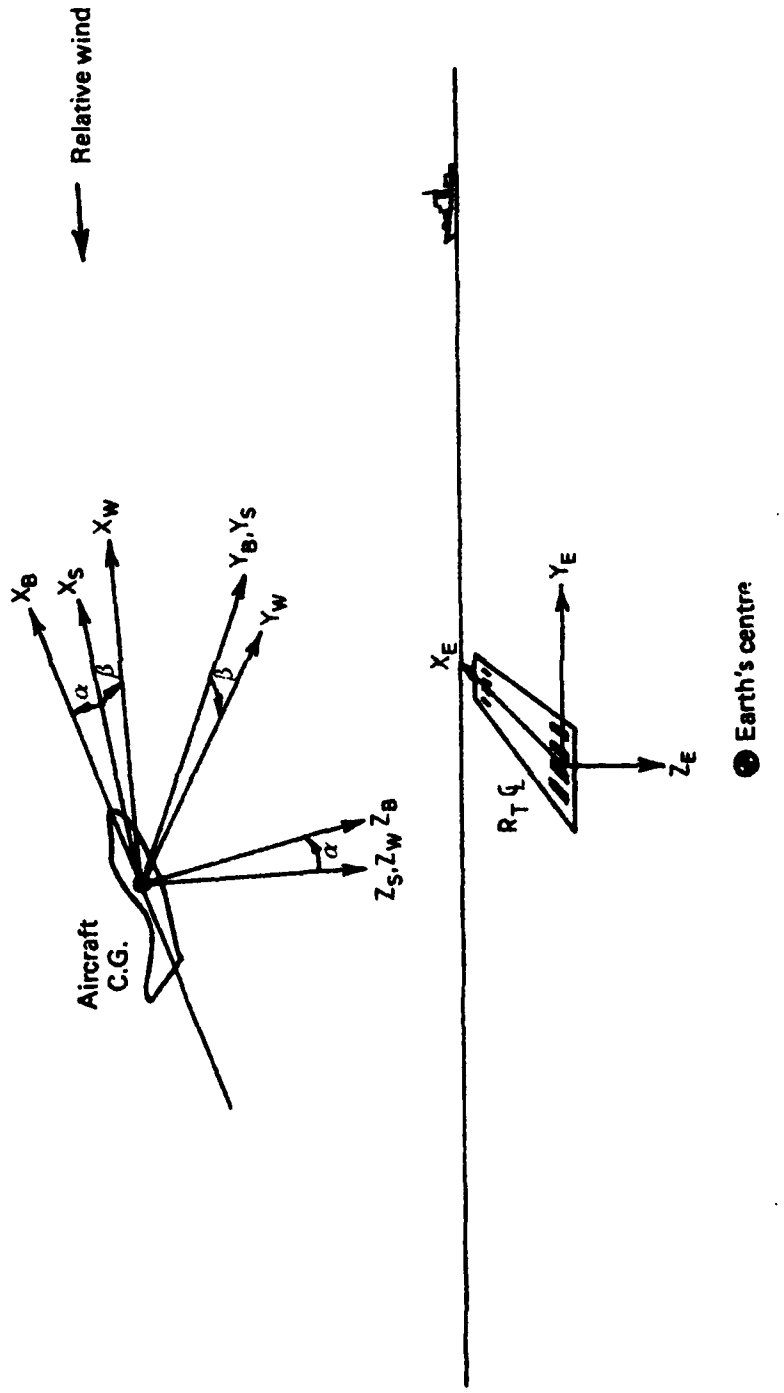

FIG. 1: RELATIONSHIP BETWEEN EARTH AXES, BODY AXES, STABILITY AXES AND FLIGHT-PATH AXES

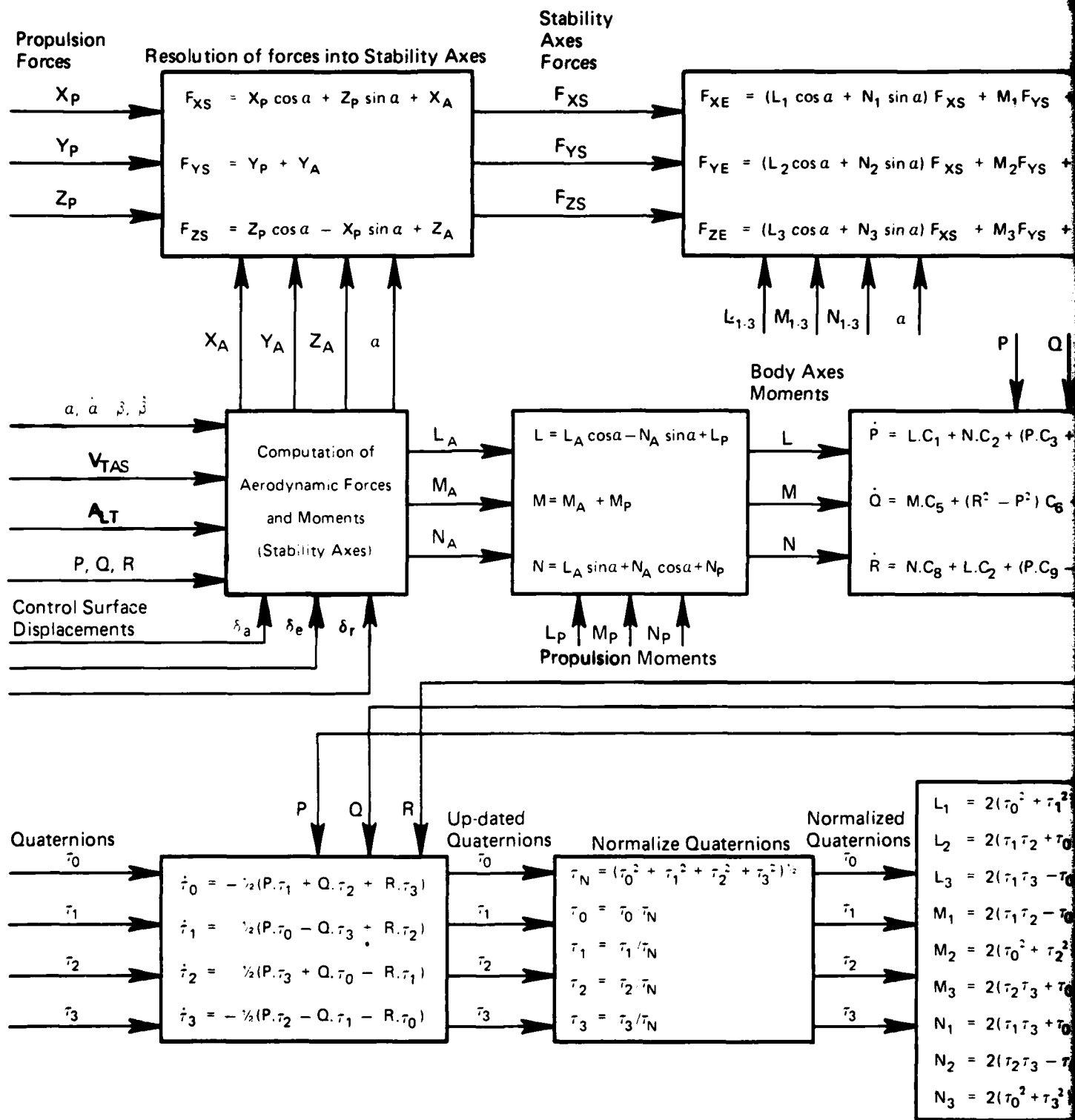
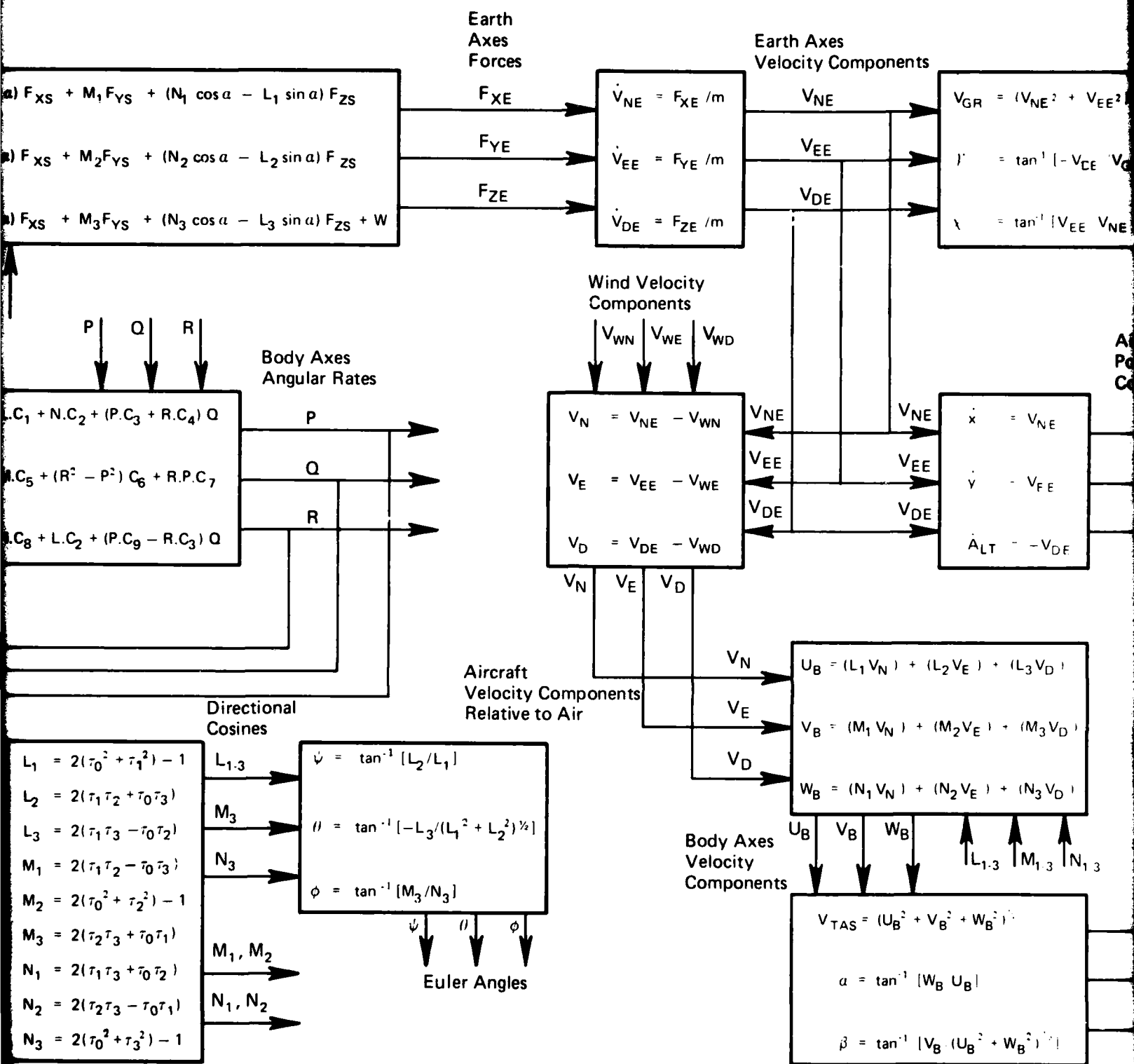
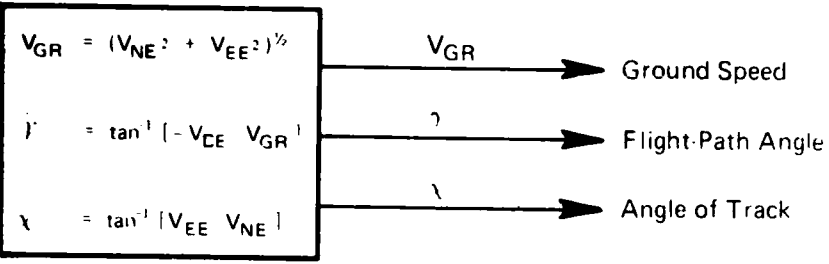

FIG. 2: BLOCK DIAGRA



BLOCK DIAGRAM OF COMBINED EARTH AXES/BODY AXES SYSTEM (FLAT EARTH) FOR AIRCRAFT MOTION.

12



Aircraft's Positional Coordinates

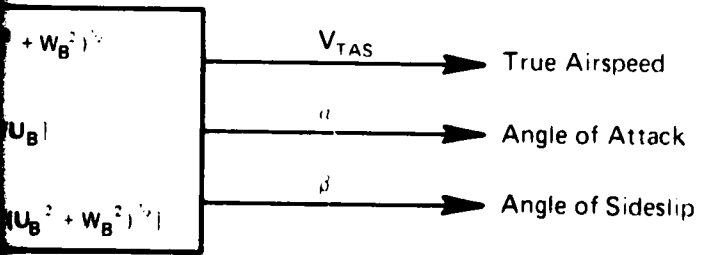
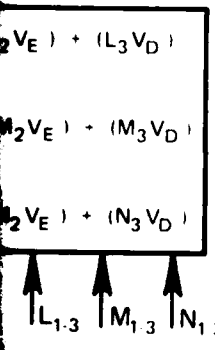
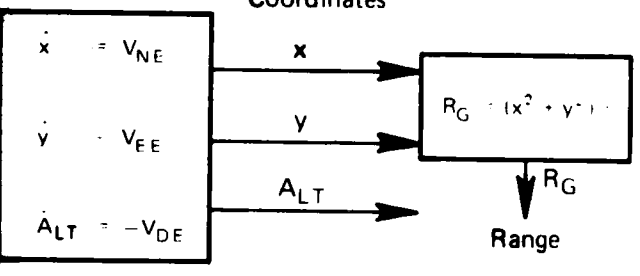

DISTRIBUTION

AUSTRALIA

Department of Defence and Department of Defence Support

Central Office

Chief Defence Scientist )  
Deputy Chief Defence Scientist )  
Superintendent, Science and Technology Programmes ) (1 copy)  
Controller, Projects and Analytical Studies )  
Defence Science Representative (U.K.) (Doc Data sheet only)  
Counsellor, Defence Science (U.S.A.) (Doc Data sheet only)  
Defence Central Library  
Document Exchange Centre, D.I.S.B. (17 copies)  
Joint Intelligence Organisation  
Librarian H Block, Victoria Barracks, Melbourne  
Director General - Army Development (NSO) (4 copies)  
Defence Industry & Materiel Policy, FAS

Aeronautical Research Laboratories

Chief Superintendent  
Library  
Superintendent - Aerodynamics  
Divisional File - Aerodynamics  
Author: P.H. Hall  
D.A. Secomb  
C.A. Martin  
R.A. Feik  
B.F. Gunn  
J.S. Drobik  
D.A. Bird  
D.C. Collis

Materials Research Laboratories

Chief Superintendent/Library

Defence Research Centre

Library

Central Studies Establishment

Information Centre

RAN Research Laboratory

Library

.../cont.

DISTRIBUTION (CONT.)

Navy Office

Navy Scientific Adviser  
RAN Aircraft Maintenance and Flight Trials Unit  
Directorate of Naval Aircraft Engineering  
Directorate of Naval Aviation Policy  
Superintendent, Aircraft Maintenance and Repair  
Directorate of Naval Ship Design

Army Office

Army Scientific Adviser  
Engineering Development Establishment, Library  
Royal Military College Library  
US Army Research, Development and Standardisation Group

Air Force Office

Air Force Scientific Adviser  
Aircraft Research & Development Unit  
Scientific Flight Group  
Library  
Technical Division Library  
Director General Aircraft Engineering-Air Force  
Director General Operational Requirements-Air Force  
HQ Operational Command  
HQ Support Command [SENGSO]  
RAAF Academy, Point Cook

Government Aircraft Factories

Manager  
Library

Department of Science & Technology

Bureau of Meteorology, Library

Department of Aviation

Library  
Flying Operations and Airworthiness Division

Statutory & State Authorities and Industry

Trans-Australia Airlines, Library  
Qantas Airways Limited  
Ansett Airlines of Australia, Library  
Commonwealth Aircraft Corporation, Library  
Hawker de Havilland Aust. Pty. Ltd., Bankstown, Library

..../cont.

DISTRIBUTION (CONT.)

Universities and Colleges

Adelaide	Barr Smith Library
Flinders	Library
Latrobe	Library
Melbourne	Engineering Library
Monash	Hargrave Library
Newcastle	Library
Sydney	Engineering Library
N.S.W.	Physical Science Library Professor D.R. Archer, Aeronautical Engineering
Queensland	Library
Tasmania	Engineering Library
Western Australia	Library
R.M.I.T.	Library E. Stokes, Civil & Aeronautical Engineering N. Mileshkin, Aeronautical Engineering I. Herzberg, Aeronautical Engineering

SPARES (15 copies)

TOTAL (103 copies)



DOCUMENT CONTROL DATA

1. A/R No. AR-90. 0001	2. Formulation No. ARL-4410 TECH-MEMO-334	3. Document Date JUNE, 1962	4. Task No. DST 79/105
4. Title 5. SET OF FLIGHT DYNAMIC EQUATIONS FOR AIRCRAFT SIMULATION.	5. Security of document UNCLASSIFIED	6. No. Pages 10	
		6. title      7. abstract U            U	7. No refs 8
8. Author(s) F. H. EMMETT (LTJ, RAAF)	9. Downgrading Instructions -		
10. Corporate Author and Address Aeronautical Research Laboratories, C.R.T.O. BOX 4311, MELBOURNE, VIC. 3001	11. Authority (as appropriate) a. Sponsor    b. Security    c. Downgrading    d. Approval -		
12. Secondary Distribution (of this document) Approved for Public Release			
Overseas enquiries outside Australia should be referred through ASDIS, Defence Information Services Branch, Department of Defence, Campbell Park, CANBERRA ACT 2601			
13. a. This document may be ANNOUNCED in catalogues and awareness services available to: No Limitations			
13. b. If notice for other purposes (as usual announcement) may be <del>desired</del> <del>desired</del> <del>desired</del>			
14. Descriptors Computerized simulation Equations of Motion Aircraft simulation Quaternions	15. COSATI Group 0101 1201		
16. Abstract The six degrees of freedom dynamic equations of aircraft motion are documented for use in aircraft simulations at ARL. Earth axes are used for the integration of the force equations, and body axes for the integration of the moment equations. The use of quaternions to calculate aircraft attitude and associated direction cosines is described. A brief description of an atmospheric data subroutine for use in aircraft simulation is also included.			

This page is to be used to record information which is required by the Establishment for its own use but which will not be added to the DISTIS data base unless specifically requested.

16. Abstract (Cont'd)		
17. Imprint Aeronautical Research Laboratories, Melbourne.		
18. Document Series and Number Aerodynamics Technical Memorandum 339	19. Cost Code 52 7730	20. Type of Report and Period Covered -
21. Computer Programs Used -		
22. Establishment File Ref(s) -		

END

DATE  
FILMED

11-18-82

DTIC