

AD-A117 449

MCDONNELL DOUGLAS CORP LONG BEACH CA

F/6 1/3

A COMBINED HAZARD INDEX FIRE TEST METHODOLOGY FOR AIRCRAFT CABI--ETC(U)

APR 82 H H SPIETH, J G GAUME, R E LUOTO

DOT-FA77WA-4019

UNCLASSIFIED

DOT/FAA/CT-82/36-2

NL

1-13

0/000

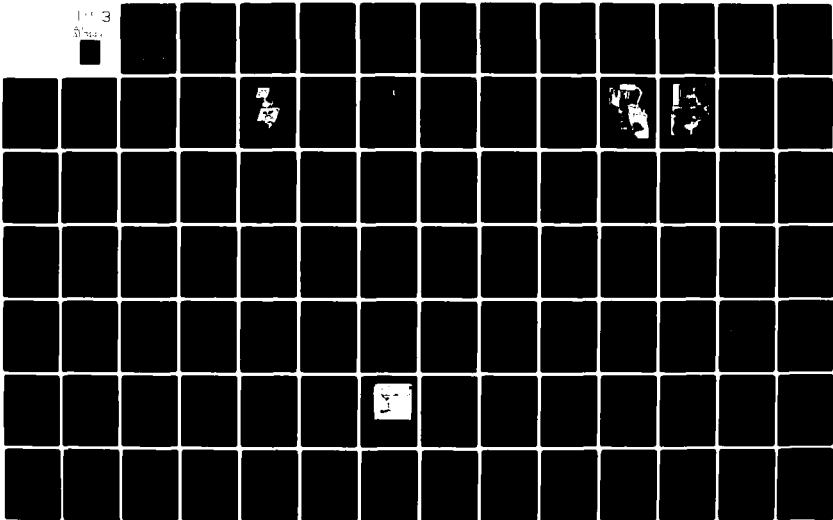

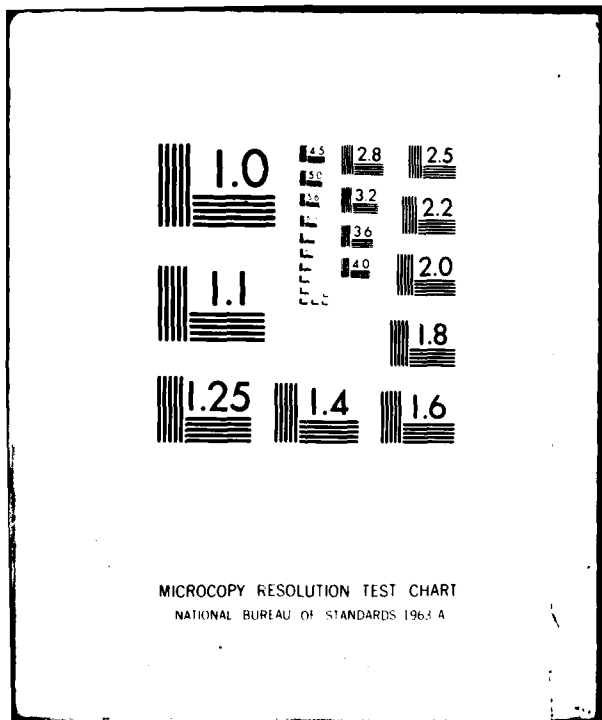

MICROCOPY RESOLUTION TEST CHART
NATIONAL BUREAU OF STANDARDS 1963-A

12

DOT/FAA/CT-82/36-II

A Combined Hazard Index Fire Test Methodology for Aircraft Cabin Materials - Volume II

AD A117449

H. H. Spieth
J. G. Gaume, M.D.
R. E. Luoto
D. M. Klinck

McDonnell Douglas Corporation
Douglas Aircraft Company
Long Beach, California 90846

Final Report

April 1982

This document is available to the U.S. public through the National Technical Information Service, Springfield, Virginia 22161.

DTIC FILE COPY



US Department of Transportation
Federal Aviation Administration
Technical Center
Atlantic City Airport, N.J. 08405

DTIC
ELECT
S JUL 26 1982 D
D

The United States Government does not endorse products or manufacturers. Trade or manufacturer's names appear herein solely because they are considered essential to the object of this report.

This document is disseminated under the sponsorship of the Department of Transportation in the interest of information exchange. The United States Government assumes no liability for the contents or use thereof.

METRIC CONVERSION FACTORS

Approximate Conversions to Metric Measures

Symbol	When You Know	Multiply by	To Find	Symbol
LENGTH				
in	inches	2.5	Centimeters	cm
ft	feet	30	centimeters	cm
yd	yards	0.9	meters	m
mi	miles	1.6	kilometers	km
AREA				
sq in	square inches	6.5	square centimeters	cm ²
sq ft	square feet	0.09	square meters	m ²
sq yd	square yards	0.8	square meters	m ²
sq mi	square miles	2.6	square kilometers	km ²
acres	acres	0.4	hectares	ha
MASS (weight)				
oz	ounces	28	grams	g
lb	pounds	4.5	kilograms	kg
	short tons (2000 lb)	0.9	tonnes	t
VOLUME				
teaspoon	teaspoons	5	milliliters	ml
tablespoon	tablespoons	15	milliliters	ml
fluid ounce	fluid ounces	30	milliliters	ml
cup	cups	0.24	liters	l
pint	pints	0.47	liters	l
quart	quarts	0.95	liters	l
gallon	gallons	3.8	liters	l
cu ft	Cubic feet	0.03	Cubic meters	m ³
cu yd	Cubic yards	0.76	Cubic meters	m ³
TEMPERATURE (exact)				
°F	Fahrenheit temperature	$\frac{5}{9}(F - 32)$	Celsius temperature	°C

* Use 2.54 (exact) for more exact conversions and use metric and tables. Use NBS 444, Part 1A, Units of Length and Measure. Price \$2.75. SD Catalog No. C13 10-74.

Symbol	When You Know	Multiply by	To Find	Symbol
LENGTH				
mm	millimeters	0.04	inches	in
cm	centimeters	0.4	inches	in
m	meters	3.3	feet	ft
km	kilometers	1.1	yards	yd
		0.6	miles	mi
AREA				
cm ²	square centimeters	0.16	square inches	in ²
m ²	square meters	1.2	square yards	yd ²
ha	square kilometers	0.4	square miles	mi ²
	hectares (10,000 m ²)	2.5	acres	acres
MASS (weight)				
g	grams	0.035	ounces	oz
kg	kilograms	2.2	pounds	lb
t	tonnes (1000 kg)	1.1	short tons	
VOLUME				
ml	milliliters	0.03	fluid ounces	fl oz
l	liters	2.1	pints	pt
		1.06	quarts	qt
m ³	Cubic meters	0.26	gallons	gal
		35	Cubic feet	ft ³
		1.3	Cubic yards	yd ³
TEMPERATURE (exact)				
°C	Celsius temperature	$\frac{9}{5}(C + 32)$	Fahrenheit temperature	°F

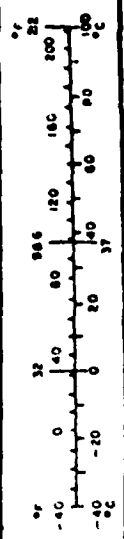

Technical Report Documentation Page

1. Report No. DOT/FAA/CT-82/36-II		2. Government Accession No. AD-A117449		3. Recipient's Catalog No.	
4. Title and Subtitle A COMBINED HAZARD INDEX FIRE TEST METHODOLOGY FOR AIRCRAFT CABIN MATERIALS, VOLUME II				5. Report Date April 1982	
7. Author(s) H. H. Spieth, J. G. Gaume, M.D., R. E. Luoto and D. M. Klinck				6. Performing Organization Code	
9. Performing Organization Name and Address Douglas Aircraft Company 3855 Lakewood Boulevard Long Beach, California 90846				8. Performing Organization Report No. DOT/FAA/CT-82/36-II	
12. Sponsoring Agency Name and Address Federal Aviation Administration Technical Center Atlantic City Airport, New Jersey 08405				10. Work Unit No. (TRAIS)	
				11. Contract or Grant No. 181-350-210	
				13. Type of Report and Period Covered	
				14. Sponsoring Agency Code	
15. Supplementary Notes Volume I - Development and Results Volume II - Design Details					
16. Abstract This report supplements the description of the methodology developed for ranking cabin materials for combined hazards generated in a survivable crash fire presented in Part I of the report. More comprehensive procedures are presented for the calibration and operation of the computer-augmented Ohio State University Calorimeter modified to derive the new materials fire hazards testing apparatus known as the Combined Hazards Analysis System (CHAS). Definitive derivations of the human survival models for temperature, smoke, and toxic gases used in the hazards analysis and a thorough presentation of the mathematics used in the Fortran Fire Analysis Computer Program are presented. A full description of the full-scale fire testing method used during the development and demonstration phases of the program is presented to give a better understanding of the capability of the laboratory methodology to rate materials on the basis of the relative passenger escape time potential from a cabin section. Part II is, essentially a working manual which will assist greatly those committed to duplicating and successfully operating the CHAS. The CHAS methodology is useful for development of new fire resistant materials.					
17. Key Words Aircraft Cabin Fire Safety Aircraft Interior Materials Combined Fire Hazards Fire Test Methodology Fire Measurements			18. Distribution Statement Document is available to the U.S. public through the National Technical Information Service, Springfield, Virginia 22161		
19. Security Classif. (of this report) Unclassified		20. Security Classif. (of this page) Unclassified		21. No. of Pages	22. Price

PREFACE

This report was prepared as Part II of a research program conducted by the Douglas Aircraft Company, a Divisional Company of the McDonnell Douglas Corporation, under Contract No. DOT-FA77WA-4019 for the Federal Aviation Administration of the U. S. Department of Transportation. Until his retirement Mr. Robert C. McGuire was Program Manager for the Federal Aviation Administration and has been succeeded by Mr. Constantine P. Sarkos at the Federal Aviation Administration Technical Center.

The report was divided into two parts: Part I described the improved technology investigated to upgrade existing methods for testing the flammability of aircraft cabin materials; Part II was prepared to satisfy the needs of investigators who are interested in building up similar laboratory test equipment and provides detailed operational procedures, computer data acquisition and processing program listings, and detailed derivations of the hazards analysis models used to rate cabin materials in fire by the common denominator of passenger escape time potential.

A large number of McDonnell Douglas personnel in many related technical fields made important contributions to the successful completion of the program. These individuals have been acknowledged in the Part I Preface. In addition to these individuals, Yolanda Cortez and Terry Johns deserve special thanks for their work with the word processors used to complete the two reports.

Accession For	
NTIS GRA&I	<input checked="" type="checkbox"/>
DTIC TAB	<input type="checkbox"/>
Unannounced	<input type="checkbox"/>
Justification	
By	
Distribution/	
Availability Codes	
Dist	Avail and/or Special
A	



PART II
TABLE OF CONTENTS

	<u>PAGE</u>
I. INTRODUCTION.....	1
II. CHI LABORATORY EQUIPMENT AND OPERATION.....	3
Laboratory Test Equipment.....	3
Modifications to the OSU HRR Calorimeter.....	3
Calibration of CHAS/SATS.....	12
CHAS/SATS Test Procedure.....	32
Running a Material.....	37
Data Processing.....	42
Final Preparations for CHAS Tests.....	42
III. HAZARD LIMIT CONCEPT.....	44
Toxic Gas Hazard Limits.....	44
Thermal Hazard Limits	47
Smoke (Visibility) Hazard Limits.....	52
SATS Animal Testing.....	55
CFS Animal Testing.....	59
IV FIRE ANALYSIS COMPUTER PROGRAM.....	63
Selection of Cabin Fire Model.....	63
Computer Program Description.....	63
Development of Differential Equations.....	68
V TEST MATERIALS.....	78
Materials Selection.....	78
Panel Fabrication.....	78
VI CABIN FIRE SIMULATOR TESTING.....	83
CFS Test Setup.....	83
CFS Test Checklist.....	97
Post Test.....	101
CFS Testing.....	101
Panel No. 1 Tests.....	102
REFERENCES.....	116
APPENDICES	
A.....	118
B.....	185
C.....	193

LIST OF ILLUSTRATIONS

FIGURE		PAGE
1	MASS LOSS TRANSDUCER AND SAMPLE HOLDER INJECTION ASSEMBLY.....	4
2	SCHEMATIC DIAGRAM OF THE CHAS/SATS.....	6
3	CHAS DATA ACQUISITION AND PROCESSING SYSTEM.....	10
4	SINGLE ANIMAL TEST CHAMBER (SATS).....	11
5	CALIBRATION CURVE-HRR CALORIMETER AIRFLOW RATE VERSUS PSI AND INCHES OF MERCURY.....	14
6	SCHEMATIC OF HRR CALIBRATION EQUIPMENT ASSEMBLY.....	15
7	GLOBAR PANEL RADIANT FLUX VS AUTOTRANSFORMER VOLTAGE SETTINGS....	19
8	HYCAL MODEL R-8015C RADIOMETER CALIBRATION CURVE.....	20
9	MLT CALIBRATION CURVE.....	21
10	CO CALIBRATION AND POLYNOMIAL EQUATION CURVE FIT.....	23
11	CO ₂ CALIBRATION AND POLYNOMIAL EQUATION CURVE FIT.....	24
12	COMPARISON OF SPAN GAS WITH SYRINGE INJECTED GAS DILUTION CALIBRATION.....	26
13	HCN CALIBRATION AND POLYNOMIAL EQUATION CURVE FIT.....	29
14	PRELIMINARY SETUP.....	38
15	HRR AIRFLOW ADJUSTMENT COMPUTER FLOW DIAGRAM.....	39
16	CHAS DATA ACQUISITION COMPUTER PROGRAM.....	40
17	FIVE-MINUTE TLV EXTRAPOLATION CURVE FOR CO.....	46
18	AIR TEMPERATURE HAZARD LIMIT CURVE FIT.....	50
19	COMBINED AIR TEMPERATURE HAZARD LIMITS.....	52
20	ESCAPE TIME VERSUS LIGHT TRANSMITTANCE THROUGH SMOKE.....	53
21	ALLARD'S LAW, $E = I/D^2 * T^D$ FOR $I = 1.650$ CANDELA.....	55
22	T VERSUS D FEET FOR THRESHOLD ILLUMINANCE.....	56
23	SINGLE ANIMAL TEST SYSTEM PLEXIGLAS CHAMBER.....	57
24	TYPICAL CHAS/SATS TI TEST RECORDING.....	60
25	TYPICAL T _i TEST PATTERN SHOWING T _d AFTER AMPLIFICATION OF RESPIRATION.....	60
26	INSULATED ANIMAL CHAMBERS AT THE CHI POINT.....	62

LIST OF ILLUSTRATIONS (Cont'd)

<u>FIGURE</u>		<u>PAGE</u>
27	FIRE DYNAMICS MODEL FOR FACP.....	64
28	20 ZONE FIRE ANALYSIS COMPUTER PROGRAM.....	65
29	20 ZONE CFS FIRE MODEL.....	66
30	TRANSIENT HEAT TRANSFER PLOT FOR EQUATION 1.....	70
31	CHI TEST SETUP IN CFS.....	84
32	CFS RADIANT HEATING ARRAY.....	86
33	CALORIMETERS POSITIONED FOR ARRAY MAPPING.....	87
34	CHI PANEL HEAT FLUX DISTRIBUTION, BTU/FT ² SEC.....	88
35	PANEL 1 BEFORE EXPOSURE WITH VERTICAL PILOT BURNER TUBE IN POSITION.....	89
36	CFS EXHAUST GAS MONITORS.....	90
37	CHI POINT GAS MONITORS.....	91
38	SOLENOID VALVE CONTROLLED GAS SAMPLING UNIT.....	94
39	CFS CAMERA, CHI, AND MIDPOINT ANIMAL LOCATIONS.....	95
40	MULTICHANNEL RECORDER AND ANIMAL TI CAGE ROTATION CONTROLLERS....	96
41	CFS VIDEO CAMERA RECORDER AND MONITOR.....	96
42	HORIZONTAL PILOT BURNER.....	99
43	TEST #3 PANEL AFTER EXPOSURE.....	100
44	PANEL 1 MASS BURNING RATE - CFS VERSUS CHAS, 4.41 BTU/FT ² SEC..	103
45	HF CONCENTRATION NEAR MULTIPLE ANIMAL TEST LOCATION IN CFS - PANEL 1, 4.41 BTU/FT ² SEC.....	105
46	HCl CONCENTRATIONS NEAR MULTIPLE ANIMAL TEST LOCATION IN CFS - PANEL 1, 4.41 BTU/FT ² SEC.....	106
47	HCN CONCENTRATION NEAR MULTIPLE ANIMAL TEST LOCATION IN CFS.....	107
48	TEMPERATURE AT CHI POINT (TMS, TUS, TLS) MID-CABIN, SOUTH SIDE..	108
49	DUCT TEMPERATURES OF AIR-IN AND AIR-OUT.....	109
50	SMOKE OPTICAL TRANSMISSIONS AT CHI LOCATION.....	110

LIST OF ILLUSTRATIONS (Conc'd)

<u>FIGURE</u>		<u>PAGE</u>
51	CO AND CO ₂ CONCENTRATIONS AT CHI LOCATION.....	111
52	OXYGEN DEPLETION AT CFS EXHAUST AND AT CHI LOCATION.....	112
53	CFS CABIN DIFFERENTIAL PRESSURE PANEL 1, 4.41 BTU/FT ² SEC.....	113

LIST OF TABLES

<u>TABLE</u>		<u>PAGE</u>
1	CHAS INSTRUMENTATION MEASUREMENT CHARACTERISTICS.....	8
2	AIRFLOW RATES VERSUS DIFFERENTIAL PRESSURE READINGS.....	13
3	HRR CALIBRATION.....	18
4	STANDARDIZED SPAN GASES & MIXTURES.....	22
5	HCN CALIBRATION DATA.....	31
6	RESPONSE OF AMPEROMETRIC HCN ANALYZER TO VARIOUS GASES.....	33
7	ADDITIONAL GAS ANALYSIS METHODS.....	34
8	MODIFICATIONS OF ASTM PROPOSED STANDARD USED IN CHI PROGRAM.....	35
9	SPECIAL FUNCTION KEY IDENTIFICATION.....	43
10	HUMAN SURVIVAL LIMITS ANALYSIS.....	48
11	CHAS/SATS TI TESTS OF PANEL 1 MATERIAL.....	61
12	COMPOSITION OF MATERIAL NO. 1.....	79
13	PANEL MATERIAL NO. 2 CONSTRUCTION.....	80
14	PANEL MATERIAL NO. 3 CONSTRUCTION.....	81
15	PANEL MATERIAL NO. 4 CONSTRUCTION.....	82
16	AVERAGE PANEL NO. 1 GAS CONCENTRATIONS COLLECTED IN IMPINGERS AT TWO LOCATIONS FROM THE CFS.....	104

ACRONYMS, ABBREVIATIONS AND INITIALISMS

A	Area
ADAS	Automatic Data Acquisition System
Adh.	Adhesive
ASTM	American Society for Testing and Materials
Av. RSD%	Average Relative Standard Deviation, Percent
Btu/ft ² sec	Heat Flux, British Thermal Units per Square Foot per Second
C	Concentration (also a conversion factor)
CA (I, K)	Array Defining Flow Coefficients Between Zones
C _{air}	Concentration of O ₂ in Air, 20.93%
C _t	Depleted Concentration of O ₂ at any time, %
C _{co}	Concentration of Carbon Monoxide
CFS	Cabin Fire Simulator (Figure 1)
CHAS	Combined Hazards Analysis System
CHI	Combined Hazards Index (Equivalent to Escape Time)
CHx, HCx	Combustible Gases, Also Unburned Hydrocarbons
CO	Carbon Monoxide
COHb	Carboxyhemoglobin (as % blood saturation)
CO ₂	Carbon Dioxide
COCl ₂	Carbonyl Chloride
C _p	Specific Heat
C ₁	Intercept of a Regression Line
C ₂	Slope of a Regression Line
D	Distance Between a Light Source and an Observer, Feet
DACFIR	University of Dayton Aircraft Fire Computer Program
DATTAP	CHAS Data on Fortran Fire Analysis Program Tape
D _i	Dose of Toxic Gas Resulting in Incapacitation
DIFFEQ	Differential Equations Program for Calculating Rate of Change of all Variables (Subroutine)
DTP	Differential Thermopile
E	Exit Sign Light Illuminance at Observer's Eye
ESTI	Subroutine in Computer Program Calculates Fractional Doses and CHI
ET	Escape time (Egress Time from a Cabin)
FACF	Fortran IV Fire Analysis Computer Program
F _{di}	Fractional Doses of Measured Hazards
GPIB	General Purpose Interface Bus
GRR	Gas Release Rate
G.S.	Gas Sampling by Syringe Method
HBr	Hydrogen Bromide
HCl	Hydrogen Chloride
HCN	Hydrogen Cyanide
HF	Hydrogen Fluoride
HRR	Heat Release Rate

ACRONYMS, ABBREVIATIONS AND INITIALISMS (Cont'd)

(HL) ₅	Five Minute Hazard Limit
HP-ADAS	Hewlett-Packard Automatic Data Acquisition System
H ₂ S	Hydrogen Sulfide
I	Zone Number in Computer Program, also Intensity of Light Source in Candela
IBM	International Business Machines (Computer)
K	Number of a Zone in an Array Connected to Zone I for Each of the Six Sides
KADL	Array Providing a Heat Transfer Between Zones in the CFS
K _{1,2,3,n}	Derived Constant Used to Calculate Fractional Effective Doses of Hazards
LD ₁ , LD ₅₀ , etc.	Lethal Dose of a Toxic Substance Needed to Kill 1, 50, etc., Percent of Test Animals
LC ₅₀	Lethal Concentration Killing 50 Percent of Test Animals
MATS	Multiple Animal Test System
MBTH	3-Methyl-2-Benzothiazoline Hydrazone
MFD	Mixture Fractional Effective Dose
MW	Molecular Weight
MLT	Mass Loss Transducer (Figure 5)
NH ₃	Ammonia
NO _x	Oxides of Nitrogen
O ₂	Oxygen
P	Pressure, Also an Array Defining the P (1,K) Interconnections Between Zones (Computer Program)
PVF	Polyvinylfluoride (Decorative Coating Material)
PVC	Polyvinylchloride (Decorative Coating Material)
PK SMO	Peak SMOKE Release Rate
PK HRR	Peak Heat Release Rate
ppm	Parts per Million
Q ₀	Statistically Derived Proportionality Constant Related to Number of Calories of Heat Absorbed by the Human Body Before Collapse.
R	Correlation Coefficient
RCHO	Total Aldehydes (as formaldehyde)
RMV	Respiratory Minute Volume
RSD	Relative Standard Deviation
R ²	Coefficient of Determination
RUNGU	Runge Kutta Technique for Numerical Integration of Differential Equations

ACRONYMS, ABBREVIATIONS AND INITIALISMS (Cont'd)

SATS	Single Animal Test System
SSU	Standard Smoke Unit (of S.M.O.K.E.)
S.M.O.K.E.	Standard Metric Optical Kinetic Emission (of smoke)
SO ₂	Sulfur Dioxide
SRR	Standard S.M.O.K.E. Release Rate Units (same as SSU)
t	Time
T	Temperature (also light transmission)
T _d	Time to Death
T _i	Time to Incapacitation
TLV	Threshold Limit Value
T _o	Ambient Temperature
T _c	Time to Thermal Collapse (humans)
V	Volume, also Human Breathing (ventilation volume) Rate
V ₁	Valve Isolating Animal Test Chamber in CHAS/SATS
W	Weight of Test Rat, Grams
Y _c	Char Yield

FIRE ANALYSIS COMPUTER PROGRAM SYMBOLS

α	Thermal Diffusivity, Ft ² /hr
A _f	Flame Area, Ft ²
AP	Area of Burning Panel, Ft ²
C _p , C _s	Specific Heat, Btu/lb. °F
h _a	Convective Heat Transfer Coefficient
h _e	Film Coefficient, Btu/hr. Ft ² °F
h _r	Radiant Heat Transfer Coefficient
k	Thermal Conductivity, Btu/hr Ft °F
L	Half Thickness, Ft
Ma	Weight of Air in a Zone, lb.
Mi IN	Mass Flow Rate of Gas into Zone or Compartment, lb/sec
Mi OUT	Mass Flow Rate of Gas Out of Zone or Compartment, lb/sec
Mi	Weight of Each Gas, lb

ACRONYMS, ABBREVIATIONS AND INITIALISMS (Cont'd)

P	Pressure, lb/ft ²
P _I	Partial Pressure of Each Gas (I) in Mixture lb/ft ²
Q	Total Heat Flux per Unit Storage Area, Btu/hr
R ₁	Gas Constant
RHO	Density of Gas Mixture, lb/ft ³
S ₁	Instantaneous Smoke Concentration Flowing into a Zone, "Particles"/ft ³
S ₂	Instantaneous Smoke Concentration Flowing out of a Zone, "Particles"/ft ³
S _{IN}	S.M.O.K.E. Flow into a Zone/ft ²
S _{OUT}	S.M.O.K.E. Flow Out of a Zone/ft ²
θ	Time, hr
T _a	Temperature of Air, °F
T _{so}	Initial Surface Temperature, °F
	Radiation View Factor
V	Volume, ft ³
WM	Weight Flow Rate of Gas Mixture, lb/sec

I. INTRODUCTION

Part I of this report presented the development and evaluation of the Combined Hazards Index (CHI) methodology for ranking aircraft materials for their collective combustion hazards.

Part II contains detailed descriptions of ancillary equipment and test procedures needed to modify a standard Ohio State University Heat Release Rate Calorimeter (OSU-HRR) into a laboratory test facility known as the Combined Hazards Analyses System (CHAS). A Single Animal Test System (SATS), integrated with CHAS, is also described. Dimensions and operational details are given for the specifically developed thermally insulated SATS and the Multiple Animal Test (MATS) chambers. These were used in correlation studies of large scale and laboratory scale animal incapacitation data reported in Part I. The CHAS, a major part of the test procedures and the supporting computer data processing programs, were developed prior to the CHI program. The original work was done as part of the McDonnell Douglas Independent Research and Development Programs in Fire Safety. This contribution greatly aided the development of the more refined test procedures and protocols used in the CHI program.

Part II provides all of the important details for use by those who wish to delve deeper or assemble and operate similar laboratory or cabin size test equipment. It should not be inferred, however, that strict adherence to the assembly details and selection of equipment is a necessity. Experience has shown that certain modifications to the chamber, use of fast response gas monitoring instruments, and proper implementation of the computerized data acquisition and reduction programs will improve materials hazards measurement precision. Thus, other combustion product gas monitors having similar operational characteristics with respect to speed of response sampling volume, stability, etc., may be used. Some of the modifications to the OSU-HRR may not be needed. Extension of sample hold chamber required to make use of the mass loss unit with an auxiliary air cooling system fall in this category.

A simultaneous opening and closing mechanism for the upper and lower radiation doors, closing off the hold chamber before and after injection of a sample, will improve precision and repeatability of measurement. The listed data acquisition and reduction programs are compatible only for use with the Hewlett Package Model 9825A controller and bus operated data scanner, digital voltmeter, clock, and a plotter.

Considerable modification of the programs will be required if other computer systems are used, since the language will differ.

All of the gas monitors, pumps and the mass loss unit are commercially available. The gas sampling system was assembled using standard parts. The SATS, refractory radiation doors and the associated opening/closing mechanism. adaption of the mass loss unit and cooling system on the sample injection assembly, the housing for the gas sampling system smoke filter, and low thermal capacitance, 10 X 10 inch, sample holders were custom built. The smoke detector was also constructed using the schematic and parts specified in the current OSU-HRR test procedure document under review by the ASTM.

Part II contains additional discussion and derivations forming the basis for the hazards limit relationships, the Fortran coding, and output of the fire analysis computer program. Other sections present supplementary information on the composition of the panel materials tested, and large scale cabin fire simulator test procedures and results.

II. CHI LABORATORY EQUIPMENT AND OPERATION

LABORATORY TEST EQUIPMENT

The CHAS/SATS is comprised of four operational subsystems:

1. A modified Ohio State University heat release rate calorimeter modified to measure rate of weight-loss of the sample as it burns, in addition to heat and smoke.
2. A gas sample extraction and release rate monitoring train for CO, HCN, CO₂, NO/NO_x, O₂ (Depletion), unburned hydrocarbons (CH_x), and gas syringe batch sampling of gases for which monitoring instruments are not available (aldehydes, HF, HCl, etc.) and a capability for determining release rates for seven additional toxic gases commonly generated by cabin materials in fires.
3. A 10-channel data acquisition/reduction, calculator controller and printer/plotter system and a formatter/tape unit needed to collect all the release rate data in compatible form for use in calculating CHI using the Fortran IV (IBM 370) Fire Analysis Computer Program (FACP).
4. An instrumented animal (rat) time-to-incapacitation (Ti) rotating wheel mounted in an airtight plexiglas enclosure (SATS) connected to the gas extraction system installed on the HRR calorimeter.

MODIFICATIONS TO THE OSU HRR CALORIMETER

The basic mechanical details and construction of the HRR equipment described in References 1 and 2 have been preserved. The sample holder and injection mechanism has been modified to accommodate a cage type cantilever mass loss transducer (MLT) so that mass burning rates can be measured while the test sample is burning in the HRR chamber. A photograph of this modification is shown in Figure 1. Detail drawings of the sample holder/injection assembly are presented in Appendix A, Figure A-1-1 through A-1-4. A wiring diagram for the MLT is available in Appendix A, Figure A-2.

A new type of sample holder having minimum weight and thermal capacitance was constructed to avoid overloading the MLT with 10 X 10 inch (25.4 X 25.4 cm) samples mounted for testing. This holder is constructed so that a sample burn both on the front and back surfaces, as could occur in an actual fire. The holder dimensions and construction are shown in Appendix A, Figure A-3. The front sample holder support tube has provision for feedthrough of a thermocouple to the center of the test specimen to monitor surface or interior temperature while a material burns. Other modifications required to successfully accommodate and use the MLT include a hold chamber extension duct, Appendix A, Figure A-4, and single action opening refractory radiation doors shown in Appendix A, Figure A-5. These radiation doors are constructed of low thermal conductivity material so that the hold chamber temperatures may be held at lower levels for each heat flux setting. Excess temperature rise inside the insulated box housing the MLT must be prevented to avoid thermal drift in the MLT baseline signal which reflects as an error in the weight loss determination. The remaining baseline drift is easily corrected to zero weight

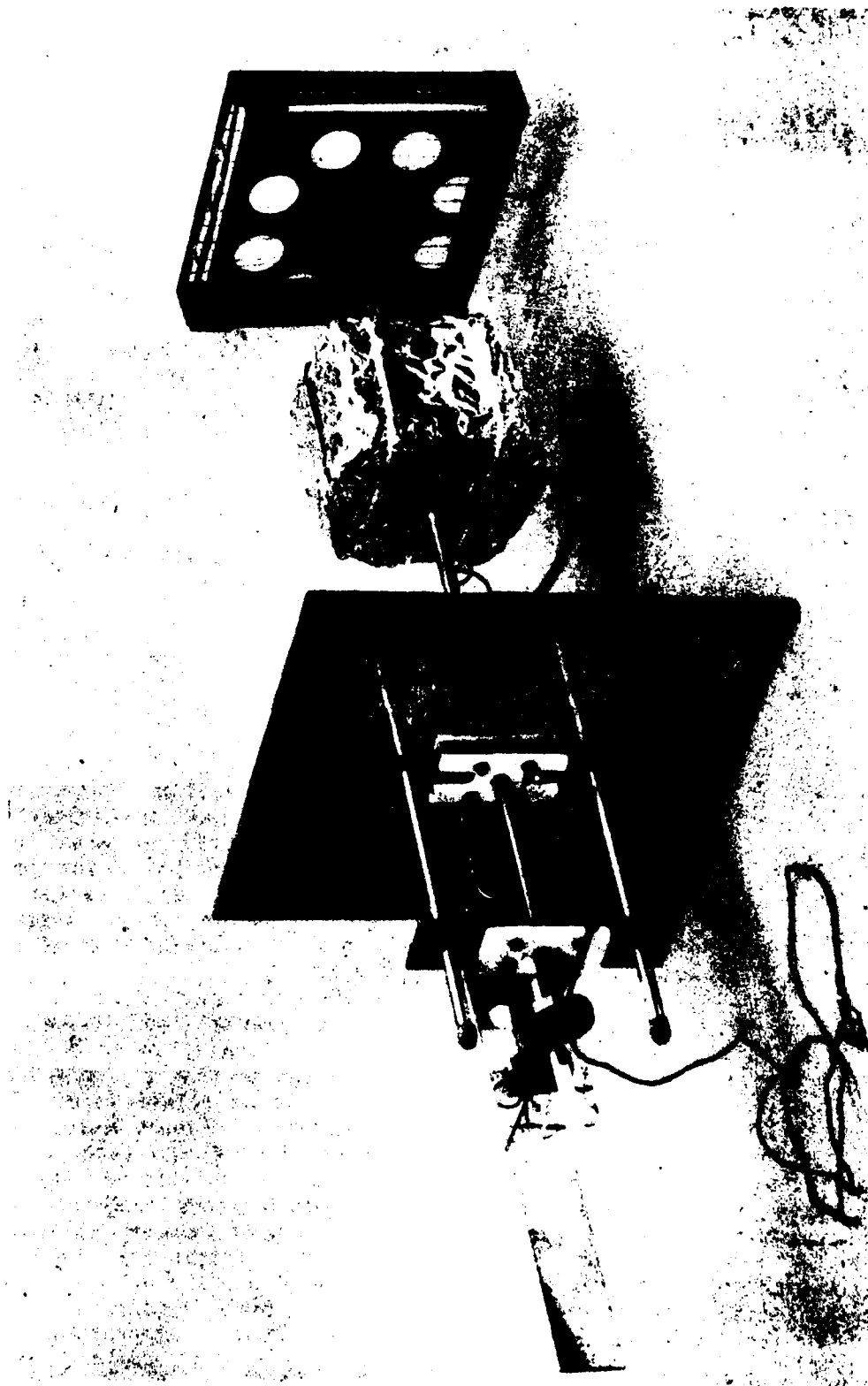

FIGURE 1. MASS LOSS TRANSDUCER AND SAMPLE HOLDER INJECTION ASSEMBLY

loss in the computer data acquisition program after standardizing runs are made. As shown in the Figure 2 schematic, a known constant flow of cool (ambient) air is introduced into the hold chamber to keep this area cooler prior to a test run. Immediately after placing the sample holder MLT assembly in the hold chamber, the 3 way valve must be turned to divert the airflow at the same rate into the MLT housing to assure temperature stability. This airflow (230 ft³/hr.), is included with the main airflow rate set for the HRR chamber. It does not shift the thermal baseline set for the calorimeter, since the air flows out of the MLT unit into the main chamber as part of the total flow, and the baseline is taken after the air is diverted into the MLT.

A six position, neutral density filter wheel is mounted in front of the smoke meter sensor housing to calibrate the smoke meter. This contains neutral density filters having optical density values of 0.1, 0.2, 0.3, 0.4, and 0.8 with the sixth left blank for the test run.

GAS SAMPLING AND CALIBRATION SYSTEM - The gas sampling and monitoring system (see schematic Figure 2) for the CHAS includes the following:

1. A 3/8" O.D. Teflon[®] (TFE) coated stainless steel (SS) gas and smoke sampling probe installed through the side wall of the chimney using a standard SS Swagelok bulkhead fitting.
2. A heated 248°F (120°C), heavy wall TFE gas distribution line conducts gas flow through a valve directly into the animal test system (SATS). A heated fiber glass smoke filter and acid gas scrubber system is connected between the pumps and gas monitors.
3. A gas monitor calibration system consisting of span gas mixtures, pure gases, and zero gas needed to adjust the monitors prior to a test run. A valve controlled auxiliary gas supply from this calibration gas manifold permits the operator to direct the flow of selected span gas mixtures through the gas monitoring train, or by turning the 3-way valve, of pure gases into the HRR chamber through a 1/4" perforated gas introduction tube.

The HCN monitor is calibrated directly using a permeation tube heated oven and flow control/mixing unit (Reference 3). HCN mixtures in compressed cylinders are generally unstable for use; because of the reactivity of this gas with cylinder walls, the concentration may change daily.

Standard flow control valves, flowmeters, SS tubing (0.25 in. x 0.026 in. wall), TFE diaphragm pumps, 47 mm diameter filters, 50 ml syringes, standard SS and TFE fittings, heating tapes and autotransformers, an electronic digital timer, and TFE diaphragm pumps complete the gas sampling system.

A descriptive list of all monitors and parts for this system appears in the Equipment List section of Appendix A.

The detection and quantitative accuracy of measurement of the individual gases depends on maintaining the integrity of the sample. Care must be exercised to prevent undue loss of the reactive gases, HF, HCl, HCN, aldehydes, etc. in the tubing. Heated TFE lines, fittings and valves are used at critical locations to reduce losses of the reactive gases by condensation or absorption up to the

HP AUTOMATIC DATA ACQ. SYSTEM

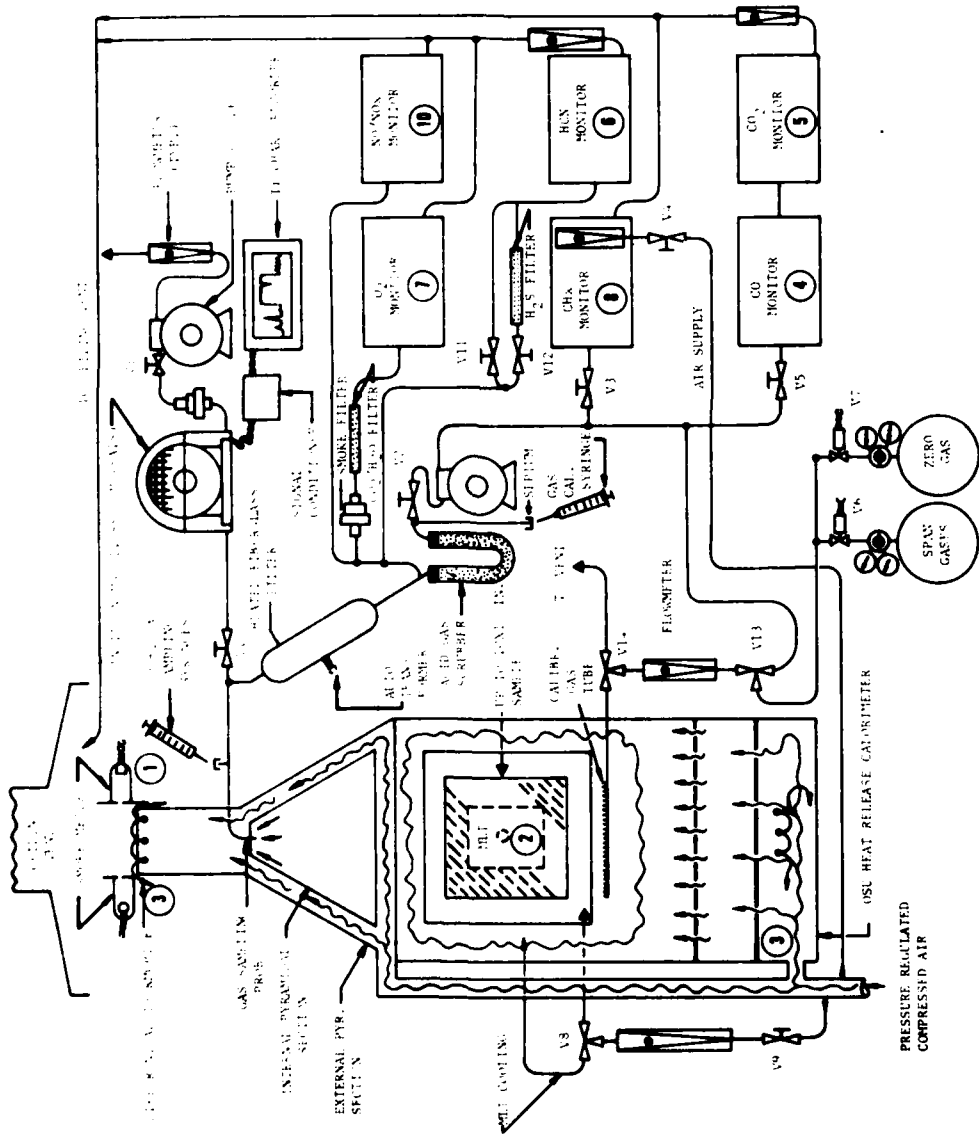
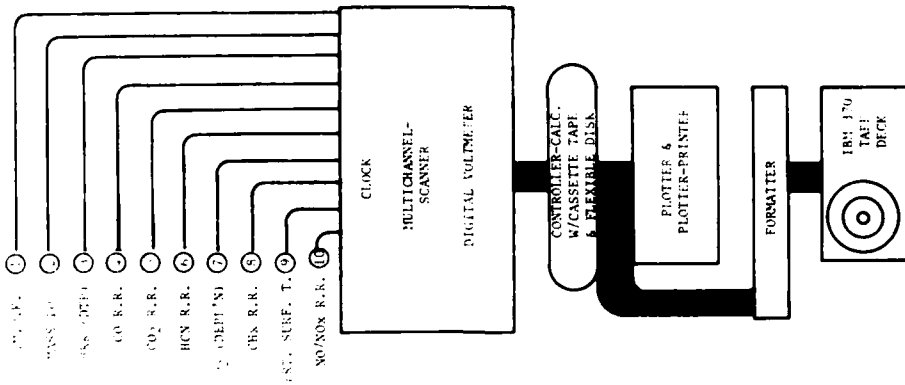

FIGURE 2. SCHEMATIC DIAGRAM OF THE CHAS/SATS

point at which they are sampled, while selectively removing the active components (HF, HCl) that will damage the CO, CO₂, O₂, and CH_x gas monitors downstream. Thus, a TFE "T" fitting with a septum is installed at the gas sampling probe line close to the chimney to withdraw syringe gas samples at timed intervals for HCl, HF, aldehydes and other gases not monitored in real time. The smoke and acid gases are removed in tandem by the heated 2 x 12 inches (50 mm O.D. X 30.48 mm) filter tube filled with fiber glass and the acid gas glass (or SS) U-tube scrubber guarding the pump and the real time gas monitors. By design, the OSU HRR Calorimeter divides the airflow so that 75% of the total flows through the outer pyramidal section (see schematic) and the remaining 25% flows upward over the burning test specimen and exits from the inner pyramidal section into the chimney. The gas sampling probe is positioned below the outlet of the inner pyramidal section to avoid the 3 times dilution of released gases that would result if the probe were placed at the top of the chimney. At a total flow of 60 ft³/min (1699 liter/min), 15 ft³/min (424.7 liters/min) flows through the internal pyramidal section. The flow rate of gases pumped through the sampling probe is much lower: 0.035 ft³/min (1 liter/min) through the CO, CO₂ and CH_x monitors (connected in series), and the HCN and NO/NO_x monitors; 0.01766 ft³/min (0.5 liter/min) through the O₂ monitor, and 0.4944 ft³/min (14 liter/min) through the SATS. Flows can be adjusted to isokinetic levels, if required by adjusting the flow rate or installing a probe with a different inlet opening size. Under current operating flow conditions the ratio of extracted gas flow to mainstream flow is so low (approximately 1%) that reversal of outer pyramidal section air flow is avoided.

The CO and CO₂ monitors are not subject to interferences or nonspecific response at the concentration levels of gases released in the analyte combustion product stream if the gas cell drying agents provided in these instruments are maintained.

The microfuel cell sensor in the O₂ monitor (Infrared Industries) is specific for oxygen and will not lose sensitivity even if it is exposed to atmospheres containing high concentrations of CO₂.

The unburned hydrocarbons and other combustible gases (including CO) are measured by the CH_x monitor in terms of a methane (CH₄) equivalent. Oxygenated and other hydrogen substituted combustible gaseous species (alcohols, ethers, esters, aldehydes, etc.) are also detected.

The HCN monitor silver electrode detector responds to Cl₂ and H₂S in addition to HCN. However, Cl₂ gas is not normally produced from chlorine containing polymeric materials subjected to fire environments. Materials such as wool carpeting or wool/nylon seat fabrics do contain sulfur and evolve quantities of H₂S in fires. A H₂S filter, Appendix A, Figure 6, was developed to remove H₂S gas from the analyte stream sampled by the gas train in the monitor. This filter, which consists of a heated "1" inch diameter (2.54 cm) glass tube 6 inches (20 cm) in length filled with a loosely stratified pack of fiber glass alternated with powdered lead carbonate, efficiently removes H₂S with little loss of HCN. During the testing of all panel materials, the HCN monitor was used without the lead carbonate filter for both the laboratory and full-scale testing, since elemental sulfur was absent and H₂S was not evolved.

TABLE 1

CHAS INSTRUMENTATION MEASUREMENT CHARACTERISTICS

INSTRUMENT	H.P. 3052A CHANNEL	RELEASE RATE PARAMETER MEASURED	RANGE	CHAS DETECTION DELAY TIME
OSU Design	1	Smoke Optical Density	0-2	0.2 sec
West Coast Res. Corp. & Dac	2	Mass-Loss, g/min	2-1000 g.	0.01 sec
OSU HRR Cal.	3	Heat Release, Kw/m ²	2-2000 kw/m ²	2 sec
MSA LIRA 303	4	CO, ppm V/V	0-7500 ppm	17 sec
Beckman 864	5	CO ₂ , % V/V	0-2.5%	18 sec
Kin-Tek (Dow)	6	HCN ppm V/V	0-100 ppm	30 sec ^③
Teledyne 326A ^①	7	O ₂ , % V/V	0-25%	20 sec
Infra Red Ind. ^②	7	O ₂ , % V/V	0-2.5%	19 sec
Teledyne 175	8	CH ₄ , % V/V	0-2.5%	19 sec
Material Surface Thermocouple CR-AL Type "K"	9	Material Temp, °K	0-1000 °K	0.1 sec
Thermoelectron Corp. ^④	10	NO/NO _x , ppm V/V	0-10,000	15 sec

① Used for Panel 1 tests

② Used for Panels 2, 3 and 4 tests.

③ Reduced to 6 sec for Panels 2, 3 and 4 tests.

④ Used only for Panel 2, 3 and 4 tests.

The gas monitors are commercially available instruments and essentially detect and quantitatively measure each gas selectively with minimum or no interference from other gases in the combustion mixture. Table 1 lists the monitors used and the analytical sensing method employed by each instrument employed in the CHAS.

Two dual pen strip chart recorders plot the analog outputs from the HRR Calorimeter thermopile, smoke meter, MLT, and one other parameter; or, alternatively, sample front surface radiant flux levels, or carbon monoxide release. These recorders are useful for pretest adjustments of airflow versus radiant panel energy settings and observation of heat and smoke meter baselines prior to beginning a test. They also afford some degree of redundancy and a check of the

reproducibility of the on-line Hewlett Packard data acquisition/reduction system (HP-ADAS). The data is stored on the HP 9825A calculator tape cassette (or disk) from each channel identified on the schematic, Figure 2 and in Table 1. For a 10 minute burn period, 6000 data points are recorded defining the primary combustion characteristics of the material for use in the FACP. At this stage, the data may be processed and reduced using the HP 9825A programs delineated in Appendix A. The output available from these programs consists of individual plots (HP 9862A) showing the rate of release of heat, smoke, and gas, and mass loss as the material burns in the HRR chamber, and a list of digitized data (HP 7245A) for each hazard over the burn period, if desired. The HP 9825A tape cassette data is then transferred to IBM 370, 9 track 900 BPI 7 inch tape using the BPIB buffered controller Dylon model 1015A formatter/tape recorder. This interface system translates the HP acquired data into language compatible for use with the Fortran IV programming required in the IBM 370 computations of CHI. Figure 3 shows the HP data acquisition/reduction system and the Dylon formatter/tape accessories.

ANIMAL TIME TO INCAPACITATION TEST CHAMBER - In order to utilize animal time-to-incapacitation (T_i) as a measure of the toxicological hazard, Douglas designed and fabricated an exposure chamber, Figure 4. The plexiglas chamber, has a central shaft driven at low RPM by a variable speed electric motor/gear reduction drive mechanism. A contact bar, positioned in the slot of the split wheel, is supported on a flexible beam containing a strain gage at each end of the contact bar. This provides an assembly that outputs deflection voltages generated when the animal (rat) steps on, or contacts the bar. The voltage outputs from each strain gage are summed in a signal conditioner and then recorded using a standard strip chart instrument having a full-scale response of 2 - 50 MV/full scale. A sensor of slightly different design was developed at FAA Technical Center, formerly NAFEC by Dr J. Spurgeon (Reference 4). This single wheel animal test system (SATS) has been integrated with the CHAS to obtain T_i data along with the other monitored release rate data. Because of the dilution occurring in the HRR continuous flow chamber, toxic dose buildup in the animal chamber must be attained rapidly to obtain a T_i or T_d (time-to-death) result in less than 20 minutes. The developed test procedure, therefore, provided for a gas and smoke pumping rate of $0.494 \text{ ft}^3/\text{min}$ (14 liters/min) through the chamber which has a free volume of 0.19 ft^3 (5.4 liters/min). This sampling rate, therefore, allows 2.59 nominal volume interchanges per minute. The SATS chamber was isolated at the highest CO production rate and held in this condition while the T_i test was completed.



FIGURE 3. CHAS DATA ACQUISITION AND PROCESSING SYSTEM

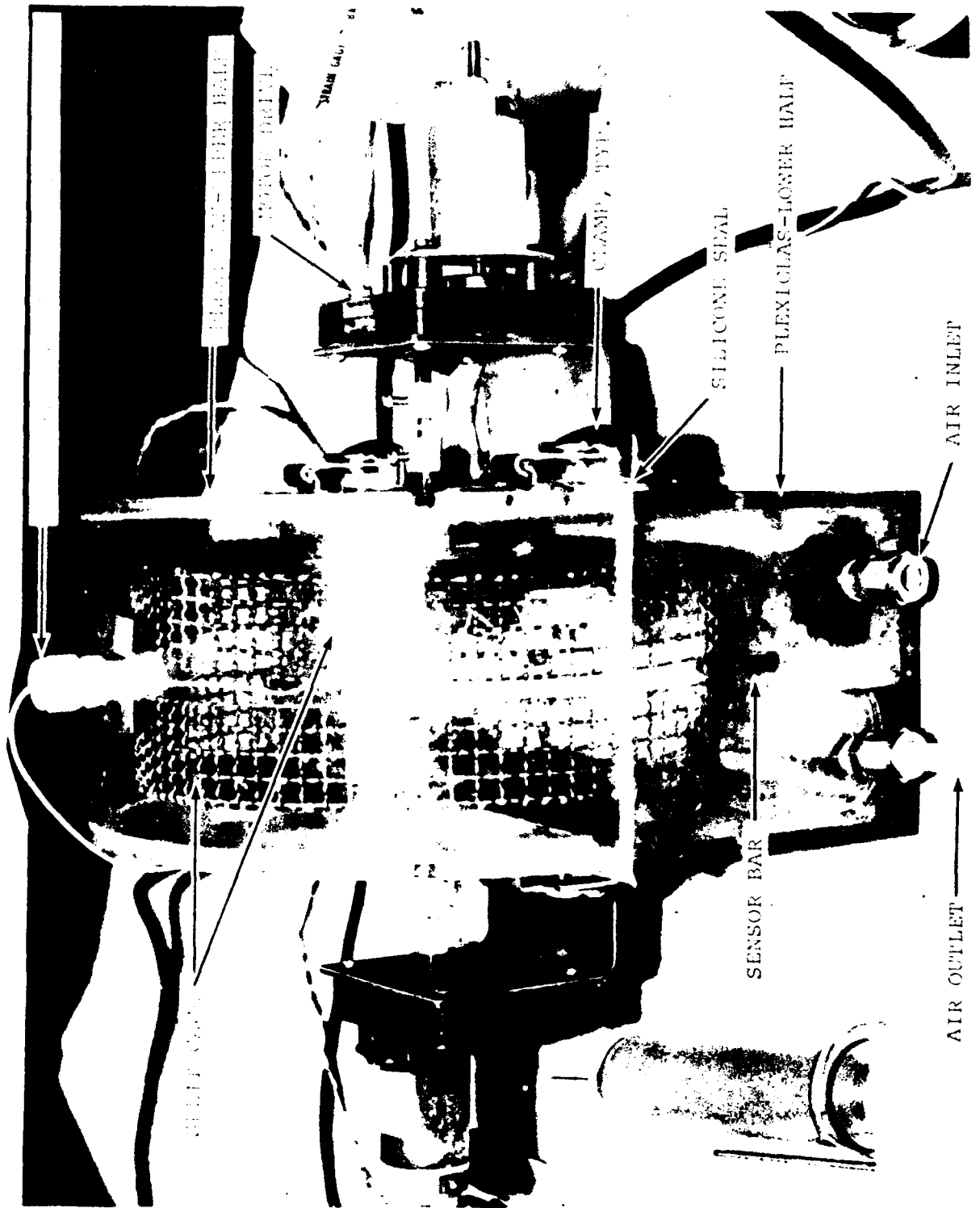

FIGURE 4. SINGLE ANIMAL TEST SYSTEM (SATS)

CALIBRATION OF CHAS/SATS

Each of the subsystems of the CHAS/SATS require calibration on a run-to-run or day-to-day basis to ensure repeatability and accuracy of measurements. A set of calibration curves must be plotted, one for each fire response parameter, that relates the change in analog signal output (millivolts) with the quantity (concentration) of the parameter being measured. A polynomial curve fit of the plotted data is calculated. The coefficients for each parametric polynomial equation are used in the HP data acquisition/reduction program to digitize the data output by the CHAS instrumentation.

HEAT RELEASE RATE BY UNCOMPENSATED DTP - Preliminary to a run, two HRR calibration measurements are made: (1) a reading of the Globar radiant heat flux at the center and at the same distance away as the front surface of the test sample during a run using a calibrated, water cooled, Hycal[®] Calorimeter, and (2) adjustment of the airflow rate to that selected for the test [60 ft³/min (1699 liters/min)] using a calibrated absolute pressure differential gauge - orifice meter and a flowmeter to set the airflow through the hold chamber/MLT unit. The HP-ADAS program contains a section useful for adjusting the differential pressure reading to set the flow rate.

The temperature difference between air entering the main burn chamber of the HRR Calorimeter and that leaving is monitored by a thermopile (TP) having 3 cold and 3 hot 24 gauge chromel-alumel junctions. The hot junctions are spaced across the top of the exhaust stack (See Figure 2). The cold junctions are located in the air distribution pan at the bottom of the chamber below the air distribution plates.

Two parameters must be set to determine the heat release factor for the HRR Calorimeter: (1) the airflow rate and (2) the volume of fuel gas, of known heat content, burned per unit time in the HRR inner chamber.

A 7-flame calibration burner tube is substituted for the lower pilot light to accomplish the calibration runs, as described in detail in Reference 1.

A sharp edge type orifice and differential pressure gauge is used to adjust the airflow rate through the HRR chamber. A standard flowmeter and parallel, valve controlled, air supply is adjusted to a flow of 230 ft³/hr to ventilate and cool, alternately, the hold chamber or the MLT unit during a run. Table 2 lists a range of differential pressure gauge settings versus the corresponding airflow rates that may be used for both calibration and test runs. Figure 5 shows a plot of differential pressure versus airflow using data from Table 2. A total flow of 60 ft³/min (1699 liters/min) total airflow split to provide 56.17 ft³/min (1591 liters/min) through the HRR air distribution system, and 3.83 ft³/min (108 liters/min) through the hold chamber or MLT unit was selected as the operational mode for all testing. Natural gas (90% methane) having a heat content of 1060 Btu/ft³ (with some seasonal variation) or some other gas, such as propane, (with a known heat content) is used for this calibration.

With the airflow adjusted to the selected test level, and the gaseous fuel supply connected to a wet test gas meter and to the multiple flame burner placed over the end of the pilot flame tubing using a gas tight connection, proceed as follows by referring to the schematic of Figure 6:

TABLE 2
AIRFLOW RATES VERSUS DIFFERENTIAL PRESSURE READINGS

P GAUGE READINGS		EQUIVALENT HRR TOTAL AIRFLOW		ADJUSTED AIRFLOW TOTAL AF-MLTAF ①		ADJUSTED P	LINEAL AIRFLOW RATE OVER SAMPLE	
PSI	INCH Hg	ft ³ /min	l/min	ft ³ /min	l/min	INCH Hg	ft./min	cm/sec
0.3	0.61	20	566	16.17	458	0.43	4.04	2.05
0.6	1.22	30	849	26.17	741	0.92	6.54	3.32
1.0	2.04	40	1133	36.17	1025	1.73	9.04	4.59
1.57	3.20	50	1416	46.17	1308	2.65	11.54	5.86
2.20	4.48	60	1699	56.17	1591	3.93	14.04	7.13
2.94	5.99	70	1982	66.17	1874	5.35	16.54	8.40
3.78	7.70	80	2265	76.17	2157	7.02	19.04	9.67
4.71	9.59	90	2548	86.17	2440	8.86	21.54	10.94
5.75	11.71	100	2832	96.17	2724	10.91	24.04	12.21
6.80	13.84	110	3115	106.17	3007	12.83	26.54	13.48
8.00	16.29	120	3398	116.17	3290	15.27	29.04	14.75
9.10	18.53	130	3681	126.17	3573	17.71	31.54	16.02
10.30	20.97	140	3964	136.17	3856	20.10	34.04	17.29

① Adjusted Airflow = Equivalent HRR Total Flow-Hold Chamber, MLT Airflow Hold Chamber or MLT Airflow = 230 ft³/Hr = 3.83 ft³/min
Equivalent HRR Total Flow used for Tests = 60 ft³/min
Substituting above airflow values:

Adjusted Airflow = Equiv. HRR Total Flow - 3.83 ft³/min = 60-3.83 = 56.17 ft³/min airflow set for HRR Chamber input.

NOTE: The values listed in Table 2 and plotted in Figure 10 relate only to the orifice meter used with the CHAS. Other meters and equipment will require individual calibration.

1. Open the valve from the natural gas main supply (be sure flow control valves V1 & V2 are closed).
2. Switch 3-way valve, V3, to supply natural gas pressure from the main tap to valve V1.
3. Slowly open V1 until wet test meter shows a low flow of gas is being delivered to the multiple flamelet burner, and ignite the burner.
4. Adjust V1 until flamelet heights are approximately 1.6 inches (4 cm) or 0.4-0.6 inch water manometer differential pressure is observed. Heat release should be not less than 80 Btu/min (1.4 kW).
5. Switch V3 to the other bypass leg supplying V2 with gas.
6. Open V2 until wet test meter shows flow, and reignite multiple flamelets on burner.

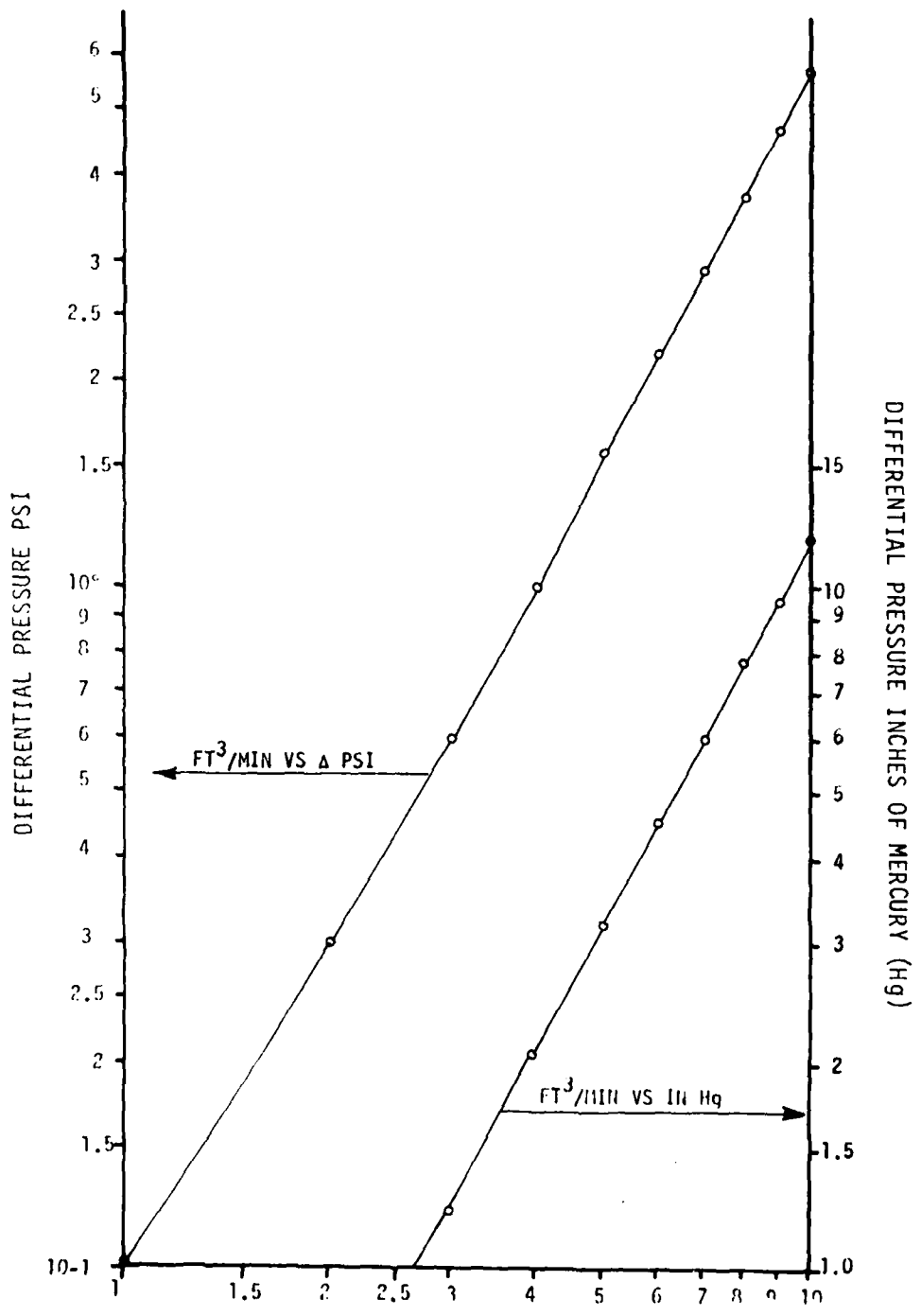

FIGURE 5. CALIBRATION CURVE-HRR CALORIMETER AIRFLOW RATE VERSUS PSI AND INCHES OF MERCURY

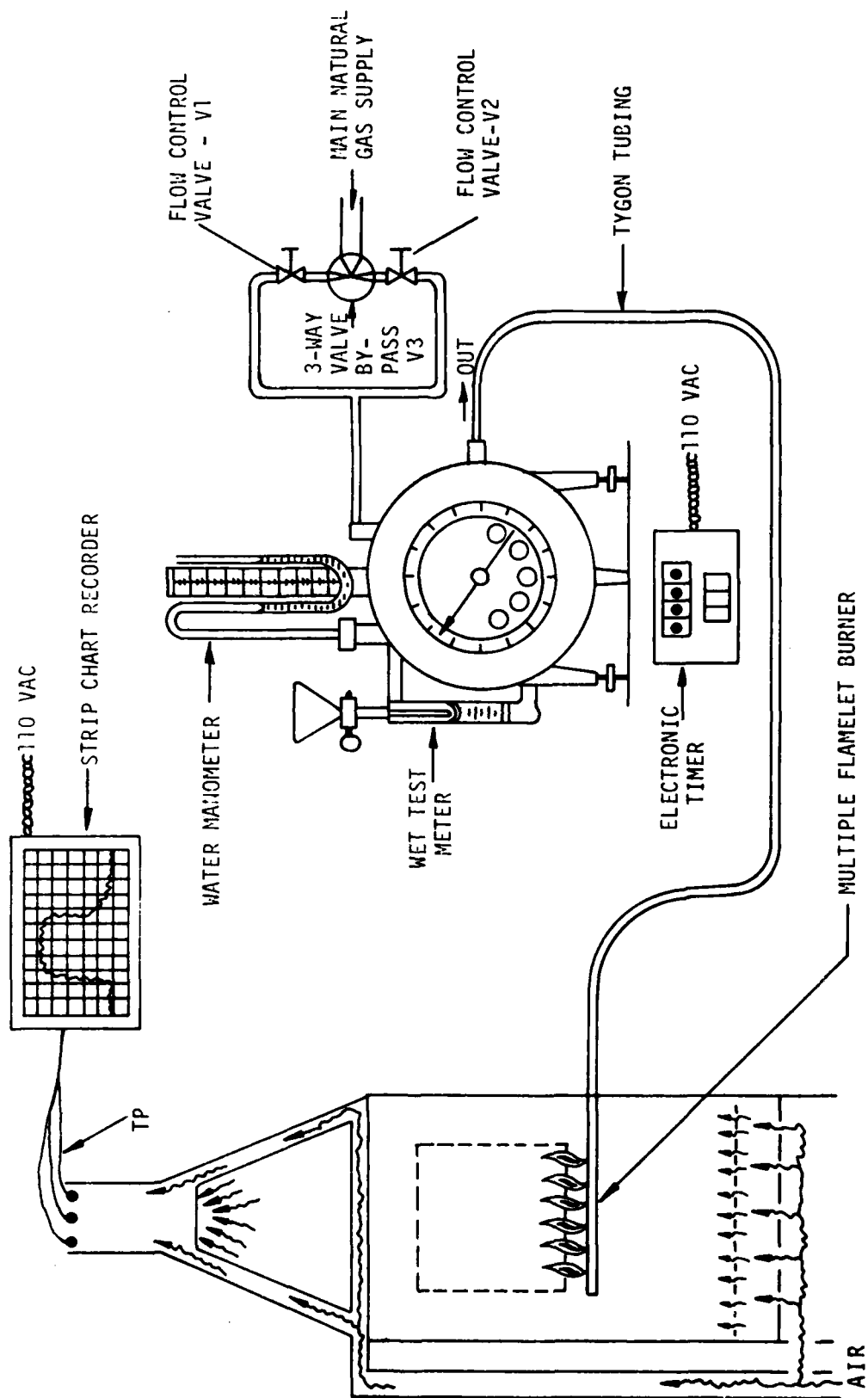

FIGURE 6. SCHEMATIC OF HRR CALIBRATION EQUIPMENT ASSEMBLY

7. Adjust V2 until flamelet heights are approximately 8-10 inches (20-25 cm.). Water manometer pressure should not exceed limits for instrument (usually about 6 inches), and heat release should not exceed 440 Btu/min (7.75 kW).
8. Switch V3 back to flow into V1 bypass leg and allow thermopile reading (mv) to stabilize on the strip chart recorder. This establishes baseline which should not vary from steady state "zero" readings for 5 minutes by more than ± 0.02 mv read from the strip chart recorder.
9. Set wet test meter dials to zero and start electronic timer as meter needle passes zero.
10. Allow low flame condition on burner to establish baseline for a time sufficient to burn 1-2 ft³ of natural gas and record the wet test volume and the time (in seconds) in the appropriate columns in Table 3.
11. Switch V3 to high flame condition in the multiple flamelet burner. The DTP signal level recorded on the strip chart recorder should move sharply upward (+ mv direction).
12. Reset to zero all dials on wet test meter and on the electronic timer. Restart time as main meter needle passes zero.
13. Allow high flame burn to continue for not less than 10 minutes. Record wet test meter volume and elapsed time on the timer and the mv response above baseline from the recorder chart in the appropriate columns of Table 3. Reference 1 calls for recording the mv response at 4-minute burn intervals until a constant increase and decrease of the mv signal to baseline is achieved.
14. Repeat steps 7 through 13 at least three more times, adjusting flamelet heights to different levels by use of valve V2. Record natural gas consumption and mv DTP response for each run in Table 3.
15. Using the formulas provided in Table 3 calculate the kW/m²/mv conversion factor that corresponds to the sample size to be tested.
16. Record baseline heat absorption profiles for the specimen holder (without specimen) at each radiant heat flux level used for testing materials.

This calibration factor for heat release, kW/m²/mv and the specimen holder baseline corrections are input into the HP-ADAS program for use in calculating and plotting the data recorded during an experimental burn test in the CHAS, only if the DTP is used to measure heat release rates.

RADIANT HEAT SOURCE - The radiant heat source, which consists of 4 silicon carbide elements (Global, Union Carbide Co.) is used with a variable autotransformer power source to generate heat flux levels up to 8.81 Btu/ft² sec (10 W/cm²). A working curve similar to Figure 7 is plotted to allow rapid setting of the radiant flux level by adjusting the voltage input into the Global elements. This is accomplished by reading the radiant flux at 4 inches (also the test sample distance) from the radiant panel using a Hycal model R-8015-C radiometer for vertical specimens and a P-8400-J pyroheliometer

TABLE 3
HRR CALIBRATION

CALIBRATION GAS : HEATING VALUE : BUT/FT³ ; AIRFLOW : FT³/MIN; DATE :

NO.	GAS FLOW-WET TEST METER		TIME SECONDS	VL FT ³ /MIN	TIME SECONDS	NET GAS FLOW FT ³ /MIN ²		HEAT RELEASE RATE BTU/HR, KW	HRR FACTOR VS SAMPLE SIZE	
	VH FT ³ /MIN	(VH x 60) - (VL x 60) SEC				BTU/HR, KW	KW/m ² /mv/SAMPLE			
										0.02323 m ²
										0.06452 m ²
										6 x 6 SAMPLE (10 x 10 SAMPLE)

V_L = VOLUME OF CAL. GAS BURNED FOR BASELINE RUN
 V_H = VOLUME OF CAL. GAS BURNED FOR SELECTED STEP RESPONSE
 $V_H \times 60$ $V_L \times 60$ STEP FLOW-FT³/MIN
NET GAS FLOW = $\frac{\text{SEC FLOW} \times \text{SEC FLOW}}{\text{PER WET TEST METER}}$

 $\text{NGF} \times 1060 = \text{HRR, BTU/MIN} \times 0.01757 = \text{HRR, KW}$
FOR 6 x 6 INCH SAMPLE, $\text{KW/m}^2/\text{mv} = [\text{NGF} \times 80] .7$
 $\div \text{mv RESPONSE FOR 10 x 10 INCH SAMPLE KW/m}^2/\text{mv} =$
 $[\text{NGF} \times 288.65] \div \text{mv RESPONSE.}$

for horizontal specimens. Figure 8 is a copy of the National Bureau of Standards based plot of the R-8015-C Calorimeter millivolts output against the measured radiant heat flux. The use of voltage settings per Figure 7 to obtain a desired radiant flux level is reliable for a period of 1-2 months. With ageing and extended use, the heat flux output versus voltage of the power transformers will change slowly, necessitating restandardization with the Hycal calorimeter.

SMOKE METER - Special neutral density filters have been mounted in a wheel. These are needed for setting the range of the smoke meter and obtaining mv versus optical density readings from which a calibration curve and polynomial equation curve fit can be determined and used during a test run. The filters have been accurately measured for optical density using a spectrophotometer.

MASS LOSS TRANSDUCER (MLT) - The mass loss transducer has the following operational parameters:

- o Total sample weight (plus holder) = up to 2 Kg (0.9 lb.)
- o Nonlinearity - less than 1% at ambient temperature
- o Baseline Thermal Drift = 0.1% for first 5 minutes; and less than + 2% for second 5 minutes of test at 5 W/cm² HRR radiant flux setting.
- o Dynamic Response = 0.1158 mv/V/100 grams

A calibration curve for the MLT is generated by plotting the change in millivolt output versus weight change by "dead loading" the sample holder, with standard calibrated analytical balance weights. An HP plot of this calibration showing the linearity of response of the MLT appears in Figure 9. The slope of this curve is calculated to obtain the dynamic response value (millivolt/100g wt. change/volt excitation) which is used in the HP data reduction program to determine the mass loss burning rate of the material mounted in the sample holder.

GAS MONITORS - Calibration of the gas monitors was accomplished either (1) directly by flowing standard analyzed gas mixtures of varying composition supplied sequentially from compressed gas cylinders fitted with 2-stage

Regulators and manifolded on the gas system input to the monitors, as shown in Figure 6, or (2) by introducing the pure gases by a tube located below and near the plane corresponding to the test specimen front surface. Method (1) was used to set zero and gas monitor span readings prior to each run. The additional span gas mixtures are useful in checking the instrument responses and preparing the calibration curves for each. Method (2) provides a technique (as discussed in Reference 2) of injecting pure gases directly into the HRR chamber to closely simulate the way in which gases are evolved by the test sample and to provide accurate system response delay time for each monitor. Method (1) was used to prepare the calibration curves for the testing described in this report, since direct calibration requires larger quantities of high purity gases for each monitor.

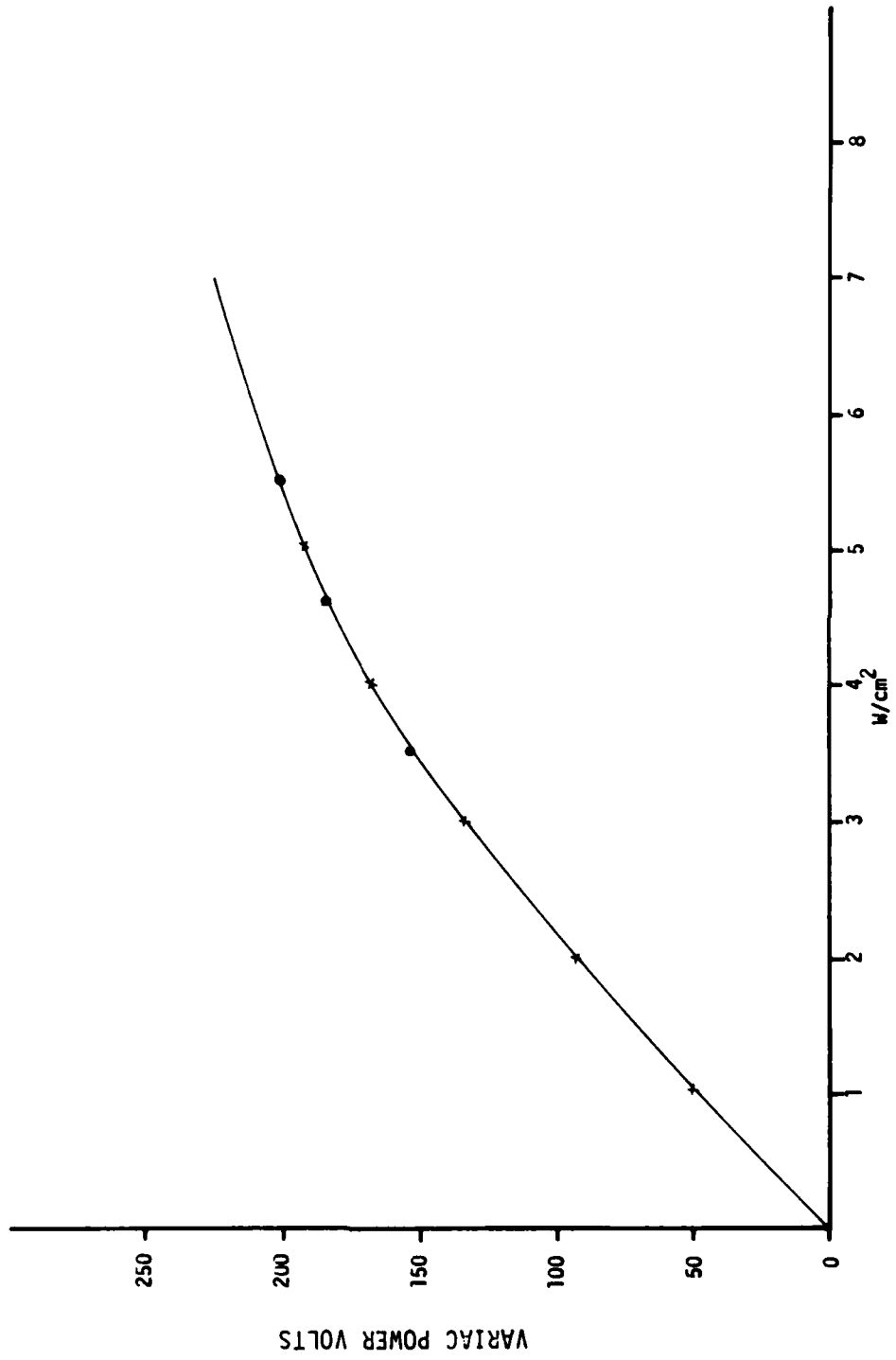

FIGURE 7. GLOBAL PANEL RADIANT FLUX VS AUTOTRANSFORMER VOLTAGE SETTINGS

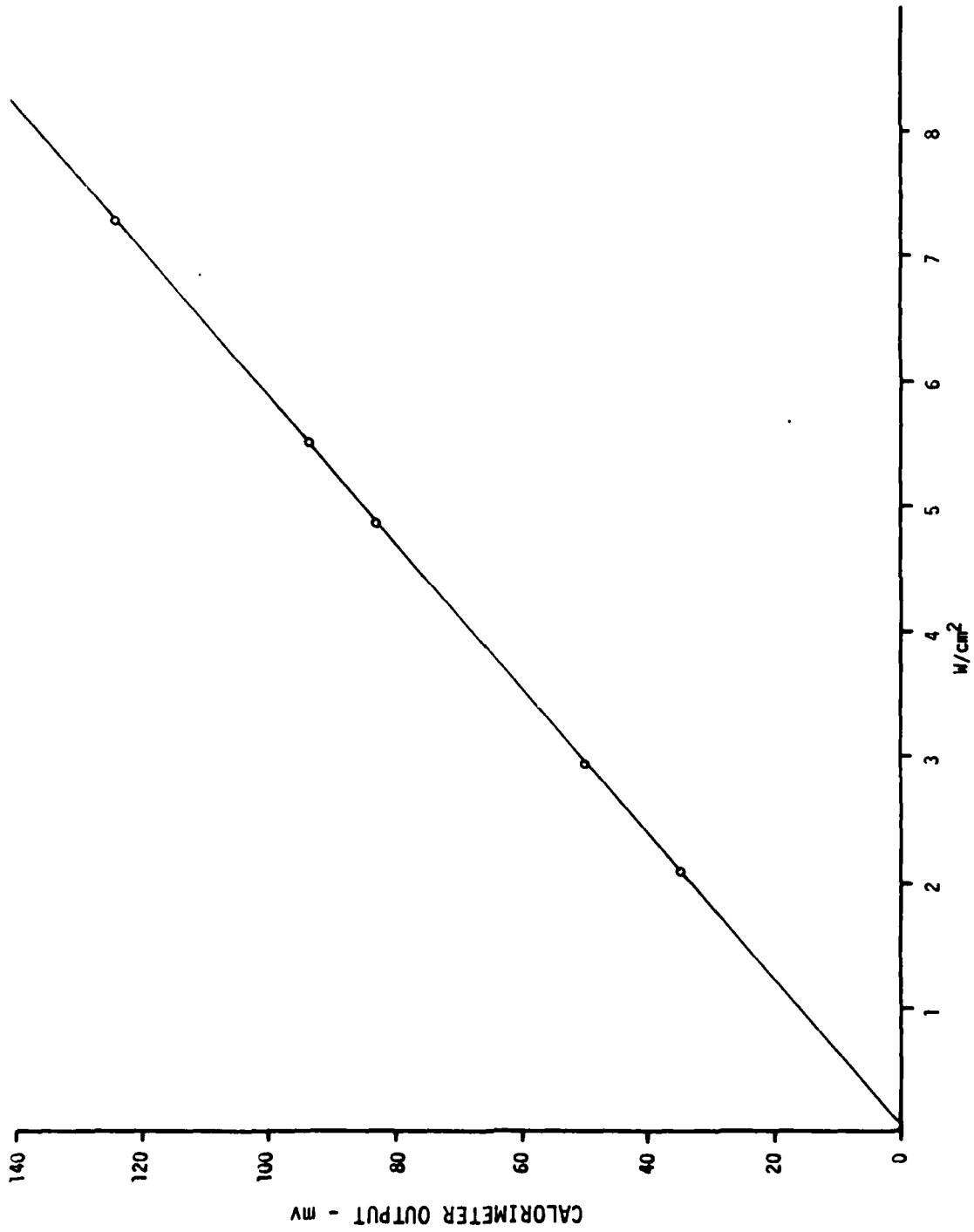

FIGURE 8. HICAL MODEL R-8015-C RADIOMETER CALIBRATION CURVE

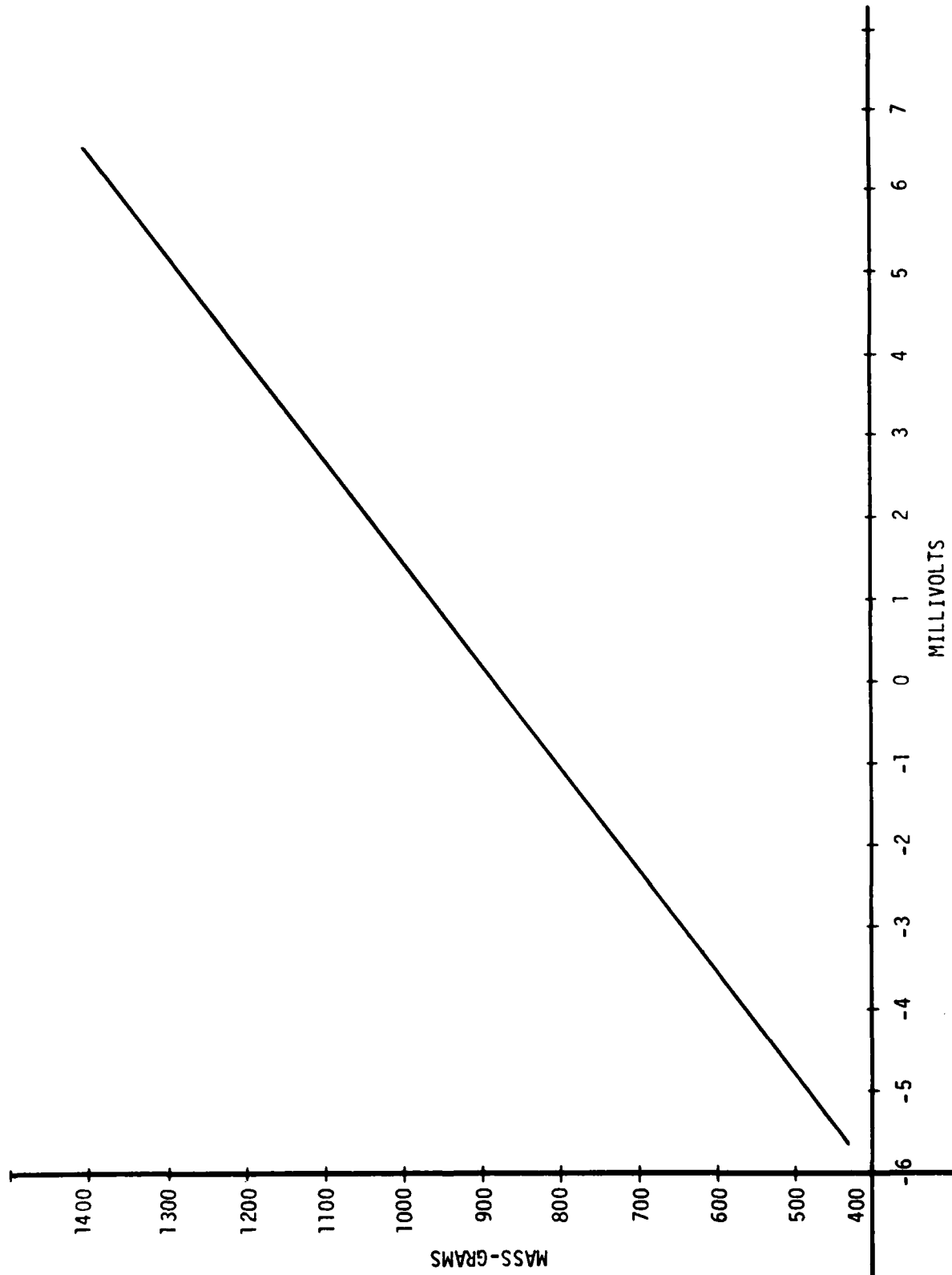

FIGURE 9. MLT CALIBRATION CURVE

Table 4 summarizes the span gas mixtures (Matheson analyzed and certified) used for calibration.

TABLE 4
STANDARDIZED SPAN GASES & MIXTURES
(Compressed Gas Cylinders)

SPAN GAS NO.	GAS CONCENTRATIONS IN CYLINDER					
	% CO	% CO ₂	% O ₂	% CH ₄	% N ₂	% NO
1-S	0.3654	2.086	18.46	0	BAL	0
2-S	0.4100	2.170	1.97	0	BAL	0
3-S	0.2086	1.245	15.88	0	BAL	0
4-S	0.1083	0.8184	12.57	0	BAL	0
5-S	0	0	0	5.0	BAL	0
6-S	0	0	0	0	99.5	0
7-S	0	0	0	0	BAL	0
1-C	99.5	0	0	0	0	0
1-B	0	99.5	0	0	0	0
1-C	0	0	0	99.5	0	0

The analyzer and certified compressed gas cylinder mixtures (span gases 1-S through 7-S) are suitable for calibration for the CO, CO₂, O₂, NO/NO_x, and CH_x monitors.

Calibration curves for CO and CO₂, Figures 10 and 11, were plotted by the HP 3052A ADAS system using the output readings obtained from the standard span gas mixtures listed in Table 4. These curves were programmed in the calculator to obtain the respective polynomial equations and coefficients using a curve fit routine.

The response of the O₂ monitor is a straight line in the range from zero to 25 percent oxygen depletion. Thus, for this instrument, the baseline is set to the known air concentration (20.95%) for each test.

Tests employing blends of methane in nitrogen gas in the range of zero to 5% methane show that the total combustibles monitor is also quite linear in response. Span gases 5-S and 6-S are used to calibrate and set the range of response of the detector output prior to a test (Method 1 and 2).

Experience with these monitors has shown each to be quite stable, uniform in repeatability and free from drift during 8-hour test periods. More frequent calibrations to set baselines and spans are required for the CO and CO₂ monitors if the barometric pressure changes greatly during the day. The CH_x monitor airflow and sample flow settings require frequent adjustment to achieve repeatable readings.

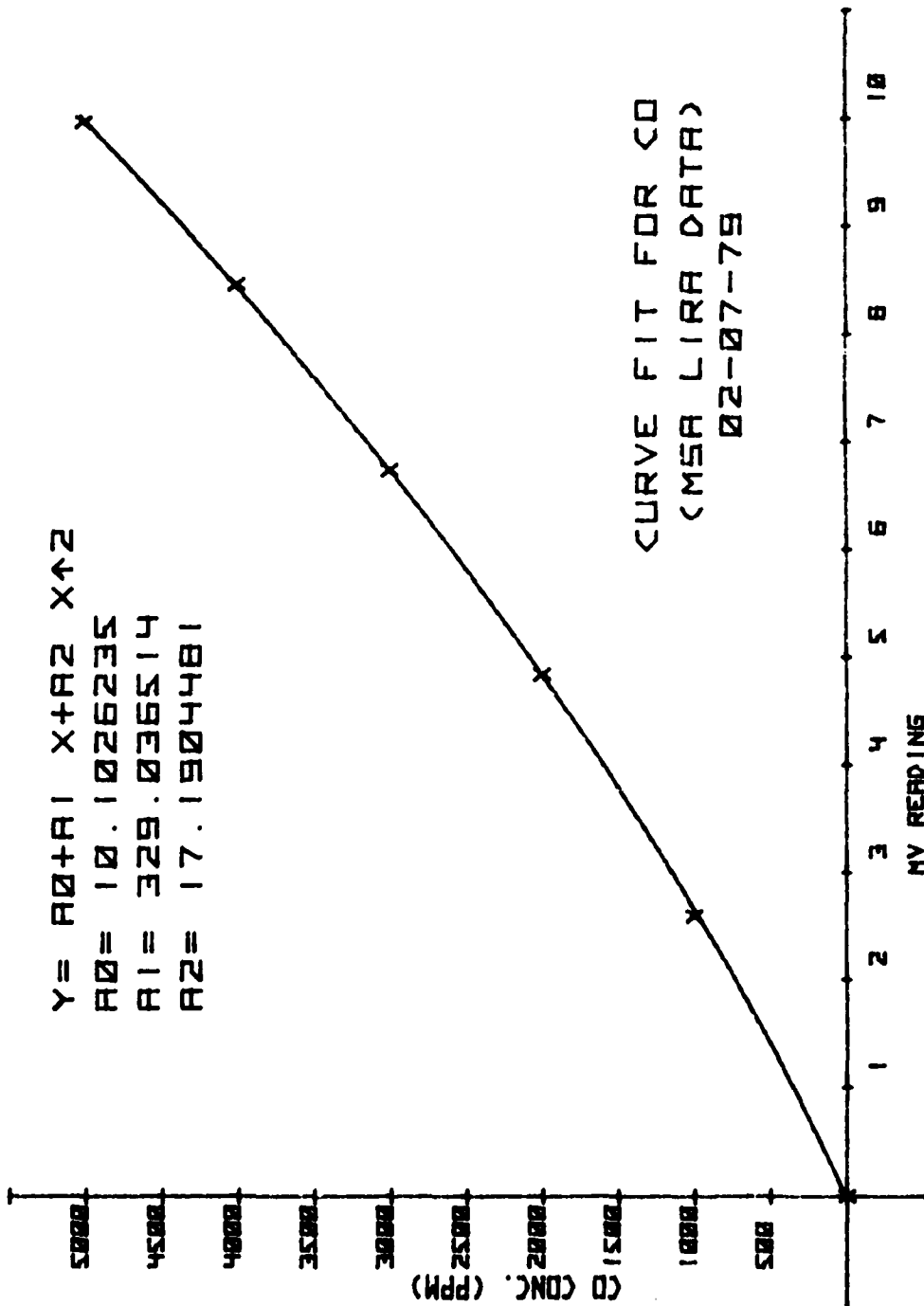

FIGURE 10. CO CALIBRATION AND POLYNOMIAL EQUATION CURVE FIT

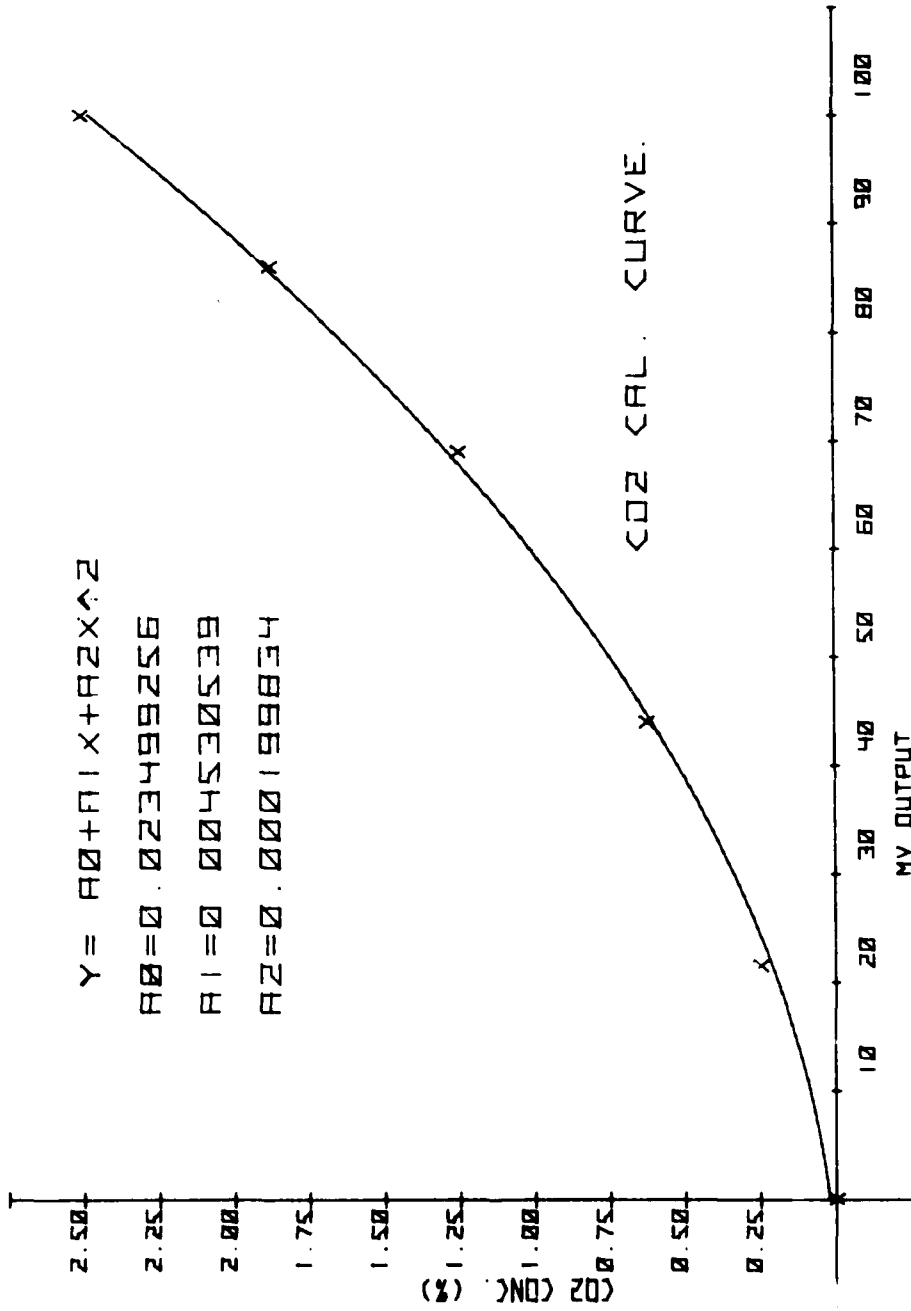

FIGURE 11. CO₂ CALIBRATION AND POLYNOMIAL EQUATION CURVE FIT

The CHAS gas sampling system (Figure 2) is provided with a hypodermic syringe septum and gas introduction line plumbed into the system upstream of the pump. This is a useful feature since it permits injection of large syringe (1500 ml) serial dilution mixtures of CO, CO₂, O₂, CH_x to check instrument calibration and the standard gas cylinder mixtures for significant changes in calibration gas concentration due to "ageing" in cylinders over long periods of use. The line connecting the acid gas scrubber to the valve upstream of the pump (V2) is removed and capped to prevent dilution of the calibration mixture. The gas system pump is used to pump the syringe dilutions through the various monitors. The response of an instrument may be charted using several dilutions employing the HP-ADAS system to take the data and plot the curves on the same chart.

Figure 12 illustrates the use of the span gas mixtures and the serial dilution syringe technique for checking instrument/data acquisition system calibration and diagnostic response. Figures 12 (a), (b) and (c) show relatively rapid, accurate, and stable response to the span gas mixture concentrations. Figure 12 (d) shows the response of the CO monitor to direct injection of the CO/N₂ syringe samples as a cross check of the span gas mixtures used to calibrate the monitors.

The real-time gas monitors require from 30 minutes to 1.5 hours to warmup and thermally stabilize. Thus, it is good practice to leave those monitors requiring the longest warmup time (CO and CO₂) turned ON overnight to avoid testing delay the next day. The heated smoke and H₂S filters, and the TFE lines connecting the gas sampling probe (HRR stack) in the HRR to these filters and the gas monitors also are maintained at a temperature of 120°C during standby periods. The oxygen analyzer should be turned off during longer periods of standby (overnight or on weekends) since the internal gas sampling pump will give longer service.

The CH_x analyzer catalytic bead type detector will lose sensitivity if it is operated without airflow mixed in with the analyte stream flowing through the sampling system. Combustibles without at least a 2 to 1 ratio mixture with oxygen should never be allowed to flow past the sensor. The range of this instrument is 0-5% combustible gas; however, it is actually operated at a sensitivity of 0-2.5% combustibles (methane equivalent) due to the one-to-one dilution with air. Accuracy is greatly dependent on maintaining the airflow through the detector at a 1:1 ratio with the sample stream.

The above monitors may be checked for response either by use of the zero and span gas cylinder mixtures, or by mixing known concentrations (by dilution) employing pure CO, CO₂, O₂, and CH_x in a 1500 ml acrylic syringe containing one or two small aluminum foil strips to aid in mixing the gases injected from a low volume syringe into the larger one. Once mixed, the gas syringe blend is injected through the septum provided on the CHAS, or it may be pumped through the monitoring train. The syringe procedure is used only when it is desired to check the regular calibration span gas mixtures for changes or to obtain monitor readings not available with the span gas mixtures.

The following instructions must be followed to activate and calibrate the real time gas monitor system (refer to schematic, Figure 2):

1. Close valve V1, isolating the SATS from the gas sampling system.

CALIBRATION OF GAS MONITORS

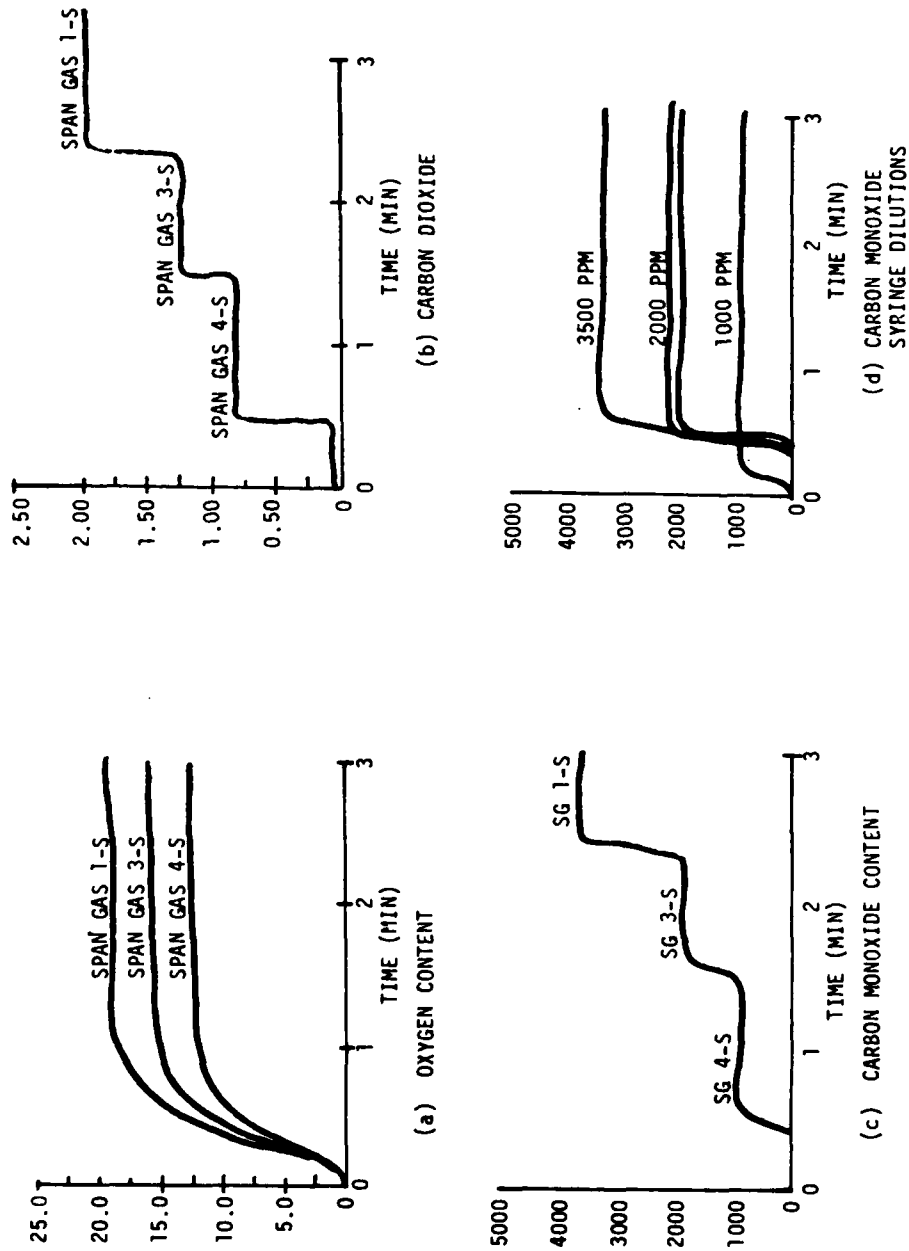

FIGURE 12. COMPARISON OF SPAN GAS WITH SYRINGE INJECTED GAS DILUTION CALIBRATION

2. Open V2 and V5 and switch the CO and CO₂ monitors on. Warmup requires 1 to 2 hours to attain thermal stability. Calibration can proceed when meter needles show constant readings near low end of the dial (use zero controls to keep needle on scale).
3. With V4 closed, turn on and adjust pressure regulated compressed air supply for the CHx monitor; then, slowly open V4 and adjust airflow through the detector to 1 liter/minute.
4. Switch the O₂ monitor (Infrared Industries) on. Press solenoid switch button on the front panel to sample ambient air (bypassing the sampling system). In this mode, the monitor is reading the O₂ percentage in room air. After warmup (5-10 min.) the digital meter reading should stabilize at 20.9 to 21.0%. See instruction manual if O₂ reading needs adjustment.
5. Switch on the main power (front panel) to the NO/NOx monitor, and in sequence, the vacuum pump, sampling system pump, sampling system heater, and the temperature controller (catalyst oven) on the front panel.
6. While catalyst oven temperature is stabilizing (as indicated by controller indicating light cycling on and off at 650°C set point), check photocell for zero and full scale meter readings. Adjust dark current to zero as outlined in instruction manual.
7. Disconnect NO/NOx monitor sampling line from the CHAS system and connect to a 10 psig regulated pressure cylinder supply certified to contain 0.0150% of NO with nitrogen. This calibration mixture is designated 7-S in Table 4.
8. Set the range switch on the front panel to 250 ppm and adjust the calibration (10 turn) potentiometer knob to 2 or 3. Then turn on the ozone generator. The needle on the meter should rise to nearly 30% of full scale. When the reading stabilizes, set the calibration pot to get a reading equivalent to the NO concentration certified for the 7-S gas mixture.
9. Reconnect the inlet line to the CHAS system after closing the calibration cylinder regulator valve.
10. Turn 3-way valve V13 to permit calibration gas flow from the manifold to the CO, CO₂ and CHx monitors.
11. Close V2 and open V3 and V5. Open main cylinder valve for N₂ zero gas and adjust two stage regulator pressure to approximately 10 psig or until a reading of 1 liter/min. flow is observed on the CO, CO₂, and CHx flowmeters. Fine adjustments are made using V3 and V5.
12. Using the zero control knobs set the meters on the three monitors to zero.
13. Close valve V7 on zero gas cylinder. Open V6 on the span gas mixture and adjust pressure regulator as outlined in Step 11. Adjust V3 and V5 to obtain 1 liter/min. flow through each monitor.

14. Using span gas mixtures 1-S and 5-S set meter needle readings with the span or gain knobs to the values corresponding to the certified gas concentrations based on the individual instrument calibration curves, Figures 10 and 11. The CHx monitor is set to full scale at 5% methane and has straight line response.
15. While span gas mixtures 2-S through 4-S may be useful for checking the calibration curves for each monitor, they are not needed for regular operations.
16. Close all span gas cylinder valves on the manifold.
17. Open pump valve V2 slowly after the pump is switched on and adjust flow rate from CHAS system into the monitors to 1 liter per minute.

The CO, CO₂, CHx, O₂ and NO/NOx monitors are now ready for a test run.

HCN MONITOR - The dynamic permeation tube-flow dilution technique developed by O'Keefe and Ditman, Reference 3 and described by Herrington in Reference 2 was employed to prepare the calibration curve for this monitor. The calibration curve is shown in Figure 13.

The following procedure must be followed to prepare the HCN monitor for operation and calibration:

1. Preparation of Electrolyte
 - a. Add:
 - 6 g KOH
 - 20 g Na₂SO₄
 - 10 g Na₂SO₃ to boiled (CO₂ free) deionized water
 - b. Seal the bottle for storage or use a stopper fitted with an ascarite guard tube.
 - c. Never use electrolyte that is older than 3 months.
2. Set up the HCN analyzer
 - a. Turn the gas pump & electrolyte pump on. The digital voltmeter in front of the analyzer should show a reading close to zero.
3. Set up the permeation device (Analytical Instrument Development Inc. Calibration System Model 309, or equivalent).
 - a. Connect the air inlet at the back of device to a pressure regulated flow of pure air, and connect the output line to the HCN monitor.
 - b. Adjust the pressure gage to approximately 40 psi.
 - c. Adjust the chamber flow to 1 liter/min (use a flow bubbler); the reading on the scale should be close to 5.1. (AID Instrument, only).
 - d. Set the temperature on the oven in accordance with the following table, and insert the permeation tubes into the AID permeation chamber as required (singly or in multiples) depending upon HCN concentration required for each calibration point.

CAUTION: This operation must be done in a well ventilated chemical fume hood. Use plastic gloves or forceps to handle the permeation tubes.

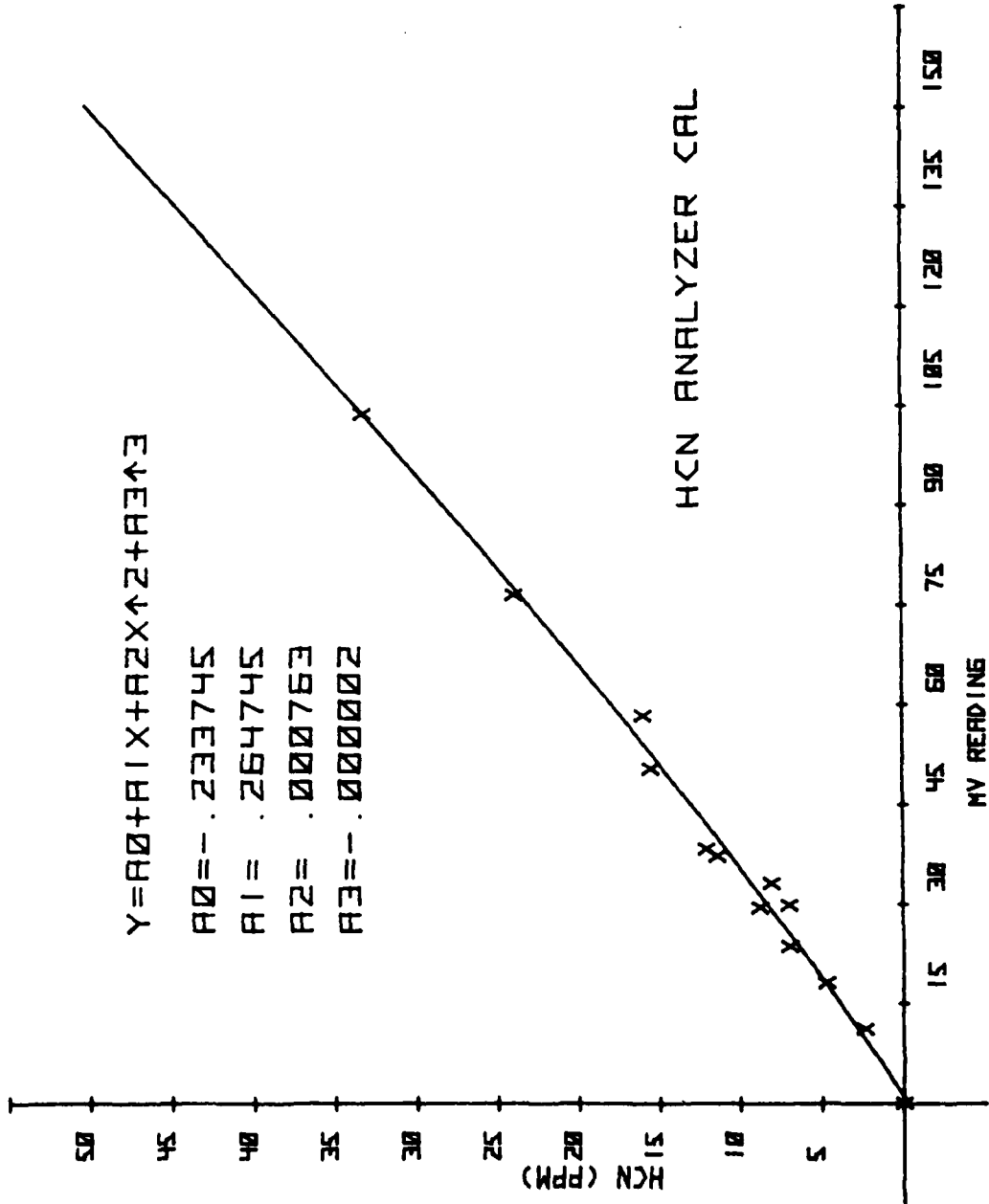

FIGURE 13. HCN CALIBRATION AND POLYNOMIAL EQUATION CURVE FIT

4. Calculation:

The permeation rates for the HCN permeation tubes are as follows:

	<u>30°C</u>	<u>50°C</u>
#1705	2487 ng/min	8112 ng/min
#1706	2528 ng/min	8112 ng/min
#1707	2570 ng/min	8209 ng/min

Equation Used:

$$C = \frac{R \times K}{F}$$

C: Concentration in ppm
R: Permeation Rate, ng/min
F: Flow Rate cc/min
K: Constant

$$K = 0.0821 \times \frac{T}{P \times MW}$$

T = Temp in °K
P = Pressure in Atmospheres
MW = Molecular Weight

Calculate R

Assume Permeation Rate is Linear response to temperature

For Tube #1705	R = 2487 + 281.25 (X-30)	NOTE: These values differ and are unique for each new set of tubes
For Tube #1706	R = 2528 + 279.20 (X-30)	
For Tube #1707	R = 2570 + 281.95 (X-30)	

X = Temp in °C

Calculate K

$$K = 0.0821 \times \frac{T (^{\circ}\text{K})}{T \times 27.026}$$

$$K = 3.0378 \times 10^{-3} \times T (^{\circ}\text{K})$$

5. Connect HCN monitor output to a standard high impedance input strip chart recorder set to 0-100 mv range.
6. Obtain 10-12 calibration readings on the chart recorder relating permeation tube (calculated) HCN concentration per step 4 to the recorded, stable mv reading. This is achieved using a combination of permeation tubes placed in the AID unit, by changing the oven temperature, and the airflow dilution rates. Table 5 shows a representative set of 5 calibration points determined using this procedure.

TABLE 5
HCN CALIBRATION DATA
(example)

DATA PT. NO.	PERM TUBES USED	TEMP. °C	AIRFLOW CC/MIN	RECORDER MV	HCN PPM
1	#1705 #1706 #1707	50.2	1000	78.1	24.16
2	Same	40.7	Same	53.5	15.82
3	Same	36.7	Same	42.5	12.45
4	Same	33.1	Same	33.3	9.48
5	Same	30.1	Same	26.9	7.38
6, etc. (Use same methodology as above)					

7. Plot the HCN ppm values calculated from the formulas and input test parameters (shown in Steps 4-6) against mv output from the HCN monitor detector cell.

8. Curve fit the above plotted data using a 3rd order polynomial curve fit routine. The coefficients of this equation are used in the HP-ADAS program to process the data recorded during a burn test (Figure 13).

The HCN monitor operational characteristics have been discussed in detail in Reference 2. The detector in this instrument is relatively free of interferences from other gases commonly found in combustion products. As reported by Dow, Table 6 gives the response of this detector to a number of gases. Spot checks, conducted by injecting quantities of diluted pure gases (CH_4 , C_3H_8 , H_2S , NO_2 , HCl , etc.) essentially substantiate these results.

GAS BATCH SAMPLING - Real-time, specific response, monitoring instruments for many combustion gases were not commercially available nor desired. Complexity of CHAS was reduced by adding batch sampling capability for gases not generally present. Methods for laboratory chemical analysis of these gases were selected from the scientific literature and modified as needed. Table 7 gives this list.

CHAS/SATS TEST PROCEDURE

Procedures for operation of the HRR calorimeter and preparation and introduction of the sample into the inner chamber were in accordance with the proposed ASTM test procedure (Reference 1) except as shown in Table 8. Modifications to the calorimeter have required additional steps.

PRETEST ADJUSTMENTS - The procedural steps for running the CHAS/SATS are as follows:

1. Turn on and adjust the main air supply regulator for the HRR chamber to the selected airflow rate ($60 \text{ ft}^3/\text{min}$).
2. Turn on electrical power to the HRR Global^R radiant panel and adjust power input to selected radiant heat flux level (2.5 , 3.5 , or 5 W/cm^2) as measured by a standardized calorimeter. Ignite the internal chamber pilot light(s).
3. Open the air supply valve and adjust the auxiliary airflow to the CHx monitor, adjusting the flowrate to 1 liter/min , before switching on the power.
4. Switch on the electrical power to the other continuous gas monitors (CO , CO_2 , O_2 , HCN and NO/NO_x), MLT unit, and the smoke photometer.
5. Allow 1-1.5 hours for warmup time. All gas monitors should equilibrate and readout very nearly to the same baseline readings as noted at the end of the previous day. Barometric pressure changes from day to day will cause slight deviations.
6. Cut samples to size (6×6 or 10×10 inches) selecting the size on the basis of the expected heat, smoke, and gas release rates, and mount in sample holder.

TABLE 6

RESPONSE OF AMPEROMETRIC HCN ANALYZER TO VARIOUS GASES
(Ref.: D. Herrington, Dow Chemical Co.)

Gas	Concentration	Response (Equivalent ppm HCN)	Recovery
acetone	5%	0	immediate
acetylene	1%	4ppm	immediate
ethylene	100%	0	immediate
methane	5%	0	immediate
butane	5%	0	immediate
methyl acetylene	2%	0	immediate
carbon monoxide	15%	0	immediate
carbon dioxide	15%	0	immediate
carbon tetrachloride	5%	0	immediate
chlorine chlorine	100ppm 200ppm	-10ppm -20ppm	immediate for short exposure, longer for long expo- sure
sulfur dioxide	1000ppm	0	1 minute
sulfur dioxide	5-10%	-10ppm	several minutes
hydrogen sulfide	10ppm	10ppm	immediate
hydrogen chloride	2%	0	immediate
ammonia	1%	1ppm	2-3 minutes
hydrogen	100%	0	immediate
oxygen	20%	0	operates in air
cigarette smoke (Pall Mall)	heavy	5ppm	immediate

TABLE 7

ADDITIONAL GAS ANALYSES METHODS

GASES	SAMPLING METHODS	ANALYTICAL METHODS	SOURCE OR REFERENCE
HCl, HBr	Impinger/NaOH batch monitoring Impinger/Na ₂ CO ₃ Gas Syringe	Aq NO ₃ titration electrometric DP polarographic Aq NO ₃ titration electrometric	ORION Handbook 5 ORION
HF	Impinger/NaOH Impinger/Na ₂ CO ₃ Impinger/NaOH Gas Syringe	Selective Ion Electrode DP polarographic Spectrophotometric Selective Ion Electrode	ORION Handbook 5 6 ORION Handbook
HCN	Impinger/NaOH Gas Syringe	Pyridine-Pyrazolone Colorimetric GC (Gas Chromatographic)	7 CAMI
H ₂ S	Impinger/Cd(OH) ₂	Spectrophotometric	7
NO ₂	Gas Syringe Real Time Monitoring	Luminescent	8 9
Formaldehyde	Impinger/NaHSO ₃	Chromotropic Acid Colorimetric	10
Acrolein	Impinger/NaHSO ₃	4-Hexylresorcinol Colorimetric	10
Toluene Diisocyanate	Impinger/HCl-CH ₃ COOH	Modified Marcali Colorimetric	11
NH ₃	Impinger/H ₂ SO ₄	Selective Ion Electrode	ORION Handbook
SO ₂	Impinger/TCA Solution	Parosaniline Colorimetric	12
Phenolics	Impinger/NaOH	4-Aminoantipyrine Colorimetric	7

TABLE 8
 MODIFICATIONS OF ASTM PROPOSED STANDARD
 USED IN CHI PROGRAM

PARAMETER	ASTM (STD)	CHI
Airflow	84 ft ³ /min	60 ft ³ /min
Radiant Panel	Globars	Same
Pilot Light	Natural Gas	Same
Smoke	0-100% T/F.S.	0-0.4 O.D./F.S.
Sample Size	Vert 6"x6" Horiz 4-3/8"x6"	Vert 6"x6" & 10" x 10" Horiz Same
Mounting	Light/low Cp/boat one surface only	Similar/optional 2 surfaces
Radiometer	2 types	1 only
Conditioning	23°C/50%RH	optional
Thermopile	compensated	no
O ₂ Consumption	no	substitute, for DTP
Sample position	Front surface, 4" from rad. panel	same
Calibration	DTP/nat. gas	same/O ₂ consumption.
Calculations Heat	HRR/M ²	same or by O ₂ consumption
Smoke	S.M.O.K.E/M ²	same

CAUTION:

Very high heat release materials will swamp the gas monitors, and flames will completely fill the burn chamber. This has been found to heat the radiant panel Globars to such an extent that main power is lost because breaker switches are activated. Smaller samples of such materials must be prepared to obtain CHAS data.

7. Turn strip chart recorder on and monitor baseline readings from the DTP. Recorded (equilibrated) DTP HRR baseline should not vary over a period of 5 minutes by more than ± 0.02 millivolts.
8. Fill 10-50 cc "batch" sample syringes with 5 cc of 0.1 normal sodium hydroxide (NaOH) solution (reagent grade, chloride and flouride free). These syringes fitted with large bore needles, must be labled to indicate to the operator the time at which a 45 cc combustion gas sample is to be withdrawn through the silicone rubber septum installed on a "T" fitting on the gas sampling probe line.

NOTE: The time intervals are optional in this program, either 30-sec or 60-second intervals were employed depending on the rate of burning of the test specimen. These samples are assayed for HCl and HF.

9. Fill 10-50 cc syringes with 5 cc of 0.05% MBTH (3-methyl-2-benzothiazoline hydrazone hydrochloride reagent dissolved in distilled water) and fit each syringe with large bore needles. These syringes must be labeled to alert the operator to take a sample at the gas line septum at 30-second intervals alternately with the syringe samples taken in step 8. These samples are assayed for total aldehyde content (as formaldehyde) after the CHAS/SATS test is complete.
10. Concurrently with the above pretest preparations, the SATS exposure chamber is cleaned and the cage rotation motor drives checked for operation and synchronized to 6 rpm. The Ti sensor and SATS chamber temperature recording instrumentation is checked out for proper operation.
11. Set the zero and output (gain controls) on each continuous gas monitor using calibrating gas mixtures (see Table 4) to span the instrument reading to the known calibrated value.
12. The ADAS (HP 3052 with 9885M floppy disc memory and 9825A controller) is initialized (Figure 14) and the data channels checked out to determine that instruments are operational. The smoke photometer is calibrated at this time by adjusting its output using standard neutral density filters to set the span in millivolts corresponding to its calibration curve. Press SF key No. 9. This calls up the accurate airflow orifice equation program. Press "Run" and input all the requested data as shown in the airflow program, Figure 15. After the airflow rates have been adjusted accurately to the selected values (e.g., 56.17 ft³/min through the HRR chamber and 3.83 ft³/min through the hold chamber of MLT), press SF key No. 7.

NOTE: The CO, CO₂, and CH_x monitors are zero set using pure nitrogen. Span is set using an appropriate certified analyzed compressed gas cylinder mixture. A special gas mixture is used for the NO/NO_x monitor, and the HCN monitor is separately calibrated.

RUNNING A MATERIAL

13. Initialize the ADAS, data acquisition program (SF Key 7, "DATAA", Figure 16) entering the following:

(a) Run No.	(h) Airflow Rate, CFM
(b) Sample Name	(i) Inlet Air Temp, °C
(c) Date	(j) Sample Area, in ²
(d) Floppy Disk No.	(k) Heat Flux, W/cm ²
(e) Disk Run No.	(l) Sample Wt., Grams
(f) Length of Test, Minutes	(m) MLT Sensitivity Factor mv/100g
14. Load a test animal (rat, Sprague Dawley derived, or other strain) into the SATS chamber and replace the top cover. Turn on the ventilation pump and isolation valve between the SATS and the CHAS combustion products sampling line, adjusting flow to 14 liters/min.
15. Check SATS cage rotation and sensor recording system for correct operation.
16. Start the strip chart recorders on CHAS and continue ADAS program.
17. Check ADAS baseline data printed out on the 9852A tape. Make last adjustments to smoke photometer span calibration points (millivolts).
18. Check O₂ monitor to assure that it has been switched over from sampling ambient air to the CHAS combustion products sampling mode.
19. Zero the digital electronic timer visible from the storage rack location near "batch" sampling syringes.
20. Place the two racks (containing 10 syringes in each) at the position provided near the CHAS gas sampling line septum.
21. Load sample/holder/injection mechanism assembly into the HRR hold chamber, clamp the seal door in place with radiation doors still closed. Immediately turn the hold chamber air cooling valve to divert this airflow (3.83 ft³/min) through the MLT.
22. Observe the TP recorder trace to determine when the HRR chamber has recovered its baseline (usually 1 to 1.5 minutes).
23. After the baseline strip chart recorder shows recovery of analog baseline, continue the data acquisition with the ADAS to record all baselines into computer 9885M disk memory (25 times once per second over 10 channels).

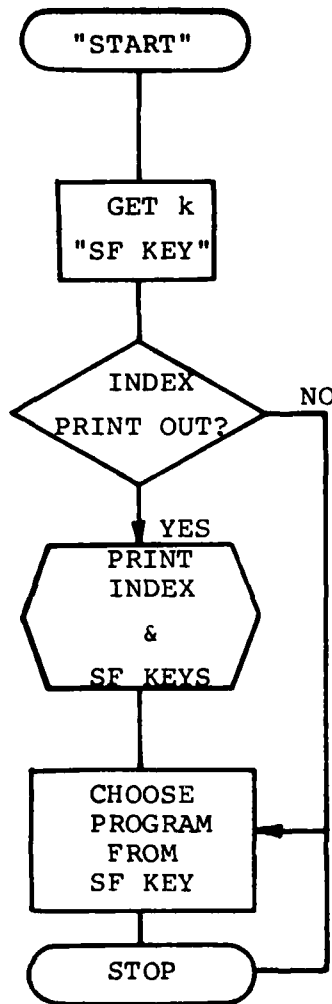

FIGURE 14. PRELIMINARY SETUP

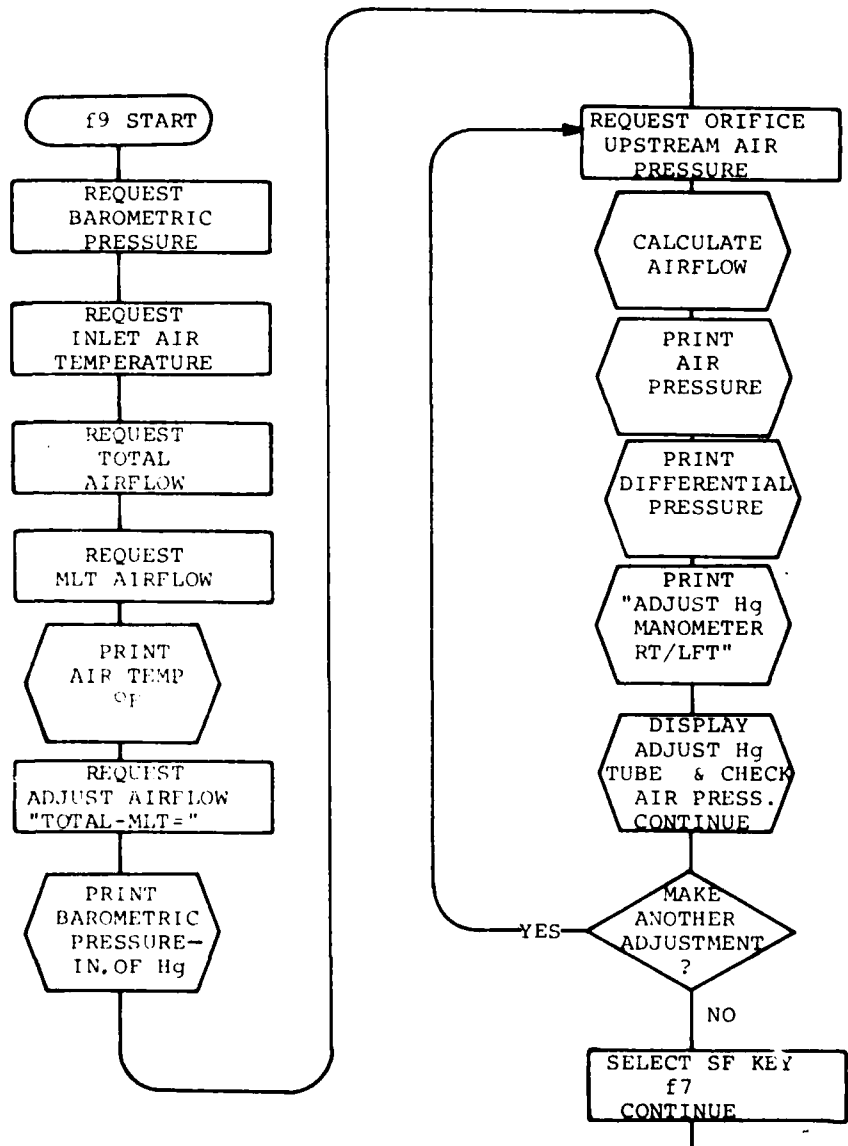

FIGURE 15. HRR AIRFLOW ADJUSTMENT COMPUTER FLOW DIAGRAM

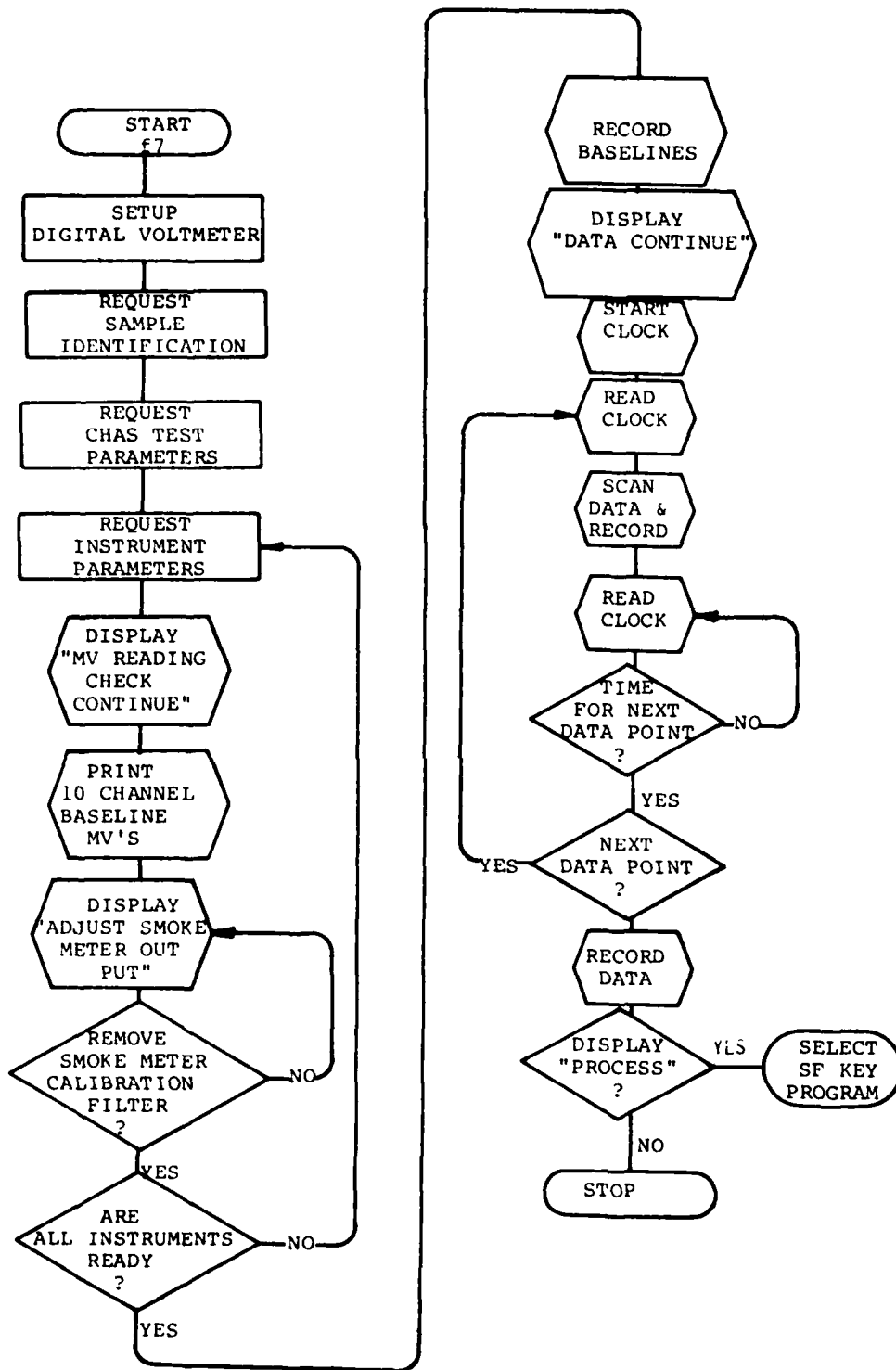

FIGURE 16. CHAS DATA ACQUISITION COMPUTER PROGRAM

24. When the baseline scans are completed, open the radiation doors immediately and inject the sample into the inner burn chamber, closing the radiation doors at the same time to protect the MLT unit from radiant heat.
25. Immediately upon completing step 24, start the data acquisition mode on the ADAS controller. This is time zero for the burn test. Start the digital electronic time at the same moment.
26. Change position within 15 seconds to take the "batch" syringe gas samples. Take 45 cc gas volumes in 5-10 seconds for the HCl/HF samples alternately with those for aldehydes in accordance with the preselected time intervals printed on the syringe labels.
27. Observe the CO monitor output meter during the test run. Record the time at which the CO concentration reaches a maximum and simultaneously turn off the air circulation pump on the SATS and close the sample line isolation valve. Continue recording the animal response for 15 minutes or until a Td occurs. If a second burn episode occurs in which the CO concentration increases again, turn on the pump and isolation valve to establish flow through the chamber. Record elapsed time for the second exposure period (valve open to valve off).
28. Continue the SATS test for an additional 5-10 minutes (20 minute total). If no results are obtained, remove the test animal and clean the SATS chamber for use in the next test.
29. After the burn test is completed, remove the sample/hold/injection mechanism from the HRR, vacuum clean the ashes, spalling off the burned specimen, from the hold chamber and the bottom of the inner HRR chamber.

CAUTION:

Take care to avoid contact with the hot Globars when vacuuming ashes from the chamber. The tube should be thermally and electrically insulated to avoid shorting the Globars or melting the vacuum hose.

30. Turn off the CHAS gas sampling train pump, the HCN monitor, and switch over the O₂ monitor to sample ambient air.
31. Replace the membrane type smoke filter protecting the pump used to ventilate the SATS and the filters (membrane and ascarite/drierite) used to filter the product stream monitored by the O₂ meter.

(NOTE: Only the drying agent is required if the data reduction program normalizes the instantaneous O₂ concentration by using the concentrations of the other gases for correction).

Repeat runs were conducted on the CHI program materials following this 31-step procedure. With all systems functioning properly, 3 to 4 test specimens were run per day. This does not include all of the data processing time, which requires one hour per test, nor the "batch" sample gas analyses which were done after a number of runs were completed.

DATA PROCESSING

The special function key overlay is placed over the special function key section of the 9825A controller. The special function keys, each dedicated to a CHAS data acquisition program or operational channel, are identified as shown in Table 9.

Ten data channels, as identified on Figure 2 provide analog data from CHAS tests for storage on a floppy disc (or on cassette) in the HP3052A Data Acquisition System. Each disc has storage space for all programs and data from 10 ten-minute CHAS tests.

It must be emphasized that the input variables consisting of the individual gas monitor calibration curve polynomial equation coefficients and other similar data are unique to the DAC system and instrumentation. The program listings below will have to be modified where the listing steps show a "*". This indicates the need for user instrument calibration (or other) data inputs before the program can become operational. Instructions for an initial HP3052A start up are given in Appendix A and are as shown in Figure 14.

FINAL PREPARATIONS FOR CHAS TESTS

With all systems "GO" press SF key No. 9. This calls up the accurate airflow orifice equation program. Press "Run" and input all the requested data as shown in the airflow program, Figure 15. After the airflow rates have been adjusted accurately to the selected values (e.g., 56.33 ft³/min through the HRR chamber and 3.67 ft³/min through the hold chamber or MLT), press SF key No. 7. This calls up the 10-channel data acquisition program. The procedure followed in this program is shown in the flow diagram Figure 16. At the conclusion of the 10-minute (or longer) test run, the data held in disc memory storage during the run is unpacked and rerecorded in separate files for each parameter. The individual parameter release rate curves may be processed and plotted optionally by selection of any of the programs called up by the SF keys, as listed in Table 9 and the flow diagram in Figure 16. The program listing is shown in Appendix A.

DATA TRANSFER TO IBM 370 The Fire Analysis Computer Program (FACP) that predicts cabin environment from CHAS data is a fairly complex semiempirical model written in FORTRAN for an IBM 370. The HP and IBM do not have a common language so it was necessary to use a Dylon formatter to transfer the HP digital data to an IBM 370 tape (SF 8). Batch gas concentrations sampled every 30 seconds had an additional data point interpolated between each pair of experimental points using a conventional straight line computer program and were also transferred to the IBM 370 tape. Only the material combustion heat flux (not the Global output) was input to the FORTRAN program.

Three specimens of Panels 2, 3 and 4 were run at each heat flux but only one set of data was needed at each heat flux. One set of specimens at each heat flux was run without animals or syringe sampling since the syringe samples caused spikes in the O₂ concentration curve. Specimen heat flux was calculated from this data set using the NBS O₂ depletion Method. Rather than attempting to obtain average run data for three runs as input to the IBM 370 tape, the data was plotted and the single most representative run selected. In some cases the heat flux, smoke and gas data were not from the same run.

TABLE 9
SPECIAL FUNCTION KEY IDENTIFICATION

SF KEY CODE	DATA REDUCTION PROGRAM
f0:/1	YES
f1:get "START"	Initiates SF key selection
f2:get "HRRO ₂ "	O ₂ Consumption heat release
f3:get "SMOKE"	Smoke release rate
f4:get "HEAT"	Heat release by differential thermopile
f5:get "TEMP"	Sample surface temperature
f6:/	NO
f7:get "DATAA"	CHAS Data acquisition
f8:get "DATRR"	Data unpacking and transfer
f9:get "HgADJ"	HRR airflow adjustment
f10:get "NO"	NO and NO _x release rate
f11:get "FIRE"	Combustion Gas Volume Corrections to f2
f12:get "CO ₂ "	CO ₂ release rate
f13:get "CO"	CO release rate
f14:get "O ₂ "	O ₂ release rate (depletion)
f15:get "HCN"	HCN release rate
f16:get "HC"	Combustible gas release rate
f17:get "MASS"	Mass Loss and mass loss rate
f18:get "CFLA"	Point connector program for batch sampled gases
f19:get "HCL"	HCL release rate
f20:get "HF"	HF release rate
f21:get "ALD"	Aliphatic aldehyde release rates

III. HAZARD LIMIT CONCEPT

TOXIC GAS HAZARD LIMITS

The term "toxicity" has been used frequently during discussions on fire gases. Many times it has been used interchangeably with quantitative units of measurement of fire gases. Quantitative units of measurements, per se, have nothing to do with denoting toxicity. The definition of toxicity (Reference 13) is "the quality of being poisonous and is expressed by a fraction indicating the ratio between the smallest amount that will cause an animal's death and the weight of that animal." This requires definition of the term "poison" (Reference 13) which, according to Dorland is "any substance which, when in- gested, inhaled or absorbed, or when applied to, injected into, or developed within the body, in relatively small amounts, by its chemical action may cause damage to structure or disturbance of function." From these definitions, then, one can conclude that the agent in question must be related to a living biological specimen, and that a quantitative unit of measurement without this relationship cannot alone indicate the degree of toxicity.

This leads to the evaluation of standard toxicological terms used to describe toxicity. These are LD₅₀ and LC₅₀ which indicate the dose or concentration required to kill 50% of the experimental animals. This criterion of LC₅₀ is untenable when it is applied to human survival and escape from the fire situation wherever it might be. Some years ago, a new term, the Time of Useful Function (TUF) was suggested by Gaume (Reference 14) as a more appropriate term to indicate the time available for a person to escape the fire environment before incapacitation by fire gases, after which it would not be possible to do so without help. The TUF may be considered as an analogue of the universally accepted (TUC) Time of Useful Consciousness applicable to flight crews upon aircraft cabin decompression.

By definition, then, the toxicities of various fire gases can be determined, for human purposes, only by collecting data on exposed animals or humans, the latter being generally unacceptable subjects for these kinds of hazardous experiments. Therefore, animal subjects are the only alternative for building a data bank of biological effects from which scale factors can be developed via further experimentation and mathematical modelling. For purposes of the data bank related to fire safety, escape and survival, the collection of physiological data should be oriented toward the TUF or the Ti rather than to the LC₅₀ concept. It would seem that the definition of poison fits the TUF concept more appropriately than that of toxicity.

The TUF/Ti will be variable under different circumstances and will depend on a variety of factors. Among these are the materials that are burning, their ignition temperatures, heat flux, fire temperatures, oxygen supply, ventilation and air currents, retardant treatment, the gases evolved, their generation rates, and others. These variables, combined with the many physiological variables present in the escapee's body, and the many types of gases evolving (asphyxiant, irritant, anaesthetic, narcotic, systemic poisons), present a very complex problem which is in urgent need of simplification. A standard test based on the TUF concept may well provide a simple, inexpensive means of determining the relative toxicities of materials, enhancing their selection, and therefore, fire safety. The TUF method provides a rapid, simple and

perhaps the only means of integrating all these complex variables without the requirement to investigate each one individually, at high cost in time and money. Once materials have been rated by such a test, the synergistic or antagonistic effects of each combination or concentrations of gases, and other single variables, can be investigated more leisurely on the basis of pre-determined priorities. Our understanding of synergism and antagonism may undergo some change as a result of investigation of controlled gas mixtures (Reference 13).

In the initial CHI development effort, the FAA desired that we take a simple approach, i.e. to consider the multiple gases evolved as having an additive effect, which is the conventional toxicological approach to that condition. Some of the more recent data, however, indicates that, in mixtures of gases, this is not always the case. In certain cases, one or more gases may inhibit the effect of others (References 14 and 15). This phenomenon has not yet been studied sufficiently to understand fully the mechanisms involved. Therefore, because of the complexity of the problem, the simple approach of additive effect was taken. In the complex context, other factors such as synergism and antagonism come into play, and the standard definitions of these two terms may not apply, and may have to be redefined. The inhibitory effect of one gas for another may be due to the fact that the high concentrations found in the fire situation may develop so rapidly that the expected responsive metabolic changes do not have time to occur before the organism succumbs; or the effect could be due to a dilution factor, alone or in combination with another factor. Delving into these complexities constitutes a fertile area for future research, which should already have begun.

APPROACH - There is a dearth of short-time (5 minute) exposure data available in the literature for use in the computer program. Therefore, Douglas was required to develop this kind of data from the best information available. The approach used is described in the following paragraphs.

To determine a 5-minute limit for CO, by starting with the Threshold Limit Value (TLV) of 50 ppm for an 8-hour work-day exposure and doubling the concentration as the time is halved, the result is approximately 4800 ppm of CO as a 5-minute limit. Figure 17 illustrates this method. This 5-minute limit provides the concentration needed to develop the escape time curve. Applicability of this method to other gases was studied, because it was limited to estimating the 5-minute limit for CO. This method can be named the "reverse extrapolation" method, and results in a hyperbolic curve.

Studies were made to determine whether the reverse extrapolation method from the TLV to a 5-minute limit was feasible for gases other than CO. The results appear to be encouraging. A generalized form of the equation was derived from available TLV data to estimate hazard limits in the absence of short term data. Toxic hazard limits in industrial toxicology are sometimes expressed as total integrated doses (TID), or ppm - minutes, as a constant for a gas. This suggested that an equation could be derived for a gas which would allow calculation of a hazard time limit as a function of the constant and the TLV concentration.

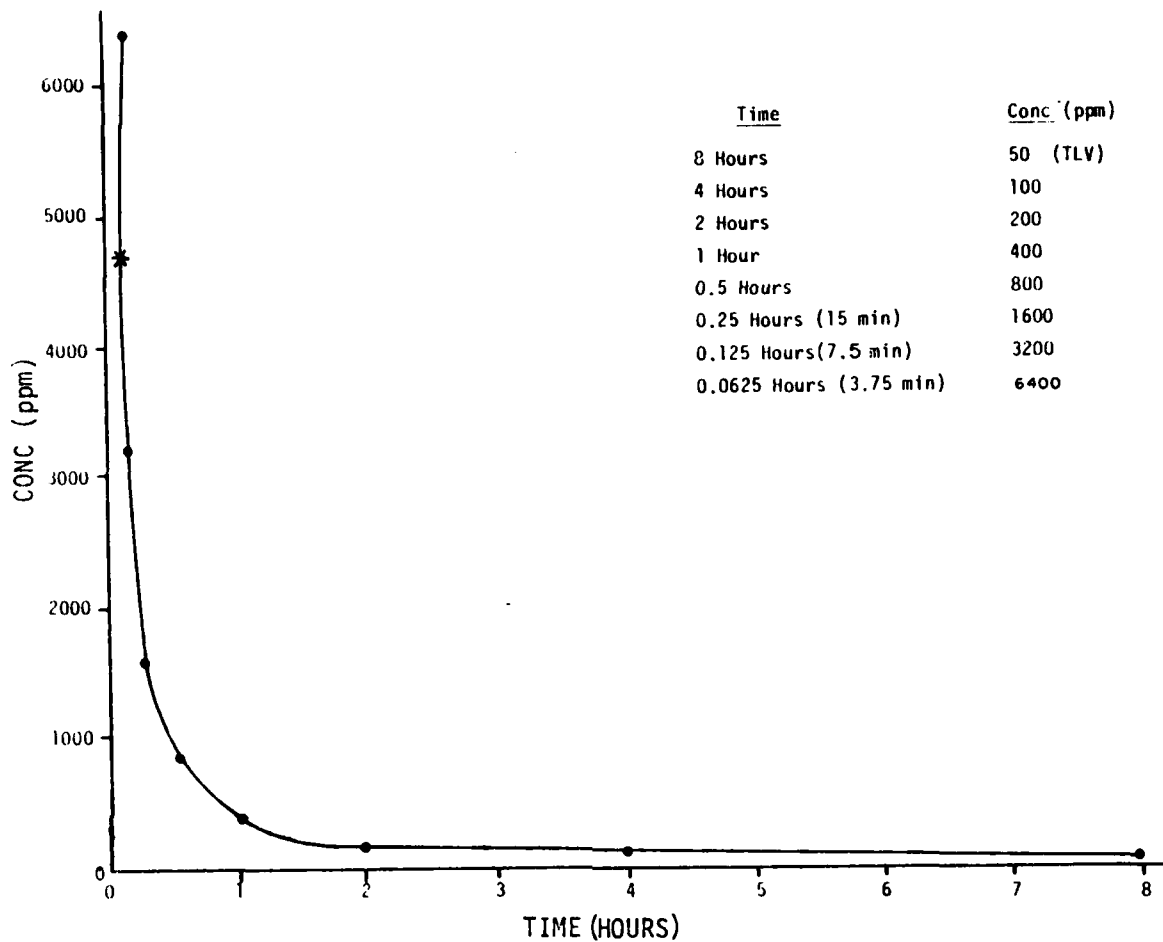

FIGURE 17. FIVE-MINUTE TLV EXTRAPOLATION CURVE FOR CO

$$HL_5 = \frac{480 \times TLV \text{ (ppm)}}{t}$$

where 480 = number of minutes in an 8 hour work day

TLV = Threshold Limit Value

t = Time of Exposure, 5 minutes

An analysis was conducted for the human survival limits of the toxic gases (15) involved. The above equation has been utilized to determine initially the estimated 5-minute hazard limit, (HL₅), for these gases. The literature

was then examined to find the data closest to a 5-minute survival time. (Very seldom does the literature present such specific data). Interpolations were made where the data were not sufficiently specific, and the result was compared with the (HL₅) for each gas as determined via the equation. In ten of the fifteen cases the equation appeared to reflect an acceptable limit. In the other five cases, reductions of the equation values appeared to be necessary, based on the mechanisms of action of these gases, and the judgment of the analyst. Table 10 shows the results of these analyses.

Hazard limit curves, as calculated for each of 15 significantly toxic gases are shown in Appendix B and were used to calculate fractional "effective" doses and escape time (CHI).

THERMAL HAZARD LIMITS

Two aspects of the thermal hazards were considered. The first was the maximum air temperature that can be tolerated by the respiratory tract; usually considered to be 400°F. The second was the time-to-incapacitation resulting from the effects of heat on the body (considered as a dose).

An extrapolated air temperature hazard limit curve described this hazard, and its escape time characteristics were determined by curve fitting the data using a modified polynomial computer routine. A simplified biothermal model of a man being exposed to high air temperatures has been used to curve fit the C. R. Crane air temperature limit data (Reference 16). Figure 18 shows the correlation between the curve fit equation and the Crane data into the higher air temperatures and lower human tolerance limits relating to the CHI program.

This simplified approach is based on an analysis that determines the time needed to raise the internal (core) body temperature by 5.5°C (to 108.5°F) when it is exposed to a heat flux by radiation and convection as well as an internally generated metabolic heat. The convective heat gain or loss includes the effect of latent cooling due to the evaporation of perspiration from the skin. It was assumed, as a simplification, that the rate of mass loss by evaporation is a function of the temperature differential between the body and the air as in the convective heat transfer term. The rate of mass loss by evaporation is usually expressed as being proportional to the difference between the vapor pressure of water and that of the surrounding air; but, vapor pressure is closely related to the temperature which makes the mass loss proportional to the temperature differential.

The least squares curve fit of the simplified biothermal man-model determines values for the radiation term coefficient, as well as the combined convective plus evaporative cooling term coefficient, when fitted to experimental data of the tolerance limit versus air temperature. An exponent of the convective heat transfer term is included to account for the variation of the heat transfer as a function of temperature. The metabolic heat rate was determined by successive trials until a best fit of the data was obtained.

An interesting result of the curve fit gave a negative value for the convective plus evaporative term coefficient. This was interpreted to mean that the data reflects a situation in which the cooling effect of evaporation is greater than the heat gain by convection, and it was assumed to be a logical result. The radiation term is positive and adds heat to the body.

TABLE 10
HUMAN SURVIVAL LIMITS ANALYSIS

HAZARD	TLV(PPH)	(HL) ₅ ESTIMATED BY EQUATION (PPH)	CLOSEST DATA IN THE LITERATURE	REFERENCE	ADJUSTED (HL) ₅ (J = JUDGMENT) (HR = NOT REQ'D)
NO ₂	C 5.0	480.0	1000 ppm 19 minutes - no deaths arising 3350 ppm - death 8-10 minutes 340 to 410 ppm 60-105 minutes death	Patty Vol. II, p 921-922, Pulm. Edema delayed action (slow hydrolysis) cyanosis, dyspnea, cardiac dilation collapse, death, eye irritation.	n.R. (Slow Action)
HC1	C 5.0	480.0	50 - 100 ppm - Work impossible 10 - 50 ppm - Work Difficult	Patty Vol. II p 851, Mucosal necrosis pulm. edema, atelectasis, emphysema dam. to pulm. bl. vessels. Laryngeal spasm & edema, eye irritation.	50.0 ppm (J) Provides Mild Safety Factor
HF	3.0	280.0	2250 ppm - Animal died in 5 minutes 1500 ppm - Caused no deaths but damaged tissue	Patty Vol. II, p 842. Damage to lung, liver, kidney	n.R.
HBr	3.0	288.0	5200 ppm - Rats survived 6 minutes. 2600 ppm - Rats survived 24 minutes.	Patty, Vol. II No data on HBr used methyl bromide as subst. p 1252 Toxicity 1/7 that of HBr.	n.R. Safety Factor of 2.5
SO ₂	5.0	480.0	400-500 Immediate danger to life.	Patty Vol. II, p. 894	350(J)
H ₂ S	10.0	960.0	400-700 ppm dangerous to life in 1/2-1 hour.	Patty, Vol. II p. 899, Systemic Effect over-shadows irritant effect at 700 ppm. CIS effect and respiratory paralysis.	600 ppm (J)

TABLE 1.0 (Continued)

HAZARD	TLV (PPM)	(HL) ₅ ESTIMATED BY EQUATION (PPM)	CLOSEST DATA IN THE LITERATURE	REFERENCE	ADJUSTED (HL) ₅ (J = JUDGMENT) (NR = NOT REQ'D)
COCl ₂	0.1	9.6	20 ppm - Severe Lung Damage 1 - 2 minutes 25 ppm - Danger to life in 30 minutes	Patty, Vol. II, pg. 940	N.R.
COF ₂	0.1 (Est.) No TLV Ref.	9.6(Est)			N.R.
NH ₃	25.0	2400	2500-6500 ppm Dangerous to Life in 30 minutes.	Patty, Vol. II, pg. 862	N.R.
Formaldehyde	C 2.0	192.0	LC ₅₀ Rat 30 minutes=800 ppm 50:100 ppm for 5 minutes may cause serious injury	Patty, Vol. II, pg. 1971	100 ppm
Acetaldehyde	100.0	9600.0	LC ₅₀ Rat = 20,000 ppm for 30 minutes Very Sketchy Data	Patty, Vol. II, pg. 1973	N.R.
Acrolein	0.1	9.6			N.R.
CO	50.0	4800.0	2000 ppm dangerous to life 1 Hour >4000 ppm fatal <1 Hour	Patty, Vol. II, pg. 928-933	N.R.
CO ₂	5000.0	480,000	10% for 1 hour no harmful effects (100,000 ppm)	Patty, Vol. II, pg. 937	150,000 ppm Based on Rat Data -IMC Expts Resp. Acidosis
HCN	1.0(Est) 10.0 Skin	96.0	Cat - 125 ppm Markedly toxic in 6-7 minutes, 12 minutes for monkey	Patty, Vol. II, pg. 1998	N.R.

C = Ceiling Value

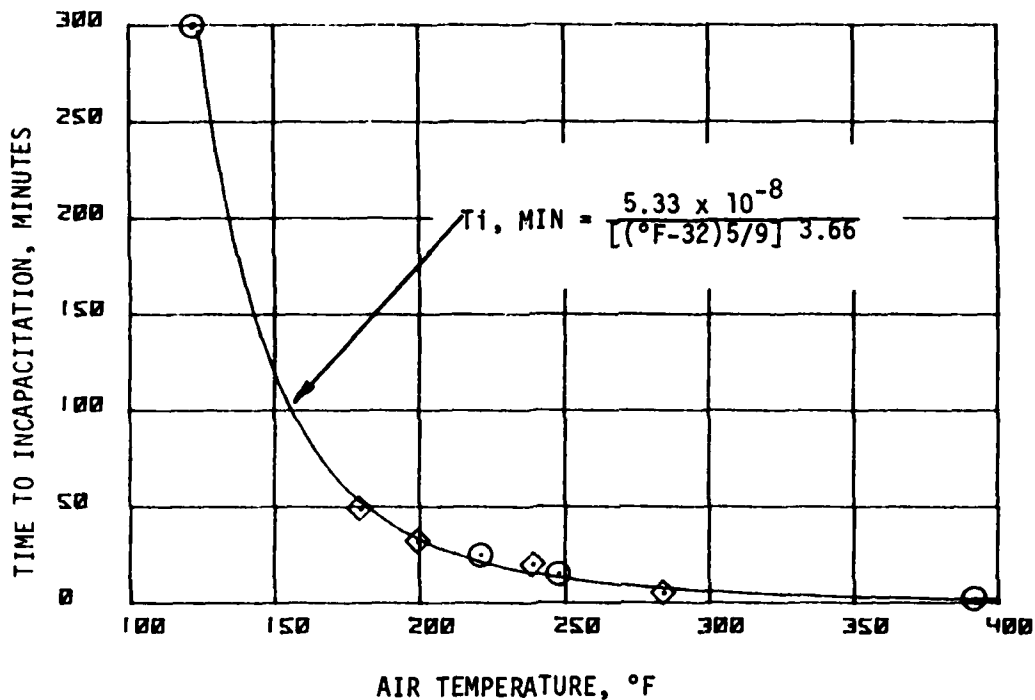

FIGURE 18. AIR TEMPERATURE HAZARD LIMIT CURVE FIT

- Table 1 Crane Data (Reference 16)
- ◇ Table 2 Crane Data

As stated before, the analysis is based on a temperature rise of the mean body temperature. The curve fit plot shown in Figure 19 indicates that it requires very high temperatures to raise the core body temperature 43°F (5.5°C) in less than one minute. Another criterion that limits the maximum air temperature, beyond which survival will not be possible, is the temperature at which third degree burns of the skin occur. This limit, 585°K, (312°C), or 593.5°F, was determined from a simplified biothermal man model with a least squares curve fit equation shown below.

$$\frac{dT}{T_i} = \frac{hCA}{WC_p} (T_a - T_m) \left(\frac{T_a}{T_0}\right)^N + \frac{hrFA}{WC_p} (T_a^4 - T_m^4) + \frac{Q_m}{WC_p}$$

- Where: Q_m = metabolic heat rate, calories
 W = weight of the man, Kg
 C_p = specific heat, average human body, (consistent units)
 $\frac{dT}{dt}$ = rate of change of body temperature, °C/min
 T_i

nc = convective plus evaporative heat transfer coefficient,
 (consistent units)
 A = body area, m^2
 T_a, T_o = air and surroundings temperature, $^{\circ}C$
 T_m = mean body temperature during the temperature rise, $^{\circ}K$
 hrF = radiant heat transfer coefficient, (consistent units)
 N = exponent of heat temperature ratio
 dT = taken as $5.5^{\circ}C$
 T_i = time to incapacitation, minutes

The equation was solved for T_i and curve fitted to the Crane data. The results of the curve fit gave the following values for the parameters:

ncA/WCp = -0.089811405
 $hrFA/WCp$ = 7.42071
 QM/WCp = 0.0345
 N = 1.55

These values appear to be quite reasonable thermodynamically, and were used in the above equation to plot the curve shown in Figure 19.

The results of experimental studies on time-temperature relationships for exposed skin thermal injury were reported in Reference 17. These experiments were performed with animal subjects (pigs) to determine the air temperature versus time on the exposed skin of the subjects. Data points taken from the report are plotted on the extrapolated air temperature hazard curve in Figure 19. It appears that third degree burns cross the hazard curve at about $593.5^{\circ}F$ ($585^{\circ}K$). These values have been selected as the upper limit of hazard above which escape would become impossible. At this temperature, the escape time would drop abruptly to zero for this hazard.

SMOKE (VISIBILITY) HAZARD LIMITS

A proposed escape time curve for the effects of reduced visibility through smoke has been selected and is shown in Figure 20. The rationale used in deriving this curve involved an evaluation of how far one can see an illuminated emergency exit sign at various smoke densities as determined by the transmittance per foot of distance. The transmittance and smoke volume generation rates are known for each material from tests in the CHAS chamber. These data are translated in the CHI computer program to full scale test conditions of smoke generation rates and transmittance as a function of time during the burn.

Allard's Law (Reference 18) calculates the illuminance, foot candles, at the observers eye from a light of a given luminous intensity (candles), at a distance from the observer. The equation expressing Allard's Law is:

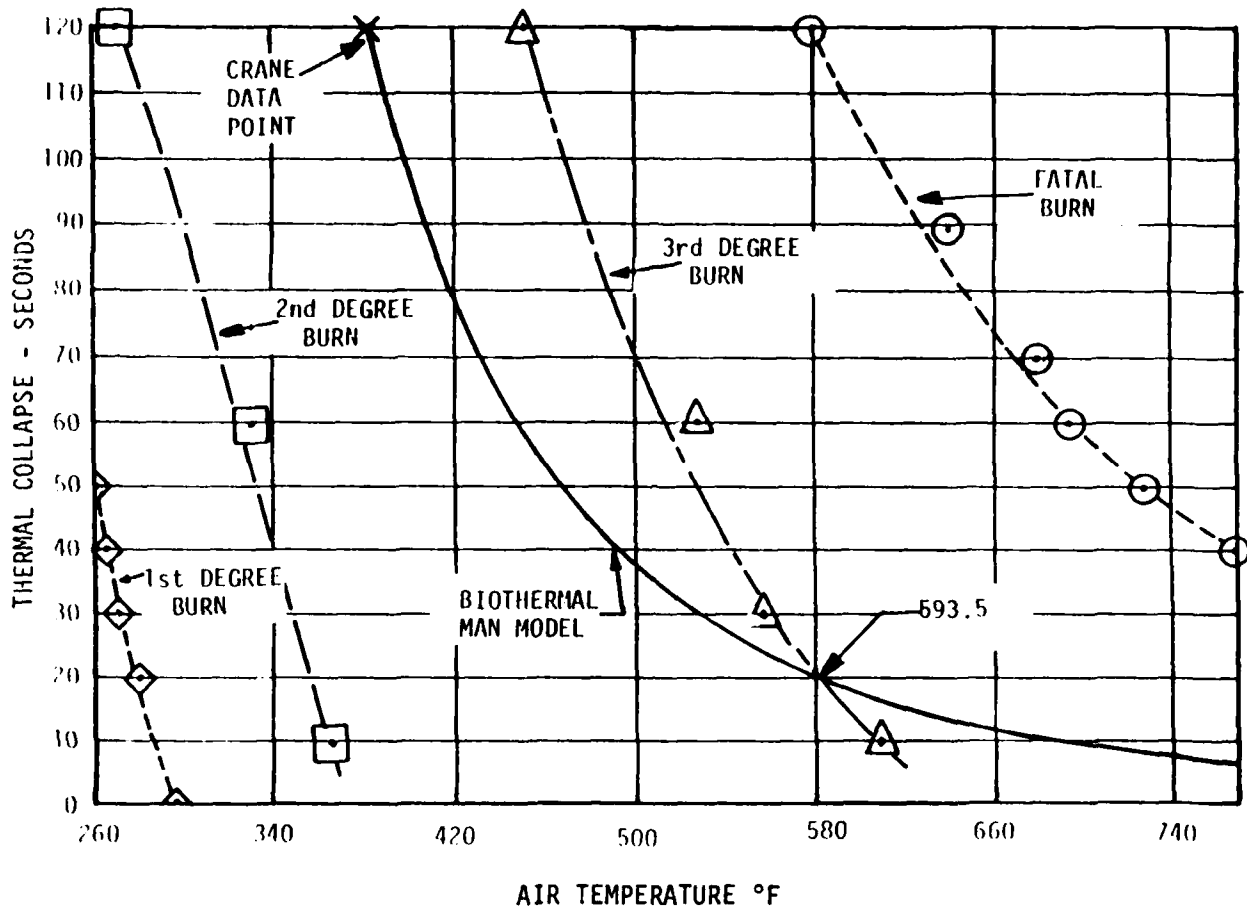

FIGURE 19. COMBINED AIR TEMPERATURE HAZARD LIMITS

$$E = \frac{I}{D^2} T^D$$

Where:

- E is the illuminance at the observer's eye in foot candles
- I is the intensity of the source light in candles or candela
- D is the distance between the source light and the observer
- T is the transmittance of the attenuating smoky atmosphere, or transmittance per unit distance

FAR Part 25 Paragraph 25.812(a) specifies the intensity requirements for emergency exit locator signs. They must have a minimum background brightness of 25 foot Lamberts, and an area of at least 21 square inches. Converting the units to candles:

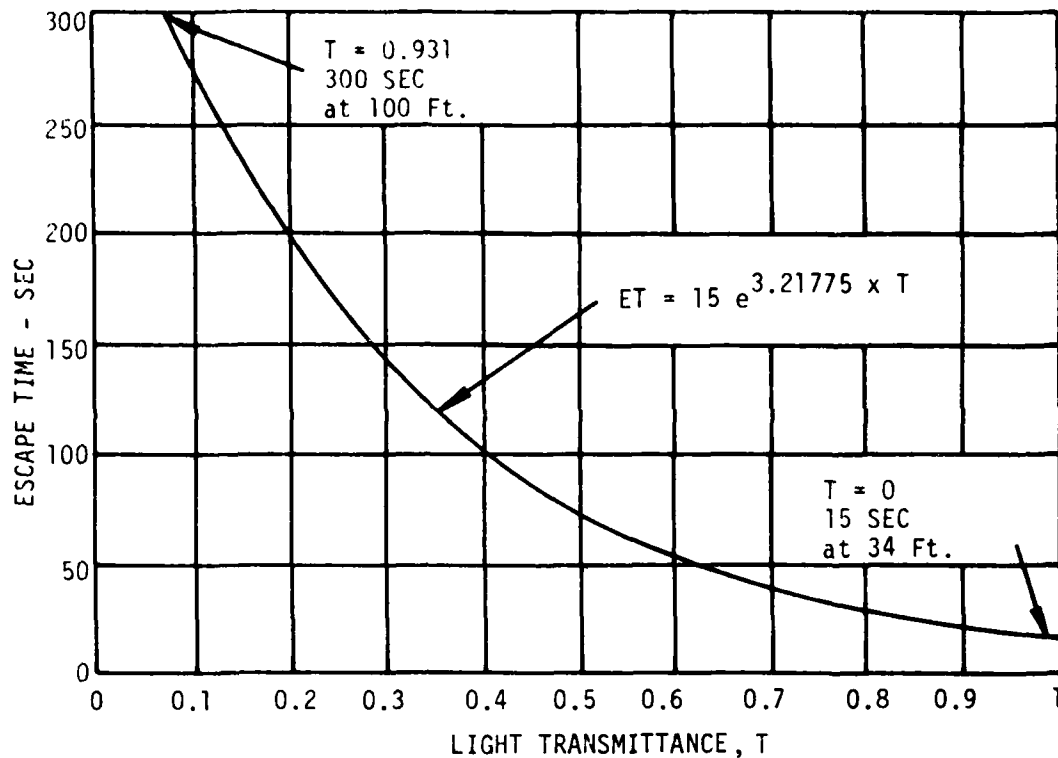

FIGURE 20. ESCAPE TIME VERSUS LIGHT TRANSMITTANCE THROUGH SMOKE

$$25 \text{ foot Lamberts} \times 0.3183 = 7.9575 \text{ candles/ft}^2$$

and the intensity

$$I = 7.9575 \text{ candles/ft}^2 \times 0.1458 \text{ ft}^2$$

$$I = 1.1605 \text{ candles (candela)}$$

A plot of the $-\text{Log } E$ of the illuminance at the observer's eye versus distance D and transmittance per unit distance is shown in Figure 21. The intensity of the light of 1.1605 candela was used in plotting the curves. Reference 18 quotes a threshold illuminance of 7×10^{-8} foot candles that is used to assess the visibility of approach and landing lights for a pilot landing an aircraft at night, which is also shown as a line in Figure 21. This horizontal line was established in Figure 21 from $-\log(7 \times 10^{-8}) = 7.155$; values above this line have an illuminance which is too low to detect by eye. Values on this line are just detectable, and values below the line are visible with increasing illuminance as points are farther below this line. The value of the illuminance in foot candles for points on this figure can be obtained by raising the ordinate values to a power of $10^{-\text{Log } E}$.

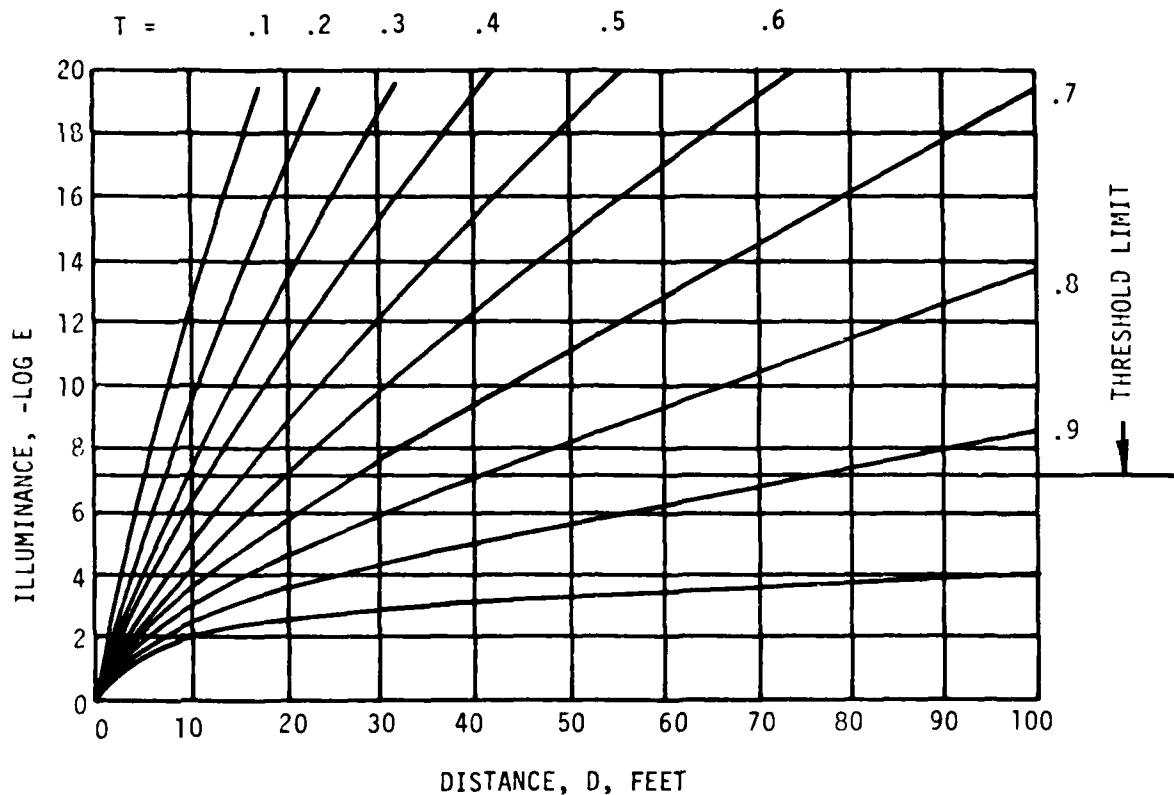

FIGURE 21. ALLARD'S LAW, $E = I/D^2 * T^D$ FOR $I=1.1605$ CANDELA

A plot of transmittance versus distance for threshold illuminance, as determined above, is shown in Figure 22. The plot shows that at increasing values of transmittance one can see farther, and that at 100 feet one can see the emergency exit from one end of a wide body jet to the other if the transmittance is greater than 93.1%. This T value was used to locate one point at the visibility level relating to an escape time at 300 seconds, i.e., for the full duration of the 5 minute fire scenario of the CHI program.

Another point on the escape time curve can be located at a time of 15 seconds at a transmittance of zero (complete darkness). An experiment indicated that one can feel their way to the nearest exit in a wide body jet, at a maximum distance of 34 feet away. The curve was assumed to be an exponential, expressed in terms of transmittance T or

$$ET = A(BT)$$

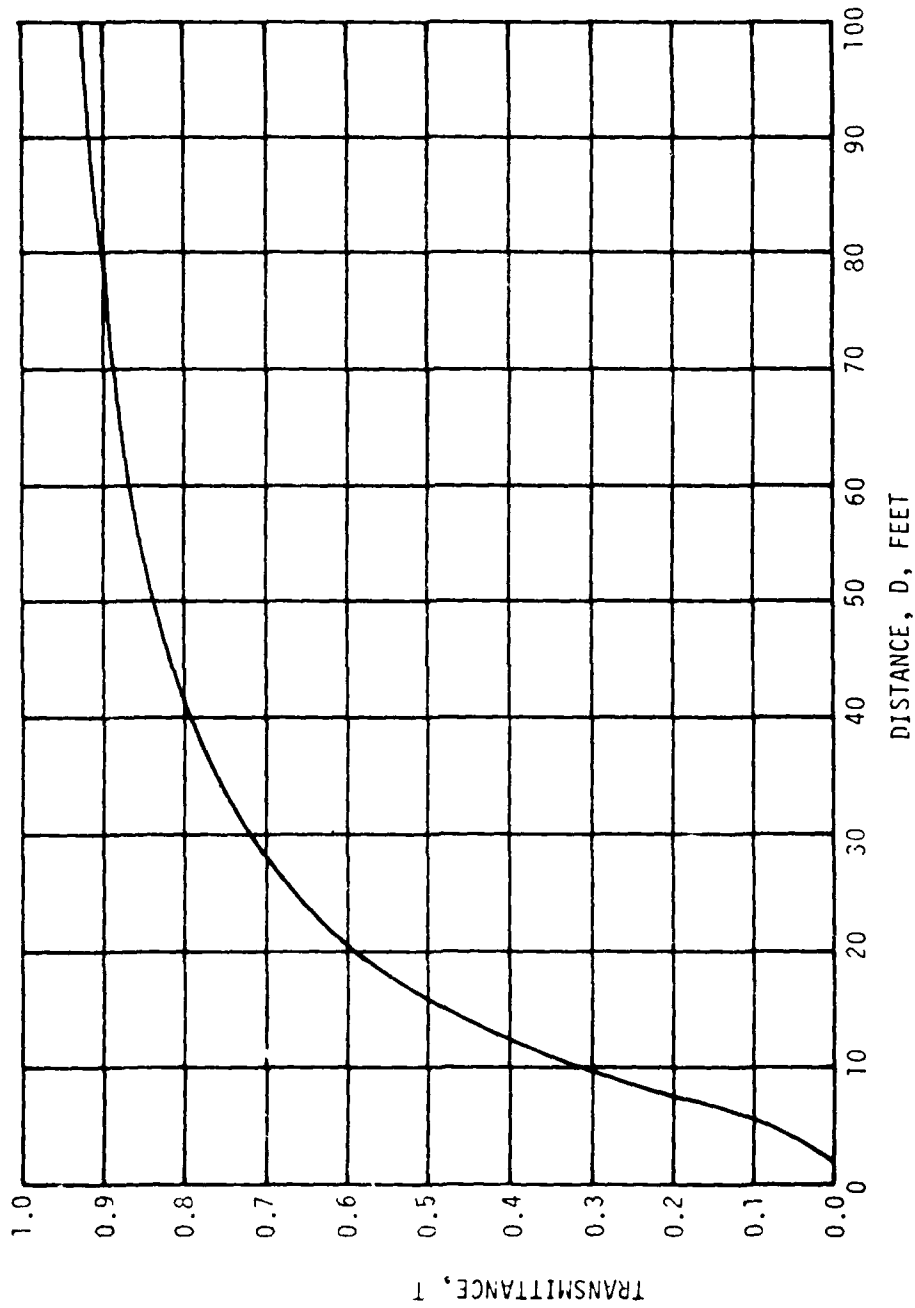

FIGURE 22. T VERSUS D FEET FOR THRESHOLD ILLUMINANCE

where, to fit the two points,

$$A = 15$$

$$B = 3.21775$$

This equation for the smoke hazard expression was used to obtain escape times resulting from smoke as a function of transmittance per unit distance in the CHI calculation. It was not used in an integrated dose sense as were the other hazards but will affect the CHI since escape time will be slowed depending on the amount of smoke generated by the material.

SATS ANIMAL TESTING

The single rotating wheel in the Single Animal Test System (SATS) plexiglas chamber (Figure 23) and the associated electrical contact bar provided two biological endpoints, T_i and T_d . Either endpoint could have been used to determine which panel material evolved the most hazardous combustion products. T_i was selected to make the comparisons since T_d 's were not observed as often and the T_i represented a more conservative endpoint related to the concept of emergency evacuation in a post crash fire cabin environment. The SATS consisted of a low volume plexiglas chamber having a free volume of 5.4 liters. The animal subject was placed in a split wheel and prompted to walk by rotating the wheel. The T_i endpoint was quite reliably determined by the changes in the pattern or recorded electrical signals transmitted when the test subject contacted a plexiglas bar. This bar was supported on strain gage sensors at each end and inserted approximately 1/8 inch inside the slotted space between the split cage halves and occupied the bottom quadrant of the cage as shown in Figure 23. Incapacitation was noted when the animal lost the ability to walk and started to slide or tumble as the wheel rotated.

This unit was designed and modified at DAC to permit parallel recording of the breathing rate by a 300X amplification of the signal. When a T_i was observed, the wheel rotation was interrupted and with the animal resting against the sensor bar, T_d (time-to-death) was determined based on cessation of the recorded breathing trace. Combustion gases were pumped into the chamber through a 3/8 inch teflon line and ball valve connected to the gas sampling probe from the HRR (see schematic, Figure 2) at a flow rate of 14 liters/min. The Teflon line and ball valve were heated to 248°F (120°C) during the run to prevent condensation of combustion products, and provided minimum transport time to the chamber. The test procedure was modified further to assure a biological endpoint in less than 30 minutes. Combustion gas dilution was reduced by adopting a test airflow rate of 60 cu ft/min through the HRR chamber and a 10 x 10 inch sample was prepared for each run instead of the conventional 6 x 6 inch sample (except for Panel 3 material).

The last procedural modification adopted for the animal Ti tests is based on the observation that the most common toxic gas produced in fires is carbon monoxide. However, carbon monoxide is not the only major toxic product evolved since these depend upon the elementary composition of the particular polymer or material being burned, the degree and character of any fire retardants added, the intensity of the fire threat, and the availability of oxygen (References 2 and 19). Since the combustion products are pumped through the animal exposure chamber during a run at 14 liter/min and vented to the CHAS exhaust system, the concentration of all the gases resident in the chamber changed rapidly with time. The effective dose rates were dependent, therefore on the generation rates of these gases and the air dilution effects. At 14 liters/min pumping rate, the nominal air change in the exposure

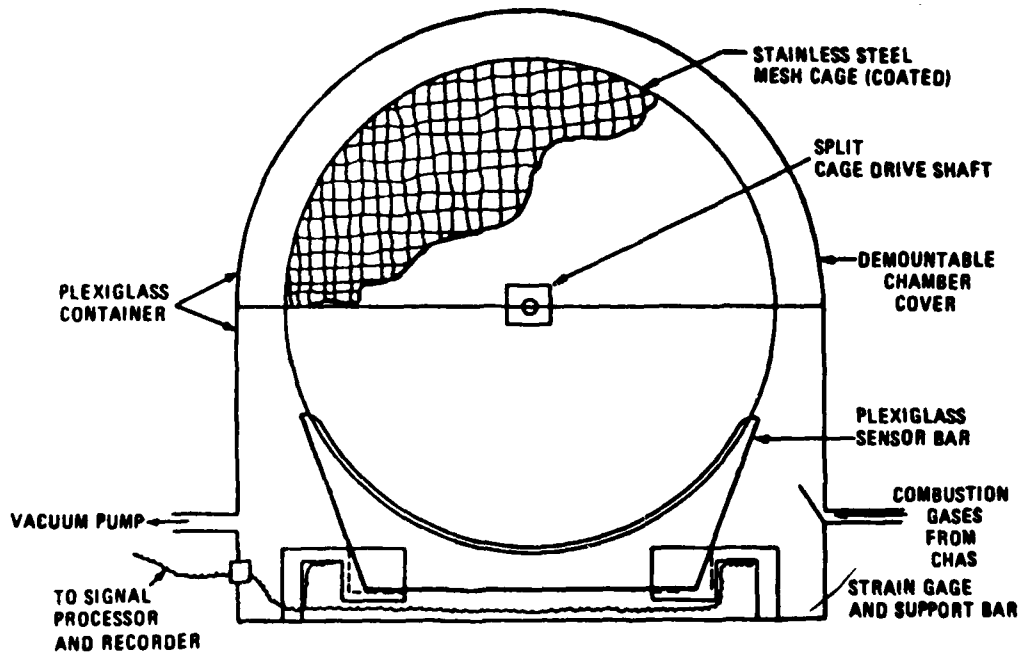

FIGURE 23. SINGLE ANIMAL TEST SYSTEM PLEXIGLAS CHAMBER

chamber was 2.8 times per minute. At high radiant flux test levels, materials burn more rapidly generating high levels of gases, but also burn out in a few minutes. Thus, a protocol and procedure that calls for exposure at constant pumping speed would not correlate with the toxic endpoints obtained with apparatus of more conventional design in which all toxic products are accumulated in the exposure chamber. The procedure that appeared to give a Ti endpoint within 30 minutes to relatively ranking materials for toxic hazard was as follows:

- (a) After chamber closure, the inlet ball valve was opened, the pump was turned on and the flow rate into the animal chamber was set to 14 liters/min.
- (b) Within 2 minutes, the sample was injected into the HRR chamber. Simultaneously an electronic timer was started along with the Ti sensor unit recorder.
- (c) As the test sample burned, the CHAS panel meters of the CO, CO₂ and HCN monitors were observed. When the CO concentration appeared to a maximize reading, the pump taking combustion gases and smoke into the animal chamber was turned off and the ball valve closed. The shut-off time in seconds was recorded.
- (d) If either the CO or HCN meter readings showed a further increasing evolution of these gases, the ball valve was reopened; the pump was turned on, and time in seconds was recorded. The pump and valve were turned off and on again if further increases in CO or HCN were observed, registering the elapsed time for each.
- (e) With the combustion gas mixture isolated in the chamber, the wheel rotation and Ti/breathing rate sensor recordings were continued for 15 or 30 minutes. Ti's and Td's were recorded for either test period option.

The observed Ti was normalized in terms of a 200g rat and the fractional accumulated dynamic exposure time based on 15 or 30 minutes in accordance with the following formula:

$$Ti \text{ (normalized)} = \frac{Ti(\text{obs.}) \times SF \times 200 \times 100}{60 \times 900 \times W \times A}$$

Where: Ti(obs.) = observed Ti in seconds from start of test

W = weight in grams of test rat

SF = summation of exposure times to gas flow, seconds

60 = 60 sec/minute conversion factor

200 = normal rat weight, grams

900 = total test time, seconds

100 = standard area of CHAS sample, in²

A = Area of CHAS sample actually burned, in²

Td's were recorded directly in minutes without normalizing calculations.

Maximum temperatures measured within the animal test chamber did not exceed 97°F (36°C) during tests for all radiant flux levels normally selected to test materials in the CHAS. This temperature level does not exceed the temperature 104°F (40°C) known to produce incapacitation of the rat in 30 minutes due to thermal stress alone (Reference 16).

The principal objective of the animal tests was to correlate the Ti results in the CHAS/SATS and the CFS, comparing the relative rankings of the panel materials with those predicted by the FACP. Typical Ti test records are shown in Figures 24 and 25.

In the preliminary development of the SATS, panel number 1 was tested 9 times at 4.41 Btu/ft² sec radiant flux to develop a suitable test procedure and protocol for use in the program. The difficulties of obtaining a Ti or Td endpoint within the time intervals required to completely consume the test materials were exemplified by the data shown in Table 11.

From the above tests, a flow rate of 14 liters/minute was finally selected as the pumping rate from the CHAS chamber through the SATS to obtain a useable endpoint for all further tests. An evaluation of SATS data is given in the Part 1 report.

CFS ANIMAL TESTING

During Panel No. 1 tests, 1 and 3 rat open mesh driven split wheel cages employing sensors of the same design as in the SATS were used and simply shielded from radiant energy by aluminum foil. As discussed in the CFS test section of this report thermal insulation was needed. A modified, insulated polycarbonate enclosure with forced ventilation was provided as shown in Figure 26

Each of the six rats (in four chambers) had one dedicated channel on an 8-channel ASTRO MED SUPER 8 hot-pen recorder. Temperatures in the four chambers were multiplexed on the seventh channel and recorded each three seconds so that each chamber temperature was recorded every 12 seconds. Ti test records from the CFS tests were similar to Figures 24 and 25.

The procedure during a run was to stop the vacuum pumps pulling air through the chambers when maximum CO concentration was reached as was done in the laboratory CHAS/SATS testing. This procedure was repeated to retain maximum gas concentration since CFS ventilation was continued until reentry could be made after the CFS had cooled.

The recorder charts for the Ti sensors in the various cages indicated that two subjects escaped from their cages prior to the start of the test. Those at the multiple cage testing location appeared to show Ti in 5 minutes. The single subject under this set of cages (Zone 12) appeared to reach Ti at approximately 5.5 minutes. With the exception of the two escapees, who survived without any ill effects, all other subjects were dead on opening the chamber 1 hour after the test

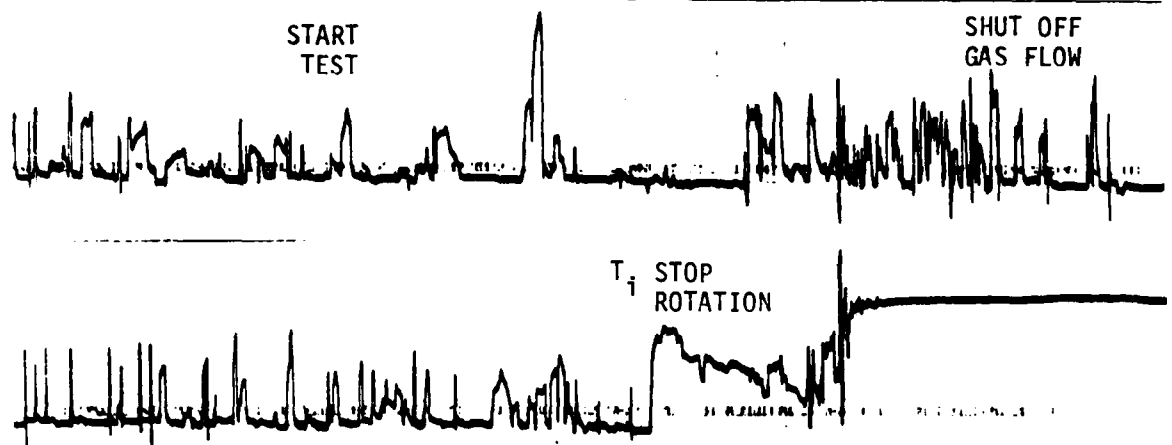

FIGURE 24. TYPICAL CHAS/SATS T_i TEST RECORDING

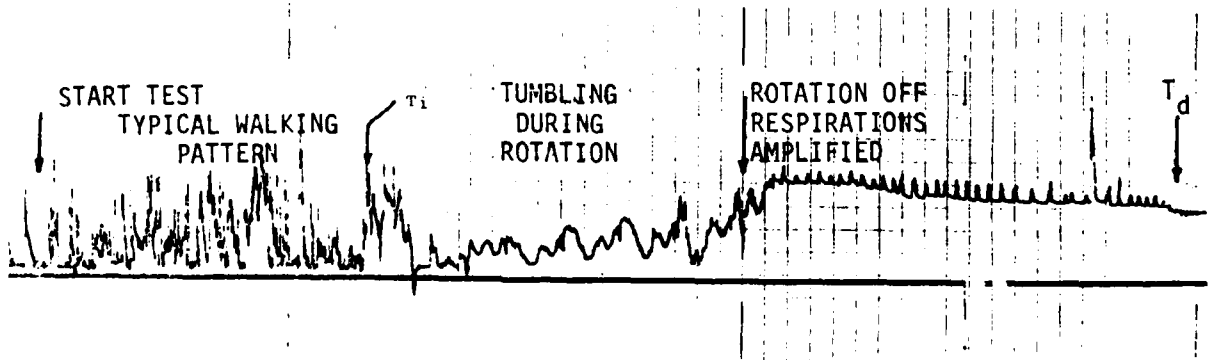

FIGURE 25. TYPICAL T_i TEST PATTERN SHOWING T_d AFTER AMPLIFICATION OF RESPIRATION

TABLE 11
CHAS/SATS TI TESTS OF PANEL 1 MATERIAL

RUN NO.	SATS FLOW RATE LITER/MIN	FLOW TERMINATED SEC	RAT WT. GRAMS	Ti SEC	Td SEC	REMARKS
47	1	1800	350	-	-	No Results
48	1	1200	356	-	-	No Results
49	4	300	334	-	-	No Results
54	5	180	210	-	-	No Results
NO CHAS DATA	10	180	230	720	-	Td Elicited with CO
NO CHAS DATA	14	216	239	972	-	Td Elicited with N ₂
72	14	192	234	990	1260	V1 Turned Off at Maximum CO
73	14	204	194	252	720	Same as Above
NO CHAS DATA	14	180	259	750	1200	Same as Above

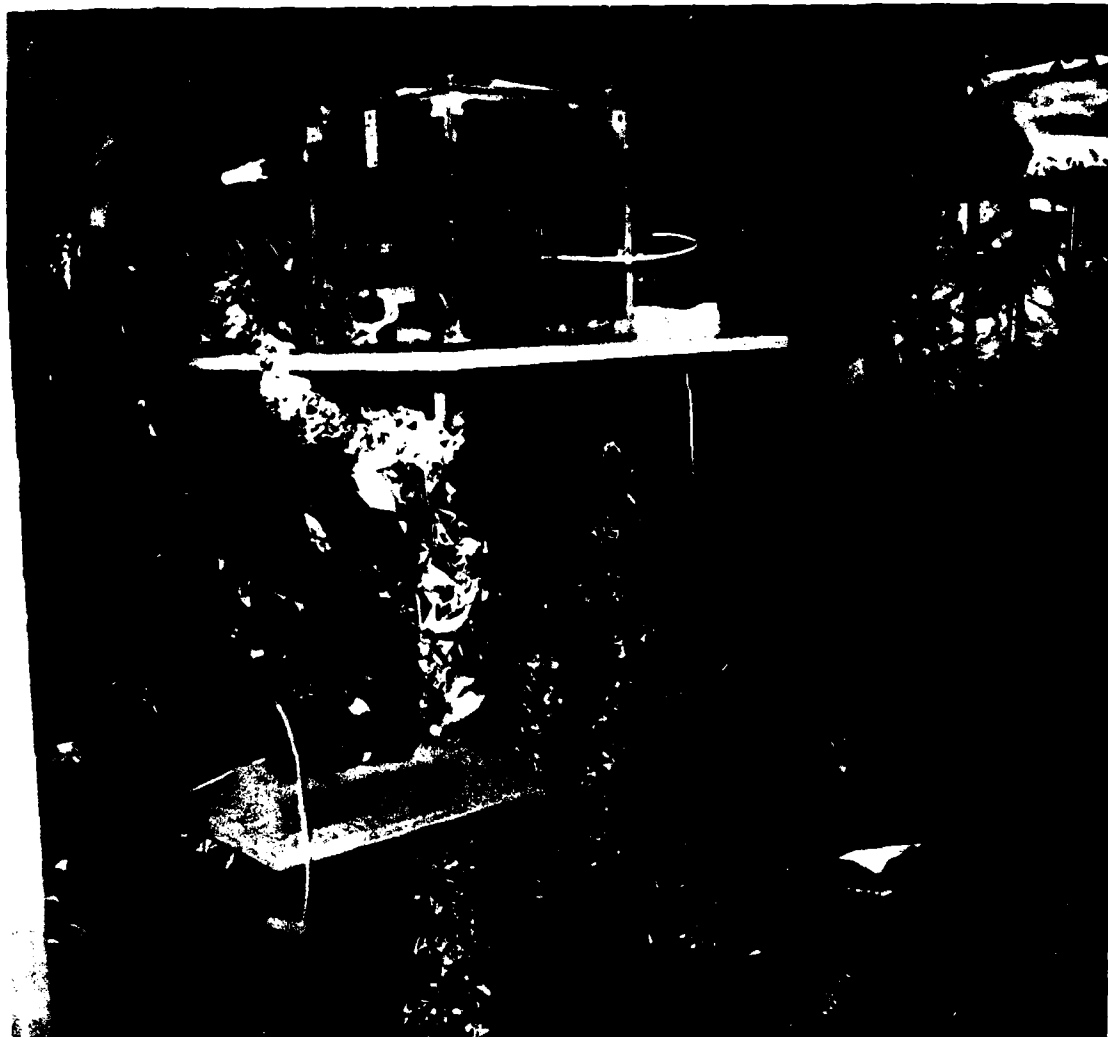

FIGURE 26. INSULATED ANIMAL CHAMBERS AT THE CHI POINT

The Ti sensor chart and computer recordings for the subject exposed inside the thermally protected polycarbonate box showed that this subject did not arrive at a Ti endpoint until after the end of computer data acquisition at 1304 seconds. However, upon opening the chamber later (1 hour) this subject had expired.

Program development was essentially completed with the scheduled burn of three No. 1 Panels in the CFS at $4.41 \text{ Btu/ft}^2 \text{ sec}$. This included CHAS/SATS test methodology, its data acquisition, writing the data reduction programs and need for computer language translation in preparing data tapes for the IBM 370 Fortran program. The personnel hazard limit curves were finalized at the best knowledge then available and with CFS testing optimized and operational. The Fortran program could not yet predict flows, to our satisfaction, through the cabin zones to match CFS data and revising the zone wall flow coefficients was continued through CFS tests on panels 2 and 3. The results of tests on these panels and the demonstration panel 4 were discussed in detail in the Part I report.

IV. FIRE ANALYSIS COMPUTER PROGRAM

SELECTION OF CABIN FIRE MODEL

The CHI program work statement (September 1977) included a task to utilize currently available cabin fire modeling technology. The model was to ... "consider the effect of the magnitude and propagation rate of heat, temperature, smoke, and gases generated by a materials fire in one cabin location on adjacent and distant cabin environments and materials."

A review of the available literature on fire modeling, in particular for aircraft cabins, did not reveal any models or computer programs that could be used (or easily modified). The specific materials fire model and the fire exposure conditions imposed by the selected crash fire scenario prevented direct application of existing model programs for use in the CHI methodology development.

The University of Dayton Cabin Fire Modeling Program (DACFIR) was designed to predict the propagation rate of flame from one fuel material surface to adjacent surfaces and the growth and space-time distribution of hazards in the cabin environment. In the CHI program a single material (composited panels) was exposed to radiant heat flux in the pilot light mode in a vertical orientation. Since the radiant flux was approximately uniform over the area of the specimen, flame involvement was nearly instantaneous. The laboratory (CHAS) and full-scale heat exposures and test panel orientations for each series of tests were kept the same. The panel area and airflow in the two test regimes were different.

Thus, fire modeling research studies such as the 2 and 3 dimensional flow studies of heated gases and smoke at the University of Notre Dame, fire plume and ceiling jet models from wood crib sources, furniture, liquid pool fires, etc. under development at the NBS Center for Fire Research, Factory Mutual Insurance Company, Harvard University and others, were not easily adaptable for use in the CHI program. A cabin Fire Analysis Computer Program (FACP) was developed in Fortran IV language based on heat and mass balance principles used in existing aircraft cabin heating and air conditioning technology. The basic elements of the fire dynamics model used to develop the FACP are depicted in Figure 27.

COMPUTER PROGRAM DESCRIPTION

The CHAS burn test data for a material were stored on the HP9825B computer disc (or tape) in processed form after each experiment. Ten channels of data consisting of 600 one-second data points were recorded in blocks (strings) for each parameter measured by the CHAS. Three additional 600 data point blocks were recorded from curves prepared from the batch sampling and analyses for HF, HCl, and aliphatic aldehydes (RCHO). The 13 blocks of processed data were transferred via the Dylon Formatter to an IBM 7-inch, 9-track 900 BPI tape, and input into the IBM 370 FACP directly or recorded on disc for more convenience in accessing and processing data on a repeat basis for development purposes.

As shown in Figure 28, the main program calls 6 subroutines in processing the IBM 370/CHAS data blocks for each hazard or measured parameter. The differential equations (DIFFEQ) subroutine calculated the derivatives of 260 differential equations in a double do-loop procedure. The number of equations depended on the number of gases recorded during CHAS burn tests and the number of zones. The same set of equations was used to calculate all hazards for the single zone program but computation time was greatly reduced since only

$$Q_{\text{FIRE}} = Q_{\text{CONVECTION}} + Q_{\text{RADIATION}}$$

$$Q_{\text{FIRE}} = Q_{\text{STORAGE}} + Q_{\text{LOSSES}} + Q_{\text{VENTILATION}}$$

WALLS
AND AIR

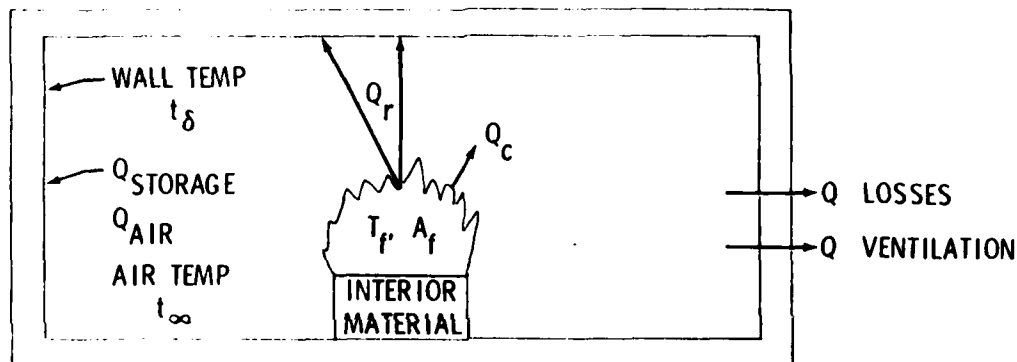

ALL PARAMETERS VARY WITH TIME

- A_f FIRE SIZE DETERMINES HEAT OUTPUT
- t_∞ AIR TEMPERATURE
- t_δ SURFACE TEMPERATURE

FIGURE 27. FIRE DYNAMICS MODEL FOR FACP

the total CFS cabin volume was involved. The flow dynamics subroutine (FLODYN) was not needed in the single zone program since the assumption of instantaneous complete mixing of gases, heat, and smoke was operative (well-mixed reactor approach). Differential equations describing the time histories for each zone wall and air temperature, smoke density, CO, CO₂, H₂O, O₂, N₂, and NO/NO_x were numerically integrated. Provision for 3 additional gases were included for printout in the program out of an optional list of 7 toxic gases.

The individual gas constants (molecular weights and specific heat capacities) were input into the program. These constants are listed in Appendix C.

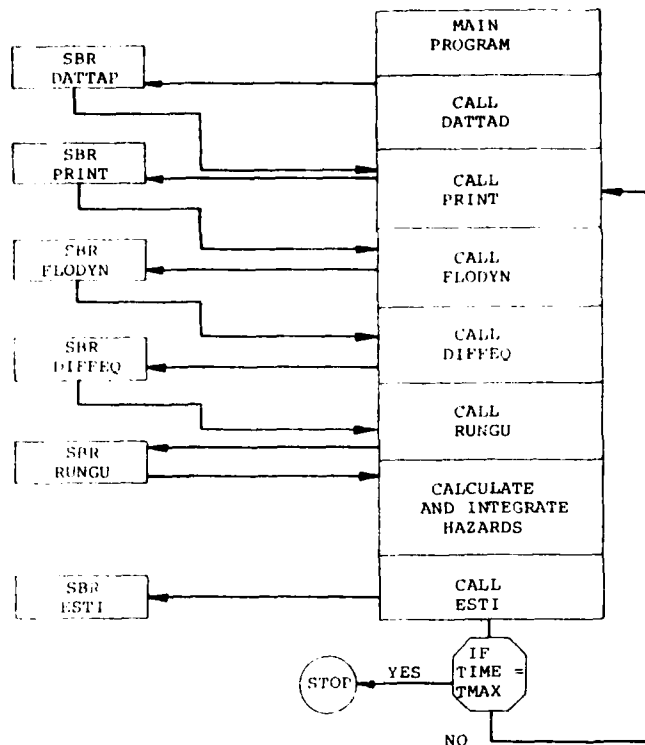

NOTES:

1. DATTAP = IBM TAPE WITH CHAS DATA
2. SBR PRINTS DATA INCLUDING CHI FOR EACH ZONE
3. SBR FLODYN CALCULATES ZONE-TO-ZONE FLOW RATES AND ENTHALPY CHANGES
4. SBR DIFFEQ CALCULATE THE RATE OF CHANGE OF ALL VARIABLES FOR EACH TIME
5. RUNGU NUMERICALLY INTEGRATES THE DIFFERENTIAL EQUATIONS
6. SBR ESTI CALCULATES THE FRACTIONAL DOSE CONCENTRATIONS AND THE CHI'S

FIGURE 28. 20 ZONE FIRE ANALYSIS COMPUTER PROGRAM

When all of the derivatives in the DIFFEQ subroutine were evaluated, a double precision differential equation (Runge Kutta) subroutine (SBR RUNGU) numerically integrated the equations to obtain the concentration values of each hazard for the next time point. The computing time interval for successful use of the Runge Kutta procedure was 0.02 seconds. Any longer time interval made the system of equations integrations unstable and resulted in incorrect data output or an IBM 370 program interrupt from an overflow in various storage registers. This highlights one of the 20 zone program deficiencies since 15 minutes of computer processing time was required to process 300 seconds of burn test data at a cost of \$700 per run (day cost) or \$350 (night-deferred).

The last subroutine (ESTI) calculates the fractional doses for each hazard based on the individual personnel hazard time to incapacitation limit curves presented in Section III, and prints out the CHI. The CHI in the 20-zone program was determined for the arbitrarily fixed "CHI location" (Zone 13) or for any zone. Only one CHI value is determine when $\sum FDi = 1$ in the case of the single zone FACP. The program loops back to the print subroutine (SBR print) and prints out all calculated data at preselected time intervals during the 300-second burn time. Five second intervals were selected as the optimum for printout in the FACP determinations. Examples of the IBM printout of processed data from runs made using the 20 zone and single zone programs are presented in Appendix C.

FLOW DYNAMICS ROUTINE - The FLODYN subroutine used to calculate zone to zone flows of smoke, heated air and gases from the vertically oriented 4 x 6 ft. panels burned in the CFS was developed on the basis of a simplified semi-empirical treatment of the problem. Each zone in the model was assumed to be instantaneously well-mixed. Thus flows were calculated only across the boundaries between zones, and temperatures, smoke and gas concentrations were considered isotropic at any instant within zone boundaries. The arrangement of the twenty zones in the cabin is shown as Figure 29.

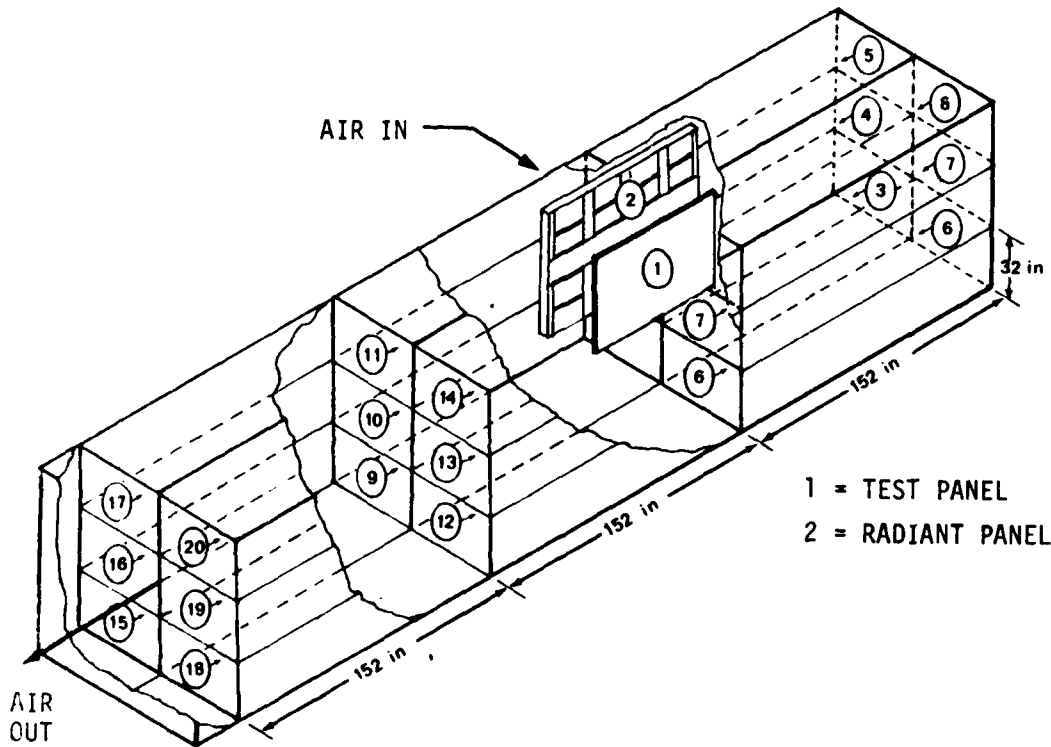

FIGURE 29. 20 ZONE CFS FIRE MODEL

Each zone has a number and its connection to other zones is defined by a two dimensional array, $P(I, K)$ where I is the zone number and K is the six sides of the zone (four walls and the top and bottom of the zone). The number K in the array defines which zone connects to the zone I for each of the six sides. If one of the sides of zone I is a wall K it is set equal to zero which will indicate that gas flow cannot pass through that surface. The dimensions of the P array are $P(20, 6)$, and thus there are one hundred and twenty numbers in the array which define all of the interconnections between zones. Another array $CA(I, K)$ defines the flow coefficient times the flow area for each of the surfaces in the $P(I, K)$ array. A third $KADL(I, K)$ array provides a KA/L heat transfer term between zones for each of the surfaces in the $P(I, K)$ array. The input value for the KA/L heat transfer term was estimated from known air atmosphere values.

When the FLODYN subroutine is called, values for each of the variables for the current time point are known. The total pressure in each zone is calculated from a summation of the partial pressures in each zone. The flow from a zone to each of the six sides of a zone is calculated in a double do-loop of zones and walls of a zone as a function of the total pressure differential across connecting zones. The P (I, K) and CA (I, K) arrays are used to determine the interconnections and flow coefficients to be used for each surface. If the K value in the array is zero, indicating an outer wall surface, the flow calculation is bypassed. This routine is continued for all of the 120 surfaces involved. The zone to zone flow equation, selected for use in the computer program, is the Perry orifice equation reported in Reference 20.

$$W = CA (I, L) \sqrt{\frac{P_T^2 (I) - P_T^2 (K)}{T_a (I)}}$$

Where: w = Mass flow rate of gas, lb/sec.
 $CA (I, L)$ = Flow coefficient x area of zone (I) to connecting zone K, $L=1, 6$
 $K = P(I, L)$: I = Zone No.; L = 6 Sides
 $P_T (I)$ = Zone (I) pressure, PSIA
 $P_T (K)$ = Connecting Zone (K) pressure, K = 1,20
 $T_a (I)$ = Zone (I) temperature differential, °R

Thus, all the possible flows through the various zones are taken into account.

The flow of smoke from zone to zone is made proportional to the total volume flow between zone ("particles" per ft³ sec). A derivation of the smoke flow algorithm and formulas used in the FACP is presented in Appendix C.

The flow of individual gases is calculated from the ratio of the partial pressure of the gas to the total pressure of gas in a zone times the molecular weight ratio of the gas to the molecular weight of the mixture:

$$W(J) = W(I) \times \frac{P (J)}{P_T (I)} \times \frac{M (J)}{M (I)}$$

Where: $W(J)$ = Flow of gas J, lb/sec
 $W(I)$ = Total flow, lb/sec
 $P(J)$ = Partial pressure of gas, psia
 $P_T(I)$ = Total zone pressure, psia
 $M(J)$ = Molecular weight of gas, lb/mole
 $M(I)$ = Molecular weight of gas mixture in zone (I), lb/mole

The enthalpy change in the zone to zone flows is calculated from the known total flows and zone temperatures and zone specific heats. The heat transfer between zones is calculated from the temperature differential between zones and the KADL term. The equation is:

$$Q (I, L) = [KADL(I, L)] [T_a(I) - T_a(K)]$$

Where:

KADL (I,L) = Heat transfer term between zones I to K,
I = 1,20; L = 1,6; $T_a(I)$ and $T_a(K)$ = zone and zone boundary air
temperatures, °F

Q (I,L) = Heat flow across zone surfaces.

The combustion gases exhaust to ambient through an exhaust duct from zone sixteen. The total flow is calculated using an incompressible flow equation:

$$WAEX = CAEXH \sqrt{\frac{P_T(16) \times [P_T(16) - P_{AMB}] \times 2g}{RM(16) \times T_a(16)}}$$

Where: CAEXH = Exhaust duct flow coefficient x area, in²
 $P_T(16)$ = Total pressure in zone 16, psia
 P_{AMB} = Ambient pressure, psia
g = Gravitational constant, 32.17 ft/sec²
 $RM(16)$ = Zone 16 gas constant 10.73,
ft-lb/lb-°R
 $T_a(16)$ = Gas temperature in zone 16

The flow of the individual gases and smoke exhausting from zone 16 is calculated in a manner similar to the zone to zone flows. The data calculated in the flow dynamics subroutine is used in subroutine DIFFEQ in obtaining the rates of change of all of the variables. The equations are then numerically integrated by the IBM RUNGE KUTTA routine which has been written into the program. The flow dynamics subroutine repeats the calculations for each computing time interval while all of the variables are varying with time.

The 120 unknown zone interface flow coefficients were not determined mathematically. The CA flow coefficients were selected and adjusted in the program on a trial and error basis using the CFS test data measured for panels 1, 2 and 3. Larger CA values were set for vertical surfaces in a zone with the largest values set for zones in and near the burning panel. Thus, the flows were generally directed to account for larger ceiling flows and with increased downward mixing toward the CFS exhaust. Because of the limitations imposed by program cost constraints and the trial and error approach required to develop the FACP, the changes in input variables needed for best predictability by the computer program were not optimized.

Only 4 first order differential equations were used in the compute program: (1) smoke, and (2) air and compartment (zone) wall temperatures, and (3) gases partial pressure (mass concentration). The calculation procedure looped through all of the equations for each time point and zone in sequence with bounding zones until all hazards were evaluated in every zone. The do-loop procedure provided a means for describing the transient changes in hazards concentrations in the system in a concise manner.

DEVELOPMENT OF DIFFERENTIAL EQUATIONS

Douglas extensively uses computer programs to solve engineering problems arising from the need to guarantee the pull-down time to cool an aircraft from a hot starting condition to comfortable air temperature using onboard or

ground equipment as a source of cooling air. This involves the solution of differential equations describing a heat balance on the aircraft as a function of time during the cooling period. Heat transfer, heat capacitance, cooling air flow rates, and temperatures are the parameters considered in solving this problem. The technique has been used on many different aircraft with good success.

In considering what happens in an aircraft fire, the same problems are faced that have been solved in transient heating or cooling of an aircraft. Unsteady heat transfer into and out of materials and equipment, thermal capacitance, heat losses, ventilation rates, and compartment sizes, are the same parameters used in a fire analysis as well as in heating and cooling problems in an aircraft.

The differential equations approach to fire analysis, explored during the early IRAD fire analysis effort, showed that fire dynamics could be handled in this manner. Transient air and surface temperatures obtained by analysis agreed very well with those obtained in actual fire tests. The concept can be further developed to describe what happens to the materials being heated or burned, and the products of combustion or material emissions can also be determined analytically as discussed in the following pages.

In fire, the temperature of the air heats up rapidly due to the convective heat flux from the fire and because the air has a very low thermal capacitance. The surface temperature of materials at a distance, and not directly in contact with the flames, increases more slowly due to the higher thermal capacitance of the material and due to the strong radiation view factor effecting on objects at a distance from the fire. Another important factor is the characteristic of the so-called unsteady temperature gradients in the material as a function of the thermal diffusivity, conductivity, and the specific heat and density. For example, a material with a low thermal conductivity would not conduct the heat away from the surface as fast as the heating rate being applied, and the surface temperature would rise faster than points within the interior of the material. The heat flux entering a surface is also a function of the surface temperature, and in order to analytically describe how the heat of a fire is being dissipated, it is necessary to describe mathematically this unsteady heat flow phenomenon.

The cabin section volume and the external environmental conditions affecting ventilation in an accidental crash fire scenario, must also be included in the mathematical model. Laboratory fire test data taken in a small chamber cannot be applied directly to a large compartment. In addition to the heat flux problem discussed above, consideration must be given to the rate at which toxic gas emissions from the decomposed material affects the concentrations of these gases in the cabin atmosphere. Obviously it is not practical to perform and interpret burn tests on all potential materials and combinations in a full-size cabin fire test chamber. This leads to the conclusion that some analytical procedure is required which will bridge the gap between laboratory tests and the fire scenario for a full-sized aircraft.

The unsteady heat flow problem has been widely treated in literature. Heat transfer notes by L.M.K. Boelter and others (Reference 21) presented plots showing the temperature change characteristics of materials suddenly thrust into a hot environment. The plots were calculated by using an infinite series

$$\frac{T_s - T_a}{T_{s_0} - T_a} = \frac{1}{\frac{ha\theta}{e^{kL}} + \sqrt{\frac{h^2}{k} a\theta}} \quad (1)$$

WHERE:

a = THERMAL DIFFUSIVITY, ft^2/sec

L = HALF THICKNESS, ft

θ = TIME, SECONDS

k = CONDUCTIVITY, $\text{Btu}/\text{sec ft } ^\circ\text{R}$

h = FILM COEFFICIENT, $^\circ\text{R}$

T_s = SURFACE TEMPERATURE, $^\circ\text{R}$

T_a = AIR TEMPERATURE, $^\circ\text{R}$

T_{s_0} = INITIAL SURFACE TEMPERATURE, $^\circ\text{R}$

DIMENSIONLESS PARAMETERS:

$\frac{a\theta}{L^2}$ = FOURIER'S MODULUS

$\frac{hL}{k}$ = BIOT'S MODULUS

$\left(\frac{h}{k}\right)^2 a\theta = \left(\frac{hL}{k}\right)^2 \left(\frac{a\theta}{L^2}\right)$

$\frac{ha\theta}{kL} = \left(\frac{hL}{k}\right) \left(\frac{a\theta}{L^2}\right)$

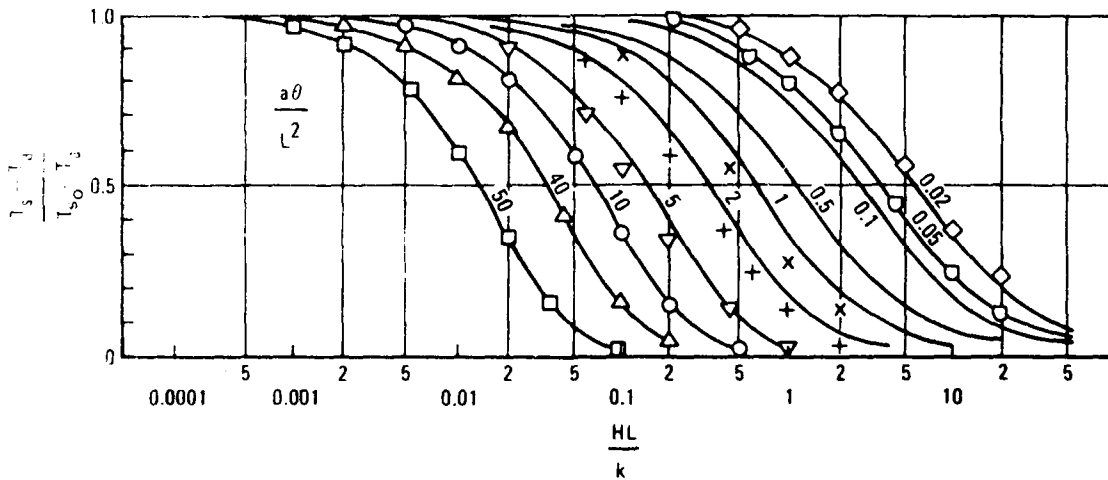

FIGURE 30 TRANSIENT HEAT TRANSFER PLOT FOR EQUATION 1

POINT PLOTTED WITH:

$\frac{a\theta}{L^2}$	50	40	10	5	2	1	0.05	0.02
	□	△	○	▽	+	x	◐	◇

solution proposed by H. Grober. The procedure used is tedious and only considers a case where the external surface heat transfer coefficient and temperature are constant. The method does not appear to have direct application in analyzing the dynamics of a fire.

During IRAD work at Douglas on the development of fire analysis techniques, an empirical equation was developed which closely fits the characteristics of a "Grober Plot" for a surface. This is Equation 1, in Figure 30, and points calculated with the equation are plotted on a Grober plot to show the agreement over a wide range of the dimensionless parameters. This equation was differentiated to put it in a differential form (Equation 2) and the surface area and the thermal capacitance of the material were included in the equation by transformation of some of the parameters.

The differentiated form of Equation 1 representing the differential equation for inside surfaces is:

$$\frac{dT_s}{d\theta} = \frac{h_e(T_a - T_s) \frac{2A_s}{M_s C_s} \left[1 + \frac{L}{2\sqrt{a\theta}} e^{-\frac{h_e a \theta}{kL}} \right]}{1 + \sqrt{\left(\frac{h_e}{k}\right)^2 a\theta} e^{-\frac{h_e a \theta}{kL}}} \quad (2)$$

Now the equation can accommodate external temperature changes as described by its differential form. The outside surfaces differential equation is:

$$\frac{dT_s}{d\theta} = \frac{\left[h_e (T_a - T_s) - U(T_{so} - T_o) \right] \frac{A_s}{M_s C_s} \left[1 + \frac{L}{2\sqrt{a\theta}} e^{-\frac{h_e a \theta}{kL}} \right]}{1 + \sqrt{\left(\frac{h_e}{k}\right)^2 a\theta} e^{-\frac{h_e a \theta}{kL}}} \quad (3)$$

Variations in the external heat transfer coefficient can be permitted by defining a combined convection plus radiation heat transfer coefficient as shown below. This is then substituted into Equation 2 and 3.

$$h_e = h_a + h_r = h_a + \tau \times 0.1714 \times 10^{-8} \frac{(T_f^4 - T_s^4) A_f}{(T_a - T_s) A_s}$$

The total heat flux per unit of surface area is:

$$Q = h_e (T_a - T_s) = Q_{\text{convection}} + Q_{\text{radiation}}$$

Where:

τ	= Radiation View Factor. Dimensionless
A_f	= Flame Area, ft^2
A_s	= Surface Area, ft^2
C_s	= Specific Heat, $\text{Btu/lb } ^\circ\text{R}$
H_a	= Convective Heat Transfer Coefficient, $\text{Btu/sec ft}^2 ^\circ\text{R}$
M_s	= Weight of the Material, lbs
T_o	= Outside Surface Temperature, $^\circ\text{R}$
U	= Overall Heat Transfer Coefficient, $\text{Btu/sec ft}^2 ^\circ\text{R}$

Equation 3 now can be used to describe the surface temperature of a material being subjected to the rapid heating which occurs during a fire when all of the parameters are changing continuously. The exponential terms automatically take care of thick or thin materials, and the effects of time. For a thin material the exponential terms remain in the equation and provides the desired relationship of surface temperature and temperature gradients within the material. Time also causes variations in the effect of the exponential term causing it to go to zero at steady state. The above approach eliminates the need to use partial differential equations to describe the unsteady heat transfer phenomenon.

Equation 2 can be used to describe the thermodynamics of interior material such as seats, partitions, and equipment where heat is flowing into both sides. An exterior wall has heat flowing into one surface and heat losses through the other to the outside. These effects have been added to the equation, giving an external wall differential equation, as shown in Equation 3.

An air temperature differential equation is shown in Equation 4. It describes effects of volume, ventilation rate, heat exchange between, materials and convection from the flame of a fire.

$$\frac{d\infty}{d\theta} = \frac{1}{M_a C_p} \left[A_f h_f (T_F - T_\infty) - W C_p (T_\infty - T_c) + h_w A_w (T_\theta - T_\infty) \right] \quad (4)$$

Where: $\frac{d\infty}{d\theta}$ = Air temperature change in a zone with time, $^\circ\text{R/sec}$

M_a	= $Rn_o \times V$, weight of air in the zone, lb.
C_p	= Average specific heat of air, $\text{Btu/lb-}^\circ\text{R}$
A_f	= Flame area, ft^2
h_f	= Convective heat transfer coefficient, $\text{Btu/sec ft}^2 ^\circ\text{R}$
T_F	= Average flame temperature, $^\circ\text{R}$
T	= Temperature in a zone, $^\circ\text{R}$
W	= Mass flow of ventilation air, lb/sec
T_c	= Temperature of incoming ventilation air, $^\circ\text{R}$
n_w	= Cabin wall heat transfer coefficient bounding a zone, $\text{Btu/sec ft}^2 ^\circ\text{R}$
A_w	= Area of wall, ft^2
T_θ	= Wall temperature, $^\circ\text{R}$

The first term within the brackets in equation 4 calculates the heat exchanged between the flame and air. The second term subtracts the heat carried out of the cabin (CFS) by ventilation air and the last term calculates the heat exchange between the walls and air.

The zone air differential temperature equation used in the FACP was derived by equating the thermal capacitance of the air times the rate of change of the air temperature to a summation of the heat flow into or out of the air. The equation is:

$$MaCpdT/dt = \sum(\text{Heat Flows})$$

Substituting the ideal gas equation ($P = \rho RT$), the equation becomes:

$$dT/dt = RT/(PV Cp) \times (Q_{in} - Q_{out}) \quad (5)$$

Where: ρ = Density of gas, lb/ft³

Q_{in} & Q_{out} includes the enthalpy change of the flowing gases plus heat from the burning material along with the heat exchange to the walls.

DIFFERENTIAL EQUATION FOR SMOKE - The smoke data obtained from the CHAS tests and stored on tape is defined by the following equation.

$$S = \text{Log}_{10}(100/T) Q/LA \quad (6)$$

Where:

S = Smoke Units, "particles"

T = Fraction of light transmission (varies from one to zero)

L = Smoke detector light path length, m

A = Sample area, m² (CHAS value)

Q = CHAS airflow rate, m³/min

The flow of smoke is assumed to be proportional to the total gas mixture volume flow rate.

The flow of smoke into and out of a zone is:

$$S_{in} - S_{out} = S_1 WM_{in}/RHO_{in} - S_2 WM_{out}/RHO_{out}$$

and the differential equation used in the FACP for smoke was:

$$dS/dT = (S_{in} - S_{out}) AP/V \quad (7)$$

Where:

S_1 = Instantaneous smoke concentration flowing into the zone, "particles"/ft³

S_2 = Instantaneous smoke concentration flowing out of the zone, "particles"/ft³

WM = Weight flow rate of the gas mixture, lbs/sec

RHO = Density of the mixture, lbs/ft³

S_{in} = Smoke flow into a zone, per ft²

S_{out} = Smoke flow out of a zone, per ft²

AP = Area of burning panel, ft²

V = Volume of the zone, ft³

The equation behaves like a differential pressure equation where gas is stored or depleted in a volume (capacitance) as a function of time. The smoke level can build up in a zone as a function of the total flow rates.

A differential equation giving the rate of change of the partial pressure of each gas is obtained by differentiating the gas Law.

The gas law is:

$$P_i V = M_i R_i T \quad (8)$$

Where:

P_i = Partial Pressure of Each Gas in Mixture, lbs/in²

M_i = Weight of each Gas, lb

R_i = Gas Constant

V = Volume of Zone, ft³

T = Absolute Temperature, °R

$$\frac{dP_i}{dt} = \frac{P_i}{T} \left(\frac{dT}{dt} \right) + \frac{R_i T}{V} \left[M_{i\text{IN}} - M_{i\text{OUT}} \right] \quad (9)$$

M_{i IN} - Mass flow rate, lb/sec of each individual gas into the zone.

M_{i OUT} - Mass flow rate, lb/sec of each individual gas out of the zone.

These quantities are functions of the flow into and out of each zone, and the generation rate from the fire for each of the individual gases.

The differential equations were numerically integrated for each gas along with the other differential equations in the CHI program. The partial pressure of each gas will be known in each zone as it varies with time.

The total pressure in the compartment can be obtained from a summation of the partial pressures.

$$P = \sum P_i \quad (10)$$

and the weight of each gas can be obtained from the gas law:

$$M_i = \frac{P_i V}{R_i T} \text{ and Total } M = \sum M_i \quad (11)$$

The gas constant for the mixture is obtained from:

$$R_m = \frac{\sum (M_i R_i)}{M} \quad (12)$$

$$\text{and } C_{p_{\text{mixture}}} = \frac{\sum (M_i C_{pi})}{M} \quad (13)$$

$$\text{and } C_{v_{\text{mixture}}} = \frac{\sum (M_i C_{vi})}{M} \quad (14)$$

$$\text{and } \gamma = \frac{C_p}{C_v} = \frac{\sum (M_i C_{pi})}{\sum (M_i C_{vi})}$$

Where:

C_v = Heat capacity of the gas at constant volume

The derivation of an equation used to express the zone to zone flow of individual gases which is used in the flow dynamics subroutine is given below:

The ideal gas law is:

$$M_T = \left[\frac{P_T V}{RT} \right] (MW)_{\text{ave}}$$

$$m_i = \left[\frac{P_i V}{RT} \right] (MW)_i$$

The mass fraction of gas "i" in a zone is:

$$m_i/M_T = P_i/P_T(MW)_i/(MW)_T$$

The constituent gas weight flow out of a zone is:

$$W_i = m_i/M_T W_T = (P_i/P_T)(MW)_i/(MW)_{ave} W_T$$

Nonmenclature used in the gas equations are as follows:

Uppercase symbols.

M Mass, lbm
P Total pressure, lbf/ft²
V Zone volume, ft³
T Temperature, °F
R Universal gas constant
MW Molecular weight
W Total flow, lbm/sec

Lowercase symbols

m Constituent gas mass, lbm
p Constituent partial pressure, lb/ft²
w Constituent flow, lbm/sec
v Constituent partial volume, ft³

Subscripts:

i Refers to specific gas constituent
T Total
ave Average gas property

The differential equations used in the FACP were: inside wall temperature (Equation 2); air temperature (Equation 5); smoke (Equation 7); and gases (Equation 9). The outside wall temperature, Equation (3), was not used in the final version of the FACP. Toxic gas concentrations (M_i) were calculated by the FACP as ratios of the individual partial pressures to the total pressures. The total pressures at any instant were not precisely known since all of the gases evolved in the combustion process were not measured in the laboratory (CHAS). However, air plus the major products of combustion that were directly measured (CO, CO₂, O₂ depletion) accounted for 90-95% of the mass balance in the CFS tests as calculated by the FACP. Nitrogen and H₂O vapor mass concentrations were calculated. A derivation for the method of calculating water is included in the Appendix. Smoke was measured in terms of optical transmission and was not included in terms of mass optical density.

Fortran versions of the four differential equations described above have been coded into the CHI computer program in do loop routines which are the same for all zones and gases. Each gas has a particular gas constant and specific heat. The zones are described by their volumes, surface areas and wall heat transfer characteristics. The program loops through the gas partial pressure equation for each gas in a zone, and it then continues on to the next zone until all of the zones have been analyzed for a time point. This cycle is repeated for each computing time interval to the maximum time specified for the run.

V. TEST MATERIALS

MATERIALS SELECTION

Candidates for selection of four materials were to satisfy largely the following criteria:

1. Represent interior cabin materials currently in airline service or under development.
2. Possess a large exposure area and potential high fire load (total weight in cabins).
3. Comprise sufficiently differing chemical compositions to evolve measurable quantities of many probable gaseous products.
4. Contain an organic resin content high enough to evolve quantities of heat, smoke, and gases at levels that substantially approach or exceed personnel hazard levels when reasonable areas are exposed to a simulating fire scenario heat source in CFS testing.

Four large area cabin panels were selected to represent a wide range of typical constructions. The first was a then current, wide-body honeycomb sandwich construction with decorative covering on both sides used for partitions, galley and lavatory walls. The second was a current production panel. The third panel was a 1958 wall panel design. The fourth panel was identical in construction to panel 1, except that epoxy resin instead of modified phenolic was used in fabrication.

PANEL FABRICATION

PANEL NO. 1 FABRICATION - Panel No. 1 was made earlier in the program than the final three. Six 48 X 96 inch panels were fabricated for use in laboratory and full scale Cabin Fire Simulator (CFS) testing. Fabrication was observed by an engineer who selected production materials to be identical in all panels. Due to press capacity, these were made in three press operations. This panel consisted of the following commercially available components.

Decorative Outer Layer: Tedlar[®] /Vinyl laminate, Type 3-10-195 polyvac T Green and Blue Cork, Mf'd. 10-25-73 lot 12723 Polyplastix United, Inc., Chicago Division. Facing: Phenolic Impregnated "C" Stage Fiberglass laminate Cloth, 31.3% resin content, Hexcel Corp., Mf'd. 11-22-77 Batch No. 41320. Core: Nomex Honeycomb, Phenolic impregnated, DMS 1947J Class 2, Type 1, Grade A, 0.700 inch thick Orbitex HMX-1/4-1.5, Mf'd 8-77. Adhesive: (Facing to Core) Epoxy film adhesive MDS 1903D, Weight 0.040, Reliable Manufacturing Company, Mf'd 2-28-78. Blocking: None. Glasing: None. Primer: National Adhesives No. 41-4463. Table 12 gives a breakdown of the structure and composition of panel material No. 1. The element content shown for each polymeric constituent is known or was obtained for certain elements using X-ray fluorescence spectroscopic analysis. The weights of each polymer type per unit area, and for the 4 X 6 foot panel size used in full scale tests, are listed also.

TABLE 12
COMPOSITION OF MATERIAL NO. 1

POLYMER	ELEMENT CONTENT	WEIGHT/AREA		
		LB/FT ²	GR/M ²	GR/CFS PANEL
TEDLAR + ADHESIVE	C, H, F ?	0.014	68	174
VINYL + ADHESIVE + INK	C, H, Ca, O, CL ?	0.040 0.002 .045	195 10 220	457 491 ?
TEDLAR	C, H, F, CL, Ti S, K, O	0.034	166	370
POLYURETH.	C, H, N, Sb, CL O	0.004	20	44
PHENOLIC	C, H, O, Si, Ca, Ti, K, CL	0.23 0.37 FG	1123 1806	2504 4027
EPOXY	C, H, O	0.09	440	981
NOMEX	C, H, N, O, Ca	0.088	430	959
	TOTAL WEIGHT	0.919	4485	10,000
	COMBUSTIBLES	0.504	2460	5,485

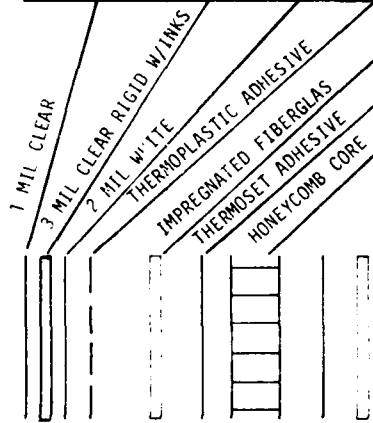

FABRICATION OF PANELS 2, 3 AND 4 - Five 4 X 8 foot panels each of three constructions shown in Tables 13, 14, and 15 were fabricated under engineering supervision with the same attention to detail as with Panel No. 1. These panels were cut to the 4 X 6 foot size for CFS tests and the ends of each panel (2 X 4 feet) cut into 10 X 10 inch specimens for CHAS testing. All specimens were identified so that data from CHAS and CFS tests were from the same panel.

TABLE 13
PANEL MATERIAL NO. 2 CONSTRUCTION

LAMINATE STRUCTURE	MATERIALS	WEIGHT LBS/FT ² (GRAM/M ²)	FINISHED PANEL PHYSICALS	
			WT. LBS/FT ²	THICKNESS-IN.
①	Polyvinyl Fluoride Decorative Film + Adhesive	0.10 (488.2)		
②	" FLY SCREEN" Phenolic Fiberglass W/Epoxy Adhesive	0.12 (585.9)	0.508 lb/ft ²	0.5
③	NOMEX Honeycomb Filled W/Fibergl. Batting W/Phenolic Binder	0.056 (273.4) 0.0225 (109.9)	(2480 g/m ²)	
④	Phenolic Fiberglass	0.10 (488.2)		
⑤	Phenolic Fiberglass With Epoxy Adhesive	0.11 (537)		
CFS TEST PANEL 4' x 6'		(2.23 m ²)	12.19 lb (5.529 Kg)	

ALL 5 TEST PANELS

①	DMS 2008, Polyvac T, Material No. 76-117, Class 1, Poyplastex United, Inc.
②	DMS 2018, Reliabond, Product R1717-1507/60 x 96 in., Lot/Roll 509/20, Mfg. Date: 3-11-80, 0.12 lbs/sq. ft., Reliable Manufacturing Inc.
③	DMS 2068, Hexcel Acousti-core, HRH 10 Acousti-core, Lot: 02609, 1.5 PCF, 0.25 in. cell size, 0.45 thick, Hexcel Structural Products.
④	DMS 2055, Type 1, Grade A, "B" Stage Phenolic/Glass, Product: MXB6032/181, Roll 42, Mfg. Date: 3-21-80, 0.10 lbs/sq. ft., Fiberite West Coast Corp.
⑤	DMS 2017, Type 1, "C" Stage Phenolic/Glass, Product: NB1306-7781, Batch 000095, Roll/unit 000048, Mfg. Date: 2-14-80, 0.11 lbs/sq. ft., Newport Adhesives

TABLE 14
PANEL MATERIAL NO. 3 CONSTRUCTION

LAMINATE STRUCTURE	MATERIALS	WEIGHT LB/FT ² (GRAM/M ²)	FINISHED PANEL PHYSICALS WT LB/FT ² THICKNESS-IN.
①	TYPICAL BOTH SIDES OF H/C CORE	PANLAM Cloud White 0.026 Gage SEMI RIGID	1.298 lb/ft ² (6335 g/m ²) 0.75 in.
②		PRIMER	
③		POPLAR WOOD	
④		ADHESIVE (Epoxy)	
⑤		PAPER HONEYCOMB CORE, 0.45" Thick. FP TREATED	
CFS TEST PANEL 4' x 6'		(2.23m ²)	31.15 lb (14.16 kg) 0.75 in.

ALL 5 TEST PANELS

①	DMS 1895, Type 5 PANLAM: .026 Gage Color: Cloud White P. O. 6BR867486-9 DATE: December 3, 1976 Vendor's Const. #76-250
②	DPM 5411 Adhesive Primer
③	DMS 1526E .125 Thick Type 1 CR F&B Poplar Wood DATE: 1-10-80 General Veneer Mfg.
④	DMS 1903 Adhesive Batch: #A-2798 Roll #2 DATE: 4-80 Fiber-Resin Corp. FR-7031-2
⑤	DMS 1925, Type 2 Paper H/C .45 Thick (No I.D. Tags)

TABLE 15
 PANEL MATERIAL NO. 4 CONSTRUCTION

Panel No.	Material	Thickness	Weight	Notes
1	DMS 1914, Type 1	0.70		
2	DMS 1914, Type 1	0.70		
3	DMS 1914, Type 1	0.70		
4	DMS 1914, Type 1	0.70		

(F-155-59)

MXB7704/181

④	DMS 1914, Type 1 Class 2, Grade A Nomex H/C .70 Thick Density 1.5 PCF Job #L245777-02 Block #HJD15N-7R204V P.C.#7BR-440728-9 Hexcel Corp.	Same as Panel 1 & 2	Same as Panel 1 & 2
---	--	---------------------	---------------------

VI. CABIN FIRE SIMULATOR TESTING

CFS TEST SETUP

The full-scale tests performed in support of the Combined Hazard Index Program were conducted in the Douglas Cabin Fire Simulator (CFS). The objective of these tests was to develop the laboratory test methodology and demonstrate the capability of the computer program to predict the environmental spectrum within the CFS. The interior of the CFS was configured as shown in Figure 31. The interior of the cabin was segmented into 18 zones plus two zones for interface with the computer program. The boundaries of 18 zones which were formed by two horizontal planes 32 and 64 inches above the floor, two vertical station planes at 152 and 314 inches and one vertical plane on the longitudinal centerline of the CFS. The two computer interfacing zones were physically located within the 18 zones and due to their physical size overlapped several compartment zones. Zone 1 was the radiant panel and zone 2 the specimen panel. The 20-zone computer program split the output of these two zones based on their area of intrusion into the 18 compartment zones. For computer identification these zones were numbered from 1-20 as shown in Figure 31. They were identified in CFS data relative to their geographic position in the chamber and their vertical location, i.e., upper, mid, and lower, so that the lower zone farthest from the radiant quartz lamp array was identified as LSW (lower southwest). Certain locations show a "T" for thermocouple or a "P" for photometer, as appropriate. Eighteen major instrumentation points were located in the center of each of these zones and in the air exhaust duct. The baseline test aluminum panel and the test samples were exposed to the radiant flux emitted from the radiant quartz lamp panel modules arranged to produce as uniform a flux as possible on the exposed panel. The test panel, during exposure was mounted on a weighing fixture with the panel face 32 inches from the quartz lamps. Ventilation of the chamber was achieved by pumping air through a plenum mounting the lamps and exited through a pumped exhaust at the far end of the chamber.

ZONE INSTRUMENTATION - A thermocouple was located in the center of each zone. Nine photometers sampled the smoke density as percent transmission through a 12-inch light beam as recorded by a Weston cell in each instrument, located in the zones on the cabin side opposite from the panels.

The temperature of the air was recorded both as it entered and exited the chamber. These measurements were made by thermocouples mounted in the entry and exit air ducts. The air temperature was also measured one inch under the ceiling on centerline between the main thermocouple mounting trees.

CHAMBER VENTILATION - Air entered the chamber at 875 cfm flow rate at ambient temperature through a plenum chamber mounting the radiant source. The air flowed uniformly around all of the radiant elements providing the necessary cooling for the power cables and ceramic reflectors. After flowing through the CFS the air exited through a simulated door opening in the end dome and out through a 6-inch duct in the center of the end dome.

AD-A117 449

MCDONNELL DOUGLAS CORP LONG BEACH CA

F/G 1/3

A COMBINED HAZARD INDEX FIRE TEST METHODOLOGY FOR AIRCRAFT CABI--ETC(U)

APR 82 H H SPIETH, J G GAUME, R E LUOTO

DOT-FA77WA-4019

DOT/FAA/CT-82/36-2

NL

UNCLASSIFIED

2 - 3

OF 811

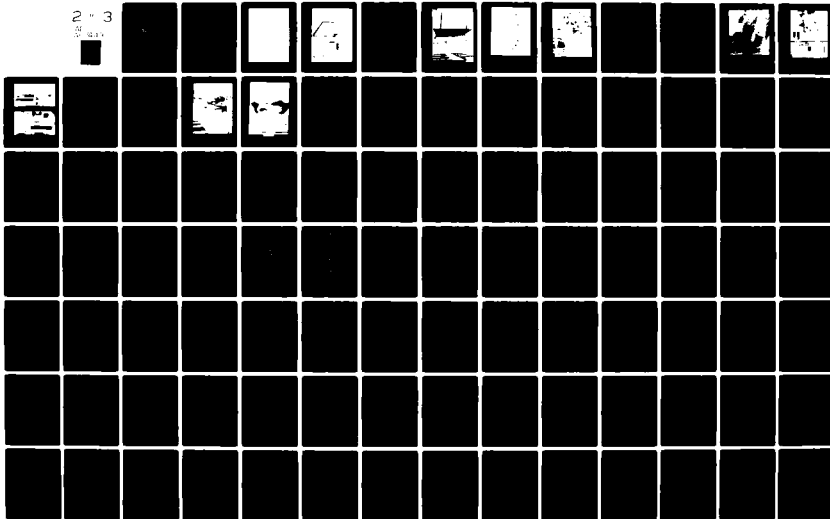

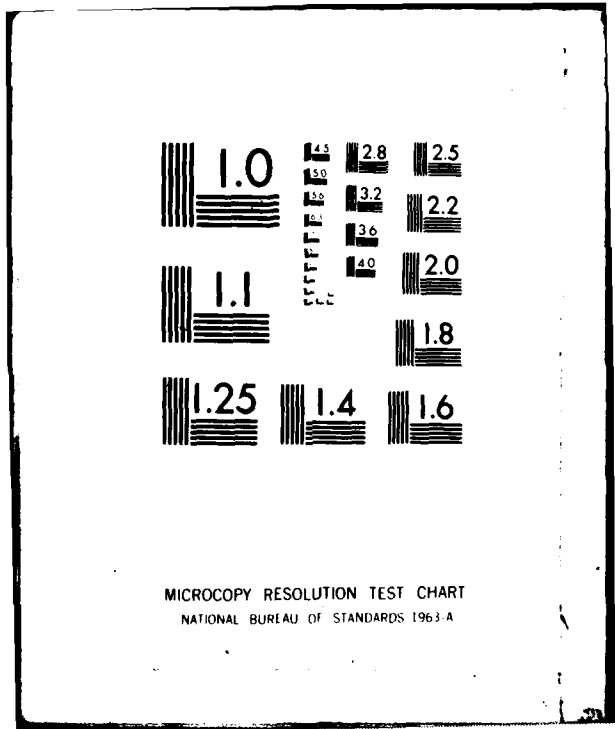

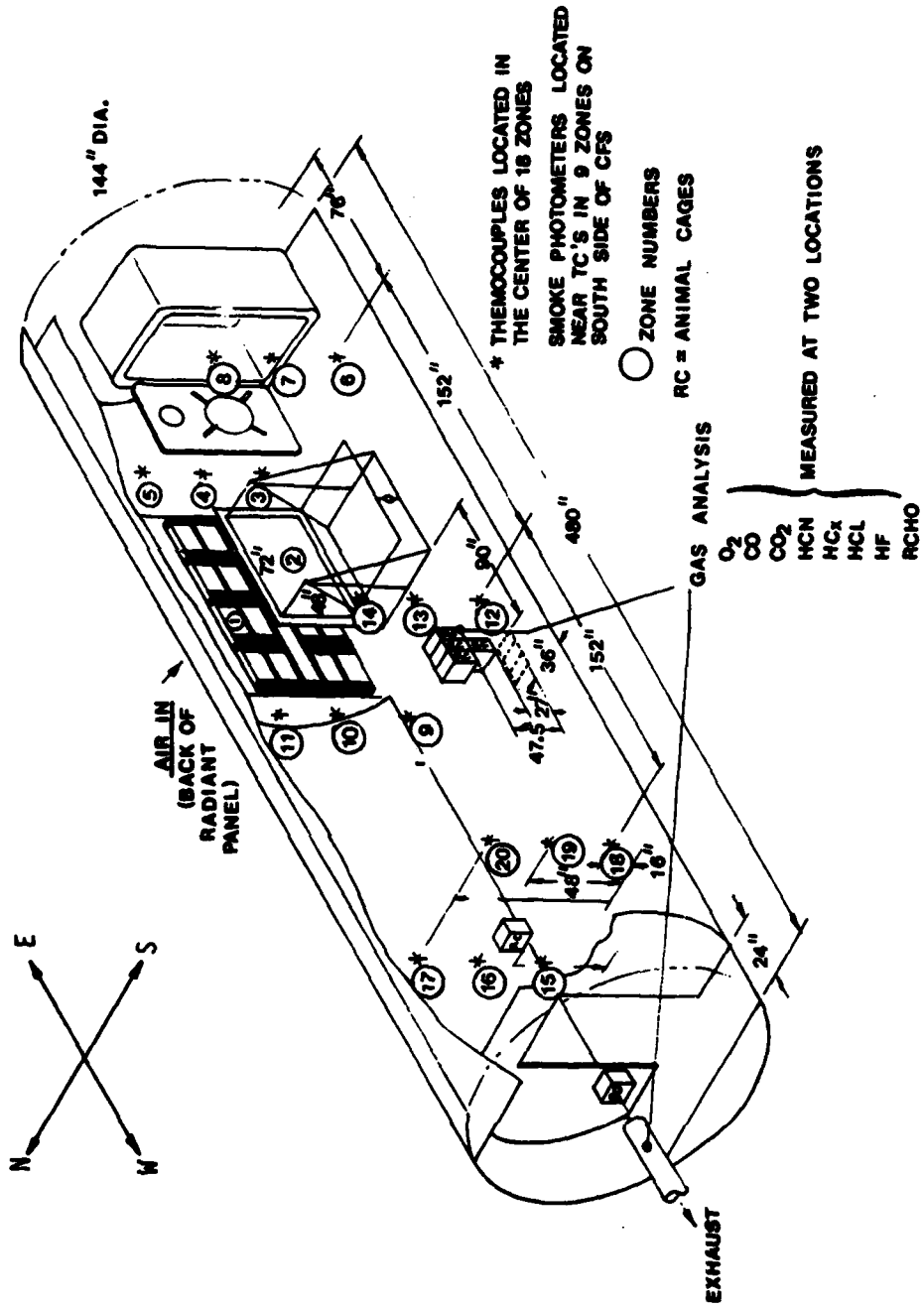

FIGURE 31. CHI TEST SETUP IN CFS

QUARTZ LAMP RADIANT ARRAY - Simulation of the post-crash fuel fire radiant flux was achieved with 16 Pyropanel modules, Model No. 4083-16-12 fabricated by Research Inc. This assembly is shown in Figure 32. The array was 91 inches wide by 64 inches high, with the 8 upper and lower units separated by a center spacer in order to achieve a more uniform flux distribution. The radiant energy of this array consisted of 184 1600T3 CL tungsten filament quartz lamps operated at 240 volts. The filament temperature at this voltage was 4000^oF with a spectral energy peak wave length of 1.2 microns. Total power to the array was 294.4 Kw. Power to the array was supplied using 4 ignitrons operated in the manual mode. Initial setting of ignition power was made by measurement of the voltage at the array to insure that 240 volts was present correcting for voltage drop in the power cables.

The radiant array was mapped (Figure 33) to determine the optimum distance for specimen location. This was accomplished using 5 Medtherm Calorimeters, each with a 0-20 BTU/ft²/sec. range. The objective was to select a plane in which the incident heat flux was most uniform at each selected heat flux. This desired flux was selected to coincide with that being used in the HRR chamber.

A plot showing the approximated flux distribution for a nominal average power setting of 4.41 Btu/ft² sec (5 W/cm²) is shown in Figure 34.

SPECIMEN MOUNTING - Figure 35 shows Panel No. 1 mounted on the weighing fixture. The attachment of this specimen to the frame was made with 3/16 machine screws, 5/8 in. diameter washers and nuts on the frame side. All other panels were held to the frame with edgebars and clamps. The mounting frame was held in position by a four bar linkage system restrained by a 0-50 lb. load cell on the side opposite from the sample, the output of which is recorded by the computer data system. This system was calibrated by adding and removing weights within the range of expected weight loss and its performance was within 0.05 lb. The load cell was insulated and air cooled to maintain stability.

GAS SAMPLING - The atmosphere of the CFS was sampled at the CHI point (zone 13) and in the air exhaust duct. For certain acids and gases, batch bubbler samples were obtained and a posttest laboratory analysis of their contents was performed.

The following gases were sampled and monitored by specific response gas instruments at the following locations: (see Figures 36 and 37).

<u>Gas</u>	<u>CFS Exhaust</u>	<u>Multiple Animal Test Point (Zone 13)</u>
O ₂	Beckman-1008, 2 liter/min flowrate	MSA-802, 2 liter/min flowrate
CO ₂	Beckman-864, 1 liter/min flowrate	MSA-LIRA, 1 liter/min flowrate
CO	MSA-LIRA, 1 liter/min flowrate	Bendix
CH _x	MSA-LIRA, 2 liter/min flowrate	-
HCN	Kin-Tek (DOW), 1 liter/min flowrate	-



FIGURE 32. CFS RADIANT HEATING ARRAY

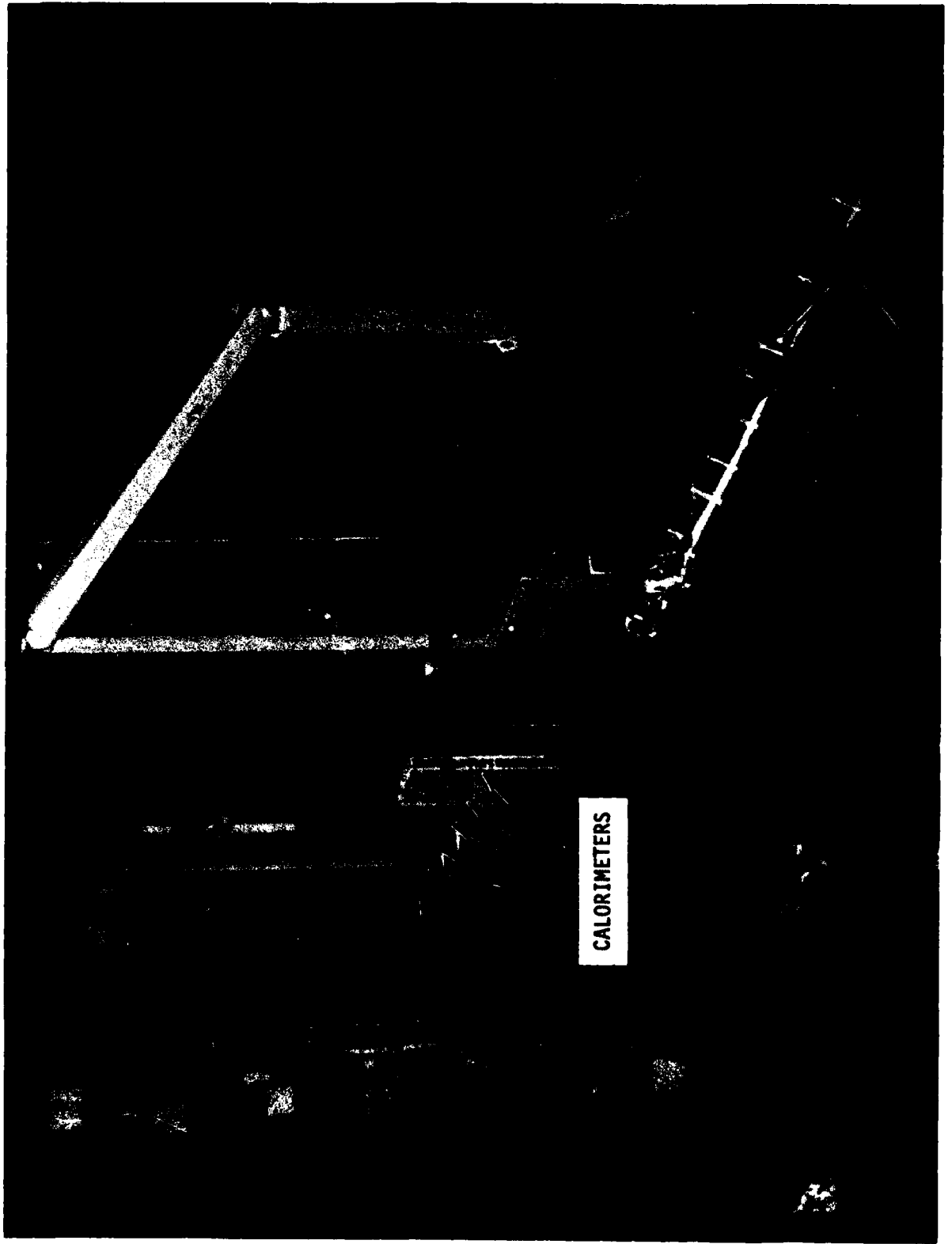

FIGURE 33. CALORIMETERS POSITIONED FOR ARRAY MAPPING

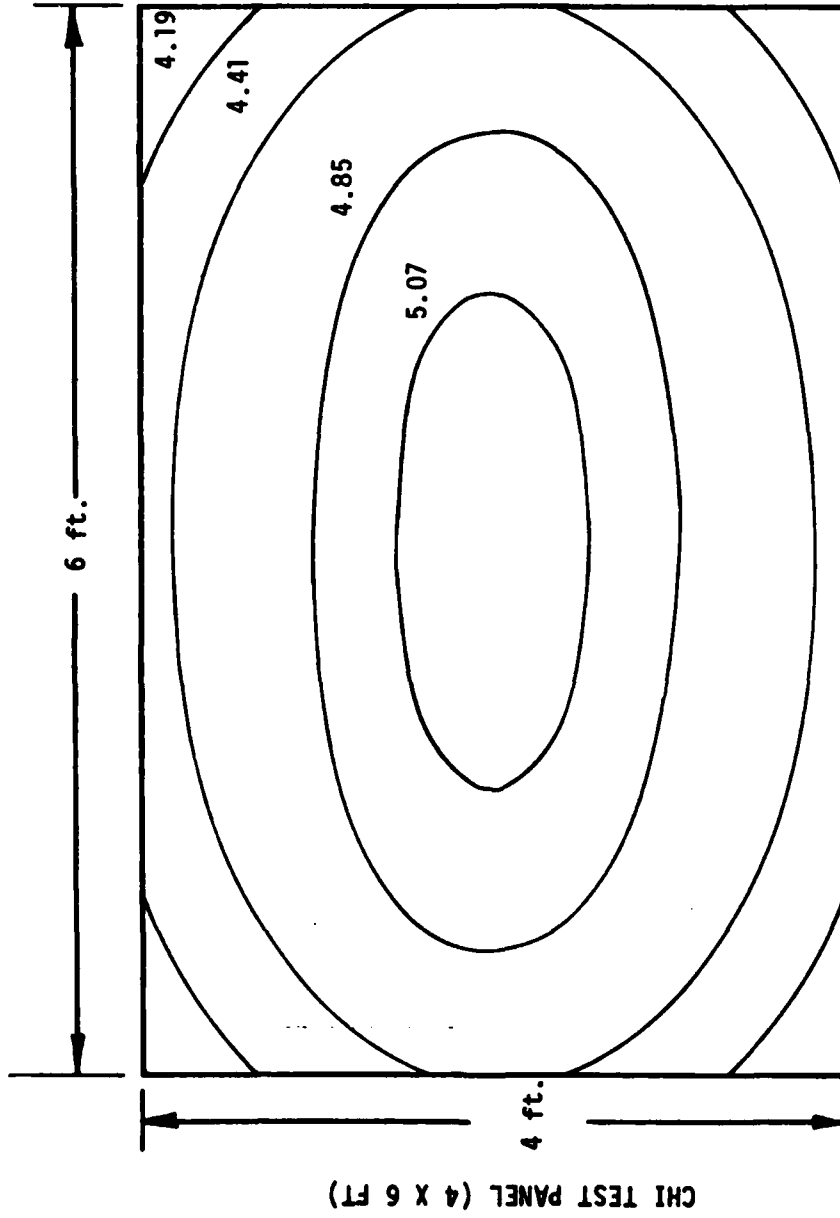

FIGURE 34. CHI PANEL HEAT FLUX DISTRIBUTION, BTU/FT² SEC
 (Average Nominal Setting = 4.41 Btu/ft² sec)

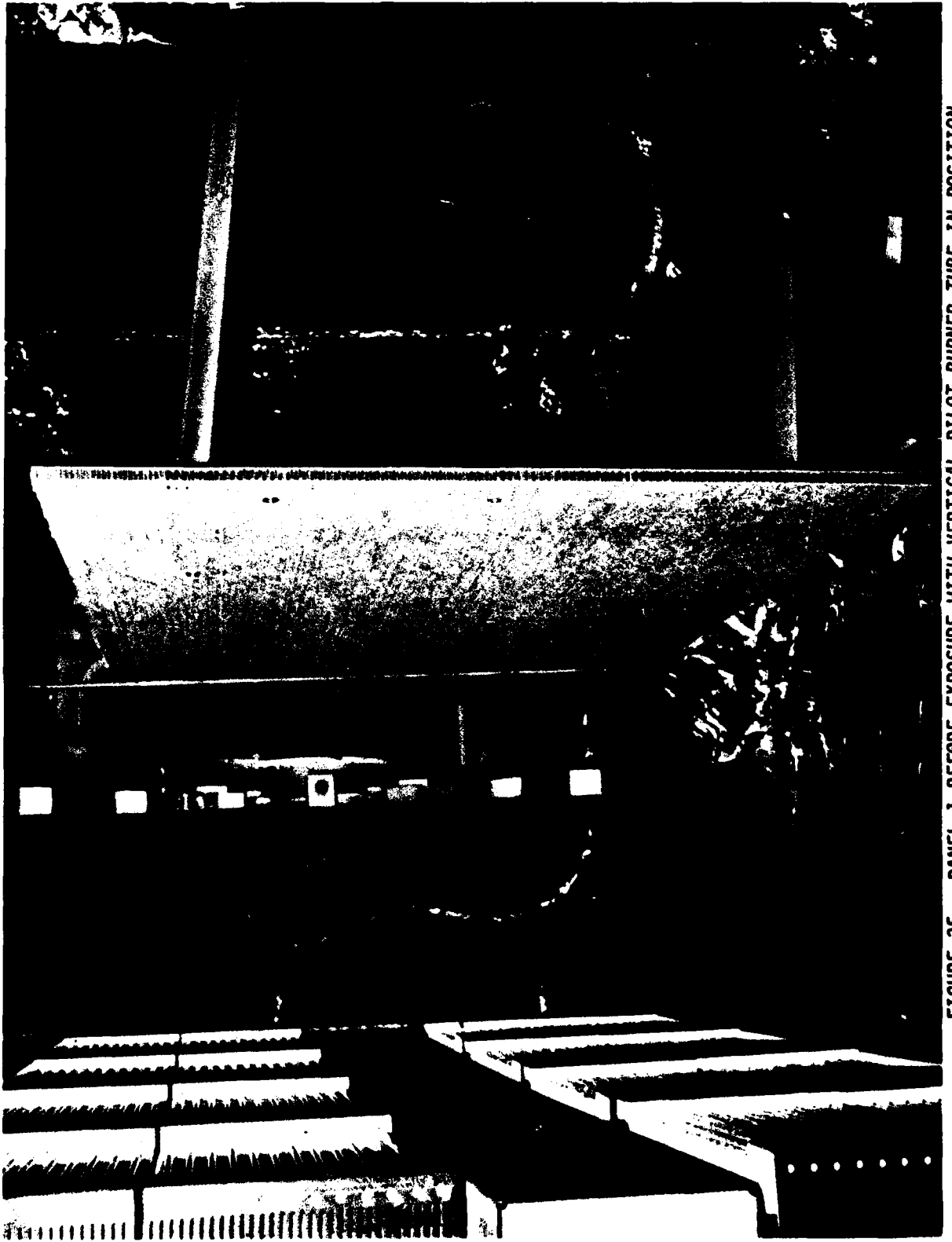

FIGURE 35. PANEL 1 BEFORE EXPOSURE WITH VERTICAL PILOT BURNER TUBE IN POSITION

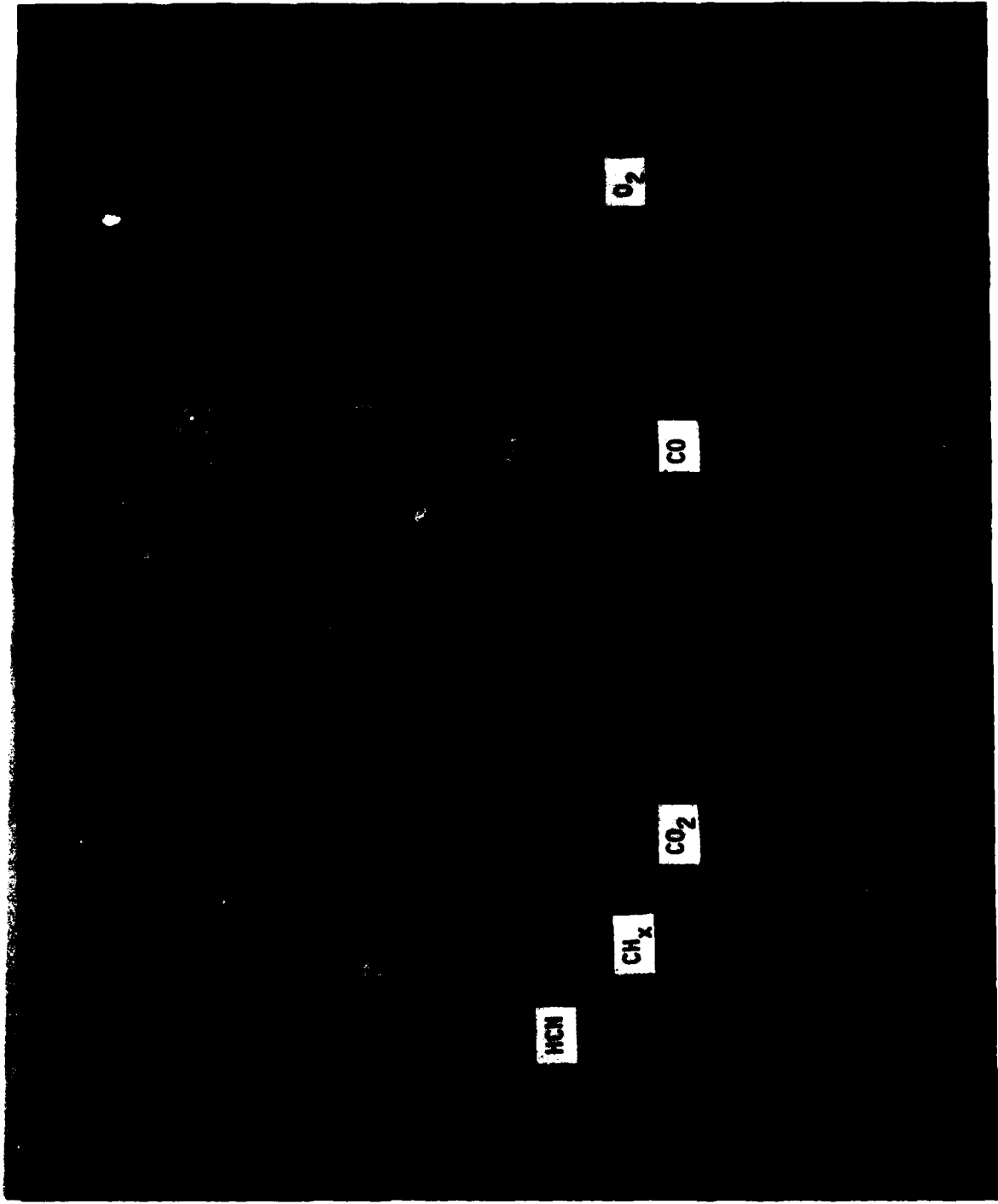

FIGURE 36. CHI EXHAUST GAS MONITORS

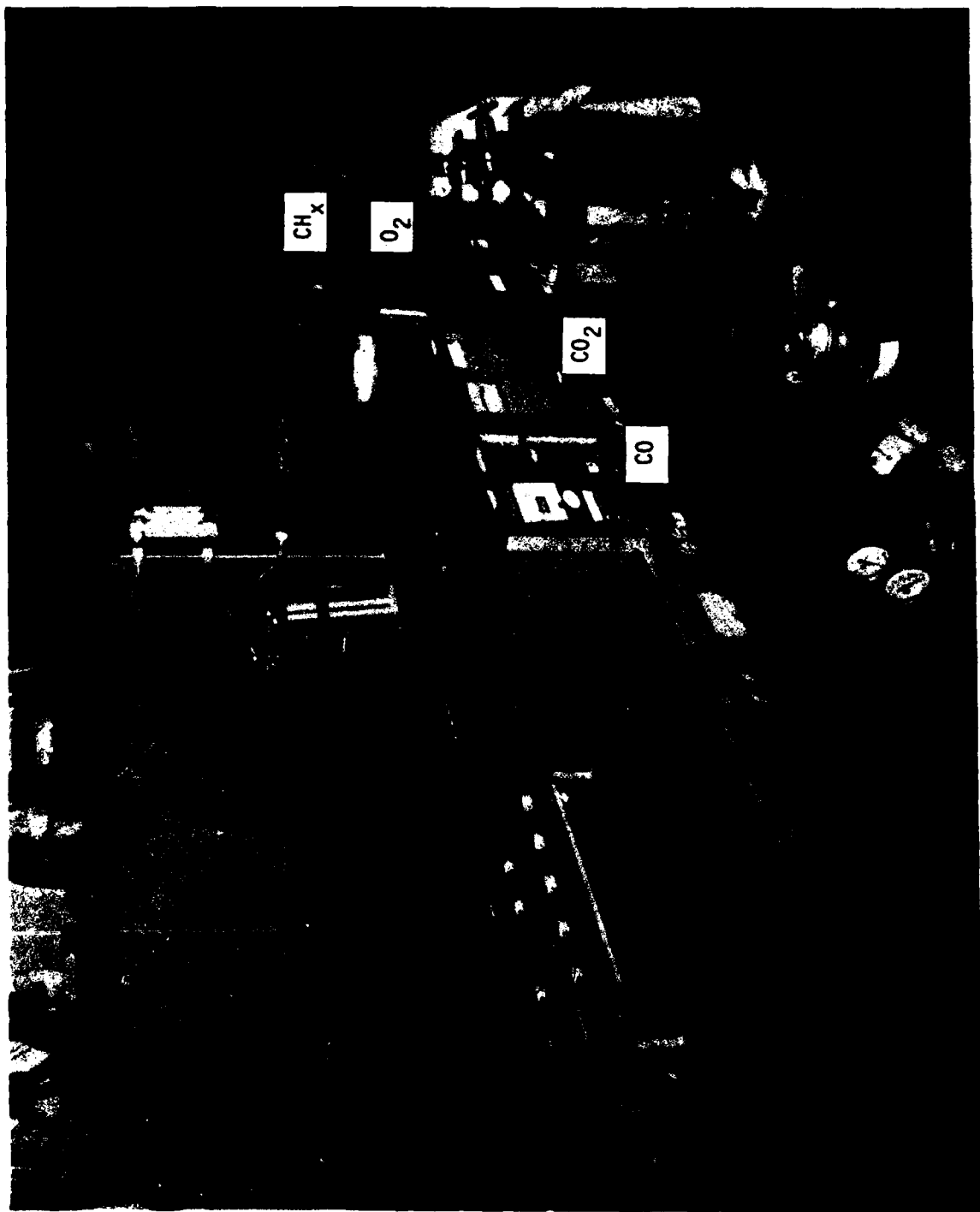

FIGURE 37. CHI POINT GAS MONITORS

DATA ACQUISITION - Output from these real time instruments was recorded by the PDP-15 computer data acquisition system beginning from time zero to the end of the data acquisition time period (21-22 minutes). In each test, power was applied to the array 20 seconds after time zero. Channel nomenclature was established as follows:

	Thermocouples	Photometers
	TUNW	PUSE
	TMNW	PMSE
	TLNW	PLSE
	TUN	PUS
	TMN	PMS
	TLN	PLS
	TUNE	PUSW
	TMNE	PMSW
	TLNE	PLSW
Basic 18TC	TUSE	Real Time Gas Exhaust
	TMSE	
	TLSE	COE
	TUS	CO ₂ E
	TMS	O ₂ E
	TLS	HCNE
		CHXE
	TUSW	At CHI Point
	TMSW	
	TLSW	COC
At Ceiling	TCW	CO ₂ C
	TCM	O ₂ C
	TCE	Sample Weight Loss
At Subject Cages		WL
Wall Temp	TNW	Cabin Pressure
	TSW	
		PC
Vent Air	TAIN	Ventilation Air Flow
	TAOUT	
		VAIN, VAOUT

TIME INTERVAL "BATCH" AND INTEGRATED (TOTAL) "BUBBLER" SAMPLES - The batch samples were taken at selected time intervals into 8 liter stainless steel cylinders containing 50 ml of 0.2 N NaOH absorption reagent. The inside surfaces of each tank were wet with the absorption solution. The tanks were mounted in parallel on a 1/4 inch stainless steel manifold which was connected to 8 feet of TFE tubing leading to the sampling point near the 3 animal Ti

test cages in zone 13 (See Figure 32). These cylinders were evacuated to 0.8 atmosphere just prior to a CFS burn test. Each cylinder was isolated from the sampling line by a solenoid valve, and each were opened sequentially at timed intervals to take samples during the test. Each absorption solution was removed at the end of a test and analyzed by microchemical techniques:

1. HF by specific ion electrode analysis
2. HCl by silver-electrometric titration
3. HCN by colorimetric analysis

The standard glass impinger "bubbler" samples for HF, HCl, and HCN and aliphatic aldehydes (as HCHO) were taken in two standard glass impinger bottles connected in tandem to either TFE or stainless steel sampling lines leading to the multiple animal test point (zone 13) and the CFS exhaust for panel No. 1 tests. For the remaining 9 tests of panels 2, 3 and 4 these bubblers were mounted inside the CFS in an insulated box to protect them from heat build up during each test. Twelve bubblers were connected in pairs on a manifold inside the box; one set contained sodium hydroxide solution for absorption of HCl and HF, and the other set contained the aldehyde absorption reagent solution. Flow rates of CFS atmosphere were sequentially taken at timed intervals into each pair of bubblers by remote control of electrically operated solenoid valves. This assembly is shown in Figure 38.

ANIMAL TEST LOCATIONS - Open mesh, split wheel cage units employing sensors of the same design used in SATS were placed in the zone locations shown in the CFS schematic (Figure 31) for panel No. 1 tests. Three cages, each containing a rat, were placed side by side in Zone 13. The fourth cage was placed in Zone 12, directly under the 3 in Zone 13. The fifth and sixth cages were located, respectively, near the center of Zone 16, and at the exhaust end of the CFS between Zones 16 and 19. For the final three materials, the exposure chambers were redesigned as closed polycarbonate boxes which were covered with insulation blankets composed of two inches of fiber glass insulation lined with a silicone material on the inside, and covered on the outside with a metallized silicone material. The CFS air was pulled through two large inlet tubes which penetrated the insulation blankets and carried the air into the exposure chambers. The air was mixed by deflectors inside the chamber and exited through a single outlet which was connected to the vacuum pump. The pump was situated on the cage platform outside the insulation blanket to avoid adding the pump's heat to the exposure chamber. Pump capacity was approximately sixteen liter per minute. Figure 39 shows the insulated animal test chambers located near the CHI location and midway between that location and the exhaust end of the CFS.

The time to incapacitation (T_i) method of monitoring the rats developed by the FAA (Reference 4) was used. The output from the contact bars were recorded on an 8-channel ASTRO MED SUPER 8 hot pen recorder with one channel dedicated to each rat. The temperatures in the four chambers (six rats) were multiplexed on the seventh channel and the temperature in each chamber was recorded for three seconds so that each chamber temperature was sampled every twelve seconds. A photograph of this equipment is presented in Figure 40. The recording time ran from approximately 20 minutes before the test to 30 minutes after the test. Test duration was 20 minutes.



FIGURE 38. SOLENOID VALVE CONTROLLED GAS SAMPLING UNIT

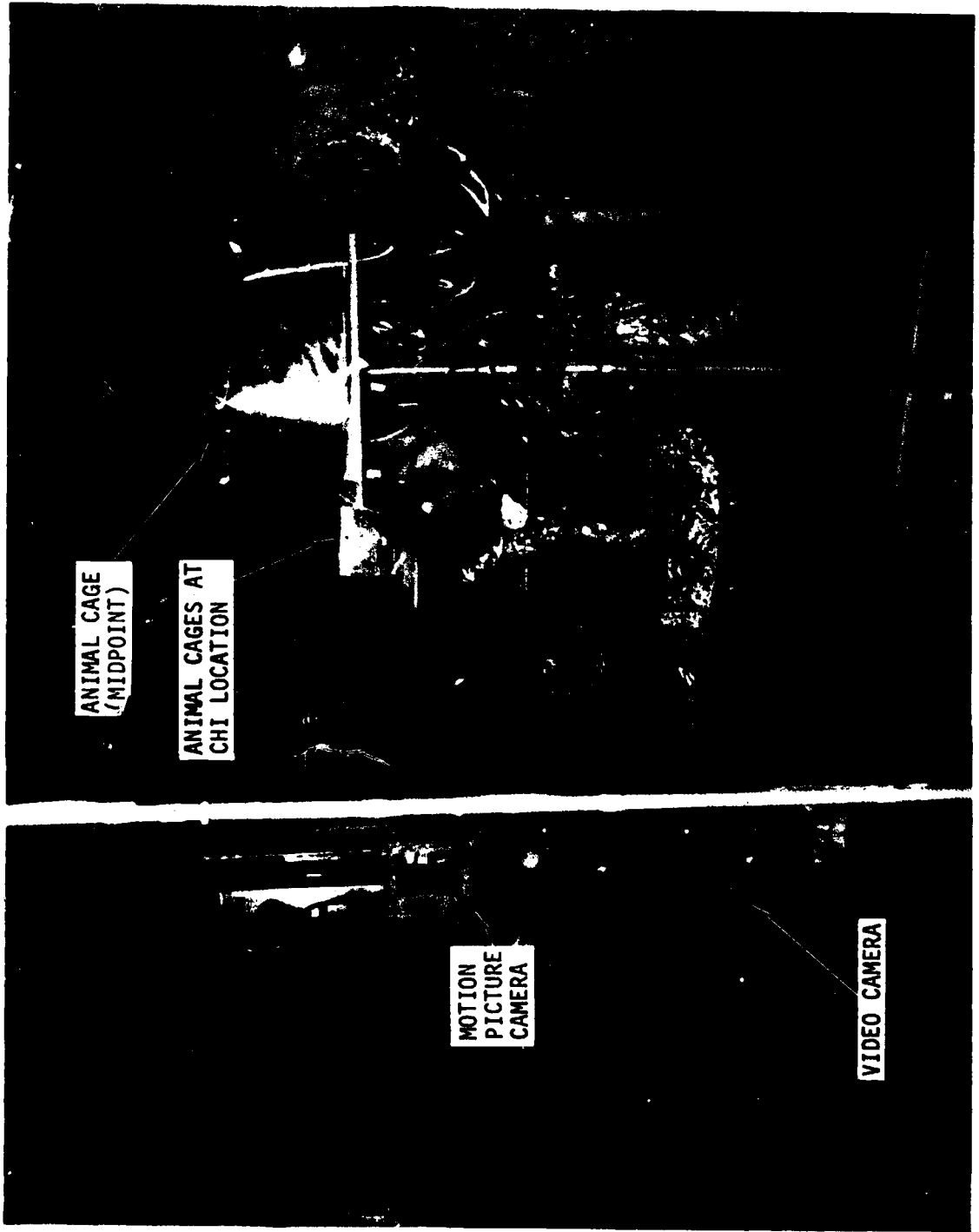

FIGURE 39. CFS CAMERA, CHI, AND MIDPOINT ANIMAL LOCATIONS



FIGURE 40. MULTICHANNEL RECORDER AND ANIMAL TI CAGE ROTATION CONTROLLERS

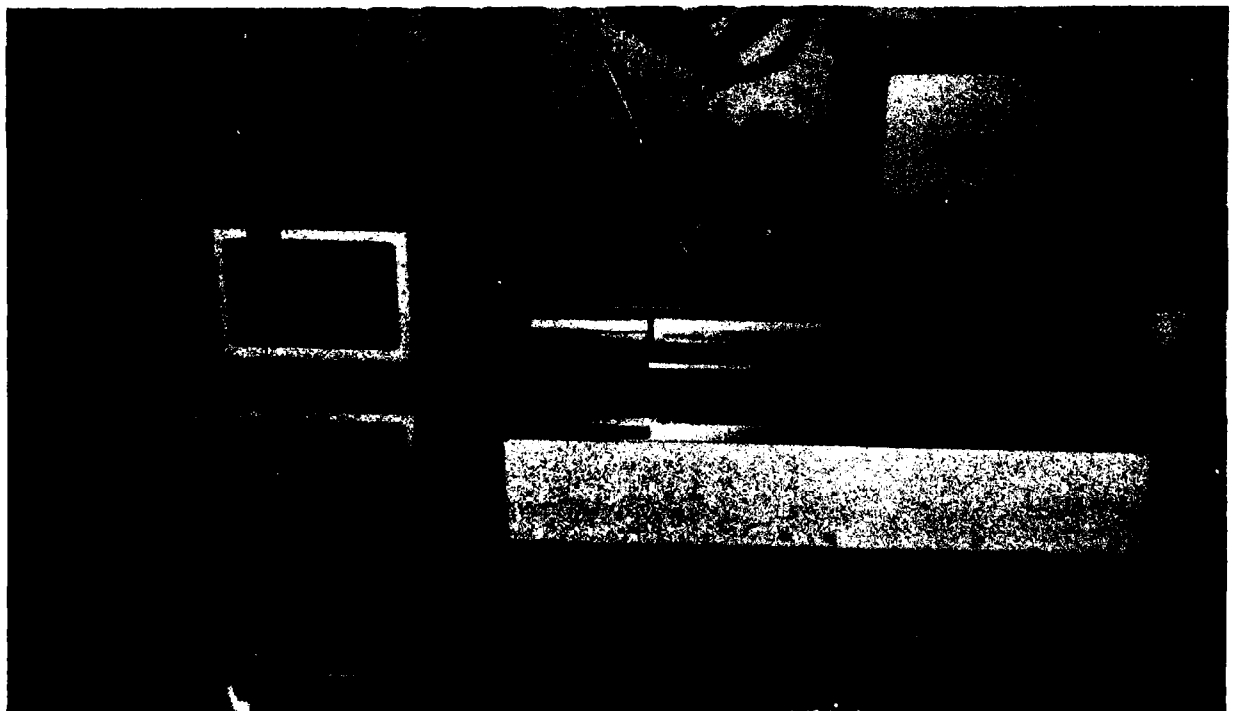

FIGURE 41. CFS VIDEO CAMERA RECORDER AND MONITOR

PHOTOGRAPHIC RECORDS - In addition to pre-test and post-test photographic records of each test, color motion pictures and video tape recordings were made of each panel exposure. The video tape unit and monitor are shown in Figure 41. The motion pictures were made at 24 frames per second from a position at the level of the panel. The color video camera was located in as low a position as possible and as close to the panel as possible. This position was chosen so as to provide as long a duration of visible record before obscuration by smoke. The cameras were totally enclosed in insulated and ventilated boxes to protect them from heat damage as shown in Figure 39.

CFS TEST CHECKLIST

Prior to each test, the following checks were made:

Weigh panel, use small platform scale.

Record Test, Material type, Specimen No. and weight.

Install panel on frame using "C" clamp bars, snug fit only. Don't crush panel by over-tightening.

Check distance from panel face to front of quartz lamps- should be 32".

Check zero calibration for load cell.

Check lamps for burn out and replace as required.

Call for fireman 30 minutes prior to anticipated test time.

Cock ignitor so that pilot orifices point away from panel and attaching nylon cord to array so that it is exposed to tubes for quick burn-through.

Install animal subjects.

Check that proper thermocouple is in each cage.

Photo. Slate test run on 16 mm. and tape and take pre-test photos with slate in view.

Inform ignitron operator the level of radiant heat flux required for the specific test, i.e., 4.41, 3.08 or 2.2 Btu/ft² sec (5, 3.5 or 2.5 w/cm²). This setting will have been determined on the array map and marked on the ignitron control.

Check operation of ventilation system on scrubber and blower.

Check to assure cooling air flow to cameras and load cell.

Check that the following are ready for the test and are on intercom:

- Photo
- Gas Analysis
- Animal Experiment
- Propane valve operator
- Computer review all channels
- Ignition operator - Arm ignition
- Fireman is present

Light all propane pilots and adjust if necessary.
Check that chamber is clear.
Close chamber.

Final Intercom Check

Photo
Gas Analysis
Animal Experiment
Propane valve operator
Computer
Ignition for green light

Computer room will take control of test and announce start of recording as zero start recording.

At zero time

Photo: Start cameras and tape
Animal Experiment: Start recording

Computer room will count each scan from zero to 10 on the intercom. On the tenth scan (20 seconds) the Ignitron operator will bring up the control to the preselected power setting (heat flux level).

The test director will view the test from the viewing port to note:

1. That the array comes on.
If it does not come on, declare Abort test.
2. That the pilot flames remain lit and that they rotate into position upon burn-through of the supporting cord.
3. When visibility of the pilot flames is lost from smoke, he will ask the propane valve operator to close the valve.
4. Look for and note any unusual occurrence.

Total radiant heat exposure time for each test specimen will be for a period of 300 seconds.

Ignitron shut-down will be at 320 seconds computer time.

At 260 seconds the computer room will announce 1 minute till shut-down of ignitron. At 300 seconds a count down will begin with ignitron shut-down declared at 320 seconds.

Recording of data will continue for 15 additional minutes with computer control announcing test termination at 1220 seconds.

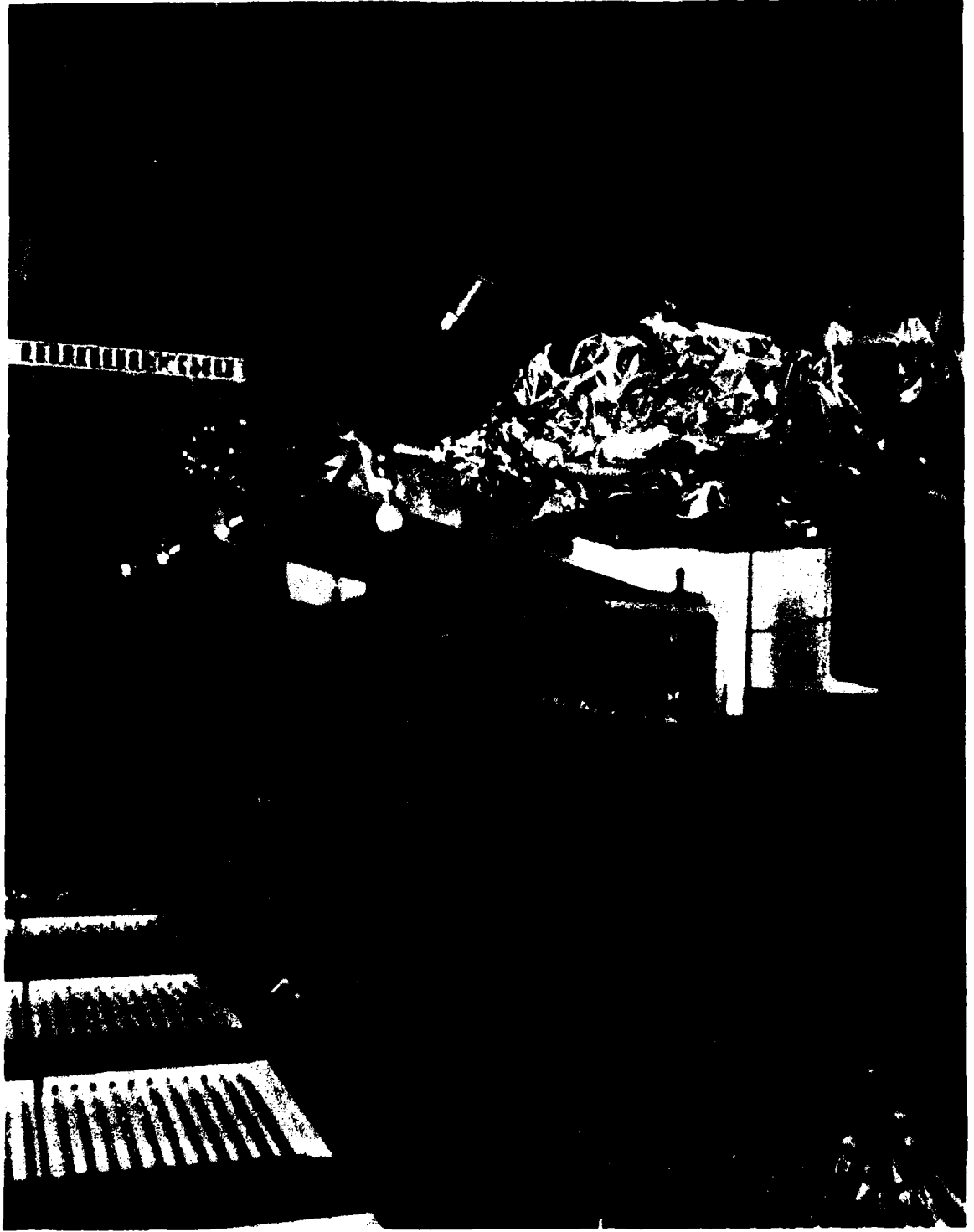

FIGURE 42. HORIZONTAL PILOT BURNER

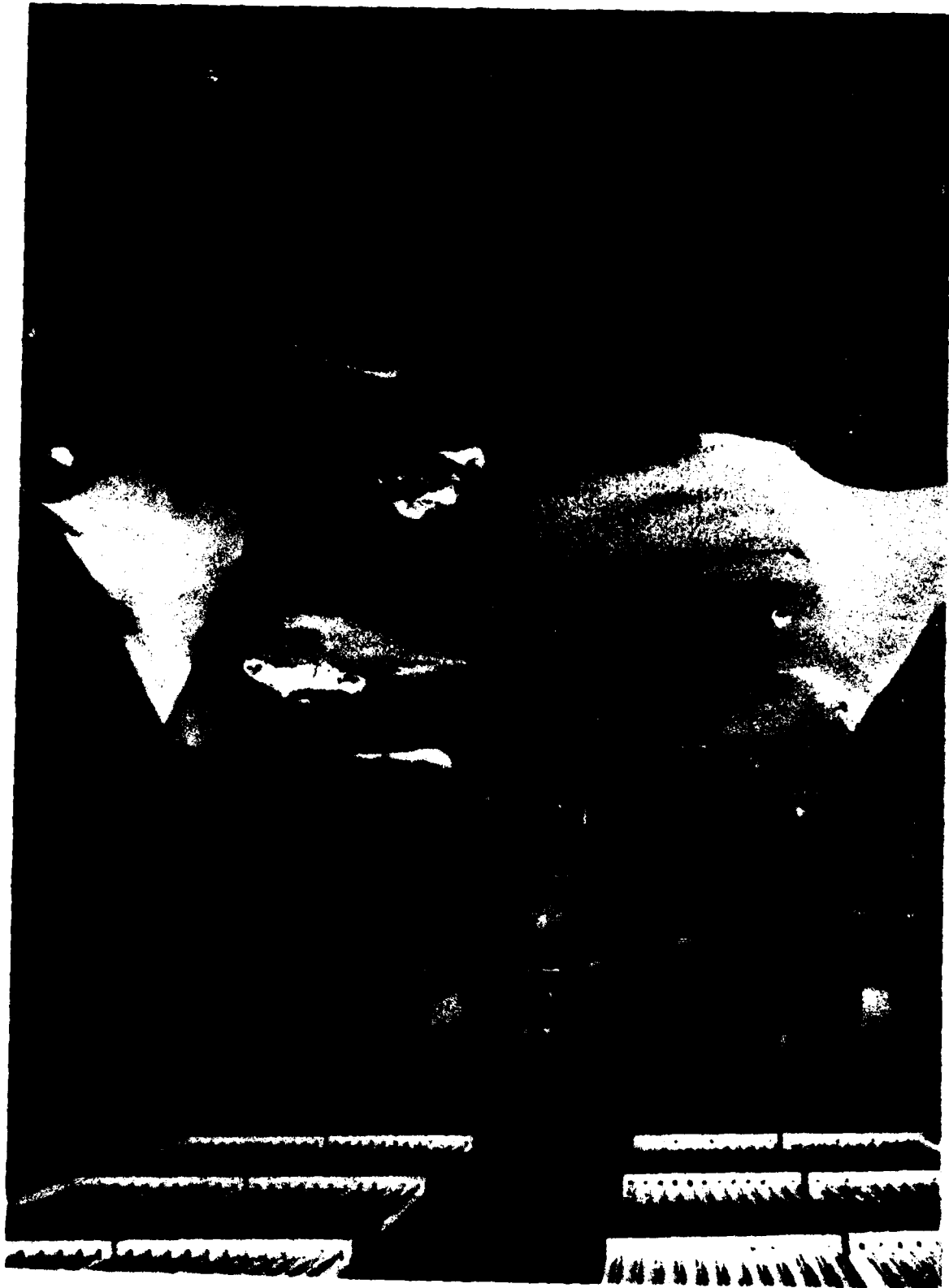

FIGURE 43. TEST #3 OF PANEL #4 AFTER EXPOSURE

Post Test

Ventilation will remain on until the chamber is clear of smoke and Gas Analysis confirms that a safe level of O₂ and CO₂ exist.

Open chamber.

Post-test photos of panel front and back and any ash on floor.

Remove animal subjects.

Remove ash on floor, weigh, and record.

Remove panel, weigh and record weight, including any residuals that drop to floor during removal.

Review data for inoperative transducers and replace where required.

Inspect and clean scrubber filters if necessary. The cabin Δp should give a good indication of their condition.

CFS TESTING

BASELINE TEST - A baseline test was conducted for the purpose of establishing the thermal levels within the CFS attributable to the radiant energy from the array. For this test, power was applied to the array for a period of 600 seconds. Plots of the data were made after this test. For this test a 4 X 6 foot sheet of aluminum was exposed to the array mounted on the weighing fixture.

In order to minimize the adverse effects of thermal stress, the aluminum sheet dummy panel was attached with three bolts at the top edge only. As expected upon exposure this panel warped convex toward the array and gradually flattened out as the temperature became more uniform throughout its thickness. The pilot flame tube mounted vertically in front of the panel warped also. In the first two panel tests where the vertical tube was used, the top end was tied to the array with steel wire to avoid any possibility of contact with the panel from thermal deflection. The weight loss experiment was adversely affected by the thermal environment, showing a loss of 36.3 lbs. at power off, when in fact a zero loss should have been indicated. This required insulating the load cell and adapting a horizontal pilot flame as described later.

The response of the photometers was affected by both the increase in visible light emitted from the array and the temperature. The increase in cabin light level caused an initial increase to over 100% transmission. A thermal effect was noticeable as a progressive reduction of indicated intensity with time and increased temperature. This effect began at approximately 100 seconds and continued to decrease for the duration of the test recording. The error resulting from the temperature effect is the most objectionable of the two. Fortunately, its effect is noticeable only after sufficient time has transpired to allow the temperature transfer to take place. In the material tests the maximum reduction in light transmission occurs within the first 100 seconds.

Concern was felt as to the advisability of a 10-minute test duration for the three material tests. Inasmuch as several failures or near failures of

instrumentation cabling had occurred and no spare cells were available for the photometers, it was decided to limit the exposure of the first material test to five minutes.

PANEL NO. 1 TESTS

Three tests of Panel No. 1 were made using a 4 x 6 ft section of panel exposed to the array in the same fashion as in the baseline exposure of the aluminum sheet. Attachment of the panel to the mounting frame of the weighing device was made with 14, 3/16 inch screws. As the three tests were conducted under similar conditions with similar results, only significant common events or differences in results or test protocol will be discussed in any detail.

The first two tests were characterized by a period of deflagration which began from 20 to 28 seconds after the start of exposure. This deflagration resulted in a pressure pulse reaching a peak of up to 1.5 psi at about 40 seconds from exposure initiation. Tests 1 and 2 were quite similar in this regard with a steep slope to the leading edge of the pulse and a maximum rise of 1.5-1.6 psi. Test 3 and all subsequent tests used a horizontal pilot ignition which exhibited a reduced pressure peak pulse with a very moderate initial slope and less area under the curve. Deflagration was believed to result from the tremendous quantities of combustible gases driven from the panel by the sudden heat load followed by ignition. This effluent, initially rich in halogens, may have extinguished the vertical pilot flames in Test 1 and 2 but did not affect the horizontal burner used in test No. 3 (Figure 42). The visual record of the initial exposure in all tests was recorded both on film and video. These records showed first, a splitting and shrinking of the decorative laminate followed by the evolution of a large amount of white vapor from the front face. The transition to flaming ignition appeared to occur when the white vapor changed to black smoke. This was followed very rapidly by gas under pressure being emitted from the edges. Upon ignition were produced jets of flame. Figure 43 is typical of the post test appearance of the panels #4 and #1.

The weight and weight loss recorded by physically weighing the panel before test and subtracting the residue remaining on the frame and that which had fallen to the floor are shown below.

	<u>Test 1</u>	<u>Test 2</u>	<u>Test 3</u>
Initial Weight, Lbs.	21.18	21.53	21.28
Weight Remaining on Frame	12.38	13.76	12.89
Weight Removed from Floor	1.14	.71	1.19
Total Consumed	7.66	7.06	7.20

The dynamic weighing of the panel during the burn was adversely affected by temperature as noted above. For test No. 1 the load cell was wrapped in fiberfrax [®] and the whole unit shielded with a foil box and a flow of cooling air was introduced into the bottom.. This provided enough protection to reduce the weight loss error to approximately 2% which, unfortunately, is not sufficiently accurate. We were reluctant to attempt additional protective measures, fearing that any effort of this nature might result in an increased

Computed from tabulated data by use
of the following correction factors:

$$\text{Weight Loss} = [\text{tab data} - (a + bt \text{ load})]$$

$$\text{Where for } t \leq 100^\circ\text{F } a = 8.0636$$

$$b = .11155$$

$$t > 100^\circ\text{F } a = -4.7474$$

$$b = .07889$$

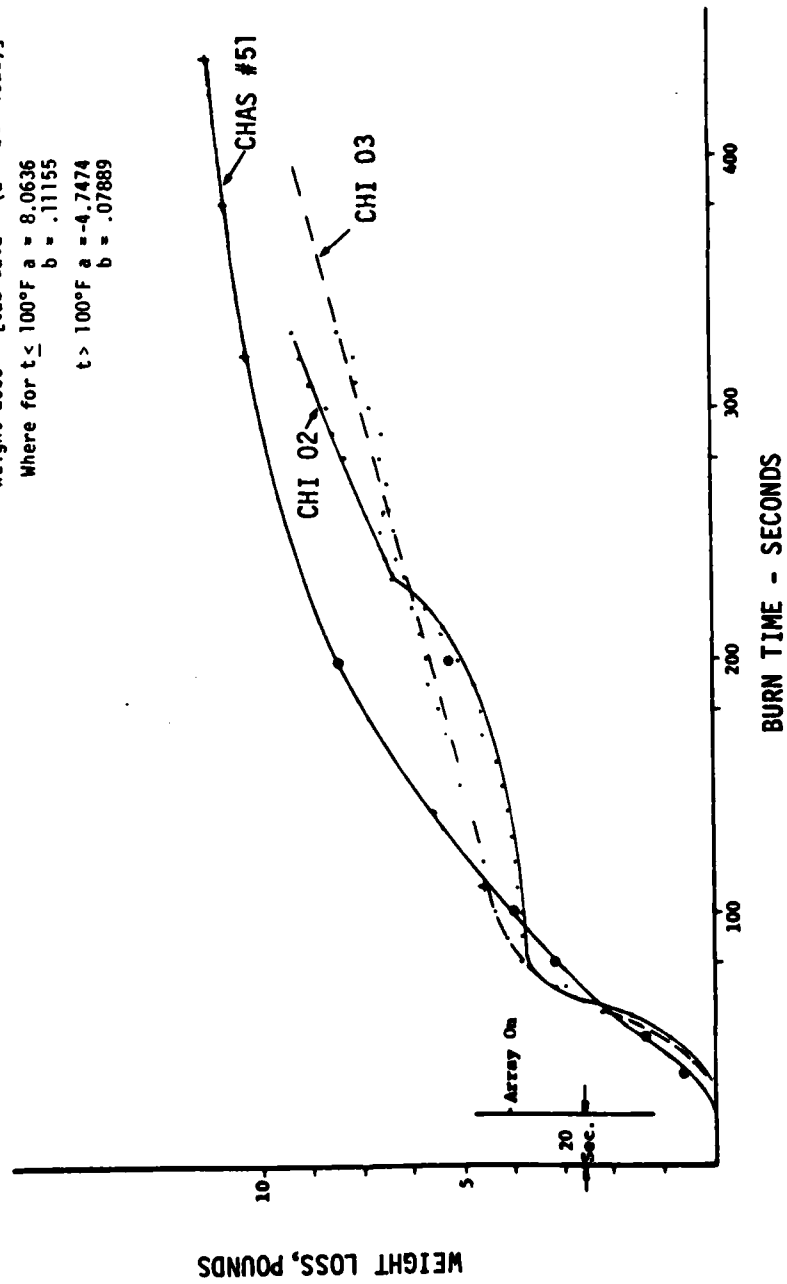

FIGURE 44. PANEL 1 MASS BURNING RATE - CFS VERSUS CHAS, 4.41 Btu-ft² SEC (4 x 6 FT. PANEL)

error from restraint of the load cell movement. In the belief that if we could relate the temperature to the error, corrective action could be taken; therefore, a thermocouple was affixed to the load cell and several tests were made using a heat gun while recording the static load and temperature with the computer. From this data, it was determined that effective correction could be achieved by application of two straight line correction factors. The application of these factors and a comparison with one run in CHAS are shown in Figure 44.

Figures 45, 46, and 47 show plots of the concentrations of HF, HCl, and HCN in Zone 13 gas samples taken over a 7-minute time span in the CFS tests. The HCl tests for Burn No. 1 were not plotted, since it was discovered that the absorption reagent in these tanks were accidentally contaminated with chloride as shown by a blank determination run after the test was completed.

The "bubbler" samples for HF, HCl, HCN and aliphatic aldehydes (as HCHO) were taken in two standard glass impinger bottles connected in tandem to either TFE or stainless steel sampling lines leading to the multiple animal test point (Zone 13) and the CFS exhaust. Table 16 summarizes the results obtained for each of the CFS burns of Material No. 1 and gives the average ppm by volumes of each gas collected over a 5-minute sampling time.

TABLE 16
AVERAGE PANEL NO. 1 GAS CONCENTRATIONS
COLLECTED IN IMPINGERS AT TWO LOCATIONS FROM THE CFS

CFS TEST NO.	CFS SAMPLING LOCATION	VOLUME OF GAS SAMPLED (LITER)	PPM OF GASES RELEASED			
			HCl	HF	HCN	RCHO (Aldehydes)
#1	Zone 13	10.8	*	6	12	5.8
	Exhaust	5	*	**	22	3.9
#2	Zone 13	10	115	12	15	4.2
	Exhaust	5	144	3	7	5.4
#3	Zone 13	6.2 & 10	34	4	22	4.3
	Exhaust	5	0	2	2	0.7

* Chloride in blank too high for accurate determination.
** Flouride contamination in impinger bottle.

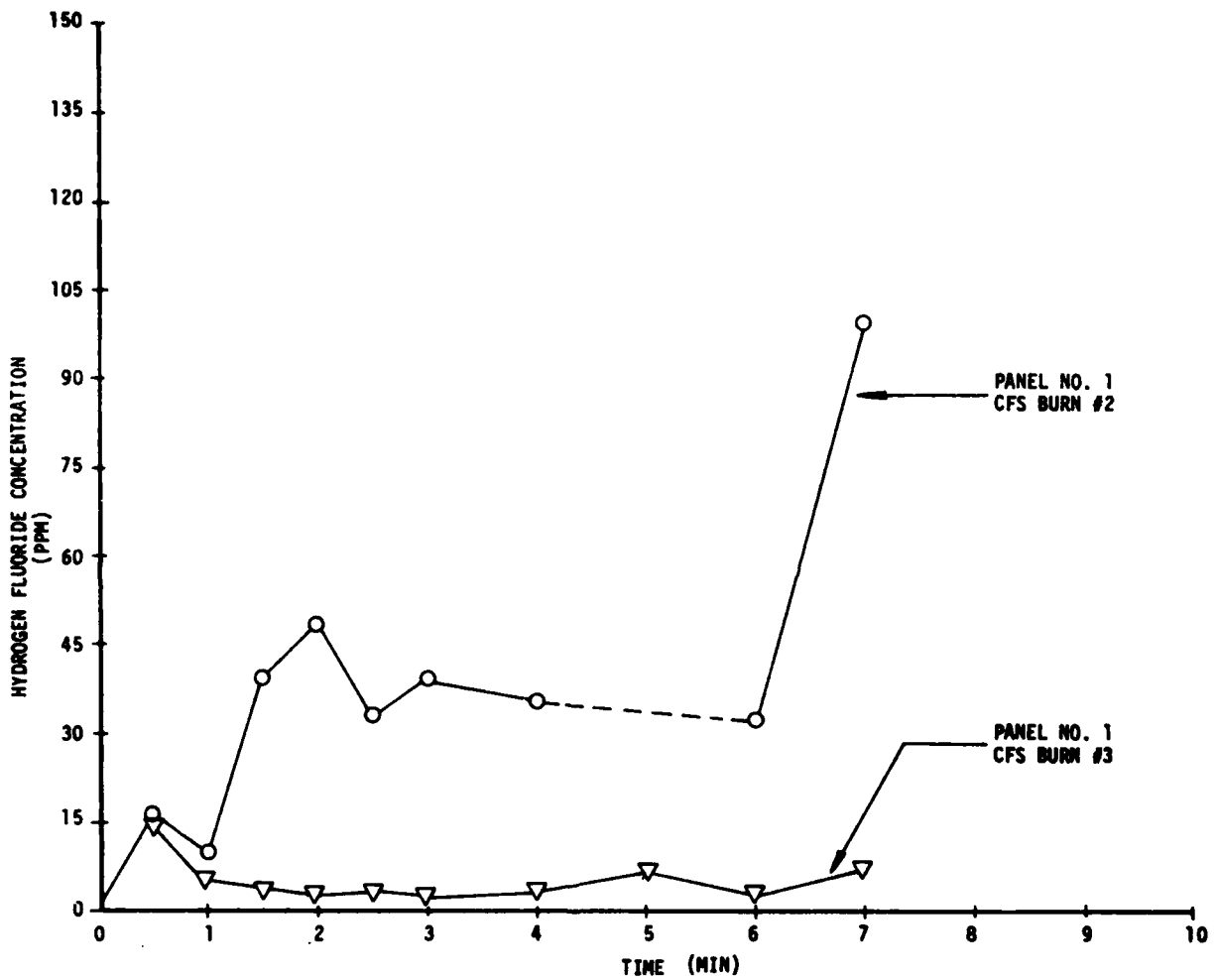

FIGURE 45. HF CONCENTRATION NEAR MULTIPLE ANIMAL TEST LOCATION (Zone 13) IN CFS - PANEL 1, 4.41 Btu/ft² SEC

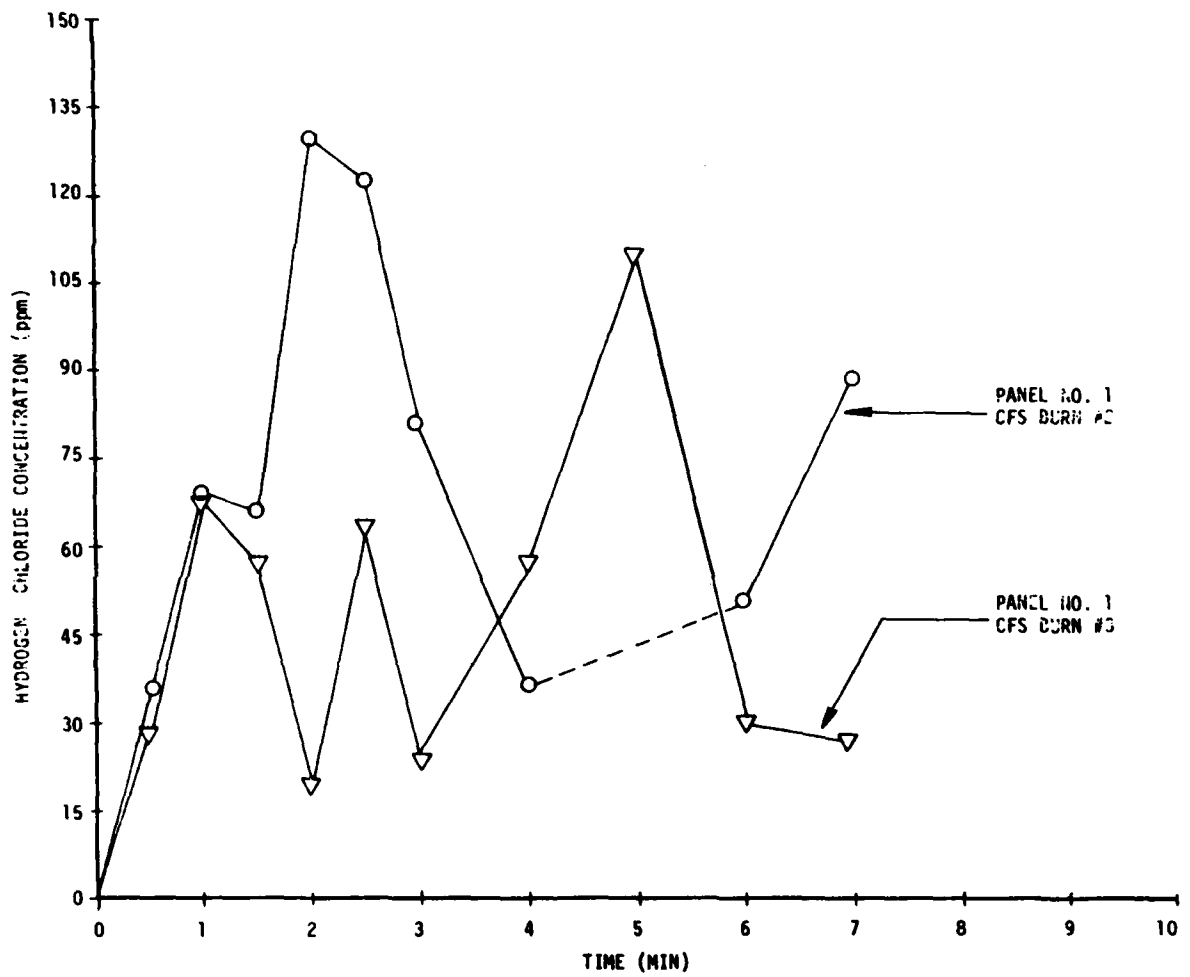

FIGURE 46. HCl CONCENTRATIONS NEAR MULTIPLE ANIMAL TEST LOCATION (Zone 13) in CFS - PANEL 1, 4.41 Btu/ft² SEC

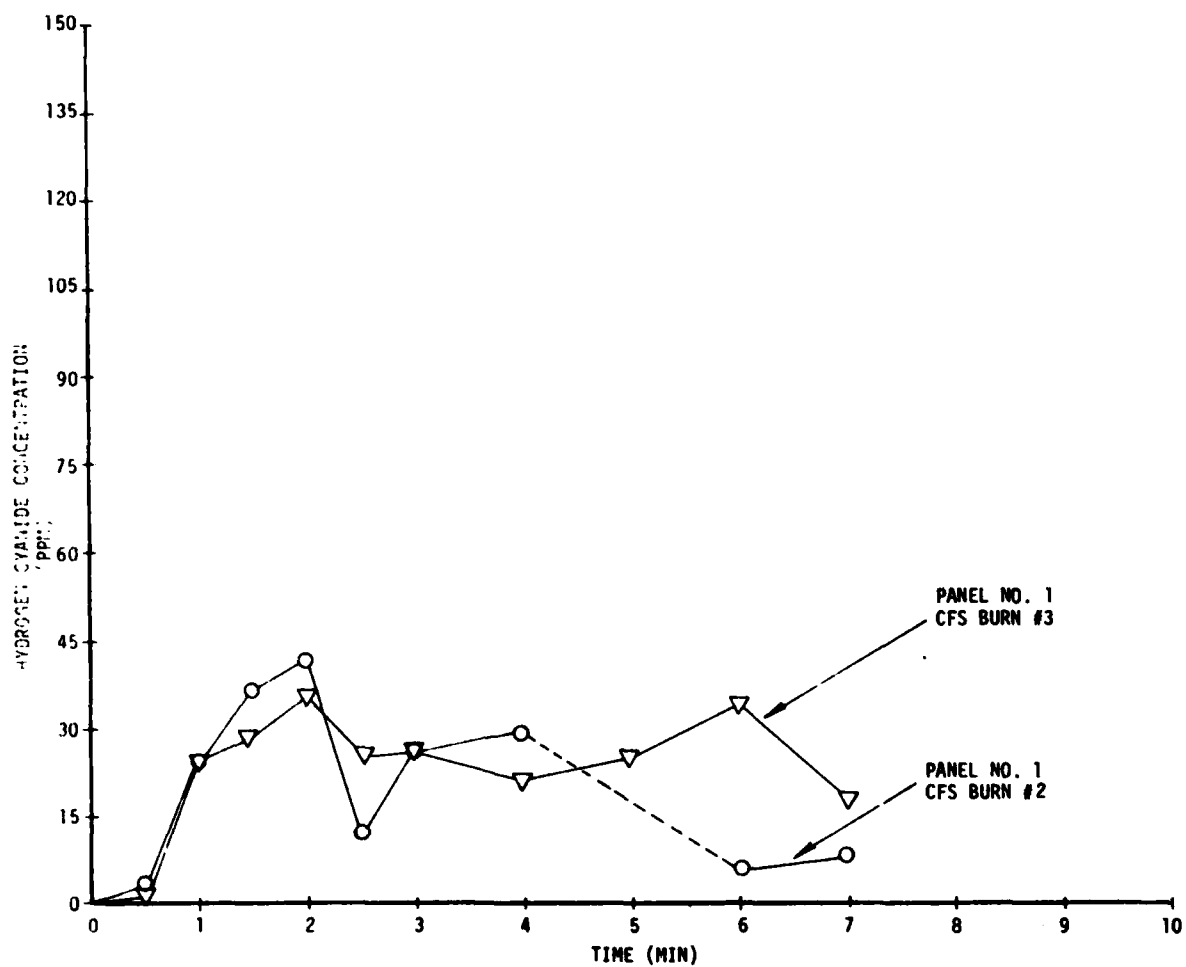

FIGURE 47. HCN CONCENTRATION NEAR MULTIPLE ANIMAL TEST LOCATION (ZONE 13) IN CFS -
 PANEL 1, 4.41 Btu/FT² SEC

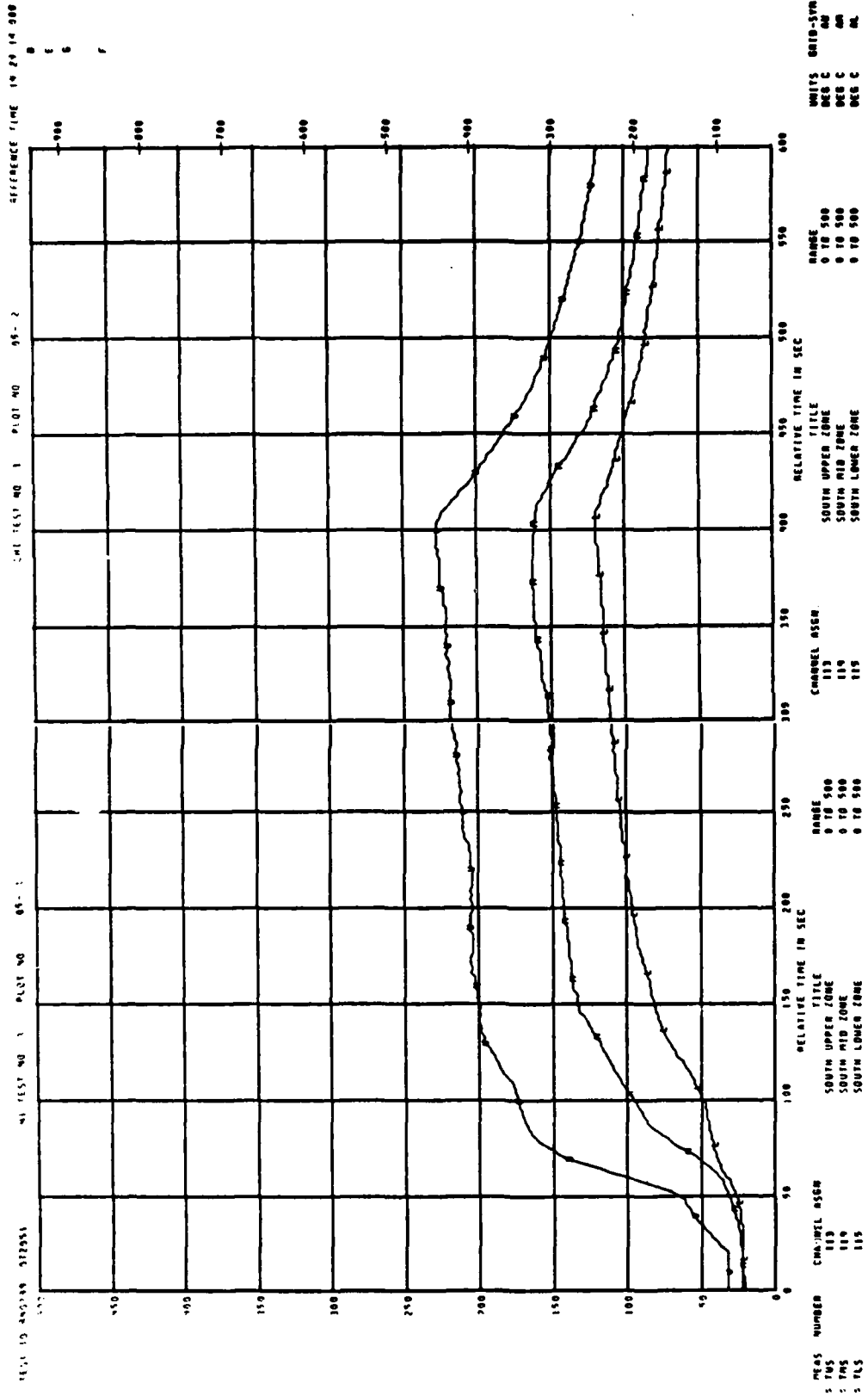

FIGURE 48. TEMPERATURE AT CHI POINT (TMS, TUS, TLS) MID CABIN, SOUTH SIDE

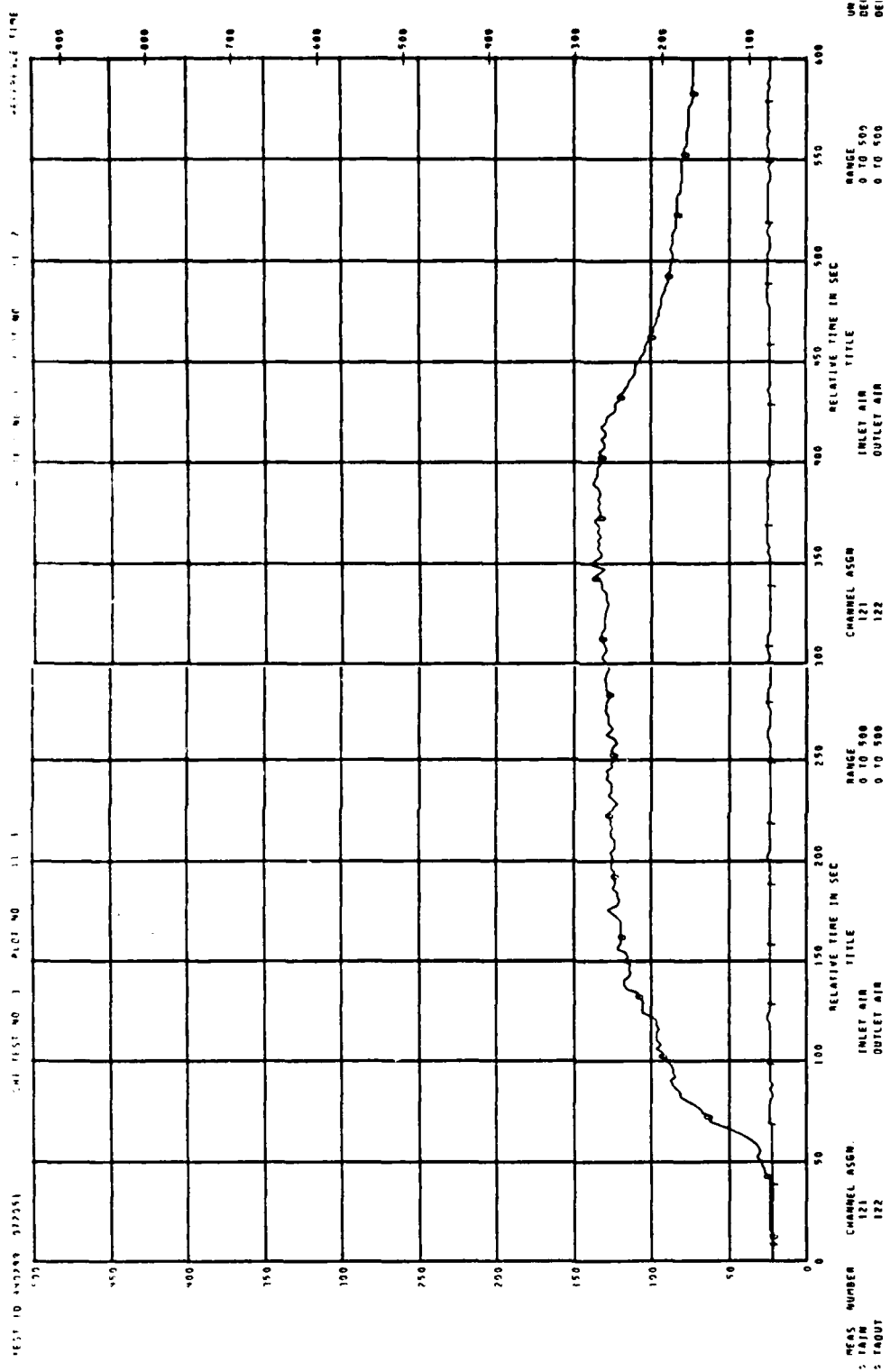

FIGURE 49. DUCT TEMPERATURES OF AIR-IN AND AIR-OUT

TEST ID: 332051 TIME: 10:24:55 DATE: 11/1/72 PAGE: 1 OF: 2 SCALE: 100%

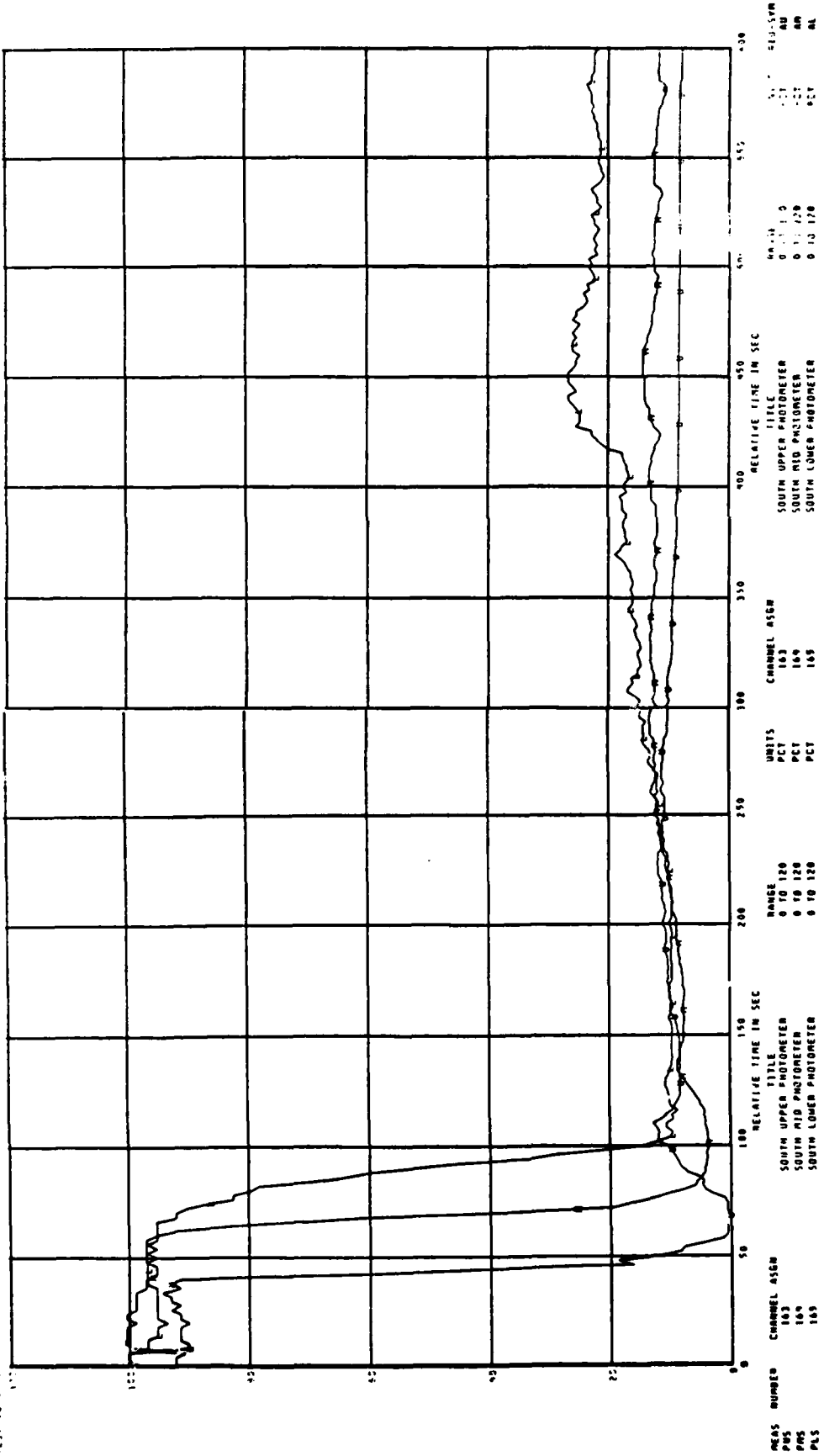

FIGURE 50. SMOKE OPTICAL TRANSMISSIONS AT CHI LOCATION

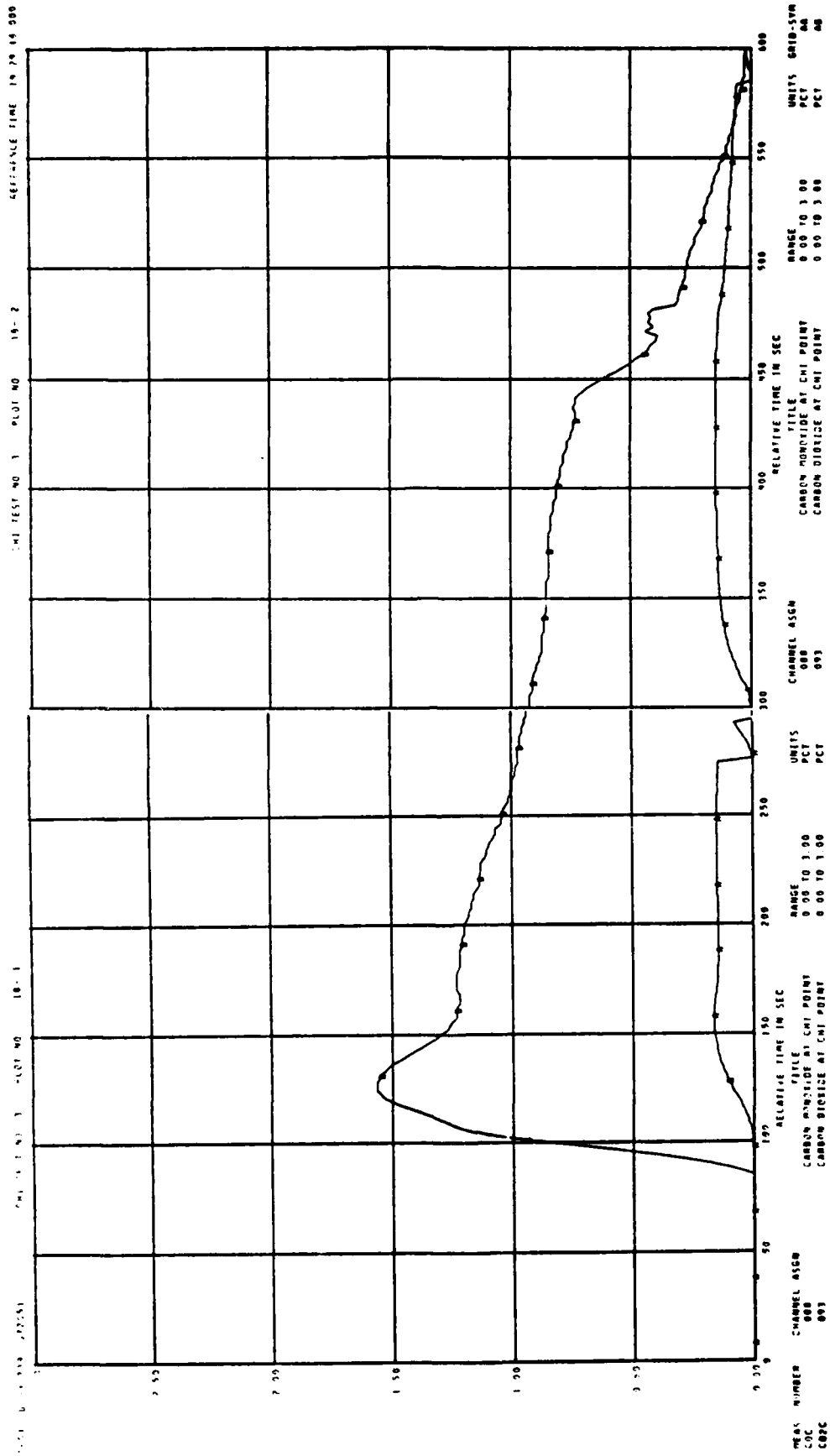

FIGURE 51. CO AND CO₂ CONCENTRATIONS AT CHI LOCATION

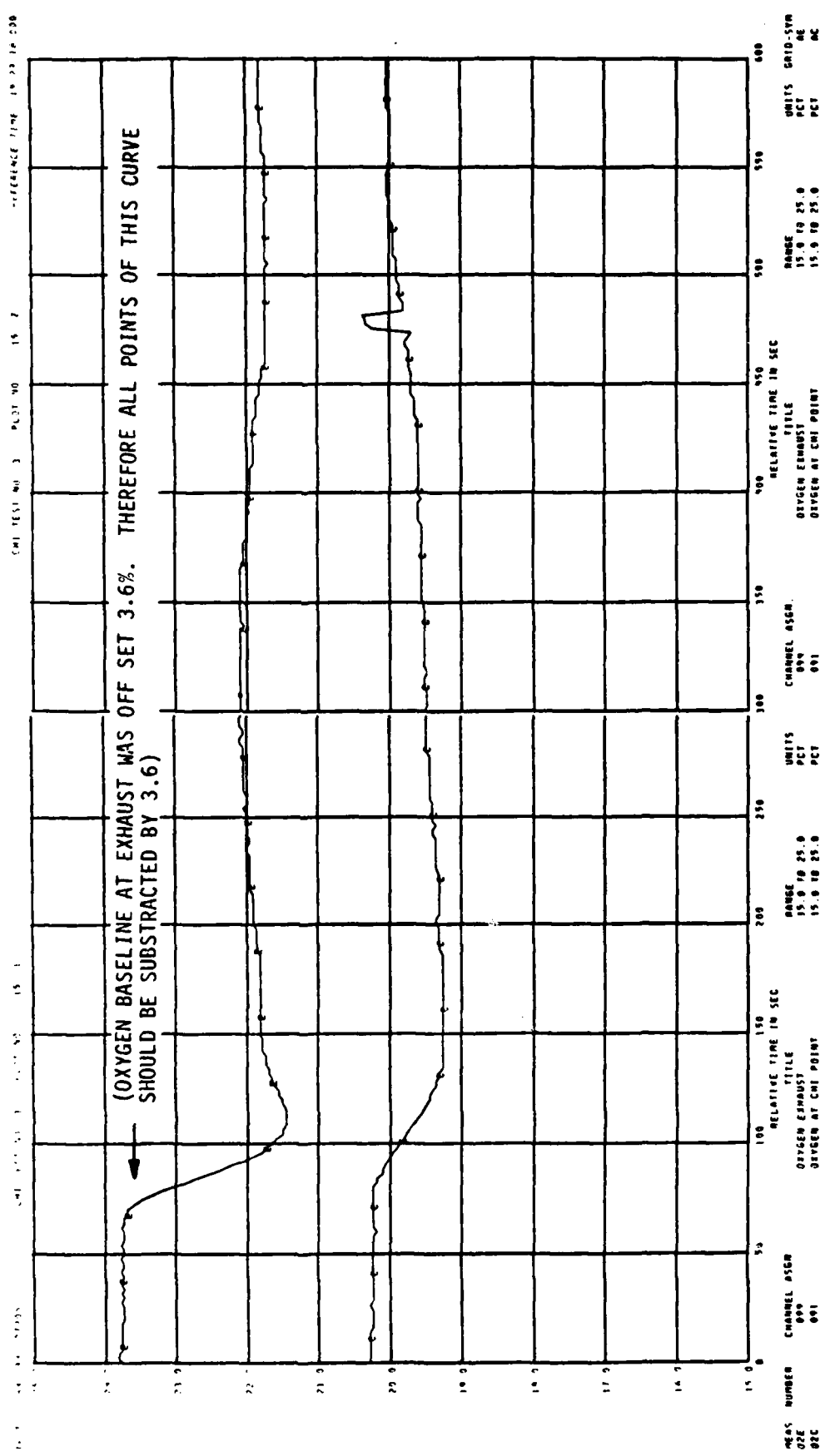

FIGURE 52. OXYGEN DEPLETION AT CFS EXHAUST AND AT CHI LOCATION

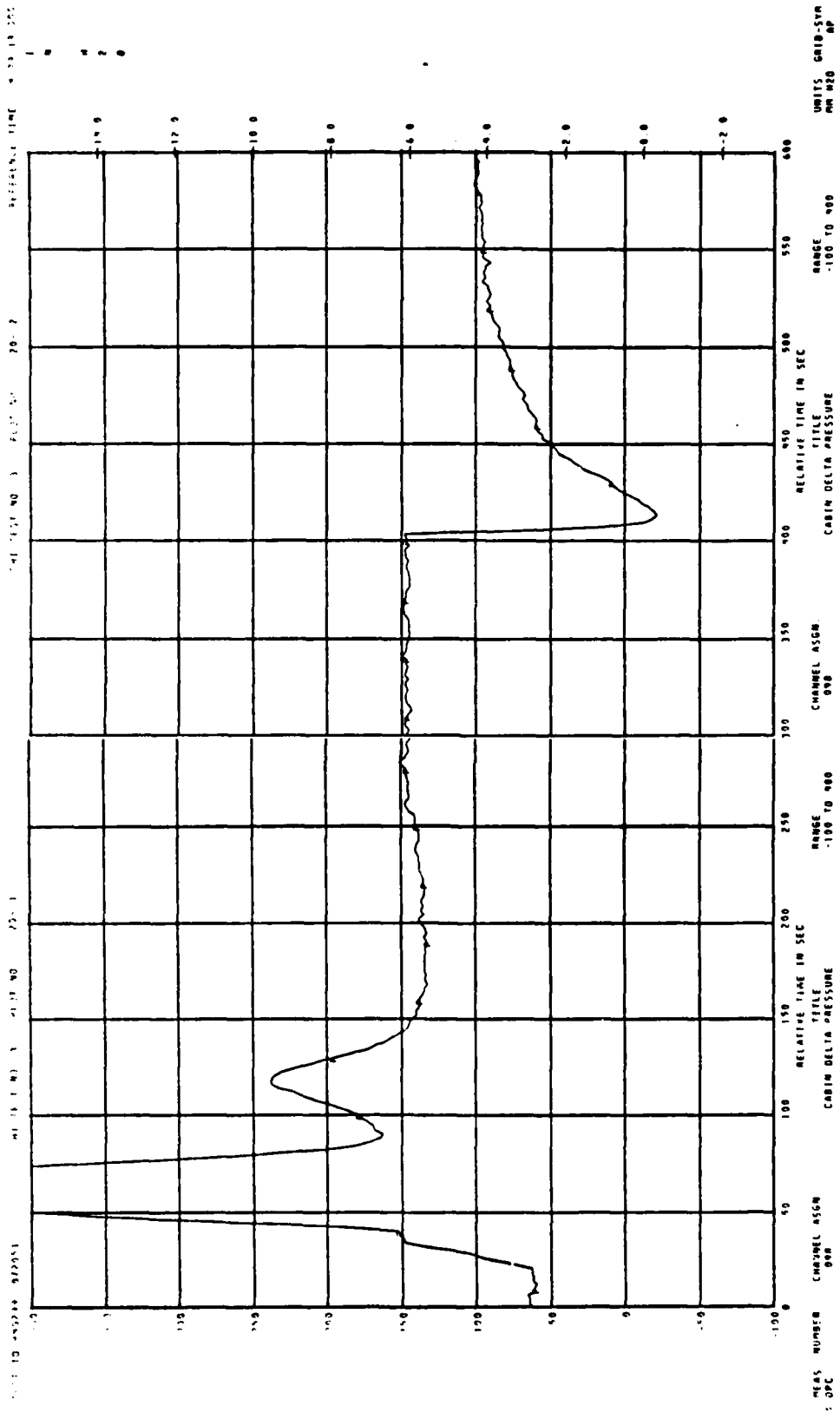

FIGURE 53. CFS CABIN DIFFERENTIAL PRESSURE PANEL 1, 4.41 Btu/ft² SEC

DATA PLOTS - The PDP-15 computer data acquisition system prepared a wealth of data. The CHI point was "MS" (mid level, south) in PDP nomenclature. Figures 48 through 53 are examples of temperature, smoke, CO, CO₂, O₂ at the CHI point and pressure in the CFS for test 3 of Panel No. 1. A single plot involves five pages for presentation to 1320 seconds but are shown only to a significant time interval to save report space. Plots were made for all real-time measurements, and all thermocouple locations.

ANIMAL TESTING - During the baseline test, one subject was placed in one of the wheels in Zone 13. At approximately 4 minutes 50 seconds, a temporary Ti sensor trace of 15 seconds duration was observed on the strip chart recorder followed by an apparent recovery and vigorous activity until 7 minutes 8 seconds when a permanent Ti occurred. Td followed, but the time could not be determined (the subject was dead by the time the CFS chamber was opened). The maximum temperature recorded near this wheel was 211°F during the 310 seconds the radiant array was energized. No material was burned during this test.

Post examination of the strain gage sensors revealed softening of the acrylic sensor bar support beams containing the strain gages. These were modified by cementing a strip of spring steel to the upper surfaces of the beams.

For burn test No. 1, six rats were used in open, Ti split cage, wheel units. Within 82 seconds after the beginning of the test, all six-wheel sensor records showed no activity on the strip chart. Upon opening the CFS, it was found that all six rats had escaped from their cages, and survived at the exhaust end of the CFS or under shielding at locations away from the fire. It was not possible to determine which rat was in a particular cage. However, one rat showed evidence of external burns on the ears and eyes. This subject also appeared to have some central nervous system damage as evidenced by periodic jerking movement. One other subject showed a severe blister on the cornea of the left eye. Both subjects survived and showed normal activity. The other subjects were unaffected by the test exposure to heat and gases.

The cages were reworked and the test procedure for the second burn was essentially the same as for the first burn, except that the four animals placed at the multiple animal test point, Zones 12 and 13, and the two placed in Zone 16 near the exhaust were partially insulated with 3/4-inch Fiberfrax on two surfaces to protect the subjects from direct heat without greatly impeding the flow of gases and smoke.

With the exception of one subject that escaped from the test cage to the cooler part of the CFS, all others ended in a Td. The temperature measurements indicated that the thermal protection provided by a radiation shield (aluminum foil) and the insulation was probably inadequate.

All expired subjects sustained etching of the cornea indicating the presence of significant concentrations of acid gases.

For the third burn test one animal was placed inside a Ti instrumented wheel (cage) housed within a Fiberfrax insulated polycarbonate (PC) box having an internal volume of 1 cu. ft. Two inlet tubes were installed with deflector shields to aid in mixing incoming smoke and gases with the atmosphere in the

box by means of an electric pump closely connected to the box opposite from the inlets. The pumping rate from the CFS into the box was set at 1.33 ft.³/min. and the box, with its test subject, was placed near the exhaust point between Zones 16 and 19. This was found to protect the subject from excess temperature for the full period of the burn; the maximum temperature recorded inside was 115°F. In this test, the radiant array was turned off at 6 minutes. The pump connected to the PC box was turned off at 6 minutes 20 seconds when it was noted that the CO monitor at the exhaust showed the CO concentration was beginning to decrease. A maximum CO level of 1700 ppm was recorded, but the actual concentration inside the PC box was not precisely known.

REFERENCES

1. Proposed Draft, American Society for Testing and Materials, Standard Test Method for Heat and Visible Smoke Release Rates for Materials and Products, Working document, ASTM Committee E5, Revised November 3, 1980.
2. Herrington, R. M. and Story, B. A., The Release Rate of Heat, Smoke and Primary Toxicants from Burning Materials, Journal of Fire and Flammability, Vol 9, pp 284-307, 1978.
3. O'Keefe, A. E., and Ortman, G. C., Primary Standards for Trace Gas Analysis, Analytical Chemistry, 38, p. 760, 1966.
4. Spurgeon, J. C., Filipczak, R. Feher, R. E., Modification of the CAMI Rotating Wheel for use in Full-Scale Fire Tests, Federal Aviation Administration, NAFEC, Atlantic City, NJ, Letter Report NA-78-22-LR, April 1978.
5. Spurgeon, J. C. and Feher, R. E., Differential Pulse Polarographic Analysis of Cyanide in Combustion Products, Federal Aviation Administration, National Aviation Facilities Experimental Center, Atlantic City, N.J. Paper presented at American Chemical Society Meeting, May 1978.
6. Yamamura, S. S., Wade, M. A., and Sikes, J. H., Direct Spectrophotometric Fluoride Determination, Analytical Chemistry, 34, pp 1308-14, 1962.
7. Standard Method for the Examination of Water and Waste Water, 13th Edition, American Public Health Association, Washington, D.C., 1971.
8. Newmark, P., Syringe Method for Measuring Nitric Oxide and Nitrogen Dioxide in 100-300 PPM Range, California Department of Public Health Vehicle Pollution Laboratory, Presented at the Pacific Conference on Chemistry and Spectroscopy, in Anaheim, California, November 1, 1967.
9. Zolner, W. J., and Helm, D. A., Multipoint Sampling NOX Using Totally Extractive Technique, Thermoelectron Corporation, Waltham, Mass. Application Engineering Paper.
10. Intersociety Committee, Methods of Air Sampling and Analysis, American Public Health Association (PUBL.), Washington, D.C., 1971.
11. Marcali, K., Microdetermination of Toluenediisocyanates in Atmosphere, Analytical Chemistry, 929, 522-558, 1957.
12. West, P. W. and Gaeke, G. C., Fixation of Sulfur Dioxide as Sulfitomercurate III and Subsequent Colorimetric Determination, Analytical Chemistry, 28, p 1816, 1956.
13. Dorland's Illustrated Medical Dictionary, 24th Edition, Published by W. B. Saunders Company, Philadelphia and London, 1965.

14. Gaume, J. G. and P. Bartek, Theoretical Determination of the Time of Useful Function (TUF) Predictions in Toxic Combustible Environments, Aerospace Medicine 40:1392, 1970.
15. Gaume, J. G., Bartek, P. and Rostami, H. J. Experimental Results on the Time of Useful Function (TUF) After Exposure to Mixtures of Serious Contaminants. Aerospace Medicine 42:987, 1971.
16. Crane, C. R., Establishing Heat Tolerance Limits for Acute Exposures in Rat, Mouse and Man. Proceedings of the Fourth International Conference on Fire Safety, Volume 4, San Francisco, January 15-20, 1979.
17. I. Moritz, A. R. and Henriques, F. C., Jr., Studies of Thermal Injury: II. The Relative Importance of Time and Surface Temperature in the Causation of Cutaneous Burns, Am J. Path., and III. The Pathology and Pathogenesis of Cutaneous Burns; an Experimental Study, Am. J. Path. Cited in: Moritz, A. R., Henriques, F. C., Jr. Dutra, F. R. and Weissinger, J. R.: Studies of Thermal Injury: IV. Exploration of Casualty Producing Attributes of Conflagrations; Local and Systemic Effects of General Cutaneous Exposure to Excessive Circumambient (Air) and Circumradiant Heat of Varying Duration and Intensity, Arch. Path., 43:489, 1947.
18. Projector, T. H., Allard's Law and Smoke-Filled Cabins, presented at the meeting of Subcommittee H-20C, of the SAE Aircraft Lighting Committee A-20 Orlando, Florida, May 16, 1977.
19. AGARD Conference Proceedings No. 166, Aircraft Fire Safety, Rome, Italy, April 7 - 11, 1975. North Atlantic Treaty Organization Advisory Group for Aerospace Research and Development, 7 Rue Ancelle 92200, Neuilly Sur Seine, France.
20. Perry, J. H., Chemical Engineers Handbook, McGraw-Hill, 3rd Edition, 1950.
21. Boelter, L. M. K., and others, Heat Transfer Notes, University of California Press, Los Angeles, CA 1948.
22. Peterson, J. E. and Stewart, R. D., Human Absorption of Carbon Monoxide from High Concentration in Air, American Industrial Hygiene Association Journal., Vol. 33, Pages 293-7, 1972

APPENDIX A

This Appendix provides drawings, check lists and computer data reduction details for the CHAS/SATS system. The following details are included:

- I. DRAWINGS OF THE MAJOR MODIFICATIONS OF THE HRR CALORIMETER
- II. CHAS/SATS CHECK LIST PRIOR TO A BURN TEST
- III. HP3052A DATA ACQUISITION SYSTEM INITIALIZATION
- IV. HP9825A PROGRAM LISTING
- V. CHAS PARTS LIST

LIST OF ILLUSTRATIONS

<u>FIGURE</u>	<u>TITLE</u>	<u>PAGE</u>
1-1	SAMPLE HOLDER INJECTION ASSEMBLY.....	119
1-2	DETAIL DRAWING OF SAMPLE HOLDER/MLT/INJECTION ASSEMBLY.....	120
1-3	DETAIL OF SAMPLE HOLDER/INJECTION ASSEMBLY GUIDE.....	121
1-4	DETAIL OF SAMPLE HOLDER/INJECTION ASSEMBLY OUTER SEAL PLATE.....	122
2	WIRING DIAGRAM OF MASS. LOSS TRANSDUCER (MLT).....	123
3	SAMPLE HOLDER.....	124
4-1	HRR HOLD CHAMBER EXTENSION DUCT.....	125
4-2	HRR HOLD CHAMBER OUTER DOOR.....	126
5-1	HRR RADIATION DOORS.....	127
5-2	HRR RADIATION DOORS AND OPENING/CLOSING MECHANISM.....	128
6	H ₂ FILTER FOR HCN MONITOR.....	129
7	CHAS DATA ACQUISITION AND PROCESSING SYSTEM.....	135
8	CHAS DATA PROCESSING FLOW DIAGRAM.....	136

II. CHAS/SATS TEST RUN CHECK LIST

1. AIRFLOW SET? PILOT LIGHT LIGHTED?
2. HEAT FLUX CORRECT?
3. TC ICE REF. FOR SURFACE TEMP. ON?
4. TC ICE REF. FOR INLET AIR TEMP. ON?
5. BRUSH SOOT OFF OF TP JUNCTIONS IN STACK
6. TURN ON & BALANCE 2-CHANNEL GOULD RECORDERS
7. TURN MLT POWER ON. (1.25 mv/100g.)
8. (3) SMOKE FILTERS REPLACED?
9. BLOW SOOT OUT OF LINE FROM SATS TO STACK.
10. RECONNECT SATS TO SAMPLING LINE

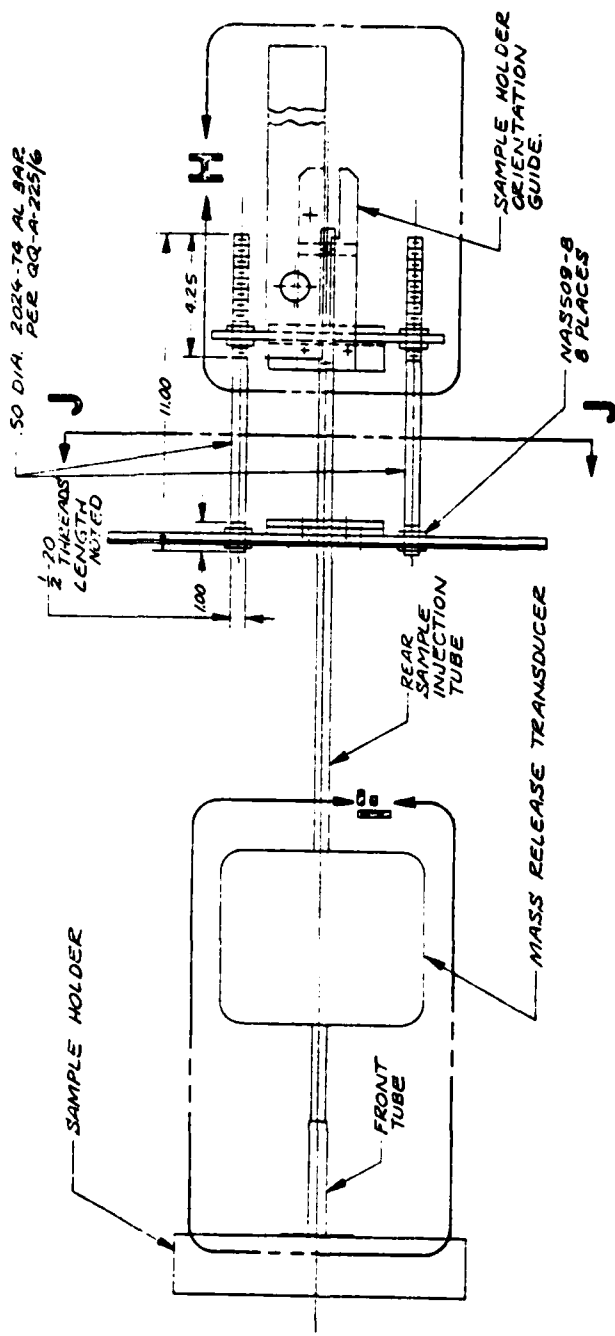

(ALL MEASUREMENTS ARE IN INCHES)

FIGURE A-1-1 SAMPLE HOLDER/INJECTION ASSEMBLY

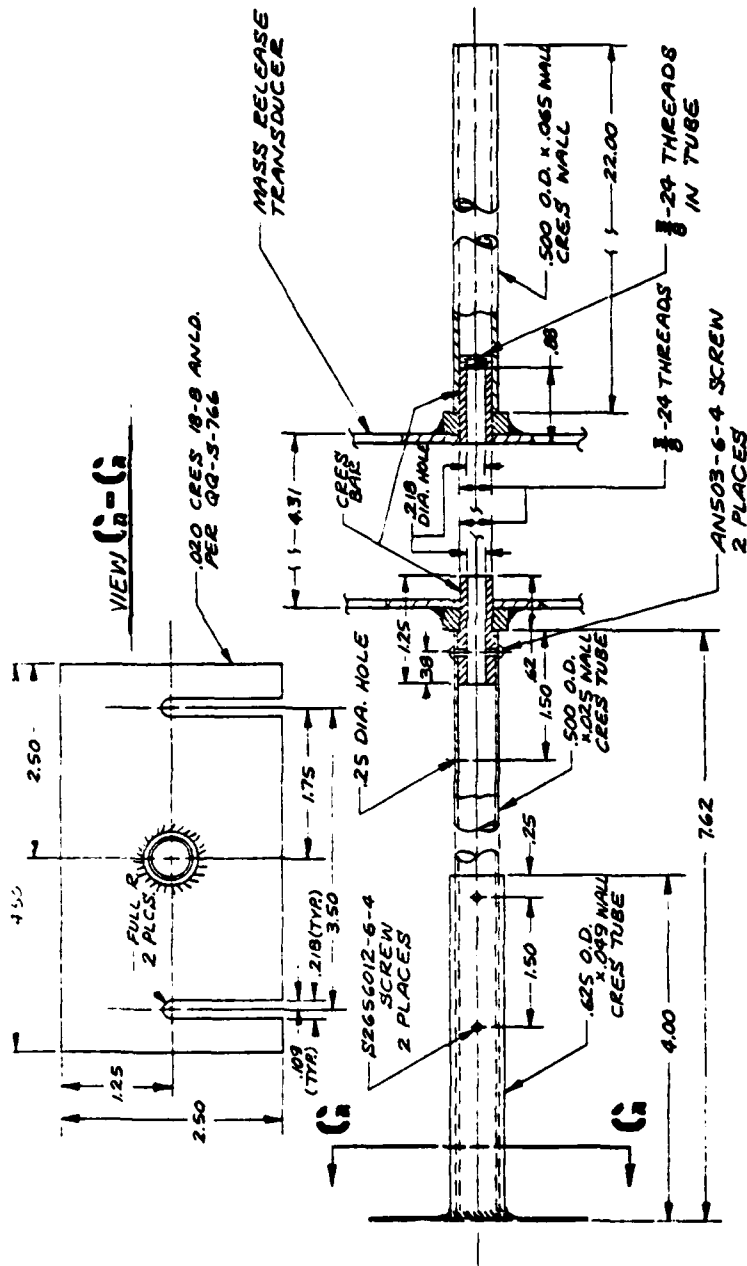

VIEW **P-P**
 (ALL MEASUREMENTS ARE IN INCHES)

FIGURE A-1-2 DETAIL DRAWING OF SAMPLE HOLDER/MLT/INJECTION ASSEMBLY

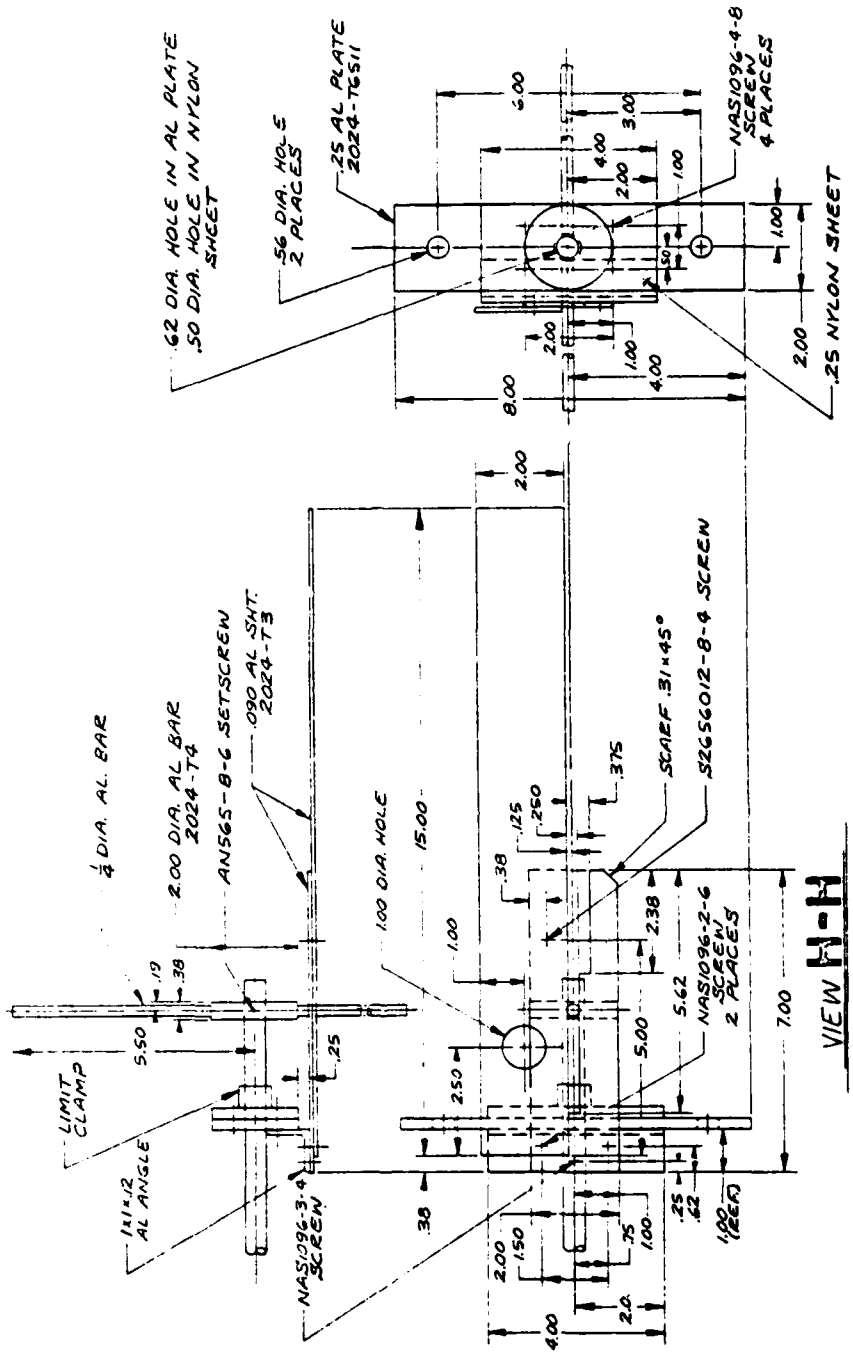

(ALL MEASUREMENTS ARE IN INCHES)
 FIGURE A-1-3 DETAIL OF SAMPLE HOLDER/INJECTION ASSEMBLY GUIDE

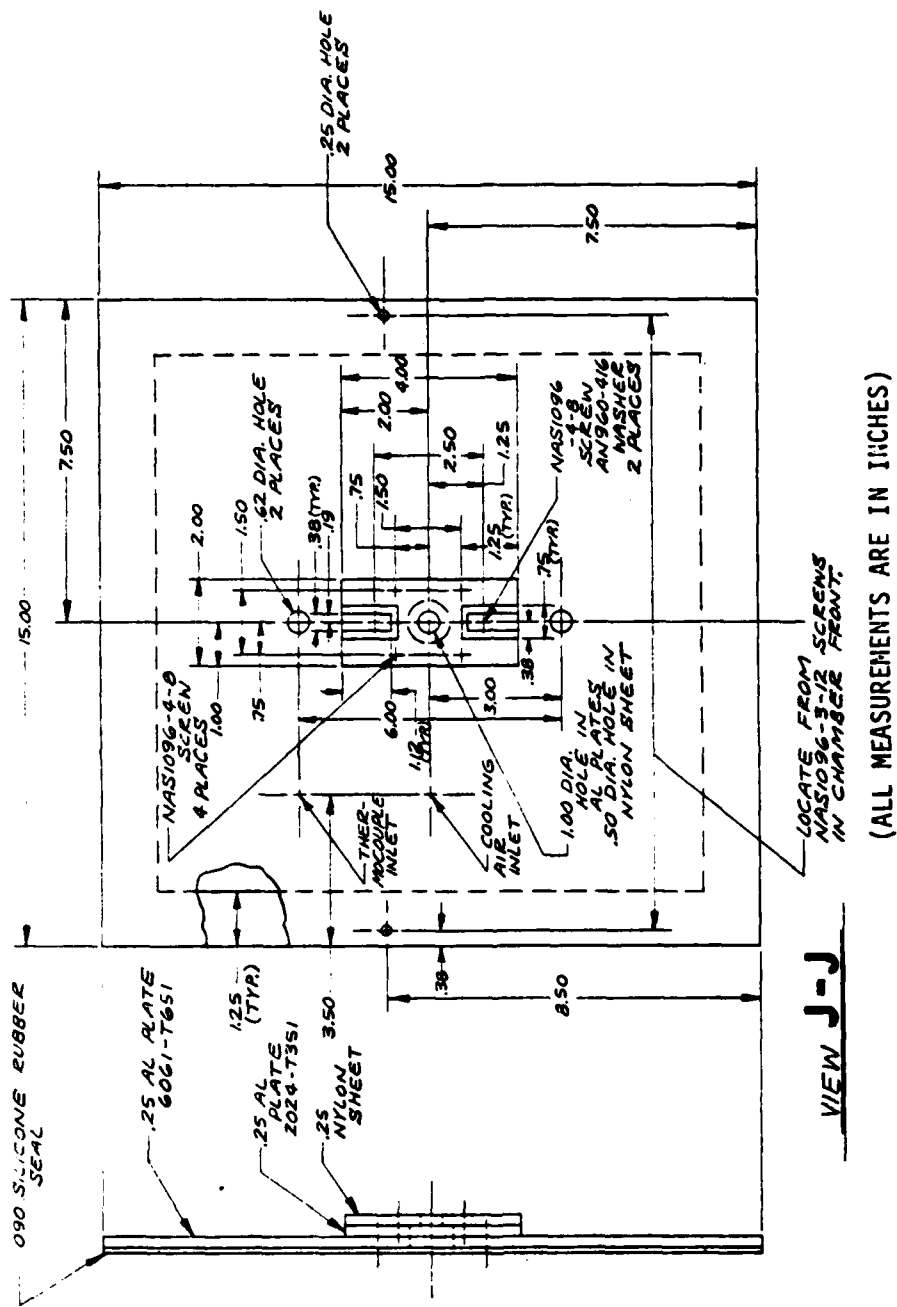

FIGURE A-1-4 DETAIL OF SAMPLE HOLDER/INJECTION ASSEMBLY OUTER SEAL PLATE

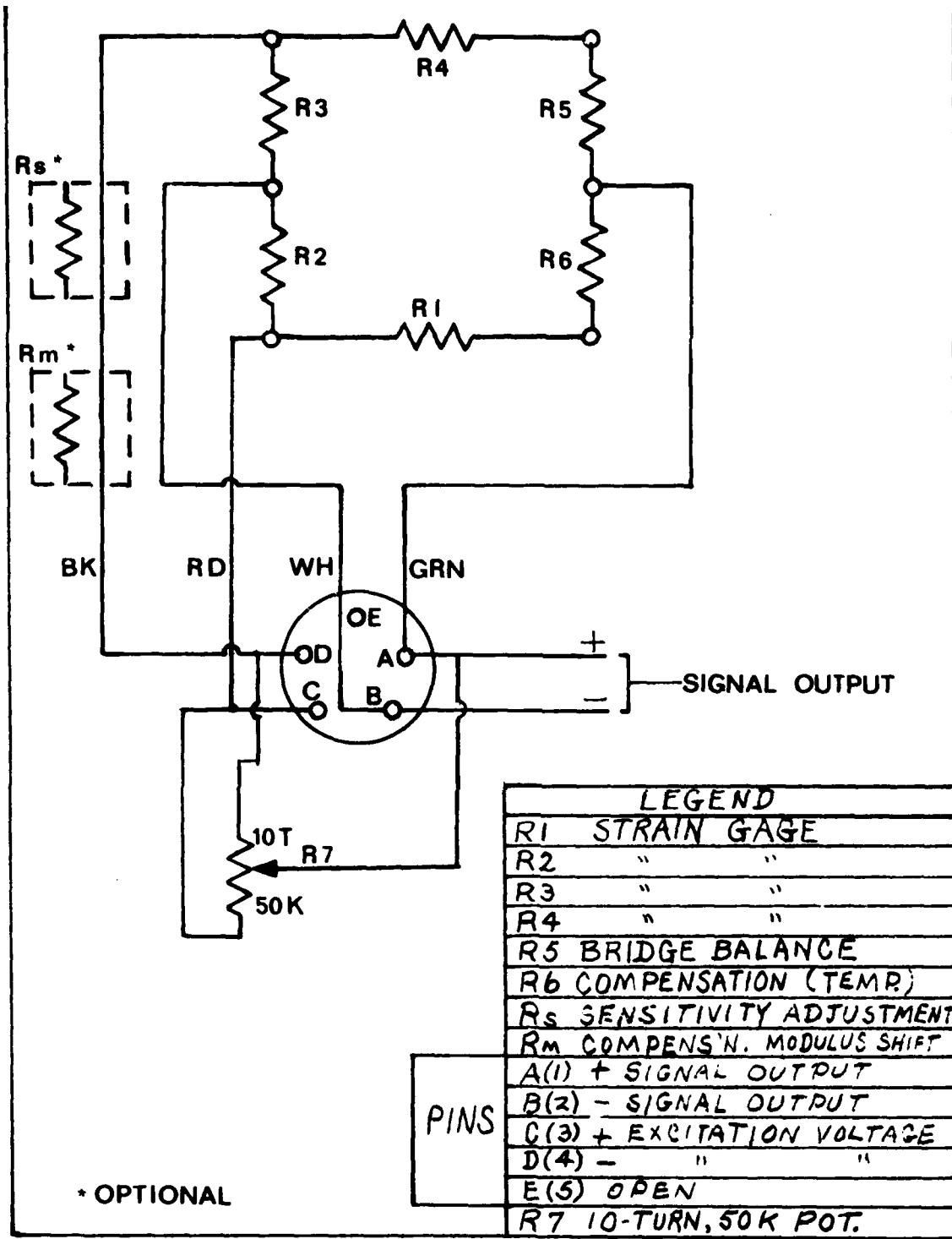
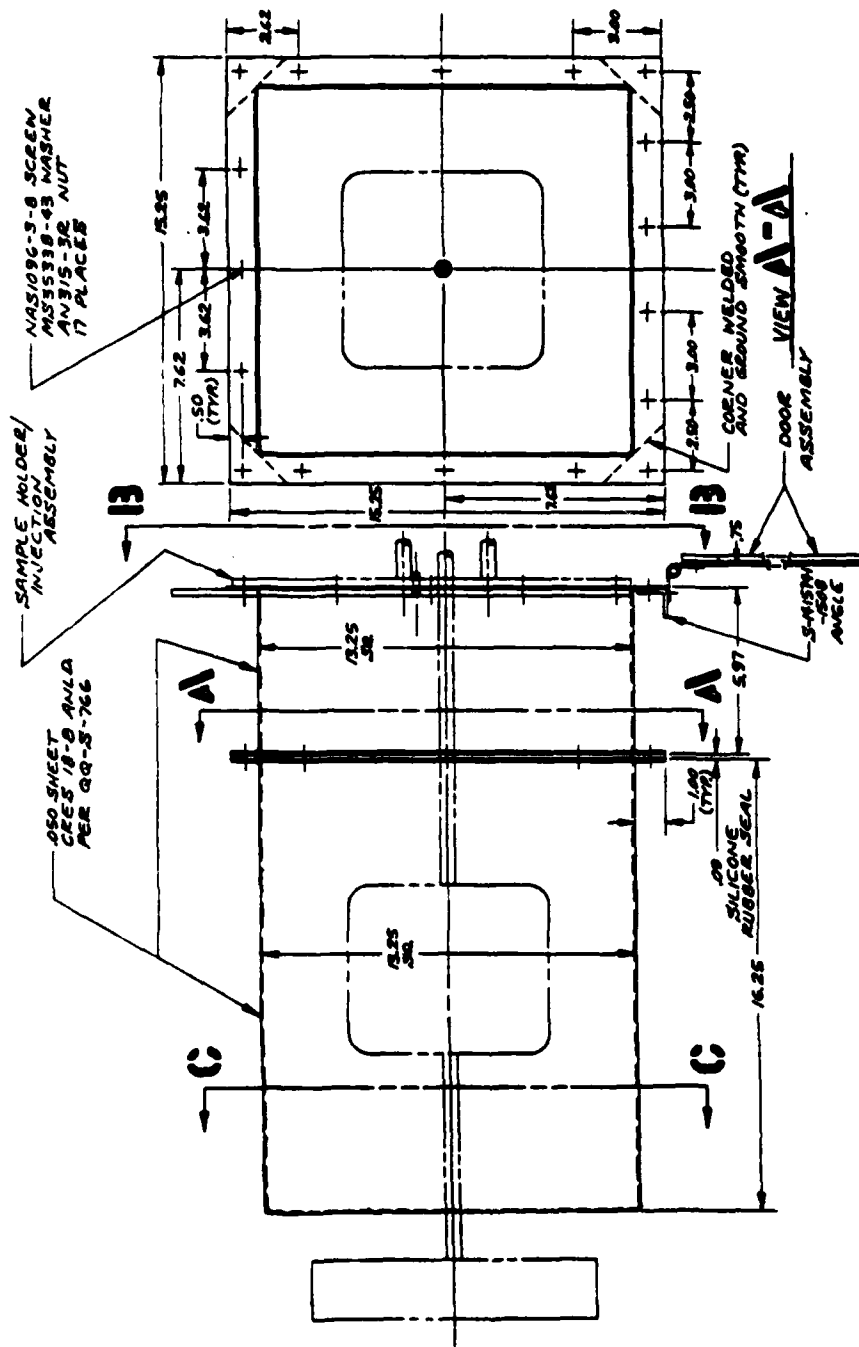
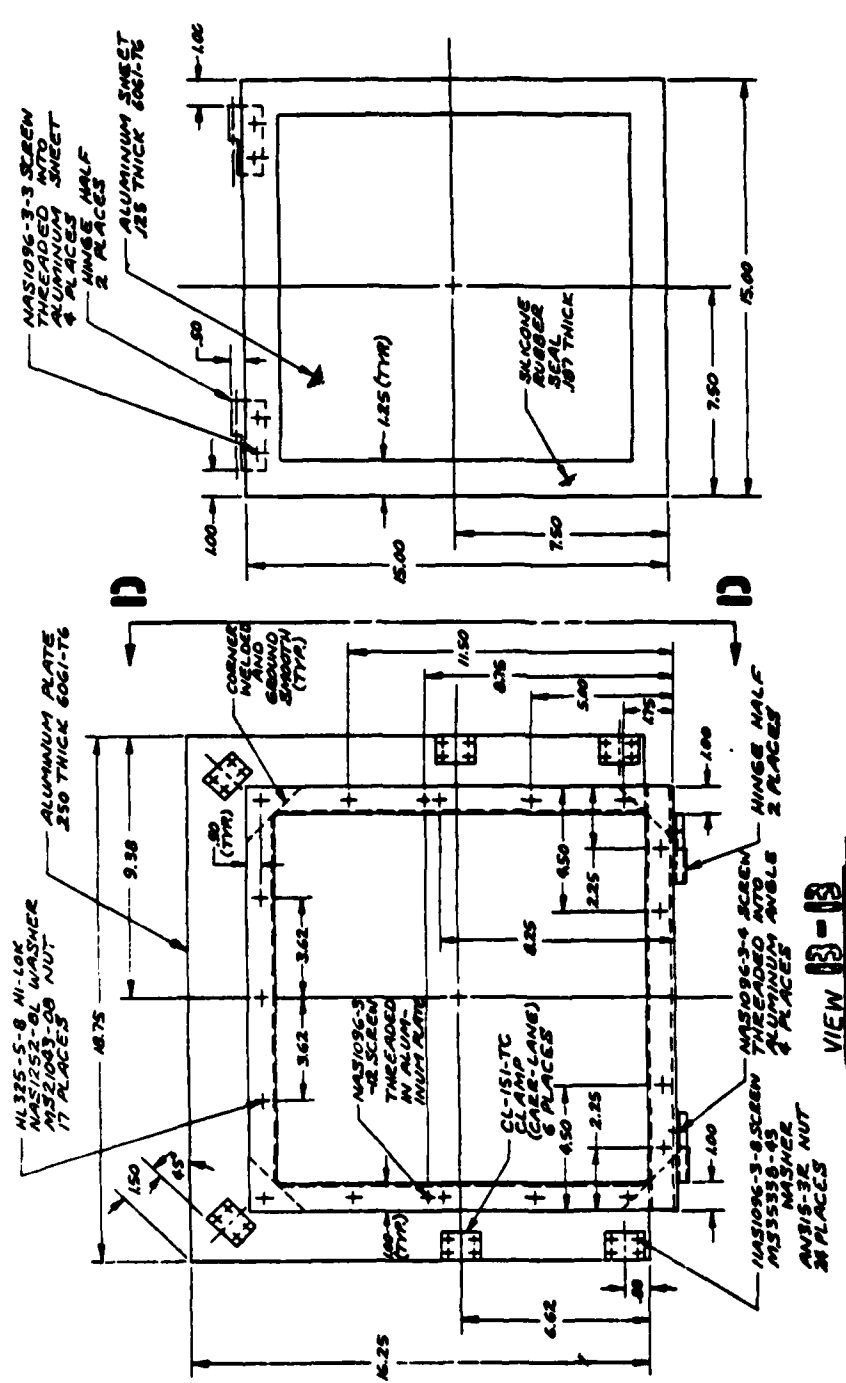

FIGURE A-2 WIRING DIAGRAM - MASS LOSS TRANSDUCER



(ALL MEASUREMENTS ARE IN INCHES)

FIGURE A-4-1 HRR HOLD CHAMBER EXTENSION DUCT



(ALL MEASUREMENTS ARE IN INCHES)

FIGURE A-4-2 HOLD CHAMBER OUTER DOOR

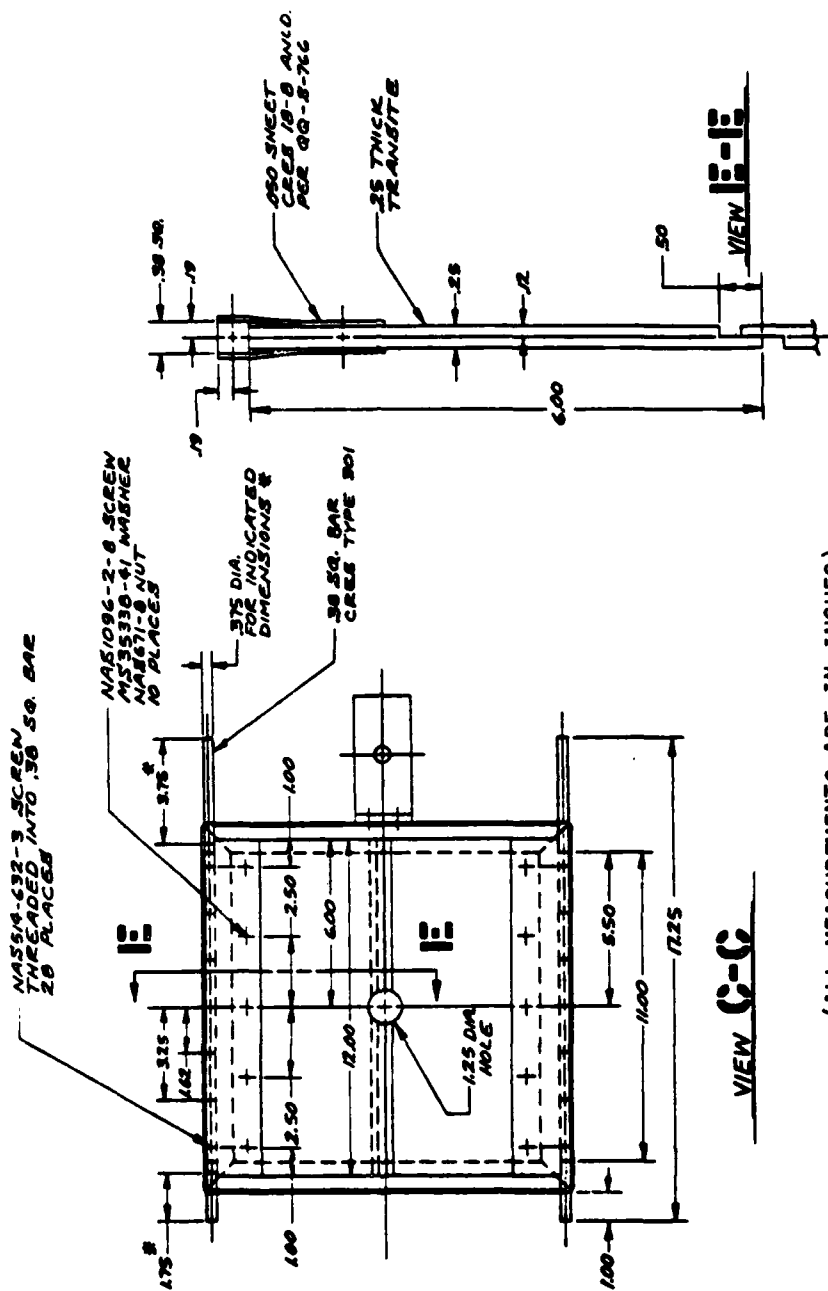

(ALL MEASUREMENTS ARE IN INCHES)

FIGURE A-5-1 HRR RADIATION DOORS

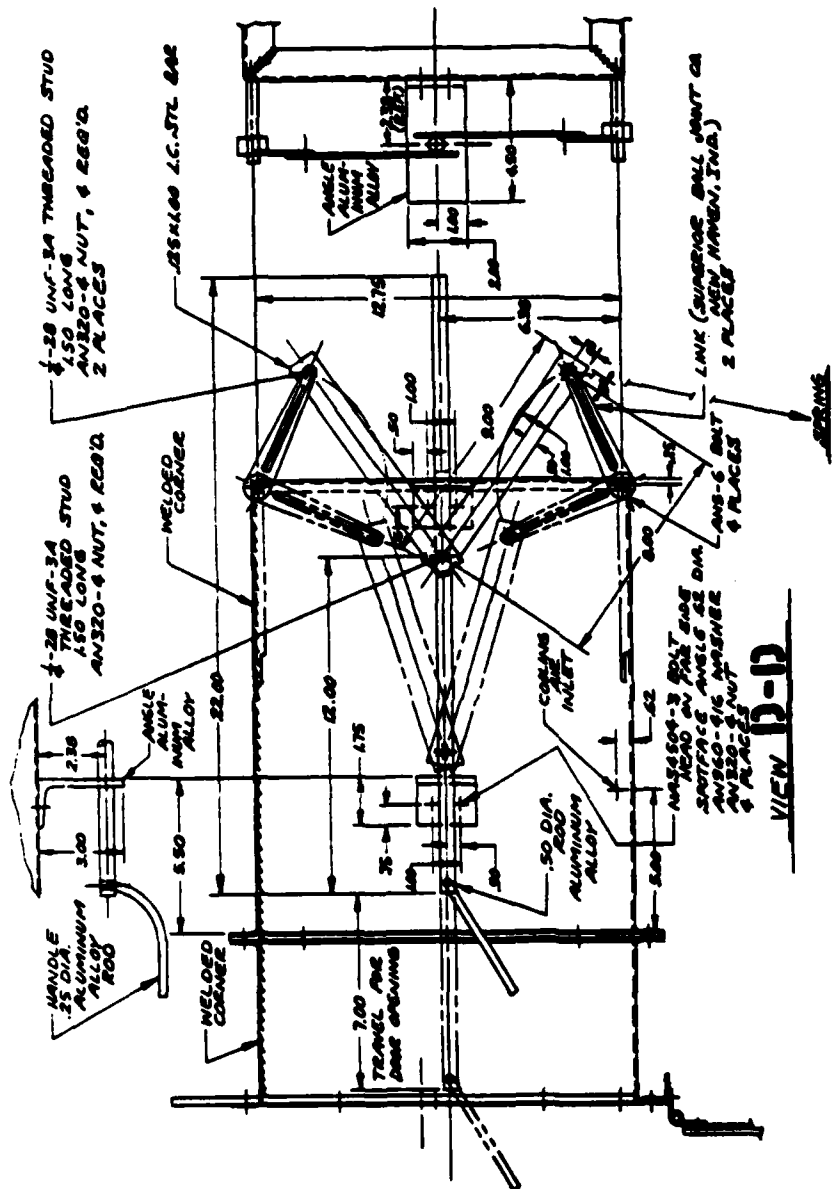

(ALL MEASUREMENTS ARE IN INCHES)

FIGURE A-5-2 HRR RADIATION DOORS AND OPENING/CLOSING MECHANISM

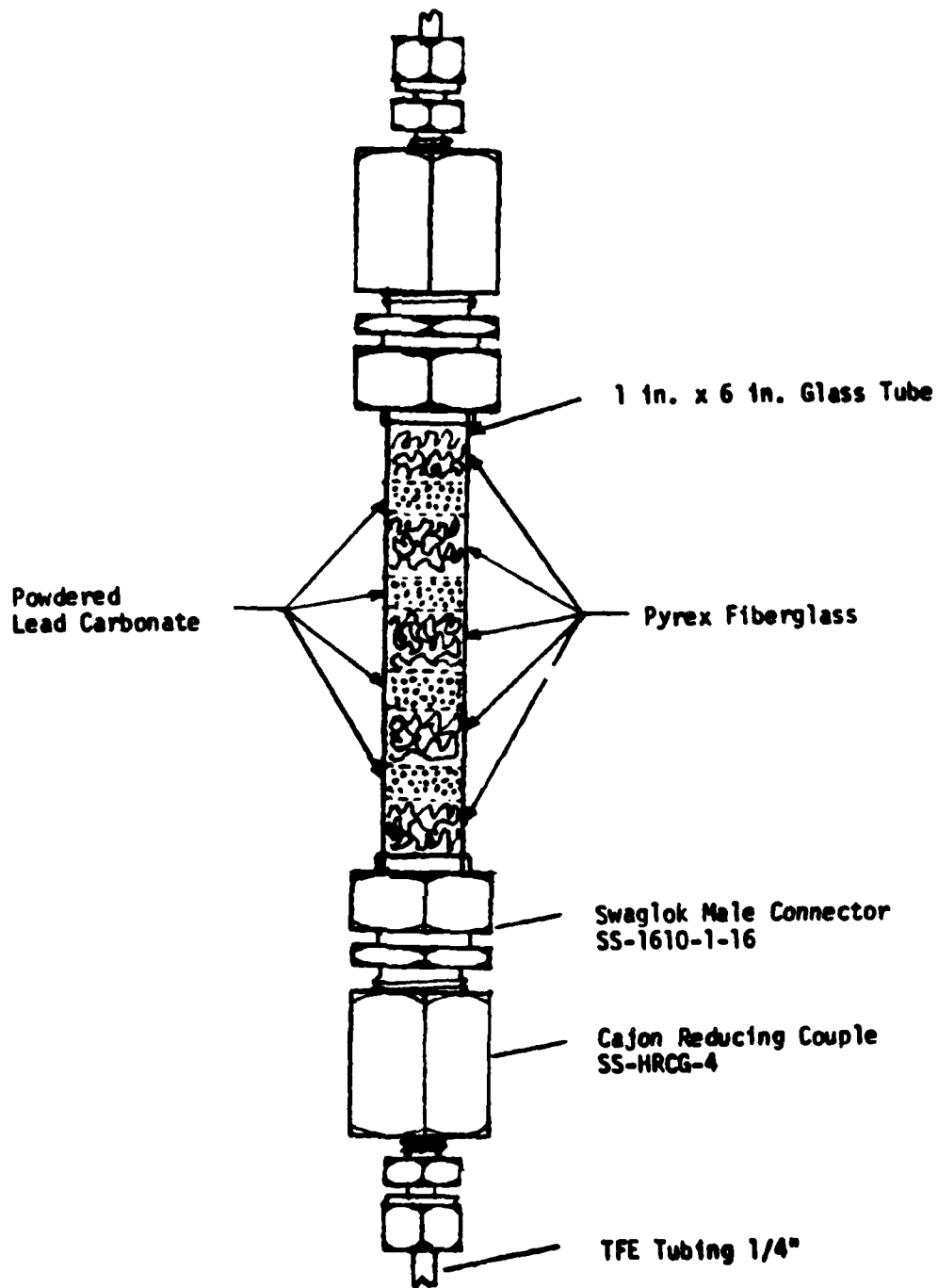

FIGURE A-6 H₂S FILTER FOR HCN MONITOR

11. REPLACE GAS SYRINGE SAMPLING PORT SEPTUM.
12. SWITCH O₂ MONITOR ON. SET ON AIR SAMPLING.
13. CK O₂ SAMPLING LINE ASCARITE/DRIER FOR DEPLETION.
14. ADJUST AIR FLOW METER VALVE ON COMBUSTION GAS MONITOR TO ("2").
15. SWITCH COMBUSTION GAS MONITOR POWER ON.
16. SET ZERO ON CO CO₂ & COMBUSTIBLE GAS MONITORS W/GN₂ FLOWING.
17. CHANGE OVER TO SPAN GAS & SET METERS (STEP 16) (MONITORS)
18. TURN SPAN GAS SUPPLY OFF.
19. SWITCH GAS TRAIN PUMP ON - ADJUST FLOW TO 1 LITER/MIN.
20. HCN MONITOR ELECTROLYTE SUPPLY, DRIER & RECEIVER FLASK OK?
21. SWITCH ELECTROLYTE PUMP & AIR SAMPLING PUMP ON.
22. ADJUST AIRFLOW TO 1.0 LITER/MIN.
23. CK DET. CELL ELECT. DROP RATE (1 DROP/20 SEC.)
24. PLUG IN & START UP NO/NO_x MONITOR MAIN POWER, VACUUM PUMP & SAMPLE CONDITIONING SYSTEM.
25. TURN NO/NO_x POWER SWITCH ON (FRONT CONSOLE).
26. ADJUST NO/NO_x DET. DARK CURRENT TO ZERO.
27. CK "ZERO" & "FULL SCALE" KNOB METER RESPONSE (NO/NO_x).
28. SWITCH BACK TO EXPECTED RANGE (OR 2.5 ppm/FS) & SWITCH O₃ GENERATOR ON.
29. TURN NO/SPAN GAS INTO MONITOR & SET 10 TURN POT TO GIVE CORRECT METER READING.
30. SWITCH GAS SAMPLING BACK TO CHAS (NO/NO_x METER SHOULD RETURN TO ZERO).
31. FILL HCL/HF & ALDEHYDE SAMPLING SYRINGES.
32. PLACE FILLED SYRINGES ON CHAS RACK.
33. LOAD RAT INTO SATS.
34. CAGE ROTATION OK/ ELECTRONICS OK?
35. CK CONNECTION OF SAMPLING LINE FROM SATS TO FILTERS.
36. SWITCH O₂ MONITOR OVER TO CHAS.
37. SET MLT & HRR RECORDER BASELINES (CHART SPEED 150 cm/Hr).
38. PLACE TOP ON SATS CHAMBER; CLAMP IN PLACE.
39. VENTILATE SATS W/PUMP ON AT 14 to 16 /MIN.
40. START CAGE ROTATION.
41. ZERO THE ELECTRONIC TIMERS.
42. CK SMOKE METER SETTINGS ("0" O.D. = 621.5 mv; 0.4 O.D. = 763.5 mv).

43. TAKE BASELINES * SWITCH AIR OVER TO MLT.
44. START DATA ACQUISITION (HP3052A) AS SAMPLE IS INJECTED & ACTIVATE ELECTRONIC TIMERS.

NOTE: ABOVE CK-LIST ASSUMES HEATED LINES & SMOKE FILTER ARE PREHEATED TO 248°F (120°C).

* AIR SWITCH-OVER NOT APPLICABLE IF MLT NOT USED.

III. STARTUP USER INSTRUCTION FOR HP 3052A

The following Operational procedure is for initial system turn on. The instructions are also valid at all times.

1. Place Disk containing CHAS/MATS program into 9855M Drive and place the special function Key (S.F. Key) overlay on 9825A (or 9825B).
2. Key in and execute "get" "START"
3. Press "RUN"
4. When "Index print out?" is displayed:
 - a) If Index is needed:
 - 1) Press "YES" From S.F. key
 - 2) The Index for CHAS/MATS program will be printed
 - b) If Index is not needed:
 - 1) Press "NO" from S.F. Key
5. When "CHOOSE PROGRAM FROM S.F. KEY" is displayed:
 - a) Press desired program on the S.F. Key

DATA ACQUISITION USER INSTRUCTIONS

1. The Program will ask a series of questions; enter all the answers promptly.
2. When "mv readings check, Cont." is displayed: press: "CONTINUE" and check the print out.
3. When "Adjust Smoke mv output" is displayed: Adjust the smoke meter to specification with unblocked light beam. The mv reading can be checked on digital voltmeter. Alternately place the 0.4 O.D. neutral density filter (or other density value filter) in the light beam and adjust readings as called for to match smoke detector calibration curve.
4. When "Remove Filter, Cont." is displayed: Remove the selected neutral density smoke filter from the light path.
5. When "Baselines, Cont." is displayed: press "CONTINUE", at 1 minute after placing the Sample and Sample injection assembly into the HRR hold chamber.
6. When "Start data, Cont." is displayed: press "CONTINUE", at the same time the sample is injected into the HRR Chamber.
7. When "Process?" is displayed (after 10 minutes):
 - a) If data processing is desired:
press "YES" on the S.F. key
Go to step 8
 - b) If data processing is not desired:
press "NO" on the S. F. key
Go to 9
8. When "CHOOSE PROGRAM FROM S.F. KEY" is displayed:
 - a) Press desired program on the S.F. KEY
 - b) Go To appropriate user instructions
9. When "SEE YOU NEXT TIME", is displayed:

This is the end of the program

GENERAL USER INSTRUCTIONS

DESCRIPTION - The following operational procedure can be applied to several data processing programs (there is very little differences in each procedure). These programs include:

1. Mass remaining & Loss
2. Smoke Release Rate
3. Heat Release Rate
 - (i) by Thermocouple

(ii) by Oxygen Consumption

4. CO Release Rate
5. CO₂ Release Rate
6. HCN Release Rate
7. O₂ Release Rate
8. CH_x Release Rate
9. Sample Temperature
10. NO_x Release Rate
11. HCL Release Rate
12. HF Release Rate
13. RCHO Release Rate

USER INSTRUCTIONS - The following instructions are followed when data has been acquired and processing is desired. Figures A-7 and A-8 show diagrams of the HP9825A Data Acquisition/Processing System.

1. When "# of run in disk (1,2,...)?" is displayed:
 - a) Type in "1" or "2" or....
 - b) press "CONTINUE"
2. For Heat Release Rate by oxygen consumption Method GO to Step 9
FOR HCl, HF or RCHO Release Rate, go to Step 10
3. When "has this been plotted before?" is displayed:
 - a) If this data has been plotted before, press "YES" on S.F. KEY
If this data has not been plotted before, press "NO" on S.F. KEY
 - b) Press "CONTINUE"
4. When "Have your plotter ready? Cont" is displayed:
 - a) Check plotter, pen and paper. Have it ready for plotting
 - b) Press "CONTINUE"
5. FOR Mass remaining & Mass loss rate go to Step 12
6. When "Another Run?" is displayed
 - a) If additional run is desired:
 - (I) press "YES" on S.F. Key
 - (II) go to step 7

- b) If no more runs are desired:
press "NO" on S.F. key
go to Step 8
7. When "CHOOSE PROGRAMS FROM S.F. KEY" is displayed:
a) Press the desired program on the S.F. KEY.
b) Go to the appropriate user instructions.
8. When "SEE YOU NEXT TIME" is displayed:
a) If an additional run is desired at this time go to Step 7(a).
b) If no more runs are desired. This is the end of program.
9. When "Do you have following file" is displayed:
a) "HF" will be displayed, after about half second
If HF data is collected in this run. press "YES" on S.F. KEY
If HF data is not collected in this run. press "NO" on S.F. KEY
b) HCl and RCHO will be displayed following HF. Use the same procedure as for HF.
c) Go To Step 3
10. When "has this been plotted before?" is displayed:
a) If data (X = HCl, or HF or RCHO) has been plotted before, press "YES" on S.F. Key
b) If X data has not been plotted before, press "NO" on S.F. key
- When "Sequence" is displayed:
Type in Which "Sequence" is used in collecting this Sample data.
When "Time (SEC)?" is displayed:
Type in Time (sec)
press "CONTINUE"
repeat until all finish sequences are finished.
- When "Sample amount? (mg/ml)" is displayed:
Type in How many "(mg sample ion in 1 ml of Gas Sample" was determined by analysis.
Press "Continue"
Repeat until all sequences are finished.

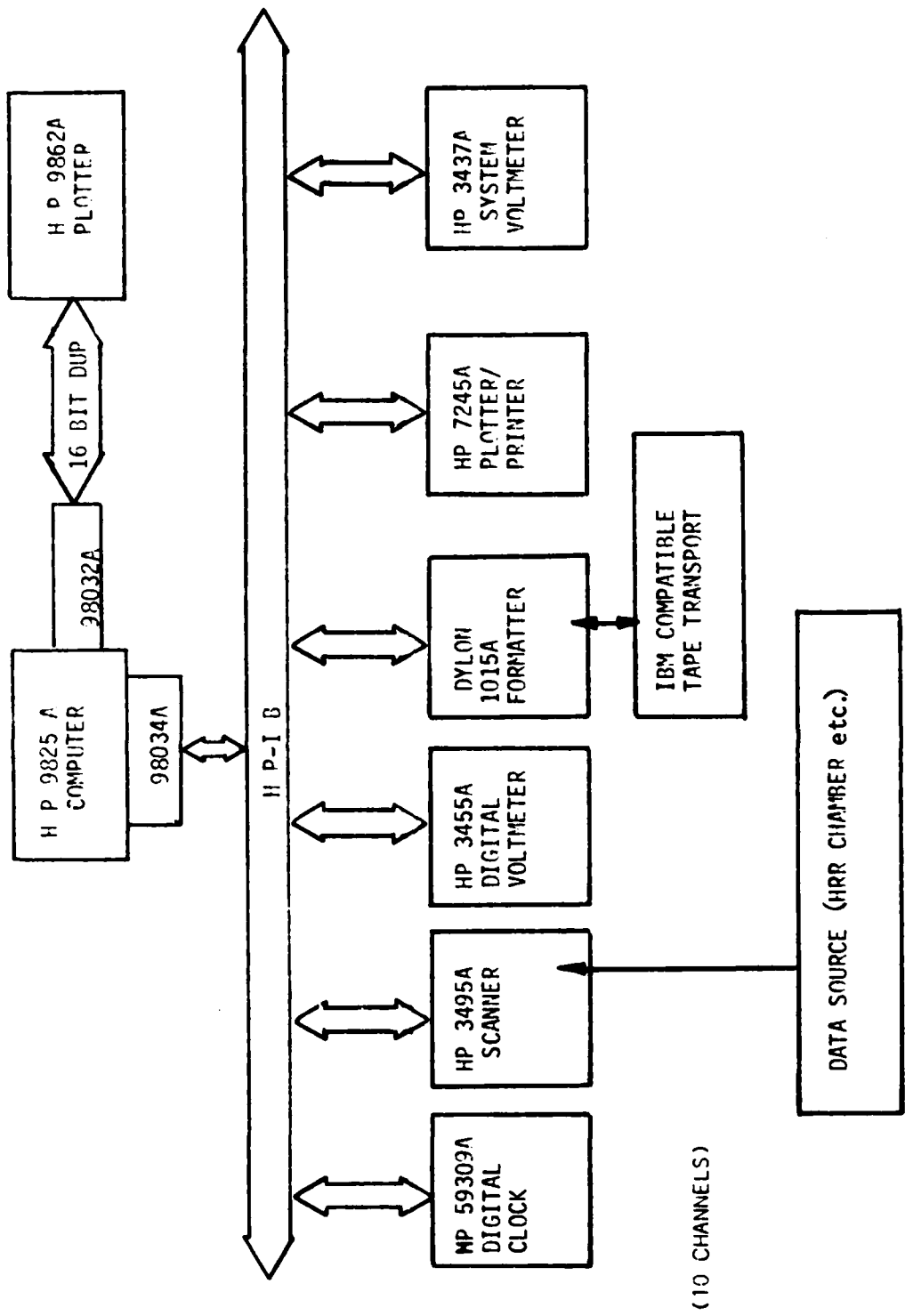

FIGURE A-7 CHAS DATA ACQUISITION AND PROCESSING SYSTEM

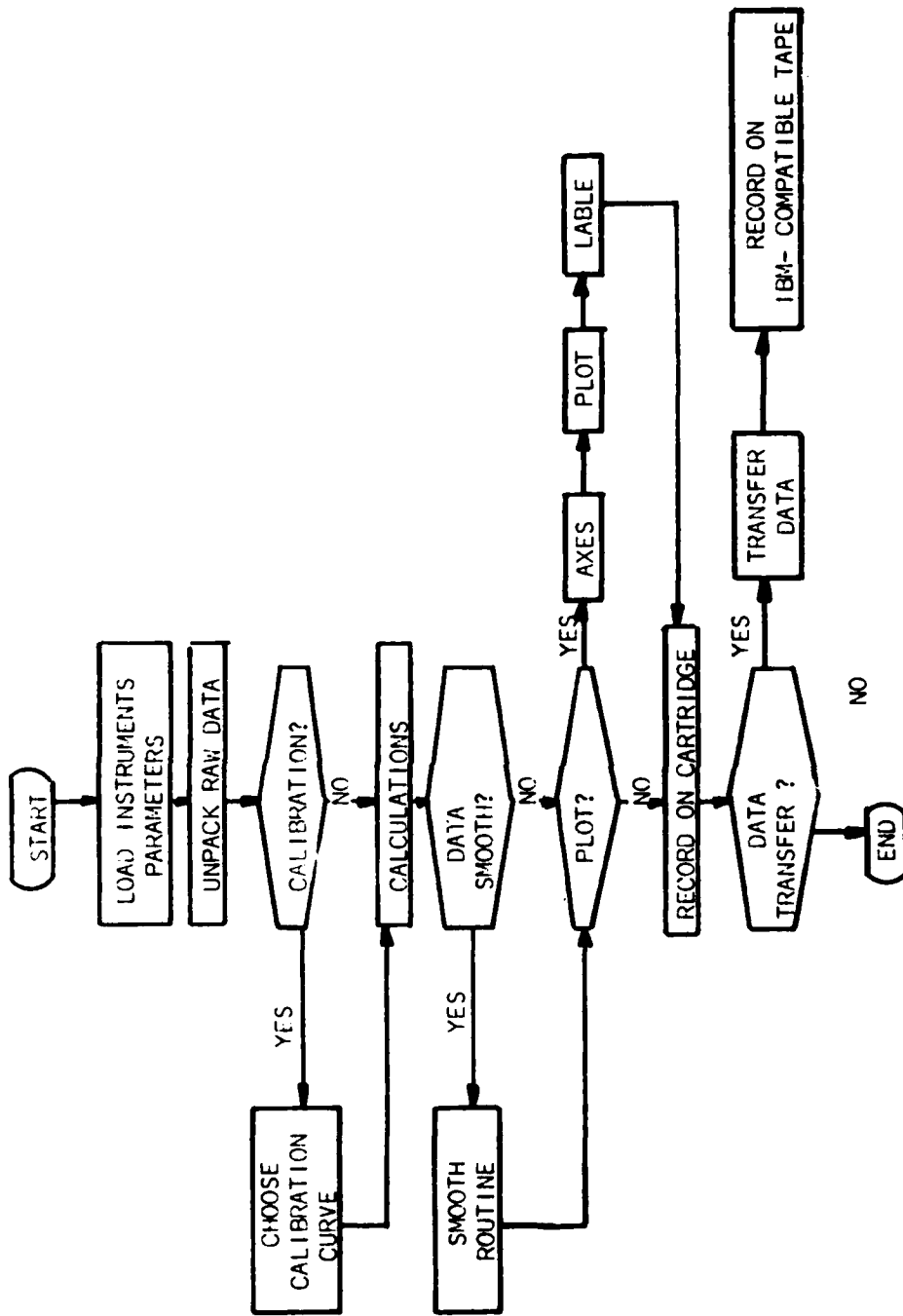

FIGURE A-8 CHAS DATA PROCESSING FLOW DIAGRAM

11. When "MAX Y-SCALE" appears
 - a) Type in the Max. Y-Scale value (ppm or %).
 - b) press "CONTINUE"
 - c) Go to step 4

12. When "Need plot for mass loss? is displayed:
 - a) If plot is to be made, press "YES" on S.F. Key
If plot is not to be made, press "NO" on S.F. Key

 - b) Go to Step 3

DATA TRANSFER

USER INSTRUCTIONS - The following procedure transfers data from the Disk to IBM magnetic tape.

1. When "LOAD MAGNETIC REEL TAPE, Cont." is displayed
 - a. LOAD MAGNETIC REEL TAPE
 - b. press "CONTINUE"

2. When "# OF RUN IN THIS DISK?" is displayed
 - a. Type in "1" or "2" or - - -
 - b. press "CONTINUE"

3. When "Do you have the following files?" is displayed
 - a. When "NOx" is displayed
if "NOx" data has been collected press "YES"
if "NOx" data has not been collected press "NO"

 - b. "NO", "NO₂", "HF", "HCL" AND "RCHO" will follow "NOx"
Use the same key operations as for "NOx"

4. When "Need Read & Printing?" appears
 - a. If Read & Printing is desired, press "YES" on S.F. key
When "IBM TAPE" is displayed
Type in IBM TAPE #, such as "965552130"
when "DATE" is displayed
Type in date, such as "8/10/81"

When "Any Note" appears

Type in any remark you want to put in.
Such as "NO HF, Hcl & RCHO is been collected"

b. If Read & Printing is not desired:

Press "NO" no S.F. key

5. When "THAT'S ALL FOR CHAS/MATS!"

This is the end of the program.

IV. HP9825A DATA PROCESSING AND DATA ACQUISITION AND PROGRAM LIST

```

0: "START";
1: gelk "SFKEY"
2: ent "INDEX print out?",A;if flg13,gt0 20
3: prt "## CHAS/MATS ##"
4: prt "## INDEX ##";spc 2
5: fmt "## CONTENT ##";wrt 16;spc
6: prt " 0 DATA ";prt " ACQUISITION";spc
7: prt " 1 SMOKE";spc
8: prt " 2 MASS ";prt " REMAINING &"
9: prt " MASS LOSS";prt " RATE";spc
10: prt " 3 HEAT R. RATE";spc
11: prt " 4 CO R. RATE";spc
12: prt " 5 CO2 R. RATE";spc
13: prt " 6 HCN R. RATE";spc
14: prt " 7 O2 D. RATE";spc
15: prt " 8 TOTAL ";prt " HYDROCARBON";spc
16: prt " 9 SAMPLE";prt " TEMPERATURE";spc
17: prt " 10 NDx or NO"
18: prt " R. RATE";spc
19: prt " 11 HCL R. RATE";spc
20: prt " 12 HF R. RATE";spc
21: prt " 13 RCHD R. RATE";spc
22: prt " 14 SPECIAL F.";prt " KEY";spc
23: prt " 15 START";spc
●24: prt " 16 Hg ADJ.";spc
●25: prt " 17 DATA "
26: prt " TRANSFER"
27: spc ;prt "*****END*****";spc 2
28: dsp "CHOOSE PROGRAM FROM S.F.KEY"
29: stp ;gt0 -1
30: dsp "SEE YOU NEXT TIME";stp

```

```

0: "10 CH Data Acq ";
1: dsp "Check avl record (>=200) cont...";stp
2: ent "is (Avl Rcrds )>=200 ?? yes or no",A
3: if A=0;dsp "Not enough rcrds,Change new disk!!!!";stp
4: dim N$(15,15),M$(15),Z(10),T$(10,10),U$(12)
5: dim A(15),A$(8),B$(20),E$(6),F$(6),M,N
6: fn: 16b;wrt 16,31,31,31,31,31,31,31,31,31,31,31,31,31,31,31;spc
7: fmt
8: prt "10 CH Data Acq 5-29-30"
9: wrt 703,"PRS"
10: fmt 2,fz2.0;fmt 3,f9.6
11: rem 722;clr 722;wrt 722.3,"F1R7T2T3M1A0H0"
12: wrt 722.3,"EY",.001,"SVEZ",0,"SZ"
13: enp "Run #?",A(10);enp "Sample Name?",B$;enp "Date?",A$
14: enp "Disk Number?",A(11)
15: enp "run# in Disc?",M$

```

```

16: enp "Length of Test Time,(min)?",N
17: enp "Data interval, sec?",M;60/M)M
18: enp "Air flow,cfm?",A[4];A[4]*.3048*3)A[4]
19: enp "Air temp(C)?",A[3];273.1+A[3]*A[3]
20: enp "Samp area,in^2?",A[2];A[2]*.0254^2)A[2]
21: enp "Used NO or NOx??",E$
22: enp "Range(ppm)Used in NO or NOx??",F$
23: enp "Heat (W/cm^2)?",A[1]
24: enp "Init. mass (gm)?",A[7]
● 25: enp "dMV/100gm,zeroed",A[8]
26: if MN>0;1)I; if MN>600;2)I; if MN>1200;3)I; if MN>1800;4)I; if MN>2400;5)I
27: if MN>3000;6)I; if MN>3600;7)I
28: I)Q;dim C$(10,2MN)
29: "xxDAT1")T$(1)
30: M$)T$(1,1,len(M$))
31: open T$(1),200M$
32: asgn T$(1),1,0
33: dsp "mV Readings Check.Cont.";stp
34: for I=1 to 10;0)Z[I];next I
35: for J=1 to 10;wrt 709.2,1;wrt 722.3,"R2";trg 722;red 722,P
36: P+Z[I])Z[I]
37: for I=2 to 10;wrt 709.2,1;wrt 722.3,"R7";trg 722;red 722,P
38: P+Z[I])Z[I];next I;next J
39: for I=1 to 10;Z[I]/10)Z[I];next I
40: spc ;fmt x,"CH.",6x,"mV";wrt 16;fmt ;spc
41: fmt ,"SMOKE",3x,f8.3;wrt 16,Z[1]
42: fmt ,"MASS ",3x,f8.3;wrt 16,Z[2]
43: fmt ,"HEAT ",3x,f8.3;wrt 16,Z[3]
44: fmt ,"CO ",3x,f8.3;wrt 16,Z[4]
45: fmt ,"CO2 ",3x,f8.3;wrt 16,Z[5]
46: fmt ,"HCN ",3x,f8.3;wrt 16,Z[6]
47: fmt ,"O2 ",3x,f8.3;wrt 16,Z[7]
48: fmt ,"HC ",3x,f8.3;wrt 16,Z[8]
49: fmt ,"TEMP ",3x,f9.3;wrt 16,Z[9]
50: fmt ,"NO ",5x,f8.3;wrt 16,Z[10];spc ;fmt
● 51: spc ;prt "Smoke Correct Readings Should Be"
● 52: spc ;prt ".4 OD=763.5 mV";prt " 0 OD=621.5 mV";spc
53: C; "Adjust Smoke mV Output"
54: wrt 709,"01";wrt 722,"R2T1";stp
55: dsp "Remove Filter,Cont";stp
56: wrt 722,"T2T3";dsp "Baselines,Cont.";stp
57: for I=1 to 10;0)Z[I];next I
58: for J=1 to 25;wrt 709.2,1;wrt 722.3,"R2";trg 722;red 722,P
59: P+Z[I])Z[I]
60: for I=2 to 10;wrt 709.2,1;wrt 722.3,"R7";trg 722;red 722,P
61: P+Z[I])Z[I];next I;next J
62: for I=1 to 10;Z[I]/25)Z[I];next I
63: sfg 14
64: 60/M)A
65: dsp "Start data,Cont";stp
66: wrt 708,"";0)S
67: for K=1 to MN;S*4)S
68: wrt 709.2,1;wrt 722.3,"R2";trg 722;red 722,P[I]
69: wrt 722.3,"R7"

```

```

70: for I=2 to 10;wrt 709.2,I
71: trg 722;red 722,P[1];next I;0}I
72: sprt 1,P[1],P[2],P[3],P[4],P[5],P[6],P[7],P[8],P[9],P[10],"end"
73: "loop";red 708,U$
74: val(U$(9,10))*60*val(U$(11,12))U;if S=MN;jmp 2
75: if S>U;gto "loop"
76: next K
77: fmt "Test Time=",f4.0;wrt 16,U
78: "xxismk")N$(1),"xx2mas")N$(2),"xx3ht")N$(3)
79: "xx4co")N$(4),"xx5co2")N$(5),"xx6hcn")N$(6),"xx7o2")N$(7)
80: "xx8hc")N$(8),"xx9tem")N$(9),"xx10no")N$(10),"xxinf")N$(11)
81: for I=1 to 11,M$)N$(I,1,len(M$));next I
82: drive 0
83: asgn T$(1),1,0
84: 128*32)C;fmt 4b," I'm Working ",x,4b;wrt 0,C,C,C,C,C,C,C,C
85: for K=1 to MN;sread 1,P[1],P[2],P[3],P[4],P[5],P[6],P[7],P[8],P[9],P[10]
86: for Y=1 to 10
87: if Y#1;fti ((P[Y]+9)^.1*10000)C$(Y,2K-1,2K)
88: if Y=1;fti ((P[Y]+200)^.1*10000)C$(Y,2K-1,2K)
89: next Y;next K
90: "xxDAT1")T$(1,M$)T$(1,1,len(M$));kill T$(1)
91: for I=1 to 10;open N$(I),G#6;next I;open N$(11),2
92: for J=1 to 10
93: asgn N$(J),3,0
94: sprt 3,Z[#],C$(J),"end"
95: next J
96: spc ;fmt x,"CH.",3x,"Baseline";wrt 16;fmt ;spc
97: fmt ,"1.SMOKE",x,f8.3;wrt 16,Z[1]
98: fmt ,"2.MASS ",x,f8.3;wrt 16,Z[2]
99: fm: ,"3.HEAT ",x,f8.3;wrt 16,Z[3]
100: fmt ,"4.CO ",x,f8.3;wrt 16,Z[4]
101: fmt ,"5.CO2 ",x,f8.3;wrt 16,Z[5]
102: fmt ,"6.HCN ",x,f8.3;wrt 16,Z[6]
103: fm: ,"7.O2 ",x,f8.3;wrt 16,Z[7]
104: fmt ,"8.HC ",x,f8.3;wrt 16,Z[8]
105: fmt ,"9.TEMP ",x,f8.3;wrt 16,Z[9]
106: fm: ,"10.NO ",x,f8.3;wrt 16,Z[10];spc ;fmt
107: asgn N$(11),3,0
108: sprt 3,A[*],A$,B$,E$,F$,M,N,N$(15),M$, "end"
109: 0)X;ent " PROCESS??" ,X;if flg13;gto +4
110: dsp "CHOOSE PROGRAM FROM S.F.KEY"
111: stp ;gto -1
112: fm: 16b;wrt 16,31,31,31,31,31,31,31,31,31,31,31,31,31,31,31;spc
113: dsp "SEE YOU NEXT TIME";stp
#20300

```

```

● 0: "Mass Remaining & Mass Loss Rate":
1: deg
2: fmt 16b;wrt 16,31,31,31,31,31,31,31,31 31,31,31,31,31,31,31,31,spc
3: prt "Mass Remaining & Mass Loss Rate";spc 2
4: dsp "Mass Remaining & Mass Loss Rate";wait 300
5: dim A[15],A#[9],B#[20],E#[6],F#[6],M,N,N#[15,10],M#[2]
6: dim W#[12,12]
7: enp "# of run in disk(1,2...)?",W#[1]
8: 0)W;ent "Has this been plotted before?";U
9: dsp "Have your plotter ready! Cont.";stp
10: "xxxinf")W#[2]
11: W#[1])W#[2,1,len(W#[1])]
12: drive 0
13: asgn W#[2],1,0
14: sread 1,A[*],A#,B#,E#,F#,M,N,N#[10],M#
15: fxd 0,prt "Run#=",A[10],B#,A#,spc
16: dsp "...WORKING ON MASS REMAINING...";gsb "CACL I"
17: gsb "PLOT I"
18: dsp "...WORKING ON MASS LOSS RATE...";gsb "CACL II"
19: ent "NEED PLOT FOR MASS LOSS?";A;if flg13;gto +2
20: gsb "PLOT II"
21: ent "ANOTHER RUN?";X;if flg13;gto +3
22: dsp "CHOOSE PROGRAM FROM S.F.KEY"
23: stp ;gto -1
24: fmt 16b;wrt 16,31,31,31,31,31,31,31,31,31,31,31,31,31,31,31,31,spc
25: dsp "SEE YOU NEXT TIME";stp
● 26: "CACL I";dim Z[10],V#[2MN]
27: dim M[MN],S[MN]
28: "xx2mas")W#[3]
29: W#[1])W#[3,1,len(W#[1])]
30: asgn W#[3],2,0
31: sread 2,Z[#],V#
32: for I=1 to MN,(1+((V#[2I-1,2I])/10000)^10-9-Z[2])M[I],next I
33: jmp 2
● 34: "MLU DRIFT DATA HERE":
35: for J=1 to 20;for I=1 to MN-2,(M[I]+M[I+1]+M[I+2])/3)S[I+1],next I
36: for I=2 to MN-2;S[I+1])M[I+1],next I
37: next J
38: for I=1 to MN;M[I]*100/A[9])S[I],next I
39: if A[2]=100#.0254^2 and A[1]=2.5;gsb "2.5"
40: if A[2]=100#.0254^2 and A[1]=3.5;gsb "3.5"
41: if A[2]=100#.0254^2 and A[1]=5;gsb "5.0"
42: if A[2]=100#.0254^2 and A[1]=7;gsb "7.0"
43: if A[2]=36#.0254^2 and A[1]=2.5;gsb "S2.5"
44: if A[2]=36#.0254^2 and A[1]=3.5;gsb "S3.5"
45: if A[2]=36#.0254^2 and A[1]=5;gsb "S5.0"
46: "Adj. Max. Wt";
47: for I=1 to 5;0)S[I],next I
48: max(S[#])-A[7])W;for I=1 to MN;S[I]-W)S[I],next I
49: "S[I]-B+C)",A[7])S[I]
50: (S[10]-S[1])/9)C,(10S[1]-S[10])/9)B
51: for I=1 to 10;B+C)S[I],next I
52: if U=1;gto +7

```

```

53: for I=1 to MN,if S(I)<-6,-5.999)S(I)
54: fti ((S(I)+6)^(1#10000))V*(2I-1,2I);next I
55: "xxsmas" W*(4);W*(1);W*(4,1,len(W*(1)))
56: open W*(4),6
57: asgn W*(4),3,0
58: sprt 3,V$, "end"
59: prt "MAX(INITIAL) MAS";spc
60: fmt f6.2,x."GM";wrt 16,A(7);spc ;ret
61: "PLOT 1":A(7)}Z
62: if Z<5000;5000)A; if Z<2000;2000)A; if Z<1000;1000)A; if Z<500;500)A
63: if Z<200;200)A; if Z<100;100)A; if Z<50;50)A; if Z<20;20)A
64: scl -12N,65N,-.2A,1.05A
65: axe 0,0,60,.1A
66: csiz 1.5,1.5,1,0
67: for I=0 to 65N by 60
68: plt I-N,-.05A,-1;fxd 0;lbl 1/60
69: next I
70: csiz 1.5,1.5,1,90
71: plt -10N,.2A,-1;lbl "Mass Remaining (grams)"
72: csiz 1.5,1.5,1,0
73: for I=0 to A by A/10;fxd 0
74: plt -7N,I,-1;lbl I
75: next I
76: plt 25N,-.09A,-1;lbl "Time (min)"
77: for I=2 to MN-2
78: plt 60I/M,S(I),-2
79: next I;pen
80: csiz 2.5,2,1,0
81: plt 8N,-.16A,-1;lbl "fig. Mass remaining "
82: fxd 0;plt 40N,A,-1;lbl "Run #",A(10)
83: csiz 1.5,1.5,1,0
84: plt 40N,.95A,-1;lbl B#
85: plt 40N,.85A,-1;lbl "INITIAL MASS"
86: plt 40N,.8A,-1;fxd 2;lbl A(7)," grams"
87: plt 40N,.7A,-1;lbl "FINAL MASS"
88: plt 40N,.65A,-1;lbl S(MN-2)," grams"
89: plt 40N,.55A,-1;lbl "HEAT FLUX"
90: fxd 1;plt 40N,.5A,-1;lbl A(1)," W/CM"
91: plt 40N,.4A,-1;lbl "SAMPLE AREA"
92: fxd 5;plt 40N,.35A,-1;lbl A(2)," M"
93: csiz 1,1.5,8.5/11,0
94: plt 52.8N,.51A,-1;lbl "2";plt 54N,.36A,-1;lbl "2";ret
95: "CACL 11":
96: for I=1 to MN-1
97: (S(I)-S(I+1))/A(2)/(60/M)S(I);next I
98: S(MN-1)S(MN)
99: if U=1;gto *7
100: for I=1 to MN,if S(I)<-6,-5.999)S(I)
101: fti ((S(I)+6)^(1#10000))V*(2I-1,2I);next I
102: "xxhmas" W*(5);W*(1);W*(5,1,len(W*(1)))
103: open W*(5),6
104: asgn W*(5),4,0
105: sprt 4,V$, "end"
106: 0)Z;for I=1 to MN,if S(I)>Z,S(I)}Z
107: next I
108: prt "MAX RATE";spc

```



```

109:  fmt f7.2,x,"G/MIN/M2";wrt 16,Z;spc ;ret
110:  "PLOT 11":
111:  if Z<5000,5000)A;if Z<2000,2000)A;if Z<1000,1000)A;if Z<500,500)A
112:  if Z<200,200)A;if Z<100,100)A
113:  scl -12N,65N,-.2A,1.05A
114:  axe 0,0,60,.1A
115:  csiz 1.5,1.5,1.0
116:  for I=0 to 65N by 60
117:  plt 1-N,-.05A,-1;fxd 0;lbl I/60;next I
118:  deg
119:  csiz 1.5,1.5,1.90
120:  plt -10N,.2A,-1;lbl "MASS LOSS RATE (G/MIN/M)"
121:  csiz 1,1.5,8.5/11,90;plt -10.6N,.685A,-1;lbl "2"
122:  csiz 1.5,1.5,1.0
123:  for I=0 to A by A/10;fxd 1
124:  plt -7N,I,-1;lbl I;next I
125:  for I=2 to MN-2;plt 60./M.S[I],-2;next I
126:  pen
127:  csiz 2.5,2,1,0
128:  plt 8N,-.16A,-1;lbl "fig.    MASS LOSS RATE  "
129:  fxd 0;plt 40N,A,-1;lbl "RUN #",A[10]
130:  csiz 1.5,1.5,1.0
131:  plt 40N,.95A,-1;lbl B#
132:  plt 40N,.85A,-1;lbl "INITIAL MASS"
133:  plt 40N,.8A,-1;fxd 2;lbl A[7],"  grams"
134:  plt 40N,.7A,-1;lbl "MAX MASS LOSS"
135:  plt 40N,.65A,-1;lbl Z,"  g/min/m  "
136:  csiz 1,1.5,8.5/11,0;plt -N,.015A,-1;lbl "2";pen;csiz 1.5,1.5,1,0
137:  plt 40N,.55A,-1;lbl "HEAT FLUX"
138:  fxd 1;plt 40N,.5A,-1;lbl A[1],"  w/cm"
139:  fxd 5;plt 40N,.4A,-1;lbl "SAMPLE AREA"
140:  fxd 5;plt 40N,.35A,-1;lbl A[2],"  m"
141:  csiz 1,1.5,8.5/11,0;plt 52.8N,.51A,-1;lbl "2"
142:  plt 54N,.36A,-1;lbl "2";ret
●143:  "2.5":
●144:  "Used Run#12381 As Baseline Correction for 2.5w/cm^2":
●145:  -.62884501)A;.0490861132)B;-.00031272304)C
●146:  8.8249508e-7)D;-1.05374061e-9)E;4.3786104e-13)F
147:  for I=1 to MN;S[I]-(A*B1+C1^2+D1^3+E1^4+F1^5)S[I];next I;ret
●148:  "3.5";for I=1 to MN
●149:  S[I]-(.01350293+.001452407I+.0000127754I^2)S[I];next I;ret
●150:  "5.0":
●151:  "Used Run#12681 As Baseline Correction for 5.0w/cm^2":
●152:  -.6358144)A;.0901975)B;-.0006398715)C;.000002027112)D
●153:  -2.56787245e-9)E;1.20057396e-12)F
●154:  for I=1 to MN;S[I]-(A*B1+C1^2+D1^3+E1^4+F1^5)S[I];next I;ret
●155:  "7.0":
●156:  "Used Run#13281-13381 As Baseline Correction for 7.0w/cm^2":
●157:  -8.759822e-1)A;9.176136e-2)B;-7.086861e-4)C
●158:  2.131036e-6)D;-2.70434e-9)E;1.258464e-12)F
159:  for I=1 to MN;S[I]-(A*B1+C1^2+D1^3+E1^4+F1^5)S[I];next I;ret
●160:  "S2.5";for I=1 to MN
●161:  S[I]-(.4131766+.03297146*I-.00005763108*I^2+.00000005104936*I^3)S[I]
162:  next I;ret

```

```

0163: "S3.5":for I=1 to MN
0164: S(I)-(1.138011+.03248146*I-.00008936823*I^2+.00000008260017*I^3))S(I)
165: next I;ret
0166: "S5.0":for I=1 to MN
0167: S(I)-(-.490928+.0355015*I-.0001139977*I^2+.0000001424141*I^3))S(I)
168: next I;ret

```

```

0: "Smoke Data Reduction":
1: fmt 16b;wrt 16,31,31,31,31,31,31,31,31,31,31,31,31,31,31,31;spc
2: prt "Smoke Data      Reduction";spc
3: dim A(15),A$(8),B$(20),E$(6),F$(6),M,N,N$(15,15),M$(15)
4: dim W$(15,15)
5: dsp "SMOKE DATA REDUCTION";wait 900
6: ent "# of run in disk(1,2..)?",W$(1)
7: ent "Has this been plotted before?",W
8: dsp "Have your plotter ready! Cont.";stp
9: "xxxinf")W$(2)
10: W$(1)W$(2,1,len(W$(1)))
11: asgn W$(2),1,0
12: sread 1,A(*),A$,B$,E$,F$,M,N,N$(15),M$
13: spc ;fxd 0;prt "Run#=",A(10),B$,A$
14: dsp "  Run#=",A(10),B$,A$;wait 1500
15: dim S(MN),H(MN),R(5)
16: dim Z(10),S$(2MN)
17: "xx3ht")W$(3)
18: W$(1)W$(3,1,len(W$(1)))
19: asgn W$(3),2,0
20: sread 2,Z(*),S$
21: dsp ".....WORKING.....";gsb "CALC"
22: gsb "PLOT"
23: gsb "LABEL"
24: ent "ANOTHER RUN?",X;if flg13;gto +4
25: dsp "CHOOSE PROGRAM FROM S.F.KEY"
26: stp ;gto -1
27: fmt 16b;wrt 16,31,31,31,31,31,31,31,31,31,31,31,31,31,31,31;spc
28: dsp "SEE YOU NEXT TIME";stp
29: "*****";
30: "CALC":for I=1 to MN
31: A(3)+((1/f(S$(2I-1,2I))/10000)^10-9-Z(3))W24.744/3)H(I)
32: next I
33: "xx1smk")W$(5)
34: W$(1)W$(5,1,len(W$(1)))
35: asgn W$(5),4,0
36: sread 4,Z(*),S$
37: gsb "CALIB"
38: for I=1 to MN,A(4)H(I)S(I)/(1.134WA(2)WA(3))S(I);next I
39: for J=1 to 5
40: for I=1 to MN-2
41: (S(I)+S(I+1)+S(I+2))/3)H(I+1);next I
42: for I=2 to MN-1;H(I)S(I);next I;next J
043: "Automatic Correct Baseline":
44: 0;V;for I=1 to MN
45: if S(I)<V,S(I)

```

```

46: next I
47: for I=1 to MN;S[I]-V)S[I];next I
48: "A.C.B";
49: for I=2 to MN-1;if S[I]>Z,S[I]]?
50: (S[I]+S[I-1])*1/2M+D)D
51: if I=1.5M;D)R[1]
52: if I=3M;D)R[2]
53: if I=5M;D)P[3]
54: if I=10M-1;D)R[4]
55: if I=MN-1;D)R[5]
56: next I
57: if W=1;gto *8

58: "prevent S[I]<-6";
59: for I=1 to MN;if S[I]<-6,-5.999)S[I]
60: fl ((S[I]+6)^.1*10000)S*(2I-1,2I);next I
61: "xxxxmk")W*(6);W*(1))W*(6.1,len(W*(1)))
62: open W*(6),6
63: asgn W*(6),5,0
64: sprt 5,S*, "end"
65: ret
66: *PLOT*:prt "Max SMOKE value=",Z,spc
67: 0)r3
68: if Z<5000;5000)A;if Z<2000;2000)A;if Z<1000;1000)A;if Z<500;500)A
69: if Z<200;200)A;if Z<100;100)A;if Z<50;50)A;if Z<20;20)A
70: if Z<10;10)A
71: A)r1
72: r1/10)r0
73: scl -12N,65N,r3-(r1-r3)1/6,r1+(r1-r3)1/10
74: axe 0,r3,60,r0
75: csiz 1.5,1.5,1,0;pen
76: for I=r3 to r1 by r0
77: plt -6N,I,-1
78: fxd 0;lbl I
79: next I
80: plt 25N,r3-(r1-r3)1/10,-1
81: lbl "Time (min)"
82: for I=0 to 65N by 60
83: plt I-N,r3-(r1-r3)1/18,-1
84: lbl I/60
85: next I;pen
86: csiz 1.5,1.5,1,90;fxd 0
87: plt -8N,r3+(r1-r3)/4,-1
88: lbl "SMOKE (S.M.O.K.E./M ) "
89: csiz 1,1.5,.77,90;plt -8.5N,r3+(r1-r3)/1.53,-1;lbl "2";pen
90: for I=2 to MN
91: plt 60I/M,S[I],-2,next I;pen;ret
●92: "one";A(6))P
93: for I=1 to MN
94: ((1+((S*(2I-1,2I))/10000)^10-200-Z(I))/P)Q
●95: .00143+.04205*Q+.0535*Q^2)S[I]
96: next I;ret
●97: "three";A(6))P
98: for I=1 to MN
99: ((1+((S*(2I-1,2I))/10000)^10-200-Z(I))/P)Q

```

```

●100. .0086R+.10054#Q+.17937#Q^2)S(I)
101. next I;ret
●102. "four";A(6)P
103. for I=1 to MN
104. ((itf(S#(2I-1,2I))/10000)^10-200-Z(I))/P)Q
●105. .0000704155+.317257665#Q+.096962657#Q^2)S(I)
106. next I;ret
●107. "infin";A(6)P
108. for I=1 to MN
109. ((itf(S#(2I-1,2I))/10000)^10-200-Z(I))/P)Q
110. Q)S(I)-next I
111. prt "Need a% response vs OD calibration curve for this OD FS";spc 3
112. stp ;ret
113. "CALIB":
114. for I=1 to MN;(itf(S#(2I-1,2I))/10000)^10-200)Q
●115. Q+621.5-Z(I))Q
●116. 14.3259075403-.05885451204Q+.00007702426Q^2-.0000003124Q^3)S(I)
117. next I;ret
118. "LABEL";csiz 2,1.5,1,0
119. plt 5N,-r1/6,-1
120. lbl "FIG. SMOKE RELEASE PLOT"
121. plt 40N,r1,-1
122. lbl "RUN #",A(10)
123. csiz 1.5,1.5,1,0;fxd 0
124. plt 40N,r1-(r1-r3).07,-1;lbl B#
125. plt 40N,r1-(r1-r3).12,-1;lbl "smoke #"
126. plt 52N,r1-(r1-r3).12,-1;lbl "Time(min)"
127. plt 40N,r1-(r1-r3).2,-1;lbl R(1)
128. plt 55N,r1-(r1-r3).2,-1;lbl "1.5"
129. plt 40N,r1-(r1-r3).25,-1;lbl R(2)
130. plt 55N,r1-(r1-r3).25,-1;lbl "3"
131. plt 40N,r1-(r1-r3).3,-1;lbl R(3)
132. plt 55N,r1-(r1-r3).3,-1;lbl "5"
133. plt 40N,r1-(r1-r3).35,-1;lbl R(4)
134. plt 55N,r1-(r1-r3).35,-1;lbl "10"
135. plt 40N,r1-(r1-r3).4,-1;lbl R(5)
136. plt 53.3N,r1-(r1-r3).4,-1;lbl N
137. plt 40N,r1-(r1-r3).5,-1;lbl "HEAT FLUX"
138. fxd 1;plt 40N,r1-(r1-r3).55,-1;lbl A(1)," w/cm"
139. plt 40N,r1-(r1-r3).6,-1;lbl "SAMPLE AREA"
140. fxd 5;plt 40N,r1-(r1-r3).65,-1;lbl A(2)," m"
141. csiz 1,1.5,8.5/11,0
142. plt 53N,r1-(r1-r3).525,-1;lbl "2"
143. plt 54N,r1-(r1-r3).625,-1;lbl "2";ret

9. "HRR FROM O2% CONSUMPTION ... (included fire gas flow adj,BTU)":
1. fmt 16b;wrt 16,31,31,31,31,31,31,31,31,31,31,31,31,31,31,31;spc ,fmt
2. prt "Heat Release Rate ";spc
3. dsp "HEAT RELEASE RATE";wait 850
4. dim A(15),A#(8),B#(20),E#(6),F#(6),M,N,N#(15,15),M#(15)
5. dim W#(15,15),E(600),Y(600),L#(10,10),D#(1200),Y#(10,10)
6. enp "# of run in disk(1,2...)";W#(1)
7. dsp "Do you have the following file?";wait 1500

```

```

8: ent 'HF',V8[1], 'HCL',V8[2], 'ALD',V8[3]
9: ent 'IS THIS BEEN PLOTTED BEFOPE?Yes=1,No=0,cont',M
10: dsp 'Have your plotter ready! Cont.',stp
11: 'xxxinf')W8[2]
12: W8[1]W8[2,1,len(M*(1))
13: drive 0
14: esgn W8[?] 1,0
15: sread 1,A[M],A8,B8,E8,F8,M,H,N8[15],M8
16: dsp 'RUN',A[10], " ",B8," ",A8;wait 1500
17: fxd 0;prt 'RUN-',A[10],B8,A8;spc
18: dim Z[10],P8[2MN],R[5],P[MN],S[MN]
19: gsb 'CACLO2';dsp 'I'M WORKING.....'
20: gsb 'AYES'
21: gsb 'PLOT'
22: gsb 'LABEL'
23: gsb 'BTU'
24: ent 'ANOTHER RUN?',X; if flg13;gto *3
25: dsp 'CHOOSE PROGRAM FROM S.F.KEY'
26: stp ;gto -1
27: dsp 'SEE YOU NEXT TIME';stp
28: '*****',
29: 'AXES';
30: if Z<500;5000)A; if Z<2000;2000)A; if Z<1000;1000)A; if Z<500;500)A
31: if Z<200;200)A; if Z<100;100)A; if Z<50;50)A
32: scl -10N,70N,-A/6,1.05A
33: exe 0,0,60,A/10;csiz 1.5,1.5,1,0;fxd 0
34: for I=0 to 10;plt -6N,I A/10,-1;fxd 0;lbl I A/10;next I
35: plt 25N,-A/10,-1;lbl 'Time (min)'
36: fxd 0;for I=0 to 65N by 50;plt I-N,-A/20,-1
37: lbl I/60;next I
38: csiz 1.5,1.5,1,90
39: plt -7N..2A,-1
40: lbl 'Heat Release Rate (kw/m )';pen
41: csiz 1,1.5,.77,90;plt -7.5N,A/1.49,-1;lbl '2';pen;ret
42: 'PLOT';
43: for K=1 to MN-13;K+13)I;plt 60K/M,P[I],-2
44: next K
45: for I=MN-13 to MN;P[MN])P[I];plt 60I/M,P[I],-2;next I;pen;ret
46: 'CACLO2';
47: 132*28)C;fmt 4b,'Converting Data',4b;wrt 0,C,C,C,C,C,C,C,C
48: 'xxgco')L8[2];'xxgco2')L8[3]
49: 'xxghcn')L8[4];'xxghc')L8[5]
50: 'xxgno')L8[6]
51: 'xxHF')L8[7];'xxHCL')L8[8];'xxALD')L8[9]
52: for T=2 to 9
53: 132*28)C;fmt 4b,'Converting Data',x,f2.0,4b;wrt 0,C,C,C,C,T,C,C,C,C
54: prt T
55: if T=7; if V8[1]#1';gto 67
56: if T=3; if V8[2]#1';gto 67
57: if T=9; if V8[3]#1';gto 67
58:

```

```

59: M$)L$[T,1,len(M$)]
60: drive 0
61: asgn L$[T],1,0
62: sread 1,0$
63: for K=1 to 600
64: (itf(D$(2K-1,2K))/10000)^10-6)E[K]
65: next K
66: jmp 2
67: for I=1 to 600;0)E[I];next I
68: for I=1 to 600;E[I]+Y[I])Y[I];next I
69: next T
70: for I=1 to 600
71: Y[I]/455*A[2]/.07695)Y[I];next I
72: 132+28)C;fmt 4b,x,"Working",x,4b;wrt 0,C,C,C,C,C,C,C,C
73: "xx7o2")W$(3]
74: W$(1])W$(3,1,len(W$(1]))
75: asgn W$(3],2,0
76: sread 2,Z[*],P$
77: for K=1 to MN;(itf(P$(2K-1,2K))/10000)^10-9-Z[7])P[K];next K
78: for I=1 to MN;(P[I]/40+21)*(Y[I]+15)/15)P[I];next I
79: P[2];P[1])Q
80: for I=1 to MN
81: 15*.21*439*60/3414*.8*(.21-P[I]/100)/.21/A[2])P[I];next I
82: for J=1 to 5
83: for I=1 to MN-4
84: (P[I]+P[I+1]+P[I+2]+P[I+3]+P[I+4])/5)P[I+2]
85: if P[I+2]<0;0)P[I+2]
86: next I;next J
87: for I=1 to MN-2;if P[I]>Z;P[I])Z
88: next I
89: prt "02 MAX HEAT=",Z;spc
90: if W=1;jmp 9
91: for I=1 to MN
92: if P[I]<-6;-5.999)P[I]
93: fti ((P[I]+6)^.1*10000)P$(2I-1,2I);next I
94: "xx02HR")H$(4];W$(1])W$(4,1,len(W$(1]))
95: open W$(4],6
96: asgn W$(4],3,0
97: sprt 3,P$, "end"
98: 0)0
99: for I=1 to MN-2
100: (P[I+1]+P[I+2])/2*1/M+0)D
101: if I=1.5*M-2;D)R[1]
102: if I=3M-2;D)R[2]
103: if I=5M-2;D)R[3]
104: if I=10M-2;D)R[4]
105: if I=NM-2;D)R[5]
106: next I
107: ret
108: "LABEL";csiz 2,1.5,1,0;plt 3N,-A/6,-1
109: lbl "Fig. Heat Release Rate"
110: 32)T
111: fxd 0;plt T,A,-1;lbl "PUNE",A[10]
112: csiz 1.5,1.5,8.5/11,0;plt 10N,.95A,-1;lbl "MAX HRR(BY 02)=",Z

```

```

113: plt T,.95A,-1
114: lbl B*
115: plt T,.9A,-1
116: lbl "INTEGRATED HEAT RELEASE"
117: plt T,.85A,-1;lbl "(by 02% Consumption)"
118: plt T,.8A,-1;lbl "(kw min/m)"
119: plt T+15N,.8A,-1;lbl "min"
120: plt T,.75A,-1;lbl R[1]
121: plt T+15N,.75A,-1;lbl "1.5"
122: plt T,.7A,-1;lbl R[2]
123: plt T+15N,.7A,-1;lbl "3"
124: plt T,.65A,-1;lbl P[3]
125: plt T+15N,.65A,-1;lbl "5"
126: plt T,.6A,-1;lbl R[4]
127: plt T+13.8N,.6A,-1;lbl "10"
129: if N=10;goto +3
129: plt T,.55A,-1;lbl R[5]
130: plt T+15N,.55A,-1;lbl H
131: plt T,.5A,-1;lbl "Heat flux"
132: fxd 1;plt T+2N,.45A,-1;lbl A[1]," w/cm "
133: fxd 5;plt T,.4A,-1;lbl "Sample Area"
134: plt T,.35A,-1;lbl A[2]," m "
135: csiz 1,1.5,8.5/11,0
136: plt T+9.34N,.81A,-1;lbl "2"
137: plt T+12.3N,.46A,-1;lbl "2"
138: plt T+11N,.36A,-1;lbl "2"
139: "BTU";
140: "Axe For KW/M^2}BTU/SEC/FT^2";
141: scl -10N,7CN,-A/E,1.05A
142: AX.088166}B;B)L
143: 0)H
144: if L<50,500}B;if L<200,200}B;if L<100,100}B;if L<50,50}B
145: if L<20,20}B;if L<10,10}B;if L<5,5}B;1)H
146: B)C
147: axe 6CN,0.0,C/.088166/10;csiz 1.5,1.5,1,0;fxd 0
148: for I=0 to 10;plt 69.2N,IC/.088166/10,-1;fxd H;lbl IC/10;next I
149: csiz 1.5,1.5,1,90
150: plt 67.5N,.2A,-1
151: lbl "Heat Release Rate (BTU/SEC/FT^2)";pen
#30536

```

```

0: "Heat Release Rate";
1: fmt 16b;wrt 16,31,31,31,31 31,31,31,31,31,31,31,31,31,31,31,31,31,31,31,31,31;spc ,fmt
2: prt "Heat Release Rate ";spc
3: dsp "HEAT RELEASE RATE";wait 850
4: dim A[15],A[8],P[20],E[6],F[6],M,M,H[15,15],M[15]
5: dim W[15,15]
6: enp "# of run in dist(1,2...)?",W[1]
7: ent "Has this been plotted before?",M
8: dsp "Have your plotter ready! Cont.";stp
9: "xxxinf")W[2]
10: W[1];W[2,1,le:(W[1])
11: drive 0

```

```

12: asgn W$(2),1,0
13: sread 1,A(1),A$,R$,E$,F$,M,N,N$(15),M$
14: dsp "RUN?",A(1)," ",3$, " ",A$,wait 1500
15: fxd 0;prt "RUN?=",A(1),3$,A$,spc
●16: if A(2)/.0254*2=36;12.889)F
●17: if A(2)/.0254*2=100;4.64)F
18: dim Z(10),R$(2MN);dim P$(2MN),R(5),P(MN),S(MN)
●19: gsb "CACL";dsp "I'M WORKING....."
20: gsb "AXES"
21: gsb "PLOT"
22: jmp 2
23: stp
24: gsb "LABEL"
25: ent "ANOTHER PUN?",X;if flg13;gto +3
26: dsp "CHOOSE PROGRAM FROM S.F.KEY"
27: stp ;gto -1
28: dsp "SEE YOU NEXT TIME";stp
29: "*****XXXXXXXXXXXXXXXXXXXXXXXX*****";
30: "AXES";
31: if Z<5000;5000)A;if Z<2000;2000)A;if Z<1000;1000)A;if Z<500;500)A
32: if Z<200;200)A;if Z<100;100)A;if Z<50;50)A;if Z<20;20)A
33: jmp 2
34: ent "MAX Y-axis????",A
35: scl -12N,65N,-A/6.1.05A
36: jmp 2
37: csiz 1.5,1.5,8.5/11,0;plt 10N,.85A,-2;lbl "MAX HRR(by TC)=",Z;ret
38: axe 0,0,60,A/10;csiz 1.5,1.5,1,0;fxd 0
39: for I=0 to 10;plt -"N,I/A/10,-1
40: fxd 0;lbl I/A/10;next I
41: plt 25N,-A/10,-1;lbl "Time (min)"
42: fxd 0;for I=0 to 65N by 60;plt I-N,-A/20,-1
43: lbl I/60;next I
44: csiz 1.5,1.5,1,90
45: plt -10.5N,.2A,-1
46: lbl "Heat Release Rate (kw/m )";pen
47: csiz 1,1.5,.77,90;plt -11N,A/1.49,-1;lbl "2";pen;ret
48: "PLOT";jmp 3
●49: "Time Delay Correction Used Before 6/1/80";
50: for I=1 to MN-4;plt 60I/M,S[I+4],-2;next I;pen;ret
51: for I=1 to MN;plt 60I/M,S[I],-2;next I;pen;ret
●52: "CACL":0)D
53: "xx3ht")W$(3)
54: W$(1))W$(3,1,len(W$(1)))
55: drive 0
56: asgn W$(3),2,0
57: sread 2,Z[*],R$
58: for I=1 to MN;(1+(R$(2I-1,2I))/10000)*10-9-Z(3))S(I);next I
59: jmp 2
●60: "EMPTY HOLDER CALIBRATION HERE";
61: for J=1 to 20
62: for I=1 to MN-2;(S(I)+S(I+1)+S(I+2))/3)P[I+1];next I;next J
63: for I=1 to MN-2;P[I+1]*F)S(I+1);next I
●64: "BASELINE CORPECTION,6x6,10x10";
65: if A(2)/.0254*2=36 and A(1)=2.5;gsb "S2.5"

```



```

●66: if A[2]/.0254^2=36 and A[1]=3.5;gsb '53.5'
67: if A[2]/.0254^2=36 and A[1]=5;gsb '55.0'
●68: if A[2]/.0254^2=100 and A[1]=1.5;gsb '1.5'
69: if A[2]/.0254^2=100 and A[1]=2;gsb '2.0'
70: if A[2]/.0254^2=100 and A[1]=2.5;gsb '2.5'
71: if A[2]/.0254^2=100 and A[1]=3;gsb '3.0'
72: if A[2]/.0254^2=100 and A[1]=3.5;gsb '3.5'
73: if A[2]/.0254^2=100 and A[1]=4;gsb '4.0'
74: if A[2]/.0254^2=100 and A[1]=4.5;gsb '4.5'
75: if A[2]/.0254^2=100 and A[1]=5;gsb '5.0'
76: for I=1 to MN-2; if S[I+1]>Z;S[I+1]Z
77: next I;prt 'MAX HEAT=',Z;spc
●78: .3434408)r1;.25827303)r2;.055849161)r3;-.028663159)r4
79: for I=1 to MN-2
80: (A[3]-273.1)/24.94+(P[I+1]+Z[3])/3)P
81: gsb 'POLYN'
82: K)P[I+1];next I
83: P[MN-2])P[MN-1])P[MN]
84: S[MN-2])S[MN-1])S[MN]
85: jmp 2
86: 'baseline correction(B) if BL lower than 0';
87: for I=1 to MN;S[I+8)S[I];next I
88: if W=1;goto +17
89: for I=1 to MN
90: if S[I]<-6;-5.999)S[I]
91: if P[I]<-6;-5.999)P[I]
92: fti ((P[I]+6)^.1*10000)P*[2I-1,2I]
93: fti ((S[I]+6)^.1*10000)P*[2I-1,2I];next I
94: 'xxpht')W*[4];W*[1])W*[4,1,len(W*[1])]
95: open W*[4],6
96: asgn W*[4],3,0
97: sprt 3,P*,'end'
98: 'xxsht')W*[5];W*[1])W*[5,1,len(W*[1])]
99: for I=1 to MN
100: if S[I]<-6;-5.999)S[I]
101: fti ((S[I]+6)^.1*10000)P*[2I-1,2I];next I
102: open W*[5],6
103: asgn W*[5],4,0
104: sprt 4,P*,'end'
105: for I=1 to MN-2
106: (S[I+1]+S[I+2])/2*(1/M+D)D
107: if I=1.5M;D)R[1]
108: if I=3M;D)R[2]
109: if I=5M;D)R[3]
110: if I=10M-2;D)R[4]
111: if I=MN-2;D)R[5]
112: next I;ret
113: 'LABEL';csiz 2,1.5,1,0;plt 3M,-A/6,-1
114: lbl 'Fig. Heat Release Rate'
115: fxd 0;plt 40N,1,-1;lbl 'RUN#',A[10]
116: csiz 1.5,1.5,8.5/11,0
117: plt 40N..95A,-1
118: lbl B#
119: plt 40N..9A,-1
120: lbl 'INTEGRATED HEAT RELEASE'

```

```

121: plt 40N,.85A,-1;lbl "(kw min/m)"
122: plt 55N,.85A,-1;lbl "min"
123: plt 40N,.8A,-1;lbl R[1]
124: plt 55N,.8A,-1;lbl "1.5"
125: plt 40N,.75A,-1;lbl R[2]
126: plt 55N,.75A,-1;lbl "3"
127: plt 40N,.7A,-1;lbl R[3]
128: plt 55N,.7A,-1;lbl "5"
129: plt 40N,.65A,-1;lbl R[4]
130: plt 53.8N,.65A,-1;lbl "10"
131: if N=10;goto +3
132: plt 40N,.6A,-1;lbl R[5]
133: plt 55N,.6A,-1;lbl N
134: plt 40N,.55A,-1;lbl "Heat flux"
135: fxd 1;plt 42N,.5A,-1;lbl A[1]," w/cm "
136: fxd 5;plt 40N,.4A,-1;lbl "Sample Area"
137: plt 40N,.35A,-1;lbl A[2]," m "
138: csiz 1,1.5,8.5/11,0
139: plt 49.34N,.86A,-1;lbl "2"
140: plt 52.3N,.51A,-1;lbl "2"
141: plt 51N,.36A,-1;lbl "2"
142: ret
143: flt 6
144: for I=10 to 600 by 10
145: fxd 2;wrt 701,I,S[I],P[I],.54*(P[I]-P[3])/S[I];next I
146: list #701,86
●147: "Baseline Correction":
148: "1.5";for I=1 to MN-2
●149: S[I]-(-.9194725+.02830508I-.00007046232I^2+.0000005605972I^3)}S[I]
150: next I;ret
151: "2.0";for I=1 to MN-2
●152: S[I]-(-.1181896+.03363331I-.00008664792I^2+.0000007093757I^3)}S[I]
153: next I;ret
154: "2.5";for I=1 to MN-2
●155: S[I]-(-1.021223+.05244359I-.0001335559I^2+.0000001089636I^3)}S[I]
156: next I;ret
157: "3.0";for I=1 to MN-2
●158: S[I]-(-.3690328+.06021497I-.0001630504I^2+.0000001382185I^3)}S[I]
159: next I;ret
160: "3.5";for I=1 to MN-2
●161: S[I]-(-1.08422+.07146245I-.0001903745I^2+.0000001640242I^3)}S[I]
162: next I;ret
163: "4.0";for I=1 to MN-2
●164: S[I]-(-.7870187+.06408617I-.0001683035I^2+.0000001450156I^3)}S[I]
165: next I;ret
166: "4.5";for I=1 to MN-2
●167: S[I]-(-.9312105+.06937803I-.0001798078I^2+.0000001483744I^3)}S[I]
168: next I;ret
169: "5.0";for I=1 to MN-2
170: "52.5";for I=1 to MN-2
●171: S[I]-(-2.589578+.01370923#I-.000016094I^2+.000000006667I^3)}S[I];next I
172: ret
173: "53.5";for I=1 to MN-2

```

```
●174: S(1)-(-3.57033+.03149085#1-.0000738175#1^2+.00000005873#1^3)S(1),next I
175: ret
●176: 'S5.0':for I=1 to MN-2
177: S(1)-(-1.67813+.01486865#1-.0000141806#1^2+.000000005143#1^3)S(1),next I
178: ret
179: 'POLYN':r1+r2P+r3P^2+r4P^3)K;ret
```

```
0: 'CO Release Rate':
```

```
1: fmt 16b;wrt 16,31,31,31,31,31,31,31,31,31,31,31,31,31,31,31,31,spc
2: prt "CO Release Rate";spc 2
3: dsp "CO RELEASE RATE";wait 900
4: dim A(15),A$(8),B$(20),E$(6),F$(6),M,N,N$(15,15),M$(15)
5: dim W$(15,15)
6: enp "% of run in disk(1,2...)?"W$(1)
7: ent "Has this been plotted before?";W
8: dsp "Have your plotter ready! Cont.";stp
9: "xxxinf")W$(2)
10: W$(1)W$(2,1,len(W$(1)))
11: drive 0
12: assign W$(2),1,0
13: sread 1,A(*),A$,B$,E$,F$,M,N,N$(15),M$
14: dsp "Run#=",A(10),"",B$,A$,wait 1500
15: fxd 0;prt "Run#=",A(10),B$,A$;spc
16: dim Z(10),G$(2MN);dim G(MN)
17: dsp ".....WORKING.....";gsb "CACL"
18: gsb "AXES"
19: gsb "PLOT"
20: gsb "LABEL"
21: ent "ANOTHER RUN?",X;if flg13;goto +3
22: dsp "CHOOSE PROGRAM FROM S.F.KEY"
23: stp ;goto -1
24: fmt 16b;wrt 16,31,31,31,31,31,31,31,31,31,31,31,31,31,31,31,31,spc
25: dsp "SEE YOU NEXT TIME";end
26: "*****";
27: "AXES";
28: scl -12N,65N,-A/6,1.05A
29: axe 0,0,60,A/10
30: csiz 1.5,1.5,1,0;fxd 0;for I=0 to 10;plt -7N,IA/10,-1
31: fxd 0;lbl IA/10;next I
32: plt 25N,-A/10,-1;lbl "Time (min)"
33: for I=0 to 65N by 60;plt I-N,-A/20,-1
34: fxd 0;lbl I/60;next I
35: csiz 1.5,1.5,1,90;fxd 0
36: plt -10N,A/4,-1
37: lbl "CO Release Rate (g/min/m)";pen
38: csiz 1,1.5,.77,90;plt -10.5N,A/1.31,-1;lbl "2";pen;ret
39: "CACL":0)0
40: "xx4co")W$(3)
41: W$(1)W$(3,1,len(W$(1)))
42: assign W$(3),2,0
43: sread 2,Z(*),G$
44: for K=1 to MN;(itf(G$(2K-1,2K))/10000)*10-9)G(K);next K
```

```

●45: *THIS CALIBRATION IS mV)ppm*:
●46: 10.102623+329.0365*Z[4]+17.19045*Z[4]^2)Z[4]
●47: for K=1 to MN;10.102623+329.0365*G[K]+17.19045*G[K]^2)G[K],G[K]-Z[4])G[K]
48: next K
49: for I=1 to MN;if G[I]/1e4>Z;G[I]/1e4)Z
50: next I;prt "Max CO";spc ifmt f6.2,5x,"Z";wrt 16,Z
51: jmp 2
52: *TEMP EFFECT AIR FLOW )T[*]*:
53: for I=1 to MN;G[I]/1e6*A[4]/4*1e3*28/.08205/298/A[2])G[I];next I
54: max(G[*])Z
55: if Z<5000;5000)A;if Z<2000;2000)A;if Z<1000;1000)A;if Z<500;500)A
56: if Z<200;200)A;if Z<100;100)A;if Z<50;50)A;if Z<20;20)A
57: if Z<10;10)A
58: fmt f6.2,x,"g/min/m^2";wrt 16,Z;spc
59: for I=2 to MN;(G[I]+G[I-1])*60/M/2/60+D);next I
60: if W=1;gto +7
61: for I=1 to MN;if G[I]<-6,-5.999)G[I]
62: fti ((G[I]+6)^.1*10000)G#[2I-1,2I];next I
63: "xxgco")W#[4];W#[1])W#[4,1,len(W#[1])]
64: open W#[4],6
65: asgn W#[4],3,0
66: sprt 3,G#,"end"
67: ret
68: jmp 3
●69: *Time Delay Correction Used Before 6/1/80*:
●70: for I=1 to MN-13;I+13)K;plt 60I/M,G[K],-2;next I;pen;ret
71: *PLOT*:for I=9 to MN;plt 60(I-8)/M,G[I],-2;next I
72: for I=MN-9 to MN;G[MN])G[I];plt 60I/M,G[I];next I;pen;ret
73: *LABEL*:csiz 2,1.5,1,0;plt 3N,-A/6,-1
74: lbl "Fig. Carbon Monoxide Release Rate"
75: fxd 0;plt 40N,A,-1;lbl "RUN #",A[10]
76: csiz 1.5,1.5,1,0;fxd 0
77: plt 40N,.95A,-1;lbl B$
78: plt 40N,.85A,-1;lbl "MAXIMUM RATE"
79: plt 40N,.8A,-1;lbl Z," g/min/m "
80: csiz 1,1.5,8.5/11,0;ipl: -N,.015A,-1;lbl "2";csiz 1.5,1.5,1,0
81: plt 40N,.7A,-1;fxd 2;lbl "total released"
82: fxd 0;plt 40N,.65A,-1;lbl D," g/m "
83: csiz 1,1.5,8.5/11,0;ipl: -N,.015A,-1;lbl "2";csiz 1.5,1.5,1,0
84: plt 40N,.55A,-1;fxd 1;lbl "heat flux "
85: fxd 1;plt 40N,.5A,-1;lbl A[1]," w/cm "
86: plt 40N,.4A,-1;lbl "Sample area "
87: fxd 5;plt 40N,.35A,-1;lbl A[2]," m "
88: csiz 1,1.5,8.5/11,0
89: plt 53N,.51A,-1;lbl "2"
90: plt 54.3N,.36A,-1;lbl "2"
91: pen;ret
#13915

```



```

54. for I=1 to MN,298)T,next I
55. for I=1 to MN,G[I]/100*A[4]/4*1e3*44/.08205/T/A[2])G[I],next I
56. max(G[*])Z
57. if Z<500,500)A,if Z<200,200)A,if Z<100,100)A,if Z<50,50)A
58. if Z<20,20)A,if Z<10,10)A,if Z<5,5)A,if Z<2,2)A
59. if Z<1,1)A,if Z<.1,.1)A,if Z<.01,.01)A
60. fmt f6.2,x,"g/min/m^2",wrt 16,Z,spc
61. for I=2 to MN,(G[I]+G[I-1])*60/M/2/60+D, next I
62. if W=1, goto +10
63. 0)G
64. for I=1 to MN
65. if G[I]<-3,prt I,"G[I]=",G[I],spc ,0)G[I],G+1)G,if G>10,stp
66. fti ((G[I]+6)*.1*10000)G#[2I-1,2I],next I
67. "xxgco2")W#[4]
68. W#[1])W#[4,1,len(W#[1])]
69. open W#[4],6
70. asgn W#[4],3,0
71. sprt 3,G#, "end"
72.
73. ret
●74. "Time Delay Correction Used Before 6/1/80":
●75. for I=1 to MN-17,I+17)K,plt 60I/M,G[K],-2,next I,pen;ret
76. "PLOT":for I=10 to MN,plt 60(I-9)/M,G[I],-2,next I,pen
77. for I=MN-10 to MN,G[MN])G[I],plt 60I/M,G[I],-2,next I,pen;ret
78. "LABEL":csiz 2,1.5,1,0,plt 3N,-A/6,-1
79. lbl "Fig. Carbon Dioxide Release Rate"
80. fxd 0,plt 40N,A,-1,lbl "RIIM #",A[10]
81. csiz 1.5,1.5,1,0,fxd 0
82. plt 40N,.95A,-1,lbl B#
83. plt 40N,.85A,-1,lbl "MAXIMUM RATE"
84. fxd 0,plt 40N,.8A,-1,lbl Z," g/min/m "
85. csiz 1,1.5,8.5/11,0,plt -N,.015A,1,lbl "Z",csiz 1.5,1.5,1,0
86. plt 40N,.7A,-1,fxd 2,lbl "total released"
87. fxd 0,plt 40N,.65A,-1,lbl D," g/m "
88. csiz 1,1.5,8.5/11,0,plt -N,.015A,1,lbl "D",csiz 1.5,1.5,1,0
89. plt 40N,.55A,-1,fxd 1,lbl "heat flux "
90. fxd 1,plt 40N,.5A,-1,lbl A[1]," w/cm "
91. plt 40N,.4A,-1,lbl "Sample area "
92. fxd 5,plt 40N,.35A,-1,lbl A[2]," m "
93. csiz 1,1.5,8.5/11,0
94. plt 53N,.51A,-1,lbl "2"
95. plt 54.3N,.36A,-1,lbl "2"
96. pen;ret
●97. "ONE":for I=1 to MN,.031095+.003916G[I]+.000205G[I]^2)G[I]
●98. .031095+.003916Z[5]+.000205Z[5]^2)Z[5],G[I]-Z[5])G[I],next I;ret
●99. "TWO":.028207+.003622Z[5]+.0001096Z[5]^2)Z[5]
●100. for I=1 to MN,.028207+.003622G[I]+.0001096G[I]^2)G[I],G[I]-Z[5])G[I]
101. next I;ret
●102. "THREE":.0013263+.0034007Z[5]+.00001575Z[5]^2)Z[5]
●103. for I=1 to MN,.0013263+.0034007G[I]+.00001575G[I]^2)G[I],G[I]-Z[5])G[I]
104. next I;ret
#17322

```

```

0: "HCN Release Rate";
1: fmt 16b,wrt 16,31,31,31,31,31,31,31,31,31,31,31,31,31,31,31,spc
2: prt "HCN Release Rate";spc
3: dsp " HCN Release Rate ";wait 300
4: dim A[15],A*[9],B*[20],E*[6],F*[6],M,N,N*[15,15],M*[15]
5: Jim W*[15,15]
6: enp "# of run in Disk(1,2)?"* ,W*[1]
7: ent "Has this data been plot before?" ,W
8: dsp "Have your plotter ready! Cont.";stp
9: "xxinf")W*[2]
10: W*[1];W*[2,1,len(W*[1])]
11: drive 0
12: asgn W*[2],1,0
13: sread 1,A[1],A*,B*,E*,F*,M,N,N*[15],M*
14: dsp " RUN#",A[10],",",B*,",",A*;wait 1500
15: fxd 0;prt "Run#=",A[10],B*,A*;spc
16: dim Z[10],G*[2MN];dim G[MN]
17: dsp ".....WORKING.....";gsb "CACL"
18: gsb "AXES"
19: gsb "PLOT"
20: gsb "LABLE"
21: ent "ANOTHER RUN?",X;if flg13;gto +3
22: dsp "CHOOSE PROGPAM FROM S.F.KEY"
23: stp ;gto -1
24: fmt 16b,wrt 16,31,31,31,31,31,31,31,31,31,31,31,31,31,31,31,spc
25: dsp "SEE YOU NEXT TIME";end
26: "*****";
27: "AXES";
28: scl -12N,65N,-A/6,1.05A
29: axe 0,0,60,A/10
30: csiz 1.5,1.5,1,0;fxd 2;for I=0 to 10;plt -7N,IA/10,-1
31: lbl IA/10;next I
32: plt 25N,-A/10,-1;lbl "Time (min)"
33: for I=0 to 65N by 60;plt I-N,-A/20,-1
34: fxd 0;lbl 1/60;next I
35: csiz 1.5,1.5,1,90
36: plt -10N,A/4,-1
37: lbl "HCN Release Rate (g/min/m )";pen
38: csiz 1,1.5,.77,90;plt -10.5N,A/1.31,-1;lbl "2";pen;ret
39: "CACL":0)D
40: "xx6hcn")W*[3]
41: W*[1];W*[3,1,len(W*[1])]
42: asgn W*[3],2,0
43: sread 2,Z[1],G*
44: for K=1 to MN;(11f(G:[2K-1,2K])/10000)*10-9)G[K],next K
●45: "THIS CALIBRATION IS mV)ppm";
●46: -.9017671+.9986752*Z[6]-.010906*Z[6]^2+.000134*Z[6]^3)Z[6]
47: for K=1 to MN
●48: -.9017671+.9986752*G[K]-.010906*G[K]^2+.000134*G[K]^3)G[K],G[K]-Z[6])G[K]
49: next K
50: for J=1 to 5;for I=1 to MN-2,(G[I]+G[I+1]+G[I+2])/3)H
51: H)G[I+1];next I;next J
52: for I=1 to MN;if G[I]/1e4>Z;G[I]/1e4)Z
53: next I;prt "Max HCN";spc ;fmt f6.2,5x,"%";wrt 16,Z

```

```

54: jmp 2
55: *TEMP EFFECT AIR FLOW )T[*]*,
56: for I=1 to MN,C[I]/1e6*A[4]/4*1e3*27.03/.08205/298/A[2]G[I];next I
57: 0)Z;for I=1 to MN;if G[I]>Z;G[I]]Z
58: next I;fmt f9.2,x,"g/min/m^2";wrt 16,Z;spc
59: for I=2 to MN,(G[I]+G[I-1])*60/(1/2/60+D)D;next I
60: if Z<5000,5000)A;if Z<2000,2000)A;if Z<1000,1000)A;if Z<500,500)A
61: if Z<200,200)A;if Z<100,100)A;if Z<50,50)A;if Z<20,20)A
62: if Z<10,10)A·if Z<1,1)A
63: if N=1;goto +7
64: for I=1 to MN;if G[I]<-6,-5.999)G[I]
65: fti ((G[I]+6)^.1*10000)G[2I-1,2I];next I
66: *xxghcn*)W[4];W[1])W[4,1,len(W[1])]
67: open W[4],6
68: asgn W[4],3,0
69: sprt 3,G,"end"
70: ret
71: *PLOT*:
72: for I=4 to MN;plt 60(I-3)/M,G[I],-2;next I
73: for I=MN-4 to MN;plt 60I/M,G[MN],-2;next I;pen;ret
74: *LABEL*:csiz 2,1.5,1,0;plt 3N,-A/6,-1
75: lbl "Fig. HYDROGEN CYANIDE RELEASE RATE"
76: fxd 0;plt 40N,A,-1;lbl "RUN #",A[10]
77: csiz 1.5,1.5,1,0
78: plt 40N,.95A,-1;lbl 8#
79: fxd 2;plt 40N,.85A,-1;lbl "MAXIMUM RATE"
80: plt 40N,.8A,-1;lbl Z," g/min/m "
81: csiz 1,1.5,8.5/11,0;plt -N,.015A,-1;lbl "2";csiz 1.5,1.5,1,0
82: plt 40N,.7A,-1;fxd 2;lbl "total released"
83: plt 40N,.65A,-1;lbl D," g/m "
84: csiz 1,1.5,8.5/11,0;plt -N,.015A,-1;lbl "2";csiz 1.5,1.5,1,0
85: plt 40N,.55A,-1;fxd 1;lbl "heat flux "
86: fxd 1;plt 40N,.5A,-1;lbl A[1]," w/cm "
87: plt 40N,.4A,-1;lbl "Sample area "
88: fxd 5;plt 40N,.35A,-1;lbl A[2]," m "
89: csiz 1,1.5,8.5/11,0
90: plt 53N,.51A,-1;lbl "2"
91: plt 54.3N,.36A,-1;lbl "2"
92: pen;ret
#23403

```

```

0: *O2 Depletion Rate*:
1: fmt 16b;wrt 16,31,31,31,31,31,31,31,31,31,31,31,31,31,31,31;spc
2: prt "O2 Depletion Rate";spc
3: dsp "O2 Release Rate";wait 300
4: dim A[15],A[3],B[20],E[6],F[6],N,N,N[15,15],M[15]
5: dim W[15,15]
6: enp "# of run in disk(1,2...)?",W[1]
7: ent "Has this been plotted before?",W
8: dsp "Have your plotter ready! Cont.";stp
9: *xxxinf*)W[2]
10: W[1])W[2,1,len(W[1])]

```



```

11: drive 0
12: asgn W$(2),1,0
13: sread 1,A[1],A$,B$,E$,F$,M,N,N$(15),M$
14: dsp "Run#=",A[10], " ",B$,A$,wait 1500
15: fxd 0;prt "Run#=",A[10],B$,A$,spc
16: dim Z[10],G$(2MN);dim G[MN]
17: 32+128)C
18: fmt 12b,"WORKING",12b;wrt 0,C,C,C,C,C,C,C,C,C,C,C,C,C,C,C,C,C,C,C
19: gsb "CACL"
20: gsb "AXES"
21: gsb "PLOT"
22: gsb "LASLE"
23: ent "ANOTHER RUN?",X;if flg13;goto +3
24: dsp "CHOOSE PPOGRAM FROM S.F.KEY"
25: stp ;goto -1
26: fmt 16b;wrt 16,31,31,31,31,31,31,31,31,31,31,31,31,31,31,31,spc
27: dsp "SEE YOU NEXT TIME";end
28: "*****":
29: "AXES":
30: scl -12N,65N,-A/6,1.05A
31: axe 0,0,60,A/10
32: csiz 1.5,1.5,1,0;fxd 0;for I=0 to 10;plt -7N,IA/10,-1
33: fxd 0;lbl IA/10;next I
34: plt 25N,-A/10,-1;lbl "Time (min)"
35: for I=0 to 65N by 60;plt I-N,-A/20,-1
36: fxd 0;lbl I/60;next I
37: csiz 1.5,1.5,1,90;fxd 0
38: plt -10N.A/4,-1
39: lbl "0 Depletion Rate (g/min/m)";pen
40: csiz 1,1.5,.77,90;plt -10N,A/3.6,-1;lbl "2";plt -10.3N,A/1.22,-1;lbl "2"
41: ret
42: "CACL":0)0
43: "xx7o2")W$(3)
44: W$(1)W$(3,1,len(W$(1)))
45: asgn W$(3),2,0
46: sread 2,Z[*],G$
47: for K=1 to MN;(1if(G$(2K-1,2K))/10000)*10-9-Z[7]*G[K];next K
48: for I=1 to MN,G[I]/40+21)G[I];next I
49: jmp 2
50: "TEMP EFFECT AIR FLOW )T[*]":
51: for I=1 to MN,21-G[I]*G[I];next I
52: for I=1 to MN,G[I]/100*A[4]/4*1e3*32/.03205/298/A[2]*G[I];next I
53: "Smoothing ":
54: for J=1 to 4
55: for I=1 to MN-4,(G[I]+G[I+1]+G[I+2]+G[I+3]+G[I+4])/5)G[I+2];next I;next J
56: 0)2;for I=1 to MN;if G[I]>Z,G[I])Z
57: next I;prt "Max 02";spc ;fmt f6.2,x,"g/min/m^2";wrt 16,Z;spc
58: for I=2 to MN,(G[I]+G[I-1])*60/M/2/60+D)D;next I
59: if Z<5000,5000)A;if Z<2000,2000)A;if Z<1000,1000)A;if Z<500,500)A
60: if Z<200,200)A
61: if Z<10,10)A;if Z<1,1)A;if Z<.1,.1)A;if Z<.01,.01)A
62: if W=1;goto +7
63: for I=1 to MN;if G[I]<-6,-5.999)G[I]
64: ft: ((G[I]+6)*.1*10000)G$(2I-1,2I);next I

```

```

65: "xgo2")W$(4),W$(1)W$(4,1,len(W$(1)))
66: open W$(4),6
67: asgn W$(4) 3,0
68: sprt 3,G$, "end"
69: ret
●70: "Time Delay Correction Used Before 6/1/80":
●71: for I=1 to MN-21,!*21)K;plt 60I/M,G[K],-2;next I;pen;ret
72: "PLOT";for I=5 to MN;plt 60(I-5)/M,G[I],-2;next I;pen
73: for I=MN-6 to MN;G[MN]G[I];plt 60I/M,G[I],-2;next I;pen;ret
74: "LABEL";csiz 2,1.5,1,0;plt 3N,-A/6,-1
75: lbl "Fig. Oxygen Depletion Rate"
76: fxd 0;plt 40N,A,-1;lbl "RUN #",A[10]
77: csiz 1.5,1.5,1,0;fxd 0
78: plt 40N,.95A,-1;lbl B$
79: plt 40N,.85A,-1;lbl "MAXIMUM RATE"
80: plt 40N,.8A,-1;lbl Z," g/min/m "
81: csiz 1,1.5,8.5/11,0;iplt -N,.015A,-1;lbl "2";csiz 1.5,1.5,1,0
82: plt 40N,.7A,-1;fxd 2;lbl "total depleted"
83: fxd 0;plt 40N,.65A,-1;lbl D," g/m "
84: csiz 1,1.5,8.5/11,0;iplt -N,.015A,-1;lbl "2";csiz 1.5,1.5,1,0
85: plt 40N,.55A,-1;fxd 1;lbl "heat flux "
86: fxd 1;plt 40N,.5A,-1;lbl A[1]," w/cm "
87: plt 40N,.4A,-1;lbl "Sample area "
88: fxd 5;plt 40N,.35A,-1;lbl A[2]," m "
89: csiz 1,1.5,8.5/11,0
90: plt 53N,.51A,-1;lbl "2"
91: plt 54.3N,.36A,-1;lbl "2"
92: pen;ret
#12789

```

```

0: "TOTAL HYDROCARBON "
1: fmt 16;prt 16,31,31,31,31,31,31,31,31,31,31,31,31,31,31,31;spc
2: prt "TOTAL HYDROCARBON ";spc 2
3: dsp "Total Hydrocarbon";wait 900
4: dim A[15],A$(8),B$(20),E$(6),F$(6),M,N,N$(15,15),M$(15)
5: dim W$(15,15)
6: enp "# of run in disk(1,2...)";W$(1)
7: ent "Has this been plotted before?";W
8: dsp "Have your platter ready! Cont.";stp
9: "xxxinf")W$(2)
10: W$(1)W$(2,1,len(W$(1)))
11: drive 0
12: asgn W$(2),1,0
13: sread 1,A[1],A$,B$,E$,F$,M,N,N$(15),M$
14: dsp "Run#",A[10],"",B$,A$,wait 1500
15: fxd 0;prt "Run#=",A[10],E$,A$;spc
16: dim Z[10],G$(2MN);dim G[MN],H[300]
17: dim T$(2MN)
18: dsp ".....WORKING.....";gsb "CACL"
19: gsb "AXES"
20: gsb "PLOT"
21: qsb "LABEL"

```

```

22. ent "ANOTHER RUN?",X,if flg13;gto +4
23.
24. dsp "CHOOSE PROGRAM FROM S.F. KEY"
25. stp ;gto -1
26. fmt 16b;wrt 16,31,31,31,31,31,31,31,31,31,31,31,31,31,31,31
27. dsp "SEE YOU NEXT TIME";stp
28. "#####";
29. "AXES";
30. scl -12N,65N,-A/6,1.05A
31. axe 0,0,60,A/10
32. csiz 1.5,1.5,8.5/11,0;fxd 0;for I=0 to 10;plt -7N,IA/10,-1
33. fxd 0;lbl IA/10;next I
34. plt 25N,-A/10,-1;lbl "Time (min)"
35. for I=0 to 65N by 60;plt I-N,-A/20,-1
36. fxd 0;lbl I/60;next I
37. csiz 1.5,1.5,1,30;fxd 0
38. plt -10N,A/4,-1
39. lbl "THC Release Rate (g/min/m)";pen
40. csiz 1,1.5,77,90;plt -10.5N,A/1.31,-1;lbl "2"
41. pen;ret
●42. "CACL":0)D
43. "xx8hc"}W#(3]
44. W#(1)}M#(3,1,len(W#(1)))
45. drive 0
46. asgn W#(3],2,0
47. sread 2,Z[*],G#
48. for K=1 to MN;(if(G#(2K-1,2K))/10000)^10-9)G[K];next K
●49. "THIS CALIBRATION IS mV)ppm";
●50. -21.852+20.335Z(8)+.01403*Z(8)^2)Z(8)
●51. for I=1 to MN;-21.852+20.335G(I)+.01403*G(I)^2)G(I);G(I)-Z(8))G(I);next I
52. for I=1 to MN;if G(I)>Z+G(I))Z
53. next I;prt "Max TH":spc ;fmt f6,4x,"ppm";wrt 16,Z
54. jmp 2
55. ldf 12,T[*]
56. for I=1 to MN;298)T;next I
57. for I=1 to MN;G(I)/1e6*A(4)/4*1e3*16/.08205/T/A(2))G(I);next I
58. 0)Z;for I=1 to MN;if G(I)>Z;G(I))Z
59. next I;fmt f6.2,x,"g/min/m^2";wrt 16,Z;spc
60. for I=2 to MN;(G(I)+G(I-1))*60/M/60/2+D)0;next I
61. if Z<5000,5000)A;if Z<2000,2000)A;if Z<1000,1000)A;if Z<500,500)A
62. if Z<200,200)A;if Z<100,100)A;if Z<50,50)A;if Z<20,20)A
63. if Z<10,10)A;if Z<1,1)A;if Z<.1,.1)A;if Z<.01,.01)A
64. if W=1;gto +7
65. for I=1 to MN;if G(I)<-6,-5.999)G(I)
66. ft1 ((G(I)+6)^.1*10000^G#(2I-1,2I);next I
67. "xx8hc"}W#(4);W#(1)}W#(4,1,len(W#(1)))
68. open W#(4),6
69. asgn W#(4),3,0
70. sprt 3,G#,"end"
71. ret
72. "PLOT";for I=10 to MN;plt 60(I-9)/M,G(I),-2;next I;pen
73. for I=MN-10 to MN;plt 60I/M,G(MN),-2;next I;pen;ret
74. for I=1 to 300;G(I)}H(I);next I
75. if W=1;gto +6

```

```

76: for I=1 to 300;fti ((H(I)*E)^.1#10000)}T$(2I-1,2I);next I
77: "xxhnc")W$(5),W$(1)}W$(5,1,len(W$(1)))
78: open W$(5),6
79: esgn W$(5),4,0
80: sprt 4,T$, "end"
81: ret
82: "LABEL":csiz 2,1.5,1,0,plt 2.5N,-A/E,-1
83: lbl "FIG. TOTAL HYDROCARBON RELEASE RATE"
84: fxd 0;plt 40N,A,-1;lbl "RUN #",A(10)
85: csiz 1.5,1.5,1,0
86: plt 40N,.95A,-1;lbl B$
87: plt 40N,.85A,-1;lbl "MAXIMUM RATE"
88: plt 40N,.8A,-1;fxd 0;lbl Z," g/min/m "
89: csiz 1,1.5,8.5/11,0;ipit -N,.015A,-1;lbl "2";csiz 1.5,1.5,1,0
90: plt 40N,.7A,-1;lbl "Total Released"
91: plt 40N,.65A,-1;lbl D," g/m "
92: csiz 1,1.5,8.5/11,0;ipit -N,.015A,-1;lbl "2";csiz 1.5,1.5,1,0
93: plt 40N,.5A,-1;fxd 1;lbl "HEAT FLUX "
94: plt 40N,.5A,-1;lbl A(1)," w/cm";fxd 5
95: plt 40N,.4A,-1;lbl "Sample area "
96: plt 40N,.35A,-1;lbl A(2)," m "
97: csiz 1,1.5,8.5/11,0
98: plt 52.8N,.51A,-1;lbl "2";plt 54N,.36A,-1;lbl "2"
99: pen;ret
#2834

```

```

0: "Sample Temperature "
1: fmt 16b;wrt 16,31,31,31,31,31,31,31,31,31,31,31,31,31,31,31,31,31;sp
2: prt "Sample Temp ";spc 2
3: dsp "Sample Temperature";wait 900
4: dim A(15),A$(8),B$(20),E$(6),F$(6),M,N,N$(15,15),M$(15),dim W$(15)
5: enp "# of run in disk(1,2...)?",W$(1)
6: ent "Has this been plotted before?",W
7: dsp "Have your plotter ready! Cont.";stp
8: "xxxinf")W$(2)
9: W$(1)}W$(2,1,len(W$(1)))
10: drive 0
11: esgn W$(2),1,0
12: sread 1,A($),A$,B$,E$,F$,M,N,N$(15),M$
13: dsp "RUN#",A(10)," ",B$, " ",A$,wait 1500
14: fxd 0;prt "Run#=",A(10),B$,A$,spc
15: dim M(MN)
16: dim Z(10),D$(2MN)
17: dsp ".....WORKING.....";gsb "CACL"
18: gsb "PLOT"
19: ent "ANOTHER RUN?",A;if flq13;gto +3
20: dsp "CHOCSE PROGRAM FROM S.F.KEY"
21: stp ;gto -1
22: fmt 16b;wrt 16,31,31,31,31,31,31,31,31,31,31,31,31,31,31,31,31,31
23: dsp "SEE YOU NEXT TIME";stp ;end
24: gsb "PLOT"
25: "PLOT";
26: scl -12N,65H,50,1550

```

```

27. axe 0,250,60,150
28. csiz 1.5,1.5,1,0,fxd 0
29. for I=250 to 1500 by 150;plt -8N,I,-1;lbl I;next I
30. plt 25N,145,-1;lbl "Time (min)"
31. for I=0 to 65N by 60;plt I-N,200,-1;lbl I/60;next I
32. csiz 1.5,1.5,1,0,fxd 0
33. plt -10N,550,-1
34. lbl "Temperature (K)"
35. for I=1 to MN;plt 60I/M,M(I),-2;next I;pen;igto 57
●36. "CACL":
37. "x<9t<m">W$(3I
38. W$(I)W$(3,1,len(W$(I)))
39. asgn W$(3I,2,0
40. sread 2,Z[*],D$
●41. -.0098421+24.796778953Z[9]-.02615333Z[9]^2)Z[9]
42. for I=1 to MN
43. (1f(D$(2I-1,2I))/10000)^10-9)M(I)
●44. -.0098421+24.796778953M(I)-.02615333M(I)^2)M(I);M(I)-Z[9])M(I)
45. M(I)+273.1)M(I)
46. next I
47. "Front Temp of Sample in deg K }f21":
48. if W=1;igto +7
49. for I=1 to MN;if M(I)<-6;-5.999)M(I)
50. fti ((M(I)+6)^.1*10000)D$(2I-1,2I);next I
51. "xxmtem" W$(4I;W$(I)W$(4,1,len(W$(I)))
52. open W$(4I).6
53. asgn W$(4I,3,0
54. sprt 3,D$,"end"
55. for I=1 to MN;if M(I)>2;M(I))Z
56. next I;prt "Max Temp";spc ;fmt f6.1,5x,"K";wrt 16,2;ret
57. "lable":
58. csiz 2,1.5,1,0;pen
59. plt 3H,50,-1
60. lbl "Fig. Back Sample Temperature "
61. 1500)A
62. fxd 0;plt 40N,A,-1;lbl "RUN #",A(10)
63. csiz 1.5,1.5,1,0
64. plt 40N,.95A,-1;lbl B$
65. plt 40N,.85A,-1;lbl "MAXIMUM TEMP"
66. plt 40N,.8A,-1;fxd 0;lbl Z," K"
67. fxd 1;plt 40N,.7A,-1;lbl "Heat Flux"
68. plt 40N,.65A,-1;lbl A(1)," w/cm"
69. fxd 5;plt 40N,.55A,-1;lbl "sample area"
70. plt 40N,.5A,-1;lbl A(2)," m "
71. csiz 1,1.5,8.5/11,0
72. plt 53.5N,.66A,-1;lbl "2";plt 55N,.51A,-1;lbl "2"
73. dsp "END";ret
*12422

```

```

0: "NO-NOx Release Rate 5/23/80 SMI";
1: fmt 16b;wrt 16,31,31,31,31,31,31,31,31,31,31,31,31,31,31,31,31,31,31,31;spc
2: prt "NO-NOx Release Rate";spc
3: dsp "NO-NOx Release Rate";wait 300
4: dim A[15],A#[8],B#[20],E#[6],F#[6],M,N,H#[15,15],M#[15],T#[5]
5: dim W#[15,15]
6: enp "# of run in disk(1,2...)?",W#[1]
7: ent "Has this been plotted before?",W
8: dsp "Have your plotter ready! Cont.";stp
9: "xxx:inf")W#[2]
10: W#[1])W#[2 1:len(W#[1])]
11: drive 0
12: asgn W#[2],1,0
13: sread 1,A[#,],A#,B#,E#,F#,M,N,W#[15],M#
14: "Mode";E#)T#
15: "ppm Range":val(F#))R
16: dsp "Run#=",A[10],," ",B#,A#;wait 1500
17: fxd 0;prt "Run#=",A[10],B#,A#;spc
18: dim Z[10],G#[2MN];dim G[MN]
19: 32*128)C;fmt 6b,"WORKING",6b;wrt 0,C,C,C,C,C,C,C,C,C,C,C,C
20: gsb "CACL"
21: gsb "AXES"
22: gsb "PLOT"
23: gsb "LABLE"
24: ent "ANOTHER RUN?",X;if fig13;gto *3
25: dsp "CHOOSE PROGRAM FROM S.F.KEY"
26: stp ;gto -1
27: fmt 16b;wrt 16,31,31,31,31,31,31,31,31,31,31,31,31,31,31,31,31,31,31,31;spc
28: dsp "SEE YOU NEXT TIME";end
29: "*****";
30: "AXES";
31: scl -12N,65N,-A/6,1.05A
32: axe 0,0,60,A/10
33: 2;X;if A>=1;1)X;if A>=10;0)X
34: csiz 1.5,1.5,1,0;fxd X;for I=0 to 10;plt -7N,IA/10,-1
35: !bl IA/10;next I
36: pl: 25N,-A/10,-1;!bl "Time (min)"
37: for I=0 to 65N by 60;plt I-N,-A/20,-1
38: fxd 0;!bl I/60;next I
39: csiz 1.5,1.5,1,90;fxd 0
40: plt -10N,A/4,-1
41: if T#="NOx";!bl "NOx Release Rate (g/min/m)";pen
42: if T#="NO";!bl "NO Release Rate (g/min/m)";pen
43: csiz 1,1.5,.77,90;plt -10.75N,A/1.32,-1;!bl "2"
44: ret
45: "CACL":0)0
46: "xx10no")W#[3]
47: W#[1])W#[3,1,len(W#[1])]
48: asgn W#[3],2,0
49: sread 2,Z[#,],G#
50: for K=1 to MN;(1+G#[2K-1,2K])/10^00)^10-9-Z[10])G[K];next K
51: for I=1 to MN;R#G[I]#A[4]*30/(4#1#4#.08205#298#A[2])G[I];next I
52: 0)Z;for I=1 to MN;if G[I]>Z;G[I])Z
53: next I

```

```

54: if T$="NOx";prt "Max NOx";spc ;fmt f6.2,x,"g/min/m^2";wrt 16,Z;pc
55: if T$="NO";prt "Max NO";spc ;fmt f6.2,x,"g/min/m^2";wrt 16,Z;pc
56: for I=2 to MN;(G[I]+G[I-1])*60/M/2/60*D;next I
57: if Z<500;500>A;if Z<200;200>A;if Z<100;100>A;if Z<50;50>A
58: if Z<20;20>A;if Z<10;10>A;if Z<5;5>A;if Z<2;2>A
59: if Z<1;1>A;if Z<.5;>A;if Z<.1;>A
60: if W=1;goto +7
61: for I=1 to MN;if G[I]<-6;-5.999)G[I]
62: ft1 ((G[I]-6)^(.1*10000))G*[2I-1,2I];next I
63: "xxgno")W$(4);W$(1)W$(4,1,len(W$(1)))
64: open W$(4),6
65: asgn W$(4),3,0
66: sprt 3,G$, "end"
67: ret
68: "PLOT";
69: if E$="NOx";jmp 3
70: for I=8 to MN;plt 60(I-7)/M,G[I],-2;next I
71: for I=MN-8 to MN;G[MN]}G[I];plt 60I/M,G[I],-2;next I;pen;ret
72: if E$="NO";jmp 3
73: for I=11 to MN-11;plt 60(I-11)/M,G[I];next I
74: for I=MN-12 to MN;G[MN]}G[I];plt 60I/M,G[I],-2;next I;pen
75: ret
76: "LABEL";csiz 2,1.5,1,0;plt 3N,-A/6,-1
77: if T$="NOx";lbl " Fig. NOx Release Rate"
78: if T$="NO";lbl " Fig. Nitric oxide Release Rate"
79: fxd 0;plt 40N,A,-1;lbl "RUN #",A(10)
80: csiz 1.5,1.5,1,0;fxd 0
81: plt 40N,.95A,-1;lbl B$
82: plt 40N,.85A,-1;lbl "MAXIMUM RATE"
83: plt 40N,.8A,-1;fxd 3;lbl Z," g/min/m "
84: fxd 0
85: csiz 1,1.5,8.5/11,0;iplt -N,.015A,-1;lbl "2";csiz 1.5,1.5,1,0
86: plt 40N,.7A,-1;lbl "total released"
87: fxd 3;plt 40N,.65A,-1;lbl D," g/m "
88: csiz 1,1.5,8.5/11,0;iplt -N,.015A,-1;lbl "2";csiz 1.5,1.5,1,0
89: plt 40N,.55A,-1;fxd 1;lbl "heat flux "
90: fxd 1;plt 40N,.5A,-1;lbl A(1)," w/cm "
91: plt 40N,.4A,-1;lbl "Sample area "
92: fxd 5;plt 40N,.35A,-1;lbl A(2)," m "
93: csiz 1,1.5,8.5/11,0
94: plt 53N,.51A,-1;lbl "2"
95: plt 54.3N,.36A,-1;lbl "2"
96: pen;ret
#29365

```

```

0: "HCL RELEASE RATE 11/17";
1: prt "HCL Release Rate"
2: dim A(15),A$(8),B$(20),F$(6),F$(6),M,N,N$(15,15),M$(15);dim T$(4)
3: dim W$(15,15)
4: ent "# of run in disk(1,2...)?",W$(1)
5: ent "Has this been plotted before?",T$
6: dsp "Have your plotter ready! Cont.";stp

```

```

7:  *xxinf*)W$(2)
8:  *xxHCL*)W$(3)
9:  W$(1)W$(2,1,len(W$(1)))
10: W$(1)W$(3,1,len(W$(1)))
11: esgn W$(2),1,0
12: sread 1,A[*],A$,B$,E$,F$,M,N,N$(15),M$
13: dsp  " Run#=",A(10),B$,A$;wait 1500
14: spc  ;fxd 0;prt  "Run#=",A(10),B$,A$;spc
15: dim Z(9),G$(2MN);dir X(MN),Y(MN),W(MN),U(MN),V(MN),P$(10)
16: if T$="1";gsb  "TF"
17: if T$="1";jmp 2
18: gsb  "DATA"
19: gsb  "CACL"
20: gsb  "AXES"
21: gsb  "PLOT"
22: gsb  "LABEL"
23: ent  "ANOTHER RUN?".X;if flg13;gto +3
24: dsp  "CHOOSE PROGRAM FROM S.F.KEY"
25: stp  ;gto -1
26: fmt 16b;wrt 16,31,31,31,31,31,31,31,31,31,31,31,31,31,31;spc  " "
27: dsp  "SEE YOU NEXT TIME";end
28: "AXES":
29: scl -12N,65N,-A/6,1.05A
30: axe 0,0,60,A/10
31: csiz 1.5,1.5,1,0;fxd 0;for I=0 to 10;plt -7N,IA/10,-1
32: fxd 0;lbl IA/10;next I
33: plt 25H,-A/10,-1;lbl "Time (min)"
34: for I=0 to 65N by 60;plt I-N,-A/20,-1
35: fxd 0;lbl I/60;next I
36: csiz 1.5,1.5,1,90;fxd 0
37: plt -10N,A/4,-1
38: lbl "HCL Release Rate (g/min/m2)";pen
39: csiz .,1.5,.77,90;plt -11N,A/1.25,-1;lbl "2"
40: pen-ret
●41: "CACL":
42: 600)P
43: if T$="1";gto "MAX"
44: for I=1 to P
45: "C1)HCL(sec)min":Y[I]*1.02843)Y[I],X[I]/60)X[I]
46: next I
●47: "5ml reagent; 45ml Gas Sample";5)V;45)G
●48: "HCLwt/vol(ug/ml)g/m3)#reagent vol(ml)/gas sample vol(ml)":
●49: "airflow(m3/min)/area(m2)g/min/m2":
50: for I=1 to P;Y[I]*1*V/G*(A[4]/4)/A[2])W[I]
51: next I
52: "MAX":
53: 0)Z;for I=1 to P;if W[I]>Z;W[I])Z
54: next I;fxd 2;prt "Max HCL(g/min/m2)=",Z
55: enp "MAX Y-Scale?",A
56: 0)D
57: for I=2 to P;(W[I]+W[I-1])/2M+0)D;next I
58: if T$="1";jmp 2
59: gsb  "FTI"
60: pen;ret

```



```

61: *PLOT*,for I=1 to P:plt 60*X[I],W[I],-2;next I;pen;ret
62: *LACLE*,csiz 2,1.5,1,0;plt 3N,-A/6,-1
63: lbl "Fig. Hydrogen Chloride Release Rate"
64: fxd 0;plt 40N,A,-1;lbl "PUN #",A[10]
65: csiz 1.5,1.5,1,0;fxd 0
66: plt 40N,.95A,-1;lbl 9$
67: plt 40N,.9A,-1;lbl "Total HCL Released"
68: plt 40N,.85A,-1;fxd 1;lbl D," g/m "
69: csiz 1,1.5,8.5/11,0;iplt -N,.015A,-1;lbl "2";csiz 1.5,1.5,1,0
70: csiz 1.5,1.5,1,0
71: plt 40N,.75A,-1;fxd 1;lbl "heat flux "
72: plt 40N,.7A,1;lbl A[1]," w/cm ";fxd 5
73: plt 40N,.6A,-1;lbl "Sample area "
74: plt 40N,.55A,-1;lbl A[2]," m "
75: csiz 1,1.5,8.5/11,0
76: plt 52.8N,.71A,-1;lbl "2";plt 54N,.56A,-1;lbl "2"
77: pen;ret
78: *FTI*,for I=1 to 600
79: fti ((W[I]+6)*.1*10000)G$(2I-1,2I)
80: next I
81: open W$(3),6
82: asgn W$(3),2,0
83: sprt 2,G$, "end"
84: ret
85: *DATA*:
86: ent "Sequence?",P$
87: fmt "SEQUENCE...",c2;wrt 16,P$
88: 10)D
89: fmt ,f2.0,x,"POINT";wrt 16.D
90: fmt "#",2x,"sec",2x,"ionug/ml";wrt 16
91: 1)R
92: if R=1,1)X[1];0)Y[1];D+1)D;1)E
93: for I=1+E to D
94: ent "Time (sec)?",X[I];next I
95: for I=1+E to D
96: ent "sample amount?( Cl =ug/ml)",Y[I]
97: next I
98: for I=1+E to D
99: fmt ,f2.0,2x,f3.0,2x,f7.3;wrt 16,I-E,X[I],Y[I]
100: next I
101: if X[D]<600,600)X[D+1];Y[D];Y[D+1];D+1)D
102: for I=1 to D
103: if X[I]=600;jmp 3
104: if Y[I]=0;.0000001)Y[I]
105: (X[I])Y[I+1]-X[I+1])Y[I])/(X[I]-X[I+1]))A
106: (Y[I]-Y[I+1])/(X[I]-X[I+1]))B
107: for T=X[I] to X[I+1]
108: T)U(T)
109: A+BU(T))V(T)
110: next T
111: next I
112: for I=1 to 600,U[I])X[I];V[I])Y[I];next I
113: ret
114: *ITF*:

```

```

115: asgn W#(3),1,0
116: sread 1,0#
117: for I=1 to 600
118: (1/(G#(2I-1,2I))/10000)*10-6)W(I)
119: I/60)X(I)
120: next I

```

```

0: "HF RELEASE RATE 11/18":
1: prt "HF Release Rate"
2: dim A(15),A$(8),B$(20),E$(6),F$(6),M,N,N$(15,15),M$(15),dim T$(4)
3: dim W$(15,15)
4: ent "# of run in disk(1,2...)?",W$(1)
5: ent "Has this been plotted before?",T#
6: dsp "Have your plotter ready! Cont.";stp
7: "xxxinf")W$(2)
8: "xxHF")W$(3)
9: W$(1)W$(2,1,len(W$(1)))
10: W$(1)W$(3,1,len(W$(1)))
11: asgn W$(2),1,0
12: sread 1,A[*],A$,B$,E$,F$,M,N,N$(15),M$
13: spc ;fxd 0;prt "Run#=",A(10),B$,A$,spc
14: dim Z(10),G$(2MN);dim X(MN),Y(MN),W(MN),U(600),V(600),P$(10)
15: if T#="1";gsb "ITF"
16: if T#="1";jmp 2
17: gsb "DATA"
18: gsb "CACL"
19: gsb "AXES"
20: gsb "PLOT"
21: gsb "LABEL"
22: ent "Another Run?",Y;if flg13;gto +3
23: dsp "CHOOSE PROGPAW FROM S.F.KEY"
24: stp ;gto -1
25: fmt 16b;wrt 16,31,31,31,31,31,31,31,31,31,31,31,31,31,31,31,31,31,spc
26: dsp "SEE YOU NEXT TIME";end
27: "AXES":
28: if Z<100;100)A;if Z<50;50)A;if Z<25;25)A;if Z<10;10)A;if Z<5;5)A
29: if Z<2;2)A;if Z<1;1)A
30: scl -12N,65N,-A/6,1.05A
31: axe 0,0,60,A/10
32: csiz 1.5,1.5,1,0;fxd 0;for I=0 to 10;plt -7N,IA/10,-1
33: fxd 1;lbl I^1/10;next I
34: plt 25N,-A/10,-1;lbl "Time (min)"
35: for I=0 to 65N by 60;plt I-N,-A/20,-1
36: fxd 0;lbl I/60;next I
37: csiz 1.5,1.5,1,90;fxd 0
38: plt -10N,A/4,-1
39: lbl "HF Release Rate (g/min/m )";pen
40: csiz 1,1.5,.77,90;plt -11N,A/1.25,-1;lbl "2"
41: pen;ret
42: "CACL";600)P
43: if T#="1";gto "MAX"
44: for I=1 to P

```

```

45: Y[I]=1.05705*Y[I],X[I]/60*X[I]
46: next I
47: 45)G;5)V
48: *HFwt/vol(ug/ml)g/m3)*reagent vol(ml)/gas sample vol(ml)*;
49: *airflow(m^3/min)/area(m^2))g/min/m^2";
50: for I=1 to P;Y[I]=1*V/G*(A[4]/4)/A[2]*W[I]
51: next I
52: *MAX";
53: 0)Z;for I=1 to P;if W[I]>Z;W[I]=Z
54: next I;fxd 2;prt "Max HF(g/min/m^2)=",Z;spc
55: enp "MAX. Y-scale",A
56: 0)D
57: for I=2 to P;(W[I]+W[I-1])/2M+D)D;next I
58: if T$="1";jmp 2
59: gsb "FTI"
60: pen;ret
61: *PLOT";for I=1 to P;plt 60X[I],W[I],-2;next I;pen;ret
62: *LABEL";csiz 2,1.5,1,0;plt 3N,-A/6,-1
63: lbl "Fig. Hydrogen Fluoride Release Rate"
64: fxd 0;plt 40N,A,-1;lbl "RUN #",A[10]
65: csiz 1.5,1.5,1,0;fxd 0
66: plt 40N,.95A,-1;lbl B$
67: plt 40N,.9A,-1;lbl "Total HF Released"
68: plt 40N,.85A,-1;fxd 1;lbl D," g/m "
69: csiz 1,1.5,8.5/11,0;iplt -N,.015A,-1;lbl "2";csiz 1.5,1.5,1,0
70: csiz 1.5,1.5,1,0
71: plt 40N,.75A,-1;fxd 1;lbl "heat flux "
72: plt 40N,.7A,-1;lbl A[I]," w/cm ";fxd 5
73: plt 40N,.6A,-1;lbl "Sample area "
74: plt 40N,.55A,-1;lbl A[2]," m "
75: csiz 1,1.5,8.5/11,0
76: plt 52.8N,.71A,-1;lbl "2";plt 54N,.56A,-1;lbl "2"
77: pen;ret
78: *FTI";for I=1 to 600
79: fti ((W[I]+6)^.1*10000))G*(2I-1,2I)
80: next I
81: W$(I)W$(3,1,len(W$(I)))
82: open W$(3).6
83: asgn W$(3),2,0
84: sprt 2,G$,"end"
85: ret
86: *DATA";
87: ent "Sequence?",P$
88: fmt "SEQUENCE...",c2;wrt 16,P$
89: 10)D
90: fmt ,f2.0,x,"POINT";wrt 16,D
91: fmt "#",2x,"sec",2x,"ionug/ml";wrt 16
92: 1)R
93: if R=1,1)X[I];0)Y[I];D+1)D;1)E
94: for I=1+E to D
95: ent "Time (sec)?",X[I];next I
96: for I=1+E to D
97: ent "sample amount?( F =ug/ml)",Y[I]
98: next I

```

```

99: for I=1+E to D
100: fmt ,f2.0,2x,f3.0,2x,f7.3,wrt 16,I-E,X[I],Y[I]
101: next I
102: if X[D]<600,E00)X[D+1],Y[D])Y[D+1],D+1)D
103: for I=1 to D
104: if X[I]=600, jmp 9
105: if Y[I]=0,.000001)Y[I]
106: (X[I]Y[I+1]-X[I+1]Y[I])/(X[I]-X[I+1])A
107: (Y[I]-Y[I+1])/(X[I]-X[I+1])B
108: for T=X[I] to X[I+1]
109: T)U[T]
110: A+BU[T])V[T]
111: next T
112: next I
113: for I=1 to 600,U[I])X[I],V[I])Y[I],next I
114: ret
115: "ITF":
116: asgn W$(3),1,0
117: sread 1,G$
118: for I=1 to 600
119: (1+(G$(2I-1,2I))/10000)*10-6)W[I]
120: 1/60)X[I]
121: next I

```

```

3: "CHO REL. R II/19":
4: prt "RCHO Release Rate"
5: dim A(15),A$(8),B$(20),E$(6),F$(6),M,N,N$(15,15),M$(15),dim T$(4)
6: dim W$(15,15)
7: ent "# of run in disk(1,2...)?" ,I$(1)
8: ent "Has this been plotted before?" ,T$
9: dsp "Have your plotter ready! Cont.",stp
10: "xxxinf")W$(2)
11: "xxALD")W$(3)
12: W$(1)W$(2,1,len(W$(1)))
13: W$(1)W$(3,1,len(W$(1)))
14: asgn W$(2),1,0
15: sread 1,A[*],A$,R$,E$,F$,M,N,N$(15),M$
16: spc ;fxd 0,prt "Run#=",A(10),B$,A$,spc
17: dim Z(10),G$(2MN),dim X(MN),Y(MN),W(MN),U(600),V(600),P$(10)
18: if T$="1";gsb "ITF"
19: if T$="1";jmp 2
20: gsb "DATA"
21: gsb "CACL"
22: gsb "AXES"
23: gsb "PLOT"
24: gsb "LABEL"
25: ent "ANOTHER RUN?",X,if flg13,9to +3
26: dsp "CHOOSE PROGRAM FROM S.F.KEY"
27: stp ,9to -1
28: fmt 16b,wrt 16,31,31,31,31,31,31,31,31,31,31,31,31,31,31,31,31,spc ,fnt
29: dsp "SEE YOU NEXT TIME",end
30: end

```

```

28:  *AXES*,
29:  scl -12N,65N,-A/6,1.05A
30:  exe 0,0,60,A/10
31:  csiz 1.5,1.5,1,0,fxd 0;for I=0 to 10;plt -7N,IA/10,-1
32:  fxd 2;lbl IA/10;next I
33:  plt 25N,-A/10,-1;lbl "Time (min)"
34:  for I=0 to 65N by 60;plt I-N,-A/20,-1
35:  fxd 0;lbl I/60;next I
36:  csiz 1.5,1.5,1,90;fxd 0
37:  plt -10N,A/4,-1
38:  lbl "RCHO Release Rate (g/min/m )";pen
39:  csiz 1,1.5,.77,90;plt -11N,A/1.25,-1;lbl "2"
40:  pen;ret
41:  *CACL*:600)P
42:  if T$="1";goto "MAX"
43:  for I=1 to P
44:  X[I]/60)X[I]
45:  next I
46:  5)V;45)G
47:  *ALDwt/vol(ug/ml)g/m3)#reagent vol(ml)/gas sample vol(ml)*;
48:  *airflow(m^3/min)/area(m^2))g/min/m^2";
49:  for I=1 to P;Y[I]=V/G*(A[4]/4)/A[2])W[I]
50:  next I
51:  *MAX":
52:  0)Z;for I=1 to P;if W[I]>Z;W[I])Z
53:  next I;fxd 2;prt "Max RCHO(g/min/m^2)=",Z;spc
54:  enp "MAX. Y-Scale??",A
55:  0)D;for I=2 to P;(W[I]+W[I-1])/2M*D);next I;pen
56:  if T$="1";jmp 2
57:  gsb "FTI"
58:  pen;ret
59:  *PLOT*:for I=1 to P;plt 60X[I],W[I],-2;next I;pen;ret
60:  *LABEL*:csiz 2,1.5,1,0;plt 3N,-A/6,-1
61:  lbl "Fig. Aliphatic Aldehyde Release Rate"
62:  fxd 0;plt 40N,A,-1;lbl "RUN #",A[10]
63:  csiz 1.5,1.5,1,0;fxd 0
64:  plt 40N,.95A,-1;lbl B#
65:  plt 40N,.9A,-1;lbl "Total Released"
66:  plt 40N,.95A,-1;fxd 1;lbl D," g/m "
67:  csiz 1,1.5,8.5/11,0;iplt -N,.015A,-1;lbl "2";csiz 1.5,1.5,1,0
68:  csiz 1.5,1.5,1,0
69:  plt 40N,.73A,-1;fxd 1;lbl "heat flux "
70:  plt 40N,.7A,-1;lbl A[1]," w/cm ";fxd 5
71:  plt 40N,.6A,-1;lbl "Sample area "
72:  plt 40N,.55A,-1;lbl A[2]," m "
73:  csiz 1,1.5,8.5/11,0
74:  plt 52.8H,.71A,-1;lbl "2";plt 54N,.56A,-1;lbl "2"
75:  pen;ret
76:  *FTI*:for I=1 to 600
77:  fti ((W[I]-6)^.1*10000))G*(2I-1,2I)
78:  next I
79:  W*(1))W*(3,1,len(W*(1)))
80:  open W*(3),6
81:  asgn W*(3),2,0

```

```

82: sprt 2,G$, "end"
83: ret
84: "DATA":
85: ent "Sequence?",P$
86: fmt "SEQUENCE...",c2,wrt 16,P$
87: 10)D
88: fmt ,f2.0,x,"POINT",wrt 16,D
89: fmt "#",2x,"sec",2x,"ionug/ml",wrt 16
90: 1)R
91: if R=1,1)X(1),0)Y(1),D+1)D,1)E
92: for I=1+E to D
93: ent "Time (sec)?",X(1);next I
94: for I=1+E to D
95: ent "sample amount?(RCHO-ug/ml)",Y(1)
96: next I
97: for I=1+E to D
98: fmt ,f2.0,2x,f3.0,2x,f7.3,wrt 16,I-E,X(1),Y(1)
99: next I
100: if X(D)<600,600)X(D+1),Y(D)Y(D+1),D+1)D
101: for I=1 to D
102: if X(I)=600;jmp 9
103: if Y(I)=0,.000001)Y(I)
104: (X(I)Y(I+1)-X(I+1)Y(I))/(X(I)-X(I+1))A
105: (Y(I)-Y(I+1))/(X(I)-X(I+1))B
106: for T=X(I) to X(I+1)
107: T)U(T)
108: A+2U(T))V(T)
109: next T
110: next I
111: for I=1 to 600,U(I))X(I),V(I))Y(I);next I
112: ret
113: "ITF":
114: asgn W$(3),1,0
115: sread 1,G$
116: for I=1 to 600
117: (itf(G$(2I-1,2I))/10000)*10-6)W(I)
118: I/60)X(I)
119: next I
120: ret
#1833

```

```

0: "RCHO REL. R II/19":
1: prt "RCHO Release Rate"
2: dim A(15),A$(8),R$(20),E$(6),F$(6),M,N,W$(15,15),W$(15);dim T$(4)
3: dim W$(15,15)
4: ent "# of run in disk(1,2...)?",W$(1)
5: ent "Has this been plotted before?",T$
6: dsp "Have your plotter ready! Cont.,";stp
7: "xxxinf")W$(2)
8: "xxALD")W$(3)
9: W$(1)W$(2,1,len(W$(1)))
10: W$(1)W$(3,1,len(W$(1)))

```

```

11: esgn W$(2),1,0
12: sread 1,A(M),A$,B$,E$,F$,M,M,N$(15),M$
13: spc ;fxd 0;prt "Run#=",A[10],B$,A$;spc
14: dim Z[10],G$(2MN);dim X(MN),Y(MN),W(MN),U[600],V[600],P$(10)
15: if T$="1";gsb "1TF"
16: if T$="1";jmp 2
17: gsb "DATA"
18: gsb "CACL"
19: gsb "AXES"
20: gsb "PLOT"
21: gsb "LABEL"
22: ent "ANOTHER RUN?",X;if flg13;gto +3
23: dsp "CHOOSE PROGRAM FROM S.F.KEY"
24: stp ;gto -1
25: fmt 16b;wrt 16,31,31,31,31,31,31,31,31,31,31,31,31,31,31,31;spc ;fmt
26: dsp "SEE YOU NEXT TIME";end
27: end
28: "AXES";
29: scl -12N,65N,-A/6,1.05A
30: axe 0,0,60,A/10
31: csiz 1.5,1.5,1,0;fxd 0;for I=0 to 10;plt -7N,IA/10,-1
32: fxd 2;lbl IA/10;next I
33: plt 25N,-A/10,-1;lbl "Time (min)"
34: for I=0 to 65N by 60;plt I-N,-A/20,-1
35: fxd 0;lbl I/60;next I
36: csiz 1.5,1.5,1,90;fxd 0
37: plt -10N,A/4,-1
38: lbl "RCHO Release Rate (g/min/m2)";pen
39: csiz 1,1.5,.77,90;plt -11N,A/1.25,-1;lbl "2"
40: pen;ret
●41: "CACL":600)P
42: if T$="1";gto "MAX"
43: for I=1 to P
44: X[I]/60)X[I]
45: next I
●46: 5)V,45)G
●47: "ALDwt/vol(ug/ml)g/m3)reagent vol(ml)/gas sample vol(ml)",
48: "airflow(m3/min)/area(m2)g/min/m2";
49: for I=1 to P;Y[I]=I*V/G*(A[4]/4)/A[2])W[I]
50: next I
51: "MAX";
52: 0)Z;for I=1 to P;if W[I]>Z;W[I])Z
53: next I;fxd 2;prt "Max RCHO(g/min/m2)=",Z;spc
54: end "MAX. Y-Scale??",A
55: 0)D;for I=2 to P;(W[I]+W[I-1])/2M+D)D;next I;pen
56: if T$="1";jmp 2
57: gsb "FTI"
58: pen;ret
59: "PLOT":for I=1 to P;plt 60X[I],W[I],-2;next I;pen;ret
60: "LABEL";csiz 2,1.5,1,0;plt 3N,-A/6,-1
61: lbl "Fig. Aliphatic Aldehyde Release Rate"
62: fxd 0;plt 40N,A,-1;lbl "RUN #",A[10]
63: csiz 1.5,1.5,1,0;fxd 0
64: plt 40N,.95A,-1;lbl B$

```

```

65: plt 40N,.9A,-1;lbl "Total Released"
66: plt 40N,.85A,-1;fxd 1;lbl D," g/m "
67: csiz 1.1.5,8.5/11,0;plt -N,-.015A,-1;lbl "2";csiz 1.5,1.5,1,0
68: csiz 1.5,1.5,1,0
69: plt 40N,.75A,-1;fxd 1;lbl "heat flux "
70: plt 40N,.7A,-1;lbl A(1)," w/cm ";fxd 5
71: plt 40N,.6A,-1;lbl "Sample area "
72: plt 40N,.55A,-1;lbl A(2)," m "
73: csiz 1,1.5,8.5/11,0
74: plt 52.8N,.71A,-1;lbl "2";plt 54N,.56A,-1;lbl "2"
75: pen;ret
76: "FTI";for I=1 to 600
77: fti ((W(I)+6)^.1*10000)G8(2I-1,2I)
78: next I
79: W8(1)W8(3,1,len(W8(1)))
80: open W8(3),6
81: asgn W8(3),2,0
82: sprt 2,G8,"end"
83: ret
84: "DATA":
85: ent "Sequence?" P8
86: fmt "SEQUENCE...",c2;wrt 16,P8
87: 10)D
88: fmt ,f2.0,x,"PGINT";wrt 16,D
89: fmt "#",2x,"sec",2x,"ionug/ml";wrt 16
90: 1)P
91: if R=1;1)X(I);0)Y(I);D+1)D;1)E
92: for I=1+E to D
93: ent "Time (sec)?",X(I);next I
94: for I=1+E to D
95: ent "sample amount?(RCHO=ug/ml)",Y(I)
96: next I
97: for I=1+E to D
98: fmt ,f2.0,2x,f3.0,2x,f7.3;wrt 16,I-E,X(I),Y(I)
99: next I
100: if X(D)<600;600)X(D+1);Y(D))Y(D+1);D+1)D
101: for I=1 to D
102: if X(I)=600;]np 9
103: if Y(I)=0;.000001)Y(I)
104: (X(I)Y(I+1)-X(I+1)Y(I))/(X(I)-X(I+1))A
105: (Y(I)-Y(I+1))/(X(I)-X(I+1))B
106: for T=X(I) to X(I+1)
107: T)UIT)
108: A+BU(T))V(T)
109: next T
110: next I
111: for I=1 to 600;U(I))X(I);V(I))Y(I);next I
112: ret
113: "ITF":
114: asgn W8(3),1,0
115: sread 1,G8
116: for I=1 to 600
117: (1+(G8(2I-1,2I))/10000)^10-6)W(I)
118: 1/60)X(I)
119: next I
120: ret

```



```

●0: *PLASTIC FLOW METER PROGRAM*
1: fxd 2
2: "trk,tape9,file18"
3: ent "BARO. PRESSURE IN.?",V
4: ent "AIR TEMPERATURE F?",T
5: ent "TOTAL AIR FLOW?",Q
●6: ent "MLT. AIR FLOW?",M
7: prt "AIR TEMPERATURE=",T
8: O-M)K
9: prt "ADJ. AIR FLOW=", "TOTAL-MLT=",K
10: prt "BARO PPE.=",V;spc 2
11: ent "AIR PRESSURE IN.?",P
12: O)W;O)H;O)Q
13: dsp "I AM WORKING....."
14: T-460)T
15: S)H
16: fxd 3
●17: 10.775662)A;381.67757)B;-1402.8801)C;2814.175)D;-2116.4421)E
18: "CAL.",
19: H/2.54/P)X
20: P/\T*(A+B*X+C*X^2+D*X^3+E*X^4))Q
21: if Q<K;.001*H)H;gto "CAL."
22: fxd 2
23: T-460)T
24: Y+1)Y
25: "PRT".
26: prt "AIR PRE.=",P
27: prt "DELT-P cm=",H
28: H/2)W
●29: prt "ADJUST MERCURY TUBE AS FOLLOW:"
30: prt "LEFT=",50-W
31: prt "RIGHT=",50+W;spc 2
32: dsp "Adj. Hg Tube & Check Air Pre.Cont.";stp
33: Y-1)Y
34: cfg 13;ent "Has Air Pre. Change any?",Y
35: if Y;dsp "Make another Adj.";gto 11
36: dsp "CHOOSE FROM S.F KEY...,CONT.";stp
37: end

●0: *TRANSFER DATA FROM DISK TO REEL AND PRINT OUT 32080 S.N L trt0,fi'=14*
1: fmt 16b;wrt 16,31,31,31,31,31,31,31,31,31,31,31,31,31,31,31;fa: spc
2: prt "Data Transfer";spc
3: dsp "LOAD MAGNETIC REEL TAPE,Cont.";stp
4: dsp "...REWINDING...";wrt 704,"Q "
5: dim A[15],A*[8],B*[20],E*[6],F*[6],M,N,M*[15],N*[17,17]
6: dim C[600],B[600],D*[1200],Z[9]
7: dim W*[15,6],Y*[10,10],G*[70],E[600],C*[40]
8: cnp " # OF RUN IN THIS DISK???" ,W*[15]
9: dsp "Do you have the following file?";wait 1500
10: ent "NOx",Y*[1],"NO",Y*[2],"NO2",Y*[3],"HF",Y*[4],"HC1",Y*[5],"P",Y*[6]
11: "xxxinf")W*[1]
12: W*[15])W*[1,1,len(W*[15])]
13: drive 0

```

```

14: asgn W$(1),1,0
15: sread 1,A$(M),A$,B$,E$,F$,M,N,N$(15),N$
16: spc ;fxd 0;prt "Run#=",A(10),E$,A$
17: "xxssmk")N$(1);"xxsmas")N$(2);"xxhmas")N$(3);"xx02HR")N$(4)
18: "xxpht")N$(5);"xxwtem")N$(6);"xxgco")N$(7);"xxgco2")N$(8)
19: "xxgo2")N$(9);"xxghcn")N$(10);"xxghe")N$(11)
20: "xxgnox")N$(12);"xxgno")N$(13);"xxgno2")N$(14)
21: "xxHF")N$(15);"xxHCL")N$(16);"xxALD")N$(17)
22: prt "DATA IS WRITTING ON....."
23: for T=1 to 17
24: if T=12;if Y$(1)="" ;gto 31
25: if T=13;if Y$(2)="" ;gto 31
26: if T=14;if Y$(3)="" ;gto 31
27: if T=15;if Y$(4)="" ;gto 31
28: if T=16;if Y$(5)="" ;gto 31
29: if T=17;if Y$(6)="" ;gto 31
30: jmp 2
31: "EMPTY FILE")N$(T);for I=1 to 600;0)C(I);next I;gto 57
32: M$(N$(T,1,len(M$)))
33: drive 0
34: asgn N$(T),1,0
35: sread 1,0$
36: for K=1 to 600;(1if(D$(2K-1,2K)/10000)*13-6)E(K)
37: if E(K)<0;0)E(K)
38: next K
39: 1)H
40: if T=1;0)E
41: if T=2;2)E
42: if T=3;2)E
43: if T=4;0)E
44: if T=5;0)E
45: if T=6;0)E
46: if T=7;17)E
47: if T=8;13)E
48: if T=9;21)E
49: if T=10;6)E
50: if T=11;19)E
51: if T=12;23)E
52: if T=13;23)E
53: if T=14;23)E
54: for I=1+E to 600+E;if I>600;E(600)C(H);jmp 2
55: E(I)C(H)
56: H=1)H;next I
57: gsb "wrt"
58: next T
59: gsb "mkf"
60: "prt";ent "Need Read & Printing?";A;if #1g13;gto +3
61: gsb "rew"
62: gsb "red"
63: dsp "That's all for CHAS/MATS !";end
64: "wrt";wrt 704,"B2000 W3 "
65: cmd 7,"?UX";fmt 1,2,e10.3;for I=1 to 600;wrt 731.1,C(I);next I;ret
66: "mkf";wrt 704,"Y ";ret
67: "rew";dsp "..REWINDING...";wrt 704,"Q ";ret

```

```

69: *red*ent "IBM TAPE",A
70: ent "DATE",C$
71: fmt "-----TAPE",x,f13.0,3x,"DATE",x,c20,"-----"
72: wrt 702,A,C$
73: wtb 702,10
74: fmt
75: wrt 702,".....DATA RECOVERING....."
76: wtb 702,10
77: fmt "RUN",f5.0,4x,"DISK-RUN",f2.0,"-",c2,5x,c15.3x,f4.1,"W/CM"
78: wrt 702,A[10],A[11],M$,B$,A[1]
79: ent "ANY NOTE",G$
80: fmt "NOTE:",c30
81: wrt 702,G$
82: wtb 702,10
83: for K=1 to 1
84: for J=1 to 17
85: dsp "...READING...",N$(J)," FILE",J,"..."
86: wtb 702,10;wrt 704,"B2048 R3 "
87: fmt 2,z,f10;for I=1 to 600;red 705.2,B[I];next I
88: fmt
89: *prt*;wrt 702,"FILE #",J," ",N$(J)
90: fmt
91: wrt 702,"First 50 points"
92: for I=1 to 50 by 5
93: fmt 3,5e15.3;wrt 702.3,B[I],B[I+1],B[I+2],B[I+3],B[I+4]
94: next I
95: fmt
96: wrt 702,"Last 50 points"
97: for I=551 to 600 by 5
98: wrt 702.3,B[I],B[I+1],B[I+2],B[I+3],B[I+4]
99: next I;next J
100: wrt 704,"K1 ";next K;wtb 702,10;ret
101: "ID";wrt 704,"B10 W1 ";cmd 7,"00%"
102: fm: 4,z,f10.0
103: wrt 731.4,A[10];ret
104: *D*;for I=1 to 600;0)C[I];next I;ret
#23972

```

CHAS/SATS COMPUTER PROGRAM PARAMETER IDENTIFICATION

N---LENGTH OF TEST TIME
M---DATA POINT
E\$-----USED NO OR NOX
F\$-----WHICH CONC. RANGE IS USED FOR NO OR NOX
B\$---SAMPLE NAME
A\$---DATE
AC1]----HEAT FLUX (W/CM²)
AC2]----SAMPLE AREA (IN² M²)
AC3]----AIR TEMPERATURE (c→K)
AC-4]---AIRFLOW RATE (FM→CMM)
AC-5]---SMOKE FILTER F.S.
AC-6]---
AC-7]---INITIAL MASS (GM)
AC-8]---DMV/100GM MLU SENSITY
AC-9]---
AC-10]--RUN NUMBER
AC-11]--DISK NUMBER
Z[1]---Z[10]
---- ---BASELINE MV OUTPUT FROM CHANNEL 1 TO 10

DATA FILE CONTENT

FILE 1→10 RESERVE FOR MV DATA
FILE 16 SMOKE
FILE 17 MASS REMAINING
FILE 18 MASS LOSS RATE
FILE 19 HEAT R. R. (T.C)
FILE 20 AIR TEMP.
FILE 21 SAMPLE TEMP.
FILE 22 CO
FILE 23 CO₂
FILE 24 O₂
FILE 25 HCN
FILE 26 HC
FILE 27 NO-NOX
FILE 28 HEAT R.R. (O₂)
FILE 29 HCL
FILE 30 HF
FILE 31 RCHO

COMPUTER SELECT CODE IDENTIFICATION

702-----7245A PLOTTER PRINTER
704-----DYLON 1015A
708-----59309 HP-18 DIGITAL CLOCK
709-----3495A SCANNER
722-----3455A DIGITAL VOLTMETER

AD-A117 449

MCDONNELL DOUGLAS CORP LONG BEACH CA F/6 1/3
A COMBINED HAZARD INDEX FIRE TEST METHODOLOGY FOR AIRCRAFT CABI--ETC(U)
APR 82 H H SPIETH, J G GAUME, R E LUOTO DOT-FA77WA-4019
DOT/FAA/CT-82/36-2 NL

UNCLASSIFIED

3 3

21 13 12

END
DATE
FILMED
9 82
DTIC

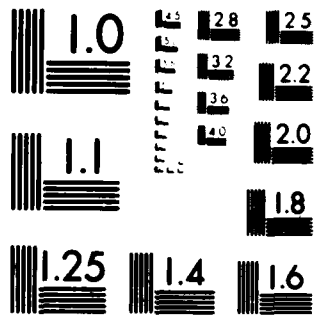

MICROCOPY RESOLUTION TEST CHART
NATIONAL BUREAU OF STANDARDS-1963-A

TABLE A-1

CHAS PARTS LIST

* Substitution not recommended
 ** May be substituted for with item of equal or better performance

PART	SUBSTITUTION	MANUFACTURER
1 - HRR CALORIMETER Incl. Thermopile, Air System, Smoke Meter, & Diff. Press. Orifice	*	Karl's Svanks Co. 67 East 9th Avenue Columbus, OHIO
1 - HRR HOLD CHAMBER EXTENSION DUCT	**	Make in-house or subcontract
5 - MODIFIED SAMPLE HOLDERS, 10" x 10"	**	Make in-house or subcontract
1 - MASS LOSS TRANSDUCER	*	West Coast Research Corp. 2301 Purdue Avenue Los Angeles, CA 90064
MLT ACCESSORIES - INSULATED AIR COOLING BOX INNER AND OUTER MOUNTING TUBES AND FITTINGS	**	Make in-house or subcontract
4 - GLOBAL RADIANT HEAT ELEMENTS - MATCHED RESISTANCE	*	Carborundum Company
1 - POWERSTAT VARIABLE TRANSFORMER 12.5 kVA, 0-270 VAC	**	Superior Electric Co.
1 - DC POWER SUPPLY HP-62568, 0-10V	**	Hewlett-Packard Co.
2 - Radiometers	*	Hy-Cal Engineering Co. 12105 Los Nietos Rd. Santa Fe Springs, CA

TABLE A-1 (Cont'd)

PART	SUBSTITUTION	MANUFACTURER
11 - NEUTRAL DENSITY FILTERS 0.1 to 1.5 O.D.	**	Melles-Griot Irvine, CA
2 - DUAL CHANNEL - Potentiometric Recorders Model 110	**	Gould, Inc. Instruments Div. 3631 Perkins Avenue Cleveland, Ohio 44114
1 - OXYGEN MONITOR MODEL 326A	**	Teledyne Analytical Instr. 333 West Mission Drive San Gabriel, CA 91776
1 - OXYGEN ANALYZER MODEL IR-2100	**	Infrared Industries Santa Barbara, CA
1 - NEUTRAL OPTICAL FILTER MEEL	**	Make in-house or subcontract
1 - COMBUSTIBLE GAS MONITOR - MODEL 175	**	Teledyne
1 - CO ANALYZER LIRA 303	**	Mine Safety Appliances Co. Pittsburg, PA
1 - CO ₂ ANALYZER NIR MODEL 864	**	Beckman Instruments Co. Fullerton, CA
1 - HCN MONITOR (DOM)	*	Kin-Tek Laboratories Texas City, TE
1 - HCN PENETRATION CALIBRATION INSTR.	**	Kin-Tek Labs.
1 - NO _x ANALYZER MODEL 10AR	*	Thermolectron Corp. Environmental Instruments Div. 108 South Street Hopkinton, MA 01748
1 - CALCULATOR/DATA ACQUISITION/PLOTTER SYSTEM - 20 CHANNEL MODEL 3052A	*	Hewlett Packard Co.
1 - PLOTTER PRINTER MODEL 7246A	*	Hewlett Packard Co.

TABLE A-1 (Cont'd)

PART	SUBSTITUTION	MANUFACTURER
1 - FORMATTER/IBM TAPE SYSTEM MODEL 1015A	*	The Dylon Corporation 3670 Ruffin Road San Diego, CA
1 - SPECIFIC ION MICRO-PROCESSOR - MODEL 901	*	Orion Research
4 - SPECIFIC ION & REF. JUNCTION ELECTRODES F, Cl, REF, DOUBLE JUNCTION	*	Orion Research
2 - TFE DIAPHRAGM AIR PUMPS - MOD. 107CA18TFE	*	Thomas Industries, Inc.
2 - ELECTRONIC TC-ICE REFERENCE UNITS MODEL MCJ	**	Omega Engineering, Inc. Box 4047 Stamford, Conn 06907
1 - LABORATORY CHRONOMETER MKIK-set	**	Lab. - Line Instruments, Inc.
<u>FLOMETERS</u>		
1 - 448 - 100	**	Fischer & Porter Co.
3 - 448 - 215	**	Fischer & Porter Co.
1 - 448 - 309	**	Fischer & Porter Co.
1 - VFB - 65	**	Dyer Instruments, Inc. Michigan City, Indiana
1 - IMC - 104	**	Dyer Instruments, Inc.
1 - MET TEST METER 0.25 Cu.Ft./Rev.	**	Any scientific supply house
2 - FILTER HOLDERS, 47 MM Cat. Log. 2220	*	Gelman Instrument Co.
1 - DIFFERENTIAL PRESSURE GAGE, MODEL 2015, 0-15 PSI	**	Dyer Instruments, Inc.

TABLE A-1 (Cont'd)

PART	SUBSTITUTION	MANUFACTURER
1 - ROLL, TWISTED PAIR SHIELDED WIRE	•	Electrical supply house
20 FT., HEAVY WALL, 3/8" TPE TUBING	•	Chemical supply house
20 FT., HEAVY WALL, 1/4" TPE TUBING	•	Chemical supply house
2 - VARIABLE TRANSFORMERS 0-120 VAC	•	Chemical supply house
10 - DATA TAPES, MP-9825A	•	Hewlett Packard
6 - ROLLS, PLOTTER PRINTER PAPER FOR MP 7245A	•	Hewlett Packard
100 - PLASTIPAK SYRINGES 50 ml, BD #5663	•	Becton - Dickinson
100 - SYRINGE NEEDLES: BD-5196	**	Becton - Dickinson
1 - TPE SMOKE FILTER HOUSING W/FITTINGS	••	Savillex Corporation 5325 Highway 101, Minnetonka, MINN 55343
1 - 501-25 Cap w/1/4" nut 1 - 501-37 Cap w/3/8" nut 3 - Segments, #504 2 - Connectors, #502	••	Savillex Corporation 5325 Highway 101, Minnetonka, MINN 55343
<u>MISCELLANEOUS</u>	••	Various suppliers
Sungplek Fittings SS & Copper Tubing Chemicals Duroboard (Carborundum) DuPont Ludox, MS-40 Glass Tubing Rubber Tubing Tygon Tubing Valves, Flow Control, 1/4" Valves, Ball, 3/8" Filters	••	Various suppliers

TABLE A-1 (Conc'd)

PART	SUBSTITUTION	MANUFACTURER
3 - NON PERMEATION CALIBRATION TUBES	**	Metronics 2991 Corvin Drive Santa Clara, CA 95051
6 - SPAN GAS MIXTURES, ANALYZED	**	Matheson
5 - 2 STAGE PRESS. REGULATORS 3104-350	**	Matheson
1 - 2 STAGE PRESS. REGULATOR 380-660	**	Matheson
4 - PURE GASES IN STD CYLINDERS AIR, N ₂ , CO, CO ₂	**	Matheson
1 - 2 STAGE PRESS. REG. 8-320, CO ₂	**	Matheson
1 - 2 STAGE REG., CO, 8-350	**	Matheson
1 - 2 STAGE REG., N ₂ 8-580	**	Matheson
1 - 2 STAGE REG., AIR 8-590	**	Matheson

APPENDIX B

This Appendix provides additional data for the personnel hazard limit concept.

1. Five minute (HL)₅ curves for fire gases.
2. Modifications of the Peterson and Stewart Co. (Carbon Monoxide) hazard equation to form compared with CHI Program Hazard Limit Curve.

LIST OF ILLUSTRATIONS

<u>FIGURE</u>	<u>TITLE</u>	<u>PAGE</u>
1	HAZARD LIMIT CURVE - NO/NOx.....	186
2	HAZARD LIMIT CURVE - HCl.....	186
3	HAZARD LIMIT CURVE - HF-HBR.....	187
4	HAZARD LIMIT CURVE - SO ₂	187
5	HAZARD LIMIT CURVE - H ₂ S.....	188
6	HAZARD LIMIT CURVE - COCl ₂ , COF ₂ & ACRROLEIN.....	188
7	HAZARD LIMIT CURVE - NH ₃	189
8	HAZARD LIMIT CURVE - FORMALDEHYDE.....	189
9	HAZARD LIMIT CURVE - ACETALDEHYDE.....	190
10	HAZARD LIMIT CURVE - CO.....	190
11	HAZARD LIMIT CURVE - CO ₂	191
12	HAZARD LIMIT CURVE - HCN.....	191

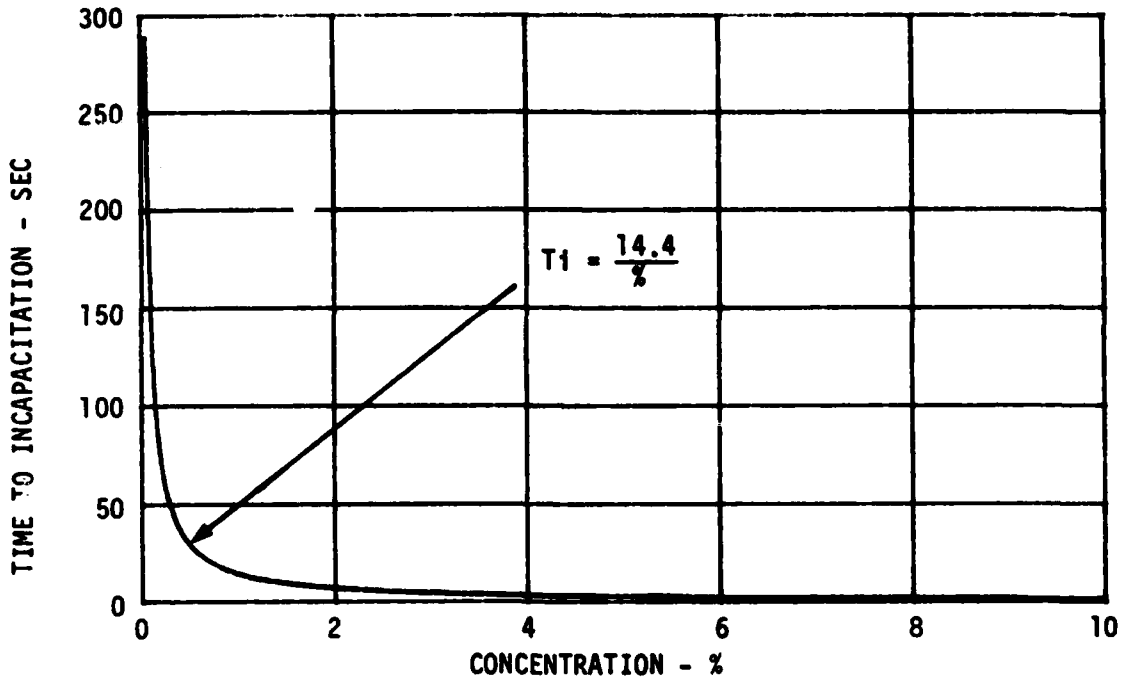

FIGURE B-1 HAZARD LIMIT CURVE - NO/NO_x

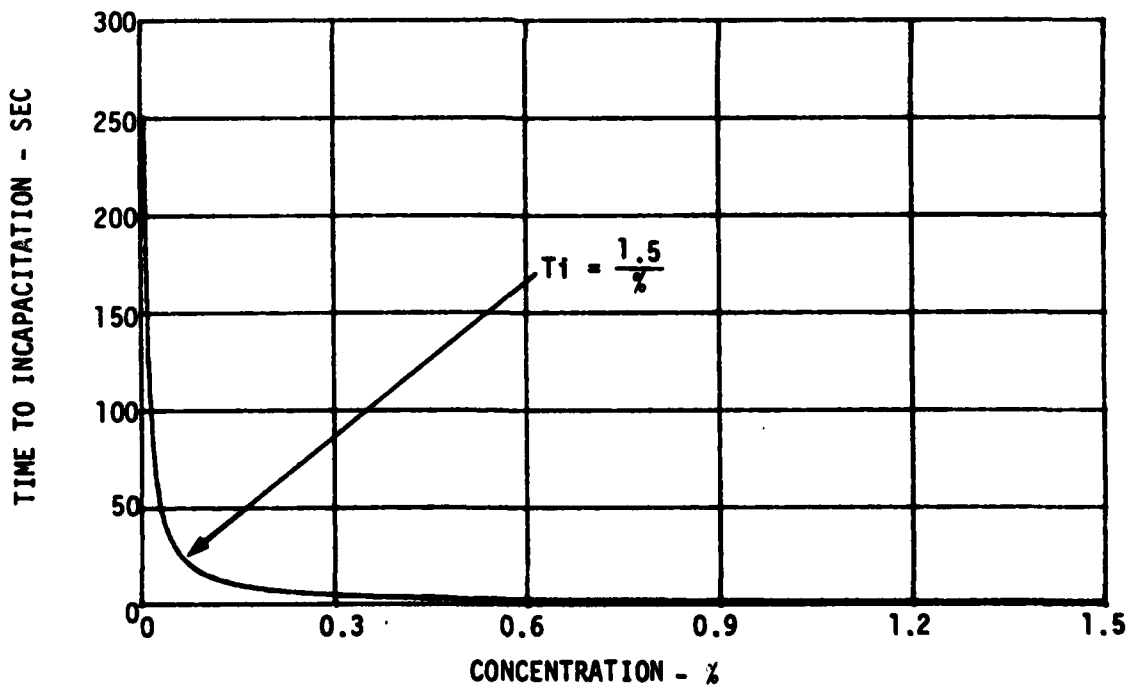

FIGURE B-2 HAZARD LIMIT CURVE - HCl

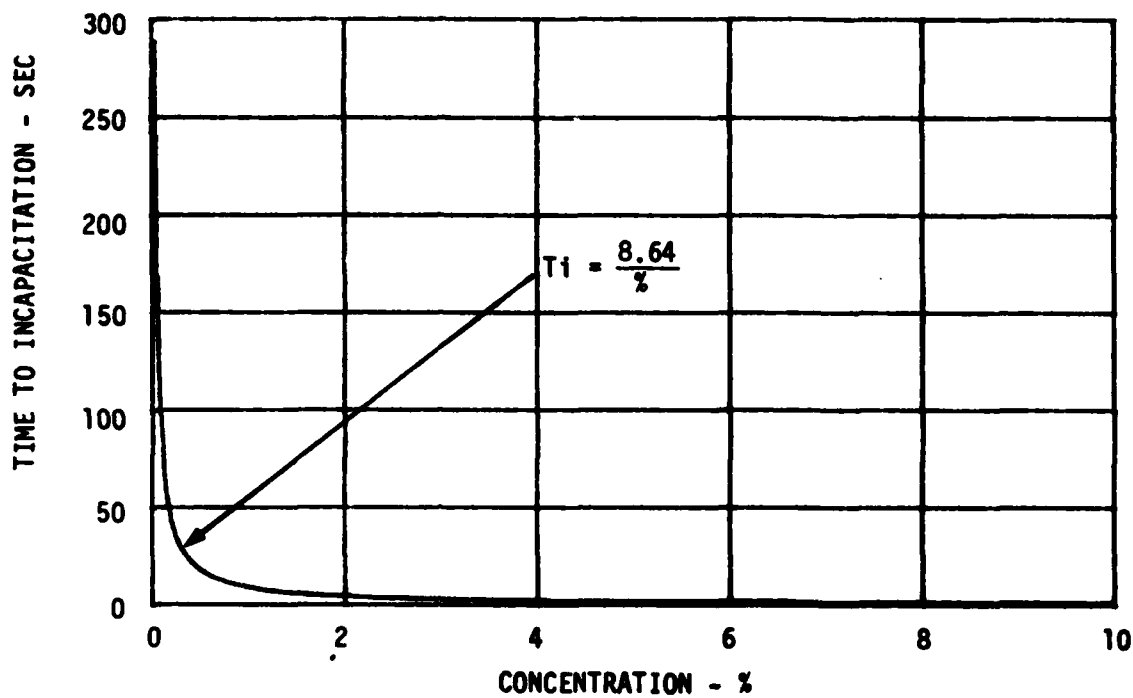

FIGURE B-3 HAZARD LIMIT CURVE - HF - HBR

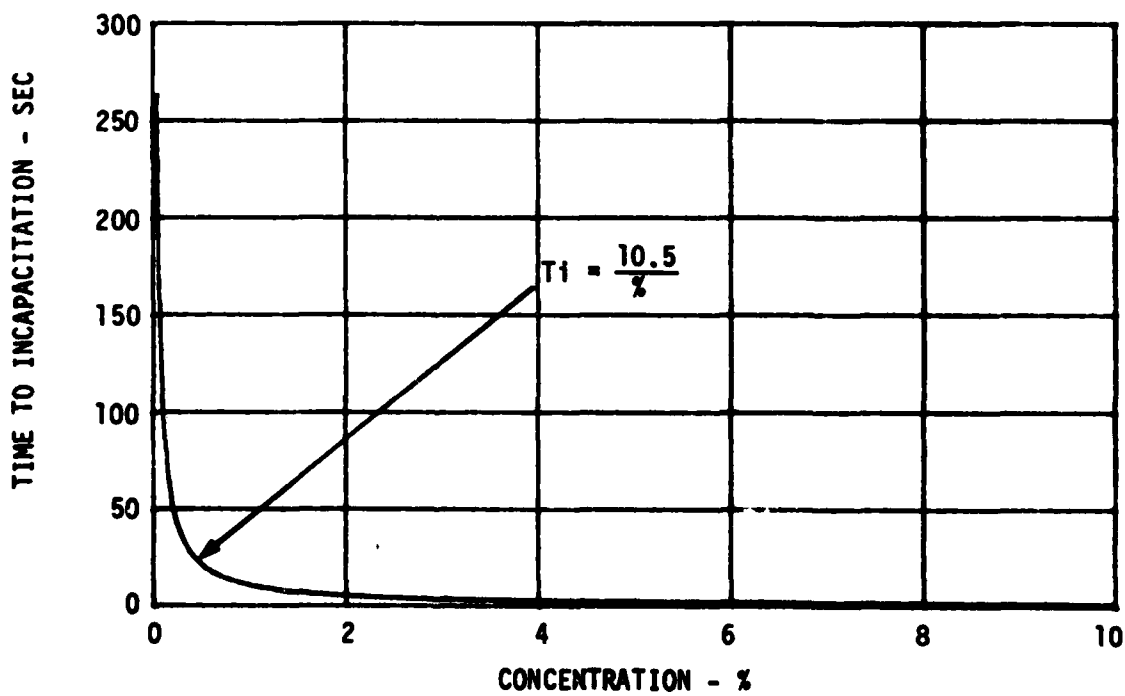

FIGURE B-4 HAZARD LIMIT CURVE - SO₂

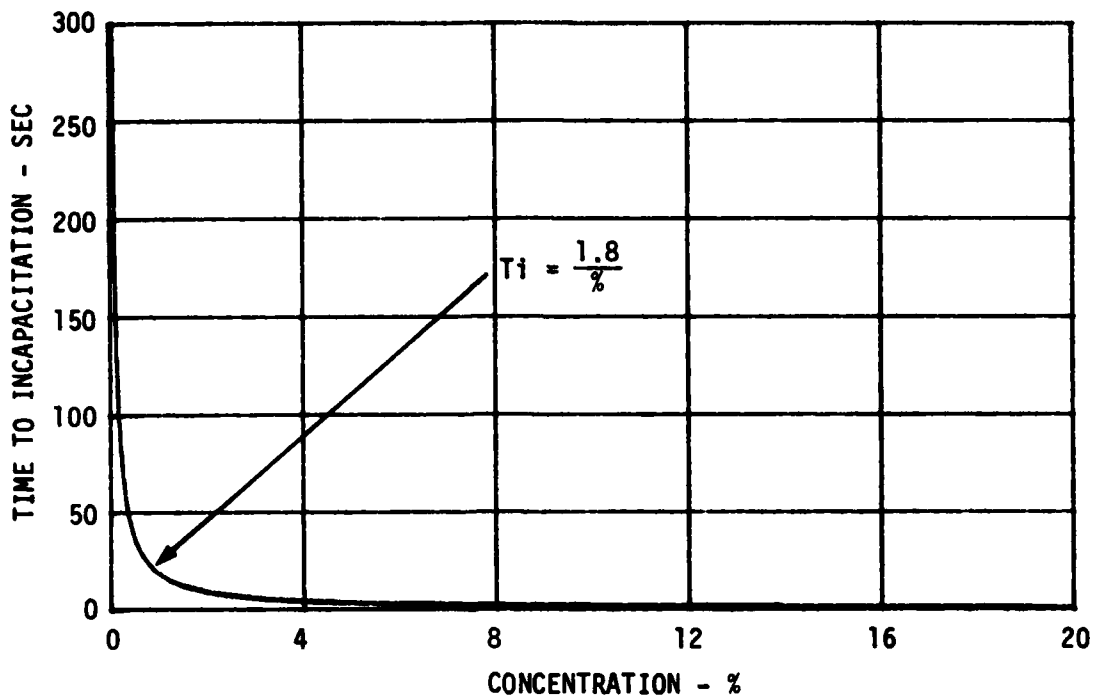

FIGURE B-5 HAZARD LIMIT CURVE - H_2S

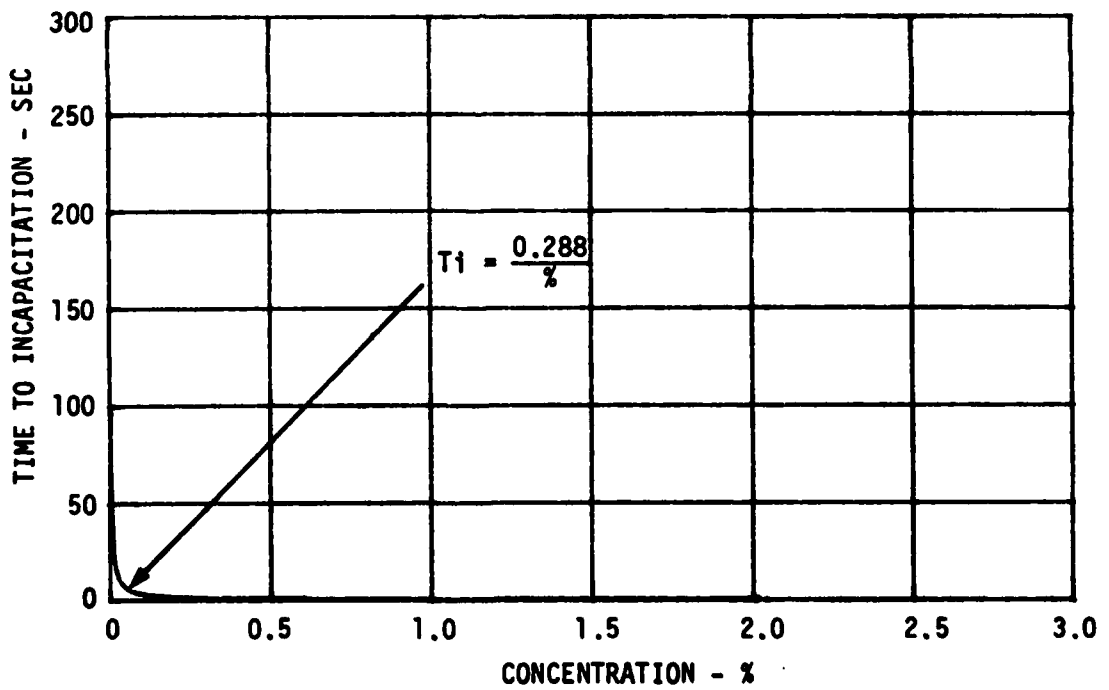

FIGURE B-6 HAZARD LIMIT CURVE - $COCl_2$, COF_2 & ACROLEIN

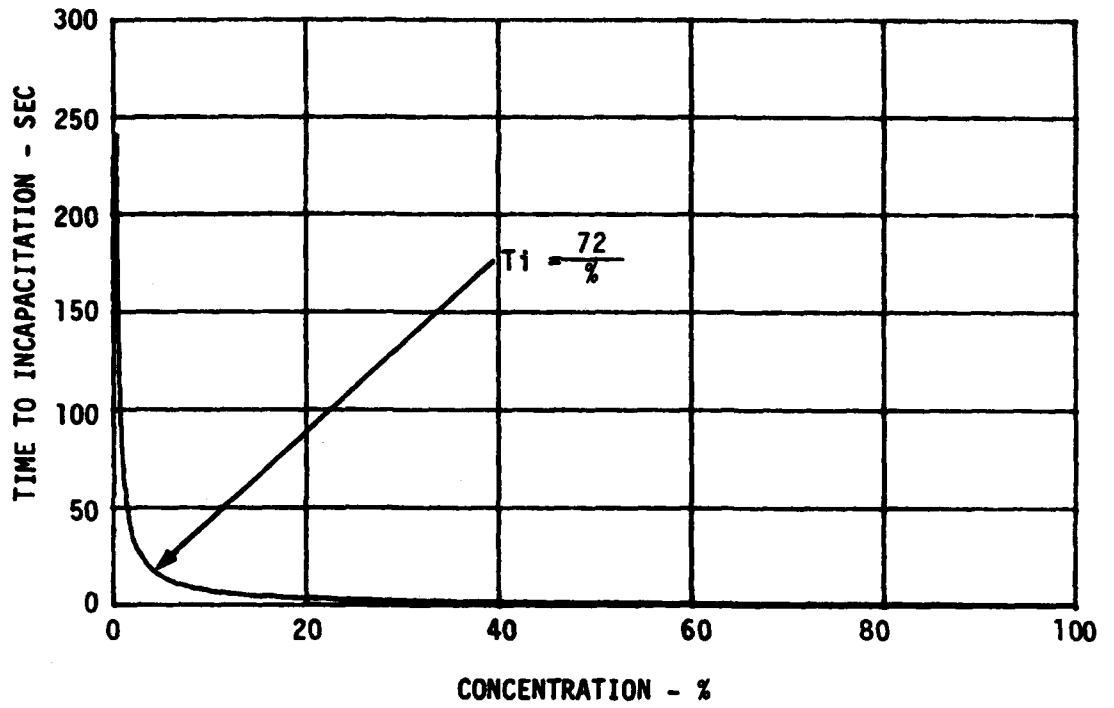

FIGURE B-7 HAZARD LIMIT CURVE - NH_3

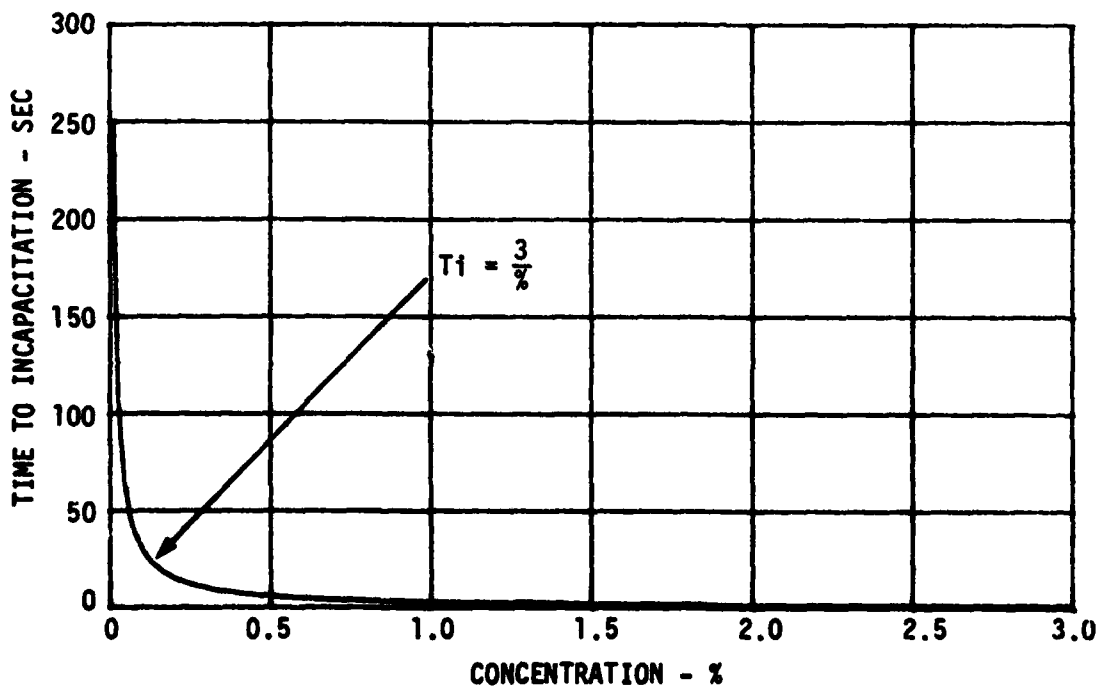

FIGURE B-8 HAZARD LIMIT CURVE - FORMALDEHYDE

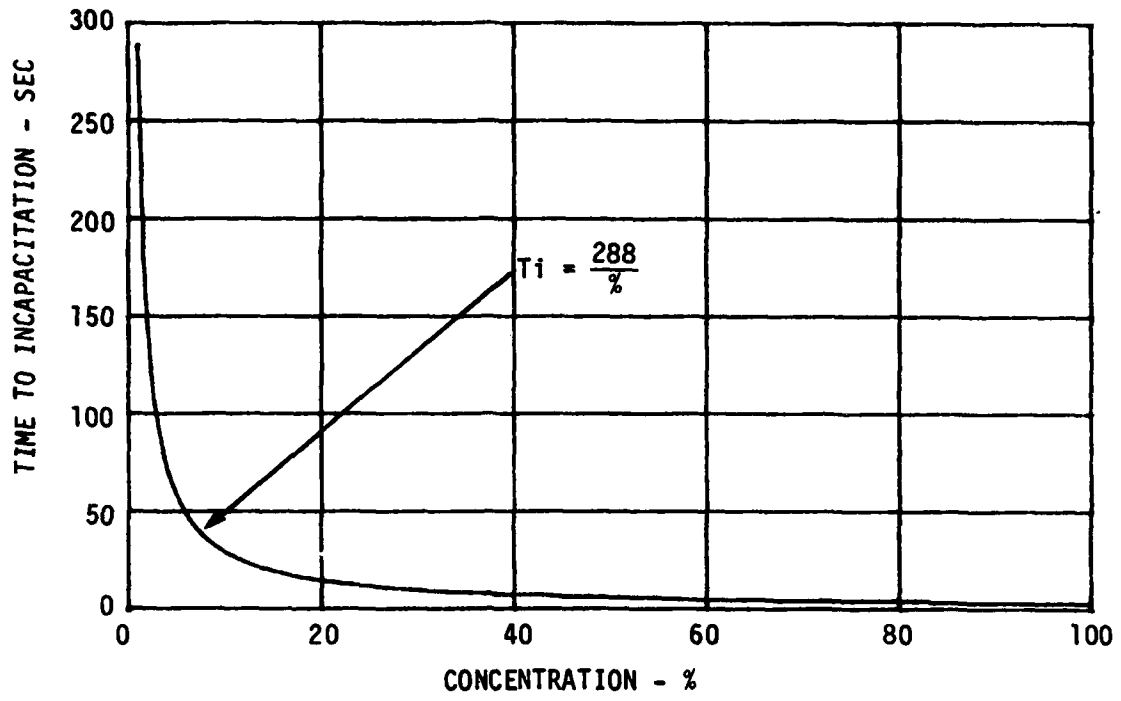

FIGURE B-9 HAZARD LIMIT CURVE - ACETALDEHYDE

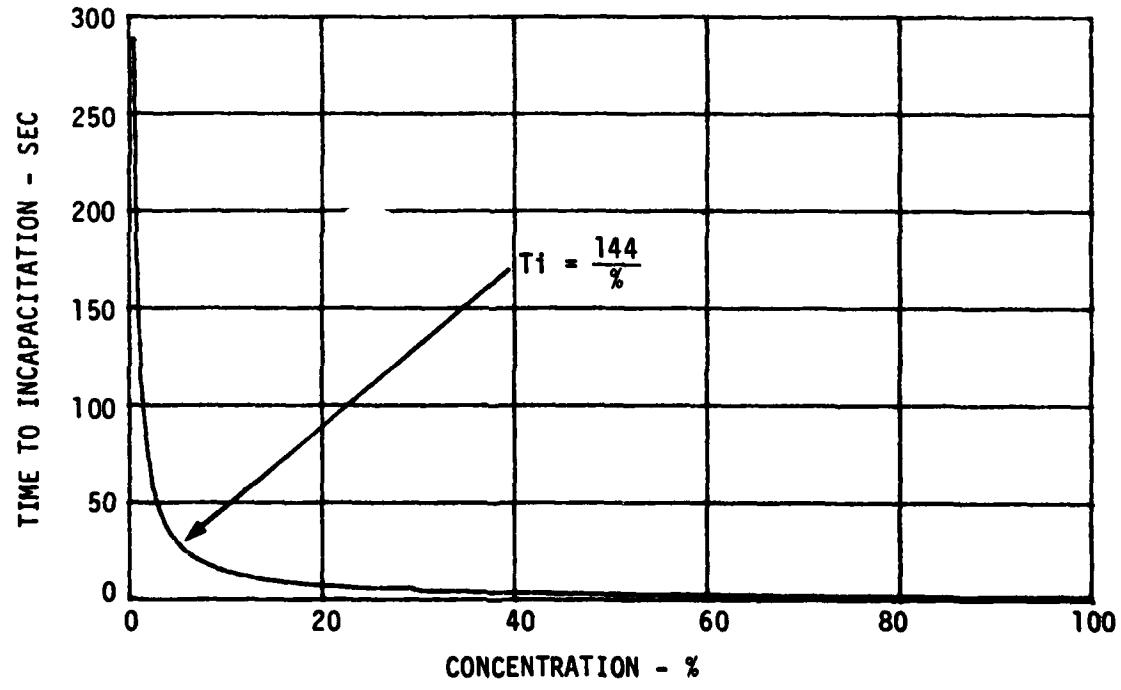

FIGURE B-10 HAZARD LIMIT CURVE - CO

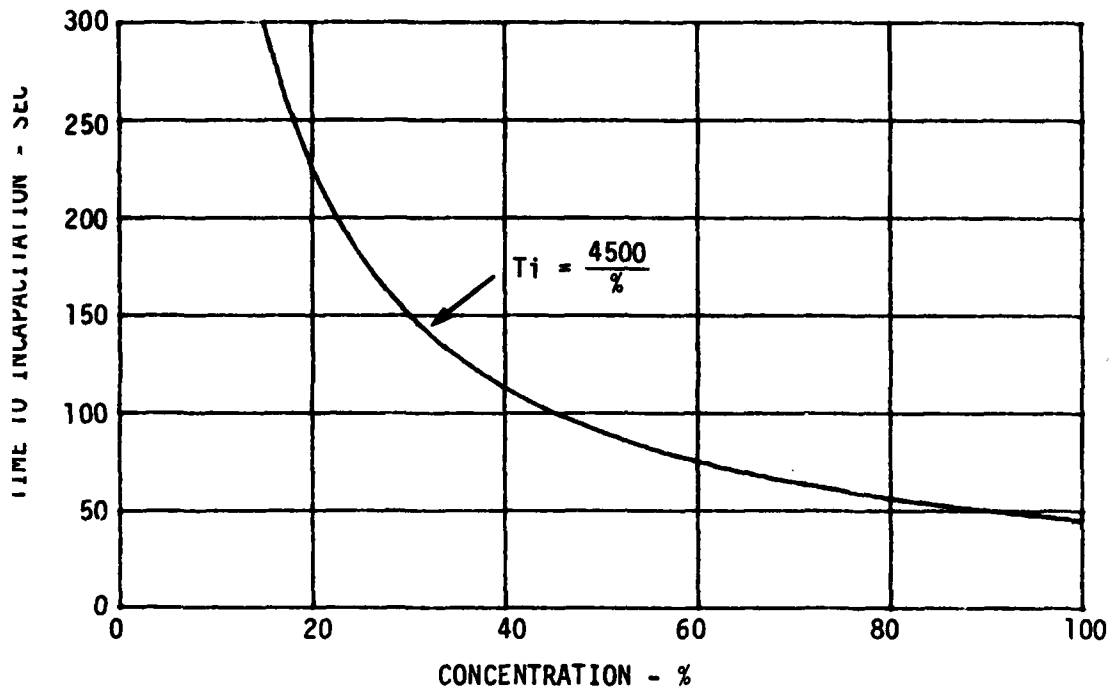

FIGURE B-11 HAZARD LIMIT CURVE - CO₂

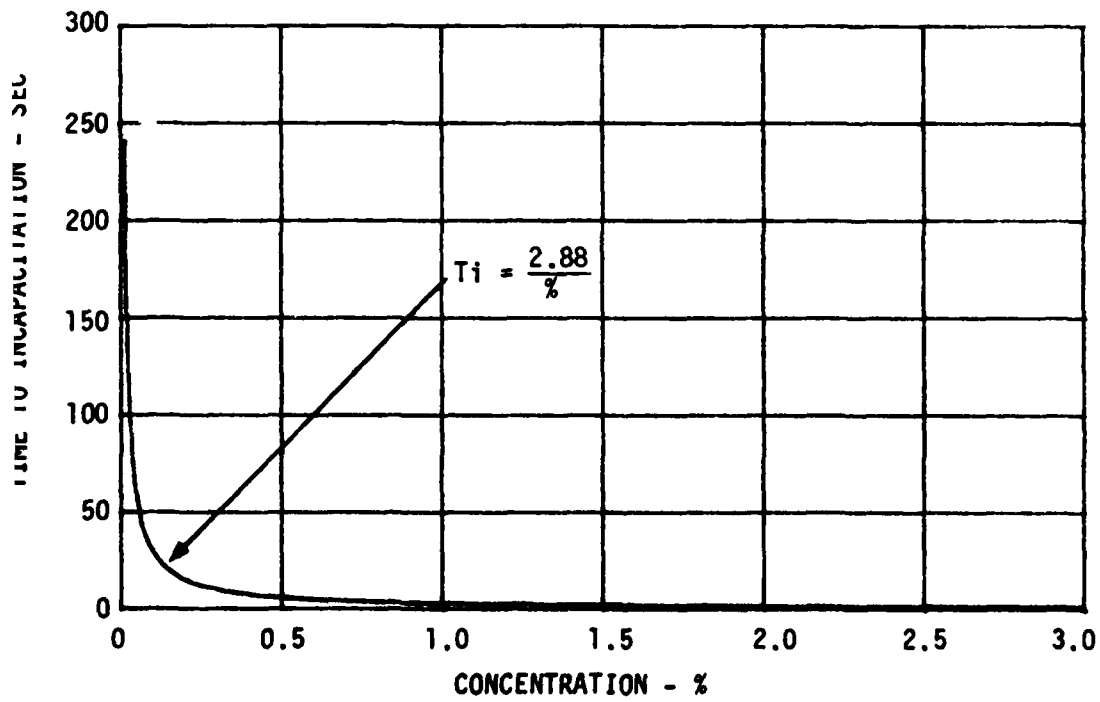

FIGURE B-12 HAZARD LIMIT CURVE - HCN

DERIVATION OF MODIFIED PETERSON AND STEWART HAZARD LIMIT EXPRESSION FOR HUMAN EXPOSURE TO CARBON MONOXIDE IN AIR

The Peterson and Stewart equation developed to relate the quantity of CO buildup in the blood versus the concentration of CO and the breathing rate is:

$$\% \text{ COHb/liter} = \Delta\% \text{ carboxyhemoglobin increase in blood per liter of contaminated air breathed.}$$

The equation recommended (Reference 22) is:

$$\log (\Delta \% \text{ COHb/liter}) = 1.036 \log (\text{ppm CO}) - 4.4793$$

Simplifying:

$$\% \text{ COHb/liter} = 10^{1.036 \log(\text{ppm CO}) - 4.4793} \times V \text{ (liter/min)}$$

Where:

V = Human Lung ventilation rate at various levels of activity:

- V = 6 liters/min at rest
- = 9.5 liters/min light activity
- = 18.0 liters/min light work
- = 30.0 liters/min heavy work

To modify the above equation to the hyperbolic form used in the CHI program:

$$T_i \text{ sec} = \frac{K (\text{ppm-sec})}{\text{ppm CO}}$$

K was, by definition, related to a concentration of COHb shown to be related to collapse, i.e.,:

$$\% \text{ COHb at } T_i = 46.5\% \text{ COHb saturation in the blood}$$

Then

$$T_i \text{ (min)} = \frac{46.5}{(10)^{1.036 \log (\text{ppm CO}) - 4.4793} \times V}$$

$$T_i \text{ (sec)} = \frac{46.5 \times 60}{(10)^{1.036 \log (\text{ppm CO}) - 4.4793} \times V}$$

$$= \frac{8.406 \times 10^7}{(10.864)^{\log (\text{ppm CO})} \times V}$$

A plot of this relationship is shown in the Part I CHI report.

APPENDIX C

FORTRAN FIRE ANALYSIS COMPUTER PROGRAM (FACP)

This Appendix contains additional information related to the FACP and its development.

- I. CHI FACP SMOKE EMISSION RATE ALGORITHM
- II. WATER (STEAM) GENERATION ALGORITHM
- III. GAS CONSTANTS USED IN PROGRAM
- IV. IBM TAPE/TEST MATERIAL IDENTIFICATION
- V. REPRESENTATIVE FACP PRINTOUTS

CHI FACP SMOKE EMISSION RATE FORMULATION

The conventional method for expressing a "concentration" of smoke in a layer or through some viewing distance relates this quantity to optical transmission or density:

$$\text{O.D.} = \log_{10} \left(\frac{100}{T} \right) = \log_{10} \left(\frac{I_0}{I} \right) = \text{SLK} \quad (\text{C-1})$$

Where:

- O.D. = Optical Density
- T = Percent Light Transmission through Pathlength L Meters
- I_0/I = Ratio of the initial light intensity to the intensity over pathlength
- K = Proportionality constant, similar to the extinction coefficient, which may be interpreted as the optical cross section of a smoke "particle" = $1 \text{ m}^2/\text{SMOKE}$.
- S = SMOKE concentration in "particles" per cubic volume.

Smoke is measured in the OSU HRR calorimeter using a photometer at the stack outlet. The photometer is calibrated and measures the dynamic changes in optical density of smoke concentrations flowing through its optical viewing path. The formulation employed in the CHI computer program uses the same emission rate calculation as currently proposed by Smith (Reference 1). As output in the CHAS measurements, the concentration of SMOKE is calculated as the "particles" emitted per cubic meter over a pathlength of 1 meter per minute per m^2 of test sample. A concentration in terms of "particle" of smoke (SRR unit) is defined as the quantity contained in one cubic meter of volume which will reduce the light transmission over 1 meter path to 10%.

Based on equation C-1, the value of K then is:

$$K = \log_{10} \frac{100}{T} = 1 \quad (C-2)$$

when S is expressed in units of "particles" per cubic meter. The light transmission T, then can be related to the smoke concentration by substitution in (C-1):

$$\log_{10} \left(\frac{100}{T} \right) = SLK \quad (C-3)$$

and solving for T

$$T = \frac{100}{10^{SLK}} \quad (C-4)$$

This states that the percent transmission for a concentration of one smoke "particle" per m^3 viewed over a 1-meter pathlength (SRR unit) would equal 10% ($S = 1, L = 1$). Two particles per m^3 would give a transmission of 100 $(0.1)^2$ or 1%; three particles per m^3 would give 100 $(0.1)^3$ or 0.001%, etc.

The instantaneous SMOKE emission values output by the CHAS are input by means of the IBM tape to the FACP as particles per second, S_{IN} , entering each of the 18 zones in the CFS (Figure 29) or as a well mixed concentration in the total CFS volume (single zone program). An additional assumption is that the flow of smoke is proportional to the total gas mixture volume flow rate. The smoke data from CHAS is calculated per m^2 of smoke whereas the panels burned in the CFS were 24 ft^2 ($2.2 m^2$) so that:

$$S_{IN} (I) = \frac{CHAS \text{ SSU}}{\text{min } m^2} \times \frac{AP}{60 \text{ sec/min}} \quad (C-5)$$

Where

CHAS SSU = Standard SMOKE units measured instantaneously by CHAS

AP = Area of Panel, m^2

$S_{IN}(I)$ = Instantaneous SMOKE "particles" per second into a zone per panel.

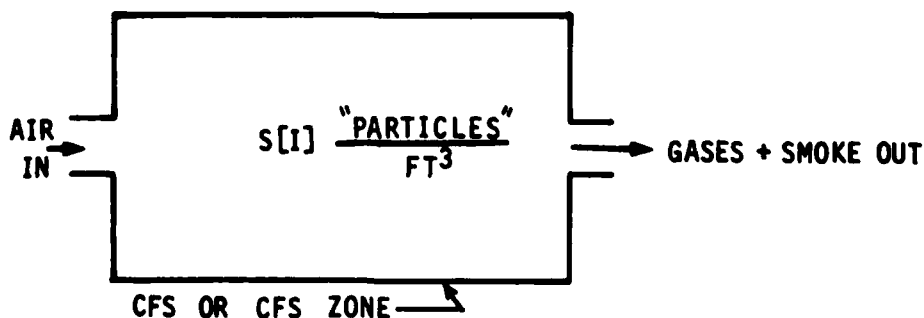

$S_{IN}(I)$ flow in "particles" per second enters the CFS or any zone in the CFS (per 20 zone FACP). Assuming that the smoke is nearly equivalent to the total mixture weight flow, WM , divided by the mixture density, RHO . The conservation equation describing the flow of SMOKE in terms of particles/ft³ for each instant of time into and out of a zone or the CFS as indicated in the above diagram is:

$$S_{IN} - S_{OUT} = S_1 \left(\frac{WM_{IN}}{RHO_{IN}} \right) - S_2 \left(\frac{WM_{OUT}}{RHO_{OUT}} \right) \quad (C-6)$$

Based on the area of material, AP , emitting smoke into a volume, V of the CFS or a CFS zone, the equation for the rate of change of smoke concentration with time can be written:

$$\begin{aligned} \frac{dS [I]}{dt} &= \frac{(S_{IN} - S_{OUT}) \times AP}{V} & (C-7) \\ &= \frac{\text{"Particles" of SMOKE (Panel)}}{\text{Volume of Compartment}} \end{aligned}$$

The subroutine FLODYN (Figure 29) calculates the $S(I)$ out of the compartment. The DIFFEQ SBR numerically integrates the difference equation, (C-6), and calculates the net rate of increase or decrease of smoke "particles" per second in the compartment. Integration of differential equation (C-7) by the RUNGKU SBR gives the $S(I)$ "particles" per ft³ after conversion to English units, and calculates the quantity of smoke in terms of transmittance over a burn time.,

$$\frac{T}{100} = \frac{1}{10 \left(\frac{SRR \times 0.305}{.02832} \right)} \quad (C-8)$$

SBR ESTI then calculates the "Fractional Dose" in the Fortran Program using Allard's Law, q, i, v .

The FD limit for smoke is limited in the calculations and plotting of the FD curve of smoke to 0.4 based on the discussion presented in the Part I report.

STEAM GENERATION

The computer program calculates the ppm concentration of each gas in terms of the partial pressure ratio of each (ith) principal combustion product to the total partial pressure sum of the air and the measured gases in the mixture (Dalton's Law). Since each test panel was composed of a variety of organic and inorganic (nonburning) materials, many organic chemical compounds are generated by thermal decomposition during burn tests. These compounds are constituted from differing quantities of the elements carbon, hydrogen, oxygen, nitrogen, etc. and yield correspondingly different quantities of lower molecular weight gaseous and liquid products in the regions near the burning surface of the parent material.

Thermal decomposition also produces carbon which can burn to produce CO or CO₂ depending on the temperature and the availability of oxygen. Smaller amounts of higher molecular weight (liquid) organic products of combustion may be generated as aerosol particles which are filtered out in the CHAS filters during a test run and are not therefore measured by the hydrocarbon analyzer.

The chemical equation for the combustion of a hydrocarbon fuel is:

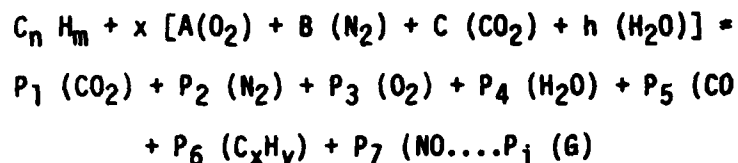

Where:

- X = moles of dry air/mole of hydrocarbon
- A = mole fraction of O₂ in inlet air, 0.2095
- B = mole fraction of N₂ (and argon) in inlet air, 0.79
- C = mole fraction of CO₂ in inlet air, 0.00032
- h = mole fraction of H₂O in inlet air
- P₁-P₇ = partial pressures of gas products
- n,m,x,y = carbon and hydrogen atoms in fuel and unburned hydrocarbons

In this equation, the dry air input to the CHAS was relatively dry, so humidity was neglected, and

$$\text{Air} = A + B + C = 1$$

The molecular weight for dry air used in the FACP was 28.9. The molecular formulas of the unburned hydrocarbons, C_xH_y, and any oxygenated varieties in the combustion products were not known. The composition of the unburned hydrocarbons in the product mixture also was not known, so a simplified calculation of the water (steam) generated as a major product was estimated and added to the other gases to calculate the total pressure.

Carbon burns to produce:



or



The CH_x analyzer used in CHAS was assumed to measure the carbon number of unburned hydrocarbons in terms of methane, CH₄ (carbon/hydrogen ratio = 4 to 1), which when burned gives:



Subtracting (C-10) from (C-11) gives:



and adding (C-12) and (C-13) gives:

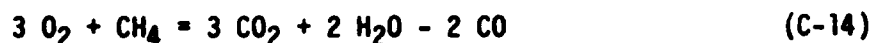

Rearranging to obtain H₂O:

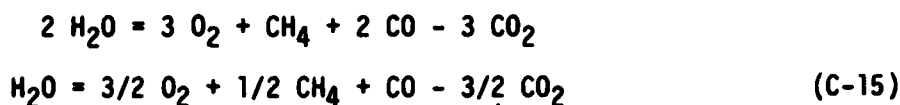

The CHAS monitors measure oxygen depletion, and the concentration of CH₄, CO, and CO₂ in real time. The other gases and products (not measured) were neglected in the FACP calculation for water (steam).

GAS CONSTANTS USED IN FACP

The gas constants input as independent variables in the FACP are listed in Table C-1.

TABLE C-1
GAS CONSTANTS USED IN FACP

FACP NO.	GAS FORUMLA	MOL. WT.	Cp	R'	AMAX *
1	O ₂	32	0.217	48.3	1
2	N ₂	28	0.247	55.2	1
3	CO ₂	44	0.205	35.1	4500
4	CO	28	0.243	55.2	144
5	NO	30	0.24	51.5	14.4
6	HCN	27	0.24	57.2	2.88
7	HF	20	0.335	77.2	8.64
8	HCl	36.5	0.185	42.3	1.5
9	RCHO (HCHO)	30	0.24	51.5	3.0
10	CHx (CH ₄)	16	0.525	96.0	1

* AMAX = K value limit established by hazard limit analyses and used to calculate the FD's and CHI values, % sec

R' = Universal gas constant/M.W. of gas, lb ft/lb °R

Cp = Heat capacity at constant pressure, Btu/lb °R

IBM TAPE IDENTIFICATION

The data from the CHAS runs transferred to IBM 7-inch tape are identified for reference purposes in Table C-2.

TABLE C-2
IBM TAPE/TEST MATERIAL IDENTIFICATION

HEAT FLUX BTU/FT ² SEC	W/CM ²	PANEL MATERIAL & TAPE NUMBER			
		1	2	3	4
2.2	2.5	-	BA 482	BA 475	BA 479
3.08	3.5	-	BA 476	BA 478	BA 480
4.41	5.0	BA 484	BA 474	BA 483	BA 477

REPRESENTIVE FACP PRINTOUTS - SINGLE AND 20 ZONE PROGRAMS

The FACP prints out various hazard concentrations changes in rate of surface temperatures, fractional doses and CHI (escape time) values at 5 second intervals.

The 20 zone program was formatted to print out all parameters at the time the summation of all FD's = 1.

The single zone program prints out values only at 5 second intervals or other intervals, if required.

Tables C-3 ad C-4 show FACP 20 zone printouts for Panel 4 run at 4.41 Btu/ft² sec heat flux; Tables C-5 is representative of FACP single zone printouts for the same material heat flux. It should be noted that the 20 zone printout has been formatted with 10 zone columns of output data per page while the single zone program prints the output data serially in separate 5-sec data blocks for each parameter in a column.

The abbreviations used in these printouts are identified as follows:

- CHI = Summation of all hazards FD's
- Flow = Gas and smoke flow, lb/sec
- Wall Temp = CFS wall temperature, °F
- Air Temp = CFS air temperature, °F
- DTA/DT = Rate of change of air temperature
- SMOKE FD = SMOKE Fractional Dose
- O₂ P = Oxygen partial pressure, ppm
- N₂ P = Nitrogen partial pressure, ppm
- CO₂ P = Carbon dioxide partial pressure, ppm
- CO₂ FD = Carbon dioxide fractional dose
- CO P = Carbon monoxide partial pressure, ppm
- H₂O = Water (steam) partial pressure, ppm
- etc.
- SMOKE or TRANS = Smoke transmittance, %T/100

TABLE C-3
20 ZONE FAC PRINTOUT OF DATA FOR PANEL 4 MATERIAL AT 4.41 BTU/FT² SEC

	1	2	3	4	5	6	7	8	9	10
TIME = 25.0 SEC										
ZONE	1	2	3	4	5	6	7	8	9	10
OHI	0.136	0.610	0.194	0.201	2.269	1.991	1.746	0.938	2.317	2.522
TOT PRESS	16.918	16.375	15.443	15.389	15.303	15.321	15.326	15.265	15.221	15.218
FLOW	0.618	0.707	0.210	0.770	0.0	0.257	0.0	0.639	0.441	0.128
WALL TEMP	90.000	90.000	70.990	71.004	70.987	70.986	71.001	70.986	70.985	71.009
AIR TEMP	0.1170+03	0.1460+03	0.1270+03	0.1240+03	0.1150+03	0.1110+03	0.1110+03	0.1080+03	0.1010+03	0.1010+03
UT/DT	0.5750+01	0.1680+02	0.1010+03	0.1240+03	0.1190+03	0.4550+02	0.1520+03	0.1810+03	0.9260+02	0.2020+03
AIR FD	0.9640-01	0.9670-01	0.9120-01	0.8970-01	0.8740-01	0.8590-01	0.8620-01	0.8440-01	0.8180-01	0.8250-01
TRAYS	0.1700+01	0.1120-01	0.6360-05	0.2290-04	0.2520-06	0.1190+00	0.1660+00	0.1180+00	0.6470-01	0.4600-01
SHAKE FD	0.4000-01	0.4000+00	0.4000+00	0.4000+00	0.4000+00	0.4000+00	0.4000+00	0.4000+00	0.4000+00	0.4000+00
U2 P	0.2100+06	0.1510+06	0.1620+06	0.1620+06	0.1900+06	0.1930+06	0.1950+06	0.2040+06	0.1900+06	0.1880+06
H2 P	0.7900+06	0.7900+06	0.7960+06	0.7960+06	0.7950+06	0.7940+06	0.7950+06	0.7920+06	0.7950+06	0.7950+06
CO2 P	0.1530-05	0.2470+05	0.1610+05	0.1620+05	0.4880+04	0.4000+04	0.3570+04	0.1070+04	0.4920+04	0.5630+04
CO2 FD	0.2270-11	0.4710-02	0.2250-02	0.2270-02	0.5060-03	0.4090-03	0.3550-03	0.9280-04	0.5140-03	0.6020-03
CO P	0.2280-06	0.1020+05	0.6210+04	0.6250+04	0.1670+04	0.1350+04	0.1220+04	0.3240+03	0.1680+04	0.1960+04
CU FD	0.1060-10	0.5170-01	0.2290-01	0.2310-01	0.4640-02	0.3710-02	0.3260-02	0.7610-03	0.4700-02	0.5580-02
H2O P	0.9790-02	0.1660+04	0.2090+04	0.2080+04	0.1490+04	0.1360+04	0.1170+04	0.6380+03	0.1530+04	0.1560+04
MCN PARTPRESS	0.1390-08	0.6900+01	0.2310+01	0.2330+01	0.3960+00	0.3190+00	0.2870+00	0.7340-01	0.3980+00	0.4700+00
MCN FU	0.4370-11	0.7980-03	0.2750-03	0.2770-03	0.5740-04	0.4740-04	0.4050-04	0.1220-04	0.5880-04	0.6750-04
NU PARTPRESS	0.1870-06	0.6940+03	0.5550+03	0.5570+03	0.2100+03	0.1760+03	0.1560+03	0.5440+02	0.2120+03	0.2370+03
NU FD	0.8660-10	0.6070-01	0.3290-01	0.3310-01	0.8410-02	0.6870-02	0.5890-02	0.1710-02	0.8570-02	0.9880-02
HCL PARTPRESS	0.4160-04	0.5700+04	0.5590+04	0.5600+04	0.2860+04	0.2490+04	0.2180+04	0.9800+03	0.2910+04	0.3100+04
HCL FU	0.1850-06	0.8180+01	0.5140+01	0.5140+01	0.1610+01	0.1360+01	0.1140+01	0.4110+00	0.1660+01	0.1840+01
FORMALDEHYD_PRESS	0.2130-06	0.3550+02	0.3270+02	0.3280+02	0.1590+02	0.1380+02	0.1210+02	0.5330+01	0.1620+02	0.1740+02
FORMALDEHYD_FU	0.4740-09	0.2280-01	0.1410-01	0.1410-01	0.4350-02	0.3670-02	0.3070-02	0.1100-02	0.4480-02	0.4980-02
TOT HYDRAULIC_PRESS	0.5340-06	0.1290+05	0.8030+04	0.8080+04	0.2230+04	0.1810+04	0.1630+04	0.4470+03	0.2250+04	0.2600+04
TOT HYDRAULIC_FU	0.0	0.0	0.0	0.0	0.0	0.0	0.0	0.0	0.0	0.0
MF PARTPRESS	0.1930-04	0.3390+04	0.3240+04	0.3270+04	0.1610+04	0.1400+04	0.1220+04	0.5400+03	0.1640+04	0.1750+04
MF FU	0.1490-07	0.7960+00	0.4940+00	0.4950+00	0.1530+00	0.1290+00	0.1080+00	0.3840-01	0.1570+00	0.1750+00

Copy available to DTIC does not
 permit fully legible reproduction

TABLE C-3 (Cont'd)

25.0 SEC (Cont'd)		CHI ZONE (Zone 13)												
ZONE		11	12	13	14	15	16	17	18	19	20			
CHI	1.032	0.609	0.611	0.411	0.600	0.716	0.252	0.193	0.199	0.176				
TOT PRESS	15.165	15.237	15.185	15.238	15.094	14.644	15.085	15.124	15.113	15.125				
MOM	0.622	0.050	0.736	0.0	0.111	1.419	0.102	0.213	0.105	0.491				
WALL TEMP	70.042	70.042	70.102	70.041	70.035	70.072	70.035	70.035	70.072	70.035				
AIR TEMP	0.994D+02	0.992D+02	0.984D+02	0.991D+02	0.930D+02	0.917D+02	0.928U+02	0.922D+02	0.926D+02	0.926D+02	0.926D+02	0.926D+02	0.926D+02	
DTA/DI	-0.176D+03	0.114D+03	-0.223D+03	0.325D+03	0.655D+02	-0.574D+03	0.730D+02	-0.450D+02	0.104D+03	-0.133D+03				
AIR FD	0.811U-01	0.818D-01	0.810D-01	0.824D-01	0.775D-01	0.754D-01	0.776D-01	0.777D-01	0.782D-01	0.776U-01				
TRANS	0.920D-01	0.704D+00	0.692D+00	0.609D+00	0.696D+00	0.583D+00	0.773D+00	0.970D+00	0.964D+00	0.926U+00				
SMOKE FD	0.400U+00	0.104U+00	0.108D+00	0.141D+00	0.106D+00	0.153D+00	0.832D-01	0.441D-01	0.449D-01	0.508U-01				
Q RAD	0.0	0.0	0.0	0.0	0.0	0.0	0.0	0.0	0.0	0.0				
O2 P	0.203D+06	0.204D+06	0.205D+06	0.207D+06	0.205D+06	0.204D+06	0.209D+06	0.209D+06	0.209D+06	0.209D+06				
N2 P	0.792D+06	0.792D+06	0.792D+06	0.791D+06	0.792D+06	0.792D+06	0.790D+06	0.790D+06	0.790D+06	0.790D+06				
CO2 P	0.124D+04	0.100D+04	0.997D+03	0.367D+03	0.977D+03	0.127D+04	0.194U+03	0.149D+03	0.154D+03	0.842D+02				
CO2 FD	0.114D-03	0.848U-04	0.870D-04	0.299D-04	0.854D-04	0.114D-03	0.143D-04	0.107D-04	0.116D-04	0.599D-05				
CO P	0.386D+03	0.302D+03	0.304D+03	0.101D+03	0.304D+03	0.406D+03	0.528U+02	0.397D+02	0.415D+02	0.207U+02				
CO FD	0.939D-03	0.693D-03	0.717D-03	0.223D-03	0.702D-03	0.981D-03	0.106D-03	0.781D-04	0.851D-04	0.605U-04				
H2O P	0.730D+03	0.635U+03	0.593D+03	0.342D+03	0.596D+03	0.583D+03	0.192D+03	0.161D+03	0.159D+03	0.121U+03				
HCN PARIPRESS	0.865U-01	0.698U-01	0.688D-01	0.278D-01	0.689D-01	0.873D-01	0.151D-01	0.121D-01	0.122D-01	0.794D-02				
HCN FD	0.149D-04	0.113D-04	0.114D-04	0.474D-05	0.112D-04	0.138D-04	0.230D-05	0.179D-05	0.190D-05	0.117D-05				
HU PARIPRESS	0.642D+02	0.518U+02	0.507D+02	0.209D+02	0.509D+02	0.607D+02	0.112D+02	0.867D+01	0.887D+01	0.524U+01				
HU FD	0.210D-02	0.157U-02	0.160D-02	0.591D-03	0.157D-02	0.203D-02	0.283D-03	0.213D-03	0.229D-03	0.124D-03				
HCL PARIPRESS	0.114D+04	0.957U+03	0.911D+03	0.465D+03	0.916D+03	0.972D+03	0.256D+03	0.208D+03	0.208D+03	0.147D+03				
HCL FD	0.499D+06	0.384U+06	0.382D+06	0.171D+06	0.377D+06	0.442D+06	0.829D-01	0.649D-01	0.689D-01	0.434D-01				
FURMALDEHYDIPRESS	6.614D+01	0.519U+01	0.495D+01	0.249D+01	0.498D+01	0.533D+01	0.137D+01	0.111D+01	0.111D+01	0.786D+06				
FORMALDEHYDE FD	0.133U-02	0.102D-02	0.102D-02	0.452D-03	0.101D-02	0.118D-02	0.219D-03	0.172D-03	0.182D-03	0.114D-03				
TOT HYDROCARBIPRESS	0.532D+03	0.418D+03	0.420D+03	0.144D+03	0.419D+03	0.552D+03	0.754D+02	0.571D+02	0.594D+02	0.305D+02				
TOT HYDROCARB FD	0.0	0.0	0.0	0.0	0.0	0.0	0.0	0.0	0.0	0.0				
HF PARIPRESS	0.627D+03	0.526U+03	0.502D+03	0.252D+03	0.504D+03	0.540D+03	0.139D+03	0.112D-03	0.113D+03	0.785D+06				
HF FD	0.467U-01	0.358D-01	0.357D-01	0.134D-01	0.352D-01	0.415D-01	0.764D-02	0.597U-02	0.634D-02	0.396U-02				

TABLE C-4
20 ZONE FACP PRINTOUT OF DATA FOR PANEL 4 MATERIAL AT 4.41 BTU/FT² SEC

TIME = 20.5 SEC	MUUT = 229.516	TMATL = 991.577	QOOTMATL = 233.642	WTMATL = 229.516						
ZONE	1	2	3	4	5	6	7	8	9	10
CHI	0.154	11.092	7.686	7.693	3.113	2.732	2.401	1.263	3.166	3.415
TOT PRESS	19.492	16.716	15.641	15.583	15.479	15.505	15.508	15.439	15.385	15.376
FLOW	0.641	0.745	0.234	0.764	0.038	0.261	0.0	0.610	0.453	0.167
WALL TEMP	540.000	540.000	530.737	530.763	530.732	530.731	530.757	530.730	530.729	530.773
AIR TEMP	0.6010+03	0.6470+03	0.6190+03	0.6140+03	0.6000+03	0.5950+03	0.5930+03	0.5890+03	0.5780+03	0.5780+03
DATA/T	0.8040+01	0.1290+02	0.1050+03	0.1230+03	0.1120+03	0.4350+02	0.1570+03	0.1800+03	0.9390+02	0.2100+03
AIR FD	0.1140+00	0.1200+00	0.1110+00	0.1090+00	0.1050+00	0.1030+00	0.1030+00	0.1010+00	0.9710-01	0.9790-01
TRANS	0.1000+01	0.4950-02	0.1060-05	0.1170-04	0.1430-07	0.3960-01	0.6720-01	0.3640-01	0.1640-01	0.1200-01
SMOKE FD	0.4000+00	0.4000+00	0.4000+00	0.4000+00	0.4000+00	0.4000+00	0.4000+00	0.4000+00	0.4000+00	0.4000+00
Q RAD	0.0	0.0	0.0	0.0	0.0	0.0	0.0	0.0	0.0	0.0
U2 P	0.2100+06	0.1510+06	0.1570+06	0.1570+06	0.1830+06	0.1870+06	0.1890+06	0.2010+06	0.1830+06	0.1810+06
U2 P	0.7940+06	0.7960+06	0.7920+06	0.7920+06	0.7940+06	0.7940+06	0.7940+06	0.7920+06	0.7940+06	0.7940+06
CU2 P	0.1200+05	0.2710+05	0.2030+05	0.2090+05	0.8110+04	0.6650+04	0.6010+04	0.2160+04	0.8030+04	0.8930+04
CU2 FD	0.2370-11	0.6730-02	0.3700-02	0.3720-02	0.1010-02	0.8200-03	0.7240-03	0.2150-03	0.1010-02	0.1170-02
CU P	0.1860-06	0.1130+05	0.8420+04	0.8450+04	0.3020+04	0.2450+04	0.2220+04	0.7320+03	0.2990+04	0.3370+04
CO FD	0.1110-10	0.7820-01	0.4080-01	0.4100-01	0.1030-01	0.8280-02	0.7380-02	0.2000-02	0.1030-01	0.1200-01
H2O P	0.7710-02	0.1470+04	0.1810+04	0.1810+04	0.1570+04	0.1460+04	0.1290+04	0.8120+03	0.1390+04	0.1570+04
H2N PARTPRESS	0.1480-09	0.1220+02	0.5900+01	0.5940+01	0.1280+01	0.9990+00	0.9120+00	0.2190+00	0.1260+01	0.1490+01
H2N FD	0.4570-11	0.1970-02	0.7610-03	0.7660-03	0.1510-03	0.1210-03	0.1080-03	0.2820-04	0.1520-03	0.1780-03
H2O PARTPRESS	0.1470-06	0.6980+03	0.6210+03	0.6230+03	0.2980+03	0.2510+03	0.2250+03	0.9440+02	0.2960+03	0.3200+03
H2O FD	0.9970-10	0.7760-01	0.4730-01	0.4750-01	0.1460-01	0.1200-01	0.1050-01	0.3500-02	0.1480-01	0.1670-01
H2L PARTPRESS	0.3270-04	0.5220+04	0.5520+04	0.5520+04	0.3660+04	0.3040+04	0.2710+04	0.1410+04	0.3460+04	0.3590+04
H2L FU	0.1940-06	0.9450+01	0.6440+01	0.6450+01	0.2350+01	0.2010+01	0.1710+01	0.6890+00	0.2410+01	0.2630+01
FORMALDEHYDE PRESS	0.1630-06	0.3420+02	0.3370+02	0.3370+02	0.1980+02	0.1730+02	0.1540+02	0.7810+01	0.1980+02	0.2070+02
FORMALDEHYD. FU	0.4960-07	0.2690-01	0.1800-01	0.1800-01	0.6440-02	0.5490-02	0.4680-02	0.1460-02	0.6580-02	0.7210-02
TOT HYDRUCARBON PRESS	0.4200-06	0.1420+05	0.1070+05	0.1070+05	0.3940+04	0.3200+04	0.2900+04	0.9780+03	0.3890+04	0.4370+04
TOT HYDRUCARB. FU	0.0	0.0	0.0	0.0	0.0	0.0	0.0	0.0	0.0	0.0
H2 PARTPRESS	0.1520-04	0.3150+04	0.3250+04	0.3250+04	0.1980+04	0.1730+04	0.1540+04	0.7880+03	0.1980+04	0.2060+04
H2 HI	0.1560-07	0.9290+00	0.6270+00	0.6270+00	0.2260+00	0.1920+00	0.1640+00	0.6520-01	0.2310+00	0.2530+00

Copy available to DTIC does not
 permit fully legible reproduction

TABLE C-4 (Cont'd)

28.5 SEC (Cont'd)	11	12	13	14	15	16	17	18	19	20
CH1	1.395	1.021	1.002	0.715	1.002	1.171	0.426	0.288	0.293	0.259
TOT PRESS	15.333	15.402	15.350	15.405	15.225	14.661	15.220	15.269	15.257	15.278
FLOW	0.665	0.076	0.720	0.0	0.143	1.561	0.139	0.209	0.148	0.459
WELL TEMP	530.064	530.064	530.157	530.063	530.054	530.111	530.054	530.053	530.111	530.053
AIR TEMP	0.5760+03	0.5750+03	0.5740+03	0.5740+03	0.5650+03	0.5640+03	0.5650+03	0.5640+03	0.5640+03	0.5640+03
DIA/DI	-0.1680+03	0.1160+03	-0.2260+03	0.3260+03	0.6830+02	-0.6310+03	0.7430+02	-0.3510+02	0.9580+02	-0.1260+03
AIR FD	0.9620-01	0.9680-01	0.9580-01	0.9730-01	0.9140-01	0.8900-01	0.9140-01	0.9140-01	0.9200-01	0.9130-01
TRANS	0.2400-01	0.5010+00	0.4990+00	0.3990+00	0.4880+00	0.3740+00	0.5780+00	0.9230+00	0.9120+00	0.8350+00
SMOKE FD	0.4000+00	0.1990+00	0.2010+00	0.2780+00	0.2080+00	0.3000+00	0.1560+00	0.5140-01	0.5310-01	0.6810-01
U RAD	0.0	0.0	0.0	0.0	0.0	0.0	0.0	0.0	0.0	0.0
U2 P	0.2000+06	0.2010+06	0.2020+06	0.2060+06	0.2010+06	0.2010+06	0.2070+06	0.2090+06	0.2080+06	0.2090+06
N2 P	0.7930+06	0.7920+06	0.7920+06	0.7910+06	0.7920+06	0.7920+06	0.7910+06	0.7910+06	0.7910+06	0.7900+06
CO2 P	0.2430+04	0.2020+04	0.1950+04	0.8030+03	0.2010+04	0.2370+04	0.4690+03	0.3760+03	0.3700+03	0.2140+03
CO2 FD	0.2540-03	0.1990-03	0.1990-03	0.7370-04	0.1990-03	0.2530-03	0.3890-04	0.3000-04	0.3100-04	0.1690-04
CO P	0.8230+03	0.6780+03	0.6600+03	0.2510+03	0.6830+03	0.8410+03	0.1450+03	0.1140+03	0.1130+03	0.6030+02
CO FD	0.2370-02	0.1840-02	0.1850-02	0.6290-03	0.1860-02	0.2460-02	0.3320-03	0.2530-03	0.2620-03	0.1320-03
H2O P	0.8970+03	0.8130+03	0.7430+03	0.4730+03	0.7470+03	0.6860+03	0.2940+03	0.2570+03	0.2440+03	0.1970+03
HCN PARTPRESS	0.2500+00	0.2000+00	0.1980+00	0.6650-01	0.2070+00	0.2850+00	0.3910-01	0.3120-01	0.3080-01	0.1760-01
HCN FU	0.3340-04	0.2420-04	0.2610-04	0.1000-04	0.2630-04	0.3410-04	0.5310-05	0.4190-05	0.4300-05	0.2620-05
NO PARTPRESS	0.1060+03	0.8980+02	0.8540+02	0.3970+02	0.8750+02	0.9630+02	0.2350+02	0.1920+02	0.1870+02	0.1180+02
NO FU	0.4140-02	0.3270-02	0.3240-02	0.1310-02	0.3240-02	0.3920-02	0.6910-03	0.5390-03	0.5530-03	0.3240-03
NCL PARTPRESS	0.1560+04	0.1380+04	0.1280+04	0.7190+03	0.1300+04	0.1300+04	0.4370+03	0.3720+03	0.3570+03	0.2650+03
NCL FU	0.8130+00	0.6560+00	0.6380+00	0.3080+00	0.6350+00	0.7070+00	0.1630+00	0.1310+00	0.1340+00	0.9050-01
FORMALDEHYD.PRESS	0.8640+01	0.7620+01	0.7100+01	0.3910+01	0.7210+01	0.7270+01	0.2370+01	0.2010+01	0.1930+01	0.1420+01
FORMALDEHYD. FD	0.2190-02	0.1770-02	0.1720-02	0.8220-03	0.1710-02	0.1920-02	0.4350-03	0.3500-03	0.3570-03	0.2400-03
TOT HYDRUCB.PRESS	0.1110+04	0.9090+03	0.8930+03	0.3430+03	0.9120+03	0.1110+04	0.1990+03	0.1580+03	0.1560+03	0.8510+02
TOT HYDRUCB.FD	0.0	0.0	0.0	0.0	0.0	0.0	0.0	0.0	0.0	0.0
HF PARTPRESS	0.8720+03	0.7690+03	0.7160+03	0.3950+03	0.7270+03	0.7310+03	0.2400+03	0.2030+03	0.1950+03	0.1430+03
HF FU	0.7690-01	0.6200-01	0.6030-01	0.2800-01	0.6010-01	0.6730-01	0.1520-01	0.1220-01	0.1250-01	0.8360-02

Copy available to DTIC does not permit fully legible reproduction

TABLE C-5 (Cont'd)

TIME	N2	O2	CO	H2O	(HCN)		(NO)		(HCl)		(HF)		(RCHO)		TOT PRESS
					GAS5	GAS7	GAS6	GAS8	GAS9	GAS10	GAS11	GAS12	GAS13	GAS14	
2:00	0.0000	0.0000	0.0000	0.0000	0.0000	0.0000	0.0000	0.0000	0.0000	0.0000	0.0000	0.0000	0.0000	0.0000	0.0000
RT OF	0.0000	0.0000	0.0000	0.0000	0.0000	0.0000	0.0000	0.0000	0.0000	0.0000	0.0000	0.0000	0.0000	0.0000	0.0000
FLUX	0.0000	0.0000	0.0000	0.0000	0.0000	0.0000	0.0000	0.0000	0.0000	0.0000	0.0000	0.0000	0.0000	0.0000	0.0000
0.0000	0.0000	0.0000	0.0000	0.0000	0.0000	0.0000	0.0000	0.0000	0.0000	0.0000	0.0000	0.0000	0.0000	0.0000	0.0000
TIME	N2	O2	CO	H2O	GAS5	GAS7	GAS6	GAS8	GAS9	GAS10	GAS11	GAS12	GAS13	GAS14	TOT PRESS
2:02	0.0000	0.0000	0.0000	0.0000	0.0000	0.0000	0.0000	0.0000	0.0000	0.0000	0.0000	0.0000	0.0000	0.0000	0.0000
RT OF	0.0000	0.0000	0.0000	0.0000	0.0000	0.0000	0.0000	0.0000	0.0000	0.0000	0.0000	0.0000	0.0000	0.0000	0.0000
FLUX	0.0000	0.0000	0.0000	0.0000	0.0000	0.0000	0.0000	0.0000	0.0000	0.0000	0.0000	0.0000	0.0000	0.0000	0.0000
0.0000	0.0000	0.0000	0.0000	0.0000	0.0000	0.0000	0.0000	0.0000	0.0000	0.0000	0.0000	0.0000	0.0000	0.0000	0.0000
TIME	N2	O2	CO	H2O	GAS5	GAS7	GAS6	GAS8	GAS9	GAS10	GAS11	GAS12	GAS13	GAS14	TOT PRESS
2:04	0.0000	0.0000	0.0000	0.0000	0.0000	0.0000	0.0000	0.0000	0.0000	0.0000	0.0000	0.0000	0.0000	0.0000	0.0000
RT OF	0.0000	0.0000	0.0000	0.0000	0.0000	0.0000	0.0000	0.0000	0.0000	0.0000	0.0000	0.0000	0.0000	0.0000	0.0000
FLUX	0.0000	0.0000	0.0000	0.0000	0.0000	0.0000	0.0000	0.0000	0.0000	0.0000	0.0000	0.0000	0.0000	0.0000	0.0000
0.0000	0.0000	0.0000	0.0000	0.0000	0.0000	0.0000	0.0000	0.0000	0.0000	0.0000	0.0000	0.0000	0.0000	0.0000	0.0000

U.S. GOVERNMENT PRINTING OFFICE: 1962-805-067/10

Copy available to DTIC does not permit fully legible reproduction

TE
MED
82