

12

Thermal properties of soils

AD A 771 734

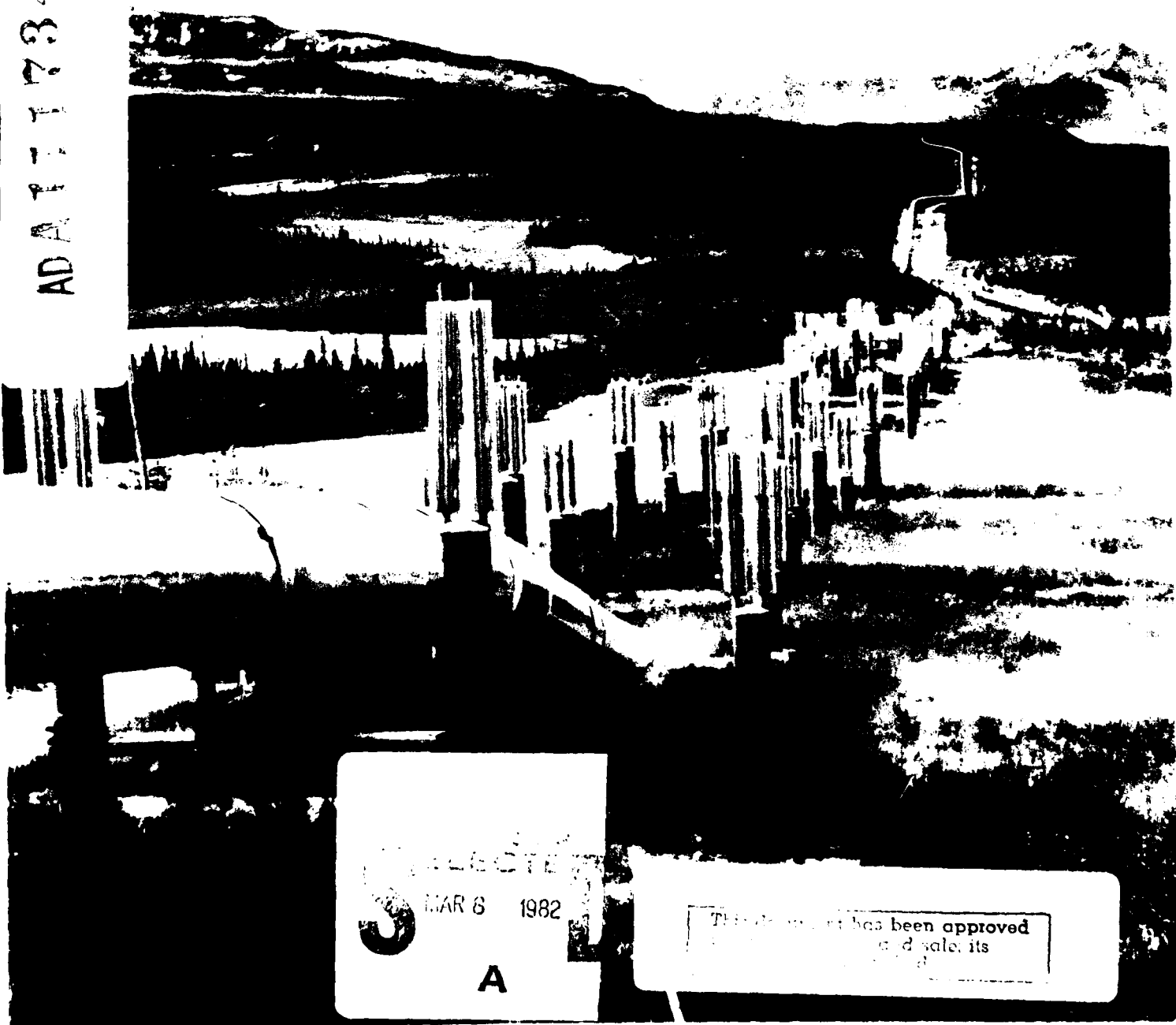

MAR 6 1982
 A

This document has been approved
 and sale its

Cover: Values of soil thermal properties were required in the thermal design of the trans-Alaska pipeline. Heat pipes were installed in the steel piles supporting the elevated sections of the warm oil pipeline to extract heat from the ground in winter so as to maintain the ground in the frozen condition. Where the pipeline was buried, the heat pipes installed in the free-standing steel piles sometimes served only to limit the thaw below the pipeline.

CRREL Monograph 81-1



Thermal properties of soils

Omar T. Farouki

December 1981

UNITED STATES ARMY CORPS OF ENGINEERS
COLD REGIONS RESEARCH AND ENGINEERING LABORATORY
HANOVER, NEW HAMPSHIRE, U.S.A.

Approved for public release, distribution unlimited

Unclassified

SECURITY CLASSIFICATION OF THIS PAGE (When Data Entered)

| REPORT DOCUMENTATION PAGE | | READ INSTRUCTIONS BEFORE COMPLETING FORM |
|--|--|---|
| 1. REPORT NUMBER CRREL Monograph 81-1 | 2. GOVT ACCESSION NO. | 3. RECIPIENT'S CATALOG NUMBER |
| 4. TITLE (and Subtitle) THERMAL PROPERTIES OF SOILS | 5. TYPE OF REPORT & PERIOD COVERED | |
| | 6. PERFORMING ORG. REPORT NUMBER | |
| 7. AUTHOR(s) Omar T. Farouki | 8. CONTRACT OR GRANT NUMBER(s) | |
| 9. PERFORMING ORGANIZATION NAME AND ADDRESS | 10. PROGRAM ELEMENT, PROJECT, TASK AREA & WORK UNIT NUMBERS DA Project IT665803M761 Task 10, Work Unit 005 | |
| 11. CONTROLLING OFFICE NAME AND ADDRESS U.S. Army Cold Regions Research and Engineering Laboratory Hanover, New Hampshire 03755 | 12. REPORT DATE December 1981 | |
| | 13. NUMBER OF PAGES 151 | |
| 14. MONITORING AGENCY NAME & ADDRESS (if different from Controlling Office) | 15. SECURITY CLASS. (of this report) Unclassified | |
| | 15a. DECLASSIFICATION/DOWNGRADING SCHEDULE | |
| 16. DISTRIBUTION STATEMENT (of this Report) Approved for public release; distribution unlimited. | | |
| 17. DISTRIBUTION STATEMENT (of the abstract entered in Block 20, if different from Report) | | |
| 18. SUPPLEMENTARY NOTES | | |
| 19. KEY WORDS (Continue on reverse side if necessary and identify by block number) Frozen soils Soil physical properties Heat transfer Soil tests Permafrost Thermal conductivity Soils Water in soils Soil dynamics | | |
| 20. ABSTRACT (Continue on reverse side if necessary and identify by block number) This monograph describes the thermal properties of soils, unfrozen or frozen. The effects on these properties of water and its phase changes are detailed. An explanation is given of the interaction between moisture and heat transfer. Other influences on soil thermal properties are described, including such factors as soil composition, structure, additives, salts, organics, hysteresis and temperature. Techniques for testing soil thermal conductivity are outlined and the methods for calculating this property are described. The monograph gives the results of an evaluation of these methods whereby their predictions were compared with measured values, thus showing their applicability to various soil types and conditions. | | |

PREFACE

The *CRREL Monograph* series is a continuation of the *Cold Regions Science and Engineering* series published by CRREL between 1961 and 1975.

This monograph was prepared by Dr. Omar T. Farouki, Senior Lecturer, Department of Civil Engineering, The Queen's University of Belfast, Northern Ireland, United Kingdom. It was written at the U.S. Army Cold Regions Research and Engineering Laboratory while the author was on sabbatical leave from the University.

This work was conducted under Invitational Travel Orders No. 10 (1 February 1977) and No. 298 (12 June 1980) issued by the U.S. Army Research and Standardization Group (Europe). Funding was provided by the CRREL Technical Information Analysis Center (TIAC).

The author is deeply indebted to the late Dr. Hans F. Winterkorn, who was responsible for the original idea for this project, and who helped in getting it started. As a former student of his, the author is conscious of the abiding influence of Professor Winterkorn, some of whose ideas are reflected in this monograph.

The author expresses his gratitude to the Queen's University of Belfast for the sabbatical leave in 1977, during which this project was begun at CRREL. Thanks are given to Dr. Alan A. Wells, then head of the Department of Civil Engineering.

Thanks are extended to William F. Quinn for his support and encouragement throughout the progress of this work. Appreciation is also expressed to Albert F. Wuori for initiating the project at CRREL and to Richard W. McGaw for interesting discussion.

This monograph was technically reviewed by Frederick J. Sanger and Dr. George K. Swinzow. The author thanks them for their efforts and for their many comments and helpful suggestions.

Figures 34, 83, 84, 96, 123, 148, 149, 152 and 153 are from *Geotechnical Engineering for Cold Regions* by O.B. Andersland and D.M. Anderson (Eds.) (Copyright McGraw-Hill Inc., 1978) and are used by permission of the McGraw-Hill Book Company.

The contents of this monograph are not to be used for advertising or promotional purposes. Citation of brand names does not constitute an official endorsement or approval of the use of such commercial products.

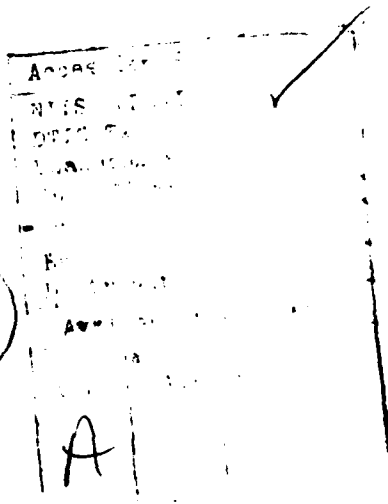

CONTENTS

| | Page |
|---|------|
| Abstract | i |
| Preface | ii |
| Metric conversion factors | x |
| Nomenclature..... | xi |
| Chapter 1. Introduction | 1 |
| 1.1 Soil and soil thermal properties | 1 |
| 1.2 Importance of soil thermal properties..... | 4 |
| 1.3 Scope and purpose of this monograph..... | 4 |
| Chapter 2. Mechanisms of heat transfer in soils..... | 6 |
| 2.1 Heat conduction..... | 6 |
| 2.2 Convection..... | 7 |
| 2.3 Radiation..... | 9 |
| 2.4 Evaporation-condensation process | 10 |
| 2.5 Other effects on soil heat transfer | 10 |
| Chapter 3. The effect of compositional, volumetric and other structural factors on the thermal properties of soils..... | 12 |
| 3.1 Composition and other structural factors..... | 13 |
| 3.2 Effect of the volumetric ratios of the constituents..... | 19 |
| 3.3 Correlations between thermal conductivity and soil density or porosity..... | 22 |
| 3.4 Effects of porosity and density on other thermal properties | 27 |
| Chapter 4. The effect of water and its migration on the thermal properties of soils | 29 |
| 4.1 Properties of water in soils and the influence of temperature..... | 29 |
| 4.2 The effects of the amount and nature of water | 38 |
| 4.3 Combined moisture and heat transfer in soils caused by temperature gradients..... | 54 |
| 4.4 Combined moisture and heat transfer during soil freezing | 60 |
| Chapter 5. Further influences on the thermal properties of soils | 69 |
| 5.1 Properties of soil components influencing thermal behavior plus the effect of temperature | 69 |
| 5.2 Effects of temperature on thermal properties of soils..... | 76 |
| 5.3 Effects of ions, salts and other solutes on soil thermal properties..... | 81 |
| 5.4 Effects of additives..... | 86 |
| 5.5 Hysteresis and history | 87 |
| 5.6 Organic factors | 88 |
| 5.7 Direction of heat flow | 89 |
| 5.8 Convectational effects | 90 |
| Chapter 6. Measurement of thermal properties of soils | 91 |
| 6.1 Steady state methods | 91 |
| 6.2 Transient methods..... | 94 |
| 6.3 Comparison of results from probe and GHP tests..... | 98 |
| Chapter 7. Methods for calculating the thermal conductivity of soils..... | 102 |
| 7.1 Parallel or series flow equations and the geometric mean | 102 |
| 7.2 Smith's method for dry soils..... | 102 |
| 7.3 Kersten's empirical equations | 103 |
| 7.4 Mickley's method | 107 |
| 7.5 Gemant's method | 108 |

| | Page |
|--|------|
| 7.6 De Vries' method..... | 109 |
| 7.7 The empirical equations of Van Rooyen and Winterkorn | 110 |
| 7.8 The method of Kunii and Smith..... | 110 |
| 7.9 The modified resistor equation..... | 111 |
| 7.10 McGaw's conductance equation..... | 111 |
| 7.11 Johansen's method | 112 |
| 7.12 Trends shown by the various methods | 117 |
| 7.13 Evaluation of the methods | 117 |
| Chapter 8. Discussion and conclusions..... | 120 |
| 8.1 The condition of water in soils | 120 |
| 8.2 The degree of saturation | 120 |
| 8.3 Effect of increase in temperature above 0°C..... | 122 |
| 8.4 Moisture and heat transfer | 122 |
| 8.5 Effects of ions and salts..... | 122 |
| 8.6 Additives, contacts and interfacial effects..... | 122 |
| 8.7 Frozen soil factors | 123 |
| 8.8 Factors in measurements of thermal conductivity..... | 123 |
| 8.9 Applicability of the thermal conductivity methods | 123 |
| 8.10 Suggestions for further research..... | 123 |
| Literature cited | 125 |
| Appendix A: Description of some test soils | 133 |

ILLUSTRATIONS

Figure

| | |
|--|----|
| 1. Heat flow through a prismatic element of soil | 2 |
| 2. Thermal properties and water content for saturated soils | 3 |
| 3. Regions of predominant influence of the various heat transfer mechanisms | 6 |
| 4. Nusselt's model of heat flow in a fissured body | 9 |
| 5. Volume relationships in binary mixtures giving minimum voids | 13 |
| 6. Shapes of air gaps in some common soil structures..... | 14 |
| 7. Effect of water tension on soil permeability | 15 |
| 8. Thermal conductivity of sand and ice mixtures as a function of sand content | 16 |
| 9. Thermal conductivity of quartzitic granular material with kaolinite binder | 16 |
| 10. Comparison of thermal conductivity data..... | 17 |
| 11. Idealized models of heat flow through a unit cube of soil..... | 19 |
| 12. Hashin-Shtrikman bounds for two-component materials as compared to the Wiener bounds at a set of thermal conductivity ratios and as functions of porosity | 20 |
| 13. Miller bounds for two-component materials as compared to the Hashin-Shtrikman bounds at a set of thermal conductivity ratios and as functions of porosity assum- ing spherical particles | 21 |
| 14. Miller bounds for normalized effective thermal conductivity of symmetric cell materi- al compared to Hashin-Shtrikman bounds at ratio $k_g/k_f = .10$ | 21 |
| 15. Miller bounds for normalized effective thermal conductivity of symmetric cell materi- al compared to Hashin-Shtrikman bounds at ratio $k_g/k_f = 100$ | 21 |
| 16. Curves for thermal conductivity compared with data on saturated quartz sand..... | 22 |
| 17. Thermal conductivities of sand and clay, unfrozen or frozen, as a function of dry density..... | 23 |

| Figure | Page |
|---|------|
| 18. Thermal conductivity of unfrozen sandy soils vs dry density at constant moisture | 23 |
| 19. Thermal conductivity of frozen sandy soils vs dry density at constant moisture content | 24 |
| 20. Thermal conductivity of unfrozen clayey soils vs dry density at constant moisture content | 24 |
| 21. Thermal conductivity of frozen clayey soils vs dry density at constant moisture content | 24 |
| 22. Logarithm of thermal conductivity as a function of porosity of homoionic kaolinite clays..... | 24 |
| 23. Effect of texture and density on thermal conductivity and on thermal diffusivity | 25 |
| 24. Thermal conductivity of dry soils as a function of dry density | 25 |
| 25. Thermal conductivity of dry Leda clay as a function of dry density..... | 25 |
| 26. Thermal conductivity of dry natural soils and crushed rock vs porosity | 26 |
| 27. Thermal conductivity of saturated Leda clay vs dry density..... | 26 |
| 28. Thermal conductivity of ocean sediment vs water content | 26 |
| 29. Thermal conductivity vs dry unit weight for frozen cores of permafrost from Inuvik ... | 27 |
| 30. Moisture transferred upon freezing as a function of porosity of a silty glacial outwash soil..... | 27 |
| 31. Thermal conductivity of ice as a function of temperature | 30 |
| 32. Flow of water in frozen soil as a function of temperature below 0°C | 30 |
| 33. Relationships among dry unit weight, ice volume and water content of frozen soil | 31 |
| 34. Diffuse electric-double-layer relationships | 33 |
| 35. Change in water density with distance from the surface of potassium bentonite at two temperatures..... | 33 |
| 36. Hypothetical decrease of water viscosity with distance from the clay surface..... | 33 |
| 37. Effect of ion dissociation on the surface-induced water structure | 34 |
| 38. Zone structure of adsorbed water and variation of its activation energy with distance from the mineral surface..... | 34 |
| 39. Thickness of adsorbed water film as a function of temperature | 34 |
| 40. Specific heat of Leda clay during freezing and thawing | 35 |
| 41. The zone of ice nuclei formation in soil water | 35 |
| 42. Schematic illustration of the silicate/water/ice interface..... | 36 |
| 43. Unfrozen water contents of typical nonsaline soils..... | 36 |
| 44. Thickness of unfrozen water as a function of temperature for three representative clays | 37 |
| 45. Unfrozen water content of kaolinite and montmorillonite clays of various exchange-able cations..... | 37 |
| 46. Curves of unfrozen water content vs temperature..... | 37 |
| 47. Unfrozen water content per unit specific surface area as a function of temperature | 37 |
| 48. Unfrozen water content of Leda clay during freezing and thawing..... | 38 |
| 49. Seasonal variation in water content of Leda clay | 38 |
| 50. Suction and relative humidity of different soil types as a function of their water content..... | 39 |
| 51. Thermal conductivity of three soils | 40 |
| 52. Thermal conductivity vs moisture content for Kersten's Lowell sand..... | 40 |
| 53. Thermal conductivity vs volume fraction of water..... | 40 |
| 54. Thermal conductivity as affected by density-moisture relations..... | 41 |
| 55. Experimental values of the thermal conductivity of sand at varying moisture contents | 41 |
| 56. Thermal conductivity of quartzitic gravel and sand..... | 42 |
| 57. Thermal conductivity of frozen material | 42 |
| 58. Assumed temperature-dependent thermal conductivity for gravel, clay and peat..... | 42 |
| 59. Percent water frozen in a soil model as a function of degree of saturation at -4.0°C | 43 |
| 60. Percent water frozen in a soil model as a function of degree of saturation at -7.5°C | 43 |

| Figure | Page |
|---|------|
| 61. Combined effect of degree of saturation and temperature upon the percentage of original water frozen..... | 43 |
| 62. Freezing point depression as a function of degree of saturation in a soil model..... | 43 |
| 63. Ratio of thermal conductivity below freezing to that above freezing as a function of moisture content..... | 44 |
| 64. Thermal conductivity vs temperature at different degrees of saturation (Penner)..... | 44 |
| 65. Thermal conductivity vs temperature at different degrees of saturation (Johansen)..... | 44 |
| 66. Logarithm of thermal conductivity as a function of moisture content of fine sand..... | 44 |
| 67. Thermal conductivity of unsaturated frozen Ottawa sand as a function of temperature..... | 45 |
| 68. Thermal conductivity of silt vs temperature..... | 45 |
| 69. Thermal conductivity of clay vs temperature..... | 46 |
| 70. Thermal conductivity vs temperature for a fine sand..... | 46 |
| 71. Thermal conductivity vs absolute temperature for a fine sand..... | 46 |
| 72. Thermal conductivity vs moisture ratio for soil B of Higashi..... | 47 |
| 73. Kersten number vs degree of saturation..... | 47 |
| 74. Hashin-Shtrikman bounds for the thermal conductivity of a saturated soil having different ratios of frozen to unfrozen water..... | 47 |
| 75. Thermal conductivity as a function of the ice content of undisturbed permafrost samples..... | 48 |
| 76. Thermal conductivity of mixtures of Ottawa sand and ice..... | 48 |
| 77. Thermal diffusivity vs fraction of water by volume..... | 49 |
| 78. Thermal properties of Russian southern black earth vs moisture content at a dry density..... | 49 |
| 79. Thermal properties of frozen glacial clay vs moisture content..... | 49 |
| 80. Heat released in saturated silt and clay on cooling below freezing point..... | 49 |
| 81. Apparent specific heat capacity of two clays as a function of temperature..... | 50 |
| 82. Relationship between specific heat capacity and moisture content of a partially frozen Na-Wyoming bentonite..... | 50 |
| 83. Average thermal conductivity of frozen peat as a function of water content and dry density..... | 51 |
| 84. Average thermal conductivity of unfrozen peat as a function of water content and dry density..... | 51 |
| 85. Thermal conductivity of unfrozen peat vs volume fraction of water..... | 52 |
| 86. Thermal conductivity of unfrozen peat vs degree of saturation..... | 52 |
| 87. Thermal conductivity of frozen peat vs water content..... | 52 |
| 88. Thermal conductivity of frozen peat vs degree of saturation..... | 52 |
| 89. Variation of ice content of peat with temperature..... | 53 |
| 90. Change in the amount of unfrozen water in a sphagnum peat with decreasing temperature..... | 53 |
| 91. Saturated apparent thermal conductivity due to vapor distillation at 1 atm and the thermal conductivities of water and air as functions of temperature..... | 56 |
| 92. Thermal moisture flux vs temperature gradient..... | 57 |
| 93. Rate of water transport in a coarse clay as a function of the temperature gradient..... | 57 |
| 94. Variation of the thermal osmosis coefficient with the moisture content for Leda clay..... | 57 |
| 95. Thermal diffusivity as a function of moisture content for sand, clay and peat..... | 58 |
| 96. Idealized ground temperature profile in permafrost terrain..... | 60 |
| 97. Soil-freezing-characteristic data for second freeze-thaw cycle and soil-water-characteristic data..... | 62 |
| 98. Gravimetric water content of soil columns at the end of each experiment..... | 64 |
| 99. The liquid water content as a function of distance from the cold plate..... | 64 |
| 100. Soil moisture and soil temperature distributions during freezing..... | 64 |

| Figure | Page |
|---|------|
| 101. Unfrozen water content vs temperature | 65 |
| 102. Freezing water-soil system with a fixed freezing front | 66 |
| 103. Freezing water-soil system with a moving freezing front..... | 67 |
| 104. Dependence on temperature of the thermal conductivity of quartz single crystal | 70 |
| 105. Variation of specific heat of dry soil with mean temperature | 72 |
| 106. Variation of specific heat of fine soils with temperature | 72 |
| 107. Specific heat of silt vs temperature..... | 72 |
| 108. Specific heat of soil types as a function of temperature | 73 |
| 109. Variation of specific heat with temperature for several representative rock materials..... | 73 |
| 110. Specific heat of 20-30 Ottawa sand vs temperature at two water contents..... | 73 |
| 111. Specific heat of Fairbanks silt vs temperature at five water contents..... | 74 |
| 112. Specific heat of ice as a function of temperature | 76 |
| 113. Relationship between heat capacity and temperature of a partially frozen Na-Wyoming bentonite | 77 |
| 114. Temperature dependence of measured values for the thermal conductivity of Ottawa sand..... | 79 |
| 115. Thermal diffusivity of a clayey sand as a function of temperature..... | 79 |
| 116. Apparent thermal diffusivity of permafrost at Barrow, Alaska | 80 |
| 117. Thermal diffusivity of a kaolinite suspension as a function of temperature | 80 |
| 118. Unfrozen water content vs temperature for the kaolinite-water system..... | 80 |
| 119. Unfrozen water content of organic soils at different temperatures | 81 |
| 120. Unfrozen water content of mineral soils at different temperatures | 81 |
| 121. Relation between temperature below the freezing point and suction in soil..... | 81 |
| 122. Effect of salinity on the magnitude of the ratio of pore area to total area in a clay | 83 |
| 123. Clay microstructure as observed in a transmission electron microscope using ultrathin acrylate-treated specimens | 83 |
| 124. Measured and calculated thermal conductivity values for air-dry and for saturated Leda clay | 84 |
| 125. Structure of Wyoming bentonite..... | 84 |
| 126. Thermal conductivity vs water content for natural kaolinite and its sodium, calcium and aluminum homoionic modifications..... | 85 |
| 127. Sodium ion diffusion coefficient for frozen Wyoming bentonite, Fairbanks silt and Barrow silt as influenced by temperature..... | 85 |
| 128. Lattice collapse and reexpansion of sodium-bentonite during a freeze-thaw cycle | 88 |
| 129. Thermal conductivity vs degree of peat formation for clayey silts with sand and for sands in the thawed and frozen states..... | 89 |
| 130. Thermal conductivity of Ottawa sand vs applied temperature difference | 89 |
| 131. CRREL guarded hot plate apparatus..... | 92 |
| 132. Kersten's soil container for thermal conductivity tests..... | 93 |
| 133. Thermal conductivity probe..... | 95 |
| 134. Typical temperature-time profiles for a probe..... | 96 |
| 135. Ratio of the amplitude of the temperature waves at the periphery and in the center of a sample | 97 |
| 136. Comparison of measurements of thermal conductivity with probe and guarded hot plate made on Johansen's sand SA1 at $\sim 18^{\circ}\text{C}$ | 98 |
| 137. Comparison of measurements of thermal conductivity with probe and guarded hot plate made by Johansen on his sand SA2 at $\sim 18^{\circ}\text{C}$ | 99 |
| 138. Comparison of measurements of thermal conductivity with probe and guarded hot plate made by Johansen on his sand SA8 at $\sim 4^{\circ}\text{C}$ | 99 |
| 139. Comparison of measurements of thermal conductivity with probe and guarded hot plate made by Johansen on his sand SA13 at $\sim 20^{\circ}\text{C}$ | 99 |

| Figure | Page |
|--|------|
| 140. Comparison of measurements of thermal conductivity with probe and guarded hot plate made by Johansen on his gravel GR7 at $\sim 4^{\circ}\text{C}$ | 99 |
| 141. Comparison of thermal conductivity measurements with probe and with the guarded hot plate on "dry" clay..... | 100 |
| 142. Comparison of measurements of thermal conductivity with probe and guarded hot plate made by Johansen on his sand SA2 in the dry condition at $\sim 18^{\circ}\text{C}$ and at different densities..... | 100 |
| 143. Comparison of measurements of thermal conductivity with probe and guarded hot plate made by Johansen on his sand SA4 in the dry condition at $\sim 18^{\circ}\text{C}$ and at different densities..... | 100 |
| 144. Comparison of measurements of thermal conductivity with probe and guarded hot plate made by Johansen on his sand SA8 in the dry condition at $\sim 18^{\circ}\text{C}$ and at different densities..... | 100 |
| 145. Comparison of measurements of thermal conductivity with probe and guarded hot plate made by Johansen on his sand SA10 in the dry condition at $\sim 18^{\circ}\text{C}$ and at different densities..... | 100 |
| 146. Thermal conductivity of unfrozen silt and clay soils as a function of moisture content and dry density..... | 103 |
| 147. Thermal conductivity of frozen silt and clay soils as a function of moisture content and dry density..... | 104 |
| 148. Average thermal conductivity of unfrozen silt and clay soils as a function of water content and dry density..... | 104 |
| 149. Average thermal conductivity of frozen silt and clay soils as a function of water content and dry density..... | 105 |
| 150. Thermal conductivity of unfrozen sandy soils as a function of moisture content and dry density..... | 105 |
| 151. Thermal conductivity of frozen sandy soils as a function of moisture content and dry density..... | 105 |
| 152. Average thermal conductivity of unfrozen sandy soils as a function of water content and dry density..... | 106 |
| 153. Average thermal conductivity of frozen sandy soils as a function of water content and dry density..... | 106 |
| 154. Theoretical unit soil structure containing solid monolith..... | 107 |
| 155. Unitary cube of moist soil..... | 108 |
| 156. Variation of adsorbed water with temperature..... | 108 |
| 157. Variation of the function $f(b^2/a)$ in Gemant's formula..... | 109 |
| 158. Schematic model of the resistor equation..... | 111 |
| 159. Schematic model of the saturated conductance equation..... | 111 |
| 160. Thermal conductivity of unfrozen mineral soils..... | 114 |
| 161. Thermal conductivity of frozen mineral soils..... | 115 |
| 162. Comparison of the methods for calculating the thermal conductivity of saturated unfrozen coarse soil..... | 116 |
| 163. Comparison of the methods for calculating the thermal conductivity of saturated unfrozen fine soil..... | 116 |
| 164. Comparison of the methods for calculating the thermal conductivity of saturated frozen coarse soil..... | 116 |
| 165. Comparison of the methods for calculating the thermal conductivity of saturated frozen fine soil..... | 116 |

TABLES

| Table | Page |
|---|------|
| 1. Experiments with free convection in crushed rocks | 8 |
| 2. Thermal properties of soil constituents | 12 |
| 3. Physical properties of liquid water..... | 29 |
| 4. Physical properties of saturated water vapor..... | 29 |
| 5. Physical properties of ice | 30 |
| 6. The pF scale in terms of the equivalent negative hydraulic head, the equivalent suction and relative humidity..... | 32 |
| 7. Comparative phase composition at selected temperatures..... | 38 |
| 8. Thermal conductivity of frozen sedge-hypnum peat at decreasing temperatures..... | 53 |
| 9. The diffusion coefficient of water vapor in air..... | 55 |
| 10. Effect of the magnitude of the temperature gradient on the amount of moisture accumulated by migration..... | 63 |
| 11. Effect of the magnitude of the temperature gradient on the moisture flow during freezing..... | 63 |
| 12. Thermal conductivity of water at different temperatures | 75 |
| 13. Dissociation and association of water..... | 75 |
| 14. Thermal conductivity of Fairbanks silt, CRREL varved clay, and Ottawa sand | 78 |
| 15. Thermal conductivity of concrete..... | 87 |
| 16. Thermal conductivity of processed material | 87 |
| 17. Recommended thermal properties for dry asphaltic pavement..... | 87 |
| 18. Assumed thermal properties of tundra soils..... | 88 |
| 19. Distribution of moisture in originally homogeneous soil after determination of thermal conductivity by a stationary method..... | 91 |
| 20. Thermal conductivity results of six stone aggregate samples..... | 93 |
| 21. Thermal conductivity values of calibration tests | 98 |
| 22. Thermal conductivity of dry sand SA13 at different temperatures, GHP tests | 101 |
| 23. Thermal structure factors | 102 |
| 24. Method for calculating thermal conductivity of mineral soils | 113 |

**CONVERSION FACTORS: U.S. CUSTOMARY TO METRIC (SI)
UNITS OF MEASUREMENT**

| <i>Multiply</i> | <i>By</i> | <i>To obtain</i> |
|-------------------------------|------------------------------|------------------|
| mcal/cm s °C | 0.4184 | W/m K |
| kcal/m hr °C | 1.1622 | W/m K |
| Btu in./ft ² hr °F | 0.1442 | W/m K |
| Btu/ft hr °F | 1.731 | W/m K |
| atmosphere | 101.3250 | kilopascal |
| calorie | 4.1868 | joule |
| cal/g °C | 4186.8 | J/kg K |
| cal/cm s °C | 418.4 | W/m K |
| degrees Fahrenheit | $t_{°C} = (t_{°F} - 32)/1.8$ | degrees Celsius |

NOMENCLATURE

| | | | |
|-----------|---|------------|--|
| c | heat capacity per gram | L | latent heat of freezing of water |
| C | heat capacity per unit volume | L_e | latent heat of evaporation of water |
| k | soil thermal conductivity | n | soil porosity |
| k_a | thermal conductivity of air | q | quartz content |
| k_f | thermal conductivity of fluid in soil | S_r | degree of saturation of soil |
| k_i | thermal conductivity of ice | t | time |
| k_q | thermal conductivity of quartz | T | temperature |
| k_o | thermal conductivity of soil solids other than quartz | w | water content of soil |
| k_s | thermal conductivity of soil solids | w_u | unfrozen water content of frozen soil |
| k_e | effective thermal conductivity of a mixture | x_a | volume fraction of air in unit soil volume |
| k_F | thermal conductivity of frozen soil | x_s | volume fraction of solids in unit soil volume |
| k_U | thermal conductivity of unfrozen soil | x_w | volume fraction of water in unit soil volume |
| k_w | thermal conductivity of water | α | soil thermal diffusivity |
| k_{dry} | thermal conductivity of dry soil | γ_d | soil dry unit weight |
| k_{sat} | thermal conductivity of saturated soil | γ_w | unit weight of water |
| K | soil permeability or hydraulic conductivity | ρ | density |
| K_e | Kersten number | θ | fraction of soil volume occupied by water in unfrozen soil or by unfrozen water in frozen soil |
| | | ψ | soil suction |

THERMAL PROPERTIES OF SOILS

Omar T. Farouki

CHAPTER 1. INTRODUCTION

Soil thermal properties are of great importance in many engineering projects and other situations where heat transfer takes place in the soil. For example, they are of great importance in the design of roads, airfields, pipelines or buildings in cold regions as well as underground power cables, hot water pipes or cold-gas pipelines in unfrozen ground. They are also important in such fields as agriculture, meteorology and geology.

This monograph deals with the thermal properties of soils and the factors influencing them. An attempt is made to provide a framework in which these various factors and their effects may be placed. The problem of heat transfer in soils is very complicated. To understand it one must subdivide it into its constituent elements and facets. A study of each of these should show its relative importance and contribution to the soil's behavior. The interactions between the different factors need to be elucidated, leading eventually to an overall comprehensive and comprehensible view. Analysis is thus followed by synthesis.

This monograph also considers the various mechanisms of heat transfer in soils and the methods of measuring a soil's thermal conductivity. The different methods of calculating this quantity are described and their predictions shown in detail and compared against reliable experimental results. In this way these methods are evaluated to determine their validity under different conditions.

1.1 SOIL AND SOIL THERMAL PROPERTIES

Agricultural "soil" is a complex, dynamic and living system where biological processes continuously take place. The term *soil*, as used by engineers, refers to a complicated material consisting of solid particles of various compositions (mineral and/or organic) and various shapes and sizes that are randomly arranged with pore spaces between them. These pores contain air and usually water in its various phases as vapor, liquid or ice. The water may also contain mineral salts and ions. Gravel and crushed rock may be designated as soil or "soil materials"; they have been used in construction, for example, as pavement components or fills.

The composition of naturally occurring soil varies continuously, chiefly because of changes in the amount and phase of water at various locations. These changes result mainly from the continuously varying temperature field to which the soil is subject. The daily temperature fluctuations are superimposed on the seasonal cycle, and there is a geothermal heat flux resulting from the flow of heat upwards from the hot interior of the earth. These changing temperature gradients alter the soil composition, particularly with regard to changes in the amount, phase and condition of water. This leads to variations in the thermal properties of the soil.

The thermal conductivity of a soil is defined as the amount of heat passing in unit time through a unit cross-sectional area of the soil under a unit temperature gradient

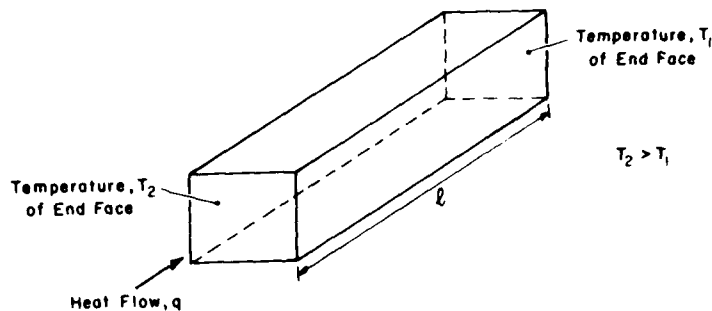

Figure 1. Heat flow through a prismatic element of soil.

applied in the direction of this heat flow. Considering a prismatic element of soil having a cross-sectional area A at right angles to the heat flow q (Fig. 1), the soil thermal conductivity k is defined as

$$k = \frac{q}{A(T_2 - T_1)/l}$$

where the temperature drops from T_2 to T_1 over the length l of the element.* One must consider a soil portion large enough by comparison with a representative cell of a homogeneous soil.

Use of the term "conductivity" is justified because heat is transferred mainly by conduction in normal circumstances. However, other mechanisms may, and usually do, contribute in some measure to the heat transfer, as described in Chapter 2. The definition should thus be understood to imply an effective thermal conductivity. Measurement necessarily results in an averaging of the thermal conductivity between two sections that are a finite distance apart. The actual thermal conductivity will vary between these sections because of variations in soil composition and temperature differences.

A further complication is that the thermal conductivity of a given soil with a given moisture content does not have a unique value because it depends on the boundary conditions, which may cause a moisture redistribution (De Vries 1963). The techniques used to measure thermal conductivity can cause such changes. Therefore, these effects must be borne in mind and the comparability of these to field conditions considered before laboratory results can be applied with confidence. Temperature is another important influence that affects the soil composition and also the values of the thermal properties of the soil constituents themselves. Even at a certain ice content, a frozen soil

may have different conductivity values from place to place, depending on the specific ice distribution (Czertski and Frese 1958).

The situation resulting from the application of a temperature gradient to a soil, whereby both heat and mass transfer occur, is too complicated to be handled rationally, especially where freezing or thawing occurs (Penner 1972). For simplicity, problems are often formulated in terms of transfer by pure conduction, but using an effective thermal conductivity. Such an approximate procedure was followed by Nakano and Brown (1972) as they derived a mathematical model of the thermal regime in tundra soil in Alaska. Also, the soil material properties and the boundary conditions often need to be simplified to solve the heat transfer problem in an actual soil. Recently, however, various finite difference techniques have been used to account for fluctuating boundary conditions and variable thermal properties (Mohan 1975).

The definition of the thermal conductivity implies a steady state condition in which the temperature at a point does not vary with time. If, however, the temperature is changing with time, it means that the soil itself must be either gaining or losing heat. If the temperature of an element of soil is increasing with time, then some of the heat flow is being used for this purpose, the amount depending on the heat capacity of this element.

The heat capacity C per unit volume of soil is the heat energy required to raise the temperature of this unit volume by 1°C . It is the product of the mass specific heat c (cal/g $^\circ\text{C}$) and the density ρ (g/cm³):

$$C = \rho c.$$

If the volume fractions of the solid, water and air components present in unit soil volume are x_s , x_w and x_a respectively, then

$$C = x_s C_s + x_w C_w + x_a C_a$$

* The units now normally used for k in soil studies are W/m K (i.e. watts per meter per kelvin). Other units have been used such as mcal/cm s $^\circ\text{C}$ or Btu in./ft² hr $^\circ\text{F}$ or Btu/ft hr $^\circ\text{F}$.

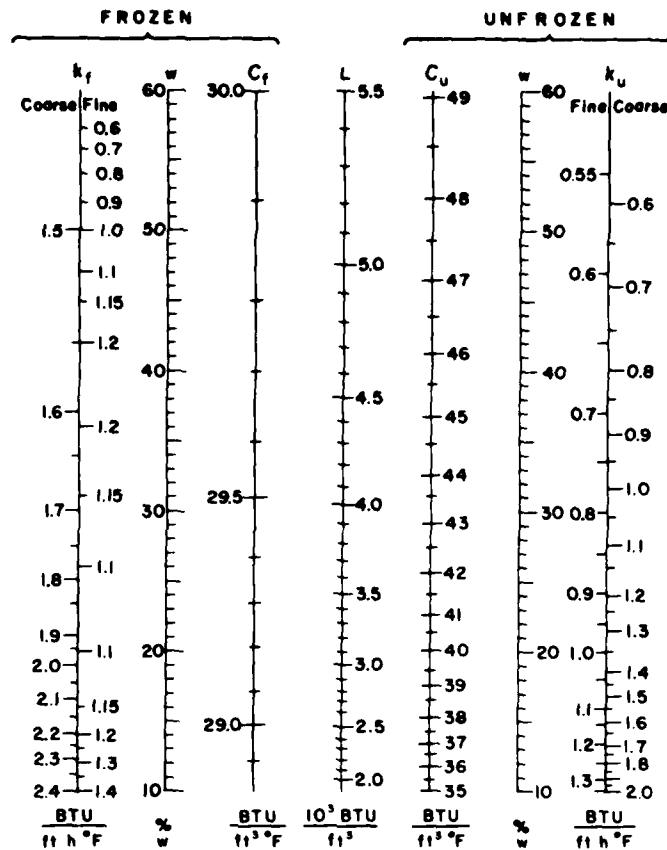

Figure 2. Thermal properties and water content for saturated soils (from Sanger 1968).

where C_s , C_w and C_a are the respective heat capacities per unit volume of the solids, water and air.

The volumetric heat capacity C_U for unfrozen soils is given by

$$C_U = \frac{\gamma_d}{\gamma_w} \left(0.18 + 1.0 \frac{w}{100} \right) C_w$$

while that for frozen soils C_F is given by

$$C_F = \frac{\gamma_d}{\gamma_w} \left(0.18 + 0.5 \frac{w}{100} \right) C_w$$

where γ_d = dry unit weight of the soil
 w = its water (or ice) content
 γ_w = unit weight of water.

Based on these formulas for C and on the thermal conductivity data of Kersten (1949), Sanger (1968) presented charts which give the thermal conductivity and volumetric heat capacity of frozen or unfrozen soils corresponding to a known moisture content (Fig. 2).

Where an unsteady state exists, the thermal behavior of a soil is governed not only by its thermal conductivity but also by its heat capacity. The ratio of these two properties is termed the thermal diffusivity α , which becomes the governing parameter in such a state and is given by

$$\alpha = k/C.$$

A high value of the thermal diffusivity implies a capability for rapid and considerable changes in temperature. A soil may have a much greater thermal diffusivity when frozen than when unfrozen because of two factors: the higher thermal conductivity of the frozen soil and the lower specific heat of the ice as compared with liquid water.* In frozen soils, temperatures can therefore change much more rapidly and to a greater extent than in unfrozen soils.†

* Ice has a thermal diffusivity about 8 times that of liquid water.

† It is important to bear in mind that two materials may have very dissimilar thermal conductivities (e.g. soil and an insulator) but, at the same time, they may have very similar diffusivities.

1.2 IMPORTANCE OF SOIL THERMAL PROPERTIES

Heat transfer in soils plays an important part in many types of problems in such varied fields as engineering, geophysics, meteorology and agriculture. An understanding of the thermal behavior of soil helps one deal with these problems, and values of the soil's thermal properties are required for quantitative analysis.

Soil thermal conductivity is important in determining the effect of cold and frost on soil used as a foundation material for roads, airfields, pipelines and buildings in cold regions. Frost heave or thaw can lead to a serious loss of stability and cause damage. Calculations of the depth of frost or thaw rely on reasonably accurate values of thermal conductivity. In Sweden, for example, the amount of soil cover required above water and drain pipes may be thereby determined. In permafrost regions the depth of thaw caused by a warm oil pipeline can also be calculated from the soil thermal properties.

As Guymon and Luthin (1974) pointed out, the thermal states of ice-rich permafrost soils are in a delicate balance that may be easily disrupted by even slight changes caused by man or nature. There are various engineering and ecological implications of disturbing the ground thermal regime in permafrost regions. If the top organic layer of tundra soils is removed, a rapid degradation of the underlying ice-rich permafrost takes place (Linell 1973).

Certain engineering projects require artificial ground freezing to get temporary stability and impermeability prior to erecting permanent structures. Knowledge of the soil's thermal properties is needed to determine the amount of heat that has to be removed and the rate of frozen barrier establishment (Sanger 1968).

Knowledge of thermal properties is also of paramount importance in tackling the problem of heat exchange at the ground surface. Heat transfer influences the temperature regimes near the surface in both the upper soil layer and the lower air layer, affecting the entire biosphere (De Vries 1974). Soil thermal behavior is thus of great importance in microclimatological research and in agriculture. According to Winterkorn (1964) understanding of the behavior of moist soil that is subject to thermal gradients is of considerable importance in understanding the role of water in living biological systems. Szent-Györgyi (Low 1961) noted that in biological materials water has greater order and rigidity than it has in the free state. This orderly state of water in living matter may be compared to the state of the adsorbed water layers in soils (unfrozen or frozen).

Studies of temperatures and heat flow in the ground have a long history (e.g. Lachenbruch 1959). In geophysics, it is important to know the amount of heat

flowing upwards from the interior of the earth. This may be determined from temperature measurements if the thermal conductivity of the soil is known, using the linear steady-state equation

$$q = k \left(\frac{\partial T}{\partial z} \right)$$

where $\partial T/\partial z$ is the temperature gradient in the vertical direction.

The depth of heat penetration into the soil and the amplitude of the daily and seasonal temperature variations are influenced by the soil's thermal properties. The diurnal penetration is on the order of 0.3-0.8 m, while the annual penetration of the temperature wave may be about 10 m.

Another situation where soil thermal properties are important is the case of underground power cables. The surrounding soil or backfill material must have a sufficiently high thermal conductivity to transfer the generated heat away so that the cable does not overheat. Moisture can migrate away from the cable and cause a serious problem because it leads to a lowering of the thermal conductivity of the soil adjacent to the cable.

On the other hand, the heat losses from underground steam and hot water pipes need to be minimized. This requires a surrounding soil of low thermal conductivity. Such insulating properties are also required where the soil is to provide a shelter from the effects of nuclear explosions or to dissipate the effect of very hot radioactive fuel capsules which may reenter the atmosphere from space and penetrate the soil (Flynn and Watson 1969).

1.3 SCOPE AND PURPOSE OF THIS MONOGRAPH

This monograph seeks to describe the thermal properties of soils in a detailed and systematic manner. The factors which influence these properties are elucidated and discussed and the effects of these factors on the various properties are shown. Chapter 2 describes the various mechanisms of heat transfer which possibly occur in soils. The effects of soil composition, structure and volumetric factors are described in Chapter 3. A very important and complex constituent of soil is water which exists in several phases and conditions. Its effect on the thermal properties is detailed in Chapter 4, including a discussion of the consequences of water migration. Chapter 5 considers further influences on soil thermal properties, such as temperature, salts, ions, additives and hysteresis. The methods of measuring soil thermal conductivity are described in Chapter 6.

Chapter 7 describes the available methods for calculating the thermal conductivity of a soil. This chapter also gives the main conclusions from a detailed evaluation of these methods (Farouki, in press). On the basis of a comparison of the methods and their pre-

dictions with experimental data obtained on soils of known composition, recommendations are made of the method or methods to apply to soils of different types, frozen or unfrozen, ranging from dry to saturated.

CHAPTER 2. MECHANISMS OF HEAT TRANSFER IN SOILS

The thermal conductivity of a soil is the rate at which heat energy flows across a unit area of the soil due to a unit temperature gradient. While the flow of heat by conduction is the predominating mechanism, all possible mechanisms are employed for the flow of heat from warmer to cooler regions. The temperature levels, in particular, as well as the soil composition and structure affect the contribution of each possible mechanism to heat transfer. Figure 3 shows the conditions under which the various mechanisms may have a significant influence in the field. This figure gives a rough idea of their domains of influence as related to soil texture and degree of saturation. It is evident that under such conditions heat transfer by conduction is the predominating mechanism.

Convection and radiation generally have relatively small or negligible effects but they may have a noticeable influence in certain situations. To account for conduction, convection and radiation in soil pores, one effective parameter may be used (Martynov 1959).

Water phase changes in soils and their associated energy may have a significant effect on the heat transfer process. In unsaturated soils moisture may migrate by a process of evaporation followed by vapor diffusion and subsequent condensation at another place, thus leading to heat transfer. Freezing of water or melting of ice within soils may also produce significant latent heat effects.

In many situations the transfer of moisture and heat occurs simultaneously and inseparably. Such combined transfer of heat and moisture is treated in Sections 4.3 and 4.4, but as De Vries (1974, p. 5) stated: "the main unsolved problems in the field of soil heat transfer are connected with the combined transfer of heat and moisture in soils." The effects of

water migration on soil thermal properties are described in detail in Chapter 4. This includes a consideration of the migration of water to the freezing front as well as water movement in warm soils due to a temperature gradient. Just as with heat transfer, nature employs every mechanism possible for moisture movement but to different extents for different soils and soil conditions (Winterkorn 1960b).

Theoretical studies of heat transfer in soils generally consider the soil to be homogeneous and assume that all processes of heat transfer take place uniformly throughout the porous medium (e.g. see De Vries 1958). In reality, of course, vapor transfer or air convection take place only in the air-filled pore space and liquid movement only in the water-filled pore space, while evaporation or condensation are associated with the water/air interfaces. However, one must necessarily take a macroscopic view in a theoretical derivation and consider a "unit cell" of the soil that is large enough to contain a representative sample of the soil constituents.

2.1 HEAT CONDUCTION

Heat conduction occurs in all the soil constituents, i.e. in the soil solids, the water (liquid, vapor or ice) and the pore air. Conduction operates in air or water vapor by a process of collision between the molecules and a consequent increase in their mean kinetic energy as heat passes from warmer to cooler regions. A similar mechanism is partly responsible for heat conduction in liquid water; however, energy transfer by breaking and making hydrogen bonds in water also appears to contribute to conduction. The behavior of liquid water lies between that of gases, with their random molecular

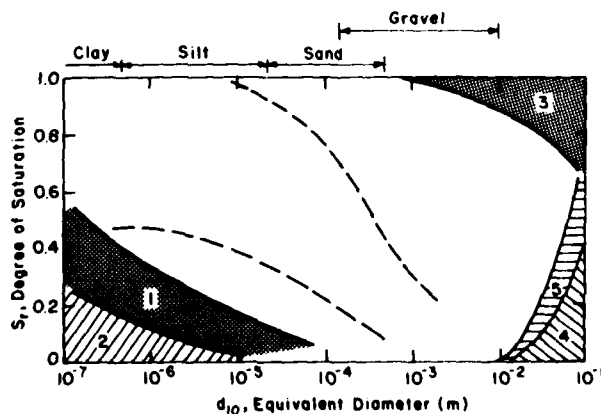

Figure 3. Regions of predominant influence of the various heat transfer mechanisms in relation to soil grain size and degree of saturation. Expected variations in degree of saturation under field conditions lie within region bounded by dashed lines (after Johansen 1975). 1-thermal redistribution of moisture, 2-vapor diffusion due to moisture gradients, 3-free convection in water, 4-free convection in air, 5-heat radiation.

motion, and that of crystals, with their orderly lattice arrangement. The flow of heat in crystalline solids, such as quartz, may be visualized as occurring by increased atomic vibrations at one end causing the neighboring atoms in the lattice to follow suit as if these atoms were linked together by springs.

The thermal conductivity of soil solids and its variation with temperature are considered in Section 5.1. Ice has a thermal conductivity about four times that of ordinary liquid water. The thermal conductivity of oriented water is likely to be greater than that of free water.* Heat conduction through air is relatively unimportant but its effect may be included in the methods of calculating soil thermal conductivity (see Chapter 7). The amount of heat transferred by true conduction increases as the soil dry density increases and as its degree of saturation increases.

Heat being conducted through soil will take all available paths. Paths through contacting solid grains generally provide the major part of heat conduction but contact resistance may exist. Other paths consist of portions of solid grains and fluid-filled spaces in series or solely of fluid-filled spaces. Chapter 7 describes how these considerations have been taken into account in developing equations for the thermal conductivity of soils. Contacts and interfacial effects come into play and limit the heat conduction (described in Section 3.1).

There is a contact resistance that gives a sudden discontinuity in the heat flow at the boundary surface between a gas and a solid or liquid (e.g. De Vries 1952a). Considering two parallel flat plates with air in between, such discontinuities effectively reduce the temperature gradient across them, with a consequent reduction in the heat flux. Similar effects may be expected to occur in the pore spaces of soils.

2.2 CONVECTION

2.2.1 Free convection

Free convection is a mass transport phenomenon resulting from temperature gradients. It is caused in fluids by changes in density with temperature. At the higher temperatures the density of the fluid is lower, resulting in an upward displacement. The fluid carries its heat with it and creates a flow pattern that is often characterized by polygonal cells. The process of free convection thus causes mixing currents which facilitate heat exchange by conduction.

The effective thermal conductivity of a fluid is increased by the contribution to heat transfer of what

* Sections 4.3.2 and 5.1.2 suggest that the thermal conductivity of the adsorbed water layer may even be greater than the thermal conductivity of ice.

has been called "lateral mixing," "dispersion" or "turbulent diffusion." This contribution is proportional to the fluid velocity, its volumetric specific heat, and the average soil particle diameter. These three quantities are incorporated in a nondimensional Péclet number (Yagi and Kunii 1957).

In soils, convection through air or water is usually negligible. The pores must be several millimeters across for natural convective transfer to become apparent* (Fig. 3 shows the conditions that may give rise to significant free convection effects). Soils with grain sizes smaller than sand are usually ruled out. However, Martynov (1959) mentioned the case of an unusually deep (10 m) seasonal freezing because of convection in air masses residing in ground fissures. He also noted that heat transfer by convection† increases rapidly with an increase in soil pore diameter above a few millimeters, with an increase in ground temperature above 30°C, and with an increase in temperature gradient above about 1°C/cm. Under natural conditions, the temperature gradient in the vertical direction is less than 1°C/cm, being usually in the range 0.01 to 0.1°C/cm.

De Vries (1952a) reported experiments with steel or glass spheres in which the measured thermal conductivity increased as the temperature difference increased. This effect was attributed to air convection, which increased with increased air pressure and with larger void spaces. Measurable convection effects also occurred in water-saturated sand. For particles less than 1 to 2 mm in size the influence of convection was generally very small.

In a given porous material filled with a fluid, there is a critical temperature gradient above which convection occurs. When this value is exceeded, the heat transport increases in proportion to the square of the temperature gradient. A dimensionless group of parameters, the Rayleigh number R_a , has been found to be a significant criterion for porous layers containing fluids (Johansen 1975). The Rayleigh number is

$$R_a = \frac{(\Delta T) a g h K}{\alpha \nu}$$

where ΔT = temperature difference across the layer

h = thickness of the layer

a = coefficient of expansion of the fluid

ν = kinematic viscosity of the fluid

α = thermal diffusivity of the fluid

K = permeability of the porous material

g = gravitational acceleration

* More than 8 mm in porous insulators according to Russell (1935). The action of porous insulators in limiting heat flow is known to be due in large measure to their small pores ("cells") which contain air that is practically stationary. Convection currents are thereby almost eliminated.

† The same applies to transfer by radiation.

Table 1. Experiments with free convection in crushed rocks. Upward heat flow with upper surface exposed (after Johansen 1975).

| Experiment | Temperature difference ΔT ($^{\circ}C$) | Mean temperature ($^{\circ}C$) | Rayleigh number R_a | Effective thermal conductivity k_e (W/m K) |
|------------|---|----------------------------------|-----------------------|--|
| 1 | 2.6 | 5.8 | 8.26 | 0.50 |
| 2 | 4.7 | 3.3 | 15.82 | 0.46 |
| 3 | 9.0 | -5.5 | 31.99 | 0.55 |
| 4 | 11.5 | -13.4 | 44.72 | 0.79 |
| 5 | 19.0 | -28.5 | 87.40 | 1.13 |

If the thickness of the layer h is larger, a smaller temperature difference (ΔT) will provide the same value of R_a . This means that the critical temperature gradient is smaller.

The contribution of convection to the fluid thermal conductivity gives rise to the effective thermal conductivity k_e . When this is averaged over an area, it is found to increase in direct proportion to the Rayleigh number R_a . The ratio between the effective conductivity and the conductivity without convection corresponds to the Nusselt number Nu^* which may be expressed in terms of R_a .

Johansen (1975) experimentally determined the effect of free convection on heat transfer in dry crushed rock (particle sizes in the range from 2-8 cm). Table 1 shows the increase in k_e as the temperature difference (ΔT) increases during heat flow upward toward an exposed surface. Under field conditions in Norway, temperature differences above the critical limit exist only during a short period in midwinter. At this time there may be appreciable heat loss from the underlying soil upwards through a rock fill; however, temperature differences across the fill soon tend to decrease below the critical value.

Considering air movement through a rockfill dam, Mukhetdinov (1969) assumed that the conductive component (in the direction of air movement) is small compared to the convective heat transfer. The coefficient of heat exchange between the air and the contact points of the fill was found to be directly proportional to the Nusselt number. Separate, closed air streams formed in the downstream shoulder of the rockfill dam and heat was transferred between these individual streams by conduction only, not by convection.

Later Mukhetdinov (1971) did a theoretical study of the effect of natural convection on the thermal regime of the downstream shoulder of a rockfill dam

with a vertical temperature gradient. Air movement took place at a certain critical temperature difference, and laminar, transitional and turbulent regimes occurred, depending on the Reynolds number. The calculated results and field observations were found to be in close agreement.

When a porous material is saturated with water, free convection starts at significantly lower temperature gradients (as compared with the dry material) and it can occur in material with a smaller average grain size. Johansen (1975) found that for a layer of water-saturated gravel, * 1 m thick, the critical temperature difference is 7.3 $^{\circ}C$ for an average temperature of 20 $^{\circ}C$. However, such temperature differences usually occur only in winter when the temperature is too low for convection to take place in the water.

2.2.2 Forced convection

Forced convection results when currents of air or water are forced to move through the pores of soils or rocks by pressure differences. One example of a forced convection effect in the field is groundwater flow. Groundwater flow is usually nearly perpendicular to the direction of heat flow and it increases heat transfer by dispersion effects. Such convection effects are usually slight in sandy soils, but in very coarse sands they may cause the thermal conductivity to increase by as much as 20% (Johansen 1975).

Adivarahan et al. (1962) performed laboratory experiments on porous rocks in which fluids[†] were caused to flow. The moving fluid contribution to heat transfer was found to be a function of the Péclet number. This number incorporates the fluid velocity, which if increased, causes an increase in the effective thermal conductivity as a result of fluid mixing. It seemed that some mixing occurred even at mass velocities near zero. There also appeared to be no sharp boundary between

* Nu expresses the ratio of the temperature gradient at the surface to the average temperature gradient in the fluid.

* Having d_{10} size of 1 mm.

† The fluids used were nitrogen, carbon dioxide and helium gases and a salt solution.

streamline and turbulent flow in porous rocks. As in the case of packed beds of unconsolidated particles, it was expected that there is a certain fluid velocity that would give rise to the full effect of mixing in the pores. A greater velocity would not increase the effective thermal conductivity any further.

In the field, forced convection may have an important heat transfer effect on exposed fill as the result of wind action. Such a situation was studied in the laboratory by Johansen (1975), who determined the effect of forced wind flow over the surface of a bed of crushed dry rock about 50 cm thick. The air temperature was higher than the temperature of this fill so that the heat flowed downward. Temperatures were measured at various points in the fill and the heat flow was monitored with gauges. Even small wind velocities resulted in large changes in the temperature distribution as the air penetrated the fill. The effective thermal conductivity of this fill more than tripled—from 0.45 to 1.46 W/m K. Johansen noted that such a mechanism can result in an extremely heavy heat loss by the ground during cold periods when there is no snow cover. (The term "advection" is sometimes used to signify the heat transfer caused by the mass flow of outside agents such as water seeping through sands or air blowing through the pores of soil.)

2.2.3 Convection and thawing

Martynov (1959) pointed out the need for further study of the convective mechanisms of heat transfer in freezing and thawing soils, but Nixon (1975) found that convective heat transfer played a very minor role in determining the rate of thaw. However, because of its energy requirement melting retards the rate of heat transfer, leading to a decrease in the heat transfer coefficient (Tien and Yen 1965).

2.3 RADIATION

Radiation occurs across air spaces (or within a transparent medium) by heat energy propagation as electromagnetic waves. The temperature of the radiating body is the most important factor, the flow of heat being proportional to the fourth power of the absolute temperature. In soils, radiation usually makes a negligible contribution to heat transfer. Its effect in sand is less than 1% of the overall heat transfer at normal atmospheric temperatures. Figure 3 shows the region of significant radiation influence on heat transfer. The boundary of this region corresponds to a contribution of about 5%. The effect is particularly noticeable for nearly dry gravel-size material. Wakao and Kato (1969),

using a particle size of 20 mm, showed that the effect of radiation could amount to 10% of total heat transfer at normal temperatures. Thus radiation can play a significant part in heat transfer in dry coarse crushed-stone materials.

According to Van Rooyen and Winterkorn (1957), Nusselt derived an equation for the thermal conductivity k of a fissured body, taking the effect of radiation into account:

$$k = \frac{L_s + L_a}{\frac{L_s}{k_s} + \frac{1}{\frac{k_a}{L_a} + 4\sigma T^3}}$$

where k_a and k_s = thermal conductivities of the air and solids respectively

T = absolute temperature

σ = radiation constant* in Stefan's Law.

He considered this body to consist of a series of parallel solid plates of thickness L_s separated by air layers of thickness L_a with heat flowing across them (Fig. 4). Nusselt's equation was applied by Van Rooyen and Winterkorn (1957) to calculate the thermal conductivity of dry soils; however, values so obtained were about one-fifth of measured values.

Van der Held (1952) noted that thermal conductivities of porous materials measured by a transient method were higher than those obtained by a steady state method. He attributed the difference to variations in the contribution of radiation to the heat transfer. This radiation contribution was found to increase linearly with increasing thickness of the specimen used in the steady state method (Van der Held 1955). Woodside (1958) also observed the influence of radiative

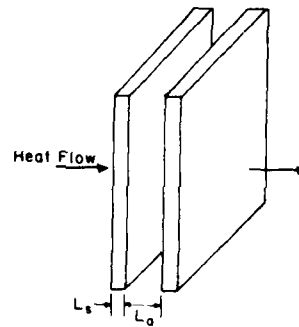

Figure 4. Nusselt's model of heat flow in a fissured body (after Van Rooyen and Winterkorn 1957).

* The commonly used value for σ in this equation is 4.96×10^{-8} erg/cm² s (Van Rooyen and Winterkorn 1957).

heat transfer on the thermal conductivity of dry silica aerogel that was measured under transient conditions. Measurements of the thermal conductivity of dry sands with the (steady state) guarded hot plate method also appear to point to possibly appreciable radiative heat transfer effects which decrease with decreasing temperature (see Section 6.3.2).

2.4 EVAPORATION-CONDENSATION PROCESS

In unsaturated soils, increased temperature at certain locations causes the water to evaporate, absorbing a latent heat of vaporization of 586 cal/g (at 20°C) (see Table 3 for values of this latent heat at different temperatures). Consequently the local vapor pressure increases and the water vapor diffuses through the interconnected pores to regions of lower vapor pressure, the diffusion coefficient depending on temperature (see Table 9). It may then condense at such locations, giving up its latent heat. By this process, and because of the high latent heat of evaporation of water, a significant amount of heat may be transferred. An expression for the consequent contribution to the effective thermal conductivity of the pore air is given in Section 4.3.1. This contribution increases rapidly with temperature so that at 60°C it becomes equal to the thermal conductivity of water (Fig. 91). A detailed discussion of vapor transfer and its effects is provided in Section 4.3.1.

Figure 3 gives a rough indication of the condition under which the process of evaporation-condensation may have an appreciable effect (Region 1).

For soil under field conditions, Hadas (1977) suggested two possible mechanisms for increasing the effective vapor diffusivity coefficient. The first results from daily reversals of the thermal gradient, giving rise to free convection within the air-filled pores of the soil and its root channels. The second is due to air turbulence at the soil surface which also increases the effective vapor diffusivity. These mechanisms, which are not taken into account by the Philip and De Vries (1957) model (see Section 4.3), give rise to a "mass transport enhancement factor" which causes an appreciable increase in the thermal conductivity as compared with the value obtained from this model.

Jones and Kohnke (1952) showed that vapor transfer is regulated by the volume of unsaturated pore spaces. The influence of water vapor diffusion increases as the dry density of the medium decreases because more pore space becomes available for the process. At low densities, like those of snow (0.10-0.60 g/cm³), water vapor diffusion has a considerable effect on the rate of temperature propagation (Yen 1966).

2.5 OTHER EFFECTS ON SOIL HEAT TRANSFER

2.5.1 Properties and structure of water

As the conditions and circumstances in soil vary, the properties of its water change. Changes may also occur in the structural configuration formed by this water. Such variations in properties or structure imply absorption or release of heat energy, thus contributing inevitably to heat transfer effects. For example, oriented water has a certain structure and a lower specific heat than ordinary water, which consequently gives rise to the heat of wetting. In frozen soils a "boundary phase" of unfrozen water exists that has peculiar properties and is of great importance. Chapter 4 contains a detailed discussion of the properties of water and their effects on soil thermal behavior.

It is interesting to note that viscous flow, dipole orientation and self-diffusion of water all require nearly the same activation energy. This suggests that all three of these processes involve essentially the same activation mechanism.

2.5.2 Exchange ions

The presence and type of exchange ions in frozen soils have certain effects on heat exchange. In winter monovalent cations enter the adsorption complex of the soil mineral particles, with consequent heat liberation (Tsytoich et al. 1959). In summer, however, multivalent cations take part in the base exchange process with absorption of heat.

2.5.3 Freezing or thawing

As Martynov (1959) noted, the freezing and thawing processes cause a great deal of heat transfer in the "phase transition zone" of field soils. The result is that the effective heat capacity is many times greater than the true heat capacity.

The processes of freezing and thawing of soils are retarded by latent heat effects. During freezing, heat must be removed from the water to form ice. In the case of fine soils, freezing occurs over a certain temperature range that extends several degrees below 0°C, and some unfrozen water may remain until quite low temperatures are encountered. The gradual freezing and release of latent heat may be taken into account in the following expression for the apparent specific heat of the freezing soil (Johansen 1975):

$$c_s + c_w w_u + c_i (w - w_u) + L \frac{\partial w_u}{\partial T}$$

where c_s , c_w , c_i = mass specific heats of the solids, water and ice respectively
 w = total moisture content (fractional)

w_u = unfrozen water content (as a fraction by weight of dry soil)

L = latent heat of freezing of water

T = absolute temperature.

This apparent specific heat is strongly dependent on temperature. It may be noted that Johansen's expression assumes that the specific heat of the unfrozen water is the same as that of ordinary water; this is questionable.

2.5.4 Ice movement

For frozen soils, Miller et al. (1975) postulated a mechanism of series-parallel ice movement involving the unfrozen water films. Due to liberation or absorption of latent heat, transfer of heat occurs but in the opposite direction to the ice movement (see Section 4.4).

CHAPTER 3. THE EFFECT OF COMPOSITIONAL VOLUMETRIC AND OTHER STRUCTURAL FACTORS ON THE THERMAL PROPERTIES OF SOILS

Soils consist of solid particles surrounding pore spaces which contain water and usually air. The solid particles may be composed of one or more minerals, such as quartz or montmorillonite, or they may consist of organic material, as in peat. Water may occur as vapor in the pore air, as ordinary water in the liquid phase above 0°C, or as ice below 0°C; unfrozen water may also be present below 0°C.

The soil "structure" or packing is important because it implies a certain arrangement of the solid primary or secondary particles, with respect to each other, and a certain orientation with respect to the direction of the heat flow or the imposed temperature gradient. The finer colloidal grains in natural soils are usually aggregated into larger secondary units of different shapes and sizes. Micropores exist between the primary particles and macropores between the larger secondary aggregates. These structural factors, which may considerably influence heat transfer, are described in Section 3.1.

Other important structural factors influencing the effective thermal conductivity of a soil are the number and nature of the contacts between the soil particles themselves and the effect on these contacts of the other soil components, particularly water. This is because most of the heat transfer occurs across these contact points or areas, particularly in the case of dry or nearly dry soils. If the solid grains are cemented together, e.g. by a clay or other binder, the thermal contact is much improved, as seen in Section 3.1.

Various changes in soil structure, and therefore in density or porosity, may occur naturally. Drying of cohesive soil leads to shrinkage and consequent fissuring, while water intake leads to swelling. The processes of freezing and thawing similarly lead to excessive compositional and structural changes, with consequent

changes in the soil's thermal conductivity. These various structural effects are also described in Section 3.1. Further structural effects, and the influence of temperature on them, are described in Chapter 5.

The thermal conductivities of some of the important soil components are given in Table 2. They vary greatly. Quartz has the greatest thermal conductivity and at the least, their ratio being about 350:1. Therefore, the volumetric proportions of the various soil components will influence the effective thermal conductivity of the soil. Section 3.2 considers the effect of the volumetric ratios of the components. The effect of the amount and nature of water is described in detail in Chapter 4.

The porosity of a soil has a strong influence on its thermal conductivity. The dry density γ_d of a soil is related to its porosity n (expressed as a fraction) by

$$\gamma_d = (1 - n)\gamma_s$$

where γ_s is the unit weight of the solid grains. An increase in the porosity means a decrease in the dry density and more space between the solid particles. In the case of dry soils this means more air is present and hence a lower thermal conductivity, especially if the air is still. When the soil is saturated with water, a larger porosity gives a lower thermal conductivity only if the soil grains possess a higher thermal conductivity than the water. The relationships between thermal conductivity and dry density or porosity in various circumstances are described in Section 3.3.

The pore spaces in soils are available for movement of air, water vapor and liquid water, the result being the transfer of both mass and heat. Chapter 4 considers water migration in detail but the specific effects of porosity on mass transfer are considered in Section 3.4.

Table 2. Thermal properties of soil constituents at 20°C and 1 atm (after Van Wijk 1963).

| Material | Density | Specific heat | Vol. heat capacity | Thermal conductivity | | Thermal diffusivity |
|----------------------|--------------------------------|-------------------|---------------------------------|---------------------------------------|---------|---|
| | ρ (g/cm ³) | c (cal/g °C) | C (cal/cm ³ °C) | k (10 ⁻³ cal/cm s °C) | (W/m K) | α (10 ⁻³ cm ² /s) |
| Quartz | 2.65 | 0.175 | 0.46 | 20 | 8.4 | 43 |
| Many soil minerals* | 2.65 | 0.175 | 0.46 | 7 | 2.9 | 15 |
| Soil organic matter* | 1.3 | 0.46 | 0.60 | 0.6 | 0.25 | 1.0 |
| Water | 1.00 | 1.00 | 1.00 | 1.42 | 0.6 | 1.42 |
| Air | 0.0012 | 0.24 | 0.00029 | 0.062 | 0.026 | 0.21 |

* Approximate average values.

3.1 COMPOSITION AND OTHER STRUCTURAL FACTORS

3.1.1 Packing, porosity and structure

A soil possesses a certain distribution of grain sizes and shapes which determines its density, porosity and pore size distribution. These properties, in turn, directly affect the soil's thermal conductivity. Naturally occurring soils may be conveniently and usefully subdivided into those which contain a granular contacting skeleton (i.e. framework) and those which do not. The former are coarse-grained soils with solid-to-solid contact which contain a small proportion of fines that does not interfere with the packing of the granular framework. The latter include the fine-grained, silt-clay soils which have water films between the particles, although they may contain some pockets of coarse granular materials. The behavior of these two classes of soils, with respect to heat transfer, is essentially different. Some natural soils may consist of a mixture of these two classes and have intermediate properties. A comprehensive description of packing and structure is given by Winterkorn and Fang (1975).

Soils with a granular contacting skeleton may have their grains packed together in numerous ways. For an ideal material made up of spherical grains of uniform size, the cubic packing gives a coordination number of 6 (the number of contact points around each sphere) and a porosity of 47.6%. The densest condition is obtained with the rhombohedral packing, which has a coordination number of 12 and a porosity of 26.0%. Smith et al. (1929) determined experimentally the coordination numbers in a well-packed aggregate of lead shot for various porosities. They found that

$$N = 26.5 - \frac{10.7}{1-n}$$

where N is the average coordination number at a porosity of n . The coordination number is important because it gives the number of solid-to-solid contacts across which heat transfer can occur between the grains. A decrease in the porosity leads to more contact points and therefore better heat transfer.

A natural material consisting of grains of uniform size may be treated as being composed of separate clusters of rhombohedral or cubic arrangements whose ratio to each other gives the observed porosity of the material (Smith et al. 1929). For natural coarse soils, Kolbuszewski (1965) showed by means of photographs that packings of sands consist of a mixture of orderly packed zones (rhombohedral or cubic) with disorderly packed zones between. Kunii and Smith (1960) regarded a given packing as a com-

bination of the cubic and rhombohedral states that gave an intermediate porosity. They obtained an interpolated number of contact points that was used in deriving an expression for the effective thermal conductivity of the granular soil (described in Section 7.8).

If smaller grains are added to a uniform-sized material, they will tend to fill the voids between the larger grains, thus providing more solid matter per unit volume. However, some of the smaller grains may interfere with the packing of the larger grains by pushing them apart. This effect becomes greater as the size ratio approaches unity (Furnas 1931). The data of Furnas have been interpreted by Winterkorn (1977) to show these volume relationships in binary mixtures (Fig. 5). The smaller particles can interfere with the packing of the larger particles, causing a reduction from 50-25% in the volume occupied by the latter, whereas the volume occupied by the smaller particles increases by only a small percentage (from about 22-26% of the total volume of the mixture). The result is an increase in the porosity of the mixture.

With a wide size range and a continuous grading of grain sizes, a lower porosity and a denser mix may be obtained (this may be determined from the Fuller gradation curves). The dry density and the number of contact points per unit volume are thereby increased. The opposite of this is an open-graded material, which shows a smaller thermal conductivity (McGaw 1977). The deviation of particle shape from spherical affects the

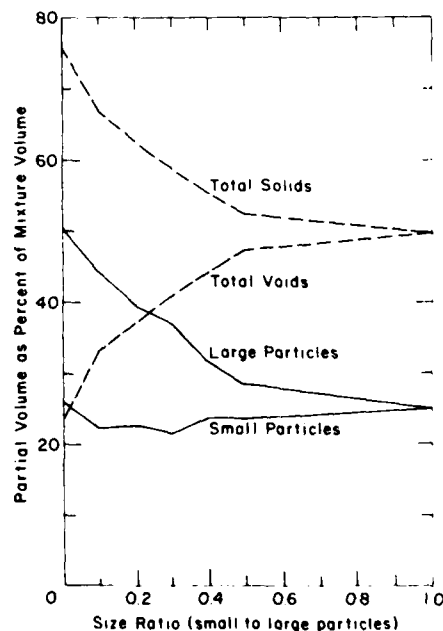

Figure 5. Volume relationships in binary mixtures giving minimum voids. Data calculated by Winterkorn (1977) from test results of Furnas (1931).

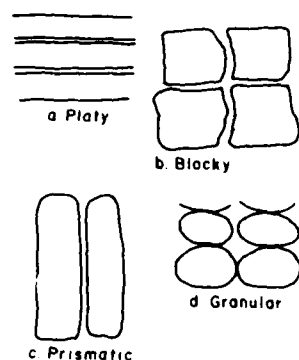

Figure 6. Shapes of air gaps in some common soil structures. Heat flow is from bottom to top (after Smith 1942).

packing characteristics. Flat, angular particles may be fitted closer together to obtain denser packings as, for instance, by mechanical vibration.

The grains' chemical composition, surface characteristics and shape may have important effects on heat transfer. Chemical composition determines the intrinsic thermal conductivity, which is covered in Section 3.2 and in Section 5.1, where the influence of temperature is considered. The thermal conductivity of rock-forming minerals increases with their density (Horai 1971). Dry soils in particular show appreciable variation in their thermal conductivity, depending upon whether they are composed of natural, rounded grains or angular grains with fresh surfaces obtained by crushing rock (see Section 3.3.2).

Natural fine-grained soils do not possess a granular contacting skeleton. These cohesive soils generally consist of small or large aggregations of particles which reflect the history of the soil. The aggregate may be platy, blocky, prismatic or granular, as illustrated in Figure 6, and results from a coherent soil mass splitting up into crumbs. Aggregation means an increased proportion of macropores relative to micropores; the density of the aggregates is greater than the soil's overall density. Smith (1942) noted that a soil with a blocky structure has fewer air gaps and therefore offers less thermal resistance than a soil with a granular or platy structure. If a structured soil is disturbed and finely fragmented, then more gaps are introduced, the thermal resistance increases, and the thermal conductivity decreases significantly. This was confirmed experimentally by Smith (1942). It is therefore important when testing soils to report whether the thermal conductivity values apply to the undisturbed or remolded condition.

3.1.2 Effects of grain and pore size and of soil structure

The grain size distribution of a soil implies a certain pore size distribution which determines the permeability of the soil. Winterkorn (1967) expressed the permeability K as a function of the soil porosity n and its internal surface area per unit volume S by the equation

$$K = Dn(n/S)^2$$

in which D is a constant, dependent on the viscosity of the water. The permeability is proportional to the cube of the porosity and inversely proportional to the square of the specific surface area (measurable by the ethylene-glycol retention method). As the grain size decreases, the specific surface area increases rapidly, leading to a substantial decrease in the permeability and an increase in the number of capillaries per unit volume. As the particle and capillary size decrease, the role of the adsorbed water layers increases since they acquire thickness of a similar order of magnitude as the pore dimensions. During the freezing process, smaller capillaries mean a sharp increase in the curvature of the water/ice interface. The radius of the water/ice interface may be related to the particle size distribution on the basis of various assumptions (Sutherland and Gaskin 1973). The temperature of pore ice nucleation decreases appreciably as the pore size decreases because the smaller pore size implies a decreased distance from the solid surfaces (Martin 1959).

An increase in density of a fine-grained soil (at a constant moisture content) means that, on the average, water is held more tightly. There is an increase in the fraction of water (per unit pore space) that is close to the solid interfaces and is appreciably influenced by them.

Grain size distribution has been used as a basis for determining frost susceptibility criteria. For example, according to the Casagrande classification, soils having more than 3% of their particles finer than 0.02 mm could be frost-susceptible. Silt soils are especially so, while the finer clay soils have too low a permeability to allow appreciable moisture migration, in spite of their high suction. The permeability of the main soil types, as related to suction, is shown in Figure 7. The range in grain size is also important since a well-graded soil has some small channels that are characteristic of its fines content (Linell and Kaplar 1959). But for uniform sandy soils the Casagrande criterion for frost susceptibility is raised from the 3% value for 2- μ m fines to 10%.

The frost heave of compacted silty soils was related by Reed (1977) to their pore size distribution (measured

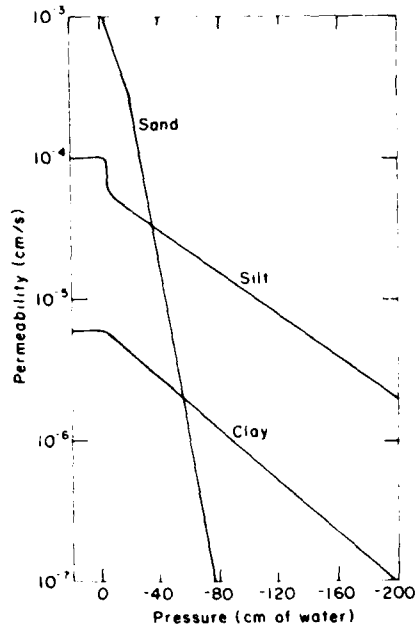

Figure 7. Effect of water tension on soil permeability (after Martin 1959).

by mercury intrusion tests). According to Csathy and Townsend (1962) the distribution of pore sizes is better than the grain size distribution as a criterion for determining frost susceptibility. They used the capillary rise test to determine the pore size distribution of subgrade soils. However, Gaskin and Raymond (1973) criticized this slow test and, on the basis of faster methods, concluded that there was no advantage in using pore size distribution as the criterion.

Soil structure in the freezing zone, as well as the number and size of pores and capillaries, significantly affects the nature and intensity of moisture migration during the freezing process. Controlled Soviet field tests showed that when the natural structure of a soil layer was disturbed and the soil then recompacted to the same density, it showed significantly less heave than the undisturbed soil in the control site (Tyutyunov et al. 1973). In addition the number and thickness of the horizontal interlayers of ice were found to be considerably fewer in the disturbed soil. However, after a period of time, the disturbed soil regained its secondary structure and showed heave characteristics as before, similar to the undisturbed soil.

3.1.3 Contacts and binding effects

The importance of heat transfer at the contacts or interfaces between soil particles has been recognized and stressed (Smith 1942, Martynov 1959, McGaw 1969, Bayer et al. 1972). This heat transfer determines

in large measure the overall thermal conductivity of the soil. In an evacuated powder, for example, the effective conduction occurring through the solids is approximately equal to the contact conduction (Merrill 1968). Thus no matter how high the intrinsic solid thermal conductivity, the contact conduction, acting as the weakest link, will be the major factor limiting the effective overall conduction (Farouki 1966). While this applies particularly to dry soils and soils with low moisture contents, general interfacial effects (i.e. solid/liquid, solid/air and liquid/air as well as solid/solid) maintain their importance to heat transfer in all types and conditions of soils. In particular they affect the relationship between the thermal conductivity of frozen and unfrozen soil.

A temperature discontinuity occurs at the interfaces mentioned above and it is a major factor in the efficiency of interfacial heat transfer. Heat transfer may be improved by adsorbed films of water between crystals, as maintained by Birch and Clark (1940) in their discussion of crystals occurring in igneous rocks, or by an oxygen bedding between soil particles as visualized by Winterkorn (1960b). Winterkorn suggested that oxygen molecules adsorbed on the dry mineral surfaces form a conductive bedding which has heat transfer properties similar to those of the soil minerals themselves. This similarity may be attributed to the fact that volumetrically the most important component of soil minerals is oxygen, which represents 98.2% of the volume of quartz and 87.2% of that of orthoclase (a granite feldspar).

Data on dry soil materials show that the thermal conductivity of crushed rocks is appreciably greater than that of natural soils having a similar mineralogical composition (Kersten 1949). Van Rooyen and Winterkorn (1959) attributed this to better particle-to-particle contact, possibly due to the different physico-chemical properties of the fresh (crushed) material. Both the Gemant and Kersten equations underpredict the thermal conductivity of crushed stone (Moulton and Dubbe 1968a, b). Johansen (1975) recognized this behavior and suggested the use of two equations to calculate the thermal conductivities of dry granular materials. One equation is for natural soils; the second, for crushed rocks, gives a higher thermal conductivity at the same dry density (see Section 7.11).

The importance of contact resistance was clearly shown by the data of McGaw (1968), who measured the thermal conductivity of mixtures of Ottawa sand and ice at 18°F. The addition of the sand caused a drop in the thermal conductivity of the mixture in spite of the fact that the sand had a thermal conductivity much higher than that of the ice it replaced (Fig. 8). The conclusion was that the boundary between the sand and the ice had a high contact resistance. It is here suggested that if adsorbed water layers had been present at such boundaries, as in fine soils, the

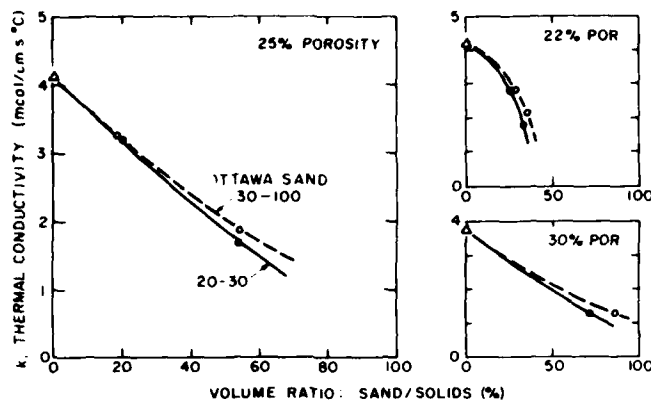

Figure 8. Thermal conductivity of sand and ice mixtures as a function of sand content at constant porosity and 18°F (after McGaw 1968).

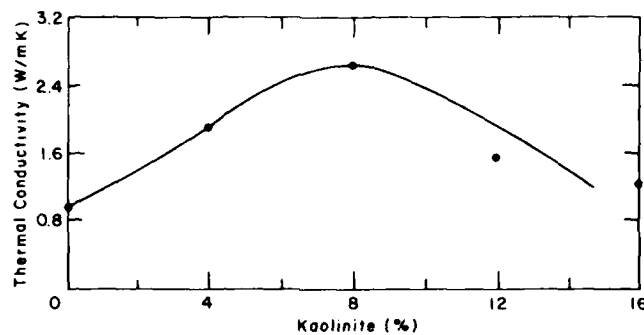

Figure 9. Thermal conductivity of quartzitic granular material with kaolinite binder in the nearly dry state (after Farouki 1966).

trend of reduction in the thermal conductivity with increased soil percentage might have been reversed.

The contact resistance measured by McGaw appeared to be less at the slightly higher temperature of 23°F. The increase in contact conduction with increased temperature over a much wider range of -73°C to 152°C was shown by the data of Hubbard et al. (1969), who found an increase in the effective thermal conductivity of various powders tested under high vacuum conditions.

Increased pressure also improves the thermal conductivity as it leads to larger contact areas. Langseth et al. (1973) measured an increase in the thermal conductivity with depth in evacuated glass beads which they attributed to greater contact areas as the compressive stress between the beads increased. The increase in contact area follows from the classical Hertz theory of contact.

Winter and Saari (1968) noted that the contact resistance between glass microbeads increased as the size of the beads decreased and total contact area rose.

These beads were tested under high vacuum conditions so that the results could be applied to lunar soil material.

Small amounts of clay colloidal particles added to a cohesionless granular material act as a binder and improve the thermal conductivity (Van Rooyen and Wintekorn 1959). With kaolinite, about 8% was found to be the optimum, giving the highest value of thermal conductivity (Farouki 1966). The effective thermal conductivity improved considerably in spite of the much lower thermal conductivity of kaolinite as compared with the quartz grains (Fig. 9). The kaolinite was thought to improve the interfacial conduction characteristics, especially in the nearly dry state. Together with its associated adsorbed water films, the kaolinite provided good thermal bridges amongst the granular skeleton. The implications of Farouki's data were substantiated by the calculations of Moulton and Dubbe (1968a, b) which showed that Kersten's empirical equations underpredicted thermal conductivity values by about 50% as compared with values determined from field temperature measurements.

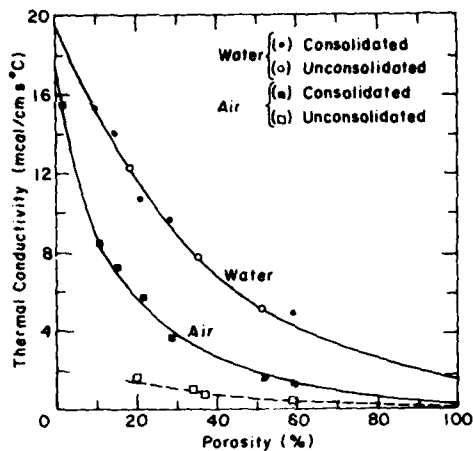

Figure 10. Comparison of thermal conductivity data related to consolidated sandstone and unconsolidated sand, saturated with water or air (after Woodside and Messmer 1961).

Data from Adivarahan et al. (1962) show that the cementation of quartz particles, as in sandstone rock, increases the thermal conductivity of the solids framework by about five times. This effect is particularly important when the material is dry, as shown by the data of Woodside and Messmer (1961) from a comparison of unconsolidated sand with consolidated sandstone (Fig. 10). This figure shows that the effect is less important when the material is saturated with water. One may conclude that the effect of water in improving heat transfer is similar to that of cementation. If oil is the saturant, however, a corresponding improvement does not take place (Woodside and Messmer 1961).

In the freezing of soil, ice cementation occurs and the adhesive forces increase as the temperature decreases (Tsytoich et al. 1957). This possibly leads to better interfacial heat transfer with a consequent increase in the thermal conductivity of the frozen ground.

The heat transfer in soils across the solid-to-solid contact area may be expressed as a function of the porosity of the soil (Masamune and Smith 1963, Huang 1971). The number of interparticle contacts per unit area of cross section is indicative of the structure (Mitchell 1964).

Various attempts have been made to account for some contact effects by deriving parameters and coefficients for use in thermal conductivity equations for soils. Kunii and Smith (1960) introduced parameters to account for heat transfer across contact surfaces between cemented or clogged particles. Masamune and Smith (1963) related the solid-to-solid contact heat transfer to the area of contact and to the characteristics

of the surfaces of the particles, among other factors. McGaw (1969) supposed that in general there is no actual solid-to-solid contact, but that there is an interfacial fluid region in between. He introduced an interfacial efficiency as described in Section 7.10. Because of their importance, future research on interfacial effects is necessary.

When soils having a low degree of saturation freeze, some of the effective "bridge water" at the contacts between the grains goes to form ice in the pores. The result is a decrease in the efficiency of thermal transfer across the contacts, leading to a lower thermal conductivity for frozen soil as compared with the unfrozen soil. These effects are described in detail in Section 4.2.2.

The unfrozen water content in frozen soils appears to play an important role in improving the thermal contact between the soil grains and ice. This effect is discussed in Sections 4.2.2 and 4.2.3 where it is shown that with decreasing temperature, and the consequent drop in the unfrozen water content, there is a reduction in the thermal conductivity of both frozen inorganic and frozen peat soils. This reduction takes place in spite of the increase in both the ice content and the intrinsic thermal conductivity of ice as the temperature drops further below 0°C (see also Section 5.2).

3.1.4 Structure of frozen soil and volumetric effects

When water crystallizes, its volume increases by about 9%. Therefore, when soil with a 90% or higher saturation freezes, the formed ice compresses the pore air or pushes the soil matrix apart. Taylor and Luthin (1976) take this into account in their thermal model of frozen soil.

Major increases in soil volume occur because of the freezing of water that has migrated to the freezing zone. For silt soils that have access to an external water supply and are subject to a slow freezing rate the increase in volume may be several times 10% (samples of fine-grained soils tested by Penner [1957] under controlled freezing conditions showed heaves up to 50% after 3 days). Clays may continue to show a volume increase as the temperature drops to -30°C and lower. On the other hand, the volume increase in sands is slight and is practically complete at -0.5 or -1°C; the sand's porosity increases only slightly.

The typical "frost texture" is formed by a reconstitution of the entire soil system with a change in its thermophysical characteristics. The ice crystals generated first continue to grow, removing water from the surrounding soil (Tsytoich et al. 1959). The growth of a crystal is proportional to its area of contact with the liquid water (Martin 1959). Crystals that are oriented with their base planes more or less parallel to

the surface of the soil mass (i.e. to the isothermal surface) continue to grow. Hence there is a tendency for crystals to fuse into polycrystalline ice layers.

Depending on soil type, rate of cooling and access to a water supply, three basic types of frozen soil structure (or texture) result:

1. A homogeneous or "massive" texture where the contained water freezes in situ with no ingress of water. This texture results from rapid freezing and the ice crystals are not visible to the naked eye if the soil is fine.
2. A layered texture consisting of more or less parallel, lens-shaped ice layers. These exhibit rhythmic banding analogous to Liesegang rings (Martin 1959). The distance between consecutive lenses increases with increasing depth (Palmer 1967). This texture results from a slower rate of freezing, which gives a certain balanced condition of heat flow and moisture flow at the freezing front (Section 4.4.3).
3. A lattice texture which is mesh-like and very inhomogeneous, and possesses irregularly oriented ice crystals.

Among these three broad classifications there exist various intermediate textures "forming a continuous series of transitions" (Tsytoich et al. 1959). A classification of frozen soils is given by Linell and Kaplar (1966).

Ice interstratifications in frozen soil may differ in direction, configuration and depth. In silts, the soil layers between ice lenses are more uniform in thickness than in clays (Penner 1963a). Removal of water from adjoining soil by the growing ice crystals leads to compression of the mineral layers, with shrinkage that is particularly evident in clay soils (Tsytoich et al. 1959). Uneven variations in volume cause pressures which lead to crack formation.

Freezing of cohesive soils results in an increase in particle size by agglomeration of the smaller aggregates (Tyutyunov et al. 1973), particularly if soluble salts are present (Tsytoich et al. 1959). Ice cements the mineral particles together, causing a new type of bond that increases in strength as the temperature decreases. The permeability of soil decreases when it freezes. If water is removed from below the freezing front, cracks occur which subsequently fill with ice (Tsytoich et al. 1959).

3.1.5 Structural effects in the thawing process

On thawing, the soil structure created by freezing remains stable to a certain extent. The destruction of this structure is not spontaneous but occurs under the influence of an external load (Tsytoich et al. 1959). In particular, layered or latticed structure often preserves the pockets, cracks and other cavities which

formed during freezing for a prolonged period. Therefore, the permeability of the thawed soil is greater than it was before freezing.

Some of the liquid water released by thawing rehydrates the particles and aggregates, causing them to swell. Excess water moves downwards and to the sides wherever possible. The net effect is usually a reduction in the overall volume of the thawed soil, resulting from reduction in the size of the macropores as the ice within them melts and the water drains away. Jump-type changes occur in the soil porosity with the destruction of the ice-cement bonds (Tsytoich 1963).

A somewhat different process takes place when frozen clay soil of homogeneous structure thaws, particularly if it has a low degree of ice saturation. The structural properties after thawing remain essentially the same as before (Bakulin et al. 1972).

3.1.6 Changes in the structure of soils

Changes in the structure of soils have important implications with regard to their thermal properties and behavior. Structural changes may occur by natural or artificial means by:

1. The process of drying and wetting. In cohesive soils, drying leads to shrinkage and the formation of fissures which introduce thermal resistance, while subsequent wetting causes swelling. Alternate cycles of drying and wetting lead to a loosening of the soil, and the formation of a honeycomb of shrinkage cracks. This is particularly evident in clayey soils of high plasticity. They form large clods with vertical fissures between them, the clods themselves being subdivided into smaller aggregates.

2. Freezing and thawing. Cycles of freezing and thawing disturb the natural structural bonds in a soil, thereby adding thermal resistance. During freezing, desiccation occurs in both the freezing zone and in the zone below it from which water may be drawn. Thus for cohesive soils, the soil structure resulting from successive cycles of freezing and thawing is similar to that resulting from cycles of drying and wetting (Czeratzki and Frese 1958). The soil forms aggregates with fissures between them. An overall loosening of the soil occurs and both its porosity and moisture content increase, with a corresponding reduction in its dry unit weight.

3. Compaction or densification. The purpose of compaction or densification is to produce a better packed material with a greater dry unit weight and more and better contacts, thus leading to a higher thermal conductivity. In placing the backfill soil around buried electric cables, for instance, this is a necessary and important procedure (Winterkorn 1958c).

4. Fragmentation and remolding. Fine-grained soil samples removed from the field for laboratory testing are often fragmented and subsequently remolded before placing in the testing apparatus. Fragmentation of fine-grained soils produces more air gaps and leads to a lower thermal conductivity (Smith 1942, Pearce and Gold 1959).

5. Flocculation and dispersion. Clay of flocculated structure can easily be destroyed, leading to marked property changes. The undisturbed flocculated structure changes to one in which the clay platelets assume a parallel arrangement, where the two long axes are normal to the direction of heat flow. The thermal conductivity across the planes of cleavage is 10 times smaller than that along these planes and the effect of this anisotropy is a considerable reduction in the thermal conductivity (Penner 1962) (see Section 5.7). Flocculated and dispersed structures are influenced by salts and ions as explained in Section 5.3.

Structural changes in any of the ways listed above (1-5) can lead to significant changes in the processes of heat transfer and in the thermal properties of the soil concerned. Whether the changes are positive or negative depends on the principles outlined in this chapter and in Chapters 4 and 5.

3.2 EFFECT OF THE VOLUMETRIC RATIOS OF THE CONSTITUENTS

The relative volume fractions occupied by the various constituents of a soil influence the value of its effective thermal conductivity. Consider first the simple case of a material with two components, such as a completely saturated or completely dry soil. The relationship between the effective thermal conductivity of this material and the volumetric ratio of the constituents, x_s/x_f , is influenced by the ratio of the thermal conductivities of the two components k_s/k_f . (The volume occupied by a component per unit total volume is denoted by x ; the subscripts s and f refer to the solid and fluid, respectively.) However, the effective thermal conductivity is *not* completely determined by k_s , k_f and the volume fractions of the components. It depends also on the spatial distribution of the components relative to each other, i.e. on the microgeometry of the material or its structure.

An upper and a lower "bound" (or limit) can be set up for the possible variations in the thermal conductivity of a macroscopically homogeneous and isotropic two-phase material which is heterogeneous on a microscopic scale. For a given volumetric ratio, the effect of

microstructure variation is represented by the difference between the upper and lower bounds. The simplest bounds, sometimes called the Wiener bounds, are obtained by imagining first that all the solid particles occur together in one rectangular block equal to their total volume and all fluid particles occur in a second similar block. These blocks are then arranged in parallel with respect to the direction of the heat flow (Fig. 11a) and the upper bound is obtained, an arithmetic mean corresponding to parallel maximum heat flow. The effective thermal conductivity k_e is then given by

$$k_e = x_s k_s + x_f k_f.$$

Arranging the blocks in series (Fig. 11b) gives the lower limit. This limit is now a harmonic mean and k_e is given by the equation

$$\frac{1}{k_e} = \frac{x_s}{k_s} + \frac{x_f}{k_f}$$

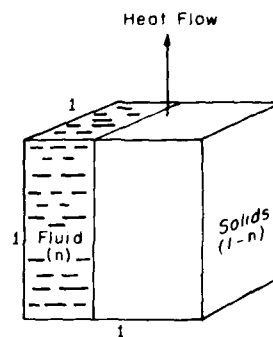

a. Parallel-flow Model

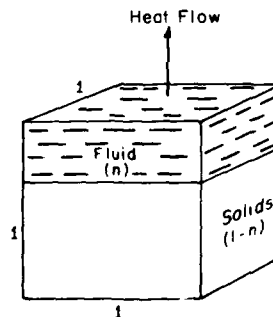

b. Series-flow Model

Figure 11. Idealized models of heat flow through a unit cube of soil (after McGaw 1969).

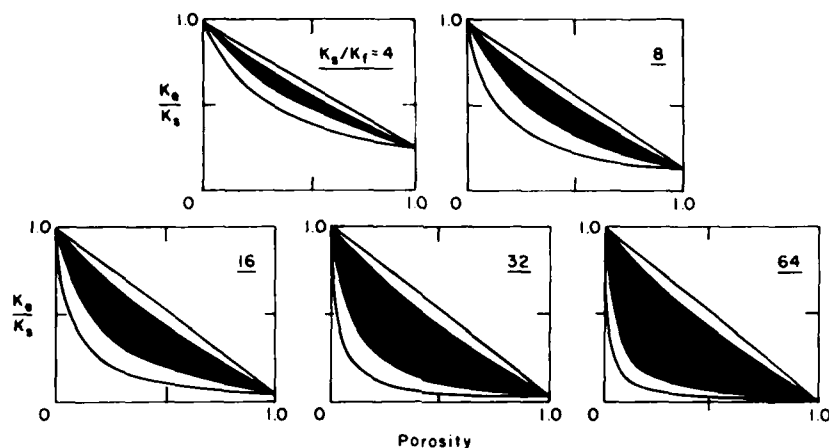

Figure 12. Hashin-Shtrikman bounds (shaded areas) for two-component materials as compared to the Wiener bounds at a set of thermal conductivity ratios (k_s/k_f) and as functions of porosity (after Johansen 1975).

which expresses the effective thermal resistivity (the reciprocal of the conductivity) as the sum of the individual block resistivities. The Wiener bounds are represented in Figure 12 as functions of porosity for different k_s/k_f ratios.

On the basis of variational principles, Hashin and Shtrikman (1962) determined narrower bounds which lie within the Wiener bounds (Fig. 12), thus allowing more accurate estimation of the effective thermal conductivity. The upper Hashin-Shtrikman bound is given by

$$k_{\text{upper}} = k_s + x_f \left(\frac{1}{k_s - k_f} + \frac{1 - x_f}{3k_s} \right)$$

and the lower bound by

$$k_{\text{lower}} = k_f + (1 - x_f) \left(\frac{1}{k_s - k_f} + \frac{x_f}{3k_f} \right).$$

These Hashin-Shtrikman bounds represent extreme variations of microgeometry at a fixed volume ratio. The effective thermal conductivity k_e may be taken as the mean of the upper and lower bounds. As the ratio k_s/k_f increases, the region encompassed by these bounds becomes wider (Fig. 12), implying greater uncertainty in predicting k_e . In dry soils, for example, the ratio k_s/k_f may be as much as 350:1, making it more difficult to obtain reliable estimates of k_e . This has been generally found to be the case. De Vries (1952a) found it necessary to use a correction factor to estimate k_e of dry soils (see Section 7.6). The use of the nomogram of Makowski and Mochlinski (1956) to predict the thermal conductivity

of very dry soils leads to inaccurate estimates (Van Rooyen and Winterkorn 1957). Kersten's empirical equations do not apply to dry soils and Johansen (1975) noted the high sensitivity of thermal conductivity to microstructure in the case of dry soils. The latter proposed the use of two different equations for dry soils, one for natural soil and the other for crushed rock, as described in Section 3.3.

If there is more information available on the composite material than that used in expressing the Hashin-Shtrikman bounds, the upper and lower bounds can be brought closer together. Miller (1969) developed bounds in terms of statistical information expressing p-point correlations (Brown 1955). These are functions which represent the probability that a certain number of specified points will all lie in one of the components. The one-point correlation is equivalent to knowledge of the volume fractions of the components and reduces to the Hashin-Shtrikman bounds. Application of three-point correlations leads to the narrower Miller bounds (Fig. 13). For real materials it may be difficult or impossible to obtain the statistical information necessary for evaluation with three-point correlations. However, for certain cell materials that have regular shapes, the three-point correlation function which appears in the bounds is simply a number for each component. For spherical-shaped cells this number is 1/9, while for platelike cells it is 1/3. Other shapes have a number between these values. Figures 14 and 15 show the Miller bounds for symmetric cell materials compared with the Hashin-Shtrikman bounds.

For low ratios of k_s/k_f , the sensitivity of the effective thermal conductivity to variations in microstructure

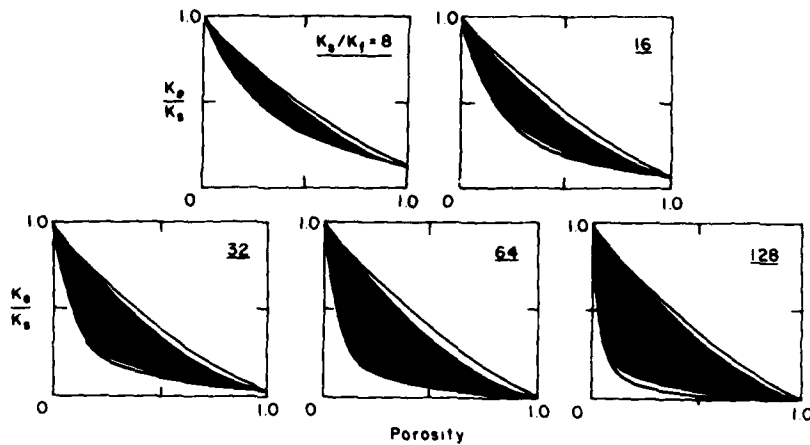

Figure 13. Miller bounds (shaded areas) for two-component materials as compared to the Hashin-Shtrikman bounds at a set of thermal conductivity ratios (k_s/k_f) and as functions of porosity assuming spherical particles (after Johansen 1975).

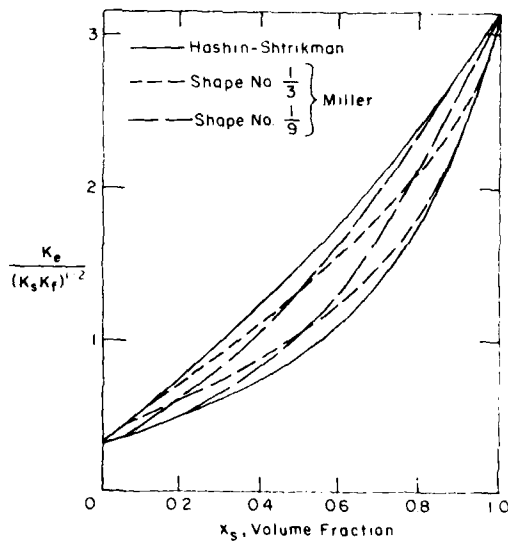

Figure 14. Miller bounds (dashed lines) for normalized effective thermal conductivity k_e of symmetric cell material compared to Hashin-Shtrikman bounds (continuous lines) at ratio $k_s/k_f = 10$ (after Miller 1969).

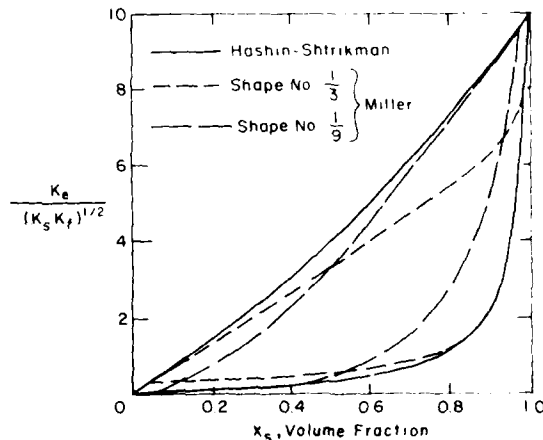

Figure 15. Miller bounds (dashed lines) for normalized effective thermal conductivity k_e of symmetric cell material compared to Hashin-Shtrikman bounds (continuous lines) at ratio $k_s/k_f = 100$ (after Miller (1969).

is low. Under these conditions the geometric mean equation has often been used to calculate k_e since this equation is simple to use:

$$k_e = k_s^{(1-n)} k_w^n$$

for water-saturated soils of porosity n , where k_w is the thermal conductivity of the water. Although this equation is not based on physical concepts, it nevertheless generally gives good estimates, since the

ratio k_s/k_w is not much larger than 10 (Woodside and Messmer 1961). For saturated soils this ratio will be a maximum of about 15 if the solids are composed of quartz and this value is acceptable. Sass et al. (1971) applied this geometric mean equation in determining the thermal conductivity of rocks from measurements made on rock fragments saturated with water.

A similar form of the equation may also be used to determine the effective thermal conductivity of solid soil particles composed of minerals of different

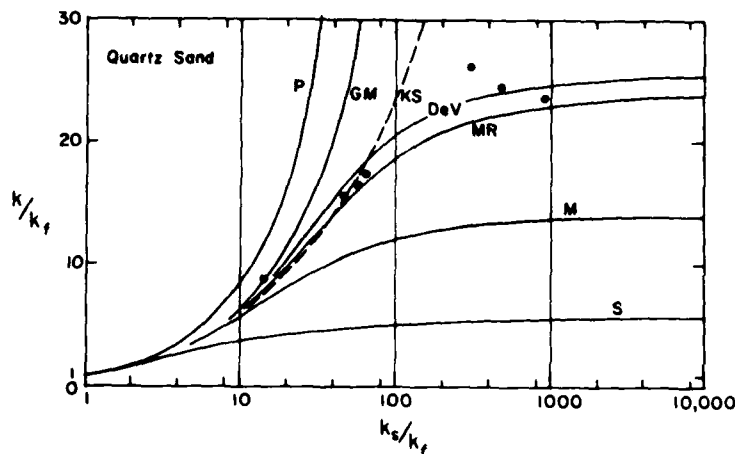

Figure 16. Curves for thermal conductivity compared with data on saturated quartz sand at various k_s/k_f ratios and a porosity of 19% (after McGaw 1969). The notation on the curves refers to the various models. P—parallel flow, S—series flow, GM—geometric mean, KS—Kurii-Smith, DeV—De Vries, MR—modified resistor, M—Maxwell.

conductivities:

$$k_s = \prod_{j=1}^m k_j^{x_j}$$

where Π represents the product of k factors, each having an exponent x , the volume fraction. The subscript j refers to the j th component, there being m components altogether.

Judge (1973b) applied the geometric mean equation to frozen soils in the form

$$k_e = k_s^{1-n} k_i^{n-\theta} k_w^\theta$$

where θ is the volume fraction of the unfrozen water per unit soil volume and k_i is the thermal conductivity of the ice. Judge found that this equation gave as good a fit to Penner's data (1970) as the De Vries model which Penner applied to his own data. The same equation as that of Judge is used by Johansen (1975) in his proposed model for calculating the thermal conductivity of saturated frozen soils and a similar equation for saturated unfrozen soils (Chapter 7).

Besides the statistical approaches involving the determination of bounds as described above, the effective thermal conductivity k_e of a soil may be estimated from various physical models with idealized geometries (described in Chapter 7). McGaw (1969) compared the predictions of some of these models with data on quartz sand (Fig. 16). Only the De Vries and modified resistor equations approximated the data over a large range of k_s/k_f values.

3.3 CORRELATIONS BETWEEN THERMAL CONDUCTIVITY AND SOIL DENSITY OR POROSITY

An increase in the dry density of a soil, with its associated decrease in porosity, leads to an increase in the thermal conductivity, mainly due to three factors:

1. More solid matter per unit soil volume
2. Less pore air or pore water per unit soil volume
3. Better heat transfer across the contacts.

There have been various correlations made between the thermal conductivity of soils and their density or porosity. The importance of this link is illustrated by the use of the thermal conductivity as an indication of the porosity of oil-bearing formations (Zierfuss and Van der Vliet 1956). Soils in situ may vary appreciably in their dry densities. As early as 1909 Patten recognized the importance of the density effect and also the difficulty of achieving uniform soil densities in experimental setups.

On the basis of Kersten's (1949) data, Terzaghi (1952) illustrated the variation with porosity of the thermal conductivity of sands or clays, frozen or unfrozen (Fig. 17). The thermal conductivity of the frozen soils is appreciably greater than that of the unfrozen soils because ice has a conductivity about four times that of water. As the porosity approaches 100% (i.e. zero solids volume) the conductivity of saturated frozen soils may be expected to approach the value for ice, while that of unfrozen saturated soils approaches the conductivity of water. At the other extreme, as the porosity decreases toward zero, the conductivity should tend toward that of the solid particles. The

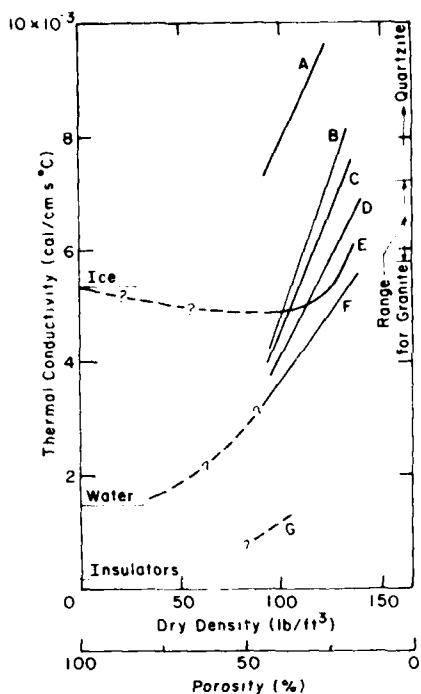

Figure 17. Thermal conductivity of sand and clay, unfrozen or frozen, as a function of dry density. A-frozen saturated sand, B-unfrozen saturated sand, C-unfrozen sand at S_r of 75%, D-unfrozen sand at S_r of 50%, E-saturated frozen clay, F-saturated unfrozen clay, G-dry unfrozen sand.

higher value for the sands is a reflection of their generally predominant quartz composition in contrast to the micaceous composition of the clays.

3.3.1 General correlations

In general, experimenters have found a linear trend between the thermal conductivity of a soil or its logarithm on the one hand and the dry density or porosity of that soil on the other. Increased dry density implies reduced porosity and leads to an increase in the thermal conductivity.

On the basis of numerous tests Kersten (1949) found that at constant moisture content the logarithm of the thermal conductivity increased linearly with the dry density γ_d . This behavior was expressed by equations of the form:

$$k = A(10)^{B\gamma_d}$$

in which the empirical parameters A and B depend on whether the soil is sandy or clayey and whether it is frozen or unfrozen. For a given soil, the slope of the linear relation is approximately the same for the different moisture contents.

The U.S.S.R. Building Code (1960) has tabulations of the thermal conductivity of sandy and clayey soils, frozen or unfrozen, at different moisture contents and unit-weights. These generally agree in magnitude with Kersten's results as shown by Sanger (1963). Figures 18-21 are based on the Soviet tables and show the

same form as Kersten's data, the lines at various moisture contents being parallel for a given soil.

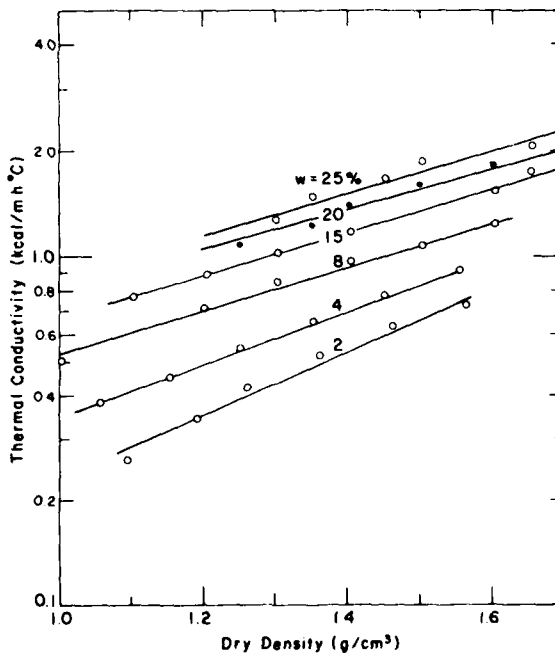

Figure 18. Thermal conductivity of unfrozen sandy soils vs dry density at constant moisture w (data from U.S.S.R. Building Code 1960).

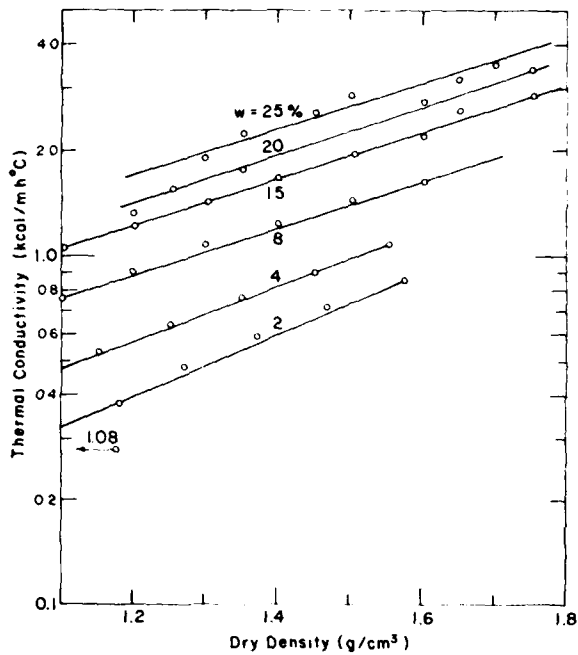

Figure 19. Thermal conductivity of frozen sandy soils vs dry density at constant moisture content w (data from U.S.S.R. Building Code 1960).

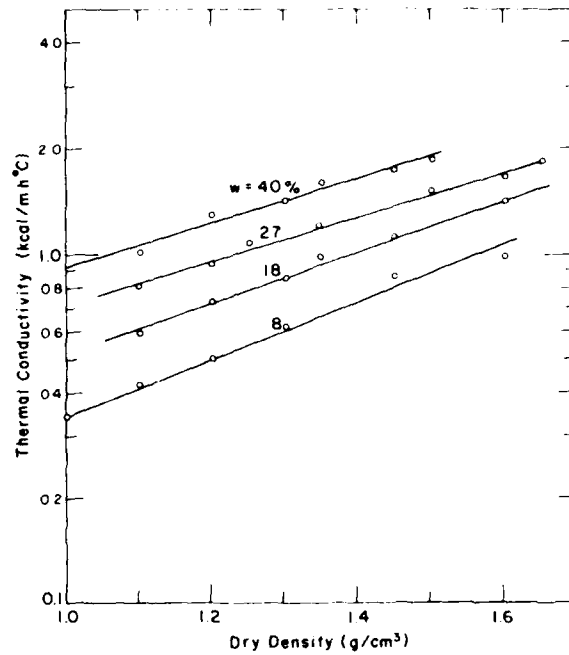

Figure 20. Thermal conductivity of unfrozen clayey soils vs dry density at constant moisture content w (data from U.S.S.R. Building Code 1960).

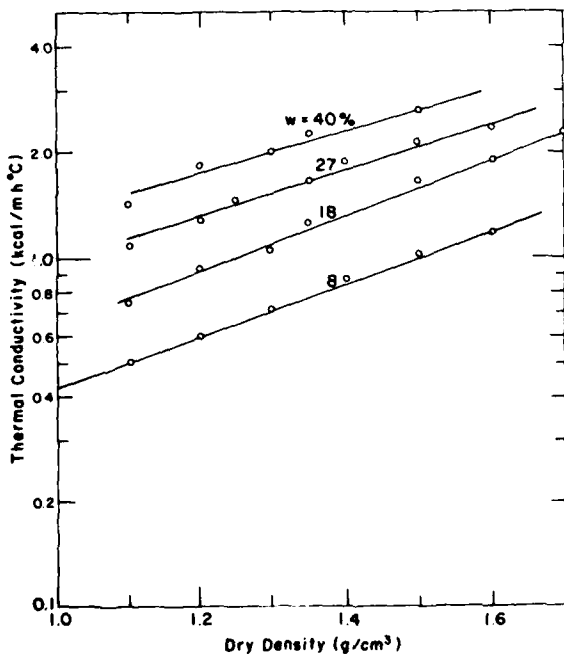

Figure 21. Thermal conductivity of frozen clayey soils vs dry density at constant moisture content w (data from U.S.S.R. Building Code 1960).

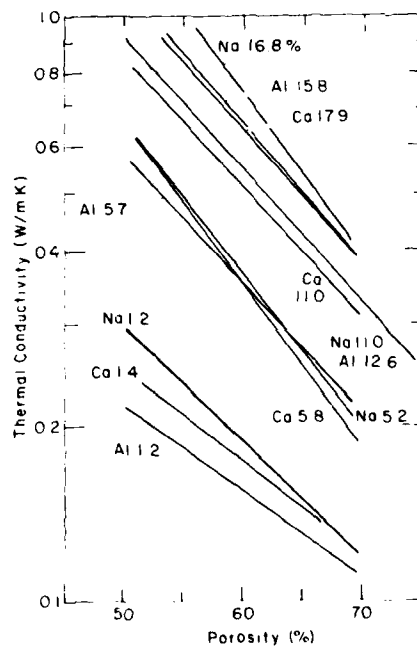

Figure 22. Logarithm of thermal conductivity as a function of porosity of homoionic kaolinite clays at indicated water contents. Na, Ca and Al represent sodium, calcium and aluminum kaolinite respectively (after Reno and Winterkorn 1967).

A trend of linearity between the thermal conductivity (rather than its logarithm) and the dry density was established for soils tested under natural conditions (Gorbunova et al. 1958) and for remolded soils (Kolyasev and Gupalo 1958).

Porosity, instead of dry density, may be used to show the variation of thermal conductivity as was done by Reno and Winterkorn (1967). For the various types of homoionic clays they tested, the logarithm of the thermal conductivity showed a linear decrease as the porosity increased at constant moisture content (Fig. 22). The rate of change is approximately the same for the different types of ionic modifications and for the various moisture contents.

3.3.2 Relationships for dry soils

An increase in dry density has a particularly important effect on the thermal conductivity of dry soils as it implies more solid matter per unit volume (replacing poorly conducting air) and better thermal contacts. In estimations of the thermal conductivity for dry soils (or soils having low degrees of saturation), there is a high sensitivity to variations in dry density and in microstructure variations such as shape differences (Johansen 1975). Figure 23 shows the general effect of dry density on thermal conductivity for different types of air-dried soils. This figure also gives an indication of the dry densities at which these soil types may exist.

Smith and Byers (1938) established that the thermal conductivity of dry natural heavy soils increased linearly with their dry density (Fig. 24). This trend was verified by Woodside and De Bruyn (1959) for dry Leda clay (Fig. 25) and by Slusarchuk and Watson (1975) for thawed permafrost soils which were reconstituted in the dry condition. De Vries' (1963) model predicts a nearly linear increase in the thermal conductivity of dry soils at low dry densities, the rate of increase becoming more rapid as the solids volume fraction increases.

The microstructure and shape factors of dry soils were taken into account by Johansen (1975) in his proposed equations for determining thermal conductivities. On the basis of empirical observations he proposed two equations, the first for dry natural soils:

$$k = \frac{0.135\gamma_d + 64.7}{2700 - 0.947\gamma_d} \pm 20\%$$

and the second for dry crushed rock:

$$k = 0.039n^{-2.2} \pm 25\%$$

The thermal conductivity (W/m K) is related to the dry density γ_d (kg/m³) for natural materials and to the porosity n (fractional) for crushed rock (see Fig. 26).

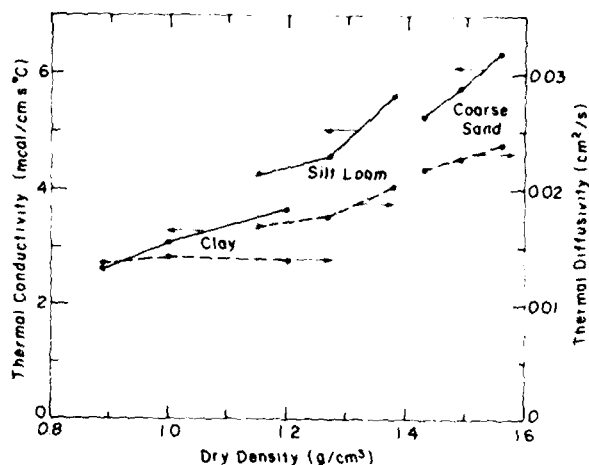

Figure 23. Effect of texture and density on thermal conductivity (solid lines) and on thermal diffusivity (dashed lines) of air-dry soils (after Al Nakshabandi and Kohnke 1965).

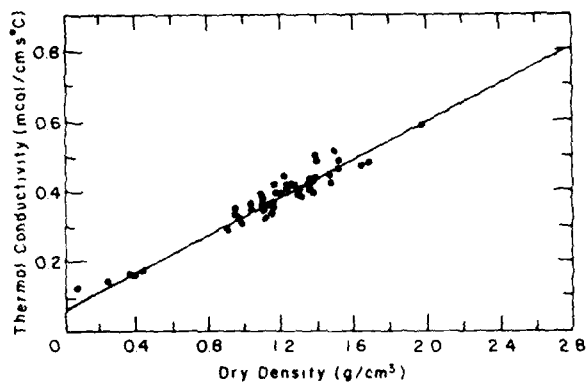

Figure 24. Thermal conductivity of dry soils as a function of dry density (after Smith and Byers 1938).

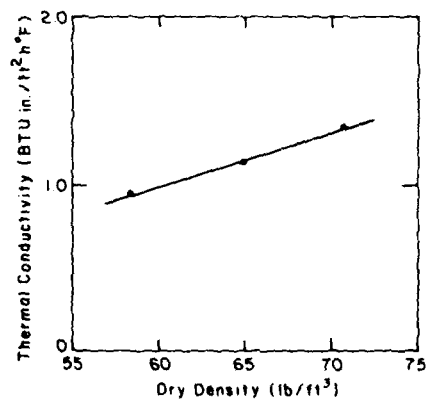

Figure 25. Thermal conductivity of dry Leda clay as a function of dry density (after Woodside and De Bruyn 1959).

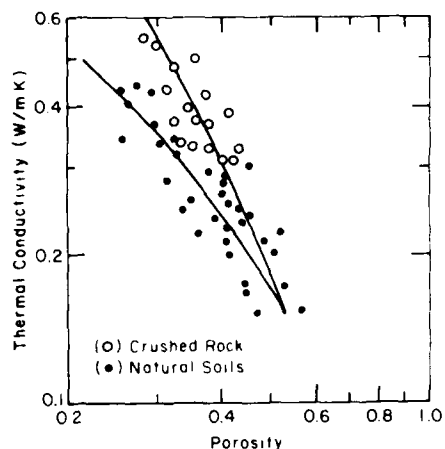

Figure 26. Thermal conductivity of dry natural soils and crushed rock vs porosity (after Johansen 1975).

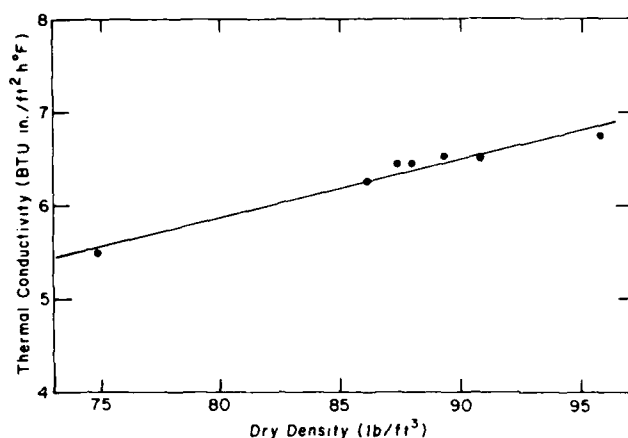

Figure 27. Thermal conductivity of saturated Leda clay vs dry density (after Penner 1962).

3.3.3 Relationships for saturated soils

The presence of a small amount of soil moisture improves the thermal contacts because of water bridges. The effects on the thermal conductivity of more water or ice, up to saturation, are described in detail in Chapter 4. In this section, the effect of dry density on saturated soils, frozen or unfrozen, is considered.

Unfrozen saturated soils

For unfrozen, fully saturated soils, an increase in dry density means that the solids fraction replaces some of the water in the pores. An increase in the thermal conductivity of the soil will therefore result only if the solid has a higher thermal conductivity than the water it replaces. Clay minerals have a thermal conductivity about four times that of water. Figure 27 shows the consequent increase in the thermal conductivity of saturated Leda clay with dry density (Penner 1962). Permafrost soil samples, thawed under load or reconstituted in a saturated (unfrozen) condition, show a similar trend (Slusarchuk and Watson 1975).

Sandy soils are often composed of quartz, which

has a thermal conductivity about 15 times that of water. Therefore, sands are expected to show a greater rate of increase in thermal conductivity with dry density than clay soils, but this effect may not be marked.

If the soil becomes oversaturated with water, as in the case of ocean sediments, there is a rapid decrease in the thermal conductivity as dry density drops. This trend is particularly evident where the solid material is quartz that is being replaced by water (Fig. 28).

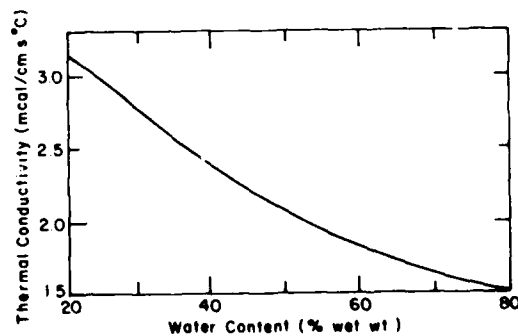

Figure 28. Thermal conductivity of ocean sediment vs water content (after Ratcliffe 1960).

The solids in organic soils, on the other hand, have a thermal conductivity of only about half that of water. The effect of variations in the solid material fraction of peat is therefore slight (Pavlova 1970) since peat contains much water (see Section 4.2.3). Doubling or tripling of this solids fraction causes only a slight increase in the thermal conductivity of the peat (MacFarlane 1969).

Frozen saturated soils

As in the case of unfrozen soils, saturated frozen soils show an increase in the thermal conductivity with the dry density. For undisturbed permafrost soils Slusarchuk and Watson (1975) found a linear relationship between the above variables (Fig. 29). It should,

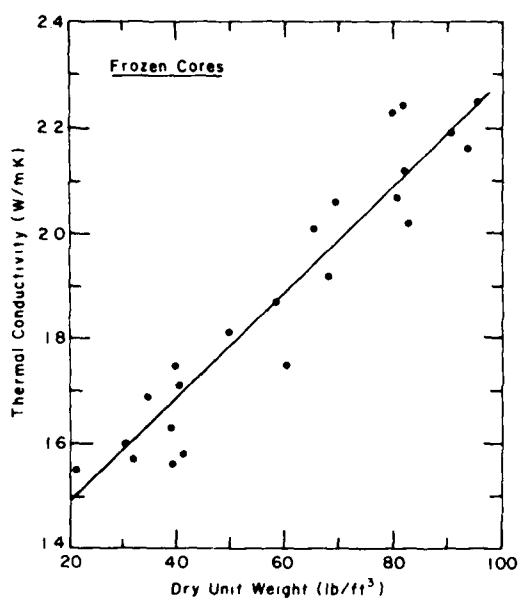

Figure 29. Thermal conductivity vs dry unit weight for frozen cores of permafrost from Inuvik (after Slusarchuk and Watson 1975).

however, be noted that these values apply to oversaturated ice-rich soils whose moisture content varies considerably (25 to 231%). If these thermal conductivity values are plotted against ice content, as in Figure 75, a marked decrease in the thermal conductivity is shown as the ice content increases. This curve is similar to Figure 28 for over-saturated ocean sediments in terms of the water content because the two cases are analogous.

3.4 EFFECTS OF POROSITY AND DENSITY ON OTHER THERMAL PROPERTIES

3.4.1 Effect on water transfer

Moisture transfer in soils is described in detail in Sections 4.3 and 4.4. The specific effects of porosity or dry density are considered in this section.

Diffusion of water vapor in soils is proportional to the air-filled porosity (Section 4.3.1). The effect of pore shape may be taken into account by means of various coefficients (Currie 1960). In cases where frost growth conditions prevail, the resistance to diffusion increases as the effective pore cross section is reduced by hoarfrost growth. The frost itself is porous and this may be taken into account. Auracher (1973) considered the variable cross section of the pore path and graphically determined the mass and location of frost growth in the pores.

Dry density affects the value of the critical moisture content, at which maximum moisture transfer (both vapor and liquid) occurs in unsaturated soils above 0°C (Section 4.3.3). A greater dry density reduces this critical moisture content because the soil is more

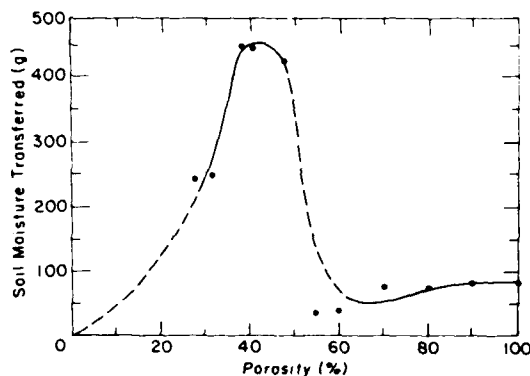

Figure 30. Moisture transferred upon freezing as a function of porosity of a silty glacial outwash soil (after Jumikis 1962).

tightly packed and the water films merge at a lower moisture content.

The amount of moisture transferred, and therefore the amount of soil heave, during freezing are profoundly influenced by the porosity (Fig. 30). Maximum transfer occurs at a certain porosity (Jumikis 1967). Low permeability limits transfer at the lower porosities while the decreased transfer at higher porosities is due to less suction. A more tightly packed soil shows greater heave characteristics (Taber 1930, Beskow 1935, Haley and Kaplar 1952), but this applies only up to a

certain dry density, beyond which heaving decreases. (Winn and Rutledge 1940). There is a critical dry density which gives the most favorable combination of capillarity and permeability. Even sand may become frost-susceptible if it is well-compacted (Janson 1963).

3.4.2 Effect of density on soil thermal diffusivity

Thermal diffusivity α is the quotient of thermal conductivity k and the volumetric heat capacity C (see Section 1.1). An increase in dry density causes an increase in the thermal conductivity, as seen in previous sections. However, the diffusivity does not increase in proportion (see Fig. 2.3) because the heat capacity also increases owing to an increase in the solids volume fraction.

CHAPTER 4. THE EFFECT OF WATER AND ITS MIGRATION ON THE THERMAL PROPERTIES OF SOILS

"Water and soil are not only the most important materials in this world, but also the most complex ones, each in its own category, water as a liquid and soil as a multi-phase dispersed system" (Winterkorn 1958a, p. 1). Water in all its forms has important and very complex effects on the thermal properties of soils. It is the soil component most affected by temperature changes.

The magnitude of the soil temperature affects the intrinsic properties of soil water, the amount of unfrozen water in frozen soils, the rate of water movement and other soil-water properties. For example, typical soil temperatures near Fairbanks, Alaska, range between 0 and -5°C in winter for considerable depths. This implies the presence of variable amounts of unfrozen water. The properties of water in soils and the effect of its amount are considered in Sections 4.1 and 4.2.

In nature there is always some water movement taking place within soils as liquid or vapor (and possibly even as ice). In addition to transferring heat, water movement leads to changes in the soil's properties because of changes in the amount and type of water at a particular position. Temperature gradients induce water migration directly (Section 4.3). They can also cause water movement indirectly by setting up suction potentials and osmotic pressures. When soil freezes, water is drawn to the freezing front,

thereby altering the soil's thermal properties in both the frozen and unfrozen zones. The nature and effects of migration during the freezing process are examined in Section 4.4.

Moisture flow and heat flow have been recognized as coupled processes with complex interactions between the effects of temperature, heat flow and moisture flow. Heat and mass transport are, in fact, the two major physical processes taking place in arctic tundra soils (Nakano and Brown 1971). The moisture and thermal regimes of such soils act in parallel in a complex manner and must be considered together (Guymon and Luthin 1974). The general coupling effect between moisture and heat flow is described in Section 4.3, and the specific coupling that exists in the freezing process is considered in Section 4.4.

4.1 PROPERTIES OF WATER IN SOILS AND THE INFLUENCE OF TEMPERATURE

Water may be present in soil in any of its three phases: ice, liquid water and water vapor. Liquid water, in particular, can have complex forms as a result of its interaction with the soil. Temperature has a paramount effect, not only in determining the phase distribution, but also by affecting the properties of the water, its movement and the degree of its interaction with the solid soil minerals.

Table 3. Physical properties of liquid water (after Van Wijk 1963).

| Temp ($^{\circ}\text{C}$) | Density (g/cm^3) | Surface tension (g/s^2) | Dynamic viscosity ($\text{g}/\text{cm s}$) $\times 10^3$ | Heat of evaporation (cal/g) | Thermal | |
|--------------------------------|---------------------------------------|---|---|---|--|---|
| | | | | | Specific heat ($\text{cal}/\text{g}^{\circ}\text{C}$) $\times 10^3$ | conductivity ($\text{cal}/\text{cm s}^{\circ}\text{C}$) $\times 10^3$ |
| -10 | 0.99794 | - | - | 603.0 | 1.02 | - |
| -5 | 0.99918 | 76.4 | - | - | - | - |
| 0 | 0.99987 | 75.6 | 1.7921 | 597.3 | 1.0074 | 1.34 |
| 4 | 1.00000 | - | - | - | - | - |
| 5 | 0.99999 | 74.8 | 1.5188 | 594.5 | 1.0037 | 1.37 |
| 10 | 0.99973 | 74.2 | 1.3077 | 591.7 | 1.0013 | 1.40 |
| 15 | 0.99913 | 73.4 | 1.1404 | 588.9 | 0.9998 | 1.42 |
| 20 | 0.99823 | 72.7 | 1.0050 | 586.0 | 0.9988 | 1.44 |
| 25 | 0.99708 | 71.9 | 0.8937 | 583.2 | 0.9983 | 1.46 |
| 30 | 0.99568 | 71.1 | 0.8007 | 580.4 | 0.9980 | 1.48 |
| 35 | 0.99406 | 70.3 | 0.7225 | 577.6 | 0.9979 | 1.50 |
| 40 | 0.99225 | 69.5 | 0.6560 | 574.7 | 0.9980 | 1.51 |
| 45 | 0.99024 | 68.7 | 0.5988 | 571.9 | 0.9982 | 1.53 |
| 50 | 0.98807 | 67.9 | 0.5494 | 569.0 | 0.9985 | 1.54 |

Table 4. Physical properties of saturated water vapor (after Van Wijk 1963).

| Temp ($^{\circ}\text{C}$) | Vapor pressure (mm mercury) | | Density (g/cm^3) | |
|--------------------------------|--------------------------------|----------|------------------------------------|-------------------------------|
| | Over water | Over ice | Over water ($\times 10^6$) | Over ice ($\times 10^6$) |
| -20 | 0.941 | 0.774 | 1.074 | 0.883 |
| -15 | 1.434 | 1.24 | 1.61 | 1.39 |
| -10 | 2.15 | 1.95 | 2.36 | 2.14 |
| -5 | 3.16 | 3.01 | 3.41 | 3.25 |
| 0 | 4.58 | 4.58 | 4.85 | 4.85 |
| 5 | 6.53 | - | 6.80 | - |
| 10 | 9.20 | - | 9.40 | - |
| 15 | 12.78 | - | 12.85 | - |
| 20 | 17.52 | - | 17.30 | - |
| 25 | 23.75 | - | 23.05 | - |
| 30 | 31.82 | - | 30.38 | - |
| 35 | 42.20 | - | 39.63 | - |
| 40 | 55.30 | - | 51.1 | - |
| 45 | 71.90 | - | 65.6 | - |
| 50 | 92.50 | - | 83.2 | - |

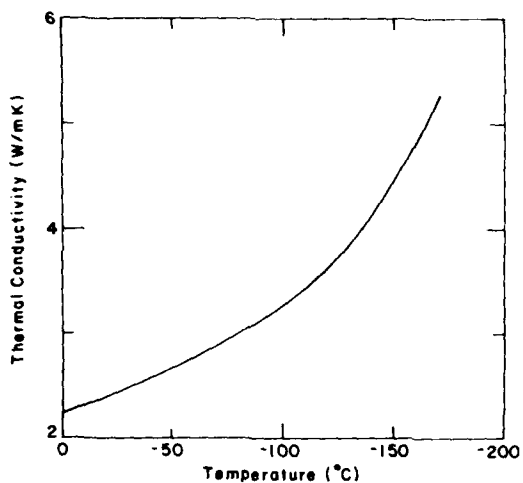

Figure 31. Thermal conductivity of ice as a function of temperature (after Sawada 1977).

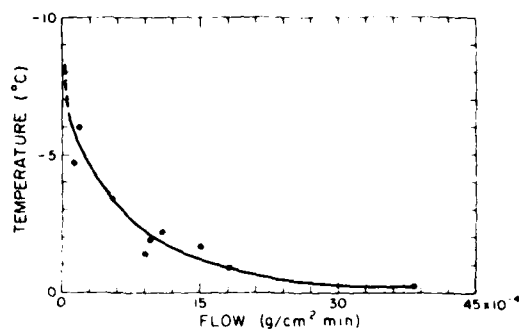

Figure 32. Flow of water in frozen soil as a function of temperature below 0°C (from Hoekstra 1969).

4.1.1 Properties of water and their dependence on temperature

Some of the relevant physical properties of liquid water, saturated water vapor and ice at different temperatures are given in Tables 3-5. The increase in the thermal conductivity of ice down to temperatures of -150°C is shown in Figure 31.

The presence of water vapor in the pores of a soil leads to an increase in the apparent thermal conductivity k_a of the pore air by an amount k_v because of the transport of latent heat. For the case where the air in the pores is saturated with water vapor, an expression for the additional effect due to vapor movement is derived in Section 4.3, the effect of temperature being evident from Figure 91.

4.1.2 Properties of soil water

The permeability of a soil decreases as the moisture content decreases. In frozen soil, the flow of water is a function of the temperature below 0°C (Fig. 32). Pore ice formation reduces permeability just as air bubbles do in the case of unsaturated flow above 0°C (Guymon and Luthin 1974).

For a fine-grained soil, the growth of ice at decreasing temperatures is a gradual process due to the continued presence of unfrozen water below 0°C. At very low temperatures, a limiting condition may be reached where the continuity of the interconnected unfrozen water films may be disrupted.

The relationships among the dry unit weight of frozen soils, their water content and their ice volume are shown in Figure 33. This figure assumes complete saturation and that all water is frozen. The effect of oversaturation with ice may be determined from it.

4.1.3 Soil-water interaction

Above freezing temperatures, water in soil may be simply subdivided into "held" moisture and "free" moisture. The latter may be removed from the soil by hydrostatic pressure or by gravity drainage. The held water may not be removed in this manner, being subject to complex attractive forces arising from its interaction with the surfaces of the soil particles. These forces, which are still being elucidated, are intermolecular, electrical, magnetic and gravitational. Some of the held water may be chemically combined in the surfaces

Table 5. Physical properties of ice (after Van Wijk 1963).

| Temp (°C) | Specific heat c_p (cal/g °C) | Thermal conductivity (cal/cm s °C) $\times 10^{-3}$ | Heat of sublimation (cal/g) | Heat of fusion (cal/g) | Density (g/cm ³) |
|--------------|---|--|-----------------------------------|------------------------------|---------------------------------|
| -20 | 0.468 | 5.81 | 677.9 | 69.0 | 0.920 |
| -10 | 0.485 | 5.54 | 677.5 | 74.5 | 0.919 |
| 0 | 0.503 | 5.35 | 677.0 | 79.7 | 0.917 |

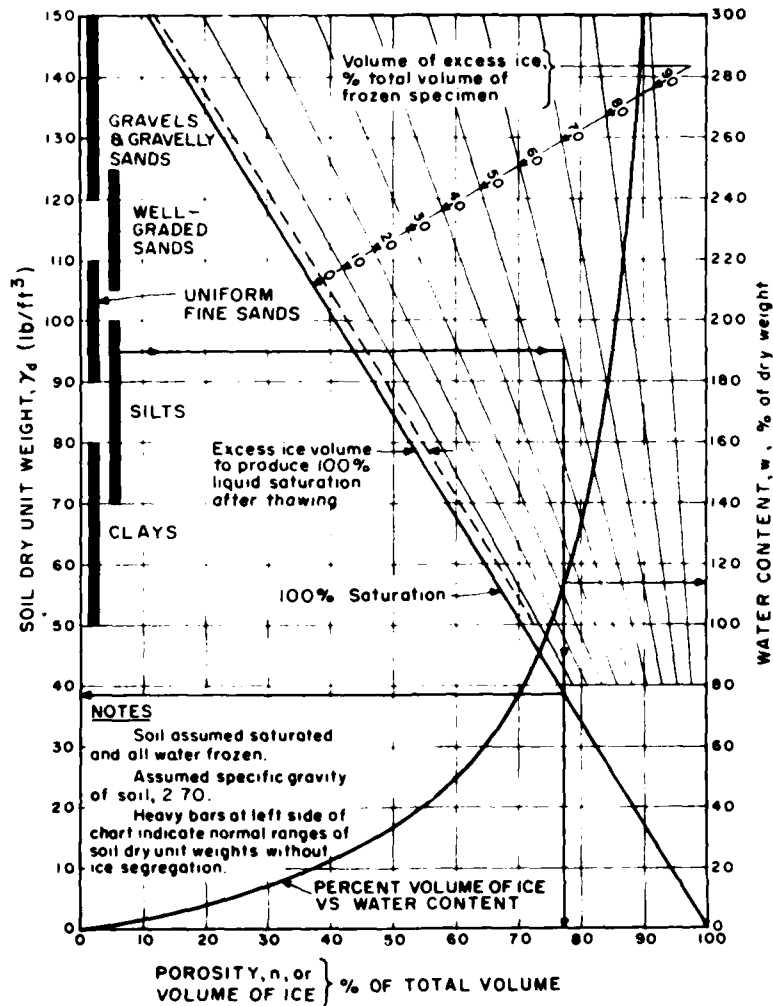

Figure 33. Relationships among dry unit weight, ice volume and water content of frozen soil (from Linell and Kaplar 1966).

or adsorbed onto them and some may be held at the particle contact points or in the capillary pores.

The effect of temperature on soil water is important because an increase in temperature increases the kinetic energy of the water molecules and leads to dispersion. Some held water may be changed into free water and vice versa by the normal temperature fluctuations occurring in the surface layers of the earth (Winterkorn and Eyring 1946).

The attraction of the soil for water, or the degree to which this water is held, has been expressed by several terms that amount to the same thing: soil moisture tension, capillary potential or suction, all designated by ψ . This concept is defined as equivalent to the work required to pull a unit mass of water away from a unit mass of soil. It is expressed in terms of

the height of a water column that the suction would support in tension. The logarithm of this height in centimeters is termed the pF value. The necessity for using the logarithm arose because of the great range of suction values possible in soils. At the one extreme of oven dryness, the suction may be many thousands of atmospheres ($pF = 7$) and at the other of complete saturation it may be zero ($pF = 0$).

The tension of soil moisture is an intrinsic property of a given soil-water system that depends on the affinity of the water for the solid soil surfaces. It represents the combined action of all the system's internal forces in displacing soil moisture (Blomquist 1961). The suction or pF value depends on the moisture content at the given point and leads to a certain associated vapor pressure in the soil pore. The relationship between

Table 6. The pF scale in terms of the equivalent negative hydraulic head, the equivalent suction ($\text{lb}/\text{in.}^2$) and relative humidity (after Croney 1952).

| pF | Equivalent negative hydraulic head | | Suction ($\text{lb}/\text{in.}^2$) | Relative humidity (%) |
|-----------|------------------------------------|-----------------------|--------------------------------------|-----------------------|
| | (cm) | (ft) | | |
| 0 | 1 | 3.28×10^{-2} | 1.42×10^{-2} | |
| 1 | 10 | 3.28×10^{-1} | 1.42×10^{-1} | |
| 2 | 10^2 | 3.28 | 1.42 | 99.99 |
| 3 | 10^3 | 3.28×10 | 1.42×10 | 99.92 |
| 4 | 10^4 | 3.28×10^2 | 1.42×10^2 | 99.27 |
| 5 | 10^5 | 3.28×10^3 | 1.42×10^3 | 93.00 |
| 6 | 10^6 | 3.28×10^4 | 1.42×10^4 | 48.43 |
| 7 | 10^7 | 3.28×10^5 | 1.42×10^5 | 00.07 |
| $-\infty$ | 0 | 0 | 0 | 100.00 |

pF and relative vapor pressure (or relative humidity) is given in Table 6 and is expressed by

$$\psi = \rho_w RT \ln \phi$$

where ϕ = relative humidity

ρ_w = density of water

R = gas constant of water vapor

T = absolute temperature.

Study of the important drying process in soils has shown how the drying rate is considerably influenced by the moisture content as it reflects the strength by which the water is held. Sudden changes in the drying rate probably occur where there are important changes in soil moisture constants* which characterize the particular soil (Kolyasev and Gupalo 1958).

Water in soils is invariably a solution, containing diverse soluble substances which move both within and with the water. Some of the solutes may enter into or come out of the soil's exchange complex, i.e. the adsorbed water layer. An increase in salt content increases the number of ice crystals formed per unit volume in saline water; this is dependent on the degree of supercooling (Golubev and Lomonosov 1973).

4.1.4 Properties of the adsorbed water layer

The adsorbed water layer on a clay particle surface has been visualized as a diffuse electric double layer (Fig. 34). There is an exponential decrease in the

* With decreasing moisture content, these are the "field capacity," the moisture content of "plant growth retardation," that of "steady plant wilting" and finally that of "maximum hygroscopicity," which are terms used in agricultural engineering.

electric potential as the concentration of the swarm of cations decreases with distance from the surface. The adsorbed water itself has a high degree of dissociation.

The properties of this adsorbed layer are different from those of ordinary free water. The density of the adsorbed layer is less but increases with distance from the surface (Fig. 35). On the other hand the viscosity is greater than that of free water and decreases with distance from the clay surface (Fig. 36). The portion of the layer near this surface has been pictured as being oriented due to the effect of the electric field of the charged soil particle on the water dipoles. The layer formation process has been visualized as one whereby free water breaks its hydrogen bonds and passes into a higher energy state, undergoing orientation and compression in the electric force field of the surface. This process is accompanied by the release of heat of wetting, which implies that the adsorbed water has a substantially lowered latent heat of freezing (Williams 1962). Physical adsorption causes a reduction in the free surface energy.

The cations associated with the surface will bind or restrain adjacent water molecules, forming hydrated shells. This results in loss of heat of hydration which contributes to the heat of wetting. The cations also enhance the structure of the water molecules (Fig. 37) and the nature of these cations influences the thickness of the layer or film. An osmotic pressure results which is inversely proportional to the film thickness (Winterkorn and Eyring 1946). The cations tend to exclude anions from the portion of the adsorbed layer near the soil surface (Fig. 34).

Some of the latest Soviet ideas on the structure of the adsorbed water are illustrated in Figure 38 (Dostovalov and Lomonosov 1973). Three zones are visualized and the decrease in activation energy with distance from the mineral surface is apparent. Heat of wetting (80 to 110 cal/g of attached water) is released on formation of zone I which is termed a "hot ice," the wetting process being partially made up of icing. The properties of zone II are considered to be a very important influence on the behavior of the entire soil-water system. There is a decreased activation energy in zone II and an increase in the mobility in comparison with free water. The result is a lowering of the temperature of phase transitions (i.e. a depressed freezing point) and increases in the ion concentration, the heat capacity and the thermal conductivity. At the same time the viscosity and the density decrease. Zone II has been called the intermediate, mobile, "detached" layer. Finally, zone III is characterized by insignificant adsorption surface forces: the water is almost free. With freezing temperatures, the free water in zone III turns to ice, while the hot ice in zone I melts.

The equilibrium of the adsorbed layer is dynamic and constantly varying. It is highly dependent on

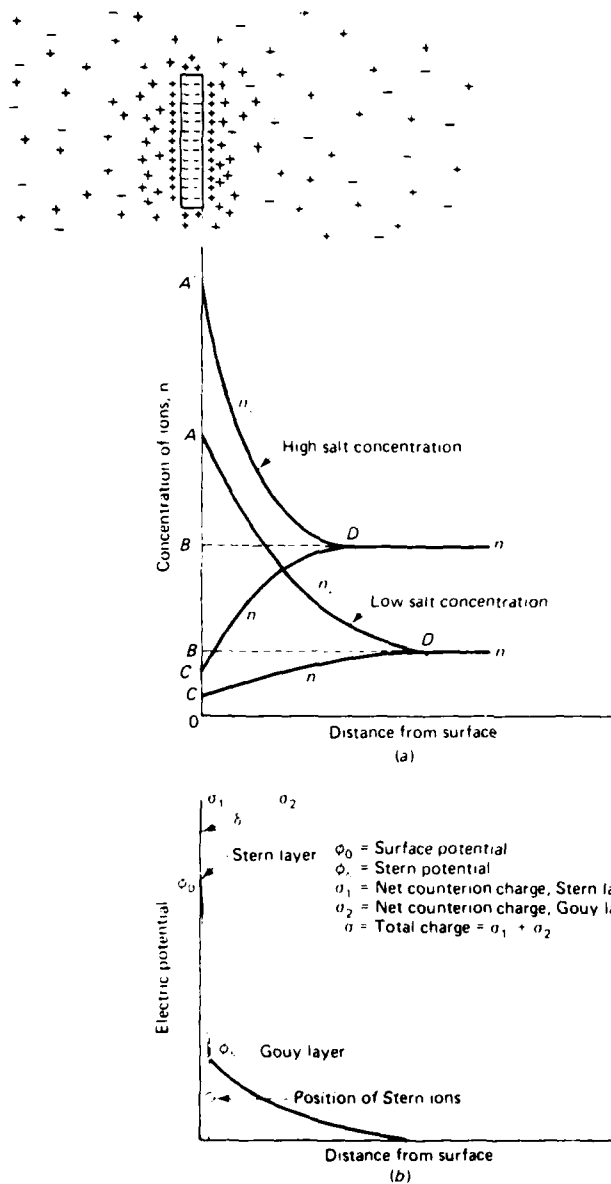

Figure 34. Diffuse electric-double-layer relationships (from Andersland and Anderson 1978).

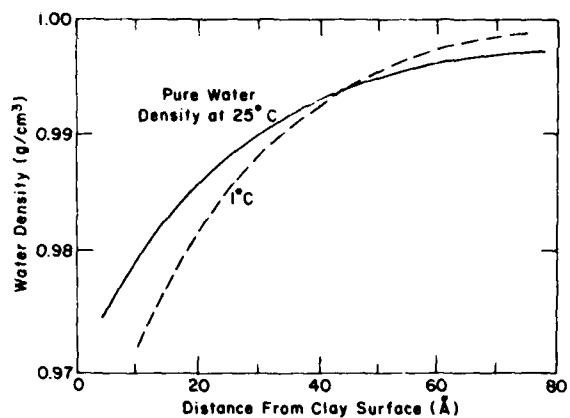

Figure 35. Change in water density with distance from the surface of potassium bentonite at two temperatures (after Low and Lovell 1959, based on data of Anderson and Low).

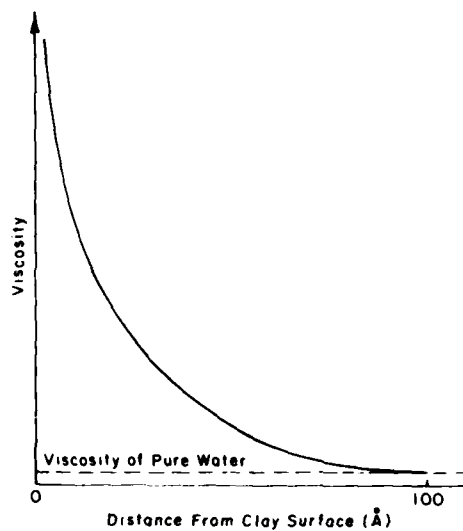

Figure 36. Hypothetical decrease of water viscosity with distance from the clay surface (after Low and Lovell 1959).

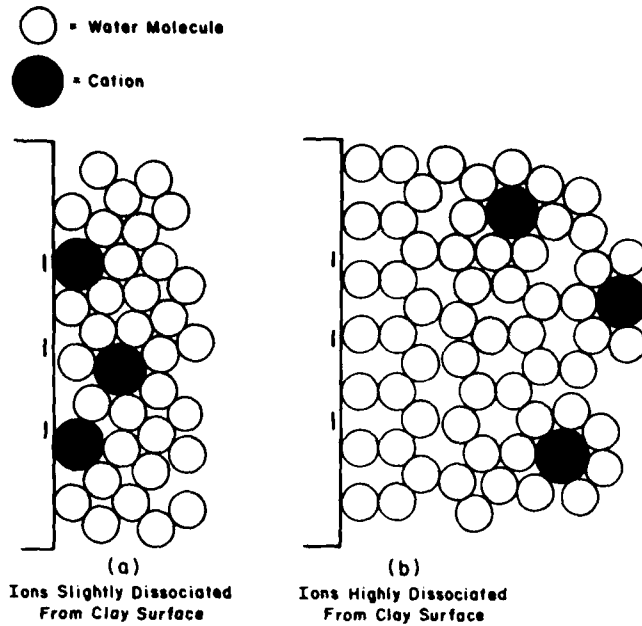

Figure 37. Effect of ion dissociation on the surface-induced water structure (illustrative only) (after Low and Lovell 1959).

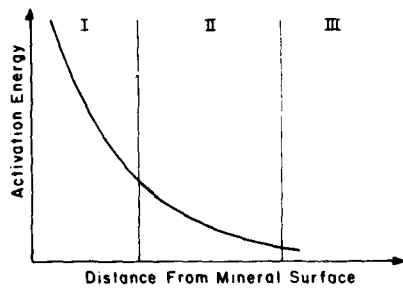

Figure 38. Zone structure of adsorbed water and variation of its activation energy with distance from the mineral surface (after Dostovalov and Lomonosov 1973).

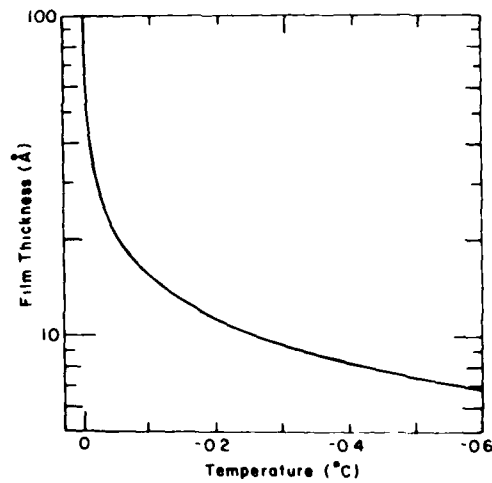

Figure 39. Thickness of adsorbed water film as a function of temperature. Calculated for an ideal diffuse electrical-double-layer model of the film, with radius of curvature equal to 20μ (after Miller et al. 1975).

temperature. Figure 39 shows how decreasing temperature decreases the thickness of an ideal diffuse film. The structure of the water next to the mineral surfaces may be visualized as resulting from the balance of two opposing tendencies, 1) the attraction of opposing electric charges and 2) the disordering and

dispersion effect of the kinetic energy (which is highly temperature-sensitive). Application of a temperature gradient "causes gradients in the surface tension of the water films, in the thickness of the ion atmosphere on the internal soil surface, in the hydration of the exchangeable ions, in the solubility of water in the solid

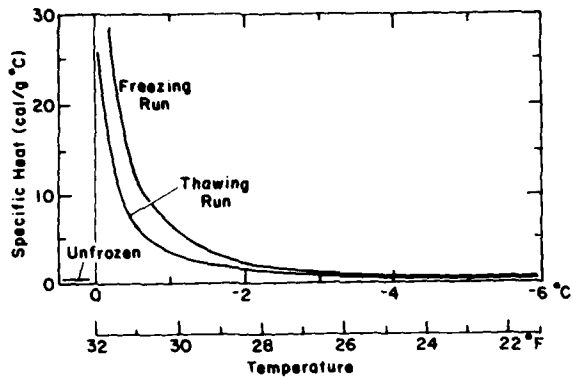

Figure 40. Specific heat of Leda clay during freezing and thawing (after Williams 1962).

surface and in the geometrical structure as well as in the dissociation and association of the water substance itself" (Winterkorn 1958b, p. 336). A decrease in temperature, especially below 0°C, leads to increasing surface activity due to:

1. An increase in the concentration of surface energy with decreased temperature,*
2. An increase in the concentration of hydrogen ions in the adsorbed layer because its thickness decreases, and
3. Pressure due to crystallization of water (Tsytoich et al. 1957).

The solids and the adsorbed layer exchange ions and these exchange reactions are intensified with decreasing temperature below 0°C.

When the adsorbed water layer has an interface with pore air, as in unsaturated soils, this interface has its own peculiar properties. Orientation of water dipoles occurs at this interface to a depth of many molecular layers (Henniker and McBain 1948), and ions tend to be excluded from it. Because anions also tend to be excluded from the interface with the solid surface, these anions concentrate in the middle region (see Fig. 34).

According to Nerpin (1974) the adsorbed layer system retains a "memory" of its previous state for a certain time. This has been termed hereditary creep and it gives rise to a hysteresis effect which is particularly evident during phase conversions. Hysteresis is obvious in the curves showing the change in specific heat of a soil during freezing and thawing (e.g. Fig. 40) and is also well known in cycles of wetting and drying.

* This behavior is indicated, among other things, by the increase in the heat of wetting as the temperature decreases.

4.1.5 Water in soils below freezing temperatures

It has been established that the strongly adsorbed water remains unfrozen after the soil freezes. This unfrozen water has been called the boundary phase by Deryagin in 1950 and the phase boundary water by Anderson (1970). Tyutyunov (1963) has pointed out the similarities that exist between the dynamic equilibrium of soil water both above and below 0°C. The phase boundary water corresponds to the hygroscopic water and the freezing process is analogous to the drying process.

Anderson (1970) describes in detail the latest concepts regarding the structure and properties of the phase boundary water. The process of ice nucleus formation is visualized with the help of a flickering cluster-mixture model of water (Fig. 41). The long-range clay-water forces are supposed to stabilize and promote the enlargement of the postulated hydrogen-bonded flickering clusters. The formation and growth of embryo ice nuclei are thereby facilitated.

After the ice forms it advances towards the silicate surface. Figure 42 shows the silicate/water/ice interface and is based on the model of Drost-Hansen. Free water

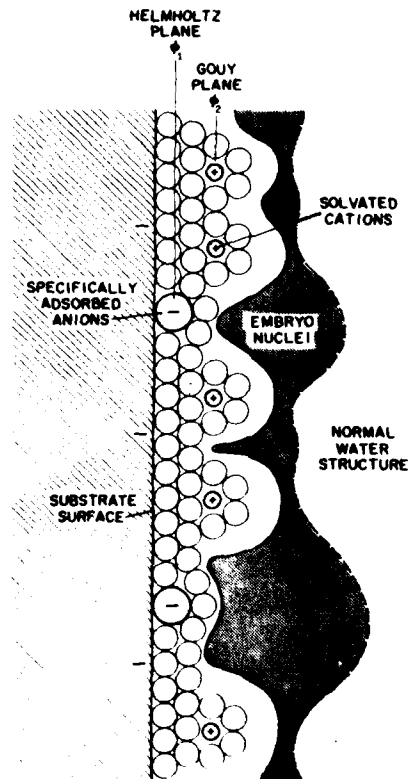

Figure 41. The zone of ice nuclei formation in soil water (from Anderson 1970).

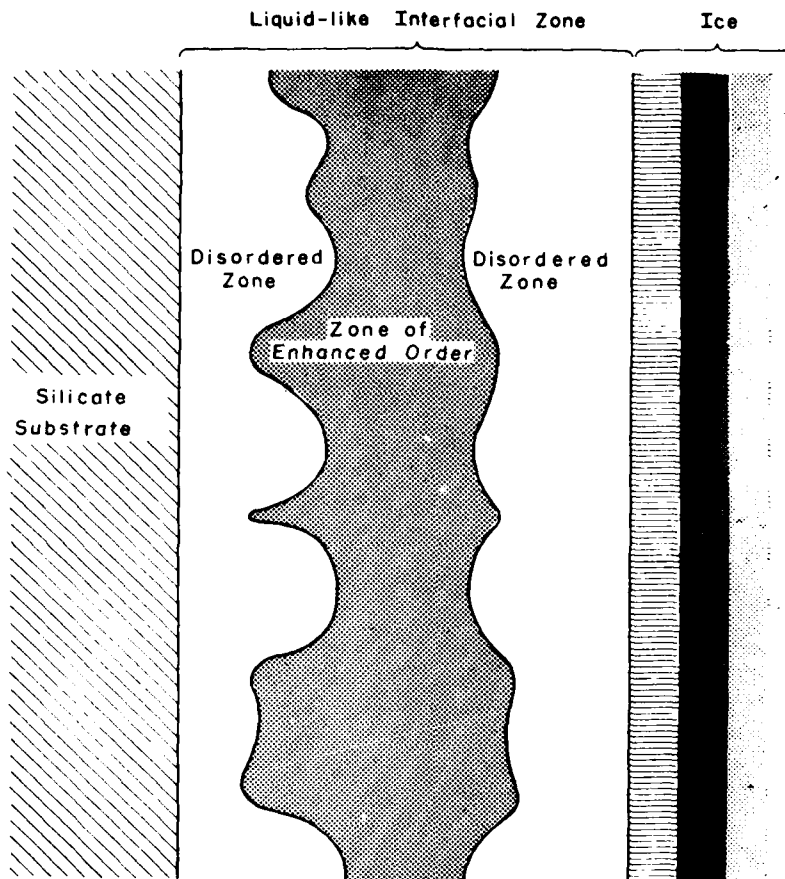

Figure 42. Schematic illustration of the silicate/water/ice interface (from Anderson 1970).

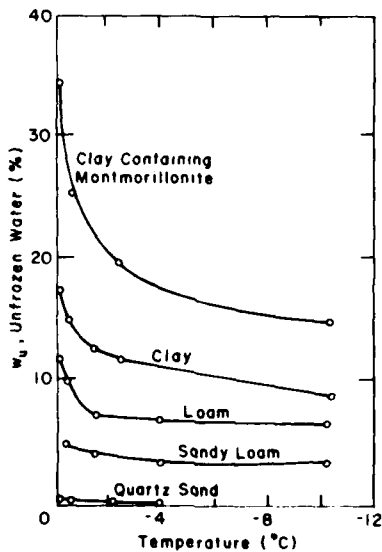

Figure 43. Unfrozen water contents of typical nonsaline soils (after Nersisova and Tsyrovich 1963).

is supposed to consist of a mixture of monomers and hydrogen-bonded clusters. The zone of enhanced order shown in Figure 42 is believed to be more structured than free water in the sense that there are more clusters of a larger size that exist for a longer time (Anderson 1970). The opposite is supposed to hold for the disordered zone.

The amount of unfrozen water has an important effect on the thermal properties of frozen soil as will be seen in Sections 4.2 and 4.4. The decrease in the unfrozen water content w_u as the temperature decreases is shown in Figure 43 and some representative values are given in Table 7. The effect of the type of clay and its exchangeable cations is shown in Figures 44 and 45. The influence of the original water content on the shape of the curves is shown in Figure 46. The internal surface area of the soil plays a very important part; Figure 47 shows w_u values normalized to unit specific surface area. When freezing is followed by thawing, there is a hysteresis effect (Fig. 48).

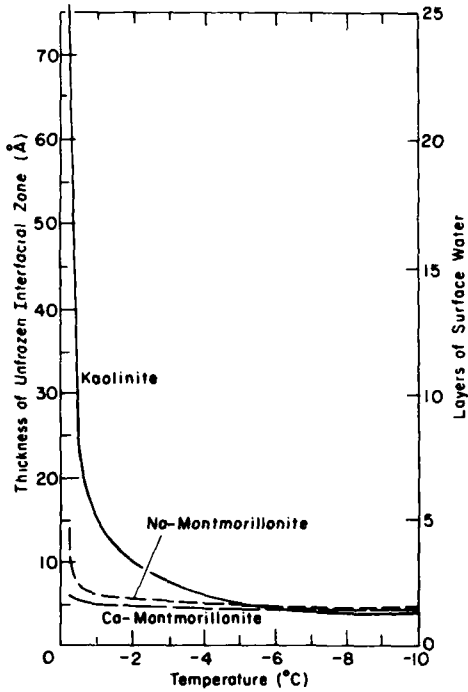

Figure 44. Thickness of unfrozen water as a function of temperature for three representative clays (after Anderson 1970).

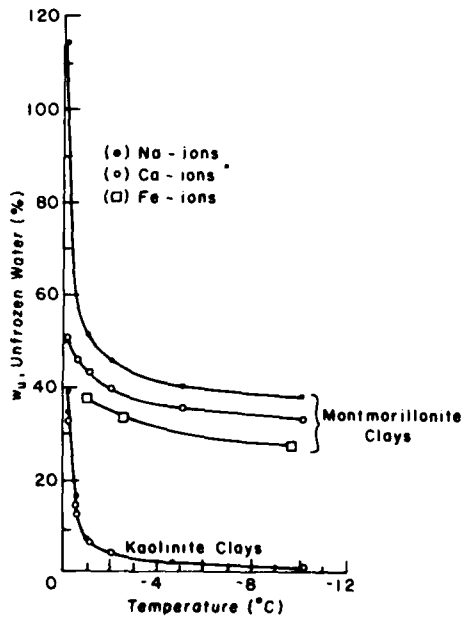

Figure 45. Unfrozen water content of kaolinite and montmorillonite clays of various exchangeable cations (after Nersisova and Tsytoich 1963).

Figure 47. Unfrozen water content per unit specific surface area as a function of temperature (after Anderson and Tice 1973).

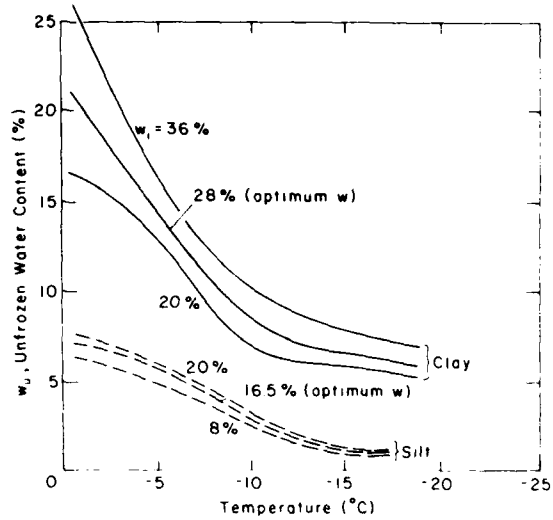
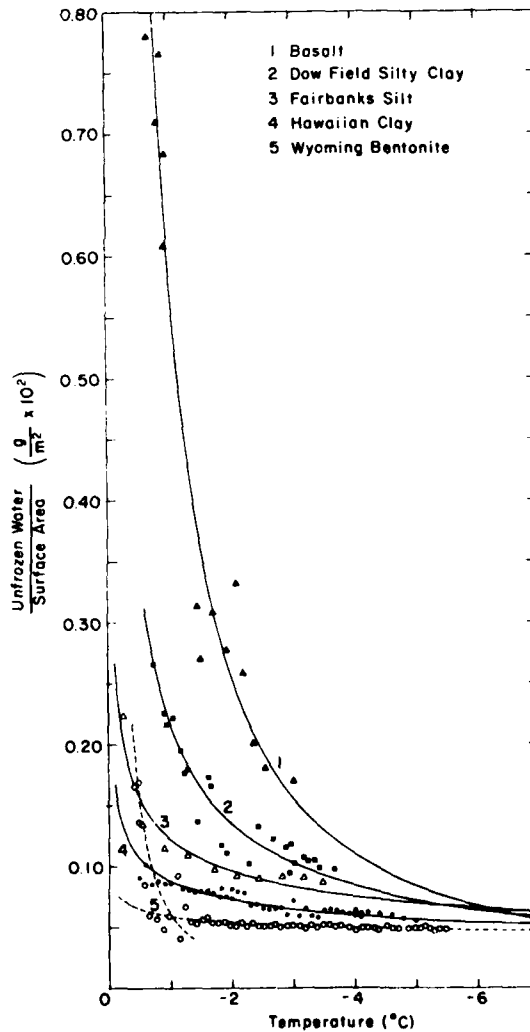

Figure 46. Curves of unfrozen water content vs temperature. Influence of original water content w_i on shape of curves (after Young 1963).



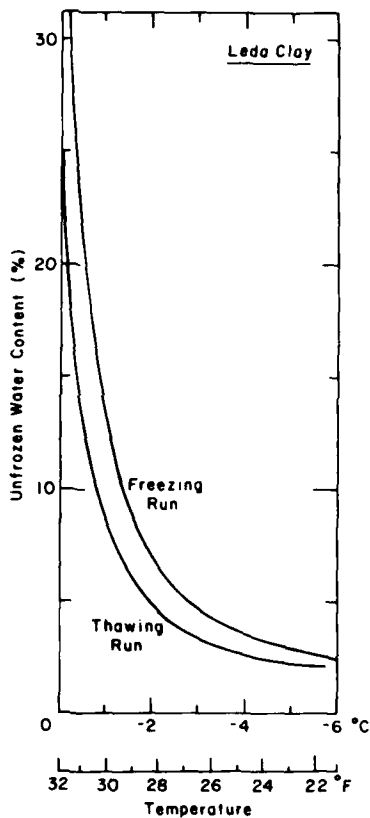

Figure 48. Unfrozen water content of Leda clay during freezing and thawing (after Williams 1962).

Table 7. Comparative phase composition at selected temperatures (after Lovell 1957).

| Soil | Unfrozen moisture content w_u (%) | | | Ratio $\frac{-3^\circ\text{C}}{-25^\circ\text{C}}$ |
|-------------|-------------------------------------|------------------------|------------------------|--|
| | at -3°C | at -15°C | at -25°C | |
| Clayey silt | 4.4 | 3.1 | 2.8 | 1.55 |
| Silty clay | 11.05 | 8.0 | 7.2 | 1.53 |
| Clay | 23.6 | 15.8 | 13.9 | 1.70 |

4.2 THE EFFECTS OF THE AMOUNT AND NATURE OF WATER

The important role of water in determining the thermal properties of soils has been recognized for many years. The earliest workers, Patten (1909), Bouyoucos (1915) and Beskow (1935), all recognized the paramount effect of moisture content on the thermal conductivity and thermal diffusivity of soils, unfrozen or frozen. Unfortunately there are difficulties in determining moisture content values in the field.

Temperature changes in soils mainly affect the soil water, which is the chief responsive medium. In frozen soils, the presence of unfrozen water is a major factor in the thermal behavior of such soils, influencing in particular the moisture migration to the freezing front. The freezing front will take longer to penetrate into a soil with a larger water content because a greater amount of latent heat has to be extracted.

When determining the thermal behavior of the back-fill soil around buried electric cables or pipes, or when assessing the thermophysical properties of permafrost, it is essential to have information on the soil's moisture content in its various forms and its possible variation with time. In the former case a runaway moisture condition would be critical because moisture migration away from the cable could lead to an excessive reduction in the thermal conductivity of the soil around the cable. In the case of permafrost, a knowledge of the moisture content distribution and its variation with time is essential for determining the thermophysical properties to be used as input parameters to a thermal model of the permafrost.

A water content which varies from point to point in a soil implies a variable thermal conductivity which, in turn, affects the temperature distribution in the soil. Inversely, the temperature stratification in the soil affects its water distribution. The seasonal variation of soil water content in a clay is illustrated in Figure 49.

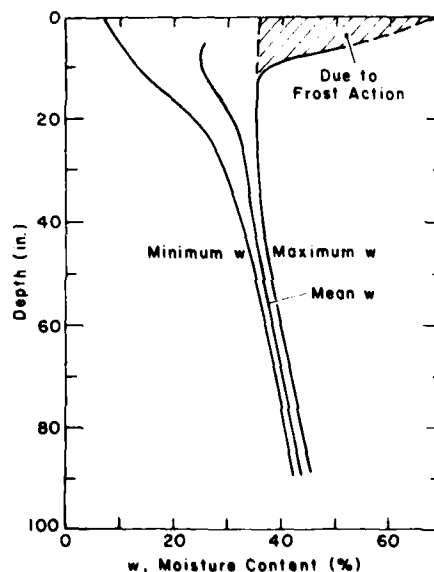

Figure 49. Seasonal variation in water content of Leda clay, depending on depth below ground surface (after Penner 1971).

The rate of freeze is greatly influenced by the moisture content, as is the depth of frost penetration. Where the soil has a low degree of saturation, the formation of ice lenses and the extent of frost heave are reduced. The thawing rate of frozen ground is directly related to its ice content, as shown in Section 4.4.6.

The interaction between water and soil minerals, and the state of the water in the pores, depend on the amount of water in relation to the physico-chemical properties of the soil minerals and their surface area.

4.2.1 Effect of the amount of water in unfrozen soils

At very low moisture contents, water is held with extreme tenacity on the surface of the soil particles and within the lattice of crystalline clay minerals. When all the soil particles have been coated with thin adsorbed water films, additional water begins to collect around the points of contact between the particles. This bridge water improves the heat transfer from grain to grain. The presence of more water around the particles leads to a decrease in both the degree of order and the binding of the water as its distance from the particle surface increases. As a result this water is freer to move, either in the liquid phase or, as long as the pores are unsaturated, in the vapor phase due to a vapor pressure gradient. As indicated in Section 4.1.3, the affinity of a soil for water, or the binding energy, is expressed by the suction pF value ψ . The variation with moisture content of this suction is shown in Figure 50 for typical soils. The relative humidity ϕ of the associated water vapor is also shown. As the moisture content increases from the oven-dry condition ($pF = 7$) the suction drops sharply while the relative humidity steeply increases. At the same moisture content, different types of soils will have differences in the amount and proportion of mobile moisture present because of variations in their specific surface area and their mineral nature. However, the significant point is that if the thermal conductivity of the soil is related to the tension ψ , rather than the moisture content, similar curves result (Fig. 51).

The amount of water present in soils is usually represented in one of three ways:

1. The moisture content w (%) based on the weight of dry solids
2. The fractional volume of water θ or x_w (i.e. the volume of water in unit soil volume)
3. The degree of saturation S_r (%), which is the fraction of the total voids that is filled with water, expressed as a percentage.

The variation in soil thermal conductivity with each of these parameters is illustrated in Figures 52-54.

As air is displaced by liquid water (which has a

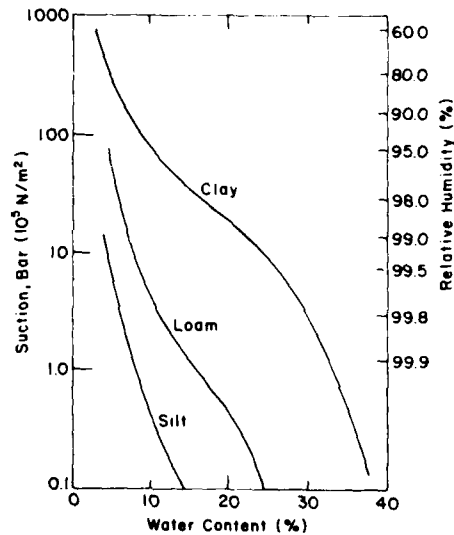
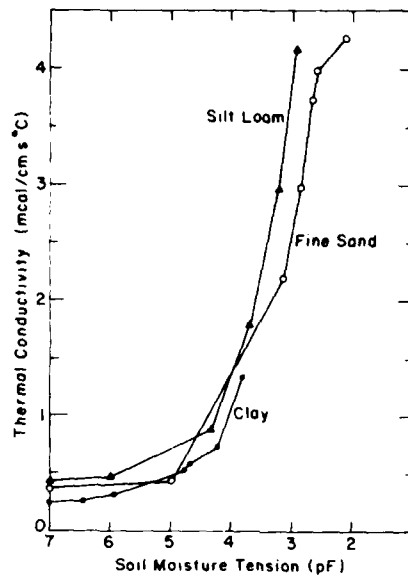
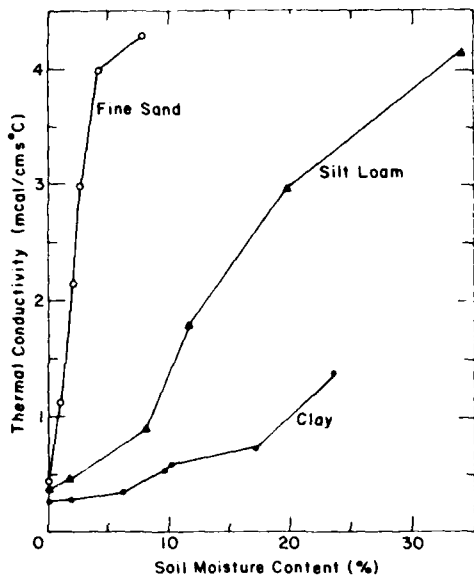

Figure 50. Suction and relative humidity of different soil types as a function of their water content (after Johansen 1975).

thermal conductivity 22 times higher than air) the soil's thermal conductivity should increase. The effect of increasing moisture content depends on the type of soil. For example, in sand the thermal conductivity increases rapidly with moisture content. Soils in general show a high rate of increase in thermal conductivity at the lower moisture contents. This is assumed to be mainly due to the water bridges at the contact points. It could also be due to the stage where the water films of a certain degree of order and binding become continuous around the particles.

Apart from the layer of highly adsorbed water at the solid surface, there is also an oriented water layer at the water/air interface (see Section 4.1.4). Clays at the plastic limit usually have no intermediate free water. Assuming a thermal conductivity value for the oriented water (at the air interface) akin to that of ice. Winterkorn (1960b) estimated the contribution of such an oriented film to the overall thermal conductivity of the soil and found it to be quite significant. Thus, as was earlier recognized by Dimo in 1948, the increase in thermal conductivity of soil with increasing moisture content depends not only on the replacement of poorly conducting air by water, but also on the changing nature of the bond between water and soil as well as the peculiar characteristics of water interfaces (Dimo 1969). Heat transfer mechanisms depend considerably on the form of the soil water (Chudnovsky 1954, cited by Kolyasev and Gupalo 1958).

The relationship between thermal conductivity and amount of water in a soil was explored in some detail



a. Thermal conductivity vs moisture content.

b. Thermal conductivity vs moisture tension.

Figure 51. Thermal conductivity of three soils (after Al Nakshabandi and Kohnke 1965).

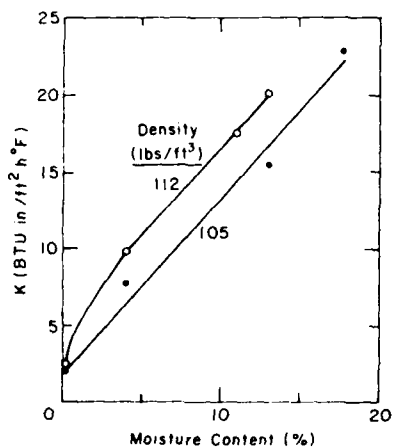

Figure 52. Thermal conductivity vs moisture content for Kersten's Lowell sand at 25°F (after Kersten 1949). See Appendix A for soil description.

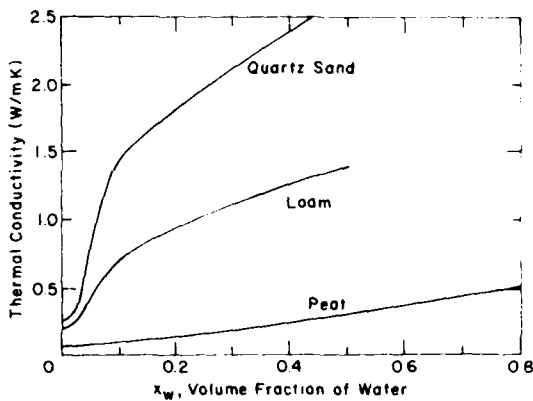

Figure 53. Thermal conductivity vs volume fraction of water (after De Vries 1974).

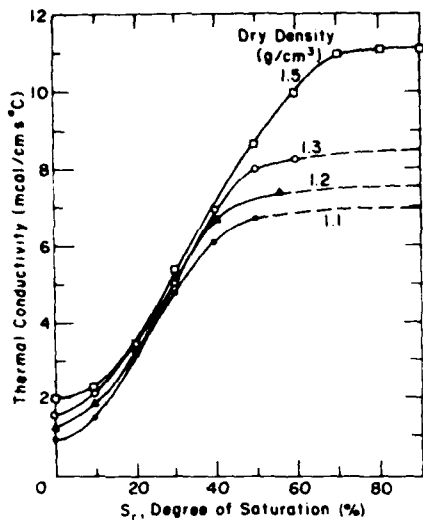

Figure 54. Thermal conductivity as affected by density-moisture relations (after *Baver et al. 1972, based on Van Rooyen and Witterkorn 1959*).

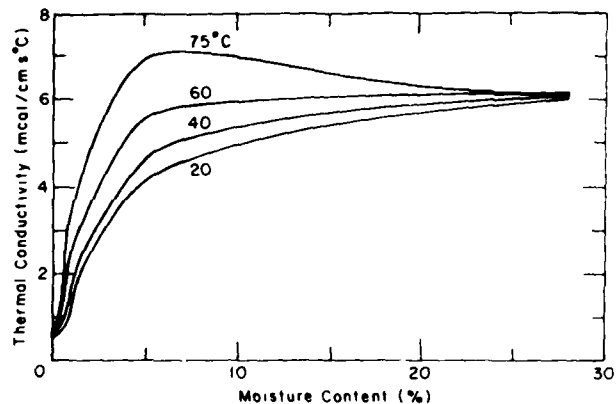

Figure 55. Experimental values of the thermal conductivity of sand at varying moisture contents for temperatures of 20, 40, 60 and 75 °C (after *De Vries 1952a*).

by Kersten (1949) on the basis of numerous tests. His empirical equations showed that the thermal conductivity is linearly related to the logarithm of the moisture content at a constant dry density. For unfrozen silt and clay soils containing 50% or more silt and clay, the equation for the thermal conductivity k is

$$k = (0.9 \log w - 0.2) 10^{0.01 \gamma_d} \quad \text{for } w \geq 7\%$$

while for unfrozen sandy soils (clean sand) it is

$$k = (0.7 \log w + 0.4) 10^{0.01 \gamma_d} \quad \text{for } w \geq 1\%$$

where the units of k are $\text{Btu in./ft}^2 \text{ hr } ^\circ\text{F}$, the moisture content w is in percent and the dry density γ_d is in lb/ft^3 . Van Rooyen and Winterkorn (1959) also obtained an empirical relationship between the thermal resistivity (the reciprocal of k) and the degree of saturation (see Section 7.7).

Gemant (1950) attempted to account for the effect of the bridge water in an equation for the thermal conductivity of an idealized soil consisting of a cubic packing of equal spheres. The moisture was assumed to collect in wedge-shaped rings around the small contact areas. An expression was derived for the thermal conductivity of this idealized soil in terms related to the volume of water per unit soil volume (Section 7.5). This expression is valid up to a moisture content of about 20% by volume that corresponds to the condition where the neighboring ring-shaped water wedges contact each other.

In his derivation of an expression for thermal conductivity De Vries (1963), unlike Gemant, started with the premise that water is the continuous medium containing the soil grains and air pockets (see Section 7.6).

To calculate the thermal conductivity k of a soil at partial saturation from known values of the conductivity in the saturated state, k_{sat} , and that in the dry state, k_{dry} , Johansen (1975) introduced the concept of the Kersten number K_e which is defined as

$$K_e = \frac{k - k_{\text{dry}}}{k_{\text{sat}} - k_{\text{dry}}}$$

from which it follows that

$$k = (k_{\text{sat}} - k_{\text{dry}}) K_e + k_{\text{dry}}$$

Basically this equation of Johansen is a simple interpolation between the conductivities in the saturated and the dry states that is based on K_e , which depends on the degree of saturation (Section 7.11). While this equation may be adequate for certain engineering purposes, it is not really based on a sound conceptual model. It also does not take into account the moisture migration which may occur at partial saturation and cause an increase in the thermal conductivity, as illustrated by the data of De Vries (1952a). These experimental results show this effect as brought about by increased temperature, leading to increased migration (Fig. 55).

If more water is added to a saturated soil, the soil

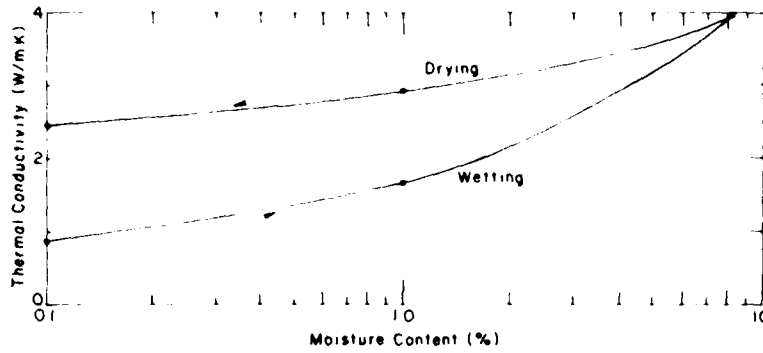

Figure 56. Thermal conductivity of quartzitic gravel and sand with 8% binder as a function of moisture content during wetting and subsequent drying (after Farouki 1966).

skeleton begins to be pushed apart. This normally results in a decrease in the thermal conductivity because the thermal conductivity of the water is usually less than that of the soil solids. This behavior may be seen in data on the thermal conductivity of ocean sediments, where the decrease is especially marked when these sediments consist of quartz (Kasameyer et al. 1972).

Hysteresis effects

The effect of the moisture content on the thermal conductivity of some soils has been found to depend

on whether the soil is in the process of drying or wetting (Farouki 1966). During the drying process thermal conductivity is higher (Fig. 56).

4.2.2 Effect of ice and unfrozen water in frozen soils

Figure 57 shows the important effect of ice on thermal conductivity. In coarse-grained soils, virtually all the water turns to ice at 0°C. However, in fine-grained soils, an appreciable percentage of unfrozen water may remain even at temperatures as low as -40°C (Anderson and Tice 1973). This temperature dependence of

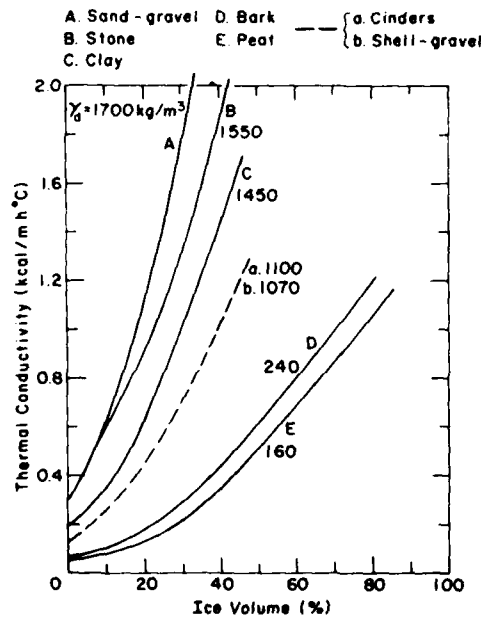

Figure 57. Thermal conductivity of frozen material at a mean temperature of -5°C and indicated dry density (after Skaven-Haug 1963).

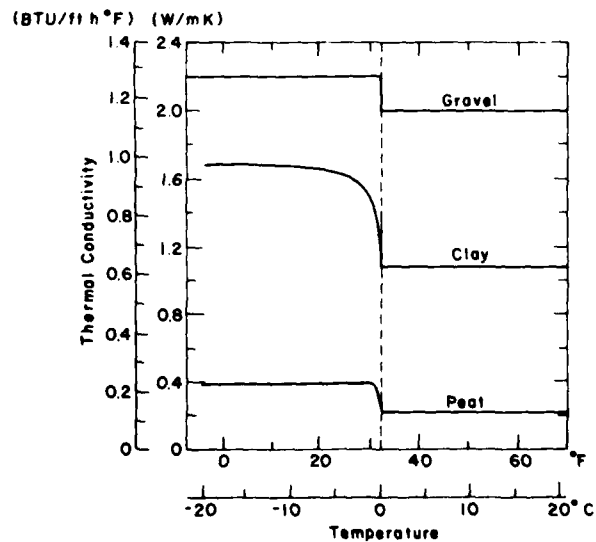

Figure 58. Assumed temperature-dependent thermal conductivity for gravel, clay and peat (after Gold et al. 1972).

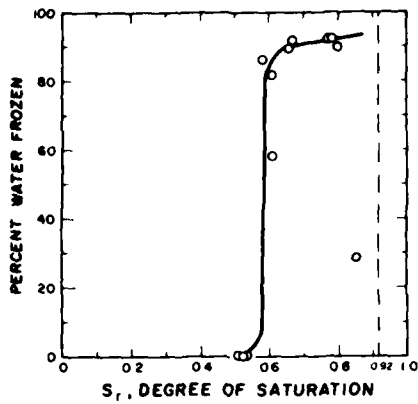

Figure 59. Percent water frozen in a soil model as a function of degree of saturation at -4.0°C (from Lange and McKim 1963).

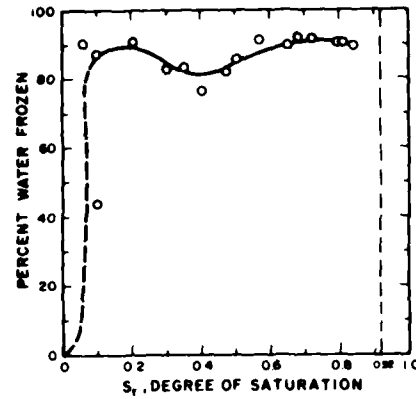

Figure 60. Percent water frozen in a soil model as a function of degree of saturation at -7.5°C (from Lange and McKim 1963).

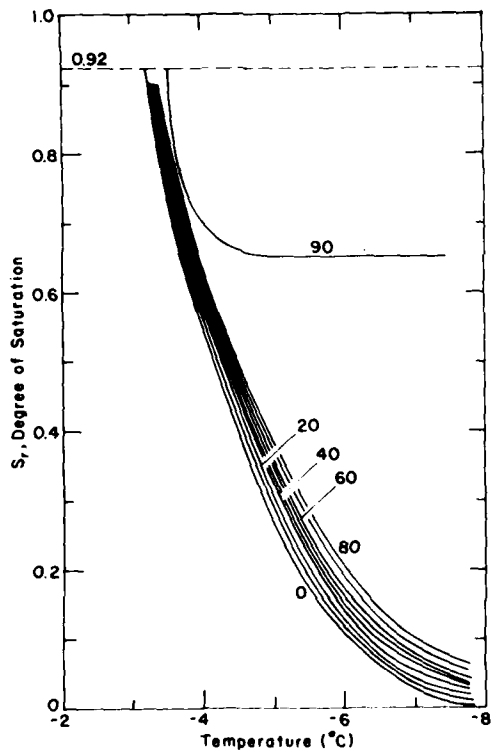

Figure 61. Combined effect of degree of saturation and temperature upon the percentage of original water frozen. This percentage is indicated on the curves which apply to a soil model (after Lange and McKim 1963).

the phase composition may be important to the thermal conductivity. In a simple manner, one may assume the increase in the thermal conductivity through the freezing point to be abrupt for gravel but gradual for fine-grained and peat soils (Fig. 58).

Lange and McKim (1963) have shown that the phase composition of water in an idealized soil model depends strongly on the degree of saturation. For a given negative temperature there is a sudden jump in the percentage of frozen water at a definite degree of saturation. This "critical degree of saturation" itself decreases from about 57% at -4°C (Fig. 59) to about 8% at -7.5°C (Fig. 60). The combined effect of degree of saturation and temperature is shown in Figure 61. A lower degree of saturation also causes an increase in the freezing point depression (Fig. 62).

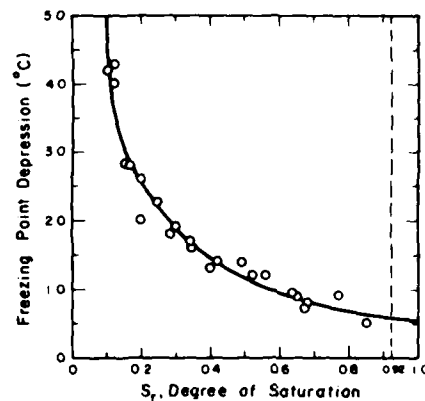

Figure 62. Freezing point depression as a function of degree of saturation in a soil model (from Lange and McKim 1963).

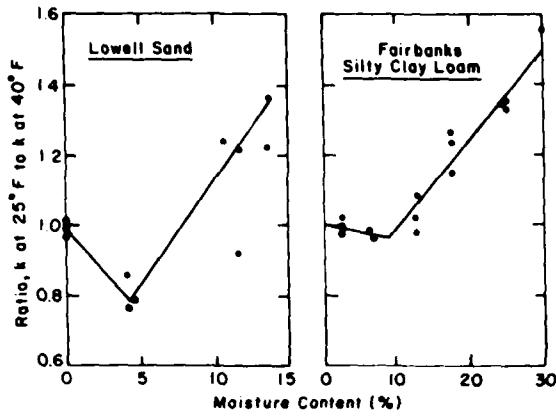

Figure 63. Ratio of thermal conductivity below freezing to that above freezing as a function of moisture content (after Kersten 1963). For information on these two Kersten soils see Appendix A.

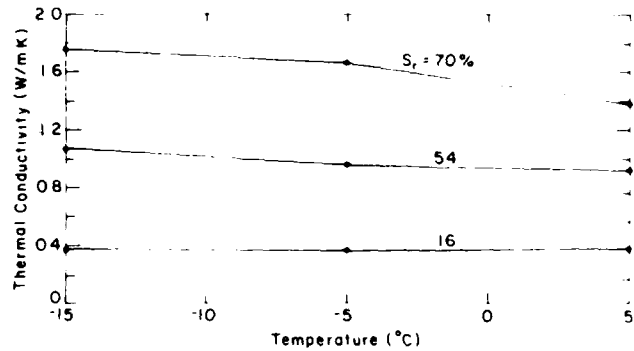

Figure 64. Thermal conductivity vs temperature at different degrees of saturation S_r . Data taken from Penner et al. (1975) for their soil no. 8, a clay-silt (for information on this soil see Appendix A).

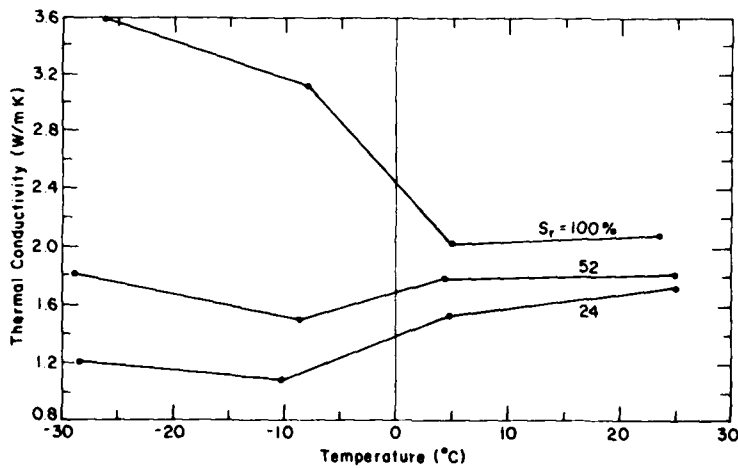

Figure 65. Thermal conductivity vs temperature at different degrees of saturation S_r . These data apply to the gravel no. 1 material tested by Johansen (pers. comm.).

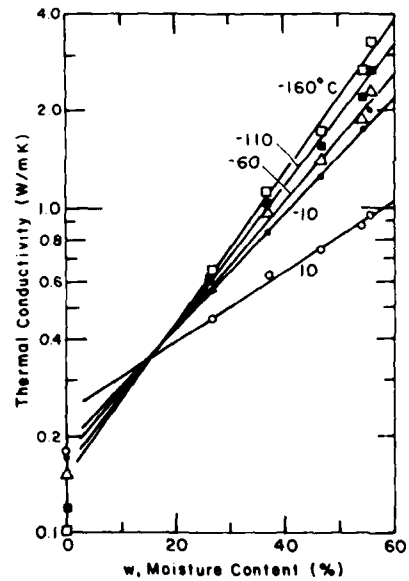

Figure 66. Logarithm of thermal conductivity as a function of moisture content of a fine sand (after Sawada 1977). For information on this sand see Appendix A.

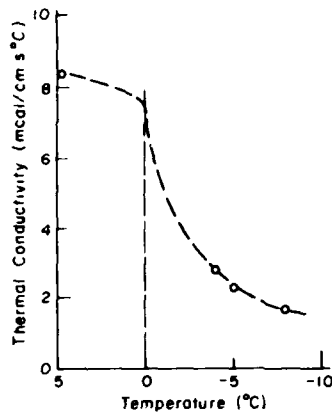

Figure 67. Thermal conductivity of unsaturated frozen Ottawa sand as a function of temperature (after Hoekstra 1969).

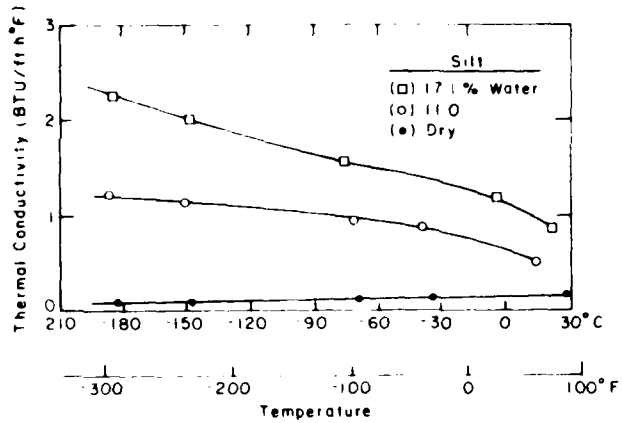

Figure 68. Thermal conductivity of silt vs temperature. Indicated percent water is based on the wet weight (after Wolfe and Thieme 1964). For information on this silt see Appendix A.

A soil with saturation below about 70% (in particular if its moisture content is held below the plastic limit) shows a marked reduction in the formation of ice lenses and in the extent of frost heave (Johnson 1952, Linell and Kaplar 1959). Also, as shown below, the degree of saturation affects the value of the thermal conductivity of the frozen soil as compared with the unfrozen value.

The thermal conductivity of ice is about four times that of water. The thermal conductivity of frozen soil k_F may therefore be expected to be greater than that of unfrozen soil k_U . This is the case for saturated soils and soils with high degrees of saturation. For soils with low degrees of saturation, however, k_F may be less than k_U .

Kersten (1963) showed that the ratio k_F/k_U may be less than unity at low moisture contents (Fig. 63). Data obtained by Penner et al. (1975) indicate the important effect the degree of saturation has on this ratio (Fig. 64). At low degrees of saturation, k_F was somewhat smaller than k_U . Penner et al. explained this behavior by assuming that when freezing occurs at low moisture contents some of the effective bridge water between the particles is removed to form ice in the pores. The result is that the efficiency of heat conduction at the contact points decreases. This observation is similar to one previously made by Martynov (1959) and a similar trend is evident from Johansen's data on gravel that had virtually no unfrozen water below 0°C (Fig. 65).

Sawada's recent data (1977) on a fine sand show the effect of moisture content on the thermal conductivity at temperatures down to -160°C (Fig. 66). There is an evident crossover point at a moisture con-

tent of about 16% which corresponds to about a 29% saturation. Below this "critical moisture content," k_F is less than k_U , which conforms with the stipulation regarding the effect of bridge water depletion just mentioned. This depletion is accentuated as the temperature is lowered, leading to a drop in k_F in the region of lower moisture content. This trend was noted by Hoekstra (1969) (Fig. 67).

When the moisture content rises above the critical value (the crossover point in Figure 66) k_F becomes greater than k_U . The increase in k_F at the lower negative temperatures is now due to the increase in the intrinsic thermal conductivity of ice with decreasing temperature (Fig. 31). As can be seen from Figure 66 this increase in k_F is more pronounced as the moisture content increases. A similar trend is indicated by Wolfe and Thieme's data (1964) on the thermal conductivity of silt (Fig. 68) and of clay (Fig. 69) down to temperatures of -180°C. The behavior of the thermal conductivity of the clay soil below a certain moisture content value (about 19%) leads to several observations. There is a definite decrease in this thermal conductivity as the temperature decreases from about -25°C to about -60°C. This behavior may be connected with a further reduction in the unfrozen water content as it continues to convert to ice between these very low temperatures. The effect of the increase in the intrinsic thermal conductivity of ice with decreasing temperature is completely counteracted and even reversed with this further loss of unfrozen water. It may therefore be suggested that the thermal conductivity of this unfrozen water is higher than that of ice and/or that the unfrozen water has an important effect in improving the thermal contact between the soil

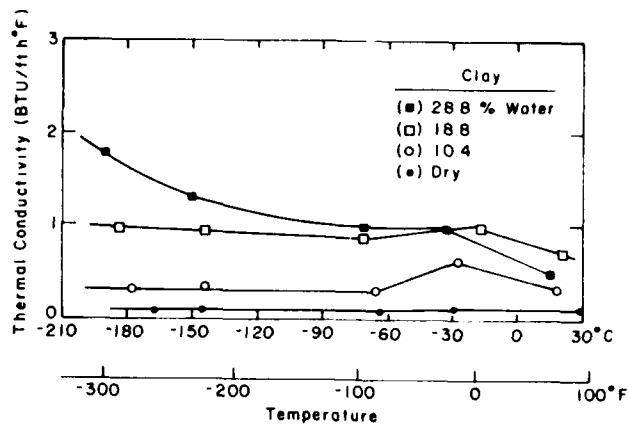

Figure 69. Thermal conductivity of clay vs temperature. Indicated percent water is based on the wet weight (after Wolfe and Thieme 1964). For information on this clay see Appendix A.

skeleton and the ice, as has been suggested by Pavlova (1970) for peat (Section 4.2.3). The first suggestion agrees with the Soviet idea, presented in Section 4.1.4, that the adsorbed unfrozen water layer has a relatively high thermal conductivity because of the high thermal conductivity of zone II water. However, very low, subfreezing temperatures may severely diminish the thickness of this zone II or even eliminate it entirely.

Where there is no unfrozen water below 0°C, there is a continuous increase in k_F as the temperature decreases. This is clearly shown by Sawada's data on a

fine sand (Fig. 70 and 71) which has practically no unfrozen water below 0°C. Sawada (1977) determined a linear relationship between the logarithm of k_F and the absolute temperature T (Fig. 71) and expressed it by the equation

$$k_F = AT^B$$

where A and B are empirical constants for the particular soil, depending on its moisture content.

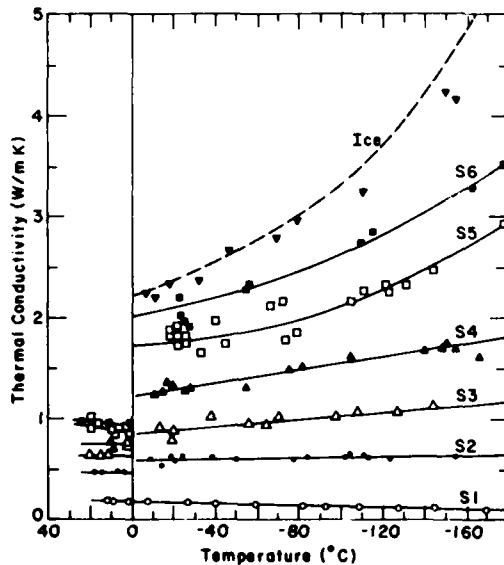

Figure 70. Thermal conductivity vs temperature for a fine sand (after Sawada 1977). S1 is the dry sand and S2, S3 etc. represent samples at increasing moisture contents (see Appendix A for additional information).

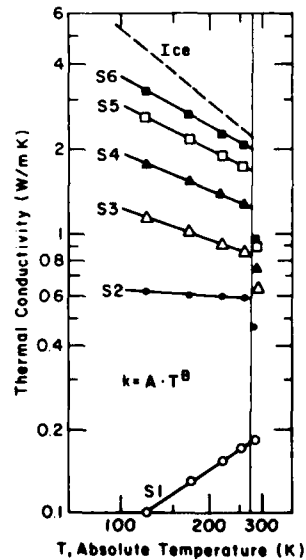

Figure 71. Thermal conductivity vs absolute temperature for a fine sand (after Sawada 1977). See Appendix A for additional information.

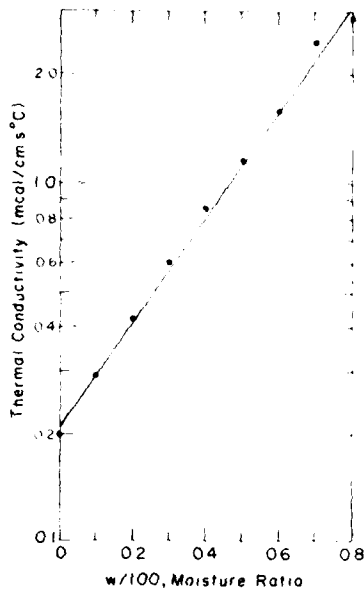

Figure 72. Thermal conductivity vs moisture ratio τ for soil B of Higashi (1953). This is a frozen clayey silty sand and the data are taken from Higashi's Table 7.

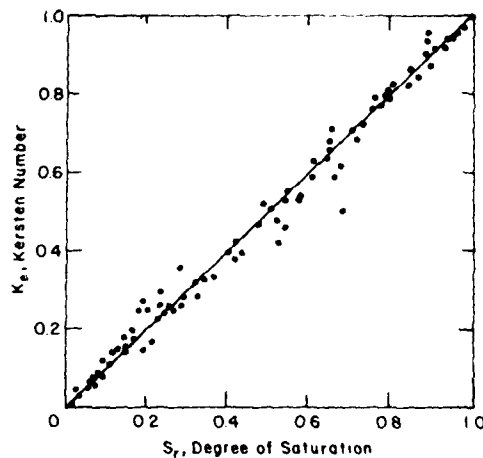

Figure 73. Kersten number vs degree of saturation (after Johansen 1975).

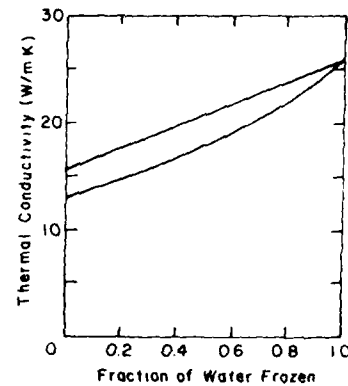

Figure 74. Hashin-Shtrikman bounds for the thermal conductivity of a saturated soil having different ratios of frozen to unfrozen water. The porosity is assumed to be 50% and the particle conductivity 3 W/m K (after Johansen 1975).

Equations for the thermal conductivity of frozen soils in terms of their moisture content

Kersten (1949) showed that the thermal conductivity of a frozen soil is linearly related to its moisture content w (%) at a constant dry density γ_d by an equation of the type

$$k = A + Bw$$

in which the empirical coefficients A and B differ for coarse-grained and fine-grained soils and vary with γ_d in each case. The equation is not valid for moisture contents below 1% for sands and gravels, nor below 7% for silts and clays.

Somewhat differently, Higashi (1953) found a linear relationship between the logarithm of the thermal conductivity of a frozen soil and the moisture ratio τ (i.e. the moisture content w [%] expressed as a fraction, $w/100$):

$$k = b e^{d\tau}$$

in which b and d are empirical coefficients for the soil, and e is the base of natural logarithms. Figure 72 is a graph of the data for one of Higashi's soils. Except at low moisture contents, Kersten's data agree with the form of Higashi's relationship within experimental error.

Sawada (1977) verified Higashi's equation and extended its validity to very low temperatures (Fig. 66).

As with unfrozen soils, Johansen (1975) expressed the thermal conductivity of frozen unsaturated soil in terms of that of frozen saturated soil k_{sat} and that of frozen dry soil k_{dry} , using the Kersten number K_e in the equation

$$k = (k_{sat} - k_{dry})K_e + k_{dry}$$

This linear interpolation is justified because Kersten's data give a linear relationship between the thermal conductivity of frozen soil and the degree of saturation S_r . When K_e is plotted against S_r , a straight line through the origin results (Fig. 73), implying that $K_e = S_r$ for a frozen soil.

Johansen (1975) and Judge (1973b) suggested the use of the following simple geometric mean equation for the calculation of the thermal conductivity of frozen saturated soil:

$$k_{sat} = k_i^{n-\theta} k_w^\theta k_s^{(1-n)}$$

where k_i = thermal conductivity of ice

k_w = thermal conductivity of ordinary unfrozen water

k_s = thermal conductivity of the solid soil mineral

(average value)
 n = porosity expressed as a fraction
 θ = fractional volume of unfrozen water.

The use of the geometric mean equation was justified by Johansen (1975) because of the narrow region encompassed by the Hashin-Shtrikman bounds for a saturated frozen soil containing varying fractions of frozen water (Fig. 74).

Oversaturation with ice

Permafrost is often ice-rich while seasonally freezing soil may become oversaturated with ice because of moisture migration and subsequent freezing. The occurrence of ice in soils can be quite complex; ice crystals vary in size and orientation. Ice banding may decrease particle contacts and air pores may develop within the ice.

Higashi's (1953) data show that beyond saturation the thermal conductivity of frozen soil tends to become constant rather than continue increasing.

The data of Slusarchuk and Watson (1975) on undisturbed ice-rich permafrost (Fig. 75) show a decrease in the thermal conductivity as the ice content increases. They attributed this trend to the presence of many small air bubbles and discontinuities in the naturally occurring ice-rich permafrost. The importance of various contact resistances and discontinuities was shown by McGaw (1968) in his experiments on the thermal conductivity of sand-ice mixtures (Fig. 76). A sharp discontinuity occurred as the mix changed from a sand matrix with ice inclusions to an ice matrix with sand inclusions. The latter system had the higher thermal conductivity, implying better thermal contacts.

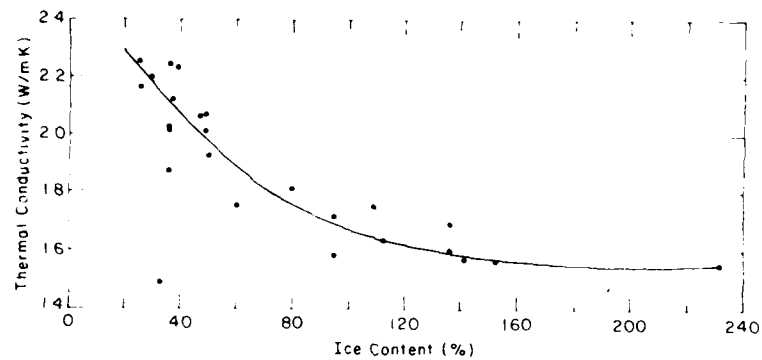

Figure 75. Thermal conductivity as a function of the ice content of undisturbed permafrost samples. Data taken from Table 1 of Slusarchuk and Watson (1975).

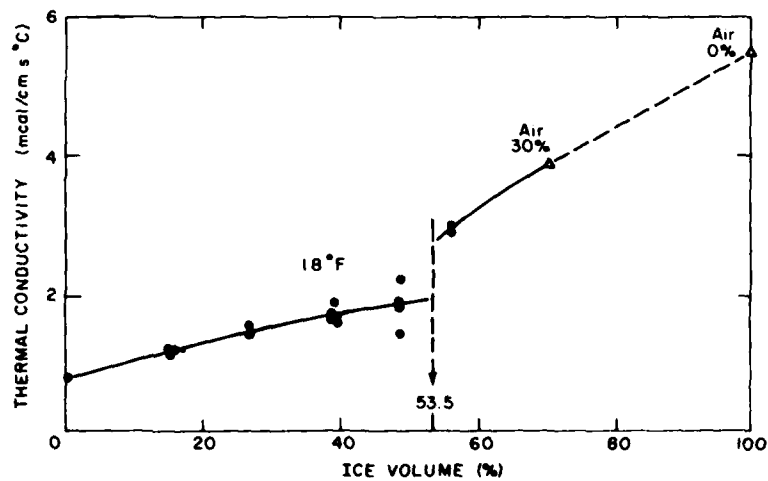

Figure 76. Thermal conductivity of mixtures of Ottawa sand (20-30) and ice (after McGaw 1968).

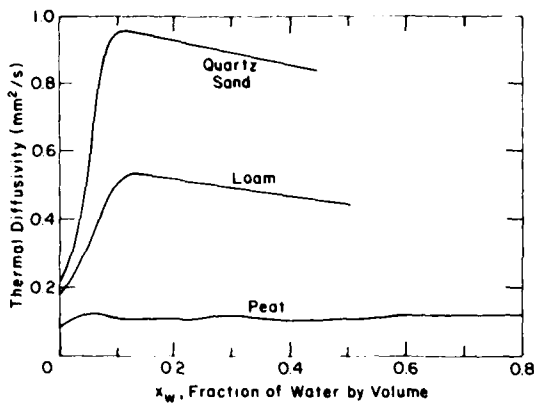

Figure 77. Thermal diffusivity vs fraction of water by volume (after De Vries 1974).

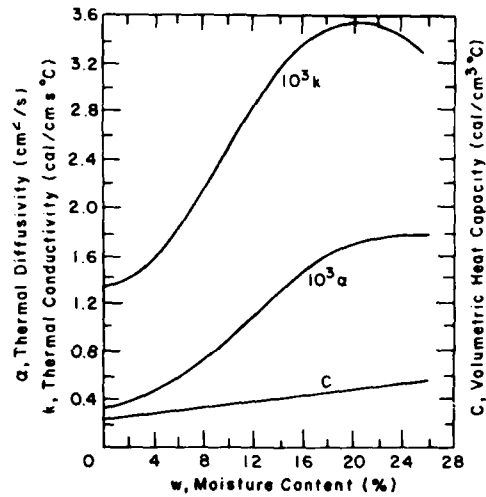

Figure 78. Thermal properties of Russian southern black earth (chernoziem) vs moisture content at a dry density of 1.2 g/cm^3 (after Kolyasev and Gupalo 1958).

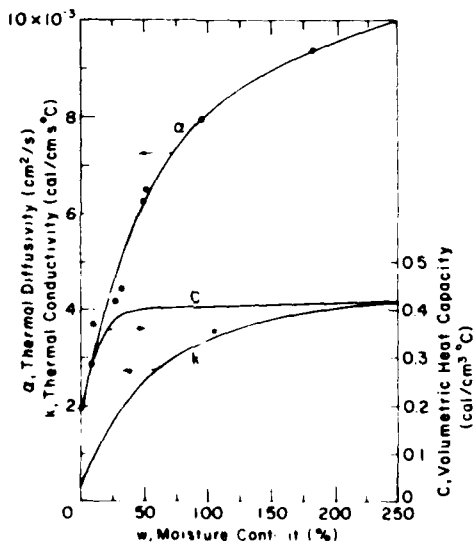

Figure 79. Thermal properties of frozen glacial clay vs moisture content (after Higashi 1958).

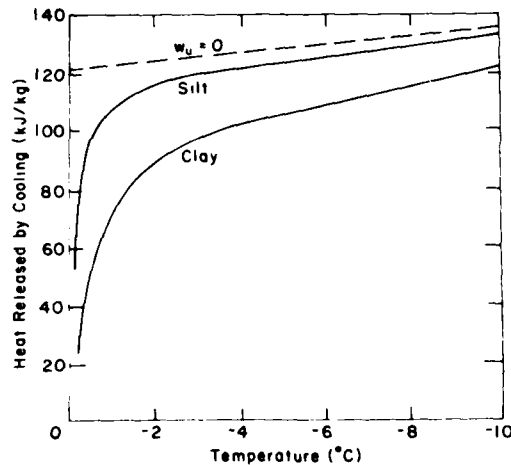

Figure 80. Heat released in saturated silt and clay on cooling below freezing point (after Johansen 1975).

Effect of moisture content on thermal diffusivity and heat capacity

For unfrozen soil, a maximum thermal diffusivity occurs at a certain moisture content, while the volumetric heat capacity continues to increase with increasing moisture content (Fig. 77 and 78). In the case of frozen soil, the rate of increase in the diffusivity with increasing ice content slows down but does not reach a maximum (Fig. 79).

When a fine-grained soil is cooled below 0°C , its latent heat is released in stages as the water freezes

gradually. The rate of heat release depends on the relationship of unfrozen water content to temperature and specific surface area. Figure 80 shows how this rate of heat release slows down with decreasing temperature for a silt and a clay. The implications of this behavior with regard to the heat capacity are illustrated in Figure 81 and further discussed in Section 5.2.1. There is a certain value of the initial water content which causes a jump increase in the heat capacity (Fig. 82).

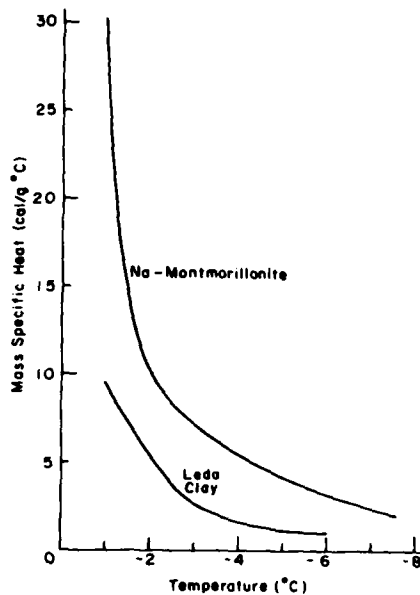

Figure 81. Apparent specific heat capacity of two clays as a function of temperature (after Hoekstra 1969).

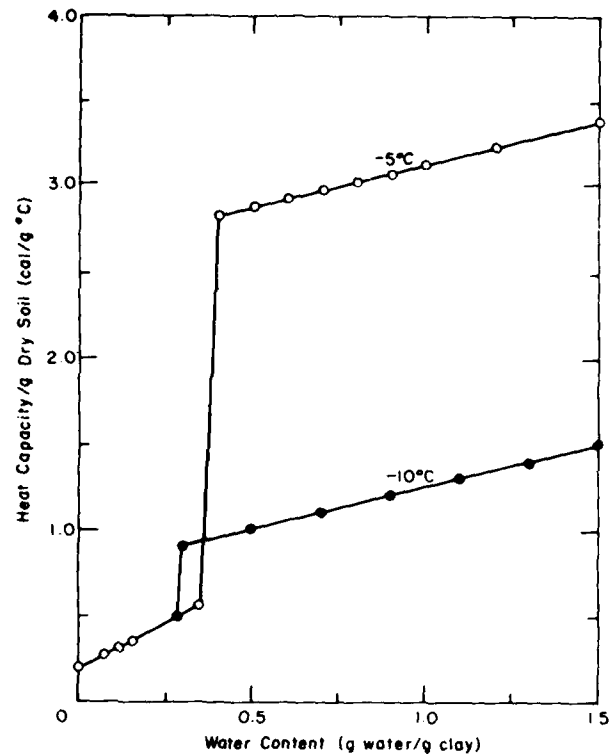

Figure 82. Relationship between specific heat capacity and moisture content of a partially frozen Na-Wyoming bentonite (after Low et al. 1968).

4.2.3 Water and peat

"Water and peat are inseparable by virtue of the very nature of peat formation" (MacFarlane and Williams 1974, p. 83). Water or ice have a major influence on the thermal properties of peats. The depth of freezing in peat depends strongly on the moisture content during freezing. The calculation of the rate of freezing and the rate of thawing of peat soils requires information on their thermal properties and their variation with the moisture content. The water content of peat can vary over a wide range; values as high as 2100% have been recorded (Pihlainen 1963).

In comparison with other soils, peat has a low thermal conductivity which depends to a large degree on the water content, while the fractional solids volume has only a small effect (MacFarlane 1969). Frozen saturated peat has a thermal conductivity about four times that of the unfrozen saturated peat (this is the approximate ratio of ice-to-water thermal conductivity). Figures 83 and 84 illustrate the average thermal conductivity of peat as a function of its water content and dry density for the frozen and unfrozen conditions, respectively.

Baver et al. (1972) illustrated the data of Van Duin

(1963) on unfrozen peat which show a linear relationship between the thermal conductivity and the volume fraction of water x_w (Fig. 85). In a different form, Johansen (1975) represented the data of Watzinger on unfrozen peat as the square root of the thermal conductivity against the degree of saturation S_r (Fig. 86). The large variations in the solids volume had little effect, and the following equation was suggested:

$$\sqrt{(k - k_{dry})} = \sqrt{(k_{sat} - k_{dry})} S_r$$

This equation gives the thermal conductivity k at a saturation S_r in terms of k_{dry} and k_{sat} . Average values are

$$k_{dry} = 0.05 \text{ W/m K and } k_{sat} = 0.55 \text{ W/m K.}$$

Izotov (1968) gave a formula (which he attributed to Romanov) for calculating the thermal conductivity of peat:

$$k = 2.61(x_w)^{1.39} \times 10^{-6}$$

where x_w is the volumetric water content expressed in

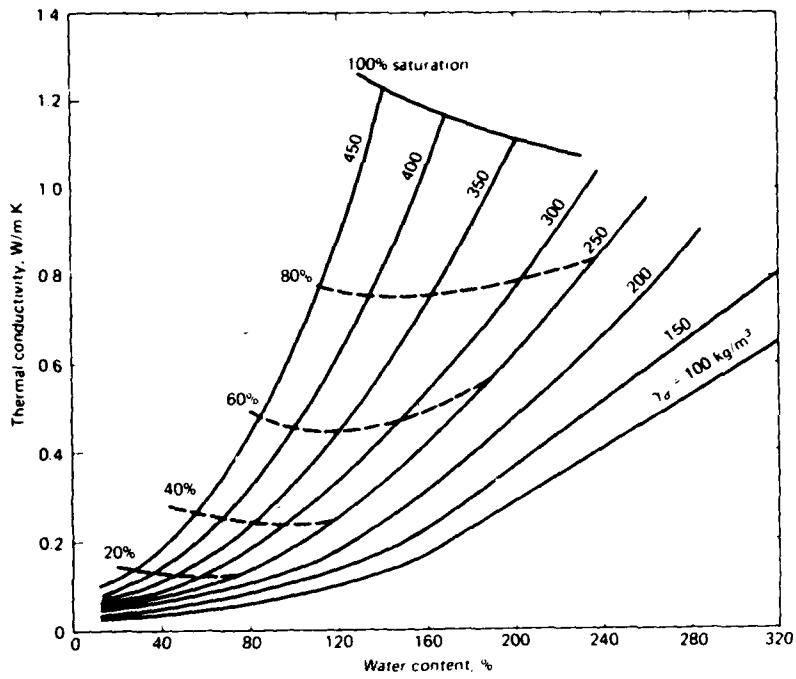

Figure 83. Average thermal conductivity of frozen peat as a function of water content and dry density (from Andersland and Anderson 1978).

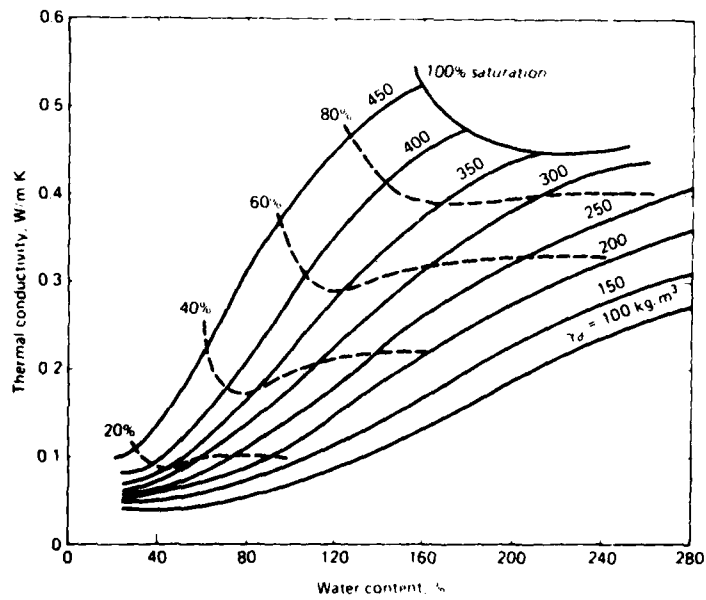

Figure 84. Average thermal conductivity of unfrozen peat as a function of water content and dry density (from Andersland and Anderson 1978).

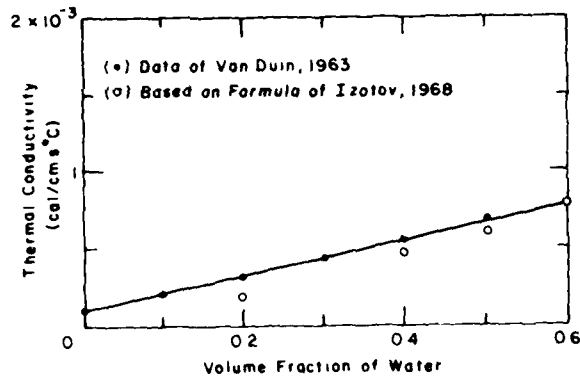

Figure 85. Thermal conductivity of unfrozen peat vs volume fraction of water. (Data of Van Duin are reproduced from Bayer et al 1972.)

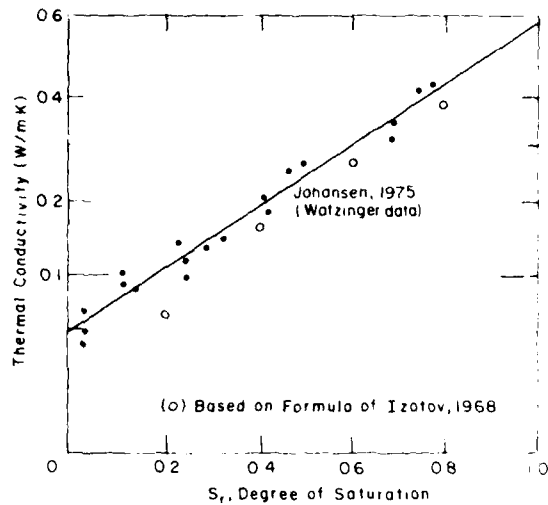

Figure 86. Thermal conductivity of unfrozen peat vs degree of saturation. (The ordinate represents the square root of the conductivity. The straight line is based on the data of Watzinger as given by Johansen 1975).

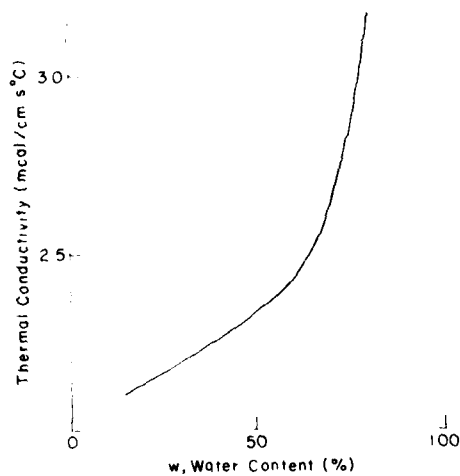

Figure 87. Thermal conductivity of frozen peat (a drained lowmoor bog) vs water content (after Pavlova 1970).

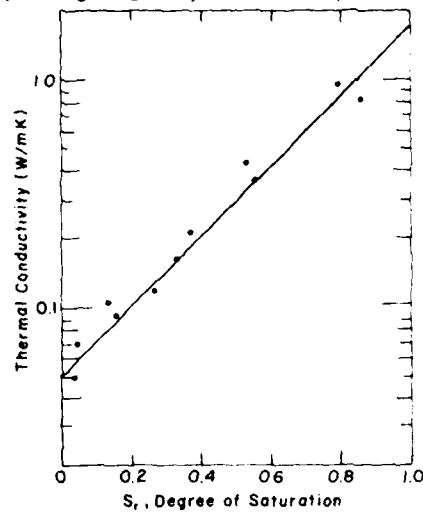

Figure 88. Thermal conductivity of frozen peat (log scale) vs degree of saturation (after Johansen 1975).

percent, given a k value in $\text{mcal/cm s } ^\circ\text{C}$. Izotov claimed that this formula applied to frozen peat which appears to be a mistake since the formula gives values for frozen peat conductivity that are about one-quarter of what may be expected. However, if the formula is applied to unfrozen peat, it works reasonably well, as may be seen from the comparison with Van Duin's results in Figure 85 and with Watzinger's data in Figure 86.

Some typical information on frozen peat obtained by Pavlova (1970) is given in Figure 87. This figure shows an exponential increase in the thermal conduc-

tivity with increasing volumetric water (ice) content. The rate of increase is greater beyond a certain ice content. Pavlova applied empirical equations of the form

$$k = A e^{Bx_w}$$

where the empirical coefficients A and B have different values, depending on whether the volumetric water content x_w is below or above 65% for the specific peat type illustrated, in this case a lowmoor bog. For a frozen sphagnum peat (highmoor) the transition point was determined roughly at 50%, and the coefficients A and

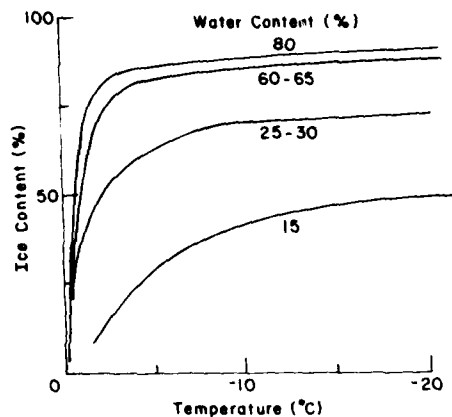

Figure 89. Variation of ice content of peat (a drained highmoor bog) with temperature, depending upon the initial water content indicated (after Pavlova 1970).

Table 8. Thermal conductivity of frozen sedge-hyphnum peat at decreasing temperatures (after Pavlova 1970).

| Temperature (°C) | Thermal conductivity (mcal/cm s °C) |
|------------------|-------------------------------------|
| - 6.2 | 5.26 |
| - 8.4 | 4.97 |
| -14.2 | 4.66 |

B were completely different from those for the low-moor peat.

Instead of the volumetric water content, Johansen (1975) used the degree of saturation from Watzinger's data on frozen peat. He found a linear relationship between the logarithm of the thermal conductivity and the degree of saturation (Fig. 88), suggesting the use of the following equation

$$k/k_{\text{dry}} = (k_{\text{sat}}/k_{\text{dry}})^{S_r}$$

for calculating the conductivity of the frozen peat *k* at intermediate saturation *S_r* in terms of *k_{dry}* (0.55 W/m K) and *k_{sat}* (average value of 1.80 W/m K). In the case of saturated peats, the thermal conductivity for the frozen material increases considerably more as the porosity increases (tending towards the value for ice) than happens for unfrozen peats.

As the temperature decreases below freezing, the ice content in peat increases (Fig. 89). For a given negative temperature, the greater the magnitude of the initial moisture content, the larger is the relative ice

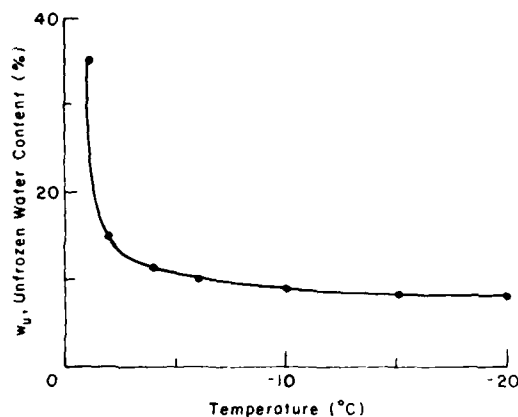

Figure 90. Change in the amount of unfrozen water in a sphagnum peat with decreasing temperature (after Pavlova 1970).

content. The decrease in *w_u* (percentage by volume of unfrozen water) with temperature $-T^{\circ}\text{C}$ is illustrated in Figure 90 and may be given by the exponential equation

$$w_u = a e^{-bT}$$

where *a* and *b* are empirical coefficients with different values in different negative temperature ranges which are dependent on the type of peat (Pavlova 1970). Like other types of soils, the percentage of unfrozen water is independent of the total water content.

Pavlova's results showed a definite decrease in the thermal conductivity of frozen peat at the lower negative temperatures (Table 8). This behavior appears at first to be surprising in view of: 1) the increasing ice contents as the temperature decreases and 2) the increase in the intrinsic thermal conductivity of ice with decreasing temperatures (Fig. 31). Thus the effect of these two factors has been negated and even reversed. Pavlova suggested the following counteracting factors:

1. Reduced mass transfer at the lower temperatures due to less free porosity (as the ice content increases) and lower mobility of the unfrozen water as well as its increased viscosity
2. Reduction in the unfrozen water leading to less efficient thermal contact between the soil skeleton and the ice.

To these factors may be added the supposition, made in Section 4.2.2, that the unfrozen water has a higher intrinsic thermal conductivity than ice. The benefit of such a high thermal conductivity for the unfrozen water would then be reduced as its amount decreases at decreasing temperatures.

One further result found from Pavlova's data is that salts produce a greater intensity of phase transformations of the water in the peat. This was shown by the behavior of the saline calcareous peat at temperatures below -6°C . Pavlova suggested that the peat particles flocculate and aggregate upon freezing when salt is present. The active soil surface therefore decreases, with a consequent reduction in the amount of unfrozen water. For example, at -20°C , the amount of unfrozen water in the saline grass-sedge peat was about 3.5%, while in the sedge-hypnum peat it was about 10% (by volume).

4.3 COMBINED MOISTURE AND HEAT TRANSFER IN SOILS CAUSED BY TEMPERATURE GRADIENTS

In addition to the upward geothermal heat flow, the soil near the earth's surface is subject to continuously varying temperature gradients, particularly due to the diurnal and seasonal cycles. The daily reversal of the temperature gradients in the soil furnishes an unceasing source of energy that causes heat and moisture transfer.

The analysis of the effect of a thermal gradient on the combined transfer of moisture and heat in soil is a complex problem with various interacting variables. Due to the temperature differences, water transfer may occur in the liquid and vapor phases and possibly even in the ice phase owing to the movement of pore ice. As a secondary effect, gradients of water concentration arise which contribute to water movement. Heat conduction is complicated by the changing thermal conductivities that are altered by the water transfer. Liquid moisture itself carries thermal energy directly, although this is usually negligible compared with the heat transferred by thermal conduction through the soil.

When testing the thermal conductivity of soils, the possibility of associated moisture transfer has to be allowed for or minimized. The electric power industry has long known that buried cables working at elevated temperatures can cause excessive moisture migration in soils surrounding the cable, leading to a large reduction in the soil's thermal conductivity. There is a critical temperature gradient beyond which migration is appreciable and this gradient is higher as soil saturation increases (Arman et al. 1964).

As shown in Section 4.1, the magnitude of the temperature influences the phase and condition of water in soil and the interaction of this water with the internal soil surfaces. Variations in temperature therefore disturb the equilibrium, or accentuate the disequilibrium, and give rise to water movement. This movement can occur by a variety of mechanisms, some or

even most of which may take place simultaneously. These mechanisms are:

1. Water vapor distillation involving latent heat transfer.
2. Vapor convection.
3. A chimney effect caused by air pressure differences which arise from temperature differences. The air currents this causes carry water vapor at a rate which can be many times that due to vapor diffusion alone.
4. Diffusion of water in solid solution.
5. Liquid film movement along internal soil surfaces due to a greater "affinity" of the soil surfaces for the film at lower temperatures.
6. Capillary movement due to differences in surface tension at different temperatures.
7. Surface migration or molecular hopping.
8. Combined-series, vapor-liquid water transfer which is an evaporation-condensation mechanism occurring in short steps (Philip and De Vries 1957).
9. Ice phase movement.

Under given soil-water conditions and temperature distributions, transfer will take place by all possible mechanisms, although one may predominate. The processes of moisture and of heat transfer are thus coupled. As shown later (Section 4.3.4), the combined process has been studied by physical modeling or with the help of the thermodynamics of irreversible processes.

While moisture transfer occurs directly as a result of temperature gradients, these may have an indirect influence. For example, temperature gradients can cause suction potentials to be set up in the freezing zone of a soil as liquid water becomes depleted by ice formation. These particular effects are dealt with in Section 4.4.

4.3.1 Transfer in the vapor phase

Vapor movement occurs in unsaturated soils which contain some air, as natural soils always do. It is particularly important in sandy soils with low moisture content. In a soil with a moisture content below hygroscopicity, moisture can move only in the vapor phase.

An increase in temperature causes a rapid increase in water vapor pressure. Therefore temperature gradients in soils give rise to vapor pressure gradients which act as driving forces causing vapor diffusion through the air-filled soil pores.

Water vapor diffusion in air is governed by Fick's law, which states that the density of the vapor flux J_v is directly proportional to the vapor pressure gradient ∇P_v :

$$J_v = \frac{D_v}{RT} (\nabla P_v)$$

Table 9. The diffusion coefficient of water vapor in air (after Van Wijk 1963).

| Temperature (°C) | Diffusion coefficient D_a (cm^2/s) |
|---------------------|---|
| -20 | 0.197 |
| -10 | 0.211 |
| 0 | 0.226 |
| 10 | 0.241 |
| 20 | 0.257 |
| 30 | 0.273 |
| 40 | 0.289 |

where R is the gas constant, T is the absolute temperature, and D_a is the diffusion coefficient of water vapor in air (Krischer and Rohalter 1940) given by

$$D_a = \frac{0.244}{P} \left(\frac{T}{273} \right)^{2.3}$$

(with P the total pressure in bars this equation gives D_a in cm^2/s). Table 9 gives values of D_a at various temperatures.

In soils, the diffusion coefficient is reduced to a value D_s , depending on the proportion n of soil volume occupied by air (incorporating a tortuosity effect) (Penman 1940):

$$D_s/D_a = 0.66 n.$$

Also, the presence of liquid moisture in soils affects the diffusion since moisture not only diminishes the pore space available for diffusion but also provides an interface with which the water vapor interacts. This liquid moisture effect therefore strongly depends on the extent of the interface between the soil water and the pore air.

If the water vapor condenses it gives up its latent heat. The effect of this latent heat transfer was described by De Vries (1974) who considered what happens on a microscopic level in an air-filled soil pore as vapor moves across this pore and condenses at the cold end. The vapor flux density J_v in such a pore may be written as

$$J_v = -D_a \frac{P}{P - P_v} \frac{M}{RT} (\nabla P_v),$$

a specific application of Fick's law. M is the molar mass of the water vapor.

If the relative humidity in the pore is h , then

$$P_v = h P_{vs}$$

where P_{vs} is the saturation vapor pressure. Leaving consideration of low moisture contents till later, we may write

$$h \cong 1$$

since, at higher moisture contents, the pore spaces are nearly saturated with water vapor. The vapor pressure gradient ∇P_v may thus be written in terms of the temperature gradient $(\nabla T)_a$ in the air-filled pore:

$$\nabla P_v = h (dP_{vs}/dT) (\nabla T)_a \cong (dP_{vs}/dT) (\nabla T)_a$$

since P_{vs} depends on T only. Because of this vapor pressure gradient, water will evaporate at the warm end of the pore and condense at its cold end, thereby transferring latent heat (the amount of sensible heat transferred is negligible because of the small vapor density).

Multiplying J_v by L_e (the latent heat of evaporation) gives the latent heat flux density

$$-L_e D_a \frac{P}{P - P_v} \frac{M}{RT} (\nabla P_v)$$

and substitution for ∇P_v gives

$$-L_e D_a \frac{P}{P - P_v} \frac{M}{RT} \frac{dP_{vs}}{dT} (\nabla T)_a.$$

If we now add to this the heat transfer across the pore due to the normal thermal conductivity k_a of air, i.e. the quantity

$$-k_a (\nabla T)_a,$$

then the total heat flux density across the air-filled pore becomes

$$-(k_a + k_{vs}) (\nabla T)_a$$

where

$$k_{vs} = L_e D_a \frac{P}{P - P_v} \frac{M}{RT} \frac{dP_{vs}}{dT}.$$

The thermal conductivity of the pore air is increased by an amount k_{vs} which is the apparent contribution of vapor diffusion. For calculating the macroscopic thermal conductivity of the soil, De Vries (1963) suggested use of $(k_a + k_{vs})$ for the effective thermal conductivity of the air component.

Figure 91 shows how k_{vs} increases appreciably as the temperature rises. The effect of k_{vs} is to multiply k_a by a factor ranging from 2 at 0°C (where $k_{vs} = k_a$)

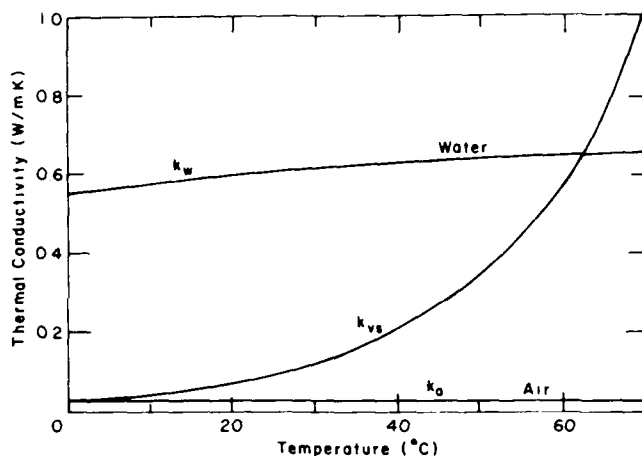

Figure 91. Saturated apparent thermal conductivity due to vapor distillation k_{vs} at 1 atm and the thermal conductivities of water and air as functions of temperature (after De Vries 1974).

to a factor of 20 near 60°C. In fact, the value of $(k_a + k_{vs})$ becomes equal to the thermal conductivity of water near 62°C. This suggests that at this temperature the thermal conductivity of a soil is independent of its moisture content as long as the relative humidity is nearly 100%. De Vries confirmed this experimentally.

At low moisture content, the relative humidity is less than 100% ($h < 1$) and depends on both the temperature and the liquid moisture content θ (volumetric). The vapor pressure gradient now contains an additional term that is proportional to the moisture gradient $(\nabla\theta)_a$ in the pore:

$$\nabla P_v = h \frac{dP_{vs}}{dT} (\nabla T)_a + P_{vs} \frac{\partial h}{\partial \theta} (\nabla\theta)_a.$$

Under such conditions of low moisture content, the vapor pressure gradient is highly dependent on the relative humidity, which is intimately related to the soil suction ψ (Section 4.1.3). A decrease in h is associated with a large increase in ψ (Fig. 50 and Table 6).

Some observations

Vapor diffusion in soils is a very slow process. Speedier movement of air, carrying water vapor, occurs due to convective currents or to pressure differences between the soil air and the outside atmosphere.

Onchukov and Ostapchik (1962) determined experimentally that the vapor transport in a soil is proportional to the temperature gradient. Their laboratory tests on sand showed a transfer of 1% of the moisture content per hour at an average temperature gradient of 1.5°C/cm, a value which may occur under natural conditions. Rollins et al. (1954) also showed a flow increase with the temperature gradient for an unsaturated silty loam.

The temperature gradient across individual pore

spaces may be considerably higher than the average gradient, resulting in more intense vapor transfer across the pore spaces (Woodside and Kuzmak 1958).

Jones and Kohnke (1952) experimentally related the amount of vapor transfer to the soil moisture tension or suction ψ . They found a maximum amount of movement at a certain pF value. This value was greater for finer soils: 2 for medium sand and 3.5 for silt. A similar trend is found when vapor transfer is related to the moisture content. Various experimenters determined a maximum vapor transfer occurring at a certain moisture content or degree of saturation (e.g. Smith 1943, Taylor and Cavazza 1954). From tests on a loam, Habib (1957) measured a maximum vapor transfer at a moisture content of 8% and an air porosity of 26%.

For subfreezing temperatures, Auracher (1973) studied vapor diffusion in porous materials with hoarfrost growth. He noted that because the hoarfrost is porous it contributes an additional diffusion resistance factor, increasing that due to the internal structure. According to Bakulin et al. (1972), water vapor is always present in thawing natural soil and plays an important part in moisture redistribution.

4.3.2 Transfer associated with the liquid phase

Heat and moisture transfer in the liquid phase is particularly important in fine-grained soils. An increase in temperature causes a decrease in the proportion of bound or restrained water and therefore produces more free water. Simultaneously the viscosity of the water is decreased thus facilitating movement. Wilkinson and Klute (1962) studied the temperature effect on the equilibrium energy status of water held by soils. As expected, desorption occurred quicker at 44°C than at 4°C. More suction is required to get the same desorption at the lower temperature.

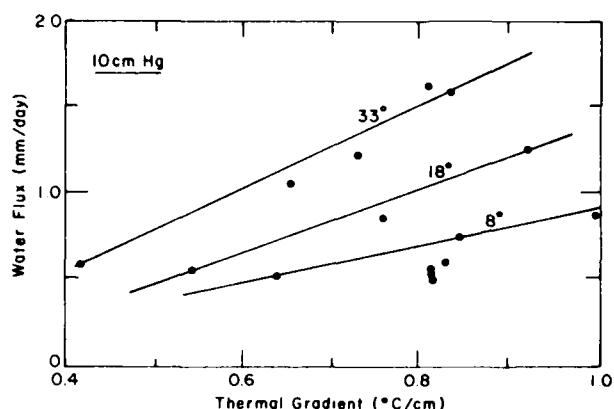

Figure 92. Thermal moisture flux vs temperature gradient. Data are for a suction of 10 cm mercury at average temperatures of 8, 18 and 33°C (after Cary 1965).

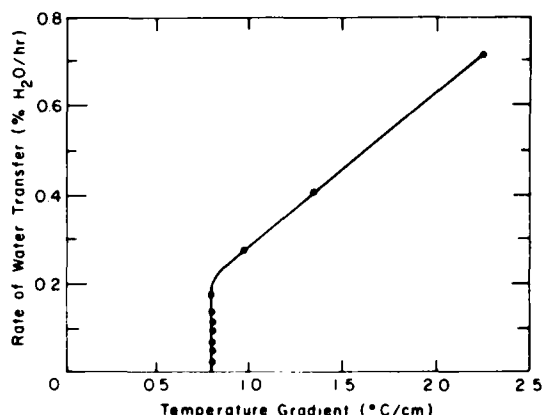

Figure 93. Rate of water transport in a coarse clay as a function of the temperature gradient (after Onchukov and Ostapchik 1962).

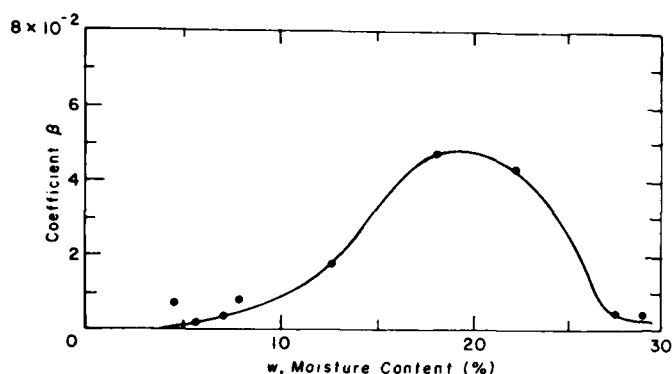

Figure 94. Variation of the thermal osmosis coefficient β with the moisture content for Leda clay (after Woodside and De Bruyn 1959). β is the change in w (fraction of dry weight) caused by a unit temperature difference (°F).

The mechanisms of liquid transfer due to a thermal gradient are as follows:

1. Increased soil suction or soil adsorptive forces caused by lower temperatures directly or indirectly as in the freezing process. At higher temperatures, increased suction may be caused by drying.
2. Lower surface tension at higher temperatures resulting in transfer from warmer to cooler regions (usually a secondary effect).
3. Kinetic energy changes associated with changes in the hydrogen bond distribution.
4. Thermally induced osmotic gradients, i.e. the Soret effect whereby dissolved salts diffuse from hot to cold regions.

The moisture flux in the liquid phase J_L may be related to the temperature gradient dT/dz , assuming one-dimensional flow, by the following phenomenological equation (Cary 1966):

$$J_L = -\frac{K}{g} \frac{Q}{T} \frac{dT}{dz}$$

where K is the capillary (hydraulic) conductivity and Q is the heat transported by the liquid moving in the z direction.

Cary (1965) measured the water flux and found it to be linearly related to the temperature gradient (Fig. 92). A similar relation was observed by Onchukov and Ostapchik (1962) for a clay soil (Fig. 93). Like other experimenters, these Soviet observers noted that a reverse flow is caused by the moisture content gradient which builds up when the moisture content increases at the cold end of a closed system. The net water flow may then drop to zero. They noted that the development of a moisture content field lagged considerably behind the development of the temperature field, particularly for fine-grained soils.

At a given temperature gradient, Swenson and Sereda (1953) showed that when the suction in Ottawa clay was increased from pF 1 to pF 3, the moisture transfer increased about 16 times. This emphasizes the importance of suction.

Several workers found experimentally that a certain moisture content gave maximum transfer in the liquid phase (Bouyoucos 1915, Mickley 1949, Woodside and De Bruyn 1959). In particular, Woodside and De Bruyn (1959) found a maximum coefficient of liquid transfer β for a remolded Leda clay sample at a moisture content of $\sim 20\%$ (Fig. 94). Winterkorn (1960b) suggested that the maximum for clays should occur at moisture contents around the plastic limit.

4.3.3 Combined vapor and liquid transfer

Combined vapor and liquid transfer can occur in unsaturated soils. By field measurements Rose (1963) showed that vapor flux in soils is comparable in magnitude to liquid flux under certain conditions. The reversal of the diurnal temperature gradient during the night reverses the direction of the vapor movement while the liquid movement remains upwards towards the soil surface (Rose 1968).

Smith (1943) was one of the first to point out that vapor flux may be enhanced by a discontinuous liquid phase. He postulated a process of moisture transfer composed of a series of evaporation-condensation steps. He used this to explain the transfer he measured, which was considerably greater than one estimated from the theory of vapor diffusion alone. As discussed by Rose (1968), vapor transfer is helped by liquid regions or islands. On evaporating upstream, vapor draws latent heat which is then released when it condenses downstream, thereby transferring heat flux. Measurements by Rose (1963) show an increase in the moisture transfer of more than one order of magnitude.

The evaporation-condensation mechanism is a function of:

1. The thermal gradient (which, as mentioned earlier, may be accentuated in individual pore spaces)
2. The moisture content
3. The soil's internal geometric properties, particularly the pore sizes and geometry, the internal surface area, and the properties of the water/air interfaces (see Section 4.3.1).

The total moisture transferred, in both the vapor and liquid phases, shows a maximum at a certain critical moisture content (Fig. 95). To explain this maximum, it may be visualized that pendulous water in the soil merges by vapor condensation to form a con-

tinuous film through which film water can transfer. The soil would then change from the pendulous state (trapped water) to the funicular state (trapped air). A critical moisture content may facilitate this change occurring and thereby lead to the maximum water transfer. A closer packing of the soil (i.e. a greater dry unit weight) should decrease this critical moisture content because merging of the water would then require less moisture. Luikov (1966) showed theoretically that such a transition point occurs when water occupies 22.6% of the pore volume of a rhombohedral packing consisting of uniform spherical grains. (With regard to buried electric cables, it has been found that the critical moisture content, at which excessive moisture transfer occurs, varies from a saturation of about 16% for sand to one of about 27% for clay [Arman et al. 1964]).

The critical moisture content is associated with a certain air-pore space which must be at least partially continuous, providing some uninterrupted paths for vapor diffusion and subsequent condensation. At the same time, the liquid film is continuous, with the maximum proportion of oriented water at the interfaces (solid/water and water/air) and with little or no middle region of free water. This condition should provide increased thermal conductivity of the liquid (Winterkorn 1960b) and facilitate water movement in the film phase. Concurrently, the maximum presence of air/water interfaces should allow evaporation and subsequent condensation to take place at many points.

The magnitude of the vapor flux relative to that of the liquid flux depends on the degree of suction. At suctions as low as 200 cm of water, the vapor flux is comparable to the liquid flux. At suctions above 5000 cm, moisture is transported entirely by vapor (Rose 1968).

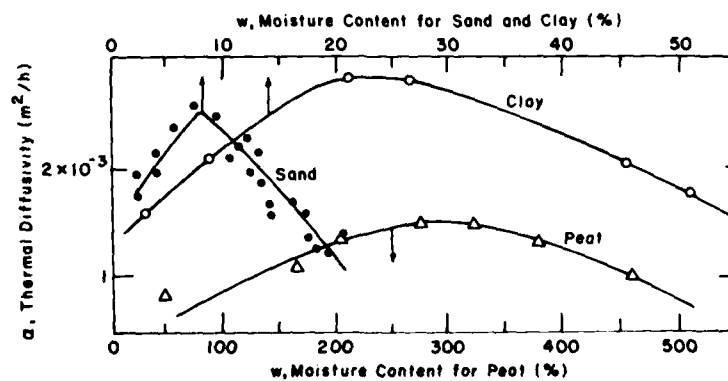

Figure 95. Thermal diffusivity as a function of moisture content for sand, clay and peat (after Luikov 1966).

4.3.4 Coupling between moisture and heat flow

There is little coupling of the processes of moisture and heat flow when the moisture content is either near saturation, or when it is lower than the moisture content corresponding to a 15-bar suction. Coupling of heat and moisture flux is significant when the water moves in the liquid phase and when soil-water interaction is pronounced. Maximum coupling would be expected near field capacity, when the soil moisture moves mainly in the liquid phase through the smaller pores (Joshua and De Jong 1973).

The problem of moisture and heat flow coupling has been tackled on the basis of 1) a physical model, mainly developed by Philip and De Vries (1957), or 2) the thermodynamics of irreversible processes (Taylor and Cary 1964).

The physical model

Temperature differences cause moisture movement which in turn leads to changes in the temperature distribution. Equations are developed for macroscopic fluxes of moisture and heat. Application of the principle of mass conservation gives a differential equation for the moisture content as a function of space coordinates and time. Another simultaneous differential equation for temperature is obtained by applying the principle of the conservation of energy. Proper boundary conditions need to be applied. In the simplified theory, transport of sensible heat due to moisture movement is neglected.

The thermodynamics of irreversible processes

This theory requires no assumptions about the nature of the flow processes. The second law of thermodynamics says that entropy remains constant in a reversible process, but always increases in irreversible processes. The time rate of entropy production, dS/dt , may be expressed as

$$\frac{dS}{dt} = \sum_i J_i X_i$$

where J_i is the water or heat flux (other fluxes, such as air, salt etc., may be studied in a more general case), and X_i is a driving force which in this case is a thermal gradient or an adsorptive force (in other situations the force considered may be electrical, gravitational, etc.).

Fluxes may be expressed as linear functions of the driving forces by the following phenomenological relations:

$$J_i = \sum_{k=1}^n L_{ik} X_k \quad (i = 1, 2, 3, \dots, n)$$

where L_{ik} are the coupling coefficients (Onsager's reciprocal equality states that $L_{ik} = L_{ki}$).

Considering only water flux J_w and heat flux J_q due to temperature gradients and moisture content gradients, we have

$$J_w = -L_{ww} \frac{\nu}{T} \frac{\Delta P}{\Delta z} - L_{wq} \frac{1}{T^2} \cdot \frac{\Delta T}{\Delta z}$$

and

$$J_q = -L_{qw} \frac{\nu}{T} \frac{\Delta P}{\Delta z} - L_{qq} \frac{1}{T^2} \cdot \frac{\Delta T}{\Delta z}$$

where ν = specific volume of the soil water

P = soil water pressure causing flow in the z direction (no gravity effect)

T = absolute temperature.

L_{qq}/T^2 is equivalent to the Fourier thermal conductivity and $L_{wq} = L_{qw}$ the coupling coefficient between moisture and heat flow. $L_{wq} = -D(\Delta\theta/\Delta T)T^2$ where D is the isothermal soil water diffusivity and θ is the volumetric moisture content. The ratio $\Delta\theta/\Delta T$ may be written

$$\frac{\Delta\theta}{\Delta T} = \frac{\Delta\theta/\Delta z}{\Delta T/\Delta z}$$

showing that it is a measure of the soil moisture gradient resulting from an imposed temperature gradient.

At normal temperatures, $\Delta\theta/\Delta T$ is negative thus making L_{wq} positive. This implies that there is positive coupling and the contributions of the two gradients (or driving forces) add to each other, causing increased water and heat fluxes. As the temperature decreases, however, $\Delta\theta/\Delta T$ becomes less negative and the contributory effect therefore decreases. Moreover, with the advent of freezing conditions $\Delta\theta/\Delta T$ may even become positive in the unfrozen portion of the soil (near the freezing front) as observed by Hutcheon (1958) and by Dirksen and Miller (1966). The coupling coefficient L_{wq} is then zero or negative, implying that the moisture flow in the unfrozen soil is not a direct consequence of the temperature gradient but is caused by events taking place in the frozen portion of the soil (i.e. suction effects due to water depletion).

Like freezing, the drying process in soils is a complicated case of coupled water and heat transfer. Kolyasev and Gupalo (1958) showed that as soil dries the mechanism of water movement changes from capillary to film-meniscus, to film movement and finally to vapor diffusion. As this process continues, the rate of water movement towards the evaporating surface decreases. The various heat transfer mechanisms occurring are

non-uniform and depend on the amount and form of the water in the soil during the different stages. As mentioned in Section 4.1.3, each type of soil is characterized by certain water constants. The moisture content of the plant-growth-retardation stage, for instance, corresponds to the transition point between the capillary and the film-meniscus mode of transfer.

Kirkham and Powell (1971) applied heat and mass transfer principles to the drying process. The resulting equation predicted the development of a dry surface layer and described the moisture redistribution where temperature effects were important. The effect of cracks was incorporated in the analysis.

4.4 COMBINED MOISTURE AND HEAT TRANSFER DURING SOIL FREEZING

The freezing process introduces complications into the thermal behavior and properties of soils. Compared with summer, the temperature gradient in winter is reversed; heat is lost and moves upwards. As the surface soil freezes, forces are set up that draw water up from the unfrozen soil below. The migration of water during soil freezing can have important engineering consequences. Apart from the well-known structural deteriorations caused by *heaving* and *subsequent thawing*, water migration influences the water regime and water storage in seasonally frozen soils (Nersesova and Tsytoich 1963).

In freezing soils, moisture migrates under the influence of the temperature gradient. This process is quite

different from that caused by temperature gradients in the range above 0°C . With the cooling of the soil surface below 0°C in winter, freezing begins and the freezing front penetrates downward. During the whole winter, a generally continuous upward flow of heat occurs, but the amount decreases as the winter progresses. One of the first to discover that water may also flow upward to the freezing zone was the Swedish scientist Johansson in 1914. He understood that it is the freezing of this moisture that causes heaving. This was also recognized by Taber (1916). The release of the latent heat of freezing is associated with this process.

Moisture and heat transfer in freezing soils are thus intimately related. The temperature gradient existing in the winter sets up the force driving these transfer processes. The temperature gradient and the changes in it are largest at the surface and decrease with depth. This damping effect may be particularly marked near the freezing front because of the effect of the phase change of the water. Figure 96 shows an idealized temperature profile in permafrost.

The rate of the imposed cooling, associated with the soil grain size distribution, influences the resulting type of freezing. Rapid cooling may give rise to in situ freezing with no water migration, whereas slow cooling may allow migration of water and growth of ice lenses. Other factors that influence the process are the permeability of the soil and the availability of a groundwater supply. It is important and necessary to distinguish between an open system which has access to a groundwater table and a closed system which does not. The latter is subject to a moisture redistribution within its

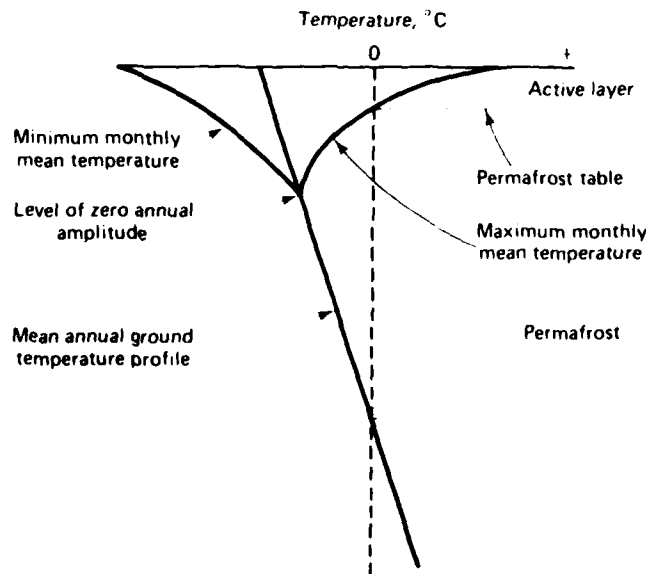

Figure 96. Idealized ground temperature profile in permafrost terrain (from Anderland and Anderson 1978).

confines. A silty soil with access to groundwater and with sufficient permeability is most liable to experience excessive moisture migration on freezing. However, the heave force is much lower than it is with clays and heaving can be controlled by surface pressure.

4.4.1 The driving force

The driving force causing water migration to the freezing zone is now generally thought to be connected with the unfrozen water films in the freezing zone and their interaction with the soil surfaces. The influence of temperature is paramount since temperature changes disturb the equilibrium of the soil-water relationship. There have been various ideas and suggestions as to the specific mechanism that gives rise to this driving force.

Cass and Miller (1959) asserted that the driving force is an osmotic effect, akin to the swelling of clays in the range above 0°C. As water turns to ice in the freezing zone the remaining solution becomes more concentrated with cations, salts, etc., producing a higher osmotic pressure. Lovell (1957) maintained that there may be a significant depression of the freezing point due to such an increased salt concentration. On the other hand, Gold (1957) argued that the freezing point depression is related to the specific pore configuration in which the ice tends to advance. The constrictions caused by the specific pore geometry and the restrictively high curvature which it tends to impose were thought to place certain conditions on the equilibrium between the ice and the water, resulting in a freezing point depression. This depression was in fact related to the grain size distribution by Penner (1957). As shown later in this section, the existence of a freezing point depression makes available free energy that acts as a driving force. Martin (1959) and others (e.g. Chalmers and Jackson 1970) suggested that supercooling of the water (relative to the equilibrium freezing point) was essential for the development of this free energy, but such supercooling is now thought to be unnecessary (Anderson and Morgenstern 1973). Also, while the osmotic effect concept of Cass and Miller and Gold's concept appear to provide some basis for part of the driving force mechanism, they do not give the main picture. The general consensus concerning the driving force now centers on the influence, properties and behavior of the unfrozen water films, as was originally envisaged by Beskow as long ago as 1935.

Beskow suggested that the adsorbed unfrozen water film between the ice crystal and the solid mineral soil particle has a certain equilibrium thickness which depends on the temperature. As part of this film freezes and attaches to the ice crystal, water is sucked up to maintain the equilibrium thickness of the film. The

situation may be compared to the dried-out region of a soil which has a high suction (pF) value. As water freezes a similar desiccation action is set up in the freezing zone. The small amount of remaining unfrozen water instigates a suction effect which, according to Taber (1929), may be as much as 150 m of water (equivalent to a pF of 4.2), causing migration of water to the frozen desiccated zone. In contrast, the diffusion or convection of water caused directly by the temperature gradient is much less important.

Koopmans and Miller (1966) showed that the soil freezing characteristic (SFC) curve is analogous to the soil water characteristic (SWC) curve. This is illustrated by Figure 97 in which the moisture content is either the unfrozen water content (SFC case) or the actual water content (SWC case). Freezing is analogous to drying while thawing is similar to wetting. In the SFC situation, ice crystals may be thought of as substituting for air pockets. The hysteresis effect is evident in both cases. The analogy was shown to apply to extreme types of soil in particular, but has a different basis for granular soils (capillary effects) than for colloidal soils (adsorption effects).

In unfrozen partially saturated soils, the suction effect sets up a pressure difference (and therefore a pressure gradient) which may be expressed in terms of a difference (or change) in the standard free energy:

$$\Delta P = (P - P_0) = \Delta\mu_0/v_w$$

where P = pressure or suction in the soil water

P_0 = standard (atmospheric) pressure

μ_0 = chemical potential (or free energy referred to a mole of material) and $\Delta\mu_0$ is the change in this chemical potential at two points in the system, i.e. the standard free energy change

v_w = volume of one mole of water.

In frozen soils, which always contain some unfrozen water, the suction gradient may also be related to the free energy difference. The energy state of frozen soil depends on the temperature, which in turn determines the unfrozen water content. As mentioned earlier, when the temperature decreases there is an increase in the concentration of surface energy, leading to a rapid rate of chemical reaction (Section 4.1.4). A gradient of chemical potential may thus give rise to a driving force or suction gradient (Tyutyunov 1957, Aguirre-Puente and Fremont 1976) which is expressible in terms of the chemical potential gradient (Johansen 1977) as

$$\frac{\partial P}{\partial z} = \frac{\partial}{\partial z} (\Delta\mu_0) = \frac{\partial}{\partial T} (\Delta\mu_0) \frac{\partial T}{\partial z}$$

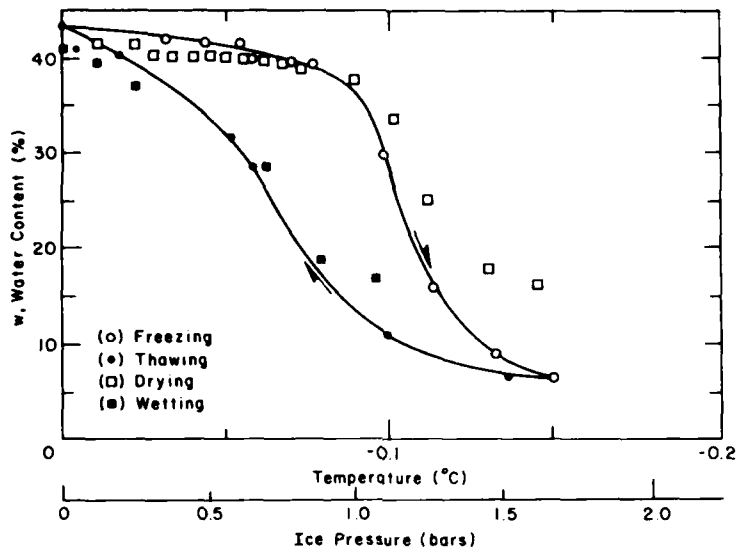

Figure 97. Soil-freezing-characteristic data for second freeze-thaw cycle and soil-water-characteristic data (after Koopmans and Miller 1966).

From thermodynamics, for a small freezing point depression,

$$\Delta\mu_0 \approx (\Delta S_F)(T - T_F)$$

where ΔS_F is the entropy change (per mole) associated with freezing and $T - T_F$ is the freezing point depression. It follows that

$$\frac{\partial P}{\partial z} = \Delta S_F \frac{\partial T}{\partial z}$$

which expresses the suction gradient in terms of the temperature gradient. Everett (1961) was one of the first to study the relationship between these two gradients on a thermodynamic basis.

It is thus apparent that, as stated by De Vries (1974), water movement in the freezing process is caused by the difference in chemical potential of the water at the ice front and the water at lower depths in the soil. According to Tyutyunov (1955) all water (free and bound) in freezing fine-grained soils is displaced because of the chemical potential gradient, but is accumulated in large quantities if the chemical potential gradient coincides with the temperature gradient. The chemical potential of a particle surface is determined by the chemical potential of the ions forming the surfaces (Tsytoich et al. 1959). With increasing valence of cations, the hydration energy increases and the associated surfaces are characterized by a larger surface energy. As a result the induced migration increases (see Section 4.4.2).

During freezing, the ice crystals that are formed

show new surfaces which require wetting since they possess surface energy. However, this situation may be modified by the presence of salts in the freezing water (Section 4.1.3).

If a high rate of freezing is imposed, there is a direct interface between the formed ice and the boundary phase (i.e. the unfrozen adsorbed water film). The surface energy of these interfaces is minimal, giving virtually no driving force or suction (water is frozen in place). There may even be a negative suction (water is squeezed out). On the other hand, the formation of dehydrated, fractured surfaces can give rise to surface energy liberation which may appreciably increase the driving force of migration (Tyutyunov 1963).

The suction forces in a freezing soil may be linearly related to the depth of freezing d (Tsytoich et al. 1959) by

$$F = F_{max}(1 - d/d_{cr})$$

where F = suction force at a depth of freezing d

F_{max} = maximum suction force near the ground surface

d_{cr} = depth at which suction forces are eliminated by external pressures.

4.4.2 Amount and nature of moisture transfer during freezing

For moisture to migrate, the temperature gradient must exceed a certain value (Nersesova and Tsytoich 1963). Laboratory experiments at the Soviet Permafrost Institute showed that in compact clay soils,

Table 10. Effect of the magnitude of the temperature gradient on the amount of moisture accumulated by migration (after Orlov 1973).

| No. of freezing cycles | Time to freeze the soil (hr) | Mean temp of external environment (°C) | Mean temp gradient of soil during freezing (°C/cm) | Amt of water entering soil sample (mg/cm ²) |
|------------------------|------------------------------|--|--|---|
| 1 | 125 | -6.0 | 0.67 | 397 |
| 2 | 188 | -9.1 | 0.91 | 1770 |
| 1 | 81 | -7.0 | 0.86 | 618 |
| 2 | 52 | -6.5 | 0.76 | 458 |
| 1 | 52 | -6.5 | 0.80 | 0 |

Table 11. Effect of the magnitude of the temperature gradient on the moisture flow during freezing.

(Data extracted from Table II and Fig. 8 of Penner 1960.)

| Soil type | Temp gradient (°C/cm) | Rate of heat extraction (Btu/hr) | Measured moisture flow (mL/hr) | Moisture flow per unit area (by weight) (mg/cm ² hr) |
|--------------|-----------------------|----------------------------------|--------------------------------|---|
| Lindsay sand | 0.21 | 0.25 | 0.65 | 3.6 |
| PFRA silt | 0.24 | 0.8 | 1.2 | 6.6 |
| Leda clay | 0.39 | 1.1 | 2.9 | 15.9 |

particularly, the migration of moisture began only when there was a rather high initial temperature gradient (Tsytoich et al. 1959). An idea of the amounts of migration involved may be gained from some of the laboratory results given by Orlov (1973) and presented in Table 10.

Kudryavtsev et al. (1973) stated that a temperature gradient on the order of 2 to 3°C/cm did not lead to a noticeable increase in moisture migration in samples of clay, loam and sandy loam. At larger temperature gradients (4 to 5°C/cm), the migration flux increased by 10 to 20%, as compared with the isothermal moisture transfer process. These authors further stated that according to numerous field observations the temperature gradient in the unfrozen zone, just below the freezing front, does not exceed 0.5°C/cm. They concluded that the effect of the temperature gradient on moisture migration during the freezing process may be neglected.

Penner's tests (1960) on the freezing rate in soils show the effect of the heat flow on the moisture flow. For the lowest rate of cooling, the moisture flow corresponding to the temperature gradient is given in Table 11. The moisture flux varies with time (Kudryavtsev et al. 1973) and Penner's tests showed that the moisture flow tends to increase with time. According to

Hoekstra (1967) the cumulative water transport is directly proportional to the square root of time.

The nature of the exchange cations influences the amount of migration. Migration increases as the hydration energy of the cations increases, in the order: K⁺, Na⁺, Ca⁺⁺, Fe⁺⁺⁺ (Tsytoich et al. 1959).

Ice crystals strongly tend to reject solutes (Anderson and Morgenstern 1973). The increase in the salt concentration in the remaining unfrozen water tends to increase the water migration.

Water motion is restricted as the water films become thinner with a consequent increase in their average degree of binding. Because of its lower specific surface area, kaolinite, for instance, has thicker water films than montmorillonite at the same moisture content (Fig. 44) and therefore has more moisture migration (Volkova and Lomonosov 1973). The effect of temperature is important since it influences the degree of binding, the energy state, and the mobility of the water films.

Gravitational forces have very little effect when the moisture content drops below the value at which discontinuity occurs in the free (capillary) moisture (Kudryavtsev et al. 1973).

The moisture redistribution which occurs as a result of freezing in a closed system has been studied experi-

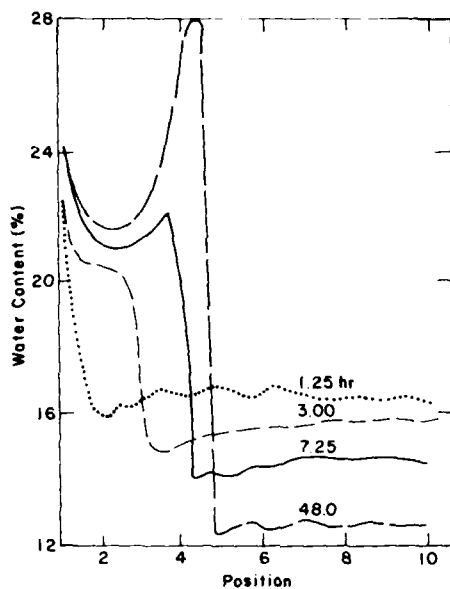

Figure 98. Gravimetric water (or ice) content of soil columns at the end of each experiment, the duration of which is indicated in hours. Freezing proceeded from left to right (after Dirksen and Miller 1966).

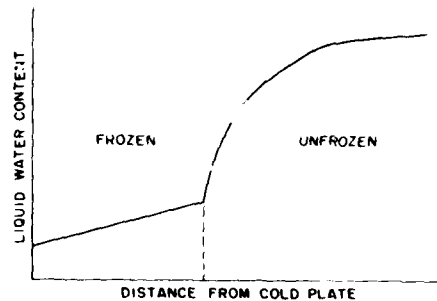

Figure 99. The liquid water content as a function of distance from the cold plate. In the frozen part of the soil, ice is also present (from Hoekstra 1967).

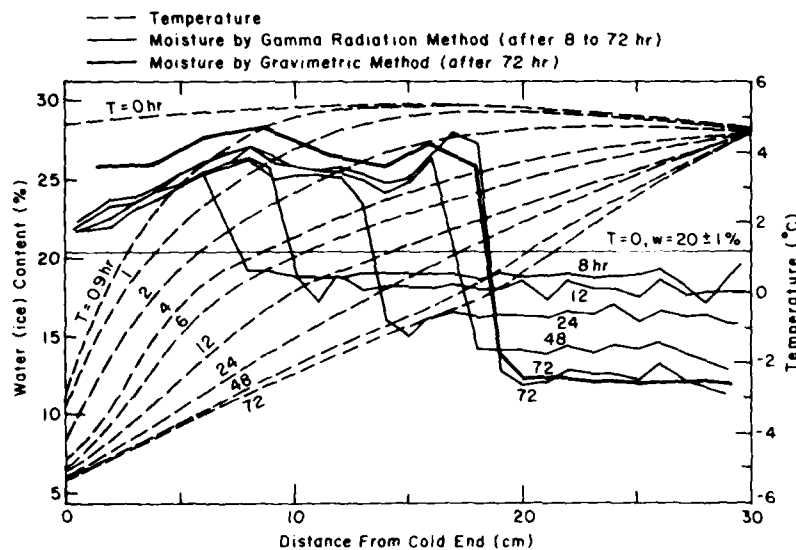

Figure 100. Soil moisture and soil temperature distributions during freezing. Initial moisture content is $20 \pm 1\%$ and the temperature gradient is $0.33^\circ\text{C}/\text{cm}$ (after Jame and Norum 1976).

mentally by various workers (e.g. Dirksen and Miller 1966). The total moisture content distribution that results is shown in Figure 98 where the moisture content in the frozen zone includes the ice content. If only the liquid moisture content is shown, the resulting distribution would be similar to Figure 99. The discontinuity at the freezing front is evident in both cases. Jame and Norum (1976) showed that it becomes sharper with time (Fig. 100).

In the freezing process, the amount of moisture transfer by vapor diffusion is very small (Jumikis 1957, Dirksen and Miller 1966).

According to Takagi (1963), ice molecules can move in three ways: surface diffusion, volume diffusion or evaporation-condensation. Miller et al. (1975) have emphasized that the ice phase *can* move, indicating that liquid water movement interacts strongly and directly with ice movement. They suggested that the

process is a special example of "series-parallel" transport involving ice and water. This was supposed to be analogous to the series-parallel transport phenomenon that can occur for liquid and vapor movement in unfrozen unsaturated soils proposed by Philip and De Vries (1957) (described in Section 4.3).

4.4.3 Properties of the freezing zone

Takagi (1965) discussed the two competitive processes in soil freezing, i.e. freezing in situ and freezing by segregation. The former constitutes the classical Stefan problem in which the freezing boundary moves smoothly and continuously downwards and there is no moisture migration. In the case of freezing by segregation, the freezing front remains stationary for a while as ice lenses develop in association with moisture migration. The necessary condition for segregation freezing is the correct balance of heat and water flow. When the nearby soil moisture is exhausted, this equilibrium is disturbed. The freezing front then jumps to a lower equilibrium position. This process eventually gives rise to rhythmic ice banding. It is a moving boundary problem where some of the physical variables are discontinuous. Thus the gradients of both water content and temperature are infinite at the ice/water interface.

In segregation freezing, three kinds of flow take place on the freezing front (Takagi 1970): 1) flow of water in the unfrozen soil, 2) heat flow by conduction and convection in the unfrozen soil and its water, and 3) heat conduction in the growing ice lenses.

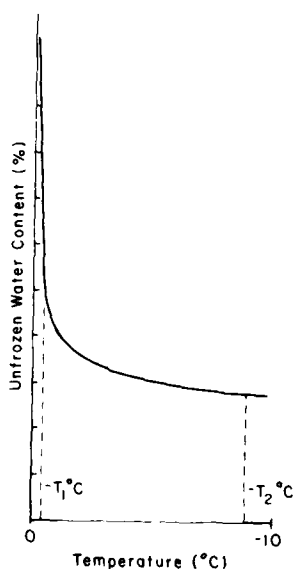

Figure 101. Unfrozen water content vs temperature, showing temperature boundaries of the phase transition zone (based on ideas of Martynov 1959).

The freezing front actually possesses an undulating shape (Penner 1971, Aguirre-Puente and Fremont 1976). In fine-grained soils, especially, the freezing front is really a zone of finite thickness called, in Soviet terminology, a phase transition zone. Its boundaries move as the temperature field varies in the soil. The curve of unfrozen water content against temperature may be used to establish these boundaries (see Fig. 101). Martynov (1959) suggested that the upper boundary corresponds to a temperature $-T_2$ °C at some arbitrary point where this curve begins to flatten out at the lower temperatures. The boundary between the phase transition zone and the thawed zone occurs at a temperature $-T_1$ °C (approximately equal to 0°C) where the curve rises sharply. Nakano and Brown (1971) determined the effect of a freezing zone of finite depth on the thermal regime of soils.

The phase transition zone may be divided into two subregions (Tsytoovich et al. 1959):

1. A region of substantial water phase transformations where the changes in the quantity of liquid water are equal to or greater than 1% (of the weight of the dry soil)/°C. For sandy soils this region is limited to temperatures from 0°C to -0.2 °C, while for heavy clay it extends down to -7 °C or lower.
2. A region of transitional phase transformations where the changes in the quantity of liquid water are between 1% and 0.1% (of the weight of the dry soil)/°C.

By implication the frozen zone corresponds to the region where the quantity of liquid water changes by less than 0.1%/°C.

In the phase transition zone ice crystals do not develop uniformly throughout the whole volume, but in the individual, larger-sized pores (Martynov 1959). The transfer of heat is always accompanied by migration of moisture. An appreciable change in the coefficient of thermal conductivity occurs as a result.

For coarse-grained soils, the thickness of the phase transition zone may be quite small and its effect is usually negligible. The large specific heat capacity of this zone may, however, be taken into account if necessary.

4.4.4 Moisture and heat transfer during freezing

Guymon and Luthin (1974, p. 995) state: "the soil moisture and thermal state of soil systems are coupled, particularly during freezing and thawing processes." The combined process, which is quite complex, may be expressed by realistic models based on principles similar to those described in Section 4.3.4. First, assumptions need to be made regarding the physics of the component processes. Ice coexists with water below freezing temperatures, and the pore ice affects water flow like air bubbles in unsaturated flow above freezing temperatures. Up to a certain ice

content Darcy's law may be applied, with the permeability depending on the liquid moisture content. The limiting condition may be expected to arise when the interconnected unfrozen water films are disrupted; however, this would probably occur at a temperature much lower than is usually encountered in situ.

Next, hysteresis effects are neglected and the principles of the conservation of mass and energy are applied. The following stage in the modeling process is the development of the phenomenological equations for the moisture and heat fluxes in terms of the driving forces, i.e. the suction potential and the temperature gradient. Those equations may be based on the thermodynamics of irreversible processes (described in Section 4.3.4). The moisture flux equation is then substituted into the mass conservation equation to give the following mass transfer equation (in one-dimensional form):

$$\frac{\partial}{\partial z} \left(K \frac{\partial \psi}{\partial z} + K \right) - \frac{\rho_i}{\rho_w} \frac{\partial \theta_i}{\partial t} = s \frac{\partial \psi}{\partial t} \quad (1)$$

while the heat flux equation is substituted into the conservation of energy equation to give the equation for heat transfer:

$$\frac{\partial}{\partial z} \left(k \frac{\partial T}{\partial z} \right) + L \rho_i \frac{\partial \theta_i}{\partial t} - c_w \rho_w v \frac{\partial T}{\partial z} = C_s \frac{\partial T}{\partial t} \quad (2)$$

- where K = soil hydraulic conductivity
 ψ = pore water pressure or suction (cm)
 ρ_i and ρ_w = mass densities of ice and water respectively
 θ_i and θ_w = volumetric ice and water contents
 c_i and c_w = mass specific heat capacities of ice and water
 $s (= \partial \theta_w / \partial \psi)$ = specific moisture capacity
 k = soil thermal conductivity
 L = latent heat of freezing of water (cal/g)
 $v (= K \partial h / \partial z)$ = water flux in the soil
 $h (= \psi + z)$ = hydraulic head
 C_s = volumetric specific heat of the soil
 t = time
 T = absolute temperature.

Taylor and Luthin (1976) showed that these two equations may be coupled by the relationship:

$$\psi' = L' (T - T_0) / T' g$$

- where T' = absolute temperature of the soil
 T_0 = freezing temperature at $\psi = 0$
 g = gravitational acceleration
 L' = latent heat of freezing of water (erg/g)
 $T < T_0$.

giving ψ' in centimeters. Taylor and Luthin show how this equation for ψ' may be used as the criterion for deciding whether heat accumulation brings about changes in phase or temperature. As the temperature decreases, the transfer equations (eq 2 and 3) determine certain values for ψ and T . If ψ is found to be greater than ψ' , then heat losses due to conduction and convection are used to transform water to ice.

On the basis of the thermodynamics of irreversible processes, Kennedy and Lielmezs (1973) considered the mass and heat transfer of an open freezing soil-water system under two specific conditions, i.e. a fixed and a moving freezing front. In a manner similar to that shown above, they derived the two transfer equations (more generalized) but did not solve them. They noted that these equations are nonlinear and that the transfer coefficients are parameters describing the physical properties of the freezing soil-water system. The non-linearity can be removed if the system is divided into zones of constant-valued transfer coefficients. In particular, the freezing front is a boundary on either side of which the transfer coefficients vary greatly. Solution of the transfer equations is subject to simplifying boundary conditions. Figure 102 shows the situation for the fixed freezing front, whereby a steady state condition is reached after a time t_e . The moving freezing front (Fig. 103) can be considerably simplified by proper zoning of the system in terms of the value of the transfer coefficients. The expected resulting temperature distribution, in space and time, is shown for either situation.

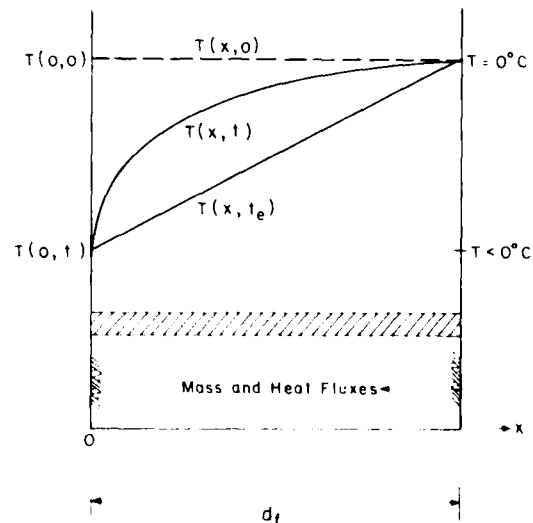

Figure 102. Freezing water-soil system with a fixed freezing front. The temperature distribution is $T(x, t)$ at time t . The condition of steady state flow is reached at time t_e and d_f is the depth of frost penetration (after Kennedy and Lielmezs 1973).

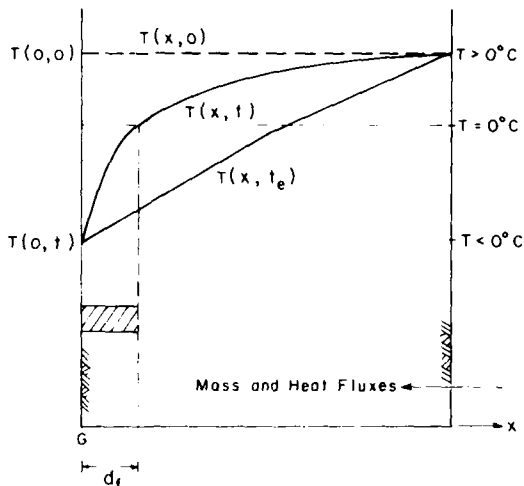

Figure 103. Freezing water-soil system with a moving freezing front. The temperature distribution is $T(x, t)$ at time t . The condition of steady state flow is reached at time t_e and d_f is the depth of frost penetration (after Kennedy and Lielmezs 1973).

None of the models mentioned in this section so far consider ice segregation and the resulting deformation of the soil. Outcalt (1976) attempted to account for this and modeled an open system near saturation. He used the soil porosity as one of the input parameters, establishing the relationship among the hydraulic head, the unsaturated hydraulic conductivity and the volumetric water content. Both the thermal and the water conductivities are functions of both the thermal and the moisture states at a point. The system is therefore both cross-coupled and strongly nonlinear. The effect of temperature disturbances on the soil-ice distribution was simulated by means of a numerical model which faithfully duplicated the range of ice distribution structures found in natural soils.

4.4.5 Changes in soil properties associated with freezing

The changes in soil thermal conductivity resulting from freezing have been described in detail in Section 4.2.2.

Freezing causes a rapid change in the physico-mechanical properties of coarse-grained soils, while those of fine-grained soils change more gradually because of two factors: the continued presence of unfrozen water below 0°C and the lower permeability of the fine-grained soils.

On freezing a fine-grained soil increases in total moisture content and porosity and decreases in unit weight. This is particularly observable in the upper strata of a glacial clay near the cooling surface. In the

lower strata, the moisture content and porosity decrease while the unit weight increases. There is, however, localized loosening due to fissures which may form in the region below the freezing front as a result of moisture extraction by the ice crystals.

After freezing, saturated soils, particularly sands, become practically impervious to water. Clays, however, do not become absolutely impervious because of the continued presence of the unfrozen water films in them.

During freezing, the ice crystals which form first are usually the ones to grow. For growth to occur, the crystals must be oriented with their base planes more or less parallel to the isothermal surface. As different crystals tend to generate simultaneously at approximately the same isothermal surface, they tend to merge, forming ice bands (Tsytovich et al. 1959). Some ice lenses may develop to considerable thicknesses, particularly if the freezing occurs slowly. Under certain conditions rhythmic ice banding occurs, a process which is analogous to the chemical process involving the formation of Liesegang rings, as described by Martin (1959) and Palmer (1967) in some detail.

4.4.6 The role of ice and water in thawing

In most cases, the thawing processes are opposite in direction to the freezing processes; some are reversible and some partly or entirely irreversible. Thawing involves migration of the thawed ice away from the thawing layer and hydration of the soil particles which have previously been desiccated by freezing (Bakulin et al. 1972).

During thawing, there is a temperature range when partial thawing of the ice occurs and when there is an abrupt rise in the temperature of frozen ground. This is followed by a narrow temperature range, slightly below 0°C , during which the basic phase transition of ice to water occurs, accompanied by a slowing down in the rate of temperature increase. A constant temperature of 0°C then becomes established, corresponding to an ice-water-vapor equilibrium.

The thawing rate of frozen soil decreases as the ice content increases. Other factors, such as the ground surface temperature and the thermal conductivity of the frozen soil, have only a small effect (Nixon and McRoberts 1973).

The size and orientation of the ice pockets have an important effect on the thawing rate. The smaller the ice pockets, the greater their specific surface area, leading to a greater heat input and quicker melting (Bakulin et al. 1973). Vertically oriented ice streaks accelerate the thawing process if, as is usually the case, the soil mineral thermal conductivity is less than that of ice. On the other hand, horizontal ice veinlets retard thawing because they take their latent heat requirement

from the heat flow. Independent of orientation, ice pockets favor heating, up to the thawing point, but delay heating when thawing starts.

During thawing, the quantity of ice in the frozen zone is independent of whether any migration is proceeding in the thawed zone or not (Tsytoich et al. 1959). Unlike freezing, migration does not influence the soil temperature regime. Also, as Nixon (1975) showed, the convective heat transfer plays a very minor role in the thawing process.

The migration and redistribution of the water after thawing depend on the type of soil. In coarse-grained soils there is little redistribution and any excess water disappears relatively quickly under the influence of hydrostatic pressure and gravitational forces. In fine-grained soils there is usually a large excess of water after thawing which causes oversaturation of the thawed layer. About 15% of this water goes to satisfy

the hydration needs of the clay minerals and associated cations (Tsytoich et al. 1959). The remainder tends to be displaced by gravitational forces. Its migration is facilitated because the thawed clay has a higher permeability than it did before freezing. The shifting of the excess water downward and to the sides can be appreciable; however, if the thawing layer is underlain by frozen soil, as may happen under natural conditions, the water cannot escape downwards.

On thawing, the soil structure is stable to a certain extent, with some compaction due to a decrease in the volume of macropores occupied by the ice inclusions. The greatest structural changes take place when thawing follows segregation freezing.

CHAPTER 5. FURTHER INFLUENCES ON THE THERMAL PROPERTIES OF SOILS

Having considered some volumetric effects and the effect of water content in Chapters 3 and 4, this chapter looks at further influences on the thermal properties of soils. In Section 5.1 the properties of the soil components themselves are described in detail, together with the effects of temperature on these properties. The soils as a whole are then considered in Section 5.2 from the point of view of the effects of temperature on their thermal and associated properties. The influence of temperature can indeed be important and is inextricable from considerations of thermal properties and behavior. Accordingly, it runs not just through this chapter but throughout this monograph. Sections 5.1 and 5.2 concentrate on some important aspects of temperature changes.

In Section 5.3 the effects of ions, salts and other solutes on the thermal properties of soils are considered. The concluding sections describe the effects of additives, hysteresis, organics, direction of heat flow and air convection.

5.1 PROPERTIES OF SOIL COMPONENTS INFLUENCING THERMAL BEHAVIOR PLUS THE EFFECT OF TEMPERATURE

Soil components consist of soil solids, water and air. This section considers their respective properties which affect the thermal behavior of soils, taking into account the influence of temperature.

5.1.1 Properties of soil solids

Surface area and its effects

"The surface of solid particles is the locus where physico-chemical reactions such as adsorption of water and of other molecules, binding of cementing substances, exchange of ions and catalytic action, may take place" (Winterkorn 1960a p. 32). The surface area of a soil depends to a great extent on its fines fraction. The clay fraction in a soil has a large specific surface area,* which may have an important influ-

*If a clay mineral is unknown, its average specific surface area may be taken to be 500 m²/g (McGaw and Tice 1976). If this value is multiplied by the clay fraction in the soil (as a proportion of unity), an estimate of the soil surface may be obtained (i.e. the surface area of coarser fractions is negligible).

ence on the thermal properties of the soil. Thus montmorillonite, which has a particularly large specific surface area, tends to have much adsorbed water that is not mobile. It also has a high adsorption capacity for certain cations, anions and organic molecules. On the other hand, kaolinite clay has a low specific surface area with little adsorbed water, so that some fluid water is likely to occur. Illite has an intermediate capacity for adsorbing water.

These properties have important implications for thermal behavior. For example, where there is much mobile water, considerable migration may occur during freezing. Also, the unfrozen water content of frozen clays has been related to parameters that depend on the specific surface area (Anderson and Tice 1972).

An important distinction has to be made concerning the surface area: Does it belong to "external surfaces" or to "internal surfaces"? Nearly all the surface area of kaolinite is exposed on external surfaces, while 80 to 90% of that of montmorillonite is exposed on internal surfaces (Anderson et al. 1974). As kaolinite has been found to retain more unfrozen water per unit of area than montmorillonite, it follows that the unfrozen water interface is thicker at a given temperature on external surfaces than on internal surfaces.

Thermal conductivity of soil solids

Inorganic soils contain solid components that are composed of various minerals whose thermal conductivity varies with temperature and also with direction of heat flow. The coarse fraction of a soil may be composed of quartz and/or other minerals such as plagioclase feldspar and pyroxene. The fine fraction may contain the clay "sheet" minerals (i.e. kaolinite, illite, montmorillonite), and/or feldspar, mica, quartz, calcite or other minerals in the clay or silt size range. The common mineral with the highest thermal conductivity is quartz so that knowledge of the quartz content is particularly important when one is attempting to evaluate more accurately the thermal properties of a soil.

Each mineral in a soil is made up of aggregates of crystals of various sizes, oriented in varying directions. There usually is some thermal resistance at the interfaces between two contacting crystals.

In crystalline, nonmetallic solids, heat transfer from hotter to colder regions was conceived by Debye as

occurring by means of thermo-elastic waves. The atoms in the crystal structure were visualized as being linked together by springs. The atoms vibrate more intensely at the hotter end and these increased vibrations are transmitted along from atom to atom. There are two kinds of waves, compressional and distortional, propagated at different speeds. There are also many simultaneous wave trains and, as each wave interacts with the atoms in its path, it loses energy and is scattered. The "mean free path" λ is defined as the distance in which the energy of the waves is reduced due to scattering by a factor of e ($= 2.718$). Debye derived the following equation for the thermal conductivity k of the crystal in terms of the mean speed v of the waves:

$$k = \frac{1}{4} v \lambda \rho c_v$$

where ρ is the density of the solid and c_v is its mass specific heat (at constant volume).

The speed v , and hence k , is greater if the forces acting between the atoms in the crystal are stronger. Quartz possesses strong bonds between the silicon and oxygen atoms in the $(\text{SiO}_4)^{-4}$ tetrahedra (Horai 1971). Hence its thermal conductivity may be expected to be relatively higher.

A quartz crystal is not isotropic; its thermal conductivity varies in different directions. The thermal conductivity parallel to the principal (optic) axis, k_{\parallel} , is greater than that perpendicular to it, k_{\perp} , as may be seen from Figure 104. The values of these two conductivities come closer together with increased temperature. The thermal conductivity k_{β} along any direction making an angle β with the principal axis is given by

$$k_{\beta} = k_{\perp} \sin^2 \beta + k_{\parallel} \cos^2 \beta.$$

The averages of $\sin^2 \beta$ and of $\cos^2 \beta$ over all directions are $2/3$ and $1/3$ respectively. This leads to an average thermal conductivity of the crystal equal to $2/3 k_{\perp} + 1/3 k_{\parallel}$, an expression representing a weighted arithmetic mean. However, as Birch and Clark (1940) noted, this average is of course not equal to the average conductivity of an aggregate made up of many crystals of various sizes that are oriented in different directions.

To calculate the mean conductivity of calcite, Eucken and Kuhn used the formula (see Van Rooyen and Winterkorn 1957)

$$k_{\text{mean}} = k_{\perp}^{2/3} \times k_{\parallel}^{1/3}$$

which is a weighted geometric mean equation giving

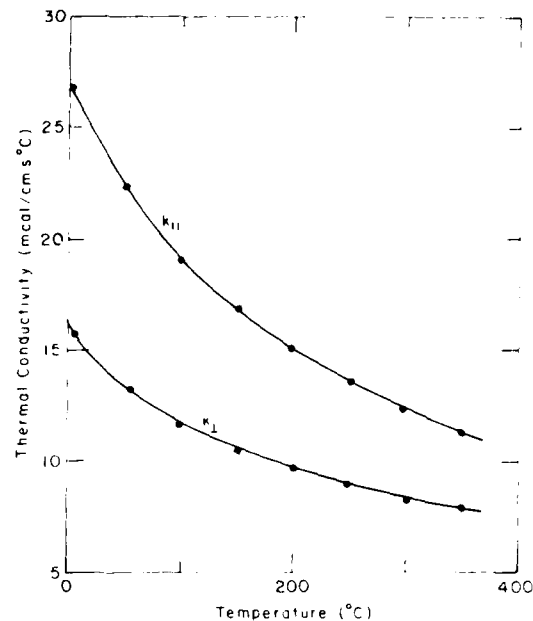

Figure 104. Dependence on temperature of the thermal conductivity of quartz single crystal—heat flow is parallel or perpendicular to the optic axis (after Birch and Clark 1940).

another approximation that may be used just as well as the arithmetic mean above. For quartz around 0°C , these two means do not differ by more than 3%. Lachenbruch (pers. comm.) used this geometric mean equation to calculate the thermal conductivity of an aggregate consisting of randomly oriented quartz crystals. It was also used by Farouki (in press) to determine the mean value at different temperatures based on the tabulated values of k_{\parallel} and k_{\perp} at those temperatures. This was in the interests of consistency since geometric mean equations were used by Woodside and Messmer (1961), Judge (1973b) and Johansen (1975) to calculate the effective thermal conductivity of soils from the conductivities of their components. Johansen, in particular, proposed the use of geometric mean equations to calculate 1) the solid particle conductivity from the conductivity of the constituent minerals, and 2) the saturated soil conductivity (frozen or unfrozen), taking into account the thermal conductivity of water and/or ice (see Section 7.11).

The thermal waves propagating in a crystal are subject to disturbances which greatly increase with temperature. Debye showed that the thermal conductivity is approximately inversely proportional to the absolute temperature. Thus the thermal conductivity of quartz and all other crystalline materials (except feldspar) decreases as the temperature increases.

Among crystalline materials, feldspar shows exceptional behavior, with its thermal conductivity increasing as the temperature increases. The reason for this behavior is not definitely known. A similar pattern is shown by the glasses, such as quartz glass or fused silica. Their thermal conductivity, like that of liquids, increases as the temperature increases. The propagation of thermal energy in glasses appears to be chiefly by an atom-to-atom exchange similar to that occurring in ordinary liquids (Birch and Clark 1940).

It is worth noting that Ratcliffe (1959) found the thermal conductivity of crystalline quartz, perpendicular to the optic axis, to be about five times that of fused quartz; k_{\perp} would therefore be nearly 10 times as great. These considerations show the importance of the crystal's atomic order in increasing the thermal conductivity. As Horai (1971) pointed out, the crystalline state greatly facilitates the propagation of the thermal waves. As silica minerals change their structure in stages from vitreous silica to crystalline quartz, the thermal conductivity increases markedly.

Impurities in crystals generally reduce the thermal conductivity because they scatter the thermal waves. Not only is the thermal conductivity reduced but also its temperature dependence. In particular, if heavier ions substitute into the crystal lattice, they will require more energy for excitation (Horai 1971) and the propagation of thermal waves through the crystal network will become less effective. On the other hand, clay minerals may absorb water molecules and fit them into their crystal structures, causing a threefold increase in thermal conductivity (Winterkorn 1960a). It is here suggested that the much lighter water molecule facilitates transmission of the thermal waves.

In many crystalline bodies there is a thin zone of disorder at the contact surfaces between neighboring crystals that leads to decreased heat transfer. Also, impurities collect at the interfaces, forming solutions that approach the properties of glasses. These solutions have a thermal conductivity which is lower than that of the pure crystal and which has a positive temperature coefficient (Winterkorn 1960a). An opposite effect results from the presence of adsorbed water films which, according to Birch and Clark (1940), maintain good thermal contact between crystals in igneous rocks.

This discussion of heat transfer within and between crystals shows the complexities existing even in simple materials such as these. Any change of order or structure can have an effect on the thermal conductivity; so consideration of heat propagation in complex minerals is fraught with difficulties. There are liable to be many variations in composition, and therefore properties, leading to differences in measured values of thermal conductivity.

There is a wide range in the thermal conductivity values of the different soil minerals. For a particular mineral, the values measured or used by different workers sometimes differ appreciably. Near the lower end of the scale, both feldspar and mica have a mean of about 2.0 W/m K around 25°C according to Horai's (1971) measurements. Sass (1965) reported values ranging from 1.6 to 2.9 W/m K for feldspars that were compositionally different. In his calculations De Vries (1952a) followed Gemant (1950) and used a value of 2.9 W/m K for feldspar and for soil solid constituents other than quartz (see Table 3).

Horai's experimental results gave mean values of 7.7, 4.4 and 3.5 W/m K for quartz, pyroxene and amphibolite respectively (all at about 25°C), but there were some significant variations around these means. De Vries (1952a) used a value for quartz of 8.7 W/m K at 20°C based on the arithmetic mean* of values of k_{\perp} and k_{\parallel} in the International Critical Tables. Later Van Wijk and De Vries (in Van Wijk 1963) suggested a slightly lower value of 8.4 W/m K at 20°C (Table 3). The measurements of Sass et al. (1971) gave a somewhat lower value of 7.2 W/m K, but this is only slightly lower than Horai's average of 7.7 W/m K.

Recently Purushothamaraj and Judge (1977) used a geometric mean equation† to infer the soil solids' thermal conductivity from the measured thermal conductivities of various soils, frozen or unfrozen. Their results gave a range of 3.2 to 9.0 W/m K for sand solids, 2.4 to 5.9 W/m K for silt solids, and 2.8 to 4.8 W/m K for clay solids, the fine-grained soils having low plasticity.

As part of his model for determining the thermal conductivity of soils, Johansen (1975) suggested the following geometric mean equation to calculate the thermal conductivity of soil solids k_s if the quartz content q (fractional) is known:

$$k_s = k_q^q k_o^{1-q} \quad (3)$$

where k_q is the thermal conductivity of quartz and k_o that of the other minerals (Section 7.11). Johansen assumed values for these, giving

$$k_s = 7.7^q 2.0^{1-q} \quad (4)$$

This equation assumes that the thermal conductivity k_o of the soil minerals other than quartz has a mean value of 2.0 W/m K, the value for feldspar or mica based on Horai's measurements. Johansen also expected the sheet clay minerals to have a similar value. However,

* $k_{\text{mean}} = \frac{2}{3} k_{\perp} + \frac{1}{3} k_{\parallel}$

† First used by Woodside and Messmer (1961).

there are indications that bentonite has a considerably lower value than kaolinite (Van Rooyen and Winterkorn 1959). If other mineral components, such as pyroxene, are present, appropriate values for k_0 should be used. For a coarse soil with a quartz content less than 20%, Johansen suggested that k_0 should be set at 3.0 W/m K.

With regard to the thermal conductivity of quartz, Johansen originally suggested the value of 7.7 W/m K at 20°C based on the measurements of Horai (1971) (used in eq 5). However, recent Norwegian measurements appear to give an appreciably higher value—around 10 W/m K (Frivik, pers. comm.). Since this is also significantly higher than the average of the results quoted in the literature, confirmation by other experimenters would appear to be necessary before such a high value could be used with complete confidence.

Soils may contain organic components which derive from the various stages of decomposition of animal and vegetable matter. Organic solids have a thermal conductivity which is about one-tenth that of mineral solids. Johansen (1975) quoted a value of 0.45 W/m K as suitable for the organic solids in peat or bog. Based on the work of Smith (1939), De Vries (1952a) used a value of 0.36 W/m K for peat. However, De Vries later suggested (in Van Wijk 1963) an even lower value of 0.25 W/m K for soil organic matter (see Table 3).

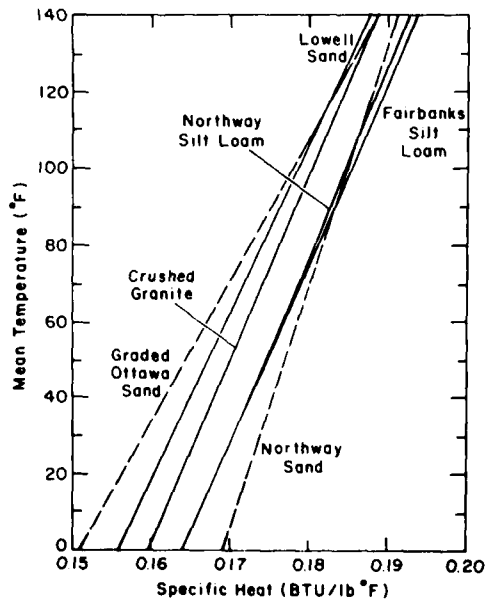

Figure 105. Variation of specific heat of dry soil with mean temperature (after Kersten 1949). For information on these soils see Appendix A.

Specific heats

The specific heats of soils decrease linearly as the temperature decreases (Fig. 105-108). The third law of thermodynamics requires that the specific heat of any material should approach zero as the temperature approaches absolute zero. Such a behavior may be seen from Figure 109, which gives data on the specific heats of rock materials in the range 20 K to 500 K. These materials include quartz and a feldspar.

Recent measurements of Haynes et al. (1980) in the range 45 to -50°C are shown in Figures 110 and 111. The lines corresponding to zero water content show an inflection point a little below 0°C. The wet materials tested by Haynes et al. showed a jump in the specific heat values in the region below 0°C. This is mainly related to the jump in the specific heat as ice turns to water.

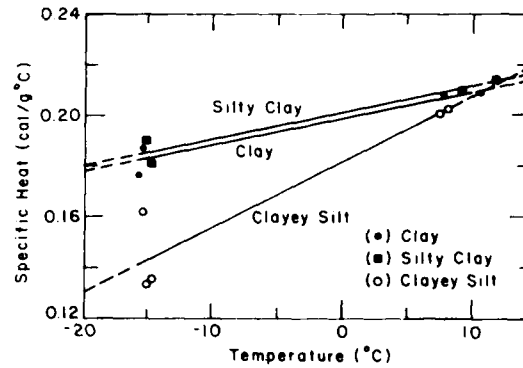

Figure 106. Variation of specific heat of fine soils with temperature (after Lovell 1957).

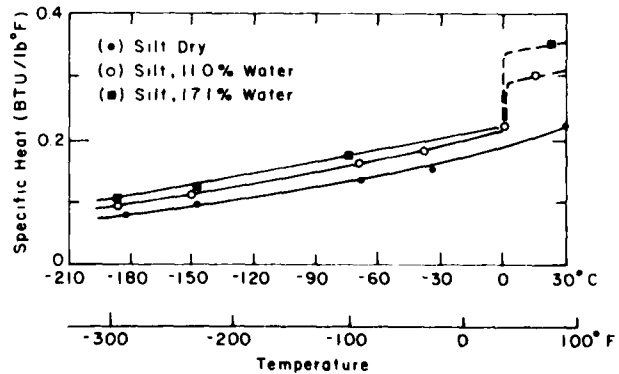

Figure 107. Specific heat of silt vs temperature (after Wolfe and Thieme 1964).

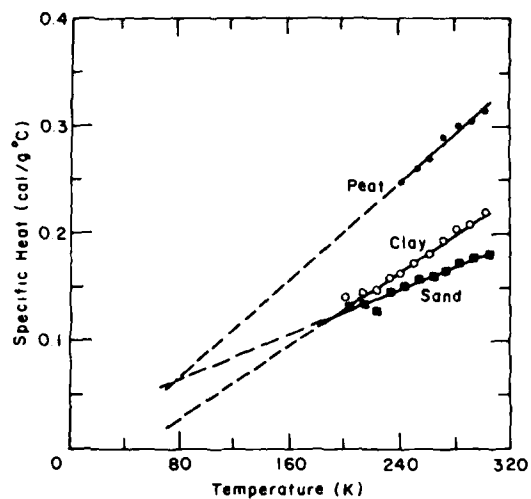

Figure 108. Specific heat of soil types as a function of temperature (after Kay and Goit 1975).

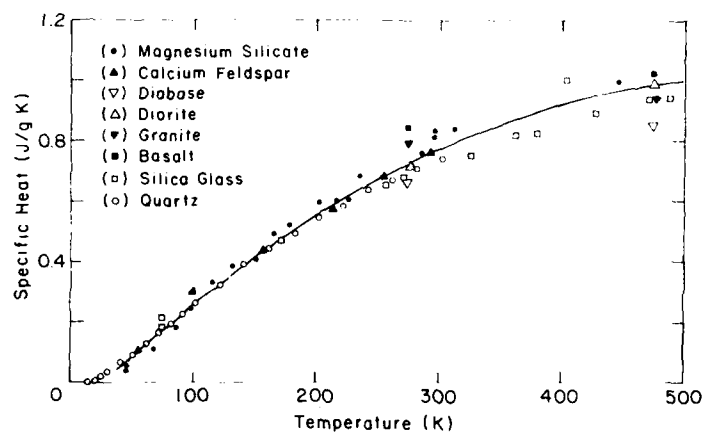

Figure 109. Variation of specific heat with temperature for several representative rock materials (after Winter and Saari 1968).

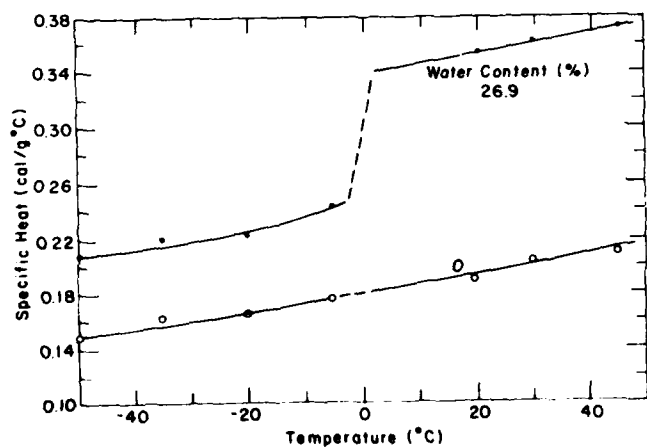

Figure 110. Specific heat of 20-30 Ottawa sand vs temperature at two water contents (after Haynes et al. 1980).

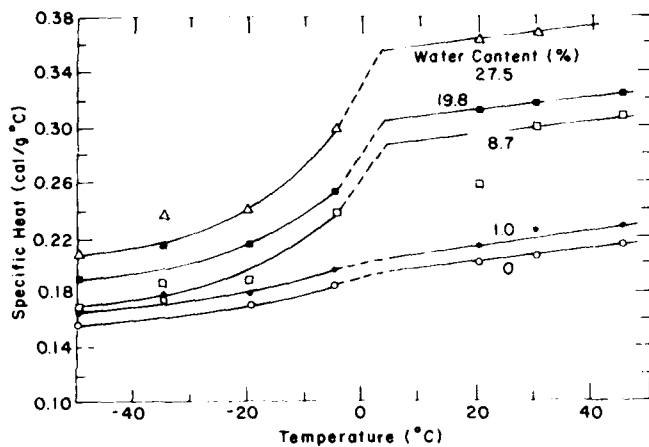

Figure 111. Specific heat of Fairbanks silt vs temperature at five water contents (after Haynes et al. 1980).

5.1.2 Properties of water

Water is a very peculiar substance. By analogy with substances of similar composition, such as hydrogen sulfide (H_2S), one would expect water to be a gas at ordinary temperatures and pressures. Yet it is a liquid under these conditions and, even as a liquid, it possesses certain solid structural properties. In particular these peculiarities of water show themselves in its interactions with dissolved ions, with nonpolar substances and with contacting surfaces, such as those of soil mineral particles (Winterkorn 1960a).

The dipole character of water molecules brings into play hydrogen bonds as the result of attractive forces between the oxygen atom of one molecule and a hydrogen atom of a neighboring water molecule. The energy in one mole of hydrogen bonds in water (i.e. 18 g of water) is about 5000 cal. If ions, molecules, or dispersed particles are introduced into liquid water, the hydrogen bond structure is disturbed and heat is liberated. This release is not dependent on the formation of a new order which may not occur. The hydrogen bonding is responsible for the unusually high values of the melting point, boiling point, dielectric constant, specific heat and viscosity of water (Low and Lovell 1959).*

Even pure water has definite structural properties and this structure is highly temperature-sensitive. Water retains the traces of its preceding state for some minutes or even hours (Nerpin 1974). This gives rise to hysteresis effects, mentioned in Section 4.1 and considered in more detail in Section 5.4.3.

Heat transfer in liquid water occurs in two ways: 1) by collisions between molecules and 2) by the mak-

ing and breaking of hydrogen bonds. The first mechanism is similar to heat conduction in gases. In the second mechanism, hydrogen bonds are broken where the temperature is higher and heat is absorbed in the process; more bonds are formed where the temperature is lower, thus releasing heat (Van Rooyen and Winterkorn 1957).

As compared with normal liquids, water and other liquids with hydrogen bonds, such as glycols and alcohols, have high thermal conductivities. It is thought that the presence of hydrogen bonding contributes to this increase in thermal conductivity (Palmer 1948).

The variation of the thermal conductivity of pure water with temperature is shown in Figure 91 and Table 12. The dissociation and association of water molecules at different temperatures is given in Table 13.

Section 4.1.3 noted that in soils the layer of water adjacent to the soil particle surfaces interacts strongly with the mineral surfaces, this interaction being especially sensitive to temperature. The adsorbed layer is highly oriented but, with an increase in temperature, the kinetic energy and dispersive properties of water molecules increase. The thickness of the adsorbed water layer therefore decreases and it fully "melts" at about 60°C (Nerpin 1974).

With decrease in temperature below 0°C the strongly adsorbed layer remains unfrozen. As Nersesova and Tsytoich (1963) stated, "All thermophysical processes in freezing and frozen soils are connected to some extent with unfrozen water and its quantitative estimation."

The structure and properties of the adsorbed layer have been described in some detail in Sections 4.1.4 and 4.1.5. In this section some points regarding the thermal properties of this layer are elaborated. With respect to the part of this layer adjacent to the solid mineral surface, i.e. zone I of Dostovalov and Lomonosov (1973), there is general agreement that it is subject

* Nersesova and Tsytoich (1963, p. 232) quote a Soviet source (Vernadskiy) as writing: "Physico-chemical properties of water molecules are absolutely exceptional among hundreds of thousands of chemical combinations known to us."

Table 12. Thermal conductivity of water at different temperatures.

| Temperature (°C) | Thermal conductivity k^* (W/m K) |
|------------------|------------------------------------|
| 30 | 0.613 |
| 20 | 0.597 |
| 15 | 0.588 |
| 10 | 0.579 |
| 5 | 0.570 |
| 0 | 0.560 |

* k values are based on the equation

$$10^6 k(\text{cgsu}) = -1390.53 + 15.1937T - 0.0190398T^2$$

(T in °K) as given by Touloukian et al. (1970).

to compression and to strong orientation forces and that it possesses a high degree of structural rigidity (e.g. see Low and Lovell 1959, Anderson 1967, Kaplan 1970).* It is quasi-crystalline and is held by the solid surface with great force, which may be tens or hundreds of atmospheres (Tyutyunov 1963). It may be suggested that these high internal forces imply strong internal bonding which would, according to Debye's concepts and equation (see Section 5.1.1), increase the speed of thermoelastic waves and therefore give rise to a high thermal conductivity, possibly even higher than that of ice.

Dostovalov and Lomonosov's concept of the "hot ice" of zone I is that its molecules, in effect, behave like atoms in a crystal lattice. They just rotate and do not possess any translational motion. Their concept of zone II (which is further away from the mineral surface than zone I) is that the water molecules are more mobile than free water molecules. Because, in addition, there is a decreased activation energy in zone II, Dostovalov and Lomonosov expected its thermal conductivity to be higher than that of ordinary water. While a definite statement cannot be made, it is suggested here that zone I may have a higher thermal conductivity than zone II.

From these considerations it is expected that the adsorbed water layer may have a higher thermal conductivity, perhaps higher than that of ice. This sup-

* Winterkorn (1960b, p. 100) stated: "The almost instantaneous establishment of a measurable electric field within a moist clay specimen upon application of a hot plate on one end and a cold plate on the other, long before establishment of a thermal gradient within the sample, points to the existence of a structure of oriented water molecules that possesses sufficient rigidity to transmit the electric disturbance caused by the temperature shock and to hold the impressed electric field."

Table 13. Dissociation and association of water (after Winterkorn 1955).

| Dissociation of water into H^+ and OH^- ions as a function of temperature | | Association of water molecules as a function of temperature (%) | | | |
|---|--|---|--------|------------|------------|
| Temperature (°C) | Concentration of H^+ and OH^- ions | Temperature (°C) | H_2O | $(H_2O)_2$ | $(H_2O)_3$ |
| 0 | 2.8×10^{-8} | Ice | 0 | 41 | 59 |
| 18 | 7.8×10^{-8} | Water at 0° | 19 | 58 | 23 |
| 25 | 1.0×10^{-7} | Water at 38° | 29 | 50 | 21 |
| 34 | 1.45×10^{-7} | Water at 98° | 36 | 51 | 13 |
| 50 | 2.3×10^{-7} | | | | |

ports the similar suggestion made in Section 4.2.2, based on data showing the decrease in the thermal conductivity of some frozen soils at lower temperatures in spite of the increase in both the ice conductivity and soil solid conductivity. This was supposed to be due to the reduction of the unfrozen water content, which appears to have a higher thermal conductivity than the ice which replaces it (or the unfrozen water may possibly produce more effective thermal contacts).

The strongly adsorbed water layer, whether it is present above 0°C or below it, is subject to strong orientation and restraint. At normal temperatures this effect manifests itself in the heat of wetting, which increases as the temperature decreases (Baver and Winterkorn 1935). This implies further restraint of the adsorbed water and less freedom of movement of its water molecules which can therefore absorb less heat so that the adsorbed layer manifests a smaller specific heat capacity at lower temperatures. Whether this behavior continues below 0°C is not definitely known but it is likely,* bearing in mind that freezing is analogous to drying (while thawing is analogous to wetting). The 'crystalline' zone I water would then be following the same trend shown by soil minerals whose specific heat decreases at lower temperatures (illustrated in Section 5.1.1†). It is also possible that, like these crystalline minerals, the thermal conductivity of the zone I water increases at lower temperatures.

Thus as the temperature decreases through, and particularly below, 0°C the thermal diffusivity of the

* According to Anderson and Morgenstern (1973), the mobility of intact water molecules becomes insignificant at -50°C.
† Also the specific heat of ice (which is much lower than that of water) decreases with temperature (Fig. 112).

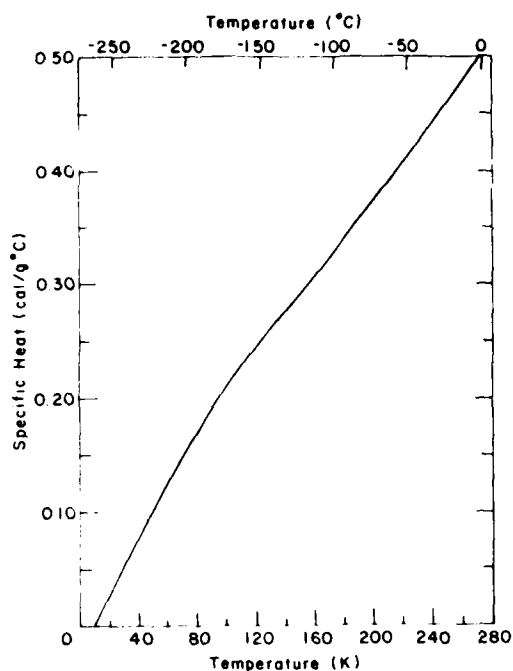

Figure 112. Specific heat of ice as a function of temperature (after Glauque and Stout 1936).

adsorbed water layer may increase due to a decrease in its specific heat and a possible increase in its thermal conductivity. While this is taking place, the amount of the adsorbed water would be slowly shrinking as the temperature keeps dropping. The overall net effect of all these changes on the thermal conductivity or diffusivity of the soil is uncertain because it depends on a combination of various factors and circumstances.

Williams (1962) suggested that the strongly adsorbed water may have a latent heat of freezing substantially lower than that of pure water. Anderson (1963) confirmed this and also showed that this difference became larger as the unfrozen water content decreased.

Some of the properties of unfrozen water in frozen soils were described in Section 4.1.5. It was seen that the relationship between unfrozen water content and temperature is multivalued because of hysteresis. It is important to assess the unfrozen water content of a fine-grained soil because, if it is taken as zero, an error of about 20% may be introduced into depth-of-frost calculations. The unfrozen water surrounding a soil particle is thickest on the warmer side and thinnest on the colder side (Anderson and Morgenstern 1973).

According to Kaplar (1970), the molecules in the thin layers of water in contact with ice have a high degree of polar orientation with the ice lattice. They thus have a fairly rigid and ordered structure, but this

is different from that of the adsorbed water on the soil particles.

Properties of ice

At low temperatures, the specific heat of ice, like that of other crystalline materials, approaches zero as the absolute temperature tends to zero (Fig. 112). As the temperature decreases below 0°C, the thermal conductivity of ice increases (Fig. 31). The equation for the solid line in Figure 31 is

$$k_i = \frac{488.19}{T} + 0.4685 \quad (5)$$

giving the thermal conductivity k_i in W/m K, in terms of the absolute temperature T .

The thermal conductivity of ice varies with direction, being about 5% greater along the crystallographic axis than normal to it (Kondrat'eva 1945).

Ice formation and its relationship with nucleating temperatures has been described by Jackson and Chalmers (1975) and Scott (1969). If ice crystals in clays are too small, they will not have the properties of pure bulk ice at atmospheric pressure. Instead, the properties of the ice will depend on the dimensions of the crystals (Low et al. 1968).

Ice occurring in natural soils is usually porous, which means it has a reduced effective thermal conductivity (Lovell and Herrin 1953, Pavlova 1970). Gold (1957) photographed air bubbles and columns in an ice lens formed in a clay-silt soil. Many small air bubbles were found by Slusarchuk and Watson (1975) in naturally occurring permafrost that contributed to a lower effective thermal conductivity. The need to study the effect of bubbles in ice has been emphasized (Permafrost Conference 1963).

5.2 EFFECTS OF TEMPERATURE ON THERMAL PROPERTIES OF SOILS

The thermal properties of soils may vary considerably with temperature. This is particularly so in a freezing soil where the transfer coefficients across the freezing front vary greatly. This variation makes it necessary to zone the freezing system so that one can assume constant values for the transfer coefficients in each zone with little error (Kennedy and Lielmezs 1973).

Even in a simple situation, such as the guarded hot plate test of a soil, its established temperature gradient implies that one is evaluating an average value of the thermal conductivity over that temperature range. In the case of a transient measurement technique, such as the probe method, variation in the temperature intro-

duces changes in the thermal properties, due, for example, to induced moisture migration.

In this section, we consider how the measured thermal properties of soils have been found to vary with temperature. Special attention is given to the effect of temperature on the properties of freezing and frozen soils. This effect, and the consequent behavior of frozen ground, is of undisputed importance (Anderson 1969).

5.2.1 Specific heat and temperature

The specific heat of dry soils has been dealt with in Section 5.1.1. Here moist soils are considered, particularly the changes in the specific heat that take place as the soil is cooled through the freezing point and below it.

In the case of a freezing soil, an additional term must be added to the expression for the volumetric heat capacity C given in Section 1.1 in order to take account of the phase change from unfrozen water to ice. For a fine-grained soil, the accompanying release of heat takes place in stages. It may be shown that (Hoekstra 1969)

$$C = C_i x_w + C_s x_s + (C_u - C_i) x_u +$$

$$\frac{1}{\Delta T} \int_T^{T+\Delta T} \Delta \bar{H}_f \frac{\delta x_u}{\delta T} dT$$

where C_u and C_i = volumetric heat capacities of the unfrozen water and ice, respectively

x_u and x_i = volume fractions of unfrozen water and ice, respectively ($x_w = x_u + x_i$)

$\Delta \bar{H}_f$ = latent heat of phase change per gram of unfrozen water

δx_u = change in unfrozen water taking place in the temperature interval δT .*

It has been mentioned in Section 4.2.2 that during the freezing of a fine-grained soil there is a gradual release of heat, the rate of which slows down at lower temperatures (Fig. 80). As shown by Low et al. (1968), immediately below the temperature at which freezing begins there is a sudden rise in the heat capacity (Fig. 113). This then falls quickly as the temperature drops further. The decrease in specific heat of some clays as the temperature continues to fall below 0°C is illus-

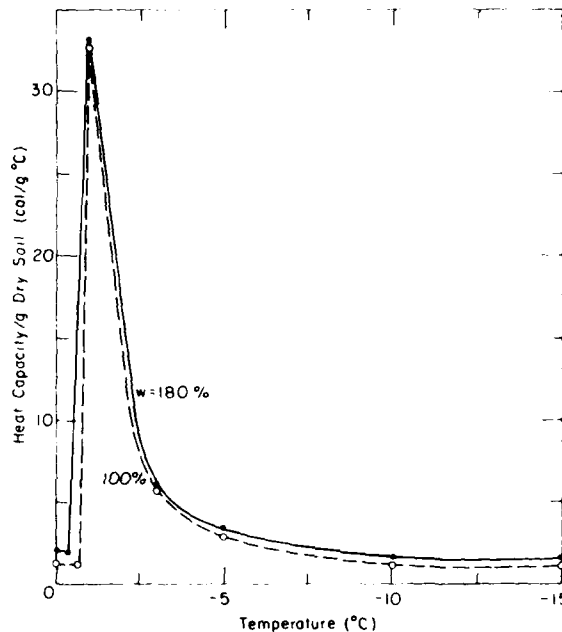

Figure 113. Relationship between heat capacity and temperature of a partially frozen Na-Wyoming bentonite (after Low et al. 1968).

trated in Figures 81 and 82. The change in specific heat for coarse soils is much more abrupt and occurs in a very narrow temperature range (virtually at 0°C for pure sand or gravel).

The specific heat of a moist soil during freezing is considerably greater than its specific heat in the unfrozen or frozen condition. The changes in specific heat through 0°C can be represented by a step function (Dempsey and Thompson 1970) or preferably by a ramp function (Merriam et al. 1975).

5.2.2 Thermal conductivity and temperature

Section 4.2.2 described the factors influencing the ratio of the thermal conductivity of frozen soil to that of unfrozen soil. Here we consider some further influences of temperature on the thermal conductivity of frozen or unfrozen soils.

Section 4.2.2 noted that below a certain critical moisture content the thermal conductivity of a freezing soil decreases as the temperature is lowered.* This behavior was attributed to the conversion of the strongly adsorbed water to ice. It was suggested that this adsorbed water had a higher thermal conductivity

* The density of unfrozen water is here assumed to be 1 g/cm³, like that of ordinary water. The heat capacity term involving air can usually be neglected.

* At a higher moisture content, this effect is masked by the large amount of ice formed and the increase in its thermal conductivity with decreasing temperatures.

Table 14. Thermal conductivity of Fairbanks silt, CRREL varved clay, and Ottawa sand (after Haynes et al. 1980).

| Dry density | | Moisture content (%) | Avg temp | | Thermal conductivity | |
|---------------------------|-------|----------------------|----------|-------|----------------------|---------------------------------|
| (g/cm ³) | (pcf) | | (°C) | (°F) | (cal/cm hr °C) | (Btu in./ft ² hr °F) |
| Fairbanks silt (ML) | | | | | | |
| 1.448* | 90.5 | 3.0 | 10.3 | 50.4 | 3.256 | 2.626 |
| | | | -9.4 | 15.1 | 3.110 | 2.508 |
| | | | -19.6 | 3.5 | 3.083 | 2.486 |
| | | | -30.0 | 21.9 | 3.034 | 2.447 |
| | | | -44.2 | -47.0 | 2.967 | 2.393 |
| 1.459* | 91.2 | 17.0 | -9.8 | 14.4 | 9.879 | 7.967 |
| | | | -20.2 | -4.6 | 9.635 | 7.770 |
| | | | -30.0 | -21.9 | 10.136 | 8.174 |
| | | | -46.6 | -51.1 | 10.301 | 8.307 |
| 1.526* | 95.4 | 25.0 | -10.3 | 13.5 | 14.953 | 12.059 |
| | | | -20.0 | -4.3 | 15.060 | 12.145 |
| | | | -29.7 | -21.3 | 15.205 | 12.262 |
| | | | -37.3 | -35.5 | 15.165 | 12.230 |
| 1.459 | 91.2 | 17.0 | -11.1 | 11.9 | 10.358 | 8.353 |
| | | | -22.6 | -9.3 | 10.643 | 8.583 |
| | | | -29.2 | -20.3 | 10.595 | 8.544 |
| CRREL varved clay (CL-ML) | | | | | | |
| 1.302 | 81.4 | 1.8 | -9.5 | 49.2 | 2.426 | 1.956 |
| | | | -9.9 | 14.1 | 2.396 | 1.932 |
| | | | -20.9 | -6.0 | 2.357 | 1.901 |
| | | | -31.1 | -24.1 | 2.316 | 1.868 |
| | | | -49.5 | -56.9 | 2.341 | 1.888 |
| 1.419 | 88.7 | 18.9 | -10.2 | 13.7 | 9.593 | 7.736 |
| | | | -20.9 | -6.0 | 9.422 | 7.598 |
| | | | -31.4 | -24.8 | 9.402 | 7.582 |
| | | | -45.2 | -48.6 | 9.513 | 7.672 |
| 1.526 | 95.4 | 25.5 | -10.6 | 12.9 | 15.874 | 12.802 |
| | | | -21.0 | -6.1 | 16.189 | 13.056 |
| | | | -30.4 | -22.8 | 16.307 | 13.151 |
| | | | -40.1 | -40.2 | 16.176 | 13.045 |
| Ottawa sand (20-30) | | | | | | |
| 1.774 | 110.9 | 0.01 | 9.4 | 49.0 | 2.932 | 2.364 |
| | | | -10.8 | 12.7 | 2.697 | 2.175 |
| | | | -20.3 | -4.9 | 2.685 | 2.165 |
| | | | -30.8 | -23.5 | 2.634 | 2.124 |
| | | | -46.9 | -51.8 | 2.541 | 2.049 |
| 1.602 | 100.1 | 8.8 | -20.9 | -5.9 | 12.577 | 10.143 |
| | | | -30.9 | -23.7 | 11.326 | 9.134 |
| | | | -42.0 | -43.3 | 11.904 | 9.600 |

* These tests were performed using two identical samples according to ASTM. All remaining tests were performed using a standard gum rubber (NBS calibrated) sample as the top sample.

than ice and further considerations given in Section 5.1.2 tend to support this view. So, when some of the adsorbed water converts to ice there may be a reduction in the effective thermal conductivity of the soil. Moreover the adsorbed water provides a continuous interconnected film in the soil and may provide strategic thermal bridges which can be impaired if some of the adsorbed water is replaced by ice.

These considerations are supported by the recent data of Haynes et al. (1980), some of which are given in Table 14. They show that Fairbanks silt and CRREL varved clay have a definite reduction in thermal conductivity with decreasing temperature, down to about -30°C. At lower temperatures, however, the thermal conductivity starts to increase, especially with the higher moisture contents. This behavior corresponds to that previously

noted in Section 4.2.2. If the moisture content is high, there is much ice formed and, as the temperature decreases, the increase in the thermal conductivity of this ice overrides any reduction in the soil's thermal conductivity due to lost unfrozen (strongly adsorbed) water.

Table 14 shows that the thermal conductivity of Ottawa sand also decreases with temperature almost continuously down to -46.9°C (with one exception between -30.9 and -42.0°C). Section 4.2.2 noted that Sawada's (1977) data on a fine sand showed similar behavior. This pattern occurred in spite of the fact that the thermal conductivity of the soil minerals and ice both increase as the temperature decreases. This behavior was attributed to loss of bridge water in a small region below 0°C . At still lower temperatures, however, the reason for these sands' peculiar behavior is open to conjecture because they are not supposed to possess any unfrozen water. To account for the continued decrease in the thermal conductivity, one must assume that the thermal bonds between the components are weakening. Whether this occurs by conversion to ice of some tenacious, still-unfrozen water, however small in amount, or by some other mechanism, remains to be elucidated.

Turning now to very high temperatures, Flynn and Watson (1969) tested some dry soil samples at temperatures up to 1600°C (in connection with the possibility of very hot material reentering the atmosphere from space and burying itself in soil). The data showed an increase in thermal conductivity with increasing temperature as illustrated for Ottawa sand in Figure 114. The thermal conductivity of the sand solids (i.e.

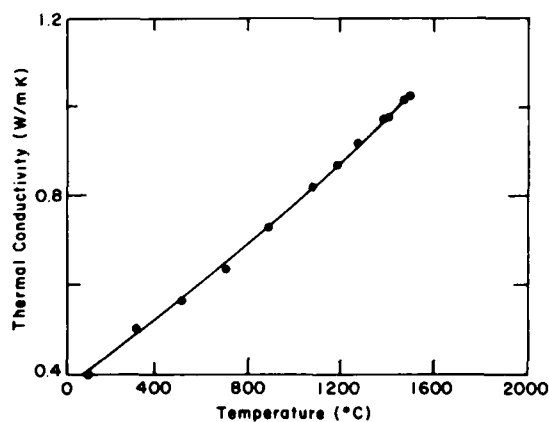

Figure 114. Temperature dependence of measured values for the thermal conductivity of Ottawa sand. These values are compared with a curve representing a cubic equation of the temperature. The density of the sand is $1.76 \times 10^3 \text{ kg/m}^3$ (after Flynn and Watson 1969).

quartz) decreases as the temperature increases, so this behavior indicates that some interfacial effects must come into play, leading to increased heat transfer. While actual sintering did not generally occur there must have been some surface bonding.

Van Rooyen and Winterkorn (1957) pointed out that burning a refractory material increases its thermal conductivity considerably. Chemical and crystallographic changes take place as well as sintering. The surface area per unit volume is reduced which, together with the improvement in the interfacial conductivity, leads to an increase in effective thermal conductivity.

5.2.3 Thermal diffusivity and temperature

Thermal diffusivity, the quotient of the thermal conductivity and the volumetric heat capacity, will vary when either of these properties varies with temperature. For soils with high moisture contents, the diffusivity of the frozen soil is considerably higher than that of the same soil unfrozen. Kersten (1952) stated that at 15% moisture content, for example, the thermal diffusivity of the frozen soil may be 50% greater.

Figure 115 shows the trend in the thermal diffusivity of a clayey sand as a function of temperature. The sharp increase in specific heat at a little below 0°C is reflected in a sharp drop in the thermal diffusivity in this range. The latent heat of phase change, which causes this behavior, can be accommodated in a variable diffusivity term that is dependent on temperature (Anderson and Morgenstern 1973). However, for simplicity it is often assumed that the thermal diffusivity jumps abruptly from one constant value to another at the freezing point of water. Nakano and Brown (1972),

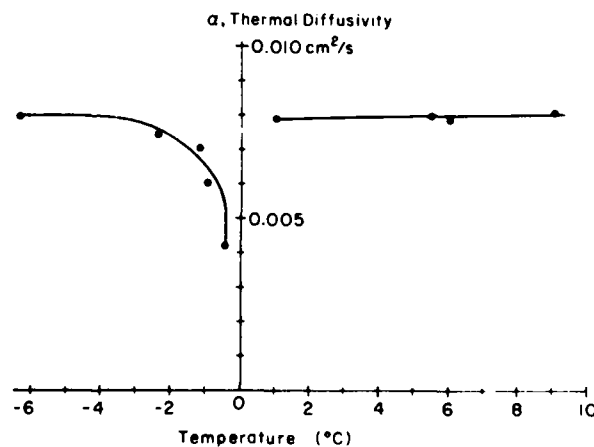

Figure 115. Thermal diffusivity of a clayey sand as a function of temperature (after Hoekstra et al. 1973).

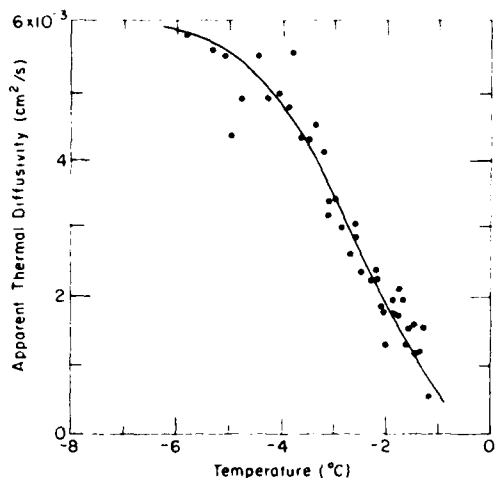

Figure 116. Apparent thermal diffusivity of permafrost (organic silt) at Barrow, Alaska (summer 1971). The data apply to a depth of 60 cm (after McGaw et al. 1978).

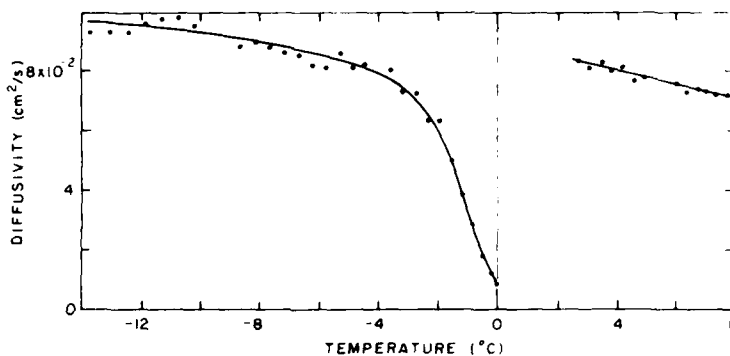

Figure 117. Thermal diffusivity of a kaolinite suspension as a function of temperature (after Hoekstra 1969).

for instance, assumed such a step function in their model of the thermal regime of tundra soils.

The data of Haynes et al. (1980) for a sand, a silt and a clay generally show an increase in the thermal diffusivity as the temperature decreases from -5 to -50°C . A much stronger temperature dependence was established by McGaw et al. (1978) for permafrost whose diffusivity increased about six-fold in the -1 to -6°C range (Fig. 116). They attributed this mainly to

the considerable changes in the unfrozen water content.

It is of interest to note the variation with temperature of the thermal diffusivity of a kaolinite suspension (Fig. 117). The shape of the curve representing the diffusivity of this frozen suspension is similar to one representing the permafrost diffusivity (Fig. 116) but the diffusivity values for the suspension are about 10 times greater than the permafrost data. Research on these aspects may be fruitful.

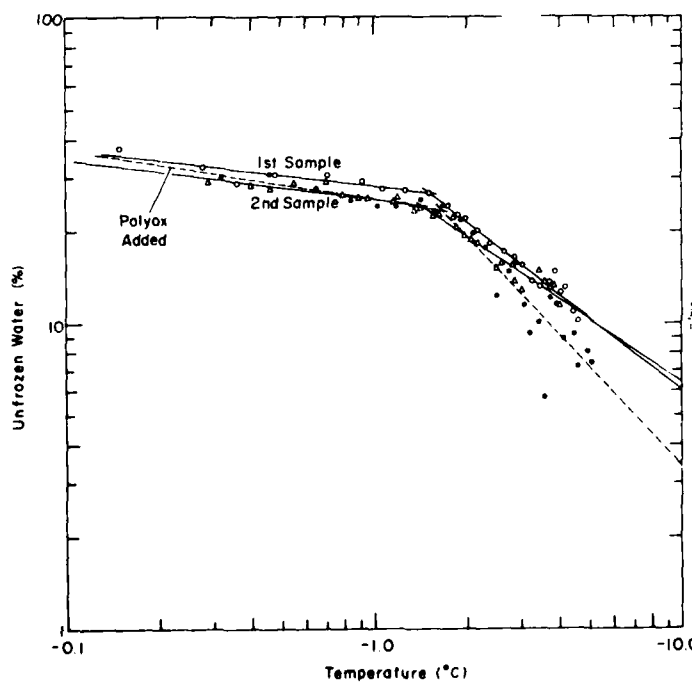

Figure 118. Unfrozen water content vs temperature for the kaolinite-water system (after Anderson et al. 1974).

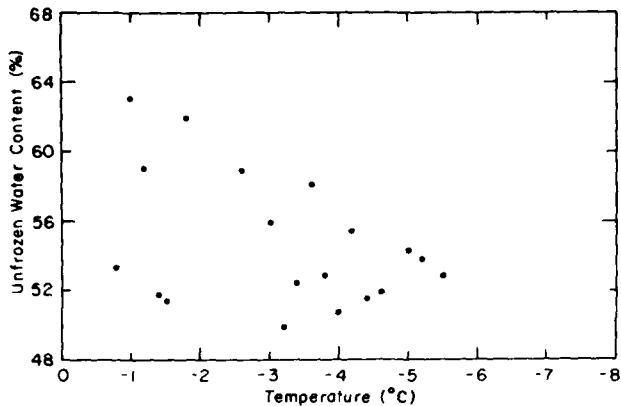

Figure 119. Unfrozen water content of organic soils at different temperatures (after Nakano and Brown 1972).

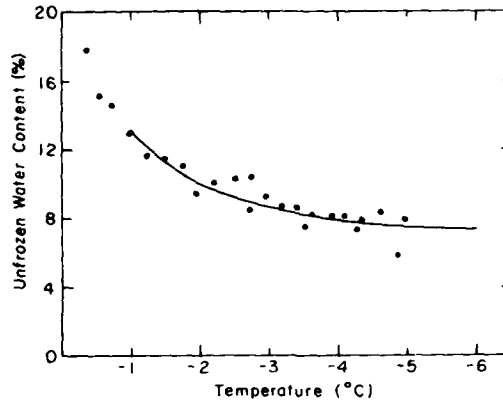

Figure 120. Unfrozen water content of mineral soils at different temperatures (after Nakano and Brown 1972).

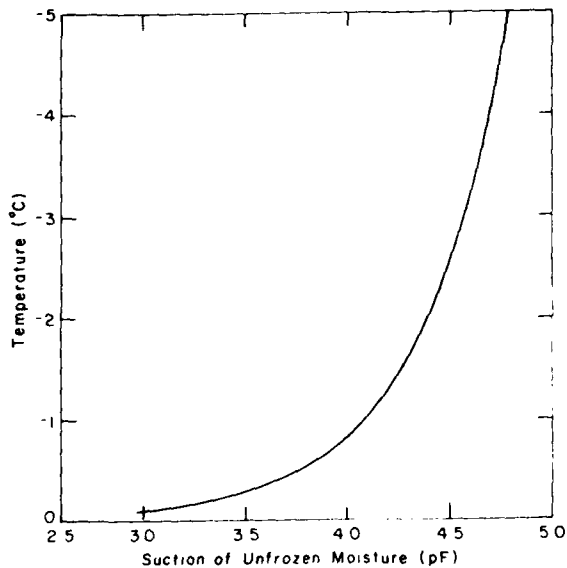

Figure 121. Relation between temperature below the freezing point and suction in soil (after Croney and Jacobs 1967).

5.2.4 Unfrozen water and temperature

The data of Anderson et al. (1974) on unfrozen water in kaolinite showed the existence of two domains in some clay-water systems, suggested by the discontinuity at -1.5°C (Fig. 118). These domains have different water contents and therefore different nucleating temperatures. The existence of a third distinctly different domain was suggested by further data and even more domains may exist.

Measurements of the unfrozen water content in organic soils were considerably scattered and varied at the same temperature (Fig. 119) when compared with

mineral soils (Fig. 120). This behavior was attributed to the heterogeneity of organic soil (Nakano and Brown 1972).

The freezing process is analogous to the drying process (Section 4.4.1). As the moisture content in an unfrozen soil decreases by drying, the suction of the soil increases. Typical relationships between suction and moisture content are shown in Figure 50. In a similar manner, when a soil freezes, the water left unfrozen will have a certain suction that depends on the amount of water and therefore on the temperature. A typical curve relating this suction to the temperature is shown in Figure 121.* Using a figure like this, the amount of unfrozen water at a certain temperature may be estimated by first determining the suction corresponding to this negative temperature and then finding the moisture content corresponding to this suction from the drying curve for this soil at ordinary temperatures (such as in Fig. 50). This moisture content is then taken as equal to the unfrozen moisture content.

5.3 EFFECTS OF IONS, SALTS AND OTHER SOLUTES ON SOIL THERMAL PROPERTIES

Solutes of one type or another are always present in the soil water. Exchangeable cations are associated with the interface between the surface of a soil particle and the adjacent water. They continuously enter into or come out of the soil's exchange complex. Salts produce both cations and anions in the water and various impurities may also be present.

* Some theoretical and experimental relationships between suction and temperature below 0°C are described by Williams (1963).

The ions and other solutes present in soils may have various direct or indirect influences on the thermal properties of the soils. The chief effects, discussed in this section, are on the structure of water, on the development and growth of ice in frozen soils, on unfrozen water, and on the structure formed by clay particles or aggregates. The resulting changes imply changes in the soil thermal properties which may be considerable.

5.3.1 Effects on soil water or ice

Cations present in the diffuse double layer of a soil particle disrupt the water structure and break hydrogen bonds. The water dipoles orient themselves around the cations, giving a closer packing than in free normal water. These dipoles have less freedom of movement; therefore they are capable of absorbing less thermal energy. This implies that their heat capacity is lowered, a fact evidenced by the heat of hydration which forms part of the heat of wetting (see Section 4.1.4). Thus assuming that the thermal conductivity of the double layer remains constant, the reduction in specific heat should contribute to an increase in the thermal diffusivity. While the amount of this affected layer may be relatively small, its influence as a thermal link between particles may be great, especially at a low moisture content.

The type of cation controls the degree of orientation of the water molecules and the thicknesses of the water layers. In montmorillonite, sodium ions give very thick water layers whereas with potassium there is little adsorption; bivalent calcium and magnesium ions give thin layers (Linell and Kaplar 1959). Anions too may have an influence on water dipole orientation but, as they are spread over the middle region of the adsorbed layer rather than near the interfaces (Section 4.1.4), their effect may be less concentrated.

It is well known that the addition of a nonvolatile solute lowers the freezing point of water.

With regard to ice formation, some foreign particles may effectively cause ice nucleation while others may not (Jackson and Chalmers 1957). Growing ice crystals tend to reject solutes. Solutes and ions thus rejected gather in the unfrozen interfacial water where they are concentrated and mixed with the exchange ions (Anderson and Morgenstern 1973). Salt concentration in the boundary zone of ice crystals retards crystal growth and causes diffusion of salts away from the crystal. Greater salinity in the water increases the number of crystals but the average crystal size is smaller and there is less variation in crystal dimensions (Golubev and Lomonosov 1973). Penner (1963a) noted that aqueous organic solutions are more effective retarders of ice growth than inorganic solutions. Ice surface energy can be changed by adding a salt to the freezing water (Tyutyunov 1963).

5.3.2 Thermal properties of water solutions and soil suspensions

The thermal conductivity of water does not change much with the addition of soluble salts (Hutt and Berg 1960). Sea water has a thermal conductivity only a few percent less than that of pure water. On the other hand, experiments have shown that just 1 g of bentonite dispersed in 1 L of water reduced the latter's thermal conductivity by one half (Highway Research Board 1961). It appears strange that such a large reduction is brought about by so small an amount of bentonite, which has a thermal conductivity somewhat greater than that of water. The explanation seems to lie in structural effects caused by the bentonite particles. According to Winterkorn (pers. comm.) these particles change the water structure and form a honeycomb system containing "fluid cells." Heat causes the water in each of these cells to swirl around faster and faster, rather than to translate randomly. Heat transfer across the suspension is thereby limited and there is in effect an increase in the heat capacity. When water is heated it has a tendency to organize its movement within such fluid cells* so that this behavior would be helped by the bentonite particle structure. The ideal structure that tends to form consists of dodecahedron-like water cells whose walls are made up of flat clay particles (Vees and Winterkorn 1967).

Using a thermal probe, Caron measured thermal conductivities of clay suspensions that were about one-tenth that of pure water (Highway Research Board 1961). One suspension contained 10 g of bentonite in 1 L of water, while another had 75 g of Provins clay in 1 L of water. His use of a transient method of measurement may be significant since the thermal diffusivity is particularly important in this method.

The nature of the ions present and their concentration determine the arrangement of the clay particles and accordingly the formation of fluid cells. As discussed in the next section, either a flocculated or dispersed clay structure may result under various circumstances. A dispersed structure is capable of a much more orderly arrangement than a flocculated structure (Winterkorn, pers. comm.). This is evident from Pusch's (1973a) data on the microstructure of clays formed under saline or nonsaline conditions. With the help of photomicrographs from ultrathin sections representing two-dimensional vertical sections through the clay matrix, Pusch determined the total pore area P as a percentage of the total area A of the micrograph. As may be seen from Figure 122, not only is P/A much higher for the clays of high salinity (marine and brackish water), but there also is greater uniformity in the

* This phenomenon has been called "self-organization out of disorder" (German Research Service 1978).

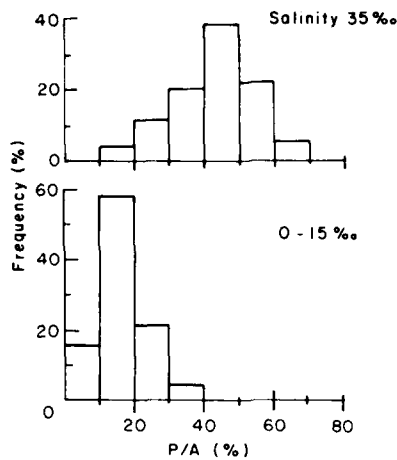

Figure 122. Effect of salinity on the magnitude of the ratio of pore area P to total area A in a clay (after Pusch 1973a).

pore dimensions in the case of the low salinity fresh-water clays.

5.3.3 Effect of ions and salts on soil structure and thermal properties

Ions and salts have greater influence on fine-grained soils because these soils have high specific surface areas.

The bonds provided by the exchange cations may make a contribution to the strength of a clay (e.g. see Scott 1963). These bonds may also be expected to influence heat transfer from particle to particle. Significant changes in this heat transfer may result from any physico-chemical changes occurring at the particle surfaces where two particles contact, or in the region between these surfaces where the particles approach each other. The response to temperature changes would therefore alter.

Clay plates nearly always form aggregates of closely located particles. These aggregates are connected by links or bridges of particles which are the weakest part of the particle network. In a flocculated marine clay there are large, dense aggregates of particles with large voids between the aggregates. The same structure may also form in brackish water. In fresh water, on the other hand, a dispersed structure is formed, with small, more porous aggregates that are uniformly dispersed with small voids between (Fig. 123). Whereas salt-rich clays generally show a random distribution of clay particles, salt-free clays show some evidence of preferred orientation and form domains with some order (Pusch 1973b).

Section 5.1 noted that better order leads to improved heat transfer properties. The more ordered structure which a dispersed clay can attain, although it is on a higher level (i.e. more macroscopic), may therefore result in a larger thermal conductivity than that of a flocculated clay.

The importance of the flocculated structure in influencing the thermal properties of clay soils, particularly in the saturated state, is shown by Penner's (1962) data on Leda clay (a marine clay). In the air-dry state, measured values of thermal conductivity were appreciably greater than calculated values (Fig. 124). Penner's data on the saturated state were somewhat lower than even the calculated values based on a rather low solids thermal conductivity. The formation of the above-mentioned fluid cells may play a part in this relative reduction of thermal conductivity. In the air-dry state, of course, no such mechanism can come into play.

Increased concentration of cations leads to increased flocculation. A possible explanation is that the cation increase reduces the repulsive force between clay particles by reducing the zeta potential and the range of the double layer.

The flocculating effect of cations on clays increases



Figure 123. Clay microstructure as observed in a transmission electron microscope using ultrathin acrylate-treated specimens. Left pictures show schematic, generalized patterns; dark parts represent mineral substance (from Andersland and Anderson 1978).

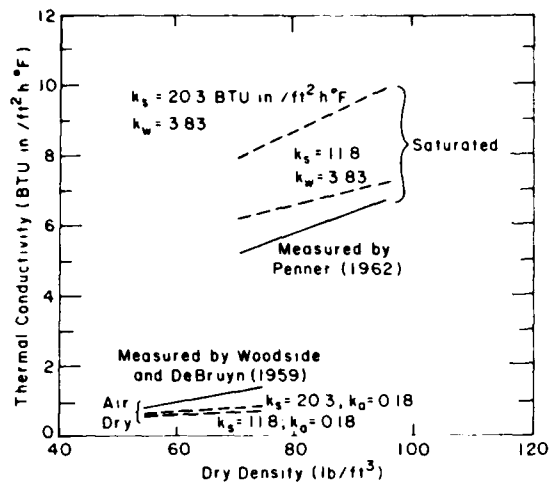

Figure 124. Measured and calculated thermal conductivity values for air-dry and for saturated Leda clay. The values of k_s , k_w and k_a assumed in the calculations are indicated next to the dashed lines (after Penner 1962).

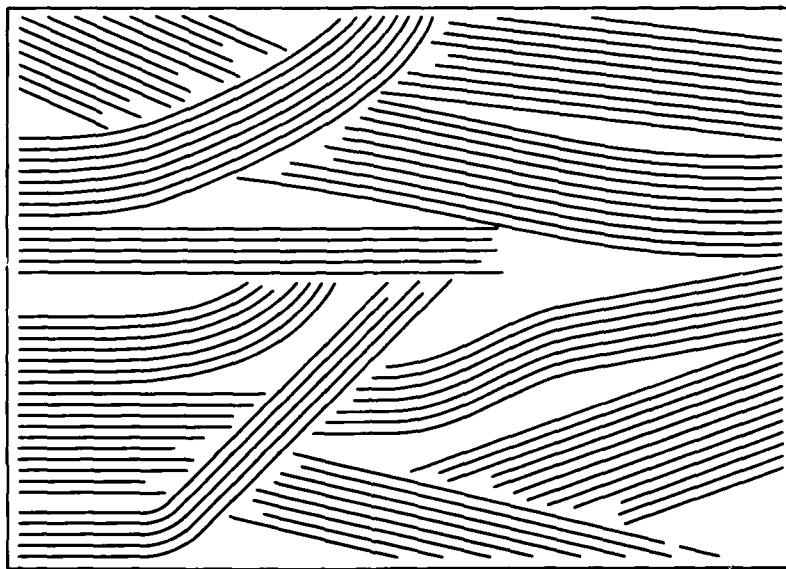

Figure 125. Structure of Wyoming bentonite (a montmorillonite) (from Anderson and Hoekstra 1965).

with increasing valence, but the dispersive effect increases with decreasing valence and size of the cation (with the exception of the hydrogen ion) (Reno and Winterkorn 1967). Thus sodium ion produces more of a dispersed structure than, say, the calcium ion. The influence of the degree of dispersion on the attainable order is shown by the different fabrics of sodium and calcium montmorillonite. Whereas in sodium montmorillonite the aggregates contain parallel sheets and form an interwoven network with a general overall alignment, the aggregates in calcium montmorillonite are arranged more irregularly (Pusch 1973b). According to Anderson and Hoekstra (1965), pure montmorillonite in the form of Wyoming bentonite has the structural pattern shown in Figure 125.

The influence of the type of exchange ion on the thermal conductivity of kaolinite clay was shown in an experimental study by Reno and Winterkorn (1967). Up to a certain water content, the sodium ion modification had higher thermal conductivity values than either the calcium or aluminum kaolinite at the same water content and porosity (Fig. 126). They supposed that the dispersive structure and high degree of orientation of the sodium clay favored heat conduction at low porosities and water contents. However, at high porosities and water contents, the dispersed clay particles tended to become isolated from each other. At these higher water contents the more flocculated structure of the calcium and aluminum modifications would therefore be likely to maintain more particle-to-

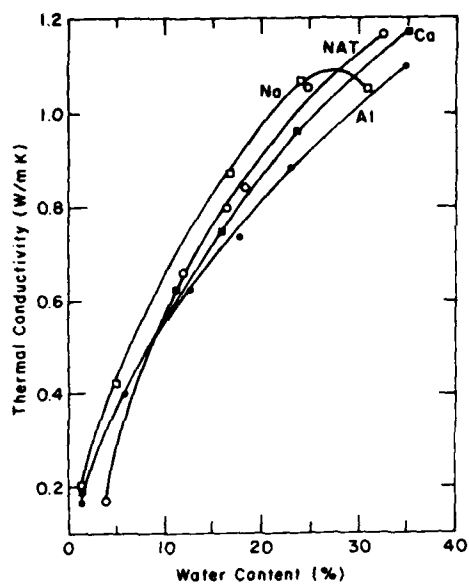

Figure 126. Thermal conductivity vs water content for natural kaolinite (NAT) and its sodium (Na), calcium (Ca) and aluminum (Al) homo-ionic modifications. The porosity is constant at 57.5% (after Reno and Winterkorn 1967).

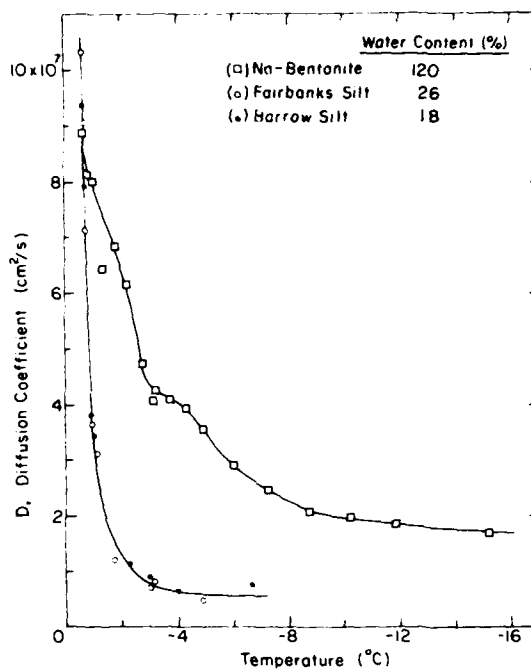

Figure 127. Sodium ion diffusion coefficient for frozen Wyoming bentonite, Fairbanks silt and Barrow silt as influenced by temperature (after Murrmann 1973).

particle contacts, possibly giving a higher effective thermal conductivity.

High temperatures may cause marked dispersion or flocculation effects, depending on the type of the clay mineral and the nature of the exchange ion (Winterkorn and Fang 1972).

During freezing salts can cause intense particle aggregation, an important effect on a soil's structural properties (Tsytoich et al. 1973). Multivalent cations intensify this effect, just as these cations give increased clay flocculation above 0°C. Pavlova (1970) found that salts in peat soils led to increased aggregation of the peat particles on freezing. The salts also caused a greater intensity of phase transformations, with a reduction in the active soil surface and the associated amount of unfrozen water.

In unfrozen soils it is known that the swelling properties and the heat of wetting are related to the nature of the exchange cations. Generally, the swelling increases as the valence decreases, but geometrical effects may come into the picture.* Similarly, for fro-

zen soils the amount of unfrozen water increases as the valence decreases (Neresova and Tsytoich 1963). For sodium and calcium montmorillonite this effect extends down to -6°C, below which the type of cation makes little difference (Fig. 44).

The salt content of the pore water has an effect on the amount of unfrozen water present (Neresova and Tsytoich 1963, Penner 1970). When this quantity is determined by the liquid-limit method, a correction is required where soluble salts are present (Tice et al. 1976). Salts also play a part in depressing the freezing point of soil water (Williams 1964), so that there is an increased amount of interfacial water, allowing increased mobility of ions (Murrmann 1973). The diffusion coefficient of sodium ions at negative temperatures is shown in Figure 127.

The chemical potential of a particle surface is determined by the chemical potential of the ions forming it (Section 4.4.1). With increasing cation valence, the associated surfaces are characterized by a larger surface energy. As a result clays with a calcium ion, for example, undergo more water migration during freezing than those with a sodium ion. The multivalent cation leads to increased frost susceptibility and heaving (Tsytoich 1975). Salinization of soils with chlorides having univalent cations completely eliminates migration

* Grim (1958) supposed that sodium, for instance, favors the development of thick layers of oriented water because of the way the sodium ion fits into the geometry of the water net.

of water toward the freezing front and frost heaving, even when free water influx is possible.

When fine-grained soils freeze, more ice is formed as the temperature decreases. This leads to an increase in the concentration of ions in the boundary phase (i.e. the adsorbed unfrozen water) and a consequent intensification of exchange reactions involving the cations (Tsytoich et al. 1959). During the thawing process as well, exchange cations show their important influence. Their nature affects the rehydration of the mineral particles and aggregates.

Apart from the influences mentioned above, ions may have a more direct effect by going into solid solution in the mineral particle. Such ions, which substitute in a crystal lattice, lead to decreased thermal conductivity because they act as scattering centers (Kingery 1959). The low thermal conductivities of certain shales were attributed by Judge and Beck (1973) to the presence of potassium ions in the lattice of clay minerals.

5.3.4 Organic matter and soil structure

Microorganisms can cause aggregation of clay particles, with some of the organic matter enclosed within and some attached outside the aggregates. The strength of the coupling between the organisms and the clay particles varies according to the type of microorganisms (Pusch 1973a).

Decayed organic matter produces humus which interacts with the clay particles in various ways, leading to dispersion or aggregation, depending on the chemical composition of the environment. Humus has large organic molecules which distort the organization of the adsorbed water. These molecules can then more easily approach the clay mineral surface. If the humus does not exceed about 6% by weight of dry soil, structures similar to those shown in Figure 123 may result. Pusch (1973a) also states that if the organic matter is less than about 2% by weight, it will generally be confined to the local pore regions. When it is higher than 6%, it may form almost continuous systems of integrated clay-organic material.

5.4 EFFECTS OF ADDITIVES

Additives are used with soil materials in various ways and for several purposes. Different substances may be added to a natural soil to waterproof it, to reduce its frost heave, or to act as binders to improve its thermal conductivity (Section 5.4.1). In road pavements, portland cement or asphalt is added to coarse granular materials, giving ordinary concrete or bituminous concrete. In each case mentioned, the additive alters the thermal properties.

Portland cement or bituminous binder (i.e. tar or asphalt) can considerably reduce or even prevent the frost heave of noncohesive soils containing appreciable quantities of fines (Croney and Jacobs 1967). The cement reduces permeability and may also prevent the formation of small ice lenses by imparting tensile strength to the soil.

Adding sodium chloride or calcium chloride to quartz sand allows the sand to retain more moisture during drying. This factor, together with the interparticle binding effect, gave a thermal conductivity in the nearly dry state higher than that of the salt-free sand (Van Rooyen and Winterkorn 1959). These salts caused no noticeable thermal effect at high moisture contents but the addition of portland cement to the sand increased its thermal conductivity in both the moist and dry states.

Depending upon the aggregate type, the moisture content, and the density, the thermal conductivity of portland cement concrete varies considerably (Table 15). It also increases as the temperature decreases from 75°F to 0°F, a trend which was confirmed by McGaw (1977b), who found an increase from 1.06 W/m K at 10°C to 1.49 W/m K at -4°C for air-dry portland cement concrete used as a surface course in a pavement (Table 16).*

Bituminous concrete exhibits less variation in thermal conductivity than portland cement concrete. Values that have been used for the thermal conductivity of dry bituminous concrete cover the range 1.21 to 1.42 W/m K (Moulton and Dubbe 1968b). The dependence of this conductivity on the proportion of bitumen was represented by the empirical equation

$$\log k_m = x_b \log k_b + (1 - x_b) \log k_s$$

where k_m , k_b and k_s are the respective thermal conductivities of the dry mixture, the bitumen and the solid aggregate, while x_b is the fraction of bitumen by volume (Saal 1950). Even small amounts of bitumen had a significant influence on the thermal conductivity of the mix.

Van Rooyen and Winterkorn (1959) found that adding asphalt to quartz sand increased the thermal conductivity at low moisture contents. The conductivity decreased at higher moisture contents and also tended to decrease as the percentage of asphalt increased (up to 2% was added).

As with portland cement concrete, the effect of a temperature drop through 0°C is to appreciably increase the thermal conductivity of air-dry bituminous concrete (Table 16). Values for the thermal properties of a dry

* Unlike uncemented natural soils (at low moisture contents). See Sections 4.2.2 and 5.2.2.

Table 15. Thermal conductivity of concrete (after Moulton and Dubbe 1968b).

| Moisture condition at test | Water content (% oven-dry wt.) | Density at test (lb/ft ³) | Thermal conductivity at indicated temp. (Btu/ft hr °F) | |
|-----------------------------------|--------------------------------|---------------------------------------|--|-------|
| | | | 0 °F | 75 °F |
| Crushed marble concrete | | | | |
| Moist | 5.2 | 152 | 1.33 | 1.25 |
| 50% rel. humidity | 2.3 | 148 | 1.33 | 1.25 |
| Oven-dry | 0.0 | 143 | 1.08 | 1.00 |
| Crushed sandstone concrete | | | | |
| Moist | 11.7 | 133 | 1.92 | 1.67 |
| 50% rel. humidity | 3.1 | 124 | 1.17 | 1.25 |
| Oven-dry | 0.0 | 120 | 0.83 | 0.83 |
| Crushed limestone concrete | | | | |
| Moist | 9.8 | 141 | 1.33 | 1.25 |
| 50% rel. humidity | 1.9 | 130 | 1.00 | 0.92 |
| Oven-dry | 0.0 | 126 | 0.92 | 0.83 |

Table 16. Thermal conductivity of processed material (after McGaw 1977).

| Material | Nominal temperature (°C) | Thermal conductivity (W/m K) |
|---|--------------------------|------------------------------|
| Portland cement concrete (Surface course and Air-dry) | 10 | 1.07 |
| | 4.5 | 1.23 |
| | -4 | 1.49 |
| Bituminous concrete (Base course and Air-dry) | 10 | 0.92 |
| | 4.5 | 1.03 |
| | -4 | 1.12 |
| Bituminous concrete (Surface course and Air-dry) | 10 | 0.92 |
| | 4.5 | 1.09 |
| | -4 | 1.24 |

Table 17. Recommended thermal properties for dry asphaltic pavement (after Kavianipour and Beck 1977).

| | Temperature | |
|-------------------------------------|-----------------------|-----------------------|
| | 255 K (0 °F) | 311 K (100 °F) |
| α (m ² /s) | 1.44×10^{-6} | 1.15×10^{-6} |
| α (ft ² /hr) | 0.056 | 0.045 |
| k (W/m K) | 2.88 | 2.28 |
| k (Btu/ft hr °F) | 1.66 | 1.31 |
| ρc_p (J/m ³ K) | 2.00×10^6 | 1.97×10^6 |
| ρc_p (Btu/ft ³ °F) | 29.8 | 29.4 |

α = thermal diffusivity; k = thermal conductivity; ρc_p = volumetric specific heat.

asphaltic pavement are given in Table 17 as recommended by Kavianipour and Beck (1977). However, the values of conductivity and diffusivity in this table are considerably higher* than those used by some other investigators, but it does give an idea of the change in these thermal properties with temperature.

5.5 HYSTERESIS AND HISTORY

"Many soils exhibit hysteresis which is, in a systems sense, memory of past states of the system" (Guymon and Luthin 1974, p. 996). Some hysteresis effects have already been mentioned in previous sections. These include the freeze-thaw cycle followed by the unfrozen moisture content's relationship with temperature, and the drying-wetting cycle followed by the suction-water content relationship, i.e. the soil water characteristic. It has been pointed out that the cycle of freezing-thawing below 0°C is analogous to the cycle of drying-wetting above 0°C (see Section 4.4).

The state of water in a soil going from wet to dry is different from the state of water in the soil going from dry to wet. These differences have been emphasized by De Vries (1974) who noted that the liquid distribution inside the soil pore system, even with a rigid matrix, is not a unique distribution for a given moisture content. It depends on the history of wetting and drying, which therefore gives rise to hysteresis effects.†

Because of hysteresis effects soils may show markedly different properties at the same water content, depending on whether this content is reached by wetting or by drying (Winterkorn 1961). Experiments have shown that the thermal conductivity of a soil depends on whether the particular moisture content is achieved by wetting or drying (Farouki 1966). The greatest difference occurred in the nearly dry state. When this was produced by drying, the thermal conductivity was much higher (Fig. 56). The drying process sets up oriented water films to their fullest extent thereby making heat transfer more effective.

In addition to the freeze-thaw cycle causing hysteresis in the unfrozen water content, there is a similar effect on the specific heat function (Fig. 40). Connected with these is the effect the freeze-thaw cycle had on the apparent spacing in the lattice of sodium-bentonite as determined by Anderson and Hoekstra

* By a factor of almost two.

† Miller (1963, p. 194) pointed out that "by a suitable sequence of wetting and drying operations, one may produce a soil with water content and suction values that will plot at any point between the two limiting curves for drying and wetting" represented by the soil water characteristic.

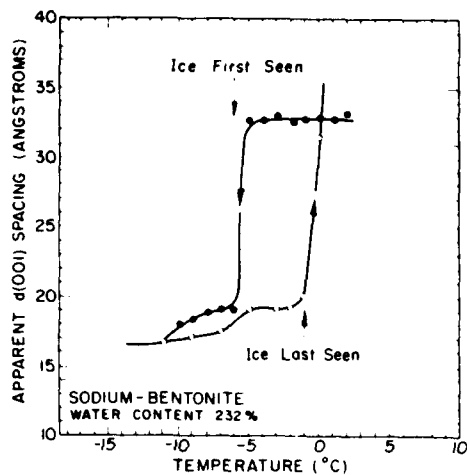

Figure 128. Lattice collapse and reexpansion of sodium-bentonite during a freeze-thaw cycle (from Anderson and Hoekstra 1965).

(1965). The resulting lattice collapse and reexpansion is shown in Figure 128. During the collapse (from about 33 to 19 Å), unfrozen water is expelled from the interlamellar space but is later taken back with increased temperature.

The history and treatment of a soil (or soil sample) is quite important. The cultivation method used has a big influence on the thermal conditions of farm soil (Eggelsmann 1972). Secondary structure formation in fine-grained soils is a significant effect which reflects the history of the system. The behavior and effects of exchange cations are also influenced by the history. Near the end of the drying process exchange ions require time for shedding their hydration hull and returning to their places within the mineral surface (Winterkorn 1961). The return to these locations in the surface layer of the crystal lattice may be impeded by occupying water molecules (Winterkorn 1958b). Also the extent to which different exchange ions influence clay structure formation and properties depends considerably on the soil history (Veas and Winterkorn 1967).

5.6 ORGANIC FACTORS

The relationship between the thermal conductivity of peat and its water or ice content has been described in detail in Section 4.2.3. The influence of organic matter on soil structure was noted in Section 5.3.4. In this section some other aspects of organic soils or soils containing organics are considered, aspects which are important to the thermal properties of these soils.

The water retention characteristics of organic soils

Table 18. Assumed thermal properties of tundra soils (after Nakano and Brown 1972).

| Soil | Thermal conductivity (Kcal/m hr °C) | Thermal diffusivity (m ² /hr) | Dry density (g/cm ³) | Total water content (%) |
|----------|-------------------------------------|--|----------------------------------|-------------------------|
| Organic | | | | |
| Frozen | 0.10 | 1.67 × 10 ⁻⁴ | 0.450 | 220 |
| Unfrozen | 0.25 | 2.50 × 10 ⁻⁴ | 0.450 | 220 |
| Mineral | | | | |
| Frozen | 0.90 | 1.50 × 10 ⁻³ | 1.200 | 60 |
| Unfrozen | 0.77 | 1.34 × 10 ⁻³ | 1.200 | 60 |

have been described by Plamondon et al. (1972) and Kay et al. (1975). Some of the moisture in organic materials is bound in the cell membranes (Cammerer 1939). The effect of moisture on the thermal conductivity of organic materials increases strongly as the dry density decreases.

In modeling the thermal regime in Alaskan tundra soils, Nakano and Brown (1972) assumed that intensive evaporative heat transfer occurred in the wet organic layer at the surface during the summer. Because these conditions cannot be duplicated in a laboratory test, this test would give a different thermal conductivity value. The thermal properties they assumed for the frozen and unfrozen organic soils are given in Table 18. They postulated that the effective thermal conductivity of the unfrozen organic soils was greater than that of the frozen organic soils. This situation is the reverse of that which usually applies for mineral soils.

McGaw (1974) measured the thermal conductivities of two organic lake sediments containing 4-7% by weight of solids. One type contained fibrous organic material and gave a thermal conductivity about 2% higher than that of pure water. The other type contained an organic gel which decreased the thermal conductivity below that of water by a few percent. This behavior was attributed to the formation of an aqueous structure induced by the gel. According to McGaw a similar trend had been reported by others with regard to inorganic gels. Such a trend agrees with the reduction in thermal conductivity caused by bentonite in water suspensions described in Section 5.3.2.

Soil colloids react with organic matter (Van Rooyen and Winterkorn 1959). The organic content of a mineral soil may have a considerable influence on its frost behavior (Linell and Kaplar 1959). Colloidal organic materials tend to increase the frost susceptibility of fine-grained soils. Montmorillonite clay adsorbs certain organic molecules, especially those with high polarity. Its power to adsorb and immobilize water is

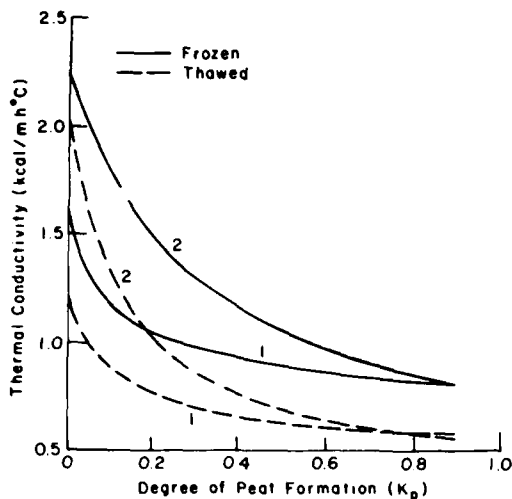

Figure 129. Thermal conductivity vs degree of peat formation K_p for clayey silts with sand (curves 1) and for sands (curves 2) in the thawed and frozen states (after Kudryavtsev et al. 1974).

thereby reduced, with the result that the frost potential of the material increases. On the other hand, fibrous peat fines caused a reduction in the rate of frost heave of fine-grained soils attributed to a reduction in permeability (Linell and Kaplar 1959). The only exception occurred at very low concentrations (0.1% and less) of peat fines in the marine clay tested.

The presence of peat in a mineral soil reduces its thermal conductivity and diffusivity in both the frozen and unfrozen states. Kudryavtsev et al. (1974) quote the following equations for the thermal conductivity in terms of the degree of peat formation K_p defined as the ratio of the weight of peat to that of the mineral components present in unit volume. For sands containing peat

$$k_U = 1.97 - \ln \left(\frac{K_p}{0.225K_p + 0.08} + 1 \right)$$

$$k_F = 2.35 - \ln \left(\frac{K_p}{0.15K_p + 0.11} + 1 \right)$$

while for clayey silt with some sand and containing peat

$$k_U = 1.15 - \ln \left(\frac{K_p}{1.02K_p + 0.21} + 1 \right)$$

$$k_F = 1.50 - \ln \left(\frac{K_p}{0.74K_p + 0.20} + 1 \right)$$

where k_U and k_F are the thermal conductivities of the unfrozen and frozen soils, respectively. These equations

are represented in Figure 129, from which one can see that when K_p is in the region of 0.6 to 0.7, the thermal conductivity of the combination (sand-peat or clay-peat) becomes practically equal to that of peat.

5.7 DIRECTION OF HEAT FLOW

The thermal conductivity of a soil may depend on the direction of heat flow. This may be related to structural effects, such as those in mica, giving rise to a thermal conductivity along the planes of cleavage about 10 times as great as that across these planes (Goldsmid and Bowley 1960). Other clay minerals may show similar differences.

When clay platelets group together under different environmental conditions, their different structure produces different thermal conductivities which vary in each case with the direction of heat flow. Penner (1963b) observed this behavior, finding that the ratio of horizontal to vertical conductivity varied from 1.05 for Leda clay (a marine clay) to 1.70 for a freshwater clay. This effect was attributed to particle alignment, there being a preferred orientation of particles in the clay mass during sedimentation.

Where moisture movement occurs due to a temperature gradient, the direction of heat flow may be of considerable importance. This was shown by Woodside and Cliffe (1959) who tested moist Ottawa sand with heat flowing either up or down (Fig. 130). The upward thermal conductivity was considerably greater than the downward value. They attributed this to gravity, which helped the capillary forces return liquid

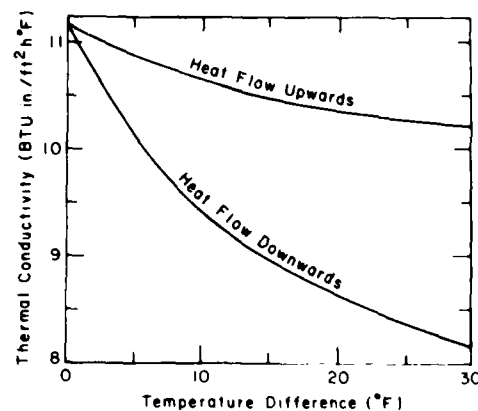

Figure 130. Thermal conductivity of Ottawa sand vs applied temperature difference. Each curve applies to heat flow upwards or downwards at a mean temperature of 74.5°F. The moisture content of the sand is 4% and its dry density is 102 lb/ft³ (after Woodside and Cliffe 1959).

moisture from the top to the hot region in the former case but not in the latter. However, Winterkorn (1960b) emphasized the importance of the contribution from water movement in the vapor phase as part of an evaporation-condensation mechanism. Such a mechanism would be more effective in the upward direction because of the lightness of the water molecule by comparison with nitrogen or oxygen molecules present in air.

De Vries (1958) noted that under certain situations the heat flux in porous media is no longer strictly proportional to the temperature difference. Such situations arise when the applied temperature gradient is vertical or when the moisture flux, consisting of liquid or vapor flux, is not zero.

5.8 CONVECTIONAL EFFECTS

Kudryavtsev et al. (1974) described how air convection can play a considerable role in the temperature regime of soils or porous rocks. Fluctuations of air temperatures and pressures cause a constant, and some-

times intense, exchange of gases with the atmosphere. Cold atmospheric air displaces the warmer and lighter air from the pores of the soils or from the cavities of the rocks and cools them. This process repeats itself.

Convective heat transfer is also considered to be very important where air moves in rockfill dams. Mukhetdinov (1969) mathematically analyzed the problem of air movement in the downstream shoulder of such a dam. Heat transfer by conduction in the air was disregarded because it was small compared to the convective heat transfer. The air, of course, carried water vapor with it and its movement had to be described in at least two dimensions. The result of the analysis was a determination of the temperature field in the downstream shoulder.

This problem of air movement in rockfill dams or soils appears to be similar to air flow in snow which is naturally compacted or unconsolidated. Yen (1965) determined the heat transfer characteristics of air flowing through snow, obtaining relationships between the effective thermal conductivity and the mass flow rate of dry air. Snow density had an effect for the naturally compacted snow but not for unconsolidated snow.

CHAPTER 6. MEASUREMENT OF THERMAL PROPERTIES OF SOILS

This chapter describes the methods that may be used to measure the thermal properties of soils in the laboratory or in situ. The properties we are concerned with are the thermal conductivity and the thermal diffusivity, these being interrelated by means of the volumetric heat capacity. The thermal conductivity governs the steady state condition of the soil, while the thermal diffusivity applies to the case where the temperature varies with time.

To measure the thermal conductivity it is necessary to set up a temperature gradient across the soil sample being tested, and this may induce appreciable moisture migration in unsaturated soils. Thus the particular measurement method may actually change the property it is attempting to measure. The extent of migration which may occur in soils under test is shown by Table 19 (based on the data of Smith 1939). While some moisture migration may also occur in situ, it is likely to be less than in the laboratory because of the generally smaller temperature gradients existing in situ. There may be a critical temperature gradient below which excessive migration does not occur.

Sections 6.1 and 6.2 describe the two main test methods, i.e. steady state or transient tests. Data from the guarded hot plate test (steady state) and the probe method (transient) are compared in Section 6.3.

6.1 STEADY STATE METHODS

In steady state methods, the sample or soil portion being tested should be in a steady state when the measurements are made. Attainment of such a state may

sometimes take considerable time after the initial temperature difference has been applied.

6.1.1 The guarded hot plate test

The most important steady state method for measuring the thermal conductivity of soils is the guarded hot plate (GHP) test, which has been standardized by the American Society for Testing and Materials (1963).

The apparatus used at CRREL (Fig. 131) conforms to the ASTM specifications. It is a 20-in. GHP apparatus capable of measurements in the range -50°F to $+250^{\circ}\text{F}$. Two identical test specimens are placed above and below a flat-plate main heater unit which is surrounded by an outer guard heater. The guard eliminates horizontal heat losses and causes heat from the main heater to flow vertically up or down through the test specimens. Liquid-cooled heat sinks are placed adjacent to the outer surfaces of the specimens. A certain temperature drop of ΔT is thereby obtained across each specimen of thickness Δx . The thermal conductivity of the specimen material is calculated from the equation

$$k = \frac{Q \Delta x}{A \Delta T}$$

where Q is the time rate of heat flow and A is the test area of the specimen.

While GHP test results obtained by different workers on the same material can vary by as much as 20% (Jackson et al. 1977; these authors quote R.P. Tye as making this point), the GHP method is generally regarded as accurate. However, it is usually quite time consuming and suitable only for laboratory use. Due

Table 19. Distribution of moisture in originally homogeneous soil after determination of thermal conductivity by a stationary method (after Van Wijk 1964, based on Smith 1939).

Different homogeneous moisture contents at the beginning.

| Position of subsample | Water content (g water/g soil) | Thermal gradient ($^{\circ}\text{C}/\text{cm}$) | Water content (g water/g soil) | Thermal gradient ($^{\circ}\text{C}/\text{cm}$) | Water content (g water/g soil) | Thermal gradient ($^{\circ}\text{C}/\text{cm}$) | Water content (g water/g soil) | Thermal gradient ($^{\circ}\text{C}/\text{cm}$) |
|-----------------------|--------------------------------|---|--------------------------------|---|--------------------------------|---|--------------------------------|---|
| Warm side | 0.0821 | | 0.0808 | | 0.121 | | 0.757 | |
| Center | 0.0918 | 10.6 | 0.192 | 10.1 | 0.624 | 8.8 | 0.996 | 3.6 |
| Cool side | 0.3772 | | 0.669 | | 0.894 | | 1.10 | |
| Warm side | 0.0029 | | 0.0040 | | 0.0105 | | 0.0533 | |
| Center | 0.0030 | 3.8 | 0.0053 | 3.7 | 0.0366 | 3.4 | 0.0545 | 1.9 |
| Cool side | 0.0034 | | 0.0279 | | 0.0443 | | 0.0674 | |

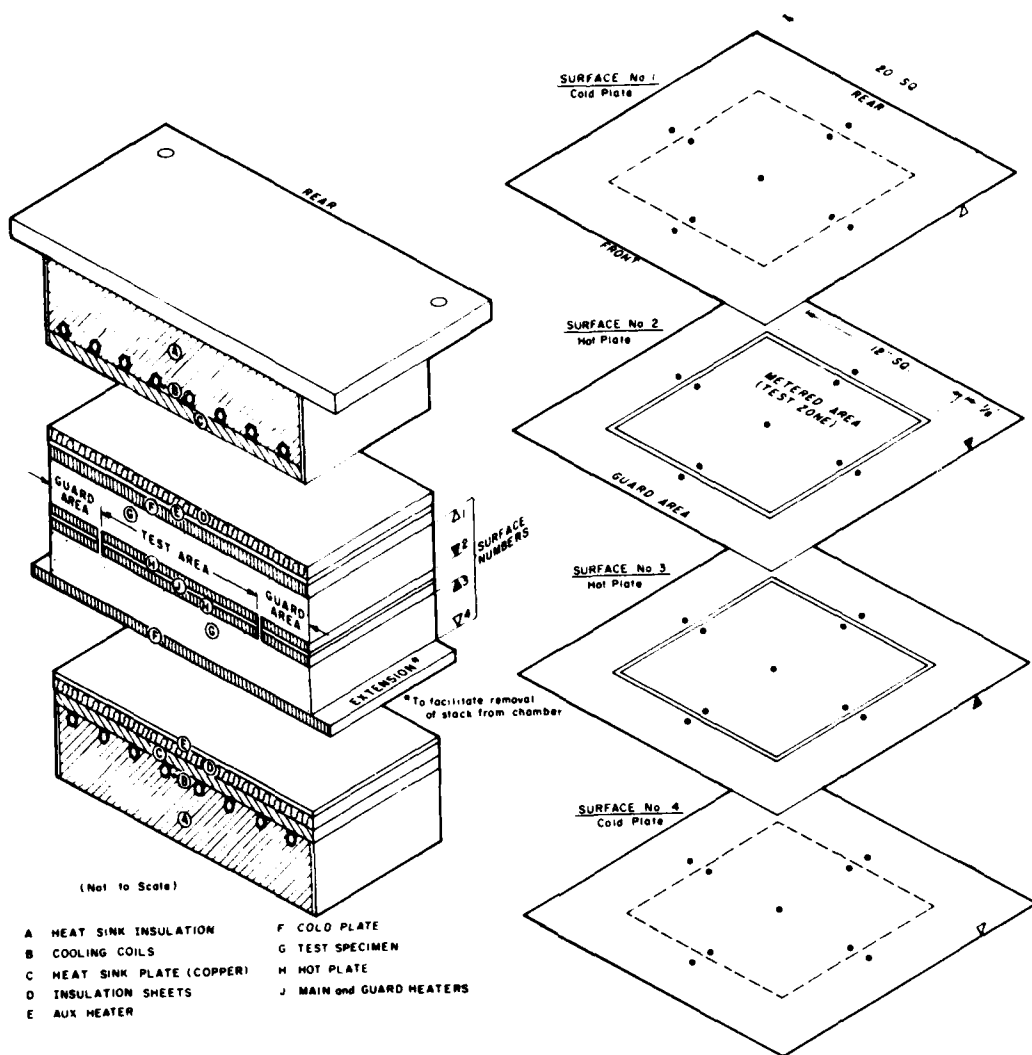

a. Stack assembly cross section.

b. Thermocouple locations in plate surfaces.

Figure 131. CRREL guarded hot plate apparatus (from Kaplar 1971).

to the considerable time required to achieve the steady state and the relatively high temperature differential that needs to be applied, appreciable moisture migration may take place in unsaturated soils (e.g. see Hutcheon and Paxton 1952). As pointed out by De Vries (1963) the resulting measured value of the thermal conductivity would be lower than the value corresponding to the average moisture content.

Another disadvantage of the GHP apparatus results from gravity effects which are consequent to vertical heat flow. The importance of such effects was recognized by Woodside and Cliffe (1959) and shown by their experimental results on moist Ottawa sand (Fig. 130). The thermal conductivity is appreciably greater with the heat flow upwards than with heat flow down-

ward (see Section 5.7). This difference increases as the applied temperature differential increases. Similar results were obtained by Van Pelt (1976) on dry gravel and on dry crushed stone. From Table 20 it may be seen that, with one exception, the thermal conductivity was appreciably greater for the upward flow direction in the GHP.

6.1.2 Cylindrical configuration

Cylindrical arrangements for the steady state test have been used by various experimenters. Kersten (1949) tested soil samples in a cylindrical arrangement as shown in Figure 132. The main heater is in the center and is guarded by upper and lower heaters. The soil specimen is placed in the surrounding annular space.

Table 20. Thermal conductivity results of six stone aggregate samples (after Van Pelt 1976).

| Material | Dry density (lb/ft ³) | Void ratio | Specific gravity | Heat flow direction | ΔT (°F) | Avg. mean test temp. (°F) | Q_s sample heat flow (Btu/hr ft ²) | k (Btu in./ft ² hr °F) |
|-------------------------|-----------------------------------|------------|------------------|---------------------|-----------------|---------------------------|--|-------------------------------------|
| 3/8-in. gravel | 104.8 | 0.63 | 2.73 | Down | 9.5 | 55.9 | 3.75 | 2.617 |
| | | | | Down | 24.6 | 61.5 | 9.96 | 2.670 |
| | | | | Down | 49.0 | 75.6 | 20.49 | 2.755 |
| | 105.3 | 0.62 | 2.73 | Up | 10.9 | 54.6 | 4.63 | 2.894 |
| | | | | Up | 27.0 | 63.8 | 11.91 | 2.880 |
| | | | | Up | 49.1 | 74.9 | 21.29 | 2.843 |
| 3/8-in. crushed stone | 106.0 | 0.73 | 2.94 | Down | 10.5 | 54.8 | 3.27 | 2.071 |
| | | | | Down | 49.1 | 75.4 | 16.83 | 2.270 |
| | | | | Up | 9.4 | 54.2 | 3.36 | 2.369 |
| | 106.0 | 0.73 | 2.94 | Up | 24.3 | 61.6 | 8.94 | 2.437 |
| | | | | Up | 50.4 | 75.0 | 18.05 | 2.374 |
| | | | | Up | 50.4 | 75.0 | 18.05 | 2.374 |
| 1/2-in. gravel | 103.4 | 0.70 | 2.77 | Down | 9.7 | 54.1 | 4.60 | 2.789 |
| | | | | Down | 50.8 | 74.6 | 22.87 | 2.836 |
| | | | | Up | 9.7 | 54.5 | 4.96 | 3.115 |
| | 103.2 | 0.68 | 2.77 | Up | 25.6 | 62.3 | 12.09 | 2.981 |
| | | | | Up | 51.4 | 73.9 | 23.52 | 2.886 |
| | | | | Up | 51.4 | 73.9 | 23.52 | 2.886 |
| 1/2-in. crushed stone | 105.6 | 0.71 | 2.89 | Down | 10.0 | 54.5 | 3.51 | 2.212 |
| | | | | Down | 47.8 | 73.4 | 20.16 | 2.644 |
| | | | | Up | 11.6 | 55.4 | 5.31 | 2.848 |
| | 105.6 | 0.71 | 2.89 | Up | 25.6 | 62.2 | 10.91 | 2.673 |
| | | | | Up | 49.9 | 74.0 | 20.60 | 2.591 |
| | | | | Up | 49.9 | 74.0 | 20.60 | 2.591 |
| 1 1/2-in. gravel | 105.9 | 0.60 | 2.71 | Down | 10.4 | 53.5 | 5.22 | 3.210 |
| | | | | Down | 47.6 | 73.9 | 24.48 | 3.290 |
| | | | | Up | 11.3 | 53.9 | 6.44 | 3.599 |
| | 106.6 | 0.59 | 2.71 | Up | 25.0 | 61.5 | 14.03 | 3.564 |
| | | | | Up | 48.9 | 74.6 | 26.52 | 3.447 |
| | | | | Up | 48.9 | 74.6 | 26.52 | 3.447 |
| 1 1/2-in. crushed stone | 102.6 | 0.77 | 2.91 | Down | 10.3 | 54.3 | 4.21 | 2.586 |
| | | | | Down | 49.9 | 75.0 | 21.65 | 2.742 |
| | | | | Up | 10.7 | 54.8 | 4.37 | 2.558 |
| | 103.3 | 0.76 | 2.91 | Up | 25.4 | 63.5 | 10.14 | 2.511 |
| | | | | Up | 49.1 | 74.1 | 19.58 | 2.505 |
| | | | | Up | 49.1 | 74.1 | 19.58 | 2.505 |

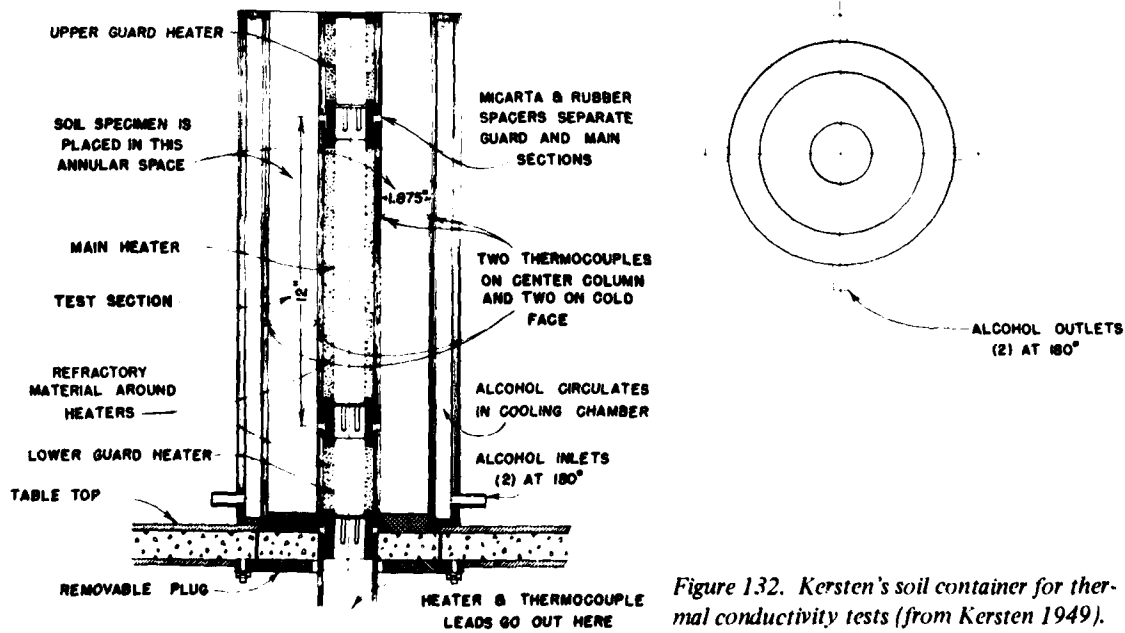

Figure 132. Kersten's soil container for thermal conductivity tests (from Kersten 1949).

The heat flows radially outward across the soil and towards the cooling chamber through which alcohol is circulated at the required temperature. A similar setup was used by Wolfe and Thieme (1964) for measuring thermal conductivity down to temperatures as low as -180°C . Another cylindrical arrangement was used by Flynn and Watson (1969) for testing soils at high temperatures (up to 1700°C).

6.1.3 In situ sphere method

In this method a spherical heater is used for in situ measurement of thermal conductivity. The method was originally developed in England by the National Physical Laboratory and the Electrical Research Association in application to underground power cables (Mochlinks 1964). The sphere may be hollow or solid and it may be copper or aluminum. Its outside diameter could be 3 or 4 in. and it should be inserted into the soil with as little disturbance as possible. This may be difficult and a soil borer with the same diameter as the sphere should be used prior to its insertion.

Assuming that the depth at which the measurement is taken is large compared with the sphere radius (which is usually the case) the thermal conductivity of the surrounding soil, after a steady state has been attained, is given by

$$k = \frac{Q}{4\pi r(T_1 - T_2)}$$

where r = sphere radius

Q = rate of heat supply to the sphere

T_2 = temperature of the heat sink

T_1 = temperature of the external surface of the sphere after a steady state has been attained, which may take 5 to 10 days (Mochlinski 1964).

In place of a sphere, a cylinder heater may be used, but such a shape has troublesome end effects and its theory is approximate (Orchard et al. 1960).

6.1.4 Heat meter

The thermal conductivity of soil in situ may be determined directly by measuring the temperatures at two points in the soil and the heat flowing between these points with the aid of a heat meter (Scott 1964).

Van Wijk and Bruijn (1964) measured the thermal conductivity of a soil in situ by applying at the surface a heat impulse of known intensity. The resulting temperature increase in a shallow layer was measured. The applied heat flux density was measured by a heat flux plate consisting of a thin slice of suitable material (of known thermal conductivity) with thermocouples at both faces. The temperature difference between

these faces, when multiplied by the thermal conductivity of the plate, gives the heat flux per unit area across the plate.

A detailed exposition of the use and theory of heat flux meters (HFM) has been given by Schwerdtfeger (1970). The important criterion is the ratio of the thermal conductivity of the meter to that of its surroundings. The design of an HFM should give a value for this ratio which is just high enough to remain above unity for the range of conductivities expected from the surroundings. Poor thermal contacts between an HFM and dry soil, for instance, can be improved by having a suitably thick film of silicone grease.

Where an HFM is required to register transient heat flows, there may be serious difficulties. To counteract these, the sensor heat capacity should be as low as possible, aiming for a high thermal diffusivity, so that the transmission of temperature waves is not impeded.

6.2 TRANSIENT METHODS

With transient methods the temperature of the soil varies with time. Such methods are more versatile than the steady state methods and can be more easily performed. Compared to the GHP test, the probe method, in particular, requires much less time.

6.2.1 The probe method

The thermal probe or "needle" is a rapid and convenient method for measuring the thermal conductivity of soils in the laboratory or in situ. According to De Vries and Peck (1958) this transient method was first suggested by Schleiermacher in 1888 and again, but independently, by Stalhane and Pyk in 1931.

The probe is inserted into the soil to be tested and, being thin, should cause little disturbance. It consists of a heater producing thermal energy at a constant rate and a temperature sensing element (thermocouple or thermistor). The rate of rise in the temperature of the probe depends on the thermal conductivity of the surrounding medium.

The first applications of the probe were by Van der Held and Van Drunen (1949) to measure the thermal conductivity of liquids, and by Hooper and Lepper (1950) to measure that of soils. The latter experimenters carried out very satisfactory tests on moist soils, noting that the obtainable accuracy was at least equal to that with the GHP apparatus. They also found that there was no substantial alteration in the moisture distribution during the short test interval (confirmed by De Vries 1952b). The rise in temperature of the probe is on the order of 1 or 2°C . Since that time many workers have used the probe in soil testing (e.g. Mason and Kurtz 1952, Lachenbruch 1957, Van Rooyen

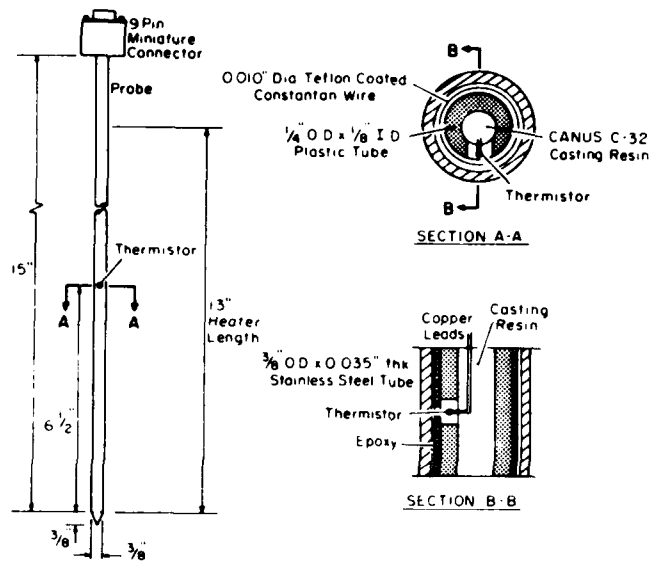

Figure 133. Thermal conductivity probe (after Slusarchuk and Foulger 1973).

and Winterkorn 1959, Woodside and Messmer 1961, Penner 1970, McGaw 1974).

The theory of the probe method is based on the theory of the line heat source placed in a semi-infinite, homogeneous and isotropic medium. The heat flowing from such a source and through a medium of thermal diffusivity α must conform to the general Fourier equation

$$\frac{\partial T}{\partial t} = \alpha \frac{\partial^2 T}{\partial x^2}$$

for one-dimensional flow in the x direction, T being the temperature at time t . For cylindrical coordinates corresponding to the expanding radial field around the probe, the equation becomes

$$\frac{\partial T}{\partial t} = \alpha \left(\frac{\partial^2 T}{\partial r^2} + \frac{1}{r} \frac{\partial T}{\partial r} \right)$$

in which r represents the radial distance from the line source. Assuming heat is produced from time $t = 0$ at a constant rate q per unit length of probe, the solution gives the temperature rise ΔT of the medium as

$$\Delta T = \frac{q}{4\pi k} \left[-Ei \left(-\frac{r^2}{4\alpha t} \right) \right]$$

where $Ei(-x)$ is an exponential integral with values listed in mathematical tables, and k is the thermal conductivity of the medium (Carslaw and Jaeger 1959).

For large values of time, the exponential integral may be approximated by a logarithm function, so that the temperature rise becomes proportional to the logarithm of time (provided k is constant with space and time). A plot of temperature against the logarithm of time then conforms to a straight line, from the slope of which the thermal conductivity can be calculated according to the equation

$$k = \frac{q}{4\pi(T_2 - T_1)} \ln \left(\frac{t_2}{t_1} \right).$$

In a real probe, the temperature values T_1 and T_2 , corresponding to times t_1 and t_2 respectively, are measured at a point within the probe (near the heat source) by means of a temperature-sensitive element situated at a point roughly equidistant from the ends of the probe (Fig. 133).

A real probe differs from the idealized line source by being a cylindrical heat source of finite length, radius and heat capacity. It also has a contact resistance between it and the medium. In spite of these differences, the same equation for k (as that given above) has been shown to apply (Jaeger 1956). However, to ensure radial heat flow conditions around the probe, its length should be at least 25 times its diameter (Blackwell 1956).^{*} The time required for the curve of temperature against the logarithm of time to

* The ratio for real probes is usually much greater (on the order of 100).

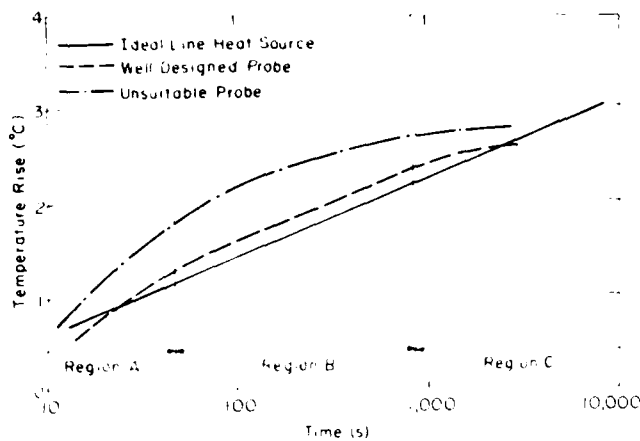

Figure 134. Typical temperature-time profiles for a probe. In Region A error is due to initial lag effects. In Region B the linear temperature-log time relationship may be used to calculate thermal conductivity. Region C is where error is due to axial losses (after Wechsler 1966).

become linear (i.e. the "initial lag error") depends on the probe radius, the thermal constants of the probe and surrounding medium, and the contact resistance. Judge (1973a) mentioned that this time is less than 1 min for a probe radius of 1 mm, but would be 1 hr for a radius of 1 cm. A suggested method of testing soil thermal resistivity by the probe technique was submitted to ASTM by Winterkorn (1970).*

At long experimental times the effects of axial heat loss along the probe and of moisture migration away from the probe may show themselves. Figure 134 shows typical temperature-time curves for various probe conditions.

Another criterion in laboratory testing is that the radius of the finite sample should be large enough that the amount of heat reaching its boundary is small compared with the heat input. According to Wechsler (1966) this necessitates that

$$\exp\left(-\frac{R^2}{4\alpha t}\right) < 0.02$$

where R is the radius of the sample. This criterion depends on the thermal diffusivity α of the material and the time t required to complete the test. The effects of long experimental time and finite sample size show themselves in a change in slope of the temperature-log time curve (Mitchell and Kao 1978) as is evident from Figure 134.

An important factor is the temperature gradient set up by the probe heater. If this gradient is too large it may cause excessive moisture migration in

unsaturated soils. According to De Vries and Peck (1958) the magnitude of the decrease of moisture content at the probe surface is approximately inversely proportional to the probe radius. The temperature gradient may also cause melting of ice in frozen soils. Penner (1970) obtained unreliable results under such conditions where changes occurred in the unfrozen water content of frozen soils at temperatures slightly below 0°C.* Use of a probe with a larger diameter would reduce the temperature gradient (Woodside 1958, Penner et al. 1975). Moench and Evans (1970) used a probe of unusually large diameter (1.91 cm) as a cylindrical heat source. They took account of the thermal contact resistance between the heat source and the sample material. Using the theory of vapor diffusion in porous media, they estimated and allowed for the effect of moisture distillation. They claimed the resulting values of thermal conductivity to be accurate to within 4%.

De Vries and Peck (1958) showed that the probe cooling curve may also be used to calculate the thermal conductivity. In fact it was said to be important to make measurements during both heating and cooling and to use both these curves. However, Lachenbruch (1957), while testing frozen soils, found that thermal conductivities determined from the cooling data were less reliable than those obtained from data taken during the warming cycle.

A probe should have low heat capacity and high thermal diffusivity. The factors affecting the design of laboratory and field probes were discussed in detail by Wechsler (1966). He considered the effects of

* Refinements of testing technique now include automatic plotting of the temperature vs log time curve and calculation of the soil thermal conductivity as at Division of Building Research, National Research Council, Ottawa, Canada.

* Not only are there changes in the soil composition and properties, but some of the heat from the probe goes to melt the interstitial ice.

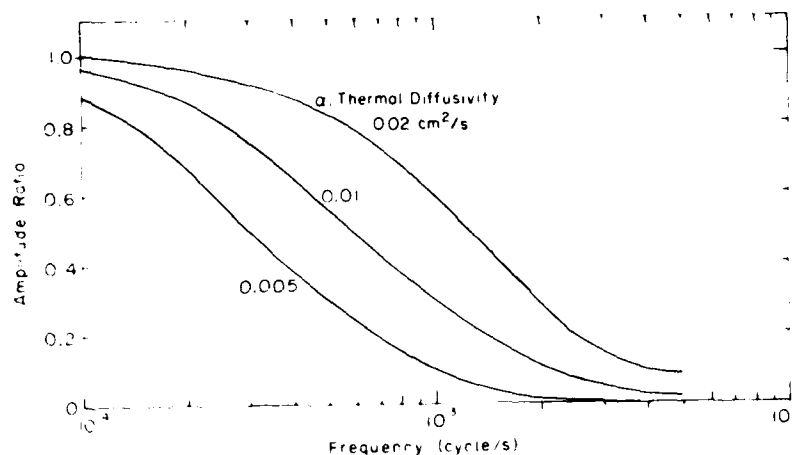

Figure 135. Ratio of the amplitude of the temperature waves at the periphery and in the center of a sample. The dependence of this ratio on the wave frequency is shown for a 10-cm-diameter sample but with variable thermal diffusivity (after Hoekstra et al. 1973).

probe diameter, length to diameter ratio, probe construction material, type and location of the temperature sensor, probe heat capacity and heater type. He noted that field probes should be mechanically strong and durable. To reduce moisture migration or ice thawing the measurement time should not exceed 20 min and the temperature rise of the probe should be less than 4°C. Lachenbruch (1957) stated that under normal field conditions thermal conductivity measurements with the probe are reproducible to within about 2%. He estimated the absolute precision of the instrument to be within 5%.

Difficulties may arise when the probe is in contact with a large pebble or lies partly in a void space (Sass et al. 1968). Measurements obtained in nonhomogeneous soil do not give a perfect, straight-line graph (Makowski and Mochlinski 1956). It is also likely that a nominally uniform soil may have an uneven distribution of moisture in the sample.

Probes have been used for measuring the thermal conductivities of sea- and lake-bottom muds (Judge 1973b) and of deep sea sediments (Von Herzen and Maxwell 1959). In the latter case each test took less than 10 min, the accuracy was within 4% and good agreement was obtained with steady-state methods.

Special applications of the probe method have included measurements of the thermal conductivity of lunar soil simulant under near-vacuum conditions (Hubbard et al. 1969) and of actual lunar soil.

According to De Vries and Peck (1958) a direct measurement of the thermal diffusivity with the probe is possible only when the contact resistance is negligibly small or if it is accurately known. Even then, a high degree of accuracy is not to be expected.

6.2.2 Periodic temperature waves

Forbes (1849) estimated the thermal diffusivity of soil in situ by analyzing the attenuation and lag of the annual temperature wave in the soil. The mathematical derivation assumes that the annual variation in temperature at the ground surface can be represented by a sine wave and that there is no change of state in the soil (Scott 1964).

Hoekstra et al. (1973) measured the thermal diffusivity of a cylindrical soil sample in the laboratory by applying a sinusoidal temperature wave to its periphery. From the resulting amplitude ratio and the frequency of the wave, they estimated the thermal diffusivity (Fig. 135). Such a method is particularly suitable where there may be a moisture migration problem or changes in the thermal properties of the soil specimen, as may happen with frozen soils in the range 0°C to -5°C.

6.2.3 Thermal shock method

Shannon and Wells (1947) measured the thermal diffusivity of a soil specimen by applying a sudden temperature change to the boundaries of a cylindrical sample and observing the resulting temperature change at its center. The sample was inserted into a cooler water bath, and the change in temperature measured by means of a thermocouple that had been placed in the center. A knowledge of the specific heat was required to calculate the thermal conductivity.* Comparison of these results with Kersten's steady state method showed satisfactory agreement.

*Mitchell and Kao (1978) discovered an error of about 20% in the time factor curve for temperature change at the center of a cylinder of diameter D and height $2D$ as given by Shannon and Wells (1947).

Table 21. Thermal conductivity values of calibration tests (after Slusarchuk and Foulger 1973).

| | Guarded hot plate (W/m °C) | Dry | | | | | Guarded hot plate (W/m °C) | Wet | | | | |
|----------------------|----------------------------|-------------------------------------|-------|-------|-------|-------|----------------------------|-------------------------------------|-------|-------|-------|-------|
| | | Thermal conductivity probe (W/m °C) | | | | | | Thermal conductivity probe (W/m °C) | | | | |
| | | C | D | E | F | G | | C | D | F | F | G |
| Screened Moffat sand | 0.247 | 0.259 | 0.259 | 0.262 | 0.263 | 0.258 | 1.47 | 1.53 | 1.61 | 1.63 | 1.62 | 1.55 |
| Coarse Ottawa sand | 0.304 | 0.296 | 0.294 | 0.304 | 0.306 | 0.310 | 2.79 | 3.12 | 2.99 | 3.27 | 3.24 | 3.20 |
| Fine Ottawa sand | 0.304 | 0.304 | 0.292 | 0.307 | 0.294 | 0.301 | 2.72 | 2.89 | 3.04 | 2.97 | 2.71 | 2.88 |
| Coarse glass beads | 0.200 | 0.201 | 0.209 | 0.210 | 0.212 | 0.207 | 0.764 | 0.826 | 0.821 | 0.829 | 0.840 | 0.819 |
| Fine glass beads | 0.171 | 0.168 | 0.178 | 0.170 | 0.169 | 0.170 | 0.775 | 0.820 | 0.830 | 0.823 | 0.839 | 0.821 |

6.3 COMPARISON OF RESULTS FROM PROBE AND GHP TESTS

Tests on insulating materials showed good agreement between the thermal conductivity values obtained by the probe method and those obtained by the GHP test (D'Eustachio and Schreiner 1952). Similarly Woodside (1958) obtained good agreement for tests on silica aerogel. Very little data exist for soils from which comparisons can be made between the results of probe experiments and those of the guarded hot plate on the same soil.

Hooper and Lepper (1950) recognized the probe as "a primary standard apparatus" for measuring soil thermal conductivity. They stated that it did not require calibration against any other standard or material. De Vries and Peck (1958) also concluded that the probe method can be applied with confidence as an absolute method for measuring thermal conductivity. Notwithstanding these conclusions, Slusarchuk and Foulger (1973) took the GHP test as a standard against which they calibrated five probes. They assumed the values from the GHP test to be correct and then used the corresponding probe values to establish a calibration curve. The results are shown in Table 21 and the associated calibration equations are:

for dry soils: $k_{GHP} = 0.902k_{Probe} + 0.0234$

for wet soils: $k_{GHP} = 0.92k_{Probe}$

Thus the GHP value is less than the probe value by about 8%.

Johansen (pers. comm.) measured the thermal conductivity of a soil by both methods (he did this for several soils). His values for tests done on coarse soils at similar temperatures have been abstracted and compared in Sections 6.3.1 and 6.3.2.

6.3.1 Data on moist soils

Johansen measured the thermal conductivities of sands SA1, SA2, SA8 and SA13 and GR7 gravel by the

GHP method and also by the probe method. In order to compare the data from the two types of test, the thermal conductivity values (corresponding to roughly the same temperature) were adjusted by the author to a common dry density of 1600 kg/m³. For this purpose it was assumed that a change of 1 kg/m³ in dry density causes a change of 0.15%* in the thermal conductivity at a constant moisture content. The thermal conductivity values so adjusted were used in plotting Figures 136-140.

One can see from Figures 136 to 138 for the sands that the probe method generally gives somewhat higher thermal conductivity values. This agrees with the results of Slusarchuk and Foulger (1973). However, Figure 140 for the gravel shows an opposite trend except for the measurement at the highest moisture content. Also Figure 139 for sand SA13 does not show any bias one way or the other.

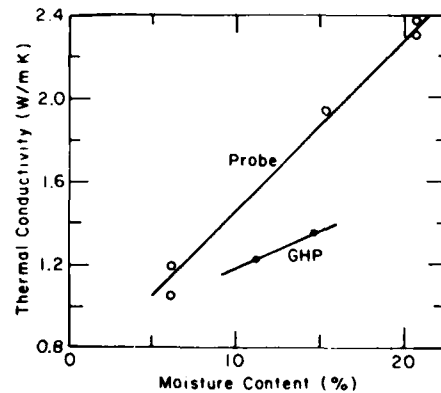

Figure 136. Comparison of measurements of thermal conductivity with probe and guarded hot plate made on Johansen's sand SA1 at ~18°C. The data have been adjusted to a common dry density of 1600 kg/m³.

* This figure is based approximately on the sensitivity values determined by Farouki (in press).

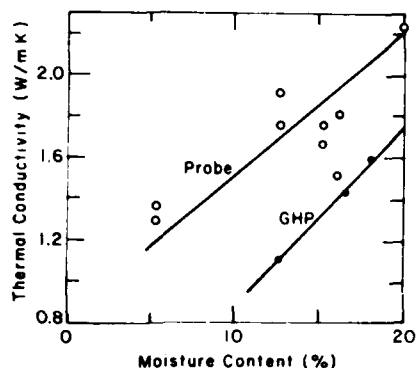

Figure 137. Comparison of measurements of thermal conductivity with probe and guarded hot plate made by Johansen on his sand SA2 at $\sim 18^{\circ}\text{C}$. The data have been adjusted to a common dry density of 1600 kg/m^3 .

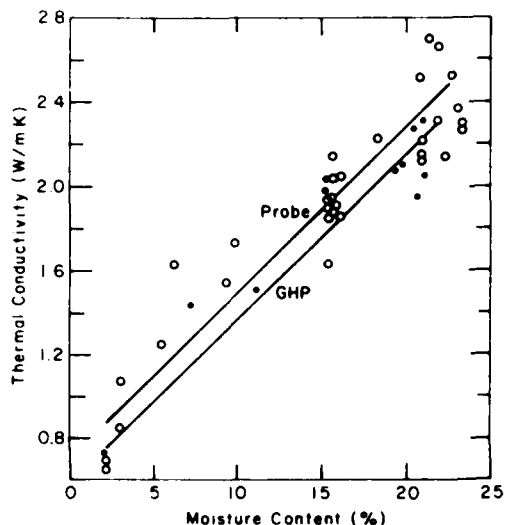

Figure 138. Comparison of measurements of thermal conductivity with probe and guarded hot plate made by Johansen on his sand SA8 at $\sim 4^{\circ}\text{C}$. The data have been adjusted to a common dry density of 1600 kg/m^3 .

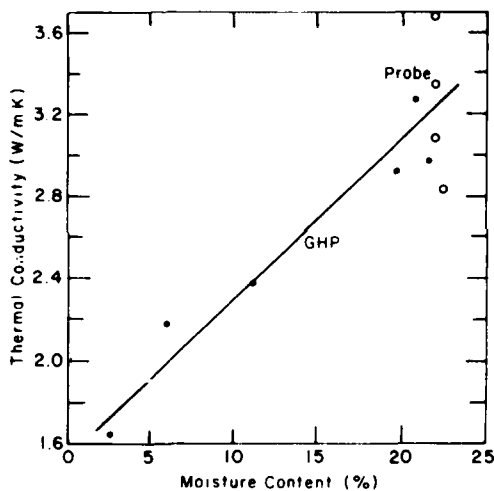

Figure 139. Comparison of measurements of thermal conductivity with probe and guarded hot plate made by Johansen on his sand SA13 at $\sim 20^{\circ}\text{C}$. The data have been adjusted to a common dry density of 1600 kg/m^3 .

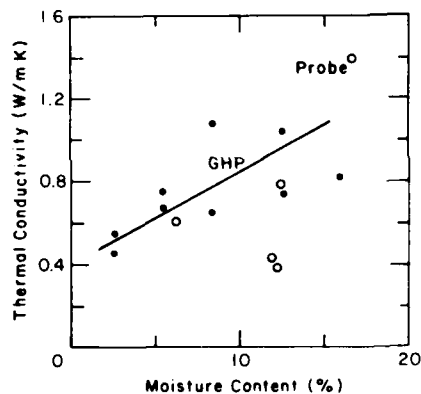

Figure 140. Comparison of measurements of thermal conductivity with probe and guarded hot plate made by Johansen on his gravel GR7 at $\sim 4^{\circ}\text{C}$. The data have been adjusted to a common dry density of 1600 kg/m^3 .

These limited data partially support Slusarchuk and Foulger's conclusion that the probe method gives higher thermal conductivity values than the GHP test. It is possible that in the latter test moisture migration leads to a condition of lower average thermal conductivity, as was suggested by De Vries (see Section 6.1.1). More comparisons of suitable data are required for a fuller elucidation of this matter.

6.3.2 Data on dry soils

The occurrence of dry soils is unusual in nature. Figure 141 shows the data of Woodside and De Bruyn (1959) on "dry" clay tested in the laboratory. The value measured with the GHP (average temperature 75°F) is somewhat lower than the probe values (temperature 85°F). Woodside and De Bruyn explained the difference as being due to the different test temperatures.

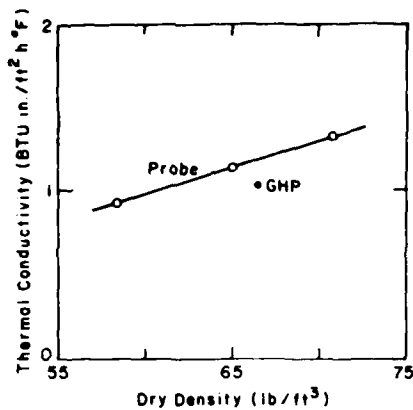

Figure 141. Comparison of thermal conductivity measurements with probe and with the guarded hot plate on "dry" clay (after Woodside and De Bruyn 1959).

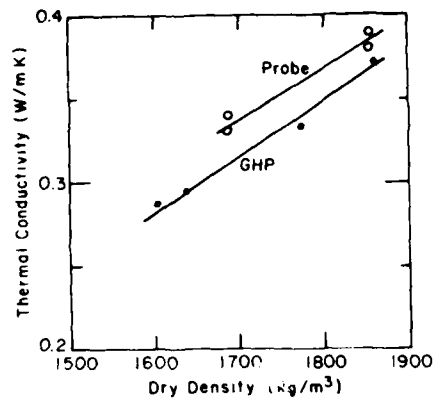

Figure 142. Comparison of measurements of thermal conductivity with probe and guarded hot plate made by Johansen on his sand SA2 in the dry condition at $\sim 18^\circ\text{C}$ and at different densities.

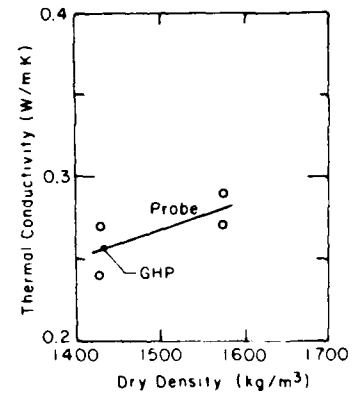

Figure 143. Comparison of measurements of thermal conductivity with probe and guarded hot plate made by Johansen on his sand SA4 in the dry condition at $\sim 18^\circ\text{C}$ and at different densities.

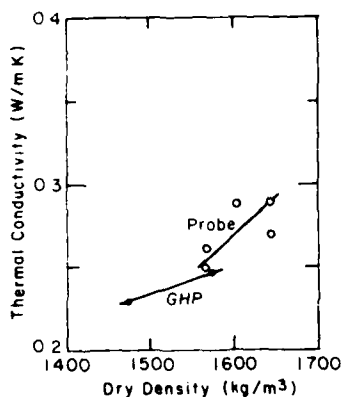

Figure 144. Comparison of measurements of thermal conductivity with probe and guarded hot plate made by Johansen on his sand SA8 in the dry condition at $\sim 18^\circ\text{C}$ and at different densities.

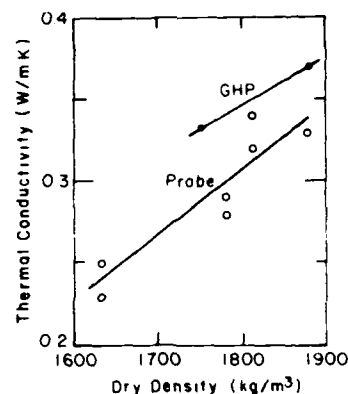

Figure 145. Comparison of measurements of thermal conductivity with probe and guarded hot plate made by Johansen on his sand SA10 in the dry condition at $\sim 18^\circ\text{C}$ and at different densities.

but this may not be a sufficient cause as the temperature difference is small. The tendency shown agrees with the results of Slusarchuk and Foulger (1973).

The data from Johansen (pers. comm.) on dry sands do not show any consistent trend (Fig. 142-145). No definite conclusions can be drawn from these limited data regarding the relative values given by the probe and GHP tests.

Woodside (1958) found appreciable radiative heat transfer in dry silica aerogel under transient conditions. He stated that Van der Held (1952) observed that in the case of materials easily penetrated by thermal radiation, thermal conductivities measured by a transient

method, such as the probe, are higher than conductivities measured by steady-state methods.

Johansen (pers. comm.) made guarded hot plate tests on dry soils at temperatures between about 28 and -26°C . The results show a definite decrease in the thermal conductivity as the temperature decreases. Table 22 illustrates this effect for sand SA13 which is 100% quartz. The drop in thermal conductivity as the temperature decreases is rather strange in view of the increase in the thermal conductivity of quartz with decreasing temperature (Section 5.1). A possible explanation lies in a limitation of convective and radiative heat transfer effects as the temperature decreases, but there may be other contributing factors.

Table 22. Thermal conductivity of dry sand SA13 at different temperatures, GHP tests (Johansen, pers. comm.).

| <i>At dry density of 1576 kg/m³</i> | | <i>At dry density of 1665 kg/m³</i> | |
|--|---|--|---|
| <i>Temperature (°C)</i> | <i>Thermal conductivity (W/m K)</i> | <i>Temperature (°C)</i> | <i>Thermal conductivity (W/m K)</i> |
| 27.3 | 0.288 | 27.3 | 0.308 |
| 0.0 | 0.265 | -1.3 | 0.284 |
| -23.8 | 0.240 | -25.9 | 0.261 |

CHAPTER 7. METHODS FOR CALCULATING THE THERMAL CONDUCTIVITY OF SOILS

This chapter describes the various methods that have been developed for calculating the thermal conductivity of soils. These methods are either purely empirical or have some theoretical basis. Most of the latter have been modified empirically, to a greater or lesser extent, thus making them semi-empirical. Altogether, eleven methods are considered in chronological order.

These methods have been evaluated in detail (Farouki, in press). A summary of some of the main conclusions from this study is given here. This includes an indication of the best method(s) to apply to soil of various types and conditions in order to estimate thermal conductivity.

7.1 PARALLEL OR SERIES FLOW EQUATIONS AND THE GEOMETRIC MEAN

Any equation for calculating the thermal conductivity of a soil should give a result lying between the upper limit, obtained from the parallel flow model, and the lower limit given by the series flow model (Fig. 11). In these models, the solid particles are all considered to be grouped together with no contact resistances between them. The fluid is also considered to be continuous.

With the assumption that heat flows through the fluid and solids in parallel, the equation for the effective soil thermal conductivity k is

$$k = n k_f + (1 - n) k_s$$

where k_f , k_s are the fluid and solids thermal conductivities, respectively, and n is the fractional porosity.

The series flow model means that the thermal resistivities (i.e. the reciprocals of the conductivities) are added together, giving

$$\frac{1}{k} = n \frac{1}{k_f} + (1 - n) \frac{1}{k_s}$$

One expects parallel flow to predominate at low k_f/k_s ratios and series flow to be dominant at high k_s/k_f ratios.

An important and useful "average" of the parallel and series thermal conductivities is obtained by taking the geometric mean as given by

$$k = k_f^n k_s^{(1-n)} = \left(\frac{k_f}{k_s} \right)^n k_s$$

These simple concepts of heat flow and effective thermal conductivity are incorporated into some of the methods developed for calculating soil thermal conductivity as described below.

7.2 SMITH'S METHOD FOR DRY SOILS

Smith (1942) derived an equation for the thermal conductivity of dry soil by considering the heat to flow through two parallel paths. One path is through continuous air columns while the other is through columns containing soil grains and some "series air." Series air represents that part of the total pore air which is "effective in introducing thermal resistance during the passage of heat from grain to grain and from aggregate to aggregate. It consists of the pore space inserted between grain and aggregate contacts across which heat is transferred" (Smith 1942, p. 446). He took into account the partial volumes of the solid and air components in series and their lengths, arriving finally at the following equation for the thermal conductivity of dry soil:

$$k = k_a (n - P_Q) + x_s (1 + \alpha') \left[(1 + k_s) + \left(\frac{1}{k_s} \right) - \left(\frac{1}{k_s} \right) \left(\frac{\alpha'}{1 + \alpha'} \right) \right]$$

where k_a is the air thermal conductivity and α' is the ratio of the series air volume P_Q to the solids volume x_s in unit total volume.

Smith termed α' the "thermal structure factor" and noted that structured soils have a higher α' value. From his experimental results, he calculated α' factors

Table 23. Thermal structure factors α' (for well-developed structures). (After Smith 1942.)

| Soil structure | α' |
|-----------------|-----------|
| Medium granular | 0.065 |
| Medium platy | 0.052 |
| Coarse platy | 0.041 |
| Medium blocky | 0.045 |
| Coarse blocky | 0.036 |

that are applicable to different types of structures (Fig. 6) as given in Table 23. He emphasized the importance of structure disturbance and fragmentation in affecting thermal conductivity.

7.3 KERSTEN'S EMPIRICAL EQUATIONS

While Kersten (1949) extensively tested 19 natural soils and crushed rocks, each of the empirical equations he proposed for thermal conductivity is based on the data for just four or five different soils. The equations give the thermal conductivity k of the soil in terms of its moisture content w (%) and its dry density γ_d . There are separate equations for the unfrozen (+4°C) and frozen (-4°C) conditions. The equations for fine soils, containing 50% or more silt-clay, were based on the data for Healy clay, Fairbanks silty clay loam, Fairbanks silt loam, Northway silt loam and Ramsey sandy loam. (For information on Kersten's soils, see Appendix A.)

For unfrozen silt-clay soils

$$k = [0.9 \log w - 0.2] 10^{0.017\gamma_d}$$

while for frozen silt-clay soils

$$k = 0.01(10)^{0.022\gamma_d} + 0.085(10)^{0.008\gamma_d} w$$

These equations give k in Btu in./ft² hr °F, with the dry density γ_d in lb/ft³. They are represented in Figures 146 and 147. In metric units the corresponding

equations are

$$k = 0.1442[0.9 \log w - 0.2] 10^{0.6243\gamma_d}$$

and

$$k = 0.001442(10)^{1.373\gamma_d} + 0.01226(10)^{0.4994\gamma_d} w$$

which give k in W/m K with γ_d in g/cm³ (Fig. 148 and 149). These equations of fit gave deviations of less than 25% from the measured thermal conductivity values of the five soils tested. They are valid for moisture contents of 7% or higher, according to Kersten.

The proposed equations for coarse soils were based on data for Fairbanks sand, Lowell sand, Chena River gravel and Dakota sand. They are applied to moisture contents of 1% or higher for coarse sandy soils

$$k = [0.7 \log w + 0.4] 10^{0.017\gamma_d}$$

while for frozen sandy soils

$$k = 0.076(10)^{0.022\gamma_d} + 0.032(10)^{0.0146\gamma_d} w$$

giving k in Btu in./ft² hr °F, with γ_d in lb/ft³. These are charted in Figures 150 and 151. The equivalent equations in metric units are

$$k = 0.1442[0.7 \log w + 0.4] 10^{0.6243\gamma_d}$$

and

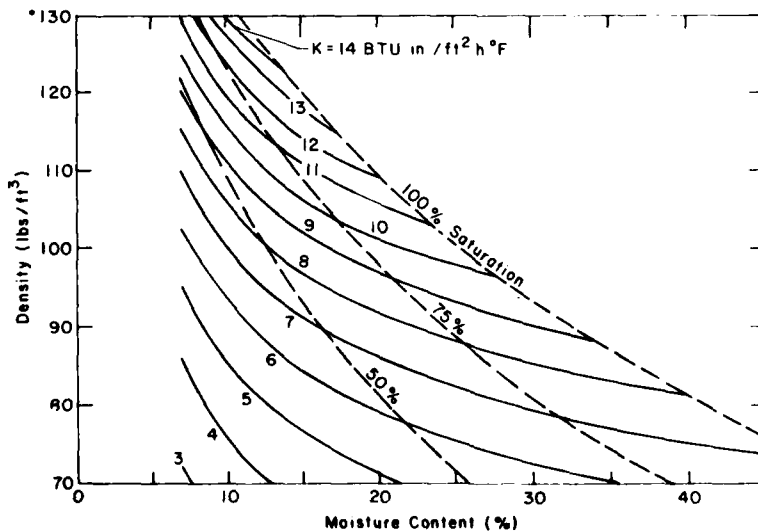

Figure 146. Thermal conductivity of unfrozen silt and clay soils as a function of moisture content and dry density (mean temperature is 40°F). The degree of accuracy is ±25% (after Kersten 1949).

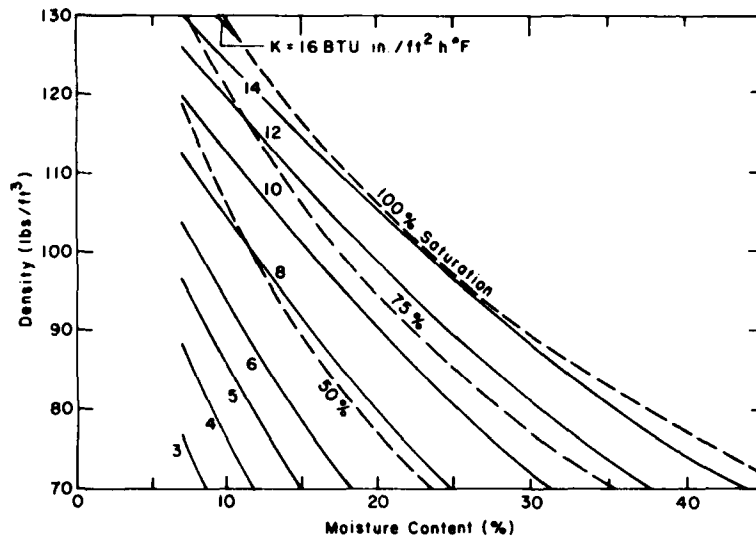

Figure 147. Thermal conductivity of frozen silt and clay soils as a function of moisture content and dry density (mean temperature is 25°F). The degree of accuracy is $\pm 25\%$ (after Kersten 1949).

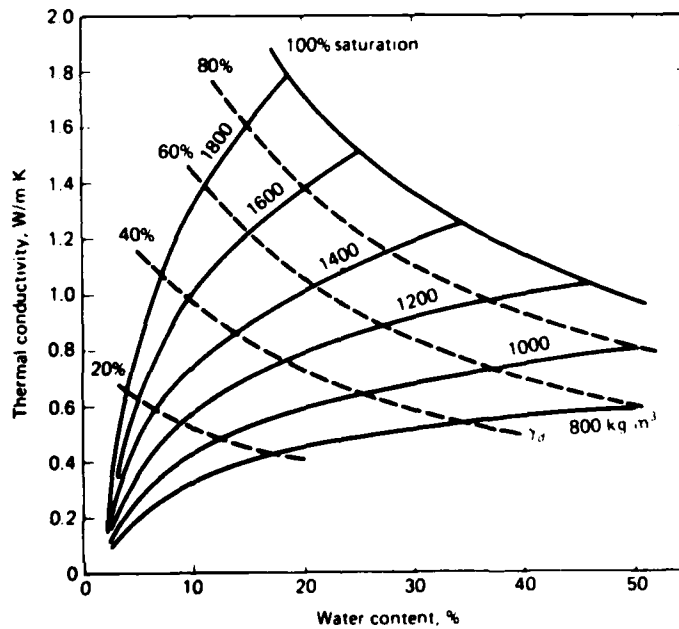

Figure 148. Average thermal conductivity of unfrozen silt and clay soils as a function of water content and dry density (from Andersland and Anderson 1978).

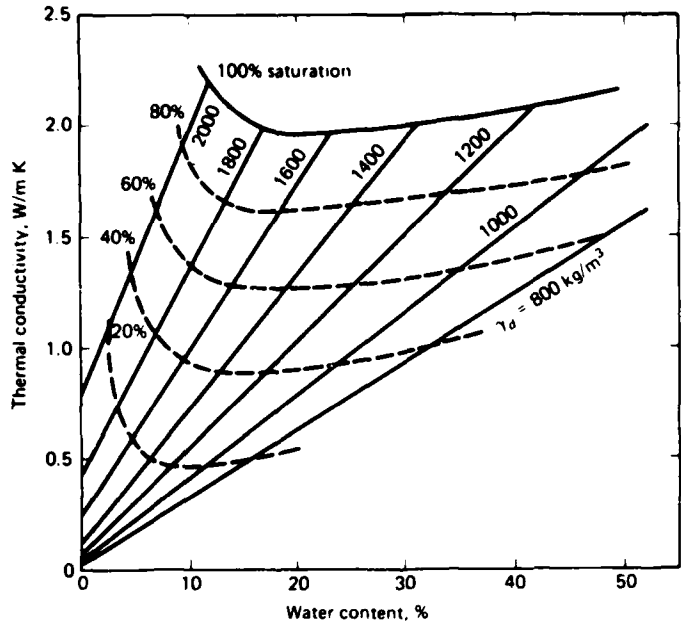

Figure 149. Average thermal conductivity of frozen silt and clay soils as a function of water content and dry density (from Andersland and Anderson 1978).

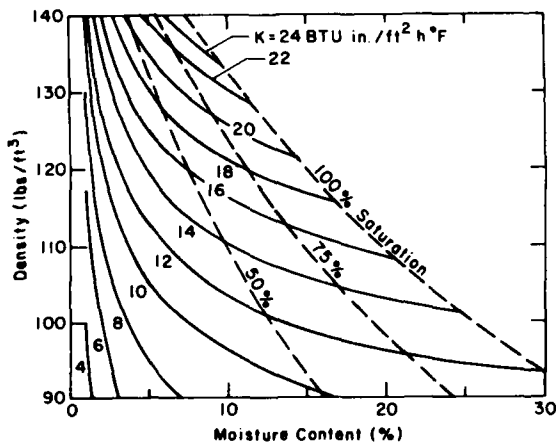

Figure 150. Thermal conductivity of unfrozen sandy soils as a function of moisture content and dry density (mean temperature is 40° F). The degree of accuracy is $\pm 25\%$ (after Kersten 1949).

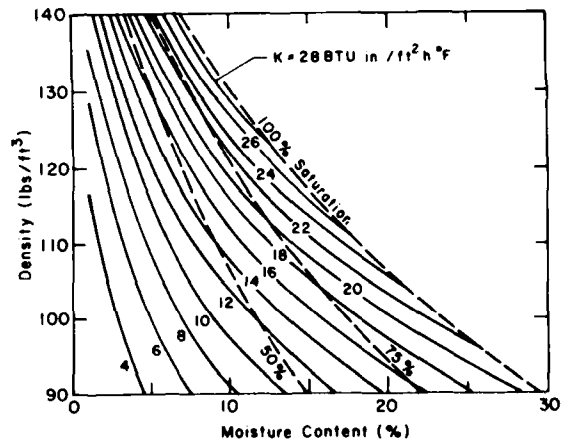

Figure 151. Thermal conductivity of frozen sandy soils as a function of moisture content and dry density (mean temperature is 25° F). The degree of accuracy is $\pm 25\%$ (after Kersten 1949).

$$k = 0.01096(10)^{0.8116\gamma_d} + 0.00461(10)^{0.9115\gamma_d w}$$

giving k in W/m K with γ_d in g/cm^3 (Fig. 152 and 153).

According to Kersten, these equations of fit gave values which generally differed by less than 25% from the measured values for the first three coarse soils mentioned. Contrarily, the Dakota sandy loam, which had a high silt-clay content of 31%, had values from these

equations that were as much as 50% higher than the measured values. Therefore, the equations generally apply to soils with a low silt-clay content (less than about 20%). They should also be used for soils that are predominantly quartz. Kersten noted that the equations gave values which were considerably higher than the measured values for the two Northway sands (also tested by Kersten) which contained little quartz.

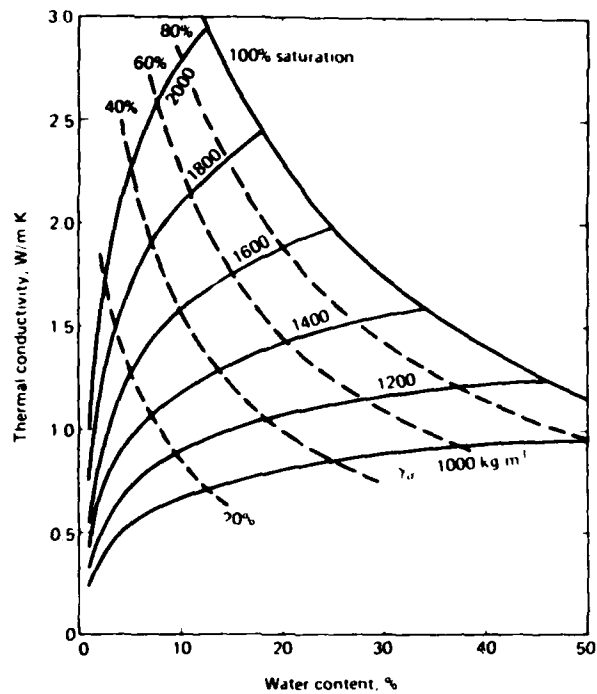

Figure 152. Average thermal conductivity of unfrozen sandy soils as a function of water content and dry density (from Andersland and Anderson 1978).

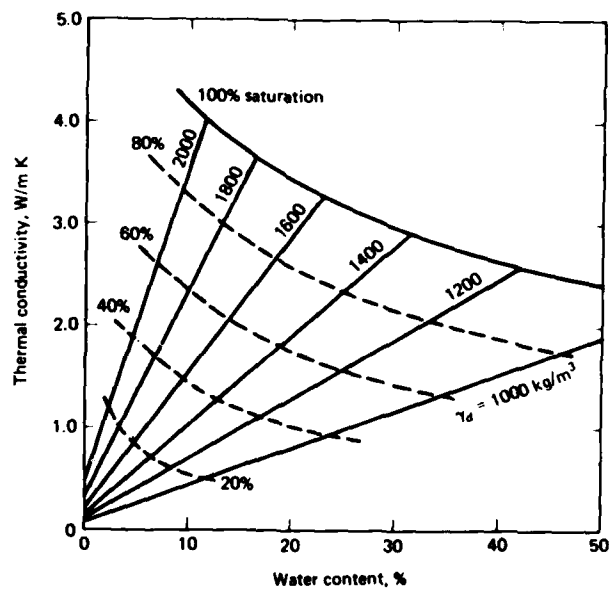

Figure 153. Average thermal conductivity of frozen sandy soils as a function of water content and dry density (from Andersland and Anderson 1978).

For intermediate soils, i.e. soils having a composition between the silt-clay group and the sandy group, Kersten suggested interpolating between the respective values given by the silt-clay equation and the equation for sandy soils (unfrozen or frozen).

While Kersten did not test saturated soils, he extrapolated his data to full saturation. Johansen (1975) analyzed these data and, comparing them with his geometric mean equation (see Section 7.11), he showed that Kersten's equations imply a solids thermal conductivity k_s of about 5 W/m K for the sandy soils and a k_s value of about 3 W/m K for the silt-clay soils. They may therefore underpredict the thermal conductivity of quartz sand or overpredict that of pure clay. Also, Kersten's equations cannot take into account variations in the quartz content or in k_s .

Kersten's equations do not apply to dry soils or to crushed rocks. His experimental values for crushed trap rock, feldspar and granite were considerably lower than the values given by the equations for sandy soils.

7.4 MICKLEY'S METHOD

Mickley (1951) considered a unit cube of soils and assumed a certain monolithic arrangement of the soil solids as shown in Figure 154. Thus the soil solids in the cube are all lumped together, giving in effect perfect thermal contacts between the soil grains. For dry soil, and for the indicated direction of heat flow, Mickley's arrangement gives four columns through which heat flow occurs in parallel: 1) a column of air space extending from face to face of unit length and cross-sectional area a^2 , 2) a column of solid material extending from face to face of unit length and cross-sectional area $(1-a)^2$, 3) and 4) two columns between the cube faces consisting of solid material in series with air space. The cross-sectional area of each column is $a(1-a)$, and its length consists of a solid length of $(1-a)$ in series with an air space of length a . The contributions of each of these columns are added to give the following equation for the effective thermal conductivity of dry soil:

$$k_{dry} = k_a a^2 + k_s (1-a)^2 + \frac{k_s k_a (2a - 2a^2)}{k_s (a) + k_a (1-a)}$$

For saturated soil, the same model applies with water replacing air, giving the equation

$$k_{sat} = k_w a^2 + k_s (1-a)^2 + \frac{k_s k_w (2a - 2a^2)}{k_s (a) + k_w (1-a)}$$

In the case of partially saturated soils, where both

water and air are present, Mickley assumed that the water lies in a uniform layer of thickness b on the six surfaces of the solid which are inside the cube (Fig. 154). This condition gives rise to the following complicated equation:

$$k = k_a c^2 + k_s (1-a)^2 + k_w (a-c)^2 + \frac{2k_w k_a c(a-c)}{k_w c + k_a (1-c)} + \frac{2k_s k_w k_a c(1-a)}{k_w k_s c + k_s k_a (a-c) + k_a k_w (1-a)} + \frac{2k_w k_s (a-c)(1-a)}{k_s a + k_w (1-a)}$$

Application of Mickley's equations is cumbersome. From the soil's dry density and moisture content, the lengths a and c ($= a-b$) can be calculated using the relationships

$$3a^2 - 2a^3 = n$$

and

$$3c^2 - 2c^3 = (1 - S_r)n$$

where n is the porosity and S_r the degree of saturation (fractional).

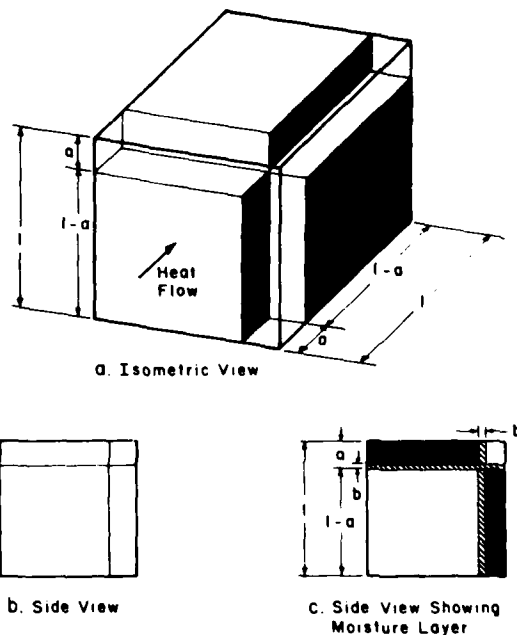

Figure 154. Theoretical unit soil structure containing solid monolith. The arrow shows the assumed direction of heat flow (after Mickley 1951).

Mickley noted that his equations do not hold for very porous soil nor for dry or nearly dry soil, and they would give high values because of the more efficient thermal contacts assumed. Better estimates should be obtained with soils having high moisture contents because water bridges would improve grain-to-grain contacts.

Kersten (1951) commented that Mickley's equations do not take soil texture into account. For clay soils, in particular, the number of grain-to-grain crossings in a unit cube would be much greater than in sandy soils. This should decrease the clay's thermal conductivity. In answer, Mickley suggested that the influence of the solid particle thermal conductivity k_s may be more important and this is taken into account in his equations.

7.5 GEMANT'S METHOD

The method of Gemant consists of applying certain equations found in a paper which explained the techniques of computation of soil thermal conductivity (Gemant 1952). He considered moist soil with point solid-to-solid contact between the soil particles. He assumed that water collected around these points of contact, forming a thermal bridge between the particles. As explained by Makowski and Mochlinski (1956), Gemant's model visualizes idealized particles piled one on top of the other. Each individual particle consists of a cube of side a , three faces of which form pyramids with square bases (Fig. 155). Assuming heat flow vertically upwards, only the bottom pyramid in series with the cube effectively takes part in heat conduction. Similarly only the water ring that collects around the bottom point of contact, as shown, is effective in contributing towards the heat flow. Part of the total water

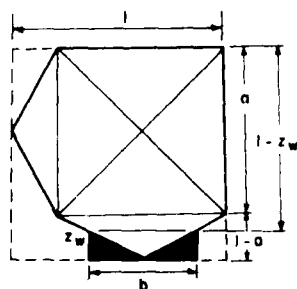

Figure 155. Unitary cube of moist soil according to Gemant (after Makowski and Mochlinski 1956).

content of the soil is made up of "apex water" (including all the apexes) while the rest consists of an amount of water h_o adsorbed as a film on the surfaces of the solid particles. Gemant assumed that h_o decreases as the temperature increases according to the curve in Figure 156 which is based on the water adsorption of glass. This quantity h_o has to be subtracted from the total water content before determining the "effective water" which must therefore necessarily be less than a third of the water content.

The equations developed by Gemant are

$$a = 0.078s^{1/2}$$

$$h = 0.16 \times 10^{-3} s w - h_o$$

$$z = \left(\frac{1-a}{a} \right)^{2/3} \left(\frac{h}{2} \right)^{1/3}$$

$$b^2 = \left(\frac{a}{1-a} \right)^{2/3} \left(\frac{h}{2} \right)^{2/3}$$

where s = soil dry density (lb/ft³)

w = moisture content (%)

h represents the apex water.

The soil thermal conductivity k is given by the equation

$$\frac{1}{k} = \frac{[(1-a)/a]^{1/3} \arctan [(k_s - k_w)/k_w]^{1/2}}{(h/2)^{1/3} [k_w(k_s - k_w)]^{1/2}} + \frac{(1-z)}{k_s a} f\left\{ \frac{b^2}{a} \right\}$$

in units corresponding to those used for k_s and k_w .

The function $f(b^2/a)$ is determined from Figure 157.

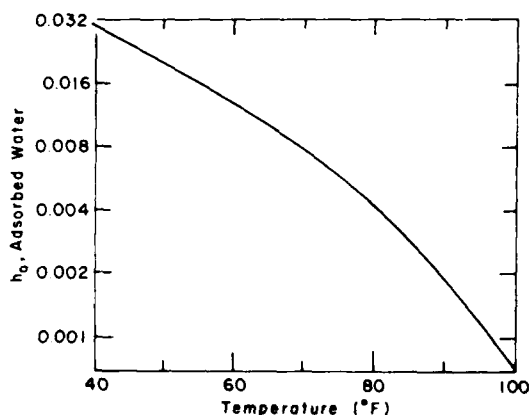

Figure 156. Variation of adsorbed water (h_o) with temperature (after Gemant 1952).

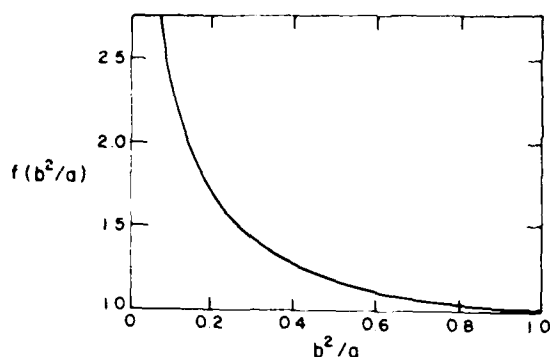

Figure 157. Variation of the function $f(b^2/a)$ in Gemant's formula (after Gemant 1952).

For the thermal conductivity of the solids k_s Gemant suggested the use of the following equation:

$$k_s = 40.5 - 0.23p \quad \text{Btu in./ft}^2 \text{ hr } ^\circ\text{F}$$

where p is the percent of clay in the soil solids. The equivalent equation in metric units is

$$k_s = 5.84 - 0.033p \quad \text{W/m K.}$$

However, the use of such an equation for k_s is open to serious question. At one extreme, with no clay, this equation gives $k_s = 5.84$ W/m K, a value which would be too low for a quartz sand by about 25%. At the other extreme, with 100% clay, the equation gives $k_s = 2.54$ W/m K which may be about 25% too high.

Williams and Kaplar (1968) tested Gemant's method on some of Kersten's soils and reported discrepancies of more than 100% between calculated and experimental values. However if a more appropriate value of k_s is used, rather than that from Gemant's equation, the deviations are reduced to about 20% (see Farouki, in press). This is better even than the values obtainable from Kersten's equations for his own soils. It would therefore be appropriate not to use Gemant's particular subsidiary equation for k_s , but instead to use a suitable k_s value depending on the soil mineral composition.*

Because of the type of particle contact assumed, Gemant expected his method to give more exact results for sandy soil than for clay. It is not applicable at all to dry soils. The soil must have a certain minimum moisture content (dependent on temperature) so as to give a positive value for h .

* This has been done in the evaluation of Gemant's method reported by Farouki (in press).

Makowski and Mochlinski (1956) expressed Gemant's equation for the thermal conductivity in the same form as Kersten's equations for unfrozen soils and thereby developed a nomogram from which the thermal conductivity of a sandy soil could be easily determined. The required input parameters are the soil's dry density, moisture content and percentage of clay. Because this nomogram is based on Gemant's particular equation for k_s , discrepancies are bound to arise. The nomogram could be redeveloped on the basis of more suitable upper and lower limits for k_s . It could then be used in conjunction with known, or suitably assumed, values of k_s , based on the soil's mineral composition. This should give more accurate results.

7.6 DE VRIES' METHOD

De Vries' method originated with Eucken (1932) who used Maxwell's equation for the electrical conductivity of a mixture of uniform spheres dispersed at random in a continuous fluid. This was later applied to the thermal conductivity k of ellipsoidal soil particles in a continuous medium of air or water, giving the equation

$$k = \frac{x_f k_f + F x_s k_s}{x_f + F x_s} \quad (6)$$

where the subscripts f and s refer to the fluid and solid respectively and x is the volume fraction in unit soil volume. The factor F is given by

$$F = \frac{1}{3} \sum_{a,b,c} \left[1 + \left(\frac{k_s}{k_f} - 1 \right) g_a \right]^{-1}$$

in which $g_a + g_b + g_c = 1$.

De Vries (1952a) found that by assuming $g_a = 0.125 = g_b$, eq 6 agreed well (within 10%) with experimental data for saturated soils having a low k_s/k_f ratio. However, for dry soils ($k_s/k_f \sim 100$) the equation gave values that were 25% too low. De Vries therefore suggested that the calculated values for dry soils should be increased by 25%.*

The derivation of the De Vries equation assumes particles that are not in contact, which is contrary to the general condition in soils. Also the g values assumed by De Vries imply a needle-like shape, unlike that of most soil particles. Thus, whereas g_a , g_b and g_c were meant to be shape factors in the original theoretical derivation, they actually turn out to be little more

* In this monograph, these are then known as the "adjusted De Vries" values.

than parameters that are adjusted to fit the empirical data. They thereby provide near agreement between calculated values and experimental results.

Equation 6 applies to more than one component in a continuous medium. For a moist, unsaturated soil, the solid particles and the air voids are considered to be two components dispersed in the continuous water medium. This assumption applies as long as the water content is above a certain minimum so that it may still be regarded as continuous. The thermal conductivity of such an unsaturated soil is given by

$$k = \frac{x_w k_w + F_a x_a k_a + F_s x_s k_s}{x_w + F_a x_a + F_s x_s}$$

where

$$F_s = \frac{1}{3} \left\{ \frac{2}{1 + [(k_a/k_w) - 1] 0.125} + \frac{1}{1 + [(k_s/k_w) - 1] 0.75} \right\}$$

and

$$F_a = \frac{1}{3} \left\{ \frac{2}{1 + [(k_a/k_w) - 1] g_a} + \frac{1}{1 + [(k_a/k_w) - 1] g_c} \right\}$$

The thermal conductivity of the air-filled pores k_a should be the effective thermal conductivity, taking into account the contribution of moisture migration. This contribution is temperature-dependent (Fig. 91) and should be added to the dry air thermal conductivity.

As an approximate procedure for determining the air pore-shape factors, De Vries assumed that g_a or g_b decreased linearly from a value of 0.333 (for spherical shape) near $x_a = 0$ to a value of 0.035 at $x_a = n$ ($x_w = 0$) giving

$$g_a = 0.333 - (x_a/n)(0.333 - 0.035)$$

which applies in the range $0.09 < x_w < n$.

For $x_w < 0.09$, the air pores may no longer be saturated with water vapor. De Vries assumed the effective air thermal conductivity to vary linearly with k_w according to

$$k_a = 0.0615 + 1.96 x_w \quad (\text{mcal/cm s } ^\circ\text{C}).$$

The shape factor g_a was also assumed to vary linearly with x_w :

$$g_a = 0.013 + 0.944 x_w \quad \text{for } 0 < x_w < 0.090.$$

De Vries (1963) suggested that one should discontinue calculations with water as a continuous medium at $x_w = 0.03$ for coarse soils or at $x_w = 0.05$ to 0.10 for fine soils.

7.7 THE EMPIRICAL EQUATIONS OF VAN ROOYEN AND WINTERKORN

On the basis of a large number of tests on crushed quartz, white sands, Ottawa sands and some natural soils, Van Rooyen and Winterkorn (1959) developed the following equation for the thermal resistivity ρ to fit the experimental data:

$$\rho = 1/k = A 10^{-BS r + s} \quad \text{cm } ^\circ\text{C/W} \quad (7)$$

where S_r is the degree of saturation (fractional) and the parameters A , B and s are functions of the dry density of the soil, its mineral type and granulometry:

$$A = 10^{a_1 - 0.44 \gamma_d^2}$$

$$B = b_1 - 5.5 \gamma_d$$

and

$$s = s_1 - s_2 \gamma_d$$

where γ_d is the dry density in g/cm^3 and a_1 , b_1 , s_1 and s_2 are functions of the type of soil material and its quartz or clay content. The application of eq 7 is complicated and the choice of the values for the parameters is uncertain.

7.8 THE METHOD OF KUNII AND SMITH

Kunii and Smith (1960) derived an expression for the heat flowing through a packing of spherical particles which is saturated with fluid. They accounted for the "series fluid" that is present around the contact points and through which heat must flow as it passes from particle to particle. However, they assumed the heat transfer across the solid-to-solid contacts was negligible. After making somewhat arbitrary simplifying assumptions, they arrived at the equation

$$k = k_f \left[n + \frac{(1-n)}{\phi + (2k_f/3k_s)} \right]$$

where ϕ is the effective length of series fluid as a ratio of the particle diameter.

The parameter ϕ is a function of the porosity of the packing and the ratio k_f/k_s . The extreme values of ϕ , which are ϕ_1 and ϕ_2 , were theoretically derived by considering the flow of heat through a cubic and a rhombohedral packing of uniform spheres, respectively. The result gave the dependence of ϕ_1 or ϕ_2 on the ratio k_s/k_f as may be obtained from

$$\phi_1 \text{ or } \phi_2 = \frac{1}{2} \frac{[(k_r-1)/k_r]^2 \sin^2 \theta}{\log_e [k_r - (k_r-1) \cos \theta] - [(k_r-1)/k_r](1-\cos \theta)}$$

$$= \frac{2}{3} \frac{1}{k_r}$$

where $k_r = k_s/k_f$ and $\sin^2 \theta = 1/N$. For ϕ_1 (cubic packing) $N = 1.5$ while for ϕ_2 (rhombohedral packing) $N = 6.9$. At intermediate porosities, ϕ may be interpolated according to the equation

$$\phi = \phi_2 + (n-0.259)(\phi_1 - \phi_2)/0.217.$$

One expects that for dry soils neglect of the contact conduction by Kunii and Smith may result in the introduction of large errors.

As McGaw (1969) noted, a basic criticism of the Kunii-Smith derivation is their assumption of parallel heat flow from grain to grain, thus neglecting the refraction of the flow lines which occurs at the spherical surfaces and depends on the ratio k_s/k_f . McGaw attempted to take this effect into account in deriving his conductance equation (see Section 7.10).

7.9 THE MODIFIED RESISTOR EQUATION

The modified resistor equation developed by Woodside and Messmer (1961) was based on the three-resistor

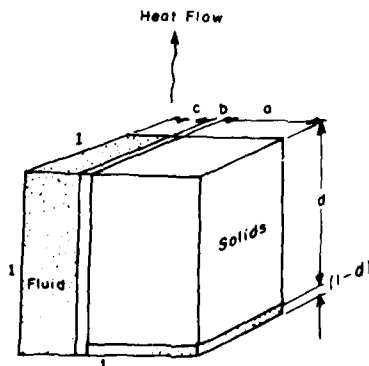

Figure 158. Schematic model of the resistor equation (after McGaw 1969).

model of Wyllie and Southwick (1954) originally used for determining electrical conductivity. For the thermal conductivity of a soil, this model visualizes heat flowing in parallel through three paths in an idealized unit cube of soil (Fig. 158):

1. A path of width c through continuous pore fluid
2. A path of width b through continuous solid material
3. A path of width a which passes through fluid and solids in series.

This gives the following equation for the thermal conductivity k :

$$k = \frac{a k_s k_f}{(1-d)k_s + d k_f} + b k_s + c k_f$$

where $a + b + c = 1$ and $b + ad = 1 - n$.

Woodside and Messmer assumed that $b = 0$ and determined a value of c which gave good agreement with experimental data. This value was $c = n - 0.03$, use of which resulted in the following semi-empirical modified resistor equation:

$$k = (n - 0.03)k_f + (1 - n + 0.03) \times \left[\frac{1-n}{1-n+0.03} \left(\frac{1}{k_s} \right) + \frac{0.03}{1-n+0.03} \left(\frac{1}{k_f} \right) \right]^{-1}$$

A shortcoming of this approach, mentioned by McGaw (1969), is that it does not take into account the geometry of the particles nor the specific arrangement of the pore fluids that enter into the series flow.

7.10 MCGAW'S CONDUCTANCE EQUATION

McGaw (1969) considered the general heat flow through a random assembly of grains saturated with fluid. He attempted to take into account refraction

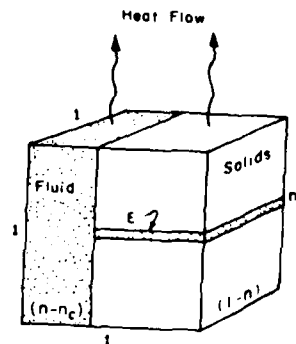

Figure 159. Schematic model of the saturated conductance equation (after McGaw 1969).

of the heat flow lines as they leave or enter the solid grains. The solid-to-solid heat conduction was neglected and the heat was considered to flow across two main paths. One is a series path of solids and intervening fluid while the other is a path passing entirely within the fluid (Fig. 159).

An equation was developed for the total series heat flow by considering the heat flow between two spherical grains and across the intervening fluid. An interfacial efficiency ϵ (at solid/fluid interfaces) was defined as

$$\epsilon = 1 - (\Delta T_i / \Delta T) \quad (0 < \epsilon < 1)$$

in which ΔT_i is the mean temperature differential across the interfacial material associated with the total temperature differential ΔT from the middle of one grain to that of the next along the heat flow path.

Adding to the series flow the contribution of the heat flow through the continuous fluid paths, McGaw obtained the "conductance equation":

$$k = (n - n_c)k_f + (1 - n + n_c) \frac{\epsilon k_s (1 - n + n_c)}{(1 - n) + n_c k_s / k_f} \quad (8)$$

The parallel and series heat flow equations are special cases of this conductance equation. It is similar in form to the modified resistor equation but allows for effects of interfacial resistance. Also n_c , the volume of series fluid in unit soil volume, can take various values, depending on the porosity, on the ratio k_s/k_f , and on grain size and shape.

The data of Woodside and Messmer (1961) on water-saturated quartz sands showed that the interfacial efficiency ϵ was equal to unity. With this assumption McGaw obtained a mean value of n_c for quartz-water equal to ~ 0.03 .

To use the conductance equation, uncertain assumptions have to be made regarding the proper values of ϵ and n_c . In the case of dry soil, ϵ is expected to be less than 1.0, but the actual value is uncertain.

As it stands eq 8 applies to saturated or dry soils. For unsaturated soils, McGaw (pers. comm.) suggested the simple addition of a term for the heat conducted by the air in parallel: $(n - n_s)k_a$. An amount of $(n - n_s)$ would then be subtracted from the coefficient of k_f in eq 8 and k_f would be set equal to k_w to give

$$k = (n_s - n_c)k_w + (1 - n + n_c) \frac{\epsilon k_s (1 - n + n_c)}{(1 - n) + n_c k_s / k_w} + (n - n_s)k_a$$

7.11 JOHANSEN'S METHOD

The method developed by Johansen (1975) is applicable to unfrozen or frozen soils. He expressed the thermal conductivity of an unsaturated soil as a function of its thermal conductivity in the dry (k_{dry}) and the saturated (k_{sat}) states at the same dry density. This was done by introducing a normalized thermal conductivity, called Kersten's number K_e , given by

$$K_e = (k - k_{dry}) / (k_{sat} - k_{dry})$$

in which k is the thermal conductivity at an intermediate degree of saturation, the dry density being constant (K_e is dimensionless).

Considering the data of Smith and Byers (1938), Smith (1942) and also his own data, Johansen noted that dry density or porosity (i.e. microstructure) was a major factor in determining the thermal conductivity in the dry state. The solid particle conductivity had little effect, and the importance of microstructure was reflected in the development of two separate equations for the dry condition, one for natural soils and the other for crushed materials.

For dry natural soils, Johansen developed a semi-empirical equation for the thermal conductivity in terms of the dry density that is based on Maxwell-Fricke's equation (taking the ratio k_s/k_a as equal to 120):

$$k_{dry} = \frac{0.135\gamma_d + 64.7}{2700 - 0.947\gamma_d} \pm 20\% \text{ W/m K}$$

where the dry density γ_d is in kg/m^3 and the solids unit weight is taken as 2700 kg/m^3 .

Johansen found that crushed rock materials gave higher thermal conductivity values than dry natural soils at the same porosity. The following empirical equation for the thermal conductivity of dry crushed rocks was found to fit the data:

$$k_{dry} = 0.039 n^{-2.2} \pm 25\% \text{ W/m K.}$$

It is a function of the porosity n only.

In the case of saturated soils, Johansen found that variations in microstructure had little effect on the thermal conductivity. He therefore proposed the use of a geometric mean equation based on the thermal conductivities of the components and their respective volume fractions. For saturated unfrozen soils, this gives

$$k_{sat} = k_s^{(1-n)} k_w^n$$

while for saturated frozen soils, containing some unfrozen water of fractional volume w_u , the equation is

$$k_{sat} = k_s^{(1-n)} k_i^{(n-w_u)} k_w^{w_u}$$

which reduces to

$$k_{sat} = k_s^{(1-n)} 2.2^n 0.269^{w_u}$$

taking the thermal conductivity of ice $k_i = 2.2$ W/m K and $k_w = 0.57$ W/m K.

To find the thermal conductivity k of an unsaturated soil, the Kersten number K_e needs to be determined. On the bases of Kersten's data, Johansen derived the following relationships between K_e and the degree of saturation S_r (fractional), the effect of the dry density being negligible. For coarse unfrozen soil,

$$K_e \cong 0.7 \log S_r + 1.0$$

where $S_r > 0.05$. For fine unfrozen soil,

$$K_e \cong \log S_r + 1.0$$

where $S_r > 0.1$, while for any type of frozen soil, $K_e = S_r$ (with a variation less than $\pm K_e = 0.1$). The thermal conductivity of an unsaturated soil may then be determined from k_{dry} , k_{sat} and S_r using the equation (Johansen 1975)

$$k = (k_{sat} - k_{dry}) K_e + k_{dry}$$

To determine the effective solids thermal conductivity k_s which is necessary for calculating k_{sat} , Johansen suggested the use of the following geometric mean equation:

$$k_s = k_q^q k_o^{1-q}$$

which is based on knowledge of the quartz content q as a fraction of the total solids content. The thermal conductivity of quartz k_q was taken by Johansen to be 7.7 W/m K, while the thermal conductivity of the other minerals k_o was taken as 2.0 W/m K. (See Section 5.1.1 for a discussion of the thermal conductivity of quartz and other minerals.) However, for coarse soils with a quartz content of less than 20%, Johansen suggested using $k_o = 3.0$ W/m K to account for the probable mineral composition of such soils.

The equations used in Johansen's method are set out schematically in Table 24. Alternatively the diagrams presented in Figures 160 and 161 may be used.

Johansen's method is a technique for interpolation between the dry and the saturated values of the thermal conductivity. It does not take into account moisture migration which may take place at intermediate saturation and significantly contribute to the effective thermal conductivity. Farouki (1966) attempted to include this effect in a comprehensive equation for the thermal conductivity of an unsaturated soil, but more experimental data are required before this equation can be used to calculate actual values.

Table 24. Method for calculating thermal conductivity of mineral soils (after Johansen 1975).

| | | | |
|-------------------------------|---|-----------------------------------|----------------------------|
| $k = (k_{sat} - k_{dry}) K_e$ | | $+ k_{dry}$ | (a) Main equation |
| Natural | $\frac{0.137\gamma_d + 64.7}{2700 - 0.947\gamma_d}$ | | (b) Dry conductivity |
| | Crushed $0.39 \cdot n^{-2.2}$ | | (c) |
| | Unfrozen | Coarse $0.7 \log S_r + 1.0$ | (d) |
| Fine $\log S_r + 1.0$ | | (e) Kersten number | |
| Frozen | S_r | | (f) |
| Unfrozen | $0.57^n \cdot k_s^{(1-n)}$ | | (g) Saturated conductivity |
| Frozen | $2.2^n \cdot k_s^{(1-n)} 0.269^{w_u}$ | | (h) |
| $q < 0.20$ Coarse | $7.7^q \cdot 2.0^{1-q}$ | | (i) Particle conductivity |
| | $7.7^q \cdot 3.0^{1-q}$ | | (j) |

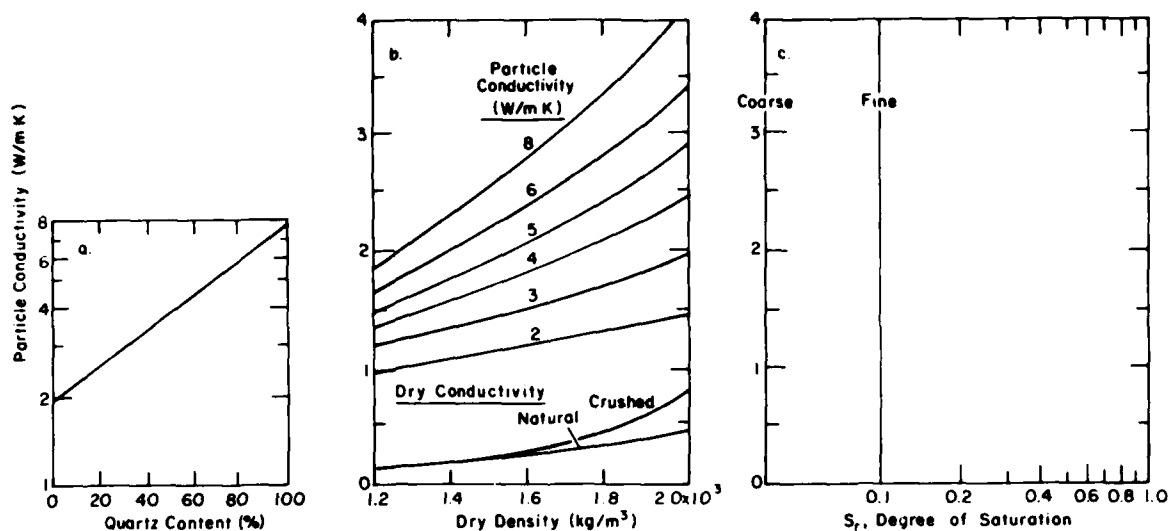

- Input variables:
1. Quartz content
 2. Crushed or natural
 3. Coarse or fine. A soil with more than 5% of material having grain size less than $2 \mu\text{m}$ is considered 'fine.'
 4. Dry density
 5. Degree of saturation

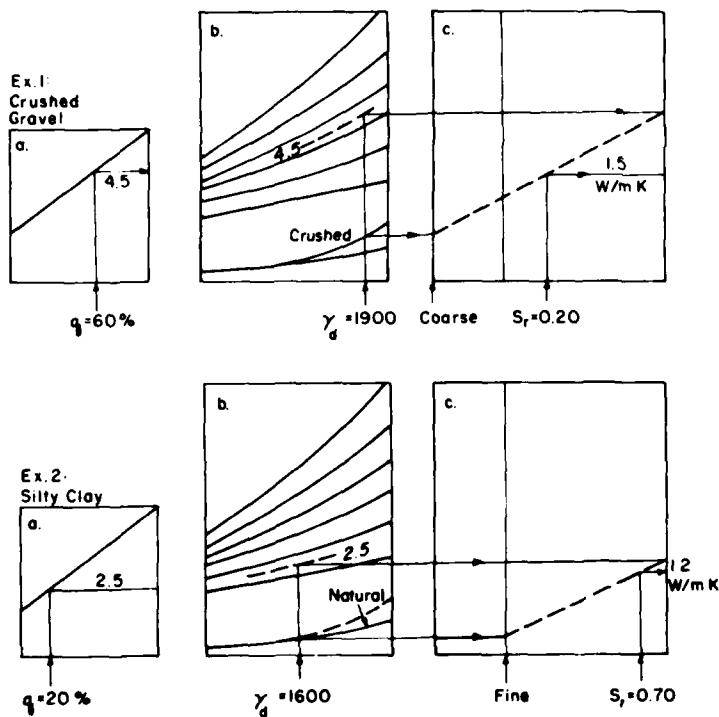

Instructions for use of the diagrams are explained by two examples: Example 1 for a coarse soil and Example 2 for a fine soil:

1. In part a, the particle thermal conductivity is estimated from the quartz content.
2. This value is then used in part b, together with the given dry density, for determining the thermal conductivity in the saturated condition.
3. The conductivity of the dry materials at the same dry density is found from the curves marked dry conductivity in part b (discriminate between crushed and natural soils).
4. From these extremes, the thermal conductivity at the actual degree of saturation is found by interpolation in part c (discriminate between coarse and fine soils).

Figure 160. Thermal conductivity of unfrozen mineral soils (after Johansen 1975).

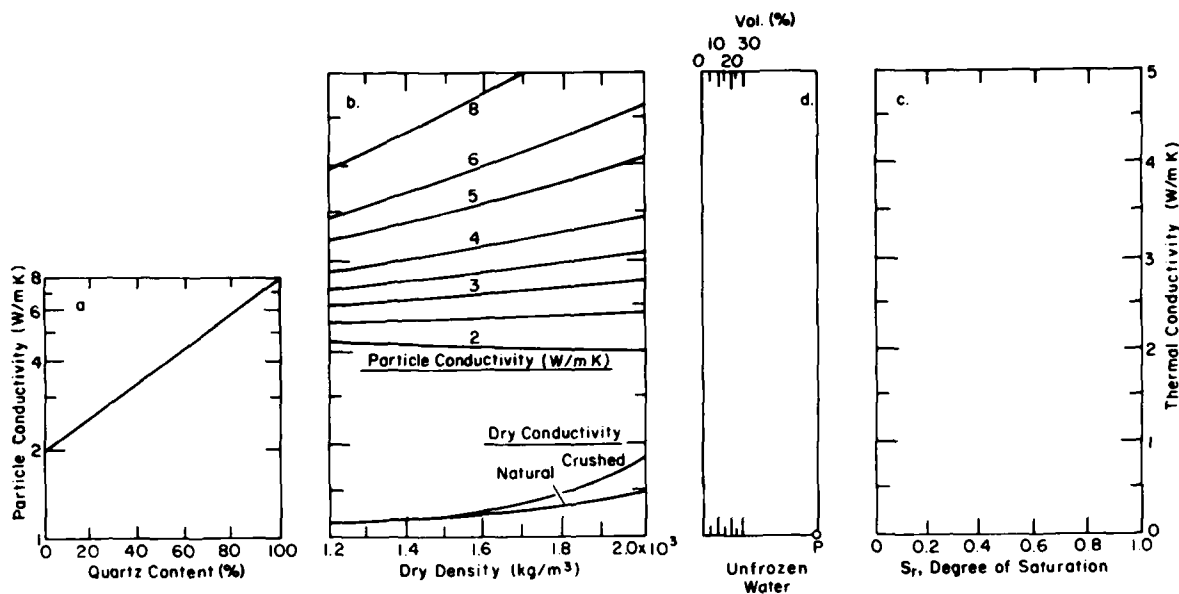

Input variables: 1. Quartz content
2. Crushed or natural
3. Dry density

4. Unfrozen water content
5. Degree of saturation

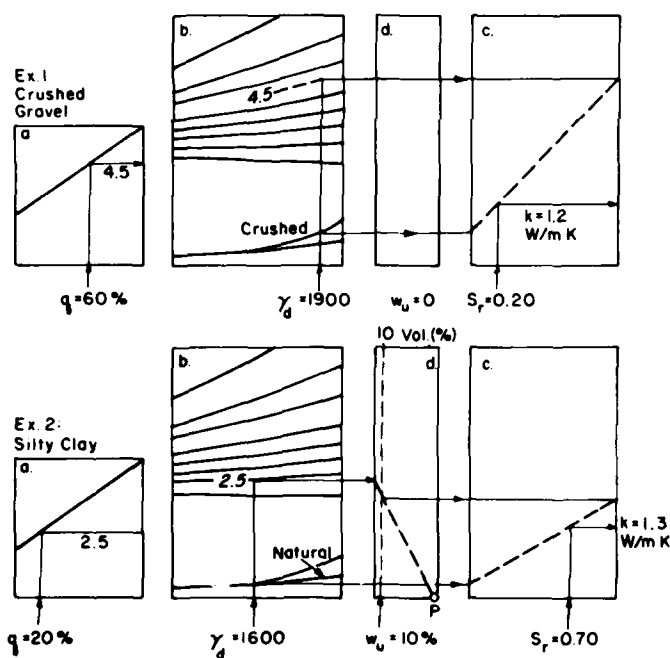

Instructions for use of the diagrams are explained by two examples: Example 1 for a coarse soil and Example 2 for a fine soil:

1. In part a the particle thermal conductivity is estimated from the quartz content.
2. This value is then used in part b, together with the given dry density, for determining the thermal conductivity in the saturated condition.
3. The conductivity of the dry materials at the same dry density is found from the curves marked dry conductivity in part b.
4. If a certain percentage of the water is unfrozen, then the saturated thermal conductivity must be reduced in the manner shown by the graphical construction in part d.
5. The thermal conductivity at the actual degree of saturation is then found by linear interpolation as in part c.

Figure 161. Thermal conductivity of frozen mineral soils (after Johansen 1975).

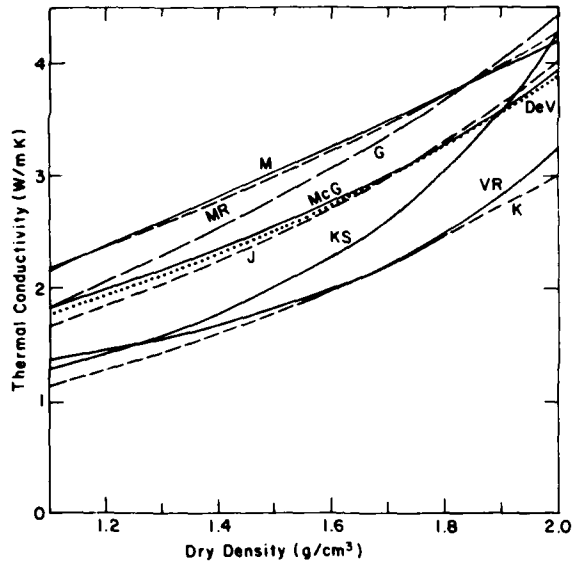

Figure 162. Comparison of the methods for calculating the thermal conductivity of saturated unfrozen coarse soil. The solids thermal conductivity is assumed to be 8.0 W/m K and the temperature 4°C. K-Kersten, M-Mickley, G-Gemant, DeV-De Vries, VR-Van Rooyen, KS-Kunii-Smith, MR-modified resistor, McG-McGaw and J-Johansen (after Farouki, in press).

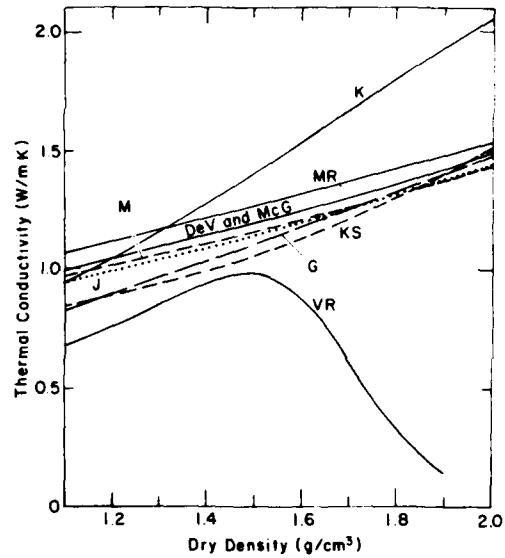

Figure 163. Comparison of the methods for calculating the thermal conductivity of saturated unfrozen fine soil. The solids thermal conductivity is assumed to be 2.0 W/m K and the temperature 4°C. K-Kersten, M-Mickley, G-Gemant, DeV-De Vries, VR-Van Rooyen, KS-Kunii-Smith, MR-modified resistor, McG-McGaw and J-Johansen (after Farouki, in press).

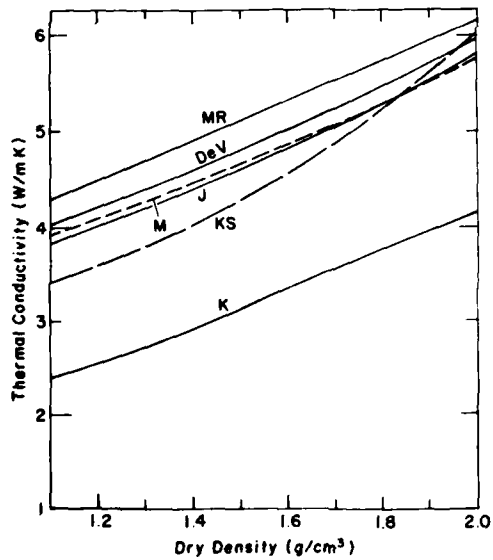

Figure 164. Comparison of the methods for calculating the thermal conductivity of saturated frozen coarse soil. The solids thermal conductivity is assumed to be 8.0 W/m K and the temperature -4°C. K-Kersten, M-Mickley, DeV-De Vries, KS-Kunii-Smith, MR-modified resistor and J-Johansen (after Farouki, in press).

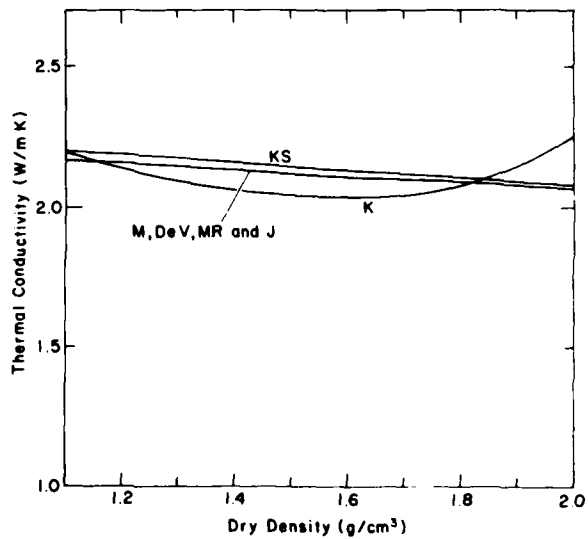

Figure 165. Comparison of the methods for calculating the thermal conductivity of saturated frozen fine soil. The solids thermal conductivity is assumed to be 2.0 W/m K and the temperature -4°C. K-Kersten, M-Mickley, DeV-De Vries, KS-Kunii-Smith, MR-modified resistor and J-Johansen (after Farouki, in press).

7.12 TRENDS SHOWN BY THE VARIOUS METHODS

The equations for thermal conductivity resulting from the various methods have been analyzed in detail by Farouki (in press). For each method, a determination was made of the sensitivity of the calculated soil thermal conductivity to variations in moisture content at constant dry density. In another series of calculations, the dry density was varied at a constant moisture content to evaluate the influence of the dry density on the thermal conductivity of the soil. These trends were determined for coarse and fine soils, unfrozen or frozen, with a range of dry densities and moisture contents. The influence of the solids thermal conductivity was also shown in detail.

Figures 162-165 give comparisons of the predictions of all the methods applicable to the saturated condition. In the computations, the values chosen for k_s were 8.0 W/m K for coarse soil and 2.0 W/m K for fine soil. These do not apply to the Kersten method, which gives the lowest curve for coarse soil (unfrozen or frozen) as it implies a k_s value of 5 W/m K (Fig. 162 and 164). For unfrozen fine soil, however, the Kersten method gives the highest values above a dry density of 1.3 g/cm³ (Fig. 163) because it implies a k_s value of about 3 W/m K for fine soils.

With regard to saturated frozen fine soil (Fig. 165), the applicable methods differ little from each other. Their predictions also do not vary much with the dry density.

7.13 EVALUATION OF THE METHODS

Farouki (in press) evaluated the various methods that have been proposed for calculating the thermal conductivity of soils. The evaluation was carried out by means of a computer program using data obtained by various experimenters on soils with stated characteristics. In particular, knowledge of the quartz content was important so that the solids thermal conductivity could be determined. The thermal conductivity predicted by each method was then computed at appropriate values of the moisture content and dry density. The deviation of this computed value from the measured value was then obtained (it was assumed that the latter was more or less accurate).

Comparison of these deviations produced by the various methods indicated which method(s) gave good agreement under the relevant conditions. The evaluation was made for moist coarse and fine soils, unfrozen or frozen, and for dry soils.

For most practical applications it is sufficient to know the thermal conductivity to within about $\pm 25\%$ of its

true value. Variation in soil properties from point to point in the field due to a lack of homogeneity could mean variations in the thermal conductivity to a similar extent. It may therefore be pointless to attempt to calculate thermal conductivity values to a higher degree of accuracy. Reasonable predictions are those that do not deviate more than about $\pm 25\%$ from measured values.

7.13.1 Applicability to unfrozen soils

The Kersten method seriously underpredicts for unfrozen coarse soils with a high quartz content and therefore should not be applied to these soils. Also it overpredicts for soils with a low quartz content. The Kersten method should therefore be applied only to those unfrozen coarse soils with an intermediate quartz content, say about 60% of the soil solids.

For degrees of saturation S_r above 0.2, the Johansen method provides the best agreement with the data for unfrozen coarse soils, giving deviations which are generally in the range of $\pm 25\%$; the methods of De Vries and Gemant generally give deviations which are a little wider. In the range of S_r values from 0.1 to 0.2, the method of De Vries gives the best agreement, with deviations between +10% and -30%, while Johansen's method is next, covering a wider range between +20% and -40%. Below an S_r value of about 0.1 none of the methods gives good predictions except Van Rooyen's. This method gives reasonable values for sands, and also generally for gravels, down to S_r values about 0.015. However it underpredicts excessively for the crushed rocks of low quartz composition; this may be because Van Rooyen's empirical equation is not based on data for such materials.

For unfrozen fine soils the Johansen method generally gives the best predictions over the whole range of S_r values. Above $S_r = 0.2$, it gives deviations lying within the range $\pm 35\%$ but below $S_r = 0.2$ they may be as low as -45%. The Kersten method may be applied above $S_r = 0.3$ when it gives deviations within the range $\pm 35\%$. The Kersten method should not be applied below $S_r = 0.3$ because it then gives excessive deviations.

7.13.2 Applicability to frozen soils

As with unfrozen coarse soils, the Kersten method overpredicts for frozen coarse soils with low quartz contents, while it underpredicts when they have a high quartz content.

For unsaturated frozen coarse soils, the Johansen method gives the best predictions. These are reasonable for S_r values above about 0.1, while below this value Johansen gives some excessive deviations, though remaining the best method. While the methods of Mickley and De Vries may be applied with good results at high S_r values (above 0.6 for Mickley and above 0.8 for

De Vries), the Johansen method is easier so that its general use is suggested for these soils.

While the predictions of the methods were compared with a limited amount of data available for unsaturated frozen fine soils, certain trends may be seen. The Kersten method provides good agreement (generally within $\pm 30\%$) up to $S_r = 0.9$. Beyond this it gives deviations that are too high for naturally occurring frozen soils. On the other hand, while the method of Johansen gives a few high deviations at S_r values below 0.1, it otherwise generally gives good predictions (within $\pm 35\%$) up to and including $S_r = 1$ (full saturation). Thus, while Kersten's method may be applied for values of S_r below 0.9, Johansen's method should be used for greater degrees of saturation. De Vries' method gives values close to Johansen's at S_r values above 0.4. Both of these methods can allow for the presence of unfrozen water in their equations, while the Kersten method is incapable of doing so.

7.13.3 Applicability to saturated soils

In a saturated soil the ratio of the thermal conductivities of the phases is low. It varies from nearly 15 for quartz-water to about 1 for clay-ice. Such a low ratio means that application of a geometric mean equation, as in the Johansen method, should give good agreement with measured values (see Section 3.2). In fact for the unfrozen soils, all the applicable methods* (except Kersten's and Van Rooyen's) gave good agreement. The resulting deviations were within the acceptable range ($\pm 25\%$). The Johansen method is easiest to use as it reduces to a simple geometric mean equation.

The situation is similar for saturated frozen coarse soils where any of the applicable methods† may be used except Kersten's. The Kersten method overpredicts for low-quartz coarse materials, frozen or unfrozen, in the saturated condition just as in the unsaturated condition.

For the saturated frozen fine soils, the methods of Johansen and De Vries give the best agreement. Moreover they are capable of taking the unfrozen water content into account, which the Kersten and other methods cannot. It is important to know the unfrozen water content present in a given fine-grained soil below 0°C . This depends in particular on the specific surface area of the soil.

One should note that the Johansen method assumes that the thermal conductivity of the unfrozen water is the same as that of ordinary water. While this may be true for a large part of the unfrozen water, previous

sections have proposed that the strongly absorbed unfrozen water (the boundary phase) may have a relatively high thermal conductivity, perhaps even higher than that of ice.

7.13.4 Applicability to dry soils

Dry soils have a high ratio of thermal conductivity between the two phases. As a result the region encompassed by the Hashin-Shtrikman bounds is wide and a geometric mean equation does not give good results. The thermal conductivity is highly sensitive to variations in microstructure (see Section 3.2). This is taken into account by the Johansen method which uses two different empirical equations, one for natural and the other for crushed materials. The former is a function only of the soil's dry density while the latter is a function of its porosity alone. This implies that the solids thermal conductivity has little effect.

The analysis of the predictions of the various methods showed that Johansen applies well to dry natural coarse soils (within $\pm 25\%$) but not to dry crushed rocks. The thermal conductivity of these was better predicted by the modified resistor or adjusted De Vries methods.* These two methods also worked well for most of the dry fine-grained soils. However, the Smith method gave the best results for a dry clay tested by Johansen (pers. comm.). This method allows for structural effects by means of a thermal structure factor. Considerations of structure and contact effects are particularly important in the case of dry soils, fine or coarse.

7.13.5 Effect of soil mineral composition

If a coarse soil has a high quartz content, the thermal conductivity of the other minerals present k_o makes little difference to the soil's thermal conductivity. On the other hand, when the quartz content is low, k_o and its variation has a considerable influence on k_s and therefore on the soil thermal conductivity. With the Johansen method, the effect of a change in k_o from 2.0 to 3.0 W/m K is to increase the deviations by 20 or 30% at intermediate S_r values for both the unfrozen and frozen conditions (Farouki, in press).

Assumption of a suitable k_s value in the Gemant method gives better agreement between its predictions and measured values. The nomogram of Makowski and Mochlinski, which is based on Gemant's equations, should therefore be redeveloped on the basis of a more suitable value for k_s . This could be calculated from the quartz content and its thermal conductivity rather than from Gemant's subsidiary equation for k_s .

* Johansen, De Vries, Gemant, Mickley, McGaw, Kunii-Smith and modified resistor.

† Johansen, De Vries, Mickley, modified resistor and Kunii-Smith.

* The Kersten method is inapplicable.

7.13.6 Summary

The best methods to apply for different types and conditions of soils are as follows (Farouki, in press):

Unfrozen coarse soils

| | |
|---------------------|---|
| 0.015 < S_r < 0.1 | Van Rooyen for sands and gravels [not for low-quartz crushed rocks] |
| 0.1 < S_r < 0.2 | De Vries |
| S_r > 0.2 | Johansen |
| Sandy silt-clay | Gemant |
| Saturated | Johansen, De Vries, modified resistor, Kunii-Smith, Mickley, Gemant, or McGaw |

Note: Kersten's method should *not* be applied to coarse soils with low or high quartz content.

Unfrozen fine soils

| | |
|-------------------|--|
| 0 < S_r < 0.1 | Johansen (increase prediction by 15%) |
| 0.1 < S_r < 0.2 | Johansen (increase prediction by 5%) |
| S_r > 0.2 | Johansen |
| Saturated | Johansen, De Vries, modified resistor, Kunii-Smith, Mickley, McGaw or Gemant |

Frozen coarse soils

| | |
|-------------|--|
| S_r > 0.1 | Johansen |
| Saturated | Johansen, De Vries, Mickley, modified resistor or Kunii-Smith |

Note: Kersten should *not* be applied to frozen coarse soils with low or high quartz content.

Frozen fine soils

| | |
|-----------------|--|
| S_r < 0.9 | Kersten |
| 0.1 < S_r < 1 | Johansen (with suitable unfrozen water content) |
| Saturated | Johansen and De Vries (Kersten should not be used where unfrozen water con- tent is appreciable) |

Dry coarse soils

| | |
|---------------|--------------------------------------|
| Natural | Johansen |
| Crushed rocks | Modified resistor, adjusted De Vries |

Dry fine soils

| | |
|---------|--------------------------------------|
| General | Modified resistor, adjusted De Vries |
| Clay | Smith |

CHAPTER 8. DISCUSSION AND CONCLUSIONS

This final chapter brings together some of the main features previously described. These are discussed and the main conclusions outlined. Some suggestions for further research are put forward.

8.1 THE CONDITION OF WATER IN SOILS

The amount and condition of water in a soil play a very important part in its thermal behavior. The complexity and peculiarity of water make it difficult to describe this role fully and to evaluate it quantitatively. Water has a dipole character leading to hydrogen bonding which has thermal implications. Water also shows hysteresis behavior. Latent heat effects due to changes in the state of water and the process of moisture migration can be important contributors to heat transfer in certain situations.

The thermal properties of freezing or frozen fine-grained soils are influenced by their unfrozen water content. Although the percentage of unfrozen water may be small, it appears to have a disproportionate effect, due perhaps to its strategic function in providing thermal bridges and continuous paths for heat transfer. Birch and Clark (1940) noted the effectiveness of adsorbed water films in maintaining good thermal contact between crystals in igneous rocks. The experimental results of Farouki (1966) showed a similar effect ascribed to the oriented water films set up by a kaolinite binder in a coarse-grained soil. This occurred as the soil dried out, a process facilitating the establishment of these films and thereby maintaining a relatively high thermal conductivity.

The freezing process in soils has been shown to be analogous to the drying process (see Sections 4.4.1 and 5.2.4). The thin unfrozen water film remaining after freezing appears to have an effect similar to that of the strongly adsorbed water layer which is still present in an air-dried soil. The suction properties and effects are similar in either case and, in fact, the amount of unfrozen water may be determined from the suction properties of the dry soil above 0°C (see Section 5.2.4). Thus, the unfrozen water films may have thermal bridging and conduction effects similar to those of adsorbed water layers at temperatures above freezing. In the case of frozen peat soils, Pavlova (1970) recognized that the reduction of the unfrozen water content with

decreasing temperatures may be responsible for less efficient thermal contact between the soil skeleton and ice.

Various considerations put forward in previous sections (Sections 4.2.2, 5.1.2 and 5.2.2) have led to the proposition that the strongly adsorbed portion of the unfrozen water present in frozen fine-grained soils may have a thermal conductivity higher than that of ordinary water, perhaps even higher than that of ice. In addition, Dostovalov and Lomonosov (1973) noted that the unfrozen water is activated more easily than is free water. Winterkorn (1969) pointed out the importance of the activation energy in improving the efficiency of the mechanism for heat conduction. While the boundary phase of the unfrozen water may have a relatively high thermal conductivity as proposed, the rest of the unfrozen water may have a thermal conductivity nearer to that of free water. Further research on the properties and behavior of the unfrozen water would be useful.

8.2 THE DEGREE OF SATURATION

The degree of saturation is an important soil parameter affecting the soil's behavior and the value of its thermal conductivity. The phase composition of soil water may depend strongly on the degree of saturation.

The thermal conductivity of a soil having a certain degree of saturation can vary within a wide region encompassed by the Hashin-Shtrikman bounds. This is so even without allowing for the various movement mechanisms and changes which the water may undergo, such as migration or changes in structure and inherent associated properties. Such changes may further increase the range of possible variations and so widen the region between the bounds.

It was shown in Chapter 4 that the degree of saturation S_r is a soil property that influences the amount of moisture migration in unfrozen soils. With a value of S_r near the optimum there is enough air space for moisture movement by vapor diffusion. It also means that some of the water is sufficiently distant from the soil surface, so that its "restraint" is less, allowing it to move away more easily in the liquid film phase.

With freezing and frozen soils similar considerations appear to apply. It was noted in Section 4.2.2 that once the degree of saturation exceeds a certain critical value

there is a jump in the percentage of frozen water. The reason appears to be that greater saturation means that the water near the interface with air is sufficiently removed from the soil mineral surface so that both its conversion to ice and the propagation of ice structure "inwards" towards the soil surface become easier. The remaining unfrozen water has a different structure because it is very much under the influence of the soil surface.*

On the basis of the data of Wolfe and Thieme (1964) it was noted in Section 4.2.2 that a frozen clay with a degree of saturation below a certain value showed a decrease in its thermal conductivity as the temperature decreased from -25°C to -60°C (approximately). Similar behavior was shown by:

1. Kersten's Healy clay, the thermal conductivity of which at low moisture content (less than 10.5%) decreased as the temperature dropped from -4°C to -29°C (at higher moisture content, the opposite effect occurred).
2. Kersten's Fairbanks silty clay loam,
3. Haynes et al.'s CRREL varved clay which also showed a tendency for the thermal conductivity to decrease at low moisture content.

The decrease in thermal conductivity at low moisture content was attributed in Section 4.2.2 to further conversion of unfrozen water to ice as the temperature dropped. This may result in a decrease in the effectiveness of heat transfer because of the loss of some of the unfrozen water and its strategic function and also because this water may possibly have a higher thermal conductivity relative to ordinary water and even to ice. Thus the conversion of such unfrozen water may have an important effect in reducing the thermal conductivity. The high contact resistance in sand-ice mixtures noted by McGaw (1968) lends support to the view that in frozen fine soils the unfrozen water plays an important part in improving thermal contacts while this effect is absent in frozen coarse soils.

Where the degree of saturation is higher than the critical value, the large amount of ice formed and the increase in its thermal conductivity with decreasing temperature have an overriding effect and lead to an increase in the overall thermal conductivity of the soil as its temperature drops well below 0°C .

The behavior of coarse soils at decreasing temperatures through and below 0°C is complicated, depending on their degree of saturation. It was noted in Section 4.2.2 that when coarse soils with a low moisture content are frozen, water is apparently drawn away from the contact bridges to form ice in the pores. This

results in a lower thermal conductivity of the frozen soil. With further decreasing temperatures, Kersten's data show that the thermal conductivity of such frozen coarse soils with a low moisture content (less than about 10%) decreases slightly as temperatures drop from 25°F to -20°F ;* on the other hand, these data show an increase in the thermal conductivity over this temperature range for coarse soils at higher moisture content.* Similar opposing trends are apparent from Johansen's (pers. comm.) data. Much of his data show an increase in the thermal conductivity of frozen coarse soils with decreasing temperatures. However, a substantial body of his data, particularly for low moisture content but also for saturated soils, show a decrease in thermal conductivity with decreasing temperature. This trend is also evident from the data of Haynes et al. (1980) on Ottawa sand and occurs despite increases in the thermal conductivity of both quartz and ice with decreasing temperature. The decrease in the soil thermal conductivity may be due to an overriding effect of the weakening of thermal bonds at the lower temperatures. Such an effect implies an increasing contact resistance, as was suggested by McGaw (1968) from his data on mixtures of Ottawa sand and ice. It is an effect which is opposite to the strengthening of thermal bonds that appears to occur in soils as the temperature increases well above 0°C (Sections 5.2.2 and 3.1.3).

The importance of the degree of saturation S_r is recognized by Johansen's method in particular, which depends explicitly on S_r , from which the Kersten number is calculated. This is then used for interpolating between the dry and the saturated values of the soil thermal conductivity, thus giving an intermediate value which depends on the degree of saturation. A thermal conductivity is thereby derived which, although having a partly empirical justification, is nevertheless based on an arbitrarily assumed variation with the degree of saturation.

At low degrees of saturation, the Johansen method appears to give particularly large deviations (Farouki, in press). Thus for unfrozen coarse soils having an S_r value less than 0.1, the Johansen method gives excessive deviations. Even when S_r is between 0.1 and 0.2, this method gives deviations of as much as -40%. The negative bias at low S_r values may be partly due to the effect of moisture migration, which is not allowed for by Johansen. For unfrozen fine soils too, the Johansen method shows a tendency to underpredict at S_r values below about 0.1. This method does not allow for the rapid increase in soil thermal conductivity due to the effect of the initial small amount of water added to a

* Anderson (1967) indicated that the silicate surface has significant effects extending at least 50A from the surface. The induced structural effects extend farther at lower temperatures.

* Sawada's (1977) data show a similar effect (Fig. 66).

dry soil. As the degree of saturation rises above 0.1 or 0.2, however, Johansen's method may tend to over-predict, as it shows a high rate of increase of the thermal conductivity with increasing moisture content.

For frozen soils, the Johansen method applies well for all degrees of saturation except that some deviations are excessive at values of S_r below about 0.1.

The thermal conductivity of peat has been expressed as a function of its degree of saturation. The relationship for unfrozen peat (Fig. 84) is different from that for frozen peat (Fig. 86).

8.3 EFFECT OF INCREASE IN TEMPERATURE ABOVE 0°C

The data of Kersten (1949), De Vries (1952a) and Johansen (pers. comm.) show an increase in the thermal conductivity of coarse soils with increasing temperature above 0°C. From his data Kersten concluded that this increase was about 4% over a temperature range from 40°F (4°C) to 70°F (21°C). Over a similar temperature range, De Vries' data on high-quartz Wageningen sand and some of Johansen's data show a larger percentage increase. For example this is about 14% for crushed rock PU9 at 58% degree of saturation.* The thermal conductivity of quartz in fact decreases by about 6% over the stated temperature range. The thermal conductivity of the other soil minerals, except feldspar, also shows a decrease with increasing temperature. This effect must be counteracted by some of the following factors, any or all of which may contribute to the measured increase in thermal conductivity with temperature:

1. The increase in the thermal conductivity of feldspar, if it is present, with temperature
2. The increase in the thermal conductivity of water with temperature
3. The increase in moisture migration and hence in the effective air thermal conductivity as the temperature increases
4. The possible improvement of thermal bonds with increasing temperature.

With regard to factor 2, the thermal conductivity of water increases by about 6% over the temperature range 4°C to 21°C. This may be allowed for in any of the methods for calculating thermal conductivity except Kersten's method. Kersten also does not allow for factor 3, moisture migration, nor does Johansen's method. De Vries (1963) found that this factor had quite a significant effect on his measurements. His method allows

* The increase is from 0.820 W/m K at 3°C to 0.938 W/m K at 20°C (Johansen pers. comm.).

for it by means of an effective air thermal conductivity which depends on temperature.

Johansen's measurements on saturated crushed rock PU9 show an increase in its thermal conductivity from 1.032 to 1.232 W/m K, which is more than 21%, over the temperature range 4°C to 21°C. Factors 1 and 2 do not appear to be capable of producing such a large effect. The strengthening of thermal bonds with increasing temperature may be a contributing factor.

8.4 MOISTURE AND HEAT TRANSFER

In many situations there is a combined transfer of moisture and heat in soils. The problem of moisture migration, with its associated heat transfer, in unsaturated soils at temperatures above 0°C has been discussed (Section 4.3). Freezing also involves moisture movement coupled with heat transfer. Some of the main unsolved problems in thermal geotechnics are connected with the combined transfer of heat and moisture in soils.

8.5 EFFECTS OF IONS AND SALTS

Section 5.3 considered the effects of ions and salts on soil water or ice and on clay structure. In particular, clay formed under saline conditions has a flocculated structure with different thermal properties than clay deposited in fresh water. The latter has a dispersed structure which is capable of more orderly arrangement. The type of ion influences soil structure formation and further research is required on this aspect and on the general effects of ions on thermal behavior. Increasing ion valence leads to increased moisture migration during freezing.

The thermal properties of solutions present in soils and of soil suspensions also merit further investigation.

8.6 ADDITIVES, CONTACTS AND INTERFACIAL EFFECTS

It has been shown that where a small amount of clay is present in a coarse soil it may have a pronounced binding effect, particularly in the nearly dry state (Farouki 1966). This leads to a considerable increase in the thermal conductivity as compared with the unbound condition (at the same moisture content). Under such circumstances, the Kersten equation can underpredict by as much as 50% (Moulton and Dubbe 1968a, b).

Bitumen or portland cement added to a coarse granular material increases its thermal conductivity appreciably (Section 5.4). Further research is required on the

thermal properties of such mixes. In particular, a full explanation is needed for the large increase in their thermal conductivity as the temperature drops through 0°C.

The thermal behavior of mixtures of sand and ice signifies the presence of a contact resistance between the two materials. This increases with decreasing negative temperature and indicates that the thermal bonds become weaker (Section 3.1.3). Further research on such bonds between different soil components at different temperatures should be useful. The transfer of heat across interfaces in soils is generally a limiting factor with respect to overall heat transfer. Determination of the efficiency of this interfacial transfer is of obvious importance. McGaw's method explicitly allows for an interfacial efficiency factor. Use of a proper value for this should improve predictions by this method, particularly at low degrees of saturation.

In frozen field soils ice banding may decrease the contacts between the solid grains. On the other hand, the presence of ice-cementation bonds may significantly improve thermal effects. These bonds are sensitive to external changes and their destruction leads to jump-type changes of porosity (Tsytoich 1963). Changes in the thermal properties may be expected in consequence.

8.7 FROZEN SOIL FACTORS

The varied structure of frozen soils means that using a parameter such as ice content is not fully descriptive of the state of the soil. Such factors as the variation in orientation of the ice crystals, ice banding and bubbles in the ice may play an important part in affecting the soil's thermal behavior. Stressed zones of ice cause changes leading to recrystallization with a reorientation of crystal axes. Changes from macrocrystallization to microcrystallization may thereby occur (Tsytoich 1963). The properties of small ice crystals in clay are different from the properties of ice in bulk.

Further research is needed on the effect of bubbles in the ice of frozen soil. It appears that bubbles may partially cause the lower measured thermal conductivity as compared with some calculated values.

The presence of unfrozen water in frozen soils and its amount are important factors which depend particularly on the temperature but also on the pressure. There is a dynamic equilibrium between unfrozen water and ice in frozen soils.

8.8 FACTORS IN MEASUREMENTS OF THERMAL CONDUCTIVITY

The probe method has certain advantages over the steady state guarded hot plate method for measuring thermal conductivity. The latter requires a considerable time for the establishment of the steady state and possibly allows appreciable moisture migration. The result is a reduction in the measured average value of the thermal conductivity. Data on moist sands presented in Section 6.3.1 showed that measurements with the probe method gave somewhat higher thermal conductivity values than those using the GHP apparatus.

In the case of dry sands or gravels, radiative heat transfer may also give rise to higher thermal conductivity values from the probe than from the GHP test. Decreasing temperature in the GHP apparatus appears to limit convectional and radiative heat transfer effects.

Some of the comparisons of the results obtained with the probe and the GHP are inconclusive. Further research on these aspects is suggested.

The transient methods of measurement, which use sinusoidal temperature waves, show much promise. In particular they eliminate the effect of moisture migration and should be further investigated.

8.9 APPLICABILITY OF THE THERMAL CONDUCTIVITY METHODS

Chapter 7 indicated the best methods for predicting soil thermal conductivity. Johansen's method generally gives the best results for unfrozen or frozen soils, coarse or fine, at degrees of saturation above 0.1. However, De Vries' method is better for unfrozen coarse soils when S_r is between 0.1 and 0.2. Below an S_r of 0.1 the methods do not generally give good predictions.

Kersten's method gives good results for frozen fine soils at S_r values below 0.9. Otherwise its predictions are not consistently good and the Johansen method is better. In particular, the Kersten method should not be applied to coarse soils (unfrozen or frozen) with either a low or high quartz content.

For saturated soils, several methods are equally applicable but Johansen's method is the easiest to use.

8.10 SUGGESTIONS FOR FURTHER RESEARCH

Various suggestions for further research have been put forward in this concluding chapter. In particular the properties and thermal effects of the unfrozen water in frozen soils need to be clarified. Does the

strongly held portion of this water indeed have a higher thermal conductivity than that of ice as suggested?

The combined transfer of heat and moisture is also an important problem which merits further study. Different mechanisms are associated with this process which takes place in both unfrozen and frozen soils.

Further research is also required on the effect of temperature on the efficiency of thermal bonds be-

tween different soil components. A general investigation of contacts and interfacial effects is important and necessary. In addition, the influence of ions, salts and additives on the thermal behavior of soils merits further research.

Regarding measurement of soil properties, further work should be done on comparative evaluation of the probe and GHP techniques under different conditions.

LITERATURE CITED

- Adivarahan, P., D. Kuntz and J.M. Smith (1962) Heat transfer in porous rocks through which single phase fluids are flowing. *Society of Petroleum Engineering Journal*, vol. 2, p. 290-296.
- Aguirre-Puente, J. and M. Fremont (1976) Frost and water propagation in porous media. *Proceedings of the Second Conference on Soil-Water Problems in Cold Regions, Edmonton, Alberta, Canada, September 1976*. Division of Hydrology, American Geophysical Union, p. 137-154.
- Al-Nakshabandi, G. and H. Kohnke (1965) Thermal conductivity and diffusivity of soils as related to moisture tension and other physical properties. *Agricultural Meteorology*, vol. 2, p. 271-279.
- American Society for Testing and Materials (1963) Thermal conductivity of materials by means of a guarded hot plate. ASTM Specification C177-63.
- Andersland, O.B. and D.M. Anderson (Eds.) (1978) *Geotechnical Engineering for Cold Regions*. New York: McGraw-Hill.
- Anderson, D.M. (1963) Discussion—Session 4. *Proceedings of First International Permafrost Conference, 11-15 November 1963, Purdue University, Lafayette, Indiana*. Building Research Advisory Board, National Academy of Sciences—National Research Council, Washington, D.C., p. 238-239.
- Anderson, D.M. (1967) The interface between ice and silicate surfaces. *Journal of Colloid and Interface Science*, vol. 25, no. 2, p. 174-191.
- Anderson, D.M. (1969) General report on thermal characteristics of soils, thermodynamics of soil systems, fluid flows, and frost action. In *Effects of Temperature and Heat on Engineering Behavior of Soils*. Highway Research Board Special Report 103, p. 6-8.
- Anderson, D.M. (1970) Phase boundary water in frozen soils. USA Cold Regions Research and Engineering Laboratory (CRREL) Research Report 274. AD 706840.
- Anderson, D.M. and P. Hoekstra (1965) Migration and crystallization of interlamellar water during freezing and thawing of Wyoming bentonite. CRREL Research Report 192. AD 631150.
- Anderson, D.M. and N.R. Morgenstern (1973) Physics, chemistry and mechanics of frozen ground: A review. *North American Contribution, Permafrost, Second International Conference, 13-28 July 1973, Yakutsk*. National Academy of Sciences, Washington, D.C., p. 257-288.
- Anderson, D.M. and A.R. Tice (1972) Predicting unfrozen water contents in frozen soils from surface area measurements. *Highway Research Record*, no. 393, p. 12-18.
- Anderson, D.M. and A.R. Tice (1973) The unfrozen interfacial phase in frozen soil water systems. In *Ecological Studies. Analysis and Synthesis* (A. Hadas et al., Eds.). Vol. 4, p. 107-124.
- Anderson, D.M., A.R. Tice and A. Banin (1974) The water-ice phase composition of clay/water systems. 1. The kaolinite/water system. CRREL Research Report 322. AD782951.
- Arman, A.N., D.M. Cherry, L. Gosland and P.M. Hollingsworth (1964) Influence of soil-moisture migration on power rating of cables in h.v. transmission systems. *Proceedings, Institution of Electrical Engineers*, vol. III, no. 5, p. 1000-1016.
- Auracher, H. (1973) Water vapor diffusion and frost in porous material. ASTM Special Technical Publication 544, p. 49-67.
- Bakulin, F.G., B.A. Savel'yev and V.F. Zhukov (1972) Physical processes in thawing ground. CRREL Draft Translation 325. AD 738672.
- Bever, L.D. and H.F. Winterkorn (1935) Sorption of liquids by soil colloids. II. Surface behavior in the hydration of clays. *Soil Science*, vol. 40, no. 5, p. 403-419.
- Bever, L.D., W.H. Gardner and W.R. Gardner (1972) *Soil Physics*. 4th ed. New York: John Wiley & Sons, Inc.
- Beakow, G. (1935) Soil freezing and frost heaving with special application to roads and railroads. Translated by J.O. Osterberg. Technological Institute, Northwestern University (1947).
- Birch, F. and H. Clark (1940) The thermal conductivity of rocks and its dependence upon temperature and composition. *American Journal of Science*, vol. 238, no. 8, p. 529-558, and no. 9, p. 613-635.
- Blackwell, H.H. (1956) The axial-flow error in the thermal-conductivity probe. *Canadian Journal of Physics*, vol. 34, p. 412-417.
- Blomquist, G.C. (1961) In *Discussion on Water and its Conduction in Soils*. Highway Research Board Bulletin 287, p. 11-18.
- Bouyoucos, G.J. (1915) Effect of temperature on the movement of water vapor and capillary moisture in soils. *Journal of Agricultural Research*, vol. 5, p. 141-172.
- Brown, W.F. (1955) Soil mixture permittivities. *Journal of Chemical Physics*, vol. 23, no. 8, p. 1514-1517.
- Cammerer, J.S. (1939) The effect of moisture on heat transmission through building and insulating materials. *Wärme-U. Kältetechnik*, vol. 41, no. 9, p. 126-135. National Research Council of Canada, Technical Translation TT-317, 1952.
- Carlsaw, H.S. and J.C. Jaeger (1959) *Conduction of Heat in Solids*. Oxford: Clarendon Press.
- Cary, J.W. (1965) Water flux in moist soil: thermal versus suction gradients. *Soil Science*, vol. 100, no. 3, p. 168-175.
- Cary, J.W. (1966) Soil moisture transport due to thermal gradients; practical aspects. *Soil Science Society of America Proceedings*, vol. 30, p. 428-433.
- Cass, L.A. and R.D. Miller (1959) Role of the electric double layer in the mechanism of frost heaving. USA Snow, Ice and Permafrost Research Establishment (SIPRE) Research Report 49. AD 237654.
- Chalmers, B. and K.A. Jackson (1970) Experimental and theoretical studies of the mechanism of frost heaving. CRREL Research Report 199. AD 714641.
- Croney, D. (1952) The movement and distribution of water in soils. *Geotechnique*, vol. 3, no. 1, p. 1-16.
- Croney, D. and J.C. Jacobs (1967) The frost susceptibility of soils and road materials. Road Research Laboratory Report LR90, Crowthorne, Berkshire, England.
- Caathy, T.I. and D.L. Townsend (1962) Pore size and field frost performance of soils. *Highway Research Bulletin* 331, p. 67-80.
- Currie, J.A. (1960) Gaseous diffusion in porous media. Part II. Dry granular materials. *British Journal of Applied Physics*, vol. 11, p. 318-324.
- Czeratzki, W. and H. Frese (1958) Importance of water in formation of soil structure. In *Water and its Conduction in Soils* (H.F. Winterkorn, Ed.). Highway Research Board Special Report 40, p. 200-211.
- Dempsey, B.J. and M.R. Thompson (1970) A heat-transfer model for evaluating frost action and temperature-related effects in multi-layered pavement systems. *Highway Research Record*, no. 342, p. 39-55.
- D'Eustachio, D. and R.E. Schreiner (1952) A study of a transient method for measuring thermal conductivity. *Transactions of the American Society of Heating and Ventilating Engineers*, vol. 58, June, p. 113-117.
- De Vries, D.A. (1952a) The thermal conductivity of soil. *Mededelingen van de Landbouwhogeschool te Wageningen*, vol. 52, no. 1, p. 1-73. Translated by Building Research Station (Library Communication No. 759), England.
- De Vries, D.A. (1952b) A nonstationary method for determining thermal conductivity of soil in situ. *Soil Science*, vol. 73, no. 2, p. 83-89.

- De Vries, D.A. (1958) Simultaneous transfer of heat and moisture in porous media. *Transactions of the American Geophysical Union*, vol. 39, no. 5, p. 909-916.
- De Vries, D.A. (1963) Thermal properties of soils. In *Physics of Plant Environment* (W.R. Van Wijk, Ed.). Amsterdam: North-Holland Publishing Company.
- De Vries, D.A. (1974) Heat transfer in soils. In *Heat and Mass Transfer in the Biosphere. I. Transfer Processes in Plant Environment* (D.A. De Vries and N.H. Afgan, Eds.). New York: John Wiley & Sons, Inc., Halsted Press.
- De Vries, D.A. and A.J. Peck (1958) On the cylindrical probe method of measuring thermal conductivity with special reference to soils. *Austr. Journal of Physics*, vol. 11, p. 225-271 and p. 409-423.
- Dimo, V.N. (1969) Physical properties and elements of the heat regime of permafrost meadow-forest soils. Delhi: Indian National Scientific Documentation Centre. CRREL Bibliography no. 24-2119.
- Dirksen, C. and R.D. Miller (1966) Closed-system freezing of unsaturated soil. *Soil Science Society of America Proceedings*, vol. 30, p. 168-173.
- Dorsey, N.E. (1940) *Properties of Ordinary Water Substance*. New York: Reinhold.
- Dostovalov, B.N. and M.V. Lomonosov (1973) Structures, phased transitions, and properties of free and attached water. In *Physics, Physical Chemistry and Mechanics of Permafrost and Ice* (N.A. Tsytoich et al., Eds.). CRREL Draft Translation 439, p. 147-159.
- Eggelsmann, R. (1972) The thermal constants of different high-bogs and sandy soil. *Proceedings of Fourth International Peat Congress, Otaniemi, Helsinki, Finland*. Finnish National Committee of the International Peat Society.
- Eucken, A. (1932) Gebiete Ingenieur, B3, VDI-Forschungsheft, p. 353.
- Everett, D.H. (1961) The thermodynamics of frost damage to porous solids. *Transactions of the Faraday Society*, vol. 57, p. 1541-1551.
- Everett, D.H. and J.M. Haynes (1965) Capillary properties of some model pore systems with special reference to frost damage. *RILEM Bulletin, New Series* 27, p. 31-38.
- Farouki, O.T. (1966) Physical properties of granular materials with reference to thermal resistivity. *Highway Research Record*, no. 128, p. 25-44.
- Farouki, O.T. (In press) Evaluation of the methods for calculating soil thermal conductivity. CRREL Report.
- Flynn, D.R. and T.W. Watson (1969) Measurements of the thermal conductivity of soils to high temperatures. Final Report (SC-CR-69-3059) prepared for Sandia Laboratories, Albuquerque (Contract No. ASB 8-6179).
- Forbes, J.D. (1849) Account of some experiments on the temperature of the Earth at different depths, and in different soils, near Edinburgh. *Transactions of the Royal Society of Edinburgh*, vol. 16, p. 189-236.
- Furnas, C.C. (1931) Grading aggregates. I. Mathematical relations for beds of broken solids of maximum density. *Industrial and Engineering Chemistry*, vol. 23, p. 1052-1058.
- Gaskin, P.N. and G.P. Raymond (1973) Pore size distribution as a frost susceptibility criterion. *Symposium on Frost Action on Roads, Oslo, Norway, October 1973*. Paris: Organisation for Economic Cooperation and Development, vol. 1, p. 295-309.
- Gemant, A. (1950) The thermal conductivity of soils. *Journal of Applied Physics*, vol. 21, Aug., p. 750-752.
- Gemant, A. (1952) How to compute thermal soil conductivities. *Heating, Piping and Air Conditioning*, vol. 24, no. 1, p. 122-123.
- German Research Service (1978) Self organization out of disorder. *Deutscher Forschungsdienst*, vol. 17, no. 10.
- Giauque, W.F. and J.W. Stout (1936) The entropy of water and the third law of thermodynamics. The heat capacity of ice from 15° to 273°K. *Journal of the American Chemistry Society*, vol. 58, p. 1144-1150.
- Gold, L.W. (1957) A possible force mechanism associated with the freezing of water in porous materials. *Highway Research Board Bulletin* 168, p. 65-73.
- Gold, L.W., G.H. Johnston, W.A. Slusarchuk and L.E. Goodrich (1972) Thermal effects in permafrost. *Proceedings, Canadian Northern Pipeline Research Conference*. National Research Council (Canada) Technical Memorandum No. 104, p. 25-39.
- Goldamid, H.J. and A.E. Bowley (1960) Thermal conduction in mica along the planes of cleavage. *Nature*, vol. 187, p. 864-865.
- Golubev, V.N. and M.V. Lomonosov (1973) Ice structure as a function of salinity of the freezing water. In *Physics, Physical Chemistry and Mechanics of Permafrost and Ice* (N.A. Tsytoich et al., Eds.). CRREL Draft Translation 439, p. 241-246.
- Gorbulnova, I.G., T.V. D'yachkova and N.V. Serova (1958) Certain results in measuring thermophysical properties of soil under natural conditions. *Trudy, Vypusk* 77, p. 79-83. (Translated by G.S. Mitchell, Weather Bureau, U.S. Department of Commerce, Washington, D.C., 1961.)
- Grim, R.E. (1958) Organization of water on clay mineral surfaces and its implications for the properties of clay-water systems. In *Water and Its Conduction in Soils* (H.F. Winterkorn, Ed.). Highway Research Board Special Report 40, p. 17-23.
- Gupalo, A.L. (1959) Thermal properties of soil as a function of its moisture and compaction. *Soviet Soil Science*, no. 4, p. 431-435.
- Guymon, G.L. and J.N. Luthin (1974) A coupled heat and moisture transport model for arctic soils. *Water Resources Research*, vol. 10, no. 5, p. 995-1001.
- Habib, P. (1957) Thermo-osmosis. *Annales de l'Institut Technique du Batiment et des Travaux Publics*, vol. 110, p. 130-136. National Research Council of Canada Technical Translation TT-708.
- Hadas, A. (1977) Evaluation of theoretically predicted thermal conductivities of soils under field and laboratory conditions. *Soil Science Society of America Proceedings*, vol. 41, p. 460-466.
- Haley, J.F. and C.W. Kaplar (1952) Cold room studies of frost action in soils. In *Frost Action in Soils, A Symposium*. Highway Research Board Special Report 2, p. 246-267.
- Hashin, Z. and S. Shtrikman (1962) A variational approach to the theory of the effective magnetic permeability of multiphase materials. *Journal of Applied Physics*, vol. 33, no. 10, p. 3125-3131.
- Haynes, D., D. Carbee and D. Vanpelt (1980) Thermal diffusivity of frozen soil. CRREL Special Report 80-38. ADA 094605.
- Henniker, J.C. and J.W. McBain (1948) The depth of a surface zone of a liquid. Stanford Research Institute Technical Report No. 6.
- Hoekstra, P. (1967) Moisture movement to a freezing front. In *Geochemistry, Precipitation, Evaporation, Soil-Moisture, Hydrometry*. International Union of Geodesy and Geophysics, General Assembly of Bern, October 1967, p. 411-417.
- Hoekstra, P. (1969) The physics and chemistry of frozen soils. In *Effects of Temperature and Heat on Engineering Behavior of Soils*. Highway Research Board Special Report 103, p. 78-90.
- Hoekstra, P., A. Delaney and R. Atkins (1973) Measuring the thermal properties of cylindrical specimens by the use of sinusoidal temperature waves. CRREL Technical Report 244. AD 770425.
- Higashi, A. (1953) On the thermal conductivity of soil, with special reference to that of frozen soil. *Transactions of the American Geophysical Union*, vol. 34, no. 5, p. 737-748.
- Higashi, A. (1958) Experimental study of frost heaving. SIPRE Research Report 45. AD 214672.
- Highway Research Board (1961) Supplementary note on work of Caron and Szuk by H.F. Winterkorn. In *Discussion on water and its conduction in soils*. Highway Research Board Bulletin 287, p. 73-80.
- Hooper, F.C. and F.R. Lepper (1950) Transient heat flow apparatus for the determination of thermal conductivities. *Heating, Piping and Air Conditioning*, vol. 22, no. 8, p. 129-134.

- Horai, K. (1971) Thermal conductivity of rock-forming minerals. *Journal of Geophysical Research*, vol. 76, no. 5, p. 1278-1308.
- Huang, J.H. (1971) Effective thermal conductivity of porous rocks. *Journal of Geophysical Research*, vol. 76, no. 26, p. 6420-6427.
- Hubbard, J.H., E.S. Gall and H.S. Kahn (1969) Lunar soil simulant study, Phase B. Part II: Thermal conductivity. U.S. Army Corps of Engineers, Ohio River Division Labs., Cincinnati, Ohio, Technical Report 4-83.
- Hutcheon, W.L. (1958) Moisture flow induced by thermal gradients within unsaturated soils. In *Water and Its Conduction in Soils* (H.F. Winterkorn, Ed.). Highway Research Board Special Report 40, p. 113-133.
- Hutcheon, N.B. and J.A. Paxton (1952) Moisture migration in a closed, guarded hot plate. *Heating, Piping and Air Conditioning*, April, p. 113-122.
- Hutt, J.R. and J.W. Berg (1968) Thermal and electrical conductivities of sandstone rocks and ocean sediments. *Geophysics*, vol. 33, no. 3, p. 489-500.
- Izotov, V.F. (1968) Pattern of soil freezing and thawing in the water-logged forests of the northern taiga subzone. *Soviet Soil Science*, no. 6, June, p. 807-813.
- Jackson, A.J., J. Adams and R.C. Millar (1977) Thermal conductivity measurements on high temperature fibrous insulations by the hot wire method. Paper presented at *Symposium on Advances in Heat Transmission Measurements on Thermal Insulations, 19-20 September 1977, Philadelphia, Pennsylvania*. American Society of Testing and Materials.
- Jackson, K.A., B. Chalmers and G. McKay (1957) Study of ice formation in soils. Arctic Construction and Frost Effects Laboratory (ACFEL) Technical Report 65. AD 134951.
- Jaeger, J.C. (1956) Conduction of heat in an infinite region bounded internally by a circular cylinder of a perfect conductor. *Austr. Journal of Physics*, vol. 9, p. 167-179.
- Jame, Y. and D.I. Norum (1976) Heat and mass transfer in freezing unsaturated soil in a closed system. *Proceedings of Second Conference on Soil-Water Problems in Cold Regions, Edmonton, Alberta, Canada, September 1976*. Division of Hydrology, American Geophysical Union, p. 46-56.
- Janson, L. (1963) Frost penetration in sandy soil. Elanders Boktryckeri, Goteborg, Sweden, 165 p.
- Johansen, O. (1975) Thermal conductivity of soils. Ph.D. thesis, Trondheim, Norway. (CRREL Draft Translation 637, 1977). ADA 044002.
- Johansen, O. (1977) Frost penetration and ice accumulation in soils. *Proceedings of International Symposium on Frost Action in Soils, University of Lulea, Sweden*, vol. 1, p. 102-111.
- Johnson, A.W. (1952) Frost action in roads and airfields. A review of the literature, 1765-1961. Highway Research Board Special Report 1.
- Jones, H.E. and H. Kohnke (1952) The influence of soil moisture tension on vapor movement of soil water. *Soil Science Society of America Proceedings*, vol. 16, p. 245-248.
- Joshua, W.D. and E. De Jong (1973) Soil moisture movement under temperature gradients. *Canadian Journal of Soil Science*, vol. 53, p. 49-57.
- Judge, A.S. (1973a) The measurement of thermal conductivity of earth materials. In *Proceedings of Seminar on the Thermal Regime and Measurements in Permafrost, May 1972*. National Research Council of Canada, Technical Memorandum 108.
- Judge, A.S. (1973b) The thermal regime of the Mackenzie Valley: Observations of the natural state. Environmental-Social Committee on Northern Pipelines, Report No. 73-38.
- Judge, A.S. and A.E. Beck (1973) Analysis of heat-flow data—several boreholes in a sedimentary basin. *Canadian Journal of Earth Sciences*, vol. 10, p. 1494-1587.
- Jumikis, A.R. (1957) Soil moisture transfer in the vapor phase upon freezing. *Highway Research Board Bulletin* 168, p. 96-115.
- Jumikis, A.R. (1962) Effective soil moisture transfer mechanisms upon freezing. *Highway Research Board Bulletin* 317, p. 1-8.
- Jumikis, A.R. (1967) Amount of soil moisture transferred in a thermo-osmotic process of freezing as a function of porosity of soil. *Highway Research Record*, no. 209, p. 86-92.
- Kaplar, C.W. (1970) Phenomenon and mechanism of frost heaving. *Highway Research Record*, no. 304, p. 1-13.
- Kaplar, C.W. (1971) Evaluation of a 20-inch guarded hot plate thermal conductivity apparatus, range -50°F to $+250^{\circ}\text{F}$. CRREL Special Report 137. AD 727668.
- Kasameyer, P.W., R.P. VonHerzen and G. Simmons (1972) Layers of high thermal conductivity in the North Atlantic. *Journal of Geophysical Research*, vol. 77, no. 17, p. 3162-3167.
- Kavianipour, A. and J.V. Beck (1977) Thermal property estimation utilizing the Laplace transform with application to asphaltic pavement. *International Journal of Heat and Mass Transfer*, vol. 20, p. 259-267.
- Kay, B.D. and J.B. Goit (1975) Temperature-dependent specific heats of dry soil materials. *Canadian Geotechnical Journal*, vol. 12, p. 209-212.
- Kay, B.D., D.B. Hons and J.B. Goit (1975) Thermophysical characteristics of the surface tier of an organic soil. In *Proceedings of Conference on Soil-Water Problems in Cold Regions, Calgary, Alberta, May 1975*. American Geophysical Union, p. 112-127.
- Kennedy, G.F. and J. Lielmezs (1973) Heat and mass transfer of freezing water-soil system. *Water Resources Research*, vol. 9, no. 2, p. 395-400.
- Kerston, M.S. (1949) Laboratory research for the determination of the thermal properties of soils. ACFEL Technical Report 23. AD 712516. (Also, Thermal properties of soils. University of Minnesota Engineering Experiment Station Bulletin No. 28.)
- Kerston, M.S. (1951) Discussion of paper by A.S. Mickley entitled "The thermal conductivity of moist soil." *American Institute of Electrical Engineers Transactions*, vol. 70, p. 1789-1797.
- Kerston, M.S. (1952) Thermal properties of soils. Highway Research Board Special Report 2, p. 161-166.
- Kerston, M.S. (1963) Thermal properties of frozen ground. *Proceedings, First International Conference on Permafrost, 11-15 November 1963, Lafayette, Indiana*. Building Research Advisory Board, National Academy of Sciences-National Research Council, Washington, D.C., p. 301-305.
- Kingery, W.D. (1959) Thermal conductivity. XIV, Conductivity of multi-component systems. *Journal of the American Ceramic Society*, vol. 42, no. 12, p. 617-627.
- Kirkham, D. and N.L. Powell (1971) Simultaneous flow of water and heat in water-unsaturated Iowa soils during evaporation. Report to Iowa State Water Resources Research Institute, Iowa State University.
- Kolbuszewski, J. (1965) Sand particles and their density. Materials Science Club's Symposium on Densification of Particulate Materials, London, England.
- Kolyasov, F.E. and A.I. Gupalo (1958) On the correlation of heat and moisture properties of soils. In *Water and Its Conduction in Soils* (H.F. Winterkorn, Ed.). Highway Research Board Special Report 40, p. 106-112.
- Kondrat'eva, A.S. (1945) Thermal conductivity of the snow cover and physical processes caused by the temperature gradient. *SizPRE Translation* 22, 1954.
- Koopmans, R.W.R. and R.D. Miller (1966) Soil freezing and soil water characteristic curves. *Soil Science Society of America Proceedings*, vol. 30, p. 680-685.
- Krischer, O. and H. Rohlfalter (1940) Wärmeleitung und Dampfdiffusion in feuchten Gutern, Verein Deut. Ing., Forschungsheft 402.

- Kudryavtsev, V.A., E.D. Yershov and V.G. Cheverev (1973) Migration of moisture in fine-grained soil of different composition, structure, and properties. In *Physics, Physical Chemistry and Mechanics of Permafrost and Ice* (N.A. Tsyrovich, et al. Eds.). CRREL Draft Translation 439, p. 160-173.
- Kudryavtsev, V.A. et al. (1974) Fundamentals of frost forecasting in geological engineering investigations. CRREL Draft Translation 606. ADA 039677.
- Kunii, D. and J.M. Smith (1960) Heat transfer characteristics of porous rocks. *American Institute of Chemical Engineers Journal*, vol. 6, no. 1, p. 71-78.
- Lachenbruch, A.H. (1957) A probe for the measurement of the thermal conductivity of frozen soils in place. *Transactions of the American Geophysical Union*, vol. 38, no. 5, p. 691-697.
- Lachenbruch, A.H. (1959) Periodic heat flow in a stratified medium with application to permafrost problems. U.S. Geological Survey Bulletin 1083-A, 36 p.
- Lange, G.R. and H.L. McKim (1963) Saturation, phase composition, and freezing-point depression in a rigid soil model. In *Proceedings, First International Conference on Permafrost, 11-15 November 1963, Lafayette, Indiana*. Building Research Advisory Board, National Academy of Sciences-National Research Council, Washington, D.C., p. 187-191.
- Langsoth, M.G., F.E. Ruccia and A.E. Wechsler (1973) Thermal conductivity of evacuated glass beads: Line source measurements in a large volume bead bed between 225 and 300K. American Society for Testing and Materials, Special Technical Publication 544, p. 256-274.
- Linell, K.A. (1973) Long-term effects of vegetative cover on permafrost stability in an area of discontinuous permafrost. *North American Contribution, Permafrost, Second International Conference, 13-28 July 1973, Yakutsk*. National Academy of Sciences, Washington, D.C., p. 688-693.
- Linell, K.A. and C.W. Kaplar (1959) The factor of soil and material type in frost action. *Highway Research Board Bulletin* 225, p. 81-128.
- Linell, K.A. and C.W. Kaplar (1966) Description and classification of frozen soils. CRREL Technical Report 150. AD 800034.
- Lovell, C.W. (1957) Temperature effects on phase composition and strength of partially-frozen soil. *Highway Research Board Bulletin* 168, p. 74-95.
- Lovell, C.W. and M. Herrin (1953) Review of certain properties and problems of frozen ground, including permafrost. SIPRE Technical Report 9. AD 014616.
- Low, P.F. (1961) In *Discussions on Water and Its Conduction in Soils*. *Highway Research Board Bulletin* 287, p. 7-10.
- Low, P.F., D.M. Anderson and P. Hoekstra (1968) Some thermodynamic relationships for soils at or below the freezing point. 1. Freezing point depression and heat capacity. *Water Resources Research*, vol. 4, no. 2, p. 379-394.
- Low, P.F. and C.W. Lovell (1959) The factor of moisture in frost action. *Highway Research Board Bulletin* 225, p. 23-44.
- Luikov, A.V. (1966) *Heat and Mass Transfer in Capillary-porous Bodies*. New York: Pergamon Press.
- MacFarlane, I.C. (Ed.) (1969) *Muskeg Engineering Handbook*. Toronto: University of Toronto Press.
- MacFarlane, I.C. and G.P. Williams (1974) Histosols: Their characteristics, classification and use. Soil Science Society of America Special Publication No. 6.
- masowski, M.W. and K. Mochlinski (1956) An evaluation of two rapid methods of assessing the thermal resistivity of soil. *Proceedings of Institution of Electrical Engineers (London)*, vol. 103, part A, no. 11, p. 453-469.
- Martin, R.T. (1959) Rhythmic ice banding in soils. *Highway Research Board Bulletin* 218, p. 11-23.
- Martynov, G.A. (1959) Heat and moisture transfer in freezing and thawing soils. In *Principles of Geocryology*. National Research Council of Canada, Technical Translation 1065, Chapter VI.
- Masamune, S. and J.M. Smith (1963) Thermal conductivity of beds of spherical particles. *Industrial and Engineering Chemistry Fundamentals*, vol. 2, no. 2, p. 136-143.
- Mason, V.V. and M. Kurtz (1952) Rapid measurement of the thermal resistivity of soil. *American Institute of Electrical Engineers Transactions*, vol. 71, Aug., p. 570-577.
- McGaw, R. (1968) Thermal conductivity of compacted sand/ice mixtures. *Highway Research Record* no. 125, p. 35-47.
- McGaw, R. (1969) Heat conduction in saturated granular materials. In *Effects of Temperature and Heat on Engineering Behavior of Soils*. Highway Research Board Special Report 103, p. 114-131.
- McGaw, R. (1974) Thermal conductivity of organic sediments from two Wisconsin lakes. CRREL Special Report 129. ADA 025086.
- McGaw, R. (1977) Thermal conductivity measurements on New Jersey pavement materials. In *Improved Drainage and Frost Action Criteria for New Jersey Pavement Design* (by R.L. Berg and R. McGaw). CRREL Special Report 78-9. ADA 055785.
- McGaw, R. and A.R. Tice (1976) A simple procedure to calculate the volume of water remaining unfrozen in a freezing soil. *Proceedings of Second Conference on Soil-Water Problems in Cold Regions, Edmonton, Alberta, September 1976*. Division of Hydrology, American Geophysical Union, p. 114-122.
- McGaw, R., S.I. Outcalt and E. Ng (1978) Thermal properties and regime of wet tundra soils at Barrow, Alaska. *Proceedings of the Third International Conference on Permafrost, July 10-13, 1978, Edmonton, Alberta, Canada*. National Research Council of Canada, Ottawa, vol. 2, p. 48-53.
- Merriam, R., A. Wechsler, R. Boorman and B. Davies (1975) Insulated hot oil-producing wells in permafrost. *Journal of Petroleum Technology*, March, p. 357-365.
- Merrill, R.B. (1968) Thermal conduction through an evacuated idealized powder over the temperature range of 100 to 500°K. Ph.D. dissertation, Brigham Young University.
- Mickley, A.S. (1949) The thermal movement of moisture in soil. *American Institute of Electrical Engineers Transactions*, vol. 68, p. 330-335.
- Mickley, A.S. (1951) The thermal conductivity of moist soil. *American Institute of Electrical Engineers Transactions*, vol. 70, p. 1789-1797.
- Miller, M.N. (1969) Bounds for effective electrical, thermal and magnetic properties of heterogeneous materials. *Journal of Math. Phys.*, vol. 10, no. 11, p. 1988-2004.
- Miller, R.D. (1963) Phase equilibria and soil freezing. *Proceedings of First International Permafrost Conference, 11-15 November 1963, Lafayette, Indiana*. Building Research Advisory Board, National Academy of Sciences-National Research Council, Washington, D.C., p. 193-197.
- Miller, R.D., J.P.G. Loch and E. Bresler (1975) Transport of water and heat in a frozen permeameter. *Soil Science Society of America Proceedings*, vol. 39, p. 1029-1036.
- Mitchell, J.K. (1964) Shearing resistance of soils as a rate process. *Proceedings of American Society of Civil Engineers*, vol. 90, no. SM1.
- Mitchell, J.K. and T.C. Kao (1978) Measurement of soil thermal resistivity. *ASCE Proceedings, Journal of the Geotechnical Engineering Division*, Oct., p. 1307-1320.
- Mochlinski, K. (1964) Some industrial measurements of thermal properties of soil. In *International Study Group on Soils. Lectures at meeting in Cambridge, England, July 12-26*. p. 168-178.
- Moench, A.F. and D.D. Evans (1970) Thermal conductivity and diffusivity of soil using a cylindrical heat source. *Soil Science Society of America Proceedings*, vol. 34, p. 377-381.
- Mohan, A. (1975) Heat transfer in soil-water-ice systems. *Journal of the Geotechnical Engineering Division (ASCE)*, Feb., p. 97-113.
- Moulton, L.K. and E.C. Dubbe (1968a) A study of the relationship between air temperatures and depth of frost penetration as related to pavement performance of West Virginia's highways. Final Report. Research Project No. 7. Engineering Experiment Station, West Virginia University.

- Moulton, L.K. and E.C. Dubbe (1968b) Prediction of the depth of frost penetration in West Virginia for pavement design purposes. Technical Supplement to the Final Report. Engineering Experiment Station, West Virginia University.
- Mukhetdinov, N.A. (1969) Thermal regime of the downstream shoulder of rockfill dams. CRREL Draft Translation 586. ADA 035988.
- Mukhetdinov, N.A. (1971) Effect of nonlinear air filtration on thermal regime of rock-fill dams. CRREL Draft Translation 580. ADA 036092.
- Murrmana, R.P. (1973) Ionic mobility in permafrost. *North American Contribution, Permafrost, Second International Conference, 13-28 July, Yakutsk*. National Academy of Sciences, Washington, D.C., p. 352-359.
- Nakano, Y. and J. Brown (1971) Effect of a zone of finite width on the thermal regime of soils. *Water Resources Research*, vol. 7, no. 5, p. 1226-1233.
- Nakano, Y. and J. Brown (1972) Mathematical modeling and validation of the thermal regimes in tundra soils, Barrow, Alaska. *Arctic and Alpine Research*, vol. 4, no. 1, p. 19-38.
- Nerpin, S.V. (1974) Thermodynamic and rheological peculiarities of soil water and their role in energy and mass transfer. In *Heat and Mass Transfer in the Biosphere. 1. Transfer Processes in Plant Environment* (D.A. De Vries and N.H. Afgan, Eds.). New York: John Wiley and Sons, Inc. Halsted Press, p. 49-65.
- Neresova, Z.A. and N.A. Tsytoich (1963) Unfrozen water in frozen soils. *Proceedings of First International Permafrost Conference, 11-15 November 1963, Lafayette, Indiana*. Building Research Advisory Board, National Academy of Sciences-National Research Council, Washington, D.C., p. 230-234.
- Nixon, J.F. (1975) The role of convective heat transport in the thawing of frozen soils. *Canadian Geotechnical Journal*, vol. 12, p. 425-429.
- Nixon, J.F. and E.C. McRoberts (1973) A study of some factors affecting the thawing of frozen soils. *Canadian Geotechnical Journal*, vol. 10, p. 439-452.
- Onchukov, D.N. and V.P. Ostapchik (1962) Laboratory studies of the transfer of heat and water in soil samples. *Soviet Soil Science*, p. 661-664.
- Orchard, R.S., C.C. Barnes, P.M. Hollingsworth and K. Mochlinski (1960) Soil thermal resistivity. A practical approach to its assessment and its influence on the current rating of buried cables. *Proceedings, Conference Internationale des Grands Réseaux Electriques a Haute Tension, Paris, 12-25 June 1960*.
- Orlov, V.O. (1973) Some heave laws of freezing ground. In *Physics, Physical Chemistry and Mechanics of Permafrost and Ice* (N.A. Tsytoich et al., Eds.). CRREL Draft Translation 439, p. 108-112.
- Outcalt, S. (1976) A numerical model of ice lensing in freezing soils. *Proceedings of the Second Conference on Soil-Water Problems in Cold Regions, Edmonton, Alberta, September 1976*. Division of Hydrology, American Geophysical Union, p. 63-74.
- Palmer, G. (1948) Thermal conductivity of liquids. *Industrial Engineering Chemistry*, vol. 40, no. 1, p. 89-92.
- Palmer, A.C. (1967) Ice lensing, thermal diffusion and water migration in freezing soil. *Journal of Glaciology*, vol. 6, no. 47, p. 681-694.
- Patten, H.E. (1909) Heat transference in soils. U.S. Department of Agriculture, Bureau of Soils Bulletin 59.
- Pavlova, K.K. (1970) Phase composition of water and thermophysical characteristics of frozen peat in the study of infiltration. *Soviet Hydrology: Selected Papers*, Issue no. 4, p. 361-378.
- Pearce, D.C. and L.W. Gold (1959) Observations of ground temperature and heat flow at Ottawa, Canada. *Journal of Geophysical Research*, vol. 64, no. 9, p. 1293-1298.
- Penman, H.L. (1940) Gas and vapour movements in the soil. 1. The diffusion of vapours through porous solids. *Journal of Agricultural Science*, vol. 30, p. 438-461.
- Penner, E. (1957) Soil moisture tension and ice segregation. *Highway Research Board Bulletin 168*, p. 50-64.
- Penner, E. (1960) The importance of freezing rate in frost action in soils. *American Society for Testing and Materials Proceedings*, vol. 60, p. 1151-1165.
- Penner, E. (1962) Thermal conductivity of saturated Leda clay. *Geotechnique*, vol. 12, no. 2, p. 168-175.
- Penner, E. (1963a) Frost-heaving in soils. *Proceedings of First International Permafrost Conference, 11-15 November 1963, Lafayette, Indiana*. Building Research Advisory Board, National Academy of Sciences-National Research Council, Washington, D.C., p. 197-202.
- Penner, E. (1963b) Anisotropic thermal conduction in clay sediments. *Proceedings, International Clay Conference, Stockholm*, vol. 1, p. 365-376. Elmsford, N.Y.: Pergamon Press.
- Penner, E. (1970) Thermal conductivity of frozen soils. *Canadian Journal of Earth Sciences*, vol. 7, p. 982-987.
- Penner, E. (1971) Soil moisture redistribution by ice lensing in freezing soils. *Proceedings, 17th Annual Meeting, Canadian Society of Soil Science, Lethbridge, Alberta, July 1971*, p. 44-62.
- Penner, E. (1972) Discussion. In *Proceedings of Seminar on the Thermal Regime and Measurements in Permafrost, May 1972*. National Research Council, Ottawa, Technical Memorandum 108, p. 44-46.
- Penner, E., G.H. Johnston and L.E. Goodrich (1975) Thermal conductivity laboratory studies of some Mackenzie Highway soils. *Canadian Geotechnical Journal*, vol. 12, no. 3, p. 271-288.
- Permafrost Conference (1963) Moderators' report. *Proceedings of First International Permafrost Conference, 11-15 November 1963, Lafayette, Indiana*. Building Research Advisory Board, National Academy of Sciences-National Research Council, Washington, D.C., p. 549-556.
- Philip, J.R. and D.A. De Vries (1957) Moisture movement in porous material under temperature gradients. *Transactions of the American Geophysical Union*, vol. 38, p. 222-232.
- Pihlainen, J.A. (1963) A review of muskeg and its associated engineering problems. CRREL Technical Report 97. AD 434077.
- Plamondon, F.A., T.A. Black and B.C. Goodell (1972) The role of hydrologic properties of the forest floor in watershed hydrology. *National Symposium on Watersheds in Transition, Ft. Collins, Colorado, June 1972*. American Water Resources Association, p. 341-348.
- Purushothamaraj, P. and A. Judge (1977) Thermal conductivity of soil solids. Unpublished paper from the Earth Physics Branch, National Research Council, Canada.
- Pusch, R. (1973a) Influence of salinity and organic matter on the formation of clay microstructure. *Proceedings, International Symposium on Soil Structure, Gothenburg, Sweden*, vol. 1, p. 161-173.
- Pusch, R. (1973b) Theme 3. Physico-chemical processes which affect soil structure and vice versa. *Proceedings, International Symposium on Soil Structure, Gothenburg, Sweden*, vol. 2, p. 27-35.
- Ratcliffe, E.H. (1959) Thermal conductivities of fused and crystalline quartz. *British Journal of Applied Physics*, vol. 10, Jan., p. 22-25.
- Ratcliffe, E.H. (1960) The thermal conductivities of ocean sediments. *Journal of Geophysical Research*, vol. 65, no. 5, p. 1535-1541.
- Reed, M.A. (1977) Frost heaving rate of silty soils as a function of pore size distribution. Joint Highway Research Project JHRP-77-15, Interim Report, Purdue University, West Lafayette, Indiana, Sept.
- Reno, W.H. and H.F. Winterkorn (1967) Thermal conductivity of kaolinite clay as a function of type of exchange ion, density and moisture content. *Highway Research Record* no. 209, p. 79-85.
- Rollins, R.L., M.G. Spangler and D. Kirkham (1954) Movement of soil moisture under a thermal gradient. *Highway Research Board Proceedings*, vol. 34, p. 492-508.

- Ross, C.W. (1968) Water transport in soil with a daily temperature wave. *Australian Journal of Soil Research*, vol. 6, p. 31-57.
- Ross, D.A. (1963) Water movement in porous materials. II. The separation of the components of water movement. *British Journal of Applied Physics*, vol. 14, p. 491 on.
- Russell, H.W. (1935) Principles of heat flow in porous insulators. *Journal of the American Ceramic Society*, vol. 18, no. 1, p. 1-5.
- Seal, R.N.J. (1950) Physical properties of asphaltic bitumen. In *The Properties of Asphaltic Bitumen* (J. Pfeiffer, Ed.). New York: Elsevier.
- Sanger, F.J. (1963) Degree-days and heat conduction in soils. *Proceedings of First International Permafrost Conference, 11-15 November 1963, Lafayette, Indiana*. Building Research Advisory Board, National Academy of Sciences-National Research Council, Washington, D.C., p. 253-262.
- Sanger, F.J. (1968) Ground freezing in construction. *Proceedings, ASCE, Journal of Soil Mechanics and Foundations Division*, vol. 94, no. SM1, Proceedings Paper 5743, p. 131-158.
- Sass, J.H. (1965) The thermal conductivity of fifteen feldspar specimens. *Journal of Geophysical Research*, vol. 70, no. 16, p. 4064-4065.
- Sass, J.H., R.J. Munroe and A.H. Lachenbruch (1968) Measurement of geothermal flux through poorly consolidated sediments. *Earth and Planetary Science Letters*, vol. 4, no. 4, p. 293-298.
- Sass, J.H., A.H. Lachenbruch and R.J. Munroe (1971) Thermal conductivity of rocks from measurements on fragments and its application to heat flow determinations. *Journal of Geophysical Research*, vol. 76, no. 4, p. 3391-3401.
- Sawada, S. (1977) Temperature dependence of thermal conductivity of frozen soil. Kitami Technical College, Kirami, Hokkaido, Japan, Research Report, vol. 9, no. 1.
- Schwerdtfeger, P. (1970) The measurement of heat flow in the ground and the theory of heat flux meters. CRREL Technical Report 232. AD 717027.
- Scott, R.F. (1963) *Principles of Soil Mechanics*. Reading, Mass.: Addison-Wesley.
- Scott, R.F. (1964) Heat exchange at the ground surface. CRREL Cold Regions Science and Engineering Monograph II-A1. AD 449434.
- Scott, R.F. (1969) The freezing process and mechanics of frozen ground. CRREL Cold Regions Science and Engineering Monograph II-D1. AD 697136.
- Shannon, W.L. and W.A. Wells (1947) Tests for thermal diffusivity of granular materials. *Proceedings, American Society for Testing and Materials*, vol. 47, p. 1044-1055.
- Skaven-Haug, Sv. (1963) Control of frost penetration in Norway. *Proceedings, First International Permafrost Conference, 11-15 November 1963, Lafayette, Indiana*. Building Research Advisory Board, National Academy of Sciences-National Research Council, Washington, D.C., p. 268-272.
- Slusarchuk, W.A. and P.H. Foulger (1973) Development and calibration of a thermal conductivity probe apparatus for use in the field and laboratory. Division of Building Research, National Research Council, Ottawa, Technical Paper 388.
- Slusarchuk, W.A. and G.H. Watson (1975) Thermal conductivity of some ice-rich permafrost soils. *Canadian Geotechnical Journal*, vol. 12, no. 3, p. 413-424.
- Smith, W.O. (1939) Thermal conductivities in moist soils. *Proceedings, Soil Science Society of America*, vol. 4, p. 32-40.
- Smith, W.O. (1942) The thermal conductivity of dry soil. *Soil Science*, vol. 53, p. 435-459.
- Smith, W.O. (1943) Thermal transfer of moisture in soils. *Transactions, American Geophysical Union*, vol. 24, p. 511-523.
- Smith, W.O. and M.G. Byers (1938) The thermal conductivity of dry soils of certain of the great soil groups. *Soil Science Society of America Proceedings*, vol. 3, p. 13-19.
- Smith, W.O., P.D. Foote and P.F. Busang (1929) Packing of homogeneous spheres. *Physical Review*, vol. 34, p. 1271-1274.
- Sutherland, H.B. and P.N. Gaskin (1973) Pore water and heaving pressures developed in partially frozen soils. *North American Contribution, Permafrost, Second International Conference, 13-28 July 1973, Yakutsk*. National Academy of Sciences, Washington, D.C., p. 409-419.
- Swenson, E.G. and P.J. Sereda (1953) Preliminary experiments on the movement of water through concrete and other materials due to a temperature gradient. *Proceedings, Building Research Conference, Ottawa, Canada, October 1953*, p. 102-109.
- Taber, S. (1916) The growth of crystals under external pressure. *American Journal of Science*, vol. 41, p. 544-545.
- Taber, S. (1929) Frost heaving. *Journal of Geology*, vol. 37, no. 5, p. 428-416.
- Taber, S. (1930) Freezing and thawing of soils as factors in the destruction of road pavements. *Public Roads*, vol. 11, p. 113-132.
- Takagi, S. (1963) Fundamentals of the theory of frost-heaving. *Proceedings, First International Permafrost Conference, 11-15 November 1963, Lafayette, Indiana*. Building Research Advisory Board, National Academy of Sciences-National Research Council, Washington, D.C., p. 203-224.
- Takagi, S. (1965) Principles of frost heaving. CRREL Research Report 140. AD 626174.
- Takagi, S. (1970) An analysis of ice lens formation. *Water Resources Research*, vol. 6, no. 3, p. 736-749.
- Taylor, G.S. and J.N. Luthin (1976) Numeric results of coupled heat-mass flow during freezing and thawing. *Proceedings, Second Conference on Soil-Water Problems in Cold Regions, Edmonton, Alberta, Sept. 1976*. Division of Hydrology, American Geophysical Union, p. 155-172.
- Taylor, S.A. and L. Cavazza (1954) The movement of soil moisture in response to temperature gradients. *Soil Science Society of America Proceedings*, vol. 18, p. 351-358.
- Taylor, S.A. and J.W. Cary (1964) Linear equations for the simultaneous flow of matter and energy in a continuous soil system. *Soil Science Society of America Proceedings*, vol. 28, p. 167-172.
- Terzaghi, K. (1952) Permafrost. *Journal of the Boston Society of Civil Engineers*, vol. 39, no. 1, p. 1-50.
- Tice, A.R., D.M. Anderson and A. Banin (1976) The prediction of unfrozen water contents in frozen soils from liquid limit determinations. CRREL Report 76-8. ADA 026623.
- Tien, C. and Y.-C. Yen (1965) The effect of melting on forced convection heat transfer. *Journal of Applied Meteorology*, vol. 4, no. 4, p. 523-527.
- Touloukian, Y.S., P.E. Liley and S.C. Saxena (1970) *Thermophysical properties of matter*, vol. 3. Thermal conductivity. Nonmetallic liquid, and gases. New York: IFI/Plenum Press.
- Tsyтович, N.A. (1963) Instability of mechanical properties of frozen and thawing soils. *Proceedings, First International Permafrost Conference, 11-15 November 1963, Lafayette, Indiana*. Building Research Advisory Board, National Academy of Sciences-National Research Council, Washington, D.C., p. 325-331.
- Tsyтович, N.A. (1975) *The Mechanics of Frozen Ground*. New York: McGraw-Hill.
- Tsyтович, N.A. et al. (1957) Changes in soil properties on freezing and thawing. CRREL Draft Translation 329. AD 739952.
- Tsyтович, N.A. et al. (1959) Physical phenomena and processes in freezing, frozen and thawing soils. In *Principles of Geocryology*. Chapter V. V.A. Obruchev Institute of Permafrost Studies, Technical Translation 1164, National Research Council of Canada (1964).
- Tsyтович, N.A., Ya.A. Kronik, K.F. Markin, V.I. Aksenov and M.V. Samuel'son (1973) Physical and mechanical properties of saline soil. In *Physics, Physical Chemistry and Mechanics of Permafrost and Ice* (N.A. Tsyтович et al., Eds.). CRREL Draft Translation 439, p. 49-64.
- Tyutyunov, I.A. (1955) Processes of cryogenesis and their effect on the temperature of top-soil and sub-soil. Manuscript Collection of the Permafrost Institute, Moscow.

- Tyutyunov, I.A. (1957) Changes and transformation in top-soil and sub-soil at below-freezing temperatures (cryogenesis). Manuscript Collection of the Permafrost Institute, Moscow (cited by Tsytovich et al. 1959).
- Tyutyunov, I.A. (1963) Phase transformations of water in soils and the nature of migration and heaving. *Proceedings, First International Permafrost Conference, 11-15 November 1963, Lafayette, Indiana*. Building Research Advisory Board, National Academy of Sciences—National Research Council, Washington, D.C., p. 234-239.
- Tyutyunov, I.A., M.V. Averochkima and V.P. Titov (1973) Effect of freezing and thawing on the structure, composition and properties of cohesive soil. In *Physics, Physical Chemistry and Mechanics of Permafrost and Ice* (N.A. Tsytovich et al., Eds.). CRREL Draft Translation 439, p. 125-132.
- U.S.S.R. Building Code (1960) Technical considerations in designing foundations in permafrost. State Construction Publishing House, Moscow, S.N. 91-60. (Also National Research Council of Canada Technical Translation 1033, 1962.)
- Van der Held, E.F.M. (1952) The contribution of radiation to the conduction of heat. *Applied Scientific Research*, Section A, vol. 3, p. 237-249.
- Van der Held, E.F.M. (1955) The contribution of radiation to heat conduction. *Centr. Tech. Inst. T.N.O. Delft, Afd. Warmtetechniek, Verslag 37*. (Also National Research Council of Canada Technical Translation TT-626, 1956.)
- Van der Held, E.F.M. and F.G. Van Drunen (1949) A method of measuring the thermal conductivity of liquids. *Physica*, vol. 15, no. 10, p. 865-881.
- Van Duin, R.H.A. (1963) The influence of soil management on the temperature wave near the surface. Institute for Land and Water Management Research, Wageningen, The Netherlands, Technical Bulletin 29.
- Van Pelt, D.J. (1976) Thermal conductivity measurements of crushed stone and gravel aggregate. CRREL Technical Note, January (unpublished).
- Van Rooyen, M. and H.F. Winterkorn (1957) Theoretical and practical aspects of the thermal conductivity of soils and similar granular systems. *Highway Research Board Bulletin* 168, p. 143-205.
- Van Rooyen, M. and H.F. Winterkorn (1959) Structural and textural influences on thermal conductivity of soils. *Highway Research Board Proceedings*, vol. 39, p. 576-621.
- Van Wijk, W.R. (Ed.) (1963) *Physics of Plant Environment*. Amsterdam: North Holland Publishing Company.
- Van Wijk, W.R. (1964) Thermal properties of soils. In *International Study Group on Soils. Lectures at Meeting in Cambridge, England, July 12-26*, p. 156-167.
- Van Wijk, W.R. and P.J. Bruijn (1964) Determination of thermal conductivity and volumetric heat capacity of soils near the surface. *Proceedings, Soil Science Society*, p. 461-464.
- Veesa, E. and H.F. Winterkorn (1967) Engineering properties of several pure clays as functions of mineral type, exchange ions, and phase composition. *Highway Research Record* no. 209, p. 55-65.
- Volkova, Ye.V. and M.V. Lomonosov (1973) Some characteristic features of water migration during freezing of fine soil. In *Physics, Physical Chemistry and Mechanics of Permafrost and Ice* (N.A. Tsytovich et al., Eds.). CRREL Draft Translation 439, p. 235-240.
- Von Herzen, R. and A.E. Maxwell (1959) The measurement of thermal conductivity of deep-sea sediments by a needle-probe method. *Journal of Geophysical Research*, vol. 64, no. 10, p. 1557-1563.
- Wakao, N. and K. Kato (1969) Effective thermal conductivity of packed beds. *Journal of Chemical Engineering of Japan*, vol. 2, no. 1, p. 24-33.
- Wechsler, A.E. (1966) Development of thermal conductivity probes for soils and insulations. CRREL Technical Report 182. AD 645337.
- Wilkinson, G.E. and A. Klute (1962) The temperature effect on the equilibrium energy status of water held by porous media. *Soil Science Society of America Proceedings*, vol. 26, p. 326-329.
- Williams, M. and C.W. Kaplar (1968) Comparison of soil thermal conductivity prediction formulae with test results. U.S. Army Terrestrial Sciences Center (now CRREL) Technical Note, October. (Unpublished.)
- Williams, P.J. (1962) Specific heats and unfrozen water content of frozen soils. *Proceedings of First Canadian Conference on Permafrost, April 1962*. National Research Council of Canada, Technical Memorandum No. 76, p. 109-126.
- Williams, P.J. (1963) Suction and its effects in unfrozen water of frozen soils. *Proceedings of First International Permafrost Conference, 11-15 November 1963, Lafayette, Indiana*. Building Research Advisory Board, National Academy of Sciences—National Research Council, Washington, D.C., p. 225-229.
- Williams, P.J. (1964) Unfrozen water content of frozen soils and soil moisture suction. *Geotechnique*, vol. 14, no. 3, p. 231-246.
- Winn, H.F. and P.C. Rutledge (1940) Frost action in highway bases and subgrades. *Purdue University Engineering Bulletin*, Research Series No. 73, vol. 24, no. 2.
- Winter, D.F. and J.M. Saari (1968) A particulate thermophysical model of the lunar soil. Boeing Scientific Research Laboratories Document D1-82-0725, Geo-astrophysics Laboratory, December.
- Winterkorn, H.F. (1955) Potentials in moisture migration. In *Proceedings of Conference on Building Materials, Ottawa, Canada, October 1953*. Division of Building Research, National Research Council of Canada, Bulletin 1, p. 86-101.
- Winterkorn, H.F. (1958a) Introductory remarks. In *Water and Its Conduction in Soils*. Highway Research Board Special Report 40, p. 1-4.
- Winterkorn, H.F. (1958b) Mass transport phenomena in moist porous systems as viewed from the thermodynamics of irreversible processes. In *Water and Its Conduction in Soils*. Highway Research Board Special Report 40, p. 324-333.
- Winterkorn, H.F. (1958c) Theory and practice of soil densification. *American Institute of Electrical Engineers, Power Apparatus and Systems*, no. 39, p. 1060-1070.
- Winterkorn, H.F. (1960a) *The Scientific Foundations of Soil Engineering*. Unpublished book in note form.
- Winterkorn, H.F. (1960b) Behavior of moist soils in a thermal energy field. *Clays and Clay Minerals*, vol. 11, p. 85-103.
- Winterkorn, H.F. (1961) Closing remarks. In *Discussion on Water and Its Conduction in Soils*. *Highway Research Board Bulletin* 287, p. 81-82.
- Winterkorn, H.F. (1964) Discussion on 'Influence of moisture content of soil on buried-cable ratings.' *Proceedings, Institution of Electrical Engineers (London)*, vol. 111, no. 12, p. 2081-2095.
- Winterkorn, H.F. (1967) Application of granulometric principles for volumization of strength and permeability of granular drainage structures. *Highway Research Record* no. 203, p. 1-7.
- Winterkorn, H.F. (1969) Keynote address. In *Effects of Temperature and Heat on Engineering Behavior of Soils*. Highway Research Board Special Report 103, p. 3-5.
- Winterkorn, H.F. (1970) Suggested method of test for thermal resistivity of soil by the thermal probe. In *Special Procedures for Testing Soil and Rock for Engineering Purposes*, ASTM Special Technical Publication 479.
- Winterkorn, H.F. (1977) Seminars on Soil Engineering at USA CRREL, Hanover, N.H., June 1977.
- Winterkorn, H.F. and H. Eyring (1946) Theoretical aspects of water accumulation in cohesive subgrade soils. *Highway Research Board Proceedings*, vol. 26, p. 422-434.
- Winterkorn, H.F. and H.Y. Fang (1972) Effect of temperature and moisture on the strength of soil-pavement systems. Fritz Engineering Laboratory Report No. 350.4, Lehigh University, Bethlehem, Pennsylvania.
- Winterkorn, H.F. and H. Fang (1975) Soil technology and engineering properties of soils. In *Foundation Engineering Handbook* (H.F. Winterkorn and H. Fang, Eds.). New York: Van Nostrand Reinhold Co.
- Wolfe, L.M. and J.O. Thieme (1964) Physical and thermal properties of frozen soil and ice. *Journal of the Society of Petroleum Engineers*, March, p. 67-72.

- Woodside, W. (1958) Probe for thermal conductivity measurements of dry and moist materials. *Heating, Piping and Air Conditioning*, vol. 30, p. 163-170.
- Woodside, W. and J.B. Cliffe (1959) Heat and moisture transfer in closed systems of two granular materials. *Soil Science*, vol. 87, p. 75-82.
- Woodside, W. and C.M.A. De Bruyn (1959) Heat transfer in moist clay. *Soil Science*, vol. 87, p. 166-173.
- Woodside, W. and J.M. Kuzmak (1958) Effect of temperature distribution on moisture flow in porous materials. *Transactions of the American Geophysical Union*, vol. 39, p. 676-680.
- Woodside, W. and J.M. Messmer (1961) Thermal conductivity of porous media. *Journal of Applied Physics*, vol. 32, no. 9, p. 1688-1706.
- Wyllie, M.R.J. and P.F. Southwick (1954) An experimental investigation of the S.P. and resistivity phenomena in dirty sands. *Journal of Petroleum Technology*, vol. 6, p. 44-57.
- Yagi, S. and D. Kunii (1957) Studies on effective thermal conductivities in packed beds. *American Institute of Chemical Engineering Journal*, vol. 3, no. 3, p. 373-381.
- Yen, Y.-C. (1965) Heat transfer characteristics of naturally compacted snow. CRREL Research Report 166. AD 619344.
- Yen, Y.-C. (1966) Heat conduction in moist porous media. CRREL Research Report 212. AD 652872.
- Yong, R.N. (1963) Soil freezing considerations in frozen soil strength. *Proceedings of First International Permafrost Conference, 11-15 November 1963, Lafayette, Indiana*. Building Research Advisory Board, National Academy of Sciences-National Research Council, Washington, D.C., p. 315-319.
- Zierfuss, H. and G.L. Van der Vliet (1956) Laboratory measurements of heat conductivity of sedimentary rocks. *Bulletin of the American Association of Petroleum Geology*, vol. 40, p. 2475-2488.

APPENDIX A: DESCRIPTION OF SOME TEST SOILS

SOILS OF KERSTEN (1949)

Table A1. General physical properties of soils.

| Soil no. | Soil designation | Mechanical analysis | | | | Liquid ² limit | Plasticity ³ index | Physical constants | | | Absorption (%) | Textural class | |
|----------|---------------------------|---------------------|-------------------|--------------------|------------------|---------------------------|-------------------------------|-----------------------------------|-----------------------|------------------|----------------|------------------------------|----------------------|
| | | Gravel over 2.00 | Sand 0.05 to 2.00 | Silt 0.005 to 0.05 | Clay under 0.005 | | | Modified optimum moisture content | Modified max. density | Specific gravity | | U.S. Bur. of Chem. and soils | Unified soil classn. |
| P4601 | Chena River gravel | 80.0 | 19.4 | — | 0.6 | — | N.P. ³ | — | — | 2.70 | 0.75 | Gravel | GP |
| P4703 | Crushed quartz | 15.5 | 79.0 | — | 5.5 | — | N.P. | — | — | 2.65 | 0.26 | Coarse sand | SW |
| P4704 | Crushed trap rock | 27.0 | 63.0 | — | 10.0 | — | N.P. | — | — | 2.97 | 0.20 | Coarse sand | SM |
| P4705 | Crushed feldspar | 25.5 | 70.3 | — | 4.2 | — | N.P. | — | — | 2.56 | 0.75 | Coarse sand | SW |
| P4706 | Crushed granite | 16.2 | 77.0 | — | 6.8 | — | N.P. | — | — | 2.67 | 0.56 | Coarse sand | SW |
| P4702 | 20-30 Ottawa sand | 0.0 | 100.0 | 0.0 | 0.0 | — | N.P. | — | — | 2.65 | 0.17 | Coarse sand | SP |
| P4701 | Graded Ottawa sand | 0.0 | 99.9 | — | 0.1 | — | N.P. | — | — | 2.65 | 0.19 | Medium sand | SP |
| P4714 | Fine crushed quartz | 0.0 | 100.0 | 0.0 | 0.0 | — | N.P. | — | — | 2.65 | — | Medium sand | SP |
| P4709 | Fairbanks sand | 27.5 | 70.0 | — | 2.5 | — | N.P. | 12.0 | 122.5 | 2.72 | — | Medium sand | SW |
| P4604 | Lowell sand | 0.0 | 100.0 | 0.0 | 0.0 | — | N.P. | 12.2 | 119.0 | 2.67 | — | Medium sand | SW |
| P4503 | Northway sand | 3.0 | 97.0 | 0.0 | 0.0 | — | N.P. | 14.0 | 112.8 | 2.74 | — | Medium sand | SW |
| P4502 | Northway fine sand | 0.0 | 97.0 | 3.0 | 0.0 | — | N.P. | 11.4 | 116.0 | 2.76 | — | Fine sand | SP |
| P4711 | Dakota sandy loam | 10.9 | 57.9 | 21.2 | 10.0 | 17.1 | 4.9 | 6.5 | 138.5 | 2.71 | — | Sandy loam | SM |
| P4713 | Ramsey sandy loam | 0.4 | 53.6 | 27.5 | 18.5 | 24.6 | 9.3 | 9.0 | 127.5 | 2.68 | — | Sandy loam | CL |
| P4505 | Northway silt loam | 1.0 | 21.0 | 64.4 | 13.6 | 27.3 | N.P. | 15.7 | 112.0 | 2.70 | — | Silt loam | ML |
| P4602 | Fairbanks silt loam | 0.0 | 7.6 | 80.9 | 11.5 | 34.0 | N.P. | 15.5 | 110.0 | 2.70 | — | Silt loam | ML |
| P4710 | Fairbanks silty clay loam | 0.0 | 9.2 | 63.8 | 27.0 | 39.2 | 12.4 | 18.0 | 102.0 | 2.71 | — | Silty clay loam | ML |
| P4708 | Healy clay | 0.0 | 1.9 | 20.1 | 78.0 | 39.4 | 15.0 | 17.0 | 108.0 | 2.59 | — | Clay | CL |
| P4707 | Fairbanks peat | — | — | — | — | — | N.P. | — | — | — | — | Peat | Pt |

¹ Size in millimeters. ² Minus no. 40 mesh fraction. ³ N.P. = non-plastic.

Table A2. Mineral and rock composition of soils (percentage by weight).

| Soil no. | Soil designation | Unified soil classn. | Quartz | | Ortho-clase feldspar | Felsite | Plagio-clase feldspar | Pyroxene, amphibole, and olivine | Basic igneous rock | Kaolinite clay min. and clay coat. min. | Hematite and magnetite | Mica | Coal | Others |
|----------|---------------------------|----------------------|-------------------|-------------------|----------------------|---------|-----------------------|----------------------------------|--------------------|---|------------------------|------|------|--------|
| | | | By petrogr. exam. | By X-ray analysis | | | | | | | | | | |
| P4601 | Chena River gravel | GP | 43.1 | | 11.6 | | 12.9 | 27.0 | | | | 2.1 | | 3.3 |
| P4703 | Crushed quartz | SW | 95 ¹ | | | | | | | | | | | |
| P4704 | Crushed trap rock | SM | 3.0 | | 10.0 | | 50.0 ² | 34.0 | | | 2.0 | | | 1.0 |
| P4705 | Crushed feldspar | SW | 15.0 | | 55.0 | | 30.0 | | | | | | | |
| P4706 | Crushed granite | SW | 20.0 | | 30.0 | | 40.0 | | | | | | | 10.0 |
| P4702 | 20-30 Ottawa sand | SP | 99 ³ | | | | | | | | | | | |
| P4701 | Graded Ottawa sand | SP | 99 ³ | | | | | | | | | | | |
| P4714 | Fine crushed quartz | SP | 99 ¹ | | | | | | | | | | | |
| P4709 | Fairbanks sand | SW | 59.4 | | 3.6 | 5.0 | 5.3 | 8.0 | 10.0 | | 2.5 | 0.1 | | 5.1 |
| P4604 | Lowell sand | SW | 72.2 | | 20.5 | | | 3.0 | | | | 1.3 | | 3.0 |
| P4503 | Northway sand | SW | 7.5 | | | 11.5 | 9.0 | 7.5 | 51.0 | | | | | 13.5 |
| P4502 | Northway fine sand | SP | 12.0 | | | 7.0 | 18.0 | 12.0 | 40.0 | | | | | 11.0 |
| P4711 | Dakota sandy loam | SM | 59.1 | | 12.9 | | 1.0 | 12.1 | | 12.4 | | | | 2.5 |
| P4713 | Ramsey sandy loam | CL | 51.3 | | 11.8 | | 5.6 | 12.6 | | 15.9 | | | | 2.8 |
| P4505 | Northway silt loam | ML | 1.5 | | | | 31.5 | 19.5 | 4.5 | 27.5 | 10.0 | | | 5.5 |
| P4602 | Fairbanks silt loam | ML | 13.3 | | 40.3 | | | | | 28.3 | | | 18.1 | |
| P4710 | Fairbanks silty clay loam | ML | 4.6 | | 59.5 | | | 2.2 | | 28.9 | 1.6 | | 3.2 | |
| P4708 | Healy clay | CL | 22.5 | | | | | | | 55.0 | | | 22.0 | 0.5 |

¹ By visual inspection; impurities less than 5%. ² Andesine feldspar. ³ By visual inspection; impurities less than 1%.

SOILS OF WOLFE AND THIEME (1964)

Wolfe and Thieme (1964) performed tests on re-compacted samples of two typical soils that may occur in underground caverns:

1. A gray, fine clay that was pulverized and mixed with water, creating a pliable mud.
2. A brown, sandy silt that was dug from a dry river bank and then mixed with water.

The moisture content of the test specimens was 17 to 22% based on the wet weight of the soil. This amount of water nearly saturated the silt, but the clay was well below saturation.

Figure A1 shows the particle size distribution for the soil fraction which is coarser than 44 μm .

Specimens used for testing were cut with a band-saw from frozen blocks of the soil and brought to equilibrium with the test temperature.

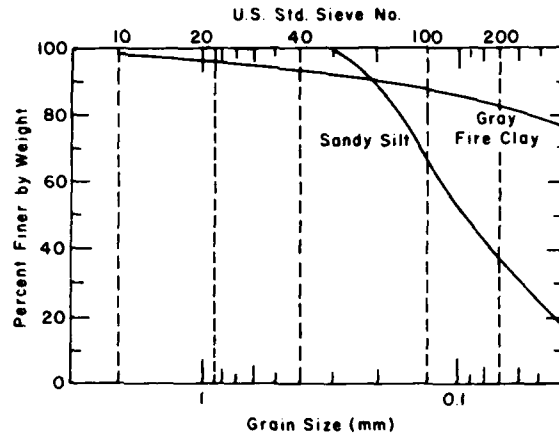

Figure A1. Grain size curves for clay and silt tested by Wolfe and Thieme (1964).

SOILS OF PENNER ET AL. (1975)

The grain size distribution curves for the ten soils tested by Penner et al. (1975) are given in Figure A2. The sieve and hydrometer analyses followed ASTM procedures. Difficulties were encountered in making a grain-size analysis for soil no. 3, as it consisted of a poorly cemented friable sandstone. It was not possible to achieve complete breakdown of the material and

therefore the hydrometer analysis given for this material was not considered to be reliable.

The Atterberg limits for soils no. 4 to 10 are given in Table A3. Soils no. 1, 2 and 3 were too coarse to give meaningful limits. Table A4 shows the relative proportions of minerals in the size fraction smaller than 2 μm .

Table A3. Atterberg limits.

| Soil no. | Liquid limit at 25 blows W_L (%) | Plastic limit, W_p (%) | Plasticity index I_p (%) |
|----------|------------------------------------|--------------------------|----------------------------|
| 1 | — | — | No plasticity index |
| 2 | — | — | No plasticity index |
| 3 | — | — | No plasticity index |
| 4 | 37 | 21 | 16 |
| 5 | 25 | 18 | 7 |
| 6 | 30 | 21 | 9 |
| 7 | 28 | 14 | 14 |
| 8 | 43 | 24 | 18 |
| 9 | 33 | 22 | 11 |
| 10 | 48 | 23 | 25 |

Table A4. Relative proportions of minerals in the < 0.002 mm size fraction.

| Soil | Quartz | Illite | Chlorite | Kaolinite | Vermiculite |
|------|--------|--------|----------|-----------|-------------|
| 1 | + | + | + | + | — |
| 2 | ++ | ++ | + | ++ | — |
| 3 | +++ | ++ | — | ++ | + |
| 4 | +++ | ++ | ++ | ++ | — |
| 5 | + | + | — | — | — |
| 6 | + | + | + | + | — |
| 7 | ++ | ++ | + | ++ | — |
| 8 | +++ | +++ | ++ | + | — |
| 9 | +++ | +++ | + | + | — |
| 10 | +++ | +++ | ++ | ++ | — |

+ = small amount present; ++ = moderate amount present; +++ = large amount present.

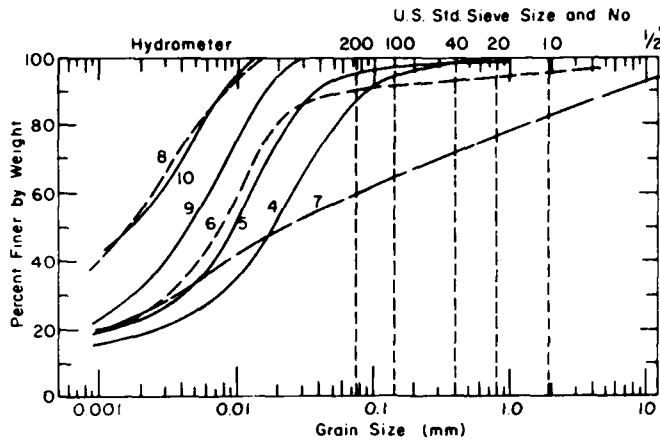

Figure A2. Grain size analysis of soils tested by Penner et al. (1975).

'FINE SAND' OF SAWADA (1977)

According to Sawada (1977) the test samples were prepared from volcanic ashes by sieving to select particles ranging from 0.105 to 0.250 mm in diameter. The samples were composed of 70% volcanic glass by weight and 15% scoria, the remainder being quartz, feldspar, etc. The specific gravity was 2.42 and the maximum dry density was 1.07 g/cm³, corresponding to an optimum moisture content of 37%.

A sample having a given moisture content was prepared by adding a corresponding amount of water to the oven-dried soil and mixing well. Table A5 gives the physical properties of the test samples. For thermal conductivity measurement, each sample was rapidly frozen to a temperature below -40°C so that no ice segregation occurred.

Table A5. Conditions of samples for thermal conductivity tests.

| | Moisture content (%) | Dry density (g/cm ³) | Degree of saturation (%) | Volumetric ratios | | |
|----|----------------------|----------------------------------|--------------------------|-------------------|-------|----------------|
| | | | | x_s | x_a | x_w or x_i |
| S1 | 0.0 | 0.893 | 0.0 | 0.369 | 0.631 | 0.00 |
| S2 | 27.0 | 0.893 | 38.2 | 0.369 | 0.390 | 0.241 |
| S3 | 37.0 | 0.893 | 52.3 | 0.369 | 0.301 | 0.330 |
| S4 | 46.9 | 0.943 | 72.5 | 0.390 | 0.168 | 0.442 |
| S5 | 54.8 | 0.956 | 86.6 | 0.395 | 0.081 | 0.524 |
| S6 | 55.9 | 0.990 | 93.6 | 0.409 | 0.038 | 0.553 |

SOILS OF JOHANSEN

Table A6. Soil materials of Johansen (pers. comm.).

| <i>Material</i> | <i>Quartz content (%)</i> | <i>Specific weight (kg/m³)</i> | <i>d₆₀ (mm)</i> | <i>d₁₀ (mm)</i> | <i>Uniformity coefficient d₆₀/d₁₀</i> |
|---------------------|---------------------------|---|----------------------------|----------------------------|---|
| Sand | | | | | |
| SA1 | 50 | 2700 | 0.69 | 0.12 | 5.7 |
| SA2 | 48 | 2600 | 0.27 | 0.067 | 4.0 |
| SA3 | 58 | 2670 | 0.15 | 0.082 | 1.8 |
| SA4 | 80 | 2670 | 0.16 | 0.125 | 1.3 |
| SA5 | 45 | 2720 | 0.26 | 0.11 | 2.4 |
| SA7 | 39 | 2700 | 1.5 | 0.10 | 15.0 |
| SA8 | 61 | 2730 | 0.20 | 0.075 | 2.7 |
| SA10 | 10 | 2850 | 0.52 | 0.125 | 4.2 |
| SA13 | 100 | 2650 | 0.70 | 0.60 | 1.2 |
| Gravel | | | | | |
| GR1 | 49 | 2740 | 2.0 | 0.21 | 9.5 |
| GR3 | 47 | 2700 | 2.0 | 0.20 | 10.0 |
| GR6 | 57 | 2700 | 6.1 | 0.27 | 22.6 |
| GR7 | 2 | 3000 | 1.4 | 0.06 | 23.3 |
| GR12 | 41 | 2700 | 1.8 | 0.15 | 12.0 |
| Crushed rock | | | | | |
| PU1 | 2 | 3000 | 31.0 | 24.0 | 1.3 |
| PU5 | 33 | 2680 | 6.1 | 0.25 | 24.4 |
| PU7 | 9 | 2750 | 35.0 | 26.0 | 1.3 |
| PU9 | 3 | 2730 | 8.5 | 1.0 | 8.5 |
| PU10 | 9 | 3100 | 17.0 | 10.5 | 1.6 |
| Clay | | | | | |
| LE1 | 22 | 2800 | 0.040 | 0.0035 | - |

A facsimile catalog card in Library of Congress MARC format is reproduced below.

Farouki, Omar T.

Thermal properties of soils / by Omar T. Farouki.
Hanover, N.H. : U.S. Cold Regions Research and Engineering
Laboratory; Springfield, Va. : available from National Technical
Information Service, 1981.

xi, 151 p., illus.; 28 cm. (CRREL Monograph 81-1.)

Bibliography: p. 125.

1. Frozen soils. 2. Heat transfer. 3. Permafrost.
4. Soils. 5. Soil dynamics. 6. Soil physical properties.
7. Soil tests. 8. Thermal conductivity. 9. Water in soils.
I. United States. Army. Corps of Engineers. II. Army Cold
Regions Research and Engineering Laboratory, Hanover, N.H.
III. Series: CRREL Monograph 81-1.