

AD-A100 952

AD A 100 952



5 0712 01017246 7

TECHNICAL  
LIBRARY

AD

TECHNICAL REPORT ARBRL-TR-02305

STATIC LOADING OF THE TM-46/MVM  
MINE-FUZE COMBINATION

George A. Coulter  
George T. Watson  
James H. Patrick

March 1981



US ARMY ARMAMENT RESEARCH AND DEVELOPMENT COMMAND  
BALLISTIC RESEARCH LABORATORY  
ABERDEEN PROVING GROUND, MARYLAND

Approved for public release; distribution unlimited.

Destroy this report when it is no longer needed.  
Do not return it to the originator.

Secondary distribution of this report by originating  
or sponsoring activity is prohibited.

Additional copies of this report may be obtained  
from the National Technical Information Service,  
U.S. Department of Commerce, Springfield, Virginia  
22161.

The findings in this report are not to be construed as  
an official Department of the Army position, unless  
so designated by other authorized documents.

*The use of trade names or manufacturers' names in this report  
does not constitute indorsement of any commercial product.*

UNCLASSIFIED

SECURITY CLASSIFICATION OF THIS PAGE (When Data Entered)

REPORT DOCUMENTATION PAGE		READ INSTRUCTIONS BEFORE COMPLETING FORM
1. REPORT NUMBER TECHNICAL REPORT ARBRL-TR- 02305	2. GOVT ACCESSION NO.	3. RECIPIENT'S CATALOG NUMBER
4. TITLE (and Subtitle) STATIC LOADING OF THE TM-46/MVM MINE-FUZE COMBINATION		5. TYPE OF REPORT & PERIOD COVERED Final
7. AUTHOR(s) George A. Coulter George T. Watson James H. Patrick		6. PERFORMING ORG. REPORT NUMBER
9. PERFORMING ORGANIZATION NAME AND ADDRESS USA Ballistic Research Laboratory ATTN: DRDAR-BLT Aberdeen Proving Ground, MD 21005		8. CONTRACT OR GRANT NUMBER(s)
11. CONTROLLING OFFICE NAME AND ADDRESS US Army Armament Research & Development Command US Army Ballistic Research Laboratory (DRDAR-BLT) Aberdeen Proving Ground, MD 21005		10. PROGRAM ELEMENT, PROJECT, TASK AREA & WORK UNIT NUMBERS See Block B.
14. MONITORING AGENCY NAME & ADDRESS (if different from Controlling Office) Naval Coastal Systems Center Panama City, FL 32407		12. REPORT DATE March 1981
		13. NUMBER OF PAGES 23
		15. SECURITY CLASS. (of this report) UNCLASSIFIED
		15a. DECLASSIFICATION/DOWNGRADING SCHEDULE
16. DISTRIBUTION STATEMENT (of this Report) Approved for public release; distribution unlimited.		
17. DISTRIBUTION STATEMENT (of the abstract entered in Block 20, if different from Report)		
18. SUPPLEMENTARY NOTES This project was funded by Naval Coastal Systems Center - Appropriation No. 17X4912; MIPR N61331-80-MP-D0012.		
19. KEY WORDS (Continue on reverse side if necessary and identify by block number) Fuze Activation            Plate Deflection Load Generator            Static Load Mine Activation            TM-46/MVM		
20. ABSTRACT (Continue on reverse side if necessary and identify by block number) A method is described for loading the irregular sensitive surface of an anti-tank mine. An example is given for the TM-46/MVM mine-fuze combination. The top surface deflection is measured by means of an optical follower during the time of the static air load application. A load-deflection curve is given for the TM-46/MVM.		

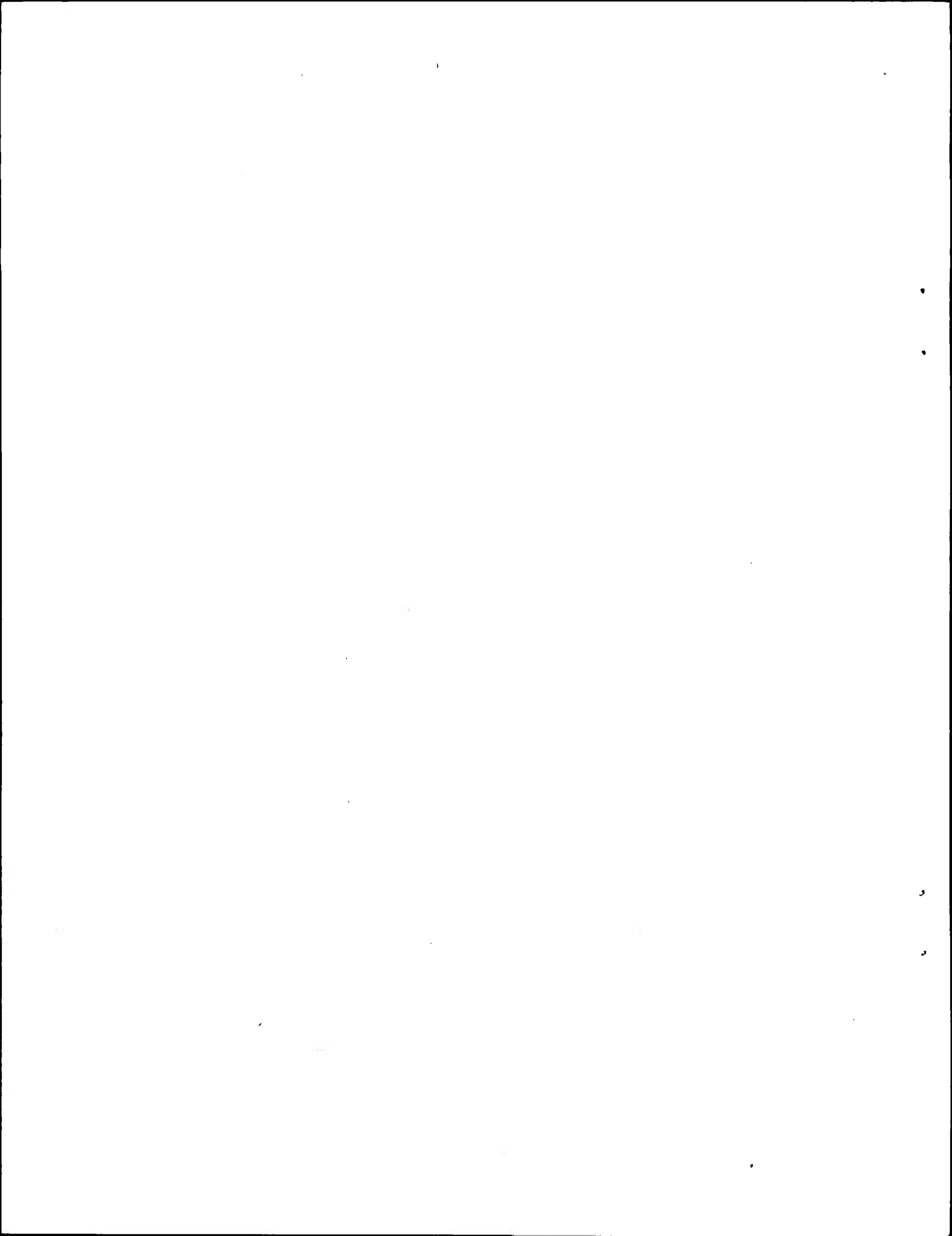
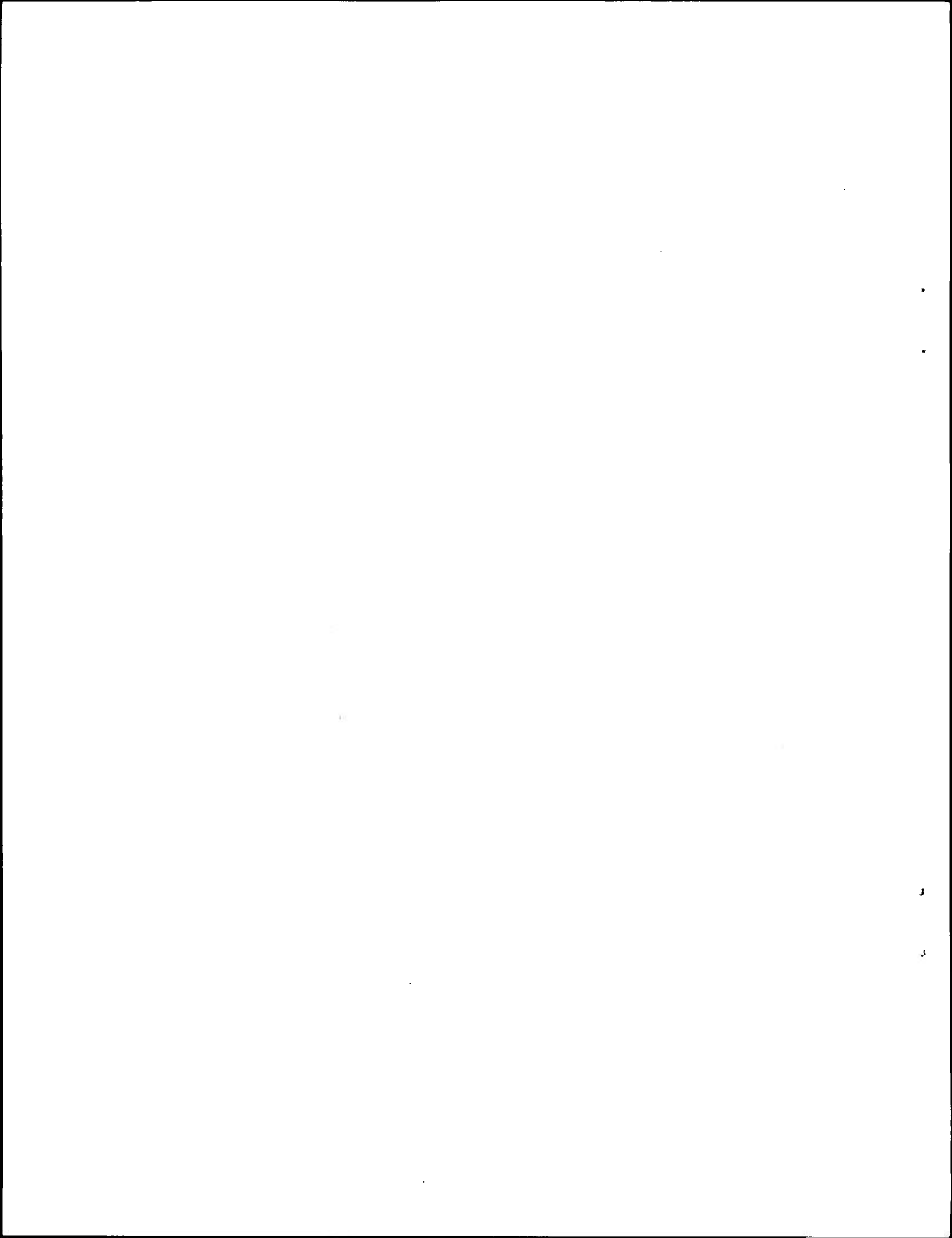

TABLE OF CONTENTS

	Page
LIST OF ILLUSTRATIONS . . . . .	5
LIST OF TABLES . . . . .	7
I. INTRODUCTION . . . . .	9
II. TEST PROCEDURE . . . . .	9
A. Mine Preparation . . . . .	9
B. Static Load Generator . . . . .	12
C. Instrumentation . . . . .	12
III. RESULTS . . . . .	15
IV. ANALYSIS . . . . .	15
V. SUMMARY AND CONCLUSIONS . . . . .	15
DISTRIBUTION LIST . . . . .	21



LIST OF ILLUSTRATIONS

Figure	Page
1. TM-46 mine and MVM pressure fuze. . . . .	10
2. Mine-fuze with wire and optical target . . . . .	11
3. Experimental set-up for static load measurements . . . . .	13
4. Schematic of data acquisition-reduction system . . . . .	14
5. Pressure and displacement curves . . . . .	16
6. Force-displacement curve . . . . .	18

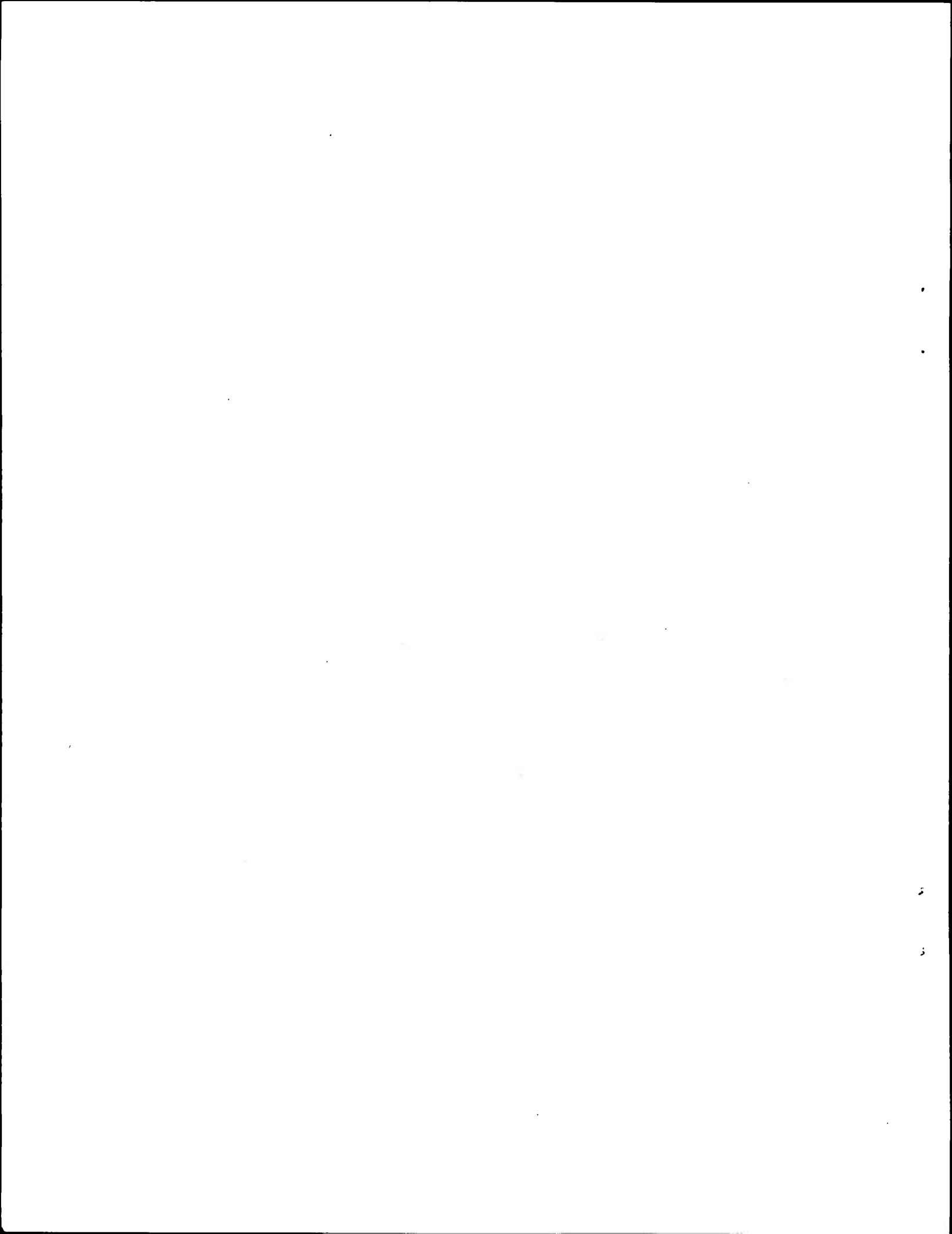



LIST OF TABLES

Table	Page
I. Deflection-Load Parameters for the TM-46/MVM Mine-Fuze Combination . . . . .	17

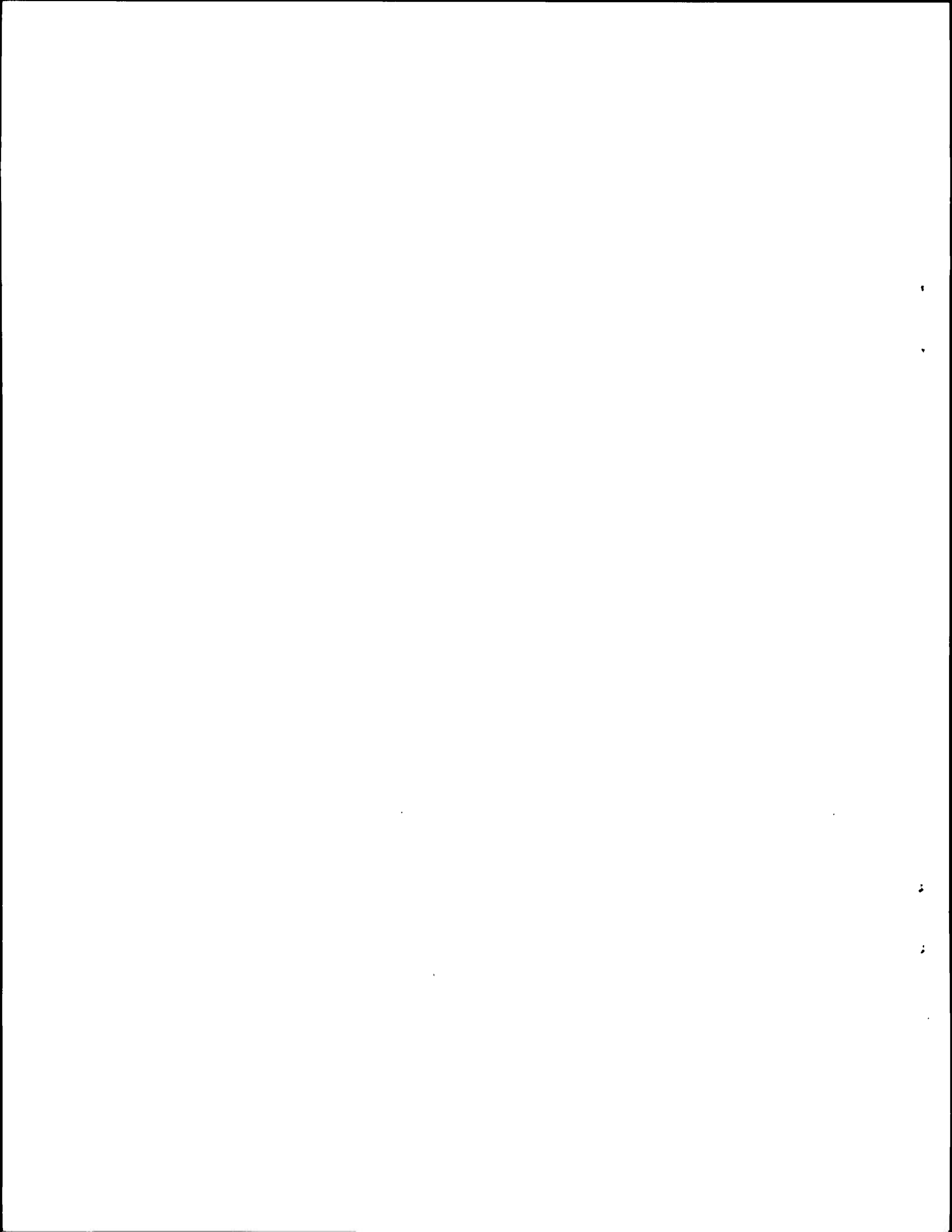

## I. INTRODUCTION

In order to establish a numerical model to assess the vulnerability and actuation characteristics of an anti-tank mine, it is necessary to have available an accurate method of determining the static load-deflection of the mine-fuze combination being studied. This is normally obtained from a standard-type load machine if the sensitive area is small or has a stiff pressure plate as in the M-15 anti-tank mine. However, for a large and irregular sensitive area, such as the TM-46 mine top, as shown in Figure 1, a loading method is needed which will equally load the entire top.

This report describes a way to uniformly load a mine of this type, the TM-46/MVM, and to measure the deflection of the top and to determine the fuze actuation pressure level. This technique combined with those of References 1 and 2 should give a quite accurate assessment for a given anti-tank mine.

## II. TEST PROCEDURE

The test procedure describes the preparation of the mine, the static load generator, and the instrumentation used.

### A. Mine Preparation

An inert TM-46 Russian anti-tank mine as shown in Figure 1, and an inert Model MVM pressure fuze with an extension tube from the MV-5 fuze as shown in Figure 2 were chosen for the deflection-load test. A small wire was silver soldered to the movable part of the fuze before installing it in the mine. A small clearance hole was drilled in the bottom plate of the mine to allow the wire attached to the fuze to extend through the end-plate of the test chamber. See Figure 3. A black paper target was attached to the fuze wire after the mine was clamped snugly at the end of the test chamber.

The deflection of the top of the mine/fuze combination when loaded with air pressure was observed by the corresponding movement of the attached paper target.

Details of the test set-up are given in Section B. below.

<sup>1</sup> Andrew Mark, "M-15 Anti-Tank Mine Vulnerability", BRL Tech Report ARBRL-TR-02211, January 1980. (AD #A080999)

<sup>2</sup> Charles Kingery, "Mine Actuation Tests", BRL Tech Report ARBRL-TR-02210, January 1980. (AD #B044271)

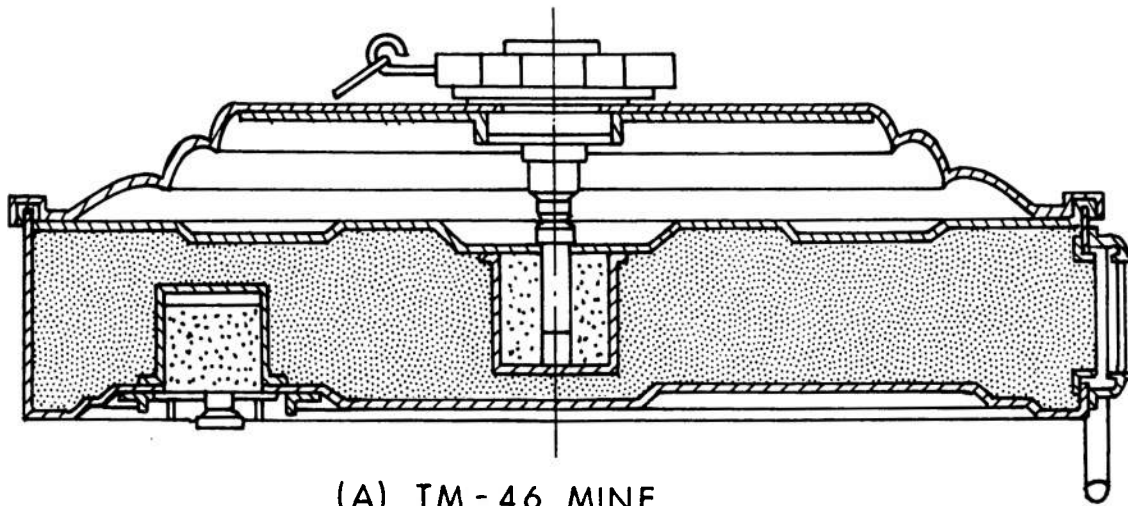

(A) TM-46 MINE

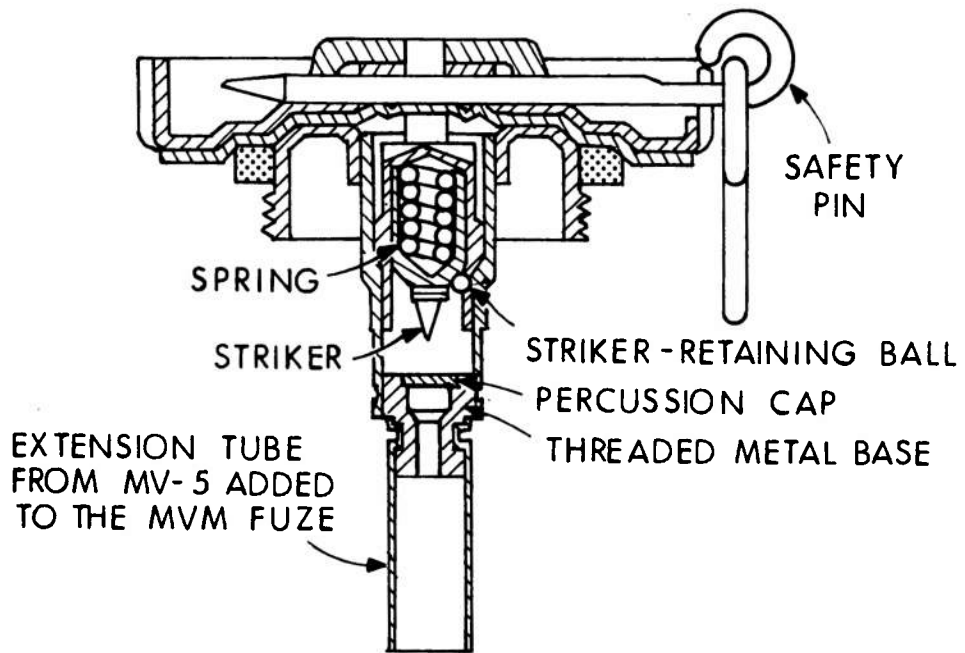

(B) MVM FUZE ASSEMBLY

Figure 1. TM-46 mine and MVM pressure fuze.

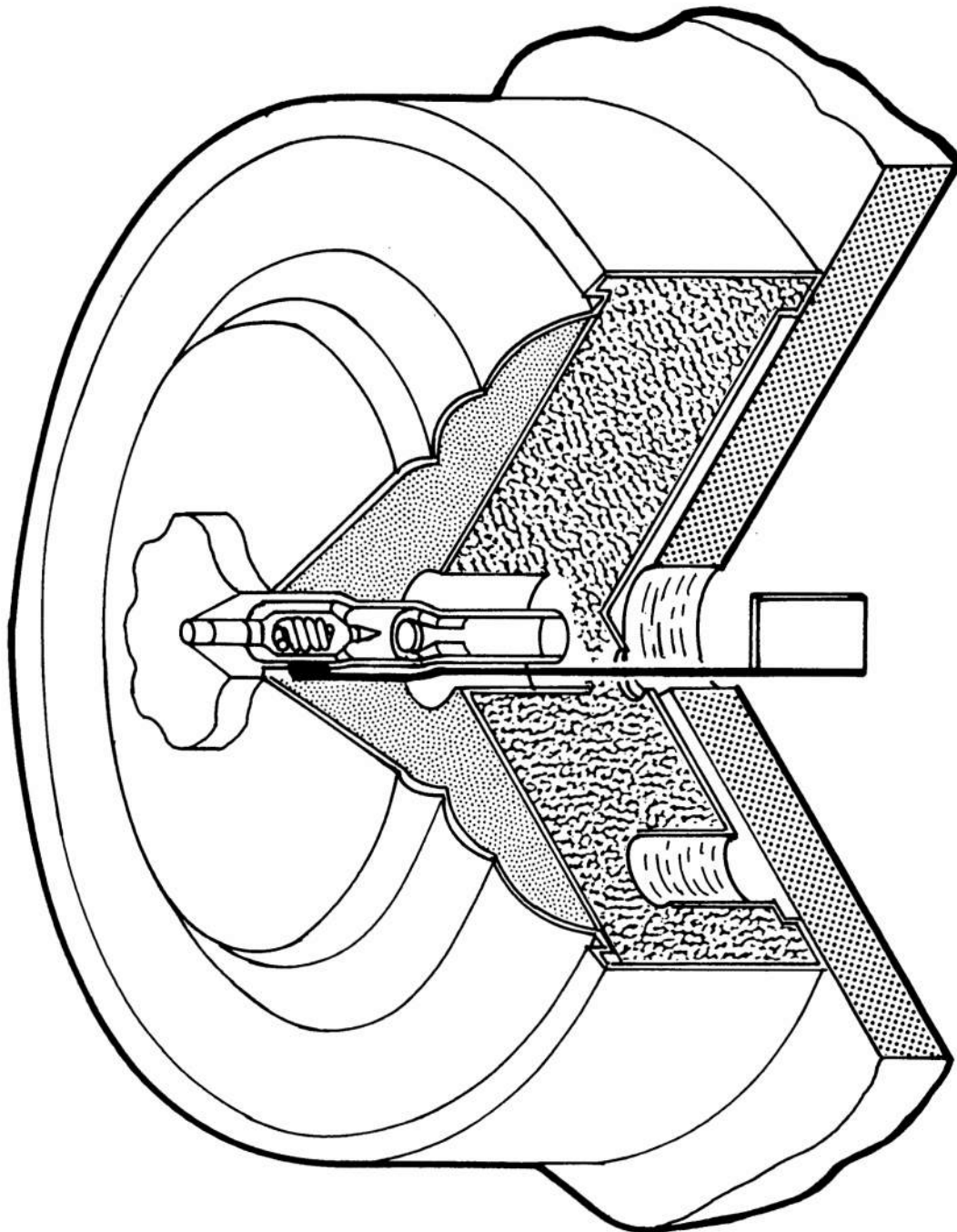

Figure 2. Mine-fuze with wire and optical target.

## B. Static Load Generator

The static load generator used was adapted from the shock tube used in the mine actuation tests of Reference 2, Section I, above. Figure 3 shows how slight modifications were made. The principal changes were to shorten the test section and to close the driver section without the normal diaphragm.

The load was applied to the entire sensitive mine top at the end of the test chamber. Air was allowed slowly into the chamber through a regulator and monitored as the pressure was applied.

Details of the instrumentation are described in the next section.

## C. Instrumentation

Figure 4 shows in schematic form the data acquisition-reduction system.

Three types of monitors were used to obtain the load-deflection data. The pressure transducer was a Tyco-Bytrex HFG50 of the strain-bridge type, with DC response. A second, Susquehanna ST-2 crystal transducer, was pressed and attached against the side of the mine where it acted as a vibration pick-up. It recorded the triggering of the fuze firing pin during the test. The third monitor was the optical displacement follower<sup>3</sup>, Optron 501, which observed the top deflection of the mine-fuze combination.

The Model 501 is designed to track a discontinuity in the intensity of the light reflected or emitted from a target surface. The lens system is used to focus the target discontinuity onto the photo cathode of an image dissector tube. Electrons are emitted from the back side of the photo cathode proportional to the intensity of the projected light. The electrons are accelerated to refocus on an aperture plate. The electrons are then collected to give a current output proportional to the number of electrons entering the aperture. The optical image is changed in this manner to an electron image - the current output is proportional to the corresponding incoming light intensity. The intensity in turn depends on the target (mine/fuze combination) movement into the illuminated field of view.

The voltage outputs from all three test monitors were suitably conditioned, amplified, and recorded with a 7600 Honeywell FM recorder. The remainder of the schematic in Figure 4 illustrates the data reduction system used to prepare the records obtained from the test.

<sup>3</sup>See company manual "Model 501 Optical Displacement Follower", OPTRON, Division of Univ. Tech. Inc., 30 Hazel Terrace, Woodbridge, Conn. 06525.

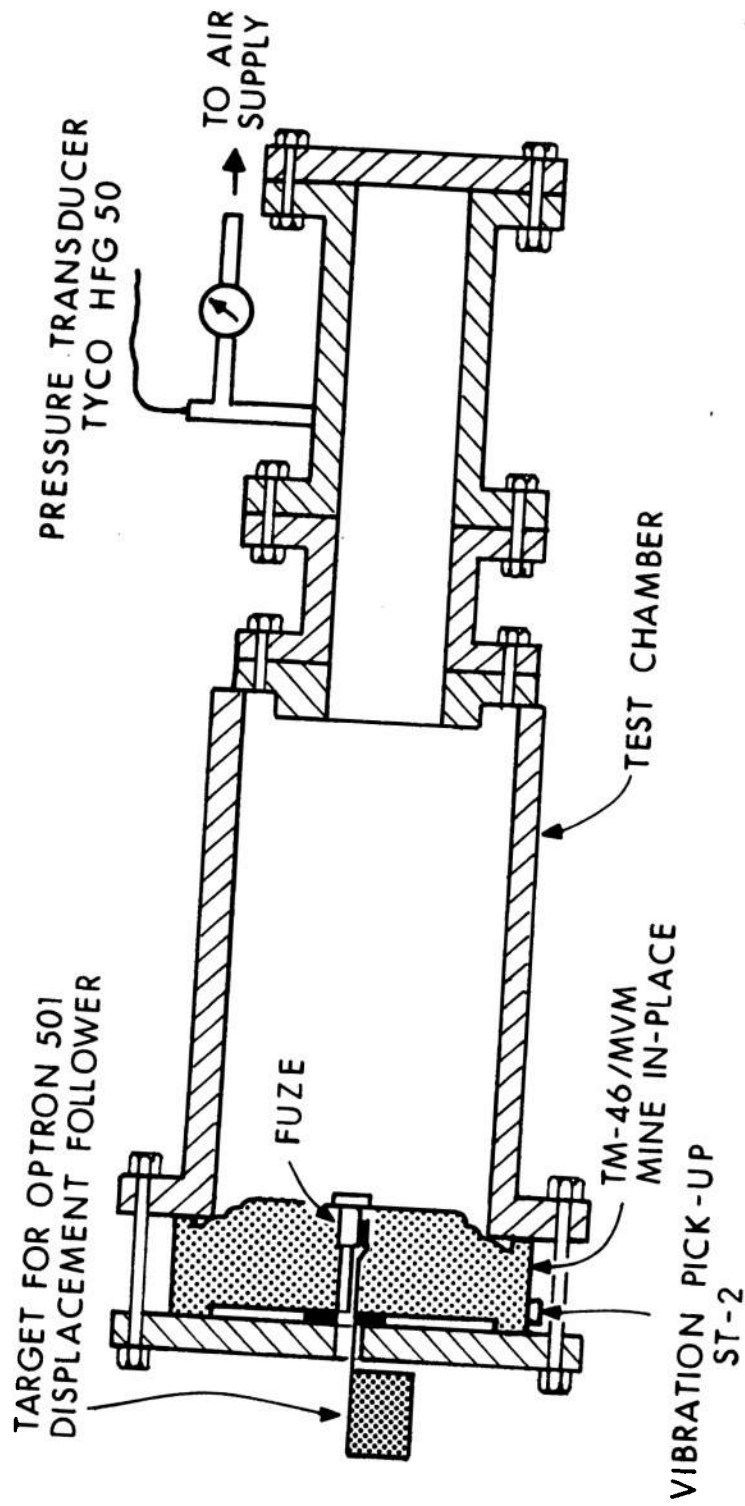

Figure 3. Experimental set-up for static load measurements.

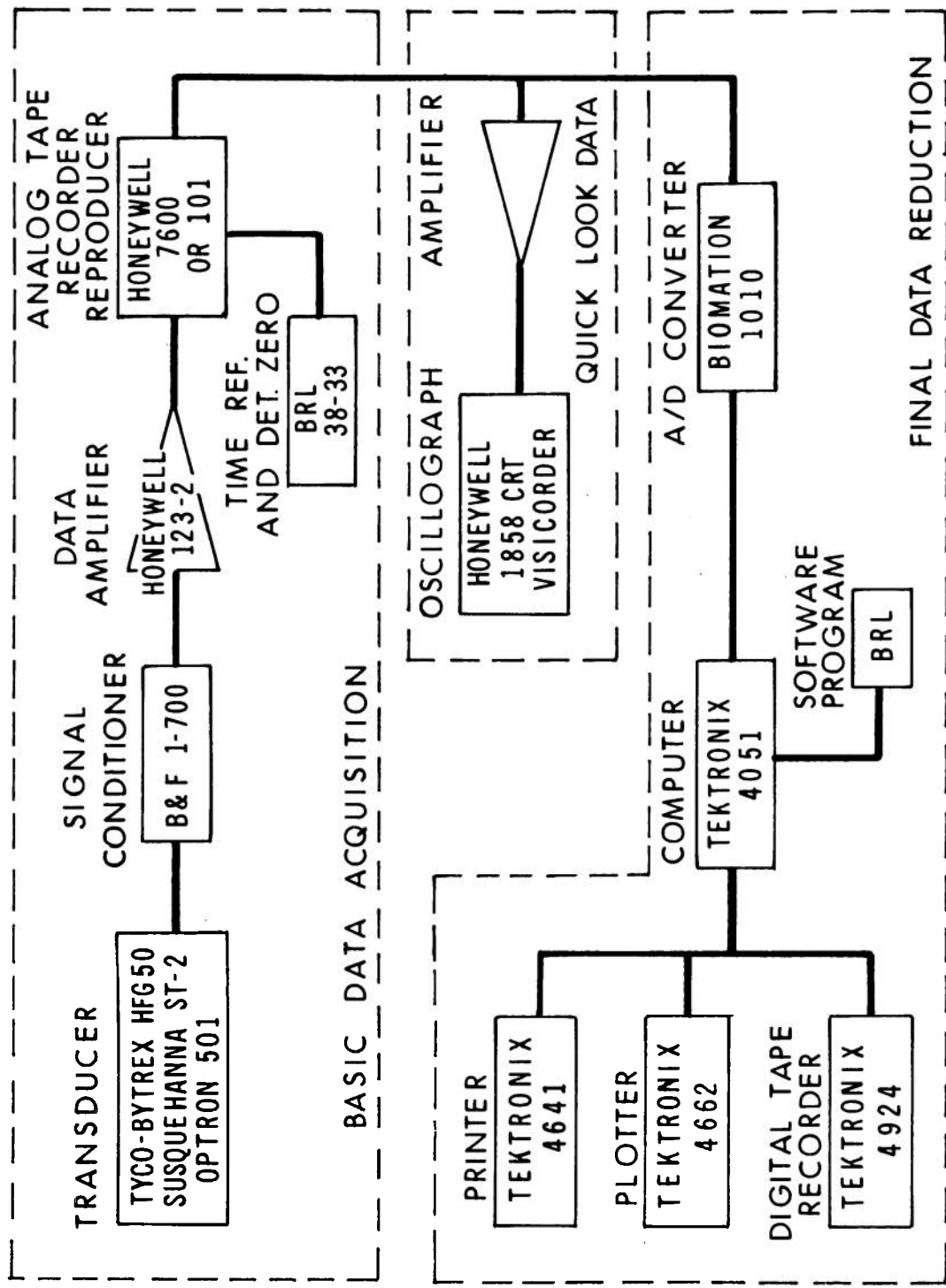

Figure 4. Schematic of data acquisition-reduction system.



### III. RESULTS

Test results are shown in Figure 5. The upper trace indicates the pressure load as it was applied over the top of the TM-46/MVM mine-fuze combination. The lower trace shows the corresponding displacement of the movable fuze body as mounted in the top of the mine.

The lower trace has indicated on it where the fuze was activated. The time was measured from the vibration pick-up record (not shown). It is the time from the initial pressure load is begun until the fuze firing pin is released under fuze activation. The vibration signal from the activation was picked up by the ST-2 sensor attached to the mine body.

The next section describes a way to combine the two load and deflection records just described.

### IV. ANALYSIS

A useful way to present the test data to be used in a numerical model is in a combined deflection-load curve. To do this, it is necessary to combine the digital output from the pressure (load) and deflection monitors. Table I gives such a listing for several time steps taken from the test records. The fuze activation is noted in the table.

The force applied to the sensitive top surface of the mine during the test was calculated by taking the projected area of the top ( $0.0699 \text{ m}^2$ ) and multiplying by each pressure increment in the table. A cross-plot of the resulting loads and deflections was then made. Figure 6 is this cross-plot. Again, the point of fuze activation is noted at 3.29 kN for a displacement of 1.93 mm.

### V. SUMMARY AND CONCLUSIONS

A method has been described for static loading of irregular sensitive surfaces of anti-tank mines. A load-deflection curve for a mine-fuze combination can be obtained by use of this method. Such a curve is helpful to establish a numerical model to be used in an assessment of a mine's vulnerability.

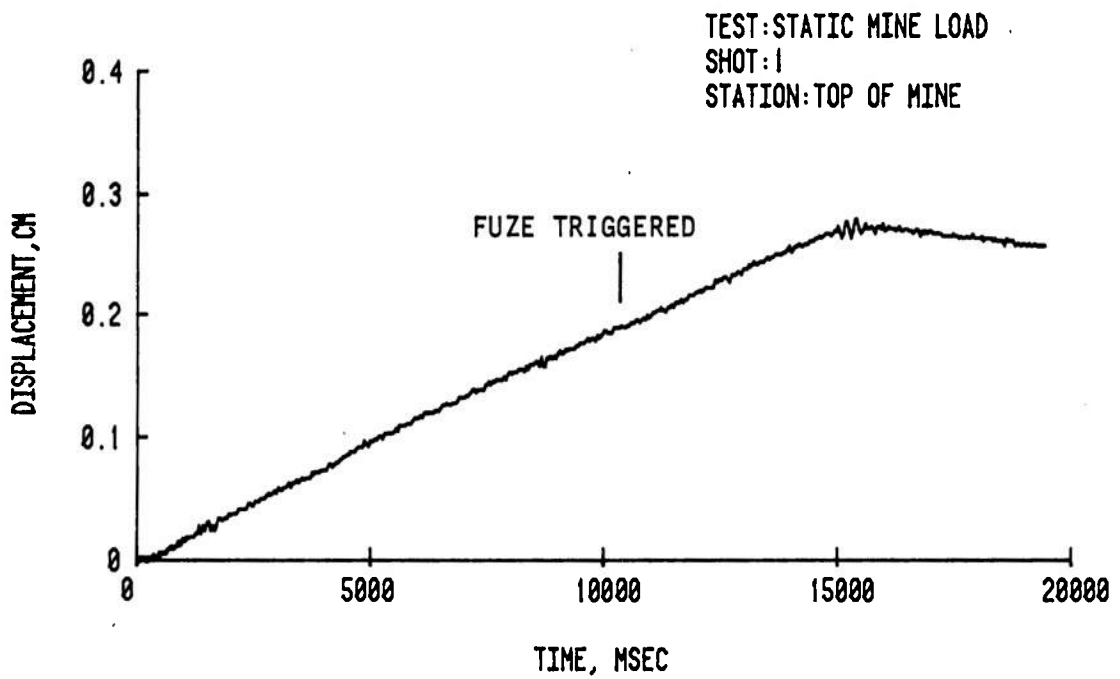
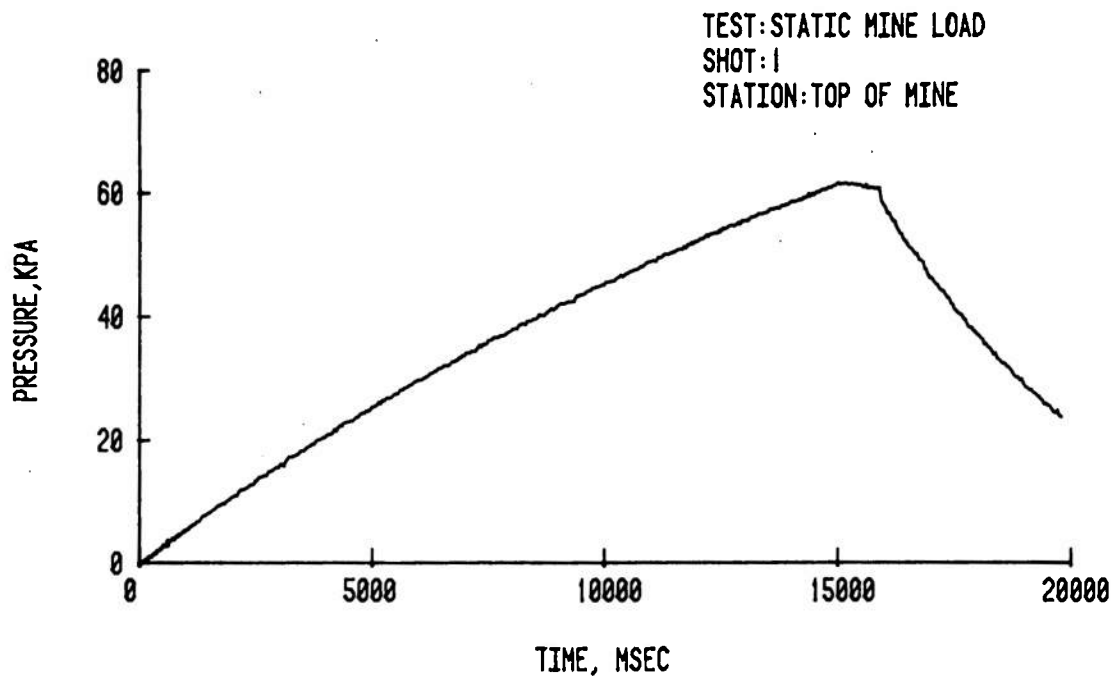

Figure 5. Pressure and displacement curves.

Table I. Deflection-Load Parameters for the TM-46/MVM Mine-Fuze Combination

<u>Pressure, kPa</u>	<u>Force, kN</u>	<u>Deflection, mm</u>	<u>Time, ms</u>
0	0	0	0
2.88	.201	.08	500
5.55	.388	.19	1000
8.22	.574	.29	1500
10.89	.761	.42	2000
13.36	.934	.50	2500
16.03	1.120	.59	3000
18.49	1.292	.69	3500
20.75	1.45	.76	4000
23.22	1.62	.90	4500
25.28	1.77	1.01	5000
27.74	1.94	1.09	5500
29.80	2.08	1.20	6000
32.06	2.24	1.26	6500
34.11	2.38	1.38	7000
35.55	2.48	1.45	7500
38.02	2.66	1.55	8000
39.87	2.79	1.64	8500
41.92	2.93	1.72	9000
43.56	3.04	1.76	9500
45.41	3.17	1.85	10000
47.06*	3.29	1.93	10410
47.26	3.29	1.93	10500
49.11	3.43	2.04	11000
50.76	3.55	2.12	11500
52.40	3.66	2.22	12000
54.04	3.78	2.33	12500
55.69	3.89	2.41	13000
55.89	3.91	2.50	13500
58.77	4.11	2.58	14000
60.00	4.19	2.64	14500
61.85	4.32	2.77	15000
61.24	4.28	2.71	15500
57.74	4.04	2.71	16000
51.58	3.61	2.71	16500
46.24	3.23	2.67	17000
41.10	2.87	2.64	17500
36.78	2.57	2.62	18000
32.47	2.27	2.60	18500
28.56	2.00	2.56	19000
25.28	1.77	2.56	19500

NOTE: (1) Force calculated for .0699 m<sup>2</sup> of top area of mine (11.75 in. dia).  
\*Fuze triggered.

TEST: STATIC MINE LOAD  
SHOT: 1  
STATION: TOP OF MINE

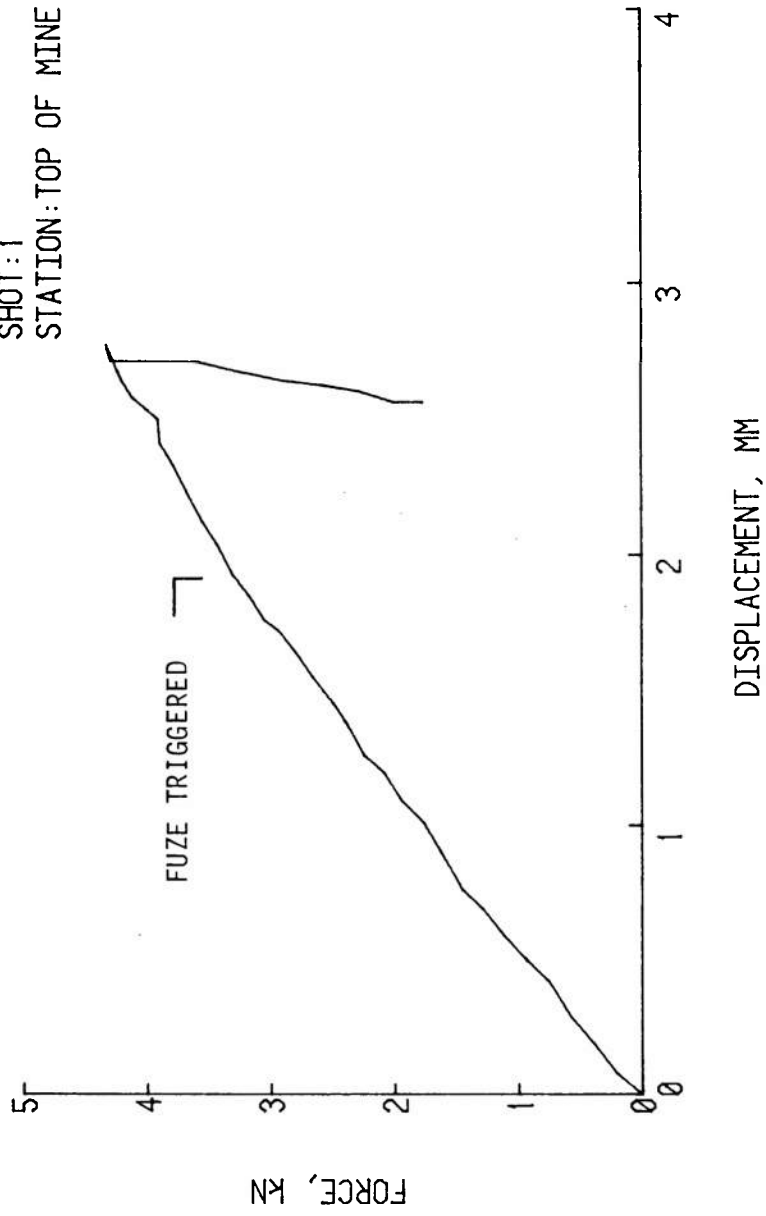

Figure 6. Force-displacement curve.

An example was presented for the TM-46/MVM mine-fuze combination. A load-deflection curve was developed and presented for this combination. The loading test showed fuze activation for the combination at 3.29 kN (47.0 kPa, 6.82 psi) force at 1.93 mm (0.075 in.) deflection.

Generally, the loading procedure is quite simple and uses available off-the-shelf equipment. The static test chamber is easily converted back to a shock tube (after static use) for the dynamic portion of the vulnerability assessment.

#### ACKNOWLEDGEMENT

The authors wish to thank Mr. Charles Kingery for his most helpful discussions during the development and use of the static load generator.

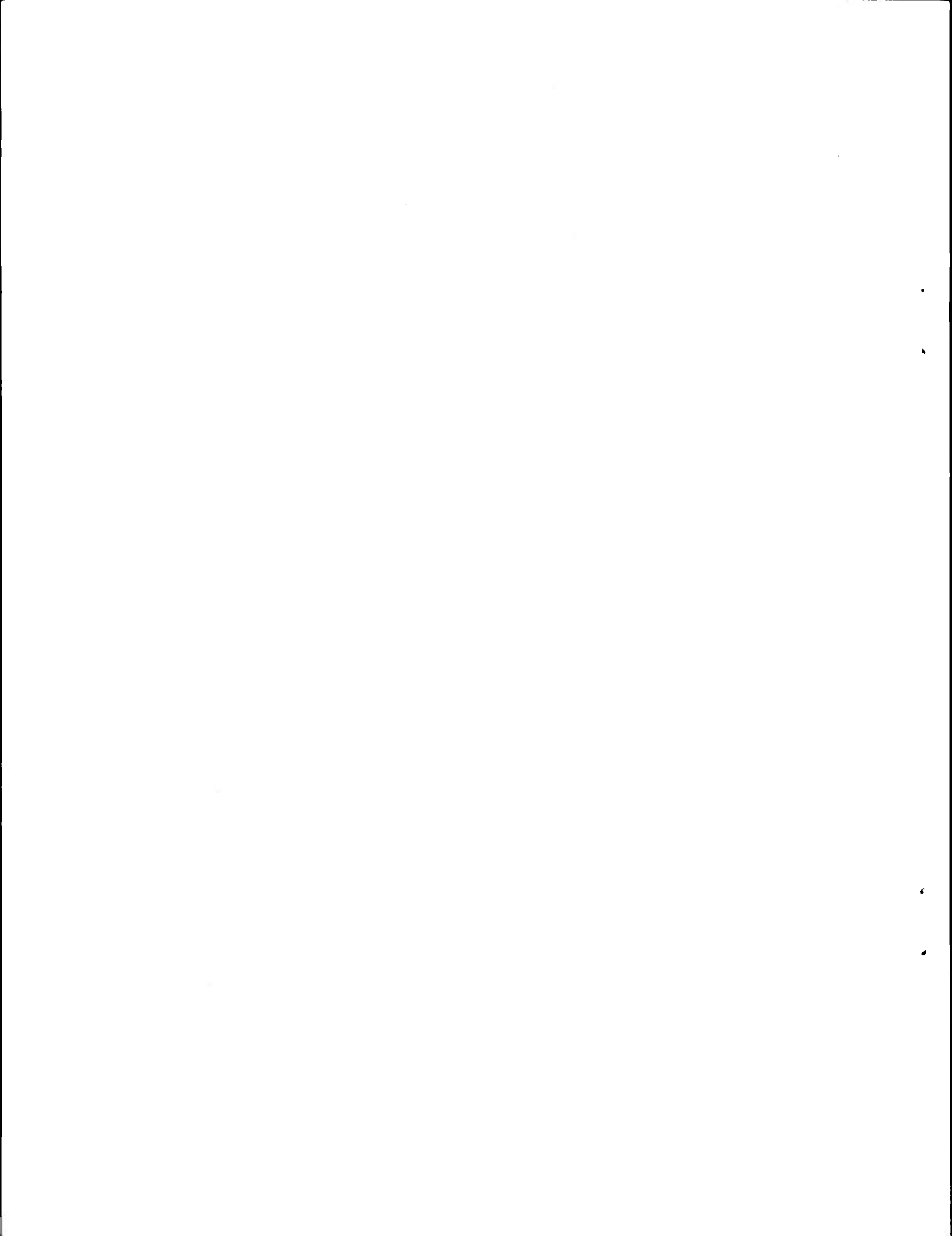

DISTRIBUTION LIST

<u>No. of Copies</u>	<u>Organization</u>	<u>No. of Copies</u>	<u>Organization</u>
12	Commander Defense Technical Info Cntr ATTN: DDC-DDA Cameron Station Alexandria, VA 22314	1	Commander US Army Materiel Development and Readiness Command ATTN: DRCDMD-ST 5001 Eisenhower Avenue Alexandria, VA 22333
4	Director of Defense Research and Engineering ATTN: DD/TWP DD/S&SS DD/I&SS AD/SW Washington, DC 20301	4	Commander US Army Armament Research and Development Command ATTN: DRDAR-TSS (2 cys) DRDAR-LCE Dr. N. Slagg Dover, NJ 07801
1	Director Defense Advanced Research Projects Agency 1400 Wilson Boulevard Arlington, VA 22209	1	Commander US Army Armament Materiel Readiness Command ATTN: DRSAR-LEP-L, Tech Lib Rock Island, IL 61229
3	Director Defense Nuclear Agency ATTN: STTL (Tech Lib, 2 cys) SPSS, Dr. George Ullrich Washington, DC 20305	1	Director US Army ARRADCOM Benet Weapons Laboratory ATTN: DRDAR-LCB-TL Watervliet, NY 12189
2	Chairman Department of Defense Explosives Safety Board ATTN: W. G. Queen Dr. Tom Zaker Room 856-C, Hoffman Bldg. I 2461 Eisenhower Avenue Alexandria, VA 22331	1	Commander US Army Aviation Research and Development Command ATTN: DRSAV-E 12th and Spruce Streets St. Louis, MO 63166
1	HQDA (DAMA-AR, NCB Division) Washington, DC 20310	1	Director US Army Air Mobility Research & Development Laboratory Ames Research Center Moffett Field, CA 94035
3	Commander US Army Engineer Waterways Experiment Station ATTN: Library W. Flateau L. F. Ingram P.O. Box 631 Vicksburg, MS 39180	1	Commander US Army Communication Research and Development Command ATTN: DRDCO-PPA-SA Fort Monmouth, NJ 07703

DISTRIBUTION LIST

<u>No. of Copies</u>	<u>Organization</u>	<u>No. of Copies</u>	<u>Organization</u>
1	Commander US Army Electronics Research and Development Command Tech Spt Activity ATTN: DELSD-L Fort Monmouth, NJ 07703	1	Director US Army Materials and Mechanics Research Center ATTN: Technical Library Watertown, MA 02172
2	Commander US Army Harry Diamond Lab. ATTN: DRXDO-TI/012 DRXDO-NP, F. Wimenitz 28 Powder Mill Road Adelphi, MD 20783	1	Director US Army TRADOC Systems Analysis Activity ATTN: ATAA-SL, Tech Library White Sands Missile Range NM 88002
3	Commander US Army Missile Command ATTN: DRSMI-R DRSMI-YDL DRSMI-S, Chief Scientist Redstone Arsenal, AL 35809	1	Director US Army Engineer School Ft. Belvoir, VA 22060
4	Commander US Army Mobility Equipment Rsch & Dev Command ATTN: DRDME-WC D. Stephani D. Vaughn I, Berg Ft. Belvoir, VA 22060	2	Commander Naval Coastal Systems Center ATTN: Code 771, Mr. K. Bartlett Panama City, FL 32407
1	Commander US Army Tank Automotive Rsch and Development Command ATTN: DRDTA-UL Warren, MI 48090	3	Commander Naval Surface Weapons Center ATTN: Code 241, J. Petes Code 730, Tech Library J. Pittman Silver Spring, MD 20910
1	Commander US Army Foreign Science and Technology Center ATTN: Research & Data Br. 1 220 7th Street, NE Charlottesville, VA 22901	1	Commander Naval Weapons Evaluation Fac ATTN: Document Control Kirtland AFB, NM 87117
		1	Commander Naval Civil Engineering Lab ATTN: Dr. W.A. Shaw, Code L31 Port Hueneme, CA 93041
		1	Director Naval Research Laboratory ATTN: Tech Lib, Code 2027 Washington, DC 20375



DISTRIBUTION LIST

<u>No. of Copies</u>	<u>Organization</u>	<u>No. of Copies</u>	<u>Organization</u>
2	Commander Mobility and Logistics Div Development Cntr, MCDEC ATTN: MAJ C.L. Guthrie, Jr. Quantico, VA 22134		<u>Aberdeen Proving Ground</u>  Director, USAMSAA ATTN: DRXSY-D Mr. R. Norman, GWD DRXSY-MP, H. Cohen Mr. R. Carne
1	HQ USAFSC (DLCAW, Tech Library) Andrews AFB Washington, DC 20331		Cdr, USATECOM ATTN: DRSTE-TO-F Bldg. 314
1	AFOSR (OAR) Bolling AFB, DC 20332		Dir, USACSL Bldg E3516, EA ATTN: DRDAR-CLB-PA
3	AFTAC (K. Rosenlof R. McBride G. Leises) Patrick AFB, FL 32925		
2	AFML (G. Schmitt, MAS: D. Schmidt, MBC) Wright-Patterson AFB, OH 45433		
2	Headquarters Energy Research & Development Administration Department of Military Application ATTN: R&D Branch Library Branch, G-043 Washington, DC 20545		
1	Commanding General Fleet Marine Force, Atlantic ATTN: G-4 (NSAP) Norfolk, VA 23511		

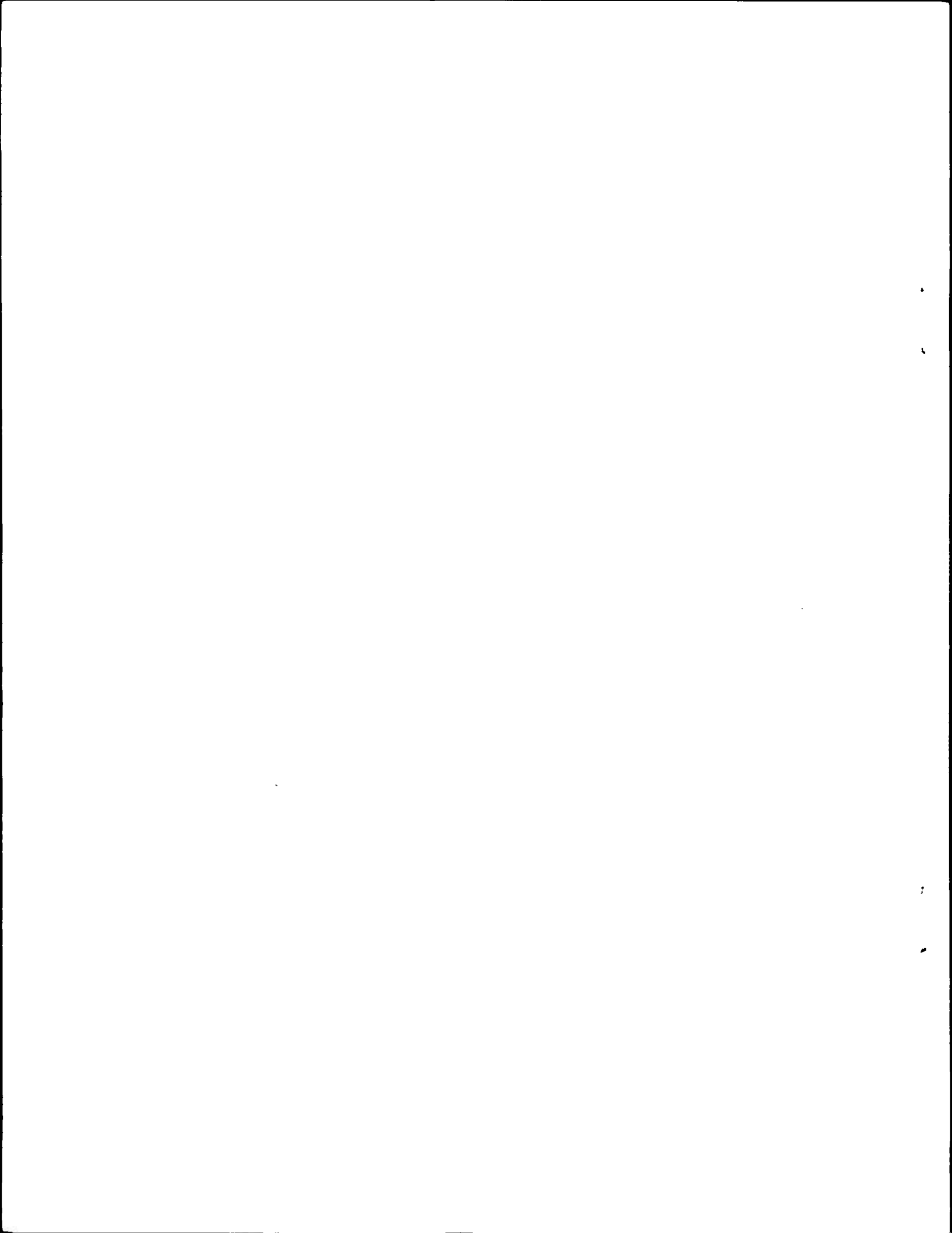

USER EVALUATION OF REPORT

Please take a few minutes to answer the questions below; tear out this sheet, fold as indicated, staple or tape closed, and place in the mail. Your comments will provide us with information for improving future reports.

1. BRL Report Number \_\_\_\_\_

2. Does this report satisfy a need? (Comment on purpose, related project, or other area of interest for which report will be used.)

\_\_\_\_\_  
\_\_\_\_\_  
\_\_\_\_\_

3. How, specifically, is the report being used? (Information source, design data or procedure, management procedure, source of ideas, etc.) \_\_\_\_\_

\_\_\_\_\_  
\_\_\_\_\_

4. Has the information in this report led to any quantitative savings as far as man-hours/contract dollars saved, operating costs avoided, efficiencies achieved, etc.? If so, please elaborate.

\_\_\_\_\_  
\_\_\_\_\_

5. General Comments (Indicate what you think should be changed to make this report and future reports of this type more responsive to your needs, more usable, improve readability, etc.) \_\_\_\_\_

\_\_\_\_\_  
\_\_\_\_\_  
\_\_\_\_\_

6. If you would like to be contacted by the personnel who prepared this report to raise specific questions or discuss the topic, please fill in the following information.

Name: \_\_\_\_\_

Telephone Number: \_\_\_\_\_

Organization Address: \_\_\_\_\_

\_\_\_\_\_  
\_\_\_\_\_

FOLD HERE

Director  
US Army Ballistic Research Laboratory  
Aberdeen Proving Ground, MD 21005

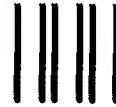

NO POSTAGE  
NECESSARY  
IF MAILED  
IN THE  
UNITED STATES

**OFFICIAL BUSINESS**  
PENALTY FOR PRIVATE USE, \$300

**BUSINESS REPLY MAIL**  
FIRST CLASS PERMIT NO 12062 WASHINGTON, DC  
POSTAGE WILL BE PAID BY DEPARTMENT OF THE ARMY

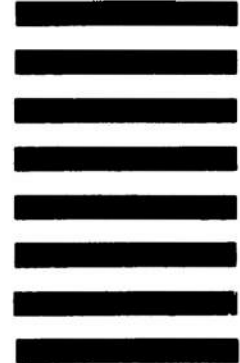

Director  
US Army Ballistic Research Laboratory  
ATTN: DRDAR-TSB  
Aberdeen Proving Ground, MD 21005

FOLD HERE

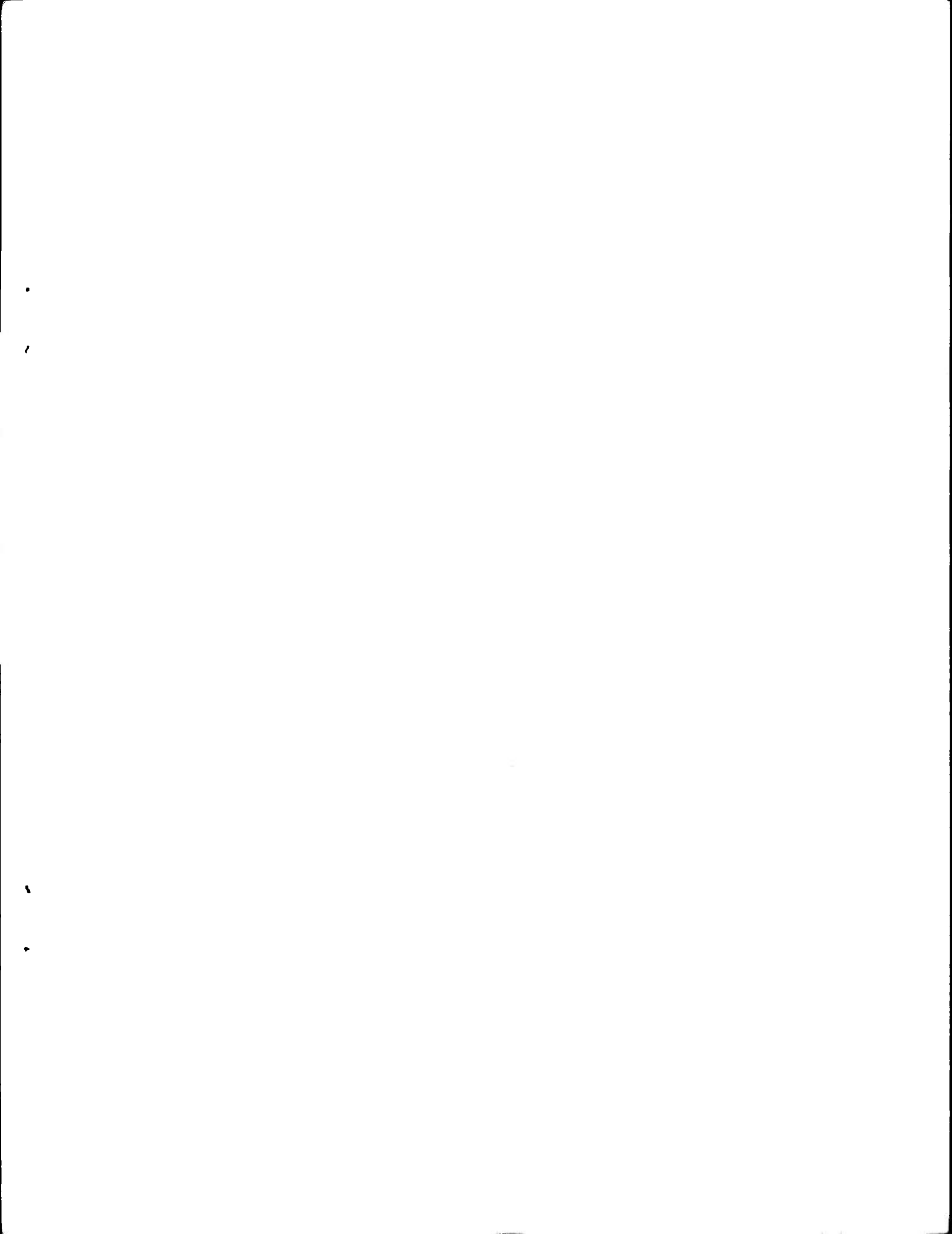

100

1

1