

12

LEVEL II

DAVID W. TAYLOR NAVAL SHIP
RESEARCH AND DEVELOPMENT CENTER



Bethesda, Maryland 20084

AT-SEA EVALUATION OF THE HYDRODYNAMIC
PERFORMANCE OF A SIMULATED
DEPRESSOR-TOWED ARRAY

P. Rispin

J.S. Diggs

APPROVED FOR PUBLIC RELEASE; DISTRIBUTION UNLIMITED

4

DTIC
ELECTE
JUN 5 1981

SHIP PERFORMANCE DEPARTMENT
DEPARTMENTAL REPORT

B

March 1981

DTNSRDC/SPD 0953-01

AD A 099 764

DTNSRDC/SPD 0953-01

AT-SEA EVALUATION OF THE HYDRODYNAMIC PERFORMANCE OF A SIMULATED DEPRESSOR-TOWED ARRAY

DTIC FILE COPY

81 6 05 012

MAJOR DTNSRDC ORGANIZATIONAL COMPONENTS

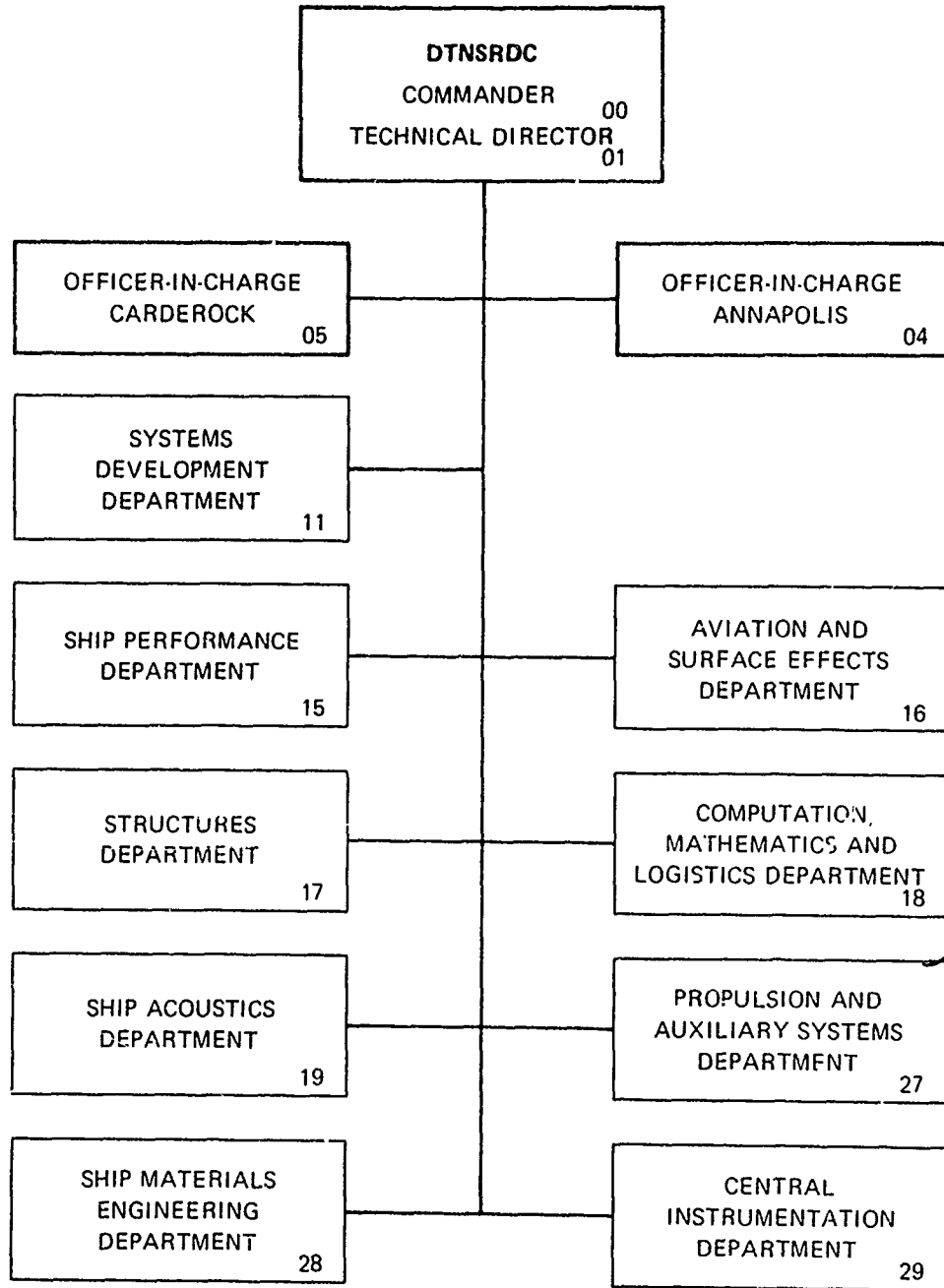

UNCLASSIFIED

SECURITY CLASSIFICATION OF THIS PAGE (When Data Entered)

REPORT DOCUMENTATION PAGE		READ INSTRUCTIONS BEFORE COMPLETING FORM
1. REPORT NUMBER 14 DTNSRDC / SPD-0953-01	2. GOVT ACCESSION NO. AD-A099764	3. RECIPIENT'S CATALOG NUMBER
4. TITLE (and Subtitle) 6 AT-SEA EVALUATION OF THE HYDRODYNAMIC PERFORMANCE OF A SIMULATED DEPRESSOR-TOWED ARRAY.		5. TYPE OF REPORT & PERIOD COVERED 9 Departmental rept.,
7. AUTHOR(s) 0 P. Rispin J.S. Diggs		6. PERFORMING ORG. REPORT NUMBER DTNSRDC/SPD 0953-01
9. PERFORMING ORGANIZATION NAME AND ADDRESS David W. Taylor Naval Ship Research and Development Center Bethesda, Maryland 20084		8. CONTRACT OR GRANT NUMBER(s) 26 F111a1
11. CONTROLLING OFFICE NAME AND ADDRESS Office of Naval Research 800 North Quincy Street Arlington, VA 22217		10. PROGRAM ELEMENT, PROJECT, TASK AREA & WORK UNIT NUMBERS Research Proj. RF 11-121-807 Program Element 62711 N Work Unit 1-1548-212
14. MONITORING AGENCY NAME & ADDRESS (if different from Controlling Office) 17 RF 11-121-807		12. REPORT DATE 11 March 1981
		13. NUMBER OF PAGES 37 12/46
		15. SECURITY CLASS. (of this report) UNCLASSIFIED
		15a. DECLASSIFICATION/DOWNGRADING SCHEDULE
16. DISTRIBUTION STATEMENT (of this Report) Approved for Public Release; Distribution Unlimited		
17. DISTRIBUTION STATEMENT (of the abstract entered in Block 20, if different from Report)		
18. SUPPLEMENTARY NOTES		
19. KEY WORDS (Continue on reverse side if necessary and identify by block number) Towed Arrays Hydrodynamic Depressors Cable Fairings Towing Dynamics		
20. ABSTRACT (Continue on reverse side if necessary and identify by block number) → This report gives details of a sea trial evaluation of the hydrodynamic performance and stability of a depressor-towed array system for the Office of Naval Research (ONR). For these hydrodynamic evaluations, a simulated towed array was used. Speeds of up to 30 knots were attained with no adverse effects of towline kiting. A depth of 75 m (245 feet) was obtained at a towline scope of 207 m (680 feet) at 30 knots. Dynamic performance was → cont (Continued on reverse side)		

DD FORM 1 JAN 73 1473

EDITION OF 1 NOV 65 IS OBSOLETE
S/N 0102-014-6601

UNCLASSIFIED

SECURITY CLASSIFICATION OF THIS PAGE (When Data Entered)

389694

UNCLASSIFIED

SECURITY CLASSIFICATION OF THIS PAGE(When Data Entered)

(Block 20 Continued)

64
↓
assessed during towship accelerations, decelerations, and maneuvers. The system responded very quickly to these speed changes and maneuvers and at no time gave any indication of instability. It was concluded that the ONR high-speed, depressor-towed array system is hydrodynamically stable up to at least 30 knots and is ready for high-speed acoustic evaluation. ↑

UNCLASSIFIED

SECURITY CLASSIFICATION OF THIS PAGE(When Data Entered)

TABLE OF CONTENTS

	Page
LIST OF FIGURES	iv
LIST OF TABLES.	v
NOTATION.	vii
LIST OF ABBREVIATIONS	viii
ABSTRACT.	1
ADMINISTRATIVE INFORMATION.	1
INTRODUCTION.	1
SYSTEM DESCRIPTION.	2
SIMULATED ARRAY.	2
DEPRESSOR.	4
TOWLINE.	4
INSTRUMENTATION.	8
TRIAL PROCEDURES.	8
RESULTS AND DISCUSSION.	15
STEADY TOWING CHARACTERISTICS OF DEPRESSOR AND SIMULATED ARRAY.	16
STEADY-TOWING CHARACTERISTICS OF FAIRED TOWLINE.	23
RESPONSE OF SYSTEM TO TOWSHIP MANEUVERS.	29
System Response to Ship Turns	30
System Response to Accelerations and Decelerations.	33
HANDLING CONSIDERATIONS.	35
SUMMARY OF RESULTS	35
CONCLUSIONS	36
RECOMMENDATIONS	37
ACKNOWLEDGMENT.	37
REFERENCES.	37

LIST OF FIGURES

	Page
1 - Overall Depiction of Simulated Depressor-Towed Array System.	3
2 - DTNSRDC Depressor	5
3 - DTNSRDC Depressor Dimensions in Meters.	5
4 - Fathom Oceanology Series 770 Flexnose Fairing	7
5 - Fathom Fairing with Antistacking Ring Installed on Cable.	9
6 - Instrumentation Block Diagram	11
7 - DTNSRDC Towpoint Gimbal and Towing Configuration	13
8 - Ship's Path During Maneuvers.	15
9 - Notation and Geometry for Depressor-Towed System.	18
10 - Towline Measurements at the Depressor as Functions of Towspeed.	19
11 - Depressor Towing Attitude as a Function of Towspeed for Two Towline Scopes.	20
12 - Free-Body Diagram of Depressor Forces	21
13 - Lift-to-Drag Ratios for Various Towspeeds	23
14 - Shipboard Towline Tension as a Function of Towspeed for the Two Scopes Tested.	24
15 - Notation for Shipboard Measurements	25
16 - Shipboard Towing Angles as Functions of Towspeed	26
17 - Depressor Depth versus Towspeed for Two Towline Scopes.	27
18 - Time History Data During Ship Maneuvers at 20 Knots	31
19 - Time History Data During Deceleration from 20 Knots to 8 Knots.	34

LIST OF TABLES

	Page
1 - Cable Properties.	7
2 - Depressor-Towed Array Steady-State Data	17

Accession For	
NTIS GRA&I	<input checked="" type="checkbox"/>
DTIC TAB	<input type="checkbox"/>
Unannounced	<input type="checkbox"/>
Justification_____	
By_____	
Distribution/_____	
Availability Codes	
Dist	Avail and/or Special
A	

v/vi

NOTATION

C_R	Towline normal drag coefficient
C_t	Simulated array tangential drag coefficient
D_a	Simulated array drag
D_d	Depressor drag
D_s	System drag
d	Simulated array diameter
f_n	Normal hydrodynamic Loading function
f_t	Tangential hydrodynamic loading function
L_d	Depressor Lift
L_s	System lift
l	Simulated array length
R_n	Reynolds Number based on diameter $V d/\nu$
S	Towline scope deployed
T_o	Towline tension at the depressor towpoint
T_s	Towline tension at the shipboard towpoint
V	Towspeed
W	Depressor weight in water
Y	Depressor depth
β	Depressor pitch angle
θ	Depressor roll angle
θ_s	Kite angle at the shipboard towpoint
ν	Kinematic viscosity of seawater
ρ	Mass density of seawater
ϕ_o	Towline angle at the depressor towpoint
ϕ_s	Towline angle at the shipboard towpoint
ψ_s	Horizontal towoff angle at the shipboard towpoint

LIST OF ABBREVIATIONS

BTL	Bell Telephone Laboratories
DTNSRDC	David W. Taylor Naval Ship Research and Development Center
IVDS	Independent Variable Depth Sonar
NUSC/NLL	Naval Underwater Systems Center/New London Laboratory
ONR	Office of Naval Research

ABSTRACT

This report gives details of a sea trial evaluation of the hydrodynamic performance and stability of a depressor-towed array system for the Office of Naval Research (ONR). For these hydrodynamic evaluations, a simulated towed array was used. Speeds of up to 30 knots were attained with no adverse effects of towline kiting. A depth of 75 m (245 feet) was obtained at a towline scope of 207 m (680 feet) at 30 knots. Dynamic performance was assessed during towship accelerations, decelerations, and maneuvers. The system responded very quickly to these speed changes and maneuvers and at no time gave any indication of instability. It was concluded that the ONR high-speed, depressor-towed array system is hydrodynamically stable up to at least 30 knots and is ready for high-speed acoustic evaluation.

ADMINISTRATIVE INFORMATION

The work described in this report was performed in support of the High-Speed Tactical Sensor Program, sponsored by ONR, Code 222, under Work Request N00014-77-WR-126. The program element was 62711N, Research Project RF11-121-807. The David W. Taylor Naval Ship Research and Development Center (D1NSRDC) Work Unit was 1-1548-212. Mr. Diggs is with MAR, Incorporated, Rockville, Maryland.

INTRODUCTION

During the past ten years, ONR has sponsored extensive research directed toward improving the performance of conventional surface ship towed arrays. Conventional towed array systems are limited to a maximum practical speed of about 25 knots. At much higher speeds, the operating depth of the array becomes very shallow and can only be adjusted by increasing towcable length, resulting in excessively high cable tensions, massive array handling equipment, and the placing of operating restrictions on the host platform's maneuverability. An alternative for tactical purposes would consist of a short-aperture, high-frequency array which is towed in close proximity to the ship, utilizing a small, high-performance depressor.

In mid-1976, the results of on-going research into small diameter arrays and the concept of a small, high-performance depressor were successfully integrated and evaluated aboard GLOVER (AGFF-1) at speeds up to 20 knots.¹ Here, the emphasis was on demonstration of the sprint-and-drift concept as a potential mid-speed ASW system. The system was evaluated for steady-state hydrodynamic performance and dynamic stability during ship maneuvers. The towline developed moderate kiting, which was corrected by adjusting trim tabs on the trailing edge of the towline fairing. The depressor was a special high-performance design that was extremely small and lightweight, deriving all of its lift (down-force) from a wing. The system handling and overboarding was easily managed by the existing Independent Variable Depth Sonar (IVDS) equipment. The significance of these evaluations was to demonstrate, both hydrodynamically and acoustically, the potential applications of depressor-towed array systems.

As an extension of the GLOVER demonstration, ONR plans to assemble another depressor-towed array system designed to offer continuous tracking capabilities at speeds in excess of 35 knots. The new demonstration system will consist of a short-aperture array towed from a heavy winged depressor. To verify system towing performance without jeopardizing the array, a demonstration evaluation was staged using a rope drogue to simulate the candidate array. The results of this initial at-sea evaluation of the new simulated depressor-towed array system are reported here, and recommendations are made as to how the system should be configured for an acoustic array trial.

SYSTEM DESCRIPTION

Figure 1 illustrates the depressor-towed system that was evaluated. The following sections detail the system components and the instrumentation.

SIMULATED ARRAY

A nylon braided rope drogue was towed from the tail of the depressor to simulate the drag that would be presented by an actual towed array. Previous experience has shown that use of a rope drogue having the same

¹A complete listing of references is given on Page 37.

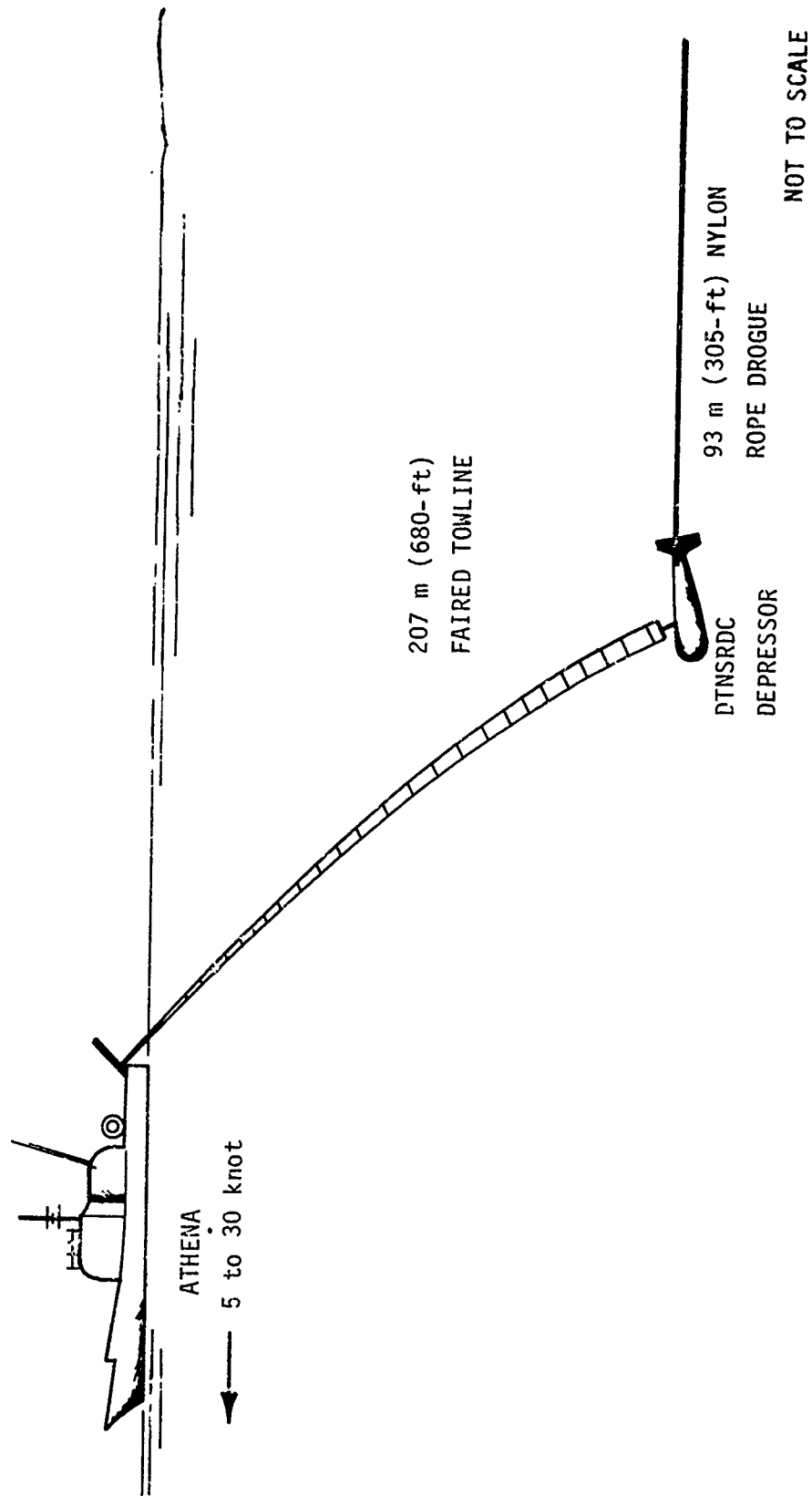

Figure 1 - Overall Depiction of Simulated Depressor-Towed Array System

drag as an array is hydrodynamically equivalent to towing the array itself. The drogue consisted of two sections of rope, 30 mm (1 1/8 inches) in diameter, for a total of 93 m (305 feet) in length. It was observed to be approximately neutrally buoyant at sea.

DEPRESSOR

The depressor used for these evaluations is pictured in Figure 2. Physical characteristics of the depressor are shown in Figure 3. The depressor has a flooded chamber suitable for locating a watertight canister to house instrumentation. The wing and the horizontal stabilizer can be adjusted manually prior to deployment. However, for these experiments, the horizontal stabilizer was fixed and only the wing was adjusted to vary the lift (downforce). On the tail of the body, and in line with the body center of gravity was a special array mounting adaptor which allowed any of several arrays or rope drogues to be attached. The depressor weighed 730 kg (1609 pounds) in water.

TOWLINE

The towline used for these tests was the same faired towline used by the Naval Underwater Systems Center, New London Laboratory (NUSC/NLL) for the 1976 tests aboard GLOVER. The cable, manufactured by Consolidated Products Corporation, is of double-armor construction and has a triaxial central conductor. Details of the cable properties are presented in Table 1. The outer steel armor shield was left bare (i.e., without polyethylene jacket) and was faired using a Fathom Flexnose Series 770 type sectional plastic fairing, which was slipped over the outside of approximately 210 m (680 feet) of the cable. Details of the Fathom Flexnose fairing are presented in Figure 4. Note that the hole in the fairing is slightly smaller than the cable. This caused binding of the fairing at low tensions in the cable; the fairings were free at higher tensions (speeds) when the cable had necked down. In an effort to minimize the kiting problem that developed with this faired towline when tested by NUSC/NLL aboard GLOVER, the trailing edge trim tabs were removed and anti-stacking rings were installed on the cable every 3.2 m (10.5 feet). The concept of anti-stacking rings evolved from the IVDS program during the

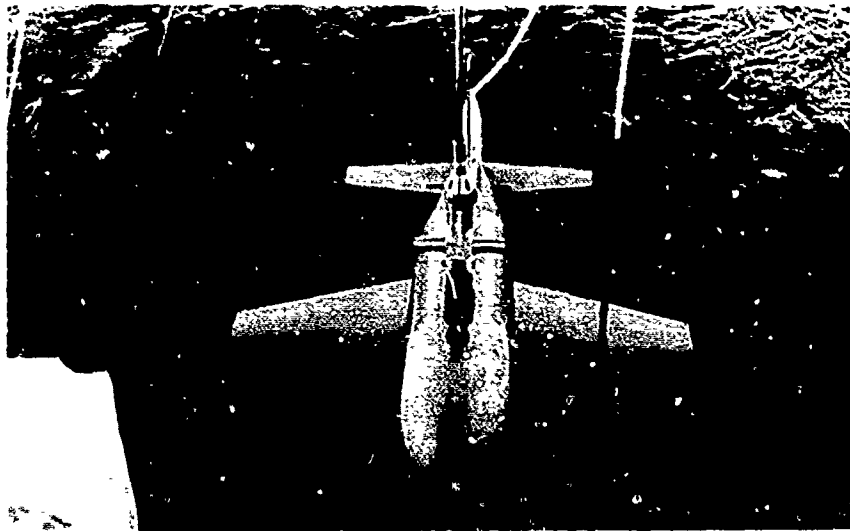

PSD 0053/25-10-77

Figure 2 - DTNSRDC Depressor

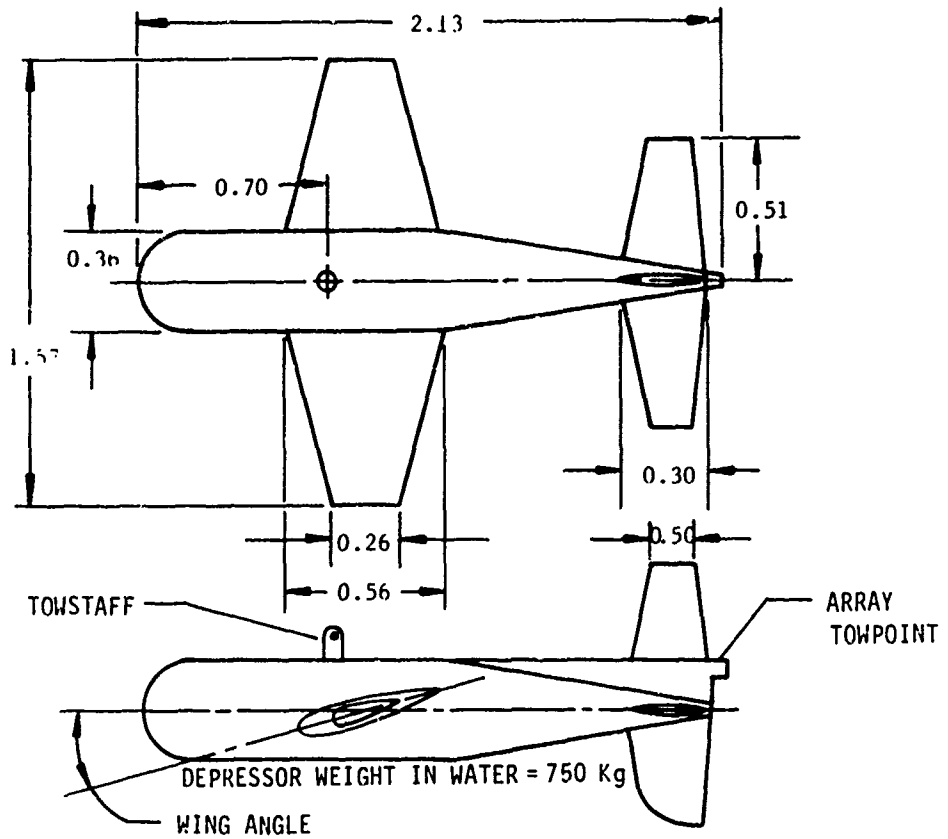

Figure 3- DTNSRDC Depressor Dimensions in Meters

TABLE 1 - CABLE PROPERTIES

Outer Diameter	16.0 mm	0.631 in.
Core Diameter	8.2 mm	0.322 in.
Length	250 m	820 ft
Breaking Strength	150,000 N	33,500 lb
Weight in Air	0.923 kg/m	0.620 lb/ft
Weight in Seawater	0.756 kg/m	0.508 lb/ft

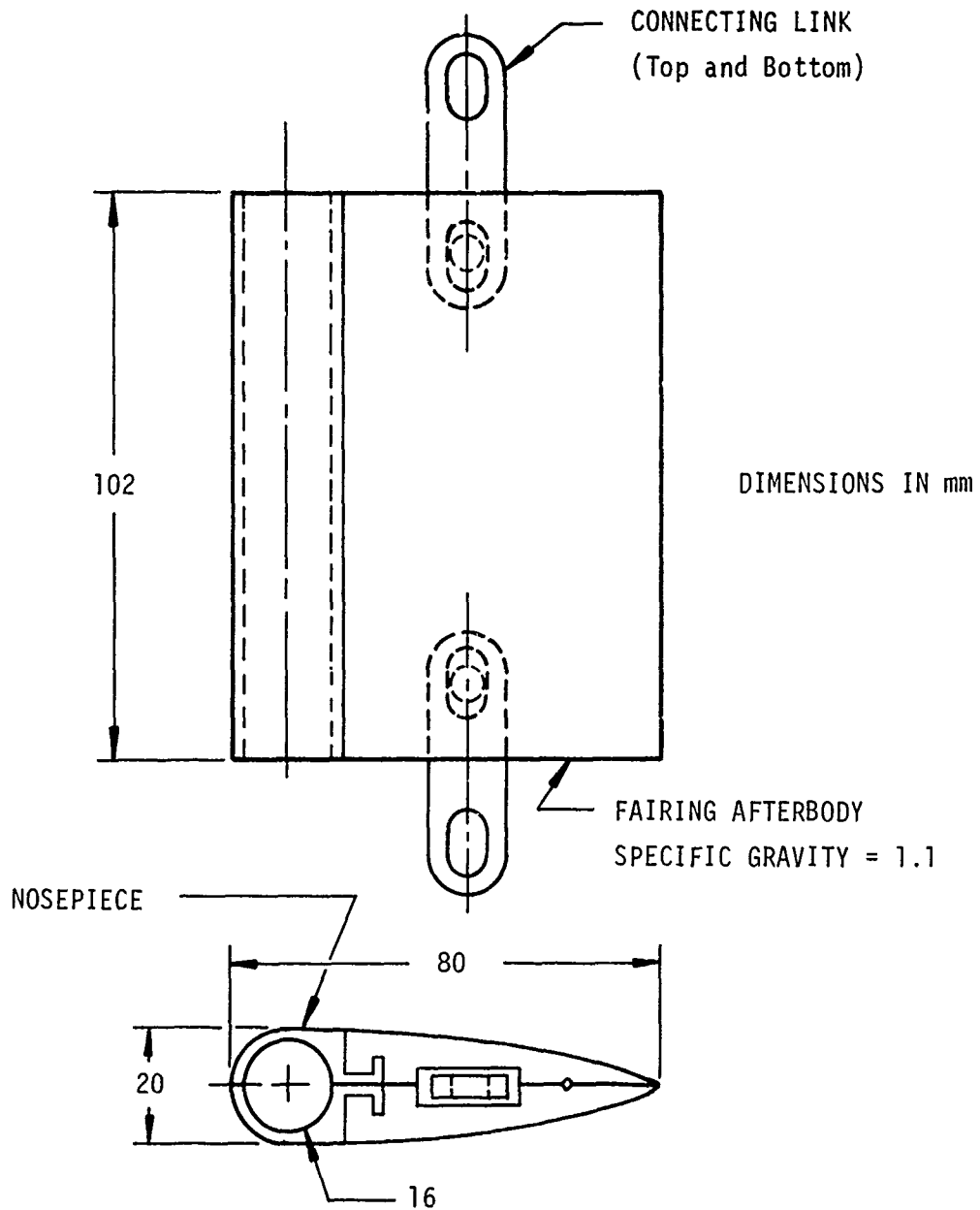

Figure 4 - Fathom Oceanology Series 770 Flexnose Fairing

mid-1960s. It has proven to be effective at transferring the fairing tangential load (due to hydrodynamic forces) to the towline, thus preventing these accumulated forces from causing each fairing to stack (or column load) onto the next lower fairing, and restricting its free-swiveling motion. If the fairing is not allowed to move freely and align itself with the flow, a side force will develop and the towline will kite in the direction of the side force.

The antistacking rings that were installed on the towline consisted of simple split-cylinders of polyvinyl chloride pipe about 3.8 cm (1.5 inches) long and were attached to the cable every 3.2 m using epoxy glue and two stainless-steel banding straps. The interval of 3.2 m was chosen rather arbitrarily based on experience with IVDS cables. Details of the antistacking rings and the attachment technique are presented in Figure 5.

INSTRUMENTATION

The instrumentation chosen for these evaluations provided data from which the steady-state and dynamic towing characteristics of the entire system was assessed. Sensors were located at two discrete points in the system to provide this information: (1) at the depressor to measure depth, roll, pitch, towline tension, and angle, and (2) at the towcable termination on the ship's transom to measure cable tension and angle, and towoff angle. In addition, the DTNSRDC towed knotmeter was deployed to measure the speed of the ship. The instrumentation was assembled and checked out at DTNSRDC prior to shipping, and then verified again at dockside checkout in Port Everglades prior to sailing. Figure 6 presents the instrumentation block diagram.

TRIAL PROCEDURES

The initial activities were depressor trim tests at the short towline scope of 23 m (75 feet). The procedures were as follows.

Upon arrival at the test site, the system electronics were verified, the depressor wing angle was set to -5.0 degrees (leading edge down), and the system was deployed while the ship maintained minimum headway (less than 5 knots). Towline scope was increased to 23 m, and a 3-m (10-foot)

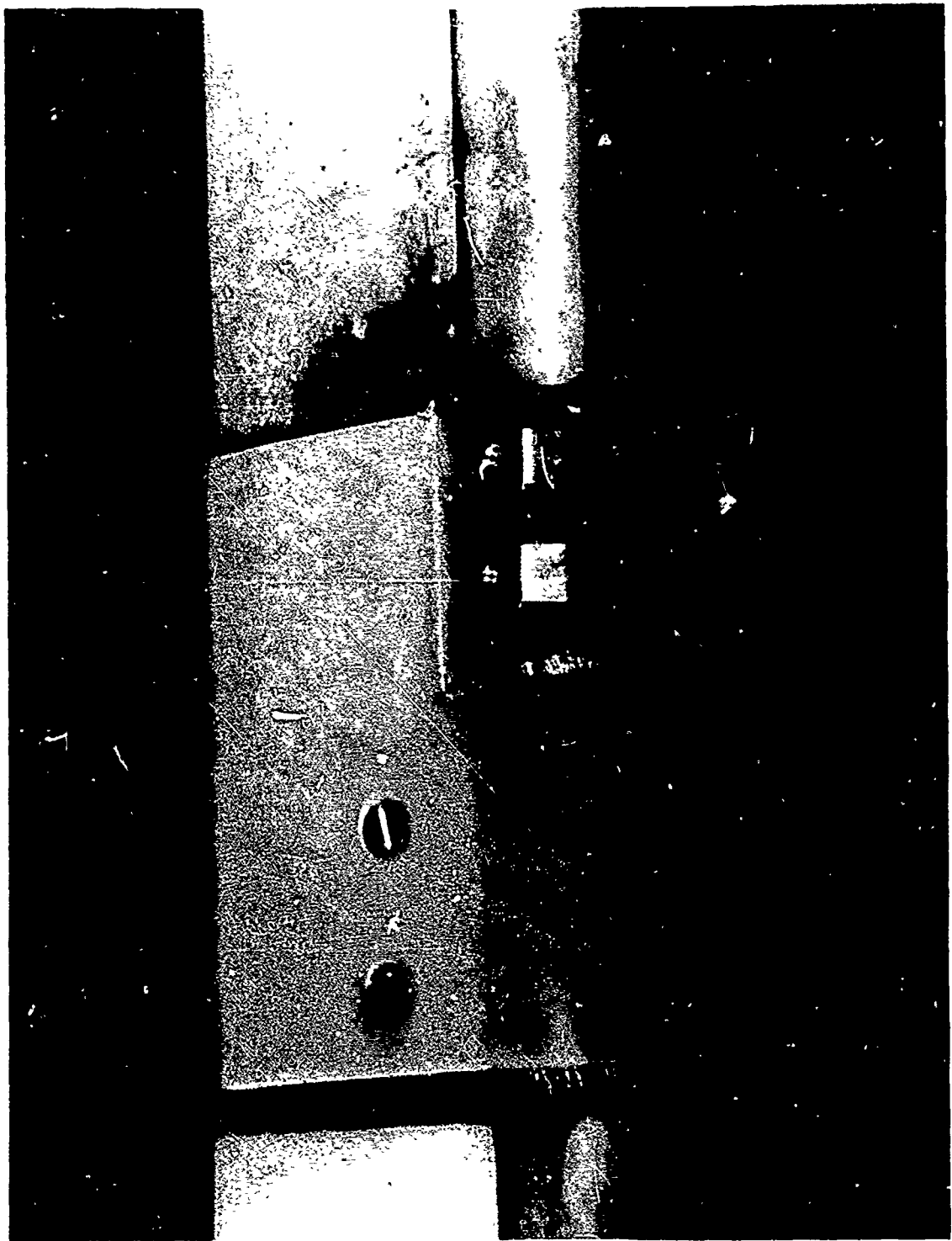

Figure 5 Fathom Oceanology Series 770 with Restraining Ring Installed on Cable

9/10

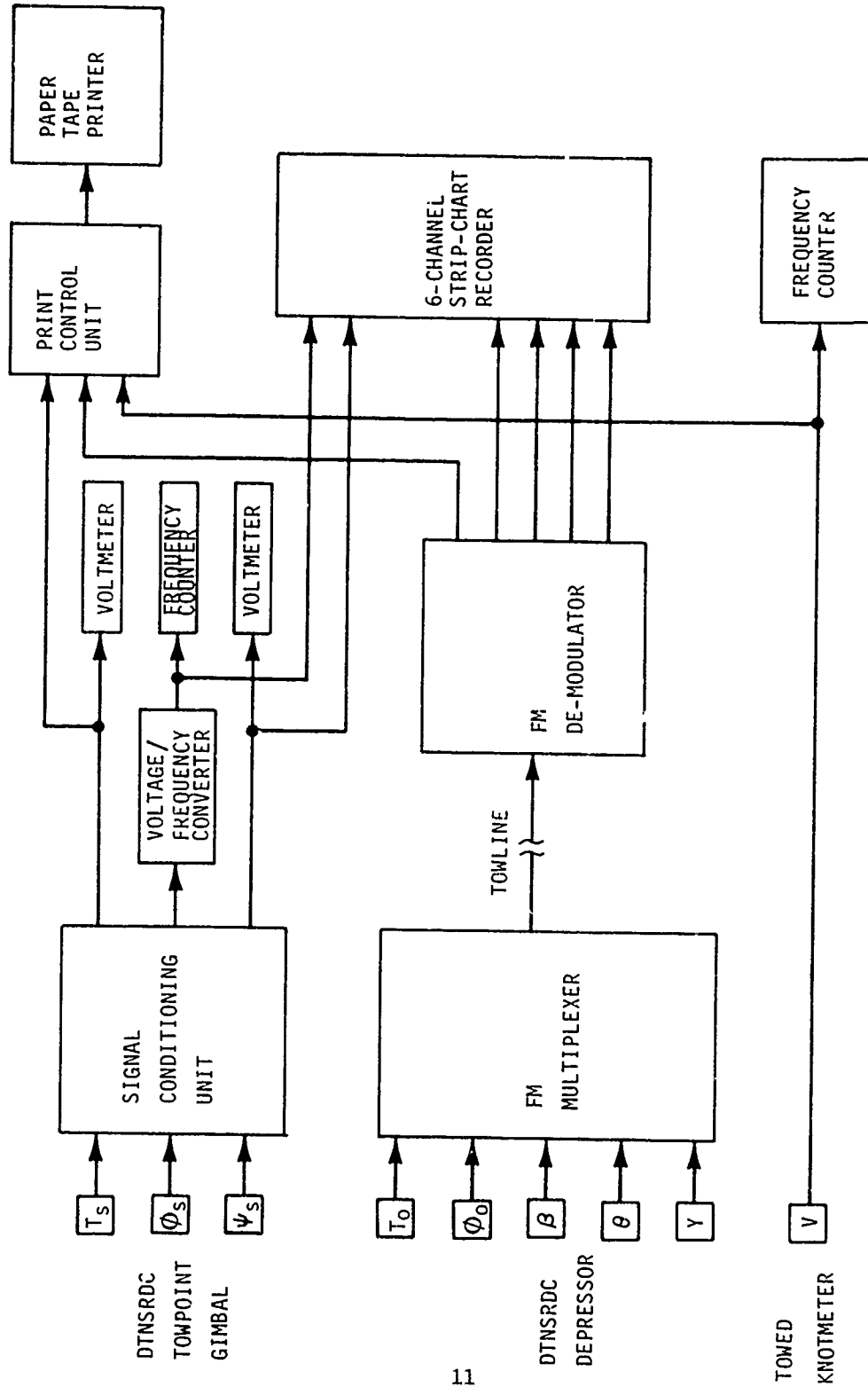

Figure 6 - Instrumentation Block Diagram

section of the fairing removed from the cable. A Preformed Line Products Model BG-2111 cable dead-end grip was then wrapped onto the newly bared section of towline, and the towing load was transferred from the winch drum to the DTNSRDC Towpoint Gimbal mounted on the ship transom. Figure 7 shows the DTNSRDC Towpoint Gimbal and the physical arrangement after the towing load had been transferred.

Steady-state hydromechanical data were obtained while the ship held speed and course for approximately 10 minutes at each speed from 5 to 30 knots in 5-knot increments. The data obtained included shipboard towline tension and angle and towoff angle, towspeed, and depressor pitch and roll.

The entire system then was retrieved and the depressor wing angle increased to -5.33 degrees (down) in an effort to achieve a greater down force at 30 knots. The system was redeployed to a scope of 23 m and re-evaluated in the same manner as before. The new towing performance appeared to satisfy the requirements for an acoustic sea trial using the towline and depressor.

The entire system then was deployed and the towline scope increased to the maximum available, 207 m. The towing load again was transferred to the Towpoint Gimbal. Steady-state hydromechanical data were acquired while the ship held speed and course for approximately 10 minutes at each speed from 5 to 30 knots in 5-knot increments. Data from the towline tension and angle at the depressor and depth were taken during these runs.

Stability data were acquired while the ship maneuvered through the figure-eight track shown in Figure 8. The initial speed was 15 knots, with a 20-degree rudder turn to port, followed by a short, straight run, then a 20-degree rudder turn to starboard, followed by another straight run with an acceleration to 25 knots, and then a repeat of the entire course. This technique offered both port and starboard turns at high speeds and an acceleration and a deceleration to a new speed, providing ample data to allow system towing stability to be assessed.

Upon completion of the figure-eight track data runs, the ship performed a deceleration test from 25 to 5 knots within a period of 140 seconds to provide additional stability data. At the conclusion of the deceleration, the ship accelerated from 5 to 30 knots within a period of 310 seconds, concluding the test at 207 m of towline scope.

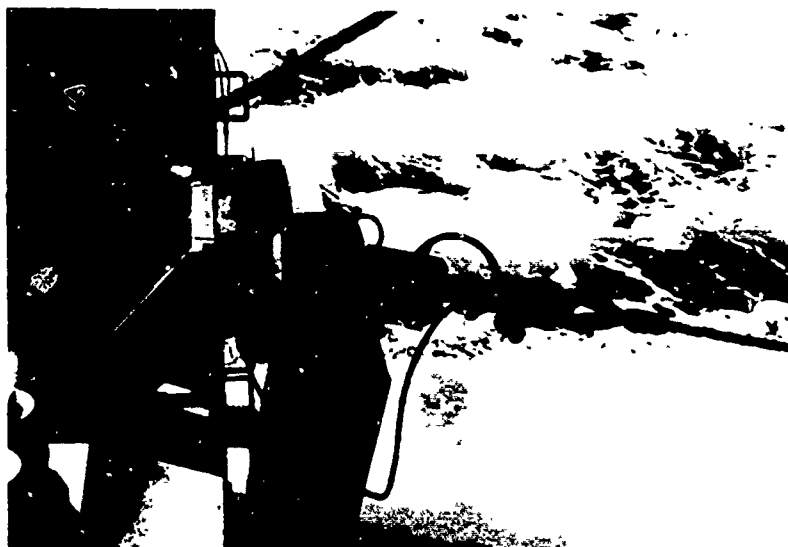

Figure 7a - Towpoint Gimbal Mounted on Fantail

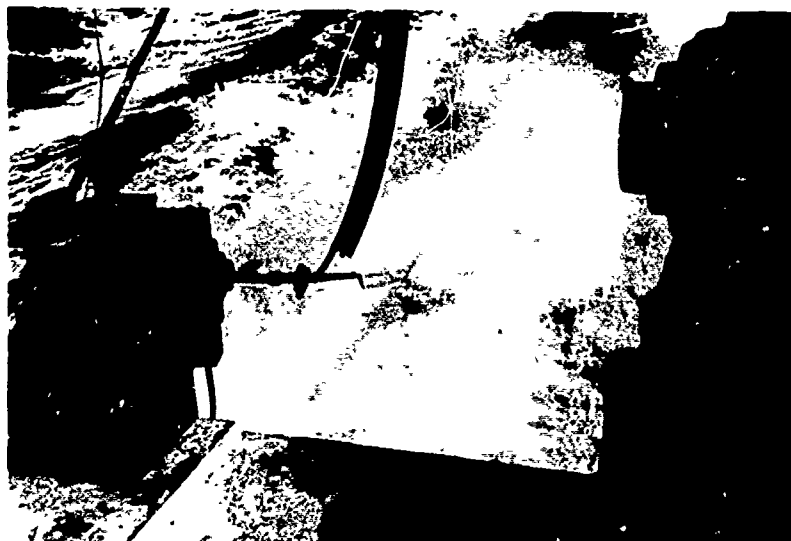
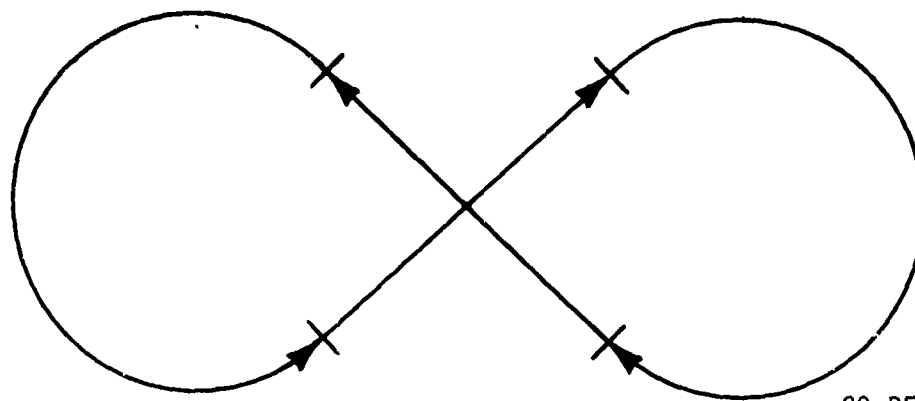

Figure 7b - Towing Configuration

Figure 7 - DTNSRDC Towpoint Gimbal and Towing Configuration

20-DEGREE RUDDER
TURN FOR 270 DEGREES



20-DEGREE RUDDER
TURN FOR 270 DEGREES

Figure 8 - Ship's Path During Maneuvers

The system was inhailed until only 122 m (400 feet) of towline was deployed, and the same procedures used for the longer cable scope were repeated.

For endurance, the system remained deployed at 122 m of cable while transitting the Gulf Stream enroute to Port Everglades at 25 knots for one hour. The Gulf Stream sea condition was estimated at about State 1 to 2 and presented no problems during either towing or retrieval.

RESULTS AND DISCUSSION

The steady-state data resulting from these at-sea evaluations of the ONR depressor system are presented in Table 2 for Data Runs 4 through 30, and Runs 37 through 43. Data Runs 1 through 3 were preliminary qualitative evaluations to verify the instrumentation and data acquisition procedures. Data Runs 31 through 35 and Runs 44 through 47 consisted of accelerations, decelerations, and ship maneuvers in accordance with the figure-eight course shown previously in Figure 8.

A discussion of the steady-state and dynamic measurements is presented in the following sections. All data presented are for a depressor wing angle setting of -5.33 degrees. Figure 9 illustrates the towing geometry, notation, and reference coordinates.

STEADY TOWING CHARACTERISTICS OF DEPRESSOR AND SIMULATED ARRAY

Figure 10 presents the results of measurements of the towline tension and angle at the depressor as a function of towspeed. For a depressor which maintains a constant pitch attitude, tension normally would vary in accordance with velocity squared and not linearly, as was found. However, this depressor did not maintain a constant pitch for all towspeeds nor did it maintain a constant roll angle.

Figure 11 presents the measurements of the depressor pitch angle β and roll angle θ as functions of towspeed. The pitch is the angle between the depressor longitudinal centerline and the horizontal x-z plane; whereas roll is the angle between the depressor vertical axis and the y-axis contained in the vertical y-z plane.

As towspeed increased, the pitch varied from -3.5 degrees (nose-down) at 2.7 knots to +2.7 degrees (nose-up) at 30 knots.

The depressor roll increased with towspeed, developing a slight roll of 7 to 8 degrees to port.

Both the total system lift-to-drag ratio $(L/D)_s$ and the depressor $(L/D)_d$ ratio are calculated from the measured data. The system $(L/D)_s$ ratio is obtained directly as a function of towspeed as follows, referring to Figure 12.

$$(L/D)_s = \frac{T_o \sin \phi_o}{T_o \cos \phi_o} = \tan \phi_o \quad (1)$$

TABLE 2 - DEPRESSOR-TOWED ARRAY STEADY-STATE DATA

RUN NO.	TOWING SPEED knots	AT THE SHIP			HORIZONTAL TOWING ANGLE deg	LEASION		TOWING ANGLE deg	HORIZONTAL ANGLE deg	AT THE DEPRESSOR		DEPTH ft	PITCH deg	ROLL** deg
		TOWING SCOPE ft	LEASION ft	LEASION ft		POSTSTAFF ANGLE deg								
4	2.8	75 (1)	1790	7960	88	-	-	-	42	-	-	-	-3.8	0.3
5	5.2	75	1950	8670	84	-	-	-	27	-	-	-	-1.8	0.3
6	10.1	75	2150	10000	74	-	-	-	19	-	-	-	0.5	-1.0
7	14.8	75	2600	11600	62	-	-	-	12	-	-	-	1.8	-1.5
8	19.5	75	2820	12500	41	-	-	-	18	-	-	-	2.5	-2.5
9	25.3	75	3320	14800	25	-	-	-	14	-	-	-	3.0	-5.0
10	27.1	75	3770	16800	24	-	-	-	14	-	-	-	3.0	-6.0
11	29.6	75	4410	19600	24	-	-	-	13	-	-	-	3.0	-8.0
12	4.8	75	1920	8540	85	-	-	-	17	-	-	-	-	-
13	7.2	75	2370	10500	74	-	-	-	18	-	-	-	-	-
14	15.0	75	2780	12400	63	-	-	-	14	-	-	-	-	-
15	20.5	75	3500	14700	43	-	-	-	6	-	-	-	-	-
16	24.9	75	4140	18400	36	-	-	-	4	-	-	-	-	-
17	27.1	75	4550	20200	34	-	-	-	2	-	-	-	-	-
18	29.7	75	4930	21900	31	-	-	-	0	-	-	-	-	-
19	5.0	680 (2)	2260	10100	73	-	-	-	12	1950	8670	680	208	0.1
20	10.2	680	3050	13600	46	-	-	-	16	2450	10900	590	180	-0.5
21	15.2	680	4230	18800	30	-	-	-	6	2750	12200	460	140	-1.6
22	19.9	680	5800	25800	21	-	-	-	6	3300	14700	375	114	-3.6
23	24.7	680	7550	34000	17	-	-	-	2	3900	17200	315	96	-5.9
24	26.8	680	8490	37800	15	-	-	-	1	3850	17100	280	86	-6.8
25	29.5	680	9860	43900	13	-	-	-	1	4000	17800	245	74	-7.1
26	26.2	680	9070	39900	15	-	-	-	4	3750	16700	280	96	-6.0
27	24.6	680	7450	33100	15	-	-	-	4	3600	16000	300	92	-5.9
28	15.2	680	5470	24300	22	-	-	-	7	3050	13600	380	116	-3.3
29	14.8	680	4140	18400	30	-	-	-	13	2650	11800	460	140	-1.7
30	10.0	680	3010	13400	47	-	-	-	16	2150	9560	570	174	-0.7
37	2.7	680	2310	10300	-	-	-	-	0	1660	7380	670	204	-2.5
38	5.3	400 (3)	2400	10700	69	-	-	-	-7	1900	8450	380	116	-0.2
39	10.0	400	2740	12200	57	-	-	-	15	2300	10200	325	100	-1.2
40	15.2	400	3560	15800	40	-	-	-	16	2650	11800	290	88	-1.5
41	20.0	400	4690	20900	28	-	-	-	10	3300	14700	250	76	-3.3
42	24.9	400	5640	26400	22	-	-	-	7	3550	16200	210	64	-5.9
43	30.0	400	7540	33500	17	-	-	-	0	3500	17300	160	48	-8.1

- No data obtained
 * Negative sign indicates nose-down.
 ** Negative sign indicates roll to port.
 † Runs 4 through 12 had a wing angle of -5 degrees
 †† Runs 13 through 43 had a wing angle of -5.33 degrees
 (1) 23 = (2) 207 = (3) 122 =

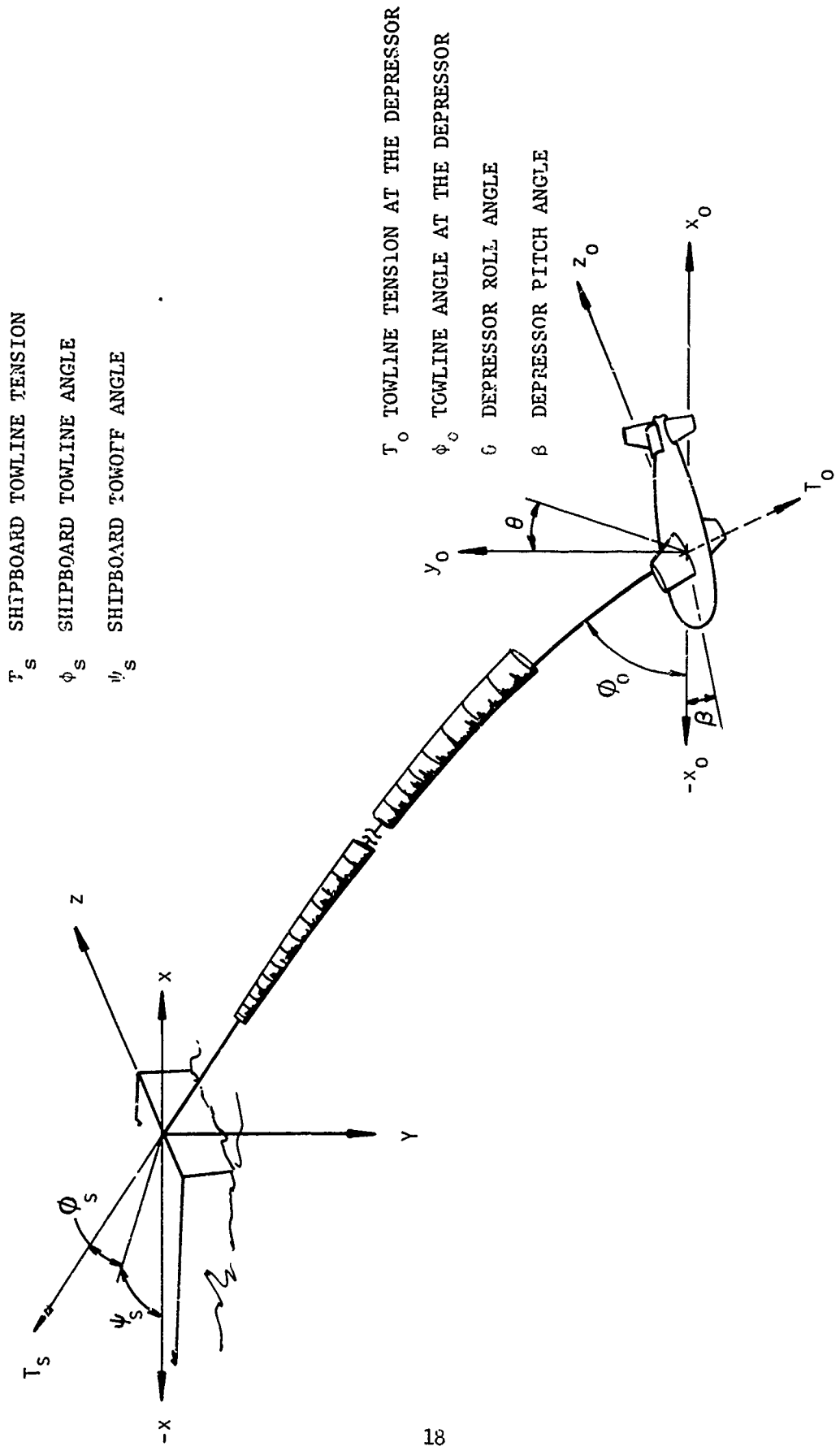

T_s SHIPBOARD TOWLINE TENSION
 φ_s SHIPBOARD TOWLINE ANGLE
 ψ_s SHIPBOARD TOWOFF ANGLE

T₀ TOWLINE TENSION AT THE DEPRESSOR
 φ₀ TOWLINE ANGLE AT THE DEPRESSOR
 ϕ DEPRESSOR ROLL ANGLE
 β DEPRESSOR PITCH ANGLE

Figure 9 - Notation and Geometry for Depressor-Towed System

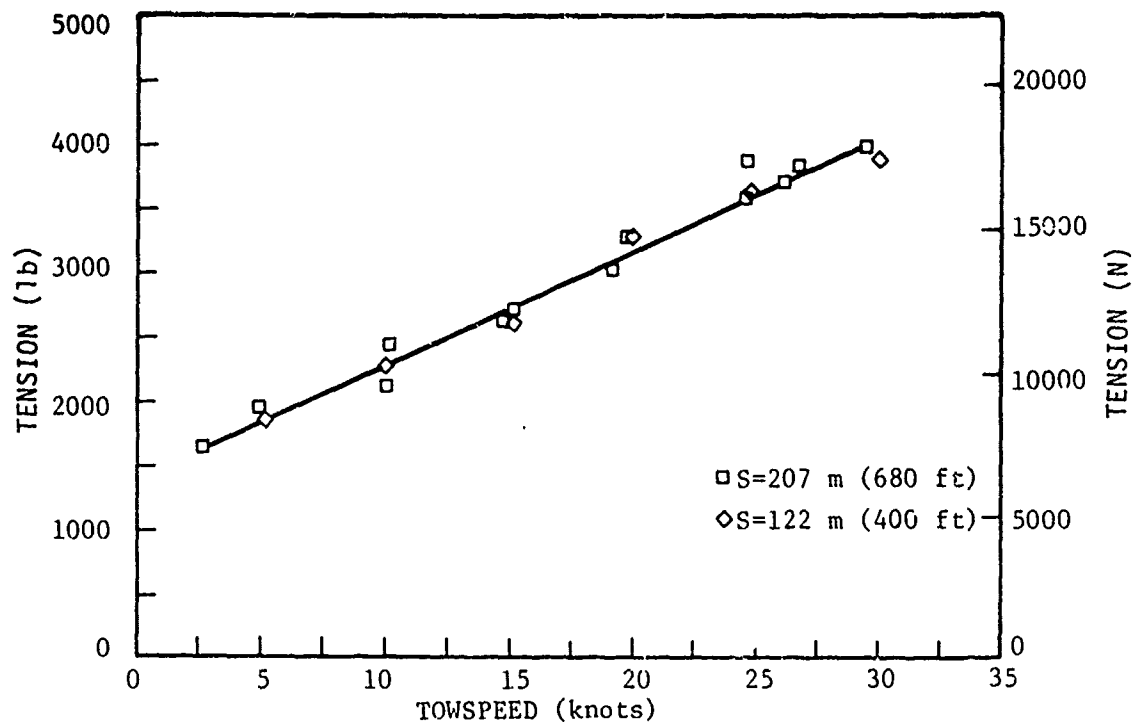

Figure 10a - Tension

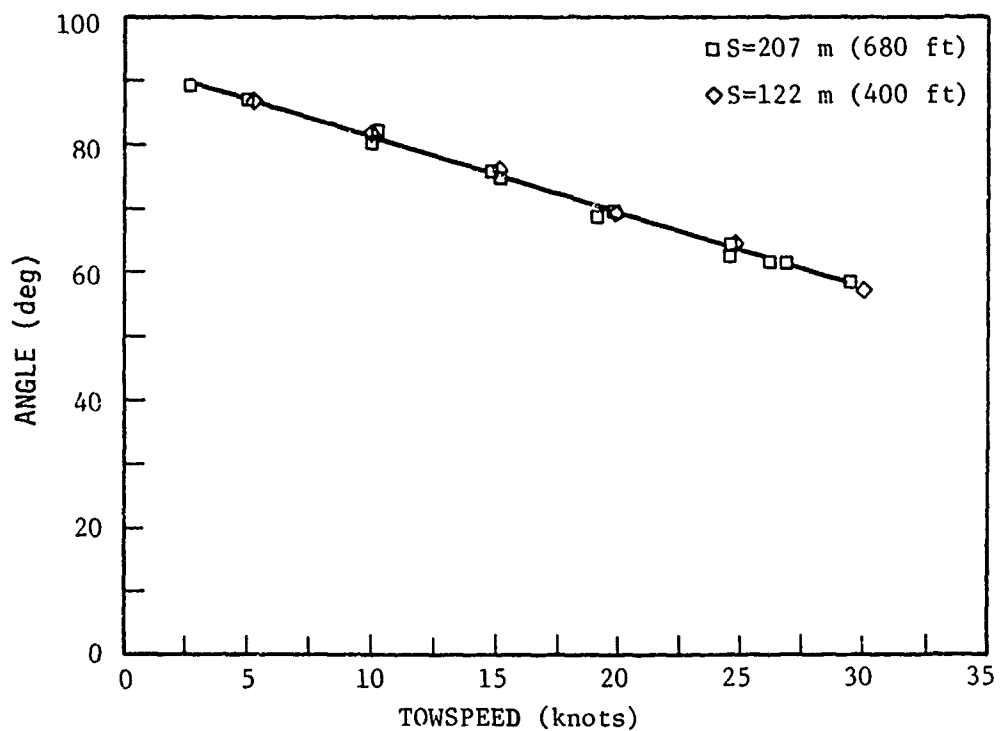

Figure 10b - Angle

Figure 10 - Towline Measurements at the Depressor as Functions of Towspeed

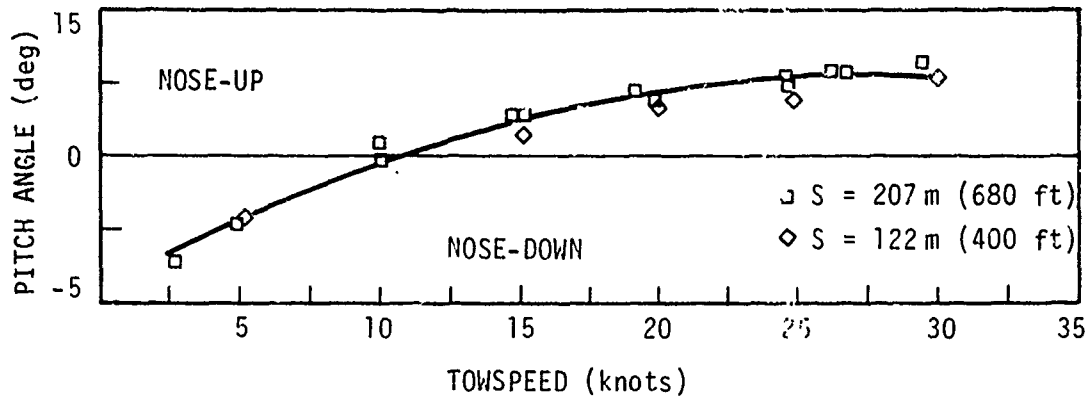

Figure 11a - Pitch Angle

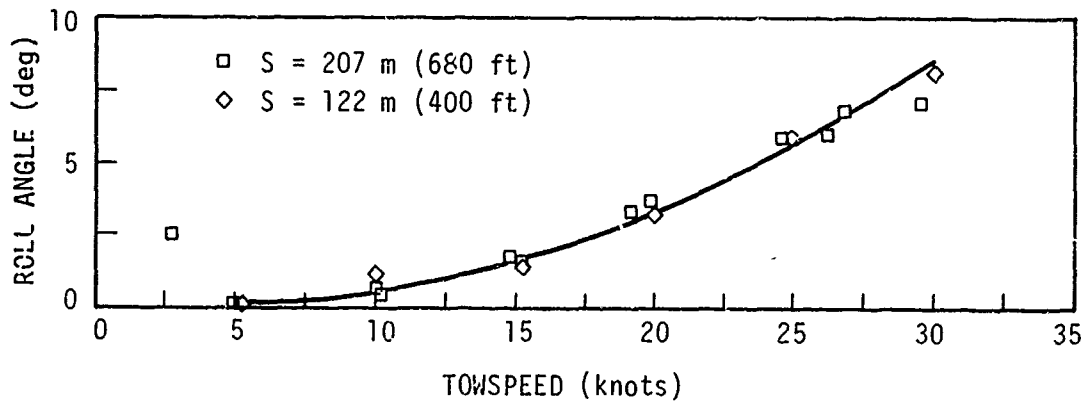

Figure 11b - Roll Angle

Figure 11 - Depressor Towing Attitude as a Function of Towspeed for Two Towline Scopes

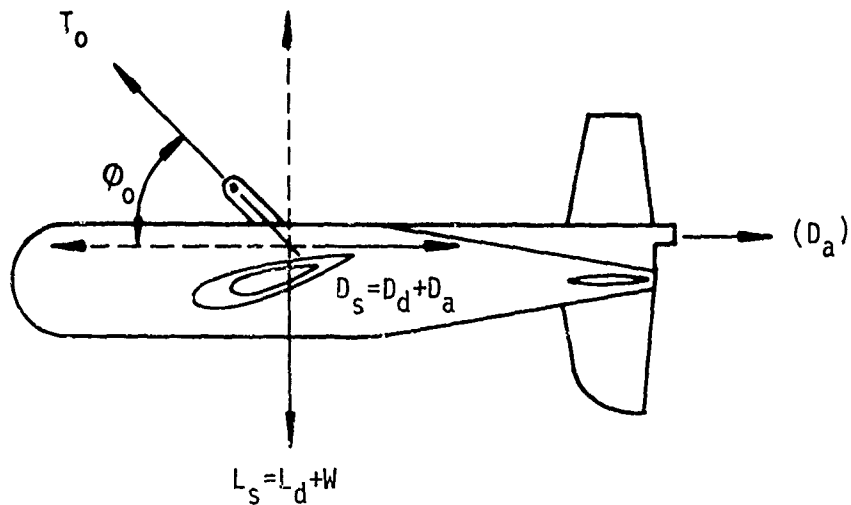

Figure 12 - Free-Body Diagram of Depressor Forces

Calculation of the $(L/D)_d$ ratio for the depressor exclusive of its weight requires that the body weight and simulated array drag be subtracted from the system forces, as follows:

$$(L/D)_d = \frac{T_o \sin \phi_o - W}{T_o \cos \phi_o - D_a} \quad (2)$$

where W represents the depressor static weight in water and D_a represents the drag of the simulated array as a function of towspeed. The drag of the nylon rope simulated array can be estimated using:

$$D_a = 1/2 \rho V^2 \pi C_t d \ell \quad (3)$$

where: C_t = nylon rope drag coefficient
 ρ = mass density of water
 d = rope diameter
 l = rope length
 V = velocity

Previous DTNSRDC measurements of nylon rope drag coefficients yielded the following relationship:

$$C_t = 0.00696 R_n^{-0.037} \quad (4)$$

where:

$$R_n = \frac{Vd}{\nu} \quad (5)$$

and ν is the kinematic viscosity of water. The results of calculating the depressor $(L/D)_d$ ratio from Equations (2), (3), (4), and (5) show that although the lift-to-drag ratio decreases slightly with increasing tow-speed, it is fairly constant at about 2.4, indicating a very stable depressor. The lift-to-drag ratios given in Equations (1) and (2) are shown graphically in Figure 13 as functions of towspeed.

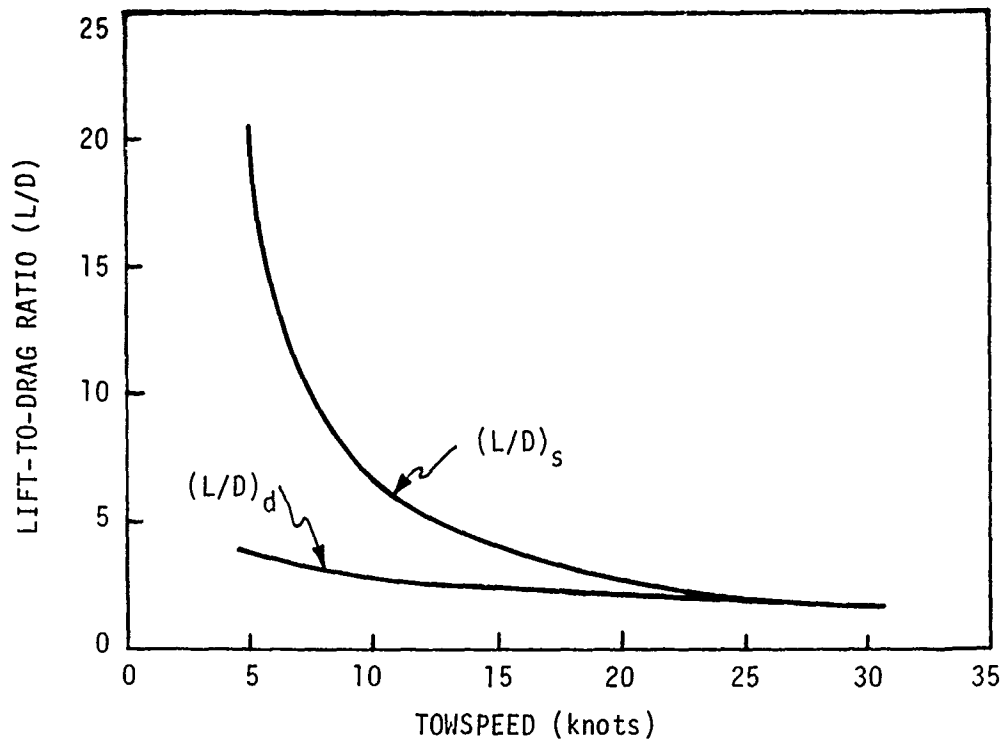

Figure 13 - Lift-to-Drag Ratios for Various Towspeeds

STEADY-TOWING CHARACTERISTICS OF FAIRED TOWLINE

Calculation of the steady-state towing characteristics of the faired towline required examination of the towing tension, towing angle and horizontal towoff angle, and the depressor measurements of depth, all as functions of towspeed. Figure 14 presents the measured towline tension at the ship as a function of towspeed for the two scopes evaluated. These measurements represent the total force acting on the towcable, including the depressor forces and the accumulated towline drag forces. Due to the complex relationship between the depressor forces and the towline forces, the shipboard towing tension does not vary exactly as the square of velocity, as might be expected for a shallow critical angle tow. Figure 15 illustrates the geometry of the force and angles at the shipboard towpoint as measured by the DTNSRDC Towpoint Gimbal. Towing angle ϕ_s is the angle between the tension vector and its projection in the horizontal x-z plane, whereas the horizontal towoff angle ψ_s is the angle between this projection and the ship centerline.

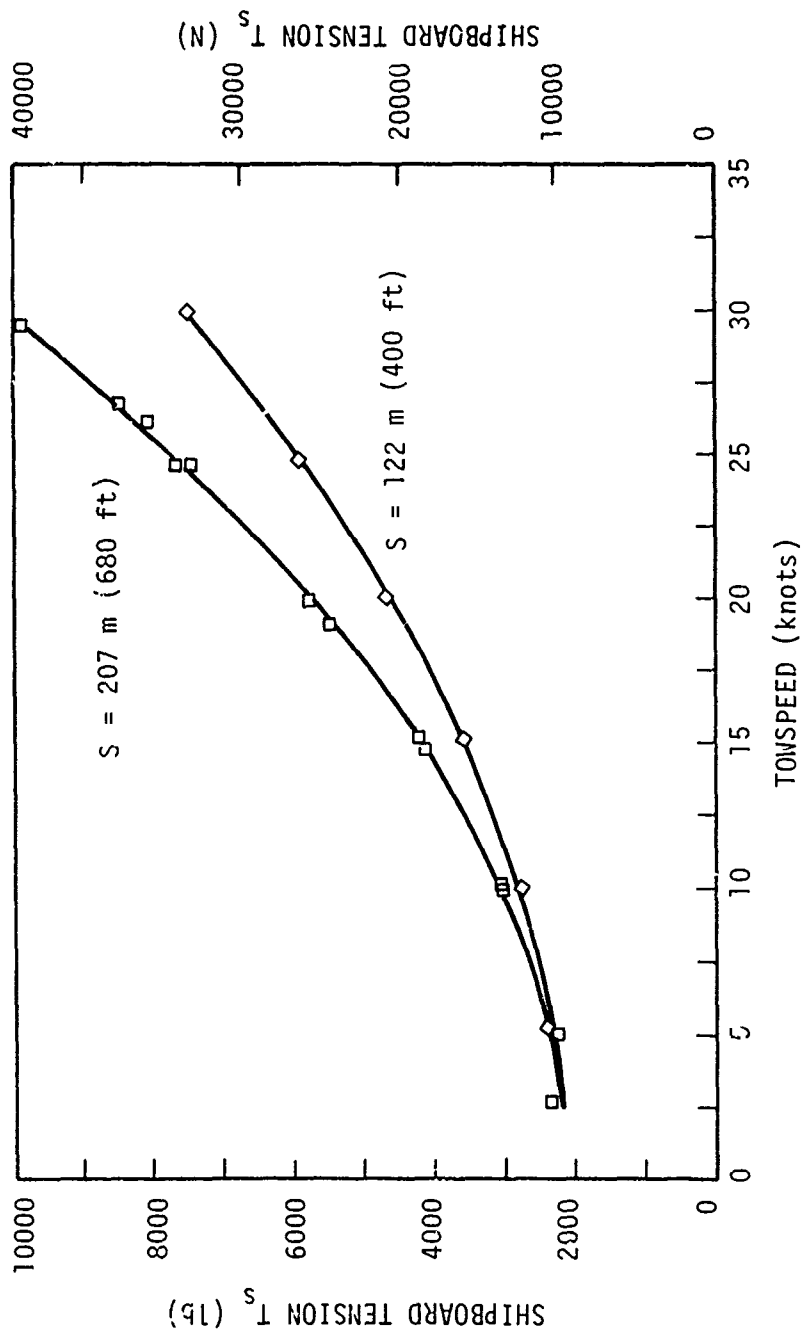

Figure 14 - Shipboard Towline Tension as a Function of Towspeed for the Two Scopes Tested

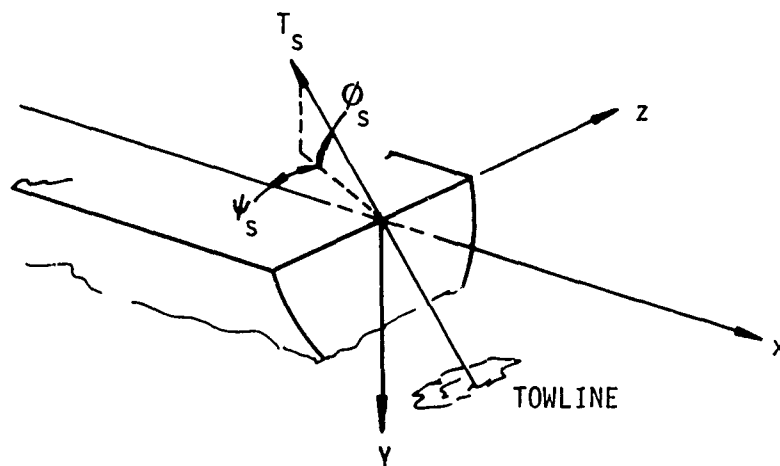

Figure 15 - Notation for Shipboard Measurements

Figure 16 presents the measured towline angle and horizontal towoff angle as a function of towspeed for the two towline scopes evaluated.

The importance of Figure 16a is that it illustrates the very shallow towing angle that occurs at high speeds. Although this is only the angle at the towpoint, a significant portion of the upper length of the towline is towing at close to this angle, and is experiencing a large component of tangential flow. This is the very component of hydrodynamic force which causes segmented fairings to compressively stack on top of each other, preventing them from free-swiveling and aligning with the flow. The use of antistacking rings on this towline was very successful at transferring the accumulated tangential force from the fairing to the cable at periodic intervals of 3.2 m.

Figure 16b presents the resulting measurements of the horizontal towoff angle ψ_s for both towline scopes evaluated as a function of towspeed. Here it is important to note that the towoff angle ψ_s was relatively independent of cable scope and reached a maximum of about 16 degrees to starboard at 10 knots. At higher towspeeds, the angle decreased and approached zero at 30 knots. The actual kiting angle at the ship, θ_s , can be found from $\tan \theta_s = \sin \psi_s / \tan \phi_s$ and is also shown in Figure 16b. The maximum occurs at a higher speed than for the horizontal towoff angle

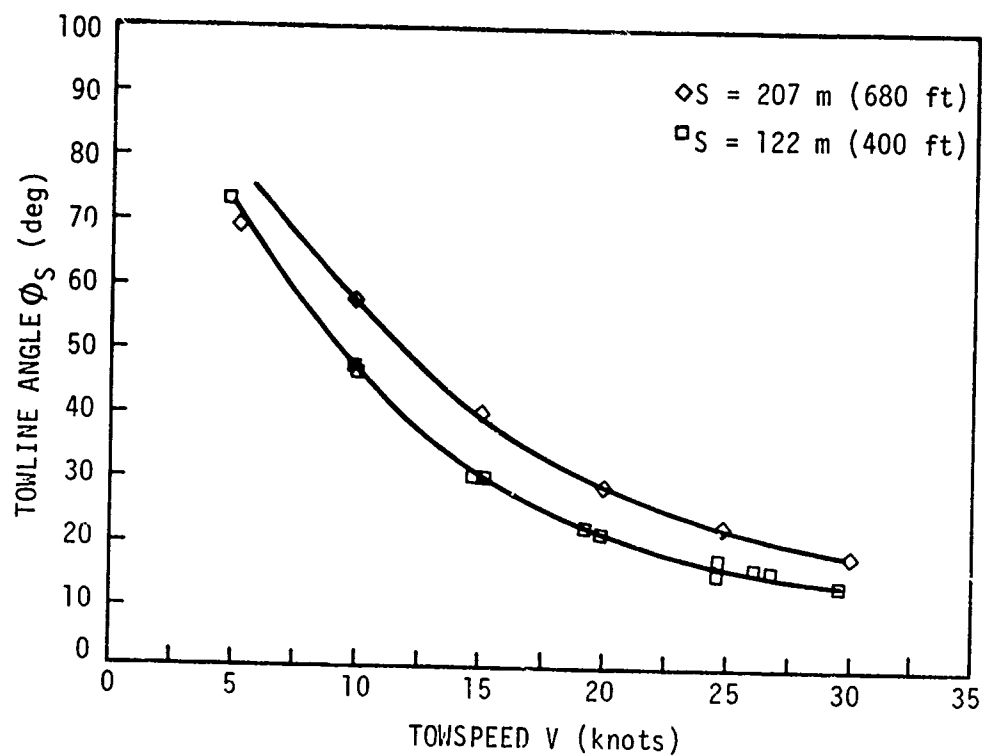

Figure 16a - Towline Angle

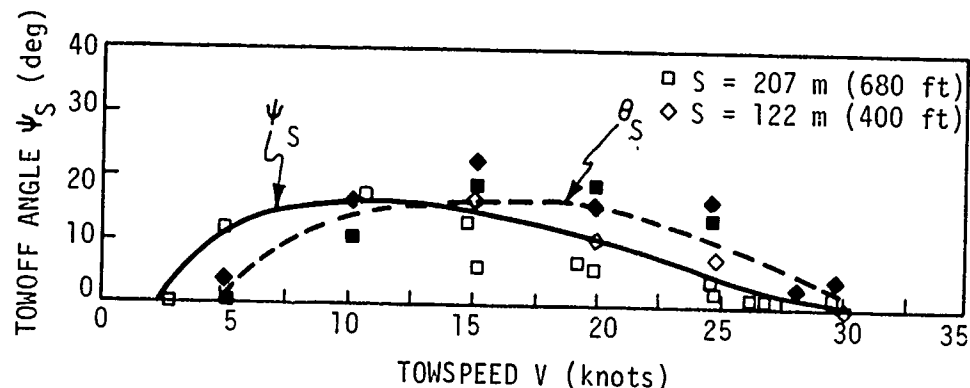

Figure 16b - Horizontal Towoff, ψ_S , and Kiting, θ_S Angles

Figure 16 - Shipboard Towing Angles as Functions of Towspeed

but goes towards zero at high speed. If the fairings were stacking and developing a side force, this force should increase as the square of velocity, and the kiting should increase significantly with towspeed. Such was not the case. What actually happened is that the increased towing load caused the cable diameter to become slightly reduced, and the fairings were free to rotate. Examination of Table 1 and Figure 4 reveals that the unten- sioned cable diameter was slightly larger than the fairing hole diameter. Therefore, the fairing actually was restricted from free-swiveling by vir- tue of the oversized cable (or undersized hole diameter) at low speeds. Only at the high speeds did the fairing perform as designed.

Figure 17 represents the depressor depth as a function of towspeed for the two towline scopes evaluated. The depressor depth gives an indi- cation of the efficiency of the fairing and a gross measure of the fairing normal drag coefficient. The deeper the depressor, the lower the normal drag coefficient. The performance goals for this ONR depressor-towed array called for 300 feet of depth at 30 knots. The actual performance was 240 feet at 30 knots. Although the performance goals could have been achieved by increasing the depressor wing angle, the resulting towline forces would have increased significantly, reducing the safety factor to below 3.0. As evaluated, the depressor wing was close to the maximum desirable angle, and any increase in downforce was not advisable.

The most useful information derived from the measurements of the steady-state performance of the towline concerns the normal drag coeffi- cient. Although it was not the purpose of these evaluations to determine either the drag coefficient or the shape of the hydrodynamic loading function, it was possible to use an assumed shape and estimate the cor- responding drag coefficient necessary to obtain agreement with the measured data. Several investigators have previously examined sectional fairings.^{2,3} It has been found that the hydrodynamic loading function is approximately:

$$f_n = -1.5716 + 1.7367 \cos \phi + 2.4065 \sin \phi - 0.1651 \cos 2\phi - 0.7808 \sin 2\phi \quad (6)$$

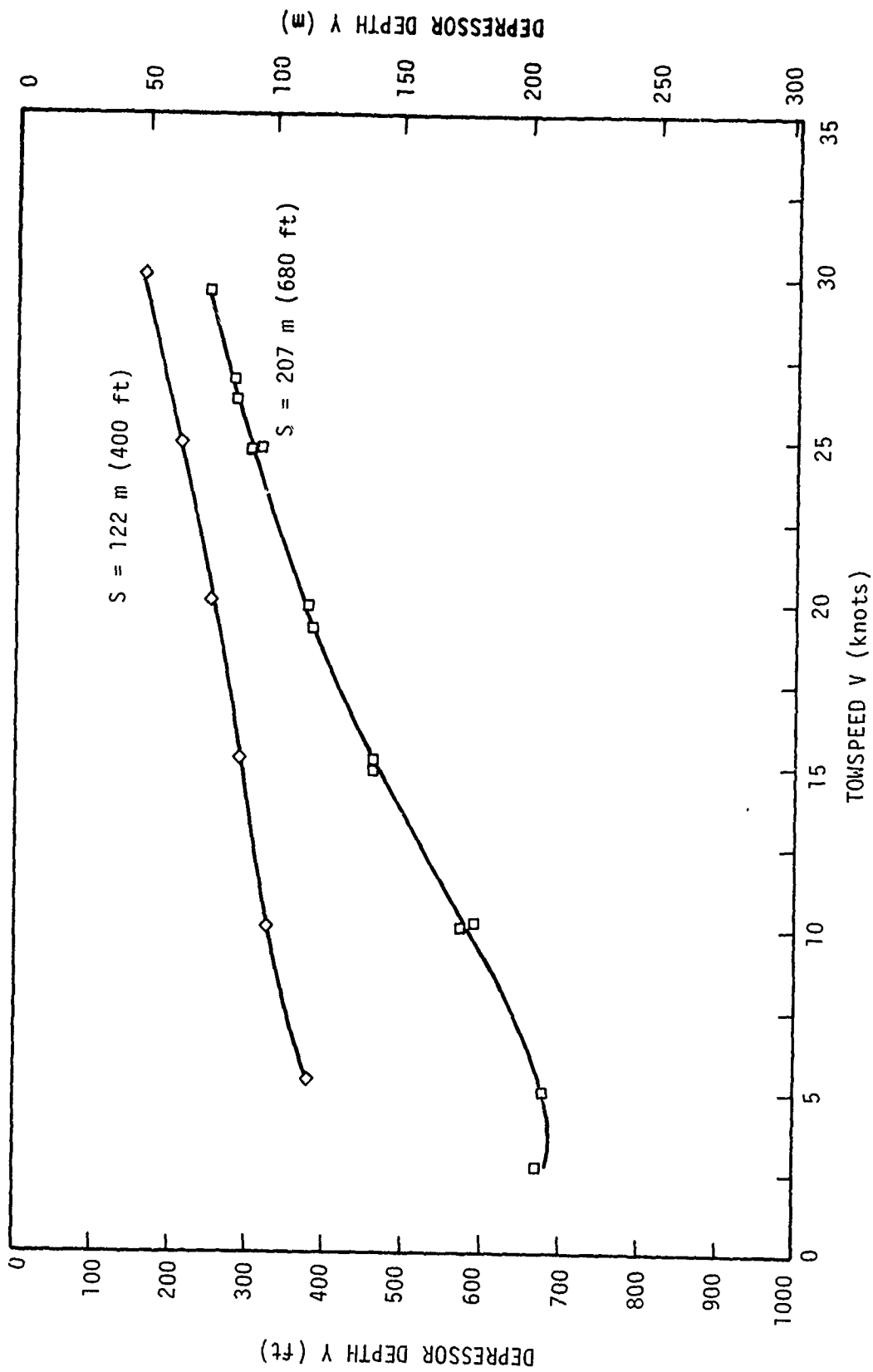

Figure 17 - Depressor Depth versus Towspeed for Two Towline Scopes

and

$$f_t = -0.1158 + 0.4641 \cos \phi + 0.1158 \sin \phi \quad (7)$$

where:

f_n = angular scaling function for the normal component of hydrodynamic drag

f_t = angular scaling function for the tangential component of hydrodynamic drag

ϕ = cable segment towing angle

Assuming that the shape of the function is correct, and neglecting any Reynolds Number effects, the only unknown is the normal drag coefficient. Using a computer program to solve the catenary equations for this depressor-towed system, various normal drag coefficients were specified until a reasonable correlation between the calculated and measured data was found. It was found that reasonable agreement with the measured data occurred for a normal drag coefficient of $C_R = 0.17$.

RESPONSE OF SYSTEM TO TCWSHIP MANEUVERS

It is important that a depressor-towed array system respond very quickly to any tactical maneuvers performed by the host platform. These maneuvers include rapid accelerations and decelerations and high-speed turns at sharp rudder angles. In general, towed arrays have limited usefulness during the period in which they deform to follow the turning contours of the host platform. Contact with a target may be lost in such circumstances.

It therefore became an objective of these depressor-towed array evaluations to measure the system response time to various ship maneuvers. As illustrated previously in Figure 8, the ship performed maneuvers and speed changes in accordance with a figure-eight track. Dynamic measurements of towline tension angle at the depressor, depressor depth, roll and pitch, and horizontal towoff kite angle at the shipboard towpoint were

recorded on a six-channel strip-chart recorder for time history analysis and monitoring. Towspeed was not recorded directly on a strip-chart but was reconstructed from digital data at specific intervals, and a time history chart plotted manually. The following sections detail the results from these measurements.

System Response to Ship Turns

Data Runs 31 through 36 consisted of various port and starboard tow-ship turns at constant speed and accelerations and decelerations while performing the figure-eight maneuvers with 207 m of towline deployed. In particular, Data Run 35 consisted of a 270-degree turn to port, followed by a short straight run, then a 270-degree turn to starboard, and ending with a short straight run. Towspeed was held fairly constant at about 22 knots, and all turns used 20-degree rudder.

Figure 18 presents the time history graphs of towspeed, depressor depth, depressor pitch and roll, towline tension and angle at the depressor and towoff angle at the shipboard towpoint. The best indication of the ship maneuvers is obtained from examination of Figure 18g, the towcable towoff angle. As shown, the ship initiated the turn to port at the 40-second mark and achieved a constant turn rate for 20-degree rudder at the 70-second mark. The ship then maintained this turn rate for about 70 seconds and then steadied-up on the new course at the 165-second mark. The turn to starboard began at the 255-second mark and ended at the 370-second mark with the ship again on the original course, completing the full figure eight. Examination of Figure 18a reveals that towspeed decreased during the ship turns from 22 knots to about 20 knots. As the speed decreased during the turns, the depressor depth increased from 109 m (360 feet) at 22 knots to 128 m (420 feet) at 20 knots, as shown in Figure 18b and is consistent with the steady-state depth data presented previously.

Figure 18c presents the depressor pitch angle measurements during the turns. Notice that the ship's pitching motion resulting from crossing its own wake was transmitted directly through the towline to the depressor. The pitching frequency was about 0.34 Hz and diminished after only six cycles as the ship moved quickly through the wake, indicating a fairly

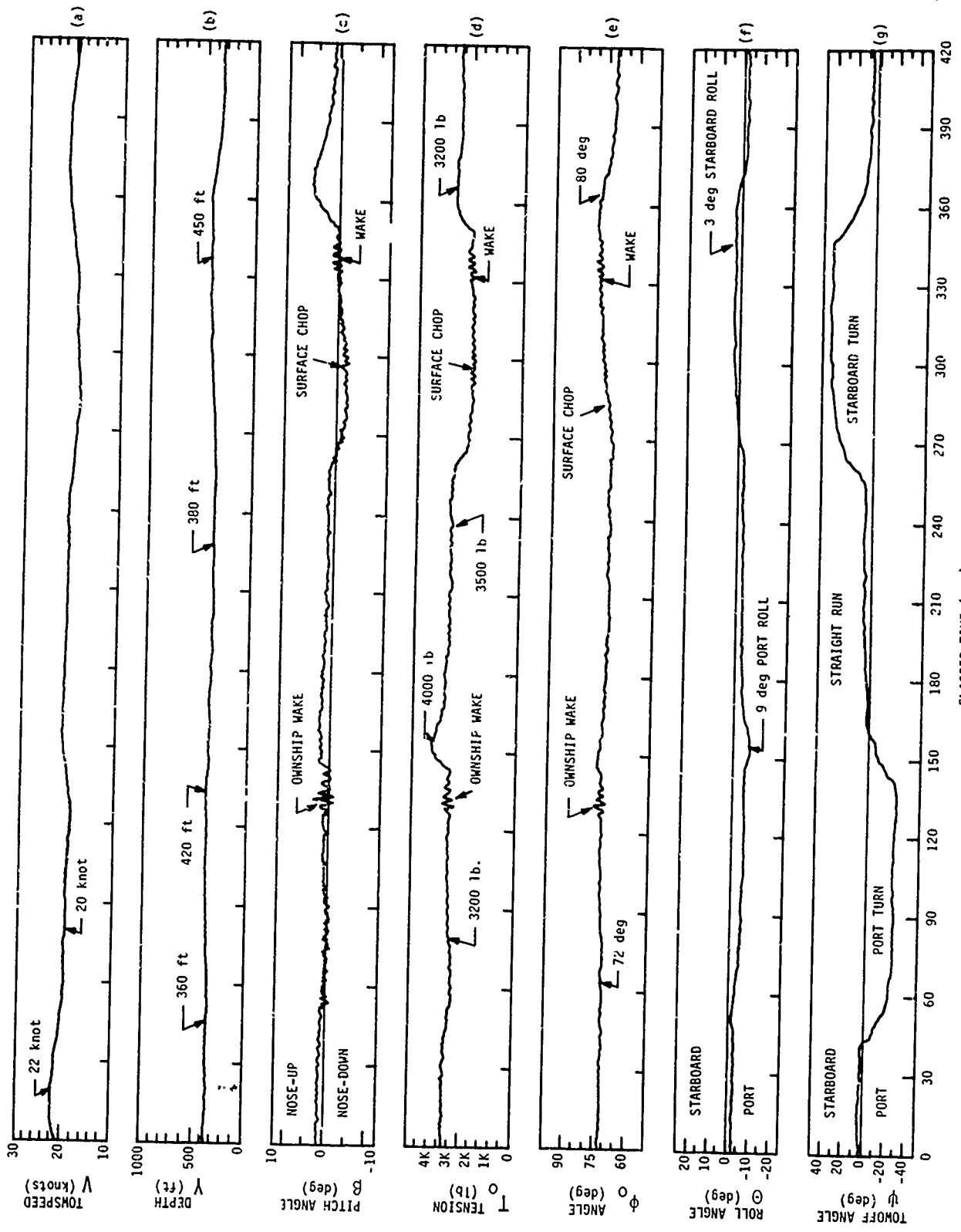

Figure 18 - Time History Data During Ship Maneuvers at 20 Knots

inelastic coupling between the ship and the depressor. For the most part, depressor pitch was constant throughout the maneuvers except after again passing through the ship's wake at the completion of the 20-degree starboard turn. As shown in Figure 18c at the 370-second mark, the depressor suddenly went +5.0 degrees nose-up as ship speed increased and the turn was completed. However, the depressor settled down within 30 seconds and assumed the steady-state attitude of +2.0 degrees nose-up.

Cable tension at the depressor also exhibited a distinct periodic surge due to ownship wake, as shown in Figure 18d. The tension oscillations had the same period as the body pitch, but experienced a sudden peak transient value near 17,000 N (4000 lb) at the 150-second mark as the port turn was near completion. As the ship continued on to the starboard turn, the ship's motion (due to the noticeable surface waves) was again transmitted directly to the depressor.

At the 345-second mark, the ship again passed through its own wake, as shown by Figures 18c, d, and e. Angle at the depressor was also very responsive to both depressor pitching motion and ship pitching motion while crossing the wake and surface waves.

Figure 18f illustrates the effect of the towship turns on the depressor roll. As might be expected, as the ship turned to port, the body rolled to port in response to the towline exertion. Then, after the ship completed the turn, the roll was reduced from 9 degrees to port and approached its steady-state value of about 3 degrees to port. As the ship proceeded into the starboard turn, the depressor also rolled to starboard and settled at about 3 degrees to starboard. For either the port or starboard turns, the net depressor roll was 6 degrees in the direction of the turn.

As is evident by the data presented in Figure 18, this ONR depressor-towed array system was very responsive to towship maneuvers and remained very stable. Based on the measurements of depth, depressor pitch, and angle, the system responded almost immediately to the ship maneuvers and then recovered and assumed its steady-state configuration within about 30 seconds from the completion of the ship maneuvers.

System Response to Accelerations and Decelerations

Several data runs consisted of measurements of the depressor response to ship accelerations and decelerations. The end of Run 35 consisted of a deceleration from 19.6 knots to 8.0 knots in about 150 seconds. Figure 19 represents the dynamic response of the depressor during this deceleration run. Although towspeed (shown on the top graph) was somewhat unsteady, and at one point dipped below 8 knots (to about 6 knots), the data are fairly representative of an actual tactical deceleration.

The best indication of depressor stability is obtained from examination of the depressor depth and pitch measurements. As the towspeed decreased, the depressor depth increased from 110 m (360 feet) to about 185 m (610 feet), which agrees with the corresponding steady-state depth measurements presented previously in Figure 17. However, the simulated array lagged the depressor depth changes and exerted an upward pull on the depressor tail as the depressor was diving to the new depth. The effect of this resistance on the part of the simulated array was indicated by the depressor pitch angle, which became nose-down during the dive. As the simulated array settled to the new depth, its drag again acted in line with the depressor centerline, imparting no moment about the CG, and the pitch angle resumed its steady-state condition for the new towspeed.

Figures 19a and 19b reveals that the depressor responded rapidly to the decrease in towspeed and assumed its new depth of 185 m within about 20 seconds from the completion of the speed reduction to 6 knots. By comparing Figures 19b and 19c, it appears that the array lagged the depressor by about 30 seconds. The data shown in Figure 19e for the towline angle at the depressor confirm this estimated lag time. Note that in Figure 19f the depressor roll decreased as expected, and in Figure 19g the towline began to experience a 16-degree towoff angle to starboard at 6 knots, as discussed previously.

In general, it appeared that the depressor responded rapidly to towship deceleration and approached its steady-state towing configuration within 50 to 60 seconds from the completion of the deceleration. Examination of the data from other runs for both accelerations and decelerations, and for both towline scopes evaluated, confirms these time estimates.

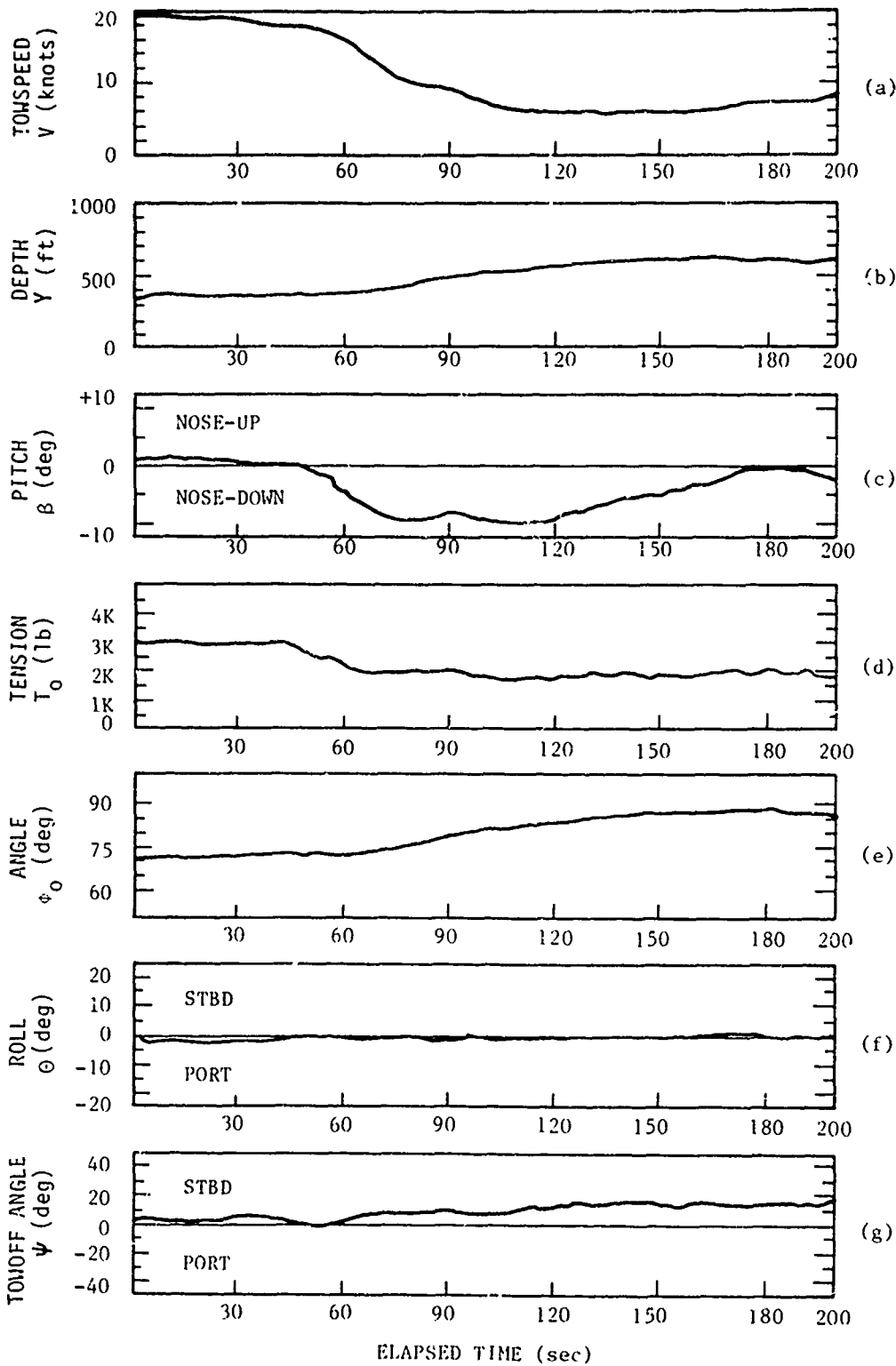

Figure 19 - Time History Data During Deceleration from 20 Knots to 8 Knots

The depressor-towed array system was both quick to respond and recover and gave no indications of instability.

HANDLING CONSIDERATIONS

The array-depressor-towline system was difficult to handle during the sea trial. The major factor was the weight of the depressor, approaching 1 ton in air. During launch, the simulated array was put overboard first and then the depressor, in a capture cradle on an A-frame, was lowered to the water surface and released. The towline then was payed out until the required scope was reached, when a dead-end grip was attached to the cable and to the towpoint gimbal. On retrieval the reverse operations were carried out.

The weight of the depressor meant that a large tension existed in the towline as it payed out or came in on the drum of the winch. The winch also was close to the A-frame, giving a large fleet angle for the towline at the drum. The combination of high tension and large fleet angle acting on a round nose faired towline caused it to roll over on its side a number of times during retrieval. Then the towline had to be payed out some distance, re-erected and winched in again. This is not acceptable for constant use, as for example during an array sea-trial.

In addition, the overboarding sheave and capture assembly had a tendency to bind. Finally, the absence of array troughs means that filled arrays would have to be manhandled on deck during pay-out and recovery.

SUMMARY OF RESULTS

The at-sea evaluation of the hydrodynamic performance of the ONR depressor-towed array system was very successful. High quality hydro-mechanical data were obtained and used to assess the steady-state and dynamic towing performance of the depressor system and its various components.

The nylon rope simulated array provided a reasonable approximation to the towing dynamics expected of an actual array. With the depressor wing at a setting of -5.33 degrees, the system was very stable at all tow-speeds from 5 to 30 knots and achieved a depth of 73 m (240 feet) at 30 knots. The depressor developed a slight roll to port, increasing to a

maximum of about 8 degrees at 30 knots. However, this small amount of roll is considered negligible. As tow speed increased, the depressor pitch angle decreased from 3 degrees nose-down to 3 degrees nose-up, causing a reduction in the wing angle of attack and net lift forces, and therefore decreasing the system depth. Both the depressor and the depressor-array system were found to be highly stable systems throughout the entire speed range of 5 to 30 knots.

During the ship maneuvering, accelerations and decelerations, the depressor-towed array system tracked almost immediately with the ship, and at no point gave any indication of dynamic or steady-state instability. As the ship maneuvered through a figure-eight course at 20 knots, the depressor system tracked exactly and fully recovered within 45 seconds from the completion of a ship turn using 20-degree rudder. This same recovery time was measured during ship accelerations and decelerations.

The Fatham Oceanology faired towline was modified by the addition of antistacking rings. The fairings were undersized for the tow cable, causing them to bind against the cable and restricting their free-swiveling alignment with the flow. However, under towing load, the cable diameter decreased slightly and the fairings were free to swivel. The horizontal towoff angle increased to a maximum of about 16 degrees at 10 knots, but then decreased to zero at 30 knots as the cable diameter was reduced by tension and allowing free-swiveling since now the fairing tangential load was transferred to the cable via the antistacking rings. Using a previously derived loading function,² the segmented fairing normal drag coefficient was found to be $C_R = 0.17$.

CONCLUSIONS

Based on the at-sea evaluation of the ONR depressor-towed array system, the following are concluded:

1. The steady-towing maneuvering and accelerating and decelerating performance indicated satisfactory stability in all modes for all speeds up to 20 knots for maneuvering and to 30 knots for steady towing.
2. The fairing should perform adequately if properly sized for the cable.

3. The -5.33-degree wing incidence angle should satisfy the present depth requirements for an acoustic sea trial using an actual array.

RECOMMENDATIONS

Based on the results and analysis presented here, the following recommendations are offered:

1. The system should be reevaluated intact, using an acoustically active array. No adjustments to the wing angle setting of -5.33 degrees should be attempted, assuming the NUSC/NLL towline is to be used.

2. For its current use in the ONR program, the depressor hydrodynamic data obtained are sufficient.

3. The overboarding and handling equipment for the ONR depressor-towed array system requires considerable improvement prior to the next evaluation of this system. The improvements recommended include modifications to the capture assembly, the overboarding sheave, the addition of array handling troughs aboard ATHENA, and reduction of the fleet angle at the winch.

ACKNOWLEDGMENT

DTNSRDC and ONR gratefully acknowledge the cooperation and assistance received from Mr. Stan Rupinski of NUSC/NLL who provided the faired towline.

REFERENCES

1. Rupinski, S.M., "The Depressor-Towed Array Concept," U.S. Navy Journal of Underwater Acoustics (Apr 1977).

2. Folb, R., "Experimental Determination of Hydrodynamic Loading for Ten Cable Fairing Models," David W. Taylor Naval Ship R&D Center SPD Report 4610 (Nov 1975).

3. Dalton, W.L. and J.P. Ramsey, "A Sea Trial Evaluation of the Flexnose Sectionally Faired Towline," MAR, Incorporated Technical Report TR 112 (Jun 1973).

DTNSRDC ISSUES THREE TYPES OF REPORTS

1. DTNSRDC REPORTS, A FORMAL SERIES, CONTAIN INFORMATION OF PERMANENT TECHNICAL VALUE. THEY CARRY A CONSECUTIVE NUMERICAL IDENTIFICATION REGARDLESS OF THEIR CLASSIFICATION OR THE ORIGINATING DEPARTMENT.
2. DEPARTMENTAL REPORTS, A SEMIFORMAL SERIES, CONTAIN INFORMATION OF A PRELIMINARY, TEMPORARY, OR PROPRIETARY NATURE OR OF LIMITED INTEREST OR SIGNIFICANCE. THEY CARRY A DEPARTMENTAL ALPHANUMERICAL IDENTIFICATION.
3. TECHNICAL MEMORANDA, AN INFORMAL SERIES, CONTAIN TECHNICAL DOCUMENTATION OF LIMITED USE AND INTEREST. THEY ARE PRIMARILY WORKING PAPERS INTENDED FOR INTERNAL USE. THEY CARRY AN IDENTIFYING NUMBER WHICH INDICATES THEIR TYPE AND THE NUMERICAL CODE OF THE ORIGINATING DEPARTMENT. ANY DISTRIBUTION OUTSIDE DTNSRDC MUST BE APPROVED BY THE HEAD OF THE ORIGINATING DEPARTMENT ON A CASE-BY-CASE BASIS.