

AD-A092 114

NAVAL RESEARCH LAB WASHINGTON DC
PERFORMANCE OF ANDVT HF MODEM WITH PEAK CLIPPING. (U)
OCT 80 W M JEWETT, R COLE
NRL-MR-4374

F/G 9/c

UNCLASSIFIED

NL

For
80c 1.2



END
DATE
FILMED
81-2
DTIC

AD 100-3174

FILE COPY

14 NRL-MK-

Memorandum Report

SECURITY CLASSIFICATION OF THIS PAGE (When Data Entered)

REPORT DOCUMENTATION PAGE		READ INSTRUCTIONS BEFORE COMPLETING FORM
1. REPORT NUMBER NRL Memorandum Report 4374	2. GOVT ACCESSION NO. AD-A092	3. RECIPIENT'S CATALOG NUMBER LTA
4. TITLE (and Subtitle) PERFORMANCE OF ANDVT HF MODEM WITH PEAK CLIPPING	5. TYPE OF REPORT & PERIOD COVERED Interim report on a continuing NRL problem	
	6. PERFORMING ORG. REPORT NUMBER	
7. AUTHOR(s) Wayne M. Jewett and Raymond Cole, Jr.	8. CONTRACT OR GRANT NUMBER(s) 11390489	
9. PERFORMING ORGANIZATION NAME AND ADDRESS Naval Research Laboratory Washington, DC 20375	10. PROGRAM ELEMENT, PROJECT, TASK AREA & WORK UNIT NUMBERS 33401N; X-0736-CC; 75-0126-0-1	
11. CONTROLLING OFFICE NAME AND ADDRESS Naval Electronic Systems Command Washington, DC 20360	12. REPORT DATE October 30, 1980	
14. MONITORING AGENCY NAME & ADDRESS (if different from Controlling Office) 152415CC	13. NUMBER OF PAGES 26	
	15. SECURITY CLASS. (of this report) UNCLASSIFIED	
16. DISTRIBUTION STATEMENT (of this Report) Approved for public release; distribution unlimited.		
17. DISTRIBUTION STATEMENT (of the abstract entered in Block 20, if different from Report)		
18. SUPPLEMENTARY NOTES		
19. KEY WORDS (Continue on reverse side if necessary and identify by block number) ANDVT Peak clipping HF channel HF modems DPSK modulation Error control Linear predictive encoding		
20. ABSTRACT (Continue on reverse side if necessary and identify by block number) The performance of the signal design for the ANDVT hf modem was investigated for the Gaussian channel with variable amounts of peak clipping on the modulator output. The advantage is an increase in average power when operating in a peak power limiting situation. A recommendation is made for use of 8.0 dB of clipping on the 16 tone DPSK signal used for transmitting the message indicator and 9.5 dB of clipping on the 39 tone DPSK signal used for transmitting digital voice.		

DD FORM 1 JAN 73 1473

EDITION OF 1 NOV 65 IS OBSOLETE
S/N 0102-LF-014-6601

25175

SECURITY CLASSIFICATION OF THIS PAGE (When Data Entered)

CONTENTS

I. INTRODUCTION 1

II. PEAK-TO-RMS RATIO 2

III. SIGNAL DESIGN 3

IV. PERFORMANCE WITH PEAK CLIPPING 4

V. CONCLUSIONS 23

VI. RECOMMENDATIONS 23

REFERENCES 24

Accession For	
NTIS CEASL	<input checked="" type="checkbox"/>
DTIC TAB	<input type="checkbox"/>
Unannounced	<input type="checkbox"/>
Justification	
Distribution/	
Availability Codes	
Dist	Special
A	

PERFORMANCE OF ANDVT HF MODEM WITH PEAK CLIPPING

I. INTRODUCTION

The Naval Electronic Systems Command is developing an Advanced Narrowband Digital Voice Terminal (ANDVT tactical terminal) comprised of an LPC-10 linear predictive encoder, a high frequency (hf) modulator/demodulator (modem), and a cryptographic security (COMSEC) module. The signal design of the hf modem is tailored to the problems of transmitting short digital voice messages over half duplex, single sideband (SSB) hf radio nets. That application requires the establishment of the communication link with each transmission. That is, prior to the detection of the digital voice signal, the receiving modem must detect signal presence, correct any frequency offsets due to either doppler or translation errors, locate modem frame synchronization, and correctly detect the COMSEC message indicator. In the ANDVT hf modem these functions are accomplished sequentially by the transmission of a special signal for each function. Each of these signals is based on a form of multiple tone transmission, ranging from three tones to 39 tones. With the simultaneous transmission of multiple tones, the envelope of the composite signal is not constant. The ratio of the peak amplitude of the composite signal to the rms amplitude increases as a function of the number of tones.

This paper is concerned with the performance of the hf modem in a Gaussian noise channel when various levels of peak clipping are applied to the individual sequences in each transmission. The reasons for performing peak clipping at the modulator output are to maximize the power per tone in each sequence, and to present the radio equipment with a signal of nearly uniform peak and rms characteristics. The maximization of the power per tone improves the detection

Manuscript submitted September 16, 1980.

capability in a constant noise environment, when the transmitter is peak power limited. The advantages of providing a signal to the radio equipment that has uniform peak and rms characteristics are that it reduces the variations in the detected signal-to-noise ratio due to fluctuations in the transmitter automatic level control and the receiver automatic gain control. It is recognized that the hf radio receiver rarely receives a signal with the same peak/rms ratio as was transmitted because of the frequency selective fading characteristics of hf channels.

The penalty paid for increasing the average power, by clipping the peaks of the composite signal, is an increase in the noise level in the transmitted signal. Amplitude clipping in the time domain produces intermodulation products which fall on all of the equally spaced frequency assignments in the tone libraries. This increase in noise level sets a lower bound on the minimum achievable bit error rate. This paper establishes the optimum clipping level for each sequence of the hf signal as a function of the performance requirements.

II. PEAK-TO-RMS RATIO

When N sinusoids, each with peak amplitude equal 1.0, are linearly combined, the composite signal can achieve a peak amplitude of N , and the rms amplitude will be $(N/2)^{1/2}$. Thus, the ratio of the peak amplitude to the rms amplitude is $(2N)^{1/2}$.

Multi-phase differentially phase shift keyed (DPSK) modem signals do not normally exhibit peak/rms ratios as high as the theoretical values since each tone can occupy only one of eight possible phases relative to the initial random phase. Also, in present designs all tones are generated from a common clock source; thus, there are no small frequency errors which cause the tones to drift relative to each other.

Nevertheless, the resulting peak/rms ratios are still significant and steps must be taken to suppress the peaks when operating with transmitters that are peak power limited. The amount of suppression that can be used is dependent on the signal design and the performance requirements.

III. SIGNAL DESIGN

For digital voice transmissions the ANDVT hf modem employs 39 parallel tones which are four-phase DPSK modulated at 44.44 frames per second. Each modem frame represents one frame of digital voice information. The 24 most sensitive information bits in each voice frame are encoded for error control with two (24, 12) Golay code words. The two code words are paired together to modulate 24 tones. The remaining 15 tones are modulated with 30 bits of uncoded information, representing the data less sensitive to transmission errors. Each frame time, the assignment of tones to the coded and uncoded information is permuted, to lessen the effects of narrowband interference, frequency selective fading, and amplitude/phase delay variations in the radio equipment.

ANDVT is designed for operation in a half duplex net mode. Thus, each transmission requires that the link be re-established. The modem provides for this by transmitting a four-part preamble. Reception of the preamble permits the demodulator to sequentially (1) establish signal presence and measure frequency offset (doppler), (2) establish modem frame synchronization, (3) determine a framing epoch to denote the beginning of COMSEC message indicator, and (4) demodulate, diversity combine, and decode the message indicator.

The doppler signal contains four unmodulated tones, which are spaced 675 Hz apart to maximize the advantage of frequency diversity. The transmission lasts for 0.32 seconds. The modem synchronization signal consists of three tones that

are biphase modulated at 75 frames per second. The transmission lasts for 0.107 seconds. The framing epoch is established by transmitting a 240 bit pseudo-random binary sequence using biphase modulation on 16 parallel tones. The modulation rate is 75 frames per second; thus, the entire sequence is transmitted in 15 frame periods (0.200 seconds). It is preceded by one frame with random phases on the 16 tones, to provide a phase reference for the DPSK modulation. The same 16 tones are used for transmission of the message indicator, with four-phase DPSK modulation. This final segment of the preamble consists of a (252, 128) BCH code word transmitted with eighth order diversity. It lasts for 63 frame periods, which is 0.84 seconds.

In summary, for half duplex net operation, each transmission contains segments consisting of either four unmodulated tones, three biphase modulated tones, 16 biphase modulated tones, 16 four-phase modulated tones, or 39 four-phase modulated tones. The latter are modulated at a frame rate of 44.44 frames per second, while all other modulation is at 75 frames per second.

When a digital processor is used to generate these signals, it is relatively simple to change the scale factors which control the peak and rms amplitudes of each segment, prior to the digital-to-analog conversion. This control can be used to produce an analog output with relatively uniform peak and average amplitudes into the SSB radio transmitter; although it does not insure that the peak-to-rms ratio is maintained after translation to the final radio frequency, owing to possible non-linear phase delay characteristics in the SSB filters [reference (1)]. The advantage of peak clipping is an increase in the average S/N for a given peak power at a constant channel noise level.

IV. PERFORMANCE WITH PEAK CLIPPING

The Naval Research Laboratory has a FORTRAN implementation of the ANDVT modem operating on a PDP-11/45 computer. This program has been used to investigate

the performance of the demodulator in the presence of additive Gaussian noise, for various amounts of peak clipping on the 16 and 39 tone signals. Peak clipping was not used on the four-tone and three-tone preambles. Their peak-to-rms ratios were controlled by the selection of the initial phases of each tone [reference (2)].

All signals were generated in the modulator by specifying the amplitude and phase of each frequency component, and performing an inverse Fast Fourier Transform (FFT^{-1}) to obtain a time domain representation of the signal. After the FFT^{-1} operation, each digital sample of the output signal was then rescaled to produce a specified amount of peak clipping. The clipped signal was then rescaled to produce the same peak signal level as the four-tone preamble, which had been scaled for an rms output of zero dBm in a 600 ohm termination. Separate scale factors were used for each segment of the transmission. Figure 1 is a block diagram of the procedure for generating the clipped signal.

Table 1 shows the measured peak amplitude, rms level, and peak/rms ratio for each of the five segments of the modem signal, for various levels of clipping. Note that for no clipping, the rms level for the four-tone doppler signal measured zero dBm, the three-tone synchronization signal measured -0.1 dBm, the 16-tone signal was -6.9 dBm on the PN sequence, and -6.7 dBm on the message indicator, and the 39-tone voice signal was -9.1 dBm. The peak signal levels for the five sequences, with no clipping, varied between 3.9 and 4.0 dBm. Thus, the peak/rms ratio varied from 3.9 dB for the four-tone signal to 13.0 dB for the 39-tone signal. Note further that when eight dB of clipping were used on the 16 tones, the peak/rms ratio was reduced to 4 dB. Likewise, with ten dB of clipping on the 39 tones, the peak/rms ratio was reduced from 13.0 to 4.0 dB. These data shown in Table 1, were measured on the sampled data at the modulated output with a 7200 Hz sampling rate. The actual peaks seen on the output, after filtering, are slightly larger.

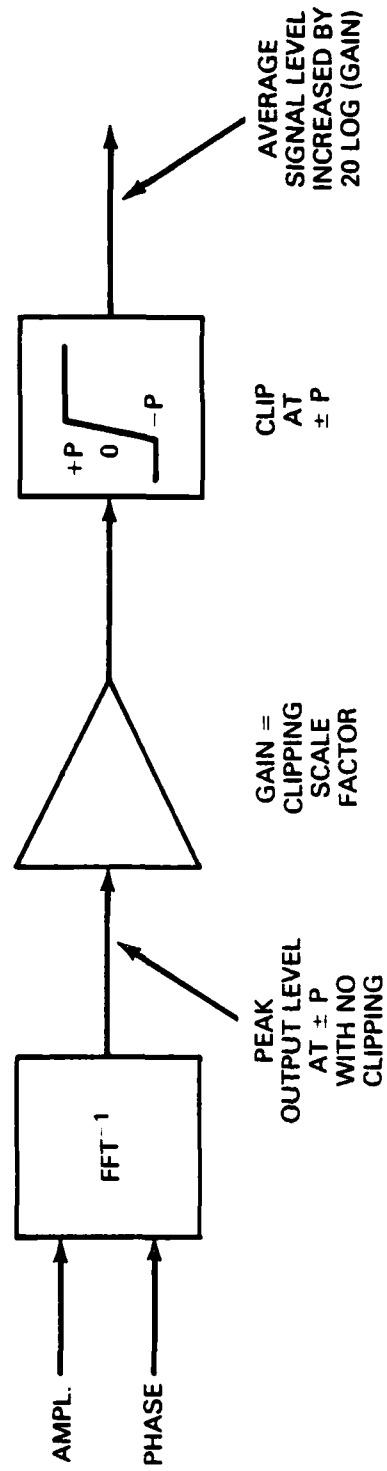

Fig. 1 — Procedure for controlling peak clipping at modulator output

Table 1. Amplitude Measurements on Output Signal versus Clipping Level

CLIPPING LEVEL (dB)	MEASURE- MENT	SIGNAL LEVEL				
		DOPPLER 4 TONES	SYNC 3 TONES, 2Ø	PN 16 TONES, 2Ø	MI 16 TONES, 4Ø	VO. CE 39 TONES, 4Ø
0	PEAK (dBm)	3.9	4.0	4.0	3.9	3.9
	RMS (dBm)	0.0	-0.1	-6.9	-6.7	-9.1
	PK/RMS (dB)	3.9	4.1	10.9	10.6	13.0
1.0	PEAK			4.0	4.0	4.0
	RMS			-5.9	-5.7	-8.1
	PK/RMS			9.9	9.7	12.1
2.0	PEAK			4.0	4.0	4.0
	RMS			-4.9	-4.7	-7.1
	PK/RMS			8.9	8.7	11.1
3.0	PEAK			4.0	4.0	4.0
	RMS			-4.0	-3.8	-6.1
	PK/RMS			8.0	7.8	10.1
4.0	PEAK			4.0	4.0	4.0
	RMS			-3.1	-2.9	-5.1
	PK/RMS			7.1	6.9	9.1
5.0	PEAK			4.0	4.0	4.0
	RMS			-2.2	-2.0	-4.2
	PK/RMS			6.2	6.0	8.2
6.0	PEAK			4.0	4.0	4.0
	RMS			-1.5	-1.3	-3.3
	PK/RMS			5.5	5.3	7.3
7.0	PEAK			4.0	4.0	4.0
	RMS			-0.8	-0.6	-2.4
	PK/RMS			4.8	4.6	6.4
8.0	PEAK			4.0	4.0	4.0
	RMS			-0.2	0.0	-1.7
	PK/RMS			4.2	4.0	5.7
9.0	PEAK			4.0	4.0	4.0
	RMS			+0.3	+0.5	-0.9
	PK/RMS			3.7	3.5	4.9
9.5	PEAK			4.0	4.0	4.0
	RMS			+0.5	+0.8	-0.6
	PK/RMS			3.5	3.2	4.6
10.0	PEAK			4.0	4.0	4.0
	RMS			+0.7	+1.0	-0.3
	PK/RMS			3.3	3.0	4.3

Amplitude clipping of the time domain signal generates intermodulation products, which fall on all of the equally spaced frequency assignments in the tone libraries. This raises the noise level in the transmitted signal. The degree to which clipping may be used beneficially to increase the average signal level, for a fixed peak signal level, is dependent upon the maximum signal-to-noise ratio required by the demodulator. This relationship between demodulator performance and clipping level was measured for the conditions that various levels of Gaussian noise were added to the sampled analog signal, prior to the FFT detection. The Gaussian noise samples, which were generated with a standard FORTRAN subroutine, were multiplied by a scale factor which was specified at run time. Figure 2 is a block diagram of this procedure for adding Gaussian noise to the sampled data at the demodulator input.

Figures 3, 4, 5, 6, and 7 show the results obtained with various clipping levels on the 39-tone digital voice signal.

In Figure 3, the data are presented in terms of P/N_T versus N_0 versus clipping level, where

P = total received signal power

N_0 = noise density of the additive Gaussian noise, in dBm/Hz

N_T = noise density of the total noise, which is the sum of the

Gaussian noise and the interference created by peak clipping.

The clipping levels cover the range of zero (no clipping) to 10.0 dB. Ten dB of clipping represents the condition where the modulator output signal has been amplified by a factor of 3.162 without an increase in peak amplitude. Data are presented on the modem performance for Gaussian noise densities ranging from -65 dBm/Hz to -30 dBm/Hz. Each noise sample was computed [reference (3)] as,

$$X = ANZ (2 \ln(u))^{1/2} \cos (2\pi V) \quad (1)$$

where u and V were random numbers (0 to 1.0) with uniform density, and ANZ was the scale factor. For a scale factor of one, the long-term rms value of the

noise samples was 1.0. That was equivalent to a voltage of 2.4426×10^{-3} for a 12 bit A/D with a ± 5.0 volt range. Thus, the rms power level of the Gaussian noise across 600 ohms was -50.0 dBm. The bandwidth of the generated noise was equal to the Nyquist frequency (3600 Hz). Thus, the noise density in dBm/Hz was,

$$N_0 = 40 \log (ANZ) - 10 \log (3600) - 10 \log ((5/2047)^2/600/0.001) \quad (2)$$

$$N_0 = 40 \log (ANZ) - 35.6 - 50.0$$

$$N_0 = 40 \log (ANZ) - 85.6$$

The assumption in (2) is that the rms value of the noise samples is exactly one. This is true for a large number of samples. For the accuracy required for this experiment at the high bit error rate of interest, the length of each test was between 200 and 2000 bauds. For these conditions there were variations in the actual noise level of a few tenths of one dB.

The total signal power to total noise density (P/N_T) measurements were made by the demodulator. They were equal to the average signal-to-noise per tone (E_t/N_T) times the bandwidth of the signal.

$$\frac{P}{N_T} = 10 \log \left(\frac{E_t}{N_T} \cdot \text{number of tones} \cdot \text{tone spacing} \right) \quad (3)$$

The E_t/N_T power ratios were computed by the demodulator from the ratio of the average signal-plus-noise energy on the data tones during the FFT integration period to the average noise energy on six unused (empty) tone assignments during the same integration period. That is,

$$E_t/N_T = \frac{E_t + N_T}{N_T} - 1.0 \quad (4)$$

The six noise frequency slots were the first three slots below and above the data tones. (The assumption here is that the interference is uniformly distributed over all of the signal and noise frequency slots.)

It is evident from the data in figure 3 that the optimum clipping level is a function of the desired operating condition. For example, when the additive Gaussian

noise density was -50 dBm/Hz, a P/N_T of 41.1 dB was measured with no clipping, and a P/N_T of 47.4 dB was obtained with 8 dB of clipping. That was a real gain of 6.3 dB in P/N_T for 8 dB of clipping. That was the optimum clipping level for that additive noise density. Further increases in the amount of clipping resulted in poorer P/N_T values because the level of the noise produced by peak clipping was increasing faster than the increase in average signal power. In comparison, at a lower additive noise level of -65 dBm/Hz, a maximum P/N_T of 59.2 dB was obtained for a clipping level of 4 dB. For this low additive noise density level, noise produced by the peak clipping rapidly became the dominating factor in performance.

Figures 4 and 5 show the bit error rates obtained on the uncoded and coded voice data, respectively, for the same clipping and noise conditions described for figure 3. These figures show how the clipping establishes a minimum obtainable bit error rate for each additive noise level. The same data are replotted in figure 6 showing bit error rate versus P/N_T for two clipping levels. From this latter figure it is evident that the slope of the curves did not deteriorate as a function of clipping levels. That is, the increase in average power that would be obtained in a peak power limited system by the use of peak clipping was directly translated into an improvement in bit error rate.

Figure 7 shows the data on the tradeoff between the additive noise level, N_0 , and the clipping level, for a constant bit error rate of 1×10^{-1} and 1×10^{-2} on the uncoded data. At these high bit error rates there is almost a linear relationship between the level of N_0 tolerated and the clipping level used. Ten dB of clipping resulted in 8 to 9 dB increase in the level of N_0 required to produce a constant error rate.

Clipping was applied to the biphase 16-tone signal that was modulated by the 240-bit PN sequence. Figure 8 shows the correlation values achieved as a function of the additive noise level for two clipping levels. The data demonstrates that

the use of clipping permits operation in significantly higher noise conditions. Figure 9 shows the same correlation data plotted as a function of the measured P/N_T . This data indicates that, for clipping levels as large as 8 dB, the correlation detector performance, as a function of P/N_T , did not deteriorate from that achieved with no clipping. That is, the FFT biphas detector and correlator did not distinguish between noise due to distortion products and Gaussian noise.

The message indicator was transmitted with the same 16 tone format as was used for the 240 bit PN sequence, except the modulation was four phase rather than biphas. The information was the 252 bit BCH code word transmitted eight times. Figure 10 shows the detected bit error rate after diversity combining, but before decoding, as a function of the additive noise level and the clipping level. The same error rate data are plotted in figure 11 as a function of P/N_T . It may be seen from these figures that clipping provides a significant improvement in performance by increasing the range of operation. At the same time, figure 11 shows that the distortion products due to clipping do cause a deterioration in the slope of the performance curve. That occurs because of the extreme sensitivity of the (252, 128) BCH code to the bit error patterns.

A combination of eighth order time diversity and inband frequency diversity was achieved by transmitting the message indicator eight times. Figure 12 shows the diversity gain achieved as a function of P/N_T before combining. Data are shown for clipping levels of zero and 8 dB. These data indicate that there were no deterioration in the diversity gain for this degree of clipping. Diversity gain is defined as the ratio of the S/N measured in the demodulator after combining to the S/N before combining.

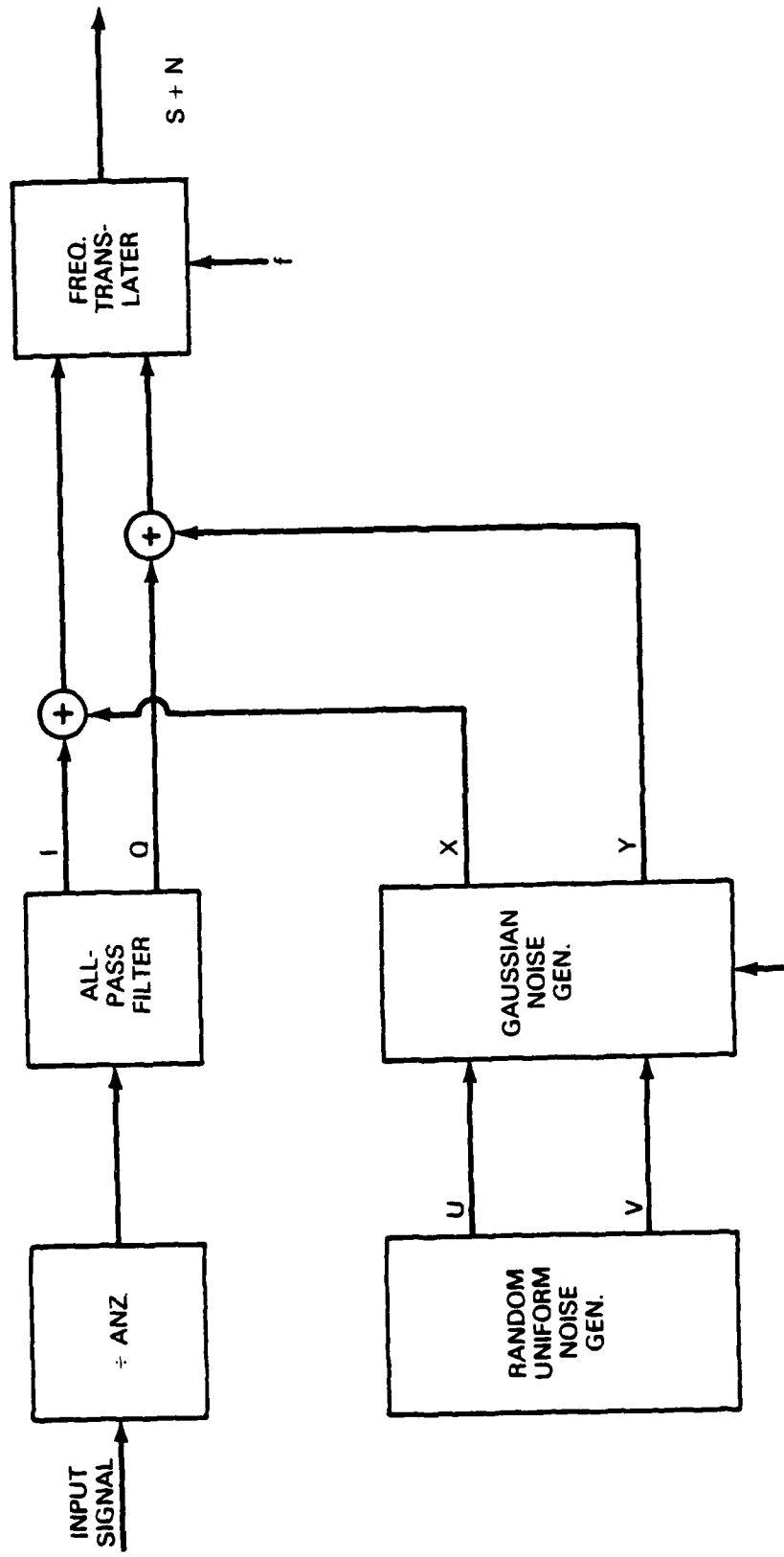

ANZ = ADDITIVE NOISE SCALE FACTOR

Fig. 2 — Procedure for controlling S/N at demodulator

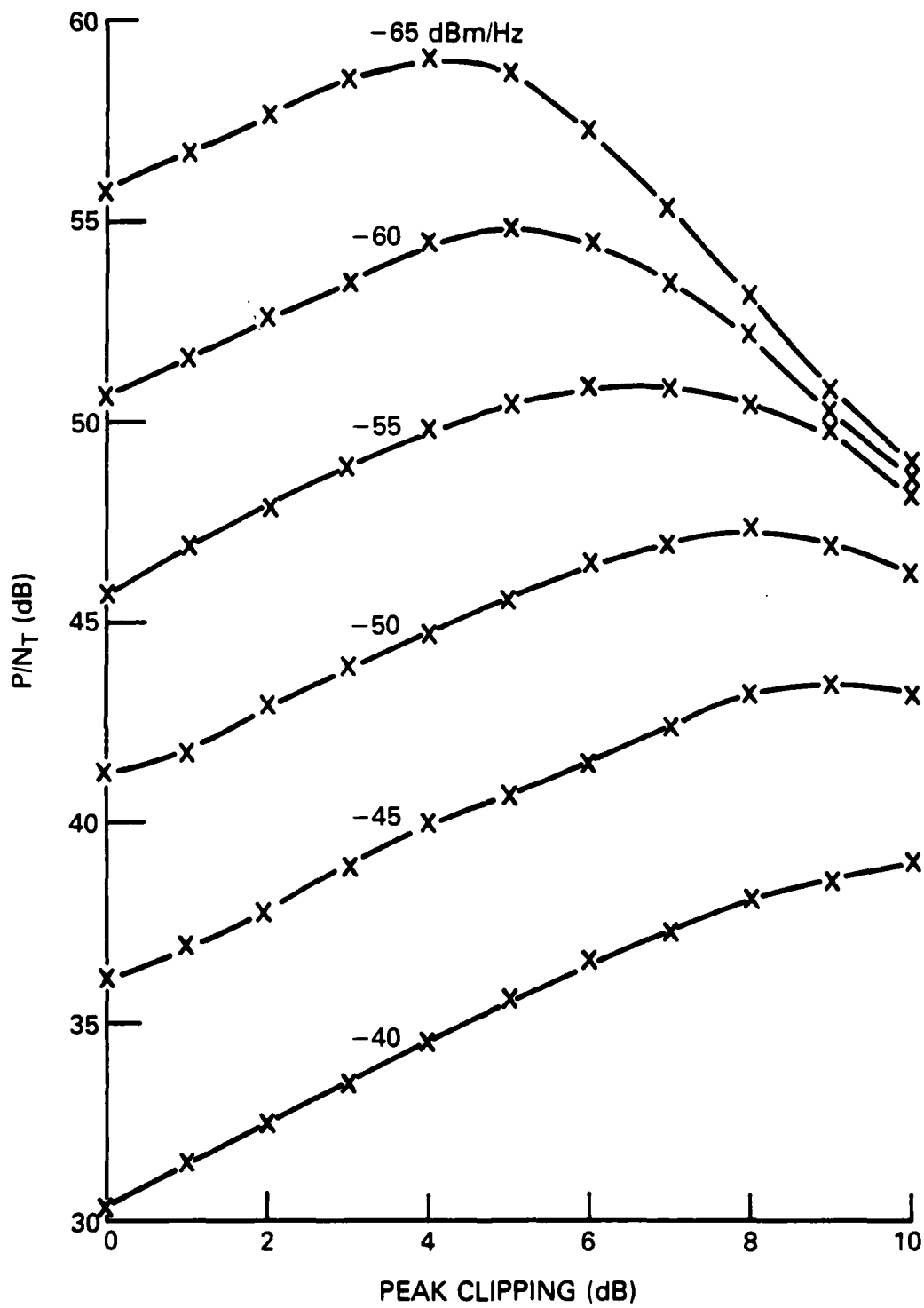

Fig. 3 - P/N_T versus clipping level for constant N_o , for 39 tones

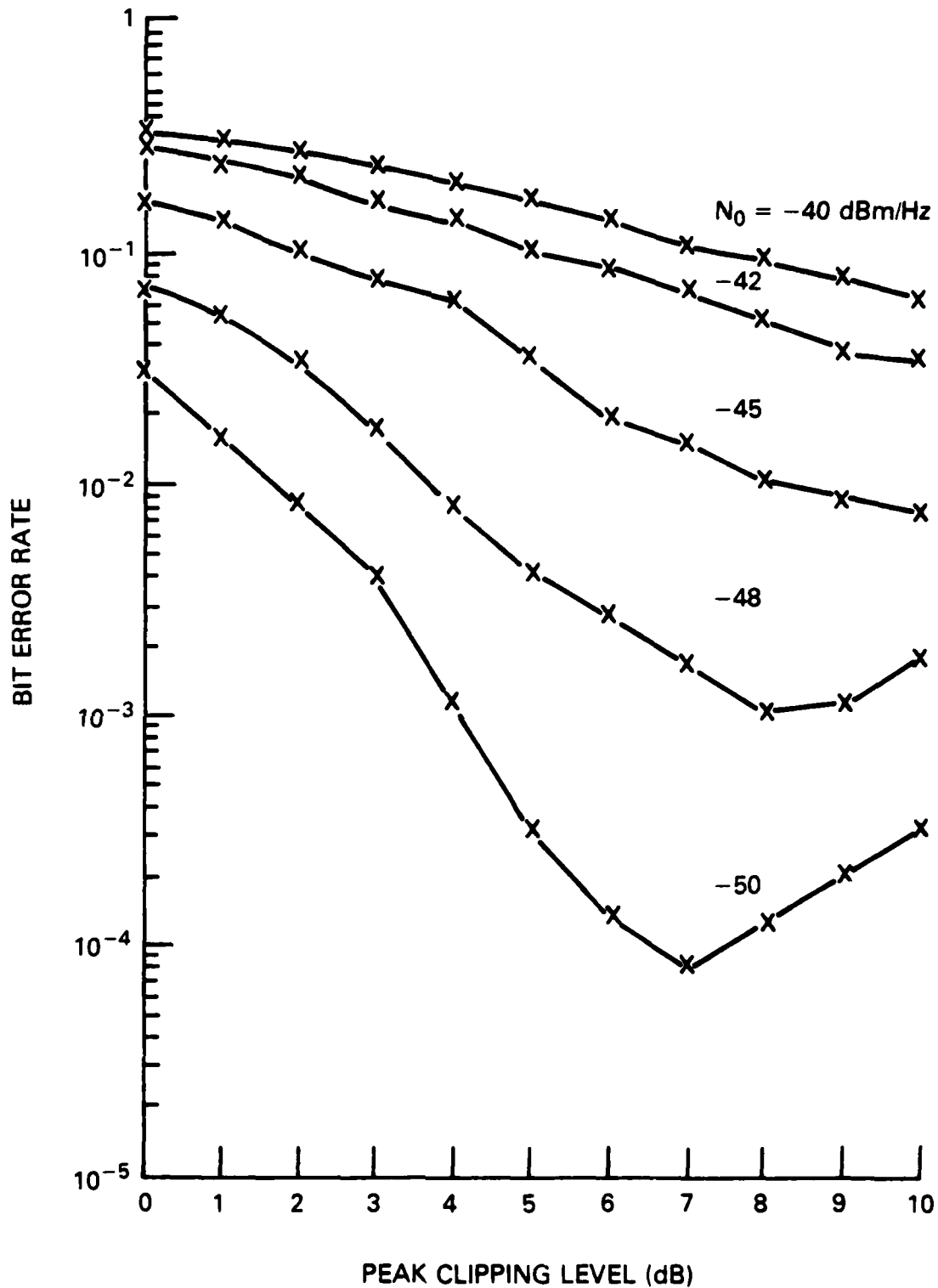

Fig. 4 - Bit error rate on uncoded voice versus clipping level for constant N_0

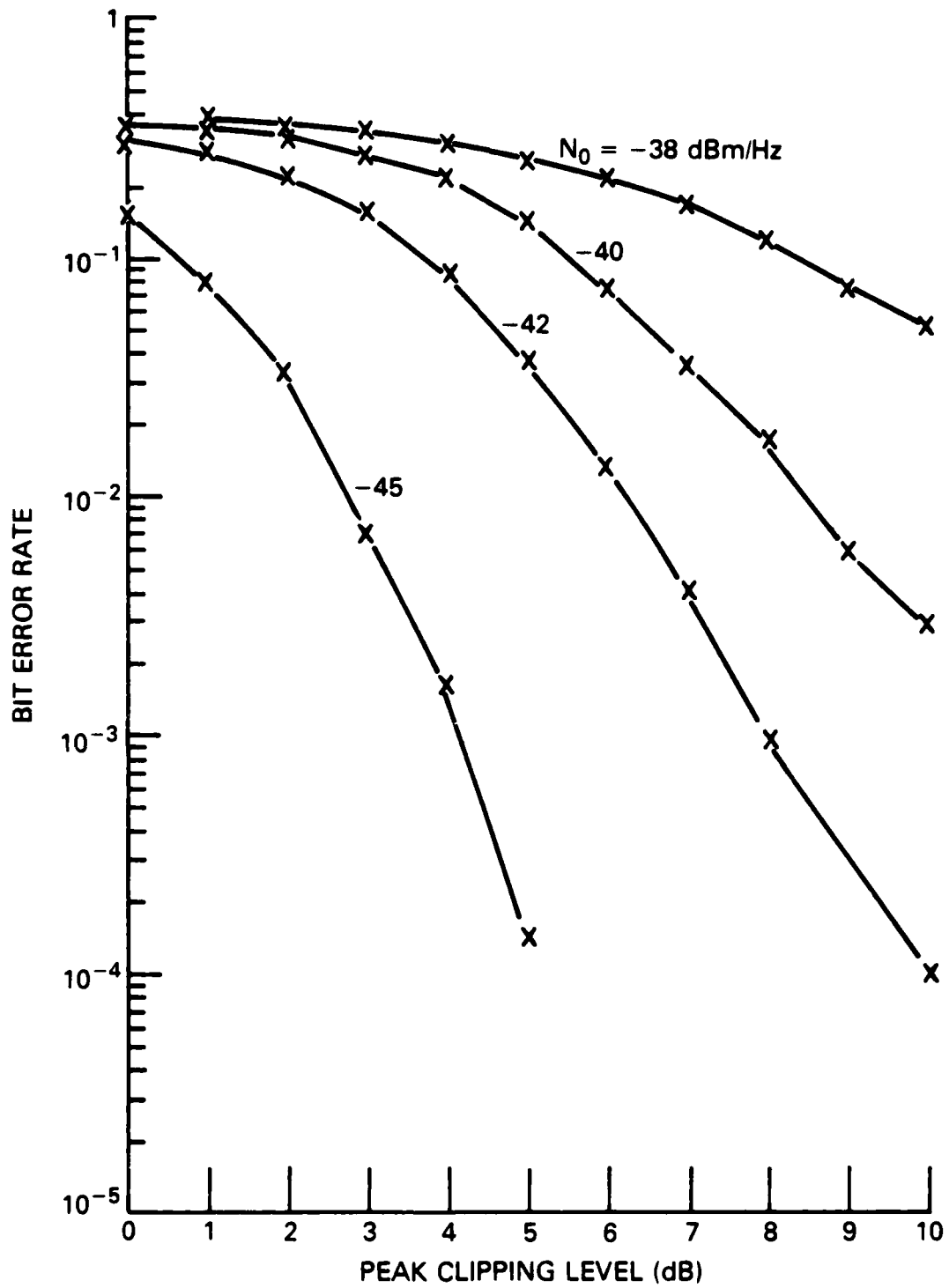

Fig. 5 — Bit error rate on coded voice versus clipping level for constant N_0 .

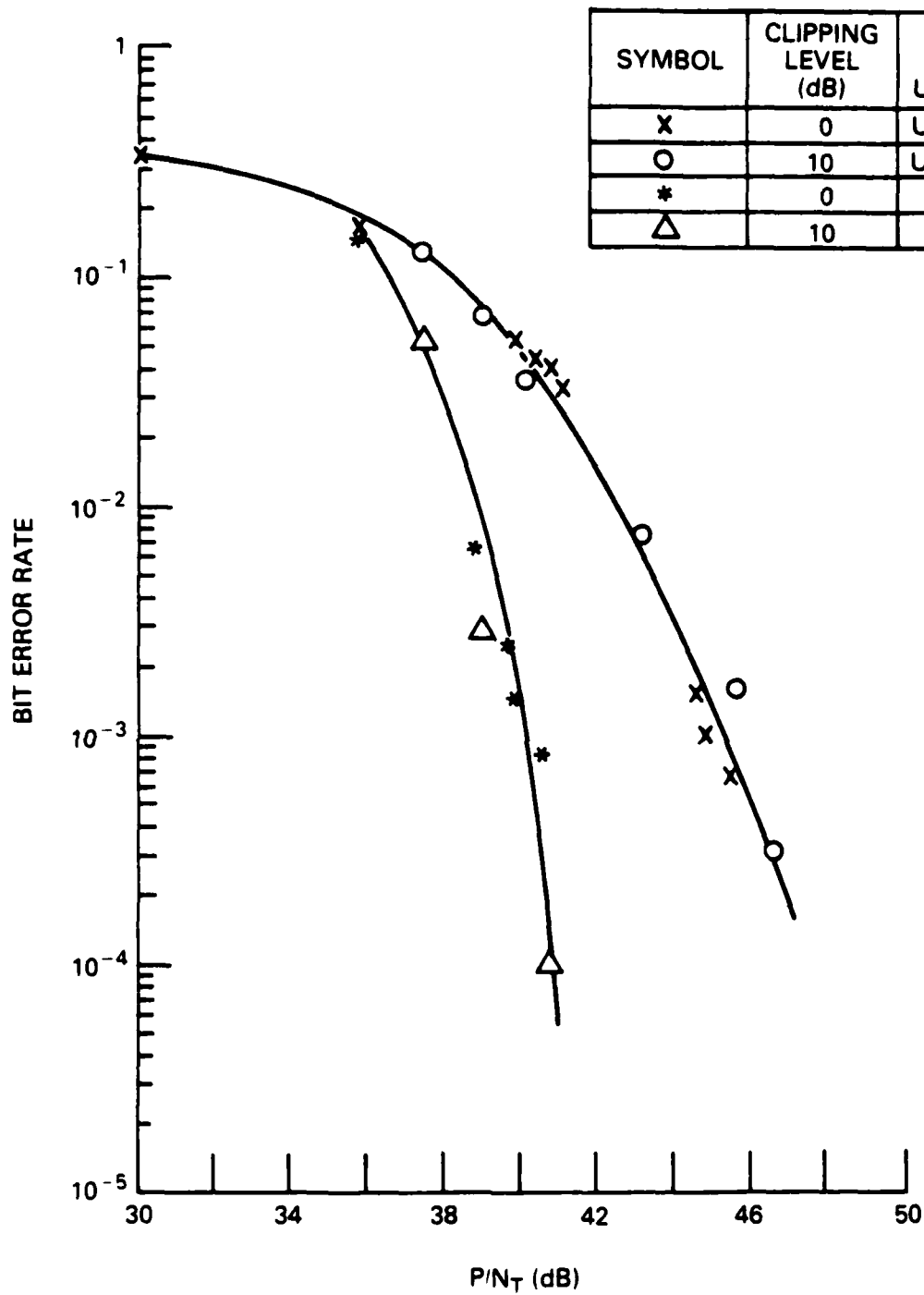

Fig. 6 - Bit error rate on coded and uncoded voice versus P/N_T

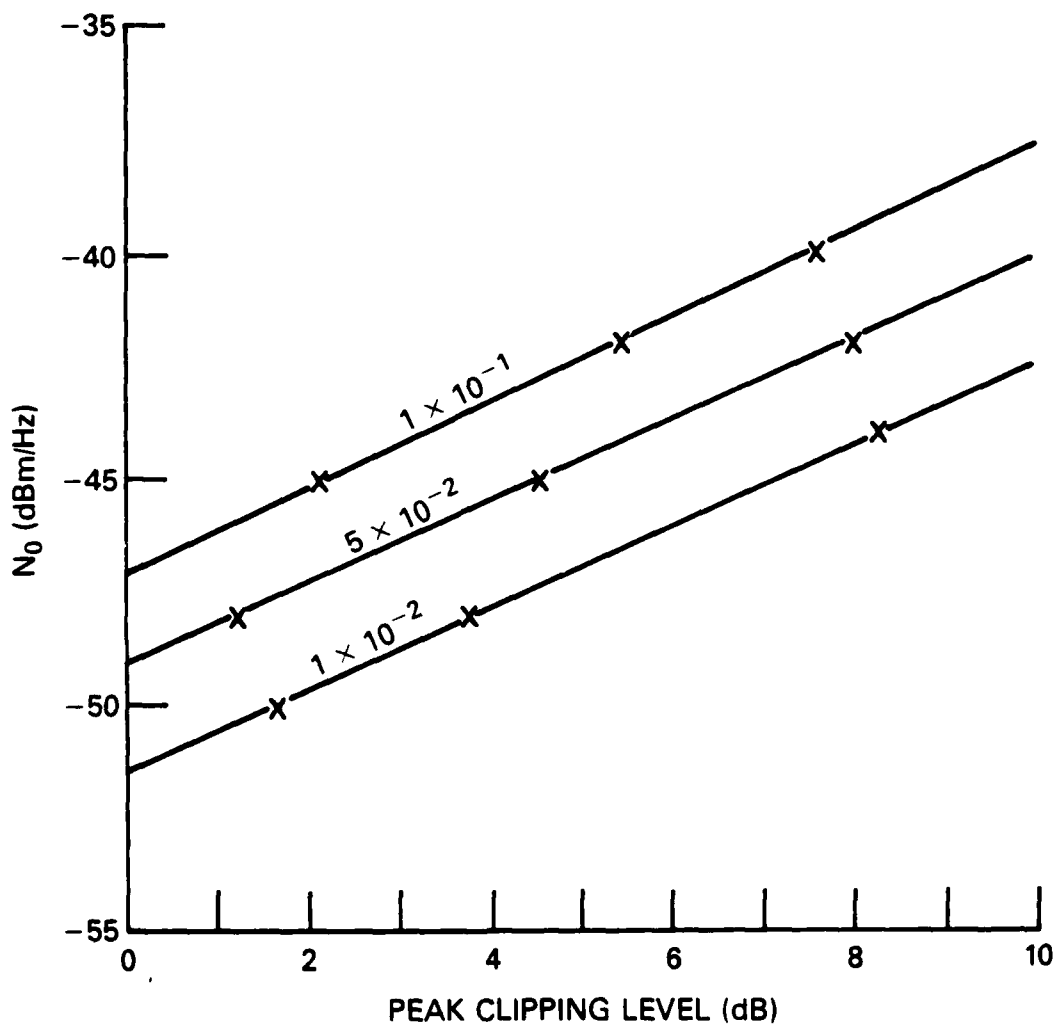

Fig. 7 — Trade-off of additive noise density versus clipping level for a constant bit error rate, for uncoded voice

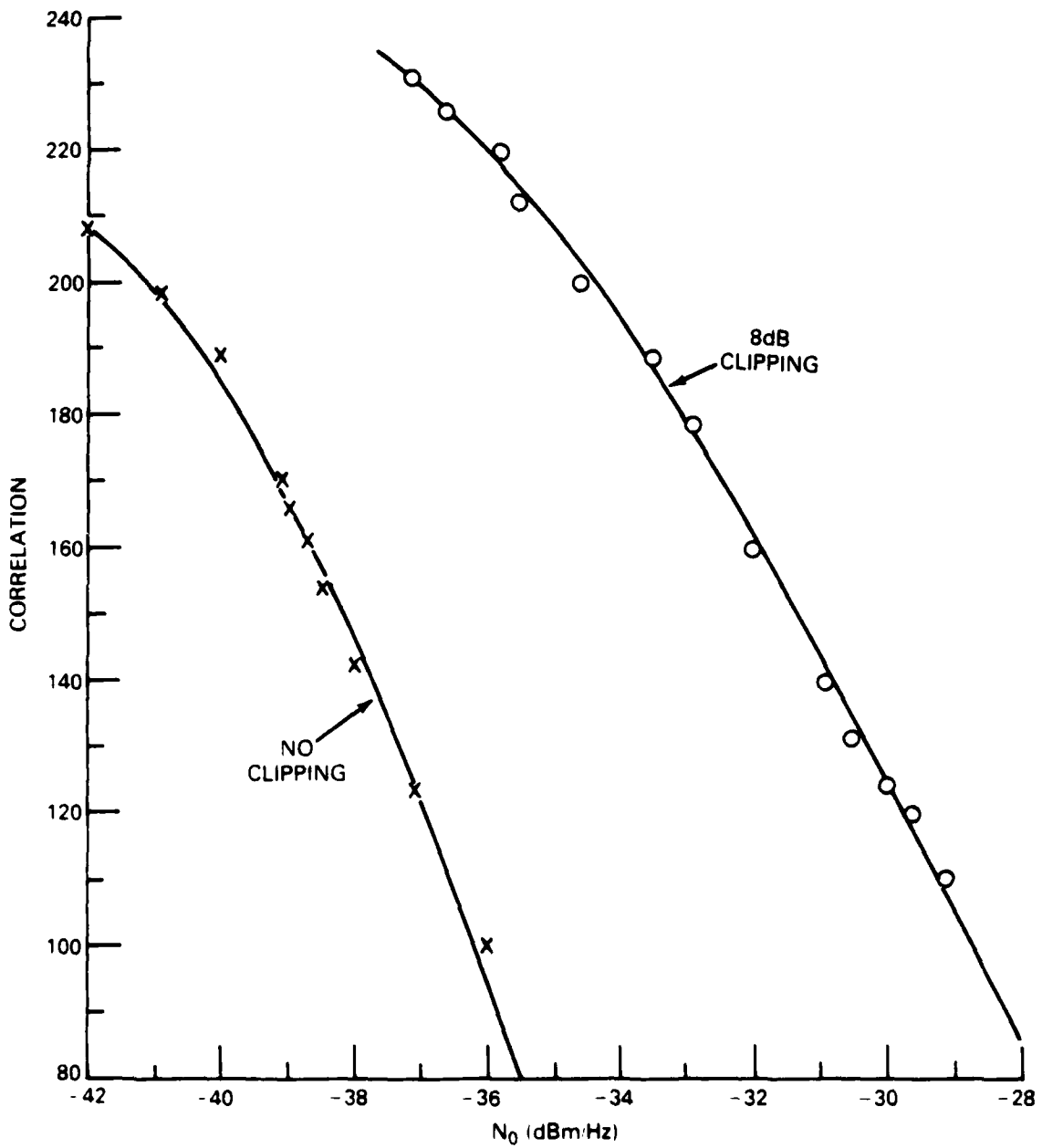

Fig. 8 - Correlation on PN sequence versus N_0 , for constant clipping level

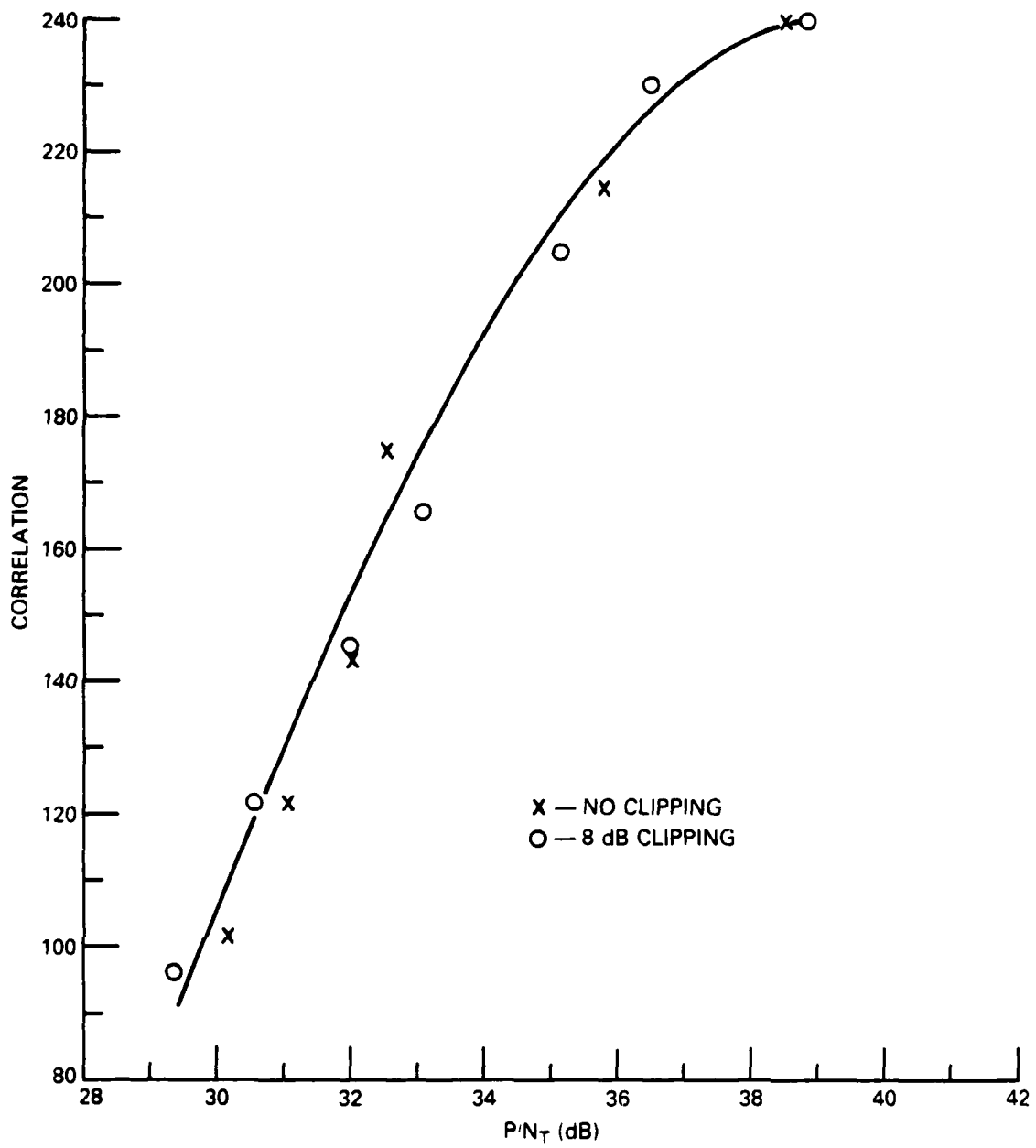

Fig. 9 — Correlation on PN sequence versus P/N_T

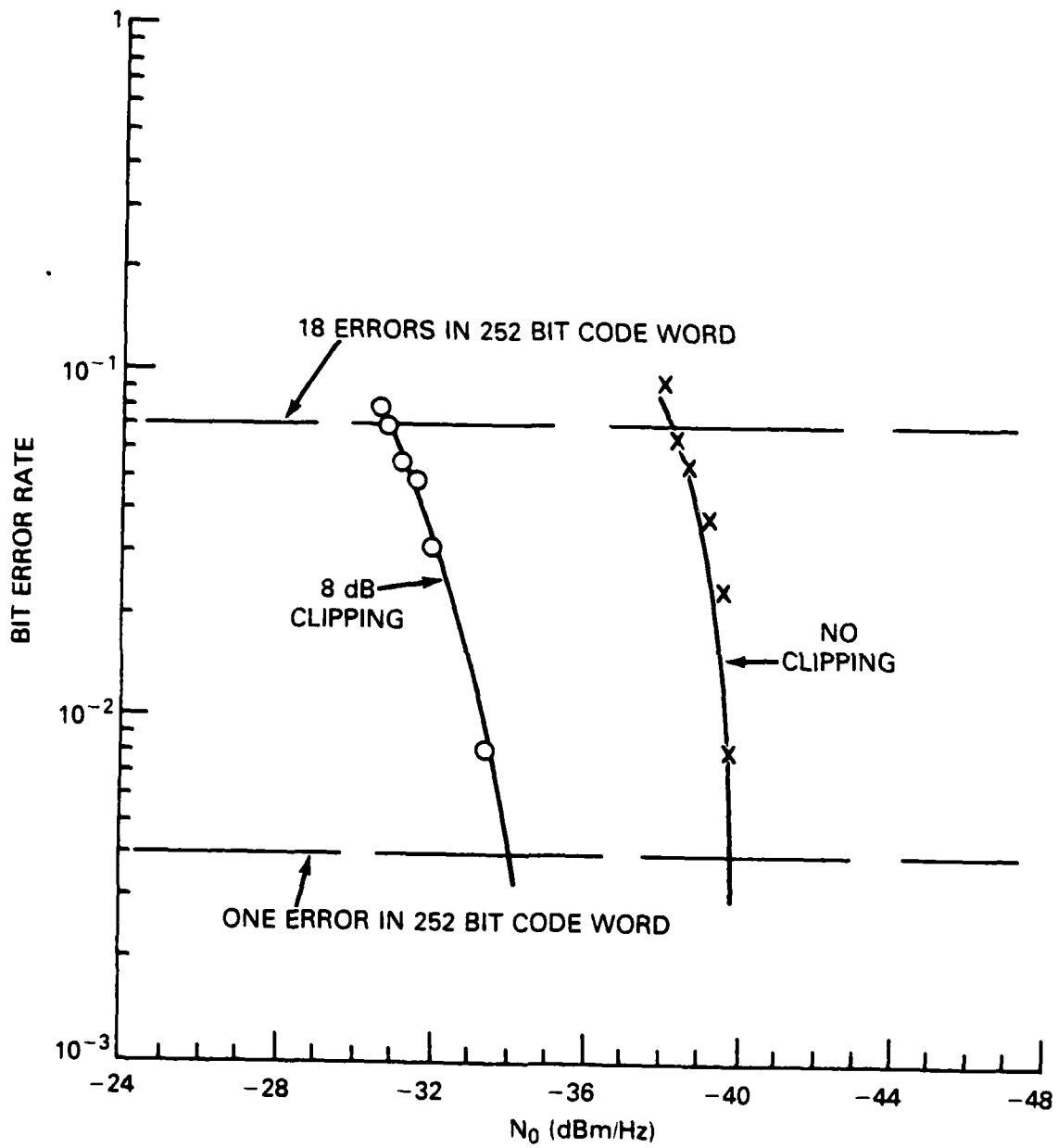

Fig. 10 — Bit error rate on message indicator before decoding versus N_0 , for constant clipping level

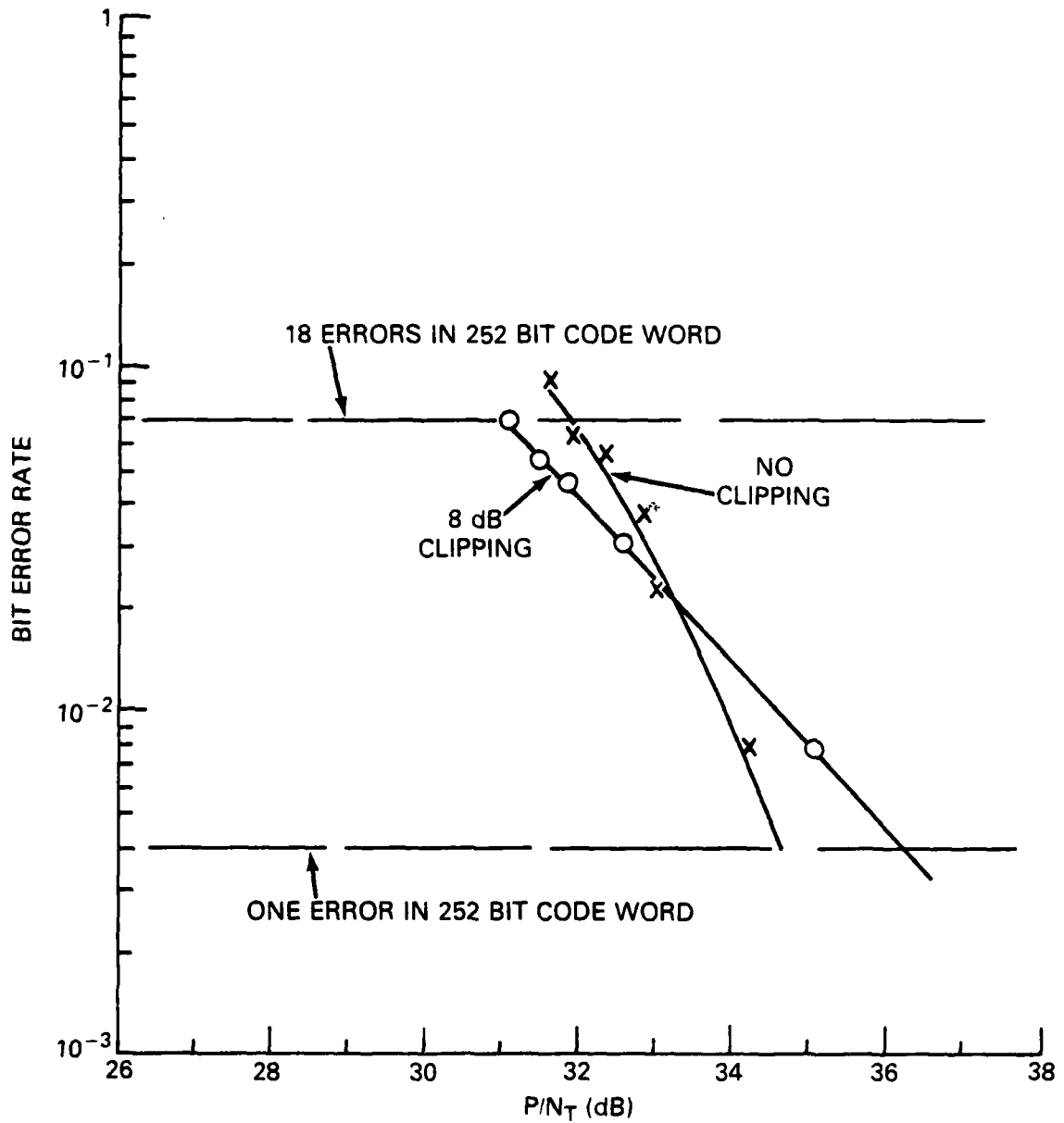

Fig. 11 — Bit error rate on message indicator before decoding versus P/N_T , for constant clipping level

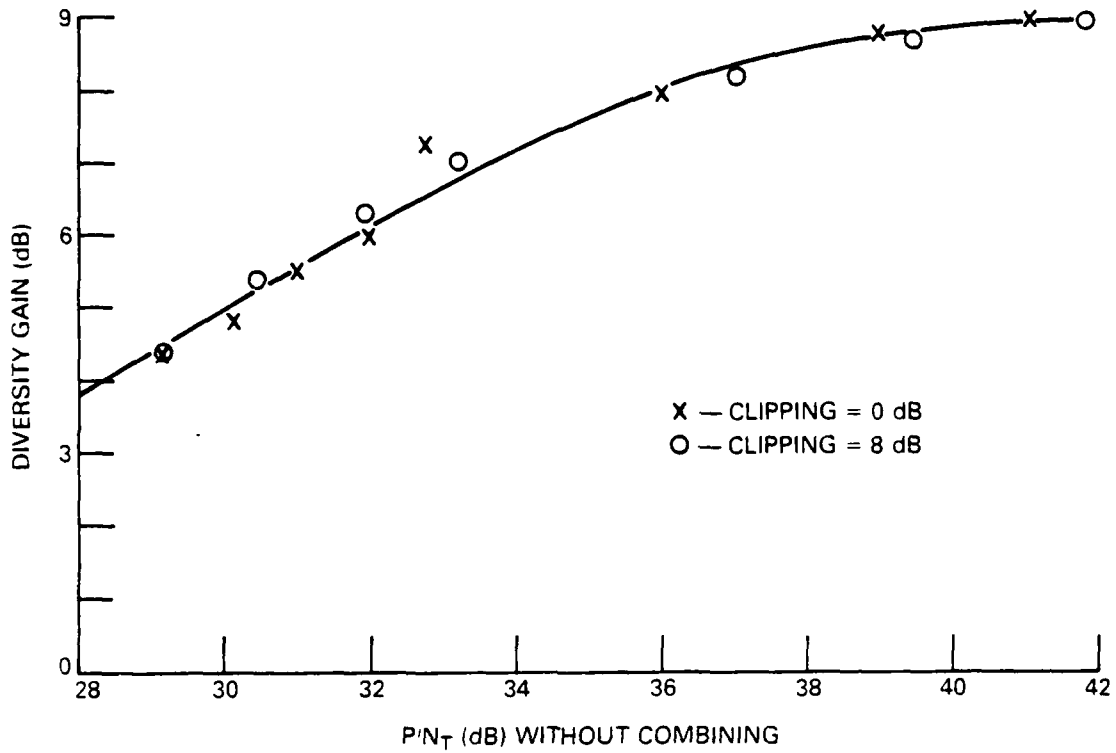

Fig. 12 — Diversity gain on message indicator versus P/N_T without combining, for constant clipping level

V. CONCLUSIONS

Tests with the ANDVT hf modem in Gaussian noise conditions indicate that a significant advantage can be achieved by applying some peak clipping to the 16 tone and 39 tone analog waveform for operation in peak power limited circuits.

The correlation threshold for the 240 bit PN sequence was set at 96. That corresponded to a 30% bit error rate on the biphase modulated, 16 tone signal. For that operating condition, the use of 8 dB of peak clipping resulted in a 7.4 dB increase in operating range. This may be seen in figure 8 where the noise level could be increased from -36 dBm/Hz to -28.6 dBm/Hz for increases in the clipping level from zero dBm to 8 dB.

The (252, 128) BCH decoder will provide a valid decode word for bit error rates less than 7.1%. For that operating condition, the use of 8 dB of peak clipping resulted in approximately 7.3 dB increase in operating range. This may be seen in figure 10 where the noise level could be increased from -38.1 dBm/Hz to -30.8 dBm/Hz for increases in the clipping level from zero dBm to 8 dB.

The threshold of operation in the digital voice mode is for a bit error rate on the uncoded bits in the range of 1% to 10%. From figure 7 it may be seen that to obtain a bit error rate of 5×10^{-2} on the uncoded bits requires a noise level of -49 dBm/Hz when no peak clipping is used. It required a noise level as high as -40 dBm/Hz when 10 dB of clipping was used. That was an increase in operating range of 9 dB. A comparable increase was obtained at a bit error rate of 1×10^{-2} .

VI. RECOMMENDATIONS

It is recommended that some peak clipping be applied to both the 16 tone and the 39 tone signal of the ANDVT hf modem. Clipping levels of approximately 8.0 dB for the 16 tone signal and 9.5 dB for the 39 tone signal are considered optimum.

REFERENCES

1. "Peak Distribution Analysis of Multitone Systems", Harris F. Rush and Hugo M. Beck, NRL Memorandum Report 1253, 8 December 1961.
2. "Phasing and/or Clipping Tones for a Peak Amplitude Limitation", Albert H. Nuttall, NUSC Technical Report 4921, 5 May 1975.
3. "Generating Random Number Having Probability Distributions Occurring in Signal Detection Problems", George M. Dillard, IEEE Transactions on Information Theory, October 1967.

